

# MARKS PUBLISHED FOR OPPOSITION

The following marks are published in compliance with section 12(a) of the Trademark Act of 1946. Applications for the registration of marks in more than one class have been filed as provided in section 30 of said act as amended by Public Law 772, 87th Congress, approved Oct. 9, 1962, 76 Stat. 769. Opposition under section 13 may be filed within thirty days of the date of this publication. See rules 2.101 to 2.105.

A separate fee of three hundred dollars (\$300.00) for opposing each mark in each class must accompany the opposition.

## SECTION 1.— INTERNATIONAL CLASSIFICATION

The short titles associated below with the international class numbers are terms designed merely for quick identification and are not an official part of the international classification. The full names of international classes are given in section 6.1 of the trademark rules of practice.

The designation "U.S. Cl." appearing in this section refers to the U.S. class in effect prior to Sep. 1, 1973 rather than the international class which applies to applications filed on or after that date. For adoption of international classification see notice in the OFFICIAL GAZETTE of Jun. 26, 1973 (911 O.G. TM 210).

### Application in more than one class

SN 76-712,917. MULTI PARTS SUPPLY USA. INC., JUPITER, FL. FILED 11-26-2012.

### **Opportunity. The Sum of Our Parts.**

THE MARK CONSISTS OF STANDARD CHARACTERS WITHOUT CLAIM TO ANY PARTICULAR FONT, STYLE, SIZE, OR COLOR.

#### CLASS 7—MACHINERY

FOR BALANCE SHAFTS IN THE NATURE OF AUTOMOBILE ENGINE COMPONENTS TIED TO THE CRANKSHAFT SYSTEM CHAINS, BALANCE SHAFT GUIDES, BALANCE SHAFT SPROCKETS, BALANCE SHAFT TENSIONERS; EXHAUST GAS RECIRCULATION (EGR) VALVES FOR AUTOMOBILES, POSITIVE CRANKCASE VENTILATION (PCV) VALVES AND IDLE AIR CONTROL (IAC) VALVES FOR AUTOMOBILES; FUEL PRESSURE REGULATING VALVES FOR AUTOMOBILES; STRUCTURAL PARTS FOR AUTOMOBILES IN THE NATURE OF AUTOMOBILE ENGINE BLOCK BREATHER VALVES; AUXILIARY FAN CONTROL UNITS; SENSORS FOR AUTOMOBILES, NAMELY, EXHAUST GAS RECIRCULATION (EGR) AND EXHAUST GAS RECIRCULATION (EGR) SENSORS AS ELECTRICAL SENSORS SOLD AS AN INTEGRAL PART OF THE EXHAUST SYSTEM; AIR PUMP CHECK VALVES; STRUCTURAL PARTS OF AUTOMOBILES IN THE NATURE OF COLD START VALVES, HEATER VALVES AND IGNITION PICK UP COILS; HYDRAULIC TIMING TENSIONERS WHICH ARE HYDRAULIC CYLINDERS USED FOR APPLYING A TENSIONING FORCE TO DRIVE BELTS, TIMING BELT TENSIONERS, TIMING BELT PULLEYS, TIMING CHAINS, TIMING CHAIN TENSIONERS, TIMING CHAIN KITS CONTAINING TIMING CHAINS, TIMING GUIDES, TIMING GEARS AND SPROCKETS, TIMING DAMPERS, TIMING CHAIN TENSIONERS, TIMING RELATED SEALS AND GASKETS, TIMING BELT KITS INCLUDING TIMING BELTS, HYDRAULIC TIMING TENSIONERS, TIMING PULLEYS, TIMING BELT TENSIONERS AND WATER PUMPS, TIMING CHAIN CRANKSHAFT GEARS, TIMING CHAIN CAMSHAFT GEARS, TIMING BELTS, CAMSHAFT TENSIONERS, CRANKSHAFT PULLEYS, TIMING CHAIN GUIDES; AUTOMOBILE TURBOCHARGERS AND THEIR STRUCTURAL PARTS, NAMELY, TURBOCHARGER WASTE GATES, TURBOCHARGER PRESSURE REGULATORS, TURBOCHARGER SOLENOIDS, TURBOCHARGER CARTRIDGE ASSEMBLIES AND TURBOCHARGER IMPELLER HOUSING ASSEMBLIES; AIR FILTERS FOR AUTOMOBILE ENGINES AND CABINS AND OIL AND FUEL FILTERS; ELECTRIC FUEL PUMPS AND MECHANICAL FUEL PUMPS

FOR AUTOMOBILES; FUEL RAILS FOR ENGINES FOR DELIVERING FUEL TO AUTOMOBILE FUEL INJECTORS; INTERNAL COMBUSTION ENGINE LAND VEHICLE PARTS, NAMELY, DISTRIBUTOR CAPS AND ASSEMBLIES FOR AUTOMOBILES, IGNITION ROTORS, IGNITION POINTS, IGNITION CONDENSERS AND IGNITION COILS FOR AUTOMOBILES; MECHANICAL AND ELECTRICAL WATER PUMPS FOR AUTOMOBILES; IGNITION SWITCHES FOR AUTOMOBILES (U.S. CLS. 13, 19, 21, 23, 31, 34 AND 35).

FIRST USE 10-24-2012; IN COMMERCE 10-25-2012.

#### CLASS 9—ELECTRICAL AND SCIENTIFIC APPARATUS

FOR ELECTRIC THERMO FAN SWITCHES AND WATER TEMPERATURE SWITCHES FOR AUTOMOBILE THERMOSTAT HOUSINGS AND THERMOSTATS FOR AUTOMOBILES; VACUUM SOLENOIDS; AND IDLE STOP SOLENOIDS AS STRUCTURAL PARTS OF AUTOMOBILES; ELECTRONIC CONTROL UNITS (ECU) COMPRISING AN ELECTRONIC CONTROL UNIT THAT MONITORS ENGINE PERFORMANCES AND DELIVERS RE-CALCULATED VALUES TO ADJUST ENGINE PERFORMANCE; AIR TEMPERATURE SENSORS, OIL LEVEL SENSORS, WATER TEMPERATURE SENSORS, COOLANT TEMPERATURE SENSORS FOR AUTOMOBILES; AUTOMOBILE WIPER MOTORS; ELECTRIC FUSE BOXES (U.S. CLS. 21, 23, 26, 36 AND 38).

FIRST USE 10-24-2012; IN COMMERCE 10-25-2012.

#### CLASS 12—VEHICLES

FOR FAN CLUTCHES FOR LAND VEHICLES; LAND VEHICLE PARTS, FOR AFTERMARKET REPLACEMENT OF ORIGINAL AUTOMOTIVE PARTS, IN THE NATURE OF AUTOMOTIVE AND ENGINE PARTS AND COMPONENTS, NAMELY, BRAKE CALIPERS AND STRUCTURAL REPLACEMENT PARTS, BRAKE CYLINDERS, BRAKE DRUMS, BRAKE LINES AND CLAMPS, BRAKE LININGS, BRAKE ROTORS, BRAKE SHOE AND PAD STEEL BLANKS, BRAKE SHOES AND PADS, BRAKE HYDRAULIC HOSES, BRAKE MASTER CYLINDER KITS AND STRUCTURAL REPLACEMENT PARTS AND BRAKE MASTER CYLINDERS, BRAKE VACUUM PUMPS, ABS BRAKE VEHICLE SPEED SENSORS, CLUTCH COVERS AND DISKS, CLUTCH MASTER CYLINDERS AND CLUTCH SLAVE CYLINDERS, AUTOMOBILE STEERING AND SUSPENSION SYSTEMS, NAMELY, BALL JOINTS AND REPLACEMENT PARTS, CONTROL ARMS AND STRUCTURAL REPLACEMENT PARTS, DRAG LINKS IN THE NATURE OF A CHASSIS STEERING COMPONENT FORMING PART OF THE STEERING LINKAGE WITH BALL JOINTS AND TIE RODS, IDLE ARM GUSSETS AND IDLER ARMS,

MOTOR AND TRANSMISSION MOUNTS, RACK AND PINION GEARS, RACK ENDS, SHOCK ABSORBERS AND STRUTS, STRUT STRUCTURAL REPLACEMENT PARTS, LEAF SPRINGS AS LAND VEHICLE PARTS, SUSPENSION SYSTEMS FOR AUTOMOBILES COMPRISED OF COIL SPRINGS, STABILIZER LINKS, STEERING UNIVERSAL JOINTS, STEERING UNITS AND PARTS THEREOF, STEERING DAMPERS AND TIE RODS, AXLE BEARINGS AND AXLE HUBS FOR LAND VEHICLES, OIL PUMP GEARS FOR VEHICLES; WATER PUMP SPROCKETS FOR LAND VEHICLES; OVERRUNNING ALTERNATOR BELT PULLEYS FOR LAND VEHICLES, CLUTCHED ALTERNATOR BELT PULLEYS FOR LAND VEHICLES, ALTERNATOR DECOUPLING BELT PULLEYS FOR LAND VEHICLES; HEADLIGHTS, TURN SIGNALS AND WIPERS ON SINGLE STALK FOR AUTOMOBILES; STRUCTURAL PARTS FOR AUTOMOBILES IN THE NATURE OF FUEL MODULE, FUEL HANGER AND FUEL SENDER ASSEMBLIES, FUEL STRAINERS, FUEL PRESSURE REGULATORS, FUEL HARNESSSES, AND FUEL INJECTORS, WATER OUTLETS; CLUTCH RELEASE ARMS FOR AUTOMOBILES; POWERTRAIN CONTROL MODULES FOR AUTOMOBILES, POWER STEERING RACKS FOR AUTOMOBILES, POWER STEERING HOSES FOR AUTOMOBILES AND POWER STEERING PUMPS FOR AUTOMOBILES; WHEEL BEARINGS, WHEEL SEALS, HUB BEARINGS AND WHEEL BEARING KITS AND HUB BEARING KITS COMPRISING WHEEL OR HUB BEARING ASSEMBLIES AND INSTALLATION RELATED COMPONENT HARDWARE FOR LAND VEHICLES, NAMELY, AUTOMOBILES; THROTTLE BODIES, CAMSHAFT SENSORS, KNOCK SENSORS, TRANSMISSION VEHICLE SPEED SENSORS, MANIFOLD ABSOLUTE PRESSURE (MAP) SENSORS, AIR CHARGE SENSORS, OXYGEN SENSORS, THROTTLE POSITION SENSORS AND VEHICLE SPEED SENSORS FOR LAND VEHICLES, NAMELY, AUTOMOBILES, SOLD AS AN INTEGRAL PART OF AN AUTOMOBILE (U.S. CLS. 19, 21, 23, 31, 35 AND 44).

FIRST USE 10-24-2012; IN COMMERCE 10-25-2012.  
WILLIAM ROSSMAN, EXAMINING ATTORNEY

SN 76-712,918. MULTI PARTS SUPPLY USA, INC., JUPITER, FL. FILED 11-26-2012.



NO CLAIM IS MADE TO THE EXCLUSIVE RIGHT TO USE "MULTI PARTS SUPPLY AFTERMARKET AUTO PARTS", APART FROM THE MARK AS SHOWN.

STYLIZED RENDITION OF LETTERS "MPS" WITH LETTER "S" TRAILING UNDERNEATH LETTERS "M" AND "P" IN A STYLIZED DEPICTION OF A ROAD, PLUS WORDS "MULTI PARTS SUPPLY," AS DEPICTED IN ATTACHED DRAWING

## CLASS 7—MACHINERY

FOR BALANCE SHAFTS IN THE NATURE OF AUTOMOBILE ENGINE COMPONENTS TIED TO THE CRANKSHAFT SYSTEM CHAINS, BALANCE SHAFT GUIDES, BALANCE SHAFT SPROCKETS, BALANCE SHAFT TENSIONERS; EXHAUST GAS RECIRCULATION (EGR) VALVES FOR AUTOMOBILES, POSITIVE CRANKCASE VENTILATION (PCV) VALVES AND IDLE AIR CONTROL (IAC) VALVES FOR AUTOMOBILES; FUEL PRESSURE REGULATING VALVES FOR AUTOMOBILES; STRUCTURAL PARTS FOR AUTOMOBILES IN THE NATURE OF AUTOMOBILE ENGINE BLOCK BREATHER VALVES; AUXILIARY FAN CONTROL UNITS; SENSORS FOR AUTOMOBILES, NAMELY, EXHAUST GAS RECIRCULATION (EGR) AND EXHAUST GAS RECIRCULATION (EGR) SENSORS AS ELECTRICAL SENSORS SOLD AS AN INTEGRAL PART OF THE EXHAUST SYSTEM; AIR PUMP CHECK VALVES; STRUCTURAL PARTS OF AUTOMOBILES IN THE NATURE OF COLD START VALVES, HEATER VALVES AND IGNITION PICK UP COILS; HYDRAULIC TIMING TENSIONERS WHICH ARE HYDRAULIC CYLINDERS USED FOR APPLYING A TENSIONING FORCE TO DRIVE BELTS, TIMING BELT TENSIONERS, TIMING BELT PULLEYS, TIMING CHAINS, TIMING CHAIN TENSIONERS, TIMING CHAIN KITS CONTAINING TIMING CHAINS, TIMING GUIDES, TIMING GEARS AND SPROCKETS, TIMING DAMPERS, TIMING CHAIN TENSIONERS, TIMING RELATED SEALS AND GASKETS, TIMING BELT KITS INCLUDING TIMING BELTS, HYDRAULIC TIMING TENSIONERS, TIMING PULLEYS, TIMING BELT TENSIONERS AND WATER PUMPS, TIMING CHAIN CRANKSHAFT GEARS, TIMING CHAIN CAMSHAFT GEARS, TIMING BELTS, CAMSHAFT TENSIONERS, CRANKSHAFT PULLEYS, TIMING CHAIN GUIDES; AUTOMOBILE TURBOCHARGERS AND THEIR STRUCTURAL PARTS, NAMELY, TURBOCHARGER WASTE GATES, TURBOCHARGER PRESSURE REGULATORS, TURBOCHARGER SOLENOIDS, TURBOCHARGER CARTRIDGE ASSEMBLIES AND TURBOCHARGER IMPELLER HOUSING ASSEMBLIES; AIR FILTERS FOR AUTOMOBILE ENGINES AND CABINS AND OIL AND FUEL FILTERS; ELECTRIC FUEL PUMPS AND MECHANICAL FUEL PUMPS FOR AUTOMOBILES; FUEL RAILS FOR ENGINES FOR DELIVERING FUEL TO AUTOMOBILE FUEL INJECTORS; INTERNAL COMBUSTION ENGINE LAND VEHICLE PARTS, NAMELY, DISTRIBUTOR CAPS AND ASSEMBLIES FOR AUTOMOBILES, IGNITION ROTORS, IGNITION POINTS, IGNITION CONDENSERS AND IGNITION COILS FOR AUTOMOBILES; MECHANICAL AND ELECTRICAL WATER PUMPS FOR AUTOMOBILES; IGNITION SWITCHES FOR AUTOMOBILES (U.S. CLS. 13, 19, 21, 23, 31, 34 AND 35).

FIRST USE 10-24-2012; IN COMMERCE 10-25-2012.

## CLASS 9—ELECTRICAL AND SCIENTIFIC APPARATUS

FOR ELECTRIC THERMO FAN SWITCHES AND WATER TEMPERATURE SWITCHES FOR AUTOMOBILE THERMOSTAT HOUSINGS AND THERMOSTATS FOR AUTOMOBILES; VACUUM SOLENOIDS; AND IDLE STOP SOLENOIDS AS STRUCTURAL PARTS OF AUTOMOBILES; ELECTRONIC CONTROL UNITS (ECU) COMPRISING AN ELECTRONIC CONTROL UNIT THAT MONITORS ENGINE PERFORMANCES AND DELIVERS RE-CALCULATED VALUES TO ADJUST ENGINE PERFORMANCE; AIR TEMPERATURE SENSORS, OIL LEVEL SENSORS, WATER TEMPERATURE SENSORS, COOLANT TEMPERATURE SENSORS FOR AUTOMOBILES; AUTOMOBILE WIPER MOTORS; ELECTRIC FUSE BOXES (U.S. CLS. 21, 23, 26, 36 AND 38).

FIRST USE 10-24-2012; IN COMMERCE 10-25-2012.



**CLASS 12—VEHICLES**

FOR FAN CLUTCHES FOR LAND VEHICLES; LAND VEHICLE PARTS, FOR AFTERMARKET REPLACEMENT OF ORIGINAL AUTOMOTIVE PARTS, IN THE NATURE OF AUTOMOTIVE AND ENGINE PARTS AND COMPONENTS, NAMELY, BRAKE CALIPERS AND STRUCTURAL REPLACEMENT PARTS, BRAKE CYLINDERS, BRAKE DRUMS, BRAKE LINES AND CLAMPS, BRAKE LININGS, BRAKE ROTORS, BRAKE SHOE AND PAD STEEL BLANKS, BRAKE SHOES AND PADS, BRAKE HYDRAULIC HOSES, BRAKE MASTER CYLINDER KITS AND STRUCTURAL REPLACEMENT PARTS AND BRAKE MASTER CYLINDERS, BRAKE VACUUM PUMPS, ABS BRAKE VEHICLE SPEED SENSORS, CLUTCH COVERS AND DISKS, CLUTCH MASTER CYLINDERS AND CLUTCH SLAVE CYLINDERS, AUTOMOBILE STEERING AND SUSPENSION SYSTEMS, NAMELY, BALL JOINTS AND REPLACEMENT PARTS, CONTROL ARMS AND STRUCTURAL REPLACEMENT PARTS, DRAG LINKS IN THE NATURE OF A CHASSIS STEERING COMPONENT FORMING PART OF THE STEERING LINKAGE WITH BALL JOINTS AND TIE RODS, IDLE ARM GUSSETS AND IDLER ARMS, MOTOR AND TRANSMISSION MOUNTS, RACK AND PINION GEARS, RACK ENDS, SHOCK ABSORBERS AND STRUTS, STRUT STRUCTURAL REPLACEMENT PARTS, LEAF SPRINGS AS LAND VEHICLE PARTS, SUSPENSION SYSTEMS FOR AUTOMOBILES COMPRISED OF COIL SPRINGS, STABILIZER LINKS, STEERING UNIVERSAL JOINTS, STEERING UNITS AND PARTS THEREOF, STEERING DAMPERS AND TIE RODS, AXLE BEARINGS AND AXLE HUBS FOR LAND VEHICLES, OIL PUMP GEARS FOR VEHICLES; WATER PUMP SPROCKETS FOR LAND VEHICLES; OVERRUNNING ALTERNATOR BELT PULLEYS FOR LAND VEHICLES, CLUTCHED ALTERNATOR BELT PULLEYS FOR LAND VEHICLES, ALTERNATOR DECOUPLING BELT PULLEYS FOR LAND VEHICLES; HEADLIGHTS, TURN SIGNALS AND WIPERS ON SINGLE STALK FOR AUTOMOBILES; STRUCTURAL PARTS FOR AUTOMOBILES IN THE NATURE OF FUEL MODULE, FUEL HANGER AND FUEL SENDER ASSEMBLIES, FUEL STRAINERS, FUEL PRESSURE REGULATORS, FUEL HARNESSSES, AND FUEL INJECTORS, WATER OUTLETS; CLUTCH RELEASE ARMS FOR AUTOMOBILES; POWERTRAIN CONTROL MODULES FOR AUTOMOBILES, POWER STEERING RACKS FOR AUTOMOBILES, POWER STEERING HOSES FOR AUTOMOBILES AND POWER STEERING PUMPS FOR AUTOMOBILES; WHEEL BEARINGS, WHEEL SEALS, HUB BEARINGS AND WHEEL BEARING KITS AND HUB BEARING KITS COMPRISING WHEEL OR HUB BEARING ASSEMBLIES AND INSTALLATION RELATED COMPONENT HARDWARE FOR LAND VEHICLES, NAMELY, AUTOMOBILES; THROTTLE BODIES, CAMSHAFT SENSORS, KNOCK SENSORS, TRANSMISSION VEHICLE SPEED SENSORS, MANIFOLD ABSOLUTE PRESSURE (MAP) SENSORS, AIR CHARGE SENSORS, OXYGEN SENSORS, THROTTLE POSITION SENSORS AND VEHICLE SPEED SENSORS FOR LAND VEHICLES, NAMELY, AUTOMOBILES, SOLD AS AN INTEGRAL PART OF AN AUTOMOBILE (U.S. CLS. 19, 21, 23, 31, 35 AND 44).

FIRST USE 10-24-2012; IN COMMERCE 10-25-2012.  
WILLIAM ROSSMAN, EXAMINING ATTORNEY

SN 76-714,825. LIBERATE IDEAS, INC., MONTCLAIR, NJ.  
FILED 8-26-2013.

**liberate**health

THE MARK CONSISTS OF THE WORDING "LIBERATE-HEALTH" AND THE LETTER "T" HAS BEEN ALTERED AND THE FIRST LETTER "E" HAS BEEN ROTATED 1800 AND REVERSED IN PLACE.

**CLASS 9—ELECTRICAL AND SCIENTIFIC APPARATUS**

FOR DOWNLOADABLE MOBILE APPLICATIONS FOR USE BY PHYSICIANS FEATURING INTERACTIVE MEDICAL AND HEALTHCARE INFORMATION IN THE NATURE OF VIDEOS, GRAPHICS, VISUALS, AUDIO, DRAWINGS, ANNOTATIONS, AND EXPLANATIONS OF MEDICAL CONDITIONS, TREATMENTS, AND PROCEDURES; DOWNLOADABLE MOBILE APPLICATIONS FOR USE BY PHYSICIANS TO PRODUCE VIDEO RECORDINGS OF PATIENT VISITS; DOWNLOADABLE MOBILE APPLICATIONS FOR USE BY PHYSICIANS TO CREATE AND SHARE MEDICAL AND HEALTHCARE INFORMATION WITH PATIENTS (U.S. CLS. 21, 23, 26, 36 AND 38).

FIRST USE 11-30-2013; IN COMMERCE 11-30-2013.

**CLASS 44—MEDICAL, BEAUTY AND AGRICULTURAL SERVICES**

FOR PROVIDING AN INTERACTIVE WEBSITE FEATURING MEDICAL INFORMATION FOR USE BY PHYSICIANS TO EDUCATE PATIENTS ABOUT THEIR DISEASES, CONDITIONS AND THEIR TREATMENT; PROVIDING AN INTERACTIVE WEBSITE FEATURING MEDICAL AND HEALTHCARE INFORMATION FOR PATIENTS IN THE FIELD OF HEALTH, WELLNESS, MEDICAL CONDITIONS, TREATMENTS, AND PROCEDURES; PROVIDING AN INTERACTIVE WEBSITE FEATURING MEDICAL AND HEALTHCARE INFORMATION IN THE NATURE OF VIDEO RECORDINGS OF PATIENT VISITS (U.S. CLS. 100 AND 101).

FIRST USE 9-30-2013; IN COMMERCE 9-30-2013.  
PRISCILLA MILTON, EXAMINING ATTORNEY

SN 76-714,869. KVH HAYWARD INC., HAYWARD, WI.  
FILED 9-3-2013.

**RETREAT HOME**

THE MARK CONSISTS OF STANDARD CHARACTERS WITHOUT CLAIM TO ANY PARTICULAR FONT, STYLE, SIZE, OR COLOR.

NO CLAIM IS MADE TO THE EXCLUSIVE RIGHT TO USE "HOME", APART FROM THE MARK AS SHOWN.

**CLASS 11—ENVIRONMENTAL CONTROL APPARATUS**

FOR LIGHTING FIXTURES, LAMPS, SCONCES AND CHANDELIERS (U.S. CLS. 13, 21, 23, 31 AND 34).

**CLASS 20—FURNITURE AND ARTICLES NOT OTHERWISE CLASSIFIED**

FOR FURNITURE (U.S. CLS. 2, 13, 22, 25, 32 AND 50).

**CLASS 35—ADVERTISING AND BUSINESS**

FOR RETAIL FURNITURE AND LIGHTING STORE SERVICES (U.S. CLS. 100, 101 AND 102).  
DANIEL CAPSHAW, EXAMINING ATTORNEY

SN 76-715,166. EDUCATIONAL OPPORTUNITIES, INC.,  
MULBERRY, FL. FILED 10-15-2013.

## The Jerusalem Center for Biblical Studies

THE MARK CONSISTS OF STANDARD CHARACTERS  
WITHOUT CLAIM TO ANY PARTICULAR FONT, STYLE,  
SIZE, OR COLOR.  
SEC. 2(F).

### CLASS 39—TRANSPORTATION AND STORAGE

FOR TRAVEL TOUR OPERATING AND ORGANIZING (U.S. CLS. 100 AND 105).  
FIRST USE 12-31-1983; IN COMMERCE 12-31-1983.

### CLASS 41—EDUCATION AND ENTERTAINMENT

FOR EDUCATIONAL SERVICES, NAMELY, CONDUCTING LECTURES AND STUDY GROUPS RELATED TO RELIGIOUS HISTORY AND HERITAGE IN OTHER COUNTRIES AND CONFERENCES IN THE FIELD OF BIBLE STUDIES (U.S. CLS. 100, 101 AND 107).  
FIRST USE 12-31-1983; IN COMMERCE 12-31-1983.  
AMY C. KEAN, EXAMINING ATTORNEY

SN 76-715,474. STILLEY, JENNY, SUMMERFIELD, NC. AND  
GOLIMOWSKI, PATRICK, SUMMERFIELD, NC. FILED  
11-29-2013.

# BOHOBLU

THE MARK CONSISTS OF STANDARD CHARACTERS  
WITHOUT CLAIM TO ANY PARTICULAR FONT, STYLE,  
SIZE, OR COLOR.

### CLASS 25—CLOTHING

FOR CLOTHING, NAMELY, SHIRTS, DRESSES, PANTS, SHORTS, HATS AND FOOTWEAR (U.S. CLS. 22 AND 39).  
FIRST USE 1-17-2012; IN COMMERCE 2-15-2012.

### CLASS 35—ADVERTISING AND BUSINESS

FOR RETAIL STORE SERVICES FEATURING APPAREL AND JEWELRY (U.S. CLS. 100, 101 AND 102).  
FIRST USE 1-17-2012; IN COMMERCE 2-15-2012.  
ODESSA BIBBINS, EXAMINING ATTORNEY

SN 76-715,584. NEW JERSEY TRANSIT CORPORATION,  
NEWARK, NJ. FILED 12-23-2013.

## NJ TRANSIT THE WAY TO GO

THE MARK CONSISTS OF STANDARD CHARACTERS  
WITHOUT CLAIM TO ANY PARTICULAR FONT, STYLE,  
SIZE, OR COLOR.

OWNER OF U.S. REG. NOS. 3,052,059 AND 3,067,046.  
NO CLAIM IS MADE TO THE EXCLUSIVE RIGHT TO  
USE "TRANSIT", APART FROM THE MARK AS SHOWN.  
SEC. 2(F) AS TO "NJ".

### CLASS 35—ADVERTISING AND BUSINESS

FOR PROMOTING THE GOODS AND SERVICES OF OTHERS THROUGH THE DISTRIBUTION OF DISCOUNT CARDS FOR THEATER, ENTERTAINMENT, SHOPPING DESTINATIONS, HOTEL AND RESORT ACCOMMODATIONS, SPORTS EVENTS AND NEW JERSEY AND PENNSYLVANIA AMUSEMENT PARKS (U.S. CLS. 100, 101 AND 102).  
FIRST USE 0-0-1992; IN COMMERCE 0-0-1992.

### CLASS 39—TRANSPORTATION AND STORAGE

FOR MASS TRANSIT FOR THE GENERAL PUBLIC AND TRAVEL INFORMATION SERVICES; TRAVEL SERVICES, NAMELY, TRANSPORTATION OF PASSENGERS BY BUS AND RAIL TO THEATER, ENTERTAINMENT, SHOPPING DESTINATIONS, HOTEL AND RESORT ACCOMMODATIONS, SPORTS EVENTS AND NEW JERSEY AND PENNSYLVANIA AMUSEMENT PARKS; ARRANGING AND CONDUCTING TRAVEL TOURS OF NEW YORK CITY (U.S. CLS. 100 AND 105).  
FIRST USE 0-0-1992; IN COMMERCE 0-0-1992.  
CURTIS FRENCH, EXAMINING ATTORNEY

SN 76-715,588. NEW JERSEY TRANSIT CORPORATION,  
NEWARK, NJ. FILED 12-23-2013.

# THE WAY TO GO

THE MARK CONSISTS OF STANDARD CHARACTERS  
WITHOUT CLAIM TO ANY PARTICULAR FONT, STYLE,  
SIZE, OR COLOR.

OWNER OF U.S. REG. NO. 3,067,046.

### CLASS 35—ADVERTISING AND BUSINESS

FOR PROMOTING THE GOODS AND SERVICES OF OTHERS THROUGH THE DISTRIBUTION OF DISCOUNT CARDS FOR THEATER, ENTERTAINMENT, SHOPPING DESTINATIONS, HOTEL AND RESORT ACCOMMODATIONS, SPORTS EVENTS AND NEW JERSEY AND PENNSYLVANIA AMUSEMENT PARKS (U.S. CLS. 100, 101 AND 102).  
FIRST USE 0-0-1992; IN COMMERCE 0-0-1992.

### CLASS 39—TRANSPORTATION AND STORAGE

FOR MASS TRANSIT FOR THE GENERAL PUBLIC AND TRAVEL INFORMATION SERVICES; TRAVEL SERVICES, NAMELY, TRANSPORTATION OF PASSENGERS BY BUS AND RAIL TO THEATER, ENTERTAINMENT, SHOPPING DESTINATIONS, HOTEL AND RESORT ACCOMMODATIONS, SPORTS EVENTS AND NEW JERSEY AND PENNSYLVANIA AMUSEMENT PARKS; ARRANGING AND CONDUCTING TRAVEL TOURS OF NEW YORK CITY (U.S. CLS. 100 AND 105).  
FIRST USE 0-0-1992; IN COMMERCE 0-0-1992.  
DAVID I, EXAMINING ATTORNEY

SN 76-715,590. NEW JERSEY TRANSIT CORPORATION,  
NEWARK, NJ. FILED 12-23-2013.



OWNER OF U.S. REG. NOS. 3,052,059 AND 3,067,046.  
NO CLAIM IS MADE TO THE EXCLUSIVE RIGHT TO  
USE "TRANSIT", APART FROM THE MARK AS SHOWN.  
THE MARK CONSISTS OF THE FOLLOWING: THE  
WORDING "NJ TRANSIT THE WAY TO GO" TO THE LEFT  
OF A QUADRILATERAL DESIGN FEATURING DIAGONAL  
LINING.  
SEC. 2(F) AS TO "NJ".

#### CLASS 35—ADVERTISING AND BUSINESS

FOR PROMOTING THE GOODS AND SERVICES OF  
OTHERS THROUGH THE DISTRIBUTION OF DIS-  
COUNT CARDS FOR THEATER, ENTERTAINMENT,  
SHOPPING DESTINATIONS, HOTEL AND RESORT  
ACCOMMODATIONS, SPORTS EVENTS AND NEW JER-  
SEY AND PENNSYLVANIA AMUSEMENT PARKS (U.S.  
CLS. 100, 101 AND 102).  
FIRST USE 0-0-1992; IN COMMERCE 0-0-1992.

#### CLASS 39—TRANSPORTATION AND STO- RAGE

FOR MASS TRANSIT FOR THE GENERAL PUBLIC  
AND TRAVEL INFORMATION SERVICES; TRAVEL  
SERVICES, NAMELY, TRANSPORTATION OF PASSEN-  
GERS BY BUS AND RAIL TO THEATER, ENTERTAIN-  
MENT, SHOPPING DESTINATIONS, HOTEL AND  
RESORT ACCOMMODATIONS, SPORTS EVENTS AND  
NEW JERSEY AND PENNSYLVANIA AMUSEMENT  
PARKS; ARRANGING AND CONDUCTING TRAVEL  
TOURS OF NEW YORK CITY (U.S. CLS. 100 AND 105).  
FIRST USE 0-0-1992; IN COMMERCE 0-0-1992.  
CURTIS FRENCH, EXAMINING ATTORNEY

SN 76-715,886. IRVING FARM COFFEE CO., INC., NEW  
YORK, NY. FILED 2-20-2014.



NO CLAIM IS MADE TO THE EXCLUSIVE RIGHT TO  
USE "FARM COFFEE ROASTERS", APART FROM THE  
MARK AS SHOWN.  
THE DESIGN CONSISTS OF A HAWK IN FLIGHT  
WITH OUTSPREAD WINGS ABOVE THE WORDS "IRVING  
FARM" WHICH ARE ABOVE THE WORDS "COFFEE  
ROASTERS" AND A SHADED SINGLE STAR WITH FIVE  
POINTS BENEATH THE WORDS "COFFEE ROASTERS".

#### CLASS 30—STAPLE FOODS

FOR COFFEE, ICED COFFEE, PREPARED COFFEE  
AND COFFEE-BASED BEVERAGES, ROASTED COFFEE  
BEANS, ESPRESSO, ESPRESSO DRINKS, SANDWICHES,  
BREAD AND CAKES (U.S. CL. 46).  
FIRST USE 11-1-2011; IN COMMERCE 11-1-2011.

#### CLASS 35—ADVERTISING AND BUSINESS

FOR RETAIL AND WHOLESALE STORE SERVICES  
AND DISTRIBUTION OF COFFEE BEANS (U.S. CLS.  
100, 101 AND 102).  
FIRST USE 11-1-2011; IN COMMERCE 11-1-2011.

#### CLASS 43—HOTEL AND RESTAURANT SER- VICES

FOR COFFEE SHOP, RESTAURANT AND CAFE  
SERVICES (U.S. CLS. 100 AND 101).  
FIRST USE 11-1-2011; IN COMMERCE 11-1-2011.  
DOMINIC J. FERRAIUOLO, EXAMINING ATTORNEY

SN 76-715,888. IRVING FARM COFFEE CO., INC., NEW  
YORK, NY. FILED 2-20-2014.



NO CLAIM IS MADE TO THE EXCLUSIVE RIGHT TO  
USE "HANDCRAFTED HUDSON VALLEY NEW YORK  
CITY FARM EST. 1996 COFFEE ROASTERS", APART  
FROM THE MARK AS SHOWN.

THE DESIGN CONSISTS OF A CREST WITH LETTERS,  
PUNCTUATION AND INSCRIPTIONS CONTAINED  
THEREIN. THE WORD "HANDCRAFTED" IS LOCATED  
JUST BENEATH THE INNER UPPER SECTION OF THE  
CREST, THE WORDS "HUDSON VALLEY - NEW YORK  
CITY" AND THE WORD "IRVING" IS WRITTEN IN A  
CURVED MANNER LOCATED BENEATH IT. BENEATH  
THE WORD "IRVING" IS THE WORD "FARM" LOCATED  
BETWEEN TWO SINGLE SHADED STARS WITH FIVE  
POINTS. THE WORDS "ESTD." AND "1996" HAVE DOUBLE  
UNDERLINES BOTH ABOVE AND BELOW EACH WORD  
WITH A HAWK IN FLIGHT WITH OUTSPREAD WINGS  
BETWEEN "ESTD." AND "1996". THE WORDS "COFFEE  
ROASTERS" ARE LOCATED ON THE INNER LOWER  
SECTION OF THE CREST WITH THE SINGLE SHADED  
STAR WITH FIVE POINTS BETWEEN "COFFEE" AND  
"ROASTERS".

#### CLASS 30—STAPLE FOODS

FOR COFFEE, ICED COFFEE, PREPARED COFFEE  
AND COFFEE-BASED BEVERAGES, ROASTED COFFEE  
BEANS, ESPRESSO, ESPRESSO DRINKS, SANDWICHES,  
BREAD AND CAKES (U.S. CL. 46).  
FIRST USE 11-1-2011; IN COMMERCE 11-1-2011.

**CLASS 43—HOTEL AND RESTAURANT SERVICES**

FOR COFFEE SHOP, RESTAURANT AND CAFE SERVICES (U.S. CLS. 100 AND 101).  
FIRST USE 11-1-2011; IN COMMERCE 11-1-2011.  
DOMINIC J. FERRAIUOLO, EXAMINING ATTORNEY

**CLASS 42—SCIENTIFIC AND COMPUTER SERVICES**

FOR TRUCK STOP SERVICES FEATURING AUTOMOBILE AND TRUCK INSPECTIONS (U.S. CLS. 100 AND 101).  
FIRST USE 3-2-2011; IN COMMERCE 3-2-2011.  
KATHLEEN LORENZO, EXAMINING ATTORNEY

SN 76-715,979. AMBEST, INC., BRENTWOOD, TN. FILED 3-11-2014.



NO CLAIM IS MADE TO THE EXCLUSIVE RIGHT TO USE "SERVICE", APART FROM THE MARK AS SHOWN.  
THE MARK CONSISTS OF THE WORDS "SERVICE CONNECTION" IN CAPITAL LETTERS AND WITH THE WORDS SEPARATED BY A CIRCULAR DESIGN OF TWO INTERLOCKING WRENCHES ON A BACKGROUND PICTURE OF A NOTCHED WHEEL.

**CLASS 35—ADVERTISING AND BUSINESS**

FOR PROVIDING A SEARCHABLE CENTRALIZED DATABASE OF CUSTOMER SERVICE HISTORIES CONTAINING SERVICE RECORDS OF SERVICES, MAINTENANCES, INSPECTIONS, REPAIRS AND PURCHASES FOR NATIONWIDE ACCESS BY A SELECTED NETWORK OF AUTHORIZED AND CERTIFIED SERVICE TECHNICIANS AND EXPERTS WHO OPERATE AT PROVIDED ONSITE TRUCK SERVICE CENTER LOCATIONS; RETAIL STORE SERVICES FEATURING DIESEL FUEL, TRUCK DRIVER AMENITIES, CONVENIENCE STORE ITEMS, AND TRUCK SUPPLIES; BUSINESS SERVICES FOR A CENTRALIZED NETWORK OF NATIONWIDE ONSITE SERVICE CENTER LOCATIONS, NAMELY, MANAGEMENT OF CUSTOMER SERVICE RECORDS, MANAGEMENT OF CUSTOMER BILLING SERVICES, DATA MANAGEMENT OF CUSTOMER PAYMENT COLLECTION SERVICES (U.S. CLS. 100, 101 AND 102).

FIRST USE 3-2-2011; IN COMMERCE 3-2-2011.

**CLASS 36—INSURANCE AND FINANCIAL**

FOR MANAGEMENT OF CUSTOMER PAYMENT COLLECTION SERVICES, NAMELY, DEBT COLLECTION (U.S. CLS. 100, 101 AND 102).

FIRST USE 3-2-2011; IN COMMERCE 3-2-2011.

**CLASS 37—CONSTRUCTION AND REPAIR**

FOR TRUCK STOP SERVICES, NAMELY, PROVIDING TRUCK AND AUTOMOBILE REPAIR AND MAINTENANCE SERVICES; EMERGENCY ROADSIDE ASSISTANCE SERVICES, NAMELY, RESPONDING TO CALLS FOR ROADSIDE ASSISTANCE, FLAT TIRE CHANGING, EMERGENCY FUEL SUPPLYING, AND BATTERY JUMP STARTING (U.S. CLS. 100, 103 AND 106).

FIRST USE 3-2-2011; IN COMMERCE 3-2-2011.

**CLASS 39—TRANSPORTATION AND STORAGE**

FOR EMERGENCY ROADSIDE ASSISTANCE SERVICES, NAMELY, TOWING, WINCH-OUT AND KEY DELIVERY SERVICES (U.S. CLS. 100 AND 105).

FIRST USE 3-2-2011; IN COMMERCE 3-2-2011.

SN 76-715,980. AMBEST, INC., BRENTWOOD, TN. FILED 3-11-2014.



OWNER OF U.S. REG. NOS. 2,126,669, 3,850,303 AND OTHERS.

NO CLAIM IS MADE TO THE EXCLUSIVE RIGHT TO USE "SERVICE CENTERS", APART FROM THE MARK AS SHOWN.

THE MARK CONSISTS OF THE LARGE FONT ALL CAPS WORD "AMBEST" STACKED ON THE SMALL FONT ALL CAPS WORD "SERVICECENTERS". A DESIGN OF A SMALL STAR IS LAYERED ON TOP OF THE STRAIGHT EDGES OF THE ADJACENT LETTERING OF "M" AND "B". TO THE LEFT OF THE STACKED WORDING IS A DESIGN OF A DRAWING OF A WRENCH HEAD LAYERED ON A BACKGROUND OF A DRAWING OF A COG WHEEL.

**CLASS 37—CONSTRUCTION AND REPAIR**

FOR TRUCK STOP SERVICES, NAMELY, PROVIDING TRUCK AND AUTOMOBILE REPAIR AND MAINTENANCE SERVICES (U.S. CLS. 100, 103 AND 106).

FIRST USE 11-4-2009; IN COMMERCE 11-4-2009.

**CLASS 42—SCIENTIFIC AND COMPUTER SERVICES**

FOR TRUCK STOP SERVICES FEATURING AUTOMOBILE AND TRUCK INSPECTIONS (U.S. CLS. 100 AND 101).

FIRST USE 11-4-2009; IN COMMERCE 11-4-2009.

YAT SYE, LEE, EXAMINING ATTORNEY

SN 76-716,314. DUCK COMMANDER, INC., WEST MONROE, LA. FILED 5-6-2014.

**STRUT COMMANDER**

THE MARK CONSISTS OF STANDARD CHARACTERS WITHOUT CLAIM TO ANY PARTICULAR FONT, STYLE, SIZE, OR COLOR.

**CLASS 25—CLOTHING**

FOR CLOTHING, NAMELY, SPORTSWEAR, NAMELY, SHIRTS, PANTS; ACTIVEWEAR, NAMELY, SHIRTS, PANTS; OUTERWEAR, NAMELY, COATS, JACKETS, RAIN COATS, WINDBREAKERS; PANTS, JACKETS, SWEATSHIRTS, JEANS, GRAPHIC TEE SHIRTS, SHIRTS, SHORTS, SWIMWEAR; SPORTSWEAR, NAMELY, TIES, SPORTS JACKETS; FOOTWEAR FOR MEN; HEADWEAR FOR MEN, NAMELY, HATS, CAPS, BANDANAS; ACCESSORIES, NAMELY, SOCKS, SCARVES, BELTS, COLD WEATHER HEADWEAR; COLD WEATHERWEAR IN THE NATURE OF COATS, JACKETS, MITTENS, SCARVES, SOCKS, GLOVES, THERMAL UNDERWEAR (U.S. CLS. 22 AND 39).

**CLASS 26—FANCY GOODS**

FOR PONY TAIL HOLDERS, NAMELY, HAIR ELASTICS; BELT BUCKLES (U.S. CLS. 37, 39, 40, 42 AND 50).  
JESSICA A. POWERS, EXAMINING ATTORNEY

SN 77-162,044. THE ARTICLE 19 GROUP INC., MONTREAL, QUEBEC, CANADA, FILED 4-20-2007.



PRIORITY CLAIMED UNDER SEC. 44(D) ON CANADA APPLICATION NO. 1338723, FILED 3-9-2007, REG. NO. TMA855076, DATED 7-12-2013, EXPIRES 7-12-2028.

THE MARK CONSISTS OF A PICTURE OF A WOMAN WITH A HEART BACKGROUND OVER THE WORDS "CARRIE THE CAREGIVER".

**CLASS 9—ELECTRICAL AND SCIENTIFIC APPARATUS**

FOR VIDEO GAME PROGRAMS; VIDEO GAME SOFTWARE; COMPUTER SCREEN SAVER SOFTWARE (U.S. CLS. 21, 23, 26, 36 AND 38).

**CLASS 25—CLOTHING**

FOR CLOTHING, NAMELY, JACKETS, COATS, DRESSES, BELTS, SHOES, SLIPPERS, SANDALS, BOOTS, GLOVES, HATS, JACKETS, MITTENS, PANTS, PONCHOS, RAINCOATS, SCARVES, SHIRTS, SHORTS, SWEATERS, SLEEPWEAR, PAJAMAS, SOCKS, SWEAT SHIRTS, T-SHIRTS, HALLOWEEN COSTUMES, BANDANAS, EARMUFFS, HATS, BERETS, VISORS, BASEBALL CAPS, CAPS; SPORTSWEAR, NAMELY, WARM-UP SUITS, GYM SHORTS, SKI WEAR; SWIMWEAR, BATHING SUITS, SWIMMING TRUNKS, BATHROBES, BEACH WEAR (U.S. CLS. 22 AND 39).

**CLASS 35—ADVERTISING AND BUSINESS**

FOR WHOLESALE DISTRIBUTORSHIP SERVICES IN THE FIELD OF CDS, DVDS AND VIDEOS FEATURING MUSIC, GAMES AND ENTERTAINMENT (U.S. CLS. 100, 101 AND 102).

**CLASS 38—COMMUNICATION**

FOR STREAMING OF AUDIO AND VIDEO MATERIAL ON THE INTERNET (U.S. CLS. 100, 101 AND 104).

**CLASS 41—EDUCATION AND ENTERTAINMENT**

FOR ENTERTAINMENT IN THE NATURE OF ANIMATED ON-GOING TELEVISION PROGRAMS, TELEVISION SERIES AND MOTION PICTURE FILMS FOR CHILDREN; PROVIDING ON-LINE INTERACTIVE CHILDREN'S STORIES, ELECTRONIC GAMES AND PUZZLES, AND ELECTRONIC CRAFT GAMES; PROVIDING ON-LINE NON-DOWNLOADABLE PRE-RECORDED MUSIC AND MUSIC VIDEOS, AND ENTERTAINMENT INFORMATION RELATED THERE-TO; PRODUCTION OF PRERECORDED CDS, DVDS AND VIDEOS FEATURING MUSIC, GAMES AND ENTERTAINMENT (U.S. CLS. 100, 101 AND 107).

TARAH HARDY, EXAMINING ATTORNEY

SN 77-162,053. THE ARTICLE 19 GROUP INC., MONTREAL, QUEBEC, CANADA, FILED 4-20-2007.

**CARRIE THE CAREGIVER**

THE MARK CONSISTS OF STANDARD CHARACTERS WITHOUT CLAIM TO ANY PARTICULAR FONT, STYLE, SIZE, OR COLOR.

PRIORITY CLAIMED UNDER SEC. 44(D) ON CANADA APPLICATION NO. 1338721, FILED 3-9-2007, REG. NO. TMA855075, DATED 7-12-2013, EXPIRES 7-12-2028.

**CLASS 9—ELECTRICAL AND SCIENTIFIC APPARATUS**

FOR VIDEO GAME PROGRAMS; VIDEO GAME SOFTWARE; COMPUTER SCREEN SAVER SOFTWARE (U.S. CLS. 21, 23, 26, 36 AND 38).

**CLASS 25—CLOTHING**

FOR CLOTHING, NAMELY, JACKETS, COATS, DRESSES, BELTS, SHOES, SLIPPERS, SANDALS, BOOTS, GLOVES, HATS, JACKETS, MITTENS, PANTS, PONCHOS, RAINCOATS, SCARVES, SHIRTS, SHORTS, SWEATERS, SLEEPWEAR, PAJAMAS, SOCKS, SWEAT SHIRTS, T-SHIRTS, HALLOWEEN COSTUMES, BANDANAS, EARMUFFS, HATS, BERETS, VISORS, BASEBALL CAPS, CAPS; SPORTSWEAR, NAMELY, WARM-UP SUITS, GYM SHORTS, SKI WEAR; SWIMWEAR, BATHING SUITS, SWIMMING TRUNKS, BATHROBES, BEACH WEAR (U.S. CLS. 22 AND 39).

**CLASS 35—ADVERTISING AND BUSINESS**

FOR WHOLESALE DISTRIBUTORSHIP SERVICES IN THE FIELD OF CDS, DVDS AND VIDEOS FEATURING MUSIC, GAMES AND ENTERTAINMENT (U.S. CLS. 100, 101 AND 102).

**CLASS 38—COMMUNICATION**

FOR STREAMING OF AUDIO AND VIDEO MATERIAL ON THE INTERNET (U.S. CLS. 100, 101 AND 104).

**CLASS 41—EDUCATION AND ENTERTAINMENT**

FOR ENTERTAINMENT IN THE NATURE OF ANIMATED ON-GOING TELEVISION PROGRAMS, TELEVISION SERIES AND MOTION PICTURE FILMS FOR CHILDREN; PROVIDING ON-LINE INTERACTIVE CHILDREN'S STORIES, ELECTRONIC GAMES AND PUZZLES, AND ELECTRONIC CRAFT GAMES; PROVIDING ON-LINE NON-DOWNLOADABLE PRE-RECORDED MUSIC AND MUSIC VIDEOS, AND ENTERTAINMENT INFORMATION RELATED THERETO; PRODUCTION OF PRERECORDED CDS, DVDS AND VIDEOS FEATURING MUSIC, GAMES AND ENTERTAINMENT (U.S. CLS. 100, 101 AND 107).

TARAH HARDY, EXAMINING ATTORNEY

SN 77-732,779. EVASC MEDICAL SYSTEMS CORP., VANCOUVER, CANADA, FILED 5-8-2009.

# EVASC

THE MARK CONSISTS OF STANDARD CHARACTERS WITHOUT CLAIM TO ANY PARTICULAR FONT, STYLE, SIZE, OR COLOR.

PRIORITY CLAIMED UNDER SEC. 44(D) ON CANADA APPLICATION NO. 1418171, FILED 11-13-2008.

OWNER OF U.S. REG. NO. 3,438,404.

SN 77-561,072. ALPARGATAS S.A., SAO PAULO, BRAZIL, FILED 9-3-2008.



PRIORITY CLAIMED UNDER SEC. 44(D) ON BRAZIL APPLICATION NO. 901131377, FILED 8-21-2008, REG. NO. 901131377, DATED 11-29-2011, EXPIRES 11-29-2021.

PRIORITY CLAIMED UNDER SEC. 44(D) ON BRAZIL APPLICATION NO. 901130729, FILED 8-21-2008, REG. NO. 901130729, DATED 11-29-2011, EXPIRES 11-29-2021.

THE COLOR(S) BROWN, BEIGE, TEAL AND ORANGE IS/ARE CLAIMED AS A FEATURE OF THE MARK.

THE MARK CONSISTS OF SEVEN LINES IN DIFFERENT COLORS. FROM TOP TO BOTTOM, THE LINES APPEAR IN THE FOLLOWING COLORS: BROWN, BEIGE, TEAL, ORANGE, TEAL, BEIGE, AND BROWN. THE LINES ARE EVEN ON THE LEFT BUT FORM A POINT ON THE RIGHT. THE COLOR WHITE IS A TRANSPARENT BACKGROUND THAT IS NOT PART OF THE MARK.

**CLASS 25—CLOTHING**

FOR GARMENTS, NAMELY, SHORTS, JACKETS, BERMUDA SHORTS, KNICKERS, T-SHIRTS, JOGGING SUITS, DRESSES, SWEAT PANTS, SWEAT SHIRTS, STOCKINGS, CAPS, SOCKS, UNDERPANTS, UNIFORMS, POLO SHIRTS, SOCIAL SHIRTS, SOCIAL PANTS, SPORTS PANTS, BIKINIS, BODY LINEN, BODY SHAPERS, BODY STOCKINGS, BODY SUITS, LONG SKIRTS, SHORT SKIRTS, SUN VISORS, HATS, OVERCOATS, COATS, SUITS, BLAZERS, PARKAS, GLOVES; FOOTWEAR, NAMELY, TENNIS SHOES, SPORTS SHOES, SHOES FOR PRACTICING SPORTS, SOCCER SHOES, BOOTS FOR PRACTICING SPORTS, BOOTS, ANKLE BOOTS, GYMNASICS SHOES, BATHING SANDALS, BATHING THONGS, SANDALS AND SOCIAL SHOES (U.S. CLS. 22 AND 39).

**CLASS 28—TOYS AND SPORTING GOODS**

FOR ELBOW GUARDS FOR ATHLETIC USE, KNEE GUARDS FOR ATHLETIC USE; GLOVES, NAMELY, BASEBALL GLOVES, BATTING GLOVES, BOXING GLOVES, FENCING GLOVES, AND GOLF GLOVES; PLAY BALLS; SHINBONE GUARDS FOR ATHLETIC USE; BALLS FOR SPORTS (U.S. CLS. 22, 23, 38 AND 50).

KIM MONINGHOFF, EXAMINING ATTORNEY

**CLASS 10—MEDICAL APPARATUS**

FOR MEDICAL DEVICES, NAMELY, STENTS, STENT GRAFTS, VASCULAR IMPLANTS COMPOSED OF ARTIFICIAL MATERIALS, CATHETERS, CATHETER BALLOONS, GUIDE WIRES, AND POSITIONING DEVICES THEREFOR (U.S. CLS. 26, 39 AND 44).

FIRST USE 2-2-2012; IN COMMERCE 2-2-2012.

**CLASS 37—CONSTRUCTION AND REPAIR**

FOR ELECTRO-POLISHING SERVICES, NAMELY, ELECTRO-POLISHING OF MEDICAL DEVICES AND INSTRUMENTS (U.S. CLS. 100, 103 AND 106).

FIRST USE 8-0-2007; IN COMMERCE 8-0-2007.

**CLASS 40—MATERIAL TREATMENT**

FOR LASER CUTTING SERVICES, NAMELY, CUTTING AND TREATMENT OF MATERIALS AND PARTS FOR MEDICAL DEVICES AND INSTRUMENTS BY LASER BEAM (U.S. CLS. 100, 103 AND 106).

FIRST USE 8-0-2007; IN COMMERCE 8-0-2007.

ANDREA K. NADELMAN, EXAMINING ATTORNEY

SN 77-845,820. ADVENT SYSTEMS, INC., ELMHURST, IL, FILED 10-9-2009.

# Advent Systems

THE MARK CONSISTS OF STANDARD CHARACTERS WITHOUT CLAIM TO ANY PARTICULAR FONT, STYLE, SIZE, OR COLOR.

NO CLAIM IS MADE TO THE EXCLUSIVE RIGHT TO USE "SYSTEMS", APART FROM THE MARK AS SHOWN.

**CLASS 37—CONSTRUCTION AND REPAIR**

FOR ELECTRICAL REPAIRS AND INSTALLATION OF SECURITY SYSTEMS, AUDIO/VISUAL SYSTEMS, ACCESS CONTROL AND BIOMETRIC SYSTEMS AND NOISE MASKING SYSTEMS (U.S. CLS. 100, 103 AND 106).

FIRST USE 6-3-1994; IN COMMERCE 6-3-1994.

**CLASS 42—SCIENTIFIC AND COMPUTER SERVICES**

FOR ELECTRONIC AND ELECTRICAL SYSTEMS DESIGN SERVICES (U.S. CLS. 100 AND 101).

FIRST USE 6-3-1994; IN COMMERCE 6-3-1994.

JACLYN KIDWELL WALKER, EXAMINING ATTORNEY

SN 77-846,627, GRUPO OSBORNE S.A., CADIZ, SPAIN,  
FILED 10-12-2009.



PRIORITY CLAIMED UNDER SEC. 44(D) ON ERPN  
CMNTY TM OFC APPLICATION NO. 008310534, FILED 5-  
20-2009, REG. NO. 008310534, DATED 3-6-2014, EXPIRES 5-20-  
2019.

THE MARK CONSISTS OF THE DESIGN OF A BULL  
IMMEDIATELY TO THE LEFT OF THE WORD "TORO",  
WHICH IS ABOVE THE WORD "OSBORNE".

THE ENGLISH TRANSLATION OF THE WORD "TORO"  
IN THE MARK IS "BULL".

#### CLASS 14—JEWELRY

FOR WATCHES, BRACELETS, JEWELRY (U.S. CLS. 2,  
27, 28 AND 50).

#### CLASS 25—CLOTHING

FOR T-SHIRTS, CAPS, SANDALS (U.S. CLS. 22 AND  
39).

KATHLEEN LORENZO, EXAMINING ATTORNEY

SN 77-933,735, TUBERT, ALFREDO HECTOR, BUENOS  
AIRES, ARGENTINA, FILED 2-11-2010.

# GADGELS

THE MARK CONSISTS OF STANDARD CHARACTERS  
WITHOUT CLAIM TO ANY PARTICULAR FONT, STYLE,  
SIZE, OR COLOR.

PRIORITY CLAIMED UNDER SEC. 44(D) ON ARGENTI-  
NA APPLICATION NO. 2971628, FILED 1-13-2010, REG. NO.  
2404619, DATED 10-29-2010, EXPIRES 10-29-2020.

PRIORITY CLAIMED UNDER SEC. 44(D) ON ARGENTI-  
NA APPLICATION NO. 2971629, FILED 1-13-2010, REG. NO.  
2404620, DATED 10-29-2010, EXPIRES 10-29-2020.

#### CLASS 20—FURNITURE AND ARTICLES NOT OTHERWISE CLASSIFIED

FOR MIRRORS; PHOTO FRAMES; HOLDERS,  
NAMELY, PLASTIC HOLDERS FOR SIGNBOARDS  
AND PHOTOGRAPHS; DISPLAYS, NAMELY, RACKS,  
DISPLAY STANDS, DISPLAYS IN THE FORM OF A  
FRAME OR HOLDER FOR DISPLAYING CLOTHING  
ACCESSORIES AND JEWELRY ACCESSORIES; PLASTIC  
DISPLAYS FOR JEWELRY AND MAKE UP AND PLAS-  
TIC SHELVES; PLASTIC DISPLAY SHELVES; NON-  
METAL FIXTURES IN THE NATURE OF HOOKS,  
HANGERS AND SHELVES MADE OF PLASTIC AND  
GEL ADHESIVE POLYMER FOR HANGING AND AF-  
FIXING GENERAL HOUSEHOLD GOODS TO SUR-  
FACES OF GLASS, METAL, TILE, AND PLEXIGLASS;  
GEL ADHESIVE DECORATIVE MOUNTING HARD-  
WARE IN THE NATURE OF HOOKS AND HANGERS;  
NON-METAL HOLDERS AND HOOKS FOR SHELVES,  
SIGNS, PHOTO FRAMES, DISPLAYS, DISPLAY  
STANDS, RACKS AND MIRRORS; DECORATIVE PLAS-  
TIC APPLIQUES FOR USE ON SURFACES OF GLASS,  
METAL, TILE, AND PLEXIGLASS; DECORATIVE GEL  
POLYMER ADHESIVE APPLIQUES FOR USE ON SUR-  
FACES OF GLASS, METAL, TILE, PLEXIGLASS; NON-  
METAL HOOKS FOR KITCHEN UTENSILS (U.S. CLS. 2,  
13, 22, 25, 32 AND 50).

#### CLASS 21—HOUSEWARES AND GLASS

FOR HOUSEHOLD AND KITCHEN CONTAINERS  
AND UTENSILS IN THE NATURE OF KITCHEN AND  
BATH ACCESSORIES, NAMELY, CUP HOLDERS, PA-  
PER TOWEL HOLDERS, TOILET PAPER HOLDERS,  
BATHROOM GLASS HOLDERS, TOOTHBRUSH  
HOLDERS, SOAP HOLDERS, SPONGE HOLDERS;  
HOUSEHOLD CONTAINERS FOR HOUSEHOLD OR  
KITCHEN USE NOT OF PRECIOUS METAL; PORCE-  
LAIN AND EARTHENWARE HOUSEHOLD CONTAIN-  
ERS AND HOLDERS; HOUSEHOLD CONTAINERS,  
NAMELY, PAPER TRAYS, AND VASES (U.S. CLS. 2,  
13, 23, 29, 30, 33, 40 AND 50).

LINDA E. BLOHM, EXAMINING ATTORNEY

SN 79-060,106, METROPOLE GESTION, F-75002 PARIS,  
FRANCE, FILED 9-3-2008.

#### METROPOLE INVESTMENT MANAGEMENT

THE MARK CONSISTS OF STANDARD CHARACTERS  
WITHOUT CLAIM TO ANY PARTICULAR FONT, STYLE,  
SIZE, OR COLOR.

OWNER OF INTERNATIONAL REGISTRATION 0980167  
DATED 9-3-2008, EXPIRES 9-3-2018.

OWNER OF U.S. REG. NOS. 3,472,522 AND 3,508,856.

NO CLAIM IS MADE TO THE EXCLUSIVE RIGHT TO  
USE "INVESTMENT MANAGEMENT", APART FROM THE  
MARK AS SHOWN.

THE ENGLISH TRANSLATION OF THE FOREIGN  
WORD(S) IN THE MARK IS: "METROPOLIS INVESTMENT  
MANAGEMENT".

#### CLASS 35—ADVERTISING AND BUSINESS

FOR BUSINESS MANAGEMENT AND ORGANIZA-  
TION CONSULTANCY; PROFESSIONAL BUSINESS  
CONSULTANCY; BUSINESS ACTIVITY MANAGEMENT  
ASSISTANCE; BUSINESS MANAGEMENT CONSUL-  
TANCY; PUBLICATION OF PUBLICITY TEXTS; DISSE-  
MINATION OF ADVERTISING MATTER; BUSINESS  
ADVICE AND INFORMATION; BUSINESS INFORMA-  
TION ENQUIRIES; DOCUMENT REPRODUCTION,  
NAMELY, REPRODUCTION OF NEWSLETTERS RE-  
LATING TO FINANCIAL, BANKING AND INSURANCE  
MATTERS (U.S. CLS. 100, 101 AND 102).

#### CLASS 36—INSURANCE AND FINANCIAL

FOR FINANCIAL AFFAIRS ANALYSIS; BANKING  
SERVICES; LIFE INSURANCE UNDERWRITING; IN-  
SURANCE CONSULTANCY; FINANCIAL CONSUL-  
TANCY; FINANCIAL AND INVESTMENT SERVICES,  
NAMELY, MANAGEMENT AND BROKERAGE IN THE  
FIELD OF STOCKS, BONDS, OPTIONS, COMMODITIES,  
FIXTURES AND OTHER SECURITIES, AND BROKER-  
AGE OF FINANCIAL PRODUCTS; FUND INVESTMENT;  
FINANCIAL ANALYSIS; FINANCIAL CONSULTING  
SERVICES; FINANCIAL PORTFOLIO MANAGEMENT;  
SECURITIES BROKERAGE; FINANCIAL INFORMA-  
TION AND EVALUATIONS RELATING TO INSURANCE  
AND BANKING; CAPITAL INVESTMENTS; INVEST-  
MENT SERVICES, NAMELY, ASSET MANAGEMENT  
SERVICES; MUTUAL FUNDS INVESTMENT; FUND  
INVESTMENT, ELECTRONIC FUNDS TRANSFER;  
FUND INVESTMENT, NAMELY, JOINT INVESTMENT  
FUNDS; UNIT TRUST MANAGEMENT; FINANCIAL  
TRUST OPERATIONS, NAMELY, CREATING UNIT  
TRUSTS; FINANCIAL MANAGEMENT; ACTUARIAL  
SERVICES; FINANCIAL MANAGEMENT ASSISTANCE  
PROVIDED TO THE FINANCIAL MANAGEMENT  
BODIES OF COMPANIES IN THE CONTEXT OF THEIR  
MAKING DECISIONS ABOUT THEIR FINANCIAL IN-  
VESTMENTS, IN PARTICULAR STOCK MARKETS (U.S.  
CLS. 100, 101 AND 102).

VIVIAN MICZNIK FIRST, EXAMINING ATTORNEY



SN 79-060,158. METROPOLE GESTION, F-75002 PARIS, FRANCE, FILED 9-3-2008.

### **METROPOLE MULTI MANAGEMENT**

THE MARK CONSISTS OF STANDARD CHARACTERS WITHOUT CLAIM TO ANY PARTICULAR FONT, STYLE, SIZE, OR COLOR.

PRIORITY DATE OF 6-3-2008 IS CLAIMED.

OWNER OF INTERNATIONAL REGISTRATION 0980340 DATED 9-3-2008, EXPIRES 9-3-2018.

OWNER OF U.S. REG. NOS. 3,472,522 AND 3,508,856.

NO CLAIM IS MADE TO THE EXCLUSIVE RIGHT TO USE "MULTI MANAGEMENT", APART FROM THE MARK AS SHOWN.

THE ENGLISH TRANSLATION OF THE FOREIGN WORD(S) IN THE MARK IS: "METROPOLIS MULTI MANAGEMENT".

### **CLASS 35—ADVERTISING AND BUSINESS**

FOR BUSINESS MANAGEMENT AND ORGANIZATION CONSULTANCY; PROFESSIONAL BUSINESS CONSULTANCY; BUSINESS ACTIVITY MANAGEMENT ASSISTANCE; BUSINESS MANAGEMENT CONSULTANCY; PUBLICATION OF PUBLICITY TEXTS; DISSEMINATION OF ADVERTISING MATTER; BUSINESS ADVICE AND INFORMATION; BUSINESS INFORMATION ENQUIRIES; DOCUMENT REPRODUCTION, NAMELY, REPRODUCTION OF NEWSLETTERS RELATING TO FINANCIAL, BANKING AND INSURANCE MATTERS (U.S. CLS. 100, 101 AND 102).

### **CLASS 36—INSURANCE AND FINANCIAL**

FOR FINANCIAL AFFAIRS ANALYSIS; BANKING SERVICES; LIFE INSURANCE UNDERWRITING; INSURANCE CONSULTANCY; FINANCIAL CONSULTANCY; FINANCIAL AND INVESTMENT SERVICES, NAMELY, MANAGEMENT AND BROKERAGE IN THE FIELD OF STOCKS, BONDS, OPTIONS, COMMODITIES, FIXTURES AND OTHER SECURITIES, AND BROKERAGE OF FINANCIAL PRODUCTS; FUND INVESTMENT; FINANCIAL ANALYSIS; FINANCIAL CONSULTING SERVICES; FINANCIAL PORTFOLIO MANAGEMENT; SECURITIES BROKERAGE; FINANCIAL INFORMATION AND EVALUATIONS RELATING TO INSURANCE AND BANKING; CAPITAL INVESTMENTS; INVESTMENT SERVICES, NAMELY, ASSET MANAGEMENT SERVICES; MUTUAL FUNDS INVESTMENT; FUND INVESTMENT, ELECTRONIC FUNDS TRANSFER; FUND INVESTMENT, NAMELY, JOINT INVESTMENT FUNDS; UNIT TRUST MANAGEMENT; FINANCIAL TRUST OPERATIONS, NAMELY, CREATING UNIT TRUSTS; FINANCIAL MANAGEMENT; ACTUARIAL SERVICES; FINANCIAL MANAGEMENT ASSISTANCE PROVIDED TO THE FINANCIAL MANAGEMENT BODIES OF COMPANIES IN THE CONTEXT OF THEIR MAKING DECISIONS ABOUT THEIR FINANCIAL INVESTMENTS, IN PARTICULAR STOCK MARKETS; PROVIDING FINANCIAL INFORMATION BY DISTRIBUTING NEWSLETTERS RELATING TO FINANCIAL, BANKING AND INSURANCE MATTERS (U.S. CLS. 100, 101 AND 102).

VIVIAN MICZNIK FIRST, EXAMINING ATTORNEY

SN 79-084,575. OBSHCHESTVO S OGRANICHENNOY OTVETSTVENNOSTYU "DELMER", S. VNUKOVO, RUSSIAN FED., FILED 12-10-2009.



OWNER OF INTERNATIONAL REGISTRATION 1043990 DATED 12-10-2009, EXPIRES 12-10-2019.

THE COLOR(S) GREEN, BLACK AND WHITE IS/ARE CLAIMED AS A FEATURE OF THE MARK.

THE MARK CONSISTS OF THE TERM "DELVIR" IN BLACK. A GREEN RING WITH SCALLOPED EDGING SURROUNDS THE "D". THE BACKGROUND OF THE MARK IS WHITE AND IN A RECTANGULAR SHAPE.

THE WORDING "DELVIR" HAS NO MEANING IN A FOREIGN LANGUAGE.

### **CLASS 3—COSMETICS AND CLEANING PREPARATIONS**

FOR BLEACHING PREPARATIONS FOR LAUNDRY USE; CLEANING, POLISHING, SCOURING AND ABRASIVE PREPARATIONS; SOAPS; PERFUMERY, ESSENTIAL OILS (U.S. CLS. 1, 4, 6, 50, 51 AND 52).

### **CLASS 7—MACHINERY**

FOR FANS FOR MOTORS AND ENGINES, DISINTEGRATORS, PUMP DIAPHRAGMS, AIR CONDENSERS, CAPSTANS, CALENDERS, SPRAY GUNS FOR PAINT, BOTTLE WASHING MACHINES, DISHWASHERS, COMPRESSED AIR MACHINES, ROAD SWEEPING MACHINES, VACUUM CLEANER BAGS, CLUTCHES OTHER THAN FOR LAND VEHICLES, VACUUM CLEANER ATTACHMENTS FOR DISSEMINATING PERFUMES AND DISINFECTANTS, ANTI-FRICTION PADS FOR MACHINES, HIGH PRESSURE WASHERS, CLEANING APPLIANCES UTILIZING STEAM, VACUUM CLEANERS, SEWAGE PULVERIZERS, AIR BRUSHES FOR APPLYING COLOUR, TURBINES OTHER THAN FOR LAND VEHICLES, HYDRAULIC TURBINES, TURBO-COMPRESSORS, CONNECTING RODS FOR MACHINES, MOTORS AND ENGINES; CENTRAL VACUUM CLEANING INSTALLATIONS, SUCTION MACHINES FOR INDUSTRIAL PURPOSES, VEHICLE WASHING INSTALLATIONS, DUST EXHAUSTING INSTALLATIONS FOR CLEANING PURPOSES, PNEUMATIC TUBE CONVEYORS DUST REMOVING INSTALLATIONS FOR CLEANING PURPOSES, AIR SUCTION MACHINES, DIVIDING MACHINES, ANTI-POLLUTION DEVICES FOR MOTORS AND ENGINES; FILTERS FOR CLEANING COOLING AIR, FOR ENGINES; VACUUM CLEANER HOSES; PARQUET WAX-POLISHERS, ELECTRIC (U.S. CLS. 13, 19, 21, 23, 31, 34 AND 35).

### **CLASS 11—ENVIRONMENTAL CONTROL APPARATUS**

FOR WATER HEATERS, AIR DEODORISING APPARATUS, IONISATION APPARATUS FOR THE TREATMENT OF AIR, HAND DRYING APPARATUS FOR WASHROOMS, WATER PURIFYING APPARATUS AND MACHINES, EXPANSION TANKS FOR CENTRAL HEATING INSTALLATIONS, REFINING TOWERS FOR DISTILLATION, ELECTRIC FANS FOR PERSONAL USE, WATER HEATERS, AIR REHEATERS, EXTRACTOR HOODS FOR KITCHENS; GAS CONDENSERS, OTHER THAT PARTS OF MACHINES; ACETYLENE GENERATORS, HYDRANTS, EVAPORATORS, AIR VALVES FOR STEAM HEATING INSTALLATIONS, THERMOSTATIC VALVES AS PARTS OF HEATING INSTALLATIONS, DISTILLATION COLUMNS, AIR CONDITIONING APPARATUS, WATERING MACHINES FOR AGRICULTURAL PURPOSES, HEATERS FOR BATHS, ANTI-SPLASH TAP NOZZLES, HEAT PUMPS, WATER FILTERING APPARATUS, AIR PURIFYING APPARATUS AND MACHINES, REGULATING ACCESSORIES FOR WATER OR GAS APPARATUS AND PIPES; WASHERS FOR WATER TAPS; STERILIZERS, WATER STERILIZERS, AIR STERILISERS, WATER-PIPES FOR SANITARY INSTALLATIONS, BATH INSTALLATIONS, AIR CONDITIONING INSTALLATIONS, AIR CONDITIONERS FOR VEHICLES, WATER PURIFICATION INSTALLATIONS, AIR FILTERING INSTALLATIONS, WATER SOFTENING APPARATUS AND INSTALLATIONS, HEATING INSTALLATIONS, HEATERS FOR VEHICLES, WATER HEATING INSTALLATIONS, AIR COOLING APPARATUS, FILTERS FOR AIR CONDITIONING, HEATING ELEMENTS (U.S. CLS. 13, 21, 23, 31 AND 34).



**CLASS 21—HOUSEWARES AND GLASS**

FOR BRUSH-MAKING MATERIALS; STEELWOOL (U.S. CLS. 2, 13, 23, 29, 30, 33, 40 AND 50).

**CLASS 35—ADVERTISING AND BUSINESS**

FOR ORGANIZATION OF EXHIBITIONS FOR COMMERCIAL OR ADVERTISING PURPOSES, ORGANIZATION OF TRADE FAIRS FOR COMMERCIAL OR ADVERTISING PURPOSES, SHOP WINDOW DRESSING, BUSINESS APPRAISALS, BUSINESS MANAGEMENT ASSISTANCE, COMMERCIAL OR INDUSTRIAL MANAGEMENT ASSISTANCE, SALES PROMOTION FOR OTHERS, OFFICE MACHINES AND EQUIPMENT RENTAL, PUBLICITY MATERIAL RENTAL, RENTAL OF VENDING MACHINES, OUTDOOR ADVERTISING, DISTRIBUTION OF SAMPLES, DISSEMINATION OF ADVERTISING MATTER, ADVERTISING, ON-LINE ADVERTISING ON A COMPUTER NETWORK, ADVERTISING BY MAIL ORDER, TELEVISION ADVERTISING, DOCUMENT REPRODUCTION; COMPILATION OF INFORMATION INTO COMPUTER DATABASES (U.S. CLS. 100, 101 AND 102).

**CLASS 37—CONSTRUCTION AND REPAIR**

FOR WINDOW CLEANING, VEHICLE MAINTENANCE, RENTAL OF CLEANING MACHINES, HEATING EQUIPMENT INSTALLATION AND REPAIR, AIR CONDITIONING APPARATUS INSTALLATION AND REPAIR, ELECTRIC APPLIANCE INSTALLATION AND REPAIR, MACHINERY INSTALLATION, MAINTENANCE AND REPAIR; CLEANING OF THE INTERIOR OF BUILDINGS, STREET CLEANING, BOILER CLEANING AND REPAIR (U.S. CLS. 100, 103 AND 106).

SAMUEL E. SHARPER JR., EXAMINING ATTORNEY

**CLASS 38—COMMUNICATION**

FOR TELECOMMUNICATIONS ACCESS SERVICES; INFORMATION ABOUT TELECOMMUNICATION; COMMUNICATIONS VIA COMPUTER TERMINALS AND VIA FIBER-OPTIC NETWORKS; RADIO AND TELEPHONE COMMUNICATIONS; COMMUNICATION BY COMPUTER TERMINALS VIA GLOBAL COMPUTER NETWORKS; ELECTRONIC TRANSMISSION OF DATA, TEXT, SOUND, IMAGE AND MULTIMEDIA CONTENT VIA GLOBAL COMPUTER NETWORKS, MOBILE RADIO TELEPHONE SERVICES; PROVIDING USER ACCESS TO A GLOBAL COMPUTER NETWORK; ELECTRONIC BULLETIN BOARD SERVICES; PROVIDING TELECOMMUNICATIONS CONNECTIONS TO A GLOBAL COMPUTER NETWORK, NEWS AGENCY SERVICES FOR ELECTRONIC TRANSMISSION; RENTAL OF TELECOMMUNICATION EQUIPMENT; RADIO AND TELEVISION BROADCASTING; TELECONFERENCING SERVICES; ELECTRONIC MESSAGING, RENTAL OF ACCESS TIME TO GLOBAL COMPUTER NETWORKS; INTERACTIVE, NAMELY, AUDIO, VIDEO AND TELEVISION BROADCASTING SERVICES RELATING TO THE PRESENTATION OF PHOTOGRAPHIC, GRAPHIC, AND AUDIOVISUAL WORKS OF ART; ELECTRONIC DATA TRANSMISSION OF IMAGES, PHOTOGRAPHS AND SOUND VIA MULTIMEDIA CARRIERS, ELECTRONIC DATA TRANSMISSION OF IMAGES AND DIGITAL FILES VIA THE INTERNET (U.S. CLS. 100, 101 AND 104).

**CLASS 40—MATERIAL TREATMENT**

FOR SERVICES FOR DEVELOPING, PROCESSING AND PRINTING PHOTOGRAPHS; PRINTING, DIGITAL PRINTING, PATTERN PRINTING; OFFSET PRINTING; MOUNTING OF PHOTOGRAPHIC PRINTS AS PART OF THE FRAMING PROCESS; PROCESSING, DEVELOPING; PRINTING, DUPLICATING IN THE NATURE OF REPRODUCTION, REPRODUCING PHOTOGRAPHS ON ALL TYPES OF MEDIA; FRAMING OF WORKS OF ART (U.S. CLS. 100, 103 AND 106).

SN 79-100,578. CURIOOS, PARIS, FRANCE, FILED 5-30-2011.



PRIORITY DATE OF 3-30-2011 IS CLAIMED.  
OWNER OF INTERNATIONAL REGISTRATION 1085543  
DATED 5-30-2011, EXPIRES 5-30-2021.

**CLASS 35—ADVERTISING AND BUSINESS**

FOR ADVERTISING; BUSINESS MANAGEMENT; BUSINESS ADMINISTRATION; OFFICE FUNCTIONS; DIRECT MAIL ADVERTISING; ARRANGING NEWSPAPER SUBSCRIPTIONS FOR OTHERS; BUSINESS MANAGEMENT AND ORGANIZATION CONSULTANCY; BOOK-KEEPING; DOCUMENT REPRODUCTION; EMPLOYMENT AGENCIES; COMPUTERIZED FILE MANAGEMENT; ORGANIZATION OF EXHIBITIONS FOR COMMERCIAL OR ADVERTISING PURPOSES; ONLINE ADVERTISING ON A COMPUTER NETWORK; RENTAL OF ADVERTISING SPACE; PUBLICATION OF PUBLICITY TEXTS; DISSEMINATION OF ADVERTISING MATTER; PUBLIC RELATIONS; PRESENTATION OF WORKS OF ART, NAMELY, PHOTOGRAPHS, GRAPHICS, AUDIOVISUAL AND MULTIMEDIA WORKS ON ALL KINDS OF COMMUNICATION MEDIA FOR RETAIL PURPOSES; CONDUCTING OF AUCTION SALES OF WORKS OF ART, NAMELY, PHOTOGRAPHS, GRAPHICS, ILLUSTRATIONS, COMPUTER GRAPHICS, AUDIOVISUAL AND MULTIMEDIA WORKS; SALES PROMOTIONS FOR OTHERS OF WORKS OF ART, NAMELY, PHOTOGRAPHS, GRAPHICS, AUDIOVISUAL AND MULTIMEDIA WORKS (U.S. CLS. 100, 101 AND 102).

**CLASS 41—EDUCATION AND ENTERTAINMENT**

FOR TEACHING IN THE FIELD OF GRAPHIC ART, NAMELY, PHOTOGRAPHY, GRAPHICS DESIGN, ILLUSTRATION, AUDIOVISUAL AND MULTIMEDIA WORKS; PROVIDING OF TRAINING IN THE FIELD OF GRAPHIC ART, NAMELY, PHOTOGRAPHY, GRAPHICS DESIGN, ILLUSTRATION, COMPUTER GRAPHICS, AUDIOVISUAL AND MULTIMEDIA WORKS; ENTERTAINMENT SERVICES, NAMELY, ART EXHIBITIONS, CONDUCTING SOCIAL ENTERTAINMENT EVENTS, INFORMATION ON ARTISTS; CULTURAL ACTIVITIES, NAMELY, ORGANIZING CULTURAL EVENTS FEATURING READINGS OF MATERIALS CONCERNING ART, ADVERTISING, COMMUNICATIONS, DECORATIVE ARTS, DESIGN AND CONTEMPORARY ART MOVEMENTS; PROVIDING INFORMATION IN THE FIELDS OF ENTERTAINMENT AND EDUCATION; PROVIDING RECREATION FACILITIES; PUBLICATION OF BOOKS; LENDING LIBRARIES; VIDEOTAPE FILM PRODUCTION; DIGITAL IMAGING SERVICES; RENTAL OF MOTION PICTURES; RENTAL OF SOUND RECORDINGS; VIDEOTAPE EDITING; PHOTOGRAPHY; PHOTOGRAPHIC REPORTING; ORGANIZATION OF COMPETITIONS, NAMELY, JURIED ART EXHIBITIONS AND ART EXHIBITIONS FOR EDUCATIONAL AND ENTERTAINMENT PURPOSES; ARRANGING AND CONDUCTING OF EDUCATIONAL COLLOQUIUMS, CONFERENCES AND CONGRESSES IN THE FIELD OF GRAPHIC ART, NAMELY, PHOTOGRAPHY, GRAPHICS DESIGN, ILLUSTRATION, COMPUTER GRAPHICS, AUDIOVISUAL AND MULTIMEDIA WORKS; ORGANIZATION OF EXHIBITIONS FOR CULTURAL AND EDUCATIONAL PURPOSES, BOOKING OF SEATS FOR SHOWS; ENTERTAINMENT SERVICES, NAMELY, PROVIDING ON-LINE COMPUTER GAME VIA A COMPUTER NETWORK; PUBLICATION OF ELECTRONIC BOOKS AND JOURNALS ON-LINE; ELECTRONIC DESKTOP PUBLISHING (U.S. CLS. 100, 101 AND 107).

**CLASS 42—SCIENTIFIC AND COMPUTER SERVICES**

FOR ENGINEERING SERVICES, NAMELY, EVALUATIONS, ESTIMATES AND RESEARCH IN THE FIELDS OF ALGORITHMS, IMAGING, GRAPHIC RENDERING, PROVIDED BY ENGINEERS; DESIGN AND DEVELOPMENT OF COMPUTERS AND SOFTWARE; RESEARCH AND DEVELOPMENT OF NEW PRODUCTS FOR OTHERS; CONDUCTING OF TECHNICAL PROJECT STUDIES ABOUT DIGITAL USER INTERFACES, NATURAL USER INTERFACES AND SOFTWARE USER EXPERIENCES; ARCHITECTURAL SERVICES; DESIGN OF INTERIOR DECOR; DEVELOPMENT, INSTALLATION, MAINTENANCE, UPDATING AND RENTAL OF COMPUTER SOFTWARE; COMPUTER PROGRAMMING; CONSULTANCY IN THE FIELD OF COMPUTER HARDWARE; DATA CONVERSION OF COMPUTER PROGRAMS AND DATA NOT PHYSICAL CONVERSION; CONVERSION OF DATA OR DOCUMENTS FROM PHYSICAL TO ELECTRIC MEDIA; GRAPHIC ARTS DESIGNING; INDUSTRIAL DESIGN; AUTHENTICATING WORKS OF ART; HOSTING COMPUTER WEB SITES (U.S. CLS. 100 AND 101).

SEAN CROWLEY, EXAMINING ATTORNEY

SN 79-105,409. SATTLER AG, AUSTRIA, FILED 1-14-2011.

# TWILIGHT

THE MARK CONSISTS OF STANDARD CHARACTERS WITHOUT CLAIM TO ANY PARTICULAR FONT, STYLE, SIZE, OR COLOR.

OWNER OF INTERNATIONAL REGISTRATION 0790641 DATED 6-28-2002, EXPIRES 6-28-2022.

**CLASS 22—CORDAGE AND FIBERS**

FOR CANOPIES AND AWNINGS OF TEXTILE MATERIAL FOR PROVIDING PROTECTION AGAINST THE SUN; BAGS OF TEXTILE SPECIFICALLY DESIGNED FOR PACKAGING CANOPIES AND AWNINGS SOLD TOGETHER AS A UNIT WITH CANOPIES AND AWNINGS (U.S. CLS. 1, 2, 7, 19, 22, 42 AND 50).

**CLASS 24—FABRICS**

FOR SEMI-FINISHED PLASTIC WOVEN ARAMID FABRICS AND FABRICS COATED WITH THERMOPLASTIC COATINGS USED IN THE MANUFACTURE OF CANOPIES AND AWNINGS (U.S. CLS. 42 AND 50).

JERI J. FICKES, EXAMINING ATTORNEY

SN 79-109,655. MEMMERT-RIEFLER GRUNDSTÜCKSGMBH + CO. KG, BÜCHENBACH, FED REP GERMANY, FILED 1-26-2012.

# memmert

THE MARK CONSISTS OF STANDARD CHARACTERS WITHOUT CLAIM TO ANY PARTICULAR FONT, STYLE, SIZE, OR COLOR.

OWNER OF INTERNATIONAL REGISTRATION 0777890 DATED 1-25-2002, EXPIRES 1-25-2022.  
OWNER OF U.S. REG. NO. 722,579.

**CLASS 9—ELECTRICAL AND SCIENTIFIC APPARATUS**

FOR WARMING AND COOLING EQUIPMENT AND APPARATUS FOR MEDICAL OR LABORATORY PURPOSES, NAMELY, TEMPERATURE, CLIMATE, AND HUMIDITY SIMULATION EQUIPMENT, COOLED INCUBATORS FOR LABORATORY USE, INCUBATORS FOR BACTERIA CULTURES, DRYING INCUBATORS FOR LABORATORY USE, VACUUM OVENS FOR LABORATORY USE, DISINFECTION OVENS FOR LABORATORY USE, REPLACEMENT PARTS FOR INCUBATORS FOR LABORATORY USE, OVENS FOR LABORATORY USE, AND WARMING AND COOLING EQUIPMENT AND APPARATUS FOR MEDICAL OR LABORATORY EQUIPMENT, NAMELY, TEMPERATURE, CLIMATE, AND HUMIDITY SIMULATION EQUIPMENT (U.S. CLS. 21, 23, 26, 36 AND 38).

**CLASS 11—ENVIRONMENTAL CONTROL APPARATUS**

FOR STERILIZERS NOT FOR MEDICAL PURPOSES, REPLACEMENT PARTS FOR STERILIZERS NOT FOR MEDICAL PURPOSES (U.S. CLS. 13, 21, 23, 31 AND 34).

**CLASS 37—CONSTRUCTION AND REPAIR**

FOR MAINTENANCE AND REPAIR SERVICES FOR WARMING AND COOLING EQUIPMENT AND APPARATUS, INCUBATORS, OVENS, AND STERILIZERS (U.S. CLS. 100, 103 AND 106).

EUGENIA MARTIN, EXAMINING ATTORNEY

SN 79-116,715. SEKIGUCHI CO., LTD., JAPAN, FILED 6-7-2012.



PRIORITY DATE OF 12-9-2011 IS CLAIMED.  
OWNER OF INTERNATIONAL REGISTRATION 1126166 DATED 6-7-2012, EXPIRES 6-7-2022.

OWNER OF U.S. REG. NOS. 3,055,482 AND 3,087,366.  
THE COLOR(S) BROWN, BLACK, WHITE, PEACH AND RED IS/ARE CLAIMED AS A FEATURE OF THE MARK.

THE MARK CONSISTS OF A 3 DIMENSIONAL FUR DOLL WITH BROWN FUR, BLACK EYES AND EYELASHES WITH BROWN AND WHITE LINING AT THE BOTTOM, BLACK NOSE, PEACH FACE, HANDS AND FEET AND RED LIPS AND A RED BIB WITH RED AND WHITE LINING ON THE TRIM AND THE WORDING "MONCHHICHI" ON THE BIB OUTLINED IN WHITE.

**CLASS 16—PAPER GOODS AND PRINTED MATTER**

FOR PASTES AND OTHER ADHESIVES FOR STATIONERY OR HOUSEHOLD PURPOSES; CONTAINERS OF PAPER FOR PACKAGING; HYGIENIC HAND TOWELS OF PAPER; TOWELS OF PAPER; TABLE NAPKINS OF PAPER; HAND TOWELS OF PAPER; HANDKERCHIEFS OF PAPER; TABLECLOTHS OF PAPER; PAPER AND CARDBOARD; STATIONERY; PRINTED MATTER, NAMELY, CATALOGUES AND PAMPHLETS IN THE FIELD OF DOLLS, STUFFED TOYS AND LIFESTYLE FASHION ACCESSORIES; CALENDARS AND DIARIES; PAINTINGS AND CALLIGRAPHIC WORKS; PHOTOGRAPHS; PHOTOGRAPH STANDS (U.S. CLS. 2, 5, 22, 23, 29, 37, 38 AND 50).

**CLASS 18—LEATHER GOODS**

FOR CLOTHING FOR DOMESTIC PETS; BAGS, NAMELY, FOLDING BRIEFCASES, SHOULDER BAGS, SUITCASES, TRUNKS, HANDBAGS, BOSTON BAGS, SCHOOLCHILDREN'S BACKPACKS AND RUCKSACKS; POUCHES, NAMELY, DRAWSTRING BAGS; UNFITTED VANITY CASES; UMBRELLAS AND THEIR PARTS (U.S. CLS. 1, 2, 3, 22 AND 41).

**CLASS 25—CLOTHING**

FOR CLOTHING AND CLOTHING FOR SPORTS, NAMELY, TEE-SHIRTS, APRONS, SOCKS, STOCKINGS, NECKERSCHIEFS, BANDANAS, HEADWEAR; GARTERS; SOCK SUSPENDERS; SUSPENDERS; WAISTBANDS; BELTS FOR CLOTHING; FOOTWEAR EXCLUDING SPECIAL FOOTWEAR FOR SPORTS; MASQUERADE COSTUMES; SPECIAL FOOTWEAR FOR SPORTS (U.S. CLS. 22 AND 39).

**CLASS 28—TOYS AND SPORTING GOODS**

FOR TOYS FOR DOMESTIC PETS; TOYS, NAMELY, DOLLS AND STUFFED TOYS; DOLLS; GO GAMES; JAPANESE PLAYING CARDS (UTAGARUTA); JAPANESE CHESS (SHOGI); DICE; JAPANESE DICE GAMES (SUGOROKU); DICE CUPS; CHINESE CHECKERS; CHESS GAMES; CHECKERS, CHECKER SETS; CONJURING APPARATUS, NAMELY, PLAYING CARDS; DOMINOS; PLAYING CARDS; JAPANESE PLAYING CARDS (HANAFUDA); MAH-JONG; SPORTS EQUIPMENT, NAMELY, SKATEBOARDS, FLYING DISKS AND BOWLING IMPLEMENTS, NAMELY, BOWLING BALLS AND BOWLING PINS (U.S. CLS. 22, 23, 38 AND 50).

**CLASS 30—STAPLE FOODS**

FOR TEA; COFFEE AND COCOA; CONFECTIONERY MADE OF SUGAR, BREAD AND BUNS (U.S. CL. 46). MICHELE SWAIN, EXAMINING ATTORNEY

**CLASS 9—ELECTRICAL AND SCIENTIFIC APPARATUS**

FOR TELEPHONES; CONFERENCE PHONES; MOBILE PHONES; MEDIA PLAYERS; PORTABLE MEDIA PLAYERS; COMPUTERS; LAPTOP COMPUTERS; TABLET COMPUTERS; HAND-HELD COMPUTERS; TELEVISION MONITORS; VIDEO MONITORS AND COMPUTER MONITORS; PROJECTION SCREENS; VIDEO PROJECTORS; CINEMATOGRAPHIC PROJECTORS; HEADSETS; HEADPHONES; MICROPHONES FOR VIRTUAL CONFERENCING, NAMELY, AUDIO-CONFERENCING, VIDEO-CONFERENCING AND DATA-CONFERENCING, NAMELY, SCREEN SHARING; COMMUNICATION HUBS; COMMUNICATION INTERFACE UNITS; WIRELESS COMMUNICATION DEVICES FOR VOICE, DATA, OR IMAGE TRANSMISSION; COMPUTER SOFTWARE FOR COMPUTING AND COMMUNICATION DEVICES, NAMELY, MOBILE PHONES, PORTABLE MEDIA PLAYERS, HANDHELD COMPUTERS, DESK PHONES, CONFERENCE PHONES FOR VIRTUAL CONFERENCING TO CREATE, MANAGE AND JOIN VIRTUAL CONFERENCES; AND SOFTWARE TO CONTROL AND IMPROVE AUDIO EQUIPMENT SOUND QUALITY AND COMPONENT PARTS FOR ALL THE FOREGOING (U.S. CLS. 21, 23, 26, 36 AND 38).

**CLASS 38—COMMUNICATION**

FOR VIDEO CONFERENCING SERVICES; TELECONFERENCING SERVICES; WEB CONFERENCING SERVICES; VIRTUAL CONFERENCING SERVICES, NAMELY, AUDIO-CONFERENCING, VIDEO-CONFERENCING AND DATA-CONFERENCING FEATURING SCREEN SHARING; NETWORK CONFERENCING SERVICES; PROVIDING FACILITIES AND EQUIPMENT FOR VIDEO CONFERENCING; SATELLITE VIDEO CONFERENCING SERVICES; COMMUNICATION SERVICES, NAMELY, TRANSMISSION OF VOICE, AUDIO, VISUAL IMAGES AND DATA BY TELECOMMUNICATIONS NETWORKS, WIRELESS COMMUNICATION NETWORKS, THE INTERNET, INFORMATION SERVICES NETWORKS AND DATA NETWORKS FOR VIRTUAL CONFERENCING SERVICES; COMMUNICATION BY SATELLITE; COMMUNICATION BY CABLE, COMPUTER, RADIO AND TELEPHONE; COMMUNICATIONS BY TELEVISION FOR MEETINGS; PROVIDING COMMUNICATIONS BETWEEN COMPUTING OR COMMUNICATIONS DEVICES, NAMELY, MOBILE PHONES, PORTABLE MEDIA PLAYERS, HAND-HELD COMPUTERS, DESK PHONES, AND CONFERENCE PHONES ALL FOR VIRTUAL CONFERENCING; COMMUNICATION SERVICES, NAMELY, ELECTRONIC TRANSMISSION OF DATA AND DOCUMENTS AMONG USERS OF COMPUTERS; RENTAL OF COMMUNICATION APPARATUS, EQUIPMENT, INSTRUMENTS AND SYSTEMS; VIDEO TELEPHONE SERVICES NAMELY, TRANSMISSION OF INFORMATION THROUGH VIDEO COMMUNICATION SYSTEMS (U.S. CLS. 100, 101 AND 104). DAVID C. REIHNER, EXAMINING ATTORNEY

SN 79-120,104, RING2 COMMUNICATIONS LIMITED, UNITED KINGDOM, FILED 7-12-2012.

SN 79-122,753, CUYLITS HOLDING GMBH, FED REP GERMANY, FILED 11-22-2012.



OWNER OF INTERNATIONAL REGISTRATION 1134857 DATED 7-12-2012, EXPIRES 7-12-2022.

THE MARK CONSISTS OF THE WORD "LOOP UP" WITH A THOUGHT BALLOON CONTAINING AN ELLIPSIS.

# CULIMETA

THE MARK CONSISTS OF STANDARD CHARACTERS WITHOUT CLAIM TO ANY PARTICULAR FONT, STYLE, SIZE, OR COLOR.

PRIORITY DATE OF 6-8-2012 IS CLAIMED. OWNER OF INTERNATIONAL REGISTRATION 1141757 DATED 11-22-2012, EXPIRES 11-22-2022.

THE WORDING "CULIMETA" HAS NO MEANING IN A FOREIGN LANGUAGE.

**CLASS 6—METAL GOODS**

FOR COMMON METALS AND THEIR ALLOYS; METAL BUILDING MATERIALS, NAMELY, GASKETS, SLEEVES IN THE NATURE OF CABLE JUNCTION SLEEVES OF METAL, METAL EXPANDING SLEEVES FOR AFFIXING SCREWS, METAL JUNCTION SLEEVES FOR NON-ELECTRIC CABLES, TRANSPORTABLE BUILDINGS OF METAL; MATERIALS OF METAL FOR RAILWAY TRACKS; NON-ELECTRIC CABLES AND WIRES OF COMMON METAL; SMALL ARTICLES OF METAL HARDWARE, NAMELY, GASKETS FOR SEALING, SLEEVES IN THE NATURE OF CABLE JUNCTION SLEEVES OF METAL, METAL EXPANDING SLEEVES FOR AFFIXING SCREWS, METAL JUNCTION SLEEVES FOR NON-ELECTRIC CABLES, SILENCERS IN THE NATURE OF SILENCERS FOR ENGINES AND MOTORS, MUFFLERS IN THE NATURE OF MUFFLERS FOR ENGINES AND MOTORS, HEAT SHIELDS, EXHAUST SYSTEMS, NAMELY, INSULATED EXHAUST SYSTEMS COMPRISING METAL CONSTRUCTION MATERIALS IN THE NATURE OF EXHAUST VENT HOSES FOR EXTERNAL VENTILATION OF FURNACES, HEATERS, STOVES AND BOILERS; PIPES AND TUBES OF METAL; METAL SAFES; GOODS OF COMMON METAL, NAMELY, BASKETS, FOILS AND BUCKLES; ALUMINUM ORES, COPPER ORES, MANGANESE ORES, CHROMIUM ORES, VANADIUM ORES, TUNGSTEN ORES, AND IRON ORES (U.S. CLS. 2, 12, 13, 14, 23, 25 AND 50).

**CLASS 12—VEHICLES**

FOR VEHICLES, NAMELY, AUTOMOBILES, TRUCKS, BUSES, MOTORCYCLES, MOTOR SCOOTERS, AND TRACTORS; APPARATUS FOR LOCOMOTION BY LAND, AIR OR WATER, NAMELY, AUTOMOBILES, TRUCKS, BUSES, MOTORCYCLES, MOTOR SCOOTERS, TRACTORS, AIRPLANES, HELICOPTERS, HOVERCRAFT, BOATS, SHIPS, AND SUBMARINES (U.S. CLS. 19, 21, 23, 31, 35 AND 44).

**CLASS 17—RUBBER GOODS**

FOR RUBBER, GUTTA-PERCHA, GUM IN THE NATURE OF NATURAL RUBBER, ASBESTOS, MICA AND GOODS MADE FROM THESE MATERIALS, NAMELY, HOSES, TIRES, ROLLERS, AIR HOSES, BALLOONS, BALLS, CUSHIONS, CHEWING GUM, RAINWEAR CLOTHING, DIVING GEAR, CHEMICAL TUBING, TUBING, LINING FOR STORAGE TANKS, PROCESSING EQUIPMENT, AND RAILROAD TANK CARS, PROTECTIVE GLOVES, SHOES, BLANKETS, BELTS, HOUSINGS FOR ELECTRICAL INSTRUMENTS, POWER-TRANSMISSION BELTING, WATER-LUBRICATED BEARINGS, BUILDING AND CONSTRUCTION MATERIALS, NAMELY, ASBESTOS CEMENT PIPE, INSULATING CEMENT, INSULATING BLOCK, PIPE COVERING, ACOUSTICAL PANELS, PLASTER, FIRE BRICK, VINYL-ASBESTOS, ASPHALT-ASBESTOS FLOOR TILE, LINOLEUM BACKING, CEILING TILE, DUCT INSULATION FOR HEATING, VENTILATION AND AIR CONDITIONING SYSTEMS, ROOFING FELT, TRANSITE FURNACE FLUE, TRANSITE SHINGLES AND SIDINGS, INSULATED ELECTRICAL WIRE AND PANELS, FIRE-PROOFING SPRAY, FIRE DOOR INTERIORS, REFRACTORY AND BOILER INSULATION MATERIALS, INSULATING SLEEVES FOR EXHAUST SYSTEMS FOR LAND VEHICLES, INSULATED ABSORPTION MATERIALS, SILENCERS, MUFFLERS, HEAT SHIELDS, INDUSTRIAL INSULATION, INSULATION JACKETS, HIGH TEMPERATURE INSULATION, TEXTILES, NAMELY, ASBESTOS CLOTH, FIREPROOF CLOTHING, FIRE-PROOF APRONS, GLASSBLOWER MITTS, CAULKING COMPOUNDS AND PANES, NAMELY, MASTICS, ADHESIVES, COATINGS, JOINT COMPOUND, PUTTY, AND ACOUSTICAL TEXTURES, FRICTION PRODUCTS, NAMELY, BRAKE LININGS, CLUTCH ASSEMBLIES, AND GASKETS; PLASTICS IN EXTRUDED FORM FOR USE IN MANUFACTURE; PACKING MATERIALS, STOPPING MATERIALS IN THE NATURE OF RUBBER STOPPERS FOR INDUSTRIAL PACKAGING CONTAINERS, STUFFING OF PLASTIC; FLEXIBLE PIPES, NOT OF METAL; FIBREGLASS GOODS, NAMELY, FOR THERMAL, ACOUSTIC OR ELECTRIC INSULATION (U.S. CLS. 1, 5, 12, 13, 35 AND 50).

KRISTINA MORRIS, EXAMINING ATTORNEY

SN 79-126,081. STOIANOV VITALII VIKTOROVYCH, UKRAINE, FILED 11-19-2012.



PRIORITY DATE OF 11-9-2012 IS CLAIMED.  
OWNER OF INTERNATIONAL REGISTRATION 1149780 DATED 11-19-2012, EXPIRES 11-19-2022.

THE COLOR(S) BLACK AND YELLOW IS/ARE CLAIMED AS A FEATURE OF THE MARK.

THE MARK CONSISTS OF A YELLOW CHEVRON POINTING TO THE RIGHT WITH THE STYLIZED WORDING "ALMAREKS" IN BLACK TO THE RIGHTS OF THE CHEVRON DESIGN.

THE WORDING "ALMAREKS" HAS NO MEANING IN A FOREIGN LANGUAGE.

**CLASS 9—ELECTRICAL AND SCIENTIFIC APPARATUS**

FOR ABACUSES; ACCOUNTING MACHINES; ACCUMULATORS, ELECTRIC; ACCUMULATORS, ELECTRIC, FOR VEHICLES; ACID HYDROMETERS; ACIDIMETERS FOR BATTERIES; ACOUSTIC CONDUITS; ACOUSTIC COUPLERS; ACOUSTIC SOUND ALARMS; ACTINOMETERS; ADDING MACHINES; AEROMETERS; AIR ANALYSIS APPARATUS; ELECTRIC DOOR ALARM BELLS; BURGLAR AND FIRE ALARMS; MEASURING APPARATUS, NAMELY, METERS FOR MEASURING ALCOHOL; ALIDADES; ALTIMETERS; AMMETERS; AMPLIFIERS; AMPLIFYING TUBES, NAMELY, AUDIO AMPLIFIERS; ANEMOMETERS; VIDEO DISKS AND VIDEO TAPES WITH RECORDED ANIMATED CARTOONS; ANODE BATTERIES; ANODES; ANSWERING MACHINES; ANTENNAS; ANTICATHODES; ANTI-GLARE GLASSES; ANTI-GLARE FILTERS FOR TELEVISIONS AND COMPUTER MONITORS; FILTERS FOR RADIO INTERFERENCE SUPPRESSION; THEFT ALARMS; APERTOMETERS, NAMELY, AN INSTRUMENT USED TO MEASURE THE NUMERICAL APERTURE OF MICROSCOPE OBJECTIVES; ASTRONOMETRIC MEASURING MACHINES AND INSTRUMENTS; APPARATUS FOR CHANGING RECORD PLAYER NEEDLES; APPARATUS FOR MEASURING THE THICKNESS OF SKINS; ELECTRONIC APPARATUS TO VERIFY AND CHECK THE AUTHENTICITY OF FRANKING; APPLIANCES FOR MEASURING THE THICKNESS OF LEATHER; ARMATURES FOR USE IN ELECTRICAL APPARATUS; ASBESTOS CLOTHING FOR PROTECTION AGAINST FIRE; ASBESTOS GLOVES FOR PROTECTION AGAINST ACCIDENTS; ASBESTOS SCREENS FOR FIREMEN; AUDIO- AND VIDEO-RECEIVERS; AUDIOVISUAL MULTIMEDIA PROJECTORS FOR USE AS TEACHING APPARATUS; AUTOMATED TELLER MACHINES (ATM); AUTOMATIC INDICATORS OF LOW PRESSURE IN VEHICLE TIRES TYRES; AZIMUTH COMPASSES; BALANCES, NAMELY, STEELYARDS; WEIGHTING EQUIPMENT, NAMELY, SCALES AND BALANCES; BAR CODE READERS; BAROMETERS; BATTERIES, ELECTRIC; BATTERIES FOR LIGHTING; BATTERY BOXES; BATTERY CHARGERS; LABORATORY EQUIPMENT, NAMELY, BATTERY JARS; LUMINOUS SAFETY BEACONS; ELECTRONIC WARNING BELLS; BETA-TRONS, NAMELY, PARTICLE ACCELERATORS; BINOCULARS; BOILER CONTROL INSTRUMENTS; BRANCH BOXES, NAMELY, ELECTRIC JUNCTION BOXES; SELF-RESCUE APPARATUS, NAMELY, OXYGEN BREATHING UNITS; BREATHING APPARATUS FOR UNDERWATER SWIMMING; BULLET-PROOF WAISTCOATS; ELECTRIC BUZZERS; CABINETS FOR LOUDSPEAKERS; CABLES, ELECTRIC; CALCULATING DISKS IN THE NATURE OF CALCULATING MACHINES; CALCULATING MACHINES; LABORATORY EQUIPMENT AND SUPPLIES, NAMELY, CALIPERS; CAMCORDERS; CAMERAS PHOTOGRAPHY; CAPILLARY TUBES, NAMELY, LABORATORY STORAGE TUBES; CARPENTERS' RULES; CARRIERS SPECIALLY ADAPTED FOR PHOTOGRAPHY DARK PLATES; CASES ESPECIALLY MADE FOR CAMERAS AND PHOTOGRAPHIC APPARATUS AND INSTRUMENTS; CASES SPECIALLY ADAPTED FOR MICROSCOPY DISSECTING INSTRUMENTS; CASH REGISTERS; CASSETTE PLAYERS; CATHODES; ANTI-CORROSION CATHODES; CELL PHONE STRAPS; CELL SWITCHES, NAMELY, ELEC-

TRICAL SWITCHES; CENTERING APPARATUS FOR PHOTOGRAPHIC TRANSPARENCIES; CHARGERS FOR ELECTRIC BATTERIES; CHEMISTRY APPARATUS AND INSTRUMENTS, NAMELY, BEAKERS AND MICROSCOPES; CHIPS, NAMELY, INTEGRATED CIRCUITS; CHOKING COILS FOR USE IN ELECTRICAL APPARATUS; CHROMATOGRAPHY APPARATUS FOR LABORATORY USE; CHRONOGRAPHS FOR USE AS SPECIALIZED TIME RECORDING APPARATUS; CINEMATOGRAPHIC CAMERAS; CINEMATOGRAPHIC FILM, EXPOSED; CIRCUIT BREAKERS; ELECTRIC CIRCUIT CLOSERS; ELECTRONIC APPARATUS FOR CLEANING SOUND RECORDING DISCS; PROTECTIVE CLOTHING ESPECIALLY MADE FOR LABORATORIES; CLOTHING FOR PROTECTION AGAINST ACCIDENTS, IRRADIATION AND FIRE; CLOTHING FOR PROTECTION AGAINST FIRE; COAXIAL CABLES; COILS, ELECTRIC; COIN-OPERATED MECHANISMS FOR TELEVISION SETS; JUKE BOXES; ELECTRIC CONDUCTORS; COMMUTATORS; COMPACT DISC PLAYERS; COMPARATORS; COMPASSES; COMPUTER GAME PROGRAMS; COMPUTER KEYBOARDS; COMPUTER MEMORY HARDWARE; COMPUTER OPERATING PROGRAMS, RECORDED; COMPUTER PERIPHERAL DEVICES; COMPUTER PROGRAMS RECORDED ON COMPUTER MEDIA FOR CUSTOMER RELATIONSHIP MANAGEMENT, FACE RECOGNITION, EMOTION RECOGNITION, FOR CONDUCTING SURVEYS, FOR DATABASE MANAGEMENT AND FOR CONNECTING COMPUTER NETWORK USERS FOR COMMUNICATION PURPOSES; COMPUTER PROGRAMS, NAMELY, DOWNLOADABLE SOFTWARE FOR CUSTOMER RELATIONSHIP MANAGEMENT, FACE RECOGNITION, EMOTION RECOGNITION, FOR CONDUCTING SURVEYS, FOR DATABASE MANAGEMENT AND FOR CONNECTING COMPUTER NETWORK USERS FOR COMMUNICATION PURPOSES; RECORDED COMPUTER SOFTWARE FOR CUSTOMER RELATIONSHIP MANAGEMENT, FACE RECOGNITION, EMOTION RECOGNITION, FOR CONDUCTING SURVEYS, FOR DATABASE MANAGEMENT AND FOR CONNECTING COMPUTER NETWORK USERS FOR COMMUNICATION PURPOSES; CONDENSERS, NAMELY, CAPACITORS; CONDUCTORS, ELECTRIC; CONNECTIONS FOR ELECTRIC LINES; ELECTRIC CONNECTORS; CONTACT LENSES; ELECTRIC CONTACTS; CONTAINERS FOR CONTACT LENSES; CONTAINERS FOR MICROSCOPE SLIDES; ELECTRIC CONTROL PANELS; ELECTRIC CONVERTERS; INSULATED ELECTRIC COPPER WIRE; CORRECTING LENSES, NAMELY, CONTACT LENSES; ELECTRONIC APPARATUS FOR DETECTING COUNTERFEIT COINS; GEIGER COUNTERS; DATA PROCESSING EQUIPMENT, NAMELY, COUPLERS; ELECTRIC COUPLINGS; COVERS FOR ELECTRIC OUTLETS; CRASH TEST DUMMIES; LABORATORY EQUIPMENT, NAMELY, CRUCIBLES; CURRENT RECTIFIERS; CYCLOTRONS; PHOTOGRAPHY DARKROOM LAMPS; MOBILE PHOTOGRAPHY DARKROOM UNIT; DATA PROCESSING APPARATUS; DECOMPRESSION CHAMBERS; DECORATIVE MAGNETS; DEMAGNETIZING APPARATUS FOR MAGNETIC TAPES; DENSIMETERS; ULTRASONIC BONE DENSITOMETER WITH COMPUTER, PRINTER, AND COMPUTER SOFTWARE FOR USE THEREWITH, SOLD AS A UNIT, FOR SCIENTIFIC USE; CARBON MONOXIDE DETECTORS; DIAGNOSTIC APPARATUS FOR THE DETECTION OF PATHOGENS FOR LABORATORY OR RESEARCH USE; DICTATING MACHINES; DIFFRACTION APPARATUS, NAMELY, MICROSCOPES; DIRECTIONAL COMPASSES; DISCHARGE TUBES, ELECTRIC, OTHER THAN FOR LIGHTING; DISK DRIVES FOR COMPUTERS; BLANK MAGNETIC DISCS; DISTANCE MEASURING APPARATUS; ELECTRICAL CIRCUIT BOARDS; ELECTRICAL DISTRIBUTION BOXES; ELECTRICAL DISTRIBUTION CONSOLES; DIVERS' MASKS; DIVING SUITS; DNA CHIPS; DOG WHISTLES; MACHINES FOR DISPENSING PRE-DETERMINED DOSAGES OF MEDICATION; DOWNLOADABLE MUSIC FILES; DOWNLOADABLE RING TONES FOR MOBILE PHONES; DRAINERS SPECIALLY ADAPTED FOR PHOTOGRAPHY USE; DRYING APPARATUS FOR PHOTOGRAPHIC PRINTS; DRYING RACKS FOR PHOTOGRAPHY USE; ELECTRICAL DUCTS; DVD PLAYERS; DYNAMOMETERS; EAR PLUGS FOR DIVERS; EDITING APPLIANCES FOR CINEMATOGRAPHIC FILMS; EGG-CANDLERS; EGG TIMERS SANDGLASSES; ELECTRIC POWER CONVERTERS; ELECTRIC DOOR BELLS; ELECTRIC INSTALLATIONS FOR THE REMOTE CONTROL OF INDUSTRIAL OPERATIONS; ELECTRICITY CONDUITS; ELECTRIC

LOSS INDICATORS, NAMELY, METERS FOR MEASURING THE LOSS OF ELECTRICITY; ELECTRIFIED FENCES; ELECTRIFIED RAILS FOR MOUNTING SPOT LIGHTS; ELECTRO-DYNAMIC APPARATUS FOR THE REMOTE CONTROL OF RAILWAY POINTS; ELECTRO-DYNAMIC APPARATUS FOR THE REMOTE CONTROL OF RAILWAY SIGNALS; ELECTROLYSERS; ELECTROMAGNETIC COILS; ELECTRONIC AGENDAS; ELECTRONIC NOTICE BOARDS; ELECTRONIC PENS; ELECTRONIC POCKET TRANSLATORS; DOWNLOADABLE ELECTRONIC PUBLICATIONS, NAMELY, PROGRAM SPECIFICATIONS, MANUALS, EDUCATIONAL AND REFERENCE GUIDES AND SOFTWARE DOCUMENTS IN THE FIELD OF CUSTOMER RELATIONSHIP MANAGEMENT, FACE RECOGNITION, EMOTION RECOGNITION, SURVEYS, DATA MANAGEMENT, NETWORK COMMUNICATION AMONG NETWORK USERS; ELECTRONIC TAGS FOR GOODS; ENCODED IDENTIFICATION BRACELETS, MAGNETIC; MAGNETICALLY ENCODED GIFT CARDS, LOYALTY PROGRAM REWARD CARDS, DISCOUNT CARDS AND BONUS CARDS; COMPUTERIZED APPARATUS FOR ENLARGING PHOTOGRAPHS; EPIDIASCOPES; ERGOMETERS NOT FOR MEDICAL USE; PHOTOGRAPHIC EXPOSURE METERS; FIRE EXTINGUISHERS; EYEGLOSS CHAINS; EYEGLOSS CORDS; EYEGLOSS FRAMES; PROTECTIVE EYEPIECES; FACSIMILE MACHINES; FIBER OPTIC CABLES; FILM CUTTING APPARATUS; FILMS, EXPOSED; FILTERS FOR RESPIRATORY MASKS; FILTERS FOR ULTRAVIOLET RAYS, FOR PHOTOGRAPHY; PHOTOGRAPHY FILTERS; FIRE ALARMS; FIRE BEATERS, NAMELY, FIRE EXTINGUISHING APPARATUS; FIRE BLANKETS; FIRE BOATS; FIRE ENGINES; SAFETY EQUIPMENT, NAMELY, FIRE ESCAPE LADDERS; FIRE HOSE; FIRE HOSE NOZZLES; FLASH-BULBS PHOTOGRAPHY; FLASHING SAFETY LIGHTS; FLASHLIGHTS FOR USE IN PHOTOGRAPHY; FLOPPY DISC DRIVES; FLUORESCENT SCREENS; FOG SIGNALS, NON-EXPLOSIVE; DIAGNOSTIC APPARATUS FOR TESTING FOOD; FRAMES FOR PHOTOGRAPHIC TRANSPARENCIES; FREQUENCY METERS; FURNACES FOR LABORATORY USE; FURNITURE ESPECIALLY MADE FOR LABORATORIES; ELECTRICAL FUSES; METAL ALLOY WIRE FOR ELECTRICAL FUSES; GALENA CRYSTALS DETECTORS FOR USE IN ELECTRONICS; GALVANIC BATTERIES; GALVANIC DRY CELLS; GALVANOMETERS; GARMENTS FOR PROTECTION AGAINST FIRE; GASOLINE GAUGES; GASOMETERS MEASURING INSTRUMENTS; GAS TESTING INSTRUMENTS; AUTOMOTIVE MEASURING INSTRUMENTS, NAMELY, WATER TEMPERATURE GAUGES, AIR FUEL/RATIO GAUGES, BOOST GAUGES, VACUUM GAUGES AND EXHAUST GAS TEMPERATURE GAUGES; GLASS COVERED WITH AN ELECTRICAL CONDUCTOR; GLAZING APPARATUS FOR PHOTOGRAPHIC PRINTS; GLOBAL POSITIONING SYSTEM GPS APPARATUS; GLOVES FOR DIVERS; GLOVES FOR PROTECTION AGAINST ACCIDENTS; GLOVES FOR PROTECTION AGAINST X-RAYS FOR INDUSTRIAL PURPOSES; GOGGLES FOR SPORTS; GRIDS FOR BATTERIES; HANDS FREE KITS FOR PHONES; HEAD CLEANING TAPES FOR AUDIO AND VIDEO RECORDERS; HEADPHONES; HEAT REGULATING APPARATUS, NAMELY, THERMOSTATS; ELECTRONIC HELIOGRAPHIC APPARATUS FOR RECORDING THE DURATION AND INTENSITY OF SUNSHINE; HIGH-FREQUENCY SWITCHES; HOLDERS FOR ELECTRIC COILS; HOLOGRAM APPARATUS; HORNS FOR LOUD-SPEAKERS; HYDROMETERS; HYGROMETERS; IDENTIFICATION SHEATHS FOR ELECTRIC WIRES; IDENTIFICATION THREADS FOR ELECTRIC WIRES; MAGNETICALLY ENCODED IDENTITY CARDS; ELECTRIC IGNITERS USED IN CONNECTION WITH BALLASTS TO START DISCHARGE LAMPS; INCUBATORS FOR BACTERIA CULTURE; ELECTRICAL INDUCTORS; OPTICAL DEVICES, NAMELY, EYE PIECES FOR HELMET MOUNTED DISPLAYS; BLANK SMART CARDS; INTEGRATED CIRCUITS; INTERCOMS; INTERFACES FOR COMPUTERS; INVERTERS ELECTRICITY; COMPUTERIZED INVOICING MACHINES; JIGS, NAMELY, GUIDES FOR CONTROLLING LOCATION AND MOTION OF MACHINES DURING WOODWORKING; JUKE BOXES FOR COMPUTERS; ELECTRICAL JUNCTION BOXES; JUNCTION SLEEVES FOR ELECTRIC CABLES; KILOMETER RECORDERS FOR VEHICLES; KNEE-PADS FOR WORKERS; LABORATORY CENTRIFUGES; LABORATORY TRAYS; LACTODENSIMETERS; LACTOMETERS; LAPTOP COMPUTERS; LASERS, NOT FOR

MEDICAL PURPOSES; LENSES FOR ASTROPHOTOGRAPHY; LENS HOODS; LETTER SCALES; LEVELING RODS AND STAFFS FOR SURVEYING; PLUMB LEVELS; SURVEYORS' LEVELS; LIFE BELTS; LIFE BUOYS; LIFE JACKETS; LIFE-SAVING RAFTS; ELECTRIC LIGHT DIMMERS AND REGULATORS; LIGHT-EMITTING DIODES LED; LIGHT-EMITTING ELECTRONIC POINTERS; LIGHTING BALLASTS; LIGHTNING CONDUCTORS RODS; ELECTRICITY LIMITERS; LOCKS, ELECTRIC; ELECTRONIC DATA LOGGERS; LOUDSPEAKERS; MAGIC LANTERNS; BLANK MAGNETIC DATA CARRIERS; MAGNETIC ENCODERS; BLANK MAGNETIC TAPES FOR TAPE RECORDERS; BLANK MAGNETIC TAPE FOR COMPUTERS; MAGNETIC WIRES; MAGNETS; MAGNIFYING GLASSES OPTICS; MARINE COMPASSES; MARINE DEPTH FINDERS; MARKING BUOYS; MARKING GAUGES FOR JOINERY PURPOSES; MASTS FOR WIRELESS AERIALS; ELECTRICAL WIRES AND CABLES FOR ELECTRICITY MAINS; ELECTRONIC APPARATUS FOR TESTING COMPRESSION, STRENGTH, HARDNESS AND TENSILE CHARACTERISTICS OF INDUSTRIAL MATERIALS; MATHEMATICAL INSTRUMENTS, NAMELY, SLIDE RULES, PROTRACTORS AND CALCULATORS; TAPE MEASURES; INSTRUMENTS FOR MEASURING LENGTH; ELECTRIC MEASURING DEVICES FOR MEASURING LENGTH; MEASURING GLASSWARE; MEASURING INSTRUMENTS, NAMELY, FOOD THERMOMETERS; MEASURING SPOONS; MECHANICAL SIGNS; MECHANISMS FOR COIN-OPERATED APPARATUS; MECHANISMS FOR COIN COUNTING APPARATUS; MEGAPHONES; LEVEL GAUGES FOR TESTING FOR MERCURY; METAL DETECTORS FOR INDUSTRIAL OR MILITARY PURPOSES; METEOROLOGICAL BALLOONS; METEOROLOGICAL INSTRUMENTS; METRONOMES; MICROMETERS; MICROMETER SCREWS FOR OPTICAL INSTRUMENTS; MICROPHONES; MICROPROCESSORS; MICROSCOPES; MICROTOMES; MIRRORS FOR INSPECTING WORK; SCIENTIFIC AND TECHNICAL APPARATUS, NAMELY, OPTICAL MIRRORS; MODEMS; MONEY COUNTING AND SORTING MACHINES; ELECTRONIC MONITORS AND MONITOR MODULES FOR MONITORING ELECTRIC CURRENT AND ELECTRICAL SIGNALS; MOTORIZED FIRE ENGINES; COMPUTER MOUSE; MOUSE PADS; NAVAL SIGNALING APPARATUS; ELECTRIC NAVIGATIONAL INSTRUMENTS; NAVIGATION APPARATUS FOR VEHICLES ON-BOARD COMPUTERS; NEEDLES FOR RECORD PLAYERS; NEON SIGNS; NETS FOR PROTECTION AGAINST ACCIDENTS; NOSE CLIPS FOR DIVERS AND SWIMMERS; NOTEBOOK COMPUTERS; OBJECTIVES, NAMELY, OPTICAL LENSES; OBSERVATION ROCKETS; OCTANTS; OHMMETERS; OPTICAL CHARACTER READERS; OPTICAL MICROSCOPE CONDENSERS; OPTICAL DATA MEDIA, NAMELY, BLANK OPTICAL DISCS; BLANK OPTICAL DISCS; OPTICAL FIBERS; OPTICAL GLASSES; OPTICAL LAMPS, NAMELY, FLASH LAMPS; OPTICAL LENSES; OSCILLOGRAPH; OXYGEN REGULATORS; OZONISERS OZONATORS; PARKING METERS; PARTICLE ACCELERATORS; PEDOMETERS; MAGNIFYING PEEPHOLES FOR DOORS; PERISCOPES; PERSONAL STEREOS; PHOTOCOPIERS; PHOTOMETERS; PHOTOTELEGRAPHY APPARATUS; PHOTOVOLTAIC CELLS; PINCE-NEZ; PINCE-NEZ CASES; PIPETTES; PLANE TABLES SURVEYING INSTRUMENTS; PLANIMETERS; PLATES FOR BATTERIES; PLOTTERS; PLUMB BOBS; PLUMB LINES; POCKET CALCULATORS; POLARIMETERS; PORTABLE MEDIA PLAYERS; PORTABLE TELEPHONES; WEIGHING EQUIPMENT, NAMELY, PRECISION BALANCES; WEIGHING EQUIPMENT, NAMELY, PRECISION MEASURING SCALES; PRESSURE GAUGES; PRESSURE INDICATOR PLUGS FOR VALVES; PRESSURE INDICATORS; MEASURING HOSES FOR MEASURING PRESSURE OF FLUIDS IN HYDRAULIC OR PNEUMATIC SYSTEMS; PRINTED CIRCUIT BOARDS; PRINTED CIRCUITS; PRINTERS FOR USE WITH COMPUTERS; PRISMS OPTICS; ULTRASOUND PROBES FOR SCIENTIFIC PURPOSES; CENTRAL PROCESSING UNITS; SLIDE PROJECTION APPARATUS; PROJECTION SCREENS; PROTECTION DEVICES AGAINST X-RAYS IN THE NATURE OF PROTECTIVE CLOTHING, NOT FOR MEDICAL PURPOSES; PROTECTIVE HELMETS; PROTECTIVE HELMETS FOR SPORTS; PROTECTIVE FACE MASKS, NOT FOR MEDICAL USE; PROTECTIVE SUITS FOR AVIATORS; PROTRACTORS MEASURING INSTRUMENTS; PUNCHED CARD MACHINES FOR OFFICES; PUSH

BUTTONS FOR ELECTRIC DOOR BELLS; PYROMETERS; TECHNICAL MEASURING, TESTING AND CHECKING APPARATUS AND INSTRUMENTS FOR MEASURING, TESTING AND CHECKING THE QUANTITY OF GAS AND LIQUIDS; RADAR APPARATUS; RADIOLOGICAL APPARATUS FOR INDUSTRIAL PURPOSES; RADIOLOGY SCREENS FOR INDUSTRIAL PURPOSES; RADIO PAGERS; RADIOS; RADIO-TELEGRAPHY SETS; RADIOTELEPHONY SETS; RAILWAY TRAFFIC SAFETY APPLIANCES, NAMELY, RAILWAY SIGNALS; RANGE FINDERS; BAR CODE READERS; RECORD PLAYERS; REFLECTING DISCS FOR WEAR, FOR THE PREVENTION OF TRAFFIC ACCIDENTS; REFRACTOMETERS; REFRACTORS, NAMELY, TELESCOPES; ELECTRIC RELAYS; REMOTE CONTROLS FOR RADIOS, TELEVISIONS, STEREOS; RESISTANCES, ELECTRIC; RESPIRATORS FOR FILTERING AIR; RESPIRATORY MASKS, OTHER THAN FOR ARTIFICIAL RESPIRATION; RESUSCITATION MANNEQUINS TEACHING APPARATUS; RETORTS FOR USE IN HIGH TEMPERATURE CHEMICAL REACTIONS; STANDS FOR LABORATORY RETORTS USED IN HIGH TEMPERATURE CHEMICAL REACTIONS; RHEOSTATS; RIDING HELMETS; ROAD SIGNS, LUMINOUS OR MECHANICAL; RODS FOR WATER DIVINERS; GRADUATED RULERS; MEASURING RULES; SACCHAROMETERS; SAFETY NETS; SAFETY RESTRAINTS, OTHER THAN FOR VEHICLE SEATS AND SPORTS EQUIPMENT; SAFETY TARPAULINS; SALINOMETERS; SATELLITE-AIDED NAVIGATION SYSTEMS; SATELLITES FOR SCIENTIFIC PURPOSES; SCALES; BAR CODE SCANNERS; SCREENS FOR PHOTOENGRAVING IN THE NATURE OF PHOTOGRAPHIC FILTERS; PHOTOGRAPHY SCREENS, NAMELY, PROJECTION SCREENS; SCREW-TAPPING GAUGES; SEMI-CONDUCTORS; SEXTANTS; SHEATHS FOR ELECTRIC CABLES; SHOES FOR PROTECTION AGAINST ACCIDENTS, IRRADIATION AND FIRE; SHUTTER RELEASES PHOTOGRAPHY; SHUTTERS PHOTOGRAPHY; SIGHTING TELESCOPES FOR FIREARMS; SIGNAL BELLS; OPTICAL SIGNAL LANTERNS; SIGNALLING BUOYS; SIGNALLING PANELS, LUMINOUS OR MECHANICAL; SIGNALLING WHISTLES; LUMINOUS OR MECHANICAL EMERGENCY SIGNAL TRANSMITTERS; SIGNS, LUMINOUS; SIMULATORS FOR THE STEERING AND CONTROL OF VEHICLES; SIRENS; SLIDE CALIPERS; SLIDE PROJECTORS; SLIDE-RULES; MEASURING DEVICES FOR MEASURING SLOPE; SMOKE DETECTORS; SOCKETS, PLUGS AND OTHER CONTACTS, NAMELY, ELECTRIC CONNECTIONS; PROTECTIVE CLOTHING, NAMELY, ELECTRICALLY HEATED SOCKS; SOLAR BATTERIES; SOLDIERERS' HELMETS; SOLENOID VALVES ELECTROMAGNETIC SWITCHES; SONARS; SOUNDING APPARATUS AND MACHINES, NAMELY, SOUNDING LEADS AND SOUNDING LINES IN THE NATURE OF SONAR EQUIPMENT AND PARTS THEREFORE; ELECTRONIC SOUND LOCATING INSTRUMENTS; SOUND RECORDING APPARATUS; BLANK SOUND RECORDING USB FLASH DRIVES; BLANK SOUND RECORDING DISCS; BLANK SOUND RECORDING TAPES; SOUND REPRODUCTION APPARATUS; SOUND TRANSMITTING APPARATUS; SPARK PLUG GAP GAUGES; SPEAKING TUBES; SPECTACLE CASES; SPECTACLE FRAMES; SPECTACLE GLASSES; SPECTACLES OPTICS; SPECTROGRAPH APPARATUS; SPECTROSCOPES; SPEEDOMETER FOR VEHICLES; SPEED INDICATORS; CAMERA SHUTTER SPEED MEASURING APPARATUS; SPEED REGULATORS FOR RECORD PLAYERS; SPHEROMETERS; SPIRIT LEVELS; SPOOLS FOR CAMERAS; SPRINKLER SYSTEMS FOR FIRE PROTECTION; STAGE LIGHTING REGULATORS; STANDS FOR PHOTOGRAPHIC APPARATUS; JUMPER CABLES FOR MOTORS; AUTOMATIC SIMULATORS FOR THE STEERING FOR VEHICLES; STEP-UP ELECTRICAL TRANSFORMERS; STEREOSCOPIC APPARATUS, NAMELY, STEREOSCOPES; STILLS FOR LABORATORY EXPERIMENTS; SULPHITOMETERS; SUNGLASSES; SURVEYING MACHINES AND INSTRUMENTS; SURVEYING CHAINS; SURVEYING INSTRUMENTS; SURVEYORS' LEVELS; SWITCHBOARDS; ELECTRIC SWITCHBOXES; SWITCHES, ELECTRIC; TACHOMETERS; TAPE RECORDERS; ELECTRIC TAXIMETERS; AUTOMATIC TELEGRAPH APPARATUS; TELEGRAPH WIRES; TELEPHONE APPARATUS; TELEPHONE RECEIVERS; TELEPHONE TRANSMITTERS; TELEPHONE WIRES; TELEPRINTERS; TELEPROMPTERS; CIRCUIT BREAKERS; TELESCOPES; TELEVISIONS; TEMPERATURE INDICATORS; ELECTRICAL TERMINAL BLOCKS; TEST TUBES; ELECTRIC THEFT

PREVENTION ALARM INSTALLATIONS; THEODOLITES; THERMIONIC TUBES; THERMOMETERS, NOT FOR MEDICAL PURPOSES; THERMOSTATS; THERMOSTATS FOR VEHICLES; ELECTRIC THREAD COUNTERS; ELECTRONIC PARKING LOT TICKET DISPENSERS; TIME CLOCKS TIME RECORDING DEVICES; TIME RECORDING APPARATUS; TIME SWITCHES, AUTOMATIC; TONE ARMS FOR RECORD PLAYERS; ADDING MACHINES; TRAFFIC-LIGHT APPARATUS SIGNALLING DEVICES; ELECTRIC TRANSFORMERS; TRANSISTORS ELECTRONIC; TRANSMITTERS OF ELECTRONIC SIGNALS; TELECOMMUNICATIONS TRANSMITTERS; PHOTOGRAPHY TRANSPARENCIES; TRANSDUCERS; TRIODES; TRIPODS FOR CAMERAS; URINOMETERS; BLANK USB FLASH DRIVES; VACUUM GAUGES; VACUUM TUBES FOR RADIOS; VARIOMETERS; VEHICLE BREAKDOWN WARNING TRIANGLES; VEHICLE RADIOS; VERNIERS; BLANK VIDEO CASSETTES; VIDEO GAME CARTRIDGES; VIDEO RECORDERS; VIDEO SCREENS; BLANK VIDEOTAPES; VIDEO TELEPHONES; VIEWFINDERS, PHOTOGRAPHIC; VISCOSIMETERS; VOLTAGE REGULATORS FOR VEHICLES; VOLTAGE SURGE PROTECTORS; VOLTMETERS; VOTING MACHINES; SILICON WAFERS; WALKIE-TALKIES; WASHING TRAYS FOR PROCESSING PHOTOGRAPHIC FILM; WATER LEVEL INDICATORS; WAVEMETERS; WEIGHT BRIDGES; WEIGHING APPARATUS AND INSTRUMENTS; WEIGHING MACHINES; TEST WEIGHTS; WHISTLE BURGLAR ALARMS; WIND SOCKS FOR INDICATING WIND DIRECTION; ELECTRIC WIRE CONNECTORS FITTINGS; WIRES, ELECTRIC; WORD PROCESSORS; WORKMEN'S PROTECTIVE FACE-SHIELDS; WRIST RESTS FOR USE WITH COMPUTERS; X-RAY APPARATUS NOT FOR MEDICAL PURPOSES; X-RAY FILMS, EXPOSED; X-RAY PHOTOGRAPHS, OTHER THAN FOR MEDICAL PURPOSES; X-RAYS PRODUCING APPARATUS AND INSTALLATIONS, NOT FOR MEDICAL PURPOSES (U.S. CLS. 21, 23, 26, 36 AND 38).

#### **CLASS 35—ADVERTISING AND BUSINESS**

FOR ADMINISTRATIVE PROCESSING OF PURCHASE ORDERS; ADVERTISING AGENCIES; ADVERTISING SERVICES BY MEANS OF MAIL ORDER CATALOGS; ADVISORY SERVICES FOR BUSINESS MANAGEMENT; ARRANGING NEWSPAPER SUBSCRIPTIONS FOR OTHERS; ARRANGING SUBSCRIPTIONS TO TELECOMMUNICATION SERVICES FOR OTHERS; AUCTIONEERING; BUSINESS AUDITING; BILL-POSTING; BOOK-KEEPING; BUSINESS APPRAISALS; BUSINESS INFORMATION AND INQUIRIES; BUSINESS INVESTIGATIONS; BUSINESS MANAGEMENT AND ORGANIZATION CONSULTANCY; BUSINESS MANAGEMENT ASSISTANCE; BUSINESS MANAGEMENT CONSULTANCY; BUSINESS MANAGEMENT OF HOTELS; BUSINESS MANAGEMENT OF PERFORMING ARTISTS; BUSINESS MANAGEMENT OF SPORTS PEOPLE; BUSINESS ORGANIZATION CONSULTANCY; BUSINESS RESEARCH; COMMERCIAL ADMINISTRATION OF THE LICENSING OF THE GOODS AND SERVICES OF OTHERS; COMMERCIAL INFORMATION AGENCIES; COMMERCIAL INFORMATION AND ADVICE FOR CONSUMERS CONSUMER ADVICE SHOP; COMMERCIAL AND INDUSTRIAL MANAGEMENT ASSISTANCE; COMPILATION OF INFORMATION INTO COMPUTER DATABASES; COMPILATION OF STATISTICS; COMPUTERIZED FILE MANAGEMENT; COST PRICE ANALYSIS; BUSINESS ADVISORY SERVICES, NAMELY, SEARCH FOR AND SELECTION OF THE BEST POTENTIAL SUPPLIERS FOR OTHERS; DEMONSTRATION OF GOODS; DIRECT MAIL ADVERTISING; DISSEMINATION OF ADVERTISING MATTER; DISTRIBUTION OF SAMPLES; DOCUMENT REPRODUCTION; DRAWING UP OF STATEMENTS OF ACCOUNTS; ECONOMIC FORECASTING; BUSINESS EFFICIENCY EXPERT SERVICES; EMPLOYMENT AGENCIES; IMPORT-EXPORT AGENCIES; INVOICING; LAYOUT SERVICES FOR ADVERTISING PURPOSES; MARKETING SERVICES; MARKETING RESEARCH; CONDUCTING MARKETING STUDIES; MODELING FOR ADVERTISING OR SALES PROMOTION; NEWS CLIPPING SERVICES; OFFICE MACHINES AND EQUIPMENT RENTAL; ON-LINE ADVERTISING ON A COMPUTER NETWORK; MARKET AND PUBLIC OPINION POLLING; ORGANIZATION OF EXHIBITIONS FOR COMMERCIAL OR ADVERTISING PURPOSES;

ORGANIZATION OF FASHION SHOWS FOR PROMOTIONAL PURPOSES; ORGANIZATION OF TRADE FAIRS FOR COMMERCIAL OR ADVERTISING PURPOSES; OUTSOURCING SERVICES BUSINESS ASSISTANCE; PAYROLL PREPARATION; PERSONNEL MANAGEMENT CONSULTANCY; PERSONNEL RECRUITMENT; PHOTOCOPYING SERVICES; PROVIDING TELEVISION HOME SHOPPING SERVICES IN THE FIELD OF GENERAL CONSUMER MERCHANDISE; PRICE COMPARISON SERVICES; PRODUCTION OF ADVERTISING FILMS; PROFESSIONAL BUSINESS CONSULTANCY; PSYCHOLOGICAL TESTING FOR THE SELECTION OF PERSONNEL; PUBLICATION OF PUBLICITY TEXTS; PUBLICITY COLUMNS PREPARATION; PUBLICITY MATERIAL RENTAL; PUBLIC RELATIONS; RADIO ADVERTISING; RELOCATION SERVICES FOR BUSINESSES; RENTAL OF ADVERTISING SPACE; RENTAL OF ADVERTISING TIME ON COMMUNICATION MEDIA; RENTAL OF PHOTOCOPYING MACHINES; RENTAL OF VENDING MACHINES; SALES PROMOTION FOR OTHERS; SECRETARIAL SERVICES; SHOP WINDOW DRESSING; SHORTHAND SERVICES; SPONSORSHIP SEARCH; SYSTEMIZATION OF INFORMATION INTO COMPUTER DATABASES; TAX PREPARATION; TELEMARKETING SERVICES; TELEPHONE ANSWERING FOR UNAVAILABLE SUBSCRIBERS; TELEVISION ADVERTISING; STENOGRAPHIC TRANSCRIPTION; TYPING; UPDATING OF ADVERTISING MATERIAL; WORD PROCESSING (U.S. CLS. 100, 101 AND 102).

#### **CLASS 38—COMMUNICATION**

FOR CABLE TELEVISION BROADCASTING; CELLULAR TELEPHONE COMMUNICATION; COMMUNICATIONS BY COMPUTER TERMINALS; COMMUNICATIONS BY FIBER FIBRE OPTIC NETWORKS; COMMUNICATIONS BY TELEGRAMS; COMMUNICATIONS BY TELEPHONE; COMPUTER AIDED TRANSMISSION OF MESSAGES AND IMAGES; ELECTRONIC BULLETIN BOARD SERVICES TELECOMMUNICATIONS SERVICES; ELECTRONIC MAIL; FACSIMILE TRANSMISSION; INFORMATION ABOUT TELECOMMUNICATION; MESSAGE SENDING; PROVIDING ACCESS TO DATABASES; PROVIDING INTERNET CHAT ROOMS; PROVIDING TELECOMMUNICATION CHANNELS FOR TELESHOPPING SERVICES; PROVIDING TELECOMMUNICATIONS CONNECTIONS TO A GLOBAL COMPUTER NETWORK; PROVIDING USER ACCESS TO GLOBAL COMPUTER NETWORKS; RADIO BROADCASTING; RENTAL OF ACCESS TIME TO GLOBAL COMPUTER NETWORKS; RENTAL OF FACSIMILE APPARATUS; RENTAL OF MODEMS; RENTAL OF TELECOMMUNICATION EQUIPMENT; RENTAL OF TELEPHONES; SATELLITE TRANSMISSION; TELECOMMUNICATIONS ROUTING AND JUNCTION SERVICES; TELECONFERENCING SERVICES; TELEGRAPH SERVICES; TELEPHONE SERVICES; TELEVISION BROADCASTING; TRANSMISSION OF DIGITAL FILES; TRANSMISSION OF GREETING CARDS ONLINE; TRANSMISSION OF TELEGRAMS; VOICE MAIL SERVICES, NEWS AGENCIES, NAMELY, THE TRANSMISSION OF NEWS ITEMS TO NEWS REPORTING ORGANIZATIONS; PAGING SERVICES; RADIO/TELEPHONE PAGING SERVICES; RENTAL OF COMPUTER COMMUNICATION APPARATUS AND INSTRUMENTS FOR SENDING MESSAGES; DATA AND INFORMATION TRANSMISSION BY TELETYPEWRITERS (U.S. CLS. 100, 101 AND 104).

#### **CLASS 42—SCIENTIFIC AND COMPUTER SERVICES**

FOR ADVICE IN REGARD TO DEVELOPMENT OF SOFTWARE AND DEVELOPMENT SERVICES RELATING TO COMPUTER SOFTWARE; ADVISORY AND CONSULTANCY SERVICES RELATING TO COMPUTER HARDWARE DEVELOPMENT; ADVISORY AND CONSULTANCY SERVICES RELATING TO COMPUTER HARDWARE AND SOFTWARE DEVELOPMENT; CONSULTANCY SERVICES RELATING TO COMPUTER SOFTWARE; CONSULTING SERVICES IN THE FIELD OF DESIGN, SELECTION, IMPLEMENTATION AND USE OF COMPUTER HARDWARE AND SOFTWARE SYSTEMS AND PERIPHERALS FOR OTHERS; PROVIDING INFORMATION IN THE FIELDS OF TECHNOLOGY AND SOFTWARE, HARDWARE AND COMPUTER

PERIPHERAL DEVELOPMENT; ADVISORY SERVICES RELATING TO GENE THERAPY RESEARCH; ADVISORY SERVICES RELATING TO INTERIOR DESIGN; AGROCHEMICAL RESEARCH SERVICES; ANALYSIS AND EVALUATION OF PRODUCT DESIGN; ANALYSIS AND EVALUATION OF PRODUCT DEVELOPMENT; PRODUCT AND SERVICE RESEARCH FOR OTHERS WITH RESPECT TO POSSIBLE FUTURE APPLICATIONS; ANALYSIS AND TESTING SERVICES RELATING TO ELECTRICAL ENGINEERING APPARATUS FOR PRODUCT DEVELOPMENT PURPOSES; SCIENTIFIC AND TECHNOLOGICAL SERVICES, NAMELY, ANALYSIS FOR OIL-FIELD EXPLOITATION; SCIENTIFIC AND TECHNOLOGICAL SERVICES, NAMELY, ANALYSIS IN THE FIELD OF MOLECULAR BIOLOGY; ANALYSIS OF STREAM WATER QUALITY; ANALYSIS OF TECHNICAL DATA, NAMELY, DEMOGRAPHIC DATA, BIOMETRIC DATA; ANALYTICAL SCIENTIFIC LABORATORY SERVICES; ARCHITECTURAL AND ENGINEERING SERVICES; ARCHITECTURAL CONSULTATION; ARCHITECTURAL PLANNING AND CONSULTANCY SERVICES; ARCHITECTURAL SERVICES; ARCHITECTURAL SERVICES FOR THE DESIGN OF BUILDINGS; ARCHITECTURAL SERVICES FOR THE DESIGN OF COMMERCIAL BUILDINGS; ARCHITECTURAL SERVICES FOR THE DESIGN OF INDUSTRIAL BUILDINGS; ARCHITECTURAL SERVICES FOR THE DESIGN OF OFFICE BUILDINGS; ARCHITECTURAL SERVICES FOR THE DESIGN OF RETAIL PREMISES; ARCHITECTURAL SERVICES FOR THE DESIGN OF SHOPPING CENTERS; ARCHITECTURAL DESIGN SERVICES IN THE FIELDS OF TRAFFIC AND TRANSPORTATION; AUTHENTICATING WORKS OF ART; BACTERIOLOGICAL RESEARCH; BIOCHEMICAL RESEARCH; BIOCHEMICAL RESEARCH AND DEVELOPMENT; BIOLOGICAL AND CHEMICAL RESEARCH; BIOLOGICAL LABORATORY SERVICES; BIOLOGICAL RESEARCH; BIOMEDICAL RESEARCH SERVICES; BIOTECHNOLOGICAL RESEARCH; BLOOD ANALYSIS SERVICES FOR SCIENTIFIC RESEARCH PURPOSES; BUILDING AND CONSTRUCTION DRAFTING AND CONSULTANCY RELATING THERETO; BUILDING AND MAINTAINING WEBSITES; CALIBRATION MEASURING; CHEMICAL ANALYSIS; CHEMICAL AND BIOLOGICAL LABORATORY SERVICES; CHEMICAL ENGINEERING; CHEMICAL LABORATORY SERVICES; CHEMICAL RESEARCH; CHEMISTRY RESEARCH AND ANALYSIS SERVICES; CHEMISTRY RESEARCH SERVICES; CIVIL ENGINEERING DESIGN; CLOUD SEEDING; COMMISSIONED WRITING OF COMPUTER PROGRAMS, SOFTWARE AND CODE FOR THE CREATION OF WEB PAGES ON THE INTERNET; HOSTING THE SOFTWARE AND WEBSITES OF OTHERS ON A VIRTUAL PRIVATE SERVER; HOSTING OF WEB PAGES FOR THE INTERNET; DIGITAL COMPRESSION OF DATA FOR ELECTRONIC STORAGE; DATA ENCRYPTION SERVICES; COMPUTER AIDED GRAPHIC DESIGN; COMPUTER CONSULTANCY SERVICES; COMPUTER AIDED ENGINEERING SERVICES FOR OTHERS; COMPUTER HARDWARE AND SOFTWARE CONSULTING SERVICES; COMPUTER HARDWARE AND SOFTWARE DESIGN; COMPUTER PROGRAMMING; COMPUTER PROGRAMMING AND COMPUTER SOFTWARE DESIGN; COMPUTER PROGRAMMING CONSULTANCY; COMPUTER PROGRAMMING FOR DATA PROCESSING; COMPUTER PROGRAMMING FOR DATA PROCESSING AND COMMUNICATION SYSTEMS; COMPUTER PROGRAMMING FOR THE ENERGY INDUSTRY; COMPUTER PROGRAMMING SERVICES FOR COMMERCIAL ANALYSIS AND REPORTING; COMPUTER PROGRAMMING SERVICES FOR DATA WAREHOUSING; COMPUTER PROGRAMMING SERVICES FOR ELECTRONIC DATA SECURITY; COMPUTER PROGRAMMING SERVICES RELATING TO MULTIMEDIA AND INTERACTIVE APPLICATIONS; COMPUTER PROJECT MANAGEMENT IN THE FIELD OF ELECTRONIC DATA PROCESSING EDP; COMPUTER RENTAL; COMPUTER SECURITY CONSULTANCY; COMPUTER SECURITY SERVICE, NAMELY, RESTRICTING ACCESS TO AND BY COMPUTER NETWORKS TO AND OF UNDESIRE WEB SITES, MEDIA AND INDIVIDUALS AND FACILITIES; RECORDING DATA FOR OTHERS ON OPTICAL, DIGITAL AND MAGNETIC MEDIA FOR ELECTRONIC STORAGE; COMPUTER SECURITY CONSULTANCY IN THE FIELD OF SCANNING AND PENETRATION TESTING OF COMPUTERS AND SOFTWARE TO ASSESS INFORMATION SECURITY VULNERABILITY; COMPUTER SOFTWARE CONSULTANCY; COMPUTER SOFTWARE

DESIGN; TECHNICAL SUPPORT SERVICES, NAMELY, TROUBLESHOOTING OF COMPUTER SOFTWARE PROBLEMS; COMPUTER SYSTEM ANALYSIS; COMPUTER SYSTEM DESIGN; COMPUTER SYSTEM DESIGN AND ANALYSIS; COMPUTER SYSTEM INTEGRATION SERVICES; COMPUTER VIRUS PROTECTION SERVICES; COMPUTER-AIDED DESIGN SERVICES; COMPUTER-AIDED INDUSTRIAL ANALYSIS OF FLUIDS SERVICES; COMPUTER-AIDED INDUSTRIAL DESIGN; COMPUTER AIDED INDUSTRIAL RESEARCH IN THE FIELD OF CUSTOMER RELATIONSHIP MANAGEMENT, MARKETING, SOCIAL STUDIES, POLITICAL SCIENCE; COMPUTER AIDED INDUSTRIAL TESTING AND ANALYSIS, NAMELY, CUSTOMER BEHAVIOR, DEMOGRAPHIC AND BIOMETRIC CHARACTERISTICS; COMPUTER-AIDED INDUSTRIAL RESEARCH SERVICES IN THE FIELD OF CUSTOMER RELATIONSHIP MANAGEMENT, MARKETING, SOCIAL STUDIES, POLITICAL SCIENCE; COMPUTER-AIDED SCIENTIFIC ANALYSIS SERVICES IN THE FIELD OF CUSTOMER RELATIONSHIP MANAGEMENT, MARKETING, SOCIAL STUDIES, POLITICAL SCIENCE; COMPUTER-AIDED SCIENTIFIC RESEARCH SERVICES; COMPUTER-AIDED SCIENTIFIC RESEARCH, TESTING AND ANALYSIS SERVICES IN THE FIELD OF CUSTOMER RELATIONSHIP MANAGEMENT, MARKETING, SOCIAL STUDIES, POLITICAL SCIENCE; COMPUTER-AIDED TESTING SERVICES, NAMELY, CUSTOMER BEHAVIOR, DEMOGRAPHIC AND BIOMETRIC CHARACTERISTICS; CONDUCTING CLINICAL TRIALS FOR OTHERS; CONDUCTING CLINICAL TRIALS FOR OTHERS PHARMACEUTICAL PRODUCTS; CONDUCTING OF QUALITY CONTROL TESTS FOR OTHERS; CONDUCTING OF QUALITY CONTROL TESTS FOR OTHERS ON GOODS AND SERVICES; CONDUCTING OF SCIENTIFIC EXPERIMENTS IN THE NATURE OF SCIENTIFIC RESEARCH; CONDUCTING OF SCIENTIFIC STUDIES IN THE NATURE OF SCIENTIFIC RESEARCH; CONDUCTING RESEARCH AND TECHNICAL PROJECT STUDIES RELATING TO THE USE OF NATURAL ENERGY; CONDUCTING SAMPLING AND ANALYSIS SERVICES TO ASSESS POLLUTION LEVELS; CONDUCTING SAMPLING AND ANALYSIS SERVICES TO CHECK FOR AIR AND WATER CONTAMINATION; SAFETY AUDITING TO IMPROVE SAFETY OF CONSTRUCTION WORKERS ON RESIDENTIAL CONSTRUCTION SITES; CONFIGURATION OF COMPUTER HARDWARE USING SOFTWARE; CONFIGURATION OF COMPUTER NETWORKS USING SOFTWARE; CONFIGURATION OF COMPUTER SOFTWARE; CONFIGURATION, INSTALLATION, FAULT DIAGNOSIS, REPAIR, UPGRADING AND MAINTENANCE OF COMPUTER SOFTWARE; CONSTRUCTION DRAFTING; CONSTRUCTION PLANNING; CONSULTANCY AND INFORMATION SERVICES RELATING TO COMPUTER PROGRAMMING; CONSULTANCY AND INFORMATION SERVICES RELATING TO COMPUTER SOFTWARE DESIGN; CONSULTANCY AND INFORMATION SERVICES RELATING TO COMPUTER SYSTEM INTEGRATION; CONSULTANCY SERVICES RELATING TO INFORMATION TECHNOLOGY; CONSULTANCY AND INFORMATION SERVICES RELATING TO INFORMATION TECHNOLOGY ARCHITECTURE AND INFRASTRUCTURE; CONSULTANCY SERVICES RELATING TO INFORMATION TECHNOLOGY, INFORMATION TECHNOLOGY ARCHITECTURE AND INFRASTRUCTURE AND COMPUTER SYSTEM INTEGRATION; CONSULTANCY AND INFORMATION SERVICES RELATING TO THE DESIGN, PROGRAMMING AND MAINTENANCE OF COMPUTER SOFTWARE; CONSULTANCY AND INFORMATION SERVICES RELATING TO THE MAINTENANCE OF COMPUTER SOFTWARE; CONSULTANCY AND INFORMATION SERVICES RELATING TO THE RENTAL OF COMPUTER SOFTWARE; CONSULTANCY AND RESEARCH SERVICES IN THE FIELDS OF SCIENCE, ENGINEERING AND INFORMATION TECHNOLOGY; CONSULTANCY IN CONNECTION WITH HARDWARE AND SOFTWARE FOR CONNECTION TO, MANAGEMENT OF, OPERATING AND USING COMPUTER NETWORKS; CONSULTANCY IN THE DESIGN AND DEVELOPMENT OF COMPUTER HARDWARE; CONSULTANCY IN THE FIELD OF ARCHITECTURE AND CONSTRUCTION DRAFTING; CONSULTANCY IN THE FIELD OF BIOTECHNOLOGY; CONSULTANCY IN THE FIELD OF CLOUD COMPUTING NETWORKS AND APPLICATIONS; CONSULTANCY IN THE FIELD OF COMPUTER HARDWARE AND SOFTWARE MANAGEMENT; CONSULTANCY IN THE FIELD OF COMPUTER HARDWARE DESIGN AND



DEVELOPMENT, COMPUTER SOFTWARE AND COMPUTER PROGRAMMING; CONSULTANCY IN THE FIELD OF COMPUTER SOFTWARE DESIGN; CONSULTANCY IN THE FIELD OF COMPUTER SYSTEM INTEGRATION; CONSULTANCY IN THE FIELD OF COMPUTER SYSTEMS ANALYSIS; CONSULTING SERVICES IN THE FIELDS OF ENERGY MEASUREMENT TO IMPROVE ENERGY EFFICIENCY; CONSULTING SERVICES IN THE FIELDS OF ENERGY MEASUREMENT TO IMPROVE ENERGY SAVING; CONSULTANCY IN THE FIELD OF FASHION DESIGN; CONSULTANCY IN THE FIELD OF INFORMATION TECHNOLOGY; CONSULTANCY IN THE FIELD OF PHARMACEUTICAL RESEARCH; CONSULTANCY IN THE FIELD OF PROGRAMMING AND DEVELOPMENT OF E-BUSINESS PORTALS; CONSULTANCY IN THE FIELD OF SCIENTIFIC RESEARCH AND INDUSTRIAL RESEARCH IN THE FIELD OF CUSTOMER RELATIONSHIP MANAGEMENT, MARKETING; CONSULTANCY IN THE FIELD OF SECURITY SOFTWARE; CONSULTANCY IN THE FIELD OF TECHNOLOGICAL DESIGN IN THE FIELD OF COMPUTER HARDWARE; CONSULTANCY IN THE FIELD OF TECHNOLOGICAL RESEARCH IN THE FIELD OF CUSTOMER RELATIONSHIP MANAGEMENT, MARKETING; CONSULTANCY IN THE FIELD OF TELECOMMUNICATIONS ENGINEERING; CONSULTANCY RELATING TO COMPUTER DATABASE SOFTWARE; CONSULTANCY RELATING TO GEOLOGICAL SURVEYS; CONSULTANCY RELATING TO SCIENTIFIC LABORATORY TESTING; CONSULTANCY RELATING TO RESEARCH AND DEVELOPMENT IN THE FIELD OF THERAPEUTICS; CONSULTANCY RELATING TO SOFTWARE FOR COMMUNICATION SYSTEMS; CONSULTANCY RELATING TO TECHNICAL AND SCIENTIFIC ANALYSIS IN THE FIELD OF CUSTOMER RELATIONSHIP MANAGEMENT; CONSULTANCY RELATING TO TECHNICAL AND SCIENTIFIC MEASURING IN THE FIELD OF CUSTOMER RELATIONSHIP MANAGEMENT; CONSULTANCY RELATING TO TECHNICAL AND SCIENTIFIC MONITORING IN THE FIELD CUSTOMER RELATIONSHIP MANAGEMENT; RELATING TO TECHNICAL RESEARCH IN THE FIELD OF FOOD AND BEVERAGES; CONSULTANCY RELATING TO TECHNOLOGICAL CONSULTING SERVICES IN THE FIELD OF ALTERNATIVE POWER AND ENERGY SUPPLY; CONSULTANCY RELATING TO THE CREATION AND DESIGN OF WEB SITES; CONSULTANCY RELATING TO THE CREATION AND DESIGN OF WEB SITES FOR E-COMMERCE; CONSULTANCY RELATING TO THE CREATION OF HOME PAGES AND INTERNET PAGES; CONSULTANCY RELATING TO THE DESIGN AND DEVELOPMENT OF COMPUTER SOFTWARE AND HARDWARE ARCHITECTURE; CONSULTANCY RELATING TO THE DESIGN AND DEVELOPMENT OF COMPUTER SOFTWARE PROGRAMS; CONSULTANCY RELATING TO THE DESIGN AND DEVELOPMENT OF INFORMATION AND COMMUNICATIONS TECHNOLOGY; CONSULTANCY RELATING TO THE DESIGN OF HOME PAGES AND INTERNET PAGES; CONSULTANCY RELATING TO THE DESIGN OF HOME PAGES AND INTERNET SITES; CONSULTANCY RELATING TO THE DESIGN, PROGRAMMING AND MAINTENANCE OF COMPUTER SOFTWARE; CONSULTANCY RELATING TO THE MAINTENANCE OF COMPUTER SOFTWARE; CONSULTANCY RELATING TO THE RECOVERY OF COMPUTER DATA; CONSULTANCY RELATING TO THE UPDATING OF COMPUTER SOFTWARE; CONSULTANCY RELATING TO WEB PAGE DESIGN; CONSULTANCY SERVICES IN THE FIELDS OF BIOTECHNOLOGY, PHARMACEUTICAL RESEARCH AND DEVELOPMENT, LABORATORY TESTING, AND PHARMACOGENETICS; CONSULTANCY SERVICES IN THE FIELDS OF ENVIRONMENTAL SCIENCE, ENGINEERING AND INFORMATION TECHNOLOGY; CONSULTANCY SERVICES RELATING TO RESEARCH IN THE FIELD OF ENVIRONMENTAL PROTECTION; CONSULTANCY SERVICES RELATING TO THE DESIGN, DEVELOPMENT AND USE OF COMPUTER HARDWARE AND SOFTWARE; CONSULTANCY SERVICES RELATING TO THE PLANNING AND DESIGN OF TRAVEL AGENCY WEB SITES; CONVERSION OF DATA OR DOCUMENTS FROM PHYSICAL TO ELECTRONIC MEDIA; CONVERSION OF IMAGES FROM PHYSICAL TO ELECTRONIC MEDIA; CONVERSION OF TEXTS TO DIGITAL FORMAT; COSMETIC RESEARCH; CREATING AND MAINTAINING CUSTOMIZED WEB PAGES; CREATING AND MAINTAINING WEB SITES; CREATING AND MAIN-

TAINING WEB SITES FOR MOBILE PHONES; CREATING AND MAINTAINING WEB SITES FOR OTHERS; CREATING, MAINTAINING AND HOSTING THE WEB SITES OF OTHERS; CREATION AND DESIGN OF WEB PAGES FOR OTHERS; CREATION AND DEVELOPMENT OF COMPUTER PROGRAMS FOR DATA PROCESSING; CREATION OF COMPUTER PROGRAMS; CREATION OF PROGRAMS FOR DATA PROCESSING; CREATION, DESIGN AND MAINTENANCE OF WEB SITES; CREATION, DESIGN, DEVELOPMENT, AND MAINTENANCE OF WEB SITES FOR THIRD PARTIES; CREATION, MAINTENANCE, AND UPDATING OF COMPUTER SOFTWARE; CUSTOMIZATION OF COMPUTER SOFTWARE; CUSTOMIZED DESIGN OF COMPUTER HARDWARE AND SOFTWARE; DATA CONVERSION OF COMPUTER PROGRAMS AND DATA, NOT PHYSICAL CONVERSION; DATA CONVERSION OF ELECTRONIC INFORMATION; DATA ENCRYPTION AND DECODING SERVICES; DATA MIGRATION SERVICES; DATA MINING; DATABASE DESIGN AND DEVELOPMENT; DEBUGGING COMPUTER SOFTWARE FOR OTHERS; DESIGN AND CONSTRUCTION OF HOME PAGES AND WEB SITES; DESIGN AND CONSTRUCTION PLANNING SERVICES AND CONSULTANCY RELATING THERETO; DESIGN AND CREATION OF HOME PAGES AND INTERNET PAGES; DESIGN AND CREATION OF HOME PAGES AND WEB PAGES; DESIGN AND CREATION OF HOME PAGES AND WEB SITES; DESIGN AND CREATION OF WEB SITES FOR OTHERS; DESIGN AND DEVELOPMENT OF COMPUTER GAME SOFTWARE; DESIGN AND DEVELOPMENT OF COMPUTER GAME SOFTWARE AND VIRTUAL REALITY SOFTWARE; DESIGN AND DEVELOPMENT OF COMPUTER HARDWARE; DESIGN AND DEVELOPMENT OF COMPUTER HARDWARE AND SOFTWARE; DESIGN AND DEVELOPMENT OF COMPUTER HARDWARE AND SOFTWARE FOR INDUSTRIAL APPLICATIONS; DESIGN AND DEVELOPMENT OF COMPUTER HARDWARE AND SOFTWARE FOR USE IN THE FIELD OF MEDICINE; DESIGN AND DEVELOPMENT OF COMPUTER HARDWARE ARCHITECTURE; DESIGN AND DEVELOPMENT OF COMPUTER HARDWARE FOR THE MANUFACTURING INDUSTRY; DESIGN AND DEVELOPMENT OF COMPUTER HARDWARE, SOFTWARE AND DATABASES; DESIGN AND DEVELOPMENT OF COMPUTER PERIPHERALS; DESIGN AND DEVELOPMENT OF COMPUTER SOFTWARE ARCHITECTURE; DESIGN AND DEVELOPMENT OF COMPUTER SOFTWARE FOR EVALUATION AND CALCULATION OF DATA; DESIGN AND DEVELOPMENT OF COMPUTER SOFTWARE FOR LOGISTICS; DESIGN AND DEVELOPMENT OF COMPUTER SOFTWARE FOR LOGISTICS, SUPPLY CHAIN MANAGEMENT AND E-BUSINESS PORTALS; DESIGN AND DEVELOPMENT OF COMPUTER SOFTWARE FOR PROCESS CONTROL; DESIGN AND DEVELOPMENT OF COMPUTER SOFTWARE FOR READING, TRANSMITTING AND ORGANIZING DATA; DESIGN AND DEVELOPMENT OF COMPUTER SOFTWARE FOR SUPPLY CHAIN MANAGEMENT; DESIGN AND DEVELOPMENT OF COMPUTER SOFTWARE FOR USE WITH MEDICAL TECHNOLOGY; DESIGN AND DEVELOPMENT OF COMPUTER SOFTWARE FOR WORD PROCESSING; DESIGN AND DEVELOPMENT OF COMPUTERS AND PROGRAMS FOR COMPUTERS; DESIGN AND DEVELOPMENT OF COMPUTERS AND SOFTWARE; DESIGN AND DEVELOPMENT OF DATA DISPLAY SYSTEMS; DESIGN AND DEVELOPMENT OF DATA ENTRY SYSTEMS; DESIGN AND DEVELOPMENT OF DATA OUTPUT SYSTEMS; DESIGN AND DEVELOPMENT OF DATA PROCESSING SYSTEMS; DESIGN AND DEVELOPMENT OF DATA STORAGE SYSTEMS; DESIGN AND DEVELOPMENT OF DIAGNOSTIC APPARATUS; DESIGN AND DEVELOPMENT OF DIGITAL SOUND AND IMAGE CARRIERS; DESIGN AND DEVELOPMENT OF ELECTRONIC DATA SECURITY SYSTEMS; DESIGN AND DEVELOPMENT OF ELECTRONIC DATABASE SOFTWARE; DESIGN AND DEVELOPMENT OF ELECTRONIC DATABASES; DESIGN AND DEVELOPMENT OF ELECTRONIC DICTIONARIES; DESIGN AND DEVELOPMENT OF ELECTRONIC GREETING CARDS E-CARDS; DESIGN AND DEVELOPMENT OF ELECTRONIC LANGUAGE TRANSLATION DICTIONARIES AND DATABASES; DESIGN AND DEVELOPMENT OF ENDOPROSTHESES; DESIGN AND DEVELOPMENT OF ENERGY DISTRIBUTION NETWORKS; DESIGN AND DEVELOPMENT OF ENERGY MANAGEMENT SOFTWARE; DESIGN AND DEVELOPMENT OF HOME

PAGES AND WEB SITES; DESIGN AND DEVELOPMENT OF INFORMATION AND COMMUNICATIONS TECHNOLOGY; DESIGN AND DEVELOPMENT OF INTERNET SECURITY PROGRAMS; DESIGN AND DEVELOPMENT OF MEDICAL DIAGNOSTIC APPARATUS; DESIGN AND DEVELOPMENT OF MEDICAL TECHNOLOGY; DESIGN AND DEVELOPMENT OF NAVIGATION SYSTEMS; DESIGN AND DEVELOPMENT OF NAVIGATION SYSTEMS AND ROUTE PLANNING SOFTWARE; DESIGN AND DEVELOPMENT OF NEW TECHNOLOGY FOR OTHERS; DESIGN AND DEVELOPMENT OF OPERATING SOFTWARE FOR ACCESSING AND USING A CLOUD COMPUTING NETWORK; DESIGN AND DEVELOPMENT OF OPERATING SOFTWARE FOR COMPUTER NETWORKS AND SERVERS; DESIGN AND DEVELOPMENT OF PHOTOVOLTAIC SYSTEMS; DESIGN AND DEVELOPMENT OF PROSTHESES; DESIGN AND DEVELOPMENT OF ROUTE PLANNING SOFTWARE; DESIGN AND DEVELOPMENT OF SOFTWARE AND HARDWARE FOR AUDIO AND VIDEO OPERATORS; DESIGN AND DEVELOPMENT OF SOFTWARE AND HARDWARE FOR COMPRESSION AND DECOMPRESSION OF MULTIMEDIA CONTENT; DESIGN AND DEVELOPMENT OF SOFTWARE AND HARDWARE FOR DATA AND MULTIMEDIA CONTENT CONVERSION FROM AND TO DIFFERENT PROTOCOLS; DESIGN AND DEVELOPMENT OF SOFTWARE AND HARDWARE FOR DIGITAL SIGNAL PROCESSING; DESIGN AND DEVELOPMENT OF SOFTWARE AND HARDWARE FOR MULTIMEDIA DATA STORING AND RECALLING; DESIGN AND DEVELOPMENT OF SOFTWARE AND HARDWARE FOR PROCESSING AND DISTRIBUTION OF MULTIMEDIA CONTENT; DESIGN AND DEVELOPMENT OF SOFTWARE AND HARDWARE FOR PRODUCING, RECORDING AND PROCESSING DIGITAL AND ANALOG SIGNALS; DESIGN AND DEVELOPMENT OF SOFTWARE AND HARDWARE FOR SIGNAL AMPLIFICATION AND TRANSMISSION; DESIGN AND DEVELOPMENT OF SOFTWARE FOR CONTROL, REGULATION AND MONITORING OF SOLAR ENERGY SYSTEMS; DESIGN AND DEVELOPMENT OF SOFTWARE FOR DATABASE MANAGEMENT; DESIGN AND DEVELOPMENT OF SOFTWARE FOR ELECTRONIC TELEVISION PROGRAM GUIDES; DESIGN AND DEVELOPMENT OF SOFTWARE FOR IMPORTING AND MANAGING DATA; DESIGN AND DEVELOPMENT OF SOFTWARE FOR INVENTORY MANAGEMENT; DESIGN AND DEVELOPMENT OF SOFTWARE FOR WEB SITE DEVELOPMENT; DESIGN AND DEVELOPMENT OF COMPUTER SYSTEMS FOR DATA INPUT, OUTPUT, PROCESSING, DISPLAY AND STORAGE; DESIGN AND DEVELOPMENT OF COMPUTER SYSTEMS FOR REGENERATIVE ENERGY GENERATION; DESIGN AND DEVELOPMENT OF TESTING AND ANALYSIS SPECIFICATIONS AND PROCEDURES IN THE FIELD OF CUSTOMER RELATIONSHIP MANAGEMENT, FACE RECOGNITION, EMOTION RECOGNITION, SURVEYS, DATA MANAGEMENT, CHAT; DESIGN AND DEVELOPMENT OF VIRTUAL REALITY SOFTWARE; DESIGN AND DEVELOPMENT OF WEB PAGES; DESIGN AND DEVELOPMENT OF WIRELESS DATA TRANSMISSION APPARATUS; DESIGN AND DEVELOPMENT OF WIRELESS DATA TRANSMISSION APPARATUS, INSTRUMENTS AND EQUIPMENT; DESIGN AND GRAPHIC ARTS DESIGNING FOR THE CREATION OF WEB PAGES ON THE INTERNET; DESIGN AND GRAPHIC ARTS DESIGNING FOR THE CREATION OF WEB SITES; DESIGN AND HOSTING OF WEB PORTALS; DESIGN AND MAINTENANCE OF INTERNET HOME PAGES; DESIGN AND MAINTENANCE OF WEB SITES FOR OTHERS; DESIGN AND DEVELOPMENT OF TELECOMMUNICATION EQUIPMENT; DESIGN AND PROGRAMMING OF WEB SITES; DESIGN AND RENTAL OF SOFTWARE; DESIGN AND UPDATING OF COMPUTER SOFTWARE; DESIGN AND UPDATING OF HOME PAGES AND WEB PAGES; DESIGN AND WRITING OF COMPUTER SOFTWARE; GRAPHIC ARTS DESIGN CONSULTANCY; DESIGN OF COMMERCIAL ARTWORK; DESIGN OF BUILDING INTERIORS AND EXTERIORS; DESIGN OF COMPUTER DATABASES; DESIGN OF COMPUTER FIRMWARE; DESIGN OF COMPUTER HARDWARE; DESIGN OF COMPUTER HARDWARE AND SOFTWARE FOR COMMERCIAL ANALYSIS AND REPORTING; DESIGN OF COMPUTER HARDWARE, SOFTWARE AND COMPUTER PERIPHERALS; DESIGN OF COMPUTER PERIPHERALS; DESIGN OF COMPUTER PROGRAMS FOR OTHERS;

DESIGN OF COMPUTER SOFTWARE, COMPUTER FIRMWARE, COMPUTER HARDWARE AND COMPUTER SYSTEMS; DESIGN OF COMPUTERS; DESIGN OF DIAGNOSTIC APPARATUS AND EQUIPMENT; DESIGN OF HOME PAGES AND INTERNET PAGES; DESIGN OF HOME PAGES AND WEB PAGES; DESIGN OF INTERIOR DECOR; DESIGN OF INTERNET PAGES; DESIGN OF MOBILE TELEPHONES; DESIGN OF PROSTHESES; DESIGN OF COMPUTER SOFTWARE USED AS PUBLICITY MATERIAL; DESIGN OF SOFTWARE FOR USE WITH PRINTING MACHINES; DESIGN OF TELECOMMUNICATIONS APPARATUS AND EQUIPMENT; DESIGN OF TELEPHONES; DESIGN OF WEB PAGES; DESIGN OF WEB PAGES FOR OTHERS; DESIGN OF WEB PORTALS; INTERIOR DESIGN SERVICES; GRAPHIC DESIGN SERVICES RELATING TO PRINTED MATTER; DESIGN, CREATION AND PROGRAMMING OF WEB PAGES; DESIGN, DEVELOPMENT AND PROGRAMMING OF COMPUTER SOFTWARE; DESIGN, DEVELOPMENT, INSTALLATION AND MAINTENANCE OF COMPUTER SOFTWARE; DESIGN, DEVELOPMENT, MAINTENANCE AND UPDATING OF COMPUTER SOFTWARE FOR DATA PROCESSING; DESIGN, DEVELOPMENT, MAINTENANCE AND UPDATING OF COMPUTER SOFTWARE FOR PROCESS CONTROL; DESIGN, DEVELOPMENT, MAINTENANCE AND UPDATING OF COMPUTER SOFTWARE FOR WORD PROCESSING; DESIGN, DEVELOPMENT, MAINTENANCE AND UPDATING OF COMPUTER SOFTWARE FOR WORD PROCESSING, DATA PROCESSING AND PROCESS CONTROL; DESIGN, INSTALLATION, UPDATING AND MAINTENANCE OF COMPUTER SOFTWARE; DESIGN, MAINTENANCE AND UPDATING OF COMPUTER SOFTWARE; DESIGN, MAINTENANCE, DEVELOPMENT AND UPDATING OF COMPUTER SOFTWARE; DESIGN, MAINTENANCE, RENTAL AND UPDATING OF COMPUTER SOFTWARE; DESIGN, PROGRAMMING AND MAINTENANCE OF COMPUTER SOFTWARE; DESIGN, UPGRADING AND RENTAL OF COMPUTER SOFTWARE; DEVELOPING COMPUTER SOFTWARE; DEVELOPMENT AND MAINTENANCE OF COMPUTER DATABASE SOFTWARE; DEVELOPMENT AND MAINTENANCE OF COMPUTER SOFTWARE; DEVELOPMENT OF COMPUTING METHODS, ALGORITHMS AND SOFTWARE; DEVELOPMENT OF COMPUTING METHODS, ALGORITHMS AND SOFTWARE FOR GENERATING TELECOMMUNICATION AND NAVIGATION DATA; DEVELOPMENT OF COMPUTING METHODS, ALGORITHMS AND SOFTWARE FOR PROCESSING TELECOMMUNICATION AND NAVIGATION SIGNALS; CONSULTING SERVICES IN THE FIELD OF DESIGN AND DEVELOPMENT OF ENGINEERING PROCESSES; DEVELOPMENT AND UPDATING OF COMPUTER SOFTWARE; DEVELOPMENT OF ALGORITHMS AND COMPUTING METHODS FOR GENERATING TELECOMMUNICATION AND NAVIGATION DATA; DEVELOPMENT OF ALGORITHMS AND COMPUTING METHODS FOR PROCESSING TELECOMMUNICATION AND NAVIGATION DATA; DEVELOPMENT OF ALGORITHMS AND COMPUTING METHODS FOR PROCESSING TELECOMMUNICATION AND NAVIGATION SIGNALS; DEVELOPMENT OF COMPUTER HARDWARE AND SOFTWARE; DEVELOPMENT OF COMPUTER HARDWARE FOR COMPUTER GAMES; DEVELOPMENT OF COMPUTER PROGRAMS; DEVELOPMENT OF COMPUTER PROGRAMS AND COMPUTER GAME SOFTWARE; DEVELOPMENT OF COMPUTER SOFTWARE APPLICATION SOLUTIONS, NAMELY, CRM SOFTWARE, FACE DETECTION SOFTWARE, EMOTION DETECTION SOFTWARE, SURVEYS SOFTWARE, CHAT SOFTWARE; DEVELOPMENT OF COMPUTER SOFTWARE FOR CREATING ELECTRONIC TELEVISION PROGRAM GUIDES; DEVELOPMENT OF COMPUTER SOFTWARE FOR LOGISTICS, SUPPLY CHAIN MANAGEMENT AND E-BUSINESS PORTALS; DEVELOPMENT OF COMPUTER SOFTWARE FOR USE WITH COMPUTER-CONTROLLED SWITCHING SYSTEMS; DEVELOPMENT OF COMPUTER SOFTWARE FOR USE WITH PROGRAMMABLE CONTROLLERS; DESIGN AND DEVELOPMENT OF COMPUTER DATA STORAGE SYSTEMS; DESIGN AND DEVELOPMENT OF COMPUTERIZED DATA TRANSMISSION SYSTEMS; DESIGN AND DEVELOPMENT OF ENERGY AND POWER MANAGEMENT COMPUTER AND COMPUTER SOFTWARE SYSTEMS; DEVELOPMENT OF COMPUTER PROGRAMS FOR DATA PROCESSING; DESIGN AND DEVELOPMENT OF PROSTHESES; DEVELOPMENT OF COMPUTER HARDWARE AND SOFTWARE SYSTEMS FOR DATA PROCESSING; DEVELOPMENT OF COMPU-

TER HARDWARE AND SOFTWARE FOR TESTING ELECTRICAL WIRES; DEVELOPMENT, PROGRAMMING AND RENTAL OF DATA PROCESSING PROGRAMS; DIAGNOSIS OF COMPUTER HARDWARE PROBLEMS THROUGH THE USE OF SOFTWARE; DIAGNOSIS OF COMPUTER SOFTWARE PROBLEMS; DIAMOND AUTHENTICATION AND CERTIFICATION SERVICES; DIGITALIZATION OF SOUND AND IMAGES; DIGITIZATION OF DOCUMENTS SCANNING; DNA SCREENING FOR SCIENTIFIC RESEARCH PURPOSES; DRAFTSMAN'S SERVICES IN THE NATURE OF TECHNICAL DRAWING; DRESS DESIGNING; DRUG DISCOVERY SERVICES; DUPLICATION OF COMPUTER PROGRAMS; DUPLICATION OF COMPUTER SOFTWARE; ELECTRICAL ENGINEERING SERVICES; ELECTRONIC DATA BACK-UP SERVICES; RECORDING DATA FOR OTHERS ON OPTICAL, DIGITAL AND MAGNETIC MEDIA FOR ELECTRONIC STORAGE; RECORDING DATA FOR OTHERS ON OPTICAL, DIGITAL AND MAGNETIC MEDIA FOR ELECTRONIC STORAGE AND BACK-UP SERVICES FOR COMPUTER HARD DRIVE DATA; RECORDING DATA FOR OTHERS ON OPTICAL, DIGITAL AND MAGNETIC MEDIA FOR ELECTRONIC STORAGE FOR OTHERS; ENERGY AUDITING; ENGINEERING; ENGINEERING AND CHEMISTRY CONSULTATION SERVICES; ENGINEERING CONSULTANCY SERVICES; ENGINEERING DESIGN; ENGINEERING DRAWING; RESEARCH RELATING TO MECHANICAL ENGINEERING; ENGINEERING RESEARCH AND DESIGN SERVICES IN THE FIELD OF DRILLING TECHNOLOGY; ENGINEERING SERVICES FOR THE GAS INDUSTRY; ENGINEERING SERVICES IN THE FIELD OF BUILDING TECHNOLOGY; ENGINEERING SERVICES IN THE FIELD OF COMMUNICATIONS TECHNOLOGY; ENGINEERING SERVICES IN THE FIELD OF ENERGY TECHNOLOGY; ENGINEERING SERVICES IN THE FIELD OF ENERGY, BUILDING, COMMUNICATIONS AND ENVIRONMENTAL TECHNOLOGY; ENGINEERING SERVICES IN THE FIELD OF ENVIRONMENTAL TECHNOLOGY; ENGINEERING SERVICES IN THE FIELD OF MOTIVE POWER; ENGINEERING SERVICES RELATING TO ENERGY SUPPLY SYSTEMS; ENGINEERING SERVICES RELATING TO GAS TRANSPORT AND SUPPLY SYSTEMS; ENGINEERING SURVEYING; CONSULTING SERVICES IN THE FIELD OF ENVIRONMENTAL ASSESSMENT AND PLANNING; ENVIRONMENTAL MONITORING SERVICES, NAMELY, MONITORING, TESTING AND ANALYZING ECOLOGICAL SUCCESS IN THE FIELD OF ENVIRONMENTALLY SENSITIVE HABITAT CONSERVATION AND PRESERVATION OF NATIVE PLANTS AND WILDLIFE; ENVIRONMENTAL TESTING AND INSPECTION SERVICES; EVALUATION OF RESULTS FROM QUALITY CONTROL TESTS CONDUCTED ON GOODS AND SERVICES; FOOTWEAR DESIGN SERVICES; GAS EXPLORATION; SCIENTIFIC RESEARCH IN THE FIELD OF GENETIC ENGINEERING; GEOLOGICAL EXPLORATION FOR THE OIL INDUSTRY; GEOLOGICAL PROSPECTING; GEOLOGICAL RESEARCH; CONDUCTING GEOLOGICAL SURVEYS; GRAPHIC ARTS DESIGNING; GRAPHIC DESIGN SERVICES; HANDWRITING ANALYSIS GRAPHOLOGY; HOSTING AN ON-LINE WEB SITE FOR CREATING AND HOSTING MICRO WEB SITES FOR BUSINESSES; HOSTING OF WEB SITES; HOSTING COMPUTER WEB SITES; APPLICATION SERVICE PROVIDER (ASP), NAMELY, HOSTING COMPUTER SOFTWARE APPLICATIONS OF OTHERS; APPLICATION SERVICE PROVIDER, NAMELY, HOSTING, MANAGING, DEVELOPING, ANALYZING, AND MAINTAINING APPLICATIONS, SOFTWARE, AND WEB SITES, OF OTHERS IN THE FIELDS OF ADVERTISING AND MARKETING; COMPUTER SERVICES, NAMELY, CLOUD HOSTING PROVIDER SERVICES; HOSTING MULTIMEDIA ENTERTAINMENT AND EDUCATIONAL INTERNET SITES FOR OTHERS; APPLICATION SERVICE PROVIDER (ASP), NAMELY, HOSTING COMPUTER SOFTWARE APPLICATIONS OF OTHERS; HOSTING OF CUSTOMIZED WEB PAGES; HOSTING OF E-COMMERCE PLATFORMS ON THE INTERNET; CLOUD COMPUTING FEATURING SOFTWARE FOR USE IN STORING DIGITAL PHOTOGRAPHS; HOSTING OF MULTIMEDIA AND INTERACTIVE COMPUTER SOFTWARE APPLICATIONS OF OTHERS; HOSTING THE LIBRARY MANAGEMENT SOFTWARE OF OTHERS; HOSTING OF WEB SITE BLOGS; HOSTING ON-LINE WEB FACILITIES FOR OTHERS FOR CONDUCTING INTERACTIVE DISCUSSIONS; HOSTING ON-LINE WEB

FACILITIES FOR OTHERS; PROVIDING AN INTERNET WEBSITE PORTAL IN THE FIELDS OF TECHNOLOGY AND SOFTWARE DEVELOPMENT; HOSTING WEB SITES FOR OTHERS ON THE INTERNET; HOSTING WEB SITES OF OTHERS; HOSTING WEB SITES ON THE INTERNET; HYDROLOGICAL RESEARCH; GRAPHIC ILLUSTRATION SERVICES FOR OTHERS; IMPLEMENTATION OF COMPUTER TECHNOLOGIES FOR OTHERS; INDUSTRIAL ANALYSIS AND RESEARCH SERVICES IN THE FIELD OF CHEMISTRY; INDUSTRIAL ANALYSIS AND RESEARCH SERVICES RELATING TO AUTOMOBILE TIRES; INFORMATION TECHNOLOGY ENGINEERING; INSPECTION OF GOODS, NAMELY, CRM SOFTWARE, FACE AND EMOTION RECOGNITION SOFTWARE, SURVEYS SOFTWARE, CHAT SOFTWARE FOR QUALITY CONTROL; INSTALLATION AND MAINTENANCE OF DATABASE SOFTWARE; INSTALLATION AND MAINTENANCE OF INTERNET ACCESS SOFTWARE; INSTALLATION AND MAINTENANCE OF SOFTWARE; INSTALLATION OF COMPUTER SOFTWARE; INSTALLATION OF DATABASE SOFTWARE; INSTALLATION OF SOFTWARE FOR INTERNET ACCESS; INSTALLATION, MAINTENANCE AND REPAIR OF SOFTWARE FOR COMPUTER SYSTEMS; INSTALLATION, MAINTENANCE AND UPDATING OF COMPUTER SOFTWARE; INSTALLATION, MAINTENANCE AND UPDATING OF DATABASE SOFTWARE; INSTALLATION, MAINTENANCE, UPDATING AND UPGRADING OF COMPUTER SOFTWARE; INSTALLATION, REPAIR AND MAINTENANCE OF COMPUTER SOFTWARE; INSTALLING COMPUTER PROGRAMS; INTERIOR ARCHITECTURAL SERVICES; INFORMATION TECHNOLOGY SOFTWARE PROGRAMMING SERVICES; CONSULTING SERVICES IN THE FIELD OF INFORMATION TECHNOLOGY PROJECT MANAGEMENT; LABORATORY RESEARCH AND ANALYSIS SERVICES IN THE FIELD OF CUSTOMER RELATIONSHIP MANAGEMENT, FACE RECOGNITION, EMOTION RECOGNITION, SURVEYS, DATA MANAGEMENT; LABORATORY RESEARCH IN THE FIELD OF BACTERIOLOGY; LABORATORY RESEARCH IN THE FIELD OF CHEMISTRY; LABORATORY RESEARCH IN THE FIELD OF COSMETICS; LABORATORY TESTING SERVICES IN THE FIELD OF CRM SOFTWARE; LAND AND ROAD SURVEYING; LAND SURVEYING; MAINTENANCE AND CONSULTANCY SERVICES RELATING TO SOFTWARE USED IN THE FIELD OF E-COMMERCE; MAINTENANCE AND REPAIR OF COMPUTER SOFTWARE; MAINTENANCE AND UPDATING OF SOFTWARE FOR COMMUNICATION SYSTEMS; MAINTENANCE OF COMPUTER PROGRAMS; MAINTENANCE OF COMPUTER SOFTWARE; MAINTENANCE OF COMPUTER SOFTWARE RELATING TO COMPUTER SECURITY AND PREVENTION OF COMPUTER RISKS; MAINTENANCE OF DATABASE SOFTWARE; MAINTENANCE OF SOFTWARE FOR INTERNET ACCESS; MAINTENANCE OF WEB SITES; MATERIAL TESTING; MEASURING AND ANALYSIS OF GREENHOUSE GAS EMISSIONS; MECHANICAL AND ELECTRICAL ENGINEERING SERVICES; MECHANICAL ENGINEERING SERVICES; MECHANICAL RESEARCH; MECHANICAL RESEARCH IN THE FIELD OF MOTOR SPORTS; MEDICAL RESEARCH; PROVIDING METEOROLOGICAL INFORMATION; MINERAL EXPLORATION; MONITORING OF COMPUTER SYSTEMS BY REMOTE ACCESS TO ENSURE PROPER FUNCTIONING; MONITORING OF EROSION AND SEDIMENTATION; MONITORING OF COMPUTERIZED TELECOMMUNICATION SIGNALS TO ENSURE PROPER FUNCTIONING; MONITORING OF STREAM WATER QUALITY; OIL PROSPECTING; OIL-FIELD SURVEYS; OIL-WELL TESTING; PACKAGING DESIGN; PHARMACEUTICAL RESEARCH AND DEVELOPMENT; PHYSICS RESEARCH; PLANNING AND DESIGN OF TRAVEL AGENCIES; PREPARATION OF BIOLOGICAL SAMPLES FOR ANALYSIS IN RESEARCH LABORATORIES; PREPARATION OF BIOLOGICAL SAMPLES FOR RESEARCH PURPOSES; PREPARATION OF BIOLOGICAL SAMPLES FOR TESTING AND ANALYSIS IN RESEARCH LABORATORIES; PREPARATION OF ENGINEERING REPORTS; PREPARATION OF IMMUNOHISTOLOGICAL SAMPLES FOR ANALYSIS IN RESEARCH LABORATORIES; PREPARATION OF REPORTS RELATING TO SCIENTIFIC RESEARCH; PREPARATION OF REPORTS RELATING TO TECHNICAL PROJECT STUDIES FOR CONSTRUCTION PROJECTS; PREPARATION OF REPORTS RELATING TO TECHNICAL RESEARCH; PREPARATION OF REPORTS RELAT-

ING TO TECHNOLOGICAL RESEARCH; PREPARATION OF SCIENTIFIC REPORTS; PREPARATION OF TECHNICAL REPORTS; NEW PRODUCT DESIGN; PRODUCT DEVELOPMENT; PRODUCT QUALITY CONTROL TESTING FOR OTHERS; PRODUCT TESTING; PROFESSIONAL CONSULTANCY RELATING TO COMPUTER SECURITY; PROFESSIONAL ARCHITECTURAL DESIGN; COMPUTER GRAPHICS DESIGN SERVICES, NAMELY, CREATING OF ANIMATIONS; PROGRAMMING OF COMPUTER SOFTWARE FOR ELECTRONIC LANGUAGE TRANSLATION DICTIONARIES AND DATABASES; PROGRAMMING OF COMPUTER SOFTWARE FOR EVALUATION AND CALCULATION OF DATA; PROGRAMMING OF COMPUTER SOFTWARE FOR READING, TRANSMITTING AND ORGANIZING DATA; COMPUTER PROGRAMMING OF CUSTOMIZED WEB PAGES; COMPUTER PROGRAMMING OF CUSTOMIZED WEB PAGES FEATURING USER-DEFINED INFORMATION, PERSONAL PROFILES AND INFORMATION; PROGRAMMING OF DATA PROCESSING PROGRAMS; PROGRAMMING OF ELECTRONIC DATA PROCESSING EDP SOFTWARE; PROGRAMMING OF ENERGY MANAGEMENT SOFTWARE; PROGRAMMING OF INTERNET SECURITY PROGRAMS; PROGRAMMING OF OPERATING SOFTWARE FOR ACCESSING AND USING A CLOUD COMPUTING NETWORK; PROGRAMMING OF OPERATING SOFTWARE FOR COMPUTER NETWORKS AND SERVERS; PROGRAMMING OF SOFTWARE FOR DATABASE MANAGEMENT; PROGRAMMING OF SOFTWARE FOR E-COMMERCE PLATFORMS; PROGRAMMING OF SOFTWARE FOR IMPORTING AND MANAGING DATA; PROGRAMMING OF SOFTWARE FOR INFORMATION PLATFORMS ON THE INTERNET; PROGRAMMING OF SOFTWARE FOR INTERNET PLATFORMS; PROGRAMMING OF SOFTWARE FOR INTERNET PORTALS, CHATROOMS, CHAT LINES AND INTERNET FORUMS; PROGRAMMING OF SOFTWARE FOR INVENTORY MANAGEMENT; PROGRAMMING OF SOFTWARE FOR WEB SITE DEVELOPMENT; PROGRAMMING OF TELECOMMUNICATIONS SOFTWARE; COMPUTER PROGRAMMING OF WEB PAGES; CUSTOMIZING COMPUTER SOFTWARE; PROVIDING INFORMATION ABOUT DESIGN AND DEVELOPMENT OF COMPUTER HARDWARE AND SOFTWARE; PROVIDING INFORMATION ABOUT MEDICAL AND SCIENTIFIC RESEARCH IN THE FIELD OF PHARMACEUTICALS; PROVIDING INFORMATION ABOUT THE DESIGN AND DEVELOPMENT OF COMPUTER SOFTWARE, SYSTEMS AND NETWORKS; PROVIDING INFORMATION ABOUT THE RESULTS OF CLINICAL TRIALS FOR PHARMACEUTICAL PRODUCTS; PROVIDING INFORMATION IN THE FIELD OF COMPUTER SOFTWARE DESIGN; PROVIDING INFORMATION IN THE FIELD OF COMPUTER SOFTWARE DEVELOPMENT; PROVIDING INFORMATION IN THE FIELD OF PRODUCT DESIGN; PROVIDING INFORMATION IN THE FIELD OF PRODUCT DEVELOPMENT; COMPUTER SERVICES, NAMELY, PROVIDING SEARCH ENGINES FOR OBTAINING SOCIAL, DEMOGRAPHIC DATA ON A GLOBAL COMPUTER NETWORK; PROVIDING ON-LINE INFORMATION ABOUT DESIGN AND DEVELOPMENT OF COMPUTER HARDWARE AND SOFTWARE; PROVIDING ON-LINE INFORMATION ABOUT INDUSTRIAL ANALYSIS AND RESEARCH SERVICES IN THE FIELD OF CUSTOMER RELATIONSHIP MANAGEMENT; PROVIDING ON-LINE INFORMATION IN THE FIELD OF TECHNOLOGICAL RESEARCH FROM A COMPUTER DATABASE OR THE INTERNET IN THE FIELD OF CUSTOMER RELATIONSHIP MANAGEMENT; PROVIDING RESEARCH INFORMATION AND RESULTS IN THE FIELDS OF TECHNOLOGY, SCIENCE AND MEDICINE FROM AN ON-LINE SEARCHABLE DATABASE; PROVIDING SEARCH ENGINES FOR OBTAINING DATA VIA COMMUNICATIONS NETWORKS; PROVIDING A WEBSITE FEATURING A SEARCH ENGINE FOR CUSTOMER RELATED DATA; PROVIDING TECHNICAL ADVICE IN THE FIELD OF SCIENTIFIC AND INDUSTRIAL RESEARCH; PROVIDING TECHNICAL INFORMATION ABOUT COMPUTERS, COMPUTER SOFTWARE AND COMPUTER NETWORKS; PROVIDING TEMPORARY USE OF NON-DOWNLOADABLE BUSINESS SOFTWARE FOR CUSTOMER RELATIONSHIP MANAGEMENT, FACE RECOGNITION, EMOTION RECOGNITION, SURVEYS, DATA MANAGEMENT, CHAT; PROVIDING TEMPORARY USE OF NON-DOWNLOADABLE SOFTWARE APPLICATIONS ACCESSIBLE VIA A WEB SITE FOR CUSTOMER RELATIONSHIP MANAGEMENT, FACE RECOGNITION, EMOTION

RECOGNITION, SURVEYS, DATA MANAGEMENT, CHAT; PROVIDING TEMPORARY USE OF NON-DOWNLOADABLE SOFTWARE FOR ANALYZING FINANCIAL DATA AND GENERATING REPORTS; PROVIDING TEMPORARY USE OF NON-DOWNLOADABLE SOFTWARE TO ENABLE CONTENT PROVIDERS TO TRACK MULTIMEDIA CONTENT; PROVIDING TEMPORARY USE OF NON-DOWNLOADABLE SOFTWARE TO ENABLE SHARING OF MULTIMEDIA CONTENT AND COMMENTS AMONG USERS; PROVIDING TEMPORARY USE OF ON-LINE NON-DOWNLOADABLE SOFTWARE DEVELOPMENT TOOLS FOR USE IN CUSTOMER RELATIONSHIP MANAGEMENT, SURVEYS, FACE AND EMOTION RECOGNITION, DATA MANAGEMENT, CHAT; PROVIDING TEMPORARY USE OF ON-LINE NON-DOWNLOADABLE INVESTMENT SOFTWARE; PROVIDING TEMPORARY USE OF ON-LINE NON-DOWNLOADABLE OPERATING SOFTWARE FOR ACCESSING AND USING A CLOUD COMPUTING NETWORK; PROVIDING TEMPORARY USE OF ON-LINE NON-DOWNLOADABLE OPERATING SOFTWARE FOR COMPUTER NETWORKS AND SERVERS; PROVIDING TEMPORARY USE OF ON-LINE NON-DOWNLOADABLE SOFTWARE FOR DATABASE MANAGEMENT; PROVIDING TEMPORARY USE OF ON-LINE NON-DOWNLOADABLE SOFTWARE FOR IMPORTING AND MANAGING DATA; PROVIDING TEMPORARY USE OF ON-LINE NON-DOWNLOADABLE SOFTWARE FOR INVENTORY MANAGEMENT; PROVIDING TEMPORARY USE OF ON-LINE NON-DOWNLOADABLE SOFTWARE FOR WEB SITE DEVELOPMENT; PROVIDING TEMPORARY USE OF ON-LINE, NON-DOWNLOADABLE COMPUTER SOFTWARE FOR LANGUAGE TRANSLATION; PROVIDING TEMPORARY USE OF ON-LINE, NON-DOWNLOADABLE COMPUTER SOFTWARE FOR USE IN BROADCAST MONITORING APPLICATIONS; PROVIDING TEMPORARY USE OF WEB-BASED APPLICATIONS FOR CUSTOMER RELATIONSHIP MANAGEMENT, FACE RECOGNITION, EMOTION RECOGNITION, SURVEYS, DATA MANAGEMENT, CHAT; PROVIDING TEMPORARY USE OF WEB-BASED SOFTWARE FOR USE IN CUSTOMER RELATIONSHIP MANAGEMENT, FACE RECOGNITION, EMOTION RECOGNITION, SURVEYS, DATA MANAGEMENT, CHAT; PROVIDING TEMPORARY USE ON NON-DOWNLOADABLE COMPUTER PROGRAMS IN DATA NETWORKS FOR CUSTOMER RELATIONSHIP MANAGEMENT, FACE RECOGNITION, EMOTION RECOGNITION, SURVEYS, DATA MANAGEMENT, CHAT; PROVISION OF INFORMATION AND DATA RELATING TO MEDICAL AND VETERINARY RESEARCH AND DEVELOPMENT; PROVISION OF INFORMATION AND DATA RELATING TO SCIENTIFIC AND TECHNOLOGICAL RESEARCH AND DEVELOPMENT; PROVISION OF INFORMATION CONCERNING RESEARCH AND TECHNICAL PROJECT STUDIES RELATING TO THE USE OF NATURAL ENERGY; PROVISION OF INFORMATION RELATING TO COMPUTER PROGRAMMING; PROVISION OF INFORMATION RELATING TO COMPUTER PROGRAM DEVELOPMENT; PROVISION OF INFORMATION RELATING TO INDUSTRIAL DESIGN; PROVISION OF INFORMATION RELATING TO TECHNOLOGICAL RESEARCH IN THE FIELD OF CUSTOMER RELATIONSHIP MANAGEMENT, FACE RECOGNITION, EMOTION RECOGNITION, SURVEYS, DATA MANAGEMENT, CHAT; PROVISION OF SCIENTIFIC INFORMATION, ADVICE AND CONSULTANCY IN RELATION TO CARBON OFFSETTING; PROVISION OF TECHNICAL INFORMATION IN RELATION TO COMPUTERS; PROVIDING TEMPORARY USE OF ON-LINE NON-DOWNLOADABLE CLOUD COMPUTING SOFTWARE FOR USE IN ELECTRONIC STORAGE OF DATA; QUALITY CONTROL FOR OTHERS; QUALITY CONTROL OF GOODS FOR OTHERS; QUALITY CONTROL OF GOODS AND SERVICES FOR OTHERS; QUALITY CONTROL SERVICES AND QUALITY CONTROL AUDITING IN THE FIELD OF INFORMATION TECHNOLOGY FOR OTHERS; QUALITY CONTROL SERVICES FOR OTHERS FOR CERTIFICATION PURPOSES; QUALITY CONTROL TESTING FOR OTHERS; QUALITY CONTROL TESTING AND CONSULTANCY RELATING THERETO FOR OTHERS; QUALITY CONTROL TESTING OF PRODUCTS FOR CERTIFICATION PURPOSES FOR OTHERS; QUALITY CONTROL TESTING SERVICES FOR OTHERS FOR AGRICULTURAL MACHINERY; QUALITY CONTROL TESTING SERVICES FOR OTHERS FOR FORESTRY

EQUIPMENT; QUALITY CONTROL TESTING SERVICES FOR OTHERS FOR HORTICULTURAL EQUIPMENT; QUALITY CONTROL TESTING SERVICES FOR OTHERS FOR INDUSTRIAL MACHINERY; QUALITY EVALUATION OF STANDING TIMBER FOR OTHERS; QUALITY EVALUATION OF WOOL FOR OTHERS; QUALITY TESTING OF PRODUCTS FOR OTHERS FOR CERTIFICATION PURPOSES; RECOVERY OF COMPUTER DATA; RENTAL AND MAINTENANCE OF COMPUTER SOFTWARE; RENTAL OF COMPUTER PROGRAMS FOR CONDUCTING FINANCIAL TRANSACTIONS; RENTAL AND UPDATING OF SOFTWARE FOR DATA PROCESSING; RENTAL OF COMPUTER DATABASE SOFTWARE; RENTAL OF COMPUTER HARDWARE; RENTAL OF COMPUTER HARDWARE AND COMPUTER PERIPHERALS; RENTAL OF COMPUTER HARDWARE AND SOFTWARE; RENTAL OF COMPUTER PROGRAMS; RENTAL OF COMPUTER SOFTWARE; RENTAL OF COMPUTER SOFTWARE AND PROGRAMS; RENTAL OF COMPUTER SOFTWARE FOR FINANCIAL MANAGEMENT; RENTAL OF COMPUTER SOFTWARE RELATING TO TRAVEL; RENTAL OF COMPUTER SOFTWARE, COMPUTERS FOR DATA PROCESSING AND COMPUTER PERIPHERAL DEVICES; RENTAL OF COMPUTERS AND COMPUTER EQUIPMENT; RENTAL OF COMPUTERS AND COMPUTER SOFTWARE; RENTAL OF COMPUTERS FOR DATA PROCESSING; RENTAL OF DATA PROCESSING PROGRAMS; RENTAL OF INTERNET SECURITY PROGRAMS; SERVER HOSTING; RENTAL OF OPERATING SOFTWARE FOR ACCESSING AND USING A CLOUD COMPUTING NETWORK; RENTAL OF OPERATING SOFTWARE FOR COMPUTER NETWORKS AND SERVERS; RENTAL OF PERIPHERAL DEVICES FOR COMPUTERS; RENTAL OF SOFTWARE FOR DATABASE MANAGEMENT; RENTAL OF SOFTWARE FOR IMPORTING AND MANAGING DATA; RENTAL OF SOFTWARE FOR INTERNET ACCESS; RENTAL OF SOFTWARE FOR INVENTORY MANAGEMENT; RENTAL OF SOFTWARE FOR WEB SITE DEVELOPMENT; RENTAL OF WEB SERVERS; REPAIR OF COMPUTER SOFTWARE; RESEARCH AND CONSULTANCY SERVICES RELATING TO COMPUTER HARDWARE; RESEARCH AND CONSULTANCY SERVICES RELATING TO COMPUTER HARDWARE AND SOFTWARE; RESEARCH AND CONSULTANCY SERVICES RELATING TO COMPUTER SOFTWARE; RESEARCH AND DESIGN OF COMPUTER SOFTWARE; RESEARCH AND DEVELOPMENT OF NEW PRODUCTS FOR OTHERS; RESEARCH AND DEVELOPMENT FOR THE PHARMACEUTICAL AND BIOTECHNOLOGY INDUSTRIES; RESEARCH AND DEVELOPMENT FOR THE PHARMACEUTICAL INDUSTRY; RESEARCH AND DEVELOPMENT IN THE FIELD OF BIOTECHNOLOGY; RESEARCH AND DEVELOPMENT IN THE FIELD OF DIAGNOSTIC PREPARATIONS; RESEARCH AND DEVELOPMENT IN THE FIELD OF MICROORGANISMS AND CELLS; RESEARCH AND DEVELOPMENT OF NEW PRODUCTS; RESEARCH AND DEVELOPMENT OF PRODUCTS; RESEARCH AND DEVELOPMENT SERVICES IN CONNECTION WITH PHYSICS; RESEARCH AND DEVELOPMENT SERVICES IN THE FIELD OF ANTIBODIES; RESEARCH AND DEVELOPMENT SERVICES IN THE FIELD OF ANTIBODY TECHNOLOGY; RESEARCH AND DEVELOPMENT SERVICES IN THE FIELD OF BACTERIOLOGY; RESEARCH AND DEVELOPMENT SERVICES IN THE FIELD OF BACTERIOLOGY, CYTOLOGY, ANTIBODY TECHNOLOGY, CHEMISTRY, IMMUNOLOGY AND GENE EXPRESSION SYSTEMS; RESEARCH AND DEVELOPMENT SERVICES IN THE FIELD OF CHEMISTRY; RESEARCH AND DEVELOPMENT SERVICES IN THE FIELD OF CYTOLOGY; RESEARCH AND DEVELOPMENT SERVICES IN THE FIELD OF GENE EXPRESSION SYSTEMS; RESEARCH AND DEVELOPMENT SERVICES IN THE FIELD OF IMMUNOHISTOLOGY; RESEARCH AND DEVELOPMENT SERVICES IN THE FIELD OF IMMUNOLOGY; RESEARCH AND DEVELOPMENT SERVICES RELATING TO AUTOMOBILE TIRES; RESEARCH AND DEVELOPMENT SERVICES RELATING TO COMPUTER HARDWARE; RESEARCH AND DEVELOPMENT SERVICES RELATING TO COMPUTER HARDWARE AND SOFTWARE; RESEARCH AND DEVELOPMENT SERVICES RELATING TO COMPUTER SOFTWARE; RESEARCH AND DEVELOPMENT SERVICES RELATING TO FERTILIZERS; RESEARCH AND DEVELOPMENT SERVICES RELATING TO MEASURING AND REGULATING TECHNOLOGY; RESEARCH AND DEVELOPMENT SERVICES RELATING TO SOLAR CELLS AND

ELECTRICITY GENERATION; RESEARCH AND DEVELOPMENT SERVICES RELATING TO VACCINES; RESEARCH IN THE FIELD OF CLIMATE CHANGE; RESEARCH IN THE FIELD OF COMMUNICATIONS TECHNOLOGY; RESEARCH IN THE FIELD OF COMPUTER HARDWARE; RESEARCH IN THE FIELD OF COMPUTER HARDWARE AND SOFTWARE; RESEARCH IN THE FIELD OF COMPUTER PROGRAMS AND SOFTWARE; RESEARCH IN THE FIELD OF COMPUTER SOFTWARE; RESEARCH IN THE FIELD OF COMPUTER TECHNOLOGY CONDUCTED USING DATABASES AND THE INTERNET; RESEARCH IN THE FIELD OF DATA PROCESSING TECHNOLOGY; RESEARCH IN THE FIELD OF ENVIRONMENTAL CONSERVATION; RESEARCH IN THE FIELD OF ENVIRONMENTAL CONSERVATION AND PROTECTION; RESEARCH IN THE FIELD OF ENVIRONMENTAL PROTECTION; RESEARCH IN THE FIELD OF GENE THERAPY; RESEARCH IN THE FIELD OF INFORMATION TECHNOLOGY; RESEARCH IN THE FIELDS OF CHEMISTRY AND BIOLOGY; RESEARCH IN THE FIELDS OF CHEMISTRY, BIOLOGY AND PHYSICS; RESEARCH IN THE FIELDS OF MATERIALS SCIENCE AND ELECTRICAL ENGINEERING; RESEARCH IN THE REDUCTION OF CARBON EMISSIONS; RESEARCH RELATING TO THE DEVELOPMENT OF COMPUTER HARDWARE; RESEARCH RELATING TO THE DEVELOPMENT OF COMPUTER PROGRAMS AND SOFTWARE; RESEARCH RELATING TO THE DEVELOPMENT OF COMPUTER SOFTWARE; RESEARCH SERVICES FOR THE DEVELOPMENT OF NEW PRODUCTS; RESEARCH SERVICES IN THE FIELD OF PROTEINS, ANTIBODIES, MICROORGANISMS AND CELLS; RESEARCH SERVICES IN THE FIELDS OF SCIENCE, ENGINEERING, INFORMATION TECHNOLOGY, MEDICINE, ECOLOGY AND THE ENVIRONMENT; RESEARCH, DEVELOPMENT, ANALYSIS AND CONSULTANCY SERVICES IN THE FIELD OF ENGINEERING; RESEARCH, DEVELOPMENT, DESIGN AND UPGRADING OF COMPUTER SOFTWARE; RESEARCH, PRODUCT DEVELOPMENT AND QUALITY CONTROL SERVICES IN THE FIELD OF PROTEINS, ANTIBODIES, MICROORGANISMS AND CELLS, AND CONSULTANCY RELATING THERETO; RESEARCH, TESTING AND ANALYSIS SERVICES; RETAIL DESIGN SERVICES; SCANNING OF IMAGES CONVERSION FROM PHYSICAL TO ELECTRONIC MEDIA; SCIENTIFIC ANALYSIS; SCIENTIFIC AND INDUSTRIAL RESEARCH; SCIENTIFIC AND INDUSTRIAL RESEARCH IN THE FIELD OF PHOTOVOLTAICS AND SOLAR COLLECTORS; SCIENTIFIC AND MEDICAL RESEARCH AND DEVELOPMENT; SCIENTIFIC AND TECHNOLOGICAL SERVICES, NAMELY, CUSTOMER RELATIONSHIP MANAGEMENT, FACE RECOGNITION, EMOTION RECOGNITION, SURVEYS, DATA MANAGEMENT, CHAT; SCIENTIFIC AND TECHNOLOGICAL SERVICES AND RESEARCH, NAMELY, CUSTOMER RELATIONSHIP MANAGEMENT, FACE RECOGNITION, EMOTION RECOGNITION, SURVEYS, DATA MANAGEMENT, CHAT; SCIENTIFIC AND TECHNOLOGICAL SERVICES AND RESEARCH, NAMELY, CUSTOMER RELATIONSHIP MANAGEMENT, FACE RECOGNITION, EMOTION RECOGNITION, SURVEYS, DATA MANAGEMENT, CHAT; AND DESIGN RELATING THERETO; SCIENTIFIC AND TECHNOLOGICAL SERVICES AND RESEARCH, NAMELY, CUSTOMER RELATIONSHIP MANAGEMENT, FACE RECOGNITION, EMOTION RECOGNITION, SURVEYS, DATA MANAGEMENT, CHAT; AND DEVELOPMENT RELATING THERETO; SCIENTIFIC LABORATORY SERVICES; SCIENTIFIC RESEARCH; SCIENTIFIC RESEARCH AND ANALYSIS; SCIENTIFIC RESEARCH AND DEVELOPMENT; SCIENTIFIC RESEARCH CONDUCTED USING DATABASES AND THE INTERNET; SCIENTIFIC RESEARCH FOR MEDICAL PURPOSES; SCIENTIFIC RESEARCH FOR MEDICAL PURPOSES IN THE FIELD OF CANCEROUS DISEASES; SCIENTIFIC RESEARCH FOR OTHERS CONDUCTED USING DATABASES; SCIENTIFIC RESEARCH FOR OTHERS CONDUCTED USING DATABASES AND THE INTERNET; SCIENTIFIC RESEARCH RELATING TO HAIR CARE PREPARATIONS; SCIENTIFIC RESEARCH, TESTING AND ANALYSIS SERVICES; SCIENTIFIC SERVICES RELATING TO THE ISOLATION AND CULTIVATION OF HUMAN TISSUES AND CELLS; CONDUCTING SCIENTIFIC RESEARCH UTILIZING SURVEYS; SCIENTIFIC, TECHNOLOGICAL, TECHNICAL SUPPORT SERVICES, NAMELY, TECHNICAL ADMINISTRATION OF SERVERS FOR OTHERS AND

TROUBLESHOOTING IN THE NATURE OF DIAGNOSING SERVER PROBLEMS; SOFTWARE DESIGN AND DEVELOPMENT; SOFTWARE ENGINEERING; SOFTWARE ENGINEERING SERVICES FOR DATA PROCESSING PROGRAMS; STEM CELL RESEARCH; STYLING, NAMELY, INDUSTRIAL DESIGN; SURVEYING; TECHNICAL ADVICE IN CONNECTION WITH ENERGY-SAVING MEASURES; TECHNICAL ADVICE RELATING TO COMPUTERS; TECHNICAL CONSULTANCY AND ADVISORY SERVICES IN THE FIELD OF COMPUTER HARDWARE AND SOFTWARE; TECHNICAL CONSULTANCY IN THE FIELD OF COMPUTER HARDWARE AND SOFTWARE; TECHNICAL CONSULTANCY IN THE FIELD OF ENERGY SAVING AND ENERGY EFFICIENCY; TECHNICAL CONSULTANCY IN THE FIELD OF ENVIRONMENTAL SCIENCE; TECHNICAL CONSULTANCY RELATING TO PRODUCT DEVELOPMENT; TECHNICAL CONSULTANCY RELATING TO RESEARCH SERVICES IN THE FIELD OF FOODS AND DIETARY SUPPLEMENTS; TECHNICAL CONSULTANCY RELATING TO THE APPLICATION AND USE OF COMPUTER SOFTWARE; TECHNICAL CONSULTANCY RELATING TO THE DESIGN OF COMPUTER HARDWARE, SOFTWARE AND COMPUTER PERIPHERALS; TECHNICAL CONSULTANCY RELATING TO THE INSTALLATION AND MAINTENANCE OF COMPUTER SOFTWARE; TECHNICAL DESIGN AND PLANNING OF HEATING INSTALLATIONS; TECHNICAL DESIGN AND PLANNING OF PIPELINES FOR GAS, WATER AND WASTE WATER; TECHNICAL DESIGN AND PLANNING OF POWER STATIONS; TECHNICAL DESIGN AND PLANNING OF SEWERAGE SYSTEMS; TECHNICAL DESIGN AND PLANNING OF TELECOMMUNICATIONS EQUIPMENT; TECHNICAL DESIGN AND PLANNING OF TELECOMMUNICATIONS NETWORKS; TECHNICAL DESIGN AND PLANNING OF WATER PURIFICATION PLANTS; TECHNICAL DESIGN SERVICES; TECHNICAL DESIGN SERVICES RELATING TO COOLING APPLIANCES AND INSTALLATIONS; TECHNICAL DESIGN SERVICES RELATING TO ELECTRICITY PLANTS; TECHNICAL DESIGN SERVICES RELATING TO HEATING INSTALLATIONS; TECHNICAL DESIGN SERVICES RELATING TO SANITARY APPARATUS AND INSTALLATIONS; TECHNICAL DESIGN SERVICES RELATING TO WATER SUPPLY INSTALLATIONS; TECHNICAL DEVELOPMENT OF STRUCTURAL ELEMENTS, DEVICES AND SYSTEMS FOR SOLAR COLLECTORS AND PHOTOVOLTAIC PLANTS; TECHNICAL ENGINEERING DRAWING SERVICES; TECHNICAL PLANNING AND CONSULTANCY IN THE FIELD OF LIGHT ENGINEERING; TECHNICAL PLANNING AND TECHNICAL PROJECT MANAGEMENT FOR THE DEVELOPMENT OF LIGHTING EQUIPMENT; TECHNICAL PROJECT STUDIES IN THE FIELD OF CARBON OFFSETTING; ENGINEERING SERVICES, NAMELY, TECHNICAL PROJECT STUDIES IN THE FIELD OF CONSTRUCTION; TECHNOLOGICAL ANALYSIS RELATING TO ENERGY AND POWER NEEDS OF OTHERS; TECHNOLOGICAL CONSULTANCY IN THE FIELD OF AEROSPACE ENGINEERING; TECHNOLOGICAL CONSULTANCY IN THE FIELD OF ALTERNATIVE ENERGY GENERATION; TECHNOLOGICAL CONSULTANCY IN THE FIELD OF GEOLOGY; TECHNOLOGICAL CONSULTANCY IN THE FIELDS OF ENERGY PRODUCTION AND USE; TECHNOLOGICAL SERVICES AND RESEARCH AND DESIGN RELATING THERETO IN THE FIELD OF DATA PROCESSING, DATA ANALYSIS AND DATA CONVERSION; TELECOMMUNICATIONS ENGINEERING; TESTING OF APPARATUS IN THE FIELD OF ELECTRICAL ENGINEERING; TESTING OF APPARATUS IN THE FIELD OF ELECTRICAL ENGINEERING FOR CERTIFICATION PURPOSES; TESTING OF COMPUTER HARDWARE TO TEST FUNCTIONALITY; TESTING OF COMPUTER HARDWARE AND SOFTWARE TO TEST FUNCTIONALITY ; TESTING OF COMPUTER INSTALLATIONS TO TEST FUNCTIONALITY; TESTING OF COMPUTER PROGRAMS TO TEST FUNCTIONALITY; TESTING OF COMPUTER SOFTWARE TO TEST FUNCTIONALITY; TESTING OF TELECOMMUNICATION SIGNALS TO TEST FUNCTIONALITY; TESTING SERVICES FOR ALARM AND MONITORING SYSTEMS TO TEST FUNCTIONALITY; TESTING SERVICES FOR COMPUTER HARDWARE AND SOFTWARE USED WITH ALARM AND MONITORING SYSTEMS TO TEST FUNCTIONALITY; TESTING, ANALYSIS AND EVALUATION OF THE GOODS AND SERVICES OF OTHERS FOR THE PURPOSE OF CERTIFICATION; TESTING, ANALYSIS AND MONITORING OF NAVIGATION SIG-

NALS TO TEST FUNCTIONALITY; TESTING, ANALYSIS AND MONITORING OF SYSTEM ALGORITHMS FOR GENERATING TELECOMMUNICATIONS AND NAVIGATION DATA TO TEST FUNCTIONALITY; TESTING, ANALYSIS AND MONITORING OF SYSTEM ALGORITHMS FOR PROCESSING TELECOMMUNICATIONS AND NAVIGATION DATA TO TEST FUNCTIONALITY ; TESTING, ANALYSIS AND MONITORING OF TELECOMMUNICATION AND NAVIGATION SIGNALS TO TEST FUNCTIONALITY; TESTING, ANALYSIS AND MONITORING OF TELECOMMUNICATION SIGNALS TO TEST FUNCTIONALITY; TEXTILE TESTING; TOPOGRAPHIC SURVEYING; TECHNICAL SUPPORT SERVICES, NAMELY, TROUBLESHOOTING OF COMPUTER SOFTWARE PROBLEMS; UNDERWATER EXPLORATION; UPDATING AND MAINTENANCE OF COMPUTER SOFTWARE; UPDATING OF COMPUTER DATABASE SOFTWARE; UPDATING OF COMPUTER PROGRAMS; UPDATING OF COMPUTER SOFTWARE; UPDATING OF COMPUTER SOFTWARE RELATING TO COMPUTER SECURITY AND PREVENTION OF COMPUTER RISKS; UPDATING OF INTERNET PAGES FOR OTHERS; UPDATING THE WEB SITES OF OTHERS; UPDATING WEB SITES FOR OTHERS; UPDATING, DESIGN AND RENTAL OF SOFTWARE; UPGRADING AND MAINTENANCE OF COMPUTER SOFTWARE; UPGRADING OF COMPUTER SOFTWARE; URBAN PLANNING; VEHICLE ROADWORTHINESS TESTING; WATER ANALYSIS; WEB PAGE DESIGN SERVICES; WEB SITE DESIGN FOR OTHERS; WEB SITE DESIGN SERVICES; WEB SITE DESIGN AND DEVELOPMENT FOR OTHERS; WEB SITE DEVELOPMENT FOR OTHERS; WEB SITE USABILITY TESTING SERVICES; WRITING AND UPDATING COMPUTER SOFTWARE; WRITING OF COMPUTER PROGRAMS; WRITING OF COMPUTER SOFTWARE; WRITING OF DATA PROCESSING PROGRAMS (U.S. CLS. 100 AND 101).

#### **CLASS 45—PERSONAL AND LEGAL SERVICES**

FOR ADOPTION AGENCY SERVICES; ALTERNATIVE DISPUTE RESOLUTION SERVICES; ARBITRATION SERVICES; BABYSITTING; BAGGAGE INSPECTION FOR SECURITY PURPOSES; CLOTHING RENTAL; COPYRIGHT MANAGEMENT; DATING SERVICES; DETECTIVE AGENCIES; EVENING DRESS RENTAL; FIRE-FIGHTING; GENEALOGICAL RESEARCH; HORSHOE CASTING; HOUSE SITTING; INSPECTION OF FACTORIES FOR SAFETY PURPOSES; INTELLECTUAL PROPERTY CONSULTANCY; INTELLECTUAL PROPERTY WATCHING SERVICES; LEGAL RESEARCH; LICENSING OF COMPUTER SOFTWARE LEGAL SERVICES; LICENSING OF INTELLECTUAL PROPERTY; LITIGATION SERVICES; LOST PROPERTY RETURN; MEDIATION; MISSING PERSON INVESTIGATIONS; MONITORING OF BURGLAR AND SECURITY ALARMS; NIGHT GUARDS; OPENING OF SECURITY LOCKS; PERSONAL BACKGROUND INVESTIGATIONS; PERSONAL BODY GUARDING; PET SITTING; PLANNING AND ARRANGING OF WEDDING CEREMONIES; RENTAL OF FIRE ALARMS; RENTAL OF FIRE EXTINGUISHERS; RENTAL OF SAFES; SECURITY CONSULTANCY, CREMATION SERVICES; FUNERAL SERVICES ACCOMPANYING CREMATION; ESCORTING IN SOCIETY, NAMELY, CHAPERONING; FUNERAL ARRANGEMENT SERVICES; FUNERAL HOMES; GUARD SERVICES; MARRIAGE BUREAUS; ORGANIZATION OF RELIGIOUS MEETINGS, NAMELY, PRAYER MEETINGS; DOMAIN NAMES REGISTRATION SERVICES (U.S. CLS. 100 AND 101).

KELLEY WELLS, EXAMINING ATTORNEY

SN 79-126,680, ITALCOM SRL, I-84030 ATENA LUCANA (SA), ITALY, FILED 8-14-2012.



OWNER OF INTERNATIONAL REGISTRATION 1151334 DATED 8-14-2012, EXPIRES 8-14-2022.

THE MARK CONSISTS OF THE WORDING "POLY-BI" UNDERLINED BY A STYLIZED DESIGN OF A LEAF WITH SEMI-CIRCLE OVER THE TOP OF THE WORDING.

#### CLASS 16—PAPER GOODS AND PRINTED MATTER

FOR PAPER, CARDBOARD AND GOODS MADE FROM THESE MATERIALS, NAMELY, BOXES OF PAPER OR CARDBOARD; CARDBOARD PACKING; PACKING PAPER; STATIONERY; ADHESIVES FOR STATIONERY OR HOUSEHOLD PURPOSES; OFFICES REQUISITES, NAMELY, ADHESIVE TAPE DISPENSERS; PLASTIC MATERIAL FOR PACKING, NAMELY, PLASTIC BAGS FOR PACKAGING, PLASTIC BUBBLE PACKS FOR WRAPPING OR PACKAGING (U.S. CLS. 2, 5, 22, 23, 29, 37, 38 AND 50).

#### CLASS 22—CORDAGE AND FIBERS

FOR ROPES AND STRINGS FOR COMMERCIAL PURPOSES; NETS, TENTS, AWNINGS, TARPULINS, SAILS, SACKS AND BAGS FOR THE TRANSPORTATION OR STORAGE OF MATERIALS IN BULK; PADDING AND STUFFING MATERIALS NOT OF RUBBER, PAPER OR PLASTIC (U.S. CLS. 1, 2, 7, 19, 22, 42 AND 50).

#### CLASS 35—ADVERTISING AND BUSINESS

FOR ADVERTISING; BUSINESS MANAGEMENT; BUSINESS ADMINISTRATION; PROVIDING OFFICE FUNCTIONS (U.S. CLS. 100, 101 AND 102).

#### CLASS 39—TRANSPORTATION AND STORAGE

FOR PACKAGING OF GOODS, NAMELY, PACKING ARTICLES FOR TRANSPORTATION (U.S. CLS. 100 AND 105).

JOSETTE BEVERLY, EXAMINING ATTORNEY

SN 79-126,868, STEFAN ANDREAS FLEER, FED REP GERMANY, FILED 11-6-2012.

Yellow Blue

PRIORITY DATE OF 5-10-2012 IS CLAIMED.  
OWNER OF INTERNATIONAL REGISTRATION 1151787 DATED 11-6-2012, EXPIRES 11-6-2022.

THE MARK CONSISTS OF THE WORDING "YELLOW" AND "BLUE" SEPARATED BY A VERTICAL DASHED LINE.

#### CLASS 9—ELECTRICAL AND SCIENTIFIC APPARATUS

FOR SPECTACLES, SPECTACLE FRAMES, SPECTACLE TEMPLES, SPECTACLE GLASSES, OPTICAL GLASSES, SUN GLASSES, GOGGLES FOR SPORT, PROTECTIVE GLASSES, ACCESSORIES FOR SPECTACLES AND SUNGLASSES, NAMELY, SPECTACLE CASES (U.S. CLS. 21, 23, 26, 36 AND 38).

#### CLASS 14—JEWELRY

FOR PRECIOUS STONES; HOROLOGICAL AND CHRONOMETRIC INSTRUMENTS, NAMELY, WATCHES, WATCHES WITH LEATHER, PLASTIC, LATEX AND METAL, WRISTBANDS, ANALOG AND DIGITAL; WATCH BANDS, JEWELLERY AND FASHION JEWELLERY, NAMELY, RINGS, NECKLACES, BRACELETS, EARRINGS (U.S. CLS. 2, 27, 28 AND 50).

#### CLASS 18—LEATHER GOODS

FOR LEATHER AND IMITATIONS OF LEATHER, AND GOODS MADE OF THESE MATERIALS, NAMELY, BAGS, HANDBAGS, RUCKSACKS, PURSES, WALLETS, KEY CASES, LEATHER CASES, RUCKSACKS AND TRAVEL CASES OF LEATHER, IMITATION LEATHER; ANIMAL SKINS AND HIDES; TRUNKS AND TRAVELING BAGS; UMBRELLAS AND PARASOLS; WALKING STICKS; WHIPS; TRAVELLING SETS COMPRISED OF LUGGAGE AND GARMENT BAGS, COSMETIC CASES SOLD EMPTY (U.S. CLS. 1, 2, 3, 22 AND 41).

#### CLASS 25—CLOTHING

FOR CLOTHING, FOOTWEAR, AND HEADGEAR, NAMELY, OUTERWEAR FOR MEN, WOMEN AND CHILDREN, NAMELY, COATS, DOWN JACKETS, SWEAT SHIRTS, SWEAT PANTS, JACKETS, BLAZERS, BOOTS, PULLOVERS, PANTS, JEANS, SHORTS, COATS, DRESSES, SKIRTS, SUITS, TIES, ROBES, SLEEPWEAR, BATHROBES, APRONS FOR COOKING, UNDERWEAR, LINGERIE, CORSETS, HOSIERY, STOCKINGS, SOCKS, BELTS, SUSPENDERS, SCARVES, HATS, SUN HATS, GLOVES, LEG WARMERS, HEADBANDS, SWIMWEAR, BEACHWEAR, CLOTHING FOR CHILDREN AND BABIES, NAMELY, T-SHIRTS, SWEATSHIRTS, SWEATERS, PULLOVERS, PANTS, JEANS, SHORTS, COATS, DRESSES, SKIRTS, ROBES, SLEEPWEAR, BATHROBES, UNDERWEAR, HOSIERY, STOCKINGS, SOCKS, BELTS, SUSPENDERS, SCARVES, HATS, SUN HATS, CAPS, GLOVES, HEADBANDS, SWIMWEAR, BEACHWEAR; POCKETS FOR CLOTHING, LEISURE AND CITY SHOES FOR GENTLEMEN AND LADIES, CHILDREN SHOES; OUTDOOR FOOTWEAR; CLOTHING, FOOTWEAR AND HEADGEAR FOR SPORTS, NAMELY, PANTS, JOGGING SUITS, T-SHIRTS, SWEATSHIRTS, SWEATERS, JACKETS, UNDERWEAR, SWIMWEAR, SPORT SHOES, ATHLETIC SHOES, SNEAKERS; OUTDOOR CLOTHING, NAMELY, OUTDOOR JACKETS (U.S. CLS. 22 AND 39).

#### CLASS 35—ADVERTISING AND BUSINESS

FOR RETAIL STORE SERVICES, WHOLESALE STORE SERVICES, ONLINE RETAIL STORE SERVICES AND MAIL ORDER CATALOG SERVICES FEATURING SPECTACLES, SPECTACLE FRAMES, SPECTACLE TEMPLES, SPECTACLE GLASSES, OPTICAL GLASSES, SUN GLASSES, GOGGLES FOR SPORT, PROTECTIVE GLASSES, ACCESSORIES FOR SPECTACLES AND SUNGLASSES, NAMELY, SPECTACLE CASES, PRECIOUS STONES, HOROLOGICAL AND CHRONOMETRIC INSTRUMENTS, NAMELY, WATCHES, WATCHES WITH LEATHER, PLASTIC, LATEX AND METAL WRISTBANDS, WATCH BANDS, JEWELLERY AND FASHION JEWELLERY, RINGS, NECKLACES, BRACELETS, EARRINGS, LEATHER AND IMITATIONS OF LEATHER, AND GOODS MADE OF THESE MATERIALS, NAMELY, BAGS, HANDBAGS, COMPUTER BAGS,

RUCKSACKS, PURSES, WALLETS, KEY CASES, LEATHER CASES, RUCKSACKS AND TRAVEL CASES OF LEATHER, POLYPROPYLENE AND IMITATIONS OF LEATHER, ANIMAL SKINS, HIDES, TRUNKS AND TRAVELLING BAGS, UMBRELLAS AND PARASOLS, WALKING STICKS, WHIPS, TRAVELLING SETS, COSMETIC CASES, CLOTHING, FOOTWEAR, HEADGEAR, NAMELY, OUTERWEAR FOR MEN, WOMEN AND CHILDREN, PANTS, JEANS, SHORTS, COATS, DRESSES, SKIRTS, SUITS, TIES, ROBES, SLEEPWEAR, BATHROBES, APRONS FOR COOKING, UNDERWEAR, LINGERIE, CORSETRY, HOSIERY, STOCKINGS, SOCKS, BELTS, SUSPENDERS, SCARVES, HATS, SUN HATS, GLOVES, LEG WARMERS, HEADBANDS, SWIMWEAR, BEACHWEAR, CLOTHING FOR CHILDREN AND BABIES, NAMELY, T-SHIRTS, SWEATSHIRTS, SWEATERS, PULLOVERS, PANTS, JEANS, SHORTS, COATS, DRESSES, SKIRTS, ROBES, SLEEPWEAR, BATHROBES, UNDERWEAR, HOSIERY, STOCKINGS, SOCKS, BELTS, SUSPENDERS, SCARVES, HATS, SUN HATS, CAPS, GLOVES, HEADBANDS, SWIMWEAR, BEACHWEAR POCKETS FOR CLOTHING, LEISURE AND CITY SHOES FOR GENTLEMEN AND LADIES, CHILDREN SHOES, OUTDOOR FOOTWEAR, CLOTHING, FOOTWEAR AND HEADGEAR FOR SPORTS, NAMELY, PANTS, JOGGING SUITS, T-SHIRTS, SWEATSHIRTS, SWEATERS, JACKETS, UNDERWEAR, SWIMWEAR, SPORT SHOES, ATHLETIC SHOES, SNEAKERS, OUTDOOR CLOTHING, NAMELY, OUTDOOR JACKETS (U.S. CLS. 100, 101 AND 102).

TRACY CROSS, EXAMINING ATTORNEY

SN 79-127,094. HIMA PAUL HILDEBRANDT GMBH + CO. KG, FED REP GERMANY, FILED 10-15-2012.

# FlexSILon

THE MARK CONSISTS OF STANDARD CHARACTERS WITHOUT CLAIM TO ANY PARTICULAR FONT, STYLE, SIZE, OR COLOR.

OWNER OF INTERNATIONAL REGISTRATION 1152494 DATED 10-15-2012, EXPIRES 10-15-2022.

## CLASS 7—MACHINERY

FOR MACHINES, NAMELY, TURBINES AND TURBO COMPRESSORS, BURNER, NAMELY, GAS BURNER, OIL BURNER, COAL BURNER, BOILER, NAMELY, ELECTRIC BOILER, OIL BOILER, GAS BOILER AND COAL FIRED BOILER, PIPELINES IN THE NATURE OF BRANCHING PIPES OF METAL, FOR THE CHEMICAL AND PETROCHEMICAL INDUSTRIES; MACHINES, NAMELY, TURBINES AND TURBO COMPRESSORS, BURNER, NAMELY, GAS BURNER, OIL BURNER, COAL BURNER, BOILER, NAMELY, ELECTRIC BOILER, OIL BOILER, GAS BOILER AND COAL FIRED BOILER, PIPELINES IN THE NATURE OF BRANCHING PIPES OF METAL, FOR THE PROCESS ENGINEERING INDUSTRY; MACHINES, NAMELY, TURBINES AND TURBO COMPRESSORS, BURNER, NAMELY, GAS BURNER, OIL BURNER, COAL BURNER, BOILER, NAMELY, ELECTRIC BOILER, OIL BOILER, GAS BOILER AND COAL FIRED BOILER, PIPELINES IN THE NATURE OF BRANCHING PIPES OF METAL, FOR PLASTIC PROCESSING AND METALWORKING; MACHINES, NAMELY, TURBINES AND TURBO COMPRESSORS, BURNER, NAMELY, GAS BURNER, OIL BURNER, COAL BURNER, BOILER, NAMELY, ELECTRIC BOILER, OIL BOILER, GAS BOILER AND COAL FIRED BOILER, PIPELINES IN THE NATURE OF BRANCHING PIPES OF METAL, FOR RAW MATERIAL EXTRACTION; MACHINES, NAMELY, TURBINES AND TURBO COMPRESSORS, BURNER, NAMELY, GAS BURNER, OIL BURNER, COAL BURNER, BOILER, NAMELY, ELECTRIC BOILER, OIL BOILER, GAS BOILER AND COAL FIRED BOILER, PIPELINES IN THE NATURE OF BRANCHING PIPES OF METAL, FOR OIL AND NATURAL GAS EXTRACTION (U.S. CLS. 13, 19, 21, 23, 31, 34 AND 35).

## CLASS 9—ELECTRICAL AND SCIENTIFIC APPARATUS

FOR CONTROL DEVICES, NAMELY, PROGRAMMABLE ELECTRONIC SYSTEMS IN THE NATURE OF AN ELECTRONIC CONTROLLER AND PROGRAMMABLE LOGIC CONTROLLERS FOR PLANNING, PROGRAMMING, CONFIGURING, OPERATING, MONITORING, EVALUATING AND VISUALIZING CONTROLS, SENSORS, ACTUATORS AND DRIVES AND FOR ANALYZING AND PLANNING SAFETY-RELATED CONTROL AND REGULATING CIRCUITS AS WELL AS FOR CALCULATING THE RELIABILITY AND THE PROBABILITY OF FAILURES OF DEVICES ALL FOR THE SAFE OPERATION OF MACHINES AS WELL AS OF CABLEWAYS, ELEVATORS, ESCALATORS AND FUN RIDES; CONTROL SYSTEMS CONSISTING OF ELECTRONIC CONTROLS, ELECTRONIC SENSORS, ELECTRIC ACTUATORS, DRIVES FOR MOTORS AND COMPUTER SOFTWARE FOR THE SAFE OPERATION OF CONVEYOR INSTALLATIONS AND ASSEMBLY SYSTEMS; SUPERVISION OF TURBOMACHINE AND COMPRESSOR OPERATION, BURNER AND BOILER OPERATION AND PIPELINE SYSTEMS BY MEANS OF: 1) MEASURING OF PRESSURE, TEMPERATURE, VIBRATIONS AND AXIAL DISPLACEMENTS, QUANTITY AND CONCENTRATION OF GAS AND LIQUIDS, 2) ELECTRONIC SIGNALING FOR DETECTING AND CONTROLLING PRESSURE, TEMPERATURE, VIBRATIONS AND AXIAL DISPLACEMENTS, QUANTITY AND CONCENTRATION OF GAS AND LIQUIDS AND/OR 3) TECHNICAL CHECKING INSTRUMENTS FOR MEASURING, TESTING AND CHECKING THE TEMPERATURE, VIBRATIONS AND AXIAL DISPLACEMENTS, PRESSURE, QUANTITY AND CONCENTRATION OF GAS AND LIQUIDS; ELECTRICAL DEVICES, NAMELY, PROGRAMMABLE ELECTRONIC SYSTEMS IN THE NATURE OF AN ELECTRONIC CONTROLLER AND PROGRAMMABLE LOGIC CONTROLLERS FOR THE CONTROL AND CLOSED LOOP CONTROL OF AUTOMATION PROCESSES; NON-SAFETY-RELATED AND SAFETY-RELATED MEMORY-PROGRAMMABLE AND WIRING-PROGRAMMABLE HARDWIRED CONTROLS FOR TURBOMACHINE AND COMPRESSOR OPERATION, BURNER AND BOILER OPERATION AND PIPELINE SYSTEMS; PROGRAMMABLE ELECTRONIC CONTROL SYSTEMS CONSISTING OF ELECTRONIC CONTROLS, ELECTRONIC SENSORS, ELECTRIC ACTUATORS, DRIVES FOR MOTORS AND COMPUTER SOFTWARE FOR PLANNING, PROGRAMMING, CONFIGURING, OPERATING, MONITORING, EVALUATING AND VISUALIZING CONTROLS, SENSORS, ACTUATORS AND DRIVES AND FOR ANALYZING AND PLANNING SAFETY-RELATED CONTROL AND REGULATING CIRCUITS AS WELL AS FOR CALCULATING THE RELIABILITY AND THE PROBABILITY OF FAILURES OF DEVICES FOR PROTECTION OF PEOPLE, MACHINES AND PLANTS IN THE SAFETY-CRITICAL PROCESS INDUSTRY AND THE MACHINE BUILDING INDUSTRY; AUTOMATION SYSTEMS CONSISTING OF INDUSTRIAL AUTOMATION CONTROLS FOR TURBOMACHINE AND COMPRESSOR OPERATION, BURNER AND BOILER OPERATION AND PIPELINE SYSTEMS; TURBOMACHINE AND COMPRESSOR OPERATION, BURNER AND BOILER OPERATION AND PIPELINE SYSTEMS FOR PROCESSING ENGINEERING AND INDUSTRIAL INSTALLATIONS AND MACHINES; PROTECTION AND MONITORING SYSTEMS FOR PROCESSING ENGINEERING AND INDUSTRIAL INSTALLATIONS AND MACHINES, NAMELY, PROGRAMMABLE ELECTRONIC SYSTEMS IN THE NATURE OF AN ELECTRONIC CONTROLLER AND PROGRAMMABLE LOGIC CONTROLLERS (U.S. CLS. 21, 23, 26, 36 AND 38).



**CLASS 42—SCIENTIFIC AND COMPUTER SERVICES**

FOR DEVELOPMENT OF SAFETY-RELATED AND NON-SAFETY-RELATED CONTROLS, NAMELY, A PROGRAMMABLE LOGIC CONTROLLER; DEVELOPMENT OF SOFTWARE FOR PROGRAMMING SAFETY-RELATED AND NON-SAFETY-RELATED CONTROLS; DEVELOPMENT OF AUTOMATION, PROTECTION AND MONITORING SYSTEMS FOR PROCESS ENGINEERING AND INDUSTRIAL INSTALLATIONS; TECHNOLOGICAL CONSULTANCY WITH REGARD TO THE ANALYSIS AND SOLUTION OF SAFETY-RELATED AUTOMATION TASKS; TECHNOLOGICAL CONSULTANCY IN THE FIELD OF SAFETY-RELATED AND NON-SAFETY-RELATED AUTOMATION SOLUTIONS AS WELL AS PLANNING AND IMPLEMENTATION THEREOF; TECHNOLOGICAL CONSULTANCY AND SUPPORT WITH REGARD TO THE TECHNICAL INSPECTION OF SAFETY-RELATED AUTOMATION SOLUTIONS; TECHNOLOGICAL SERVICES, NAMELY, TECHNOLOGICAL INTEGRATION OF SAFETY-RELATED AND NON-SAFETY-RELATED CONTROLS INTO PROCESS CONTROL AND FIELD SYSTEMS; SCIENTIFIC AND INDUSTRIAL RESEARCH IN THE FIELD OF SAFETY-RELATED AND NON-SAFETY-RELATED CONTROLS, AND THE PROGRAMMING AND INTEGRATION THEREOF (U.S. CLS. 100 AND 101).

C. DIONNE CLYBURN, EXAMINING ATTORNEY

SN 79-127,685. BOEHRINGER INGELHEIM PHARMA; GMBH & CO. KG, FED REP GERMANY, FILED 9-14-2012.

**BOEHRINGER INGELHEIM BIOXCELLENCE**

THE MARK CONSISTS OF STANDARD CHARACTERS WITHOUT CLAIM TO ANY PARTICULAR FONT, STYLE, SIZE, OR COLOR.

PRIORITY DATE OF 5-15-2012 IS CLAIMED.

OWNER OF INTERNATIONAL REGISTRATION 1153932 DATED 9-14-2012, EXPIRES 9-14-2022.

OWNER OF U.S. REG. NOS. 641,166, 2,934,276 AND OTHERS.

SEC. 2(F) AS TO "INGELHEIM".

**CLASS 1—CHEMICALS**

FOR CHEMICAL, BIOCHEMICAL AND BIOLOGICAL PRODUCTS, SUBSTANCES AND PREPARATIONS FOR INDUSTRIAL AND SCIENTIFIC PURPOSES AS WELL AS FOR RESEARCH PURPOSES (U.S. CLS. 1, 5, 6, 10, 26 AND 46).

**CLASS 5—PHARMACEUTICALS**

FOR PHARMACEUTICAL PREPARATIONS FOR THE TREATMENT OF DISEASES AND DISORDERS OF THE ALIMENTARY TRACT AND METABOLISM, AND BLOOD AND BLOOD FORMING ORGANS; PHARMACEUTICAL PREPARATIONS FOR THE TREATMENT OF DISEASES AND DISORDERS OF THE CARDIOVASCULAR SYSTEM, MUSCULOSKELETAL SYSTEM, CENTRAL NERVOUS SYSTEM, PERIPHERAL NERVOUS SYSTEM, GENITOURINARY SYSTEM AND RESPIRATORY SYSTEM; AND PHARMACEUTICAL PREPARATIONS FOR THE TREATMENT OF DERMATOLOGICAL, HORMONAL, INFECTIOUS, VIRAL AND ONCOLOGICAL DISEASES AND DISORDERS; PREPARATIONS FOR DESTROYING VERMIN; FUNGICIDES, HERBICIDES; BACTERIOLOGICAL CULTURES FOR MEDICAL AND VETERINARY PURPOSES AS WELL AS CULTURE MEDIA FOR BACTERIOLOGICAL CULTURES; BACTERIOLOGICAL PREPARATIONS FOR MEDICAL AND VETERINARY USE FOR THE TREATMENT OF DISEASES AND DISORDERS OF THE ALIMENTARY TRACT AND METABOLISM, BLOOD AND BLOOD FORMING ORGANS, CARDIOVASCULAR SYSTEM, MUSCULOSKELETAL SYSTEM, CENTRAL NERVOUS SYSTEM, PERIPHERAL NERVOUS SYSTEM, GENITOURINARY SYSTEM AND RESPIRATORY SYSTEM AND FOR THE TREATMENT OF DERMATOLOGICAL, HORMONAL, INFECTIOUS, VIRAL AND ONCOLOGICAL DISEASES AND DISORDERS; BIOLO-

GICAL PREPARATIONS FOR MEDICAL AND FOR VETERINARY PURPOSES FOR THE TREATMENT OF DISEASES AND DISORDERS OF THE ALIMENTARY TRACT AND METABOLISM, BLOOD AND BLOOD FORMING ORGANS, CARDIOVASCULAR SYSTEM, MUSCULOSKELETAL SYSTEM, CENTRAL NERVOUS SYSTEM, PERIPHERAL NERVOUS SYSTEM, GENITOURINARY SYSTEM AND RESPIRATORY SYSTEM AND FOR THE TREATMENT OF DERMATOLOGICAL, HORMONAL, INFECTIOUS, VIRAL AND ONCOLOGICAL DISEASES AND DISORDERS; BIOCHEMICAL PREPARATIONS FOR MEDICAL AND VETERINARY PURPOSES FOR THE TREATMENT OF DISEASES AND DISORDERS OF THE ALIMENTARY TRACT AND METABOLISM, BLOOD AND BLOOD FORMING ORGANS, CARDIOVASCULAR SYSTEM, MUSCULOSKELETAL SYSTEM, CENTRAL NERVOUS SYSTEM, PERIPHERAL NERVOUS SYSTEM, GENITOURINARY SYSTEM AND RESPIRATORY SYSTEM AND FOR THE TREATMENT OF DERMATOLOGICAL, HORMONAL, INFECTIOUS, VIRAL AND ONCOLOGICAL DISEASES AND DISORDERS; CHEMICAL PREPARATIONS FOR PHARMACEUTICAL OR MEDICAL PURPOSES, NAMELY, FOR DISEASES AND DISORDERS OF THE ALIMENTARY TRACT AND METABOLISM, AND BLOOD AND BLOOD FORMING ORGANS; PHARMACEUTICAL PREPARATIONS FOR THE TREATMENT OF DISEASES AND DISORDERS OF THE CARDIOVASCULAR SYSTEM, MUSCULOSKELETAL SYSTEM, CENTRAL NERVOUS SYSTEM, PERIPHERAL NERVOUS SYSTEM, GENITOURINARY SYSTEM AND RESPIRATORY SYSTEM; AND PHARMACEUTICAL PREPARATIONS FOR THE TREATMENT OF DERMATOLOGICAL, HORMONAL, INFECTIOUS, VIRAL AND ONCOLOGICAL DISEASES AND DISORDERS; FERMENTS FOR PHARMACEUTICAL PURPOSES; VACCINES; CULTURE MEDIA FOR MICROORGANISMS; PLASTERS AND DRESSINGS FOR MEDICAL PURPOSES (U.S. CLS. 6, 18, 44, 46, 51 AND 52).

**CLASS 16—PAPER GOODS AND PRINTED MATTER**

FOR PRINTED MATTER, NAMELY, NEWSPAPERS, PHOTOGRAPHS, MAGAZINES, BOOKS, PRINTED PERIODICALS, NEWSLETTERS, AND BROCHURES ALL IN THE FIELD OF PHARMACEUTICAL PREPARATIONS; PAPER; CARDBOARD; GOODS MADE FROM PAPER AND CARDBOARD, NAMELY, BOXES OF PAPER AND CARDBOARD BOXES; CARDBOARD PACKAGING, NAMELY, PHARMACEUTICAL PACKAGING; PATIENT RECORD CARDS AND PRESCRIPTION PADS; IN THE FIELD OF IN THE FIELDS OF MEDICINE AND PHARMACEUTICALS; PRINTED TEACHING AND INSTRUCTIONAL MATERIALS, NAMELY, PHARMACEUTICAL INFORMATION LEAFLETS; BOOKS IN THE FIELDS OF MEDICINE AND PHARMACEUTICALS; PRINTED PUBLICATIONS, NAMELY, MAGAZINES, NEWSLETTERS, PAMPHLETS, REPORTS, INSTRUCTIONAL AND INFORMATION LEAFLETS, AND POSTERS IN THE FIELDS OF MEDICINE AND PHARMACEUTICALS; PAPER PACKAGING, NAMELY, PACKAGING CONTAINERS OF PAPER; STATIONERY; PRINTED INSTRUCTIONAL AND TEACHING MATERIALS RELATING TO THE PHARMACEUTICAL, HEALTH CARE AND MEDICAL FIELDS, IN THE FIELD OF RESEARCH, MEDICINE, VETERINARY AND LABORATORY TECHNIQUES (U.S. CLS. 2, 5, 22, 23, 29, 37, 38 AND 50).

**CLASS 35—ADVERTISING AND BUSINESS**

FOR COMPILATION OF DATA IN COMPUTER DATABASES, IN PARTICULAR IN THE FIELD OF BIOTECHNOLOGY AND BIOPHARMACEUTICS; MANAGEMENT IN CONNECTION WITH THE COMMERCIALIZATION OF TECHNICAL OR SCIENTIFIC RESULTS; MANAGEMENT RELATING TO THE ORGANISATION OF RESEARCH; CREATION, NAMELY, WRITING AND COMPILING OF MANUFACTURING AND REGISTRATION DOSSIERS FOR PHARMACEUTICAL PRODUCTS FOR THIRD PARTIES; OFFICE WORK, NAMELY, OPERATION OF REGISTRATION PROCEEDINGS FOR PHARMACEUTICAL PRODUCTS (U.S. CLS. 100, 101 AND 102).

**CLASS 38—COMMUNICATION**

FOR TRANSMITTING MEDICAL AND SCIENTIFIC INFORMATION BY MEANS OF A DATABASE (U.S. CLS. 100, 101 AND 104).

**CLASS 40—MATERIAL TREATMENT**

FOR CUSTOM MANUFACTURE OF PHARMACEUTICALS, PHARMACEUTICAL INGREDIENTS, CHEMICAL PRODUCTS AND CHEMICAL INTERMEDIATES AS WELL AS OF BIOLOGICAL AND BIOCHEMICAL PRODUCTS FOR THIRD PARTIES; TREATMENT OF BIOLOGICAL MATERIALS, NAMELY, BATCH TREATMENT SERVICES WITH RESPECT TO MICROORGANISMS AND PROTEINS (U.S. CLS. 100, 103 AND 106).

**CLASS 42—SCIENTIFIC AND COMPUTER SERVICES**

FOR SCIENTIFIC AND TECHNOLOGICAL SERVICES, NAMELY, SCIENTIFIC RESEARCH, ANALYSIS AND TESTING OF ACTIVE SUBSTANCES, MEDICINE AND TREATMENT IN THE FIELD OF BIOTECHNOLOGY; RESEARCH AND DEVELOPMENT OF NEW PRODUCTS FOR OTHER AND SCIENTIFIC LABORATORY SERVICES IN THE FIELD OF BIOTECHNOLOGY; PERFORMANCE OF CHEMICAL, BIOCHEMICAL AND BIOLOGICAL ANALYSIS; DEVELOPMENT OF BIOLOGICAL, BIOTECHNOLOGICAL AND PHARMACEUTICAL ANALYSIS AND THEIR APPLICATION FOR OTHERS; TECHNICAL AND SCIENTIFIC CONSULTANCY, PARTICULARLY IN THE FIELD OF BIOTECHNOLOGY; SCIENTIFIC RESEARCH; CONDUCTING CLINICAL TRIALS FOR OTHERS OF PHARMACEUTICAL PRODUCTS; PROVIDING SCIENTIFIC INFORMATION VIA THE INTERNET IN THE FIELD OF PHARMACEUTICAL, HEALTH CARE AND MEDICAL FIELDS; SCIENTIFIC RESEARCH CONSULTING IN THE FIELD OF PHARMACEUTICAL, HEALTH CARE AND MEDICAL FIELDS (U.S. CLS. 100 AND 101).

**CLASS 44—MEDICAL, BEAUTY AND AGRICULTURAL SERVICES**

FOR MEDICAL AND VETERINARY CONSULTING; PROVIDING MEDICAL AND VETERINARY INFORMATION VIA THE INTERNET; ALL THE FOREMENTIONED CONSULTATIONS AND SERVICES ALSO PROVIDED THROUGH A DATABASE; PROVIDING MEDICAL INFORMATION VIA THE INTERNET (U.S. CLS. 100 AND 101).

JOHN DALIER, EXAMINING ATTORNEY

SN 79-127,848. CONFEDERATION AFRICAINE DE FOOTBALL, 6TH OCTOBER CITY, EGYPT, FILED 9-18-2012.



OWNER OF INTERNATIONAL REGISTRATION 1154452 DATED 9-18-2012, EXPIRES 9-18-2022.

NO CLAIM IS MADE TO THE EXCLUSIVE RIGHT TO USE "AFRICA" AND THE OUTLINE OF THE CONTINENT OF AFRICA, IN ALL CLASSES, AND THE WORDING "CUP OF NATIONS" FOR INTERNATIONAL CLASSES 9 AND 38, APART FROM THE MARK AS SHOWN.

THE COLOR(S) BLACK, WHITE, RED, YELLOW, LIGHT BROWN AND GREEN IS/ARE CLAIMED AS A FEATURE OF THE MARK.

THE MARK CONSISTS OF A GREEN MAP OF AFRICA WITH A WHITE STAR INSIDE A YELLOW CIRCLE WITH LIGHT BROWN SPOTS SURROUNDED BY A RED CIRCLE WITH YELLOW TRIANGLES, ALL THESE ELEMENTS APPEARING IN A BLACK FRAME WITH THE WHITE WORDING "CAF AFRICA CUP OF NATIONS".

**CLASS 4—LUBRICANTS AND FUELS**

FOR ALL-PURPOSE LUBRICANTS FOR INDUSTRIAL AND DOMESTIC USE; DIESEL OIL, DIESEL FUEL; BIOFUELS; CANDLES; WAXES; GENERAL PURPOSES GREASES; NATURAL GAS; LIQUEFIED NATURAL GASES; INDUSTRIAL OILS AND GREASES; LUBRICATING OILS AND GREASES; CARBURANTS, NAMELY, FUELS; LIQUEFIED PETROLEUM GAS; NON-CHEMICAL ADDITIVES FOR MOTOR FUELS, LUBRICANTS AND GREASES; LIGHTING FUEL; LUBRICANTS, OILS AND GREASES AND LUBRICATING PREPARATIONS FOR INDUSTRIAL USE; CUTTING OILS FOR INDUSTRIAL USE; MILLING OILS, NAMELY, LUBRICATING OILS (U.S. CLS. 1, 6 AND 15).

**CLASS 9—ELECTRICAL AND SCIENTIFIC APPARATUS**

FOR EYEGLASSES, SUNGLASSES, CASES AND CORDS FOR SUNGLASSES AND GLASSES; BINOCULARS; MAGNETS AND DECORATIVE MAGNETS; DIRECTIONAL COMPASSES; APPARATUS FOR RECORDING, TRANSMITTING AND REPRODUCING SOUND AND IMAGES; TELEVISIONS; RADIOS; VIDEO RECORDERS; CD PLAYERS; DVD PLAYERS; LOUD-SPEAKERS; HEADPHONES; COMPUTERS; COMPUTER KEYBOARDS; COMPUTER MONITORS; MODEMS; ELECTRONIC POCKET TRANSLATORS; DICTATING MACHINES; ELECTRONIC AGENDAS; SCANNERS; PRINTERS; PHOTOCOPY MACHINES; FACSIMILE TRANSMISSION MACHINES; TELEPHONES, TELEPHONE ANSWERING APPARATUS; VIDEO TELEPHONE; CELLULAR TELEPHONES; ACCESSORIES FOR CELLULAR TELEPHONES, NAMELY, TELEPHONE HEADSETS, HANDS FREE SETS, AND CAR ADAPTERS; CALCULATING MACHINES; CREDIT CARD ENCODING MACHINES; VIDEO CAMERAS, CAMCORDERS; PHOTOGRAPHIC EQUIPMENT, NAMELY, CAMERAS, PROJECTORS, EXPOSED FILMS, SLIDES, FLASH BULBS, CASES AND STRAPS SPECIALLY ADAPTED FOR CAMERA AND PHOTOGRAPHIC EQUIPMENT; BATTERIES; VIDEO GAME SOFTWARE; COMPUTER SOFTWARE FOR ARCADE APPARATUS AND GAMES, NAMELY, SOFTWARE FOR VIDEO GAMES IN RELATION WITH AFRICAN FOOTBALL; VIDEO GAME CASSETTES; PRE-RECORDED COMPUTER SOFTWARE IN THE NATURE OF COMPUTER GAME SOFTWARE; COMPUTER PROGRAMS FOR VIDEO GAMES; COMPUTER DATABASE MANAGEMENT SOFTWARE FOR VIDEO GAMES; COMPUTER SCREEN SAVER SOFTWARE; BLANK MAGNETIC, NUMERICAL OR ANALOGICAL CARRIERS FOR RECORDING SOUND OR IMAGES; BLANK VIDEO DISCS, VIDEO TAPES, MAGNETIC TAPES, MAGNETIC DISCS, DVDS, FLOPPY DISCS, OPTICAL DISCS, COMPACT DISCS, CD-ROMS, PRE-RECORDED VIDEO DISCS, VIDEO TAPES, MAGNETIC TAPES, MAGNETIC DISCS, DVSS FLOPPY DISCS, OPTICAL DISCS, COMPACT DISCS, CD-ROMS, ALL FEATURING SOCCER TOURNAMENTS; MAGNETICALLY ENCODED CHARGE CARDS; BLANK FLASH MEMORY CARDS; MICROCHIP CARDS; MAGNETICALLY ENCODED CREDIT CARDS, PRE-PAID MAGNETICALLY ENCODED PHONE CARDS, MAGNETICALLY ENCODED ATM CARDS, MAGNETICALLY ENCODED CHARGE CARDS FOR USE IN THE AREAS OF TRAVEL AND ENTERTAINMENT, MAGNETICALLY ENCODED CHECK GUARANTEE AND DEBIT CARDS; SECURITY ALARMS; WINDSOCKS FOR INDICATING WIND DIRECTION AND INTENSITY; DISTANCE MEASURING APPARATUS; SPEED MEASURING AND INDICATION

EQUIPMENT, NAMELY, LASER SPEED DETECTORS AND SPEED INDICATORS; DOWNLOADABLE ELECTRONIC PUBLICATIONS, NAMELY, BOOKS ABOUT FOOTBALL COMPETITIONS, E-BOOKS, SPORT MAGAZINES, AND MAGAZINES CONCERNING AFRICA AND AFRICA FOOTBALL; PROTECTIVE INSULATED WORK GLOVES (U.S. CLS. 21, 23, 26, 36 AND 38).

#### **CLASS 12—VEHICLES**

FOR VEHICLES, NAMELY, AIRPLANES, AUTOMOBILES, LAND VEHICLES EXCLUDING LOCOMOTIVES, RAILWAY VEHICLES AND WAGONS; BOATS; APPARATUS FOR LOCOMOTION BY LAND, AIR OR WATER, NAMELY, AIRPLANES, BOATS AND AUTOMOBILES, BUT NOT INCLUDING APPARATUS FOR LOCOMOTIVES, RAILWAY VEHICLES AND WAGONS; ENGINES AND MOTORS FOR LAND VEHICLES, EXCLUDING LOCOMOTIVES, RAILWAY VEHICLES AND WAGONS; SUSPENSION SHOCK ABSORBERS FOR VEHICLES, EXCLUDING LOCOMOTIVES, RAILWAY VEHICLES AND WAGONS; BODIES FOR VEHICLES, EXCLUDING LOCOMOTIVES, RAILWAY VEHICLES AND WAGONS; ANTI-SKID CHAINS FOR VEHICLES, EXCLUDING LOCOMOTIVES, RAILWAY VEHICLES AND WAGONS; MOTOR VEHICLES CHASSIS AND BUMPERS, EXCLUDING LOCOMOTIVES, RAILWAY VEHICLES AND WAGONS; SUN-BLINDS ADAPTED FOR AUTOMOBILES; SAFETY BELT FOR VEHICLE SEATS, EXCLUDING LOCOMOTIVES, RAILWAY VEHICLES AND WAGONS; ELECTRIC VEHICLES, NAMELY, ELECTRIC AUTOMOBILES, CROSS OVER VEHICLES, AND SPORTS COUPES, BUT NOT INCLUDING LOCOMOTIVES, RAILWAY VEHICLES AND WAGONS; TRACTORS; MOPEDS; FRAMES, KICKSTANDS, BRAKES, HANDLEBARS, WHEEL RIMS, TIRES, WHEELS AND SADDLES FOR BICYCLES; STROLLERS; TRICYCLES; AUTOMOBILE ACCESSORIES, NAMELY, SEAT CUSHIONS, SUNBLINDS ADAPTED FOR AUTOMOBILES, TYRES FOR VEHICLE WHEELS, ROOF RACKS, SPORTS RACKS FOR VEHICLES EXCLUDING LOCOMOTIVES, RAILWAY VEHICLES AND WAGONS; HUBCAPS AND VEHICLE WHEELS, EXCLUDING LOCOMOTIVES, RAILWAY VEHICLES AND WAGONS; CAR SEAT COVERS, FITTED COVERS FOR VEHICLES EXCLUDING LOCOMOTIVES, RAILWAY VEHICLES AND WAGONS; PRAMS, CAR SEATS FOR BABIES AND CHILDREN (U.S. CLS. 19, 21, 23, 31, 35 AND 44).

#### **CLASS 25—CLOTHING**

FOR SPORTS ATTIRE, NAMELY, ATHLETIC UNIFORMS AND SPORTS JERSEYS; FOOTWEAR; CASUAL WEAR IN THE NATURE OF T-SHIRTS, SHORTS, POLO SHIRTS, JERSEYS, CAPS, BERETS AND SCARVES; BELTS; GLOVES; SCARVES; NECKTIES; HOSIERY SOCKS; BOOTIES; BEACH SHOES; SPORT SHOES; BIBS NOT OF PAPER; PAJAMAS; PLAY CLOTHES FOR INFANTS AND CHILDREN, NAMELY, SLEEPSUITS; SUSPENDERS AND BRACES (U.S. CLS. 22 AND 39).

#### **CLASS 28—TOYS AND SPORTING GOODS**

FOR HAND-HELD ELECTRONIC GAMES ADAPTED FOR USE WITH TELEVISION RECEIVERS ONLY; VIDEO GAME MACHINES FOR USE WITH TELEVISIONS (U.S. CLS. 22, 23, 38 AND 50).

#### **CLASS 30—STAPLE FOODS**

FOR COFFEE, TEA, COCOA, SUGAR, RICE, TAPIOCA, SAGO, ARTIFICIAL COFFEE; FLOUR, PREPARATIONS MADE FROM CEREALS, NAMELY, CEREAL BARS, CHOCOLATE BARS; BREAD; EDIBLE ICES; HONEY, GOLDEN SYRUP; YEAST, YEAST POWDER; SALT, MUSTARD; MAYONNAISE; VINEGAR; SAUCES; SPICES; ICE; SANDWICHES; PIZZAS; CREPES; COOKIES; CAKES; RUSKS; FROZEN CONFECTIONS; CHOCOLATE; COCOA, COFFEE, CHOCOLATE AND TEA BASED BEVERAGES (U.S. CL. 46).

#### **CLASS 32—LIGHT BEVERAGES**

FOR NON-ALCOHOLIC BEVERAGES, NAMELY, MINERAL AND AERATED WATERS; FRUIT DRINKS AND FRUIT JUICES; SYRUPS FOR MAKING BEVERAGES; PREPARATIONS FOR MAKING BEVERAGES, NAMELY, FRUIT DRINKS AND FRUIT JUICES; LEMONADES; FRUIT NECTARS; SODA WATER; NON-ALCOHOLIC APERITIFS, ISOTONIC BEVERAGES; ENERGY BEVERAGES; BEER (U.S. CLS. 45, 46 AND 48).

#### **CLASS 36—INSURANCE AND FINANCIAL**

FOR ISSUANCE AND FINANCIAL ADMINISTRATION OF CREDIT CARDS AND TRAVELERS' CHECKS; FINANCIAL SERVICES, NAMELY, MONEY LENDING; BANKING SERVICES; CREDIT SERVICES, NAMELY, HOME LOAN AND CAR LOAN SERVICES; INSURANCE UNDERWRITING IN THE FIELD OF AUTOMOBILES; HIRE-PURCHASE FINANCING; SERVICES IN THE NATURE OF PROVIDING FINANCIAL SPONSORSHIP OF SOCCER AND FOOTBALL COMPETITIONS; FINANCIAL AND INSURANCE INFORMATION PROVIDED VIA A COMPUTER DATABASE OR VIA THE INTERNET OR ON ANY WIRELESS ELECTRONIC COMMUNICATION NETWORK; HOME BANKING SERVICES; ELECTRONIC BANKING SERVICES VIA THE INTERNET OR ON ANY WIRELESS ELECTRONIC COMMUNICATION NETWORK; SAFE DEPOSIT BOX SERVICES (U.S. CLS. 100, 101 AND 102).

#### **CLASS 38—COMMUNICATION**

FOR TELECOMMUNICATION SERVICES, NAMELY, LOCAL AND LONG DISTANCE TRANSMISSION OF VOICE, DATA, GRAPHICS BY MEANS OF TELEPHONE, CABLE AND SATELLITE TRANSMISSIONS; COMMUNICATIONS BY MOBILE TELEPHONES; COMMUNICATIONS BY TELETXT MACHINES; COMMUNICATIONS BY ELECTRONIC COMPUTER TERMINALS, DATABASES AND INTERNET RELATED TELECOMMUNICATIONS NETWORKS AND WIRELESS ELECTRONIC COMMUNICATION DEVICE; COMMUNICATIONS BY TELEGRAPH; COMMUNICATION BY TELEPHONE; COMMUNICATIONS BY FACSIMILE; PAGING BY RADIO; COMMUNICATIONS BY TELECONFERENCING; TELEVISION BROADCASTING; CABLE TELEVISION BROADCASTING; RADIO BROADCASTING; PRESS AGENCY SERVICES, NAMELY, TRANSMISSION OF NEWS, SPORTS AND ENTERTAINMENT RELATED INFORMATION; ELECTRONIC MESSAGE TRANSMISSION SERVICES; LEASING OF TELEPHONE SETS, FACSIMILE AND OTHER COMMUNICATION EQUIPMENT; BROADCASTING OF A COMMERCIAL SITE ON THE INTERNET AND ON WIRELESS ELECTRONIC COMMUNICATION DEVICE; ELECTRONIC MESSAGING; PROVIDING ACCESS TO COMPUTER BULLETIN BOARDS AND REAL-TIME CHAT FORUMS FOR TRANSMISSION OF MESSAGES AND IMAGES FEATURING HOME AND OFFICE SHOPPING AND ORDERING SERVICES VIA COMPUTER; TELECOMMUNICATION OF INFORMATION IN THE NATURE OF WEB PAGES, COMPUTER PROGRAMS AND ANY OTHER DATA, SPECIFICALLY, DATA TRANSMITTED BY ELECTRONIC COMMUNICATIONS NETWORKS; ELECTRONIC MAIL SERVICES; PROVIDING USER ACCESS TO THE INTERNET; PROVIDING TELECOMMUNICATIONS CONNECTIONS TO THE INTERNET OR DATABASES; PROVIDING ACCESS TO DIGITAL MUSIC WEB SITES ON THE INTERNET; PROVIDING ACCESS TO MP3 WEB SITES ON THE INTERNET; DELIVERY OF DIGITAL MUSIC BY ELECTRONIC TRANSMISSION; PROVIDING ACCESS TO SEARCH ENGINES FOR RETRIEVING DATA AND INFORMATION VIA GLOBAL NETWORKS; BROADCASTING OF RADIO AND TELEVISION PROGRAMS RELATED TO SPORTS AND SPORTING EVENTS; PROVIDING ACCESS TO CHAT ROOMS FOR THE TRANSMISSION OF INFORMATION THROUGH COMPUTERS; PROVIDING CONNECTIONS TO COMPUTER INSTALLATIONS, NAMELY, PROVIDING ACCESS TO THE INTERNET VIA A GLOBAL COMPUTER NETWORK OR VIA WIRELESS ELECTRONIC COMMUNICATION DEVICES; PROVIDING ACCESS TO COMPUTER DATABASES; PROVIDING ACCESS TO COMPUTER DATABASES FEATURING HOME AND OFFICE SHOPPING AND ORDERING SERVICE, VIA A GLOBAL COMPUTER NETWORK (U.S. CLS. 100, 101 AND 104).

MARC LEIPZIG, EXAMINING ATTORNEY

SN 79-128,510. DANSK LANDBRUGS GROVVARESELSKAB;  
A.M.B.A., DENMARK, FILED 3-22-2013.SN 79-127,933. BSA GUNS (UK) LTD, UNITED KINGDOM,  
FILED 2-6-2013.OWNER OF INTERNATIONAL REGISTRATION 1119518  
DATED 4-18-2012, EXPIRES 4-18-2022.OWNER OF U.S. REG. NOS. 68,285, 2,309,566 AND  
2,600,688.NO CLAIM IS MADE TO THE EXCLUSIVE RIGHT TO  
USE "GUNS", APART FROM THE MARK AS SHOWN.THE MARK CONSISTS OF RECTANGLES WITH  
CURVED CORNERS CONTAINING THE WORDING "BSA"  
APPEARING ON TOP OF THE WORDING "GUNS" AND ON  
TOP OF ALL THE WORDING IS A DESIGN OF THREE  
RIFLES.**CLASS 9—ELECTRICAL AND SCIENTIFIC  
APPARATUS**FOR SPOTTING SCOPES FOR GUNS; TELESCOPIC  
SIGHTS FOR GUNS; MEASURING AND SIGHTING  
APPARATUS FOR GUNS AND WEAPONS, NAMELY,  
SCOPES, ILLUMINATED SCOPES, SPOTTING SCOPES,  
OPTICAL OR TELESCOPIC LENS SIGHTS FOR USE  
WITH GUNS, AIR GUNS, RIFLES, AIR RIFLES, PIS-  
TOLS, AIR PISTOLS OR CROSSBOWS, LASER POINT-  
ING DEVICES FOR USE WITH FIREARMS AND LASER  
DISTANCE METERS; TELESCOPES FOR MARINE,  
LAND OR ASTRONOMY USE; BINOCULARS; MONO-  
CULARS; LASERS NOT FOR MEDICAL USE; MICRO-  
SCOPES; TELEMETERS; COMPASSES; CDS, DVDS, AND  
SOUND AND IMAGE RECORDINGS, ALL FEATURING  
SHOOTING, HUNTING, FIREARMS, GUNS, PISTOLS,  
RIFLES OR FIREARM INSTRUCTION; COMPUTER  
GAME PROGRAMS; VIDEO GAMES SOFTWARE; COM-  
PUTER GAMES SOFTWARE; PROTECTIVE CLOTHING  
FOR SHOOTING, NAMELY, BULLET RESISTANT  
CLOTHING; BULLET PROOF VESTS; STRUCTURAL  
AND REPLACEMENT PARTS FOR THE FOREGOING  
APPARATUS (U.S. CLS. 21, 23, 26, 36 AND 38).**CLASS 13—FIREARMS**FOR FIREARMS; GUNS; RIFLES, AIR GUNS; AIR  
RIFLES; AIR WEAPONS, NAMELY, AIR PISTOLS; PIS-  
TOLS; SHOT GUNS; SPORTING GUNS; SMALL ARMS;  
AMMUNITION, PELLETS AND PROJECTILES; SILEN-  
CERS FOR FIREARMS; SCOPE MOUNTS BEING  
MOUNTS FOR ATTACHING TELESCOPIC SIGHTS TO  
A FIREARMS; SIGHT MOUNTS BEING MOUNTS FOR  
ATTACHING GUN SIGHTS TO A FIREARM; GUN  
MOUNTS; BAGS SPECIALLY ADAPTED FOR GUNS;  
SPECIALLY ADAPTED BAGS FOR CARRYING AND  
STORING FIREARMS; CARRYING CASES SPECIALLY  
ADAPTED FOR GUNS; STRUCTURAL AND REPLACE-  
MENT PARTS FOR THE FOREGOING APPARATUS  
(U.S. CLS. 2 AND 9).

HAI-LY LAM, EXAMINING ATTORNEY

# Vilofoss

THE MARK CONSISTS OF STANDARD CHARACTERS  
WITHOUT CLAIM TO ANY PARTICULAR FONT, STYLE,  
SIZE, OR COLOR.

PRIORITY DATE OF 10-4-2012 IS CLAIMED.

OWNER OF INTERNATIONAL REGISTRATION 1156014  
DATED 3-22-2013, EXPIRES 3-22-2023.THE WORDING "VILOFOSS" HAS NO MEANING IN A  
FOREIGN LANGUAGE.**CLASS 4—LUBRICANTS AND FUELS**FOR INDUSTRIAL OILS AND GREASES; INDUS-  
TRIAL LUBRICANTS; DUST ABSORBING, WETTING  
AND BINDING COMPOSITIONS FOR AGRICULTURAL  
PURPOSES; FUELS, MOTOR FUELS AND ILLUMI-  
NANTS IN THE NATURE OF LIGHTING FUEL; CAN-  
DLES AND WICKS FOR LIGHTING (U.S. CLS. 1, 6 AND  
15).**CLASS 7—MACHINERY**FOR AGRICULTURAL MACHINES AND MACHINE  
TOOLS FOR PREPARING THE SOIL IN THE NATURE  
OF TILLERS AND FERTILIZER SPREADERS, SEED  
PLANTERS AND SOWERS AND HARVESTERS FOR  
CROPS AND VEGETABLES; MOTORS AND ENGINES  
EXCEPT FOR LAND VEHICLES; MACHINE COUPLING  
AND TRANSMISSION COMPONENTS EXCEPT FOR  
LAND VEHICLES; AGRICULTURAL IMPLEMENTS  
OTHER THAN HAND-OPERATED, NAMELY, TILLERS,  
SEED DRILLS, HAY BALERS, COMPLETE DIET MIX-  
ERS, GRASS DISC MOWERS, FORAGE HARVESTERS,  
SINGLE AND DOUBLE GRASS ROTOR RAKES, GRASS  
TEDDERS, PNEUMATIC GRAIN CONVEYERS, ME-  
CHANICAL GRAIN CONVEYERS, GRAIN CLEANERS,  
HARVEST DRYING MACHINES, NAMELY, GRAIN  
DRYERS, PLOUGHS, WEED CUTTERS; CONVEYING  
SYSTEM EQUIPMENT IN THE NATURE OF BLOWERS;  
CENTRIFUGAL DUST SEPARATORS; GRANULATING  
AND CUTTING MACHINES; ASPIRATORS IN THE  
NATURE OF VACUUM PUMPS; CYCLONES; MULTI  
SUCTION HEADS FOR AIR SUCTION MACHINES;  
ROTARY VALVE ENGINE INJECTORS; INCUBATORS  
FOR EGGS; AUTOMATIC VENDING MACHINES (U.S.  
CLS. 13, 19, 21, 23, 31, 34 AND 35).**CLASS 9—ELECTRICAL AND SCIENTIFIC  
APPARATUS**FOR APPARATUS AND INSTRUMENTS FOR CON-  
DUCTING, SWITCHING, TRANSFORMING, ACCUMU-  
LATING, REGULATING OR CONTROLLING  
ELECTRICITY, NAMELY, ELECTRICAL RELAYS AND  
TRANSFORMERS; APPARATUS FOR RECORDING,  
TRANSMISSION OR REPRODUCTION OF SOUND OR  
IMAGES; BLANK MAGNETIC DATA CARRIERS,  
BLANK RECORDABLE OPTICAL DISCS; MECHANISMS  
FOR COIN-OPERATED APPARATUS; CASH REGIS-  
TERS, CALCULATING MACHINES AND DATA PRO-  
CESSING EQUIPMENT, COMPUTERS; COMPUTER  
SOFTWARE FOR AGRICULTURAL PURPOSES,  
NAMELY, DATABASE SOFTWARE FOR FARMERS;  
FIRE-EXTINGUISHING APPARATUS (U.S. CLS. 21, 23,  
26, 36 AND 38).**CLASS 26—FANCY GOODS**FOR LACE AND EMBROIDERY, RIBBONS AND  
BRAID; BUTTONS, HOOKS AND EYES, SEWING PINS  
AND NEEDLES; ARTIFICIAL FLOWERS (U.S. CLS. 37,  
39, 40, 42 AND 50).

**CLASS 29—MEATS AND PROCESSED FOODS**

FOR MEAT, FISH, POULTRY AND GAME, NOT LIVE; MEAT EXTRACTS; PRESERVED, FROZEN, DRIED AND COOKED FRUITS AND VEGETABLES; JELLIES, JAMS, COMPOTES; EGGS; MILK AND MILK PRODUCTS, EXCLUDING ICE CREAM, ICE MILK AND FROZEN YOGURT; EDIBLE OILS AND FATS (U.S. CL. 46).

**CLASS 30—STAPLE FOODS**

FOR COFFEE, TEA, COCOA AND ARTIFICIAL COFFEE; RICE; TAPIOCA AND SAGO; FLOUR AND PREPARATIONS MADE FROM CEREALS, NAMELY, WHOLEMEAL, RYE FLOUR, RYE KERNEL, PEARLED SPELT, PEARLED BARLEY AND WHEAT GRAIN; BREAD, PASTRY AND CONFECTIONERY MADE OF SUGAR; FLAVORED ICES; SUGAR, HONEY, TREACLE; YEAST, BAKING-POWDER; SALT; MUSTARD; VINEGAR, SAUCES; SPICES; ICE (U.S. CL. 46).

**CLASS 31—NATURAL AGRICULTURAL PRODUCTS**

FOR UNPROCESSED GRAINS AND AGRICULTURAL, HORTICULTURAL AND FORESTRY PRODUCTS, NAMELY, AGRICULTURAL GRAINS FOR PLANTING; LIVE ANIMALS; FRESH FRUITS AND VEGETABLES; UNPROCESSED SEEDS FOR AGRICULTURAL USE; NATURAL PLANTS AND FLOWERS; FOODSTUFFS FOR ANIMALS; MALT FOR BREWING AND DISTILLING (U.S. CLS. 1 AND 46).

**CLASS 35—ADVERTISING AND BUSINESS**

FOR ADVERTISING; BUSINESS MANAGEMENT; BUSINESS ADMINISTRATION AND OFFICE WORK (U.S. CLS. 100, 101 AND 102).

**CLASS 38—COMMUNICATION**

FOR TELECOMMUNICATION SERVICES, NAMELY, TELEPHONE, TELEVISION AND BROADBAND COMMUNICATION SERVICES (U.S. CLS. 100, 101 AND 104).  
KATHLEEN M. VANSTON, EXAMINING ATTORNEY

**CLASS 36—INSURANCE AND FINANCIAL**

FOR CHARITABLE FUND RAISING SERVICES; CHARITABLE CAMPAIGN SERVICES IN THE NATURE OF CHARITABLE FUNDRAISING SERVICES BY MEANS OF ORGANIZING AND CONDUCTING PROJECTS TO PROMOTE AWARENESS OF THE USE AND EFFECTS OF WEAPONS, LANDMINES AND OTHER EXPLOSIVE REMNANTS OF WAR, THE RELIEF OF POVERTY, COMBAT OF DISTRESS AND ALLEVIATING SUFFERING IN ANY PART OF THE WORLD, AND THE CAUSE AND THE EFFECT OF POVERTY, DISTRESS AND SUFFERING ON PEOPLE; PROVISION OF CHARITABLE FUNDRAISING SERVICES RELATING TO THE USE AND EFFECTS OF WEAPONS, LANDMINES AND OTHER EXPLOSIVE REMNANTS OF WAR; CHARITABLE FUNDRAISING SERVICES RELATED TO THE RELIEF OF POVERTY, COMBAT OF DISTRESS AND ALLEVIATING SUFFERING IN ANY PART OF THE WORLD; ARRANGING OF FUNDS FOR OVERSEAS AID PROJECTS IN THE NATURE OF CHARITABLE FUNDRAISING SERVICES; ARRANGING CHARITABLE COLLECTIONS, NAMELY, CHARITABLE FUNDRAISING SERVICES; ADVISORY, CONSULTANCY AND INFORMATION SERVICES IN RESPECT OF THE AFOREMENTIONED SERVICES; NONE OF THE INFORMATION INCLUDING FINANCIAL SERVICES RELATING TO MORTGAGE PLANNING, MORTGAGE REFINANCING, REAL ESTATE TRANSACTIONS, FINANCIAL INVESTMENTS, INVESTMENT CONSULTATION, OR FINANCIAL ANALYSIS AND CONSULTATION (U.S. CLS. 100, 101 AND 102).

**CLASS 41—EDUCATION AND ENTERTAINMENT**

FOR EDUCATIONAL SERVICES, NAMELY, PROVIDING SEMINARS, CONFERENCES, WORKSHOPS, AND CLASSES IN THE FIELD OF THE USE AND EFFECTS OF WEAPONS, LANDMINES AND OTHER EXPLOSIVE REMNANTS OF WAR, THE RELIEF OF POVERTY, COMBAT OF DISTRESS AND ALLEVIATING SUFFERING IN ANY PART OF THE WORLD, AND THE CAUSE AND THE EFFECT OF POVERTY, DISTRESS AND SUFFERING ON PEOPLE; TRAINING SERVICES IN THE FIELD OF THE USE AND EFFECTS OF WEAPONS, LANDMINES AND OTHER EXPLOSIVE REMNANTS OF WAR, THE RELIEF OF POVERTY, COMBAT OF DISTRESS AND ALLEVIATING SUFFERING IN ANY PART OF THE WORLD, AND THE CAUSE AND THE EFFECT OF POVERTY, DISTRESS AND SUFFERING ON PEOPLE; ORGANIZING AND CONDUCTING WORKSHOPS, CONFERENCES, AND SEMINARS FOR EDUCATIONAL PURPOSES IN THE FIELD OF THE USE AND EFFECTS OF WEAPONS, LANDMINES AND OTHER EXPLOSIVE REMNANTS OF WAR, THE RELIEF OF POVERTY, COMBAT OF DISTRESS AND ALLEVIATING SUFFERING IN ANY PART OF THE WORLD, AND THE CAUSE AND THE EFFECT OF POVERTY, DISTRESS AND SUFFERING ON PEOPLE; EDUCATIONAL SERVICES, NAMELY, PROVIDING CLASSES, SEMINARS, CONFERENCES, TRAINING AND WORKSHOP SERVICES RELATED TO THE RELIEF OF SUFFERING CAUSED BY THE USE OF WEAPONS, LANDMINES AND OTHER EXPLOSIVE REMNANTS OF WAR; EDUCATIONAL TRAINING SERVICES RELATED TO THE RELIEF OF POVERTY, COMBAT OF DISTRESS AND ALLEVIATING SUFFERING IN ANY PART OF THE WORLD; ADVISORY, CONSULTANCY AND INFORMATION SERVICES IN RESPECT OF THE AFOREMENTIONED SERVICES; NONE OF THE FOREGOING INCLUDING TRAINING IN MACHINE TOOL OPERATION (U.S. CLS. 100, 101 AND 107).

SN 79-128,919, THE MINES ADVISORY GROUP, UNITED KINGDOM, FILED 9-27-2012.



PRIORITY DATE OF 9-19-2012 IS CLAIMED.  
OWNER OF INTERNATIONAL REGISTRATION 1157236  
DATED 9-27-2012, EXPIRES 9-27-2022.

THE MARK CONSISTS OF A SKULL AND CROSSBONES DESIGN TO THE LEFT OF THE STYLIZED WORDING "MAG", ALL ON A RECTANGLE.

**CLASS 42—SCIENTIFIC AND COMPUTER SERVICES**

FOR SCIENTIFIC AND TECHNOLOGICAL SERVICES AND RESEARCH AND DESIGN, NAMELY, OPERATIONAL FIELD EVALUATION OF TECHNOLOGY AND DEVELOPMENT OF NEW APPROACHES, TECHNOLOGY, AND METHODOLOGIES FOR MINE ACTION AND CLEARANCE OPERATIONS, VEGETATION CUTTING, GROUND PREPARATION, THE APPLICATION OF MINE AND AMMUNITION DETECTION TECHNOLOGY, GROUND PENETRATING RADAR, AND SIFTING AND TECHNIQUES TO DESTROY WEAPONS AND AMMUNITION; SCIENTIFIC RESEARCH SERVICES RELATING TO POVERTY, COMBAT OF DISTRESS AND ALLEVIATING SUFFERING IN ANY PART OF THE WORLD; ADVISORY, CONSULTANCY AND INFORMATION SERVICES IN RESPECT OF ALL THE AFORESAID SERVICES (U.S. CLS. 100 AND 101).

**CLASS 45—PERSONAL AND LEGAL SERVICES**

FOR POLITICAL RESEARCH, NAMELY, LEGAL RESEARCH IN THE FIELD OF LAWS AND REGULATIONS CONCERNING WEAPONS, LANDMINES AND OTHER EXPLOSIVE REMNANTS OF WAR, FOOD AND RESOURCES, THE USE AND SALE OF LAND, CLIMATE CHANGE, WORLD HUNGER AND POVERTY; POLITICAL RESEARCH, NAMELY, LEGAL RESEARCH IN THE FIELD OF LAWS AND REGULATIONS CONCERNING SOCIO-ECONOMIC DEVELOPMENT, ARMS CONTROL, DISARMAMENT AND HUMANITARIAN MINE ACTION; POLITICAL LOBBYING; POLITICAL LOBBYING SERVICES IN RESPECT OF THE USE OF WEAPONS, LANDMINES AND OTHER EXPLOSIVE REMNANTS OF WAR; POLITICAL LOBBYING SERVICES IN RESPECT OF FOOD AND RESOURCES, THE USE AND SALE OF LAND, CLIMATE CHANGE, WORLD HUNGER AND POVERTY; ADVISORY SERVICES RELATING TO NATIONAL AND INTERNATIONAL LAWS AND REGULATIONS CONCERNING WEAPONS, LANDMINES AND OTHER EXPLOSIVE REMNANTS OF WAR, FOOD AND RESOURCES, THE USE AND SALE OF LAND, CLIMATE CHANGE, WORLD HUNGER AND POVERTY; ADVISORY, CONSULTANCY AND INFORMATION SERVICES IN RESPECT OF ALL THE AFORESAID SERVICES (U.S. CLS. 100 AND 101).

KRISTINA MORRIS, EXAMINING ATTORNEY

SN 79-128,974. G-STAR RAW C.V., NETHERLANDS, FILED 1-21-2013.

# RAW

THE MARK CONSISTS OF STANDARD CHARACTERS WITHOUT CLAIM TO ANY PARTICULAR FONT, STYLE, SIZE, OR COLOR.

OWNER OF INTERNATIONAL REGISTRATION 1131972 DATED 6-27-2012, EXPIRES 6-27-2022.

**CLASS 18—LEATHER GOODS**

FOR BAGS, NAMELY, RUCKSACKS, TRAVEL BAGS, TOTE BAGS, CARRY-ALL BAGS, BACKPACKS, ALL-PURPOSE SPORTS BAGS, PURSES, MESSENGER BAGS, SHOULDER BAGS, BEACH BAGS; WALLETS; UMBRELLAS (U.S. CLS. 1, 2, 3, 22 AND 41).

**CLASS 35—ADVERTISING AND BUSINESS**

FOR RETAIL STORE SERVICES IN THE FIELD OF SOAPS, PERFUMERY, ESSENTIAL OILS, COSMETICS, HAIR LOTIONS, SUNGLASSES AND SPECTACLES, SPECTACLE FRAMES, SPECTACLE CASES, SOUND, IMAGE AND DATA CARRIERS SUCH AS CD'S AND DVD'S, JEWELRY, WATCHES, BAGS, WALLETS, UMBRELLAS, CLOTHING, FOOTWEAR, HEADWEAR, AND FASHION ACCESSORIES; BUSINESS INTERMEDIARY SERVICES RELATING TO THE PURCHASE AND SALE OF SOAPS, PERFUMERY, ESSENTIAL OILS, COSMETICS, HAIR LOTIONS, SUNGLASSES AND SPECTACLES, SPECTACLE FRAMES, SPECTACLE CASES, SOUND, IMAGE AND DATA CARRIERS, SUCH AS CD'S AND DVD'S, JEWELRY, WATCHES, BAGS, WALLETS, UMBRELLAS, CLOTHING, FOOTWEAR, HEADWEAR, AND FASHION ACCESSORIES; BUSINESS MANAGEMENT; BUSINESS ADMINISTRATION AND ADMINISTRATIVE SERVICES; SALES PROMOTION; COMMERCIAL BUSINESS AND ADMINISTRATIVE SERVICES IN THE FIELD OF THE FRANCHISING AND EXPLOITATION OF RETAIL BUSINESSES (U.S. CLS. 100, 101 AND 102).

APRIL REEVES, EXAMINING ATTORNEY

SN 79-129,669. SHARE IN THE SUCCESS LTD, UNITED KINGDOM, FILED 11-26-2012.

# XENCA

THE MARK CONSISTS OF STANDARD CHARACTERS WITHOUT CLAIM TO ANY PARTICULAR FONT, STYLE, SIZE, OR COLOR.

PRIORITY DATE OF 5-24-2012 IS CLAIMED.

OWNER OF INTERNATIONAL REGISTRATION 1159010 DATED 11-26-2012, EXPIRES 11-26-2022.

**CLASS 3—COSMETICS AND CLEANING PREPARATIONS**

FOR SOAPS; PERFUMERY, ESSENTIAL OILS, COSMETICS, HAIR LOTIONS; DENTIFRICES; NON-MEDICATED SKIN CARE PREPARATIONS; COSMETIC PREPARATIONS FOR SLIMMING PURPOSES; NON-MEDICATED TOILETRIES (U.S. CLS. 1, 4, 6, 50, 51 AND 52).

**CLASS 5—PHARMACEUTICALS**

FOR DIETETIC FOOD, BEVERAGES AND SUBSTANCES, NAMELY, NUTRITIONAL SUPPLEMENT MEAL REPLACEMENT SHAKES AND BARS FOR WEIGHT LOSS AND BOOSTING ENERGY, ELECTROLYTE REPLACEMENT SOLUTIONS ADAPTED FOR MEDICAL OR VETERINARY USE; FOOD FOR BABIES; DIETARY SUPPLEMENTS FOR HUMANS AND ANIMALS; VITAMINS FOR MEDICAL OR VETERINARY PURPOSES; MINERAL SUPPLEMENTS FOR MEDICAL OR VETERINARY PURPOSES; AMINO ACIDS FOR MEDICAL OR VETERINARY PURPOSES; PROTEIN SUPPLEMENTS FOR MEDICAL OR VETERINARY PURPOSES; DIETARY SUPPLEMENTS CONTAINING COLLAGEN FOR MEDICAL OR VETERINARY PURPOSES; DIETARY SUPPLEMENTS, CONTAINING FISH OILS; DIETARY SUPPLEMENTS CONTAINING TRACE MINERALS FOR MEDICAL OR VETERINARY PURPOSES; DIETARY SUPPLEMENTS CONSISTING PRIMARILY OF FOLIC ACID FOR MEDICAL OR VETERINARY PURPOSES; BUT NOT INCLUDING FUNGICIDES (U.S. CLS. 6, 18, 44, 46, 51 AND 52).

**CLASS 35—ADVERTISING AND BUSINESS**

FOR ADVERTISING; BUSINESS MANAGEMENT; BUSINESS ADMINISTRATION; OFFICE FUNCTIONS; ARRANGING AND CONDUCTING INCENTIVE REWARD PROGRAMS TO PROMOTE THE SALE OF COSMETICS, SKIN AND HAIR CARE PRODUCTS, NUTRITIONAL SUPPLEMENTS, DIETARY SUPPLEMENTS AND WEIGHT LOSS PRODUCTS; ADVERTISING SERVICES PROVIDED VIA THE INTERNET; DATA PROCESSING; PROVISION OF BUSINESS INFORMATION; ONLINE RETAIL STORE SERVICES FEATURING COSMETICS, HEALTH AND NUTRITIONAL PRODUCTS (U.S. CLS. 100, 101 AND 102).

**CLASS 36—INSURANCE AND FINANCIAL**

FOR FINANCIAL SERVICES, NAMELY, FINANCIAL MANAGEMENT, ELECTRONIC PAYMENT SERVICES INVOLVING ELECTRONIC PROCESSING AND SUBSEQUENT TRANSMISSION OF BILL PAYMENT DATA, CREDIT CARD AND GIFT CARD TRANSACTION PROCESSING SERVICES PROVIDED VIA THE INTERNET; ISSUING OF TOKENS OF VALUE IN RELATION TO BONUS AND LOYALTY SCHEMES; PROVISION OF FINANCIAL INFORMATION (U.S. CLS. 100, 101 AND 102).

**CLASS 38—COMMUNICATION**

FOR PROVIDING INTERNET CHAT ROOMS; PROVIDING ACCESS TO INTERNET PORTALS; E-MAIL SERVICES; PROVIDING USER ACCESS TO THE INTERNET (U.S. CLS. 100, 101 AND 104).

**CLASS 41—EDUCATION AND ENTERTAINMENT**

FOR EDUCATION, NAMELY, CLASSES, SEMINARS AND WORKSHOPS IN THE FIELD OF BUSINESS MANAGEMENT, MARKETING, CONDUCTING INCENTIVE REWARD PROGRAMS, SALES OF COSMETICS, HEALTH AND NUTRITIONAL PRODUCTS; PROVIDING OF TRAINING IN THE FIELD OF BUSINESS MANAGEMENT, MARKETING, CONDUCTING INCENTIVE REWARD PROGRAMS, SALES OF COSMETICS, HEALTH AND NUTRITIONAL PRODUCTS (U.S. CLS. 100, 101 AND 107).

DEBORAH LOBO, EXAMINING ATTORNEY

**CLASS 16—PAPER GOODS AND PRINTED MATTER**

FOR PRINTED MATTER, NAMELY, BOOKS, MAGAZINES IN THE FIELD OF SKILL TRAINING AND DEVELOPMENT COURSES FOR OCCUPATIONS IN HUMAN RESOURCES, ACCOUNTING, FINANCE, LAW, COMMUNICATIONS, PUBLIC ADMINISTRATION AND SECRETARIAL WORK; PRINTED INSTRUCTION AND TEACHING MATERIAL, NAMELY, COURSE MATERIALS IN THE FIELD OF SKILL TRAINING AND DEVELOPMENT FOR OCCUPATIONS IN THE AREA OF HUMAN RESOURCES, ACCOUNTING, FINANCE, LAW, COMMUNICATIONS, PUBLIC ADMINISTRATION, SECRETARIAL WORK AND LOCAL GOVERNMENT (U.S. CLS. 2, 5, 22, 23, 29, 37, 38 AND 50).

**CLASS 35—ADVERTISING AND BUSINESS**

FOR ARRANGING NEWSPAPER SUBSCRIPTIONS FOR OTHERS, BUSINESS MANAGEMENT ASSISTANCE, DISSEMINATION OF ADVERTISEMENTS (U.S. CLS. 100, 101 AND 102).

**CLASS 38—COMMUNICATION**

FOR ELECTRONIC MESSAGING SYSTEM, NAMELY, ELECTRONIC QUEUING SERVICES, COMPUTER-AIDED TRANSMISSION OF MESSAGES AND IMAGES, COMMUNICATIONS BY COMPUTER TERMINALS, TRANSMISSION OF INFORMATION BY ELECTRONIC COMMUNICATION NETWORKS (U.S. CLS. 100, 101 AND 104).

**CLASS 41—EDUCATION AND ENTERTAINMENT**

FOR ARRANGING AND CONDUCTING OF SYMPOSIUMS, COLLOQUIUMS, SEMINARS, CONFERENCES, IN THE FIELD OF SKILL TRAINING AND DEVELOPMENTS FOR OCCUPATIONS IN THE AREA OF HUMAN RESOURCES, ACCOUNTING, FINANCE, LAW, COMMUNICATIONS, PUBLIC ADMINISTRATION, LOCAL AUTHORITIES AND SECRETARIAL WORK; ORGANIZATION OF EDUCATIONAL COMPETITIONS; EDUCATION IN THE FIELDS OF TEAM MANAGEMENT, PERSONAL DEVELOPMENT, PROFESSIONAL EFFECTIVENESS, FOREIGN LANGUAGES RENDERED THROUGH CORRESPONDENCE COURSES; PROVIDING TEACHING AND INSTRUCTION AND VOCATIONAL TRAINING IN THE FIELDS OF TEAM MANAGEMENT, PERSONAL DEVELOPMENT, PROFESSIONAL EFFECTIVENESS, FOREIGN LANGUAGES, MECHANICS AND COMPUTERS (U.S. CLS. 100, 101 AND 107).

**CLASS 42—SCIENTIFIC AND COMPUTER SERVICES**

FOR COMPUTER PROGRAMMING FOR OTHERS, COMPUTER SOFTWARE DEVELOPMENT, NON-BUSINESS PROFESSIONAL CONSULTING IN THE FIELDS OF COMPUTERS AND COMPUTER SOFTWARE (U.S. CLS. 100 AND 101).

CHRISTOPHER BUONGIORNO, EXAMINING ATTORNEY

SN 79-129,775. DEMOS S.A., FRANCE, FILED 4-5-2013.

**Learning is changing**

PRIORITY DATE OF 12-11-2012 IS CLAIMED.  
OWNER OF INTERNATIONAL REGISTRATION 1159301  
DATED 4-5-2013. EXPIRES 4-5-2023.  
THE MARK CONSISTS OF THE STYLIZED WORDING  
"LEARNING IS CHANGING".

**CLASS 9—ELECTRICAL AND SCIENTIFIC APPARATUS**

FOR AUDIO AND VIDEO CASSETTES AND DIGITAL AUDIO AND VIDEO COMPACT DISKS FEATURING SKILL TRAINING AND DEVELOPMENT COURSES FOR OCCUPATIONS IN THE FIELDS OF HUMAN RESOURCES, ACCOUNTING, FINANCE, LAW, COMMUNICATIONS, PUBLIC ADMINISTRATION AND SECRETARIAL WORK (U.S. CLS. 21, 23, 26, 36 AND 38).

SN 79-129,981. BIRGIT SIEBENHANDL-BOUFFIER, FED REP GERMANY, AND JULIEN SIEBENHANDL-BOUFFIER, FED REP GERMANY, FILED 12-11-2012.

**IVIATOR**

THE MARK CONSISTS OF STANDARD CHARACTERS WITHOUT CLAIM TO ANY PARTICULAR FONT, STYLE, SIZE, OR COLOR.

PRIORITY DATE OF 6-12-2012 IS CLAIMED.  
OWNER OF INTERNATIONAL REGISTRATION 1159851  
DATED 12-11-2012, EXPIRES 12-11-2022.

### CLASS 9—ELECTRICAL AND SCIENTIFIC APPARATUS

FOR SPECTACLES, SPECTACLE CASES, SPECTACLE FRAMES, SPECTACLE LENSES, SUNGLASSES, OPTICAL GOODS, NAMELY, CASES FOR SPECTACLES AND CARRYING CASES AND CONTAINERS FOR CONTACT LENSES AND HOLDERS FOR CONTACT LENSES, OPTICAL LENSES, OPTICAL APPARATUS AND INSTRUMENTS, NAMELY, OPTICAL INSPECTION APPARATUS (U.S. CLS. 21, 23, 26, 36 AND 38).

### CLASS 35—ADVERTISING AND BUSINESS

FOR ON-LINE RETAIL STORE SERVICES FEATURING OPTICAL GOODS, NAMELY, SPECTACLES (U.S. CLS. 100, 101 AND 102).

### CLASS 44—MEDICAL, BEAUTY AND AGRICULTURAL SERVICES

FOR OPTICIANS' SERVICES (U.S. CLS. 100 AND 101).  
MICHELE SWAIN, EXAMINING ATTORNEY

SN 79-130,067. CIS S.R.L., POGNO (NO), ITALY, FILED 3-14-2013.



PRIORITY DATE OF 2-6-2013 IS CLAIMED.  
OWNER OF INTERNATIONAL REGISTRATION 1160057  
DATED 3-14-2013, EXPIRES 3-14-2023.

THE MARK CONSISTS OF THE TERM "CIS" NEXT TO A SQUARE CONTAINING A STYLIZED DEPICTION OF A LYRE, ALL OF THE FOREGOING FOUND ON A CONTRASTING RECTANGLE.

### CLASS 7—MACHINERY

FOR AIR CONDENSERS; AGITATORS FOR CIRCULATING LIQUID MEDIA; AGITATORS FOR CHEMICAL PROCESSING; FEEDING APPARATUS FOR ENGINE BOILERS IN THE NATURE OF CONVEYORS; AUTOMATIC VENDING MACHINES AND MECHANISMS FOR COIN-OPERATED APPARATUS SOLD AS A UNIT; FOOD CHOPPING MACHINES FOR COMMERCIAL USE; FOOD CUTTING MACHINES FOR COMMERCIAL USE; FOOD SLICING MACHINES FOR COMMERCIAL USE; FOOD PEELING MACHINES FOR COMMERCIAL USE; GRINDING MACHINES FOR COFFEE AND FOOD; VENDING MACHINES FOR COLD DRINKS, HOT DRINKS, SODA; ALTERNATORS; LUBRICATION RINGS, AS A PARTS OF MACHINES; PISTON RINGS; WASHING MACHINES FOR BOTTLES; HIGH PRESSURE WASHERS; ELECTROMECHANICAL MACHINES FOR BEVERAGE PREPARATION; ELECTROMECHANICAL MACHINES FOR FOOD PREPARATION; AERATED BEVERAGE-MAKING MACHINES; AERATED WATER MAKING APPARATUS; MINERAL WATER MAKING MACHINES; GAS WELDING MACHINES; APPARATUS FOR DRAWING UP BEER UNDER PRESSURE COMPRISED OF BEER PUMPS, CO<sub>2</sub>/N<sub>2</sub> PRESSURE REGULATORS BEING PART OF A MACHINE, AIR COOLED CONDENSERS, BEER TAPS, PIPES AND CONNECTIONS, BEER TOWERS AND DISPENSE HEADS, FOR THE BEVERAGE INDUSTRY; ELECTRIC CAN OPENERS; VACUUM CLEANERS; ELECTRIC BEATERS;

MANGLES; STEAM ENGINE BOILERS; FLUES FOR ENGINE BOILERS; GAS-OPERATED SOLDERING BLOW PIPES; GAS OPERATED CUTTING BLOW PIPES; CARTRIDGES FOR FILTERING MACHINES FOR CHEMICAL PROCESSING; CENTRIFUGAL MACHINES IN THE NATURE OF GRINDING MACHINES, PUMPS, SEPARATORS; CYLINDERS FOR MOTORS AND VEHICLES; SCALE COLLECTORS FOR BOILER MACHINE; HYDRAULIC CONTROLS FOR MACHINES, MOTORS AND ENGINES; PNEUMATIC CONTROLS FOR MACHINES, MOTORS AND ENGINES; COMPRESSED AIR MACHINES; COMPRESSORS FOR REFRIGERATORS; STEAM CONDENSERS, AS A PARTS OF MACHINES; BENDING MACHINES; BEARINGS, AS PARTS OF MACHINES; SELF-OILING BEARINGS, AS PARTS OF MACHINES; BEARINGS, AS A PARTS OF MACHINES OR ENGINES; ANTI-FRICTION BEARINGS FOR MACHINES; BEARINGS FOR TRANSMISSION SHAFTS, BEING PARTS OF MACHINES; DE-AERATORS FOR FEEDWATER, BEING MACHINES; MACHINES IN THE NATURE OF AUTOMATIC SCRUBBERS; STEAM AND OIL SEPARATORS, BEING PARTS OF MACHINES; AUTOMATIC VENDING MACHINES; ELECTRIC FOOD BLENDERS FOR HOUSEHOLD PURPOSES; FILTERS, AS A PARTS OF MACHINES OR ENGINES; FILTERS FOR CLEANING COOLING AIR, FOR ENGINES; MIXING MACHINES; WHISKS, ELECTRIC, FOR HOUSEHOLD PURPOSES; GASIFIERS; SEALING JOINTS, AS A PARTS OF ENGINES; FITTINGS FOR ENGINE BOILERS; CARD CLOTHING, AS A PARTS OF CARDING MACHINES; EDIBLE PASTE WORKING MACHINES; KNEADING MACHINES; CENTRAL VACUUM CLEANING INSTALLATIONS; CONDENSING INSTALLATIONS, NAMELY, MECHANICAL CONDENSATORS; RINSING MACHINES; DISHWASHERS; STEAM ENGINES; SEWING MACHINES; MACHINES FOR MAKING PASTA; FILTERING MACHINES FOR FILTERING MILK; FILTERING MACHINES FOR CHEMICAL PROCESSING; FILTERING MACHINES FOR FILTERING WATER; GRATING MACHINES FOR VEGETABLES; BOTTLE STOPPERING MACHINES; PACKAGING MACHINES; FLOUR MILL MACHINES; SUGAR MAKING MACHINES; BOTTLE WASHING MACHINES; FILLING MACHINES; POWER-OPERATED COFFEE GRINDERS; MILLS FOR HOUSEHOLD PURPOSES, NAMELY, ELECTRIC SALT AND PEPPER MILLS; PUMP DIAPHRAGMS; COMPRESSED AIR PUMPS; COMPRESSED AIR PUMPS FOR GARAGE INSTALLATIONS; CENTRIFUGAL PUMPS; AERATING PUMPS FOR AQUARIUMS; PUMPS FOR MACHINES; PUMPS, AS A PARTS OF MACHINES, ENGINES OR MOTORS; BEER PUMPS; VACUUM PUMPS BEING MACHINES; PRESSURE REGULATORS, AS PARTS OF MACHINES; REGULATORS, AS PARTS OF MACHINES; PRESSURE REDUCERS, AS PARTS OF MACHINES; BOTTLE FILLING MACHINES; WATER HEATERS, AS A PARTS OF MACHINES; TAPS, AS A PARTS OF MACHINES, ENGINES OR MOTORS; ELECTRIC WELDING MACHINES; HEAT EXCHANGERS, AS A PARTS OF MACHINES; DRAIN COCKS; CREAM AND MILK SEPARATORS BEING MACHINES; FRUIT PRESSES, ELECTRIC, FOR HOUSEHOLD PURPOSES; GAS-OPERATED BLOW TORCHES; MEAT CHOPPERS MACHINES, NAMELY, ELECTRIC POWERED MEAT CHOPPING MACHINES FOR COMMERCIAL USE; ELECTRIC DOMESTIC FOOD GRINDERS; BOILER TUBES, AS A PARTS OF MACHINES; CLACK VALVES, AS A PARTS OF MACHINES; PRESSURE VALVES, AS A PARTS OF MACHINES; VALVES, AS A PARTS OF MACHINES; EXPANSION TANKS, AS A PARTS OF MACHINES IN THE NATURE OF, EXPANSION TANKS FOR CONTAINING EXCESS FLUIDS; STEAM CLEANING MACHINES (U.S. CLS. 13, 19, 21, 23, 31, 34 AND 35).

### CLASS 9—ELECTRICAL AND SCIENTIFIC APPARATUS

FOR ALCOHOLMETERS, NAMELY, HYDROMETERS; HEAT REGULATING APPARATUS, NAMELY, TECHNICAL MEASURING, TESTING AND CHECKING APPARATUS AND INSTRUMENTS FOR MEASURING, TESTING AND CHECKING THE TEMPERATURE OF GAS AND LIQUIDS; LABORATORY APPARATUS, NAMELY, FOR FERMENTATION; IONIZATION APPARATUS FOR SCIENTIFIC OR LABORATORY USE; FOOD ANALYSIS APPARATUS, NAMELY, DIAGNOSTIC APPARATUS FOR TESTING FOOD; BAROMETERS; ELECTROMAGNETIC COILS; ELECTRIC COILS; METERS, NAMELY, ELECTRIC METERS, FLOW METERS,



GAS METERS; PROTECTION DEVICES FOR PERSONAL USE AGAINST ACCIDENTS, NAMELY, PROTECTIVE EYEWEAR, PROTECTIVE WORK GLOVES, PROTECTIVE WORK SHOES; DOSIMETERS; FIRE-EXTINGUISHING APPARATUS; GLOVES FOR PROTECTION AGAINST ACCIDENTS; HYDROMETERS; HYGROMETERS; WATER LEVEL INDICATORS; TEMPERATURE INDICATORS; VACUUM GAUGES; CLOTHING FOR PROTECTION AGAINST ACCIDENTS, IRRADIATION AND FIRE; FIRE HOSE NOZZLES; PRESSURE MEASURING APPARATUS; PROTECTIVE MASKS NOT FOR MEDICAL PURPOSES; MECHANISMS FOR COIN-OPERATED APPARATUS; MECHANISMS FOR APPLIANCES OPERATING WITH THE INTRODUCTION OF A COIN OR A TOKEN; MEMBRANES FOR SCIENTIFIC APPARATUS, NAMELY, SCIENTIFIC APPARATUS FOR USE WITH MEMBRANE FILTRATION, IN THE NATURE OF, WATER FILTER CONTROLLERS AND COMPUTER SOFTWARE FOR DETECTING AND MEASURING WATER QUALITY; LABORATORY APPARATUS, NAMELY, CELLULAR MIXED ESTER MEMBRANES FOR USE IN THE SCIENCE AND RESEARCH INDUSTRY; PRESSURE MEASURING APPARATUS; FURNITURE ESPECIALLY MADE FOR LABORATORIES; SMOKE DETECTORS; SPRINKLER SYSTEMS FOR FIRE PROTECTION; BOILER CONTROL INSTRUMENTS; MEASURING INSTRUMENTS FOR MEASURING WEIGHT, LENGTH, TEMPERATURE, PRESSURE; HOLDERS FOR ELECTRIC COILS; PRESSURE INDICATING PLUGS FOR VALVES; THERMOMETERS, NOT FOR MEDICAL PURPOSES; TEMPERATURE CONTROLLING APPARATUS, NAMELY, TEMPERATURE SWITCHES AND SENSORS FOR MONITORING, CONTROLLING, AND SWITCHING HYDRAULIC OR PNEUMATIC SYSTEMS; TEMPERATURE CONTROLLER FOR CONTROLLING TEMPERATURE OF MEDICAL INSTRUMENTS AND CONTAINERS FOR MEDICAL FLUIDS; FIRE HOSE; VACUUM TUBES FOR RADIOS; SOLENOID VALVES IN THE NATURE OF ELECTROMAGNETIC SWITCHES; VISCOSIMETERS (U.S. CLS. 21, 23, 26, 36 AND 38).

#### **CLASS 11—ENVIRONMENTAL CONTROL APPARATUS**

FOR REGULATING ACCESSORIES FOR GAS PIPES; REGULATING ACCESSORIES FOR WATER OR GAS APPARATUS AND PIPES; HEAT ACCUMULATORS; STEAM ACCUMULATORS; STILLS NOT FOR SCIENTIFIC PURPOSES; FEEDING APPARATUS FOR HEATING BOILERS, NAMELY, ECONOMISERS, IN THE NATURE OF, DEVICES FOR WARMING FEED WATER IN HEATING BOILERS; HOT AIR SPACE HEATING APPARATUS; HYDROMASSAGE BATH APPARATUS; SWIMMING POOL CHLORINATING APPARATUS; AQUARIUM FILTRATION APPARATUS; REFRIGERATING APPLIANCES AND INSTALLATIONS; ICE MACHINES AND APPARATUS; WATER PURIFYING APPARATUS AND MACHINES; DRYING APPARATUS AND INSTALLATIONS FOR DRYING APPARATUS FOR USE IN HEATING, VENTILATION SYSTEMS, AIR CONDITIONING SYSTEMS AND REFRIGERATION SYSTEMS; WATER SOFTENING UNITS; COOKING APPARATUS AND INSTALLATIONS, NAMELY, COOKTOPS, MICROWAVE OVENS; APPARATUS FOR SANITARY PURPOSES IN THE NATURE OF STEAM ROOMS, PIPES BEING PARTS OF SANITARY FACILITIES; ELECTRIC HEATING APPARATUS, NAMELY, RADIATORS, HEATING FANS; BATH FITTINGS, NAMELY, SHOWERS, TAPS, SPOUTS, SAUNA BATH INSTALLATIONS, FITTED LINERS; KILNS; WATER FILTERING APPARATUS; BEVERAGE COOLING APPARATUS; WATER INTAKE APPARATUS AS COMPONENT PARTS BATH, KITCHEN AND SAUNA INSTALLATIONS; COFFEE ROASTERS; MALT ROASTERS; REFRIGERATING CABINETS; HYDRANTS; ELECTRIC KETTLES; BURNERS, NAMELY, GAS BURNERS, BURNERS FOR LAMPS; GAS BURNERS; ELECTRIC COFFEE PERCOLATORS; GAS BOILERS, NAMELY, HEATING BOILERS; HEATING BOILERS; BOILERS, OTHER THAN PARTS OF MACHINES, NAMELY, ELECTRICAL BOILERS, HEATING BOILERS; COOLING APPARATUS, NAMELY, AIR COOLING APPARATUS, BEVERAGE COOLING APPARATUS; EXTRACTOR HOODS FOR KITCHENS; VENTILATION HOODS; VENTILATION HOODS FOR LABORATORIES; WATER-PIPES FOR SANITARY INSTALLATIONS; FREEZERS; SHOWERS; EVAPORATORS; FILTERS PARTS OF HOUSEHOLD OR

INDUSTRIAL INSTALLATIONS, NAMELY, FILTER DEVICES FOR AIR AND GAS CONDITIONING; COFFEE FILTERS NOT OF PAPER BEING PART OF ELECTRIC COFFEE MAKERS; FILTERS FOR DRINKING WATER; DRINKING FOUNTAINS; FURNACES, OTHER THAN FOR LABORATORY USE; ELECTRIC DEEP FRYERS; STEAM BOILERS, OTHER THAN PARTS OF MACHINES; AUTOMATIC WATERING INSTALLATIONS FOR AGRICULTURAL PURPOSES; BATH PLUMBING FIXTURES; WATER DISTRIBUTION INSTALLATIONS IN THE NATURE OF PIPES, FILTERS; STEAM GENERATING APPARATUS; DESALINATION PLANTS; MILK COOLING INSTALLATIONS; WATER SUPPLY INSTALLATIONS IN THE NATURE OF COOLING INSTALLATIONS, PURIFICATION INSTALLATIONS; WATER PURIFICATION INSTALLATIONS; WASH-HAND BASINS, AS A PARTS OF SANITARY INSTALLATIONS; SINKS; BREAD BAKING MACHINES; URINALS; PASTEURIZERS FOR USE IN FOOD, BEVERAGE, PHARMACEUTICAL; ELECTRIC PRESSURE COOKING SAUCEPANS; PLATE WARMERS; HEAT PUMPS; RADIATORS, ELECTRIC; WATER COOLERS; COOLING INSTALLATIONS FOR LIQUIDS; REFRIGERATED SHIPPING CONTAINERS; HEAT REGENERATORS; WATER HEATERS; ANTI-SPLASH TAP NOZZLES; WASHERS FOR WATER TAPS; TAPS; MIXER TAPS FOR WATER PIPES; TAPS FOR PIPES; FOOD WARMERS; HEAT EXCHANGERS, NOT PARTS OF MACHINES; PRESSURE WATER TANKS; COILS, AS A PARTS OF DISTILLING, HEATING OR COOLING INSTALLATIONS; STERILIZERS; WATER STERILIZERS; ELECTRIC ROASTERS; BOILER PIPES FOR HEATING INSTALLATIONS; ELECTRIC COOKING POTS, ELECTRIC COOKING OVENS, ELECTRIC GRIDDLES; LEVEL CONTROLLING VALVES IN TANKS, NAMELY, WATER CONTROL VALVES FOR FAUCETS, PLUMBING FITTINGS IN THE NATURE OF TUB CONTROL VALVES; THERMOSTATIC VALVES, AS A PARTS OF HEATING INSTALLATIONS; EXPANSION TANKS FOR CENTRAL HEATING INSTALLATIONS, NAMELY, DRAINAGE WATER TANKS; REFRIGERATING DISPLAY CABINETS; ELECTRIC YOGURT MAKERS (U.S. CLS. 13, 21, 23, 31 AND 34).

#### **CLASS 35—ADVERTISING AND BUSINESS**

FOR ADVERTISING, BUSINESS MANAGEMENT, BUSINESS ADMINISTRATION, OFFICE FUNCTIONS; ALL THE FOREGOING IN THE FIELD OF THE WATER, FOOD, BEVERAGE SUPPLY AND SANITARY INSTALLATIONS INDUSTRIES (U.S. CLS. 100, 101 AND 102).  
MICHAEL P EISNACH, EXAMINING ATTORNEY

SN 79-130,491. DOG ROCKS PTY LTD, MALVERN VIC 3144, AUSTRALIA, FILED 10-23-2012.

# Dog Rocks

THE MARK CONSISTS OF STANDARD CHARACTERS WITHOUT CLAIM TO ANY PARTICULAR FONT, STYLE, SIZE, OR COLOR.

OWNER OF INTERNATIONAL REGISTRATION 1161205 DATED 10-23-2012, EXPIRES 10-23-2022.

NO CLAIM IS MADE TO THE EXCLUSIVE RIGHT TO USE "DOG", APART FROM THE MARK AS SHOWN.

**CLASS 16—PAPER GOODS AND PRINTED MATTER**

FOR PAPER, CARDBOARD AND GOODS MADE FROM THESE MATERIALS, NAMELY, SHOPPING CARRYING BAGS OF PAPER AND CARDBOARD, PACKAGING AND STATIONERY OF PAPER AND CARDBOARD; PRINTED MATTER, NAMELY, PRINTED PACKAGING OF PAPER, PRINTED INSTRUCTION SHEETS AND INSTRUCTION MANUALS IN THE FIELD OF WATER ADDITIVES, LAWN MAINTENANCE AND PET CARE; PROMOTIONAL MATERIALS FOR INFORMATIONAL PURPOSES, NAMELY, BROCHURES AND FLYERS ABOUT WATER ADDITIVES, LAWN MAINTENANCE AND PET CARE BEING GOODS IN TRADE; BOOKS IN THE FIELD OF WATER ADDITIVES, LAWN MAINTENANCE AND PET CARE; PRINTED INSTRUCTIONAL MANUALS IN THE FIELD OF WATER ADDITIVES, LAWN MAINTENANCE AND PET CARE (U.S. CLS. 2, 5, 22, 23, 29, 37, 38 AND 50).

**CLASS 31—NATURAL AGRICULTURAL PRODUCTS**

FOR NON MEDICATED ADDITIVES IN THE NATURE OF MINERAL ADDITIVES BEING FOOD ADDITIVES FOR NON-INDUSTRIAL USE FOR ANIMAL DRINKING WATER (U.S. CLS. 1 AND 46).

**CLASS 35—ADVERTISING AND BUSINESS**

FOR WHOLESALE DISTRIBUTORSHIP RELATED TO AN ADDITIVE FOR PETS DRINKING WATER, NOT FOR MEDICAL PURPOSES; WHOLESALE STORE SERVICES INCLUDING ONLINE WHOLESALE STORE SERVICES RELATED TO AN ADDITIVE FOR PETS DRINKING WATER, NOT FOR MEDICAL PURPOSES; RETAIL STORE SERVICES INCLUDING ONLINE RETAIL STORE SERVICES RELATED TO AN ADDITIVE FOR PETS DRINKING WATER, NOT FOR MEDICAL PURPOSES; ADVERTISING AND PROMOTIONAL SERVICES RELATED TO AN ADDITIVE FOR PETS DRINKING WATER, NOT FOR MEDICAL PURPOSES (U.S. CLS. 100, 101 AND 102).

BERNICE MIDDLETON, EXAMINING ATTORNEY

**CLASS 9—ELECTRICAL AND SCIENTIFIC APPARATUS**

FOR SOFTWARE FOR FACILITATING WEB-BASED CONTENT MANAGEMENT, DELIVERY, SEARCHING, LINKING, AND WORD PROCESSING USED IN THE FIELD OF PROJECT MANAGEMENT; ELECTRONIC BOOKS IN THE FIELD OF PROJECT MANAGEMENT RECORDED ON COMPUTER MEDIA; TEACHING MATERIALS IN THE FIELD OF PROJECT MANAGEMENT RECORDED ON COMPUTER MEDIA; ELECTRONIC PUBLICATIONS, NAMELY, DOWNLOADABLE E-BOOKS RELATING TO PROJECT MANAGEMENT PROVIDED ONLINE OVER A COMMUNICATIONS NETWORK OR THE INTERNET; COMPUTER APPLICATION SOFTWARE FOR MOBILE DEVICES FOR PROJECT MANAGEMENT; DOWNLOADABLE PODCASTS RELATING TO PROJECT MANAGEMENT; DOWNLOADABLE COMPUTER APPLICATIONS FOR ANY COMPUTING DEVICE OR PLATFORM, NAMELY, DESKTOP, LAPTOP AND TABLET COMPUTERS, AS WELL AS MOBILE DEVICES, FOR FACILITATING WEB-BASED CONTENT MANAGEMENT, DELIVERY, SEARCHING, LINKING, AND WORD PROCESSING USED IN THE FIELD OF PROJECT MANAGEMENT (U.S. CLS. 21, 23, 26, 36 AND 38).

**CLASS 16—PAPER GOODS AND PRINTED MATTER**

FOR PRINTED MATERIALS, NAMELY, MANUALS, GUIDES, BOOKS, PRINTED INSTRUCTIONAL AND TEACHING MATERIALS ALL IN THE FIELD OF PROJECT MANAGEMENT (U.S. CLS. 2, 5, 22, 23, 29, 37, 38 AND 50).

**CLASS 35—ADVERTISING AND BUSINESS**

FOR BUSINESS INFORMATION, MANAGEMENT, ORGANIZATION AND ADVISORY SERVICES; BUSINESS RESEARCH; MARKET ASSESSMENT SERVICES; BUSINESS BENCHMARKING SERVICES, NAMELY, COMPARING ORGANIZATIONAL PROJECT MANAGEMENT PRACTICES AND PERFORMANCES TO CREATE NEW BUSINESS STANDARDS AND TO IMPROVE BUSINESS PRACTICES; BUSINESS MANAGEMENT CONSULTING; CONSULTING SERVICES WITH RESPECT TO THE EXECUTION OF BUSINESS PROJECTS; PROVIDING INTERIM BUSINESS MANAGEMENT SERVICES FOR OTHERS; DATA PROCESSING (U.S. CLS. 100, 101 AND 102).

SN 79-130,615. THE MINISTER FOR THE CABINET OFFICE, UNITED KINGDOM, FILED 7-20-2012.

# PRINCE2

THE MARK CONSISTS OF STANDARD CHARACTERS WITHOUT CLAIM TO ANY PARTICULAR FONT, STYLE, SIZE, OR COLOR.

OWNER OF INTERNATIONAL REGISTRATION 1161499 DATED 7-20-2012, EXPIRES 7-20-2022.

OWNER OF U.S. REG. NO. 2,746,458.

**CLASS 38—COMMUNICATION**

FOR ELECTRONIC MAIL; TRANSMISSION AND DISTRIBUTION OF DATA AND AUDIO VISUAL IMAGES BY ELECTRONIC, SATELLITE, CABLE AND COMPUTING MEANS; TELECOMMUNICATIONS SERVICES, NAMELY, PROVIDING FIBER OPTIC NETWORK SERVICES; PROVISION OF ACCESS TO DATABASES AND THE INTERNET; PROVIDING ON-LINE COMMUNICATIONS LINKS WHICH TRANSFER THE WEB SITE USER TO OTHER LOCAL AND GLOBAL WEB PAGES; PROVISION OF ONLINE FORUMS FOR TRANSMISSION OF MESSAGES AMONG COMPUTER USERS (U.S. CLS. 100, 101 AND 104).

**CLASS 41—EDUCATION AND ENTERTAINMENT**

FOR PROVIDING ON-LINE NON-DOWNLOADABLE ELECTRONIC PUBLICATIONS IN THE NATURE OF BOOKS, JOURNALS AND MANUALS IN THE FIELD OF PROJECT MANAGEMENT; PRODUCTION, RECORDING OF PODCASTS IN THE FIELD OF PROJECT MANAGEMENT; EDUCATIONAL ASSESSMENT SERVICES; EDUCATIONAL EXAMINATION SERVICES; EDUCATION AND TRAINING SERVICES, NAMELY, CLASSES, LECTURES, SEMINARS IN THE FIELD OF PROJECT MANAGEMENT; EDUCATION AND TRAINING SERVICES, NAMELY, ADMINISTERING QUALIFICATION EXAMINATIONS IN THE FIELD OF PROJECT MANAGEMENT; TRAINING AND EDUCATION BY MEANS OF COURSES, CLASSES, SEMINARS, WORKSHOPS, TUTORIALS, ONE-TO-ONE MENTORING AND TUTORING, AND BRIEFINGS IN THE FIELD OF PROJECT MANAGEMENT; ARRANGING AND CONDUCTING EDUCATIONAL CONFERENCES IN THE FIELD OF PROJECT MANAGEMENT (U.S. CLS. 100, 101 AND 107).

**CLASS 42—SCIENTIFIC AND COMPUTER SERVICES**

FOR PROVIDING ON-LINE DATABASES FEATURING INFORMATION ABOUT THE OPERATION AND MANAGEMENT OF INFORMATION TECHNOLOGY SERVICES; NON-DOWNLOADABLE SOFTWARE APPLICATIONS DELIVERED ONLINE THROUGH A WEB-BROWSER FOR FACILITATING WEB-BASED CONTENT MANAGEMENT, DELIVERY, SEARCHING, LINKING, AND WORD PROCESSING USED IN THE FIELD OF IT SERVICE MANAGEMENT (U.S. CLS. 100 AND 101).

BARBARA GAYNOR, EXAMINING ATTORNEY

SN 79-131,173. BALDOMERO VENTURA, S.L., E-08430 LA ROCA DEL VALLES (BARCELONA), SPAIN, FILED 4-8-2013.



PRIORITY DATE OF 4-1-2013 IS CLAIMED.  
OWNER OF INTERNATIONAL REGISTRATION 1162995 DATED 4-8-2013, EXPIRES 4-8-2023.

OWNER OF U.S. REG. NO. 3,852,537.  
THE TRADEMARK CONSISTS OF THE DESIGNATION "VENTURA" PRECEDED BY A GRAPHIC ELEMENT CONSISTING OF A CIRCLE WITH THE LETTER "V" INSIDE IT. THE ENGLISH TRANSLATION OF "VENTURA" IN THE MARK IS "FORTUNE".

**CLASS 10—MEDICAL APPARATUS**

FOR SURGICAL APPARATUS AND INSTRUMENTS FOR MEDICAL, DENTAL OR VETERINARY USE, AS WELL AS ARTIFICIAL LIMBS, EYES AND TEETH; ORTHOPEDIC DEVICES FOR DIAGNOSTIC AND THERAPEUTIC USE; SUTURE MATERIALS; MEDICAL INSTRUMENTS FOR THEIR USE IN REHABILITATION, NEUROREHABILITATION, NEUROPHYSIOLOGY, TO TREAT DISEASES OF THE RIBCAGE, GASTROINTESTINAL, NEUROSURGERY, OTOLARYNGOLOGY, PNEUMOLOGIA, TRAUMATOLOGY, GYNECOLOGY-OBSTETRICS, UROLOGY, CARDIOLOGY AND OPHTHALMOLOGY (U.S. CLS. 26, 39 AND 44).

**CLASS 40—MATERIAL TREATMENT**

FOR TREATMENT OF METAL PARTS FOR THE AUTOMOTIVE, AERONAUTICS, GENERAL INDUSTRY AND BIOMEDICINE SECTORS AND MILLWORKING FOR THE AUTOMOTIVE, AERONAUTICS, GENERAL INDUSTRY AND BIOMEDICINE SECTORS (U.S. CLS. 100, 103 AND 106).

TASNEEM HUSSAIN, EXAMINING ATTORNEY

SN 79-131,550. JET-ZONE BVBA, B-8550 ZWEVEGEM, BELGIUM, FILED 3-5-2013.

# JET-ZONE

THE MARK CONSISTS OF STANDARD CHARACTERS WITHOUT CLAIM TO ANY PARTICULAR FONT, STYLE, SIZE, OR COLOR.

PRIORITY DATE OF 10-1-2012 IS CLAIMED.  
OWNER OF INTERNATIONAL REGISTRATION 1163962 DATED 3-5-2013, EXPIRES 3-5-2023.

**CLASS 7—MACHINERY**

FOR MACHINES AND MACHINE TOOLS, NAMELY, DUST SUPPRESSION MACHINES AND MACHINE TOOLS FOR SHREDDERS; MOTORS AND ENGINES EXCEPT FOR LAND VEHICLES; MACHINE COUPLING AND TRANSMISSION COMPONENTS EXCEPT FOR LAND VEHICLES; AIR CONDENSERS; AIR SUCTION MACHINES FOR INDUSTRIAL PURPOSES; CONTROL MECHANISMS FOR MACHINES, NAMELY, CONTROL MECHANISMS FOR DUST SUPPRESSION DEVICES FOR SHREDDERS, ENGINES OR MOTORS OTHER THAN FOR LAND VEHICLES; FIBER BLOWING AND SCUTCHING MACHINES; BLOWING MACHINES FOR EXHAUSTION; CONDENSING INSTALLATIONS, NAMELY, AIR, MECHANICAL AND CENTRIFUGAL FAN CONDENSERS; OIL, GAS AND AIR FILTERS AS PARTS OF ENGINES, MOTORS OR OF MACHINES; FILTERING MACHINES FOR CHEMICAL PROCESSING; HAND-HELD TOOLS, NAMELY, HAND-HELD DUST SUPPRESSION TOOLS FOR SHREDDERS, NAMELY, MIST INJECTORS; DUST REMOVING INSTALLATIONS FOR CLEANING PURPOSES; DIVIDING MACHINES; SPRAYING MACHINES (U.S. CLS. 13, 19, 21, 23, 31, 34 AND 35).

**CLASS 9—ELECTRICAL AND SCIENTIFIC APPARATUS**

FOR APPARATUS AND INSTRUMENTS FOR THE CONDUCTION, DISTRIBUTION, CONVERSION, STORAGE, REGULATION AND MANAGEMENT OF ELECTRICITY, NAMELY, POWER SUPPLIES AND POWER REGULATING APPARATUS FOR DUST SUPPRESSION DEVICES FOR SHREDDERS; CAPACITORS; AIR ANALYSIS APPARATUS; RESPIRATORS FOR FILTERING AIR OTHER THAN FOR ARTIFICIAL RESPIRATION; SPRINKLER SYSTEMS FOR FIRE PROTECTION; FIRE-EXTINGUISHING PUMPS; FIRE HOSE NOZZLES; COMPUTER SOFTWARE FOR CONTROLLING AND MANAGEMENT OF DUST SUPPRESSION FOR SHREDDERS (U.S. CLS. 21, 23, 26, 36 AND 38).

**CLASS 11—ENVIRONMENTAL CONTROL APPARATUS**

FOR REFRIGERATING AND VENTILATING APPARATUS USED FOR DUST SUPPRESSION APPARATUS FOR SHREDDERS; COOLING APPLIANCES AND INSTALLATIONS FOR SHREDDERS; FAN PARTS OF AIR-CONDITIONING INSTALLATIONS; DUST FILTERS AS PARTS OF DOMESTIC OR INDUSTRIAL FACILITIES; IONIZATION APPARATUS FOR THE TREATMENT OF AIR; AIR FILTERING INSTALLATIONS; AIR COOLING APPARATUS; AIR STERILIZERS; AIR PURIFYING APPARATUS AND MACHINES; EVAPORATORS; ELECTRIC VAPORIZERS FOR DRIP IRRIGATION (U.S. CLS. 13, 21, 23, 31 AND 34).

**CLASS 37—CONSTRUCTION AND REPAIR**

FOR REPAIR OF SHREDDERS; INSTALLATION SERVICES, NAMELY, OF DUST SUPPRESSION DEVICES FOR SHREDDERS; MACHINERY INSTALLATION, MAINTENANCE AND REPAIR; PLANT HIRE, NAMELY, LEASING OF MACHINES AND MACHINE TOOLS; REPAIR INFORMATION, NAMELY, PROVIDING INFORMATION RELATING TO THE REPAIR OF SHREDDERS; REBUILDING MACHINES THAT HAVE BEEN WORN OR PARTIALLY DESTROYED (U.S. CLS. 100, 103 AND 106).

HEATHER THOMPSON, EXAMINING ATTORNEY

SN 79-131,628. SALSICHARIA TRANCOSENSE, LDA., PORTUGAL, FILED 1-17-2013.

**PRISCA**

THE MARK CONSISTS OF STANDARD CHARACTERS WITHOUT CLAIM TO ANY PARTICULAR FONT, STYLE, SIZE, OR COLOR.

PRIORITY DATE OF 12-19-2012 IS CLAIMED.

OWNER OF INTERNATIONAL REGISTRATION 1164161 DATED 1-17-2013, EXPIRES 1-17-2023.

THE WORDING "PRISCA" HAS NO MEANING IN A FOREIGN LANGUAGE.

**CLASS 29—MEATS AND PROCESSED FOODS**

FOR MEAT, POULTRY AND GAME; MEAT EXTRACTS; TRADITIONAL SMOKED MEAT PRODUCTS, NAMELY, SMOKED HAM, SMOKED BACON, CHORIZO, SALAMI; SAUSAGE, BOILED AND SMOKED; HAMS; PROCESSED FRUITS AND VEGETABLES, BEING PRESERVED, DRIED AND COOKED; JAMS, JELLIES, JAMS AND TRADITIONAL COMPOTES, EGGS; MILK AND DAIRY PRODUCTS, EXCLUDING ICE CREAM, ICE MILK, AND FROZEN YOGURT; EDIBLE OILS AND FATS; PASTES AND PÂTES BASED ON MEAT, VEGETABLES AND OLIVES (U.S. CL. 46).

**CLASS 30—STAPLE FOODS**

FOR COFFEE, TEA, COCOA, RICE, TAPIOCA, SAGO, ARTIFICIAL COFFEE; FROZEN CONFECTIONERY; REGIONAL FROZEN CONFECTIONERY; ICES, HONEY, TREACLE, YEAST, BAKING-POWDER, SALT, MUSTARD, VINEGAR, SAUCES BEING CONDIMENTS; SPICES, ICE (U.S. CL. 46).

SUSAN BILLHEIMER, EXAMINING ATTORNEY

SN 79-132,167. PERSAN TEKSTIL; SANAYI VE TICARET ANONIM SİRKETİ, TURKEY, FILED 1-24-2013.

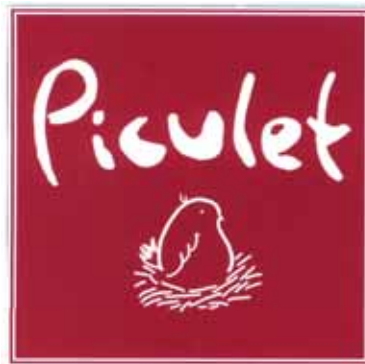

PRIORITY DATE OF 12-28-2012 IS CLAIMED.

OWNER OF INTERNATIONAL REGISTRATION 1165537 DATED 1-24-2013, EXPIRES 1-24-2023.

THE COLOR(S) PURPLE AND WHITE IS/ARE CLAIMED AS A FEATURE OF THE MARK.

THE MARK CONSISTS OF A PURPLE SQUARE WITH THREE CONSECUTIVE BORDERS- TWO WHITE, AND THE INTERIOR IN PURPLE, WITH THE WORD "PICULET" IN A STYLIZED WHITE FONT, APPEARING ABOVE THE DESIGN OF A PURPLE BIRD LINED IN WHITE ON TOP OF A WHITE NEST.

**CLASS 18—LEATHER GOODS**

FOR BAGS, NAMELY, ALL-PURPOSE CARRYING BAGS; PURSES; SMALL BAGS; BRIDAL BAGS; BRIEF-CASE BAGS; SUITCASES; WAIST BAGS; SPORTS BAGS; BACK PACKS; BEACH BAGS (U.S. CLS. 1, 2, 3, 22 AND 41).

**CLASS 20—FURNITURE AND ARTICLES NOT OTHERWISE CLASSIFIED**

FOR PILLOWS (U.S. CLS. 2, 13, 22, 25, 32 AND 50).

**CLASS 24—FABRICS**

FOR CURTAINS (U.S. CLS. 42 AND 50).

RON FAIRBANKS, EXAMINING ATTORNEY

SN 79-132,172. AREVA GMBH, 91052 ERLANGEN, FED REP GERMANY, FILED 4-2-2013.

**OPANASEC**

THE MARK CONSISTS OF STANDARD CHARACTERS WITHOUT CLAIM TO ANY PARTICULAR FONT, STYLE, SIZE, OR COLOR.

PRIORITY DATE OF 11-15-2012 IS CLAIMED.

OWNER OF INTERNATIONAL REGISTRATION 1165548 DATED 4-2-2013, EXPIRES 4-2-2023.

**CLASS 9—ELECTRICAL AND SCIENTIFIC APPARATUS**

FOR COMPUTER HARDWARE AND COMPUTER SOFTWARE RELATING TO NUCLEAR AND POWER GENERATING PLANTS AND INSTALLATIONS, ESPECIALLY FOR USE TO PROTECT NUCLEAR REACTORS, NAMELY, FOR USE IN MONITORING AND INSPECTING FOR SEVERE ACCIDENTS IN CONNECTION WITH NUCLEAR REACTORS AND NUCLEAR POWER STATIONS; SCIENTIFIC, ELECTRICAL, ELECTROTECHNICAL AND ELECTRONIC APPARATUS, EQUIPMENT AND INSTRUMENTS, NAMELY, ELECTRONIC NUCLEAR REACTOR CONTROLS, ELECTRONIC SAFETY INSTALLATIONS FOR USE WITH NUCLEAR REACTORS, NAMELY, APPARATUS AND INSTRUMENTS FOR DETECTING, MEASURING AND MONITORING RADIOACTIVITY AND RADIOACTIVE CONTAMINATION; ELECTRIC AND ELECTRONIC, MEASURING, CHECKING, SUPERVISION, MONITORING, SIGNALING, CONTROLLING, AUTOMATIC CONTROLLING, AND SWITCHGEAR APPARATUS AND STRUCTURAL PARTS AND FITTINGS THEREFOR, NAMELY, CAMERAS FOR MONITORING AND INSPECTING EQUIPMENT IN A NUCLEAR POWER STATION, NUCLEAR ACCIDENT ALARMS; ELECTROMECHANICAL SWITCHGEAR AND SWITCHBOARD UNITS CONSISTING THEREOF; APPARATUS FOR RECORDING, TRANSMISSION OR REPRODUCTION OF ALL KINDS OF DATA (U.S. CLS. 21, 23, 26, 36 AND 38).

**CLASS 11—ENVIRONMENTAL CONTROL APPARATUS**

FOR NUCLEAR REACTORS AND STRUCTURAL PARTS THEREFOR; PARTS AND FITTINGS OF NUCLEAR REACTORS, NAMELY, NUCLEAR POWER PLANTS AND TRANSPORTABLE NUCLEAR POWER PLANTS (U.S. CLS. 13, 21, 23, 31 AND 34).

**CLASS 42—SCIENTIFIC AND COMPUTER SERVICES**

FOR DESIGN AND DEVELOPMENT OF COMPUTER HARDWARE; DESIGN, DEVELOPMENT, INSTALLATION, UPDATING AND MAINTENANCE OF COMPUTER SOFTWARE, ESPECIALLY FOR USE TO PROTECT NUCLEAR REACTORS; COMPUTER SECURITY SERVICES, NAMELY, RESTRICTING ILLEGAL ACCESS TO AND BY COMPUTER NETWORKS (U.S. CLS. 100 AND 101).

DOMINIC FATHY, EXAMINING ATTORNEY

---

SN 79-132,670. DEUTSCHE TELEKOM AG, FED REP GERMANY, FILED 3-11-2013.

# Fabplace

THE MARK CONSISTS OF STANDARD CHARACTERS WITHOUT CLAIM TO ANY PARTICULAR FONT, STYLE, SIZE, OR COLOR.

PRIORITY DATE OF 9-12-2012 IS CLAIMED.  
OWNER OF INTERNATIONAL REGISTRATION 1166831 DATED 3-11-2013, EXPIRES 3-11-2023.

**CLASS 35—ADVERTISING AND BUSINESS**

FOR ADVERTISING; BUSINESS MANAGEMENT; BUSINESS ADMINISTRATION CONSULTANCY; PROVIDING OFFICE FUNCTIONS; ALL AFOREMENTIONED SERVICES IN THE FIELD OF THREE DIMENSIONAL PRINTING (U.S. CLS. 100, 101 AND 102).

**CLASS 38—COMMUNICATION**

FOR TELECOMMUNICATIONS SERVICES, NAMELY, ELECTRIC, DIGITAL, CELLULAR AND WIRELESS TRANSMISSION OF VOICE, DATA, INFORMATION, IMAGES, SIGNALS, MESSAGES AND TRANSMISSION OF VOICE, DATA, IMAGES, AUDIO, VIDEO AND INFORMATION VIA TELEPHONE, TELEVISION AND GLOBAL COMMUNICATION NETWORK; ALL AFOREMENTIONED SERVICES IN THE FIELD OF THREE DIMENSIONAL PRINTING (U.S. CLS. 100, 101 AND 104).

**CLASS 40—MATERIAL TREATMENT**

FOR MATERIAL PROCESSING, NAMELY, THREE DIMENSIONAL PRINTING (3DP) SERVICES; ALL AFOREMENTIONED SERVICES IN THE FIELD OF THREE DIMENSIONAL PRINTING (U.S. CLS. 100, 103 AND 106).

**CLASS 42—SCIENTIFIC AND COMPUTER SERVICES**

FOR SCIENTIFIC AND TECHNOLOGICAL SERVICES, NAMELY, RESEARCH AND DESIGN RELATING TO THE FIELD OF INFORMATION AND COMMUNICATIONS TECHNOLOGY; INDUSTRIAL COMPUTER SYSTEMS ANALYSIS; TECHNICAL RESEARCH; ALL IN THE FIELD OF INFORMATION AND COMMUNICATIONS TECHNOLOGY, NAMELY, IN THE FIELD OF THREE DIMENSIONAL PRINTING (U.S. CLS. 100 AND 101).

**CLASS 45—PERSONAL AND LEGAL SERVICES**

FOR SOCIAL SERVICES RENDERED BY THIRD PARTIES REGARDING NEEDS OF INDIVIDUALS, NAMELY, INTERNET-BASED SOCIAL INTRODUCTION AND SOCIAL NETWORKING SERVICES; ONLINE SOCIAL NETWORKING SERVICES FOR THE PURPOSE OF FACILITATING SOCIAL INTERACTION AMONG INDIVIDUALS AND FOR FINDING PERSONS WITH PARTICULAR HOBBLES, INTEREST AND BACKGROUNDS; PROVIDING A SOCIAL NETWORKING WEBSITE FOR ENTERTAINMENT PURPOSES; SECURITY SERVICES FOR THE PROTECTION OF PROPERTY, NAMELY, MONITORING OF COMPUTER SYSTEMS FOR SECURITY PURPOSES; ALL AFOREMENTIONED SERVICES IN THE FIELD OF THREE DIMENSIONAL PRINTING (U.S. CLS. 100 AND 101).

VIVIAN MICZNIK FIRST, EXAMINING ATTORNEY

---

SN 79-132,852. KABA GMBH, FED REP GERMANY, FILED 12-27-2012.

# B-inspired

THE MARK CONSISTS OF STANDARD CHARACTERS WITHOUT CLAIM TO ANY PARTICULAR FONT, STYLE, SIZE, OR COLOR.

PRIORITY DATE OF 6-28-2012 IS CLAIMED.  
OWNER OF INTERNATIONAL REGISTRATION 1167285 DATED 12-27-2012, EXPIRES 12-27-2022.

**CLASS 9—ELECTRICAL AND SCIENTIFIC APPARATUS**

FOR TIME AND DATA LOGGING APPARATUS, NAMELY, TIME AND DATE STAMPING MACHINES, ELECTRONIC TIME AND DATA LOGGERS; DATA TRANSMISSION AND PROCESSING APPARATUS, IN PARTICULAR FOR LOGGING AND PROCESSING WORK TIME AND OPERATIONAL DATA; CHECKING AND SUPERVISION APPARATUS AND INSTRUMENTS, IN PARTICULAR FOR ACCESS CONTROL, NAMELY, ACCESS CONTROL AND ALARM MONITORING SYSTEMS, NAMELY, ACCESS CONTROL AND ALARM MONITORING SYSTEMS COMPRISED PRIMARILY OF ELECTRONIC READERS AND CONTROLLERS FOR CONTROLLING ACCESS TO A PREMISE; APPARATUS FOR RECORDING TRANSMISSION AND REPRODUCTION OF SOUND OR IMAGES, OTHER THAN EQUIPMENT FOR OPTICAL, IMAGING, AND IMAGE PROCESSING PURPOSES; BADGE READERS, NAMELY, MAGNETIC CODED CARD READERS, SMART CARD READERS; DATA INPUT AND OUTPUT APPARATUS, NAMELY, COMPUTERS AND DIGITAL INPUT AND OUTPUT SCANNERS; MOBILE AND PERMANENTLY INSTALLED ELECTRONIC DATA TERMINALS, IN PARTICULAR FOR LOGGING WORK TIME AND OPERATIONAL DATA, AND ACCESS CONTROL TERMINALS FOR CONTROLLING ACCESS TO A PREMISE; ELECTRIC TESTING, MONITORING AND CHECKING EQUIPMENT AND APPARATUS, NAMELY, MONITORING CAMERAS, VIDEO MONITORS, PRESENCE DETECTORS, MOTION SENSORS, MICRO WAVE MOTION DETECTORS AND ELECTRIC SENSORS FOR MONITORING PURPOSES; MACHINE-READABLE DATA CARRIERS AND DATA CARDS, NAMELY, BLANK ELECTRONIC CHIP CARDS AND BLANK MAGNETIZABLE CARDS, BLANK MAGNETIC CODED CARDS AND BLANK SMART CARDS; ENTRY ACCESS CONTROL APPARATUS, NAMELY, BIOMETRIC FINGERPRINT DOOR LOCK, IRIS RECOGNITION SECURITY DEVICES, ACCESS CONTROL TERMINALS, NAMELY, READERS FOR MAGNETIC CODED ACCESS CARDS OR SMART ACCESS CARDS, ELECTRONIC ACCESS CONTROL SYSTEMS COMPRISED OF ELECTRONIC CARD READERS, ELECTRIC STRIKES AND ELECTRONICALLY CONTROLLED DOOR LOCKS; WORK TIME RECORDING APPARATUS, PRODUCTION DATA RECORDING APPARATUS, ELECTRIC PROCESS CONTROL EQUIPMENT, NAMELY, COMPUTERS AND DATA PROCESSING DEVICES FOR CONTROLLING PRODUCTION PROCESSES, MACHINES, ACCESS CONTROL AND ALARM MONITORING SYSTEMS; COMPUTER HARDWARE, DATA PROCESSING APPARATUS AND DATA PROCESSING PROGRAMS FOR LOGGING OPERATIONAL DATA, MACHINE DATA AND TIME DATA AND FOR CONTROLLING ACCESS AND INTERNAL BUSINESS COMMUNICATION; COMPUTER SOFTWARE, NAMELY, SOFTWARE FOR COMMUNICATION BETWEEN COMPUTER APPLICATION SOFTWARE AND DATA TERMINALS AND SOFTWARE FOR INTERNAL BUSINESS COMMUNICATION; APPLICATION SOFTWARE FOR MOBILE DATA PROCESSING APPARATUS AND STATIONARY DATA TERMINALS, IN PARTICULAR APPLICATION SOFTWARE FOR INTERNAL BUSINESS COMMUNICATION (U.S. CLS. 21, 23, 26, 36 AND 38).

**CLASS 42—SCIENTIFIC AND COMPUTER SERVICES**

FOR SOFTWARE DESIGN AND DEVELOPMENT, INSTALLING AND UPDATING OF COMPUTER SOFTWARE, MAINTENANCE AND REPAIR OF SOFTWARE, CUSTOM SOFTWARE ADAPTATION; CONSULTANCY IN THE DESIGN AND DEVELOPMENT OF COMPUTER HARDWARE; CONSULTANCY IN THE FIELD OF COMPUTER SOFTWARE; RENTING OUT HARDWARE AND SOFTWARE; TECHNICAL CONSULTANCY RELATING TO DESIGN, DEVELOPMENT AND RESEARCH IN THE FIELD OF INTERNAL BUSINESS COMMUNICATION (U.S. CLS. 100 AND 101).

**CLASS 45—PERSONAL AND LEGAL SERVICES**

FOR LICENSING OF COMPUTER SOFTWARE (U.S. CLS. 100 AND 101).

JANICE L. MCMORROW, EXAMINING ATTORNEY

SN 79-133,003. INSONLINE LTD, CYPRUS, FILED 6-7-2013.

# eZeeCard

THE MARK CONSISTS OF STANDARD CHARACTERS WITHOUT CLAIM TO ANY PARTICULAR FONT, STYLE, SIZE, OR COLOR.

PRIORITY DATE OF 6-4-2013 IS CLAIMED.

OWNER OF INTERNATIONAL REGISTRATION 1167625 DATED 6-7-2013, EXPIRES 6-7-2023.

**CLASS 9—ELECTRICAL AND SCIENTIFIC APPARATUS**

FOR COMPUTER SOFTWARE FOR USE IN RELATION TO FINANCIAL SERVICES, NAMELY, FINANCIAL TRANSACTION AND PAYMENT PROCESSING SERVICES, AND CREDIT AND DEBIT CARD SERVICES; COMPUTER SOFTWARE FOR USE IN ASSISTING AND ENABLING TRANSFER OF FUNDS AND PURCHASE OF PRODUCTS AND SERVICES OFFERED BY OTHERS; COMPUTER SOFTWARE FOR USE IN ENABLING ELECTRONIC FUNDS TRANSFER; MAGNETIC CODED CARDS FOR FACILITATING TRANSFER OF FUNDS; MAGNETICALLY ENCODED CREDIT CARDS AND DEBIT CARDS (U.S. CLS. 21, 23, 26, 36 AND 38).

**CLASS 36—INSURANCE AND FINANCIAL**

FOR BILL PAYMENT SERVICES; CREDIT AND DEBIT CARD SERVICES; FINANCIAL SERVICES IN THE NATURE OF ASSISTING AND ENABLING TRANSFER OF FUNDS AND PURCHASE OF PRODUCTS AND SERVICES OFFERED BY OTHERS; ELECTRONIC FUNDS TRANSFER SERVICES (U.S. CLS. 100, 101 AND 102).

KELLY TRUSILO, EXAMINING ATTORNEY

SN 79-133,455. EFLUID, F-57000 METZ, FRANCE, FILED 5-17-2013.



The logo for 'efluid' features a stylized lowercase 'e' inside a blue circle, followed by the word 'fluid' in a bold, lowercase, sans-serif font. The entire logo is rendered in a dark blue color.

OWNER OF INTERNATIONAL REGISTRATION 1168976 DATED 5-17-2013, EXPIRES 5-17-2023.

THE COLOR(S) WHITE, BLUE, GRAY AND DARK BLUE IS/ARE CLAIMED AS A FEATURE OF THE MARK.

THE MARK CONSISTS OF A WHITE LOWERCASE LETTER "E" INSIDE A BLUE CIRCLE WITH A GRAY BORDER, ALL TO THE LEFT OF THE WORDING "FLUID" IN DARK BLUE.

**CLASS 9—ELECTRICAL AND SCIENTIFIC APPARATUS**

FOR SOFTWARE FOR BUSINESS MANAGEMENT OF THE CLIENTS AND THEIR TECHNICAL INSTALLATION OF ELECTRICITY, GAS, WATER, SANITATION, HEATING, VIDEO COMMUNICATION; SOFTWARE PACKAGES, NAMELY, SOFTWARE FOR BUSINESS MANAGEMENT OF THE CLIENTS AND THEIR TECHNICAL INSTALLATION OF ELECTRICITY, GAS, WATER, SANITATION, HEATING, VIDEO COMMUNICATION; RECORDED COMPUTER PROGRAM INFORMATION SYSTEMS COMPRISED OF COMPUTER HARDWARE, COMPUTER GAME PROGRAMS, COMPUTER OPERATING SYSTEM (U.S. CLS. 21, 23, 26, 36 AND 38).

**CLASS 35—ADVERTISING AND BUSINESS**

FOR BUSINESS MANAGEMENT; ACCOUNTING; COMPUTER FILE MANAGEMENT (U.S. CLS. 100, 101 AND 102).

**CLASS 38—COMMUNICATION**

FOR TELECOMMUNICATIONS, NAMELY, TRANSMISSION OF DATA, VOICE AND DOCUMENTS IN THE FIELD OF BUSINESS MANAGEMENT OF THE CLIENTS AND THEIR TECHNICAL INSTALLATIONS; PROVISION OF ACCESS TO GLOBAL COMPUTER NETWORK; VIDEO COMMUNICATION, NAMELY, VIDEO BROADCASTING SERVICES OVER THE INTERNET OR OTHER COMMUNICATIONS NETWORK, NAMELY, ELECTRONICALLY TRANSMITTING VIDEO (U.S. CLS. 100, 101 AND 104).

**CLASS 39—TRANSPORTATION AND STORAGE**

FOR PHYSICAL STORAGE OF ELECTRONICALLY-STORED DATA OR DOCUMENTS (U.S. CLS. 100 AND 105).

**CLASS 42—SCIENTIFIC AND COMPUTER SERVICES**

FOR DESIGN, DEVELOPMENT, INSTALLATION, MAINTENANCE, UPDATING OR RENTAL OF SOFTWARE, SOFTWARE PACKAGES, INFORMATION SYSTEMS, DATABASES (U.S. CLS. 100 AND 101).  
GILBERT SWIFT, EXAMINING ATTORNEY

SN 79-133,514. OBSHCHESTVO S OGRANICHENNOY OTVETSTVENNOSTYU "TORGOVYI DOM "NIKA", RU-115407 MOSKVA, RUSSIAN FED., FILED 4-30-2013.



THE MARK CONSISTS OF STANDARD CHARACTERS WITHOUT CLAIM TO ANY PARTICULAR FONT, STYLE, SIZE, OR COLOR.

OWNER OF INTERNATIONAL REGISTRATION 1169127 DATED 4-30-2013, EXPIRES 4-30-2023.

THE WORD(S) "QWILL" HAS NO MEANING IN A FOREIGN LANGUAGE.

**CLASS 14—JEWELRY**

FOR BARRELS FOR CLOCK AND WATCH MAKING; WATCH STRAPS; ALARM CLOCKS; WATCH CASES; CLOCK CASES; PENDULUMS FOR CLOCK AND WATCH MAKING; MOVEMENTS FOR CLOCKS AND WATCHES; CLOCKWORKS; CHRONOMETRICAL INSTRUMENTS; WATCH SPRINGS; STOPWATCHES; WATCH GLASSES; CLOCK HANDS FOR CLOCK AND WATCH MAKING; CASES FOR WATCHES PRESENTATION; CASES FOR CLOCK AND WATCH MAKING; CHRONOGRAPHS AS WATCHES; WATCH CHAINS; DIALS FOR CLOCK AND WATCH MAKING; ATOMIC CLOCKS; WATCHES; SUNDIALS; CLOCKS AND WATCHES, ELECTRIC; CLOCKS; WRISTWATCHES (U.S. CLS. 2, 27, 28 AND 50).

**CLASS 35—ADVERTISING AND BUSINESS**

FOR IMPORT AND EXPORT AGENCIES; COMMERCIAL INFORMATION AND DIRECTORY AGENCIES; COST PRICE ANALYSIS; COMPUTERIZED FILE MANAGEMENT; DEMONSTRATION OF GOODS; CONDUCTING MARKETING STUDIES; BUSINESS INFORMATION AND INQUIRIES; COMMERCIAL INFORMATION AND ADVICE FOR CONSUMERS; MARKETING RESEARCH; MARKETING; UPDATING OF ADVERTISING MATERIAL; ORGANIZATION OF EXHIBITIONS FOR COMMERCIAL OR ADVERTISING PURPOSES; ORGANIZATION OF TRADE FAIRS FOR COMMERCIAL OR ADVERTISING PURPOSES; SHOP WINDOW DISPLAY ARRANGEMENT SERVICES; PAYROLL PREPARATION; DATA SEARCHING IN COMPUTER FILES FOR OTHERS FOR BUSINESS PURPOSES; SALES PROMOTION FOR OTHERS; COMPILATION AND SYSTEMIZATION OF INFORMATION INTO COMPUTER DATABASES FOR BUSINESS PURPOSES; COMPILATION OF STATISTICS FOR BUSINESS PURPOSES; BUSINESS INQUIRIES; COMMERCIAL ADMINISTRATION OF THE LICENSING OF THE GOODS AND SERVICES OF OTHERS; ADMINISTRATIVE PROCESSING OF PURCHASE ORDERS; PROCUREMENT SERVICES FOR OTHERS, NAMELY, PURCHASING GOODS AND SERVICES FOR OTHER BUSINESSES; PROVIDING TELEVISION HOME SHOPPING SERVICES IN THE FIELD OF GENERAL CONSUMER MERCHANDISE (U.S. CLS. 100, 101 AND 102).

JEFF DEFORD, EXAMINING ATTORNEY

SN 79-133,855. LEONHARD KURZ STIFTUNG & CO. KG, 90763 FÜRTH, FED REP GERMANY, FILED 2-8-2013.

# DM-LINER

THE MARK CONSISTS OF STANDARD CHARACTERS WITHOUT CLAIM TO ANY PARTICULAR FONT, STYLE, SIZE, OR COLOR.

PRIORITY DATE OF 8-14-2012 IS CLAIMED.

OWNER OF INTERNATIONAL REGISTRATION 1169898 DATED 2-8-2013, EXPIRES 2-8-2023.

**CLASS 7—MACHINERY**

FOR STAMPING MACHINES, NAMELY, AUTOMATIC HOT STAMPING MACHINES, AUTOMATIC COLD STAMPING MACHINES; LABEL STAMPING MACHINES; MACHINES AND PARTS THEREFORE FOR APPLICATION OF STAMPING FOILS OR LAMINATING FOILS ONTO SUBSTRATES; MACHINE TOOLS FOR STAMPING; STAMPING DIES, EMBOSSING DIES, EMBOSSING ROLLERS ALL AS MACHINE PARTS; MACHINES FOR PLASTICS PROCESSING, FOR PAPER PROCESSING AND FOR FOIL PROCESSING; PRINTING MACHINES AND THEIR PARTS; AUXILIARY AND ACCESSORY DEVICES FOR PRINTING MACHINES, NAMELY, FEEDERS, HEATING AND COOLING APPARATUS, DRYING APPARATUS, CLEANING APPARATUS, FOLDING APPARATUS, STACKING APPARATUS, CUTTING APPARATUS, PRESSING APPARATUS, COATING APPARATUS, BINDING APPARATUS, GLU-

ING APPARATUS, BONDING APPARATUS, HEAT SEALING APPARATUS, WRAPPING APPARATUS, EMBOSSING APPARATUS, STAMPING APPARATUS; MACHINES FOR PROCESSING OF PRINTED PRODUCTS, NAMELY, FOR DRYING, COOLING, CLEANING, FOLDING, STACKING, CUTTING, PRESSING, COATING, BINDING, GLUING, BONDING, SEALING, EMBOSSING, STAMPING OR WRAPPING PRINTED PRODUCTS; PACKAGING MACHINES AND THEIR PARTS; LABELLING MACHINES; MACHINES AND MECHANISMS WITH PRINTING UNITS, AS PARTS OF OTHER MACHINES AND OF MECHANISMS OR AS AUXILIARY/ACCESSORY DEVICES FOR OTHER MACHINES AND MECHANISMS, NAMELY, XEROGRAPHIC PRINTERS AND XEROGRAPHIC PRINTING MACHINES, EMBOSSED PRINTING MECHANISMS, INKJET PRINTERS AND INKJET PRINTING MECHANISMS, OFFSET PRINTERS AND OFFSET PRINTING MECHANISMS, PRINTING ROLLERS; PATTERN TRANSFERRING MACHINES FOR TRANSFERRING OF PATTERNS, DECORS, STRUCTURES AND FUNCTIONAL SURFACE STRUCTURES THAT ARE PRINTED, VAPOUR-DEPOSITED OR OTHERWISE APPLIED ON BASE FOILS ONTO THE SURFACES OF ARTICLES OR SUBSTRATES; FOIL OVERLAYING MACHINES FOR OVERLAYING AND COATING THE SURFACES OF ARTICLES OR OF SUBSTRATES WITH FOILS WITH PATTERNS, DECORS, STRUCTURES AND FUNCTIONAL SURFACE STRUCTURES; CONVEYOR BELTS, CONVEYOR LINES, FLEXIBLE CONVEYORS, ROLLER CONVEYORS AND CARRIER ROLLERS FOR FEEDING AND CARRYING-OFF OF UNPROCESSED AND PROCESSED MATERIALS AND GOODS; ROLL-UP MECHANISMS AND ROLL-OFF MECHANISMS FOR USE WITH OTHER MACHINES; FOIL FEEDING MECHANISMS AND FOIL PREPARATION MECHANISMS AS PARTS OF LARGER MACHINES, AND FOR COUPLING WITH OTHER MACHINES, PARTICULARLY FOR USE WITH PATTERN TRANSFERRING MACHINES, WITH FOIL OVERLAYING MACHINES, WITH PRINTING MACHINES AND WITH PACKAGING MACHINES; ARTICLE FEEDING AND SUBSTRATE FEEDING MECHANISMS AND ARTICLE PREPARATION AND SUBSTRATE PREPARATION MECHANISMS AS PARTS OF LARGER MACHINES, AND FOR COUPLING WITH OTHER MACHINES, PARTICULARLY FOR USE WITH PATTERN TRANSFERRING MACHINES, WITH FOIL OVERLAYING MACHINES, WITH PRINTING MACHINES AND WITH PACKAGING MACHINES; ALL THE AFOREMENTIONED GOODS ALSO AS PARTS OF OTHER MACHINES OR FOR INTEGRATION AS COMPONENTS INTO OTHER MACHINES AND REPLACEMENT PARTS FOR ALL AFOREMENTIONED; HYDRAULIC CONTROLLERS, PNEUMATIC CONTROLLERS; ELECTRIC DRIVES, NAMELY, DRIVES FOR MOTORS AND VARIABLE SPEED DRIVES FOR MACHINES, AND MOTORS FOR MACHINES, ELECTRIC ACTUATORS (U.S. CLS. 13, 19, 21, 23, 31, 34 AND 35).

#### **CLASS 9—ELECTRICAL AND SCIENTIFIC APPARATUS**

FOR ELECTRIC CONTROLLERS AND ELECTRIC INSTALLATIONS FOR CONTROLLING, REMOTE-CONTROLLING INDUSTRIAL INSTALLATIONS AND MACHINES, AND ELECTRIC INSTALLATIONS FOR MONITORING AND SUPERVISION OF THE OPERATION OF INDUSTRIAL INSTALLATIONS AND MACHINES; ELECTRIC SENSORS; DATA PROCESSING APPARATUS AND COMPUTERS; ELECTRIC CONTROLLING APPARATUS AND REGULATING APPARATUS, NAMELY, DATA ENTRY AND PROCESSING DEVICES COMPRISING TOUCH SCREENS, KEYPADS OR KEYBOARDS; ELECTRICAL AND ELECTRONIC CONTROLLERS, AND PROGRAMMABLE ELECTRONIC CONTROLLERS FOR INDUSTRIAL MACHINES FOR THE PRINTING AND PACKAGING INDUSTRY; PROGRAMMABLE LOGIC CONTROLLERS (PLC); ELECTRIC REGULATORS BEING PARTS OF MACHINES; ELECTRIC MEASURING AND MONITORING APPARATUS AND MEASURING AND MONITORING DEVICES, NAMELY, APPARATUS COMPRISING ELECTRIC SENSORS FOR MEASURING AND MONITORING LIGHT, TEMPERATURE, PRESSURE, ELECTRIC RESISTANCE, ELECTRIC CAPACITY, ELECTRIC INDUCTIVITY, LENGTH, WIDTH, THICKNESS, HUMIDITY FOR USE IN INDUSTRIAL MACHINES AND PROCESSES; ELECTRIC SWITCHES AND RELAYS; ELECTRIC CONTROL-

TERS; COMPUTER PROGRAMS AND SOFTWARE FOR USE IN THE PRINTING INDUSTRY, AND PACKAGING INDUSTRY, FOR DESKTOP PUBLISHING AND FOR GRAPHIC DESIGN; COMPUTER GRAPHICS SOFTWARE; COMPUTER SOFTWARE FOR PROCESSING DIGITAL IMAGES, GRAPHICS AND TEXT; INDUSTRIAL PROCESS CONTROL SOFTWARE; SOFTWARE FOR MONITORING AND CONTROLLING COMMUNICATION BETWEEN COMPUTERS AND AUTOMATED MACHINE SYSTEMS; COMPUTER PROGRAMS AND SOFTWARE FOR CONTROLLING PRINTING MACHINES, STAMPING MACHINES AND PACKAGING MACHINES; FIRMWARE FOR CONTROLLING, MONITORING AND REMOTE-CONTROLLING AND REMOTE MAINTENANCE OF PRINTING MACHINES, STAMPING MACHINES AND PACKAGING MACHINES; BLANK MAGNETIC DATA CARRIERS; BLANK OPTICAL DATA CARRIERS; PRE-RECORDED MAGNETIC OR OPTICAL DATA CARRIERS CONTAINING COMPUTER SOFTWARE FOR USE IN THE PRINTING AND PACKAGING INDUSTRY AND FOR DESKTOP PUBLISHING AND FOR GRAPHIC DESIGN, FOR PROCESSING DIGITAL IMAGES, GRAPHICS AND TEXT; COMPUTER PROGRAMS AND SOFTWARE FOR INDUSTRIAL PROCESS CONTROL AND FOR MONITORING AND CONTROLLING COMMUNICATION BETWEEN COMPUTERS AND AUTOMATED MACHINE SYSTEMS; COMPUTER PROGRAMS AND SOFTWARE FOR CONTROLLING PRINTING MACHINES, STAMPING MACHINES AND PACKAGING MACHINES (U.S. CLS. 21, 23, 26, 36 AND 38).

#### **CLASS 37—CONSTRUCTION AND REPAIR**

FOR INSTALLATION, CUSTOMIZATION SET-UP, MAINTENANCE AND REPAIR OF MACHINE-DRIVEN APPARATUS FOR PRINTING, FOR STAMPING, FOR HOT STAMPING AND COLD STAMPING; INSTALLATION, CUSTOMIZATION, SET-UP, MAINTENANCE AND REPAIR OF MACHINES FOR APPLICATION OF STAMPING FOILS OR LAMINATING FOILS ONTO SUBSTRATES; INSTALLATION, CUSTOMIZATION, SET-UP, MAINTENANCE AND REPAIR OF PLASTICS PROCESSING, PAPER PROCESSING AND FOIL PROCESSING MACHINES; INSTALLATION, CUSTOMIZATION, SET-UP, MAINTENANCE AND REPAIR OF PRINTING MACHINES; INSTALLATION, CUSTOMIZATION, SET-UP, MAINTENANCE AND REPAIR OF LABELING MACHINES AND PACKAGING MACHINES; INSTALLATION, CUSTOMIZATION, SET-UP, MAINTENANCE AND REPAIR OF PATTERN TRANSFERRING MACHINES, FOIL OVERLAYING MACHINES, FOIL FEEDING MACHINES AND FOIL PREPARATION MACHINES; INSTALLATION, CUSTOMIZATION, SET-UP, MAINTENANCE AND REPAIR OF ARTICLE FEEDING MACHINES, SUBSTRATE FEEDING MACHINES, ARTICLE PREPARATION MACHINES AND SUBSTRATE PREPARATION MACHINES; INSTALLATION, CUSTOMIZATION, SET-UP, MAINTENANCE AND REPAIR OF CONVEYOR BELTS AND CONVEYOR MACHINES FOR FEEDING AND CARRYING-OFF OF UNPROCESSED AND PROCESSED MATERIALS AND GOODS; INSTALLATION, CUSTOMIZATION, SET-UP SERVICES, MAINTENANCE AND REPAIR OF ROLL-UP AND ROLL-OFF MACHINES (U.S. CLS. 100, 103 AND 106).

#### **CLASS 42—SCIENTIFIC AND COMPUTER SERVICES**

FOR TECHNOLOGICAL CONSULTANCY IN THE TECHNOLOGY FIELD OF SURFACE DECORATION AND SURFACE COATING BY MEANS OF STAMPING FOILS, TRANSFER FOILS AND LAMINATING FOILS; TECHNOLOGICAL CONSULTANCY IN THE TECHNOLOGY FIELD OF PLASTICS TREATMENT AND PLASTICS PROCESSING AS WELL AS IN THE TECHNOLOGY FIELD OF PLASTIC PROCESSING MACHINES; TECHNOLOGICAL CONSULTANCY IN THE TECHNOLOGY FIELD OF PAPER PROCESSING AND IN THE TECHNOLOGY FIELD OF PAPER PROCESSING MACHINES; TECHNOLOGICAL CONSULTANCY IN THE TECHNOLOGY FIELD OF PROCESSES AND MACHINES FOR THE TRANSFER OF PATTERNS, OF DECORS, OF STRUCTURES AND FUNCTIONAL SURFACE STRUCTURES; TECHNOLOGICAL CONSULTANCY IN THE TECHNOLOGY FIELD OF PACKAGING MACHINES AND PRINTING MACHINES AND IN THE TECHNOLOGY FIELD



OF PRINTING PROCESSES; TECHNOLOGICAL CONSULTANCY IN THE TECHNOLOGY FIELD OF STAMPING MACHINES, TRANSFER MACHINES AND LAMINATING MACHINES; INDUSTRIAL DESIGN SERVICES; CONSULTING IN THE FIELD OF ENGINEERING AND ENGINEERING SERVICES; DEVELOPMENT AND CONSULTING SERVICES RELATED THERETO IN THE FIELD OF INDUSTRIAL MACHINES AND MACHINE TOOLS, IT PROJECT MANAGEMENT AND TECHNICAL CONSULTANCY CONCERNING SET-UP, CONFIGURATION, AND USE OF MACHINES AND MACHINE TOOLS, PARTICULARLY OF MACHINES FOR THE GRAPHICS INDUSTRY, OF STAMPING MACHINES, OF FOIL PROCESSING MACHINES, OF FOIL FEEDING MECHANISMS AND FOIL CARRYING-OFF MECHANISMS, OF MATERIAL FEEDING MECHANISMS AND MATERIAL CARRYING-OFF MECHANISMS, OF MATERIAL PREPARATION MECHANISMS, OF FOIL PREPARATION MECHANISMS, OF FOIL OVERLAYING MACHINES, OF SEALING MACHINES, OF PACKAGING MACHINES, OF LABELING MACHINES, OF PRINTING MACHINES, OF LAMINATING MACHINES, OF LAMINATORS AND LAMINATION COATING MACHINES AND OF COMPONENTS AND CONTROLS FOR MACHINES; DEVELOPMENT OF COMPUTER HARDWARE, SOFTWARE AND INDUSTRIAL AUTOMATION MACHINERY, IT PROJECT MANAGEMENT, AND TECHNICAL CONSULTATION IN THE FIELD OF SET-UP, INSTALLATION, CONFIGURATION, AND USE OF COMPUTER HARDWARE AND SOFTWARE IN THE FIELD OF INDUSTRIAL AUTOMATION TECHNOLOGY; TECHNOLOGICAL CONSULTING IN THE FIELD OF INSTALLATION, MAINTENANCE AND SUPPORT IN THE NATURE OF TROUBLESHOOTING OF COMPUTER HARDWARE, COMPUTER SOFTWARE FOR DATA PROCESSING, OF FIRMWARE AND OF SOFTWARE CONTROL PROGRAMS; INSTALLATION, MAINTENANCE AND SUPPORT IN THE NATURE OF TROUBLESHOOTING OF COMPUTER HARDWARE, COMPUTER SOFTWARE AND SOFTWARE FOR DATA PROCESSING, OF FIRMWARE AND OF CONTROL SOFTWARE PROGRAMS (U.S. CLS. 100 AND 101).

ELLEN PERKINS, EXAMINING ATTORNEY

SN 79-134,724. ITO EN, LTD., TOKYO 151-8550, JAPAN, FILED 6-26-2013.



PRIORITY DATE OF 5-27-2013 IS CLAIMED.  
OWNER OF INTERNATIONAL REGISTRATION 1172058  
DATED 6-26-2013, EXPIRES 6-26-2023.

THE COLOR(S) GREEN AND WHITE IS/ARE CLAIMED AS A FEATURE OF THE MARK.

THE MARK CONSISTS OF GREEN DESIGN ELEMENT WITH AN OVERALL SQUARE SHAPE WITH A V-SHAPED NOTCH CUT OUT OF THE TOP OF THE GREEN DESIGN ELEMENT AND WITH THE BOTTOM OF THE GREEN DESIGN ELEMENT CONTAINING A BREAK AT THE CENTER WHERE THE COLOR WHITE EXTENDS UPWARDS INTO THE CENTER OF THE DESIGN ELEMENT TO CREATE A WHITE HEART SHAPE.

#### CLASS 29—MEATS AND PROCESSED FOODS

FOR LACTIC ACID BACTERIA DRINKS; MILK BEVERAGES, NAMELY, BEVERAGES HAVING A MILK BASE; MILK; CHEESE; MILK PRODUCTS EXCLUDING ICE CREAM, ICE MILK AND FROZEN YOGURT; MILK SUBSTITUTE, NAMELY, SOYA MILK; FROZEN VEGETABLES; FROZEN FRUITS; PROCESSED VEGETABLES; DRIED FRUITS; JAMS; PROCESSED FRUITS; SAUSAGES; HAM; BACON (U.S. CL. 46).

#### CLASS 30—STAPLE FOODS

FOR TEA; TEA-BASED BEVERAGES; COFFEE; COCOA; SWEETS, NAMELY, JAPANESE TRADITIONAL CONFECTIONERY; ICE CANDIES; ICE CREAM; WAFERS; CASTILIA SPONGE CAKES; BISCUITS, NAMELY, HARDTACKS; CARAMELS; SWEETS, NAMELY, CANDIES; COOKIES; CRACKERS; CONES FOR ICE-CREAM; SORBETS, NAMELY, SHERBETS; CREAM PUFFS; SPONGE CAKES; TOFFEES AND TAFFIES; CHEWING GUMS; CHOCOLATE; DOUGHNUTS; DROPS, NAMELY, CANDY; NOUGAT; PIES; BISCUITS; FRUIT JELLY CANDY; CONFECTIONERY ICES, NAMELY, FROZEN YOGHURT; BALLS OF SWEETS, NAMELY, BISCUITS; PANCAKES; POPCORN; MARSHMALLOWS; BAKED APPLES, NAMELY, APPLE TURNOVERS, APPLE FRITTERS; RUSKS; WAFFLES; BREAD AND BUNS; SANDWICHES; STEAMED BUNS STUFFED WITH MINCED MEAT (CHUKA-MANJU); HAMBURGER SANDWICHES; PIZZAS; HOT DOGS SANDWICHES; MEAT PIES; SPICES; UNCOOKED SPAGHETTI; UNCOOKED MACARONI (U.S. CL. 46).

#### CLASS 32—LIGHT BEVERAGES

FOR BEVERAGES, NAMELY, MINERAL WATER; COFFEE SYRUP, NAMELY, SYRUP FOR SWEETENING COFFEE; NON-ALCOHOLIC CIDER; SODA WATER, NAMELY, AERATED WATER; SYRUPS FOR BEVERAGES; SOY-BASED BEVERAGES, NOT BEING MILK SUBSTITUTES; REFRESHING BEVERAGES, NAMELY, CARBONATED SOFT DRINKS; FRUIT JUICES; BEVERAGES, NAMELY, VEGETABLE JUICES; BEER; WHEY BEVERAGES (U.S. CLS. 45, 46 AND 48).

#### CLASS 35—ADVERTISING AND BUSINESS

FOR RETAIL STORE SERVICES AND WHOLESALE STORE SERVICES FEATURING FOODS AND BEVERAGES; RETAIL STORE SERVICES AND WHOLESALE STORE SERVICES FEATURING VEGETABLES AND FRUITS; RETAIL STORE SERVICES AND WHOLESALE STORE SERVICES FEATURING BREAD AND BUNS; RETAIL STORE SERVICES AND WHOLESALE STORE SERVICES FEATURING MILK AND MILK PRODUCTS; RETAIL STORE SERVICES AND WHOLESALE STORE SERVICES FEATURING CARBONATED DRINKS, REFRESHING BEVERAGES AND NONALCOHOLIC FRUIT JUICE BEVERAGES; RETAIL STORE SERVICES AND WHOLESALE STORE SERVICES FEATURING TEA, COFFEE AND COCOA; RETAIL STORE SERVICES AND WHOLESALE STORE SERVICES FEATURING ICE CANDIES, ICE CREAM, WAFERS, CASTILIA SPONGE CAKES, HARDTACKS (CONFECTIONERY), CARAMELS, CANDIES, SWEETS, COOKIES, CRACKERS, CONES FOR ICE-CREAM, SHERBETS, SORBETS, CREAM PUFFS, SPONGE CAKES, TOFFEES, TAFFIES, CHEWING GUMS, CHOCOLATE, DOUGHNUTS, DROPS, NOUGAT, PIES, BISCUITS, FRUIT JELLIES, CONFECTIONERY, FROZEN YOGHURT, CONFECTIONERY ICES, BALLS OF SWEETS, NAMELY, BISCUITS, PANCAKES, POPCORN, MARSHMALLOWS, BAKED APPLES, RUSKS, WAFFLES; RETAIL STORE SERVICES AND WHOLESALE STORE SERVICES FEATURING LIQUOR; RETAIL STORE SERVICES AND WHOLESALE STORE SERVICES FEATURING FOR PROCESSED FOOD (U.S. CLS. 100, 101 AND 102).

#### CLASS 43—HOTEL AND RESTAURANT SERVICES

FOR PROVIDING FOODS AND BEVERAGES (U.S. CLS. 100 AND 101).

KRISTIN CARLSON, EXAMINING ATTORNEY

SN 79-134,810. LUXIN (GREEN PLANET) AG, SWITZERLAND, FILED 6-24-2013.

# Luxin

THE MARK CONSISTS OF STANDARD CHARACTERS WITHOUT CLAIM TO ANY PARTICULAR FONT, STYLE, SIZE, OR COLOR.

OWNER OF INTERNATIONAL REGISTRATION 1063357 DATED 9-2-2010, EXPIRES 9-2-2020.  
OWNER OF U.S. REG. NO. 4,107,291.

## CLASS 19—NON-METALLIC BUILDING MATERIALS

FOR BUILDING MATERIALS, NOT MADE OF METAL, NAMELY, CEMENT FOR USE IN BUILDING BRICKS (U.S. CLS. 1, 12, 33 AND 50).

## CLASS 40—MATERIAL TREATMENT

FOR SERVICES IN AGRICULTURE AND FORESTRY, IN PARTICULAR SERVICES OF THE TIMBER INDUSTRY, NAMELY, TIMBER FELLING AND PROCESSING, TIMBER LOGGING (U.S. CLS. 100, 103 AND 106).

## CLASS 44—MEDICAL, BEAUTY AND AGRICULTURAL SERVICES

FOR SERVICES IN THE FIELD OF AGRICULTURE, NAMELY, TREE NURSERIES; REFORESTATION, NAMELY, TREE PLANTING FOR CARBON OFFSETTING PURPOSES; HORTICULTURE SERVICES, NAMELY, SOIL IMPROVEMENT IN THE NATURE OF SPREADING OF SOIL AMENDMENT (U.S. CLS. 100 AND 101).

EVELYN BRADLEY, EXAMINING ATTORNEY

SN 79-135,226. ZETA FARMACEUTICI S.P.A., I-36100 VICE-NZA, ITALY, FILED 7-11-2013.

# EUPHIDRA

THE MARK CONSISTS OF STANDARD CHARACTERS WITHOUT CLAIM TO ANY PARTICULAR FONT, STYLE, SIZE, OR COLOR.

PRIORITY DATE OF 2-15-2013 IS CLAIMED.  
OWNER OF INTERNATIONAL REGISTRATION 1173258 DATED 7-11-2013, EXPIRES 7-11-2023.

## CLASS 3—COSMETICS AND CLEANING PREPARATIONS

FOR CLEANING, POLISHING, SCOURING AND ABRASIVE PREPARATIONS; SOAPS, NAMELY, BAR SOAP, BATH SOAP, ANTIBACTERIAL SOAPS, LAUNDRY SOAP, LIQUID SOAP, AND TOILET SOAP; PERFUMERY, ESSENTIAL OILS, COSMETICS, HAIR LOTIONS; DENTIFRICES; FLEXIBLE ABRASIVES; EAU DE COLOGNE; LAVENDER WATER; TOILET WATER; SCENTED LINEN WATER; NAIL ART STICKERS; ADHESIVES FOR COSMETIC PURPOSES; ADHESIVES FOR AFFIXING FALSE HAIR; ADHESIVES FOR AFFIXING FALSE EYELASHES; SCOURING SOLUTIONS; AMMONIA FOR CLEANING PURPOSES; ALOE VERA GEL FOR COSMETIC PURPOSES; AMBER, NAMELY, PERFUME; STARCH GLAZE FOR LAUNDRY PURPOSES; FABRIC SOFTENERS FOR LAUNDRY USE; CANNED PRESSURIZED AIR FOR CLEANING AND DUSTING PURPOSES; AROMATIC ESSENTIAL OILS; FLAVOR-

INGS FOR BEVERAGES, NAMELY, ESSENTIAL OILS; CAKE FLAVOURINGS, NAMELY, ESSENTIAL OILS; ASTRINGENTS FOR COSMETIC PURPOSES; BASES FOR FLOWER PERFUMES, NAMELY, OILS FOR PERFUMES AND SCENTS; JOSS STICKS; COTTON STICKS FOR COSMETIC PURPOSES; MAKE-UP; WHITING, NAMELY, SKIN WHITENING CREAMS; LAUNDRY BLUEING; JAVELLE WATER, NAMELY, TOILET WATER; LAUNDRY BLEACH; CARBIDES OF METAL, NAMELY, ABRASIVE STRIPS; SILICON CARBIDE, NAMELY, ABRASIVE STRIPS; POLISHING PAPER; EMERY PAPER; SANDPAPER; ABRASIVE PAPER; VOLCANIC ASH FOR CLEANING; NON-SLIPPING WAX FOR FLOORS; SHOEMAKERS' WAX; DEPILATORY WAX; MUSTACHE WAX; LAUNDRY WAX; POLISHING WAX; FLOOR WAX; TAILORS' WAX; SHOE WAX; POLISH FOR FURNITURE AND FLOORING; FALSE EYELASHES; MAKE-UP POWDER; HAIR DYES; COLORANTS FOR TOILET PURPOSES, NAMELY, HAIR COLORANTS; CORUNDUM, NAMELY, ABRASIVE PASTE; QUILLAIA BARK FOR WASHING, NAMELY, WASHING POWDER; COSMETICS FOR ANIMALS; COSMETIC PREPARATIONS FOR EYELASHES; EYEBROW COSMETICS; COSMETIC CREAMS; SHOE CREAM; POLISHING WAXES FOR LEATHER; POLISHING CREAMS; SKIN WHITENING CREAMS; WASHING SODA, FOR CLEANING, NAMELY, CLEANING PREPARATIONS; BLEACHING PREPARATIONS FOR COSMETIC PURPOSES; DEODORANTS FOR PETS; DEODORANTS FOR HUMAN BEINGS OR FOR ANIMALS; DETERGENTS OTHER THAN FOR USE IN MANUFACTURING OPERATIONS AND FOR MEDICAL PURPOSES FOR HOUSEHOLD USE; DIAMANTINE, NAMELY, ABRASIVE ROLLS; HELIOTROPINE, NAMELY, FRAGRANCES; BADIEN ESSENCE, NAMELY, FLOWER ESSENCES FOR COSMETIC PURPOSES; MINT ESSENCE, NAMELY, ESSENTIAL OIL; BERGAMOT OIL; ETHEREAL ESSENCES; DRYING AGENTS FOR DISHWASHING MACHINES; EXTRACTS OF FLOWERS, NAMELY, PERFUMES; MASSAGE GELS OTHER THAN FOR MEDICAL PURPOSES; DENTAL BLEACHING GELS; PETROLEUM JELLY FOR COSMETIC PURPOSES; GERANIOL, NAMELY, PERFUME OILS; CLEANING CHALK; GREASES FOR COSMETIC PURPOSES; HENNA FOR COSMETIC PURPOSES; INCENSE; IONONE, NAMELY, PERFUMERY; HAIR SPRAY; NAIL POLISH; ALMOND MILK FOR COSMETIC PURPOSES; CLEANSING MILK FOR TOILET PURPOSES; SCENTED WOOD; NON-SLIPPING LIQUIDS FOR FLOORS; WIND-SCREEN CLEANING LIQUIDS; SODA LYE; AFTER-SHAVE LOTIONS; LOTIONS FOR COSMETIC PURPOSES; LIP GLOSSES; SHOE POLISH; MASCARA; BEAUTY MASKS; EYEBROW PENCILS; COSMETIC PENCILS; MINT FOR PERFUMERY, NAMELY, ESSENTIAL OILS; DECORATIVE TRANSFERS FOR COSMETIC PURPOSES; MUSK; COSMETIC KITS, NAMELY, MAKE-UP KITS COMPRISED OF LIPSTICK, LIPGLOSS, EYELINER, EYESHADOWS, PENCILS, MASCARA, POWDER, FOUNDATION; NEUTRALIZERS FOR PERMANENT WAVING, NAMELY, PERMANENT WAVING LOTIONS; OILS FOR TOILETRY PURPOSES; ETHEREAL OILS; ESSENTIAL OILS OF CEDARWOOD; ESSENTIAL OILS OF LEMON; OILS FOR PERFUMES AND SCENTS; OILS FOR CLEANING PURPOSES; OILS FOR COSMETIC PURPOSES; ESSENTIAL OILS OF CITRON; GAULTHERIA ESSENTIAL OIL; JASMINE OIL FOR PERSONAL USE; LAVENDER OIL; ALMOND ESSENTIAL OIL; ROSE OIL FOR COSMETIC PURPOSES; COTTON WOOL FOR COSMETIC PURPOSES; PASTES FOR RAZOR STROPS; COBBLERS' WAX; HYDROGEN PEROXIDE FOR COSMETIC PURPOSES; FOOT SMOOTHING STONES; POLISHING STONES; PUMICE STONE FOR PERSONAL USE; ALUM STONES; SHAVING STONES; POMADES FOR COSMETIC PURPOSES; POTPOURRI; SUN-TANNING PREPARATIONS; COSMETIC PREPARATIONS FOR BATHS; DOUCHING PREPARATIONS FOR PERSONAL SANITARY OR DEODORANT PURPOSES; LAUNDRY GLAZE; PREPARATIONS FOR CLEANING DENTURES; POLISHING PREPARATIONS; HAIR WAVING PREPARATIONS; DENTURE POLISHES; SUNSCREEN PREPARATIONS; PREPARATIONS FOR UNBLOCKING DRAIN PIPES, NAMELY, DRAIN OPENERS; SCALE REMOVING PREPARATIONS FOR HOUSEHOLD PURPOSES; COSMETIC PREPARATIONS FOR SLIMMING PURPOSES; COLOR-BRIGHTENING CHEMICALS FOR HOUSEHOLD PURPOSES, NAMELY, LAUNDRY BLEACH; ANTISTATIC PREPARATIONS FOR HOUSEHOLD PURPOSES; COSMETIC PREPARATIONS FOR SKIN CARE; DEPILA-

TORIES; LAUNDRY PREPARATIONS, NAMELY, LAUNDRY SOAP; ANTIPERSPIRANTS; GRINDING PREPARATIONS, NAMELY, ABRASIVE CLOTH; SHINING PREPARATIONS; CLEANING AND SHINING PREPARATIONS TO MAKE SHINY THE LEAVES OF PLANTS; FUMIGATION PREPARATIONS, NAMELY, PERFUMES; DRY-CLEANING PREPARATIONS; MAKE-UP PREPARATIONS; LEATHER PRESERVATIVES, NAMELY, LEATHER PRESERVING POLISHES; MOUTH WASHES, NOT FOR MEDICAL PURPOSES; NAIL CARE PREPARATIONS; CLEANING PREPARATIONS; SHAVING PREPARATIONS; TOILETRIES, NAMELY, TOILET WATERS; SMOOTHING PREPARATIONS, NAMELY, STARCH GLAZE FOR LAUNDRY PURPOSES; LAUNDRY SOAKING PREPARATIONS, NAMELY, LAUNDRY PRE-SOAK; SACHETS FOR PERFUMING LINEN; WALLPAPER CLEANING PREPARATIONS; RUST REMOVING PREPARATIONS; LEATHER BLEACHING PREPARATIONS FOR HOUSEHOLD USE; MAKE-UP REMOVING PREPARATIONS; PAINT STRIPPING PREPARATIONS; LACQUER-REMOVING PREPARATIONS; COLOR-REMOVING PREPARATIONS FOR HAIR; VARNISH-REMOVING PREPARATIONS; PERFUMES; AIR FRAGRANCING PREPARATIONS; LIPSTICKS; POLISHING ROUGE; SAFROL, NAMELY, ESSENTIAL OIL; LAUNDRY STARCH; BATH SALTS, NOT FOR MEDICAL PURPOSES; BLEACHING SALTS; ALMOND SOAP; SHAVING SOAP; CAKES OF TOILET SOAP; SOAP FOR FOOT PERSPIRATION; ANTIPERSPIRANT SOAP; DEODORANT SOAP; DISINFECTANT SOAP; MEDICATED SOAP; SOAP FOR BRIGHTENING TEXTILE; SHAMPOOS; SHAMPOOS FOR PETS; DRY SHAMPOOS; STAIN REMOVERS; EMERY PAPER; BLEACHING SODA; FURBISHING PREPARATIONS, NAMELY, CLEANING PREPARATIONS; BREATH FRESHENING SPRAYS; BREATH FRESHENING STRIPS; CLOTHS IMPREGNATED WITH A DETERGENT FOR CLEANING; FLOOR WAX REMOVERS; TALCUM POWDER, FOR TOILET USE; SANDCLOTH, NAMELY, ABRASIVE CLOTH; EMERY CLOTH; GLASS CLOTH; TERPENES, NAMELY, ESSENTIAL OILS; COSMETIC DYES, NAMELY, HAIR DYES; BEARD DYES; TISSUES IMPREGNATED WITH COSMETIC LOTIONS; TURPENTINE, FOR DEGREASING, NAMELY, DEGREASING PREPARATIONS FOR HOUSEHOLD PURPOSES; TRIPOLI STONE FOR POLISHING; FALSE NAILS (U.S. CLS. 1, 4, 6, 50, 51 AND 52).

#### CLASS 5—PHARMACEUTICALS

FOR MEDICAL PLASTERS, GAUZE FOR DRESSINGS; MATERIAL FOR STOPPING TEETH, DENTAL WAX; ALL-PURPOSE DISINFECTANTS; PREPARATIONS FOR DESTROYING VERMIN; FUNGICIDES, HERBICIDES; TANNING PILLS, NAMELY, DIETARY SUPPLEMENTS; DENTAL ABRASIVES; ACARICIDES; FLY CATCHING PAPER; MINERAL WATERS FOR MEDICAL PURPOSES; THERMAL WATER, NAMELY, MEDICATED SKIN CARE PREPARATIONS; NUTRITIONAL SUPPLEMENTS; ADHESIVES FOR DENTURES; ALCOHOL FOR PHARMACEUTICAL PURPOSES; MEDICINAL ALCOHOL; DENTAL AMALGAMS; DENTAL AMALGAMS OF GOLD; STARCH FOR PHARMACEUTICAL PURPOSES; AMINO ACIDS FOR MEDICAL PURPOSES; AMINO ACIDS FOR VETERINARY PURPOSES; ANALGESICS; ANTI-RHEUMATISM RINGS; CORN RINGS FOR THE FEET; ANAESTHETICS; FUMIGATING STICKS; ANTIBIOTICS; FOOD SUPPLEMENTS, NAMELY, ANTIOXIDANT PILLS; ANTISEPTICS; ARTICLES FOR HEADACHE, NAMELY, HEADACHE PENCILS; DRESSINGS, MEDICAL; SANITARY TOWELS; SANITARY PADS; STYPTIC PENCILS; OXYGEN BATHS, NAMELY, OXYGEN FOR MEDICAL USE; BATH PREPARATIONS, MEDICATED; VAGINAL WASHES; BALMS FOR MEDICAL PURPOSES; FROSTBITE SALVE FOR PHARMACEUTICAL PURPOSES; GURJUN BALM FOR MEDICAL PURPOSES; STICK LIQUORICE FOR PHARMACEUTICAL PURPOSES; BANDAGES FOR DRESSINGS; DIETETIC BEVERAGES ADAPTED FOR MEDICAL PURPOSES, NAMELY, NUTRITIONALLY FORTIFIED BEVERAGES; BICARBONATE OF SODA FOR PHARMACEUTICAL PURPOSES; BIOCIDES; MEDICINE CASES, PORTABLE, FILLED, NAMELY, CONTAINERS FOR VETERINARY AND HUMAN MEDICAL AND CLINICAL USE SOLD FILLED WITH A PLATELET ADDITIVE SOLUTION; ANTI-RHEUMATISM BRACELETS; MAGNETIC BRACELETS FOR MEDICAL PURPOSES; BACTERIOLOGICAL CULTURE MEDIUMS,

NAMELY, CELL GROWTH MEDIA FOR GROWING CELLS FOR MEDICAL OR CLINICAL USE; BROMINE FOR PHARMACEUTICAL PURPOSES; CORN PADS; CALOMEL FOR MEDICAL PURPOSES; CAMPHOR FOR MEDICAL PURPOSES; CAPSULES FOR MEDICINES, NAMELY, CAPSULES SOLD EMPTY FOR PHARMACEUTICALS; CANDY, MEDICATED; CHARCOAL FOR PHARMACEUTICAL PURPOSES; CARBOLINEUM, NAMELY, PARASITICIDE; FLY GLUE; MOTHPROOFING PAPER; PAPER FOR MUSTARD PLASTERS, NAMELY, POULTICES; REAGENT PAPER FOR MEDICAL OR VETERINARY PURPOSES; POULTICES; RUBBER FOR DENTAL PURPOSES; CAUSTIC PENCILS FOR PHARMACEUTICAL PURPOSES; STEM CELLS FOR MEDICAL PURPOSES; STEM CELLS FOR VETERINARY PURPOSES; DENTAL CEMENTS; CEMENT FOR ANIMAL HOOVES; BONE CEMENT FOR SURGICAL AND ORTHOPAEDIC PURPOSES; MOLDING WAX FOR DENTISTS; ADHESIVE MEDICAL PLASTERS; CINCHONA FOR MEDICAL PURPOSES; QUININE FOR MEDICAL PURPOSES; CHINOLINE FOR MEDICAL PURPOSES; BELTS FOR SANITARY NAPKINS; CHLOROFORM; ADJUVANTS FOR MEDICAL PURPOSES; ANTIPARASITIC COLLARS FOR ANIMALS; COLLYRIUM; COLLODION FOR PHARMACEUTICAL PURPOSES; BIOLOGICAL TISSUE CULTURES FOR MEDICAL PURPOSES; BIOLOGICAL TISSUE CULTURES FOR VETERINARY PURPOSES; ALBUMIN DIETARY SUPPLEMENTS; DIETARY SUPPLEMENTS FOR ANIMALS; MEDICATED COMPRESSES; CACHETS FOR PHARMACEUTICAL PURPOSES, NAMELY, CAPSULES SOLD EMPTY FOR PHARMACEUTICALS; CHEMICAL CONDUCTORS FOR ELECTROCARDIOGRAPH ELECTRODES; CHEMICAL CONTRACEPTIVE PREPARATIONS; ANTISEPTIC COTTON; ASEPTIC COTTON; COTTON FOR MEDICAL PURPOSES; CREAM OF TARTAR FOR PHARMACEUTICAL PURPOSES; CREOSOTE FOR PHARMACEUTICAL PURPOSES; CULTURES OF MICROORGANISMS FOR MEDICAL AND VETERINARY USE, NAMELY, BACTERIAL AND BACTERIOLOGICAL PREPARATIONS FOR MEDICAL OR VETERINARY PURPOSES; CURARE FOR MEDICAL PURPOSES; BUNION PADS; AIR DEODORANTS, OTHER THAN FOR HUMAN BEINGS OR FOR ANIMALS; AIR DEODORISING PREPARATIONS; DEODORANTS FOR CLOTHING AND TEXTILES; DEPURATIVES FOR THE BODY; DETERGENTS FOR MEDICAL PURPOSES; DIASTASE FOR MEDICAL PURPOSES; DIGESTIVES FOR PHARMACEUTICAL PURPOSES; DISINFECTANTS FOR HYGIENE PURPOSES; DISINFECTANTS FOR CHEMICAL TOILETS; HEMATOGEN, NAMELY, MEDICATED CANDY; HEMOGLOBIN; ENZYMES FOR MEDICAL PURPOSES; ENZYMES FOR VETERINARY PURPOSES; SICCATIVES FOR MEDICAL PURPOSES; EXTRACTS OF HOPS FOR PHARMACEUTICAL PURPOSES; TOBACCO EXTRACTS, NAMELY, INSECTICIDES; CELLULOSE ETHERS FOR PHARMACEUTICAL PURPOSES; EVACUANTS; MEDICINAL MUD, NAMELY, HERBAL MUD PACKS FOR THERAPEUTIC PURPOSES; MUD FOR BATHS, NAMELY, HERBAL MUD PACKS FOR THERAPEUTIC PURPOSES; LINSEED MEAL FOR PHARMACEUTICAL PURPOSES; FISH MEAL FOR PHARMACEUTICAL PURPOSES; LACTEAL FLOUR FOR BABIES; MEAL FOR PHARMACEUTICAL PURPOSES; FIRST-AID BOXES, FILLED, NAMELY, FIRST AID KITS; APPETITE SUPPRESSANTS FOR MEDICAL PURPOSES; FEBRIFUGES; MILK FERMENTS FOR PHARMACEUTICAL PURPOSES; FERMENTS FOR PHARMACEUTICAL PURPOSES; DIETARY FIBER TO AID DIGESTION; LINT FOR MEDICAL PURPOSES, NAMELY, WADDING FOR DRESSINGS; GAUZE FOR DRESSINGS; GASES FOR MEDICAL IMAGING USE; PETROLEUM JELLY FOR MEDICAL PURPOSES; GLYCERINE FOR MEDICAL PURPOSES; GLUCOSE FOR MEDICAL PURPOSES; CHEWING GUM FOR MEDICAL PURPOSES; GUM FOR MEDICAL PURPOSES, NAMELY, MEDICATED CHEWING GUM; GREASES FOR MEDICAL PURPOSES; GREASES FOR VETERINARY PURPOSES; MILKING GREASE FOR VETERINARY PURPOSES; HYDRATED CHLORAL FOR PHARMACEUTICAL PURPOSES; SURGICAL IMPLANTS COMPRISING LIVING TISSUES; INSECT REPELLENT INCENSE; INSECTICIDES; INSECT REPELLENTS; ALGINATE DIETARY SUPPLEMENTS; CASEIN DIETARY SUPPLEMENTS; ENZYME DIETARY SUPPLEMENTS; WHEAT GERM DIETARY SUPPLEMENTS; GLUCOSE DIETARY SUPPLEMENTS; LECITHIN DIETARY SUPPLEMENTS; YEAST DIETARY SUPPLEMENTS; POLLEN DIETARY SUPPLEMENTS;

PROPOLIS DIETARY SUPPLEMENTS; PROTEIN DIETARY SUPPLEMENTS; PROTEIN SUPPLEMENTS FOR ANIMALS; MINERAL FOOD SUPPLEMENTS; IODINE FOR PHARMACEUTICAL PURPOSES; IODOFORM, NAMELY, ANTISEPTICS; ISOTOPES FOR MEDICAL PURPOSES; DENTAL LACQUER; LAXATIVES; MALTED MILK BEVERAGES FOR MEDICAL PURPOSES; LACTOSE FOR PHARMACEUTICAL PURPOSES; LECITHIN FOR MEDICAL PURPOSES; ALLOYS OF PRECIOUS METALS FOR DENTAL PURPOSES; CEDAR WOOD FOR USE AS AN INSECT REPELLENT; YEAST FOR PHARMACEUTICAL PURPOSES; LINIMENTS; LIQUORICE FOR PHARMACEUTICAL PURPOSES; DOG LOTIONS, NAMELY, MEDICATED LOTIONS FOR TREATING DERMATOLOGICAL CONDITIONS; LOTIONS FOR PHARMACEUTICAL PURPOSES, NAMELY, PHARMACEUTICAL SKIN LOTIONS; LOTIONS FOR VETERINARY PURPOSES, NAMELY, MEDICATED LOTIONS FOR TREATING DERMATOLOGICAL CONDITIONS; PERSONAL SEXUAL LUBRICANTS; EYEPATCHES FOR MEDICAL PURPOSES; DENTAL MASTICS; DENTAL IMPRESSION MATERIALS; TEETH FILLING MATERIAL; WART PENCILS, NAMELY, WART REMOVING PREPARATIONS; CAUSTIC PENCILS; HEADACHE PENCILS; HEMOSTATIC PENCILS, NAMELY, STYPTIC PENCILS; MEDICINES FOR DENTAL PURPOSES; MENTHOL FOR PHARMACEUTICAL PURPOSES; PANTS, ABSORBENT, FOR INCONTINENTS, NAMELY, INCONTINENCE GARMENTS; SANITARY PANTIES; ADHESIVE BANDS FOR MEDICAL PURPOSES; NERVINNESS, NAMELY, MEDICINAL HERB EXTRACTS; MEDICINAL OILS; CAMPHOR OIL FOR MEDICAL PURPOSES; COD LIVER OIL; CASTOR OIL FOR MEDICAL PURPOSES; LINSEED OIL DIETARY SUPPLEMENTS; OPODELDOC, NAMELY, LINIMENTS; HORMONES FOR MEDICAL PURPOSES; OXYGEN FOR MEDICAL PURPOSES; ABSORBENT COTTON FOR MEDICAL PURPOSES; WADDING FOR MEDICAL PURPOSES FOR DRESSINGS; DIABETIC BREAD ADAPTED FOR MEDICAL USE; BABIES' DIAPER-PANTS; NAPKINS FOR INCONTINENTS, NAMELY, DIAPERS FOR INCONTINENCE; DIAPERS FOR PETS; BABIES' NAPKINS; ROYAL JELLY DIETARY SUPPLEMENTS; ROYAL JELLY FOR PHARMACEUTICAL PURPOSES; PARASITICIDES; JUJUBE, MEDICATED; MEDICATED LOZENGES FOR PHARMACEUTICAL PURPOSES; HYDROGEN PEROXIDE FOR MEDICAL PURPOSES; PESTICIDES; SLIMMING PILLS, NAMELY, MEDICAL PREPARATIONS FOR SLIMMING PURPOSES; APPELITE SUPPRESSANT PILLS; BLOOD PLASMA; POWDER OF CANTHARIDES, NAMELY, CENTRAL NERVOUS SYSTEM STIMULANTS; PEARL POWDER FOR MEDICAL PURPOSES; PYRETHRUM POWDER, NAMELY, INSECTICIDE; PORCELAIN FOR DENTAL PROSTHESES; MEDICINAL DRINKS; CHEMICAL PREPARATIONS FOR THE DIAGNOSIS OF PREGNANCY, NAMELY, PREGNANCY TEST KITS FOR HOME USE; ALOE VERA PREPARATIONS FOR PHARMACEUTICAL PURPOSES, NAMELY, ALOE VERA GEL FOR THERAPEUTIC PURPOSES; PREPARATIONS OF TRACE ELEMENTS FOR HUMAN AND ANIMAL USE, NAMELY, MINERAL SUPPLEMENTS; ENZYME PREPARATIONS FOR MEDICAL PURPOSES; ENZYME PREPARATIONS FOR VETERINARY PURPOSES; MEDICINAL HAIR GROWTH PREPARATIONS; BRONCHODILATING PREPARATIONS; DOUCHING PREPARATIONS FOR MEDICAL PURPOSES; CONTACT LENS CLEANING PREPARATIONS; EYE-WASHES; ALBUMINOUS PREPARATIONS FOR MEDICAL PURPOSES, NAMELY, PROTEIN SUPPLEMENTS; BISMUTH PREPARATIONS FOR PHARMACEUTICAL PURPOSES; VITAMIN PREPARATIONS; MEDICAL PREPARATIONS FOR SLIMMING PURPOSES; PREPARATIONS TO FACILITATE TEETHING, NAMELY, TEETH FILLING MATERIAL; MEDICATED THERAPEUTIC PREPARATIONS FOR THE BATH; ANTICRYPTOGAMIC PREPARATIONS, NAMELY, FUNGICIDES; HEMORRHOID TREATMENT PREPARATIONS; ANTIPARASITIC PREPARATIONS; MEDICATED SUNBURN OINTMENTS; MOTHPROOFING PREPARATIONS; CHEMICAL PREPARATIONS TO TREAT MILDEW; CHEMICAL PREPARATIONS TO TREAT WHEAT SMUT; CHEMICAL PREPARATIONS FOR TREATING PHYLLOXERA; VINE DISEASE TREATING CHEMICALS, NAMELY, PREPARATIONS TO DESTROY MILDEW; SUNBURN PREPARATIONS FOR PHARMACEUTICAL PURPOSES; PREPARATIONS FOR DESTROYING DRY ROT FUNGUS; CHILBLAIN PREPARATIONS; PREPARATIONS FOR CALLOUSES, NAMELY, MEDICATED SKIN CARE PREPARATIONS;

PHARMACEUTICAL PREPARATIONS FOR THE TREATMENT OF BURNS; PHARMACEUTICAL PREPARATIONS FOR TREATING DANDRUFF; PHARMACEUTICAL PREPARATIONS FOR SKIN CARE; OPOTHERAPY PREPARATIONS, NAMELY, SALIVARY GLAND HORMONE PREPARATIONS; VERMIN DESTROYING PREPARATIONS; PREPARATIONS FOR DESTROYING MICE; LARVAE EXTERMINATING PREPARATIONS; SLUG EXTERMINATING PREPARATIONS; FUMIGATION PREPARATIONS FOR MEDICAL PURPOSES; DIAGNOSTIC PREPARATIONS FOR MEDICAL PURPOSES; AIR PURIFYING PREPARATIONS; PHARMACEUTICAL PREPARATIONS FOR REDUCING SEXUAL ACTIVITY; STERILISING PREPARATIONS; MEDICATED MOUTHWASHES FOR MEDICAL PURPOSES; ANIMAL WASHES, NAMELY, SALINE WASH FOR MEDICAL PURPOSES; DOG WASHES, NAMELY, SALINE WASH FOR MEDICAL PURPOSES; CATTLE WASHES, NAMELY, SALINE WASH FOR MEDICAL PURPOSES; RADIOACTIVE SUBSTANCES FOR USE IN NUCLEAR MEDICINE; SOIL-STERILISING PREPARATIONS, NAMELY, SOIL DISINFECTANTS FOR THE CONTROL OF NEMATODES, SOIL INSECTS AND SOIL FUNGI; PANTY LINERS; CHEMICAL REAGENTS FOR MEDICAL OR VETERINARY PURPOSES; REPELLENTS FOR DOGS; BY-PRODUCTS OF THE PROCESSING OF CEREALS FOR MEDICAL PURPOSES; MEDICINES FOR ALLEVIATING CONSTIPATION; REMEDIES FOR PERSPIRATION, NAMELY, PHARMACEUTICAL PREPARATIONS FOR THE TREATMENT OF EXCESSIVE PERSPIRATION; REMEDIES FOR FOOT PERSPIRATION, NAMELY, MEDICATED FOOT POWDER; MINERAL WATER SALTS, NAMELY, EPSOM SALTS; POTASSIUM SALTS FOR MEDICAL PURPOSES; SODIUM SALTS FOR MEDICAL PURPOSES; SMELLING SALTS; SALTS FOR MINERAL WATER BATHS, NAMELY, BATH SALTS FOR MEDICAL USE; BATH SALTS FOR MEDICAL PURPOSES; SARSAPARILLA FOR MEDICAL PURPOSES; BLOOD FOR MEDICAL PURPOSES; LEECHES FOR MEDICAL PURPOSES; SCAPULARS FOR SURGICAL PURPOSES; SYRUPS FOR PHARMACEUTICAL PURPOSES, NAMELY, COUGH SYRUPS; ANGOSTURA BARK FOR MEDICAL PURPOSES; CONDURANGO BARK FOR MEDICAL PURPOSES; TOBACCO-FREE CIGARETTES FOR MEDICAL PURPOSES; MUSTARD PLASTERS FOR MEDICAL PURPOSES; SOLUTIONS FOR CONTACT LENSES; SOPORIFICS; RADIOLOGICAL CONTRAST SUBSTANCES FOR MEDICAL PURPOSES; NUTRITIVE SUBSTANCES FOR MICROORGANISMS, NAMELY, CELL GROWTH MEDIA FOR GROWING CELLS FOR MEDICAL OR CLINICAL USE; SEMEN FOR ARTIFICIAL INSEMINATION; COOLING SPRAYS FOR MEDICAL PURPOSES; STEROIDS; SURGICAL DRESSINGS; SULPHUR STICKS; STRYCHNINE POISON; SULPHONAMIDES AS MEDICINES; SUPPOSITORIES; SANITARY TAMPONS; CREAM OF TARTAR FOR PHARMACEUTICAL PURPOSES; ASTHMATIC TEA; MEDICINAL TEA; SURGICAL TISSUES, NAMELY, BIOLOGICAL TISSUE GRAFTS; TINCTURE OF IODINE; HERBAL TEAS FOR MEDICINAL PURPOSES; TISSUES IMPREGNATED WITH PHARMACEUTICAL LOTIONS; SEDATIVES; MERCURIAL OINTMENTS FOR MEDICAL USE; ANTI-BIOTIC OINTMENTS FOR PHARMACEUTICAL PURPOSES; VACCINES; POISONS, NAMELY, RAT POISONS; BACTERIAL POISONS; RAT POISON; VERMIFUGES, NAMELY, ANTHELMINTICS; VESICANTS, NAMELY, PHARMACEUTICAL SKIN LOTIONS; CANDY FOR MEDICAL PURPOSES; DIETETIC SUGAR FOR MEDICAL PURPOSES (U.S. CLS. 6, 18, 44, 46, 51 AND 52).

#### CLASS 10—MEDICAL APPARATUS

FOR SURGICAL AND MEDICAL APPARATUS AND INSTRUMENTS FOR USE IN GENERAL SURGERY; VETERINARY APPARATUS AND INSTRUMENTS, NAMELY, SURGICAL APPARATUS AND INSTRUMENTS FOR VETERINARY USE; ARTIFICIAL LIMBS, EYES AND TEETH; ORTHOPEDIC APPARATUS AND INSTRUMENTS FOR DIAGNOSTIC AND THERAPEUTIC USE; SUTURE MATERIALS; ACUPUNCTURE NEEDLES; SUTURE NEEDLES; NEEDLES FOR MEDICAL PURPOSES; RADIUM TUBES, NAMELY, X-RAY TUBES FOR MEDICAL PURPOSES; TEETHING RINGS; HEARING AIDS FOR THE DEAF; DENTAL APPARATUS, ELECTRIC, NAMELY, DENTAL DRILLS; AEROSOL DISPENSERS FOR MEDICAL PURPOSES; SURGICAL APPARATUS AND INSTRUMENTS; DENTAL APPARA-

TUS AND INSTRUMENTS, NAMELY, DENTAL IMPRESSION TRAYS; MEDICAL APPARATUS AND INSTRUMENTS FOR MONITORING BLOOD PROPERTIES AND RESPIRATORY EVENTS; UROLOGICAL APPARATUS AND INSTRUMENTS, NAMELY, UROLOGICAL IMAGING SYSTEMS; APPARATUS FOR THE PRODUCTION OF X-RAYS, FOR MEDICAL PURPOSES; PHYSICAL EXERCISE APPARATUS, FOR MEDICAL PURPOSES; OBSTETRIC APPARATUS, NAMELY, NON-PNEUMATIC, ANTI-SHOCK WRAPS AND GARMENTS FOR OBSTETRIC PATIENTS; OBSTETRIC APPARATUS FOR CATTLE; DIALYZERS, NAMELY, DIALYSIS MACHINES; FUMIGATION APPARATUS FOR MEDICAL PURPOSES; MASSAGE APPARATUS; APPARATUS FOR THE TREATMENT OF DEAFNESS, NAMELY, HEARING AIDS FOR THE DEAF; NURSING APPLIANCES, NAMELY, BABY NURSE; BLOOD TESTING APPARATUS; APPARATUS FOR USE IN MEDICAL ANALYSIS, NAMELY, MEDICAL DIAGNOSTIC INSTRUMENTS FOR THE ANALYSIS OF BODY FLUIDS; ANAESTHETIC APPARATUS, NAMELY, ANAESTHETIC INHALERS; ORTHODONTIC APPLIANCES; DIAGNOSTIC APPARATUS FOR MEDICAL PURPOSES FOR DETECTING CANCER; PHYSIOTHERAPY APPARATUS, NAMELY, WEIGHT LIFTING MACHINES FOR PHYSICAL THERAPY; SPHYGMOMANOMETERS; HEARING PROTECTORS, NAMELY, EAR PLUGS FOR MEDICAL PURPOSES; RADIOTHERAPY APPARATUS; APPARATUS FOR ARTIFICIAL RESPIRATION; APPLIANCES FOR WASHING BODY CAVITIES; ESTHETIC MASSAGE APPARATUS; MICRODERMABRASION APPARATUS; RADIOLOGICAL APPARATUS FOR MEDICAL PURPOSES; X-RAY APPARATUS FOR MEDICAL PURPOSES; BODY REHABILITATION APPARATUS FOR MEDICAL PURPOSES; RESUSCITATION APPARATUS; HOT AIR THERAPEUTIC APPARATUS, NAMELY, INFRARED RADIATOR UNITS FOR THERAPEUTIC PURPOSES; GALVANIC THERAPEUTIC APPLIANCES, NAMELY, ELECTRONIC MEDICAL APPLIANCES FOR WOUND HEALING; BED VIBRATORS; TRACTION APPARATUS FOR MEDICAL PURPOSES; BASINS FOR MEDICAL PURPOSES; LOVE DOLLS; STRETCHERS, WHEELED; AMBULANCE STRETCHERS; PLASTER SUPPORT BANDAGES FOR ORTHOPEDIC PURPOSES; ICE BAGS FOR MEDICAL PURPOSES; WATER BAGS FOR MEDICAL PURPOSES, NAMELY, THERAPEUTIC HOT AND COLD THERAPY PACKS; FITTED MEDICAL INSTRUMENT CASES FOR USE BY DOCTORS; ELASTIC STOCKINGS FOR SURGICAL PURPOSES; ELASTIC STOCKINGS FOR VARICES; STRAIT JACKETS; BOUGIES; CANNULAE; CATHETERS; CATGUT FOR SURGICAL USE; FEEDING BOTTLE VALVES; TRUSSES; ABDOMINAL BELTS; BELTS, ELECTRIC, FOR MEDICAL PURPOSES; HYPOGASTRIC BELTS FOR MEDICAL PURPOSES; UMBILICAL BELTS; ORTHOPEDIC BELTS; MATERNITY ABDOMINAL BELTS; BELTS FOR MEDICAL PURPOSES; SURGICAL CUTLERY; KNIVES FOR SURGICAL PURPOSES; ABDOMINAL PADS; THERMO-ELECTRIC COMPRESSES; SURGICAL COMPRESSORS; DROPPERS FOR ADMINISTERING MEDICATION, SOLD EMPTY FOR MEDICAL PURPOSES; CONTRACEPTIVES, NON-CHEMICAL, NAMELY, CONTRACEPTIVE APPARATUS; EAR TRUMPETS, NAMELY, HEARING AIDS; ABDOMINAL CORSETS; SPOONS FOR ADMINISTERING MEDICINE; PADS FOR PREVENTING PRESSURE SORES ON PATIENT BODIES, NAMELY, ORTHOPEDIC SUPPORTS; THERMAL PACKS FOR FIRST AID PURPOSES; ORTHOPEDIC AIR CUSHIONS FOR MEDICAL PURPOSES; ORTHOPEDIC CUSHIONS FOR MEDICAL PURPOSES; HEATING PADS, ELECTRIC, FOR MEDICAL PURPOSES; DEBRILLATORS; ARTIFICIAL TEETH; DENTURES; PROTECTION DEVICES AGAINST X-RAYS, FOR MEDICAL PURPOSES, NAMELY, RADIATION DOSIMETERS FOR ASSESSING THERAPEUTIC DOSES OF RADIATION DELIVERED TO PATIENTS; INVALIDS' HOISTS; FINGER GUARDS FOR MEDICAL PURPOSES; ELECTROCARDIOGRAPHS; ELECTRODES FOR MEDICAL USE; HEMATIMETERS; TEMPERATURE INDICATOR LABELS FOR MEDICAL PURPOSES; GALVANIC BELTS FOR MEDICAL PURPOSES; BANDAGES, ELASTIC; SUPPORTIVE BANDAGES; MEDICAL GUIDEWIRES; THREAD, SURGICAL; FILTERS FOR ULTRAVIOLET RAYS, FOR MEDICAL PURPOSES; DROPPER BOTTLES FOR ADMINISTERING MEDICATION, SOLD EMPTY FOR MEDICAL PURPOSES; SCISSORS FOR SURGERY; FORCEPS FOR MEDICAL USE; DENTAL BURRS; GASTROSCOPES; KNEE BANDAGES, ORTHOPEDIC; CORSETS FOR THERAPEUTIC USE FOR MEDICAL

PURPOSES; AIR PILLOWS FOR MEDICAL PURPOSES; SOPORIFIC PILLOWS FOR INSOMNIA; GLOVES FOR MASSAGE; GLOVES FOR MEDICAL PURPOSES; INHALERS FOR MEDICAL PURPOSES; INCUBATORS FOR BABIES; INCUBATORS FOR MEDICAL PURPOSES; MEDICAL FLUID INJECTORS FOR MEDICAL PURPOSES; INSUFFLATORS FOR MEDICAL PURPOSES; ENEMA APPARATUS FOR MEDICAL PURPOSES; ULTRAVIOLET RAY LAMPS FOR MEDICAL PURPOSES; QUARTZ LAMPS FOR MEDICAL PURPOSES; EXAMINATION LAMPS FOR MEDICAL PURPOSES; LANCETS; LASERS FOR MEDICAL PURPOSES; SURGICAL DRAPES; INCONTINENCE SHEETS; STERILE SHEETS, SURGICAL; WATER BEDS FOR MEDICAL PURPOSES; HYDROSTATIC BEDS, SPECIALLY MADE FOR MEDICAL PURPOSES; ARTIFICIAL JAWS; ANESTHESIA MASKS; MASKS FOR USE BY MEDICAL PERSONNEL; AIR MATTRESSES, FOR MEDICAL PURPOSES; CHILD-BIRTH MATTRESSES FOR MEDICAL PURPOSES; FURNITURE ESPECIALLY MADE FOR MEDICAL PURPOSES; ARTIFICIAL EYES; OPHTHALMOMETERS; OPHTHALMOSCOPIES; URINALS FOR MEDICAL PURPOSES; BED PANS; ARTIFICIAL SKIN FOR SURGICAL PURPOSES; PINS FOR ARTIFICIAL TEETH FOR MEDICAL USE; PESSARIES; ARCH SUPPORTS FOR FOOTWEAR; DENTISTS' ARMCHAIRS, NAMELY, DENTAL CHAIRS; ARMCHAIRS FOR MEDICAL OR DENTAL PURPOSES, NAMELY, MEDICAL PROCEDURE CHAIRS; VACUUM PUMPS FOR MEDICAL PURPOSES; BABIES' BOTTLES; CONDOMS; HAIR PROSTHESES; SURGICAL IMPLANTS COMPRISING ARTIFICIAL MATERIALS; INTRAOCULAR PROSTHESES FOR SURGICAL IMPLANTATION; EAR PICKS; PULSE METERS; TIPS FOR CRUTCHES FOR INVALIDS; CLIPS, SURGICAL; X-RAY PHOTOGRAPHS FOR MEDICAL PURPOSES; TONGUE SCRAPERS; RECEPTACLES FOR APPLYING MEDICINES, NAMELY, CUPS FOR DISPENSING MEDICINE; CONTAINERS ESPECIALLY MADE FOR MEDICAL WASTE; RESPIRATORS FOR ARTIFICIAL RESPIRATION; DOUCHE BAGS; SCALPELS; ORTHOPEDIC FOOTWEAR; RADIOLOGY SCREENS FOR MEDICAL PURPOSES, NAMELY, MEDICAL RADIATION APPARATUS; SLINGS; BRUSHES FOR CLEANING BODY CAVITIES; COMMUNE CHAIRS, NAMELY, TOILETS ADAPTED FOR MEDICAL PATIENTS OR FOR USE BY DISABLED PERSONS; SAWS FOR SURGICAL PURPOSES; ARTIFICIAL BREASTS; HYPODERMIC SYRINGES; SYRINGES FOR INJECTIONS; SYRINGES FOR MEDICAL PURPOSES; URETHRAL PROBE SYRINGES; UTERINE SYRINGES; VAGINAL SYRINGES; PROBES FOR MEDICAL PURPOSES; URETHRAL PROBES; SUPPORTIVE BANDAGES; MIRRORS FOR SURGEONS; MIRRORS FOR DENTISTS; SPIROMETERS; SURGICAL SPONGES; SPITTOONS FOR MEDICAL PURPOSES; CRUTCHES; SPLINTS, SURGICAL; STENTS; STETHOSCOPES; HEART PACEMAKERS; BOOTS FOR MEDICAL PURPOSES; ELECTRIC ACUPUNCTURE INSTRUMENTS; BALLING GUNS, NAMELY, INJECTION INSTRUMENTS WITHOUT NEEDLES; TEATS; ORTHOPEDIC SOLES; SUPPORTS FOR FLAT FEET FOR MEDICAL USE; CORN KNIVES FOR MEDICAL USE; EAR PLUGS FOR NOISE REDUCTION; OPERATING TABLES; CASTRATING PINNERS; BLANKETS, ELECTRIC, FOR MEDICAL PURPOSES; THERMOMETERS FOR MEDICAL PURPOSES; FEEDING BOTTLE TEATS; BREAST PUMPS; DRAW-SHEETS FOR SICK BEDS; TROCARS; X-RAY TUBES FOR MEDICAL PURPOSES; DRAINAGE TUBES FOR MEDICAL PURPOSES; CASES FITTED FOR MEDICAL INSTRUMENTS; SPRAYERS FOR MEDICAL PURPOSES FOR CLEANING GUMS AND TEETH USED IN DENTISTS' OFFICES DURING DENTAL PROCEDURES; CUPPING GLASSES; CLOTHING ESPECIALLY FOR OPERATING ROOMS, NAMELY, SURGICAL SCRUB SUITS; HOT AIR BED VIBRATORS FOR MEDICAL PURPOSES; VIBROMASSAGE DEVICES (U.S. CLS. 26, 39 AND 44).

**CLASS 30—STAPLE FOODS**

FOR COFFEE, TEA, COCOA AND ARTIFICIAL COFFEE; RICE; TAPIOCA AND SAGO; FLOUR AND PREPARATIONS MADE FROM CEREALS, NAMELY, CEREAL BASED SNACK FOODS; BREAD, PASTRY AND FROZEN CONFECTIONERY; FRUIT ICES; SUGAR, HONEY, TREACLE; YEAST, BAKING-POWDER; SALT; MUSTARD; VINEGAR, SAUCES; SPICES; ICE; BEER VINEGAR; SEA WATER FOR COOKING; GLUTEN ADDITIVES FOR CULINARY PURPOSES; SEAWEED FOR USE AS A CONDIMENT; OAT-BASED FOOD, NAMELY, OAT FLAKES; FARINACEOUS FOOD PASTES FOR HUMAN CONSUMPTION; STARCH FOR USE IN MANUFACTURING FOOD; ANISEED FOR USE AS A FLAVORING IN FOOD AND DRINKS; STAR ANISEED FOR USE AS A FLAVORING IN FOOD AND DRINKS; SEASONINGS; COFFEE FLAVORINGS; FLAVORINGS, OTHER THAN ESSENTIAL OILS; FLAVORINGS, OTHER THAN ESSENTIAL OILS, FOR BEVERAGES; FLAVORINGS, OTHER THAN ESSENTIAL OILS, FOR CAKES; CRUSHED OATS; HUSKED OATS; HIGH-PROTEIN CEREAL BARS; CEREAL BARS; STICK LIQUORICE; COCOA-BASED BEVERAGES; COFFEE-BASED BEVERAGES; CHOCOLATE-BASED BEVERAGES; TEA-BASED BEVERAGES; BAKING SODA; COOKIES; MALT BISCUITS; PETIT-BEURRE BISCUITS; SWEETMEATS; BUNS; PUDDINGS; COCOA BEVERAGES WITH MILK; COFFEE BEVERAGES WITH MILK; UNROASTED COFFEE; CINNAMON; CAPERS; CARAMELS; PEPPERMINT SWEETS; CHEESEBURGER SANDWICHES; CLOVES; CHOW-CHOW; CHUTNEYS; WAFFLES; CHICORY BASED COFFEE SUBSTITUTE; CHOCOLATE; CHOCOLATE-BASED BEVERAGES WITH MILK; AROMATIC PREPARATIONS FOR FOOD, NAMELY, DRIED HERBS; CONDIMENTS, NAMELY, KETCHUP AND MUSTARD; PEANUT CONFECTIONERY, NAMELY, PEANUT BRITTLE; ALMOND CONFECTIONERY, NAMELY, ALMOND PASTE; PRALINES; CORN FLAKES; FRUIT COULIS; CRACKERS; CREAM OF TARTAR FOR CULINARY PURPOSES; CUSTARD; PANCAKES; MACAROONS; TURMERIC FOR FOOD; CURRY; COUSCOUS; CAKES; NATURAL SWEETENERS; CONFECTIONERY FOR DECORATING CHRISTMAS TREES; GARDEN HERBS, PRESERVED; ESSENCES FOR FOODSTUFFS, EXCEPT ETHERIC ESSENCES AND ESSENTIAL OILS, NAMELY, FLAVORINGS; MALT EXTRACT FOR FOOD; BEAN MEAL, NAMELY, BEAN FLOUR; WHEAT FLOUR; CORN MEAL; BARLEY MEAL; POTATO FLOUR FOR FOOD; MUSTARD POWDER; SOYA FLOUR; TAPIOCA FLOUR FOR FOOD; GRUEL, WITH A MILK BASE, FOR FOOD, NAMELY, OATMEAL; HOMINY; MEAL, NAMELY, CRACKER MEAL; FERMENTS FOR PASTES, NAMELY, YEAST; OAT FLAKES; GRAIN-BASED CHIPS; GROATS FOR HUMAN FOOD, NAMELY, ROLLED OATS AND WHEAT; PIES; FONDANTS; FRUIT JELLIES; HAM GLAZE; WHEAT GERM FOR HUMAN CONSUMPTION; EDIBLE ICES; ICE, NATURAL OR ARTIFICIAL, NAMELY, ICE CUBES; ICE FOR REFRESHMENT; CAKE FROSTING; GLUCOSE FOR CULINARY PURPOSES; GLUTEN PREPARED AS FOODSTUFF, NAMELY, GLUTEN ADDITIVES FOR CULINARY PURPOSES; CHEWING GUM; CORN, MILLED; CORN, ROASTED; POPCORN; HALVAH; DOUGH; HERBAL INFUSIONS, NOT MEDICINAL; SPRING ROLLS; THICKENING AGENTS FOR COOKING FOODSTUFFS; KETCHUP; STARCH-BASED BINDING AGENTS FOR ICE CREAM; SAUSAGE BINDING MATERIALS, NAMELY, SOYA FLOUR; YEAST; BAKING POWDER; LEAVEN, NAMELY, FOOD LEAVENING AGENTS; LIQUORICE; MACARONI; MAYONNAISE; MALT FOR HUMAN CONSUMPTION FOR FOOD PURPOSES; MALTOSE FOR FOOD; MARINADES; MARZIPAN; MOLASSES FOR FOOD; MINT FOR CONFECTIONERY, NAMELY, CANDY MINTS; CHOCOLATE MOUSSES; DESSERT MOUSSES; MUESLI; ALLSPICE; NUTMEGS; CRUSHED BARLEY; HUSKED BARLEY; GINGERBREAD; RUSKS; UNLEAVENED BREAD; BREADCRUMBS; BREAD ROLLS; ROYAL JELLY FOR FOOD PURPOSES; ALMOND PASTE; SOYA BEAN PASTE; PASTA; PASTRIES, NAMELY, PASTIES; NOODLE-BASED PREPARED MEALS; PASTRIES; NON-MEDICATED LOZENGES; PETITS FOURS; MEAT PIES; PEPPER; PESTO; PIZZAS; CAKE POWDER, NAMELY, BAKING POWDER; POWDERS FOR ICE CREAM; CEREAL PREPARATIONS, NAMELY, BREAKFAST CEREALS; VEGETABLE PREPARATIONS FOR USE AS COFFEE SUBSTITUTES; FLOUR-MILLING PRODUCTS, NAMELY, RICE FLOUR;

MEAT TENDERIZERS, FOR HOUSEHOLD PURPOSES; PREPARATIONS FOR STIFFENING WHIPPED CREAM, NAMELY, STARCH-BASED THICKENERS FOR WHIPPED CREAM; BEE GLUE, NAMELY, PROPOLIS FOR HUMAN CONSUMPTION; QUICHES; RELISH; RAVIOLI; COOKING SALT; CELERY SALT; SALT FOR PRESERVING FOODSTUFFS; TOMATO SAUCE; SOYA SAUCE; DRESSINGS FOR SALAD; PASTA SAUCE; SANDWICHES; PEPPER; GOLDEN SYRUP; LINSEED FOR HUMAN CONSUMPTION; OATMEAL; PROCESSED SEMOLINA; HOMINY GRITS; CEREAL-BASED SNACK FOOD; RICE-BASED SNACK FOOD; SORBETS; SPAGHETTI; MEAT GRAVIES; SUSHI; TABBOULEH; TACOS; NOODLES; ICED TEA; TARTS; RICE CAKES; TORTILLAS; VANILLA; VANILLIN, NAMELY, VANILLA FLAVORINGS; VERMICELLI; FROZEN YOGURT; SAFFRON FOR USE AS A FOOD SEASONING; GINGER; CANDY; PALM SUGAR (U.S. CL. 46).

**CLASS 35—ADVERTISING AND BUSINESS**

FOR ADVERTISING; BUSINESS MANAGEMENT; BUSINESS ADMINISTRATION; PROVIDING OFFICE FUNCTIONS; BILL-POSTING; RENTAL OF VENDING MACHINES; RENTAL OF ADVERTISING TIME ON COMMUNICATION MEDIA; COMMERCIAL INFORMATION AGENCIES; PUBLICITY BUREAU SERVICES; IMPORT-EXPORT AGENCIES; UPDATING OF ADVERTISING MATERIAL; COMMERCIAL ADMINISTRATION OF THE LICENSING OF THE GOODS AND SERVICES OF OTHERS; COST PRICE ANALYSIS; COMMERCIAL AND INDUSTRIAL MANAGEMENT ASSISTANCE; PROFESSIONAL BUSINESS CONSULTANCY; BUSINESS MANAGEMENT CONSULTANCY; PERSONNEL MANAGEMENT CONSULTANCY; ACCOUNTING; SHOP WINDOW DRESSING; DISSEMINATION OF ADVERTISING MATTER; DISTRIBUTION OF SAMPLES; DEMONSTRATION OF GOODS; BUSINESS MANAGEMENT OF PERFORMING ARTISTS; DIRECT MAIL ADVERTISING; COMPILATION OF STATISTICS; INVOICING; BUSINESS MANAGEMENT OF HOTELS; BUSINESS MANAGEMENT OF SPORTS PEOPLE; COMPUTERIZED FILE MANAGEMENT; BUSINESS INFORMATION; COMMERCIAL INFORMATION AND ADVICE FOR CONSUMERS; BUSINESS INVESTIGATIONS; LAYOUT SERVICES FOR ADVERTISING PURPOSES; RENTAL OF ADVERTISING SPACE; MARKETING; RENTAL OF PHOTOCOPYING MACHINES; OFFICE MACHINES AND EQUIPMENT RENTAL; PUBLICITY MATERIAL RENTAL; ORGANIZATION OF EXHIBITIONS FOR COMMERCIAL OR ADVERTISING PURPOSES; ORGANIZATION OF TRADE FAIRS FOR COMMERCIAL OR ADVERTISING PURPOSES; ORGANIZATION OF FASHION SHOWS FOR PROMOTIONAL PURPOSES; BUSINESS EFFICIENCY EXPERT SERVICES; PAYROLL PREPARATION; PRESENTATION OF GOODS ON COMMUNICATION MEDIA, FOR RETAIL PURPOSES, NAMELY, DEMONSTRATION OF GOODS; ECONOMIC FORECASTING; PRODUCTION OF ADVERTISING FILMS; BUSINESS MANAGEMENT ASSISTANCE; SALES PROMOTION FOR OTHERS; PUBLICATION OF PUBLICITY TEXTS; ON-LINE ADVERTISING ON A COMPUTER NETWORK; ADVERTISING BY MAIL ORDER; PUBLICITY COLUMNS PREPARATION, NAMELY, WRITING OF PUBLICITY TEXTS; RADIO ADVERTISING; TELEVISION ADVERTISING; COMPILATION AND SYSTEMATIZATION OF INFORMATION INTO COMPUTER DATABASES; BUSINESS INQUIRIES; PERSONNEL RECRUITMENT; WRITING OF PUBLICITY TEXTS; PUBLIC RELATIONS; SPONSORSHIP SEARCH; DATA SEARCH IN COMPUTER FILES FOR OTHERS, NAMELY, DATABASE MANAGEMENT; MARKETING RESEARCH; BUSINESS RESEARCH; DOCUMENT REPRODUCTION; PSYCHOLOGICAL TESTING FOR THE SELECTION OF PERSONNEL; ARRANGING NEWSPAPER SUBSCRIPTIONS FOR OTHERS; ARRANGING SUBSCRIPTIONS TO TELECOMMUNICATION SERVICES FOR OTHERS; PRICE COMPARISON SERVICES; BUSINESS MANAGEMENT AND ORGANIZATION CONSULTANCY; BUSINESS ORGANIZATION CONSULTANCY; ADVISORY SERVICES FOR BUSINESS MANAGEMENT; TYPING; PHOTOCOPYING SERVICES; MODELLING FOR ADVERTISING OR SALES PROMOTION; NEWS CLIPPING SERVICES; RELOCATION SERVICES FOR BUSINESSES; TELEPHONE ANSWERING FOR UNAVAILABLE SUBSCRIBERS; SECRETARIAL SERVICES; SHORTHAND SERVICES; OUTSOURCING SERVICES; TELEMARKETING SERVICES; RETAIL

AND WHOLESALE STORE SERVICES FEATURING PHARMACEUTICAL, VETERINARY AND SANITARY PREPARATIONS AND MEDICAL SUPPLIES; SYSTEMIZATION OF INFORMATION INTO COMPUTER DATABASES; PUBLIC OPINION POLLING; TAX PREPARATION; DRAWING UP OF STATEMENTS OF ACCOUNTS, NAMELY, ACCOUNT AUDITING; BUSINESS APPRAISALS; CONDUCTING MARKETING STUDIES; STENOGRAPHIC TRANSCRIPTION; ADMINISTRATIVE PROCESSING OF PURCHASE ORDERS; WORD PROCESSING; EMPLOYMENT AGENCIES; AUCTIONEERING; BUSINESS AUDITING (U.S. CLS. 100, 101 AND 102).

#### **CLASS 44—MEDICAL, BEAUTY AND AGRICULTURAL SERVICES**

FOR MEDICAL SERVICES; VETERINARY SERVICES; HYGIENIC AND BEAUTY CARE FOR HUMAN BEINGS OR ANIMALS; AGRICULTURE, HORTICULTURE AND FORESTRY SERVICES, NAMELY, VERMIN EXTERMINATING, CONTRACT FARMING FOR OTHERS AND HORTICULTURE SERVICES; ANIMAL BREEDING; LANDSCAPE DESIGN; DENTISTRY; VETERINARY SURGERY; OPERATION OF PUBLIC BATHS FOR SANITARY PURPOSES; PROVIDING TURKISH BATH FACILITIES; NURSING HOMES; REST HOMES; CHIROPRACTICS; TREE SURGERY; PLASTIC SURGERY; HEALTH CENTERS, NAMELY, HEALTH CARE; FLOWER ARRANGING; WREATH MAKING; PHARMACEUTICAL ADVICE; HEALTH COUNSELING; REHABILITATION FOR SUBSTANCE ABUSE PATIENTS; VERMIN EXTERMINATING FOR AGRICULTURE, HORTICULTURE AND FORESTRY; WEED KILLING; PHYSIOTHERAPY; GARDENING SERVICES; HAIR IMPLANTATION; LAWN CARE; MASSAGE; MEDICAL EQUIPMENT RENTAL; RENTAL OF SANITATION FACILITIES; FARMING EQUIPMENT RENTAL; HOSPICES; TREE PLANTING FOR CARBON OFFSETTING PURPOSES; PET GROOMING; BEAUTY SALONS; HAIRDRESSING SALONS; SANATORIUM SERVICES; PLANT NURSERIES; OPTICIANS' SERVICES; AQUACULTURE SERVICES, NAMELY, THE CULTIVATION AND BREEDING OF PLANTS OR ANIMALS IN A WATER ENVIRONMENT; AROMATHERAPY SERVICES; HEALTH SPA SERVICES, NAMELY, COSMETIC BODY CARE SERVICES; BLOOD BANK SERVICES; MEDICAL CLINIC SERVICES; PHARMACISTS' SERVICES TO MAKE UP PRESCRIPTIONS; IN VITRO FERTILIZATION SERVICES; LANDSCAPE GARDENING; NURSING SERVICES; ARTIFICIAL INSEMINATION SERVICES; SPEECH THERAPY SERVICES; MANICURING; ALTERNATIVE MEDICINE SERVICES; MIDWIFE SERVICES; SERVICES OF A PSYCHOLOGIST; SAUNA SERVICES; SOLARIUM SERVICES; TELEMEDICINE SERVICES; VISA GISTS' SERVICES, NAMELY, MAKE-UP APPLICATION SERVICES; HOSPITALS; HEALTH CARE; PHYSICAL THERAPY SERVICES; AERIAL AND SURFACE SPREADING OF FERTILIZERS AND OTHER AGRICULTURAL CHEMICALS; ANIMAL GROOMING; TATTOOING (U.S. CLS. 100 AND 101).

ROBERT STRUCK, EXAMINING ATTORNEY

#### **CLASS 9—ELECTRICAL AND SCIENTIFIC APPARATUS**

FOR ELECTRONIC CIRCUITS, INTEGRATED CIRCUITS, AND COMPUTER CHIPS; COMPUTER GRAPHICS ELECTRONIC CIRCUITS, INTEGRATED CIRCUITS, AND COMPUTER CHIPS; IMAGE PROCESSING ELECTRONIC CIRCUITS, INTEGRATED CIRCUITS, AND COMPUTER CHIPS; MULTIMEDIA ELECTRONIC CIRCUITS, INTEGRATED CIRCUITS, AND COMPUTER CHIPS; MULTIMEDIA PROCESSOR ELECTRONIC CIRCUITS, INTEGRATED CIRCUITS, AND COMPUTER CHIPS; MICROPROCESSOR ELECTRONIC CIRCUITS, INTEGRATED CIRCUITS, AND COMPUTER CHIPS; COMPUTER MODULES FOR INCLUSION IN INTEGRATED CIRCUITS AND COMPUTER CHIPS, NAMELY, GRAPHICS MODULES, IMAGE PROCESSING MODULES, MULTIMEDIA PROCESSING MODULES, AND MICROPROCESSING MODULES; GRAPHICS DISPLAY DEVICES, NAMELY, LCD MONITORS, HANDHELD ELECTRONIC DEVICES INCLUDING GRAPHIC DISPLAY, NAMELY, DIGITAL AUDIO AND VIDEO PLAYERS; TELEVISION APPARATUS AND SET-TOP BOXES; COMPUTER SOFTWARE FOR GRAPHICS PROCESSING; COMPUTER SOFTWARE FOR DEVELOPMENT OF GRAPHICS SOFTWARE AND INTEGRATED CIRCUITS; COMPUTER SOFTWARE FOR MULTIMEDIA PROCESSING; COMPUTER SOFTWARE FOR MICROPROCESSOR OPERATING SYSTEMS AND APPLICATIONS; RADIO RECEIVING APPARATUS, DIGITAL RADIOS, INTERNET RADIOS, IN-CAR RADIOS, COMBINED RADIO AND CD PLAYERS, COMBINED RADIO AND MP3 DOCKING STATIONS, MP3 PLAYERS, PORTABLE AUDIO DEVICES, NAMELY, DIGITAL MUSIC FILE PLAYERS, AMPLIFIERS, RADIO RECEIVERS, LOUD SPEAKERS; BATTERY CHARGING APPARATUS; BATTERIES; VEHICLE ANTENNAS; REMOTE CONTROLS FOR SOUND REPRODUCING APPARATUS; HEADPHONES; DOWNLOADABLE DIGITAL MUSIC; PRE-RECORDED DISCS AND TAPES FEATURING MUSIC; DOWNLOADABLE DIGITAL MUSIC AVAILABLE FROM INTERNET PORTALS AND WEBSITES; DIGITAL MUSIC FILES DOWNLOADABLE USING DIGITAL RADIO TECHNOLOGY AND INTERNET RADIOS OVER A WIRELESS NETWORK (U.S. CLS. 21, 23, 26, 36 AND 38).

#### **CLASS 42—SCIENTIFIC AND COMPUTER SERVICES**

FOR DESIGN AND DEVELOPMENT OF ELECTRONIC CIRCUITS, INTEGRATED CIRCUITS AND COMPUTER CHIPS AND PART THEREOF, INCLUDING COMPUTER GRAPHICS, ELECTRONIC CIRCUITS, INTEGRATED CIRCUITS AND COMPUTER CHIPS, IMAGE PROCESSING ELECTRONIC CIRCUITS, INTEGRATED CIRCUITS AND CHIPS, MULTIMEDIA ELECTRONIC CIRCUITS, INTEGRATED CIRCUITS AND CHIPS, MICROPROCESSOR ELECTRONIC CIRCUITS, INTEGRATED CIRCUITS AND CHIPS, MICROPROCESSOR ELECTRONIC CIRCUITS, INTEGRATED CIRCUITS AND CHIPS, AS WELL AS DESIGN AND DEVELOPMENT OF THE FOREMENTIONED GOODS FOR INCLUSION IN OTHER INTEGRATED CIRCUITS AND COMPUTER CHIPS; DESIGN AND DEVELOPMENT OF ELECTRONIC AND COMPUTER HARDWARE AND SOFTWARE FOR COMPUTER GRAPHICS, IMAGE PROCESSING, MULTIMEDIA APPLICATIONS, MULTIMEDIA PROCESSORS, AND MICROPROCESSORS (U.S. CLS. 100 AND 101).

SN 79-135,293. IMAGINATION TECHNOLOGIES LTD, HERTS WD4 8LZ, UNITED KINGDOM, FILED 7-4-2013.

# Imagination

PRIORITY DATE OF 1-4-2013 IS CLAIMED.  
OWNER OF INTERNATIONAL REGISTRATION 1173393  
DATED 7-4-2013, EXPIRES 7-4-2023.  
OWNER OF U.S. REG. NOS. 3,161,547 AND 4,120,011.

#### **CLASS 45—PERSONAL AND LEGAL SERVICES**

FOR LICENSING OF INTELLECTUAL PROPERTY, NAMELY, UTILITY PATENTS, DESIGN PATENTS, COPYRIGHTS, TRADEMARKS, TECHNOLOGY, AND INFORMATION RELATED TO THE FOREGOING (U.S. CLS. 100 AND 101).

SAMUEL PAQUIN, EXAMINING ATTORNEY

SN 79-135.405. ADVANTICA; INTELLECTUAL PROPERTY LIMITED, UNITED KINGDOM, FILED 7-26-2013.



PRIORITY DATE OF 4-5-2013 IS CLAIMED.  
OWNER OF INTERNATIONAL REGISTRATION 1173657  
DATED 7-26-2013, EXPIRES 7-26-2023.

NO CLAIM IS MADE TO THE EXCLUSIVE RIGHT TO USE "ACCESS MANAGER COMMERCIAL GAS MANAGEMENT", APART FROM THE MARK AS SHOWN.

THE MARK CONSISTS OF THE STYLIZED WORDING "ACCESS MANAGER COMMERCIAL GAS MANAGEMENT" AS WELL AS THE DEPICTION OF A HORIZONTAL LINE AND THREE CONCENTRIC CIRCLES HAVING A SINGLE PIE-SHAPED TRIANGLE AT THE BOTTOM. THE WORDING "ACCESS MANAGER" APPEARS BELOW THE DEPICTION OF THE THREE CONCENTRIC CIRCLES HAVING A SINGLE PIE-SHAPED TRIANGLE AT THE BOTTOM. A HORIZONTAL LINE IS DEPICTED BELOW THE "ACCESS MANAGER" WORDING. BELOW THE HORIZONTAL LINE APPEARS THE STYLIZED WORDING "COMMERCIAL GAS MANAGEMENT".

#### CLASS 9—ELECTRICAL AND SCIENTIFIC APPARATUS

FOR COMPUTER HARDWARE FOR GAS AND ENERGY MANAGEMENT; COMPUTER SOFTWARE, NAMELY, COMPUTER SOFTWARE FOR USE IN GAS MANAGEMENT TO SUPPORT THE HYDROCARBON ACCOUNTING AND COMMERCIAL OPERATIONS OF THIRD PARTIES AND THE STORAGE, TRANSMISSION AND/OR RETAIL OF GAS; COMPUTER SOFTWARE, NAMELY, A COMPUTER PROGRAM THAT IS AN INTEGRATED RULES ENGINE FOR USE IN MODULAR ANALYSIS OF CLOSED CONDUIT NETWORKS OF PIPES, REGULATORS, VALVES, PUMPS, RESERVOIRS, TANKS, WELLS AND BOREHOLES IN THE OIL AND GAS INDUSTRY; COMPUTER SOFTWARE USED TO MODEL AND ANALYZE CLOSED CONDUIT NETWORKS OF PIPES, REGULATORS, VALVES, PUMPS, RESERVOIRS, TANKS, WELLS AND BOREHOLES; COMPUTER SOFTWARE FOR USE IN DATABASE MANAGEMENT; OPERATING SYSTEM PROGRAMS; MAGNETIC DATA CARRIERS AND RECORDING DISCS, NAMELY, PRERECORDED MAGNETIC DATA CARRIERS, OPTICAL DISKS AND CD-ROMS FEATURING INSTRUCTION MANUALS; COMPACT DISCS, DVDS AND OTHER DIGITAL RECORDING MEDIA, NAMELY, PRERECORDED COMPACT DISKS, OPTICAL DISKS AND CD-ROMS FEATURING INSTRUCTION MANUALS; DATA PROCESSING APPARATUS, COMPUTERS (U.S. CLS. 21, 23, 26, 36 AND 38).

#### CLASS 42—SCIENTIFIC AND COMPUTER SERVICES

FOR SCIENTIFIC AND TECHNOLOGICAL SERVICES AND RESEARCH AND DESIGN RELATING THERETO, NAMELY, RESEARCH IN THE FIELD OF ENERGY, AND RESEARCH AND DESIGN OF COMPUTER HARDWARE AND SOFTWARE SYSTEMS USED IN THE FIELD OF COMPUTER DATACENTER ARCHITECTURE; INDUSTRIAL ANALYSIS AND RESEARCH SERVICES, NAMELY, PROVIDING PIPELINE RISK ANALYSIS AND ASSESSMENT OF CLOSED CONDUIT NETWORKS OF PIPES, REGULATORS, VALVES, PUMPS, RESERVOIRS, TANKS, WELLS AND BOREHOLES FOR OTHERS; DESIGN AND DEVELOPMENT OF COMPUTER HARDWARE AND SOFTWARE FOR OTHERS IN THE OIL AND GAS INDUSTRIES; COMPUTER CONSULTATION; INFORMATION TECHNOLOGY CONSULTING SERVICES IN THE FIELD OF COMPUTER TECHNOLOGY AND PROGRAMMING USED IN THE OIL AND GAS INDUSTRIES; INFORMATION SERVICES RELATING TO THE DEVELOPMENT OF COMPUTER SYSTEMS, NAMELY, PROVIDING TECHNOLOGY INFORMATION RELATING TO THE OIL AND GAS INDUSTRY, AND PROVIDING A WEB SITE THAT FEATURES INFORMATION ON COMPUTER TECHNOLOGY AND PROGRAMMING USED IN THE OIL AND GAS INDUSTRY (U.S. CLS. 100 AND 101).

MICHAEL TANNER, EXAMINING ATTORNEY

SN 79-135.654. SUNING APPLIANCE COMPANY LIMITED, JIANGSU PROVINCE, CHINA, FILED 1-29-2013.

OWNER OF INTERNATIONAL REGISTRATION 1174217  
DATED 1-29-2013, EXPIRES 1-29-2023.

THE ENGLISH TRANSLATION OF THE FOREIGN WORD(S) IN THE MARK IS: "REVIVING" AND "TRANQUIL" RESPECTIVELY, THE TWO WORDS AS A WHOLE HAS NO MEANING.

THE TRANSLITERATION OF THE TWO CHINESE CHARACTERS APPEARING IN THE MARK IS "SU" AND "NING" RESPECTIVELY.

#### CLASS 9—ELECTRICAL AND SCIENTIFIC APPARATUS

FOR DATA PROCESSING APPARATUS; DVD PLAYERS; PORTABLE TELEPHONES; TELEVISIONS; CAMERAS; EYEGLASSES; BATTERIES (U.S. CLS. 21, 23, 26, 36 AND 38).

#### CLASS 11—ENVIRONMENTAL CONTROL APPARATUS

FOR APPARATUS FOR COOKING, NAMELY, COOK-TOPS; REFRIGERATING APPLIANCES AND INSTALLATIONS; AIR PURIFYING APPARATUS AND MACHINES; TAPS; WATER PURIFYING APPARATUS; RADIATORS (U.S. CLS. 13, 21, 23, 31 AND 34).



**CLASS 35—ADVERTISING AND BUSINESS**

FOR ADVERTISEMENT AND PUBLICITY SERVICES BY TELEVISION, INTERNET RADIO, AND MAIL; DEMONSTRATION OF GOODS; PUBLICITY AND SALES PROMOTION SERVICES; PURCHASING AND PROCUREMENT SERVICES, NAMELY, PROCURING OF CONTRACTS FOR OTHERS FOR THE PURCHASE OF GOODS AND LABOR CONTRACTING SERVICES; ORGANIZING EXHIBITIONS FOR COMMERCIAL OR ADVERTISING PURPOSES; BUSINESS MANAGEMENT AND ENTERPRISE ORGANIZATION CONSULTANCY; BUSINESS MANAGEMENT OF HOTELS FOR OTHERS; COMMERCIAL INFORMATION AND ADVICE FOR CONSUMERS (U.S. CLS. 100, 101 AND 102).

KATHRYN COWARD, EXAMINING ATTORNEY

**CLASS 35—ADVERTISING AND BUSINESS**

FOR COMPILATION OF INFORMATION INTO COMPUTER DATABASES; UPDATING AND ADMINISTRATION OF DATA IN COMPUTER DATABASES; SYSTEMIZATION OF DATA IN COMPUTER DATABASES; NEWS CLIPPING SERVICES; COMPILATION OF BUSINESS EXPERTISE, NAMELY, COMPILATION OF EXPERTISE FOR PRINT OR DIGITAL PUBLICATIONS, SEMINARS, AND CONFERENCES RELATING TO ELECTRIC VEHICLES; COMMERCIAL INFORMATION AND ADVICE FOR CONSUMERS BEING CONSUMER COUNSELING; CONDUCTING MARKETING STUDIES; DATA PROCESSING SERVICES, NAMELY, ORGANIZATIONAL PROJECT MANAGEMENT IN EDP, NAMELY, PROJECT MANAGEMENT SERVICES IN EDP FOR THE FIELD OF ELECTRIC VEHICLES; PRICE COMPARISON SERVICES; ADVERTISING SERVICES; ADVERTISING ON THE INTERNET FOR OTHERS; SALES PROMOTION FOR OTHERS; BUSINESS ORGANIZATION CONSULTANCY; ARRANGING AND PROCURING OF CONTRACTS FOR THE USE OF ELECTRIC VEHICLES FOR THIRD PARTIES (U.S. CLS. 100, 101 AND 102).

SN 79-135,723. ENERGYBUS E.V., FED REP GERMANY, FILED 3-1-2013.



PRIORITY DATE OF 9-11-2012 IS CLAIMED.  
OWNER OF INTERNATIONAL REGISTRATION 1174427  
DATED 3-1-2013, EXPIRES 3-1-2023.

THE MARK CONSISTS OF A SHADED INCOMPLETE CIRCLE, WITH TWO DOTS IN THE CENTER OF THE CIRCLE AND A LINE CONNECTING THE DOT ON THE RIGHT TO THE RIGHT SIDE OF THE CIRCLE.

**CLASS 9—ELECTRICAL AND SCIENTIFIC APPARATUS**

FOR APPARATUS AND INSTRUMENTS FOR CONVEYING, DISTRIBUTING, TRANSFORMING, STORING, REGULATING OR CONTROLLING ELECTRIC CURRENT; BATTERIES AND ACCUMULATORS BEING ELECTRIC; BATTERIES AND ACCUMULATORS FOR VEHICLES; RECHARGERS FOR ELECTRIC ACCUMULATORS; BATTERY JARS; ACCUMULATOR JARS; BATTERY BOXES; ACCUMULATOR BOXES; PLATES FOR BATTERIES OR ACCUMULATORS; CONNECTORS, ELECTRIC; CONDUCTORS, ELECTRIC; SOCKETS, PLUGS AND OTHER CONTACTS BEING ELECTRIC CONNECTIONS; COUPLINGS, ELECTRIC; COILS, ELECTRIC; CONTACTS, ELECTRIC; MEASURING DEVICES, ELECTRIC, NAMELY, FOR MEASURING AT LEAST A PHYSICAL QUANTITY, SUCH AS VOLTAGE, CURRENT, ELECTRIC POWER, ELECTRIC RESISTANCE, ELECTRIC CONDUCTANCE, ELECTRIC CAPACITANCE, ELECTRIC INDUCTANCE, TEMPERATURE, SPEED, DISTANCE TRAVELLED OR CADENCE (U.S. CLS. 21, 23, 26, 36 AND 38).

**CLASS 42—SCIENTIFIC AND COMPUTER SERVICES**

FOR SCIENTIFIC AND TECHNOLOGICAL SERVICES, NAMELY, ENGINEERING, ENGINEERING DESIGN SERVICES, CONDUCTING ENGINEERING SURVEYS, CONSULTING IN THE FIELD OF ENGINEERING, SCIENTIFIC RESEARCH, ANALYSIS, TESTING AND RESEARCH AND DESIGN SERVICES RELATING THERETO IN THE FIELD OF ELECTRIC VEHICLES; SCIENTIFIC LABORATORY SERVICES, NAMELY, SERVICES OF A TECHNICAL MEASUREMENT AND TESTING LABORATORY; REALIZATION OF TECHNICAL TESTS, NAMELY, TESTING OF ELECTRIC VEHICLES AND ELECTRIC VEHICLE COMPONENTS; SCIENTIFIC RESEARCH; CHEMICAL ANALYSIS; CALIBRATION AND FUNCTIONAL CHECK OF MEASURING INSTRUMENTS; MATERIAL TESTING; SURVEYING; QUALITY CONTROL FOR OTHERS; TECHNICAL CONSULTANCY IN THE FIELD OF ELECTRIC VEHICLES, NAMELY, ENGINEERING CONSULTANCY AND ENVIRONMENTAL ASSESSMENT CONSULTANCY IN THE FIELD OF ELECTRIC VEHICLES; VEHICLE ROADWORTHINESS TESTING; TECHNICAL RESEARCH IN THE FIELD OF ELECTRIC VEHICLES; ENVIRONMENTAL ASSESSMENTS SERVICES; TESTING SERVICES FOR THE CERTIFICATION OF QUALITY AND STANDARDS, NAMELY, TESTING, ANALYSIS AND EVALUATION OF THE GOODS AND SERVICES OF OTHERS FOR THE PURPOSE OF CERTIFICATION (U.S. CLS. 100 AND 101).

SCOTT BIBB, EXAMINING ATTORNEY

SN 79-135,962. NOWCOM CO., LTD., GYEONGGI-DO, REPUBLIC OF KOREA, FILED 3-4-2013.



PRIORITY DATE OF 2-21-2013 IS CLAIMED.  
OWNER OF INTERNATIONAL REGISTRATION 1175092  
DATED 3-4-2013, EXPIRES 3-4-2023.

OWNER OF U.S. REG. NO. 4,133,861.  
THE COLOR(S) BLUE, RED, GREEN, BLACK, AND WHITE IS/ARE CLAIMED AS A FEATURE OF THE MARK.  
THE MARK CONSISTS OF THE STYLIZED BLUE WORDING "AFREeca TV" FOLLOWED BY A BLACK CHARACTER WITH A RED LEFT EYE AND A BLUE RIGHT EYE, A GREEN NOSE, AND A WHITE SMILE. ON TOP OF THE CHARACTER ARE BLACK ANTENNAE. THE EYES AND NOSE ARE TRIMMED IN WHITE AND CONTAIN BLACK DOTS TRIMMED IN WHITE.

**CLASS 9—ELECTRICAL AND SCIENTIFIC APPARATUS**

FOR COMPUTER SOFTWARE TO ENABLE THE UPLOADING, POSTING, SHARING, TAGGING, AND RATING OF INFORMATION, DATA, AND MULTIMEDIA CONTENT VIA THE INTERNET AND OTHER COMMUNICATION NETWORKS; COMPUTER SOFTWARE FOR BROADCASTING VIDEO CLIPS, AUDIO CLIPS, IMAGES, PHOTOS, AND OTHER MULTIMEDIA CONTENT VIA THE INTERNET AND OTHER COMMUNICATION NETWORKS; DOWNLOADABLE MUSIC FILES; PRE-RECORDED NON-MUSICAL ELECTRONIC MEDIA EXCLUDING COMPUTER SOFTWARE (U.S. CLS. 21, 23, 26, 36 AND 38).

**CLASS 35—ADVERTISING AND BUSINESS**

FOR ADVERTISING AGENCIES; SALES PROMOTION FOR OTHERS; MARKETING RESEARCH; PROVIDING EMPLOYMENT INFORMATION ON JOBS AND CASUAL JOBS (U.S. CLS. 100, 101 AND 102).

**CLASS 38—COMMUNICATION**

FOR INTERNET BROADCASTING SERVICES; ELECTRONIC TRANSMISSION OF INFORMATION, DATA, AND MULTIMEDIA CONTENT OF GENERAL INTEREST OVER THE INTERNET AND OTHER COMMUNICATION NETWORKS; ELECTRONIC BULLETIN BOARD SERVICES; PROVIDING ON-LINE CHAT ROOMS IN THE FIELD OF GENERAL INTEREST; COMPUTER COMMUNICATION SERVICES; TRANSMISSION OF DIGITAL FILES (U.S. CLS. 100, 101 AND 104).

**CLASS 41—EDUCATION AND ENTERTAINMENT**

FOR ENTERTAINMENT SERVICES, NAMELY, PROVIDING A WEBSITE FEATURING AUDIO CLIPS, VIDEO CLIPS, MUSICAL PERFORMANCES, MUSICAL VIDEOS, FILM CLIPS, PHOTOGRAPHS, AND OTHER MULTIMEDIA MATERIALS, NAMELY, NON-DOWNLOADABLE RECORDINGS, ALL FEATURING USER-CREATED AUDIO CLIPS, VIDEO CLIPS, MUSICAL PERFORMANCES, MUSICAL VIDEOS, FILM CLIPS, AND PHOTOGRAPHS; PROVIDING A WEBSITE FEATURING ENTERTAINMENT INFORMATION IN THE FIELD OF USER-CREATED AUDIO CLIPS, VIDEO CLIPS, MUSICAL PERFORMANCES, MUSICAL VIDEOS, FILM CLIPS, AND PHOTOGRAPHS; PUBLICATION OF JOURNALS ON-LINE, NAMELY, BLOGS FEATURING INFORMATION, DATA, AND MULTIMEDIA CONTENT OF GENERAL INTEREST; CONDUCTING CONTESTS IN THE FIELD OF ENTERTAINMENT; PROVIDING AUDIO OR VIDEO STUDIO SERVICES, NAMELY, LIVE MUSICAL AND DRAMATIC EVENT AND CONCERT PRODUCTIONS; RECORDING STUDIO SERVICES; PRODUCTION OF FILMS AND VIDEO FILMS; PRODUCTION OF RADIO AND TELEVISION PROGRAMS FOR TRANSMISSION OVER THE INTERNET AND OTHER COMMUNICATIONS NETWORKS; DISTRIBUTION OF TELEVISION PROGRAMS FOR OTHERS; PRODUCTION OF TELEVISION PROGRAMS; ENTERTAINMENT SERVICES, NAMELY, PROVIDING ON-LINE COMPUTER GAMES; PROVIDING INFORMATION ABOUT EDUCATION (U.S. CLS. 100, 101 AND 107).

**CLASS 42—SCIENTIFIC AND COMPUTER SERVICES**

FOR PROVIDING A WEBSITE THAT GIVES COMPUTER USERS THE ABILITY TO UPLOAD, POST, SHARE, TAG, AND RATE VIDEO CLIPS, AUDIO CLIPS, IMAGES, PHOTOS, AND OTHER MULTIMEDIA CONTENT FEATURING A WIDE VARIETY OF TOPICS AND SUBJECTS OVER THE INTERNET AND OTHER COMMUNICATIONS NETWORKS; COMPUTER SOFTWARE DEVELOPMENT; HOSTING THE WEBSITES OF OTHERS; MAINTENANCE OF WEBSITES; PROVIDING INTERNET SEARCH ENGINES (U.S. CLS. 100 AND 101).  
MARCIE MILONE, EXAMINING ATTORNEY

SN 79-136,171. ALFRED C. TOEPFER INTERNATIONAL; G.M.B.H., FED REP GERMANY, FILED 2-7-2013.



**Let it grow.**

PRIORITY DATE OF 11-1-2012 IS CLAIMED.  
OWNER OF INTERNATIONAL REGISTRATION 1175665 DATED 2-7-2013, EXPIRES 2-7-2023.

THE MARK CONSISTS OF A RECTANGLE WITH ROUNDED CORNERS CONTAINING A STEM WITH TWO ATTACHED LEAVES ALL ABOVE THE STYLIZED WORDING "LET IT GROW" WITH A PERIOD AT THE END.

**CLASS 1—CHEMICALS**

FOR BACTERIOLOGICAL PREPARATIONS, NAMELY, BIOLOGICAL ADDITIVES FOR CONVERTING PLANTS TO AGRICULTURAL FODDER; FERTILIZERS, NAMELY, CARBAMIDE, MOP BEING POTASSIUM CHLORIDE, DAP BEING DI-AMMONIUM PHOSPHATE, CAN BEING CALCIUM AMMONIUM NITRATE (U.S. CLS. 1, 5, 6, 10, 26 AND 46).

**CLASS 29—MEATS AND PROCESSED FOODS**

FOR EDIBLE VEGETABLE OILS, NAMELY, SOY OIL, CANOLA OIL, SUNFLOWER OIL, CORN OIL, PALM OIL; EDIBLE FATS, NAMELY, TALLOW FEED; DRIED LEGUMES (U.S. CL. 46).

**CLASS 30—STAPLE FOODS**

FOR SUGAR, MALT FOR HUMAN CONSUMPTION, RICE, TAPIOCA, MOLASSES (U.S. CL. 46).

**CLASS 31—NATURAL AGRICULTURAL PRODUCTS**

FOR AGRICULTURAL SEEDS FOR OIL SEEDS, NAMELY, SOY BEANS, CANOLA SEEDS, SUNFLOWER SEEDS; FODDER; FODDER FOR ANIMALS, NAMELY, OIL SEED MEAL EXTRACTIONS FROM SOY AND CANOLA, PALM KERNEL EXPELLER, COCONUT EXPELLER, SUGAR BEET PULP; ANCILLARY PROCESSED GRAIN PRODUCTS FOR COW FEED, NAMELY, DDGS BEING DRIED STILLAGE; UNPROCESSED CORN PRODUCTS FOR ANIMAL FEEDING PURPOSES, NAMELY, CORN GERM MEAL AND CORN GLUTEN MEAL; UNPROCESSED ANIMAL FEED BARLEY; UNPROCESSED MALTING BARLEY; UNPROCESSED CORN; UNPROCESSED RYE; UNPROCESSED WHEAT; UNPROCESSED SORGHUM; UNPROCESSED DURUM; UNPROCESSED FIELD PEAS; FODDER IN PELLET FORM, NAMELY, CITRUS PELLETS; FODDER FOR ANIMALS, NAMELY, GLYCERIN FEED (U.S. CLS. 1 AND 46).

**CLASS 35—ADVERTISING AND BUSINESS**

FOR ADVERTISING; BUSINESS MANAGEMENT; BUSINESS ADMINISTRATION AND OFFICE WORK; RETAIL ELECTRICITY PROVIDER SERVICES, NAMELY, PROVIDING A SERVICE THAT ALLOWS CUSTOMERS TO PURCHASE ENERGY, NAMELY, ELECTRICITY; RETAIL AND WHOLESALE STORE SERVICES FEATURING COAL; PROCUREMENT SERVICES, NAMELY, PROCUREMENT OF CONTRACTS FOR OTHERS FOR THE PURCHASE OF ENERGY; PROCUREMENT, NAMELY, PURCHASING GRAIN, OIL SEED, AND FODDER FOR OTHERS; INTERMEDIARY SERVICES RELATING TO THE NEGOTIATING AND CONCLUDING OF BUSINESS TRANSACTIONS AND AGREEMENTS FOR THIRD PARTIES; INTERMEDIARY SERVICES RELATING TO THE NEGOTIATING AND CONCLUDING OF BUSINESS TRANSACTIONS FOR THIRD PARTIES; INTERMEDIARY SERVICES RELATING TO THE NEGOTIATING AND CONCLUDING OF BUSINESS TRANSACTIONS AND AGREEMENTS FOR THIRD PARTIES IN THE ENERGY PROCUREMENT AND SUPPLY SECTORS; INTERMEDIARY SERVICES RELATING TO THE NEGOTIATING AND CONCLUDING OF BUSINESS TRANSACTIONS AND AGREEMENTS FOR THIRD PARTIES IN THE GRAIN, OIL SEED, AND FEEDING AGENT SECTORS; BUSINESS MANAGEMENT FOR COMMERCIAL AND SERVICE COMPANIES; COMPILING AND SYSTEMATIZING OF PRICE AND STATISTICAL INFORMATION REGARDING COMMERCE AND TRADE IN COMPUTER DATABANKS; CONDUCTING AND ANALYZING MARKET ANALYSES; DRAFTING OF MARKET REPORTS; CONDUCTING AND ANALYZING STATISTICAL ANALYSES FOR BUSINESS PURPOSES; PROVIDING AGRICULTURAL POLICY INFORMATION REGARDING COMMERCIAL AND BUSINESS MATTERS; COMPILING COMMERCIAL INFORMATION IN COMPUTER DATABANKS; MARKET RESEARCH REGARDING COMMERCIAL MATTERS (U.S. CLS. 100, 101 AND 102).

**CLASS 36—INSURANCE AND FINANCIAL**

FOR INSURANCE CLAIMS PROCESSING; FINANCIAL ADVICE; FOREIGN EXCHANGE TRANSACTIONS; LEASING OF REAL ESTATE; FINANCING OF LOANS; BROKERAGE SERVICES FOR FINANCING AND FINANCIAL INVESTMENTS; CO<sub>2</sub> EMISSIONS TRADE BROKERAGE ACTIVITIES; BROKERING FINANCIAL INVESTMENTS IN COMPANIES ACTIVE IN THE ENERGY PROCUREMENT AND ENERGY SUPPLY SECTORS; BROKERING FINANCIAL INVESTMENTS IN COMPANIES ACTIVE IN THE FUELS AND ELECTRIC ENERGY TRADE; SECURITY BROKERAGE SERVICES INCLUDING, BUT NOT LIMITED TO, TRADE IN COMMODITY CERTIFICATES AND EMISSIONS LEGAL CERTIFICATES; BROKERING ASSET INVESTMENTS INCLUDING, BUT NOT LIMITED TO, CAPITAL INVESTMENTS, FINANCING, AND INSURANCE MATTERS; CURRENCY EXCHANGE AND FOREIGN CURRENCY ADVICE; FINANCING AND LOAN SERVICES, NAMELY, BROKERING AND AWARDED LOANS, PROVIDING LOAN ADVICE, FINANCING OF LOANS, MORTGAGES, AND SECURITY, AND EFFECTING LOAN-RELATED TRANSACTIONS FINANCE SERVICES (U.S. CLS. 100, 101 AND 102).

**CLASS 39—TRANSPORTATION AND STORAGE**

FOR TRANSPORT, PACKAGING AND STORAGE OF GOODS; TRANSPORT LOGISTICS, NAMELY, SEARCH AND DISPOSITION OF FREIGHT HOLDS AND CARGO, NAMELY, PROVIDING INFORMATION CONCERNING COLLECTION AND DELIVERY OF ASSETS IN TRANSIT, NAMELY, CARGO AND DELIVERY CONTAINERS; SHIP TRANSPORT; FREIGHTING BROKERING SHIP CARGO; FREIGHTING TRANSPORT OF GOODS BY SHIP; TRANSPORT OF OIL SEEDS, FODDERS, FERTILIZERS, AND GRAIN BY SHIP; TRANSPORT BROKERAGE SERVICES, NAMELY, OFFERING FREIGHTING RATES; TRANSPORT, DISTRIBUTION, AND DELIVERY OF ENERGY AND FUELS BY MEANS OF DISTRIBUTION NETWORKS AND BY MEANS OF SERVICE

AGREEMENTS WITH THIRD PARTIES; WAREHOUSING, TRANSPORT, AND DISTRIBUTION OF ENERGY AND FUELS BY MEANS OF PIPING AND BY MEANS OF SERVICE AGREEMENTS WITH THIRD PARTIES; WAREHOUSING, TRANSPORT, AND DISTRIBUTION OF ENERGY, FUELS, AND COMMODITIES, NAMELY, BIOMASS FROM AGRICULTURE AND FORESTRY FOR ENERGY EXTRACTION; FREIGHTING OF SHIPS FOR TRANSPORT AND DISTRIBUTION OF ENERGY, FUELS, AND COMMODITIES, NAMELY, BIOMASS FROM AGRICULTURE AND FORESTRY FOR ENERGY EXTRACTION (U.S. CLS. 100 AND 105).

**CLASS 41—EDUCATION AND ENTERTAINMENT**

FOR PUBLISHING MARKET REPORTS, MARKET AND AGRICULTURAL POLICY INFORMATION IN THE FORM OF PRINTED MATTER (U.S. CLS. 100, 101 AND 107).

KEVIN MITTLER, EXAMINING ATTORNEY

SN 79-136,287. KLEMSAN ELEKTRIK ELEKTRONIK SANAYI VE TICARET ANONIM SIRKETI, TR-35170 KEMLPASA, IZMIR, TURKEY, FILED 1-23-2013.



OWNER OF INTERNATIONAL REGISTRATION 1175955 DATED 1-23-2013, EXPIRES 1-23-2023.

THE COLOR(S) ORANGE IS/ARE CLAIMED AS A FEATURE OF THE MARK.

THE MARK CONSISTS OF THE TERM "KLEMSAN" IN STYLIZED, ORANGE FONT.

**CLASS 9—ELECTRICAL AND SCIENTIFIC APPARATUS**

FOR APPARATUS AND EQUIPMENT USED IN MEASURING AND EVALUATION, NAMELY, ELECTRICAL TERMINAL BLOCKS FOR USE IN SCIENTIFIC, LABORATORY, NAUTICAL, TOPOGRAPHY, METEOROLOGY, ELECTRIC, PHOTOGRAPHY, CINEMATOGRAPHY, INDUSTRIAL AND OPTICAL AREAS; TOOLS AND APPARATUS FOR ELECTRICITY TRANSMISSION, CONVERSION, INSTALLATION, ADJUSTMENT, MANAGEMENT AND ADMINISTRATION FOR POWERFUL FIELD TECHNIQUES, NAMELY, ELECTRICAL DUCTS, ELECTRONIC DEVICES, NAMELY, ENERGY METERS FOR TRACKING AND MONITORING ENERGY USAGE, POWER LINE CONDITIONERS, ELECTRICAL SIGNAL ATTENUATORS, ELECTRONIC CONTROLLERS FOR USE WITH POWER CONVERTERS, ELECTRONIC CONTROLLERS USED TO REDUCE POWER CONSUMPTION, TIMERS, ELECTRICAL COMPONENTS IN THE NATURE OF PROTECTION RELAYS, ELECTRIC CONDUCTOR RAILS, ELECTRICAL TERMINATORS, CURRENT TRANSFORMERS AND ELECTRICAL POWER SUPPLIES; APPARATUS AND EQUIPMENT FOR TESTING MATERIALS, NAMELY, AMMETERS AND VOLTMETERS; ELECTRONIC COMPONENTS USED IN MACHINERY AND DEVICES, NAMELY, SEMI-CONDUCTORS, ELECTRONIC CIRCUITS, COMPUTER AND SILICON CHIPS, PHOTOCELLS, CIRCUIT BOARDS, CAPACITORS IN THE NATURE OF CONDENSERS, INTERFACE CIRCUITS FOR VIDEO CAMERAS AND INTERFACE CARDS FOR DATA PROCESSING EQUIPMENT IN THE FORM OF PRINTED CIRCUITS; HEAT SENSORS IN THE NATURE OF THERMISTORS; CONVERTERS; COUNTERS, NAMELY, ELECTRIC POWER METERS, WATER METERS, GAS COUNTERS IN THE NATURE OF GAS METERS, TIMERS; ELECTRICAL EQUIPMENT, NAMELY, PLUGS, SOCKETS, JUNCTION BOXES, SWITCHES, CIRCUIT BREAKERS, CIRCUIT INTERRUPTERS, FUSES, LIGHTING BALLASTS, ELEVATOR ELECTRIC CONTROL PANELS, ELECTRIC CONNECTORS; CABLE DUCTS IN THE NATURE OF DUCTING FOR ELECTRIC CABLES, ELECTRIC SWITCHES, RE-

SISTORS, CONNECTION PARTS USED IN ELECTRICAL AND ELECTRONICS IN THE NATURE OF ELECTRIC CONNECTORS AND ELECTRIC SOCKETS; ELECTRIC DOOR BELLS, ALARMS EXCEPT VEHICLE ALARMS, SIRENS; WIRES, NAMELY, ELECTRIC AND ELECTRONIC CABLES, OPTICAL FIBERS, FIBER OPTIC CABLES; POWER SUPPLIES, NAMELY, ACCUMULATORS, SOLAR CELLS, BATTERIES, UNINTERRUPTED ELECTRICAL POWER SUPPLIES; LIGHTNING CONDUCTORS, SURGE ARRESTERS IN THE NATURE OF VOLTAGE SURGE SUPPRESSORS (U.S. CLS. 21, 23, 26, 36 AND 38).

### CLASS 35—ADVERTISING AND BUSINESS

FOR THE BRINGING TOGETHER, FOR THE BENEFIT OF OTHERS A VARIETY OF GOODS, EXCLUDING THE TRANSPORT THEREOF, ENABLING CUSTOMERS TO CONVENIENTLY VIEW AND PURCHASE THOSE GOODS, NAMELY, WHOLESALE STORE SERVICES, RETAIL STORE SERVICES AND MAIL ORDER GENERAL MERCHANDISE CATALOGUE SERVICES, AND WEB-BASED CATALOG SERVICES, ALL FEATURING A VARIETY OF APPARATUS AND EQUIPMENT USED IN MEASURING AND EVALUATION IN SCIENTIFIC, LABORATORY, NAUTICAL, TOPOGRAPHY, METEOROLOGY, ELECTRIC, PHOTOGRAPHY, CINEMATOGRAPHY, INDUSTRIAL AND OPTICAL AREAS, APPARATUS AND EQUIPMENT FOR TESTING MATERIALS, NAMELY, AMMETERS, VOLTMETERS, ELECTRONIC COMPONENTS USED IN MACHINERY AND DEVICES, NAMELY, SEMI-CONDUCTORS, ELECTRONIC CIRCUITS, CHIPS, PHOTOCELLS, CIRCUIT BOARDS, CAPACITORS, INTERFACE CIRCUITS, HYBRID CYCLES, THERMISTORS IN THE NATURE OF HEAT SENSORS, CONVERTERS, COUNTERS, NAMELY, ELECTRIC POWER METERS, WATER, METERS, GAS COUNTERS, AND TIMERS, AND ELECTRICAL EQUIPMENT, NAMELY, PLUGS, SOCKETS, JUNCTION BOXES, SWITCHES, CIRCUIT BREAKERS, CIRCUIT INTERRUPTERS AND CIRCUIT SEPARATORS, FUSES, BALLASTS, STARTERS, ELECTRICAL PANELS, ELEVATOR CONTROL PANELS, CONNECTORS, PIPES USED IN ELECTRICITY, CABLE DUCTS, ELECTRIC SWITCHES, RESISTORS, CONNECTION PARTS USED IN ELECTRICAL AND ELECTRONICS IN THE NATURE OF CONNECTORS AND SOCKETS AND TOOLS AND APPARATUS FOR ELECTRICITY TRANSMISSION, CONVERSION, INSTALLATION, ADJUSTMENT, MANAGEMENT AND ADMINISTRATION FOR POWERFUL FIELD TECHNIQUES, AND ELECTRIC BELLS, ALARMS EXCEPT VEHICLE ALARMS, SIRENS, CABLES, WIRES, NAMELY, CABLES USED IN ELECTRIC AND ELECTRONIC, OPTICAL FIBERS, FIBER OPTIC CABLES, POWER SUPPLIES, NAMELY, ACCUMULATORS, SOLAR CELLS, CELLS, BATTERIES, UNINTERRUPTED POWER SUPPLIES, LIGHTNING CONDUCTORS, SURGE ARRESTERS (U.S. CLS. 100, 101 AND 102).

ANDREA K. NADELMAN, EXAMINING ATTORNEY

### CLASS 18—LEATHER GOODS

FOR LUGGAGE; WALLETS; PURSES; UMBRELLAS; BAGS, NAMELY, HANDBAGS, BAGS FOR SPORT, BACKPACKS, BEACH BAGS, CARRY-ON BAGS, DUFFLE BAGS, MESSENGER BAGS, WASH BAGS FOR CARRYING TOILETRIES, TOTE BAGS, CLUTCH BAGS, HOBO BAGS, DRAWSTRING BAGS, COSMETIC BAGS, SOLD EMPTY; OVERNIGHT BAGS, SHOULDER BAGS, TRAVEL BAGS, WHEELED BAGS, ALL-PURPOSE CARRYING BAGS; BRIEFCASES, CARRYING CASES; LEATHER GOODS, NAMELY, CREDIT CARD CASES, CREDIT CARD HOLDERS, DOCUMENT CASES, HOLLERS, JEWELLERY POUCHES, KEY CASES, BOXES MADE OF LEATHER, BUSINESS CARD CASES, WALLETS INCLUDING CARD HOLDERS, CARD WALLETS (U.S. CLS. 1, 2, 3, 22 AND 41).

### CLASS 25—CLOTHING

FOR CLOTHING, NAMELY, COATS, JACKETS, CASUAL JACKETS, WATERPROOF AND WEATHERPROOF JACKETS AND COATS, PARKAS, GILETS; TROUSERS, JEANS, PANTS, SHORTS, SPORT SHORTS, SHIRTS, T-SHIRTS, POLO SHIRTS; SPORT SHIRTS, SOCCER AND RUGBY SHIRTS, TOPS, SWEATSHIRTS, SWEATERS, PULLOVERS, HOODED PULLOVERS, FLEECE PULLOVERS, HOODED SWEATSHIRTS, BLAZERS, CARDIGANS, DRESSES, TIGHTS, SKIRTS, LEGGINGS, BLOUSES, TUNICS, VESTS, UNDERWEAR, UNDER GARMENTS, SWIMWEAR, SWIM SHORTS, BIKINIS, SURF WEAR, LOUNGEWEAR, SLEEPWEAR, PYJAMAS, SCARVES, SHAWLS, SOCKS, GLOVES, WRIST WARMERS, NECK TIES, MUFFS, EAR MUFFS; FOOTWEAR; HEADGEAR, NAMELY, HATS, CAPS AND HEADBANDS; BELTS (U.S. CLS. 22 AND 39).

DEBORAH LOBO, EXAMINING ATTORNEY

SN 79-136,724. DAKO DENMARK A/S, DK-2600 GLOSTRUP, DENMARK, FILED 8-9-2013.

# DAKO OMNIS

THE MARK CONSISTS OF STANDARD CHARACTERS WITHOUT CLAIM TO ANY PARTICULAR FONT, STYLE, SIZE, OR COLOR.

PRIORITY DATE OF 2-12-2013 IS CLAIMED.

OWNER OF INTERNATIONAL REGISTRATION 1177111 DATED 8-9-2013, EXPIRES 8-9-2023.

OWNER OF U.S. REG. NOS. 1,220,474, 3,807,228 AND OTHERS.

### CLASS 1—CHEMICALS

FOR CHEMICALS FOR USE IN INDUSTRY AND SCIENCE; CHEMICAL REAGENTS FOR NON-MEDICAL PURPOSES; DIAGNOSTIC REAGENTS AND PREPARATIONS, EXCEPT FOR MEDICAL OR VETERINARY USE; DIAGNOSTIC PREPARATIONS FOR CLINICAL OR MEDICAL LABORATORY USE; DIAGNOSTIC PREPARATIONS USED IN SCIENCE; CHEMICAL REAGENTS AND DIAGNOSTIC PREPARATIONS FOR USE IN RESEARCH LABORATORIES AND FOR USE IN INDUSTRY (U.S. CLS. 1, 5, 6, 10, 26 AND 46).

### CLASS 5—PHARMACEUTICALS

FOR PHARMACEUTICAL AND VETERINARY PREPARATIONS FOR THE TREATMENT OF INFECTIOUS DISEASES, CANCER AND OTHER IMMUNODEFICIENCY DISEASES; CHEMICAL REAGENTS AND DIAGNOSTIC PREPARATIONS FOR MEDICAL AND VETERINARY PURPOSES; MEDICAL DIAGNOSTIC REAGENTS; CLINICAL MEDICAL REAGENTS (U.S. CLS. 6, 18, 44, 46, 51 AND 52).

SN 79-136,548. WEIRD FISH LIMITED, UNITED KINGDOM, FILED 4-24-2013.

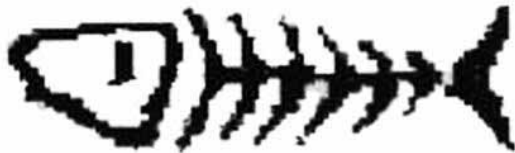

OWNER OF INTERNATIONAL REGISTRATION 1176681 DATED 4-24-2013, EXPIRES 4-24-2023.

THE MARK CONSISTS OF A STYLIZED FISH SKELETON.

**CLASS 9—ELECTRICAL AND SCIENTIFIC APPARATUS**

FOR DIAGNOSTIC APPARATUS AND INSTRUMENTS, NOT FOR MEDICAL PURPOSES, NAMELY, APPARATUS FOR STAINING AND/OR VISUALIZATION OF TISSUE OR CELL BASED SAMPLES FOR DIAGNOSTIC OR SCIENTIFIC USE; APPARATUS FOR DETECTION OF TISSUE AND/OR CELL BASED SAMPLES NOT FOR MEDICAL PURPOSES AND SCIENTIFIC APPARATUS FOR HIGH SPEED CELL AND/OR BEAD SORTING AND ANALYSIS; RECORDED AND DOWNLOADABLE SOFTWARE FOR IDENTIFYING AND DIAGNOSING CANCER AND OTHER IMMUNODEFICIENCY DISEASES AND PROCESSING DIGITAL IMAGES; RECORDED AND DOWNLOADABLE BIOINFORMATICS-ENABLED DIAGNOSTIC SOFTWARE FOR IDENTIFYING AND DIAGNOSING CANCER AND OTHER IMMUNODEFICIENCY DISEASES; ANALYSIS APPARATUS FOR LABORATORY USE FOR ANALYZING THE RESULTS OF TISSUES AND CELL BASED SAMPLES OBTAINED THROUGH OPERATION OF TISSUE AND CELL SAMPLE STAINING APPARATUS, HIGH SPEED CELL AND/OR BEAD SORTING APPARATUS AND BIOINFORMATICS-ENABLED DIAGNOSTIC SOFTWARE DATA; MEASURING APPARATUS USED TO IDENTIFY AND/OR DIAGNOSE CANCER AND OTHER IMMUNODEFICIENCY DISEASES, NOT FOR MEDICAL USE (U.S. CLS. 21, 23, 26, 36 AND 38).

SN 79-136,892. HAYASHIGO CO., LTD., OSAKA 541-0056, JAPAN, FILED 6-10-2013.

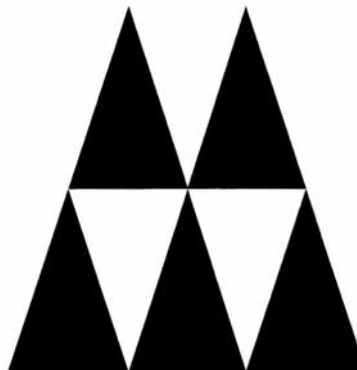

PRIORITY DATE OF 2-5-2013 IS CLAIMED.  
OWNER OF INTERNATIONAL REGISTRATION 1177564  
DATED 6-10-2013, EXPIRES 6-10-2023.

THE MARK CONSISTS OF TWO TRIANGLES SITTING ON TOP OF THREE TRIANGLES. THE SPACE IN BETWEEN THE TRIANGLES CREATES A NEGATIVE SPACE WHERE TWO UPSIDE DOWN TRIANGLES ARE FORMED.

**CLASS 10—MEDICAL APPARATUS**

FOR DIAGNOSTIC APPARATUS AND INSTRUMENTS FOR MEDICAL USE, NAMELY, APPARATUS FOR STAINING AND/OR VISUALIZATION OF TISSUE OR CELL BASED SAMPLES FOR DIAGNOSTIC OR MEDICAL USE; APPARATUS FOR DETECTION OF TISSUE AND/OR CELL BASED SAMPLES AND APPARATUS FOR HIGH SPEED CELL AND/OR BEAD SORTING AND ANALYSIS, ALL FOR MEDICAL PURPOSES; MEDICAL ANALYSIS AND MEDICAL MEASURING APPARATUS, NAMELY, MEDICAL DIAGNOSTIC INSTRUMENTS FOR THE ANALYSIS OF BODY FLUIDS AND TISSUE FOR MEDICAL DIAGNOSTIC USES (U.S. CLS. 26, 39 AND 44).

**CLASS 14—JEWELRY**

FOR BRACELETS; TRINKETS, NAMELY, NECKLACES, MEDALS, SILVER THREAD; BROOCHES; TIE CLIPS; ORNAMENTAL COINS OF PRECIOUS METAL FOR CLOTHING OR BAGS; JEWELRY; MEDALLIONS; PEARLS; ARTIFICIAL JEWELS; RINGS; EARRINGS; JEWELRY, NAMELY, PERSONAL ORNAMENTS; JEWELRY, NAMELY, ORNAMENTS FOR SHOES; PINS BEING JEWELRY; KEY RINGS OF PRECIOUS METAL; CLOCKS; WRIST WATCHES; JEWELRY CASES; SEMI-WROUGHT PRECIOUS STONES AND THEIR IMITATIONS (U.S. CLS. 2, 27, 28 AND 50).

**CLASS 42—SCIENTIFIC AND COMPUTER SERVICES**

FOR MEDICAL RESEARCH; INSTALLATION AND INTEGRATION OF SOFTWARE, INCLUDING WITHIN EXISTING HOSPITAL AND LABORATORY INFRASTRUCTURE; MAINTENANCE, SERVICING, UPDATING AND UPGRADING OF SOFTWARE; ALL THE AFOREMENTIONED FOR USE IN CONNECTION WITH MEDICAL ANALYSIS, DIAGNOSIS AND RESEARCH (U.S. CLS. 100 AND 101).

HAI-LY LAM, EXAMINING ATTORNEY

**CLASS 16—PAPER GOODS AND PRINTED MATTER**

FOR PHOTO ALBUMS; SCRAPBOOKS; LOOSE-LEAF BINDERS; NOTE BOOKS; LETTER TRAYS; POSTCARDS; BLANK CARDS; BLANK NOTE CARDS; BUSINESS CARDS; CARD FILES; CHRISTMAS CARDS; CORRESPONDENCE CARDS; GREETING CARDS; MAILING LABELS NOT OF TEXTILE; POSTERS; BOOKS IN THE FIELD OF FASHION; ADVERTISING PAMPHLETS; PHOTOGRAPH STANDS; INDUSTRIAL PACKAGING CONTAINER OF PAPER OR PLASTIC; BOXES OF PAPER; PEN CLIPS FOR OFFICES; PAPER CLIPS FOR OFFICES; DOCUMENT FILES; PAPER FOLDERS; CARD FILES FOR OFFICES; LETTER FILES FOR OFFICES; WRAPPING PAPER; WRAPPING BOXES; PAPER CLIPS; HOLDERS FOR ADDRESS STAMPS, DATE STAMPS, MARKING STAMPS, NAME STAMPS, NUMBER STAMPS AND STAMP INKS; STANDS FOR PENS AND PENCILS; DESKTOP STATIONERY CABINETS; PEN CASES WITH FASTENERS IN THE NATURE OF FOLDERS; HOLDERS FOR DOCUMENTS; STATIONERY; DESKTOP BUSINESS CARD HOLDERS; DESKTOP REVOLVING ROTARY CARD FILES; HOLDERS SPECIALLY ADAPTED FOR HOLDING GREETING CARDS; PAPER BOXES FOR STORING GREETING CARDS; PRINTED MATTER, NAMELY, CATALOGUES, CALENDARS, PAMPHLETS AND PICTURE BOOKS (U.S. CLS. 2, 5, 22, 23, 29, 37, 38 AND 50).

**CLASS 18—LEATHER GOODS**

FOR LEATHER, UNWORKED OR SEMI-WORKED; IMITATION LEATHER; CATTLE HIDE; PURSES; POCKET WALLETS; LEATHER WALLETS; LEATHER KEY CASES; LEATHER HOLDER FOR CHEQUES; LEATHER HOLDER FOR PASSPORTS; DOCUMENT PORTFOLIOS; NAME CARD CASES; BUSINESS CARD CASES; COMMUTER PASS CASES; TRAVELLING TRUNKS; RUCKSACKS; WHEELED SHOPPING BAGS; ATTACHÉ CASES; ALL-PURPOSE CARRYING BAGS FOR CLIMBERS; BEACH BAGS; HANDBAGS; TOTE BAGS; BOSTON BAGS; SHOULDER BAGS; SUITCASES; BAGS FOR SPORTS; GENERAL PURPOSE SPORT TROLLEY BAGS; LEATHER AND IMITATION LEATHER SPORT BAGS AND GENERAL PURPOSE TROLLEY BAGS; BAGS OF LEATHER, FOR PACKAGING; POUCHES, OF LEATHER, PACKAGING; CLOTH BAGS FOR PACKAGING; BRIEFCASE; LEATHER POUCHES FOR USE IN TRAVELING KITS; TRAVELLING BAGS; LUGGAGE AND TRUNKS; VANITY CASES SOLD EMPTY, NOT FITTED; HAVERSACKS; LEATHER STRAPS; BANDS OF LEATHER, NAMELY, BELLY BANDS FOR DOGS AND HARNESS STRAPS; LEATHER SHOULDER BELTS; ALL-PURPOSE CARRYING BAGS; FELT POUCHES; POUCHES MADE OF CLOTH; INDUSTRIAL PACKAGING CONTAINERS OF LEATHER; HANDBAG FRAMES; PURSE FRAMES (U.S. CLS. 1, 2, 3, 22 AND 41).

JASON BLAIR, EXAMINING ATTORNEY

SN 79-136,977. SARONG SOCIETA' PER AZIONI, ITALY, FILED 9-10-2013.



OWNER OF INTERNATIONAL REGISTRATION 1060109 DATED 8-11-2010, EXPIRES 8-11-2020.

THE MARK CONSISTS OF THE DESIGN OF A SQUARE WITH ROUNDED CORNERS AND A CURVED BAND BISSECTING THE SQUARE FROM THE TOP RIGHT CORNER AND OUT THE BOTTOM RIGHT CORNER.

**CLASS 6—METAL GOODS**

FOR CONTAINERS OF METAL, NAMELY, METAL STORAGE CONTAINERS FOR TRANSPORT OR SHIPPING, METAL STORAGE CONTAINERS FOR MEDICATIONS, FOOD, BEVERAGE, COSMETICS PRODUCTS, LIQUIDS; SHEETS OF METAL, NAMELY, SHEET METAL; SHEETS OF METAL INCLUDING THOSE FROM ALLOY STEEL AND TITANIUM; SHEETS OF METAL FOR PACKAGING, NAMELY, METAL BINDING STRIPS USED ON PACKAGING, FOILS OF METAL FOR WRAPPING AND PACKAGING (U.S. CLS. 2, 12, 13, 14, 23, 25 AND 50).

**CLASS 7—MACHINERY**

FOR MACHINE TOOLS FOR FORMING, RIVETING, SWAGING, AND FLARING OF METAL AND PLASTICS; MACHINE TOOLS, NAMELY, ROTARY DIES FOR CUTTING BOXES FOR PACKAGING INDUSTRY; PACKAGING MACHINES; PACKING MACHINES; CANNING MACHINES; MACHINES FOR WORKING PLASTICS, NAMELY, MACHINES FOR PLASTIC WORKING, SEALING MACHINES FOR INDUSTRIAL PURPOSES, NAMELY, THERMOFORMING MACHINES AND HOT SEALING MACHINES; DIE-STAMPING MACHINES (U.S. CLS. 13, 19, 21, 23, 31, 34 AND 35).

**CLASS 16—PAPER GOODS AND PRINTED MATTER**

FOR PAPER SHEETS, NAMELY, PAPER FOR WRAPPING AND PACKAGING MEDICATIONS, FOOD, BEVERAGE, COSMETICS PRODUCTS, LIQUIDS AND FOR GENERAL USE; PLASTIC SHEETS, NAMELY, PLASTIC FILM FOR USE AS WRAPPING AND PACKAGING MATERIAL FOR MEDICATIONS, FOOD, BEVERAGE, COSMETICS PRODUCTS, LIQUIDS AND FOR GENERAL USE; STARCH SHEETS FOR PACKAGING, NAMELY, PACKAGING AND CONTAINERS COMPRISED OF STARCH-BASED MATERIALS IN THE NATURE OF A PAPER SUBSTITUTE FOR FOOD, BEVERAGES AND CONSUMER PRODUCTS (U.S. CLS. 2, 5, 22, 23, 29, 37, 38 AND 50).

**CLASS 17—RUBBER GOODS**

FOR PLASTIC SHEETS FOR USE IN THE MANUFACTURE OF PACKAGING CONTAINERS (U.S. CLS. 1, 5, 12, 13, 35 AND 50).

**CLASS 20—FURNITURE AND ARTICLES NOT OTHERWISE CLASSIFIED**

FOR CONTAINERS FOR COMMERCIAL USE, NAMELY, CONTAINERS, NOT OF METAL FOR BEVERAGE, FOOD, COSMETIC PRODUCTS, MEDICATIONS, LIQUID PRODUCTS, LIQUID SOLUTIONS; CONTAINERS, NAMELY, CONTAINERS, NOT OF METAL FOR COMMERCIAL USE; CONTAINERS FOR MEDICATIONS SOLD EMPTY FOR COMMERCIAL USE; PLASTIC MEDICATION CONTAINERS FOR COMMERCIAL USE; NON-METAL AND NON-PAPER CONTAINERS FOR STORAGE OR TRANSPORT OF FOOD, BEVERAGES OR MEDICINES; NON-METALLIC CONTAINERS FOR COMMERCIAL USE, NAMELY, CONTAINERS FOR TRANSPORT; NON-METALLIC CONTAINERS FOR COMMERCIAL USE MADE FROM SHEETS, NAMELY, CONTAINERS, NOT OF METAL FOR BEVERAGE, FOOD, COSMETIC PRODUCTS, MEDICATIONS, LIQUID PRODUCTS; NON-METALLIC CONTAINERS FOR COMMERCIAL USE MADE FROM SHEETS, NAMELY, CONTAINERS, NOT OF METAL FOR COMMERCIAL USE; NON-METALLIC CONTAINERS FOR COMMERCIAL USE MADE FROM SHEETS, NAMELY, CONTAINERS FOR TRANSPORT, NOT OF METAL; NON-METALLIC CONTAINERS FOR COMMERCIAL USE MADE FROM SHEETS, NAMELY, PACKAGING CONTAINERS OF PLASTIC (U.S. CLS. 2, 13, 22, 25, 32 AND 50).

**CLASS 39—TRANSPORTATION AND STORAGE**

FOR PACKAGING FOR OTHERS, NAMELY, MERCHANDISE PACKAGING FOR OTHERS; PACKAGING FOR OTHERS, NAMELY, PACKAGING ARTICLES TO THE ORDER AND SPECIFICATION OF OTHERS; PACKING OF GOODS FOR OTHERS, NAMELY, PACKING ARTICLES FOR TRANSPORTATION; PACKING OF GOODS FOR OTHERS, NAMELY, MERCHANDISE PACKAGING FOR OTHERS; PACKING OF GOODS FOR OTHERS, NAMELY, PACKING ARTICLES FOR TRANSPORTATION AND PACKAGING ARTICLES TO THE ORDER AND SPECIFICATION OF OTHERS (U.S. CLS. 100 AND 105).

**CLASS 40—MATERIAL TREATMENT**

FOR PROCESSING OF SHEET MATERIALS FOR OTHERS, NAMELY, PROCESSING OF PLASTICS; PROCESSING OF SHEET MATERIALS FOR OTHERS, NAMELY, METAL HEAT TREATING SERVICES BY MEANS OF FORMING AND SEALING (U.S. CLS. 100, 103 AND 106).

JEANIE LEE, EXAMINING ATTORNEY

SN 79-137,018. LISA CLARK, AUSTRALIA, AND TONY CLARK, AUSTRALIA, FILED 2-28-2013.

SN 79-137,007. YUEQING JIAHUA; IMPORT & EXPORT CO., LTD., ZHEJIANG, CHINA, FILED 5-7-2013.

# BOSKY

PRIORITY DATE OF 11-21-2012 IS CLAIMED.  
OWNER OF INTERNATIONAL REGISTRATION 1177757  
DATED 5-7-2013, EXPIRES 5-7-2023.

THIS TRADEMARK HAS NO MEANING AND ALSO EXPRESSES NO GEOGRAPHY APPELLATION.

**CLASS 7—MACHINERY**

FOR MACHINES FOR PLASTICS WORKING; AGRICULTURAL MACHINES, NAMELY, MOWING MACHINE; METALWORKING MACHINE TOOLS; METALWORKING MACHINES, NAMELY, MACHINING CENTERS; OIL FIELD EQUIPMENT, NAMELY, DRILLING RIG MECHANIZATION MACHINES AND DEVICES; PNEUMATIC VALVE ACTUATORS; ELECTRIC WELDING MACHINES; MIXING MACHINES; AUTOMATED MACHINES FOR THE MANUFACTURE OF CIGARETTES; ASSEMBLY LINES, NAMELY, A SERIES OF MACHINES FOR ASSEMBLING ELECTRIC TOOLS IN SUCCESSIVE STAGES; ENGRAVING MACHINES; BALL VALVES BEING PARTS OF MACHINES; BEARINGS, AS PARTS OF MACHINES; GARBAGE DISPOSALS; SAW MACHINES; DRILLING MACHINES; ELECTRIC HAMMERS; METAL WORKING MACHINES; BLADES FOR POWER TOOLS; POWER DRILL BITS; CEMENTED CARBIDE CUTTING TOOLS; POWER-OPERATED HAND-HELD CRIMPERS; ELECTRIC SCREWDRIVERS; PAINT SPRAY GUNS (U.S. CLS. 13, 19, 21, 23, 31, 34 AND 35).

**CLASS 8—HAND TOOLS**

FOR HAND TOOLS, NAMELY, HAMMERS; HAND TOOLS, NAMELY, REAMERS; HAND TOOLS, NAMELY, MILLING CUTTERS; BIT BRACES FOR MANUAL DRILLS; SCREWDRIVERS; HAND TOOLS, NAMELY, PUNCHES; HAND-OPERATED CUTTING TOOLS; HAND TOOLS, NAMELY, DRILLS; GLAZIERS' DIAMONDS BEING PARTS OF HAND TOOLS (U.S. CLS. 23, 28 AND 44).

**CLASS 9—ELECTRICAL AND SCIENTIFIC APPARATUS**

FOR WEIGHING APPARATUS AND INSTRUMENTS; MICROMETER GAUGES; LENGTH MEASURING GAUGES; TELEMETERS; LEVEL GAUGES; ELECTRIC WIRES AND CABLES; CLOSED CIRCUIT TV SYSTEMS FOR SECURITY AND SURVEILLANCE, NAMELY, CAMERAS, SWITCHES, MONITORS, MICROPHONES, AND RECORDERS; VOLTAGE TESTERS; APPARATUS AND INSTRUMENTS FOR CONVEYING, DISTRIBUTING, TRANSFORMING, STORING, REGULATING OR CONTROLLING ELECTRIC CURRENT; REMOTE CONTROL TELEMETERING MACHINES AND APPARATUS (U.S. CLS. 21, 23, 26, 36 AND 38).

LINDA MICKLEBURGH, EXAMINING ATTORNEY

# Litetrex

THE MARK CONSISTS OF STANDARD CHARACTERS WITHOUT CLAIM TO ANY PARTICULAR FONT, STYLE, SIZE, OR COLOR.

OWNER OF INTERNATIONAL REGISTRATION 1177795  
DATED 2-28-2013, EXPIRES 2-28-2023.

**CLASS 22—CORDAGE AND FIBERS**

FOR BAGS, BEING ENVELOPES AND POUCHES, OF TEXTILE, FOR PACKAGING; BAGS OR SACKS FOR PACKAGING MATERIALS IN BULK; BAGS OR SACKS FOR THE TRANSPORT AND STORAGE OF MATERIALS IN BULK; BAGS FOR STORAGE PURPOSES, NAMELY, STORAGE BAGS FOR BELONGINGS, STORAGE BAGS FOR CAMPING ITEMS, STORAGE BAGS FOR BEDDING ITEMS, STORAGE BAGS FOR OUTDOOR GOODS, STORAGE BAGS FOR DEFENSE PURPOSES, STORAGE BAGS FOR OUTDOOR USE, STORAGE BAGS FOR INDOOR USE, STORAGE BAGS FOR DISASTER RELIEF AND STORAGE BAGS FOR MATERIAL AID; BAGS IN THE NATURE OF SACKS, NAMELY, BIVOUAC SACKS, SACKS FOR THE STORAGE OF MATERIALS IN BULK; BAGS MADE OF TEXTILE FOR THE STORAGE OF TENTS; BAGS MADE OF TEXTILE MATERIAL FOR PACKAGING; BODY BAGS; MAIL BAGS; SACKS OR BAGS OF TEXTILE FOR PACKAGING; SAIL STORAGE BAGS; CAMPING TENTS; TENTS; TENTS OR AWNINGS NOT OF METAL FOR CARAVANS; TENTS OR AWNINGS NOT OF METAL FOR VEHICLES; TENTS FOR CAMPING; TENTS FOR MOUNTAINEERING; TENTS FOR USE AS AN ADJUNCT TO VEHICLES; TENTS MADE OF TEXTILE MATERIALS; FABRIC IN THE FORM OF A CANOPY COVER; LAUNDRY SACKS; SACKS FOR THE STORAGE OF MATERIALS; SACKS FOR THE TRANSPORT OF MATERIALS; SACKS FOR TRANSPORTING WASTE; SACKS MADE OF TEXTILE MATERIALS; STRAPS MADE OF PLASTIC MATERIALS FOR TYING PURPOSES FOR SECURING CAMPING GOODS, OUTDOOR GOODS, INDOOR GOODS, DEFENSE GOODS AND DISASTER RELIEF GOODS; STRAPS MADE OF PLASTIC MATERIALS FOR WRAPPING PURPOSES; BEACH AWNINGS AND CANOPIES, NOT OF METAL; CANOPIES BEING AWNINGS, NOT OF METAL; SHADE AWNINGS AND CANOPIES, NOT OF METAL; SHADE CLOTH, NAMELY, AWNINGS; SHADE SAILS; FABRIC ROOFED STRUCTURES, NAMELY, TENTS AND BIVOUACS; TEMPORARY STRUCTURES MADE OF FABRICS, NAMELY, TENTS AND BIVOUACS; MATERIAL FOR MAKING SAILS, NAMELY, SAIL CLOTH AND SAIL THREAD; PADDING AND STUFFING MATERIALS EXCEPT OF RUBBER, PAPER OR PLASTICS; COCOONS; COVERINGS IN THE NATURE OF TARPAULINS; TARPAULINS; WATERPROOF COVERS BEING TARPAULINS; SCREENS FOR PROTECTION AGAINST THE WIND; OUTDOOR SUN SCREENS, OF TEXTILE; WINDBREAKS BEING PROTECTION SCREENING; FLEXIBLE CONTAINERS IN THE NATURE OF SACKS FOR THE TRANSPORTATION OR STORAGE OF MATERIALS IN BULK; GROUND-SHEETS; MARKET AWNINGS AND CANOPIES, NOT OF METAL; VEHICLE COVERS NOT FITTED (U.S. CLS. 1, 2, 7, 19, 22, 42 AND 50).

**CLASS 24—FABRICS**

FOR BREATHABLE WATERPROOF FABRICS FOR MANUFACTURING CLOTHING, FURNITURE, AUTOMOBILE UPHOLSTERY, AND LUGGAGE; CHEMICAL FIBER LOOP KNIT FABRICS; CHEMICAL FIBER MIXED FABRICS; COATED POLYESTER FABRICS; COATED NYLON FABRICS; NATURAL OR SYNTHETIC FABRIC; NATURAL OR SYNTHETIC FABRIC COATED WITH RUBBER POLYVINYL CHLORIDE, POLYURETHANE, SILICONE ELASTOMER, FLUOROPOLYMERS, WAX OR PLASTICS; COATED TEXTILE FABRIC FOR FOOTWEAR; FABRIC FOR USE IN THE MANUFACTURE OF BAGS; FABRIC FOR USE IN THE MANUFACTURE OF CLOTHING; FABRICS BEING TEXTILE GOODS IN ROLL FORM; COATED FABRICS FOR FURNITURE; FABRICS FOR INTERIOR DECORATING; FABRICS FOR TEXTILE USE; FABRICS MADE FROM SYNTHETIC THREADS; FABRICS MADE FROM SYNTHETIC YARNS; FLAME RESISTANT FABRICS FOR MANUFACTURE OF BEDDING, CAMPING ITEMS, RECREATIONAL ITEMS, CLOTHING, FOOTWEAR, TENTS, BACKPACKS, BIVOUACS, WINDBREAKS, AWNINGS AND UPHOLSTERY; HEAT RESISTANT FABRICS OTHER THAN FOR INSULATION; HORTICULTURAL FABRICS FOR PROTECTING CROPS, GREENHOUSE USE, GROUNDCOVER AND BLOCKING WEEDS; INDUSTRIAL FABRICS FOR THE MANUFACTURE OF BEDDING, CLOTHING, FOOTWEAR, TENTS, BIVOUACS, BACKPACKS, WINDBREAKS, AWNINGS, PRODUCTS FOR DISASTER RELIEF USE, DEFENSE USE, AND UPHOLSTERED FURNITURE; INORGANIC FIBER MIXED FABRICS; KNITTED FABRIC; MIXED AND SYNTHETIC FABRICS; MULTIPLE-PLY ANTISTATIC FABRICS; NON-WOVEN FABRICS OF SYNTHETIC FIBERS; NON-WOVEN TEXTILE FABRICS; POLYMER COATED FABRICS FOR THE MANUFACTURE OF BEDDING, CLOTHING, FOOTWEAR, TENTS, BIVOUACS, BACKPACKS, WINDBREAKS, AWNINGS, PRODUCTS FOR DISASTER RELIEF USE, DEFENSE USE, AND UPHOLSTERED FURNITURE; WATER BREATHABLE FABRICS FOR THE MANUFACTURE OF BEDDING, CLOTHING, FOOTWEAR, TENTS, BIVOUACS, BACKPACKS, WINDBREAKS, AWNINGS, PRODUCTS FOR DISASTER RELIEF USE, DEFENSE USE AND UPHOLSTERED FURNITURE; WATER RESISTANT FABRICS FOR THE MANUFACTURE OF BEDDING, CLOTHING, FOOTWEAR, TENTS, BIVOUACS, BACKPACKS, WINDBREAKS, AWNINGS, PRODUCTS FOR DISASTER RELIEF USE, DEFENSE USE AND UPHOLSTERED FURNITURE; WATERPROOF FABRICS FOR THE MANUFACTURING CLOTHING, FOOTWEAR, TENTS, BIVOUACS, BACKPACKS, WINDBREAKS, AWNINGS, PRODUCTS FOR DISASTER RELIEF USE, DEFENSE USE, FURNITURE, AUTOMOBILE UPHOLSTERY, AND LUGGAGE; COATED TEXTILES FOR MANUFACTURING CLOTHING, FOOTWEAR, TENTS, BIVOUACS, BACKPACKS, WINDBREAKS, AWNINGS, PRODUCTS FOR DISASTER RELIEF USE, DEFENSE USE, FURNITURE, AUTOMOBILE UPHOLSTERY AND LUGGAGE; COATED WOVEN TEXTILE MATERIALS FOR MANUFACTURING CLOTHING, FOOTWEAR, TENTS, BIVOUACS, BACKPACKS, WINDBREAKS, AWNINGS, PRODUCTS FOR DISASTER RELIEF USE, DEFENSE USE, FURNITURE, AUTOMOBILE UPHOLSTERY AND LUGGAGE; LABELS MADE OF TEXTILE MATERIALS; OUTDOOR BLINDS OF TEXTILE; TEXTILE GOODS, NAMELY, A SYNTHETIC SHEET WITH FRAGRANCE FOR THE PURPOSE OF INSERTING INTO PILLOW SLIP AND UNDER FITTED SHEET TO EMIT FRAGRANCE; TEXTILES, NAMELY, A SYNTHETIC SHEET WITH FRAGRANCE FOR THE PURPOSE OF INSERTING INTO PILLOW SLIP AND UNDER FITTED SHEET TO EMIT FRAGRANCE; TEXTILES MADE OF SYNTHETIC MATERIALS FOR

MANUFACTURING CLOTHING, FOOTWEAR, TENTS, BIVOUACS, BACKPACKS, WINDBREAKS, AWNINGS, PRODUCTS FOR DISASTER RELIEF USE, DEFENSE USE, FURNITURE, AUTOMOBILE UPHOLSTERY AND LUGGAGE; TEXTILES TREATED WITH A FIRE RESISTANT FINISH FOR MANUFACTURING CLOTHING, FOOTWEAR, TENTS, BIVOUACS, BACKPACKS, WINDBREAKS, AWNINGS, PRODUCTS FOR DISASTER RELIEF USE, DEFENSE USE, FURNITURE, AUTOMOBILE UPHOLSTERY AND LUGGAGE; TEXTILES TREATED WITH A FLAME RESISTANT FINISH FOR MANUFACTURING CLOTHING, FOOTWEAR, TENTS, BIVOUACS, BACKPACKS, WINDBREAKS, AWNINGS, PRODUCTS FOR DISASTER RELIEF USE, DEFENSE USE, FURNITURE, AUTOMOBILE UPHOLSTERY AND LUGGAGE; SLEEPING BAG SHEET LINERS; OIL, LINEN, FLAX, SILK CLOTH; BANNERS OF TEXTILE (U.S. CLS. 42 AND 50).

ZACHARY CROMER, EXAMINING ATTORNEY

SN 79-137,154. RUSMASTER LIMITED LIABILITY COMPANY, RU-105318 MOSCOW, RUSSIAN FED., FILED 7-17-2013.

# KAISER

OWNER OF INTERNATIONAL REGISTRATION 1178138 DATED 7-17-2013, EXPIRES 7-17-2023.

**CLASS 19—NON-METALLIC BUILDING MATERIALS**

FOR FLOORS NOT METAL; PARQUET FLOORING; PARQUET FLOOR BOARDS; LAMINATED PARQUET FLOORING; MASSIVE FLOOR BOARDS, MADE OF WOOD; SUBSTRATE FOR LAMINATED PARQUET FLOORING, NAMELY, FLOORING UNDERLAYMENT MADE OF PLASTIC OR CORK; PROFILED LATHS, NOT OF METAL; WOOD PANELING; DOOR SILLS, NOT OF METAL; ARCHITECTURAL MOLDINGS, NOT OF METAL, FOR FLOOR (U.S. CLS. 1, 12, 33 AND 50).

**CLASS 27—FLOOR COVERINGS**

FOR FLOOR COVERINGS; CARPET UNDERLAY (U.S. CLS. 19, 20, 37, 42 AND 50).

JEANIE LEE, EXAMINING ATTORNEY

SN 79-137,266. NAF NEUNKIRCHENER ACHSENFABRIK AG, 91077 NEUNKIRCHEN, FED REP GERMANY, FILED 9-5-2013.

# PBBS

THE MARK CONSISTS OF STANDARD CHARACTERS WITHOUT CLAIM TO ANY PARTICULAR FONT, STYLE, SIZE, OR COLOR.

OWNER OF INTERNATIONAL REGISTRATION 1178500 DATED 9-5-2013, EXPIRES 9-5-2023.



**CLASS 12—VEHICLES**

FOR VEHICLES, NAMELY, LAND VEHICLES; HYDRAULIC CIRCUITS FOR VEHICLES; HYDROMOTORS FOR LAND VEHICLES; GEAR BOXES FOR LAND VEHICLES, IN PARTICULAR POWER SHIFT TRANSMISSIONS, GEAR BOXES, GEAR ATTACHMENTS, STEP-DOWN GEARS, TRANSMISSIONS AND HYDRAULIC GEARS; VEHICLE AXLES, IN PARTICULAR STEERING-TYPE AXLES, EPICYCLIC STEERING-TYPE GEARS, RIGID AXLES, EPICYCLIC FULL FLOATING AXLES AND TANDEM AXLES; AUTOMOBILE BODIES; TRANSMISSION SHAFTS FOR LAND VEHICLES; TRANSMISSION CHAINS FOR LAND VEHICLES; BRAKES FOR VEHICLES; CLUTCHES AND AUTOMATIC COUPLINGS FOR MOTOR VEHICLES; TORSION BAR FOR AUTOMOBILES (U.S. CLS. 19, 21, 23, 31, 35 AND 44).

**CLASS 40—MATERIAL TREATMENT**

FOR MANUFACTURE OF DRIVE COMPONENTS FOR MOTOR VEHICLES, IN PARTICULAR FOR WORK MACHINES AND VEHICLES, AND SPECIAL-PURPOSE VEHICLES, TO ORDER AND/OR SPECIFICATION OF OTHERS; MANUFACTURE OF BRAKE SYSTEMS FOR MOTOR VEHICLES, IN PARTICULAR FOR WORK MACHINES AND VEHICLES, AND SPECIAL-PURPOSE VEHICLES, TO ORDER AND/OR SPECIFICATION OF OTHERS (U.S. CLS. 100, 103 AND 106).

**CLASS 42—SCIENTIFIC AND COMPUTER SERVICES**

FOR PRODUCT DEVELOPMENT, NAMELY, DEVELOPMENT OF DRIVE COMPONENTS FOR MOTOR VEHICLES, IN PARTICULAR FOR WORK MACHINES AND VEHICLES, AND SPECIAL-PURPOSE VEHICLES, FOR OTHERS; PRODUCT DEVELOPMENT, NAMELY, DEVELOPMENT OF BRAKE SYSTEMS FOR MOTOR VEHICLES, IN PARTICULAR FOR WORK MACHINES AND VEHICLES, AND SPECIAL-PURPOSE VEHICLES, FOR OTHERS (U.S. CLS. 100 AND 101).

ALAIN LAPTER, EXAMINING ATTORNEY

SN 79-137,377. JOE & THE JUICE A/S, DENMARK, FILED 9-4-2013.

# Joe & the Juice

THE MARK CONSISTS OF STANDARD CHARACTERS WITHOUT CLAIM TO ANY PARTICULAR FONT, STYLE, SIZE, OR COLOR.

OWNER OF INTERNATIONAL REGISTRATION 1178711 DATED 9-4-2013, EXPIRES 9-4-2023.

OWNER OF U.S. REG. NOS. 3,885,639 AND 4,085,961.

**CLASS 30—STAPLE FOODS**

FOR COFFEE, TEA, COCOA, SUGAR, RICE, TAPIOCA, SAGO, ARTIFICIAL COFFEE, FLOUR AND PREPARATIONS MADE FROM CEREALS, NAMELY, READY TO EAT CEREAL DERIVED FOOD BARS; BREAD, PASTRY AND CONFECTIONERY, NAMELY, CAKES; FLAVORED ICES, HONEY, TREACLE, YEAST, BAKING POWDER, SALT, MUSTARD, VINEGAR, SAUCES (CONDIMENTS), SPICES, ICE (U.S. CL. 46).

**CLASS 32—LIGHT BEVERAGES**

FOR BEER, MINERAL AND AERATED WATERS AND OTHER NON-ALCOHOLIC DRINKS, NAMELY, IN THE NATURE OF SWEET CIDER; FRUIT DRINKS AND FRUIT JUICES, SYRUPS AND OTHER PREPARATIONS FOR MAKING BEVERAGES (U.S. CLS. 45, 46 AND 48).

**CLASS 43—HOTEL AND RESTAURANT SERVICES**

FOR SERVICES FOR PROVIDING FOOD AND DRINK, PROVIDING TEMPORARY ACCOMMODATION (U.S. CLS. 100 AND 101).

THOMAS MANOR, EXAMINING ATTORNEY

SN 79-137,439. KLARNA AB, SWEDEN, FILED 8-1-2013.



OWNER OF INTERNATIONAL REGISTRATION 1178877 DATED 8-1-2013, EXPIRES 8-1-2023.

THE MARK CONSISTS OF A STYLIZED LETTER "K".

**CLASS 35—ADVERTISING AND BUSINESS**

FOR ADVERTISING; BUSINESS MANAGEMENT; BUSINESS ADMINISTRATION; OFFICE FUNCTIONS SERVICES, NAMELY, TRACKING AND TRACING OF DOCUMENTS, LETTERS, PACKAGES, AND PARCELS IN TRANSIT; DESIGN OF BUSINESS SURVEYS FOR OTHERS; CONDUCTING BUSINESS AND MARKET RESEARCH SURVEYS FOR OTHERS; BUSINESS ENQUIRIES AND INVESTIGATIONS; BUSINESS INFORMATION; INVOICING; BOOK-KEEPING SERVICES; COMPUTERIZED FILE MANAGEMENT (U.S. CLS. 100, 101 AND 102).

**CLASS 36—INSURANCE AND FINANCIAL**

FOR INSURANCE, NAMELY, INSURANCE CONSULTANCY, INSURANCE INFORMATION; FINANCIAL AFFAIRS, NAMELY, FINANCIAL ADVICE, FINANCIAL INFORMATION, FINANCIAL MANAGEMENT AND FINANCIAL ANALYSIS SERVICES; MONETARY AFFAIRS, NAMELY, PROVIDING MONETARY EXCHANGE, ACQUISITION AND TRANSFER OF MONETARY CLAIMS; ELECTRONIC PAYMENT SERVICES, NAMELY, PROVIDING ELECTRONIC PROCESSING OF ACH AND CREDIT CARD TRANSACTIONS AND ELECTRONIC PAYMENTS VIA A GLOBAL COMPUTER NETWORK; BILL PAYMENT SERVICES; CREDIT INFORMATION SERVICES, NAMELY, BUSINESS CREDIT REPORTING SERVICES; EVALUATION OF THE CREDIT WORTHINESS OF COMPANIES AND PRIVATE INDIVIDUALS; PROVIDING OF LENDING AND CREDIT SERVICES; PROVIDING OF FACTORING SERVICES; DEBT COLLECTION SERVICES (U.S. CLS. 100, 101 AND 102).

**CLASS 42—SCIENTIFIC AND COMPUTER SERVICES**

FOR DESIGN AND DEVELOPMENT OF COMPUTER HARDWARE AND SOFTWARE FOR OTHERS; COMPUTER PROGRAMMING FOR OTHERS; DESIGN AND DEVELOPMENT OF SOFTWARE APPLICATIONS FOR USE MOBILE TELEPHONES FOR OTHERS; PROVIDING TEMPORARY USE OF ONLINE NON-DOWNLOADABLE COMPUTER SOFTWARE FOR ELECTRONIC PAYMENT, NAMELY, PROVIDING TEMPORARY USE OF ONLINE NON-DOWNLOADABLE COMPUTER SOFTWARE FOR USE IN PREPARING, PROCESSING AND TRACKING ELECTRONIC PAYMENT TRANSACTIONS; PROVIDING TEMPORARY USE OF ONLINE NON-DOWNLOADABLE COMPUTER SECURITY SOFTWARE FOR USE IN VERIFYING AND CONTROLLING ACCESS TO AND COMMUNICATION WITH COMPUTERS AND COMPUTER NETWORKS, NAMELY, SOFTWARE FOR ACCESSING THE INTERNET, PROVIDING OF TEMPORARY USE OF ONLINE NON-DOWNLOADABLE MOBILE APPLICATION COMPUTER SOFTWARE FOR FINANCIAL TRANSACTIONS, NAMELY, SOFTWARE FOR PROCESSING FINANCIAL TRANSACTION PAYMENTS (U.S. CLS. 100 AND 101).

**CLASS 45—PERSONAL AND LEGAL SERVICES**

FOR LEGAL SERVICES; SECURITY SERVICES FOR THE PROTECTION OF PROPERTY AND INDIVIDUALS, NAMELY, COMPUTER SECURITY ASSURANCE AND ADMINISTRATION OF DIGITAL KEYS AND DIGITAL CERTIFICATES, MONITORING OF COMPUTER SYSTEMS FOR SECURITY PURPOSES, PROVIDING USER AUTHENTICATION SERVICES IN E-COMMERCE TRANSACTIONS; PERSONAL BACKGROUND INVESTIGATIONS (U.S. CLS. 100 AND 101).

SAIMA MAKHDOOM, EXAMINING ATTORNEY

**CLASS 7—MACHINERY**

FOR MOTORS AND ENGINES EXCEPT FOR LAND VEHICLES, INCLUDING GEAR MOTORS, SPUR WHEEL BACK-GEARED MOTORS, WORM GEAR MOTORS, FRICTION GEAR MOTORS, BEVEL GEAR MOTORS, PLANETARY BACK-GEARED MOTORS, GEAR MOTORS WITH ELECTRONIC SPEED REGULATORS, SHADE-POLE MOTORS, CAPACITOR MOTORS, COMPOSITE MOTORS, COMPOSITE ROTARY MOTORS, THREE-PHASE MOTORS, SERVOMOTORS, EC MOTORS, PUMP, FAN, BLOWER AND STIRRER MOTORS; MOTORS AND ENGINES EXCEPT FOR LAND VEHICLES, NAMELY, SPUR WHEEL BACK-GEARED MOTORS AND PLANETARY BACK-GEARED MOTORS, FOR PHOTOCOPYING EQUIPMENT, OFFICE MACHINES, MECHANICAL ENGINEERING, THE CONSTRUCTION OF APPARATUS, ELECTRONIC EQUIPMENT, THE CONSTRUCTION OF AUTOMATIC MACHINES, GALVANISING APPARATUS, CAPSTAN DRIVES, AUTOMATIC DATA PROCESSING MACHINES, ADVERTISING EQUIPMENT, DENTAL EQUIPMENT, ROLLER DRIVES, FEEDING AND ADJUSTING DRIVES AND TEXTILE MACHINES; MOTORS AND ENGINES EXCEPT FOR LAND VEHICLES, NAMELY, BEVEL GEAR MOTORS, WORM GEAR MOTORS AND OTHER ANGULAR GEAR MOTORS, FOR THE CONSTRUCTION OF AUTOMATIC MACHINES, SWITCHING APPARATUS, THE CONSTRUCTION OF MACHINES, PRECISION ENGINEERING APPARATUS, THE CONSTRUCTION OF ELECTRIC EQUIPMENT AND APPARATUS, FOR ELECTRO-MEDICAL PURPOSES, CHEMICAL EQUIPMENT AND LABORATORY EQUIPMENT; MOTORS AND ENGINES EXCEPT FOR LAND VEHICLES, NAMELY, SHADE-POLE MOTORS FOR FAN HEATERS, VENTILATORS, PROJECTORS, PHOTOCOPYING EQUIPMENT, PRINTING MACHINES, PROGRAMMABLE SWITCH SYSTEMS, AUTOMATIC MACHINES, MEDICAL EQUIPMENT, PHOTOGRAPHIC AND PHONOGRAPH EQUIPMENT AND MACHINE TOOLS; BRAKES FOR MACHINES (U.S. CLS. 13, 19, 21, 23, 31, 34 AND 35).

**CLASS 9—ELECTRICAL AND SCIENTIFIC APPARATUS**

FOR DATA PROCESSING APPARATUS AND COMPUTERS, BLANK MAGNETIC DATA CARRIERS (U.S. CLS. 21, 23, 26, 36 AND 38).

**CLASS 42—SCIENTIFIC AND COMPUTER SERVICES**

FOR RESEARCH AND DEVELOPMENT IN THE FIELDS OF NATURAL AND ENGINEERING SCIENCES; ENGINEERING; CREATING AND UPDATING COMPUTER SOFTWARE AND COMPUTER PROGRAMS FOR OTHERS; COMPUTER SOFTWARE AND COMPUTER PROGRAM DESIGN; COMPUTER PROGRAMS AND DATA FOR DATA PROCESSING; RENTAL OF COMPUTER SOFTWARE AND COMPUTER PROGRAMS FOR DATA PROCESSING; HOSTING OF DATABASES FOR OTHERS (U.S. CLS. 100 AND 101).

BILL DAWE, EXAMINING ATTORNEY

SN 79-137,447. HEIDRIVE GMBH & CO.KG, FED REP GERMANY, FILED 4-15-2013.

# HEIDRIVE

THE MARK CONSISTS OF STANDARD CHARACTERS WITHOUT CLAIM TO ANY PARTICULAR FONT, STYLE, SIZE, OR COLOR.

OWNER OF INTERNATIONAL REGISTRATION 1178910 DATED 4-15-2013, EXPIRES 4-15-2023.

THE WORDING "HEIDRIVE" HAS NO MEANING IN A FOREIGN LANGUAGE.

SN 79-137,490. CHIC SPÓLKA Z OGRANICZONA ODPOWIEDZIALNOSCIA SPÓLKA KOMANDYTOWA, OSTRZESZOW, POLAND, FILED 8-9-2013.



**mild**  
more than a cigarette

PRIORITY DATE OF 5-24-2013 IS CLAIMED.  
OWNER OF INTERNATIONAL REGISTRATION 1179053 DATED 8-9-2013, EXPIRES 8-9-2023.

NO CLAIM IS MADE TO THE EXCLUSIVE RIGHT TO USE "MILD", APART FROM THE MARK AS SHOWN.

THE COLOR(S) ORANGE, BLACK AND WHITE IS/ARE CLAIMED AS A FEATURE OF THE MARK.

THE WORD "MILD", WHICH IS SITUATED IN AN UPPER ROW, IS WRITTEN WITH A BIGGER, SIGNIFICANTLY BOLD FONT, OF AN ORANGE COLOUR; THE LOWERCASE LETTER "I" USED IN THE WORD "MILD" DOES NOT CONTAIN A DOT; THE PHRASE "MORE THAN A CIGARETTE", WHICH IS SITUATED IN A LOWER ROW, IS WRITTEN WITH A SMALLER, BOLD FONT, OF A BLACK COLOUR; THE MARK HAS A WHITE BACKGROUND.

#### CLASS 5—PHARMACEUTICALS

FOR TOBACCO-FREE CIGARETTES FOR MEDICAL PURPOSES; AMPOULES AND REFILL CARTRIDGES FILLED WITH FLAVORED LIQUIDS FOR TOBACCO-FREE CIGARETTES FOR MEDICAL PURPOSES; FLAVORED LIQUIDS FOR TOBACCO-FREE CIGARETTES FOR MEDICAL PURPOSES (U.S. CLS. 6, 18, 44, 46, 51 AND 52).

#### CLASS 9—ELECTRICAL AND SCIENTIFIC APPARATUS

FOR ELECTRIC ACCUMULATORS FOR ELECTRONIC CIGARETTES; ELECTRIC BATTERIES FOR ELECTRONIC CIGARETTES; LIGHT-EMITTING DIODES LED; ELECTRIC DOSAGE DISPENSERS/DOSIMETERS; CHARGERS FOR ELECTRIC ACCUMULATORS (U.S. CLS. 21, 23, 26, 36 AND 38).

#### CLASS 34—SMOKERS' ARTICLES

FOR ELECTRONIC CIGARETTES; ELECTRONIC CIGARETTE REFILL AMPOULES SOLD EMPTY; ELECTRONIC CIGARETTE REFILL CARTRIDGES SOLD EMPTY; AMPOULES AND CARTRIDGES SOLD EMPTY FOR ELECTRONIC CIGARETTES; MOUTHPIECES FOR ELECTRONIC CIGARETTES (U.S. CLS. 2, 8, 9 AND 17).  
AISHA CLARKE, EXAMINING ATTORNEY

SN 79-137,516. SOCIETE HARRIS WILSON TEXTILES SA, F-59100 ROUBAIX, FRANCE, FILED 6-27-2013.

# HARRISWILSON

THE MARK CONSISTS OF STANDARD CHARACTERS WITHOUT CLAIM TO ANY PARTICULAR FONT, STYLE, SIZE, OR COLOR.

PRIORITY DATE OF 1-30-2013 IS CLAIMED.  
OWNER OF INTERNATIONAL REGISTRATION 1179120 DATED 6-27-2013, EXPIRES 6-27-2023.

THE NAME(S), PORTRAIT(S), AND/OR SIGNATURE(S) SHOWN IN THE MARK DOES NOT IDENTIFY A PARTICULAR LIVING INDIVIDUAL.

#### CLASS 18—LEATHER GOODS

FOR LEATHER AND IMITATIONS OF LEATHER; PURSES; LEATHER KEY CASES; ATTACHÉ CASES; BUSINESS CARD CASES; DOCUMENT HOLDERS; WALLETS; LEATHER COIN PURSES; HANDBAGS; BRIEF-CASES; LEATHER BAGS; BACKPACKS; BEACH BAGS; TRAVEL BAGS; GARMENT BAGS FOR TRAVEL; VANITY CASES SOLD EMPTY (U.S. CLS. 1, 2, 3, 22 AND 41).

#### CLASS 25—CLOTHING

FOR UNDERWEAR FOR MEN, WOMEN AND CHILDREN; BLOUSONS AND JACKETS; RAINCOATS; COATS; MITTENS; OVERCOATS; TRENCH COATS; PARKAS; PELERINES; PELISSES; STUFF JACKETS; SUITS; JACKETS; OVERALLS; APRONS; COMBINATIONS; CARDIGANS; PULLOVERS; SWEATSHIRTS; SWEATERS; KNITWEAR, NAMELY, SWEATERS; TANK TOPS; VESTS; SKIRTS; PETTICOATS; TROUSERS; CAPRI PANTS; JEANS; TAPERED PANTS; BIB OVERALLS; DRESSES; SHIRTS; SHORT-SLEEVE SHIRTS; TEE-SHIRTS; SHORTS; BERMUDA SHORTS; TOP COATS; PAJAMAS; ROBES; DRESSING GOWNS; BRIEFS; JERSEYS; LEOTARDS; BUSTIERS; BREECHES FOR WEAR; UNDERPANTS; BRASSIERES; SOCKS; STOCKINGS; TIGHTS; NECKERCHIEFS; SCARVES; SHAWLS; NECKWEAR; SASHES FOR WEAR; GLOVES; BELTS; SUSPENDERS; NECKTIES; BOW TIES; POCKET SQUARES; COLLAR PROTECTORS; FOOTWEAR; BEACH FOOTWEAR; FOOTWEAR FOR SPORTS; BOOTS; HALF-BOOTS; CLOGS; ESPARTO SHOES OR SANDALS; SANDALS; SLIPPERS; BEDROOM SLIPPERS; HATS; HALF VEILS; HEADGEAR, NAMELY, HEADWEAR; CAPS; CAP PEAKS; BERETS; HEADBANDS (U.S. CLS. 22 AND 39).

JANICE L. MCMORROW, EXAMINING ATTORNEY

SN 79-137,592. JGMK TRADEMARK FOR FASHION B.V., NETHERLANDS, FILED 9-6-2013.



PRIORITY DATE OF 5-31-2013 IS CLAIMED.  
OWNER OF INTERNATIONAL REGISTRATION 1179420 DATED 9-6-2013, EXPIRES 9-6-2023.

NO CLAIM IS MADE TO THE EXCLUSIVE RIGHT TO USE "LE SALON DES FEMMES", APART FROM THE MARK AS SHOWN.

THE MARK CONSISTS OF THE WORDING "LE SALON DES FEMMES" IN A STYLIZED FONT WITH A STYLIZED DESIGN COMPRISED OF A LINE WITH THREE CURVATURES SUPERIMPOSED OVER THE WORDING.

THE ENGLISH TRANSLATION OF "LE SALON DES FEMMES" IN THE MARK IS "THE SALON OF WOMEN".

#### CLASS 14—JEWELRY

FOR JEWELRY, NAMELY, BRACELETS, NECKLACES, EARRINGS, BROOCHES, RINGS AND CUFF LINKS; WATCHES (U.S. CLS. 2, 27, 28 AND 50).

#### CLASS 18—LEATHER GOODS

FOR LEATHER AND IMITATIONS OF LEATHER AND GOODS MADE OF THESE MATERIALS, NAMELY, LEATHER BAGS, PURSES AND WALLETS; TRAVELING BAGS; BAGS, NAMELY, HAND BAGS, TOTE BAGS AND SHOPPING BAGS; POCKET WALLETS; UMBRELLAS (U.S. CLS. 1, 2, 3, 22 AND 41).

#### CLASS 25—CLOTHING

FOR CLOTHING, NAMELY, SHIRTS, BLOUSES, T-SHIRTS, SWEATERS, PANTS, JEANS, SKIRTS, DRESSES, BLAZERS, VESTS, JACKETS, COATS, SHAWLS, SCARVES, TIES, SOCKS, AND GLOVES; FOOTWEAR, HEADGEAR, NAMELY, HATS, CAPS AND BEANIES; BELTS (U.S. CLS. 22 AND 39).

KATHRYN COWARD, EXAMINING ATTORNEY

SN 79-137,615. BEIJING REFRESH ENERGY HEALTH TECHNOLOGY CO., LTD., BEIJING, CHINA, FILED 9-13-2013.

LUSJOY

OWNER OF INTERNATIONAL REGISTRATION 1179484 DATED 9-13-2013, EXPIRES 9-13-2023.

### CLASS 3—COSMETICS AND CLEANING PREPARATIONS

FOR MOUTH WASHES, NOT FOR MEDICAL PURPOSES; DENTIFRICES; DENTURE POLISHES; BREATH FRESHENING SPRAYS; DENTAL BLEACHING GELS; COSMETICS; EMERY CLOTH; COLOUR-REMOVING PREPARATIONS FOR HAIR; BLEACHING SALTS (U.S. CLS. 1, 4, 6, 50, 51 AND 52).

### CLASS 10—MEDICAL APPARATUS

FOR DENTAL APPARATUS, NAMELY, APEX LOCATOR; ELECTRIC DENTAL APPARATUS, NAMELY, DENTAL DRILLS; HEARING AIDS FOR THE DEAF; FEEDING BOTTLES; NON-CHEMICAL CONTRACEPTIVES APPARATUS; LENSES BEING INTRAOCULAR PROSTHESES FOR SURGICAL IMPLANTATION; TIPS FOR CRUTCHES FOR INVALIDS; SUTURE MATERIALS (U.S. CLS. 26, 39 AND 44).

KATHY WANG, EXAMINING ATTORNEY

SN 79-137,747. PUTZMEISTER ENGINEERING GMBH, FED REP GERMANY, FILED 9-12-2013.

ESC

THE MARK CONSISTS OF STANDARD CHARACTERS WITHOUT CLAIM TO ANY PARTICULAR FONT, STYLE, SIZE, OR COLOR.

PRIORITY DATE OF 3-22-2013 IS CLAIMED.

OWNER OF INTERNATIONAL REGISTRATION 1179807 DATED 9-12-2013, EXPIRES 9-12-2023.

### CLASS 7—MACHINERY

FOR HYDRAULIC AND PNEUMATIC CONTROLS, NAMELY, FOR CONCRETE PUMPS, MORTAR PUMPS, CONCRETE MIXERS, DRIVING MIXERS FOR CONCRETE, CONVEYORS AND THEIR PARTS (U.S. CLS. 13, 19, 21, 23, 31, 34 AND 35).

### CLASS 9—ELECTRICAL AND SCIENTIFIC APPARATUS

FOR ELECTRIC MEASURING AND CONTROL DEVICES AND INSTRUMENTS FOR USE IN MONITORING AND CONTROL OF MACHINES, NAMELY, PUMPS FOR CONCRETE, MORTAR, AND VISCOUS MATERIAL, CONCRETE MIXERS, DRIVING MIXERS FOR CONCRETE, AND CONVEYORS; COMPUTER PROGRAMS FOR USE IN THE CONTROL AND MONITORING OF MACHINES, NAMELY, PUMPS FOR CONCRETE, MORTAR, AND VISCOUS MATERIAL, CONCRETE MIXERS, DRIVING MIXERS FOR CONCRETE, AND CONVEYORS; ELECTRIC, ELECTRONIC AND ELECTRO-OPTICAL CONTROL AND REGULATION DEVICES FOR USE IN THE CONTROL AND MONITORING OF MACHINES, NAMELY, PUMPS FOR CONCRETE, MORTAR, AND VISCOUS MATERIAL, CONCRETE MIXERS, DRIVING MIXERS FOR CONCRETE, AND CONVEYORS; REMOTE CONTROLS FOR MACHINES, NAMELY, PUMPS FOR CONCRETE, MORTAR, AND VISCOUS MATERIAL, CONCRETE MIXERS, DRIVING MIXERS FOR CONCRETE, AND CONVEYORS (U.S. CLS. 21, 23, 26, 36 AND 38).

STEVEN PEREZ, EXAMINING ATTORNEY

SN 79-137,912. LEONHARD KURZ STIFTUNG & CO. KG, FED REP GERMANY, FILED 3-14-2013.

TRUSTCOLOR

THE MARK CONSISTS OF STANDARD CHARACTERS WITHOUT CLAIM TO ANY PARTICULAR FONT, STYLE, SIZE, OR COLOR.

PRIORITY DATE OF 10-17-2012 IS CLAIMED.

OWNER OF INTERNATIONAL REGISTRATION 1180240 DATED 3-14-2013, EXPIRES 3-14-2023.

### CLASS 9—ELECTRICAL AND SCIENTIFIC APPARATUS

FOR BLANK MAGNETIC DATA CARRIERS; BLANK OPTICAL DATA CARRIERS; PRERECORDED MAGNETIC, OPTICAL, ELECTRIC AND ELECTRONIC INFORMATION CARRIERS CONTAINING DATA FOR IDENTIFICATION OF PERSONS OR OBJECTS AND INFORMATION FOR AUTHENTICATION OF DOCUMENTS OR OBJECTS, IN THE FORM OF FOIL STRIPS, FOIL SHEETINGS AND FOIL BANDS, STICKERS, LABELS, TOKENS, SEALS, VIGNETTES, BANDS, THREADS, DISCS, CARDS AND PLATES, ALL THE AFOREMENTIONED FOR THE STORAGE, MODIFICATION AND/OR REPRODUCTION OF DATA OR INFORMATION, NAMELY, OF DATA OR INFORMATION SERVING THE PURPOSE OF IDENTIFICATION AND/OR AUTHENTICATION; AND ALL THE AFOREMENTIONED GOODS CONTAINING ENCODING DEVICES, DIFFRACTION STRUCTURES, HOLOGRAPHIC STRUCTURES OR OPTICAL LENS STRUCTURES, OR COMBINATIONS THEREOF; OPTICAL IDENTIFICATION DEVICES AND AUTHENTICATION DEVICES, CONTAINING DIFFRACTION STRUCTURES, HOLOGRAPHIC STRUCTURES OR COMBINATIONS THEREOF, NAMELY, FOILS AND FOIL PIECES MADE OF PLASTICS AND/OR METAL WITH SUCH STRUCTURES; OPTICAL SECURITY ELEMENTS IN FORM OF ENCODED INFORMATION CARRIERS FOR BANKNOTES; ELECTRONIC AND NON-ELECTRONIC INFORMATION CARRIERS CARRYING MAGNETICALLY, OPTICALLY, OR ELECTRONICALLY RECORDED OR ENCODED INFORMATION AS IDENTIFICATION DEVICES, AUTHENTICATION DEVICES OR MONEY REPLACEMENT MEANS, IN THE FORM OF TOKENS, CARDS, DISCS, TAGS, BANDS, SHEETS, COVERS, SLEEVES, FOILS AND STAMPING FOILS OF PAPER, PLASTICS AND/OR METAL, THE AFOREMENTIONED GOODS CONTAINING ENCODING DEVICES, DIFFRACTION STRUCTURES AND/OR HOLOGRAPHIC STRUCTURES AND/OR OPTICAL LENS STRUCTURES; SECURITY THREADS IN THE FORM OF NARROW STAMPING FOIL BANDS, TRANSFER FOIL BANDS OR LAMINATING FOIL BANDS FOR IDENTIFICATION

OR AUTHENTICATION PURPOSES CARRYING MAGNETICALLY, OPTICALLY, OR ELECTRONICALLY RECORDED OR ENCODED INFORMATION (U.S. CLS. 21, 23, 26, 36 AND 38).

#### **CLASS 16—PAPER GOODS AND PRINTED MATTER**

FOR STICKERS, LABELS, TOKENS, SEALS, VIGNETTES, BANDS, DISCS, CARDS, SHEETS, AS WELL AS PACKAGING MATERIALS IN FORM OF COVERS, SLEEVES AND FOILS OF PAPER OR OF PLASTICS AND TAGS, BANDS, SHEETS AND FOILS OF PAPER OR PRIMARILY OF PAPER, ALL THE AFOREMENTIONED GOODS USED AS NON-ELECTRONIC INFORMATION CARRIERS AS WELL AS FOR USE WITH IDENTIFICATION OR AUTHENTICATION DEVICES OR FOR IDENTIFICATION PURPOSES OR AUTHENTICATION PURPOSES OR FOR USE WITH PAYMENT MEANS OR WITH MONEY REPLACEMENT MEANS; SELF-ADHESIVE PLASTIC FOILS AND PLASTIC LAMINATE FILMS FOR PACKAGING PURPOSES; PAPER LABELS, LABELS OF PLASTICS AND SELF-ADHESIVE LABELS, NOT OF TEXTILES; FOIL STRIPS AND FOILS OF PLASTICS FOR PACKAGING PURPOSES FOR IDENTIFICATION AND AUTHENTICATION PURPOSES; STAMPING FOILS, HOT STAMPING FOILS, COLD STAMPING FOILS, TRANSFER FOILS AND LAMINATING FOILS, ALSO IN THE FORM OF STRIPS, OF PAPER; STAMPING FOILS, HOT STAMPING FOILS, COLD STAMPING FOILS, TRANSFER FOILS AND LAMINATING FOILS, ALSO IN THE FORM OF STRIPS, OF PLASTICS FOR PACKAGING PURPOSES; STAMPING FOILS AND LAMINATING FOILS PRIMARILY OF PAPER AS WELL AS STAMPING FOILS AND LAMINATING FOILS PRIMARILY OF PLASTICS FOR PACKAGING PURPOSES; ALL THE AFOREMENTIONED FOILS FOR USE WITH IDENTIFICATION DEVICES OR FOR USE WITH AUTHENTICATION DEVICES OR FOR IDENTIFICATION PURPOSES OR AUTHENTICATION PURPOSES AND/OR FOR USE WITH PAYMENT MEANS OR WITH MONEY REPLACEMENT MEANS; PACKAGING COVERS CONSISTING OF FOILS PRIMARILY OF PLASTICS FOR COVERING AND COATING PACKAGING AND PACKAGING MATERIALS (U.S. CLS. 2, 5, 22, 23, 29, 37, 38 AND 50).

#### **CLASS 17—RUBBER GOODS**

FOR SYNTHETIC PLASTIC AS SEMI-FINISHED PRODUCTS IN THE FORM OF TOKENS, SEALS, VIGNETTES, BANDS, THREADS, DISCS, CARDS, SHEETING, PLATES, SHEETS AND FOILS IN THE NATURE OF SEMI-FINISHED GOODS OF PLASTICS OR PRIMARILY OF PLASTICS AS WELL AS LAMINATES OF PLASTICS OR PRIMARILY OF PLASTICS, ALL THE AFOREMENTIONED GOODS INTENDED TO BE USED IN FURTHER MANUFACTURE TO CONTAIN AS A FINAL PRODUCT ENCODING DEVICES AND/OR DIFFRACTION STRUCTURES AND/OR HOLOGRAPHIC STRUCTURES AND/OR OPTICAL LENS STRUCTURES, PARTICULARLY AS NON-ELECTRONIC INFORMATION CARRIERS AS WELL AS FOR IDENTIFICATION OR AUTHENTICATION OR FOR USE WITH IDENTIFICATION DEVICES OR FOR USE WITH AUTHENTICATION DEVICES AND/OR FOR USE WITH PAYMENT MEANS OR WITH MONEY REPLACEMENT MEANS; SYNTHETIC PLASTIC AS SEMI-FINISHED PRODUCTS IN FORM OF FOILS, FOR EVENTUAL USE AS OPTICAL SECURITY DEVICES; SYNTHETIC MATERIALS OF PLASTICS OR POLYMERS FOR FURTHER MANUFACTURE IN FORM OF SLEEVES AND SHEATHS, EXCEPT FOR PACKAGING PURPOSES; SEMI-FINISHED GOODS OF PLASTICS OR PRIMARILY OF PLASTICS, PARTICULARLY IN FORM OF TOKENS, VIGNETTES, BANDS, THREADS, DISCS, CARDS, SHEETING, PLATES, SHEETS AND FOILS AS WELL AS PLASTIC LAMINATES, PARTICULARLY FOR USE IN FURTHER MANUFACTURING DATA CARRIERS AND INFORMATION CARRIERS, IDENTIFICATION OR AUTHENTICATION DEVICES, PAYMENT MEANS OR MONEY REPLACEMENT MEANS; STAMPING FOILS, TRANSFER FOILS AND LAMINATING FOILS MADE OF PLASTIC OR PRIMARILY OF PLASTIC FOR USE IN MANUFACTURING; SEMI-WORKED SYNTHETIC PLASTIC AND SYNTHETIC RESINS AS SEMI-FINISHED PRODUCTS IN THE FORM OF STAMPING FOILS, HOT

STAMPING FOILS, COLD STAMPING FOILS, TRANSFER FOILS AND LAMINATING FOILS AS WELL AS FOIL STRIPS, PARTICULARLY SUCH FOILS INTENDED TO EVENTUALLY CONTAIN AFTER FURTHER MANUFACTURE ENCODING DEVICES AND/OR DIFFRACTION STRUCTURES AND/OR HOLOGRAPHIC STRUCTURES AND/OR OPTICAL LENS STRUCTURES; STAMPING FOILS NOT FOR PACKAGING, HOT STAMPING FOILS, COLD STAMPING FOILS, TRANSFER FOILS, ALSO IN THE FORM OF STRIPS, CONSISTING OF A CARRIER FILM PRIMARILY MADE OF PLASTICS AND AT LEAST ONE TRANSFER LAYER WHICH IS REMOVABLE FROM SAID CARRIER FILM FOR APPLICATION TO A SUBSTRATE FOR USE IN MANUFACTURING; LAMINATING FOILS CONSISTING OF A CARRIER SHEET MATERIAL MADE PRIMARILY OF PLASTICS AND AT LEAST ONE FURTHER LAYER PRIMARILY OF PLASTICS FOR LAMINATING ONTO A SUBSTRATE; BANDS, SHEETS, PRIMARILY OF PLASTICS AND/OR SYNTHETIC MATERIALS, FOR USE IN FURTHER MANUFACTURING (U.S. CLS. 1, 5, 12, 13, 35 AND 50).

#### **CLASS 42—SCIENTIFIC AND COMPUTER SERVICES**

FOR TECHNOLOGICAL CONSULTING IN THE FIELD OF SELECTING, DESIGNING AND DEVELOPING GOODS SUITABLE FOR THEIR INTENDED USES AS WELL AS USING SUCH GOODS FOR IDENTIFICATION AND AUTHENTICATION PURPOSES, NAMELY, CONCERNING POSSIBILITIES OF APPLICATION OF SECURITY ELEMENTS IN THE FORM OF IDENTIFICATION DEVICES, AUTHENTICATION DEVICES AND PRODUCT/RETAIL SECURITY MEANS, PARTICULARLY OF DATA CARRIERS AND INFORMATION CARRIERS IN THE FORM OF FOIL STRIPS, FOIL SHEETS AND FOIL BANDS, STICKERS, LABELS, TOKENS, SEALS, VIGNETTES, BANDS, THREADS, DISCS, CARDS, PLATES, SHEETS AND FOILS OF PLASTICS, OF PAPER OR OF METAL; TECHNOLOGICAL CONSULTING IN THE NATURE OF DESIGNING AND DEVELOPMENT OF ELECTRONIC AND NON-ELECTRONIC SECURITY SYSTEMS AND IN THE NATURE OF SELECTING, DESIGNING AND DEVELOPING PRODUCTS WITH RESPECT TO INCREASING SECURITY AGAINST FORGERY BY USING AND APPLYING SECURITY ELEMENTS IN THE AFOREMENTIONED FORMS ON GOODS, ARTICLES AND/OR THEIR PACKAGING, ON DOCUMENTS, ON PAYMENT MEANS OR ON MONEY REPLACEMENT MEANS; TECHNOLOGICAL CONSULTING CONCERNING THE USE OF STAMPING FOILS, TRANSFER FOILS AND LAMINATING FOILS FOR THE PURPOSES OF SURFACE DECORATION OR APPLICATION OF MARKINGS, OF LETTERING OR OF DECORATION ELEMENTS; TECHNOLOGICAL CONSULTING AND TECHNOLOGICAL SERVICES IN THE NATURE OF PRODUCT DESIGN AND DEVELOPMENT IN THE FIELD OF GOODS USED IN CONNECTION WITH THE PACKAGING, THE MARKING, THE MONITORING AND SUPERVISION, THE IDENTIFICATION, THE TRACKING AND TRACING AND THE SORTING OF GOODS AND OF ARTICLES, AND IN THE NATURE OF DESIGN AND DEVELOPMENT OF MANUFACTURING SYSTEMS AND PACKAGING SYSTEMS, MARKING SYSTEMS, MONITORING AND SUPERVISION SYSTEMS, IDENTIFICATION SYSTEMS, TRACKING AND TRACING SYSTEMS AND SORTING SYSTEMS FOR GOODS AND ARTICLES; TECHNOLOGICAL PLANNING OF SECURITY SYSTEMS, NAMELY, DESIGN AND DEVELOPMENT OF ELECTRONIC AND NON-ELECTRONIC SECURITY SYSTEMS USING SECURITY ELEMENTS, PARTICULARLY FOR ACCESS CONTROL, FOR IDENTIFICATION OF PERSONS AND OBJECTS, FOR AUTHENTICATION OF OBJECTS, PAYMENT MEANS, MONEY REPLACEMENT MEANS AND DOCUMENTS, FOR AUTHENTICATION CHECKS OF DOCUMENTS, OF PAYMENT MEANS AND OF MONEY REPLACEMENT MEANS, FOR DATA PROTECTION AS WELL AS FOR SECURING OF GOODS AGAINST THEFT AND FALSIFICATION (U.S. CLS. 100 AND 101).

GINA FINK, EXAMINING ATTORNEY

SN 79-138,084. COPAN ITALIA S.P.A., I-25125 BRESCIA, ITALY, FILED 4-30-2013.

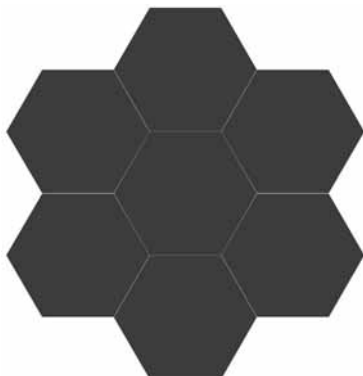

PRIORITY DATE OF 11-6-2012 IS CLAIMED.  
OWNER OF INTERNATIONAL REGISTRATION 1180674 DATED 4-30-2013, EXPIRES 4-30-2023.  
OWNER OF U.S. REG. NO. 4,363,668.  
THE MARK CONSISTS OF SEVEN EQUAL-SIZED HEXAGONS WITH ONE IN THE CENTER AND THE OTHER SIX ARRANGED IN A CIRCULAR, HONEYCOMB DESIGN WITH EACH SHARING ONE INTERIOR SIDE WITH THE CENTER HEXAGON.

#### CLASS 1—CHEMICALS

FOR CHEMICAL TEST PAPER FOR COLLECTING, TRANSPORTING, PRESERVING AND ANALYZING DIAGNOSTIC, BIOLOGICAL AND CHEMICAL SAMPLES; CHEMICAL SUBSTANCES WHICH CAN BE OR ARE APPLIED TO AGENTS AND MATRICES FOR COLLECTING, TRANSPORTING, STORING AND ANALYSIS OF SAMPLES, NOT FOR MEDICAL PURPOSES (U.S. CLS. 1, 5, 6, 10, 26 AND 46).

#### CLASS 9—ELECTRICAL AND SCIENTIFIC APPARATUS

FOR ELECTRIC AND SCIENTIFIC EQUIPMENT FOR USE IN MEDICAL LABORATORIES FOR AUTOMATIC HANDLING OF CLINICAL SAMPLES, NAMELY, ANALYTICAL APPARATUS, SOLD AS UNITS, FOR THE AUTOMATIC INOCULATION ONTO MICROBIOLOGICAL CULTURE-MEDIA PLATES OF SPECIMENS FOR BACTERIOLOGY CULTURE INVESTIGATION, FOR PREPARATION OF MICROSCOPE SLIDES AND OF TEST SAMPLES, SCIENTIFIC RESEARCH EQUIPMENT FOR ROBOTIC MANIPULATING OF CLINICAL SAMPLES AND FOR AUTOMATED ANALYSIS OF IMAGES; MACHINES FOR INOCULATION OF MICROBIOLOGICAL SAMPLES ON CULTURE MEDIA OR CULTURE DISHES FOR ANALYSIS OF MICROBIOLOGICAL CULTURES FOR ANALYTICAL OR SCIENTIFIC USE; DEVICES FOR COLLECTING AND PRESERVING BIOLOGICAL, CHEMICAL OR DIAGNOSTIC SAMPLES, NAMELY, MEDIA FORMULATION AND TEST TUBES FOR USE IN COLLECTING, PRESERVING STABILITY AND TRANSPORT OF MICROBIOLOGY SAMPLES AND BACTERIA FOR DIAGNOSTIC TESTING, NOT FOR MEDICAL PURPOSES; DISPOSABLE DEVICES FOR COLLECTING AND PRESERVING BIOLOGICAL, CHEMICAL OR DIAGNOSTIC SAMPLES, NAMELY, TRANSPORT AND PRESERVATION KITS SOLD AS UNITS CONSISTING OF FLOCKED SWABS AND TEST TUBES CONTAINING MEDIA FORMULATION FOR THE PRESERVATION AND TRANSPORT OF MICROBIOLOGY SAMPLES AND BACTERIA, NOT FOR MEDICAL PURPOSES; FLOCKED AND/OR ABSORBENT PADS FOR COLLECTING BIOLOGICAL, CHEMICAL OR DIAGNOSTIC SAMPLES FOR LABORATORY USE; CONSUMABLES FOR LABORATORY ANALYSIS, NAMELY, TEST TUBES FOR TRANSPORTING AND PRESERVING BIOLOGICAL, CHEMICAL AND DIAGNOSTIC SAMPLES, NOT FOR MEDICAL PURPOSES; CONTAINERS FOR TRANSPORTING AND PRESERVING BIOLOGICAL, CHEMICAL AND DIAGNOSTIC SAMPLES, NAMELY,

TEST TUBES; LABORATORY HAND TOOLS AND INSTRUMENTS, NAMELY, FLOCKED AND/OR ABSORBENT SWABS FOR THE COLLECTION, PRESERVATION AND TRANSPORT OF MICROBIOLOGY SAMPLES AND BACTERIA, NOT FOR MEDICAL PURPOSES (U.S. CLS. 21, 23, 26, 36 AND 38).

#### CLASS 10—MEDICAL APPARATUS

FOR MEDICAL DEVICES IN THE NATURE OF ROBOTIC MACHINES FOR THE DIAGNOSIS OF DISEASE, NAMELY, MACHINES SOLD AS UNITS, FOR USE IN MEDICAL LABORATORIES, FOR AUTOMATIC HANDLING OF CLINICAL SAMPLES, FOR PREPARATION OF MICROSCOPE SLIDES AND OF TEST SAMPLES, FOR ROBOTIC MANIPULATING OF CLINICAL SAMPLES AND FOR AUTOMATED ANALYSIS OF IMAGES; MEDICAL AND/OR SURGICAL INSTRUMENTS AND APPARATUS FOR USE IN MICROBIOLOGY TESTING FOR MEDICAL PURPOSES; MACHINES FOR THE INOCULATION OF MICROBIOLOGICAL SAMPLES ON CULTURE MEDIA OR CULTURE DISHES FOR ANALYSIS OF MICROBIOLOGICAL CULTURES FOR MEDICAL PURPOSES; HAND TOOLS AND INSTRUMENTS, NAMELY, FLOCKED AND/OR ABSORBENT SWABS FOR THE COLLECTION, PRESERVATION AND TRANSPORT OF MICROBIOLOGY SAMPLES AND BACTERIA FOR MEDICAL PURPOSES; BRUSHES FOR CLEANING BODY CAVITIES; APPARATUS FOR MEDICAL USE, NAMELY, TEST TUBES FOR TRANSPORTING AND PRESERVING BIOLOGICAL, CHEMICAL AND DIAGNOSTIC SAMPLES, FOR MEDICAL PURPOSES; DEVICES FOR COLLECTING AND PRESERVING BIOLOGICAL AND CHEMICAL SAMPLES FOR MEDICAL PURPOSES, NAMELY, TEST TUBES AND MEDIA FORMULATION FOR THE PRESERVATION AND TRANSPORT OF MICROBIOLOGY SAMPLES AND BACTERIA, FOR MEDICAL PURPOSES; DISPOSABLE DEVICES FOR COLLECTING AND PRESERVING BIOLOGICAL AND CHEMICAL SAMPLES FOR MEDICAL PURPOSES, NAMELY, TRANSPORT AND PRESERVATION KITS SOLD AS A UNIT, CONSISTING OF FLOCKED SWABS AND TEST TUBES CONTAINING MEDIA FORMULATION FOR THE PRESERVATION AND TRANSPORT OF MICROBIOLOGY SAMPLES AND BACTERIA, FOR MEDICAL PURPOSES; CONTAINERS FOR TRANSPORTING DIAGNOSTIC SAMPLES FOR MEDICAL PURPOSES, NAMELY, TEST TUBES FOR MEDICAL PURPOSES; MEDICAL STORAGE MEDIA FOR USE IN FORENSIC MEDICINE (U.S. CLS. 26, 39 AND 44).

PAULA MAHONEY, EXAMINING ATTORNEY

SN 79-138,121. KABUSHIKI KAISHA HANSHIN METALICS; (DOING BUSINESS AS; HANSHIN METALICS CORP), JAPAN, FILED 7-1-2013.

# Dmet

THE MARK CONSISTS OF STANDARD CHARACTERS WITHOUT CLAIM TO ANY PARTICULAR FONT, STYLE, SIZE, OR COLOR.

PRIORITY DATE OF 5-14-2013 IS CLAIMED.  
OWNER OF INTERNATIONAL REGISTRATION 1180830 DATED 7-1-2013, EXPIRES 7-1-2023.

**CLASS 35—ADVERTISING AND BUSINESS**

FOR ADVERTISING AND PUBLICITY SERVICES; START-UP BUSINESS CONSULTANCY; PROVIDING BUSINESS INFORMATION ON START-UP BUSINESSES; PROVIDING BUSINESS CONSULTANCY AND ADVICE FOR START-UP BUSINESSES; BUSINESS MANAGEMENT CONSULTANCY; PROVIDING INFORMATION ON BUSINESS MANAGEMENT CONSULTANCY; PERSONNEL ADMINISTRATION SERVICES, NAMELY, BUSINESS ADMINISTRATION ASSISTANCE IN THE FIELD OF PERSONNEL; PROVIDING OFFICE FUNCTIONS; ACCOUNTING SERVICES; SALES PROMOTION SERVICES; BUSINESS MANAGEMENT ASSISTANCE SERVICES; MARKETING RESEARCH AND MARKET ANALYSIS; IMPORT-EXPORT AGENCIES; BUSINESS CONSULTANCY AND BUSINESS ASSISTANCE IN THE FIELDS OF BUSINESS TRANSFERS, BUSINESS COLLABORATIONS AND BUSINESS MERGERS; PROVIDING INFORMATION IN BUSINESS MATTERS IN THE FIELD OF CONSULTING AND AGENCY SERVICES OF TRANSFER OF BUSINESS, BUSINESS COLLABORATION AND MERGER; BUSINESS PLANNING IN THE FIELD OF NEW PRODUCTS AND NEW SERVICES; BUSINESS PLANNING AND BUSINESS CONSULTANCY IN THE FIELD OF IMPLEMENTATION SYSTEM OF BUSINESS; STRATEGIC BUSINESS CONSULTANCY AND BUSINESS PLANNING; BUSINESS RESEARCH AND BUSINESS CONSULTANCY IN THE FIELDS OF BUSINESS PROJECTS, PRODUCT CREATION PROCESSES, BUSINESS BETWEEN COMPANIES, COOPERATION BETWEEN COMPANIES AND PRODUCT LIFECYCLE; BUSINESS PLANNING AND BUSINESS CONSULTANCY IN THE FIELD OF BUSINESS PROJECT MANAGEMENT; BUSINESS INFORMATION AND INQUIRIES ON COMPANIES DOING BUSINESS WITH EXPLOITATION OF INTELLECTUAL PROPERTY RIGHTS; RETAIL STORE SERVICES AND WHOLESALE STORE SERVICES FEATURING GOODS IN THE FIELDS OF CLOTHING, FOODS AND BEVERAGES, AND HOUSEWARES; RETAIL STORE SERVICES AND WHOLESALE STORE SERVICES FEATURING PERSONAL ARTICLES, NAMELY, TOWEL, HAND-HELD FANS, GARTERS, SUSPENDERS, WAISTBANDS, HEADBANDS FOR CLOTHING, BELTS FOR CLOTHING, WRISTBANDS, SOCK SUSPENDERS, ARMBAND FOR HOLDING SLEEVES, PERSONAL ORNAMENTS, NAMELY, EARRINGS, TIE PINS, TIE CLIPS, NECKLACES, BRACELETS, PENDANTS, MEDALS, LOCKETS, INSIGNIAS OF PRECIOUS METAL, BADGES OF PRECIOUS METAL, BONNET PINS OF PRECIOUS METAL, RINGS, TRINKET, CUFF LINKS, GEM BROOCHES, BONNET PINS, ORNAMENTAL ADHESIVE PATCHES FOR JACKETS, INSIGNIAS FOR WEAR, BUCKLES FOR CLOTHING, BADGES FOR WEAR, BROOCHES FOR CLOTHING, SPECIAL SASH CLIPS FOR OBI, BRASARDS, HAIR ORNAMENTS, BUTTONS AND THE LIKE, FALSE NAILS, FALSE EYELASHES, ADHESIVES FOR AFFIXING FALSE EYELASHES, SHAVING CASES, EYELASH CURLERS, PEDICURE SET, NAMELY, EMERY BOARD, NAIL FILE, NAIL POLISH, NAIL BRUSH, EAR PICKS, VANITY CASES, COSMETIC AND TOILET UTENSILS, FALSE BEARDS, FALSE MOUSTACHES, HAIR CURLERS, UMBRELLAS AND THEIR PARTS, FERRULES OF METAL FOR CANES AND WALKING-STICKS, CANES, HANDLES FOR CANES AND WALKING STICKS, METAL PARTS OF CANES AND WALKING-STICKS, WALKING STICKS; RETAIL STORE SERVICES AND WHOLESALE STORE SERVICES FEATURING WOVEN FABRICS AND BEDDINGS; RETAIL STORE SERVICES AND WHOLESALE STORE SERVICES FEATURING FOOTWEAR OTHER THAN SPECIAL FOOTWEAR FOR SPORTS; RETAIL STORE SERVICES AND WHOLESALE STORE SERVICES FEATURING BAGS AND POUCHES; RETAIL STORE SERVICES AND WHOLESALE STORE SERVICES FEATURING FURNITURE; RETAIL STORE SERVICES AND WHOLESALE STORE SERVICES FEATURING JOINERY FITTINGS; RETAIL STORE SERVICES AND WHOLESALE STORE SERVICES FEATURING TATAMI MATS; RETAIL STORE SERVICES AND WHOLESALE STORE SERVICES FEATURING ELECTRICAL MACHINERY AND APPARATUS, NAMELY, ELECTRICAL MACHINERY FOR HOUSEHOLD PURPOSES, ELECTRICAL MACHINERY FOR INDUSTRIAL PURPOSES; RETAIL STORE SERVICES AND WHOLESALE STORE SERVICES FEATURING BLADED OR POINTED HAND TOOLS, HAND TOOLS AND HARDWARE; RETAIL STORE SERVICES AND WHOLESALE STORE SERVICES FEATURING

KITCHEN EQUIPMENT, CLEANING TOOLS AND WASHING UTENSILS; RETAIL STORE SERVICES AND WHOLESALE STORE SERVICES FEATURING PHARMACEUTICAL, VETERINARY AND SANITARY PREPARATIONS AND MEDICAL SUPPLIES; RETAIL STORE SERVICES AND WHOLESALE STORE SERVICES FEATURING COSMETICS, TOILETRIES, DENTIFRICES, SOAPS AND DETERGENTS; RETAIL STORE SERVICES AND WHOLESALE STORE SERVICES FEATURING FUEL FOR FIRELIGHTERS, KINDLING WOOD, CHARCOAL BRIQUETTES, FIREWOOD, GASOLINE, COKE, BENZINE FOR FUEL, LIGNITE, LIQUEFIED PETROLEUM GASES, LIQUID FUELS, GASEOUS FUELS, GAS OIL, CRUDE OILS, SOLID FUELS, HEAVY OILS, ARTIFICIAL PETROLEUM, COAL, COAL GAS, NATURAL GAS, KEROSENE, METHYLATED SPIRITS FOR FUEL, DENATURATED FUEL ALCOHOLS, CHARCOAL FOR FUEL, COMBUSTIBLE BRIQUETTES, CHARCOAL BRIQUETTES; RETAIL STORE SERVICES AND WHOLESALE STORE SERVICES FEATURING CLOCKS, WATCHES AND SPECTACLES EYEGLASSES AND GOGGLES; RETAIL STORE SERVICES AND WHOLESALE STORE SERVICES FEATURING TOBACCOS AND SMOKERS' ARTICLES; RETAIL STORE SERVICES AND WHOLESALE STORE SERVICES FEATURING PLAY EQUIPMENT, NAMELY, FLYING DISC, TOY BOOMERANG, KITE, IN-LINE SKATE, SKATE BOARD, TOY VEHICLE, TRAMPOLINE FOR KIDS; RETAIL STORE SERVICES AND WHOLESALE STORE SERVICES FEATURING PLAYGROUND EQUIPMENT; RETAIL STORE SERVICES AND WHOLESALE STORE SERVICES FEATURING TOYS, DOLLS, GAME MACHINES AND APPARATUS, NAMELY, BOARD GAME, CARD GAME, PUZZLE GAME, ELECTRICAL GAME, GAME CONSOLE, ARCADE GAME; RETAIL STORE SERVICES AND WHOLESALE STORE SERVICES FEATURING SPORTS GOODS; RETAIL STORE SERVICES AND WHOLESALE STORE SERVICES FEATURING PRINTED MATTER, NAMELY, CATALOGUES, CALENDARS, NEWSLETTERS, PAMPHLETS, SONG BOOKS, PICTURE POSTCARDS, SHEET MUSIC, MAGAZINES, PRINTED TIMETABLES, BOOKS, NEWSPAPERS, GEOGRAPHICAL MAPS, DIARIES; RETAIL STORE SERVICES AND WHOLESALE STORE SERVICES FEATURING PAPER AND STATIONERY; RETAIL STORE SERVICES AND WHOLESALE STORE SERVICES FEATURING LEATHER BAGS AND LEATHER POUCHES; RETAIL STORE SERVICES AND WHOLESALE STORE SERVICES FEATURING LEATHER STRAPS FOR CELL PHONE; RETAIL STORE SERVICES AND WHOLESALE STORE SERVICES FEATURING PACKAGING CONTAINERS MADE OF LEATHER; RETAIL STORE SERVICES AND WHOLESALE STORE SERVICES FEATURING LEATHER FOOTWEAR OTHER THAN SPECIAL FOOTWEAR FOR SPORTS; RETAIL STORE SERVICES AND WHOLESALE STORE SERVICES FEATURING PERSONAL ARTICLES MADE OF LEATHER, NAMELY, BRIEFCASES, BUSINESS CARD CASES, CARD CASES, NOTECASES, COMMUTATION TICKET HOLDERS, FOLDING BRIEFCASES, HANDBAGS, KEY CASES, PURSES, RUCKSACKS, SUITCASES, TRUNKS, WALLET; RETAIL STORE SERVICES AND WHOLESALE STORE SERVICES FEATURING LEATHER CLOTHING; RETAIL STORE SERVICES AND WHOLESALE STORE SERVICES FEATURING SEMI-WROUGHT PRECIOUS STONES AND THEIR IMITATIONS (U.S. CLS. 100, 101 AND 102).

**CLASS 36—INSURANCE AND FINANCIAL**

FOR CROWDFUNDING FINANCIAL SERVICES, NAMELY, BUSINESS FUNDRAISING FOR OTHERS; BROKERAGE SERVICES IN THE FIELD OF BUSINESS PROJECT FINANCING; FINANCIAL PLANNING AND FINANCIAL CONSULTANCY IN THE FIELD OF BUSINESS PROJECT FINANCING; FINANCING SERVICES, BROKERAGE SERVICES FOR CAPITAL INVESTMENTS AND FINANCIAL MANAGEMENT SERVICES IN THE FIELD OF INVESTMENT WITH FOUNDING INVESTMENT PARTNERSHIP; BUYING AND SELLING OF SECURITIES, NAMELY, TRADING IN SECURITIES; SECURITIES BROKERAGE; BROKERAGE IN THE FIELD OF SECURITIES, SECURITIES INDEX FUTURES, SECURITIES OPTIONS, AND OVERSEAS MARKET SECURITIES FUTURES (U.S. CLS. 100, 101 AND 102).

**CLASS 41—EDUCATION AND ENTERTAINMENT**

FOR EDUCATIONAL SERVICES, NAMELY, CONDUCTING COURSES IN THE FIELD OF BUSINESS FOR START-UP BUSINESSES; PROVIDING EDUCATIONAL INFORMATION RELATING TO COURSES IN THE FIELD OF BUSINESS FOR START-UP BUSINESSES; ARRANGING, CONDUCTING AND ORGANIZATION OF EDUCATIONAL SEMINARS IN THE FIELD OF BUSINESS FOR ENTREPRENEURS; PROVIDING EDUCATIONAL INFORMATION RELATING TO EDUCATIONAL SEMINARS IN THE FIELD OF BUSINESS (U.S. CLS. 100, 101 AND 107).

**CLASS 42—SCIENTIFIC AND COMPUTER SERVICES**

FOR GRAPHIC ADVERTISEMENT DESIGNING SERVICES; COMPUTER PROGRAMING; DESIGNING AND MAINTAINING INTERNET HOMEPAGES AND WEB SITES FOR OTHERS; TECHNICAL ADVICE RELATING TO COMPUTER PROGRAMING AND DESIGNING AND MAINTAINING INTERNET HOMEPAGES AND WEB SITES (U.S. CLS. 100 AND 101).

CHRISTOPHER BUONGIORNO, EXAMINING ATTORNEY

SN 79-138,140. BRAINSWAY LTD., JERUSALEM, ISRAEL, FILED 9-8-2013.

# BRAINSWAY

THE MARK CONSISTS OF STANDARD CHARACTERS WITHOUT CLAIM TO ANY PARTICULAR FONT, STYLE, SIZE, OR COLOR.

PRIORITY DATE OF 3-21-2013 IS CLAIMED.

OWNER OF INTERNATIONAL REGISTRATION 1180874 DATED 9-8-2013, EXPIRES 9-8-2023.

**CLASS 10—MEDICAL APPARATUS**

FOR SURGICAL AND MEDICAL APPARATUS AND INSTRUMENTS, NAMELY, TRANSCRANIAL MAGNETIC STIMULATION APPARATUS FOR TREATMENT OF BRAIN DISORDERS (U.S. CLS. 26, 39 AND 44).

**CLASS 44—MEDICAL, BEAUTY AND AGRICULTURAL SERVICES**

FOR MEDICAL SERVICES FOR TREATMENT OF BRAIN DISORDERS (U.S. CLS. 100 AND 101).

CHRISTINA SOBRAL, EXAMINING ATTORNEY

SN 79-138,176. MONO PUMPS LIMITED, MANCHESTER, UNITED KINGDOM, FILED 2-15-2013.

# INVIZIQ

THE MARK CONSISTS OF STANDARD CHARACTERS WITHOUT CLAIM TO ANY PARTICULAR FONT, STYLE, SIZE, OR COLOR.

PRIORITY DATE OF 10-18-2012 IS CLAIMED.

OWNER OF INTERNATIONAL REGISTRATION 1180988 DATED 2-15-2013, EXPIRES 2-15-2023.

**CLASS 7—MACHINERY**

FOR PRESSURE SEWAGE SYSTEMS COMPRISING PUMPS, GRINDERS, MOTORS, MACERATORS, TANKS, AS WELL AS PARTS AND FITTINGS THEREFOR, SUCH AS COUPLINGS, COUPLING RODS, TUBING, PIPES, ROTOR AND ROD ASSEMBLIES, SHAFT AND ROD ASSEMBLIES, PROGRESSING CAVITY PUMPS; MACHINES, NAMELY, MACERATORS; MACERATORS AS PARTS OF MACHINES; GRINDERS; MACHINES, NAMELY, SEWAGE PULVERISERS; SEWAGE PULVERISERS AS PARTS OF MACHINES; COMBINED SEWAGE MACERATORS AND PUMPS; MACHINE PARTS, NAMELY, CUTTERS FOR MACERATORS; SEWAGE AND WASTE WATER HANDLING EQUIPMENT, NAMELY, SYSTEMS COMPRISING PUMPS, MACERATORS, GRINDERS, AND SCREENS THAT BREAKDOWN, CAPTURE AND EXTRACT SOLIDS FROM WASTEWATER AND SEWAGE; SEWAGE AND WASTE WATER HANDLING EQUIPMENT, NAMELY, PUMPS FOR THE PUMPING OF WASTEWATER AND SEWAGE WITHIN DRAINAGE AND SEWAGE SYSTEMS; FILTERING AND SCREENING MACHINES AND APPARATUS THAT BREAKDOWN, COLLECT AND EXTRACT SOLIDS FROM WASTEWATER AND SEWAGE; SCREENING MACHINES THAT CAPTURE AND EXTRACT SOLIDS FROM SEWAGE AND WASTEWATER; STRUCTURAL PARTS FOR THE AFORESAID GOODS (U.S. CLS. 13, 19, 21, 23, 31, 34 AND 35).

**CLASS 9—ELECTRICAL AND SCIENTIFIC APPARATUS**

FOR AUTOMATION CONTROLS FOR PRESSURE SEWAGE SYSTEMS; AUTOMATION CONTROLS FOR PUMPS AND PUMP SYSTEMS; ELECTRONIC CONTROL SYSTEMS AND ELECTRONIC CONTROLLERS FOR PRESSURE SEWAGE SYSTEMS; ELECTRONIC PRESSURE MONITORING SENSORS FOR PRESSURE SEWAGE SYSTEMS; ELECTRIC POWER GENERATORS FOR PRESSURE SEWAGE SYSTEMS, PUMPS AND PUMP SYSTEMS; SENSORS, NAMELY, PRESSURE SENSORS, ELECTRIC SENSORS, AND TEMPERATURE SENSORS FOR USE WITH PRESSURE SEWAGE SYSTEMS; FLOW METERS FOR PRESSURE SEWAGE SYSTEMS AND PUMPING SYSTEMS; MONITORING AND DATA PROCESSING AND STORAGE APPARATUS AND INSTRUMENTS, NAMELY, BATTERY MONITORS, DIGITAL SIGNAL MONITORS, FLOW METER MONITORS, DATA PROCESSING APPARATUS, ELECTRIC STORAGE BATTERIES, COMPUTER STORAGE DEVICES IN THE NATURE OF HARD DRIVES, AND DISC STORAGE CONTAINERS FOR PRESSURE SEWAGE SYSTEMS; STRUCTURAL PARTS FOR THE AFORESAID GOODS (U.S. CLS. 21, 23, 26, 36 AND 38).

**CLASS 37—CONSTRUCTION AND REPAIR**

FOR INSTALLATION, MAINTENANCE AND REPAIR OF PRESSURE SEWAGE SYSTEMS; INSTALLATION, MAINTENANCE AND REPAIR OF PUMPS AND PUMPING SYSTEMS; INSTALLATION, MAINTENANCE AND REPAIR OF SEWAGE AND WASTE WATER HANDLING MACHINES AND THEIR ASSOCIATED PARTS, FITTINGS AND ACCESSORIES (U.S. CLS. 100, 103 AND 106).

ELIZABETH CHANG, EXAMINING ATTORNEY



SN 79-138,178. MECHADYNE INTERNATIONAL LIMITED, OXFORDSHIRE, UNITED KINGDOM, FILED 4-19-2013.



PRIORITY DATE OF 12-19-2012 IS CLAIMED.  
OWNER OF INTERNATIONAL REGISTRATION 1180993 DATED 4-19-2013, EXPIRES 4-19-2023.

THE MARK CONSISTS OF THE STYLIZED LETTERS "MD" WITH A DESIGN OF A GEAR FORMING THE "D" IN THE MARK. THE BLACK IN THE MARK REPRESENTS BACKGROUND AND IS NOT A FEATURE OF THE MARK.

#### CLASS 7—MACHINERY

FOR BEARINGS, NAMELY, BEARINGS AS PARTS OF MACHINES; MECHANICAL CONTROLS, NAMELY, POWER DRIVEN MECHANICAL CONTROLS FOR THE OPERATION OF CAMSHAFTS, PUMP CONTROL VALVES, THERMOSTATIC CONTROL VALVES FOR MACHINES; ENGINE NOISE SHIELDS, NAMELY, NOISE SHIELDS FOR VEHICLE ENGINE COMPARTMENTS IN THE NATURE OF MUFFLERS AND SILENCERS; CAMSHAFTS, NAMELY, ENGINE CAMSHAFTS; ACTUATORS FOR CAMSHAFTS, NAMELY, CAM PHASERS, DUAL-EQUAL PHASERS, DUPLEX PHASERS, AND DUAL INDEPENDENT PHASERS FOR ENGINE CAMSHAFTS; ADJUSTABLE VALVE TRAINS, NAMELY, MECHANICALLY ADJUSTABLE VALVE TRAINS FOR VEHICLE ENGINES; HYDRAULIC CYLINDERS, NAMELY, HYDRAULIC ENGINE CYLINDERS FOR VEHICLES, AND HYDRAULIC MOTORS; ENGINE MOUNTINGS, NAMELY, INTERNAL COMBUSTION ENGINE MOUNTS; PARTS FOR ENGINES AND MOTORS, NAMELY, OIL DIPSTICKS, CONTACT POINTS (U.S. CLS. 13, 19, 21, 23, 31, 34 AND 35).

#### CLASS 9—ELECTRICAL AND SCIENTIFIC APPARATUS

FOR ELECTRONIC CONTROL SYSTEMS, NAMELY, ELECTRONIC CONTROL SYSTEMS FOR MACHINES AND ENGINES; ELECTRONIC SENSORS FOR PRESSURE, TEMPERATURE, TORQUE, SPEED, ANGLE, TIME, AND DISTANCE; ELECTRONIC PROCESSORS, NAMELY, ELECTRONIC DATA PROCESSING APPARATUS, ELECTRONIC MICROPROCESSORS; ELECTRONIC MEASURING INSTRUMENTS, NAMELY, MEASURING INSTRUMENTS FOR PRESSURE, TEMPERATURE, TORQUE, SPEED, ANGLE, TIME, AND DISTANCE; ELECTRIC SWITCHES AND RELAYS; WIRING HARNESSSES, NAMELY, ELECTRIC CABLE HARNESSSES; TEMPERATURE SENSORS; VOLTAGE SENSORS, NAMELY, ELECTRICAL VOLTAGE SENSORS AND SENSORS FOR SENSING VERTICAL STRESS; ELECTRICAL TRANSDUCERS; ELECTRONIC CONTROL MODULES FOR MACHINES AND ENGINES; AND STRUCTURAL PARTS AND FITTINGS FOR ALL THE AFORESAID GOODS (U.S. CLS. 21, 23, 26, 36 AND 38).

#### CLASS 12—VEHICLES

FOR MOTOR VEHICLES, NAMELY, TWO-WHEELED MOTOR VEHICLES, CUSTOM HOT RODS, AUTOMOBILES, VANS, TRUCKS, AND SPORT UTILITY VEHICLES; PARTS AND FITTINGS FOR MOTOR LAND VEHICLES, NAMELY, ASSEMBLIES AND SUB-SYSTEMS IN THE NATURE OF ENGINES AND MOTORS; PARTS AND FITTINGS FOR MOTOR LAND VEHICLES, NAMELY, VEHICLE AXLE ASSEMBLIES COMPRISED OF MOUNTING BOLTS, MOUNTING NUTS, WASHERS, SPACERS, BREATHER HOSES, SHIFT SWITCH CONNECTORS, PROTECTORS, PROTECTORS, AXLE CASE ASSEMBLIES, DRIVE SHAFT ASSEMBLIES, HUB ASSEMBLIES, PROPELLER SHAFTS AND BOLTS, ALL BEING STRUCTURAL PARTS FOR MOTOR LAND VEHICLES; PARTS AND FITTINGS FOR MOTOR LAND VEHICLES, NAMELY, WHEEL HUBS COMPRISED OF HUB FLANGES, THREADED STUDS, HUBS, LUG NUTS, SPRINGS, STABILIZER BARS, STEERING LINKAGES, SUSPENSIONS IN THE NATURE OF SUSPENSION SPRINGS FOR MOTOR CARS, SUSPENSION SYSTEMS FOR MOTOR VEHICLES, AND WHEEL SUSPENSIONS, TORSION BARS, BRAKES, BRAKE PADS, BRAKE LININGS AND BRAKING INSTALLATIONS IN THE NATURE OF BRAKE SHOES FOR VEHICLES, BRAKE SYSTEMS FOR VEHICLES, CLUTCHES, DIFFERENTIAL GEARS, DRIVE GEARS, DRIVE SHAFTS, GEAR CHANGE SELECTORS, TRANSMISSIONS, COUPLINGS IN THE NATURE OF SHAFT COUPLINGS FOR LAND VEHICLES, TRAILER COUPLINGS, MANUAL AND POWER STEERING APPARATUS, AND STEERING COLUMNS AND ANTI-THEFT DEVICES, ALL BEING STRUCTURAL PARTS FOR MOTOR LAND VEHICLES; AND STRUCTURAL PARTS AND FITTINGS FOR ALL THE AFORESAID GOODS (U.S. CLS. 19, 21, 23, 31, 35 AND 44).

#### CLASS 42—SCIENTIFIC AND COMPUTER SERVICES

FOR RESEARCH AND DEVELOPMENT OF INDUSTRIAL AND SCIENTIFIC PRODUCTS; ENGINEERING DESIGN SERVICES; ENGINEERING DRAWING SERVICES; ENGINEERING TESTING SERVICES; DESIGN SERVICES, DRAWING SERVICES AND TESTING SERVICES RELATING TO AUTOMOTIVE ENGINEERING, NAMELY, TESTING AND EVALUATION OF AUTOMOBILES TO IMPROVE PERFORMANCE AND EFFICIENCY; ADVISORY AND CONSULTANCY SERVICES RELATING TO THE ABOVE (U.S. CLS. 100 AND 101).

KATHERINE E. HALMEN, EXAMINING ATTORNEY

SN 79-138,182. CENTRE VINICOLE CHAMPAGNE; NICOLAS FEUILLATTE; UNION DE COOPERATIVES AGRICOLES, FRANCE, FILED 6-17-2013.

## BUBBLY HOURS

THE MARK CONSISTS OF STANDARD CHARACTERS WITHOUT CLAIM TO ANY PARTICULAR FONT, STYLE, SIZE, OR COLOR.

PRIORITY DATE OF 5-21-2013 IS CLAIMED.  
OWNER OF INTERNATIONAL REGISTRATION 1181008 DATED 6-17-2013, EXPIRES 6-17-2023.

NO CLAIM IS MADE TO THE EXCLUSIVE RIGHT TO USE "BUBBLY" IN CLASS 33, APART FROM THE MARK AS SHOWN.

#### CLASS 33—WINES AND SPIRITS

FOR ALCOHOLIC BEVERAGES EXCEPT BEERS (U.S. CLS. 47 AND 49).

**CLASS 35—ADVERTISING AND BUSINESS**

FOR ORGANIZATION OF EXHIBITIONS FOR COMMERCIAL OR ADVERTISING PURPOSES AND FESTIVE EVENTS IN THE NATURE OF SPECIAL EVENTS FOR COMMERCIAL OR ADVERTISING PURPOSES; PROVIDING INFORMATION AND ADVICE IN THE FIELD OF ADVERTISING; COMMERCIAL INFORMATION AND ADVICE FOR CONSUMERS; ADVICE IN THE FIELD OF EVENTS FOR ADVERTISING OR COMMERCIAL PURPOSES; WHOLESALE AND RETAIL SALE STORE SERVICES FEATURING ALCOHOLIC BEVERAGES PROVIDED BY MEANS OF TELECOMMUNICATION AND/OR COMPUTER NETWORKS (U.S. CLS. 100, 101 AND 102).

**CLASS 41—EDUCATION AND ENTERTAINMENT**

FOR ENTERTAINMENT SERVICES, NAMELY, CONDUCTING PARTIES AND WINE AND FOOD TASTINGS; PROVIDING ENTERTAINMENT ADVICE AND INFORMATION; ORGANIZATION OF SHOWS, NAMELY, CULTURAL, SPORT, FASHION, FOOD AND WINE SHOWS, ALL FOR ENTERTAINMENT PURPOSES; ARRANGING AND CONDUCTING CONCERTS; CONDUCTING ENTERTAINMENT EXHIBITIONS IN THE NATURE OF CULTURAL FESTIVALS, ARTS FESTIVALS, SPORTS FESTIVALS, MUSIC FESTIVALS, WINE FESTIVALS AND GASTRONOMICAL FESTIVALS; ALCOHOLIC BEVERAGE TASTING EVENTS FOR EDUCATIONAL PURPOSES (U.S. CLS. 100, 101 AND 107).

KATHERINE E. HALMEN, EXAMINING ATTORNEY

**CLASS 35—ADVERTISING AND BUSINESS**

FOR ADVERTISING AGENCIES, ADVERTISING AND MARKETING; ARRANGING AND ORGANIZING TRADE SHOWS AND TRADE FAIRS FOR COMMERCIAL AND ADVERTISING PURPOSES; PROVIDING OFFICE FUNCTIONS, BUSINESS ADMINISTRATION CONSULTANCY; COMMERCIAL ASSISTANCE IN BUSINESS MANAGEMENT; BUSINESS MANAGEMENT CONSULTING AND BUSINESS ORGANIZATION CONSULTING, IMPORT AND EXPORT AGENCIES; BUSINESS EVALUATIONS, EXPERT APPRAISALS, INFORMATION AND RESEARCH; AUCTIONEERING; RETAIL STORE SERVICES, ON-LINE RETAIL STORE SERVICES, WHOLESALE STORE SERVICES, ON-LINE WHOLESALE STORE SERVICES, MAIL ORDER CATALOG SERVICES AND TELEVISION HOME SHOPPING SERVICES, ALL OF THE FOREGOING FEATURING CLOTHING, NAMELY, TROUSERS, JACKETS, OVERCOATS, SUITS, JERSEYS, WAISTCOATS, SHIRTS, T-SHIRTS, SWEATSHIRTS, UNDERCLOTHING, NAMELY, BOXER SHORTS, SOCKS; FOOTWEAR, NAMELY, LEATHER SHOES, CANVAS SHOES, BOOTS, SHOES; HEADGEAR, NAMELY, CAPS, SKULL CAPS, HATS, BERETS (U.S. CLS. 100, 101 AND 102).

NANCY CLARKE, EXAMINING ATTORNEY

SN 79-138,265. BISSE TEKSTİL ÜRÜNLERİ SANAYİ VE TİCARET LIMITED ŞİRKETİ, SISLI - İSTANBUL, TÜRKİYE, FILED 9-17-2013.



OWNER OF INTERNATIONAL REGISTRATION 1055194 DATED 5-17-2010, EXPIRES 5-17-2020.

THE MARK CONSISTS OF THE LETTER "B" AND BELOW THIS THE WORD "BISSE", BOTH IN STYLIZED FORM. THE LETTER "B" IS ENCLOSED WITHIN A STYLIZED, ABSTRACT DESIGN IN THE SHAPE OF A PARENTHESIS HAVING EXTRANEIOUS PEN STROKES TO EACH SIDE AND ABOVE THE ABSTRACT DESIGN. THE ENTIRE MARK IS ENCLOSED WITHIN A RECTANGULAR FORM.

THE WORDING "BISSE" HAS NO MEANING IN A FOREIGN LANGUAGE.

**CLASS 25—CLOTHING**

FOR CLOTHING, NAMELY, TROUSERS, JACKETS, OVERCOATS, SUITS, JERSEYS, WAISTCOATS, SHIRTS, T-SHIRTS, SWEATSHIRTS, UNDERCLOTHING, NAMELY, BOXER SHORTS, SOCKS; FOOTWEAR, NAMELY, LEATHER SHOES, CANVAS SHOES, BOOTS, SHOES; HEADGEAR, NAMELY, CAPS, SKULL CAPS, HATS, BERETS (U.S. CLS. 22 AND 39).

SN 79-138,280. LIMITED LIABILITY COMPANY MIRANI, RU-123022 MOSCOW, RUSSIAN FED., FILED 6-11-2013.



OWNER OF INTERNATIONAL REGISTRATION 1181250 DATED 6-11-2013, EXPIRES 6-11-2023.

THE COLOR(S) PURPLE AND WHITE IS/ARE CLAIMED AS A FEATURE OF THE MARK.

THE MARK CONSISTS OF THE DESIGN OF A BIRD IN WHITE WITH ITS WINGS OUTSTRETCHED COMING AROUND THE BIRD ABOVE THE TERM "EXCELLANCE" IN WHITE, BOTH ON A PURPLE BACKGROUND.

**CLASS 3—COSMETICS AND CLEANING PREPARATIONS**

FOR TOILET WATER; DEODORANTS FOR PERSONAL USE; PERFUMES; PERFUMERY; COSMETIC PENCILS; COSMETIC CREAMS; SKIN WHITENING CREAMS; CREAMS FOR LEATHER; WAXES FOR LEATHER; HAIR SPRAY; NAIL POLISH; AFTERSHAVE LOTIONS; HAIR LOTIONS; LOTIONS FOR COSMETIC PURPOSES; BEAUTY MASKS; OILS FOR COSMETIC PURPOSES; SOAP; COSMETIC KITS COMPRISED OF COSMETICS; DENTIFRICES; LIPSTICKS; POMADES FOR COSMETIC PURPOSES; SHAVING PREPARATIONS; COSMETIC PREPARATIONS FOR BATHS; NON-MEDICATED TOILETRIES; HAIR WAVING PREPARATIONS; LEATHER BLEACHING PREPARATIONS FOR HOUSEHOLD USE; MOUTH WASHES, NOT FOR MEDICAL PURPOSES; COSMETIC PREPARATIONS FOR SLIMMING PURPOSES; MAKE-UP REMOVING PREPARATIONS; NAIL CARE PREPARATIONS; TISSUES IMPREGNATED WITH COSMETIC LOTIONS; BATH SALTS, NOT FOR MEDICAL PURPOSES; EYEBROW COSMETICS; SUN-TANNING PREPARATIONS FOR COSMETIC USE; HAIR COLORANTS; COSMETIC PREPARATIONS FOR EYELASHES; DEPILATORY PREPARATIONS; COSMETIC PREPARATIONS FOR SKIN CARE; COSMETICS; COSMETICS FOR ANIMALS; MASCARA; ANTIPERSPIRANTS BEING TOILETRIES; SHAMPOOS; SHAMPOOS FOR PETS (U.S. CLS. 1, 4, 6, 50, 51 AND 52).

**CLASS 5—PHARMACEUTICALS**

FOR SEA WATER FOR MEDICINAL BATHING; MINERAL WATERS FOR MEDICAL PURPOSES FOR TREATMENT OF DERMATOLOGICAL CONDITIONS; MUD FOR BATHS, NAMELY, MEDICATED BATH PREPARATIONS COMPRISED OF MUD; MINERAL FOOD SUPPLEMENTS; NUTRITIONAL SUPPLEMENTS FOR MEDICAL PURPOSES; ADHESIVE PLASTERS FOR MEDICAL USE; SKIN LOTIONS FOR PHARMACEUTICAL PURPOSES; MEDICATED SUNBURN OINTMENTS; MEDICINES FOR HUMAN PURPOSES FOR TREATMENT OF DERMATOLOGICAL CONDITIONS; POMADES FOR MEDICAL PURPOSES; BIOLOGICAL PREPARATIONS FOR MEDICAL PURPOSES FOR TREATMENT OF DERMATOLOGICAL CONDITIONS; VETERINARY PREPARATIONS FOR DOGS AND CATS FOR TREATMENT OF DERMATOLOGICAL CONDITIONS; PREPARATIONS FOR THE TREATMENT OF BURNS; PHARMACEUTICAL PREPARATIONS FOR SKIN CARE; MEDICINAL HAIR GROWTH PREPARATIONS; PHARMACEUTICAL PREPARATIONS FOR TREATMENT OF DERMATOLOGICAL CONDITIONS; SUNBURN PREPARATIONS FOR PHARMACEUTICAL PURPOSES; ALBUMINOUS FOODSTUFFS FOR MEDICAL PURPOSES, NAMELY, EGGS ADAPTED FOR MEDICAL USE; TISSUES IMPREGNATED WITH PHARMACEUTICAL LOTIONS FOR TREATMENT OF DERMATOLOGICAL CONDITIONS; SUPPOSITORIES; GREASES FOR MEDICAL PURPOSES; MEDICATED SALTS FOR MINERAL WATER BATHS; ADJUVANTS FOR MEDICAL PURPOSES; MEDICAL PREPARATIONS FOR SLIMMING PURPOSES; MOUTHWASHES FOR MEDICAL PURPOSES; NERVINES, NAMELY, CENTRAL NERVOUS SYSTEM STIMULANTS; VULNERARY SPONGES IMPREGNATED WITH WOUND-HEALING PREPARATIONS FOR MEDICAL USE; ELIXIRS, NAMELY, PHARMACEUTICAL PREPARATIONS FOR TREATMENT OF DERMATOLOGICAL CONDITIONS (U.S. CLS. 6, 18, 44, 46, 51 AND 52).

**CLASS 35—ADVERTISING AND BUSINESS**

FOR IMPORT-EXPORT AGENCIES; ADVERTISING AGENCIES; RENTAL OF ADVERTISING SPACE; SHOP WINDOW DRESSING; SALES PROMOTION FOR OTHERS; PROCUREMENT SERVICES FOR OTHERS, NAMELY, PURCHASING OF COSMETICS AND MEDICATED PREPARATION FOR OTHER BUSINESSES (U.S. CLS. 100, 101 AND 102).

**CLASS 44—MEDICAL, BEAUTY AND AGRICULTURAL SERVICES**

FOR BEAUTY SALONS (U.S. CLS. 100 AND 101).

WILLIAM P. SHANAHAN, EXAMINING ATTORNEY

SN 79-138,387. NONOS ART.DESIGN.PRODUCTS, M + F WELTE OG, A-6800 FELDKIRCH, AUSTRIA, FILED 8-19-2013.

# NONOS

THE MARK CONSISTS OF STANDARD CHARACTERS WITHOUT CLAIM TO ANY PARTICULAR FONT, STYLE, SIZE, OR COLOR.

PRIORITY DATE OF 7-31-2013 IS CLAIMED.

OWNER OF INTERNATIONAL REGISTRATION 1181502 DATED 8-19-2013, EXPIRES 8-19-2023.

THE WORDING "NONOS" HAS NO MEANING IN A FOREIGN LANGUAGE.

**CLASS 6—METAL GOODS**

FOR STATUES AND FIGURINES OF COMMON METAL, ALSO IN COMBINATION WITH OTHER MATERIALS; WORKS OF ART OF COMMON METAL, ALSO IN COMBINATION WITH OTHER MATERIALS (U.S. CLS. 2, 12, 13, 14, 23, 25 AND 50).

**CLASS 14—JEWELRY**

FOR STATUES AND FIGURINES OF PRECIOUS METAL, ALSO IN COMBINATION WITH OTHER MATERIALS; WORKS OF ART OF PRECIOUS METAL, ALSO IN COMBINATION WITH OTHER MATERIALS; JEWELLERY (U.S. CLS. 2, 27, 28 AND 50).

**CLASS 16—PAPER GOODS AND PRINTED MATTER**

FOR PAINTINGS (PICTURES), FRAMED OR UNFRAMED; PHOTOGRAPHS; STATUES AND FIGURINES OF PAPIER MACHÉ, ALSO IN COMBINATION WITH OTHER MATERIALS; WORKS OF ART OF PAPER OR PAPIER MACHE, ALSO IN COMBINATION WITH OTHER MATERIALS (U.S. CLS. 2, 5, 22, 23, 29, 37, 38 AND 50).

**CLASS 20—FURNITURE AND ARTICLES NOT OTHERWISE CLASSIFIED**

FOR STATUES AND FIGURINES OF WOOD, WAX, GYPSUM OR PLASTIC MATERIAL, ALSO IN COMBINATION WITH OTHER MATERIALS; WORKS OF ART OF WOOD, WAX, GYPSUM OR PLASTIC MATERIAL, ALSO IN COMBINATION WITH OTHER MATERIALS (U.S. CLS. 2, 13, 22, 25, 32 AND 50).

**CLASS 25—CLOTHING**

FOR CLOTHING, NAMELY, SHIRTS AND PANTS, FOOTWEAR, HEADGEAR FOR WEAR, NAMELY, BASEBALL CAPS (U.S. CLS. 22 AND 39).

**CLASS 42—SCIENTIFIC AND COMPUTER SERVICES**

FOR INDUSTRIAL DESIGN; DRESS DESIGNING; NEW PRODUCT DESIGN; WORK OF ARTS DESIGN; DESIGN OF JEWELLERY, FASHION ACCESSORIES, INTERIOR DECORATION AND FURNITURES; CUSTOM DESIGN OF LOGOS AND BROCHURES; CUSTOM DESIGN SERVICES RELATING TO GRAPHIC ARTS (U.S. CLS. 100 AND 101).

FLORENTINA BLANDU, EXAMINING ATTORNEY

SN 79-138.402. NENCO HOLDING B.V., NL-3071 EL ROTTERDAM, NETHERLANDS, FILED 5-27-2013.



PRIORITY DATE OF 11-28-2012 IS CLAIMED.  
OWNER OF INTERNATIONAL REGISTRATION 1181543 DATED 5-27-2013, EXPIRES 5-27-2023.

THE COLOR(S) ORANGE, GREY, AND WHITE IS/ARE CLAIMED AS A FEATURE OF THE MARK.

THE MARK CONSISTS OF A VERTICAL ORANGE RECTANGLE WITH A CURVED BASE LINE AND GREY AND WHITE BORDERS CONTAINING THE WHITE STYLIZED WORD "PEAK'S" UNDERLINED BY A WHITE CURVE.

#### CLASS 29—MEATS AND PROCESSED FOODS

FOR MEAT, FISH, POULTRY AND GAME, NOT LIVE; MEAT EXTRACTS; PRESERVED, FROZEN, DRIED AND COOKED FRUITS AND VEGETABLES; JELLIES, JAMS, COMPOTES; EGGS; EDIBLE OILS AND FATS, NAMELY, OLIVE OIL; ALL THE AFOREMENTIONED GOODS BEING GLUTEN-FREE (U.S. CL. 46).

#### CLASS 30—STAPLE FOODS

FOR TEA; COCOA; TAPIOCA AND SAGO; FLOUR AND PREPARATIONS MADE FROM CEREALS, NAMELY, BUCKWHEAT FLOUR; BREAD, PASTRY AND FROZEN CONFECTIONERY; ICES; SUGAR, HONEY, TREACLE; YEAST; BAKING-POWDER; SALT; MUSTARD; VINEGAR, CONDIMENTS, NAMELY, PASTA SAUCES; SPICES; WHEAT, CORN AND BUCKWHEAT PRODUCTS, NAMELY, GLUTEN-FREE BREADS, GLUTEN-FREE MIXES FOR PANCAKES, GLUTEN-FREE GRITS FOR HUMAN CONSUMPTION, GLUTEN-FREE BISCUITS AND GLUTEN-FREE CEREALS; PRODUCTS BASED ON BUCKWHEAT GRAINS, NAMELY, GLUTEN-FREE BREADS, GLUTEN-FREE MIXES FOR PANCAKES, GLUTEN-FREE GRITS FOR HUMAN CONSUMPTION, GLUTEN-FREE BISCUITS AND GLUTEN-FREE CEREALS; GLUTEN-FREE BAKING INGREDIENTS, NAMELY, BAKING POWDER, BAKING MIXES FOR BREAD, BAKING MIXES PANCAKES, BAKING MIXES FOR CAKES, SALT FOR BREAD, AND STARCH FOR USE IN FOOD AND BREADCRUMBS; GLUTEN-FREE DELICACIES, NAMELY, GLUTEN-FREE MUSTARD DIPS, GLUTEN-FREE PESTO AND GLUTEN-FREE TAPENADE; GLUTEN-FREE DRESSINGS, NAMELY, GLUTEN-FREE SALAD DRESSINGS; GLUTEN-FREE GRANOLA, MUESLI AND CORNFLAKES; GLUTEN-FREE PASTAS, NAMELY, SPAGHETTI, MACARONI AND RAVIOLI; GLUTEN-FREE PASTA SAUCES AND GLUTEN-FREE WOK SAUCES; GLUTEN-FREE PRETZELS, GRANOLA SNACKS AND CRACKERS (U.S. CL. 46).

#### CLASS 31—NATURAL AGRICULTURAL PRODUCTS

FOR FRESH FRUITS AND VEGETABLES; SEEDS; NATURAL PLANTS AND FLOWERS; UNPROCESSED BUCKWHEAT, UNPROCESSED BUCKWHEAT KERNELS, UNPROCESSED BUCKWHEAT GRITS, UNPROCESSED BUCKWHEAT FLAKES, UNPROCESSED BUCKWHEAT PODS AND UNPROCESSED BUCKWHEAT BRAN; UNPROCESSED OATS, UNPROCESSED HOPS, UNPROCESSED CORN, UNPROCESSED WHEAT BRAN, UNPROCESSED NUTS, UNPROCESSED POLLEN, UNPROCESSED WHEAT, UNPROCESSED RYE, UNPROCESSED CEREALS FOR MUESLI, CEREAL CROPS AND PRODUCTS THEREOF, NAMELY, UNPROCESSED CEREALS AND SEEDS (U.S. CLS. 1 AND 46).

#### CLASS 35—ADVERTISING AND BUSINESS

FOR BUSINESS MEDIATION IN RELATION TO THE PURCHASE AND SALE AS WELL AS IMPORT AND EXPORT OF GLUTEN-FREE FOOD PRODUCTS; RETAIL SERVICES IN THE FIELD OF GLUTEN-FREE FOOD PRODUCTS; ALL THE AFORESAID SERVICES TO BE RENDERED ONLINE AND OFFLINE; ALL THE AFOREMENTIONED RETAIL AND WHOLESALE SERVICES TO BE OFFERED THROUGH RETAIL AND WHOLESALE OUTLETS, MAIL ORDER COMPANIES AND ONLINE WEBSHOPS; ADMINISTRATIVE PROCESSING OF ORDERS AS PART OF THE SERVICES PROVIDED BY A MAIL ORDER OR WEBSHOP; ADMINISTRATIVE INVENTORY STOCK CONTROL; ORGANIZATION OF FAIRS, EXHIBITIONS AND OTHER EVENTS FOR COMMERCIAL OR ADVERTISING PURPOSES (U.S. CLS. 100, 101 AND 102).

SAMUEL PAQUIN, EXAMINING ATTORNEY

SN 79-138.566. E. DOLD & SÖHNE KG, FED REP GERMANY, FILED 9-3-2013.

# DOLD

THE MARK CONSISTS OF STANDARD CHARACTERS WITHOUT CLAIM TO ANY PARTICULAR FONT, STYLE, SIZE, OR COLOR.

PRIORITY DATE OF 3-13-2013 IS CLAIMED.  
OWNER OF INTERNATIONAL REGISTRATION 1182023 DATED 9-3-2013, EXPIRES 9-3-2023.  
SEC. 2(F).

#### CLASS 9—ELECTRICAL AND SCIENTIFIC APPARATUS

FOR ELECTRIC AND ELECTRONIC SWITCHING DEVICES AND WIRELESS ELECTRIC AND ELECTRONIC SWITCHING DEVICES FOR CONTROLLING AND MONITORING THE INDUSTRIAL WORK PROCESSES OF ELECTRIC MACHINES AND SYSTEMS, NAMELY, PERSONNEL PROTECTION DEVICES, MOTOR PROTECTION DEVICES, MOTOR BRAKE DEVICES, EMERGENCY STOP DEVICES, SAFETY SWITCHING DEVICES, AND ELECTRIC AND ELECTRONIC SWITCHING DEVICES FOR THE RECORDING, CONDUCTING, SWITCHING, TRANSFORMING, STORING, REGULATING, AND CONTROLLING OF ELECTRICITY (U.S. CLS. 21, 23, 26, 36 AND 38).

**CLASS 40—MATERIAL TREATMENT**

FOR CONTRACT AND CUSTOM MANUFACTURE, FOR OTHERS, OF ELECTRIC AND ELECTRONIC SWITCHING DEVICES AND WIRELESS ELECTRIC AND ELECTRONIC SWITCHING DEVICES FOR COMMUTATION, CONTROLLING AND MONITORING INDUSTRIAL MANUFACTURING PROCESSES ON ELECTRIC MACHINES AND INSTALLATIONS, APPARATUS FOR DETECTING, CONDUCTING, SWITCHING, TRANSFORMING, ACCUMULATING, REGULATING OR CONTROLLING ELECTRICITY, AND PARTS THEREFOR ACCORDING TO CUSTOMER SPECIFICATIONS; CONTRACT AND CUSTOM MANUFACTURE, FOR OTHERS, OF HOUSING SYSTEMS FOR THE ELECTRONICS SECTOR, IN PARTICULAR FOR ELECTRIC AND ELECTRONIC SWITCHING DEVICES FOR COMMUTATION, AND PARTS THEREFOR ACCORDING TO CUSTOMER SPECIFICATIONS (U.S. CLS. 100, 103 AND 106).

TIMOTHY O. SCHIMPF, EXAMINING ATTORNEY

SN 79-138,667, PODOPRODUCTIONS, SOCIÉTÉ PRIVÉE À RESPONSABILITÉ LIMITÉE, B-1490 COURT-SAINT-ETIENNE, BELGIUM, FILED 8-20-2013.

**PODOPRODUCTIONS**

THE MARK CONSISTS OF STANDARD CHARACTERS WITHOUT CLAIM TO ANY PARTICULAR FONT, STYLE, SIZE, OR COLOR.

OWNER OF INTERNATIONAL REGISTRATION 1182184 DATED 8-20-2013, EXPIRES 8-20-2023.

**CLASS 9—ELECTRICAL AND SCIENTIFIC APPARATUS**

FOR SOFTWARE FOR THE DESIGN AND PRODUCT QUALITY CONTROL TESTING OF SOLES, STRETCHERS FOR FOOTWEAR, AND FOOTWEAR; OPTICAL SCANNERS (U.S. CLS. 21, 23, 26, 36 AND 38).

**CLASS 10—MEDICAL APPARATUS**

FOR ORTHOPEDIC SUPPORTS; MAGNETIC RESONANCE IMAGING (MRI) DIAGNOSTIC SCANNERS; PLANTAR SURFACE SCANNERS FOR MEDICAL PURPOSES; ORTHOPEDIC FOOTWEAR; ORTHOTIC INSERTS FOR FOOTWEAR; ORTHOPEDIC SOLES (U.S. CLS. 26, 39 AND 44).

**CLASS 25—CLOTHING**

FOR FOOTWEAR SOLES; FOOTWEAR (U.S. CLS. 22 AND 39).

**CLASS 35—ADVERTISING AND BUSINESS**

FOR WHOLESALE ORDERING SERVICES, RETAIL STORE SERVICES, AND ONLINE RETAIL STORE SERVICES FEATURING SOFTWARE FOR THE DESIGN AND PRODUCT QUALITY CONTROL TESTING OF SOLES, STRETCHERS FOR FOOTWEAR AND FOOTWEAR, OPTICAL SCANNERS, ORTHOPEDIC CUSHIONS, MAGNETIC RESONANCE IMAGING (MRI) DIAGNOSTIC SCANNERS, PLANTAR SURFACE SCANNERS FOR MEDICAL PURPOSES, ORTHOPEDIC FOOTWEAR, ORTHOTIC INSERTS FOR FOOTWEAR, ORTHOPEDIC SOLES, FOOTWEAR, AND SOLES FOR FOOTWEAR (U.S. CLS. 100, 101 AND 102).

SIMON TENG, EXAMINING ATTORNEY

SN 79-138,770. LABORATOIRES EXPANSCIENCE, F-92419 COURBEVOIE CEDEX, FRANCE, FILED 6-6-2013.



PRIORITY DATE OF 12-7-2012 IS CLAIMED.

OWNER OF INTERNATIONAL REGISTRATION 1182485 DATED 6-6-2013, EXPIRES 6-6-2023.

OWNER OF U.S. REG. NOS. 2,029,761, 3,872,898 AND OTHERS.

THE COLOR(S) GREEN AND BLUE IS/ARE CLAIMED AS A FEATURE OF THE MARK.

THE MARK CONSISTS OF A GREEN HAND FACING DOWN OVER A BLUE HAND FACING UP. BETWEEN THE TWO HANDS IS A PLANT WITH A GREEN STEM, TWO GREEN LEAVES AND ONE BLUE LEAF. "WWW.MUSTELA.COM" APPEARS IN GREEN BELOW THE BLUE HAND AND EXTENDING UP TO THE WRIST OF THE GREEN HAND.

**CLASS 1—CHEMICALS**

FOR ACTIVE CHEMICALS AND NATURAL ACTIVE CHEMICALS FOR USE IN THE MANUFACTURE OF COSMETICS (U.S. CLS. 1, 5, 6, 10, 26 AND 46).

**CLASS 3—COSMETICS AND CLEANING PREPARATIONS**

FOR COSMETIC PRODUCTS AND PREPARATIONS FOR PREGNANT WOMEN, NAMELY, SKIN, BODY, FACE AND HAIR LOTIONS AND CREAMS, COSMETIC CREAMS AND LOTIONS; COSMETIC PRODUCTS AND PREPARATIONS FOR SKIN CARE, NAMELY, SKIN LOTIONS AND CREAMS; COSMETIC PRODUCTS AND PREPARATIONS FOR BREAST BEAUTY CARE, NAMELY, SKIN AND BODY LOTIONS AND CREAMS, COSMETIC CREAMS AND LOTIONS; NON-MEDICATED COSMETIC PRODUCTS AND PREPARATIONS AGAINST SWOLLEN LEGS, NAMELY, SKIN AND BODY LOTIONS AND CREAMS, COSMETIC CREAMS AND LOTIONS; NON-MEDICATED COSMETIC PRODUCTS AND PREPARATIONS AGAINST PREGNANCY BLEMISHES, NAMELY, SKIN, FACE AND BODY LOTIONS AND CREAMS, COSMETIC CREAMS AND LOTIONS; NON-MEDICATED COSMETIC PRODUCTS AND PREPARATIONS FOR DRY SKIN CAUSED BY PREGNANCY, NAMELY, SKIN, BODY AND FACE LOTIONS AND CREAMS, COSMETIC CREAMS AND LOTIONS; NON-MEDICATED COSMETIC PRODUCTS AND PREPARATIONS AGAINST PREGNANCY BLEMISHES, NAMELY, SKIN, FACE AND BODY LOTIONS AND CREAMS, COSMETIC CREAMS AND LOTIONS; NON-MEDICATED COSMETIC PRODUCTS AND PREPARATIONS AGAINST STRETCH MARKS, NAMELY, SKIN, FACE AND BODY LOTIONS AND CREAMS, COSMETIC CREAMS AND LOTIONS; COSMETIC CREAMS, TOWELETTS IMPREGNATED WITH COSMETIC LOTIONS; COSMETIC KITS COMPRISED OF CREAMS AND LOTIONS FOR THE SKIN, BODY, FACE AND HAIR, COSMETIC CREAMS AND LOTIONS; LOTIONS FOR COSMETIC USE; BEAUTY MASKS; MAKE-UP REMOVAL PREPARATIONS; MEDICATED SOAPS; DISINFECTANT SOAPS; DERMATOLOGICAL SOAPS; CLEANSING MILK FOR TOILET PURPOSES; ALMOND MILK FOR COSMETIC USE; OILS FOR COSMETIC USE; ALMOND OILS FOR COSMETIC USE; SUN CARE

PRODUCTS, NAMELY, SUNSCREEN PRODUCTS AND SUNSCREEN LOTIONS; ASTRINGENTS FOR COSMETIC USE; NON-MEDICATED BATH COSMETICS; COTTON BUDS FOR COSMETIC USE; SKIN WHITENING CREAMS; ESSENTIAL OILS; COSMETICS; HAIR LOTIONS; DENTIFRICES; CLEANSING SOLUTIONS FOR COSMETIC USE; PRODUCTS AND PREPARATIONS FOR CLEANSING THE SKIN, NAMELY, SOAPS; PERFUMERY; PERFUMERY AND HYGIENE PRODUCTS FOR COSMETIC USE, IN PARTICULAR, A LOTION AND A CREAM FOR SKIN CARE; SHAMPOOS; COSMETIC PRODUCTS AND PREPARATIONS FOR SCALP CARE; NON-MEDICAL TOILETRY PRODUCTS AND PREPARATIONS FOR BABIES, NAMELY, COSMETIC LOTIONS, SHAMPOO, SOAP, SOAP CREAMS FOR THE BODY, CLEANSING MILK, BODY EMULSIONS, SHOWER GEL, COSMETIC PREPARATION IN POWDER FORM; ALCOHOL-FREE BABIES' TOILET WATER; EAU-DE-COLOGNE; NON-MEDICINAL PREPARATIONS FOR SKIN CARE, NAMELY, SOAPS, CREAMS, MOISTURIZING STICKS, CREAM SOAPS FOR THE BODY, CREAM SOAPS FOR THE HANDS, COSMETIC LOTIONS, CLEANSING MILKS FOR TOILET USE, SKIN TONICS, SKIN MOISTURIZERS, BODY EMULSIONS, SHOWER GELS, COSMETIC POWDERS, SUN CREAMS FOR COSMETIC USE, SUN BLOCKING LOTIONS, BUBBLE BATH; NON-MEDICATED PRODUCTS FOR BABY SKIN CARE, NAMELY, SHAMPOOS, SUNBLOCK CREAMS, MOISTURIZING FACE CREAMS AND SOAPS, MOISTURIZING BODY CREAMS AND SOAPS; TISSUES IMPREGNATED WITH COSMETIC LOTIONS; THICK WIPES IMPREGNATED WITH COSMETIC LOTIONS FOR BABY CHANGING; LIQUID SKIN CLEANSER; SHAMPOOS FOR INFANTS; BABY SHAMPOOS; CONDITIONING SHAMPOO; BODY AND HAIR CLEANSING SOLUTION; SUPER-FATTY SOAPS; BODY CREAM SOAP; BUBBLE BATH FOR BABIES; TOILETRIES FOR BABIES, NAMELY, COSMETIC LOTIONS, SHAMPOO, SOAP, SOAP CREAMS FOR THE BODY, CLEANSING MILK, BODY EMULSIONS, SHOWER GEL, COSMETIC PREPARATION IN POWDER FORM; BATH COSMETICS FOR BABIES; COSMETICS FOR PROTECTING BABIES; SKIN CREAMS AND MILKS; SKIN PROTECTION FOR NON-MEDICAL USE, NAMELY, COSMETIC PREPARATIONS FOR PROTECTING THE SKIN FROM THE SUN'S RAYS; FACE MILKS AND CREAMS; BODY MILKS AND CREAMS; MILKS AND CREAMS FOR THE FUNDAMENT AND BOTTOM; NON-MEDICAL PROTECTIVE STICKS FOR THE SKIN, NAMELY, CREAMS, LOTIONS, MILKS, SPRAYS AND OILS CONTAINING SUNSCREEN; BODY CREAMS, MOISTURIZING CREAMS, VITAMIN SKIN CREAMS, VITAMIN SKIN CREAMS FOR BABY CHANGING; SCENTED PREPARATIONS FOR THE SHOWER, PARTICULARLY GELS; COSMETIC SUN PROTECTION CREAMS AND MILKS; MOISTURIZING ANTI-MOSQUITO MILK FOR COSMETIC USE; PERFUMED SOAP; CREAM SOAPS; NON-MEDICATED SOAPLESS DERMATOLOGICAL CLEANSING BARS; NON-MEDICATED SOAPLESS DERMATOLOGICAL WASHING GELS; HAND CREAMS (U.S. CLS. 1, 4, 6, 50, 51 AND 52).

#### **CLASS 5—PHARMACEUTICALS**

FOR PHARMACEUTICAL PREPARATIONS FOR TREATING AND PREVENTING HEALTH CONDITIONS RELATED TO DERMATOLOGY, RHEUMATOLOGY, DENTISTRY AND PERIODONTOLOGY; SANITARY PRODUCTS, NAMELY, CHEMICAL PREPARATIONS FOR SANITARY PURPOSES, CHEMICAL PREPARATIONS FOR SANITARY USE, KITS COMPRISING SANITIZER GEL, DISINFECTING WIPES, SANITARY MASKS, PLASTIC GLOVES AND HAND CREAM USED FOR GERM PREVENTION, SANITARY NAPKINS, SANITARY PANTIES, SANITARY PREPARATIONS FOR MEDICAL USE, SANITARY STERILIZING PREPARATIONS, SANITARY TAMPONS; DIETETIC SUPPLEMENTAL BEVERAGES ADAPTED FOR MEDICAL USE; DIETARY FOODSTUFFS, NAMELY, DRINKS, BARS, READY-MEALS FOR MEDICAL USE; DIETETIC SUBSTANCES FOR MEDICAL USE, NAMELY, DIETETIC SUGAR SUBSTITUTES, DIETETIC FIBER TO AID DIGESTION; PLASTERS FOR MEDICAL PURPOSES; MATERIALS FOR DRESSINGS, NAMELY, WADDINGS, BANDAGES, GAUZES, COMPRESSES; PHARMACEUTICAL PREPARATIONS AND MEDICATED SANITARY PREPARATIONS FOR SKIN CARE; SANITARY PRODUCTS FOR MEDICAL USE AND FOR INTIMATE

HYGIENE, NAMELY, SANITARY TOWELS, SANITARY PADS, ABSORBENT SANITARY ARTICLES; LOTIONS FOR PHARMACEUTICAL USE; CHEMICAL PREPARATIONS FOR PHARMACEUTICAL USE, NAMELY, FOR TREATING AND PREVENTING HEALTH CONDITIONS RELATED TO DERMATOLOGY, RHEUMATOLOGY, DENTISTRY AND PERIODONTOLOGY; ACTIVE CHEMICAL PREPARATIONS FOR PHARMACEUTICAL USE, NAMELY, FOR TREATING AND PREVENTING HEALTH CONDITIONS RELATED TO DERMATOLOGY, RHEUMATOLOGY, DENTISTRY AND PERIODONTOLOGY; MEDICINES FOR HUMAN MEDICINE FOR TREATING AND PREVENTING HEALTH CONDITIONS RELATED TO DERMATOLOGY, RHEUMATOLOGY, DENTISTRY AND PERIODONTOLOGY; MILK OF ALMONDS FOR PHARMACEUTICAL USE; ANTISEPTICS; SUNBURN PRODUCTS FOR PHARMACEUTICAL USE; RECONSTITUTING PHARMACEUTICALS FOR TREATING AND PREVENTING HEALTH CONDITIONS RELATED TO DERMATOLOGY, RHEUMATOLOGY, DENTISTRY AND PERIODONTOLOGY; GLYCERIN FOR MEDICAL USE; MEDICAL OR SANITARY DISINFECTANTS, EXCLUDING SOAPS (U.S. CLS. 6, 18, 44, 46, 51 AND 52).

#### **CLASS 10—MEDICAL APPARATUS**

FOR SURGICAL, MEDICAL, DENTAL AND VETERINARY APPARATUS AND INSTRUMENTS FOR USE IN DERMATOLOGY, RHEUMATOLOGY, DENTISTRY AND PERIODONTOLOGY; ARTIFICIAL LIMBS, EYES AND TEETH; ORTHOPEDIC ARTICLES, NAMELY, WALKING STICKS, CRUTCHES, WALKING FRAMES; SUTURE MATERIAL (U.S. CLS. 26, 39 AND 44).

#### **CLASS 42—SCIENTIFIC AND COMPUTER SERVICES**

FOR COSMETIC SCIENCE RESEARCH; SCIENTIFIC RESEARCH FOR MEDICAL PURPOSES; CHEMICAL RESEARCH; BACTERIOLOGICAL RESEARCH; RESEARCH AND DEVELOPMENT OF NEW PRODUCTS FOR OTHERS IN THE FIELD OF COSMETICS, MEDICINE, PHARMACEUTICALS AND CHEMICALS (U.S. CLS. 100 AND 101).

#### **CLASS 44—MEDICAL, BEAUTY AND AGRICULTURAL SERVICES**

FOR ADVICE, ADVISORY, INFORMATION AND CONSULTANCY SERVICES IN THE FIELD OF MEDICINE, PHARMACEUTICALS, COSMETICS AND SANITARY CARE IN THE FIELD OF HYGIENE AND BEAUTY FOR HUMAN BEINGS; MEDICAL INFORMATION AND ADVICE SERVICES FOR PREGNANT WOMEN, YOUNG AND FUTURE PARENTS, NAMELY, INFORMATION AND ADVISORY SERVICES RELATING TO PREGNANCY, CHILDBIRTH, CARE, HEALTH, WELL-BEING AND NUTRITION FOR BABIES, PREGNANT WOMEN, YOUNG MOTHERS AND INFANTS; INFORMATION AND CONSULTING SERVICES IN THE FIELD OF HYGIENE AND BEAUTY CARE FOR HUMAN BEINGS FOR PREGNANT WOMEN, YOUNG AND FUTURE PARENTS, NAMELY, INFORMATION AND ADVISORY SERVICES RELATING TO THE HYGIENE AND BEAUTY OF BABIES, PREGNANT WOMEN, YOUNG MOTHERS AND INFANTS (U.S. CLS. 100 AND 101).

COLLEEN MULCRONE, EXAMINING ATTORNEY



SN 79-138,776, LA GARDENIA BEAUTY S.P.A., ITALY,  
FILED 2-15-2013.



OWNER OF INTERNATIONAL REGISTRATION 1182497  
DATED 2-15-2013, EXPIRES 2-15-2023.

NO CLAIM IS MADE TO THE EXCLUSIVE RIGHT TO  
USE "MAISON BIO", APART FROM THE MARK AS  
SHOWN.

THE COLOR(S) BLACK, GREY, AND GREEN IS/ARE  
CLAIMED AS A FEATURE OF THE MARK.

THE MARK CONSISTS OF THE STYLIZED WORDING  
"MAISON" IN BLACK ABOVE THE STYLIZED WORDING  
"BIO" IN GREY. A GREEN LINE APPEARS TO THE LEFT  
OF THE WORDING "BIO". THREE OVAL-SHAPED LEAVES  
APPEAR ABOVE AND TO THE RIGHT OF THE WORDING  
IN BLACK AND GREY OUTLINING. THE WHITE AREAS  
IN THE MARK REPRESENT BACKGROUND OR TRANSPARENCY  
AND ARE NOT PART OF THE MARK.

THE ENGLISH TRANSLATION OF THE FOREIGN  
WORD(S) IN THE MARK IS "HOUSE BIO".

### CLASS 3—COSMETICS AND CLEANING PREPARATIONS

FOR PERFUMERY, PERFUMES, ESSENTIAL OILS  
FOR PERSONAL USE, COSMETICS, NON-MEDICATED  
TOILETRIES, SOAPS FOR BODY CARE, HAIR LOTIONS,  
DENTIFRICES, DEODORANTS FOR BODY CARE (U.S. CLS. 1, 4, 6, 50, 51 AND 52).

### CLASS 5—PHARMACEUTICALS

FOR DIETARY FOOD SUPPLEMENTS (U.S. CLS. 6, 18,  
44, 46, 51 AND 52).

### CLASS 9—ELECTRICAL AND SCIENTIFIC APPARATUS

FOR SPECTACLES, SUNGLASSES AND GOGGLES  
FOR SPORTS; CASES FOR SPECTACLES AND SUNGLASSES,  
CASES FOR CONTACT LENSES; CHAINS FOR SPECTACLES  
AND FOR SUNGLASSES, EYEGGLASS CORDS (U.S. CLS. 21,  
23, 26, 36 AND 38).

### CLASS 11—ENVIRONMENTAL CONTROL APPARATUS

FOR LAMPS, NAMELY, TABLE LAMPS, FLOOR LAMPS;  
CHANDELIERS, STANDARD LAMPS, STREET LAMPS,  
LANTERNS FOR LIGHTING, LAMP SHADES, CEILING LIGHTS,  
LAMP GLASSES, WALL LIGHTS (U.S. CLS. 13, 21, 23,  
31 AND 34).

### CLASS 14—JEWELRY

FOR CLOCKS, WATCHES, WRIST WATCHES, POCKET  
WATCHES; JEWELLERY AND COSTUME JEWELRY,  
NAMELY, RINGS, BRACELETS, WATCH STRAPS,  
NECKLACES, EARRINGS, ORNAMENTAL PINS, TIE PINS,  
CUFF LINKS, KEY RINGS OF PRECIOUS METALS,  
JEWELRY CHAINS, CHARMS FOR COLLAR JEWELRY  
AND BRACELETS, JEWELLERY BOXES (U.S. CLS. 2, 27,  
28 AND 50).

### CLASS 18—LEATHER GOODS

FOR LEATHER AND IMITATION LEATHER GOODS,  
NAMELY, LEATHER BAGS, VALISES, SHOULDER BAGS,  
ALL-PURPOSE SPORT BAGS, DOCUMENT SUITCASES,  
COIN PURSES, MAKE-UP BAGS SOLD EMPTY,  
POCKET WALLETS, TRAVEL BAGS, RUCKSACKS,  
SUITCASES, ATTACHÉ CASES, BRIEFCASES, BACKPACKS,  
UMBRELLAS (U.S. CLS. 1, 2, 3, 22 AND 41).

### CLASS 20—FURNITURE AND ARTICLES NOT OTHERWISE CLASSIFIED

FOR WORKS OF ART OF WAX, PLASTER, WOOD,  
PLASTIC; FURNITURE, NAMELY, LOCKERS, CABINETS,  
COAT STANDS, SHELVES, TABLES; MAGAZINE RACKS;  
UMBRELLA STANDS; ARMCHAIRS; DIVANS; CHAIRS;  
SEATS; SOFAS; DESKS; MIRRORS; DRESSING TABLES;  
DISPLAY CASES; PICTURE FRAMES OF PRECIOUS METAL  
(U.S. CLS. 2, 13, 22, 25, 32 AND 50).

### CLASS 21—HOUSEWARES AND GLASS

FOR WORKS OF ART MADE OF PORCELAIN,  
EARTHENWARE OR GLASS; GLASS BOWLS; JUGS;  
PITCHERS; CANDLESTICKS; NON-ELECTRIC CANDLELABRAS;  
DECORATIVE CENTERPIECES OF CRYSTAL, GLASS,  
PORCELAIN, CERAMIC; CERAMICS FOR HOUSEHOLD  
PURPOSES, NAMELY, CERAMIC VASES, BOWLS,  
PLATES AND POTS; BASKETS FOR DOMESTIC USE,  
NOT OF METAL; CUPS; FLOWERPOTS; VASES;  
CLAY POTS; PLATES; PORCELAIN WARES, NAMELY,  
VASES, VESSELS, BOWLS, PLATES AND POTS;  
SERVING TRAYS; OPAL GLASS (U.S. CLS. 2, 13, 23,  
29, 30, 33, 40 AND 50).

### CLASS 25—CLOTHING

FOR MEN, WOMEN AND CHILDREN'S CLOTHING,  
NAMELY, BLAZERS, JACKETS, STUFF JACKETS,  
SCARVES, HEADSCARVES; WOVEN OR KNITTED UNDERWEAR;  
JERSEYS; T-SHIRTS; VESTS; TROUSERS; SHORTS;  
SKIRTS; SPORTS JACKETS; POLO SHIRTS; SHIRTS;  
SWEATSHIRTS; HEADWEAR, NAMELY, HATS, CAPS,  
EAR MUFFS, BERETS; GLOVES; STOCKINGS; SHAWLS;  
HEADBANDS; BONNETS; CLOTHING, NAMELY, BELTS;  
SUSPENDERS, NAMELY, BRACES; FOOTWEAR, NAMELY,  
SHOES, SNEAKERS, GYMNAS-TIC SHOES, BOOTS,  
ANKLE BOOTS, SANDALS, SLIPPERS (U.S. CLS. 22  
AND 39).

### CLASS 35—ADVERTISING AND BUSINESS

FOR FRANCHISING, NAMELY, OFFERING BUSINESS  
MANAGEMENT ASSISTANCE IN THE ESTABLISHMENT  
AND/OR OPERATION OF PERFUMERY STORES; RETAIL  
COSMETICS AND PERFUMERY STORES; ADVERTISING  
SERVICES; SALES PROMOTION SERVICES; BUSINESS  
ADMINISTRATION AND MANAGEMENT; BUSINESS  
MANAGEMENT FOR SHOPS; COMPUTERIZED FILE  
MANAGEMENT; ORGANIZATION OF EXHIBITIONS FOR  
COMMERCIAL OR ADVERTISING PURPOSES; ORGANISATION  
OF EVENTS FOR COMMERCIAL OR ADVERTISING PURPOSES;  
SERVICES WITH REGARD TO PRODUCT PRESENTATION  
TO THE PUBLIC; OUTDOOR ADVERTISING; WINDOW  
DRESSING AND DISPLAY ARRANGEMENT SERVICES;  
MARKETING RESEARCH

SERVICES; COMMERCIAL ADMINISTRATION OF LICENSING OF GOODS AND SERVICES FOR OTHERS; RADIO AND TELEVISION ADVERTISING; MAIL ORDER CATALOG SERVICES FEATURING COSMETICS AND PERFUMERY; RENTAL OF ADVERTISING SPACE; ADVERTISING SERVICES, NAMELY, PROVIDING ADVERTISING SPACE IN A PERIODICAL; DIRECT MAIL ADVERTISING SERVICES; ADVERTISING TEXT PUBLICATION SERVICES; DISTRIBUTION AND DISSEMINATION OF ADVERTISING MATERIALS IN THE NATURE OF LEAFLETS, PROSPECTUSES, PRINTED MATTER, SAMPLES (U.S. CLS. 100, 101 AND 102).

#### CLASS 38—COMMUNICATION

FOR TELECOMMUNICATION SERVICES, NAMELY, PROVIDING ACCESS TO TELECOMMUNICATION NETWORKS; ELECTRONIC TRANSMISSION OF PURCHASE AND SALES ORDERS VIA A GLOBAL COMPUTER NETWORK, NAMELY, THE INTERNET; TELEVISION BROADCASTING SERVICES FOR INTERACTIVE USE RELATING TO PRODUCTS PRESENTATIONS; NEWS AGENCY SERVICES, NAMELY, GATHERING AND DISSEMINATION OF NEWS; RADIO BROADCASTING, COMMUNICATIONS VIA TELEGRAPH, TELEPHONE, VIDEOPHONE, AND TELEVISION TRANSMISSIONS; TELEVISION BROADCASTING; INFORMATION TRANSMISSION SERVICES VIA COMPUTERS CONNECTED TO THE SAME TELEMATIC NETWORKS; COMPUTER AIDED TRANSMISSION OF IMAGES; PROVIDING VOICE COMMUNICATION SERVICES OVER AN OPEN GLOBAL COMPUTER NETWORK, NAMELY, THE INTERNET, OR A CLOSED NETWORK, NAMELY, AN INTRANET (U.S. CLS. 100, 101 AND 104).

JOANNA FIORELLI, EXAMINING ATTORNEY

SN 79-138,910. MAGGIE SOTTERO DESIGNS LLC, SALT LAKE CITY, UT. FILED 7-5-2013.

Love,  
MAGGIE  
Notes to the Bride

PRIORITY DATE OF 6-11-2013 IS CLAIMED.  
OWNER OF INTERNATIONAL REGISTRATION 1182817  
DATED 7-5-2013, EXPIRES 7-5-2023.

#### CLASS 25—CLOTHING

FOR CLOTHING, HEADGEAR AND FOOTWEAR, NAMELY, FORMAL, EVENING AND BRIDAL WEAR, NAMELY, DRESSES, GOWNS, EVENING GOWNS, WEDDING DRESSES, WEDDING GOWNS, VEILS, SHOES (U.S. CLS. 22 AND 39).

#### CLASS 41—EDUCATION AND ENTERTAINMENT

FOR ON-LINE JOURNALS, NAMELY, BLOGS IN THE FIELD OF CLOTHING AND FASHION (U.S. CLS. 100, 101 AND 107).

MATTHEW EINSTEIN, EXAMINING ATTORNEY

SN 79-138,914. DON ELECTRONICS LTD, LEEDS, UNITED KINGDOM, FILED 1-30-2013.



PRIORITY DATE OF 7-30-2012 IS CLAIMED.  
OWNER OF INTERNATIONAL REGISTRATION 1182828  
DATED 1-30-2013, EXPIRES 1-30-2023.

THE COLOR(S) BLACK AND GREY IS/ARE CLAIMED AS A FEATURE OF THE MARK.

THE MARK CONSISTS OF THE WORD "HAZARDMON" IN STYLIZED FONT WHERE THE "H" IS MADE UP OF A GRAY HORIZONTAL SEISMOGRAPH LINE OVER TWO BLACK VERTICAL LINES AND "AZARDMON" IS IN BLACK.

THE WORD(S) "HAZARDMON" HAS NO MEANING IN A FOREIGN LANGUAGE.

#### CLASS 9—ELECTRICAL AND SCIENTIFIC APPARATUS

FOR COMPUTER HARDWARE; COMPUTER HARDWARE AND SOFTWARE ALL FOR THE CAPTURE, COLLECTION, STORAGE, PROCESSING, RETRIEVAL, TRANSMISSION, DISPLAY, MANAGEMENT, ANALYSIS, INTERPRETATION, IDENTIFICATION, DIAGNOSTICS, REPORTING, AND ARCHIVING OF DATA, REAL-TIME ANALYTICS AND HAZARD DETECTION, PROCESS AUTOMATION, SIGNAL PROCESSING, SIGNAL ANALYSIS, ALARMS, ALARM ANALYSIS AND MANAGEMENT; ELECTRONIC APPARATUS AND INSTRUMENTS, ALL FOR RECOGNIZING DIGITAL AND ANALOGUE CODES IN MICROPROCESSOR BASED ELECTRONIC CONTROLLERS AND COMPUTERS; COMPUTER SOFTWARE FOR USE IN DATABASE MANAGEMENT IN THE FIELD OF REAL-TIME ANALYTICS AND HAZARD DETECTION; ELECTRONIC CONTROLLERS AND SENSORS FOR USE IN HAZARD MONITORING AND DETECTION; ALARM SENSORS FOR USE IN HAZARD MONITORING AND DETECTION; DOWNLOADABLE ELECTRONIC PUBLICATIONS, NAMELY, MANUALS, NEWSLETTERS, JOURNALS, BULLETINS, BOOKS AND INSTRUCTIONAL MATERIALS IN THE FIELD OF REAL-TIME ANALYTICS AND HAZARD DETECTION (U.S. CLS. 21, 23, 26, 36 AND 38).

#### CLASS 38—COMMUNICATION

FOR DATA COMMUNICATION AND TRANSMISSION BY ELECTRONIC MAIL; ELECTRONIC TRANSMISSION OF DATA OVER A GLOBAL COMMUNICATIONS NETWORKS, INCLUDING THE INTERNET AND SATELLITE NETWORKS; PROVIDING USER ACCESS TO COMPUTER PROGRAMS IN DATA NETWORKS; DATA TRANSMISSION SERVICES BETWEEN NETWORKED COMPUTER SYSTEMS; ELECTRONIC COMMUNICATION SERVICES BY MEANS OF COMPUTER; TELECOMMUNICATIONS AND COMMUNICATIONS SERVICES, NAMELY, ELECTRONIC COMMUNICATION SERVICES; ELECTRONIC TRANSMISSION OF COMPUTER PROGRAMS, NAMELY, DATA AND DOCUMENTS VIA THE INTERNET; COMPUTERIZED DATA COMMUNICATIONS, NAMELY, COMMUNICATION BY COMPUTER TERMINALS; TRANSMISSION AND DISTRIBUTION OF DATA OR AUDIO VISUAL IMAGES VIA A GLOBAL COMPUTER NETWORK OR THE INTERNET; ADVISORY, INFORMATION AND CONSULTANCY SERVICES AND THE PREPARATION OF REPORTS ALL RELATING TO ALL THE AFORESAID SERVICES (U.S. CLS. 100, 101 AND 104).



**CLASS 42—SCIENTIFIC AND COMPUTER SERVICES**

FOR UPDATING SERVICES ALL RELATING TO COMPUTER SOFTWARE; COMPUTER PROGRAMMING AND SOFTWARE DESIGN SERVICES ALL FOR THE CAPTURE, COLLECTION, STORAGE, PROCESSING, RETRIEVAL, TRANSMISSION, DISPLAY, MANAGEMENT, ANALYSIS, INTERPRETATION, IDENTIFICATION, DIAGNOSTICS, REPORTING, AND ARCHIVING OF DATA, REAL-TIME ANALYTICS AND HAZARD DETECTION, PROCESS AUTOMATION, SIGNAL PROCESSING, SIGNAL ANALYSIS, ALARMS, ALARM ANALYSIS AND MANAGEMENT; DESIGN, CUSTOMIZATION, DEVELOPMENT, AND TECHNICAL SUPPORT SERVICES ALL RELATING TO COMPUTER HARDWARE AND SOFTWARE; INTEGRATION OF COMPUTER SOFTWARE INTO MULTIPLE SYSTEMS AND NETWORKS; ADVISORY, INFORMATION AND CONSULTANCY SERVICES AND THE PREPARATION OF REPORTS ALL RELATING TO ALL THE AFORESAID SERVICES (U.S. CLS. 100 AND 101).

JILLIAN CANTOR, EXAMINING ATTORNEY

SN 79-138,988. CORTINETIX PHARMA SRL, ITALY, FILED 7-31-2013.

**SWITCH ON YOUR MIND**

THE MARK CONSISTS OF STANDARD CHARACTERS WITHOUT CLAIM TO ANY PARTICULAR FONT, STYLE, SIZE, OR COLOR.

PRIORITY DATE OF 2-1-2013 IS CLAIMED.

OWNER OF INTERNATIONAL REGISTRATION 1183011 DATED 7-31-2013, EXPIRES 7-31-2023.

**CLASS 5—PHARMACEUTICALS**

FOR PHARMACEUTICAL AND VETERINARY PREPARATIONS FOR INCREASE BRAIN AND MUSCULAR ACTIVITY; SANITARY PREPARATIONS FOR MEDICAL PURPOSES; FOODS AND DIETETIC SUBSTANCES ADAPTED FOR MEDICAL AND VETERINARY USE NAMELY DRINKS, ICE CREAM AND CHOCOLATE; FOOD FOR BABIES; DIETETIC SUPPLEMENTS FOR HUMAN AND VETERINARY USE; PLASTERS FOR MEDICAL PURPOSES; MATERIAL FOR STOPPING TEETH, DENTAL WAX; ALL-PURPOSE DISINFECTANTS; PREPARATIONS FOR DESTROYING VERMIN; FUNGICIDES, HERBICIDES (U.S. CLS. 6, 18, 44, 46, 51 AND 52).

**CLASS 32—LIGHT BEVERAGES**

FOR BEERS; MINERAL AND AERATED WATERS AND OTHER NON-ALCOHOLIC DRINKS NAMELY SPORTS DRINKS, COLA DRINKS, ENERGY DRINKS, FRUIT DRINKS, VEGETABLE DRINKS; FRUIT DRINKS AND FRUIT JUICES; SYRUPS AND OTHER PREPARATIONS IN NATURE OF CONCENTRATES AND POWERS FOR MAKING BEVERAGES (U.S. CLS. 45, 46 AND 48).

**CLASS 35—ADVERTISING AND BUSINESS**

FOR ADVERTISING SERVICES; BUSINESS MANAGEMENT; BUSINESS ADMINISTRATION; PROVIDING OFFICE FUNCTIONS (U.S. CLS. 100, 101 AND 102).

JACLYN KIDWELL WALKER, EXAMINING ATTORNEY

SN 79-138,993. KRISNO CO., LTD., JAPAN, FILED 9-9-2013.

**Krisno**

PRIORITY DATE OF 3-12-2013 IS CLAIMED.

OWNER OF INTERNATIONAL REGISTRATION 1183021 DATED 9-9-2013, EXPIRES 9-9-2023.

THE MARK CONSISTS OF THE WORD "KRISNO" IN A STYLIZED FORM.

**CLASS 16—PAPER GOODS AND PRINTED MATTER**

FOR DECORATORS' PAINTBRUSHES; WRITING BRUSHES; PAINTBRUSHES; STATIONERY (U.S. CLS. 2, 5, 22, 23, 29, 37, 38 AND 50).

**CLASS 21—HOUSEWARES AND GLASS**

FOR MAKE-UP BRUSHES; NAIL BRUSHES; COSMETIC UTENSILS, NAMELY, COSMETIC BRUSHES, COSMETIC BRUSH CASES, COMPACTS SOLD EMPTY; BRUSHES, NAMELY, NAIL ART BRUSHES, EYEBROW BRUSHES, LIP BRUSHES; BRUSH GOODS, NAMELY, CAPS FOR MAKE-UP BRUSHES, NAIL BRUSHES, COSMETIC BRUSHES, NAIL ART BRUSHES, EYEBROW BRUSHES, AND LIP BRUSHES (U.S. CLS. 2, 13, 23, 29, 30, 33, 40 AND 50).

MATTHEW MCDOWELL, EXAMINING ATTORNEY

SN 79-139,042. KONG, JUNG IN, CHUNGCHEONGNAM-DO, REPUBLIC OF KOREA, FILED 7-19-2013.

**612**

THE MARK CONSISTS OF STANDARD CHARACTERS WITHOUT CLAIM TO ANY PARTICULAR FONT, STYLE, SIZE, OR COLOR.

PRIORITY DATE OF 1-21-2013 IS CLAIMED.

OWNER OF INTERNATIONAL REGISTRATION 1183154 DATED 7-19-2013, EXPIRES 7-19-2023.

**CLASS 3—COSMETICS AND CLEANING PREPARATIONS**

FOR DENTIFRICES; LIQUID TOOTHPASTE; TOOTHPASTE CONTAINING FLUORINE MIXTURES; BREATH FRESHENING SPRAYS; TOOTH CLEANING PREPARATIONS; TOOTH POWDER; DENTURE CLEANING PREPARATIONS; GARGLES, NOT FOR MEDICAL PURPOSES; COSMETICS; LIP PROTECTORS; HAND LOTIONS; BODY SOAPS; SHAMPOOS (U.S. CLS. 1, 4, 6, 50, 51 AND 52).

**CLASS 21—HOUSEWARES AND GLASS**

FOR TOOTHBRUSHES; ELECTRIC TOOTHBRUSHES (U.S. CLS. 2, 13, 23, 29, 30, 33, 40 AND 50).

JACLYN KIDWELL WALKER, EXAMINING ATTORNEY

SN 79-139,060. MYUTRON INC., TOKYO 133-0057, JAPAN,  
FILED 9-17-2013.



OWNER OF INTERNATIONAL REGISTRATION 1183191  
DATED 9-17-2013, EXPIRES 9-17-2023.

THE MARK CONSISTS OF A STYLIZED GREEK LETTER MU, WITH A RAISED DOT TO THE RIGHT OF IT, FOLLOWED BY THE WORD "TRON" WITH THREE DOTS IN THE MIDDLE OF THE "O".

#### CLASS 9—ELECTRICAL AND SCIENTIFIC APPARATUS

FOR OPTICAL LENSES; MICROSCOPES; PHOTOGRAPHIC MACHINES; CINEMATOGRAPHIC MACHINES AND APPARATUS; OPTICAL MACHINES; CCD CAMERA; IMAGE PROCESSING APPARATUS; COMPUTER SOFTWARE FOR IMAGE PROCESSING (U.S. CLS. 21, 23, 26, 36 AND 38).

#### CLASS 11—ENVIRONMENTAL CONTROL APPARATUS

FOR ELECTRIC LAMPS AND LIGHTING APPARATUS, NAMELY, LED LIGHTING MACHINES, LIGHTING FIXTURES, AND LED LIGHTING SYSTEMS, NAMELY, LED MODULES, POWER SUPPLIES, AND WIRING THEREFOR (U.S. CLS. 13, 21, 23, 31 AND 34).

CHARLES L. JENKINS, EXAMINING ATTORNEY

SN 79-139,152. HODARA S.R.L., MILANO (MI), ITALY,  
FILED 4-19-2013.



THE MARK CONSISTS OF STANDARD CHARACTERS WITHOUT CLAIM TO ANY PARTICULAR FONT, STYLE, SIZE, OR COLOR.

PRIORITY DATE OF 4-17-2013 IS CLAIMED.

OWNER OF INTERNATIONAL REGISTRATION 1183446  
DATED 4-19-2013, EXPIRES 4-19-2023.

THE WORDING "HODARA" HAS NO MEANING IN A FOREIGN LANGUAGE.

#### CLASS 20—FURNITURE AND ARTICLES NOT OTHERWISE CLASSIFIED

FOR FURNITURE, MIRRORS, PICTURE FRAMES; GOODS OF WOOD, CORK, REED, CANE, WICKER, HORN, BONE, IVORY, WHALEBONE, SHELL, AMBER, MOTHER-OF PEARL, MEERSCHAUM, OR OF PLASTICS; BED FITTINGS, NOT OF METAL; FURNITURE FITTINGS, NOT OF METAL; DOOR FITTINGS, NOT OF METAL; CUPBOARDS; MEDICINE CABINETS; COAT-STANDS; CHESTS, NOT OF METAL; TROLLEYS FURNITURE; LOCKERS; CHESTS OF DRAWERS; MOBILES DECORATION; CONTAINERS, NOT OF METAL STORAGE, TRANSPORT; PICTURE FRAMES; CUSHIONS; DIVANS; EDGINGS OF PLASTIC FOR FURNITURE; MIRROR TILES; DOOR HANDLES, NOT OF METAL; WORKS OF ART, OF WOOD, WAX, PLASTER OR PLASTIC; WICKERWORK; KEYBOARDS FOR HANGING KEYS; FURNITURE PARTITIONS OF WOOD; SCREENS FURNITURE; TABLE TOPS; ARMCHAIRS; TOWEL CLOSETS FURNITURE; HAT STANDS; BOOK RESTS FURNITURE; UMBRELLA STANDS; MAGAZINE RACKS; BOTTLE RACKS; DOORS FOR FURNITURE; FURNITURE SHELVES; SHELVES FOR STORAGE; RACKS FURNITURE; FILING CABINETS; LADDERS OF WOOD OR PLASTICS; BOXES OF WOOD OR PLASTIC; WRITING DESKS; DESKS; EASY CHAIRS; CHAIRS SEATS; SEATS OF METAL; STOOLS; SOFAS; STAKES FOR PLANTS OR TREES; MIRRORS LOOKING GLASSES; DRAUGHTMAN'S TABLES; DRESSING TABLES; TABLES OF METAL; WASHSTANDS FURNITURE; CARTS FOR COMPUTERS FURNITURE; SHOWCASES FURNITURE (U.S. CLS. 2, 13, 22, 25, 32 AND 50).

#### CLASS 21—HOUSEWARES AND GLASS

FOR HOUSEHOLD OR KITCHEN UTENSILS AND CONTAINERS; COMBS AND SPONGES; BRUSHES EXCEPT PAINT BRUSHES; BRUSH-MAKING MATERIALS; ARTICLES FOR CLEANING PURPOSES, NAMELY, STEELWOOL; UNWORKED OR SEMI-WORKED GLASS EXCEPT GLASS USED IN BUILDING; GLASSWARE, PORCELAIN AND EARTHENWARE; TOWEL RAILS AND RINGS; BOTTLE OPENERS; DRINKING GLASSES; TANKARDS; BOTTLES; MUGS; CANDELABRA CANDLESTICKS; DECANTERS; CORKSCREWS; EPERGNE; BREAD BASKETS, DOMESTIC; BASKETS FOR DOMESTIC USE; WASTE PAPER BASKETS; FRUIT CUPS; CHEESE-DISH COVERS; TEA COZIES; COVERS, NOT OF PAPER, FOR FLOWER POTS; PLATE GLASS RAW MATERIAL; CRYSTAL GLASSWARE; TOILET PAPER DISPENSERS; SOAP DISPENSERS; SALAD BOWLS; MAJOLICA; TOILET CASES; WORKS OF ART OF PORCELAIN, CERAMIC, EARTHENWARE OR GLASS; OIL CRUETS; PORCELAIN WARE; KNIFE RESTS FOR THE TABLE; MENU CARD HOLDERS; SHAVING BRUSH STANDS; SOAP HOLDERS; SPONGE HOLDERS; TOOTHPICK HOLDERS; NAPKIN HOLDERS; POWDER COMPACTS; TOILET PAPER HOLDERS; EGG CUPS; CERAMICS FOR HOUSEHOLD PURPOSES; DRINKING VESSELS; LUNCH BOXES; BREAD BINS; CONTAINERS FOR HOUSEHOLD OR KITCHEN USE; KITCHEN CONTAINERS; SALT CELLARS; PIGGY BANKS; BOXES OF GLASS; BOXES FOR DISPENSING PAPER TOWELS; COOKIE JARS; TEA CADDIES; SOAP BOXES; COOLERS ICE PAILS; COFFEE SERVICES TABLEWARE; LIQUEUR SETS; TEA SERVICES TABLEWARE; SPICE SETS; SERVICES DISHES; TRIVETS TABLE UTENSILS; STATUES OF PORCELAIN, CERAMIC, EARTHENWARE OR GLASS; HOLDERS FOR FLOWERS AND PLANTS FLOWER ARRANGING; KITCHEN UTENSILS; UTENSILS FOR HOUSEHOLD PURPOSES; TOILET UTENSILS; TABLEWARE, OTHER THAN KNIVES, FORKS AND SPOONS; POTTERY; POTS; VASES; CABARETS TRAYS; GLASS RECEPTACLES; SUGAR BOWLS; SOUP BOWLS (U.S. CLS. 2, 13, 23, 29, 30, 33, 40 AND 50).

**CLASS 42—SCIENTIFIC AND COMPUTER SERVICES**

FOR SCIENTIFIC AND TECHNOLOGICAL SERVICES AND RESEARCH AND DESIGN RELATING THERETO IN THE FIELD OF HOME FURNISHING AND INTERIOR DECORATION IN PUBLIC SPACES AND PRIVATE BUILDING AND HOUSES; INDUSTRIAL ANALYSIS AND RESEARCH SERVICES; DESIGN AND DEVELOPMENT OF COMPUTER HARDWARE AND SOFTWARE; CONSULTANCY IN THE FIELD OF DESIGN; DESIGN OF MODELS CONCERNING FURNITURE, MIRRORS, PICTURE FRAMES; GOODS (NOT INCLUDED IN OTHER CLASSES) OF WOOD, CORK, REED, WICKER, HORN, BONE, IVORY, WHALEBONE, SHELL, AMBER, MOTHER-OF-PEARL, MEERSCHAUM AND SUBSTITUTES FOR ALL THESE MATERIALS, OR OF PLASTICS; BED FITTINGS NOT OF METAL; FURNITURE FITTINGS, NOT OF METAL; DOOR FITTINGS, NOT OF METAL; CUPBOARDS; MEDICINE CABINETS; COAT-STANDS; CHESTS, NOT OF METAL; TROLLEYS (FURNITURE); LOCKERS; CHESTS OF DRAWERS; MOBILES (DECORATION); CONTAINERS, NOT OF METAL (STORAGE, TRANSPORT); PICTURE FRAMES; CUSHIONS; DIVANS; EDGINGS OF PLASTIC FOR FURNITURE; MIRROR TILES; DOOR HANDLES, NOT OF METAL; WORKS OF ART, OF WOOD, WAX, PLASTER OR PLASTIC; WICKERWORK; KEYBOARDS FOR HANGING KEYS; FURNITURE PARTITION OF WOOD; SCREENS (FURNITURE); TABLES TOPS; ARMCHAIRS; TOWEL CLOSETS (FURNITURE); HAT STANDS; BOOK RESTS (FURNITURE); UMBRELLA STANDS; MAGAZINE RACKS; BOTTLE RACKS; DOORS FOR FURNITURE; FURNITURE SHELVES; SHELVES FOR STORAGE; RACKS (FURNITURE); FILING CABINETS; LADDERS OF WOOD OR PLASTICS; BOXES OF WOOD OR PLASTIC; WRITING DESKS; DESKS; EASY CHAIRS; CHAIRS (SEATS); SEATS OF METAL; STOOLS; SOFAS; STAKES FOR PLANTS OR TREES; MIRRORS (LOOKING CUPS; CHEESE-DISH COVERS; TEA COZIES; COVERS, NOT OF PAPERS, FOR FLOWER POTS; PLATE GLASS (RAW MATERIAL); CRYSTAL (GLASSWARE); TOILET PAPER DISPENSER; SOAP DISPENSERS; SALAD BOWLS; MAJOLICA; TOILET CASES; WORKS OF ART OF PORCELAIN, CERAMIC, EARTHENWARE OR GLASS; OIL CRUETS; PORCELAIN WARE; KNIFE RESTS FOR THE TABLE; MENU CARD HOLDERS; SHAVING BRUSH STANDS; SOAP HOLDERS; SPONGE HOLDERS; TOOTHPICK HOLDERS; NAPKIN HOLDERS; POWDER COMPACTS, TOILET PAPER HOLDERS; EGG CUPS; CERAMICS FOR HOUSEHOLD PURPOSES; DRINKING VESSELS; LUNCH BOXES; BREAD BINS; CONTAINERS FOR HOUSEHOLD OR KITCHEN USE; KITCHEN CONTAINERS; SALT CELLARS; PIGGY BANKS; BOXES OF GLASS; BOXES FOR DISPENSING PAPER TOWELS; COOKIE JARS; TEA CADDIES; SOAP BOXES; COOLERS (ICE PAILS); COFFEE SERVICES (TABLEWARE); LIQUEUR SETS; TEA SERVICES (TABLEWARE); SPICE SETS; SERVICES (DISHES); TRIVETS (TABLE UTENSILS); STATUES OF PORCELAIN, CERAMIC, EARTHENWARE OR GLASS; HOLDERS FOR FLOWERS AND PLANTS (FLOWER ARRANGING); KNIVES, FORKS AND SPOONS; POTTERY; POTS; VASES; CABARETS (TRAYS); GLASS (RECEPTACLES); SUGAR BOWLS; SOUP BOWLS; FURNITURE DESIGN CONCERNING FURNITURE INCLUDED IN CLASS 20; GRAPHIC DESIGN; DESIGN OF HOUSEHOLD OR KITCHEN UTENSILS, INSTRUMENTS AND CONTAINERS; DESIGN SERVICES; INTERIOR DESIGN; DESIGN AND INTERIOR DECORATION (U.S. CLS. 100 AND 101).

MATTHEW KLINE, EXAMINING ATTORNEY

SN 79-139,157. INFODENT S.R.L., ITALY, FILED 6-12-2013.

 The logo for INFOMEDIX features the word "INFOMEDIX" in a bold, sans-serif font. A stylized graphic of a heart with a vertical zigzag line through it is positioned between the 'O' and 'M' in "MEDIX".

PRIORITY DATE OF 6-4-2013 IS CLAIMED.  
OWNER OF INTERNATIONAL REGISTRATION 1183461  
DATED 6-12-2013, EXPIRES 6-12-2023.

THE MARK CONSISTS OF THE TERM "INFOMEDIX" IN STYLIZED FONT WITH A VERTICAL ZIGZAG LINE REPRESENTING A HEARTBEAT WITHIN THE LETTER "O".

**CLASS 9—ELECTRICAL AND SCIENTIFIC APPARATUS**

FOR ELECTRONIC DOWNLOADABLE PUBLICATIONS, NAMELY, BROCHURES, BOOKLETS, AND TEACHING MATERIALS IN THE FIELD OF SCIENCE AND MEDICINE, FOR THE PURPOSE OF CONNECTING MEDICAL BUSINESSES TO POTENTIAL BUSINESS PARTNERS WORLDWIDE, SPECIFICALLY EXCLUDING THE FIELD OF ELECTRONIC MEDICAL RECORD STORAGE AND MANAGEMENT, AND THE FIELD OF PHARMACEUTICALS (U.S. CLS. 21, 23, 26, 36 AND 38).

**CLASS 16—PAPER GOODS AND PRINTED MATTER**

FOR PUBLICATIONS, NAMELY, BROCHURES, BOOKLETS, AND TEACHING MATERIALS IN THE FIELD OF SCIENCE AND MEDICINE, FOR THE PURPOSE OF CONNECTING MEDICAL BUSINESSES TO POTENTIAL BUSINESS PARTNERS WORLDWIDE, SPECIFICALLY EXCLUDING THE FIELD OF ELECTRONIC MEDICAL RECORD STORAGE AND MANAGEMENT, AND THE FIELD OF PHARMACEUTICALS (U.S. CLS. 2, 5, 22, 23, 29, 37, 38 AND 50).

**CLASS 35—ADVERTISING AND BUSINESS**

FOR RENTAL OF ADVERTISING SPACE AND ADVERTISING MATERIAL; PROMOTING THE GOODS AND SERVICES OF OTHERS BY PREPARING AND PLACING ADVERTISEMENTS IN AN ELECTRONIC MAGAZINE ACCESSED THROUGH A GLOBAL COMPUTER NETWORK; DISPLAYING ADVERTISEMENTS FOR OTHERS, ALL IN THE FIELD OF SCIENCE AND MEDICINE, FOR THE PURPOSE OF CONNECTING MEDICAL BUSINESSES TO POTENTIAL BUSINESS PARTNERS WORLDWIDE, AND ALL SPECIFICALLY EXCLUDING THE FIELD OF ELECTRONIC MEDICAL RECORD STORAGE AND MANAGEMENT, AND THE FIELD OF PHARMACEUTICALS (U.S. CLS. 100, 101 AND 102).

**CLASS 41—EDUCATION AND ENTERTAINMENT**

FOR PROVIDING INFORMATION, NEWS AND COMMENTARY IN THE FIELD OF SCIENCE AND MEDICINE; PROVIDING ON-LINE NON-DOWNLOADABLE PUBLICATIONS IN THE NATURE OF BROCHURES, NEWSLETTERS, BOOKLETS IN THE FIELD OF MEDICINE; PUBLICATION OF BOOKS, OF MAGAZINES, OF JOURNALS, OF NEWSPAPERS, OF PERIODICALS, OF CATALOGS, OF BROCHURES IN THE FIELD OF SCIENCE AND MEDICINE; PUBLICATION OF ELECTRONIC MAGAZINES, IN THE FIELD OF SCIENCE AND MEDICINE, ALL FOR THE PURPOSE OF CONNECTING MEDICAL BUSINESSES TO POTENTIAL BUSINESS PARTNERS WORLDWIDE, AND ALL SPECIFICALLY EXCLUDING THE FIELD OF ELECTRONIC MEDICAL RECORD STORAGE AND MANAGEMENT, AND THE FIELD OF PHARMACEUTICALS (U.S. CLS. 100, 101 AND 107).

KATHRYN COWARD, EXAMINING ATTORNEY

SN 79-139,158. OPERA DI SANTA MARIA DEL FIORE, ITALY, FILED 7-10-2013.

IL GRANDE  
MUSEO DEL  
DUOMO  
FIRENZE

PRIORITY DATE OF 6-14-2013 IS CLAIMED.  
OWNER OF INTERNATIONAL REGISTRATION 1183464 DATED 7-10-2013, EXPIRES 7-10-2023.

NO CLAIM IS MADE TO THE EXCLUSIVE RIGHT TO USE "FIRENZE", APART FROM THE MARK AS SHOWN.

THE TRADEMARK CONSISTS OF THE WORDS "IL GRANDE MUSEO DEL DUOMO" REPRESENTED ON THREE LINES IN A TYPEFACE INSPIRED TO THE RENAISSANCE EPIGRAPHY; ON THE FOURTH LINE IS REPRESENTED THE WORD "FIRENZE" IN SMALLER CHARACTERS.

THE ENGLISH TRANSLATION OF "IL GRANDE MUSEO DEL DUOMO FIRENZE" IN THE MARK IS "THE GREAT MUSEUM OF THE DUOMO, FLORENCE".

**CLASS 18—LEATHER GOODS**

FOR UNWORKED LEATHER AND IMITATION LEATHER SOLD IN BULK; ANIMAL SKINS, ANIMAL HIDES; TRUNKS; TRAVELLING BAGS; HANDBAGS; SPORT BAGS; SHOE BAGS FOR TRAVEL; BILLFOLDS, PURSES; SHOULDER BAGS; SCHOOL BAGS; BELT BAGS; WALLETS; CREDIT CARD CASES; CHANGE PURSES; KEY CASES; ALL-PURPOSE CARRYING BAGS; BRIEFCASES; BACKPACKS; BOXES OF LEATHER OR CARDBOARD; HAT BOXES OF LEATHER; UMBRELLAS; PARASOLS AND WALKING STICKS; WHIPS, HARNESS AND SADDLERY; CLOTHING FOR ANIMALS; COLLARS FOR ANIMALS; LEASHES OF LEATHER FOR ANIMALS; MUZZLES (U.S. CLS. 1, 2, 3, 22 AND 41).

**CLASS 25—CLOTHING**

FOR CLOTHING FOR MEN, WOMEN AND CHILDREN, NAMELY, COATS, RAINCOATS, JACKETS, TROUSERS, SKIRTS, DRESSES, SUITS, SHIRTS AND CHEMISES, T-SHIRTS, SWEATERS, UNDERWEAR, PAJAMAS, SWIMWEAR, BEACHWEAR, SOCKS AND STOCKINGS, GLOVES, TIES, SCARVES, FOULARDS, HATS AND CAPS; BOOTS, SHOES, SANDALS AND SLIPPERS, BELTS FOR CLOTHING (U.S. CLS. 22 AND 39).

KATHRYN COWARD, EXAMINING ATTORNEY

SN 79-139,193. LINBIT INFORMATION TECHNOLOGIES GMBH, WIEN, AUSTRIA, FILED 10-18-2013.

DRBD

THE MARK CONSISTS OF STANDARD CHARACTERS WITHOUT CLAIM TO ANY PARTICULAR FONT, STYLE, SIZE, OR COLOR.

OWNER OF INTERNATIONAL REGISTRATION 0848071 DATED 2-4-2005, EXPIRES 2-4-2015.

OWNER OF U.S. REG. NO. 3,598,806.

**CLASS 9—ELECTRICAL AND SCIENTIFIC APPARATUS**

FOR COMPUTER HARDWARE, COMPUTER SOFTWARE FOR MIRRORING DATA VOLUMES OVER IP-NETWORKS AND BUILDING HIGH AVAILABLE SHARED NOTHING SERVER CLUSTERS (U.S. CLS. 21, 23, 26, 36 AND 38).

**CLASS 42—SCIENTIFIC AND COMPUTER SERVICES**

FOR DESIGN AND DEVELOPMENT OF COMPUTER HARDWARE AND SOFTWARE (U.S. CLS. 100 AND 101).  
KIMBERLY PARKS, EXAMINING ATTORNEY

SN 79-139,233. ELAURA ASIA PTE LTD, SINGAPORE, SINGAPORE, FILED 9-30-2013.

hoozyu

THE MARK CONSISTS OF STANDARD CHARACTERS WITHOUT CLAIM TO ANY PARTICULAR FONT, STYLE, SIZE, OR COLOR.

PRIORITY DATE OF 8-28-2013 IS CLAIMED.  
OWNER OF INTERNATIONAL REGISTRATION 1183588 DATED 9-30-2013, EXPIRES 9-30-2023.

**CLASS 35—ADVERTISING AND BUSINESS**

FOR PSYCHOLOGICAL TESTING FOR THE SELECTION OF PERSONNEL (U.S. CLS. 100, 101 AND 102).

**CLASS 41—EDUCATION AND ENTERTAINMENT**

FOR COACHING, NAMELY, TRAINING IN THE FIELD OF ENTERING THE WORKFORCE; VOCATIONAL GUIDANCE (U.S. CLS. 100, 101 AND 107).

**CLASS 44—MEDICAL, BEAUTY AND AGRICULTURAL SERVICES**

FOR PSYCHOLOGICAL LIFESTYLE COUNSELLING; PREPARING PSYCHOLOGICAL PROFILES, NAMELY, PSYCHOLOGICAL ASSESSMENT SERVICES (U.S. CLS. 100 AND 101).

DAVID HOFFMAN, EXAMINING ATTORNEY

SN 79-139,271. OBSHCHESTVO S OGRANICHENNOI OT-VETSTVENNOSTYU "ALEKSANDROVY POGREBA", RU-127410 MOSCOW, RUSSIAN FED., FILED 10-16-2013.

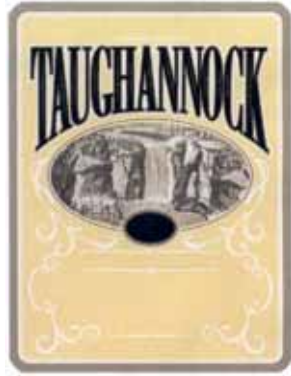

PRIORITY DATE OF 4-22-2013 IS CLAIMED.  
OWNER OF INTERNATIONAL REGISTRATION 1183706 DATED 10-16-2013, EXPIRES 10-16-2023.

THE COLOR(S) WHITE, GRAY, BEIGE, BROWN AND BLACK IS/ARE CLAIMED AS A FEATURE OF THE MARK. THE MARK CONSISTS OF A BEIGE RECTANGLE OUTLINED IN WHITE, BEIGE AND GRAY. INSIDE THE BEIGE RECTANGLE IS THE WORD "TAUGHANNOCK" IN BLACK WITH GRAY AND WHITE SHADING. THE WORD ELEMENT IS ALIGNED IN A SPECIAL WAY: THE TOP BORDER IS HORIZONTAL AND BOTTOM BORDER IS ALIGNED TO THE INVISIBLE ARCH CURVE. ON THE FRONT OF EACH LETTER THERE ARE ONE OR TWO SMALL GRAY LINES EACH SEPARATED BY A GRAY DOT IN THE MIDDLE. A SMALL WHITE HORIZONTAL LINE SEPARATED BY THE WHITE DOT IN THE MIDDLE APPEARS ABOVE THE WORD "TAUGHANNOCK". BELOW THE WORD IS AN OVAL OUTLINED IN WHITE, BEIGE AND BROWN FEATURING A BLACK, GRAY AND WHITE DRAWING OF A WATERFALL, SURROUNDING CLIFFS AND IN THE LEFT BOTTOM PART OF THE DRAWING A GROUP OF PEOPLE. A SMALLER BLACK OVAL OUTLINED IN WHITE, BLACK AND DOTTED BROWN LINES IS SUPERIMPOSED OVER THE BOTTOM CENTER PORTION OF THE OVAL CONTAINING THE WATERFALL DESIGN. BELOW THE OVALS THERE ARE TWO WHITE HORIZONTAL LINES, BENT IN THE MIDDLE. IN THE LOWER PART OF THE MARK IS THE WHITE HORIZONTAL LINE SEPARATED BY THE WHITE DOT IN THE MIDDLE. ORNAMENTAL WHITE SCROLLWORK APPEARS WITHIN THE BEIGE RECTANGLE AROUND AND BELOW THE OVAL CONTAINING THE WATERFALL DESIGN.

#### CLASS 32—LIGHT BEVERAGES

FOR BEERS; MINERAL AND AERATED WATERS; FRUIT DRINKS AND FRUIT JUICES; SYRUPS FOR MAKING BEVERAGES (U.S. CLS. 45, 46 AND 48).

#### CLASS 33—WINES AND SPIRITS

FOR ALCOHOLIC BEVERAGES EXCEPT BEERS (U.S. CLS. 47 AND 49).  
LINDA LAVACHE, EXAMINING ATTORNEY

SN 79-139,291. INOUE JIKUUE KOGYO CO., LTD., OSAKA 587-0042, JAPAN, FILED 9-20-2013.



PRIORITY DATE OF 9-2-2013 IS CLAIMED.

OWNER OF INTERNATIONAL REGISTRATION 1183770 DATED 9-20-2013, EXPIRES 9-20-2023.  
OWNER OF U.S. REG. NOS. 2,447,622 AND 3,153,564.

#### CLASS 7—MACHINERY

FOR MACHINE PARTS, NAMELY, TRANSMISSION SHAFTS, AXLES AND HIGH FREQUENCY MOTOR SPINDLES NOT FOR LAND VEHICLES; BEARINGS BEING MACHINE ELEMENTS NOT FOR LAND VEHICLES; SHAFT COUPLINGS AND CONNECTORS BEING MACHINE ELEMENTS NOT FOR LAND VEHICLES (U.S. CLS. 13, 19, 21, 23, 31, 34 AND 35).

#### CLASS 12—VEHICLES

FOR LAND VEHICLE PARTS, NAMELY, DRIVE SHAFTS, AXLES AND SPINDLES FOR LAND VEHICLES; BEARINGS FOR LAND VEHICLES, NAMELY, BALL BEARINGS; SHAFT COUPLINGS AND CONNECTORS FOR LAND VEHICLES; MECHANICAL ELEMENTS FOR LAND VEHICLES, NAMELY, AXLE BOOT KITS, SUSPENSION STRUTS AND DRIVE SHAFTS (U.S. CLS. 19, 21, 23, 31, 35 AND 44).

ALISON POLLACK, EXAMINING ATTORNEY

SN 79-139,326. KRISNO CO., LTD., JAPAN, FILED 9-9-2013.



PRIORITY DATE OF 3-12-2013 IS CLAIMED.  
OWNER OF INTERNATIONAL REGISTRATION 1183872 DATED 9-9-2013, EXPIRES 9-9-2023.

THE MARK CONSISTS OF A STYLIZED LETTER "R" WITH A WING DESIGN ON THE LEFT EMANATING FROM THE STEM OF THE "R" AND A PERIOD ON THE RIGHT.

#### CLASS 16—PAPER GOODS AND PRINTED MATTER

FOR DECORATORS' PAINTBRUSHES; WRITING BRUSHES; PAINTBRUSHES; STATIONERY (U.S. CLS. 2, 5, 22, 23, 29, 37, 38 AND 50).

#### CLASS 21—HOUSEWARES AND GLASS

FOR MAKE-UP BRUSHES; NAIL BRUSHES; BRUSHES, NAMELY, NAIL ART BRUSHES, EYEBROW BRUSHES, LIP BRUSHES; BRUSH GOODS, NAMELY, CAPS FOR MAKE-UP BRUSHES, NAIL BRUSHES, COSMETIC BRUSHES, NAIL ART BRUSHES, ART BRUSHES, EYEBROW BRUSHES, AND LIP BRUSHES (U.S. CLS. 2, 13, 23, 29, 30, 33, 40 AND 50).

MATTHEW MCDOWELL, EXAMINING ATTORNEY

SN 79-139,375. A. DE KEIZER ELEKTROTECHNIEK AMSTERDAM BEHEER B.V., NL-1851 AS HEILOO, NETHERLANDS, FILED 5-6-2013.

SN 79-139,380. XL-PROTEIN GMBH, FED REP GERMANY, FILED 4-26-2013.



# XL-protein

THE MARK CONSISTS OF STANDARD CHARACTERS WITHOUT CLAIM TO ANY PARTICULAR FONT, STYLE, SIZE, OR COLOR.

PRIORITY DATE OF 10-26-2012 IS CLAIMED.

OWNER OF INTERNATIONAL REGISTRATION 1184012 DATED 4-26-2013, EXPIRES 4-26-2023.

THE WORD(S) "XL-PROTEIN" HAS NO MEANING IN A FOREIGN LANGUAGE.

OWNER OF INTERNATIONAL REGISTRATION 1183999 DATED 5-6-2013, EXPIRES 5-6-2023.

NO CLAIM IS MADE TO THE EXCLUSIVE RIGHT TO USE "MARINE ENGINEERING", APART FROM THE MARK AS SHOWN.

THE COLOR(S) RED AND WHITE IS/ARE CLAIMED AS A FEATURE OF THE MARK.

THE MARK CONSISTS OF THE TERM "ADK" IN RED, SURROUNDED BY AN INCOMPLETE RED RECTANGLE. TO THE RIGHT OF THE RECTANGLE ARE THE WORDS "DE KEIZER" IN RED ABOVE "MARINE ENGINEERING" IN RED. ALL OF THE FOREGOING APPEARS ON A WHITE BACKGROUND.

THE ENGLISH TRANSLATION OF "DE KEIZER" IN THE MARK IS "THE EMPEROR".

## CLASS 9—ELECTRICAL AND SCIENTIFIC APPARATUS

FOR SWITCHBOARDS; ELECTRO TECHNICAL INSTALLATIONS FOR YACHT BUILDING AND SHIP BUILDING, NAMELY, BURGLAR ALARMS, SMOKE AND FIRE ALARMS, ACOUSTIC SOUND ALARMS, COMPUTERIZED ALARMS; MONITORING AND CONTROL SYSTEMS FOR YACHT BUILDING AND SHIP BUILDING, NAMELY, ALARM MONITORING SYSTEMS COMPRISED PRIMARILY OF MASTER SERVERS, BACKUP SERVERS, REMOTE DISTRIBUTED PANELS, CLOSED CIRCUIT TELEVISION CAMERAS AND MONITORS, NETWORK COMMUNICATION DEVICES, AND PROGRAMMABLE COMPUTERS AND LIGHTING CONTROL SYSTEMS COMPRISED PRIMARILY OF LIGHTING CONTROL DIMMERS AND RELAYS; COMPUTER SOFTWARE FOR PROGRAMMING AND MANAGING ALARM, MONITORING, AND CONTROL SYSTEMS FOR SHIP FACILITIES (U.S. CLS. 21, 23, 26, 36 AND 38).

## CLASS 12—VEHICLES

FOR ANTI-THEFT ALARMS FOR SHIPS (U.S. CLS. 19, 21, 23, 31, 35 AND 44).

## CLASS 37—CONSTRUCTION AND REPAIR

FOR INSTALLATION, REPAIR AND MAINTENANCE OF FIRE AND ANTI-THEFT ALARMS FOR SHIPS, YACHTS AND BOATS; REPAIR OF GENERATORS, ELECTRIC MOTORS, SWITCH BOXES AND LIGHTING SYSTEMS FOR SHIPS, YACHTS AND BOATS; CONSULTANCY SERVICES REGARDING THE INSTALLATION OF ELECTRIC INSTALLATIONS FOR SHIPS, YACHTS AND BOATS (U.S. CLS. 100, 103 AND 106).

## CLASS 42—SCIENTIFIC AND COMPUTER SERVICES

FOR DESIGN OF ELECTRO TECHNICAL INSTALLATIONS AND COMPUTERIZED ALARM, MONITORING AND CONTROL SYSTEMS FOR YACHT BUILDING AND SHIP BUILDING, NAMELY, SWITCHBOARDS, BURGLAR ALARMS, SMOKE AND FIRE ALARMS, ACOUSTIC SOUND ALARMS, ALARM MONITORING SYSTEMS AND LIGHTING SYSTEMS (U.S. CLS. 100 AND 101).

COLLEEN MULCRONE, EXAMINING ATTORNEY

## CLASS 1—CHEMICALS

FOR CHEMICAL AND BIOCHEMICAL PREPARATIONS FOR USE IN RESEARCH AND LABORATORIES, EXCEPT FOR MEDICAL AND VETERINARY USE, AS WELL AS FOR INDUSTRIAL AND SCIENTIFIC USE; UNPROCESSED ARTIFICIAL RESINS, UNPROCESSED PLASTICS (U.S. CLS. 1, 5, 6, 10, 26 AND 46).

## CLASS 5—PHARMACEUTICALS

FOR PHARMACEUTICAL AND VETERINARY PREPARATIONS, PREPARATIONS FOR HUMAN MEDICAL PURPOSES FOR USE IN TREATING GROWTH DEFICIENCIES, INFLAMMATION, INFECTIONS, OBESITY, DIABETES, MALIGNANCIES, METABOLIC DISEASES, CANCER, CARDIOVASCULAR DISEASES, DISEASES OF THE CNS, EYE DISEASES, BONE DISEASES; SANITARY PREPARATIONS FOR MEDICAL PURPOSES; DIETETIC SUBSTANCES ADAPTED FOR MEDICAL USE, NAMELY, NUTRITIONAL SUPPLEMENTS CONTAINING PROTEINS, PEPTIDES, FOOD FOR BABIES; PREPARATIONS FOR DESTROYING VERMIN; FUNGICIDES, HERBICIDES; PHARMACEUTICAL AND DIAGNOSTIC PREPARATIONS FOR MEDICAL, DENTAL AND FORENSIC PURPOSES AND FOR PURPOSES OF FORENSIC MEDICINE AND LABORATORY MEDICINE, NAMELY, PHARMACEUTICAL AND DIAGNOSTIC PREPARATIONS FOR DIAGNOSIS, PREVENTION, TREATMENT OR CURE OF GROWTH DEFICIENCIES, INFLAMMATION, INFECTIONS, OBESITY, DIABETES, MALIGNANCIES, METABOLIC DISEASES, CANCER, CARDIOVASCULAR DISEASES, DISEASES OF THE CNS, EYE DISEASES, BONE DISEASES; TESTING REAGENTS IN KIT FORM FOR MEDICAL, DENTAL AND FORENSIC PURPOSES AND FOR PURPOSES OF FORENSIC MEDICINE AND LABORATORY MEDICINE, NAMELY, MEDICAL AND FORENSIC DIAGNOSTIC REAGENTS AND ASSAYS FOR TESTING OF BODY TISSUES AND BODY FLUIDS; CHEMICAL AND BIOTECHNOLOGICAL PREPARATIONS FOR MEDICAL AND DIAGNOSTIC PURPOSES, NAMELY, REAGENTS AND SOLVENTS FOR SAMPLE PREPARATION, MODIFICATION AND MANIPULATION OF CELLS AND FOR PERFORMING OF MARKING, SEPARATION, ISOLATION, PURIFICATION, AMPLIFICATION AND/OR ANALYTICAL METHODS FOR BIOPOLYMERS, IN PARTICULAR NUCLEIC ACIDS, PROTEINS, MACROMOLECULES AND BIOLOGICALLY ACTIVE SUBSTANCES FOR DIAGNOSTIC PURPOSES INCLUDED IN THIS CLASS; MEDICAMENTS FOR PREVENTIVE, CURATIVE AND PALLIATIVE PURPOSES FOR PREVENTING, TREATING OR CURING OF GROWTH DEFICIENCIES, INFLAMMATION, INFECTIONS, OBESITY, DIABETES, MALIGNANCIES, METABOLIC DISEASES, CANCER, CARDIOVASCULAR DISEASES, DISEASES OF THE CNS, EYE DISEASES, BONE DISEASES; MEDICAL BIOMARKERS, IN PARTICULAR FOR PREVENTATIVE, DIAGNOSTIC, PROGNOSTIC OR PREDICTIVE PURPOSES, NAMELY, POLYPEPTIDE SEQUENCES; MEDICAL PREPARATIONS, NAMELY, KITS FOR LABORATORY MEDICINE IN PARTICULAR FOR PREVENTIVE, DIAGNOSTIC, PROGNOSTIC OR PREDICTIVE PURPOSES, NAMELY, DIAGNOSTIC KITS CONSISTING PRIMARILY OF PROTEINS, BUFFERS, AND REAGENTS FOR USE IN DETECTING GROWTH DEFICIENCIES, INFLAMMATION, INFECTIONS, OBESITY, DIABETES, MALIGNANCIES, METABOLIC DIS-



EASES, CANCER, CARDIOVASCULAR DISEASES, DISEASES OF THE CNS, EYE DISEASES, BONE DISEASES; BIOMOLECULES (TARGETS) FOR MEDICAL PURPOSES, NAMELY, PROTEINS, PEPTIDES AND SMALL MOLECULE DRUGS WITH CONJUGATED POLYPEPTIDE SEQUENCES FOR BINDING OF ACTIVE SUBSTANCES; MEDICAL PREPARATIONS FOR ANALYTICAL PURPOSES, NAMELY, REAGENTS FOR DETECTING GROWTH DEFICIENCIES, INFLAMMATION, INFECTIONS, OBESITY, DIABETES, MALIGNANCIES, METABOLIC DISEASES, CANCER, CARDIOVASCULAR DISEASES, DISEASES OF THE CNS, EYE DISEASES, BONE DISEASES; PREPARATIONS FOR HEALTH CARE, NAMELY, FOR DIAGNOSIS, PREVENTION, TREATMENT, OR CURE OF GROWTH DEFICIENCIES, INFLAMMATION, INFECTIONS, OBESITY, DIABETES, MALIGNANCIES, METABOLIC DISEASES, CANCER, CARDIOVASCULAR DISEASES, DISEASES OF THE CNS, EYE DISEASES, BONE DISEASES (U.S. CLS. 6, 18, 44, 46, 51 AND 52).

#### CLASS 42—SCIENTIFIC AND COMPUTER SERVICES

FOR SCIENTIFIC AND TECHNOLOGICAL SERVICES AND RESEARCH, NAMELY, SCIENTIFIC RESEARCH, ANALYSIS, TESTING, IN THE FIELD OF CHEMISTRY, GENETICS, BIOLOGY, BIOTECHNOLOGY AND BIOCHEMISTRY; TECHNICAL SERVICES, NAMELY, COMPUTER DIAGNOSTIC SERVICES IN THE FIELD OF DNA, RNA AND PROTEIN EXPRESSION, DETECTION AND ANALYSIS AND RESPECTIVE DESIGN SERVICES, IN PARTICULAR IN THE FIELD OF CHEMISTRY, GENETICS, BIOLOGY, BIOTECHNOLOGY AND BIOCHEMISTRY; INDUSTRIAL ANALYSIS AND RESEARCH SERVICES IN THE FIELD OF MEDICAL, DENTAL, FORENSIC AND SCIENTIFIC RESEARCH; DESIGN AND DEVELOPMENT OF COMPUTER HARDWARE AND SOFTWARE; SERVICES OF A CHEMICAL AND BIOCHEMICAL LABORATORY; SCIENTIFIC RESEARCH INCLUDING CONDUCTING OF SCIENTIFIC EXAMINATIONS AND PREPARATION OF SCIENTIFIC OPINIONS; QUALITY CHECKING, NAMELY, QUALITY EVALUATION SERVICES FOR THE MEDICAL AND PHARMACEUTICAL INDUSTRY; DESIGN AND DEVELOPMENT OF PROGRAMS FOR DATA PROCESSING; CONSULTANCY FOR SCIENTIFIC, LABORATORY AND RESEARCH PURPOSES IN THE FIELD OF CHEMISTRY, GENETICS, BIOLOGY, BIOTECHNOLOGY AND BIOCHEMISTRY; SCIENTIFIC SERVICES OF A TECHNICAL MEASURING AND TEST LABORATORY; TECHNOLOGICAL CONSULTING SERVICES PERTAINING TO SCIENTIFIC AND INDUSTRIAL SCIENTIFIC RESEARCH IN THE FIELDS OF GENERATION, TECHNICAL PROCESSING AND TECHNICAL ANALYSIS OF BIOMATERIALS AND MEDICALLY RELEVANT DATA (U.S. CLS. 100 AND 101).

PAUL MORENO, EXAMINING ATTORNEY

#### CLASS 9—ELECTRICAL AND SCIENTIFIC APPARATUS

FOR INTEGRATED CIRCUITS; INTEGRATED CIRCUIT MODULES; SEMICONDUCTORS; SEMICONDUCTOR DEVICES; WIRE ELECTRICITY CONNECTORS; SWITCHES, ELECTRIC; ELECTRIC COILS; ELECTROMAGNETIC COILS; TRANSFORMERS FOR ELECTRICITY; ELECTRICAL INDUCTORS FOR ELECTRICITY; CONDENSERS BEING CAPACITORS; PRESSURE SENSORS; ACCELERATION SENSORS; BAROMETRIC PRESSURE SENSORS; AC ADAPTERS; DC ADAPTERS; TACTILE SWITCHES, ELECTRIC; MICRO SWITCHES, ELECTRIC; REGULATING APPARATUS, ELECTRIC, FOR REGULATING ELECTRIC CURRENT; REGULATING APPARATUS, ELECTRIC, FOR REGULATING ELECTRIC VOLTAGE; POWER SUPPLY UNITS FOR LIGHT-EMITTING DIODES (LED) LIGHTING APPARATUS; POWER SUPPLY UNITS EMBEDDED IN PRINTERS FOR USE WITH COMPUTERS; POWER SUPPLY UNITS EMBEDDED IN PHOTOCOPIERS; POWER SUPPLY UNITS EMBEDDED IN CD PLAYERS; POWER SUPPLY UNITS EMBEDDED IN COMPUTER PERIPHERAL DEVICES; POWER SUPPLY UNITS EMBEDDED IN TELEVISION APPARATUS; POWER SUPPLY UNITS EMBEDDED IN TELECOMMUNICATION TRANSMITTERS; ANTENNAS; TUNERS FOR TELEVISION APPARATUS; TUNERS FOR RADIOS; TELEVISION APPARATUS; SET-TOP BOXES FOR TELEVISION APPARATUS; ELECTRIC KEYBOARD SWITCHES; STREAMING DEVICES FOR TAPE RECORDERS; MAGNETIC HEADS FOR VIDEO RECORDERS; MAGNETIC HEADS FOR COMPUTER PERIPHERAL DEVICES; DIGITAL CAMERAS; COMPUTERS; CAMERA MODULES; MOBILE PHONES; COMPUTER PERIPHERAL DEVICES; COMPUTER MOUSE BEING DATA PROCESSING EQUIPMENT; BATTERY CHARGERS; ELECTRONIC COMPONENT, NAMELY, MICRO-ELECTROMECHANICAL SYSTEMS (MEMS) DEVICES FOR IMAGE AND VIDEO PROJECTIONS; ELECTRONIC COMPONENT, NAMELY, MICRO-ELECTROMECHANICAL SYSTEMS (MEMS) DEVICES FOR ELECTRIC OR ELECTRONIC SENSORS FOR SENSING THE PRESENCE OR ABSENCE OF INDIVIDUALS OR OBJECTS BY CONTACT OR PRESSURE; TELECOMMUNICATION MACHINES AND THEIR PARTS, NAMELY, RADIO FREQUENCY MODULES USED FOR TUNERS FOR TELEVISION APPARATUS, TUNERS FOR RADIOS, TELEVISION APPARATUS, SET-TOP BOXES FOR TELEVISION APPARATUS, COMPUTERS, MOBILE PHONES, COMPUTER PERIPHERAL DEVICES, PERSONAL DIGITAL ASSISTANTS (PDA) AND MOBILE DATA TERMINAL (MDT) (U.S. CLS. 21, 23, 26, 36 AND 38).

ALICIA COLLINS, EXAMINING ATTORNEY

SN 79-139,454, HYUNDAI MOTOR COMPANY, SEOUL, REPUBLIC OF KOREA, FILED 7-23-2013.

SN 79-139,435, MITSUMI ELECTRIC CO., LTD., TOKYO, JAPAN, FILED 9-2-2013.

# MITSUMI

OWNER OF INTERNATIONAL REGISTRATION 1184130 DATED 9-2-2013, EXPIRES 9-2-2023.

OWNER OF U.S. REG. NOS. 922,271 AND 2,056,977. THE WORDING "MITSUMI" HAS NO MEANING IN A FOREIGN LANGUAGE.

#### CLASS 7—MACHINERY

FOR AC MOTORS AND DC MOTORS AND THEIR PARTS NOT FOR LAND VEHICLES; AC GENERATORS BEING ALTERNATORS; DC GENERATORS (U.S. CLS. 13, 19, 21, 23, 31, 34 AND 35).



OWNER OF INTERNATIONAL REGISTRATION 1184175 DATED 7-23-2013, EXPIRES 7-23-2023.

THE NAME(S), PORTRAIT(S), AND/OR SIGNATURE(S) SHOWN IN THE MARK DOES NOT IDENTIFY A PARTICULAR LIVING INDIVIDUAL.

THE COLOR(S) BLUE, WHITE, AND ORANGE IS/ARE CLAIMED AS A FEATURE OF THE MARK.

THE MARK CONSISTS OF THE WORDING "BLUE-WILL'S" APPEARING IN THE COLOR WHITE IN A BLUE BANNER LOCATED ABOVE THE WORDING "VROOM" IN BLUE, WITH A BLUE CAR WITH WHITE AND BLUE EYES AND A WHITE WINDSHIELD REPRESENTING THE "O O" IN "VROOM" AND THE WORDING "LAND" IN ORANGE.

SN 79-139,456. HYUNDAI MOTOR COMPANY, REPUBLIC OF KOREA, FILED 7-23-2013.

#### CLASS 21—HOUSEWARES AND GLASS

FOR SOAP BOXES; DISHES FOR SOAP; COMBS; TOOTH BRUSHES; TRASH CANS; TABLEWARE, OTHER THAN KNIVES, FORKS AND SPOONS, NAMELY, TEA SERVICES, COFFEE SERVICES, SERVINGWARE FOR SERVING FOOD AND DRINKS; CUPS; DISHES; GLASS CUPS; CONTAINERS FOR FOODSTUFFS, NAMELY, HOUSEHOLD CONTAINERS FOR FOOD; SERVING TRAYS, NAMELY, CABARETS; BASKETS FOR DOMESTIC USE, NAMELY, LAUNDRY BASKETS, PICNIC BASKETS SOLD EMPTY, PLANT BASKETS, WASTE BASKETS, STEAMER BASKETS; TABLEWARE COVERS, NAMELY, TEXTILE TABLE CLOTHS; BUCKETS; THERMAL INSULATED BOTTLES FOR BEVERAGES SOLD EMPTY; HOLDERS FOR TOILET PAPER; PIGGY BANKS; PORTABLE BABY BATHS FOR USE IN BATHTUBS; BASINS; BOXES FOR SWEETMEATS (U.S. CLS. 2, 13, 23, 29, 30, 33, 40 AND 50).

#### CLASS 24—FABRICS

FOR FITTED TOILET LID COVERS OF FABRIC; SHOWER CURTAINS OF TEXTILE; SHOWER CURTAINS OF PLASTIC; TABLE NAPKINS OF TEXTILE; PLACE MATS OF TEXTILE; WASHING MACHINES COVERS OF TEXTILE OR PLASTIC; CURTAINS OF TEXTILE OR PLASTIC; TAPESTRY WALL HANGINGS, OF TEXTILE; DECORATIVE WALL HANGINGS OF TEXTILE; TABLE LINEN, NAMELY, COASTERS; DESK CLOTHS, NAMELY, FITTED OR UNFITTED CLOTH FOR COVERING DESKS IN THE NATURE OF A TABLE CLOTH; TABLE RUNNERS OF TEXTILE OR PLASTIC; QUILTS; SLEEPING BAGS IN THE NATURE OF SHEETING; BED COVERS; TRAVELLING RUGS LAP ROBES; COVERS FOR CUSHIONS; PILLOW SHAMS; TOWELS OF TEXTILE; TEXTILE GOODS, NAMELY, BED SHEETS (U.S. CLS. 42 AND 50).

#### CLASS 25—CLOTHING

FOR CLOTHING, NAMELY, SHIRTS, PANTS, SHORTS, SKIRTS, DRESSES, GLOVES, HEADWEAR, PULLOVERS, SWEATERS, SWIMWEAR; FOOTWEAR; HEADWEAR, NAMELY, CAPS; SPORTSWEAR, NAMELY, TENNIS WEAR, GOLF PANTS, GOLF SHIRTS, GOLF SKIRTS; SPORT SHIRTS; OVERCOATS; OUTERCLOTHING, NAMELY, COATS, OUTER JACKETS; AND KOREAN CLOTHES, NAMELY, SHIRTS, PANTS, SHORTS, SKIRTS, DRESSES, GLOVES, HEADWEAR, PULLOVERS, SWEATERS, SWIMWEAR; CHILDREN'S CLOTHING, NAMELY, SHIRTS, PANTS, SHORTS, SKIRTS, DRESSES, GLOVES, HEADWEAR, PULLOVERS, SWEATERS, SWIMWEAR; UNDERWEAR; SLEEPING GARMENTS; WINTER GLOVES; EAR MUFFS; MASKS FOR THE PROTECTION AGAINST THE COLD, NAMELY, SKI MASKS; SOCKS; SASHES FOR WEAR; WATERPROOF CLOTHING NAMELY, RAINWEAR, PONCHOS, RAIN COATS, RAIN JACKETS, WETSUITS; BELTS FOR CLOTHING (U.S. CLS. 22 AND 39).

NAKIA HENRY, EXAMINING ATTORNEY



PRIORITY DATE OF 1-23-2013 IS CLAIMED.  
OWNER OF INTERNATIONAL REGISTRATION 1184177 DATED 7-23-2013, EXPIRES 7-23-2023.

THE COLOR(S) PINK, RED, WHITE, BLACK, YELLOW, SILVER AND GRAY IS/ARE CLAIMED AS A FEATURE OF THE MARK.

THE MARK CONSISTS OF THE WORDING "PINKO" IN THE COLOR PINK TO THE LEFT OF A STYLIZED IMAGE OF A CAR FEATURING RED, WHITE AND BLACK EYES IN PLACE OF HEADLIGHTS, AN OPEN-MOUTH WHITE SMILE, AND A YELLOW WATER DROP SHAPED NOSE HOOD ORNAMENT. THE BODY OF THE CAR IS PINK WITH SILVER SIDE MIRRORS, A BLACK WINDSHIELD, YELLOW FOG LIGHTS, BLACK AND SILVER TIRES, AND GRAY SHADING UNDERNEATH REPRESENTING SHADOW. ATTACHED TO THE TOP OF THE CAR IS A YELLOW PROPELLER.

#### CLASS 21—HOUSEWARES AND GLASS

FOR COMBS; TOOTH BRUSHES; TRASH CANS; TABLEWARE, OTHER THAN KNIVES, FORKS AND SPOONS, NAMELY, TEA SERVICES, COFFEE SERVICES, SERVINGWARE FOR SERVING FOOD AND DRINKS; CUPS; DISHES; GLASS CUPS; CONTAINERS FOR FOODSTUFFS, NAMELY, HOUSEHOLD CONTAINERS FOR FOOD; SERVING TRAYS, NAMELY, CABARETS; BASKETS FOR DOMESTIC USE, NAMELY, LAUNDRY BASKETS, PICNIC BASKETS SOLD EMPTY, PLANT BASKETS, WASTE BASKETS, STEAMER BASKETS; TABLEWARE COVERS, NAMELY, TEXTILE TABLE CLOTHS; BUCKETS; THERMAL INSULATED BOTTLES FOR BEVERAGES SOLD EMPTY; HOLDERS FOR TOILET PAPER; PIGGY BANKS; PORTABLE BABY BATHS FOR USE IN BATHTUBS; BASINS; BOXES FOR SWEETMEATS (U.S. CLS. 2, 13, 23, 29, 30, 33, 40 AND 50).

#### CLASS 24—FABRICS

FOR FITTED TOILET LID COVERS OF FABRIC; SHOWER CURTAINS OF TEXTILE; SHOWER CURTAINS OF PLASTIC; TABLE NAPKINS OF TEXTILE; PLACE MATS OF TEXTILE; WASHING MACHINES COVERS OF TEXTILE OR PLASTIC; CURTAINS OF TEXTILE OR PLASTIC; TAPESTRY WALL HANGINGS, OF TEXTILE; DECORATIVE WALL HANGINGS OF TEXTILE; TABLE LINEN, NAMELY, COASTERS; DESK CLOTHS, NAMELY, FITTED OR UNFITTED CLOTH FOR COVERING DESKS IN THE NATURE OF A TABLE CLOTH; TABLE RUNNERS OF TEXTILE OR PLASTIC; QUILTS; SLEEPING BAGS IN THE NATURE OF SHEETING; BED COVERS; TRAVELLING RUGS LAP ROBES; COVERS FOR CUSHIONS; PILLOW SHAMS; TOWELS OF TEXTILE; TEXTILE GOODS, NAMELY, BED SHEETS (U.S. CLS. 42 AND 50).

NAKIA HENRY, EXAMINING ATTORNEY



SN 79-139,466. NIDA TECH SWEDEN AB, SWEDEN, FILED 9-25-2013.

SN 79-139,502. THE AMTICO COMPANY LIMITED, UNITED KINGDOM, FILED 1-14-2013.

# WITTRA

THE MARK CONSISTS OF STANDARD CHARACTERS WITHOUT CLAIM TO ANY PARTICULAR FONT, STYLE, SIZE, OR COLOR.

OWNER OF INTERNATIONAL REGISTRATION 1184196 DATED 9-25-2013, EXPIRES 9-25-2023.

## CLASS 9—ELECTRICAL AND SCIENTIFIC APPARATUS

FOR ELECTRONIC GLOBAL POSITIONING SYSTEMS, NAMELY, SYSTEMS FOR LOCALIZATION, POSITIONING AND TRACKING OF ELECTRONIC DEVICES, LOST ARTICLES, PEOPLE, PETS; ELECTRONIC POSITIONING SYSTEMS FOR GEOLOCATION; WIRELESS COMMUNICATION APPARATUS, NAMELY, CELL PHONES, WIRELESS COMMUNICATION DEVICES FOR TRANSMITTING AUDIO, WIRELESS COMMUNICATION DEVICES FOR TRANSMITTING ELECTRONIC MESSAGES, WIRELESS COMMUNICATION APPARATUS FOR GEOLOCATION; WIRELESS TELECOMMUNICATION DEVICES FOR CONNECTING TO THE INTERNET, NAMELY, WIRELESS ROUTERS, WIRELESS COMPUTER PERIPHERALS; INTERCOMPUTER COMMUNICATIONS EQUIPMENT, NAMELY, LAN ACCESS POINTS, COMPUTER NETWORK ROUTERS, COMMUTATORS, MODEMS, WIRELESS CARDS, AERIALS, WIRELESS NETWORK DEVICES, NAMELY, WIRELESS ROUTERS, WIRELESS COMPUTER PERIPHERALS FOR LOCALIZATION; COMPUTER PROGRAMS FOR MANAGEMENT OF APPLICATIONS, MANAGEMENT OF POSITIONING DEVICES, USE IN POSITIONING, TRACKING AND LOCALIZATION; COMPUTER SOFTWARE FOR ENABLING USERS TO PROVIDE ASSISTANCE TO OTHER USERS, FORM VIRTUAL COMMUNITIES, ENGAGE IN SOCIAL NETWORKING, AND PROVIDE TROUBLESHOOTING ADVICE; COMMUNICATION SOFTWARE FOR PROVIDING ACCESS TO COMMUNICATION DEVICES; COMPUTER SOFTWARE TO ENABLE THE SEARCHING OF DATA; APPARATUS FOR IDENTIFICATION, NAMELY, RADIO-FREQUENCY IDENTIFICATION (RFID) TAGS, BIOMETRIC IDENTIFICATION APPARATUS, TRACKING DEVICE FOR LOCATING AND TRACKING LOST ARTICLES, PEOPLE, AND PETS USING RADIO FREQUENCY, GLOBAL POSITIONING SYSTEMS, AND CELLULAR COMMUNICATION NETWORKS, ELECTRONIC APPARATUS FOR IDENTIFICATION OF LOST ARTICLES, PEOPLE, AND PETS VIA LOCALIZATION USING CLOSE-RANGE ELECTRONIC SIGNALS (U.S. CLS. 21, 23, 26, 36 AND 38).

## CLASS 38—COMMUNICATION

FOR TELECOMMUNICATION SERVICES, NAMELY, TRANSMISSION OF VOICE, AUDIO, VISUAL IMAGES AND DATA BY TELECOMMUNICATIONS NETWORKS, WIRELESS COMMUNICATION NETWORKS, THE INTERNET, INFORMATION SERVICES NETWORKS; MOBILE COMMUNICATION SERVICES, NAMELY COMMUNICATIONS BY MOBILE PHONES, MOBILE RADIO COMMUNICATION; WIRELESS AND CELLULAR COMMUNICATION SERVICES, NAMELY, TRANSMISSION OF VOICE, AUDIO, VISUAL IMAGES AND DATA BY TELECOMMUNICATIONS NETWORKS, WIRELESS COMMUNICATION NETWORKS, THE INTERNET, INFORMATION SERVICES NETWORKS AND DATA NETWORKS; COMMUNICATION SERVICES FOR CONSTRUCTION INDUSTRY, NAMELY, TELECOMMUNICATION ACCESS SERVICES (U.S. CLS. 100, 101 AND 104).

COLLEEN MULCRONE, EXAMINING ATTORNEY



PRIORITY DATE OF 8-14-2012 IS CLAIMED.

OWNER OF INTERNATIONAL REGISTRATION 1184307 DATED 1-14-2013, EXPIRES 1-14-2023.

OWNER OF U.S. REG. NOS. 2,023,153, 2,060,378 AND 2,125,999.

THE MARK CONSISTS OF THE LETTER A WITHIN A SINGLE DROP FOLLOWED BY THE WORD "AMTICO".

## CLASS 19—NON-METALLIC BUILDING MATERIALS

FOR NON-METALLIC FLOOR TILES; FLOOR MAKING MATERIALS, NAMELY, NON-METAL FLOOR BOARDS, RUBBER FLOOR TILES, FLOORING UNDERLAYMENTS, WATERPROOF MEMBRANES FOR USE AS FLOOR UNDERLAY, WOODEN FLOOR BOARDS (U.S. CLS. 1, 12, 33 AND 50).

## CLASS 27—FLOOR COVERINGS

FOR FLOOR COVERINGS; FLOOR TILES, NAMELY, FLOOR TILES MADE WHOLLY OR PRINCIPALLY OF PLASTICS FOR COVERING EXISTING FLOORS (U.S. CLS. 19, 20, 37, 42 AND 50).

## CLASS 35—ADVERTISING AND BUSINESS

FOR RETAIL STORE SERVICES FEATURING FLOORING, FLOORING COVERINGS AND FLOORING ACCESSORIES; ONLINE RETAIL STORE SERVICES FEATURING FLOORING, FLOORING COVERINGS AND FLOORING ACCESSORIES (U.S. CLS. 100, 101 AND 102).

## CLASS 37—CONSTRUCTION AND REPAIR

FOR CONSTRUCTION, REPAIR, MAINTENANCE AND RETEXTURING OF FLOORS; FLOOR COVERINGS; APPLICATION OF COATINGS TO FLOORS; LAYING OF TILES ON FLOORS; LAYING OF FLOORS AND REPAIR OF FLOORS AND FLOOR COVERINGS (U.S. CLS. 100, 103 AND 106).

CHRISTOPHER LAW, EXAMINING ATTORNEY

SN 79-139,504. KMP MEDIA CO., LTD., GYEONGGI-DO, REPUBLIC OF KOREA, FILED 2-21-2013.



PRIORITY DATE OF 12-21-2012 IS CLAIMED.

OWNER OF INTERNATIONAL REGISTRATION 1184309 DATED 2-21-2013, EXPIRES 2-21-2023.

THE MARK CONSISTS OF THE STYLIZED LETTERS "KMP" WITH THE LETTER "M" REPLACED BY TWO TRIANGLES.

**CLASS 9—ELECTRICAL AND SCIENTIFIC APPARATUS**

FOR VIDEO CAMERAS, CAMCORDERS; TAPE RECORDERS; SOUND REPRODUCTION APPARATUS; RADIOS; APPARATUS FOR TRANSMITTING AND REPRODUCING SOUND OR IMAGES; SOUND AND VIDEO RECORDING AND PLAYBACK MACHINES; RADIO RECEIVERS AND MONITORS FOR THE REPRODUCTION OF SOUND AND SIGNALS; APPARATUS FOR THE RECORDING AND TRANSMISSION OR REPRODUCTION OF SOUND AND IMAGES; RECORDING AND PLAYING DEVICES FOR SOUND AND IMAGE CARRIERS; SOUND RECORDING APPARATUS; PORTABLE RADIOS; MPEG AUDIO LAYER-3 MP3 PLAYERS; COMPUTER PROGRAMS FOR PRE-RECORDED GAMES; COMPUTER SOFTWARE, FOR PLAYING MULTI-MEDIA; RECORDED COMPUTER OPERATING PROGRAMS; RECORDED COMPUTER PROGRAMS, FOR PLAYING MULTI-MEDIA; DOWNLOADABLE COMPUTER PROGRAMS FOR PLAYING MULTI-MEDIA; SOFTWARE FOR PROCESSING IMAGES, GRAPHICS AND TEXT; COMPUTER PROGRAMS FOR EDITING IMAGES, SOUND AND VIDEO; SOFTWARE TO CONTROL AND IMPROVE AUDIO EQUIPMENT SOUND QUALITY; COMPUTER SOFTWARE TO ENABLE THE TRANSMISSION OF PHOTOGRAPHS TO MOBILE TELEPHONES; COMPUTER APPLICATION SOFTWARE FOR MOBILE PHONES FOR PLAYING MULTI-MEDIA; COMPUTER GAME PROGRAMS; COMPUTER SOFTWARE FOR PLAYING MULTI-MEDIA; DOWNLOADABLE MUSIC FILES; PRE-RECORDED MUSIC ON ELECTRONIC MEDIA; DOWNLOADABLE ELECTRONIC PUBLICATIONS, NAMELY, PAMPHLETS, NEWSLETTERS, JOURNALS, MAGAZINES, IN THE FIELD OF MUSIC AND MULTI-MEDIA; DOWNLOADABLE ELECTRONIC BOOKS IN THE FIELD OF MUSIC AND MULTI-MEDIA; PORTABLE MEDIA PLAYERS (U.S. CLS. 21, 23, 26, 36 AND 38).

**CLASS 35—ADVERTISING AND BUSINESS**

FOR DISSEMINATION OF ADVERTISING FOR OTHERS VIA THE INTERNET; ON-LINE ADVERTISING ON A COMPUTER NETWORK; INFORMATION RETRIEVAL SERVICES ON THE INTERNET FOR OTHERS, NAMELY, INFORMATION SERVICES RELATING TO BUSINESS MATTERS; COMMERCIAL INTERMEDIARY SERVICES, NAMELY, ON-LINE RETAIL STORE SERVICES IN THE FIELD OF DOWNLOADABLE ELECTRONIC MUSIC; ON-LINE RETAIL STORE SERVICES FEATURING DOWNLOADABLE ELECTRONIC MUSIC; COMMERCIAL INTERMEDIARY SERVICES, NAMELY, ON-LINE RETAIL STORE SERVICES IN THE FIELD OF ELECTRONIC MUSIC FILES; ON-LINE RETAIL STORE SERVICES FEATURING ELECTRONIC MUSIC FILES; COMMERCIAL INTERMEDIARY SERVICES, NAMELY, ON-LINE RETAIL STORE SERVICES IN THE FIELD OF COMPUTER SOFTWARE; ON-LINE RETAIL STORE SERVICES FEATURING COMPUTER SOFTWARE (U.S. CLS. 100, 101 AND 102).

**CLASS 38—COMMUNICATION**

FOR VIDEO-ON-DEMAND BROADCASTING; INTERNET BROADCASTING SERVICES (U.S. CLS. 100, 101 AND 104).

**CLASS 41—EDUCATION AND ENTERTAINMENT**

FOR GAME SERVICES PROVIDED ON-LINE FROM A COMPUTER NETWORK; PROVIDING ON-LINE ELECTRONIC PUBLICATIONS IN THE NATURE OF PAMPHLETS, NEWSLETTERS, JOURNALS, MAGAZINES IN THE FIELD OF MUSIC AND MULTI-MEDIA (U.S. CLS. 100, 101 AND 107).

**CLASS 42—SCIENTIFIC AND COMPUTER SERVICES**

FOR DEVELOPING OF DRIVER AND OPERATING SYSTEM SOFTWARE; PROGRAMMING OF MULTIMEDIA APPLICATIONS; WEB SITE DEVELOPMENT; DEVELOPING OF COMPUTER APPLICATION SOFTWARE FOR MOBILE PHONES; CREATING AND MAINTAINING WEB SITES FOR OTHERS; HOSTING COMPUTER SITES WEB SITES; RENTAL OF WEB SERVERS; HOSTING, MAINTAINING, UPDATING OF WEB SITES FOR ELECTRONIC COMMERCE; COMPUTER PROGRAMMING FOR ELECTRONIC COMMERCE; DEVELOPMENT OF COMPUTER GAME SOFTWARE; MAINTENANCE OF COMPUTER GAME SOFTWARE; DESIGN OF COMPUTER SOFTWARE; INSTALLATION OF COMPUTER SOFTWARE; COMPUTER SOFTWARE RESEARCH; MAINTENANCE OF COMPUTER SOFTWARE; ADVICE AND DEVELOPMENT SERVICES RELATING TO COMPUTER SOFTWARE; COMPUTER PROGRAMMING; DEVELOPMENT OF COMPUTER PROGRAMS (U.S. CLS. 100 AND 101).

JESSICA A. POWERS, EXAMINING ATTORNEY

SN 79-139,509, PHOENIX CONTACT GMBH & CO. KG, BLOMBERG, FED REP GERMANY, FILED 1-15-2013.



PRIORITY DATE OF 7-16-2012 IS CLAIMED.

OWNER OF INTERNATIONAL REGISTRATION 1184318 DATED 1-15-2013, EXPIRES 1-15-2023.

THE MARK CONSISTS OF TWO POLYGONS, ONE SHADED AND ONE NOT SHADED, INSIDE OF A RECTANGLE.

**CLASS 9—ELECTRICAL AND SCIENTIFIC APPARATUS**

FOR ELECTRONIC APPLIANCES, NAMELY, ELECTRICAL AND ELECTRONIC POWER SUPPLY EQUIPMENT, SWITCHED-MODE AND FREE-RUNNING, PRIMARY AND SECONDARY AND HIGH-FREQUENCY SWITCHING POWER SUPPLIES; ELECTRIC TRANSFORMERS; BRACKETS AS PART OF ELECTRIC COILS; CHARGERS FOR ELECTRIC BATTERIES; ELECTRIC COILS; TRANSMITTERS FOR ELECTRIC SIGNALS, IN PARTICULAR WLAN AND WLAN ACCESS POINTS; MODEMS; AUTOMATIC SWITCHING EQUIPMENT; NETWORK ACCESS SERVER OPERATING COMPUTER SOFTWARE; REMOTE CONTROLS OF SIGNALS, NAMELY, ELECTRONIC APPARATUS FOR THE REMOTE MEASUREMENT AND CONTROL OF INDUSTRIAL AUTOMATION CONTROLS; CIRCUIT BREAKERS; ELECTRONIC SWITCHES, ESPECIALLY ETHERNET SWITCHES; NETWORK COMPONENTS, ESPECIALLY ROUTERS; CONTACT AND CONNECTION ELEMENTS OF METAL AND SYNTHETICS FOR ELECTRIC AND ELECTRONIC PURPOSES IN INDUSTRIAL APPLICATIONS, NAMELY, ELECTRICAL CONNECTIONS; ELECTRONIC COMPONENTS AND EQUIPMENT FOR SIGNAL TRANSFORMATION, FOR SIGNAL CONVERSION AND SIGNAL AND DATA TRANSMISSION, NAMELY, CABLES FOR ELECTRICAL SIGNAL AND DATA TRANSMISSION; PROGRAMMABLE AUTOMATION EQUIPMENT, NAMELY, INDUSTRIAL AUTOMATION CONTROLS AND PARTS THEREOF; APPARATUS AND INSTRUMENTS FOR CONVEYING, DISTRIBUTING, TRANSFORMING, STORING, REGULATING OR CONTROLLING ELECTRIC CURRENT; MACHINES AND INSTRUMENTS FOR LIGHT CURRENT ENGINEERING, NAMELY, FOR TELECOMMUNICATION, RADIO TECHNOLOGY AND CYBERNETICS, NAMELY, CHANGE-OVER SWITCHES,

COMPUTER HARDWARE; DATA PROCESSING EQUIPMENT; ELECTRIC CONDUIT ESPECIALLY ADAPTED CONTAINERS AND BOXES AS WELL AS ELECTRIC SOCKETS AND TERMINAL ESPECIALLY ADAPTED CONTAINERS AND BOXES; ELECTRIC DISPLAY APPARATUS, NAMELY, ELECTRIC CONTROL PANELS AND ELECTRIC LUMINESCENT DISPLAY PANELS; ELECTRIC METERS; ELECTRIC RELAYS; ELECTRIC RESISTORS; ELECTRIC VOLTAGE CONVERTERS AND CURRENT TRANSFORMERS; ELECTRIC TERMINALS FOR CONNECTING AND JOINING ELECTRIC CONDUCTORS, IN PARTICULAR TERMINAL STRIPS, DUAL CONNECTORS, LEAD THROUGH TERMINALS, HEAVY CURRENT CONNECTORS, INSTALLATION CONTACTS, SWITCHABLE TERMINALS, UNIVERSAL TERMINALS, PROTECTIVE CONDUCTOR TERMINALS, SAFETY CLIPS, UNIVERSAL CONTACTS, SPRING CAGE TERMINALS AND TERMINALS MOUNTED ON DIN RAILS; TESTING ACCESSORIES, ESPECIALLY TEST PLUGS AND SHORT-CIRCUITING PLUGS FOR ELECTRONIC CIRCUITS; ACCESSORIES FOR BRIDGING ELECTRICAL TERMINALS, NAMELY, ELECTRICAL JUMPERS AND ELECTRICAL BYPASSES IN THE NATURE OF JUMPER CABLES, ELECTRICAL SWITCHES AND ELECTRONIC CIRCUITS; ACCESSORIES FOR MARKING ELECTRICAL TERMINALS, NAMELY, CABLE AND WIRING MARKERS, NAMELY, PRINT HEADS FOR PRINTERS AND PLOTTERS; ACCESSORIES FOR MARKING ELECTRICAL TERMINALS, NAMELY, PRINTERS AND THERMAL TRANSFER PRINTERS, INCLUDING PRINTERS FOR MARKING CABLES, WIRES, AND SHRINK TUBING; MARKING MATERIAL FOR ELECTRIC TERMINALS, IN PARTICULAR, CONDUIT AND CABLE MARKERS; ELECTRICAL AND ELECTRONIC NETWORK ROUTERS AND ELECTRONIC DIVIDER CIRCUITS FOR MULTI SWITCHES; HUBS, NAMELY, COMPUTER NETWORK HUBS, SWITCHES AND ROUTERS; MEDIA CONVERTERS, NAMELY, ANALOG TO DIGITAL CONVERTERS; ELECTRICAL INSTALLATIONS, NAMELY, DATA PROCESSING EQUIPMENT AND COMPUTERS FOR THE REMOTE CONTROL AND DIAGNOSIS OF INDUSTRIAL WORK PROCESSES; ENCLOSURES OF PLASTIC FOR ELECTRICAL AND ELECTRONIC INSTALLATIONS, NAMELY, FOR ELECTRICAL AND ELECTRONIC COMPONENTS FOR INDUSTRIAL AUTOMATION CONTROLS; ELECTRONIC DOWNLOADABLE PUBLICATIONS IN THE NATURE OF MANUALS AND TECHNICAL INFORMATION IN THE FIELD OF INDUSTRIAL AUTOMATION; ELECTRIC METERS; ELECTRONIC MEASURING DEVICES, NAMELY, ELECTRONIC INSTRUMENTS FOR USE IN REMOTE MEASUREMENT OF INDUSTRIAL COMPONENTS USING REMOTE VISUAL DEVICES; MEASURING INSTRUMENTS, NAMELY, BEVELS; TRANSMITTERS AND RECEIVERS FOR ELECTRONIC SIGNALS; ELECTRICAL CURRENT TRANSDUCERS; ELECTRICAL MONITORING APPARATUS, NAMELY, ELECTRONIC MONITORS AND MONITOR MODULES FOR MONITORING ELECTRIC CURRENT AND ELECTRICAL SIGNALS AND FOR MONITORING PROCESS FLOW IN THE NATURE OF INDUSTRIAL PROCESS CONTROL ELECTRICAL DISTRIBUTION BOXES; ELECTRICAL DISTRIBUTION BOXES; ELECTRICAL DISTRIBUTION BOARDS (U.S. CLS. 21, 23, 26, 36 AND 38).

#### **CLASS 16—PAPER GOODS AND PRINTED MATTER**

FOR MANUALS IN THE FIELD OF TECHNICAL INSTRUCTION FOR INDUSTRIAL AUTOMATION CONTROLS; BINDERS; FOLDERS; CATALOGUES IN THE FIELD OF TECHNICAL INSTRUCTION FOR INDUSTRIAL AUTOMATION CONTROLS; BROCHURES ABOUT PRODUCTS AND PROCESSES IN THE FIELD OF INDUSTRIAL AUTOMATION CONTROLS; PRINTED MATTER, NAMELY, PRINTED INFORMATION AND INSTRUCTIONAL FOLDERS IN THE FIELD OF INDUSTRIAL AUTOMATION; PRINTED TEACHING MATERIAL, NAMELY, PRINTED INFORMATION LEAFLETS AND TEACHING MATERIALS IN THE FIELD OF INDUSTRIAL AUTOMATION; PRINTED SLEEVES IN THE NATURE OF FOLDERS FOR HOLDING AND PROTECTING PRINTED BROCHURES AND TECHNICAL RELATED PRINTED PAPER IN THE FIELD OF INDUSTRIAL AUTOMATION; CARDBOARD PACKA-

GING, NAMELY, CARDBOARD BOXES AND CARDBOARD ARTICLES, NAMELY, CARDBOARD PACKAGING BOXES IN COLLAPSIBLE FORM AND IN MADE-UP FORM; PRINTED TEACHING AND TRAINING MATERIAL IN THE FIELD OF INDUSTRIAL AUTOMATION; PACKAGING MATERIAL OF SYNTHETIC MATERIAL, NAMELY, PACKAGING CONTAINERS OF PLASTIC; PRINTING LETTERS AND PRINTING BLOCKS; MARKING MATERIAL FOR ELECTRICAL TERMINALS, IN PARTICULAR WIRE AND CABLE MARKERS, NAMELY, PAPER LABELS (U.S. CLS. 2, 5, 22, 23, 29, 37, 38 AND 50).

#### **CLASS 42—SCIENTIFIC AND COMPUTER SERVICES**

FOR UPDATING OF COMPUTER SOFTWARE; ENGINEERING CONSULTATION SERVICES IN THE FIELD OF INDUSTRIAL AUTOMATION CONTROLS RELATING TO THE DESIGN AND DEVELOPMENTS OF INDUSTRIAL AUTOMATION CONTROLS; INSTALLATION OF COMPUTER PROGRAMMES; DESIGN OF DATA PROCESSING PROGRAMMES (U.S. CLS. 100 AND 101).

JESSICA A. POWERS, EXAMINING ATTORNEY

SN 79-139,570. SARONG SOCIETA' PER AZIONI, ITALY, FILED 9-10-2013.

# SARONG

THE MARK CONSISTS OF STANDARD CHARACTERS WITHOUT CLAIM TO ANY PARTICULAR FONT, STYLE, SIZE, OR COLOR.

OWNER OF INTERNATIONAL REGISTRATION 1050388 DATED 8-9-2010, EXPIRES 8-9-2020.

#### **CLASS 6—METAL GOODS**

FOR CONTAINERS OF METAL, NAMELY, METAL STORAGE CONTAINERS FOR TRANSPORT OR SHIPPING, METAL STORAGE CONTAINERS FOR MEDICATIONS, FOOD, BEVERAGE, COSMETICS PRODUCTS, LIQUIDS; SHEETS OF METAL, NAMELY, SHEET METAL; SHEETS OF METAL INCLUDING THOSE FROM ALLOY STEEL AND TITANIUM; SHEETS OF METAL FOR PACKAGING, NAMELY, METAL BINDING STRIPS USED ON PACKAGING, FOILS OF METAL FOR WRAPPING AND PACKAGING (U.S. CLS. 2, 12, 13, 14, 23, 25 AND 50).

#### **CLASS 7—MACHINERY**

FOR MACHINE TOOLS FOR FORMING, RIVETING, SWAGING, AND FLARING OF METAL AND PLASTICS; MACHINE TOOLS, NAMELY, ROTARY DIES FOR CUTTING BOXES FOR PACKAGING INDUSTRY; PACKAGING MACHINES; PACKING MACHINES; CANNING MACHINES; MACHINES FOR WORKING PLASTICS, NAMELY, MACHINES FOR PLASTIC WORKING, SEALING MACHINES FOR INDUSTRIAL PURPOSES, NAMELY, THERMOFORMING MACHINES AND HOT SEALING MACHINES; DIE-STAMPING MACHINES (U.S. CLS. 13, 19, 21, 23, 31, 34 AND 35).

**CLASS 16—PAPER GOODS AND PRINTED MATTER**

FOR PAPER SHEETS, NAMELY, PAPER FOR WRAPPING AND PACKAGING MEDICATIONS, FOOD, BEVERAGE, COSMETICS PRODUCTS, LIQUIDS AND FOR GENERAL USE; PLASTIC SHEETS, NAMELY, PLASTIC FILM FOR USE AS WRAPPING AND PACKAGING MATERIAL FOR MEDICATIONS, FOOD, BEVERAGE, COSMETICS PRODUCTS, LIQUIDS AND FOR GENERAL USE; STARCH SHEETS FOR PACKAGING, NAMELY, PACKAGING AND CONTAINERS COMPRISED OF STARCH-BASED MATERIALS IN THE NATURE OF A PAPER SUBSTITUTE FOR FOOD, BEVERAGES AND CONSUMER PRODUCTS (U.S. CLS. 2, 5, 22, 23, 29, 37, 38 AND 50).

**CLASS 17—RUBBER GOODS**

FOR PLASTIC SHEETS FOR USE IN THE MANUFACTURE OF PACKAGING CONTAINERS (U.S. CLS. 1, 5, 12, 13, 35 AND 50).

**CLASS 20—FURNITURE AND ARTICLES NOT OTHERWISE CLASSIFIED**

FOR CONTAINERS FOR COMMERCIAL USE, NAMELY, CONTAINERS, NOT OF METAL FOR BEVERAGE, FOOD, COSMETIC PRODUCTS, MEDICATIONS, LIQUID PRODUCTS, LIQUID SOLUTIONS; CONTAINERS, NAMELY, CONTAINERS, NOT OF METAL FOR COMMERCIAL USE; CONTAINERS FOR MEDICATIONS SOLD EMPTY FOR COMMERCIAL USE; PLASTIC MEDICATION CONTAINERS FOR COMMERCIAL USE; NON-METAL AND NON-PAPER CONTAINERS FOR STORAGE OR TRANSPORT OF FOOD, BEVERAGES OR MEDICINES; NON-METALLIC CONTAINERS FOR COMMERCIAL USE, NAMELY, CONTAINERS FOR TRANSPORT; NON-METALLIC CONTAINERS FOR COMMERCIAL USE MADE FROM SHEETS, NAMELY, CONTAINERS, NOT OF METAL FOR BEVERAGE, FOOD, COSMETIC PRODUCTS, MEDICATIONS, LIQUID PRODUCTS; NON-METALLIC CONTAINERS FOR COMMERCIAL USE MADE FROM SHEETS, NAMELY, CONTAINERS, NOT OF METAL FOR COMMERCIAL USE; NON-METALLIC CONTAINERS FOR COMMERCIAL USE MADE FROM SHEETS, NAMELY, CONTAINERS FOR TRANSPORT, NOT OF METAL; NON-METALLIC CONTAINERS FOR COMMERCIAL USE MADE FROM SHEETS, NAMELY, PACKAGING CONTAINERS OF PLASTIC (U.S. CLS. 2, 13, 22, 25, 32 AND 50).

**CLASS 39—TRANSPORTATION AND STORAGE**

FOR PACKAGING FOR OTHERS, NAMELY, MERCHANDISE PACKAGING FOR OTHERS; PACKAGING FOR OTHERS, NAMELY, PACKAGING ARTICLES TO THE ORDER AND SPECIFICATION OF OTHERS; PACKING OF GOODS FOR OTHERS, NAMELY, PACKING ARTICLES FOR TRANSPORTATION; PACKING OF GOODS FOR OTHERS, NAMELY, MERCHANDISE PACKAGING FOR OTHERS; PACKING OF GOODS FOR OTHERS, NAMELY, PACKING ARTICLES FOR TRANSPORTATION AND PACKAGING ARTICLES TO THE ORDER AND SPECIFICATION OF OTHERS (U.S. CLS. 100 AND 105).

**CLASS 40—MATERIAL TREATMENT**

FOR PROCESSING OF SHEET MATERIALS FOR OTHERS, NAMELY, PROCESSING OF PLASTICS; PROCESSING OF SHEET MATERIALS FOR OTHERS, NAMELY, METAL HEAT TREATING SERVICES BY MEANS OF FORMING AND SEALING (U.S. CLS. 100, 103 AND 106).

JEANIE LEE, EXAMINING ATTORNEY

SN 79-139,597. IN TECH DRUSTVO S OGRANICENOM ODGOVORNOSCU ZA USLUGE I TRGOVINU, HR-51000 RIJEKA, CROATIA, FILED 3-11-2013.

# INTECHOPEN

THE MARK CONSISTS OF STANDARD CHARACTERS WITHOUT CLAIM TO ANY PARTICULAR FONT, STYLE, SIZE, OR COLOR.

OWNER OF INTERNATIONAL REGISTRATION 1184510 DATED 3-11-2013, EXPIRES 3-11-2023.

**CLASS 9—ELECTRICAL AND SCIENTIFIC APPARATUS**

FOR COMPUTER GAME PROGRAMS; COMPUTER OPERATING PROGRAMS RECORDED ON CD-ROM; COMPUTER PROGRAMS RECORDED ON CD-ROM FOR USE IN DATABASE MANAGEMENT; DOWNLOADABLE COMPUTER SOFTWARE FOR USE IN WORD PROCESSING; COMPUTER SOFTWARE RECORDED ON CD-ROM FOR USE IN WORD PROCESSING; DOWNLOADABLE IMAGE FILES CONTAINING ARTWORK AND TEXT; DOWNLOADABLE MUSIC FILES; DOWNLOADABLE ELECTRONIC PUBLICATIONS, NAMELY, NEWSLETTERS, JOURNALS AND BOOKS IN THE FIELD OF PHYSICAL SCIENCES, ENGINEERING AND TECHNOLOGY, LIFE SCIENCES, HEALTH SCIENCES, SOCIAL SCIENCES AND HUMANITIES; DOWNLOADABLE ELECTRONIC TAGS FOR GOODS; NOTEBOOK COMPUTERS (U.S. CLS. 21, 23, 26, 36 AND 38).

**CLASS 35—ADVERTISING AND BUSINESS**

FOR COMMERCIAL ADMINISTRATION OF THE LICENSING OF THE GOODS AND SERVICES; ADMINISTRATIVE PROCESSING OF PURCHASE ORDERS; ADVERTISING; ADVERTISING AGENCIES; ADVERTISING BY MAIL ORDER; COMMERCIAL INFORMATION AND ADVICE FOR CONSUMERS IN THE NATURE OF A CONSUMER ADVICE SHOP; ARRANGING NEWSPAPER SUBSCRIPTIONS FOR OTHERS, ARRANGING SUBSCRIPTIONS TO TELECOMMUNICATION SERVICES FOR OTHERS; PROFESSIONAL BUSINESS CONSULTANCY; BUSINESS INFORMATION; BUSINESS MANAGEMENT AND ORGANIZATION CONSULTANCY; BUSINESS ORGANIZATION CONSULTANCY; BUSINESS RESEARCH; RELOCATION SERVICES FOR BUSINESSES; COMPILATION OF INFORMATION INTO COMPUTER DATABASES; DATA SEARCH IN COMPUTER FILES FOR OTHERS; DIRECT MAIL ADVERTISING; DISSEMINATION OF ADVERTISING MATTER; DISTRIBUTION OF SAMPLES; DOCUMENT REPRODUCTION; COMPUTERIZED FILE MANAGEMENT; LAYOUT SERVICES FOR ADVERTISING PURPOSES; ADVISORY SERVICES FOR BUSINESS MANAGEMENT FOR THE PUBLISHING INDUSTRY; MARKETING SERVICES; MARKETING RESEARCH; MARKETING STUDIES; MODELLING FOR ADVERTISING OR SALES PROMOTION; ON-LINE ADVERTISING ON A COMPUTER NETWORK; ORGANIZATION OF EXHIBITIONS FOR COMMERCIAL OR ADVERTISING PURPOSES; OUTDOOR ADVERTISING; OUTSOURCING SERVICES IN CONNECTION WITH BUSINESS ASSISTANCE; PRODUCTION OF ADVERTISING FILMS; PUBLIC RELATIONS; PUBLICATION OF PUBLICITY TEXTS; RADIO ADVERTISING; RENTAL OF ADVERTISING SPACE, RENTAL OF ADVERTISING TIME ON COMMUNICATION MEDIA; PRESENTATION OF GOODS ON COMMUNICATION MEDIA, FOR RETAIL PURPOSES; SALES PROMOTION FOR OTHERS; SPONSORSHIP SEARCH; SYSTEMATIZATION OF INFORMATION INTO COMPUTER DATABASES; TELEMARKETING SERVICES; TELEVISION ADVERTISING; UPDATING OF ADVERTISING MATERIAL; WORD PROCESSING; WRITING OF PUBLICITY TEXTS (U.S. CLS. 100, 101 AND 102).

**CLASS 36—INSURANCE AND FINANCIAL**

FOR FINANCIAL SPONSORSHIP OF BOOK AND JOURNAL PUBLISHING; ELECTRONIC FUNDS TRANSFER (U.S. CLS. 100, 101 AND 102).

**CLASS 38—COMMUNICATION**

FOR COMMUNICATIONS BY COMPUTER TERMINALS; COMMUNICATIONS BY FIBER OPTIC NETWORKS; ELECTRONIC MAIL, TRANSMISSION OF GREETING CARDS ONLINE; ONLINE MESSAGE SENDING; PROVIDING ACCESS TO DATABASES; PROVIDING INTERNET CHATROOMS; PROVIDING USER ACCESS TO GLOBAL COMPUTER NETWORKS; RENTAL OF ACCESS TIME TO GLOBAL COMPUTER NETWORKS (U.S. CLS. 100, 101 AND 104).

**CLASS 40—MATERIAL TREATMENT**

FOR PRINTING, LITHOGRAPHIC PRINTING, OFFSET PRINTING, PHOTOGRAPHIC PRINTING (U.S. CLS. 100, 103 AND 106).

**CLASS 41—EDUCATION AND ENTERTAINMENT**

FOR EDUCATIONAL SERVICES, NAMELY, ACADEMIES IN THE FIELD OF PHYSICAL SCIENCES, ENGINEERING AND TECHNOLOGY, LIFE SCIENCES, HEALTH SCIENCES, SOCIAL SCIENCES AND HUMANITIES; ARRANGING AND CONDUCTING OF COLLOQUIUMS IN THE FIELD OF PHYSICAL SCIENCES, ENGINEERING AND TECHNOLOGY, LIFE SCIENCES, HEALTH SCIENCES, SOCIAL SCIENCES AND HUMANITIES; ARRANGING AND CONDUCTING OF CONCERTS; ARRANGING AND CONDUCTING OF CONFERENCES IN THE FIELD OF PHYSICAL SCIENCES, ENGINEERING AND TECHNOLOGY, LIFE SCIENCES, HEALTH SCIENCES, SOCIAL SCIENCES AND HUMANITIES; ARRANGING AND CONDUCTING OF CONGRESSES IN THE FIELD OF PHYSICAL SCIENCES, ENGINEERING AND TECHNOLOGY, LIFE SCIENCES, HEALTH SCIENCES, SOCIAL SCIENCES AND HUMANITIES; ARRANGING AND CONDUCTING OF SEMINARS IN THE FIELD OF PHYSICAL SCIENCES, ENGINEERING AND TECHNOLOGY, LIFE SCIENCES, HEALTH SCIENCES, SOCIAL SCIENCES AND HUMANITIES; ARRANGING AND CONDUCTING OF SYMPOSIUMS IN THE FIELD OF PHYSICAL SCIENCES, ENGINEERING AND TECHNOLOGY, LIFE SCIENCES, HEALTH SCIENCES, SOCIAL SCIENCES AND HUMANITIES; ARRANGING AND CONDUCTING OF WORKSHOPS IN THE FIELD OF PHYSICAL SCIENCES, ENGINEERING AND TECHNOLOGY, LIFE SCIENCES, HEALTH SCIENCES, SOCIAL SCIENCES AND HUMANITIES; COACHING IN THE FIELD OF PHYSICAL SCIENCES, ENGINEERING AND TECHNOLOGY, LIFE SCIENCES, HEALTH SCIENCES, SOCIAL SCIENCES AND HUMANITIES; EDUCATION INFORMATION; EDUCATIONAL EXAMINATION; EDUCATIONAL SERVICES, NAMELY, CONDUCTING CLASSES IN THE FIELD OF PHYSICAL SCIENCES, ENGINEERING AND TECHNOLOGY, LIFE SCIENCES, HEALTH SCIENCES, SOCIAL SCIENCES AND HUMANITIES; ELECTRONIC DESKTOP PUBLISHING; EDUCATIONAL INSTRUCTION SERVICES, NAMELY, CONDUCTING SEMINARS IN THE FIELD OF PHYSICAL SCIENCES, ENGINEERING AND TECHNOLOGY, LIFE SCIENCES, HEALTH SCIENCES, SOCIAL SCIENCES AND HUMANITIES; LAYOUT SERVICES, OTHER THAN FOR ADVERTISING PURPOSES; LENDING LIBRARIES; MOBILE LIBRARY SERVICES; ORGANIZATION OF EXHIBITIONS FOR CULTURAL OR EDUCATIONAL PURPOSES; PROVIDING ON-LINE NON-DOWNLOADABLE ELECTRONIC PUBLICATIONS, NAMELY, BOOKS, MAGAZINES AND JOURNALS IN THE FIELD OF PHYSICAL SCIENCES, ENGINEERING AND TECHNOLOGY, LIFE SCIENCES, HEALTH SCIENCES, SOCIAL SCIENCES AND HUMANITIES; PUBLICATION OF BOOKS; PUBLICATION OF TEXTS, OTHER THAN PUBLICITY TEXTS; TEACHING IN THE FIELD OF PHYSICAL SCIENCES, ENGINEERING AND TECHNOLOGY, LIFE SCIENCES, HEALTH SCIENCES, SOCIAL SCIENCES AND HUMANITIES; WRITING OF TEXTS, OTHER THAN PUBLICITY TEXTS (U.S. CLS. 100, 101 AND 107).

**CLASS 42—SCIENTIFIC AND COMPUTER SERVICES**

FOR CHEMICAL ANALYSIS; COMPUTER PROGRAMMING; COMPUTER SOFTWARE CONSULTANCY; COMPUTER SOFTWARE DESIGN; INSTALLATION OF COMPUTER SOFTWARE; UPDATING OF COMPUTER SOFTWARE; COMPUTER SYSTEM ANALYSIS; COMPUTER SYSTEM DESIGN; CONSULTANCY IN THE DESIGN AND DEVELOPMENT OF COMPUTER HARDWARE; CONSULTANCY IN THE FIELD OF ENERGY-SAVING, NAMELY, CONSULTING SERVICES IN THE FIELDS OF ENERGY MEASUREMENT TO IMPROVE ENERGY EFFICIENCY; CREATING AND MAINTAINING WEB SITES FOR OTHERS; DATA CONVERSION OF COMPUTER PROGRAMS AND DATA, NOT INCLUDING PHYSICAL CONVERSION; HOSTING COMPUTER SITES AND WEB SITES; INDUSTRIAL DESIGN; MAINTENANCE OF COMPUTER SOFTWARE; MONITORING OF COMPUTER SYSTEMS BY REMOTE ACCESS TO ENSURE PROPER FUNCTIONING; PROVIDING SEARCH ENGINES FOR THE INTERNET; PROVISION OF SCIENTIFIC INFORMATION; ADVICE AND CONSULTANCY IN RELATION TO CARBON OFFSETTING; RENTAL OF WEB SERVERS; RESEARCH AND DEVELOPMENT OF NEW PRODUCTS FOR OTHERS; RENTAL OF COMPUTER SOFTWARE (U.S. CLS. 100 AND 101).

MICHAEL KEATING, EXAMINING ATTORNEY

SN 79-139,601. HYUNDAI MOTOR COMPANY, SEOCHO-GU SEOUL, REPUBLIC OF KOREA, FILED 4-22-2013.

**HYUNDAI KEFICO**

PRIORITY DATE OF 11-19-2012 IS CLAIMED.

OWNER OF INTERNATIONAL REGISTRATION 1184516 DATED 4-22-2013, EXPIRES 4-22-2023.

OWNER OF U.S. REG. NOS. 1,104,727, 1,567,009 AND 3,991,863.

THE ENGLISH TRANSLATION OF "HYUNDAI" IN THE MARK IS "MODERN". THE WORDING "KEFICO" HAS NO MEANING IN A FOREIGN LANGUAGE.

**CLASS 41—EDUCATION AND ENTERTAINMENT**

FOR INSTRUCTION OF MANUFACTURE OF PARTS FOR AUTOMOBILES; INSTRUCTION OF TECHNICAL DEVELOPMENT PARTS FOR AUTOMOBILES (U.S. CLS. 100, 101 AND 107).

**CLASS 42—SCIENTIFIC AND COMPUTER SERVICES**

FOR PROVISION OF MANUFACTURING TECHNOLOGY OF PARTS FOR AUTOMOBILES; RESEARCH AND DEVELOPMENT OF ELECTRONIC COMPONENTS; DESIGN OF MOTOR VEHICLE PARTS; MOTOR VEHICLE DESIGN; PRODUCT DESIGN; DESIGN OF PARTS OF MACHINES; DEVELOPMENT OF DATA PROCESSING PROGRAMS; COMPUTER SOFTWARE DEVELOPMENT; COMPUTER SOFTWARE RESEARCH; ADVICE AND DEVELOPMENT SERVICES RELATING TO COMPUTER SOFTWARE; COMPUTER PROGRAMMING; DEVELOPMENT OF COMPUTER PROGRAMS; COMPUTER HARDWARE DEVELOPMENT; RESEARCH RELATING TO MECHANICAL ENGINEERING; AUTOMOBILE INSPECTION; PRODUCT ANALYSIS IN THE FIELD OF AUTOMOBILES; VEHICLE ROADWORTHINESS TESTING (U.S. CLS. 100 AND 101).

CARYN GLASSER, EXAMINING ATTORNEY

SN 79-139,608. KABUSHIKI KAISHA K-TEC, DBA K-TEC CORPORATION, AKASHI-SHI HYOGO 673-8666, JAPAN, FILED 2-21-2013.



PRIORITY DATE OF 2-5-2013 IS CLAIMED.  
OWNER OF INTERNATIONAL REGISTRATION 1184539 DATED 2-21-2013, EXPIRES 2-21-2023.  
THE MARK CONSISTS OF THE WORD "KTEC" IN STYLIZED FORM.

#### CLASS 12—VEHICLES

FOR VESSELS AND THEIR STRUCTURAL PARTS AND FITTINGS; ALL-TERRAIN VEHICLES (ATVS); UTILITY TERRAIN VEHICLES (UTVS); OFF-ROAD RECREATION UTILITY VEHICLES DESIGNED TO CARRY PASSENGERS AND A PAYLOAD OF CARGO; AUTOMOBILES AND THEIR STRUCTURAL PARTS AND FITTINGS; TWO-WHEELED MOTOR VEHICLES BEING TWO-WHEELED MOTORIZED VEHICLES, MOTORCYCLES, BICYCLES AND THEIR STRUCTURAL PARTS AND FITTINGS; LUGGAGE CARRIERS FOR MOTORCYCLES AND VEHICLES; FAIRINGS FOR MOTORCYCLES; FRAME COVERS FOR MOTORCYCLES; ENGINE GUARDS FOR MOTORCYCLES; CHAIN CASES FOR MOTORCYCLES; TANK PADS FOR MOTORCYCLES; FUEL TANKS FOR MOTORCYCLES; FENDERS FOR LAND MOTORCYCLES; SEATS FOR MOTORCYCLES; REAR VIEW MIRRORS FOR MOTORCYCLES; WHEELS FOR MOTORCYCLES; FRAME CAPS FOR MOTORCYCLES; MUFFLERS FOR MOTORCYCLES; HANDLE BARS FOR VEHICLES, NAMELY, BICYCLES, MOTORCYCLES AND PERSONAL WATERCRAFT; MOTORCYCLE BAGS, NAMELY, TANK BAGS, SADDLE BAGS AND TAIL BAGS (U.S. CLS. 19, 21, 23, 31, 35 AND 44).

#### CLASS 18—LEATHER GOODS

FOR SHOULDER BAGS; BACKPACKS; BAGS, NAMELY, ALL-PURPOSE CARRYING BAGS; POUCHES, NAMELY, POUCHES OF LEATHER, WEARABLE STRAP-ON POUCH, POUCHES FOR HOLDING KEYS AND OTHER PERSONAL ITEMS (U.S. CLS. 1, 2, 3, 22 AND 41).

#### CLASS 35—ADVERTISING AND BUSINESS

FOR PRODUCTION OF ADVERTISING FILMS; PRODUCTION OF ADVERTISING VIDEO, CD-ROM OR DVD; PRODUCTION OF ADVERTISING MATERIALS USED ON WEB HOMEPAGES; ADVERTISING AND PUBLICITY SERVICES; CONSUMER RESEARCH IN THE NATURE OF COLLECTING OR PROVIDING MERCHANDISE INFORMATION ON TRENDS; BUSINESS CONSULTANCY RELATING TO THE INTRODUCTION OR SYSTEM ARCHITECTURE OF INFORMATION TECHNOLOGY; ORGANIZATION OR ARRANGEMENT OF EVENTS FOR COMMERCIAL OR ADVERTISEMENT PURPOSE; BUSINESS MANAGEMENT ANALYSIS OR BUSINESS CONSULTANCY; MARKETING RESEARCH; PROVIDING STATISTICAL INFORMATION CONCERNING COMMERCIAL SALES (U.S. CLS. 100, 101 AND 102).

#### CLASS 42—SCIENTIFIC AND COMPUTER SERVICES

FOR DESIGN OF COMPUTER SOFTWARE, NEW PRODUCTS; DESIGN OF MACHINES IN THE FIELD OF BOATS, PERSONAL WATERCRAFT, ALL-TERRAIN VEHICLES, UTILITY VEHICLES, RECREATION UTILITY VEHICLES, AUTOMOBILES, TWO-WHEELED MOTOR VEHICLES, BICYCLES, AND MOTORCYCLES AND MACHINES PARTS DESIGN; COMPUTER SOFTWARE DESIGN, COMPUTER PROGRAMMING, OR MAINTENANCE OF COMPUTER SOFTWARE; PROVIDING COMPUTER PROGRAMS, NAMELY, TEMPORARY USE OF NON-DOWNLOADABLE SOFTWARE FOR DATA STORAGE, DATA MANAGEMENT (U.S. CLS. 100 AND 101).

CARYN GLASSER, EXAMINING ATTORNEY

SN 79-139,610. COLEP PORTUGAL, S.A., VALE DE CAMBRA, PORTUGAL, FILED 5-14-2013.



OWNER OF INTERNATIONAL REGISTRATION 1184547 DATED 5-14-2013, EXPIRES 5-14-2023.

THE COLOR(S) GREEN IS/ARE CLAIMED AS A FEATURE OF THE MARK.

THE MARK CONSISTS OF A HEART WITH THE TEXT "LOVE TOMORROW" ALONG THE BOTTOM TO MIDDLE RIGHT PORTION OF THE OUTLINE OF THE HEART, ALL IN THE COLOR GREEN.

#### CLASS 3—COSMETICS AND CLEANING PREPARATIONS

FOR BLEACHING PREPARATIONS AND OTHER SUBSTANCES FOR LAUNDRY USE, NAMELY, LAUNDRY BLEACH, LAUNDRY DETERGENT, LAUNDRY FABRIC CONDITIONER; CLEANING, POLISHING, SCOURING AND ABRASIVE PREPARATIONS; SOAPS; PERFUMERY, ESSENTIAL OILS, COSMETICS, HAIR LOTIONS; DENTIFRICES; DEODORANTS FOR PERSONAL USE; PERFUMES; TOILET WATERS; EAU DE COLOGNE; ESSENTIAL OILS; COSMETICS; SOAPS; COSMETICS; ANTI-PERSPIRANTS; DEODORANTS FOR PERSONAL CARE; COSMETIC PREPARATIONS FOR THE HAIR, THE SCALP, THE SKIN AND THE NAILS; SHAMPOOS, HAIR CONDITIONERS; BEAUTY AND BODY CARE PREPARATIONS, NAMELY, HAND AND BODY LOTIONS; DENTIFRICES; SHAVING PREPARATIONS; DYES FOR HAIR; NON-MEDICATED BATH PREPARATIONS; BODY SPRAYS; AFTER SHAVE PREPARATIONS, NAMELY, AFTER-SHAVE AND AFTER-SHAVE LOTIONS; PRE-ELECTRIC SHAVING PREPARATIONS, NAMELY, PRE-SHAVE CREAMS, GELS AND LIQUID; HOUSEHOLD AND INDUSTRIAL ALL PURPOSE CLEANING PREPARATIONS; AFOREMENTIONED GOODS ARE NOT MEANT FOR THE FIELD OF DENTISTRY AND DENTAL TECHNIQUE (U.S. CLS. 1, 4, 6, 50, 51 AND 52).

**CLASS 5—PHARMACEUTICALS**

FOR PHARMACEUTICAL AND VETERINARY PREPARATIONS, NAMELY, PHARMACEUTICAL PREPARATIONS FOR THE TREATMENT OF ALLERGIES, HEART DISEASE OR CANCER; SANITARY PREPARATIONS FOR MEDICAL PURPOSES; DIETETIC SUBSTANCES ADAPTED FOR MEDICAL USES, NAMELY, FOOD FOR BABIES; MEDICAL PLASTERS, MEDICAL DRESSINGS; DISINFECTANTS FOR HYGIENE PURPOSES; PREPARATIONS FOR DESTROYING VERMIN; FUNGICIDES, HERBICIDES; FOODS AND BEVERAGES WHICH ARE ADAPTED FOR MEDICAL PURPOSES, NAMELY, DIETETIC BREAD, VITAMIN FORTIFIED BEVERAGES, MALTED MILK BEVERAGES FOR MEDICAL PURPOSES; AIR DEODORISING PREPARATIONS; AFOREMENTIONED GOODS ARE NOT MEANT FOR THE FIELD OF DENTISTRY AND DENTAL TECHNIQUE (U.S. CLS. 6, 18, 44, 46, 51 AND 52).

**CLASS 6—METAL GOODS**

FOR PACKAGING MATERIALS MADE OF METAL, NAMELY, INDUSTRIAL METAL PACKAGING CONTAINERS, METAL BOXES FOR PACKAGING; CONTAINERS OF ALUMINUM FOIL FOR PACKAGING FOOD OR DRINK; DISPOSABLE PACKAGING CONTAINERS MADE OF ALUMINUM FOIL; FOILS OF METAL FOR WRAPPING AND PACKAGING; METALLIC FOIL FOR PACKAGING; RECEPTACLES, BEING CONTAINERS OF METAL FOR PACKAGING; SHEETS OF METAL FOR PACKAGING; METAL SHEETS WITH AN ALUMINIUM BASE FOR PACKAGING PURPOSES; STACKABLE TRAYS OF METAL FOR THE PACKAGING OF MATERIALS; STEELS FOR PACKAGING; STRIPS OF FILM METAL FOR PACKAGING; METAL PACKAGING FOR FOOD, NAMELY, METAL CONTAINERS AND FOILS OF METAL FOR WRAPPING AND PACKAGING; METAL TINS FOR PACKAGING; TINPLATE PACKAGING; BISCUIT TINS OF METAL; METAL DRUMS FOR PACKAGING; BOTTLES, NAMELY, TIN CANS SOLD EMPTY AND BOTTLE CAPS OF METAL (U.S. CLS. 2, 12, 13, 14, 23, 25 AND 50).

**CLASS 20—FURNITURE AND ARTICLES NOT OTHERWISE CLASSIFIED**

FOR PACKAGING CONTAINERS OF PLASTIC, PLASTIC BOXES, RIGID PLASTIC TRAYS OF PLASTIC; BOXES MADE OF PLASTICS MATERIALS FOR PACKAGING; CONTAINERS, NON-METALLIC, OF PLASTIC ADAPTED FOR PACKAGING; CONTAINERS MADE OF PLASTICS FOR PACKAGING; EGG CARTONS PACKAGING OF PLASTIC; INDUSTRIAL PACKAGING CONTAINERS MADE OF WOOD; PACKAGING CONTAINERS MADE PRINCIPALLY OF PLASTICS; PANELS OF TRANSPARENT PLASTICS BEING PARTS OF PACKAGING CONTAINERS; RIGID PLASTIC TRAYS CONTAINERS USED IN FOOD PACKAGING; PLASTICS COMPONENTS FOR PACKAGING CONTAINERS NAMELY, PLASTIC INSERTS FOR USE AS CONTAINER LINERS; PLASTIC PORTABLE CONTAINERS PACKAGING HAVING INTERNAL SHOCK RELIEVING MEANS FOR THE CONTENTS; TRANSPARENT PLASTIC FOOD CONTAINERS FOR COMMERCIAL PACKAGING USE; CAPS OF PLASTIC; HANDLES AND CLOSURES OF PLASTIC FOR CONTAINERS; CLOSURES FOR BOTTLES NOT OF METAL; NON-METALLIC STOPPERS FOR BOTTLES (U.S. CLS. 2, 13, 22, 25, 32 AND 50).

**CLASS 21—HOUSEWARES AND GLASS**

FOR AEROSOL DISPENSERS NOT FOR MEDICAL USE; CONTAINERS FOR HOUSEHOLD USE; ANTI-D RIP DEVICES FOR BOTTLES, NAMELY, ANTI-D RIP NOZZLES ADAPTED FOR BEVERAGE BOTTLES, ANTI-D RIP NOZZLES ADAPTED FOR HOUSEHOLD BLEACHING AND LAUNDRY PREPARATION BOTTLES; FRAGRANCE BOTTLES SOLD EMPTY; GLASS BOTTLES SOLD EMPTY; PERFUME BOTTLES SOLD EMPTY; PLASTIC BOTTLES SOLD EMPTY; SPRAY BOTTLES, NAMELY, VAPORIZERS FOR PERFUMES SOLD EMPTY; BOTTLES OF PLASTIC, NAMELY, REUSABLE PLASTIC WATER BOTTLES SOLD EMPTY (U.S. CLS. 2, 13, 23, 29, 30, 33, 40 AND 50).

**CLASS 39—TRANSPORTATION AND STORAGE**

FOR TRANSPORT OF GOODS; PACKAGING AND STORAGE OF GOODS; PACKAGING OUTSOURCING; TRAVEL ARRANGEMENT; PACKAGING SERVICES, NAMELY, PACKING ARTICLES FOR TRANSPORTATION; BLISTER PACKING OF ARTICLES FOR TRANSPORTATION; CLAM PACKING OF ARTICLES FOR TRANSPORTATION; CARTOONING, BEING PACKAGING OF ARTICLES FOR TRANSPORTATION; REPACKING OF ARTICLES FOR TRANSPORTATION; PACKING OF PROMOTIONAL MATERIALS FOR TRANSPORTATION; STICKERING OF GOODS FOR TRANSPORTATION; SLEEVEING BEING PACKAGING OF GOODS FOR TRANSPORTATION; SHRINK WRAPPING GOODS FOR TRANSPORTATION; AEROSOL FILLING, BEING PACKING OF GOODS FOR TRANSPORTATION; TINPLATE PACKAGING SERVICES OF GOODS FOR TRANSPORTATION; INFORMATION, ADVICE AND CONSULTANCY RELATING TO ALL THE AFORESAID (U.S. CLS. 100 AND 105).

**CLASS 40—MATERIAL TREATMENT**

FOR CUSTOM MANUFACTURING OF GOODS FOR OTHERS IN THE FIELD OF COSMETICS, PHARMACEUTICALS, VETERINARY PHARMACEUTICALS, SOAPS, PERFUMES, DENTIFRICES, DEODORANTS FOR PERSONAL USE, PREPARATIONS FOR THE HAIR, FOOD, BEVERAGES, CLEANING SOLUTIONS AND PREPARATIONS FOR DOMESTIC OR INDUSTRIAL USE, CLEANING PREPARATIONS AND SOLUTIONS FOR PERSONAL USE, CHEMICALS, PAINTS, FOOD PRESERVATIVES, VARNISHES, CLEANING SOLUTIONS AND PREPARATIONS FOR MOTOR VEHICLES, OILS AND GREASES FOR MOTOR VEHICLES, DISINFECTANTS, MEDICINES FOR HUMAN AND ANIMAL USE, SKINCARE PREPARATIONS, ORAL CARE PREPARATIONS, MEDICAL DEVICES, WOUND CARE GOODS BEING MEDICATED AND ANTIBACTERIAL PREPARATIONS, WOUND DRESSINGS, HAIR REMOVAL PREPARATIONS, INSECT REPELLENTS, SUN-CARE AND TANNING PREPARATIONS, HIGH ENERGY NUTRITIONAL PRODUCTS FOR HUMAN CONSUMPTION IN THE FORM OF LIQUIDS, GELS OR VAPOURS FOR OTHERS; FORMULATION OF GOODS FOR OTHERS, NAMELY, THE CUSTOM MANUFACTURING OF COSMETICS, PHARMACEUTICALS, VETERINARY PHARMACEUTICALS, SOAPS, PERFUMES, DENTIFRICES, DEODORANTS FOR PERSONAL USE, PREPARATIONS FOR THE HAIR, FOOD, BEVERAGES, CLEANING SOLUTIONS AND PREPARATIONS FOR DOMESTIC OR INDUSTRIAL USE, CLEANING PREPARATIONS AND SOLUTIONS FOR PERSONAL USE, CHEMICALS, PAINTS, FOOD PRESERVATIVES, VARNISHES, CLEANING SOLUTIONS AND PREPARATIONS FOR MOTOR VEHICLES, OILS AND GREASES FOR MOTOR VEHICLES, DISINFECTANTS, MEDICINES FOR HUMAN AND ANIMAL USE, SKINCARE PREPARATIONS, ORAL CARE PREPARATIONS, MEDICAL DEVICES, WOUND CARE GOODS BEING MEDICATED AND ANTIBACTERIAL PREPARATIONS, WOUND DRESSINGS, HAIR REMOVAL PREPARATIONS, INSECT REPELLENTS, SUN-CARE AND TANNING PREPARATIONS, HIGH ENERGY NUTRITIONAL PRODUCTS FOR HUMAN CONSUMPTION IN THE FORM OF LIQUIDS, GELS OR VAPOURS; CUSTOM MANUFACTURE OF PACKAGING FOR OTHERS; BLOW MOULDING OF CONTAINERS AND PACKAGING FOR OTHERS; FORMULATION OF GOODS FOR OTHERS, NAMELY, THE CUSTOM MANUFACTURE OF GOODS BY THE MIXING AND DEVELOPMENT OF INGREDIENTS SUCH AS CHEMICALS TO PRODUCE A PRODUCT FOR CLIENT, NAMELY, CUSTOM BLENDING AEROSOL AND NON-AEROSOL PRODUCTS, PERSONAL CARE PRODUCTS, CLEANING PRODUCTS AND COSMETIC AND HEALTHCARE PRODUCTS; PRINTING OF PACKAGING MATERIALS; INFORMATION, ADVICE AND CONSULTANCY RELATING TO ALL THE AFORESAID (U.S. CLS. 100, 103 AND 106).

**CLASS 42—SCIENTIFIC AND COMPUTER SERVICES**

FOR SCIENTIFIC AND TECHNOLOGICAL SERVICES, NAMELY, RESEARCH AND DESIGN RELATING THERETO IN THE FIELD OF PACKAGING, CONTAINERS, BINS, BOXES, BOTTLES AND TRAYS; INDUSTRIAL ANALYSIS AND RESEARCH SERVICES RELATING TO THE DESIGN OF INDUSTRIAL PACKAGING, CONTAINERS, BINS, BOXES, BOTTLES AND TRAYS; RESEARCH, DESIGN AND DEVELOPMENT SERVICES OF NEW PRODUCTS FOR OTHERS; RESEARCH DESIGN AND DEVELOPMENT SERVICES IN THE FIELD OF THE FORMULATION AND PACKAGING OF GOODS FOR OTHERS; PRODUCT DESIGN AND DEVELOPMENT IN THE FIELD OF PACKAGING OF GOODS FOR OTHERS; INFORMATION, ADVICE AND CONSULTANCY RELATING TO ALL THE AFORESAID (U.S. CLS. 100 AND 101).

CARYN GLASSER, EXAMINING ATTORNEY

SN 79-139,618. EUROPEAN ENERGY EXCHANGE AG, FED REP GERMANY, FILED 6-27-2013.



PRIORITY DATE OF 2-20-2013 IS CLAIMED.  
OWNER OF INTERNATIONAL REGISTRATION 1184559 DATED 6-27-2013, EXPIRES 6-27-2023.  
NO CLAIM IS MADE TO THE EXCLUSIVE RIGHT TO USE "PAN-EUROPEAN GAS COOPERATION", APART FROM THE MARK AS SHOWN.

THE COLOR(S) BLACK, BLUE, AND PURPLE IS/ARE CLAIMED AS A FEATURE OF THE MARK.

THE MARK CONSISTS OF A CURVED VERTICAL BAND, BLUE ON THE BOTTOM LEFT AND PURPLE ON THE UPPER RIGHT, ALL TO THE LEFT OF THE STYLIZED TEXT "PEGAS" OVER THE STYLIZED TEXT "PAN-EUROPEAN GAS COOPERATION" WHERE "PE" AND "PAN-EUROPEAN GAS COOPERATION" ARE IN BLUE AND "GAS" IS IN BLACK.

**CLASS 9—ELECTRICAL AND SCIENTIFIC APPARATUS**

FOR COMPUTER PROGRAMS, BOTH STORED ON DATA MEDIA OR DOWNLOADABLE, IN CONNECTION WITH STOCK EXCHANGE AND FINANCIAL SERVICES, FEATURING QUOTATION OF COMMODITY EXCHANGE PRICES AS WELL AS DETERMINATION AND CALCULATION OF INDICES IN CONNECTION WITH OFFICIALLY QUOTED COMMODITY AND COMMODITY DERIVATIVES (U.S. CLS. 21, 23, 26, 36 AND 38).

**CLASS 35—ADVERTISING AND BUSINESS**

FOR BUSINESS MANAGEMENT AND BUSINESS ADMINISTRATION OF AN ENERGY EXCHANGE; COMPILING AND SYSTEMATIC ORDERING OF INFORMATION AND DATA IN A COMPUTER DATABASE, IN PARTICULAR RELATED TO THE SERVICES OF AN ENERGY EXCHANGE; AUCTIONEERING SERVICES (U.S. CLS. 100, 101 AND 102).

**CLASS 36—INSURANCE AND FINANCIAL**

FOR FINANCIAL AFFAIRS, IN PARTICULAR SERVICES OF AN ENERGY EXCHANGE; SECURITIES BROKERAGE SERVICES; FINANCIAL INVESTMENT BROKERAGE SERVICES; QUOTATION OF STOCK EXCHANGE PRICES; FINANCIAL SERVICES, NAMELY, DETERMINING, CALCULATING OF INDICES RELATED TO QUOTED SECURITIES AND FUTURES CONTRACTS; FINANCIAL CONSULTANCY IN THE AREA OF ENERGY TRADING; PROVIDING DETAILED INFORMATION REGARDING QUOTED SECURITIES AND FUTURE CONTRACTS (U.S. CLS. 100, 101 AND 102).

**CLASS 38—COMMUNICATION**

FOR TELECOMMUNICATIONS, NAMELY, RECEPTION, STORAGE AND TRANSMISSION OF INFORMATION AND DATA BY MEANS OF ELECTRONIC TRANSMISSION; PROVIDING TELECOMMUNICATIONS CONNECTIONS TO GLOBAL COMPUTER AND RADIO NETWORKS; PROVIDING MULTIPLE USER ACCESS TO TRADING PLATFORMS VIA COMPUTER NETWORKS; PROVIDING MULTIPLE USER ACCESS TO PLATFORMS AND PORTALS ON THE INTERNET; ELECTRONIC MAIL; RENTAL OF ACCESS TIME TO DATABASES AND GLOBAL COMPUTER NETWORKS (U.S. CLS. 100, 101 AND 104).

**CLASS 42—SCIENTIFIC AND COMPUTER SERVICES**

FOR INFORMATION TECHNOLOGY CONSULTING, NAMELY, TECHNICAL CONSULTANCY IN ORDER TO ENABLE INTERESTED PARTIES TO ACCESS ENERGY TRADING AND ENERGY SUPPLY PLATFORMS VIA GLOBAL COMPUTER NETWORKS AND THE INTERNET; COMPUTER SERVICES, NAMELY, PROGRAMMING AND UPDATING OF DATA PROCESSING SOFTWARE AND SOFTWARE FOR DATABASES; AFOREMENTIONED SERVICES IN PARTICULAR RELATED TO TRADING WITH AND SUPPLYING OF ENERGY; DESIGN AND DEVELOPMENT OF COMPUTER DATABASES RELATED TO STOCK EXCHANGE AND FINANCIAL SERVICES; SERVICES IN THE NATURE OF COMPUTER PROGRAMMING FOR COMPILATION OF DATABASES RELATED TO STOCK EXCHANGE AND FINANCIAL SERVICES (U.S. CLS. 100 AND 101).

KEVIN MITTLER, EXAMINING ATTORNEY

SN 79-139,672. EBLANA BEVERAGES LIMITED, DALKEY, CO. DUBLIN, IRELAND, FILED 5-20-2013.

**PAINT THE TOWN RED**

THE MARK CONSISTS OF STANDARD CHARACTERS WITHOUT CLAIM TO ANY PARTICULAR FONT, STYLE, SIZE, OR COLOR.

PRIORITY DATE OF 11-20-2012 IS CLAIMED.  
OWNER OF INTERNATIONAL REGISTRATION 1184711 DATED 5-20-2013, EXPIRES 5-20-2023.

**CLASS 32—LIGHT BEVERAGES**

FOR BEERS; MINERAL AND AERATED WATERS; NON-ALCOHOLIC DRINKS, NAMELY, FRUIT DRINKS; FRUIT DRINKS AND FRUIT JUICES; SYRUPS FOR MAKING BEVERAGES; SHANDY, DE-ALCOHOLISED DRINKS, NAMELY, FRUIT DRINKS, NON-ALCOHOLIC BEERS AND WINES (U.S. CLS. 45, 46 AND 48).

**CLASS 33—WINES AND SPIRITS**

FOR ALCOHOLIC WINE; SPIRITS AND LIQUEURS; ALCOHOLIC FRUIT COCKTAIL DRINKS; PREPARED ALCOHOLIC COCKTAILS; ALCOHOLIC COCKTAIL MIXES; GIN, WHISKEY; VODKA; RUM (U.S. CLS. 47 AND 49).



**CLASS 43—HOTEL AND RESTAURANT SERVICES**

FOR SERVICES FOR PROVIDING FOOD AND DRINK; PROVIDING TEMPORARY ACCOMMODATION; RESTAURANT, BAR AND CATERING SERVICES; PROVISION OF TEMPORARY ACCOMMODATION FOR HOLIDAYS; BOOKING AND RESERVATION SERVICES FOR RESTAURANTS AND TEMPORARY ACCOMMODATION FOR HOLIDAYS; RETIREMENT HOME SERVICES; CRECHE SERVICES (U.S. CLS. 100 AND 101).  
JAMES LOVELACE, EXAMINING ATTORNEY

SN 79-139,732. FERIT SARPER, ISTANBUL, TURKEY, FILED 10-10-2013.



SN 79-139,683. MACSA ID, S.A., SPAIN, FILED 7-30-2013.



OWNER OF INTERNATIONAL REGISTRATION 1184731 DATED 7-30-2013, EXPIRES 7-30-2023.

NO CLAIM IS MADE TO THE EXCLUSIVE RIGHT TO USE "ID", APART FROM THE MARK AS SHOWN.

THE COLOR(S) RED AND WHITE IS/ARE CLAIMED AS A FEATURE OF THE MARK.

THE MARK CONSISTS OF THE WORDING "MACSA ID A CODE YOU CAN TRUST" IN A STYLIZED WHITE FONT, ALL ON A RED SQUARE.

**CLASS 7—MACHINERY**

FOR MARKING MACHINES AND EQUIPMENT, NAMELY, INDUSTRIAL MACHINERY IN THE NATURE OF ELECTROMECHANICAL AND LASER MARKING MACHINES AND ENGRAVING MACHINES (U.S. CLS. 13, 19, 21, 23, 31, 34 AND 35).

**CLASS 9—ELECTRICAL AND SCIENTIFIC APPARATUS**

FOR CODING EQUIPMENT, NAMELY, ELECTRONIC CODING UNITS, ENCODING AND DECODING APPARATUS, CREDIT CARD ENCODING MACHINES; LASER MARKING EQUIPMENT AND MACHINES, NAMELY, LASER EQUIPMENT DESIGNED FOR CUTTING DRILLING, MARKING, ENGRAVING AND SHAPING OPTICAL LENSES FOR EYEGLASSES (U.S. CLS. 21, 23, 26, 36 AND 38).

JAMES MACFARLANE, EXAMINING ATTORNEY

OWNER OF INTERNATIONAL REGISTRATION 1184873 DATED 10-10-2013, EXPIRES 10-10-2023.

THE MARK CONSISTS OF THE WORDING "MÜNFERIT" IN STYLIZED FORM ON A SHADED BACKGROUND.

THE ENGLISH TRANSLATION OF "MÜNFERIT" IN THE MARK IS "SEPARATE" OR "DISCRETE" OR "INDIVIDUAL".

**CLASS 33—WINES AND SPIRITS**

FOR ALCOHOLIC BEVERAGES EXCLUDING BEERS, NAMELY, RAKI (TURKISH TRADITIONAL ANISE FLAVORED ALCOHOLIC BEVERAGE) (U.S. CLS. 47 AND 49).

**CLASS 43—HOTEL AND RESTAURANT SERVICES**

FOR PROVIDING OF FOOD AND DRINK; RESTAURANT AND CAFE SERVICES; ARRANGING TEMPORARY HOUSING ACCOMMODATIONS, NAMELY, MOTEL SERVICES (U.S. CLS. 100 AND 101).

SETH A. RAPPAPORT, EXAMINING ATTORNEY

SN 79-139,801. THE OBJECTIVE 2013, S.L., MADRID, SPAIN, FILED 8-14-2013.

**THE OBJECTIVE**

THE MARK CONSISTS OF STANDARD CHARACTERS WITHOUT CLAIM TO ANY PARTICULAR FONT, STYLE, SIZE, OR COLOR.

PRIORITY DATE OF 6-13-2013 IS CLAIMED.

OWNER OF INTERNATIONAL REGISTRATION 1185046 DATED 8-14-2013, EXPIRES 8-14-2023.

**CLASS 9—ELECTRICAL AND SCIENTIFIC APPARATUS**

FOR ELECTRONIC PUBLICATIONS RECORDED ON COMPUTER MEDIA AND DOWNLOADABLE ELECTRONIC PUBLICATIONS IN THE NATURE OF ARTICLES, JOURNALS, BOOKS, DIARIES, SPECIALIST MAGAZINES, NEWSLETTERS, PERIODICAL PUBLICATIONS, PERIODICALS, BULLETINS, BROCHURES, LEAFLETS, BOOKLETS AND TRAINING, TEACHING OR INSTRUCTIONAL MATERIALS FEATURING A WIDE RANGE OF TOPICS OF GENERAL INTEREST (U.S. CLS. 21, 23, 26, 36 AND 38).

**CLASS 16—PAPER GOODS AND PRINTED MATTER**

FOR PAPER, CARDBOARD; PRINTED MATTER, NAMELY MAGAZINES, BOOKS AND WRITINGS IN THE NATURE OF WRITTEN ARTICLES, NEWS BULLETINS, REVIEW ARTICLES, NEWSPAPERS, NEWSLETTERS, PERIODICALS, BULLETINS, PAMPHLETS, LEAFLETS, PRINTED TEACHING MATERIAL AND EDUCATIONAL AND INSTRUCTIONAL MATERIAL FEATURING A WIDE RANGE OF TOPICS OF GENERAL INTEREST (U.S. CLS. 2, 5, 22, 23, 29, 37, 38 AND 50).

**CLASS 41—EDUCATION AND ENTERTAINMENT**

FOR PUBLICATION AND EDITING OF PRINTED MATTER, NAMELY, MAGAZINES, BOOKS, WRITINGS, NEWS BULLETINS, WRITTEN REVIEW ARTICLES, NEWSPAPERS FEATURING EDITORIALS, WRITTEN ARTICLES, DIARIES, NEWSLETTERS, PERIODICALS, BULLETINS, PAMPHLETS, BOOKLETS AND TRAINING MANUALS FEATURING A WIDE RANGE OF TOPICS OF GENERAL INTEREST; PUBLISHING OF ELECTRONIC PUBLICATIONS; PUBLICATION OF PRINTED MATTER; PROVIDING A WEBSITE FEATURING NON-DOWNLOADABLE PUBLICATIONS IN THE NATURE OF ARTICLES, MAGAZINES, NEWSLETTERS, NEWSPAPERS, PERIODICALS, BULLETINS, BROCHURES, LEAFLETS AND BOOKLETS FEATURING A WIDE RANGE OF TOPICS OF GENERAL INTEREST; PROVIDING A WEBSITE FEATURING NON-DOWNLOADABLE PUBLICATIONS IN THE NATURE OF MAGAZINES, BOOKS, NEWS BULLETINS, REVIEW ARTICLES, NEWSPAPER EDITORIALS, ARTICLES, DIARIES, NEWSLETTERS, PERIODICALS, BULLETINS, PAMPHLETS AND BOOKLETS FEATURING A WIDE RANGE OF TOPICS OF GENERAL INTEREST (U.S. CLS. 100, 101 AND 107).

EVELYN BRADLEY, EXAMINING ATTORNEY

SN 79-139,979. NOVITEC ROSSO GMBH & CO. KG, 87778 STETTEN, FED REP GERMANY, FILED 10-1-2013.

# SPOFEC

THE MARK CONSISTS OF STANDARD CHARACTERS WITHOUT CLAIM TO ANY PARTICULAR FONT, STYLE, SIZE, OR COLOR.

OWNER OF INTERNATIONAL REGISTRATION 1185507 DATED 10-1-2013, EXPIRES 10-1-2023.

**CLASS 12—VEHICLES**

FOR AUTOMOBILES AND STRUCTURAL PARTS THEREFOR (U.S. CLS. 19, 21, 23, 31, 35 AND 44).

**CLASS 35—ADVERTISING AND BUSINESS**

FOR WHOLESALE AND RETAIL STORE SERVICES FEATURING MOTOR VEHICLES AND MOTOR VEHICLE PARTS (U.S. CLS. 100, 101 AND 102).

DONALD JOHNSON, EXAMINING ATTORNEY

SN 79-140,010. E-RAG, FRANCE, FILED 9-17-2013.

# Fuu

THE MARK CONSISTS OF STANDARD CHARACTERS WITHOUT CLAIM TO ANY PARTICULAR FONT, STYLE, SIZE, OR COLOR.

OWNER OF INTERNATIONAL REGISTRATION 1185637 DATED 9-17-2013, EXPIRES 9-17-2023.

**CLASS 5—PHARMACEUTICALS**

FOR PHARMACEUTICAL AND VETERINARY PRODUCTS, NAMELY, TOBACCO-FREE CIGARETTES FOR MEDICAL USE; CHEMICALS FOR PHARMACEUTICAL OR MEDICAL USE, NAMELY, TOBACCO SUBSTITUTES FOR MEDICAL USE IN TOBACCO-FREE CIGARETTES FOR THE TREATMENT OF NICOTINE ADDICTION (U.S. CLS. 6, 18, 44, 46, 51 AND 52).

**CLASS 34—SMOKERS' ARTICLES**

FOR TOBACCO; SMOKERS' ARTICLES, NAMELY, TOBACCO SUBSTITUTES NOT FOR MEDICAL USE, CIGARETTES CONTAINING TOBACCO SUBSTITUTES NOT FOR MEDICAL USE, ELECTRONIC CIGARETTE CARTRIDGES, ELECTRONIC CIGARETTE TIPS, LIQUIDS FOR FILLING ELECTRONIC CIGARETTES, TANKS FOR ELECTRONIC CIGARETTES, PORTABLE CHARGING CASES FOR ELECTRONIC CIGARETTES, BATTERIES AND CHARGERS FOR ELECTRONIC CIGARETTES, HOOKAHS; MATCHES; CIGARETTES; CIGARETTE PAPER; PIPES, NAMELY, ELECTRONIC SMOKING PIPE; LIGHTERS FOR SMOKERS; CIGAR BOXES OR CASES; CIGARETTE BOXES OR CASES; ASHTRAYS FOR SMOKERS; ELECTRONIC CIGARETTE (U.S. CLS. 2, 8, 9 AND 17).

DONALD JOHNSON, EXAMINING ATTORNEY

SN 79-140,023. DAVIDOFF & CIE SA, SWITZERLAND, FILED 7-8-2013.



PRIORITY DATE OF 3-25-2013 IS CLAIMED.  
OWNER OF INTERNATIONAL REGISTRATION 1185682 DATED 7-8-2013, EXPIRES 7-8-2023.

OWNER OF U.S. REG. NOS. 1,052,564 AND 2,283,156.  
NO CLAIM IS MADE TO THE EXCLUSIVE RIGHT TO USE "EST 1911", APART FROM THE MARK AS SHOWN.

THE MARK CONSISTS OF A STYLIZED "D" DESIGN WITHIN AN OVAL "EST" TO THE LEFT OF THE OVAL AND "1911" TO THE RIGHT.

**CLASS 34—SMOKERS' ARTICLES**

FOR TOBACCO, RAW OR MANUFACTURED; SMOKING TOBACCO, CHEWING TOBACCO, SNUFF TOBACCO; TOBACCO PRODUCTS; NAMELY, CIGARS, CIGARILLOS, CIGARS WITH PRE-CUT ENDS, CIGARETTES; TOBACCO SUBSTITUTES (NOT FOR MEDICAL USE); NAMELY, ELECTRONIC CIGARETTES; SMOKERS' ARTICLES; NAMELY, TOBACCO PIPES, PIPE CLEANERS, PIPE TAMPERS, CIGAR CUTTERS, NON-ELECTRIC CIGAR AND CIGARETTE LIGHTERS, CIGARETTE AND CIGAR TUBES, CIGAR AND CIGARETTE CASES, TOBACCO PRODUCT HUMIDORS; TOBACCO BOXES, SNUFF BOXES, ASHTRAYS, LIGHTERS FOR SMOKERS, FLINTS FOR LIGHTERS FOR SMOKERS; MATCHES (U.S. CLS. 2, 8, 9 AND 17).

**CLASS 35—ADVERTISING AND BUSINESS**

FOR SALES PROMOTION FOR OTHERS; RETAIL STORE SERVICES AND ON-LINE RETAIL STORE SERVICES FEATURING TOBACCO, TOBACCO PRODUCTS AND SMOKERS' ARTICLES; ALL THESE SERVICES CONCERNING TOBACCO PRODUCTS AND SMOKERS' ARTICLES (U.S. CLS. 100, 101 AND 102).

**CLASS 43—HOTEL AND RESTAURANT SERVICES**

FOR CATERING OF FOOD AND DRINKS; SERVICES FOR PROVIDING FOOD AND DRINKS, NAMELY, SERVING FOOD AND DRINKS; PROVISION OF MEETING ROOMS, NAMELY, RENTAL OF MEETING ROOMS; BAR SERVICES; PROVIDING TEMPORARY ACCOMMODATION; ALL THESE SERVICES CONCERNING THE OPERATION OF SMOKING ROOMS OR SERVICES RELATING THERETO OR SERVICES FOR SMOKERS (U.S. CLS. 100 AND 101).

MATTHEW MCDOWELL, EXAMINING ATTORNEY

**CLASS 9—ELECTRICAL AND SCIENTIFIC APPARATUS**

FOR COMPUTER PROGRAMS, NAMELY, PROGRAMS FOR TRAINING OF COMPUTER SOFTWARE OPERATION AND KEYBOARD TYPING AND PROGRAMS FOR TEACHING LANGUAGES IN SCHOOLS; DOWNLOADABLE COMPUTER SOFTWARE IN THE FIELD OF MEMORY TRAINING ACTIVITIES, ANTI-SPYWARE SOFTWARE, AND ANTI-VIRUS SOFTWARE; COMPUTER PROGRAMS FOR CREATING FIREWALLS AND FOR ENSURING ELECTRONIC MAIL SECURITY; COMPUTER SOFTWARE TO ENABLE THE TRANSMISSION OF PHOTOGRAPHS TO MOBILE TELEPHONES; COMPUTER GRAPHICS SOFTWARE; SOFTWARE FOR PROCESSING IMAGES, GRAPHICS AND TEXT; SOFTWARE FOR ORGANIZING AND VIEWING DIGITAL IMAGES AND PHOTOGRAPHS; SOFTWARE FOR USE IN RELATION TO DIGITAL ANIMATION AND SPECIAL EFFECTS OF IMAGES; SOFTWARE TO ENHANCE THE AUDIO-VISUAL CAPABILITIES OF MULTIMEDIA APPLICATIONS, NAMELY, FOR INTEGRATION OF TEXT, AUDIO, GRAPHICS, STILL IMAGES AND MOVING PICTURES; SOFTWARE FOR EDITING IMAGES, SOUND AND VIDEO; SOFTWARE FOR PROCESSING DIGITAL MUSIC FILES; SOFTWARE TO CONTROL AND IMPROVE AUDIO EQUIPMENT SOUND QUALITY; SOFTWARE FOR MANIPULATING DIGITAL AUDIO INFORMATION FOR USE IN AUDIO MEDIA APPLICATIONS; MUSIC-COMPOSITION SOFTWARE; SOFTWARE FOR ENCRYPTION; DATA COMPRESSION SOFTWARE; SOFTWARE FOR OPTICAL CHARACTER RECOGNITION; COMPUTER SCREEN SAVER SOFTWARE; SOFTWARE FOR USE IN DATABASE MANAGEMENT, SPREADSHEET PREPARATION AND WORD PROCESSING; TAX MANAGEMENT SOFTWARE; COMPUTER PROGRAMS FOR DOCUMENT MANAGEMENT; SOFTWARE FOR COMPUTER SYSTEM AND APPLICATION DEVELOPMENT, DEPLOYMENT AND MANAGEMENT; SOFTWARE FOR ADMINISTRATION OF COMPUTER LOCAL AREA NETWORKS; NETWORK ACCESS SERVER OPERATING SOFTWARE; SOFTWARE FOR VOICE RECOGNITION; COMPUTER SEARCH ENGINE SOFTWARE; COMPUTER PROGRAMS FOR MAKING CHRISTMAS CARDS; DATABASE MANAGEMENT SOFTWARE FOR CHRISTMAS CARDS; COMPUTER PROGRAMS FOR TEACHING SCHOOL SUBJECTS, NAMELY, MATHEMATICS AND LANGUAGES; COMPUTER PROGRAMS THAT PROVIDE INSTRUCTION TO EDUCATORS ON TEACHING SCHOOL SUBJECTS; COMPUTERS (U.S. CLS. 21, 23, 26, 36 AND 38).

SN 79-140,092, SOURCENEXT CORPORATION, TOKYO, JAPAN, FILED 5-21-2013.



PRIORITY DATE OF 4-12-2013 IS CLAIMED.  
OWNER OF INTERNATIONAL REGISTRATION 1185885  
DATED 5-21-2013, EXPIRES 5-21-2023.  
THE MARK CONSISTS OF AN OVAL INSIDE OF A  
CIRCLE.

**CLASS 42—SCIENTIFIC AND COMPUTER SERVICES**

FOR PROVIDING TEMPORARY USE OF ONLINE NON-DOWNLOADABLE SOFTWARE FOR USE IN SPREADSHEET PREPARATION, WORD PROCESSING AND DOCUMENT PRESENTATION; PROVIDING TEMPORARY USE OF NON-DOWNLOADABLE SOFTWARE FOR SCANNING, DETECTING, QUARANTINING AND ELIMINATING VIRUSES, SPYWARE, ADWARE, MALWARE AND UNAUTHORIZED DATA AND PROGRAMS ON COMPUTERS AND ELECTRONIC DEVICES (U.S. CLS. 100 AND 101).

KEVON CHISOLM, EXAMINING ATTORNEY

SN 79-140,114. KRONOZ LLC (KRONOZ SARL), SWITZERLAND, FILED 8-22-2013.



PRIORITY DATE OF 8-22-2013 IS CLAIMED.  
OWNER OF INTERNATIONAL REGISTRATION 1185924  
DATED 8-22-2013, EXPIRES 8-22-2023.

THE COLOR(S) BLACK AND RED IS/ARE CLAIMED AS  
A FEATURE OF THE MARK.

THE MARK CONSISTS OF THE TERM "MY KRONOZ" IN  
BLACK, BELOW "KRONOZ" ARE THE TERMS "MORE  
THAN TIME" IN RED. BETWEEN THE TERMS "MY" AND  
"KRONOZ" ARE TWO CLOCK HANDS WITH THE BIG  
HAND IN BLACK AND POINTING DOWN AND THE  
SMALL HAND IN RED AND POINTING UP.

#### **CLASS 9—ELECTRICAL AND SCIENTIFIC APPARATUS**

FOR WIRELESS ELECTRONIC DEVICES FOR RECEP-  
TION OR TELEPHONE CALLS, WITH OR WITHOUT  
GPS NAVIGATION CAPABILITIES; ORGANIC LIGHT-  
EMITTING DIODE (OLED) DISPLAYS; BATTERIES;  
CHIPS IN THE NATURE OF INTEGRATED CIRCUITS  
(U.S. CLS. 21, 23, 26, 36 AND 38).

#### **CLASS 14—JEWELRY**

FOR WATCHES; WRISTWATCHES (U.S. CLS. 2, 27, 28  
AND 50).

#### **CLASS 38—COMMUNICATION**

FOR COMMUNICATIONS BY TELEPHONE (U.S. CLS.  
100, 101 AND 104).

#### **CLASS 42—SCIENTIFIC AND COMPUTER SERVICES**

FOR DESIGN AND DEVELOPMENT OF WIRELESS  
ELECTRONIC DEVICES AND SOFTWARE FOR RECEP-  
TION OF TELEPHONE CALLS (U.S. CLS. 100 AND 101).  
ALAIN LAPTER, EXAMINING ATTORNEY

SN 79-140,122. STARSHAPE GAMES LIMITED, UNITED  
KINGDOM, FILED 9-23-2013.

# STARSHAPE

THE MARK CONSISTS OF STANDARD CHARACTERS  
WITHOUT CLAIM TO ANY PARTICULAR FONT, STYLE,  
SIZE, OR COLOR.

PRIORITY DATE OF 9-18-2013 IS CLAIMED.  
OWNER OF INTERNATIONAL REGISTRATION 1185950  
DATED 9-23-2013, EXPIRES 9-23-2023.

#### **CLASS 9—ELECTRICAL AND SCIENTIFIC APPARATUS**

FOR COMPUTER GAME SOFTWARE; COMPUTER  
GAME SOFTWARE PLAYABLE ON MOBILE DEVICES;  
COMPUTER GAME SOFTWARE FOR USE ON MOBILE  
OR CELLULAR TELEPHONES WHETHER HANDHELD  
OR FREESTANDING AND/OR OTHER WIRELESS DE-  
VICES; DOWNLOADABLE COMPUTER GAME SOFT-  
WARE; DOWNLOADABLE COMPUTERS GAME  
SOFTWARE PLAYABLE ON MOBILE DEVICES; INTER-  
ACTIVE COMPUTER GAME SOFTWARE; SOFTWARE  
FOR ENABLING VIDEO COMPUTER AND ONLINE  
GAMES TO BE RUN ON MULTIPLE PLATFORMS;  
DOWNLOADABLE SOFTWARE FOR DEVELOPING, DE-  
SIGNING, MODIFYING AND CUSTOMISING VIDEO,  
COMPUTER AND ONLINE GAMES (U.S. CLS. 21, 23, 26,  
36 AND 38).

#### **CLASS 38—COMMUNICATION**

FOR PROVIDING OF INTERNET CHATROOMS, FOR-  
UMS AND BULLETIN BOARDS FOR TRANSMISSION  
OF MESSAGES AMONG COMPUTER USERS; PROVID-  
ING OF INFORMATION FORUMS FOR TRANSMISSION  
OF MESSAGES AMONG COMPUTER USERS RELATING  
TO GAMES, ENTERTAINMENT, COMPUTER GAMES,  
COMPUTER SOFTWARE, PROVIDED VIA A GLOBAL  
COMPUTER NETWORK; PROVISION OF ONLINE  
ELECTRONIC BULLETIN BOARDS FOR TRANSMIS-  
SION OF MESSAGES AMONG COMPUTER USERS  
CONCERNING TOPICS OF ENTERTAINMENT AND  
COMPUTER GAMES (U.S. CLS. 100, 101 AND 104).

#### **CLASS 41—EDUCATION AND ENTERTAIN- MENT**

FOR ONLINE GAMING SERVICES; PROVIDING ON-  
LINE COMPUTER GAMES; PROVIDING ONLINECOM-  
PUTER GAMES ACCESSED AND PLAYED VIA MOBILE  
OR CELLULAR TELEPHONES AND/OR OTHER WIRE-  
LESS DEVICES; MULTI-PLAYER MATCHING SER-  
VICES, NAMELY, THE ORGANIZATION OF FANTASY  
SPORTS LEAGUES, TOURNAMENTS AND GAME  
SHOWS; PROVISION OF GAMES VIA CELLULAR TELE-  
PHONE COMMUNICATIONS; PROVISION OF ONLINE  
ELECTRONIC GAMES BY OR FOR USE ON CELLULAR  
TELEPHONES; PROVISION OF INFORMATION IN RE-  
SPECT OF COMPUTER GAMES; PROVISION OF IN-  
FORMATION IN RESPECT OF COMPUTER GAMES  
AND INTERACTIVE ENTERTAINMENT VIA MOBILE  
OR CELLULAR TELEPHONES AND/OR OTHER WIRE-  
LESS DEVICES; ELECTRONIC GAMES SERVICES PRO-  
VIDED BY MEANS OF THE INTERNET (U.S. CLS. 100,  
101 AND 107).

#### **CLASS 42—SCIENTIFIC AND COMPUTER SERVICES**

FOR TECHNOLOGICAL SERVICES AND RESEARCH  
AND DESIGN RELATING THERETO, NAMELY, COM-  
PUTER GAME SOFTWARE DEVELOPMENT, RE-  
SEARCH AND DESIGN; DESIGN, DEVELOPMENT  
AND MAINTENANCE OF COMPUTER SOFTWARE;  
DESIGN, DEVELOPMENT AND MAINTENANCE OF  
COMPUTER GAMES; DESIGN, DEVELOPMENT AND  
MAINTENANCE OF ONLINE GAMES SITES; TECHNICAL  
INFORMATION AND SUPPORT SERVICES IN  
RESPECT OF COMPUTER GAMES, NAMELY, PROVID-  
ING REMOTE ADMINISTRATION AND MANAGE-  
MENT OF HOSTED COMPUTER GAME SOFTWARE;  
COMPUTER SOFTWARE DESIGN; COMPUTER GAME  
SOFTWARE DESIGN; DESIGN AND HOSTING OF  
INTERNET CHATROOMS AND BULLETIN BOARDS  
(U.S. CLS. 100 AND 101).

MICHELLE DUBOIS, EXAMINING ATTORNEY

SN 79-140,179. VEKOMA RIDES ENGINEERING B.V., BA  
VLODRUP, NETHERLANDS, FILED 11-14-2013.

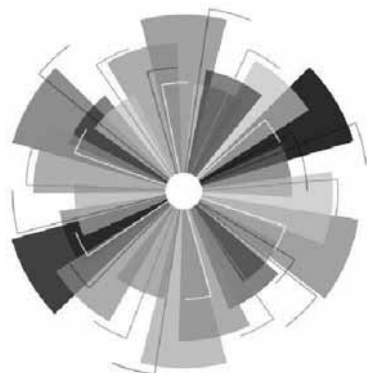

OWNER OF INTERNATIONAL REGISTRATION 1186109  
DATED 11-14-2013, EXPIRES 11-14-2023.

THE MARK CONSISTS OF A DESIGN OF MULTIPLE  
TRIANGLES AND LINES ARRANGED IN A CIRCULAR  
PATTERN WITH A CIRCULAR CENTER.

#### CLASS 6—METAL GOODS

FOR TRANSPORTABLE BUILDINGS OF METAL  
WHICH CAN BE USED ON SITE, IN AMUSEMENT  
PARKS AND IN OTHER RECREATION PARKS (U.S.  
CLS. 2, 12, 13, 14, 23, 25 AND 50).

#### CLASS 28—TOYS AND SPORTING GOODS

FOR FERRIS WHEELS, ROLLER COASTERS AND  
AMUSEMENT PARK RIDES FOR AMUSEMENT PARKS,  
RECREATION PARKS AND FAIR GROUNDS (U.S. CLS.  
22, 23, 38 AND 50).

#### CLASS 37—CONSTRUCTION AND REPAIR

FOR CONSTRUCTION, MAINTENANCE, REPAIR  
AND INSTALLATION SERVICES IN THE FIELD OF  
FERRIS WHEELS, ROLLER COASTERS AND AMUSE-  
MENT PARK RIDES (U.S. CLS. 100, 103 AND 106).

#### CLASS 41—EDUCATION AND ENTERTAIN- MENT

FOR ENTERTAINMENT AND RECREATION SER-  
VICES, ALSO PROVIDED ON SITE, IN AMUSEMENT  
PARKS OR IN THEME PARKS, NAMELY, AMUSEMENT  
PARK RIDES, AMUSEMENT PARK AND THEME PARK  
SERVICES (U.S. CLS. 100, 101 AND 107).

HAI-LY LAM, EXAMINING ATTORNEY

SN 79-140,183. STARSHAPE GAMES LIMITED, UNITED  
KINGDOM, FILED 9-24-2013.



**STARSHAPE**

PRIORITY DATE OF 9-16-2013 IS CLAIMED.

OWNER OF INTERNATIONAL REGISTRATION 1186115  
DATED 9-24-2013, EXPIRES 9-24-2023.

THE MARK CONSISTS OF THE WORD "STARSHAPE"  
BELOW A DESIGN OF A FIVE-POINTED STAR.

#### CLASS 9—ELECTRICAL AND SCIENTIFIC APPARATUS

FOR COMPUTER GAME SOFTWARE; COMPUTER  
GAME SOFTWARE PLAYABLE ON MOBILE DEVICES;  
COMPUTER GAME SOFTWARE FOR USE ON MOBILE  
OR CELLULAR TELEPHONES WHETHER HANDHELD  
OR FREESTANDING AND/OR OTHER WIRELESS DE-  
VICES; DOWNLOADABLE COMPUTER GAME SOFT-  
WARE; DOWNLOADABLE GAME COMPUTERS GAME  
SOFTWARE PLAYABLE ON MOBILE DEVICES; INTER-  
ACTIVE COMPUTER GAME SOFTWARE; SOFTWARE  
FOR ENABLING VIDEO COMPUTER AND ONLINE  
GAMES TO BE RUN ON MULTIPLE PLATFORMS;  
DOWNLOADABLE SOFTWARE FOR DEVELOPING, DE-  
SIGNING, MODIFYING AND CUSTOMISING VIDEO,  
COMPUTER AND ONLINE GAMES (U.S. CLS. 21, 23, 26,  
36 AND 38).

#### CLASS 38—COMMUNICATION

FOR PROVIDING OF INTERNET CHATROOMS, FOR-  
UMS AND BULLETIN BOARDS FOR TRANSMISSION  
OF MESSAGES AMONG COMPUTER USERS; PROVID-  
ING OF INFORMATION FORUMS FOR TRANSMISSION  
OF MESSAGES AMONG COMPUTER USERS RELATING  
TO GAMES, ENTERTAINMENT, COMPUTER GAMES,  
COMPUTER SOFTWARE, PROVIDED VIA A GLOBAL  
COMPUTER NETWORK; PROVISION OF ONLINE  
ELECTRONIC BULLETIN BOARDS FOR TRANSMIS-  
SION OF MESSAGES AMONG COMPUTER USERS  
CONCERNING TOPICS OF ENTERTAINMENT AND  
COMPUTER GAMES (U.S. CLS. 100, 101 AND 104).

#### CLASS 41—EDUCATION AND ENTERTAIN- MENT

FOR ONLINE GAMING SERVICES; PROVIDING ON-  
LINE COMPUTER GAMES; PROVIDING ONLINECOM-  
PUTER GAMES ACCESSED AND PLAYED VIA MOBILE  
OR CELLULAR TELEPHONES AND/OR OTHER WIRE-  
LESS DEVICES; MULTI-PLAYER MATCHING SER-  
VICES, NAMELY, THE ORGANIZATION OF FANTASY  
SPORTS LEAGUES, TOURNAMENTS AND GAME  
SHOWS; PROVISION OF GAMES VIA CELLULAR TELE-  
PHONE COMMUNICATIONS; PROVISION OF ONLINE  
ELECTRONIC GAMES BY OR FOR USE ON CELLULAR  
TELEPHONES; PROVISION OF INFORMATION IN RE-  
SPECT OF COMPUTER GAMES; PROVISION OF IN-  
FORMATION IN RESPECT OF COMPUTER GAMES  
AND INTERACTIVE ENTERTAINMENT VIA MOBILE  
OR CELLULAR TELEPHONES AND/OR OTHER WIRE-  
LESS DEVICES; ELECTRONIC GAMES SERVICES PRO-  
VIDED BY MEANS OF THE INTERNET (U.S. CLS. 100,  
101 AND 107).

#### CLASS 42—SCIENTIFIC AND COMPUTER SERVICES

FOR TECHNOLOGICAL SERVICES AND RESEARCH  
AND DESIGN RELATING THERETO, NAMELY, COM-  
PUTER GAME SOFTWARE DEVELOPMENT, RE-  
SEARCH AND DESIGN; DESIGN, DEVELOPMENT  
AND MAINTENANCE OF COMPUTER SOFTWARE;  
DESIGN, DEVELOPMENT AND MAINTENANCE OF  
COMPUTER GAMES; DESIGN, DEVELOPMENT AND  
MAINTENANCE OF ONLINE GAMES SITES; TECHN-  
ICAL INFORMATION AND SUPPORT SERVICES IN  
RESPECT OF COMPUTER GAMES, NAMELY, PROVID-  
ING REMOTE ADMINISTRATION AND MANAGE-  
MENT OF HOSTED COMPUTER GAME SOFTWARE;  
COMPUTER SOFTWARE DESIGN; COMPUTER GAME  
SOFTWARE DESIGN; DESIGN AND HOSTING OF  
INTERNET CHATROOMS AND BULLETIN BOARDS  
(U.S. CLS. 100 AND 101).

MICHELLE DUBOIS, EXAMINING ATTORNEY

SN 79-140,192. KEMON S.P.A., SAN GIUSTINO (PG), ITALY,  
FILED 8-1-2013.

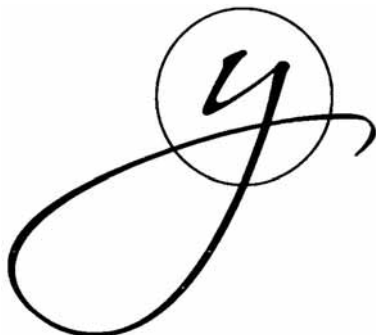

PRIORITY DATE OF 7-30-2013 IS CLAIMED.  
OWNER OF INTERNATIONAL REGISTRATION 1186132  
DATED 8-1-2013, EXPIRES 8-1-2023.  
THE TRADEMARK CONSISTS OF THE WORDING "YO"  
IN FANCY CHARACTERS WITH BOTH LETTERS OVER-  
LAPPING.

### CLASS 3—COSMETICS AND CLEANING PREPARATIONS

FOR COSMETIC SOAPS, DENTIFRICES, COSMETIC CREAMS FOR BODY AND HANDS, BLEACHING PREPARATIONS FOR COSMETIC PURPOSES; HAIR DYES; HAIR COLOURING PREPARATIONS; COLOUR REMOVING PREPARATIONS FOR HAIR; OXIDANT FOR HAIR DYEING IN THE NATURE OF HAIR DYES; HAIR COLOUR ENHANCERS IN THE NATURE OF HAIR COLORANTS; OXIDATIVE HAIR COLOUR REMOVERS; HAIR CREAMS; HAIR WEAVING PREPARATIONS IN THE NATURE OF HAIR CURLING PREPARATIONS; HAIR TREATMENT MASKS; HAIR GELS; MOISTURIZING GELS FOR SKIN CARE WITH HIGH LEVELS OF WETTING AGENTS; HAIR LOTIONS; HAIR SPRAY; SHAMPOO AND HAIR CONDITIONERS, ALL NON-MEDICATED; SHAMPOO, ALL MEDICATED (U.S. CLS. 1, 4, 6, 50, 51 AND 52).

### CLASS 5—PHARMACEUTICALS

FOR MEDICATED HAIR TREATMENT MASKS; MEDICATED HAIR MASSAGE LOTIONS IN THE NATURE OF MEDICATED HAIR CARE LOTIONS; MEDICATED HAIR LOTIONS AND PRODUCTS FOR HAIR TREATMENT, NAMELY, MEDICATED BALMS AND SERUMS FOR TREATMENT OF HAIRS (U.S. CLS. 6, 18, 44, 46, 51 AND 52).

JUHI KAVEESHVAR, EXAMINING ATTORNEY

SN 79-140,266. URBAN FRESH FOODS LTD., UNITED KINGDOM, FILED 9-20-2013.

# URBAN FRUIT

THE MARK CONSISTS OF STANDARD CHARACTERS WITHOUT CLAIM TO ANY PARTICULAR FONT, STYLE, SIZE, OR COLOR.

PRIORITY DATE OF 7-1-2013 IS CLAIMED.  
OWNER OF INTERNATIONAL REGISTRATION 1185322  
DATED 9-20-2013, EXPIRES 9-20-2023.

OWNER OF U.S. REG. NO. 4,235,832.  
NO CLAIM IS MADE TO THE EXCLUSIVE RIGHT TO USE "FRUIT", APART FROM THE MARK AS SHOWN.

### CLASS 29—MEATS AND PROCESSED FOODS

FOR PRESERVED, DRIED, COOKED, FROZEN AND BAKED FRUITS AND VEGETABLES; FRUIT AND VEGETABLE BASED SNACK FOODS; JELLIES; JAMS; COMPOTES; MILK; MILK PRODUCTS EXCLUDING ICE CREAM, ICE MILK, AND FROZEN YOGHURT; YOGHURT; SNACKS OF YOGHURT, EXCLUDING ICE CREAM, ICE MILK, AND FROZEN YOGHURT (U.S. CL. 46).

### CLASS 32—LIGHT BEVERAGES

FOR FRUIT JUICES; FRUIT DRINKS; VEGETABLE JUICES; VEGETABLE DRINKS; CARBONATED FRUIT DRINKS (U.S. CLS. 45, 46 AND 48).

JOANNA FIORELLI, EXAMINING ATTORNEY

SN 79-140,330. SIEMENS AKTIENGESELLSCHAFT, MÜNCHEN, FED REP GERMANY, FILED 10-30-2013.

# ADMIRE

THE MARK CONSISTS OF STANDARD CHARACTERS WITHOUT CLAIM TO ANY PARTICULAR FONT, STYLE, SIZE, OR COLOR.

PRIORITY DATE OF 8-28-2013 IS CLAIMED.  
OWNER OF INTERNATIONAL REGISTRATION 1186417  
DATED 10-30-2013, EXPIRES 10-30-2023.

### CLASS 9—ELECTRICAL AND SCIENTIFIC APPARATUS

FOR COMPUTER SOFTWARE FOR USE IN THE FIELD OF MEDICAL IMAGING, NAMELY, COMPUTER SOFTWARE FOR ITERATIVE RECONSTRUCTION OF IMAGES, COMPUTER SOFTWARE FOR USE IN MEDICAL IMAGING TO IMPROVE QUALITY OF IMAGES AT LOWER DOSES, COMPUTER SOFTWARE FOR USE IN THE FIELD OF MEDICAL IMAGING TO RECORD, TRANSMIT, ANALYZE AND DISPLAY IMAGES; DATA PROCESSING PROGRAMS (U.S. CLS. 21, 23, 26, 36 AND 38).

### CLASS 10—MEDICAL APPARATUS

FOR MEDICAL AND ELECTROMEDICAL APPARATUS, NAMELY, MEDICAL X-RAY APPARATUS, MEDICAL COMPUTED TOMOGRAPHY APPARATUS; STRUCTURAL PARTS OF ALL THE AFORESAID APPARATUS AND EQUIPMENT (U.S. CLS. 26, 39 AND 44).

TASNEEM HUSSAIN, EXAMINING ATTORNEY

SN 79-140,371. EUROPEAN ENERGY EXCHANGE AG, 04109 LEIPZIG, FED REP GERMANY, FILED 6-27-2013.

# PEGAS

THE MARK CONSISTS OF STANDARD CHARACTERS WITHOUT CLAIM TO ANY PARTICULAR FONT, STYLE, SIZE, OR COLOR.

PRIORITY DATE OF 2-20-2013 IS CLAIMED.  
OWNER OF INTERNATIONAL REGISTRATION 1186533  
DATED 6-27-2013, EXPIRES 6-27-2023.

**CLASS 9—ELECTRICAL AND SCIENTIFIC APPARATUS**

FOR COMPUTER PROGRAMS, BOTH STORED ON DATA MEDIA OR DOWNLOADABLE, IN CONNECTION WITH STOCK EXCHANGE AND FINANCIAL SERVICES, FEATURING QUOTATION OF COMMODITY EXCHANGE PRICES AS WELL AS DETERMINATION AND CALCULATION OF INDICES IN CONNECTION WITH OFFICIALLY QUOTED COMMODITY AND COMMODITY DERIVATIVES (U.S. CLS. 21, 23, 26, 36 AND 38).

**CLASS 35—ADVERTISING AND BUSINESS**

FOR BUSINESS MANAGEMENT AND BUSINESS ADMINISTRATION OF AN ENERGY EXCHANGE; COMPILING AND SYSTEMATIC ORDERING OF INFORMATION AND DATA IN A COMPUTER DATABASE, IN PARTICULAR RELATED TO THE SERVICES OF AN ENERGY EXCHANGE; AUCTIONEERING SERVICES (U.S. CLS. 100, 101 AND 102).

**CLASS 36—INSURANCE AND FINANCIAL**

FOR FINANCIAL AFFAIRS, IN PARTICULAR SERVICES OF AN ENERGY EXCHANGE; SECURITIES BROKERAGE SERVICES; FINANCIAL INVESTMENT BROKERAGE SERVICES; QUOTATION OF STOCK EXCHANGE PRICES; FINANCIAL SERVICES, NAMELY, DETERMINING, CALCULATING OF INDICES RELATED TO QUOTED SECURITIES AND FUTURES CONTRACTS; FINANCIAL CONSULTANCY IN THE AREA OF ENERGY TRADING; PROVIDING DETAILED INFORMATION REGARDING QUOTED SECURITIES AND FUTURE CONTRACTS (U.S. CLS. 100, 101 AND 102).

**CLASS 38—COMMUNICATION**

FOR TELECOMMUNICATIONS, NAMELY, RECEPTION AND TRANSMISSION OF INFORMATION AND DATA BY MEANS OF ELECTRONIC TRANSMISSION; PROVIDING TELECOMMUNICATIONS CONNECTIONS TO GLOBAL COMPUTER AND RADIO NETWORKS; PROVIDING MULTIPLE USER ACCESS TO TRADING PLATFORMS VIA COMPUTER NETWORKS; PROVIDING MULTIPLE USER ACCESS TO PLATFORMS AND PORTALS ON THE INTERNET; ELECTRONIC MAIL; RENTAL OF ACCESS TIME TO DATABASES AND GLOBAL COMPUTER NETWORKS (U.S. CLS. 100, 101 AND 104).

**CLASS 42—SCIENTIFIC AND COMPUTER SERVICES**

FOR INFORMATION TECHNOLOGY CONSULTING, NAMELY, TECHNICAL CONSULTANCY IN ORDER TO ENABLE INTERESTED PARTIES TO ACCESS ENERGY TRADING AND ENERGY SUPPLY PLATFORMS VIA GLOBAL COMPUTER NETWORKS AND THE INTERNET; COMPUTER SERVICES, NAMELY, PROGRAMMING AND UPDATING OF DATA PROCESSING SOFTWARE AND SOFTWARE FOR DATABASES; AFOREMENTIONED SERVICES IN PARTICULAR RELATED TO TRADING WITH AND SUPPLYING OF ENERGY; DESIGN AND DEVELOPMENT OF COMPUTER DATABASES RELATED TO STOCK EXCHANGE AND FINANCIAL SERVICES; SERVICES IN THE NATURE OF COMPUTER PROGRAMMING FOR COMPILATION OF DATABASES RELATED TO STOCK EXCHANGE AND FINANCIAL SERVICES (U.S. CLS. 100 AND 101).

ZACHARY BELLO, EXAMINING ATTORNEY

SN 79-140,380. KROSS SA, PL-06-300 PRZASNYSZ, POLAND, FILED 8-23-2013.



OWNER OF INTERNATIONAL REGISTRATION 1186560 DATED 8-23-2013, EXPIRES 8-23-2023.

THE COLOR(S) GREY, RED AND BLACK IS/ARE CLAIMED AS A FEATURE OF THE MARK.

THE MARK CONSISTS OF THE WORD "KROSS" WITH TWO ANGLES TO THE LEFT OF IT. THE COLOR GREY APPEARS IN THE WORD "KROSS". THE COLORS RED AND GREY APPEAR IN THE TWO ANGLES. THE COLOR BLACK APPEARS IN THE RECTANGLE WHICH FORMS THE BACKGROUND OF THE MARK.

**CLASS 11—ENVIRONMENTAL CONTROL APPARATUS**

FOR BICYCLE LIGHTS (U.S. CLS. 13, 21, 23, 31 AND 34).

**CLASS 12—VEHICLES**

FOR BICYCLES AND STRUCTURAL PARTS THEREOF; BICYCLE PARTS, NAMELY, BICYCLE PUMPS, BICYCLE SUPPORTS, BEING BICYCLE STANDS, STEERING SYSTEM, COMPRISED OF HANDLE BAR ENDS, CROSSBARS BEING HANDLE BARS, BASKETS ADAPTED FOR BICYCLES, FITTED BICYCLE COVERS, BICYCLE CARRIERS FOR VEHICLES, MUDGUARDS, BICYCLE TIRES AND WHEELS, BRAKES, PEDALS, CHAINS, GEAR CABLES, BICYCLE BELLS AND WATER BOTTLE CAGES OR HOLDERS FOR BICYCLES (U.S. CLS. 19, 21, 23, 31, 35 AND 44).

**CLASS 21—HOUSEWARES AND GLASS**

FOR EMPTY WATER BOTTLES FOR BICYCLES, MADE OF METAL AND LEATHER (U.S. CLS. 2, 13, 23, 29, 30, 33, 40 AND 50).

EVELYN BRADLEY, EXAMINING ATTORNEY

SN 79-140,640. EGSTON SYSTEM ELECTRONICS EGGENBURG GMBH, A-3730 EGGENBURG, AUSTRIA, FILED 6-18-2013.



PRIORITY DATE OF 4-23-2013 IS CLAIMED.

OWNER OF INTERNATIONAL REGISTRATION 1187309 DATED 6-18-2013, EXPIRES 6-18-2023.

OWNER OF U.S. REG. NO. 2,461,964.

THE MARK CONSISTS OF THE DESIGN OF A CASTLE THAT IS FORMED BY THREE INCOMPLETE VERTICAL RECTANGLES THAT ARE TOPPED BY TRIANGLES TO THE LEFT OF THE STYLIZED WORDING "EGSTON".



**CLASS 7—MACHINERY**

FOR MACHINES FOR ABRASIVE BLAST CLEANING, BAGGING, CANNING, DREDGING, ELECTRIC ARC WELDING; MACHINE TOOLS, NAMELY, GEAR CUTTERS, LATHES, BROACHERS, CHASERS, MILLING CUTTERS; MOTORS AND ENGINES EXCEPT FOR LAND VEHICLES; IGNITION MAGNETOS FOR ENGINES; MACHINE PARTS, NAMELY, BEARING HOUSINGS; SHAFT COUPLINGS OTHER THAN FOR LAND VEHICLES; MACHINE COUPLING OTHER THAN FOR LAND VEHICLES; CLUTCHES OTHER THAN FOR LAND VEHICLES, NAMELY, CLUTCHES FOR MACHINES AND AUTOMATIC TRANSMISSIONS FOR MACHINES (U.S. CLS. 13, 19, 21, 23, 31, 34 AND 35).

**CLASS 9—ELECTRICAL AND SCIENTIFIC APPARATUS**

FOR SCIENTIFIC, NAUTICAL, SURVEYING, PHOTOGRAPHIC, CINEMATOGRAPHIC, OPTICAL, WEIGHING, MEASURING, SIGNALING, CHECKING/SUPERVISION, LIFE-SAVING AND TEACHING APPARATUS AND INSTRUMENTS, NAMELY, CAMERAS, CAMERA TRIPODS, DIRECTIONAL COMPASSES, MARINE COMPASSES, MICROSCOPES, DIGITAL SIGNAL PROCESSORS; APPARATUS AND INSTRUMENTS FOR CONDUCTING, SWITCHING, TRANSFORMING, ACCUMULATING, REGULATING OR CONTROLLING ELECTRICITY, NAMELY, ADAPTERS, LIMITERS, DISTRIBUTION CONSOLES, FUSES, INDUCTORS, POWER DISTRIBUTION UNITS; ELECTRICAL AND ELECTRONIC DEVICES FOR EXTRA LOW-VOLTAGE TECHNOLOGY, INDUCTIVE COMPONENTS, ELECTROTECHNICAL AND ELECTRONIC COMPONENTS AND ASSEMBLIES, INCLUDED IN THIS CLASS, NAMELY, ELECTRICAL ARC DETECTION AND SUPPRESSING DEVICE USED IN LOW VOLTAGE SWITCHGEAR, ELECTRICAL INDUCTORS, LOW PASS INDUCTOR FILTERS; ELECTRICAL NOISE FILTERS FOR AUDIO, VIDEO, DIGITAL AND ALTERNATING CURRENT (AC) SIGNALS; ELECTRIC CURRENT INTERFERENCE NOISE SUPPRESSION CHOKES; ELECTRIC NOISE SUPPRESSION STORAGE CHOKES; CURRENT TRANSFORMERS; ELECTRIC, INDUCTIVE AND CAPACITATIVE VOLTAGE TRANSFORMERS; COMPONENTS FOR ELECTROMAGNETIC COMPATIBILITY (EMC), NAMELY, PRESSURE, RADIATION, RESISTANCE MEASURING INSTRUMENTS; ELECTRONIC MEASURING DEVICES FOR USE IN MEASURING ENVIRONMENTAL POLLUTANTS, IDENTIFYING AND MEASURING COLORS; ELECTRIC CABLES AND ELECTRICAL WIRES; CONNECTING ELEMENTS FOR ELECTRIC CABLES AND ELECTRIC LINES AND PARTS THEREFOR, IN PARTICULAR PLUGS AND PLUG-AND— SOCKET CONNECTORS AND PARTS THEREFOR, THE AFORESAID GOODS BEING INCLUDED IN THIS CLASS; ACCESSORIES FOR CONNECTING ELEMENTS FOR ELECTRIC CABLES AND ELECTRIC LINES, PARTS THEREOF INCLUDED IN THIS CLASS, NAMELY, JUNCTION SLEEVES, SHEATHS; SCREW CONNECTIONS ADAPTED FOR ELECTRIC CABLES AND ELECTRIC LINES; ACCESSORIES FOR SCREW CONNECTIONS ADAPTED FOR ELECTRIC CABLES AND ELECTRIC LINES, AND FOR ELECTRIC CABLES AND ELECTRIC LINES, PARTS THEREOF INCLUDED IN THIS CLASS, NAMELY, TERMINAL CONNECTOR CLAMPS, PATCH PANELS; ELECTRIC COMPONENTS, IN PARTICULAR ELECTRIC TRANSFORMERS, INTERFERENCE SUPPRESSION CHOKING COILS FOR USE IN ELECTRICAL APPARATUS AND MICROWAVE TRANSMISSION APPARATUS FOR DELIVERING WIRELESS CONTENT; GUIDES FOR ELECTRIC CABLES AND LINES; ADAPTED FASTENING ELEMENTS FOR ELECTRIC CABLES AND ELECTRIC LINES; ELECTRIC CHOKES; RADIO INTERFERENCE-SUPPRESSION FILTRATION COILS; FIBER OPTIC COMPONENTS, NAMELY, PLANAR LIGHTWAVE CIRCUIT CHOKES; CAMERA SPOOLS; APPARATUS FOR ELECTRICAL POWER TRANSMISSION SYSTEMS, NAMELY, FILTER COILS; REPEATING ELECTRICAL COILS; ELECTRONIC SIGNAL TRANSMITTERS; WIRELESS POWER TRANSMITTERS; ELECTRONIC DRIVE TRANSMITTERS FOR JAMMING SIGNALS; LOW-LEVEL PRESSURE, RADIO, ELECTRONIC TRANSMITTERS; ELECTRIC, POWER, DISTRIBUTION, CURRENT, AUDIO-FREQUENCY TRANSFORMERS FOR POWER SOURCES; PLANAR ELECTRICAL TRANSFORMERS;

CURRENT AND VOLTAGE TRANSFORMERS; NETWORK EQUIPMENT, NAMELY, NETWORK HUBS, SERVERS, SWITCHES, INTERFACE DEVICES, ADAPTERS; BATTERY CHARGERS; CHOKING COILS FOR USE IN ELECTRICAL APPARATUS IMPEDANCE; ELECTRIC TRANSFORMERS AND STEP-UP ELECTRIC TRANSFORMERS; ELECTRIC COILS; ELECTROMAGNETIC COILS; HOLDERS FOR ELECTRIC COILS; SPOOLS FOR USE IN PHOTOGRAPHY, NAMELY, SPOOLS FOR CAMERAS; MAGNETS; MAGNETIC WIRES; BLANK MAGNETIC DISCS; SOLENOID VALVES ELECTROMAGNETIC SWITCHES; AERIALS; ELECTRIC CONVERTERS; CHARGERS FOR ELECTRIC BATTERIES; ELECTRIC LOSS INDICATORS; SHEATHS FOR ELECTRIC CABLES; ELECTRIC RESISTANCES; LASERS, NOT FOR MEDICAL PURPOSES; ELECTRIC AND BATTERY STARTER CABLES FOR MOTORS; ELECTRICITY CONDUITS; IDENTIFICATION THREADS FOR ELECTRIC WIRES; IDENTIFICATION SHEATHS FOR ELECTRIC WIRES; WIRE CONNECTORS ELECTRICITY; CABLES, ELECTRIC; FUSE WIRE; WIRES, ELECTRIC; INSULATED COPPER WIRE; ELECTRIC COUPLINGS; FILTERS AND CHOKES, NAMELY, PHOTOGRAPHIC, OPTICAL, LENS, LABORATORY FILTERS; RESISTORS, NAMELY, ELECTRIC RESISTORS, LIGHT-DEPENDENT RESISTORS; POTENTIOMETERS; LINEAR PROTRACTORS; LENGTH MEASURING APPARATUS, NAMELY, LASER DISTANCE METER, SENSORS FOR MEASURING DISTANCE; THERMISTORS AND VARISTORS; PLUG CONNECTIONS; POWER ADAPTERS; PROBES FOR TESTING INTEGRATED CIRCUITS, SEMICONDUCTORS; ELECTRIC CORDS; ACOUSTIC CONDUITS; ELECTRICITY CONDUITS; WIRES, NAMELY, ELECTRIC, FUSE, MAGNETIC, POWER WIRES; FIBER OPTIC CABLES; ELECTRIC SWITCHES; ELECTRIC RELAYS; ELECTRICAL FUSES; FUSE BLOCK BOXES; FUSE HOLDERS, NAMELY, CLIPS AND PANEL— MOUNTED FUSE HOLDERS; THERMAL FUSES; MAGNETS; ELECTRICAL CIRCUIT BOARDS; STRIP CHART RECORDERS IN THE NATURE OF ELECTRONIC RECORDERS; POWER SUPPLIES AND POWER SUPPLY UNITS; ELECTRIC PLUGS; ELECTRIC CONNECTIONS; ELECTRIC CONNECTION ADAPTERS; ELECTRIC CONTACT CONNECTORS (U.S. CLS. 21, 23, 26, 36 AND 38).

**CLASS 42—SCIENTIFIC AND COMPUTER SERVICES**

FOR SCIENTIFIC AND TECHNOLOGICAL SERVICES AND RESEARCH AND DESIGN RELATING THERETO, NAMELY, SCIENTIFIC RESEARCH IN THE FIELD OF ELECTRONICS PRODUCTS, POWER ELECTRONIC, POWER SUPPLIES, ELECTROMECHANICAL APPLIANCES AND WIRE HARNESSSES; TECHNOLOGICAL PLANNING AND CONSULTATION IN THE FIELD OF ELECTRONICS PRODUCTS, POWER ELECTRONIC, POWER SUPPLIES, ELECTROMECHANICAL APPLIANCES AND WIRE HARNESSSES; INDUSTRIAL ANALYSIS AND RESEARCH SERVICES, NAMELY, INDUSTRIAL RESEARCH IN THE FIELD OF ELECTRONICS PRODUCTS, POWER ELECTRONIC, POWER SUPPLIES, ELECTROMECHANICAL APPLIANCES AND WIRE HARNESSSES; ENGINEERING SERVICES; PHYSICS AND CHEMISTRY SERVICES, NAMELY, CONSULTING IN THE FIELD OF PHYSICS, PHYSICS RESEARCH, LABORATORY ANALYSIS IN THE FIELD OF CHEMISTRY, RESEARCH IN THE FIELD OF CHEMISTRY; TECHNICAL CONSULTANCY RELATING TO DESIGN, DEVELOPMENT AND RESEARCH IN THE FIELD OF POWER ELECTRONIC, POWER SUPPLIES, ELECTROMECHANICAL APPLIANCES AND WIRE HARNESS; COMPUTER RENTAL; COMPUTER SOFTWARE PROGRAM DEVELOPMENT FOR USE WITH DATA PROCESSING TECHNOLOGY; MATERIAL TESTING; PRODUCT QUALITY TESTING; SURVEYING; TECHNICAL PROJECT PLANNING SERVICES FOR THE PRODUCTION OF ELECTRONICS PRODUCTS, POWER ELECTRONIC, POWER SUPPLIES, ELECTROMECHANICAL APPLIANCES AND WIRE HARNESSSES (U.S. CLS. 100 AND 101).

AMY C. KEAN, EXAMINING ATTORNEY



SN 79-140,654, MESSAGENET S.P.A., MILANO, ITALY,  
FILED 8-30-2013.

# MTALK

THE MARK CONSISTS OF STANDARD CHARACTERS WITHOUT CLAIM TO ANY PARTICULAR FONT, STYLE, SIZE, OR COLOR.

PRIORITY DATE OF 3-12-2013 IS CLAIMED.  
OWNER OF INTERNATIONAL REGISTRATION 1187331  
DATED 8-30-2013, EXPIRES 8-30-2023.

## CLASS 9—ELECTRICAL AND SCIENTIFIC APPARATUS

FOR APPLICATION PROGRAMMING INTERFACE (API) FOR COMPUTER SOFTWARE WHICH FACILITATES ONLINE SERVICES FOR SOCIAL NETWORKING, BUILDING SOCIAL NETWORKING APPLICATIONS AND FOR ALLOWING DATA RETRIEVAL, UPLOAD, DOWNLOAD, ACCESS AND MANAGEMENT; COMPUTER SOFTWARE TO ENABLE UPLOADING, DOWNLOADING, ACCESSING, POSTING, DISPLAYING, TAGGING, BLOGGING, STREAMING, LINKING, SHARING OR OTHERWISE PROVIDING ELECTRONIC MEDIA OR INFORMATION VIA COMPUTER AND COMMUNICATION NETWORKS; TELECOMMUNICATIONS PRODUCTS, NAMELY, COMPUTER HARDWARE AND SOFTWARE FOR RECEIVING, CONVERTING, TRANSMITTING, STREAMING, AND REVIEWING AUDIO, VIDEO, GRAPHICS, IMAGES, DATA AND INFORMATION RECORDED ON DIGITAL VIDEO RECORDERS; DOWNLOADABLE COMPUTER SOFTWARE FOR OPERATING TELECOMMUNICATIONS PRODUCTS; DOWNLOADABLE COMPUTER SOFTWARE IN THE NATURE OF A MOBILE APPLICATION FOR OPERATING TELECOMMUNICATIONS PRODUCTS; COMPUTER HARDWARE AND COMMUNICATIONS SOFTWARE FOR USE IN CONNECTING TELECOMMUNICATIONS EQUIPMENT, TELEPHONES, COMPUTERS, WIRED AND WIRELESS COMPUTER NETWORKS; ALL OF THE FOREMENTIONED EXCLUDES SOFTWARE AND HARDWARE THAT ALLOWS RADIO LISTENERS TO COMMUNICATE WITH ON-AIR PERSONALITIES VIA TEXT MESSAGING (U.S. CLS. 21, 23, 26, 36 AND 38).

## CLASS 35—ADVERTISING AND BUSINESS

FOR DISSEMINATION OF ADVERTISING MATTER; ON-LINE ADVERTISING ON A COMPUTER NETWORK (U.S. CLS. 100, 101 AND 102).

## CLASS 38—COMMUNICATION

FOR TELECOMMUNICATIONS SERVICES, BROADCASTING AND COMMUNICATIONS SERVICES, NAMELY, TRANSMISSION AND STREAMING OF AUDIO, VISUAL AND AUDIO-VISUAL CONTENT VIA COMPUTER NETWORKS, COMMUNICATION NETWORKS AND THE GLOBAL INFORMATION NETWORK; PEER-TO-PEER PHOTO SHARING SERVICES, NAMELY, ELECTRONIC TRANSMISSION OF DIGITAL PHOTO FILES AMONG INTERNET USERS; DELIVERY OF DIGITAL MEDIA, NAMELY, PRE-RECORDED DIGITAL SOUND, VIDEO AND DATA RECORDINGS FEATURING MUSIC, TEXT, VIDEO, GAMES, COMEDY, DRAMA, ACTION, ADVENTURE OR ANIMATION BY ELECTRONIC TRANSMISSION; TELECOMMUNICATION SERVICES PROVIDED VIA PREPAID TELEPHONE CALLING CARDS; TELECOMMUNICATIONS, NAMELY, PROVIDING ADVANCED CALLING FEATURES, NAMELY, CHANGING A PERSON'S CALLER ID, CALL RECORDING SERVICES, CHANGING THE SOUND OF A PERSON'S VOICE AND THEIR MANNER ON THE TELEPHONE; ELECTRONIC MAIL AND MESSAGING SERVICES; DELIVERY OF PERSONALISED GREETINGS VIA COMPUTER NETWORKS, COMMUNICATION NETWORKS AND GLOBAL INFORMATION NETWORKS; ALL OF THE FOREMENTIONED SERVICES EXCLUDE COMMUNICATION SERVICES BY MOBILE PHONES, NAMELY, TO ALLOW RADIO LISTENERS TO COMMUNICATE WITH ON-AIR PERSONALITIES VIA TEXT MESSAGING (U.S. CLS. 100, 101 AND 104).

## CLASS 42—SCIENTIFIC AND COMPUTER SERVICES

FOR ELECTRONIC STORAGE OF FILES AND DOCUMENTS FOR OTHERS (U.S. CLS. 100 AND 101).

## CLASS 45—PERSONAL AND LEGAL SERVICES

FOR PROVIDING ONLINE SOCIAL NETWORKING SERVICES PROVIDED THROUGH A COMMUNITY WEBSITE; IDENTIFICATION VERIFICATION SERVICES, NAMELY, PROVIDING AUTHENTICATION OF PERSONAL IDENTIFICATION INFORMATION; ALL OF THE FOREMENTIONED SERVICES EXCLUDE SERVICES DIRECTED TOWARDS RADIO LISTENERS TO COMMUNICATE WITH ON-AIR PERSONALITIES VIA TEXT MESSAGING (U.S. CLS. 100 AND 101).

CURTIS FRENCH, EXAMINING ATTORNEY

SN 79-140,759, HANSA METALLWERKE AG, FED REP GERMANY, FILED 4-25-2013.

# HANSAEMOTION

THE MARK CONSISTS OF STANDARD CHARACTERS WITHOUT CLAIM TO ANY PARTICULAR FONT, STYLE, SIZE, OR COLOR.

PRIORITY DATE OF 11-21-2012 IS CLAIMED.  
OWNER OF INTERNATIONAL REGISTRATION 1187576  
DATED 4-25-2013, EXPIRES 4-25-2023.  
OWNER OF U.S. REG. NOS. 3,275,425, 3,960,715 AND OTHERS.

**CLASS 11—ENVIRONMENTAL CONTROL APPARATUS**

FOR FITTINGS FOR PLUMBING, WATER HEATING, BATHING, SHOWERING, FLUSHING, BIDET AND WASHING FACILITIES, NAMELY, MANUALLY, THERMOSTATICALLY AND ELECTRONICALLY CONTROLLED MIXER TAPS, CONTACTLESSLY CONTROLLED SANITARY FITTINGS IN THE NATURE OF URINALS, SHOWERS AND TAPS, MIXING VALVES, AND CONTROL VALVES, ALL OF THE FOREGOING BEING PARTS OF SANITARY FACILITIES; SHOWERS, SHOWER COMBINATIONS COMPRISED OF A PLURALITY OF SHOWER HEADS, OVERHEAD SHOWER HEAD ATTACHMENTS, LATERAL SHOWER HEAD ATTACHMENTS, AND SPRAY NOZZLES FOR SHOWERS, TUBS, AND BATHS; PLUMBING FIXTURES AND FITTINGS, NAMELY, SHOWER ATTACHMENT BAR SUPPORTS BEING STRUCTURAL PARTS OF SHOWERS, SHOWER HOSES, SHOWER RAILS, HOSE COUPLINGS FOR SUCH SHOWERS AND BATH HANDLES; UPPER PARTS OF SANITARY FITTINGS, NAMELY, WATER INLETS AND WATER OUTLETS IN THE NATURE OF PIPES AND FAUCETS AS PARTS OF SANITARY FACILITIES; MECHANICAL SAFETY VALVES MADE OF METAL AND SAFETY GROUPS SUBSTANTIALLY COMPOSED THEREOF, THE AFOREMENTIONED GOODS AS CONNECTION, CONTROL AND SAFETY FITTINGS FOR SANITARY INSTALLATIONS; WATER CONDITIONING UNITS; PARTS OF THE AFOREMENTIONED GOODS, NAMELY, REPLACEMENT AND COMPONENT PARTS FOR THE FIXTURES AND FITTINGS (U.S. CLS. 13, 21, 23, 31 AND 34).

**CLASS 20—FURNITURE AND ARTICLES NOT OTHERWISE CLASSIFIED**

FOR ACCESSORIES FOR BATHROOMS AND SHOWERS, NAMELY, MIRRORS AND NON-METAL TOWEL HOOKS (U.S. CLS. 2, 13, 22, 25, 32 AND 50).

**CLASS 21—HOUSEWARES AND GLASS**

FOR ACCESSORIES FOR THE BATH AND SHOWERS, NAMELY, BATHROOM GLASS HOLDERS, SOAP HOLDERS, TOWELS RACKS AS BATHROOM FIXTURES, SPARE TOILET PAPER HOLDERS, TOILET BRUSH HOLDERS, HAND TOWEL RINGS, SOAP DISPENSERS (U.S. CLS. 2, 13, 23, 29, 30, 33, 40 AND 50).

ELI HELLMAN, EXAMINING ATTORNEY

SN 79-140,767. IDEA RS S.R.O., CZ-616 00 BRNO, CZECH REPUBLIC, FILED 5-20-2013.

**IDEA STATICA**

THE MARK CONSISTS OF STANDARD CHARACTERS WITHOUT CLAIM TO ANY PARTICULAR FONT, STYLE, SIZE, OR COLOR.

PRIORITY DATE OF 5-16-2013 IS CLAIMED.

OWNER OF INTERNATIONAL REGISTRATION 1187603 DATED 5-20-2013, EXPIRES 5-20-2023.

THE ENGLISH TRANSLATION OF "STATICA" IN THE MARK IS "STATICS".

**CLASS 37—CONSTRUCTION AND REPAIR**

FOR BUILDING CONSTRUCTION (U.S. CLS. 100, 103 AND 106).

**CLASS 42—SCIENTIFIC AND COMPUTER SERVICES**

FOR SCIENTIFIC AND TECHNOLOGICAL SERVICES, NAMELY, ENGINEERING SERVICES; SCIENTIFIC RESEARCH; DESIGN SERVICES, NAMELY, STRUCTURAL ENGINEERING DESIGN SERVICES, COMPUTER AIDED DESIGN FOR OTHERS; DESIGN AND DEVELOPMENT OF COMPUTER HARDWARE AND SOFTWARE (U.S. CLS. 100 AND 101).

ELI HELLMAN, EXAMINING ATTORNEY

SN 79-140,792. ÅLÖ AB, SWEDEN, FILED 8-13-2013.



PRIORITY DATE OF 7-3-2013 IS CLAIMED.

OWNER OF INTERNATIONAL REGISTRATION 1187662 DATED 8-13-2013, EXPIRES 8-13-2023.

OWNER OF U.S. REG. NO. 3,953,515.

THE COLOR(S) GREY IS/ARE CLAIMED AS A FEATURE OF THE MARK.

THE MARK CONSISTS OF THE STYLIZED WORDING "QUICKE" APPEARING IN GRAY.

**CLASS 7—MACHINERY**

FOR FRONT END SHOVEL LOADERS FOR TRACTORS AND OTHER EQUIPMENT-CARRYING VEHICLES; MECHANICAL AND HYDRAULIC LOADING, LIFTING AND DIGGING EQUIPMENT FOR TRACTORS AND OTHER EQUIPMENT-CARRYING VEHICLES, NAMELY, FRONT END LOADERS, BACK END LOADERS, GRAPPLES, FORKS, GRAPPLE BUCKETS FOR MOVING EARTH AND LOOSE OBJECTS, SILAGE FORKS, SILAGE CUTTERS, BLOCK TRENCH CUTTERS, BALE SPLITTERS, PALLET FORK LIFTERS, TIMBER BLADES FOR MOVING EARTH AND LOOSE OBJECTS, TIMBER FORKS IN THE NATURE OF MECHANICAL AND HYDRAULIC LIFTS, GRAB ATTACHMENTS IN THE NATURE OF BUCKETS, GRAPPLES AND FORKS, BIG SACK LIFTERS IN THE NATURE OF MECHANICAL AND HYDRAULIC LIFTS, MANURE FORKS IN THE NATURE OF LIFTING AND MOVING EQUIPMENT, POTATO FORKS IN THE NATURE OF LIFTING AND MOVING EQUIPMENT, STONE FORKS IN THE NATURE OF LIFTING AND MOVING EQUIPMENT, ROOT FORKS IN THE NATURE OF LIFTING AND MOVING EQUIPMENT, BALE SPIKES, BALES FORKS, PLOUGHS, MECHANICAL SAND SPREADERS, MECHANICAL AND HYDRAULIC ARMS FOR USE AS BALE CARRIERS AND MECHANICAL AND HYDRAULIC LIFTS; MECHANICAL AND HYDRAULIC FASTENING, LOCKING AND DAMPING DEVICES FOR THE AFORESAID LOADING, LIFTING AND DIGGING EQUIPMENT, NAMELY, LOAD DAMPING COUNTERWEIGHTS, HYDRAULIC COUPLERS, SHOCK ABSORBERS, AND HYDRAULIC IMPLEMENT LOCKS; STRUCTURAL PARTS FOR THE AFOREMENTIONED GOODS (U.S. CLS. 13, 19, 21, 23, 31, 34 AND 35).

**CLASS 12—VEHICLES**

FOR TRACTORS; EQUIPMENT-CARRYING LAND VEHICLES WITH MECHANICAL AND HYDRAULIC LOADING, LIFTING AND DIGGING EQUIPMENT ATTACHED THERETO; STRUCTURAL PARTS FOR THE AFORESAID GOODS (U.S. CLS. 19, 21, 23, 31, 35 AND 44).

JOANNA FIORELLI, EXAMINING ATTORNEY

SN 79-140,925. DR. GÜNTER RESCH, WIEN, AUSTRIA,  
FILED 10-2-2013.

# NEXPERION

THE MARK CONSISTS OF STANDARD CHARACTERS WITHOUT CLAIM TO ANY PARTICULAR FONT, STYLE, SIZE, OR COLOR.

PRIORITY DATE OF 4-12-2013 IS CLAIMED.  
OWNER OF INTERNATIONAL REGISTRATION 1188002  
DATED 10-2-2013, EXPIRES 10-2-2023.

## CLASS 9—ELECTRICAL AND SCIENTIFIC APPARATUS

FOR RESEARCH AND INDUSTRY SOFTWARE AND COMPUTER PROGRAMS FOR CONTROLLING DEVICES AND COLLECTING, MANAGING, ANALYZING, AND EVALUATING DATA, ALL IN THE FIELDS OF MICROSCOPY, ELECTRON MICROSCOPY, AND MICROSCOPY AND ELECTRON MICROSCOPY SAMPLE PREPARATION (U.S. CLS. 21, 23, 26, 36 AND 38).

## CLASS 41—EDUCATION AND ENTERTAINMENT

FOR PROVIDING OF TRAINING AND FURTHER TRAINING; ARRANGING AND CONDUCTING OF TRAINING COURSES, SEMINARS AND WORKSHOPS, AND CORRESPONDENCE COURSES; ALL THE FOREGOING IN THE FIELDS OF MICROSCOPY, ELECTRON MICROSCOPY, AND MICROSCOPY AND ELECTRON MICROSCOPY SAMPLE PREPARATION (U.S. CLS. 100, 101 AND 107).

## CLASS 42—SCIENTIFIC AND COMPUTER SERVICES

FOR SCIENTIFIC AND TECHNOLOGICAL SERVICES, NAMELY, TESTING AND DEVELOPMENT OF INSTRUMENTS AND METHODS AND COLLECTING AND ANALYZING DATA; SCIENTIFIC AND TECHNICAL CONSULTANCY; COMPUTER SOFTWARE CONSULTANCY; DESIGN, DEVELOPMENT AND MAINTENANCE OF COMPUTER SOFTWARE; ALL THE FOREGOING IN THE FIELDS OF MICROSCOPY, ELECTRON MICROSCOPY, AND MICROSCOPY AND ELECTRON MICROSCOPY SAMPLE PREPARATION; PREPARING MATERIAL SAMPLES FOR USE WITH MICROSCOPES AND ELECTRON MICROSCOPES (U.S. CLS. 100 AND 101).

ANDREW LEASER, EXAMINING ATTORNEY

SN 79-140,963. AMBIENTE DIRECT GMBH, FED REP GERMANY, FILED 9-16-2013.

# AmbienteDirect

THE MARK CONSISTS OF STANDARD CHARACTERS WITHOUT CLAIM TO ANY PARTICULAR FONT, STYLE, SIZE, OR COLOR.

PRIORITY DATE OF 3-18-2013 IS CLAIMED.  
OWNER OF INTERNATIONAL REGISTRATION 1188110  
DATED 9-16-2013, EXPIRES 9-16-2023.

THE ENGLISH TRANSLATION OF "AMBIENTE" IN THE MARK IS "AMBIENCE".

## CLASS 16—PAPER GOODS AND PRINTED MATTER

FOR PRINTED MATTER, NAMELY, CATALOGS AND FLYERS IN THE FIELD OF HOUSEHOLD UTENSILS; PLASTIC MATERIALS FOR PACKAGING (U.S. CLS. 2, 5, 22, 23, 29, 37, 38 AND 50).

## CLASS 35—ADVERTISING AND BUSINESS

FOR MARKETING IN THE FIELD OF WHOLESALING AND RETAIL STORE SERVICES; ADVERTISING IN THE FIELD OF WHOLESALING AND RETAIL STORE SERVICES; DISSEMINATION AND UPDATING OF ADVERTISING MATERIAL IN THE FIELD OF WHOLESALING AND RETAIL STORE SERVICES; WHOLESALING AND RETAIL STORE SERVICES, PROVIDED ONLINE AND OFFLINE, AND MAIL ORDER SERVICES THROUGH MAIL ORDER CATALOGUES OR VIA ELECTRONIC MEDIA IN THE FIELDS OF LIGHTING APPARATUS AND INSTALLATIONS; PRINTED MATTER, STATIONERY AND WRITING UTENSILS, OFFICE REQUISITE, FURNISHINGS AND DECORATIVE ARTICLES, ELECTRICAL GOODS AND ELECTRONICS GOODS; HOUSEHOLD OR KITCHEN UTENSILS AND CONTAINERS, GLASSWARE, PORCELAIN AND EARTHENWARE, FURNITURE, MIRRORS, PICTURE FRAMES, MATS AND OTHER MATERIALS FOR COVERING FLOORS, HOROLOGICAL AND CHRONOMETRIC INSTRUMENTS, TEXTILES AND TEXTILE GOODS; PROMOTING THE GOODS AND SERVICES OF OTHERS BY MEANS OF OPERATING AN ON-LINE SHOPPING MALL PRESENTING THE GOODS OF OTHERS WITH LINKS TO THE RETAIL AND WHOLESALE WEB SITES OF OTHERS; OUTSOURCING SERVICES IN THE NATURE OF ARRANGING PROCUREMENT OF GOODS AND SERVICES FOR OTHERS; COMPUTER-AIDED ONLINE ORDERING OF GENERAL GOODS AND GENERAL CONSUMER GOODS, ALL OF THE FOREGOING LIMITED TO WHOLESALING AND RETAIL STORE SERVICES (U.S. CLS. 100, 101 AND 102).

## CLASS 38—COMMUNICATION

FOR PROVIDING ACCESS TO PORTALS ON THE INTERNET; PROVIDING ACCESS TO COMPUTER PROGRAMS ON DATA NETWORKS; PROVIDING ACCESS TO INFORMATION ON THE INTERNET; E-MAIL FORWARDING SERVICES; COMPUTER-AIDED TRANSMISSION OF MESSAGES, DATA, SOUND AND IMAGES; COMMUNICATION OF DATA VIA THE INTERNET (U.S. CLS. 100, 101 AND 104).

KEVIN MITTLER, EXAMINING ATTORNEY

SN 79-140,975. FUTURE GMBH, FED REP GERMANY,  
FILED 5-15-2013.

# Ultra Red

THE MARK CONSISTS OF STANDARD CHARACTERS WITHOUT CLAIM TO ANY PARTICULAR FONT, STYLE, SIZE, OR COLOR.

OWNER OF INTERNATIONAL REGISTRATION 1188138  
DATED 5-15-2013, EXPIRES 5-15-2023.

## CLASS 9—ELECTRICAL AND SCIENTIFIC APPARATUS

FOR RECORDED AUDIO AND VIDEO DATA CARRIERS FEATURING MUSIC; MUSIC COMPOSITION SOFTWARE AND MANUALS SOLD THEREWITH; APPARATUS FOR RECORDING, TRANSMISSION OR REPRODUCTION OF SOUND OR IMAGES (U.S. CLS. 21, 23, 26, 36 AND 38).

## CLASS 41—EDUCATION AND ENTERTAINMENT

FOR ENTERTAINMENT SERVICES, NAMELY, LIVE MUSICAL PERFORMANCES BY MUSICAL GROUPS, MUSICIANS, BANDS, AND SOLOISTS; DISC JOCKEYS SERVICES; PLANNING ARRANGEMENT OF MUSICAL PERFORMANCES (U.S. CLS. 100, 101 AND 107).

JOHN E. MICHOS, EXAMINING ATTORNEY

SN 79-140,990. HYUNDAI MOTOR COMPANY, SEOCHO-GU  
SEOUL 137-938, REPUBLIC OF KOREA, FILED 7-23-2013.



PRIORITY DATE OF 1-23-2013 IS CLAIMED.  
OWNER OF INTERNATIONAL REGISTRATION 1188170  
DATED 7-23-2013, EXPIRES 7-23-2023.

THE COLOR(S) PEACH, VIOLET, PINK, PURPLE, WHITE,  
BLACK, AND YELLOW IS/ARE CLAIMED AS A FEATURE  
OF THE MARK.

THE MARK CONSISTS OF THE DESIGN OF A GIRL  
WITH PEACH SKIN TONE AND BLACK HAIR WEARING A  
PINK, PURPLE, AND WHITE OUTFIT WITH SHADES OF  
PURPLE IN THE SKIRT. SHE IS WEARING PINK AND  
BLACK BOOTS, A YELLOW NECKLACE, AND A PINK  
HAIR BOW. HER EYES ARE BLACK WITH VIOLET AND  
WHITE. THE WORD "RADI" APPEARS IN PINK NEXT TO  
THE GIRL.

THE WORDING "RADI" HAS NO MEANING IN A  
FOREIGN LANGUAGE.

#### CLASS 27—FLOOR COVERINGS

FOR FLOOR MATS; BATH MATS; MATTING FOR  
COVERING EXISTING FLOORS; RUSH MATS; WALL-  
PAPER; TEXTILE WALLPAPER; FLOOR COVERINGS;  
FUR RUGS; NON-SLIP MATS FOR BATHS; CARPET  
UNDERLAY; NON-TEXTILE WALL HANGINGS; CAR-  
PETS; ORNAMENTAL NON-TEXTILE WALL HANG-  
INGS; AUTOMOBILE CARPETS; CARPET TILES;  
DOOR MATS; SPORTS MATS USED AS GYMNASTIC  
MATS; GYMNASIUM MATS (U.S. CLS. 19, 20, 37, 42  
AND 50).

#### CLASS 28—TOYS AND SPORTING GOODS

FOR TOYS, NAMELY, ACTION FIGURES; ORNA-  
MENTS FOR CHRISTMAS TREES EXCEPT ILLUMINA-  
TION ARTICLES AND CONFECTIONERY;  
FAIRGROUND RIDE APPARATUS; DOLLS; PLAY-  
THINGS, NAMELY, BABY RATTLES; TOY MOBILES;  
BUILDING BLOCKS TOYS; TOY MODEL TRAIN SETS;  
TOY CONSTRUCTIONS SETS; TOY CAR SETS; TOY  
RACING SETS; PUPPETS; MODEL VEHICLES FOR  
CHILDREN; PLAYTHINGS, NAMELY, TOY TRICYCLES  
FOR CHILDREN OTHER THAN FOR TRANSPORT;  
ROCKING HORSES; THEATRICAL MASKS; TOY  
CLOCKS AND WATCHES; TOY MUSICAL INSTRU-  
MENTS; TOY FURNITURE; PLAYING BALLS FOR  
GAMES AND SPORTS; TOY SCOOTERS; TOY HOUSES;  
PLAYTHINGS, NAMELY, PLAYGROUND SLIDES; TOY  
VEHICLES; PAPER TOYS, NAMELY, DOLLS; CARNI-  
VAL MASKS; TOYS, NAMELY, SPINNING TOPS; PLAS-  
TIC TOYS, NAMELY, TOY CARS, CHARACTER TOYS;  
TOYS, NAMELY, SCALE MODEL KITS; APPARATUS  
FOR BADMINTON AND VOLLEY BALL GAMES,  
NAMELY, BADMINTON AND VOLLEYBALL GAME  
PLAYING EQUIPMENT; BOARD GAMES; PARLOR  
GAMES; PUZZLES; PLAY BALLOONS; COMPUTER  
GAMES APPARATUS, NAMELY, GAME CONTROL-  
LERS FOR COMPUTER GAMES AND COMPUTER  
GAME CONSOLES FOR USE WITH AN EXTERNAL  
DISPLAY SCREEN OR MONITOR; SPORTING ARTI-  
CLES OTHER THAN GOLF ARTICLES AND CLIMBING  
ARTICLES, NAMELY, BALLS FOR SPORTS, NETS FOR  
SPORTS, TENNIS RACKETS, BASEBALL BATS; SPORTS  
ARTICLES, NAMELY, SWINGS; SPORTS ARTICLES,  
NAMELY, KNEE GUARDS (U.S. CLS. 22, 23, 38 AND 50).

#### CLASS 41—EDUCATION AND ENTERTAIN- MENT

FOR PRODUCTION OF ANIMATED FILMS; DISTRI-  
BUTION OF ANIMATED FILMS; PRESENTATION OF  
LIVE PERFORMANCES BY A MUSICAL BAND, BY A  
THEATRICAL COMPANY, BY A DANCE TROUPE;  
PRESENTATION OF MUSICAL PERFORMANCES; PRO-  
DUCTION OF TELEVISION SHOWS; PROVIDING LIVE  
PERFORMANCES IN THE NATURE OF DOLL PLAY  
PERFORMANCES; FILM PRODUCTION OTHER THAN  
ADVERTISING FILMS; TELEVISION SHOW PRODU-  
CTION; PRODUCTION OF TELEVISION PROGRAMS;  
PUBLICATION OF EDUCATIONAL MATERIALS,  
NAMELY, BOOKS; PUBLICATION OF BOOKS; PROVID-  
ING NON-DOWNLOADABLE ON-LINE ELECTRONIC  
PUBLICATIONS IN THE NATURE OF ARTICLES IN  
THE FIELD OF AUTOMOBILE DESIGN, MANUFAC-  
TURE, SAFETY AND ENVIRONMENTAL ISSUES; AR-  
RANGING AND CONDUCTING OF EDUCATIONAL  
EVENTS IN THE NATURE OF SEMINARS IN THE  
FIELD OF AUTOMOBILE DESIGN, MANUFACTURE,  
SAFETY AND ENVIRONMENTAL ISSUES; PROVISION  
OF SPORTS FACILITIES; ARCADE GAMING SERVICES;  
GAME SERVICES PROVIDED ON-LINE FROM A COM-  
PUTER NETWORK, NAMELY, PROVIDING ONLINE  
COMPUTER GAMES; CHILDREN'S PLAYGROUND OPE-  
RATION, NAMELY, PROVISION OF CHILDREN'S  
PLAYGROUNDS; PROVIDING AND OPERATING OF  
AMUSEMENT FACILITIES; OPERATION OF SPORTS  
FACILITIES; PROVISION OF THEME PARK AND RE-  
CREATIONAL PARK FACILITIES; PROVISION OF  
AMUSEMENT PARK FACILITIES (U.S. CLS. 100, 101  
AND 107).

AHSEN KHAN, EXAMINING ATTORNEY

SN 79-141,231. AKTIEBOLAGET TRAV OCH GALOPP,  
SWEDEN, FILED 11-29-2013.

# HARRY

THE MARK CONSISTS OF STANDARD CHARACTERS  
WITHOUT CLAIM TO ANY PARTICULAR FONT, STYLE,  
SIZE, OR COLOR.

PRIORITY DATE OF 6-5-2013 IS CLAIMED.  
OWNER OF INTERNATIONAL REGISTRATION 1188786  
DATED 11-29-2013, EXPIRES 11-29-2023.

#### CLASS 36—INSURANCE AND FINANCIAL

FOR FINANCIAL SERVICES, NAMELY, THE RECEIPT OF BETS FOR HORSE RACING AND THE PAY OUT OF PRIZE MONEY FOR WINNING BETS MADE ON HORSE RACING (U.S. CLS. 100, 101 AND 102).

#### CLASS 41—EDUCATION AND ENTERTAINMENT

FOR OPERATING LOTTERIES AND LOTTERY BUSINESS, NAMELY, CONDUCTING LOTTERY SERVICES FOR OTHERS; ENTERTAINMENT SERVICES, NAMELY, CONDUCTING HORSE RACES; BETTING SERVICES, GAMBLING SERVICES, SPORTING AND CULTURAL ACTIVITIES, NAMELY, ARRANGING AND CONDUCTING SPORTS AND CULTURAL COMPETITIONS (U.S. CLS. 100, 101 AND 107).

HEATHER SAPP, EXAMINING ATTORNEY

#### CLASS 11—ENVIRONMENTAL CONTROL APPARATUS

FOR LAMPS; LIGHTING APPARATUS, NAMELY, LIGHTING INSTALLATIONS; FLARES; FAIRY LIGHTS FOR FESTIVE DECORATION; LUMINOUS TUBES FOR LIGHTING; STREET LAMPS; LIGHTING APPARATUS FOR THE STAGE; FLUORESCENT LIGHTING TUBES; LANTERNS FOR LIGHTING; LIGHTING APPARATUS FOR VEHICLE (U.S. CLS. 13, 21, 23, 31 AND 34).

JAMES GRIFFIN, EXAMINING ATTORNEY

SN 79-141,606. PRÜFTECHNIK DIETER BUSCH; AKTIENGESELLSCHAFT, ISMANING, FED REP GERMANY, FILED 4-27-2013.



PRÜFTECHNIK

PRIORITY DATE OF 2-27-2013 IS CLAIMED.  
OWNER OF INTERNATIONAL REGISTRATION 1189782  
DATED 4-27-2013, EXPIRES 4-27-2023.

OWNER OF U.S. REG. NO. 2,864,156.

THE MARK CONSISTS OF THE STYLIZED LETTERS "DB" INSIDE OF A SQUARE. TO THE RIGHT OF THE LETTERS AND DESIGN IS THE STYLIZED TERM "PRÜFTECHNIK".

THE ENGLISH TRANSLATION OF "PRÜFTECHNIK" IN THE MARK IS "TESTING".

SEC. 2(F) AS TO "PRÜFTECHNIK".

SN 79-141,289. MLS CO., LTD., GUANGDONG PROVINCE, CHINA, FILED 3-20-2013.



OWNER OF INTERNATIONAL REGISTRATION 1188936  
DATED 3-20-2013, EXPIRES 3-20-2023.

THE MARK CONSISTS OF AN OVAL WITH A CHINESE CHARACTER THAT TRANSLITERATES TO "SEN" INSIDE IT, TO THE LEFT OF THE STYLIZED LETTERS "MLS".

THE NON-LATIN CHARACTERS IN THE MARK TRANSLITERATE TO "SEN" AND THIS MEANS "A LARGE NUMBER OF TRESS" IN ENGLISH.

#### CLASS 9—ELECTRICAL AND SCIENTIFIC APPARATUS

FOR ELECTRONIC AGENDAS; ELECTRONIC CHIPS FOR THE MANUFACTURE OF INTEGRATED CIRCUITS; MONEY COUNTING AND SORTING MACHINES; PHOTOGRAPHIC EQUIPMENT, NAMELY, LIGHT BOXES; NEON SIGNS; ELECTRONIC NOTICE BOARDS; VEHICLE TRAFFIC SIGNAL LIGHTS, NAMELY, BLINKERS; SATELLITE NAVIGATIONAL APPARATUS; PORTABLE TELEPHONES; MEGAPHONES; SEMI-CONDUCTORS; AIR ANALYSIS APPARATUS; MEASURING INSTRUMENTS IN THE NATURE OF LOGS, NAMELY, DISTANCE MEASURING APPARATUS; ELECTRIC CONTROL PANELS; ELECTRONIC TRANSISTORS; ELECTRIC LIGHT DIMMERS; INTEGRATED CIRCUITS; SEMI-CONDUCTOR DEVICES, NAMELY, MEMORIES, STRUCTURED WAFERS; CAPACITORS; RESISTANCE WIRES; ELECTRON TUBES; VACUUM TUBES FOR RADIOS; SILICON EPITAXIAL SLICES; WAFERS SILICON SLICES; REMOTE CONTROL APPARATUS FOR TELEVISIONS; LIGHT CONDUCTING FILAMENTS OPTICAL FIBERS; ELECTRIC RELAYS; THERMIONIC TUBES; CHARGERS FOR ELECTRONIC BATTERIES; LIGHT-EMITTING ELECTRONIC POINTERS (U.S. CLS. 21, 23, 26, 36 AND 38).

#### CLASS 9—ELECTRICAL AND SCIENTIFIC APPARATUS

FOR SENSORS AND SENSOR ASSEMBLIES FOR MEASURING, TESTING AND MONITORING THE ALIGNMENT OF MACHINES, PARTS OF MACHINES AND SHAFTS; OPTICAL SENSORS; LASER-OPTICAL SENSORS; ELECTRIC AND ELECTRO-OPTICAL SENSORS; VIBRATION METERS; VIBRATION MEASURING APPARATUS; GRADIENT MEASURING APPARATUS; PROTRACTORS; WEIGHING APPARATUSES AND INSTRUMENTS; DISTANCE MEASURING APPARATUSES AND INSTRUMENTS; SIGNALING APPARATUSES AND INSTRUMENTS FOR MEASUREMENT AND QUALITY CONTROL OF MATERIALS PROCESSING BY LASER; SENSING APPARATUS AND INSTRUMENTS FOR MEASUREMENT AND QUALITY CONTROL OF MATERIALS PROCESSING BY LASER; CONTROL APPARATUS AND INSTRUMENTS FOR CAPTURING, TESTING, MONITORING, INTERPRETING AND ANALYSIS OF THE ALIGNMENT DATA OF MACHINES AND PARTS OF MACHINES; COMPUTER SOFTWARE FOR MEASURING, MONITORING, STORING AND TRANSMITTING OVER A GLOBAL COMPUTER NETWORK PHYSICAL QUANTITY DATA VALUES, ORGANIZING METROLOGICAL DATA, AND MEASURING, MONITORING, STORING AND TRANSMITTING OVER A GLOBAL COMPUTER NETWORK MACHINE AND MACHINE PART ALIGNMENT DATA, DATA ON THE OPERATING CONDITION OF MACHINES AND MACHINE PARTS, AND RECORDINGS OF SOUNDS FROM MACHINES AND MACHINE PARTS; COMPUTER APPLICATION SOFTWARE FOR MEASURING, MONITORING, STORING AND TRANSMITTING OVER A GLOBAL COMPUTER NETWORK PHYSICAL QUANTITY DATA VALUES, ORGANIZING METROLOGICAL DATA, AND MEASURING, MONITORING, STORING AND TRANSMITTING OVER A GLOBAL COMPUTER NETWORK MACHINE AND MACHINE PART ALIGNMENT DATA, DATA ON THE OPERATING CONDITION OF MACHINES AND MACHINE PARTS, AND RECORDINGS OF SOUNDS FROM MACHINES AND MACHINE PARTS; SOFTWARE FOR USE IN CAPTURING, TESTING, MONITORING, INTERPRETING AND ANALYZING SENSOR SIGNALS AND SENSOR SIGNAL DATA AND MEASUREMENTS; DATA PROCESSING EQUIPMENT; COMPUTERS; ELECTRONIC APPARATUS AND COMPUTERS FOR CAPTURING, INTERPRETING AND ANALYZING SENSOR SIGNALS AND SENSOR SIGNAL

DATA AND MEASUREMENTS; AUTOMATIC SENSOR CONTROL APPARATUS; WEIGHING CONTROL APPARATUS AND INSTRUMENTS; ELECTRONIC APPARATUS FOR THE CONTROL OF SENSORS; SIGNALING CONTROL APPARATUS AND INSTRUMENTS FOR MEASUREMENT AND QUALITY CONTROL OF MATERIALS PROCESSING BY LASER; CONTROL APPARATUS AND INSTRUMENTS FOR CAPTURING, TESTING, MONITORING, INTERPRETING AND ANALYSIS OF THE ALIGNMENT DATA OF MACHINES, PARTS OF MACHINES AND SHAFTS (U.S. CLS. 21, 23, 26, 36 AND 38).

SN 79-141,661. 2BIK IMPORTS PTY LTD, BONDI JUNCTION, AUSTRALIA, FILED 7-15-2013.

ECOHEADS



#### **CLASS 11—ENVIRONMENTAL CONTROL APPARATUS**

FOR INDUCTIVE HEATING APPARATUSES, NAMELY, INDUCTION BEARING HEATERS (U.S. CLS. 13, 21, 23, 31 AND 34).

OWNER OF INTERNATIONAL REGISTRATION 1189940 DATED 7-15-2013, EXPIRES 7-15-2023.

THE MARK CONSISTS OF THE LITERAL ELEMENTS "ECOHEADS" WITH A LINE SLANTED FROM LEFT TO RIGHT WITH A CIRCLE AT THE BOTTOM TO THE RIGHT OF THE WORDS.

#### **CLASS 35—ADVERTISING AND BUSINESS**

FOR COMPILATION AND SYSTEMIZATION OF INFORMATION INTO COMPUTER DATABASES; DATABASE MANAGEMENT; UPDATING AND MAINTENANCE OF DATA IN COMPUTER DATABASES (U.S. CLS. 100, 101 AND 102).

#### **CLASS 3—COSMETICS AND CLEANING PREPARATIONS**

FOR HAIR CLEANING PREPARATIONS; HAIR CARE AND CLEANING PREPARATIONS; GELS, SPRAYS, MOUSSES AND NON-MEDICATED BALM FOR HAIR STYLING AND HAIR CARE; PREPARATIONS FOR CLEANING, TINTING, COLORING, BLEACHING, SETTING AND STYLING OF HAIR; PREPARATIONS FOR CLEANING THE HAIR; PREPARATIONS FOR THE CLEANING OF THE HAIR (U.S. CLS. 1, 4, 6, 50, 51 AND 52).

#### **CLASS 37—CONSTRUCTION AND REPAIR**

FOR INSTALLATION, MAINTENANCE AND REPAIR OF MACHINES AND PARTS OF MACHINES; INSTALLATION, MAINTENANCE AND REPAIR OF SENSORS; INSTALLATION, MAINTENANCE AND REPAIR OF APPARATUSES, INSTRUMENTS AND EQUIPMENT FOR CAPTURING, TESTING, MONITORING, INTERPRETING AND ANALYSIS OF THE ALIGNMENT OF MACHINES, PARTS OF MACHINES AND SHAFTS (U.S. CLS. 100, 103 AND 106).

#### **CLASS 26—FANCY GOODS**

FOR HAIR COLOURING SHEETS, NAMELY, PAPER, PLASTIC AND CELLULOSE SHEETS FOR USE AS HAIR DRESSING AIDS FOR STYLING AND COLOURING (U.S. CLS. 37, 39, 40, 42 AND 50).

#### **CLASS 42—SCIENTIFIC AND COMPUTER SERVICES**

FOR INDUSTRIAL ANALYSIS AND RESEARCH SERVICES IN THE FIELD OF ENGINEERING; TECHNOLOGICAL ANALYSIS SERVICES IN THE FIELD OF ENGINEERING; QUALITY TESTING OF THE ALIGNMENT OF MACHINES, PARTS OF MACHINES AND SHAFTS; QUALITY CONTROL; MATERIAL TESTING; ENGINEERING SERVICES; TECHNICAL PROJECT STUDIES IN THE FIELD OF ENGINEERING; MEASUREMENT EVALUATIONS IN THE FIELD OF INDUSTRIAL MACHINERY; METROLOGY SERVICES; DESIGN AND DEVELOPMENT OF SOFTWARE FOR INTERPRETATION OF DATA AND MEASUREMENTS FROM AUDIO AND VISUAL SIGNALS; DESIGN AND DEVELOPMENT OF SOFTWARE FOR ANALYSIS OF DATA AND MEASUREMENTS FROM AUDIO AND VISUAL SIGNALS; SURVEYING SERVICES; DEVELOPMENT AND DESIGN OF COMPUTER SOFTWARE; DESIGN OF APPLICATION PROGRAMS FOR DATA PROCESSING APPARATUSES, COMPUTERS, LAPTOPS, TABLET COMPUTERS, TELEPHONES, MOBILE TELEPHONES AND SMARTPHONES; APPLICATION SERVICE PROVIDER SERVICES (ASP), NAMELY HOSTING OF COMPUTER SOFTWARE APPLICATIONS FOR OTHERS; CONSULTING SERVICES IN THE FIELD OF SOFTWARE AS A SERVICE (SAAS); RENTAL OF APPLICATION SOFTWARE; APPLICATION SERVICE PROVIDER (ASP), NAMELY, HOSTING COMPUTER SOFTWARE APPLICATIONS OF OTHERS (U.S. CLS. 100 AND 101).  
MATTHEW GALAN, EXAMINING ATTORNEY

#### **CLASS 44—MEDICAL, BEAUTY AND AGRICULTURAL SERVICES**

FOR HAIRDRESSING SERVICES (U.S. CLS. 100 AND 101).

KATHLEEN LORENZO, EXAMINING ATTORNEY

SN 79-141,709. CESARE REGNOLI & FIGLIO, S.R.L., I-40125 BOLOGNA, ITALY, FILED 6-24-2013.

MEDUSA

THE MARK CONSISTS OF STANDARD CHARACTERS WITHOUT CLAIM TO ANY PARTICULAR FONT, STYLE, SIZE, OR COLOR.

OWNER OF INTERNATIONAL REGISTRATION 1190057 DATED 6-24-2013, EXPIRES 6-24-2023.

**CLASS 29—MEATS AND PROCESSED FOODS**

FOR PREPARED FOODS, NAMELY, PRE-COOKED FISHING INGREDIENTS, NAMELY, SEAFOOD MIXTURES OF MOLLUSKS IN THE NATURE OF CUTTLE-FISH, SQUIDS, MUSSELS, OCTOPUS, CLAMS AND CRUSTACEANS; CARPACCIOS MADE FROM FISH AND OCTOPUS; FILLETS OF MACKERELS, SARDINES AND ANCHOVIES IN OIL AND IN NATURAL JUICE; PRESERVES AND SEMI-PRESERVES OF FISH, NAMELY, TUNA, ANCHOVIES IN OIL, MARINATED EELS AND MIXED FRIED FISH; BOILED, SALTED, SMOKED FISH, MOLLUSKS, AND CRUSTACEANS IN NATURAL JUICE AND IN OIL; PREPARED VEGETABLE MEALS CONSISTING OF GRILLED AND STEAMED VEGETABLES, LEGUMES AND OLIVES IN NATURAL JUICE AND IN OIL; PRECOOKED MEALS CONSISTING PRIMARILY OF FRIED, BLACKENED, GRILLED, BOILED FISH, MOLLUSKS AND CRUSTACEANS AND ALSO WITH VEGETABLES (U.S. CL. 46).

**CLASS 30—STAPLE FOODS**

FOR READY-MADE SAUCES, SALAD DRESSINGS AND SEASONINGS (U.S. CL. 46).

JULIE GUTTADAURO, EXAMINING ATTORNEY

---

SN 79-141,959. SÖKTAS TEKSTİL; SANAYİ VE TİCARET ANONİM ŞİRKETİ, TURKEY, FILED 9-13-2013.



OWNER OF INTERNATIONAL REGISTRATION 1190777 DATED 9-13-2013, EXPIRES 9-13-2023.

OWNER OF U.S. REG. NOS. 3,458,282 AND 4,473,167.

THE COLOR(S) PURPLE AND ORANGE IS/ARE CLAIMED AS A FEATURE OF THE MARK.

THE MARK CONSISTS OF A PURPLE SWIRL DESIGN WITH AN ORANGE STRIPE ON THE CENTER CURVE ABOVE THE WORD "SOKTAS" APPEARING IN PURPLE.

**CLASS 24—FABRICS**

FOR WOVEN AND NON-WOVEN FABRICS FOR THE MANUFACTURE OF CLOTHING, NAMELY, COTTON FABRICS, NYLON FABRICS, POLYESTER FABRICS, WOVEN LINEN FABRICS, HEMP-COTTON MIXED FABRICS, COTTON-NYLON MIXED FABRICS, COTTON-POLYESTER MIXED FABRICS, FIBERGLASS FABRICS FOR TEXTILE USE; YARN DYED SHIRTING FABRICS, PLAIN DYED SHIRTING FABRICS (U.S. CLS. 42 AND 50).

**CLASS 25—CLOTHING**

FOR SHIRTS (U.S. CLS. 22 AND 39).

KELLY TRUSILO, EXAMINING ATTORNEY

SN 79-141,988. ROMANOVA NATALIYA VICTOROVNA, MOSCOW, RUSSIAN FED., FILED 10-3-2013.

# FABRETTI

OWNER OF INTERNATIONAL REGISTRATION 1190837 DATED 10-3-2013, EXPIRES 10-3-2023.

**CLASS 18—LEATHER GOODS**

FOR HANDBAGS; BAGS FOR CAMPERS, NAMELY, HIKING BAGS; TEXTILE SHOPPING BAGS; SCHOOL BAGS; TRAVELLING BAGS; SUITCASES; ATTACHE CASES; LEATHER STRAPS (U.S. CLS. 1, 2, 3, 22 AND 41).

**CLASS 25—CLOTHING**

FOR GLOVES AS CLOTHING; BELTS FOR CLOTHING; SASHES FOR WEAR; SCARVES; COLLAR PROTECTORS; SHAWLS (U.S. CLS. 22 AND 39).

**CLASS 35—ADVERTISING AND BUSINESS**

FOR SALES PROMOTION FOR OTHERS; PROCUREMENT SERVICES FOR OTHERS, NAMELY, PURCHASING BAGS, CLOTHING, CLOTHING ACCESSORIES, HEADWEAR (U.S. CLS. 100, 101 AND 102).

JOANNA FIORELLI, EXAMINING ATTORNEY

---

SN 79-142,014. BREDENT MEDICAL GMBH & CO. KG, 89250 SENDEN, FED REP GERMANY, FILED 7-10-2013.

# HELBO

OWNER OF INTERNATIONAL REGISTRATION 0630359 DATED 12-28-1994, EXPIRES 12-28-2014.

THE WORD "HELBO" HAS NO MEANING IN A FOREIGN LANGUAGE.

**CLASS 9—ELECTRICAL AND SCIENTIFIC APPARATUS**

FOR ELECTRIC AND ELECTRONIC, SURVEYING, WEIGHING, MEASURING, SIGNALING, DISPLAYING, AND CHECKING APPARATUS AND INSTRUMENTS, NAMELY, ELECTRIC AND ELECTRONIC INSTALLATIONS, APPARATUS AND CONTROLS, IN THE NATURE OF ELECTRONIC INTERFACE EQUIPMENT FOR MACHINE TOOLS TO INPUT OR OUTPUT COMPUTER NUMERICAL CONTROL (CNC) AND DIGITAL NUMERICAL CONTROL (DNC) DATA; ELECTRONIC CONTROL COMPUTERS AND ELECTRONIC DISPLAY PANELS FOR SOLAR HEATING INSTALLATION MANAGEMENT; COMPUTERS; COMPUTER TERMINALS; DIGITAL VIDEO RECORD PLAYERS, MICROPROCESSORS; INTEGRATED SWITCHING CIRCUITS; COMPUTER CHIPS AND INTEGRATED CIRCUIT CHIPS FOR COMPUTERS; ELECTRON MICROSCOPES; CENTRAL PROCESSING UNITS (CPUS) FOR CONTROLLING AND/OR MONITORING OF PRODUCTION PROCESSES; COMPUTER-ASSISTED HIGH-VOLTAGE TRANSFORMERS FOR TEST POSITIONS AND MEASUREMENTS; ELECTRIC AND/OR ELECTRONIC DEVICES AND INSTRUMENTS FOR MONITORING, CHECKING, DISPLAYING AND CONTROLLING, NAMELY, COMPUTER-CONTROLLED LASERS FOR MEASURING AND FOR INDUSTRIAL USE; COMPUTER OPERATING SOFTWARE FOR ALL THE AFORESAID GOODS (U.S. CLS. 21, 23, 26, 36 AND 38).

**CLASS 10—MEDICAL APPARATUS**

FOR SURGICAL APPARATUS AND INSTRUMENTS FOR MEDICAL, DENTAL OR VETERINARY USE; BLOOD TESTING APPARATUS; BREAST PUMPS; ANESTHESIA DELIVERY APPARATUS; ANESTHESIA MASKS; APPARATUS FOR ARTIFICIAL RESPIRATION; CARDIAC PACEMAKERS; BLOOD PRESSURE MEASURING APPARATUS; ACOUSTIC PROTECTION APPARATUS, NAMELY, EAR PLUGS FOR NOISE REDUCTION; HEARING AIDS; HOT-AIR VIBRATION DEVICES FOR MEDICAL PURPOSES, NAMELY, ELECTRICALLY-POWERED APPARATUS FOR TREATING SKIN BY APPLYING SONIC HOT-AIR VIBRATIONS TO THE SKIN; IRRADIATION LASERS FOR MEDICAL USE (U.S. CLS. 26, 39 AND 44).

**CLASS 42—SCIENTIFIC AND COMPUTER SERVICES**

FOR TECHNOLOGY CONSULTATION IN THE FIELD OF MANUFACTURING, NAMELY, CONSULTANCY IN THE PLANNING AND DEVELOPMENT OF MANUFACTURING AND INDUSTRIAL PROCESSES USED IN THE MANUFACTURE OF ELECTRIC AND ELECTRONIC INSTALLATIONS AND APPARATUS USED IN THE FIELDS OF HEATING TECHNOLOGY, SOLAR TECHNOLOGY, MEDICAL TECHNOLOGY AND HIGH-VOLTAGE MEASURING TECHNOLOGY, AS WELL AS CONSULTANCY IN THE PLANNING AND DEVELOPMENT OF MANUFACTURING AND INDUSTRIAL PROCESSES USED IN MANUFACTURING SURGICAL, MEDICAL, DENTAL AND VETERINARY APPARATUS; COMPUTER SOFTWARE DESIGN (U.S. CLS. 100 AND 101).

DAVID ELTON, EXAMINING ATTORNEY

**CLASS 35—ADVERTISING AND BUSINESS**

FOR RETAIL STORE SERVICES AND ONLINE RETAIL STORE SERVICES, FEATURING SHOES, CHEMICAL IMPREGNATING PREPARATIONS, LEATHER STRETCH SPRAY, CLEANING CARE PREPARATIONS FOR LEATHER, SUNGLASSES, REAL AND IMITATION JEWELLERY, CLOCKS, ALARM CLOCKS, OFFICE REQUISITES, EXCLUDING FURNITURE, HANDBAGS, LEATHER POUCHES, SHOULDER BAGS, PURSES, WALLETS, TRUNKS AND TRAVELLING BAGS, ALL THE AFORESAID GOODS IN PARTICULAR OF LEATHER OR IMITATIONS OF LEATHER, SHOE CARRIERS AND SHOE BAGS, BELT BAGS, SHOE BLOCKS, NECKERCHIEFS, SHOES, BOOTS, SLIPPERS, SANDALS, ANKLE BOOTS, HIKING SHOES, ESPADRILLES, PLIMSOLLS, RUBBER BOOTS, SOCKS, STOCKINGS, TIGHTS, LEG WARMERS, INNER SOLES, CLOTHING, UNDERWEAR, HEADGEAR, SCARVES, GLOVES, BIKINIS, SWEAT BANDS, HEADBANDS, BELTS, SHOE LACES, HAIR SLIDES, GAMES, TOYS, GYMNASIAC AND SPORTING GOODS, AND DECORATIONS FOR CHRISTMAS TREES (U.S. CLS. 100, 101 AND 102).

DAVID ELTON, EXAMINING ATTORNEY

SN 79-142,100. HÜTTLIN GMBH, FED REP GERMANY, FILED 11-21-2013.

# Hüttlin

SN 79-142,024. LEDER & SCHUH INTERNATIONAL AG, A-8020 GRAZ, AUSTRIA, FILED 10-9-2013.

# VALDASAAR

THE MARK CONSISTS OF STANDARD CHARACTERS WITHOUT CLAIM TO ANY PARTICULAR FONT, STYLE, SIZE, OR COLOR.

OWNER OF INTERNATIONAL REGISTRATION 1100043 DATED 6-7-2011, EXPIRES 6-7-2021.

THE WORD "VALDASAAR" HAS NO MEANING IN A FOREIGN LANGUAGE.

**CLASS 18—LEATHER GOODS**

FOR BAGS, NAMELY, HANDBAGS, LEATHER POUCHES, SHOULDER BAGS, PURSES, POCKET WALLETS, TRUNKS AND TRAVELLING BAGS, ALL THE AFORESAID GOODS IN PARTICULAR OF LEATHER OR IMITATION LEATHER; SHOE BAGS AND SHOE POUCHES FOR TRAVEL (U.S. CLS. 1, 2, 3, 22 AND 41).

**CLASS 25—CLOTHING**

FOR CLOTHING, NAMELY, SHOES, BOOTS, SLIPPERS, SANDALS, HALF-BOOTS, HIKING SHOES, ESPADRILLES, GYMNASIAC SHOES, RUBBER BOOTS, SOCKS, STOCKINGS, TIGHTS, LEG WARMERS, INSOLES (U.S. CLS. 22 AND 39).

THE MARK CONSISTS OF STANDARD CHARACTERS WITHOUT CLAIM TO ANY PARTICULAR FONT, STYLE, SIZE, OR COLOR.

OWNER OF INTERNATIONAL REGISTRATION 1191057 DATED 11-21-2013, EXPIRES 11-21-2023.

THE WORDING "HÜTTLIN" HAS NO MEANING IN A FOREIGN LANGUAGE.

**CLASS 7—MACHINERY**

FOR PACKAGING MACHINES; MACHINES FOR GRANULATION AND COATING OF PHARMACEUTICAL PRODUCTS AND FINE CHEMICALS IN GRANULAR OR POWDER FORM FOR THE CHEMICAL INDUSTRY (U.S. CLS. 13, 19, 21, 23, 31, 34 AND 35).

**CLASS 11—ENVIRONMENTAL CONTROL APPARATUS**

FOR DRYING APPARATUS FOR GOODS IN POWDER OR GRANULAR FORM FOR CHEMICAL PROCESSING (U.S. CLS. 13, 21, 23, 31 AND 34).

**CLASS 42—SCIENTIFIC AND COMPUTER SERVICES**

FOR RESEARCH IN THE FIELD OF MECHANICAL ENGINEERING IN REGARD TO EQUIPMENT AND PLANTS FOR DRYING, GRANULATION AND COATING GOODS IN POWDER OR GRANULAR FORM; DESIGN AND DEVELOPMENT OF EQUIPMENT AND PLANTS FOR DRYING, GRANULATING AND COATING GOODS IN POWDER OR GRANULAR FORM FOR CHEMICAL PROCESSING (U.S. CLS. 100 AND 101).

RAMONA ORTIGA, EXAMINING ATTORNEY



SN 79-142,134. SIEMENS AKTIENGESELLSCHAFT, FED REP GERMANY, FILED 10-21-2013.

# CYPT

THE MARK CONSISTS OF STANDARD CHARACTERS WITHOUT CLAIM TO ANY PARTICULAR FONT, STYLE, SIZE, OR COLOR.

PRIORITY DATE OF 8-8-2013 IS CLAIMED.  
OWNER OF INTERNATIONAL REGISTRATION 1191165 DATED 10-21-2013, EXPIRES 10-21-2023.

## CLASS 9—ELECTRICAL AND SCIENTIFIC APPARATUS

FOR COMPUTER HARDWARE AND COMPUTER SOFTWARE FOR COMPILATION, ANALYSIS, PRESENTATION, AND SIMULATION OF DATA RELATING TO URBAN AND REGIONAL TRANSPORTATION, DEVELOPMENT AND CONSTRUCTION PROJECTS FOR PLANNING PROJECTS AND FOR ANALYZING THE IMPACT AND INFLUENCE OF PROJECTS IN THE CONTEXT OF URBAN AND REGIONAL PLANNING; DATA PROCESSING COMPUTER HARDWARE AND COMPUTER PERIPHERAL DEVICES THEREFOR (U.S. CLS. 21, 23, 26, 36 AND 38).

## CLASS 42—SCIENTIFIC AND COMPUTER SERVICES

FOR SCIENTIFIC AND TECHNOLOGICAL SERVICES AND RESEARCH AND DESIGN RELATING THERETO, NAMELY, RESEARCH AND DESIGN IN THE FIELD OF COMPUTER HARDWARE AND COMPUTER SOFTWARE FOR URBAN AND REGIONAL PLANNING AND ANALYSIS OF THE IMPACT OF URBAN AND REGIONAL CONSTRUCTION, DEVELOPMENT AND TRANSPORTATION PROJECTS; INDUSTRIAL RESEARCH SERVICES, NAMELY, INDUSTRIAL ANALYSIS AND RESEARCH SERVICES IN THE FIELD OF URBAN AND REGIONAL PLANNING; CONSTRUCTION AND URBAN AND REGIONAL DESIGN PLANNING AND CONSULTANCY; DESIGN AND DEVELOPMENT OF COMPUTER HARDWARE AND SOFTWARE; ENGINEERING CONSULTANCY SERVICES; COMPUTER PROJECT MANAGEMENT SERVICES, NAMELY, TECHNICAL PROJECT MANAGEMENT IN THE FIELD OF ELECTRONIC DATA PROCESSING TECHNOLOGY, IN PARTICULAR IN THE FIELD TECHNOLOGY FOR THE REPRESENTATION, SIMULATION AND ANALYSIS OF CONSTRUCTION PROJECTS AND THE INFLUENCE THEREOF IN THE CONTEXT OF TOWN PLANNING AND COUNTRY PLANNING; COMPUTER PROGRAMMING; MAINTENANCE AND INSTALLATION OF SOFTWARE (U.S. CLS. 100 AND 101).

NATALIE POLZER, EXAMINING ATTORNEY

SN 79-142,252. CIFA S.P.A., ITALY, FILED 11-18-2013.

# Smartronic

OWNER OF INTERNATIONAL REGISTRATION 1191471 DATED 11-18-2013, EXPIRES 11-18-2023.

OWNER OF U.S. REG. NO. 3,594,977.

CONSISTING IN THE FANCY WORDING "SMARTRONIC" IN FANCY CHARACTERS, WHOSE LETTER "O" IS COMPOSED OF TWO CONCENTRIC CIRCLES OF WHICH THE OUTER ONE IS INTERRUPTED IN TWO DIAMETRICALLY OPPOSED PORTIONS, THE SAME CROSSED BY TWO OPPOSING CURVES EMERGING FROM THE INNER CIRCLE AND LINKED UP WITH THE SAME.

## CLASS 7—MACHINERY

FOR CONCRETE MIXERS; CONCRETE PLANTS; STATIONARY PUMPS FOR PUMPING CONCRETE; MIXERS IN THE NATURE OF MIXING MACHINES, CONCRETE MIXERS, GRINDERS, MILLS IN THE NATURE OF MILLING MACHINES, TRUCK MILLS, PUMPS IN THE NATURE OF PUMPS FOR MACHINES, COMPRESSED AIR PUMPS, MACHINES FOR SPRAYING CONCRETE IN THE NATURE OF COMPRESSORS FOR MACHINES, GAS COMPRESSORS, AIR COMPRESSORS, TUBES IN THE NATURE OF PNEUMATIC TUBE CONVEYORS, VALVES IN THE NATURE OF PUMP CONTROL VALVES, VALVES FOR PUMPS, VALVES BEING PARTS OF MACHINES, HEAT EXCHANGERS BEING PARTS OF MACHINES; HEAT EXCHANGERS BEING PARTS OF ENGINES NOT FOR LAND VEHICLES; TRUCK-MOUNTED CONCRETE PUMPS AND CONVEYORS WITH ARTICULATED ROBOTIC ARMS AND CONCRETE PLACING BOOM; ELECTRONIC CONTROL SYSTEMS FOR THE ABOVE SAID PLANTS, PUMPS AND CONVEYORS WITH ARTICULATED ROBOTIC ARMS, SOLD TOGETHER AS A UNIT WITH THE AFOREMENTIONED GOODS (U.S. CLS. 13, 19, 21, 23, 31, 34 AND 35).

## CLASS 12—VEHICLES

FOR TRUCK-MOUNTED CONCRETE MIXERS, TRUCK-MOUNTED CONCRETE PUMPS AND THEIR RELEVANT ELECTRONIC CONTROL SYSTEMS SPECIALLY ADAPTED FOR FITTING ON CONCRETE MIXING TRUCKS, SOLD TOGETHER AS A UNIT WITH THE AFOREMENTIONED GOODS (U.S. CLS. 19, 21, 23, 31, 35 AND 44).

ALISON POLLACK, EXAMINING ATTORNEY

SN 79-142,355. SIEMENS MEDICAL INSTRUMENTS PTE. LTD., SINGAPORE, FILED 12-6-2013.

# EASYPOCKET

THE MARK CONSISTS OF STANDARD CHARACTERS WITHOUT CLAIM TO ANY PARTICULAR FONT, STYLE, SIZE, OR COLOR.

OWNER OF INTERNATIONAL REGISTRATION 1191669 DATED 12-6-2013, EXPIRES 12-6-2023.

## CLASS 9—ELECTRICAL AND SCIENTIFIC APPARATUS

FOR ELECTRIC AND ELECTRONIC APPARATUS AND INSTRUMENTS FOR THE RECEPTION, FOR RECORDING, FOR AMPLIFICATION, FOR STORAGE, FOR PROCESSING AND REPRODUCTION OF SIGNALS, DATA, IMAGES AND SOUND, NAMELY, ELECTRIC AND ELECTRONIC APPARATUS FOR THE REMOTE CONTROL OF HEARING AIDS (U.S. CLS. 21, 23, 26, 36 AND 38).

## CLASS 10—MEDICAL APPARATUS

FOR MEDICAL HEARING AIDS AND PARTS THEREOF (U.S. CLS. 26, 39 AND 44).

WILLIAM JACKSON, EXAMINING ATTORNEY

SN 79-142,495. ARTIGO S.P.A., ITALY, FILED 11-7-2013.

# ARTIGO

THE MARK CONSISTS OF STANDARD CHARACTERS WITHOUT CLAIM TO ANY PARTICULAR FONT, STYLE, SIZE, OR COLOR.

PRIORITY DATE OF 10-30-2013 IS CLAIMED.

OWNER OF INTERNATIONAL REGISTRATION 1192008 DATED 11-7-2013, EXPIRES 11-7-2023.

## CLASS 19—NON-METALLIC BUILDING MATERIALS

FOR WOOD PAVING, PARQUET FLOORING, CERAMIC TILES FOR FLOORING, RUBBER AND WOOD FLOOR TILES, VINYL FLOOR COVERINGS FOR FORMING A FLOOR, WOOD PANELING FOR THE INSTALLATION OF FLOORS (U.S. CLS. 1, 12, 33 AND 50).

## CLASS 27—FLOOR COVERINGS

FOR FLOOR COVERINGS, VINYL FLOOR COVERINGS, FLOOR COVERINGS OF RUBBER, ANTI-SLIP MATERIAL FOR USE UNDER FLOOR COVERINGS, FLOOR MATS, RUGS, CARPETS, LINOLEUM (U.S. CLS. 19, 20, 37, 42 AND 50).

REBECCA POVARCHUK, EXAMINING ATTORNEY

SN 79-142,553. FERRARI S.P.A., ITALY, FILED 11-27-2012.



## *Corse Clienti*

PRIORITY DATE OF 6-12-2012 IS CLAIMED.

OWNER OF INTERNATIONAL REGISTRATION 1192206 DATED 11-27-2012, EXPIRES 11-27-2022.

OWNER OF U.S. REG. NOS. 2,585,555, 4,434,485 AND OTHERS.

THE MARK CONSISTS OF THE WORDING "CORSE CLIENTI" IN FANCY PROFILED CHARACTERS SLIGHTLY INCLINED TOWARDS THE RIGHT, SAID WORDING BEING UNDERLINED BY A HORIZONTAL SEGMENT AND FLANKED ON THE LEFT BY A FIGURE SHAPED LIKE A SHIELD SURMOUNTED BY THREE HORIZONTAL BANDS OF DIFFERENT SIZES PLACED ONE ABOVE THE OTHER, INTERRUPTED AT THE CENTRE AND SLOPING, THIS FIGURE CONTAINING IN THE CENTRE A STRONGLY STYLIZED RAMPANT HORSE FACING LEFT AND THE LETTER "S" AND "F" IN FANCY CHARACTERS UNDERNEATH.

THE ENGLISH TRANSLATION OF THE FOREIGN WORD(S) IN THE MARK IS: "CORSE CLIENTI" MEANS "CUSTOMER RACES".

## CLASS 16—PAPER GOODS AND PRINTED MATTER

FOR BROCHURES, CALENDARS, CATALOGUES, MAGAZINES, YEARBOOKS, BOOKS, BOOKLETS, PAMPHLETS, LEAFLETS, MANUALS, DIRECTORIES, NEWSLETTERS, AND PRINTED GUIDES ALL ON THE SUBJECTS OF AUTOMOBILES, SPORT AUTOMOBILES, AUTOMOBILE RACES AND AUTOMOBILE COMPETITIONS AND ON THE SUBJECTS OF MOTOR AND AUTOMOTIVE NEWS, SPORTS, ENTERTAINMENT AND SAFE DRIVING SCHOOLS; BROCHURES, LEAFLETS, BOOKLETS, CATALOGUES, AND GUIDES ALL FEATURING INFORMATION ABOUT AUTOMOBILES AND AUTOMOTIVE PRODUCTS; POSTERS; GRAPHIC REPRESENTATIONS; GRAPHIC REPRODUCTIONS; PHOTOGRAPHS; WRAPPING PAPER; WRITING PAPER; BOXES OF CARDBOARD OR PAPER; CARDBOARD CONTAINERS; COIN ALBUMS; PHOTOGRAPHIC ALBUMS; STICKERS, BEING STATIONERY; ALBUMS FOR STICKERS; PHOTO HOLDERS MADE OF PAPER; SCRAPBOOKS; BOOKMARKERS; FOUNTAIN PENS; BALLPOINT PENS; ROLLER TIP PENS; WRITING PENS; PENCILS; BOXES FOR PENS; BOXES FOR PENCILS; PEN TOPPERS; PENCIL TOPPERS; PEN CASES; PENCIL CASES; PENHOLDERS; PENCIL HOLDERS; STANDS FOR PENS; STANDS FOR PENCILS; DOCUMENT COVERS, BEING STATIONERY; BOOK COVERS; EXERCISE BOOK COVERS; DOCUMENT FILES, BEING STATIONERY; DESK PADS; DESK TOP ORGANIZERS; EXERCISE BOOKS; NOTEBOOKS; CUBE-SHAPED NOTEBOOKS; NOTE PADS; PAPER SHEETS FOR NOTE TAKING; DIARIES; NON-ELECTRONIC AGENDAS; WEEKLY PLANNERS, BEING STATIONERY; COVERS FOR AGENDAS; COVERS FOR WEEKLY PLANNERS; COVERS FOR ADDRESS BOOKLETS; COVERS FOR ALBUMS; FOLDERS FOR PAPERS, CARDS AND DOCUMENTS; ADHESIVE LABELS; PAPERWEIGHTS; PENCIL SHARPENERS, ELECTRIC OR NON-ELECTRIC; DRAWING BOOKS; ADHESIVE BANDS FOR STATIONERY OR HOUSEHOLD PURPOSES; ADHESIVE TAPE DISPENSERS, BEING OFFICE REQUISITES; ADHESIVE TAPES FOR STATIONERY OR HOUSEHOLD PURPOSES; PAPER CUTTERS, BEING OFFICE REQUISITES; RUBBER ERASERS; ERASERS; CORRESPONDENCE HOLDERS; PLASTIC SHOPPING BAGS; PAPER SHOPPING BAGS; PLASTIC OR PAPER BAGS FOR MERCHANDISE PACKAGING, BEING ENVELOPES AND POUCHES; PLACARDS OF PAPER OR CARDBOARD; PAPER BANNERS; FLAGS OF PAPER; PENNANTS MADE OF PAPER; PENNONS MADE OF PAPER; PASSENGER TICKETS MADE OF PAPER; PAPER TICKET HOLDERS; TICKETS, NAMELY, ENTRY TICKETS, PASSENGER TICKETS, AND PRICE TICKETS; NON-MAGNETICALLY ENCODED PASSES OR IDENTIFICATION CARDS MADE OF PAPER FOR ACCESS TO A RESTRICTED AREA; DECALCOMANIAS; IRON-ON TRANSFERS BEING DECALCOMANIAS; PLASTIC TRANSFERS BEING DECALCOMANIAS; COMMEMORATIVE STAMPS; STAMPS FOR COLLECTORS; LANYARDS FOR CARRYING PAPER CARDS, PAPER BADGES AND PAPER PASSES (U.S. CLS. 2, 5, 22, 23, 29, 37, 38 AND 50).

## CLASS 25—CLOTHING

FOR JACKETS, BEING CLOTHING; SLEEVED OR SLEEVELESS JACKETS; BOMBER JACKETS; REVERSIBLE JACKETS; RAIN JACKETS; LEATHER JACKETS; PADDED JACKETS; WIND-RESISTANT JACKETS; WATERPROOF JACKETS; STUFF JACKETS, BEING CLOTHING; DOWN JACKETS; SPORTS JACKETS; SKI JACKETS; WAISTCOATS; WINDCHEATERS; OVERCOATS; COATS; RAINCOATS; ANORAKS; CARDIGANS; PULLOVERS; SHIRTS; T-SHIRTS; POLO SHIRTS; BLOUSES; SWEATSHIRTS; SWEAT PANTS; SWEATERS; JUMPERS; JERSEYS, BEING CLOTHING; SPORTS JERSEYS; TROUSERS; SHORTS; BERMUDA SHORTS; JEANS; SKIRTS; OVERALLS; JOGGING SUITS; JOGGING SUIT TROUSERS; TRAINING SUITS; TRACK SUITS; AUTOMOBILE RACING SUITS NOT IN THE

NATURE OF PROTECTIVE CLOTHING; SUITS; DRESSES; SINGLET; BRACES, BEING SUSPENDERS; WRISTBANDS, BEING CLOTHING; BATHING SUITS; SWIMMING COSTUMES; BATHING DRAWERS; BATHING TRUNKS; BIKINI; BATH ROBES; UNDERWEAR; PAJAMAS; BABIES' OVERALLS; INFANTS' TRAINING OUTFITS; RACING ROMPER SUITS FOR BABIES; ROMPERS; LAYETTES, BEING CLOTHING; BIBS, NOT OF PAPER; SOCKS; FOOTWEAR; NECKWEAR; GLOVES, BEING CLOTHING; DRIVING GLOVES; BELTS, BEING CLOTHING; CAPS; HEADWEAR (U.S. CLS. 22 AND 39).

#### CLASS 41—EDUCATION AND ENTERTAINMENT

FOR ORGANIZATION OF EXHIBITIONS FOR CULTURAL OR EDUCATIONAL PURPOSES; ORGANIZATION OF SPORTS COMPETITIONS; ARRANGING AND CONDUCTING OF CONFERENCES, CONGRESSES, COLLOQUIUMS, WORKSHOPS, BEING TRAINING, SEMINARS AND SYMPOSIUMS IN THE FIELD OF SELF-AWARENESS AND ART APPRECIATION; SPORTS TRAINING SERVICES IN THE NATURE OF INSTRUCTION IN DRIVING AUTOMOBILES, SPORT AUTOMOBILES AND RACING AUTOMOBILES; ARRANGING AND CONDUCTING SPECIAL EVENTS FOR SOCIAL ENTERTAINMENT PURPOSES; ORGANIZING RECREATIONAL EVENTS IN THE FORM OF COMPETITIONS AND MEETINGS FOR AMATEURS AND COLLECTORS OF AUTOMOBILES; ENTERTAINMENT IN THE NATURE OF AUTOMOBILE RACES; FAN CLUBS IN THE NATURE OF ENTERTAINMENT; CLUB SERVICES FOR ENTHUSIASTS OF AUTOMOBILES AND FOR OWNERS OF AUTOMOBILES; MUSEUM SERVICES, NAMELY, EXHIBITING TO THE PUBLIC A HISTORICAL SITE; PROVIDING INFORMATION RELATING TO SPORTS AND SPORTING EVENTS (U.S. CLS. 100, 101 AND 107).

CAROL SPILS, EXAMINING ATTORNEY

SN 79-142,668. KURTZ BESITZ GMBH & CO. KG, KREUZ-WERTHEIM, FED REP GERMANY, FILED 5-8-2013.



OWNER OF INTERNATIONAL REGISTRATION 1192377 DATED 5-8-2013, EXPIRES 5-8-2023.

THE COLOR(S) BLUE AND LIGHT BLUE IS/ARE CLAIMED AS A FEATURE OF THE MARK.

THE MARK CONSISTS OF TWO CHECK MARKS WITH THE CHECK MARK ON THE LEFT BEING INVERTED AND IN DARK BLUE. THE CHECK MARK ON THE RIGHT IS LIGHT BLUE.

#### CLASS 7—MACHINERY

FOR MACHINES FOR PLASTICS WORKING; MACHINES FOR PLASTICS PROCESSING INDUSTRY, IN PARTICULAR FOR THE PRODUCTION OF BLOCKS, PLATES, BLANKS AND MOLDINGS OF EXPANDABLE PLASTICS; FOUNDRY MACHINERY INCLUSIVE OF MOLDING TOOLS IN THE FORM OF MACHINE PARTS AND MACHINES FOR THE RECOVERY AND REUSE OF PLASTICS AND METALS, IN PARTICULAR CUTTING, IMPACTING AND GRINDING MACHINES AND MILLS AND EXTRUDER SYSTEMS, WITH THE EXCEPTION OF MACHINES AND DEVICES FOR THE APPLICATION OF EMBOSSING AND LAMINATING FOILS, TRANSFER FOILS, IN PARTICULAR EMBOSSING AND LAMINATING FOILS; SOLDERING STATIONS FOR

USE IN INDUSTRY, PARTICULARLY FOR PRINTED CIRCUIT BOARDS; MACHINES AND DEVICES FOR THE APPLICATION OF LOW-VISCOSITY UP TO HIGH VISCOSITY LIQUID MEDIA AND MATERIALS, IN PARTICULAR SOLDER PASTES, FLUXING AGENTS, ADHESIVES, PAINTS, ORGANIC AND SYNTHETIC PASTES, AS WELL AS SILICON; ELECTRIC SOLDERING MACHINES, ELECTRIC SOLDERING APPARATUS, ELECTRIC SOLDERING DEVICES AND SOLDERING INSTRUMENTS AND SYSTEMS COMPOSED THEREOF; GAS-DRIVEN SOLDERING STATIONS; ELECTRIC WAVE SOLDERING MACHINES AND SYSTEMS COMPOSED THEREOF, PROTECTIVE GAS SOLDERING MACHINES AND SYSTEMS COMPOSED THEREOF; OVERFLOW AND REFLOW ELECTRIC SOLDERING MACHINES AND SYSTEMS COMPOSED THEREOF; SELECTIVE SOLDERING SYSTEMS FOR USE IN INDUSTRY, PARTICULARLY FOR PRINTED CIRCUIT BOARDS; DIGITAL PRINTING MACHINES, STENCIL PRINTING MACHINES; MANUAL SOLDERING TOOLS AND PARTS OF MANUAL SOLDERING TOOLS, NAMELY, SOLDERING IRONS, SOLDERING TIPS AND HEATING ELEMENTS; ELECTRIC SOLDERING IRONS; SOLDERING PUMPS FOR USE IN INDUSTRY FOR REWORK OF CONTROL CIRCUIT BOARDS; CASTING MACHINES; TRIMMING GAS-HEATED SOLDERING IRONS; MACHINES FOR THE CUTTING AND FORMING OF MATERIALS; HOLDERS FOR GAS-HEATED SOLDERING IRONS; ELECTRIC SOLDERING AND DESOLDERING DEVICES; ELECTRIC SOLDERING IRONS, IN PARTICULAR LOW-VOLTAGE IRONS; ELECTRIC SOLDERING GUNS MACHINES FOR PLASTICS WORKING; MACHINES FOR PLASTICS PROCESSING INDUSTRY, IN PARTICULAR FOR THE PRODUCTION OF BLOCKS, PLATES, BLANKS AND MOLDINGS OF EXPANDABLE PLASTICS, FOUNDRY MACHINERY INCLUSIVE OF MOLDING TOOLS IN THE FORM OF MACHINE PARTS AND MACHINES FOR THE RECOVERY AND REUSE OF PLASTICS AND METALS, IN PARTICULAR CUTTING, IMPACTING AND GRINDING MACHINES AND MILLS AND EXTRUDER SYSTEMS, WITH THE EXCEPTION OF MACHINES AND DEVICES FOR THE APPLICATION OF EMBOSSING AND LAMINATING FOILS, TRANSFER FOILS, IN PARTICULAR EMBOSSING AND LAMINATING FOILS; SOLDERING STATIONS FOR USE IN INDUSTRY, PARTICULARLY FOR PRINTED CIRCUIT BOARDS; MACHINES AND DEVICES FOR THE APPLICATION OF LOW-VISCOSITY UP TO HIGH VISCOSITY LIQUID MEDIA AND MATERIALS, IN PARTICULAR SOLDER PASTES, FLUXING AGENTS, ADHESIVES, PAINTS, ORGANIC AND SYNTHETIC PASTES, AS WELL AS SILICON; ELECTRIC SOLDERING MACHINES, ELECTRIC SOLDERING APPARATUS, ELECTRIC SOLDERING DEVICES AND SOLDERING INSTRUMENTS AND SYSTEMS COMPOSED THEREOF; GAS-DRIVEN SOLDERING STATIONS; ELECTRIC WAVE SOLDERING MACHINES AND SYSTEMS COMPOSED THEREOF; PROTECTIVE GAS SOLDERING MACHINES AND SYSTEMS COMPOSED THEREOF; OVERFLOW AND REFLOW ELECTRIC SOLDERING MACHINES AND SYSTEMS COMPOSED THEREOF; SELECTIVE SOLDERING SYSTEMS FOR USE IN INDUSTRY, PARTICULARLY FOR PRINTED CIRCUIT BOARDS; DIGITAL PRINTING MACHINES, STENCIL PRINTING MACHINES; MANUAL SOLDERING TOOLS AND PARTS OF MANUAL SOLDERING TOOLS, NAMELY, SOLDERING IRONS, SOLDERING TIPS AND HEATING ELEMENTS; ELECTRIC SOLDERING IRONS; SOLDERING PUMPS FOR USE IN INDUSTRY FOR REWORK OF CONTROL CIRCUIT BOARDS; CASTING MACHINES; TRIMMING GAS-HEATED SOLDERING IRONS; MACHINES FOR THE CUTTING AND FORMING OF MATERIALS; HOLDERS FOR GAS-HEATED SOLDERING IRONS; ELECTRIC SOLDERING AND DESOLDERING DEVICES; ELECTRIC SOLDERING IRONS, IN PARTICULAR LOW-VOLTAGE IRONS; ELECTRIC SOLDERING GUNS (U.S. CLS. 13, 19, 21, 23, 31, 34 AND 35).

**CLASS 9—ELECTRICAL AND SCIENTIFIC APPARATUS**

FOR MEASURING AND TESTING DEVICES, NAMELY, OPTICAL, ELECTRONIC AND OPTO-ELECTRONIC INSTRUMENTS, MEASURING DEVICES AND CONTROL APPARATUSES, PARTICULARLY TECHNICAL MICROSCOPES AND RIGID AND FLEXIBLE NON-MEDICAL ENDOSCOPES FOR CAVITY AND GAP INSPECTION; OBJECTIVE LENSES, OCULAR LENSES AND OPTICAL COMPONENTS FOR TECHNICAL MICROSCOPES AND RIGID AND FLEXIBLE NON-MEDICAL ENDOSCOPES; ELECTRIC COMPUTERIZED SOLDERING DOCKING STATIONS; ELECTRIC LEAD FREE SOLDERING MACHINES; ELECTRIC LEAD FREE SOLDERING PUMPS; SOLDERING ACCESSORIES, NAMELY, COPPER TIPS FOR LEAD FREE SOLDERING IRONS; AND ASSOCIATED TRANSFORMERS, IN PARTICULAR REGULATING TRANSFORMERS; ELECTRICALLY HEATED TOOLS FOR PLASTICS MACHINING AND PROCESSING, NAMELY, WELDING AND SEPARATING TOOLS FOR PLASTIC MATERIALS; HOLDERS FOR ELECTRIC SOLDERING IRONS; CRUCIBLES WHICH ARE ELECTRICALLY HEATED AND IN WHICH TIN IS MELTED (U.S. CLS. 21, 23, 26, 36 AND 38).

**CLASS 11—ENVIRONMENTAL CONTROL APPARATUS**

FOR ELECTRIC HEATING RADIATORS FOR USE WITH SOLDERING IRONS; ELECTRONIC HEATING DEVICES, NAMELY, ELECTRICAL TIN BATHS AND ELECTRICAL MELTING POTS (U.S. CLS. 13, 21, 23, 31 AND 34).

**CLASS 37—CONSTRUCTION AND REPAIR**

FOR CONSTRUCTION OF FOUNDRIES AND FOUNDRY INSTALLATIONS FOR HOUSING MACHINES FOR WORKING METAL MATERIALS, AND COMPANY PLANTS AND INSTALLATIONS FOR HOUSING MACHINES FOR RECYCLING AND REPROCESSING OF PLASTIC MATERIALS AND METALS (U.S. CLS. 100, 103 AND 106).

**CLASS 40—MATERIAL TREATMENT**

FOR FOUNDRY SERVICES, IN PARTICULAR CASTING OF FERROUS AND NON-FERROUS METALS AS HANDMADE OR MACHINE-MADE CASTINGS; HEAT TREATMENT OF METALS AND METAL PARTS; STENCIL PRINTING WORKS; RENTAL OF MACHINE TOOLS (U.S. CLS. 100, 103 AND 106).

**CLASS 42—SCIENTIFIC AND COMPUTER SERVICES**

FOR ARCHITECTURAL SERVICES AND ENGINEERING SERVICES IN THE FIELDS OF FOUNDRY ENGINEERING AND THE PROCESSING OF PLASTICS AND THE RECYCLING OF PLASTIC MATERIAL AND METALS; ENGINEERING SERVICES, PARTICULARLY, TECHNICAL PLANNING OF FOUNDRIES AND FOUNDRY INSTALLATIONS, MACHINES FOR WORKING PLASTIC MATERIALS, COMPANY INSTALLATIONS AND MACHINES FOR RECYCLING AND REPROCESSING OF PLASTIC MATERIALS AND METALS; RENTAL OF ELECTRONIC DATA PROCESSING EQUIPMENT (U.S. CLS. 100 AND 101).

MARK T. MULLEN, EXAMINING ATTORNEY

**CLASS 31—NATURAL AGRICULTURAL PRODUCTS**

FOR FRESH ALMONDS; FRESH PEANUTS; FRESH FRUITS AND VEGETABLES; AGRICULTURAL PRODUCE, NEITHER PREPARED NOR PROCESSED, NAMELY FRESH VEGETABLES SUCH AS CARROT, RADISH, CUCUMBER, CELERY, MELON, TOMATO, BEANS, SALAD, BEET, ZUCCHINI, EGGPLANT AND FRESH FRUITS SUCH AS BANANA, APPLE, PEACH, CHERRY, APRICOT, GRAPE, STRAWBERRY, RASPBERRY, PEAR, WATERMELON; NATURAL PLANTS AND FLOWERS (U.S. CLS. 1 AND 46).

**CLASS 32—LIGHT BEVERAGES**

FOR BEERS; MINERAL AND AERATED WATERS AND OTHER NON-ALCOHOLIC BEVERAGES, NAMELY, NON-ALCOHOLIC FRUIT JUICE BEVERAGES; BEVERAGES BASED ON FRUIT AND FRUIT JUICES; MIXED FRUIT OR VEGETABLE BEVERAGES, NAMELY, SMOOTHIES; SYRUPS AND OTHER PREPARATIONS FOR MAKING BEVERAGES, NAMELY, SCENTED WATER FOR MAKING BEVERAGES (U.S. CLS. 45, 46 AND 48).

COLLEEN MULCRONE, EXAMINING ATTORNEY

SN 79-142,824. YOOX S.P.A., ZOLA PREDOSA (BO), ITALY, FILED 10-11-2013.

**George J. Love**

SN 79-142,743. DAUNAT, FRANCE, FILED 8-12-2013.

**DAUNATURE**

PRIORITY DATE OF 2-13-2013 IS CLAIMED.  
OWNER OF INTERNATIONAL REGISTRATION 1192571 DATED 8-12-2013, EXPIRES 8-12-2023.

THE MARK CONSISTS OF STANDARD CHARACTERS WITHOUT CLAIM TO ANY PARTICULAR FONT, STYLE, SIZE, OR COLOR.

PRIORITY DATE OF 7-9-2013 IS CLAIMED.  
OWNER OF INTERNATIONAL REGISTRATION 1192786 DATED 10-11-2013, EXPIRES 10-11-2023.

THE NAME(S), PORTRAIT(S), AND/OR SIGNATURE(S) SHOWN IN THE MARK DOES NOT IDENTIFY A PARTICULAR LIVING INDIVIDUAL.

**CLASS 18—LEATHER GOODS**

FOR LEATHER AND IMITATIONS OF LEATHER, GOODS MADE OF THESE MATERIALS AND NOT INCLUDED IN OTHER CLASSES, NAMELY, POUCHES, LUGGAGE, LUGGAGE TAGS, WHEELED BAGS, CARRYALLS, ALL-PURPOSE CARRYING BAGS, ALL-PURPOSE ATHLETIC BAGS, SHOPPING BAGS, MONEY PURSES, CHANGE PURSES, BRIEFCASE-TYPE PORTFOLIOS, ATTACHÉ CASES, HANDBAGS, SHOULDER BAGS, POCHETTES, CLUTCH BAGS, DRAWSTRING BAGS, BACKPACKS, KNAPSACKS, COSMETIC AND TOILETRY CASES SOLD EMPTY; ARTICLES FOR PETS INCLUDED IN THIS CLASS, NAMELY, CLOTHING FOR PETS, ANIMAL CARRIER BAGS, BACKPACKS FOR PETS, COLLARS, PET HAIR ORNAMENTS, PET TAGS SPECIALLY ADAPTED FOR ATTACHING TO PET LEASHES OR COLLARS, PET COLLAR ACCESSORIES, NAMELY, BOWS, CHARMS, BELLS, SILENCERS, SAFETY LIGHTS AND BLINKERS AND PENDANTS; ANIMAL SKINS, TRUNKS, TRAVELING TRUNKS AND TRAVELING BAGS; UMBRELLAS AND PARASOLS; WALKING STICKS; WHIPS AND SADDLERY; UMBRELLA RINGS; SADDLE TREES; SADDLERY; KEY CASES; FASTENINGS FOR SADDLES; BANDOLIERS MADE OF LEATHER; HARNESES; MOUNTAINEERING STICKS; UMBRELLA STICKS, NAMELY, UMBRELLAS; VANITY CASES SOLD EMPTY; BAGS, NAMELY, CARRYALLS, ALL-PURPOSE CARRYING BAGS, ALL-PURPOSE ATHLETIC BAGS, CANVAS, LEATHER, MESH, REUSABLE, AND TEXTILE SHOPPING BAGS; SLING BAGS FOR CARRYING INFANTS; BAGS FOR SPORTS; CHAIN MESH PURSES; TOOL BAGS MADE OF LEATHER, SOLD EMPTY; PURSES; HANDBAGS; BRIDLES; BRIDDOONS; GUT FOR MAKING SAUSAGE CASINGS; BANDOLIERS; KID, NAMELY, KID LEATHER; HUNTERS' ACCESSORIES, NAMELY, GAME BAGS; SATCHELS, TEXTILE POUCHES; SCHOOL BAGS; CASES MADE OF LEATHER OR LEATHERBOARD; HORSE HALTERS; LEATHER STRAPS; COLLARS FOR ANIMALS; HORSE COLLARS; COVERS MADE OF SKINS, NAMELY, HORSE BLANKETS; COVERS FOR HORSES; LEATHER LACES; UMBRELLA CASES; LEATHER LEASHES; POUCHES MADE OF LEATHER, IMITATION LEATHER OR TEXTILE; POUCHES FOR CARRYING BABIES; MUZZLES; PARASOLS; ANIMAL SKINS; CREDIT CARD HOLDERS, BUSINESS CARD HOLDERS IN THE NATURE OF WALLETS AND CARD CASES; WALLETS; SHEET MUSIC WALLETS; REINS; NET BAGS FOR SHOPPING; NOSE BAGS FOR HORSES; BAGS MADE OF LEATHER FOR PACKING; SPORTS BAGS, NAMELY, BAGS FOR CAMPERS AND BAGS MADE FOR CLIMBERS; BEACH BAGS; TRAVEL BAGS; SHOULDER BAGS, NAMELY, ROULETTE BAGS; BOXES MADE OF LEATHER OR LEATHERBOARD; BOXES OF VULCANISED FIBRE; HAT BOXES OF LEATHER; SUITCASES; BRIEFCASES; ATTACHE CASES; GARMENT BAGS FOR TRAVEL; RUCKSACKS (U.S. CLS. 1, 2, 3, 22 AND 41).

**CLASS 25—CLOTHING**

FOR CLOTHING, NAMELY, ATHLETIC SHORTS, BANDANAS, BATHING TRUNKS, BATH ROBES, BEACH COVER-UPS, BELTS, BERMUDA SHORTS, BIKINIS, BLAZERS, BLOUSES, BOAS, BOXER SHORTS, CAPTANS, CAPES, CLOAKS, COATS, DRESSES, DRESSING GOWNS, FOULARDS, GLOVES, JACKETS, JUMPERS, LEG WARMERS, LEOTARDS, LINGERIE, MANTLES, MUFFS, NIGHT GOWNS, OVERALLS, OVERCOATS, PAJAMAS, PANTYHOSE, PAREOS, PETTICOATS, PONCHOS, PULLOVERS, SARONGS, SCARVES, SHAWLS AND STOLEES, SHIRTS, SHORTS, SHRUGS, SINGLETS, SKIRTS, SLIPS, SOCK SUSPENDERS, SOCKS, SUITS, SWEATERS, SWEATSHIRTS, SWEAT SUITS, SWIMSUITS, T-SHIRTS, TAILLEURS, TANK TOPS, TIES, TIGHTS, TOPS, TROUSERS, UNDERPANTS, UNDERWEAR, VESTS, WAISTCOATS, WRAPS; FOOTWEAR; HEADWEAR; ACCESSORIES OF CLOTHING OF ANY KIND AND STYLE INCLUDED IN THIS CLASS, NAMELY, SUSPENDERS, NECKTIES, COLLARS, COLLAR PROTECTORS, DETACHABLE COLLARS (U.S. CLS. 22 AND 39).

JENNIFER RICHARDSON, EXAMINING ATTORNEY

SN 79-142,927. GLOBAL CARBON CAPTURE AND STORAGE INSTITUTE LTD, CANBERRA, AUSTRALIA, FILED 5-29-2013.

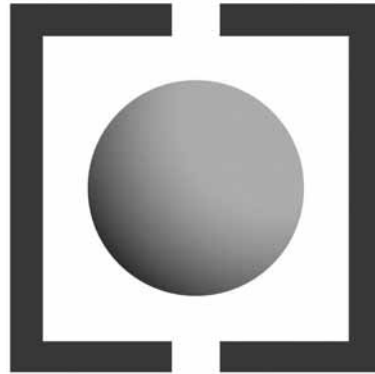

PRIORITY DATE OF 2-22-2013 IS CLAIMED.  
OWNER OF INTERNATIONAL REGISTRATION 1193053 DATED 5-29-2013, EXPIRES 5-29-2023.

OWNER OF U.S. REG. NOS. 4,184,719 AND 4,460,633.  
THE MARK CONSISTS OF A SHADED CIRCLE WITHIN AN INCOMPLETE SQUARE BROKEN AT THE TOP AND BOTTOM OF THE DESIGN.

**CLASS 35—ADVERTISING AND BUSINESS**

FOR BUSINESS NETWORKING, NAMELY, ARRANGING BUSINESS INTRODUCTIONS TO FACILITATE COLLABORATION AND PARTNERSHIPS INCLUDING PARTNERSHIPS IN THE FIELDS OF ENVIRONMENTAL SCIENCE, CARBON CAPTURE AND STORAGE, GREENHOUSE EMISSIONS; ARRANGING EXHIBITIONS FOR BUSINESS PURPOSES; BUSINESS AUDITING; BUSINESS CONSULTANCY; BUSINESS INVESTIGATIONS; BUSINESS MONITORING OF THE CARBON CAPTURE AND STORAGE OF GREENHOUSE EMISSIONS FOR BUSINESS PURPOSES; STATISTICAL ANALYSIS FOR BUSINESS PURPOSES; COLLECTION OF DATA FOR BUSINESS PURPOSES; BUSINESS DATA ANALYSIS; DATA VERIFICATION IN THE NATURE OF BUSINESS DATA ANALYSIS IN THE FIELD OF CARBON CAPTURE AND THE STORAGE OF GREENHOUSE EMISSIONS; BUSINESS EVALUATION SERVICES, NAMELY, EVALUATION OF BUSINESS OPPORTUNITIES FOR THE DEVELOPMENT OF TECHNOLOGIES TO CAPTURE CARBON AND STORE GREENHOUSE EMISSIONS; COMMERCIAL LOBBYING SERVICES, NAMELY, PROMOTING, PUBLICISING OR OTHERWISE REPRESENTING THE INTERESTS OR CONCERNS OF OTHERS; MARKET RESEARCH; PROJECT MANAGEMENT SERVICES FOR BUSINESS PURPOSES, NAMELY, PROJECT STUDIES FOR BUSINESSES IN THE FIELD OF THE CAPTURE OF CARBON AND STORAGE OF GREENHOUSE EMISSIONS; PROVISION OF BUSINESS INFORMATION; PUBLIC RELATIONS; RESEARCH OF BUSINESS INFORMATION; SURVEYS FOR BUSINESS SERVICES; ECONOMIC RESEARCH; PROMOTIONAL SERVICES, NAMELY, ENCOURAGING THE ADVANCEMENT, DEPLOYMENT AND ACCELERATION OF INNOVATION AND PROJECTS INCLUDING IN RELATION TO ENVIRONMENTAL SCIENCE, CARBON CAPTURE AND STORAGE, GREENHOUSE EMISSIONS; PROMOTIONAL SERVICES, NAMELY, FACILITATING COLLABORATION AND PARTNERSHIPS INCLUDING PARTNERSHIPS IN THE FIELDS OF ENVIRONMENTAL SCIENCE, CARBON CAPTURE AND STORAGE, GREENHOUSE EMISSIONS (U.S. CLS. 100, 101 AND 102).

**CLASS 36—INSURANCE AND FINANCIAL**

FOR PROVIDING GRANTS TO SUPPORT RESEARCH IN THE FIELDS OF ENVIRONMENTAL SCIENCE, CARBON CAPTURE AND STORAGE AND GREENHOUSE EMISSIONS FOR THE DEVELOPMENT OF STRATEGIES AND TECHNOLOGY IN THE AFORESAID FIELDS; FINANCIAL RESEARCH (U.S. CLS. 100, 101 AND 102).

**CLASS 42—SCIENTIFIC AND COMPUTER SERVICES**

FOR SCIENTIFIC AND TECHNOLOGICAL RESEARCH, NAMELY, RESEARCH IN THE FIELDS OF ENVIRONMENTAL SCIENCE, CARBON CAPTURE AND STORAGE, GREENHOUSE EMISSIONS AND ASSOCIATED TECHNOLOGIES; PROVIDING INFORMATION AND ADVICE IN THE FIELDS OF ENVIRONMENTAL SCIENCE, CARBON CAPTURE AND STORAGE, GREENHOUSE EMISSIONS (U.S. CLS. 100 AND 101).

JOANNA FIORELLI, EXAMINING ATTORNEY

SN 79-143,046. LIFE BOND LTD., CAESAREA, ISRAEL, FILED 10-9-2013.

# Lifeseal

THE MARK CONSISTS OF STANDARD CHARACTERS WITHOUT CLAIM TO ANY PARTICULAR FONT, STYLE, SIZE, OR COLOR.

OWNER OF INTERNATIONAL REGISTRATION 1193213 DATED 10-9-2013, EXPIRES 10-9-2023.

**CLASS 5—PHARMACEUTICALS**

FOR BIOMATERIALS, NAMELY, BIOLOGICAL TISSUE SEALANTS AND ADHESIVES COMPRISED OF GELATIN, CROSS-LINKING ENZYMES OR PROTEINS, OR CROSS-LINKED GELATIN, FOR SURGICAL APPLICATIONS (U.S. CLS. 6, 18, 44, 46, 51 AND 52).

**CLASS 10—MEDICAL APPARATUS**

FOR SURGICAL ADHESIVES IN THE NATURE OF SURGICAL GLUES, INCLUDING FOR HOSPITAL USE, AND TISSUE SEALANTS FOR SURGICAL USE (U.S. CLS. 26, 39 AND 44).

ADA HAN, EXAMINING ATTORNEY

SN 79-143,049. ALTI PARMAK GIDA; SANAYI VE TICARET ANONIM SIRKETI, TURKEY, FILED 11-6-2013.

# Balparmak ApiterA

OWNER OF INTERNATIONAL REGISTRATION 1193216 DATED 11-6-2013, EXPIRES 11-6-2023.

OWNER OF U.S. REG. NO. 4,430,665.

THE MARK CONSISTS OF THE STYLIZED WORDING "BALPARMAK APITERA" WITH A SHADED CIRCLE INSIDE BOTH LETTER A'S IN "APITERA".

THE ENGLISH TRANSLATION OF "BALPARMAK" IN THE MARK IS "HONEY FINGER". THE WORDING "APITERA" HAS NO MEANING IN A FOREIGN LANGUAGE.

**CLASS 5—PHARMACEUTICALS**

FOR PHARMACEUTICAL PREPARATIONS FOR THE TREATMENT OF LACK OF ENERGY, ANTI AGING; SANITARY PREPARATIONS FOR MEDICAL PURPOSES; DIETETIC SUBSTANCES, NAMELY, FOOD FOR BABIES ADAPTED FOR MEDICAL USE, SUPPORTING CHILDREN'S IMMUNE SYSTEM, ANTI AGING, SUPPORTING ENERGY; MEDICAL PLASTERS, NAMELY, BANDAGES AND GAUZE FOR DRESSINGS; MATERIAL FOR STOPPING TEETH, DENTAL WAX; DISINFECTANTS FOR HYGIENE AND SANITARY PURPOSES; PREPARATIONS FOR DESTROYING VERMIN; FUNGICIDES, HERBICIDES (U.S. CLS. 6, 18, 44, 46, 51 AND 52).

**CLASS 29—MEATS AND PROCESSED FOODS**

FOR MEAT, FISH, POULTRY AND GAME, NOT LIVE; MEAT EXTRACTS; PRESERVED, DRIED AND COOKED FRUITS AND VEGETABLES; JELLIES, JAMS, COMPOSITES; EGGS, MILK AND MILK PRODUCTS EXCLUDING ICE CREAM, ICE MILK AND FROZEN YOGURT; EDIBLE OILS AND FATS (U.S. CL. 46).

**CLASS 30—STAPLE FOODS**

FOR COFFEE, TEA, COCOA, SUGAR, RICE, ARTIFICIAL COFFEE; FLOUR AND PREPARATIONS MADE FROM CEREALS, NAMELY, BREAD, PASTRY AND CONFECTIONERY MADE OF SUGAR; HONEY, TREATMENT; YEAST, BAKING-POWDER; SALT, MUSTARD; VINEGAR; SPICES; ICE (U.S. CL. 46).

DAVID ALESKOW, EXAMINING ATTORNEY

SN 79-143,136. ROLL4YOU, S.R.O., OLSANY, CZECH REPUBLIC, FILED 9-26-2013.



PRIORITY DATE OF 6-6-2013 IS CLAIMED.

OWNER OF INTERNATIONAL REGISTRATION 1193461 DATED 9-26-2013, EXPIRES 9-26-2023.

THE MARK CONSISTS OF THE WORDING "ROLL4YOU" AND A SHADED RECTANGLE.

**CLASS 16—PAPER GOODS AND PRINTED MATTER**

FOR GREETINGS CARDS, WRITING PADS; SCORE PADS; MEMO PADS; PAMPHLETS IN THE FIELD OF SMOKING ACCESSORIES; OFFICE REQUISITES EXCEPT FURNITURE, NAMELY, STAPLERS, STAPLE REMOVERS AND RUBBER BANDS; CATALOGUES IN THE FIELD OF SMOKING ACCESSORIES; ADHESIVE BANDS FOR STATIONERY OR HOUSEHOLD PURPOSES; STEEL WRITING PENS; STATIONERY PENS; FOUNTAIN PENS; TRAYS FOR SORTING AND COUNTING MONEY, WRITING INSTRUMENTS; PEN AND PENCIL CASES; STICKERS, NOTEBOOKS (U.S. CLS. 2, 5, 22, 23, 29, 37, 38 AND 50).

**CLASS 34—SMOKERS' ARTICLES**

FOR BOOKS OF CIGARETTE PAPERS; CIGARETTE CASES; CIGARETTE FILTERS; POCKET MACHINES FOR ROLLING CIGARETTES; TOBACCO JARS; MATCH HOLDERS; MATCH BOXES; CIGARETTE PAPERS; GAS CONTAINERS SPECIALLY ADAPTED FOR CIGAR LIGHTERS; ASHTRAYS NOT OF PRECIOUS METAL FOR SMOKERS; TOBACCO; TOBACCO POUCHES; MATCHES; LIGHTERS FOR SMOKERS (U.S. CLS. 2, 8, 9 AND 17).

**CLASS 35—ADVERTISING AND BUSINESS**

FOR ADVERTISING BY MAIL ORDER, TELEMAR-  
KETING SERVICES, DEMONSTRATION OF GOODS,  
ADVERTISING, PUBLICITY, ON-LINE ADVERTISING  
ON A COMPUTER NETWORK, DIRECT MAIL ADVER-  
TISING, UPDATING OF ADVERTISING MATERIAL,  
DIRECT MAIL ADVERTISING, DISTRIBUTION OF  
SAMPLES, OUTDOOR ADVERTISING (U.S. CLS. 100,  
101 AND 102).

TRACY FLETCHER, EXAMINING ATTORNEY

SN 79-143,286. SIDEL S.P.A., ITALY, FILED 6-5-2013.

# SIMONAZZI

OWNER OF INTERNATIONAL REGISTRATION 0599665  
DATED 2-4-1993, EXPIRES 2-4-2023.  
OWNER OF U.S. REG. NO. 1,799,083.

**CLASS 7—MACHINERY**

FOR INSTALLATIONS FOR BOTTLING AND FILL-  
ING CONTAINERS, NAMELY, BOTTLING AND FILL-  
ING MACHINES; BOTTLE-WASHING MACHINES;  
RINSING MACHINES, NAMELY, CONTAINER RIN-  
SING MACHINES; BLOWING MACHINES, NAMELY,  
PLASTIC CONTAINER BLOWING MACHINES; MA-  
CHINES FOR FILLING CONTAINERS WITH LIQUIDS;  
ASEPTIC FILLING MACHINES; MACHINES FOR  
ALIGNING BOTTLES OR CONTAINERS; MACHINES  
FOR CONVEYING FOR BOTTLING INSTALLATIONS,  
NAMELY, CONVEYORS, BELT CONVEYORS, ASSEM-  
BLY LINE CONVEYOR MACHINERY; PACKAGING  
MACHINES; BOTTLE-CAPPING MACHINES; STRAIGH-  
TENING MACHINES FOR PLASTIC BOTTLES; MA-  
CHINES FOR LOADING PALLETS; MARKING  
MACHINES, NAMELY, ELECTROMECHANICAL  
MARKING MACHINES (U.S. CLS. 13, 19, 21, 23, 31, 34  
AND 35).

**CLASS 11—ENVIRONMENTAL CONTROL AP-  
PARATUS**

FOR PASTEURIZERS FOR USE IN THE FOOD IN-  
DUSTRY, BEVERAGE INDUSTRY, PHARMACEUTICAL  
INDUSTRY; SANITIZING MACHINES, NAMELY, SANI-  
TIZERS FOR AIR AND WATER AND CONTAINERS,  
ELECTRIC AIR AND CONTAINERS SANITIZING UNIT;  
STERILIZING APPARATUS AND INSTALLATIONS,  
NAMELY, STERILIZERS; HEAT EXCHANGERS, EVA-  
PORATORS (U.S. CLS. 13, 21, 23, 31 AND 34).

HAI-LY LAM, EXAMINING ATTORNEY

SN 79-143,141. KARUPOEG PUHH OÜ, TALLINN, ESTONIA,  
FILED 9-30-2013.

PRIORITY DATE OF 7-31-2013 IS CLAIMED.  
OWNER OF INTERNATIONAL REGISTRATION 1193471  
DATED 9-30-2013, EXPIRES 9-30-2023.

THE NAME(S), PORTRAIT(S), AND/OR SIGNATURE(S)  
SHOWN IN THE MARK DOES NOT IDENTIFY A PARTI-  
CULAR LIVING INDIVIDUAL.

THE COLOR(S) RED, YELLOWISH GREEN, DARK BLUE,  
ORANGE, YELLOW, LIGHT GREEN, BROWNISH GREEN,  
PINK AND WHITE IS/ARE CLAIMED AS A FEATURE OF  
THE MARK.

THE MARK CONSISTS OF THE WORDING "GERAR-  
DO'S" IN STYLIZED FONT IN WHICH THE LETTER "G" IS  
RED, "E" IS YELLOWISH GREEN, "R" IS DARK BLUE, "A"  
IS ORANGE, "R" IS YELLOW, "D" IS LIGHT GREEN, "O" IS  
BROWNISH GREEN, THE APOSTROPHE IS RED, "S" IS  
PINK AND LETTERS AND APOSTROPHE ARE SUR-  
ROUNDED BY A WHITE FRAME.

**CLASS 20—FURNITURE AND ARTICLES NOT  
OTHERWISE CLASSIFIED**

FOR FURNITURE FOR HOUSE; PICTURE FRAMES;  
MATTRESSES; FURNITURE FOR BABIES AND CHIL-  
DREN; INFANT BEDS; BOOSTER SEATS FOR CHIL-  
DREN; CARRY-COTS FOR BABIES; TRAVEL COTS FOR  
BABIES; BABY-CHANGING PLATFORMS AND MATS;  
INFANT WALKERS; FEEDING CHAIRS FOR SMALL  
CHILDREN; CHILDREN'S MATS USED FOR SLEEPING;  
NON-METAL SAFETY GATES FOR BABIES, CHIL-  
DREN, AND PETS; INFANT BOUNCERS; INFANT  
CRADLES; BABY CHANGING TABLES; PLAYPENS  
FOR BABIES; HIGH CHAIRS FOR BABIES; PORTABLE  
BABY BATH SEATS FOR USE IN BATH TUBS; TOY  
BOXES AND CHESTS (U.S. CLS. 2, 13, 22, 25, 32 AND 50).

**CLASS 28—TOYS AND SPORTING GOODS**

FOR DECORATIONS FOR CHRISTMAS TREES; RIDE-  
ON TOYS AND ACCESSORIES THEREFOR; CHIL-  
DREN'S TOY BICYCLES OTHER THAN FOR TRANS-  
PORT; TOY PUSHCHAIRS; TOY SCOOTERS; ROLLER  
SKATES; PLAYGROUND SLIDES; WATER SLIDES; IN-  
FANT TOYS; MUSICAL TOYS; ELECTRONIC TOY  
VEHICLES; FURNITURE FOR DOLL'S HOUSES; CHIL-  
DREN'S MULTIPLE ACTIVITY TOYS; TOY CHRISTMAS  
TREES; BATH TOYS; COLLECTABLE TOY FIGURES;  
CONSTRUCTION TOYS; CRIB TOYS; EDUCATIONAL  
TOYS FOR TEACHING MATH PRINCIPLES TO CHIL-  
DREN, NAMELY, MANIPULATIVE BLOCKS FOR DIS-  
PLAYING PATTERNS AND GROUPINGS;  
MECHANICAL TOYS; NON-ELECTRONIC TOY VEHI-  
CLES; PLAY MATS CONTAINING INFANT TOYS; PLAY  
MATS FOR USE WITH TOY VEHICLES; PULL TOYS;  
PUNCHING TOYS; PUSH TOYS; SANDBOX TOYS; TOY  
FURNITURE; TOY VEHICLES (U.S. CLS. 22, 23, 38 AND  
50).

STEVEN JACKSON, EXAMINING ATTORNEY

SN 79-143,492. GHOST-BIKES GMBH, FED REP GERMANY,  
FILED 9-23-2013.

# RIOT

THE MARK CONSISTS OF STANDARD CHARACTERS  
WITHOUT CLAIM TO ANY PARTICULAR FONT, STYLE,  
SIZE, OR COLOR.

PRIORITY DATE OF 3-25-2013 IS CLAIMED.  
OWNER OF INTERNATIONAL REGISTRATION 1194295  
DATED 9-23-2013, EXPIRES 9-23-2023.

**CLASS 12—VEHICLES**

FOR BICYCLES, BICYCLE PARTS, PARTICULARLY  
FRAMES FOR BICYCLES, BICYCLE FORKS, SUSPEN-  
SION FORKS, HANDLE BARS FOR BICYCLES, BAR  
ENDS, HANDLE BAR STEMS, STEERING BEARINGS,  
BICYCLE HANDLEBAR GRIPS, HUBS, TYRES, WHEEL  
TRIMS, PEDALS, BICYCLE SEAT POSTS, BICYCLE  
SADDLES, SUSPENSION SHOCK ABSORBERS, SUSPEN-  
SION FORKS, CHAINSTAY PROTECTION AND CYCLE  
MUDGUARDS (U.S. CLS. 19, 21, 23, 31, 35 AND 44).



**CLASS 28—TOYS AND SPORTING GOODS**

FOR PROTECTIVE SUPPORTS, NAMELY, KNEE GUARDS FOR ATHLETIC SPORTS USE; SPORTS ARTICLES, NAMELY, PROTECTORS FOR ELBOWS, SPORTS ARTICLES, NAMELY, BACK PROTECTORS FOR CYCLING SPORTS (U.S. CLS. 22, 23, 38 AND 50).

SIMON TENG, EXAMINING ATTORNEY

SN 79-143,564. AKTIEBOLAGET TRAV OCH GALOPP, SWEDEN, FILED 1-22-2014.



PRIORITY DATE OF 7-26-2013 IS CLAIMED. OWNER OF INTERNATIONAL REGISTRATION 1194473 DATED 1-22-2014, EXPIRES 1-22-2024.

THE COLOR(S) BROWN, BLUE, WHITE AND BLACK IS/ARE CLAIMED AS A FEATURE OF THE MARK.

THE MARK CONSISTS OF A GRINNING HORSE FIGURE IN A WHITE-T-SHIRT. THE HORSE HEAD IS COLORED BROWN, ITS EYES ARE COLORED BLUE, AND ITS EYEBROWS ARE COLORED BLACK. THE TEETH AND SCLERA OF THE HORSE FIGURE ARE COLORED WHITE.

SN 79-143,523. ALLER MEDIA A/S, DENMARK, FILED 11-6-2013.

# ROYALISTA

THE MARK CONSISTS OF STANDARD CHARACTERS WITHOUT CLAIM TO ANY PARTICULAR FONT, STYLE, SIZE, OR COLOR.

PRIORITY DATE OF 6-30-2013 IS CLAIMED.

OWNER OF INTERNATIONAL REGISTRATION 1194369 DATED 11-6-2013, EXPIRES 11-6-2023.

**CLASS 9—ELECTRICAL AND SCIENTIFIC APPARATUS**

FOR ELECTRONIC DOWNLOADABLE PUBLICATIONS, NAMELY, NEWSPAPERS, MAGAZINES, PERIODICALS AND BOOKS, ALL IN ELECTRONIC FORMAT OR DISTRIBUTED ONLINE OR VIA MULTIMEDIA NETWORK IN THE FIELD OF FAMOUS PEOPLE, PARTICULARLY ROYALTY (U.S. CLS. 21, 23, 26, 37 AND 38).

**CLASS 16—PAPER GOODS AND PRINTED MATTER**

FOR PRINTED MATTER, NAMELY, NEWSPAPERS, JOURNALS, MAGAZINES AND BOOKS IN THE FIELD OF FAMOUS PEOPLE, PARTICULARLY ROYALTY; POSTERS; PHOTOGRAPHS (U.S. CLS. 2, 5, 22, 23, 29, 37, 38 AND 50).

**CLASS 41—EDUCATION AND ENTERTAINMENT**

FOR ELECTRONIC PUBLISHING SERVICES, NAMELY, ONLINE ELECTRONIC PUBLISHING OF MAGAZINES, NEWSPAPERS, PERIODICALS AND BOOKS; ON-LINE JOURNALS, NAMELY, BLOGS FEATURING CELEBRITIES, PARTICULARLY ROYALTY; PUBLICATION OF NEWSPAPERS, MAGAZINES, PERIODICALS AND BOOKS; ENTERTAINMENT CLUB SERVICES, NAMELY, FAN CLUBS; PRODUCTION OF TELEVISION AND RADIO PROGRAMS, NAMELY, TELEVISION AND RADIO PROGRAMS FOR USE IN DATA NETWORKS; PRODUCTION OF FILMS AND VIDEO PROGRAMS STORED ON VIDEO CASSETTES AND DVDS; PROVIDING NON-DOWNLOADABLE ONLINE MAGAZINES, NEWSPAPERS, PERIODICALS AND BOOKS IN THE FIELD OF CELEBRITIES, PARTICULARLY ROYALTY (U.S. CLS. 100, 101 AND 107).

LINDA MICKLEBURGH, EXAMINING ATTORNEY

**CLASS 36—INSURANCE AND FINANCIAL**

FOR FINANCIAL SERVICES, NAMELY, THE RECEIPT OF BETS FOR HORSE RACING AND THE PAY OUT OF PRIZE MONEY FOR WINNING BETS MADE ON HORSE RACING (U.S. CLS. 100, 101 AND 102).

**CLASS 41—EDUCATION AND ENTERTAINMENT**

FOR OPERATING LOTTERIES AND LOTTERY BUSINESS; ENTERTAINMENT; BETTING; GAMBLING SERVICES; SPORTING AND CULTURAL ACTIVITIES (U.S. CLS. 100, 101 AND 107).

HEATHER SAPP, EXAMINING ATTORNEY

SN 79-143,574. LODERS CROKLAAN B.V., WORMERVEER, NETHERLANDS, FILED 2-10-2014.

# LODERS CROKLAAN

OWNER OF INTERNATIONAL REGISTRATION 0733581 DATED 3-31-2000, EXPIRES 3-31-2020.

OWNER OF U.S. REG. NO. 4,468,327.

THE WORDING "LODERS CROKLAAN" HAS NO MEANING IN A FOREIGN LANGUAGE.

**CLASS 1—CHEMICALS**

FOR LINOLEIC ACIDS AND FATTY ACIDS FOR MANUFACTURING FOOD AND COSMETICS (U.S. CLS. 1, 5, 6, 10, 26 AND 46).

**CLASS 3—COSMETICS AND CLEANING PREPARATIONS**

FOR OILS FOR COSMETIC AND TOILETRY USE (U.S. CLS. 1, 4, 6, 50, 51 AND 52).

**CLASS 29—MEATS AND PROCESSED FOODS**

FOR EDIBLE OILS AND FATS (U.S. CL. 46).



BARNEY CHARLON, EXAMINING ATTORNEY

SN 79-143,704. QIAGEN GMBH, FED REP GERMANY,  
FILED 9-19-2013.SN 79-143,650. SOLA SWITZERLAND EU S.R.O., SLOVAKIA,  
FILED 1-13-2014.

PRIORITY DATE OF 11-11-2013 IS CLAIMED.  
OWNER OF INTERNATIONAL REGISTRATION 1194657  
DATED 1-13-2014, EXPIRES 1-13-2024.

THE MARK CONSISTS OF ONE STYLIZED WORD  
"LUSOL" WITH CAPITAL FIRST LETTER, TO THE RIGHT  
OF FOUR SOLID SQUARES.

THE WORDING "LUSOL" HAS NO MEANING IN A  
FOREIGN LANGUAGE.

#### CLASS 8—HAND TOOLS

FOR TABLE FORKS; SILVER-PLATED KNIVES,  
FORKS AND SPOONS; HAND-OPERATED CHOPPERS  
IN THE NATURE OF KNIVES; CLEAVERS; PARING  
KNIVES; FLATWARE, NAMELY, KNIVES, FORKS AND  
SPOONS; SHEARS IN THE NATURE OF SCISSORS;  
KNIVES; CUTLERY; VEGETABLE SLICERS; MINCING  
KNIVES; SPOONS (U.S. CLS. 23, 28 AND 44).

#### CLASS 21—HOUSEWARES AND GLASS

FOR KITCHEN UTENSILS, NAMELY, POT AND PAN  
SCRAPERS, ROLLING PINS, SPATULAS, TURNERS,  
WHISKS, COCKTAIL STRAINERS, DRINK STIRRERS,  
BOTTLE OPENERS, TEA TUBES IN THE NATURE OF  
TEA INFUSERS, GARLIC PRESSERS, SPAGHETTI SER-  
VING FORKS, SPAGHETTI SERVING TONGS; DISHES;  
TABLEWARE, NAMELY, COFFEE SERVICES, TEA SER-  
VICES, SERVING TRAYS, TABLE NUMBER STANDS IN  
THE NATURE OF TABLE PLACE CARD HOLDERS NOT  
OF PRECIOUS METAL, SALT AND PEPPER SHAKERS,  
CHAMPAGNE COOLERS, PORTABLE BOTTLE COOL-  
ERS, ICE BUCKETS, NAPKIN HOLDERS, CANDLE  
HOLDERS, FRUIT BASKETS FOR DOMESTIC USE,  
NOT OF METAL; EARTHENWARE, NAMELY, MUGS,  
POTS, AND JARS IN THE NATURE OF JARS FOR  
COOKING GREASE SOLD EMPTY, INSULATING JARS,  
COOKIE JARS; COOKING POT SETS; TABLE PLATES;  
CONTAINERS FOR HOUSEHOLD OR KITCHEN USE;  
KITCHEN CONTAINERS; NON-ELECTRIC COOKING  
UTENSILS, NAMELY, NON-ELECTRIC GRIDDLES,  
POTS, PANS, STEAMERS; UTENSILS FOR HOUSEHOLD  
USE, NAMELY, POT AND PAN SCRAPERS, ROLLING  
PINS, SPATULAS, TURNERS, WHISKS, COCKTAIL  
STRAINERS, DRINK STIRRERS, BOTTLE OPENERS,  
TEA TUBES IN THE NATURE OF TEA INFUSERS,  
GARLIC PRESSERS, SPAGHETTI SERVING FORKS,  
SPAGHETTI SERVING TONGS; TEA SERVICES; SER-  
VICES IN THE NATURE OF DISHES; COFFEE SER-  
VICES; SCOOPS; KITCHEN LADLES IN THE NATURE  
OF BASTING SPOONS; CRYSTAL BEVERAGE GLASS-  
WARE; PAINTED BEVERAGE GLASSWARE; DRINK-  
ING GLASSES; RECEPTACLES IN THE NATURE OF  
DRINKING GLASSES; CUPS; GLASS JARS IN THE  
NATURE OF CARBOYS; POTS; MUGS; POTTERY  
DISHES; COOKING POTS; NON-ELECTRICALLY  
HEATED HOT POTS; EARTHENWARE SAUCEPANS;  
FRYING PANS; WORKS OF ART OF PORCELAIN;  
CERAMIC; EARTHENWARE OR GLASS; CUTTING  
BOARDS FOR THE KITCHEN (U.S. CLS. 2, 13, 23, 29,  
30, 33, 40 AND 50).

KIMBERLY PARKS, EXAMINING ATTORNEY

# BRIGHT BEAD

THE MARK CONSISTS OF STANDARD CHARACTERS  
WITHOUT CLAIM TO ANY PARTICULAR FONT, STYLE,  
SIZE, OR COLOR.

PRIORITY DATE OF 3-22-2013 IS CLAIMED.  
OWNER OF INTERNATIONAL REGISTRATION 1194813  
DATED 9-19-2013, EXPIRES 9-19-2023.

NO CLAIM IS MADE TO THE EXCLUSIVE RIGHT TO  
USE "BEAD", APART FROM THE MARK AS SHOWN.

#### CLASS 1—CHEMICALS

FOR CHEMICAL, BIOCHEMICAL, AND BIOTECHNO-  
LOGICAL PRODUCTS, NAMELY, CHEMICALS AND  
BIOCHEMICALS FOR INDUSTRIAL AND SCIENTIFIC  
PURPOSES; SCIENTIFIC REAGENTS AND SOLVENTS  
FOR SAMPLE PREPARATION, AS WELL AS FOR  
METHODS FOR LABELING, SEPARATING, IDENTIFY-  
ING, QUANTIFYING, ISOLATING, PURIFYING, AM-  
PLIFYING AND/OR ANALYZING BIOPOLYMERS,  
NAMELY, NUCLEIC ACIDS, PROTEINS, MACROMOLE-  
CULES AND BIOLOGICALLY ACTIVE SUBSTANCES IN  
THE NATURE OF ASSAYS; KITS COMPRISING CHE-  
MICAL PRODUCTS, NAMELY, CHEMICALS FOR SAM-  
PLE PREPARATION, AS WELL AS FOR THE  
LABELING, SEPARATION, IDENTIFICATION, QUAN-  
TIFICATION, ISOLATION, PURIFICATION, AMPLIFI-  
CATION AND/OR ANALYSIS OF BIOPOLYMERS,  
NAMELY, NUCLEIC ACIDS, PROTEINS, MACROMOLE-  
CULES AND BIOLOGICALLY ACTIVE SUBSTANCES,  
NAMELY, NUCLEIC ACIDS FROM BIOLOGICAL OR  
BIOCHEMICAL SAMPLE MATERIAL (U.S. CLS. 1, 5, 6,  
10, 26 AND 46).

#### CLASS 5—PHARMACEUTICALS

FOR DIAGNOSTICS AGENTS, REAGENTS, SUB-  
STANCES AND/OR PREPARATIONS FOR MEDICAL  
PURPOSES; PRODUCTS FOR HUMAN MEDICAL AND  
VETERINARY MEDICAL PURPOSES IN THE NATURE  
OF DIAGNOSTICS, NAMELY, FOR SAMPLE PREPARA-  
TION, AS WELL AS FOR THE LABELING, SEPARA-  
TION, IDENTIFICATION, QUANTIFICATION,  
ISOLATION, PURIFICATION, AMPLIFICATION AND/  
OR ANALYSIS OF BIOPOLYMERS, NAMELY, NUCLEIC  
ACIDS, PROTEINS, MACROMOLECULES AND BIOLO-  
GICALLY ACTIVE SUBSTANCES IN THE NATURE OF  
ASSAYS; CHEMICAL, BIOCHEMICAL AND BIOTECH-  
NOLOGICAL PRODUCTS, NAMELY, MEDICAL RE-  
AGENTS AND SOLVENTS FOR SAMPLE  
PREPARATION, AS WELL AS FOR METHODS FOR  
LABELING, SEPARATING, IDENTIFYING, QUANTIFY-  
ING, ISOLATING, PURIFYING, AMPLIFYING AND/OR  
ANALYZING BIOPOLYMERS, NAMELY, NUCLEIC  
ACIDS, PROTEINS, MACROMOLECULES AND BIOLO-  
GICALLY ACTIVE SUBSTANCES IN THE NATURE OF  
ASSAYS FOR DIAGNOSTIC PURPOSES; KITS COM-  
PRISING PRODUCTS FOR HUMAN MEDICAL AND  
VETERINARY MEDICAL DIAGNOSTIC PURPOSES,  
NAMELY, FOR SAMPLE PREPARATION, AS WELL AS  
FOR THE LABELING, SEPARATION, IDENTIFICA-  
TION, QUANTIFICATION, ISOLATION, PURIFICA-  
TION, AMPLIFICATION AND/OR ANALYSIS OF  
BIOPOLYMERS, NAMELY, NUCLEIC ACIDS, PRO-  
TEINS, MACROMOLECULES AND BIOLOGICALLY AC-  
TIVE SUBSTANCES IN THE NATURE OF NUCLEIC  
ACIDS FROM BIOLOGICAL OR BIOCHEMICAL SAM-  
PLE MATERIAL (U.S. CLS. 6, 18, 44, 46, 51 AND 52).

**CLASS 9—ELECTRICAL AND SCIENTIFIC APPARATUS**

FOR SCIENTIFIC APPARATUS, INSTRUMENTS AND EQUIPMENT FOR RESEARCH AND ANALYSIS PURPOSES, AS WELL AS LABORATORY APPARATUSES, MEASURING APPARATUSES AND INSTRUMENTS FOR THE USE OF PRODUCTS FOR HUMAN MEDICAL AND VETERINARY MEDICAL DIAGNOSTIC PURPOSES, NAMELY, FOR SAMPLE PREPARATION, AS WELL AS FOR THE LABELING, SEPARATION, IDENTIFICATION, QUANTIFICATION, ISOLATION, PURIFICATION, AMPLIFICATION AND/OR ANALYSIS OF BIOPOLYMERS, NAMELY, NUCLEIC ACIDS, PROTEINS, MACROMOLECULES AND BIOLOGICALLY ACTIVE SUBSTANCES, NAMELY, NUCLEIC ACIDS FROM BIOLOGICAL OR BIOCHEMICAL SAMPLE MATERIAL, IN THE NATURE OF TUBES, VESSELS, COLUMNS, SAMPLE HOLDERS, BOXES FOR INCUBATION OF BIOLOGICAL OR BIOCHEMICAL SAMPLES, FILTER DEVICES FOR BIOLOGICAL OR BIOCHEMICAL SAMPLES, AS FAR AS INCLUDED IN THIS CLASS (U.S. CLS. 21, 23, 26, 36 AND 38).

NATALIE POLZER, EXAMINING ATTORNEY

SN 79-144,172. SANSAN, INC., TOKYO, JAPAN, FILED 10-3-2013.

# Sansan

OWNER OF INTERNATIONAL REGISTRATION 1196047 DATED 10-3-2013, EXPIRES 10-3-2023.

THE MARK CONSISTS OF THE STYLIZED WORDING "SANSAN".

**CLASS 9—ELECTRICAL AND SCIENTIFIC APPARATUS**

FOR COMPUTER SOFTWARE FOR USE IN DATABASE MANAGEMENT; COMPUTER SOFTWARE FOR PROVIDING AN ON-LINE DATABASE IN THE FIELD OF BUSINESS CARDS; COMPUTER SOFTWARE FOR DATABASE INTEGRATION; COMPUTER SOFTWARE FOR DATABASE MANAGEMENT IN THE FIELD OF CUSTOMER RELATIONSHIP MANAGEMENT; DOWNLOADABLE COMPUTER SOFTWARE FOR USE IN DATABASE MANAGEMENT; DOWNLOADABLE COMPUTER SOFTWARE FOR PROVIDING AN ON-LINE DATABASE IN THE FIELD OF BUSINESS CARDS; DOWNLOADABLE COMPUTER SOFTWARE FOR DATABASE INTEGRATION; DOWNLOADABLE COMPUTER SOFTWARE FOR DATABASE MANAGEMENT IN THE FIELD OF CUSTOMER RELATIONSHIP MANAGEMENT; PRE-RECORDED DIGITAL MEDIA CONTAINING RECORDED COMPUTER SOFTWARE FOR USE IN DATABASE MANAGEMENT; PRE-RECORDED DIGITAL MEDIA CONTAINING RECORDED COMPUTER SOFTWARE FOR PROVIDING AN ON-LINE DATABASE IN THE FIELD OF BUSINESS CARDS; PRE-RECORDED DIGITAL MEDIA CONTAINING RECORDED COMPUTER SOFTWARE FOR DATABASE INTEGRATION; PRE-RECORDED DIGITAL MEDIA CONTAINING RECORDED COMPUTER SOFTWARE FOR DATABASE MANAGEMENT IN THE FIELD OF CUSTOMER RELATIONSHIP MANAGEMENT; INFORMATION PROCESSING APPARATUS, NAMELY, DATA PROCESSORS FOR USE IN DATABASE MANAGEMENT; INFORMATION PROCESSING APPARATUS, NAMELY, DATA PROCESSORS FOR PROVIDING AN ON-LINE DATABASE IN THE FIELD OF BUSINESS CARDS; INFORMATION PROCESSING APPARATUS, NAMELY, DATA PROCESSORS FOR DATABASE INTEGRATION; INFORMATION PROCESSING APPARATUS, NAMELY, DATA PROCESSORS FOR USE IN CUSTOMER RELATIONSHIP MANAGEMENT; COMPUTERS FOR USE IN DATABASE MANAGEMENT; COMPUTERS FOR PROVIDING AN ON-LINE DATABASE IN THE FIELD OF BUSINESS

CARDS; COMPUTERS FOR DATABASE INTEGRATION; COMPUTERS FOR USE IN CUSTOMER RELATIONSHIP MANAGEMENT (U.S. CLS. 21, 23, 26, 36 AND 38).

**CLASS 35—ADVERTISING AND BUSINESS**

FOR COMPUTERIZED FILE MANAGEMENT; OFFICE FUNCTIONS, NAMELY, FILING DOCUMENTS OR ELECTRONIC MEDIA DATA; SYSTEMIZATION OF INFORMATION INTO COMPUTER DATABASES; PROVIDING INFORMATION AND ADVICE REGARDING SYSTEMIZATION OF INFORMATION INTO COMPUTER DATABASES; COMPILATION OF INFORMATION INTO COMPUTER DATABASES; PROVIDING INFORMATION AND ADVICE REGARDING COMPILATION OF INFORMATION INTO COMPUTER DATABASES (U.S. CLS. 100, 101 AND 102).

**CLASS 42—SCIENTIFIC AND COMPUTER SERVICES**

FOR PROVIDING TEMPORARY USE OF ON-LINE NON-DOWNLOADABLE COMPUTER SOFTWARE FOR USE IN DATABASE MANAGEMENT; PROVIDING TEMPORARY USE OF ON-LINE NON-DOWNLOADABLE COMPUTER SOFTWARE FOR PROVIDING AN ON-LINE DATABASE IN THE FIELD OF BUSINESS CARDS; PROVIDING TEMPORARY USE OF ON-LINE NON-DOWNLOADABLE COMPUTER SOFTWARE FOR DATABASE INTEGRATION; PROVIDING TEMPORARY USE OF ON-LINE NON-DOWNLOADABLE COMPUTER SOFTWARE FOR DATABASE MANAGEMENT IN THE FIELD OF CUSTOMER RELATIONSHIP MANAGEMENT; PROVIDING TEMPORARY USE OF ON-LINE NON-DOWNLOADABLE COMPUTER SOFTWARE FOR USE IN DATABASE MANAGEMENT BY APPLICATION SERVICE PROVIDER; PROVIDING TEMPORARY USE OF ON-LINE NON-DOWNLOADABLE COMPUTER SOFTWARE FOR PROVIDING AN ON LINE DATABASE IN THE FIELD OF BUSINESS CARDS BY APPLICATION SERVICE PROVIDER; PROVIDING TEMPORARY USE OF ON-LINE NON-DOWNLOADABLE COMPUTER SOFTWARE FOR DATABASE INTEGRATION BY APPLICATION SERVICE PROVIDER; PROVIDING TEMPORARY USE OF ON-LINE NON-DOWNLOADABLE COMPUTER SOFTWARE FOR DATABASE MANAGEMENT IN THE FIELD OF CUSTOMER RELATIONSHIP MANAGEMENT BY APPLICATION SERVICE PROVIDER; RENTAL OF COMPUTER SOFTWARE; RENTAL OF COMPUTERS; COMPUTER SOFTWARE DESIGN; COMPUTER PROGRAMMING; MAINTENANCE OF COMPUTER SOFTWARE (U.S. CLS. 100 AND 101).

PAUL MORENO, EXAMINING ATTORNEY

SN 79-144,264. SYNERGY HEALTH PLC, UNITED KINGDOM, FILED 11-13-2013.

# SYNERGYTRAK

THE MARK CONSISTS OF STANDARD CHARACTERS WITHOUT CLAIM TO ANY PARTICULAR FONT, STYLE, SIZE, OR COLOR.

PRIORITY DATE OF 10-25-2013 IS CLAIMED.

OWNER OF INTERNATIONAL REGISTRATION 1196188 DATED 11-13-2013, EXPIRES 11-13-2023.

OWNER OF U.S. REG. NO. 4,120,153.

**CLASS 37—CONSTRUCTION AND REPAIR**

FOR LAUNDRY SERVICES; RENTAL OF LAUNDRY EQUIPMENT; CLEANING AND DISINFECTING SERVICES FOR MEDICAL AND LABORATORY PREMISES; INSTALLATION, MAINTENANCE AND REPAIR OF STERILIZERS AND ELECTRIC AND NON-ELECTRIC AUTOCLAVES; REPAIR AND MAINTENANCE OF AIR CONDITIONING AND AIR STERILIZATION APPARATUS; INSTALLATION AND REPLACEMENT OF CONTAINERS AND RECEPTACLES FOR USED AND WASTE ARTICLES; JANITORIAL SERVICES, NAMELY, CLEANING AND MAINTENANCE OF BUILDINGS; MEDICAL WASTE DISPOSAL; FACILITIES MANAGEMENT, NAMELY, PROVIDING THE SERVICES OF LAUNDERING, CLEANING, DISINFECTING OF BEDDING, PATIENT'S GOWNS, STAFF UNIFORMS, GOWNS AND OTHER PROTECTIVE ITEMS FOR WEAR, MEDICAL AND SURGICAL INSTRUMENTS AND APPARATUS AND PREMISES IN THE HEALTHCARE SECTOR; INFORMATION AND ADVISORY SERVICES RELATED TO THE AFORESAID SERVICES; FILLING OF TOWEL DISPENSERS AND SOAP DISPENSERS AS PART OF BUILDING MAINTENANCE SERVICE (U.S. CLS. 100, 103 AND 106).

**CLASS 39—TRANSPORTATION AND STORAGE**

FOR TRANSPORT OF GOODS; COLLECTION AND REMOVAL IN THE NATURE OF TRANSPORT OF WASTE MATERIALS FROM HEALTHCARE ESTABLISHMENTS; COLLECTION, DELIVERY AND DISTRIBUTION SERVICES IN THE FIELD OF CLOTHING FOR HEALTH CARE PROFESSIONALS, MEDICAL AND SURGICAL INSTRUMENTS, APPARATUS AND EQUIPMENT; SECURE AND MONITORED DELIVERY AND DISTRIBUTION SERVICES IN THE FIELD OF CLOTHING FOR HEALTH CARE PROFESSIONALS, MEDICAL AND SURGICAL INSTRUMENTS, APPARATUS AND EQUIPMENT; COLLECTION, DELIVERY AND DISTRIBUTION OF PATIENT GOWNS, MEDICAL STAFF UNIFORMS, BED LINING FOR LAUNDERING, CLEANING, DISINFECTING AND DECONTAMINATION; RENTAL OF STORAGE CONTAINERS AND RECEPTACLES FOR USED AND WASTE ARTICLES; INFORMATION AND ADVISORY SERVICES RELATED TO THE AFORESAID SERVICES; RENTAL OF STORAGE RECEPTACLES FOR THE RETURN AND REPROCESSING OF SURGICAL INSTRUMENTS; RENTAL OF RECYCLING RECEPTACLES FOR RECYCLING OF WASTE (U.S. CLS. 100 AND 105).

**CLASS 40—MATERIAL TREATMENT**

FOR BIOLOGICAL AND MEDICAL WASTE, BLOOD AND FLUID DECONTAMINATION SERVICES; STERILIZATION SERVICES FOR MEDICAL DEVICES AND IN THE FIELD OF PHARMACEUTICAL AND BIOLOGICAL TISSUE INDUSTRIES; DECONTAMINATION AND STERILIZATION OF SURGICAL INSTRUMENTS; DESTRUCTION AND INCINERATION OF WASTE; RECYCLING OF WASTE; INFORMATION AND ADVISORY SERVICES RELATED TO THE AFORESAID SERVICES (U.S. CLS. 100, 103 AND 106).

HAI-LY LAM, EXAMINING ATTORNEY

SN 79-144,324. WELSER PROFILE AUSTRIA GMBH, AUSTRIA, FILED 11-21-2013.



PRIORITY DATE OF 11-19-2013 IS CLAIMED.  
OWNER OF INTERNATIONAL REGISTRATION 1196341  
DATED 11-21-2013, EXPIRES 11-21-2023.  
OWNER OF U.S. REG. NO. 3,312,924.

THE COLOR(S) BLACK, WHITE AND VIOLET IS/ARE CLAIMED AS A FEATURE OF THE MARK.

THE MARK CONSISTS OF A DESIGN OF AN OVERALL RECTANGULAR SHAPE THAT IS SPLIT INTO THREE BLACK RECTANGULAR AND POLYGONAL SHAPES ON THE TOP AND TWO VIOLET POLYGONAL SHAPES ON THE BOTTOM WITH WHITE BANDS INTERSECTING THE RECTANGULAR SHAPE.

**CLASS 6—METAL GOODS**

FOR METAL BUILDING MATERIALS, NAMELY, SOFFITS, FASCIA; METAL PROFILES, IN PARTICULAR METAL PROFILES MANUFACTURED BY ROLL FORMING, NAMELY, DECORATIVE METAL PROFILES FOR USE IN FURTHER MANUFACTURE, METAL PROFILES FOR ARRANGING DEVICES ON AND IN WALLS, CEILING AND OTHER SURFACES; FACADES OF METAL, NAMELY, WALL PANELS OF METAL, METAL FACADE PANELS FOR CONSTRUCTION PURPOSES; FACADE CONSTRUCTION COMPONENTS OF METAL, NAMELY, SHORES, BRACES (U.S. CLS. 2, 12, 13, 14, 23, 25 AND 50).

**CLASS 7—MACHINERY**

FOR ROLL FORMING FACILITIES FOR THE MANUFACTURE OF PROFILES, NAMELY, ROLLING MILLS, ROLLING MACHINES FOR ROLLING METALS; WELDING INSTALLATIONS, NAMELY, HIGH FREQUENCY WELDING MACHINES, GAS WELDING MACHINES, LASER WELDING MACHINES; PUNCHING MACHINES, NAMELY, PUNCHING PRESSES; BENDING MACHINES (U.S. CLS. 13, 19, 21, 23, 31, 34 AND 35).

**CLASS 42—SCIENTIFIC AND COMPUTER SERVICES**

FOR SCIENTIFIC AND TECHNOLOGICAL SERVICES, NAMELY, SCIENTIFIC RESEARCH, SCIENTIFIC ANALYSIS IN THE FIELD OF METAL BUILDING MATERIALS AND PRODUCT RESEARCH AND DESIGN RELATING THERETO IN THE FIELD OF METAL BUILDING MATERIALS; INDUSTRIAL ANALYSIS AND RESEARCH SERVICES IN THE FIELD OF INDUSTRIAL DESIGN; ENGINEERING SERVICES; CIVIL ENGINEERING DESIGN SERVICES (U.S. CLS. 100 AND 101).

HAI-LY LAM, EXAMINING ATTORNEY

SN 79-144,356. FIBERTRONIX AB, HUDIKSVALL, SWEDEN,  
FILED 1-3-2014.

# FIBERTRONIX

THE MARK CONSISTS OF STANDARD CHARACTERS WITHOUT CLAIM TO ANY PARTICULAR FONT, STYLE, SIZE, OR COLOR.

PRIORITY DATE OF 7-3-2013 IS CLAIMED.  
OWNER OF INTERNATIONAL REGISTRATION 1196409  
DATED 1-3-2014, EXPIRES 1-3-2024.

## CLASS 9—ELECTRICAL AND SCIENTIFIC APPARATUS

FOR APPARATUS AND INSTRUMENTS FOR MEASURING, SIGNALING, AND CHECKING PRESSURE AND TEMPERATURE IN OIL WELLS; SENSORS AND DETECTORS FOR MEASURING, SIGNALING, AND CHECKING PRESSURE AND TEMPERATURE IN OIL WELLS (U.S. CLS. 21, 23, 26, 36 AND 38).

## CLASS 11—ENVIRONMENTAL CONTROL APPARATUS

FOR LIGHTING APPARATUS, NAMELY, LIGHTING INSTALLATIONS (U.S. CLS. 13, 21, 23, 31 AND 34).  
JOHN HWANG, EXAMINING ATTORNEY

SN 79-144,420. BEST BRANDS CONSULTING, RUDDERVOORDE, BELGIUM, AND FMC DISTRI, DOTTIGNIES, BELGIUM, FILED 11-18-2013.

# POWER DISTRIBUTION

THE MARK CONSISTS OF STANDARD CHARACTERS WITHOUT CLAIM TO ANY PARTICULAR FONT, STYLE, SIZE, OR COLOR.

OWNER OF INTERNATIONAL REGISTRATION 1196574  
DATED 11-18-2013, EXPIRES 11-18-2023.

## CLASS 35—ADVERTISING AND BUSINESS

FOR ADVERTISING SERVICES; BUSINESS MANAGEMENT; BUSINESS ADMINISTRATION; PROVIDING OFFICE FUNCTIONS; ACCOUNTANCY SERVICES; RETAIL AND WHOLESALE STORE SERVICES RELATING TO FOOD AND DRINKS; BUSINESS ADVISORY SERVICES RELATING TO FRANCHISING; NONE OF THE AFOREMENTIONED SERVICES WITH RESPECT TO THE DISTRIBUTION OF ENERGY OR ELECTRICITY (U.S. CLS. 100, 101 AND 102).

## CLASS 36—INSURANCE AND FINANCIAL

FOR INSURANCE SERVICES, NAMELY, INSURANCE ADMINISTRATION, INSURANCE CONSULTATION, INSURANCE BROKERAGE AND INSURANCE INFORMATION IN THE FIELD OF FRANCHISING; FINANCIAL AFFAIRS SERVICES, NAMELY, FINANCIAL CONSULTATION, FINANCIAL INFORMATION, FINANCIAL MANAGEMENT, FINANCIAL RESEARCH AND FINANCIAL PLANNING IN THE FIELD OF FRANCHISING; MONETARY AFFAIRS SERVICES, NAMELY, MONETARY EXCHANGE, MONETARY STRATEGY CONSULTATION AND RESEARCH; FINANCIAL CONSULTANCY; NONE OF THE AFOREMENTIONED SERVICES WITH RESPECT TO THE DISTRIBUTION OF ENERGY OR ELECTRICITY (U.S. CLS. 100, 101 AND 102).

## CLASS 38—COMMUNICATION

FOR TELECOMMUNICATIONS SERVICES, NAMELY, ELECTRONIC TRANSMISSION OF MESSAGES, TRANSMISSION OF VOICE, DATA, GRAPHICS, IMAGES, AUDIO AND VIDEO BY MEANS OF TELECOMMUNICATIONS NETWORKS, WIRELESS COMMUNICATION NETWORKS AND THE INTERNET; COMMUNICATIONS BY COMPUTER TERMINALS AND BY FIBRE OPTIC NETWORKS; RADIO BROADCASTING; COMMUNICATIONS BY TELEPHONE; COMMUNICATIONS BY MOBILE TELEPHONES; PROVIDING ACCESS TO A GLOBAL COMPUTER NETWORK FOR THE TRANSFER AND DISSEMINATION OF INFORMATION; RENTAL OF TELECOMMUNICATION EQUIPMENT; ELECTRONIC MESSAGE SENDING AND TRANSMISSION SERVICES; RENTAL OF ACCESS TIME TO GLOBAL COMPUTER NETWORKS; NONE OF THE AFOREMENTIONED SERVICES WITH RESPECT TO THE DISTRIBUTION OF ENERGY OR ELECTRICITY (U.S. CLS. 100, 101 AND 104).

## CLASS 39—TRANSPORTATION AND STORAGE

FOR TRANSPORT SERVICES, NAMELY, TRANSPORT OF GOODS; PACKAGING AND STORAGE OF GOODS; RENTAL AND HIRE OF VEHICLES; NONE OF THE AFOREMENTIONED SERVICES WITH RESPECT TO THE DISTRIBUTION OF ENERGY OR ELECTRICITY (U.S. CLS. 100 AND 105).

## CLASS 41—EDUCATION AND ENTERTAINMENT

FOR EDUCATION SERVICES, NAMELY, CLASSES, SEMINARS AND WORKSHOPS IN THE FIELD OF SALES AND USE OF SOFTWARE AND HARDWARE; PROVIDING OF TRAINING IN THE FIELD OF SALES AND USE OF SOFTWARE AND HARDWARE; ENTERTAINMENT SERVICES, NAMELY, PROVIDING FASHION SHOWS, DANCE PERFORMANCES, ART EXHIBITIONS AND LIVE MUSICAL PERFORMANCES; SPORTING AND CULTURAL ACTIVITIES, NAMELY, PROVIDING AUTOMOBILE RACING AND FOOTBALL GAMES, ORGANIZING EVENTS AND EXHIBITIONS FOR CULTURAL PURPOSES; NONE OF THE AFOREMENTIONED SERVICES WITH RESPECT TO THE DISTRIBUTION OF ENERGY OR ELECTRICITY (U.S. CLS. 100, 101 AND 107).

## CLASS 42—SCIENTIFIC AND COMPUTER SERVICES

FOR SCIENTIFIC AND TECHNOLOGICAL SERVICES AND RESEARCH AND DESIGN RELATING THERETO, NAMELY, SCIENTIFIC RESEARCH; INDUSTRIAL ANALYSIS AND RESEARCH SERVICES IN THE FIELDS OF STATISTICAL ANALYSIS FOR SCIENTIFIC PURPOSES AND COMPUTER SOFTWARE AND HARDWARE; DESIGN AND DEVELOPMENT OF COMPUTER HARDWARE AND SOFTWARE; RESEARCH AND DEVELOPMENT OF NEW PRODUCTS FOR OTHERS; RENTAL OF SOFTWARE; DATA CONVERSION OF COMPUTER PROGRAMS AND DATA, NOT PHYSICAL CONVERSION; CONVERSION OF DATA OR DOCUMENTS FROM PHYSICAL TO ELECTRONIC MEDIA; NONE OF THE AFOREMENTIONED SERVICES WITH RESPECT TO THE DISTRIBUTION OF ENERGY OR ELECTRICITY (U.S. CLS. 100 AND 101).

## CLASS 45—PERSONAL AND LEGAL SERVICES

FOR LEGAL SERVICES; LEGAL RESEARCH; LEGAL CONSULTANCY RELATING TO INTELLECTUAL PROPERTY RIGHTS; NONE OF THE AFOREMENTIONED SERVICES WITH RESPECT TO THE DISTRIBUTION OF ENERGY OR ELECTRICITY (U.S. CLS. 100 AND 101).

LINDA LAVACHE, EXAMINING ATTORNEY

SN 79-144,432. PHARMA ACTION GMBH, FED REP GERMANY, FILED 12-18-2013.

# HEPASAFE

THE MARK CONSISTS OF STANDARD CHARACTERS WITHOUT CLAIM TO ANY PARTICULAR FONT, STYLE, SIZE, OR COLOR.

PRIORITY DATE OF 10-15-2013 IS CLAIMED.  
OWNER OF INTERNATIONAL REGISTRATION 1196597 DATED 12-18-2013, EXPIRES 12-18-2023.

## CLASS 5—PHARMACEUTICALS

FOR PHARMACEUTICAL PREPARATIONS USED FOR THE TREATMENT OF DEEP VEIN THROMBOSIS, PULMONARY EMBOLISM, ARTERIAL EMBOLISM, UNSTABLE ANGINA PECTORIS, AND CYSTIC FIBROSIS; VETERINARY PREPARATIONS USED FOR THE TREATMENT OF DEEP VEIN THROMBOSIS, PULMONARY EMBOLISM, ARTERIAL EMBOLISM, AND UNSTABLE ANGINA PECTORIS IN RESPECT TO CATS, DOGS, RABBITS, DOMESTIC RODENTS, HORSES, COWS, PIGS, SHEEPS, AND GOATS; ADHESIVE MEDICAL PLASTERS; MEDICAL DRESSINGS; BANDAGES FOR DRESSINGS; BIOLOGICAL PREPARATIONS FOR MEDICAL USE IN THE TREATMENT OF DEEP VEIN THROMBOSIS, PULMONARY EMBOLISM, ARTERIAL EMBOLISM, UNSTABLE ANGINA PECTORIS, AND CYSTIC FIBROSIS; BIOLOGICAL PREPARATIONS FOR VETERINARY PURPOSES IN THE TREATMENT OF DEEP VEIN THROMBOSIS, PULMONARY EMBOLISM, ARTERIAL EMBOLISM, AND UNSTABLE ANGINA PECTORIS IN RESPECT TO CATS, DOGS, RABBITS, DOMESTIC RODENTS, HORSES, COWS, PIGS, SHEEPS, AND GOATS; CHEMICAL PREPARATIONS FOR PHARMACEUTICAL OR MEDICAL USE IN THE TREATMENT OF DEEP VEIN THROMBOSIS, PULMONARY EMBOLISM, ARTERIAL EMBOLISM, UNSTABLE ANGINA PECTORIS, AND CYSTIC FIBROSIS; CHEMICAL PREPARATIONS FOR VETERINARY PURPOSES IN THE TREATMENT OF DEEP VEIN THROMBOSIS, PULMONARY EMBOLISM, ARTERIAL EMBOLISM, AND UNSTABLE ANGINA PECTORIS IN RESPECT TO CATS, DOGS, RABBITS, DOMESTIC RODENTS, HORSES, COWS, PIGS, SHEEPS, AND GOATS; BLOOD FOR MEDICAL PURPOSES; ANTICOAGULANTS FOR BLOOD; BLOOD PLASMA; BLOOD PURIFICATION PREPARATIONS; OINTMENTS FOR PHARMACEUTICAL PURPOSES IN THE TREATMENT OF SUPERFICIAL THROMBOPHLEBITIS, SUPERFICIAL BRUISING, HAEMATOMA, HAEMORRHOIDS, PERIANAL ECZEMA, PRURITUS, ANAL FISSURE, PROCTITIS, PERIPROCTITIS; MEDICAL PREPARATIONS FOR PROPHYLAXIS AND THERAPY OF THROMBOSIS (U.S. CLS. 6, 18, 44, 46, 51 AND 52).

## CLASS 42—SCIENTIFIC AND COMPUTER SERVICES

FOR SCIENTIFIC LABORATORY SERVICES IN THE FIELD OF BLOOD AND BLOOD DISORDERS; SCIENTIFIC RESEARCH IN THE FIELD OF BLOOD AND BLOOD DISORDERS; MEDICAL RESEARCH; RESEARCH IN THE FIELD OF PHARMACY AND/OR MEDICINE; RESEARCH IN THE FIELD OF CHEMISTRY; PERFORMANCE OF CHEMICAL ANALYSES; BIOLOGICAL RESEARCH; QUALITY CONTROL FOR OTHERS; PERFORMANCE OF CLINICAL DRUG TESTING, NAMELY, CONDUCTING CLINICAL DRUG TRIALS FOR OTHERS (U.S. CLS. 100 AND 101).

## CLASS 44—MEDICAL, BEAUTY AND AGRICULTURAL SERVICES

FOR MEDICAL AND VETERINARY SERVICES; PHARMACY ADVICE, NAMELY, PHARMACEUTICAL ADVICE, IN PARTICULAR PROVIDING INFORMATION RELATING TO DIAGNOSTIC, PROPHYLACTIC AND THERAPEUTIC PROPERTIES OF PHARMACEUTICALS (U.S. CLS. 100 AND 101).  
HOWARD B. LEVINE, EXAMINING ATTORNEY

SN 79-144,520. CITIZEN HOLDINGS KABUSHIKI KAISHA, TA CITIZEN HOLDINGS CO., LTD., TOKYO, JAPAN, FILED 12-20-2013.

# LFV

PRIORITY DATE OF 10-21-2013 IS CLAIMED.  
OWNER OF INTERNATIONAL REGISTRATION 1196843 DATED 12-20-2013, EXPIRES 12-20-2023.

## CLASS 7—MACHINERY

FOR METAL WORKING MACHINES AND TOOLS, NAMELY, TURNING CENTERS, MACHINING CENTERS, LATHES FOR METALWORKING; LUMBERING, WOODWORKING, OR VENEER OR PLYWOOD MAKING MACHINES, NAMELY, WOOD LATHES, WOOD MILLING MACHINES; PLASTIC PROCESSING MACHINES; PLASTIC PROCESSING MACHINES, NAMELY, PLASTIC-CUTTING MACHINES; STONE WORKING MACHINES, NAMELY, MILLING MACHINES FOR THE TREATMENT OF STONES, GRINDING MACHINES FOR THE TREATMENT OF STONES, CERAMIC PROCESSING MACHINES, NAMELY, MILLING MACHINES FOR THE TREATMENT OF CERAMIC, GRINDING MACHINES FOR THE TREATMENT OF CERAMIC; MACHINES AND APPARATUS FOR MANUFACTURING RUBBER GOODS, NAMELY, RUBBER FORMING MACHINES; GLASS WORKING MACHINES, NAMELY, MILLING MACHINES FOR THE TREATMENT OF GLASS, GRINDING MACHINES FOR THE TREATMENT OF GLASS, GLASS-CUTTING MACHINES (U.S. CLS. 13, 19, 21, 23, 31, 34 AND 35).

## CLASS 9—ELECTRICAL AND SCIENTIFIC APPARATUS

FOR COMPUTER SOFTWARE FOR USE IN THE MAINTENANCE, DIAGNOSIS OR REPAIR OF MACHINE TOOLS AND NUMERICALLY CONTROLLED MACHINE TOOLS; COMPUTER SOFTWARE FOR PERFORMING MACHINING BY NUMERICALLY CONTROLLED MACHINE TOOLS; COMPUTER SOFTWARE FOR EDITING MACHINING PROGRAMS OF NUMERICALLY CONTROLLED MACHINE TOOLS (U.S. CLS. 21, 23, 26, 36 AND 38).

MAYUR VAGHANI, EXAMINING ATTORNEY

SN 79-144,628. TALENTIA SOFTWARE, RUEIL MALMAISON, FRANCE, FILED 11-13-2013.



PRIORITY DATE OF 5-24-2013 IS CLAIMED.  
OWNER OF INTERNATIONAL REGISTRATION 1197038 DATED 11-13-2013, EXPIRES 11-13-2023.

THE COLOR(S) PINK, YELLOW AND GRAY IS/ARE CLAIMED AS A FEATURE OF THE MARK.

THE MARK CONSISTS OF THE WORD "TALENTIA" IN GREY WITH A YELLOW DOT OVER THE LETTER "I" IN THE WORD "TALENTIA". A PINK CURVED LINE IS UNDER THE LETTERS "ENTIA" OF THE WORD "TALENTIA".

THE WORDING "TALENTIA" HAS NO MEANING IN A FOREIGN LANGUAGE.

**CLASS 9—ELECTRICAL AND SCIENTIFIC APPARATUS**

FOR COMPUTER SOFTWARE AND SOFTWARE PACKAGES FOR COMPANIES IN ALL FIELDS OF ACTIVITY FOR BUSINESS MANAGEMENT FOR MANAGING PAYROLL, TAX PREPARATION, MANAGING BUSINESS RECORDS, MANAGING COLLECTIONS AND PAYMENT, FINANCIAL ANALYSIS AND FINANCIAL REPORTING, ACCOUNTING, FINANCIAL CONSOLIDATION OF DATA, HUMAN RESOURCE MANAGEMENT RELATIVE TO STREAMLINING WORKFLOW, TRACKING PERFORMANCE AND COMPENSATION; COMPUTER PROGRAMS, NAMELY, DOWNLOADABLE SOFTWARE FOR MANAGING PAYROLL, TAX PREPARATION, MANAGING BUSINESS RECORDS, MANAGING COLLECTIONS AND PAYMENT, FINANCIAL ANALYSIS AND FINANCIAL REPORTING, ACCOUNTING, FINANCIAL CONSOLIDATION OF DATA, HUMAN RESOURCE MANAGEMENT RELATIVE TO STREAMLINING WORKFLOW, TRACKING PERFORMANCE AND COMPENSATION; RECORDED COMPUTER PROGRAMS FOR BUSINESS MANAGEMENT FOR MANAGING PAYROLL, TAX PREPARATION, MANAGING BUSINESS RECORDS, MANAGING COLLECTIONS AND PAYMENT, FINANCIAL ANALYSIS AND FINANCIAL REPORTING, ACCOUNTING, CONSOLIDATION, HUMAN RESOURCE MANAGEMENT RELATIVE TO STREAMLINING WORKFLOW, TRACKING PERFORMANCE AND COMPENSATION; RECORDED COMPUTER OPERATING PROGRAMS (U.S. CLS. 21, 23, 26, 36 AND 38).

**CLASS 35—ADVERTISING AND BUSINESS**

FOR PROVIDING BUSINESS ADVICE TO COMPANIES IN ALL SECTORS OF ACTIVITY IN CONNECTION WITH BUSINESS MANAGEMENT AND ORGANIZATION, BUSINESS RESEARCH AND INVESTIGATIONS, MARKET STUDIES, BUSINESS EFFICIENCY EXPERTS; COMPUTER FILE MANAGEMENT, COLLECTION AND SYSTEMATIZATION OF DATA IN A CENTRAL FILE; DATABASE MANAGEMENT, NAMELY, DATA SEARCH IN COMPUTER FILES FOR OTHERS (U.S. CLS. 100, 101 AND 102).

**CLASS 38—COMMUNICATION**

FOR TELECOMMUNICATION SERVICES, NAMELY, PROVIDING USER ACCESS TO GLOBAL COMPUTER NETWORK; ELECTRONIC MESSAGING; COMPUTER-AIDED MESSAGE AND IMAGE TRANSMISSION; TRANSMISSION OF INFORMATION HELD IN DATA BANKS INTENDED FOR COMPANIES; COMMUNICATION SERVICE VIA COMPUTER TERMINALS ON NATIONAL AND GLOBAL NETWORKS; INFORMATION TRANSMISSION SERVICES VIA ELECTRONIC AND TELEMATIC MEANS, PARTICULARLY VIA GLOBAL COMMUNICATION NETWORKS, PARTICULARLY THE INTERNET, OR VIA PRIVATE OR RESERVED ACCESS INTRANET NETWORKS, WITH A VIEW TO ENABLING EXCHANGES OF GOODS AND SERVICES BETWEEN COMPANIES (U.S. CLS. 100, 101 AND 104).

**CLASS 41—EDUCATION AND ENTERTAINMENT**

FOR ORGANIZATION AND CONDUCTING OF TRAINING WORKSHOPS FOR USING COMPUTER SOFTWARE; EDUCATIONAL SERVICES, NAMELY, ORGANIZATION AND CONDUCTING OF COLLOQUIUMS, CONFERENCES, CONGRESSES AND SEMINARS FOR USING COMPUTER SOFTWARE; EDUCATIONAL SERVICES, NAMELY, PROVIDING CORRESPONDENCE COURSES FOR USING COMPUTER SOFTWARE; PUBLISHING OF ELECTRONIC PUBLICATIONS ONLINE; PRACTICAL TRAINING, NAMELY, PROVIDING EDUCATIONAL DEMONSTRATIONS FOR USING COMPUTER SOFTWARE; PUBLICATION OF BOOKS, ELECTRONIC PUBLICATION OF BOOKS AND PERIODICALS ONLINE, PUBLICATION OF TEXTS OTHER THAN ADVERTISING TEXTS (U.S. CLS. 100, 101 AND 107).

**CLASS 42—SCIENTIFIC AND COMPUTER SERVICES**

FOR DESIGN AND DEVELOPMENT OF COMPUTER PROGRAMS, SOFTWARE AND SOFTWARE PACKAGES; COMPUTER SYSTEM DESIGN SERVICES; DATA CONVERSION OF COMPUTER PROGRAMS AND DATA, NOT PHYSICAL CONVERSION; CONVERSION OF DATA OR DOCUMENTS FROM PHYSICAL TO ELECTRONIC MEDIA; RENTAL AND MAINTENANCE OF SOFTWARE AND SOFTWARE PACKAGES; DUPLICATION OF COMPUTER PROGRAMS; TECHNICAL PROJECT STUDIES, NAMELY, CONDUCTING OF FEASIBILITY STUDIES; PROGRAMMING FOR COMPUTERS; RENTAL OF HOSTED COMPUTER SOFTWARE APPLICATIONS FOR DATA TRANSFER; TECHNICAL ASSISTANCE IN CONNECTION WITH BUSINESS-ORIENTED DATA PROCESSING, NAMELY, DESIGN AND DEVELOPMENT OF COMPUTER PROGRAMS FOR BUSINESS DATA PROCESSING (U.S. CLS. 100 AND 101).  
DAVID MURRAY, EXAMINING ATTORNEY

---

SN 79-144,633. BIOMÉRIEUX, FRANCE, FILED 8-26-2013.

# SCANRDI

THE MARK CONSISTS OF STANDARD CHARACTERS WITHOUT CLAIM TO ANY PARTICULAR FONT, STYLE, SIZE, OR COLOR.

PRIORITY DATE OF 4-30-2013 IS CLAIMED.  
OWNER OF INTERNATIONAL REGISTRATION 1197046 DATED 8-26-2013, EXPIRES 8-26-2023.  
OWNER OF U.S. REG. NO. 2,402,392.

**CLASS 1—CHEMICALS**

FOR CHEMICAL AND BIOCHEMICAL PRODUCTS FOR USE IN INDUSTRY AND SCIENCE, CHEMICAL AND BIOCHEMICAL SUBSTANCES, SOLUTIONS, MEDIA AND REAGENTS NOT FOR MEDICAL USE, FOR COLLECTING, ANALYZING, MONITORING AND DETECTING CONTAMINANTS IN INDUSTRIAL, AGRIFOOD, COSMETIC, PHARMACEUTICAL AND VETERINARY PRODUCTS AND IN THE PRODUCTION ENVIRONMENT FOR THESE PRODUCTS AS IT RELATES TO WATER, AIR, WORK SURFACES, NAMELY, CHEMICALS FOR USE IN THE DIAGNOSTIC FIELD IN INDUSTRY AND SCIENCE; COLORANTS FOR ANALYSIS, MONITORING AND DIAGNOSIS, NAMELY, CHEMICALS FOR USE IN THE DIAGNOSTIC FIELD IN INDUSTRY AND SCIENCE; CHEMICAL PRODUCTS FOR USE IN INDUSTRY AND SCIENCE, NAMELY, CHEMICALS FOR USE IN THE DIAGNOSTIC FIELD (U.S. CLS. 1, 5, 6, 10, 26 AND 46).

**CLASS 5—PHARMACEUTICALS**

FOR REAGENTS AND CULTURE MEDIA FOR MEDICAL, PHARMACEUTICAL AND VETERINARY USE, NAMELY, MEDICAL DIAGNOSTIC REAGENTS, REAGENTS FOR MEDICAL USE, MEDIA FOR BACTERIOLOGICAL CULTURES; CHEMICAL PREPARATIONS FOR MEDICAL, PHARMACEUTICAL AND VETERINARY USE, NAMELY, FOR DIAGNOSTIC USE (U.S. CLS. 6, 18, 44, 46, 51 AND 52).

**CLASS 9—ELECTRICAL AND SCIENTIFIC APPARATUS**

FOR SCIENTIFIC APPARATUS AND INSTRUMENTS, NAMELY, IMMUNO ANALYSERS, NUCLEIC ACID ANALYSERS, BACTERIOLOGIC ANALYSERS, MICROBIOLOGIC ANALYSERS, COMPUTER SOFTWARE USED TO PROCESS AND INTERPRET THE RESULTS OF TESTS ENSUING FROM THE ABOVE APPARATUS AND INSTRUMENTS, DIAGNOSTIC APPARATUS NOT FOR MEDICAL PURPOSES, NAMELY, EQUIPMENT AND DEVICES IN THE NATURE OF IMMUNO ANALYSERS, BACTERIOLOGIC AND MICROBIOLOGIC ANALYSERS, MOLECULAR ANALYSERS, BIOCHEMISTRY ANALYSERS; ALL THE AFOREMENTIONED GOODS USED ALONE OR IN COMBINATION FOR USE AT THE ANALYSIS AND STUDY PHASES OF SAMPLING, WITH THE AIM OF OBTAINING A RESULT INDICATING THE PRESENCE OR ABSENCE OF MICRO-ORGANISMS (U.S. CLS. 21, 23, 26, 36 AND 38).

**CLASS 10—MEDICAL APPARATUS**

FOR SCIENTIFIC MEDICAL APPARATUS AND INSTRUMENTS, NAMELY, EQUIPMENT AND DEVICES IN THE NATURE OF IMMUNO ANALYSERS, NUCLEIC ACID ANALYSERS, BACTERIOLOGIC ANALYSERS, MICROBIOLOGIC ANALYSERS, USED ALONE OR IN COMBINATION IN THE ANALYSIS AND STUDY PHASES OF SAMPLING SO AS TO OBTAIN A RESULT INDICATING THE PRESENCE OR ABSENCE OF INFECTIOUS DISEASES (U.S. CLS. 26, 39 AND 44).

**CLASS 37—CONSTRUCTION AND REPAIR**

FOR INSTALLATION, REPAIR AND MAINTENANCE OF IN VITRO DIAGNOSTIC APPARATUS AND INSTRUMENTS, NAMELY, EQUIPMENT AND DEVICES IN THE NATURE OF IMMUNO ANALYSERS, NUCLEIC ACID ANALYSERS, BACTERIOLOGIC ANALYSERS, MICROBIOLOGIC ANALYSERS, USED ALONE OR IN COMBINATION; TECHNICAL DEVELOPMENT, NAMELY, PROVIDING TECHNICAL ADVICE CONCERNING THE INSTALLATION, REPAIR AND MAINTENANCE OF SYSTEMS OR COMBINATIONS OF SYSTEMS FOR IN VITRO DIAGNOSIS SYSTEMS TAILORED TO MEET THE CLIENT'S NEEDS (U.S. CLS. 100, 103 AND 106).

MARK SPARACINO, EXAMINING ATTORNEY

---

SN 79-145,101. PEGASO CONTROL SYSTEM S.R.L., (VERONA), ITALY, FILED 3-5-2014.

# FOTOSMILE

THE MARK CONSISTS OF STANDARD CHARACTERS WITHOUT CLAIM TO ANY PARTICULAR FONT, STYLE, SIZE, OR COLOR.

OWNER OF INTERNATIONAL REGISTRATION 1198291 DATED 3-5-2014, EXPIRES 3-5-2024.

**CLASS 9—ELECTRICAL AND SCIENTIFIC APPARATUS**

FOR PHOTOGRAPHIC, CINEMATOGRAPHIC, OPTICAL, SIGNALLING APPARATUS AND INSTRUMENTS, NAMELY, CAMERAS, CAMERA HARDWARE SYSTEMS FOR IP (INTERNET PROTOCOL) VIDEO SURVEILLANCE, DIGITAL CAMERAS, DIGITAL VIDEO CAMERAS, MOTION-ACTIVATED CAMERAS, VIDEO CAMERAS, WIRELESS COMMUNICATION DEVICES FOR TRANSMITTING IMAGES TAKEN BY A CAMERA; APPARATUS FOR RECORDING, TRANSMISSION OR REPRODUCTION OF SOUND OR IMAGES; BLANK MAGNETIC DATA CARRIERS; BLANK RECORDABLE DVDS; BLANK RECORDABLE CDS; BLANK RECORDABLE OPTICAL DISCS; COIN-OPERATED MECHANISMS, NAMELY, PHOTOGRAPHY AND VIDEOGRAPHY BOOTHS FOR TAKING OF PICTURES AND VIDEOS; DATA PROCESSING EQUIPMENT, AND COMPUTERS; COMPUTER SOFTWARE FOR USE IN DATABASE MANAGEMENT, USE AS A SPREADSHEET, AND WORD PROCESSING (U.S. CLS. 21, 23, 26, 36 AND 38).

**CLASS 16—PAPER GOODS AND PRINTED MATTER**

FOR PAPER, CARDBOARD AND GOODS MADE FROM THESE MATERIALS, NAMELY, GIFT BOXES MADE OF CARDBOARD; PRINTED MATTER, NAMELY, PAPER SIGNS, BOOKS, MANUALS, CURRICULA, NEWSLETTERS, INFORMATIONAL CARDS AND/OR BROCHURES IN THE FIELD OF HISTORY, TRAVEL AND CURRENT EVENTS; BOOKBINDING MATERIAL; PHOTOGRAPHS; ARTISTS' MATERIALS, NAMELY, ARTISTS' PASTELS, ARTISTS' PENCILS, ARTISTS' PENS, ARTISTS' WATERCOLOR SAUCERS, CANVAS PANELS FOR ARTISTS, CANVAS STRETCHER BARS FOR ARTISTS; PLASTIC BAGS AND BUBBLE PACKS FOR PACKAGING; PRINTING BLOCKS (U.S. CLS. 2, 5, 22, 23, 29, 37, 38 AND 50).

**CLASS 37—CONSTRUCTION AND REPAIR**

FOR INSTALLATION AND MAINTENANCE OF PHOTOGRAPHIC SYSTEM USED TO PHOTOGRAPH RIDERS DURING RIDES AT AMUSEMENT PARKS AND AUTOMATIC PHOTO BOOTHS (U.S. CLS. 100, 103 AND 106).

**CLASS 42—SCIENTIFIC AND COMPUTER SERVICES**

FOR SCIENTIFIC AND TECHNOLOGICAL SERVICES, NAMELY, SCIENTIFIC RESEARCH, ANALYSIS AND TESTING IN THE FIELD OF MACHINE DESIGN AND CONTROL OF MACHINERY; INDUSTRIAL ANALYSIS AND RESEARCH IN THE FIELD OF ELECTRONIC DIGITIZING OF PHOTOGRAPHS INTO A COMPUTER READABLE MEDIA; DESIGN AND DEVELOPMENT OF COMPUTER HARDWARE AND SOFTWARE (U.S. CLS. 100 AND 101).

MATTHEW CUCCIAS, EXAMINING ATTORNEY

---

SN 79-145,189. SCHMITZ-WERKE GMBH + CO. KG, FED REP GERMANY, FILED 12-17-2013.

# TRACFIX

THE MARK CONSISTS OF STANDARD CHARACTERS WITHOUT CLAIM TO ANY PARTICULAR FONT, STYLE, SIZE, OR COLOR.

PRIORITY DATE OF 6-19-2013 IS CLAIMED.

OWNER OF INTERNATIONAL REGISTRATION 1198522 DATED 12-17-2013, EXPIRES 12-17-2023.

**CLASS 6—METAL GOODS**

FOR AWNINGS OF METAL (U.S. CLS. 2, 12, 13, 14, 23, 25 AND 50).

**CLASS 22—CORDAGE AND FIBERS**

FOR AWNINGS OF TEXTILES; AWNINGS OF SYNTHETIC MATERIALS (U.S. CLS. 1, 2, 7, 19, 22, 42 AND 50).

**CLASS 24—FABRICS**

FOR FABRICS, NAMELY, UPHOLSTERY FABRICS FOR USE ON GARDEN FURNITURE, BALCONY SEATING, DECK CHAIRS, AND FOR USE ON SEATS FOR AUTOMOBILES AND BOATS (U.S. CLS. 42 AND 50).  
DAVID ELTON, EXAMINING ATTORNEY

SN 79-145,238. ITALIANA FERRAMENTA S.R.L., ITALY, FILED 1-24-2014.



OWNER OF INTERNATIONAL REGISTRATION 1198602 DATED 1-24-2014, EXPIRES 1-24-2024.

NO CLAIM IS MADE TO THE EXCLUSIVE RIGHT TO USE "ITALIANA FERRAMENTA", APART FROM THE MARK AS SHOWN.

THE MARK CONSISTS OF THE LETTERS "IF" IN A SINGLE-LINE CIRCLE, WITH AN ANGLED LINE THROUGH THE DOT OF THE LETTER "I", NEXT TO THE WORDING "ITALIANA FERRAMENTA" IN STYLIZED FORM WITH A FOUR-POINTED STAR AT THE TOP OF THE LETTER "N" IN "ITALIANA".

THE ENGLISH TRANSLATION OF "ITALIANA FERRAMENTA" IN THE MARK IS "ITALIAN HARDWARE".

**CLASS 6—METAL GOODS**

FOR COMMON METALS AND THEIR ALLOYS; METAL BUILDING MATERIALS, NAMELY, METAL CONSTRUCTION PROFILES FOR ARRANGING DEVICES ON AND IN WALLS, CEILING AND OTHER SURFACE, METAL FITTINGS FOR FURNITURE; TRANSPORTABLE BUILDINGS OF METAL; MATERIALS OF METAL FOR RAILWAY TRACKS, NAMELY, METAL RAILROAD TIES; NON-ELECTRIC CABLES AND WIRES OF COMMON METAL; PIPES AND TUBES OF METAL; METAL SAFES; GOODS OF COMMON METAL NOT INCLUDED IN OTHER CLASSES, NAMELY, BRACKETS FOR GENERAL USE, PLATES, SHEETS, SHELVES, FRAMEWORKS, SCREWS, HINGES, HANGERS, NUTS; IRON ORES; IRONMONGERY, NAMELY, SHELF SUPPORT BRACKETS, DOOR BUFFERS OF METAL; METAL HARDWARE, NAMELY, PULLEYS, SPRINGS; FITTINGS OF METAL FOR FURNITURE (U.S. CLS. 2, 12, 13, 14, 23, 25 AND 50).

**CLASS 20—FURNITURE AND ARTICLES NOT OTHERWISE CLASSIFIED**

FOR FURNITURE, MIRRORS, PICTURE FRAMES; GOODS NOT INCLUDED IN OTHER CLASSES, NAMELY, SHELVES OF WOOD, CORK, REED, CANE, WICKER, HORN, BONE, IVORY, WHALEBONE, SHELL, AMBER, MOTHER-OF-PEARL, MEERSCHAUM AND SUBSTITUTES FOR ALL THESE MATERIALS, OR OF PLASTICS; FITTINGS, NOT OF METAL, FOR FURNITURE (U.S. CLS. 2, 13, 22, 25, 32 AND 50).  
ALLISON HOLTZ, EXAMINING ATTORNEY

SN 79-145,421. SEGESTA YACHTING S.R.L., ITALY, FILED 1-8-2014.

**SEGESTA YACHTING**

THE MARK CONSISTS OF STANDARD CHARACTERS WITHOUT CLAIM TO ANY PARTICULAR FONT, STYLE, SIZE, OR COLOR.

PRIORITY DATE OF 7-16-2013 IS CLAIMED.

OWNER OF INTERNATIONAL REGISTRATION 1199055 DATED 1-8-2014, EXPIRES 1-8-2024.

NO CLAIM IS MADE TO THE EXCLUSIVE RIGHT TO USE "YACHTING", APART FROM THE MARK AS SHOWN.

**CLASS 12—VEHICLES**

FOR VEHICLES AND APPARATUS FOR LOCOMOTION BY WATER, NAMELY, BOATS, SHIPS AND YACHTS (U.S. CLS. 19, 21, 23, 31, 35 AND 44).

**CLASS 25—CLOTHING**

FOR CLOTHING, NAMELY, PANTS, SHIRTS, DRESSES, COATS, SHORTS, SWEATERS, FOOTWEAR, AND HEADWEAR (U.S. CLS. 22 AND 39).  
TRACY FLETCHER, EXAMINING ATTORNEY

SN 79-145,483. NEMIROFF; INTELLECTUAL PROPERTY ESTABLISHMENT, VADÚZ, LIECHTENSTEIN, FILED 2-11-2014.

**NEWMIROFF**

PRIORITY DATE OF 10-3-2013 IS CLAIMED.

OWNER OF INTERNATIONAL REGISTRATION 1199247 DATED 2-11-2014, EXPIRES 2-11-2024.

OWNER OF U.S. REG. NOS. 3,006,780, 4,215,936 AND OTHERS.

THE MARK CONSISTS OF THE WORDING "NEWMIROFF" IN STYLIZED FONT.

**CLASS 33—WINES AND SPIRITS**

FOR ALCOHOLIC BEVERAGES EXCEPT BEERS, NAMELY, VODKA (U.S. CLS. 47 AND 49).

**CLASS 35—ADVERTISING AND BUSINESS**

FOR ADVERTISING SERVICES, BUSINESS MANAGEMENT SERVICES, BUSINESS ADMINISTRATION, PROVIDING OFFICE FUNCTIONS; IMPORTATION AND EXPORTATION AGENCY SERVICES FEATURING ALCOHOLIC BEVERAGES; RETAIL STORE AND WHOLESALE DISTRIBUTORSHIP SERVICES FEATURING ALCOHOLIC BEVERAGES (U.S. CLS. 100, 101 AND 102).  
MICHELLE DUBOIS, EXAMINING ATTORNEY

SN 79-145,732. DREVE DENTAMID GMBH, FED REP GERMANY, FILED 2-28-2014.

**DocSnoreNix**

THE MARK CONSISTS OF STANDARD CHARACTERS WITHOUT CLAIM TO ANY PARTICULAR FONT, STYLE, SIZE, OR COLOR.

OWNER OF INTERNATIONAL REGISTRATION 1199827 DATED 2-28-2014, EXPIRES 2-28-2024.



**CLASS 5—PHARMACEUTICALS**

FOR MEDICATED NASAL STRIPS FOR THE TREATMENT OF SNORING; PHARMACEUTICAL PREPARATIONS FOR THE TREATMENT OF SNORING (U.S. CLS. 6, 18, 44, 46, 51 AND 52).

**CLASS 10—MEDICAL APPARATUS**

FOR RESPIRATORY MASKS FOR ARTIFICIAL RESPIRATION FOR MEDICAL PURPOSES; MEDICAL APPARATUS FOR THE TREATMENT OF SNORING, NAMELY, EXTERNAL NASAL DILATORS, INTERNAL NASAL DILATORS, THERAPEUTIC MOUTHPIECES FOR THE PREVENTION OF SNORING, THERAPEUTIC NOSE CLIPS FOR THE PREVENTION OF SNORING, MANDIBULAR REPOSITIONING DEVICES, TONGUE RETAINING DEVICES; MEDICAL APPARATUS AND INSTRUMENTS, NAMELY, CONTINUOUS POSITIVE AIRWAY PRESSURE (CPAP) DEVICES; TESTING APPARATUS FOR MEDICAL PURPOSES, NAMELY, DEVICES FOR MEASURING LEG MOVEMENTS DURING SLEEP, POLYSOMNOGRAPHS, ELECTROENCEPHALOGRAPHY, ELECTROMYOGRAPHY, ELECTROOCULOGRAPHY; THERAPEUTIC, HEATING, AND ORTHOPEDIC CUSHIONS FOR MEDICAL PURPOSES (U.S. CLS. 26, 39 AND 44).

LEIGH LOWRY, EXAMINING ATTORNEY

SN 79-145,736. BOEHRINGER INGELHEIM INTERNATIONAL GMBH, FED REP GERMANY, FILED 2-19-2014.

**RE-SPECT ESUS**

THE MARK CONSISTS OF STANDARD CHARACTERS WITHOUT CLAIM TO ANY PARTICULAR FONT, STYLE, SIZE, OR COLOR.

PRIORITY DATE OF 11-15-2013 IS CLAIMED.

OWNER OF INTERNATIONAL REGISTRATION 1199836 DATED 2-19-2014, EXPIRES 2-19-2024.

NO CLAIM IS MADE TO THE EXCLUSIVE RIGHT TO USE "ESUS", APART FROM THE MARK AS SHOWN.

**CLASS 41—EDUCATION AND ENTERTAINMENT**

FOR PUBLICATION OF PRINTED MATTER WITH THE RESULTS OF CLINICAL STUDIES INVOLVING PHARMACEUTICAL PREPARATIONS INCLUDING IN ELECTRONIC FORM (U.S. CLS. 100, 101 AND 107).

**CLASS 42—SCIENTIFIC AND COMPUTER SERVICES**

FOR CONDUCTING OF CLINICAL STUDIES FOR PHARMACEUTICAL PREPARATIONS (U.S. CLS. 100 AND 101).

MATTHEW EINSTEIN, EXAMINING ATTORNEY

SN 79-145,761. VALADE, LUBERSAC, FRANCE, FILED 2-3-2014.

**LEONCE BLANC**

THE MARK CONSISTS OF STANDARD CHARACTERS WITHOUT CLAIM TO ANY PARTICULAR FONT, STYLE, SIZE, OR COLOR.

PRIORITY DATE OF 9-19-2013 IS CLAIMED.

OWNER OF INTERNATIONAL REGISTRATION 1199900 DATED 2-3-2014, EXPIRES 2-3-2024.

THE NAME(S), PORTRAIT(S), AND/OR SIGNATURE(S) SHOWN IN THE MARK DOES NOT IDENTIFY A PARTICULAR LIVING INDIVIDUAL.

**CLASS 29—MEATS AND PROCESSED FOODS**

FOR PRESERVED FRUITS, CANNED FRUITS, FROZEN FRUITS, DRIED FRUITS, STEWED FRUITS, CRYSTALLIZED FRUITS; DRIED FRUIT-BASED SNACKS, FRUIT COMPOTES AND PUREED FRUIT, FRUIT JEL-LIES; JAMS, MARMALADES; FRUIT PULP, FRUIT SALADS, FRUIT CHIPS, FRUIT PEEL (U.S. CL. 46).

**CLASS 30—STAPLE FOODS**

FOR FLOUR PREPARATIONS FROM CEREAL, NAMELY, BISCUITS AND CAKES; PASTRY AND CONFECTIONERY, NAMELY, CONFECTIONERY MADE OF SUGAR, FROZEN CONFECTIONERY, FONDANTS; EDIBLE ICES, SUGAR, HONEY, GOLDEN SYRUP; SAUCES, NAMELY, FRUIT COULIS, INT (U.S. CL. 46).

**CLASS 32—LIGHT BEVERAGES**

FOR FRUIT BEVERAGES AND FRUIT JUICES; FRUIT NECTARS; NON-ALCOHOLIC FRUIT EXTRACTS FOR USE IN PREPARATION OF BEVERAGES (U.S. CLS. 45, 46 AND 48).

PRISCILLA MILTON, EXAMINING ATTORNEY

SN 79-145,931. ARTURO SALICE S.P.A., I-22060 NOVEDRATE (CO), ITALY, FILED 10-16-2013.

**Lapis**

PRIORITY DATE OF 5-30-2013 IS CLAIMED.  
OWNER OF INTERNATIONAL REGISTRATION 1200348 DATED 10-16-2013, EXPIRES 10-16-2023.

THE MARK CONSISTS OF THE STYLIZED WORD "LAPIS" WHERE THE DOT ABOVE THE LETTER "I" IS FORMED BY A TRIANGLE.

**CLASS 6—METAL GOODS**

FOR HINGES AND AESTHETIC OR PROTECTIVE CASINGS OF METAL (U.S. CLS. 2, 12, 13, 14, 23, 25 AND 50).

**CLASS 20—FURNITURE AND ARTICLES NOT OTHERWISE CLASSIFIED**

FOR HINGES AND AESTHETIC OR PROTECTIVE CASINGS OF PLASTIC; FURNITURE (U.S. CLS. 2, 13, 22, 25, 32 AND 50).

ADA HAN, EXAMINING ATTORNEY

SN 79-145,935. YOAV MAZAR, HERZELIAH, ISRAEL, FILED 11-6-2013.

**SIMPLE PARENTING**

THE MARK CONSISTS OF STANDARD CHARACTERS WITHOUT CLAIM TO ANY PARTICULAR FONT, STYLE, SIZE, OR COLOR.

OWNER OF INTERNATIONAL REGISTRATION 1200361 DATED 11-6-2013, EXPIRES 11-6-2023.

**CLASS 12—VEHICLES**

FOR LAND VEHICLES; APPARATUS FOR LOCOMOTION BY LAND, NAMELY, BABY STROLLERS, BABY CARRIAGES, CHILDREN'S AND INFANT'S BICYCLES AND TRICYCLES, STRUCTURAL PARTS FOR ALL THE FOREGOING GOODS, AND ACCESSORIES FOR ALL THE FOREGOING GOODS, NAMELY, BICYCLE AND TRICYCLE BELLS AND HORNS, TRAINING WHEELS, BASKETS ADAPTED FOR BICYCLES AND TRICYCLES, AND CANOPIES AND COVERS FOR BABY STROLLERS; MOTORIZED AND NON-MOTORIZED SCOOTERS; SAFETY SEATS FOR USE IN CARS, PORTABLE BABIES' SAFETY SEATS FOR VEHICLES AND BOOSTERS SEATS FOR USE IN VEHICLES; STRUCTURAL PARTS AND FITTINGS FOR THE AFOREMENTIONED GOODS (U.S. CLS. 19, 21, 23, 31, 35 AND 44).

**CLASS 18—LEATHER GOODS**

FOR ALL-PURPOSE CARRYING BAGS; DIAPER BAGS; NAPPY BAGS; STROLLER BAGS IN THE NATURE OF DIAPER BAGS; CHANGING BAGS IN THE NATURE OF DIAPER BAGS; SUITCASES, POUCH BABY CARRIERS (U.S. CLS. 1, 2, 3, 22 AND 41).  
ADA HAN, EXAMINING ATTORNEY

SN 79-146,074. ALEXANDRA BERNHARDT, FED REP GERMANY, FILED 2-8-2014.

# SARENGUE

THE MARK CONSISTS OF STANDARD CHARACTERS WITHOUT CLAIM TO ANY PARTICULAR FONT, STYLE, SIZE, OR COLOR.

PRIORITY DATE OF 11-18-2013 IS CLAIMED.  
OWNER OF INTERNATIONAL REGISTRATION 1200716 DATED 2-8-2014, EXPIRES 2-8-2024.

**CLASS 9—ELECTRICAL AND SCIENTIFIC APPARATUS**

FOR PRE-RECORDED COMPACT DISCS IN THE FIELD OF MUSIC AND DANCE (U.S. CLS. 21, 23, 26, 36 AND 38).

**CLASS 41—EDUCATION AND ENTERTAINMENT**

FOR EDUCATIONAL SERVICES, NAMELY, CONDUCTING CLASSES AND WORKSHOPS IN THE FIELD OF PHYSICAL EXERCISE (U.S. CLS. 100, 101 AND 107).

**CLASS 44—MEDICAL, BEAUTY AND AGRICULTURAL SERVICES**

FOR THERAPY SERVICES, NAMELY, PHYSICAL THERAPY, INTEGRATED DANCE MOVEMENTS AND MUSIC THERAPY (U.S. CLS. 100 AND 101).  
MICHAEL KEATING, EXAMINING ATTORNEY

SN 79-146,231. SEKISUI SEIKI KOGYO KABUSHIKI KAISHA, DBA SEKISUI SEIKI, LTD, OSAKA, JAPAN, FILED 12-6-2013.

# Steritainer<sup>+</sup> PLUS

PRIORITY DATE OF 9-5-2013 IS CLAIMED.  
OWNER OF INTERNATIONAL REGISTRATION 1201148 DATED 12-6-2013, EXPIRES 12-6-2023.

THE MARK CONSISTS OF THE STYLIZED WORDING "STERITAINER" AND A RECTANGLE APPEARS AT THE LOWER RIGHT-HAND CORNER OF THE WORD "STERITAINER" WITH THE STYLIZED WORDING "PLUS" INSIDE THE RECTANGLE. ON THE UPPER RIGHT-HAND CORNER OF THE LETTER "R" OF THE WORD "STERITAINER" IS A PLUS SIGN DESIGN, THE LOWER RIGHT SIDE OF THE HORIZONTAL BAR OF THE PLUS SIGN DESIGN OVERLAPS THE LETTER "R" OF THE WORD "STERITAINER", FORMING A PLAIN SQUARE.

**CLASS 10—MEDICAL APPARATUS**

FOR PACIFIERS FOR BABIES; ICE BAG PILLOWS FOR MEDICAL PURPOSES; SUPPORTIVE BANDAGES; SURGICAL CATGUTS; FEEDING CUPS FOR MEDICAL PURPOSES; DROPPING PIPETTES FOR MEDICAL PURPOSES; TEATS; ICE BAGS FOR MEDICAL PURPOSES; ICE BAG HOLDERS FOR MEDICAL PURPOSES; BABY BOTTLES; VACUUM BABY BOTTLES FOR NURSING, NAMELY, BABY BOTTLES THAT SIMULATE BREAST-FEEDING; FINGER GUARDS FOR MEDICAL PURPOSES; ARTIFICIAL TYMPANIC MEMBRANES; PROSTHETIC OR FILLING MATERIALS, NOT FOR DENTAL USE, NAMELY, ARTIFICIAL MATERIALS FOR USE IN THE REPLACEMENT OF BONES; CONTAINERS FOR MEDICAL INSTRUMENTS; CONTAINERS FOR ESPECIALLY ADAPTED FOR DISPOSAL OF MEDICAL INSTRUMENTS, STERILIZATION OF MEDICAL INSTRUMENTS; CONTAINERS ESPECIALLY ADAPTED FOR DISPOSAL OF, STERILIZATION OF MEDICAL PARENTERAL AGENT; CONTAINERS ESPECIALLY ADAPTED FOR DISPOSAL OF, STERILIZATION OF MEDICATION; CONTAINERS FOR MEDICAL TRANSFUSION THAT ARE SOLD EMPTY; STERILIZATION BAGS FOR MEDICAL PURPOSES; MEDICAL APPARATUS AND INSTRUMENTS, NAMELY, MEDICAL APPARATUS AND INSTRUMENTS FOR USE IN SURGERY, MEDICAL APPARATUS FOR DETECTING CANCER; ELECTRIC MASSAGE APPARATUS FOR HOUSEHOLD PURPOSES; GLOVES FOR MEDICAL PURPOSES; URINALS FOR MEDICAL PURPOSES; BED PANS; EAR PICKS (U.S. CLS. 26, 39 AND 44).

**CLASS 20—FURNITURE AND ARTICLES NOT OTHERWISE CLASSIFIED**

FOR LOADING PALLETS, NOT OF METAL; VALVES OF PLASTICS NOT BEING MACHINE PARTS; LIQUID STORAGE TANKS, NOT OF METAL OR MASONRY, LIQUID STORAGE RESERVOIRS IN THE NATURE OF STORAGE DRUMS, NOT OF METAL OR MASONRY; INDUSTRIAL WATER TANKS, NOT OF METAL OR MASONRY; CONTAINERS FOR TRANSPORT, NOT OF METAL; INDUSTRIAL PACKAGING CONTAINERS OF PLASTICS; PLASTIC STOPPERS FOR INDUSTRIAL PACKAGING CONTAINERS; PLASTIC LIDS; WATER TANKS FOR HOUSEHOLD PURPOSES, NOT OF METAL OR MASONRY (U.S. CLS. 2, 13, 22, 25, 32 AND 50).  
KATHY WANG, EXAMINING ATTORNEY

SN 79-146,418. ASOCIACIÓN ESPAÑOLA DE NORMALIZACIÓN Y CERTIFICACIÓN (AENOR), E-28004 MADRID, SPAIN, FILED 1-23-2014.



PRIORITY DATE OF 7-31-2013 IS CLAIMED.  
OWNER OF INTERNATIONAL REGISTRATION 1201589  
DATED 1-23-2014, EXPIRES 1-23-2024.  
OWNER OF U.S. REG. NO. 4,423,491.  
THE MARK CONSISTS OF A VERTICAL RECTANGLE  
CONTAINING THE WORD "AENOR" APPEARING ABOVE  
A STYLIZED LETTER "N".

#### CLASS 41—EDUCATION AND ENTERTAINMENT

FOR EDUCATION SERVICES, NAMELY, PROVIDING CLASSES, SEMINARS AND WORKSHOPS IN THE FIELD OF THE ENVIRONMENT AND IMPROVING QUALITY, EXCELLENCE, SUSTAINABILITY AND COMPETITIVENESS OF COMPANIES' OFFICE SUPPLIES, ENERGY RESOURCES, BUSINESS PROCESSES AND CUSTOMER SERVICE; TRAINING IN THE FIELD OF THE ENVIRONMENT AND IMPROVING QUALITY, EXCELLENCE, SUSTAINABILITY AND COMPETITIVENESS OF COMPANIES' OFFICE SUPPLIES, ENERGY RESOURCES, BUSINESS PROCESSES AND CUSTOMER SERVICE; CULTURAL ACTIVITIES, NAMELY, ORGANIZATION OF CULTURAL SHOWS, ORGANIZATION OF EXHIBITIONS FOR CULTURAL PURPOSES AND ORGANIZING CULTURAL EVENTS IN THE FIELD OF THE ENVIRONMENT AND IMPROVING QUALITY, EXCELLENCE, SUSTAINABILITY AND COMPETITIVENESS OF COMPANIES' OFFICE SUPPLIES, ENERGY RESOURCES, BUSINESS PROCESSES AND CUSTOMER SERVICE (U.S. CLS. 100, 101 AND 107).

#### CLASS 42—SCIENTIFIC AND COMPUTER SERVICES

FOR SCIENTIFIC AND TECHNOLOGICAL SERVICES, NAMELY, SCIENTIFIC RESEARCH, ANALYSIS AND TESTING IN THE FIELD OF MANAGEMENT SYSTEMS; INDUSTRIAL ANALYSIS AND RESEARCH SERVICES IN THE FIELD OF MANAGEMENT SYSTEMS; DESIGN AND DEVELOPMENT OF COMPUTER HARDWARE AND SOFTWARE; ELECTRONIC CERTIFICATION SERVICES, NAMELY, TESTING, ANALYSIS AND EVALUATION OF THE GOODS AND SERVICES OF OTHERS VIA ELECTRONIC MEANS FOR THE PURPOSE OF CERTIFICATION; RESEARCH IN THE FIELD OF ENVIRONMENTAL PROTECTION; CHEMICAL, BIOLOGICAL AND PHYSICS RESEARCH; TECHNICAL RESEARCH IN THE FIELD OF MANAGEMENT SYSTEMS; RESEARCH AND DEVELOPMENT, IN THE FIELD OF MANAGEMENT SYSTEMS; RESEARCH AND DEVELOPMENT OF NEW PRODUCTS FOR OTHERS; MATERIALS TRIALS, NAMELY, CONDUCTING CLINICAL TRIALS FOR OTHERS; MATERIALS TESTING; CHEMICAL ANALYSIS; CONSULTANCY ON QUALITY CONTROL; PRODUCT QUALITY CONTROL AND TESTING; CERTIFICATION, NAMELY, TESTING, ANALYSIS AND EVALUATION OF THE GOODS AND SERVICES OF OTHERS FOR THE PURPOSE OF CERTIFICATION; QUALITY CONTROL FOR OTHERS; PROVIDING QUALITY ASSURANCE SERVICES VIA MONITORING PROCESSES IN THE FIELD OF SOFTWARE AND COMPUTER PROGRAMS AND TECHNOLOGICAL SYSTEMS; PROVIDING QUALITY ASSURANCE SERVICES IN THE FIELD OF SOFTWARE AND COMPUTER PROGRAMS AND TECHNOLOGICAL SYSTEMS (U.S. CLS. 100 AND 101).

CRISTIANA SCHWAB, EXAMINING ATTORNEY

SN 79-146,487. TRADECHANNEL HOLDING AB, STOCKHOLM, SWEDEN, FILED 12-18-2013.



PRIORITY DATE OF 11-26-2013 IS CLAIMED.  
OWNER OF INTERNATIONAL REGISTRATION 1201773  
DATED 12-18-2013, EXPIRES 12-18-2023.  
THE COLOR(S) BLACK, ORANGE AND GRAY IS/ARE  
CLAIMED AS A FEATURE OF THE MARK.

THE MARK CONSISTS OF THE WORDING "TRADESEC BY TRADECHANNEL" WITH "TRADE" IN BLACK, "SEC" IN ORANGE AND "BY TRADECHANNEL" IN GRAY, APPEARING AGAINST A TRIANGLE DESIGN COMPRISED OF ORANGE AND GRAY SQUARES.

#### CLASS 9—ELECTRICAL AND SCIENTIFIC APPARATUS

FOR COMPUTER SOFTWARE THAT ALLOWS USERS TO MONITOR AND MAKE FINANCIAL TRANSACTIONS, POSITIONS AND SECURITIES; INTERNET BASED COMPUTER SOFTWARE PLATFORMS, NAMELY, PROVIDING DOWNLOADABLE SOFTWARE THAT ALLOWS USERS TO MONITOR AND MAKE FINANCIAL TRANSACTIONS AND TO ACCESS INFORMATION FOR EXTERNAL PORTFOLIO MANAGERS AND TO COMMUNICATE BETWEEN APPLICATIONS (U.S. CLS. 21, 23, 26, 36 AND 38).

**CLASS 36—INSURANCE AND FINANCIAL**

FOR FINANCIAL ADVISORY SERVICES; PROVIDING REPORTING AND ANALYSIS SERVICES FOR OTHERS VIA A COMPUTER NETWORK, ALL IN THE FINANCIAL INDUSTRY, NAMELY, PROVIDING FINANCIAL ADVISORY SERVICES; COMPUTERIZED FINANCIAL INFORMATION SERVICES; FINANCIAL INFORMATION, DATA, ADVICE AND CONSULTANCY SERVICES; PROVISION OF FINANCIAL SERVICES BY MEANS OF A GLOBAL COMPUTER NETWORK OR THE INTERNET, NAMELY, PROVIDING FINANCIAL ADVISORY SERVICES; FINANCIAL INFORMATION MANAGEMENT AND ANALYSIS SERVICES, NAMELY, PROVIDING FINANCIAL ADVISORY SERVICES (U.S. CLS. 100, 101 AND 102).

**CLASS 42—SCIENTIFIC AND COMPUTER SERVICES**

FOR DESIGN, DEVELOPMENT AND IMPLEMENTATION OF SOFTWARE SOLUTIONS FOR MANAGING FINANCIAL PROCESSES; COMPUTER SOFTWARE CONSULTANCY SERVICES; INSTALLATION AND MAINTENANCE OF SOFTWARE; ADVISORY SERVICES IN THE FIELD OF PRODUCT DEVELOPMENT AND QUALITY IMPROVEMENT OF SOFTWARE (U.S. CLS. 100 AND 101).

**CLASS 45—PERSONAL AND LEGAL SERVICES**

FOR LICENSING OF COMPUTER SOFTWARE FOR THE FINANCIAL INDUSTRY (U.S. CLS. 100 AND 101).  
SEAN CROWLEY, EXAMINING ATTORNEY

SN 79-146,524. NUTRIQUINE, NAAMLOZE VENNOOTSCHAP, BELGIUM, FILED 2-18-2014.

# GASTRO 8

OWNER OF INTERNATIONAL REGISTRATION 1201888 DATED 2-18-2014, EXPIRES 2-18-2024.

NO CLAIM IS MADE TO THE EXCLUSIVE RIGHT TO USE "GASTRO", APART FROM THE MARK AS SHOWN.

**CLASS 5—PHARMACEUTICALS**

FOR PHARMACEUTICAL PREPARATIONS FOR TREATING GASTRIC IRRITATION AND GASTRIC ULCERS IN ANIMALS; VETERINARY PREPARATIONS FOR TREATING GASTRO-INTESTINAL DISEASES AND CONDITIONS IN HORSES; MINERAL FOOD SUPPLEMENTS FOR ANIMALS, SPECIFICALLY HORSES, FOR MEDICAL USE; VITAMIN PREPARATIONS FOR ANIMALS; HYGIENIC DISINFECTANTS FOR ANIMALS; PREPARATIONS FOR DESTROYING NOXIOUS ANIMALS; FUNGICIDES AND HERBICIDES (U.S. CLS. 6, 18, 44, 46, 51 AND 52).

**CLASS 31—NATURAL AGRICULTURAL PRODUCTS**

FOR LIVE ANIMALS; FODDER FOR ANIMALS; MALT FOR USE AS ANIMAL FOODSTUFFS (U.S. CLS. 1 AND 46).  
LINDA LAVACHE, EXAMINING ATTORNEY

SN 79-146,591. IMD - INTERNATIONAL INSTITUTE FOR MANAGEMENT DEVELOPMENT, CH-1007 LAUSANNE, SWITZERLAND, FILED 1-27-2014.

## SEVEN SEISMIC SHIFTS

THE MARK CONSISTS OF STANDARD CHARACTERS WITHOUT CLAIM TO ANY PARTICULAR FONT, STYLE, SIZE, OR COLOR.

PRIORITY DATE OF 11-12-2013 IS CLAIMED.  
OWNER OF INTERNATIONAL REGISTRATION 1202067 DATED 1-27-2014, EXPIRES 1-27-2024.

**CLASS 9—ELECTRICAL AND SCIENTIFIC APPARATUS**

FOR DOWNLOADABLE ELECTRONIC PUBLICATIONS, IN THE NATURE OF MAGAZINES, PAMPHLETS, BROCHURES, LECTURE PRESENTATION MATERIALS AND DIGITAL AUDIO AND DOWNLOADABLE VIDEO DOWNLOADABLE DIGITAL AND AUDIO FILES, ALL IN THE FIELDS OF ECONOMICS AND BUSINESS, AS WELL AS IN THE FIELDS OF MANAGEMENT, LEADERSHIP, MARKETING, ADMINISTRATION, NON-SCIENTIFIC RESEARCH AND HUMAN RESOURCES, AND ALL INTENDED TO IMPROVE THE PERFORMANCE OF PUBLIC AND PRIVATE CORPORATIONS; PRERECORDED MAGNETIC OR OPTICAL DATA CARRIERS, NAMELY, COMPACT DISCS, COMPACT DISCS READ-ONLY MEMORY (CD-ROM), AND DIGITAL VERSATILE DISCS AND OPTICAL DISCS (DVDs), ALL FEATURING INFORMATION IN THE FIELDS OF BUSINESS AND ECONOMICS, AS WELL AS IN THE FIELDS OF MANAGEMENT, LEADERSHIP, MARKETING, ADMINISTRATION, NON-SCIENTIFIC RESEARCH AND HUMAN RESOURCES, AND ALL INTENDED TO IMPROVE THE PERFORMANCE OF PUBLIC OR PRIVATE CORPORATIONS; DOWNLOADABLE COMPUTER SOFTWARE AND MICRO-SOFTWARE FOR MICRO-COMPUTERS, LAPTOPS, TABLETS AND SMARTPHONES FOR THE PURPOSE OF PROVIDING INFORMATION RELATED TO MANAGEMENT, LEADERSHIP, MARKETING, ADMINISTRATION, NON-SCIENTIFIC RESEARCH AND HUMAN RESOURCES (U.S. CLS. 21, 23, 26, 36 AND 38).

**CLASS 16—PAPER GOODS AND PRINTED MATTER**

FOR TEACHING AND INSTRUCTIONS MANUALS IN THE FIELD OF BUSINESS MANAGEMENT; BOOKS IN THE FIELD OF BUSINESS MANAGEMENT, MARKETING AND HUMAN RESOURCES; PRINTED PUBLICATIONS, NAMELY, BROCHURES, PAMPHLETS AND LECTURE PRESENTATIONS IN THE FIELD OF BUSINESS MANAGEMENT, MARKETING AND HUMAN RESOURCES; PRINTED EDUCATIONAL, INSTRUCTIONAL AND TEACHING MATERIALS IN THE FIELD OF BUSINESS MANAGEMENT, MARKETING AND HUMAN RESOURCES (U.S. CLS. 2, 5, 22, 23, 29, 37, 38 AND 50).

**CLASS 35—ADVERTISING AND BUSINESS**

FOR BUSINESS ORGANIZATION AND MANAGEMENT CONSULTANCY INTENDED TO IMPROVE THE PERFORMANCE OF PUBLIC OR PRIVATE CORPORATIONS; BUSINESS INFORMATION; BUSINESS INVESTIGATIONS; BUSINESS MANAGEMENT ASSISTANCE INTENDED TO IMPROVE THE PERFORMANCE OF PUBLIC OR PRIVATE CORPORATIONS; COMMERCIAL OR INDUSTRIAL MANAGEMENT ASSISTANCE INTENDED TO IMPROVE THE PERFORMANCE OF SUCH BUSINESSES; COMPILATION OF ECONOMIC AND BUSINESS DATA IN A CENTRAL DATABASE FILE ON BEHALF OF PUBLIC OR PRIVATE CORPORATIONS; COMPILATION OF ECONOMIC AND BUSINESS STATISTICS; ECONOMIC FORECASTING; BUSINESS EFFICIENCY EXPERTS; MARKET RESEARCH; MARKET STUDIES; HUMAN RESOURCES CONSULTANCY PERTAINING TO PERSONNEL ISSUES (U.S. CLS. 100, 101 AND 102).

**CLASS 41—EDUCATION AND ENTERTAINMENT**

FOR ARRANGING AND CONDUCTING OF SEMINARS, WORKSHOPS, EDUCATIONAL CONFERENCES AND LECTURES AND PRACTICAL COURSES ON ECONOMICS AND BUSINESS, AS WELL AS IN THE FIELDS OF MANAGEMENT, LEADERSHIP, MARKETING, ADMINISTRATION, NON-SCIENTIFIC RESEARCH AND HUMAN RESOURCES, ALL OF WHICH ARE INTENDED TO IMPROVE THE PERFORMANCE OF PUBLIC AND PRIVATE CORPORATIONS; PROVISION OF NON-DOWNLOADABLE ONLINE PUBLICATIONS, NAMELY, MAGAZINES, PAMPHLETS AND CASE STUDIES ON ECONOMICS AND BUSINESS, AS WELL AS IN THE FIELDS OF MANAGEMENT, LEADERSHIP, MARKETING, ADMINISTRATION, NON-SCIENTIFIC RESEARCH AND HUMAN RESOURCES, ALL OF WHICH ARE INTENDED TO IMPROVE THE PERFORMANCE OF PUBLIC AND PRIVATE CORPORATIONS; PROVISION OF SEMINARS, LECTURES, EDUCATIONAL AND TRAINING PROGRAMS THROUGH INTERNET COURSES, ALL IN THE FIELD OF BUSINESS MANAGEMENT, MARKETING AND HUMAN RESOURCES (U.S. CLS. 100, 101 AND 107).

**CLASS 42—SCIENTIFIC AND COMPUTER SERVICES**

FOR DEVELOPMENT, DESIGN AND UPDATING OF SOFTWARE AND MICRO-SOFTWARE (U.S. CLS. 100 AND 101).

MEGHAN REINHART, EXAMINING ATTORNEY

SN 79-146,611. CHUNG, SANG MIN, REPUBLIC OF KOREA, FILED 1-6-2014.



PRIORITY DATE OF 11-27-2013 IS CLAIMED.  
OWNER OF INTERNATIONAL REGISTRATION 1202125 DATED 1-6-2014, EXPIRES 1-6-2024.

OWNER OF U.S. REG. NO. 4,220,061.

THE MARK CONSISTS OF A DESIGN OF AN EYE WITH A DIAGONAL LINE AND SPIRAL ENDING IN A POINT BELOW THE EYE AND A LINE ABOVE THE EYE THAT IS CURVED IN PART ABOVE THE STYLIZED WORDING "RAMUN".

**CLASS 9—ELECTRICAL AND SCIENTIFIC APPARATUS**

FOR LABORATORY EQUIPMENT, NAMELY, TEST TUBES; LABORATORY TRAYS; PIPETTES; ELECTRIC ALARM BELLS; ELECTRIC DOOR BELLS; SOUND TRANSMITTING APPARATUS; INTERCOMMUNICATION APPARATUS, NAMELY, SIGNAL BELLS; APPARATUS FOR WIRELESS TRANSMISSION OF ACOUSTIC INFORMATION; TELECOMMUNICATION MACHINES AND IMPLEMENTS, NAMELY, ELECTRIC SIGNAL BELLS AND SIGNAL PROCESSORS; TELECOMMUNICATION TRANSMITTERS; TELECOMMUNICATION TRANSMITTING SETS COMPRISED OF TELECOMMUNICATION TRANSMITTERS AND RECEIVERS; TRANSMITTERS OF ELECTRONIC SIGNALS; SIGNAL BELLS; ELECTRONIC CALL BELLS; ELECTRONIC WIRELESS CALL BELLS; ELECTRIC WIRELESS CALL BELLS; ELECTRONIC CALL BELLS FOR USE IN RESTAURANTS; ELECTRIC BUZZERS; INCUBATORS FOR BACTERIA CULTURE; PETRI DISHES USED IN LABORATORY RESEARCH (U.S. CLS. 21, 23, 26, 36 AND 38).

**CLASS 11—ENVIRONMENTAL CONTROL APPARATUS**

FOR LIGHT EMITTING DIODE LED LAMPS; LIGHT EMITTING DIODE LED BULBS; NEON LAMPS; CHANDELIERS; MINIATURE LIGHT BULBS; LIGHTING APPARATUS FOR SHOWCASES; SPOTLIGHTS; LAMPS FOR OUTDOOR USE; DECORATION LAMPS; ELECTRIC LAMPS; ELECTRIC LIGHTING FIXTURES; ELECTRIC LIGHTING DEVICES OTHER THAN FOR VEHICLES, NAMELY, DESK LAMPS; LIGHTING APPARATUS, NAMELY, LIGHTING INSTALLATIONS; ELECTRIC TORCHES FOR LIGHTING; CEILING LIGHTS; FAIRY LIGHTS FOR FESTIVE DECORATION; ELECTRIC LIGHTS FOR CHRISTMAS TREES; TABLE LAMPS; ARTIFICIAL SOLAR LAMPS; FLASHLIGHTS BEING ELECTRIC TORCHES FOR LIGHTING (U.S. CLS. 13, 21, 23, 31 AND 34).

**CLASS 14—JEWELRY**

FOR ALARM CLOCKS; ELECTRIC CLOCKS AND WATCHES; ELECTRONIC CLOCKS AND WATCHES; TABLE CLOCKS; WRISTWATCHES; JEWELRY WATCHES; PARTS FOR WATCHES; WATCH CASES; WATCH STRAPS; CLOCKS AND WATCHES HAVING FUNCTION OF TRANSMITTING AND RECEIVING ELECTRONIC SIGNALS; WATCHES WITH PACE COUNTERS; CLOCKS AND WATCHES WITH ELECTRONIC SCHEDULERS; CLOCKS AND WATCHES WITH ELECTRONIC CALENDARS (U.S. CLS. 2, 27, 28 AND 50).

KRISTINA MORRIS, EXAMINING ATTORNEY

SN 79-146,697. DURAN GROUP GMBH, FED REP GERMANY, FILED 3-12-2014.

# Youility

THE MARK CONSISTS OF STANDARD CHARACTERS WITHOUT CLAIM TO ANY PARTICULAR FONT, STYLE, SIZE, OR COLOR.

PRIORITY DATE OF 9-16-2013 IS CLAIMED.  
OWNER OF INTERNATIONAL REGISTRATION 1202386 DATED 3-12-2014, EXPIRES 3-12-2024.

**CLASS 9—ELECTRICAL AND SCIENTIFIC APPARATUS**

FOR LABORATORY GLASSWARE (U.S. CLS. 21, 23, 26, 36 AND 38).

**CLASS 21—HOUSEWARES AND GLASS**

FOR HOUSEHOLD CONTAINERS MADE OF GLASS; GLASS BOTTLES SOLD EMPTY (U.S. CLS. 2, 13, 23, 29, 30, 33, 40 AND 50).

TARAH HARDY, EXAMINING ATTORNEY

SN 79-146,700. FUNCTIONAL GUMS S.R.L., ITALY, FILED 2-6-2014.



PRIORITY DATE OF 1-30-2014 IS CLAIMED.

OWNER OF INTERNATIONAL REGISTRATION 1202390 DATED 2-6-2014, EXPIRES 2-6-2024.

NO CLAIM IS MADE TO THE EXCLUSIVE RIGHT TO USE "GUM", APART FROM THE MARK AS SHOWN.

THE MARK CONSISTS OF THE STYLIZED WORDS "DRIVE" AND "GUM" IN LOWER CASE PLACED ON TWO LINES; THE LETTER "G" FEATURES A CIRCLE IN THE CENTER. TO THE RIGHT OF THE WORDING IS THE STYLIZED IMAGE OF A BATTERY FEATURING FOUR RECTANGLES INSIDE WITH A STYLIZED THUNDER-BOLT PLACED IN THE RIGHTMOST RECTANGLE.

**CLASS 5—PHARMACEUTICALS**

FOR CHEWING GUM FOR MEDICAL PURPOSES; NUTRITIONAL SUPPLEMENTS IN THE FORM OF CHEWING GUMS (U.S. CLS. 6, 18, 44, 46, 51 AND 52).

**CLASS 30—STAPLE FOODS**

FOR CLEAR CHEWING GUMS AS CONFECTIONERY; CHEWING GUM; SUGAR FREE CHEWING GUM; NON-MEDICATED CHEWING SWEETS HAVING LIQUID FRUIT FILLINGS; NON-MEDICATED CHEWY SWEETS; CHEWING GUM FOR ORAL HYGIENE, NON-MEDICATED; CHEWING CANDY; NON-MEDICATED CANDIES WITH MINT; NON-MEDICATED MINT FLAVOURED SWEETS; SWEETS, NOT FOR MEDICAL PURPOSES; SUGARLESS SWEETS; PEPPERMINT SWEETS, NOT FOR MEDICAL PURPOSES; CARAMELS AS CANDY; PEPPERMINT SWEETS NOT FOR MEDICINAL USE; SWEETMEATS AS CANDY; NON-MEDICATED SWEETS IN THE FORM OF CONFECTIONERY; GLUCOSE TABLETS FOR CULINARY PURPOSES, NOT FOR MEDICAL PURPOSES, CONTAINING CAFFEINE (U.S. CL. 46).

TASNEEM HUSSAIN, EXAMINING ATTORNEY

SN 79-146,725. BRANDOPUS LLP, LONDON, UNITED KINGDOM, FILED 12-18-2013.



OWNER OF INTERNATIONAL REGISTRATION 1202470 DATED 12-18-2013, EXPIRES 12-18-2023.

THE MARK CONSISTS OF A STYLIZED DESIGN OF A BUTTERFLY WHERE THE PATTERNS ON THE WINGS AND OUTER BORDER OF THE WINGS FORM DESIGNS OF HUMAN FACES POINTING OUTWARDS.

**CLASS 35—ADVERTISING AND BUSINESS**

FOR ADVERTISING SERVICES; MARKETING SERVICES; PROMOTIONAL SERVICES, NAMELY, PROMOTING THE GOODS OF OTHERS THROUGH PROMOTIONAL OFFERS AND PUBLIC RELATIONS SERVICES; BRAND CONSULTANCY AND BRAND CREATION SERVICES, NAMELY, BRANDING SERVICES FOR BUSINESSES AND/OR INDIVIDUALS; BRAND EVALUATION SERVICES; BRAND POSITIONING; BRAND TESTING FOR BUSINESS AND/OR INDIVIDUALS; BRAND STRATEGY; BUSINESS MANAGEMENT SERVICES IN RELATION TO FRANCHISING; EVENT MARKETING SERVICES; BUSINESS SERVICES RELATING TO THE PROVISION OF SPONSORSHIP; PROMOTING THE GOODS AND SERVICES OF OTHERS BY ARRANGING FOR SPONSORS TO AFFILIATE THEIR GOODS AND SERVICES WITH SPORTING, MUSICAL AND CULTURAL EVENTS AND AWARDS PROGRAMS; MARKETING AND ADVERTISING MEDIA ANALYSIS SERVICES, MARKETING AND ADVERTISING MEDIA MANAGEMENT SERVICES; MARKETING AND ADVERTISING CONSULTING SERVICES IN THE MEDIA INDUSTRY; MEDIA PLANNING BEING MEDIA MARKETING AND ADVERTISING STRATEGY; MEDIA BUYING SERVICES, NAMELY, OBTAINING MEDIA SPACE TO BE USED FOR MARKETING PURPOSES; TALENT AGENCY SERVICES, NAMELY, BUSINESS REPRESENTATION OF SPORTS PEOPLE, ARTISTS AND CELEBRITIES; MARKET RESEARCH; BUSINESS MANAGEMENT, ADMINISTRATION AND CONSULTANCY SERVICES; RECRUITMENT SERVICES, NAMELY, RECRUITMENT AND PLACEMENT OF PERSONNEL IN THE FIELD OF MARKETING; CONDUCTING PUBLIC OPINION POLLS; BUSINESS INTRODUCTION SERVICES, NAMELY, BUSINESS NETWORKING; BUSINESS MANAGEMENT OF EVENT HOSPITALITY SERVICES; ARRANGING AND CONDUCTING OF COMMERCIAL EXHIBITIONS AND SHOWS FOR BUSINESS AND PROMOTIONAL PURPOSES; ADVERTISING BY MAIL ORDER; COMPILATION OF DIRECT MAILING LISTS; COMPILATION OF MAILING LISTS; DIRECT MAIL ADVERTISING; MARKETING BY MAIL; PREPARATION OF MAILING LISTS; PREPARATION OF MAILING LISTS FOR DIRECT MAIL ADVERTISING SERVICES; DIRECT MARKETING, TELEMARKETING; STATISTICAL ANALYSIS AND REPORTING FOR BUSINESS PURPOSES; DATABASE MANAGEMENT; BUSINESS INFORMATION SERVICES AND APPRAISALS; LETTER SHOP AND DIRECT MAIL SERVICES; INFORMATION, RESEARCH, EVALUATION AND CONSULTANCY SERVICES RELATING TO ANY OF THE AFORESAID (U.S. CLS. 100, 101 AND 102).

**CLASS 41—EDUCATION AND ENTERTAINMENT**

FOR ORGANIZATION OF CULTURAL, EDUCATIONAL AND ENTERTAINMENT SHOWS AND CONCERTS; AUDIO AND VIDEO RECORDING SERVICES; PUBLISHING OF BOOKS, MAGAZINES, ELECTRONIC PUBLICATIONS AND NEWSLETTER; PRODUCTION OF RADIO AND OF TELEVISION PROGRAMMES; ELECTRONIC PUBLICATION SERVICES, NAMELY, PUBLICATION OF TEXT AND GRAPHIC WORKS OF OTHERS ON CD, DVD AND ON-LINE FEATURING MARKETING RELATED MATERIALS; INFORMATION, ADVISORY AND CONSULTANCY SERVICES RELATING TO THE AFORESAID (U.S. CLS. 100, 101 AND 107).

**CLASS 42—SCIENTIFIC AND COMPUTER SERVICES**

FOR DESIGN SERVICES, NAMELY, THE DESIGN OF GRAPHIC WORKS, PACKAGING, COMPUTER PROGRAMS AND CONSUMER MERCHANDISE; CORPORATE IDENTITY AND BRAND DESIGN SERVICES, NAMELY, BRAND NAME DEVELOPMENT, CREATING GRAPHIC ELEMENTS OF CORPORATE IDENTITIES; GRAPHIC DESIGN SERVICES; WEBSITE DESIGN SERVICES FOR OTHERS; COMPUTER AIDED DESIGN OF VIDEO GRAPHICS; PROVIDING A WEBSITE FEATURING ON-LINE NON-DOWNLOADABLE SOFTWARE THAT ENABLES USERS TO CREATE DIGITAL ARTWORK AND DIGITAL IMAGE MANIPULATION OF IMAGES; LEGAL SERVICES; PROVISION OF WEBSITES RELATING TO ANY OF THE AFORESAID SERVICES; DESIGN, CREATION AND MAINTENANCE OF COMPUTER DATABASE SYSTEMS; CREATING DATABASE SOFTWARE; PRODUCT RESEARCH AND DEVELOPMENT, NAMELY, RESEARCH INTO CONSUMER AND BUSINESS BUYING HABITS, PATTERNS AND TRENDS FOR THE PURPOSE OF DEVELOPING NEW PRODUCTS; PRODUCT RESEARCH AND DEVELOPMENT, NAMELY, RESEARCH INTO CONSUMER AND BUSINESS BUYING MOTIVATION FOR THE PURPOSE OF DEVELOPING NEW PRODUCTS; RESEARCH, EVALUATION AND CONSULTANCY SERVICES RELATING TO ANY OF THE AFORESAID (U.S. CLS. 100 AND 101).

JONATHAN FALK, EXAMINING ATTORNEY

SN 79-147,039. MARC ZELLWEGER, SWITZERLAND, FILED 2-28-2014.

# WHITE DUST

THE MARK CONSISTS OF STANDARD CHARACTERS WITHOUT CLAIM TO ANY PARTICULAR FONT, STYLE, SIZE, OR COLOR.

PRIORITY DATE OF 10-2-2013 IS CLAIMED.

OWNER OF INTERNATIONAL REGISTRATION 1203226 DATED 2-28-2014, EXPIRES 2-28-2024.

**CLASS 25—CLOTHING**

FOR CLOTHING, NAMELY, PANTS, SKIRTS, SHORTS, JACKETS, FOOTWEAR, HEADWEAR (U.S. CLS. 22 AND 39).

**CLASS 35—ADVERTISING AND BUSINESS**

FOR ADVERTISING; BUSINESS MANAGEMENT; BUSINESS ADMINISTRATION; PROVIDING OFFICE FUNCTION (U.S. CLS. 100, 101 AND 102).  
LEIGH LOWRY, EXAMINING ATTORNEY

SN 79-147,266. CREMAGAMES S.L., SPAIN, FILED 12-23-2013.

# OH MY GOAT

THE MARK CONSISTS OF STANDARD CHARACTERS WITHOUT CLAIM TO ANY PARTICULAR FONT, STYLE, SIZE, OR COLOR.

OWNER OF INTERNATIONAL REGISTRATION 1203810 DATED 12-23-2013, EXPIRES 12-23-2023.

**CLASS 9—ELECTRICAL AND SCIENTIFIC APPARATUS**

FOR VIDEO GAMES SOFTWARE FOR MOBILE DEVICES; PERSONAL COMPUTERS; DIGITAL TABLET COMPUTERS; ELECTRONIC GAME PROGRAMS; DOWNLOADABLE ELECTRONIC GAME PROGRAMS; ELECTRONIC GAME SOFTWARE; COMPUTER GAME PROGRAMS; DOWNLOADABLE COMPUTER GAME PROGRAMS; INTERACTIVE GAME PROGRAMS; INTERACTIVE GAME SOFTWARE; COMPUTER GAME SOFTWARE DOWNLOADABLE VIA A GLOBAL COMPUTER NETWORK AND WIRELESS DEVICES; DOWNLOADABLE ELECTRONIC PUBLICATIONS IN THE FIELD OF COMPUTER GAMES; PRE-RECORDED VIDEO DISCS AND VIDEO TAPES FEATURING COMPUTER GAMES SOFTWARE AND COMPUTER GAMES; COMPUTER GAME JOYSTICKS; CINEMATOGRAPHIC APPARATUS; PROTECTIVE CARRYING CASES SPECIALLY ADAPTED FOR PHONES AND HANDHELD COMPUTERS (U.S. CLS. 21, 23, 26, 36 AND 38).

**CLASS 28—TOYS AND SPORTING GOODS**

FOR BOARD GAMES; ELECTRONIC GAME EQUIPMENT FOR PLAYING VIDEO GAMES, NAMELY, HAND HELD UNITS FOR PLAYING VIDEO GAMES OTHER THAN THOSE ADAPTED FOR USE WITH AN EXTERNAL DISPLAY SCREEN OR MONITOR; PROMOTIONAL GAME CARDS; HANDHELD GAME CONSOLES; VIDEO GAME CONSOLES; COMPUTER GAME CONSOLES FOR USE WITH AN EXTERNAL DISPLAY SCREEN OR MONITOR; NON-ELECTRIC HAND-HELD SKILL GAMES; SOFT DOLLS, NOT FOR ANIMALS; PUZZLES; TOY ACTION FIGURES, NOT FOR ANIMALS; BALLOONS AND YO-YOS; PLUSH TOYS, NOT FOR ANIMALS; CHRISTMAS TREE DECORATIONS; TOY FIGURES ATTACHABLE TO PENCILS; PLUSH TOYS THAT CONNECT TO BELTS BY A HOOK; NON-ARTICULATED PVC TOY FIGURES; RUBBER BALLS; APPARATUS FOR GAMES ADAPTED FOR USE WITH TELEVISION RECEIVERS; PAPER PARTY HATS; PLAYING CARDS (U.S. CLS. 22, 23, 38 AND 50).

**CLASS 41—EDUCATION AND ENTERTAINMENT**

FOR PROVIDING ENTERTAINMENT INFORMATION IN THE FIELDS OF ELECTRONIC GAME PROGRAMS, ELECTRONIC GAME PRODUCTS, AND ELECTRONIC GAME PROGRAMS AND PRODUCTS VIA A WEBSITE; MULTIMEDIA PUBLISHING OF BOOKS, MAGAZINES, JOURNALS, SOFTWARE, GAMES, MUSIC, AND ELECTRONIC PUBLICATIONS; ENTERTAINMENT SERVICES, NAMELY, PROVIDING ONLINE ELECTRONIC GAMES; ELECTRONIC GAMES SERVICES PROVIDED BY MEANS OF THE INTERNET; PRODUCTION OF TELEVISION PROGRAMS IN THE FIELD OF ENTERTAINMENT; ENTERTAINMENT SERVICES IN THE NATURE OF CREATION, DEVELOPMENT, AND PRODUCTION OF FILMS, ANIMATION OR ANIMATED FILMS, AND TELEVISION PROGRAMS (U.S. CLS. 100, 101 AND 107).

KEVIN MITTLER, EXAMINING ATTORNEY

SN 79-147,285. WHITWORTHS LIMITED, NORTHAMPTONSHIRE NN9 5DB, UNITED KINGDOM, FILED 2-21-2014.

# SUNNY RAISIN

THE MARK CONSISTS OF STANDARD CHARACTERS WITHOUT CLAIM TO ANY PARTICULAR FONT, STYLE, SIZE, OR COLOR.

OWNER OF INTERNATIONAL REGISTRATION 1203855 DATED 2-21-2014, EXPIRES 2-21-2024.

NO CLAIM IS MADE TO THE EXCLUSIVE RIGHT TO USE "RAISIN", APART FROM THE MARK AS SHOWN.

**CLASS 29—MEATS AND PROCESSED FOODS**

FOR PRESERVED, DRIED AND COOKED FRUITS; MIXTURES CONSISTING PRIMARILY OF OR PRIMARILY INCLUDING PRESERVED, DRIED AND/OR COOKED FRUITS; RAISINS; DRIED FRUITS, NAMELY, SULTANAS AND CURRANTS; DRIED VINE FRUITS (U.S. CL. 46).

**CLASS 30—STAPLE FOODS**

FOR DRIED FRUIT CONFECTIONERY AND DRIED FRUIT CHOCOLATE PRODUCTS, NAMELY, CHOCOLATE-COATED RAISINS AND YOGURT-COATED RAISINS; DRIED FRUIT SWEETS; DRIED FRUIT CANDY; RAISINS COATED IN FLAVOURED CANDY (U.S. CL. 46).

ANDREW LEASER, EXAMINING ATTORNEY

SN 79-147,313. FORTIS MARINE PTY.LTD., DANDENONG SOUTH VIC 3175, AUSTRALIA, FILED 3-6-2014.

# PROPWELL

THE MARK CONSISTS OF STANDARD CHARACTERS WITHOUT CLAIM TO ANY PARTICULAR FONT, STYLE, SIZE, OR COLOR.

PRIORITY DATE OF 3-5-2014 IS CLAIMED.  
OWNER OF INTERNATIONAL REGISTRATION 1203963 DATED 3-6-2014, EXPIRES 3-6-2024.

**CLASS 1—CHEMICALS**

FOR COMMERCIAL ADHESIVE NOT FOR HOUSEHOLD AND STATIONERY USE; RUBBER-BASED ADHESIVE NOT FOR HOUSEHOLD AND STATIONERY USE (U.S. CLS. 1, 5, 6, 10, 26 AND 46).

**CLASS 2—PAINTS**

FOR RUBBER BASED COATING IN THE NATURE OF PAINT FOR COATING METAL, NAMELY, FOR COATING BOAT AND SHIP PROPELLERS AND RUNNING GEAR; ELASTOMER COATINGS FOR COATING METAL; COATINGS FOR USE AS PRIMERS (U.S. CLS. 6, 11 AND 16).

CAITLIN WATTS-FITZGERALD, EXAMINING ATTORNEY

SN 79-147,358. NOJOB S.R.L., ROMA, ITALY, FILED 12-4-2013.



OWNER OF INTERNATIONAL REGISTRATION 1204094 DATED 12-4-2013, EXPIRES 12-4-2023.  
OWNER OF U.S. REG. NO. 4,449,600.

THE TRADEMARK CONSISTS OF THE WORD "NOWORK GENERATION", ACCOMPANIED BY THE IMAGE OF A TRIANGULAR ROAD SIGN, DEPICTING INSIDE IT A STICKMAN RECLINING AGAINST A HEAP OF EARTH WITH A SHOVEL STICKING OUT.

**CLASS 18—LEATHER GOODS**

FOR UNWORKED LEATHER AND IMITATIONS OF LEATHER SOLD IN BULK; ANIMAL SKINS, HIDES; TRUNKS AND TRAVELLING BAGS; BAGS FOR SPORTS, SHOE BAGS FOR TRAVEL, CHANGE PURSES, HANDBAGS, SHOULDER BAGS, SCHOOL BAGS, BELT BAGS, WALLETS, CREDIT CARD CASES, PURSES, KEY CASES, BRIEFCASES, BACKPACKS, UMBRELLAS, PARASOLS AND WALKING STICKS; WHIPS, HARNESS AND SADDLERY, HAT BOXES OF LEATHER, CLOTHES FOR ANIMALS; COLLARS FOR ANIMALS, LEATHER LEADS, MUZZLES (U.S. CLS. 1, 2, 3, 22 AND 41).

**CLASS 25—CLOTHING**

FOR CLOTHING FOR MEN, WOMEN AND CHILDREN, NAMELY, COATS, RAINCOATS, JACKETS, TROUSERS, SKIRTS, DRESSES, SUITS, SHIRTS AND CHEMISES, T-SHIRTS, SWEATERS, FLEECE JACKETS AND TOPS, UNDERWEAR, PAJAMAS, SWIMWEAR, BEACHWEAR, SOCKS AND STOCKINGS, GLOVES, TIES, SCARVES, FOULARDS, HATS AND CAPS; BOOTS, SHOES, SANDALS AND SLIPPERS, BELTS FOR CLOTHING (U.S. CLS. 22 AND 39).

**CLASS 28—TOYS AND SPORTING GOODS**

FOR TOYS FOR DOMESTIC PETS, BALLS FOR GAMES, PLAY BALLS, SAILBOARDS, SURF BOARDS, BODY SURFBOARDS, WINDSURFING BOARDS, WATER SKIS, KITEBOARDS, FINS FOR DIVING, LIFE BUOYS FOR RECREATIONAL USE, INFLATABLE TOYS FOR SWIMMING POOLS, BAGS ESPECIALLY DESIGNED FOR SKIS AND SURFBOARDS, ROLLER SKATES, SKATEBOARDS, ELBOW PROTECTORS FOR SKATEBOARDING, TOY SCOOTERS, STATIONARY EXERCISE BICYCLES, KNEE PROTECTORS FOR SKATING, ELBOW PROTECTORS FOR SKATING, ICE SKATES, SLEIGHS, SNOWBOARDS, SKIS, BINDINGS FOR SKIS AND COMPONENTS THEREFOR, SNOWSHOES, TENNIS RACKETS, TABLE TENNIS AND SQUASH RACKETS, CASES FOR RACKETS, TABLE TENNIS TABLES, GYMNASIUM EXERCISE APPARATUS, BENCHES FOR GYMNASIUM USE, PORTABLE HOME GYMNASIUM APPARATUS, CASES SPECIALLY ADAPTED FOR SPORTS EQUIPMENT, FISHING TACKLE; ARTICLES FOR PLAYING GOLF, NAMELY, GOLF CLUBS, GOLF BAGS, GOLF BALLS, TEES; BILLIARD TABLES, BASEBALL GLOVES, BASKETBALL HOOPS, NETS FOR FOOTBALL GOALS, DARTBOARDS, TOY HOOP SETS, TABLES FOR TABLE FOOTBALL, FLYING DISCS GAMES, BOWLING BAGS, BOWLING BALLS, BASEBALL BATS, NETS FOR BALL GAMES, BUILDING GAMES; GAMES, NAMELY, CHECKERS; PARLOR GAMES, PLUSH TOYS OF CLOTH, TALKING TOYS, SKILL AND ACTION GAMES, CHILDREN'S EDUCATIONAL TOYS FOR DEVELOPING FINE MOTOR SKILLS, DOLLS' HOUSES, DOLLS, TOY KITCHEN ITEMS, HAND-HELD UNITS FOR PLAYING ELECTRONIC GAMES, PROTECTIVE CASES SPECIALLY ADAPTED FOR HANDHELD VIDEO GAMES, AUTOMATIC COIN-OPERATED OR TOKEN-OPERATED AMUSEMENT MACHINES, PINBALL MACHINES, ELECTRONIC TOY VEHICLES, TOY MODELS, TOY MODEL TRAIN SETS, REMOTE-CONTROLLED FLYING TOYS, RACING TRACKS FOR TOY CARS, WATER PISTOLS, DICE GAMES, TOY PUZZLES, PLAYING CARDS, TOY MUSICAL INSTRUMENTS, KITES, TOY MASKS, ARTICLES FOR PLAYING JOKES, NAMELY, MAGIC TRICKS, PAPER PARTY FAVORS, ROULETTE TABLES, CHRISTMAS TREES OF SYNTHETIC MATERIAL, ARTIFICIAL SNOW FOR CHRISTMAS TREES, DECORATIONS FOR CHRISTMAS TREES (U.S. CLS. 22, 23, 38 AND 50).

JAMES LOVELACE, EXAMINING ATTORNEY



SN 79-147,461. AIGLE INTERNATIONAL, F-92100 BOULOGNE-BILLANCOURT, FRANCE, FILED 2-20-2014.



OWNER OF INTERNATIONAL REGISTRATION 1204411 DATED 2-20-2014, EXPIRES 2-20-2024.

OWNER OF U.S. REG. NOS. 1,386,086, 3,876,440 AND OTHERS.

THE MARK CONSISTS OF THE WORDING "AIGLE" WITH THE DESIGN OF AN EAGLE ABOVE THE WORDING.

THE ENGLISH TRANSLATION OF "AIGLE" IN THE MARK IS "EAGLE".

#### CLASS 18—LEATHER GOODS

FOR LEATHER AND IMITATION LEATHER; ANIMAL SKINS, HIDES; TRUNKS AND SUITCASES; HARNESSES AND SADDLERY (U.S. CLS. 1, 2, 3, 22 AND 41).

#### CLASS 25—CLOTHING

FOR CLOTHING, NAMELY, TOPS, BOTTOMS, PANTS, SHIRTS, BLOUSES, T-SHIRTS, JERSEYS, SPORT SHIRTS, POLO SHIRTS, SWEATERS, SHORTS, COATS, JACKETS, WIND RESISTANT JACKETS, DRESSES, RAINWEAR; FOOTWEAR INCLUDING BOOTS; HEADGEAR, NAMELY, HEADWEAR, CAPS AND HATS (U.S. CLS. 22 AND 39).

NICHOLAS COLEMAN, EXAMINING ATTORNEY

SN 79-148,718. ELO DIGITAL OFFICE GMBH, FED REP GERMANY, FILED 4-8-2014.

# ELOenterprise

THE MARK CONSISTS OF STANDARD CHARACTERS WITHOUT CLAIM TO ANY PARTICULAR FONT, STYLE, SIZE, OR COLOR.

PRIORITY DATE OF 10-8-2013 IS CLAIMED.

OWNER OF INTERNATIONAL REGISTRATION 1207716 DATED 4-8-2014, EXPIRES 4-8-2024.

#### CLASS 9—ELECTRICAL AND SCIENTIFIC APPARATUS

FOR COMPUTER PROGRAMS AND SOFTWARE FOR ELECTRONIC DOCUMENT MANAGEMENT; PRE-RECORDED MAGNETIC DATA CARRIERS CONTAINING ELECTRONIC DOCUMENT MANAGEMENT SOFTWARE (U.S. CLS. 21, 23, 26, 36 AND 38).

#### CLASS 41—EDUCATION AND ENTERTAINMENT

FOR TRAINING IN THE USE OF SOFTWARE PRODUCTS (U.S. CLS. 100, 101 AND 107).

#### CLASS 42—SCIENTIFIC AND COMPUTER SERVICES

FOR DESIGN, DEVELOPMENT, MAINTENANCE, INSTALLATION, UPDATING AND CUSTOMISATION OF COMPUTER SOFTWARE; SOFTWARE CONSULTANCY (U.S. CLS. 100 AND 101).

ALLISON HOLTZ, EXAMINING ATTORNEY

SN 79-148,841. DATALOGIC ADC S.R.L., ITALY, FILED 3-19-2014.

# COBALTO

THE MARK CONSISTS OF STANDARD CHARACTERS WITHOUT CLAIM TO ANY PARTICULAR FONT, STYLE, SIZE, OR COLOR.

PRIORITY DATE OF 3-10-2014 IS CLAIMED.

OWNER OF INTERNATIONAL REGISTRATION 1207971 DATED 3-19-2014, EXPIRES 3-19-2024.

THE ENGLISH TRANSLATION OF THE FOREIGN WORD(S) IN THE MARK IS: COBALT.

#### CLASS 9—ELECTRICAL AND SCIENTIFIC APPARATUS

FOR BAR CODE SCANNERS; OPTICAL CODE READERS; DOWNLOADABLE USER MANUALS FOR BAR CODE SCANNERS AND OPTICAL CODE READERS (U.S. CLS. 21, 23, 26, 36 AND 38).

#### CLASS 16—PAPER GOODS AND PRINTED MATTER

FOR INSTRUCTION, INSTALLATION AND MAINTENANCE MANUALS FOR BAR CODE SCANNERS AND OPTICAL CODE READERS; DOCUMENTATION AND PRINTED MATTER, NAMELY, BROCHURES, DATA-SHEETS, REFERENCE GUIDES AND INFORMATIONAL FLYERS FOR CUSTOMER INFORMATION ON BAR CODE SCANNERS AND OPTICAL CODE READERS (U.S. CLS. 2, 5, 22, 23, 29, 37, 38 AND 50).

#### CLASS 37—CONSTRUCTION AND REPAIR

FOR INSTALLATION, REPAIR AND MAINTENANCE SERVICES FOR BAR CODE SCANNERS AND OPTICAL CODE READERS (U.S. CLS. 100, 103 AND 106).

STEVEN PEREZ, EXAMINING ATTORNEY

SN 79-148,856. CHINA CAPITAL BRANDS LIMITED, UNITED KINGDOM, FILED 2-20-2014.

# f-bar

THE MARK CONSISTS OF STANDARD CHARACTERS WITHOUT CLAIM TO ANY PARTICULAR FONT, STYLE, SIZE, OR COLOR.

PRIORITY DATE OF 10-25-2013 IS CLAIMED.

OWNER OF INTERNATIONAL REGISTRATION 1208023 DATED 2-20-2014, EXPIRES 2-20-2024.

**CLASS 35—ADVERTISING AND BUSINESS**

FOR BUSINESS MANAGEMENT AND ORGANIZATION CONSULTANCY; BUSINESS MARKETING SERVICES; FRANCHISING, NAMELY, CONSULTATION AND ASSISTANCE IN BUSINESS MANAGEMENT, ORGANIZATION AND PROMOTION; BUSINESS MANAGEMENT SERVICES (U.S. CLS. 100, 101 AND 102).

**CLASS 43—HOTEL AND RESTAURANT SERVICES**

FOR HOTELS AND RESTAURANTS, SERVICES FOR PROVIDING FOOD AND DRINK; TEMPORARY ACCOMMODATION, ON-SITE AND OFF-SITE CONTRACT CATERING FOOD SERVICES; CATERING (U.S. CLS. 100 AND 101).

SHANNON TWOHIG, EXAMINING ATTORNEY

SN 85-228,893. CURIOSITY, LLC, CINCINNATI, OH. FILED 1-28-2011.

# CURIOSITY

THE MARK CONSISTS OF STANDARD CHARACTERS WITHOUT CLAIM TO ANY PARTICULAR FONT, STYLE, SIZE, OR COLOR.

**CLASS 35—ADVERTISING AND BUSINESS**

FOR ADVERTISING AND ADVERTISEMENT SERVICES, NAMELY, MARKETING THE GOODS AND SERVICES OF OTHERS THROUGH ALL PUBLIC COMMUNICATION MEANS SUCH AS TELEVISION RADIO, GLOBAL COMPUTER NETWORKS, SOCIAL MEDIA, MOBILE DEVICES AND OTHER FORMS OF COMMUNICATIONS CHANNELS; CREATIVE MARKETING DESIGN; PRODUCTION OF ADVERTISING MATTER (U.S. CLS. 100, 101 AND 102).

FIRST USE 1-0-2010; IN COMMERCE 1-0-2010.

**CLASS 42—SCIENTIFIC AND COMPUTER SERVICES**

FOR PACKAGING DESIGN AND CONSULTATION RELATING THERETO (U.S. CLS. 100 AND 101).

FIRST USE 0-0-2010; IN COMMERCE 0-0-2010.

JOHN E. MICHOS, EXAMINING ATTORNEY

SN 85-230,235. HYLIFE FOODS INTERNATIONAL LTD., ST. MICHAEL, BARBADOS, FILED 1-31-2011.



THE MARK CONSISTS OF A LEAFY BRANCH OVER A CIRCULAR SHADED ELEMENT.

**CLASS 5—PHARMACEUTICALS**

FOR ALL GENETIC MATERIAL FOR ARTIFICIAL INSEMINATION OF ANIMALS, NAMELY, SEMEN AND OVA (U.S. CLS. 6, 18, 44, 46, 51 AND 52).

**CLASS 29—MEATS AND PROCESSED FOODS**

FOR MEAT, NAMELY, FRESH AND PROCESSED PORK; PROCESSED MEAT PRODUCTS, NAMELY, BACON, HAM, SAUSAGES, WIENERS, KIELBASA AND BOLOGNA; FOOD PRODUCTS, NAMELY, MARINATED MEAT, SEASONED MEAT AND PREPARED MEALS CONTAINING MEAT (U.S. CL. 46).

**CLASS 31—NATURAL AGRICULTURAL PRODUCTS**

FOR LIVE ANIMALS, NAMELY, PIGS, SWINE, HOGS, BOARS, SOWS, WEANLING PIGS, FEEDER PIGS, GILTS, BREEDING STOCK PIGS AND MARKET HOGS; ANIMAL EMBRYOS (U.S. CLS. 1 AND 46).

**CLASS 44—MEDICAL, BEAUTY AND AGRICULTURAL SERVICES**

FOR ANIMAL GENETIC SERVICES, NAMELY, GENETIC TESTING OF ANIMALS AND ANIMAL HUSBANDRY; FARM MANAGEMENT SERVICES, NAMELY, PIG FARMS, AND CONDUCTING SURVEYS OF FARMING ACTIVITIES AND CONSULTATION IN CONNECTION THEREWITH (U.S. CLS. 100 AND 101).

KATHRYN COWARD, EXAMINING ATTORNEY

SN 85-234,927. UNICONNECT L.C., SANDY, UT. FILED 2-4-2011.

# UNIFLOW

THE MARK CONSISTS OF STANDARD CHARACTERS WITHOUT CLAIM TO ANY PARTICULAR FONT, STYLE, SIZE, OR COLOR.

**CLASS 9—ELECTRICAL AND SCIENTIFIC APPARATUS**

FOR COMPUTER SOFTWARE, NAMELY, SOFTWARE FOR INFORMATION MANAGEMENT, PROCESS IMPROVEMENT, PROCESS TRACKING AND PROJECT AND RESEARCH MANAGEMENT FOR USE IN THE LIFE SCIENCE RESEARCH AND BIOTECHNOLOGY LABORATORY INDUSTRIES; COMPUTER SOFTWARE FOR ENTERPRISE ADMINISTRATIVE AND OPERATIONS ORGANIZATIONAL AND PROCESS MANAGEMENT FOR HEALTHCARE FACILITIES AND LIFE SCIENCE RESEARCH AND BIOTECHNOLOGY LABORATORIES AND RESEARCH FACILITIES; AND COMPUTER SOFTWARE FOR USE IN MONITORING QUALITY MANAGEMENT AND COMPLIANCE WITH GOVERNMENT AND REGULATORY STANDARDS FOR HEALTHCARE FACILITIES AND LIFE SCIENCE AND BIOTECHNOLOGY LABORATORIES AND RESEARCH FACILITIES (U.S. CLS. 21, 23, 26, 36 AND 38).

FIRST USE 7-26-2005; IN COMMERCE 7-26-2005.

**CLASS 42—SCIENTIFIC AND COMPUTER SERVICES**

FOR SOFTWARE AS A SERVICE (SAAS) SERVICES, PLATFORM AS A SERVICE (PAAS), AND APPLICATION SERVICE PROVIDER (ASP) SERVICES FEATURING SOFTWARE FOR INFORMATION MANAGEMENT, PROCESS IMPROVEMENT, PROCESS TRACKING AND PROJECT AND RESEARCH MANAGEMENT FOR USE IN HEALTHCARE FACILITIES AND LIFE SCIENCE RESEARCH AND BIOTECHNOLOGY LABORATORY INDUSTRIES, ENTERPRISE ADMINISTRATIVE AND OPERATIONS ORGANIZATIONAL AND PROCESS MANAGEMENT FOR HEALTHCARE FACILITIES AND LIFE SCIENCE RESEARCH AND BIOTECHNOLOGY LABORATORIES AND RESEARCH FACILITIES, AND MONITORING QUALITY MANAGEMENT AND COMPLIANCE WITH GOVERNMENT AND REGULATORY STANDARDS FOR HEALTHCARE FACILITIES AND LIFE SCIENCE AND BIOTECHNOLOGY LABORATORIES AND RESEARCH FACILITIES (U.S. CLS. 100 AND 101).

FIRST USE 7-26-2005; IN COMMERCE 7-26-2005.  
KATHLEEN M. VANSTON, EXAMINING ATTORNEY

SN 85-326,045. HOOVER & STRONG, INC., RICHMOND, VA.  
FILED 5-20-2011.

**THE GOLD STANDARD**

THE MARK CONSISTS OF STANDARD CHARACTERS WITHOUT CLAIM TO ANY PARTICULAR FONT, STYLE, SIZE, OR COLOR.

OWNER OF U.S. REG. NO. 3,529,979.  
NO CLAIM IS MADE TO THE EXCLUSIVE RIGHT TO USE "GOLD", APART FROM THE MARK AS SHOWN.

**CLASS 6—METAL GOODS**

FOR HARD SOLDER, SOLDER PASTES, SOLDER WIRE, SILVER SOLDER, GOLD SOLDER (U.S. CLS. 2, 12, 13, 14, 23, 25 AND 50).

FIRST USE 9-1-2007; IN COMMERCE 9-1-2007.

**CLASS 14—JEWELRY**

FOR JEWELRY; JEWELRY OBTAINED FROM, AND MANUFACTURED WITH, ECOLOGICALLY FRIENDLY METHODS AND SOURCES; DIAMONDS; DIAMONDS OBTAINED FROM CONFLICT-FREE SOURCES; GEMS; DIAMONDS AND GEMS OBTAINED IN AN ETHICAL MANNER; PRECIOUS METALS AND PRECIOUS METAL ALLOYS; RECYCLED PRECIOUS METALS AND PRECIOUS METAL ALLOYS; NON-MONETARY COINS; PRECIOUS METAL BULLION, GOLD BULLION; METAL WIRE AND TUBING FOR USE IN THE MAKING OF JEWELRY, NAMELY, JEWELRY CABLE AND TUBING (U.S. CLS. 2, 27, 28 AND 50).

FIRST USE 9-1-2007; IN COMMERCE 9-1-2007.

**CLASS 40—MATERIAL TREATMENT**

FOR JEWELRY CASTING; JEWELRY REMOUNTING; CUSTOM MANUFACTURE OF JEWELRY FOR OTHERS; DIE CASTING, METAL CASTING, AND TREATMENT OF METAL IN THE FIELD OF PRECIOUS METALS AND JEWELRY MAKING; METAL REFINING SERVICES, NAMELY, JEWELRY SCRAP, GOLD, PLATINUM, AND PALLADIUM REFINING; PROVIDING A WEBSITE FEATURING INFORMATION ABOUT ENVIRONMENTALLY FRIENDLY MANUFACTURING AND RECYCLING PRACTICES IN THE JEWELRY INDUSTRY (U.S. CLS. 100, 103 AND 106).

FIRST USE 9-1-2007; IN COMMERCE 9-1-2007.  
KAREN SEVERSON, EXAMINING ATTORNEY

SN 85-278,798. MAURICE D. SLAUGHTER, PORTSMOUTH, VA. FILED 3-28-2011.

**OUTER BANKS BIKE WEEK**

THE MARK CONSISTS OF STANDARD CHARACTERS WITHOUT CLAIM TO ANY PARTICULAR FONT, STYLE, SIZE, OR COLOR.

OWNER OF U.S. REG. NO. 2,826,745.  
NO CLAIM IS MADE TO THE EXCLUSIVE RIGHT TO USE "BIKE WEEK", APART FROM THE MARK AS SHOWN.  
SEC. 2(F).

**CLASS 14—JEWELRY**

FOR LAPEL PINS (U.S. CLS. 2, 27, 28 AND 50).  
FIRST USE 6-15-2002; IN COMMERCE 6-15-2002.

**CLASS 25—CLOTHING**

FOR T-SHIRTS, JACKETS, CAPS (U.S. CLS. 22 AND 39).  
FIRST USE 6-15-2002; IN COMMERCE 6-15-2002.

**CLASS 35—ADVERTISING AND BUSINESS**

FOR ARRANGING AND CONDUCTING TRADESHOWS IN THE FIELD OF MOTORCYCLES (U.S. CLS. 100, 101 AND 102).

FIRST USE 6-15-2002; IN COMMERCE 6-15-2002.  
JOHN SCHUYLER YARD, EXAMINING ATTORNEY

SN 85-365,264. ASSOCIATION FRANCAISE DE NORMALISATION (AFNOR), LA PLAINE SAINT-DENIS, FRANCE, FILED 7-7-2011.



NO CLAIM IS MADE TO THE EXCLUSIVE RIGHT TO USE "VALIDATION", APART FROM THE MARK AS SHOWN.

THE COLOR(S) BLUE AND WHITE IS/ARE CLAIMED AS A FEATURE OF THE MARK.

THE MARK CONSISTS OF A BLUE OVAL CONTAINING THE WORDING "NF VALIDATION" IN WHITE, THE BACKGROUND OF THE BLUE OVAL CONTAINS SIX CIRCLES AND ONE CURVED BAR ALL IN DIFFERENT SHADES OF BLUE.

#### **CLASS 16—PAPER GOODS AND PRINTED MATTER**

FOR PAPER, CARDBOARD AND GOODS MADE FROM THESE MATERIALS, NAMELY, CARDBOARD ARTICLES, CARDBOARD TUBES, BAGS, SACHETS, FILMS AND SHEETS FOR PACKAGING; PRINTED MATTER; REVIEWS; BOOKS; INSTRUCTIONAL AND TEACHING MANUALS; PERIODICALS; GUIDES; STATIONERY; ARTISTS' MATERIALS; INSTRUCTIONAL, TRAINING AND TEACHING MATERIAL, EXCEPT APPARATUS; PLASTIC MATERIALS FOR PACKAGING, NAMELY, BAGS, SACHETS, FILM AND FOILS; PHOTOGRAPHS AND PRINTING BLOCKS (U.S. CLS. 2, 5, 22, 23, 29, 37, 38 AND 50).

#### **CLASS 35—ADVERTISING AND BUSINESS**

FOR AUDITING OF LABORATORIES AND OF CHEMICAL, BIOCHEMICAL, BIOLOGICAL, BACTERIOLOGICAL AND MICROBIOLOGICAL ANALYSES; ADVERTISING; BUSINESS MANAGEMENT; BUSINESS ADMINISTRATION; OFFICE FUNCTIONS; DISTRIBUTION OF LEAFLETS; CONSULTANCY AND ASSISTANCE FOR INDUSTRIAL OR COMMERCIAL ENTERPRISES IN THE CONDUCT OF THEIR BUSINESS; BUSINESS MANAGEMENT CONSULTATIONS; SYSTEMATIC ORDERING OF DATA IN A CENTRAL FILE; COMPILATION OF INFORMATION RELATING TO NORMS AND STANDARDS IN THE AGRI-FOODSTUFFS SECTOR; STATISTICAL ANALYSES AND WORK; COMPUTERIZED FILE MANAGEMENT; TRANSCRIPTION, COMPOSITION, COMPILATION, PROCESSING, ENCODING AND DISPLAY OF DATA, TEXTS, SOUNDS AND/OR IMAGES; DOCUMENT REPRODUCTION; EMPLOYMENT AGENCIES; PERSONNEL RECRUITMENT; BUSINESS CONSULTANCY REGARDING RECRUITMENT AND PERSONNEL MANAGEMENT; ARRANGING NEWSPAPER SUBSCRIPTION; ORGANIZATION OF EXHIBITIONS FOR COMMERCIAL ADVERTISING PURPOSES; MANAGEMENT CONSULTANCY (U.S. CLS. 100, 101 AND 102).

#### **CLASS 38—COMMUNICATION**

FOR COMMUNICATIONS BY COMPUTER TERMINALS AND THE INTERNET; TRANSMISSION AND DISSEMINATION OF DATA, INFORMATION, IMAGES AND SOUNDS, IN PARTICULAR BY DATA TRANSMISSION, BY THE INTERNET OR BY AN INTRANET OR EXTRANET; TRANSMISSION OF INFORMATION ONLINE; TRANSMISSION OF DATA CONTAINED IN DATA BANKS (U.S. CLS. 100, 101 AND 104).

#### **CLASS 41—EDUCATION AND ENTERTAINMENT**

FOR TEACHING, PROVIDING OF TRAINING, EDUCATION, SEMINARS; TRAINING COURSES; EDUCATIONAL ESTABLISHMENTS; ARRANGING AND CONDUCTING OF TRAINING WORKSHOPS, ARRANGING AND CONDUCTING OF COLLOQUIUMS, CONFERENCES AND CONGRESSES; FILM PRODUCTION; ORGANIZATION OF EXHIBITIONS FOR EDUCATIONAL PURPOSES; EMPLOYMENT TRAINING (U.S. CLS. 100, 101 AND 107).

#### **CLASS 42—SCIENTIFIC AND COMPUTER SERVICES**

FOR QUALITY CONTROL AND AUDITING IN THE FIELD OF WATER ANALYSIS, THE ENVIRONMENT AND IN THE FIELD OF AGRI-FOODSTUFFS; CHEMICAL, BIOCHEMICAL, BIOLOGICAL AND MICROBIOLOGICAL RESEARCH AND ANALYSIS; ASSESSMENT OF TEST RESULTS IN THE FIELD OF AGRI-FOODSTUFFS AND WATER ANALYSIS; RECORDING OF DATA, TEXT, SOUND AND/OR IMAGES; ENGINEERING WORK; TECHNICAL PROJECT STUDIES; SURVEYING; PREPARATION OF ALTERNATIVE METHODS OF ANALYSIS IN THE FIELD OF MEASURING PHYSICAL PROPERTIES, DOSAGE AND CHEMICAL, BIOCHEMICAL, BIOLOGICAL AND MICROBIOLOGICAL DETECTIONS, IN THE AGRI-FOODSTUFFS SECTOR, IN THE ENVIRONMENTAL SECTOR AND IN THE SECTOR OF WATER ANALYSIS; ENVIRONMENT CONSULTANCY SERVICES (U.S. CLS. 100 AND 101).

ALICIA COLLINS, EXAMINING ATTORNEY

SN 85-402,616. WILLIAMS, CHANDLER, FREEPORT, FL. FILED 8-19-2011.

## 30A LIFE

THE MARK CONSISTS OF STANDARD CHARACTERS WITHOUT CLAIM TO ANY PARTICULAR FONT, STYLE, SIZE, OR COLOR.

#### **CLASS 16—PAPER GOODS AND PRINTED MATTER**

FOR STICKERS; TRANSFERS; BUMPER STICKERS (U.S. CLS. 2, 5, 22, 23, 29, 37, 38 AND 50).

#### **CLASS 25—CLOTHING**

FOR CLOTHING, NAMELY, TOPS, BOTTOMS, T-SHIRTS, POLO SHIRTS, SWEAT SHIRTS, HATS, SHORTS (U.S. CLS. 22 AND 39).

LEIGH CAROLINE CASE, EXAMINING ATTORNEY

SN 85-485,053. TELECITYGROUP INTERNATIONAL LIMITED, LONDON, UNITED KINGDOM, FILED 12-1-2011.



OWNER OF ERPN CMNTY TM OFC REG. NO. 007603269, DATED 1-1-2010, EXPIRES 2-12-2019.

OWNER OF U.S. REG. NO. 3,872,956.

THE COLOR(S) RED AND BLACK IS/ARE CLAIMED AS A FEATURE OF THE MARK.

THE MARK CONSISTS OF THE WORD "TELECITYGROUP" IN THE COLOR BLACK WITH A CIRCLE DESIGN PLACED IN SUPERSCRIPIT POSITION TO THE RIGHT OF THE WORD "TELECITYGROUP". THE CIRCLE IS THE COLOR RED, AND A SUNBURST DESIGN APPEARS WITHIN THE CIRCLE. UNDER "TELECITYGROUP" IS THE PHRASE "WHERE CONTENT MEETS CONNECTIVITY" IN THE COLOR RED.

**CLASS 35—ADVERTISING AND BUSINESS**

FOR BUSINESS ADVISORY SERVICES; BUSINESS INFORMATION SERVICES; BUSINESS SERVICES, NAMELY, FACILITIES MANAGEMENT OF TECHNICAL OPERATIONS (U.S. CLS. 100, 101 AND 102).

**CLASS 37—CONSTRUCTION AND REPAIR**

FOR EQUIPMENT INSTALLATION, MAINTENANCE, AND REPAIR IN THE NATURE OF FAULT RECOVERY OF DATA CENTER SYSTEMS, NAMELY, HEATING, COOLING, FIRE SUPPRESSION AND REDUNDANT POWER SUPPLY SYSTEMS (U.S. CLS. 100, 103 AND 106).

**CLASS 38—COMMUNICATION**

FOR RENTAL OF FACSIMILE APPARATUS; RENTAL OF MESSAGE SENDING APPARATUS; RENTAL OF TELECOMMUNICATION EQUIPMENT, NAMELY, MESSAGE SENDING APPARATUS, NAMELY, TELEPHONES; RENTAL OF MODEMS AND TELECOMMUNICATIONS EQUIPMENT; RENTAL OF MODEMS AND TELECOMMUNICATIONS EQUIPMENT, NAMELY, TELEPHONES AND FACSIMILE MACHINES; TELECOMMUNICATION SERVICES, NAMELY, TRANSMISSION OF VOICE, AUDIO, VISUAL IMAGES, AND DATA BY TELECOMMUNICATIONS NETWORKS, WIRELESS COMMUNICATIONS NETWORKS, THE INTERNET, INFORMATION SERVICES NETWORKS AND DATA NETWORK (U.S. CLS. 100, 101 AND 104).

**CLASS 42—SCIENTIFIC AND COMPUTER SERVICES**

FOR DATA CENTER MONITORING SERVICES WITH RESPECT TO ELECTRICAL, MECHANICAL AND ENVIRONMENTAL SYSTEMS; DATA CENTER MONITORING SERVICES, NAMELY, MONITORING TECHNOLOGICAL FUNCTIONS OF COMPUTER NETWORK SYSTEMS; FACILITIES MANAGEMENT SERVICES, NAMELY, PROVIDING FACILITIES FOR THE LOCATION OF COMPUTER SERVERS WITH THE EQUIPMENT OF OTHERS; ENGINEERING SERVICES FOR FACILITY MANAGEMENT; RENTAL OF COMPUTERS AND SOFTWARE; SOFTWARE DESIGN SERVICES; DESIGN OF INTERNET SITES AND WEBSITES AND PAGES; COMPUTER AND INFORMATION TECHNOLOGY CONSULTANCY SERVICES; TELECOMMUNICATION SERVICES, NAMELY, PROVIDING ON-LINE INTERNET AND TELECOMMUNICATION FACILITIES FOR REAL-TIME INTERACTION BETWEEN AND AMONG USERS OF COMPUTERS, MOBILE AND HANDHELD COMPUTERS AND WIRED AND WIRELESS COMMUNICATION DEVICES (U.S. CLS. 100 AND 101).

MARIA-VICTORIA SUAREZ, EXAMINING ATTORNEY

SN 85-519,642. ALLOY LTD., CHURT, FARNHAM, SURREY, UNITED KINGDOM, FILED 1-18-2012.

**WELLTOGETHER**

THE MARK CONSISTS OF STANDARD CHARACTERS WITHOUT CLAIM TO ANY PARTICULAR FONT, STYLE, SIZE, OR COLOR.

PRIORITY CLAIMED UNDER SEC. 44(D) ON UNITED KINGDOM APPLICATION NO. 2605066, FILED 12-20-2011, REG. NO. 2605066, DATED 3-30-2012, EXPIRES 12-20-2021.

**CLASS 43—HOTEL AND RESTAURANT SERVICES**

FOR ARRANGING TEMPORARY HOUSING ACCOMMODATIONS IN CONVALESCENT HOMES; ARRANGING TEMPORARY HOUSING ACCOMMODATIONS IN REST HOMES; PROVISION OF RESPITE CARE FOR THE ELDERLY, NAMELY, RESPITE CARE SERVICES IN THE NATURE OF ADULT DAY CARE (U.S. CLS. 100 AND 101).

**CLASS 44—MEDICAL, BEAUTY AND AGRICULTURAL SERVICES**

FOR HOMECARE SERVICES, NAMELY, HOME HEALTH CARE SERVICES, HOME-VISIT NURSING CARE; CONVALESCENT HOME SERVICES; NURSING HOME SERVICES; MEDICAL CARE SERVICES; MEDICAL CLINIC SERVICES; MEDICAL CLINICS; PHYSICAL THERAPY SERVICES FOR THE ELDERLY; PROVISION OF RESPITE CARE, NAMELY, RESPITE CARE SERVICES IN THE NATURE OF HOME NURSING AID SERVICES; ALL THE AFOREMENTIONED SERVICES RELATING TO CARE FOR THE ELDERLY (U.S. CLS. 100 AND 101).

**CLASS 45—PERSONAL AND LEGAL SERVICES**

FOR HOMECARE SERVICES, NAMELY, NON-MEDICAL IN-HOME PERSONAL CARE SERVICES FOR ASSISTING WITH DAILY LIVING ACTIVITIES OF THE ELDERLY (U.S. CLS. 100 AND 101).

KEVIN CORWIN, EXAMINING ATTORNEY

SN 85-548,944. BEAR RIVER INTERNATIONAL, LOGAN, UT. FILED 2-21-2012.

**BLACK OPS**

THE MARK CONSISTS OF STANDARD CHARACTERS WITHOUT CLAIM TO ANY PARTICULAR FONT, STYLE, SIZE, OR COLOR.

**CLASS 9—ELECTRICAL AND SCIENTIFIC APPARATUS**

FOR WALKIE TALKIES (U.S. CLS. 21, 23, 26, 36 AND 38).

**CLASS 25—CLOTHING**

FOR T-SHIRTS; HATS; JACKETS; COATS; VESTS; BANDANAS (U.S. CLS. 22 AND 39).

**CLASS 28—TOYS AND SPORTING GOODS**

FOR TOY ACTION FIGURES; PLAYSETS, NAMELY, PLAYSCAPES CONFIGURED TO PRESENT MILITARY-TYPE ENGAGEMENTS; PLAYSCAPES IN THE FORM OF CITY SCAPES WHERE TOY ACTION FIGURES CAN BE POSITIONED FOR PLAY FIGHTING IN AN URBAN ENVIRONMENT; PLAYSCAPES IN THE FORM OF DESERT, JUNGLE AND MOUNTAIN SCAPES WHERE TOY ACTION FIGURES CAN BE POSITIONED; INFRARED TOYS, NAMELY, INTERACTIVE ACTION FIGURES THAT UTILIZE INFRARED COMMUNICATION AND INFRARED REMOTE CONTROLLED TOY VEHICLES; TOY VEHICLES AND ACCESSORIES THEREFOR; REMOTE CONTROL TOYS, NAMELY, REMOTE CONTROL TOY VEHICLES (U.S. CLS. 22, 23, 38 AND 50).

MICHAEL ENGEL, EXAMINING ATTORNEY

SN 85-553,676. BEATY, THOMAS H., STATESVILLE, NC. AND MORRISON, PAYTON A., STATESVILLE, NC. FILED 2-27-2012.

## GERM GEEK

THE MARK CONSISTS OF STANDARD CHARACTERS WITHOUT CLAIM TO ANY PARTICULAR FONT, STYLE, SIZE, OR COLOR.

NO CLAIM IS MADE TO THE EXCLUSIVE RIGHT TO USE "GERM", APART FROM THE MARK AS SHOWN.

### CLASS 3—COSMETICS AND CLEANING PREPARATIONS

FOR CLEANING PREPARATIONS FOR COMPUTERS, COMPUTER KEYBOARDS, AND COMPUTER ACCESSORIES (U.S. CLS. 1, 4, 6, 50, 51 AND 52).

### CLASS 9—ELECTRICAL AND SCIENTIFIC APPARATUS

FOR MACHINE AND APPARATUS IN THE NATURE OF NON-POWERED HANDHELD DEVICES FEATURING BRUSHES FOR CLEANING COMPUTER KEYBOARDS (U.S. CLS. 21, 23, 26, 36 AND 38).

FONG HSU, EXAMINING ATTORNEY

---

SN 85-554,225. YODLEE, INC., REDWOOD CITY, CA. FILED 2-27-2012.

## INNOVATION APPLIED

THE MARK CONSISTS OF STANDARD CHARACTERS WITHOUT CLAIM TO ANY PARTICULAR FONT, STYLE, SIZE, OR COLOR.

### CLASS 9—ELECTRICAL AND SCIENTIFIC APPARATUS

FOR COMPUTER SOFTWARE FOR AGGREGATION OF BANKING, FINANCIAL, INVESTMENT AND PERSONAL RECORDS AND INFORMATION; COMPUTER SOFTWARE FOR ACCESSING ONLINE AND ELECTRONIC DATA AND FOR CONVERTING AND TRANSFERRING THAT DATA TO AND FOR USE IN CONNECTION WITH COMPUTER SOFTWARE PROGRAMS, PERSONAL AND BUSINESS ELECTRONIC DEVICES, MOBILE AND SMART PHONES, TABLETS AND OTHER COMPUTER SOFTWARE APPLICATIONS; COMPUTER SOFTWARE FOR CONDUCTING AND ACCEPTING ONLINE FINANCIAL AND E-COMMERCE TRANSACTIONS; COMPUTER PROGRAM DEVELOPMENT TOOLS FOR THE CREATION, DEVELOPMENT, DISTRIBUTION AND CONTROL OF COMPUTER SOFTWARE IN THE FIELD OF FINANCIAL MANAGEMENT AND ONLINE FINANCIAL AND E-COMMERCE TRANSACTIONS; COMPUTER SOFTWARE FOR THE CREATION AND OPERATION OF AN E-COMMERCE BUSINESS AND FOR THE OPERATION OF AN ONLINE RETAIL STORE SITE FOR THE PURCHASE AND DOWNLOAD OF COMPUTER SOFTWARE APPLICATIONS (U.S. CLS. 21, 23, 26, 36 AND 38).

### CLASS 35—ADVERTISING AND BUSINESS

FOR ONLINE RETAIL STORE SERVICES FOR THE PURCHASE AND DOWNLOAD OF COMPUTER SOFTWARE APPLICATIONS IN THE FIELD OF FINANCIAL MANAGEMENT AND ONLINE FINANCIAL AND E-COMMERCE TRANSACTIONS; PROVIDING BILLING ALERTS (U.S. CLS. 100, 101 AND 102).

### CLASS 36—INSURANCE AND FINANCIAL

FOR FINANCIAL SERVICES, NAMELY, PROVIDING AN ONLINE AUTOMATED FINANCIAL RECORDS AGGREGATION SERVICE TO AGGREGATE AND SUMMARIZE PERSONAL AND CORPORATE BANKING, FINANCIAL, INVESTMENT AND GENERAL FINANCIAL INFORMATION; ONLINE MONITORING AND TRACKING SERVICES FOR FINANCIAL AND E-COMMERCE TRANSACTIONS RELATING TO STATUS OF SECURITIES AND OTHER FINANCIAL INSTRUMENTS; FINANCIAL SERVICES, NAMELY, COLLECTING AND ANALYZING FINANCIAL AFFAIRS RECORDS AND SUMMARIES IN THE NATURE OF BANK ACCOUNTS, INVESTMENTS ACCOUNTS, BILL PAYMENTS, MORTGAGES, RETIREMENT ACCOUNTS, RETIREMENT PROGRAMS, CREDIT CARD ACCOUNTS, INSURANCE POLICIES AND LOANS ALL OVER ELECTRONIC COMMUNICATIONS NETWORKS; PROVIDING FINANCIAL INFORMATION IN THE FORM OF RECORDS AND SUMMARIES IN THE FIELDS OF FINANCIAL AFFAIRS, BANK ACCOUNTS, INVESTMENTS ACCOUNTS, BILL PAYMENT, MORTGAGES, RETIREMENT ACCOUNTS, RETIREMENT PROGRAMS, CREDIT CARD ACCOUNTS, INSURANCE AND LOANS BY MEANS OF ELECTRONIC COMMUNICATIONS NETWORKS; PROVIDING ONLINE PERSONAL BANKING SERVICES; PROVIDING ONLINE FINANCIAL MANAGEMENT SERVICES FOR PERSONAL, HOUSEHOLD AND BUSINESS APPLICATIONS; PROVIDING ONLINE ELECTRONIC FUNDS TRANSFER, DEBIT CARD AND BILL PAYMENT SERVICES; PROVIDING ELECTRONIC AND WEB-BASED PROCESSING AND SUBSEQUENT TRANSMISSION OF FUNDS TRANSFERS, BILL PAYMENTS AND ELECTRONIC PAYMENT DATA; ELECTRONIC PAYMENT SERVICES, NAMELY, ELECTRONIC PROCESSING AND SUBSEQUENT TRANSMISSION OF BILL PAYMENT DATA; FINANCIAL TRANSACTION SERVICES, NAMELY, PROVIDING SECURE COMMERCIAL TRANSACTIONS AND ELECTRONIC PAYMENT OPTIONS; PROVIDING ELECTRONIC PROCESSING OF ELECTRONIC PAYMENTS AND TRANSFERS VIA A GLOBAL COMPUTER NETWORK; ELECTRONIC DEBIT TRANSACTIONS (U.S. CLS. 100, 101 AND 102).

### CLASS 42—SCIENTIFIC AND COMPUTER SERVICES

FOR COMPUTER SERVICES, NAMELY, CREATING AN ONLINE VIRTUAL ENVIRONMENT FOR THE CREATION, DEVELOPMENT, DISTRIBUTION AND CONTROL OF COMPUTER SOFTWARE IN THE FIELD OF FINANCIAL MANAGEMENT AND ONLINE PAYMENTS; DEVELOPING AND HOSTING A SERVER ON A COMPUTER NETWORK FOR THE PURPOSE OF FACILITATING E-COMMERCE VIA SUCH A SERVER FEATURING COMPUTER SOFTWARE APPLICATIONS; CUSTOMER TECHNICAL SUPPORT SERVICES, NAMELY, CUSTOM INTEGRATION SUPPORT OF COMPUTER SOFTWARE INTO MULTIPLE SYSTEMS AND NETWORKS PROVIDED IN CONNECTION WITH ONLINE BANKING, ONLINE FINANCIAL TRANSACTION SERVICES AND ONLINE AUTOMATED AND ON-DEMAND BANKING, FINANCIAL, INVESTMENT AND PERSONAL RECORDS AND INFORMATION AGGREGATION SERVICES; TECHNICAL ASSISTANCE IN THE FIELD OF COMPUTER SYSTEMS, NETWORKS AND SOFTWARE ALL OF WHICH ARE PROVIDED IN CONNECTION WITH ONLINE BANKING, ONLINE FINANCIAL TRANSACTION SERVICES AND ONLINE AUTOMATED AND ON-DEMAND BANKING, FINAN-

CIAL, INVESTMENT AND PERSONAL RECORDS AND INFORMATION AGGREGATION SERVICES; CUSTOMER TECHNICAL SUPPORT SERVICES, NAMELY, CONSULTING AND CUSTOMIZATION SERVICES FOR CUSTOM INTEGRATION AND CUSTOMIZATION OF COMPUTER APPLICATIONS PROVIDED IN CONNECTION WITH ONLINE BANKING, ONLINE FINANCIAL TRANSACTION SERVICES AND ONLINE AUTOMATED AND ON-DEMAND BANKING, FINANCIAL, INVESTMENT AND PERSONAL RECORDS AND INFORMATION AGGREGATION SERVICES (U.S. CLS. 100 AND 101).

GRETCHEN ULRICH, EXAMINING ATTORNEY

SN 85-575,997. CARDOLA LIMITED, LONDON, UNITED KINGDOM, FILED 3-21-2012.

SN 85-563,140. CORN CAPITAL INNOVATIONS, LLC, OLIVIA, MN. FILED 3-7-2012.



THE MARK CONSISTS OF ONE "C" AND ONE BACKWARDS "C" THAT OVERLAP EACH OTHER.

**CLASS 35—ADVERTISING AND BUSINESS**

FOR BUSINESS MANAGEMENT AND BUSINESS MARKETING CONSULTATION SERVICES FOR FARMERS AND OTHER AGRICULTURAL PRODUCERS (U.S. CLS. 100, 101 AND 102).

FIRST USE 4-0-2011; IN COMMERCE 4-0-2011.

**CLASS 36—INSURANCE AND FINANCIAL**

FOR CROP INSURANCE CONSULTATION SERVICES FOR FARMERS AND OTHER AGRICULTURAL PRODUCERS; FINANCIAL ANALYSIS AND FINANCIAL CONSULTATION SERVICES FOR FARMERS AND OTHER AGRICULTURAL PRODUCERS (U.S. CLS. 100, 101 AND 102).

FIRST USE 4-0-2011; IN COMMERCE 4-0-2011.  
BARBARA RUTLAND, EXAMINING ATTORNEY

OWNER OF ERPN CMNTY TM OFC REG. NO. 010742898, DATED 8-29-2012, EXPIRES 3-20-2022.

THE COLOR(S) DARK BLUE, LIGHT BLUE IS/ARE CLAIMED AS A FEATURE OF THE MARK.

THE MARK CONSISTS OF THE WORD "CARDOLA" IN SPECIAL FORM IN DARK BLUE AND 3 PARALLEL ARCS OF DOTS IN DARK BLUE AND LIGHT BLUE.

**CLASS 9—ELECTRICAL AND SCIENTIFIC APPARATUS**

FOR (BASED ON USE IN COMMERCE) (BASED ON 44(E)) BLANK RECORDABLE COMPACT DISCS AND DVDS; ELECTRONIC, OPTICAL AND MAGNETIC DATA STORAGE MEANS, NAMELY, BLANK MAGNETIC DATA CARRIERS, BLANK OPTICAL DATA CARRIERS, BLANK ELECTRONIC STORAGE MEDIA; ELECTRONIC, OPTICAL AND MAGNETIC APPARATUS FOR RECORDING OF SOUND, IMAGES OR DATA; DATA RECORDINGS, NAMELY, ELECTRONIC DATABASES IN THE FIELD OF HOTEL SERVICES RECORDED ON COMPUTER MEDIA; COMPUTER SOFTWARE FOR PROVIDING INTEGRATED TELEPHONE COMMUNICATION WITH COMPUTERISED GLOBAL INFORMATION NETWORKS; COMPUTER SOFTWARE FOR USE IN THE BUSINESS AND OPERATIONAL MANAGEMENT OF HOTEL SERVICES, CONCIERGE SERVICES AND ROOM SERVICE, NAMELY, FOR MANAGING GUEST RESERVATIONS AND BOOKINGS, FOR MANAGEMENT OF EMPLOYEE SCHEDULES, AND FOR SCHEDULING AND MONITORING ROOM SERVICE REQUESTS AND ROOM MAID AND MAINTENANCE SERVICES; COMMUNICATIONS NETWORKS COMPRISED OF COMPUTER HARDWARE AND PERIPHERAL DEVICES AND COMPUTER SOFTWARE FOR DATA COMMUNICATION AND TRANSLATING AND TRANSMITTING DATA SOLD THEREWITH (U.S. CLS. 21, 23, 26, 36 AND 38).

FIRST USE 7-15-2013; IN COMMERCE 7-15-2013.



**CLASS 35—ADVERTISING AND BUSINESS**

FOR (BASED ON 44(E)) ADVERTISING AND PROMOTIONAL SERVICES; BUSINESS CONSULTATION SERVICES; BUSINESS MANAGEMENT SERVICES; BUSINESS ADMINISTRATION SERVICES; MARKETING SERVICES; BUSINESS OPERATION, PROMOTION, ADMINISTRATION AND MANAGEMENT SERVICES; COMMERCIAL INFORMATION AGENCY SERVICES; PROVISION OF BUSINESS INFORMATION RELATING TO BUSINESSES AND COMPANIES; AUCTIONEERING SERVICES INCLUDING VIA THE INTERNET; COMPILED OF BUSINESS DIRECTORIES; INFORMATION AND DATA COMPILING AND ANALYZING RELATING TO BUSINESS MANAGEMENT; RECORDS MANAGEMENT SERVICES, NAMELY, DOCUMENT INDEXING FOR OTHERS; PROVISION AND OR RENTAL OF ADVERTISING SPACE ON THE INTERNET; THE BRINGING TOGETHER, FOR THE BENEFIT OF OTHERS, OF A VARIETY OF GOODS, ENABLING CUSTOMERS TO CONVENIENTLY VIEW AND PURCHASE THOSE GOODS FROM A GENERAL MERCHANDISE INTERNET WEB SITE; THE BRINGING TOGETHER, FOR THE BENEFIT OF OTHERS, OF A VARIETY OF SERVICES, ENABLING CUSTOMERS TO CONVENIENTLY VIEW AND PURCHASE THOSE SERVICES FROM AN INTERNET WEBSITE SPECIALIZING IN THE PROVISION OF HOTEL, RESTAURANT, SPA, BEAUTICIAN, TRAVEL, TRANSPORT, AND TELECOMMUNICATIONS RELATED SERVICES; INFORMATION, ADVISORY AND CONSULTANCY SERVICES RELATING TO ALL THE AFORESAID SERVICES (U.S. CLS. 100, 101 AND 102).

STEVEN PEREZ, EXAMINING ATTORNEY

**CLASS 9—ELECTRICAL AND SCIENTIFIC APPARATUS**

FOR (BASED ON USE IN COMMERCE) (BASED ON 44(E)) BLANK RECORDABLE COMPACT DISCS AND DVDS; ELECTRONIC, OPTICAL AND MAGNETIC DATA STORAGE, MEANS NAMELY, BLANK MAGNETIC DATA CARRIERS, BLANK OPTICAL DATA CARRIERS, BLANK ELECTRONIC STORAGE MEDIA; ELECTRONIC, OPTICAL AND MAGNETIC APPARATUS FOR RECORDING OF SOUND, IMAGES OR DATA; DATA RECORDINGS, NAMELY, ELECTRONIC DATABASES IN THE FIELD OF HOTEL SERVICES RECORDED ON COMPUTER MEDIA; COMPUTER SOFTWARE FOR PROVIDING INTEGRATED TELEPHONE COMMUNICATION WITH COMPUTERISED GLOBAL INFORMATION NETWORKS; COMPUTER SOFTWARE FOR USE IN THE BUSINESS AND OPERATIONAL MANAGEMENT OF HOTEL SERVICES, CONCIERGE SERVICES AND ROOM SERVICE, NAMELY, FOR MANAGING GUEST RESERVATIONS AND BOOKINGS, FOR MANAGEMENT OF EMPLOYEE SCHEDULES, AND FOR SCHEDULING AND MONITORING ROOM SERVICE REQUESTS AND ROOM MAID AND MAINTENANCE SERVICES; COMMUNICATIONS NETWORKS COMPRISED OF COMPUTER HARDWARE AND PERIPHERAL DEVICES AND COMPUTER SOFTWARE FOR DATA COMMUNICATION AND TRANSLATING AND TRANSMITTING DATA SOLD THEREWITH (U.S. CLS. 21, 23, 26, 36 AND 38).

FIRST USE 7-15-2013; IN COMMERCE 7-15-2013.

**CLASS 35—ADVERTISING AND BUSINESS**

FOR (BASED ON 44(E)) ADVERTISING AND PROMOTIONAL SERVICES; BUSINESS CONSULTATION SERVICES; BUSINESS MANAGEMENT SERVICES; BUSINESS ADMINISTRATION SERVICES; MARKETING SERVICES; BUSINESS OPERATION, PROMOTION, ADMINISTRATION AND MANAGEMENT SERVICES; COMMERCIAL INFORMATION AGENCY SERVICES; PROVISION OF BUSINESS INFORMATION RELATING TO BUSINESSES AND COMPANIES; AUCTIONEERING SERVICES INCLUDING VIA THE INTERNET; COMPILED OF BUSINESS DIRECTORIES; INFORMATION AND DATA COMPILING AND ANALYZING RELATING TO BUSINESS MANAGEMENT; RECORDS MANAGEMENT SERVICES, NAMELY, DOCUMENT INDEXING FOR OTHERS; PROVISION AND OR RENTAL OF ADVERTISING SPACE ON THE INTERNET; THE BRINGING TOGETHER, FOR THE BENEFIT OF OTHERS, OF A VARIETY OF GOODS, ENABLING CUSTOMERS TO CONVENIENTLY VIEW AND PURCHASE THOSE GOODS FROM A GENERAL MERCHANDISE INTERNET WEB SITE; THE BRINGING TOGETHER, FOR THE BENEFIT OF OTHERS, OF A VARIETY OF SERVICES, ENABLING CUSTOMERS TO CONVENIENTLY VIEW AND PURCHASE THOSE SERVICES FROM AN INTERNET WEBSITE SPECIALIZING IN THE PROVISION OF HOTEL, RESTAURANT, SPA, BEAUTICIAN, TRAVEL, TRANSPORT, AND TELECOMMUNICATIONS RELATED SERVICES; INFORMATION, ADVISORY AND CONSULTANCY SERVICES RELATING TO ALL THE AFORESAID SERVICES (U.S. CLS. 100, 101 AND 102).

STEVEN PEREZ, EXAMINING ATTORNEY

SN 85-576,050. CARDOLA LIMITED, LONDON, UNITED KINGDOM, FILED 3-21-2012.

VirtualHotel

SN 85-576,330. TERMINOTIX INC., MONTREAL, QUEBEC, CANADA, FILED 3-21-2012.

ALIGNFACTORY

OWNER OF ERPN CMNTY TM OFC REG. NO. 010742931, DATED 8-23-2012, EXPIRES 3-20-2022.

THE COLOR(S) DARK BLUE, LIGHT BLUE IS/ARE CLAIMED AS A FEATURE OF THE MARK.

THE MARK CONSISTS OF THE WORDING "VIRTUALHOTEL" IN STYLIZED FONT WITH THE TERM "VIRTUAL" IN DARK BLUE AND THE TERM "HOTEL" IN LIGHT BLUE.

THE MARK CONSISTS OF STANDARD CHARACTERS WITHOUT CLAIM TO ANY PARTICULAR FONT, STYLE, SIZE, OR COLOR.



PRIORITY CLAIMED UNDER SEC. 44(D) ON CANADA APPLICATION NO. 1548061, FILED 10-17-2011, REG. NO. TMA879001, DATED 5-29-2014, EXPIRES 5-29-2029.

### CLASS 9—ELECTRICAL AND SCIENTIFIC APPARATUS

FOR DOWNLOADABLE SOFTWARE FOR USE IN COMPUTER-ASSISTED TRANSLATION, NAMELY, DOWNLOADABLE SOFTWARE FOR AUTOMATED AND/OR ASSISTED TRANSLATION, CONCORDANCING, EDITING, TERMINOLOGY ANALYSIS AND DATA CONVERSION, DOWNLOADABLE SOFTWARE FOR AUTOMATED BITEXT CREATION FOR USE IN TRANSLATION, CONCORDANCING, EDITING AND TERMINOLOGY ANALYSIS; DOWNLOADABLE SOFTWARE FOR THE CONCORDANCING OF TEXT FOR USE IN COMPUTER ASSISTED TRANSLATION, EDITING AND TERMINOLOGY ANALYSIS; DOWNLOADABLE SOFTWARE FOR SEARCHING TERMINOLOGY, BITEXTS AND UNILINGUAL DOCUMENTS; TERM EXTRACTION SOFTWARE TO EXTRACT TERMINOLOGY AND CREATE RECORDS IN THE FIELD OF COMPUTER-ASSISTED TRANSLATION; SOFTWARE RECORDED ON CD-ROM, DVD AND OPTICAL DISCS FOR USE IN COMPUTER-ASSISTED TRANSLATION, NAMELY, SOFTWARE FOR AUTOMATED AND/OR ASSISTED TRANSLATION, CONCORDANCING, EDITING, TERMINOLOGY ANALYSIS AND DATA CONVERSION, SOFTWARE FOR AUTOMATED BITEXT CREATION FOR USE IN TRANSLATION, CONCORDANCING, EDITING AND TERMINOLOGY ANALYSIS; SOFTWARE RECORDED ON CD-ROM, DVD AND OPTICAL DISCS FOR THE CONCORDANCING OF TEXT FOR USE IN ASSISTED TRANSLATION, EDITING AND TERMINOLOGY ANALYSIS; SOFTWARE RECORDED ON CD-ROM, DVD AND OPTICAL DISCS FOR SEARCHING TERMINOLOGY, BITEXTS AND UNILINGUAL DOCUMENTS; TERM EXTRACTION SOFTWARE RECORDED ON CD-ROM, DVD AND OPTICAL DISCS USED TO EXTRACT TERMINOLOGY AND CREATE RECORDS IN THE FIELD OF COMPUTER-ASSISTED TRANSLATION (U.S. CLS. 21, 23, 26, 36 AND 38).

FIRST USE 8-0-2005; IN COMMERCE 7-0-2006.

### CLASS 41—EDUCATION AND ENTERTAINMENT

FOR TRAINING SERVICES IN THE FIELD OF COMPUTER-ASSISTED TRANSLATION (U.S. CLS. 100, 101 AND 107).

### CLASS 42—SCIENTIFIC AND COMPUTER SERVICES

FOR PROVIDING THE TEMPORARY LIMITED OR FULL USE OF NON-DOWNLOADABLE SOFTWARE FOR USE IN COMPUTER-ASSISTED TRANSLATION, NAMELY, NON-DOWNLOADABLE SOFTWARE FOR AUTOMATED AND/OR ASSISTED TRANSLATION, CONCORDANCING, EDITING, TERMINOLOGY ANALYSIS AND DATA CONVERSION, NON-DOWNLOADABLE SOFTWARE FOR AUTOMATED SEGMENTATION OF TEXT TO BE USED IN TRANSLATION, NON-DOWNLOADABLE SOFTWARE FOR BITEXT CREATION FOR USE IN TRANSLATION, CONCORDANCING, EDITING AND TERMINOLOGY ANALYSIS; PROVIDING THE TEMPORARY LIMITED OR FULL USE OF NON-DOWNLOADABLE SOFTWARE FOR THE CONCORDANCING OF TEXT FOR USE IN ASSISTED TRANSLATION, EDITING AND TERMINOLOGY ANALYSIS; PROVIDING THE TEMPORARY USE OF NON-DOWNLOADABLE SOFTWARE FOR SEARCHING TERMINOLOGY, BITEXTS AND ARCHIVES IN THE FIELD OF COMPUTER-ASSISTED TRANSLATION; PROVIDING THE TEMPORARY USE OF NON-DOWNLOADABLE TERM EXTRACTION SOFTWARE TO EXTRACT TERMINOLOGY AND CREATE RECORDS IN THE FIELD OF COMPUTER-ASSISTED TRANSLATION; PROVIDING AN ON-LINE COMPUTER DATABASE FOR COMPUTER-ASSISTED AUTOMATED TRANSLATIONS, CONCORDANCING, TERMINOLOGY, EDITING AND DATA CONVERSION, ASSISTED TRANSLATION, TERMINOLOGY, EDITING AND DATA CONVERSION; DATA CONVERSION AND BITEXT DATA CONVER-

SION OF ELECTRONIC INFORMATION; TECHNICAL SUPPORT SERVICES, NAMELY, TROUBLESHOOTING OF COMPUTER SOFTWARE PROBLEMS IN THE FIELD OF COMPUTER-ASSISTED TRANSLATION; SOFTWARE MAINTENANCE SERVICES, NAMELY, UPDATE AND MAINTENANCE OF COMPUTER SOFTWARE; COMPUTER SOFTWARE CONSULTING SERVICES CONSISTING OF CREATING, VALIDATING AND CONVERTING BITEXTS INTO TRANSLATION MEMORIES; COMPUTER SOFTWARE CONSULTING SERVICES CONSISTING OF CREATING BITEXTS FROM TEXT ARCHIVES (U.S. CLS. 100 AND 101).

FIRST USE 8-0-2005; IN COMMERCE 7-0-2006.  
DEBORAH LOBO, EXAMINING ATTORNEY

SN 85-579,860. DIGITAL POWER CORPORATION, FREMONT, CA. FILED 3-26-2012.



NO CLAIM IS MADE TO THE EXCLUSIVE RIGHT TO USE "DIGITAL POWER" AND "FLEXIBLE POWER SOLUTIONS", APART FROM THE MARK AS SHOWN.

THE MARK CONSISTS OF AN ARCHED LINE ABOVE THE LETTERS "DP" NEXT TO THE TERMS "DIGITAL POWER" ABOVE THE TERMS "FLEXIBLE POWER SOLUTIONS".

### CLASS 9—ELECTRICAL AND SCIENTIFIC APPARATUS

FOR ELECTRONIC POWER SUPPLIES (U.S. CLS. 21, 23, 26, 36 AND 38).

FIRST USE 2-0-2010; IN COMMERCE 2-0-2010.

### CLASS 40—MATERIAL TREATMENT

FOR CUSTOM MANUFACTURE OF POWER SUPPLIES, SWITCHING POWER SUPPLIES, AND POWER SUPPLIES WITH CONVERTERS FOR TELECOMMUNICATION, INDUSTRIAL, MEDICAL AND MILITARY APPLICATIONS AND EQUIPMENT (U.S. CLS. 100, 103 AND 106).

FIRST USE 2-0-2010; IN COMMERCE 2-0-2010.

### CLASS 42—SCIENTIFIC AND COMPUTER SERVICES

FOR DESIGN OF POWER SUPPLIES, SWITCHING POWER SUPPLIES AND POWER CONVERTERS FOR TELECOMMUNICATION, INDUSTRIAL, MEDICAL AND MILITARY APPLICATIONS AND EQUIPMENT (U.S. CLS. 100 AND 101).

FIRST USE 2-0-2010; IN COMMERCE 2-0-2010.  
WENDY GOODMAN, EXAMINING ATTORNEY

SN 85-593,482. ALTICAST CORPORATION, SEOCHO-GU, SEOUL, REPUBLIC OF KOREA, FILED 4-10-2012.

SN 85-608,251. WATERSMART SOLUTIONS LTD., CALGARY, ALBERTA, CANADA, FILED 4-25-2012.



OWNER OF REPUBLIC OF KOREA REG. NO. 45-0046328, DATED 9-26-2013, EXPIRES 9-26-2023.

OWNER OF U.S. REG. NO. 3,990,119.  
THE MARK CONSISTS OF THE WORD "ALTICAST" WITH A RECTANGULAR GEOMETRIC SHAPE AND DOWNWARD POINTING ARROW TO THE WORD'S UPPER RIGHT.

**CLASS 9—ELECTRICAL AND SCIENTIFIC APPARATUS**

FOR COMPUTER SOFTWARE FOR THE DEVELOPMENT, PRODUCTION, DISTRIBUTION, BROADCAST, RECEIPT, AND DISPLAY OF INTERACTIVE TELEVISION PROGRAMMING FOR USE IN THE FIELD OF DIGITAL INTERACTIVE TELEVISION; COMPUTER SOFTWARE FOR USE IN AUTHORING INTERACTIVE DATA SERVICE APPLICATIONS, FOR FETCHING, STORING, ENCODING, SCHEDULING, AND TRANSMITTING INTERACTIVE DATA AND APPLICATIONS OVER FIXED AND WIRELESS MEDIUM, FOR MANAGING RESOURCES UTILIZED FOR BROADCASTING DATA AND APPLICATIONS OVER FIXED AND WIRELESS MEDIUM, FOR COLLECTING AND MANAGING INTERACTIVE RESPONSES BROADCAST OVER FIXED AND WIRELESS MEDIUM, AND FOR ENABLING THE OPERATION OF FIXED AND WIRELESS TRANSCEIVERS USED TO FACILITATE INTERACTIVE OPERATIONS; COMPUTER SOFTWARE FOR USE IN PRODUCING INTERACTIVE DATA SERVICE APPLICATIONS FOR BROADCAST OVER FIXED AND WIRELESS MEDIUM (U.S. CLS. 21, 23, 26, 36 AND 38).

**CLASS 35—ADVERTISING AND BUSINESS**

FOR COMPILATION OF INFORMATION INTO COMPUTER DATABASES, COMPILATION OF STATISTICS, COMPILATION AND SYSTEMIZATION OF INFORMATION INTO COMPUTER DATABASES (U.S. CLS. 100, 101 AND 102).

**CLASS 42—SCIENTIFIC AND COMPUTER SERVICES**

FOR COMPUTER SERVICES, NAMELY, PROVIDING SEARCH ENGINES FOR OBTAINING DATA ON A GLOBAL COMPUTER NETWORK; RECOVERY OF COMPUTER DATA, COMPUTER PROGRAMMING, INSTALLATION OF COMPUTER SOFTWARE, MAINTENANCE OF COMPUTER SOFTWARE, UPDATING OF COMPUTER SOFTWARE FOR OTHERS, COMPUTER SOFTWARE CONSULTANCY, COMPUTER SOFTWARE DESIGN, COMPUTER SYSTEM DESIGN, COMPUTER SYSTEMS ANALYSIS (U.S. CLS. 100 AND 101).  
ALICE BENMAMAN, EXAMINING ATTORNEY



OWNER OF CANADA REG. NO. TMA875379, DATED 4-10-2014, EXPIRES 4-10-2029.

NO CLAIM IS MADE TO THE EXCLUSIVE RIGHT TO USE "ALBERTA" AND "WATER", APART FROM THE MARK AS SHOWN.

THE MARK CONSISTS OF THE STYLIZED "!" TO THE RIGHT OF THE STYLIZED WORD "ALBERTA" AND ABOVE THE STYLIZED WORD "WATERSMART".

**CLASS 35—ADVERTISING AND BUSINESS**

FOR PROMOTING PUBLIC AWARENESS OF THE NEED FOR IMPROVED WATER MANAGEMENT PLANNING, TECHNOLOGIES AND PRACTICES; CONSULTATION REGARDING PROMOTING PUBLIC AWARENESS OF THE NEED FOR IMPROVED WATER MANAGEMENT PLANNING (U.S. CLS. 100, 101 AND 102).

**CLASS 42—SCIENTIFIC AND COMPUTER SERVICES**

FOR PROVIDING INFORMATION IN THE FIELD OF WATER ANALYSIS RELATED TO GROUND AND SURFACE WATER CONDITIONS, WATER MANAGEMENT POLICIES, BEST PRACTICE AND WATER CONSERVATION INITIATIVES; CONSULTING IN THE FIELD OF WATER TECHNOLOGY DEPLOYMENT; PROVIDING TECHNOLOGICAL INFORMATION IN THE FIELD OF INNOVATION REGARDING THE IMPROVEMENT OF WATER MANAGEMENT AWARENESS, TECHNOLOGIES AND PRACTICES; TECHNOLOGICAL CONSULTATION REGARDING WATER TECHNOLOGIES AND WATER TECHNOLOGY PRACTICES (U.S. CLS. 100 AND 101).

ELIZABETH KAJUBI, EXAMINING ATTORNEY

SN 85-627,212. ADDLER LOGOS, LLC, FORT WORTH, TX, FILED 5-16-2012.



OWNER OF U.S. REG. NOS. 1,304,212, 1,461,419 AND 3,530,587.

THE COLOR(S) RED IS/ARE CLAIMED AS A FEATURE OF THE MARK.

THE MARK CONSISTS OF A RED CIRCLE WITH A TRIANGULAR PORTION REMOVED AND OFFSET, REPRESENTING A PIZZA WITH A SLICE PULLED OUT. THE COLOR WHITE IS NOT CLAIMED AS A FEATURE OF THE MARK AND REPRESENTS BACKGROUND ONLY.

#### CLASS 30—STAPLE FOODS

FOR PREPARED FOODS, NAMELY, PIZZA AND SANDWICHES FOR CONSUMPTION ON AND OFF THE PREMISES (U.S. CL. 46).

FIRST USE 1-1-1972; IN COMMERCE 1-1-1972.

#### CLASS 43—HOTEL AND RESTAURANT SERVICES

FOR RESTAURANT SERVICES; CARRY OUT RESTAURANT SERVICES (U.S. CLS. 100 AND 101).

FIRST USE 1-1-1972; IN COMMERCE 1-1-1972.

JENNIFER RICHARDSON, EXAMINING ATTORNEY

SN 85-639,111. HANGZHOU XIAOSHAN IMPORT&EXPORT TRADE CO., LTD., HANGZHOU, ZHEJIANG, CHINA, FILED 5-31-2012.

鼎升  
Ding Sheng

THE MARK CONSISTS OF STYLIZED CHINESE CHARACTERS AND "DING SHENG".

THE ENGLISH TRANSLATION OF "DING SHENG" IN THE MARK IS "TRIPOD RISES".

THE NON-LATIN CHARACTERS IN THE MARK TRANSLITERATE TO "DING SHENG" AND THIS MEANS "TRIPOD RISES" IN ENGLISH.

#### CLASS 7—MACHINERY

FOR AGRICULTURAL IMPLEMENTS, NAMELY, SEED DRILLS; AGRICULTURAL MACHINERY, NAMELY, COMBINES; AGRICULTURAL MACHINERY, NAMELY, THRESHERS; AGRICULTURAL MACHINERY, NAMELY, TILLERS; COMPRESSORS FOR MACHINES; CUTTING MACHINES; ELECTRIC HAND-HELD DRILLS; ELECTRIC MIXERS; ELECTRIC WASHING MACHINES FOR HOUSEHOLD PURPOSES; ELECTRIC WASHING MACHINES FOR INDUSTRIAL PURPOSES; ELEVATORS; EXCAVATING MACHINES; LAWNMOWERS; PAINT SPRAY GUNS; VALVES AS MACHINE COMPONENTS; WELDING TORCHES; WIND TURBINES (U.S. CLS. 13, 19, 21, 23, 31, 34 AND 35).

FIRST USE 7-25-2009; IN COMMERCE 7-25-2009.

#### CLASS 12—VEHICLES

FOR AUTOMOBILES; BABY CARRIAGES; BICYCLES; CARTS; MOTORCYCLES; STEERING WHEEL COVERS; TRUCK ACCESSORIES, NAMELY, RETRACTABLE TAILGATE BENCHES; UPHOLSTERY FOR VEHICLES; VEHICLE SEAT CUSHIONS (U.S. CLS. 19, 21, 23, 31, 35 AND 44).

FIRST USE 7-28-2009; IN COMMERCE 7-28-2009.

WILLIAM P. SHANAHAN, EXAMINING ATTORNEY

SN 85-640,249. PMI INDUSTRIES, INC., CLEVELAND, OH. FILED 5-31-2012.



THE MARK CONSISTS OF THE CAPITAL LETTERS "PMI" WITH TWO PARALLEL, WAVY LINES EXTENDING BELOW THE LETTERS "P" AND "M".

#### CLASS 6—METAL GOODS

FOR TERMINATIONS, NAMELY, METAL LOOPS AND RINGS FOR LINES, CABLE, STRANDS AND SYNTHETIC ROPES; METAL DEAD ENDS FOR SECURING, GRIPPING, SUPPORTING, AND PROTECTING LINES, CABLES, STRANDS, SYNTHETIC ROPES, AND WIRES; STRANDS, NAMELY, NON-ELECTRIC SINGLE OR MULTI-STRAND WIRE; SPACERS FOR PARALLEL LINES, CABLE, STRANDS, AND SYNTHETIC ROPES, NAMELY, SPACER BRACKETS OF METAL; METAL SUPPORT PIECES AND TANGENT SUPPORTS FOR CABLES AND WIRES; METAL HARDWARE FOR SECURING, GRIPPING, SUPPORTING, AND PROTECTING LINES, CABLE, STRANDS AND SYNTHETIC ROPES, NAMELY, SUSPENSIONS, DEAD ENDS, SPACERS, REPAIR RODS, SUPPORTS AND COMPONENTS THEREOF; YOKE PLATES, CLEAVISES, SOCKET EYES IN THE NATURE OF METAL EYE BOLTS, AND HOLD DOWN SHACKLES IN THE NATURE OF METAL SHACKLES FOR LIFTING AND RIGGING; STEEL LASHING RODS AND WIRES AND TERMINATIONS FOR GRIPPING UNDERWATER CABLES; STEEL ARMOR RODS FOR SECURING, GRIPPING, SUPPORTING AND PROTECTING LINES, CABLE, STRANDS AND SYNTHETIC ROPES; METAL SUSPENSION ASSEMBLIES FOR LINES, CABLE, STRANDS AND SYNTHETIC ROPES, NAMELY, BRACKETS, CONNECTORS, AND PLATES; METAL HARDWARE, NAMELY, CABLE SEPARATORS, NAMELY, METAL BLOCKS FOR SUPPORTING AND SEPARATING CABLES, LINES, SYNTHETIC ROPES AND WIRES, AND STRANDS; SUPPORTING AND ROUTING DEVICES FOR DATA CONDUCTORS, NAMELY, METAL BRACKETS, SUPPORTS, SUPPORT BLOCKS, AND METAL CLAMPS; METAL CLAMPS FOR WIRE ROPE AND ELECTROMECHANICAL AND OPTICAL CABLES (U.S. CLS. 2, 12, 13, 14, 23, 25 AND 50).

#### CLASS 9—ELECTRICAL AND SCIENTIFIC APPARATUS

FOR HARDWARE ACCESSORIES FOR ELECTRICAL ROPES, CABLES, STRANDS, WIRES AND FIBER OPTIC CABLES, NAMELY, CABLE CONNECTORS, SOLD SEPARATELY OR AS A UNIT; DISTANCE SPACING ASSEMBLIES FOR ELECTRICAL ROPES, CABLES, STRANDS, WIRES AND FIBER OPTIC CABLES, NAMELY, ELECTRICAL SHIELDING SPACERS FOR CABLES AND CABLE ASSEMBLIES; DAMPING ASSEMBLIES FOR ELECTRICAL ROPES, CABLES, STRANDS, WIRES AND FIBER OPTIC CABLES, NAMELY, VIBRATION DAMPENERS; ELECTRICAL CONNECTORS; CABLE PROTECTORS, NAMELY, SHEATHS FOR ELECTRICAL CABLES; SUSPENSION ASSEMBLIES FOR ELECTRICAL ROPES, CABLES, STRANDS, WIRES AND FIBER OPTIC CABLES, NAMELY, BRACKETS, AND PLATES; ELECTRO-MECHANICAL CABLES AND FIBER OPTIC CABLES; SPLICES FOR NON-ELECTRIC WIRE AND CABLE, ELECTRO-MECHANICAL CABLE, AND FIBER OPTIC CABLE; METAL SPLICE CONNECTORS FOR NON-ELECTRIC WIRE AND CABLE, ELECTRO-MECHANICAL CABLE, AND FIBER OPTIC CABLE; ELECTRIC STRAIN RELIEF COUPLINGS FOR USE WITH UNDERWATER CABLES (U.S. CLS. 21, 23, 26 AND 38).

**CLASS 17—RUBBER GOODS**

FOR WATERPROOF SPLICE COVERS FOR CABLES, WIRES, STRANDS, AND SYNTHETIC ROPES (U.S. CLS. 1, 5, 12, 13, 35 AND 50).

**CLASS 20—FURNITURE AND ARTICLES NOT OTHERWISE CLASSIFIED**

FOR HARDWARE, NAMELY, CABLE SEPARATORS, NAMELY, NON-METAL SUPPORT BLOCKS FOR SUPPORTING AND SEPARATING CABLES, SYNTHETIC ROPES AND WIRES, AND STRANDS (U.S. CLS. 2, 13, 22, 25, 32 AND 50).

**CLASS 37—CONSTRUCTION AND REPAIR**

FOR REPAIR OF UNDERWATER CABLE SYSTEMS (U.S. CLS. 100, 103 AND 106).

**CLASS 42—SCIENTIFIC AND COMPUTER SERVICES**

FOR DESIGN OF UNDERWATER CABLE SYSTEMS; SPECIALIZED TESTING OF OFFSHORE AND UNDERWATER CABLE, WIRE AND SYNTHETIC ROPE, FLEXIBLE RISERS, TOWED ARRAY, AND CABLE SYSTEMS (U.S. CLS. 100 AND 101).

SANI KHOURI, EXAMINING ATTORNEY

SN 85-709,041. NETNAMES OPERATIONS LIMITED, LONDON, UNITED KINGDOM, FILED 8-21-2012.



PRIORITY CLAIMED UNDER SEC. 44(D) ON ERP N CMNTY TM OFC APPLICATION NO. 11001369, FILED 6-28-2012, REG. NO. 011001369, DATED 1-25-2014, EXPIRES 6-28-2022.

OWNER OF U.S. REG. NO. 3,362,436.

THE COLOR(S) GRAY AND ORANGE IS/ARE CLAIMED AS A FEATURE OF THE MARK.

THE MARK CONSISTS OF THE WORDING "NETNAMES" IN GRAY WITH THE SLIGHTLY SLANTED SUPERSCRIPT "NN" IN ORANGE IMMEDIATELY FOLLOWING "NETNAMES" AND THE PHRASE "ONE STEP AHEAD" IN GRAY APPEARING BELOW "NETNAMES".

SEC. 2(F) AS TO "NETNAMES".

**CLASS 9—ELECTRICAL AND SCIENTIFIC APPARATUS**

FOR DOWNLOADABLE ELECTRONIC NEWSLETTERS IN THE FIELD OF DOMAIN NAME MANAGEMENT, BRAND PROTECTION, DOMAIN NAME ACQUISITIONS, ANTI-PIRACY AND ONLINE SECURITY; DOWNLOADABLE PUBLICATIONS, NAMELY, BOOKS, MAGAZINES, BROCHURES, AND PAMPHLETS, IN THE FIELD OF DOMAIN NAME MANAGEMENT, BRAND PROTECTION, DOMAIN NAME ACQUISITIONS, ANTI-PIRACY AND ONLINE SECURITY; COMPUTER SOFTWARE FOR ONLINE BRAND MANAGEMENT AND THE PROVISION OF INTERNET-BASED SERVICES TO THIRD PARTIES, AND/OR FOR USE IN DATABASE MANAGEMENT (U.S. CLS. 21, 23, 26, 36 AND 38).

**CLASS 35—ADVERTISING AND BUSINESS**

FOR BUSINESS ADVISORY SERVICES; BUSINESS RESEARCH SERVICES; PROVIDING BUSINESS INFORMATION IN THE FIELD OF GLOBAL COMPUTER NETWORK ADDRESS AND URL REGISTRATION; BRAND ANALYSIS, CREATION, DEVELOPMENT, AND EVALUATION SERVICES IN THE FIELD OF TRADE NAMES AND DOMAIN NAMES; PROCUREMENT OF DOMAIN NAMES FOR OTHERS, NAMELY, THE ACQUISITION OF DOMAIN NAMES FROM THIRD PARTIES (U.S. CLS. 100, 101 AND 102).

**CLASS 38—COMMUNICATION**

FOR TELECOMMUNICATIONS SERVICES, NAMELY, THE TRANSMISSION OF DATA, GRAPHICS, IMAGES OR AUDIO AND VIDEO BY MEANS OF TELECOMMUNICATIONS NETWORKS, WIRELESS TELECOMMUNICATIONS NETWORKS AND THE INTERNET; DATA COMMUNICATION SERVICES, NAMELY, THE TRANSMISSION OF DATA, GRAPHICS, IMAGES OR AUDIO AND VIDEO BY MEANS OF TELECOMMUNICATIONS NETWORKS, WIRELESS TELECOMMUNICATIONS NETWORKS AND THE INTERNET; EMAIL SERVICES; SERVICES RELATING TO THE SECURITY OF ONLINE COMMUNICATIONS AND ONLINE TRANSACTIONS, NAMELY, PROVIDING SECURE ACCESS TO ONLINE COMMUNICATION FACILITIES FOR OTHERS TO UPLOAD, VIEW, COPY, PRINT, DOWNLOAD AND SHARE DOCUMENTS AND IMAGES FOR THE PURPOSE OF CONSUMER DRIVEN TRANSACTIONS AND ONLINE BRAND MANAGEMENT (U.S. CLS. 100, 101 AND 104).

**CLASS 39—TRANSPORTATION AND STORAGE**

FOR COMPUTERIZED STORAGE OF DATA (U.S. CLS. 100 AND 105).

**CLASS 41—EDUCATION AND ENTERTAINMENT**

FOR EDUCATION SERVICES, NAMELY, DEVELOPING EDUCATIONAL MANUALS FOR OTHERS IN THE FIELD OF DOMAIN NAME MANAGEMENT, BRAND PROTECTION, DOMAIN NAME ACQUISITIONS, ANTI-PIRACY AND ONLINE SECURITY; EDUCATIONAL SERVICES, NAMELY, PROVIDING TRAINING, CONFERENCES AND SEMINARS IN THE FIELD OF DOMAIN NAME MANAGEMENT, BRAND PROTECTION, DOMAIN NAME ACQUISITIONS, ANTI-PIRACY AND ONLINE SECURITY (U.S. CLS. 100, 101 AND 107).

**CLASS 42—SCIENTIFIC AND COMPUTER SERVICES**

FOR THE PROVISION OF DATA BACK-UP SERVICES FOR COMPUTER HARD DRIVE DATA; THE PROVISION OF TECHNICAL ASSISTANCE TO THIRD PARTIES, NAMELY, TROUBLESHOOTING COMPUTER SOFTWARE AND INTERNET PROBLEMS; COMPUTER SOFTWARE SERVICES, NAMELY, THE DESIGN AND REMOTE MANAGEMENT OF INFORMATION TECHNOLOGY SYSTEMS FOR OTHERS; WEB AND WEBSITE HOSTING SERVICES FOR THIRD PARTIES (U.S. CLS. 100 AND 101).

**CLASS 45—PERSONAL AND LEGAL SERVICES**

FOR DOMAIN NAME MANAGEMENT AND ADVISORY SERVICES, NAMELY, DOMAIN NAME REGISTRATION SERVICES AND ADVISORY SERVICES IN THE FIELD OF DOMAIN NAME REGISTRATIONS; ANTI-COUNTERFEITING SERVICES RELATING TO ONLINE BRAND PROTECTION AND MONITORING, ANTI-COUNTERFEITING AND ANTI-PIRACY, NAMELY, SEARCHES, INVESTIGATIONS AND REPORTING ON THE MISAPPROPRIATION OF BRANDS, THE SALE OR OFFER FOR SALE OF COUNTERFEIT GOODS, AND THE UNLAWFUL PROVISION OF COPYRIGHT WORKS BY THIRD PARTIES ON THE INTERNET; DOMAIN NAME SEARCHING SERVICES, NAMELY, CONDUCTING ONLINE COMPUTERIZED SEARCHES FOR THE AVAILABILITY OF DOMAIN NAMES; INTELLECTUAL PROPERTY CONSULTING SERVICES, NAMELY, THE REVIEW AND ANALYSIS OF THIRD PARTY INTELLECTUAL PROPERTY RIGHTS (U.S. CLS. 100 AND 101).

Laurie Kaufman, Examining Attorney

SN 85-724,908. 30DC, INC., NEW YORK, NY. FILED 9-10-2012.

# MagCast

THE MARK CONSISTS OF STANDARD CHARACTERS WITHOUT CLAIM TO ANY PARTICULAR FONT, STYLE, SIZE, OR COLOR.

**CLASS 41—EDUCATION AND ENTERTAINMENT**

FOR DIGITAL VIDEO, AUDIO, AND MULTIMEDIA PUBLISHING SERVICES; PROVISION OF INFORMATION RELATING TO MULTIMEDIA PUBLISHING (U.S. CLS. 100, 101 AND 107).

FIRST USE 7-7-2011; IN COMMERCE 7-7-2011.

**CLASS 42—SCIENTIFIC AND COMPUTER SERVICES**

FOR SOFTWARE AS A SERVICE (SAAS) SERVICES, NAMELY, HOSTING SOFTWARE FOR USE BY OTHERS FOR USE IN CREATING DIGITAL PUBLICATIONS (U.S. CLS. 100 AND 101).

FIRST USE 7-7-2011; IN COMMERCE 7-7-2011.

Ronald MCMorrow, Examining Attorney

SN 85-725,748. THE UNITED DISTRIBUTION GROUP, INC., BRISTOL, TN. FILED 9-11-2012.



NO CLAIM IS MADE TO THE EXCLUSIVE RIGHT TO USE "DISTRIBUTION GROUP, INC.", APART FROM THE MARK AS SHOWN.

THE MARK CONSISTS OF "UDG" IN LARGE BOLD CAPITAL LETTERS ABOVE "THE UNITED DISTRIBUTION GROUP, INC." WITH RAYS OF LIGHT EMANATING FROM THE "G" OF "UDG".

**CLASS 35—ADVERTISING AND BUSINESS**

FOR BUSINESS MANAGEMENT; BUSINESS ADMINISTRATION AND OFFICE WORK; MANAGEMENT OF OFFICE FUNCTIONS AND ADMINISTRATIVE SERVICES, NAMELY, BOOKKEEPING, TRACKING AND MONITORING INSURANCE COMPLIANCE, AND CONTRACT MANAGEMENT, NAMELY, ADMINISTRATION OF CONTRACTS, NAMELY, NEGOTIATION AND SETTLEMENT OF COMMERCIAL TRANSACTIONS FOR THIRD PARTIES AND CONTRACT MANAGEMENT AND SUPPLIER MANAGEMENT SERVICES, NAMELY, PROCUREMENT AND MANAGEMENT OF GOODS AND SERVICES BY SUPPLIERS AND MANAGEMENT OF CUSTOMER AND SUPPLIER RELATIONSHIPS; BUSINESS RISK MANAGEMENT; ADMINISTRATION OF BUSINESS PAYROLL FOR OTHERS; HUMAN RESOURCE SERVICES, NAMELY, HUMAN RESOURCES MANAGEMENT, AND SERVING AS A HUMAN RESOURCES DEPARTMENT FOR OTHERS; BUSINESS DEVELOPMENT SERVICES, NAMELY, ASSISTANCE, ADVISORY SERVICES AND CONSULTANCY WITH REGARD TO BUSINESS PLANNING, BUSINESS ANALYSIS, BUSINESS MANAGEMENT, AND BUSINESS ORGANIZATION; BUSINESS CONSULTING AND INFORMATION SERVICES; DATA MANAGEMENT, NAMELY, INFORMATION AND DATA COMPILING AND ANALYZING RELATING TO BUSINESS MANAGEMENT (U.S. CLS. 100, 101 AND 102).

**CLASS 42—SCIENTIFIC AND COMPUTER SERVICES**

FOR GRAPHIC DESIGN; INFORMATION TECHNOLOGY SERVICES AND INFRASTRUCTURE, NAMELY, DESIGN AND DEVELOPMENT OF COMPUTER NETWORKS AND COMPUTER DATABASES, COMPUTER HARDWARE AND SOFTWARE DESIGN, IT CONSULTING AND IT INTEGRATION SERVICES, AND REMOTE AND ON-SITE MANAGEMENT AND ADMINISTRATION OF THE IT SYSTEMS (U.S. CLS. 100 AND 101).

**CLASS 45—PERSONAL AND LEGAL SERVICES**

FOR LEGAL AND CONTRACT SUPPORT SERVICES, NAMELY, PROVIDING LEGAL REVIEW AND LEGAL ANALYSIS OF DOCUMENTS FOR CORPORATE DEPARTMENTS AND BUSINESS UNITS; CONSULTATION ON LITIGATION; LEGAL SERVICES, NAMELY, CONTRACT DRAFTING AND NEGOTIATION (U.S. CLS. 100 AND 101).

David Murray, Examining Attorney

SN 85-744,090. D B INDUSTRIES, LLC, DBA CAPITAL SAFETY USA, RED WING, MN. FILED 10-2-2012.



NO CLAIM IS MADE TO THE EXCLUSIVE RIGHT TO USE "SAFETY", APART FROM THE MARK AS SHOWN. THE MARK CONSISTS OF THE STYLIZED WORDING "CAPITAL SAFETY" WITHIN A SQUARE.

**CLASS 9—ELECTRICAL AND SCIENTIFIC APPARATUS**

FOR FALL PROTECTION EQUIPMENT FOR FALL RESTRAINT AND FALL ARREST, NAMELY, HOOKS (U.S. CLS. 21, 23, 26, 36 AND 38).  
FIRST USE 8-0-2006; IN COMMERCE 8-0-2006.

**CLASS 37—CONSTRUCTION AND REPAIR**

FOR MAINTENANCE AND REPAIR OF FALL PROTECTION EQUIPMENT (U.S. CLS. 100, 103 AND 106).  
FIRST USE 11-7-2006; IN COMMERCE 11-7-2006.

**CLASS 40—MATERIAL TREATMENT**

FOR CUSTOM MANUFACTURING OF FALL PROTECTION EQUIPMENT (U.S. CLS. 100, 103 AND 106).  
FIRST USE 11-7-2006; IN COMMERCE 11-7-2006.

**CLASS 41—EDUCATION AND ENTERTAINMENT**

FOR TRAINING IN THE FIELD OF FALL ARREST AND FALL PROTECTION; TRAINING IN THE USE OF FALL ARREST AND FALL PROTECTION EQUIPMENT; EDUCATIONAL SERVICES, NAMELY, CLASSES, WORKSHOPS, SEMINARS, AND EDUCATIONAL CONFERENCES IN THE FIELD OF FALL ARREST AND FALL PROTECTION, FALL ARREST AND FALL PROTECTION EQUIPMENT, AND RESTRAINT AND SAFETY EQUIPMENT (U.S. CLS. 100, 101 AND 107).  
FIRST USE 1-0-2007; IN COMMERCE 1-0-2007.  
BRIAN PINO, EXAMINING ATTORNEY

SN 85-758,477. COMMUNITECH CORPORATION, KITCHENER, ONTARIO, CANADA, FILED 10-19-2012.

**COMMUNITECH HUB**

THE MARK CONSISTS OF STANDARD CHARACTERS WITHOUT CLAIM TO ANY PARTICULAR FONT, STYLE, SIZE, OR COLOR.  
PRIORITY CLAIMED UNDER SEC. 44(D) ON CANADA APPLICATION NO. 1,574,553, FILED 4-23-2012, REG. NO. TMA876742, DATED 4-30-2014, EXPIRES 4-30-2029.

**CLASS 35—ADVERTISING AND BUSINESS**

FOR BUSINESS DEVELOPMENT SERVICES, NAMELY, PROVIDING START-UP SUPPORT FOR BUSINESSES OF OTHERS NAMELY, ACCELERATING THE STARTUP AND GROWTH OF TECHNOLOGY ORIENTED COMPANIES; ARRANGING AND CONDUCTING SPECIAL EVENTS FOR BUSINESS PURPOSES; PROVIDING BUSINESS ADVICE (U.S. CLS. 100, 101 AND 102).

**CLASS 36—INSURANCE AND FINANCIAL**

FOR VENTURE CAPITAL ADVISORY SERVICES TO EMERGING AND START-UP COMPANIES (U.S. CLS. 100, 101 AND 102).  
SCOTT BIBB, EXAMINING ATTORNEY

SN 85-758,488. COMMUNITECH CORPORATION, KITCHENER, ONTARIO, CANADA, FILED 10-19-2012.



PRIORITY CLAIMED UNDER SEC. 44(D) ON CANADA APPLICATION NO. 1,574,551, FILED 4-23-2012, REG. NO. TMA876741, DATED 4-30-2014, EXPIRES 4-30-2029.

THE MARK CONSISTS OF THE WORD "COMMUNITECH" WITH A TRIANGLE SHOWN BEHIND THE LETTER "T".

**CLASS 35—ADVERTISING AND BUSINESS**

FOR BUSINESS DEVELOPMENT SERVICES, NAMELY, PROVIDING START-UP SUPPORT FOR BUSINESSES OF OTHERS NAMELY, ACCELERATING THE STARTUP AND GROWTH OF TECHNOLOGY ORIENTED COMPANIES; ARRANGING AND CONDUCTING SPECIAL EVENTS FOR BUSINESS PURPOSES; PROVIDING BUSINESS ADVICE (U.S. CLS. 100, 101 AND 102).

**CLASS 36—INSURANCE AND FINANCIAL**

FOR VENTURE CAPITAL ADVISORY SERVICES TO EMERGING AND START-UP COMPANIES (U.S. CLS. 100, 101 AND 102).  
SCOTT BIBB, EXAMINING ATTORNEY

SN 85-762,507. TODD BLACKWOOD, TAPPAN, NY. FILED 10-24-2012.

**WORLD PRESERVATION PARTY**

THE MARK CONSISTS OF STANDARD CHARACTERS WITHOUT CLAIM TO ANY PARTICULAR FONT, STYLE, SIZE, OR COLOR.  
NO CLAIM IS MADE TO THE EXCLUSIVE RIGHT TO USE "PARTY", APART FROM THE MARK AS SHOWN.

**CLASS 16—PAPER GOODS AND PRINTED MATTER**

FOR PUBLICATIONS, NAMELY, BUMPER STICKERS, CALENDARS, POSTERS, PAMPHLETS IN THE FIELD OF POLITICS, BROCHURES IN THE FIELD OF POLITICS, ADVERTISING SIGNS OF PAPER, ADVERTISING SIGNS OF CARDBOARD; BALL POINT PENS AND FOUNTAIN PENS (U.S. CLS. 2, 5, 22, 23, 29, 37, 38 AND 50).

**CLASS 20—FURNITURE AND ARTICLES NOT OTHERWISE CLASSIFIED**

FOR NON-LEATHER AND NON-METAL KEY CHAINS, PLASTIC BANNERS, VINYL BANNERS (U.S. CLS. 2, 13, 22, 25, 32 AND 50).

**CLASS 24—FABRICS**

FOR BANNERS OF TEXTILE (U.S. CLS. 42 AND 50).

**CLASS 25—CLOTHING**

FOR CLOTHING, NAMELY, T-SHIRTS AND HATS, JACKETS, SWEAT SHIRTS (U.S. CLS. 22 AND 39).

**CLASS 26—FANCY GOODS**

FOR CAMPAIGN BUTTONS (U.S. CLS. 37, 39, 40, 42 AND 50).

**CLASS 35—ADVERTISING AND BUSINESS**

FOR POLITICAL PARTY SERVICES, NAMELY, PROMOTING THE INTERESTS OF A POLITICAL PARTY, PROVIDING AN ON-LINE SEARCHABLE DATABASE FEATURING INFORMATION ON POLITICAL CAMPAIGNS; POLITICAL CONSULTATION SERVICES (U.S. CLS. 100, 101 AND 102).

**CLASS 42—SCIENTIFIC AND COMPUTER SERVICES**

FOR CREATING AN ON-LINE COMMUNITY FOR REGISTERED USERS FOR THE PURPOSE OF PARTICIPATING IN POLITICAL DISCUSSIONS (U.S. CLS. 100 AND 101).

**CLASS 45—PERSONAL AND LEGAL SERVICES**

FOR ON-LINE SOCIAL NETWORKING SERVICES (U.S. CLS. 100 AND 101).  
MICHAEL KEATING, EXAMINING ATTORNEY

SN 85-768,923. TIERRA CALIENTE MUSIC GROUP, S.A. DE C.V., SAN PEDRO GZA GCIA, NL, MEXICO, FILED 11-1-2012.



NO CLAIM IS MADE TO THE EXCLUSIVE RIGHT TO USE "MUSIC", APART FROM THE MARK AS SHOWN. THE COLOR(S) RED, GREEN, WHITE AND BLACK IS/ ARE CLAIMED AS A FEATURE OF THE MARK.

THE MARK CONSISTS OF THE WORD "REMEX" WITH THE LETTERS "R","E" IN WHITE, THE LETTER "M" APPEARING MUCH BIGGER THAN THE OTHER LETTERS WITH GREEN ON THE LEFT SIDE, RED ON THE RIGHT SIDE AND WHITE IN THE MIDDLE, AND THE LETTERS "E","X" IN WHITE. ALL OUTLINED IN BLACK. BELOW IS THE WORD "MUSIC" IN RED AND OUTLINED IN BLACK.

THE WORDING "REMEX" HAS NO MEANING IN A FOREIGN LANGUAGE.

**CLASS 35—ADVERTISING AND BUSINESS**

FOR MANAGEMENT OF PERFORMING AND RECORDING ARTISTS; PERSONAL MANAGEMENT SERVICES FOR MUSICAL PERFORMERS (U.S. CLS. 100, 101 AND 102).

FIRST USE 11-0-2011; IN COMMERCE 11-0-2011.

**CLASS 36—INSURANCE AND FINANCIAL**

FOR COLLECTING LICENSE FEES ON BEHALF OF INDEPENDENT WRITERS AND PUBLISHERS AND MAKING PAYMENTS TO THE COPYRIGHT OWNERS OF THE MUSIC; CONSULTING ON THE SUBJECT OF INTELLECTUAL PROPERTY VALUATION; FINANCIAL ADMINISTRATION OF COPYRIGHTS AND INTELLECTUAL PROPERTY LICENSES, NAMELY, FINANCIAL ADMINISTRATION OF LICENSE FEES COLLECTED ON BEHALF OF COPYRIGHT AND INTELLECTUAL PROPERTY OWNERS (U.S. CLS. 100, 101 AND 102).

FIRST USE 11-0-2011; IN COMMERCE 11-0-2011.

**CLASS 41—EDUCATION AND ENTERTAINMENT**

FOR ARRANGING AND CONDUCTING SPECIAL EVENTS FOR SOCIAL ENTERTAINMENT PURPOSES; AUDIO AND VIDEO RECORDING SERVICES; AUDIO RECORDING AND PRODUCTION; DIGITAL VIDEO, AUDIO, AND MULTIMEDIA PUBLISHING SERVICES; ENTERTAINMENT INFORMATION; MULTIMEDIA ENTERTAINMENT SERVICES IN THE NATURE OF RECORDING, PRODUCTION AND POST-PRODUCTION SERVICES IN THE FIELDS OF MUSIC, VIDEO, AND FILMS; PRODUCTION OF SOUND RECORDINGS, NAMELY, CD'S, DVD'S, AUDIOTAPES, MP3 RECORDINGS (U.S. CLS. 100, 101 AND 107).

FIRST USE 11-0-2011; IN COMMERCE 11-0-2011.

KATHERINE CONNOLLY, EXAMINING ATTORNEY

SN 85-771,948. WIN (GIBRALTAR) LIMITED, EUROPORT, GIBRALTAR, FILED 11-5-2012.

**SLOTS CRAZE**

THE MARK CONSISTS OF STANDARD CHARACTERS WITHOUT CLAIM TO ANY PARTICULAR FONT, STYLE, SIZE, OR COLOR.

OWNER OF ERPN CMNTY TM OFC REG. NO. 11251691, DATED 3-7-2013, EXPIRES 9-10-2022.

NO CLAIM IS MADE TO THE EXCLUSIVE RIGHT TO USE "SLOTS", APART FROM THE MARK AS SHOWN.

**CLASS 9—ELECTRICAL AND SCIENTIFIC APPARATUS**

FOR COMPUTER-GAMING SOFTWARE; COMPUTER GAME SOFTWARE; COMPUTER-GAMING SOFTWARE DOWNLOADABLE FROM THE INTERNET; APPLICATION PROGRAMMING INTERFACE SOFTWARE TO ACCESS OTHER COMPUTER SOFTWARE GAMING PROGRAMS; INTERACTIVE VIDEO GAME PROGRAMS; COMPUTER SOFTWARE PLATFORMS FOR SOCIAL NETWORKING; COMPUTER SOFTWARE TO ENABLE UPLOADING, DOWNLOADING, ACCESSING, POSTING, DISPLAYING, TAGGING, BLOGGING, STREAMING, LINKING, SHARING OR OTHERWISE PROVIDING ELECTRONIC MEDIA OR INFORMATION VIA COMPUTER AND COMMUNICATION NETWORKS; COMPUTER SOFTWARE TO ENABLE SEARCHING, BROWSING AND RETRIEVING INFORMATION, WEBSITES OF OTHERS ON GLOBAL COMPUTER NETWORKS FOR OTHERS; DOWNLOADABLE ELECTRONIC PUBLICATIONS IN THE NATURE OF NEWSLETTERS, BOOKS, PAMPHLETS, AND MAGAZINE AND JOURNAL ARTICLES THAT ARE DOWNLOADABLE FROM A PUBLIC DATA NETWORK RELATED TO THE FIELD OF SPORTS AND GAMING PROVIDED ONLINE FROM COMPUTER DATABASES AND THE INTERNET; DOWNLOADABLE ELECTRONIC GAME PROGRAMS VIA THE INTERNET AND COMPUTER AND COMMUNICATION NETWORKS; DOWNLOADABLE ELECTRONIC PUBLICATIONS IN THE NATURE OF NEWSLETTERS, BOOKS, PAMPHLETS, AND MAGAZINE AND JOURNAL ARTICLES IN THE FIELD OF SPORTS, GAMBLING AND GAMING, DOWNLOADABLE VIA THE INTERNET AND ELECTRONIC MAIL; INTERACTIVE COMPUTER SOFTWARE FOR INTERACTIVE DATA PROCESSING OF STATISTICS AND ODDS IN THE FIELD OF SPORTS, GAMBLING AND GAMING; MAGNETICALLY ENCODED CREDIT CARDS; MAGNETICALLY ENCODED PREPAID STORED VALUE CARDS FOR THE PURPOSE OF PROMOTING AND REWARDING CUSTOMER LOYALTY; MAGNETICALLY ENCODED PREPAID CREDIT, CHARGE AND DISCOUNT CARDS; MAGNETICALLY ENCODED CREDIT, PURCHASE AND DISCOUNT CARDS FOR USE IN CONNECTION WITH PROMOTIONAL CAMPAIGNS AND CONTESTS; DOWNLOADABLE INTERACTIVE COMPUTER GAME PROGRAMS; COMPUTER GAME PROGRAMS DOWNLOADABLE VIA THE INTERNET (U.S. CLS. 21, 23, 26, 36 AND 38).

**CLASS 38—COMMUNICATION**

FOR TELECOMMUNICATIONS SERVICES, NAMELY, ELECTRONIC TRANSMISSION OF INSTANT MESSAGES VIA GLOBAL COMPUTER NETWORKS, THE INTERNET, TELEPHONES, CELLULAR PHONES, MOBILE PHONES; COMMUNICATIONS SERVICES, NAMELY, TRANSMITTING STREAMED SOUND AND AUDIOVISUAL RECORDINGS VIA THE INTERNET; ELECTRONIC TRANSMISSION OF DOWNLOADABLE AUDIO, VIDEO AND COMPUTER GAME PROGRAM FILES VIA COMPUTER AND ELECTRONIC COMMUNICATIONS NETWORKS; TRANSMISSION OF INFORMATION OVER A GLOBAL COMPUTER NETWORK SUCH AS THE INTERNET; ELECTRONIC MAIL SERVICES; TELECOMMUNICATION SERVICES, NAMELY, PROVIDING MULTIPLE USER ACCESS TO A GLOBAL COMPUTER INFORMATION NETWORK; PROVISION OF TELECOMMUNICATIONS GATEWAY LINKS TO COMPUTER DATABASES AND WEBSITES ON THE INTERNET; TELECOMMUNICATIONS SERVICES DEDICATED TO RETAILING GOODS AND PROVIDING SERVICES THROUGH INTERACTIVE COMMUNICATIONS WITH CUSTOMERS, NAMELY, PROVIDING TELECOMMUNICATION CONNECTIONS TO THE INTERNET OR DATABASES; TRANSMISSION OF SOUND AND PICTURES; COMPUTER AIDED TRANSMISSION OF MESSAGES AND IMAGES; TRANSMISSION AND COMMUNICATION SERVICES, NAMELY, ELECTRONIC DATA TRANSMISSION, ELECTRONIC MESSAGE TRANSMISSION, COMMUNICATIONS BY SATELLITE; INSTANT MESSAGING SERVICES; MESSAGE SENDING SERVICES; INTERNET AND TELEVISION BROADCASTING AND TRANSMISSION OF INTERACTIVE PROGRAMS, SHOWS, GAMES, QUIZ SHOWS AND COMPETITIONS IN THE FIELD OF SPORTS, NEWS AND GAMING AND GAMES OF CHANCE VIA THE INTERNET AND TELECOMMUNICATIONS NET-

WORKS; PROVIDING INTERNET ACCESS TO A DATABASE STORING INFORMATION RELATING TO A VARIETY OF CONSUMER GOODS AND SERVICES OF OTHERS; INTERNET ACCESS PROVIDER SERVICES; PROVIDING ELECTRONIC TELECOMMUNICATION CONNECTIONS, NAMELY, PROVISION OF A CONNECTION BETWEEN WEBSITES AND TELEVISION VIEWERS VIA AN INTERACTIVE TELEVISION PORTAL; PROVIDING ACCESS TO COMPUTER DATABASES IN THE FIELDS OF SOCIAL NETWORKING; PROVIDING ONLINE FORUMS FOR COMMUNICATION ON TOPICS OF GENERAL INTEREST; COMPUTER SERVICES, NAMELY, PROVIDING ONLINE FACILITIES FOR REAL-TIME INTERACTION WITH OTHER COMPUTER USERS, VIA A GLOBAL COMPUTER NETWORK AND OTHER COMPUTER AND ELECTRONIC COMMUNICATION NETWORKS, TO ENABLE USERS TO ACCESS MULTIMEDIA CONTENT FEATURING TOPICS OF GENERAL INTEREST INCLUDING SOCIAL MEDIA GAMING; RENTAL OF ACCESS TIME TO AN INFORMATION DATABASE RELATING TO SPORTS, GAMBLING AND GAMING; PROVISION OF INFORMATION AND ADVISORY SERVICES IN CONNECTION WITH ALL THE AFORESAID SERVICES (U.S. CLS. 100, 101 AND 104).

**CLASS 41—EDUCATION AND ENTERTAINMENT**

FOR ENTERTAINMENT SERVICES, NAMELY, PROVIDING GAMES OF CHANCE VIA THE INTERNET; ENTERTAINMENT SERVICES, NAMELY, PROVIDING TEMPORARY USE OF NON-DOWNLOADABLE INTERACTIVE GAMES; ENTERTAINMENT SERVICES, NAMELY, PROVIDING VIRTUAL ENVIRONMENTS IN WHICH USERS CAN INTERACT THROUGH SOCIAL GAMES FOR RECREATIONAL, LEISURE OR ENTERTAINMENT PURPOSES; ENTERTAINMENT SERVICES, NAMELY, PROVIDING A WEB-BASED SYSTEM AND ONLINE PORTAL FOR CUSTOMERS TO PARTICIPATE IN ONLINE GAMING, ONLINE INTERACTIVE COMPUTER GAMES, ONLINE VIDEO GAMES, AND IN VIRTUAL ENVIRONMENTS IN WHICH USERS CAN INTERACT THROUGH ONLINE SOCIAL GAMES; ARRANGING, ORGANIZING AND CONDUCTING ENTERTAINMENT SERVICES IN THE FORM OF ONLINE CONTESTS AND GAMES OF CHANCE VIA THE INTERNET; CONDUCTING OF SPORTS BETTING SERVICES; ORGANIZING AND CONDUCTING SPORTS EVENTS COMPETITIONS; INTERACTIVE MULTI-PLAYER OR SINGLE PLAYER GAME SERVICES PROVIDED ONLINE OVER A COMPUTER NETWORK OR THE INTERNET; PROVIDING ONLINE NON-DOWNLOADABLE COMPUTER GAMES VIA THE INTERNET OR WIRELESS ELECTRONIC COMMUNICATION DEVICES, NAMELY, MOBILE PHONES, PERSONAL DIGITAL ASSISTANTS, CELLULAR TELEPHONES, AND HANDHELD COMPUTERS; ENTERTAINMENT SERVICES, NAMELY, PROVIDING TEMPORARY USE OF NON-DOWNLOADABLE INTERACTIVE GAMES; ENTERTAINMENT SERVICES, NAMELY, PROVIDING ONLINE COMPUTER GAMES AND LOTTERY SERVICES VIA A GLOBAL COMMUNICATIONS NETWORK; ONLINE INTERACTIVE GAMING SERVICES, NAMELY, PROVIDING ONLINE VIDEO GAMES, COMPUTER GAMES, AND ELECTRONIC GAMES VIA A GLOBAL COMMUNICATIONS NETWORK; PROVIDING AN INTERACTIVE WEBSITE FEATURING ENTERTAINMENT INFORMATION IN THE FIELD OF GAMING, AMUSEMENTS AND ENTERTAINMENT; ALL OF THE AFORESAID SERVICES PROVIDED ONLINE; CONSULTANCY SERVICES RELATING TO ONLINE GAMING; PROVIDING INFORMATION ABOUT AND ADVISORY SERVICES RELATING TO ALL THE AFORESAID SERVICES (U.S. CLS. 100, 101 AND 107).

BARBARA A. GOLD, EXAMINING ATTORNEY



SN 85-780,860. S.M. ENTERTAINMENT CO., LTD., SEOUL, REPUBLIC OF KOREA, FILED 11-15-2012.



OWNER OF REPUBLIC OF KOREA REG. NO. 0976200, DATED 6-19-2013, EXPIRES 6-19-2023.

OWNER OF REPUBLIC OF KOREA REG. NO. 0976188, DATED 6-19-2013, EXPIRES 6-19-2023.

OWNER OF REPUBLIC OF KOREA REG. NO. 0976132, DATED 6-19-2013, EXPIRES 6-19-2023.

OWNER OF REPUBLIC OF KOREA REG. NO. 0976127, DATED 6-19-2013, EXPIRES 6-19-2023.

THE STIPPLING IS FOR SHADING PURPOSES ONLY. THE MARK CONSISTS OF THE STYLIZED WORDING "SM" APPEARING INSIDE A RECTANGLE WITH THE WORDING "S.M. ENTERTAINMENT" APPEARING BELOW THE RECTANGLE.

### CLASS 3—COSMETICS AND CLEANING PREPARATIONS

FOR AROMATIC PREPARATIONS, NAMELY, BODY SPRAY; COSMETIC SOAPS; COSMETICS; DENTIFRICES; ESSENTIAL OILS; HAIR RINSES; PET SHAMPOO; SHAMPOOS (U.S. CLS. 1, 4, 6, 50, 51 AND 52).

### CLASS 14—JEWELRY

FOR CLOCKS; COMMEMORATIVE STATUARY CUPS MADE OF PRECIOUS METAL; EARRINGS; JEWELRY; KEY RINGS OF PRECIOUS METALS; NECKLACES; PERSONAL ORNAMENTS OF PRECIOUS METAL; RINGS; TIE PINS (U.S. CLS. 2, 27, 28 AND 50).

### CLASS 18—LEATHER GOODS

FOR CANES; PET CLOTHING; UMBRELLAS (U.S. CLS. 1, 2, 3, 22 AND 41).

### CLASS 25—CLOTHING

FOR BATHING SUITS; BOOTS FOR SPORT; CAPS; JACKETS; LEATHER BELTS; MUFFLERS; NECKTIES; SCARFS; SHIRTS; SHOES; SOCKS; SPORT COATS; SPORT SHIRTS; SPORTS JACKETS; SPORTS JERSEYS; SPORTS PANTS; SPORTS SHIRTS; SUSPENDERS; TOPS (U.S. CLS. 22 AND 39).

ASMAT KHAN, EXAMINING ATTORNEY

SN 85-786,556. MASSACHUSETTS EDUCATIONAL FINANCING AUTHORITY, BOSTON, MA. FILED 11-25-2012.

MEFA MASSACHUSETTS  
EDUCATIONAL FINANCING  
AUTHORITY

THE MARK CONSISTS OF STANDARD CHARACTERS WITHOUT CLAIM TO ANY PARTICULAR FONT, STYLE, SIZE, OR COLOR.

OWNER OF U.S. REG. NOS. 3,003,505, 3,005,592 AND 3,509,367.

NO CLAIM IS MADE TO THE EXCLUSIVE RIGHT TO USE "EDUCATIONAL FINANCING", APART FROM THE MARK AS SHOWN.

SEC. 2(F) AS TO "MASSACHUSETTS EDUCATIONAL FINANCING AUTHORITY".

### CLASS 36—INSURANCE AND FINANCIAL

FOR FINANCIAL SERVICES, NAMELY, PROVIDING EDUCATIONAL SAVINGS PROGRAMS; PROVIDING EDUCATIONAL LOANS; INVESTMENT OF FUNDS FOR OTHERS FOR THE PURPOSE OF FINANCING COLLEGE EDUCATION; PROVIDING A WEB SITE FEATURING INFORMATION ON FEDERAL, STATE AND INSTITUTIONAL EDUCATIONAL FINANCIAL AID, PRIVATE SCHOLARSHIPS, AND EDUCATIONAL LOANS AND SAVINGS PLANS AND TUITION PAYMENT PLANS; PROVISION OF COLLEGE EDUCATION SAVINGS ACCOUNTS AND FINANCIAL ADMINISTRATION OF PRE-PAID COLLEGE TUITION PROGRAMS THROUGH WHICH PARTICIPANTS MAY LOCK IN THE COST OF COLLEGE TUITION BY PURCHASING A PRE-PAID TUITION PLAN AT A GUARANTEED RATE; INVESTMENT OF FUNDS FOR OTHERS FOR THE PURPOSE OF FINANCING COLLEGE EDUCATION (U.S. CLS. 100, 101 AND 102).

FIRST USE 12-0-2005; IN COMMERCE 12-0-2005.

### CLASS 41—EDUCATION AND ENTERTAINMENT

FOR EDUCATIONAL SERVICES, NAMELY, CONDUCTING SEMINARS IN THE FIELD OF COLLEGE PLANNING AND FINANCING; PROVIDING A WEB SITE FEATURING INFORMATION ON STATE AND FEDERAL EDUCATIONAL RESOURCES, NAMELY, PROVIDING INFORMATION RELATING TO STATE AND FEDERAL EDUCATIONAL SERVICES (U.S. CLS. 100, 101 AND 107).

FIRST USE 12-0-2005; IN COMMERCE 12-0-2005.

### CLASS 42—SCIENTIFIC AND COMPUTER SERVICES

FOR PROVIDING A WEB SITE FEATURING TECHNOLOGY THAT ENABLES USERS TO APPLY FOR EDUCATIONAL LOANS, FEDERAL, STATE AND INSTITUTIONAL FINANCIAL AID AND PRIVATE SCHOLARSHIPS, CALCULATE FEDERAL EDUCATIONAL FORMULAS, EXPLORE STATE AND FEDERAL EDUCATIONAL RESOURCES AND ENROLL IN MONTHLY SAVINGS PLANS AND TUITION PAYMENT PLANS (U.S. CLS. 100 AND 101).

FIRST USE 12-0-2005; IN COMMERCE 12-0-2005.

MARY CRAWFORD, EXAMINING ATTORNEY

SN 85-806,063. KICKS/HI LLC, DBA KICKS/HI, HONOLULU, HI. FILED 12-18-2012.

LOVE & ALOHA

THE MARK CONSISTS OF STANDARD CHARACTERS WITHOUT CLAIM TO ANY PARTICULAR FONT, STYLE, SIZE, OR COLOR.

THE ENGLISH TRANSLATION OF "ALOHA" IN THE MARK IS "HELLO", "GOODBYE" AND "LOVE".

**CLASS 25—CLOTHING**

FOR BASEBALL CAPS; BASEBALL CAPS AND HATS; CAPS; CREW NECK SWEATERS; HOODED SWEAT SHIRTS; HOODED SWEATSHIRTS; JACKETS; KNIT SHIRTS; KNITTED CAPS; POLO SHIRTS; SPORTS CAPS AND HATS; SPORTS JACKETS; T-SHIRTS; TEE SHIRTS; TRACK JACKETS; TURTLE NECK SHIRTS; WEARABLE GARMENTS AND CLOTHING, NAMELY, SHIRTS; WIND RESISTANT JACKETS; WIND-JACKETS (U.S. CLS. 22 AND 39).

FIRST USE 4-1-2005; IN COMMERCE 4-1-2005.

**CLASS 35—ADVERTISING AND BUSINESS**

FOR RETAIL APPAREL STORES (U.S. CLS. 100, 101 AND 102).

FIRST USE 4-1-2005; IN COMMERCE 4-1-2005.

JACQUELINE ABRAMS, EXAMINING ATTORNEY

SN 85-814.484, PERMIAN GLOBAL RESEARCH LIMITED, LONDON, UNITED KINGDOM, FILED 1-3-2013.



**PERMIAN  
GLOBAL**

PRIORITY CLAIMED UNDER SEC. 44(D) ON ERPN CMNTY TM OFC APPLICATION NO. 011464757, FILED 1-3-2013.

NO CLAIM IS MADE TO THE EXCLUSIVE RIGHT TO USE "GLOBAL", APART FROM THE MARK AS SHOWN.

THE MARK CONSISTS OF AN ILLUSTRATION OF FIVE ROUNDED TRIANGLES FACING INWARDS AND CREATING THE SHAPE OF A CIRCLE, WITH THE WORDING "PERMIAN GLOBAL" APPEARING TO THE RIGHT.

**CLASS 35—ADVERTISING AND BUSINESS**

FOR BUSINESS MANAGEMENT SERVICES; BUSINESS ADMINISTRATION SERVICES; ADVERTISING SERVICES; BUSINESS PROMOTIONAL SERVICES, NAMELY, PROMOTING AND CONDUCTING TRADE SHOWS IN THE FIELD OF ENVIRONMENTAL CONSERVATION, FORESTRY AND FORESTRY CONSERVATION, PROMOTING SOCIETAL, ECOLOGICAL AND ECONOMIC BENEFITS FROM APPROPRIATE USES OF BIOTECHNOLOGY IN FORESTRY WORLDWIDE; BUSINESS MANAGEMENT AND ADMINISTRATION FOR BUSINESSES ENGAGED IN COMMERCIAL CARBON CREDIT SCHEMES; BUSINESS MANAGEMENT AND ADMINISTRATION OF ENVIRONMENTAL CONSERVATION PROJECTS; BUSINESS MANAGEMENT AND ADMINISTRATION OF FORESTRY AND FORESTRY CONSERVATION PROJECTS; BUSINESS MANAGEMENT AND ADMINISTRATION OF ENVIRONMENTAL PROTECTION POLICIES FOR BUSINESSES; ADVISORY, CONSULTANCY AND INFORMATION SERVICES ALL IN RELATION TO THE AFORESAID SERVICES; THE AFORESAID SERVICES PROVIDED BOTH ONLINE VIA THE INTERNET AND OFFLINE; ARRANGING AND CONDUCTING TRADE SHOWS IN THE FIELDS OF ENVIRONMENTAL CONSERVATION, FORESTRY AND FORESTRY CONSERVATION; THE AFORESAID SERVICES PROVIDED BOTH ONLINE VIA THE INTERNET AND OFFLINE (U.S. CLS. 100, 101 AND 102).

**CLASS 41—EDUCATION AND ENTERTAINMENT**

FOR EDUCATION SERVICES, NAMELY, EDUCATION TRAINING SERVICES IN THE FIELD OF FORESTRY, FORESTRY CONSERVATION AND ENVIRONMENTAL CONSERVATION, TUTORING, ONE-ON-ONE MENTORING, CLASSES, SEMINARS AND WORKSHOPS IN THE FIELD OF FORESTRY, FORESTRY CONSERVATION AND ENVIRONMENTAL CONSERVATION, CONDUCTING ON-LINE PROGRAMS, EXHIBITIONS AND DISPLAYS AND INTERACTIVE PROGRAMS AND EXHIBITS IN THE FIELD OF FORESTRY, FORESTRY CONSERVATION AND ENVIRONMENTAL CONSERVATION, PROVIDING OF TRAINING IN THE FIELDS OF FORESTRY, FORESTRY CONSERVATION AND ENVIRONMENTAL CONSERVATION; EDUCATION SERVICES RELATING TO ENVIRONMENTAL CONSERVATION PROJECTS, NAMELY, PROVIDING COURSES OF INSTRUCTION RELATING TO ENVIRONMENTAL CONSERVATION; EDUCATION SERVICES RELATING TO FORESTRY AND FORESTRY CONSERVATION PROJECTS, NAMELY, PROVIDING COURSES OF INSTRUCTION RELATING TO FORESTRY AND FORESTRY CONSERVATION; BUSINESS EDUCATIONAL AND TRAINING SERVICES, NAMELY, LEADERSHIP DEVELOPMENT TRAINING IN THE FIELD OF FORESTRY, FORESTRY CONSERVATION AND ENVIRONMENTAL CONSERVATION; BUSINESS TRAINING SERVICES RELATING TO ENVIRONMENTAL CONSERVATION PROJECTS; BUSINESS TRAINING SERVICES RELATING TO FORESTRY AND FORESTRY CONSERVATION PROJECTS; ORGANIZING AND ARRANGING OF EDUCATIONAL CONFERENCES, LECTURES, DISPLAYS, EXHIBITIONS, PRESENTATIONS, SEMINARS IN THE FIELD OF FORESTRY, FORESTRY CONSERVATION AND ENVIRONMENTAL CONSERVATION; ORGANIZING AND ARRANGING OF EDUCATIONAL CONFERENCES, LECTURES, DISPLAYS, EXHIBITIONS, PRESENTATIONS, AND SEMINARS IN THE FIELDS OF ENVIRONMENTAL CONSERVATION, FORESTRY AND FORESTRY CONSERVATION; THE AFORESAID SERVICES PROVIDED BOTH ONLINE VIA THE INTERNET AND OFFLINE (U.S. CLS. 100, 101 AND 107).

**CLASS 42—SCIENTIFIC AND COMPUTER SERVICES**

FOR ENVIRONMENTAL CONSERVATION SERVICES AND ENVIRONMENTAL CONSERVATION SERVICES RELATING TO FORESTRY AND FORESTRY CONSERVATION PROJECTS, NAMELY, MONITORING, TESTING AND ANALYZING ECOLOGICAL SUCCESS IN THE FIELD OF FORESTRY, ENVIRONMENTALLY SENSITIVE HABITAT CONSERVATION AND PRESERVATION OF NATIVE PLANTS AND WILDLIFE; RESEARCH SERVICES AND ENVIRONMENTAL RESEARCH SERVICES, NAMELY, RESEARCH IN THE FIELD OF ENVIRONMENTAL PROTECTION; RESEARCH SERVICES RELATING TO ENVIRONMENTAL CONSERVATION, FORESTRY AND FORESTRY CONSERVATION, NAMELY, RESEARCH IN THE FIELD OF ENVIRONMENTAL PROTECTION; ADVISORY, CONSULTANCY AND INFORMATION SERVICES RELATING TO ALL THE AFORESAID SERVICES; THE AFORESAID SERVICES PROVIDED BOTH ONLINE VIA THE INTERNET AND OFFLINE (U.S. CLS. 100 AND 101).

INGRID C. EULIN, EXAMINING ATTORNEY

SN 85-815,213. CONSOLIDATED IP COMPANY LLC,  
ATLANTA, GA. FILED 1-3-2013.

## NASH COUNTRY

THE MARK CONSISTS OF STANDARD CHARACTERS WITHOUT CLAIM TO ANY PARTICULAR FONT, STYLE, SIZE, OR COLOR.

NO CLAIM IS MADE TO THE EXCLUSIVE RIGHT TO USE "COUNTRY", APART FROM THE MARK AS SHOWN.

### CLASS 16—PAPER GOODS AND PRINTED MATTER

FOR PRINTED PUBLICATIONS, NAMELY, ENTERTAINMENT MAGAZINES FEATURING COUNTRY MUSIC ENTERTAINMENT NEWS AND RELATED CONTENT (U.S. CLS. 2, 5, 22, 23, 29, 37, 38 AND 50).

### CLASS 38—COMMUNICATION

FOR RADIO AND TELEVISION BROADCASTING SERVICES FEATURING COUNTRY MUSIC AND RELATED CONTENT; INTERNET RADIO SERVICES, NAMELY, TRANSMISSION OF AUDIO MATERIAL VIA THE INTERNET FEATURING COUNTRY MUSIC AND RELATED CONTENT (U.S. CLS. 100, 101 AND 104).

### CLASS 41—EDUCATION AND ENTERTAINMENT

FOR PROVIDING ONLINE PUBLICATIONS IN THE NATURE OF ENTERTAINMENT MAGAZINES FEATURING COUNTRY MUSIC ENTERTAINMENT NEWS AND RELATED CONTENT; ENTERTAINMENT SERVICES IN THE NATURE OF AWARD CEREMONIES HONORING ACHIEVEMENTS IN THE FIELD OF COUNTRY MUSIC; PROVIDING RECOGNITION AND INCENTIVES BY THE WAY OF CONDUCTING AWARD CEREMONIES TO DEMONSTRATE EXCELLENCE IN THE FIELDS OF COUNTRY MUSICAL PERFORMANCES, TALK RADIO, ENTERTAINMENT CELEBRITIES, AND RELATED RADIO BROADCASTING; PROVIDING AN INTERNET WEBSITE FEATURING NEWS AND INFORMATION IN THE FIELDS OF COUNTRY MUSIC AND RELATED CONTENT; ENTERTAINMENT SERVICES, NAMELY, CONTINUING COUNTRY MUSIC SHOWS BROADCAST OVER THE INTERNET; PROVIDING ENTERTAINMENT SERVICES IN THE NATURE OF ONGOING INTERNET PROTOCOL TELEVISION (IPTV) TELEVISION PROGRAMMING SEGMENTS IN THE FIELDS OF COUNTRY MUSIC AND ENTERTAINMENT NEWS (U.S. CLS. 100, 101 AND 107).

PAULA MAHONEY, EXAMINING ATTORNEY

SN 85-815,221. CONSOLIDATED IP COMPANY LLC,  
ATLANTA, GA. FILED 1-3-2013.

## NASH MAGAZINE

THE MARK CONSISTS OF STANDARD CHARACTERS WITHOUT CLAIM TO ANY PARTICULAR FONT, STYLE, SIZE, OR COLOR.

NO CLAIM IS MADE TO THE EXCLUSIVE RIGHT TO USE "MAGAZINE", APART FROM THE MARK AS SHOWN.

### CLASS 16—PAPER GOODS AND PRINTED MATTER

FOR PRINTED PUBLICATIONS, NAMELY, ENTERTAINMENT MAGAZINES FEATURING COUNTRY MUSIC ENTERTAINMENT NEWS AND RELATED CONTENT (U.S. CLS. 2, 5, 22, 23, 29, 37, 38 AND 50).

### CLASS 38—COMMUNICATION

FOR RADIO AND TELEVISION BROADCASTING SERVICES FEATURING COUNTRY MUSIC AND RELATED CONTENT; INTERNET RADIO SERVICES, NAMELY, TRANSMISSION OF AUDIO MATERIAL VIA THE INTERNET FEATURING COUNTRY MUSIC AND RELATED CONTENT (U.S. CLS. 100, 101 AND 104).

### CLASS 41—EDUCATION AND ENTERTAINMENT

FOR PROVIDING ONLINE PUBLICATIONS IN THE NATURE OF ENTERTAINMENT MAGAZINES FEATURING COUNTRY MUSIC ENTERTAINMENT NEWS AND RELATED CONTENT; ENTERTAINMENT SERVICES IN THE NATURE OF AWARD CEREMONIES HONORING ACHIEVEMENTS IN THE FIELD OF COUNTRY MUSIC; PROVIDING RECOGNITION AND INCENTIVES BY THE WAY OF CONDUCTING AWARD CEREMONIES TO DEMONSTRATE EXCELLENCE IN THE FIELDS OF COUNTRY MUSICAL PERFORMANCES, TALK RADIO, ENTERTAINMENT CELEBRITIES, AND RELATED RADIO BROADCASTING; PROVIDING AN INTERNET WEBSITE FEATURING NEWS AND INFORMATION IN THE FIELDS OF COUNTRY MUSIC AND RELATED CONTENT; ENTERTAINMENT SERVICES, NAMELY, CONTINUING COUNTRY MUSIC SHOWS BROADCAST OVER THE INTERNET; PROVIDING ENTERTAINMENT SERVICES IN THE NATURE OF ONGOING INTERNET PROTOCOL TELEVISION (IPTV) TELEVISION PROGRAMMING SEGMENTS IN THE FIELDS OF COUNTRY MUSIC AND ENTERTAINMENT NEWS (U.S. CLS. 100, 101 AND 107).

PAULA MAHONEY, EXAMINING ATTORNEY

SN 85-815,230. CONSOLIDATED IP COMPANY LLC,  
ATLANTA, GA. FILED 1-3-2013.

## NASH ENTERTAINMENT

THE MARK CONSISTS OF STANDARD CHARACTERS WITHOUT CLAIM TO ANY PARTICULAR FONT, STYLE, SIZE, OR COLOR.

NO CLAIM IS MADE TO THE EXCLUSIVE RIGHT TO USE "ENTERTAINMENT", APART FROM THE MARK AS SHOWN.

### CLASS 16—PAPER GOODS AND PRINTED MATTER

FOR PRINTED PUBLICATIONS, NAMELY, ENTERTAINMENT MAGAZINES FEATURING COUNTRY MUSIC ENTERTAINMENT NEWS AND RELATED CONTENT (U.S. CLS. 2, 5, 22, 23, 29, 37, 38 AND 50).

### CLASS 38—COMMUNICATION

FOR RADIO AND TELEVISION BROADCASTING SERVICES FEATURING COUNTRY MUSIC AND RELATED CONTENT; INTERNET RADIO SERVICES, NAMELY, TRANSMISSION OF AUDIO MATERIAL VIA THE INTERNET FEATURING COUNTRY MUSIC AND RELATED CONTENT (U.S. CLS. 100, 101 AND 104).

**CLASS 41—EDUCATION AND ENTERTAINMENT**

FOR PROVIDING ONLINE PUBLICATIONS IN THE NATURE OF ENTERTAINMENT MAGAZINES FEATURING COUNTRY MUSIC ENTERTAINMENT NEWS AND RELATED CONTENT; ENTERTAINMENT SERVICES IN THE NATURE OF AWARD CEREMONIES HONORING ACHIEVEMENTS IN THE FIELD OF COUNTRY MUSIC; PROVIDING RECOGNITION AND INCENTIVES BY THE WAY OF CONDUCTING AWARD CEREMONIES TO DEMONSTRATE EXCELLENCE IN THE FIELDS OF COUNTRY MUSICAL PERFORMANCES, TALK RADIO, ENTERTAINMENT CELEBRITIES, AND RELATED RADIO BROADCASTING; PROVIDING AN INTERNET WEBSITE FEATURING NEWS AND INFORMATION IN THE FIELDS OF COUNTRY MUSIC AND RELATED CONTENT; ENTERTAINMENT SERVICES, NAMELY, CONTINUING COUNTRY MUSIC SHOWS BROADCAST OVER THE INTERNET; PROVIDING ENTERTAINMENT SERVICES IN THE NATURE OF ONGOING INTERNET PROTOCOL TELEVISION (IPTV) TELEVISION PROGRAMMING SEGMENTS IN THE FIELDS OF COUNTRY MUSIC AND ENTERTAINMENT NEWS (U.S. CLS. 100, 101 AND 107).

PAULA MAHONEY, EXAMINING ATTORNEY

SN 85-815,448. CRIF CORPORATION, ATLANTA, GA. FILED 1-4-2013.



OWNER OF U.S. REG. NO. 4,077,592.  
THE COLOR(S) BLUE AND ORANGE IS/ARE CLAIMED AS A FEATURE OF THE MARK.  
THE MARK CONSISTS OF THE WORDING "CRIF ACHIEVE" IN BLUE AND FOUR CIRCLES NEXT TO THE WORD "ACHIEVE", WITH THREE OF THE CIRCLES BEING BLUE AND ONE BEING ORANGE WITH A BLUE BORDER.

**CLASS 35—ADVERTISING AND BUSINESS**

FOR BUSINESS INTELLIGENCE SERVICES IN THE FIELD OF CREDIT ANALYSIS (U.S. CLS. 100, 101 AND 102).

FIRST USE 1-9-2011; IN COMMERCE 1-9-2011.

**CLASS 36—INSURANCE AND FINANCIAL**

FOR FINANCIAL SERVICES RENDERED IN CONNECTION WITH THE ISSUANCE, RECEIPT AND TRANSFER OF LINES OF CREDIT, NAMELY, CREDIT PROCESSING SERVICES; FINANCIAL CREDIT SCORING SERVICES; AND CONSULTATION SERVICES IN THE FIELD OF CREDIT ANALYSIS AND SCORING, NAMELY, ASSESSING CLIENT CREDIT SCORING NEEDS AND ALTERING CLIENTS' CREDIT SCORING MODEL ADAPTED TO THEIR SPECIFIC NEEDS (U.S. CLS. 100, 101 AND 102).

FIRST USE 1-9-2011; IN COMMERCE 1-9-2011.  
WANDA KAY PRICE, EXAMINING ATTORNEY

SN 85-816,476. PULLEY, DAVID A., CHEYENNE, WY. FILED 1-6-2013.

**HELL SNAKE**

THE MARK CONSISTS OF STANDARD CHARACTERS WITHOUT CLAIM TO ANY PARTICULAR FONT, STYLE, SIZE, OR COLOR.

**CLASS 12—VEHICLES**

FOR AUTOMOBILES AND STRUCTURAL PARTS THEREFOR; STRUCTURAL PARTS FOR AUTOMOBILES; AUTOMOTIVE CONVERSION KITS COMPRISED OF FIRE SUPPRESSION COMPONENTS, SWAY BARS, STRUTS, SUPERCHARGERS, CUSTOM BADGES, RADIATOR COVERS, BATTERY COVERS, SHOCK TOWER COVERS, CARBON FIBER HOODS, FRONT SPLITTERS, REAR SPOILERS, TRUNK LIDS, DOOR HANDLES, AND INTERIOR CONSOLE COVERS, TO MAKE STRUCTURAL AND COSMETIC CHANGES TO AN AUTOMOBILE (U.S. CLS. 19, 21, 23, 31, 35 AND 44).

**CLASS 35—ADVERTISING AND BUSINESS**

FOR DISTRIBUTORSHIP SERVICES IN THE FIELD OF AUTOMOTIVE PARTS; RESELLER SERVICES, NAMELY, DISTRIBUTORSHIP SERVICES IN THE FIELD OF AFTERMARKET AUTOMOTIVE PARTS (U.S. CLS. 100, 101 AND 102).

**CLASS 37—CONSTRUCTION AND REPAIR**

FOR AUTOMOBILE CUSTOMIZATION SERVICES; AUTOMOTIVE CONVERSION SERVICES, NAMELY, INSTALLING SPECIALTY AUTOMOTIVE EQUIPMENT AND CUSTOM PAINTING; INSTALLATION OF AFTER-MARKET AUTOMOTIVE PARTS (U.S. CLS. 100, 103 AND 106).

SETH A. RAPPAPORT, EXAMINING ATTORNEY

SN 85-823,778. STICKERAPP SWEDEN AB, 234 35 LOMMA, SWEDEN, FILED 1-15-2013.



OWNER OF ERPN CMNTY TM OFC REG. NO. 011000676, DATED 12-11-2012, EXPIRES 12-11-2022.

NO CLAIM IS MADE TO THE EXCLUSIVE RIGHT TO USE "STICKER", APART FROM THE MARK AS SHOWN.  
THE COLOR(S) WHITE, BLACK AND YELLOW IS/ARE CLAIMED AS A FEATURE OF THE MARK.

THE MARK CONSISTS OF "STICKER" ABOVE THE PHRASE "APP" ALL IN WHITE AND WITH A BORDER OF BLACK AND YELLOW.

**CLASS 16—PAPER GOODS AND PRINTED MATTER**

FOR PAPER; CARDBOARD; GOODS MADE FROM PAPER AND CARDBOARD, NAMELY, LABELS; PRINTED MATTER, NAMELY, PRINTED PAPER LABELS; BOOKBINDING MATERIAL; PHOTOGRAPHS; STATIONERY; ADHESIVES FOR STATIONERY OR HOUSEHOLD PURPOSES; PAINT BRUSHES; TYPEWRITERS; PRINTED INSTRUCTIONAL AND TEACHING MATERIAL IN THE FIELD OF LABEL PRODUCTION; PRINTERS' TYPE; PRINTING BLOCKS (U.S. CLS. 2, 5, 22, 23, 29, 37, 38 AND 50).

**CLASS 35—ADVERTISING AND BUSINESS**

FOR ADVERTISING; LAYOUT FOR ADVERTISING PURPOSES; RETAIL STORE SERVICES FEATURING PRINTED ADVERTISING MATTER AND PROMOTIONAL ITEMS (U.S. CLS. 100, 101 AND 102).

**CLASS 40—MATERIAL TREATMENT**

FOR PRINTING; CUSTOM MANUFACTURE OF PRINTED ADVERTISING MATTER AND PROMOTIONAL ITEMS (U.S. CLS. 100, 103 AND 106).

**CLASS 42—SCIENTIFIC AND COMPUTER SERVICES**

FOR GRAPHIC DESIGN (U.S. CLS. 100 AND 101).  
ALLISON HOLTZ, EXAMINING ATTORNEY

SN 85-825,174. CONSOLIDATED IP COMPANY LLC,  
ATLANTA, GA. FILED 1-16-2013.

**NASHFM**

THE MARK CONSISTS OF STANDARD CHARACTERS WITHOUT CLAIM TO ANY PARTICULAR FONT, STYLE, SIZE, OR COLOR.

**CLASS 16—PAPER GOODS AND PRINTED MATTER**

FOR PRINTED PUBLICATIONS, NAMELY, ENTERTAINMENT MAGAZINES FEATURING COUNTRY MUSIC ENTERTAINMENT NEWS AND RELATED CONTENT (U.S. CLS. 2, 5, 22, 23, 29, 37, 38 AND 50).

**CLASS 38—COMMUNICATION**

FOR RADIO BROADCASTING SERVICES FEATURING COUNTRY MUSIC AND RELATED CONTENT; INTERNET RADIO SERVICES, NAMELY, TRANSMISSION OF AUDIO MATERIAL VIA THE INTERNET FEATURING COUNTRY MUSIC AND RELATED CONTENT (U.S. CLS. 100, 101 AND 104).

**CLASS 41—EDUCATION AND ENTERTAINMENT**

FOR PROVIDING ONLINE PUBLICATIONS IN THE NATURE OF ENTERTAINMENT MAGAZINES FEATURING COUNTRY MUSIC ENTERTAINMENT NEWS AND RELATED CONTENT; ENTERTAINMENT SERVICES IN THE NATURE OF AWARD CEREMONIES HONORING ACHIEVEMENTS IN THE FIELD OF COUNTRY MUSIC; PROVIDING RECOGNITION AND INCENTIVES BY THE WAY OF CONDUCTING AWARD CEREMONIES TO DEMONSTRATE EXCELLENCE IN THE FIELDS OF COUNTRY MUSICAL PERFORMANCES, TALK RADIO, ENTERTAINMENT CELEBRITIES, AND RELATED RADIO BROADCASTING; PROVIDING AN INTERNET WEBSITE FEATURING NEWS AND INFORMATION IN THE FIELDS OF COUNTRY MUSIC AND RELATED CONTENT; ENTERTAINMENT SERVICES, NAMELY, CONTINUING COUNTRY MUSIC SHOWS BROADCAST OVER THE INTERNET (U.S. CLS. 100, 101 AND 107).

PAULA MAHONEY, EXAMINING ATTORNEY

SN 85-825,177. CONSOLIDATED IP COMPANY LLC,  
ATLANTA, GA. FILED 1-16-2013.

**NASHTV**

THE MARK CONSISTS OF STANDARD CHARACTERS WITHOUT CLAIM TO ANY PARTICULAR FONT, STYLE, SIZE, OR COLOR.

**CLASS 16—PAPER GOODS AND PRINTED MATTER**

FOR PRINTED PUBLICATIONS, NAMELY, ENTERTAINMENT MAGAZINES FEATURING COUNTRY MUSIC ENTERTAINMENT NEWS AND RELATED CONTENT (U.S. CLS. 2, 5, 22, 23, 29, 37, 38 AND 50).

**CLASS 38—COMMUNICATION**

FOR TELEVISION BROADCASTING SERVICES FEATURING COUNTRY MUSIC AND RELATED CONTENT (U.S. CLS. 100, 101 AND 104).

**CLASS 41—EDUCATION AND ENTERTAINMENT**

FOR PROVIDING ONLINE PUBLICATIONS IN THE NATURE OF ENTERTAINMENT MAGAZINES FEATURING COUNTRY MUSIC ENTERTAINMENT NEWS AND RELATED CONTENT; ENTERTAINMENT SERVICES IN THE NATURE OF AWARD CEREMONIES HONORING ACHIEVEMENTS IN THE FIELD OF COUNTRY MUSIC; PROVIDING RECOGNITION AND INCENTIVES BY THE WAY OF CONDUCTING AWARD CEREMONIES TO DEMONSTRATE EXCELLENCE IN THE FIELDS OF COUNTRY MUSICAL PERFORMANCES, TALK RADIO, ENTERTAINMENT CELEBRITIES, AND RELATED RADIO BROADCASTING; PROVIDING AN INTERNET WEBSITE FEATURING NEWS AND INFORMATION IN THE FIELDS OF COUNTRY MUSIC AND RELATED CONTENT; ENTERTAINMENT SERVICES, NAMELY, CONTINUING COUNTRY MUSIC SHOWS BROADCAST OVER THE INTERNET; PROVIDING ENTERTAINMENT SERVICES IN THE NATURE OF ONGOING INTERNET PROTOCOL TELEVISION (IPTV) TELEVISION PROGRAMMING SEGMENTS IN THE FIELDS OF COUNTRY MUSIC AND ENTERTAINMENT NEWS (U.S. CLS. 100, 101 AND 107).

PAULA MAHONEY, EXAMINING ATTORNEY

SN 85-831,269. THE CORPORATION FOR TRAVEL PROMOTION, DBA BRAND USA, WASHINGTON, DC. FILED 1-24-2013.



DiscoverAmerica.com

OWNER OF U.S. REG. NOS. 915,811 AND 3,616,705.  
NO CLAIM IS MADE TO THE EXCLUSIVE RIGHT TO USE "USA", APART FROM THE MARK AS SHOWN.  
THE MARK CONSISTS OF THE STYLIZED WORD "USA" ABOVE THE TERM "DISCOVERAMERICA.COM".

#### CLASS 35—ADVERTISING AND BUSINESS

FOR PROMOTING PUBLIC AWARENESS OF MISPERCEPTIONS REGARDING UNITED STATES ENTRY POLICIES AROUND THE WORLD; PROMOTING INTERNATIONAL VISITATION TO THE UNITED STATES BY MEANS OF PROVIDING DOMESTIC AND INTERNATIONAL WEBSITES SHOWCASING TRAVEL DESTINATIONS AND ACTIVITIES ACROSS THE UNITED STATES; PROVIDING DOMESTIC AND INTERNATIONAL ADVERTISING PROMOTING INTERNATIONAL VISITATION TO THE UNITED STATES; IN MARKET PUBLIC RELATIONS EFFORTS PROMOTING INTERNATIONAL VISITATION TO THE UNITED STATES; PROMOTING AND CONDUCTING INTERNATIONAL AND DOMESTIC TRADE AND CONSUMER SHOWS IN THE FIELD OF TRAVEL TO THE UNITED STATES; PROVIDING ADVERTISING, MARKETING AND PROMOTIONAL SERVICES, NAMELY, DEVELOPMENT OF ADVERTISING CAMPAIGNS FOR SOCIAL MEDIA AND PRINT MEDIA FOR INTERNATIONAL VISITATION TO THE UNITED STATES; PROMOTIONAL EFFORTS FOR INTERNATIONAL VISITATION TO THE UNITED STATES, NAMELY, DISTRIBUTION OF PRINTED PROMOTIONAL MATERIALS (U.S. CLS. 100, 101 AND 102).

FIRST USE 1-5-2012; IN COMMERCE 1-5-2012.

#### CLASS 39—TRANSPORTATION AND STORAGE

FOR OPERATING TRAVEL TOURS FOR INTERNATIONAL VISITATION TO THE UNITED STATES (U.S. CLS. 100 AND 105).

FIRST USE 1-5-2012; IN COMMERCE 1-5-2012.  
ALISON POLLACK, EXAMINING ATTORNEY

SN 85-835,709. MCMILLAN, DESTRIE CE, DBA BLISS BEGINS, MAX, ND. FILED 1-29-2013.

# Bliss Begins

THE MARK CONSISTS OF STANDARD CHARACTERS WITHOUT CLAIM TO ANY PARTICULAR FONT, STYLE, SIZE, OR COLOR.

#### CLASS 25—CLOTHING

FOR COSTUMES FOR USE IN CHILDREN'S DRESS UP PLAY; COSTUMES FOR USE IN ROLE-PLAYING GAMES; COSTUMES FOR USE IN THE AMUSEMENT INDUSTRY; HALLOWEEN COSTUMES; HALLOWEEN COSTUMES AND MASKS SOLD IN CONNECTION THEREWITH; MASQUERADE COSTUMES; MASQUERADE COSTUMES AND MASKS SOLD IN CONNECTION THEREWITH (U.S. CLS. 22 AND 39).

FIRST USE 9-1-2011; IN COMMERCE 9-1-2011.

#### CLASS 41—EDUCATION AND ENTERTAINMENT

FOR PARTY AND WEDDING PLANNING, COORDINATION AND CONSULTATION SERVICES; PARTY AND WEDDING RECEPTION PLANNING AND COORDINATION SERVICES; PARTY AND WEDDING RECEPTION PLANNING CONSULTATION SERVICES; PROVIDING INFORMATION IN THE FIELD OF WEDDING PARTY PLANNING; PROVIDING INFORMATION REGARDING WEDDING PLANNING FOR WEDDING PARTIES; RENTAL OF COSTUMES; WEDDING RECEPTION PLANNING AND COORDINATION SERVICES (U.S. CLS. 100, 101 AND 107).

FIRST USE 9-1-2011; IN COMMERCE 9-1-2011.

#### CLASS 43—HOTEL AND RESTAURANT SERVICES

FOR RENTAL OF BANQUET AND SOCIAL FUNCTION FACILITIES FOR SPECIAL OCCASIONS, NAMELY, WEDDINGS, FAMILY FUNCTIONS, COMPANY PARTIES; RENTAL OF CHAIRS, TABLES, TABLE LINEN, GLASSWARE; RENTAL OF LIGHTING APPARATUS FOR WEDDINGS, SOCIAL EVENTS, PARTIES; RENTAL OF TENTS (U.S. CLS. 100 AND 101).

FIRST USE 9-1-2011; IN COMMERCE 9-1-2011.

#### CLASS 45—PERSONAL AND LEGAL SERVICES

FOR PLANNING AND ARRANGING OF WEDDING CEREMONIES; PROVIDING FACILITIES FOR WEDDING CEREMONIES (U.S. CLS. 100 AND 101).

FIRST USE 9-1-2011; IN COMMERCE 9-1-2011.  
MICHAEL ENGEL, EXAMINING ATTORNEY

SN 85-838,252. SEAL INDUSTRIES, INC., THE WOODLANDS, TX. FILED 2-1-2013.

# SealTech

THE MARK CONSISTS OF STANDARD CHARACTERS WITHOUT CLAIM TO ANY PARTICULAR FONT, STYLE, SIZE, OR COLOR.  
SEC. 2(F).

#### CLASS 37—CONSTRUCTION AND REPAIR

FOR REPAIR IN THE FIELD OF ENVIRONMENTAL COMPLIANCE, NAMELY, VALVE, PIPING AND PROCESS EQUIPMENT FOR THE PETROCHEMICAL AND REFINING ENERGY INDUSTRIES, AND CONSULTING RELATED THERETO (U.S. CLS. 100, 103 AND 106).

FIRST USE 6-16-1983; IN COMMERCE 6-16-1983.

**CLASS 42—SCIENTIFIC AND COMPUTER SERVICES**

FOR ENGINEERING, DESIGN, ENERGY AUDIT, AND RELATED CONSULTING SERVICES IN THE FIELD OF ENVIRONMENTAL COMPLIANCE, NAMELY, VALVE, PIPING, AND PROCESS EQUIPMENT FOR THE PETROCHEMICAL AND REFINING ENERGY INDUSTRIES; AUDIT SERVICES, NAMELY, TESTING, ANALYSIS AND EVALUATION SERVICES AND RELATED CONSULTING SERVICES IN THE FIELD OF ENERGY INDUSTRY VALVE, PIPING AND PROCESS EQUIPMENT FOR ENVIRONMENTAL COMPLIANCE PURPOSES (U.S. CLS. 100 AND 101).

FIRST USE 6-16-1983; IN COMMERCE 6-16-1983.  
KIM MONINGHOFF, EXAMINING ATTORNEY

**CLASS 35—ADVERTISING AND BUSINESS**

FOR ADVERTISING AND MARKETING; ADVERTISING, INCLUDING ON-LINE ADVERTISING ON A COMPUTER NETWORK AND DISSEMINATION OF ADVERTISING FOR OTHERS VIA WIRELESS NETWORKS FOR DISPLAY ON MOBILE DEVICES; DEVELOPMENT OF MARKETING SERVICES, NAMELY, STRATEGIES, PLANS AND CONCEPTS FOR DIGITAL MEDIA DESIGNED TO TARGET USERS BASED ON USER-PROVIDED DATA AND SURVEY RESPONSES; ADVERTISING ANALYSIS AND OPTIMIZATION SERVICES, NAMELY, CONDUCTING BUSINESS FEASIBILITY STUDIES ON THE OPTIMIZATION AND EFFECTIVENESS OF ADVERTISING AND VARIOUS ADVERTISING METHODS, ANALYZING BUSINESS DATA AND MARKET RESEARCH TO PROVIDE CUSTOMER SEGMENTATION ANALYSES, BUSINESS AND ADVERTISING CONSULTATION IN THE NATURE OF GUIDANCE FOR BUSINESS PROCESSES AND ADVERTISING RELATED RECOMMENDATIONS BASED ON THE BUSINESS DATA AND MARKET RESEARCH DATA ANALYSIS OF SUCH BUSINESS DATA AND MARKET RESEARCH DATA, AND PROVIDING BUSINESS DATA AND MARKET RESEARCH DATA ANALYSIS TO OTHERS TO TARGET ADVERTISING OR DRIVE OTHER BUSINESS PROCESSES; ARRANGING AND CONDUCTING INCENTIVE REWARD PROGRAMS THAT PROMOTE THE SALE OF GOODS AND SERVICES OF OTHERS; DEVELOPMENT AND MANAGEMENT OF DIGITAL AND WEB-BASED ADVERTISING SOLUTIONS, NAMELY, ADVERTISING STRATEGIES AND CONCEPTS FOR ADVERTISING AND MARKETING CAMPAIGNS; PROMOTING THE GOODS AND SERVICES OF OTHERS THROUGH TARGETED ADVERTISING, MARKETING AND SOLICITING; SOCIAL MEDIA ADVERTISING SOLUTIONS, NAMELY, DEVELOPMENT OF MARKETING PLANS, CONCEPTS AND STRATEGIES FOR DIGITAL MEDIA DESIGNED TO TARGET USERS BASED ON USER-PROVIDED DATA AND SURVEY RESPONSES (U.S. CLS. 100, 101 AND 102).

SN 85-838,588. TRUOX MEDIA INC., LOS ANGELES, CA.  
FILED 2-1-2013.

**TRUE TARGETING**

THE MARK CONSISTS OF STANDARD CHARACTERS WITHOUT CLAIM TO ANY PARTICULAR FONT, STYLE, SIZE, OR COLOR.

NO CLAIM IS MADE TO THE EXCLUSIVE RIGHT TO USE "TARGETING", APART FROM THE MARK AS SHOWN.

**CLASS 9—ELECTRICAL AND SCIENTIFIC APPARATUS**

FOR COMPUTER SOFTWARE FOR BUSINESS USE IN DEVELOPING MARKETING AND ADVERTISING STRATEGIES; COMPUTER SOFTWARE FOR USE IN SHARING DIGITAL CONTENT AND MATERIAL; COMPUTER SOFTWARE FOR USE IN ENABLING INTERACTIVITY WITH DIGITAL CONTENT AND MATERIAL; COMPUTER SOFTWARE FOR USE IN ADVERTISING THIRD-PARTY GOODS AND SERVICES; DATA PROCESSING SOFTWARE; COMPUTER SOFTWARE FOR ASSIMILATING DATA FOR USE IN ADVERTISING; SOFTWARE FOR MONITORING AND REPORTING ON THE EFFECTIVENESS OF ADVERTISEMENTS (U.S. CLS. 21, 23, 26, 36 AND 38).

**CLASS 42—SCIENTIFIC AND COMPUTER SERVICES**

FOR APPLICATION SERVICE PROVIDER (ASP), FEATURING SOFTWARE FOR USE IN CREATING, SERVING, MANAGING, TARGETING, MONITORING, TRACKING, ANALYZING, AND SELLING ADVERTISING AND IMPLEMENTING ADVERTISING CAMPAIGNS; APPLICATION SERVICE PROVIDER (ASP), FEATURING SOFTWARE FOR THE CREATION, MANAGEMENT, DELIVERY, PUBLISHING AND DISTRIBUTION OF MOBILE, WEB AND DIGITAL CONTENT, INCLUDING ADVERTISING, ACROSS MULTIPLE CHANNELS; APPLICATION SERVICE PROVIDER (ASP), FEATURING SOFTWARE FOR THE CREATION, CUSTOMIZATION AND IMPLEMENTATION OF ON-LINE CUSTOMER AND USER SURVEYS AND FOR ANALYZING THE REPORTING OF THE RESULTS OF SUCH SURVEYS; APPLICATION SERVICE PROVIDER (ASP), FEATURING SOFTWARE FOR CREATING, FORECASTING, EXECUTING, MANAGING, MONITORING, TRACKING, AND OPTIMIZING THE PERFORMANCE AND EFFECTIVENESS OF DIGITAL ADVERTISING AND MARKETING CAMPAIGNS ACROSS MULTIPLE CHANNELS, INCLUDING WEBSITES, SOCIAL NETWORKS, ONLINE VIDEO, MOBILE WEBSITES, MOBILE APPLICATIONS, MOBILE DEVICES, AND DISPLAY ADVERTISING; PROVIDING TEMPORARY USE OF ONLINE, NON-DOWNLOADABLE SOFTWARE FOR MANAGING, COLLECTING, INTEGRATING, REPORTING, ANALYZING, VISUALIZING, INDEXING, FILTERING AND SHARING A WIDE VARIETY OF DATA AND INFORMATION FROM VARIOUS SOURCES; COMPUTER SERVICES, NAMELY, HOSTING AN INTERACTIVE WEBSITE WHICH ENABLES COMPUTER USERS AND ONLINE PUBLISHERS TO INTERACT, NAMELY, COMMUNICATE OR SHARE, WITH ADVERTISEMENTS AND OTHER DIGITAL CONTENT FOR MARKETING AND PROMOTION PURPOSES; PROVIDING TEMPORARY USE OF ONLINE, NON-DOWNLOADABLE SOFTWARE FOR USE IN DISPLAYING INFORMATION AND ADVERTISEMENTS OF OTHERS ABOUT THE PRODUCTS AND SERVICES OF OTHERS WHERE SUCH INFORMATION OR ADVERTISEMENTS APPEAR IN RESPONSE TO USER-PRO-

VIDED DATA AND BASED ON USER INTERESTS; COMPUTER SOFTWARE APPLICATION DEVELOPMENT, NAMELY, INTEGRATING BRAND DEVELOPMENT SERVICES AND ADVERTISING AND PROMOTIONAL MATERIALS INTO GAMES AND COMPUTER-BASED ENTERTAINMENT IN THE NATURE OF COMPUTER GAME SOFTWARE; DEVELOPMENT AND MANAGEMENT OF DIGITAL AND WEB-BASED TECHNOLOGY SOLUTIONS, NAMELY, SOFTWARE FOR ADVERTISING AND MARKETING CAMPAIGNS (U.S. CLS. 100 AND 101).

JUHI KAVEESHVAR, EXAMINING ATTORNEY

#### CLASS 42—SCIENTIFIC AND COMPUTER SERVICES

FOR CUSTOM COMPUTER SOFTWARE CONSULTING; COMPUTER SOFTWARE DEVELOPMENT SERVICES (U.S. CLS. 100 AND 101).

DAVID I, EXAMINING ATTORNEY

SN 85-845,197. SLM TECHNOLOGY, LLC, MADISON, WI. FILED 2-8-2013.



THE MARK CONSISTS OF A PIN-LIKE ICON HAVING A SUBSTANTIALLY TRIANGULAR LOWER BODY AND AN OPEN-CIRCLE TOP PORTION HAVING A CONCENTRIC CIRCLE THEREIN.

#### CLASS 9—ELECTRICAL AND SCIENTIFIC APPARATUS

FOR SOFTWARE TO PROVIDE CONSUMERS WITH PERMISSIONS-BASED IDENTITY MANAGEMENT SERVICES, NAMELY, SMARTPHONE APPLICATIONS CONNECTED TO A COMPUTER SOFTWARE PLATFORM, TO ENABLE CONSUMERS TO SHARE, EDIT, OR REVOKE SPECIFIC PIECES OF PERSONAL IDENTITY INFORMATION TO ALLOW CONSUMERS TO EXCHANGE INFORMATION ABOUT THEMSELVES IN RETURN FOR MONEY OR OTHER THINGS OF VALUE; COMPUTER SOFTWARE PLATFORMS TO CONNECT TO DIGITAL APPLICATIONS TO PROVIDE IDENTITY SERVICES, NAMELY, STORING AND PROVIDING ACCESS TO INFORMATION ABOUT AN ENTITY'S IDENTITY, INCLUDING TOOLS IN THE FORM OF SMARTPHONE APPLICATIONS CONNECTED TO THE COMPUTER SOFTWARE PLATFORM TO PROVIDE, EDIT, OR REVOKE SPECIFIC PIECES OF PERSONAL IDENTITY INFORMATION; COMPUTER SOFTWARE PLATFORMS FOR MONITORING THE LOCATION OF MOBILE PHONES AND OTHER INTERACTIVE ELECTRONIC DEVICES AND THEIR RELATIVE POSITIONS FROM RETAILERS WHO MAY BE OFFERING LOCATION-BASED SPECIAL OFFERS OR OTHER INCENTIVES; COMPUTER SOFTWARE PLATFORMS FOR MATCHING POTENTIAL USERS OR PURCHASERS OF GOODS OR SERVICES BASED ON THEIR PHYSICAL LOCATIONS AND/OR PERSONAL IDENTITY INFORMATION WITH PURVEYORS OFFERING GOODS OR SERVICES; COMPUTER SOFTWARE PLATFORMS FOR PROVIDING PERMISSIONS-BASED IDENTITY SERVICES IN THE NATURE OF CONTROLLING ACCESS TO INFORMATION ABOUT AN ENTITY'S IDENTITY; COMPUTER SOFTWARE PLATFORMS THAT MONITOR THE LOCATION OF MOBILE PHONES AND OTHER INTERACTIVE ELECTRONIC DEVICES AND PROVIDES POTENTIAL CONSUMER LOCATION AND IDENTITY DATA WITH PURVEYORS OF GOODS AND SERVICES (U.S. CLS. 21, 23, 26, 36 AND 38).

SN 85-846,418. AVBM LIMITED, DOUGLAS, ISLE OF MAN, UNITED KINGDOM, FILED 2-11-2013.

*Somerset*  
BY ALICE TEMPERLEY

OWNER OF ERPN CMNTY TM OFC REG. NO. 011110152, DATED 1-4-2013, EXPIRES 8-9-2022.

OWNER OF U.S. REG. NOS. 3,006,671 AND 3,533,989.

THE NAME(S), PORTRAIT(S), AND/OR SIGNATURE(S) SHOWN IN THE MARK IDENTIFIES "ALICE TEMPERLEY", WHOSE CONSENT(S) TO REGISTER IS MADE OF RECORD.

THE MARK CONSISTS OF THE WORD "SOMERSET" ABOVE THE WORDS "BY ALICE TEMPERLEY".

#### CLASS 3—COSMETICS AND CLEANING PREPARATIONS

FOR COSMETICS, PERFUMERY AND NON-MEDICATED TOILETRIES; PERFUMES; COLOGNES; ESSENTIAL OILS; NON-MEDICATED SKIN CARE LOTIONS; SKIN CREAMS; SKIN MOISTURIZING GELS; BLEACHING PREPARATIONS FOR LAUNDRY USE; CLEANING, POLISHING, SCOURING AND ABRASIVE PREPARATIONS; SOAPS; PERFUMERY, ESSENTIAL OILS, COSMETICS, HAIR LOTIONS; DENTIFRICES (U.S. CLS. 1, 4, 6, 50, 51 AND 52).

#### CLASS 9—ELECTRICAL AND SCIENTIFIC APPARATUS

FOR LEATHER GOODS, NAMELY, HOLDERS FOR LAPTOPS IN THE NATURE OF PROTECTIVE SLEEVES AND CARRYING CASES AND HOLDERS SPECIFICALLY ADAPTED FOR HOLDING ELECTRONIC DEVICES, NAMELY, LAPTOPS, TABLET PCS, ELECTRONIC BOOK READERS, MP3 PLAYERS, MOBILE TELEPHONES, SMART TELEPHONES, DIGITAL CAMERAS, GLOBAL POSITIONING SYSTEMS AND PERSONAL DIGITAL ASSISTANTS; LAPTOP CARRYING CASES; CARRYING CASES SPECIFICALLY ADAPTED FOR ELECTRONIC DEVICES, NAMELY, TABLET PCS, ELECTRONIC BOOK READERS, MP3 PLAYERS, MOBILE TELEPHONES, SMART TELEPHONES, DIGITAL CAMERAS, GLOBAL POSITIONING SYSTEMS AND PERSONAL DIGITAL ASSISTANTS (U.S. CLS. 21, 23, 26, 36 AND 38).



**CLASS 14—JEWELRY**

FOR FASHION JEWELLERY; PRECIOUS METALS AND THEIR ALLOYS; JEWELLERY, COSTUME JEWELLERY, PRECIOUS STONES; HOROLOGICAL AND CHRONOMETRIC INSTRUMENTS, CLOCKS AND WATCHES; JEWELLERY; WATCHES; CLOCKS; JEWELLERY CHAINS; BRACELETS; BANGLES; ARM CUFFS; CUFFLINKS; EARRINGS; RINGS; BROOCHES; BODY JEWELLERY; KEY RINGS OF PRECIOUS METAL; TIE BARS; KEY FOBS OF PRECIOUS METAL; BADGES OF PRECIOUS METAL; PASTE JEWELLERY; PARTS AND FITTINGS FOR WATCHES AND CLOCKS (U.S. CLS. 2, 27, 28 AND 50).

**CLASS 16—PAPER GOODS AND PRINTED MATTER**

FOR LEATHER GOODS, NAMELY, PASSPORT HOLDERS AND HOLDERS FOR PERSONAL ORGANIZERS; PERSONAL ORGANIZER CASES (U.S. CLS. 2, 5, 22, 23, 29, 37, 38 AND 50).

**CLASS 18—LEATHER GOODS**

FOR LEATHER AND IMITATIONS OF LEATHER; ANIMAL SKINS AND HIDES; TRUNKS AND TRAVELLING BAGS; HANDBAGS, RUCKSACKS, PURSES; UMBRELLAS, PARASOLS AND WALKING STICKS; WHIPS, HARNESS AND SADDLERY; CLOTHING FOR ANIMALS; HANDBAGS; SACHELS; LUGGAGE; TRAVELLING BAGS; TRUNKS; SUITCASES; HOLDALLS; BACKPACKS; SACHELS; BEACH BAGS; RUCKSACKS; SCHOOL BAGS; SPORTS BAGS; SHOULDER BAGS; CLUTCH BAGS; CASES, NAMELY, OVERNIGHT CASES; SHOULDER BAGS; WAIST BAGS; ATTACHE CASES; LEATHER BRIEFCASES; BRIEFCASES; DOCUMENT CASES; VANITY CASES SOLD EMPTY; TOILET BAGS; TOILETRY BAGS SOLD EMPTY; WALLETS; PURSES; PLASTIC LABELS AND TAGS FOR LUGGAGE; WALLETS; CHANGE PURSES; KEY CASES; BUSINESS AND CREDIT CARD CASES; UMBRELLAS; PARASOLS AND WALKING STICKS (U.S. CLS. 1, 2, 3, 22 AND 41).

**CLASS 20—FURNITURE AND ARTICLES NOT OTHERWISE CLASSIFIED**

FOR FURNITURE, MIRRORS, PICTURE FRAMES; GARDEN FURNITURE; PILLOWS AND CUSHIONS; BEDSIDE TABLES; BEDS; TABLES; CHAIRS; ARMCHAIRS; SOFAS; DESKS; LIBRARY SHELVES; MIRRORS; FOOTSTOOLS; BASKETS FOR TRANSPORTING FOODS FOR STORAGE PURPOSES; HAMPERS IN THE NATURE OF BASKETS FOR TRANSPORTING GOODS FOR COMMERCIAL AND STORAGE PURPOSES; MAGAZINE RACKS; KEY FOBS NOT OF METAL (U.S. CLS. 2, 13, 22, 25, 32 AND 50).

**CLASS 25—CLOTHING**

FOR FOOTWEAR; HEADGEAR, NAMELY, HATS AND CAPS; DRESSES; WEDDING GOWNS; WEDDING DRESSES; DRESSES; GOWNS; SARIS; SKIRTS; KNITWEAR, NAMELY, SWEATERS; T-SHIRTS; SHIRTS; FLEECE TOPS; JUMPERS; SWEATERS; NIGHT SHIRTS; RUGBY SHIRTS; POLO SHIRTS; CARDIGANS; JERSEYS; UNIFORMS; BLAZERS; DRESS SHIRTS; JEANS; SHORTS; UNDERWEAR; TOPS; SWEAT PANTS; TRACK SUITS; PLAY SUITS; BLOUSES; VESTS; SNOW SUITS; PARKAS; CAPES; ANORAKS; PONCHOS; JACKETS; REVERSIBLE JACKETS; WATERPROOF CLOTHING, NAMELY, TROUSERS, TOPS, JACKETS AND COATS; COATS; PULLOVERS; TROUSERS; SHORTS; SKI CLOTHING, NAMELY, TROUSERS, TOPS, JACKETS, SALOPETTES, SPORTSWEAR, NAMELY, TROUSERS, TOPS, SKIRTS, SHORTS, TOPS AND JACKETS; INFANTS SLEEPERS; BOOTIES; CAPS; SWIM CAPS; BERTS; VISORS; WRIST BANDS; SWEAT BANDS; EAR MUFFS; APRONS; SUSPENDERS; NECKWEAR; NECKERCHIEFS; UNDERWEAR; BRIEFS; SWIM AND BATHING TRUNKS; BRAS; SPORTS BRAS; BUSTIERS; CORSETS; PANTIES; THONGS; GARTERS AND GARTER BELTS; UNDERGARMENTS; UNDERWEAR; VESTS; TIGHTS; SOCKS; LOUNGEWEAR; ROBES; PYJAMAS; SLEEPWEAR; NIGHTWEAR; NIGHT GOWNS;

LINGERIE; CAMISOLES; STOCKINGS; LEGGINGS; TIGHTS; LEOTARDS; LINGERIE; HOSIERY; DRESSING GOWNS; SWIMSUITS; BEACHWEAR; BIKINIS; STOCKINGS; OUTERWEAR, NAMELY, JACKETS, COATS AND PONCHOS; MASQUERADE COSTUMES; RAIN JACKETS; SUITS; GLOVES; SCARVES; BELTS; MUFFS; SHOES; BOOTS; TRAINERS; INSOLES; OUTSOLES AND OUTER-SOLES FOR FOOTWEAR; SHOES; BOOTS FOR SPORTS; SPORTS SHOES; SNEAKERS; SANDALS; FLIP-FLOPS; SHOES; BATH SLIPPERS; SLIPPERS; HATS; CAPS; BEANIES; HEADBANDS; SHOWER CAPS; SUN VISORS; CUFFS; CHILDREN'S CLOTHING, NAMELY, COATS, JACKETS, DRESSES, SKIRTS, SHORTS, TROUSERS, JEANS, PANTS, SHIRTS, BLOUSES, JUMPERS, SWEATERS, FLEECE TOPS, CARDIGANS, GLOVES, SCARVES, HATS, SWIMWEAR, NIGHTWEAR, ONE PIECE GARMENT FOR INFANTS AND TODDLERS, UNDERWEAR, SOCKS, TIGHTS; CHILDREN'S FOOTWEAR; CHILDREN'S HEADWEAR (U.S. CLS. 22 AND 39).

**CLASS 35—ADVERTISING AND BUSINESS**

FOR DEMONSTRATION OF GOODS; SALES PROMOTION SERVICES; MARKETING CONNECTED WITH THE SALE OF CLOTHING, FOOTWEAR AND HEADGEAR; RETAIL STORE SERVICES PROVIDING COSMETICS, PERFUMERY AND TOILETRIES, PERFUMES, COLOGNES, ESSENTIAL OILS, SKIN CARE LOTIONS, CREAMS, GELS, BLEACHING PREPARATIONS AND OTHER SUBSTANCES FOR LAUNDRY USE, CLEANING, POLISHING, SCOURING AND ABRASIVE PREPARATIONS, SOAPS, PERFUMERY, ESSENTIAL OILS, COSMETICS, HAIR LOTIONS, DENTIFRICES, FASHION JEWELLERY, PRECIOUS METALS AND THEIR ALLOYS, JEWELLERY, COSTUME JEWELLERY, PRECIOUS STONES, HOROLOGICAL AND CHRONOMETRIC INSTRUMENTS, CLOCKS AND WATCHES, JEWELLERY, WATCHES, CLOCKS, ARTICLES OF PRECIOUS OR SEMI-PRECIOUS METAL, CHAINS, BRACELETS, BANGLES, CUFFS, ARM CUFFS, SHIRT STUDS, CUFFLINKS, EARRINGS, RINGS, BROOCHES, BODY JEWELLERY, MONEY CLIPS OF PRECIOUS METAL, KEY RINGS OF PRECIOUS METAL, TIE BARS, KEY FOBS OF PRECIOUS METAL, BADGES OF PRECIOUS METAL, PASTE JEWELLERY, LEATHER AND IMITATIONS OF LEATHER, ANIMAL SKINS, HIDES, TRUNKS AND TRAVELLING BAGS, HANDBAGS, RUCKSACKS, PURSES, UMBRELLAS, PARASOLS AND WALKING STICKS, WHIPS, HARNESS AND SADDLERY, CLOTHING FOR ANIMALS, BAGS, HANDBAGS, SACHELS, LUGGAGE, TRAVELLING BAGS, TRUNKS, SUITCASES, HOLDALLS, BACKPACKS, SACHELS, BEACH BAGS, RUCKSACKS, SCHOOL BAGS, SPORTS BAGS, SHOULDER BAGS, CLUTCH BAGS, LEATHER GOODS, CASES, SHOULDER BAGS, WAIST BAGS, ATTACHE CASES, LEATHER BRIEFCASES, BRIEFCASES, DOCUMENT CASES, VANITY CASES, TOILET BAGS, TOILETRY BAGS SOLD EMPTY, WALLETS, PURSES, LABELS AND TAGS FOR LUGGAGE, WALLETS, CHANGE PURSES, KEY CASES, BUSINESS AND CREDIT CARD CASES, UMBRELLAS, PARASOLS AND WALKING STICKS, KEY FOBS, FURNITURE, MIRRORS, PICTURE FRAMES, ARTICLES MADE OF WOOD, CORK, REED, CANE, WICKER, HORN, BONE, IVORY, WHALEBONE, SHELL, AMBER, MOTHER-OF-PEARL, MEERSCHAUM OR PLASTIC, GARDEN FURNITURE, PILLOWS AND CUSHIONS, BEDSIDE TABLES, BEDS, TABLES, CHAIRS, ARMCHAIRS, SOFAS, DESKS, LIBRARY SHELVES, MIRRORS, FOOTSTOOLS, BASKETS, HAMPERS, MAGAZINE RACKS, READY TO WEAR CLOTHING, CLOTHING, FOOTWEAR, HEADGEAR, DRESSES, WEDDING GOWNS, WEDDING DRESSES, DRESSES, GOWNS, SARIS, SKIRTS, KNITWEAR, T-SHIRTS, SHIRTS, FLEECE TOPS, JUMPERS, SWEATERS, NIGHT SHIRTS, RUGBY SHIRTS, POLO SHIRTS, CARDIGANS, JERSEYS, UNIFORMS, BLAZERS, DRESS SHIRTS, JEANS, SHORTS, UNDERWEAR, TOPS, SWEAT PANTS, TRACK SUITS, PLAY SUITS, BLOUSES, VESTS, SNOW SUITS, PARKAS, CAPES, ANORAKS, PONCHOS, JACKETS, REVERSIBLE JACKETS, WATERPROOF CLOTHING, COATS, PULLOVERS, TROUSERS, SHORTS, SKI CLOTHING, SPORTSWEAR, INFANTS SLEEPERS, BOOTIES, CAPS, SWIM CAPS, BERTS, VISORS, WRIST BANDS, SWEAT BANDS, EAR MUFFS, APRONS, SUSPENDERS, NECKWEAR, NECKERCHIEFS, UNDERWEAR, BRIEFS, SWIM AND BATHING TRUNKS,

BRAS, SPORTS BRAS, BUSTIERS, CORSETS, PANTIES, THONGS, GARTERS AND GARTER BELTS, UNDERGARMENTS, UNDERWEAR, VESTS, TIGHTS, SOCKS, LOUNGEWEAR, ROBES, PYJAMAS, SLEEPWEAR, NIGHTWEAR, NIGHT GOWNS, LINGERIE, CAMISOLES, STOCKINGS, LEGGINGS, TIGHTS, LEOTARDS, LINGERIE, HOSIERY, DRESSING GOWNS, SWIMSUITS, BEACHWEAR, BIKINIS, STOCKINGS, OUTERWEAR, COSTUMES, RAIN JACKETS, SUITS, THERMAL, GLOVES, SCARVES, BELTS, MUFFS, SHOES, BOOTS, TRAINERS, INSOLES, OUTSOLES AND OUTER-SOLES FOR FOOTWEAR, SHOES, BOOTS FOR SPORTS, SPORTS SHOES, SNEAKERS, SANDALS, FLIP-FLOPS, SHOES, BATH SLIPPERS, SLIPPERS, HATS, CAPS, BEANIES, HEADBANDS, SHOWER CAPS, SUN VISORS (U.S. CLS. 100, 101 AND 102).

WON TEAK OH, EXAMINING ATTORNEY

SN 85-847,998. ROMAINE ELECTRIC CORPORATION, KENT, WA. FILED 2-12-2013.

## Romaine Electric

THE MARK CONSISTS OF STANDARD CHARACTERS WITHOUT CLAIM TO ANY PARTICULAR FONT, STYLE, SIZE, OR COLOR.

NO CLAIM IS MADE TO THE EXCLUSIVE RIGHT TO USE "ELECTRIC", APART FROM THE MARK AS SHOWN.

### CLASS 37—CONSTRUCTION AND REPAIR

FOR REPAIR SERVICES FOR AUTOMOTIVE, TRUCK, INDUSTRIAL, MARINE, AGRICULTURAL AND MILITARY VEHICLE, ALTERNATOR AND STARTER UNIT PARTS (U.S. CLS. 100, 103 AND 106).

FIRST USE 6-1-1921; IN COMMERCE 6-1-1921.

### CLASS 39—TRANSPORTATION AND STORAGE

FOR DISTRIBUTION SERVICES, NAMELY, DELIVERY OF AUTOMOTIVE, TRUCK, INDUSTRIAL, MARINE, AGRICULTURAL AND MILITARY VEHICLE, ALTERNATOR AND STARTER UNIT PARTS (U.S. CLS. 100 AND 105).

FIRST USE 6-1-1921; IN COMMERCE 6-1-1921.  
STEVEN JACKSON, EXAMINING ATTORNEY

SN 85-848,994. MENTAL HEALTH SERVICES FOR HOMELESS PERSONS, INC., CLEVELAND, OH. FILED 2-13-2013.

## FRONTLINE SERVICE

THE MARK CONSISTS OF STANDARD CHARACTERS WITHOUT CLAIM TO ANY PARTICULAR FONT, STYLE, SIZE, OR COLOR.

NO CLAIM IS MADE TO THE EXCLUSIVE RIGHT TO USE "SERVICE", APART FROM THE MARK AS SHOWN.

### CLASS 36—INSURANCE AND FINANCIAL

FOR CHARITABLE FUNDRAISING SERVICES; HOUSING AGENCY SERVICES, NAMELY, ARRANGING OF PERMANENT HOUSING FOR HOMELESS AND DISABLED PERSONS; CONSULTING SERVICES IN THE FIELD OF PERMANENT HOUSING FOR HOMELESS AND DISABLED PERSONS (U.S. CLS. 100, 101 AND 102).

### CLASS 43—HOTEL AND RESTAURANT SERVICES

FOR HOUSING SERVICES, NAMELY, ARRANGING TEMPORARY HOUSING FOR HOMELESS AND DISABLED PERSONS; PROVIDING PUBLIC HOUSING SERVICES FOR HOMELESS AND DISABLED PERSONS; CONSULTING SERVICES IN THE FIELDS OF TEMPORARY HOUSING AND PUBLIC HOUSING SERVICES FOR HOMELESS AND DISABLED PERSONS (U.S. CLS. 100 AND 101).

### CLASS 44—MEDICAL, BEAUTY AND AGRICULTURAL SERVICES

FOR COUNSELING SERVICES IN THE FIELDS OF MENTAL AND PHYSICAL HEALTH, NUTRITION, WELL-BEING AND PSYCHOLOGY FOR DISABLED AND HOMELESS PERSONS AND PERSONS EXPERIENCING PHYSICAL OR MENTAL HEALTH CRISES (U.S. CLS. 100 AND 101).

### CLASS 45—PERSONAL AND LEGAL SERVICES

FOR COUNSELING IN THE FIELD OF PERSONAL DEVELOPMENT, NAMELY, PROVIDING COUNSELING TO HOMELESS AND DISABLED PERSONS REGARDING SELF-IMPROVEMENT, INTERPERSONAL COMMUNICATION, AND DEVELOPING, STRENGTHENING AND SUSTAINING FAMILY RELATIONSHIPS; COUNSELING SERVICES IN THE FIELD OF SUPPORT FOR VICTIMS AND SURVIVORS OF VIOLENT CRIMES, NAMELY, PROVIDING COMPASSIONATE CARE, PRACTICAL PLANNING, AND SERVICE COORDINATION ADVICE AND SERVICES (U.S. CLS. 100 AND 101).  
LINDA ORNDORFF, EXAMINING ATTORNEY

SN 85-849,072. MENTAL HEALTH SERVICES FOR HOMELESS PERSONS, INC., CLEVELAND, OH. FILED 2-13-2013.

## REACHING OUT. RESOLVING CRISIS.

THE MARK CONSISTS OF STANDARD CHARACTERS WITHOUT CLAIM TO ANY PARTICULAR FONT, STYLE, SIZE, OR COLOR.

### CLASS 36—INSURANCE AND FINANCIAL

FOR CHARITABLE FUNDRAISING SERVICES; HOUSING AGENCY SERVICES, NAMELY, ARRANGING OF PERMANENT HOUSING FOR HOMELESS AND DISABLED PERSONS; CONSULTING SERVICES IN THE FIELD OF PERMANENT HOUSING FOR HOMELESS AND DISABLED PERSONS (U.S. CLS. 100, 101 AND 102).

**CLASS 43—HOTEL AND RESTAURANT SERVICES**

FOR HOUSING SERVICES, NAMELY, ARRANGING TEMPORARY HOUSING FOR HOMELESS AND DISABLED PERSONS; PROVIDING PUBLIC HOUSING SERVICES FOR HOMELESS AND DISABLED PERSONS; CONSULTING SERVICES IN THE FIELDS OF TEMPORARY HOUSING AND PUBLIC HOUSING SERVICES FOR HOMELESS AND DISABLED PERSONS (U.S. CLS. 100 AND 101).

**CLASS 44—MEDICAL, BEAUTY AND AGRICULTURAL SERVICES**

FOR COUNSELING SERVICES IN THE FIELDS OF MENTAL AND PHYSICAL HEALTH, NUTRITION, WELL-BEING AND PSYCHOLOGY FOR DISABLED AND HOMELESS PERSONS AND PERSONS EXPERIENCING PHYSICAL OR MENTAL HEALTH CRISES (U.S. CLS. 100 AND 101).

**CLASS 45—PERSONAL AND LEGAL SERVICES**

FOR COUNSELING IN THE FIELD OF PERSONAL DEVELOPMENT, NAMELY, PROVIDING COUNSELING TO HOMELESS AND DISABLED PERSONS REGARDING SELF-IMPROVEMENT, INTERPERSONAL COMMUNICATION, AND DEVELOPING, STRENGTHENING AND SUSTAINING FAMILY RELATIONSHIPS; COUNSELING SERVICES IN THE FIELD OF SUPPORT FOR VICTIMS AND SURVIVORS OF VIOLENT CRIMES, NAMELY, PROVIDING COMPASSIONATE CARE, PRACTICAL PLANNING, AND SERVICE COORDINATION ADVICE AND SERVICES (U.S. CLS. 100 AND 101).  
LINDA ORNDORFF, EXAMINING ATTORNEY

SN 85-849,186. GUERRA, AUSTIN P., PARADISE VALLEY, AZ. FILED 2-13-2013.

# Highlight

THE MARK CONSISTS OF STANDARD CHARACTERS WITHOUT CLAIM TO ANY PARTICULAR FONT, STYLE, SIZE, OR COLOR.

THE NAME "HIGHLIGHT" SHOWN IN THE MARK IDENTIFIES THE STAGE NAME OF AUSTIN GUERRA, A LIVING INDIVIDUAL WHOSE CONSENT TO REGISTER IS MADE OF RECORD.

**CLASS 9—ELECTRICAL AND SCIENTIFIC APPARATUS**

FOR AUDIO AND VIDEO RECORDINGS FEATURING MUSIC AND ARTISTIC PERFORMANCES; AUDIO RECORDINGS FEATURING MUSIC; AUDIO TAPES FEATURING MUSIC; COMPACT DISCS FEATURING MUSIC; DIGITAL MUSIC DOWNLOADABLE FROM THE INTERNET; DOWNLOADABLE MUSIC FILES; SOUND RECORDINGS FEATURING MUSIC; ALL THE FOREGOING OFFERED SOLELY IN CONNECTION WITH A DISC JOCKEY AND EXCLUDING CHILDREN'S MUSIC (U.S. CLS. 21, 23, 26, 36 AND 38).  
FIRST USE 5-10-2010; IN COMMERCE 5-10-2010.

**CLASS 41—EDUCATION AND ENTERTAINMENT**

FOR COMPOSITION OF ELECTRONIC DANCE MUSIC FOR OTHERS; DISC JOCKEY SERVICES; DISC JOCKEYS FOR PARTIES AND SPECIAL EVENTS; ENTERTAINMENT, NAMELY, LIVE ELECTRONIC DANCE MUSIC CONCERTS; ALL THE FOREGOING OFFERED SOLELY IN CONNECTION WITH A DISC JOCKEY (U.S. CLS. 100, 101 AND 107).

FIRST USE 5-10-2010; IN COMMERCE 5-10-2010.  
JEAN IM, EXAMINING ATTORNEY

SN 85-849,964. WIDDLE, LLC, STRONGSVILLE, OH. FILED 2-14-2013.

# Widdle

THE MARK CONSISTS OF STANDARD CHARACTERS WITHOUT CLAIM TO ANY PARTICULAR FONT, STYLE, SIZE, OR COLOR.

**CLASS 35—ADVERTISING AND BUSINESS**

FOR ADVERTISING AND MARKETING; ADVERTISING SERVICES; ONLINE ADVERTISING AND MARKETING SERVICES; BUSINESS DATA ANALYSIS; PROMOTIONAL SERVICES, NAMELY, PROMOTING THE GOODS OF OTHERS BY PROVIDING ONLINE ADVERTISING SPACE FOR USE BY OTHERS; BUSINESS NETWORKING; ONLINE SERVICE FOR CONNECTING SOCIAL NETWORK USERS WITH BUSINESSES FOR THE PURPOSE OF FACILITATING DISCOUNT PURCHASES; BUSINESS MONITORING AND CONSULTING SERVICES, NAMELY, TRACKING USERS AND ADVERTISING OF OTHERS TO PROVIDE STRATEGY, INSIGHT, MARKETING GUIDANCE, AND FOR ANALYZING, UNDERSTANDING AND PREDICTING CONSUMER BEHAVIOR AND MOTIVATIONS, AND MARKET TRENDS (U.S. CLS. 100, 101 AND 102).

**CLASS 38—COMMUNICATION**

FOR TELECOMMUNICATIONS SERVICES, NAMELY, PROVIDING ONLINE AND TELECOMMUNICATION FACILITIES FOR REAL-TIME INTERACTION BETWEEN AND AMONG USERS OF COMPUTERS, MOBILE AND HANDHELD COMPUTERS, AND WIRED AND WIRELESS COMMUNICATION DEVICES CONCERNING TOPICS OF PERSONAL INTEREST; PROVIDING AN ONLINE COMMUNITY FORUM FOR USERS TO SHARE INFORMATION, PHOTOS, AUDIO AND VIDEO CONTENT ABOUT THEMSELVES (U.S. CLS. 100, 101 AND 104).

SANI KHOURI, EXAMINING ATTORNEY

SN 85-850,550. GANYMED PHARMACEUTICALS AG, 55131 MAINZ, FED REP GERMANY, FILED 2-14-2013.

# CLAUDETECT

THE MARK CONSISTS OF STANDARD CHARACTERS WITHOUT CLAIM TO ANY PARTICULAR FONT, STYLE, SIZE, OR COLOR.

PRIORITY CLAIMED UNDER SEC. 44(D) ON FED REP GERMANY APPLICATION NO. 302012062252, FILED 12-4-2012, REG. NO. 302012062252, DATED 2-28-2013, EXPIRES 12-31-2022.

SN 85-851,035. SRM INSTITUTE OF SCIENCE AND TECHNOLOGY, WEST MAMBALAM, CHENNAI, INDIA, FILED 2-15-2013.

### CLASS 1—CHEMICALS

FOR BIOCHEMICALS, NAMELY, MONOCLONAL AND POLYCLONAL ANTIBODIES, NOT FOR MEDICAL PURPOSES FOR RESEARCH USE OR IN VITRO SCIENTIFIC USE; CHEMICAL, BIOLOGICAL AND BIOCHEMICAL PRODUCTS FOR COMMERCIAL AND SCIENTIFIC PURPOSES, IN PARTICULAR FOR BIOCHEMICAL AND BIOPHARMACEUTICAL RESEARCH AND DEVELOPMENT, NAMELY, REAGENTS FOR IMMUNOHISTOCHEMICAL ANALYSIS, REAGENTS AND KITS COMPRISED OF REAGENTS FOR IMMUNOHISTOCHEMICAL DETECTION OF CANCER ANTIGENS FOR USE IN SCIENTIFIC APPARATUS OR SCIENTIFIC ASSAYS FOR CHEMICAL, BIOCHEMICAL, BIOLOGICAL OR BIOPHARMACEUTICAL ANALYSIS (U.S. CLS. 1, 5, 6, 10, 26 AND 46).



NO CLAIM IS MADE TO THE EXCLUSIVE RIGHT TO USE "AI", APART FROM THE MARK AS SHOWN.

THE COLOR(S) WHITE AND PURPLE IS/ARE CLAIMED AS A FEATURE OF THE MARK.

THE MARK CONSISTS OF WHITE LETTERS "AI" ON A PURPLE RECTANGULAR BACKGROUND; THE LETTER "I" IS THE STYLIZED FORM OF A PERSON.

### CLASS 5—PHARMACEUTICALS

FOR PHARMACEUTICAL AND VETERINARY PRODUCTS, NAMELY, MEDICAL DIAGNOSTIC AND THERAGNOSTIC REAGENTS AND THERAPEUTIC PREPARATIONS FOR MEDICAL AND VETERINARY USE FOR TREATMENT OF ONCOLOGICAL DISEASES AND DISORDERS; MEDICINAL PREPARATIONS FOR THERAPY AND DIAGNOSIS OF CANCER DISEASES; MEDICAL PREPARATIONS, NAMELY, ANTIBODIES, ANTIBODY DERIVATIVES, ANTIBODY CONJUGATES, ANTIBODY FRAGMENTS AND ANTISERA FOR MEDICAL PURPOSES, IN PARTICULAR THOSE FOR DIAGNOSTIC, THERAPEUTIC AND THERAGNOSTIC PURPOSES OF ONCOLOGICAL DISEASES AND DISORDERS; DIAGNOSTIC AND THERAGNOSTIC TEST KITS CONSISTING OF ANTIBODIES AND TISSUE SECTION OF HUMAN, ANIMAL OR SYNTHETICALLY PRODUCED TISSUE FOR USE IN DIAGNOSING OF CANCER DISEASES AND STRATIFICATION OF CANCER PATIENTS (U.S. CLS. 6, 18, 44, 46, 51 AND 52).

### CLASS 9—ELECTRICAL AND SCIENTIFIC APPARATUS

FOR COMPUTER SOFTWARE FOR ASSESSMENT SYSTEM TO BE USED IN SYSTEMS SUCH AS EDUCATIONAL INFORMATION SYSTEMS FOR USE IN EVALUATING AND ANALYZING THE PERFORMANCE OF ENTITIES OF AN EDUCATIONAL INSTITUTION SUCH AS STUDENTS BASED ON STUDENT SPECIFIC PRODUCTIVITY METRICS, FACULTY MEMBERS BASED ON FACULTY MEMBER SPECIFIC PRODUCTIVITY METRICS, LABORATORIES BASED ON LABORATORY SPECIFIC PRODUCTIVITY METRICS, AND LIBRARIES BASED ON LIBRARY SPECIFIC PRODUCTIVITY METRICS, IN ORDER TO PROVIDE FOR ACHIEVING IMPROVEMENTS OVER A PERIOD OF TIME BY EDUCATIONAL INSTITUTIONS, AND TO BE USED IN MANUFACTURING INFORMATION SYSTEMS AND ENTERPRISE INFORMATION SYSTEMS FOR EVALUATING AND ANALYZING THE PERFORMANCE OF EMPLOYEES BASED ON EMPLOYEE SPECIFIC PRODUCTIVITY METRICS OF A MANUFACTURING ORGANIZATION OR AN ENTERPRISE IN ORDER TO PROVIDE FOR ACHIEVING IMPROVEMENTS OVER A PERIOD OF TIME BY MANUFACTURING ORGANIZATIONS AND ENTERPRISES; ASSESSMENT SYSTEM BASED SOFTWARE RECORDED ON CD-ROMS AND DVDS FOR USE IN EVALUATING AND ANALYZING PERFORMANCE OF ENTITIES OF AN EDUCATIONAL INSTITUTION SUCH AS STUDENTS BASED ON STUDENT SPECIFIC PRODUCTIVITY METRICS, FACULTY MEMBERS BASED ON FACULTY MEMBER SPECIFIC PRODUCTIVITY METRICS, LABORATORIES BASED ON LABORATORY SPECIFIC PRODUCTIVITY METRICS, AND LIBRARIES BASED ON LIBRARY SPECIFIC PRODUCTIVITY METRICS, OR EMPLOYEES BASED ON EMPLOYEE SPECIFIC PRODUCTIVITY METRICS OF A MANUFACTURING ORGANIZATION OR AN ENTERPRISE IN ORDER TO PROVIDE FOR ACHIEVING IMPROVEMENTS OVER A PERIOD OF TIME BY EDUCATIONAL INSTITUTIONS, MANUFACTURING ORGANIZATIONS, AND ENTERPRISES; COMPUTER NETWORKS BASED HOSTING OF ASSESSMENT SYSTEM BASED SOFTWARE FOR EVALUATING AND ANALYZING THE PERFORMANCE OF ENTITIES OF AN EDUCATIONAL INSTITUTION SUCH AS SUCH AS STUDENTS BASED ON STUDENT SPECIFIC PRODUCTIVITY METRICS, FACULTY MEMBERS BASED ON FACULTY MEMBER SPECIFIC PRODUCTIVITY METRICS, LABORATORIES BASED ON LABORATORY SPECIFIC PRODUCTIVITY METRICS, AND LIBRARIES BASED ON LIBRARY SPECIFIC PRODUCTIVITY METRICS, OR EMPLOYEES BASED ON EMPLOYEE SPECIFIC PRODUCTIVITY METRICS OF A

### CLASS 42—SCIENTIFIC AND COMPUTER SERVICES

FOR SCIENTIFIC SERVICES, NAMELY, SCIENTIFIC RESEARCH IN THE FIELD OF DIAGNOSTIC SERVICES, AND THERAGNOSTIC SERVICES, AND IMMUNOLOGICAL DISEASES/DISORDERS; SCIENTIFIC SERVICES, NAMELY, IMMUNOHISTOCHEMICAL ANALYSIS, INVESTIGATIONS AND RESEARCH FOR MEDICAL PURPOSES (U.S. CLS. 100 AND 101).

### CLASS 44—MEDICAL, BEAUTY AND AGRICULTURAL SERVICES

FOR MEDICAL-DIAGNOSTIC SERVICES; MEDICAL-THERAGNOSTIC SERVICES (U.S. CLS. 100 AND 101).  
MEGHAN REINHART, EXAMINING ATTORNEY

MANUFACTURING ORGANIZATION OR AN ENTERPRISE IN ORDER TO PROVIDE FOR ACHIEVING IMPROVEMENTS OVER A PERIOD OF TIME BY EDUCATIONAL INSTITUTIONS, MANUFACTURING ORGANIZATIONS, AND ENTERPRISES; ASSESSMENT SYSTEM BASED SOFTWARE ON MOBILE PHONES, PERSONAL DIGITAL ASSISTANTS, HANDHELD COMPUTERS, LAPTOP COMPUTERS, DESKTOP COMPUTERS, AND SERVER COMPUTERS FOR EVALUATING AND ANALYZING THE PERFORMANCE OF ENTITIES OF AN EDUCATIONAL INSTITUTION SUCH AS SUCH AS STUDENTS BASED ON STUDENT SPECIFIC PRODUCTIVITY METRICS, FACULTY MEMBERS BASED ON FACULTY MEMBER SPECIFIC PRODUCTIVITY METRICS, LABORATORIES BASED ON LABORATORY SPECIFIC PRODUCTIVITY METRICS, AND LIBRARIES BASED ON LIBRARY SPECIFIC PRODUCTIVITY METRICS, OR EMPLOYEES BASED ON EMPLOYEE SPECIFIC PRODUCTIVITY METRICS OF A MANUFACTURING ORGANIZATION OR AN ENTERPRISE IN ORDER TO PROVIDE FOR ACHIEVING IMPROVEMENTS OVER A PERIOD OF TIME BY EDUCATIONAL INSTITUTIONS, MANUFACTURING ORGANIZATIONS, AND ENTERPRISES; ASSESSMENT SYSTEM BASED SOFTWARE ON SERVER COMPUTERS PROVIDING THE ABILITY TO DOWNLOAD ASSESSMENT BASED SOFTWARE FOR EVALUATING AND ANALYZING THE PERFORMANCE OF ENTITIES OF AN EDUCATIONAL INSTITUTION SUCH AS SUCH AS STUDENTS BASED ON STUDENT SPECIFIC PRODUCTIVITY METRICS, FACULTY MEMBERS BASED ON FACULTY MEMBER SPECIFIC PRODUCTIVITY METRICS, LABORATORIES BASED ON LABORATORY SPECIFIC PRODUCTIVITY METRICS, AND LIBRARIES BASED ON LIBRARY SPECIFIC PRODUCTIVITY METRICS, OR EMPLOYEES BASED ON EMPLOYEE SPECIFIC PRODUCTIVITY METRICS OF A MANUFACTURING ORGANIZATION OR AN ENTERPRISE IN ORDER TO PROVIDE FOR ACHIEVING IMPROVEMENTS OVER A PERIOD OF TIME BY EDUCATIONAL INSTITUTIONS, MANUFACTURING ORGANIZATIONS, AND ENTERPRISES (U.S. CLS. 21, 23, 26, 36 AND 38).

#### **CLASS 42—SCIENTIFIC AND COMPUTER SERVICES**

FOR PROVIDING ON-LINE NON-DOWNLOADABLE SOFTWARE FOR ASSESSMENT SYSTEM TO BE USED IN SYSTEMS SUCH AS EDUCATIONAL INFORMATION SYSTEMS, MANUFACTURING INFORMATION SYSTEMS, AND ENTERPRISE INFORMATION SYSTEMS FOR EVALUATING AND ANALYZING THE PERFORMANCE OF ENTITIES OF AN EDUCATIONAL INSTITUTION SUCH AS STUDENTS BASED ON STUDENT SPECIFIC PRODUCTIVITY METRICS, FACULTY MEMBERS BASED ON FACULTY MEMBER SPECIFIC PRODUCTIVITY METRICS, LABORATORIES BASED ON LABORATORY SPECIFIC PRODUCTIVITY METRICS, AND LIBRARIES BASED ON LIBRARY SPECIFIC PRODUCTIVITY METRICS, OR EMPLOYEES BASED ON EMPLOYEE SPECIFIC PRODUCTIVITY METRICS OF A MANUFACTURING ORGANIZATION OR AN ENTERPRISE IN ORDER TO PROVIDE FOR ACHIEVING IMPROVEMENTS OVER A PERIOD OF TIME BY EDUCATIONAL INSTITUTIONS, MANUFACTURING ORGANIZATIONS, AND ENTERPRISES; COMPUTER NETWORKS BASED HOSTING OF ASSESSMENT SYSTEM BASED SOFTWARE IN THE NATURE OF SOFTWARE AS A SERVICE (SAAS) FEATURING SOFTWARE FOR USE IN EVALUATING AND ANALYZING THE PERFORMANCE OF ENTITIES OF AN EDUCATIONAL INSTITUTION SUCH AS STUDENTS BASED ON STUDENT SPECIFIC PRODUCTIVITY METRICS, FACULTY MEMBERS BASED ON FACULTY MEMBER SPECIFIC PRODUCTIVITY METRICS, LABORATORIES BASED ON LABORATORY SPECIFIC PRODUCTIVITY METRICS, AND LIBRARIES BASED ON LIBRARY SPECIFIC PRODUCTIVITY METRICS, OR EMPLOYEES BASED ON EMPLOYEE SPECIFIC PRODUCTIVITY METRICS OF A MANUFACTURING ORGANIZATION OR AN ENTERPRISE IN ORDER TO PROVIDE FOR ACHIEVING IMPROVEMENTS OVER A PERIOD OF TIME BY EDUCATIONAL INSTITUTIONS, MANUFACTURING ORGANIZATIONS, AND ENTERPRISES BASED ON THEIR RESPECTIVE DATA; PROVIDING ON-LINE NON-DOWNLOADABLE ASSESSMENT SYSTEM BASED SOFTWARE FOR USE ON MOBILE

PHONES, PERSONAL DIGITAL ASSISTANTS, HANDHELD COMPUTERS, LAPTOP COMPUTERS, AND DESKTOP COMPUTERS FOR EVALUATING AND ANALYZING THE PERFORMANCE OF ENTITIES OF AN EDUCATIONAL INSTITUTION SUCH AS SUCH AS STUDENTS BASED ON STUDENT SPECIFIC PRODUCTIVITY METRICS, FACULTY MEMBERS BASED ON FACULTY MEMBER SPECIFIC PRODUCTIVITY METRICS, LABORATORIES BASED ON LABORATORY SPECIFIC PRODUCTIVITY METRICS, AND LIBRARIES BASED ON LIBRARY SPECIFIC PRODUCTIVITY METRICS, OR EMPLOYEES BASED ON EMPLOYEE SPECIFIC PRODUCTIVITY METRICS OF A MANUFACTURING ORGANIZATION OR AN ENTERPRISE IN ORDER TO PROVIDE FOR ACHIEVING IMPROVEMENTS OVER A PERIOD OF TIME BY EDUCATIONAL INSTITUTIONS, MANUFACTURING ORGANIZATIONS, AND ENTERPRISES BASED ON THEIR RESPECTIVE DATA (U.S. CLS. 100 AND 101).  
AMEEN IMAM, EXAMINING ATTORNEY

SN 85-851,071. SRM INSTITUTE OF SCIENCE AND TECHNOLOGY, WEST MAMBALAM. CHENNAI, INDIA, FILED 2-15-2013.



THE COLOR(S) BLACK, WHITE, PURPLE, GREY, TAN IS/ ARE CLAIMED AS A FEATURE OF THE MARK.

THE MARK CONSISTS OF BLACK LETTERS "AITHA" ON A WHITE BACKGROUND WITH THE LETTERS FRAMED BY TWO PURPLE ARCS AND A GRAPHIC REPRESENTATION OF A GREY, TAN AND WHITE BUILDING IN THE BACKGROUND.

#### **CLASS 9—ELECTRICAL AND SCIENTIFIC APPARATUS**

FOR COMPUTER SOFTWARE FOR ASSESSMENT SYSTEM TO BE USED IN SYSTEMS SUCH AS EDUCATIONAL INFORMATION SYSTEMS FOR USE IN EVALUATING AND ANALYZING THE PERFORMANCE OF ENTITIES OF AN EDUCATIONAL INSTITUTION SUCH AS STUDENTS BASED ON STUDENT SPECIFIC PRODUCTIVITY METRICS, FACULTY MEMBERS BASED ON FACULTY MEMBER SPECIFIC PRODUCTIVITY METRICS, LABORATORIES BASED ON LABORATORY SPECIFIC PRODUCTIVITY METRICS, AND LIBRARIES BASED ON LIBRARY SPECIFIC PRODUCTIVITY METRICS, IN ORDER TO PROVIDE FOR ACHIEVING IMPROVEMENTS OVER A PERIOD OF TIME BY EDUCATIONAL INSTITUTIONS, AND TO BE USED IN MANUFACTURING INFORMATION SYSTEMS AND ENTERPRISE INFORMATION SYSTEMS FOR EVALUATING AND ANALYZING THE PERFORMANCE OF EMPLOYEES BASED ON EMPLOYEE SPECIFIC PRODUCTIVITY METRICS OF A MANUFACTURING ORGANIZATION OR AN ENTERPRISE IN ORDER TO PROVIDE FOR ACHIEVING IMPROVEMENTS OVER A PERIOD OF TIME BY MANUFACTURING ORGANIZATIONS AND ENTERPRISES; ASSESSMENT SYSTEM BASED SOFTWARE RECORDED ON CD-ROMS AND DVDS FOR USE IN EVALUATING AND ANALYZING PERFORMANCE OF ENTITIES OF AN EDUCATIONAL INSTITUTION SUCH AS STUDENTS BASED ON STUDENT SPECIFIC PRODUCTIVITY METRICS, FACULTY MEMBERS BASED ON FACULTY MEMBER SPECIFIC PRODUCTIVITY METRICS, LABORATORIES BASED ON LABORATORY SPECIFIC PRODUCTIVITY METRICS, AND LIBRARIES BASED ON LIBRARY SPECIFIC PRODUCTIVITY METRICS, OR EMPLOYEES BASED ON EMPLOYEE SPECIFIC PRODUCTIVITY METRICS OF A MANUFACTURING ORGANIZATION

OR AN ENTERPRISE IN ORDER TO PROVIDE FOR ACHIEVING IMPROVEMENTS OVER A PERIOD OF TIME BY EDUCATIONAL INSTITUTIONS, MANUFACTURING ORGANIZATIONS, AND ENTERPRISES; COMPUTER NETWORKS BASED HOSTING OF ASSESSMENT SYSTEM BASED SOFTWARE FOR EVALUATING AND ANALYZING THE PERFORMANCE OF ENTITIES OF AN EDUCATIONAL INSTITUTION SUCH AS SUCH AS STUDENTS BASED ON STUDENT SPECIFIC PRODUCTIVITY METRICS, FACULTY MEMBERS BASED ON FACULTY MEMBER SPECIFIC PRODUCTIVITY METRICS, LABORATORIES BASED ON LABORATORY SPECIFIC PRODUCTIVITY METRICS, AND LIBRARIES BASED ON LIBRARY SPECIFIC PRODUCTIVITY METRICS, OR EMPLOYEES BASED ON EMPLOYEE SPECIFIC PRODUCTIVITY METRICS OF A MANUFACTURING ORGANIZATION OR AN ENTERPRISE IN ORDER TO PROVIDE FOR ACHIEVING IMPROVEMENTS OVER A PERIOD OF TIME BY EDUCATIONAL INSTITUTIONS, MANUFACTURING ORGANIZATIONS, AND ENTERPRISES; ASSESSMENT SYSTEM BASED SOFTWARE ON MOBILE PHONES, PERSONAL DIGITAL ASSISTANTS, HANDHELD COMPUTERS, LAPTOP COMPUTERS, DESKTOP COMPUTERS, AND SERVER COMPUTERS FOR EVALUATING AND ANALYZING THE PERFORMANCE OF ENTITIES OF AN EDUCATIONAL INSTITUTION SUCH AS SUCH AS STUDENTS BASED ON STUDENT SPECIFIC PRODUCTIVITY METRICS, FACULTY MEMBERS BASED ON FACULTY MEMBER SPECIFIC PRODUCTIVITY METRICS, LABORATORIES BASED ON LABORATORY SPECIFIC PRODUCTIVITY METRICS, AND LIBRARIES BASED ON LIBRARY SPECIFIC PRODUCTIVITY METRICS, OR EMPLOYEES BASED ON EMPLOYEE SPECIFIC PRODUCTIVITY METRICS OF A MANUFACTURING ORGANIZATION OR AN ENTERPRISE IN ORDER TO PROVIDE FOR ACHIEVING IMPROVEMENTS OVER A PERIOD OF TIME BY EDUCATIONAL INSTITUTIONS, MANUFACTURING ORGANIZATIONS, AND ENTERPRISES; ASSESSMENT SYSTEM BASED SOFTWARE ON SERVER COMPUTERS PROVIDING THE ABILITY TO DOWNLOAD ASSESSMENT BASED SOFTWARE FOR EVALUATING AND ANALYZING THE PERFORMANCE OF ENTITIES OF AN EDUCATIONAL INSTITUTION SUCH AS SUCH AS STUDENTS BASED ON STUDENT SPECIFIC PRODUCTIVITY METRICS, FACULTY MEMBERS BASED ON FACULTY MEMBER SPECIFIC PRODUCTIVITY METRICS, LABORATORIES BASED ON LABORATORY SPECIFIC PRODUCTIVITY METRICS, AND LIBRARIES BASED ON LIBRARY SPECIFIC PRODUCTIVITY METRICS, OR EMPLOYEES BASED ON EMPLOYEE SPECIFIC PRODUCTIVITY METRICS OF A MANUFACTURING ORGANIZATION OR AN ENTERPRISE IN ORDER TO PROVIDE FOR ACHIEVING IMPROVEMENTS OF A PERIOD OF TIME BY EDUCATIONAL INSTITUTIONS, MANUFACTURING ORGANIZATIONS, AND ENTERPRISES (U.S. CLS. 21, 23, 26, 36 AND 38).

#### **CLASS 42—SCIENTIFIC AND COMPUTER SERVICES**

FOR PROVIDING ON-LINE NON-DOWNLOADABLE SOFTWARE FOR ASSESSMENT SYSTEM TO BE USED IN SYSTEMS SUCH AS EDUCATIONAL INFORMATION SYSTEMS, MANUFACTURING INFORMATION SYSTEMS, AND ENTERPRISE INFORMATION SYSTEMS FOR EVALUATING AND ANALYZING THE PERFORMANCE OF ENTITIES OF AN EDUCATIONAL INSTITUTION SUCH AS STUDENTS BASED ON STUDENT SPECIFIC PRODUCTIVITY METRICS, FACULTY MEMBERS BASED ON FACULTY MEMBER SPECIFIC PRODUCTIVITY METRICS, LABORATORIES BASED ON LABORATORY SPECIFIC PRODUCTIVITY METRICS, AND LIBRARIES BASED ON LIBRARY SPECIFIC PRODUCTIVITY METRICS, OR EMPLOYEES BASED ON EMPLOYEE SPECIFIC PRODUCTIVITY METRICS OF A MANUFACTURING ORGANIZATION OR AN ENTERPRISE IN ORDER TO PROVIDE FOR ACHIEVING IMPROVEMENTS OVER A PERIOD OF TIME BY EDUCATIONAL INSTITUTIONS, MANUFACTURING ORGANIZATIONS, AND ENTERPRISES; COMPUTER NETWORKS BASED HOSTING OF ASSESSMENT SYSTEM BASED SOFTWARE IN THE NATURE OF SOFTWARE AS A SERVICE (SAAS) FEATURING SOFTWARE FOR USE IN EVALUATING AND ANALYZING THE PERFORMANCE OF ENTITIES OF AN EDUCATIONAL

INSTITUTION SUCH AS STUDENTS BASED ON STUDENT SPECIFIC PRODUCTIVITY METRICS, FACULTY MEMBERS BASED ON FACULTY MEMBER SPECIFIC PRODUCTIVITY METRICS, LABORATORIES BASED ON LABORATORY SPECIFIC PRODUCTIVITY METRICS, AND LIBRARIES BASED ON LIBRARY SPECIFIC PRODUCTIVITY METRICS, OR EMPLOYEES BASED ON EMPLOYEE SPECIFIC PRODUCTIVITY METRICS OF A MANUFACTURING ORGANIZATION OR AN ENTERPRISE IN ORDER TO PROVIDE FOR ACHIEVING IMPROVEMENTS OVER A PERIOD OF TIME BY EDUCATIONAL INSTITUTIONS, MANUFACTURING ORGANIZATIONS, AND ENTERPRISES BASED ON THEIR RESPECTIVE DATA; PROVIDING ON-LINE NON-DOWNLOADABLE ASSESSMENT SYSTEM BASED SOFTWARE FOR USE ON MOBILE PHONES, PERSONAL DIGITAL ASSISTANTS, HANDHELD COMPUTERS, LAPTOP COMPUTERS, AND DESKTOP COMPUTERS FOR EVALUATING AND ANALYZING THE PERFORMANCE OF ENTITIES OF AN EDUCATIONAL INSTITUTION SUCH AS SUCH AS STUDENTS BASED ON STUDENT SPECIFIC PRODUCTIVITY METRICS, FACULTY MEMBERS BASED ON FACULTY MEMBER SPECIFIC PRODUCTIVITY METRICS, LABORATORIES BASED ON LABORATORY SPECIFIC PRODUCTIVITY METRICS, AND LIBRARIES BASED ON LIBRARY SPECIFIC PRODUCTIVITY METRICS, OR EMPLOYEES BASED ON EMPLOYEE SPECIFIC PRODUCTIVITY METRICS OF A MANUFACTURING ORGANIZATION OR AN ENTERPRISE IN ORDER TO PROVIDE FOR ACHIEVING IMPROVEMENTS OF A PERIOD OF TIME BY EDUCATIONAL INSTITUTIONS, MANUFACTURING ORGANIZATIONS, AND ENTERPRISES BASED ON THEIR RESPECTIVE DATA (U.S. CLS. 100 AND 101).

AMEEN IMAM, EXAMINING ATTORNEY

SN 85-851,489. TOYO KOHAN CO., LTD., TOKYO, JAPAN, FILED 2-15-2013.

## **TK WORKS**

THE MARK CONSISTS OF STANDARD CHARACTERS WITHOUT CLAIM TO ANY PARTICULAR FONT, STYLE, SIZE, OR COLOR.

PRIORITY CLAIMED UNDER SEC. 44(D) ON JAPAN APPLICATION NO. 2012-66279, FILED 8-16-2012, REG. NO. 5584045, DATED 5-24-2013, EXPIRES 5-24-2023.

NO CLAIM IS MADE TO THE EXCLUSIVE RIGHT TO USE "WORKS", APART FROM THE MARK AS SHOWN.

#### **CLASS 5—PHARMACEUTICALS**

FOR MEDICAL REAGENTS AND DIAGNOSTIC PHARMACEUTICAL PREPARATIONS; REAGENTS USED AS DIAGNOSTIC PHARMACEUTICALS USING DNA CHIPS AND PROTEIN CHIPS, OTHER PHARMACEUTICALS, NAMELY, MEDICAL DIAGNOSTIC REAGENTS (U.S. CLS. 6, 18, 44, 46, 51 AND 52).

#### **CLASS 6—METAL GOODS**

FOR IRON AND STEEL; NON-FERROUS METALS AND ALLOYS THEREOF; METAL INGREDIENTS MADE ESPECIALLY FOR ARCHITECTURE AND CONSTRUCTION FOR FURTHER MANUFACTURE; ASSEMBLY SETS FOR METAL BUILDINGS COMPRISING ROOF, WALL, CEILING, DUCT, DOOR, AND PREFABRICATED BATH; METAL JOINERY FITTINGS FOR USE IN DOORS, WINDOWS, STATIONERIES, HOME ELECTRONIC APPLIANCES, ELECTRONIC AUDIO-VISUAL APPLIANCES, PERSONAL COMPUTERS, OFFICE AUTOMATION DEVICES, BOLTS AND PIPES; PACKAGING CONTAINERS MADE OF METAL; JOINERY FITTINGS MADE OF METAL (U.S. CLS. 2, 12, 13, 14, 23, 25 AND 50).

**CLASS 7—MACHINERY**

FOR MACHINES AND APPLIANCES FOR METAL PROCESSING; MACHINES AND APPLIANCES FOR LOADING; WRAPPING MACHINES AND APPLIANCES; MACHINES AND APPLIANCES FOR PLASTIC PROCESSING; POWER-OPERATED MACHINES AND APPLIANCES, EXCLUDING FOR LAND VEHICLES, AND PARTS THEREOF, NAMELY, ENGINES, ENGINE PARTS, CYLINDER, BOILERS, AGITATOR WINGS, INTERIOR WALL PARTS, STRAPPING MACHINES, AIR BEARINGS, HEAVY LOAD CARRIERS, VALVE ACTUATORS, BEARING SEALS, CUTTERS, GEARS, HOUSING; WIND AND AQUA POWERED MACHINES AND APPLIANCES, EXCLUDING FOR LAND VEHICLES, NAMELY, PLUNGERS, SLEEVES, IMPELLERS, MECHANICAL SEALS; LOADING MACHINES, NAMELY, TURNTABLES AND TRAVERSERS; POWER DRILL BITS OF METAL (U.S. CLS. 13, 19, 21, 23, 31, 34 AND 35).

DAVID HOFFMAN, EXAMINING ATTORNEY

SN 85-851,584. TOYO KOHAN CO., LTD., TOKYO, JAPAN, FILED 2-15-2013.



**TK WORKS**

PRIORITY CLAIMED UNDER SEC. 44(D) ON JAPAN APPLICATION NO. 2013-003117, FILED 1-22-2013, REG. NO. 5624760, DATED 10-25-2013, EXPIRES 10-25-2023.

NO CLAIM IS MADE TO THE EXCLUSIVE RIGHT TO USE "WORKS", APART FROM THE MARK AS SHOWN.

THE MARK CONSISTS OF THE WORDING "TK WORKS" IN A STYLIZED FONT AND A TRIANGLE WITH ONE CURVED SIDE ON ITS UPPER RIGHT SHOULDER.

**CLASS 5—PHARMACEUTICALS**

FOR MEDICAL REAGENTS AND DIAGNOSTIC PHARMACEUTICAL PREPARATIONS; REAGENTS USED AS DIAGNOSTIC PHARMACEUTICALS USING DNA CHIPS AND PROTEIN CHIPS, OTHER PHARMACEUTICALS, NAMELY, MEDICAL DIAGNOSTIC REAGENTS (U.S. CLS. 6, 18, 44, 46, 51 AND 52).

**CLASS 6—METAL GOODS**

FOR IRON AND STEEL; NON-FERROUS METALS AND ALLOYS THEREOF; METAL INGREDIENTS MADE ESPECIALLY FOR ARCHITECTURE AND CONSTRUCTION FOR FURTHER MANUFACTURE; ASSEMBLY SETS FOR METAL BUILDINGS COMPRISING ROOF, WALL, CEILING, DUCT, DOOR, AND PREFABRICATED BATH; METAL JOINERY FITTINGS FOR USE IN DOORS, WINDOWS, STATIONERIES, HOME ELECTRONIC APPLIANCES, ELECTRONIC AUDIO-VISUAL APPLIANCES, PERSONAL COMPUTERS, OFFICE AUTOMATION DEVICES, BOLTS AND PIPES; PACKAGING CONTAINERS MADE OF METAL; JOINERY FITTINGS MADE OF METAL (U.S. CLS. 2, 12, 13, 14, 23, 25 AND 50).

**CLASS 7—MACHINERY**

FOR MACHINES AND APPLIANCES FOR METAL PROCESSING; MACHINES AND APPLIANCES FOR LOADING; WRAPPING MACHINES AND APPLIANCES; MACHINES AND APPLIANCES FOR PLASTIC PROCESSING; POWER-OPERATED MACHINES AND APPLIANCES, EXCLUDING FOR LAND VEHICLES, AND PARTS THEREOF, NAMELY, ENGINES, ENGINE PARTS, CYLINDER, BOILERS, AGITATOR WINGS, INTERIOR WALL PARTS, STRAPPING MACHINES, AIR BEARINGS, HEAVY LOAD CARRIERS, VALVE ACTUATORS, BEARING SEALS, CUTTERS, GEARS, HOUSING; WIND AND AQUA POWERED MACHINES AND APPLIANCES, EXCLUDING FOR LAND VEHICLES, NAMELY, PLUNGERS, SLEEVES, IMPELLERS, MECHANICAL SEALS; LOADING MACHINES, NAMELY, TURNTABLES AND TRAVERSERS; POWER DRILL BITS OF METAL (U.S. CLS. 13, 19, 21, 23, 31, 34 AND 35).

DAVID HOFFMAN, EXAMINING ATTORNEY

SN 85-854,779. DALER ROWNEY LIMITED, BRACKNELL, BERKSHIRE, ENGLAND, FILED 2-20-2013.



*Estd.*  
**1783**  
*England*

THE MARK CONSISTS OF THE NUMBERS "1783" IN A LARGE FONT WITH THE ABBREVIATION "ESTD." ABOVE THE NUMBER "7" IN A SMALLER FONT, WITH THE LITERAL ELEMENT "ENGLAND" LOCATED AT THE BOTTOM CENTERED IN BETWEEN THE NUMBERS "7" AND "3".

SEC. 2(F).

**CLASS 2—PAINTS**

FOR PAINTS AND VARNISHES FOR PAINTERS, DECORATORS, PRINTERS AND ARTISTS (U.S. CLS. 6, 11 AND 16).

FIRST USE 0-0-1963; IN COMMERCE 0-0-1963.

**CLASS 16—PAPER GOODS AND PRINTED MATTER**

FOR PAPER AND GOODS MADE FROM PAPER AND CARDBOARD, NAMELY, PAPER PADS FOR PAINTING (U.S. CLS. 2, 5, 22, 23, 29, 37, 38 AND 50).

FIRST USE 0-0-1963; IN COMMERCE 0-0-1963.

ZACHARY R. SPARER, EXAMINING ATTORNEY

SN 85-855,925. LORD HERITAGE INC., HAMBURG, NY, FILED 2-21-2013.

**NEW COVENANT EDUCATION**

THE MARK CONSISTS OF STANDARD CHARACTERS WITHOUT CLAIM TO ANY PARTICULAR FONT, STYLE, SIZE, OR COLOR.

NO CLAIM IS MADE TO THE EXCLUSIVE RIGHT TO USE "EDUCATION", APART FROM THE MARK AS SHOWN.



**CLASS 9—ELECTRICAL AND SCIENTIFIC APPARATUS**

FOR COMPUTER SOFTWARE FEATURING TOOLS TO AID IN PLANNING AND ORGANIZING A SELF-DIRECTED LEARNING PROGRAM AND PERSONAL DEVELOPMENT PROGRAM; COMPUTER SOFTWARE FEATURING CURRICULA IN THE FIELD OF CHRISTIAN ELEMENTARY AND SECONDARY EDUCATION INCLUDING THE SUBJECTS OF READING, WRITING, LANGUAGE ARTS, MATH, FINANCE, HISTORY, GEOGRAPHY, SCIENCE, PRACTICAL ARTS, PHYSICAL EDUCATION, MUSIC, ART, AND CHRISTIAN THEOLOGY; ELECTRONIC PUBLICATIONS, NAMELY, BOOKS FEATURING EDUCATION AND PERSONAL DEVELOPMENT RECORDED ON COMPUTER MEDIA (U.S. CLS. 21, 23, 26, 36 AND 38).

**CLASS 16—PAPER GOODS AND PRINTED MATTER**

FOR BOOKS IN THE FIELD OF EDUCATION AND PERSONAL DEVELOPMENT; CURRICULA IN THE FIELD OF CHRISTIAN ELEMENTARY AND SECONDARY EDUCATION INCLUDING THE SUBJECTS OF READING, WRITING, LANGUAGE ARTS, MATH, FINANCE, HISTORY, GEOGRAPHY, SCIENCE, PRACTICAL ARTS, PHYSICAL EDUCATION, MUSIC, ART, AND CHRISTIAN THEOLOGY (U.S. CLS. 2, 5, 22, 23, 29, 37, 38 AND 50).

TINA L. SNAPP, EXAMINING ATTORNEY

**CLASS 35—ADVERTISING AND BUSINESS**

FOR PROVIDING CREDIBLE BUSINESS STATISTICAL INFORMATION RELATED TO THE AUTOMOBILE MANUFACTURING INDUSTRY VIA A WEBSITE ON A GLOBAL COMPUTER NETWORK; PROVIDING A WEBSITE ON A GLOBAL COMPUTER NETWORK FEATURING BUSINESS STATISTICAL INFORMATION FOR BUSINESSES AND THE GENERAL PUBLIC RELATED TO THE AUTOMOBILE MANUFACTURING INDUSTRY; PROVIDING CREDIBLE INFORMATION ON THE ECONOMIC IMPACT AND CONTRIBUTION OF THE AUTOMOBILE MANUFACTURING INDUSTRY TO THE NATIONAL ECONOMY, SUCH AS INFORMATION REGARDING JOB CREATION, EMPLOYMENT, AND TAX REVENUE GENERATED, VIA A WEBSITE ON A GLOBAL COMPUTER NETWORK; PROVIDING A WEBSITE ON A GLOBAL COMPUTER NETWORK FEATURING INFORMATION ON THE ECONOMIC IMPACT AND CONTRIBUTION OF THE AUTOMOBILE MANUFACTURING INDUSTRY TO THE NATIONAL ECONOMY, SUCH AS INFORMATION REGARDING JOB CREATION, EMPLOYMENT, AND TAX REVENUE GENERATED, FOR BUSINESSES AND THE GENERAL PUBLIC; ASSOCIATION SERVICES, NAMELY, PROMOTING THE INTERESTS OF AUTOMOBILE MANUFACTURERS BY PROVIDING MEMBER COMPANIES WITH A FORUM TO WORK TOGETHER ON PUBLIC POLICY MATTERS OF COMMON INTEREST, TO DEVELOP CONSTRUCTIVE APPROACHES, AND TO WORK WITH GOVERNMENT AND OTHER STAKEHOLDERS TO FIND SENSIBLE AND EFFECTIVE SOLUTIONS TO INDUSTRY, ENVIRONMENTAL, AND REGULATORY PROBLEMS (U.S. CLS. 100, 101 AND 102).

FIRST USE 2-13-2013; IN COMMERCE 2-13-2013.

**CLASS 42—SCIENTIFIC AND COMPUTER SERVICES**

FOR PROVIDING CREDIBLE INFORMATION ON AUTOMOBILE DESIGN INNOVATIONS, AUTOMOBILE DESIGN IMPROVEMENTS THAT RESULT IN GREATER FUEL ECONOMY, AND AUTOMOBILE SAFETY TESTING, ALL RELATED TO THE AUTOMOBILE MANUFACTURING INDUSTRY, VIA A WEBSITE ON A GLOBAL COMPUTER NETWORK; PROVIDING A WEBSITE ON A GLOBAL COMPUTER NETWORK FEATURING INFORMATION ON AUTOMOBILE DESIGN INNOVATIONS, AUTOMOBILE DESIGN IMPROVEMENTS THAT RESULT IN GREATER FUEL ECONOMY, AND AUTOMOBILE SAFETY TESTING, ALL RELATED TO THE AUTOMOBILE MANUFACTURING INDUSTRY FOR BUSINESSES AND THE GENERAL PUBLIC (U.S. CLS. 100 AND 101).

FIRST USE 2-25-2013; IN COMMERCE 2-25-2013.

**CLASS 45—PERSONAL AND LEGAL SERVICES**

FOR PROVIDING CREDIBLE INFORMATION ON COMPLIANCE WITH ENVIRONMENTAL LAWS AND REGULATIONS RELATED TO THE AUTOMOBILE MANUFACTURING INDUSTRY VIA A WEBSITE ON A GLOBAL COMPUTER NETWORK; PROVIDING A WEBSITE ON A GLOBAL COMPUTER NETWORK FEATURING INFORMATION ON COMPLIANCE WITH ENVIRONMENTAL LAWS AND REGULATIONS RELATED TO THE AUTOMOBILE MANUFACTURING INDUSTRY FOR BUSINESSES AND THE GENERAL PUBLIC (U.S. CLS. 100 AND 101).

FIRST USE 2-25-2013; IN COMMERCE 2-25-2013.

KIMBERLY FRYE, EXAMINING ATTORNEY

SN 85-857,123. ALLIANCE OF AUTOMOBILE MANUFACTURERS, WASHINGTON, DC. FILED 2-22-2013.



THE MARK CONSISTS OF A DESIGN DEPICTING AN AUTOMOBILE DRIVING ON A ROAD, BOTH ENTIRELY ENCLOSED BY AN OVAL SHAPED SOLID LINE WHICH APPEARS NARROW AT THE TOP AND GETS PROGRESSIVELY WIDER ON THE SIDES AND BOTTOM.



SN 85-857,484. PIQUANTE BRANDS INTERNATIONAL (PTY) LTD, BRYANSTON, SOUTH AFRICA, FILED 2-22-2013.



OWNER OF U.S. REG. NOS. 2,729,883 AND 3,665,110.  
THE COLOR(S) RED, YELLOW/GOLD, WHITE, AND BLACK IS/ARE CLAIMED AS A FEATURE OF THE MARK.  
THE MARK CONSISTS OF A BLACK RECTANGLE TOWARD THE TOP RIGHT CORNER OF THE RECTANGLE IS THE TERM "PEPPADEW" IN WHITE. UNDERNEATH THE LETTERS "ADEW," IN THE RECTANGLE AND EXTENDING SLIGHTLY BELOW IT IS A YELLOW/GOLD SQUARE CONTAINING A RED PEPPER.

#### CLASS 29—MEATS AND PROCESSED FOODS

FOR PRESERVED, DRIED AND COOKED FRUITS AND VEGETABLES; JELLIES; SOUP; SPREADS, NAMELY, FRUIT-BASED SPREADS, CHEESE SPREADS, VEGETABLE-BASED SPREADS (U.S. CL. 46).  
FIRST USE 6-0-2007; IN COMMERCE 6-0-2007.

#### CLASS 30—STAPLE FOODS

FOR SAUCES, RELISHES AND CHUTNEYS (U.S. CL. 46).  
FIRST USE 6-0-2007; IN COMMERCE 6-0-2007.  
MICHAEL WIENER, EXAMINING ATTORNEY

SN 85-858,678. F.X. IMPORT COMPANY LIMITED, WATFORD, UNITED KINGDOM, FILED 2-25-2013.

**WHISTLE AND CROWE**

PRIORITY CLAIMED UNDER SEC. 44(D) ON ERPN CMNTY TM OFC APPLICATION NO. 011139904, FILED 8-24-2012, REG. NO. 011139904, DATED 3-8-2013, EXPIRES 8-24-2022.

THE MARK CONSISTS OF THE STYLIZED WORDING "WHISTLE AND CROWE" WITH A STYLIZED UNDERLINE UNDER THE WORD "AND".

#### CLASS 18—LEATHER GOODS

FOR TRAVEL BAGS; HANDBAGS; RUCKSACKS; SHAVING BAGS; BAGS MADE OF IMITATION LEATHER; BAGS MADE OF LEATHER; BEACH BAGS; CLUTCH BAGS; DIAPER BAGS; DUFFEL BAGS; EVENING BAGS; POUCHES FOR HOLDING MAKE-UP KEYS AND OTHER PERSONAL ITEMS; SHOE BAGS FOR TRAVEL; SHOULDER BAGS; SLING BAGS; SUIT CARRIERS; TOILET BAGS IN THE NATURE OF WASH BAGS FOR CARRYING TOILETRIES; TOILETRY BAGS SOLD EMPTY; TOTE BAGS; UMBRELLA BAGS; WEEK-END BAGS, NAMELY, OVERNIGHT BAGS; PURSES; CHANGE PURSES; CLUTCH PURSES; COIN PURSES; COSMETIC PURSES; EVENING PURSES; LEATHER PURSES; PURSES NOT OF PRECIOUS METAL; KEY WALLETS; LEATHER WALLETS; POCKET WALLETS; WALLETS FOR ATTACHMENT TO BELTS; UMBRELLAS, PARASOLS; PARTS AND FITTINGS FOR ALL THE AFORESAID GOODS, NAMELY, STRAPS FOR LUGGAGE, REPLACEMENT WHEELS AND HANDLES (U.S. CLS. 1, 2, 3, 22 AND 41).

#### CLASS 25—CLOTHING

FOR CLOTHING, NAMELY, T-SHIRTS, GRANDDAD SHIRTS, KNITWEAR, NAMELY, JUMPERS, CARDIGANS AND SLEEVELESS JUMPERS, POLOS, ALL JERSEY GARMENTS, NAMELY, JERSEYS AND PANTS MADE OF JERSEY MATERIAL, ALL SWEATSHIRT GARMENTS, NAMELY, SWEATSHIRTS INCLUDING CREW AND HOODED SWEATSHIRTS, SHORTS, CHINOS, JEANS, COMBAT PANTS, JACKETS, SHIRTS, SOCKS, UNDERWEAR, SUITS AND COATS, FOOTWEAR AND HEADGEAR, NAMELY, CAPS AND HATS; MENSWEAR, NAMELY, T-SHIRTS, GRANDDAD SHIRTS, KNITWEAR, NAMELY, JUMPERS, CARDIGANS AND SLEEVELESS JUMPERS, POLOS, ALL JERSEY GARMENTS, NAMELY, JERSEYS AND PANTS MADE OF JERSEY MATERIAL, ALL SWEATSHIRT GARMENTS, NAMELY, SWEATSHIRTS INCLUDING CREW AND HOODED SWEATSHIRTS, SHORTS, CHINOS, JEANS, COMBAT PANTS, JACKETS, SHIRTS, SOCKS, UNDERWEAR, SUITS AND COATS, FOOTWEAR AND HEADGEAR, NAMELY, CAPS AND HATS; WOMENS WEAR, NAMELY, NAMELY, T-SHIRTS, GRANDDAD SHIRTS, KNITWEAR, NAMELY, JUMPERS, CARDIGANS AND SLEEVELESS JUMPERS, POLOS, ALL JERSEY GARMENTS, NAMELY, JERSEYS AND PANTS MADE OF JERSEY MATERIAL, ALL SWEATSHIRT GARMENTS, NAMELY, SWEATSHIRTS INCLUDING CREW AND HOODED SWEATSHIRTS, SHORTS, CHINOS, JEANS, COMBAT PANTS, JACKETS, SHIRTS, SOCKS, UNDERWEAR, SUITS AND COATS, FOOTWEAR AND HEADGEAR, NAMELY, CAPS AND HATS; CLOTHING FOR CHILDREN, NAMELY, T-SHIRTS, GRANDDAD SHIRTS, KNITWEAR, NAMELY, JUMPERS, CARDIGANS AND SLEEVELESS JUMPERS, POLOS, ALL JERSEY GARMENTS, NAMELY, JERSEYS AND PANTS MADE OF JERSEY MATERIAL, ALL SWEATSHIRT GARMENTS, NAMELY, SWEATSHIRTS INCLUDING CREW AND HOODED SWEATSHIRTS, SHORTS, CHINOS, JEANS, COMBAT PANTS, JACKETS, SHIRTS, SOCKS, UNDERWEAR, SUITS AND COATS, FOOTWEAR AND HEADGEAR, NAMELY, CAPS AND HATS FOR CHILDREN AND BABIES; SPORTSWEAR, NAMELY, TRACKSUITS, JOGGERS, NAMELY, JOGGING SUITS, SHORTS AND LEGGINGS; OUTDOOR CLOTHING, NAMELY, TRACKSUITS, JOGGERS, NAMELY, JOGGING SUITS, SHORTS AND LEGGINGS; UNDERWEAR; LINGERIE; ALL TYPES OF FOOTWEAR EXCLUDING ORTHOPAEDIC FOOTWEAR (U.S. CLS. 22 AND 39).

#### CLASS 35—ADVERTISING AND BUSINESS

FOR RETAIL STORE SERVICES FEATURING CLOTHING, FOOTWEAR AND HEADGEAR, CLOTHING ACCESSORIES, BAGS, BELTS AND ASSOCIATED LEATHER GOODS AND LEATHER APPAREL GOODS; DEPARTMENT STORE RETAIL SERVICES FEATURING CLOTHING, FOOTWEAR AND HEADGEAR, CLOTHING ACCESSORIES, BAGS, BELTS AND ASSOCIATED LEATHER APPAREL GOODS; RETAIL STORE SERVICES IN THE FIELD OF CLOTHING, FOOTWEAR AND HEADGEAR, CLOTHING ACCESSORIES, BAGS, BELTS AND ASSOCIATED LEATHER APPAREL GOODS (U.S. CLS. 100, 101 AND 102).  
MEGHAN REINHART, EXAMINING ATTORNEY

SN 85-863,134. BUSHTRACKS AFRICAN EXPEDITIONS, INC., HEALDSBURG, CA. FILED 2-28-2013.

## BUILD YOUR TRIP

THE MARK CONSISTS OF STANDARD CHARACTERS WITHOUT CLAIM TO ANY PARTICULAR FONT, STYLE, SIZE, OR COLOR.

NO CLAIM IS MADE TO THE EXCLUSIVE RIGHT TO USE "TRIP", APART FROM THE MARK AS SHOWN.

**CLASS 39—TRANSPORTATION AND STORAGE**

FOR ARRANGING AND CONDUCTING TRAVEL TOURS; PROVIDING AN ONLINE SEARCHABLE COMPUTER DATABASE FEATURING INFORMATION ON TRAVEL; PROVIDING INFORMATION CONCERNING TRAVEL AND TRAVEL-RELATED TOPICS, NAMELY, TRAVEL TOURS AND TRANSPORT AND LODGING FOR SAFARIS (U.S. CLS. 100 AND 105).  
FIRST USE 5-1-2013; IN COMMERCE 5-1-2013.

**CLASS 41—EDUCATION AND ENTERTAINMENT**

FOR PROVIDING INFORMATION CONCERNING TRAVEL AND TRAVEL-RELATED TOPICS, NAMELY, RECREATIONAL SAFARIS (U.S. CLS. 100, 101 AND 107).  
FIRST USE 5-1-2013; IN COMMERCE 5-1-2013.  
APRIL ROACH, EXAMINING ATTORNEY

SN 85-864,053. WESTPORT POWER INC., VANCOUVER, CANADA, FILED 3-1-2013.

# READY-LINK

THE MARK CONSISTS OF STANDARD CHARACTERS WITHOUT CLAIM TO ANY PARTICULAR FONT, STYLE, SIZE, OR COLOR.

**CLASS 7—MACHINERY**

FOR MACHINE ENGINE FUEL MODULES CONTAINING THE FOLLOWING, ALL SOLD AS A UNIT: A FUEL TANK, A FILL PANEL IN THE NATURE OF A PANEL THAT INTEGRATES COMPONENTS IN THE NATURE OF FUEL RECEPTACLES, PRESSURE GAUGES AND PRESSURE RELIEF VALVES, FILL VALVES, FUEL FILLER PIPES BEING THE PIPE THROUGH WHICH FUEL FLOWS TO THE COMPONENTS OF THE MODULE, COUPLINGS FOR USE WITH FUEL LINES, CONTROL ELEMENTS IN THE NATURE OF A FUEL FLOW RATE CONTROL, AND ASSOCIATED INSTRUMENTATION, NAMELY, PRESSURE SENSORS AND TEMPERATURE SENSORS, AND REPLACEMENT PARTS THEREFOR; MACHINE ENGINE FUEL MODULES CONTAINING THE FOLLOWING, ALL SOLD AS A UNIT: A FUEL TANK, A FILL PANEL IN THE NATURE OF A PANEL THAT INTEGRATES COMPONENTS IN THE NATURE OF FUEL RECEPTACLES, PRESSURE GAUGES AND PRESSURE RELIEF VALVES, AND ASSOCIATED HARDWARE, NAMELY, MOUNTING BRACKETS, AND MOUNTING FASTENERS, AND REPLACEMENT PARTS THEREFOR; MACHINE ENGINE FUEL SYSTEMS COMPRISED OF FUEL INJECTION MODULES AND REPLACEMENT PARTS THEREFOR; MACHINE ENGINE FUEL MODULES AND REPLACEMENT PARTS THEREFOR; AUTOMOTIVE ELECTRONIC FUEL INJECTION MODULES (U.S. CLS. 13, 19, 21, 23, 31, 34 AND 35).

**CLASS 12—VEHICLES**

FOR LAND VEHICLE FUEL MODULES CONTAINING THE FOLLOWING, ALL SOLD AS A UNIT: A FUEL TANK, A FILL PANEL IN THE NATURE OF A PANEL THAT INTEGRATES COMPONENTS IN THE NATURE OF FUEL RECEPTACLES, PRESSURE GAUGES AND PRESSURE RELIEF VALVES, FILL VALVES, FUEL FILLER PIPES THROUGH WHICH FUEL FLOWS TO THE COMPONENTS OF THE MODULE, COUPLINGS FOR USE WITH FUEL LINES, AND COUPLINGS FOR USE WITH THE OTHER COMPONENTS OF THE MODULES, CONTROL ELEMENTS IN THE NATURE OF A FUEL FLOW RATE CONTROL, AND ASSOCIATED INSTRUMENTATION, NAMELY, PRESSURE SENSORS AND TEMPERATURE SENSORS AND REPLACEMENT PARTS THEREFOR; LAND VEHICLE FUEL MODULES CONTAINING THE FOLLOWING, ALL SOLD AS A UNIT: A FUEL TANK, A FILL PANEL IN THE NATURE OF A PANEL THAT INTEGRATES COMPONENTS IN THE NATURE OF RECEPTACLES, PRESSURE GAUGES AND PRESSURE RELIEF VALVES AND ASSOCIATED HARDWARE, NAMELY, MOUNTING BRACKETS, AND MOUNTING FASTENERS, AND REPLACEMENT PARTS THEREFOR; AUTOMOTIVE FUEL SYSTEMS COMPRISED OF FUEL STORAGE TANKS AND FUEL LINE HOSES, AND REPLACEMENT PARTS THEREFOR (U.S. CLS. 19, 21, 23, 31, 35 AND 44).

**CLASS 35—ADVERTISING AND BUSINESS**

FOR RETAIL STORE SERVICES FEATURING FUEL SYSTEMS AND COMPONENTS THEREOF; ONLINE ORDERING SERVICES FEATURING FUEL SYSTEMS AND COMPONENTS THEREOF (U.S. CLS. 100, 101 AND 102).

**CLASS 37—CONSTRUCTION AND REPAIR**

FOR INSTALLATION, MAINTENANCE AND REPAIR OF AUTOMOTIVE FUEL SYSTEMS AND COMPONENTS THEREOF (U.S. CLS. 100, 103 AND 106).

**CLASS 40—MATERIAL TREATMENT**

FOR CUSTOM MANUFACTURE OF AUTOMOTIVE FUEL SYSTEMS AND COMPONENTS THEREOF (U.S. CLS. 100, 103 AND 106).

**CLASS 42—SCIENTIFIC AND COMPUTER SERVICES**

FOR DESIGN, ENGINEERING, AND TESTING OF NEW PRODUCTS FOR OTHERS IN THE AUTOMOTIVE INDUSTRY, NAMELY, FUEL SYSTEMS AND FUEL MODULES, AND COMPONENTS THEREOF (U.S. CLS. 100 AND 101).

SUE LAWRENCE, EXAMINING ATTORNEY

SN 85-866,525. ENVIRONMENTAL DRILLING SOLUTIONS, LLC, LAFAYETTE, LA. FILED 3-4-2013.



**ENVIRONMENTAL**  
Drilling Solutions

NO CLAIM IS MADE TO THE EXCLUSIVE RIGHT TO USE "ENVIRONMENTAL DRILLING SOLUTIONS", APART FROM THE MARK AS SHOWN.

THE MARK CONSISTS OF THE WORDS "ENVIRONMENTAL DRILLING SOLUTIONS" AND A DESIGN COMPRISING THREE PAIRS OF POINTED ELEMENTS GENERALLY FORMING A TRIANGLE.

SN 85-867,999. GENERAL ELECTRIC CAPITAL COMPANY, STAMFORD, CT. FILED 3-6-2013.

#### CLASS 7—MACHINERY

FOR EQUIPMENT IN THE NATURE OF MACHINES AND DEVICES USED IN CONNECTION WITH THE HANDLING AND PROCESSING OF EARTHEN CUTTINGS GENERATED IN OIL AND GAS WELL DRILLING, AND OF DRILLING FLUIDS USED IN OIL AND GAS WELL DRILLING (U.S. CLS. 13, 19, 21, 23, 31, 34 AND 35).

FIRST USE 7-2-2009; IN COMMERCE 7-2-2009.

#### CLASS 40—MATERIAL TREATMENT

FOR WASTE AND SOLIDS MANAGEMENT, NAMELY, MATERIAL PROCESSING OF EARTHEN CUTTINGS GENERATED IN OIL AND GAS WELL DRILLING, AND OF DRILLING FLUIDS USED IN OIL AND GAS WELL DRILLING (U.S. CLS. 100, 103 AND 106).

FIRST USE 7-2-2009; IN COMMERCE 7-2-2009.  
DAVID HOFFMAN, EXAMINING ATTORNEY

## SMARTCHART

THE MARK CONSISTS OF STANDARD CHARACTERS WITHOUT CLAIM TO ANY PARTICULAR FONT, STYLE, SIZE, OR COLOR.

#### CLASS 9—ELECTRICAL AND SCIENTIFIC APPARATUS

FOR COMPUTER APPLICATION SOFTWARE FOR DESKTOP AND MOBILE DEVICES, NAMELY, SOFTWARE FOR PROVIDING LOCATION, DEMOGRAPHIC, AND FINANCIAL INFORMATION AND METRICS TO CUSTOMERS FOR THE PURPOSES OF ANALYZING AND COMPARING THEIR BUSINESS FUNDAMENTALS (U.S. CLS. 21, 23, 26, 36 AND 38).

FIRST USE 1-0-2013; IN COMMERCE 1-0-2013.

#### CLASS 42—SCIENTIFIC AND COMPUTER SERVICES

FOR PROVIDING ON-LINE NON-DOWNLOADABLE SOFTWARE FOR PROVIDING LOCATION, DEMOGRAPHIC, AND FINANCIAL INFORMATION AND METRICS TO CUSTOMERS FOR THE PURPOSES OF ANALYZING AND COMPARING THEIR BUSINESS FUNDAMENTALS (U.S. CLS. 100 AND 101).

FIRST USE 1-0-2013; IN COMMERCE 1-0-2013.  
ODESSA BIBBINS, EXAMINING ATTORNEY

SN 85-867,342. CHILDREN WITHOUT A VOICE USA, INC., ALPHARETTA, GA. FILED 3-5-2013.

## CWAV

THE MARK CONSISTS OF STANDARD CHARACTERS WITHOUT CLAIM TO ANY PARTICULAR FONT, STYLE, SIZE, OR COLOR.

OWNER OF U.S. REG. NO. 3,780,770.

#### CLASS 35—ADVERTISING AND BUSINESS

FOR PROMOTING PUBLIC AWARENESS OF CHILD ABUSE; PUBLIC ADVOCACY TO PROMOTE PUBLIC AWARENESS OF CHILD ABUSE; PROVIDING A WEBSITE FEATURING INFORMATION IN THE FIELD OF PROMOTING PUBLIC AWARENESS OF CHILD ABUSE; PROVIDING A WEBSITE FEATURING EDUCATIONAL INFORMATION IN THE FIELD OF PROMOTING PUBLIC AWARENESS OF CHILD ABUSE (U.S. CLS. 100, 101 AND 102).

FIRST USE 7-18-2008; IN COMMERCE 7-18-2008.

#### CLASS 41—EDUCATION AND ENTERTAINMENT

FOR EDUCATIONAL SERVICES, NAMELY, PROVIDING CLASSES, SEMINARS, AND WORKSHOPS IN THE FIELD OF PROMOTING PUBLIC AWARENESS OF CHILD ABUSE; ORGANIZING AND HOSTING OF EVENTS FOR CULTURAL PURPOSES (U.S. CLS. 100, 101 AND 107).

FIRST USE 10-4-2008; IN COMMERCE 10-4-2008.  
JUHI KAVEESHVAR, EXAMINING ATTORNEY

SN 85-871,860. GREGORY S. ERICKSEN, BOUNTIFUL, UT. FILED 3-9-2013.

## OPEN CALL CAFE

THE MARK CONSISTS OF STANDARD CHARACTERS WITHOUT CLAIM TO ANY PARTICULAR FONT, STYLE, SIZE, OR COLOR.

NO CLAIM IS MADE TO THE EXCLUSIVE RIGHT TO USE "CAFE", APART FROM THE MARK AS SHOWN.

#### CLASS 35—ADVERTISING AND BUSINESS

FOR PROVIDING ON-LINE ENTERTAINMENT EMPLOYMENT INFORMATION, NAMELY, INFORMATION ABOUT AUDITION REQUESTS AND CASTING CALLS FROM THEATERS AND PRODUCTION STUDIOS FROM AROUND THE WORLD (U.S. CLS. 100, 101 AND 102).

#### CLASS 41—EDUCATION AND ENTERTAINMENT

FOR PROVIDING ON-LINE ENTERTAINMENT INFORMATION, NAMELY, INFORMATION ABOUT CURRENT MOVIE AND TELEVISION SHOWS THAT ARE CURRENTLY IN PRODUCTION INCLUDING COOKING WEB AND TELEVISION SHOWS (U.S. CLS. 100, 101 AND 107).

**CLASS 43—HOTEL AND RESTAURANT SERVICES**

FOR RESTAURANT SERVICES; PREPARATION OF FOOD AND BEVERAGES (U.S. CLS. 100 AND 101).  
DOMINIC J. FERRAIUOLO, EXAMINING ATTORNEY

**CLASS 9—ELECTRICAL AND SCIENTIFIC APPARATUS**

FOR A FULL LINE OF INDOOR AND OUTDOOR ELECTRONIC EQUIPMENT CABINETS AND ENCLOSURES SPECIALLY ADAPTED TO HOUSE AND PROTECT ELECTRONIC EQUIPMENT FOR THE TELECOMMUNICATIONS, SECURITY, RAIL, UTILITIES, AEROSPACE, AND DATA CENTER INDUSTRIES, NAMELY, TELECOMMUNICATIONS EQUIPMENT, SECURITY EQUIPMENT, RAIL EQUIPMENT, UTILITIES EQUIPMENT, AEROSPACE EQUIPMENT, AND DATA CENTER EQUIPMENT; MOUNTING COMPONENTS FOR ELECTRONIC EQUIPMENT ENCLOSURES AND CABINETS, NAMELY, MOUNTING BRACKETS AND ATTACHMENT HARDWARE; ELECTRICAL OUTLETS; ALARMS FOR DETECTING INTRUSION, POWER LOSS, AND TEMPERATURE, AND ALARM REPORTING DEVICES (U.S. CLS. 21, 23, 26, 36 AND 38).

SN 85-873,644. ROSEMANN, TOM, PACIFIC, MO. FILED 3-12-2013.

**CLASS 11—ENVIRONMENTAL CONTROL APPARATUS**

FOR ENCLOSURE AND CABINET COOLING EQUIPMENT FOR ELECTRONIC EQUIPMENT, NAMELY, HEAT EXCHANGERS, AIR CONDITIONERS, FAN VENTILATORS, AND HEAT PIPES; ELECTRIC HEATERS NAMELY, ELECTRIC HEATERS FOR COMMERCIAL AND INDUSTRIAL USE, ELECTRIC HEATERS FOR RESIDENTIAL USE, AND PORTABLE ELECTRIC HEATERS; ELECTRICAL PADS FOR PRE-HEATING BATTERIES (U.S. CLS. 13, 21, 23, 31 AND 34).

**CORRECT DIRECTION**

THE MARK CONSISTS OF STANDARD CHARACTERS WITHOUT CLAIM TO ANY PARTICULAR FONT, STYLE, SIZE, OR COLOR.

**CLASS 42—SCIENTIFIC AND COMPUTER SERVICES**

FOR DESIGN, CUSTOM DESIGN, DEVELOPMENT AND TESTING SERVICES FOR ELECTRONIC EQUIPMENT, NAMELY, ENCLOSURES AND CABINETS EXPRESSLY DESIGNED TO HOUSE ELECTRONIC EQUIPMENT FOR THE TELECOMMUNICATIONS, SECURITY, RAIL, UTILITIES, AEROSPACE, AND DATA CENTER INDUSTRIES, AND ENCLOSURE AND CABINET COOLING EQUIPMENT, NAMELY, HEAT EXCHANGERS, AIR CONDITIONERS, FAN VENTILATORS, AND HEAT PIPES; DESIGN, CUSTOM DESIGN, DEVELOPMENT AND TESTING SERVICES FOR ELECTRIC HEATERS, AND MOUNTING COMPONENTS FOR ELECTRONIC EQUIPMENT ENCLOSURES AND CABINETS, NAMELY, MOUNTING BRACKETS AND ATTACHMENT HARDWARE; ELECTRICAL OUTLETS, ALARMS FOR DETECTING INTRUSION, POWER LOSS, AND TEMPERATURE, AND ALARM REPORTING DEVICES (U.S. CLS. 100 AND 101).  
ELIZABETH CHANG, EXAMINING ATTORNEY

**CLASS 35—ADVERTISING AND BUSINESS**

FOR AUTOMOBILE CAR TRADE SHOWS FEATURING VINTAGE CARS AND AUTOMOBILES, ARRANGING AND CONDUCTING AUTOMOBILE CAR SWAP MEETS, AND PROVIDING CONSUMER INFORMATION RELATING TO AUTOMOBILE CARS AT SUCH EVENTS (U.S. CLS. 100, 101 AND 102).

**CLASS 41—EDUCATION AND ENTERTAINMENT**

FOR ENTERTAINMENT SERVICES IN THE NATURE OF AUTOMOBILE CAR RACES, AND PROVIDING INFORMATION RELATING TO AUTOMOBILE CARS AT SUCH EVENTS; PROVIDING INFORMATION ONLINE RELATING TO VEHICLES FOR HOBBY OR ENTERTAINMENT PURPOSES (U.S. CLS. 100, 101 AND 107).  
RUDY R. SINGLETON, EXAMINING ATTORNEY

SN 85-875,833. SPECIAL PRODUCT COMPANY, SHAWNEE, KS. FILED 3-14-2013.

SN 85-875,839. SPECIAL PRODUCT COMPANY, SHAWNEE, KS. FILED 3-14-2013.



UNLOCK YOUR DESIGN

OWNER OF U.S. REG. NOS. 2,210,816 AND 2,630,112.  
THE MARK CONSISTS OF THE CAPITAL LETTERS "SPC" SLANTED SLIGHTLY TO THE RIGHT, ALL TO THE RIGHT OF A CIRCLE HAVING THE DRAWING OF A THREE DIMENSIONAL BOX INSIDE.

THE MARK CONSISTS OF STANDARD CHARACTERS WITHOUT CLAIM TO ANY PARTICULAR FONT, STYLE, SIZE, OR COLOR.

**CLASS 9—ELECTRICAL AND SCIENTIFIC APPARATUS**

FOR A FULL LINE OF INDOOR AND OUTDOOR ELECTRONIC EQUIPMENT CABINETS AND ENCLOSURES SPECIALLY ADAPTED TO HOUSE AND PROTECT ELECTRONIC EQUIPMENT FOR THE TELECOMMUNICATIONS, SECURITY, RAIL, UTILITIES, AEROSPACE, DATA CENTER AND ALTERNATIVE ENERGY INDUSTRIES, NAMELY, TELECOMMUNICATIONS EQUIPMENT, SECURITY EQUIPMENT, RAIL EQUIPMENT, UTILITIES EQUIPMENT, AEROSPACE EQUIPMENT, DATA CENTER EQUIPMENT, AND ALTERNATIVE ENERGY EQUIPMENT; MOUNTING COMPONENTS FOR ELECTRONIC EQUIPMENT ENCLOSURES AND CABINETS, NAMELY, MOUNTING BRACKETS AND ATTACHMENT HARDWARE; AC CIRCUIT BREAKER LOAD CENTERS; AC AND DC VOLTAGE SURGE SUPPRESSORS; DC ELECTRICAL POWER SYSTEM SUPPLIES, FUSES, CONTROLLERS, AND BREAKERS; RECTIFIERS; DC-DC VOLTAGE CONVERTERS; POWER INVERTERS; ELECTRIC GENERATOR CONNECTORS AND SWITCHES; PEDESTALS FOR USE IN MOUNTING BACKUP BATTERIES; BATTERY HOOKUP CABLES; DC BACKUP BATTERY; AC UPS SYSTEMS TO PROVIDE BACKUP POWER, CONSISTING OF BATTERIES, FLYWHEELS, CHARGERS, CONVERTERS, INVERTERS, AND RECTIFIERS; DATA LINE SURGE PROTECTION PANELS; COPPER CROSS ELECTRICAL CONNECTORS; PATCH PANELS FOR HOUSING FIBER OPTICS; FIBER OPTIC SPOOLS; FIBER OPTIC COMPONENTS, NAMELY, FIBER OPTIC PATCH CORDS, FIBER OPTIC PIGTAILS, AND FIBER OPTIC CABLES; CASES AND ENCLOSURES DESIGNED TO HOUSE COPPER AND FIBER SPLICES; ELECTRICAL OUTLETS; ALARMS FOR DETECTING INTRUSION, POWER LOSS, AND TEMPERATURE, AND ALARM REPORTING DEVICES (U.S. CLS. 21, 23, 26, 36 AND 38).

**CLASS 11—ENVIRONMENTAL CONTROL APPARATUS**

FOR ENCLOSURE AND CABINET COOLING EQUIPMENT FOR ELECTRONIC EQUIPMENT, NAMELY, HEAT EXCHANGERS, AIR CONDITIONERS, FAN VENTILATORS, AND HEAT PIPES; ELECTRIC HEATERS, NAMELY, ELECTRIC HEATERS FOR COMMERCIAL AND INDUSTRIAL USE, ELECTRIC HEATERS FOR RESIDENTIAL USE, AND PORTABLE ELECTRIC HEATERS; ELECTRICAL PADS FOR PRE-HEATING BATTERIES (U.S. CLS. 13, 21, 23, 31 AND 34).

**CLASS 42—SCIENTIFIC AND COMPUTER SERVICES**

FOR DESIGN, CUSTOM DESIGN, DEVELOPMENT AND TESTING SERVICES FOR ELECTRONIC EQUIPMENT, NAMELY, ENCLOSURES AND CABINETS EXPRESSLY DESIGNED TO HOUSE ELECTRONIC EQUIPMENT FOR THE TELECOMMUNICATIONS, SECURITY, RAIL, UTILITIES, AEROSPACE, DATA CENTER AND ALTERNATIVE ENERGY INDUSTRIES, AND ENCLOSURE AND CABINET COOLING EQUIPMENT, NAMELY, HEAT EXCHANGERS, AIR CONDITIONERS, FAN VENTILATORS, AND HEAT PIPES; DESIGN, CUSTOM DESIGN, DEVELOPMENT AND TESTING SERVICES FOR ELECTRIC HEATERS, AND MOUNTING COMPONENTS FOR ELECTRONIC EQUIPMENT ENCLOSURES AND CABINETS, NAMELY, MOUNTING BRACKETS AND ATTACHMENT HARDWARE; DESIGN, CUSTOM DESIGN, DEVELOPMENT AND TESTING SERVICES FOR POWER METERS AND ELECTRICAL SOCKETS, AC CIRCUIT BREAKER LOAD CENTERS; AC AND DC VOLTAGE SURGE SUPPRESSORS, DC ELECTRICAL POWER SYSTEM SUPPLIES, ELECTRICAL FUSES, ELECTRICAL CONTROLLERS, AND CIRCUIT BREAKERS; DESIGN, CUSTOM DESIGN, DEVELOPMENT AND TESTING SERVICES FOR RECTIFIERS, DC-DC VOLTAGE CONVERTERS, POWER INVERTERS, GENERATOR CONNECTORS AND SWITCHES, PEDESTALS FOR USE IN MOUNTING BACKUP BATTERIES, ELECTRICAL PADS FOR PRE-HEATING BATTERIES, BATTERY HOOKUP CABLES, DC BACKUP BATTERY, AC UPS SYSTEMS TO PRO-

VIDE BACKUP POWER, DATA LINE SURGE PROTECTION PANELS, COPPER CROSS ELECTRICAL CONNECTORS, PATCH PANELS FOR HOUSING FIBER OPTICS, FIBER OPTIC SPOOLS, FIBER OPTIC COMPONENTS, NAMELY, FIBER OPTIC PATCH CORDS, FIBER OPTIC PIGTAILS, AND FIBER OPTIC CABLES; DESIGN, CUSTOM DESIGN, DEVELOPMENT AND TESTING SERVICES FOR CASES AND ENCLOSURES DESIGNED TO HOUSE COPPER AND FIBER SPLICES, ELECTRICAL OUTLETS, ALARMS FOR DETECTING INTRUSION, POWER LOSS, AND TEMPERATURE, AND ALARM REPORTING DEVICES (U.S. CLS. 100 AND 101).  
ELIZABETH CHANG, EXAMINING ATTORNEY

SN 85-877,087. TOTUS SOLUTIONS, INC., CARROLLTON, TX. FILED 3-15-2013.

**TOTUS SOLUTIONS**

THE MARK CONSISTS OF STANDARD CHARACTERS WITHOUT CLAIM TO ANY PARTICULAR FONT, STYLE, SIZE, OR COLOR.

NO CLAIM IS MADE TO THE EXCLUSIVE RIGHT TO USE "SOLUTIONS", APART FROM THE MARK AS SHOWN.

**CLASS 37—CONSTRUCTION AND REPAIR**

FOR INSTALLATION OF SECURITY SYSTEMS; INSTALLATION OF LIGHTING AND ELECTRONIC SURVEILLANCE DEVICES; INSTALLATION OF TELECOMMUNICATIONS HARDWARE; INSTALLATION OF HARDWARE AND PERIPHERALS TO LIGHTING AND ELECTRONIC SURVEILLANCE DEVICES (U.S. CLS. 100, 103 AND 106).

**CLASS 38—COMMUNICATION**

FOR TELECOMMUNICATION SERVICES, NAMELY, PROVIDING ACCESS TO PICTURES, VIDEO, AUDIO, WEATHER, SECURITY EVENTS, ALARM STATUS AND OTHER INFORMATIONAL, SAFETY AND SECURITY INFORMATION AT A REMOTE STATION; TELECOMMUNICATION SERVICES, NAMELY, PROVIDING ELECTRONIC MESSAGES AND INFORMATION NOTIFYING INDIVIDUALS OF A CHANGED STATUS OR CONDITION OF A SENSING DEVICE IN A SECURITY SYSTEM (U.S. CLS. 100, 101 AND 104).

**CLASS 42—SCIENTIFIC AND COMPUTER SERVICES**

FOR INSTALLATION OF TELECOMMUNICATIONS SOFTWARE, INSTALLATION OF SOFTWARE FOR LIGHTING AND ELECTRONIC SURVEILLANCE DEVICES (U.S. CLS. 100 AND 101).

**CLASS 45—PERSONAL AND LEGAL SERVICES**

FOR MONITORING OF SECURITY SYSTEMS; MONITORING OF COMPUTER SYSTEMS FOR SECURITY PURPOSES; MONITORING OF SECURITY SYSTEMS USED IN ELECTRONIC TRACKING FOR USE IN CONNECTION WITH SECURITY; MONITORING OF SECURITY SYSTEMS USED IN POLICE AND CIVIL PROTECTION SERVICES; SECURITY SERVICES, NAMELY, PROVIDING A WEBSITE AND/OR SOFTWARE FOR NOTIFYING INDIVIDUALS OF A CHANGED STATUS AND/OR CONDITION OF A SENSING DEVICE IN A SECURITY SYSTEM; VIDEO MONITORING OF FACILITIES, VIEWABLE THROUGH A GLOBAL COMPUTER NETWORK FOR SAFETY PURPOSES (U.S. CLS. 100 AND 101).

DAWN FELDMAN, EXAMINING ATTORNEY

SN 85-879,055, ASSOCIATION OF SMALL BUSINESS DEVELOPMENT CENTERS, BURKE, VA. FILED 3-18-2013.



NO CLAIM IS MADE TO THE EXCLUSIVE RIGHT TO USE "AMERICA'S SBDC", APART FROM THE MARK AS SHOWN.

THE COLOR(S) RED, BLUE AND GRAY IS/ARE CLAIMED AS A FEATURE OF THE MARK.

THE MARK CONSISTS OF THE WORDING "AMERICA'S SBDC", WITH THE WORD "AMERICA'S" IN RED AND THE APOSTROPHE FORMED FROM AN INCOMPLETE STAR IN THE COLOR BLUE, WITH A BLUE CURVED LINE TO THE LEFT OF THE STAR; BELOW "AMERICA'S" IS "SBDC" IN BLUE WITH GRAY SHADOWING. THE WHITE IN THE MARK REPRESENTS TRANSPARENT BACKGROUND AREAS AND IS NOT CLAIMED AS A FEATURE OF THE MARK.

#### **CLASS 9—ELECTRICAL AND SCIENTIFIC APPARATUS**

FOR DOWNLOADABLE PUBLICATIONS, NAMELY, DOWNLOADABLE BOOKS IN THE FIELD OF SMALL-TO-MEDIUM BUSINESS OWNERSHIP AND OPERATION; DOWNLOADABLE PUBLICATIONS, NAMELY, DOWNLOADABLE INFORMATIONAL FLYERS IN THE FIELD OF SMALL-TO-MEDIUM BUSINESS OWNERSHIP AND OPERATION, AND SMALL BUSINESS DEVELOPMENT; DOWNLOADABLE PRINTABLE PRESENTATIONS IN THE NATURE OF PRINTED SLIDE SHOWS IN THE FIELD OF SMALL-TO-MEDIUM BUSINESS OWNERSHIP AND OPERATION, AND SMALL-TO-MEDIUM BUSINESS DEVELOPMENT (U.S. CLS. 21, 23, 26, 36 AND 38).

FIRST USE 1-0-2013; IN COMMERCE 1-0-2013.

#### **CLASS 35—ADVERTISING AND BUSINESS**

FOR ASSOCIATION SERVICES, NAMELY, PROMOTING THE INTERESTS OF SMALL-TO-MEDIUM BUSINESSES, CURRENT AND PROSPECTIVE OWNERS AND OPERATORS OF SMALL-TO-MEDIUM BUSINESSES, AND PROVIDERS OF SMALL-TO-MEDIUM BUSINESS DEVELOPMENT ASSISTANCE; PROMOTING PUBLIC AWARENESS IN THE FIELD OF SMALL-TO-MEDIUM BUSINESSES AND SMALL-TO-MEDIUM BUSINESS DEVELOPMENT; PUBLIC ADVOCACY TO PROMOTE AWARENESS OF SMALL-TO-MEDIUM BUSINESSES AND PROVIDERS OF SMALL-TO-MEDIUM BUSINESS DEVELOPMENT ASSISTANCE; LOBBYING SERVICES, NAMELY, PROMOTING THE INTERESTS OF CURRENT AND PROSPECTIVE SMALL-TO-MEDIUM BUSINESS OWNERS AND OPERATORS, AND PROVIDERS OF SMALL-TO-MEDIUM BUSINESS DEVELOPMENT ASSISTANCE, IN THE FIELDS OF POLITICS, LEGISLATION, AND REGULATION; PROVIDING AN ONLINE BUSINESS DIRECTORY FEATURING CONTACT INFORMATION OF OTHERS WHO CAN PROVIDE CONSULTATION AND TRAINING TO CURRENT AND PROSPECTIVE OWNERS AND OPERATORS OF SMALL-TO-MEDIUM BUSINESSES; BUSINESS CONSULTING SERVICES IN THE FIELD OF SMALL-TO-MEDIUM BUSINESS OWNERSHIP AND OPERATION, AND SMALL-TO-MEDIUM BUSINESS DEVELOPMENT; PROVIDING BUSINESS MANAGEMENT AND TECHNICAL ASSISTANCE WITH BUSINESS MANAGEMENT AND BUSINESS PLANNING TO SMALL-TO-MEDIUM BUSINESSES, AND CURRENT AND PROSPECTIVE OWNERS OF SMALL-TO-MEDIUM BUSINESSES; PROVIDING INFORMATION AND NEWS IN THE FIELD OF SMALL-TO-MEDIUM BUSINESS OWNERSHIP AND OP-

ERATION, AND SMALL-TO-MEDIUM BUSINESS DEVELOPMENT; PROVIDING BUSINESS INFORMATION AND NEWS OF INTEREST TO CURRENT AND PROSPECTIVE OWNERS AND OPERATORS OF SMALL BUSINESSES, AND PROVIDERS OF SMALL-TO-MEDIUM BUSINESS DEVELOPMENT ASSISTANCE; CONDUCTING EXHIBITIONS FOR COMMERCIAL AND ADVERTISING PURPOSES IN THE FIELD OF SMALL-TO-MEDIUM BUSINESS OWNERSHIP AND OPERATION, AND SMALL-TO-MEDIUM BUSINESS DEVELOPMENT; PROVIDING A WEBSITE FEATURING LINKS TO THE WEBSITES OF OTHERS IN THE FIELD OF SMALL-TO-MEDIUM BUSINESS OWNERSHIP AND OPERATION, AND SMALL-TO-MEDIUM BUSINESS DEVELOPMENT; PROVIDING A WEBSITE FEATURING LINKS TO THE WEBSITES OF OTHERS ON THE SUBJECT OF BUSINESS INFORMATION FEATURING WEBSITES THAT CAN PROVIDE INFORMATION, RESOURCES AND SERVICES TO CURRENT AND PROSPECTIVE OWNERS AND OPERATORS OF SMALL-TO-MEDIUM BUSINESSES, AND PROVIDERS OF SMALL-TO-MEDIUM BUSINESS DEVELOPMENT ASSISTANCE; PROVIDING AN ONLINE DATABASE FEATURING EMPLOYMENT OPPORTUNITIES IN THE FIELD OF SMALL-TO-MEDIUM BUSINESS DEVELOPMENT; AND BUSINESS SERVICES FOR OTHERS, NAMELY, REGISTERING, SCREENING AND VERIFYING THE CREDENTIALS OF PROVIDERS OF SMALL-TO-MEDIUM BUSINESS DEVELOPMENT ASSISTANCE (U.S. CLS. 100, 101 AND 102).

FIRST USE 1-0-2013; IN COMMERCE 1-0-2013.

#### **CLASS 41—EDUCATION AND ENTERTAINMENT**

FOR EDUCATIONAL SERVICES, NAMELY, ARRANGING, CONDUCTING AND PROVIDING CLASSES, CONFERENCES, TRAINING MEETINGS, SEMINARS, TRAINING, NON-DOWNLOADABLE WEBINARS AND WORKSHOPS IN THE FIELD OF, AND RELATING TO, SMALL-TO-MEDIUM BUSINESS OWNERSHIP AND OPERATION, AND DISTRIBUTION OF EDUCATIONAL MATERIALS IN CONNECTION THEREWITH; EDUCATIONAL SERVICES, NAMELY, ARRANGING, CONDUCTING AND PROVIDING CLASSES, CONFERENCES, TRAINING MEETINGS, SEMINARS, TRAINING, NON-DOWNLOADABLE WEBINARS AND WORKSHOPS IN THE FIELD OF SMALL-TO-MEDIUM BUSINESS DEVELOPMENT, AND DISTRIBUTION OF EDUCATIONAL MATERIALS IN CONNECTION THEREWITH; EDUCATIONAL SERVICES, NAMELY, PROVIDING NON-DOWNLOADABLE WEBINARS IN THE FIELD OF, AND RELATING TO, SMALL-TO-MEDIUM BUSINESS OWNERSHIP AND OPERATION; ONLINE JOURNALS, NAMELY, BLOGS FEATURING INFORMATION IN THE FIELD OF, AND RELATING TO, SMALL-TO-MEDIUM BUSINESS OWNERSHIP AND OPERATION, AND SMALL-TO-MEDIUM BUSINESS DEVELOPMENT (U.S. CLS. 100, 101 AND 107).

FIRST USE 1-0-2013; IN COMMERCE 1-0-2013.

#### **CLASS 42—SCIENTIFIC AND COMPUTER SERVICES**

FOR ACCREDITATION SERVICES, NAMELY, DEVELOPING, EVALUATING, AND TESTING STANDARDS FOR THE PROVISION OF SMALL BUSINESS DEVELOPMENT ASSISTANCE, FOR THE PURPOSE OF ACCREDITATION (U.S. CLS. 100 AND 101).

FIRST USE 1-0-2013; IN COMMERCE 1-0-2013.

#### **CLASS 200—COLLECTIVE MEMBERSHIP**

FOR COLLECTIVE MEMBERSHIP MARK INDICATING MEMBERSHIP IN AN ORGANIZATION, CONSISTING OF INDIVIDUAL MEMBERS AND GROUP MEMBERS IN THE NATURE OF CHAPTERS, OF SMALL-TO-MEDIUM BUSINESSES, CURRENT AND PROSPECTIVE OWNERS AND OPERATORS OF SMALL-TO-MEDIUM BUSINESSES, AND PROVIDERS OF SMALL-TO-MEDIUM BUSINESS DEVELOPMENT ASSISTANCE.

FIRST USE 1-0-2013; IN COMMERCE 1-0-2013.

CHARLOTTE CORWIN, EXAMINING ATTORNEY

SN 85-879,478. MAHALAKSHMI BRAND, LLC, BUFFALO, WY. FILED 3-19-2013.

SN 85-881,100. ZITRO IP, S.À.R.L., LUXEMBOURG, LUXEMBOURG, FILED 3-20-2013.

## TIRUPATHI

THE MARK CONSISTS OF STANDARD CHARACTERS WITHOUT CLAIM TO ANY PARTICULAR FONT, STYLE, SIZE, OR COLOR.

THE ENGLISH TRANSLATION OF "TIRUPATHI" IS "TEMPLE".

### CLASS 29—MEATS AND PROCESSED FOODS

FOR DRIED LENTILS; EDIBLE OILS AND EDIBLE FATS; PICKLES; PULSES (U.S. CL. 46).

### CLASS 30—STAPLE FOODS

FOR COFFEE; CURRY PASTES; CURRY POWDER; FLOUR; RICE; SPICES; TEA (U.S. CL. 46).  
KATHY DE JONGE, EXAMINING ATTORNEY



OWNER OF EUROPEAN UNION REG. NO. 011668274, DATED 8-8-2013, EXPIRES 3-19-2023.

OWNER OF U.S. REG. NO. 3,898,377.

NO CLAIM IS MADE TO THE EXCLUSIVE RIGHT TO USE "LOTTO", APART FROM THE MARK AS SHOWN.

THE COLOR(S) YELLOW, GOLD, RED, ORANGE, LIGHT BLUE, BLACK AND WHITE IS/ARE CLAIMED AS A FEATURE OF THE MARK.

THE MARK CONSISTS OF THE WORD "LOTTO" IN STYLIZED BLOCK LETTERING, EACH LETTER BEING YELLOW WITH A GOLD BACKGROUND WITH THIN OUTLINES IN RED AND THEN LIGHT BLUE ON THE OUTSIDE OF THE LETTERS, ABOVE THE WORD "TOUCH" IN STYLIZED BLOCK LETTERING, EACH LETTER BEING GOLD WITH AN ORANGE BACKGROUND THAT FADES TO RED AT THE BOTTOM OF THE LETTERS WITH A THIN LIGHT BLUE OUTLINE AROUND THE LETTERS, AND A RED STAR IN THE CENTER OF THE "O" IN THE WORD "TOUCH", ALL OVER A WHITE BACKGROUND WITH BLACK SHADOWING BEHIND THE WORDS.

### CLASS 9—ELECTRICAL AND SCIENTIFIC APPARATUS

FOR COMPUTER SOFTWARE AND FIRMWARE FOR GAMES OF CHANCE ON ANY COMPUTERIZED PLATFORM, INCLUDING DEDICATED GAMING CONSOLES, VIDEO BASED SLOT MACHINES, REEL BASED SLOT MACHINES, AND VIDEO LOTTERY TERMINALS; COMPUTER SOFTWARE FOR ON-LINE GAMING, NAMELY, SOFTWARE FOR GENERATING OR DISPLAYING WAGER OUTCOMES AND FOR ENABLING ELECTRONIC CREDIT WAGERING (U.S. CLS. 21, 23, 26, 36 AND 38).

### CLASS 28—TOYS AND SPORTING GOODS

FOR GAMING DEVICES, NAMELY, GAMING MACHINES, SLOT MACHINES, BINGO MACHINES, WITH OR WITHOUT VIDEO OUTPUT (U.S. CLS. 22, 23, 38 AND 50).

PATRICIA EVANKO, EXAMINING ATTORNEY

SN 85-880,768. SARATOGA HARNESS RACING, INC., SARATOGA SPRINGS, NY. FILED 3-20-2013.



NO CLAIM IS MADE TO THE EXCLUSIVE RIGHT TO USE "SARATOGA CASINO BLACK HAWK", APART FROM THE MARK AS SHOWN.

THE MARK CONSISTS OF A PAVILION ATOP OF A CURVED LINE WITH THE STYLIZED WORDS "SARATOGA CASINO BLACK HAWK".

### CLASS 41—EDUCATION AND ENTERTAINMENT

FOR CASINO GAMING (U.S. CLS. 100, 101 AND 107).

### CLASS 43—HOTEL AND RESTAURANT SERVICES

FOR HOTEL SERVICES (U.S. CLS. 100 AND 101).  
SANI KHOURI, EXAMINING ATTORNEY

SN 85-881,895. RACKSPACE US, INC., SAN ANTONIO, TX. FILED 3-20-2013.

## ZeroVM

THE MARK CONSISTS OF STANDARD CHARACTERS WITHOUT CLAIM TO ANY PARTICULAR FONT, STYLE, SIZE, OR COLOR.



**CLASS 9—ELECTRICAL AND SCIENTIFIC APPARATUS**

FOR COMPUTER OPERATING SYSTEMS; COMPUTER SOFTWARE FOR CREATING SEARCHABLE DATABASES OF INFORMATION AND DATA; OPERATING SYSTEM PROGRAMS (U.S. CLS. 21, 23, 26, 36 AND 38).

SN 85-883,182. 8 BLOCK, LLC, SNOQUALMIE, WA. FILED 3-21-2013.

**CLASS 42—SCIENTIFIC AND COMPUTER SERVICES**

FOR COMPUTER SERVICES, NAMELY, INTEGRATION OF PRIVATE AND PUBLIC CLOUD COMPUTING ENVIRONMENTS; CONSULTING SERVICES IN THE FIELD OF CLOUD COMPUTING; PROVIDING VIRTUAL COMPUTER SYSTEMS AND VIRTUAL COMPUTER ENVIRONMENTS THROUGH CLOUD COMPUTING; TECHNICAL CONSULTING SERVICES IN THE FIELDS OF DATA CENTER ARCHITECTURE, PUBLIC AND PRIVATE CLOUD COMPUTING SOLUTIONS, AND EVALUATION AND IMPLEMENTATION OF INTERNET TECHNOLOGY AND SERVICES; TECHNICAL SUPPORT SERVICES, NAMELY, REMOTE AND ON-SITE INFRASTRUCTURE MANAGEMENT SERVICES FOR MONITORING, ADMINISTRATION AND MANAGEMENT OF PUBLIC AND PRIVATE CLOUD COMPUTING IT AND APPLICATION SYSTEMS (U.S. CLS. 100 AND 101).

FRANK LATTUCA, EXAMINING ATTORNEY

**THE ST8 OF N8**

THE MARK CONSISTS OF STANDARD CHARACTERS WITHOUT CLAIM TO ANY PARTICULAR FONT, STYLE, SIZE, OR COLOR.

**CLASS 14—JEWELRY**

FOR JEWELRY IN THE NATURE OF WRISTBANDS, BRACELETS AND ANKLE BANDS CONTAINING BUILT-IN ANTENNA DEVICES FOR INTERACTING WITH THE BODY'S ELECTROMAGNETIC FIELD, FOR IMPROVING STRENGTH, BALANCE, PERFORMANCE, FLEXIBILITY AND ENDURANCE IN HUMANS (U.S. CLS. 2, 27, 28 AND 50).

**CLASS 35—ADVERTISING AND BUSINESS**

FOR ADVERTISING SERVICES, NAMELY, PROMOTING THE BRANDS, GOODS AND SERVICES OF OTHERS; ENDORSEMENT SERVICES, NAMELY, PROMOTING THE GOODS AND SERVICES OF OTHERS; ON-LINE RETAIL STORE SERVICES FEATURING BRACELETS, JEWELRY, APPAREL, SHOES, BASEBALL CAPS, T-SHIRTS, SHORTS, JACKETS, SWEATPANTS, SPORTING GOODS, TOYS, AND VIDEO GAMES (U.S. CLS. 100, 101 AND 102).

CIMMERIAN COLEMAN, EXAMINING ATTORNEY

SN 85-883,179. 8 BLOCK, LLC, SNOQUALMIE, WA. FILED 3-21-2013.

SN 85-883,195. 8 BLOCK, LLC, SNOQUALMIE, WA. FILED 3-21-2013.

**THE STATE OF NATE**

THE MARK CONSISTS OF STANDARD CHARACTERS WITHOUT CLAIM TO ANY PARTICULAR FONT, STYLE, SIZE, OR COLOR.

**CLASS 14—JEWELRY**

FOR JEWELRY IN THE NATURE OF WRISTBANDS, BRACELETS AND ANKLE BANDS CONTAINING BUILT-IN ANTENNA DEVICES FOR INTERACTING WITH THE BODY'S ELECTROMAGNETIC FIELD, FOR IMPROVING STRENGTH, BALANCE, PERFORMANCE, FLEXIBILITY AND ENDURANCE IN HUMANS (U.S. CLS. 2, 27, 28 AND 50).

**CLASS 35—ADVERTISING AND BUSINESS**

FOR ADVERTISING SERVICES, NAMELY, PROMOTING THE BRANDS, GOODS AND SERVICES OF OTHERS; ENDORSEMENT SERVICES, NAMELY, PROMOTING THE GOODS AND SERVICES OF OTHERS; ON-LINE RETAIL STORE SERVICES FEATURING BRACELETS, JEWELRY, APPAREL, SHOES, BASEBALL CAPS, T-SHIRTS, SHORTS, JACKETS, SWEATPANTS, SPORTING GOODS, TOYS, AND VIDEO GAMES (U.S. CLS. 100, 101 AND 102).

CIMMERIAN COLEMAN, EXAMINING ATTORNEY

**ST8OFN8**

THE MARK CONSISTS OF STANDARD CHARACTERS WITHOUT CLAIM TO ANY PARTICULAR FONT, STYLE, SIZE, OR COLOR.

**CLASS 14—JEWELRY**

FOR JEWELRY IN THE NATURE OF WRISTBANDS, BRACELETS AND ANKLE BANDS CONTAINING BUILT-IN ANTENNA DEVICES FOR INTERACTING WITH THE BODY'S ELECTROMAGNETIC FIELD, FOR IMPROVING STRENGTH, BALANCE, PERFORMANCE, FLEXIBILITY AND ENDURANCE IN HUMANS (U.S. CLS. 2, 27, 28 AND 50).

**CLASS 35—ADVERTISING AND BUSINESS**

FOR ADVERTISING SERVICES, NAMELY, PROMOTING THE BRANDS, GOODS AND SERVICES OF OTHERS; ENDORSEMENT SERVICES, NAMELY, PROMOTING THE GOODS AND SERVICES OF OTHERS; ON-LINE RETAIL STORE SERVICES FEATURING BRACELETS, JEWELRY, APPAREL, SHOES, BASEBALL CAPS, T-SHIRTS, SHORTS, JACKETS, SWEATPANTS, SPORTING GOODS, TOYS, AND VIDEO GAMES (U.S. CLS. 100, 101 AND 102).

CIMMERIAN COLEMAN, EXAMINING ATTORNEY



SN 85-883,408. FARMLIFE, LLC, WILLISTON, FL. FILED 3-22-2013.

## FARM LIFE

THE MARK CONSISTS OF STANDARD CHARACTERS WITHOUT CLAIM TO ANY PARTICULAR FONT, STYLE, SIZE, OR COLOR.

OWNER OF U.S. REG. NO. 4,191,968.

### CLASS 6—METAL GOODS

FOR NON-LUMINOUS AND NON-MECHANICAL METAL SIGNS (U.S. CLS. 2, 12, 13, 14, 23, 25 AND 50).  
FIRST USE 3-24-2012; IN COMMERCE 3-24-2012.

### CLASS 16—PAPER GOODS AND PRINTED MATTER

FOR BUMPER STICKERS (U.S. CLS. 2, 5, 22, 23, 29, 37, 38 AND 50).  
FIRST USE 3-24-2012; IN COMMERCE 3-24-2012.

### CLASS 21—HOUSEWARES AND GLASS

FOR INSULATING SLEEVE HOLDER FOR BOTTLES; INSULATING SLEEVE HOLDERS FOR BEVERAGE CANS (U.S. CLS. 2, 13, 23, 29, 30, 33, 40 AND 50).  
FIRST USE 3-24-2012; IN COMMERCE 3-24-2012.

### CLASS 25—CLOTHING

FOR BUTTON DOWN SHIRTS; COLLARED SHIRTS; DRESS SHIRTS; HATS; JACKETS; LONG-SLEEVED SHIRTS; PANTS; SHORTS; T-SHIRTS (U.S. CLS. 22 AND 39).  
FIRST USE 3-24-2012; IN COMMERCE 3-24-2012.  
ELIZABETH CHANG, EXAMINING ATTORNEY

SN 85-883,611. E. E. WINE, INC., MANASSAS, VA. FILED 3-22-2013.



THE MARK CONSISTS OF THE LETTER "W" IN STYLIZED FORM, WHICH APPEARS SLIGHTLY TILTED TOWARD THE RIGHT, WITHIN A SQUARE SHAPED CARRIER WITH TWO ROUND SIDES AND ON A SHADED BACKGROUND, WITH TOP AND BOTTOM BACKGROUND REGIONS VARYING IN SHADING.

### CLASS 35—ADVERTISING AND BUSINESS

FOR RETAIL STORE SERVICES FEATURING CONVENIENCE STORE ITEMS AND GASOLINE (U.S. CLS. 100, 101 AND 102).

### CLASS 37—CONSTRUCTION AND REPAIR

FOR MOTOR VEHICLE MAINTENANCE SERVICES; HVAC CONTRACTOR SERVICES; HEATING CONTRACTOR SERVICES; AIR CONDITIONING CONTRACTOR SERVICES; INSTALLATION AND REPLACEMENT SERVICE FOR HEATING, VENTILATING AND AIR CONDITIONING SYSTEMS; INSTALLATION, REPAIR AND MAINTENANCE OF HEATING, VENTILATING AND AIR CONDITIONING EQUIPMENT AND HEATING, VENTILATING AND AIR CONDITIONING INSTALLATIONS; DUCT CLEANING; REPAIR OF HOUSEHOLD APPLIANCES AND OF RESIDENTIAL HEATING, PLUMBING, AIR CONDITIONING, AND ELECTRICAL SYSTEMS; PLUMBING; PLUMBING SERVICES; PLUMBING CONTRACTOR SERVICES; PLUMBING AND GAS AND WATER INSTALLATION (U.S. CLS. 100, 103 AND 106).

### CLASS 39—TRANSPORTATION AND STORAGE

FOR PROVIDING TRANSPORTATION, STORAGE AND DELIVERY SERVICES OF GOODS; TRANSPORTATION, STORAGE AND DELIVERY OF FUELS; TRANSPORTATION, STORAGE AND DELIVERY OF GOODS (U.S. CLS. 100 AND 105).  
JUDITH HELFMAN, EXAMINING ATTORNEY

SN 85-883,867. POOTJES, REMKO, DBA REMI KUBANA, AHRENSFELDE, ALEMANIA, FED REP GERMANY, FILED 3-22-2013.

## REMI KUBANA

THE MARK CONSISTS OF STANDARD CHARACTERS WITHOUT CLAIM TO ANY PARTICULAR FONT, STYLE, SIZE, OR COLOR.

OWNER OF FED REP GERMANY REG. NO. 011288991, DATED 3-6-2013, EXPIRES 10-24-2022.

THE NAME "REMI KUBANA" DOES NOT IDENTIFY A LIVING INDIVIDUAL.

### CLASS 9—ELECTRICAL AND SCIENTIFIC APPARATUS

FOR CARRYING CASES FOR CELL PHONES; CARRYING CASES FOR MOBILE COMPUTERS; CELL PHONE CASES; CELL PHONE COVERS; CELL PHONE FACEPLATES; CELL PHONE STRAPS; CELL PHONES (U.S. CLS. 21, 23, 26, 36 AND 38).

### CLASS 25—CLOTHING

FOR BODY SHIRTS; BUTTON DOWN SHIRTS; COLLARED SHIRTS; COMBINATIONS; DRESS SHIRTS; FOOTWEAR; FOOTWEAR FOR MEN AND WOMEN; FROCKS; HEAD WRAPS; HEADBANDS FOR CLOTHING; HOODS; JACKETS; JERSEYS; LEATHER BELTS; LEATHER SHIRTS; LEATHER SKIRTS; LEISURE SUITS; MEN'S SUITS, WOMEN'S SUITS; POLO SHIRTS; RUGBY SHIRTS; SHIRTS FOR SUITS; SKI SUITS; SKIRTS AND DRESSES; SUIT COATS; SUITS OF LEATHER; WOMEN'S CLOTHING, NAMELY, SHIRTS, DRESSES, SKIRTS, BLOUSES (U.S. CLS. 22 AND 39).

MARK PILARO, EXAMINING ATTORNEY

SN 85-886,636. SHAREWAVE, LLC, FORMERLY THE CROWD FUNDS, LLC, NEW YORK, NY. FILED 3-26-2013.

SN 85-890,472. HIRE QUEST LLC, NORTH CHARLESTON, SC. FILED 3-29-2013.

## SHAREWAVE

THE MARK CONSISTS OF STANDARD CHARACTERS WITHOUT CLAIM TO ANY PARTICULAR FONT, STYLE, SIZE, OR COLOR.

### CLASS 35—ADVERTISING AND BUSINESS

FOR ONLINE SERVICES FOR THE COMPILATION OF FINANCIAL RECORDS, NAMELY, CAPITALIZATION TABLES AND OWNERSHIP RECORDS FOR RECORD-KEEPING PURPOSES (U.S. CLS. 100, 101 AND 102).

### CLASS 36—INSURANCE AND FINANCIAL

FOR ONLINE SERVICES FOR THE ORGANIZATION AND EXCHANGE OF FINANCIAL INFORMATION FOR INVESTORS IN THE FIELDS OF REGISTERED AND UNREGISTERED SECURITIES, NAMELY, PROVIDING INVESTORS WITH FINANCIAL INFORMATION, FINANCIAL ADMINISTRATION OF SECURITIES ACCOUNTS, NAMELY, ADMINISTERING THE ISSUANCE, UNDERWRITING AND DISTRIBUTION OF SECURITIES AND SHARES (U.S. CLS. 100, 101 AND 102).  
MARLENE BELL, EXAMINING ATTORNEY

---

SN 85-890,431. HIRE QUEST LLC, NORTH CHARLESTON, SC. FILED 3-29-2013.

## HIRE QUEST

THE MARK CONSISTS OF STANDARD CHARACTERS WITHOUT CLAIM TO ANY PARTICULAR FONT, STYLE, SIZE, OR COLOR.

OWNER OF U.S. REG. NOS. 3,964,137 AND 3,964,138.

### CLASS 35—ADVERTISING AND BUSINESS

FOR OPERATION OF LONG TERM PLACEMENT AND STAFFING BUSINESSES; PROVIDING BUSINESS SUPPORT STAFF SERVICES TO LONG TERM PLACEMENT AND STAFFING BUSINESSES; PROVIDING BUSINESS ADMINISTRATIVE CONSULTATION SERVICES TO LONG TERM PLACEMENT AND STAFFING BUSINESSES; FRANCHISING SUPPORT SERVICES IN THE NATURE OF BUSINESS MANAGEMENT AND CONSULTATION TO LONG TERM PLACEMENT AND STAFFING BUSINESSES (U.S. CLS. 100, 101 AND 102).

### CLASS 36—INSURANCE AND FINANCIAL

FOR PROVIDING FRANCHISING SUPPORT SERVICES IN THE NATURE OF FINANCIAL CONSULTATION TO LONG TERM PLACEMENT AND STAFFING BUSINESSES; PROVIDING FINANCIAL CONSULTATION SERVICES TO LONG TERM PLACEMENT AND STAFFING BUSINESSES; PROVIDING INSURANCE CONSULTATION SERVICES TO LONG TERM PLACEMENT AND STAFFING BUSINESSES (U.S. CLS. 100, 101 AND 102).

GINA HAYES, EXAMINING ATTORNEY

## HIRE QUEST LONG TERM STAFFING

THE MARK CONSISTS OF STANDARD CHARACTERS WITHOUT CLAIM TO ANY PARTICULAR FONT, STYLE, SIZE, OR COLOR.

OWNER OF U.S. REG. NOS. 3,964,137 AND 3,964,138.

NO CLAIM IS MADE TO THE EXCLUSIVE RIGHT TO USE "LONG TERM STAFFING", APART FROM THE MARK AS SHOWN.

### CLASS 35—ADVERTISING AND BUSINESS

FOR OPERATION OF LONG TERM PLACEMENT AND STAFFING BUSINESSES; PROVIDING BUSINESS SUPPORT STAFF SERVICES TO LONG TERM PLACEMENT AND STAFFING BUSINESSES; PROVIDING BUSINESS ADMINISTRATIVE CONSULTATION SERVICES TO LONG TERM PLACEMENT AND STAFFING BUSINESSES; FRANCHISING SUPPORT SERVICES IN THE NATURE OF BUSINESS MANAGEMENT AND CONSULTATION TO LONG TERM PLACEMENT AND STAFFING BUSINESSES (U.S. CLS. 100, 101 AND 102).

### CLASS 36—INSURANCE AND FINANCIAL

FOR PROVIDING FRANCHISING SUPPORT SERVICES IN THE NATURE OF FINANCIAL CONSULTATION TO LONG TERM PLACEMENT AND STAFFING BUSINESSES; PROVIDING FINANCIAL CONSULTATION SERVICES TO LONG TERM PLACEMENT AND STAFFING BUSINESSES; PROVIDING INSURANCE CONSULTATION SERVICES TO LONG TERM PLACEMENT AND STAFFING BUSINESSES (U.S. CLS. 100, 101 AND 102).

GINA HAYES, EXAMINING ATTORNEY

---

SN 85-890,495. HIRE QUEST LLC, NORTH CHARLESTON, SC. FILED 3-29-2013.



OWNER OF U.S. REG. NOS. 3,892,216, 3,964,137 AND 3,964,138.

THE MARK CONSISTS OF A STYLIZED TRIANGLE ABOVE THE WORDS "HIRE QUEST".

### CLASS 35—ADVERTISING AND BUSINESS

FOR OPERATION OF LONG TERM PLACEMENT AND STAFFING BUSINESSES; PROVIDING BUSINESS SUPPORT STAFF SERVICES TO LONG TERM PLACEMENT AND STAFFING BUSINESSES; PROVIDING BUSINESS ADMINISTRATIVE CONSULTATION SERVICES TO LONG TERM PLACEMENT AND STAFFING BUSINESSES; FRANCHISING SUPPORT SERVICES IN THE NATURE OF BUSINESS MANAGEMENT AND CONSULTATION TO LONG TERM PLACEMENT AND STAFFING BUSINESSES (U.S. CLS. 100, 101 AND 102).

**CLASS 36—INSURANCE AND FINANCIAL**

FOR PROVIDING FRANCHISING SUPPORT SERVICES IN THE NATURE OF FINANCIAL CONSULTATION TO LONG TERM PLACEMENT AND STAFFING BUSINESSES; PROVIDING FINANCIAL CONSULTATION SERVICES TO LONG TERM PLACEMENT AND STAFFING BUSINESSES; PROVIDING INSURANCE CONSULTATION SERVICES TO LONG TERM PLACEMENT AND STAFFING BUSINESSES (U.S. CLS. 100, 101 AND 102).

GINA HAYES, EXAMINING ATTORNEY

SN 85-890,513, HIRE QUEST LLC, NORTH CHARLESTON, SC. FILED 3-29-2013.



OWNER OF U.S. REG. NOS. 3,892,216, 3,964,137 AND 3,964,138.

THE COLOR(S) YELLOW AND BLUE IS/ARE CLAIMED AS A FEATURE OF THE MARK.

THE MARK CONSISTS OF A STYLIZED TRIANGLE WITH YELLOW HORIZONTAL STRIPES MAKING UP THE LEFT SIDE WITH THE RIGHT SIDE BEING FILLED IN WITH THE COLOR BLUE.

**CLASS 35—ADVERTISING AND BUSINESS**

FOR OPERATION OF LONG TERM PLACEMENT AND STAFFING BUSINESSES; PROVIDING BUSINESS SUPPORT STAFF SERVICES TO LONG TERM PLACEMENT AND STAFFING BUSINESSES; PROVIDING BUSINESS ADMINISTRATIVE CONSULTATION SERVICES TO LONG TERM PLACEMENT AND STAFFING BUSINESSES; FRANCHISING SUPPORT SERVICES IN THE NATURE OF BUSINESS MANAGEMENT AND CONSULTATION TO LONG TERM PLACEMENT AND STAFFING BUSINESSES (U.S. CLS. 100, 101 AND 102).

**CLASS 36—INSURANCE AND FINANCIAL**

FOR PROVIDING FRANCHISING SUPPORT SERVICES IN THE NATURE OF FINANCIAL CONSULTATION TO LONG TERM PLACEMENT AND STAFFING BUSINESSES; PROVIDING FINANCIAL CONSULTATION SERVICES TO LONG TERM PLACEMENT AND STAFFING BUSINESSES; PROVIDING INSURANCE CONSULTATION SERVICES TO LONG TERM PLACEMENT AND STAFFING BUSINESSES (U.S. CLS. 100, 101 AND 102).

GINA HAYES, EXAMINING ATTORNEY

SN 85-892,368, WATERTECTONICS, INC., EVERETT, WA. FILED 4-1-2013.

**WATERTECTONICS**

THE MARK CONSISTS OF STANDARD CHARACTERS WITHOUT CLAIM TO ANY PARTICULAR FONT, STYLE, SIZE, OR COLOR.

**CLASS 11—ENVIRONMENTAL CONTROL APPARATUS**

FOR WATER TREATMENT EQUIPMENT, NAMELY, AUTOMATED WATER AND WASTEWATER PURIFYING APPARATUS FOR USE IN MUNICIPAL, INDUSTRIAL, AND CONSTRUCTION APPLICATIONS (U.S. CLS. 13, 21, 23, 31 AND 34).

FIRST USE 8-0-2000; IN COMMERCE 6-0-2005.

**CLASS 40—MATERIAL TREATMENT**

FOR WATER FILTRATION AND TREATMENT SERVICES (U.S. CLS. 100, 103 AND 106).

FIRST USE 8-0-2000; IN COMMERCE 6-0-2005.

**CLASS 42—SCIENTIFIC AND COMPUTER SERVICES**

FOR ENGINEERING; DESIGN CONSULTING AND ENGINEERING SERVICES FOR THE DESIGN AND CONSTRUCTION OF WATER FILTRATION AND TREATMENT PLANTS (U.S. CLS. 100 AND 101).

FIRST USE 8-0-2000; IN COMMERCE 6-0-2005.

MEGHAN REINHART, EXAMINING ATTORNEY

SN 85-896,443, MEIDI ELECTRONICS, INC., CHINO, CA. FILED 4-5-2013.

**momo**

THE MARK CONSISTS OF STANDARD CHARACTERS WITHOUT CLAIM TO ANY PARTICULAR FONT, STYLE, SIZE, OR COLOR.

OWNER OF U.S. REG. NO. 4,337,991.

THE WORDING "MOMO" HAS NO MEANING IN A FOREIGN LANGUAGE.

**CLASS 9—ELECTRICAL AND SCIENTIFIC APPARATUS**

FOR BATTERY CHARGERS; DIGITAL PHOTO FRAMES FOR DISPLAYING DIGITAL PICTURES, VIDEO CLIPS AND MUSIC (U.S. CLS. 21, 23, 26, 36 AND 38).

FIRST USE 6-15-2012; IN COMMERCE 6-15-2012.

**CLASS 11—ENVIRONMENTAL CONTROL APPARATUS**

FOR LED LIGHTS FOR LIGHTING PURPOSES INCORPORATED INTO KEY CHAINS, SMALL TOYS OR OTHER SIMILAR PERSONAL ITEMS (U.S. CLS. 13, 21, 23, 31 AND 34).

MARILYN IZZI, EXAMINING ATTORNEY

SN 85-899,320. CASSAR, SIMON, DBA FLEXSWEEP INDUSTRIES, WATSONVILLE, CA. FILED S.R. 4-9-2013; AM. P.R. 7-21-2014.

## Flex-Power Unbreakable

THE MARK CONSISTS OF STANDARD CHARACTERS WITHOUT CLAIM TO ANY PARTICULAR FONT, STYLE, SIZE, OR COLOR.

NO CLAIM IS MADE TO THE EXCLUSIVE RIGHT TO USE "UNBREAKABLE", APART FROM THE MARK AS SHOWN.

### CLASS 6—METAL GOODS

FOR METAL BROOM HANDLES (U.S. CLS. 2, 12, 13, 14, 23, 25 AND 50).

FIRST USE 12-10-2005; IN COMMERCE 12-15-2005.

### CLASS 21—HOUSEWARES AND GLASS

FOR MOPS (U.S. CLS. 2, 13, 23, 29, 30, 33, 40 AND 50).

FIRST USE 1-20-2005; IN COMMERCE 1-20-2005.  
SUZANNE BLANE, EXAMINING ATTORNEY

SN 85-899,845. WEST DES MOINES COMMUNITY SCHOOLS, WEST DES MOINES, IA. FILED 4-10-2013.



THE MARK CONSISTS OF TIGER MOVING FORWARD WITH ONE PAW IN FRONT OF THE LETTER "V".

### CLASS 25—CLOTHING

FOR CLOTHING, NAMELY, SHIRTS, T-SHIRTS, SWEATSHIRTS, KNIT SHIRTS, BLOUSES, TANK TOPS, JERSEYS, CAPS, HATS, BELTS, PANTS, GLOVES, MITTENS, TIES, SUSPENDERS, SCARVES, SOCKS, BANDANAS, ATHLETIC JERSEYS, HEADWEAR AND PAINTER'S CAPS (U.S. CLS. 22 AND 39).

FIRST USE 8-1-2012; IN COMMERCE 8-1-2012.

### CLASS 41—EDUCATION AND ENTERTAINMENT

FOR EDUCATION SERVICES, NAMELY, HIGH SCHOOL CLASSES, ACTIVITIES AND EVENTS, NAMELY, LIVE SPORTING EVENTS, ARTISTIC EVENTS, AND ENTERTAINMENT ACTIVITIES, NAMELY, LIVE MUSIC AND DRAMA PERFORMANCES (U.S. CLS. 100, 101 AND 107).

FIRST USE 8-1-2012; IN COMMERCE 8-1-2012.  
TOBY BULLOFF, EXAMINING ATTORNEY

SN 85-907,077. PACIFICPHARMA CORPORATION, SEOUL, REPUBLIC OF KOREA, FILED 4-17-2013.



# AESTURA

OWNER OF SINGAPORE REG. NO. T1306403A, DATED 4-23-2013, EXPIRES 4-23-2023.

OWNER OF U.S. REG. NOS. 3,939,423 AND 4,033,042.

THE MARK CONSISTS OF THE BLOCK WORD "AESTURA" DIRECTLY BELOW A RECTANGLE WHICH IS DIVIDED INTO TWO PARTS BY A CLOCK-SHAPED BAND, WHEREIN BOTH ARE CENTERED AT THE MIDDLE OF THE MARK.

### CLASS 3—COSMETICS AND CLEANING PREPARATIONS

FOR COSMETIC PREPARATIONS FOR BATH AND SHOWER; COSMETIC PREPARATIONS FOR BODY CARE; COSMETIC PREPARATIONS FOR SKIN CARE; COSMETIC SUNSCREEN PREPARATIONS; COSMETICS; DENTIFRICES; HAIR SHAMPOO; MAKE-UP PREPARATIONS; PERFUMES; PET SHAMPOO (U.S. CLS. 1, 4, 6, 50, 51 AND 52).

### CLASS 5—PHARMACEUTICALS

FOR ANTIFUNGAL CREAMS FOR MEDICAL USE; BALMS FOR MEDICAL PURPOSES; DRUG DELIVERY AGENTS IN THE FORM OF TABLETS THAT PROVIDE CONTROLLED RELEASE OF THE ACTIVE INGREDIENTS FOR A WIDE VARIETY OF PHARMACEUTICALS; FOOD FOR BABIES; LACTEAL FLOUR FOR BABIES; MEDICATED BABY POWDERS; MEDICATED PRE-MOISTENED TISSUES; MEDICINAL OILS; PHARMACEUTICAL PREPARATIONS FOR SKIN CARE; PHARMACEUTICAL PREPARATIONS FOR THE TREATMENT OF SKIN DISORDERS; PHARMACEUTICAL PREPARATIONS FOR TREATING ALLERGIES; PHARMACEUTICAL PREPARATIONS FOR USE IN DERMATOLOGY; PHARMACEUTICAL SKIN LOTIONS (U.S. CLS. 6, 18, 44, 46, 51 AND 52).

DOMINIC FATHY, EXAMINING ATTORNEY

SN 85-907,142. NORANDEX BUILDING MATERIALS DISTRIBUTION, INC., HUDSON, OH. FILED 4-17-2013.



OWNER OF U.S. REG. NO. 1,891,085.

NO CLAIM IS MADE TO THE EXCLUSIVE RIGHT TO USE "BUILDING MATERIALS DISTRIBUTION, INC.", APART FROM THE MARK AS SHOWN.

THE MARK CONSISTS OF THE STYLIZED WORDING "NX NORANDEX BUILDING MATERIALS DISTRIBUTION, INC." WITH THE LETTERS "NX" FORMING A RECTANGULAR DESIGN TO THE LEFT OF THE WORDING "NORANDEX". THE WORDING "BUILDING MATERIALS DISTRIBUTION, INC." APPEARS IN SMALLER FONT BENEATH A HORIZONTAL LINE SEPARATING IT FROM THE STYLIZED WORDING "NX NORANDEX" ABOVE.

#### CLASS 6—METAL GOODS

FOR METAL SIDING; METAL SOFFITS; METAL WINDOWS AND PATIO DOORS; METAL ENTRY DOORS; METAL ROOFING; METAL ROOFING TILES; METAL DECKING; METAL RAILING FOR DECKS; METAL ARCHITECTURAL COLUMNS; EXTERIOR METAL SHUTTERS; METAL GUTTERS; METAL DOWNSPOUTS; NAILS; METAL BUILDING TRIM AND METAL GUTTER COIL (U.S. CLS. 2, 12, 13, 14, 23, 25 AND 50).

#### CLASS 19—NON-METALLIC BUILDING MATERIALS

FOR NON-METAL BUILDING MATERIALS, NAMELY, SOFFITS AND SIDING; NON-METAL WINDOWS AND PATIO DOORS; NON-METAL ENTRY DOORS; NON-METAL ROOFING; NON-METAL ROOFING SHINGLES; NON-METAL DECKING; NON-METAL RAILING FOR DECKS; NON-METAL ARCHITECTURAL COLUMNS; EXTERIOR NON-METAL SHUTTERS; NON-METAL GUTTERS; NON-METAL DOWNSPOUTS; NON-METAL WINDOW FRAMES, TRIM AND CASINGS (U.S. CLS. 1, 12, 33 AND 50).

#### CLASS 42—SCIENTIFIC AND COMPUTER SERVICES

FOR WHOLESALE DISTRIBUTORSHIP SERVICES FEATURING EXTERIOR BUILDING PRODUCTS (U.S. CLS. 100 AND 101).

NICHOLAS ALTREE, EXAMINING ATTORNEY

#### CLASS 9—ELECTRICAL AND SCIENTIFIC APPARATUS

FOR COMPUTER APPLICATION SOFTWARE FOR MOBILE PHONES TO HELP ADULT CHILDREN ASSESS AND MANAGE THE INDEPENDENCE AND OVERALL WELL-BEING OF AGING PARENTS (U.S. CLS. 21, 23, 26, 36 AND 38).

FIRST USE 1-20-2013; IN COMMERCE 5-6-2013.

#### CLASS 45—PERSONAL AND LEGAL SERVICES

FOR PROVIDING AN INTERNET WEBSITE PORTAL IN THE FIELD OF REMOTE MONITORING OF WIRELESS SECURITY SYSTEMS TO HELP ADULT CHILDREN ASSESS AND MANAGE THE INDEPENDENCE AND OVERALL WELL-BEING OF AGING PARENTS (U.S. CLS. 100 AND 101).

FIRST USE 1-20-2013; IN COMMERCE 5-6-2013.

MICHELE SWAIN, EXAMINING ATTORNEY

SN 85-914,388. LED PARTNERS, LLC, WASHINGTON, DC. FILED 4-25-2013.



SN 85-908,182. ALCHERA INCORPORATED, DBA SAFE IN HOME, WALNUT CREEK, CA. FILED 4-18-2013.



THE COLOR(S) PURPLE, DARK BLUE, AND LIGHT BLUE IS/ARE CLAIMED AS A FEATURE OF THE MARK.

THE MARK CONSISTS OF A STYLIZED CELL PHONE THAT RESEMBLES A HOUSE IN WHICH THE LEFT SIDE OF THE PHONE IS DARK BLUE AND THE RIGHT SIDE IS LIGHT BLUE WITH FOUR PURPLE SQUARES IN THE CENTER AND A PURPLE WI-FI SIGNAL EMERGING FROM THE CHIMNEY ANTENNA.

NO CLAIM IS MADE TO THE EXCLUSIVE RIGHT TO USE "LED PARTNERS", APART FROM THE MARK AS SHOWN.

THE MARK CONSISTS OF AN ARCH COMPRISED OF TWO LINES THAT INTERSECT FORMING A BRIDGE OVER TWO STRAIGHT LINES THAT NEARLY INTERSECT. TO THE RIGHT OF AND BELOW THE ARCH AND STRAIGHT LINES APPEARS THE STYLIZED WORDS "LED PARTNERS". UNDERNEATH THE WORDS "LED PARTNERS" ARE THE WORDS "YOUR BRIDGE TO THE FUTURE OF LIGHTING".

#### CLASS 37—CONSTRUCTION AND REPAIR

FOR INSTALLATION OF ENERGY EFFICIENT COMMERCIAL AND RESIDENTIAL LIGHT EMITTING DIODE (LED) PRODUCTS; RECYCLING SERVICES, NAMELY, COLLECTION OF INCANDESCENT AND OF LIGHTING PRODUCTS FOR RECYCLING (U.S. CLS. 100, 103 AND 106).

#### CLASS 42—SCIENTIFIC AND COMPUTER SERVICES

FOR PROVIDING CUSTOMIZED DESIGN OF RETROFIT LIGHTING SOLUTIONS AND ENERGY EFFICIENT COMMERCIAL AND RESIDENTIAL LIGHT EMITTING DIODE (LED) AND SOLAR PRODUCTS; CONSULTING SERVICES RELATING TO ENERGY EFFICIENT LIGHTING PRODUCTS, NAMELY, CONDUCTING ENERGY AUDITS TO EVALUATE EXISTING LIGHTING INSTALLATIONS (U.S. CLS. 100 AND 101).

RAUL CORDOVA, EXAMINING ATTORNEY

SN 85-914,663. POWERLANE CORPORATION, ORINDA, CA. FILED 4-25-2013.

SN 85-914,944. MASHANTUCKET PEQUOT TRIBE, MASHANTUCKET, CT. FILED 4-25-2013.

## POWERLANE

THE MARK CONSISTS OF STANDARD CHARACTERS WITHOUT CLAIM TO ANY PARTICULAR FONT, STYLE, SIZE, OR COLOR.

### CLASS 7—MACHINERY

FOR AIR COMPRESSORS FOR POSITIONING ENERGY HARVESTING ARMS IN ELECTRICAL DEVICES; HYDRAULIC PUMPS FOR POSITIONING ENERGY HARVESTING ARMS (U.S. CLS. 13, 19, 21, 23, 31, 34 AND 35).

### CLASS 9—ELECTRICAL AND SCIENTIFIC APPARATUS

FOR ELECTRIC AND ELECTRONIC ENERGY APPARATUS, NAMELY, CHARGING ARM FOR ELECTRIC VEHICLES; ELECTRICAL APPARATUS, NAMELY, CHARGING STATIONS FOR CHARGING ELECTRIC VEHICLES; ELECTRICAL HARVESTING ARM AND CONTROLS; CHARGING STATIONS FOR ELECTRIC VEHICLES; ARMATURES FOR USE IN ELECTRICAL APPARATUS; RECHARGEABLE ELECTRIC BATTERIES; STORAGE BATTERIES; ELECTRIC POWER DISTRIBUTION UNITS; ELECTRIC CONTROLLING DEVICES; ELECTRIC POWER CONNECTORS AND DISTRIBUTION DEVICES; ELECTRONIC POWER SUPPLIES FOR DRIVING ELECTRIC MOTORS; ENERGY HARVESTING ARM AND CONTROL SYSTEM (U.S. CLS. 21, 23, 26, 36 AND 38).

### CLASS 12—VEHICLES

FOR ELECTRIC VEHICLES, NAMELY, LAND VEHICLES; VEHICLE PARTS, NAMELY, ELECTRIC DRIVES FOR LAND VEHICLES AND ELECTRIC POWER AND ENERGY SYSTEMS; VEHICLE ENGINE AND DRIVE PARTS FOR USE IN CONVERTING TO ELECTRIC VEHICLE (U.S. CLS. 19, 21, 23, 31, 35 AND 44).

### CLASS 37—CONSTRUCTION AND REPAIR

FOR ROAD CONSTRUCTION; ELECTRIC ROAD CONSTRUCTION, NAMELY, INSTALLATION OF UNDERGROUND UTILITIES AND ENERGY HARVESTING POINTS; REPAIR AND MAINTENANCE OF ROADWAYS, UTILITIES AND ROAD POWER SYSTEMS; VEHICLE CONVERSION SERVICES, NAMELY, ELECTRIC VEHICLE CONVERSION; BATTERY CHARGING SERVICES; CHARGING STATIONS FOR ELECTRIC VEHICLES (U.S. CLS. 100, 103 AND 106).

### CLASS 42—SCIENTIFIC AND COMPUTER SERVICES

FOR RESEARCH AND DEVELOPMENT OF ENERGY AND POWER SYSTEMS FOR ROADWAYS (U.S. CLS. 100 AND 101).  
JORDAN BAKER, EXAMINING ATTORNEY

## Resort to Anything

THE MARK CONSISTS OF STANDARD CHARACTERS WITHOUT CLAIM TO ANY PARTICULAR FONT, STYLE, SIZE, OR COLOR.

### CLASS 41—EDUCATION AND ENTERTAINMENT

FOR ENTERTAINMENT SERVICES IN THE NATURE OF CASINOS, ARRANGING AND CONDUCTING BINGO GAMES, CINEMA THEATERS, GOLF CLUB FACILITIES; BETTING SERVICES; ARRANGING AND CONDUCTING LIVE MUSICAL AND DANCE PERFORMANCES AND COMPETITIONS IN GAMES OF CHANCE; NIGHT CLUBS (U.S. CLS. 100, 101 AND 107).

### CLASS 43—HOTEL AND RESTAURANT SERVICES

FOR HOTEL ACCOMMODATIONS; CAFE AND RESTAURANT SERVICES; COCKTAIL LOUNGE SERVICES (U.S. CLS. 100 AND 101).  
KATHLEEN M. VANSTON, EXAMINING ATTORNEY

SN 85-918,105. APOLLO EDUCATION GROUP, INC., PHOENIX, AZ. FILED 4-29-2013.



NO CLAIM IS MADE TO THE EXCLUSIVE RIGHT TO USE "PHOENIX CAREER SERVICES", APART FROM THE MARK AS SHOWN.

THE MARK CONSISTS OF THE STACKED WORDING "PHOENIX CAREER SERVICES" WITH FOUR STYLIZED CHEVRONS TO THE IMMEDIATE LEFT.

### CLASS 35—ADVERTISING AND BUSINESS

FOR PROVIDING INFORMATION IN THE FIELD OF PROFESSIONAL DEVELOPMENT, NAMELY, RESUME BUILDING AND INTERVIEW PREPARATION; PROVIDING EMPLOYMENT INFORMATION; PROVIDING AN ON-LINE INFORMATION DIRECTORY FEATURING EMPLOYMENT AND EMPLOYER INFORMATION; ON-LINE PROFESSIONAL NETWORKING SERVICES (U.S. CLS. 100, 101 AND 102).  
FIRST USE 12-11-2012; IN COMMERCE 12-11-2012.

### CLASS 41—EDUCATION AND ENTERTAINMENT

FOR ON-LINE JOURNALS, NAMELY, BLOGS, FEATURING CAREER PLANNING, PERSONAL AND PROFESSIONAL DEVELOPMENT, AND EMPLOYMENT; CAREER COUNSELING SERVICES, NAMELY, PROVIDING ADVICE CONCERNING EDUCATION OPTIONS TO PURSUE CAREER OPPORTUNITIES (U.S. CLS. 100, 101 AND 107).  
FIRST USE 12-11-2012; IN COMMERCE 12-11-2012.

**CLASS 42—SCIENTIFIC AND COMPUTER SERVICES**

FOR PROVIDING A WEBSITE FEATURING TECHNOLOGY THAT ENABLES USERS TO RESEARCH CAREER OPTIONS, CAREER-RELATED STATISTICS, AND EDUCATION REQUIREMENTS FOR CAREERS (U.S. CLS. 100 AND 101).

FIRST USE 12-11-2012; IN COMMERCE 12-11-2012.  
SAMUEL E. SHARPER JR., EXAMINING ATTORNEY

---

SN 85-920,216. CREATIVE REALITIES, INC., BOSTON, MA.  
FILED 5-1-2013.

**CREATIVE REALITIES**

THE MARK CONSISTS OF STANDARD CHARACTERS WITHOUT CLAIM TO ANY PARTICULAR FONT, STYLE, SIZE, OR COLOR.

OWNER OF U.S. REG. NO. 4,051,704.

**CLASS 35—ADVERTISING AND BUSINESS**

FOR BUSINESS INNOVATION CONSULTING, NAMELY, ADVISING OTHERS IN THE AREAS OF SERVICE INNOVATION, PROCESS INNOVATION, AND BUSINESS MODEL INNOVATION (U.S. CLS. 100, 101 AND 102).

FIRST USE 8-1-1988; IN COMMERCE 8-1-1988.

**CLASS 41—EDUCATION AND ENTERTAINMENT**

FOR TRAINING, FACILITATING, AND COACHING OTHERS IN THE AREAS OF PRODUCT AND SERVICE INNOVATION, PROCESS INNOVATION, AND BUSINESS MODEL INNOVATION (U.S. CLS. 100, 101 AND 107).

FIRST USE 8-1-1988; IN COMMERCE 8-1-1988.

**CLASS 42—SCIENTIFIC AND COMPUTER SERVICES**

FOR BUSINESS INNOVATION CONSULTING, NAMELY, ADVISING OTHERS IN THE AREA OF PRODUCT INNOVATION (U.S. CLS. 100 AND 101).

FIRST USE 8-1-1988; IN COMMERCE 8-1-1988.  
HEATHER SAPP, EXAMINING ATTORNEY

---

SN 85-921,699. COHEN, MELVIN A., LOBELVILLE, TN.  
FILED 5-2-2013.

**AN AMERICAN CRISIS:**

THE MARK CONSISTS OF STANDARD CHARACTERS WITHOUT CLAIM TO ANY PARTICULAR FONT, STYLE, SIZE, OR COLOR.

**CLASS 9—ELECTRICAL AND SCIENTIFIC APPARATUS**

FOR DOWNLOADABLE SERIES OF NON-FICTION BOOKS IN ELECTRONIC FORMATS (U.S. CLS. 21, 23, 26, 36 AND 38).

FIRST USE 5-2-2013; IN COMMERCE 5-2-2013.

**CLASS 16—PAPER GOODS AND PRINTED MATTER**

FOR A BOOK TITLE FOR A SERIES OF NON-FICTION BOOKS CONSISTING OF WRITTEN ARTICLES IN THE FIELD OF VETERANS IN PRINT AND ELECTRONIC FORM (U.S. CLS. 2, 5, 22, 23, 29, 37, 38 AND 50).

FIRST USE 5-2-2013; IN COMMERCE 5-2-2013.  
LINDA MICKLEBURGH, EXAMINING ATTORNEY

---

SN 85-927,265. A. BRAND, LLC, WINOOSKI, VT. FILED 5-9-2013.

**A FAB BRAND**

THE MARK CONSISTS OF STANDARD CHARACTERS WITHOUT CLAIM TO ANY PARTICULAR FONT, STYLE, SIZE, OR COLOR.

NO CLAIM IS MADE TO THE EXCLUSIVE RIGHT TO USE "BRAND", APART FROM THE MARK AS SHOWN.

**CLASS 25—CLOTHING**

FOR WEARABLE FABRIC PRODUCTS, NAMELY, EAR WARMERS, WRISTBANDS INCORPORATING WALLETS, WRISTBANDS CONTAINING A COOLING SUBSTANCE TO COOL THE WEARER, AND BODY COOLERS WORN AROUND THE NECK IN THE NATURE OF NECKBANDS AND NECK TUBES CONTAINING A COOLING SUBSTANCE TO COOL THE WEARER AND FEATURING A DETACHABLE BANDANA (U.S. CLS. 22 AND 39).

**CLASS 40—MATERIAL TREATMENT**

FOR CUSTOMIZED PRINTING OF COMPANY NAMES AND LOGOS ON PROMOTIONAL MERCHANDISE MADE FROM FABRIC, HOUSEHOLD ITEMS MADE FROM FABRIC, BODY COOLERS, EAR WARMERS, WRIST WALLETS, BACKPACKS, FABRIC LUNCH BAGS, NAPKINS, AND PILLOWS FOR ADVERTISING PURPOSES; MANUFACTURING OF CUSTOMIZED PROMOTIONAL PRODUCTS FOR OTHERS, NAMELY, PROMOTIONAL MERCHANDISE IN THE NATURE OF SEAT CUSHIONS, LENS CLOTHS AND LENS CASES, AND LUMBAR PILLOWS, BODY COOLERS IN THE NATURE OF WRISTBANDS, NECKBANDS AND NECK TUBES CONTAINING A COOLING SUBSTANCE TO COOL THE WEARER, EAR WARMERS, WRIST WALLETS, BACKPACKS, FABRIC LUNCH BAGS, NAPKINS, AND PILLOWS (U.S. CLS. 100, 103 AND 106).

**CLASS 42—SCIENTIFIC AND COMPUTER SERVICES**

FOR DESIGN OF CUSTOMIZED PROMOTIONAL PRODUCTS FOR OTHERS, NAMELY, PROMOTIONAL MERCHANDISE MADE FROM FABRIC, HOUSEHOLD ITEMS MADE FROM FABRIC, BODY COOLERS IN THE NATURE OF WRISTBANDS, NECKBAND AND NECK TUBES CONTAINING A COOLING SUBSTANCE TO COOL THE WEARER, EAR WARMERS, WRIST WALLETS, BACKPACKS, FABRIC LUNCH BAGS, NAPKINS, AND PILLOWS (U.S. CLS. 100 AND 101).

ELIZABETH CHANG, EXAMINING ATTORNEY

---

SN 85-929,206. THE PARADIGM PROJECT, LLC., COLORADO SPRINGS, CO. FILED 5-10-2013.

**EZY**

THE MARK CONSISTS OF STANDARD CHARACTERS WITHOUT CLAIM TO ANY PARTICULAR FONT, STYLE, SIZE, OR COLOR.

OWNER OF U.S. REG. NO. 4,385,408.

**CLASS 11—ENVIRONMENTAL CONTROL APPARATUS**

FOR WOOD BURNING AND CHARCOAL BURNING COOKING STOVES; SOLAR POWERED LIGHTING FIXTURES AND PARTS THEREFOR; DRINKING WATER FILTERS (U.S. CLS. 13, 21, 23, 31 AND 34).

**CLASS 35—ADVERTISING AND BUSINESS**

FOR RETAIL STORE SERVICES FEATURING WOOD BURNING AND CHARCOAL BURNING COOKING STOVES, SOLAR POWERED LIGHTING FIXTURES AND PARTS THEREFOR AND DRINKING WATER FILTERS; PROMOTING CHARITABLE DONATIONS FOR OTHERS RELATING TO SAME (U.S. CLS. 100, 101 AND 102).

JONATHAN FALK, EXAMINING ATTORNEY

---

SN 85-931,175. SINAI SPECIAL NEEDS INSTITUTE, TEANECK, NJ. FILED 5-14-2013.



NO CLAIM IS MADE TO THE EXCLUSIVE RIGHT TO USE "SCHOOLS" AND "SPECIAL EDUCATION", APART FROM THE MARK AS SHOWN.

THE MARK CONSISTS OF THE WORD "SINAI" ON TOP OF A RECTANGLE CONTAINING THE WORD "SCHOOLS" UNDERNEATH THE RECTANGLE IS THE WORDING "A UNIQUELY SPECIAL EDUCATION". THERE IS A CURVED LINE ABOVE THE WORD "SINAI" AND A MOUNTAIN BEHIND THE WORD "SINAI".

**CLASS 41—EDUCATION AND ENTERTAINMENT**

FOR EDUCATIONAL SERVICES, NAMELY, PROVIDING SCHOOLS FEATURING COURSES OF INSTRUCTION AT THE KINDERGARTEN THROUGH POST-HIGH SCHOOL LEVEL FOR CHILDREN AND YOUNG ADULTS WITH DEVELOPMENTAL AND LEARNING DISABILITIES (U.S. CLS. 100, 101 AND 107).

FIRST USE 11-29-2007; IN COMMERCE 11-29-2007.

**CLASS 43—HOTEL AND RESTAURANT SERVICES**

FOR PROVIDING SUPERVISED HOUSING ACCOMMODATIONS, NAMELY, RESIDENTIAL HOMES AND HOUSING SERVICES FOR YOUNG ADULTS WITH DEVELOPMENTAL DISABILITIES (U.S. CLS. 100 AND 101).

FIRST USE 11-29-2007; IN COMMERCE 11-29-2007.  
TINA BROWN, EXAMINING ATTORNEY

---

SN 85-931,436. ENIGMEDIA, S.L., 20018 SAN SEBASTIAN, SPAIN, FILED 5-14-2013.

**ENIGMEDIA**

THE MARK CONSISTS OF STANDARD CHARACTERS WITHOUT CLAIM TO ANY PARTICULAR FONT, STYLE, SIZE, OR COLOR.

OWNER OF ERPN CMNTY TM OFC REG. NO. 011131001, DATED 12-28-2012, EXPIRES 12-28-2022.

**CLASS 9—ELECTRICAL AND SCIENTIFIC APPARATUS**

FOR COMPUTER GAME SOFTWARE AND HARDWARE; SECURE SOFTWARE AND HARDWARE FOR THE COMMUNICATION OF DATA, VOICE AND IMAGES; SOFTWARE FOR ENCRYPTION, ENCODING AND DECODING OF DATA, VOICE AND IMAGES (U.S. CLS. 21, 23, 26, 36 AND 38).

**CLASS 38—COMMUNICATION**

FOR TELECOMMUNICATIONS BY E-MAIL; TRANSMISSION OF MESSAGES BY COMPUTER, AND BY FIXED AND MOBILE TELEPHONE; TRANSMISSION OF DATA, VOICE AND IMAGES BY COMPUTER, AND BY FIXED AND MOBILE TELEPHONE (U.S. CLS. 100, 101 AND 104).

**CLASS 42—SCIENTIFIC AND COMPUTER SERVICES**

FOR DESIGN AND DEVELOPMENT OF COMPUTER HARDWARE AND SOFTWARE; DESIGN AND DEVELOPMENT OF SECURE SOFTWARE AND HARDWARE FOR THE COMMUNICATION OF DATA, VOICE AND IMAGES; DESIGN AND DEVELOPMENT OF SOFTWARE AND HARDWARE FOR ENCRYPTION, ENCODING AND DECODING OF DATA, VOICE AND IMAGES; ENGINEERING WORK, NAMELY, ENGINEERING DESIGN SERVICES; PROFESSIONAL CONSULTANCY RELATING TO DEVELOPMENT OF SECURE SOFTWARE AND HARDWARE FOR THE COMMUNICATION OF DATA, VOICE AND IMAGES; PROFESSIONAL CONSULTANCY RELATING TO DEVELOPMENT OF SOFTWARE AND HARDWARE FOR ENCRYPTION, ENCODING AND DECODING OF DATA, VOICE AND IMAGES; DESIGN AND DEVELOPMENT OF WEBPAGES; MAINTENANCE OF WEBPAGES FOR OTHERS; DESIGN AND DEVELOPMENT OF WEBPAGES FOR THE COMMUNICATION OF DATA, VOICE AND IMAGES; CONSULTANCY SERVICES RELATING TO COMPUTER SECURITY; PROVIDING OF SECURITY SERVICES FOR COMPUTER NETWORKS, COMPUTER ACCESS AND COMPUTERISED TRANSFERS OF DOCUMENTS (U.S. CLS. 100 AND 101).

FLORENTINA BLANDU, EXAMINING ATTORNEY



SN 85-943,946. KUDER, INC., ADEL, IA. FILED 5-28-2013.

SN 85-947,092. BOOMSLANG RECORDS, LLC, DANIA BEACH, FL. FILED 5-31-2013.

## Kuder Career Interests Assessment

THE MARK CONSISTS OF STANDARD CHARACTERS WITHOUT CLAIM TO ANY PARTICULAR FONT, STYLE, SIZE, OR COLOR.

NO CLAIM IS MADE TO THE EXCLUSIVE RIGHT TO USE "CAREER INTERESTS ASSESSMENT", APART FROM THE MARK AS SHOWN.

### CLASS 35—ADVERTISING AND BUSINESS

FOR CAREER COUNSELING, NAMELY, PROVIDING ADVICE CONCERNING CAREER OPPORTUNITIES THROUGH THE ADMINISTRATION AND SCORING OF ASSESSMENT EVALUATIONS TO DETERMINE APPROPRIATE CAREER CHOICE FOR INDIVIDUALS (U.S. CLS. 100, 101 AND 102).

FIRST USE 8-6-2012; IN COMMERCE 8-6-2012.

### CLASS 41—EDUCATION AND ENTERTAINMENT

FOR PROVIDING EDUCATIONAL ASSESSMENT SERVICES TO HELP INDIVIDUALS DETERMINE APPROPRIATE CAREER CHOICES (U.S. CLS. 100, 101 AND 107).

FIRST USE 8-6-2012; IN COMMERCE 8-6-2012.

WON TEAK OH, EXAMINING ATTORNEY

---

SN 85-944,069. KUDER, INC., ADEL, IA. FILED 5-28-2013.

WE HELP YOU SEE WHAT YOU  
CAN BE

THE MARK CONSISTS OF STANDARD CHARACTERS WITHOUT CLAIM TO ANY PARTICULAR FONT, STYLE, SIZE, OR COLOR.

### CLASS 35—ADVERTISING AND BUSINESS

FOR CAREER COUNSELING, NAMELY, PROVIDING ADVICE CONCERNING CAREER OPPORTUNITIES THROUGH THE ADMINISTRATION AND SCORING OF ASSESSMENT EVALUATIONS TO DETERMINE APPROPRIATE CAREER CHOICE FOR INDIVIDUALS (U.S. CLS. 100, 101 AND 102).

FIRST USE 8-10-2012; IN COMMERCE 8-10-2012.

### CLASS 41—EDUCATION AND ENTERTAINMENT

FOR PROVIDING EDUCATIONAL ASSESSMENT SERVICES TO HELP INDIVIDUALS DETERMINE APPROPRIATE CAREER CHOICES (U.S. CLS. 100, 101 AND 107).

FIRST USE 8-10-2012; IN COMMERCE 8-10-2012.

WON TEAK OH, EXAMINING ATTORNEY

## SHATTERGLASS

THE MARK CONSISTS OF STANDARD CHARACTERS WITHOUT CLAIM TO ANY PARTICULAR FONT, STYLE, SIZE, OR COLOR.

### CLASS 9—ELECTRICAL AND SCIENTIFIC APPARATUS

FOR DOWNLOADABLE MUSIC FILES; DOWNLOADABLE MUSICAL SOUND RECORDINGS; DOWNLOADABLE VIDEO RECORDINGS FEATURING MUSIC; DOWNLOADABLE MUSIC VIA THE INTERNET AND WIRELESS DEVICES; MUSICAL SOUND RECORDINGS; MUSICAL VIDEO RECORDINGS (U.S. CLS. 21, 23, 26, 36 AND 38).

FIRST USE 12-7-2012; IN COMMERCE 12-7-2012.

### CLASS 41—EDUCATION AND ENTERTAINMENT

FOR ENTERTAINMENT IN THE NATURE OF VISUAL AND AUDIO PERFORMANCES, NAMELY, MUSICAL BAND, ROCK GROUP, GYMNASTIC, DANCE, AND BALLET PERFORMANCES; ENTERTAINMENT IN THE NATURE OF LIVE PERFORMANCES BY A MUSICAL GROUP; ENTERTAINMENT SERVICES IN THE NATURE OF LIVE MUSICAL PERFORMANCES; ENTERTAINMENT, NAMELY, LIVE PERFORMANCES BY A MUSICAL BAND; LIVE PERFORMANCES BY A MUSICAL GROUP (U.S. CLS. 100, 101 AND 107).

FIRST USE 12-7-2012; IN COMMERCE 12-7-2012.

TRACY CROSS, EXAMINING ATTORNEY

---

SN 85-947,117. PRIME AE GROUP, INC., OWINGS MILLS, MD. FILED 5-31-2013.



NO CLAIM IS MADE TO THE EXCLUSIVE RIGHT TO USE "AE", APART FROM THE MARK AS SHOWN.

THE MARK CONSISTS OF THE WORDS "PRIME AE", WHERE THE WORDING IN "AE" IS WRITTEN VERTICALLY, WITH A DESIGN OF A ROOFTOP ABOVE THE WORDS.

### CLASS 36—INSURANCE AND FINANCIAL

FOR REAL ESTATE CONSULTING; EVALUATION OF REAL PROPERTY (U.S. CLS. 100, 101 AND 102).

**CLASS 37—CONSTRUCTION AND REPAIR**

FOR INSPECTIONS IN THE COURSE OF CONSTRUCTION OF BRIDGES, FACILITIES, HIGHWAYS, ROADS, WATER LINES, WASTEWATER LINES, TRANSIT, AND RAIL; CONSTRUCTION MANAGEMENT; BRIDGE INSPECTIONS; INSPECTION SERVICES IN THE COURSE OF CONSTRUCTION OF INDUSTRIAL FACILITIES; LAND DEVELOPMENT, NAMELY, PLANNING AND LAYING OUT OF COMMERCIAL BUILDINGS AND INFRASTRUCTURE; LAND DEVELOPMENT CONSULTATION SERVICES FOR THE PLANNING AND DEVELOPMENT OF RESIDENTIAL COMMUNITIES, SCHOOLS, AND SENIOR CENTERS (U.S. CLS. 100, 103 AND 106).

**CLASS 42—SCIENTIFIC AND COMPUTER SERVICES**

FOR HIGHWAY AND TRANSPORTATION ENGINEERING; CIVIL ENGINEERING; ENVIRONMENTAL ENGINEERING; WASTEWATER ENGINEERING; HYDROLOGIC ENGINEERING; BRIDGE DESIGN AND ENGINEERING; STRUCTURAL ENGINEERING; SURVEYING; ARCHITECTURAL DESIGN; GIS SERVICES IN THE NATURE OF MAPPING; DATA CONVERSION OF ELECTRONIC INFORMATION; DATABASE DESIGN AND DEVELOPMENT; COMPUTER MODELING SERVICES THROUGH THE CREATION OF PHYSICAL AND DIGITAL 3-D MODELS OF BUILDINGS; ENGINEERING SERVICES FOR BUILDING AND PROPERTY CONDITION ASSESSMENT (U.S. CLS. 100 AND 101).

CIMMERIAN COLEMAN, EXAMINING ATTORNEY

---

SN 85-947,733. NATIONAL COALITION FOR CANCER SURVIVORSHIP, INC., SILVER SPRING, MD. FILED 5-31-2013.

WHILE WE HOPE FOR THE  
CURE...WE MUST FOCUS ON  
THE CARE

THE MARK CONSISTS OF STANDARD CHARACTERS WITHOUT CLAIM TO ANY PARTICULAR FONT, STYLE, SIZE, OR COLOR.

**CLASS 35—ADVERTISING AND BUSINESS**

FOR PROMOTING PUBLIC AWARENESS OF ISSUES AFFECTING CANCER SURVIVORS; LOBBYING SERVICES, NAMELY, PROMOTING THE INTERESTS OF CANCER SURVIVORS IN THE FIELDS OF POLITICS, LEGISLATION AND REGULATION; PUBLIC ADVOCACY TO PROMOTE AWARENESS OF ISSUES AFFECTING CANCER SURVIVORS; PROVIDING INFORMATION, INCLUDING PROVIDING INFORMATION BY EMAIL, IN THE FIELD OF PUBLIC ADVOCACY EFFORTS ON BEHALF OF CANCER SURVIVORS (U.S. CLS. 100, 101 AND 102).

**CLASS 45—PERSONAL AND LEGAL SERVICES**

FOR PROVIDING INFORMATION RELATING TO LEGAL AFFAIRS, INCLUDING LEGAL INFORMATION BY EMAIL, IN THE FIELD OF POLITICAL, LEGISLATIVE AND REGULATORY EFFORTS ON BEHALF OF CANCER SURVIVORS (U.S. CLS. 100 AND 101).

GISELLE AGOSTO, EXAMINING ATTORNEY

SN 85-950,634. STRATEGY FIRST INC., MONTRÉAL, QUEBEC, CANADA, FILED 6-4-2013.

TIMELINES: ASSAULT ON  
AMERICA

THE MARK CONSISTS OF STANDARD CHARACTERS WITHOUT CLAIM TO ANY PARTICULAR FONT, STYLE, SIZE, OR COLOR.

**CLASS 9—ELECTRICAL AND SCIENTIFIC APPARATUS**

FOR COMPUTER GAME SOFTWARE AND RELATED INSTRUCTION MANUAL SOLD TOGETHER AS A UNIT; INTERACTIVE VIDEO GAME PROGRAMS; COMPUTER GAME CARTRIDGES; COMPUTER GAME DISCS; DOWNLOADABLE COMPUTER GAME SOFTWARE; INTERACTIVE VIDEO GAME COMPRISED OF A CARTRIDGE; DOWNLOADABLE COMPUTER GAME SOFTWARE; INTERACTIVE VIDEO GAME COMPRISED OF A DVD (U.S. CLS. 21, 23, 26, 36 AND 38).

**CLASS 41—EDUCATION AND ENTERTAINMENT**

FOR ENTERTAINMENT SERVICES, NAMELY, PROVIDING AN ON-LINE COMPUTER GAME; ONLINE ENTERTAINMENT IN THE NATURE OF COMPUTER GAME TOURNAMENTS; PROVIDING ONLINE NEWS AND INFORMATION IN THE FIELD OF COMPUTER GAMES; ENTERTAINMENT SERVICES, NAMELY, CONDUCTING CONTESTS ONLINE; PROVIDING A WEBSITE FOR ORGANIZING, PLANNING AND CONDUCTING EXHIBITIONS AND SPECIAL EVENTS BETWEEN COMPUTER GAME PLAYERS AND INTEREST GROUPS FOR ENTERTAINMENT PURPOSES (U.S. CLS. 100, 101 AND 107).

DEIRDRE ROBERTSON, EXAMINING ATTORNEY

---

SN 85-952,002. UNITED PHOENIX FIREFIGHTER CHARITIES, PHOENIX, AZ. FILED 6-5-2013.

Firestrong

THE MARK CONSISTS OF STANDARD CHARACTERS WITHOUT CLAIM TO ANY PARTICULAR FONT, STYLE, SIZE, OR COLOR.

**CLASS 36—INSURANCE AND FINANCIAL**

FOR PROVIDING EDUCATIONAL RESOURCES, NAMELY, PROVIDING INFORMATION ON FINANCIAL PROGRAMS, FINANCIAL TOOLS, AND FINANCIAL COUNSELING AVAILABLE TO BOTH FIREFIGHTERS AND NON-FIREFIGHTERS (U.S. CLS. 100, 101 AND 102).

FIRST USE 8-15-2011; IN COMMERCE 8-15-2011.

**CLASS 44—MEDICAL, BEAUTY AND AGRICULTURAL SERVICES**

FOR PROVIDING EDUCATIONAL RESOURCES, NAMELY, PROVIDING MENTAL HEALTH AND WELLNESS AND DRUG AND ALCOHOL ADDICTION INFORMATION FOR BOTH FIREFIGHTERS AND NON-FIREFIGHTERS; ASSESSMENT TOOLS FOR BOTH FIREFIGHTERS AND NON-FIREFIGHTERS, NAMELY, WEB-BASED HEALTH AND MENTAL WELLNESS ASSESSMENT SERVICES FEATURING HEALTH-RELATED QUESTIONS FOR RESPONSE FROM THE USER THAT RESULT IN A REPORT THAT PROVIDES HEALTH AND MENTAL WELLNESS-RELATED INFORMATION IN THE FORM OF RECOMMENDED EDUCATIONAL RESOURCES AND TREATMENT INFORMATION (U.S. CLS. 100 AND 101).

FIRST USE 8-15-2011; IN COMMERCE 8-15-2011.

CHRISTOPHER REAMS, EXAMINING ATTORNEY

---

SN 85-953,550. THE INTERNATIONAL DONUT PLANT LLC, NEW YORK, NY. FILED 6-7-2013.



OWNER OF U.S. REG. NO. 3,604,921.

NO CLAIM IS MADE TO THE EXCLUSIVE RIGHT TO USE "DOUGHNUT" AND "NEW YORK CITY", APART FROM THE MARK AS SHOWN.

THE MARK CONSISTS OF GOING FROM LEFT TO RIGHT: NINE SMALL CIRCLES OF EQUAL SIZE WITH LIGHT SHADING ON THE INSIDE OF EACH CIRCLE AND THE NINE CIRCLES ARE ARRANGED IN A GRID OF THREE ROWS AND THREE COLUMNS; IMMEDIATELY TO THE RIGHT OF THE NINE CIRCLES ARE FOUR LARGER CIRCLES OF EQUAL SIZE WITH A SOLID DOT IN THE CENTER OF EACH CIRCLE AND THE FOUR CIRCLES ARE ARRANGED IN A GRID OF TWO ROWS AND TWO COLUMNS; IMMEDIATELY TO THE RIGHT OF THE FOUR CIRCLES ARE TWO CONCENTRIC SQUARES HAVING A SOLID DOT IN THE CENTER OF THE INNER SQUARE; IMMEDIATELY TO THE RIGHT OF THE TWO CONCENTRIC SQUARES IS ONE CIRCLE WITH A SOLID DOT IN THE CENTER AND A STRAIGHT HORIZONTAL LINE EXTENDS TO THE RIGHT FROM THE CENTER OF THE RIGHT SIDE OF THE DRAWN CIRCLE; AND IMMEDIATELY TO THE RIGHT OF THE ONE LARGER CIRCLE ARE THE WORDS "DOUGHNUT PLANT" ABOVE THE HORIZONTAL LINE AND THE WORDS "NEW YORK CITY" BELOW THE HORIZONTAL LINE.

**CLASS 29—MEATS AND PROCESSED FOODS**

FOR FILLINGS, GLAZES, COATINGS, TOPPINGS, GARNISHES, SAUCES, PUDDINGS, CREAMS, POWDERS, PRESERVES, CONCENTRATES NOT INCLUDING FRUIT JUICE CONCENTRATES, JAMS, JELLIES, SPREADS, DIPS, BUTTERS, MOUSSES, PASTES, FLAVORINGS, EXTRACTS, AND JUICES CONTAINING OR MADE WITH FRUITS, NUTS, PROCESSED EDIBLE SEEDS, PROCESSED BEANS NOT INCLUDING COFFEE BEANS, PROCESSED PULSES, AND/OR DAIRY PRODUCTS AND WHICH MAY BE USED ALONE OR AS AN INGREDIENT FOR ALL TYPES OF BAKERY PRODUCTS, NAMELY, DOUGHNUTS, BREADS, ROLLS, BUNS, CAKES, COOKIES, PIES, BAGELS, PASTRIES, MUFFINS, VEGETARIAN PATTIES, CUSTARDS, PUDDINGS, AND ICE CREAMS; MILKS CONTAINING OR MADE FROM NUTS NOT INCLUDING COCONUTS OR ALMONDS, FRUITS, GRAINS, BEANS, SEEDS, GRASSES, AND PLANTS (U.S. CL. 46).

FIRST USE 12-1-2000; IN COMMERCE 12-1-2000.

**CLASS 30—STAPLE FOODS**

FOR DOUGHNUTS; BAKERY PRODUCTS, NAMELY, DOUGH-BASED FOODSTUFFS WHICH ARE SWEET OR SAVORY, NAMELY, BREADS, DOUGHNUTS, ROLLS, BUNS, CAKES, COOKIES, PIES, BAGELS, PASTRIES, MUFFINS, PATTIES; DOUGH-BASED FOODSTUFFS, WHICH CONTAIN OR ARE FILLED, GLAZED, COATED, TOPPED, MADE, OR GARNISHED WITH ANY FORM OF FRUITS, VEGETABLES, DAIRY, NUTS, SEEDS, LEGUMES, ROOTS, GRAINS, CEREALS, FLOURS, BEANS, PULSES, ROOTS, COCOA, CHOCOLATE, COFFEE, ESPRESSO, TEA, FLAVORINGS, EXTRACTS, HONEY, SUGARS, SWEETENERS, SALTS, HERBS, SPICES, EDIBLE FLOWERS, EDIBLE PLANTS, CUSTARDS, PUDDINGS, CREAMS, SAUCES, POWDERS, PRESERVES, JAMS, JELLIES, AND/OR CONFECTIONERY PRODUCTS; FOODSTUFFS, NAMELY, DOUGH-BASED EDIBLE GOODS WHICH ARE FRIED, DEEP FRIED, RAW, BAKED, BOILED, COOKED, STEAMED, SAUTÉED, BROILED, AND/OR ROASTED; FLOUR-BASED MIXES FOR BREADS, DOUGHNUTS, ROLLS, BUNS, CAKES, COOKIES, BAGELS, PASTRIES, MUFFINS, AND PATTIES; COFFEES; TEAS; CHOCOLATE-BASED BEVERAGES; COCOA-BASED BEVERAGES; ICE CREAMS; FILLINGS, GLAZES, COATINGS, TOPPINGS, GARNISHES, SAUCES, CUSTARDS, PUDDINGS, CREAMS, POWDERS, PRESERVES, CONCENTRATES, SPREADS, DIPS, BUTTERS, SYRUPS, MOUSSES, PASTES, FLAVORINGS, EXTRACTS, AND JUICES CONTAINING OR MADE WITH CHOCOLATE, COCOA, PROCESSED EDIBLE GRAINS, COFFEE AND COFFEE BEANS AND TEA AND WHICH MAY BE USED ALONE OR AS AN INGREDIENT FOR ALL TYPES OF BAKERY PRODUCTS, NAMELY, DOUGHNUTS, BREADS, ROLLS, BUNS, CAKES, COOKIES, PIES, BAGELS, PASTRIES, MUFFINS, VEGETARIAN PATTIES, CUSTARDS, PUDDINGS, AND ICE CREAMS (U.S. CL. 46).

FIRST USE 12-1-2000; IN COMMERCE 12-1-2000.

JEFF DEFORD, EXAMINING ATTORNEY

---

SN 85-958,030. PR NEWSWIRE ASSOCIATION LLC, NEW YORK, NY. FILED 6-12-2013.

# PRN GLOBAL

THE MARK CONSISTS OF STANDARD CHARACTERS WITHOUT CLAIM TO ANY PARTICULAR FONT, STYLE, SIZE, OR COLOR.

OWNER OF U.S. REG. NO. 3,307,144.

NO CLAIM IS MADE TO THE EXCLUSIVE RIGHT TO USE "GLOBAL", APART FROM THE MARK AS SHOWN.

**CLASS 35—ADVERTISING AND BUSINESS**

FOR ADVICE IN THE FIELD OF BUSINESS MANAGEMENT; MEDIA MONITORING SERVICES, NAMELY, MONITORING PRINT MEDIA, TELEVISION, RADIO AND OTHER MEDIA FOR CUSTOMER-SPECIFIED TOPICS, GATHERING RELEVANT CONTENT ON THOSE TOPICS AND PROVIDING DOCUMENTATION AND ANALYSIS OF THAT MEDIA CONTENT TO OTHERS FOR BUSINESS PURPOSES; NEWS CLIPPING SERVICES; ONLINE MEDIA MONITORING SERVICES USING COMPUTER SOFTWARE TO AUTOMATICALLY MONITOR INTERNET WEBSITES AND ONLINE PUBLICATIONS FOR CUSTOMER-SPECIFIED TOPICS TO CAPTURE RELEVANT CONTENT ON THOSE TOPICS, AND PROVIDING DOCUMENTATION AND ANALYSIS OF THAT ONLINE CONTENT TO OTHERS FOR BUSINESS PURPOSES; REGULATORY SUBMISSION MANAGEMENT, NAMELY, ASSISTING OTHERS IN PREPARING AND FILING DOCUMENTS WITH GOVERNMENTAL REGULATORY BODIES; PROVIDING AN ONLINE SEARCHABLE DATABASE FEATURING BUSINESS INFORMATION AND JOURNALIST BUSINESS CONTACTS NAMELY, CONTACT INFORMATION, RECENT PUBLICATIONS, EDITORIAL INTERESTS, INDUSTRY BEATS, GEOGRAPHIC LOCATION, DESIGNATION MARKET AREA RANKINGS AND SCORES REFLECTING MEASUREMENTS OF A PERSON'S INFLUENCE, FOR USE BY OTHERS (U.S. CLS. 100, 101 AND 102).

**CLASS 38—COMMUNICATION**

FOR SATELLITE TRANSMISSION OF AUDIO, VIDEO AND MULTIMEDIA CONTENT; TRANSMISSION OF AUDIO, VIDEO AND MULTIMEDIA CONTENT VIA THE INTERNET; TELECOMMUNICATIONS IN THE NATURE OF AUDIO, VIDEO AND MULTIMEDIA CONTENT BY EMAIL; AUDIO AND VIDEO BROADCASTING SERVICES; TRANSMISSION OF PRESS RELEASES, NEWS, AND BUSINESS AND ENTERTAINMENT INFORMATION VIA THE INTERNET, FACSIMILE, EMAIL AND MOBILE DEVICES; ELECTRONIC DELIVERY OF PHOTOGRAPHS VIA A GLOBAL COMPUTER NETWORK (U.S. CLS. 100, 101 AND 104).

**CLASS 39—TRANSPORTATION AND STORAGE**

FOR STORAGE SERVICES FOR ARCHIVING ELECTRONIC DATA, IMAGES AND AUDIO, VIDEO AND MULTIMEDIA RECORDINGS IN THE NATURE OF NEWS AND RELATED INFORMATION (U.S. CLS. 100 AND 105).

**CLASS 40—MATERIAL TREATMENT**

FOR PRINTING SERVICES (U.S. CLS. 100, 103 AND 106).

**CLASS 41—EDUCATION AND ENTERTAINMENT**

FOR PHOTOGRAPHY SERVICES (U.S. CLS. 100, 101 AND 107).

**CLASS 42—SCIENTIFIC AND COMPUTER SERVICES**

FOR PROVIDING A WEBSITE THAT GIVES USERS THE ABILITY TO REVIEW AND UTILIZE A TEMPLATE TO CREATE AND MAINTAIN ONLINE PRESS KITS; HOSTING WEBSITES THAT CONTAIN ONLINE PRESS KITS FOR OTHERS; INFORMATION TECHNOLOGY CONSULTING SERVICES IN THE FIELD OF TAXONOMY OF DATA AND METADATA AND THE CLASSIFICATION, CATEGORIZATION AND TAGGING OF DATA FOR THE PURPOSE OF SEARCHING AND RETRIEVING PERTINENT INFORMATION; INTERACTIVE WEBSITE DEVELOPMENT FOR OTHERS; COMPUTER SERVICES NAMELY, SEARCH ENGINE OPTIMIZATION; CREATING AND MAINTAINING AN ONLINE COMMUNITY FOR JOURNALISTS, COMMUNICATIONS PROFESSIONALS AND OTHER REGISTERED USERS TO FACILITATE THE LOCATION OF EXPERT SOURCES IN VARIOUS FIELDS (U.S. CLS. 100 AND 101).

MICHAEL WEBSTER, EXAMINING ATTORNEY

SN 85-958,386. ROWENTA WERKE GMBH, OFFENBACH AM MAIN, FED REP GERMANY, FILED 6-12-2013.



OWNER OF ERPN CMNTY TM OFC REG. NO. 002795714, DATED 2-26-2004, EXPIRES 7-29-2022.

OWNER OF U.S. REG. NOS. 1,969,134, 2,918,498 AND OTHERS.

THE MARK CONSISTS OF THE WORD "ROWENTA" IN STYLIZED FORM.

**CLASS 8—HAND TOOLS**

FOR ELECTRIC AND MANUAL HAIR CLIPPERS, DEPILATORY APPLIANCES, ELECTRIC SHAVERS, ELECTRIC RAZORS, ELECTRIC HAIR DRYERS AND PEDICURE SETS, (BASED ON 44(E)) ELECTRIC HAIR STRAIGHTENERS (U.S. CLS. 23, 28 AND 44).

**CLASS 11—ENVIRONMENTAL CONTROL APPARATUS**

FOR HEATING APPARATUS, NAMELY, RADIATORS AND ELECTRIC RADIANT HEATERS FOR HOUSEHOLD PURPOSES, ELECTRIC HAIR DRYERS AND REPLACEMENT PARTS AND FITTINGS THEREFOR, ELECTRICALLY HEATED HAIR CRIMPERS, ROOM AIR CONDITIONERS, ELECTRIC VENTILATION FANS FOR HOUSEHOLD USE, ELECTRIC HUMIDIFIERS, ELECTRIC PLATE WARMERS; APPARATUS FOR MAKING BEVERAGES MADE WITH HOT WATER, NAMELY, ELECTRIC KETTLES, ELECTRICAL COFFEE BREWING MACHINES AND ELECTRIC ESPRESSO MACHINES, ELECTRIC APPARATUS FOR COOKING EGGS, ELECTRIC DEEP-FAT FRYERS, ELECTRIC WOKS, ELECTRIC GRIDDLE, ELECTRIC RACLETTE APPARATUS, NAMELY, ELECTRIC APPARATUS CONSISTING OF A GRILL UNDER WHICH INDIVIDUAL FRYING PANS ARE SET IN ORDER TO MELT CHEESE, NAMELY, RACLETTE CHEESE, AND ON TOP OF WHICH A METALLIC PIECE SERVES AS A CHAFING DISH, ELECTRIC WAFFLE IRONS, ELECTRIC RICE STEAMERS, ELECTRIC RICE COOKERS, ELECTRIC SANDWICH TOASTERS, ELECTRIC COOKING OVENS, ELECTRIC GRILL PANS/FRYING PANS AND ROTISERIES, AND REPLACEMENT PARTS OF THE AFORESAID GOODS; GARMENT STEAMERS; STEAMER BRUSHES FOR GARMENTS (U.S. CLS. 13, 21, 23, 31 AND 34).

**CLASS 21—HOUSEWARES AND GLASS**

FOR HAIR BRUSHES, TOOTH BRUSHES, COMBS AND ELECTRICALLY-HEATED HAIR BRUSHES, ELECTRIC TOOTH BRUSHES, SKILLETS, POT LIDS, NON-ELECTRIC PRESSURE COOKERS, KITCHEN AND HOUSEHOLD UTENSILS AND CONTAINERS, NAMELY, GLASS CANS, TRASH CANS AND UTENSIL HOLDERS; THERMO-INSULATED DRINKING FLASKS, REPLACEMENT PART OF THE AFORESAID GOODS; HAND-OPERATED DOMESTIC APPLIANCES, NAMELY, COFFEE GRINDERS, FRUIT AND VEGETABLE PRESSES; STEAMER BRUSHES; IRONING BOARD (U.S. CLS. 2, 13, 23, 29, 30, 33, 40 AND 50).

GENE MACIOL, EXAMINING ATTORNEY

SN 85-961,135, PEGASYS, INC., TOKYO 130-0023, JAPAN, FILED 6-17-2013.

**PGMX**

THE MARK CONSISTS OF STANDARD CHARACTERS WITHOUT CLAIM TO ANY PARTICULAR FONT, STYLE, SIZE, OR COLOR.

OWNER OF JAPAN REG. NO. 8632456, DATED 11-23-2013, EXPIRES 11-23-2023.

**CLASS 9—ELECTRICAL AND SCIENTIFIC APPARATUS**

FOR COMPUTER SOFTWARE FOR CONVERTING, COMPRESSING OR CREATING VIDEO FILES; DOWNLOADABLE SOFTWARE FOR CONVERTING, COMPRESSING OR CREATING VIDEO FILES; INTEGRATED CIRCUITS AND IMAGE CAPTURE DEVICE, NAMELY, ANALOG TO DIGITAL CONVERTER, FOR USE WITH COMPUTER SOFTWARE FOR CONVERTING, COMPRESSING OR CREATING VIDEO FILES (U.S. CLS. 21, 23, 26, 36 AND 38).

**CLASS 42—SCIENTIFIC AND COMPUTER SERVICES**

FOR RENTAL AND LEASING OF COMPUTERS, RENTAL AND LEASING OF COMPUTER SOFTWARE FOR CONVERTING, COMPRESSING OR CREATING VIDEO FILES; COMPUTER SOFTWARE DESIGN FOR OTHERS, UPDATING OF COMPUTER SOFTWARE, MAINTENANCE OF COMPUTER SOFTWARE; RENTAL AND LEASING OF INTEGRATED CIRCUITS AND IMAGE CAPTURE DEVICE, NAMELY, ANALOG TO DIGITAL CONVERTER, FOR USE WITH COMPUTER SOFTWARE FOR CONVERTING, COMPRESSING OR CREATING VIDEO FILES (U.S. CLS. 100 AND 101).

MICHELLE DUBOIS, EXAMINING ATTORNEY

SN 85-961,440, KALEO SOFTWARE, INC., EL SEGUNDO, CA. FILED 6-17-2013.

**KALEO**

THE MARK CONSISTS OF STANDARD CHARACTERS WITHOUT CLAIM TO ANY PARTICULAR FONT, STYLE, SIZE, OR COLOR.

**CLASS 9—ELECTRICAL AND SCIENTIFIC APPARATUS**

FOR COMPUTER SOFTWARE IN THE FIELD OF ENTERPRISE KNOWLEDGE MANAGEMENT FOR USERS TO ASK AND ANSWER QUESTIONS REGARDING A VARIETY OF TOPICS RELATING TO JOB KNOWLEDGE, JOB RESOURCES, JOB FUNCTION, ORGANIZATIONAL EXPERTISE, AND THE INTERACTION OF TEAMS, ALL WITHIN AN ENTERPRISE, WITH THIRD PARTIES, AND WITHIN SOCIAL AND KNOWLEDGE COMMUNITIES; COMPUTER SOFTWARE IN THE FIELD OF ENTERPRISE KNOWLEDGE MANAGEMENT FOR SEARCHING FOR, STORING, ORGANIZING, AND RETRIEVING INFORMATION AND DATA REGARDING A VARIETY OF TOPICS RELATING TO JOB KNOWLEDGE, JOB RESOURCES, JOB FUNCTION, ORGANIZATIONAL EXPERTISE, AND THE INTERACTION OF TEAMS, ALL WITHIN AN ENTERPRISE, WITH THIRD PARTIES, AND WITHIN SOCIAL AND KNOWLEDGE COMMUNITIES; COMPUTER SOFTWARE IN THE FIELD OF ENTERPRISE KNOWLEDGE MANAGEMENT FOR USERS TO PARTICIPATE IN DISCUSSIONS, GET FEEDBACK FROM THEIR PEERS, FORM VIRTUAL COMMUNITIES, AND ENGAGE IN BUSINESS AND SOCIAL NETWORKING AND COLLABORATION; COMPUTER SOFTWARE, NAMELY, DOWNLOADABLE APPLICATIONS AND SOFTWARE PLUG-INS FOR USE IN THE FIELD OF ENTERPRISE KNOWLEDGE MANAGEMENT; COMPUTER SOFTWARE, NAMELY, DOWNLOADABLE APPLICATIONS AND SOFTWARE PLUG-INS IN THE NATURE OF MULTI-FUNCTION TOOL BAR PLUG-INS AND DOWNLOADABLE SEARCH ENGINE PORTALS IN THE FORM OF SEARCH BARS, ALL FOR USE IN THE FIELD OF ENTERPRISE KNOWLEDGE MANAGEMENT; COMPUTER APPLICATION SOFTWARE FOR MOBILE ELECTRONIC DEVICES, NAMELY, SOFTWARE IN THE FIELD OF ENTERPRISE KNOWLEDGE MANAGEMENT FOR USERS TO ASK AND ANSWER QUESTIONS ON A VARIETY OF TOPICS RELATING TO JOB KNOWLEDGE, JOB RESOURCES, JOB FUNCTION, ORGANIZATIONAL EXPERTISE, AND THE INTERACTION OF TEAMS, ALL WITHIN AN ENTERPRISE, WITH THIRD PARTIES, AND WITHIN SOCIAL AND KNOWLEDGE COMMUNITIES; COMPUTER APPLICATION SOFTWARE FOR MOBILE ELECTRONIC DEVICES, NAMELY, SOFTWARE IN THE FIELD OF ENTERPRISE KNOWLEDGE MANAGEMENT FOR SEARCHING FOR, STORING, ORGANIZING, AND RETRIEVING INFORMATION AND DATA REGARDING A VARIETY OF TOPICS RELATING TO JOB KNOWLEDGE, JOB RESOURCES, JOB FUNCTION, ORGANIZATIONAL EXPERTISE, AND THE INTERACTION OF TEAMS, ALL WITHIN AN ENTERPRISE, WITH THIRD PARTIES, AND WITHIN SOCIAL AND KNOWLEDGE COMMUNITIES (U.S. CLS. 21, 23, 26, 36 AND 38).

**CLASS 35—ADVERTISING AND BUSINESS**

FOR ADVERTISING ON THE INTERNET FOR OTHERS; ONLINE BUSINESS NETWORKING SERVICES; PROVIDING ONLINE COMPUTER DATABASES AND ONLINE SEARCHABLE DATABASES IN THE FIELD OF ENTERPRISE KNOWLEDGE MANAGEMENT ON TOPICS RELATING TO JOB KNOWLEDGE, JOB RESOURCES, JOB FUNCTION, BUSINESS ORGANIZATIONAL EXPERTISE, AND INTERACTION OF TEAMS, NAMELY, BUSINESS MANAGEMENT CONSULTING IN THE FIELD OF TEAM DEVELOPMENT ALL WITHIN AN BUSINESS ENTERPRISE, WITH THIRD PARTIES, AND WITHIN SOCIAL AND KNOWLEDGE COMMUNITIES (U.S. CLS. 100, 101 AND 102).

**CLASS 38—COMMUNICATION**

FOR (BASED ON USE IN COMMERCE) PROVIDING ONLINE FORUMS, CHAT ROOMS, AND ELECTRONIC BULLETIN BOARDS FOR TRANSMISSION OF MESSAGES AMONG USERS FOR USE IN ENTERPRISE KNOWLEDGE MANAGEMENT; COMPUTER SERVICES, NAMELY, PROVIDING ONLINE FACILITIES FOR REAL-TIME INTERACTION WITH OTHER COMPUTER USERS FOR USE IN ENTERPRISE KNOWLEDGE MANAGEMENT; PROVIDING ONLINE FORUMS FOR COMMUNICATIONS ON TOPICS RELATING TO JOB KNOWLEDGE, JOB RESOURCES, JOB FUNCTION, ORGANIZATIONAL EXPERTISE, AND THE INTERACTION OF TEAMS, ALL WITHIN AN ENTERPRISE, WITH THIRD PARTIES, AND WITHIN SOCIAL AND KNOWLEDGE COMMUNITIES, FOR USE IN ENTERPRISE KNOWLEDGE MANAGEMENT; PROVIDING SERVICES IN RELATION TO ONLINE CHAT ROOMS FOR TRANSMISSION OF MESSAGES FEATURING INFORMATION RELATING TO JOB KNOWLEDGE, JOB RESOURCES, JOB FUNCTION, ORGANIZATIONAL EXPERTISE, AND THE INTERACTION OF TEAMS, ALL WITHIN AN ENTERPRISE, WITH THIRD PARTIES, AND WITHIN SOCIAL AND KNOWLEDGE COMMUNITIES, FOR USE IN ENTERPRISE KNOWLEDGE MANAGEMENT; PROVIDING SERVICES IN RELATION TO ONLINE CHAT ROOMS FOR TRANSMISSION OF MESSAGES FEATURING INFORMATION RELATING TO JOB KNOWLEDGE, JOB RESOURCES, JOB FUNCTION, ORGANIZATIONAL EXPERTISE, AND THE INTERACTION OF TEAMS, ALL WITHIN AN ENTERPRISE, WITH THIRD PARTIES, AND WITHIN SOCIAL AND KNOWLEDGE COMMUNITIES, FOR USE IN ENTERPRISE KNOWLEDGE MANAGEMENT; PROVIDING SERVICES IN RELATION TO ONLINE CHAT ROOMS FOR BUSINESS AND SOCIAL NETWORKING (BASED ON INTENT TO USE) TELECOMMUNICATION SERVICES, NAMELY, WORLDWIDE SWITCHED TEXT AND MESSAGE TRANSMISSION SERVICES, ELECTRONIC MESSAGE SENDING, AND OUTCALL NOTIFICATION SERVICES; PROVIDING ELECTRONIC TRANSMISSION OF MESSAGES AND DATA IN RELATION TO USING MOBILE ELECTRONIC DEVICES, NAMELY, FOR USERS TO ASK AND ANSWER QUESTIONS REGARDING A VARIETY OF TOPICS RELATING TO JOB KNOWLEDGE, JOB RESOURCES, JOB FUNCTION, ORGANIZATIONAL EXPERTISE, AND THE INTERACTION OF TEAMS, ALL WITHIN AN ENTERPRISE, WITH THIRD PARTIES, AND WITHIN SOCIAL AND KNOWLEDGE COMMUNITIES, FOR USE IN ENTERPRISE KNOWLEDGE MANAGEMENT; ELECTRONIC TRANSMISSION OF INSTANT MESSAGES AND DATA; TELECOMMUNICATIONS SERVICES, NAMELY, ELECTRONIC TRANSMISSION OF DATA AND DIGITAL MESSAGING VIA MOBILE HANDHELD DEVICES AND VIA WIRED AND WIRELESS COMMUNICATION DEVICES; TELECOMMUNICATIONS SERVICES, NAMELY, ENABLING USERS TO ELECTRONICALLY TRANSMIT MESSAGES, TEXT, MULTIMEDIA CONTENT, VIDEOS, PHOTOS, AUDIO, ANIMATION AND IMAGES VIA A GLOBAL COMPUTER NETWORK; PROVIDING ACCESS TO THE INTERNET, NAMELY, PROVIDING ACCESS TO INFORMATION, ONLINE FORUMS, AND CHAT ROOMS OVER THE INTERNET; PROVIDING ACCESS TO COMPUTER DATABASES (U.S. CLS. 100, 101 AND 104).

FIRST USE 10-24-2011; IN COMMERCE 10-24-2011.

**CLASS 41—EDUCATION AND ENTERTAINMENT**

FOR PROVIDING ONLINE NON-DOWNLOADABLE PUBLICATIONS IN THE NATURE OF BROCHURES, PAMPHLETS, AND ARTICLES IN THE FIELD OF ENTERPRISE KNOWLEDGE MANAGEMENT (U.S. CLS. 100, 101 AND 107).

**CLASS 42—SCIENTIFIC AND COMPUTER SERVICES**

FOR SOFTWARE AS A SERVICE (SAAS) SERVICES FEATURING SOFTWARE FOR USE IN THE FIELD OF ENTERPRISE KNOWLEDGE MANAGEMENT; APPLICATION SERVICE PROVIDER (ASP) FEATURING SOFTWARE IN THE FIELD OF ENTERPRISE KNOWLEDGE MANAGEMENT; COMPUTER SERVICES, NAMELY, CREATING ONLINE COMMUNITIES FOR USE IN THE FIELD OF ENTERPRISE KNOWLEDGE MANAGEMENT FOR USERS TO ASK AND ANSWER QUESTIONS REGARDING A VARIETY OF TOPICS RELATING TO JOB KNOWLEDGE, JOB RESOURCES, JOB FUNCTION, ORGANIZATIONAL EXPERTISE, AND THE INTERACTION OF TEAMS, ALL WITHIN AN ENTERPRISE, WITH THIRD PARTIES, AND WITHIN SOCIAL AND KNOWLEDGE COMMUNITIES; COMPUTER SERVICES, NAMELY, CREATING ONLINE COM-

MUNITIES FOR USE IN THE FIELD OF ENTERPRISE KNOWLEDGE MANAGEMENT FOR SEARCHING FOR, STORING, ORGANIZING, AND RETRIEVING INFORMATION AND DATA REGARDING A VARIETY OF TOPICS RELATING TO JOB KNOWLEDGE, JOB RESOURCES, JOB FUNCTION, ORGANIZATIONAL EXPERTISE, AND THE INTERACTION OF TEAMS, ALL WITHIN AN ENTERPRISE, WITH THIRD PARTIES, AND WITHIN SOCIAL AND KNOWLEDGE COMMUNITIES; COMPUTER SERVICES, NAMELY, HOSTING ONLINE ELECTRONIC FACILITIES FOR OTHERS FOR USE IN THE FIELD OF ENTERPRISE KNOWLEDGE MANAGEMENT FOR USERS TO ASK AND ANSWER QUESTIONS REGARDING A VARIETY OF TOPICS RELATING TO JOB KNOWLEDGE, JOB RESOURCES, JOB FUNCTION, ORGANIZATIONAL EXPERTISE, AND THE INTERACTION OF TEAMS, ALL WITHIN AN ENTERPRISE, WITH THIRD PARTIES, AND WITHIN SOCIAL AND KNOWLEDGE COMMUNITIES; COMPUTER SERVICES, NAMELY, HOSTING ONLINE ELECTRONIC FACILITIES FOR OTHERS FOR USE IN THE FIELD OF ENTERPRISE KNOWLEDGE MANAGEMENT FOR SEARCHING FOR, STORING, ORGANIZING, AND RETRIEVING INFORMATION AND DATA REGARDING A VARIETY OF TOPICS RELATING TO JOB KNOWLEDGE, JOB RESOURCES, JOB FUNCTION, ORGANIZATIONAL EXPERTISE, AND THE INTERACTION OF TEAMS, ALL WITHIN AN ENTERPRISE, WITH THIRD PARTIES, AND WITHIN SOCIAL AND KNOWLEDGE COMMUNITIES; COMPUTER SERVICES, NAMELY, CREATING ONLINE COMMUNITIES FOR USE IN THE FIELD OF ENTERPRISE KNOWLEDGE MANAGEMENT FOR USERS TO ENGAGE IN BUSINESS AND SOCIAL NETWORKING; PROVIDING TEMPORARY USE OF ONLINE NON-DOWNLOADABLE SOFTWARE IN THE FIELD OF ENTERPRISE KNOWLEDGE MANAGEMENT FOR ALLOWING WEBSITE USERS TO ASK AND ANSWER QUESTIONS REGARDING A VARIETY OF TOPICS RELATING TO JOB KNOWLEDGE, JOB RESOURCES, JOB FUNCTION, ORGANIZATIONAL EXPERTISE, AND THE INTERACTION OF TEAMS, ALL WITHIN AN ENTERPRISE, WITH THIRD PARTIES, AND WITHIN SOCIAL AND KNOWLEDGE COMMUNITIES; PROVIDING TEMPORARY USE OF ONLINE NON-DOWNLOADABLE SOFTWARE IN THE FIELD OF ENTERPRISE KNOWLEDGE MANAGEMENT FOR SEARCHING FOR, STORING, ORGANIZING, AND RETRIEVING INFORMATION AND DATA REGARDING A VARIETY OF TOPICS RELATING TO JOB KNOWLEDGE, JOB RESOURCES, JOB FUNCTION, ORGANIZATIONAL EXPERTISE, AND THE INTERACTION OF TEAMS, ALL WITHIN AN ENTERPRISE, WITH THIRD PARTIES, AND WITHIN SOCIAL AND KNOWLEDGE COMMUNITIES; PROVIDING A WEBSITE FEATURING TEMPORARY USE OF NON-DOWNLOADABLE SOFTWARE IN THE FIELD OF ENTERPRISE KNOWLEDGE MANAGEMENT ENABLING USERS TO ASK AND ANSWER QUESTIONS REGARDING A VARIETY OF TOPICS RELATING TO JOB KNOWLEDGE, JOB RESOURCES, JOB FUNCTION, ORGANIZATIONAL EXPERTISE, AND THE INTERACTION OF TEAMS, ALL WITHIN AN ENTERPRISE, WITH THIRD PARTIES, AND WITHIN SOCIAL AND KNOWLEDGE COMMUNITIES; PROVIDING A WEBSITE FEATURING TEMPORARY USE OF NON-DOWNLOADABLE SOFTWARE IN THE FIELD OF ENTERPRISE KNOWLEDGE MANAGEMENT FOR SEARCHING FOR, STORING, ORGANIZING, AND RETRIEVING INFORMATION AND DATA REGARDING A VARIETY OF TOPICS RELATING TO JOB KNOWLEDGE, JOB RESOURCES, JOB FUNCTION, ORGANIZATIONAL EXPERTISE, AND THE INTERACTION OF TEAMS, ALL WITHIN AN ENTERPRISE, WITH THIRD PARTIES, AND WITHIN SOCIAL AND KNOWLEDGE COMMUNITIES; PROVIDING CUSTOMIZED COMPUTER SEARCHING SERVICES, NAMELY, FOR USE IN THE FIELD OF ENTERPRISE KNOWLEDGE MANAGEMENT FOR USERS TO ASK AND ANSWER QUESTIONS REGARDING A VARIETY OF TOPICS RELATING TO JOB KNOWLEDGE, JOB RESOURCES, JOB FUNCTION, ORGANIZATIONAL EXPERTISE, AND THE INTERACTION OF TEAMS, ALL WITHIN AN ENTERPRISE, WITH THIRD PARTIES, AND WITHIN SOCIAL AND KNOWLEDGE COMMUNITIES; PROVIDING CUSTOMIZED COMPUTER SEARCHING SERVICES, NAMELY, FOR USE IN THE FIELD OF ENTERPRISE KNOWLEDGE MANAGEMENT FOR SEARCHING FOR, STORING, ORGANIZING, AND RETRIEVING INFORMATION AND DATA REGARDING A VARIETY OF TOPICS

RELATING TO JOB KNOWLEDGE, JOB RESOURCES, JOB FUNCTION, ORGANIZATIONAL EXPERTISE, AND THE INTERACTION OF TEAMS, ALL WITHIN AN ENTERPRISE, WITH THIRD PARTIES, AND WITHIN SOCIAL AND KNOWLEDGE COMMUNITIES (U.S. CLS. 100 AND 101).

FIRST USE 10-24-2011; IN COMMERCE 10-24-2011.

#### **CLASS 45—PERSONAL AND LEGAL SERVICES**

FOR ONLINE SOCIAL NETWORKING SERVICES (U.S. CLS. 100 AND 101).

FIRST USE 6-25-2012; IN COMMERCE 6-25-2012.

NAKIA HENRY, EXAMINING ATTORNEY

SN 85-963,062. TELEVISA, S.A. DE C.V., SANTA FE, MEXICO, FILED 6-18-2013.

LA TEMPESTAD

THE MARK CONSISTS OF STANDARD CHARACTERS WITHOUT CLAIM TO ANY PARTICULAR FONT, STYLE, SIZE, OR COLOR.

OWNER OF MEXICO REG. NO. 1360355, DATED 1-17-2013, EXPIRES 1-17-2023.

OWNER OF MEXICO REG. NO. 1391863, DATED 5-31-2013, EXPIRES 5-31-2023.

THE ENGLISH TRANSLATION OF "LA TEMPESTAD" IN THE MARK IS "THE STORM".

#### **CLASS 9—ELECTRICAL AND SCIENTIFIC APPARATUS**

FOR PRE-RECORDED DIGITAL AND ELECTRONIC MEDIA, NAMELY, CDS AND DVDS FEATURING A DRAMATIC TELEVISION SHOW (U.S. CLS. 21, 23, 26, 36 AND 38).

#### **CLASS 41—EDUCATION AND ENTERTAINMENT**

FOR ENTERTAINMENT SERVICES IN THE NATURE OF A CONTINUING DRAMATIC SHOW BROADCAST OVER THE INTERNET AND AN ONGOING DRAMATIC TELEVISION PROGRAM (U.S. CLS. 100, 101 AND 107).

MARK SHINER, EXAMINING ATTORNEY

SN 85-966,658. SANDRA LUZ CARRETERO VAZQUEZ, BROWNSVILLE, TX. FILED 6-21-2013.



THE MARK CONSISTS OF ONE WAVY HORIZONTAL LINE ABOVE AND ONE WAVY HORIZONTAL LINE BELOW THE WORDS "PRET A PORTER".

THE ENGLISH TRANSLATION OF "PRET A PORTER" IN THE MARK IS "READY TO WEAR".

#### **CLASS 3—COSMETICS AND CLEANING PREPARATIONS**

FOR MAKE-UP, MAKE-UP PALETTES, EYE SHADOW, EYE SHADOW PALETTES, EYE SHADOW STICK, LIP GLOSS, LIPSTICK, COMPACT BLUSH, CREAM FOUNDATION, CREAM TO POWDER MAKEUP, CREAM CONCEALER, LOOSE TRANSLUCENT POWDER, BRUSH CLEANER, COMPACT POWDERS, WET-DRY POWDER, INDELIBLE GEL EYELINER, BRUSH SHIMMER, FACE POWDER, FALSE EYELASHES, MASCARA, MINERAL MIST FOR COSMETIC PURPOSES, GLUE FOR COSMETIC PURPOSES, SEALER FOR COSMETIC PURPOSES, COSMETIC MINERAL PIGMENTS, MAKE-UP PRIMER, EYELINER PENCIL, LIQUID MAKEUP, SPARKLING LIP GLOSS, LIP LACQUER, NON-MEDICATED MAKEUP REMOVER TOWELETTES, MAKE UP KITS, LIPSTICK PALETTES AND MAKE-UP KITS COMPRISED OF A VARIETY OF COSMETICS CONTAINED IN A BRIEFCASE (U.S. CLS. 1, 4, 6, 50, 51 AND 52).

FIRST USE 12-31-1997; IN COMMERCE 12-31-1997.

#### **CLASS 21—HOUSEWARES AND GLASS**

FOR MAKE-UP BRUSHES, MASCARA BRUSHES, MAKE-UP SPONGES AND MAKEUP BRUSH KITS (U.S. CLS. 2, 13, 23, 29, 30, 33, 40 AND 50).

FIRST USE 12-31-1997; IN COMMERCE 12-31-1997.

JULIE GUTTADAURO, EXAMINING ATTORNEY

SN 85-969,482. WORLD MUSIC MEDIA SL, IBIZA, SPAIN, FILED 6-25-2013.



THE MARK CONSISTS OF THE TERM "ANTS" IN UPPERCASE LETTERS WITH THE DRAWING OF AN ANT ABOVE THE TERM "ANTS".

#### **CLASS 25—CLOTHING**

FOR SWIMSUITS; BANDANAS; HEADBANDS; FOOTWEAR; BEACH SHOES; PANTS; SHIRTS; SHORT-SLEEVE SHIRTS; SINGLET; TEE-SHIRTS; HOODIES; VESTS; SHAWLS; JACKETS; BELTS NOT MADE OF LEATHER; CAPS; SHOULDER WRAPS; SPORTS SHOES; MASQUERADE COSTUMES; GIRDLES; SKIRTS; SCARVES; SHOES; BATHING CAPS; GLOVES; LEGGINGS; UNDERWEAR; EAR MUFFS; TIGHTS; DRESSES; PAJAMAS; BEACH CLOTHES, NAMELY, SWIM WEAR, COVER-UPS, AND SANDALS; PULL-OVERS; CLOTHING FOR GYMNASTICS, NAMELY, LEOTARDS; SARONGS; BATHING TRUNKS; HATS; SWEATERS; SUITS; WET SUITS FOR WATER-SPORTS; UNIFORMS; ALL IN CONNECTION WITH THE TRADEMARK OWNER'S FESTIVALS AND EVENTS (U.S. CLS. 22 AND 39).

#### **CLASS 41—EDUCATION AND ENTERTAINMENT**

FOR ENTERTAINMENT SERVICES, NAMELY, CONDUCTING PARTIES AND DANCE FESTIVALS (U.S. CLS. 100, 101 AND 107).

JENNIFER RICHARDSON, EXAMINING ATTORNEY

SN 85-970,187. RESOLUTION (BRANDS) LIMITED, LONDON, UNITED KINGDOM, FILED 6-26-2013.

## RESOLUTION LIFE

THE MARK CONSISTS OF STANDARD CHARACTERS WITHOUT CLAIM TO ANY PARTICULAR FONT, STYLE, SIZE, OR COLOR.

NO CLAIM IS MADE TO THE EXCLUSIVE RIGHT TO USE "LIFE", APART FROM THE MARK AS SHOWN.

### CLASS 9—ELECTRICAL AND SCIENTIFIC APPARATUS

FOR COMPUTER SOFTWARE IN USE IN PROVIDING FINANCIAL SERVICES, NAMELY, SOFTWARE USED TO CREATE AND EDIT DOCUMENTS, SPREAD SHEETS, PRESENTATIONS, E-MAIL AND WEB PAGES; ELECTRONIC DATABASES IN THE FIELD OF BUSINESS, INVESTMENT AND FINANCIAL SERVICES RECORDED ON COMPUTER MEDIA; PRE-RECORDED AUDIO DISKS, CD-ROMS AND DIGITAL VIDEO DISKS FEATURING FINANCIAL INFORMATION AND ADVICE; ENCODED SMART CARDS FEATURING PROGRAMMING USED TO PROVIDE INFORMATION REGARDING BUSINESS, INVESTMENT AND FINANCIAL SERVICES; ENCODED IDENTITY CARDS; MAGNETIC ENCODED CARDS BEARING MACHINE READABLE INFORMATION FOR USE IN KEY CARDS; BLANK MAGNETIC DATA CARRIERS; MAGNETIC DATA CARRIERS FEATURING INFORMATION IN THE FIELD OF BUSINESS, INVESTMENT AND FINANCIAL SERVICES; DOWNLOADABLE ON-LINE ELECTRONIC PUBLICATIONS IN THE NATURE OF MAGAZINES, BOOKS, NEWSLETTERS, BROCHURES, LEAFLETS AND PAMPHLETS IN THE FIELD OF BUSINESS, INVESTMENT AND FINANCIAL SERVICES (U.S. CLS. 21, 23, 26, 36 AND 38).

### CLASS 16—PAPER GOODS AND PRINTED MATTER

FOR PRINTED MATTER, NAMELY, STATIONERY; PRINTED PUBLICATIONS, NAMELY, BOOKS, MANUALS, BROCHURES, LEAFLETS, INSTRUCTIONAL AND TEACHING MATERIALS IN THE FIELD OF BUSINESS, INVESTMENT AND FINANCIAL SERVICES (U.S. CLS. 2, 5, 22, 23, 29, 37, 38 AND 50).

### CLASS 35—ADVERTISING AND BUSINESS

FOR BUSINESS MANAGEMENT; BUSINESS ADMINISTRATION; OFFICE FUNCTIONS; COMMERCIAL RESEARCH SERVICES, NAMELY, COLLECTION AND COMPILATION OF INFORMATION INTO DATABASES IN THE FIELD OF BUSINESS, INVESTMENT AND FINANCIAL SERVICES; ANALYSIS OF BUSINESS RESEARCH AND PROVISION OF BUSINESS REPORTS; ECONOMIC FORECASTING AND ANALYSIS FOR BUSINESS AND FINANCIAL PURPOSES; ADVERTISING SERVICES; MARKETING SERVICES; SALES PROMOTION SERVICES; BUSINESS MANAGEMENT, ADMINISTRATION, MARKETING AND ADVERTISING SERVICES; INFORMATION, CONSULTANCY AND ADVISORY SERVICES RELATED TO ALL OF THE AFORESAID (U.S. CLS. 100, 101 AND 102).

### CLASS 36—INSURANCE AND FINANCIAL

FOR FINANCIAL ADVISORY AND CONSULTANCY SERVICES; FINANCING SERVICES; ADVISORY SERVICES RELATING TO CREDIT AND DEBIT CONTROL, INVESTMENT, GRANTS AND FINANCING OF LOANS; FINANCIAL AND INVESTMENT SERVICES, NAMELY, ASSET AND INVESTMENT ACQUISITION, CONSULTATION, ADVISORY AND DEVELOPMENT; FINANCIAL PLANNING AND INVESTMENT ADVISORY SERVICES; INFORMATION, ADVISORY, CONSULTANCY AND RESEARCH SERVICES RELATING TO FINANCE AND INVESTMENTS; INVESTMENT ADVISORY SERVICES; STRATEGIC CORPORATE FINANCIAL ADVISORY SERVICES; VENTURE CAPITAL ADVISORY SERVICES; FINANCIAL CONSULTING AND ADVISING IN THE FIELD OF MERGERS AND ACQUISITIONS; INVESTMENT SERVICES, NAMELY, ASSET ACQUISITION, CONSULTATION, DEVELOPMENT AND MANAGEMENT SERVICES; BUSINESS BROKERAGE SERVICES AND RELATED CONSULTING PERTAINING TO BUSINESS SALES, MERGERS, ACQUISITIONS AND BUSINESS VALUATIONS; INSURANCE ADMINISTRATION, NAMELY, ADMINISTRATION OF CLOSED BOOKS OF EXISTING LIFE INSURANCE POLICIES; NONE OF THE FOREGOING TO INCLUDE ANY CONFLICT RESOLUTION, TAX RESOLUTION, DEBT RESOLUTION, UNDERWRITING OR BROKERAGE OF INSURANCE OR REINSURANCE, OR FINANCIAL RISK MANAGEMENT SERVICES (U.S. CLS. 100, 101 AND 102).

### CLASS 39—TRANSPORTATION AND STORAGE

FOR ELECTRONIC STORAGE OF FILES AND DOCUMENTS IN THE FIELD OF BUSINESS, INVESTMENT AND FINANCIAL SERVICES (U.S. CLS. 100 AND 105).

### CLASS 41—EDUCATION AND ENTERTAINMENT

FOR PROVIDING ON-LINE, NON-DOWNLOADABLE ELECTRONIC PUBLICATIONS, NAMELY, MAGAZINE, BOOKS, BROCHURES, LEAFLETS AND PAMPHLETS IN THE FIELD OF BUSINESS, INVESTMENT AND FINANCIAL SERVICES; EDUCATIONAL SERVICES, NAMELY, PROVIDING TRAINING AND INSTRUCTION IN THE FIELD OF BUSINESS, INVESTMENT AND FINANCIAL SERVICES; ARRANGING AND CONDUCTING OF CONFERENCES, SEMINARS, SYMPOSIA, WORKSHOPS, AND EXHIBITIONS FOR EDUCATIONAL PURPOSES IN THE FIELD OF BUSINESS, INVESTMENT AND FINANCIAL SERVICES; PROVIDING INFORMATION, ADVISORY AND CONSULTANCY SERVICES RELATING TO ALL THE AFORESAID SERVICES (U.S. CLS. 100, 101 AND 107).

### CLASS 45—PERSONAL AND LEGAL SERVICES

FOR LEGAL CONSULTANCY, IN PARTICULAR IN THE FIELD OF EMPLOYMENT, PENSIONS, FINANCE AND INSURANCE; LEGAL SERVICES AND CONSULTANCY WITH REGARD TO DRAWING UP DEEDS, AGREEMENTS, CONTRACTS (U.S. CLS. 100 AND 101).  
KAREN BRACEY, EXAMINING ATTORNEY



SN 85-970,211. RESOLUTION (BRANDS) LIMITED, LONDON, UNITED KINGDOM, FILED 6-26-2013.



The logo for Resolution Life features the word "Resolution" in a bold, blue, sans-serif font, and the word "Life" in a similar font but in a lighter blue color. A small red wedge is positioned above the letter "i" in "Life".

NO CLAIM IS MADE TO THE EXCLUSIVE RIGHT TO USE "LIFE", APART FROM THE MARK AS SHOWN.

THE COLOR(S) BLUE, AND RED IS/ARE CLAIMED AS A FEATURE OF THE MARK.

THE MARK CONSISTS OF THE WORDS "RESOLUTION LIFE" IN STYLIZED FORM IN BLUE WITH A WEDGE IN RED APPEARING OVER THE LETTER "I" IN "RESOLUTION".

#### **CLASS 9—ELECTRICAL AND SCIENTIFIC APPARATUS**

FOR COMPUTER SOFTWARE IN USE IN PROVIDING FINANCIAL SERVICES, NAMELY, SOFTWARE USED TO CREATE AND EDIT DOCUMENTS, SPREAD SHEETS, PRESENTATIONS, E-MAIL AND WEB PAGES; ELECTRONIC DATABASES IN THE FIELD OF BUSINESS, INVESTMENT AND FINANCIAL SERVICES RECORDED ON COMPUTER MEDIA; PRE-RECORDED AUDIO DISKS, CD-ROMS AND DIGITAL VIDEO DISKS FEATURING FINANCIAL INFORMATION AND ADVICE; ENCODED SMART CARDS FEATURING PROGRAMMING USED TO PROVIDE INFORMATION REGARDING BUSINESS, INVESTMENT AND FINANCIAL SERVICES; ENCODED IDENTITY CARDS; MAGNETIC ENCODED CARDS BEARING MACHINE READABLE INFORMATION FOR USE IN KEY CARDS; BLANK MAGNETIC DATA CARRIERS; MAGNETIC DATA CARRIERS FEATURING INFORMATION IN THE FIELD OF BUSINESS, INVESTMENT AND FINANCIAL SERVICES; DOWNLOADABLE ON-LINE ELECTRONIC PUBLICATIONS IN THE NATURE OF MAGAZINES, BOOKS, NEWSLETTERS, BROCHURES, LEAFLETS AND PAMPHLETS IN THE FIELD OF BUSINESS, INVESTMENT AND FINANCIAL SERVICES (U.S. CLS. 21, 23, 26, 36 AND 38).

#### **CLASS 16—PAPER GOODS AND PRINTED MATTER**

FOR PRINTED MATTER, NAMELY, STATIONERY; PRINTED PUBLICATIONS, NAMELY, BOOKS, MANUALS, BROCHURES, LEAFLETS, INSTRUCTIONAL AND TEACHING MATERIALS IN THE FIELD OF BUSINESS, INVESTMENT AND FINANCIAL SERVICES (U.S. CLS. 2, 5, 22, 23, 29, 37, 38 AND 50).

#### **CLASS 35—ADVERTISING AND BUSINESS**

FOR BUSINESS MANAGEMENT; BUSINESS ADMINISTRATION; OFFICE FUNCTIONS; COMMERCIAL RESEARCH SERVICES, NAMELY, COLLECTION AND COMPILATION OF INFORMATION INTO DATABASES IN THE FIELD OF BUSINESS, INVESTMENT AND FINANCIAL SERVICES; ANALYSIS OF BUSINESS RESEARCH AND PROVISION OF BUSINESS REPORTS; ECONOMIC FORECASTING AND ANALYSIS FOR BUSINESS AND FINANCIAL PURPOSES; ADVERTISING SERVICES; MARKETING SERVICES; SALES PROMOTION SERVICES; BUSINESS MANAGEMENT, ADMINISTRATION, MARKETING AND ADVERTISING SERVICES; INFORMATION, CONSULTANCY AND ADVISORY SERVICES RELATED TO ALL OF THE AFORESAID (U.S. CLS. 100, 101 AND 102).

#### **CLASS 36—INSURANCE AND FINANCIAL**

FOR FINANCIAL ADVISORY AND CONSULTANCY SERVICES; FINANCING SERVICES; ADVISORY SERVICES RELATING TO CREDIT AND DEBIT CONTROL, INVESTMENT, GRANTS AND FINANCING OF LOANS; FINANCIAL AND INVESTMENT SERVICES, NAMELY, ASSET AND INVESTMENT ACQUISITION, CONSULTATION, ADVISORY AND DEVELOPMENT; FINANCIAL PLANNING AND INVESTMENT ADVISORY SERVICES; INFORMATION, ADVISORY, CONSULTANCY AND RESEARCH SERVICES RELATING TO FINANCE AND INVESTMENTS; INVESTMENT ADVISORY SERVICES; STRATEGIC CORPORATE FINANCIAL ADVISORY SERVICES; VENTURE CAPITAL ADVISORY SERVICES; FINANCIAL CONSULTING AND ADVISING IN THE FIELD OF MERGERS AND ACQUISITIONS; INVESTMENT SERVICES, NAMELY, ASSET ACQUISITION, CONSULTATION, DEVELOPMENT AND MANAGEMENT SERVICES; BUSINESS BROKERAGE SERVICES AND RELATED CONSULTING PERTAINING TO BUSINESS SALES, MERGERS, ACQUISITIONS AND BUSINESS VALUATIONS; INSURANCE ADMINISTRATION, NAMELY, ADMINISTRATION OF CLOSED BOOKS OF EXISTING LIFE INSURANCE POLICIES; NONE OF THE FOREGOING TO INCLUDE ANY CONFLICT RESOLUTION, TAX RESOLUTION, DEBT RESOLUTION, UNDERWRITING OR BROKERAGE OF INSURANCE OR REINSURANCE, OR FINANCIAL RISK MANAGEMENT SERVICES (U.S. CLS. 100, 101 AND 102).

#### **CLASS 39—TRANSPORTATION AND STORAGE**

FOR ELECTRONIC STORAGE OF FILES AND DOCUMENTS IN THE FIELD OF BUSINESS, INVESTMENT AND FINANCIAL SERVICES (U.S. CLS. 100 AND 105).

#### **CLASS 41—EDUCATION AND ENTERTAINMENT**

FOR PROVIDING ON-LINE, NON-DOWNLOADABLE ELECTRONIC PUBLICATIONS, NAMELY, MAGAZINE, BOOKS, BROCHURES, LEAFLETS AND PAMPHLETS IN THE FIELD OF BUSINESS, INVESTMENT AND FINANCIAL SERVICES; EDUCATIONAL SERVICES, NAMELY, PROVIDING TRAINING AND INSTRUCTION IN THE FIELD OF BUSINESS, INVESTMENT AND FINANCIAL SERVICES; ARRANGING AND CONDUCTING OF CONFERENCES, SEMINARS, SYMPOSIA, WORKSHOPS, AND EXHIBITIONS FOR EDUCATIONAL PURPOSES IN THE FIELD OF BUSINESS, INVESTMENT AND FINANCIAL SERVICES; PROVIDING INFORMATION, ADVISORY AND CONSULTANCY SERVICES RELATING TO ALL THE AFORESAID SERVICES (U.S. CLS. 100, 101 AND 107).

#### **CLASS 45—PERSONAL AND LEGAL SERVICES**

FOR LEGAL CONSULTANCY, IN PARTICULAR IN THE FIELD OF EMPLOYMENT, PENSIONS, FINANCE AND INSURANCE; LEGAL SERVICES AND CONSULTANCY WITH REGARD TO DRAWING UP DEEDS, AGREEMENTS, CONTRACTS (U.S. CLS. 100 AND 101).  
KAREN BRACEY, EXAMINING ATTORNEY

SN 85-971,789. SOMFY SAS, 74300 CLUSES, FRANCE, FILED 6-27-2013.

SN 85-971,802. ROXAR SOFTWARE SOLUTIONS AS, STAVANGER, NORWAY, FILED 6-27-2013.

# TAHOMA

THE MARK CONSISTS OF STANDARD CHARACTERS WITHOUT CLAIM TO ANY PARTICULAR FONT, STYLE, SIZE, OR COLOR.

OWNER OF U.S. REG. NOS. 3,853,934 AND 4,023,177.

## CLASS 9—ELECTRICAL AND SCIENTIFIC APPARATUS

FOR HOME AUTOMATION SYSTEMS COMPRISED OF ELECTRONIC WIRELESS AND WIRED CONTROLLERS, CONTROLLED DEVICES, NAMELY, SENSORS AND SOFTWARE FOR ON-SITE REMOTE CONTROL AND MANAGEMENT OF ELECTRICAL AND ELECTRONIC CIRCUITS, LIGHTING, HEATING, AIR CONDITIONING, THERMOSTATS, VENTILATION HATCHES, WATERING AND IRRIGATION SYSTEMS, WINDOWS, BLINDS, SCREENS, SHUTTERS, ROLLING SHUTTERS, AWNINGS, DRAPERIES, GATES, BARRIERS, FENCES, LOCKS, DOORS, GARAGE DOORS, SWIMMING POOL AUTOMATION SYSTEMS, LEAKS AND FAUCETS, TEMPERATURE, HOME LIQUID CONSUMPTION LEVELS, ALARMS, FIRE, SURVEILLANCE SYSTEMS, ACCESS TO RESTRICTION AND SECURITY SYSTEMS, LIGHTNING DETECTION, SOUND AND IMAGE RECORDING APPARATUS, BROADCASTING, INTERCOMMUNICATION, TELECOMMUNICATION OF IMAGES WITHIN AND AROUND THE HOME, AND CONTROL OF ENTERTAINMENT SYSTEMS, PROJECTION SCREENS, TELEPHONES, TELEVISIONS, COMPUTER SYSTEMS AND DOMESTIC APPLIANCES VIA COMPUTERS, SMARTPHONES, TOUCH TABLETS, AND OTHER MOBILE DEVICES (U.S. CLS. 21, 23, 26, 36 AND 38).

FIRST USE 12-0-2010; IN COMMERCE 11-0-2011.

## CLASS 37—CONSTRUCTION AND REPAIR

FOR ON SITE OR REMOTE INSTALLATION, SERVICE AND MAINTENANCE OF HOME AUTOMATION SYSTEMS COMPRISED OF WIRELESS AND WIRED CONTROLLERS, CONTROLLED DEVICES, SENSORS AND SOFTWARE FOR ON SITE OR REMOTE MANAGEMENT VIA COMPUTER, SMARTPHONE, TOUCH TABLET, OR OTHER MOBILE DEVICE, OF ELECTRICAL AND ELECTRONIC CIRCUITS, LIGHTING, HEATING, AIR CONDITIONING, THERMOSTATS, VENTILATION HATCHES, WATERING AND IRRIGATION SYSTEMS, WINDOWS, BLINDS, SCREENS, SHUTTERS, ROLLING SHUTTERS, AWNINGS, DRAPERIES, GATES, BARRIERS, FENCES, LOCKS, DOORS, GARAGE DOORS, SWIMMING POOL AUTOMATION SYSTEMS, LEAK AND FAUCET MANAGEMENT, TEMPERATURE, LIQUID CONSUMPTION LEVELS, AND OF ALARM, FIRE, SURVEILLANCE, ACCESS RESTRICTION AND SECURITY SYSTEMS, LIGHTNING DETECTION, AND OF SOUND AND / OR IMAGE RECORDING, AND / OR BROADCASTING, INTERCOMMUNICATION, TELECOMMUNICATION, AND ENTERTAINMENT SYSTEMS, PROJECTION SCREENS, TELEPHONE, TELEVISION, COMPUTER SYSTEMS AND DOMESTIC APPLIANCES (U.S. CLS. 100, 103 AND 106).

FIRST USE 12-0-2010; IN COMMERCE 11-0-2011.  
MARY I. SPARROW, EXAMINING ATTORNEY

# DOTROX

THE MARK CONSISTS OF STANDARD CHARACTERS WITHOUT CLAIM TO ANY PARTICULAR FONT, STYLE, SIZE, OR COLOR.

PRIORITY CLAIMED UNDER SEC. 44(D) ON NORWAY APPLICATION NO. 201306594, FILED 5-30-2013, REG. NO. 272381, DATED 9-24-2013, EXPIRES 5-30-2023.

## CLASS 9—ELECTRICAL AND SCIENTIFIC APPARATUS

FOR COMPUTER SOFTWARE FOR USE IN DEVELOPMENT OF SOFTWARE; COMPUTER SOFTWARE FOR DEVELOPMENT AND MANAGEMENT OF DATABASES; COMPUTER SOFTWARE FOR INTEGRATION WITH DIFFERENT SOFTWARE APPLICATIONS, DATA PLATFORMS, AND COMPUTER FRAMEWORK, ALL THE AFOREMENTIONED GOODS FOR USE IN CONNECTION WITH EXPLORATION, DEVELOPMENT, ASSET MANAGEMENT AND PRODUCTION OF OIL AND GAS (U.S. CLS. 21, 23, 26, 36 AND 38).

## CLASS 42—SCIENTIFIC AND COMPUTER SERVICES

FOR DESIGN AND DEVELOPMENT OF COMPUTER SOFTWARE; COMPUTER SOFTWARE CONSULTANCY SERVICES; PROVIDING INFORMATION REGARDING COMPUTER SOFTWARE; USER SUPPORT SERVICES FOR COMPUTER SOFTWARE (U.S. CLS. 100 AND 101).  
KIM MONINGHOFF, EXAMINING ATTORNEY

---

SN 85-980,572. COGNIZANT TECHNOLOGY SOLUTIONS U.S. CORPORATION, TEANECK, NJ. FILED 4-17-2013.

# CODE HALO

THE MARK CONSISTS OF STANDARD CHARACTERS WITHOUT CLAIM TO ANY PARTICULAR FONT, STYLE, SIZE, OR COLOR.

NO CLAIM IS MADE TO THE EXCLUSIVE RIGHT TO USE "CODE", APART FROM THE MARK AS SHOWN.

**CLASS 9—ELECTRICAL AND SCIENTIFIC APPARATUS**

FOR COMPUTER SOFTWARE TO ENABLE SOFTWARE AS A SERVICE (SAAS) AND PLATFORM AS A SERVICE (PAAS) CAPABILITIES; DOWNLOADABLE NEWSLETTERS, REPORTS AND PUBLICATIONS IN THE NATURE OF BLOGS, NEWSLETTERS, WHITE PAPERS, BOOKS IN THE FIELDS OF INFORMATION TECHNOLOGY, RESEARCH AND ANALYSIS OF COMPUTER HARDWARE, SOFTWARE, COMMUNICATIONS AND RELATED TECHNOLOGY INDUSTRIES, INFORMATION TECHNOLOGY SERVICES FOR ENTERPRISES, SOFTWARE DEVELOPMENT, INVESTMENT IN EMERGING AND ESTABLISHED BUSINESSES IN THE INFORMATION INDUSTRY, FINANCIAL APPLICATION SOFTWARE PRODUCTS AND SERVICES, ADVANCED SOLUTIONS DELIVERY, BUSINESS PROCESS OUTSOURCING, BUSINESS TECHNOLOGY CONSULTING, CUSTOMER SOLUTIONS PRACTICE, DATA WAREHOUSING AND BUSINESS INTELLIGENCE, ENTERPRISE ANALYTICS, ENTERPRISE RESOURCE PLANNING, INFORMATION SECURITY AND PRIVACY, PORTALS AND CONTENT MANAGEMENT AND PROGRAM MANAGEMENT (U.S. CLS. 21, 23, 26, 36 AND 38).

**CLASS 16—PAPER GOODS AND PRINTED MATTER**

FOR NEWSLETTERS, REPORTS AND PUBLICATIONS IN THE NATURE OF NEWSLETTERS, WHITE PAPERS, BOOKS IN THE FIELDS OF INFORMATION TECHNOLOGY, RESEARCH AND ANALYSIS OF COMPUTER HARDWARE, SOFTWARE, COMMUNICATIONS AND RELATED TECHNOLOGY INDUSTRIES, INFORMATION TECHNOLOGY SERVICES FOR ENTERPRISES, SOFTWARE DEVELOPMENT, INVESTMENT IN EMERGING AND ESTABLISHED BUSINESSES IN THE INFORMATION INDUSTRY, FINANCIAL APPLICATION SOFTWARE PRODUCTS AND SERVICES, ADVANCED SOLUTIONS DELIVERY, BUSINESS PROCESS OUTSOURCING, BUSINESS TECHNOLOGY CONSULTING, CUSTOMER SOLUTIONS PRACTICE, DATA WAREHOUSING AND BUSINESS INTELLIGENCE, ENTERPRISE ANALYTICS, ENTERPRISE RESOURCE PLANNING, INFORMATION SECURITY AND PRIVACY, IT INFRASTRUCTURE SERVICES, PORTALS AND CONTENT MANAGEMENT AND PROGRAM MANAGEMENT (U.S. CLS. 2, 5, 22, 23, 29, 37, 38 AND 50).  
ELIZABETH CHANG, EXAMINING ATTORNEY

SN 86-003,721. HAXAN PARTNERS, CULVER CITY, CA. FILED 7-8-2013.

**PHANTOM CARRIAGE**

THE MARK CONSISTS OF STANDARD CHARACTERS WITHOUT CLAIM TO ANY PARTICULAR FONT, STYLE, SIZE, OR COLOR.

**CLASS 32—LIGHT BEVERAGES**

FOR BEER (U.S. CLS. 45, 46 AND 48).

**CLASS 43—HOTEL AND RESTAURANT SERVICES**

FOR BAR SERVICES (U.S. CLS. 100 AND 101).  
MARYNELLE WILSON, EXAMINING ATTORNEY

SN 86-005,850. Q P PRINTING LIMITED, NEW TERRITORIES, HONG KONG, FILED 7-9-2013.



NO CLAIM IS MADE TO THE EXCLUSIVE RIGHT TO USE "CREATEJIGSAWPUZZLES.COM", APART FROM THE MARK AS SHOWN.

THE MARK CONSISTS OF THE STYLIZED TEXT "CREATEJIGSAWPUZZLES.COM" WITH THE IMAGE OF A JIGSAW PUZZLE PIECE APPEARING TO THE RIGHT OF THE TEXT.

**CLASS 16—PAPER GOODS AND PRINTED MATTER**

FOR PAPER, CARDBOARD AND GOODS MADE FROM THESE MATERIALS, NAMELY, STATIONERY WRITING PAPER AND ENVELOPES, PAPER FOLDERS, BOXES OF PAPER OR CARDBOARD, PAPER LABELS, NOTEPADS, CARDBOARD BOXES, NOTE PAPER, STATIONERY, FOLDING CARTON BOXES AND PACKAGING BOXES; PRINTED MATTER, NAMELY, BOOKS, MAGAZINES, NEWSPAPERS, BROCHURES, AND MANUALS IN THE FIELD OF GAMES, TOYS, PUZZLES, AND GIFTS (U.S. CLS. 2, 5, 22, 23, 29, 37, 38 AND 50).

**CLASS 28—TOYS AND SPORTING GOODS**

FOR TOYS, GAMES AND PLAYTHINGS, NAMELY, PLUSH TOYS, BOARD GAMES, PUZZLES, CARD GAMES, TOY FIGURES (U.S. CLS. 22, 23, 38 AND 50).  
NATALIE KENEALY, EXAMINING ATTORNEY

SN 86-010,756. HIS HAIR CLINIC LIMITED, BIRMINGHAM, UNITED KINGDOM, FILED 7-15-2013.

SMP

THE MARK CONSISTS OF STANDARD CHARACTERS WITHOUT CLAIM TO ANY PARTICULAR FONT, STYLE, SIZE, OR COLOR.

PRIORITY CLAIMED UNDER SEC. 44(D) ON ERPN CMNTY TM OFC APPLICATION NO. 011563897, FILED 2-11-2013, REG. NO. 011563897, DATED 9-26-2013, EXPIRES 2-11-2023.

**CLASS 8—HAND TOOLS**

FOR TATTOOING APPARATUS; TATTOOING MACHINES; TATTOOING NEEDLES (U.S. CLS. 23, 28 AND 44).

**CLASS 41—EDUCATION AND ENTERTAINMENT**

FOR TRAINING SERVICES RELATING TO TATTOOING, COSMETIC TREATMENTS AND PIGMENTATION SERVICES (U.S. CLS. 100, 101 AND 107).

**CLASS 44—MEDICAL, BEAUTY AND AGRICULTURAL SERVICES**

FOR COSMETIC TATTOOING SERVICES; TATTOOING SERVICES; MEDICAL HYGIENIC AND BEAUTY CARE FOR HUMAN BEINGS; VETERINARY SERVICES; HYGIENIC AND BEAUTY CARE FOR ANIMALS; HAIR SALON SERVICES; CONSULTANCY AND ADVISORY SERVICES RELATING TO VETERINARY SERVICES, HYGIENIC AND BEAUTY CARE FOR ANIMALS, TATTOOING SERVICES AND HAIR SALON SERVICES (U.S. CLS. 100 AND 101).

CHRIS WELLS, EXAMINING ATTORNEY

**CLASS 41—EDUCATION AND ENTERTAINMENT**

FOR PROVIDING ONLINE NON-DOWNLOADABLE PUBLICATIONS THAT FEATURE ADVERTISEMENTS FOR THE GOODS AND SERVICES OF OTHERS, NAMELY, TELEPHONE DIRECTORIES IN THE FIELDS OF BUSINESS, RESIDENTIAL, COMMERCIAL AND GOVERNMENT; PROVIDING AN ONLINE INTERACTIVE DATABASE FEATURING ENTERTAINMENT INFORMATION IN THE FIELDS OF LIVE MUSICAL PERFORMANCES, LIVE THEATRICAL PERFORMANCES, LIVE DRAMATIC PERFORMANCES, MOTION PICTURE FILMS AND SPORTING EVENTS, NAMELY, FOOTBALL, BASEBALL, BASKETBALL, TENNIS, SWIMMING AND MOTOR SPORTS EVENTS (U.S. CLS. 100, 101 AND 107).

**CLASS 42—SCIENTIFIC AND COMPUTER SERVICES**

FOR PHYSICAL AND ELECTRONIC NAVIGATION AND INDEX SERVICES AVAILABLE VIA GLOBAL COMPUTER NETWORKS AND WIRELESS AND WIRE-BASED COMMUNICATION DEVICES, NAMELY, PROVIDING CUSTOMIZED ONLINE WEB PAGES FEATURING USER-IDENTIFIED INFORMATION AND INCLUDING SEARCH ENGINES AND ONLINE WEB LINKS TO OTHER WEB SITES; MAPPING SERVICES (U.S. CLS. 100 AND 101).

BRENDAN REGAN, EXAMINING ATTORNEY

SN 86-013,759. YP INTELLECTUAL PROPERTY, LLC, TUCKER, GA. FILED 7-18-2013.

**THE NEW WAY TO DO**

THE MARK CONSISTS OF STANDARD CHARACTERS WITHOUT CLAIM TO ANY PARTICULAR FONT, STYLE, SIZE, OR COLOR.

**CLASS 16—PAPER GOODS AND PRINTED MATTER**

FOR PRINTED PUBLICATIONS, NAMELY, PUBLISHED TELEPHONE DIRECTORIES IN THE FIELDS OF BUSINESS, RESIDENTIAL, COMMERCIAL AND GOVERNMENT (U.S. CLS. 2, 5, 22, 23, 29, 37, 38 AND 50).

**CLASS 35—ADVERTISING AND BUSINESS**

FOR PROVIDING ADVERTISEMENT SERVICES FOR OTHERS VIA A GLOBAL COMPUTER NETWORK; ELECTRONIC YELLOW PAGE DIRECTORY SERVICES, NAMELY, PROVIDING ONLINE AND WIRELESS DIRECTORY INFORMATION SERVICE ABOUT WEB SITES AND PHYSICAL LOCATIONS OF ESTABLISHMENTS FEATURING HYPERLINKS TO OTHER WEB SITES (U.S. CLS. 100, 101 AND 102).

**CLASS 39—TRANSPORTATION AND STORAGE**

FOR TRAVEL AGENCY SERVICES, NAMELY, MAKING RESERVATIONS AND BOOKINGS FOR TRANSPORTATION; PROVIDING TRAVEL INFORMATION SERVICES; PROVIDING AN ONLINE INTERACTIVE DATABASE FEATURING INFORMATION IN THE FIELDS OF TRAVEL, NAMELY, INFORMATION ON RESERVATIONS AND BOOKINGS FOR TRANSPORTATION; PROVIDING AN ONLINE INTERACTIVE DATABASE FEATURING INFORMATION IN THE FIELD OF TRANSPORTATION OF PASSENGERS AND/OR GOODS BY AIR, BOAT, BUS, TRAIN AND TRUCKS; PROVIDING AN ONLINE INTERACTIVE DATABASE FEATURING INFORMATION IN THE FIELD OF VEHICLE PARKING; PROVIDING NAVIGATION, TRAFFIC AND POINT-OF-INTEREST INFORMATION VIA TELECOMMUNICATION NETWORKS, CELLULAR TELEPHONES AND WIRELESS DEVICES (U.S. CLS. 100 AND 105).

SN 86-013,763. YP INTELLECTUAL PROPERTY, LLC, TUCKER, GA. FILED 7-18-2013.



OWNER OF U.S. REG. NOS. 3,947,963 AND 4,400,504.  
THE MARK CONSISTS OF THE LETTERS "YP" ABOVE A BAR.

**CLASS 16—PAPER GOODS AND PRINTED MATTER**

FOR PRINTED PUBLICATIONS, NAMELY, PUBLISHED TELEPHONE DIRECTORIES IN THE FIELDS OF BUSINESS, RESIDENTIAL, COMMERCIAL AND GOVERNMENT (U.S. CLS. 2, 5, 22, 23, 29, 37, 38 AND 50).

**CLASS 35—ADVERTISING AND BUSINESS**

FOR PROVIDING ADVERTISEMENT SERVICES FOR OTHERS VIA A GLOBAL COMPUTER NETWORK; ELECTRONIC YELLOW PAGE DIRECTORY SERVICES, NAMELY, PROVIDING ONLINE AND WIRELESS DIRECTORY INFORMATION SERVICE ABOUT WEB SITES AND PHYSICAL LOCATIONS OF ESTABLISHMENTS FEATURING HYPERLINKS TO OTHER WEB SITES (U.S. CLS. 100, 101 AND 102).

**CLASS 39—TRANSPORTATION AND STORAGE**

FOR TRAVEL AGENCY SERVICES, NAMELY, MAKING RESERVATIONS AND BOOKINGS FOR TRANSPORTATION; PROVIDING TRAVEL INFORMATION SERVICES; PROVIDING AN ONLINE INTERACTIVE DATABASE FEATURING INFORMATION IN THE FIELDS OF TRAVEL, NAMELY, INFORMATION ON RESERVATIONS AND BOOKINGS FOR TRANSPORTATION; PROVIDING AN ONLINE INTERACTIVE DATABASE FEATURING INFORMATION IN THE FIELD OF TRANSPORTATION OF PASSENGERS AND/OR GOODS BY AIR, BOAT, BUS, TRAIN AND TRUCKS; PROVIDING AN ONLINE INTERACTIVE DATABASE FEATURING INFORMATION IN THE FIELD OF VEHICLE PARKING; PROVIDING NAVIGATION, TRAFFIC AND POINT-OF-INTEREST INFORMATION VIA TELECOMMUNICATION NETWORKS, CELLULAR TELEPHONES AND WIRELESS DEVICES (U.S. CLS. 100 AND 105).

**CLASS 41—EDUCATION AND ENTERTAINMENT**

FOR PROVIDING ONLINE NON-DOWNLOADABLE PUBLICATIONS THAT FEATURE ADVERTISEMENTS FOR THE GOODS AND SERVICES OF OTHERS, NAMELY, TELEPHONE DIRECTORIES IN THE FIELDS OF BUSINESS, RESIDENTIAL, COMMERCIAL AND GOVERNMENT; PROVIDING AN ONLINE INTERACTIVE DATABASE FEATURING ENTERTAINMENT INFORMATION IN THE FIELDS OF LIVE MUSICAL PERFORMANCES, LIVE THEATRICAL PERFORMANCES, LIVE DRAMATIC PERFORMANCES, MOTION PICTURE FILMS AND SPORTING EVENTS, NAMELY FOOTBALL, BASEBALL, BASKETBALL, TENNIS, SWIMMING AND MOTOR SPORTS EVENTS (U.S. CLS. 100, 101 AND 107).

**CLASS 42—SCIENTIFIC AND COMPUTER SERVICES**

FOR PHYSICAL AND ELECTRONIC NAVIGATION AND INDEX SERVICES AVAILABLE VIA GLOBAL COMPUTER NETWORKS AND WIRELESS AND WIREBASED COMMUNICATION DEVICES, NAMELY, PROVIDING CUSTOMIZED ONLINE WEB PAGES FEATURING USER-IDENTIFIED INFORMATION AND INCLUDING SEARCH ENGINES AND ONLINE WEB LINKS TO OTHER WEB SITES; MAPPING SERVICES (U.S. CLS. 100 AND 101).

BRENDAN REGAN, EXAMINING ATTORNEY

SN 86-014,172. TWIN CITIES PUBLIC TELEVISION, INC., ST. PAUL, MN, MN. FILED 7-18-2013.

**Fiftysomething Diet**

THE MARK CONSISTS OF STANDARD CHARACTERS WITHOUT CLAIM TO ANY PARTICULAR FONT, STYLE, SIZE, OR COLOR.

NO CLAIM IS MADE TO THE EXCLUSIVE RIGHT TO USE "DIET", APART FROM THE MARK AS SHOWN.

**CLASS 41—EDUCATION AND ENTERTAINMENT**

FOR PROVIDING INFORMATION IN THE FIELD OF FITNESS VIA NON-DOWNLOADABLE ARTICLES, VIDEOS, WEBINARS, SLIDESHOWS, AND PODCASTS; ENTERTAINMENT AND EDUCATIONAL SERVICES, NAMELY, PROVIDING NON-DOWNLOADABLE ARTICLES, NON-DOWNLOADABLE VIDEOS, NON-DOWNLOADABLE WEBINARS, NON-DOWNLOADABLE SLIDESHOWS, AND NON-DOWNLOADABLE PODCASTS IN THE FIELD OF DIET, FITNESS, HEALTH AND WELLNESS; CONDUCTING LIVE WORKSHOPS, SEMINARS AND CLASSES IN THE FIELD OF DIET, FITNESS, HEALTH AND WELLNESS AND PRINTED MATERIALS DISTRIBUTED THEREWITH (U.S. CLS. 100, 101 AND 107).

**CLASS 44—MEDICAL, BEAUTY AND AGRICULTURAL SERVICES**

FOR PROVIDING INFORMATION IN THE FIELD OF DIET, HEALTH, AND WELLNESS VIA NON-DOWNLOADABLE ARTICLES, VIDEOS, WEBINARS, SLIDESHOWS, AND PODCASTS (U.S. CLS. 100 AND 101).

MEGHAN REINHART, EXAMINING ATTORNEY

SN 86-014,715. WEBCOR SA, GENÈVE, SWITZERLAND, FILED 7-19-2013.



OWNER OF SWITZERLAND REG. NO. 533471, DATED 5-12-2005, EXPIRES 2-4-2015.

THE MARK CONSISTS OF THE WORD "WEBCOR" TO THE RIGHT OF A SWIRL DESIGN WITH AN IMAGE RESEMBLING A HEAD AND BEAK OF A BIRD.

**CLASS 2—PAINTS**

FOR BUILDING MATERIALS, NOT OF METAL, NAMELY, PAINTS (U.S. CLS. 6, 11 AND 16).

**CLASS 11—ENVIRONMENTAL CONTROL APPARATUS**

FOR BUILDING MATERIALS, NOT OF METAL, NAMELY, TOILETS (U.S. CLS. 13, 21, 23, 31 AND 34).

**CLASS 19—NON-METALLIC BUILDING MATERIALS**

FOR BUILDING MATERIALS, NOT OF METAL, NAMELY, GLASS FOR BUILDING, TILES OF CLAY, GLASS, GYPSUM, CERAMIC AND EARTHENWARE FOR WALLS, FLOORS OR CEILINGS, CERAMIC FLOOR TILES, CERAMIC ROOFING TILES, WOODEN FLOOR TILES, AND BLOCKS OF CONCRETE (U.S. CLS. 1, 12, 33 AND 50).

**CLASS 22—CORDAGE AND FIBERS**

FOR BAGS IN THE NATURE OF POLYPROPYLENE BAGS AND SACKS FOR THE TRANSPORT AND STORAGE OF MATERIALS IN BULK (U.S. CLS. 1, 2, 7, 19, 22, 42 AND 50).

**CLASS 29—MEATS AND PROCESSED FOODS**

FOR POULTRY, FROZEN; EDIBLE OILS, NAMELY, VEGETABLE OIL (U.S. CL. 46).

**CLASS 30—STAPLE FOODS**

FOR RICE, SUGAR, WHEAT FLOUR (U.S. CL. 46).

**CLASS 32—LIGHT BEVERAGES**

FOR MINERAL AND AERATED WATERS AND OTHER NON-ALCOHOLIC BEVERAGES, NAMELY, NON-ALCOHOLIC COCKTAILS (U.S. CLS. 45, 46 AND 48).

**CLASS 35—ADVERTISING AND BUSINESS**

FOR BUSINESS MANAGEMENT; IMPORT-EXPORT AGENCIES; BUSINESS MANAGEMENT AND ORGANIZATION CONSULTANCY; BOOK-KEEPING (U.S. CLS. 100, 101 AND 102).

**CLASS 39—TRANSPORTATION AND STORAGE**

FOR TRANSPORT BY BOAT, RAILWAY, ROAD AND AIR; TRANSPORT BROKERAGE; PACKAGING AND STORAGE OF GOODS; FREIGHT FORWARDING AND FREIGHT BROKERAGE; PROVIDING INFORMATION IN THE FIELD OF TRANSPORTATION; VEHICLE AND BOAT RENTAL (U.S. CLS. 100 AND 105).

MARY CRAWFORD, EXAMINING ATTORNEY

SN 86-014,802. T.A. COOK & PARTNER CONSULTANTS GMBH, BERLIN 10117, FED REP GERMANY, FILED 7-19-2013.

# TARfighter

THE MARK CONSISTS OF STANDARD CHARACTERS WITHOUT CLAIM TO ANY PARTICULAR FONT, STYLE, SIZE, OR COLOR.

PRIORITY CLAIMED UNDER SEC. 44(D) ON ERP N CMNTY TM OFC APPLICATION NO. 011741402, FILED 4-16-2013, REG. NO. 011741402, DATED 9-16-2013, EXPIRES 4-16-2023.

**CLASS 16—PAPER GOODS AND PRINTED MATTER**

FOR PRINTED INSTRUCTIONAL AND TEACHING MATERIAL IN THE FIELD OF INDUSTRIAL AND BUSINESS PROJECT MANAGEMENT FOR SHUTDOWN AND TURNAROUND PROJECTS; PRINTED INSTRUCTIONAL AND TEACHING MATERIAL IN THE FORM OF MANUALS AND GUIDELINES FOR THE SIMULATION OF REAL LIFE BUSINESS SITUATIONS IN PRACTICAL TRAINING FOR TEACHING AND LEARNING IN THE FIELD OF INDUSTRIAL PROCESSES AND INDUSTRIAL PROCESS MANAGEMENT FOR SHUTDOWN AND TURNAROUND PROJECTS (U.S. CLS. 2, 5, 22, 23, 29, 37, 38 AND 50).

**CLASS 41—EDUCATION AND ENTERTAINMENT**

FOR PROVIDING OF TRAINING, NAMELY, ARRANGING AND CONDUCTING OF SEMINARS AND WORKSHOPS IN THE FIELD OF INDUSTRIAL AND BUSINESS PROJECT MANAGEMENT FOR SHUTDOWN AND TURNAROUND PROJECTS; BUSINESS TRAINING, NAMELY, ARRANGING AND CONDUCTING OF BUSINESS SIMULATION GAMES FOR TEACHING AND LEARNING IN THE FIELD OF INDUSTRIAL AND BUSINESS PROJECT MANAGEMENT AND OPTIMIZATION; PRACTICAL BUSINESS TRAINING, NAMELY, DEMONSTRATION OF REALISTIC SCENARIOS AND SIMULATIONS OF INDUSTRIAL SHUTDOWN AND TURNAROUND PROJECTS (U.S. CLS. 100, 101 AND 107).

APRIL REEVES, EXAMINING ATTORNEY

SN 86-015,544. OPEN TODAY, LLC, OVERLAND PARK, KS. FILED 7-19-2013.

# Open Today

THE MARK CONSISTS OF STANDARD CHARACTERS WITHOUT CLAIM TO ANY PARTICULAR FONT, STYLE, SIZE, OR COLOR.

**CLASS 35—ADVERTISING AND BUSINESS**

FOR ADVERTISING AND DIRECTORY SERVICES, NAMELY, PROVIDING AN ONLINE DIRECTORY OF BUSINESSES AND ORGANIZATIONS AND THEIR LOCATIONS; PROVIDING AN ONLINE SEARCHABLE DATABASE FEATURING BUSINESS INFORMATION (U.S. CLS. 100, 101 AND 102).

**CLASS 42—SCIENTIFIC AND COMPUTER SERVICES**

FOR COMPUTER SERVICES, NAMELY, PROVIDING ONLINE, NON-DOWNLOADABLE SOFTWARE FOR POSTING AND VIEWING INFORMATION OF INTEREST TO CONSUMERS OF BUSINESSES AND ORGANIZATIONS; PROVIDING ONLINE, NON-DOWNLOADABLE SOFTWARE FOR SEARCHING FOR BUSINESSES AND ORGANIZATIONS BASED ON A USER'S GEOLOCATION (U.S. CLS. 100 AND 101).

GRETCHEN ULRICH, EXAMINING ATTORNEY

SN 86-016,029. MAINSTREETS, MARTINEZ, CA. FILED 7-22-2013.

# LOCAL KNOWLEDGE

THE MARK CONSISTS OF STANDARD CHARACTERS WITHOUT CLAIM TO ANY PARTICULAR FONT, STYLE, SIZE, OR COLOR.

NO CLAIM IS MADE TO THE EXCLUSIVE RIGHT TO USE "LOCAL", APART FROM THE MARK AS SHOWN.

**CLASS 9—ELECTRICAL AND SCIENTIFIC APPARATUS**

FOR SOFTWARE-ENABLED MOBILE COMMUNICATIONS DEVICE THAT PROVIDE SHARING CONSUMER EVALUATIONS OF LOCAL BUSINESSES, NAMELY, CELL PHONES (U.S. CLS. 21, 23, 26, 36 AND 38).

**CLASS 35—ADVERTISING AND BUSINESS**

FOR BUSINESS EVALUATIONS FOR OTHERS, NAMELY, PROVIDING CUSTOMER EVALUATIONS OF LOCAL BUSINESSES; BUSINESS EVALUATIONS FOR OTHERS, NAMELY, PROVIDING CUSTOMER EVALUATIONS IN RESPONSE TO A BUSINESS LOCATION SPECIFIC REQUEST; BUSINESS EVALUATIONS FOR OTHERS, NAMELY, PROVIDING INFORMATION IN RESPONSE TO A SITE-SPECIFIC REQUEST FOR CONSUMER EVALUATIONS OF A SERVICE PROVIDER OR A GOODS VENDOR; PROVIDING AN ONLINE COMMERCIAL INFORMATION DIRECTORY FEATURING BUSINESS SITES AND OFFICES OF OTHERS, NAMELY GOODS VENDORS AND SERVICE PROVIDERS, RELATIVE TO A SPECIFIED GEOGRAPHIC LOCATION; PROMOTIONAL SERVICES FOR BUSINESSES PROFESSIONALS AND INDIVIDUALS, FOR THE PURPOSE OF FACILITATING NETWORKING FOR BUSINESS VIA A GLOBAL COMMUNICATIONS NETWORK; PROMOTIONAL, MARKETING AND ADVERTISING SERVICES, NAMELY, PROMOTING, MARKETING AND ADVERTISING THE GOODS AND SERVICES OF OTHERS BY PROVIDING ELECTRONIC MESSAGING THAT FEATURES OFFERS TO PROVIDE GOODS AND SERVICES, COUPONS, CUSTOMER LOYALTY REWARD CARDS, AND CONSUMER PRODUCT AND SERVICE REVIEWS (U.S. CLS. 100, 101 AND 102).

**CLASS 38—COMMUNICATION**

FOR WIRELESS COMMUNICATIONS SERVICES, NAMELY, MOBILE COMMUNICATIONS DEVICE SERVICES THAT ENABLE SOCIAL NETWORKING BY BUSINESSES, PROFESSIONALS AND INDIVIDUALS; MOBILE TELEPHONY COMMUNICATIONS DEVICE SERVICES THAT ENABLE SHARING OF CONSUMER EVALUATIONS OF LOCAL BUSINESSES; WIRELESS COMMUNICATIONS SERVICES, NAMELY, MOBILE COMMUNICATIONS DEVICE SERVICES THAT ENABLE PROVIDING CUSTOMER EVALUATIONS OF LOCAL BUSINESSES; WIRELESS COMMUNICATIONS SERVICES, NAMELY, MOBILE COMMUNICATIONS DEVICE SERVICES THAT ENABLE PROVIDING CUSTOMER EVALUATIONS IN RESPONSE TO A LOCATION SPECIFIC REQUEST; WIRELESS COMMUNICATIONS SERVICES, NAMELY, MOBILE COMMUNICATIONS DEVICE SERVICES THAT ENABLE PROVIDING INFORMATION IN RESPONSE TO A SITE-SPECIFIC REQUEST FOR CONSUMER EVALUATIONS OF A SERVICE PROVIDER OR A GOODS VENDOR (U.S. CLS. 100, 101 AND 104).

**CLASS 45—PERSONAL AND LEGAL SERVICES**

FOR ONLINE SOCIAL NETWORKING SERVICES FOR BUSINESSES, PROFESSIONALS AND INDIVIDUALS, PROVIDED THROUGH COMMUNITY WEBSITES (U.S. CLS. 100 AND 101).

DAVID MURRAY, EXAMINING ATTORNEY

SN 86-016,059. SILGAN CONTAINERS LLC, WOODLAND HILLS, CA. FILED 7-22-2013.

# CanVision 20/20

THE MARK CONSISTS OF STANDARD CHARACTERS WITHOUT CLAIM TO ANY PARTICULAR FONT, STYLE, SIZE, OR COLOR.

**CLASS 40—MATERIAL TREATMENT**

FOR CUSTOM MANUFACTURING OF METAL CANS AND METALLIC CAN ENDS FOR OTHERS (U.S. CLS. 100, 103 AND 106).

**CLASS 42—SCIENTIFIC AND COMPUTER SERVICES**

FOR CUSTOM DESIGN OF METAL CANS AND METALLIC CAN ENDS FOR OTHERS; ENGINEERING AND TECHNOLOGICAL SERVICES, NAMELY, ANALYSIS AND TESTING IN THE FIELD OF METAL CANS AND METALLIC CAN ENDS; RESEARCH AND DESIGN SERVICES IN THE FIELD OF METAL CANS AND METALLIC CAN ENDS; CONSULTATION SERVICES RELATED TO THE DESIGN AND DEVELOPMENT OF METAL CANS AND METALLIC CAN ENDS (U.S. CLS. 100 AND 101).

EVIN L. KOZAK, EXAMINING ATTORNEY

SN 86-016,541. BYBOX HOLDINGS LIMITED, WANTAGE, OXFORDSHIRE, UNITED KINGDOM, FILED 7-22-2013.



THE COLOR(S) BLUE, YELLOW AND GREY IS/ARE CLAIMED AS A FEATURE OF THE MARK.

THE MARK CONSISTS OF A DESIGN ELEMENT OF A CUBE WHICH IS COMPRISED OF THREE SQUARES, THE TOP SQUARE AND LEFT SQUARE ARE GREY, AND THE RIGHT SQUARE IS YELLOW; THE STYLIZED WORDING "BYBOX", IN BLUE, IS TO THE RIGHT OF THE CUBE.

**CLASS 9—ELECTRICAL AND SCIENTIFIC APPARATUS**

FOR SYSTEM FOR GENERATING AND PROCESSING SECURITY CODES FOR THE DELIVERY AND COLLECTION OF GOODS COMPRISED OF COMPUTER SOFTWARE AND HARDWARE; ELECTRONIC EQUIPMENT AND SOFTWARE FOR SCANNING AND INPUTTING SECURITY CODES FOR THE DELIVERY AND COLLECTION OF GOODS (U.S. CLS. 21, 23, 26, 36 AND 38).

FIRST USE 4-0-2001; IN COMMERCE 4-24-2012.

**CLASS 20—FURNITURE AND ARTICLES NOT OTHERWISE CLASSIFIED**

FOR LOCKERS; ELECTRONIC LOCKERS; COIN-OPERATED LOCKERS; STORAGE SYSTEMS COMPRISED OF SHELVES, DRAWERS, CUPBOARDS, BASKETS AND CLOTHES RODS, SOLD AS A UNIT (U.S. CLS. 2, 13, 22, 25, 32 AND 50).

FIRST USE 4-0-2001; IN COMMERCE 4-24-2012.

**CLASS 39—TRANSPORTATION AND STORAGE**

FOR DELIVERY OF GOODS, PARCELS, DOCUMENTS AND LETTERS; SECURE DELIVERY OF GOODS, PARCELS, DOCUMENTS AND LETTERS; DISTRIBUTION SERVICES, NAMELY, DELIVERY OF PARCELS; STORAGE OF GOODS, PARCELS, PHYSICAL DOCUMENTS AND LETTERS (U.S. CLS. 100 AND 105).

FIRST USE 4-0-2001; IN COMMERCE 4-24-2012.

CHRISTOPHER REAMS, EXAMINING ATTORNEY

SN 86-016,546. BYBOX HOLDINGS LIMITED, WANTAGE, OXFORDSHIRE, UNITED KINGDOM, FILED 7-22-2013.

# BYBOX

THE MARK CONSISTS OF STANDARD CHARACTERS WITHOUT CLAIM TO ANY PARTICULAR FONT, STYLE, SIZE, OR COLOR.

## CLASS 9—ELECTRICAL AND SCIENTIFIC APPARATUS

FOR SYSTEM FOR GENERATING AND PROCESSING SECURITY CODES FOR THE DELIVERY AND COLLECTION OF GOODS COMPRISED OF COMPUTER SOFTWARE AND HARDWARE; ELECTRONIC EQUIPMENT AND SOFTWARE FOR SCANNING AND INPUTTING SECURITY CODES FOR THE DELIVERY AND COLLECTION OF GOODS (U.S. CLS. 21, 23, 26, 36 AND 38).

FIRST USE 2-0-2000; IN COMMERCE 4-24-2012.

## CLASS 20—FURNITURE AND ARTICLES NOT OTHERWISE CLASSIFIED

FOR LOCKERS; ELECTRONIC LOCKERS; COIN-OPERATED LOCKERS; STORAGE SYSTEMS COMPRISED OF SHELVES, DRAWERS, CUPBOARDS, BASKETS AND CLOTHES RODS, SOLD AS A UNIT (U.S. CLS. 2, 13, 22, 25, 32 AND 50).

FIRST USE 2-0-2000; IN COMMERCE 4-24-2012.

## CLASS 39—TRANSPORTATION AND STORAGE

FOR DELIVERY OF GOODS, PARCELS, DOCUMENTS AND LETTERS; SECURE DELIVERY OF GOODS, PARCELS, DOCUMENTS AND LETTERS; DISTRIBUTION SERVICES, NAMELY, DELIVERY OF PARCELS; STORAGE OF GOODS, PARCELS, PHYSICAL DOCUMENTS AND LETTERS (U.S. CLS. 100 AND 105).

FIRST USE 2-0-2000; IN COMMERCE 4-24-2012.

CHRISTOPHER REAMS, EXAMINING ATTORNEY

---

SN 86-017,326. FREMANTLEMEDIA LIMITED, LONDON, UNITED KINGDOM, FILED 7-23-2013.

# DATE WITH FATE

THE MARK CONSISTS OF STANDARD CHARACTERS WITHOUT CLAIM TO ANY PARTICULAR FONT, STYLE, SIZE, OR COLOR.

PRIORITY CLAIMED UNDER SEC. 44(D) ON ERP CMNTY TM OFC APPLICATION NO. 011519113, FILED 1-25-2013, REG. NO. 011519113, DATED 5-20-2013, EXPIRES 1-25-2023.

## CLASS 9—ELECTRICAL AND SCIENTIFIC APPARATUS

FOR CINEMATOGRAPHIC FILMS FEATURING MUSIC, SOUNDTRACKS, ARTISTIC PERFORMANCES, DOCUMENTARIES, DRAMAS, COMEDIES, AND ANIMATION; ANIMATED CARTOONS RECORDED ON VIDEO DISCS AND VIDEO TAPES; MAGNETIC RECORDINGS, NAMELY, PRE-RECORDED VIDEO CASSETTES, MULTIMEDIA SOFTWARE PRE-RECORDED ON CD-ROMS, PRE-RECORDED DVD, PRE-RECORDED HIGH DEFINITION VIDEO CASSETTES, PRE-RECORDED HIGH DEFINITION DVD, PRE-RECORDED COMPUTER HARD DISCS, AND PRE-RECORDED LASERDISCS FEATURING MUSIC, DOCUMENTARIES, DRAMAS, COMEDIES, ANIMATIONS, AND CARTOONS; OPTICAL RECORDINGS, NAMELY, PRE-RECORDED VIDEO CASSETTES, PRE-RECORDED CD-ROM, PRE-RECORDED DVD, PRE-RECORDED HIGH DEFINITION VIDEO CASSETTES, PRE-RECORDED HIGH DEFINITION DVD, PRE-RECORDED COMPUTER HARD DISCS, AND PRE-RECORDED LASERDISCS FEATURING MUSIC, DOCUMENTARIES, DRAMAS, COMEDIES, ANIMATIONS, AND CARTOONS; MAGNETO-OPTICAL RECORDINGS, NAMELY, PRE-RECORDED DVDS AND COMPACT DISCS FEATURING MUSIC, DOCUMENTARIES, DRAMAS, ANIMATIONS, CARTOONS AND COMEDIES; SOLID-STATE RECORDINGS, NAMELY, PRE-RECORDED FLASH MEMORY CARDS FEATURING MUSIC, DOCUMENTARIES, DRAMAS, ANIMATIONS, CARTOONS AND COMEDIES; DOWNLOADABLE ELECTRONIC BOOKS AND PUBLICATIONS IN THE NATURE OF BOOKS AND MAGAZINES FEATURING MUSIC, DOCUMENTARIES, DRAMAS, COMEDIES, ANIMATIONS, AND CARTOONS; MULTI-MEDIA DISCS RECORDED ON COMPUTER MEDIA AND DOWNLOADABLE ELECTRONIC PUBLICATIONS, NAMELY, ELECTRONIC BOOKS AND MAGAZINES ALL FEATURING MUSIC, DOCUMENTARIES, DRAMAS, COMEDIES, ANIMATIONS, AND CARTOONS; LASER-READABLE DISCS FEATURING MUSIC, DOCUMENTARIES, DRAMAS, COMEDIES, ANIMATIONS, AND CARTOONS; COMPUTER SOFTWARE, NAMELY, COMPUTER GAMES SOFTWARE, VIDEO GAMES SOFTWARE AND APPLICATIONS FOR USE IN DISTRIBUTION OF DIGITAL VIDEO, VIDEO FILES, VIDEO GAMES, AND MULTIMEDIA CONTENT FOR USE IN CONNECTION WITH COMPUTERS, MOBILE COMPUTERS, MEDIA PLAYERS, CELLULAR PHONES, WIRELESS DEVICES AND PORTABLE AND HANDHELD DIGITAL ELECTRONIC DEVICES; AUDIO TAPES FEATURING MUSIC, SOUNDTRACKS, ARTISTIC PERFORMANCES, DOCUMENTARIES, DRAMAS, COMEDIES, AND ANIMATION; PRE-RECORDED TAPE CASSETTES FEATURING MUSIC, SOUNDTRACKS, ARTISTIC PERFORMANCES, DOCUMENTARIES, DRAMAS, COMEDIES, AND ANIMATION; PRE-RECORDED VIDEO TAPES FEATURING MUSIC, SOUNDTRACKS, ARTISTIC PERFORMANCES, DOCUMENTARIES, DRAMAS, COMEDIES, AND ANIMATION; LASER DISCS FEATURING MUSIC, SOUNDTRACKS, ARTISTIC PERFORMANCES, DOCUMENTARIES, DRAMAS, COMEDIES, AND ANIMATION; COMPACT DISCS AND INTERACTIVE MULTIMEDIA SOFTWARE RECORDED ON CD ROMS FEATURING MUSIC, SOUNDTRACKS, ARTISTIC PERFORMANCES, DOCUMENTARIES, DRAMAS, COMEDIES, AND ANIMATION; PRE-RECORDED DIGITAL VIDEO DISCS FEATURING MUSIC, SOUNDTRACKS, ARTISTIC PERFORMANCES, DOCUMENTARIES, DRAMAS, COMEDIES, AND ANIMATION; TELEPHONES; MOBILE PHONES; BATTERY CHARGERS; BATTERY CHARGERS FOR MOBILE PHONES; DOWNLOADABLE MOBILE PHONE GAMES SOFTWARE; KARAOKE MACHINES, NAMELY, KARAOKE PLAYERS; PARTS AND FITTINGS FOR ALL THE AFORESAID GOODS; DOWNLOADABLE DIGITAL GAMES SOFTWARE, DOWNLOADABLE MOBILE PHONE GAMES SOFTWARE; DVD GAMES BEING GAME SOFTWARE RECORDED ON DVD, NAMELY, GAME PROGRAMS ON DVD (U.S. CLS. 21, 23, 26, 36 AND 38).



**CLASS 28—TOYS AND SPORTING GOODS**

FOR GAME, TOYS AND PLAYTHINGS, NAMELY, TARGET GAMES, BOARD GAMES AND CARD GAMES, KITES, TOY ACTION FIGURES, DISC TOSS TOYS, TOY BOWS AND ARROWS, SPORT BALLS AND PLAYGROUND BALLS, DOLLS AND DOLLS' CLOTHING, DOLL PLAYSETS, ACCESSORIES FOR DOLLS; DOLLS' HOUSES; DOLLS' FURNITURE; DOLLS' FURNITURE ACCESSORIES; TEDDY BEARS; TOY ACTION FIGURES; PLUSH TOYS, TOY VEHICLES, TOY BUCKET AND SHOVEL SETS COMPRISED PRIMARILY OF TOY SHOVELS, SPORTING ARTICLES, NAMELY, ROLLER SKATES, TOY MODEL HOBBYCRAFT KITS, TOY ROCKETTS, TOY GUNS, TOY HOLSTERS, MUSICAL TOYS, JIGSAW PUZZLES, SPORTING ARTICLES, NAMELY, BADMINTON SETS, BUBBLE MAKING WANDS AND SOLUTION SETS, TOY FIGURINES, TOY BANKS, PUPPETS, TOY BALLOONS, YO-YOS, SPORTING ARTICLES, NAMELY, SKATEBOARDS, TOY SCOOTERS, TOY AND NOVELTY FACE MASKS; PAPER PARTY HATS, BALLOONS; PLAYING CARDS; BLOW-OUTS BEING NOISE MAKING PARTY FAVORS; PARTY FAVORS IN THE NATURE OF SMALL TOYS; PARTY FAVORS IN THE NATURE OF CRACKERS; HAND-HELD COMPUTER GAME EQUIPMENT WHICH IS SELF CONTAINED AND NOT ADAPTED FOR USE WITH TV RECEIVERS; ELECTRONIC TOYS AND ELECTRONIC GAMES, NAMELY, ELECTRONIC ACTION TOYS, ELECTRONIC LEARNING TOYS, AND ELECTRONIC GAMES, NAMELY, HAND HELD UNIT FOR PLAYING ELECTRONIC GAMES, TABLETOP UNITS FOR PLAYING ELECTRONIC GAMES OTHER THAN IN CONJUNCTION WITH A TELEVISION OR COMPUTER, ARCADE TYPE ELECTRONIC VIDEO GAMES; ELECTRONIC GAMES OTHER THAN THOSE ADAPTED FOR USE WITH TELEVISION RECEIVERS ONLY; AMUSEMENT GAME MACHINES; COIN-OPERATED ELECTRONIC AMUSEMENT MACHINES; GAMING MACHINES, NAMELY, SLOT MACHINES AND VIDEO LOTTERY TERMINALS; HAND-HELD COMPUTER GAMES WITH LIQUID CRYSTAL DISPLAYS; DOLLS AND DOLLS' CLOTHING; AMUSEMENT APPARATUS ADAPTED FOR USE WITH TELEVISION RECEIVERS ONLY; INTERACTIVE VIDEO OUTPUT GAMES ADAPTED FOR USE WITH TELEVISION RECEIVERS; ELECTRICAL AND VIDEO AMUSEMENT APPARATUS AND INSTRUMENTS, NAMELY, VIDEO GAME MACHINES ADAPTED FOR USE WITH TELEVISION RECEIVERS (U.S. CLS. 22, 23, 38 AND 50).

**CLASS 41—EDUCATION AND ENTERTAINMENT**

FOR ENTERTAINMENT SERVICES, NAMELY, PRODUCTION AND PRESENTATION OF TELEVISION PROGRAMS, LIVE SHOW PERFORMANCES, STAGE PLAYS, LIVE MUSICAL CONCERTS, COMPUTER GAMES SOFTWARE, RADIO PROGRAMS, CABLE TELEVISION PROGRAMS, SATELLITE TELEVISION PROGRAMS AND CONTINUING INTERNET PROGRAMS FEATURING DATING, ROMANCE, LIVE ACTION, COMEDY AND DRAMA; ENTERTAINMENT SERVICES, NAMELY, AN ONGOING TELEVISION SERIES FEATURING DRAMA, COMEDY, ACTION, ADVENTURE AND ROMANCE; ENTERTAINMENT SERVICES, NAMELY, AN ONGOING TELEVISION GAME SHOW; ENTERTAINMENT SERVICES, NAMELY, PROVIDING TEMPORARY USE OF AN ON-LINE NON-DOWNLOADABLE COMPUTER GAME; ENTERTAINMENT SERVICES, NAMELY, PROVIDING A WEBSITE FEATURING ONLINE NON-DOWNLOADABLE DIGITIZED PRINT AND AUDIO-VISUAL ENTERTAINMENT INFORMATION IN THE FORM OF IMAGES, TEXT, ELECTRONIC DOCUMENTS AND COMPUTER-GENERATED GRAPHICS ABOUT A TELEVISION SERIES VIA A GLOBAL COMPUTER NETWORK; ENTERTAINMENT SERVICES IN THE NATURE OF AN AMUSEMENT PARK ATTRACTION, NAMELY, A THEMED AREA; PRODUCTION AND RENTAL OF TELEVISION AND RADIO PROGRAMMES AND OF FILMS AND SOUND AND VIDEO RECORDINGS; PRESENTATION OF TELEVISION AND RADIO PROGRAMMES AND SOUND AND VIDEO RECORDINGS IN THE NATURE OF LIVE PERFORMANCES; ORGANIZATION, PRODUCTION AND PRESENTATION OF COMPETITIONS, GAMES, QUIZZES, FUN DAYS BEING SOCIAL ENTERTAINMENT EVENTS FEATURING INSTRUCTION, ENTERTAINMENT, AND INFORMATION IN THE FIELDS OF

MUSIC, DRAMA, FILM, ART, COMEDY, GENERAL KNOWLEDGE, GAMES, QUIZZES, INFORMATION, NEWS, TELEVISION AND RADIO PROGRAMS INCLUDING CHILDREN'S RADIO AND TELEVISION PROGRAMS, EVENTS, SPORT, HISTORY, FICTION, NON-FICTION TOPICS, SCIENCE AND TECHNOLOGY; ORGANIZATION, PRESENTATION AND PRODUCTION OF LIVE TELEVISION SHOWS, LIVE SHOW PERFORMANCES AND AUDIENCE PARTICIPATION IN SUCH EVENTS IN THE FIELDS OF MUSIC, DRAMA, FILM, ART, COMEDY, GENERAL KNOWLEDGE, GAMES, QUIZZES, INFORMATION, NEWS, TELEVISION AND RADIO PROGRAMS INCLUDING CHILDREN'S RADIO AND TELEVISION PROGRAMS, EVENTS, SPORT, HISTORY, FICTION, NON-FICTION TOPICS, SCIENCE AND TECHNOLOGY; PROVISION OF ONLINE NON-DOWNLOADABLE GAMES SOFTWARE VIA MOBILE AND COMPUTER NETWORKS; PROVISION OF TEMPORARY USE OF ONLINE NON-DOWNLOADABLE INTERACTIVE VOICE RECOGNITION GAMES AND COMPETITIONS IN THE FIELD OF MUSIC, DRAMA, FILM, ART, COMEDY, GENERAL KNOWLEDGE, GAMES, QUIZZES, INFORMATION, NEWS, TELEVISION AND RADIO PROGRAMS INCLUDING CHILDREN'S RADIO AND TELEVISION PROGRAMS, EVENTS, SPORT, HISTORY, FICTION, NON-FICTION TOPICS, SCIENCE AND TECHNOLOGY; QUIZZES BEING ELECTRONIC GAMES AND LOTTERIES PROVIDED ON-LINE; ENTERTAINMENT SERVICES, NAMELY, OPERATION OF LOTTERY AND PROVIDING GAMES OF CHANCE VIA THE INTERNET; PROVISION OF A WEBSITE FEATURING NON-DOWNLOADABLE VIDEO CLIPS FEATURING MUSIC, SOUNDTRACKS, ARTISTIC PERFORMANCES, DOCUMENTARIES, DRAMAS, COMEDIES, AND ANIMATION VIA MOBILE AND COMPUTER NETWORKS FOR ENTERTAINMENT AND EDUCATIONAL PURPOSES (U.S. CLS. 100, 101 AND 107).

ALISON POLLACK, EXAMINING ATTORNEY

SN 86-019,156, EXXON MOBIL CORPORATION, IRVING, TX, FILED 7-24-2013.

**ENERGY LIVES HERE**

THE MARK CONSISTS OF STANDARD CHARACTERS WITHOUT CLAIM TO ANY PARTICULAR FONT, STYLE, SIZE, OR COLOR.

**CLASS 1—CHEMICALS**

FOR UNSATURATED ALIPHATIC HYDROCARBONS, NAMELY, OLEFINS; SATURATED HYDROCARBONS, UNSATURATED HYDROCARBONS, CYCLOALKANES, AND AROMATIC HYDROCARBONS; PARAFFINIC, AROMATIC, DEAROMATIZED, AND OXYGENATED SOLVENTS FOR INDUSTRIAL USE; POLYMERS FOR USE IN THE MANUFACTURE OF A VARIETY OF GOODS; BRAKE FLUIDS; HYDRAULIC FLUIDS; ANTI-FREEZE; COOLANT; DE-ICING PREPARATIONS FOR THE SURFACES OF PASSENGER AND COMMERCIAL VEHICLES AND INDUSTRIAL EQUIPMENT; UNPROCESSED ARTIFICIAL RESINS AND PLASTICS; SYNTHETIC FLUIDS, NAMELY, BASESTOCK COMPRISED OF POLYALPHAOLEFINS OR ESTERS (U.S. CLS. 1, 5, 6, 10, 26 AND 46).

**CLASS 4—LUBRICANTS AND FUELS**

FOR LUBRICATING OILS AND GREASES; CUTTING FLUIDS; PARAFFIN; SYNTHETIC LUBRICANTS FOR USE IN INDUSTRIAL EQUIPMENT, COMMERCIAL AND PASSENGER VEHICLES, MARINE AND AVIATION VESSELS; MOTOR OIL; BASESTOCKS, NAMELY, PETROLEUM OR LIQUID NATURAL GAS PRODUCT USED IN THE MANUFACTURE OF LUBRICANTS; FUELS; DIESEL OIL; HEATING OIL; GASOLINE (U.S. CLS. 1, 6 AND 15).

**CLASS 16—PAPER GOODS AND PRINTED MATTER**

FOR ALL KINDS OF PRINTED MATTER, NAMELY, PERIODICALS, REPORTS, BOOKLETS, BROCHURES, PAMPHLETS, NEWSLETTERS, AND POSTERS CONCERNING THE CHEMICAL AND PETROLEUM INDUSTRIES (U.S. CLS. 2, 5, 22, 23, 29, 37, 38 AND 50).  
LESLIE RICHARDS, EXAMINING ATTORNEY

SN 86-019,760. AGREEN ENERGY, LLC, BOSTON, MA.  
FILED 7-25-2013.

# Agreen Energy

THE MARK CONSISTS OF STANDARD CHARACTERS WITHOUT CLAIM TO ANY PARTICULAR FONT, STYLE, SIZE, OR COLOR.

NO CLAIM IS MADE TO THE EXCLUSIVE RIGHT TO USE "ENERGY", APART FROM THE MARK AS SHOWN.

**CLASS 40—MATERIAL TREATMENT**

FOR OPERATION OF ANAEROBIC DIGESTERS FOR OTHERS IN CONNECTION WITH THE SOURCING AND PRODUCTION OF FERTILIZER AND ENERGY (U.S. CLS. 100, 103 AND 106).

**CLASS 42—SCIENTIFIC AND COMPUTER SERVICES**

FOR DESIGN AND DEVELOPMENT OF ANAEROBIC DIGESTERS FOR USE IN CONNECTION WITH THE SOURCING AND PRODUCTION OF FERTILIZER AND ENERGY (U.S. CLS. 100 AND 101).

RICHARD WHITE, EXAMINING ATTORNEY

SN 86-020,730. SB ALLIANCE SNC, 78220 VIROFLAY, FRANCE, FILED 7-26-2013.

# SAVELIANS

THE MARK CONSISTS OF STANDARD CHARACTERS WITHOUT CLAIM TO ANY PARTICULAR FONT, STYLE, SIZE, OR COLOR.

**CLASS 1—CHEMICALS**

FOR INGREDIENTS FOR USE IN THE MANUFACTURE OF PHARMACEUTICAL AND VETERINARY PRODUCTS, NAMELY, EXCIPIENTS; LACTOSE FOR USE IN THE MANUFACTURE OF PHARMACEUTICALS (U.S. CLS. 1, 5, 6, 10, 26 AND 46).

**CLASS 5—PHARMACEUTICALS**

FOR PHARMACEUTICAL PRODUCTS, NAMELY, NUTRITIONAL SUPPLEMENTS, WHEY PROTEIN SUPPLEMENTS; DIETETIC FOODS, NAMELY, NUTRITIONAL FOOD BARS AND MEAL REPLACEMENT SHAKES FOR WEIGHT LOSS PURPOSES; FOOD FOR BABIES, PARTICULARLY MILK AND POWDERED MILK FOR BABIES, INFANT MILK; DIETARY SUPPLEMENTS FOR MEDICAL PURPOSES; MEDICAL PREPARATIONS FOR SLIMMING PURPOSES; APPETITE SUPPRESSANTS FOR MEDICAL PURPOSES; DIETARY FIBER; LACTEAL FLOUR FOR BABIES; MALTED MILK BEVERAGES FOR MEDICAL PURPOSES; DIETETIC SUGAR FOR MEDICAL PURPOSES; DIETETIC SUGAR SUBSTITUTES FOR MEDICAL PURPOSES; SODIUM SALT SUBSTITUTES FOR DIETETIC OR MEDICAL USE; K-CASEIN PROTEIN AS DIETARY SUPPLEMENTS (U.S. CLS. 6, 18, 44, 46, 51 AND 52).

**CLASS 29—MEATS AND PROCESSED FOODS**

FOR MEAT AND MEAT PREPARATIONS, NAMELY, PRESERVED MEATS AND SAUSAGES, PROCESSED MEAT, SLICED MEAT; FISH AND FISH PREPARATIONS, NAMELY, PROCESSED FISH; POULTRY AND GAME AND POULTRY AND GAME PREPARATIONS, NAMELY, POULTRY AND GAME PRESERVES; MEAT EXTRACTS; MILK AND MILK PRODUCTS EXCLUDING ICE CREAM, ICE MILK AND FROZEN YOGURT; CHEESE AND CHEESE-BASED CULINARY PREPARATIONS, NAMELY, CHEESE DIP, CHEESE FOOD; BUTTER; YOGHURT; EDIBLE OILS AND FATS; CHARCUTERIE PRODUCTS, NAMELY, PREPARED MEATS; HAM; SALTED MEATS AND FISH; CRUSTACEANS, NOT LIVE; TINNED MEAT AND FISH; MILK-BASED BEVERAGES; MILK DESSERTS MADE PREDOMINANTLY OF MILK, FRUIT-FLAVORED AND CONTAINING FRUIT, NAMELY, MILK SHAKES; GELLED MILK; READY-MADE DISHES BASED ON MEAT, FISH, POULTRY, GAME AND CHEESE; CHARCUTERIE; HAM; RILLETES IN THE NATURE OF MEAT PATE, OFFAL IN THE NATURE OF MEAT INTESTINES, BLACK AND WHITE PUDDING; LIVER PATES; FISH MOUSSES; SAUSAGES; PREPARED FISH EGGS; PREPARATIONS FOR MAKING SOUP AND BOUILLON; TINNED MEAT OR FISH, FROZEN, DEHYDRATED AND FREEZE-DRIED TINNED FOOD BASED ON MEAT OR FISH; PROTEINS FOR HUMAN CONSUMPTION, NAMELY, PROTEIN MILK, MILK SERUM, WHEY (U.S. CL. 46).

**CLASS 30—STAPLE FOODS**

FOR COFFEE, TEA, COCOA, CHOCOLATE AND CHOCOLATE-BASED PRODUCTS, NAMELY, CHOCOLATE CONFECTIONS, CHOCOLATE AND CHOCOLATE-BASED READY TO EAT CANDIES AND SNACKS; COCOA PRODUCTS, NAMELY, COCOA-BASED CONDIMENTS AND SEASONINGS FOR FOOD AND DRINK; COCOA-AND CHOCOLATE-BASED BEVERAGES; SUGAR, PASTRIES AND CONFECTIONERY, NAMELY, CONFECTIONERY MADE OF SUGAR; EDIBLE ICES, ICE CREAM AND SHERBETS; COFFEE OR CHOCOLATE DESSERTS, NAMELY, COFFEE OR CHOCOLATE-BASED COOKIES, BISCUITS, PASTRIES AND CAKES, CHOCOLATE FONDUE; MILK DESSERTS BASED ON SEMOLINA, NAMELY, SEMOLINA PUDDING, PROCESSED SEMOLINA BASED BEVERAGES WITH MILK; CHOCOLATE MILK DESSERTS, NAMELY, CHOCOLATE-BASED BEVERAGES WITH MILK; PASTRY DESSERTS, NAMELY, CLAFOUTIS, BABAS, CHARLOTTE, CUSTARDS, PIES, PUDDINGS; SAUCES AS CONDIMENTS; ICE; SANDWICHES, PIZZAS; RICE-BASED READY-MADE DISHES, PANCAKES; COOKIES; PASTRY; CAKES; SWEETS; CHEESE SAUCE; CUSTARDS; DESSERT CREMES BASED ON MILK OR MILK CREAM, NAMELY, CREAMY PUDDINGS (U.S. CL. 46).

**CLASS 31—NATURAL AGRICULTURAL PRODUCTS**

FOR ANIMAL FOODSTUFFS; AGRICULTURAL PRODUCTS NOT PREPARED, NOT TRANSFORMED, NAMELY, RAW WHEAT; GRAINS IN THE NATURE OF UNPROCESSED EDIBLE SEEDS; PET FOOD; SALT LICKS FOR CATTLE; RAW COCOA BEANS; UNPROCESSED CEREAL SEEDS; MILK-BASED MEAL FOR ANIMALS; STRENGTHENING ANIMAL FOODSTUFFS; FOODS DERIVED FROM MILK FOR CATTLE; GRAINS FOR ANIMAL CONSUMPTION (U.S. CLS. 1 AND 46).

SN 86-020,795. METROPIA, INC., TUCSON, AZ. FILED 7-26-2013.

**CLASS 32—LIGHT BEVERAGES**

FOR MINERAL AND AERATED WATERS, SYRUPS FOR BEVERAGES, FRUIT JUICES AND OTHER NON-ALCOHOLIC BEVERAGES, NAMELY, SODAS, WHEY BEVERAGES, LEMONADES, VEGETABLE JUICES, NON-ALCOHOLIC APERITIFS ; PREPARATIONS FOR MAKING BEVERAGES, NAMELY, FRUIT DRINKS, WHEY DRINKS; ESSENCES FOR MAKING NON-ALCOHOLIC BEVERAGES; POWDERS FOR EFFERVESCING BEVERAGES, NAMELY, FRUIT DRINKS, WHEY DRINKS; ISOTONIC BEVERAGES (U.S. CLS. 45, 46 AND 48).

**CLASS 35—ADVERTISING AND BUSINESS**

FOR BUSINESS SERVICES, NAMELY, BUSINESS MANAGEMENT ASSISTANCE, BUSINESS MANAGEMENT AND ORGANIZATION CONSULTANCY, BUSINESS MANAGEMENT CONSULTANCY, PROFESSIONAL BUSINESS CONSULTANCY, BUSINESS EFFICIENCY ADVICE, BUSINESS INFORMATION, BUSINESS INQUIRIES, BUSINESS MANAGEMENT, BUSINESS ADMINISTRATION, BUSINESS INVESTIGATIONS, COMMERCIAL INFORMATION AGENCIES; RENTAL OF ADVERTISING SPACE; ON-LINE ADVERTISING ON A COMPUTER NETWORK; ORGANIZATION OF EXHIBITIONS FOR COMMERCIAL OR ADVERTISING PURPOSES; COMMERCIAL INFORMATION AND ADVICE FOR CONSUMERS; RETAIL SERVICES FEATURING FOODSTUFFS, NAMELY, ONLINE RETAIL STORE AND MAIL ORDER SERVICES; PROMOTIONAL CAMPAIGNS AND ADVERTISING FOR COMMERCIAL PURPOSES (U.S. CLS. 100, 101 AND 102).

**CLASS 42—SCIENTIFIC AND COMPUTER SERVICES**

FOR SCIENTIFIC AND TECHNOLOGICAL SERVICES, NAMELY, ANALYSIS AND TESTING IN THE FIELD OF FOOD MANUFACTURING CONDUCTED BY ENGINEERS; SERVICES OF ANALYSIS AND INDUSTRIAL RESEARCH, NAMELY CHEMICAL ANALYSIS, ANALYSIS FOR IMPLEMENTATION OF COMPUTER SYSTEMS, RESEARCH AND DEVELOPMENT OF NEW PRODUCTS FOR THIRD PARTIES, BIOLOGICAL RESEARCH, RESEARCH IN BACTERIOLOGY, RESEARCH IN CHEMISTRY, TECHNICAL RESEARCH IN THE FIELD OF FOOD MANUFACTURING; TECHNICAL PROJECT STUDIES IN THE FIELD OF FOOD MANUFACTURING; RESEARCH IN THE FIELD OF ENVIRONMENT PROTECTION; SCIENTIFIC AND TECHNICAL RESEARCH IN THE FIELD OF FOOD FOR HUMANS AND ANIMALS; QUALITY CONTROL; SCIENTIFIC LABORATORIES FOR FOOD ANALYSIS; PACKAGING DESIGN; PROFESSIONAL CONSULTANCY IN THE FIELD OF DEVELOPMENT OF NEW PRODUCTS AND FOOD SUBSTANCES CONDUCTED BY ENGINEERS (U.S. CLS. 100 AND 101).

**CLASS 43—HOTEL AND RESTAURANT SERVICES**

FOR SERVICES FOR PROVIDING FOOD AND DRINK; CATERING SERVICES; HOME CATERING SERVICES; BAR, CAFE AND CAFETERIA SERVICES (U.S. CLS. 100 AND 101).

DOMINIC FATHY, EXAMINING ATTORNEY

# METROPIA

THE MARK CONSISTS OF STANDARD CHARACTERS WITHOUT CLAIM TO ANY PARTICULAR FONT, STYLE, SIZE, OR COLOR.

**CLASS 9—ELECTRICAL AND SCIENTIFIC APPARATUS**

FOR CONSUMER SOFTWARE IN THE NATURE OF MOBILE APPLICATIONS FOR REDUCTION OF TRAFFIC CONGESTION, NAMELY, COMPUTER APPLICATION SOFTWARE FOR USE IN ROADWAY INCENTIVE-BASED DEMAND MANAGEMENT, PREDICTING TRAFFIC FLOW, GENERATING TRAVEL ROUTES, GPS NAVIGATION, MONITORING, PREDICTING AND CALCULATING THE TRAJECTORY OF A PARTICULAR ROUTE OF TRAVEL, AND ISSUING AND PROVIDING INCENTIVES TO USERS TO USE A PARTICULAR TRAVEL ROUTE, DEPARTURE TIME OR MODE OF TRANSPORTATION, ALL FOR USE IN THE REDUCTION OF TRAFFIC CONGESTION AND DESIGNED FOR USE WITH CELLULAR AND MOBILE TELEPHONES AND ELECTRONIC COMMUNICATIONS DEVICES (U.S. CLS. 21, 23, 26, 36 AND 38).

**CLASS 39—TRANSPORTATION AND STORAGE**

FOR TRAFFIC MANAGEMENT, NAMELY, MANAGEMENT OF VEHICULAR TRAFFIC FLOW THROUGH ADVANCED COMMUNICATIONS NETWORKS AND NETWORK FLOW ALGORITHMS; MOBILITY AND ROUTING CONSULTING SERVICES, NAMELY, PROVIDING ROAD AND TRAFFIC INFORMATION, VEHICLE ROUTING BY COMPUTERS ON DATA NETWORKS, TRAVEL ROUTE PLANNING, MANAGEMENT OF VEHICULAR TRAFFIC FLOW THROUGH ADVANCED COMMUNICATIONS NETWORKS AND ALGORITHMS, CREATING SPECIAL EVENT TRAFFIC PLANS FOR OTHERS (U.S. CLS. 100 AND 105).

**CLASS 42—SCIENTIFIC AND COMPUTER SERVICES**

FOR MOBILITY, TRAFFIC AND TRANSPORTATION PLANNING AND LOGISTICS SERVICES, NAMELY, TRAFFIC AND TRANSPORTATION PLANNING SERVICES AND PROVIDING TEMPORARY USE OF ONLINE NON-DOWNLOADABLE COMPUTER SOFTWARE ALL FOR USE IN TRANSPORTATION SYSTEM MANAGEMENT, ROADWAY INCENTIVE-BASED DEMAND MANAGEMENT, PREDICTING TRAFFIC FLOW, GENERATING TRAVEL ROUTES, GPS NAVIGATION, MONITORING, PREDICTING AND CALCULATING THE TRAJECTORY OF A PARTICULAR ROUTE OF TRAVEL, AND ISSUING AND PROVIDING INCENTIVES TO USERS TO USE A PARTICULAR TRAVEL ROUTE, DEPARTURE TIME OR MODE OF TRANSPORTATION, ALL FOR USE IN THE REDUCTION OF TRAFFIC CONGESTION (U.S. CLS. 100 AND 101).

MICHAEL TANNER, EXAMINING ATTORNEY

SN 86-021,074. ONE SOURCE NETWORKS, INC., AUSTIN, TX. FILED 7-26-2013.

SN 86-022,628. VOLCANO CORPORATION, SAN DIEGO, CA. FILED 7-29-2013.



NO CLAIM IS MADE TO THE EXCLUSIVE RIGHT TO USE "NETWORKS", APART FROM THE MARK AS SHOWN.

THE MARK CONSISTS OF THE WORDING "ONE SOURCE NETWORKS. ONE SOURCE" IS ABOVE THE WORDING "NETWORKS". A VERTICAL LINE IS TO THE LEFT OF THE WORDING. TO THE LEFT OF THE VERTICAL LINE IS A CIRCLE WITHIN A CIRCLE, WITH A LINE THROUGH BOTH CIRCLES.

#### CLASS 38—COMMUNICATION

FOR TELECOMMUNICATIONS GATEWAY SERVICES; PROVIDING ACCESS TO TELECOMMUNICATION NETWORKS; PROVIDING TELECOMMUNICATIONS CONNECTIONS TO A GLOBAL COMPUTER NETWORK; PROVIDING TELECOMMUNICATIONS CONNECTIONS TO THE INTERNET OR DATABASES; PROVIDING THIRD PARTY USERS WITH ACCESS TO TELECOMMUNICATION INFRASTRUCTURE; ELECTRONIC EXCHANGE OF DATA STORED IN DATABASES ACCESSIBLE VIA TELECOMMUNICATION NETWORKS; HIGH BIT-RATE DATA TRANSMISSION SERVICES FOR TELECOMMUNICATION NETWORK OPERATORS; COMMUNICATIONS VIA MULTINATIONAL TELECOMMUNICATION NETWORKS; DATA TRANSMISSION AND RECEPTION SERVICES VIA TELECOMMUNICATION MEANS; PROVIDING ACCESS TO TELECOMMUNICATION NETWORKS; PROVIDING ELECTRONIC TELECOMMUNICATION CONNECTIONS; PROVIDING TELECOMMUNICATION CONNECTIONS TO THE INTERNET OR DATABASES; PROVIDING TELECOMMUNICATION CONNECTIVITY SERVICES FOR TRANSFER OF IMAGES, MESSAGES, AUDIO, VISUAL, AUDIOVISUAL AND MULTIMEDIA WORKS; COMMUNICATION SERVICES, NAMELY, TRANSMISSION OF VOICE, AUDIO, VISUAL IMAGES AND DATA BY TELECOMMUNICATIONS NETWORKS, WIRELESS COMMUNICATION NETWORKS, THE INTERNET, INFORMATION SERVICES NETWORKS AND DATA NETWORKS; DIGITAL NETWORK TELECOMMUNICATIONS SERVICES; TELECOMMUNICATION SERVICES, NAMELY, LOCAL AND LONG DISTANCE TRANSMISSION OF VOICE, DATA, GRAPHICS AND VIDEO BY MEANS OF BROADBAND, COPPER AND OPTICAL OR WIRELESS NETWORKS; COMMUNICATION SERVICES, NAMELY, TRANSMISSION OF VOICE, AUDIO, VISUAL IMAGES AND DATA BY CLOUD-BASED TELECOMMUNICATIONS NETWORKS (U.S. CLS. 100, 101 AND 104).

FIRST USE 1-0-2012; IN COMMERCE 1-0-2012.

#### CLASS 42—SCIENTIFIC AND COMPUTER SERVICES

FOR MANAGED NETWORK SERVICES, NAMELY, MANAGEMENT OF WAN NETWORKS FOR OTHERS; DESIGN, DEVELOPMENT, DEPLOYMENT, MANAGEMENT OF COMPUTER NETWORKS AND WIRELESS NETWORKS FOR OTHERS FEATURING NETWORK DESIGN AND ENGINEERING, NETWORK PROJECT MANAGEMENT AND IMPLEMENTATION, NETWORK MONITORING SERVICES, NETWORK MIGRATION SERVICES, NETWORK UPGRADES EXPANSIONS AND DEPLOYMENTS; COMPUTER SERVICES, NAMELY, MANAGEMENT OF CLOUD COMPUTING SYSTEMS AND SOFTWARE APPLICATIONS FOR OTHERS; CONSULTING IN THE FIELD OF VIRTUALIZATION TECHNOLOGIES FOR ENTERPRISES AND BUSINESSES; CONSULTING SERVICES IN THE FIELD OF CLOUD COMPUTING (U.S. CLS. 100 AND 101).

FIRST USE 1-0-2012; IN COMMERCE 1-0-2012.  
JESSICA A. POWERS, EXAMINING ATTORNEY

# FACT

THE MARK CONSISTS OF STANDARD CHARACTERS WITHOUT CLAIM TO ANY PARTICULAR FONT, STYLE, SIZE, OR COLOR.

#### CLASS 9—ELECTRICAL AND SCIENTIFIC APPARATUS

FOR SOFTWARE FOR MINIMALLY INVASIVE, CATHETER-BASED COMPUTED TOMOGRAPHY DIAGNOSTICS, THERAPEUTICS, AND IMAGING FOR THE ASSESSMENT AND TREATMENT OF CARDIOVASCULAR DISEASE (U.S. CLS. 21, 23, 26, 36 AND 38).

#### CLASS 10—MEDICAL APPARATUS

FOR MEDICAL EQUIPMENT, NAMELY, MINIMALLY INVASIVE, CATHETER-BASED COMPUTED TOMOGRAPHY APPARATUS FOR DIAGNOSTICS, THERAPEUTICS, AND IMAGING, AND COMPONENTS, NAMELY, CATHETERS, GUIDE WIRES, PATIENT ISOLATION MODULES, AND CONNECTORS, ALL FOR THE ASSESSMENT AND TREATMENT OF CARDIOVASCULAR DISEASE (U.S. CLS. 26, 39 AND 44).

JOHN SCHUYLER YARD, EXAMINING ATTORNEY

SN 86-024,895. CARDPLATFORMS LLC, BOCA RATON, FL. FILED 7-31-2013.

# LIME CARD

THE MARK CONSISTS OF STANDARD CHARACTERS WITHOUT CLAIM TO ANY PARTICULAR FONT, STYLE, SIZE, OR COLOR.

NO CLAIM IS MADE TO THE EXCLUSIVE RIGHT TO USE "CARD", APART FROM THE MARK AS SHOWN.

#### CLASS 9—ELECTRICAL AND SCIENTIFIC APPARATUS

FOR PREPAID PLASTIC MAGNETICALLY ENCODED DEBIT CARDS FOR USE IN INCENTIVE PROGRAMS USED TO MOTIVATE AND RECOGNIZE ACHIEVEMENT, SHOW APPRECIATION TO EMPLOYEES, AFFILIATES, RESELLERS, CONSUMERS AND VENDORS, OR REWARD EMPLOYEES OR CUSTOMERS; VIRTUAL DEBIT CARDS, NAMELY, DOWNLOADABLE ELECTRONIC DATA FILES CONTAINING FINANCIAL INFORMATION FOR USE WITH AN INCENTIVE PROGRAMS USED TO MOTIVATE AND RECOGNIZE ACHIEVEMENT, SHOW APPRECIATION TO EMPLOYEES, AFFILIATES, RESELLERS, CONSUMERS AND VENDORS, OR REWARD EMPLOYEES OR CUSTOMERS (U.S. CLS. 21, 23, 26, 36 AND 38).

FIRST USE 8-31-2013; IN COMMERCE 8-31-2013.

**CLASS 36—INSURANCE AND FINANCIAL**

FOR DEBIT ACCOUNT SERVICES FEATURING COMPUTER READABLE PREPAID PLASTIC CARDS AND AN ONLINE DEBIT ACCOUNT USED WITH AN INCENTIVE PROGRAMS TO MOTIVATE AND RECOGNIZE ACHIEVEMENT, SHOW APPRECIATION TO EMPLOYEES, AFFILIATES, RESELLERS, CONSUMERS AND VENDORS, OR REWARD EMPLOYEES OR CUSTOMERS (U.S. CLS. 100, 101 AND 102).

FIRST USE 8-31-2013; IN COMMERCE 8-31-2013.  
WILLIAM P. SHANAHAN, EXAMINING ATTORNEY

SN 86-024,898. CARDPLATFORMS LLC, BOCA RATON, FL. FILED 7-31-2013.

# LIME

THE MARK CONSISTS OF STANDARD CHARACTERS WITHOUT CLAIM TO ANY PARTICULAR FONT, STYLE, SIZE, OR COLOR.

**CLASS 9—ELECTRICAL AND SCIENTIFIC APPARATUS**

FOR PREPAID PLASTIC MAGNETICALLY ENCODED DEBIT CARDS FOR USE IN INCENTIVE PROGRAMS USED TO MOTIVATE AND RECOGNIZE ACHIEVEMENT, SHOW APPRECIATION TO EMPLOYEES, AFFILIATES, RESELLERS, CONSUMERS AND VENDORS, OR REWARD EMPLOYEES OR CUSTOMERS; VIRTUAL DEBIT CARDS, NAMELY, DOWNLOADABLE ELECTRONIC DATA FILES CONTAINING FINANCIAL INFORMATION FOR USE WITH AN INCENTIVE PROGRAMS USED TO MOTIVATE AND RECOGNIZE ACHIEVEMENT, SHOW APPRECIATION TO EMPLOYEES, AFFILIATES, RESELLERS, CONSUMERS AND VENDORS, OR REWARD EMPLOYEES OR CUSTOMERS (U.S. CLS. 21, 23, 26, 36 AND 38).

FIRST USE 8-31-2013; IN COMMERCE 8-31-2013.

**CLASS 36—INSURANCE AND FINANCIAL**

FOR DEBIT ACCOUNT SERVICES FEATURING COMPUTER READABLE PREPAID PLASTIC CARDS AND AN ONLINE DEBIT ACCOUNT USED WITH AN INCENTIVE PROGRAMS TO MOTIVATE AND RECOGNIZE ACHIEVEMENT, SHOW APPRECIATION TO EMPLOYEES, AFFILIATES, RESELLERS, CONSUMERS AND VENDORS, OR REWARD EMPLOYEES OR CUSTOMERS (U.S. CLS. 100, 101 AND 102).

FIRST USE 8-31-2013; IN COMMERCE 8-31-2013.  
WILLIAM P. SHANAHAN, EXAMINING ATTORNEY

SN 86-024,968. TAYLOR, YUL, CLEARWATER, FL. FILED 7-31-2013.

# YUL TAYLOR

THE MARK CONSISTS OF STANDARD CHARACTERS WITHOUT CLAIM TO ANY PARTICULAR FONT, STYLE, SIZE, OR COLOR.

THE NAME(S), PORTRAIT(S), AND/OR SIGNATURE(S) SHOWN IN THE MARK IDENTIFIES "YUL TAYLOR", WHOSE CONSENT(S) TO REGISTER IS MADE OF RECORD.

**CLASS 14—JEWELRY**

FOR JEWELRY (U.S. CLS. 2, 27, 28 AND 50).  
FIRST USE 3-15-2011; IN COMMERCE 3-5-2012.

**CLASS 18—LEATHER GOODS**

FOR HANDBAGS; PURSES; WALLETS (U.S. CLS. 1, 2, 3, 22 AND 41).  
FIRST USE 2-1-2010; IN COMMERCE 2-1-2011.

**CLASS 25—CLOTHING**

FOR SHIRTS; TUNICS; BELTS, COATS; DRESSES; HATS; HOSIERY; JACKETS; LINGERIE; LOUNGEWEAR; NECKWEAR; PAJAMAS; PANTS; SCARVES; SHOES; SHORTS; SKIRTS; SUITS; SWEATERS; SWIMWEAR; TANK TOPS; TOPS; UNDERWEAR (U.S. CLS. 22 AND 39).

FIRST USE 10-15-2008; IN COMMERCE 10-15-2008.  
KATHLEEN KOLACZ, EXAMINING ATTORNEY

SN 86-025,380. OLD GRINGO, LP, CHULA VISTA, CA. FILED 7-31-2013.

# RAZZ

THE MARK CONSISTS OF STANDARD CHARACTERS WITHOUT CLAIM TO ANY PARTICULAR FONT, STYLE, SIZE, OR COLOR.

**CLASS 18—LEATHER GOODS**

FOR LEATHER ACCESSORIES, NAMELY, HANDBAGS, WALLETS, LEATHER POUCHES, PURSES (U.S. CLS. 1, 2, 3, 22 AND 41).

**CLASS 25—CLOTHING**

FOR LEATHER CLOTHING ITEMS, LEATHER FOOTWEAR, AND LEATHER APPAREL, NAMELY, LEATHER JACKETS, COATS, SHIRTS, PANTS, SKIRTS, LEATHER BELTS, BOOTS, SHOES (U.S. CLS. 22 AND 39).

JUHI KAVEESHVAR, EXAMINING ATTORNEY

SN 86-025,658. IDT TELECOM, INC., NEWARK, NJ. FILED 8-1-2013.

# GOOOL

THE MARK CONSISTS OF STANDARD CHARACTERS WITHOUT CLAIM TO ANY PARTICULAR FONT, STYLE, SIZE, OR COLOR.

**CLASS 16—PAPER GOODS AND PRINTED MATTER**

FOR PREPAID TELEPHONE CALLING CARDS, NOT MAGNETICALLY ENCODED (U.S. CLS. 2, 5, 22, 23, 29, 37, 38 AND 50).

FIRST USE 7-23-2005; IN COMMERCE 7-23-2005.

**CLASS 36—INSURANCE AND FINANCIAL**

FOR PRE-PAID TELEPHONE CALLING CARD AND TELEPHONE DEBIT CARD SERVICES (U.S. CLS. 100, 101 AND 102).  
FIRST USE 7-23-2005; IN COMMERCE 7-23-2005.

**CLASS 38—COMMUNICATION**

FOR TELEPHONE TELECOMMUNICATIONS SERVICES PROVIDED VIA PREPAID TELEPHONE CALLING CARDS (U.S. CLS. 100, 101 AND 104).  
FIRST USE 7-23-2005; IN COMMERCE 7-23-2005.  
BARBARA A. GOLD, EXAMINING ATTORNEY

SN 86-028,437. QEP MIDSTREAM PARTNERS, LP, DENVER, CO. FILED 8-5-2013.



OWNER OF U.S. REG. NOS. 4,035,921, 4,053,908 AND OTHERS.

NO CLAIM IS MADE TO THE EXCLUSIVE RIGHT TO USE "MIDSTREAM PARTNERS, LP", APART FROM THE MARK AS SHOWN.

THE MARK CONSISTS OF THE STYLIZED LETTERS "QEPM", WITH A FLAME FORMING PART OF THE "Q", AND THE WORDS "QEP MIDSTREAM PARTNERS, LP" BENEATH IT.

**CLASS 4—LUBRICANTS AND FUELS**

FOR NATURAL GAS, LIQUEFIED NATURAL GAS AND CRUDE OIL (U.S. CLS. 1, 6 AND 15).

**CLASS 35—ADVERTISING AND BUSINESS**

FOR OPERATING OIL AND GAS WELLS FOR OTHERS (U.S. CLS. 100, 101 AND 102).

**CLASS 36—INSURANCE AND FINANCIAL**

FOR BROKERAGE OF ENERGY, NAMELY, OIL AND GAS (U.S. CLS. 100, 101 AND 102).

**CLASS 37—CONSTRUCTION AND REPAIR**

FOR DRILLING AND COMPLETING OIL AND GAS WELLS; EQUIPPING OIL AND GAS WELLS, NAMELY, INSTALLING CASING, TUBING, AND PIPES INTO OIL AND GAS WELLS; EXTRACTION OF OIL AND GAS, NAMELY, GATHERING OF OIL AND GAS FOR OTHERS (U.S. CLS. 100, 103 AND 106).

**CLASS 39—TRANSPORTATION AND STORAGE**

FOR STORAGE AND DISTRIBUTION OF OIL AND GAS (U.S. CLS. 100 AND 105).

**CLASS 40—MATERIAL TREATMENT**

FOR PROCESSING OF OIL AND GAS (U.S. CLS. 100, 103 AND 106).

**CLASS 42—SCIENTIFIC AND COMPUTER SERVICES**

FOR OIL AND GAS EXPLORATION (U.S. CLS. 100 AND 101).  
CATHERINE TARCU, EXAMINING ATTORNEY

SN 86-028,446. QEP MIDSTREAM PARTNERS, LP, DENVER, CO. FILED 8-5-2013.



OWNER OF U.S. REG. NOS. 4,035,921, 4,053,908 AND OTHERS.

THE MARK CONSISTS OF THE STYLIZED LETTERS "QEPM", WITH A FLAME FORMING PART OF THE "Q".

**CLASS 4—LUBRICANTS AND FUELS**

FOR NATURAL GAS, LIQUEFIED NATURAL GAS AND CRUDE OIL (U.S. CLS. 1, 6 AND 15).

**CLASS 35—ADVERTISING AND BUSINESS**

FOR OPERATING OIL AND GAS WELLS FOR OTHERS (U.S. CLS. 100, 101 AND 102).

**CLASS 36—INSURANCE AND FINANCIAL**

FOR BROKERAGE OF ENERGY, NAMELY, OIL AND GAS (U.S. CLS. 100, 101 AND 102).

**CLASS 37—CONSTRUCTION AND REPAIR**

FOR DRILLING AND COMPLETING OIL AND GAS WELLS; EQUIPPING OIL AND GAS WELLS, NAMELY, INSTALLING CASING, TUBING, AND PIPES INTO OIL AND GAS WELLS; EXTRACTION OF OIL AND GAS, NAMELY, GATHERING OF OIL AND GAS FOR OTHERS (U.S. CLS. 100, 103 AND 106).

**CLASS 39—TRANSPORTATION AND STORAGE**

FOR STORAGE AND DISTRIBUTION OF OIL AND GAS (U.S. CLS. 100 AND 105).

**CLASS 40—MATERIAL TREATMENT**

FOR PROCESSING OF OIL AND GAS (U.S. CLS. 100, 103 AND 106).

**CLASS 42—SCIENTIFIC AND COMPUTER SERVICES**

FOR OIL AND GAS EXPLORATION (U.S. CLS. 100 AND 101).  
CATHERINE TARCU, EXAMINING ATTORNEY

SN 86-029,554. KABUSHIKI KAISHA INTERNET INITIATIVE, TA INTERNET INITIATIVE JAPAN INC., TOKYO, JAPAN, FILED 8-6-2013.

# IIJ GIO

THE MARK CONSISTS OF STANDARD CHARACTERS WITHOUT CLAIM TO ANY PARTICULAR FONT, STYLE, SIZE, OR COLOR.

OWNER OF U.S. REG. NOS. 2,403,188 AND 2,405,087.

THE WORDING "IIJ GIO" HAS NO MEANING IN A FOREIGN LANGUAGE.

## CLASS 38—COMMUNICATION

FOR TELECOMMUNICATION SERVICES, NAMELY, PROVIDING TELECOMMUNICATION CONNECTIONS TO A GLOBAL COMPUTER NETWORK; AUDIO AND VIDEO BROADCASTING SERVICES; PROVIDING MULTIPLE-USER ACCESS TO A GLOBAL COMPUTER NETWORK; RELAY BROADCASTING SERVICES USING REAL TIME APPLICATIONS FOR THE TRANSFER AND DISSEMINATION OF A WIDE RANGE OF INFORMATION; ELECTRONIC MAIL SERVICES (U.S. CLS. 100, 101 AND 104).

FIRST USE 10-5-2009; IN COMMERCE 3-28-2012.

## CLASS 42—SCIENTIFIC AND COMPUTER SERVICES

FOR DESIGNING AND HOSTING WEB PAGES AND WEB SITES FOR OTHERS; COMPUTER SECURITY SERVICES, NAMELY, PROVIDING MANAGED FIREWALL SERVICES FOR OTHERS; COMPUTER SERVICES, NAMELY, CLOUD HOSTING PROVIDER SERVICES; PROVIDING VIRTUAL COMPUTER SYSTEMS AND VIRTUAL COMPUTER ENVIRONMENTS THROUGH CLOUD COMPUTING; TECHNICAL CONSULTING SERVICES IN THE FIELDS OF DATACENTER ARCHITECTURE, PUBLIC AND PRIVATE CLOUD COMPUTING SOLUTIONS, AND EVALUATION AND IMPLEMENTATION OF INTERNET TECHNOLOGY AND SERVICES; TECHNICAL SUPPORT SERVICES, NAMELY, REMOTE AND ON-SITE INFRASTRUCTURE MANAGEMENT SERVICES FOR THE MONITORING, ADMINISTRATION AND MANAGEMENT OF PUBLIC AND PRIVATE CLOUD COMPUTING AND APPLICATION SYSTEMS; HOSTING THE SOFTWARE, WEBSITES AND OTHER COMPUTER APPLICATIONS OF OTHERS ON A VIRTUAL PRIVATE SERVER (U.S. CLS. 100 AND 101).

FIRST USE 10-5-2009; IN COMMERCE 3-28-2012.  
DEBORAH MEINERS, EXAMINING ATTORNEY

SN 86-032,050. SHOOGEE GMBH & CO. KG, 48143 MÜNSTER, FED REP GERMANY, FILED 8-8-2013.



PRIORITY CLAIMED UNDER SEC. 44(D) ON FED REP GERMANY APPLICATION NO. 302013003286, FILED 5-15-2013, REG. NO. 302013003286, DATED 6-25-2013, EXPIRES 5-15-2023.

PRIORITY CLAIMED UNDER SEC. 44(D) ON ERPNCMNTY TM OFC APPLICATION NO. 011952728, FILED 7-3-2013.

THE MARK CONSISTS OF THE WORD "DIVE" IN STYLIZED TYPE HAVING CIRCLES ABOVE THE LETTER "I" REPRESENTING RISING BUBBLES.

## CLASS 9—ELECTRICAL AND SCIENTIFIC APPARATUS

FOR EYEGLASS FRAMES WITH A SUPPORT FOR MOUNTING ELECTRONIC DISPLAYS; HEAD MOUNTS FOR ELECTRONIC DISPLAYS; COMPUTER PERIPHERALS (U.S. CLS. 21, 23, 26, 36 AND 38).

## CLASS 28—TOYS AND SPORTING GOODS

FOR CONTROL DEVICES FOR STAND-ALONE GAMES CONSOLES AND FOR GAMES CONSOLES FOR USE WITH EXTERNAL DISPLAY; STAND-ALONE VIDEO GAME CONSOLES AND VIDEO GAME CONSOLES FOR USE WITH EXTERNAL DISPLAY; ELECTRONIC OR ELECTRIC CONTROL APPARATUS FOR VIDEO GAME CONSOLES (U.S. CLS. 22, 23, 38 AND 50).

NATALIE KENEALY, EXAMINING ATTORNEY

SN 86-034,106. DETROIT RADIANT PRODUCTS COMPANY, WARREN, MI, FILED 8-9-2013.



NO CLAIM IS MADE TO THE EXCLUSIVE RIGHT TO USE "MADE BY DETROIT", APART FROM THE MARK AS SHOWN.

THE MARK CONSISTS OF BURNER IMAGE WITH THE WORDS "MADE BY DETROIT" IN A CIRCULAR FORM.

## CLASS 11—ENVIRONMENTAL CONTROL APPARATUS

FOR ELECTRIC OR GAS RADIANT HEATERS FOR HOUSEHOLD OR COMMERCIAL USE; HEATING EQUIPMENT, NAMELY, GAS OR ELECTRIC RADIANT HEATERS, HEATING RADIATORS AND PARTS THEREFOR AS PART OF HEATING INSTALLATIONS (U.S. CLS. 13, 21, 23, 31 AND 34).

## CLASS 16—PAPER GOODS AND PRINTED MATTER

FOR STICKERS (U.S. CLS. 2, 5, 22, 23, 29, 37, 38 AND 50).

KELLY BOULTON, EXAMINING ATTORNEY

SN 86-035,259. PENSKE SYSTEM, INC., BLOOMFIELD HILLS, MI. FILED 8-12-2013.

# PENSKE

THE MARK CONSISTS OF STANDARD CHARACTERS WITHOUT CLAIM TO ANY PARTICULAR FONT, STYLE, SIZE, OR COLOR.

OWNER OF U.S. REG. NOS. 1,795,304, 2,132,515 AND 3,993,196.  
SEC. 2(F).

## CLASS 35—ADVERTISING AND BUSINESS

FOR RETAIL STORE SERVICES, ONLINE RETAIL STORE SERVICES, AND WHOLESALE DISTRIBUTORSHIP SERVICES FEATURING MOTOR VEHICLES, ENGINES, AND VEHICLE PARTS; VEHICLE DEALERSHIP SERVICES IN PERSON AND THROUGH THE INTERNET (U.S. CLS. 100, 101 AND 102).

FIRST USE 4-2-1982; IN COMMERCE 4-2-1982.

## CLASS 37—CONSTRUCTION AND REPAIR

FOR VEHICLE MAINTENANCE AND REPAIR (U.S. CLS. 100, 103 AND 106).

FIRST USE 4-2-1982; IN COMMERCE 4-2-1982.

## CLASS 39—TRANSPORTATION AND STORAGE

FOR LEASING OF VEHICLES; RENTAL OF VEHICLES (U.S. CLS. 100 AND 105).

FIRST USE 4-2-1982; IN COMMERCE 4-2-1982.

GEOFFREY FOSDICK, EXAMINING ATTORNEY

SN 86-035,264. PENSKE SYSTEM, INC., BLOOMFIELD HILLS, MI. FILED 8-12-2013.



OWNER OF U.S. REG. NOS. 1,795,304, 2,132,515 AND 3,993,196.

THE MARK CONSISTS OF THE WORD "PENSKE" INSIDE A ROUNDED RECTANGLE.

SEC. 2(F).

## CLASS 35—ADVERTISING AND BUSINESS

FOR RETAIL STORE SERVICES, ONLINE RETAIL STORE SERVICES, AND WHOLESALE DISTRIBUTORSHIP SERVICES FEATURING MOTOR VEHICLES, ENGINES, AND VEHICLE PARTS; VEHICLE DEALERSHIP SERVICES IN PERSON AND THROUGH THE INTERNET (U.S. CLS. 100, 101 AND 102).

FIRST USE 4-2-1982; IN COMMERCE 4-2-1982.

## CLASS 37—CONSTRUCTION AND REPAIR

FOR VEHICLE MAINTENANCE AND REPAIR (U.S. CLS. 100, 103 AND 106).

FIRST USE 4-2-1982; IN COMMERCE 4-2-1982.

## CLASS 39—TRANSPORTATION AND STORAGE

FOR LEASING OF VEHICLES; RENTAL OF VEHICLES (U.S. CLS. 100 AND 105).

FIRST USE 4-2-1982; IN COMMERCE 4-2-1982.

GEOFFREY FOSDICK, EXAMINING ATTORNEY

SN 86-035,639. ZANE BEADLES PARADE FOUNDATION, DENVER, CO. FILED 8-12-2013.



NO CLAIM IS MADE TO THE EXCLUSIVE RIGHT TO USE "FOUNDATION", APART FROM THE MARK AS SHOWN.

THE NAME "ZANE BEADLES" IDENTIFIES A LIVING INDIVIDUAL WHOSE CONSENT IS OF RECORD.

THE MARK CONSISTS OF A DESIGN OF THREE MARCHING ELEPHANTS WITH DESIGNS OF WRAPPED GIFTS ON THEIR BACKS WITH THE LEAD ELEPHANT CARRYING A FOOTBALL. BENEATH THE ELEPHANTS IS THE WORDING "ZANE BEADLES PARADE FOUNDATION" IN STYLIZED FONT WITH THE WORD "PARADE" INSIDE A BANNER AND SMALL CIRCLES ON EITHER SIDE OF THE WORD "FOUNDATION".

## CLASS 36—INSURANCE AND FINANCIAL

FOR CHARITABLE FUNDRAISING; CHARITABLE FUNDRAISING SERVICES FOR ENRICHING THE LIVES OF CHILDREN FACING LIFE-THREATENING MEDICAL CONDITIONS AND OTHER DISADVANTAGED CHILDREN; CHARITABLE FUNDRAISING SERVICES FOR SENDING DISADVANTAGED YOUNG PEOPLE TO CULTURAL, ARTS AND SPORTING EVENTS (U.S. CLS. 100, 101 AND 102).

FIRST USE 8-5-2013; IN COMMERCE 8-5-2013.

## CLASS 41—EDUCATION AND ENTERTAINMENT

FOR CHARITABLE SERVICES, NAMELY, PROVIDING DISADVANTAGED YOUNG PEOPLE WITH RECREATIONAL AND ENTERTAINMENT ACTIVITIES, NAMELY, PERSONAL APPEARANCES BY SPORTS CELEBRITIES (U.S. CLS. 100, 101 AND 107).

FIRST USE 8-5-2013; IN COMMERCE 8-5-2013.

STEVEN PEREZ, EXAMINING ATTORNEY



SN 86-037,519. STAPLES GOLF RESOURCE GROUP, LLC, PEWAUKEE, WI. FILED 8-14-2013.

## COMMUNITY LINKS

THE MARK CONSISTS OF STANDARD CHARACTERS WITHOUT CLAIM TO ANY PARTICULAR FONT, STYLE, SIZE, OR COLOR.

NO CLAIM IS MADE TO THE EXCLUSIVE RIGHT TO USE "LINKS", APART FROM THE MARK AS SHOWN.

### CLASS 35—ADVERTISING AND BUSINESS

FOR PROVIDING BUSINESS MANAGEMENT PRACTICES FOR GOLF FACILITIES AND FOR INTEGRATING GOLF FACILITIES INTO COMMUNITIES (U.S. CLS. 100, 101 AND 102).

### CLASS 41—EDUCATION AND ENTERTAINMENT

FOR CONSULTING AND ADVISORY SERVICES IN THE FIELDS OF GOLF COURSE FACILITIES, GOLF COURSE OPERATIONS, AND GOLF EDUCATION (U.S. CLS. 100, 101 AND 107).

JASON BLAIR, EXAMINING ATTORNEY

SN 86-039,850. GPARTS INTERNATIONAL LLC, KENNESAW, GA. FILED 8-16-2013.



NO CLAIM IS MADE TO THE EXCLUSIVE RIGHT TO USE "PARTS", APART FROM THE MARK AS SHOWN.

THE COLOR(S) RED, WHITE AND BLACK IS/ARE CLAIMED AS A FEATURE OF THE MARK.

THE MARK CONSISTS OF A STYLIZED LETTER "G" BEING WHITE IN COLOR AND LOCATED WITHIN A RED OVAL, FOLLOWED BY THE WORD "PARTS" WRITTEN IN ALL CAPITAL LETTERS THAT ARE BLACK IN COLOR; THE LETTER "A" IS STYLIZED IN DESIGN WITH THE CROSS PIECE BEING MISSING BUT SUGGESTED BY AN AREA OF RED COLOR THAT EXTENDS FROM THE BOTTOM LEFT LEG OF THE LETTER "A" AND COVERS MOST OF THE AREA BETWEEN THE TWO LEGS OF THE LETTER "A".

### CLASS 7—MACHINERY

FOR AUTOMOBILE PARTS, NAMELY, TIMING BELTS FOR ENGINES FOR LAND VEHICLES; AUTOMOBILE PARTS, NAMELY, RADIATORS FOR MOTORS AND ENGINES; AUTOMOBILE ENGINE PARTS, NAMELY, OIL COOLERS, AND CHARGE AIR COOLERS AND THEIR COMPONENT PARTS; AUTOMOBILE PARTS, NAMELY, WATER PUMPS (U.S. CLS. 13, 19, 21, 23, 31, 34 AND 35).

### CLASS 12—VEHICLES

FOR AUTOMOBILE PARTS, NAMELY, LAND VEHICLE TRANSMISSIONS AND REPLACEMENT PARTS THEREOF; AUTOMOBILE PARTS, NAMELY, SERPENTINE BELTS; AUTOMOBILE PARTS, NAMELY, BELT TENSIONERS FOR LAND VEHICLE TRANSMISSION BELTS; AUTOMOBILE PARTS, NAMELY, ALTERNATOR BELT PULLEYS FOR LAND VEHICLES (U.S. CLS. 19, 21, 23, 31, 35 AND 44).

JOHN KELLY, EXAMINING ATTORNEY

SN 86-040,057. CARLOS GRACIE JR., IRVINE, CA. FILED 8-16-2013.

## JIU-JITSU FOR EVERYONE

THE MARK CONSISTS OF STANDARD CHARACTERS WITHOUT CLAIM TO ANY PARTICULAR FONT, STYLE, SIZE, OR COLOR.

NO CLAIM IS MADE TO THE EXCLUSIVE RIGHT TO USE "JIU-JITSU", APART FROM THE MARK AS SHOWN.

### CLASS 25—CLOTHING

FOR CLOTHING, NAMELY, MARTIAL ART UNIFORMS, T-SHIRTS, JACKETS, SWEATSHIRTS, SPORT PANTS, SPORT SHIRTS, MARTIAL ART SHORTS, BEANIES, HATS, SANDALS, AND BOARD SHORTS (U.S. CLS. 22 AND 39).

### CLASS 41—EDUCATION AND ENTERTAINMENT

FOR EDUCATIONAL SERVICES IN THE NATURE OF BRAZILIAN JIU JITSU SCHOOLS; MARTIAL ARTS INSTRUCTION; AND OPERATION OF MARTIAL ARTS SCHOOLS (U.S. CLS. 100, 101 AND 107).

JAMES LOVELACE, EXAMINING ATTORNEY

SN 86-040,087. CARLOS GRACIE JR., IRVINE, CA. FILED 8-16-2013.

## BARRAFIT

THE MARK CONSISTS OF STANDARD CHARACTERS WITHOUT CLAIM TO ANY PARTICULAR FONT, STYLE, SIZE, OR COLOR.

### CLASS 25—CLOTHING

FOR CLOTHING, NAMELY, MARTIAL ART UNIFORMS, T-SHIRTS, JACKETS, SWEATSHIRTS, SPORT PANTS, SPORT SHIRTS, MARTIAL ART SHORTS, BEANIES, HATS, SANDALS, AND BOARD SHORTS (U.S. CLS. 22 AND 39).

**CLASS 41—EDUCATION AND ENTERTAINMENT**

FOR EDUCATIONAL SERVICES, NAMELY, PROVIDING TRAINING AND COURSES OF INSTRUCTION IN THE FIELD OF MARTIAL ARTS AND EXERCISE; SPORTING ACTIVITIES, NAMELY, PROVIDING EXERCISE CLASSES AND GROUP FITNESS CLASSES; SPORTING ACTIVITIES, NAMELY, MARTIAL ARTS INSTRUCTION; EDUCATIONAL SERVICES, NAMELY, PROVIDING TRAINING AND COURSES OF INSTRUCTION IN THE FIELD OF GYMNASTICS AND MARTIAL ARTS (U.S. CLS. 100, 101 AND 107).

JAMES LOVELACE, EXAMINING ATTORNEY

SN 86-041,747. CORRIDOR CLEAN FUELS, LLC, ALBERTVILLE, AL. FILED 8-19-2013.

**CYNERGY**

THE MARK CONSISTS OF STANDARD CHARACTERS WITHOUT CLAIM TO ANY PARTICULAR FONT, STYLE, SIZE, OR COLOR.

SN 86-041,183. PANDUIT CORP., TINLEY PARK, IL. FILED 8-19-2013.

**PANDUIT UNITE**

THE MARK CONSISTS OF STANDARD CHARACTERS WITHOUT CLAIM TO ANY PARTICULAR FONT, STYLE, SIZE, OR COLOR.

PRIORITY CLAIMED UNDER SEC. 44(D) ON ERPNCMNTY TM OFC APPLICATION NO. 011585213, FILED 2-19-2013.

OWNER OF U.S. REG. NOS. 1,754,908, 2,597,492 AND OTHERS.

**CLASS 35—ADVERTISING AND BUSINESS**

FOR BUSINESS AND COMMERCIAL INFORMATION SERVICES; ELECTRONIC DATA STORAGE; DATA PROCESSING; MANAGEMENT OF COMPUTER DATABASES; DATABASE SERVICES FOR BUSINESSES, NAMELY, COMPILING OF INFORMATION INTO COMPUTER DATABASES; ENERGY USAGE MANAGEMENT CONSULTANCY FOR BUILDINGS AND DATA CENTERS; CONSULTING SERVICES IN THE FIELDS OF ENERGY CONSUMPTION AND USAGE CONSERVATION TO IMPROVE ENERGY EFFICIENCY IN BUILDING AND DATA CENTERS (U.S. CLS. 100, 101 AND 102).

**CLASS 37—CONSTRUCTION AND REPAIR**

FOR INSTALLATION AND MAINTENANCE OF POWER SYSTEMS AND ENVIRONMENTAL MONITORS; CONSTRUCTION AND MAINTENANCE OF DATA CENTERS, SERVER ROOMS AND IT FACILITIES; INSTALLATION, MAINTENANCE AND REPAIR OF COOLING SYSTEMS, AIR CONDITIONING SYSTEMS, AND ENVIRONMENTAL MONITORING SYSTEMS FOR DATA CENTERS, SERVER ROOMS AND IT FACILITIES (U.S. CLS. 100, 103 AND 106).

**CLASS 42—SCIENTIFIC AND COMPUTER SERVICES**

FOR ADVISORY SERVICES IN THE FIELD OF ENERGY AUDITING FOR BUILDINGS AND DATA CENTERS; CONSULTANCY IN THE DESIGN OF DATA CENTERS; DESIGN OF DATA CENTERS, SERVERS, SERVER ROOMS AND IT FACILITIES; DESIGN OF COOLING SYSTEMS, AIR CONDITIONING SYSTEMS, AND ENVIRONMENTAL MONITORING SYSTEMS ALL FOR DATA CENTERS, SERVER ROOMS AND IT FACILITIES (U.S. CLS. 100 AND 101).

BERYL GARDNER, EXAMINING ATTORNEY

**CLASS 35—ADVERTISING AND BUSINESS**

FOR CONSULTING SERVICES IN THE FIELD OF NATURAL GAS ENERGY USAGE MANAGEMENT AND NATURAL GAS ENERGY EFFICIENCY; NATURAL GAS ENERGY USAGE MANAGEMENT; BUSINESS CONSULTATION IN THE FIELD OF NATURAL GAS USAGE AND CONVERSION OF VEHICLE FLEETS TO NATURAL GAS; BUSINESS SERVICES, NAMELY, OPERATING COMPRESSED NATURAL GAS FUELING STATIONS ON THE PREMISES OF OTHERS FOR SUPPLYING GAS TO THEIR VEHICULAR FLEETS (U.S. CLS. 100, 101 AND 102).

**CLASS 37—CONSTRUCTION AND REPAIR**

FOR VEHICLE SERVICE STATION SERVICES, NAMELY, OPERATING COMPRESSED NATURAL GAS FUELING STATIONS ON THE PREMISES OF OTHERS FOR SUPPLYING GAS TO THEIR VEHICULAR FLEETS (U.S. CLS. 100, 103 AND 106).

**CLASS 42—SCIENTIFIC AND COMPUTER SERVICES**

FOR TECHNOLOGICAL PLANNING AND CONSULTING SERVICES IN THE FIELD OF NATURAL GAS USAGE AND CONVERSION OF VEHICLE FLEETS TO NATURAL GAS (U.S. CLS. 100 AND 101).

MARILYN IZZI, EXAMINING ATTORNEY

SN 86-042,161. WINDCATCHER TECHNOLOGY LLC, PORTLAND, OR. FILED 8-19-2013.



NO CLAIM IS MADE TO THE EXCLUSIVE RIGHT TO USE "RAPID INFLATION TECHNOLOGY", APART FROM THE MARK AS SHOWN.

THE COLOR GRAY IS USED TO INDICATE SHADING AND IS NOT A PART OF THE MARK.

THE MARK CONSISTS OF THE WORDING "WINDCATCHER RAPID INFLATION TECHNOLOGY" CENTERED IN A SHIELD, WITH A GRAPHICAL DESIGN OF BLOWING WIND AT THE TOP OF THE SHIELD.

**CLASS 20—FURNITURE AND ARTICLES NOT OTHERWISE CLASSIFIED**

FOR INFLATABLE MATTRESSES FOR USE WHEN CAMPING; INFLATABLE PADS FOR USE WHEN CAMPING; INFLATION DEVICES FOR MATTRESSES AND PADS FOR USE WHEN CAMPING (U.S. CLS. 2, 13, 22, 25, 32 AND 50).

FIRST USE 5-14-2013; IN COMMERCE 5-14-2013.

**CLASS 28—TOYS AND SPORTING GOODS**

FOR INFLATABLE MATTRESSES FOR RECREATIONAL USE; INFLATION DEVICES FOR MATTRESSES FOR RECREATIONAL USE (U.S. CLS. 22, 23, 38 AND 50).

FIRST USE 5-14-2013; IN COMMERCE 5-14-2013.

ERIN FALK, EXAMINING ATTORNEY

SN 86-042,255. TRAX POWERSPORTS RENTALS, INC., MORGAN, UT. FILED 8-19-2013.



NO CLAIM IS MADE TO THE EXCLUSIVE RIGHT TO USE "POWERSPORTS RENTALS", APART FROM THE MARK AS SHOWN.

THE MARK CONSISTS OF THE WORD "TRAX" IN CAPITAL, SLIGHTLY ITALICIZED LETTERING, WHERE THE DIAGONAL STROKE OF THE LETTER "X" EXTENDING FROM THE RIGHT TOPMOST CORNER OF THE WORD TO THE TERMINAL END OF THE PREVIOUS LETTER "A" COMPRISES TIRE TRACKS; THE WORD "POWERSPORTS" IN BOLD, SLIGHTLY ITALICIZED LETTERING DIRECTLY UNDER AND CENTERED WITH THE WORD "TRAX"; AND THE WORD "RENTALS" IN CURSIVE, SLIGHTLY ITALICIZED LETTERING DIRECTLY UNDER AND RIGHT-JUSTIFIED WITH THE WORD "POWERSPORTS".

**CLASS 35—ADVERTISING AND BUSINESS**

FOR (BASED ON USE IN COMMERCE): FRANCHISE SERVICES, NAMELY, OFFERING BUSINESS MANAGEMENT ASSISTANCE IN THE ESTABLISHMENT, PROMOTION, AND OPERATION OF BUSINESSES RENTING AND SERVICING RECREATIONAL VEHICLES AND THE LIKE; (BASED ON INTENT TO USE): RETAIL STORE AND ONLINE RETAIL STORE SERVICES FEATURING RECREATIONAL VEHICLES, ASSOCIATED EQUIPMENT AND ACCESSORIES AND THE LIKE (U.S. CLS. 100, 101 AND 102).

FIRST USE 7-24-2013; IN COMMERCE 7-24-2013.

**CLASS 39—TRANSPORTATION AND STORAGE**

FOR (BASED ON INTENT TO USE): RENTAL SERVICES FOR RECREATIONAL VEHICLES AND EQUIPMENT, NAMELY, ALL-TERRAIN VEHICLES, FOUR-WHEELED UTILITY TERRAIN VEHICLES, MOTORIZED DUNE BUGGIES, MOTORCYCLES, SCOOTERS, TRIKES, SNOWMOBILES, BOATS, PERSONAL WATERCRAFT, TRAILERS AND ACCESSORIES FOR THE FOREGOING (U.S. CLS. 100 AND 105).

JEFFREY LOOK, EXAMINING ATTORNEY

SN 86-042,342. AMOS INTERNATIONAL (HOLDING) COMPANY LTD., HONG KONG, HONG KONG, FILED 8-20-2013.



PRIORITY CLAIMED UNDER SEC. 44(D) ON HONG KONG APPLICATION NO. 302707957, FILED 8-16-2013, REG. NO. 302707957, DATED 8-16-2013, EXPIRES 8-15-2023.

THE MARK CONSISTS OF THE WORDING "AMOS" IN STYLIZED FORMAT AND CHINESE CHARACTERS.

THE WORDING "AMOS" HAS NO MEANING IN A FOREIGN LANGUAGE.

THE NON-LATIN CHARACTERS IN THE MARK TRANSLITERATE TO "YA MO SI" AND THIS HAS NO MEANING IN A FOREIGN LANGUAGE.

**CLASS 7—MACHINERY**

FOR ELECTRIC EGG BEATERS; ELECTRIC FOOD BLENDERS FOR HOUSEHOLD PURPOSES; COFFEE GRINDERS, OTHER THAN HAND-OPERATED; DOMESTIC GRINDERS, ELECTRIC; DISHWASHERS; DYNAMOS; FEEDWATER REGULATORS BEING PARTS OF MACHINES; FRUIT PRESSES, ELECTRIC, FOR HOUSEHOLD PURPOSES; GRINDERS, ELECTRIC, FOR HOUSEHOLD PURPOSES; ELECTRIC KITCHEN MACHINES, NAMELY, MIXERS; ELECTRIC SALT AND PEPPER MILLS FOR HOUSEHOLD PURPOSES; ELECTRIC SALT AND PEPPER MILLS; MIXING MACHINES; CAN OPENERS, ELECTRIC; TIN OPENERS, ELECTRIC; PLOUGH SHARES; TYPOGRAPHIC MACHINES, NAMELY, PRESSES; WHISKS, ELECTRIC, FOR HOUSEHOLD PURPOSES; ELECTRIC ICE CRUSHERS FOR HOUSEHOLD PURPOSES; ELECTRIC DOMESTIC GARBAGE CRUSHERS; PRESSURE REDUCERS AS PARTS OF MACHINES; SPARK PLUGS; ELECTRIC LIGHT SOCKETS; CONTACT POINTS FOR ENGINES; VACUUM DISTILLATION EQUIPMENT; SPIN DRIERS; FORGING MOLDS (U.S. CLS. 13, 19, 21, 23, 31, 34 AND 35).

**CLASS 9—ELECTRICAL AND SCIENTIFIC APPARATUS**

FOR ACOUSTIC ALARMS; GAS ALARMS; ANTI-THEFT WARNING APPARATUS FOR HOMES; ELECTRIC BUZZERS; CIRCUIT BREAKERS; CIRCUIT CLOSERS; COILS, ELECTRIC; CONDENSERS; LIGHTING CONTROL PANELS; SMOKE DETECTORS; DYNAMOMETERS; EGG-CANDLERS; FIRE EXTINGUISHING APPARATUS; FLASHING SAFETY LIGHTS; FRAMES FOR PHOTOGRAPHIC TRANSPARENCIES; GALVANOMETERS; HEAT REGULATING APPARATUS, NAMELY, THERMOSTATS; HOURGLASSES; INTEGRATED CIRCUITS; JUNCTION BOXES; LOCKS, ELECTRIC; LOUDSPEAKERS; MAGNIFYING GLASSES; MICROSCOPES; OPTICAL LAMPS; OPTICAL LANTERNS; ELECTRICAL PLUGS, SOCKETS, AND CONTACTS; ELECTRICAL CONDUIT REDUCERS; ELECTRIC CURRENT REGULATING APPARATUS; RESISTANCES, ELECTRIC; SURVEYING CHAINS; ELECTRIC THEFT PREVENTION INSTALLATIONS FOR HOMES; TRANSFORMERS; WIRES, ELECTRIC; DISTILLATION APPARATUS FOR SCIENTIFIC PURPOSES; GLASS DRIERS FOR LABORATORIES; FIRE SPRINKLERS (U.S. CLS. 21, 23, 26, 36 AND 38).

**CLASS 11—ENVIRONMENTAL CONTROL APPARATUS**

FOR AIR COOLING APPARATUS; ELECTRIC AIR DEODORIZING APPARATUS; AIR DEHUMIDIFIERS; AIR FILTERING INSTALLATIONS; ANTI-SPLASH TAP NOZZLES; ELECTRIC AUTOCLAVES; BAKING OVENS; ELECTRIC BREAD TOASTERS; COFFEE ROASTERS; GAS COOKERS; ELECTRIC KNIVES; DEEP FRYERS; ELECTRIC; DRYING APPARATUS; ELECTRIC APPLIANCES FOR MAKING YOGURT; EXTRACTOR HOODS FOR KITCHENS; ELECTRIC FANS; FOOTMUFFS, ELECTRICALLY HEATED; ELECTRIC FOOTWARMERS; HEADLIGHTS FOR AUTOMOBILES; HEATERS, ELECTRIC, FOR FEEDING BOTTLES; HOT AIR OVENS; KETTLES, ELECTRIC; MICROWAVE OVENS; NON-ELECTRIC POCKET WARMERS, NAMELY, CHEMICALLY-ACTIVATED HEATING PACKETS FOR WARMING HANDS; PRESSURE COOKING SAUCEPANS, ELECTRIC; RADIATORS, ELECTRIC; ROASTING JACKS; DISTILLATION APPARATUS NOT FOR SCIENTIFIC PURPOSES; GAS STOVES; PERSONAL SAUNAS, NAMELY, PORTABLE TURKISH BATH CABINETS; ELECTRIC REGULATING APPARATUS, NAMELY, METERED VALVES; ELECTRIC LIGHT SOCKETS; FLASHING STROBE LIGHT APPARATUS; SINK STRAINERS; IRRIGATION SPRINKLERS (U.S. CLS. 13, 21, 23, 31 AND 34).

**CLASS 21—HOUSEWARES AND GLASS**

FOR NON-ELECTRIC EGG BEATERS; NON-ELECTRIC FOOD BLENDERS FOR HOUSEHOLD PURPOSES; BUCKETS; COFFEE FILTERS NOT OF PAPER BEING PART OF NON-ELECTRIC COFFEE MAKERS; CONTAINERS FOR HOUSEHOLD OR KITCHEN USE; NON-ELECTRIC COOKING UTENSILS, NAMELY, GRILLS AND TONGS; NON-ELECTRIC PORTABLE COOLERS; CRUET STANDS FOR OIL AND VINEGAR; FRUIT PRESSES, NON-ELECTRIC, FOR HOUSEHOLD PURPOSES; GRIDIRON SUPPORTS; GRILL SUPPORTS; HOT POTS, NOT ELECTRICALLY HEATED; KITCHEN MIXERS, NON-ELECTRIC; KITCHEN UTENSILS, NAMELY, GRATERS; HAND-OPERATED SEA SALT AND PEPPERCORN MILLS FOR DOMESTIC PURPOSES; MIXING SPOONS; CAKE MOLDS; PEPPER MILLS, HAND-OPERATED; PRESSURE COOKERS, NON-ELECTRIC; HOUSEHOLD UTENSILS, NAMELY, SPATULAS; LAWN SPRINKLERS; COOKING STRAINERS; THERMALLY INSULATED CONTAINERS FOR FOOD; WHISKS, NON-ELECTRIC, FOR HOUSEHOLD PURPOSES; HAND-OPERATED SALT AND PEPPER MILLS; MILK CHURNS; NON-ELECTRIC PRESSURE COOKERS; NON-ELECTRIC BREAD TOASTERS; DUTCH OVENS; NON-ELECTRIC AUTOCLAVES (U.S. CLS. 2, 13, 23, 29, 30, 33, 40 AND 50).

SAMUEL PAQUIN, EXAMINING ATTORNEY

SN 86-043,481. DENY DESIGNS, DENVER, CO. FILED 8-21-2013.



OWNER OF U.S. REG. NO. 4,226,616.  
NO CLAIM IS MADE TO THE EXCLUSIVE RIGHT TO USE "DESIGNS", APART FROM THE MARK AS SHOWN.

THE MARK CONSISTS OF FOUR SQUARE BOXES IN A HORIZONTAL MANNER WITH THE LETTERS "D"- "E"- "N"- "Y" NEXT TO THE WORD "DESIGNS" IN ALL CAPS WHICH IS VERTICAL ON THE RIGHT HAND SIDE NEXT TO THE "Y" BOX.

**CLASS 14—JEWELRY**

FOR JEWELRY BOXES AND CLOCKS (U.S. CLS. 2, 27, 28 AND 50).  
FIRST USE 7-8-2013; IN COMMERCE 7-8-2013.

**CLASS 20—FURNITURE AND ARTICLES NOT OTHERWISE CLASSIFIED**

FOR FURNITURE, PILLOWS, NAMELY, ACCENT PILLOWS, BED PILLOWS, FLOOR PILLOWS, NOVELTY PILLOWS AND THROW PILLOWS, DISPLAY BOARDS, MIRRORS (U.S. CLS. 2, 13, 22, 25, 32 AND 50).  
FIRST USE 7-8-2013; IN COMMERCE 7-8-2013.

**CLASS 21—HOUSEWARES AND GLASS**

FOR SERVING TRAYS (U.S. CLS. 2, 13, 23, 29, 30, 33, 40 AND 50).  
FIRST USE 7-8-2013; IN COMMERCE 7-8-2013.

**CLASS 24—FABRICS**

FOR BED SHEETS, PILLOW CASES, DUVET COVERS, BLANKET THROWS, BED BLANKETS AND SHOWER CURTAINS (U.S. CLS. 42 AND 50).  
FIRST USE 7-8-2013; IN COMMERCE 7-8-2013.

**CLASS 27—FLOOR COVERINGS**

FOR RUGS (U.S. CLS. 19, 20, 37, 42 AND 50).  
FIRST USE 7-8-2013; IN COMMERCE 7-8-2013.  
JASON TURNER, EXAMINING ATTORNEY

SN 86-043,482. DENY DESIGNS, DENVER, CO. FILED 8-21-2013.



OWNER OF U.S. REG. NO. 4,226,616.  
NO CLAIM IS MADE TO THE EXCLUSIVE RIGHT TO USE "DESIGNS", APART FROM THE MARK AS SHOWN.  
THE MARK CONSISTS OF FOUR INDIVIDUAL BOXES WITH TWO BOXES CONTAINING THE LETTERS "D" AND "E" OVER TWO BOXES CONTAINING THE LETTERS "N" AND "Y" ALL OVER THE WORD "DESIGNS".

**CLASS 14—JEWELRY**

FOR JEWELRY BOXES AND CLOCKS (U.S. CLS. 2, 27, 28 AND 50).  
FIRST USE 7-8-2013; IN COMMERCE 7-8-2013.

**CLASS 20—FURNITURE AND ARTICLES NOT OTHERWISE CLASSIFIED**

FOR FURNITURE, PILLOWS, NAMELY, ACCENT PILLOWS, BED PILLOWS, FLOOR PILLOWS, NOVELTY PILLOWS AND THROW PILLOWS, DISPLAY BOARDS, MIRRORS (U.S. CLS. 2, 13, 22, 25, 32 AND 50).  
FIRST USE 7-8-2013; IN COMMERCE 7-8-2013.

**CLASS 21—HOUSEWARES AND GLASS**

FOR SERVING TRAYS (U.S. CLS. 2, 13, 23, 29, 30, 33, 40 AND 50).  
FIRST USE 7-8-2013; IN COMMERCE 7-8-2013.

**CLASS 24—FABRICS**

FOR BED SHEETS, PILLOW CASES, DUVET COVERS, BLANKET TROWS, BED BLANKETS AND SHOWER CURTAINS (U.S. CLS. 42 AND 50).  
FIRST USE 7-8-2013; IN COMMERCE 7-8-2013.

**CLASS 27—FLOOR COVERINGS**

FOR RUGS (U.S. CLS. 19, 20, 37, 42 AND 50).  
FIRST USE 7-8-2013; IN COMMERCE 7-8-2013.

**CLASS 35—ADVERTISING AND BUSINESS**

FOR ONLINE RETAIL STORE SERVICES FEATURING BED SHEETS, PILLOW CASES, DUVET COVERS, BLANKET TROWS, BED BLANKETS, SHOWER CURTAINS, PILLOWS, FURNITURE, MIRRORS, DISPLAY BOARDS, JEWELRY BOXES, CLOCKS, RUGS AND SERVING TRAYS; RETAIL STORE SERVICES FEATURING BED SHEETS, PILLOW CASES, DUVET COVERS, BLANKET TROWS, BED BLANKETS, SHOWER CURTAINS, PILLOWS, FURNITURE, MIRRORS, DISPLAY BOARDS, JEWELRY BOXES, CLOCKS, RUGS AND SERVING TRAYS (U.S. CLS. 100, 101 AND 102).  
FIRST USE 7-8-2013; IN COMMERCE 7-8-2013.  
JASON TURNER, EXAMINING ATTORNEY

SN 86-044,022. BARE FRUIT, LLC, WALNUT, CA. FILED 8-21-2013.

# BARE KIDS

THE MARK CONSISTS OF STANDARD CHARACTERS WITHOUT CLAIM TO ANY PARTICULAR FONT, STYLE, SIZE, OR COLOR.

OWNER OF U.S. REG. NO. 3,163,402.  
NO CLAIM IS MADE TO THE EXCLUSIVE RIGHT TO USE "KIDS", APART FROM THE MARK AS SHOWN.

**CLASS 29—MEATS AND PROCESSED FOODS**

FOR BAKED VEGETABLES, NAMELY, BAKED VEGETABLE SNACK CHIPS MADE FROM POTATOES, YUCCA, OR SWEET POTATO; SNACK MIXES CONSISTING OF DEHYDRATED FRUIT; SNACK MIXES CONSISTING OF BAKED FRUIT; NUT-BASED SNACK FOODS; BEAN-BASED SNACK FOODS; SEED-BASED SNACK FOODS; POTATO CHIPS, SWEET POTATO CHIPS; SNACKS, NAMELY, VEGETABLE CHIPS AND SNACK FOODS MADE FROM POTATOES, YUCCA, AND SWEET POTATO; SNACKS, NAMELY, POTATO FLOUR BASED SNACK FOODS AND POTATO STARCH BASED SNACK FOODS, NAMELY, POTATO CRISPS (U.S. CL. 46).

**CLASS 30—STAPLE FOODS**

FOR CEREAL-BASED SNACK FOODS; SNACKS, NAMELY, GRAIN-BASED, NUTRIENT-DENSE READY-TO-EAT FOOD BARS, ALSO CONTAINING DRIED FRUITS, CHOCOLATE, NUTS, SEEDS, AND SOY; ENERGY BARS COMPRISED PRIMARILY OF BROWN RICE SYRUP; READY-TO-EAT GRAIN BASED FOOD BARS; GRAIN BASED SNACK FOODS, NAMELY, READY-TO-EAT GRAIN BASED FOOD BARS; GRANO-LA BARS, NAMELY, CEREAL BASED SNACK FOOD BARS; YOGURT-BASED SNACK FOODS, NAMELY, YOGURT COVERED NUTS AND FRUIT (U.S. CL. 46).  
APRIL ROACH, EXAMINING ATTORNEY

SN 86-044,091. BOSTON HEART DIAGNOSTICS CORPORATION, FRAMINGHAM, MA. FILED 8-21-2013.



THE MARK CONSISTS OF A HEART WITH A STEM AND LEAF AT THE TOP OF THE HEART.

**CLASS 42—SCIENTIFIC AND COMPUTER SERVICES**

FOR LABORATORY RESEARCH IN THE FIELD OF DIABETES AND CARDIOVASCULAR HEALTH (U.S. CLS. 100 AND 101).  
FIRST USE 5-31-2011; IN COMMERCE 5-31-2011.

**CLASS 44—MEDICAL, BEAUTY AND AGRICULTURAL SERVICES**

FOR MEDICAL DIAGNOSTIC TESTING, MONITORING AND REPORTING IN THE FIELD OF CARDIOVASCULAR DISEASE; PROVIDING INFORMATION RELATING TO CARDIOVASCULAR HEALTH AND CARDIOVASCULAR HEALTH TESTING (U.S. CLS. 100 AND 101).  
FIRST USE 5-31-2011; IN COMMERCE 5-31-2011.  
ANDREA BUTLER, EXAMINING ATTORNEY

SN 86-044,630. «SKY PASS» LIMITED PARTNERSHIP, SOUTH LANARKSHIRE, UNITED KINGDOM, FILED 8-21-2013.



THE COLOR(S) BLUE, WHITE IS/ARE CLAIMED AS A FEATURE OF THE MARK.

THE MARK CONSISTS OF A BLUE RECTANGULAR WITH THE WORDING "NETWORK OF SOCIAL COOPERATION" IN WHITE COLOR INSIDE.

#### **CLASS 9—ELECTRICAL AND SCIENTIFIC APPARATUS**

FOR COMPUTER GAME SOFTWARE; COMPUTER OPERATING SOFTWARE; COMPUTER SOFTWARE FOR PUBLISHING AND SHARING DIGITAL MEDIA AND INFORMATION VIA GLOBAL COMPUTER AND COMMUNICATION NETWORKS; COMPUTER SOFTWARE DEVELOPMENT TOOLS; COMPUTER SOFTWARE FOR USE AS AN APPLICATION PROGRAMMING INTERFACE (API); COMPUTER SOFTWARE FOR CREATING INDEXES OF INFORMATION, INDEXES OF WEB SITES AND INDEXES OF OTHER INFORMATION RESOURCES (U.S. CLS. 21, 23, 26, 36 AND 38).

#### **CLASS 35—ADVERTISING AND BUSINESS**

FOR ARRANGING OF SUBSCRIPTIONS OF TELECOMMUNICATIONS SERVICES FOR OTHERS, NAMELY, ARRANGING OF SUBSCRIPTIONS TO ELECTRONIC MAIL SERVICES FOR OTHERS; PUBLIC OPINION POLLING; BUSINESS ADVICE AND COMMERCIAL INFORMATION; ORGANIZATION AND CONDUCTING OF PRODUCT PRESENTATIONS; ADVERTISING, MARKETING AND PROMOTION SERVICES; DISSEMINATION SERVICES OF ADVERTISEMENT MATTER; PUBLIC RELATIONS; PROCUREMENT, NAMELY, PURCHASING SOFTWARE FOR OTHERS (U.S. CLS. 100, 101 AND 102).

#### **CLASS 38—COMMUNICATION**

FOR TELECOMMUNICATIONS SERVICES, NAMELY, ELECTRONIC TRANSMISSION OF DATA AND DIGITAL MESSAGING VIA INTERNET; PROVIDING ON-LINE FORUMS, CHAT ROOMS AND ELECTRONIC BULLETIN BOARDS FOR TRANSMISSION OF MESSAGES AMONG USERS IN THE FIELD OF GENERAL INTEREST; DIGITAL MULTIMEDIA BROADCASTING SERVICES OVER THE INTERNET, NAMELY, POSTING, DISPLAYING, AND ELECTRONICALLY TRANSMITTING DATA, AUDIO AND VIDEO; PROVIDING ACCESS TO COMPUTER DATABASES IN THE FIELDS OF GENERAL INTEREST; INTERNET ACCESS PROVIDER SERVICES; PROVIDING TELECOMMUNICATION CHANNELS FOR TELESHOPPING SERVICES; COMMUNICATION BY ELECTRONIC COMPUTER TERMINALS; TELECOMMUNICATIONS ROUTING AND JUNCTION SERVICES (U.S. CLS. 100, 101 AND 104).

#### **CLASS 42—SCIENTIFIC AND COMPUTER SERVICES**

FOR PROVIDING TEMPORARY USE OF ON-LINE NON-DOWNLOADABLE SOFTWARE FOR PUBLISHING AND SHARING DIGITAL MEDIA AND INFORMATION VIA INTERNET; PROVIDING TEMPORARY USE OF ON-LINE NON-DOWNLOADABLE SOFTWARE DEVELOPMENT TOOLS; PROVIDING TEMPORARY USE OF ON-LINE NON-DOWNLOADABLE SOFTWARE FOR USE AS AN APPLICATION PROGRAMMING INTERFACE (API); PROVIDING TEMPORARY USE OF ON-LINE NON-DOWNLOADABLE SOFTWARE FOR CREATING INDEXES OF INFORMATION, INDEXES OF WEB SITES AND INDEXES OF OTHER INFORMATION RESOURCES; TECHNICAL SUPPORT SERVICES, NAMELY, ON-LINE TROUBLESHOOTING OF COMPUTER SOFTWARE PROBLEMS FOR NON-DOWNLOADABLE COMPUTER PROGRAM USERS AND MONITORING TECHNOLOGICAL FUNCTIONS OF COMPUTER NETWORK SYSTEMS; PROVIDING A WEB HOSTING PLATFORM FOR OTHERS FOR ORGANIZING AND CONDUCTING MEETINGS, EVENTS AND INTERACTIVE TEXT, AUDIO, AND VIDEO DISCUSSIONS; PROVIDING A WEB SITE FEATURING TECHNOLOGY THAT ENABLES INTERNET USERS TO CREATE, BOOKMARK, ANNOTATE, AND PUBLICLY SHARE DATA; SOFTWARE DESIGN AND DEVELOPMENT; COMPUTER PROGRAMMING AND COMPUTER SYSTEM ANALYSIS; DESIGNING, CREATING, MAINTAINING, AND HOSTING WEBSITES FOR OTHERS (U.S. CLS. 100 AND 101).

#### **CLASS 45—PERSONAL AND LEGAL SERVICES**

FOR ON-LINE SOCIAL NETWORKING SERVICES (U.S. CLS. 100 AND 101).  
CHRISTOPHER REAMS, EXAMINING ATTORNEY

---

SN 86-044,959. NOVA COMMUNICATIONS, INC., PLYMOUTH, MN. FILED 8-22-2013.

### **NOVA COMMUNICATIONS**

THE MARK CONSISTS OF STANDARD CHARACTERS WITHOUT CLAIM TO ANY PARTICULAR FONT, STYLE, SIZE, OR COLOR.

NO CLAIM IS MADE TO THE EXCLUSIVE RIGHT TO USE "COMMUNICATIONS", APART FROM THE MARK AS SHOWN.

#### **CLASS 37—CONSTRUCTION AND REPAIR**

FOR INSTALLATION OF MULTILINE TELECOMMUNICATIONS SYSTEMS, INCLUDING VOICE-OVER INTERNET PROTOCOL ("VOIP") AND PRIVATE-BRANCH EXCHANGE ("PBX")-BASED SYSTEMS, AND EQUIPMENT THEREFOR (U.S. CLS. 100, 103 AND 106).  
FIRST USE 3-0-2002; IN COMMERCE 3-0-2002.

#### **CLASS 42—SCIENTIFIC AND COMPUTER SERVICES**

FOR DESIGN SERVICES FEATURING MULTILINE TELECOMMUNICATIONS SYSTEMS, INCLUDING VOICE-OVER INTERNET PROTOCOL ("VOIP") AND PRIVATE-BRANCH EXCHANGE ("PBX")-BASED SYSTEMS (U.S. CLS. 100 AND 101).  
FIRST USE 3-0-2002; IN COMMERCE 3-0-2002.  
SHAUNIA CARLYLE, EXAMINING ATTORNEY

SN 86-045,068. UNITED BUILDING ENVELOPE RENOVATION, LLC, MANASSAS, VA. FILED 8-22-2013.



THE MARK CONSISTS OF A SET OF INTERSECTING LINES, ONE HORIZONTAL AND ONE VERTICAL, WITH THE INTERSECTION IN THE UPPER LEFT AND A LIGHTER FIELD WITH THE CAPITAL LETTERS "UBER" IN STYLIZED TEXT APPEARING IN THE CENTER OF THE FIELD.

#### CLASS 37—CONSTRUCTION AND REPAIR

FOR BUILDING CONSTRUCTION SERVICES; RENOVATION AND REPAIR SERVICES FOR BUILDINGS, HOMES AND COMMERCIAL, INDUSTRIAL AND INSTITUTIONAL FACILITIES; CONSTRUCTION AND CONTRACTING SERVICES, NAMELY, GENERAL CONSTRUCTION CONTRACTING AND BUILDING CONSTRUCTION SERVICES FOR COMMERCIAL, EDUCATIONAL, HISTORIC, INSTITUTIONAL, INDUSTRIAL, RETAIL AND RESIDENTIAL BUILDINGS, HOMES AND COMMERCIAL, INDUSTRIAL AND INSTITUTIONAL FACILITIES, AND BUILDING COMPLEXES; BUILDING CONSTRUCTION AND REPAIR; CUSTOM CONSTRUCTION OF COMMERCIAL, INDUSTRIAL, RETAIL, EDUCATIONAL, HISTORIC AND RESIDENTIAL BUILDINGS AND HOMES; CONSTRUCTION, MAINTENANCE AND RENOVATION OF PROPERTY; CUSTOM CONSTRUCTION AND BUILDING RENOVATION; RENOVATION IN THE FIELD OF EDUCATIONAL, HISTORIC, INSTITUTIONAL, INDUSTRIAL, RETAIL AND RESIDENTIAL BUILDINGS, HOMES AND COMMERCIAL, INDUSTRIAL AND INSTITUTIONAL FACILITIES, AND BUILDING COMPLEXES; REMODELING OF EDUCATIONAL, HISTORIC, INSTITUTIONAL, INDUSTRIAL, RETAIL AND RESIDENTIAL BUILDINGS, HOMES AND COMMERCIAL, INDUSTRIAL AND INSTITUTIONAL FACILITIES, AND BUILDING COMPLEXES; CONSTRUCTION OF COMMERCIAL, EDUCATIONAL, HISTORIC, INSTITUTIONAL, INDUSTRIAL, RETAIL AND RESIDENTIAL BUILDINGS, HOMES AND COMMERCIAL, INDUSTRIAL AND INSTITUTIONAL FACILITIES, AND BUILDING COMPLEXES; CUSTOM CONSTRUCTION OF COMMERCIAL, INDUSTRIAL, RETAIL, EDUCATIONAL, HISTORIC AND RESIDENTIAL BUILDINGS, HOMES AND COMMERCIAL, INDUSTRIAL AND INSTITUTIONAL FACILITIES, AND BUILDING COMPLEXES; BUILDING CONSTRUCTION; GENERAL BUILDING CONTRACTOR SERVICES; CONSTRUCTION PLANNING AND MANAGEMENT; CONSTRUCTION PLANNING; CONSTRUCTION MANAGEMENT; CONSTRUCTION SUPERVISION; BUILDING INSPECTION, NAMELY, INSPECTING STRUCTURAL, MECHANICAL, ELECTRICAL SYSTEMS OF BUILDINGS AND COMMERCIAL, INDUSTRIAL AND INSTITUTIONAL FACILITIES; OFF SITE BUILDING CONSTRUCTION PROJECT MANAGEMENT; GENERAL CONSTRUCTION CONTRACTING; CONSTRUCTION CONSULTATION (U.S. CLS. 100, 103 AND 106).

FIRST USE 6-30-2012; IN COMMERCE 6-30-2012.

#### CLASS 42—SCIENTIFIC AND COMPUTER SERVICES

FOR CONSULTING SERVICES IN THE FIELD OF DESIGN AND DEVELOPMENT OF COMPUTER SOFTWARE FOR PREVENTIVE MAINTENANCE PROGRAMS FOR THE STRUCTURAL, MECHANICAL, ELECTRICAL SYSTEMS OF BUILDINGS AND COMMERCIAL, INDUSTRIAL AND INSTITUTIONAL FACILITIES; ENGINEERING DESIGN SERVICES; ENGINEERING IN THE FIELD OF PROPERTY DEVELOPMENT AND ARCHITECTURE; DRAWING UP OF CONSTRUCTION PLANS, NAMELY, CONSTRUCTION DRAFTING; CONSTRUCTION DRAFTING IN THE FIELD OF COMMERCIAL, INDUSTRIAL, RETAIL, EDUCATIONAL, HISTORIC AND RESIDENTIAL BUILDINGS; INDUSTRIAL DESIGN; ARCHITECTURAL DESIGN; ARCHITECTURAL CONSULTING, PLANNING, CONCEPT DESIGN, PERMIT DRAWING DESIGN AND POST-PERMIT BUILDING DESIGN SERVICES (U.S. CLS. 100 AND 101).

FIRST USE 6-30-2012; IN COMMERCE 6-30-2012.

PAUL MORENO, EXAMINING ATTORNEY

SN 86-045,151. LOCUS TELECOMMUNICATIONS, INC., FORT LEE, NJ. FILED 8-22-2013.



THE MARK CONSISTS OF THE STYLIZED LETTERS "EZILD". THE BLACK LINES OUTLINING THE "EZILD" LETTERS ARE SHOWN FOR ILLUSTRATION PURPOSES ONLY AND DOES NOT FORM PART OF THE MARK.

#### CLASS 35—ADVERTISING AND BUSINESS

FOR ONLINE RETAIL STORE SERVICES FEATURING TELECOMMUNICATIONS PRODUCTS AND SERVICES (U.S. CLS. 100, 101 AND 102).

FIRST USE 12-30-2011; IN COMMERCE 12-30-2011.

#### CLASS 38—COMMUNICATION

FOR LONG DISTANCE TELEPHONE SERVICES (U.S. CLS. 100, 101 AND 104).

FIRST USE 12-30-2011; IN COMMERCE 12-30-2011.

LINDA POWELL, EXAMINING ATTORNEY

SN 86-045,159. LOCUS TELECOMMUNICATIONS, INC., FORT LEE, NJ. FILED 8-22-2013.



THE MARK CONSISTS OF STANDARD CHARACTERS WITHOUT CLAIM TO ANY PARTICULAR FONT, STYLE, SIZE, OR COLOR.

#### CLASS 35—ADVERTISING AND BUSINESS

FOR ONLINE RETAIL STORE SERVICES FEATURING TELECOMMUNICATIONS PRODUCTS AND SERVICES (U.S. CLS. 100, 101 AND 102).

FIRST USE 12-30-2011; IN COMMERCE 12-30-2011.

**CLASS 38—COMMUNICATION**

FOR LONG DISTANCE TELEPHONE SERVICES (U.S. CLS. 100, 101 AND 104).  
FIRST USE 12-30-2011; IN COMMERCE 12-30-2011.  
LINDA POWELL, EXAMINING ATTORNEY

**CLASS 9—ELECTRICAL AND SCIENTIFIC APPARATUS**

FOR COMPUTER PROCESSING HARDWARE AND SOFTWARE, AND OTHER ELECTRONIC EQUIPMENT, NAMELY, COMPUTER PROCESSING HARDWARE AND SOFTWARE, AND OTHER ELECTRONIC EQUIPMENT FOR CONVERTING, INTERPRETING, PROCESSING, OR TRANSPORTING COLOR INFORMATION IN VIDEO IMAGE RECORDS AND STILL IMAGE RECORDS (U.S. CLS. 21, 23, 26, 36 AND 38).

SN 86-046,266. DANIEL MICHAEL NORRIS, LONDON, GREAT BRITAIN, FILED 8-23-2013.

**CLASS 42—SCIENTIFIC AND COMPUTER SERVICES**

FOR IMAGE PROCESSING SERVICES, NAMELY, PROCESSING OF DIGITAL INFORMATION REPRESENTING IMAGES, IN THE FIELD OF CONVERTING, INTERPRETING, PROCESSING, OR TRANSPORTING COLOR INFORMATION IN VIDEO IMAGE RECORDS AND STILL IMAGE RECORDS (U.S. CLS. 100 AND 101).  
ESTHER BELENKER, EXAMINING ATTORNEY

# A REAL PLACE

THE MARK CONSISTS OF STANDARD CHARACTERS WITHOUT CLAIM TO ANY PARTICULAR FONT, STYLE, SIZE, OR COLOR.

SN 86-047,725. HOYT, CHARLES, FRESNO, CA. FILED 8-26-2013.

**CLASS 35—ADVERTISING AND BUSINESS**

FOR PROVIDING A MEETING PLACE FOR PEOPLE TO PHYSICALLY MEET AND INTERACT IN PERSON BASED ON A DISPLAYED TOPIC, THE MEETING PLACE BEING TEMPORARY IN NATURE FOR A SELECT PERIOD OF TIME OR PERMANENT IN NATURE IN A FIXED LOCATION, NAMELY, PROVIDING FACILITIES FOR BUSINESS MEETINGS, NAMELY, CONVENTIONS, CONFERENCES, AND BUSINESS NETWORKING SETTINGS (U.S. CLS. 100, 101 AND 102).

# THRUTHINK

THE MARK CONSISTS OF STANDARD CHARACTERS WITHOUT CLAIM TO ANY PARTICULAR FONT, STYLE, SIZE, OR COLOR.

**CLASS 43—HOTEL AND RESTAURANT SERVICES**

FOR PROVIDING A MEETING PLACE FOR PEOPLE TO PHYSICALLY MEET AND INTERACT IN PERSON BASED ON A DISPLAYED TOPIC, THE MEETING PLACE BEING TEMPORARY IN NATURE FOR A SELECT PERIOD OF TIME OR PERMANENT IN NATURE IN A FIXED LOCATION, NAMELY, PROVIDING FACILITIES TO ENABLE PEOPLE TO ENGAGE IN FACE TO FACE SOCIAL NETWORKING (U.S. CLS. 100 AND 101).

HANNO RITTNER, EXAMINING ATTORNEY

**CLASS 9—ELECTRICAL AND SCIENTIFIC APPARATUS**

FOR COMPUTER SOFTWARE FOR EVALUATING AND ANALYZING A BUSINESS BASED ON USER INPUT FOR USE IN A POTENTIAL PURCHASE, SALE, VALUATION, DEBT ACQUISITION, EQUITY ACQUISITION OR OTHER RELATED BUSINESS MATTER OR BUSINESS TRANSACTION INVOLVING THE BUSINESS; DOWNLOADABLE COMPUTER SOFTWARE FOR EVALUATING AND ANALYZING A BUSINESS BASED ON USER INPUT FOR USE IN A POTENTIAL PURCHASE, SALE, VALUATION, DEBT ACQUISITION, EQUITY ACQUISITION OR OTHER RELATED BUSINESS MATTER OR BUSINESS TRANSACTION INVOLVING THE BUSINESS (U.S. CLS. 21, 23, 26, 36 AND 38).

SN 86-046,310. GERLACH CONSULTING GROUP, INC., DRAPER, UT. FILED 8-23-2013.

**CLASS 35—ADVERTISING AND BUSINESS**

FOR BUSINESS CONSULTING SERVICES IN THE NATURE OF EVALUATING AND ANALYZING A BUSINESS BASED ON INFORMATION PROVIDED ABOUT THE BUSINESS FOR USE IN A POTENTIAL PURCHASE, SALE, VALUATION, DEBT ACQUISITION, EQUITY ACQUISITION OR OTHER RELATED BUSINESS MATTER OR BUSINESS TRANSACTION INVOLVING THE BUSINESS (U.S. CLS. 100, 101 AND 102).

# PantoChrome

**CLASS 42—SCIENTIFIC AND COMPUTER SERVICES**

FOR PROVIDING TEMPORARY USE OF ON-LINE NON-DOWNLOADABLE SOFTWARE FOR EVALUATING AND ANALYZING A BUSINESS BASED ON USER INPUT FOR USE IN A POTENTIAL PURCHASE, SALE, VALUATION, DEBT ACQUISITION, EQUITY ACQUISITION OR OTHER RELATED BUSINESS MATTER OR BUSINESS TRANSACTION INVOLVING THE BUSINESS (U.S. CLS. 100 AND 101).

ANDREW RHIM, EXAMINING ATTORNEY

THE MARK CONSISTS OF STANDARD CHARACTERS WITHOUT CLAIM TO ANY PARTICULAR FONT, STYLE, SIZE, OR COLOR.

THE WORDING "PANTOCHROME" HAS NO MEANING IN A FOREIGN LANGUAGE.



SN 86-048,345. ARKANSAS STATE UNIVERSITY, STATE UNIVERSITY, AR. FILED 8-26-2013.

# RED WOLF

THE MARK CONSISTS OF STANDARD CHARACTERS WITHOUT CLAIM TO ANY PARTICULAR FONT, STYLE, SIZE, OR COLOR.

OWNER OF U.S. REG. NOS. 3,596,375, 3,677,815 AND 3,796,310.

## CLASS 25—CLOTHING

FOR CLOTHING, NAMELY, SHIRTS, JACKETS, COATS, PANTS, TOPS, HEADWEAR, FOOTWEAR, AND INFANT AND TODDLER ONE-PIECE CLOTHING (U.S. CLS. 22 AND 39).

FIRST USE 8-26-2013; IN COMMERCE 8-26-2013.

## CLASS 41—EDUCATION AND ENTERTAINMENT

FOR EDUCATIONAL SERVICES, NAMELY, PROVIDING COURSES OF INSTRUCTION AT THE UNIVERSITY LEVEL; AND ENTERTAINMENT SERVICES, NAMELY, ORGANIZING AND CONDUCTING SPORTING EVENTS, SPORTS AND ATHLETIC COMPETITIONS, AND CULTURAL EVENTS (U.S. CLS. 100, 101 AND 107).

FIRST USE 8-26-2013; IN COMMERCE 8-26-2013.  
SANI KHOURI, EXAMINING ATTORNEY

SN 86-048,667. VOCUS, INC., BELTSVILLE, MD. FILED 8-27-2013.

# DEMAND SUCCESS

THE MARK CONSISTS OF STANDARD CHARACTERS WITHOUT CLAIM TO ANY PARTICULAR FONT, STYLE, SIZE, OR COLOR.

## CLASS 16—PAPER GOODS AND PRINTED MATTER

FOR PRINTED EDUCATIONAL MATERIALS, NAMELY, GUIDES, WHITE PAPERS, AND NEWSLETTERS IN THE FIELDS OF MARKETING, PUBLIC RELATIONS, PROMOTION, E-MAIL MARKETING, SALES, CUSTOMER INFORMATION MANAGEMENT, CUSTOMER RELATIONSHIP MANAGEMENT, SALES SUPPORT AND EMPLOYEE EFFICIENCY (U.S. CLS. 2, 5, 22, 23, 29, 37, 38 AND 50).

FIRST USE 6-20-2013; IN COMMERCE 6-20-2013.

## CLASS 35—ADVERTISING AND BUSINESS

FOR PROVIDING INFORMATION IN THE FORM OF INFO-GRAPHICS, TIPS AND BEST PRACTICES GUIDELINES IN THE FIELDS OF MARKETING, PUBLIC RELATIONS, PROMOTION, E-MAIL MARKETING, RETAIL STORE SALES, BUSINESS INFORMATION MANAGEMENT REGARDING CUSTOMERS, CUSTOMER RELATIONSHIP MANAGEMENT, SALES OFFICE SUPPORT STAFF SERVICES AND BUSINESS EFFICIENCY OF EMPLOYEES (U.S. CLS. 100, 101 AND 102).

FIRST USE 6-20-2013; IN COMMERCE 6-20-2013.

## CLASS 41—EDUCATION AND ENTERTAINMENT

FOR EDUCATIONAL SERVICES, NAMELY, PROVIDING SEMINARS, CONFERENCES, WORKSHOPS, AND INDIVIDUAL TRAINING ON COMPUTER APPLICATIONS IN THE FIELDS OF MARKETING, PUBLIC RELATIONS, PROMOTION, E-MAIL MARKETING, SALES, CUSTOMER INFORMATION MANAGEMENT, CUSTOMER RELATIONSHIP MANAGEMENT, SALES SUPPORT AND EMPLOYEE EFFICIENCY, AND DISTRIBUTION OF DIGITAL EDUCATIONAL MATERIALS IN CONNECTION THEREWITH; EDUCATIONAL SERVICES, NAMELY, PROVIDING BLOGS IN THE FIELDS OF MARKETING, PUBLIC RELATIONS, PROMOTION, E-MAIL MARKETING, SALES, CUSTOMER INFORMATION MANAGEMENT, CUSTOMER RELATIONSHIP MANAGEMENT, SALES SUPPORT AND EMPLOYEE EFFICIENCY; PROVIDING ONLINE VIDEOS IN THE FIELDS OF MARKETING, PUBLIC RELATIONS, PROMOTION, E-MAIL MARKETING, RETAIL STORE SALES, BUSINESS INFORMATION MANAGEMENT REGARDING CUSTOMERS, CUSTOMER RELATIONSHIP MANAGEMENT, SALES OFFICE SUPPORT STAFF SERVICES AND BUSINESS EFFICIENCY OF EMPLOYEES (U.S. CLS. 100, 101 AND 107).

FIRST USE 6-20-2013; IN COMMERCE 6-20-2013.  
CHARLOTTE CORWIN, EXAMINING ATTORNEY

SN 86-048,759. AN EVENING WITH THERESA INC., BEVERLY HILLS, CA. FILED 8-27-2013.

# THE HIGHER THE HAIR, THE CLOSER TO GOD

THE MARK CONSISTS OF STANDARD CHARACTERS WITHOUT CLAIM TO ANY PARTICULAR FONT, STYLE, SIZE, OR COLOR.

## CLASS 14—JEWELRY

FOR JEWELRY AND PRECIOUS STONES; WATCHES; PRECIOUS METALS AND THEIR ALLOYS; GOODS IN PRECIOUS METALS OR COATED THEREWITH, NAMELY, BOXES AND KEY RINGS; HOROLOGICAL AND CHRONOMETRIC INSTRUMENTS (U.S. CLS. 2, 27, 28 AND 50).

## CLASS 16—PAPER GOODS AND PRINTED MATTER

FOR POSTERS; SERIES OF NON-FICTION BOOKS IN THE SPIRITUAL AND NEW AGE FIELD; SELF-IMPROVEMENT HELP BOOKS; AUTOBIOGRAPHICAL BOOKS; PRINTED SERIES OF FICTIONAL SHORT STORIES; PRINTED SERIES OF NON-FICTION SHORT STORIES IN THE SPIRITUAL AND NEW AGE FIELD; BLANK JOURNALS; PAPER; CARDBOARD; GOODS MADE FROM PAPER AND CARDBOARD, NAMELY, BOTTLE WRAPPERS, BOXES, ADVERTISEMENT BOARDS AND SIGNBOARD; PRINTED MATTER, NAMELY, CALENDARS, GRAPHIC PRINTS, GREETING CARDS, POSTERS, STICKERS; BOOKBINDING MATERIAL; PHOTOGRAPHS; STATIONERY; ADHESIVES FOR STATIONERY OR HOUSEHOLD PURPOSES; PAINT BRUSHES; PRINTED MATERIAL, NAMELY, CATALOGUES, INFORMATIONAL FLYERS, MAGAZINES, NEWSLETTERS, PAMPHLETS, BROCHURES, BOOKLETS IN THE SPIRITUAL AND NEW AGE FIELD (U.S. CLS. 2, 5, 22, 23, 29, 37, 38 AND 50).

**CLASS 21—HOUSEWARES AND GLASS**

FOR MUGS, COFFEE CUPS, TEA CUPS, AND BOWLS; SAGE BOWLS; INCENSE BURNERS; HOUSEHOLD OR KITCHEN CONTAINERS; COMBS; UNWORKED OR SEMI-WORKED GLASS EXCEPT GLASS USED IN BUILDING; GLASSWARE, PORCELAIN AND EARTH-ENWARE, NAMELY, COCKTAIL GLASSES, DRINKING GLASSES, BEER MUGS, FLASKS, DRINKING VESSELS, DRINKING FLASKS FOR TRAVELERS, BEVERAGE COOLERS, JUGS, PITCHERS AND TANKARDS (U.S. CLS. 2, 13, 23, 29, 30, 33, 40 AND 50).

**CLASS 25—CLOTHING**

FOR CLOTHING, NAMELY, APRONS, BABIES' PANTS, BANDANAS, BATH ROBES, BATHING TRUNKS, BATHING SUITS, BELTS, BIBS NOT OF PAPER, CAMISOLES, COATS, DRESSES, DRESSING GOWNS, GLOVES, HEADBANDS, JACKETS, JUMPER DRESSES, LEGGINGS, MITTENS, NECKTIES, OVERCOATS, PANTS, PARKAS, PETTICOATS, PONCHOS, PULLOVERS, PAJAMAS, SARONGS, SHAWLS, SHIRTS, SHORT-SLEEVE SHIRTS, SKIRTS, SKORTS, SOCKS, STOCKINGS, SUITS, TEDDIES, T-SHIRTS, TIGHTS, TROUSERS, UNDERCLOTHING, VESTS; OUTERWEAR, NAMELY, JACKETS, COATS, AND SWEATERS; FOOTWEAR AND HEADWEAR; FURS, NAMELY, COATS, JACKETS AND HATS (U.S. CLS. 22 AND 39).

ANGELA M. MICHELL, EXAMINING ATTORNEY

SN 86-048,774. AN EVENING WITH THERESA INC., BEVERLY HILLS, CA. FILED 8-27-2013.

THERESA CAPUTO

THE MARK CONSISTS OF STANDARD CHARACTERS WITHOUT CLAIM TO ANY PARTICULAR FONT, STYLE, SIZE, OR COLOR.

THE NAME(S), PORTRAIT(S), AND/OR SIGNATURE(S) SHOWN IN THE MARK IDENTIFIES "THERESA CAPUTO", WHOSE CONSENT(S) TO REGISTER IS MADE OF RECORD.

**CLASS 14—JEWELRY**

FOR JEWELRY AND PRECIOUS STONES; WATCHES; PRECIOUS METALS AND THEIR ALLOYS; GOODS IN PRECIOUS METALS OR COATED THEREWITH, NAMELY, BOXES AND KEY RINGS; HOROLOGICAL AND CHRONOMETRIC INSTRUMENTS (U.S. CLS. 2, 27, 28 AND 50).

**CLASS 16—PAPER GOODS AND PRINTED MATTER**

FOR POSTERS; SERIES OF NON-FICTION BOOKS IN THE SPIRITUAL AND NEW AGE FIELD; SELF-IMPROVEMENT HELP BOOKS; AUTOBIOGRAPHICAL BOOKS; PRINTED SERIES OF FICTIONAL SHORT STORIES; PRINTED SERIES OF NON-FICTION SHORT STORIES IN THE SPIRITUAL AND NEW AGE FIELD; BLANK JOURNALS; PAPER; CARDBOARD; GOODS MADE FROM PAPER AND CARDBOARD, NAMELY, BOTTLE WRAPPERS, BOXES, ADVERTISEMENT BOARDS AND SIGNBOARD; PRINTED MATTER, NAMELY, CALENDARS, GRAPHIC PRINTS, GREETING CARDS, POSTERS, STICKERS; BOOKBINDING MATERIAL; PHOTOGRAPHS; STATIONERY; ADHESIVES FOR STATIONERY OR HOUSEHOLD PURPOSES; PAINT BRUSHES; PRINTED MATERIAL, NAMELY, CATALOGUES, INFORMATIONAL FLYERS, MAGAZINES, NEWSLETTERS, PAMPHLETS, BROCHURES, BOOKLETS IN THE SPIRITUAL AND NEW AGE FIELD (U.S. CLS. 2, 5, 22, 23, 29, 37, 38 AND 50).

**CLASS 21—HOUSEWARES AND GLASS**

FOR MUGS, COFFEE CUPS, TEA CUPS, AND BOWLS; SAGE BOWLS; INCENSE BURNERS; HOUSEHOLD OR KITCHEN CONTAINERS; COMBS; UNWORKED OR SEMI-WORKED GLASS EXCEPT GLASS USED IN BUILDING; GLASSWARE, PORCELAIN AND EARTH-ENWARE, NAMELY, COCKTAIL GLASSES, DRINKING GLASSES, BEER MUGS, FLASKS, DRINKING VESSELS, DRINKING FLASKS FOR TRAVELERS, BEVERAGE COOLERS, JUGS, PITCHERS AND TANKARDS (U.S. CLS. 2, 13, 23, 29, 30, 33, 40 AND 50).

**CLASS 25—CLOTHING**

FOR CLOTHING, NAMELY, APRONS, BABIES' PANTS, BANDANAS, BATH ROBES, BATHING TRUNKS, BATHING SUITS, BELTS, BIBS NOT OF PAPER, CAMISOLES, COATS, DRESSES, DRESSING GOWNS, GLOVES, HEADBANDS, JACKETS, JUMPER DRESSES, LEGGINGS, MITTENS, NECKTIES, OVERCOATS, PANTS, PARKAS, PETTICOATS, PONCHOS, PULLOVERS, PAJAMAS, SARONGS, SHAWLS, SHIRTS, SHORT-SLEEVE SHIRTS, SKIRTS, SKORTS, SOCKS, STOCKINGS, SUITS, TEDDIES, T-SHIRTS, TIGHTS, TROUSERS, UNDERCLOTHING, VESTS; OUTERWEAR, NAMELY, JACKETS, COATS, AND SWEATERS; FOOTWEAR AND HEADWEAR; FURS, NAMELY, COATS, JACKETS AND HATS (U.S. CLS. 22 AND 39).

ANGELA M. MICHELL, EXAMINING ATTORNEY

SN 86-048,826. MARMON UTILITY LLC, MILFORD, NH. FILED 8-27-2013.

DR-EPR

THE MARK CONSISTS OF STANDARD CHARACTERS WITHOUT CLAIM TO ANY PARTICULAR FONT, STYLE, SIZE, OR COLOR.

**CLASS 9—ELECTRICAL AND SCIENTIFIC APPARATUS**

FOR HIGH VOLTAGE CABLES (U.S. CLS. 21, 23, 26, 36 AND 38).

**CLASS 17—RUBBER GOODS**

FOR INSULATION FOR CABLES (U.S. CLS. 1, 5, 12, 13, 35 AND 50).

NICHOLAS COLEMAN, EXAMINING ATTORNEY

SN 86-049,282. PLANETARY POWER, INC., REDMOND, WA. FILED 8-27-2013.

HyGen

THE MARK CONSISTS OF STANDARD CHARACTERS WITHOUT CLAIM TO ANY PARTICULAR FONT, STYLE, SIZE, OR COLOR.

**CLASS 7—MACHINERY**

FOR HYBRID POWER GENERATORS FOR THE GENERATION OF ELECTRICITY USING A COMBINATION OF A COMBUSTIBLE FUEL SOURCE AND STORED ELECTRICAL POWER; GENERATORS FOR ELECTRICITY (U.S. CLS. 13, 19, 21, 23, 31, 34 AND 35).

**CLASS 9—ELECTRICAL AND SCIENTIFIC APPARATUS**

FOR BULK ENERGY STORAGE DEVICES, NAMELY, COMPRESSED AIR ENERGY STORAGE UNITS FOR STORING SPILLED ELECTRIC POWER AND WASTE HEAT IN COMPRESSED AIR CYLINDERS, FOR AVAILABILITY AT A LATER TIME THROUGH THE METERED RELEASE OF THE COMPRESSED AIR THROUGH AN AIR MOTOR THAT GENERATES ELECTRIC CURRENT WHEN ENGAGED; BULK ENERGY STORAGE DEVICE, NAMELY, A HYBRID ENERGY STORAGE SYSTEM, NAMELY, A BATTERY FOR STORING NON-PEAK OR OTHERWISE SPILLED ELECTRIC POWER AND WASTE HEAT; SOLAR BATTERIES; SOLAR CELLS; SOLAR WAFERS; SOLAR PANELS FOR PRODUCTION OF ELECTRICITY (U.S. CLS. 21, 23, 26, 36 AND 38).

ALICIA COLLINS, EXAMINING ATTORNEY

**CLASS 41—EDUCATION AND ENTERTAINMENT**

FOR EDUCATIONAL SERVICES, NAMELY, TRAINING PROGRAMS, SEMINARS, AND LECTURES DELIVERED LIVE AND THROUGH A WEBSITE VIA THE INTERNET, EDUCATIONAL BLOGS AND NON-DOWNLOADABLE WEBINARS DELIVERED THROUGH A WEBSITE VIA THE INTERNET, ALL OF THE FOREGOING IN THE FIELD OF INSURANCE, NAMELY, INSURANCE PLANNING AND RISK MANAGEMENT WITH A PRIMARY FOCUS ON THE PROTECTION OF WEALTH AND ASSETS AND/OR THE PREVENTION OR LIMITATION OF LIABILITIES AND LOSSES FOR INDIVIDUALS, AND PROCESSES, STRATEGIES, METHODOLOGIES AND/OR INFORMATION RELATING THERETO (U.S. CLS. 100, 101 AND 107).

ALICIA COLLINS, EXAMINING ATTORNEY

SN 86-049,292. UPTOWN EVENTS LLC, CHICAGO, IL. FILED 8-27-2013.

**Electric Theatre Co.**

THE MARK CONSISTS OF STANDARD CHARACTERS WITHOUT CLAIM TO ANY PARTICULAR FONT, STYLE, SIZE, OR COLOR.

NO CLAIM IS MADE TO THE EXCLUSIVE RIGHT TO USE "THEATRE CO.", APART FROM THE MARK AS SHOWN.

**CLASS 35—ADVERTISING AND BUSINESS**

FOR PROMOTING THE LIVE MUSIC CONCERTS OF OTHERS (U.S. CLS. 100, 101 AND 102).

**CLASS 41—EDUCATION AND ENTERTAINMENT**

FOR ENTERTAINMENT SERVICES, NAMELY, LIVE MUSIC PRODUCTION SERVICES; PRODUCTION OF LIVE MUSIC VIDEO RECORDINGS (U.S. CLS. 100, 101 AND 107).

**CLASS 43—HOTEL AND RESTAURANT SERVICES**

FOR ARENA SERVICES, NAMELY, PROVIDING GENERAL PURPOSE FACILITIES FOR USE AS VENUES FOR LIVE MUSIC CONCERTS (U.S. CLS. 100 AND 101).

ALICIA COLLINS, EXAMINING ATTORNEY

SN 86-049,311. GRAND MATE CO., LTD., TAICHUNG, TAIWAN, FILED 8-27-2013.



PRIORITY CLAIMED UNDER SEC. 44(D) ON TAIWAN APPLICATION NO. 102041881, FILED 7-31-2013, REG. NO. 01625901, DATED 2-1-2014, EXPIRES 1-31-2024.

SN 86-049,287. WEALTH EXPOSED PLANNING GROUP, INC., FLORAL PARK, NY. FILED 8-27-2013.

**WEALTH EXPOSED**

THE MARK CONSISTS OF STANDARD CHARACTERS WITHOUT CLAIM TO ANY PARTICULAR FONT, STYLE, SIZE, OR COLOR.

NO CLAIM IS MADE TO THE EXCLUSIVE RIGHT TO USE "WEALTH", APART FROM THE MARK AS SHOWN.

**CLASS 16—PAPER GOODS AND PRINTED MATTER**

FOR BOOKS AND INSTRUCTIONAL MATERIALS IN THE FIELD OF PERSONAL RISK MANAGEMENT AND INSURANCE PLANNING, AND PROCESSES, STRATEGIES, METHODOLOGIES AND INFORMATION RELATING THERETO (U.S. CLS. 2, 5, 22, 23, 29, 37, 38 AND 50).

**CLASS 36—INSURANCE AND FINANCIAL**

FOR INSURANCE CONSULTING, INSURANCE PLANNING, AND FINANCIAL RISK MANAGEMENT SERVICES IN THE FIELDS OF PROTECTION OF WEALTH AND ASSETS AND THE PREVENTION OR LIMITATION OF FINANCIAL LIABILITIES AND LOSSES FOR INDIVIDUALS COMPRISED OF PROCESSES, STRATEGIES, METHODOLOGIES AND INFORMATION RELATED THERETO; INSURANCE BROKERAGE SERVICES; PROVIDING A WEBSITE FEATURING INFORMATION RELATING TO INSURANCE PLANNING AND FINANCIAL RISK MANAGEMENT, NAMELY, INFORMATION CONCERNING THE PROTECTION OF WEALTH AND ASSETS AND/OR THE PREVENTION OR LIMITATION OF FINANCIAL LIABILITIES AND LOSSES FOR INDIVIDUALS, AND PROCESSES, STRATEGIES, AND METHODOLOGIES RELATED THERETO (U.S. CLS. 100, 101 AND 102).

PRIORITY CLAIMED UNDER SEC. 44(D) ON TAIWAN APPLICATION NO. 102041877, FILED 7-31-2013, REG. NO. 01621584, DATED 1-16-2014, EXPIRES 1-15-2024.

PRIORITY CLAIMED UNDER SEC. 44(D) ON TAIWAN APPLICATION NO. 102041876, FILED 7-31-2013, REG. NO. 01621490, DATED 1-16-2014, EXPIRES 1-15-2024.

NO CLAIM IS MADE TO THE EXCLUSIVE RIGHT TO USE "HOME", APART FROM THE MARK AS SHOWN.

THE MARK CONSISTS OF AN OUTLINE OF A HOUSE WITH THE WORD "REVO" APPEARING INSIDE THE HOUSE AND THE LETTER "R" CONSISTS OF A STAR. ALSO, THE WORD "HOME" IS LOCATED ON THE RIGHT OF THE HOUSE DESIGN.

### CLASS 9—ELECTRICAL AND SCIENTIFIC APPARATUS

FOR GAS FLOW CONTROL VALVE AND GAS AUTOMATIC BLOW VALVE; GAS ALARM; GAS SENSOR FOR MEASURING GAS CONCENTRATION; GAS DETECTORS FOR DETECTING THE PRESSURE OF GAS; CARBON MONOXIDE DETECTORS; THERMOSTAT; PROGRAMMABLE LOGIC CONTROLLER; POWER INPUT MODULE, NAMELY, VOLTAGE MONITOR MODULE; ELECTRIC AND LIGHT CONTROL PANEL; BOILER CONTROL INSTRUMENTS; SIGNAL REMOTE CONTROL ELECTRIC EQUIPMENT AND REMOTE CONTROL EQUIPMENT, NAMELY, REMOTE CONTROLS FOR GAS STOVES AND FIREPLACES; MANOMETER, PIEZOMETER, BAROMETER; OXYGEN CONCENTRATION METER; ELECTRIC, ELECTRONIC AND ELECTROCHEMICAL OXYGEN DETECTORS; GAS POWER SWITCH; WATER HEATER DEVICE, NAMELY, WATER HEATER CONTROL (U.S. CLS. 21, 23, 26, 36 AND 38).

### CLASS 11—ENVIRONMENTAL CONTROL APPARATUS

FOR HOT WATER EQUIPMENT, NAMELY, HOT WATER HEATERS; GEYSER FOR BATHROOM, NAMELY, SHOWERS AND SHOWER SURROUNDS; WATER HEATER DEVICE, NAMELY, WATER HEATER; GAS FIRE REGULATOR FOR WATER HEATER; GAS FIRE REGULATOR FOR GAS STOVE; PRESSURE REGULATOR FOR GAS INSTALLATION; GAS PRESSURE REGULATING VALVE; AIR VALVE, NAMELY, VALVES FOR AIR CONDITIONER; FEED WATER REGULATOR, NAMELY, FEED WATER HEATER; GAS PIPELINE REGULATOR; GAS PIPELINE REGULATOR ACCESSORIES (U.S. CLS. 13, 21, 23, 31 AND 34).

### CLASS 37—CONSTRUCTION AND REPAIR

FOR HOUSEHOLD APPLIANCE INSTALLING AND REPAIRING (U.S. CLS. 100, 103 AND 106).

SAMUEL E. SHARPER JR., EXAMINING ATTORNEY

SN 86-049,926. KENNETH COLE PRODUCTIONS (LIC), LLC, NEW YORK, NY. FILED 8-28-2013.

## AWEARNNESS

THE MARK CONSISTS OF STANDARD CHARACTERS WITHOUT CLAIM TO ANY PARTICULAR FONT, STYLE, SIZE, OR COLOR.

OWNER OF U.S. REG. NOS. 3,427,910 AND 4,384,110. SEC. 2(F).

THE 2(F) CLAIM IS RESTRICTED TO CLASS(ES) 035

### CLASS 35—ADVERTISING AND BUSINESS

FOR PUBLIC ADVOCACY TO PROMOTE INTEREST IN HIV/AIDS AND OTHER HEALTH ISSUES, DISASTER RELIEF, CIVIL LIBERTIES, HUMAN RIGHTS, FREEDOM OF EXPRESSION, ENVIRONMENTAL ISSUES, EDUCATION, VOLUNTEERISM, SOCIAL CHANGE AND OTHER CHARITABLE AND PUBLIC ADVOCACY PURPOSES; PROVIDING A WEBSITE FEATURING INFORMATION IN THE FIELD OF POLITICAL ISSUES, NAMELY, CIVIL LIBERTIES, HUMAN RIGHTS AND FREEDOM OF EXPRESSION AND IN THE FIELD OF PROMOTING PUBLIC AWARENESS OF VOLUNTEERISM AND SOCIAL CHANGE (U.S. CLS. 100, 101 AND 102).

FIRST USE 5-31-2007; IN COMMERCE 8-31-2007.

### CLASS 36—INSURANCE AND FINANCIAL

FOR CHARITABLE FUNDRAISING SERVICES; PROVIDING A WEBSITE FEATURING INFORMATION IN THE FIELD OF DISASTER RELIEF, NAMELY, CHARITABLE FUNDRAISING FOR DISASTER RELIEF (U.S. CLS. 100, 101 AND 102).

FIRST USE 9-30-2007; IN COMMERCE 9-30-2007.

### CLASS 41—EDUCATION AND ENTERTAINMENT

FOR PROVIDING A WEBSITE FEATURING NON-DOWNLOADABLE PUBLICATIONS, NAMELY, ARTICLES IN THE FIELDS OF HIV/AIDS AND OTHER HEALTH ISSUES, DISASTER RELIEF, CIVIL LIBERTIES, HUMAN RIGHTS, FREEDOM OF EXPRESSION, ENVIRONMENTAL ISSUES, EDUCATION, VOLUNTEERISM, SOCIAL CHANGE AND CHARITABLE SERVICES AND PUBLIC ADVOCACY; PROVIDING A WEBSITE FEATURING INFORMATION IN THE FIELD OF EDUCATION (U.S. CLS. 100, 101 AND 107).

FIRST USE 12-31-2010; IN COMMERCE 12-31-2010.

BRITTANY ESTELL, EXAMINING ATTORNEY

SN 86-050,174. CALIFORNIA STATE UNIVERSITY, FRESNO, FRESNO, CA. FILED 8-28-2013.

## FRESNO STATE

THE MARK CONSISTS OF STANDARD CHARACTERS WITHOUT CLAIM TO ANY PARTICULAR FONT, STYLE, SIZE, OR COLOR.

SEC. 2(F).

### CLASS 16—PAPER GOODS AND PRINTED MATTER

FOR PENS, NOTE PADS, BUSINESS CARDS, LETTER-HEAD PAPER (U.S. CLS. 2, 5, 22, 23, 29, 37, 38 AND 50).

FIRST USE 0-0-1911; IN COMMERCE 0-0-1911.

### CLASS 21—HOUSEWARES AND GLASS

FOR DRINKING GLASSES, MUGS (U.S. CLS. 2, 13, 23, 29, 30, 33, 40 AND 50).

FIRST USE 0-0-1911; IN COMMERCE 0-0-1911.

### CLASS 25—CLOTHING

FOR T-SHIRTS, SWEATSHIRTS, CAPS, JERSEYS, SWEATPANTS, POLO SHIRTS, SOCKS, SHORTS, BOXER SHORTS, INFANT ONE PIECE OUTFITS (U.S. CLS. 22 AND 39).

FIRST USE 0-0-1911; IN COMMERCE 0-0-1911.

**CLASS 28—TOYS AND SPORTING GOODS**

FOR TABLE TENNIS TABLES; OUTDOOR ACTIVITY GAME EQUIPMENT IN THE NATURE OF WASHER TOSS; HEAD COVERS FOR GOLF CLUBS; GOLF BALL MARKERS (U.S. CLS. 22, 23, 38 AND 50).

FIRST USE 0-0-1911; IN COMMERCE 0-0-1911.

**CLASS 41—EDUCATION AND ENTERTAINMENT**

FOR EDUCATIONAL SERVICES, NAMELY, PROVIDING COURSES OF INSTRUCTION AT THE UNIVERSITY LEVEL; ENTERTAINMENT SERVICES, NAMELY, ARRANGING AND CONDUCTING ATHLETIC COMPETITIONS, ATHLETIC EVENTS, ATHLETIC TOURNAMENTS, AND ATHLETIC EXHIBITIONS (U.S. CLS. 100, 101 AND 107).

FIRST USE 0-0-1911; IN COMMERCE 0-0-1911.  
JENNIFER DIXON, EXAMINING ATTORNEY

SN 86-050,178. CALIFORNIA STATE UNIVERSITY, FRESNO, FRESNO, CA. FILED 8-28-2013.

**FRESNO STATE BULLDOGS**

THE MARK CONSISTS OF STANDARD CHARACTERS WITHOUT CLAIM TO ANY PARTICULAR FONT, STYLE, SIZE, OR COLOR.

OWNER OF U.S. REG. NO. 2,675,862.  
SEC. 2(F) AS TO "FRESNO STATE".

**CLASS 25—CLOTHING**

FOR T-SHIRTS, SWEATSHIRTS, CAPS, SWEATPANTS, INFANT ONE PIECE OUTFITS (U.S. CLS. 22 AND 39).

FIRST USE 0-0-1921; IN COMMERCE 0-0-1921.

**CLASS 41—EDUCATION AND ENTERTAINMENT**

FOR EDUCATIONAL SERVICES, NAMELY, PROVIDING COURSES OF INSTRUCTION AT THE UNIVERSITY LEVEL; ENTERTAINMENT SERVICES, NAMELY, ARRANGING AND CONDUCTING ATHLETIC COMPETITIONS, ATHLETIC EVENTS, ATHLETIC TOURNAMENTS, AND ATHLETIC EXHIBITIONS (U.S. CLS. 100, 101 AND 107).

FIRST USE 0-0-1921; IN COMMERCE 0-0-1921.  
JENNIFER DIXON, EXAMINING ATTORNEY

SN 86-051,463. CONCH CO. INC., EGG HARBOR, WI. FILED 8-29-2013.

**Fat Louie's**

THE MARK CONSISTS OF STANDARD CHARACTERS WITHOUT CLAIM TO ANY PARTICULAR FONT, STYLE, SIZE, OR COLOR.

THE NAME "FAT LOUIE" DOES NOT IDENTIFY A LIVING INDIVIDUAL.

**CLASS 29—MEATS AND PROCESSED FOODS**

FOR FRUIT-BASED SPREADS, NAMELY, JAMS, JELLIES, MARMALADES, AND PRESERVES; PICKLED FOODS, NAMELY, PICKLED VEGETABLES AND EGGS; SNACK FOOD DIPS (U.S. CL. 46).

FIRST USE 3-1-2010; IN COMMERCE 7-1-2010.

**CLASS 30—STAPLE FOODS**

FOR DRESSINGS FOR FOOD; GLAZES FOR FOOD; MARINADES; MUSTARDS; SAUCES, NAMELY, BARBECUE SAUCE, GRILLING SAUCE, HOT SAUCE, PASTA SAUCE, SPAGHETTI SAUCE, STEAK SAUCE, AND WING SAUCE (U.S. CL. 46).

FIRST USE 3-1-2010; IN COMMERCE 7-1-2010.

**CLASS 35—ADVERTISING AND BUSINESS**

FOR RETAIL STORES FEATURING CONDIMENTS, FOODS, FOOD INGREDIENTS, AND GIFT ITEMS; ONLINE RETAIL STORES FEATURING FOODS, FOOD INGREDIENTS, AND GIFT ITEMS (U.S. CLS. 100, 101 AND 102).

FIRST USE 3-1-2010; IN COMMERCE 7-1-2010.  
HEATHER BIDDULPH, EXAMINING ATTORNEY

SN 86-051,531. ASPIRE ZONE FOUNDATION, DOHAR, QATAR, FILED 8-29-2013.



PRIORITY CLAIMED UNDER SEC. 44(D) ON QATAR APPLICATION NO. 81126, FILED 4-18-2013, REG. NO. 81126, DATED 4-18-2013, EXPIRES 4-18-2023.

PRIORITY CLAIMED UNDER SEC. 44(D) ON QATAR APPLICATION NO. 81125, FILED 4-18-2013, REG. NO. 81125, DATED 4-18-2013, EXPIRES 4-18-2023.

THE COLOR(S) BLUE IS/ARE CLAIMED AS A FEATURE OF THE MARK.

THE MARK CONSISTS OF WORDING AND DESIGNS, ALL IN BLUE. THE WORDING "ASPETAR" APPEARS TO THE LEFT OF A DESIGN OF A FEATHER. TO THE RIGHT OF THE FEATHER, THE ARABIC CHARACTERS TRANSLITERATED AS "ASPETAR" APPEAR. A CURVED LINE APPEARS BELOW THE WORDING, INTERRUPTED BY THE BOTTOM OF THE FEATHER DESIGN.

THE WORD "ASPETAR" HAS NO MEANING IN A FOREIGN LANGUAGE.

THE NON-LATIN CHARACTERS IN THE MARK TRANSLITERATE TO "ASPETAR" AND THIS HAS NO MEANING IN A FOREIGN LANGUAGE.

**CLASS 16—PAPER GOODS AND PRINTED MATTER**

FOR NEWSPAPERS IN THE FIELD OF SPORTS AND SPORTS-RELATED SUBJECTS; PRINTED PERIODICALS IN THE FIELD OF SPORTS AND SPORTS-RELATED SUBJECTS; BOOKS IN THE FIELD OF SPORTS AND SPORTS-RELATED SUBJECTS; BROCHURES IN THE FIELD OF SPORTS AND SPORTS-RELATED SUBJECTS; WRITING INSTRUMENTS; STATIONERY; ARTICLES OF PAPER OR CARDBOARD, NAMELY, BOXES, BAGS, ENVELOPES, AND POUCHES FOR PACKAGING; WRAPPING PAPER; POUCHES FOR WRITING INSTRUMENTS; CASES FOR WRITING INSTRUMENTS; DESK SETS; BLANK WRITING BOOKS; CALENDARS; NOTE BOOKS; INDEX BOOKS; FILE FOLDERS; ANNOUNCEMENT CARDS; WRITING PAPER; ENVELOPES; INDEX CARDS; BUSINESS CARDS; WRITING PADS; PAPERWEIGHTS; DIARIES; COVERS FOR DIARIES; REPLACEMENT PAPER FOR DIARIES; DOCUMENT HOLDERS; PHOTO ALBUMS; BOOKENDS (U.S. CLS. 2, 5, 22, 23, 29, 37, 38 AND 50).

**CLASS 42—SCIENTIFIC AND COMPUTER SERVICES**

FOR RESEARCH IN THE FIELD OF SPORTS MEDICINE; RESEARCH AND DEVELOPMENT IN THE FIELD OF SPORTS MEDICINE; COMPUTER PROGRAMMING; COMPUTER SOFTWARE DESIGN; COMPUTER SYSTEM DESIGN; ALL IN THE FIELD OF SPORTS AND SPORTS-RELATED FIELDS (U.S. CLS. 100 AND 101).

**CLASS 44—MEDICAL, BEAUTY AND AGRICULTURAL SERVICES**

FOR MEDICAL SERVICES; HEALTH CARE SERVICES, NAMELY, TREATING AND PREVENTING SPORTS INJURIES; HOSPITAL SERVICES, MEDICAL CLINICS; PROVIDING HEALTH CARE AND MEDICAL SERVICES IN THE FIELD OF SPORTS (U.S. CLS. 100 AND 101).

CORY BOONE, EXAMINING ATTORNEY

**CLASS 16—PAPER GOODS AND PRINTED MATTER**

FOR BOOKBINDING MATERIAL; PHOTOGRAPHS; STATIONERY; ADHESIVES FOR STATIONERY OR HOUSEHOLD PURPOSES; PAINT BRUSHES; TYPEWRITERS; PRINTERS' TYPE; PRINTING BLOCKS; ART PRINTS AND OTHER PAPER BASED ART WORKS; ADHESIVE BANDS FOR STATIONERY OR HOUSEHOLD PURPOSES; PRICE TAGS; ADHESIVE TAPES FOR STATIONERY OR HOUSEHOLD PURPOSES; COMIC BOOKS; GRAPHIC PRINTS; GRAPHIC REPRESENTATIONS; LABELS, NOT OF TEXTILE, NAMELY, PAPER LABELS; LITHOGRAPHIC WORKS OF ART; LITHOGRAPHS; MAGAZINES IN THE FIELD OF ART, CLOTHING AND FASHION; PATTERNS FOR DRESSMAKING; PATTERNS FOR MAKING CLOTHES; PICTURES; POSTCARDS; POSTERS; GRAPHIC REPRODUCTIONS; SELF-ADHESIVE TAPES FOR STATIONERY OR HOUSEHOLD PURPOSES; STICKERS; TRACING PATTERNS (U.S. CLS. 2, 5, 22, 23, 29, 37, 38 AND 50).

**CLASS 25—CLOTHING**

FOR CLOTHING, FOOTWEAR, AND HEADGEAR, NAMELY, APRONS; BANDANAS; BATH SLIPPERS; BEACH CLOTHES; BEACH SHOES; BELTS; BERETS; BODICES; BOOT UPPERS; BOOTS; CAPS; COATS; CORSETS; CUFFS; WRISTBANDS; DRESSES; EAR MUFFS; HAT FRAMES; DRESSING GOWNS; HALF-BOOTS; HATS; HEADBANDS; HOODS; STUFF JACKETS; JACKETS; JERSEYS; JUMPER DRESSES; PINAFORE DRESSES; KNITWEAR, NAMELY, KNIT BOTTOMS, KNIT TOPS, KNIT DRESSES; LACE BOOTS; LEGGINGS; LEG WARMERS; LEGGINGS (TROUSERS); MITTENS; MOTORISTS' CLOTHING, NAMELY, LEATHER PANTS, LEATHER JACKETS; MUFFS; NECKTIES; OUTERCLOTHING, NAMELY, JACKETS, VESTS, COATS; OVERALLS; SMOCKS; OVERCOATS; TOP COATS; PANTS; DRAWERS; PARKAS; CAP PEAKS; POCKET SQUARES; POCKETS FOR CLOTHING; PONCHOS; PULLOVERS; JUMPERS; PAJAMAS; SARIS; SARONGS; SASHES FOR WEAR; SCARVES; SCARFS; SHAWLS; DRESS SHIELDS; SHIRT FRONTS; SHIRTS; SHOES; SHORT-SLEEVE SHIRTS; SINGLET; SPORTS JERSEYS; SKIRTS; SKORTS; SKULL CAPS; SLIPPERS; SLIPS; SOCKS; SUITS; BATHING SUITS; SWIMSUITS; SWEATERS; TEDDIES; TEE-SHIRTS; TROUSERS; UNDERPANTS; UNDERWEAR; UNIFORMS; VISORS; WAISTCOATS; VESTS; WATERPROOF CLOTHING, NAMELY, RAINCOATS; SHIRT YOKES (U.S. CLS. 22 AND 39).

**CLASS 35—ADVERTISING AND BUSINESS**

FOR ONLINE RETAIL STORE SERVICES FEATURING PAPER, CARDBOARD AND GOODS MADE FROM THESE MATERIALS, PRINTED MATTER, BOOKBINDING MATERIAL, PHOTOGRAPHS, STATIONERY, ADHESIVES FOR STATIONERY OR HOUSEHOLD PURPOSES, ARTISTS' MATERIALS, PAINT BRUSHES, TYPEWRITERS AND OFFICE REQUISITES (EXCEPT FURNITURE), INSTRUCTIONAL AND TEACHING MATERIAL (EXCEPT APPARATUS), PLASTIC MATERIALS FOR PACKAGING, PRINTERS' TYPE, PRINTING BLOCKS, ART PRINTS AND OTHER PAPER BASED ART WORKS, ADHESIVE BANDS, PRICE TAGS, ADHESIVE TAPES, COMIC BOOKS, GRAPHIC PRINTS, GRAPHIC REPRESENTATIONS, LABELS, NOT OF TEXTILE, LITHOGRAPHIC WORKS OF ART, LITHOGRAPHS, MAGAZINES, PATTERNS FOR DRESSMAKING, PATTERNS FOR MAKING CLOTHES, PICTURES, POSTCARDS, POSTERS, GRAPHIC REPRODUCTIONS, SELF-ADHESIVE TAPES FOR STATIONERY OR HOUSEHOLD PURPOSES, STICKERS, TRACING PATTERNS, LEATHER AND IMITATIONS OF LEATHER, AND GOODS MADE OF THESE MATERIALS, ANIMAL SKINS, HIDES, TRUNKS AND TRAVELLING BAGS, UMBRELLAS AND PARASOLS, WALKING STICKS, WHIPS, HARNESS AND SADDLERY, BAGS, BEACH BAGS, BAGS FOR SPORTS, HANDBAGS, PURSES, SHOPPING BAGS, SCHOOL BAGS, POCKET WALLETS, CLOTHING, FOOTWEAR, HEADGEAR, APRONS, BANDANAS, BATH SLIPPERS, BEACH CLOTHES, BEACH SHOES, BELTS, BERETS, BODICES, BOOT UPPERS, BOOTS, CAPS, COATS, COMBINATIONS, CORSETS,

SN 86-052,527. 8DIX LTD., N12 ORG LONDON, UNITED KINGDOM, FILED 8-30-2013.

# 8DIX

THE MARK CONSISTS OF STANDARD CHARACTERS WITHOUT CLAIM TO ANY PARTICULAR FONT, STYLE, SIZE, OR COLOR.

OWNER OF ERPN CMNTY TM OFF REG. NO. 011618758, DATED 7-25-2013, EXPIRES 3-1-2023.

CUFFS, WRISTBANDS, DRESSES, EAR MUFFS, HAT FRAMES, DRESSING GOWNS, HALF-BOOTS, HATS, HEADBANDS, HOODS, STUFF JACKETS, JACKETS, JERSEYS, JUMPER DRESSES, PINAFORE DRESSES, KNITWEAR, LACE BOOTS, LEGGINGS, LEG WARMERS, LEGGINGS (TROUSERS), MITTENS, MOTORISTS' CLOTHING, MUFFS, NECKTIES, OUTERCLOTHING, OVERALLS, SMOCKS, OVERCOATS, TOP COATS, TOPCOATS, PANTS, DRAWERS, PARKAS, CAP PEAKS, POCKET SQUARES, POCKETS FOR CLOTHING, PONCHOS, PULLOVERS, JUMPERS, PAJAMAS, READY-MADE CLOTHING, SARIS, SARONGS, SASHES FOR WEAR, SCARVES, SCARFS, SHAWLS, DRESS SHIELDS, SHIRT FRONTS, SHIRTS, SHOES, SHORT-SLEEVE SHIRTS, SINGLET, SPORTS JERSEYS, SKIRTS, SKORTS, SKULL CAPS, SLIPPERS, SLIPS, SOCKS, SUITS, BATHING SUITS, SWIMSUITS, SWEATERS, TEDDIES, TEE-SHIRTS, TROUSERS, UNDERPANTS, UNDERWEAR, UNIFORMS, VISORS, WAISTCOATS, VESTS, WATERPROOF CLOTHING, SHIRT YOKES; COMMERCIAL ADMINISTRATION OF THE LICENSING OF THE GOODS AND SERVICES OF OTHERS; SHOP WINDOW DRESSING; DISSEMINATION OF ADVERTISING MATTER (U.S. CLS. 100, 101 AND 102).

KATINA MISTER, EXAMINING ATTORNEY

#### CLASS 43—HOTEL AND RESTAURANT SERVICES

FOR CAFES; CAFETERIAS; CANTEENS; RESTAURANT SERVICES; COFFEE SHOPS; TAKE-AWAY FOOD AND DRINK SERVICES; SNACK BARS; BISTRO SERVICES; CATERING SERVICES; RESTAURANT CHAINS; FOOD COOKING SERVICES; SELF-SERVICE RESTAURANTS; FOOD PREPARATION; CONSULTANCY SERVICES IN RELATION TO FOOD RECIPES, FOOD PREPARATION AND FOOD COOKING SERVICES; ADVISORY SERVICES RELATING TO CATERING; PROVIDING BANQUET AND SOCIAL FUNCTION FACILITIES FOR SPECIAL OCCASIONS (U.S. CLS. 100 AND 101).

EUGENIA MARTIN, EXAMINING ATTORNEY

SN 86-052,818. PACIFIC UNITED HOLDINGS PTE. LTD., SINGAPORE, SINGAPORE, FILED 8-30-2013.

SN 86-053,118. KODAK ALARIS INC., ROCHESTER, NY, FILED 8-30-2013.

# BAKERZIN

THE MARK CONSISTS OF STANDARD CHARACTERS WITHOUT CLAIM TO ANY PARTICULAR FONT, STYLE, SIZE, OR COLOR.

OWNER OF U.S. REG. NOS. 3,280,028 AND 3,283,163.

#### CLASS 30—STAPLE FOODS

FOR BREAD ROLLS; BREAD AND BAKERY PRODUCTS; FUDGE; TARTS; PIES; CHOCOLATE; CHOCOLATE-BASED FOODSTUFFS, NAMELY, CAKES; CAKES; COOKIES; BISCUITS; PASTRIES; CONFECTIONERIES, NAMELY, FLAN, MACARONS, MARZIPAN, PASTILLES; FLAVORED CUSTARD; ICE CREAM AND FROZEN CONFECTIONS; SNACKS AND FOODS COMPRISING OR CONTAINING FLOUR, WHEAT FLOUR OR WHEAT MEAL, NAMELY, CORN CHIPS AND FLOUR BASED CHIPS; PUFFS PASTRY; SANDWICHES; CHOCOLATE FOOD BEVERAGES NOT BEING DAIRY-BASED OR VEGETABLE BASED; COCOA-BASED BEVERAGES; FOOD FLAVORINGS FOR BEVERAGES AND CAKES; EDIBLE DECORATIONS FOR CAKES; CARAMELS; COCOA PRODUCTS, NAMELY, COCOA MIXES AND COCOA SPREADS; COFFEE; COFFEE FLAVORED SYRUP USED IN MAKING FOOD BEVERAGES; VEGETABLE PREPARATIONS FOR USE AS COFFEE SUBSTITUTES; COFFEE-BASED BEVERAGE CONTAINING MILK; FROZEN YOGHURT, CONFECTIONARY ICES; CONFECTIONERY, NAMELY, FRUIT JELLIES; HONEY; EDIBLE ICES; PANARY LEAVEN YEAST; LICORICE; CAKES, NAMELY, PETIT FOURS; PIZZAS; PRALINES; TEA; WAFFLES; BEVERAGES MADE OF TEA; PREPARED WHEAT-BASED SNACK FOODS; PREPARED MEALS CONSISTING PRIMARILY OF PASTA OR RICE; PUDDINGS; FLAVORED CUSTARD-BASED FILLINGS FOR CAKES AND PIES (U.S. CL. 46).

# ALARIS

THE MARK CONSISTS OF STANDARD CHARACTERS WITHOUT CLAIM TO ANY PARTICULAR FONT, STYLE, SIZE, OR COLOR.

#### CLASS 1—CHEMICALS

FOR UNEXPOSED PHOTOGRAPHIC FILMS; UNEXPOSED CAMERA FILM; SILVER HALIDE; PHOTOGRAPHIC CHEMICALS, NAMELY, EMULSIONS, COATINGS AND SUBSTRATES USED FOR MANUFACTURING AND DEVELOPING SILVER HALIDE AND THERMAL PAPERS; CHEMICALLY-SENSITIZED PHOTOGRAPHIC PAPER; PHOTOGRAPHIC DRY PLATES (U.S. CLS. 1, 5, 6, 10, 26 AND 46).

#### CLASS 2—PAINTS

FOR FILLED INK CARTRIDGES FOR PRINTERS; INK JET PRINTER INK; FILLED TONER CARTRIDGES; PRINTING TONER (U.S. CLS. 6, 11 AND 16).

**CLASS 9—ELECTRICAL AND SCIENTIFIC APPARATUS**

FOR PHOTO PRINTERS; IMAGE TRANSFER KITS FOR COMPUTER PRINTERS, NAMELY, KITS FORMING PARTS OF PRINTERS COMPRISING BELTS, TONER AND DRUMS FOR THE PURPOSE OF TRANSFERRING IMAGES ONTO PAPER; DIGITAL IMAGING DEVICES, NAMELY, DIGITAL PHOTO IMAGE CONVERTERS; BLANK DIGITAL STORAGE MEDIA; PRE-RECORDED CDS, VIDEO TAPES, LASER DISKS AND DVDS FEATURING PHOTOS, ARCHIVE PHOTOS, AND MOVIES; SCANNERS; SCANNING SYSTEMS COMPRISING SCANNERS AND SCANNER OPERATING SOFTWARE; DIGITAL FILM SCANNERS; TOUCH SCREENS; CAMERAS; DISPOSABLE CAMERAS; VIDEO CAMERAS; BAGS FOR CAMERAS AND PHOTOGRAPHIC EQUIPMENT; CAMERA CASES; CAMERA MOUNTS AND SUPPORTS; CAMERA STRAPS; INTERACTIVE PHOTO KIOSKS FOR CAPTURING, PRINTING AND UPLOADING DIGITAL IMAGES FOR FUTURE USE; INTERACTIVE COMPUTER KIOSKS COMPRISING COMPUTERS, COMPUTER HARDWARE, COMPUTER PERIPHERALS, AND COMPUTER OPERATING SOFTWARE, FOR USE IN EDITING PHOTOGRAPHS, PRINTING PHOTOGRAPHS, SIZING AND ARRANGING PHOTOGRAPHS, MAKING PHOTO BOOKS, GREETING CARDS, CALENDARS, POSTERS, PHOTOGRAPH ENLARGEMENTS, PICTURE MOVIE DVDS AND ARCHIVE PHOTOGRAPH DVDS; COMPUTER SOFTWARE FOR MANAGING LABORATORY PRODUCTION AND WORKFLOW; COMPUTER SOFTWARE FOR CREATING, PRINTING AND SHARING PHOTOGRAPH COLLAGES, CARDS, CALENDARS, AND BOOKS ON A PERSONAL COMPUTER; DOWNLOADABLE MOBILE APPLICATIONS FOR USE WITH MOBILE PHONES AND TABLETS, NAMELY, SOFTWARE FOR FORMATTING AND PRINTING PHOTOGRAPHS AND DOCUMENTS, PUBLISHING, AND DOCUMENT MANAGEMENT; COMPUTER OPERATING SOFTWARE; COMPUTER SOFTWARE FOR USE IN INFORMATION MANAGEMENT, NAMELY, PRODUCTION WORKFLOW SOLUTIONS, BRAND AND MARKETING WORKFLOW, COLOR MANAGEMENT AND SCREENING, AND PROOFING SOLUTIONS; COMPUTER PROGRAMS FOR DOCUMENT MANAGEMENT; DRY MINILABS COMPRISED OF A PHOTO PRINTER AND AN INTEGRATED COMPUTER FOR PROCESSING OF PHOTOGRAPHS (U.S. CLS. 21, 23, 26, 36 AND 38).

**CLASS 16—PAPER GOODS AND PRINTED MATTER**

FOR REEL PAPER FOR PRINTERS; DIGITAL PRINTING PAPER; PHOTO MEMORY PRODUCTS, NAMELY, PRINTS, PHOTO BOOKS, GREETING CARDS, CALENDARS, POSTERS (U.S. CLS. 2, 5, 22, 23, 29, 37, 38 AND 50).

**CLASS 20—FURNITURE AND ARTICLES NOT OTHERWISE CLASSIFIED**

FOR KIOSKS FOR VENDING PURPOSES COMPRISED OF DISPLAY STANDS (U.S. CLS. 2, 13, 22, 25, 32 AND 50).

**CLASS 35—ADVERTISING AND BUSINESS**

FOR ADVERTISING, MARKETING AND PROMOTING THE GOODS AND SERVICES OF OTHERS USING KIOSKS; RECORDS MANAGEMENT SERVICES, NAMELY, DOCUMENT INDEXING FOR OTHERS; BRANDING SERVICES, NAMELY, CONSULTING, DEVELOPMENT, MANAGEMENT AND MARKETING OF BRANDS FOR BUSINESSES AND/OR INDIVIDUALS; PROMOTING, ADVERTISING AND MARKETING OF BRANDS, PRODUCTS, SERVICES AND ONLINE WEBSITES OF INDIVIDUALS, BUSINESSES AND NONPROFIT ORGANIZATIONS (U.S. CLS. 100, 101 AND 102).

**CLASS 37—CONSTRUCTION AND REPAIR**

FOR INSTALLATION AND REPAIR OF BUSINESS AND OFFICE MACHINERY AND EQUIPMENT; TECHNICAL SUPPORT SERVICES, NAMELY, TROUBLESHOOTING IN THE NATURE OF THE REPAIR OF COMPUTER HARDWARE AND BUSINESS AND OFFICE MACHINERY AND EQUIPMENT (U.S. CLS. 100, 103 AND 106).

**CLASS 40—MATERIAL TREATMENT**

FOR PHOTOGRAPHIC FILM DEVELOPING; FILM PROCESSING AND PHOTOFINISHING; PRINTING OF PHOTOGRAPHIC IMAGES FROM DIGITAL MEDIA; FLEXOGRAPHIC AND LETTERPRESS PRINTING; OFFSET PRINTING; DIGITAL PRINTING; DIGITAL PHOTO PRINTING SERVICES (U.S. CLS. 100, 103 AND 106).

**CLASS 41—EDUCATION AND ENTERTAINMENT**

FOR PHOTOGRAPHY SERVICES; PORTRAIT PHOTOGRAPHY; CONSULTING SERVICES IN THE FIELD OF PHOTOGRAPHY; PHOTOGRAPHY DIGITAL IMAGING SERVICES; PROVIDING FACILITIES FOR PRODUCING VIDEO, CINEMA AND PHOTOGRAPHY PRODUCTIONS; FILM PRODUCTION; MOTION PICTURE FILM PRODUCTION; MEDIA PRODUCTION SERVICES, NAMELY, VIDEO AND FILM PRODUCTION; MULTIMEDIA ENTERTAINMENT SERVICES IN THE NATURE OF DEVELOPMENT, PRODUCTION AND POST-PRODUCTION SERVICES IN THE FIELDS OF VIDEO AND FILMS; BUSINESS TRAINING CONSULTANCY SERVICES; BUSINESS TRAINING IN THE FIELD OF INFORMATION MANAGEMENT; COMPUTER EDUCATION TRAINING; TRAINING IN THE FIELD OF PHOTOGRAPHY OPERATIONS (U.S. CLS. 100, 101 AND 107).

**CLASS 42—SCIENTIFIC AND COMPUTER SERVICES**

FOR TECHNICAL ADVICE RELATING TO OPERATION OF COMPUTERS; TECHNICAL SUPPORT SERVICES, NAMELY, TROUBLESHOOTING IN THE NATURE OF DIAGNOSING COMPUTER HARDWARE AND SOFTWARE PROBLEMS; TECHNICAL CONSULTING SERVICES IN THE FIELDS OF DATACENTER ARCHITECTURE, PUBLIC AND PRIVATE CLOUD COMPUTING SOLUTIONS, AND EVALUATION AND IMPLEMENTATION OF INTERNET TECHNOLOGY AND SERVICES; DESIGN AND IMPLEMENTATION OF SOFTWARE AND TECHNOLOGY SOLUTIONS FOR THE PURPOSE OF PRODUCT AND DOCUMENT AUTHENTICATION AND TRACKING, AND BRAND MONITORING AND PROTECTION, TO PROTECT AGAINST COUNTERFEITING, TAMPERING, AND DIVERSION, AND TO ENSURE THE INTEGRITY OF GENUINE PRODUCTS AND DOCUMENTS (U.S. CLS. 100 AND 101).

KRISTIN DAHLING, EXAMINING ATTORNEY

SN 86-053,125, KODAK ALARIS INC., ROCHESTER, NY.  
FILED 8-30-2013.

**ALARIS TECHNOLOGIES**

THE MARK CONSISTS OF STANDARD CHARACTERS WITHOUT CLAIM TO ANY PARTICULAR FONT, STYLE, SIZE, OR COLOR.

NO CLAIM IS MADE TO THE EXCLUSIVE RIGHT TO USE "TECHNOLOGIES", APART FROM THE MARK AS SHOWN.



**CLASS 1—CHEMICALS**

FOR UNEXPOSED PHOTOGRAPHIC FILMS; UNEXPOSED CAMERA FILM; SILVER HALIDE; PHOTOGRAPHIC CHEMICALS, NAMELY, EMULSIONS, COATINGS AND SUBSTRATES USED FOR MANUFACTURING AND DEVELOPING SILVER HALIDE AND THERMAL PAPERS; CHEMICALLY-SENSITIZED PHOTOGRAPHIC PAPER; PHOTOGRAPHIC DRY PLATES (U.S. CLS. 1, 5, 6, 10, 26 AND 46).

**CLASS 2—PAINTS**

FOR FILLED INK CARTRIDGES FOR PRINTERS; INK JET PRINTER INK; FILLED TONER CARTRIDGES; PRINTING TONER (U.S. CLS. 6, 11 AND 16).

**CLASS 9—ELECTRICAL AND SCIENTIFIC APPARATUS**

FOR PHOTO PRINTERS; IMAGE TRANSFER KITS FOR COMPUTER PRINTERS, NAMELY, KITS FORMING PARTS OF PRINTERS COMPRISING BELTS, TONER AND DRUMS FOR THE PURPOSE OF TRANSFERRING IMAGES ONTO PAPER; DIGITAL IMAGING DEVICES, NAMELY, DIGITAL PHOTO IMAGE CONVERTERS; BLANK DIGITAL STORAGE MEDIA; PRE-RECORDED CDS, VIDEO TAPES, LASER DISKS AND DVDS FEATURING PHOTOS, ARCHIVE PHOTOS, AND MOVIES; SCANNERS; SCANNING SYSTEMS COMPRISING SCANNERS AND SCANNER OPERATING SOFTWARE; DIGITAL FILM SCANNERS; TOUCH SCREENS; CAMERAS; DISPOSABLE CAMERAS; VIDEO CAMERAS; BAGS FOR CAMERAS AND PHOTOGRAPHIC EQUIPMENT; CAMERA CASES; CAMERA MOUNTS AND SUPPORTS; CAMERA STRAPS; INTERACTIVE PHOTO KIOSKS FOR CAPTURING, PRINTING AND UPLOADING DIGITAL IMAGES FOR FUTURE USE; INTERACTIVE COMPUTER KIOSKS COMPRISING COMPUTERS, COMPUTER HARDWARE, COMPUTER PERIPHERALS, AND COMPUTER OPERATING SOFTWARE, FOR USE IN EDITING PHOTOGRAPHS, PRINTING PHOTOGRAPHS, SIZING AND ARRANGING PHOTOGRAPHS, MAKING PHOTO BOOKS, GREETING CARDS, CALENDARS, POSTERS, PHOTOGRAPH ENLARGEMENTS, PICTURE MOVIE DVDS AND ARCHIVE PHOTOGRAPH DVDS; COMPUTER SOFTWARE FOR MANAGING LABORATORY PRODUCTION AND WORKFLOW; COMPUTER SOFTWARE FOR CREATING, PRINTING AND SHARING PHOTOGRAPH COLLAGES, CARDS, CALENDARS, AND BOOKS ON A PERSONAL COMPUTER; DOWNLOADABLE MOBILE APPLICATIONS FOR USE WITH MOBILE PHONES AND TABLETS, NAMELY, SOFTWARE FOR FORMATTING AND PRINTING PHOTOGRAPHS AND DOCUMENTS, PUBLISHING, AND DOCUMENT MANAGEMENT; COMPUTER OPERATING SOFTWARE; COMPUTER SOFTWARE FOR USE IN INFORMATION MANAGEMENT, NAMELY, PRODUCTION WORKFLOW SOLUTIONS, BRAND AND MARKETING WORKFLOW, COLOR MANAGEMENT AND SCREENING, AND PROOFING SOLUTIONS; COMPUTER PROGRAMS FOR DOCUMENT MANAGEMENT; DRY MINILABS COMPRISED OF A PHOTO PRINTER AND AN INTEGRATED COMPUTER FOR PROCESSING OF PHOTOGRAPHS (U.S. CLS. 21, 23, 26, 36 AND 38).

**CLASS 16—PAPER GOODS AND PRINTED MATTER**

FOR REEL PAPER FOR PRINTERS; DIGITAL PRINTING PAPER; PHOTO MEMORY PRODUCTS, NAMELY, PRINTS, PHOTO BOOKS, GREETING CARDS, CALENDARS, POSTERS (U.S. CLS. 2, 5, 22, 23, 29, 37, 38 AND 50).

**CLASS 20—FURNITURE AND ARTICLES NOT OTHERWISE CLASSIFIED**

FOR KIOSKS FOR VENDING PURPOSES COMPRISED OF DISPLAY STANDS (U.S. CLS. 2, 13, 22, 25, 32 AND 50).

**CLASS 35—ADVERTISING AND BUSINESS**

FOR ADVERTISING, MARKETING AND PROMOTING THE GOODS AND SERVICES OF OTHERS USING KIOSKS; RECORDS MANAGEMENT SERVICES, NAMELY, DOCUMENT INDEXING FOR OTHERS; BRANDING SERVICES, NAMELY, CONSULTING, DEVELOPMENT, MANAGEMENT AND MARKETING OF BRANDS FOR BUSINESSES AND/OR INDIVIDUALS; PROMOTING, ADVERTISING AND MARKETING OF BRANDS, PRODUCTS, SERVICES AND ONLINE WEBSITES OF INDIVIDUALS, BUSINESSES AND NONPROFIT ORGANIZATIONS (U.S. CLS. 100, 101 AND 102).

**CLASS 37—CONSTRUCTION AND REPAIR**

FOR INSTALLATION AND REPAIR OF BUSINESS AND OFFICE MACHINERY AND EQUIPMENT; TECHNICAL SUPPORT SERVICES, NAMELY, TROUBLESHOOTING IN THE NATURE OF THE REPAIR OF COMPUTER HARDWARE AND BUSINESS AND OFFICE MACHINERY AND EQUIPMENT (U.S. CLS. 100, 103 AND 106).

**CLASS 40—MATERIAL TREATMENT**

FOR PHOTOGRAPHIC FILM DEVELOPING; FILM PROCESSING AND PHOTOFINISHING; PRINTING OF PHOTOGRAPHIC IMAGES FROM DIGITAL MEDIA; FLEXOGRAPHIC AND LETTERPRESS PRINTING; OFFSET PRINTING; DIGITAL PRINTING; DIGITAL PHOTO PRINTING SERVICES (U.S. CLS. 100, 103 AND 106).

**CLASS 41—EDUCATION AND ENTERTAINMENT**

FOR PHOTOGRAPHY SERVICES; PORTRAIT PHOTOGRAPHY; CONSULTING SERVICES IN THE FIELD OF PHOTOGRAPHY; PHOTOGRAPHY DIGITAL IMAGING SERVICES; PROVIDING FACILITIES FOR PRODUCING VIDEO, CINEMA AND PHOTOGRAPHY PRODUCTIONS; FILM PRODUCTION; MOTION PICTURE FILM PRODUCTION; MEDIA PRODUCTION SERVICES, NAMELY, VIDEO AND FILM PRODUCTION; MULTIMEDIA ENTERTAINMENT SERVICES IN THE NATURE OF DEVELOPMENT, PRODUCTION AND POST-PRODUCTION SERVICES IN THE FIELDS OF VIDEO AND FILMS; BUSINESS TRAINING CONSULTANCY SERVICES; BUSINESS TRAINING IN THE FIELD OF INFORMATION MANAGEMENT; COMPUTER EDUCATION TRAINING; TRAINING IN THE FIELD OF PHOTOGRAPHY OPERATIONS (U.S. CLS. 100, 101 AND 107).

**CLASS 42—SCIENTIFIC AND COMPUTER SERVICES**

FOR TECHNICAL ADVICE RELATING TO OPERATION OF COMPUTERS; TECHNICAL SUPPORT SERVICES, NAMELY, TROUBLESHOOTING IN THE NATURE OF DIAGNOSING COMPUTER HARDWARE AND SOFTWARE PROBLEMS; TECHNICAL CONSULTING SERVICES IN THE FIELDS OF DATACENTER ARCHITECTURE, PUBLIC AND PRIVATE CLOUD COMPUTING SOLUTIONS, AND EVALUATION AND IMPLEMENTATION OF INTERNET TECHNOLOGY AND SERVICES; DESIGN AND IMPLEMENTATION OF SOFTWARE AND TECHNOLOGY SOLUTIONS FOR THE PURPOSE OF PRODUCT AND DOCUMENT AUTHENTICATION AND TRACKING, AND BRAND MONITORING AND PROTECTION, TO PROTECT AGAINST COUNTERFEITING, TAMPERING, AND DIVERSION, AND TO ENSURE THE INTEGRITY OF GENUINE PRODUCTS AND DOCUMENTS (U.S. CLS. 100 AND 101).

KRISTIN DAHLING, EXAMINING ATTORNEY

SN 86-053,957. CERN - EUROPEAN ORGANIZATION FOR NUCLEAR RESEARCH, GENEVA, SWITZERLAND, FILED 9-3-2013.

SN 86-054,638. BEERTROPOLIS LLC, EVANSVILLE, IN. FILED 9-3-2013.

# ZENODO

THE MARK CONSISTS OF STANDARD CHARACTERS WITHOUT CLAIM TO ANY PARTICULAR FONT, STYLE, SIZE, OR COLOR.

## CLASS 9—ELECTRICAL AND SCIENTIFIC APPARATUS

FOR ELECTRONIC PUBLICATIONS, NAMELY, BOOKS, MAGAZINES, NEWSLETTERS, NEWSPAPERS, BROCHURES, AND MANUALS; ELECTRONIC PUBLICATIONS IN THE FORM OF E-BOOKS AND ELECTRONIC MULTIMEDIA FILES CONTAINING TEXTS; ALL AFOREMENTIONED GOODS RELATING TO EDUCATIONAL AND INFORMATIONAL TOPICS, NAMELY, SCIENCE, MEDICINE, HISTORY, LITERATURE, AND LINGUISTICS WHICH ARE DOWNLOADABLE FROM ONLINE DATABASES OR FROM THE INTERNET (U.S. CLS. 21, 23, 26, 36 AND 38).

## CLASS 38—COMMUNICATION

FOR PROVIDING ACCESS TO WEBSITES ON THE INTERNET; PROVIDING ACCESS TO DATA NETWORKS, NAMELY, TO THE INTERNET, TO INTERNET FORUMS, TO THE GLOBAL INTERNET NETWORK AND TO SERVERS; ELECTRONIC TRANSMISSION OF DATA AND DOCUMENTS BY COMPUTER; DATA TRANSMISSION VIA THE GLOBAL COMPUTER NETWORK; PROVIDING ACCESS TO AN INTERNET PORTAL WITH COMMERCIAL CONTENT IN THE FIELDS OF SCIENCE, MEDICINE, HISTORY, LITERATURE, AND LINGUISTICS (U.S. CLS. 100, 101 AND 104).

## CLASS 41—EDUCATION AND ENTERTAINMENT

FOR EDUCATIONAL AND ENTERTAINMENT SERVICES, NAMELY, PUBLISHING ELECTRONIC PUBLICATIONS; PROVIDING NON-DOWNLOADABLE ELECTRONIC PUBLICATIONS, NAMELY, E-BOOKS IN THE FIELD OF SCIENCE, MEDICINE, HISTORY, LITERATURE, AND LINGUISTICS VIA GLOBAL COMPUTER NETWORK OR INTERNET; PUBLICATION OF BOOKS, PRINTED MATERIAL AND TEXTS; ONLINE LIBRARIES AND IN PARTICULAR PROVIDING ELECTRONIC LIBRARY SERVICES RELATING TO BOOKS, MAGAZINES, PHOTOGRAPHS AND IMAGES VIA A COMPUTERIZED NETWORK; LIBRARY SERVICES PROVIDED BY MEANS OF A COMPUTERIZED DATABASE CONTAINING INFORMATION EXTRACTED FROM BOOKS, NEWSPAPERS, MAGAZINES (U.S. CLS. 100, 101 AND 107).

SIMON TENG, EXAMINING ATTORNEY

# BEERTROPOLIS

THE MARK CONSISTS OF STANDARD CHARACTERS WITHOUT CLAIM TO ANY PARTICULAR FONT, STYLE, SIZE, OR COLOR.

## CLASS 25—CLOTHING

FOR WEARABLE GARMENTS AND CLOTHING, NAMELY, SHIRTS (U.S. CLS. 22 AND 39).  
FIRST USE 7-3-2013; IN COMMERCE 7-3-2013.

## CLASS 43—HOTEL AND RESTAURANT SERVICES

FOR BAR SERVICES; RESTAURANT SERVICES (U.S. CLS. 100 AND 101).  
FIRST USE 7-3-2013; IN COMMERCE 7-3-2013.  
LUCY ARANT, EXAMINING ATTORNEY

SN 86-055,536. NATIONAL RESIDENT MATCHING PROGRAM, WASHINGTON, DC. FILED 9-4-2013.

# THE MATCH

THE MARK CONSISTS OF STANDARD CHARACTERS WITHOUT CLAIM TO ANY PARTICULAR FONT, STYLE, SIZE, OR COLOR.  
SEC. 2(F).

## CLASS 41—EDUCATION AND ENTERTAINMENT

FOR PLACEMENT SERVICES PROVIDED TO TRAINING INSTITUTIONS, MEDICAL SCHOOLS, DOCTORS AND MEDICAL STUDENTS FOR PLACING DOCTORS AND MEDICAL STUDENTS IN GRADUATE MEDICAL EDUCATION TRAINING PROGRAMS (U.S. CLS. 100, 101 AND 107).  
FIRST USE 0-0-1984; IN COMMERCE 0-0-1984.

## CLASS 42—SCIENTIFIC AND COMPUTER SERVICES

FOR PROVIDING SOFTWARE TO FACILITATE PLACEMENT SERVICES PROVIDED TO TRAINING INSTITUTIONS, MEDICAL SCHOOLS, DOCTORS AND MEDICAL STUDENTS FOR PLACING DOCTORS AND MEDICAL STUDENTS IN GRADUATE MEDICAL EDUCATION TRAINING PROGRAMS (U.S. CLS. 100 AND 101).  
FIRST USE 0-0-1984; IN COMMERCE 0-0-1984.  
EMILY CARLSEN, EXAMINING ATTORNEY

SN 86-055,566. BLOOM CLASSIC CO., LTD., TOKYO, JAPAN, FILED 9-4-2013.

*Power tree*

OWNER OF HONG KONG REG. NO. 302722635, DATED 8-30-2013, EXPIRES 8-30-2023.  
THE MARK CONSISTS OF THE WORDS "POWER TREE" IN STYLIZED FORM.

**CLASS 3—COSMETICS AND CLEANING PREPARATIONS**

FOR COSMETICS; SOAPS FOR PERSONAL USE; SOAPS NOT FOR PERSONAL USE, NAMELY, LAUNDRY SOAP AND DETERGENT SOAPS; MASK PACK FOR COSMETIC PURPOSES; MASSAGE GEL OTHER THAN FOR MEDICAL PURPOSES; LOTIONS FOR COSMETIC PURPOSES; SKIN MILK LOTIONS FOR COSMETIC PURPOSES; COSMETIC CLEANSING CREAMS; COSMETIC FOUNDATION CREAMS; FACE POWDER FOR COSMETICS PURPOSES; BEAUTY MASKS (U.S. CLS. 1, 4, 6, 50, 51 AND 52).

**CLASS 10—MEDICAL APPARATUS**

FOR NON-ELECTRIC APPARATUS FOR ACUPRESSURE THERAPY; NON-ELECTRIC MASSAGING APPARATUS FOR PERSONAL USE (U.S. CLS. 26, 39 AND 44).

**CLASS 44—MEDICAL, BEAUTY AND AGRICULTURAL SERVICES**

FOR BEAUTY SALONS, PROVIDING BEAUTY INFORMATION, BEAUTY CONSULTANCY, MAKE-UP SERVICES, MASSAGE SERVICES (U.S. CLS. 100 AND 101).  
AMY HELLA, EXAMINING ATTORNEY

SN 86-055,598. FRANCESCO DIPAOLO, NEW YORK, NY. FILED 9-4-2013.



THE MARK CONSISTS OF A SHIELD INSIDE AN OVAL

WITH THE OVERLAPPING LETTERS "HN", SURROUNDED ON EACH SIDE BY WINGS. ALONG THE TOP CURVE OF THE OVAL ARE TWO CIRCLES AND ABOVE THE CENTER OF THE OVAL IS A STYLIZED TRIANGLE. THERE IS A STYLIZED OUTLINE OF LIPS NEXT TO EACH CIRCLE, OUTSIDE THE OVAL. EXTENDING DOWN FROM THE MIDDLE OF EACH WING ARE TWO STRAIGHT LINES, INTERSECTING TWO CONCENTRIC CIRCLES, FROM THE SIDE OF WHICH EXTEND TWO STRAIGHT LINES CONNECTING TO THE BOTTOM OF THE WINGS.

**CLASS 25—CLOTHING**

FOR BELTS MADE FROM IMITATION LEATHER; BELTS MADE OF LEATHER; BELTS MADE OUT OF CLOTH; BERMUDA SHORTS; BLAZERS; BLOUSES; COATS; COLLARED SHIRTS; DRESSES; FOOTWEAR FOR MEN AND WOMEN; HATS; JACKETS; MEN'S AND WOMEN'S JACKETS, COATS, TROUSERS, VESTS; MEN'S SUITS, WOMEN'S SUITS; MEN'S SOCKS; MEN'S UNDERWEAR; NECKTIES; OVERCOATS; PANTS; POLO SHIRTS; PULLOVERS; RAIN COATS; SCARVES; SHIRTS; SHOES; SOCKS; SUIT COATS; SUITS; TOP-COATS; WOMEN'S CLOTHING, NAMELY, SHIRTS, DRESSES, SKIRTS, BLOUSES; LEATHER JACKETS; BASEBALL CAPS, HATS; GLOVES (U.S. CLS. 22 AND 39).

**CLASS 35—ADVERTISING AND BUSINESS**

FOR RETAIL APPAREL STORES; ON-LINE RETAIL STORE SERVICES FEATURING MEN'S AND WOMEN'S APPAREL AND ACCESSORIES (U.S. CLS. 100, 101 AND 102).  
EVIN L. KOZAK, EXAMINING ATTORNEY

SN 86-056,914. DIGITAL RISK, LLC, MAITLAND, FL. FILED 9-5-2013.

ValuationIQ

THE MARK CONSISTS OF STANDARD CHARACTERS WITHOUT CLAIM TO ANY PARTICULAR FONT, STYLE, SIZE, OR COLOR.

**CLASS 36—INSURANCE AND FINANCIAL**

FOR FINANCIAL DUE DILIGENCE SERVICES IN THE FIELD OF REAL ESTATE; REAL ESTATE APPRAISAL AND VALUATION; FINANCIAL RISK ASSESSMENT (U.S. CLS. 100, 101 AND 102).  
FIRST USE 7-2-2012; IN COMMERCE 7-2-2012.

**CLASS 42—SCIENTIFIC AND COMPUTER SERVICES**

FOR INSPECTIONS OF REAL ESTATE; PROVIDING QUALITY CONTROL SERVICES FOR THE MORTGAGE INDUSTRY (U.S. CLS. 100 AND 101).  
FIRST USE 7-2-2012; IN COMMERCE 7-2-2012.  
PATRICIA EVANKO, EXAMINING ATTORNEY

SN 86-057,895. THE SKATEPARK OF TAMPA, INCORPORATED, TAMPA, FL. FILED 9-6-2013.

# DAMN AM

THE MARK CONSISTS OF STANDARD CHARACTERS WITHOUT CLAIM TO ANY PARTICULAR FONT, STYLE, SIZE, OR COLOR.

## CLASS 25—CLOTHING

FOR CLOTHING, NAMELY, HATS AND SHIRTS (U.S. CLS. 22 AND 39).

## CLASS 41—EDUCATION AND ENTERTAINMENT

FOR ENTERTAINMENT SERVICES, NAMELY, PRODUCING, ARRANGING AND CONDUCTING SKATEBOARDING EVENTS, TOURNAMENTS AND EXHIBITIONS; ENTERTAINMENT SERVICES, NAMELY, SKATEBOARDING EVENTS, TOURNAMENTS AND EXHIBITIONS; ENTERTAINMENT SERVICES, NAMELY, PROVIDING NEWS, INFORMATION AND VIDEOS VIA A WEBSITE IN THE FIELD OF SKATEBOARDING, SKATEBOARDING EVENTS, TOURNAMENTS AND EXHIBITIONS AND THE CULTURE OF SKATEBOARDING (U.S. CLS. 100, 101 AND 107).

FIRST USE 12-31-2001; IN COMMERCE 12-31-2001.  
LUCY ARANT, EXAMINING ATTORNEY

SN 86-058,096. ARROW LINE MARKETING LIMITED, HAMPSHIRE, UNITED KINGDOM, FILED 9-6-2013.



OWNER OF UNITED KINGDOM REG. NO. UK2656011, DATED 7-19-2013, EXPIRES 3-14-2023.

NO CLAIM IS MADE TO THE EXCLUSIVE RIGHT TO USE "MANGOSTEEN", APART FROM THE MARK AS SHOWN.

THE MARK CONSISTS OF THE STYLIZED TERMS "VIE 100" ABOVE THE TERM "MANGOSTEEN" IN SMALLER STYLIZED LETTERING.

## CLASS 5—PHARMACEUTICALS

FOR DIETARY FOOD SUPPLEMENTS; DIETARY FOOD SUPPLEMENTS IN PILL, TABLET AND CAPSULE FORM; FOOD SUPPLEMENTS FOR MEDICAL PURPOSES; ANTI-OXIDANT FOOD SUPPLEMENTS; DIETARY SUPPLEMENTS IN POWDER OR LIQUID FORM, EACH ADAPTED FOR MEDICAL USE; DIETARY SUPPLEMENTAL DRINKS; ALL THE FOREGOING GOODS CONTAIN MANGOSTEEN (U.S. CLS. 6, 18, 44, 46, 51 AND 52).

## CLASS 32—LIGHT BEVERAGES

FOR FRUIT JUICES; FRUIT DRINKS; NON-ALCOHOLIC DRINKS AND BEVERAGES CONTAINING FRUIT JUICE; SYRUPS AND OTHER PREPARATIONS FOR MAKING FRUIT DRINK BEVERAGES; ALL THE FOREGOING GOODS CONTAIN MANGOSTEEN (U.S. CLS. 45, 46 AND 48).

ANTHONY RINKER, EXAMINING ATTORNEY

SN 86-058,371. BTS S.P.A., GARBAGNATE MILANESE MI, ITALY, FILED 9-6-2013.

# G-WALK

THE MARK CONSISTS OF STANDARD CHARACTERS WITHOUT CLAIM TO ANY PARTICULAR FONT, STYLE, SIZE, OR COLOR.

## CLASS 9—ELECTRICAL AND SCIENTIFIC APPARATUS

FOR SCIENTIFIC RESEARCH AND LABORATORY APPARATUS, INSTRUMENTS AND DEVICES, NAMELY, ACCELERATION SENSORS, GYROSCOPES, AND MAGNETOMETERS; MEASURING INSTRUMENTS, NAMELY, ELECTROMAGNETIC APPARATUS USED TO MEASURE MAGNETIC FIELDS AND SENSORS FOR DETERMINING POSITION, VELOCITY, ACCELERATION AND TEMPERATURE; ELECTRIC CONTROL APPARATUS, NAMELY, ELECTRIC CONTROL DEVICES FOR SPATIO-TEMPORAL PARAMETER DETECTION AS WELL AS PELVIC ROTATION PARAMETER DETECTION; EDUCATIONAL APPARATUS AND SIMULATORS, NAMELY, ELECTRONIC ORTHOPEDICS TRAINING SIMULATOR IN THE NATURE OF SOFTWARE-BASED TEACHING APPARATUS, ELECTRONIC NEUROLOGISTS TRAINING SIMULATOR IN THE NATURE OF SOFTWARE-BASED TEACHING APPARATUS, ELECTRONIC CLINICIANS TRAINING SIMULATOR IN THE NATURE OF SOFTWARE-BASED TEACHING APPARATUS, ELECTRONIC GERIATRICIANS TRAINING SIMULATOR IN THE NATURE OF SOFTWARE-BASED TEACHING APPARATUS, AND ELECTRONIC SPORTS DOCTORS TRAINING SIMULATOR IN THE NATURE OF SOFTWARE-BASED TEACHING APPARATUS; COMPUTER SOFTWARE FOR ANALYZING SPATIO-TEMPORAL PARAMETERS AND PELVIC KINEMATIC DATA FOR USE WITH INERTIAL SENSORS; INTEGRATED COMPUTER SOFTWARE FOR ACQUIRING, PROCESSING, COLLECTING AND REPORTING SPATIO-TEMPORAL DATA AND PELVIC KINEMATIC DATA; APPARATUS FOR THE TRANSMISSION OF DATA IN NATURE OF AN ELECTRONIC COMMUNICATIONS SYSTEM COMPRISED OF COMPUTER HARDWARE AND SOFTWARE; COMPUTER SOFTWARE THAT PROCESSES AND ANALYZES BIOMETRIC DATA FOR THE STUDY OF DYSFUNCTIONAL MOVEMENT AND ALL PATHOLOGIES RELATED TO THE SOMATIC NERVOUS SYSTEM, WALKING, AND POSTURAL STABILITY (U.S. CLS. 21, 23, 26, 36 AND 38).

## CLASS 10—MEDICAL APPARATUS

FOR TESTING INSTRUMENTS FOR MEDICAL DIAGNOSTIC PURPOSES, NAMELY, TESTING PROBES FOR MEDICAL DIAGNOSTIC PURPOSES, TEST PROBES FOR MEDICAL USE, PROBES FOR USE WITH INTEGRATED CIRCUITS FOR MEDICAL DIAGNOSIS, PROBES CONNECTED TO MICRO-PROCESSING APPARATUS FOR MEDICAL DIAGNOSIS, ELECTRODES FOR PICKING UP BIOLOGICAL PARAMETERS, AND BELTS FOR ATTACHING SENSORS TO PATIENTS FOR MEDICAL USE (U.S. CLS. 26, 39 AND 44).

**CLASS 42—SCIENTIFIC AND COMPUTER SERVICES**

FOR BIOTECHNOLOGY TESTING; DEVELOPMENT OF MEASURING PROBES FOR BIOTECHNOLOGICAL APPLICATIONS; DESIGN SERVICES FOR DATA PROCESSING SYSTEMS; CREATION OF COMPUTER PROGRAMMES FOR DATA PROCESSING; DESIGN SERVICES RELATING TO DATA PROCESSORS; LABORATORY RESEARCH SERVICES IN THE FIELD OF PHYSICAL REHABILITATION, ERGONOMICS, SPORTS MEDICINE, CLINICAL TRIALS, AND ASSESSMENT OF FUNCTIONAL ABILITY AND MUSCULAR FATIGUE; SCIENTIFIC RESEARCH; DESIGN SERVICES RELATING TO DATA TRANSMISSION TEST TOOLS; DEVELOPMENT OF SYSTEMS FOR THE TRANSMISSION OF DATA (U.S. CLS. 100 AND 101).

**CLASS 44—MEDICAL, BEAUTY AND AGRICULTURAL SERVICES**

FOR MEDICAL TESTING SERVICES, NAMELY, FITNESS EVALUATION TESTING SERVICES (U.S. CLS. 100 AND 101).

BRIN ANDERSON, EXAMINING ATTORNEY

**CLASS 44—MEDICAL, BEAUTY AND AGRICULTURAL SERVICES**

FOR PROVIDING MEDICAL INFORMATION SERVICES; PROVIDING MEDICAL INFORMATION CONSULTING SERVICES; PROVIDING HEALTH CARE INFORMATION SERVICES BY ELECTRONIC MEANS; PROVIDING HEALTH CARE INFORMATION CONSULTING SERVICES; PROVIDING MEDICAL, PREVENTIVE, AND WELLNESS INFORMATION TO HEALTH CARE PROVIDERS; PROVIDING DISEASE-SPECIFIC HEALTH CARE INFORMATION TO HEALTH CARE PROVIDERS; PROVIDING MEDICAL INFORMATION TO PHYSICIANS REGARDING PRESCRIPTION DRUGS AND TREATMENT GUIDELINES; PROVIDING ONLINE MEDICAL RECORD ANALYSIS SERVICES DESIGNED TO PROVIDE CUSTOM-TAILORED OUTPUTS ABOUT RECOMMENDED RESOURCES AND TREATMENTS ASSOCIATED WITH A DEFINED SET OF SYMPTOMS AND CONCERNS TO PHYSICIANS, HOSPITALS, CLINICIANS, HEALTH INSURANCE PROVIDERS, HEALTH INFORMATION TECHNOLOGY VENDORS, ELECTRONIC HEALTH RECORD VENDORS, CLINICAL SOLUTION VENDORS, MEDICAL PUBLISHERS, MEDICAL STUDENTS, AND OTHER HEALTH CARE PROFESSIONALS (U.S. CLS. 100 AND 101).

STEVEN JACKSON, EXAMINING ATTORNEY

SN 86-059,055, MOTIVE MEDICAL INTELLIGENCE, SAN FRANCISCO, CA, FILED 9-9-2013.

SN 86-059,057, MOTIVE MEDICAL INTELLIGENCE, SAN FRANCISCO, CA, FILED 9-9-2013.

**EVIDENCE 2.0**

THE MARK CONSISTS OF STANDARD CHARACTERS WITHOUT CLAIM TO ANY PARTICULAR FONT, STYLE, SIZE, OR COLOR.

NO CLAIM IS MADE TO THE EXCLUSIVE RIGHT TO USE "EVIDENCE", APART FROM THE MARK AS SHOWN.

**MOTIVE MEDICAL INTELLIGENCE**

THE MARK CONSISTS OF STANDARD CHARACTERS WITHOUT CLAIM TO ANY PARTICULAR FONT, STYLE, SIZE, OR COLOR.

NO CLAIM IS MADE TO THE EXCLUSIVE RIGHT TO USE "MEDICAL INTELLIGENCE", APART FROM THE MARK AS SHOWN.

**CLASS 42—SCIENTIFIC AND COMPUTER SERVICES**

FOR DATABASE DEVELOPMENT SERVICES IN THE FIELD OF HEALTH CARE; COMPUTER SERVICES, NAMELY, PROVIDING ANALYSIS OF COMPUTER DATABASES IN THE FIELD OF HEALTH CARE; DATABASE DEVELOPMENT AND COMPUTER SOFTWARE DESIGN; DATABASE DESIGN AND DEVELOPMENT CONSULTING IN THE FIELD OF HEALTH CARE, MEDICAL, AND PHARMACEUTICAL; COMPUTER AND INFORMATION TECHNOLOGY CONSULTATION SERVICES FOR THE HEALTH CARE INDUSTRY; SOFTWARE AS A SERVICE (SAAS) SERVICES FEATURING SOFTWARE IN THE FIELD OF CONTROLLED ACCESS SERVICE THAT MAINTAINS DATABASES OF PATIENT HEALTH INFORMATION AND PROVIDES ACCESS TO SUCH INFORMATION TO HEALTH CARE PERSONNEL AND HEALTH CARE INSTITUTIONS; PROVIDING TEMPORARY USE OF NONDOWNLOADABLE COMPUTER SOFTWARE FOR CONTROLLING AND MANAGING PATIENT MEDICAL INFORMATION; PROVIDING TEMPORARY USE OF NONDOWNLOADABLE COMPUTER SOFTWARE FOR COLLECTING, ANALYZING, EDITING, MANAGING, ORGANIZING, PROCESSING, MODIFYING, REFERENCING, BOOKMARKING, TRANSMITTING, STORING, AND SHARING DATA AND INFORMATION IN THE FIELD OF HEALTH CARE; SOFTWARE AS A SERVICE (SAAS) SERVICES FEATURING SOFTWARE FOR USE IN THE HEALTH CARE FIELD, NAMELY, SOFTWARE FOR MANAGING, STORING, ANALYZING, MAINTAINING, PROCESSING, STRUCTURING, REVIEWING, BUILDING, EDITING, DISTRIBUTING, COMMUNICATING, ORGANIZING, SHARING, REFERENCING, MONITORING, AND INTEGRATING HEALTH CARE INFORMATION (U.S. CLS. 100 AND 101).

**CLASS 42—SCIENTIFIC AND COMPUTER SERVICES**

FOR DATABASE DEVELOPMENT SERVICES IN THE FIELD OF HEALTH CARE; COMPUTER SERVICES, NAMELY, PROVIDING ANALYSIS OF COMPUTER DATABASES IN THE FIELD OF HEALTH CARE; DATABASE DEVELOPMENT AND COMPUTER SOFTWARE DESIGN; DATABASE DESIGN AND DEVELOPMENT CONSULTING IN THE FIELD OF HEALTH CARE, MEDICAL, AND PHARMACEUTICAL; COMPUTER AND INFORMATION TECHNOLOGY CONSULTATION SERVICES FOR THE HEALTH CARE INDUSTRY; SOFTWARE AS A SERVICE (SAAS) SERVICES FEATURING SOFTWARE IN THE FIELD OF CONTROLLED ACCESS SERVICE THAT MAINTAINS DATABASES OF PATIENT HEALTH INFORMATION AND PROVIDES ACCESS TO SUCH INFORMATION TO HEALTH CARE PERSONNEL AND HEALTH CARE INSTITUTIONS; PROVIDING TEMPORARY USE OF NONDOWNLOADABLE COMPUTER SOFTWARE FOR CONTROLLING AND MANAGING PATIENT MEDICAL INFORMATION; PROVIDING TEMPORARY USE OF NONDOWNLOADABLE COMPUTER SOFTWARE FOR COLLECTING, ANALYZING, EDITING, MANAGING, ORGANIZING, PROCESSING, MODIFYING, REFERENCING, BOOKMARKING, TRANSMITTING, STORING, AND SHARING DATA AND INFORMATION IN THE FIELD OF HEALTH CARE; SOFTWARE AS A SERVICE (SAAS) SERVICES FEATURING SOFTWARE FOR USE IN THE HEALTH CARE FIELD, NAMELY, SOFTWARE FOR MANAGING, STORING, ANALYZING, MAINTAINING, PROCESSING, STRUCTURING, REVIEWING, BUILDING, EDITING, DISTRIBUTING, COMMUNICATING, ORGANIZING, SHARING, REFERENCING, MONITORING, AND INTEGRATING HEALTH CARE INFORMATION (U.S. CLS. 100 AND 101).

**CLASS 44—MEDICAL, BEAUTY AND AGRICULTURAL SERVICES**

FOR PROVIDING MEDICAL INFORMATION SERVICES; PROVIDING MEDICAL INFORMATION CONSULTING SERVICES; PROVIDING HEALTH CARE INFORMATION SERVICES BY ELECTRONIC MEANS; PROVIDING HEALTH CARE INFORMATION CONSULTING SERVICES; PROVIDING MEDICAL, PREVENTIVE, AND WELLNESS INFORMATION TO HEALTH CARE PROVIDERS; PROVIDING DISEASE-SPECIFIC HEALTH CARE INFORMATION TO HEALTH CARE PROVIDERS; PROVIDING MEDICAL INFORMATION TO PHYSICIANS REGARDING PRESCRIPTION DRUGS AND TREATMENT GUIDELINES; PROVIDING ONLINE MEDICAL RECORD ANALYSIS SERVICES DESIGNED TO PROVIDE CUSTOM-TAILORED OUTPUTS ABOUT RECOMMENDED RESOURCES AND TREATMENTS ASSOCIATED WITH A DEFINED SET OF SYMPTOMS AND CONCERNS TO PHYSICIANS, HOSPITALS, CLINICIANS, HEALTH INSURANCE PROVIDERS, HEALTH INFORMATION TECHNOLOGY VENDORS, ELECTRONIC HEALTH RECORD VENDORS, CLINICAL SOLUTION VENDORS, MEDICAL PUBLISHERS, MEDICAL STUDENTS, AND OTHER HEALTH CARE PROFESSIONALS (U.S. CLS. 100 AND 101).

STEVEN JACKSON, EXAMINING ATTORNEY

---

SN 86-059,370. PROTOCOL CRIMINAL JUSTICE, INC., BOCA RATON, FL. FILED 9-9-2013.

# PROTOCOL

THE MARK CONSISTS OF STANDARD CHARACTERS WITHOUT CLAIM TO ANY PARTICULAR FONT, STYLE, SIZE, OR COLOR.

**CLASS 35—ADVERTISING AND BUSINESS**

FOR BUSINESS MARKETING AND DIRECT MARKETING SERVICES FOR OTHERS; DIRECT MARKETING ADVERTISING FOR OTHERS; TELEMARKETING; MARKET RESEARCH; ORDER FULFILLMENT SERVICES; OPERATION OF TELEPHONE CALL CENTERS AND CONTACT CENTERS FOR OTHERS; E-MARKETING SERVICES FOR OTHERS, NAMELY, BUSINESS DATA ANALYSIS AND DATABASE MANAGEMENT, MAILING LIST PREPARATION AND MANAGEMENT, E-MAIL MARKETING SERVICES FOR OTHERS (U.S. CLS. 100, 101 AND 102).

FIRST USE 1-0-2001; IN COMMERCE 1-0-2001.

**CLASS 38—COMMUNICATION**

FOR PROVIDING ON-LINE CHAT ROOMS AND ELECTRONIC BULLETIN BOARDS FOR TRANSMISSION OF MESSAGES AMONG USERS IN THE FIELD OF OUTSOURCED CUSTOMER SERVICE, CASE MANAGEMENT SUPPORT AND ENHANCED OFFENDER MONITORING IN THE COMMUNITY CORRECTIONS INDUSTRY (U.S. CLS. 100, 101 AND 104).

FIRST USE 1-0-2001; IN COMMERCE 1-0-2001.  
INGA ERVIN, EXAMINING ATTORNEY

SN 86-059,520. PROTOCOL CRIMINAL JUSTICE, INC., BOCA RATON, FL. FILED 9-9-2013.

**PROTOCOL GLOBAL SOLUTIONS**

THE MARK CONSISTS OF STANDARD CHARACTERS WITHOUT CLAIM TO ANY PARTICULAR FONT, STYLE, SIZE, OR COLOR.

NO CLAIM IS MADE TO THE EXCLUSIVE RIGHT TO USE "GLOBAL SOLUTIONS", APART FROM THE MARK AS SHOWN.

**CLASS 35—ADVERTISING AND BUSINESS**

FOR BUSINESS MARKETING AND DIRECT MARKETING SERVICES FOR OTHERS; DIRECT MARKETING ADVERTISING FOR OTHERS; TELEMARKETING; MARKET RESEARCH; ORDER FULFILLMENT SERVICES; OPERATION OF TELEPHONE CALL CENTERS AND CONTACT CENTERS FOR OTHERS; E-MARKETING SERVICES FOR OTHERS, NAMELY, BUSINESS DATA ANALYSIS AND DATABASE MANAGEMENT, MAILING LIST PREPARATION AND MANAGEMENT, EMAIL MARKETING SERVICES FOR OTHERS (U.S. CLS. 100, 101 AND 102).

FIRST USE 1-0-2009; IN COMMERCE 1-0-2009.

**CLASS 38—COMMUNICATION**

FOR PROVIDING ON-LINE CHAT ROOMS AND ELECTRONIC BULLETIN BOARDS FOR TRANSMISSION OF MESSAGES AMONG USERS IN THE FIELD OF OUTSOURCED CUSTOMER SERVICE, CASE MANAGEMENT SUPPORT AND ENHANCED OFFENDER MONITORING IN THE COMMUNITY CORRECTIONS INDUSTRY (U.S. CLS. 100, 101 AND 104).

FIRST USE 1-0-2009; IN COMMERCE 1-0-2009.  
INGA ERVIN, EXAMINING ATTORNEY

---

SN 86-060,047. DAIRY MANAGEMENT, INC., ROSEMONT, IL. FILED 9-10-2013.

# Cow of the Future

THE MARK CONSISTS OF STANDARD CHARACTERS WITHOUT CLAIM TO ANY PARTICULAR FONT, STYLE, SIZE, OR COLOR.

NO CLAIM IS MADE TO THE EXCLUSIVE RIGHT TO USE "COW", APART FROM THE MARK AS SHOWN.

**CLASS 42—SCIENTIFIC AND COMPUTER SERVICES**

FOR AGRICULTURAL SERVICES, NAMELY, RESEARCH AND ANALYSIS RELATING TO REDUCING ENVIRONMENTAL IMPACT THROUGH IMPROVEMENTS IN DAIRY COW NUTRITION, GENETICS AND HEALTH (U.S. CLS. 100 AND 101).

FIRST USE 12-31-2010; IN COMMERCE 12-31-2010.

**CLASS 44—MEDICAL, BEAUTY AND AGRICULTURAL SERVICES**

FOR AGRICULTURAL ADVICE, NAMELY, PROVIDING RECOMMENDATIONS FOR IMPROVEMENTS IN DAIRY COW NUTRITION, GENETICS AND HEALTH TO REDUCE ENVIRONMENTAL IMPACT (U.S. CLS. 100 AND 101).

FIRST USE 12-31-2010; IN COMMERCE 12-31-2010.  
ZACHARY BELLO, EXAMINING ATTORNEY

---

SN 86-060,380. SH GROUP GLOBAL IP HOLDINGS, L.L.C., GREENWICH, CT. FILED 9-10-2013.



OWNER OF U.S. REG. NOS. 4,226,104, 4,226,105 AND 4,226,106.

NO CLAIM IS MADE TO THE EXCLUSIVE RIGHT TO USE "HOTEL & HOMES SOUTH BEACH", APART FROM THE MARK AS SHOWN.

THE MARK CONSISTS OF A NUMERAL "1" LOCATED ABOVE THE TEXT "HOTEL & HOMES" WHICH IS LOCATED ABOVE THE TEXT "SOUTH BEACH".

**CLASS 35—ADVERTISING AND BUSINESS**

FOR HOTEL MANAGEMENT FOR OTHERS; BUSINESS MANAGEMENT AND CONSULTATION IN THE HOTEL INDUSTRY (U.S. CLS. 100, 101 AND 102).

**CLASS 36—INSURANCE AND FINANCIAL**

FOR LEASING, RENTAL, AND MANAGEMENT OF CONDOMINIUMS, APARTMENTS, VILLAS AND RESIDENTIAL HOMES; LEASING, RENTAL, AND MANAGEMENT OF CONDOMINIUMS, APARTMENTS, VILLAS AND RESIDENTIAL HOMES IN VACATION AND RESORT COMMUNITIES; REAL ESTATE BROKERAGE SERVICES (U.S. CLS. 100, 101 AND 102).

**CLASS 37—CONSTRUCTION AND REPAIR**

FOR REAL ESTATE DEVELOPMENT, NAMELY, HOTEL DEVELOPMENT FOR OTHERS; REAL ESTATE DEVELOPMENT, NAMELY, RESORT COMMUNITIES DEVELOPMENT FOR OTHERS; REAL ESTATE DEVELOPMENT IN THE NATURE OF HOTEL DEVELOPMENT AND RESORT COMMUNITIES (U.S. CLS. 100, 103 AND 106).

**CLASS 41—EDUCATION AND ENTERTAINMENT**

FOR CASINOS, NAMELY, GAMBLING AND GAMING SERVICES; LIVE ENTERTAINMENT, NAMELY, LIVE PERFORMANCES BY MUSICAL BANDS AND LIVE COMEDY SHOWS; NIGHT CLUB SERVICES; HEALTH CLUB SERVICES, NAMELY, PROVIDING INSTRUCTION AND EQUIPMENT IN THE FIELD OF PHYSICAL EXERCISE; LEISURE CLUB SERVICES, NAMELY, COUNTRY CLUB AND GOLF CLUB SERVICES; PROVIDING GOLF FACILITIES; PROVIDING GOLF INSTRUCTION AND GOLF EQUIPMENT; PROVIDING TENNIS FACILITIES; PROVIDING TENNIS INSTRUCTION AND TENNIS EQUIPMENT; SKI RESORTS; PROVIDING SKIING FACILITIES; PROVIDING SKIING INSTRUCTION AND SKIING EQUIPMENT; PROVISION OF SPORT AND RECREATIONAL FACILITIES; ARRANGING AND CONDUCTING EDUCATIONAL CONFERENCES; ARRANGING AND CONDUCTING ENTERTAINMENT EXHIBITIONS IN THE NATURE OF COMEDY ACTS, DANCE ACTS, THEATER ACTS, PLAYS, STAGE PRODUCTIONS, MAGIC SHOWS, PERFORMANCE ART SHOWS; THEATRICAL BOOKING AGENCIES, NAMELY, THEATER, OPERA AND CONCERT TICKET RESERVATIONS (U.S. CLS. 100, 101 AND 107).

**CLASS 43—HOTEL AND RESTAURANT SERVICES**

FOR HOTELS; CONDOMINIUM HOTELS; HOTEL SERVICES; RESORT HOTEL SERVICES; SPA SERVICES, NAMELY, PROVIDING TEMPORARY ACCOMMODATIONS AND MEALS TO CLIENTS OF A HEALTH OR BEAUTY SPA; RESTAURANTS; BARS; RESTAURANT AND BAR SERVICES (U.S. CLS. 100 AND 101).

**CLASS 44—MEDICAL, BEAUTY AND AGRICULTURAL SERVICES**

FOR HEALTH SPA SERVICES FOR HEALTH AND WELLNESS OF THE BODY AND SPIRIT OFFERED AT HEALTH RESORTS; HEALTH SPA SERVICES, NAMELY, COSMETIC BODY CARE SERVICES (U.S. CLS. 100 AND 101).

TAMARA FRAZIER, EXAMINING ATTORNEY

---

SN 86-060,660. EDWARD & SONS TRADING CO., INC., CARPINTERIA, CA. FILED 9-10-2013.

Convenience Without  
Compromise

THE MARK CONSISTS OF STANDARD CHARACTERS WITHOUT CLAIM TO ANY PARTICULAR FONT, STYLE, SIZE, OR COLOR.

OWNER OF U.S. REG. NO. 3,657,452.

**CLASS 5—PHARMACEUTICALS**

FOR BABY FOODS; DIETETIC FOODS, NAMELY, PASTA AND CRACKERS ADAPTED FOR MEDICAL USE; FOOD FOR BABIES; WHEAT-FREE AND GLUTEN-FREE BABY FOODS FOR THE TREATMENT OF SPECIAL MEDICAL AND HEALTH CONDITIONS (U.S. CLS. 6, 18, 44, 46, 51 AND 52).

FIRST USE 10-26-1978; IN COMMERCE 10-26-1978.

**CLASS 29—MEATS AND PROCESSED FOODS**

FOR BOUILLON; CANNED FRUITS AND VEGETABLES; CANNED OR BOTTLED FRUITS; CANNED OR BOTTLED VEGETABLES; COCONUT CREAM; COCONUT OIL; COCONUT POWDER; DESICCATED COCONUT; FLAKED COCONUT; MASHED POTATOES; SOUP MIXES (U.S. CL. 46).

FIRST USE 10-26-1978; IN COMMERCE 10-26-1978.

**CLASS 30—STAPLE FOODS**

FOR BREADCRUMBS; CANDY SPRINKLES; CONES FOR ICE CREAM; CORN STARCH; CRACKERS; CROUTONS; DIPPING SAUCES; GLUTEN-FREE PASTA; GRAVY MIXES; HOT SAUCE; PACKAGED MEAL KITS CONSISTING PRIMARILY OF PASTA OR RICE; PASTA; PASTA SAUCE; RICE CRACKERS (SENBEI); SAUCE MIXES; SAUCES; SOY SAUCE; TAPIOCA; TERIYAKI SAUCE; WORCESTERSHIRE SAUCE (U.S. CL. 46).

FIRST USE 10-26-1978; IN COMMERCE 10-26-1978.

**CLASS 32—LIGHT BEVERAGES**

FOR COCONUT MILK; COCONUT WATER (U.S. CLS. 45, 46 AND 48).

FIRST USE 10-26-1978; IN COMMERCE 10-26-1978.  
KEVIN CORWIN, EXAMINING ATTORNEY

SN 86-060,824. OHIO HEALTHCARE FEDERAL CREDIT UNION, DUBLIN, OH. FILED 9-10-2013.



NO CLAIM IS MADE TO THE EXCLUSIVE RIGHT TO USE "HEALTHCARE CREDIT UNION SYSTEM", APART FROM THE MARK AS SHOWN.

THE MARK CONSISTS OF THE WORDING "HEALTHCARE CREDIT UNION SYSTEM" ACCOMPANYING A DESIGN COMPRISING TWO L-SHAPED ELEMENTS ARRANGED TO FORM A SQUARE THEREBETWEEN AND TWO CROSSES FORMED AT THE INTERSECTIONS OF THE TWO L-SHAPED ELEMENTS.

**CLASS 35—ADVERTISING AND BUSINESS**

FOR BUSINESS SERVICES, NAMELY, PROVIDING AND ADMINISTERING AN ORGANIZATION OF MEMBER CREDIT UNIONS; PROMOTING THE BUSINESS INTERESTS OF MEMBER CREDIT UNIONS; PROMOTION OF CREDIT UNION SERVICES OF MEMBER CREDIT UNIONS; AND PROVIDING BACK OFFICE SOLUTIONS FOR MEMBER CREDIT UNIONS (U.S. CLS. 100, 101 AND 102).

**CLASS 36—INSURANCE AND FINANCIAL**

FOR CREDIT UNION SERVICES (U.S. CLS. 100, 101 AND 102).  
LUCY ARANT, EXAMINING ATTORNEY

SN 86-060,912. NOVA WILDCAT AMEROCK, LLC, MOORESVILLE, NC. FILED 9-10-2013.

**PIEDMONT**

THE MARK CONSISTS OF STANDARD CHARACTERS WITHOUT CLAIM TO ANY PARTICULAR FONT, STYLE, SIZE, OR COLOR.

**CLASS 6—METAL GOODS**

FOR CABINET HARDWARE OF METAL, NAMELY, DOOR AND DRAWER PULLS AND KNOBS, DOOR HINGES, AND DOOR AND DRAWER CATCHES; DESK HARDWARE OF METAL, NAMELY, LEVELERS, DRAWER STOPS, DRAWER PULLS, AND KNOBS; FURNITURE HARDWARE OF METAL, NAMELY, CHAIR FITTINGS AND CASTERS; SHELF HARDWARE OF METAL, NAMELY, SHELF SUPPORTS, SHELF BRACKETS, AND PEGS; COAT AND GARMENT HOOKS OF METAL; DOOR STOPS OF METAL; METAL HAND-RAIL BRACKETS; METAL PULLS, HINGES AND LATCHES FOR VENDING MACHINES, DISHWASHERS, WASHERS, OVENS AND REFRIGERATORS; METAL ROLLERS, PULLS AND LOCKS FOR WINDOWS AND SLIDING PATIO DOORS; FITTINGS OF METAL FOR WINDOWS, NAMELY, FINGER LIFTS, OPERATORS AND COUNTERBALANCING DEVICES; METAL KNOBS, HINGES, CABINET DOOR CATCHES, AND MOLDINGS; METAL DECORATIVE MOLDINGS; DOOR HARDWARE, NAMELY, METAL HINGES; METAL HARDWARE, NAMELY, PICTURE WIRE, PICTURE HOOKS, PICTURE RINGS, PICTURE HANGERS, MIRROR HOLDERS IN THE NATURE OF FASTENING ANCHORS, DRAPERY HOOKS, WALL FASTENING ANCHORS AND HOOKS FOR HANGING PLANTS, FRAME HANGERS, CUP HOOKS, CLOSET ROD BRACKETS, WARDROBE LOOPS, MAGNETIC HOOKS; METAL HARDWARE, NAMELY, METAL CABINET CATCHES, CLOSET ROD BRACKETS, WIRE, COAT AND HAT HOOKS, DOOR STOPS, GATE HOOKS AND EYES, KEYS FOR LOCKS, NAILS, CLOTHES HANGERS, SCREW EYES AND HOOKS, STORAGE HOOKS, SWAG AND SWIVEL HOOKS, WOODRUFF KEYS IN THE NATURE OF METAL FASTENERS, TURNBUCKLES, WALL ANCHORS, ANCHOR AND TOGGLE BOLTS, SCREWS, BOLTS, COTTER PINS, NUTS, WASHERS, TACKS, TENSION AND ESCUTCHEON PINS AND RIVETS; DOOR AND WINDOW HARDWARE MADE PRIMARILY OF METAL, NAMELY, PIVOT/BALANCE ASSEMBLIES CONSISTING OF BALANCE HOUSINGS/SHOES, ROTORS/CAMS AND PIVOT BARS, METAL TILT-LATCHES AND COMPONENTS THEREOF, NAMELY, HOUSINGS, LATCH BOLTS, ACTUATORS AND SPRINGS, METAL INSERT CLIPS AND SASH LOCKS; METAL CASEMENT WINDOW/AWNING COMPONENTS, NAMELY, OPERATORS, HINGES, LOCK ASSEMBLIES, CRANK HANDLES AND CASEMENT WINDOW SNUBBERS; METAL SWING/SLIDING/ENTRY DOOR COMPONENTS, NAMELY, DOOR HINGES, LOCK ASSEMBLIES CONSISTING OF LOCKS, STRIKE BARS AND EXTENSION BARS; METAL TRIM SETS, NAMELY, METAL DOOR HANDLES AND ESCUTCHEONS FOR DOORS; METAL ROLLER ASSEMBLIES FOR GARAGE DOORS CONSISTING OF METAL HOUSINGS, WHEELS/AXLES AND BALL BEARINGS, METAL DOOR HANDLES, AND METAL DOOR BALANCE SYSTEMS COMPRISING METAL BLOCK AND TACKLE BALANCES AND COIL BALANCES; METAL MASTER KEYS FOR LOCKS; METAL KEY RINGS (U.S. CLS. 2, 12, 13, 14, 23, 25 AND 50).



**CLASS 8—HAND TOOLS**

FOR APPLICATORS IN THE NATURE OF HAND TOOLS USED TO APPLY WALLCOVERINGS AND WALLCOVERING ADHESIVES; PLASTIC PUTTY KNIVES; WALLCOVERING TOOL KITS COMPOSED OF HAND-OPERATED ADHESIVE APPLICATOR PADS, TRIM KNIFE, PUSH PIN AND A PLUMB BOB; PLASTIC HAND OPERATED SMOOTHING TOOLS AND STRAIGHT EDGE TOOLS USED TO APPLY WALLCOVERINGS; PLASTIC SANDING BLOCKS; HAND-OPERATED METAL CUTTING TOOLS FOR MOLDINGS (U.S. CLS. 23, 28 AND 44).

**CLASS 16—PAPER GOODS AND PRINTED MATTER**

FOR PAINTING TOOLS, NAMELY, FOAM PAINT BRUSHES; PAINT TRAYS; TRAY KITS CONSISTING OF FOAM PAINT BRUSHES AND PAINT APPLICATORS; FLAT PAD TYPE APPLICATORS FOR APPLYING PAINTS, STAINS, AND VARNISHES; ROLLER TYPE PAINT APPLICATOR WITH SPLATTER SHIELD; TEXTURED PAINT ROLLER COVERS; AND TEXTURING KIT CONSISTING OF PAINT ROLLER AND SHIELD AND SMALL PAINT ROLLER AND PAINT PAD; PAINT APPLICATORS, NAMELY, PAINT EDGERS, PAINT APPLICATORS, PAINT ROLLERS, REPLACEMENT PAINT EDGER PADS AND APPLICATOR PADS, REPLACEMENT COVERS FOR ROLLERS, BRUSH HANDLE EXTENDERS; PUSH PINS AND THUMB TACKS; SELF-ADHESIVE PADS AND MOUNTING TAPES FOR HOUSEHOLD USE FOR MOUNTING HOOKS AND HANGERS ON WALLS (U.S. CLS. 2, 5, 22, 23, 29, 37, 38 AND 50).

**CLASS 20—FURNITURE AND ARTICLES NOT OTHERWISE CLASSIFIED**

FOR NON-METAL CABINET HARDWARE, NAMELY, HINGES, DOOR CATCHES, DRAWER CATCHES, PLASTIC AND WOOD PULLS, AND PLASTIC AND WOOD KNOBS; NON-METAL DESK HARDWARE, NAMELY, LEVELERS, DRAWER STOPS, DRAWER BUMPERS, PLASTIC AND WOOD PULLS, AND PLASTIC AND WOOD KNOBS; NONMETAL SHELF HARDWARE, NAMELY, SHELF SUPPORTS, SHELF BRACKETS, AND PEGS; NON-METAL COAT HOOKS; PLASTIC HARDWARE, NAMELY, PICTURE HOOKS, PICTURE HANGERS, STICK MOUNTS AND TAP MOUNTS IN THE NATURE OF NON-METAL HOOKS, WALL ANCHORS, ANCHOR AND TOGGLE BOLTS AND STORAGE HOOKS; DOOR STOPS OF PLASTIC AND WOOD; DECORATIVE DRAPERY HARDWARE, NAMELY, CURTAIN RODS, POLES, FINIALS, NON-METAL CURTAIN RINGS AND CURTAIN TIE-BACKS IN THE NATURE OF NON-METAL CURTAIN HOLDERS; DOOR AND WINDOW HARDWARE MADE PRIMARILY OF PLASTIC, NAMELY, PIVOT/BALANCE ASSEMBLIES CONSISTING OF BALANCE HOUSINGS/SHOES, ROTORS/CAMS AND PIVOT BARS, PLASTIC BALANCE PLUGS, BALANCE ANCHORS, HOLE PLUGS, FLANKER STOPS, WINDOW AND DOOR HANDLES, PIVOT BARS, PIVOT CORNERS, TILT-LATCHES AND COMPONENTS THEREOF, NAMELY, HOUSINGS, LATCH BOLTS, ACTUATORS AND SPRINGS, PLASTIC MUNTIN CLIPS, MUNTIN JOINERS, GAS PLUGS, PLUNGERS AND CAPS, PLASTIC SLIDE BOLTS, INSERT CLIPS, SCREEN CORNERS, SCREEN AND GLASS LIFTS, ROLLER ASSEMBLIES CONSISTING OF HOUSINGS, WHEELS/AXLES AND BALL BEARINGS, ROTARY ACTUATORS, SASH LOCKS, CASEMENT WINDOW SNUBBERS, VENT STOPS, WEEP HOLE COVERS, HOPPER HANDLES AND KEEPERS, AND TILT AND TURN SHOE ASSEMBLIES CONSISTING OF HOUSINGS/SHOES, ROTORS/CAMS, BRAKE MEMBERS AND PIVOT BARS; FURNITURE HARDWARE, NAMELY, METAL DRAWER SLIDES; METAL CURTAIN RODS; METAL SHOWER CURTAIN RINGS; DECORATIVE DRAPERY HARDWARE, NAMELY, CURTAIN RODS, POLES, FINIALS, METAL CURTAIN RINGS AND CURTAIN TIE-BACKS IN THE NATURE OF NON-TEXTILE CURTAIN HOLDERS; SELFADHESIVE POLYURETHANE PADS FOR PLACEMENT ON THE UNDERSIDE OF TRAYS TO PREVENT SLIDING AND/OR SCRATCHING; DOOR, CABINET

AND DESK HARDWARE, NAMELY, CERAMIC AND GLASS PULLS AND KNOBS (U.S. CLS. 2, 13, 22, 25, 32 AND 50).

**CLASS 21—HOUSEWARES AND GLASS**

FOR TOWEL BARS; TOWEL RINGS; TOILET TISSUE HOLDERS; TOILET TISSUE DISPENSERS; CLEANING AND POLISHING PADS FOR USE IN WAXING, WASHING, AND WIPING SURFACES (U.S. CLS. 2, 13, 23, 29, 30, 33, 40 AND 50).

STEVEN PEREZ, EXAMINING ATTORNEY

SN 86-060,936, NOVA WILDCAT AMEROCK, LLC, MOORVILLE, NC. FILED 9-10-2013.

**PIEDMONT HARDWARE BRANDS**

THE MARK CONSISTS OF STANDARD CHARACTERS WITHOUT CLAIM TO ANY PARTICULAR FONT, STYLE, SIZE, OR COLOR.

NO CLAIM IS MADE TO THE EXCLUSIVE RIGHT TO USE "HARDWARE BRANDS", APART FROM THE MARK AS SHOWN.

**CLASS 6—METAL GOODS**

FOR CABINET HARDWARE OF METAL, NAMELY, DOOR AND DRAWER PULLS AND KNOBS, DOOR HINGES, AND DOOR AND DRAWER CATCHES; DESK HARDWARE OF METAL, NAMELY, LEVELERS, DRAWER STOPS, DRAWER PULLS, AND KNOBS; FURNITURE HARDWARE OF METAL, NAMELY, CHAIR FITTINGS AND CASTERS; SHELF HARDWARE OF METAL, NAMELY, SHELF SUPPORTS, SHELF BRACKETS, AND PEGS; COAT AND GARMENT HOOKS OF METAL; DOOR STOPS OF METAL; METAL HANDRAIL BRACKETS; METAL PULLS, HINGES AND LATCHES FOR VENDING MACHINES, DISHWASHERS, WASHERS, OVENS AND REFRIGERATORS; METAL ROLLERS, PULLS AND LOCKS FOR WINDOWS AND SLIDING PATIO DOORS; FITTINGS OF METAL FOR WINDOWS, NAMELY, FINGER LIFTS, OPERATORS AND COUNTERBALANCING DEVICES; METAL KNOBS, HINGES, CABINET DOOR CATCHES, AND MOLDINGS; METAL DECORATIVE MOLDINGS; DOOR HARDWARE, NAMELY, METAL HINGES; METAL HARDWARE, NAMELY, PICTURE WIRE, PICTURE HOOKS, PICTURE RINGS, PICTURE HANGERS, MIRROR HOLDERS IN THE NATURE OF FASTENING ANCHORS, DRAPERY HOOKS, WALL FASTENING ANCHORS AND HOOKS FOR HANGING PLANTS, FRAME HANGERS, CUP HOOKS, CLOSET ROD BRACKETS, WARDROBE LOOPS, MAGNETIC HOOKS; METAL HARDWARE, NAMELY, METAL CABINET CATCHES, CLOSET ROD BRACKETS, WIRE, COAT AND HAT HOOKS, DOOR STOPS, GATE HOOKS AND EYES, KEYS FOR LOCKS, NAILS, CLOTHES HANGERS, SCREW EYES AND HOOKS, STORAGE HOOKS, SWAG AND SWIVEL HOOKS, WOODRUFF KEYS IN THE NATURE OF METAL FASTENERS, TURNBUCKLES, WALL ANCHORS, ANCHOR AND TOGGLE BOLTS, SCREWS, BOLTS, COTTER PINS, NUTS, WASHERS, TACKS, TENSION AND ESCUTCHEON PINS AND RIVETS; DOOR AND WINDOW HARDWARE MADE PRIMARILY OF METAL, NAMELY, PIVOT/BALANCE ASSEMBLIES CONSISTING OF BALANCE HOUSINGS/SHOES, ROTORS/CAMS AND PIVOT BARS, METAL TILT-LATCHES AND COMPONENTS THEREOF, NAMELY, HOUSINGS, LATCH BOLTS, ACTUATORS AND SPRINGS, METAL INSERT CLIPS AND SASH LOCKS; METAL CASEMENT WINDOW/AWNING COMPONENTS, NAMELY, OPERATORS, HINGES, LOCK ASSEMBLIES, CRANK HANDLES AND CASEMENT WINDOW SNUBBERS; METAL SWING/SLIDING/ENTRY DOOR COMPONENTS, NAMELY, DOOR HINGES,

LOCK ASSEMBLIES CONSISTING OF LOCKS, STRIKE BARS AND EXTENSION BARS; METAL TRIM SETS, NAMELY, METAL DOOR HANDLES AND ESCUTCHEONS FOR DOORS; METAL ROLLER ASSEMBLIES FOR GARAGE DOORS CONSISTING OF METAL HOUSINGS, WHEELS/AXLES AND BALL BEARINGS, METAL DOOR HANDLES, AND METAL DOOR BALANCE SYSTEMS COMPRISING METAL BLOCK AND TACKLE BALANCES AND COIL BALANCES; METAL MASTER KEYS FOR LOCKS; METAL KEY RINGS (U.S. CLS. 2, 12, 13, 14, 23, 25 AND 50).

#### **CLASS 8—HAND TOOLS**

FOR APPLICATORS IN THE NATURE OF HAND TOOLS USED TO APPLY WALLCOVERINGS AND WALLCOVERING ADHESIVES; PLASTIC PUTTY KNIVES; WALLCOVERING TOOL KITS COMPOSED OF HAND-OPERATED ADHESIVE APPLICATOR PADS, TRIM KNIFE, PUSH PIN AND A PLUMB BOB; PLASTIC HAND OPERATED SMOOTHING TOOLS AND STRAIGHT EDGE TOOLS USED TO APPLY WALLCOVERINGS; PLASTIC SANDING BLOCKS; HAND-OPERATED METAL CUTTING TOOLS FOR MOLDINGS (U.S. CLS. 23, 28 AND 44).

#### **CLASS 16—PAPER GOODS AND PRINTED MATTER**

FOR PAINTING TOOLS, NAMELY, FOAM PAINT BRUSHES; PAINT TRAYS; TRAY KITS CONSISTING OF FOAM PAINT BRUSHES AND PAINT APPLICATORS; FLAT PAD TYPE APPLICATORS FOR APPLYING PAINTS, STAINS, AND VARNISHES; ROLLER TYPE PAINT APPLICATOR WITH SPLATTER SHIELD; TEXTURED PAINT ROLLER COVERS; AND TEXTURING KIT CONSISTING OF PAINT ROLLER AND SHIELD AND SMALL PAINT ROLLER AND PAINT PAD; PAINT APPLICATORS, NAMELY, PAINT EDGERS, PAINT APPLICATORS, PAINT ROLLERS, REPLACEMENT PAINT EDGER PADS AND APPLICATOR PADS, REPLACEMENT COVERS FOR ROLLERS, BRUSH HANDLE EXTENDERS; PUSH PINS AND THUMB TACKS; SELF-ADHESIVE PADS AND MOUNTING TAPES FOR HOUSEHOLD USE FOR MOUNTING HOOKS AND HANGERS ON WALLS (U.S. CLS. 2, 5, 22, 23, 29, 37, 38 AND 50).

#### **CLASS 20—FURNITURE AND ARTICLES NOT OTHERWISE CLASSIFIED**

FOR NON-METAL CABINET HARDWARE, NAMELY, HINGES, DOOR CATCHES, DRAWER CATCHES, PLASTIC AND WOOD PULLS, AND PLASTIC AND WOOD KNOBS; NON-METAL DESK HARDWARE, NAMELY, LEVELERS, DRAWER STOPS, DRAWER BUMPERS, PLASTIC AND WOOD PULLS, AND PLASTIC AND WOOD KNOBS; NONMETAL SHELF HARDWARE, NAMELY, SHELF SUPPORTS, SHELF BRACKETS, AND PEGS; NON-METAL COAT HOOKS; PLASTIC HARDWARE, NAMELY, PICTURE HOOKS, PICTURE HANGERS, STICK MOUNTS AND TAP MOUNTS IN THE NATURE OF NON-METAL HOOKS, WALL ANCHORS, ANCHOR AND TOGGLE BOLTS AND STORAGE HOOKS; DOOR STOPS OF PLASTIC AND WOOD; DECORATIVE DRAPERY HARDWARE, NAMELY, CURTAIN RODS, POLES, FINIALS, NON-METAL CURTAIN RINGS AND CURTAIN TIE-BACKS IN THE NATURE OF NON-METAL CURTAIN HOLDERS; DOOR AND WINDOW HARDWARE MADE PRIMARILY OF PLASTIC, NAMELY, PIVOT/BALANCE ASSEMBLIES CONSISTING OF BALANCE HOUSINGS/SHOES, ROTORS/CAMS AND PIVOT BARS, PLASTIC BALANCE PLUGS, BALANCE ANCHORS, HOLE PLUGS, FLANKER STOPS, WINDOW AND DOOR HANDLES, PIVOT BARS, PIVOT CORNERS, TILT-LATCHES AND COMPONENTS THEREOF, NAMELY, HOUSINGS, LATCH BOLTS, ACTUATORS AND SPRINGS, PLASTIC MUNTIN CLIPS, MUNTIN JOINERS, GAS PLUGS, PLUNGERS AND CAPS, PLASTIC SLIDE BOLTS, INSERT CLIPS, SCREEN CORNERS, SCREEN AND GLASS LIFTS, ROLLER ASSEMBLIES CONSISTING OF HOUSINGS, WHEELS/AXLES AND BALL BEARINGS, ROTARY ACTUATORS, SASH LOCKS, CASEMENT WINDOW SNUBBERS, VENT STOPS, WEEP HOLE COVERS, HOPPER HANDLES AND KEEPERS, AND TILT AND TURN SHOE ASSEMBLIES

CONSISTING OF HOUSINGS/SHOES, ROTORS/CAMS, BRAKE MEMBERS AND PIVOT BARS; FURNITURE HARDWARE, NAMELY, METAL DRAWER SLIDES; METAL CURTAIN RODS; METAL SHOWER CURTAIN RINGS; DECORATIVE DRAPERY HARDWARE, NAMELY, CURTAIN RODS, POLES, FINIALS, METAL CURTAIN RINGS AND CURTAIN TIE-BACKS IN THE NATURE OF NON-TEXTILE CURTAIN HOLDERS; SELFADHESIVE POLYURETHANE PADS FOR PLACEMENT ON THE UNDERSIDE OF TRAYS TO PREVENT SLIDING AND/OR SCRATCHING; DOOR, CABINET AND DESK HARDWARE, NAMELY, CERAMIC AND GLASS PULLS AND KNOBS (U.S. CLS. 2, 13, 22, 25, 32 AND 50).

#### **CLASS 21—HOUSEWARES AND GLASS**

FOR TOWEL BARS; TOWEL RINGS; TOILET TISSUE HOLDERS; TOILET TISSUE DISPENSERS; CLEANING AND POLISHING PADS FOR USE IN WAXING, WASHING, AND WIPING SURFACES (U.S. CLS. 2, 13, 23, 29, 30, 33, 40 AND 50).

STEVEN PEREZ, EXAMINING ATTORNEY

SN 86-061,319. SQUARE ENIX LIMITED, WIMBLEDON, UNITED KINGDOM, FILED 9-11-2013.

## **HITMAN SNIPER**

THE MARK CONSISTS OF STANDARD CHARACTERS WITHOUT CLAIM TO ANY PARTICULAR FONT, STYLE, SIZE, OR COLOR.

PRIORITY CLAIMED UNDER SEC. 44(D) ON UNITED KINGDOM APPLICATION NO. 3021369, FILED 9-10-2013, REG. NO. 3021369, DATED 12-13-2013, EXPIRES 9-10-2023.

OWNER OF U.S. REG. NOS. 2,724,811, 4,416,731 AND OTHERS.

NO CLAIM IS MADE TO THE EXCLUSIVE RIGHT TO USE "SNIPER", APART FROM THE MARK AS SHOWN.

#### **CLASS 9—ELECTRICAL AND SCIENTIFIC APPARATUS**

FOR COMPUTER GAME SOFTWARE; COMPUTER GAMES RECORDED ON COMPUTER DISCS; VIDEO GAME SOFTWARE; VIDEO GAMES RECORDED ON COMPUTER DISCS; ELECTRONIC GAME SOFTWARE FOR MOBILE PHONES; DOWNLOADABLE ELECTRONIC PUBLICATIONS IN THE NATURE OF NEWSLETTERS AND MAGAZINES FEATURING ELECTRONIC GAMES, COMPUTER GAME STRATEGY GUIDES FEATURING INFORMATION ABOUT VIDEO, COMPUTER, AND ELECTRONIC GAMES PROVIDED BY MEANS OF MULTI-MEDIA ELECTRONIC BROADCAST OR NETWORK TRANSMISSION; DOWNLOADABLE DATA IN THE NATURE OF DOWNLOADABLE ELECTRONIC GAMES FEATURING INFORMATION ABOUT VIDEO, COMPUTER AND ELECTRONIC GAMES PROVIDED BY MEANS OF MULTI-MEDIA ELECTRONIC BROADCAST OR NETWORK TRANSMISSION, DISKS AND TAPES PRE-RECORDED WITH COMPUTER GAME SOFTWARE, VIDEO GAME SOFTWARE, OR OTHER ELECTRONIC PUBLICATIONS IN THE NATURE OF GAME GUIDES HAVING GAMES AS THEIR SUBJECT MATTER (U.S. CLS. 21, 23, 26, 36 AND 38).

**CLASS 41—EDUCATION AND ENTERTAINMENT**

FOR ENTERTAINMENT SERVICES, NAMELY, PROVIDING ON-LINE COMPUTER GAMES, VIDEO GAMES, TEMPORARY USE OF NONDOWNLOADABLE INTERACTIVE GAMES, AND VIDEO GAMES PROVIDED ON-LINE FROM DATABASES OR WEB SITES AND GLOBAL COMPUTER NETWORKS; AND PUBLICATION OF BOOKS, MAGAZINES, AND MANUALS RELATING TO COMPUTER GAMES, VIDEO GAMES, AND ON-LINE COMPUTER GAMES (U.S. CLS. 100, 101 AND 107).

KHANH LE, EXAMINING ATTORNEY

SN 86-061,652. RESPONSE GENETICS, INC., NEW YORK, NY. FILED 9-11-2013.

 The logo for Response Genetics features the word "RESPONSE" in a large, bold, sans-serif font above the word "GENETICS" in a smaller, spaced-out, sans-serif font. To the left of the text are several horizontal lines of varying lengths, resembling a stylized DNA helix or a barcode.

OWNER OF U.S. REG. NOS. 2,800,718, 4,067,404 AND OTHERS.

NO CLAIM IS MADE TO THE EXCLUSIVE RIGHT TO USE "GENETICS", APART FROM THE MARK AS SHOWN.

**CLASS 41—EDUCATION AND ENTERTAINMENT**

FOR EDUCATIONAL SERVICES, NAMELY, PROVIDING ONLINE WEBINARS, WORKSHOPS AND SPECIALIZED TRAINING IN THE FIELD OF MEDICINE (U.S. CLS. 100, 101 AND 107).

**CLASS 42—SCIENTIFIC AND COMPUTER SERVICES**

FOR MEDICAL SERVICES, NAMELY, RESEARCH, TESTING AND ANALYSIS OF HUMAN TISSUES AND BODY FLUIDS FOR MEDICAL RESEARCH PURPOSES; PROVIDING AN ON-LINE COMPUTER DATABASE AND INTERFACE IN THE FIELD OF MEDICINE FOR RESEARCH PURPOSES; PROVIDING TEMPORARY USE OF ONLINE NON-DOWNLOADABLE SOFTWARE FOR PROVIDING AN INTERFACE BETWEEN A COMPUTER DATABASE FEATURING MEDICAL INFORMATION AND THE USER (U.S. CLS. 100 AND 101).

**CLASS 44—MEDICAL, BEAUTY AND AGRICULTURAL SERVICES**

FOR MEDICAL SERVICES, NAMELY, TESTING AND ANALYSIS OF HUMAN TISSUES AND BODY FLUIDS FOR DIAGNOSTIC AND TREATMENT PURPOSES; PROVIDING MEDICAL-RELATED INFORMATION ON MEDICAL TREATMENTS, MEDICAL RESULTS, PATIENTS AND PHARMACEUTICALS; PROVIDING AN ON-LINE COMPUTER DATABASE IN THE FIELD OF MEDICINE FOR DIAGNOSTIC AND TREATMENT PURPOSES (U.S. CLS. 100 AND 101).

AMY HELLA, EXAMINING ATTORNEY

SN 86-061,926. TAT & G, LLC, TA ZEKE'S COFFEE, BALTIMORE, MD. FILED 9-11-2013.

 The logo for Zeke's Coffee consists of the words "ZEKE'S COFFEE" in a bold, serif font. The letters are closely spaced and have a classic, slightly ornate appearance.

THE MARK CONSISTS OF STANDARD CHARACTERS WITHOUT CLAIM TO ANY PARTICULAR FONT, STYLE, SIZE, OR COLOR.

NO CLAIM IS MADE TO THE EXCLUSIVE RIGHT TO USE "COFFEE", APART FROM THE MARK AS SHOWN.

**CLASS 25—CLOTHING**

FOR ATHLETIC APPAREL, NAMELY, SHIRTS, PANTS, JACKETS, FOOTWEAR, HATS AND CAPS, ATHLETIC UNIFORMS (U.S. CLS. 22 AND 39).

FIRST USE 11-6-2005; IN COMMERCE 11-6-2005.

SN 86-061,325. SQUARE ENIX LIMITED, WIMBLEDON, UNITED KINGDOM, FILED 9-11-2013.

 The logo for Hitman Go features the words "HITMAN GO" in a bold, sans-serif font. The letters are widely spaced, giving it a clean, modern look.

THE MARK CONSISTS OF STANDARD CHARACTERS WITHOUT CLAIM TO ANY PARTICULAR FONT, STYLE, SIZE, OR COLOR.

PRIORITY CLAIMED UNDER SEC. 44(D) ON UNITED KINGDOM APPLICATION NO. 3021374, FILED 9-10-2013, REG. NO. 3021374, DATED 12-6-2013, EXPIRES 9-10-2023.

OWNER OF U.S. REG. NOS. 2,690,302, 4,218,790 AND OTHERS.

**CLASS 9—ELECTRICAL AND SCIENTIFIC APPARATUS**

FOR COMPUTER GAME SOFTWARE; COMPUTER GAMES RECORDED ON COMPUTER DISCS; VIDEO GAME SOFTWARE; VIDEO GAMES RECORDED ON COMPUTER DISCS; ELECTRONIC GAME SOFTWARE FOR MOBILE PHONES; DOWNLOADABLE ELECTRONIC PUBLICATIONS IN THE NATURE OF NEWSLETTERS AND MAGAZINES FEATURING ELECTRONIC GAMES, COMPUTER GAME STRATEGY GUIDES FEATURING INFORMATION ABOUT VIDEO, COMPUTER, AND ELECTRONIC GAMES PROVIDED BY MEANS OF MULTI-MEDIA ELECTRONIC BROADCAST OR NETWORK TRANSMISSION; DOWNLOADABLE DATA IN THE NATURE OF DOWNLOADABLE ELECTRONIC GAMES FEATURING INFORMATION ABOUT VIDEO, COMPUTER AND ELECTRONIC GAMES PROVIDED BY MEANS OF MULTI-MEDIA ELECTRONIC BROADCAST OR NETWORK TRANSMISSION, DISKS AND TAPES PRE-RECORDED WITH COMPUTER GAME SOFTWARE, VIDEO GAME SOFTWARE, OR OTHER ELECTRONIC PUBLICATIONS IN THE NATURE OF GAME GUIDES HAVING GAMES AS THEIR SUBJECT MATTER (U.S. CLS. 21, 23, 26, 36 AND 38).

**CLASS 41—EDUCATION AND ENTERTAINMENT**

FOR ENTERTAINMENT SERVICES, NAMELY, PROVIDING ON-LINE COMPUTER GAMES, VIDEO GAMES, TEMPORARY USE OF NONDOWNLOADABLE INTERACTIVE GAMES, AND VIDEO GAMES PROVIDED ON-LINE FROM DATABASES OR WEB SITES AND GLOBAL COMPUTER NETWORKS; AND PUBLICATION OF BOOKS, MAGAZINES, AND MANUALS RELATING TO COMPUTER GAMES, VIDEO GAMES, AND ON-LINE COMPUTER GAMES (U.S. CLS. 100, 101 AND 107).

KHANH LE, EXAMINING ATTORNEY

**CLASS 30—STAPLE FOODS**

FOR BEVERAGES MADE OF COFFEE; CAFFEINE-FREE COFFEE; COFFEE; COFFEE BEANS; GROUND COFFEE BEANS; ICED COFFEE; PREPARED COFFEE AND COFFEE-BASED BEVERAGES; ROASTED COFFEE BEANS (U.S. CL. 46).

FIRST USE 11-6-2005; IN COMMERCE 11-6-2005.  
MATTHEW EINSTEIN, EXAMINING ATTORNEY

SN 86-061,969. TAT & G, LLC, TA ZEKE'S COFFEE, BALTIMORE, MD. FILED 9-11-2013.



NO CLAIM IS MADE TO THE EXCLUSIVE RIGHT TO USE "COFFEE", APART FROM THE MARK AS SHOWN. THE MARK CONSISTS OF DESIGN OF STYLIZED WORDS "ZEKE'S COFFEE" WITH BANNER.

**CLASS 25—CLOTHING**

FOR ATHLETIC APPAREL, NAMELY, SHIRTS, PANTS, JACKETS, FOOTWEAR, HATS AND CAPS, ATHLETIC UNIFORMS (U.S. CLS. 22 AND 39).  
FIRST USE 11-6-2005; IN COMMERCE 11-6-2005.

**CLASS 30—STAPLE FOODS**

FOR BEVERAGES MADE OF COFFEE; CAFFEINE-FREE COFFEE; COFFEE; COFFEE BEANS; GROUND COFFEE BEANS; ICED COFFEE; PREPARED COFFEE AND COFFEE-BASED BEVERAGES; ROASTED COFFEE BEANS (U.S. CL. 46).

FIRST USE 11-6-2005; IN COMMERCE 11-6-2005.  
MATTHEW EINSTEIN, EXAMINING ATTORNEY

SN 86-062,274. CHOW TAI FOOK JEWELLERY CO., LTD., HONG KONG, HONG KONG, FILED 9-11-2013.



OWNER OF HONG KONG REG. NO. 199602725AA, DATED 3-2-1992, EXPIRES 3-2-2023.

OWNER OF HONG KONG REG. NO. 199712161, DATED 2-10-1992, EXPIRES 2-10-2023.

OWNER OF U.S. REG. NO. 4,352,803.

THE MARK CONSISTS OF THREE CHINESE CHARACTERS.

THE NON-LATIN CHARACTERS IN THE MARK TRANSLATE TO "CHOW", "TAI", "FOOK" IN CANTONESE, AND "ZHOU", "DA", "FU" IN MANDARIN, RESPECTIVELY. THE CHARACTER FOR "CHOW" OR "ZHOU" REFERS TO A SURNAME OR CAN HAVE THE MEANING OF WEEK OR CIRCUMFERENCE. THE CHARACTER FOR "TAI" OR "DA" HAS THE MEANING OF BIG OR GREAT. THE CHARACTER FOR "FOOK" OR "FU" HAS THE MEANING OF "FORTUNE".

**CLASS 14—JEWELRY**

FOR PRECIOUS METALS AND THEIR ALLOYS; GOODS IN PRECIOUS METALS OR COATED THEREWITH, NOT INCLUDED IN OTHER CLASSES, NAMELY, CHARMS, FIGURINES, STATUES, STATUETTES, NON-MONETARY COINS; JEWELRY; COSTUME JEWELRY; BODY JEWELRY; PASTE JEWELRY; PRECIOUS STONES; PEARLS; PASTE GEMS, NAMELY, CUT GLASS THAT RESEMBLES GEMSTONES (U.S. CLS. 2, 27, 28 AND 50).

**CLASS 35—ADVERTISING AND BUSINESS**

FOR ONLINE RETAIL STORE SERVICES FEATURING JEWELRY, PRECIOUS STONES, HOROLOGICAL AND CHRONOMETRIC INSTRUMENTS, AND GOODS IN PRECIOUS METALS OR COATED THEREWITH; RETAIL STORE SERVICES FEATURING JEWELRY, PRECIOUS STONES, HOROLOGICAL AND CHRONOMETRIC INSTRUMENTS, AND GOODS IN PRECIOUS METALS OR COATED THEREWITH (U.S. CLS. 100, 101 AND 102).

KATHY WANG, EXAMINING ATTORNEY

SN 86-062,290. CHOW TAI FOOK JEWELLERY CO., LTD., HONG KONG, HONG KONG, FILED 9-11-2013.

**CHOW TAI FOOK**

THE MARK CONSISTS OF STANDARD CHARACTERS WITHOUT CLAIM TO ANY PARTICULAR FONT, STYLE, SIZE, OR COLOR.

OWNER OF HONG KONG REG. NO. 199602721AA, DATED 3-2-1992, EXPIRES 3-2-2023.

OWNER OF HONG KONG REG. NO. 199710362, DATED 2-10-1992, EXPIRES 2-10-2023.

OWNER OF U.S. REG. NO. 4,352,803.

THE WORD "CHOW" IS THE CANTONESE TRANSLITERATION OF A CHINESE CHARACTER THAT REFERS TO A SURNAME OR CAN HAVE THE MEANING OF WEEK OR CIRCUMFERENCE. THE WORD "TAI" IS THE CANTONESE TRANSLITERATION OF A CHINESE CHARACTER THAT HAS THE MEANING OF BIG OR GREAT. THE WORD "FOOK" IS THE CANTONESE TRANSLITERATION OF A CHINESE CHARACTER THAT HAS THE MEANING OF "FORTUNE".

**CLASS 14—JEWELRY**

FOR PRECIOUS METALS AND THEIR ALLOYS; GOODS IN PRECIOUS METALS OR COATED THEREWITH, NOT INCLUDED IN OTHER CLASSES, NAMELY, CHARMS, FIGURINES, STATUES, STATUETTES, NON-MONETARY COINS; JEWELRY; COSTUME JEWELRY; BODY JEWELRY; PASTE JEWELRY; PRECIOUS STONES; PEARLS; PASTE GEMS, NAMELY, CUT GLASS THAT RESEMBLES GEMSTONES (U.S. CLS. 2, 27, 28 AND 50).

**CLASS 35—ADVERTISING AND BUSINESS**

FOR ONLINE RETAIL STORE SERVICES FEATURING JEWELRY, PRECIOUS STONES, HOROLOGICAL AND CHRONOMETRIC INSTRUMENTS, AND GOODS IN PRECIOUS METALS OR COATED THEREWITH; RETAIL STORE SERVICES FEATURING JEWELRY, PRECIOUS STONES, HOROLOGICAL AND CHRONOMETRIC INSTRUMENTS, AND GOODS IN PRECIOUS METALS OR COATED THEREWITH (U.S. CLS. 100, 101 AND 102).

KATHY WANG, EXAMINING ATTORNEY

SN 86-062,469. LAMDA LIMITED, LONDON, UNITED KINGDOM, FILED 9-12-2013.

LAMDA

THE MARK CONSISTS OF STANDARD CHARACTERS WITHOUT CLAIM TO ANY PARTICULAR FONT, STYLE, SIZE, OR COLOR.

**CLASS 9—ELECTRICAL AND SCIENTIFIC APPARATUS**

FOR PRE-RECORDED CDS, DVDS, AND CD ROMS FEATURING SOUND AND VIDEO IN THE FIELDS OF ARTISTIC PERFORMANCES AND INSTRUCTION IN THE FIELDS OF MUSIC, SPEECH, DRAMA AND BUSINESS LEADERSHIP; AUDIO RECORDINGS, VIDEO RECORDINGS FEATURING ARTISTIC PERFORMANCES AND INSTRUCTION IN THE FIELDS OF MUSIC, SPEECH, DRAMA AND BUSINESS LEADERSHIP; DOWNLOADABLE MULTIMEDIA FILES FEATURING MUSIC, SOUNDS, IMAGES, TEXT, AND INFORMATION IN THE FIELDS OF ARTISTIC PERFORMANCES AND INSTRUCTION IN THE FIELDS OF MUSIC, SPEECH, DRAMA AND BUSINESS LEADERSHIP PROVIDED VIA TELECOMMUNICATIONS NETWORKS, BY ON-LINE DELIVERY AND BY THE INTERNET; DOWNLOADABLE PUBLICATIONS IN ELECTRONIC FORM SUPPLIED ON-LINE, FROM DATABASES OR FROM FACILITIES PROVIDED ON THE INTERNET, NAMELY, BOOKS, MAGAZINES, AND JOURNALS IN THE FIELD OF ARTISTIC PERFORMANCE AND INSTRUCTION IN THE FIELDS OF MUSIC, SPEECH, DRAMA AND BUSINESS LEADERSHIP (U.S. CLS. 21, 23, 26, 36 AND 38).

**CLASS 16—PAPER GOODS AND PRINTED MATTER**

FOR BOOKS, MAGAZINES, JOURNALS, PRINTED PUBLICATIONS, NAMELY, TEXTBOOKS, GUIDEBOOKS, INSTRUCTION MANUALS, AND REFERENCE WORKS IN THE FIELDS OF ARTISTIC PERFORMANCE AND INSTRUCTION IN THE FIELDS OF MUSIC, SPEECH, DRAMA AND BUSINESS LEADERSHIP; PHOTOGRAPHS; STATIONERY; FOLDERS, LOOSE-LEAF BINDERS; PRINTED INSTRUCTIONAL AND TEACHING MATERIALS IN THE FIELDS OF ARTISTIC PERFORMANCE AND INSTRUCTION IN THE FIELDS OF MUSIC, SPEECH, DRAMA AND BUSINESS LEADERSHIP (U.S. CLS. 2, 5, 22, 23, 29, 37, 38 AND 50).

**CLASS 36—INSURANCE AND FINANCIAL**

FOR CHARITABLE FUND RAISING; ORGANIZATION OF CHARITABLE COLLECTIONS, NAMELY, CHARITABLE FUNDRAISING SERVICES BY MEANS OF ORGANIZING AND CONDUCTING SPECIAL EVENTS FEATURING ART OR ALTERNATIVES TO ART, NAMELY, MUSIC, SPEECH AND DRAMA PERFORMANCES (U.S. CLS. 100, 101 AND 102).

**CLASS 38—COMMUNICATION**

FOR STREAMING MULTIMEDIA FILES, NAMELY, OF AUDIO, VISUAL AND AUDIOVISUAL MATERIAL FEATURING MUSIC, SOUNDS, IMAGES, TEXT, AND INFORMATION IN THE FIELDS OF ARTISTIC PERFORMANCES AND INSTRUCTION IN THE FIELDS OF MUSIC, SPEECH, DRAMA AND BUSINESS LEADERSHIP PROVIDED VIA TELECOMMUNICATIONS NETWORKS, BY ON-LINE DELIVERY AND BY THE INTERNET CLASSES AND WORKSHOPS IN RELATION TO PUBLIC SPEAKING; STREAMING MULTIMEDIA FILES, NAMELY, OF AUDIO, VISUAL AND AUDIOVISUAL MATERIAL FEATURING MUSIC, SOUNDS, IMAGES, TEXT, AND INFORMATION IN THE FIELDS OF ARTISTIC PERFORMANCES AND INSTRUCTION IN THE FIELDS OF MUSIC, SPEECH, DRAMA AND BUSINESS LEADERSHIP PROVIDED VIA TELECOMMUNICATIONS NETWORKS, BY ON-LINE DELIVERY AND BY THE INTERNET (U.S. CLS. 100, 101 AND 104).

**CLASS 41—EDUCATION AND ENTERTAINMENT**

FOR TRAINING IN RELATION TO MUSIC, SPEECH AND DRAMA; TRAINING IN RELATION TO BUSINESS LEADERSHIP; TRAINING IN RELATION TO PUBLIC SPEAKING; EDUCATION, NAMELY, PROVIDING CLASSES AND WORKSHOPS IN RELATION TO MUSIC, SPEECH AND DRAMA; EDUCATION, NAMELY, PROVIDING CLASSES AND WORKSHOPS IN RELATION TO BUSINESS LEADERSHIP; EDUCATION, NAMELY, PROVIDING CLASSES AND WORKSHOPS IN RELATION TO PUBLIC SPEAKING; ENTERTAINMENT SERVICES, NAMELY, ORGANIZATION OF MUSIC, SPEECH AND DRAMA PERFORMANCES; ORGANIZATION OF EXAMINATIONS, NAMELY, EDUCATIONAL EXAMINATION SERVICES; EDUCATION, EXAMINATION AND ENTERTAINMENT SERVICES, NAMELY, PROVIDING A WEBSITE FEATURING NON-DOWNLOADABLE MULTIMEDIA FILES FEATURING MUSIC, SOUNDS, IMAGES, TEXT, AND INFORMATION IN THE FIELDS OF ARTISTIC PERFORMANCES AND INSTRUCTION IN THE FIELDS OF MUSIC, SPEECH, DRAMA AND BUSINESS LEADERSHIP PROVIDED VIA TELECOMMUNICATIONS NETWORKS, BY ON-LINE DELIVERY AND BY THE INTERNET (U.S. CLS. 100, 101 AND 107).

**CLASS 45—PERSONAL AND LEGAL SERVICES**

FOR ON-LINE SOCIAL NETWORKING SERVICES FOR USE BY STUDENTS, FACULTY, ALUMNI, STAFF AND OTHERS TO EXCHANGE INFORMATION CONCERNING ACADEMIC COLLABORATIONS, BUSINESS OPPORTUNITIES, AND GENERAL INTEREST INFORMATION; ONLINE SOCIAL NETWORKING SERVICES; ASSISTING IN THE TRACING OF FORMER FRIENDS, COLLEAGUES AND CONTEMPORARIES BY MEANS OF PROVIDING A SOCIAL NETWORKING WEBSITE; SOCIAL NETWORKING SERVICES IN THE FIELD OF MUSIC, SPEECH AND DRAMA PROVIDED VIA A WEBSITE; PROVIDING A WEBSITE FOR SOCIAL NETWORKING FOR ENTERTAINMENT AND INFORMATION PURPOSES (U.S. CLS. 100 AND 101).

BERNICE MIDDLETON, EXAMINING ATTORNEY

SN 86-062,835. ANNCO, INC., NEW YORK, NY. FILED 9-12-2013.

LOFT

THE MARK CONSISTS OF STANDARD CHARACTERS WITHOUT CLAIM TO ANY PARTICULAR FONT, STYLE, SIZE, OR COLOR.

OWNER OF U.S. REG. NOS. 3,359,615, 4,201,711 AND OTHERS.

### **CLASS 3—COSMETICS AND CLEANING PREPARATIONS**

FOR SOAPS FOR PERSONAL USE, PERFUMERY, FRAGRANCES, COSMETICS, MAKEUP FOR LIPS, NON-MEDICATED SKIN CARE PREPARATIONS, NAIL CARE PREPARATIONS, NAIL POLISH, NON-MEDICATED LIP CARE PREPARATIONS (U.S. CLS. 1, 4, 6, 50, 51 AND 52).

### **CLASS 9—ELECTRICAL AND SCIENTIFIC APPARATUS**

FOR SUNGLASSES; EYEGLASSES; SUNGLASS FRAMES; EYEGLASS FRAMES; CASES FOR EYEGLASSES; CASES FOR SUNGLASSES; MAGNETIC CODED GIFT CARDS AND ELECTRONIC ENCODED GIFT CERTIFICATES WHICH MAY THEN BE REDEEMED FOR GOODS OR SERVICES (U.S. CLS. 21, 23, 26, 36 AND 38).

### **CLASS 18—LEATHER GOODS**

FOR BAGS, NAMELY, HANDBAGS, POCKETBOOKS, SHOULDER BAGS, EVENING HANDBAGS, COSMETIC CASES SOLD EMPTY, WALLETS, KEY CASES, COIN PURSES, CLUTCH PURSES, CLUTCH BAGS, TOTE BAGS, UMBRELLAS, ROLL BAGS, DRAWSTRING POUCHES, BACKPACKS, SLING BAGS, BRIEFCASES, SATCHELS, MESSENGER BAGS, TRAVEL BAGS, LEATHER CREDIT CARD CASES, BUSINESS CARD CASES, BELT BAGS (U.S. CLS. 1, 2, 3, 22 AND 41).

### **CLASS 35—ADVERTISING AND BUSINESS**

FOR ON-LINE AND IN STORE RETAIL STORE SERVICES IN THE FIELDS OF CLOTHING, FOOTWEAR, HEADGEAR, BAGS, HANDBAGS, WALLETS, SMALL LEATHER ACCESSORIES, CLOTHING ACCESSORIES, HAIR ACCESSORIES, SUNGLASSES AND EYEGLASSES, EYEWEAR, WATCHES, FRAGRANCES, TOILETRIES AND COSMETIC PRODUCTS; PROVIDING INCENTIVE AWARDS BY MEANS OF ISSUANCE OF LOYALTY REWARDS CARDS; PROVIDING AN INCENTIVE AWARDS PROGRAM WHEREBY CUSTOMERS ARE AWARDED LOYALTY POINTS FOR PURCHASES OF COMPANY'S GOODS AND FOR USE OF COMPANY'S CO-BRANDED CREDIT CARD (U.S. CLS. 100, 101 AND 102).

PAUL CROWLEY, EXAMINING ATTORNEY

SN 86-063,019. ABBOTT DIABETES CARE INC., ALAMEDA, CA. FILED 9-12-2013.

## **FREESTYLE LIBRE**

THE MARK CONSISTS OF STANDARD CHARACTERS WITHOUT CLAIM TO ANY PARTICULAR FONT, STYLE, SIZE, OR COLOR.

OWNER OF U.S. REG. NOS. 2,670,744, 3,111,863 AND OTHERS.

THE ENGLISH TRANSLATION OF "LIBRE" IN THE MARK IS "FREE".

### **CLASS 9—ELECTRICAL AND SCIENTIFIC APPARATUS**

FOR COMPUTER SOFTWARE APPLICATION USED FOR THE MANAGEMENT OF DIABETES (U.S. CLS. 21, 23, 26, 36 AND 38).

### **CLASS 10—MEDICAL APPARATUS**

FOR SENSOR-BASED GLUCOSE MONITORS (U.S. CLS. 26, 39 AND 44).  
DOMINIC J. FERRAIUOLO, EXAMINING ATTORNEY

SN 86-063,033. GTECH UK INTERACTIVE LIMITED, LONDON WC2A 1AF, UNITED KINGDOM, FILED 9-12-2013.

## **CRAZY WIZARD**

THE MARK CONSISTS OF STANDARD CHARACTERS WITHOUT CLAIM TO ANY PARTICULAR FONT, STYLE, SIZE, OR COLOR.

### **CLASS 9—ELECTRICAL AND SCIENTIFIC APPARATUS**

FOR COMPUTER-GAMING SOFTWARE; GAMING SOFTWARE THAT GENERATES AND DISPLAYS WAGER OUTCOMES OF GAMING MACHINES; DOWNLOADABLE SOFTWARE IN THE NATURE OF A MOBILE APPLICATION FOR PLAYING GAMES; DOWNLOADABLE ELECTRONIC GAME PROGRAMS PLAYABLE VIA A GLOBAL COMPUTER NETWORK, HANDHELD ELECTRONIC DEVICES, PORTABLE VIDEO PLAYERS, PORTABLE MUSIC PLAYERS, SMART PHONES, LAPTOP COMPUTERS, HANDHELD COMPUTERS, TABLET COMPUTERS, CELLULAR PHONES, PAGERS, PERSONAL DIGITAL ASSISTANTS, DIGITAL TELEVISION SET-TOP BOXES, INTERACTIVE DIGITAL TELEVISION CONTROLLERS AND PROGRAMMABLE DIGITAL TELEVISION RECORDERS; DOWNLOADABLE SOFTWARE AND COMPUTER PROGRAMS FOR PLAYING CASINO GAMES, SLOT GAMES, LOTTERY GAMES, ONLINE WAGERING GAMES AND ONLINE ELECTRONIC GAMES; DOWNLOADABLE ELECTRONIC GAME PROGRAMS AND SOFTWARE (U.S. CLS. 21, 23, 26, 36 AND 38).

### **CLASS 41—EDUCATION AND ENTERTAINMENT**

FOR GAMING SERVICES, NAMELY, ON-LINE GAMBLING; GAMING SERVICES, NAMELY, OPERATION OF AN ON-LINE CASINO PROVIDING VIDEO SLOT GAMES PLAYABLE VIA A GLOBAL COMPUTER NETWORK; PROVIDING ON-LINE GAMING SOFTWARE FOR PLAYING GAMES VIA A GLOBAL COMPUTER NETWORK; ENTERTAINMENT SERVICES, NAMELY, CONDUCTING A GAME OF CHANCE SIMULTANEOUSLY AT MULTIPLE, INDEPENDENT GAMING ESTABLISHMENTS ; ENTERTAINMENT SERVICES, NAMELY, PROVIDING ONLINE ELECTRONIC GAMES; ENTERTAINMENT SERVICES, NAMELY, PROVIDING TEMPORARY USE OF NON-DOWNLOADABLE ELECTRONIC GAMES (U.S. CLS. 100, 101 AND 107).

CHARLES L. JENKINS, EXAMINING ATTORNEY

SN 86-063,386. LOYAKK, INC., SUNNYVALE, CA. FILED 9-12-2013.

# LOYAKK

THE MARK CONSISTS OF STANDARD CHARACTERS WITHOUT CLAIM TO ANY PARTICULAR FONT, STYLE, SIZE, OR COLOR.

## CLASS 9—ELECTRICAL AND SCIENTIFIC APPARATUS

FOR COMPUTER SOFTWARE PLATFORMS USED TO CREATE AND BUILD AN ONLINE LOCATION-AWARE COMMUNITY; COMPUTER SOFTWARE DEVELOPMENT TOOLS FOR SOCIAL NETWORKING, BUILDING SOCIAL NETWORKING APPLICATIONS AND FOR ALLOWING DATA RETRIEVAL, UPLOAD, ACCESS AND MANAGEMENT; DOWNLOADABLE MOBILE APPLICATIONS FOR CREATING AND BUILDING AN ONLINE LOCATION-AWARE COMMUNITY; DOWNLOADABLE SOFTWARE IN THE NATURE OF A MOBILE APPLICATION FOR CREATING AND BUILDING ONLINE LOCATION-AWARE COMMUNITIES; SOFTWARE FOR CREATING AND BUILDING AN ONLINE LOCATION-AWARE COMMUNITY (U.S. CLS. 21, 23, 26, 36 AND 38).

FIRST USE 7-18-2011; IN COMMERCE 1-15-2012.

## CLASS 42—SCIENTIFIC AND COMPUTER SERVICES

FOR APPLICATION SERVICE PROVIDER (ASP) FEATURING SOFTWARE FOR USE TO ENABLE OR FACILITATE THE UPLOADING, DOWNLOADING, STREAMING, POSTING, DISPLAYING, BLOGGING, LINKING, SHARING OF AUDIO AND VIDEO CONTENT, PHOTOGRAPHIC IMAGES, TEXT, GRAPHICS AND DATA; COMPUTER SERVICES, NAMELY, CREATING AN ON-LINE COMMUNITY FOR REGISTERED USERS TO PARTICIPATE IN DISCUSSIONS, GET FEEDBACK FROM THEIR PEERS, FORM VIRTUAL COMMUNITIES, AND ENGAGE IN SOCIAL NETWORKING SERVICES IN THE FIELD OF COMMUNITY SERVICES, POLITICS, EDUCATION, SPECIAL INTERESTS, HOBBIES, SPORTS, PROFESSIONS, VOCATIONS; HOSTING AN ONLINE COMMUNITY WEBSITE FEATURING SHARED COMMUNICATIONS BETWEEN COMMUNITY MEMBERS INTERESTED IN SELF-IMPROVEMENT, SELF-FULFILLMENT, CHARITABLE, PHILANTHROPIC, VOLUNTEER, PUBLIC AND COMMUNITY SERVICE, AND HUMANITARIAN ACTIVITIES ALL VIA GLOBAL COMMUNICATION NETWORKS; COMPUTER SERVICES, NAMELY, CREATING AN ON-LINE COMMUNITY FOR REGISTERED USERS TO ORGANIZE GROUPS AND EVENTS, PARTICIPATE IN DISCUSSIONS, AND ENGAGE IN SOCIAL, BUSINESS AND COMMUNITY NETWORKING; COMPUTER SERVICES, NAMELY, HOSTING AND MAINTAINING AN ON-LINE WEB SITE FOR OTHERS FOR ORGANIZING AND CONDUCTING MEETINGS, EVENTS AND INTERACTIVE DISCUSSIONS VIA COMMUNICATION NETWORKS; COMPUTER SERVICES IN THE NATURE OF CUSTOMIZED WEB PAGES FEATURING USER-DEFINED OR SPECIFIED INFORMATION IN THE NATURE OF PERSONAL PROFILES, AUDIO AND VIDEO CONTENT, PHOTOGRAPHIC IMAGES, TEXT, GRAPHICS AND DATA; PROVIDING A WEB SITE FEATURING TECHNOLOGY THAT ENABLES USERS TO CONNECT WITH OTHER PEOPLE IN THEIR NEIGHBORHOOD OR CITY FOR ANY NUMBER OF USER-SPECIFIED REASONS, INCLUDING PROVIDING A SERVICE OR ORGANIZING AN EVENT; PROVIDING A WEB SITE FEATURING TECHNOLOGY THAT ENABLES USERS TO CREATE AND BUILD AN ONLINE COMMUNITY; PROVIDING A WEBSITE FEATURING TECHNOLOGY THAT ENABLES USERS TO CREATE PERSONAL PROFILES FEATURING SOCIAL NETWORKING INFORMATION AND TO TRANSFER AND

SHARE SUCH INFORMATION AMONG MULTIPLE WEBSITES; PROVIDING TEMPORARY USE OF NON-DOWNLOADABLE SOFTWARE APPLICATIONS FOR ENABLING, FACILITATING, OR ENHANCING SOCIAL NETWORKING, CREATING A VIRTUAL COMMUNITY, AND TRANSMISSION OF AUDIO, VIDEO, PHOTOGRAPHIC IMAGES, TEXT, GRAPHICS AND DATA; SOFTWARE AS A SERVICE (SAAS) SERVICES FEATURING SOFTWARE USED TO CREATE AND BUILD ONLINE LOCATION-AWARE COMMUNITIES; SOFTWARE AS A SERVICE (SAAS) SERVICES, NAMELY, HOSTING SOFTWARE FOR USE BY OTHERS FOR USE TO CREATE AND BUILD ONLINE LOCATION-AWARE COMMUNITIES (U.S. CLS. 100 AND 101).

FIRST USE 7-18-2011; IN COMMERCE 1-15-2012.

SARA BENJAMIN, EXAMINING ATTORNEY

---

SN 86-063,789. TEACHING STRATEGIES, LLC, BETHESDA, MD. FILED 9-13-2013.

# GOLD

THE MARK CONSISTS OF STANDARD CHARACTERS WITHOUT CLAIM TO ANY PARTICULAR FONT, STYLE, SIZE, OR COLOR.

OWNER OF U.S. REG. NO. 3,978,659.

## CLASS 9—ELECTRICAL AND SCIENTIFIC APPARATUS

FOR DOWNLOADABLE ELECTRONIC PUBLICATIONS IN THE NATURE OF BOOKS, CHAPTERS OF BOOKS, AND NEWSLETTERS IN THE FIELD OF EARLY CHILDHOOD EDUCATION; COMPUTER APPLICATION SOFTWARE FOR MOBILE PHONES, MOBILE COMPUTERS, TABLET COMPUTERS, AND PORTABLE MEDIA PLAYERS AND DEVICES, FEATURING SOFTWARE FOR USE WITH ASSESSMENTS IN THE FIELD OF EARLY CHILDHOOD EDUCATION; DVDS IN THE FIELD OF EARLY CHILDHOOD EDUCATION; DVDS AND DOWNLOADABLE AUDIO AND VIDEO DIGITAL RECORDINGS FEATURING TRAINING FOR EARLY CHILDHOOD EDUCATORS, PARENTS, AND ALL ADULTS WORKING WITH CHILDREN, AND PRINTED INSTRUCTIONAL MANUALS SOLD AS A UNIT THEREWITH IN THE FIELD OF EARLY CHILDHOOD EDUCATION (U.S. CLS. 21, 23, 26, 36 AND 38).

## CLASS 16—PAPER GOODS AND PRINTED MATTER

FOR PUBLICATIONS, NAMELY, BOOKS, BOOKLETS, NEWSLETTERS IN THE FIELD OF EARLY CHILDHOOD EDUCATION (U.S. CLS. 2, 5, 22, 23, 29, 37, 38 AND 50).

**CLASS 41—EDUCATION AND ENTERTAINMENT**

FOR EDUCATION SERVICES, NAMELY, COURSES, SEMINARS AND CLASSES IN THE FIELD OF EARLY CHILDHOOD EDUCATION; EDUCATION SERVICES, NAMELY, CONDUCTING INTERNET WEBINAR CLASSES IN THE FIELD OF EARLY CHILDHOOD EDUCATION; EDUCATION SERVICES IN THE NATURE OF COURSES, CLASSES, SEMINARS AND CONFERENCES DISTRIBUTED BY PODCAST OR VIA A GLOBAL COMPUTER NETWORK, IN THE FIELD OF EARLY CHILDHOOD EDUCATION; EDUCATION SERVICES, NAMELY, PROVIDING COURSES, CLASSES, SEMINARS AND WORKSHOPS VIA INTERACTIVE ONLINE COURSES IN THE FIELD OF EARLY CHILDHOOD EDUCATION; PROVIDING ON-LINE NEWSLETTERS IN THE FIELD OF EARLY CHILDHOOD EDUCATION; CONSULTING SERVICES IN THE FIELD OF EARLY CHILDHOOD EDUCATION; RESEARCH SERVICES IN THE FIELD OF EARLY CHILDHOOD EDUCATION; EDUCATION SERVICES IN THE NATURE OF PROVIDING ONLINE NON-DOWNLOADABLE VIDEO CLIPS IN THE FIELD OF EARLY CHILDHOOD EDUCATION (U.S. CLS. 100, 101 AND 107).

**CLASS 42—SCIENTIFIC AND COMPUTER SERVICES**

FOR COMPUTER SERVICES, NAMELY, ACTING AS AN APPLICATION SERVICE PROVIDER FEATURING SOFTWARE FOR USE IN THE FIELD OF EARLY CHILDHOOD EDUCATION (U.S. CLS. 100 AND 101).  
ELLEN BURNS, EXAMINING ATTORNEY

SN 86-063,851. RESORT TRAVEL & XCHANGE, LLC, ASHEVILLE, NC. FILED 9-13-2013.

**RTX TRAVELER**

THE MARK CONSISTS OF STANDARD CHARACTERS WITHOUT CLAIM TO ANY PARTICULAR FONT, STYLE, SIZE, OR COLOR.

NO CLAIM IS MADE TO THE EXCLUSIVE RIGHT TO USE "TRAVELER", APART FROM THE MARK AS SHOWN.

**CLASS 16—PAPER GOODS AND PRINTED MATTER**

FOR MAGAZINES RELATED TO TRAVEL, RESORTS, VACATIONS, AND TRAVEL-RELATED TOPICS (U.S. CLS. 2, 5, 22, 23, 29, 37, 38 AND 50).

FIRST USE 2-1-2013; IN COMMERCE 2-1-2013.

**CLASS 41—EDUCATION AND ENTERTAINMENT**

FOR PROVIDING ONLINE NON-DOWNLOADABLE ELECTRONIC PUBLICATIONS IN THE NATURE OF MAGAZINES RELATED TO TRAVEL, RESORTS, VACATIONS, AND TRAVEL-RELATED TOPICS (U.S. CLS. 100, 101 AND 107).

FIRST USE 2-1-2013; IN COMMERCE 2-1-2013.

RONALD MCMORROW, EXAMINING ATTORNEY

SN 86-064,109. TEACHING STRATEGIES, LLC, BETHESDA, MD. FILED 9-13-2013.

**GOLDPLUS**

THE MARK CONSISTS OF STANDARD CHARACTERS WITHOUT CLAIM TO ANY PARTICULAR FONT, STYLE, SIZE, OR COLOR.

OWNER OF U.S. REG. NO. 3,978,659.

**CLASS 9—ELECTRICAL AND SCIENTIFIC APPARATUS**

FOR DOWNLOADABLE ELECTRONIC PUBLICATIONS IN THE NATURE OF BOOKS, CHAPTERS OF BOOKS, MAGAZINES AND NEWSLETTERS IN THE FIELD OF EARLY CHILDHOOD EDUCATION; COMPUTER APPLICATION SOFTWARE FOR MOBILE PHONES, MOBILE COMPUTERS, TABLET COMPUTERS, AND PORTABLE MEDIA PLAYERS AND DEVICES, FEATURING SOFTWARE FOR USE WITH CURRICULUM AND ASSESSMENTS IN THE FIELD OF EARLY CHILDHOOD EDUCATION; DVDS IN THE FIELD OF EARLY CHILDHOOD EDUCATION; DVDS AND DOWNLOADABLE AUDIO AND VIDEO DIGITAL RECORDINGS FEATURING TRAINING FOR EARLY CHILDHOOD EDUCATORS, PARENTS, AND ALL ADULTS WORKING WITH CHILDREN, AND PRINTED INSTRUCTIONAL MANUALS SOLD AS A UNIT THEREWITH IN THE FIELD OF EARLY CHILDHOOD EDUCATION (U.S. CLS. 21, 23, 26, 36 AND 38).

**CLASS 16—PAPER GOODS AND PRINTED MATTER**

FOR PUBLICATIONS, NAMELY, BOOKS, BOOKLETS, NEWSLETTERS IN THE FIELD OF EARLY CHILDHOOD EDUCATION (U.S. CLS. 2, 5, 22, 23, 29, 37, 38 AND 50).

**CLASS 41—EDUCATION AND ENTERTAINMENT**

FOR EDUCATION SERVICES, NAMELY, COURSES, SEMINARS AND CLASSES IN THE FIELD OF EARLY CHILDHOOD EDUCATION; EDUCATION SERVICES, NAMELY, CONDUCTING INTERNET WEBINAR CLASSES IN THE FIELD OF EARLY CHILDHOOD EDUCATION; EDUCATION SERVICES IN THE NATURE OF COURSES, CLASSES, SEMINARS AND CONFERENCES DISTRIBUTED BY PODCAST OR VIA A GLOBAL COMPUTER NETWORK, IN THE FIELD OF EARLY CHILDHOOD EDUCATION; EDUCATION SERVICES, NAMELY, PROVIDING COURSES, CLASSES, SEMINARS AND WORKSHOPS VIA INTERACTIVE ONLINE COURSES IN THE FIELD OF EARLY CHILDHOOD EDUCATION; PROVIDING ON-LINE NEWSLETTERS IN THE FIELD OF EARLY CHILDHOOD EDUCATION; CONSULTING SERVICES IN THE FIELD OF EARLY CHILDHOOD EDUCATION; RESEARCH SERVICES IN THE FIELD OF EARLY CHILDHOOD EDUCATION; EDUCATION SERVICES IN THE NATURE OF PROVIDING ONLINE NON-DOWNLOADABLE VIDEO CLIPS IN THE FIELD OF EARLY CHILDHOOD EDUCATION (U.S. CLS. 100, 101 AND 107).

**CLASS 42—SCIENTIFIC AND COMPUTER SERVICES**

FOR COMPUTER SERVICES, NAMELY, ACTING AS AN APPLICATION SERVICE PROVIDER FEATURING SOFTWARE FOR USE IN THE FIELD OF EARLY CHILDHOOD EDUCATION (U.S. CLS. 100 AND 101).

ELLEN BURNS, EXAMINING ATTORNEY



SN 86-064,271. THE CAMPUS KITCHENS PROJECT, WASHINGTON, DC. FILED 9-13-2013.

## Campus Kitchen

THE MARK CONSISTS OF STANDARD CHARACTERS WITHOUT CLAIM TO ANY PARTICULAR FONT, STYLE, SIZE, OR COLOR.

NO CLAIM IS MADE TO THE EXCLUSIVE RIGHT TO USE "KITCHEN", APART FROM THE MARK AS SHOWN. SEC. 2(F).

### CLASS 35—ADVERTISING AND BUSINESS

FOR CHARITABLE SERVICES, NAMELY, ORGANIZING AND CONDUCTING VOLUNTEER PROGRAMS AND COMMUNITY SERVICE PROJECTS (U.S. CLS. 100, 101 AND 102).

FIRST USE 1-31-2001; IN COMMERCE 12-31-2001.

### CLASS 43—HOTEL AND RESTAURANT SERVICES

FOR CHARITABLE SERVICES, NAMELY, PROVIDING FOOD TO NEEDY PERSONS (U.S. CLS. 100 AND 101).

FIRST USE 1-31-2001; IN COMMERCE 12-31-2001.  
KHANH LE, EXAMINING ATTORNEY

SN 86-064,534. KARORA, LTD., DUBLIN, IRELAND, FILED 9-13-2013.



THE MARK CONSISTS OF A STYLIZED LETTER "K" COMPRISED OF THE WORD "KARORA" IN ALL CAPITAL LETTERS APPEARING VERTICALLY AS THE LEFT PORTION OF THE LETTER "K", WITH A CIRCLE SURROUNDING THE ENTIRE MARK WHICH STARTS FROM THE BOTTOM RIGHT EDGE OF THE LETTER "K" AND STOPPING SHORTLY BEFORE IT TOUCHES THE POINT OF ITS BEGINNING, LEAVING AN OPENING UNDER THE BOTTOM RIGHT EDGE OF THE LETTER "K".

THE WORDING "KARORA" HAS NO MEANING IN A FOREIGN LANGUAGE.

### CLASS 3—COSMETICS AND CLEANING PREPARATIONS

FOR COSMETICS, PERFUMES, PERFUMERY, TOILET WATER, EAU DE COLOGNE, SOAPS, ESSENTIAL OILS, OILS FOR COSMETIC PURPOSES, HAIR LOTIONS, NON-MEDICATED TOILETRIES, BODY CREAMS, ASTRINGENTS FOR COSMETIC PURPOSES, FOAM BATHS, BODY MILKS, BODY LOTIONS, LIQUID BATH SOAPS, BATH GELS, BABY OILS AND LOTIONS FOR SKIN CARE, SKIN CLEANSERS, EXFOLIANT CREAMS, BEAUTY MASKS, COSMETIC PREPARATIONS FOR THE BATH, SHAMPOOS AND HAIR CARE PREPARATIONS, DEODORANTS FOR PERSONAL USE, ANTIPERSPIRANTS, MAKE-UP PREPARATIONS AND MAKE-UP REMOVING PREPARATIONS, NON-MEDICATED LIP CARE PREPARATIONS AND LIPSTICKS, NAIL CARE PREPARATIONS AND NAIL VARNISH, COSMETIC PREPARATIONS FOR USE ON NAILS IN MANICURES AND PEDICURES, DOUCHING PREPARATIONS FOR PERSONAL SANITARY OR DEODORANT PURPOSES, SUN-TANNING PREPARATIONS AND SUNSCREEN PREPARATIONS, SELF-TANNING PREPARATIONS, DEPILATORIES, MAKE-UP POWDER, COSMETIC PREPARATION FOR SLIMMING PURPOSES, AFTER-BATH BODY POWDER, TALCUM POWDER FOR TOILET USE, DENTIFRICES AND MOUTHWASHES, ALL AFOREMENTIONED GOODS EXCLUDING COTTON WOOL FOR COSMETIC PURPOSES, LAYERED COTTON WOOL, COSMETIC COTTON WOOL BALLS, COTTON WOOLS PADS, COTTON BUDS AND COTTON WOOL IN STRIPS FOR COSMETIC PURPOSES AS WELL AS COTTON WOOL COMBINED WITH NONWOVEN FABRIC MATERIALS, AND PROTECTIVE FILMS OR LINEN, FOR COSMETIC PURPOSES (U.S. CLS. 1, 4, 6, 50, 51 AND 52).

### CLASS 25—CLOTHING

FOR CLOTHING, NAMELY, UNDERGARMENTS, BATHING SUITS, SHIRTS, T-SHIRTS, SCARVES, SKIRTS, DRESSES; FOOTWEAR; HEADWEAR (U.S. CLS. 22 AND 39).

### CLASS 35—ADVERTISING AND BUSINESS

FOR RETAIL STORE SERVICES, WHOLESALE STORE SERVICES, ON-LINE RETAIL STORE SERVICES, CATALOG ORDERING SERVICES, MAIL ORDER SERVICES AND RETAIL SERVICES BY DIRECT SOLICITATION BY SALES AGENTS, ALL IN THE FIELD OF COSMETICS, PERFUMES, PERSONAL HYGIENE PRODUCTS, CLEANING PREPARATIONS, JEWELRY, HOROLOGICAL AND CHRONOMETRIC INSTRUMENTS, CLOTHING, FOOTWEAR, HEADWEAR, ALL AFOREMENTIONED SERVICES EXCLUDING THE SALE OF COTTON WOOL FOR COSMETIC PURPOSES, LAYERED COTTON WOOL, COSMETIC COTTON WOOL BALLS, COTTON WOOL PADS, COTTON BUDS AND COTTON WOOL IN STRIPS FOR COSMETIC PURPOSES AS WELL AS OF COTTON WOOL COMBINED WITH NON-WOVEN FABRIC MATERIAL, AND PROTECTIVE FILMS OR LINEN, FOR COSMETIC PURPOSES AS WELL AS OF COTTON WOOL FOR SANITARY PREPARATIONS, SANITARY TOWELS, PANTY LINERS, TAMPONS, MINI-TOWELS, PROTECTIVE INSERTS FOR LINEN BEING PROTECTION AGAINST MOISTURE FOR UNDERWEAR, NAPKIN LINERS OF VISCOSE; BUSINESS MANAGEMENT FOR RETAIL, WHOLESALE, AND INTERNET SHOPS, ALL AFOREMENTIONED SERVICES EXCLUDING THE SALE OF COTTON WOOL FOR COSMETIC PURPOSES, LAYERED COTTON WOOL, COSMETIC COTTON WOOL BALLS, COTTON WOOL PADS, COTTON BUDS AND COTTON WOOL IN STRIPS FOR COSMETIC PURPOSES AS WELL AS OF COTTON WOOL COMBINED WITH NON-WOVEN FABRIC MATERIAL, AND PROTECTIVE FILMS OR LINEN, FOR COSMETIC PURPOSES AS WELL AS OF COTTON WOOL FOR SANITARY PREPARATIONS, SANITARY TOWELS, PANTY LINERS, TAMPONS, MINI-TOWELS, PROTECTIVE INSERTS FOR LINEN BEING PROTECTION AGAINST MOISTURE FOR UNDERWEAR, NAPKIN LINERS OF VISCOSE (U.S. CLS. 100, 101 AND 102).

KATHERINE STOIDES, EXAMINING ATTORNEY

SN 86-064,636. BROADBAND T CORPORATION, COLORADO SPRINGS, CO. FILED 9-13-2013.

## Broadband T

THE MARK CONSISTS OF STANDARD CHARACTERS WITHOUT CLAIM TO ANY PARTICULAR FONT, STYLE, SIZE, OR COLOR.

NO CLAIM IS MADE TO THE EXCLUSIVE RIGHT TO USE "BROADBAND", APART FROM THE MARK AS SHOWN.

### CLASS 9—ELECTRICAL AND SCIENTIFIC APPARATUS

FOR CIRCUIT BOARDS; CIRCUIT BOARDS PROVIDED WITH INTEGRATED CIRCUITS; COMPUTER SOFTWARE FOR USE IN PROCESSING SEMICONDUCTOR WAFERS; CUSTOM PRINTED CIRCUIT BOARDS; DESIGN LIBRARIES, NAMELY, DOWNLOADABLE ELECTRONIC DATA FILES FOR USE IN INTEGRATED CIRCUIT AND SEMICONDUCTOR DESIGN; ELECTRIC AND ELECTRONIC CIRCUITS; ELECTRICAL CIRCUIT BOARDS; ELECTRONIC CHIPS FOR THE MANUFACTURER OF INTEGRATED CIRCUITS; ELECTRONIC CIRCUIT BOARD; ELECTRONIC CIRCUIT CARDS; ELECTRONIC CIRCUITS; ELECTRONIC CIRCUITS FOR ERROR CORRECTION; ELECTRONIC COMPONENTS IN THE NATURE OF SEMICONDUCTORS AND INTEGRATED CIRCUITS; ELECTRONIC INTEGRATED CIRCUITS; INTEGRATED CIRCUIT CARDS AND COMPONENTS; INTEGRATED CIRCUIT MODULE; INTEGRATED CIRCUIT MODULES; INTEGRATED CIRCUITS; INTEGRATED CIRCUITS AND INTEGRATED CIRCUIT CORES FOR USE IN WIRELESS COMMUNICATIONS AND WIRELESS COMMUNICATION EQUIPMENT AND APPARATI AND DIGITAL SIGNAL PROCESSORS (DSP); INTEGRATED CIRCUITS INCORPORATING ALGORITHMS FOR USE IN PROCESSING TELEVISION SIGNALS; INTEGRATED CIRCUITS, INTEGRATED CIRCUIT CHIPS, AND INTEGRATED CIRCUIT MODULES FOR DIGITAL VIDEO COMPRESSION AND DECOMPRESSION; INTEGRATED CIRCUITS, INTEGRATED CIRCUIT CHIPS, AND INTEGRATED CIRCUIT MODULES FOR ENCODING AND DECODING DIGITAL VIDEO; INTERFACE CARDS FOR DATA PROCESSING EQUIPMENT IN THE FORM OF PRINTED CIRCUITS; LARGE SCALE INTEGRATED CIRCUITS; PRINTED CIRCUIT BOARDS; PRINTED CIRCUIT BOARDS (PCBS); PRINTED CIRCUITS; PRINTED ELECTRONIC CIRCUITS FOR APPARATUS AND CARDS BEARING INTEGRATED CIRCUITS; SEMICONDUCTOR CHIPS; SEMICONDUCTOR DEVICES; SEMICONDUCTOR POWER ELEMENTS; SEMICONDUCTORS; VERY LARGE SCALE INTEGRATION (VLSI) SEMICONDUCTOR INTEGRATED CIRCUITS; VIDEO CIRCUIT BOARDS; WAFERS FOR INTEGRATED CIRCUITS (U.S. CLS. 21, 23, 26, 36 AND 38).

### CLASS 42—SCIENTIFIC AND COMPUTER SERVICES

FOR DESIGN AND DEVELOPMENT OF SOFTWARE AND HARDWARE FOR DIGITAL SIGNAL PROCESSING; DESIGN AND DEVELOPMENT OF SOFTWARE AND HARDWARE FOR SIGNAL AMPLIFICATION AND TRANSMISSION; DESIGN AND DEVELOPMENT OF WIRELESS COMMUNICATION SYSTEMS FOR TRANSMISSION AND RECEPTION OF VOICE, DATA AND VIDEO; DESIGN FOR OTHERS OF INTEGRATED CIRCUITS AND INTEGRATED CIRCUIT CORES FOR USE IN WIRELESS COMMUNICATIONS AND WIRELESS COMMUNICATION EQUIPMENT AND APPARATI AND DIGITAL SIGNAL PROCESSORS (DSP); DESIGN OF COMPUTER HARDWARE, INTEGRATED CIRCUITS, COMMUNICATIONS HARDWARE AND SOFTWARE AND COMPUTER NETWORKS FOR OTHERS; ELECTRONIC AND ELECTRICAL SYSTEMS DESIGN SERVICES (U.S. CLS. 100 AND 101).

JENNY PARK, EXAMINING ATTORNEY

SN 86-064,709. HI-PRO FEEDS LP, TORONTO, ONTARIO, CANADA, FILED 9-13-2013.



OWNER OF U.S. REG. NOS. 1,952,692 AND 1,959,518. NO CLAIM IS MADE TO THE EXCLUSIVE RIGHT TO USE "FEEDS", APART FROM THE MARK AS SHOWN.

THE MARK CONSISTS OF THE WORDING "HI-PRO FEEDS" AND THE DESIGN OF TWO TRIANGLES.

### CLASS 31—NATURAL AGRICULTURAL PRODUCTS

FOR ANIMAL FEEDS FOR THE LIVESTOCK AND CATTLE INDUSTRY (U.S. CLS. 1 AND 46).

### CLASS 35—ADVERTISING AND BUSINESS

FOR DISTRIBUTORSHIP SERVICES IN THE FIELD OF ANIMAL HEALTH PRODUCT, NAMELY, ANIMAL FEED (U.S. CLS. 100, 101 AND 102).

### CLASS 44—MEDICAL, BEAUTY AND AGRICULTURAL SERVICES

FOR NUTRITIONAL ADVISORY SERVICES (U.S. CLS. 100 AND 101).

KIM SAITO, EXAMINING ATTORNEY

SN 86-064,717. HI-PRO FEEDS LP, TORONTO, ONTARIO, CANADA, FILED 9-13-2013.



OWNER OF U.S. REG. NOS. 1,952,692 AND 1,959,518.  
THE MARK CONSISTS OF THE WORDING "HI-PRO" AND THE DESIGN OF TWO TRIANGLES.

**CLASS 31—NATURAL AGRICULTURAL PRODUCTS**

FOR ANIMAL FEEDS FOR THE LIVESTOCK AND CATTLE INDUSTRY (U.S. CLS. 1 AND 46).

**CLASS 35—ADVERTISING AND BUSINESS**

FOR DISTRIBUTORSHIP SERVICES IN THE FIELD OF ANIMAL HEALTH PRODUCT, NAMELY, ANIMAL FEED (U.S. CLS. 100, 101 AND 102).

**CLASS 44—MEDICAL, BEAUTY AND AGRICULTURAL SERVICES**

FOR NUTRITIONAL ADVISORY SERVICES (U.S. CLS. 100 AND 101).  
KIM SAITO, EXAMINING ATTORNEY

SN 86-065,204. THE BILTMORE COMPANY, ASHEVILLE, NC. FILED 9-16-2013.

**BILTMORE**

THE MARK CONSISTS OF STANDARD CHARACTERS WITHOUT CLAIM TO ANY PARTICULAR FONT, STYLE, SIZE, OR COLOR.

OWNER OF U.S. REG. NOS. 3,690,732 AND 3,703,686.

**CLASS 29—MEATS AND PROCESSED FOODS**

FOR SEAFOOD, NAMELY, SMOKED SALMON; VEGETABLE OILS, NAMELY, CANOLA OIL; SOUP MIXES; DIPS FOR FRUITS, VEGETABLES AND MEATS (U.S. CL. 46).

**CLASS 30—STAPLE FOODS**

FOR HONEY (U.S. CL. 46).

**CLASS 32—LIGHT BEVERAGES**

FOR JUICES, NAMELY, GRAPE JUICE (U.S. CLS. 45, 46 AND 48).  
KATHY DE JONGE, EXAMINING ATTORNEY

SN 86-065,240. TRUFOOD MFG., INC., PITTSBURGH, PA. FILED 9-16-2013.

**TRUFOOD**

THE MARK CONSISTS OF STANDARD CHARACTERS WITHOUT CLAIM TO ANY PARTICULAR FONT, STYLE, SIZE, OR COLOR.

**CLASS 5—PHARMACEUTICALS**

FOR DIETARY FOOD SUPPLEMENTS, NAMELY, CHOCOLATE-BASED MEAL REPLACEMENT BARS FOR WEIGHT LOSS AND SPORTS NUTRITION (U.S. CLS. 6, 18, 44, 46, 51 AND 52).

**CLASS 29—MEATS AND PROCESSED FOODS**

FOR PROCESSED FRUIT AND NUT BASED FOOD BARS; ORGANIC NUT AND SEED BASED SNACK BARS (U.S. CL. 46).

**CLASS 30—STAPLE FOODS**

FOR CEREAL BARS; CANDY BARS; GRAIN BASED SNACK FOOD, NAMELY, GRAIN BASED SNACK BARS (U.S. CL. 46).

**CLASS 40—MATERIAL TREATMENT**

FOR MANUFACTURING SERVICES FOR OTHERS FOR NUTRITIONAL AND CANDY BAR FOOD ITEMS, NAMELY, MEAL REPLACEMENT, CEREAL, FRUIT AND NUT, DIET, ORGANIC, AND CANDY BARS (U.S. CLS. 100, 103 AND 106).  
DAVID MURRAY, EXAMINING ATTORNEY

SN 86-065,415. PUBLIC INTEREST LAW INITIATIVE, CHICAGO, IL. FILED 9-16-2013.



OWNER OF U.S. REG. NO. 2,308,547.

THE MARK CONSISTS OF FOUR SQUARES WITH THE LARGEST SQUARE ON TOP AND THREE SMALL SQUARES PARTIALLY COVERED BY THE LARGEST SQUARE AND THE TEXT "PILI" APPEARING ON TOP OF THE LARGEST SQUARE.

**CLASS 35—ADVERTISING AND BUSINESS**

FOR INTERNSHIP PLACEMENT SERVICES, NAMELY, ARRANGING INTERNSHIP AND FELLOWSHIP PROGRAMS FOR THE PLACEMENT OF INTERNS, FELLOWS, LAW CLERKS AND SUPPORT PERSONNEL IN PUBLIC INTEREST LAW ORGANIZATIONS (U.S. CLS. 100, 101 AND 102).

**CLASS 41—EDUCATION AND ENTERTAINMENT**

FOR EDUCATIONAL SERVICES, NAMELY, PROVIDING INTERNSHIPS IN THE FIELD OF LAW; JOB SKILLS TRAINING TO LAW STUDENTS AND NEW ATTORNEYS IN PUBLIC INTEREST LAW ORGANIZATIONS; CONDUCTING SEMINARS, CONFERENCES AND PUBLIC OUTREACH PROGRAMS WITHIN THE LEGAL COMMUNITY TO EDUCATE MEMBERS OF THE LEGAL COMMUNITY OF THE NEED FOR PRO BONO LEGAL ASSISTANCE IN THE AREA OF PUBLIC INTEREST LAW (U.S. CLS. 100, 101 AND 107).

LESLIE RICHARDS, EXAMINING ATTORNEY

SN 86-065,456. BREATHABLEBABY, LLC, EAGAN, MN. FILED 9-16-2013.

# AIRFLOWBABY

THE MARK CONSISTS OF STANDARD CHARACTERS WITHOUT CLAIM TO ANY PARTICULAR FONT, STYLE, SIZE, OR COLOR.

**CLASS 24—FABRICS**

FOR RECEIVING BLANKETS USED AS NURSING COVERS (U.S. CLS. 42 AND 50).

**CLASS 25—CLOTHING**

FOR CLOTHING FOR BABIES, NAMELY, BABY LAYETTES, BABY CAPS, ONE-PIECE GARMENTS FOR BABIES, PAJAMAS, JACKETS, SHIRTS, PANTS, JUMPERS, BABY DRESSES, T-SHIRTS, COATS, HATS, BABY UNDERWEAR, BABY BOTTOMS; BABY TOPS, ONE-PIECE GARMENTS FOR INFANTS AND TODDLERS, BODYSUITS, BABY SHOES, BABY HEADWEAR, BABY BIBS NOT OF PAPER (U.S. CLS. 22 AND 39).

VERNA BETH RIRIE, EXAMINING ATTORNEY

SN 86-065,509. ABBOTT INDUSTRIES, INC., SANTA ANA, CA. FILED 9-16-2013.

# ABBOTT AWNINGS

THE MARK CONSISTS OF STANDARD CHARACTERS WITHOUT CLAIM TO ANY PARTICULAR FONT, STYLE, SIZE, OR COLOR.

NO CLAIM IS MADE TO THE EXCLUSIVE RIGHT TO USE "AWNINGS", APART FROM THE MARK AS SHOWN. SEC. 2(F).

**CLASS 20—FURNITURE AND ARTICLES NOT OTHERWISE CLASSIFIED**

FOR RETRACTABLE, FIXED, MANUAL AND ELECTRIC DROP SHADES AND SUNSCREENS FOR WINDOWS, DOORS AND PATIOS (U.S. CLS. 2, 13, 22, 25, 32 AND 50).

FIRST USE 2-0-1994; IN COMMERCE 2-0-1994.

**CLASS 22—CORDAGE AND FIBERS**

FOR RETRACTABLE, FIXED, MANUAL AND ELECTRIC AWNINGS AND CABANAS COMPRISED PRIMARILY OF FABRIC (U.S. CLS. 1, 2, 7, 19, 22, 42 AND 50).

FIRST USE 2-0-1994; IN COMMERCE 2-0-1994.

**CLASS 37—CONSTRUCTION AND REPAIR**

FOR INSTALLATION, MAINTENANCE AND REPAIR OF AWNINGS, DROP SHADES, SUNSCREENS, CABANAS, SECURITY SHUTTERS AND UMBRELLAS (U.S. CLS. 100, 103 AND 106).

FIRST USE 2-0-1994; IN COMMERCE 2-0-1994.

LEIGH CAROLINE CASE, EXAMINING ATTORNEY

SN 86-065,580. TICTOC PLANET, INC., DBA FRANKLY, SAN FRANCISCO, CA. FILED 9-16-2013.

# FRANKLY

THE MARK CONSISTS OF STANDARD CHARACTERS WITHOUT CLAIM TO ANY PARTICULAR FONT, STYLE, SIZE, OR COLOR.

PRIORITY CLAIMED UNDER SEC. 44(D) ON REPUBLIC OF KOREA APPLICATION NO. 41-2013-0021, FILED 5-30-2013.

PRIORITY CLAIMED UNDER SEC. 44(D) ON REPUBLIC OF KOREA APPLICATION NO. 40-2013-0035, FILED 5-30-2013.

**CLASS 9—ELECTRICAL AND SCIENTIFIC APPARATUS**

FOR COMPUTER HARDWARE; COMPUTERS; TABLET COMPUTERS; MOBILE TELEPHONES; SMART PHONES; COMPUTER SOFTWARE FOR FACILITATING REAL-TIME INTERACTION AND COMMUNICATION; COMPUTER PROGRAMS FOR PROVIDING ELECTRONIC MAIL AND SCHEDULING CAPABILITIES; COMPUTER SOFTWARE FOR DATA, TEXT, GRAPHICS, AND IMAGE TRANSMISSION; COMPUTER PROGRAMS FOR MEETING AND EVENT SCHEDULING; COMPUTER SOFTWARE TO ENABLE UPLOADING, ACCESSING, POSTING, DISPLAYING, BLOGGING, LINKING, SHARING OR OTHERWISE PROVIDING ELECTRONIC MEDIA OR INFORMATION VIA COMPUTER AND COMMUNICATION NETWORKS; COMPUTER SOFTWARE FOR THE COLLECTION, EDITING, ORGANIZING, MODIFYING, TRANSMISSION, STORAGE AND SHARING OF DATA AND INFORMATION IN THE FIELDS OF BUSINESS AND SOCIAL NETWORKING; COMPUTER PROGRAMS FOR MANAGING AND DEVELOPING SOCIAL NETWORKS FOR PROFESSIONAL ASSOCIATIONS ONLINE; COMPUTER SOFTWARE FOR ENABLING USERS TO IDENTIFY PROFESSIONAL RELATIONSHIPS AND TO LEVERAGE PROFESSIONAL RELATIONSHIPS BY CREATING AND MANAGING PROFESSIONAL NETWORKS WITH OTHERS; COMPUTER SOFTWARE FOR THE TRANSMISSION OF SECURE MESSAGES, EMAILS AND ANNOUNCEMENTS; COMPUTER SOFTWARE FOR ENSURING SECURITY OF ELECTRONIC MAIL AND SECURE MESSAGING SERVICES (U.S. CLS. 21, 23, 26, 36 AND 38).

**CLASS 35—ADVERTISING AND BUSINESS**

FOR ONLINE BUSINESS NETWORKING SERVICES; ADVERTISING AND COMMERCIAL INFORMATION SERVICES, VIA THE INTERNET; PROVIDING COMMERCIAL INFORMATION IN THE FIELD OF ELECTRONIC MESSAGING AND SOCIAL NETWORKING; BUSINESS NETWORKING, NAMELY, ESTABLISHING BUSINESS CONTACTS; PROVIDING INFORMATION ABOUT BUSINESS MANAGEMENT AND ORGANIZATION; BUSINESS ADVISORY SERVICES WITH RESPECT TO CONDUCTING ONLINE BUSINESS ACTIVITIES; ONLINE BUSINESS NETWORKING SERVICES FOR PROFESSIONAL ASSOCIATIONS AND THEIR MEMBERS; PROVIDING DIRECTORY INFORMATION SERVICES ONLINE; BUSINESS CONSULTATION SERVICES IN THE NATURE OF ONLINE PROJECT COLLABORATION SERVICES IN THE FIELD OF ELECTRONIC MESSAGING AND SOCIAL NETWORKING (U.S. CLS. 100, 101 AND 102).

PLATFORMS, PROVIDING CLIENT DEVICE GEOLOCATION INFORMATION, POSTING COMMENTS AND RATINGS, AND PUSH NOTIFICATIONS TO USER DEVICES; PROVIDING TEMPORARY USE OF ONLINE NON-DOWNLOADABLE SOFTWARE FOR COMMUNICATION AND COLLABORATION AMONG USERS; HOSTING AN ONLINE COMMUNITY FOR USERS TO SHARE INFORMATION, PHOTOS, AUDIO AND VIDEO CONTENT AND ENGAGE IN COMMUNICATION AND COLLABORATION BETWEEN AND AMONG THEMSELVES, TO FORM GROUPS AND TO ENGAGE IN SOCIAL NETWORKING (U.S. CLS. 100 AND 101).

**CLASS 45—PERSONAL AND LEGAL SERVICES**

FOR ONLINE SOCIAL NETWORKING SERVICES (U.S. CLS. 100 AND 101).  
ROBERT C. CLARK JR., EXAMINING ATTORNEY

**CLASS 38—COMMUNICATION**

FOR ELECTRONIC MAIL AND SECURE MESSAGING SERVICES; ELECTRONIC TRANSMISSION OF DATA, TEXT, IMAGES, INFORMATION, DOCUMENTS, AND SOUND VIA COMPUTER NETWORKS; PROVIDING ONLINE FORUMS, CHAT ROOMS AND ELECTRONIC BULLETIN BOARDS FOR TRANSMISSION OF MESSAGES AMONG USERS IN THE FIELD OF GENERAL INTEREST; PROVIDING ONLINE FACILITIES FOR REAL-TIME INTERACTION WITH OTHER COMPUTER USERS CONCERNING TOPICS OF INTEREST RELATING TO THE FIELD OF GENERAL INTEREST; PROVIDING MULTIPLE USE ACCESS TO GLOBAL COMPUTER NETWORKS FOR THE TRANSFER AND DISSEMINATION OF A WIDE RANGE OF INFORMATION; TELECOMMUNICATIONS ACCESS SERVICES, NAMELY, PROVIDING ACCESS TO TELECOMMUNICATIONS NETWORKS VIA PROFESSIONAL NETWORK PLATFORMS; PROVIDING ACCESS TO COMPUTER DATABASES IN THE FIELDS OF SOCIAL NETWORKING AND SOCIAL INTRODUCTION; PROVIDING ACCESS TO ONLINE DATABASES FOR PROFESSIONAL NETWORKING AND SHARING OF DOCUMENTS, TEXTS AND IMAGES; COMMUNICATION BY ELECTRONIC COMPUTER TERMINALS; ELECTRONIC MESSAGING (U.S. CLS. 100, 101 AND 104).

SN 86-065,696. INTERNATIONAL FAIR TIMESHARE AGENCY LLC, WILMINGTON, DE. FILED 9-16-2013.

**INTERNATIONAL FAIR  
TIMESHARE AGENCY**

THE MARK CONSISTS OF STANDARD CHARACTERS WITHOUT CLAIM TO ANY PARTICULAR FONT, STYLE, SIZE, OR COLOR.

NO CLAIM IS MADE TO THE EXCLUSIVE RIGHT TO USE "INTERNATIONAL" AND "TIMESHARE AGENCY", APART FROM THE MARK AS SHOWN.

**CLASS 35—ADVERTISING AND BUSINESS**

FOR REAL ESTATE TIMESHARE SALES MANAGEMENT; PROVIDING A WEB SITE FEATURING PRODUCT RATINGS OF THE CONSUMER SERVICES OF OTHERS IN THE FIELD OF REAL ESTATE TIMESHARES AND TRANSACTIONS INVOLVING REAL ESTATE TIMESHARES (U.S. CLS. 100, 101 AND 102).

**CLASS 42—SCIENTIFIC AND COMPUTER SERVICES**

FOR COMPUTER SERVICES, NAMELY, CREATING AN ON-LINE COMMUNITY FOR REGISTERED USERS TO PARTICIPATE IN DISCUSSIONS, GET FEEDBACK FROM THEIR PEERS, FORM VIRTUAL COMMUNITIES, AND ENGAGE IN SOCIAL NETWORKING SERVICES IN THE FIELD OF BUSINESS, COMMUNITY, AND PERSONAL INTERESTS, HOBBIES, AND NETWORKING; PROVIDING TEMPORARY USE OF ON-LINE NON-DOWNLOADABLE SOFTWARE FOR ALLOWING USERS TO COMMUNICATE INFORMATION OF GENERAL INTEREST; PROVIDING TEMPORARY USE OF NON-DOWNLOADABLE SOFTWARE APPLICATIONS FOR SOCIAL NETWORKING, CREATING A VIRTUAL COMMUNITY, AND TRANSMISSION OF AUDIO, VIDEO, PHOTOGRAPHIC IMAGES, TEXT, GRAPHICS AND DATA; PROVIDING TEMPORARY USE OF ON-LINE NON-DOWNLOADABLE SOFTWARE AND APPLICATIONS FOR EMAIL, CALENDARING, AND CONTACTS MANAGEMENT; COMPUTER SERVICES, NAMELY, CREATING AN ON-LINE COMMUNITY FOR REGISTERED USERS TO ORGANIZE GROUPS, EVENTS, PARTICIPATE IN DISCUSSIONS, SHARE INFORMATION AND RESOURCES, AND ENGAGE IN SOCIAL, BUSINESS AND COMMUNITY NETWORKING; COMPUTER SERVICES, NAMELY, HOSTING ELECTRONIC FACILITIES FOR OTHERS FOR ORGANIZING AND CONDUCTING MEETINGS, EVENTS AND INTERACTIVE DISCUSSIONS VIA THE INTERNET; PROVIDING ONLINE NON-DOWNLOADABLE SOFTWARE FOR CONNECTING TO MAJOR SOCIAL NETWORKING

**CLASS 36—INSURANCE AND FINANCIAL**

FOR VACATION REAL ESTATE TIMESHARE SERVICES, NAMELY, PROVIDING A WEBSITE FEATURING TIMESHARE LISTINGS (U.S. CLS. 100, 101 AND 102).

STEVEN JACKSON, EXAMINING ATTORNEY

SN 86-065,740. INTERNATIONAL FAIR TIMESHARE AGENCY LLC, WILMINGTON, DE. FILED 9-16-2013.

**PARADISE APPROVED**

THE MARK CONSISTS OF STANDARD CHARACTERS WITHOUT CLAIM TO ANY PARTICULAR FONT, STYLE, SIZE, OR COLOR.

**CLASS 35—ADVERTISING AND BUSINESS**

FOR REAL ESTATE TIMESHARE SALES MANAGEMENT; PROVIDING A WEB SITE FEATURING PRODUCT RATINGS OF THE CONSUMER SERVICES OF OTHERS IN THE FIELD OF REAL ESTATE TIMESHARES AND TRANSACTIONS INVOLVING REAL ESTATE TIMESHARES (U.S. CLS. 100, 101 AND 102).

**CLASS 36—INSURANCE AND FINANCIAL**

FOR VACATION REAL ESTATE TIMESHARE SERVICES, NAMELY, PROVIDING A WEBSITE FEATURING TIMESHARE LISTINGS (U.S. CLS. 100, 101 AND 102).

STEVEN JACKSON, EXAMINING ATTORNEY

SN 86-065,763. GRADUATE HOTEL HOLDINGS LLC, CHICAGO, IL. FILED 9-16-2013.

**THE SMARTER PLACE TO STAY**

THE MARK CONSISTS OF STANDARD CHARACTERS WITHOUT CLAIM TO ANY PARTICULAR FONT, STYLE, SIZE, OR COLOR.

**CLASS 25—CLOTHING**

FOR CLOTHING, NAMELY, VISORS, BASEBALL CAPS, GOLF CAPS, GOLF SHIRTS, TENNIS SHIRTS, SHORTS, SKIRTS, T-SHIRTS, SWEAT PANTS, SWEAT SHIRTS, AND WARM-UP SUITS (U.S. CLS. 22 AND 39).

**CLASS 43—HOTEL AND RESTAURANT SERVICES**

FOR HOTEL SERVICES; RESTAURANT, CATERING, BAR AND COCKTAIL LOUNGE SERVICES; RESORT LODGING SERVICES; PROVISION OF GENERAL PURPOSE FACILITIES FOR BUSINESS MEETINGS, BUSINESS CONFERENCES AND EXHIBITIONS; PROVISION OF BANQUET AND SOCIAL FUNCTION FACILITIES FOR SPECIAL OCCASIONS; AND RESERVATION SERVICE FOR HOTEL ACCOMMODATIONS FOR OTHERS (U.S. CLS. 100 AND 101).

ARETHA SOMERVILLE, EXAMINING ATTORNEY

SN 86-065,882. GALLETTI MEDIA, LLC, SAN PEDRO, CA. FILED 9-16-2013.

**SUNCAT**

THE MARK CONSISTS OF STANDARD CHARACTERS WITHOUT CLAIM TO ANY PARTICULAR FONT, STYLE, SIZE, OR COLOR.

**CLASS 25—CLOTHING**

FOR BEANIES; HATS; SWEATSHIRTS; T-SHIRTS (U.S. CLS. 22 AND 39).

**CLASS 35—ADVERTISING AND BUSINESS**

FOR ENTERTAINMENT MARKETING SERVICES, NAMELY, MARKETING, PROMOTION AND ADVERTISING FOR RECORDING AND PERFORMING ARTISTS; ON-LINE RETAIL STORE SERVICES FEATURING DOWNLOADABLE PRE-RECORDED MUSIC AND VIDEO; PROMOTIONAL ADVERTISING OF PRODUCTS AND SERVICES OF THIRD PARTIES THROUGH SPONSORING ARRANGEMENTS AND LICENSE AGREEMENTS RELATING TO INDEPENDENT MUSICIANS AND THEIR MUSIC; PROVIDING A WEBSITE FOR USERS WITH SPECIFIC INFORMED RECOMMENDATIONS OF SPECIFIC CONSUMER PRODUCTS AND SERVICES VALIDATED BY THE USERS' INPUTTED PREFERENCES AND SOCIAL NETWORK; PROVIDING CONSUMER INFORMATION SERVICES AND MAKING REFERRALS IN THE FIELD OF ENTERTAINMENT SERVICES FOR PRODUCTS, SERVICES, EVENTS, ACTIVITIES, FACILITIES AND LOCATIONS (U.S. CLS. 100, 101 AND 102).

**CLASS 38—COMMUNICATION**

FOR PROVIDING AN ON-LINE FORUM FOR INDEPENDENT MUSICIANS AND THEIR FANS ON THE SUBJECT OF MUSIC; PROVIDING INTERNET CHAT ROOMS (U.S. CLS. 100, 101 AND 104).

**CLASS 41—EDUCATION AND ENTERTAINMENT**

FOR ENTERTAINMENT EVENT BOOKING AGENCIES; ENTERTAINMENT INFORMATION SERVICES, NAMELY, PROVIDING INFORMATION AND NEWS RELEASES ABOUT A MUSICAL ARTIST; ENTERTAINMENT SERVICES, NAMELY, PROVIDING NON-DOWNLOADABLE PLAYBACK OF MUSIC VIA GLOBAL COMMUNICATIONS NETWORKS; ENTERTAINMENT SERVICES, NAMELY, PROVIDING NON-DOWNLOADABLE PRERECORDED MUSIC, INFORMATION IN THE FIELD OF MUSIC, AND COMMENTARY AND ARTICLES ABOUT MUSIC, ALL ON-LINE VIA A GLOBAL COMPUTER NETWORK; ENTERTAINMENT SERVICES, NAMELY, PROVIDING ON-LINE REVIEWS OF INDEPENDENT MUSICIANS' PERFORMANCES, ONSTAGE AND OFFSTAGE ACTIVITIES, AND MUSIC; ENTERTAINMENT, NAMELY, LIVE MUSIC CONCERTS; MULTIMEDIA ENTERTAINMENT SERVICES IN THE NATURE OF RECORDING, PRODUCTION AND POST-PRODUCTION SERVICES IN THE FIELDS OF MUSIC, VIDEO, AND FILMS; ON-LINE JOURNALS, NAMELY, BLOGS FEATURING INFORMATION ON INDEPENDENT MUSICIANS AND MUSIC, REVIEWS AND RECOMMENDATIONS OF MUSIC; PROVIDING A DATABASE FEATURING INFORMATION ABOUT ARTISTS; PROVIDING A WEBSITE FEATURING BLOGS AND NON-DOWNLOADABLE PUBLICATIONS IN THE NATURE OF ARTICLES WITH INFORMATION ON INDEPENDENT MUSICIANS AND MUSIC AND REVIEWS AND RECOMMENDATIONS IN THE FIELD(S) OF MUSIC; PROVIDING A WEBSITE FEATURING INFORMATION IN THE FIELD OF MUSIC AND ENTERTAINMENT; PROVIDING AN INTERNET WEBSITE PORTAL FEATURING LINKS TO MUSICAL ARTIST WEBSITES AND MUSIC PERFORMANCE TICKET INFORMATION; PROVIDING AN INTERNET WEBSITE PORTAL IN THE FIELD OF MUSIC; PROVISION OF INFORMATION RELATING TO LIVE PERFORMANCES, ROAD SHOWS, LIVE STAGE EVENTS, THEATRICAL PERFORMANCES, LIVE MUSIC CONCERTS AND AUDIENCE PARTICIPATION IN SUCH EVENTS (U.S. CLS. 100, 101 AND 107).

**CLASS 42—SCIENTIFIC AND COMPUTER SERVICES**

FOR COMPUTER SERVICES, NAMELY, CREATING AN ON-LINE COMMUNITY FOR REGISTERED USERS TO PROMOTE INDEPENDENT MUSICIANS AND THEIR MUSIC, PARTICIPATE IN DISCUSSIONS, GET FEEDBACK FROM THEIR PEERS, FORM VIRTUAL COMMUNITIES, ENGAGE IN SOCIAL NETWORKING, PROVIDE REVIEWS AND RECOMMENDATIONS, ALL IN THE FIELD OF MUSIC; COMPUTER SERVICES, NAMELY, PROVIDING SEARCH PLATFORMS TO ALLOW USERS TO LOCATE INDEPENDENT MUSICIANS AND THEIR MUSIC, PROVIDE LOCATION INFORMATION TO ATTEND MUSICAL PERFORMANCES, ACCESS MUSIC REVIEWS, AND LOCATE DOWNLOADABLE PRE-RECORDED MUSIC AND VIDEO; PROVIDING A WEBSITE ALLOWING USERS TO UPLOAD AND DOWNLOAD MUSIC (U.S. CLS. 100 AND 101).

ANTHONY RINKER, EXAMINING ATTORNEY

**CLASS 43—HOTEL AND RESTAURANT SERVICES**

FOR CAFE AND RESTAURANT SERVICES; COFFEE AND JUICE BAR SERVICES; COFFEE AND TEA BARS; COFFEE BARS; RESTAURANT SERVICES; SNACK BAR SERVICES; TEA BARS (U.S. CLS. 100 AND 101).

SANJEEV VOHRA, EXAMINING ATTORNEY

SN 86-066,567. CAROLYN HIER, SYKESVILLE, MD. FILED 9-17-2013.

## Porch Pockets

THE MARK CONSISTS OF STANDARD CHARACTERS WITHOUT CLAIM TO ANY PARTICULAR FONT, STYLE, SIZE, OR COLOR.

NO CLAIM IS MADE TO THE EXCLUSIVE RIGHT TO USE "PORCH", APART FROM THE MARK AS SHOWN.

**CLASS 20—FURNITURE AND ARTICLES NOT OTHERWISE CLASSIFIED**

FOR FITTED FABRIC SLIPCOVERS FOR FURNITURE, SUITABLE FOR INDOOR AND OUTDOOR USE (U.S. CLS. 2, 13, 22, 25, 32 AND 50).

**CLASS 24—FABRICS**

FOR PILLOW COVERS SUITABLE FOR INDOOR OR OUTDOOR USE; PILLOW CASES SUITABLE FOR INDOOR OR OUTDOOR USE; COVERS FOR CUSHIONS SUITABLE FOR INDOOR OR OUTDOOR USE (U.S. CLS. 42 AND 50).

DEBORAH MEINERS, EXAMINING ATTORNEY

SN 86-067,270. TOBY'S ESTATE COFFEE (ASIA) PTE LTD, CHINA SQUARE CENTRAL, SINGAPORE, FILED 9-17-2013.

## CASCARA

THE MARK CONSISTS OF STANDARD CHARACTERS WITHOUT CLAIM TO ANY PARTICULAR FONT, STYLE, SIZE, OR COLOR.

**CLASS 35—ADVERTISING AND BUSINESS**

FOR MOBILE CARTS BEING MOBILE FOOD AND BEVERAGE DISPENSING OUTLETS; FOOD AND BEVERAGE KIOSK SERVICES (U.S. CLS. 100, 101 AND 102).

**CLASS 43—HOTEL AND RESTAURANT SERVICES**

FOR PROVISION OF FOOD AND DRINK PREPARED FOR CONSUMPTION; PREPARATION OF TAKE-AWAY AND FAST FOOD; CAFES; CAFETERIAS; RESTAURANTS INCLUDING SELF SERVICE RESTAURANTS; SNACK BARS; PROVIDING OF FOOD AND DRINK VIA A MOBILE VAN (U.S. CLS. 100 AND 101).

SUNG IN, EXAMINING ATTORNEY

SN 86-066,294. HUANG, YU-LIANG, SAN GABRIEL, CA. FILED 9-16-2013.



OWNER OF U.S. REG. NOS. 2,415,304 AND 3,722,064. NO CLAIM IS MADE TO THE EXCLUSIVE RIGHT TO USE "TEA", APART FROM THE MARK AS SHOWN.

THE COLOR(S) GREEN AND WHITE IS/ARE CLAIMED AS A FEATURE OF THE MARK.

THE MARK CONSISTS OF A GREEN CIRCLE WITH A STYLIZED "T" FRAMED IN WHITE WITHIN THE CIRCLE, THE "T" BEING FORMED FROM A VERTICALLY ORIENTED GREEN RECTANGLE AND A HORIZONTALLY ARRANGED GREEN LEAF ON TOP OF THE RECTANGLE, THE GREEN CIRCLE BEING SURROUNDED BY A RING OF GREEN LEAVES, ALL OF WHICH IS ENCLOSED BY A CIRCULAR GREEN BORDER. THE FOREGOING IS FOLLOWED BY THE WORDS "TEA STATION" IN WHITE LETTERS FRAMED IN GREEN, WITH THE HORIZONTAL BAR OF THE INITIAL "T" BEING FORMED FROM A HORIZONTALLY ARRANGED GREEN LEAF.

**CLASS 21—HOUSEWARES AND GLASS**

FOR COFFEE CUPS; COFFEE CUPS, TEA CUPS AND MUGS; TEA POTS; TEA POTS NOT OF PRECIOUS METAL (U.S. CLS. 2, 13, 23, 29, 30, 33, 40 AND 50).

**CLASS 25—CLOTHING**

FOR BASEBALL CAPS AND HATS; HATS; SHORT-SLEEVED OR LONG-SLEEVED T-SHIRTS; SPORT SHIRTS; SPORTS CAPS AND HATS; SPORTS SHIRTS WITH SHORT SLEEVES; SWEATSHIRTS; T-SHIRTS (U.S. CLS. 22 AND 39).

**CLASS 30—STAPLE FOODS**

FOR BEVERAGES MADE OF COFFEE; BEVERAGES MADE OF TEA; BEVERAGES WITH A COFFEE BASE; BEVERAGES WITH A TEA BASE; BLACK TEA; COFFEE; COFFEE AND TEA; COFFEE BASED BEVERAGES; COFFEE BEVERAGES WITH MILK; COFFEE-BASED ICED BEVERAGES; FLAVORED ICES; FRUIT TEAS; GINGER TEA; GINSENG TEA; GREEN TEA; ICED COFFEE; ICED TEA; OOLONG TEA; SHAVED ICE CONFECTIONS; TEA; TEA BAGS; TEA FOR INFUSIONS; TEA-BASED BEVERAGES; TEA-BASED BEVERAGES WITH FRUIT FLAVORING; TEA-BASED ICED BEVERAGES (U.S. CL. 46).

SN 86-067,875. QLOGIK TECHNOLOGIES, INC., BOCA RATON, FL. FILED 9-18-2013.

# QLOGIK

THE MARK CONSISTS OF STANDARD CHARACTERS WITHOUT CLAIM TO ANY PARTICULAR FONT, STYLE, SIZE, OR COLOR.

## CLASS 9—ELECTRICAL AND SCIENTIFIC APPARATUS

FOR COMPUTER SOFTWARE FOR QUEUE MANAGEMENT AND CUSTOMER FLOW MANAGEMENT (U.S. CLS. 21, 23, 26, 36 AND 38).

## CLASS 35—ADVERTISING AND BUSINESS

FOR CUSTOMER SERVICES MANAGEMENT FOR OTHERS IN THE NATURE OF CONSULTING SERVICES RELATING TO QUEUE MANAGEMENT AND CUSTOMER FLOW MANAGEMENT (U.S. CLS. 100, 101 AND 102).

KATHERINE STOIDES, EXAMINING ATTORNEY

---

SN 86-068,459. ELEMENT FLEET MANAGEMENT INC., TORONTO, ONTARIO, CANADA, FILED 9-18-2013.

ELEMENT FLEET MANAGEMENT

THE MARK CONSISTS OF STANDARD CHARACTERS WITHOUT CLAIM TO ANY PARTICULAR FONT, STYLE, SIZE, OR COLOR.

NO CLAIM IS MADE TO THE EXCLUSIVE RIGHT TO USE "FLEET MANAGEMENT", APART FROM THE MARK AS SHOWN.

## CLASS 35—ADVERTISING AND BUSINESS

FOR VEHICLE FLEET MANAGEMENT SERVICES, NAMELY, COMMERCIAL ADMINISTRATION OF THE LICENSING OF VEHICLES OF OTHERS, ACQUISITION OF VEHICLES FOR OTHERS, FUEL MANAGEMENT SERVICES IN THE FIELD OF FLEET VEHICLES, AND MARKETING SERVICES RELATING TO THE VEHICLES OF OTHERS, EXPRESSLY EXCLUDING MOTOR HOMES AND RECREATIONAL VEHICLES (U.S. CLS. 100, 101 AND 102).

## CLASS 36—INSURANCE AND FINANCIAL

FOR VEHICLE ACCIDENT INSURANCE ADMINISTRATION (U.S. CLS. 100, 101 AND 102).

## CLASS 37—CONSTRUCTION AND REPAIR

FOR VEHICLE FLEET MANAGEMENT SERVICES, NAMELY, MAINTENANCE OF VEHICLES AND ACCIDENT REPAIR OF VEHICLES, EXPRESSLY EXCLUDING MOTOR HOMES AND RECREATIONAL VEHICLES (U.S. CLS. 100, 103 AND 106).

## CLASS 38—COMMUNICATION

FOR TELEMATIC SENDING OF INFORMATION RELATING TO VEHICLES, EXPRESSLY EXCLUDING MOTOR HOMES AND RECREATIONAL VEHICLES (U.S. CLS. 100, 101 AND 104).

## CLASS 39—TRANSPORTATION AND STORAGE

FOR LEASING OF VEHICLES, EXPRESSLY EXCLUDING MOTOR HOMES AND RECREATIONAL VEHICLES (U.S. CLS. 100 AND 105).

## CLASS 42—SCIENTIFIC AND COMPUTER SERVICES

FOR LEASING OF COMPUTER HARDWARE AND SOFTWARE EQUIPMENT TO COMMERCIAL LESSEES FOR USE IN VEHICLE FLEET MANAGEMENT (U.S. CLS. 100 AND 101).

## CLASS 45—PERSONAL AND LEGAL SERVICES

FOR PERSONAL BACKGROUND INVESTIGATIONS IN THE NATURE OF DRIVING RECORD CHECKS; VEHICLE AND DRIVER TELEMATICS SERVICES IN THE NATURE OF PROVIDING INFORMATION CONCERNING SAFETY RISKS ON DRIVER BEHAVIOR TO CONSUMERS AND AUTOMOBILE INSURANCE COMPANIES (U.S. CLS. 100 AND 101).

NICHOLAS ALTREE, EXAMINING ATTORNEY

---

SN 86-068,470. IMPACT UNLIMITED, INC., DAYTON, NJ. FILED 9-18-2013.



OWNER OF U.S. REG. NO. 2,922,656.

THE MARK CONSISTS OF A SOLID CIRCLE WITH TWO EXCLAMATION POINTS, THE FIRST FACING UP AND THE SECOND FACING DOWN WITHIN THE CIRCLE.

## CLASS 9—ELECTRICAL AND SCIENTIFIC APPARATUS

FOR COMPUTER PROGRAMS AND COMPUTER SOFTWARE FEATURING EDUCATIONAL AND PROMOTIONAL MATERIALS FOR USE IN ADVERTISING, PUBLIC RELATIONS AND MARKETING SERVICES (U.S. CLS. 21, 23, 26, 36 AND 38).

FIRST USE 9-0-2012; IN COMMERCE 9-0-2012.



**CLASS 35—ADVERTISING AND BUSINESS**

FOR CONSULTATION SERVICES IN THE FIELD OF ADVERTISING AND EVENT PLANNING FOR BUSINESS PURPOSES; CONDUCTING BUSINESS AND MARKET RESEARCH, BUSINESS CONSULTATION, BUSINESS MARKETING CONSULTING SERVICES, MARKET ANALYSIS SERVICES; PUBLIC RELATIONS SERVICES; ADVERTISING AND MARKETING SERVICES RELATING TO MEDIA PLANNING, NAMELY, ASSISTING OTHERS IN DETERMINING APPROPRIATE AND COST-EFFECTIVE MEDIA AND MARKETING STRATEGIES TO TARGET AN AUDIENCE; DIRECT MAIL ADVERTISEMENTS, BILLBOARD ADVERTISEMENTS AND ADVERTISEMENTS FOR DISSEMINATION VIA AN ON-LINE ELECTRONIC COMMUNICATIONS NETWORK; PREPARING AUDIO-VISUAL PRESENTATIONS FOR USE IN ADVERTISING (U.S. CLS. 100, 101 AND 102).

FIRST USE 9-0-2012; IN COMMERCE 9-0-2012.

**CLASS 42—SCIENTIFIC AND COMPUTER SERVICES**

FOR GRAPHIC ART DESIGN FOR OTHERS; INTERIOR DECORATING CONSULTATION FOR MUSEUMS, SHOWROOMS AND BUSINESSES; WEBSITE DESIGN FOR OTHERS, AND DESIGN FOR OTHERS IN THE FIELD OF INTERACTIVE COMPUTER PROGRAMS FEATURING EDUCATIONAL AND PROMOTIONAL MATERIALS FOR USE IN ADVERTISING, PUBLIC RELATIONS AND MARKETING SERVICES (U.S. CLS. 100 AND 101).

FIRST USE 9-0-2012; IN COMMERCE 9-0-2012.  
ALLISON SCHRODY, EXAMINING ATTORNEY

SN 86-068,935. UNITED ORTHOPEDIC GROUP, INC., PLANO, TX. FILED 9-19-2013.



NO CLAIM IS MADE TO THE EXCLUSIVE RIGHT TO USE "ORTHOPEDIC CONSULTING SERVICES", APART FROM THE MARK AS SHOWN.

THE MARK CONSISTS OF THE STYLIZED LETTERS "UOCS", WHICH ARE EACH IN A BOX, WHICH ARE ABOVE THE STYLIZED WORDS "UNITED ORTHOPEDIC", WHICH ARE ABOVE THE STYLIZED WORD "CONSULTING" WHICH IS ABOVE THE STYLIZED WORD "SERVICES".

**CLASS 35—ADVERTISING AND BUSINESS**

FOR CONSULTING SERVICES IN THE FIELDS OF MANAGEMENT OF ORTHOPEDIC PRACTICES, INVENTORY MANAGEMENT, MEDICAL CODING AND MEDICAL BILLING (U.S. CLS. 100, 101 AND 102).

**CLASS 42—SCIENTIFIC AND COMPUTER SERVICES**

FOR SOFTWARE AS A SERVICE (SAAS) SERVICES FEATURING SOFTWARE FOR MANAGEMENT OF ORTHOPEDIC PRACTICES, INVENTORY MANAGEMENT, MEDICAL CODING AND MEDICAL BILLING (U.S. CLS. 100 AND 101).

AISHA CLARKE, EXAMINING ATTORNEY

SN 86-068,937. UNITED ORTHOPEDIC GROUP, INC., PLANO, TX. FILED 9-19-2013.



NO CLAIM IS MADE TO THE EXCLUSIVE RIGHT TO USE "ORTHOPEDIC CONSULTING SERVICES", APART FROM THE MARK AS SHOWN.

THE MARK CONSISTS OF THE STYLIZED LETTERS "UOCS", WHICH ARE EACH IN A BOX, TO THE LEFT OF THE STYLIZED WORDS "UNITED ORTHOPEDIC", WHICH ARE ABOVE THE STYLIZED WORD "CONSULTING", WHICH IS ABOVE THE STYLIZED WORD "SERVICES".

**CLASS 35—ADVERTISING AND BUSINESS**

FOR CONSULTING SERVICES IN THE FIELDS OF MANAGEMENT OF ORTHOPEDIC PRACTICES, INVENTORY MANAGEMENT, MEDICAL CODING AND MEDICAL BILLING (U.S. CLS. 100, 101 AND 102).

**CLASS 42—SCIENTIFIC AND COMPUTER SERVICES**

FOR SOFTWARE AS A SERVICE (SAAS) SERVICES FEATURING SOFTWARE FOR MANAGEMENT OF ORTHOPEDIC PRACTICES, INVENTORY MANAGEMENT, MEDICAL CODING AND MEDICAL BILLING (U.S. CLS. 100 AND 101).

AISHA CLARKE, EXAMINING ATTORNEY

SN 86-069,241. EMS INTERNET LIMITED, WARRINGTON, UNITED KINGDOM, FILED 9-19-2013.

# APPITIZED

THE MARK CONSISTS OF STANDARD CHARACTERS WITHOUT CLAIM TO ANY PARTICULAR FONT, STYLE, SIZE, OR COLOR.

PRIORITY CLAIMED UNDER SEC. 44(D) ON UNITED KINGDOM APPLICATION NO. 2657271, FILED 3-21-2013, REG. NO. UK0000265727, DATED 7-19-2013, EXPIRES 7-19-2023.

**CLASS 9—ELECTRICAL AND SCIENTIFIC APPARATUS**

FOR COMPUTER APPLICATION SOFTWARE FOR VIDEO SHARING, DOCUMENT MANAGEMENT AND ORGANIZATION, ADVICE AND INFORMATION ON FITNESS AND LIFESTYLE DECISIONS, ENTERTAINMENT, EDUCATION, MARKETING, ADVERTISING AND PROMOTION, ARCHITECTURE AND SPACE DESIGN, REAL ESTATE, AUTOMOBILE INSURANCE, FASHION, FOOTWEAR, SPORTSWEAR, MAPPING, AND SOCIAL NETWORKING MOBILE TELEPHONE SOFTWARE FOR VIDEO SHARING, DOCUMENT MANAGEMENT AND ORGANIZATION, ADVICE AND INFORMATION ON FITNESS AND LIFESTYLE DECISIONS, ENTERTAINMENT, EDUCATION, MARKETING, ADVERTISING AND PROMOTION, ARCHITECTURE AND SPACE DESIGN, REAL ESTATE, AUTOMOBILE INSURANCE, FOOTWEAR, SPORTSWEAR, MAPPING, AND SOCIAL NETWORKING; COMPUTER SOFTWARE TO ENABLE THE VIEWING OF WEBSITE CONTENT VIA PERSONAL AND HANDHELD COMPUTERS AND MOBILE DEVICES (U.S. CLS. 21, 23, 26, 36 AND 38).

**CLASS 35—ADVERTISING AND BUSINESS**

FOR ADVERTISING, MARKETING AND PROMOTIONAL SERVICES; ADVERTISING AGENCY SERVICES; ADVERTISING AND MARKETING CONSULTATION; DESIGN AND DEVELOPMENT OF ADVERTISING AND MARKETING CAMPAIGNS VIA MOBILE TELEPHONY AND MOBILE APPLICATIONS; DISSEMINATION OF ADVERTISING FOR OTHERS VIA THE INTERNET AND VIA MOBILE TELEPHONY AND MOBILE APPLICATIONS; SALES PROMOTION SERVICES; MARKET RESEARCH; ANALYSIS OF ADVERTISING RESPONSE AND MARKET RESEARCH; CREATION, PREPARATION, PRODUCTION, AND DISSEMINATION OF ADVERTISEMENTS AND ADVERTISING, MARKETING AND PROMOTIONAL MATERIALS FOR OTHERS; PROVIDING BUSINESS AND COMMERCIAL INFORMATION OVER COMPUTER NETWORKS AND GLOBAL COMMUNICATION NETWORKS; DISSEMINATION OF ADVERTISING FOR OTHERS VIA COMPUTER NETWORKS AND GLOBAL COMMUNICATION NETWORKS; DATA PROCESSING SERVICES; PROVIDING INFORMATION, DATABASES, DIRECTORIES, AND PODCASTS IN THE FIELDS OF ADVERTISING AND MARKETING; BUSINESS MONITORING AND CONSULTING SERVICES, NAMELY, TRACKING WEB SITES AND APPLICATIONS OF OTHERS TO PROVIDE STRATEGY, INSIGHT, MARKETING, SALES, OPERATION, PRODUCT DESIGN, PARTICULARLY SPECIALIZING IN THE USE OF ANALYTIC AND STATISTIC MODELS FOR THE UNDERSTANDING AND PREDICTING OF CONSUMERS, BUSINESSES, AND MARKET TRENDS AND ACTIONS (U.S. CLS. 100, 101 AND 102).

**CLASS 42—SCIENTIFIC AND COMPUTER SERVICES**

FOR SERVICES FOR SOFTWARE DEVELOPMENT, UPDATING, DESIGN, INSTALLATION, MAINTENANCE AND RENTAL OF SOFTWARE; ELECTRONIC DATA STORAGE AND RETRIEVAL SERVICES; COMPUTERIZED DATA STORAGE AND RETRIEVAL SERVICES FOR DIGITAL TEXT, DATA, IMAGE, AUDIO, VIDEO AND MULTIMEDIA CONTENT; INTERNET SERVICES, NAMELY, CREATING INDEXES OF INFORMATION, SITES AND OTHER RESOURCES AVAILABLE ON GLOBAL COMPUTER NETWORKS AND OTHER ELECTRONIC AND COMMUNICATIONS NETWORKS FOR OTHERS; COMPUTER SERVICES, NAMELY, MONITORING, TESTING, ANALYZING, AND REPORTING ON THE INTERNET TRAFFIC CONTROL AND CONTENT CONTROL OF THE WEB SITES OF OTHERS; APPLICATION SERVICE PROVIDER (ASP), NAMELY, HOSTING COMPUTER SOFTWARE APPLICATIONS OF OTHERS; APPLICATION SERVICE PROVIDER, NAMELY, HOSTING, MANAGING, DEVELOPING, AND MAINTAINING APPLICATIONS, SOFTWARE, AND WEB SITES, IN THE FIELDS OF PERSONAL PRODUCTIVITY, WIRELESS COMMUNICATION, MOBILE INFORMATION ACCESS, AND REMOTE DATA MANAGEMENT FOR WIRELESS DELIVERY OF CON-

TENT TO HANDHELD COMPUTERS, LAPTOPS AND MOBILE ELECTRONIC DEVICES; COMPUTER SOFTWARE DEVELOPMENT IN THE FIELD OF MOBILE APPLICATIONS; PROVIDING TEMPORARY USE OF NON-DOWNLOADABLE SOFTWARE APPLICATIONS FOR VIDEO SHARING; PROVIDING TEMPORARY USE OF NON-DOWNLOADABLE SOFTWARE APPLICATIONS FOR DOCUMENT MANAGEMENT AND ORGANIZATION; PROVIDING TEMPORARY USE OF NON-DOWNLOADABLE SOFTWARE APPLICATIONS FOR FITNESS AND LIFESTYLE ADVICE, INFORMATION AND MANAGEMENT; PROVIDING TEMPORARY USE OF NON-DOWNLOADABLE COMPUTER SOFTWARE AND MOBILE APPLICATIONS IN THE FIELDS OF FITNESS, ENTERTAINMENT, EDUCATION, MARKETING, ADVERTISING AND PROMOTION, ARCHITECTURE, SPACE DESIGN, REAL ESTATE, AUTOMOBILE INSURANCE, FASHION, FOOTWEAR, SPORTSWEAR, MAPPING, AND SOCIAL NETWORKING; PROVIDING TEMPORARY USE OF NON-DOWNLOADABLE SOFTWARE ALLOWING WEB SITE USERS TO POST AND DISPLAY ONLINE VIDEOS AND PHOTOS FOR SHARING WITH OTHERS FOR ENTERTAINMENT PURPOSES; PROVIDING TEMPORARY USE OF NON-DOWNLOADABLE SOFTWARE USED TO ALLOW USERS TO COLLABORATE IN REAL-TIME, WITH SHARED ACCESS TO DATA, DOCUMENTS, IMAGES, AUDIO, VIDEO, AND SOFTWARE APPLICATIONS THROUGH A WEB BROWSER; PROVIDING TEMPORARY USE OF NON-DOWNLOADABLE SOFTWARE APPLICATIONS FOR SOCIAL NETWORKING, CREATING A VIRTUAL COMMUNITY, AND TRANSMISSION OF AUDIO, VIDEO, PHOTOGRAPHIC IMAGES, TEXT, GRAPHICS AND DATA; AND PROVIDING TEMPORARY USE OF NON-DOWNLOADABLE SOFTWARE TO ENABLE THE VIEWING OF WEBSITE CONTENT VIA PERSONAL AND HANDHELD COMPUTERS AND MOBILE DEVICES (U.S. CLS. 100 AND 101).

ALEXANDER L. POWERS, EXAMINING ATTORNEY

SN 86-069,569. URBAN ORGANICS, LLC, ST. PAUL, MN.  
FILED 9-19-2013.

**URBAN ORGANICS**

THE MARK CONSISTS OF STANDARD CHARACTERS WITHOUT CLAIM TO ANY PARTICULAR FONT, STYLE, SIZE, OR COLOR.

NO CLAIM IS MADE TO THE EXCLUSIVE RIGHT TO USE "ORGANICS", APART FROM THE MARK AS SHOWN.

**CLASS 29—MEATS AND PROCESSED FOODS**

FOR FISH, NOT LIVE (U.S. CL. 46).

**CLASS 31—NATURAL AGRICULTURAL PRODUCTS**

FOR ORGANIC FRESH FRUITS AND VEGETABLES (U.S. CLS. 1 AND 46).

**CLASS 43—HOTEL AND RESTAURANT SERVICES**

FOR RESTAURANT SERVICES FEATURING ORGANIC FOOD (U.S. CLS. 100 AND 101).  
HEATHER SAPP, EXAMINING ATTORNEY

SN 86-069,962. QUICK QUAKES, BRANDON, MS. FILED 9-20-2013.

SN 86-070,545. URBAN ORGANICS, LLC, ST. PAUL, MN. FILED 9-20-2013.

## QUAKE SHAKES

THE MARK CONSISTS OF STANDARD CHARACTERS WITHOUT CLAIM TO ANY PARTICULAR FONT, STYLE, SIZE, OR COLOR.

NO CLAIM IS MADE TO THE EXCLUSIVE RIGHT TO USE "SHAKES", APART FROM THE MARK AS SHOWN.

### CLASS 5—PHARMACEUTICALS

FOR PROTEIN SUPPLEMENT SHAKES (U.S. CLS. 6, 18, 44, 46, 51 AND 52).

### CLASS 35—ADVERTISING AND BUSINESS

FOR RETAIL STORE AND ONLINE RETAIL STORE SERVICES FEATURING PROTEIN SUPPLEMENTS, DIETARY AND NUTRITIONAL SUPPLEMENTS, HERBAL SUPPLEMENTS AND VITAMIN AND MINERAL SUPPLEMENTS (U.S. CLS. 100, 101 AND 102).

DAVID MURRAY, EXAMINING ATTORNEY

---

SN 86-070,173. FONDRISI, JOHN J., GREENWICH, CT. FILED 9-20-2013.



THE MARK CONSISTS OF A PROFILE DRAWING OF A WOMAN'S FACE BENEATH THE NUMBER "1926", ALL STYLIZED IN THE ART DECO PERIOD MANNER, AND CIRCUMSCRIBED BY A CIRCLE.

### CLASS 16—PAPER GOODS AND PRINTED MATTER

FOR NOTE CARDS; STATIONERY GOODS, NAMELY, PAPER GIFT CARDS, WRITING PAPERS, MEMO PADS, LETTERHEAD; NOTE PADS; ENVELOPES; AND PAPER WEIGHTS (U.S. CLS. 2, 5, 22, 23, 29, 37, 38 AND 50).

### CLASS 25—CLOTHING

FOR APPAREL AND FASHION ACCESSORIES, NAMELY, T-SHIRTS, SWEATSHIRTS, AND HATS (U.S. CLS. 22 AND 39).

WILLIAM JACKSON, EXAMINING ATTORNEY



THE MARK CONSISTS OF THE LETTER "U" AND THE LETTER "O" AND A PROLATE SPHEROID.

### CLASS 29—MEATS AND PROCESSED FOODS

FOR FISH, NOT LIVE (U.S. CL. 46).

### CLASS 31—NATURAL AGRICULTURAL PRODUCTS

FOR FRESH FRUITS AND VEGETABLES (U.S. CLS. 1 AND 46).

### CLASS 43—HOTEL AND RESTAURANT SERVICES

FOR RESTAURANT SERVICES (U.S. CLS. 100 AND 101).

HEATHER SAPP, EXAMINING ATTORNEY

---

SN 86-070,553. STAR SHIELD SOLUTIONS, LLC, ONTARIO, CA. FILED 9-20-2013.



NO CLAIM IS MADE TO THE EXCLUSIVE RIGHT TO USE "CLEAR PROTECTION FILMS", APART FROM THE MARK AS SHOWN.

THE MARK CONSISTS OF THE WORDS "STAR SHIELD" ABOVE THE WORD "SOLUTIONS" WITH A PARTIAL OUTLINE OF A STAR SURROUNDING THOSE WORDS ON THEIR TOP AND LEFT SIDES, AND THE WORDS "CLEAR PROTECTION FILMS" IN ONE LINE WRITTEN BENEATH THE REMAINDER OF THE MARK.

### CLASS 17—RUBBER GOODS

FOR TRANSPARENT SELF-ADHESIVE PLASTIC SHEETS FOR USE IN PROTECTING SURFACES OF MOTOR VEHICLES, BOATS AND WATERCRAFT, FIBERGLASS, ELECTRONIC DEVICES, AND SPORTING GOODS (U.S. CLS. 1, 5, 12, 13, 35 AND 50).

FIRST USE 2-28-2013; IN COMMERCE 2-28-2013.

**CLASS 37—CONSTRUCTION AND REPAIR**

FOR INSTALLATION OF TRANSPARENT SELF-ADHESIVE FILM ON MOTOR VEHICLES, BOATS AND WATERCRAFT, FIBERGLASS, ELECTRONIC DEVICES, AND SPORTING GOODS TO PROTECT THE SURFACES (U.S. CLS. 100, 103 AND 106).

FIRST USE 2-28-2013; IN COMMERCE 2-28-2013.

**CLASS 41—EDUCATION AND ENTERTAINMENT**

FOR TRAINING OTHERS TO INSTALL TRANSPARENT SELF-ADHESIVE FILM FOR USE IN PROTECTING SURFACES (U.S. CLS. 100, 101 AND 107).

FIRST USE 2-28-2013; IN COMMERCE 2-28-2013.

AISHA CLARKE, EXAMINING ATTORNEY

**CLASS 11—ENVIRONMENTAL CONTROL APPARATUS**

FOR ELECTRIC COFFEE MACHINES (U.S. CLS. 13, 21, 23, 31 AND 34).

**CLASS 16—PAPER GOODS AND PRINTED MATTER**

FOR PAPER FILTERS FOR COFFEE MAKERS (U.S. CLS. 2, 5, 22, 23, 29, 37, 38 AND 50).

**CLASS 21—HOUSEWARES AND GLASS**

FOR COFFEE CUPS AND MUGS (U.S. CLS. 2, 13, 23, 29, 30, 33, 40 AND 50).

**CLASS 30—STAPLE FOODS**

FOR COFFEE, ESPRESSO, DECAFFEINATED COFFEE, COFFEE PODS, COFFEE BASED BEVERAGES, COFFEE EXTRACTS, AND TEA (U.S. CL. 46).

JOANNA DUKOVIC, EXAMINING ATTORNEY

SN 86-070,658. ELLWOOD GROUP INVESTMENT CORP., WILMINGTON, DE. FILED 9-20-2013.

**ELLWOOD SPECIALTY STEEL**

THE MARK CONSISTS OF STANDARD CHARACTERS WITHOUT CLAIM TO ANY PARTICULAR FONT, STYLE, SIZE, OR COLOR.

NO CLAIM IS MADE TO THE EXCLUSIVE RIGHT TO USE "SPECIALTY STEEL", APART FROM THE MARK AS SHOWN.

**CLASS 6—METAL GOODS**

FOR STEEL PRODUCTS, NAMELY, SPECIALTY TOOL, DIE, AND MOLD STEELS (U.S. CLS. 2, 12, 13, 14, 23, 25 AND 50).

FIRST USE 11-12-1991; IN COMMERCE 1-1-1992.

**CLASS 40—MATERIAL TREATMENT**

FOR CUSTOM MANUFACTURING IN THE FIELDS OF STEEL IN BLOCK, BAR, PLATE, AND/OR DISK FORM FOR USE IN THE FURTHER MANUFACTURE OF SPECIALTY TOOLS, DIES, AND MOLDS (U.S. CLS. 100, 103 AND 106).

FIRST USE 11-12-1991; IN COMMERCE 1-1-1992.

HAI-LY LAM, EXAMINING ATTORNEY

SN 86-070,790. ZINZINO AB, 421 31 VASTRA FROLUNDA, SWEDEN, FILED 9-20-2013.

**ZINZINO**

THE MARK CONSISTS OF STANDARD CHARACTERS WITHOUT CLAIM TO ANY PARTICULAR FONT, STYLE, SIZE, OR COLOR.

OWNER OF SWEDEN REG. NO. 0375779, DATED 10-28-2005, EXPIRES 10-28-2015.

THE ENGLISH TRANSLATION OF "ZINZINO" IN THE MARK IS "TINY BIT", OR "SMALL AMOUNT", OR "TINY QUANTITY".

SN 86-070,836. MLINKU CORPORATION, SAN JOSE, CA. FILED 9-20-2013.

**MLINKME**

THE MARK CONSISTS OF STANDARD CHARACTERS WITHOUT CLAIM TO ANY PARTICULAR FONT, STYLE, SIZE, OR COLOR.

**CLASS 38—COMMUNICATION**

FOR COMPUTER SERVICES, NAMELY, PROVIDING ON-LINE FACILITIES FOR REAL-TIME INTERACTION WITH OTHER COMPUTER USERS CONCERNING TOPICS OF GENERAL INTEREST; MESSAGE SENDING VIA A WEBSITE; STREAMING OF AUDIO, VISUAL AND AUDIOVISUAL MATERIAL VIA A GLOBAL COMPUTER NETWORK; PEER-TO-PEER FILE SHARING SERVICES, NAMELY, ELECTRONIC TRANSMISSION OF VISUAL, AUDIO AND DATA CONTENT FILES AMONG INTERNET USERS (U.S. CLS. 100, 101 AND 104).

**CLASS 42—SCIENTIFIC AND COMPUTER SERVICES**

FOR FILE SHARING SERVICES, NAMELY, PROVIDING A WEBSITE FEATURING TECHNOLOGY ENABLING USERS TO UPLOAD AND DOWNLOAD ELECTRONIC FILES, NAMELY, STILL IMAGES, PHOTOS, TEXT, DATA, AUDIO, VIDEO AND THE COMBINATION THEREOF; APPLICATION SERVICE PROVIDER (ASP), NAMELY, HOSTING COMPUTER SOFTWARE APPLICATIONS OF OTHERS (U.S. CLS. 100 AND 101).

STEVEN PEREZ, EXAMINING ATTORNEY

SN 86-070,984. ALASKA NURSES ASSOCIATION, ANCHORAGE, AK. FILED 9-20-2013.



NO CLAIM IS MADE TO THE EXCLUSIVE RIGHT TO USE "ALASKA NURSES ASSOCIATION" AND THE MAP OF THE STATE OF ALASKA, APART FROM THE MARK AS SHOWN.

THE MARK CONSISTS OF AN IMAGE OF THE STATE OF "ALASKA" WITH AN "A" IN THE CENTER OF THE IMAGE AND THE LETTERS "ANA" AFTER, ABOVE A LINE, WITH THE PHRASE "ALASKA NURSES ASSOCIATION" CENTERED IN BLOCK FORMAT UNDER THE LINE.

#### CLASS 35—ADVERTISING AND BUSINESS

FOR ASSOCIATION SERVICES, NAMELY, PROMOTING THE INTERESTS OF NURSES IN THE STATE OF ALASKA; PROVIDING COLLECTIVE BARGAINING SERVICES; PROVISION OF INFORMATION IN THE FIELD OF NURSING IN THE STATE OF ALASKA; LOBBYING SERVICES, NAMELY, PROMOTING THE INTERESTS OF NURSES IN THE FIELDS OF LEGISLATION AND REGULATION IN THE STATE OF ALASKA; PUBLIC ADVOCACY TO PROMOTE AWARENESS OF THE NURSING PROFESSION IN THE STATE OF ALASKA (U.S. CLS. 100, 101 AND 102).

FIRST USE 3-12-2010; IN COMMERCE 5-31-2010.

#### CLASS 41—EDUCATION AND ENTERTAINMENT

FOR EDUCATIONAL SERVICES, NAMELY, PROVIDING CONTINUING EDUCATION PROGRAMS, CONFERENCES, COURSES, MEETINGS, PROGRAMS, SEMINARS, SYMPOSIUMS, AND WORKSHOPS IN THE FIELD OF NURSING IN THE STATE OF ALASKA (U.S. CLS. 100, 101 AND 107).

FIRST USE 4-7-2010; IN COMMERCE 4-7-2010.  
JOHN WILKE, EXAMINING ATTORNEY

THE MARK CONSISTS OF A SHADED CIRCLE WITH AN IMAGE OF THE STATE OF "ALASKA" ON THE LEFT SIDE AND AN "A" IN THE CENTER OF THE IMAGE AND THE LETTERS "ANA" AFTER, WITH THE PHRASE "ALASKA NURSES ASSOCIATION" CENTERED IN BLOCK FORMAT UNDER THE IMAGE AND THE PHRASE "UNION NURSES UNITED FOR QUALITY PATIENT CARE" CURVED ALONG THE OUTER TOP EDGE OF THE SHADED CIRCLE.

#### CLASS 35—ADVERTISING AND BUSINESS

FOR ASSOCIATION SERVICES, NAMELY, PROMOTING THE INTERESTS OF NURSES IN THE STATE OF ALASKA; PROVIDING COLLECTIVE BARGAINING SERVICES; PROVISION OF INFORMATION IN THE FIELD OF NURSING IN THE STATE OF ALASKA; LOBBYING SERVICES, NAMELY, PROMOTING THE INTERESTS OF NURSES IN THE FIELDS OF LEGISLATION AND REGULATION IN THE STATE OF ALASKA; PUBLIC ADVOCACY TO PROMOTE AWARENESS OF THE NURSING PROFESSION IN THE STATE OF ALASKA (U.S. CLS. 100, 101 AND 102).

FIRST USE 7-4-2012; IN COMMERCE 8-31-2013.

#### CLASS 41—EDUCATION AND ENTERTAINMENT

FOR EDUCATIONAL SERVICES, NAMELY, PROVIDING CONTINUING EDUCATION PROGRAMS, CONFERENCES, COURSES, MEETINGS, PROGRAMS, SEMINARS, SYMPOSIUMS, AND WORKSHOPS IN THE FIELD OF NURSING IN THE STATE OF ALASKA (U.S. CLS. 100, 101 AND 107).

FIRST USE 7-4-2012; IN COMMERCE 8-31-2013.

JOHN WILKE, EXAMINING ATTORNEY

SN 86-071,010. CINEMAPUB, L.L.C., SALT LAKE CITY, UT. FILED 9-20-2013.

SN 86-070,991. ALASKA NURSES ASSOCIATION, ANCHORAGE, AK. FILED 9-20-2013.



NO CLAIM IS MADE TO THE EXCLUSIVE RIGHT TO USE "ALASKA NURSES ASSOCIATION" AND THE MAP OF THE STATE OF ALASKA, APART FROM THE MARK AS SHOWN.

#### BREWVIES CINEMA PUB

THE MARK CONSISTS OF STANDARD CHARACTERS WITHOUT CLAIM TO ANY PARTICULAR FONT, STYLE, SIZE, OR COLOR.

OWNER OF U.S. REG. NO. 4,405,744.

NO CLAIM IS MADE TO THE EXCLUSIVE RIGHT TO USE "CINEMA PUB", APART FROM THE MARK AS SHOWN.

**CLASS 41—EDUCATION AND ENTERTAINMENT**

FOR MOVIE THEATERS; CINEMA THEATERS; MOVIE SHOWING; PROVIDING FACILITIES FOR MOVIES; PROVIDING CINEMA FACILITIES; RENTAL OF MOVIE THEATERS; ENTERTAINMENT SERVICES IN THE NATURE OF LIVE MUSIC, LIVE MUSICAL PERFORMANCES, LIVE MUSIC CONCERTS, LIVE PERFORMANCES BY MUSICAL BANDS, COMEDY SHOWS, AND ARRANGING DANCE, VARIETY AND ENTERTAINMENT CONTESTS; ENTERTAINMENT SERVICES IN THE NATURE OF CONTESTS AND INCENTIVE AWARD PROGRAMS DESIGNED TO REWARD PROGRAM PARTICIPANTS WHO ENGAGE IN MUSICAL OR LIVE ENTERTAINMENT PERFORMANCES; ENTERTAINMENT SERVICES, NAMELY, PROVIDING PODCASTS IN THE FIELDS OF MOVIES AND ENTERTAINMENT; PROVIDING INFORMATION AND ONLINE INFORMATION IN THE FIELDS OF MOVIES AND ENTERTAINMENT; PROVIDING A WEBSITE AND SOCIAL MEDIA PORTALS FEATURING BLOGS AND NON-DOWNLOADABLE PUBLICATIONS IN THE NATURE OF ARTICLES AND COMMENTS DEALING WITH OPINION IN THE FIELDS OF MOVIES AND ENTERTAINMENT; AND PROVIDING A WEBSITE FEATURING ENTERTAINMENT INFORMATION FROM REMOTE LOCATIONS VIA DEVICES THAT FEED INFORMATION TO THE WEBSITE THAT IS PROCESSED AND ACCESSED IN REAL-TIME BY USERS (U.S. CLS. 100, 101 AND 107).

FIRST USE 5-1-2007; IN COMMERCE 5-1-2007.

**CLASS 43—HOTEL AND RESTAURANT SERVICES**

FOR RESTAURANTS; RESTAURANT SERVICES; BAR SERVICES; PUB SERVICES; SIT-DOWN RESTAURANT SERVICES; TAKE-OUT RESTAURANT SERVICES; RESTAURANT SERVICES, NAMELY, PROVIDING OF FOOD AND BEVERAGES FOR CONSUMPTION ON AND OFF THE PREMISES; RESTAURANT BEER AND ALCOHOL BEVERAGE SERVICES, NAMELY, PROVIDING BEER AND ALCOHOLIC BEVERAGES FOR CONSUMPTION ON THE PREMISES; RESTAURANT RESERVATION SERVICES; RESTAURANT INFORMATION SERVICES; PROVIDING INFORMATION AND ONLINE INFORMATION IN THE FIELDS OF RESTAURANTS, FOOD PREPARATION, BEER PREPARATION, ALCOHOL AND BEVERAGE PREPARATION; AND PROVIDING A WEBSITE AND SOCIAL MEDIA PORTALS FEATURING BLOGS AND INFORMATION, ARTICLES, COMMENTS AND OPINIONS IN THE FIELDS OF RESTAURANTS, FOOD PREPARATION, BEER PREPARATION, AND ALCOHOL AND BEVERAGE PREPARATION (U.S. CLS. 100 AND 101).

FIRST USE 5-1-2007; IN COMMERCE 5-1-2007.  
STEVEN JACKSON, EXAMINING ATTORNEY

SN 86-071,046. NORTH AMERICAN SPECIALTY PRODUCTS LLC, HOUSTON, TX. FILED 9-20-2013.

**YELOMINE**

THE MARK CONSISTS OF STANDARD CHARACTERS WITHOUT CLAIM TO ANY PARTICULAR FONT, STYLE, SIZE, OR COLOR.  
SEC. 2(F).

**CLASS 17—RUBBER GOODS**

FOR NON-METAL FLEXIBLE PVC PIPES; NON-METAL FLEXIBLE PVC PIPES FOR IRRIGATION, MUNICIPAL WATER, MUNICIPAL SEWERS, AGRICULTURE, AGRICULTURAL IRRIGATION, MINING, AND ENERGY APPLICATIONS AND SYSTEMS; NON-METAL FLEXIBLE PVC PIPES CONTAINING IMPACT MODIFIERS AND UV INHIBITORS, FOR IRRIGATION, MUNICIPAL WATER, MUNICIPAL SEWERS, AGRICULTURE, AGRICULTURAL IRRIGATION, MINING, AND ENERGY APPLICATIONS AND SYSTEMS (U.S. CLS. 1, 5, 12, 13, 35 AND 50).

FIRST USE 1-1-1975; IN COMMERCE 1-1-1975.

**CLASS 19—NON-METALLIC BUILDING MATERIALS**

FOR NON-METAL RIGID PVC PIPES, COUPLINGS, JOINTS, AND FITTINGS THEREFOR; NON-METAL RIGID PVC PIPES, COUPLINGS, JOINTS, AND FITTINGS THEREFOR FOR IRRIGATION, MUNICIPAL WATER, MUNICIPAL SEWERS, AGRICULTURE, AGRICULTURAL IRRIGATION, MINING, AND ENERGY APPLICATIONS AND SYSTEMS; NON-METAL RIGID PVC PIPES COUPLINGS, JOINTS, AND FITTINGS, CONTAINING IMPACT MODIFIERS AND UV INHIBITORS, FOR IRRIGATION, MUNICIPAL WATER, MUNICIPAL SEWERS, AGRICULTURE, AGRICULTURAL IRRIGATION, MINING, AND ENERGY APPLICATIONS AND SYSTEMS (U.S. CLS. 1, 12, 33 AND 50).

FIRST USE 1-1-1975; IN COMMERCE 1-1-1975.  
STEPHANIE ALI, EXAMINING ATTORNEY

SN 86-071,254. IT COSMETICS, LLC, JERSEY CITY, NJ. FILED 9-22-2013.

**GO VERTICAL**

THE MARK CONSISTS OF STANDARD CHARACTERS WITHOUT CLAIM TO ANY PARTICULAR FONT, STYLE, SIZE, OR COLOR.

**CLASS 3—COSMETICS AND CLEANING PREPARATIONS**

FOR COSMETICS AND MAKE-UP; NON-MEDICATED SKIN CARE PREPARATIONS (U.S. CLS. 1, 4, 6, 50, 51 AND 52).

**CLASS 35—ADVERTISING AND BUSINESS**

FOR ON-LINE RETAIL STORE SERVICES FEATURING COSMETICS AND MAKE-UP (U.S. CLS. 100, 101 AND 102).  
JENNIFER RICHARDSON, EXAMINING ATTORNEY

SN 86-071,322. ROSS OPERATING VALVE COMPANY, DBA ROSS CONTROLS, TROY, MI. FILED 9-22-2013.

SN 86-071,331. TYLER PERRY STUDIOS, LLC, LOS ANGELES, CA. FILED 9-22-2013.

**TUBO-FUZE**

THE MARK CONSISTS OF STANDARD CHARACTERS WITHOUT CLAIM TO ANY PARTICULAR FONT, STYLE, SIZE, OR COLOR.

OWNER OF U.S. REG. NO. 2,852,904.  
THE ENGLISH TRANSLATION OF "TUBO" IN THE MARK IS "TUBE".

**CLASS 6—METAL GOODS**

FOR METAL VALVES NOT BEING PARTS OF MACHINES; METAL SLIDE VALVES NOT BEING PARTS OF MACHINES; METAL EXCESS FLOW CUTOFF VALVES NOT BEING PARTS OF MACHINES (U.S. CLS. 2, 12, 13, 14, 23, 25 AND 50).

**CLASS 7—MACHINERY**

FOR VALVES AS MACHINE COMPONENTS; SLIDE VALVES AS MACHINE COMPONENTS; EXCESS FLOW CUTOFF VALVES AS MACHINE COMPONENTS (U.S. CLS. 13, 19, 21, 23, 31, 34 AND 35).

**CLASS 9—ELECTRICAL AND SCIENTIFIC APPARATUS**

FOR AUTOMATIC VALVES; AUTOMATIC SLIDE VALVES; AUTOMATIC EXCESS FLOW CUTOFF VALVES; PROTECTIVE FEATURES FOR WATER DEVICES, GAS DEVICES, WATER LINES, GAS LINES, NAMELY, AUTOMATIC EXCESS FLOW CUTOFF VALVES (U.S. CLS. 21, 23, 26, 36 AND 38).

**CLASS 11—ENVIRONMENTAL CONTROL APPARATUS**

FOR VALVE BEING PLUMBING FITTINGS; SLIDE VALVE BEING PLUMBING FITTINGS; EXCESS FLOW CUTOFF VALVES BEING PLUMBING FITTINGS; PROTECTIVE FEATURES FOR WATER DEVICES, GAS DEVICES, WATER LINES, GAS LINES, NAMELY, EXCESS FLOW CUTOFF VALVES BEING PLUMBING FITTINGS (U.S. CLS. 13, 21, 23, 31 AND 34).

**CLASS 20—FURNITURE AND ARTICLES NOT OTHERWISE CLASSIFIED**

FOR VALVES OF PLASTIC BEING OTHER THAN MACHINE PARTS; SLIDE VALVES OF PLASTIC BEING OTHER THAN MACHINE PARTS; EXCESS FLOW CUTOFF VALVES OF PLASTIC BEING OTHER THAN MACHINE PARTS (U.S. CLS. 2, 13, 22, 25, 32 AND 50).  
MATTHEW EINSTEIN, EXAMINING ATTORNEY

**TYLER PERRY'S SINGLE MOMS CLUB**

THE MARK CONSISTS OF STANDARD CHARACTERS WITHOUT CLAIM TO ANY PARTICULAR FONT, STYLE, SIZE, OR COLOR.

OWNER OF U.S. REG. NO. 4,099,618.  
NO CLAIM IS MADE TO THE EXCLUSIVE RIGHT TO USE "SINGLE MOMS CLUB", APART FROM THE MARK AS SHOWN.

THE NAME(S), PORTRAIT(S), AND/OR SIGNATURE(S) SHOWN IN THE MARK IDENTIFIES "TYLER PERRY", WHOSE CONSENT(S) TO REGISTER IS MADE OF RECORD.

**CLASS 9—ELECTRICAL AND SCIENTIFIC APPARATUS**

FOR DOWNLOADABLE FILMS AND TELEVISION PROGRAMS FEATURING LIFESTYLE, COMEDY AND DRAMATIC SITUATIONS PROVIDED VIA A VIDEO-ON-DEMAND SERVICE (U.S. CLS. 21, 23, 26, 36 AND 38).

**CLASS 41—EDUCATION AND ENTERTAINMENT**

FOR EDUCATIONAL AND ENTERTAINMENT SERVICES, NAMELY, A CONTINUING PROGRAM ABOUT LIFESTYLE, COMEDY AND DRAMATIC SITUATIONS ACCESSIBLE BY RADIO, TELEVISION, SATELLITE, AUDIO, VIDEO AND COMPUTER NETWORKS; ENTERTAINMENT IN THE NATURE OF ON-GOING TELEVISION PROGRAMS IN THE FIELD OF COMEDY AND DRAMATIC SITUATIONS; ENTERTAINMENT IN THE NATURE OF VISUAL AND AUDIO PERFORMANCES, AND MUSICAL, VARIETY, NEWS AND COMEDY SHOWS; ENTERTAINMENT IN THE NATURE OF TELEVISION COMEDY SERIES; ENTERTAINMENT INFORMATION; ENTERTAINMENT MEDIA PRODUCTION SERVICES FOR MOTION PICTURES, TELEVISION AND INTERNET; ENTERTAINMENT SERVICES IN THE NATURE OF COMEDY SHOWS; ENTERTAINMENT SERVICES IN THE NATURE OF DEVELOPMENT, CREATION, PRODUCTION AND POST-PRODUCTION SERVICES OF MULTIMEDIA ENTERTAINMENT CONTENT; ENTERTAINMENT SERVICES, NAMELY, A MULTIMEDIA PROGRAM SERIES FEATURING COMEDY, ACTION AND ADVENTURE DISTRIBUTED VIA VARIOUS PLATFORMS ACROSS MULTIPLE FORMS OF TRANSMISSION MEDIA; ENTERTAINMENT SERVICES, NAMELY, AN ON-GOING SERIES FEATURING LIFESTYLE, COMEDY AND DRAMATIC SITUATIONS PROVIDED THROUGH BROADCAST, CABLE, SATELLITE AND INTERNET; ENTERTAINMENT SERVICES, NAMELY, DISPLAYING A SERIES OF FILMS; ENTERTAINMENT SERVICES, NAMELY, MULTIMEDIA PRODUCTION SERVICES; ENTERTAINMENT SERVICES, NAMELY, PRODUCTION AND DISTRIBUTION OF ONGOING TELEVISION PROGRAMS IN THE FIELD OF LIFESTYLE, COMEDY AND DRAMATIC SITUATIONS; ENTERTAINMENT SERVICES, NAMELY, PROVIDING ON-GOING TELEVISION PROGRAMS IN THE FIELD OF LIFESTYLE, COMEDY AND DRAMATIC SITUATIONS VIA A GLOBAL COMPUTER NETWORK; ENTERTAINMENT SERVICES, NAMELY, PROVIDING ON-GOING WEBISODES FEATURING LIFESTYLE, COMEDY AND DRAMATIC SITUATIONS VIA A GLOBAL COMPUTER NETWORK; ENTERTAINMENT SERVICES, NAMELY, PROVIDING VIDEO PODCASTS IN THE FIELD OF LIFESTYLE, COMEDY AND DRAMATIC SITUATIONS; ENTERTAINMENT SERVICES, NAMELY, PROVIDING WEBCASTS IN THE FIELD OF LIFESTYLE, COMEDY AND DRAMATIC SITUATIONS; ENTERTAINMENT SERVICES, NAMELY, THE PROVISION OF CONTINUING TELEVISION SHOWS FEATURING LIFESTYLE, COMEDY AND DRAMATIC SITUATIONS DELIVERED BY BROAD-

CAST, CABLE, SATELLITE AND INTERNET; ENTERTAINMENT, NAMELY, A CONTINUING DRAMATIC SITUATION COMEDY SHOW BROADCAST OVER TELEVISION, SATELLITE, AUDIO, AND VIDEO MEDIA; ENTERTAINMENT, NAMELY, PRODUCTION OF PLAYS, MOTION PICTURES AND TELEVISION SHOWS; MULTIMEDIA ENTERTAINMENT SOFTWARE PRODUCTION SERVICES; ORGANIZING AND ARRANGING EXHIBITIONS FOR ENTERTAINMENT PURPOSES; PRESENTATION OF LIVE SHOW PERFORMANCES; PROVIDING A WEBSITE FEATURING ENTERTAINMENT INFORMATION; PROVIDING A WEBSITE FEATURING INFORMATION IN THE FIELD OF MUSIC AND ENTERTAINMENT; PROVIDING ONLINE ENTERTAINMENT INFORMATION, NAMELY, INFORMATION ABOUT TELEVISION PROGRAMMING; RADIO ENTERTAINMENT PRODUCTION (U.S. CLS. 100, 101 AND 107).

ALICE BENMAMAN, EXAMINING ATTORNEY

SN 86-071,548. HOWARD HUGHES MEDICAL INSTITUTE, CHEVY CHASE, MD. FILED 9-23-2013.

## SCIENCE FORWARD

THE MARK CONSISTS OF STANDARD CHARACTERS WITHOUT CLAIM TO ANY PARTICULAR FONT, STYLE, SIZE, OR COLOR.

NO CLAIM IS MADE TO THE EXCLUSIVE RIGHT TO USE "SCIENCE", APART FROM THE MARK AS SHOWN.

### CLASS 36—INSURANCE AND FINANCIAL

FOR PROVIDING EDUCATION SCHOLARSHIPS FOR MEDICAL RESEARCH AND STUDY, AND PROVIDING GRANTS WHICH INVOLVE THE PROVISION OF FUNDING FOR EDUCATION PROGRAMS IN MEDICINE, BIOLOGY AND RELATED SCIENCES, AND MEDICAL RESEARCH AND MEDICAL STUDY (U.S. CLS. 100, 101 AND 102).

### CLASS 41—EDUCATION AND ENTERTAINMENT

FOR EDUCATIONAL SERVICES, NAMELY, CONDUCTING CLASSES, SEMINARS, CONFERENCES, WORKSHOPS, AND LECTURES IN THE SCIENTIFIC FIELDS OF CARDIOVASCULAR BIOLOGY, NEUROLOGY, IMMUNOLOGY, INFECTIOUS DISEASES, AND OTHER RELATED SCIENCES; EDUCATIONAL SERVICES, NAMELY, CONDUCTING ONLINE EXHIBITIONS, DISPLAYS, INTERACTIVE EXHIBITS, AND INTERACTIVE TEACHING MODULES IN THE NATURE OF ON-LINE ANIMATED VIDEOS, ARTICLES, LECTURES, ON-LINE VIDEOS, AND SHORT FILMS FOR TEACHING AND LEARNING SCIENCE RELATED TOPICS IN SCIENTIFIC FIELDS OF CARDIOVASCULAR BIOLOGY, NEUROLOGY, IMMUNOLOGY, BIOMEDICAL RESEARCH, PHYSICS, CHEMISTRY, BIOLOGY, ENGINEERING, INFECTIOUS AND GENETIC DISEASE, MOLECULAR BIOLOGY, CELL BIOLOGY, EVOLUTION, ENVIRONMENTAL SCIENCE AND GEO-SCIENCES; EDUCATION SERVICES, NAMELY, PROVIDING WORKSHOPS, SEMINARS, AND CONFERENCES, IN THE FIELD OF PHYSICS, CHEMISTRY, BIOLOGY, BIOMEDICS AND MEDICINE; ENTERTAINMENT SERVICES, NAMELY, MULTIMEDIA PRODUCTION SERVICES; ON-LINE JOURNALS, NAMELY, BLOGS FEATURING SCIENCE TOPICS (U.S. CLS. 100, 101 AND 107).

### CLASS 42—SCIENTIFIC AND COMPUTER SERVICES

FOR MEDICAL RESEARCH SERVICES; PROVIDING ONLINE SCIENTIFIC INFORMATION IN THE SCIENTIFIC FIELDS OF CARDIOVASCULAR BIOLOGY, NEUROLOGY, IMMUNOLOGY, INFECTIOUS DISEASES, AND OTHER RELATED SCIENCES; PROVIDING VIRTUAL RESEARCH LABORATORIES IN SCIENTIFIC FIELDS RELATED TO CARDIOVASCULAR BIOLOGY, NEUROLOGY, IMMUNOLOGY, BIOMEDICAL RESEARCH, PHYSICS, CHEMISTRY, BIOLOGY, ENGINEERING, INFECTIOUS AND GENETIC DISEASE, MOLECULAR BIOLOGY, CELL BIOLOGY, EVOLUTION, ENVIRONMENTAL SCIENCE AND GEO-SCIENCES; SCIENTIFIC RESEARCH IN THE FIELDS OF PHYSICS, CHEMISTRY AND BIOLOGY; SCIENTIFIC RESEARCH AND DEVELOPMENT; MEDICAL AND SCIENTIFIC RESEARCH SERVICES, NAMELY, BIOMEDICAL RESEARCH SERVICES; TECHNOLOGY RESEARCH IN THE FIELD OF BIOMEDICS; LABORATORY RESEARCH IN THE FIELD OF BIOMEDICS; DEVELOPMENT OF NEW TECHNOLOGY FOR OTHERS IN THE FIELD OF BIOMEDICS; ENGINEERING; TECHNOLOGY CONSULTATION AND DEVELOPMENT OF NEW TECHNOLOGY, SOFTWARE, TOOLS, DEVICES AND ANIMAL MODELS FOR OTHERS IN THE FIELDS OF COMPUTATION, BIOLOGY AND ENGINEERING WORKS, NAMELY, IN THE FIELD OF PHYSICS, OPTICS, CHEMISTRY AND BIOLOGY (U.S. CLS. 100 AND 101).

ELLEN PERKINS, EXAMINING ATTORNEY

SN 86-071,820. MEDICAL VISION AB, SVERIGE, SWEDEN, FILED 9-23-2013.

**Medical Vision** 

OWNER OF SWEDEN REG. NO. 0891000, DATED 6-2-2006, EXPIRES 6-2-2016.

NO CLAIM IS MADE TO THE EXCLUSIVE RIGHT TO USE "MEDICAL VISION", APART FROM THE MARK AS SHOWN.

THE STIPLING IS A FEATURE OF THE MARK AND DOES NOT INDICATE COLOR.

THE MARK CONSISTS OF THE WORDS "MEDICAL VISION" FOLLOWED BY THREE UPWARDLY ASCENDING SHADED OVALS, IN DIFFERENT SIZES.

### CLASS 10—MEDICAL APPARATUS

FOR SURGICAL AND MEDICAL APPARATUS AND INSTRUMENTS FOR USE IN ARTHROSCOPIC PROCEDURES; SUTURE MATERIALS (U.S. CLS. 26, 39 AND 44).

FIRST USE 12-1-2005; IN COMMERCE 2-1-2011.

### CLASS 42—SCIENTIFIC AND COMPUTER SERVICES

FOR MEDICAL RESEARCH; DESIGN AND DEVELOPMENT OF MEDICAL EQUIPMENT (U.S. CLS. 100 AND 101).

FIRST USE 12-1-2005; IN COMMERCE 2-1-2011.

FLORENTINA BLANDU, EXAMINING ATTORNEY



SN 86-071,884. DIVERSEY, INC., STURTEVANT, WI. FILED 9-23-2013.

SN 86-072,103. MCKAY ENTERPRISES, BIRCH RUN, MI. FILED 9-23-2013.

# ACTSCENT

THE MARK CONSISTS OF STANDARD CHARACTERS WITHOUT CLAIM TO ANY PARTICULAR FONT, STYLE, SIZE, OR COLOR.

## CLASS 3—COSMETICS AND CLEANING PREPARATIONS

FOR AIR FRESHENERS, NAMELY, AIR FRAGRANCING PREPARATIONS FOR COMMERCIAL, INDUSTRIAL AND INSTITUTIONAL USE (U.S. CLS. 1, 4, 6, 50, 51 AND 52).  
FIRST USE 8-26-2013; IN COMMERCE 8-26-2013.

## CLASS 5—PHARMACEUTICALS

FOR AIR FRESHENERS, NAMELY, AIR DEODORIZING PREPARATIONS AND ROOM DEODORIZERS FOR COMMERCIAL, INDUSTRIAL AND INSTITUTIONAL USE (U.S. CLS. 6, 18, 44, 46, 51 AND 52).  
FIRST USE 8-26-2013; IN COMMERCE 8-26-2013.  
NATALIE POLZER, EXAMINING ATTORNEY

SN 86-072,041. ALASKA NURSES ASSOCIATION, ANCHORAGE, AK. FILED 9-23-2013.

# AANA ALASKA NURSES ASSOCIATION

THE MARK CONSISTS OF STANDARD CHARACTERS WITHOUT CLAIM TO ANY PARTICULAR FONT, STYLE, SIZE, OR COLOR.

NO CLAIM IS MADE TO THE EXCLUSIVE RIGHT TO USE "ALASKA NURSES ASSOCIATION", APART FROM THE MARK AS SHOWN.

## CLASS 35—ADVERTISING AND BUSINESS

FOR ASSOCIATION SERVICES, NAMELY, PROMOTING THE INTERESTS OF NURSES IN THE STATE OF ALASKA; PROVIDING COLLECTIVE BARGAINING SERVICES; PROVISION OF INFORMATION IN THE FIELD OF NURSING IN THE STATE OF ALASKA; LOBBYING SERVICES, NAMELY, PROMOTING THE INTERESTS OF NURSES IN THE FIELDS OF LEGISLATION AND REGULATION IN THE STATE OF ALASKA; PUBLIC ADVOCACY TO PROMOTE AWARENESS OF THE NURSING PROFESSION IN THE STATE OF ALASKA (U.S. CLS. 100, 101 AND 102).  
FIRST USE 10-5-1953; IN COMMERCE 7-31-1969.

## CLASS 41—EDUCATION AND ENTERTAINMENT

FOR EDUCATIONAL SERVICES, NAMELY, PROVIDING CONTINUING EDUCATION PROGRAMS, CONFERENCES, COURSES, MEETINGS, PROGRAMS, SEMINARS, SYMPOSIUMS, AND WORKSHOPS IN THE FIELD OF NURSING IN THE STATE OF ALASKA (U.S. CLS. 100, 101 AND 107).  
FIRST USE 10-5-1953; IN COMMERCE 7-31-1969.  
JOHN WILKE, EXAMINING ATTORNEY

# Perfect Fit Bridal Tuxedos Prom

THE MARK CONSISTS OF STANDARD CHARACTERS WITHOUT CLAIM TO ANY PARTICULAR FONT, STYLE, SIZE, OR COLOR.

NO CLAIM IS MADE TO THE EXCLUSIVE RIGHT TO USE "BRIDAL TUXEDOS PROM", APART FROM THE MARK AS SHOWN.

## CLASS 35—ADVERTISING AND BUSINESS

FOR ON-LINE RETAIL STORE SERVICES FEATURING BRIDAL GOWNS, BRIDAL PARTY DRESSES, PROM DRESSES, FORMAL ACCESSORIES AND SHOES; RETAIL STORE SERVICES FEATURING BRIDAL GOWNS, BRIDAL PARTY DRESSES, PROM DRESSES, FORMAL ACCESSORIES AND SHOES (U.S. CLS. 100, 101 AND 102).  
FIRST USE 5-31-2009; IN COMMERCE 6-16-2009.

## CLASS 40—MATERIAL TREATMENT

FOR CLOTHING ALTERATION (U.S. CLS. 100, 103 AND 106).  
FIRST USE 5-31-2009; IN COMMERCE 6-16-2009.

## CLASS 45—PERSONAL AND LEGAL SERVICES

FOR TUXEDO RENTAL (U.S. CLS. 100 AND 101).  
FIRST USE 5-31-2009; IN COMMERCE 6-16-2009.  
JENNIFER MARTIN, EXAMINING ATTORNEY

SN 86-072,179. CGATE SOLUTIONS LTD., HAIFA, ISRAEL, FILED 9-23-2013.

ALUMINUM COMPOSITE PANELS

**CBOND**

www.cgategroup.com

PRIORITY CLAIMED UNDER SEC. 44(D) ON ERP N CMNTY TM OFC APPLICATION NO. 011684495, FILED 3-25-2013, REG. NO. 011684495, DATED 8-22-2013, EXPIRES 8-22-2023.

NO CLAIM IS MADE TO THE EXCLUSIVE RIGHT TO USE "ALUMINUM COMPOSITE PANELS" AND "WWW.CGATEGROUP.COM", APART FROM THE MARK AS SHOWN.

THE COLOR(S) BLACK, ORANGE AND WHITE IS/ARE CLAIMED AS A FEATURE OF THE MARK.

THE MARK CONSISTS OF A STYLIZED "CBOND" WHERE THE "O" IS COMPRISED OF TWO ORANGE SEMI-CIRCLES AND A BLACK CIRCLE IN THE MIDDLE AND THE LETTERS "C" "B" "N" AND "D" IN "CBOND" ARE IN BLACK, WITH THE WORDS "ALUMINUM COMPOSITE PANELS" IN BLACK AND A THIN LINE APPEARING IN BLACK ABOVE THE STYLIZED "CBOND" AND "WWW.CGATEGROUP.COM" IN BLACK AND A THIN LINE APPEARING IN BLACK BELOW THE STYLIZED "CBOND". THE ENTIRE MARK IS SET ON A WHITE BACKGROUND AS PART OF THE MARK.

**CLASS 6—METAL GOODS**

FOR BUILDING MATERIALS, NAMELY, COMPOSITE PANELS OF METAL, PRIMARILY ALUMINUM; SIGNAGE MATERIALS, NAMELY, COMPOSITE PANELS OF METAL, PRIMARILY ALUMINUM (U.S. CLS. 2, 12, 13, 14, 23, 25 AND 50).

FIRST USE 9-0-2005; IN COMMERCE 9-0-2005.

**CLASS 19—NON-METALLIC BUILDING MATERIALS**

FOR BUILDING MATERIALS, NAMELY, COMPOSITE PANELS, NOT OF METAL; SIGNAGE MATERIALS, NAMELY, COMPOSITE PANELS, NOT OF METAL (U.S. CLS. 1, 12, 33 AND 50).

FIRST USE 9-0-2005; IN COMMERCE 9-0-2005.  
BRITTANY ESTELL, EXAMINING ATTORNEY

---

SN 86-072.406. I DO DIAMOND RING BOUTIQUE, LLC, SARASOTA, FL. FILED 9-23-2013.

GET YOUR SEXY ON

THE MARK CONSISTS OF STANDARD CHARACTERS WITHOUT CLAIM TO ANY PARTICULAR FONT, STYLE, SIZE, OR COLOR.

**CLASS 14—JEWELRY**

FOR JEWELRY; DIAMONDS (U.S. CLS. 2, 27, 28 AND 50).

**CLASS 35—ADVERTISING AND BUSINESS**

FOR RETAIL STORE SERVICES AND ONLINE RETAIL STORE SERVICES FEATURING JEWELRY (U.S. CLS. 100, 101 AND 102).

KAREN SEVERSON, EXAMINING ATTORNEY

---

SN 86-072.602. DERMA DREAM GROUP LTD., TORTOLA, BR.VIRGIN ISLANDS, FILED 9-24-2013.

Sensica

THE MARK CONSISTS OF STANDARD CHARACTERS WITHOUT CLAIM TO ANY PARTICULAR FONT, STYLE, SIZE, OR COLOR.

THE WORDING "SENSICA" HAS NO MEANING IN A FOREIGN LANGUAGE.

**CLASS 3—COSMETICS AND CLEANING PREPARATIONS**

FOR AGE SPOT REDUCING CREAMS; ALOE VERA GEL FOR COSMETIC PURPOSES; ANTI-AGING CREAM; ANTI-AGING MOISTURIZER; ANTI-FRECKLE CREAMS; ANTI-WRINKLE CREAM; BEAUTY CREAMS; BEAUTY CREAMS FOR BODY CARE; BEAUTY GELS; BEAUTY LOTIONS; BEAUTY SERUMS; BODY AND BEAUTY CARE COSMETICS; BODY CREAMS; BODY LOTIONS; CLEANSING CREAMS; COSMETIC CREAMS; COSMETIC CREAMS FOR SKIN CARE; COSMETIC MASSAGE CREAMS; COSMETIC NOURISHING CREAMS; COSMETIC PREPARATIONS, NAMELY, FIRING CREAMS; COSMETIC PREPARATIONS, NAMELY, FIRING LOTIONS; CREAMS FOR CELLULITE REDUCTION; FACE AND BODY BEAUTY CREAMS; FACE AND BODY CREAMS; FACE CREAMS; FACE CREAMS FOR COSMETIC USE; FACIAL CLEANSERS; FACIAL CREAMS; LOTIONS FOR CELLULITE REDUCTION; LOTIONS FOR COSMETIC PURPOSES; LOTIONS FOR FACE AND BODY CARE; MASSAGE CREAMS; MASSAGE GELS OTHER THAN FOR MEDICAL PURPOSES; MASSAGE LOTIONS; MASSAGE OIL; MOISTURIZING CREAMS; NON-MEDICATED ACNE TREATMENT PREPARATIONS; NON-MEDICATED ANTI-AGING SERUM; NON-MEDICATED FOOT CREAM; NON-MEDICATED FOOT LOTIONS; NON-MEDICATED SERUMS FOR USE ON FACE; NON-MEDICATED SKIN CARE CREAMS AND LOTIONS; NON-MEDICATED SKIN CARE PREPARATIONS; NON-MEDICATED SKIN CARE PREPARATIONS, NAMELY, CREAMS, LOTIONS, GELS, TONERS, CLEANSERS AND PEELS; NON-MEDICATED SKIN CREAMS; SKIN AND BODY TOPICAL LOTIONS, CREAMS AND OILS FOR COSMETIC USE; SKIN CARE PRODUCTS, NAMELY, NON-MEDICATED SKIN SERUM; SKIN CONDITIONING CREAMS FOR COSMETIC PURPOSES; SKIN CREAMS; SKIN LIGHTENERS; SKIN LIGHTENING CREAMS; SKIN LOTION; SKIN MOISTURIZER; SKIN WHITENING CREAMS; SKIN WHITENING PREPARATIONS; TONING LOTION, FOR THE FACE, BODY AND HANDS; WRINKLE REMOVING SKIN CARE PREPARATIONS; WRINKLE RESISTANT CREAM; WRINKLE-MINIMIZING COSMETIC PREPARATIONS FOR TOPICAL FACIAL USE (U.S. CLS. 1, 4, 6, 50, 51 AND 52).

FIRST USE 12-0-2012; IN COMMERCE 9-1-2013.

**CLASS 5—PHARMACEUTICALS**

FOR ACNE TREATMENT PREPARATIONS; ELECTROPHORESIS GELS FOR MEDICAL OR VETERINARY PURPOSES; GELS, CREAMS AND SOLUTIONS FOR DERMATOLOGICAL USE; GLYCERINE FOR MEDICAL PURPOSES; MEDICATED COSMETICS; MEDICATED CREAMS FOR TREATING DERMATOLOGICAL CONDITIONS; MEDICATED LOTIONS FOR TREATING DERMATOLOGICAL CONDITIONS; MEDICATED MASSAGE OILS; MEDICATED SERUMS FOR TREATMENT OF SKIN; MEDICATED SKIN CARE PREPARATIONS; MEDICATED SKIN CARE PREPARATIONS, NAMELY, CREAMS, LOTIONS, GELS, TONERS, CLEANSERS AND PEELS (U.S. CLS. 6, 18, 44, 46, 51 AND 52).

FIRST USE 12-0-2012; IN COMMERCE 9-1-2013.

**CLASS 8—HAND TOOLS**

FOR ELECTRIC PEDICURE SETS; ELECTRIC SHAVERS; FOOT CARE IMPLEMENTS, NAMELY, FOOT FILES; FOOT CARE IMPLEMENTS, NAMELY, FOOT SCRAPERS; PEDICURE SETS (U.S. CLS. 23, 28 AND 44).

FIRST USE 12-0-2012; IN COMMERCE 9-1-2013.

**CLASS 10—MEDICAL APPARATUS**

FOR APPARATUS FOR CELLULITE TREATMENT, REDUCTION AND ELIMINATION; COSMETIC APPARATUS, NAMELY, LIGHT BASED DEVICES PROVIDING MAINLY PULSED LIGHT FOR PERFORMING NON-ABLATIVE AESTHETIC SKIN TREATMENT PROCEDURES; ELECTRIC MASSAGE APPARATUS FOR HOUSEHOLD USE; ELECTRIC MASSAGE APPLIANCES, NAMELY, ELECTRIC VIBRATING MASSAGER; ELECTRONIC LIGHT THERAPY APPARATUS FOR THE SKIN; INFUSION SETS; LIGHT EMITTING DEVICES, NAMELY, LAMPS AND LED DEVICES FOR TREATMENT OF A VARIETY OF SKIN CONDITIONS; MASSAGE APPARATUS; MASSAGE APPARATUS; MASSAGE APPARATUS AND INSTRUMENTS; MASSAGING APPARATUS FOR PERSONAL USE; MEDICAL APPARATUS, NAMELY, INFUSION AND INJECTION DEVICES FOR ADMINISTERING DRUGS; MEDICAL DEVICES FOR NONSURGICAL COSMETIC TREATMENTS; MICRODERMABRASION APPARATUS (U.S. CLS. 26, 39 AND 44).

FIRST USE 12-0-2012; IN COMMERCE 9-1-2013.  
JANICE KIM, EXAMINING ATTORNEY

---

SN 86-072,609. DERMA DREAM GROUP LTD., TORTOLA, BR. VIRGIN ISLANDS, FILED 9-24-2013.

# SensiMatch

THE MARK CONSISTS OF STANDARD CHARACTERS WITHOUT CLAIM TO ANY PARTICULAR FONT, STYLE, SIZE, OR COLOR.

**CLASS 3—COSMETICS AND CLEANING PREPARATIONS**

FOR ALOE VERA GEL FOR COSMETIC PURPOSES; BEAUTY CREAMS; BEAUTY CREAMS FOR BODY CARE; BEAUTY GELS; BEAUTY LOTIONS; BODY AND BEAUTY CARE COSMETICS; BODY CREAMS; BODY LOTIONS; CLEANSING CREAMS; COSMETIC CREAMS; COSMETIC CREAMS FOR SKIN CARE; COSMETIC MASSAGE CREAMS; COSMETIC NOURISHING CREAMS; LOTIONS FOR COSMETIC PURPOSES; LOTIONS FOR FACE AND BODY CARE; MASSAGE CREAMS; MASSAGE GELS OTHER THAN FOR MEDICAL PURPOSES; MASSAGE LOTIONS; MASSAGE OIL; MOISTURIZING CREAMS; NON-MEDICATED FOOT CREAM; NON-MEDICATED FOOT LOTIONS; NON-MEDICATED SKIN CARE CREAMS AND LOTIONS; NON-MEDICATED SKIN CARE PREPARATIONS; NON-MEDICATED SKIN CARE PREPARATIONS, NAMELY, CREAMS, LOTIONS, GELS, TONERS, CLEANERS AND PEELS; NON-MEDICATED SKIN CREAMS; SKIN AND BODY TOPICAL LOTIONS, CREAMS AND OILS FOR COSMETIC USE; SKIN CARE PRODUCTS, NAMELY, NON-MEDICATED SKIN SERUM; SKIN CONDITIONING CREAMS FOR COSMETIC PURPOSES; SKIN CREAMS; SKIN LOTION; SKIN MOISTURIZER (U.S. CLS. 1, 4, 6, 50, 51 AND 52).

FIRST USE 7-0-2013; IN COMMERCE 9-1-2013.

**CLASS 5—PHARMACEUTICALS**

FOR GELS, CREAMS AND SOLUTIONS FOR DERMATOLOGICAL USE; MEDICATED COSMETICS; MEDICATED CREAMS FOR TREATING DERMATOLOGICAL CONDITIONS; MEDICATED LOTIONS FOR TREATING DERMATOLOGICAL CONDITIONS; MEDICATED MASSAGE OILS; MEDICATED SERUMS FOR TREATMENT OF SKIN; MEDICATED SKIN CARE PREPARATIONS; MEDICATED SKIN CARE PREPARATIONS, NAMELY, CREAMS, LOTIONS, GELS, TONERS, CLEANERS AND PEELS (U.S. CLS. 6, 18, 44, 46, 51 AND 52).

FIRST USE 7-0-2013; IN COMMERCE 9-1-2013.

**CLASS 8—HAND TOOLS**

FOR ELECTRIC PEDICURE SETS; ELECTRIC SHAVERS; FOOT CARE IMPLEMENTS, NAMELY, FOOT FILES; FOOT CARE IMPLEMENTS, NAMELY, FOOT SCRAPERS; PEDICURE SETS (U.S. CLS. 23, 28 AND 44).

FIRST USE 7-0-2013; IN COMMERCE 9-1-2013.

**CLASS 10—MEDICAL APPARATUS**

FOR ELECTRIC MASSAGE APPARATUS FOR HOUSEHOLD USE; ELECTRIC MASSAGE APPLIANCES, NAMELY, ELECTRIC VIBRATING MASSAGER; MASSAGE APPARATUS; MASSAGE APPARATUS; MASSAGE APPARATUS AND INSTRUMENTS; MASSAGING APPARATUS FOR PERSONAL USE; MICRODERMABRASION APPARATUS (U.S. CLS. 26, 39 AND 44).

FIRST USE 7-0-2012; IN COMMERCE 9-1-2013.

JANICE KIM, EXAMINING ATTORNEY

---

SN 86-072,771. SPEEDWAY LLC, ENON, OH. FILED 9-24-2013.

# SPEEDY PREMIUM

THE MARK CONSISTS OF STANDARD CHARACTERS WITHOUT CLAIM TO ANY PARTICULAR FONT, STYLE, SIZE, OR COLOR.

OWNER OF U.S. REG. NOS. 3,847,232, 4,261,669 AND OTHERS.

NO CLAIM IS MADE TO THE EXCLUSIVE RIGHT TO USE "PREMIUM", APART FROM THE MARK AS SHOWN.

**CLASS 30—STAPLE FOODS**

FOR COFFEE; COFFEE-BASED BEVERAGES; TEA; TEA-BASED BEVERAGES; AND FLAVORED HOT, COLD AND SEMI-FROZEN COFFEE, TEA AND COCOA BASED BEVERAGES FOR CONSUMPTION ON OR OFF THE PREMISES (U.S. CL. 46).

**CLASS 35—ADVERTISING AND BUSINESS**

FOR RETAIL CONVENIENCE STORE SERVICES FEATURING BEVERAGES, NAMELY, COFFEE, TEA AND FLAVORED BEVERAGES (U.S. CLS. 100, 101 AND 102).

CHRISTINA SOBRAL, EXAMINING ATTORNEY

SN 86-072,799. SPEEDWAY LLC, ENON, OH. FILED 9-24-2013.



OWNER OF U.S. REG. NOS. 3,847,232, 4,261,669 AND OTHERS.

NO CLAIM IS MADE TO THE EXCLUSIVE RIGHT TO USE "PREMIUM", APART FROM THE MARK AS SHOWN. THE MARK CONSISTS OF THE STYLIZED WORDING "SPEEDY PREMIUM" SUPERIMPOSED ON AN OVAL WITH A SWIRL DESIGN BORDERING THE OVAL. OFF OF THE LETTER "S" IN "SPEEDY", ARE LINES RADIATING TO THE LEFT TO SHOW SPEED.

**CLASS 30—STAPLE FOODS**

FOR COFFEE; COFFEE-BASED BEVERAGES; TEA; TEA-BASED BEVERAGES; AND FLAVORED HOT, COLD AND SEMI-FROZEN COFFEE, TEA AND COCOA BASED BEVERAGES FOR CONSUMPTION ON OR OFF THE PREMISES (U.S. CL. 46).

**CLASS 35—ADVERTISING AND BUSINESS**

FOR RETAIL CONVENIENCE STORE SERVICES FEATURING BEVERAGES, NAMELY, COFFEE, TEA AND FLAVORED BEVERAGES (U.S. CLS. 100, 101 AND 102). CHRISTINA SOBRAL, EXAMINING ATTORNEY

SN 86-072,824. KLICKLE LLC, DES MOINES, IA. FILED 9-24-2013.

**KLICKLE**

THE MARK CONSISTS OF STANDARD CHARACTERS WITHOUT CLAIM TO ANY PARTICULAR FONT, STYLE, SIZE, OR COLOR.

**CLASS 9—ELECTRICAL AND SCIENTIFIC APPARATUS**

FOR COMPUTER APPLICATION SOFTWARE FOR MOBILE PHONES, HANDHELD COMPUTERS, NAMELY, SOFTWARE FOR CREATION, EVALUATION, LOCATION, SHARING, REDEMPTION AND DOWNLOAD OF VOUCHERS, DISCOUNTS, COUPONS, REBATES, PROMOTIONS, OFFERS, EVENTS, COMMUNITY INFORMATION, LINKS TO OTHER SITES, CUSTOMER LOYALTY, AND REWARDS; COMPUTER SOFTWARE FOR MERCHANT ANALYTICS AND FOR EVALUATING AND MANAGING INFORMATION ON BUSINESS PERFORMANCE AND CUSTOMERS OR USERS (U.S. CLS. 21, 23, 26, 36 AND 38).

**CLASS 35—ADVERTISING AND BUSINESS**

FOR PROVIDING ADVERTISING, PROMOTIONAL, INFORMATIONAL AND BUSINESS NETWORKING SERVICES FOR CONSUMER PRODUCTS, CONSUMER GOODS, CONSUMER SERVICES, ACTIVITIES, ATTRACTIONS, EVENTS AND FACILITIES OF OTHERS; ADMINISTRATION OF A CUSTOMER LOYALTY REWARDS PROGRAM WHICH PROVIDES OFFERS SPECIFIC TO EACH MERCHANT'S PRODUCTS OR SERVICES; PROVIDING INFORMATION IN THE FIELD OF PROMOTING, SCHEDULING AND EXECUTING MARKETPLACE INFORMATION AND DETAILS ON MERCHANTS, BUSINESSES, PRODUCTS, EVENTS, VOUCHERS, DISCOUNTS, COUPONS, REBATES, PROMOTIONS, OFFERS, FACILITIES AND SERVICES VIA A WEBSITE AND A WIRELESS OR MOBILE DEVICE; PROVIDING INFORMATION AND FEEDBACK FROM CUSTOMERS OR USERS TO BUSINESSES AND MERCHANTS VIA WEBSITE, A WIRELESS OR MOBILE DEVICE (U.S. CLS. 100, 101 AND 102).

**CLASS 42—SCIENTIFIC AND COMPUTER SERVICES**

FOR PROVIDING TEMPORARY USE OF ONLINE NONDOWNLOADABLE CLOUD COMPUTING SOFTWARE FOR MERCHANT ANALYTICS, FOR EVALUATING AND MANAGING INFORMATION ON BUSINESS PERFORMANCE AND CUSTOMERS OR USERS, SCHEDULING, MANAGING AND EXECUTING CREATION AND REDEMPTION OF VOUCHERS, DISCOUNTS, COUPONS, REBATES, PROMOTIONS AND OFFERS, AND ADMINISTRATION OF A CUSTOMER LOYALTY PROGRAM WHICH PROVIDES OFFERS SPECIFIC TO EACH MERCHANT'S PRODUCTS OR SERVICES (U.S. CLS. 100 AND 101). ANNE E. GUSTASON, EXAMINING ATTORNEY

SN 86-072,946. SHAKESPEARE COMPANY, LLC, COLUMBIA, SC. FILED 9-24-2013.

**FURY**

THE MARK CONSISTS OF STANDARD CHARACTERS WITHOUT CLAIM TO ANY PARTICULAR FONT, STYLE, SIZE, OR COLOR.

**CLASS 7—MACHINERY**

FOR GRASS AND WEED TRIMMER HEADS AND REPLACEMENT TRIMMER HEAD SPOOLS (U.S. CLS. 13, 19, 21, 23, 31, 34 AND 35).

**CLASS 22—CORDAGE AND FIBERS**

FOR MONOFILAMENT GRASS AND WEED TRIMMER LINE (U.S. CLS. 1, 2, 7, 19, 22, 42 AND 50). VIVIAN MICZNIK FIRST, EXAMINING ATTORNEY

SN 86-073,218. GEOFFREY, LLC, WAYNE, NJ. FILED 9-24-2013.

SN 86-073,350. MICRO-STAR INT'L CO., LTD., NEW TAIPEI CITY 235, TAIWAN, FILED 9-24-2013.

## PUPPIESRUS

THE MARK CONSISTS OF STANDARD CHARACTERS WITHOUT CLAIM TO ANY PARTICULAR FONT, STYLE, SIZE, OR COLOR.  
OWNER OF U.S. REG. NOS. 2,442,370, 3,849,863 AND OTHERS.

### CLASS 3—COSMETICS AND CLEANING PREPARATIONS

FOR DENTAL CARE PRODUCTS FOR PETS, NAMELY, TOOTHPASTE AND DENTAL CHEWS FOR BREATH FRESHENING; GROOMING TOOLS FOR PETS, NAMELY, PET SHAMPOOS AND CONDITIONERS (U.S. CLS. 1, 4, 6, 50, 51 AND 52).

### CLASS 18—LEATHER GOODS

FOR PET PRODUCTS, NAMELY, PET CARRIERS, PET TRAVEL CARRIERS, SOFT-SIDED PET CARRIERS, PET COLLARS, PET LEASHES, PET APPAREL; DENTAL CARE PRODUCTS FOR PETS, NAMELY, RAWHIDE CHEWS (U.S. CLS. 1, 2, 3, 22 AND 41).

### CLASS 20—FURNITURE AND ARTICLES NOT OTHERWISE CLASSIFIED

FOR PET PRODUCTS, NAMELY, PET BEDS AND PET CUSHIONS; PET FURNITURE; PET CRATES; NON-METAL PET SAFETY GATES (U.S. CLS. 2, 13, 22, 25, 32 AND 50).

### CLASS 21—HOUSEWARES AND GLASS

FOR GROOMING TOOLS FOR PETS, NAMELY, BRUSHES, COMBS, AND SHEDDING RAKES; DENTAL CARE PRODUCTS FOR PETS, NAMELY, TOOTHBRUSHES; DENTAL KITS FOR PETS CONSISTING PRIMARILY OF A TOOTHBRUSH, TOOTHPASTE, AND BREATH FRESHENER; PET WASTE MANAGEMENT PRODUCTS, NAMELY, SCOOPS FOR PET WASTE DISPOSAL, PLASTIC BAGS FOR DISPOSING OF PET WASTE; PET WASTE MANAGEMENT KITS COMPRISING SCOOPS FOR PET WASTE DISPOSAL, PLASTIC BAGS AND LINERS, PORTABLE DISPENSERS FOR PLASTIC BAGS AND LINERS, AND HOUSE TRAINING PADS FOR PETS SOLD AS A UNIT; PET FEEDING AND DRINKING PRODUCTS, NAMELY, BOWLS, NON-MECHANIZED PET WATERERS IN THE NATURE OF PORTABLE WATER AND FLUID DISPENSERS FOR PETS, AND BOTTLES SOLD EMPTY (U.S. CLS. 2, 13, 23, 29, 30, 33, 40 AND 50).

### CLASS 28—TOYS AND SPORTING GOODS

FOR PET TOYS; GAMES FOR PETS, NAMELY, BALL GAMES FOR PETS, TUG GAMES FOR PETS, TREAT-DISPENSING GAMES; NON-EDIBLE PET CHEW TOYS (U.S. CLS. 22, 23, 38 AND 50).

### CLASS 35—ADVERTISING AND BUSINESS

FOR RETAIL STORE AND ON-LINE RETAIL STORE SERVICES FEATURING PET PRODUCTS AND ACCESSORIES (U.S. CLS. 100, 101 AND 102).  
ANGELA M. MICHELI, EXAMINING ATTORNEY



PRIORITY CLAIMED UNDER SEC. 44(D) ON TAIWAN APPLICATION NO. 102051065, FILED 9-13-2013, REG. NO. 102051065, DATED 7-1-2014, EXPIRES 6-30-2024.

THE MARK CONSISTS OF A DRAGON DESIGN.

### CLASS 9—ELECTRICAL AND SCIENTIFIC APPARATUS

FOR COMPUTER SERVERS; LAPTOP COMPUTERS; COMPUTER PERIPHERALS AND PARTS, NAMELY, COMPUTER HARDWARE, COMPUTER SOFTWARE IN THE NATURE OF OPERATING SYSTEM PROGRAMS, COMPUTER MEMORIES, BLANK HARD COMPUTER DISCS, CD-ROM DRIVE, CD-ROM DRIVE IN THE NATURE OF CD BURNERS, SCANNER, HOST CASES IN THE NATURE OF COMPUTER HOUSING FOR PERSONAL COMPUTERS, WIRELESS ACCESS POINT (WAP) DEVICES, WIRELESS ROUTER, MEDIA PLAYERS; COMPUTER MOTHERBOARDS; VIDEO DISPLAY CARDS; COMPUTER MOUSE; COMPUTER KEYBOARDS; COMPUTER TFT-LCD MONITORS; COMPUTER NETWORK ROUTERS (U.S. CLS. 21, 23, 26, 36 AND 38).

### CLASS 37—CONSTRUCTION AND REPAIR

FOR INSTALLATION, MAINTENANCE AND REPAIR OF COMPUTER HARDWARE (U.S. CLS. 100, 103 AND 106).

SETH A. RAPPAPORT, EXAMINING ATTORNEY

SN 86-073,441. MART INDUSTRIES, CREVE COEUR, MO. FILED 9-24-2013.

## SUPERPUFF

THE MARK CONSISTS OF STANDARD CHARACTERS WITHOUT CLAIM TO ANY PARTICULAR FONT, STYLE, SIZE, OR COLOR.

### CLASS 30—STAPLE FOODS

FOR ELECTRONIC CIGARETTE LIQUID (E-LIQUID) COMPRISED OF FLAVORINGS IN LIQUID FORM USED TO REFILL ELECTRONIC CIGARETTE CARTRIDGES (U.S. CL. 46).

FIRST USE 9-18-2013; IN COMMERCE 9-18-2013.

**CLASS 34—SMOKERS' ARTICLES**

FOR CARTOMIZERS, NAMELY, COMBINATION ELECTRONIC CIGARETTE REFILL CARTRIDGES SOLD EMPTY AND ATOMIZERS, SOLD AS A COMPONENT OF ELECTRONIC CIGARETTES; ELECTRONIC CIGARETTES FOR USE AS AN ALTERNATIVE TO TRADITIONAL CIGARETTES (U.S. CLS. 2, 8, 9 AND 17).  
FIRST USE 9-18-2013; IN COMMERCE 9-18-2013.  
PARKER HOWARD, EXAMINING ATTORNEY

SN 86-074,026. SHISEIDO COMPANY, LIMITED, TOKYO, JAPAN, FILED 9-25-2013.

**PROBRIGHT 4MR**

THE MARK CONSISTS OF STANDARD CHARACTERS WITHOUT CLAIM TO ANY PARTICULAR FONT, STYLE, SIZE, OR COLOR.

**CLASS 1—CHEMICALS**

FOR CHEMICALS USED IN THE COSMETICS, SOAPS, AND PERFUMERY INDUSTRY (U.S. CLS. 1, 5, 6, 10, 26 AND 46).

**CLASS 3—COSMETICS AND CLEANING PREPARATIONS**

FOR SOAPS, PERFUMERIES, AND COSMETICS; NON-MEDICATED SKIN CARE PREPARATIONS, HAIR CARE PREPARATIONS, BODY CARE COSMETICS, AND MAKE-UP (U.S. CLS. 1, 4, 6, 50, 51 AND 52).  
MICHAEL ENGEL, EXAMINING ATTORNEY

SN 86-074,096. KYOCHON F & B CO., LTD., GYEONGSANG-BUK-DO, REPUBLIC OF KOREA, FILED 9-25-2013.

**K**  
Y  
O  
C  
H  
O  
N

OWNER OF U.S. REG. NOS. 3,458,945, 3,918,697 AND OTHERS.  
THE MARK CONSISTS OF THE WORD "KYOCHON" WRITTEN VERTICALLY IN A STYLIZED FORMAT.  
THE ENGLISH TRANSLATION OF THE WORD "KYOCHON" IN THE MARK IS "A VILLAGE WITH A KOREAN TRADITIONAL LOCAL SCHOOL".

**CLASS 29—MEATS AND PROCESSED FOODS**

FOR VEGETABLE SOUP; PRESERVED WALNUT; PHEASANT MEAT; CHICKEN; PORK; HORSE MEAT; BEEF; DUCK; PORK CHOP (U.S. CL. 46).

**CLASS 43—HOTEL AND RESTAURANT SERVICES**

FOR TOURIST RESTAURANTS; TEA ROOMS; RESTAURANTS; BUFFET RESTAURANTS; WESTERN STYLE RESTAURANTS; SELF-SERVICE RESTAURANTS; SNACK-BARS; CATERING SERVICES; SERVING FOODS AND DRINK; CAFES; CAFETERIAS; PROVIDING RESTAURANT SERVICES; CHAIN RESTAURANTS (U.S. CLS. 100 AND 101).  
REBECCA POVARCHUK, EXAMINING ATTORNEY

SN 86-074,108. KYOCHON F & B CO., LTD., GYEONGSANG-BUK-DO, REPUBLIC OF KOREA, FILED 9-25-2013.



OWNER OF U.S. REG. NOS. 3,458,945 AND 3,918,697.  
THE COLOR(S) RED IS/ARE CLAIMED AS A FEATURE OF THE MARK.  
THE MARK CONSISTS OF THREE ARBITRARY OVAL-LIKE SHAPES IN RED.

**CLASS 29—MEATS AND PROCESSED FOODS**

FOR VEGETABLE SOUP; PRESERVED WALNUT; PHEASANT MEAT; CHICKEN; PORK; HORSE MEAT; BEEF; DUCK; PORK CHOP (U.S. CL. 46).

**CLASS 43—HOTEL AND RESTAURANT SERVICES**

FOR TOURIST RESTAURANTS; TEA ROOMS; RESTAURANTS; BUFFET RESTAURANTS; WESTERN STYLE RESTAURANTS; SELF-SERVICE RESTAURANTS; SNACK-BARS; CATERING SERVICES; SERVING FOODS AND DRINK; CAFES; CAFETERIAS; PROVIDING RESTAURANT SERVICES; CHAIN RESTAURANTS (U.S. CLS. 100 AND 101).  
REBECCA POVARCHUK, EXAMINING ATTORNEY

SN 86-074,115. INSTAGRAM, LLC, MENLO PARK, CA, FILED 9-25-2013.

**INSTASTOP**

THE MARK CONSISTS OF STANDARD CHARACTERS WITHOUT CLAIM TO ANY PARTICULAR FONT, STYLE, SIZE, OR COLOR.

**CLASS 9—ELECTRICAL AND SCIENTIFIC APPARATUS**

FOR INTERACTIVE PHOTO AND VIDEO EQUIPMENT, NAMELY, KIOSKS FOR CAPTURING, UPLOADING, EDITING, PRINTING AND SHARING DIGITAL IMAGES AND VIDEO (U.S. CLS. 21, 23, 26, 36 AND 38).

SN 86-074,184. HARMONIST INC., CITY OF INDUSTRY, CA. FILED 9-25-2013.

**CLASS 35—ADVERTISING AND BUSINESS**

FOR ADVERTISING, MARKETING AND PROMOTION SERVICES; ADVERTISING, MARKETING AND PROMOTING THE GOODS AND SERVICES OF OTHERS BY MEANS OF PROVIDING PHOTO AND VIDEO EQUIPMENT AT SPECIAL EVENTS (U.S. CLS. 100, 101 AND 102).

**THE HARMONIST**

THE MARK CONSISTS OF STANDARD CHARACTERS WITHOUT CLAIM TO ANY PARTICULAR FONT, STYLE, SIZE, OR COLOR.

**CLASS 38—COMMUNICATION**

FOR TELECOMMUNICATIONS SERVICES, NAMELY, ELECTRONIC TRANSMISSION OF DATA, MESSAGES, GRAPHICS, IMAGES, VIDEOS AND INFORMATION; PEER-TO-PEER PHOTO AND VIDEO SHARING SERVICES, NAMELY, ELECTRONIC TRANSMISSION OF DIGITAL PHOTOS, VIDEO AND AUDIO-VISUAL FILES AMONG INTERNET USERS (U.S. CLS. 100, 101 AND 104).

**CLASS 3—COSMETICS AND CLEANING PREPARATIONS**

FOR PERFUME FOR LINEN, CARPETS AND THE ATMOSPHERE; INCENSE; OILS FOR PERFUMERY; ESSENTIAL OILS; OILS FOR TOILET PURPOSES; BATH OILS; OILS FOR COSMETIC PURPOSES; HOME FRAGRANCES; BASES FOR FLOWER PERFUMES; SCENTED WOOD STICKS FOR ADDING SCENT TO A ROOM; FLOWER EXTRACTS SOLD AS A COMPONENT OF COSMETICS; SCENTED POLISHING WAX; SCENTED POWDERS FOR GENERAL PURPOSE CLEANING; COSMETICS; COSMETIC CREAMS, NAMELY, MILK CREAM, SHOWER CREAM, HAND CREAM; LIP BALM NOT FOR MEDICAL USE; MILK FOR TOILET PURPOSES, ALMOND MILK FOR COSMETIC PURPOSES; POWDERED ALMOND MILK FOR COSMETIC PURPOSES; BEAUTY MASK; LOTIONS FOR COSMETIC PURPOSES; SKIN CARE GOODS AND HAIR CARE GOODS NOT FOR MEDICAL USE, NAMELY, SKIN LOTION, SKIN CREAM, SKIN EMOLLIENTS, CHEMICAL PEELS FOR SKIN, FRUIT ACID PEELS FOR SKIN, BODY POLISH, BODY BALM, SKIN PEELS, NON-MEDICATED SKIN SERUM, SKIN CLARIFIERS, SKIN CLEANSERS, SKIN CONDITIONERS, SKIN CONDITIONING CREAMS FOR COSMETIC PURPOSES, SKIN LIGHTENERS, SKIN FRESHENERS, SKIN GELS FOR ACCELERATING, ENHANCING OR EXTENDING TANS, SKIN MASKS, SKIN MOISTURIZER, SKIN TEXTURIZERS, SKIN TONERS, SKIN WHITENING CREAMS, SHAMPOO, HAIR CONDITIONERS, HAIR CARE CREAMS, HAIR CARE LOTIONS, HAIR CARE PREPARATIONS, NAMELY, HAIR EMOLLIENTS, HAIR GEL AND HAIR MOUSSE, HAIR MASKS, HAIR NOURISHERS, HAIR OILS, HAIR TONIC; MAKEUP; MAKEUP REMOVER; EAUX DE TOILETTE; PERFUMES; EAUX DE PARFUM; SCENTED TOILET WATER; TISSUES IMPREGNATED WITH COSMETIC LOTION OR PERFUMED; PERFUME BASES, NAMELY, ESSENTIAL OILS AND FLOWER EXTRACTS; SOAPS; TOILET SOAPS; COSMETIC PREPARATIONS FOR BATH; BATH SALTS; HAIR LOTION; SHAVING GOODS, NAMELY, SHAVING LOTIONS, SHAVING CREAMS; SHAVING PREPARATIONS; SHAVING SOAPS, AFTERSHAVE LOTIONS (U.S. CLS. 1, 4, 6, 50, 51 AND 52).

**CLASS 40—MATERIAL TREATMENT**

FOR PRINTING SERVICES (U.S. CLS. 100, 103 AND 106).

**CLASS 41—EDUCATION AND ENTERTAINMENT**

FOR RENTAL OF PHOTOGRAPHY AND/OR VIDEOGRAPHY KIOSKS FOR CAPTURING, UPLOADING, EDITING AND SHARING OF PICTURES AND VIDEOS (U.S. CLS. 100, 101 AND 107).

**CLASS 42—SCIENTIFIC AND COMPUTER SERVICES**

FOR RENTAL OF COMPUTER SOFTWARE THAT GIVES USERS THE ABILITY TO UPLOAD, EDIT, AND SHARE IMAGES, VIDEOS AND AUDIO-VISUAL CONTENT; PROVIDING USE OF ONLINE TEMPORARY NON-DOWNLOADABLE SOFTWARE FOR MODIFYING THE APPEARANCE AND ENABLING TRANSMISSION OF IMAGES AND AUDIOVISUAL AND VIDEO CONTENT; PROVIDING TEMPORARY USE OF NON-DOWNLOADABLE SOFTWARE FOR SOCIAL NETWORKING, CREATING A VIRTUAL COMMUNITY, AND TRANSMISSION OF AUDIO, VIDEO, PHOTOGRAPHIC IMAGES, TEXT, GRAPHICS AND DATA (U.S. CLS. 100 AND 101).

**CLASS 4—LUBRICANTS AND FUELS**

FOR CANDLES; PERFUMED CANDLES; TEA LIGHT CANDLES; LAMP WICKS; CANDLE GEL FOR USE IN THE MANUFACTURE OF CANDLES; TAPERS; TEXTILE OILS (U.S. CLS. 1, 6 AND 15).

**CLASS 45—PERSONAL AND LEGAL SERVICES**

FOR ONLINE SOCIAL NETWORKING SERVICES (U.S. CLS. 100 AND 101).  
SANJEEV VOHRA, EXAMINING ATTORNEY

**CLASS 21—HOUSEWARES AND GLASS**

FOR PERFUME BURNERS; INCENSE BURNERS; CANDLESTICKS; NON-ELECTRIC CANDELABRAS; CANDLE HOLDERS; CERAMIC TEA LIGHT HOLDERS; SOAP DISPENSERS, SOAP BOXES, SOAP HOLDERS, AEROSOL DISPENSERS NOT FOR MEDICAL USE; PERFUME SPRAYERS SOLD EMPTY; PERFUME VAPORIZERS SOLD EMPTY (U.S. CLS. 2, 13, 23, 29, 30, 33, 40 AND 50).

**CLASS 35—ADVERTISING AND BUSINESS**

FOR RETAIL AND WHOLESALE STORE SERVICES, NAMELY, MAIL ORDER SERVICES AND ONLINE RETAIL AND WHOLESALE STORE SERVICES FEATURING PERFUME FOR LINEN, CARPETS AND THE ATMOSPHERE, INCENSE, OILS FOR PERFUMERY, ESSENTIAL OILS, OILS FOR TOILET, BATH OILS, OILS FOR COSMETIC PURPOSES, HOME FRAGRANCES, BASES FOR FLOWER PERFUMES, AROMATIC WOOD STICKS, EXTRACTS OF FLOWER, POLISHING WAX SCENTED, POWDERS SCENTED FOR CLEANERS, COSMETICS, COSMETIC CREAMS, NAMELY MILK CREAM, SHOWER CREAM, HAND CREAM, LIP BALM NOT FOR MEDICAL USE, MILK FOR TOILET PURPOSES, ALMOND MILK FOR COSMETIC PURPOSES, POWDERED ALMOND MILK, BEAUTY MASK, LOTIONS FOR COSMETIC PURPOSES, SKIN CARE GOODS AND HAIR NOT FOR MEDICAL USE, MAKEUP, MAKEUP REMOVER, EAUX DE TOILETTE, PERFUMES, EAUX DE PARFUM, SCENTED WATER, TISSUES IMPREGNATED WITH COSMETIC LOTION OR PERFUMED, BASE FOR PERFUMES, SOAPS, TOILET SOAPS, COSMETIC PREPARATIONS FOR BATH, BATH SALTS, HAIR LOTION, SHAVING GOODS, SHAVING PREPARATIONS, RAZORS, SHAVING SOAPS, AFTER-SHAVE LOTIONS, DEPILATORY WAX, DEPILATORIES, CANDLES, PERFUMED CANDLES, TEA LIGHTS, LAMP WICKS, CANDLE GEL, TAPERS, CANDLES, TEXTILE OILS, PERFUME BURNERS, INCENSE BURNERS, CANDLESTICKS, CANDELABRAS, CANDLE HOLDERS, LIGHT HOLDERS, SOAP DISPENSERS, SOAP BOXES, SOAP HOLDERS, AEROSOL DISPENSERS NOT FOR MEDICAL USE, PERFUME SPRAYERS, PERFUME VAPORIZERS, DEODORIZING APPARATUS (U.S. CLS. 100, 101 AND 102).

**CLASS 44—MEDICAL, BEAUTY AND AGRICULTURAL SERVICES**

FOR BEAUTY CONSULTATION SERVICES FOR HUMAN BEINGS; BEAUTY SPA SERVICES, NAMELY, COSMETIC BODY CARE; APPLICATION OF COSMETIC PRODUCTS TO THE BODY; INFORMATION RELATING TO MASSAGE; MASSAGE SERVICES (U.S. CLS. 100 AND 101).

KAREN SEVERSON, EXAMINING ATTORNEY

SN 86-074,365. KAHIKI FOODS, INC., GAHANNA, OH. FILED 9-25-2013.

# Kahiki

OWNER OF U.S. REG. NOS. 3,191,671, 4,294,553 AND OTHERS.

THE MARK CONSISTS OF THE WORD "KAHIKI" IN STYLIZED SCRIPT.

THE ENGLISH TRANSLATION OF "KAHIKI" IN THE MARK IS "TAHITI".

SEC. 2(F) AS TO "KAHIKI".

**CLASS 29—MEATS AND PROCESSED FOODS**

FOR ORIENTAL AND PACIFIC RIM CUISINE PREPARED FOODS, NAMELY, FROZEN AND CHILLED ENTREES CONSISTING PRIMARILY OF MEAT, FISH, POULTRY OR VEGETABLES; FROZEN TEMPURA KITS CONSISTING PRIMARILY OF MEAT, FISH POULTRY OR VEGETABLES; PREPARED STIR-FRY MEALS COMPRISED PRIMARILY OF MEAT AND VEGETABLES; PREPARED ORIENTAL AND PACIFIC RIM CUISINE MEALS COMPRISED PRIMARILY OF MEAT AND CONTAINING SOME RICE (U.S. CL. 46).

FIRST USE 10-1-2013; IN COMMERCE 1-1-2014.

**CLASS 30—STAPLE FOODS**

FOR ORIENTAL AND PACIFIC RIM CUISINE PREPARED FOODS, NAMELY, FROZEN AND CHILLED ENTREES CONSISTING PRIMARILY OF PASTA OR RICE; FROZEN EGG ROLLS; FROZEN POT STICKERS; FROZEN TEMPURA KITS CONSISTING PRIMARILY OF PASTA OR RICE; CHILLED EGG ROLLS; CHILLED POT STICKERS; CONDIMENT SAUCES FOR ORIENTAL AND PACIFIC RIM CUISINE MEALS (U.S. CL. 46).

FIRST USE 10-1-2013; IN COMMERCE 1-1-2014.  
ODESSA BIBBINS, EXAMINING ATTORNEY

SN 86-074,388. COMMANDO, LLC, SOUTH BURLINGTON, VT. FILED 9-25-2013.

## TAKE-OFFS

THE MARK CONSISTS OF STANDARD CHARACTERS WITHOUT CLAIM TO ANY PARTICULAR FONT, STYLE, SIZE, OR COLOR.

**CLASS 25—CLOTHING**

FOR LINGERIE ACCESSORIES, NAMELY, REMOVABLE SILICONE, FOAM, FABRIC AND PLASTIC BREAST PADS USED EXTERNALLY IN A BRA OR SWIMWEAR; BRA LIFTERS, NAMELY, DEVICES MADE OF SILICONE, FABRIC, PLASTIC AND FOAM FOR LIFTING BREASTS; BRAS; ADHESIVE BRAS; BRA INSERTS FOR BREAST ENHANCEMENT; SWIMWEAR INSERTS FOR BREAST ENHANCEMENT (U.S. CLS. 22 AND 39).

**CLASS 26—FANCY GOODS**

FOR BODY TAPE, NAMELY, BREAST LIFTING TAPE (U.S. CLS. 37, 39, 40, 42 AND 50).

LOURDES AYALA, EXAMINING ATTORNEY

SN 86-074,656. GIANNI VERSACE S.P.A., MILAN, ITALY, FILED 9-25-2013.



OWNER OF U.S. REG. NOS. 2,121,984, 2,278,257 AND OTHERS.

**CLASS 35—ADVERTISING AND BUSINESS**

FOR ARRANGING AND CONDUCTING BUSINESS CONFERENCES; ORGANIZING OF BUSINESS CONFERENCES (U.S. CLS. 100, 101 AND 102).

**CLASS 37—CONSTRUCTION AND REPAIR**

FOR CLEANING AND MAINTENANCE OF CONFERENCE FACILITIES (U.S. CLS. 100, 103 AND 106).



**CLASS 41—EDUCATION AND ENTERTAINMENT**

FOR COUNTRY CLUBS; SOCIAL CLUB SERVICES, NAMELY, ARRANGING, ORGANIZING, AND HOSTING SOCIAL EVENTS, GET-TOGETHERS, AND PARTIES FOR CLUB MEMBERS (U.S. CLS. 100, 101 AND 107).

**CLASS 43—HOTEL AND RESTAURANT SERVICES**

FOR PROVISION OF CONFERENCE FACILITIES; HOTEL, MOTEL, RESTAURANT, BAR AND CATERING SERVICES; PROVISION OF FOOD AND NON-ALCOHOLIC DRINK; RESTAURANTS; COCKTAIL LOUNGE SERVICES, CAFES, CAFETERIAS, CATERING, SELF-SERVICE RESTAURANTS AND SNACK BARS; MOBILE CATERING OF FOOD AND DRINK; ARRANGING AND BOOKING OF TEMPORARY HOUSING ACCOMMODATIONS; TEMPORARY ACCOMMODATION SERVICES, NAMELY, PROVIDING HOTELS, MOTELS, BOARDING HOUSES, GUEST HOUSES, AND TOURIST HOMES (U.S. CLS. 100 AND 101).

KRISTIN DAHLING, EXAMINING ATTORNEY

SN 86-074,975. TALIA'S LEGACY, INC., OVIEDO, FL. FILED 9-25-2013.

**TALIA'S LEGACY**

THE MARK CONSISTS OF STANDARD CHARACTERS WITHOUT CLAIM TO ANY PARTICULAR FONT, STYLE, SIZE, OR COLOR.

THE NAME(S), PORTRAIT(S), AND/OR SIGNATURE(S) SHOWN IN THE MARK DOES NOT IDENTIFY A PARTICULAR LIVING INDIVIDUAL.

**CLASS 36—INSURANCE AND FINANCIAL**

FOR CHARITABLE FUNDRAISING SERVICES; PROVIDING RESEARCH GRANTS TO ORGANIZATIONS IN THE FIELD OF PUBLIC HEALTH, CANCER, CANCER RECOVERY AND SURVIVAL (U.S. CLS. 100, 101 AND 102).

**CLASS 41—EDUCATION AND ENTERTAINMENT**

FOR PROVIDING A WEBSITE FEATURING BLOGS, ONLINE NON-DOWNLOADABLE PUBLICATIONS IN THE NATURE OF ARTICLES, RESEARCH REPORTS AND JOURNALS, AND VIDEOS FEATURING PERSONAL NARRATIVE STORIES RELATING TO CANCER, CANCER RECOVERY AND SURVIVAL FOR INSTRUCTIONAL AND ENTERTAINMENT PURPOSES; PROVIDING ONLINE NEWSLETTERS IN THE FIELD OF SUPPORTIVE PERSONAL NARRATIVE STORIES ON THE SUBJECTS OF CANCER, CANCER RECOVERY AND SURVIVAL VIA EMAIL; PROVIDING A WEBSITE FEATURING NON-DOWNLOADABLE VIDEOS IN THE FIELD OF SUPPORTIVE PERSONAL NARRATIVE STORIES ON THE SUBJECTS OF CANCER, CANCER RECOVERY AND SURVIVAL (U.S. CLS. 100, 101 AND 107).

**CLASS 44—MEDICAL, BEAUTY AND AGRICULTURAL SERVICES**

FOR PROVIDING MEDICAL INFORMATION IN THE FIELD OF CANCER, CANCER RECOVERY AND CANCER PREVENTION (U.S. CLS. 100 AND 101).

**CLASS 45—PERSONAL AND LEGAL SERVICES**

FOR PROVIDING A WEBSITE VIA A GLOBAL COMPUTER NETWORK FEATURING SUPPORTIVE PERSONAL NARRATIVE STORIES ON THE SUBJECTS OF CANCER, CANCER RECOVERY AND SURVIVAL; ONLINE SOCIAL NETWORKING SERVICES IN THE FIELD OF NARRATIVE STORIES RELATING TO CANCER, CANCER RECOVERY AND SURVIVAL; ONLINE SOCIAL NETWORKING IN THE FIELD OF PERSONAL NARRATIVE STORIES RELATING TO CANCER, CANCER RECOVERY AND SURVIVAL VIA ONLINE WEBSITES (U.S. CLS. 100 AND 101).

AMEEN IMAM, EXAMINING ATTORNEY

SN 86-074,989. MAUSNER, DESIREE CASTELLANO, OVIEDO, FL. FILED 9-25-2013.

**MAKEUP IS MY WIG**

THE MARK CONSISTS OF STANDARD CHARACTERS WITHOUT CLAIM TO ANY PARTICULAR FONT, STYLE, SIZE, OR COLOR.

**CLASS 3—COSMETICS AND CLEANING PREPARATIONS**

FOR COSMETICS AND MAKE-UP (U.S. CLS. 1, 4, 6, 50, 51 AND 52).

**CLASS 36—INSURANCE AND FINANCIAL**

FOR CHARITABLE FUNDRAISING SERVICES; PROVIDING RESEARCH GRANTS TO ORGANIZATIONS IN THE FIELD OF PUBLIC HEALTH, CANCER, CANCER RECOVERY AND SURVIVAL (U.S. CLS. 100, 101 AND 102).

**CLASS 41—EDUCATION AND ENTERTAINMENT**

FOR PROVIDING A WEBSITE FEATURING BLOGS, NON-DOWNLOADABLE PUBLICATIONS IN THE NATURE OF ARTICLES, RESEARCH REPORTS, AND JOURNALS, AND NON-DOWNLOADABLE VIDEOS, ALL FEATURING PERSONAL NARRATIVE STORIES RELATING TO CANCER, CANCER RECOVERY AND SURVIVAL FOR INSTRUCTIONAL AND ENTERTAINMENT PURPOSES; ON-LINE NON-DOWNLOADABLE ELECTRONIC NEWSLETTERS DELIVERED BY E-MAIL FEATURING PERSONAL NARRATIVE STORIES RELATING TO CANCER, CANCER RECOVERY AND SURVIVAL (U.S. CLS. 100, 101 AND 107).

**CLASS 44—MEDICAL, BEAUTY AND AGRICULTURAL SERVICES**

FOR PROVIDING MEDICAL INFORMATION IN THE FIELD OF CANCER, CANCER RECOVERY AND CANCER PREVENTION VIA ONLINE WEBSITES, SOCIAL MEDIA WEBSITES, E-MAILS, ONLINE ACCESSIBLE VIDEOS AND THROUGH MOBILE TECHNOLOGY (U.S. CLS. 100 AND 101).

**CLASS 45—PERSONAL AND LEGAL SERVICES**

FOR ONLINE SOCIAL NETWORKING AND SOCIAL MEDIA SERVICES IN THE NATURE OF WEBSITES AND SOCIAL MEDIA WEBSITES FEATURING PERSONAL NARRATIVE STORIES RELATING TO CANCER, CANCER RECOVERY AND SURVIVAL AVAILABLE VIA GLOBAL COMPUTER NETWORKS AND MOBILE TECHNOLOGY (U.S. CLS. 100 AND 101).  
ANDREW LEASER, EXAMINING ATTORNEY

SN 86-075,747. SAMSUNG ELECTRONICS CO., LTD., GYEONGGI-DO, REPUBLIC OF KOREA, FILED 9-26-2013.

**WELL@GING**

PRIORITY CLAIMED UNDER SEC. 44(D) ON ERPN CMNTY TM OFC APPLICATION NO. 012158838, FILED 9-20-2013, REG. NO. 012158838, DATED 2-12-2014, EXPIRES 2-12-2024.

THE MARK CONSISTS OF THE COMPOUND WORD "WELL@GING".

**CLASS 7—MACHINERY**

FOR AUTOMATIC DISHWASHERS; DISH WASHERS; ELECTRIC COMPRESSORS; ELECTRIC MIXERS FOR HOUSEHOLD PURPOSES; ELECTRIC SHOE POLISHERS; ELECTRIC VACUUM CLEANER BAGS; ELECTRIC VACUUM CLEANER HOSES; ELECTRIC VACUUM CLEANERS; ELECTRIC WASHING MACHINES FOR HOUSEHOLD PURPOSES; ROBOTIC VACUUM CLEANERS (U.S. CLS. 13, 19, 21, 23, 31, 34 AND 35).

**CLASS 9—ELECTRICAL AND SCIENTIFIC APPARATUS**

FOR COMPUTER SOFTWARE FOR ENCODING AND DECODING OF VOICE AND AUDIO SIGNALS; ANALOG AND DIGITAL SOUND ENHANCING SOFTWARE FOR PROCESSING, RECORDING, CAPTURING, RECEIVING, TRANSMITTING, RENDERING AND STORING VOICE AND AUDIO SIGNALS, FILES AND SOUNDS; AUDIO AMPLIFIERS; AUDIO SPEAKERS; BLANK UNIVERSAL SERIAL BUS (USB) FLASH MEMORY DRIVE; BUILT-IN WIRELESS AUDIO AND VIDEO RECEIVERS AND ELECTRONIC DOCKING STATIONS FOR USE WITH ELECTRONIC BOOK READERS, TABLET COMPUTERS, MP3 PLAYERS, MP4 PLAYERS, MOBILE PHONES AND SMART PHONES; CAMCORDERS; COMPUTER AND MOBILE DEVICE SOFTWARE TO PERSONALIZE WIDGETS AND MOBILE APPLICATIONS; COMPUTER APPLICATION SOFTWARE FOR MOBILE PHONES, PORTABLE MEDIA PLAYERS AND HANDHELD COMPUTERS, NAMELY, SOFTWARE FOR USE IN VOICE RECOGNITION; COMPUTER GAME SOFTWARE; COMPUTER MONITORS; COMPUTER NETWORK HUBS, SWITCHES AND ROUTERS; COMPUTER SOFTWARE EMBEDDED ON PORTABLE PHONES AND/OR PORTABLE COMPUTERS THAT ALLOWS USERS TO PLAY AND DOWNLOAD ELECTRONIC GAMES, LISTEN TO AND DOWNLOAD RING TONES AND MUSIC, AND VIEW AND DOWNLOAD SCREEN SAVERS AND WALLPAPERS; COMPUTER SOFTWARE FOR CONTROLLING HOME APPLIANCES; COMPUTER SOFTWARE FOR INSTANT MESSAGING, SENDING AND RECEIVING EMAILS AND CONTACT INFORMATION, SCHEDULE SHARING AND CONTENTS SHARING; COMPUTER SOFTWARE FOR MANAGING AND ORGANIZING VARIOUS DIGITAL READING CONTENTS NAMELY DIGITAL ELECTRONIC-BOOKS, DIGITAL ELECTRONIC-NEWSPAPERS, THESIS, AND DIGITAL ELECTRONIC-MAGAZINES; COMPUTER SOFTWARE FOR PERSONAL INFORMATION MANAGEMENT; COMPUTER SOFTWARE FOR

PLAYING, SHARING AND MANAGING MULTIMEDIA FILES; COMPUTER SOFTWARE FOR PURCHASING, DOWNLOADING, PLAYING OR LISTENING TO MUSIC; COMPUTER SOFTWARE FOR PURCHASING, SUBSCRIBING, DOWNLOADING, PLAYING OR LISTENING TO DIGITAL READING CONTENTS NAMELY DIGITAL ELECTRONIC-BOOKS, DIGITAL ELECTRONIC-NEWSPAPERS, THESIS AND DIGITAL ELECTRONIC-MAGAZINES AND ELECTRONIC GAMES; COMPUTER SOFTWARE FOR TRAVEL INFORMATION SYSTEMS FOR THE PROVISION OR RENDERING OF TRAVEL ADVICE AND FOR INFORMATION CONCERNING HOTELS, LANDMARKS, MUSEUMS, PUBLIC TRANSPORTATION, RESTAURANTS AND OTHER INFORMATION REGARDING TRAVEL AND TRANSPORT; COMPUTER SOFTWARE FOR TRAVEL INFORMATION SYSTEMS FOR THE PROVISION OR RENDERING OF TRAVEL ADVICE AND FOR INFORMATION CONCERNING HOTELS, LANDMARKS, MUSEUMS, PUBLIC TRANSPORTATION, RESTAURANTS AND OTHER INFORMATION REGARDING TRAVEL AND TRANSPORT; COMPUTER SOFTWARE FOR USE IN RECORDING, ORGANIZING, TRANSMITTING, MANIPULATING, AND REVIEWING TEXT, AUDIO FILES, VIDEO FILES AND COMPUTER GAME PROGRAMS IN CONNECTION WITH TELEVISIONS, COMPUTERS, MUSIC PLAYERS, VIDEO PLAYERS, MEDIA PLAYERS AND MOBILE PHONES; COMPUTER SOFTWARE FOR USE IN SEARCHING FOR, BROWSING, AND PURCHASING SOFTWARE ON AN ELECTRONIC DATABASE; COMPUTER SOFTWARE FOR USE WITH SATELLITE AND GLOBAL POSITIONING SYSTEM (GPS) NAVIGATION SYSTEMS FOR NAVIGATION, ROUTE AND TRIP PLANNING, AND ELECTRONIC MAPPING; COMPUTER SOFTWARE SUGGESTING THE MOST SUITABLE PEN-INPUT APPLICATIONS FOR THE MOBILE DEVICE; COMPUTER SOFTWARE TO ACCESS INTERNET AND VARIOUS APPLICATIONS; COMPUTER SOFTWARE TO BE USED FOR VIEWING AND DOWNLOADING ELECTRONIC MAPS; COMPUTER SOFTWARE TO EDIT DAILY ACTIVITIES, ADDRESS BOOK, CALENDAR, MEMOS, AND MULTIMEDIA CONTENTS STORED IN MOBILE DEVICES; COMPUTER SOFTWARE TO ENABLE AUTHORING, POSTING, UPLOADING, DOWNLOADING, TRANSMITTING, RECEIVING, EDITING, EXTRACTING, ENCODING, DECODING, PLAYING, STORING, ORGANIZING, SHOWING, DISPLAYING, TAGGING, BLOGGING AND/OR SHARING ELECTRONIC MEDIA AND INFORMATION OVER THE INTERNET, LOCAL AREA NETWORK OR TELECOMMUNICATION NETWORK; COMPUTER SOFTWARE TO ENABLE USERS TO PROGRAM AND DISTRIBUTE AUDIO, VIDEO, TEXT AND OTHER MULTIMEDIA CONTENT, NAMELY, MUSIC, CONCERTS, VIDEOS, RADIO, TELEVISION, NEWS, SPORTS, GAMES, CULTURAL EVENTS, AND ENTERTAINMENT-RELATED AND EDUCATIONAL PROGRAMS VIA COMMUNICATION NETWORK; COMPUTER SOFTWARE TO RECEIVE, TRANSPORT, ENCODE, DECODE, DECRYPT, ENCRYPT, TRANSMIT, MULTIPLEX, DEMULTIPLEX, AND MANIPULATE VIDEO, AUDIO AND TEXT IN DIGITAL FORMAT TO DELIVER TELEVISION AND OTHER VIDEO PROGRAMMING TO APPROPRIATE VIDEO DEVICES FOR DISTRIBUTION OF TELEVISION PROGRAMMING FOR VIEWING ON TELEVISION SETS AND COMPUTER MONITORS; COMPUTER SOFTWARE USED TO ENHANCE AND OPTIMIZE AUDIO AND VIDEO SOUND; COMPUTERS; DIGITAL CAMERAS; DIGITAL PHOTO ALBUMS FOR DISPLAYING DIGITAL PICTURES, VIDEO CLIPS AND MUSIC; DIGITAL PHOTO FRAMES FOR DISPLAYING DIGITAL PICTURES, VIDEO CLIPS AND MUSIC; DIGITAL SET-TOP BOXES, NAMELY DIGITAL MEDIA RECEIVERS AND DECODERS, CABLE TELEVISION CONVERTERS, ETHERNET STREAMING MEDIA CONVERTERS; DOWNLOADABLE DIGITAL IMAGES, NAMELY, PHOTOGRAPHIC OR VIDEO IMAGES IN THE FIELD OF ARCHITECTURE, BALLET DANCERS, COSTUMES, MUSICAL INSTRUMENTS, SET DESIGNS, COMMUNICATION EQUIPMENT, SOUND WAVES, POLITICAL FIGURES, POVERTY, MOUNTAINS, LAKES, ROCK STRATA, SOLDIERS, HISTORICAL FIGURES AND PLACES, COURTHOUSES, LAWYERS, COURT SCENES, JUDGES, CRIMINALS, MANUSCRIPTS, BOOKS, BOOK COVER ART, ORCHESTRAS, ROCK BANDS, SINGERS, GUITAR PLAYERS, GUITARS, PHILOSOPHERS, PRINTING PRESSES, NEWSPAPERS, NEWSROOMS, LABORATORIES, SCIENCE LABS, SPACE, PLANETS, GALAXIES, THE MOON, PLANTS,

SPACE ALIENS, SPACE SHIPS, SCIENCE FICTION CREATURES, CARS AND COMPUTERS; DOWNLOADABLE RING TONES FOR MOBILE PHONES AND TABLET COMPUTERS; DVD PLAYERS; ELECTRONIC WHITEBOARDS; FACSIMILE MACHINES; HARD DISK DRIVES; INTERCOM KEY PHONE TERMINALS FOR CONNECTION TO A TELEPHONE NETWORK; INTERNET PROTOCOL PHONES; INTERNET PROTOCOL PRIVATE BRANCH EXCHANGE (PBX) SWITCHBOARDS; KEY PHONE OPERATING SYSTEM SOFTWARE; KEY PHONE SWITCH BOARDS; LOCAL AREA NETWORK (LAN) SWITCHES; MOBILE PHONE AND TABLET COMPUTER ACCESSORIES NAMELY BATTERIES, ELECTRIC BATTERY CHARGERS, DATA COMMUNICATION CABLES, HEADSETS, EAR PHONES, BATTERY CHARGERS FOR USE IN A CAR, LEATHER CASES ADAPTED FOR MOBILE PHONES AND TABLET COMPUTERS, FLIP COVERS FOR MOBILE PHONES AND TABLET COMPUTERS, HANDS FREES KITS AND SNAP ON CASES ADAPTED FOR MOBILE PHONES AND TABLET COMPUTERS, STYLUS, AUDIO DOCKING STATIONS, SCREEN PROTECTIVE FILMS ADAPTED FOR MOBILE PHONES AND TABLET COMPUTERS AND PORTABLE SPEAKERS; MOBILE PHONE OPERATING SYSTEM SOFTWARE; MOBILE TELEPHONES; MP3 PLAYERS; NETWORK ACCESS SERVER HARDWARE; NETWORK ACCESS SERVER OPERATING SOFTWARE; OPTICAL DISK DRIVES; OPTICAL DISK PLAYERS; PERSONAL DIGITAL ASSISTANTS (PDAS); PORTABLE COMPUTERS; PORTABLE MEDIA PLAYER; PRINTERS FOR COMPUTERS; SEMICONDUCTORS (CHIPS); SMART PHONES; STEREO AUDIO SPEAKERS; STYLUS FOR PORTABLE ELECTRONIC DEVICES; TABLET COMPUTER OPERATING SYSTEM SOFTWARE; TABLET COMPUTERS; TELEPHONES; TELEPHONES USED AS TERMINAL DEVICES FOR INTERNET PROTOCOL (IP) PRIVATE BRANCH EXCHANGE (PBX); TELEVISION RECEIVERS; THREE DIMENSIONAL (3D) EYEGLASSES; WIDE AREA NETWORK(WAN) ROUTERS (U.S. CLS. 21, 23, 26, 36 AND 38).

#### CLASS 11—ENVIRONMENTAL CONTROL APPARATUS

FOR AIR CONDITIONERS; AIR STERILIZERS; COOKING OVENS; BIDET (AUTOMATICAL PERSONAL SANITATION APPARATUS AFTER TOILET USE); ELECTRIC LAUNDRY DRYERS; ELECTRIC REFRIGERATORS; ELECTRIC REFRIGERATORS FOR FERMENTING AND STORING KIMCHI; INDUCTION RANGES; LIGHT EMITTING DIODES (LED) LAMPS; MICROWAVE OVENS (U.S. CLS. 13, 21, 23, 31 AND 34).  
KATINA MISTER, EXAMINING ATTORNEY

SN 86-076,228. SIDECAR DOUGHNUTS, LLC, COSTA MESA, CA. FILED 9-26-2013.



NO CLAIM IS MADE TO THE EXCLUSIVE RIGHT TO USE "DOUGHNUTS & COFFEE", APART FROM THE MARK AS SHOWN.

THE MARK CONSISTS OF THE WORD "SIDECAR" IN A STYLIZED FONT ATOP THE WORDS "DOUGHNUTS & COFFEE" ALSO IN A STYLIZED FONT.

#### CLASS 30—STAPLE FOODS

FOR BAKED GOODS, PREPARED FOODS, PACKAGED FOODS AND FROZEN CONFECTIONS, NAMELY, DONUTS, DONUT HOLES, PACKAGED DONUTS, MUFFINS, INSTANT DONUT MIXES, TOPPINGS IN THE NATURE OF CANDY SPRINKLES, CINNAMON STREUSEL, AND ICING, COOKIES, PASTRIES, CAKES, BISCUITS, CROISSANTS, BAGELS, PIES, SANDWICHES AND ICE CREAM; HOT AND COLD NON-ALCOHOLIC BEVERAGES, NAMELY, COFFEE, ESPRESSO, CAPPUCINO, TEA, HOT CHOCOLATE, COFFEE-BASED BEVERAGES; ROASTED COFFEE BEANS (U.S. CL. 46).

#### CLASS 43—HOTEL AND RESTAURANT SERVICES

FOR RESTAURANT SERVICES; COFFEE SHOP SERVICES; CAFÉ RESTAURANT SERVICES; CAFÉ SERVICES; AND CATERING SERVICES FOR FOOD AND BEVERAGES (U.S. CLS. 100 AND 101).

FIRST USE 3-1-2012; IN COMMERCE 3-1-2012.  
SEAN CROWLEY, EXAMINING ATTORNEY

SN 86-076,577. DORIA ADMINISTRAÇÃO DE BENS LTDA, SÃO PAULO, SÃO PAULO, BRAZIL, FILED 9-27-2013.



THE MARK CONSISTS OF STANDARD CHARACTERS WITHOUT CLAIM TO ANY PARTICULAR FONT, STYLE, SIZE, OR COLOR.

THE ENGLISH TRANSLATION OF "LIDE" IN THE MARK IS AS A VERB "TO DEAL", "TO GET ALONG" AND AS A NOUN "DISPUTE", "CONTEST" OR "LITIGATION".

#### CLASS 35—ADVERTISING AND BUSINESS

FOR ARRANGING AND CONDUCTING FAIRS, EXHIBITIONS, CONVENTIONS, EVENTS AND CONFERENCES FOR BUSINESS, ADVERTISING AND PUBLICITY PURPOSES (U.S. CLS. 100, 101 AND 102).

#### CLASS 41—EDUCATION AND ENTERTAINMENT

FOR ARRANGING AND CONDUCTING BUSINESS, ADVERTISING AND PUBLICITY SEMINARS IN THE FIELDS OF BUSINESS ACTIVITIES, BUSINESS RELATIONS, CORPORATE GOVERNANCE, ENTREPRENEURSHIP, INNOVATION, PUBLIC POLITICS, ECONOMIC GROWTH, SOCIAL DEVELOPMENT, SUSTAINABILITY, HEALTH CARE, EDUCATION AND ENTERTAINMENT (U.S. CLS. 100, 101 AND 107).

WILLIAM VERHOSEK, EXAMINING ATTORNEY

SN 86-076,910. ABCD ENTERPRISES, LLC, BUFFALO GROVE, IL. FILED 9-27-2013.

## BETTY BOARDS

THE MARK CONSISTS OF STANDARD CHARACTERS WITHOUT CLAIM TO ANY PARTICULAR FONT, STYLE, SIZE, OR COLOR.

THE NAME(S), PORTRAIT(S), AND/OR SIGNATURE(S) SHOWN IN THE MARK IDENTIFIES "BETTY" CANTOR-JACKSON, WHOSE CONSENT(S) TO REGISTER IS MADE OF RECORD.

### CLASS 9—ELECTRICAL AND SCIENTIFIC APPARATUS

FOR DIGITAL MUSIC DOWNLOADABLE FROM THE INTERNET; DOWNLOADABLE MP3 FILES, MP3 RECORDINGS, ON-LINE DISCUSSION BOARD POSTS, WEBCASTS, WEBINARS AND PODCASTS FEATURING MUSIC, AUDIO BOOKS IN THE FIELD OF MUSIC, AND NEWS BROADCASTS (U.S. CLS. 21, 23, 26, 36 AND 38).

### CLASS 41—EDUCATION AND ENTERTAINMENT

FOR ENTERTAINMENT SERVICES IN THE NATURE OF RECORDING, PRODUCTION AND POST-PRODUCTION SERVICES IN THE FIELD OF MUSIC; ENTERTAINMENT SERVICES, NAMELY, PROVIDING NON-DOWNLOADABLE PLAYBACK OF MUSIC VIA GLOBAL COMMUNICATIONS NETWORKS; MUSIC PRODUCTION SERVICES; MUSIC PUBLISHING SERVICES; POST-PRODUCTION EDITING SERVICES IN THE FIELD OF MUSIC, VIDEOS AND FILM; PROVIDING AN INTERNET WEBSITE PORTAL IN THE FIELD OF MUSIC (U.S. CLS. 100, 101 AND 107).

### CLASS 42—SCIENTIFIC AND COMPUTER SERVICES

FOR PROVIDING A WEBSITE ALLOWING USERS TO UPLOAD AND DOWNLOAD MUSIC (U.S. CLS. 100 AND 101).

DORITT L. CARROLL, EXAMINING ATTORNEY

SN 86-077,009. ZELTIQ AESTHETICS, INC., PLEASANTON, CA. FILED 9-27-2013.

## COOLCONNECT

THE MARK CONSISTS OF STANDARD CHARACTERS WITHOUT CLAIM TO ANY PARTICULAR FONT, STYLE, SIZE, OR COLOR.

### CLASS 9—ELECTRICAL AND SCIENTIFIC APPARATUS

FOR COMPUTER HARDWARE AND SOFTWARE FOR COLLECTING, PROCESSING AND TRANSMITTING MEDICAL DEVICE USAGE DATA TO A CENTRAL REPOSITORY VIA TELECOMMUNICATION AND GLOBAL COMPUTER NETWORKS FOR ANALYSIS, STORAGE AND REMOTE ACCESS (U.S. CLS. 21, 23, 26, 36 AND 38).

### CLASS 38—COMMUNICATION

FOR PROVIDING AN ON-LINE FORUM FOR MEDICAL INFORMATION (U.S. CLS. 100, 101 AND 104).

### CLASS 44—MEDICAL, BEAUTY AND AGRICULTURAL SERVICES

FOR PROVIDING AN ON-LINE COMPUTER DATABASE FEATURING MEDICAL INFORMATION (U.S. CLS. 100 AND 101).

GIANCARLO CASTRO, EXAMINING ATTORNEY

SN 86-077,095. HDPB SYSTEM INTERNACIONAL, S.A., MIAMI, FL. FILED 9-27-2013.



THE MARK CONSISTS OF TWO SLANTED LINES APPEARING ABOVE THE WORDING "PICGLAZE", WITH THE TOP LINE BEING SHORTER THAN THE SECOND LINE.

### CLASS 16—PAPER GOODS AND PRINTED MATTER

FOR CALENDARS; HANDBOOKS, NAMELY, MANUALS IN THE FIELD OF PHOTOGRAPHY; POSTERS; PLASTIC FILMS AND BAGS FOR PACKAGING; PHOTOGRAPHS; PRINTS; PRINT ENGRAVINGS; STATIONERY; PHOTOGRAPH ALBUMS (U.S. CLS. 2, 5, 22, 23, 29, 37, 38 AND 50).

### CLASS 20—FURNITURE AND ARTICLES NOT OTHERWISE CLASSIFIED

FOR FURNITURE, MIRRORS, PICTURE FRAMES (U.S. CLS. 2, 13, 22, 25, 32 AND 50).

### CLASS 35—ADVERTISING AND BUSINESS

FOR PHOTOCOPYING SERVICES (U.S. CLS. 100, 101 AND 102).

### CLASS 40—MATERIAL TREATMENT

FOR DIGITAL PRINTING, PHOTOGRAPHIC PRINTING, PRINTING OF ADVERTISING MATERIAL, PRINTING OF BOOKS; PHOTOMONTAGE IN THE NATURE OF ALTERATION AND RETOUCHING OF PHOTOGRAPHIC IMAGES; FINE ART PRINTING SERVICES; SCREEN PRINTING (U.S. CLS. 100, 103 AND 106).

### CLASS 42—SCIENTIFIC AND COMPUTER SERVICES

FOR PHOTO SCANNING SERVICES (U.S. CLS. 100 AND 101).

### CLASS 45—PERSONAL AND LEGAL SERVICES

FOR PREPARATION OF CUSTOM FAMILY ALBUMS, PHOTOGRAPH ALBUMS AND SPECIAL EVENT ALBUMS FOR OTHERS (U.S. CLS. 100 AND 101).

WENDELL PHILLIPS, EXAMINING ATTORNEY

SN 86-077.102. SAMBONET PADERNO INDUSTRIE S.P.A.,  
CASALINO (NO), ITALY, FILED 9-27-2013.

CUCINA  TAVOLA

NO CLAIM IS MADE TO THE EXCLUSIVE RIGHT TO USE "CUCINA AND TAVOLA", APART FROM THE MARK AS SHOWN.

THE MARK CONSISTS OF THE WORD "CUCINA", FOLLOWED BY A CIRCULAR DESIGN ELEMENT WITH A STYLIZED AMPERSAND ENCLOSED THEREIN, AND FOLLOWED BY THE WORD "TAVOLA".

THE ENGLISH TRANSLATION OF "CUCINA" AND "TAVOLA" IN THE MARK IS ART OF COOKING AND SUPPLYING FOOD ON THE TABLE.

#### CLASS 8—HAND TOOLS

FOR BAGEL SLICERS; BIODEGRADABLE CUTLERY, NAMELY, KNIVES, FORKS AND SPOONS; BOXES SPECIALLY ADAPTED FOR THE STORAGE OF CUTLERY AND FLATWARE; BREAD KNIVES; BUTCHER KNIVES; CAKE CUTTERS; CAN OPENERS; CARVING FORKS; CARVING KNIVES; CHEESE SLICERS; CHEESE SLICERS; CHEF KNIVES; COMPOSTABLE AND BIODEGRADABLE CUTLERY, NAMELY, KNIVES, SPOONS, FORKS; CUTLERY; CUTLERY, NAMELY, SCALERS; CUTLERY, NAMELY, FORKS, SPOONS AND KNIVES; DISPOSABLE TABLEWARE, NAMELY, KNIVES, FORKS AND SPOONS; DISPOSABLE TABLEWARE, NAMELY, SPOONS; EGG SLICERS; EGG SLICERS; FILLETING KNIVES; FISH SLICING KITCHEN KNIVES; FLATWARE, NAMELY, FORKS, KNIVES, AND SPOONS; FORKS; FORKS; FORKS AND SPOONS; FORKS MADE OF PRECIOUS METAL; FRUIT MUDDLER; GRAPE-FRUIT TRIMMER, NAMELY, A KITCHEN KNIFE WITH SERRATED EDGES; HAND OPERATED FOOD DICERS; HAND TOOLS FOR USE IN CARVING OR DECORATING PUMPKINS, MINI-PUMPKINS, GOURDS, AND OTHER FRUITS AND VEGETABLES, NAMELY, KNIVES, SAWS, SCOOPS, CHISELS AND DRILLS; HAND TOOLS, NAMELY, FOUNDRY LADLES; HAND TOOLS, NAMELY, FRUIT PICKERS; HAND TOOLS, NAMELY, ICE PICKS; HAND TOOLS, NAMELY, KNIFE SHARPENERS; HAND TOOLS, NAMELY, STAMPING-OUT TOOLS; HAND TOOLS, NAMELY, STAMPS; HAND TOOLS, NAMELY, TONGS; HAND-OPERATED CHOPPERS; HAND-OPERATED CUTTERS FOR MAKING PASTA; HAND-OPERATED FOOD PROCESSOR; HAND-OPERATED FRUIT SHREDDERS; HAND-OPERATED KITCHEN APPLIANCE FOR DICING, MINCING, SLICING AND CHOPPING FOOD; HAND-OPERATED SHARPENING TOOLS AND INSTRUMENTS; HAND-OPERATED SLICERS; HAND-OPERATED VEGETABLE SHREDDERS; HOUSEHOLD KNIVES; ICE TONGS; KNIFE BAGS; KNIFE SHARPENERS; KNIFE SHEATHS; KNIFE SHEATHS OF LEATHER; KNIFE STEELS; KNIVES; KNIVES MADE OF PRECIOUS METAL; KNIVES, FORKS AND SPOONS; LADLES FOR WINE; MANUALLY OPERATED CONTAINER OPENER FOR HOUSEHOLD OR DOMESTIC USE; MANUALLY OPERATED SHARPENERS; MORTARS AND PESTLES; NON-ELECTRIC CAN OPENERS; NON-ELECTRIC FRUIT PEELERS; NON-ELECTRIC PASTA MAKERS FOR DOMESTIC USE; NON-ELECTRIC VEGETABLE PEELERS; OYSTER OPENERS; PARING KNIVES; PIZZA CUTTERS; PIZZA CUTTERS; PIZZA SLICERS; PLASTIC CUTLERY, NAMELY, KNIVES, FORKS, AND SPOONS; PRUNING KNIVES; PRUNING SCISSORS; SCISSOR BLADES; SCISSORS; SCISSORS FOR HOUSEHOLD USE; SERVING KNIVES; SHARPENING STEELS; SHARPENING STONES; SHARPENING WHEELS FOR KNIVES AND BLADES; SHOVELS; SILVERWARE, NAMELY,

FORKS, KNIVES AND SPOONS THAT ARE MADE OF SILVER OR SILVER-PLATED; SPORT KNIVES; SPREADER IN THE NATURE OF A SMALL KNIFE FOR BUTTER OR CHEESE; STAINLESS STEEL TABLE KNIVES, FORKS AND SPOONS; STERLING SILVER TABLE FORKS; STERLING SILVER TABLE KNIVES; STERLING SILVER TABLE KNIVES, FORKS AND SPOONS; STERLING SILVER TABLE SPOONS; SUGAR SCOOPS; SUGAR TONGS; TABLE FORKS; TABLE KNIVES; TABLEWARE, NAMELY, KNIVES, FORKS AND SPOONS; TABLEWARE, NAMELY, KNIVES, FORKS AND SPOONS MADE OF PRECIOUS METAL; THIN-BLADED KITCHEN KNIVES; THROWING KNIVES; TWEEZERS; VEGETABLE CORERS; VEGETABLE KNIVES; VEGETABLE SLICERS; WHET STEELS; WHET-STONES (U.S. CLS. 23, 28 AND 44).

#### CLASS 14—JEWELRY

FOR WORKS OF ART OF PRECIOUS METAL (U.S. CLS. 2, 27, 28 AND 50).

#### CLASS 21—HOUSEWARES AND GLASS

FOR BASINS; BASKETS FOR DOMESTIC USE, NOT OF METAL; BASKETS FOR WASTE PAPER LITTERING; BASKETS OF WICKER, STRAW, WOOD, CLOTH; BASTING SPOONS; BASTING SPOONS, FOR KITCHEN USE; BATTERY-OPERATED COOKIE PRESSES; BEER JUGS; BEER MUGS; BEVERAGE GLASSWARE; BIODEGRADABLE PAPER PULP-BASED PLATES, BOWLS AND CUPS; BOTTLE OPENERS; BOTTLE STOPPERS SPECIALLY ADAPTED FOR USE WITH WINE BOTTLES; BOTTLES, SOLD EMPTY; BOWLS; BOWLS MADE OF PRECIOUS METAL; BOXES FOR DISPENSING PAPER TOWELS FOR HOUSEHOLD USE; BOXES FOR SWEETMEATS; BREAD BASKETS FOR DOMESTIC USE; BREAD BINS; BREAD BOARDS; BREAD BOXES; BREAD-CASES; BROOMS; BRUSHES FOR BASTING MEAT; BRUSHES FOR PARQUET FLOORS; BRUSHES FOR WASHING UP; BUCKETS; BUCKETS OF WOVEN FABRIC; BUSTS OF CRYSTAL, CHINA, CERAMIC, TERRA COTTA, EARTHENWARE, GLASS, PORCELAIN; BUTLERS' TRAYS; BUTTER DISHES; BUTTER PANS; BUTTER-DISH AND CHEESE-DISH COVERS; CAKE BRUSHES; CAKE DECORATING SETS SOLD AS A UNIT COMPRISED PRIMARILY OF DECORATING TUBES, COUPLERS AND TIPS; CAKE DOMES; CAKE MOLDS; CAKE PANS; CAKE PLATES; CAKE RESTS; CAKE RINGS; CAKE SERVERS; CAKE STANDS; CAKE SUPPORTS, NAMELY, CAKE BASES; CAKE TINS; CANDLE HOLDERS; CANDLESTICKS; CANDLESTICKS OF GLASS; CANDY BOXES; CANISTER SETS; CARPET SWEEPERS; CARVER RESTS; CARVING BOARDS; CASEROLE; CAULDRONS; CERAMIC SCULPTURES, VASES, VESSELS, BOWLS, PLATES AND POTS; CHAMBER POTS; CHAMPAGNE BUCKETS; CHEESE BOARD AND KNIFE SET; CHEESE GRATERS; CHINA ORNAMENTS; CHOCOLATE MOLDS; CHOPPING BOARDS FOR KITCHEN USE; CHOPSTICK CASES; CHOPSTICK RESTS; CHOPSTICKS; CLAY FLOOR VASES; CLAY POTS; CLEANING AND POLISHING CLOTHS; CLEANING BRUSHES FOR HOUSEHOLD USE; CLEANING CLOTHS; CLEANING, DUSTING AND POLISHING CLOTHS; CLOTH FOR WASHING FLOORS; CLOTHS FOR CLEANING; COASTERS, NOT OF PAPER AND OTHER THAN TABLE LINEN; COCKTAIL GLASSES; COCKTAIL PICKS; COCKTAIL SHAKERS; COCKTAIL STIRRERS; COFFEE CUPS; COFFEE CUPS, TEA CUPS AND MUGS; COFFEE FILTERS NOT OF PAPER BEING PART OF NON-ELECTRIC COFFEE MAKERS; COFFEE MEASURES; COFFEE MUGS; COFFEE POTS; COFFEE POTS NOT OF PRECIOUS METAL; COFFEE POTS OF PRECIOUS METAL; COFFEE SCOOPS; COFFEE SERVERS; COFFEE SERVICES; COFFEE SERVICES NOT OF PRECIOUS METAL; COFFEE SERVICES OF PRECIOUS METAL; COFFEE STIRRERS; COLD PACKS USED TO KEEP FOOD AND DRINK COLD; COLORED SHEET GLASS; COMMON SHEET GLASS; CONFECTIONERS' MOLDS; CONTAINERS FOR HOUSEHOLD OR KITCHEN USE; CONTAINERS FOR HOUSEHOLD USE; CONTAINERS FOR ICE; COOKERY MOLDS; COOKIE CUTTERS; COOKIE JARS; COOKIE SHEETS; COOKING FORKS; COOKING FUNNELS; COOKING GRATERS; COOKING PANS; COOKING POT SETS; COOKING POTS; COOKING POTS AND PANS; COOKING SIEVES AND SIFTERS; COOKING SKEWERS; COOKING

SPOONS; COOKING STEAMERS; COOKING STRAINERS; COOKING UTENSIL, NAMELY, BATTER DISPENSER; COOKING UTENSILS, NAMELY, GRILLS; COOKING UTENSILS, NAMELY, WIRE BASKETS; COOKWARE, NAMELY, POTS AND PANS; COOLERS FOR WINE; COOLING BUCKETS FOR WINE; CORK HOLDERS; CORKSCREWS; CORN COB HOLDERS; COUNTERTOP HOLDERS FOR PAPER TOWELS; CREAM AND SUGAR SET; CREAMER PITCHERS; CROCKERY, NAMELY, POTS, DISHES, DRINKING CUPS AND SAUCERS, BOWLS, SERVING BOWLS AND TRAYS; CRUET SETS FOR OIL AND VINEGAR; CRUET STANDS; CRUET STANDS FOR OIL AND VINEGAR; CRUET STANDS FOR OIL OR VINEGAR NOT OF PRECIOUS METAL; CRUET STANDS FOR OIL OR VINEGAR OF PRECIOUS METAL; CRUET STANDS NOT OF PRECIOUS METAL; CRUET STANDS OF PRECIOUS METAL; CRUETS; CRUETS NOT OF PRECIOUS METAL; CRUETS OF PRECIOUS METAL; CRUMB BRUSHES; CRUMB TRAYS; CRUMB-SWEETERS; CUP CAKE MOLDS; CUPS; CUPS AND MUGS; CUTTING BOARDS; CUTTING BOARDS FOR THE KITCHEN; DECANTERS; DECORATIVE GLASS; DECORATIVE PLATES; DEMITASSE SETS COMPRISED OF CUPS AND SAUCERS; DEMITASSE SETS COMPRISED OF CUPS, SAUCERS AND STIRRING SPOONS SOLD AS A UNIT; DESSERT PLATES; DISH COVERS; DISHES; DISHES AND PLATES; DISHWASHING BRUSHES; DISPOSABLE SERVING SPOONS; DOUBLE WALL CUPS; DRINKING CUPS AND SAUCERS; DRINKING CUPS SOLD WITH LIDS THEREFOR; DRINKING FLASKS; DRINKING GLASSES; DRINKING GLASSES, NAMELY, TUMBLERS; DRINKING STRAWS; DRINKING STRAWS OF GLASS; DRINKING VESSELS; DRIP MATS FOR TEA; DUSTING BRUSHES; DUSTING OR CLEANING CLOTHS; EARTHENWARE BASINS; EARTHENWARE MUGS; EARTHENWARE SAUCEPANS; EGG CUPS; EGG CUPS; ELECTRIC DEVICES FOR ATTRACTING AND KILLING INSECTS; ENAMELLED GLASS; EPERGNES; FEATHER BROOMS; FIGURED PLATE GLASS; FITTED LINERS FOR ICE BUCKETS; FITTED PICNIC BASKETS; FLASKS; FLOOR VASES; FLOWER BASKETS; FLOWER BOWLS; FLOWER BOWLS OF PRECIOUS METAL; FLOWER POT HOLDERS; FLOWER POTS; FLOWER VASES; FLOWER VASES AND BOWLS; FLOWER VASES AND BOWLS OF PRECIOUS METAL; FLOWER-POT COVERS, NOT OF PAPER; FONDUE POTS WITHOUT HEAT SOURCE; FOOD AND BEVERAGE COOLING AND HEATING RECEPTACLES CONTAINING HEAT EXCHANGE FLUID FOR HOUSEHOLD PURPOSES; FOOD PRESERVING JARS OF GLASS; FREE-STANDING AND WALL-MOUNTED CONTAINERS MADE OF ACRYLIC GLASS FOR DEPOSITING A WRITTEN MESSAGE OR PRAYER WISHING A LOVED ONE WELL, FOR USE IN HOSPITALS, ELDER CARE RESIDENCES, SCHOOLS, AND INSTITUTIONS; FRUIT BOWLS; FRUIT BOWLS OF GLASS; FUNNELS; GARLIC PRESSES; GAS PRESSURIZED BEVERAGE SIPHON CONTAINERS, NAMELY, CREAM WHIPPERS, CREAM PITCHERS AND SODA WATER HOLDERS AND GAS CARTRIDGES SOLD EMPTY; GLASS BEVERAGEWARE; GLASS BOWLS; GLASS BOWLS FOR LIVE GOLDFISH; GLASS BOXES; GLASS CARAFES; GLASS DISHES; GLASS ETCHED BY ACID; GLASS FIBERS AND GLASS FIBER ROVINGS FOR NON-TEXTILE PURPOSES; GLASS FLOOR VASES; GLASS JARS; GLASS MUGS; GLASS PANS; GLASS RODS; GLASS STOPPERS; GLASS STORAGE JARS; GLASS VIALS AND AMPOULES FOR MEDICATION SOLD EMPTY; GOBLETS; GRATERS FOR HOUSEHOLD PURPOSES; HAND BASINS; HAND WASH BASINS; HAND-OPERATED COFFEE GRINDERS; HAND-OPERATED COFFEE GRINDERS AND PEPPER MILLS; HAND-OPERATED FOOD GRINDERS; HAND-OPERATED GRINDERS; HAND-OPERATED SPICE GRINDERS; HARD BROOMS; HOLDER FOR CUTTING BOARD; HOLDERS FOR FLOWERS AND PLANTS; HOT POTS; HOUSEHOLD CONTAINERS FOR FOODS; HOUSEHOLD UTENSILS, NAMELY, GRATERS; HOUSEHOLD UTENSILS, NAMELY, KITCHEN TONGS; HOUSEHOLD UTENSILS, NAMELY, SIEVES; HOUSEHOLD UTENSILS, NAMELY, SKIMMERS; HOUSEHOLD UTENSILS, NAMELY, SPATULAS; HOUSEHOLD UTENSILS, NAMELY, STRAINERS; HOUSEHOLD UTENSILS, NAMELY, TURNERS; ICE BUCKETS; ICE CREAM SCOOPS; ICE CUBE MOLDS; ICE CUBE MOLDS FOR REFRIGERATORS; ICE CUBE TRAYS; ICE PAILS; ICE SCOOPS; INSULATED BAGS FOR FOOD OR BEVERAGE FOR DOMESTIC USE; INSULATED CONTAINERS FOR BEVERAGE CANS FOR DOMESTIC USE; INSULATED

CONTAINERS FOR FOOD OR BEVERAGE FOR DOMESTIC USE; INSULATED FLASKS; INSULATED LIDS FOR PLATES AND DISHES; INSULATING JARS; INSULATING SLEEVE HOLDER FOR BEVERAGE CUPS; INSULATING SLEEVE HOLDER FOR BOTTLES; INSULATING SLEEVE HOLDERS FOR BEVERAGE CANS; JAPANESE RICE BOWLS (CHAWAN); JAPANESE RICE BOWLS NOT OF PRECIOUS METAL (CHAWAN); JAPANESE RICE BOWLS OF PRECIOUS METAL (CHAWAN); JAPANESE STYLE SOUP SERVING BOWLS (WAN); JAR OPENERS; JARS FOR JAMS AND JELLIES OF EARTHENWARE, GLASS, PORCELAIN, PLASTIC; JUGS; KITCHEN CONTAINERS; KITCHEN UTENSILS, NAMELY, POURING AND STRAINING SPOUTS; KNIFE BLOCKS; KNIFE BOARDS; KNIFE RESTS; LAZY SUSANS; LUNCH BOXES; LUNCH BOXES MADE OF METAL; LUNCH BOXES MADE OF PLASTIC; LUNCH-BOXES; MARGARITA GLASSES; MARTINI GLASSES; MEAL TRAYS; MENU CARD HOLDERS; METAL COOKING PANS; MIXING BOWLS; MIXING CUPS; MIXING SPOONS; MOP WRINGERS; MOPS; MUGS; MUGS, NOT OF PRECIOUS METAL; MUSTARD POTS; NAPKIN DISPENSERS FOR HOUSEHOLD USE; NAPKIN HOLDERS; NAPKIN HOLDERS AND NAPKIN RINGS NOT OF PRECIOUS METAL; NAPKIN HOLDERS OF PRECIOUS METAL; NAPKIN HOLDERS, NOT OF PRECIOUS METAL; NAPKIN RINGS; NAPKIN RINGS NOT OF PRECIOUS METALS; NAPKIN RINGS OF PRECIOUS METAL; NON-ELECTRIC CANDELABRAS; NON-ELECTRIC CANDELABRAS MADE OF PRECIOUS METAL; NON-ELECTRIC CANDELABRAS, NOT OF PRECIOUS METAL; NON-ELECTRIC COFFEE DRIPPER FOR BREWING COFFEE; NON-ELECTRIC COFFEE MAKERS; NON-ELECTRIC COFFEE PERCOLATORS; NON-ELECTRIC COFFEE POTS; NON-ELECTRIC COFFEE POTS NOT OF PRECIOUS METAL; NON-ELECTRIC COFFEE SERVERS NOT OF PRECIOUS METAL; NON-ELECTRIC COFFEE SERVERS OF PRECIOUS METAL; NON-ELECTRIC DEEP FRYERS; NON-ELECTRIC EGG BEATERS; NON-ELECTRIC FOOD BLENDERS; NON-ELECTRIC FOOD MIXERS; NON-ELECTRIC FRUIT SQUEEZERS; NON-ELECTRIC GRIDDLES; NON-ELECTRIC MEAT GRINDERS; NON-ELECTRIC PRESSURE COOKING SAUCEPANS; NON-ELECTRIC ROTARY CHEESE GRATERS; NON-ELECTRIC COFFEE GRINDERS; OPAL GLASS; OPALINE GLASS; ORNAMENTAL GLASS SPHERES; PAPER AND PLASTIC CUPS; PAPER PLATES AND PAPER CUPS; PASTA SERVING FORKS; PASTRY BAGS; PASTRY BOARDS; PASTRY BRUSHES; PASTRY CUTTERS; PASTRY MOLDS; PEPPER GRINDERS; PEPPER MILLS; PEPPER POTS; PEPPER POTS, SUGAR BOWLS AND SALT SHAKERS; PERFUME ATOMIZERS, SOLD EMPTY; PERFUME BOTTLES SOLD EMPTY; PERFUME BURNERS; PERFUME SPRAYERS; PERFUME SPRAYERS SOLD EMPTY; PICNIC BASKETS SOLD EMPTY; PITCHERS; PLANTERS FOR FLOWERS AND PLANTS; PLASTIC CONTAINERS IN THE SHAPE OF FRUITS AND VEGETABLES FOR STORING INDIVIDUAL FRUITS AND VEGETABLES, AND FOR EXTENDING THE LIFE OF THOSE FRUITS AND VEGETABLES; PLASTIC CONTAINERS, NAMELY, CAKE BOXES FOR HOUSEHOLD USE; PLASTIC PLATES; PLATES; POLISHING CLOTHS; POLISHING GLOVES; PORCELAIN CAKE DECORATIONS; PORCELAIN FLOWER POTS; PORCELAIN MUGS; PORTABLE BEVERAGE CONTAINER HOLDER; PORTABLE BEVERAGE COOLERS; PORTABLE COLD BOXES; PORTABLE COOLERS; PORTABLE ICE CHESTS FOR FOOD AND BEVERAGES; POT CLEANING BRUSHES; POT LIDS; POTS; POURING SPOUTS FOR HOUSEHOLD USE; PUDDING MOLDS; REAMERS FOR FRUIT JUICE; RECIPE BOXES; REUSABLE PLASTIC WATER BOTTLES SOLD EMPTY; REUSABLE SELF-SEALING LIDS FOR HOUSEHOLD USE FOR BOWLS, CUPS, CONTAINERS AND THE STORAGE OF FOOD; REUSABLE STAINLESS STEEL WATER BOTTLES SOLD EMPTY; RICE COOKING POTS; RINSING BOWLS; ROLLING PINS; ROLLING PINS; ROUGH BROOMS; SALAD BOWLS; SALAD BOWLS; SALAD SPINNERS; SALAD TONGS; SALT AND PEPPER MILLS; SALT AND PEPPER SHAKERS; SALT CELLARS; SALT MILLS ; SALT SHAKERS; SANDWICH BOXES; SAUCEPAN SCOURERS; SAUCEPANS; SAUCERS; SAUCERS FOR FLOWER POTS; SCOOPS; SCRUBBING BRUSHES; SERVING BOWLS (HACHI); SERVING DISHES; SERVING SPOONS; SERVING TRAY LINERS; SERVING TRAYS; SERVING TRAYS MADE OF RAT-TAN; SERVING TRAYS NOT OF PRECIOUS METAL; SERVING TRAYS OF PRECIOUS METAL; SERVING TRAYS, NAMELY, CABARETS; SHALLOW BOWLS;

SHOT GLASSES; SIEVES; SIPHON BOTTLES FOR CARBONATED WATER; SLOTTED SPOONS; SMALL JUGS; SOAP BOXES; SOAP HOLDERS; SOAP HOLDERS AND BOXES; SOUP TUREENS; SPICE RACKS; SPONGE HOLDERS; SPOON RESTS; STAINED GLASS; STAINED GLASS FIGURINES; STATUES OF CHINA, CRYSTAL, CERAMIC, EARTHENWARE, GLASS, TERRA COTTA, PORCELAIN; STEMWARE HOLDERS; STEW-PANS; STONE FLOOR VASES; STRAINERS FOR HOUSEHOLD PURPOSES; SUGAR BASINS; SUGAR BOWLS; SUGAR BOWLS OF PRECIOUS METAL; SYRUP JUGS; TABLE PLACE CARD HOLDERS NOT OF PRECIOUS METAL; TART SCOOPS; TEA BALLS; TEA CADDIES; TEA CANISTERS; TEA COSIES; TEA INFUSERS; TEA KETTLES; TEA POTS; TEA POTS NOT OF PRECIOUS METAL; TEA POTS OF PRECIOUS METAL; TEA SERVICES; TEA SERVICES NOT OF PRECIOUS METAL; TEA SERVICES OF PRECIOUS METAL; TEA SETS; TEA STRAINERS; TENSION CLOSING DEVICES FOR POT LIDS; THERMAL INSULATED BAGS FOR FOOD OR BEVERAGES; THERMAL INSULATED CONTAINERS FOR FOOD OR BEVERAGES; THERMAL INSULATED WRAP FOR CANS TO KEEP THE CONTENTS COLD OR HOT; TOOTHPICK HOLDERS; TOOTHPICK HOLDERS OF PRECIOUS METAL; TRASH CANS; TRASH CONTAINERS FOR HOUSEHOLD USE; TRAYS FOR DOMESTIC PURPOSES; TRIFLE BOWLS; TRIVETS; UNWORKED OR SEMI-WORKED GLASS; UTENSILS FOR BARBECUES, NAMELY, FORKS, TONGS, TURNERS; VACUUM BOTTLE STOPPERS SPECIALLY ADAPTED FOR USE WITH WINE BOTTLES; VACUUM PUMPS FOR WINE BOTTLES; VAPORIZERS FOR PERFUME SOLD EMPTY; VASES; VASES OF PRECIOUS METAL; VINEGAR CRUETS; VOTIVE CANDLE HOLDERS; WAFFLE IRONS; WASH BASINS; WASHING BRUSHES; WASHING CLOTHS; WASTE BASKETS; WASTE PAPER BASKETS; WINE AERATORS; WINE BOTTLE CRADLES; WINE BUCKETS; WINE COASTERS OF PRECIOUS METAL; WINE COOLING PAILS; WINE DRIP COLLARS SPECIALLY ADAPTED FOR USE AROUND THE TOP OF WINE BOTTLES TO STOP DRIPS; WINE GLASSES; WINE JUGS; WINE OPENERS; WINE POURERS; WINE STRAINERS; WINE TASTERS; WOOD CHOPPING BOARDS FOR KITCHEN USE; WOODEN COOKING SPOONS; WORKS OF ART MADE OF GLASS; WORKS OF ART OF CHINA, CRYSTAL, CERAMIC, EARTHENWARE, GLASS, PORCELAIN, TERRA COTTA (U.S. CLS. 2, 13, 23, 29, 30, 33, 40 AND 50).

### CLASS 35—ADVERTISING AND BUSINESS

FOR ADMINISTRATIVE PROCESSING OF PURCHASE ORDERS; ADVERTISEMENT AND PUBLICITY SERVICES BY TELEVISION, RADIO, MAIL; ADVERTISEMENT FOR OTHERS ON THE INTERNET; ADVERTISEMENT VIA MOBILE PHONE NETWORKS; ADVERTISING AND COMMERCIAL INFORMATION SERVICES, VIA THE INTERNET; ADVERTISING AND MARKETING; ADVERTISING AND MARKETING CONSULTANCY; ADVERTISING AND MARKETING SERVICES, NAMELY, PROMOTING THE GOODS AND SERVICES OF OTHERS; ADVERTISING AND PROMOTIONAL SERVICES; ADVERTISING AND PUBLICITY SERVICES; ADVERTISING AND PUBLICITY SERVICES, NAMELY, PROMOTING THE GOODS, SERVICES, BRAND IDENTITY AND COMMERCIAL INFORMATION AND NEWS OF THIRD PARTIES THROUGH PRINT, AUDIO, VIDEO, DIGITAL AND ON-LINE MEDIUM; ADVERTISING BY TRANSMISSION OF ON-LINE PUBLICITY FOR THIRD PARTIES THROUGH ELECTRONIC COMMUNICATIONS NETWORKS; ADVERTISING COPYWRITING; ADVERTISING FLYER DISTRIBUTION FOR OTHERS; ADVERTISING IN PERIODICALS, BROCHURES AND NEWSPAPERS; ADVERTISING IN THE POPULAR AND PROFESSIONAL PRESS; ADVERTISING ON THE INTERNET FOR OTHERS; ADVERTISING PARTICULARLY SERVICES FOR THE PROMOTION OF GOODS; ADVERTISING SERVICES; ADVERTISING SERVICES, NAMELY, PROMOTING THE BRANDS, GOODS AND SERVICES OF OTHERS; ADVERTISING THROUGH ALL PUBLIC COMMUNICATION MEANS; ADVERTISING VIA ELECTRONIC MEDIA AND SPECIFICALLY THE INTERNET; ADVERTISING, MARKETING AND PROMOTING THE GOODS AND SERVICES OF OTHERS USING KIOSKS; BANNER ADVERTISING; BUSINESS MANAGEMENT; BUSINESS MANAGEMENT ASSISTANCE TO INDUSTRIAL OR COMMERCIAL COMPANIES; COMMERCIAL

ADMINISTRATION OF THE LICENSING OF THE GOODS AND SERVICES OF OTHERS; COMMERCIAL INFORMATION AGENCIES; COMMERCIAL INFORMATION AND ADVICE FOR CONSUMERS; COMMERCIAL INFORMATION AND DIRECTORY AGENCY; COMPILATION OF STATISTICS; COMPILATION, PRODUCTION AND DISSEMINATION OF ADVERTISING MATTER; COMPILING AND ANALYZING STATISTICS, DATA AND OTHER SOURCES OF INFORMATION FOR BUSINESS PURPOSES; DEMONSTRATION OF GOODS; DEMONSTRATION OF GOODS AND SERVICES BY ELECTRONIC MEANS, ALSO FOR THE BENEFIT OF THE SO-CALLED TEleshopping AND HOMESHOPPING SERVICES; DEMONSTRATION OF PRODUCTS; DIRECT MAIL ADVERTISING SERVICES; DISPLAYING ADVERTISEMENTS FOR OTHERS; DISSEMINATION OF ADVERTISEMENTS; DISSEMINATION OF ADVERTISEMENTS AND OF ADVERTISING MATERIAL; DISSEMINATION OF ADVERTISING FOR OTHERS VIA PUBLIC AND PRIVATE WIRELESS NETWORKS FOR DISPLAY ON MOBILE DEVICES; DISSEMINATION OF ADVERTISING FOR OTHERS VIA THE INTERNET; DISSEMINATION OF ADVERTISING MATERIAL; DISSEMINATION OF ADVERTISING MATTER; DISTRIBUTION AND DISSEMINATION OF ADVERTISING MATERIALS; DISTRIBUTION OF ADVERTISEMENTS AND COMMERCIAL ANNOUNCEMENTS; DISTRIBUTION OF ADVERTISING MATERIALS; DISTRIBUTION OF PRODUCTS FOR ADVERTISING PURPOSES; DISTRIBUTION OF PROSPECTUSES AND SAMPLES; DISTRIBUTION OF PUBLICITY MATERIALS (FLYERS, PROSPECTUSES, BROCHURES, SAMPLES, PARTICULARLY FOR CATALOGUE LONG DISTANCE SALES) WHETHER CROSS BORDER OR NOT; DISTRIBUTION OF PUBLICITY MATERIALS, NAMELY, FLYERS, PROSPECTUSES, BROCHURES, SAMPLES, PARTICULARLY FOR CATALOGUE LONG DISTANCE SALES; DISTRIBUTION OF SAMPLES FOR PUBLICITY PURPOSES; ELECTRONIC BILLBOARD ADVERTISING; EXPORT AND IMPORT AGENCIES; IMPORT AND EXPORT AGENCIES; ISSUING AND UPDATING OF ADVERTISING TEXTS; LAYOUT SERVICES FOR ADVERTISING PURPOSES; MANAGEMENT OF PERFORMING ARTISTS; MARKET ANALYSIS; MARKET REPORTS AND STUDIES; MARKET RESEARCH; MARKET RESEARCH AND BUSINESS ANALYSES; MARKET RESEARCH AND MARKET INTELLIGENCE SERVICES; ORGANIZATION OF EVENTS, EXHIBITIONS, FAIRS AND SHOWS FOR COMMERCIAL, PROMOTIONAL AND ADVERTISING PURPOSES; ORGANIZATION OF EXHIBITIONS FOR COMMERCIAL OR ADVERTISING PURPOSES; ORGANIZATION OF FAIRS AND EXHIBITIONS FOR COMMERCIAL AND ADVERTISING PURPOSES; ORGANIZATION OF FAIRS FOR COMMERCIAL AND ADVERTISING PURPOSES; OUTDOOR ADVERTISING; PRODUCT DEMONSTRATION; PRODUCT DEMONSTRATION SERVICES IN SHOP WINDOWS BY LIVE MODELS; PRODUCTION AND DISTRIBUTION OF RADIO AND TELEVISION COMMERCIALS; PRODUCTION OF ADVERTISING FILMS; PRODUCTION OF ADVERTISING MATERIALS; PRODUCTION OF ADVERTISING MATTER AND COMMERCIALS; PRODUCTION OF FILM AND TELEVISION ADVERTISING; PRODUCTION OF TELEVISION COMMERCIALS; PUBLIC RELATIONS; PUBLICATION OF PUBLICITY MATERIALS; PUBLICATION OF PUBLICITY TEXTS; PUBLICITY AND SALES PROMOTION SERVICES; RENTAL OF ADVERTISEMENT SPACE AND ADVERTISING MATERIAL; RENTAL OF ADVERTISING SPACE; RENTAL OF ADVERTISING SPACE ON WEB SITES; RENTAL OF ADVERTISING TIME ON COMMUNICATION MEDIA; RENTAL OF ALL PUBLICITY AND MARKETING PRESENTATION MATERIALS; RENTAL OF BILLBOARDS; RENTAL OF PUBLICITY MATERIAL; RENTAL OF SALES STANDS; RENTAL OF SIGNS FOR ADVERTISING PURPOSES; RETAIL SHOP WINDOW DISPLAY ARRANGEMENT SERVICES; SALES PROMOTION; SALES PROMOTION FOR THIRD PARTIES; SAMPLE DISTRIBUTION; SHOP WINDOW DISPLAY ARRANGEMENT SERVICES; STREET DISSEMINATION OF ADVERTISING MATERIALS; WINDOW DRESSING AND DISPLAY ARRANGEMENT SERVICES; WRITING OF PUBLICITY TEXTS (U.S. CLS. 100, 101 AND 102).

TRACY FLETCHER, EXAMINING ATTORNEY

SN 86-077,448. NEUROCRINE BIOSCIENCES, INC., SAN DIEGO, CA. FILED 9-27-2013.



THE MARK CONSISTS OF 5 FILLED CIRCLES OR PARTS OF CIRCLES, REPRESENTING A CRESCENT MOON TO A FULL MOON.

#### CLASS 5—PHARMACEUTICALS

FOR PHARMACEUTICAL PREPARATIONS FOR THE TREATMENT OF INSOMNIA AND SLEEP DISORDERS (U.S. CLS. 6, 18, 44, 46, 51 AND 52).

#### CLASS 44—MEDICAL, BEAUTY AND AGRICULTURAL SERVICES

FOR MEDICAL INFORMATION SERVICES, NAMELY, PROVIDING INFORMATION IN THE FIELDS OF INSOMNIA AND SLEEP DISORDERS; ON-LINE INFORMATION SERVICES, NAMELY, PROVIDING HEALTH INFORMATION IN THE FIELDS OF INSOMNIA AND SLEEP DISORDERS (U.S. CLS. 100 AND 101).  
BRIAN PINO, EXAMINING ATTORNEY

SN 86-078,213. WHITE, PATRICK, BALDWIN, NY. FILED 9-30-2013.

# Tax E Man

THE MARK CONSISTS OF STANDARD CHARACTERS WITHOUT CLAIM TO ANY PARTICULAR FONT, STYLE, SIZE, OR COLOR.

NO CLAIM IS MADE TO THE EXCLUSIVE RIGHT TO USE "TAX", APART FROM THE MARK AS SHOWN.

#### CLASS 35—ADVERTISING AND BUSINESS

FOR TAX PREPARATION AND TAX CONSULTING (U.S. CLS. 100, 101 AND 102).

#### CLASS 45—PERSONAL AND LEGAL SERVICES

FOR REPRESENTATION OF CLIENTS IN TAX MATTERS BEFORE TAX AUTHORITIES (U.S. CLS. 100 AND 101).

B. PARADEWELAI, EXAMINING ATTORNEY

SN 86-077,657. AIRNET GROUP, INC., CHATTANOOGA, TN. FILED 9-28-2013.



THE MARK CONSISTS OF THE WORD "AIRNET" WITH SEVERAL GENERALLY CIRCULAR, AND GENERALLY CONCENTRIC, LINES POSITIONED TO THE UPPER LEFT OF THE WORD.

#### CLASS 35—ADVERTISING AND BUSINESS

FOR DATA MANAGEMENT SERVICES, NAMELY, DATA CENTER SERVICES IN THE NATURE OF MANAGEMENT AND PROCESSING OF DATA; SERVICES FOR THE COLLECTION, COMPILATION, MANIPULATION, MODIFICATION, ANALYSIS, SHARING, COMMUNICATING, AND INTERCONNECTING OF DATA (U.S. CLS. 100, 101 AND 102).

FIRST USE 12-1-2005; IN COMMERCE 12-1-2005.

#### CLASS 38—COMMUNICATION

FOR ELECTRONIC DATA TRANSMISSION (U.S. CLS. 100, 101 AND 104).

FIRST USE 12-1-2005; IN COMMERCE 12-1-2005.

#### CLASS 39—TRANSPORTATION AND STORAGE

FOR ELECTRONIC STORAGE OF DATA (U.S. CLS. 100 AND 105).

FIRST USE 12-1-2005; IN COMMERCE 12-1-2005.  
KATINA MISTER, EXAMINING ATTORNEY

SN 86-078,383. MCALISTER TECHNOLOGIES, LLC, PHOENIX, AZ. FILED 9-30-2013.

# GEE WIZ

THE MARK CONSISTS OF STANDARD CHARACTERS WITHOUT CLAIM TO ANY PARTICULAR FONT, STYLE, SIZE, OR COLOR.

#### CLASS 3—COSMETICS AND CLEANING PREPARATIONS

FOR DISPOSABLE WIPES IMPREGNATED WITH CLEANING CHEMICALS OR COMPOUNDS FOR USE ON FOOD WASTE DISPOSALS, APPLIANCES, MACHINES AND MACHINE PARTS, SOLAR PANELS, FUEL INJECTORS, AND GENERATORS FOR INDUSTRIAL AND COMMERCIAL USE (U.S. CLS. 1, 4, 6, 50, 51 AND 52).

#### CLASS 5—PHARMACEUTICALS

FOR DISPOSABLE WIPES IMPREGNATED WITH DISINFECTING CHEMICALS OR COMPOUNDS FOR USE ON FOOD WASTE DISPOSALS, APPLIANCES, MACHINES AND MACHINE PARTS, SOLAR PANELS, FUEL INJECTORS, GENERATORS, AND OTHER COMMERCIAL AND INDUSTRIAL MACHINE SURFACES (U.S. CLS. 6, 18, 44, 46, 51 AND 52).

#### CLASS 7—MACHINERY

FOR FOOD WASTE DISPOSALS (U.S. CLS. 13, 19, 21, 23, 31, 34 AND 35).

TASNEEM HUSSAIN, EXAMINING ATTORNEY



SN 86-079,207. THE BANCORP INC., WILMINGTON, DE.  
FILED 10-1-2013.

TRANSACTIONING POSSIBILITY.

THE MARK CONSISTS OF STANDARD CHARACTERS WITHOUT CLAIM TO ANY PARTICULAR FONT, STYLE, SIZE, OR COLOR.

#### CLASS 35—ADVERTISING AND BUSINESS

FOR PROMOTING THE GOODS AND SERVICES OF OTHERS THROUGH THE DEVELOPMENT AND ADMINISTRATION OF STORED VALUE CARDS PROGRAMS AND THE ISSUANCE OF STORED VALUE CARDS FOR OTHERS (U.S. CLS. 100, 101 AND 102).

#### CLASS 36—INSURANCE AND FINANCIAL

FOR BANKING SERVICES; ONLINE BANKING SERVICES; BANKING SERVICES FEATURING THE PROVISION OF CERTIFICATES OF DEPOSIT; ADMINISTRATION OF HEALTH SAVINGS ACCOUNTS; ELECTRONIC TRANSFER OF FUNDS; CREDIT CARD AND DEBIT CARD SERVICES; CREDIT CARD AND DEBIT CARD TRANSACTION PROCESSING SERVICES; ISSUING PREPAID CREDIT CARDS; ISSUING PREPAID DEBIT CARDS; ISSUING STORED VALUE CARDS; PROVIDING STORED VALUE CARD SERVICES; MORTGAGE LENDING; MORTGAGE BANKING; HOME EQUITY LOANS; FINANCING OF LOANS; PROVIDING PERSONAL LOANS AND LINES OF CREDIT; INDIVIDUAL RETIREMENT ACCOUNT SERVICES; LENDING SERVICES, NAMELY, COMMERCIAL LOANS AND COMMERCIAL LOAN FINANCING; PROVIDING ELECTRONIC PROCESSING OF ELECTRONIC FUNDS TRANSFER, ACH, CREDIT CARD, DEBIT CARD, ELECTRONIC CHECK AND ELECTRONIC PAYMENTS (U.S. CLS. 100, 101 AND 102).

CIMMERIAN COLEMAN, EXAMINING ATTORNEY

SN 86-079,568. THE GREAT LAKES COLLABORATIVE FOR AUTISM, TOLEDO, OH. FILED 10-1-2013.

AUTISM.

NO CLAIM IS MADE TO THE EXCLUSIVE RIGHT TO USE "AUTISM", APART FROM THE MARK AS SHOWN. THE MARK CONSISTS OF THE WORD "IS" SUPERIMPOSED ON THE LETTERS "IS" OF THE WORD "AUTISM" FOLLOWED BY A PERIOD.  
SEC. 2(F).

#### CLASS 35—ADVERTISING AND BUSINESS

FOR CHARITABLE SERVICES, NAMELY, ORGANIZING AND CONDUCTING VOLUNTEER PROGRAMS AND COMMUNITY SERVICE PROJECTS (U.S. CLS. 100, 101 AND 102).

FIRST USE 6-19-2009; IN COMMERCE 6-19-2009.

#### CLASS 36—INSURANCE AND FINANCIAL

FOR CHARITABLE FUNDRAISING SERVICES FOR PROMOTING RESEARCH, EDUCATION AND OTHER ACTIVITIES RELATING TO AUTISM (U.S. CLS. 100, 101 AND 102).

FIRST USE 6-19-2009; IN COMMERCE 6-19-2009.

LOURDES AYALA, EXAMINING ATTORNEY

SN 86-079,751. DOUGLAS M. STANEART, ARLINGTON, TX.  
FILED 10-1-2013.

THE LEADER'S INSTITUTE

THE MARK CONSISTS OF STANDARD CHARACTERS WITHOUT CLAIM TO ANY PARTICULAR FONT, STYLE, SIZE, OR COLOR.

NO CLAIM IS MADE TO THE EXCLUSIVE RIGHT TO USE "INSTITUTE", APART FROM THE MARK AS SHOWN.  
SEC. 2(F).

#### CLASS 16—PAPER GOODS AND PRINTED MATTER

FOR PRINTED MATERIALS, NAMELY, BOOKS, WHITE PAPERS, WORKSHOP MANUALS, AND SELF-PACED TEACHING MATERIALS IN THE FIELD OF PERSONAL AND PROFESSIONAL DEVELOPMENT, LEADERSHIP, COMMUNICATION, AND TEAM BUILDING (U.S. CLS. 2, 5, 22, 23, 29, 37, 38 AND 50).

FIRST USE 12-15-2002; IN COMMERCE 12-15-2002.

#### CLASS 35—ADVERTISING AND BUSINESS

FOR BUSINESS CONSULTING AND ADVISORY SERVICES IN THE FIELDS OF LEADERSHIP DEVELOPMENT, COMMUNICATIONS AND TEAM BUILDING (U.S. CLS. 100, 101 AND 102).

FIRST USE 12-15-2002; IN COMMERCE 12-15-2002.

#### CLASS 41—EDUCATION AND ENTERTAINMENT

FOR EDUCATIONAL SERVICES, NAMELY, CONDUCTING CLASSES, SEMINARS, WORKSHOPS, LECTURES, AND SELF-PACED TRAINING PROGRAMS IN THE FIELD OF PERSONAL AND PROFESSIONAL DEVELOPMENT, LEADERSHIP, COMMUNICATION, AND TEAM BUILDING AND DISTRIBUTION OF EDUCATIONAL MATERIALS IN CONNECTION THEREWITH; PERSONAL COACHING SERVICES IN THE FIELD OF PERSONAL AND PROFESSIONAL DEVELOPMENT FOR INDIVIDUALS AND GROUPS (U.S. CLS. 100, 101 AND 107).

FIRST USE 12-15-2002; IN COMMERCE 12-15-2002.

KELLY BOULTON, EXAMINING ATTORNEY

SN 86-080,071. FBSCIENCES HOLDINGS, INC., COLLIERVILLE, TN. FILED 10-1-2013.

# OPTIFY

THE MARK CONSISTS OF STANDARD CHARACTERS WITHOUT CLAIM TO ANY PARTICULAR FONT, STYLE, SIZE, OR COLOR.

THE WORD(S) "OPTIFY" HAS NO MEANING IN A FOREIGN LANGUAGE.

## CLASS 1—CHEMICALS

FOR CHEMICAL PREPARATIONS FOR USE IN AGRICULTURE AND HORTICULTURE, NAMELY, PREPARATIONS FOR THE REGULATION OF GROWTH OF PLANTS; PLANT NUTRIENTS, NAMELY, FOLIAR-APPLIED LIQUID FERTILIZERS FOR AGRICULTURAL AND HORTICULTURAL USE; PLANT NUTRIENTS, NAMELY, SOIL-APPLIED FERTILIZERS FOR AGRICULTURAL OR HORTICULTURAL USE; FERTILIZER WITH BIOSIMULANTS FOR AGRICULTURAL OR HORTICULTURAL USE; SOIL AMENDMENTS; AND ADJUVANTS FOR USE WITH AGRICULTURAL CHEMICALS, NAMELY, ADJUVANTS FOR USE IN THE MANUFACTURE OF FOLIAR AND SOIL-APPLIED PLANT NUTRIENT SOLUTIONS (U.S. CLS. 1, 5, 6, 10, 26 AND 46).

## CLASS 5—PHARMACEUTICALS

FOR AGRICULTURAL BIOPESTICIDES (U.S. CLS. 6, 18, 44, 46, 51 AND 52).

ANDREW RHIM, EXAMINING ATTORNEY

---

SN 86-080,346. THE PROVIDENCE SERVICE CORPORATION, TUCSON, AZ. FILED 10-2-2013.

PROVIDENCE HUMAN SERVICES

THE MARK CONSISTS OF STANDARD CHARACTERS WITHOUT CLAIM TO ANY PARTICULAR FONT, STYLE, SIZE, OR COLOR.

OWNER OF U.S. REG. NOS. 2,252,504 AND 3,098,098.  
NO CLAIM IS MADE TO THE EXCLUSIVE RIGHT TO USE "HUMAN SERVICES", APART FROM THE MARK AS SHOWN.

## CLASS 35—ADVERTISING AND BUSINESS

FOR DRUG-AND-ALCOHOL ABUSE SERVICES, NAMELY, JOB PLACEMENT; EMPLOYMENT COUNSELING TO ASSIST INDIVIDUALS TO OBTAIN AND RETAIN EMPLOYMENT (U.S. CLS. 100, 101 AND 102).

## CLASS 44—MEDICAL, BEAUTY AND AGRICULTURAL SERVICES

FOR BEHAVIORAL HEALTH SERVICES (U.S. CLS. 100 AND 101).

RUDY R. SINGLETON, EXAMINING ATTORNEY

SN 86-080,347. THE PROVIDENCE SERVICE CORPORATION, TUCSON, AZ. FILED 10-2-2013.



OWNER OF U.S. REG. NOS. 2,252,504 AND 3,098,098.  
NO CLAIM IS MADE TO THE EXCLUSIVE RIGHT TO USE "SERVICE CORPORATION", APART FROM THE MARK AS SHOWN.

THE COLOR(S) WHITE, BLUE, GREEN AND GRAY IS/ARE CLAIMED AS A FEATURE OF THE MARK.

THE MARK CONSISTS OF THE LETTERS "P", "S" AND "C", ALL IN A WHITE FONT. THE LETTER "P" IS IN A BLUE SQUARE. THE LETTER "S" IS IN A GREEN SQUARE. THE LETTER "C" IS IN A GRAY SQUARE. THESE THREE SQUARES ARE ARRANGED HORIZONTALLY AND ARE IMMEDIATELY ABOVE THE WORDS "PROVIDENCE SERVICE CORPORATION", ALL IN GRAY.

## CLASS 35—ADVERTISING AND BUSINESS

FOR DRUG-AND-ALCOHOL ABUSE SERVICES, NAMELY, JOB PLACEMENT; EMPLOYMENT COUNSELING TO ASSIST INDIVIDUALS TO OBTAIN AND RETAIN EMPLOYMENT (U.S. CLS. 100, 101 AND 102).

## CLASS 39—TRANSPORTATION AND STORAGE

FOR NON-EMERGENCY MEDICAL TRANSPORTATION SERVICES, NAMELY, PROVIDING TRANSPORTATION FOR PEOPLE BY AMBULANCE, GROUND VEHICLES, AND MEDICAL AIRPLANE (U.S. CLS. 100 AND 105).

## CLASS 44—MEDICAL, BEAUTY AND AGRICULTURAL SERVICES

FOR BEHAVIORAL HEALTH SERVICES (U.S. CLS. 100 AND 101).

RUDY R. SINGLETON, EXAMINING ATTORNEY

---

SN 86-080,351. THE PROVIDENCE SERVICE CORPORATION, TUCSON, AZ. FILED 10-2-2013.



OWNER OF U.S. REG. NOS. 2,252,504 AND 3,098,098.  
NO CLAIM IS MADE TO THE EXCLUSIVE RIGHT TO USE "SERVICE CORPORATION", APART FROM THE MARK AS SHOWN.

THE COLOR(S) WHITE, BLUE, GREEN AND GRAY IS/ARE CLAIMED AS A FEATURE OF THE MARK.

THE MARK CONSISTS OF THE LETTERS "P", "S" AND "C", ALL IN A WHITE FONT. THE LETTER "P" IS IN A BLUE SQUARE. THE LETTER "S" IS IN A GREEN SQUARE. THE LETTER "C" IS IN A GRAY SQUARE. THESE THREE SQUARES ARE ARRANGED HORIZONTALLY AND ARE IMMEDIATELY TO THE LEFT OF THE WORDS "PROVIDENCE SERVICE CORPORATION" ALL IN GRAY.

## CLASS 35—ADVERTISING AND BUSINESS

FOR DRUG-AND-ALCOHOL ABUSE SERVICES, NAMELY, JOB PLACEMENT; EMPLOYMENT COUNSELING TO ASSIST INDIVIDUALS TO OBTAIN AND RETAIN EMPLOYMENT (U.S. CLS. 100, 101 AND 102).

**CLASS 39—TRANSPORTATION AND STORAGE**

FOR NON-EMERGENCY MEDICAL TRANSPORTATION SERVICES, NAMELY, PROVIDING TRANSPORTATION FOR PEOPLE BY AMBULANCE, GROUND VEHICLES, AND MEDICAL AIRPLANE (U.S. CLS. 100 AND 105).

**CLASS 44—MEDICAL, BEAUTY AND AGRICULTURAL SERVICES**

FOR BEHAVIORAL HEALTH SERVICES (U.S. CLS. 100 AND 101).

RUDY R. SINGLETON, EXAMINING ATTORNEY

SN 86-081,027. INTELECHY LLC, SILVER SPRING, MD. FILED 10-2-2013.



THE MARK CONSISTS OF A DESIGN OF A RISING PHOENIX STAR (3-D EFFECT) AND TRAILING EMBER STREAMS BENEATH AND TO THE LEFT OF THE PHOENIX STAR RISING THROUGH THE MIDDLE AND FROM BEHIND THE STYLIZED TEXT "INTELECHY".

**CLASS 35—ADVERTISING AND BUSINESS**

FOR BUSINESS PROJECT MANAGEMENT SERVICES FOR OTHERS IN THE FIELDS OF ORGANIZATIONAL DEVELOPMENT AND BUSINESS STRATEGIC PLANNING FOR THE GLOBAL IT, IT, EDUCATION, EDUCATION SUPPORT, DEFENSE, INTELLIGENCE, SECURITY, MANUFACTURING AND OPERATIONS, HEALTHCARE, FINANCIAL SERVICES, AND GENERAL US GOVERNMENT SERVICE SECTORS; STRATEGIC CAREER PLANNING SERVICES TO OTHERS IN THE FIELDS OF GLOBAL IT, IT, EDUCATION, EDUCATION SUPPORT, DEFENSE, INTELLIGENCE, SECURITY, MANUFACTURING AND OPERATIONS, HEALTHCARE, FINANCIAL SERVICES, AND GENERAL US GOVERNMENT SERVICES (U.S. CLS. 100, 101 AND 102).

FIRST USE 9-17-2013; IN COMMERCE 9-21-2013.

**CLASS 41—EDUCATION AND ENTERTAINMENT**

FOR EDUCATIONAL SUPPORT SERVICES FOR OTHERS IN THE DEVELOPMENT OF MENTAL FACULTIES OF PERSONS OF ALL AGES, INCLUDING AGES 4 TO ADULTS WHO ARE 20 TO 40+ YEARS, NAMELY, MENTORING, TUTORING, COMMUNICATION TRAINING IN THE FIELDS OF COMMUNICATIONS, SCIENCE, TECHNOLOGY, ENGINEERING, AND MATH; SERVICES INTENDED TO ENGAGE THE ATTENTION, NAMELY, PROVIDING MOTIVATIONAL SPEAKING SERVICES AND WORKSHOPS IN THE FIELD OF SELF AND PERSONAL IMPROVEMENT; PROVIDING TRAINING IN THE FIELDS OF PUBLIC SPEAKING; PROVIDING CAREER COUNSELING, NAMELY, PROVIDING ADVICE CONCERNING EDUCATION OPTIONS TO PURSUE CAREER OPPORTUNITIES AND CAREER ADVANCEMENT; EDUCATIONAL CONSULTING SERVICES, NAMELY, PROVIDING INFORMATION ABOUT EDUCATION IN THE FIELD OF ENGINEERING, INFORMATION TECH-

NOLOGY, SCIENCE, MATHEMATICS, GENERAL BUSINESS DISCIPLINES, AND MANAGEMENT; PROVIDING ADMISSIONS CONSULTING SERVICES, NAMELY, CONSULTING IN THE FIELD OF STRATEGIC EDUCATION AND CAREER PLANNING, PRE-COLLEGE ACADEMIC STRATEGIES, COLLEGE ADMISSIONS, COLLEGE SELECTION, COLLEGE SCHOLARSHIP SEARCHES, COMPLETING ADMISSIONS APPLICATIONS AND PREPARATION FOR COLLEGE ADMISSIONS AND INTERVIEWS; PROVIDING WORKSHOPS IN THE FIELDS OF MATHEMATICS, VERBAL AND WRITTEN COMMUNICATIONS, SCIENCE, TECHNOLOGY, ENGINEERING, PROFESSIONAL PRESENTATIONS, PROFESSIONAL IMAGE AND SELF-ESTEEM, BUILDING PROFESSIONAL REPUTATIONS AND CREDENTIALS, NETWORKING, CAREER CURRICULUMS, STRATEGIC EDUCATION AND CAREER PLANNING; ARRANGING WORKSHOPS, SEMINARS, AND TRAINING COURSES FOR OTHERS IN THE FIELD OF IT, EDUCATION, EDUCATION SUPPORT, HEALTHCARE, ENGINEERING, DEFENSE, INTELLIGENCE, SECURITY, SCIENCE, AND TECHNOLOGY; PROVIDING ONLINE EDUCATIONAL CLASSES, SEMINARS, WORKSHOPS IN THE FIELD OF SCIENCE, TECHNOLOGY, ENGINEERING, MATH, WRITTEN AND VERBAL COMMUNICATIONS; PROVIDING ONLINE CONTINUING EDUCATION SERVICES, NAMELY, PROVIDING ON-LINE NON-DOWNLOADABLE WEBINARS AND CONTINUING PROFESSIONAL EDUCATION SEMINARS IN THE FIELD OF ENGINEERING, EDUCATION, BUSINESS MANAGEMENT, BUSINESS PROCESSES, TECHNOLOGY, IT, AND HEALTHCARE; PROVIDING ONLINE NON-DOWNLOADABLE PUBLICATIONS IN THE NATURE OF JOURNALS, ARTICLES, AND WORKSHEETS IN THE FIELDS OF SCIENCE, TECHNOLOGY, ENGINEERING, MATH, PUBLIC SPEAKING, MOTIVATIONAL SPEAKING, SELF-ESTEEM, WRITTEN AND VERBAL COMMUNICATIONS AND NETWORKING (U.S. CLS. 100, 101 AND 107).

FIRST USE 9-17-2013; IN COMMERCE 9-21-2013.

**CLASS 42—SCIENTIFIC AND COMPUTER SERVICES**

FOR CONSULTING SERVICES FOR OTHERS IN THE FIELD OF TECHNICAL PROJECT MANAGEMENT, INFORMATION TECHNOLOGY, IT PROJECT MANAGEMENT OF SMALL TO LARGE PROJECTS AND PROGRAMS, AND CONFIGURATION MANAGEMENT OF TECHNICAL AND SCIENTIFIC RESEARCH AND APPLICATIONS; CONSULTING SERVICES FOR OTHERS IN THE FIELD OF DEVELOPMENT OF COMPUTER SOFTWARE AND HARDWARE, COMPUTER SOFTWARE AND HARDWARE DEVELOPMENT LIFE CYCLE ACTIVITIES, AND TECHNOLOGY APPLICATIONS FEATURING CYBER TECHNOLOGY, INFORMATION ASSURANCE, INFORMATION SCIENCE, ENGINEERING, AND IT HEALTHCARE; PROVIDING CONSULTING IN COMPUTER SYSTEMS PROJECT MANAGEMENT (U.S. CLS. 100 AND 101).

FIRST USE 9-17-2013; IN COMMERCE 9-21-2013.

NATALIE POLZER, EXAMINING ATTORNEY

SN 86-081,209. SYNCLAIRE BRANDS, INC., HICKSVILLE, NY. FILED 10-2-2013.

**EMPORIO ENZO**

THE MARK CONSISTS OF STANDARD CHARACTERS WITHOUT CLAIM TO ANY PARTICULAR FONT, STYLE, SIZE, OR COLOR.

OWNER OF U.S. REG. NO. 4,404,231.

NO CLAIM IS MADE TO THE EXCLUSIVE RIGHT TO USE "EMPORIO", APART FROM THE MARK AS SHOWN.

THE ENGLISH TRANSLATION OF THE WORD "EMPORIO" IN THE MARK IS "STORE".

**CLASS 9—ELECTRICAL AND SCIENTIFIC APPARATUS**

FOR CELLULAR PHONE ACCESSORIES, NAMELY, CELLULAR PHONE CASES AND CELLULAR PHONE CHARMS (U.S. CLS. 21, 23, 26, 36 AND 38).

**CLASS 14—JEWELRY**

FOR JEWELRY (U.S. CLS. 2, 27, 28 AND 50).

**CLASS 18—LEATHER GOODS**

FOR HANDBAGS; PURSES; WALLETS; LUGGAGE; AND SMALL LEATHER GOODS, NAMELY, KEY-CHAINS AND LEATHER LACES (U.S. CLS. 1, 2, 3, 22 AND 41).

**CLASS 25—CLOTHING**

FOR HATS; CAPS; SCARVES; SOCKS; BELTS (U.S. CLS. 22 AND 39).  
VERNA BETH RIRIE, EXAMINING ATTORNEY

**CLASS 25—CLOTHING**

FOR CLOTHING, NAMELY, BLOUSES, DRESSES, SKIRTS, SHORTS, SLEEPWEAR, ROBES, SWIMWEAR, SCARVES, APRONS, FOOTWEAR, HEADWEAR; INTIMATE APPAREL, NAMELY, PANTIES AND BRAS (U.S. CLS. 22 AND 39).

LAURIE KAUFMAN, EXAMINING ATTORNEY

SN 86-081,788. SALIX PHARMACEUTICALS, LTD., RALEIGH, NC. FILED 10-3-2013.

# SALIX

THE MARK CONSISTS OF STANDARD CHARACTERS WITHOUT CLAIM TO ANY PARTICULAR FONT, STYLE, SIZE, OR COLOR.

**CLASS 5—PHARMACEUTICALS**

FOR PRESCRIPTION PHARMACEUTICAL PREPARATIONS FOR THE TREATMENT AND PREVENTION OF GASTROINTESTINAL DISEASES AND DISORDERS IN HUMANS (U.S. CLS. 6, 18, 44, 46, 51 AND 52).

FIRST USE 8-0-1993; IN COMMERCE 8-0-1993.

**CLASS 42—SCIENTIFIC AND COMPUTER SERVICES**

FOR RESEARCH AND DEVELOPMENT AND CONSULTATION RELATED THERETO IN THE FIELD OF HUMAN PHARMACEUTICAL PREPARATIONS AND SUBSTANCES (U.S. CLS. 100 AND 101).

FIRST USE 4-1-1989; IN COMMERCE 4-1-1989.

**CLASS 44—MEDICAL, BEAUTY AND AGRICULTURAL SERVICES**

FOR PROVIDING HEALTH INFORMATION (U.S. CLS. 100 AND 101).

FIRST USE 1-1-2003; IN COMMERCE 1-1-2003.

PAM WILLIS, EXAMINING ATTORNEY

SN 86-081,316. GROOVY PEOPLE, LLC, DALLAS, TX. FILED 10-2-2013.



THE MARK CONSISTS OF THE STYLIZED WORD "ANGELLE" BELOW A FLOWER DESIGN.

**CLASS 14—JEWELRY**

FOR JEWELRY, NAMELY, RINGS, NECKLACES, BRACELETS, BANGLES, ARM CUFFS, EARRINGS, CHARMS (U.S. CLS. 2, 27, 28 AND 50).

**CLASS 16—PAPER GOODS AND PRINTED MATTER**

FOR NOTEBOOKS, CALENDARS, GREETING CARDS, STATIONERY, PAPER NAPKINS, PAPER TABLE CLOTHS, SCRATCH PADS, BLANK FORMS, WRAPPING PAPER, SHELF PAPER, GIFT WRAPPING TISSUE (U.S. CLS. 2, 5, 22, 23, 29, 37, 38 AND 50).

**CLASS 24—FABRICS**

FOR TEXTILES AND TEXTILE GOODS, NAMELY, PRINTED FABRICS FOR USE IN THE MANUFACTURE OF CLOTHING, HOUSEHOLD FURNISHINGS, WALL-PAPER, WALL HANGINGS, BED AND TABLE COVERS, CURTAINS, BED SHEETS, BATH SHEETS, BATH TOWELS, WASH MITTS, CONTOUR SHEETS, SHOWER CURTAINS, TABLE LINENS, PRINTED FABRICS OF COTTON, LINEN, SILK, NYLON, RUGS AND WALL HANGINGS (U.S. CLS. 42 AND 50).

SN 86-081,905. MADRE:X CO., LTD., TOKYO, JAPAN, FILED 10-3-2013.

# Ex:beaute

THE MARK CONSISTS OF STANDARD CHARACTERS WITHOUT CLAIM TO ANY PARTICULAR FONT, STYLE, SIZE, OR COLOR.

**CLASS 3—COSMETICS AND CLEANING PREPARATIONS**

FOR MAKE-UP POWDER; CREAMY FACE POWDER; PRESSED FACE POWDER; LOOSE FACE POWDER; FACE POWDER PASTE; LIQUID FOUNDATION; SKIN LOTIONS; CLEANSING CREAMS; COLD CREAMS; VANISHING CREAMS; SUNSCREEN CREAMS; SKIN WHITENING CREAMS; CREAMY FOUNDATION; LIP CREAMS; LIPSTICKS; CREAMY ROUGES; EYE SHADOWS; NAIL POLISH; BEAUTY MASKS; MASCARAS; EYEBROW PENCILS; CONCEALERS; MAKEUP BASE IN THE NATURE OF FOUNDATION; SUNSCREEN MILK; FACIAL WASHES; FACIAL SOAPS; BEAUTY SERUMS; SKIN WHITENING FACIAL WASHES; WHITENING BEAUTY SERUMS; ANTI-AGING FACIAL WASHES; ANTI-AGING LOTIONS; NON-MEDICATED ANTI-AGING SERUM; ANTI-AGING CREAMS; ANTI-AGING SKIN MASKS; COTTON FOR COSMETIC PURPOSES; COTTON WOOLS FOR COSMETIC PURPOSES; COTTON PUFFS FOR COSMETIC PURPOSES (U.S. CLS. 1, 4, 6, 50, 51 AND 52).

**CLASS 21—HOUSEWARES AND GLASS**

FOR SPONGES FOR COSMETIC PURPOSES (U.S. CLS. 2, 13, 23, 29, 30, 33, 40 AND 50).  
PAUL CROWLEY, EXAMINING ATTORNEY

SN 86-082,255. VONTOBEL HOLDING AG, ZURICH, SWITZERLAND, FILED 10-3-2013.



OWNER OF SWITZERLAND REG. NO. 653167, DATED 1-6-2014, EXPIRES 9-17-2023.

THE COLOR(S) BLUE, WHITE AND BLACK IS/ARE CLAIMED AS A FEATURE OF THE MARK.

THE MARK CONSISTS OF THE WORD "HARCOURT" IN BLACK BLOCK PRINT FONT, AND ALL CAPITAL LETTERS. TO THE LEFT OF THE WORD "HARCOURT" APPEARS A STYLIZED LETTER "H" IN A BLUE CIRCLE, AND THE "H" APPEARS IN WHITE BLOCK PRINT CAPITALIZED FONT, WITH A SMALL CIRCLE FORMED IN THE MIDDLE OF THE "H" IN WHITE.

**CLASS 36—INSURANCE AND FINANCIAL**

FOR FINANCIAL CONSULTANCY, PROVIDING FINANCIAL INFORMATION, FINANCIAL ANALYSIS, INVESTMENT OF ASSETS IN FUNDS AND ADVISORY SERVICES REGARDING INVESTMENTS; FINANCIAL CONSULTANCY, PROVIDING FINANCIAL INFORMATION, FINANCIAL ANALYSIS, INVESTMENT OF ASSETS IN FUNDS AND ADVISORY SERVICES REGARDING INVESTMENTS, ALL PROVIDED VIA THE INTERNET; RESEARCH IN THE FIELDS OF INVESTMENT OF ASSETS AND FINANCIAL MARKETS; BUSINESS FINANCE PROCUREMENT SERVICES; PROCUREMENT OF FINANCIAL CONSULTANCY AND INVESTMENT ADVISORY SERVICES, NAMELY, BUSINESS BROKERAGE SERVICES, FINANCIAL INVESTMENT BROKERAGE SERVICES AND FINANCIAL RESEARCH BROKERAGE SERVICES; RESEARCH IN THE FIELD OF INVESTMENT OF ASSETS AND FINANCIAL MARKETS, NAMELY, RESEARCH IN THE FIELDS OF FINANCE AND FINANCIAL INVESTMENTS AND MONETARY RESEARCH (U.S. CLS. 100, 101 AND 102).

**CLASS 41—EDUCATION AND ENTERTAINMENT**

FOR EDUCATIONAL SERVICES, NAMELY, PROVIDING SEMINARS ABOUT FINANCIAL ANALYSIS, INVESTMENT OF ASSETS IN FUNDS AND INVESTMENT ADVISORY SERVICES (U.S. CLS. 100, 101 AND 107).

DAWN FELDMAN, EXAMINING ATTORNEY

SN 86-082,527. MICHALSKY, DANIEL, AURORA, CANADA, FILED 10-4-2013.

**MARCH MULLET**

THE MARK CONSISTS OF STANDARD CHARACTERS WITHOUT CLAIM TO ANY PARTICULAR FONT, STYLE, SIZE, OR COLOR.

**CLASS 35—ADVERTISING AND BUSINESS**

FOR CHARITABLE SERVICES, NAMELY, PROMOTING PUBLIC AWARENESS OF MENTAL HEALTH AWARENESS, MENTAL HEALTH ISSUES, MENTAL HEALTH PROGRAMS AND RESEARCH (U.S. CLS. 100, 101 AND 102).

FIRST USE 12-5-2012; IN COMMERCE 12-5-2012.

**CLASS 36—INSURANCE AND FINANCIAL**

FOR CHARITABLE FUNDRAISING SERVICES; CHARITABLE FOUNDATION SERVICES, NAMELY, PROVIDING FUNDRAISING ACTIVITIES TO SUPPORT MENTAL HEALTH AWARENESS AND MENTAL HEALTH PROGRAMS AND RESEARCH (U.S. CLS. 100, 101 AND 102).

FIRST USE 12-5-2012; IN COMMERCE 12-5-2012.

KAREN BRACEY, EXAMINING ATTORNEY

SN 86-082,872. ESPOSITO, DAVID A., PORTAGE, MI. FILED 10-4-2013.

**SELF AWARENESS MATRIX**

THE MARK CONSISTS OF STANDARD CHARACTERS WITHOUT CLAIM TO ANY PARTICULAR FONT, STYLE, SIZE, OR COLOR.

NO CLAIM IS MADE TO THE EXCLUSIVE RIGHT TO USE "SELF AWARENESS", APART FROM THE MARK AS SHOWN.

**CLASS 35—ADVERTISING AND BUSINESS**

FOR BUSINESS CONSULTING SERVICES IN THE FIELD OF LEADERSHIP DEVELOPMENT AND MANAGEMENT (U.S. CLS. 100, 101 AND 102).

**CLASS 41—EDUCATION AND ENTERTAINMENT**

FOR WORKSHOPS AND SEMINARS IN THE FIELD OF PERSONAL IMPROVEMENT AND LEADERSHIP DEVELOPMENT FOR INDIVIDUALS AND FAMILIES (U.S. CLS. 100, 101 AND 107).

SETH A. RAPPAPORT, EXAMINING ATTORNEY

SN 86-082,885. Groupon, Inc., Chicago, IL. Filed 10-4-2013.

# FRANKLIN FOX

THE MARK CONSISTS OF STANDARD CHARACTERS WITHOUT CLAIM TO ANY PARTICULAR FONT, STYLE, SIZE, OR COLOR.

THE NAME(S), PORTRAIT(S), AND/OR SIGNATURE(S) SHOWN IN THE MARK DOES NOT IDENTIFY A PARTICULAR LIVING INDIVIDUAL.

### CLASS 18—LEATHER GOODS

FOR BAGS, NAMELY, ATHLETIC BAGS, BACKPACKS, BOOK BAGS, BRIEFCASES, CARRYING BAGS, COURIER BAGS, DUFFEL BAGS, GYM BAGS, HAND BAGS, HIKING BAGS, MESSENGER BAGS, SHOULDER BAGS, SPORTS BAGS, TRAVEL BAGS, WHEELED BAGS, WALLETS, PURSES, SCHOOL BAGS, DIAPER BAGS; LEATHER GOODS MADE OF LEATHER AND IMITATION LEATHER, NAMELY, LEATHER AND IMITATION LEATHER BAGS, LUGGAGE, WALLETS AND POUCHES (U.S. CLS. 1, 2, 3, 22 AND 41).

### CLASS 25—CLOTHING

FOR CLOTHING, NAMELY, JUMPERS, SLEEPWEAR, PAJAMAS, ROMPERS, ONE-PIECE GARMENTS FOR CHILDREN, SHIRTS, TANK TOPS, CAMISOLES, CARDIGANS, SWEATSHIRTS, SWEATERS, DRESSES, JACKETS, COATS, BLAZERS, PANTS, BOTTOMS, JEANS, SLACKS, SHORTS, CAPRIS, LEGGINGS, BELTS, SWIMWEAR, SOCKS, SUITS, UNDERGARMENTS, UNDERPANTS, UNDERSHIRTS, UNDERWEAR, AND TIGHTS; FOOTWEAR; HEADGEAR, NAMELY, HATS, CAPS, AND HEADWEAR (U.S. CLS. 22 AND 39).

### CLASS 35—ADVERTISING AND BUSINESS

FOR ONLINE RETAIL STORE SERVICES, ONLINE MOBILE RETAIL STORE SERVICES, AND RETAIL STORE SERVICES, ALL FEATURING A WIDE VARIETY OF CLOTHING, FOOTWEAR, BAGS AND HEADGEAR (U.S. CLS. 100, 101 AND 102).

JORDAN BAKER, EXAMINING ATTORNEY

SN 86-082,894. Groupon, Inc., Chicago, IL. Filed 10-4-2013.

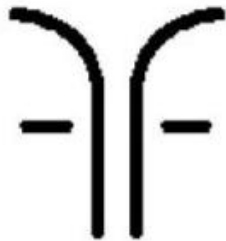

THE MARK CONSISTS OF MIRRORED IMAGES OF LOWERCASE LETTER "F".

### CLASS 18—LEATHER GOODS

FOR BAGS, NAMELY, ATHLETIC BAGS, BACKPACKS, BOOK BAGS, BRIEFCASES, CARRYING BAGS, COURIER BAGS, DUFFEL BAGS, GYM BAGS, HAND BAGS, HIKING BAGS, MESSENGER BAGS, SHOULDER BAGS, SPORTS BAGS, TRAVEL BAGS, WHEELED BAGS, WALLETS, PURSES, SCHOOL BAGS, DIAPER BAGS; LEATHER GOODS MADE OF LEATHER AND IMITATION LEATHER, NAMELY, LEATHER AND IMITATION LEATHER BAGS, LUGGAGE, WALLETS AND POUCHES (U.S. CLS. 1, 2, 3, 22 AND 41).

### CLASS 25—CLOTHING

FOR CLOTHING, NAMELY, JUMPERS, SLEEPWEAR, PAJAMAS, ROMPERS, ONE-PIECE GARMENTS FOR CHILDREN, SHIRTS, TANK TOPS, CAMISOLES, CARDIGANS, SWEATSHIRTS, SWEATERS, DRESSES, JACKETS, COATS, BLAZERS, PANTS, BOTTOMS, JEANS, SLACKS, SHORTS, CAPRIS, LEGGINGS, BELTS, SWIMWEAR, SOCKS, SUITS, UNDERGARMENTS, UNDERPANTS, UNDERSHIRTS, UNDERWEAR, AND TIGHTS; FOOTWEAR; HEADGEAR, NAMELY, HATS, CAPS, AND HEADWEAR (U.S. CLS. 22 AND 39).

### CLASS 35—ADVERTISING AND BUSINESS

FOR ONLINE RETAIL STORE SERVICES, ONLINE MOBILE RETAIL STORE SERVICES, AND RETAIL STORE SERVICES, ALL FEATURING A WIDE VARIETY OF CLOTHING, FOOTWEAR, BAGS AND HEADGEAR (U.S. CLS. 100, 101 AND 102).

JORDAN BAKER, EXAMINING ATTORNEY

SN 86-083,149. AESYNT INCORPORATED, CRANBERRY, PA. Filed 10-4-2013.

# AESYNT

THE MARK CONSISTS OF STANDARD CHARACTERS WITHOUT CLAIM TO ANY PARTICULAR FONT, STYLE, SIZE, OR COLOR.

### CLASS 7—MACHINERY

FOR AUTOMATED ROBOTIC STORAGE AND RETRIEVAL SYSTEM NOT FOR LABORATORY USE CONSISTING PRIMARILY OF MECHANICAL MACHINERY, NAMELY, A MULTI-AXIS ROBOTIC AUTOMATION FOR INVENTORY HANDLING SOLUTIONS WITHIN THE PHARMACEUTICAL AND HEALTHCARE INDUSTRY, COMPUTER HARDWARE AND SOFTWARE ALL SOLD TOGETHER AS A UNIT, FOR SORTING, STORING, IDENTIFYING, DISPENSING, STANDARDIZING, TRACKING AND REPLENISHING MEDICATIONS AND SUPPLIES FOR ADMINISTERING MEDICATIONS (U.S. CLS. 13, 19, 21, 23, 31, 34 AND 35).

**CLASS 9—ELECTRICAL AND SCIENTIFIC APPARATUS**

FOR COMPUTER SOFTWARE AND HARDWARE THAT ASSISTS HOSPITAL AND HEALTH SYSTEM PERSONNEL AND PHARMACISTS IN SORTING, STORING, IDENTIFYING, DISPENSING, STANDARDIZING, TRACKING AND REPLENISHING MEDICATIONS AND SUPPLIES FOR ADMINISTERING MEDICATIONS; STORAGE CABINET SPECIALLY ADAPTED FOR USE WITH COMPUTER HARDWARE AND COMPUTER SOFTWARE ALL SOLD TOGETHER AS A UNIT THAT ASSISTS HOSPITAL AND HEALTH SYSTEM PERSONNEL AND PHARMACISTS IN SORTING, STORING, IDENTIFYING, DISPENSING, STANDARDIZING, TRACKING AND REPLENISHING MEDICATIONS AND SUPPLIES FOR ADMINISTERING MEDICATIONS; MACHINES FOR DISPENSING PRE-DETERMINED DOSAGES OF MEDICATION (U.S. CLS. 21, 23, 26, 36 AND 38).

**CLASS 35—ADVERTISING AND BUSINESS**

FOR INVENTORY CONTROL, NAMELY, DESIGNING, BUILDING, IMPLEMENTING AND OPTIMIZING SYSTEMS AND SERVICES FOR MEDICATION AND PHARMACEUTICAL INVENTORY MANAGEMENT; TRACKING OF PACKAGES CONTAINING MEDICATIONS AND SUPPLIES FOR ADMINISTERING MEDICATIONS FOR BUSINESS PURPOSES (U.S. CLS. 100, 101 AND 102).

**CLASS 39—TRANSPORTATION AND STORAGE**

FOR DELIVERY OF MEDICATION AND SUPPLIES FOR WAREHOUSING, STORING, DISPENSING AND ADMINISTERING MEDICATION (U.S. CLS. 100 AND 105).

**CLASS 42—SCIENTIFIC AND COMPUTER SERVICES**

FOR DESIGN AND DEVELOPMENT OF COMPUTER HARDWARE AND SOFTWARE THAT ENABLES USERS TO IMPLEMENT AND OPTIMIZE SYSTEMS AND SERVICES FOR MEDICATION AND PHARMACEUTICAL INVENTORY MANAGEMENT (U.S. CLS. 100 AND 101).  
DEBORAH MEINERS, EXAMINING ATTORNEY

---

SN 86-083,372. KEYHUBS, LLC, AKA KEYHUBS, MINNEAPOLIS, MN. FILED 10-4-2013.

# Keyhubs

THE MARK CONSISTS OF STANDARD CHARACTERS WITHOUT CLAIM TO ANY PARTICULAR FONT, STYLE, SIZE, OR COLOR.

**CLASS 35—ADVERTISING AND BUSINESS**

FOR BUSINESS CONSULTING SERVICES FOR WORKPLACE AND COMMUNITY SOCIAL ANALYTICS (U.S. CLS. 100, 101 AND 102).  
FIRST USE 2-0-2009; IN COMMERCE 2-0-2009.

**CLASS 42—SCIENTIFIC AND COMPUTER SERVICES**

FOR PROVIDING ON-LINE NON-DOWNLOADABLE SOFTWARE FOR WORKPLACE AND COMMUNITY SOCIAL ANALYTICS (U.S. CLS. 100 AND 101).  
FIRST USE 6-20-2008; IN COMMERCE 6-20-2008.  
TINA MAI, EXAMINING ATTORNEY

---

SN 86-083,455. AG GLOBAL PRODUCTS, LLC, LOS ANGELES, CA. FILED 10-4-2013.

## FHI HEAT ESSENCE

THE MARK CONSISTS OF STANDARD CHARACTERS WITHOUT CLAIM TO ANY PARTICULAR FONT, STYLE, SIZE, OR COLOR.

OWNER OF U.S. REG. NOS. 3,730,432, 3,731,453 AND 3,733,134.

NO CLAIM IS MADE TO THE EXCLUSIVE RIGHT TO USE "HEAT", APART FROM THE MARK AS SHOWN.

**CLASS 8—HAND TOOLS**

FOR ELECTRIC HAIR STRAIGHTENER; ELECTRIC HAIR STRAIGHTENING IRONS; ELECTRIC IRONS FOR STYLING HAIR; ELECTRIC RAZORS AND ELECTRIC HAIR CLIPPERS; HAIR CLIPPERS; HAND-OPERATED HAIR CLIPPERS (U.S. CLS. 23, 28 AND 44).

**CLASS 11—ENVIRONMENTAL CONTROL APPARATUS**

FOR ELECTRIC HAIR DRYERS; HAIR DRYERS (U.S. CLS. 13, 21, 23, 31 AND 34).  
MARK SPARACINO, EXAMINING ATTORNEY

---

SN 86-083,460. RHIANNON CREATIONS, INC., SEDONA, AZ. FILED 10-4-2013.

## INTENTIONAL AROMATHERAPY

THE MARK CONSISTS OF STANDARD CHARACTERS WITHOUT CLAIM TO ANY PARTICULAR FONT, STYLE, SIZE, OR COLOR.

NO CLAIM IS MADE TO THE EXCLUSIVE RIGHT TO USE "AROMATHERAPY", APART FROM THE MARK AS SHOWN.

**CLASS 3—COSMETICS AND CLEANING PREPARATIONS**

FOR BATH OILS AND BATH SALTS; BODY LOTIONS; BODY SPRAYS; BODY WASH; COSMETICS; ESSENTIAL OILS FOR AROMATHERAPY USE; ESSENTIAL OILS FOR PERSONAL USE; FACIAL WASHES; HAIR SHAMPOOS AND CONDITIONERS; MASSAGE OILS; PERFUME OILS; ROOM FRAGRANCES; SKIN CLEANSERS; SKIN MOISTURIZER; SOAPS (U.S. CLS. 1, 4, 6, 50, 51 AND 52).

**CLASS 42—SCIENTIFIC AND COMPUTER SERVICES**

FOR PROVIDING TEMPORARY USE OF A NON-DOWNLOADABLE WEB APPLICATION FOR CUSTOMIZED MIXING AND SELECTION OF AROMATHERAPY PRODUCTS (U.S. CLS. 100 AND 101).

**CLASS 44—MEDICAL, BEAUTY AND AGRICULTURAL SERVICES**

FOR HEALTH SPA SERVICES FOR HEALTH AND WELLNESS OF THE BODY AND SPIRIT (U.S. CLS. 100 AND 101).

MARK SPARACINO, EXAMINING ATTORNEY

SN 86-083,466. BREAD ZEPPELIN HOLDINGS, DALLAS, TX. FILED 10-4-2013.

# Zeppelin

THE MARK CONSISTS OF STANDARD CHARACTERS WITHOUT CLAIM TO ANY PARTICULAR FONT, STYLE, SIZE, OR COLOR.

OWNER OF U.S. REG. NO. 4,433,966.

**CLASS 30—STAPLE FOODS**

FOR BAGUETTES; BREAD; SANDWICHES (U.S. CL. 46).

FIRST USE 8-13-2013; IN COMMERCE 8-13-2013.

**CLASS 43—HOTEL AND RESTAURANT SERVICES**

FOR BAR AND RESTAURANT SERVICES; BISTRO SERVICES; CAFE; CAFE AND RESTAURANT SERVICES; CAFE-RESTAURANTS; CAFES; CATERING; CATERING OF FOOD AND DRINKS; CATERING SERVICES; FAST-FOOD RESTAURANT SERVICES; FAST-FOOD RESTAURANTS; FAST-FOOD RESTAURANTS AND SNACKBARS; FOOD AND DRINK CATERING; FOOD PREPARATION; FOOD PREPARATION SERVICES; FOOD PREPARATION SERVICES FEATURING FRESH, PROPERLY PROPORTIONED, HEALTHY MEALS DESIGNED TO FUEL METABOLISM AND BURN FAT AND MADE TO ORDER FOR DELIVERY OR PICK UP; RESTAURANT; RESTAURANT AND BAR SERVICES; RESTAURANT AND BAR SERVICES, INCLUDING RESTAURANT CARRYOUT SERVICES; RESTAURANT AND CAFE SERVICES; RESTAURANT AND CATERING SERVICES; RESTAURANT SERVICES; RESTAURANT SERVICES FEATURING SANDWICHES; RESTAURANT SERVICES FEATURING SALADS; RESTAURANT SERVICES, INCLUDING SIT-DOWN SERVICE OF FOOD AND TAKE-OUT RESTAURANT SERVICES; RESTAURANT SERVICES, NAMELY, PROVIDING OF FOOD AND BEVERAGES FOR CONSUMPTION ON AND OFF THE PREMISES; RESTAURANT, BAR AND CATERING SERVICES; SERVING FOOD AND DRINKS; SERVING OF FOOD AND DRINK/BEVERAGES; TAKE-OUT RESTAURANT SERVICES (U.S. CLS. 100 AND 101).

FIRST USE 8-13-2013; IN COMMERCE 8-13-2013.  
WILLIAM JACKSON, EXAMINING ATTORNEY

SN 86-084,029. PORT O'CONNOR OFFSHORE ASSOCIATION, HOUSTON, TX. FILED 10-7-2013.



OWNER OF U.S. REG. NO. 1,225,436.

THE MARK CONSISTS OF A CIRCLE CONTAINING A JUG WITH THE WORD "POCO" ON ITS LABEL, ABOVE WHICH APPEAR THE WORDS "POCO BUENO".

THE ENGLISH TRANSLATION OF "POCO BUENO" IN THE MARK IS "LITTLE ONE".

**CLASS 21—HOUSEWARES AND GLASS**

FOR INSULATING SLEEVE HOLDER FOR BOTTLES; INSULATING SLEEVE HOLDERS FOR BEVERAGE CANS (U.S. CLS. 2, 13, 23, 29, 30, 33, 40 AND 50).

FIRST USE 7-31-1985; IN COMMERCE 7-31-1985.

**CLASS 25—CLOTHING**

FOR CAPS; T-SHIRTS (U.S. CLS. 22 AND 39).

FIRST USE 6-30-1969; IN COMMERCE 6-30-1969.

**CLASS 35—ADVERTISING AND BUSINESS**

FOR PROMOTIONAL SPONSORSHIP OF FISHING TOURNAMENTS (U.S. CLS. 100, 101 AND 102).

FIRST USE 6-30-1969; IN COMMERCE 6-30-1969.

**CLASS 41—EDUCATION AND ENTERTAINMENT**

FOR CONDUCTING AND ORGANIZING FISHING TOURNAMENTS (U.S. CLS. 100, 101 AND 107).

FIRST USE 6-30-1969; IN COMMERCE 6-30-1969.

STEPHANIE ALI, EXAMINING ATTORNEY

SN 86-085,019. CHROMATIC TECHNOLOGIES, INC., COLORADO SPRINGS, CO. FILED 10-7-2013.

# COLOROO

THE MARK CONSISTS OF STANDARD CHARACTERS WITHOUT CLAIM TO ANY PARTICULAR FONT, STYLE, SIZE, OR COLOR.



**CLASS 16—PAPER GOODS AND PRINTED MATTER**

FOR CHILDREN'S ARTS AND CRAFTS MATERIALS, NAMELY, ARTS AND CRAFTS MATERIALS FOR DRAWING, NAMELY, PENS AND MARKERS WITH THERMOCHROMIC PIGMENT, AND MATS THAT CONTAIN THERMOCHROMIC PIGMENT AND CHANGE COLOR WHEN TOUCHED (U.S. CLS. 2, 5, 22, 23, 29, 37, 38 AND 50).

**CLASS 27—FLOOR COVERINGS**

FOR FOAM MATS FOR USE ON PLAY AREA SURFACES (U.S. CLS. 19, 20, 37, 42 AND 50).  
TOBY BULLOFF, EXAMINING ATTORNEY

SN 86-085,062. PHILLIP BUCHANON TECHNOLOGIES, DBA PHILLIP BUCHANON ENTERPRISES, TORRANCE, FL. FILED 10-7-2013.

## Canon Publishing

THE MARK CONSISTS OF STANDARD CHARACTERS WITHOUT CLAIM TO ANY PARTICULAR FONT, STYLE, SIZE, OR COLOR.

NO CLAIM IS MADE TO THE EXCLUSIVE RIGHT TO USE "PUBLISHING", APART FROM THE MARK AS SHOWN.

**CLASS 16—PAPER GOODS AND PRINTED MATTER**

FOR COMIC BOOKS; GRAPHIC NOVELS (U.S. CLS. 2, 5, 22, 23, 29, 37, 38 AND 50).

**CLASS 28—TOYS AND SPORTING GOODS**

FOR BOARD GAMES (U.S. CLS. 22, 23, 38 AND 50).

**CLASS 41—EDUCATION AND ENTERTAINMENT**

FOR PROVIDING ONLINE NON-DOWNLOADABLE COMIC BOOKS AND GRAPHIC NOVELS (U.S. CLS. 100, 101 AND 107).

DEBORAH LOBO, EXAMINING ATTORNEY

SN 86-085,474. ENI S.P.A., ROME, ITALY, FILED 10-8-2013.

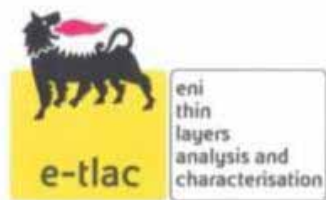

PRIORITY CLAIMED UNDER SEC. 44(D) ON ERP CMNTY TM OFC APPLICATION NO. 011840857, FILED 5-23-2013, REG. NO. 011840857, DATED 10-15-2013, EXPIRES 5-23-2023.

OWNER OF U.S. REG. NOS. 4,345,221, 4,345,223 AND OTHERS.

NO CLAIM IS MADE TO THE EXCLUSIVE RIGHT TO USE "THIN LAYERS ANALYSIS AND CHARACTERISATION", APART FROM THE MARK AS SHOWN.

THE COLOR(S) YELLOW, BLACK, WHITE AND RED IS/ARE CLAIMED AS A FEATURE OF THE MARK.

THE MARK CONSISTS OF A YELLOW SQUARE WITH THE WORDING "E-TLAC" APPEARING IN THE LOWER PORTION OF THE SQUARE, IN BLACK, AND A BLACK SIX-LEGGED FIRE-BREATHING DOG, HAVING A WHITE EYE, WHITE COLLAR, AND WHITE AREA BENEATH ITS TAIL, WITH THE FIRE BEING SHOWN IN THE COLOR RED; TO THE RIGHT OF THE YELLOW SQUARE IS A WHITE SQUARE OUTLINED IN BLACK WITH THE WORDING "ENI THIN LAYERS ANALYSIS AND CHARACTERISATION" APPEARING IN BLACK.

**CLASS 9—ELECTRICAL AND SCIENTIFIC APPARATUS**

FOR COMPUTER SOFTWARE FOR DATA PROCESSING (U.S. CLS. 21, 23, 26, 36 AND 38).

**CLASS 42—SCIENTIFIC AND COMPUTER SERVICES**

FOR SCIENTIFIC AND TECHNOLOGICAL SERVICES, NAMELY, SCIENTIFIC RESEARCH AND DESIGN IN THE FIELD OF PETROLEUM AND ENERGY SOURCES; SERVICES OF A CHEMICAL ENGINEER CONSISTING OF THE PREPARATION OF METHODOLOGIES FOR THE HYDROCARBON, PETROLEUM, AND ENERGY INDUSTRIES; PREPARATION OF MODELS, NAMELY, COMPUTER MODELING SERVICES IN THE FIELD OF HYDROCARBONS, PETROLEUM AND ENERGY SOURCES; ESTIMATION SERVICES, NAMELY, PREPARING GEOLOGICAL ESTIMATIONS IN THE FIELD OF HYDROCARBONS, PETROLEUM AND ENERGY SOURCES; ANALYSIS AND TESTING OF HYDROCARBONS, PETROLEUM, AND OTHER GEOLOGICALLY EXTRACTABLE ENERGY SOURCES (U.S. CLS. 100 AND 101).

LIEF MARTIN, EXAMINING ATTORNEY

SN 86-087,103. CUBIC CORPORATION, SAN DIEGO, CA. FILED 10-9-2013.

## GLOBAL. INNOVATIVE. TRUSTED.

THE MARK CONSISTS OF STANDARD CHARACTERS WITHOUT CLAIM TO ANY PARTICULAR FONT, STYLE, SIZE, OR COLOR.

NO CLAIM IS MADE TO THE EXCLUSIVE RIGHT TO USE "GLOBAL", APART FROM THE MARK AS SHOWN.

**CLASS 9—ELECTRICAL AND SCIENTIFIC APPARATUS**

FOR COMPUTER HARDWARE AND SOFTWARE FOR PROCESSING, AUTHORIZING, AND TRANSFERRING DATA BETWEEN POINT OF SALE DEVICES AND CONTACTLESS SMARTCARDS; COMPUTER HARDWARE AND SOFTWARE FOR CONFIGURING AND PROCESSING SMARTCARDS; TRANSPORT TICKETING COMPUTER HARDWARE AND SOFTWARE; COMPUTER SOFTWARE AND HARDWARE FOR THE SALE AND PURCHASE OF TICKETS; ELECTRONIC FARE COLLECTION EQUIPMENT SOLD AS A UNIT, NAMELY, SMART CARDS AND MAGNETIC ENCODED CARDS CONTAINING PROGRAMMING FOR USE WITH ELECTRONIC FARE COLLECTION, FARE BOXES, TICKET MACHINES, MAGNETIC CARD PROCESSORS, SMART CARD READERS, TICKET PROCESSORS, TURNSTILES, ELECTRONIC CONTROL PROCESSORS; SOFTWARE FOR FINANCIAL ANALY-

SIS AND ACCOUNTING IN THE FIELD OF CONSUMER SPENDING; AUTOMATED PARKING SYSTEMS, NAMELY, COMPUTER SOFTWARE TO RUN PARKING FEE COLLECTION DEVICES AND COMPUTER HARDWARE, FARE BOXES, TICKET MACHINES, MAGNETIC CARD PROCESSORS, SMART CARD READERS, TICKET PROCESSORS, ELECTRONIC CONTROL PROCESSORS, SMART CARDS AND MAGNETIC ENCODED CARDS CONTAINING PROGRAMMING FOR USE WITH AUTOMATED PARKING; PERSONNEL LOCATOR COMPUTER HARDWARE AND SOFTWARE; COMBAT SIMULATORS FOR TRAINING PURPOSES; TRAINING SYSTEMS FOR AIRCRAFT, VEHICLES, WEAPONS AND PERSONNEL IN LIVE, CONSTRUCTIVE AND VIRTUAL ENVIRONMENTS CONSISTING OF TRANSCIEVERS, LASERS NOT FOR MEDICAL USE, GPS TECHNOLOGY IN THE NATURE OF A GLOBAL POSITIONING SYSTEM, DATA LINK TECHNOLOGY IN THE NATURE OF ELECTRONIC AND OPTICAL COMMUNICATIONS INSTRUMENTS AND COMPONENTS, NAMELY, OPTICAL DATA LINKS, ELECTRONIC ENCRYPTION UNITS, RADIO FREQUENCY IDENTIFICATION TAG READERS, WIRELESS COMMUNICATION TRANSPONDERS AND RADIO RECEIVERS; COMPUTER HARDWARE, ELECTRONIC DISPLAY INTERFACES; COMPUTER SOFTWARE FOR TRACKING PEOPLE AND VEHICLES, COLLECTING RECORDING AND REPLAYING INSTRUMENTATION DATA, PROVIDING AUTOMATED PROCESSING AND ANALYSIS OF INSTRUMENTATION DATA, COMPUTER NETWORKING, MONITORING HIT/MISS NOTIFICATIONS, SCORING THE OUTCOME OF WEAPONS ENGAGEMENTS AND SIMULATIONS OF KINETIC AND NON-KINETIC THREAT WEAPONS SYSTEMS; ELECTRONIC APPARATUS FOR TRACKING PEOPLE AND VEHICLES, COLLECTING, RECORDING AND REPLAYING INSTRUMENTATION DATA, PROVIDING AUTOMATED PROCESSING AND ANALYSIS OF INSTRUMENTATION DATA, NETWORKING, MONITORING HIT/MISS NOTIFICATIONS, SCORING THE OUTCOME OF WEAPONS ENGAGEMENTS AND SIMULATIONS OF KINETIC AND NON-KINETIC THREAT WEAPONS SYSTEMS; COMPUTER PERIPHERAL EQUIPMENT FOR TRACKING PEOPLE AND VEHICLES, COLLECTING, RECORDING AND REPLAYING INSTRUMENTATION DATA, PROVIDING AUTOMATED PROCESSING AND ANALYSIS OF INSTRUMENTATION DATA, COMPUTER NETWORKING, MONITORING HIT/MISS NOTIFICATIONS, SCORING THE OUTCOME OF WEAPONS ENGAGEMENTS AND SIMULATIONS OF KINETIC AND NON-KINETIC THREAT WEAPONS SYSTEMS, ALL OF THE FOREGOING FOR EDUCATION, TRAINING DEVELOPMENT, MANAGEMENT SUPPORT, AND OPERATIONS AND MAINTENANCE SUPPORT; COMMUNICATION AND ELECTRONIC PRODUCTS FOR INTELLIGENCE, SURVEILLANCE, SEARCH-AND-RESCUE, AIR TRAFFIC CONTROL AND MILITARY/CIVIL COMMUNICATION MARKETS CONSISTING OF RADIO AND OPTICAL DATA LINKS FOR TRANSFERRING RADAR, VIDEO, AND OTHER INFORMATION OBTAINED VIA SENSORS; RADIOS; RADIO, ELECTRONIC OPTICAL AND MOBILE DATA TRANSMITTERS; RADIO RECEIVERS, FILTERS, AND EXCITERS; HIGH POWER AMPLIFIERS, ANTENNAS, DIRECTION-FINDING TRANSPONDERS AND RADIO RECEIVERS, COMPUTERS, COMPUTER DISPLAY SCREENS AND MONITORS AND SOFTWARE TO TRANSMIT, NETWORK, DETECT, INTERCEPT, ANALYZE, DISTRIBUTE AND PROCESS INTELLIGENCE AND COMMUNICATIONS SIGNALS; COMPUTER HARDWARE AND SOFTWARE FOR SURVEILLANCE; ELECTRONIC COMMUNICATIONS COMPUTER HARDWARE AND SOFTWARE, TRANSPONDERS AND RADIO RECEIVERS; COMPUTER HARDWARE AND SOFTWARE, TRANSPONDERS AND RADIO RECEIVERS FOR USE WITH SHELTERS AND UNMANNED AERIAL VEHICLES; COMPUTER HARDWARE AND SOFTWARE FOR THE DELIVERY OF AIR-TO-AIR, AIR-TO-GROUND, AIR-TO-WATER, GROUND-TO-GROUND AND GROUND-TO-WATER MISSILES; COMPUTER HARDWARE AND SOFTWARE FOR THE SIMULATION OF, AND REAL TIME DISSEMINATION AND DISPLAY OF THE DELIVERY OF SURVEILLANCE APPARATUS AND EXPLOSIVES; AUTOMATIC FARE COLLECTION SYSTEMS FOR RAIL, BUS AND PARKING LOTS SOLD AS A UNIT, CONSISTING OF ENCODED SMART CARDS CONTAINING PROGRAMMING FOR FARE COLLECTION, MAGNETIC ENCODED CARDS CONTAINING PROGRAMMING FOR FAIR COLLECTION, CARD PRO-

DUCTION MACHINES USED TO PRODUCE THE FOREGOING ENCODED SMART CARDS AND MAGNETIC ENCODED CARDS, PAY STATIONS, TICKET ISSUING AND VALIDATING MACHINES, ELECTRONIC PROCESSORS OF SMART CARDS AND TICKETS AND PAYMENTS, ELECTRONIC POINT OF SALE DEVICES, SMART CARD READERS, FARE BOXES, ENTRY/EXIT TERMINALS, ENTRY/EXIT GATES, AND WIRELESS COMMUNICATION TRANSPONDERS AND RADIO RECEIVERS; COMPUTER HARDWARE AND SOFTWARE FOR TRANSIT AND PARKING FINANCIAL ANALYSIS AND ACCOUNTING, MOTION SENSORS, ANTI-INTRUSION ALARMS AND FIRE ALARMS, CAMERAS, AUDIO AND VIDEO RECORDERS, AND EXPLOSIVES DETECTORS FOR SECURITY; CALORIMETRIC WATTMETERS, ELECTRONIC TRACKING EQUIPMENT, TRACKING SYSTEMS, INFORMATION HANDLING SYSTEMS, PRECISION REFERENCES, VOLTMETERS, OHMMETERS, RATIOMETERS, SOLID STATE COMMUTATOR SCANNERS, ELECTRONIC DISTANCE MEASURING EQUIPMENT, ELECTRONIC ANGLE MEASURING EQUIPMENT AND ELECTRONIC SURVEYING EQUIPMENT, AND PARTS AND ACCESSORIES THEREFOR; AMPLIFIERS, DC AMPLIFIERS, DIFFERENCE AMPLIFIERS, POWER SUPPLIES, PRE-AMPLIFIERS, KLYSTRON POWER SUPPLIES, CIRCULATING LIQUID HEAT EXCHANGERS, TRANSPONDERS, TRANSMITTERS, RECEIVERS, COMMUNICATIONS EQUIPMENT, AND PARTS AND ACCESSORIES THEREFOR (U.S. CLS. 21, 23, 26, 36 AND 38).

#### **CLASS 35—ADVERTISING AND BUSINESS**

FOR BUSINESS MANAGEMENT FOR OTHERS PERTAINING TO COMBAT TRAINING SYSTEMS; BUSINESS CONSULTING SERVICES IN THE FIELD OF AUTOMATED PARKING SYSTEMS (U.S. CLS. 100, 101 AND 102).

#### **CLASS 36—INSURANCE AND FINANCIAL**

FOR FINANCIAL ANALYSIS, CONSULTATION AND CLEARING HOUSE SERVICES IN THE FIELD OF ELECTRONIC FARE COLLECTION SYSTEMS, AUTOMATED PARKING SYSTEMS AND PUBLIC TRANSPORTATION; FINANCIAL CONSULTING SERVICES IN THE FIELD OF ELECTRONIC FARE COLLECTION SYSTEMS, AUTOMATED PARKING SYSTEMS AND PUBLIC TRANSPORTATION (U.S. CLS. 100, 101 AND 102).

#### **CLASS 37—CONSTRUCTION AND REPAIR**

FOR REPAIR AND MAINTENANCE FOR OTHERS OF COMBAT TRAINING SYSTEMS; COMPUTER HARDWARE TECHNICAL SUPPORT SERVICES FOR THE INSTALLATION AND MAINTENANCE OF COMBAT SIMULATION TRAINING SYSTEMS, WEAPONS EFFECTS ANALYSIS SYSTEMS, AND WEAPONS SIMULATION SYSTEMS, NAMELY, TROUBLESHOOTING IN THE NATURE OF THE REPAIR OF COMPUTER HARDWARE; CONSULTING SERVICES WITH REGARD TO THE INSTALLATION AND MAINTENANCE OF ELECTRONIC FARE COLLECTION SYSTEMS; CONSULTING RELATED TO THE INSTALLATION AND MAINTENANCE OF COMPUTER HARDWARE SYSTEMS FOR PROCESSING, AUTHORIZING AND TRANSFERRING DATA BETWEEN POINT OF SALE DEVICES AND CONTACTLESS SMARTCARDS; CONSULTING RELATED TO THE INSTALLATION AND MAINTENANCE OF COMPUTER HARDWARE RELATED TO SMARTCARDS AND COMPUTER HARDWARE RELATED TO THE SALE AND PURCHASE OF TICKETS; COMPUTER HARDWARE TECHNICAL SUPPORT SERVICES FOR THE MAINTENANCE OF AUTOMATIC FARE COLLECTION SYSTEMS FOR RAIL, BUS, AND PARKING LOTS, NAMELY, TROUBLESHOOTING IN THE NATURE OF THE REPAIR OF COMPUTER HARDWARE (U.S. CLS. 100, 103 AND 106).

#### **CLASS 40—MATERIAL TREATMENT**

FOR CUSTOM MANUFACTURE OF ELECTRONIC FARE COLLECTION SYSTEMS AND AUTOMATED PARKING SYSTEMS; MANUFACTURING SERVICES FOR OTHERS IN THE FIELD OF COMBAT TRAINING SYSTEMS (U.S. CLS. 100, 103 AND 106).

**CLASS 41—EDUCATION AND ENTERTAINMENT**

FOR EDUCATIONAL SERVICES, NAMELY CONDUCTING CLASSES, SEMINARS, CONFERENCES AND WORKSHOPS RELATING TO THE OPERATION AND MAINTENANCE OF COMBAT TRAINING SYSTEMS; EDUCATIONAL SERVICES, NAMELY, TRAINING RELATED TO THE DEVELOPMENT AND IMPLEMENTATION OF SIMULATED COMBAT TRAINING AND CONSEQUENCE MANAGEMENT EXERCISES, NAMELY, EXERCISES RELATED TO RESPONDING TO LIFE THREATENING OR DESTRUCTIVE EVENTS; EDUCATIONAL SERVICES, NAMELY, TRAINING RELATED TO ALLIED FORCE MODERNIZATION FOR COMBAT, SECURITY AND PEACEKEEPING MISSIONS; EDUCATIONAL SERVICES, NAMELY, PROVIDING CLASSES, SEMINARS AND WORKSHOPS IN THE FIELD OF MILITARY COMBAT, SECURITY AND PEACEKEEPING MISSIONS (U.S. CLS. 100, 101 AND 107).

**CLASS 42—SCIENTIFIC AND COMPUTER SERVICES**

FOR MILITARY TECHNICAL RESEARCH AND DEVELOPMENT FOR OTHERS IN THE FIELD OF TECHNICAL WARFARE COMMUNICATIONS; ENGINEERING TECHNICAL SUPPORT SERVICES AND SOFTWARE TECHNICAL SUPPORT SERVICES FOR THE DESIGN, DEVELOPMENT, INSTALLATION, AND MAINTENANCE OF COMPUTER SOFTWARE FOR COMBAT SIMULATION TRAINING SYSTEMS, WEAPONS EFFECTS ANALYSIS SYSTEMS, AND WEAPONS SIMULATION SYSTEMS, NAMELY, TROUBLESHOOTING OF SOFTWARE PROBLEMS; CONSULTATION AND ADVICE RELATED TO ALLIED FORCE MODERNIZATION FOR COMBAT, SECURITY AND PEACEKEEPING MISSIONS, NAMELY, CONSULTATION AND ADVICE REGARDING THE DESIGN AND DEVELOPMENT OF MODERN VEHICLES AND COMPUTER SYSTEMS FOR COMBAT, SECURITY AND PEACEKEEPING MISSIONS; COMPUTER HARDWARE TECHNICAL SUPPORT SERVICES FOR THE DESIGN, DEVELOPMENT, AND OPERATION OF COMBAT SIMULATION TRAINING SYSTEMS, WEAPONS EFFECTS ANALYSIS SYSTEMS, AND WEAPONS SIMULATION SYSTEMS, NAMELY, TROUBLESHOOTING IN THE NATURE OF DIAGNOSING COMPUTER HARDWARE PROBLEMS; CUSTOM SOFTWARE DESIGN FOR OTHERS; TECHNICAL CONSULTATION SERVICES RELATED TO THE DESIGN OF ELECTRONIC FARE COLLECTION SYSTEMS AND AUTOMATED PARKING SYSTEMS USED IN PUBLIC TRANSPORTATION; ENGINEERING AND DESIGN SERVICES IN THE FIELDS OF AUTOMATIC REVENUE COLLECTION SYSTEMS, SURVEYING AND ELECTRONIC MEASURING EQUIPMENT, COMMUNICATION SYSTEMS, FLIGHT COLLISION WARNING SYSTEMS, AND ELECTRONIC TRACKING SYSTEMS FOR OTHERS; CONSULTING RELATED TO THE DESIGN, DEVELOPMENT, ENGINEERING, OPERATION AND MAINTENANCE OF SOFTWARE FOR COMPUTER SYSTEMS FOR PROCESSING, AUTHORIZING AND TRANSFERRING DATA BETWEEN POINT OF SALE DEVICES AND CONTACTLESS SMARTCARDS, SOFTWARE RELATED TO SMARTCARDS, TRANSPORT TICKETING COMPUTER SYSTEMS AND SOFTWARE RELATED TO THE SALE AND PURCHASE OF TICKETS; ENGINEERING TECHNICAL SUPPORT SERVICES AND SOFTWARE TECHNICAL SUPPORT SERVICES FOR THE DESIGN, DEVELOPMENT AND MAINTENANCE OF COMPUTER SOFTWARE FOR AUTOMATIC FARE COLLECTION SYSTEMS FOR RAIL, BUS, AND PARKING LOTS, NAMELY, TROUBLESHOOTING OF SOFTWARE PROBLEMS; CONSULTING SERVICES WITH REGARD TO THE DESIGN AND DEVELOPMENT OF ELECTRONIC FARE COLLECTION SYSTEMS; CONSULTING RELATED TO THE DESIGN, DEVELOPMENT, ENGINEERING AND OPERATION OF COMPUTER HARDWARE RELATED TO SMARTCARDS AND COMPUTER HARDWARE RELATED TO THE SALE AND PURCHASE OF TICKETS; COMPUTER HARDWARE TECHNICAL SUPPORT SERVICES FOR THE DESIGN, DEVELOPMENT, AND OPERATION OF AUTOMATIC FARE COLLECTION SYSTEMS FOR RAIL, BUS, AND PARKING LOTS, NAMELY, TROUBLESHOOTING IN THE NATURE OF DIAGNOSING COMPUTER HARDWARE PROBLEMS; COMPUTER HARDWARE AND SOFTWARE CONSULTING SERVICES IN THE FIELD OF AUTOMATED PARKING SYSTEMS (U.S. CLS. 100 AND 101).

WARE CONSULTING SERVICES IN THE FIELD OF AUTOMATED PARKING SYSTEMS (U.S. CLS. 100 AND 101).

**CLASS 45—PERSONAL AND LEGAL SERVICES**

FOR SECURITY CONSULTATION AND SECURITY ADVICE RELATED TO THE DEVELOPMENT AND IMPLEMENTATION OF SIMULATED COMBAT TRAINING AND CONSEQUENCE MANAGEMENT EXERCISES, NAMELY, EXERCISES RELATED TO RESPONDING TO LIFE THREATENING OR DESTRUCTIVE EVENTS; SECURITY CONSULTATION AND SECURITY ADVICE RELATED TO ALLIED FORCE MODERNIZATION FOR COMBAT, SECURITY AND PEACEKEEPING MISSIONS (U.S. CLS. 100 AND 101).

CAITLIN WATTS-FITZGERALD, EXAMINING ATTORNEY

SN 86-087,137. SATA GMBH & CO. KG, KORNWESTHEIM, FED REP GERMANY, FILED 10-9-2013.

rotawall

THE MARK CONSISTS OF STANDARD CHARACTERS WITHOUT CLAIM TO ANY PARTICULAR FONT, STYLE, SIZE, OR COLOR.

PRIORITY CLAIMED UNDER SEC. 44(D) ON ERP NCMNTY TM OFC APPLICATION NO. 11727716, FILED 4-10-2013, REG. NO. 11727716, DATED 9-18-2013, EXPIRES 4-10-2023.

**CLASS 16—PAPER GOODS AND PRINTED MATTER**

FOR CARDBOARD CONTAINERS; PACKAGING MATERIALS MADE OF CARDBOARD; BOXES OF CARDBOARD OR PAPER (U.S. CLS. 2, 5, 22, 23, 29, 37, 38 AND 50).

**CLASS 20—FURNITURE AND ARTICLES NOT OTHERWISE CLASSIFIED**

FOR NONMETAL AND NON-PAPER CONTAINERS FOR STORAGE PURPOSES FOR COMMERCIAL USE; CONTAINERS NOT OF METAL FOR COMMERCIAL USE; CLOSURES, NOT OF METAL, FOR CONTAINERS; CONTAINERS MADE OF PLASTIC FOR COMMERCIAL USE; RACKS FOR STORAGE PURPOSES (U.S. CLS. 2, 13, 22, 25, 32 AND 50).

**CLASS 39—TRANSPORTATION AND STORAGE**

FOR STORAGE OF GOODS; PACKAGING AND STORAGE OF GOODS; PHYSICAL STORAGE OF COMPONENTS, NAMELY, BEAKERS, BOWLS, CANS, CUPS, GOBLETs, MUGS, TUMBLERS, LIDS, CAPS, CASK COVERS, UPPER SHELLS, CLOSURE HEADS, CLOSURE PLATES, INSERTS, LINERS, FILTERS, SIEVES, MICROSTRAINERS, PIPES AND TUBES; CONSULTANCY SERVICES RELATING TO WAREHOUSING; PROVIDING A WEBSITE FEATURING INFORMATION ABOUT STORAGE OF GOODS; STORAGE OF COMMERCIAL GOODS; ADVICE AND CONSULTATION REGARDING STORAGE OF GOODS (U.S. CLS. 100 AND 105).

CYNTHIA RINALDI, EXAMINING ATTORNEY

SN 86-087,204. SATA GMBH & CO. KG, KORNWESTHEIM, FED REP GERMANY, FILED 10-9-2013.

## RPS rotafloor

THE MARK CONSISTS OF STANDARD CHARACTERS WITHOUT CLAIM TO ANY PARTICULAR FONT, STYLE, SIZE, OR COLOR.

PRIORITY CLAIMED UNDER SEC. 44(D) ON ERP N CMNTY TM OFC APPLICATION NO. 11727823, FILED 4-10-2013, REG. NO. 11727823, DATED 8-9-2013, EXPIRES 4-10-2023.

OWNER OF U.S. REG. NO. 2,981,217.

### CLASS 16—PAPER GOODS AND PRINTED MATTER

FOR CARDBOARD CONTAINERS; PACKAGING MATERIALS MADE OF CARDBOARD; BOXES OF CARDBOARD OR PAPER (U.S. CLS. 2, 5, 22, 23, 29, 37, 38 AND 50).

### CLASS 20—FURNITURE AND ARTICLES NOT OTHERWISE CLASSIFIED

FOR NONMETAL AND NON-PAPER CONTAINERS FOR STORAGE PURPOSES FOR COMMERCIAL USE; CONTAINERS NOT OF METAL FOR COMMERCIAL USE; CLOSURES, NOT OF METAL, FOR CONTAINERS; CONTAINERS MADE OF PLASTIC FOR COMMERCIAL USE; RACKS FOR STORAGE PURPOSES (U.S. CLS. 2, 13, 22, 25, 32 AND 50).

### CLASS 39—TRANSPORTATION AND STORAGE

FOR STORAGE OF GOODS; PACKAGING AND STORAGE OF GOODS; PHYSICAL STORAGE OF COMPONENTS, NAMELY, BEAKERS, BOWLS, CANS, CUPS, GOBLETS, MUGS, TUMBLERS, LIDS, CAPS, CASK COVERS, UPPER SHELLS, CLOSURE HEADS, CLOSURE PLATES, INSERTS, LINERS, FILTERS, SIEVES, MICRO-STRAINERS, PIPES AND TUBES; CONSULTANCY SERVICES RELATING TO WAREHOUSING; PROVIDING A WEBSITE FEATURING INFORMATION ABOUT STORAGE OF GOODS; STORAGE OF COMMERCIAL GOODS; ADVICE AND CONSULTATION REGARDING STORAGE OF GOODS (U.S. CLS. 100 AND 105).

CYNTHIA RINALDI, EXAMINING ATTORNEY

SN 86-087,441. AMCAN BEARING USA, INC., ADDISON, IL, FILED 10-9-2013.

## AMCAN BEARING

THE MARK CONSISTS OF STANDARD CHARACTERS WITHOUT CLAIM TO ANY PARTICULAR FONT, STYLE, SIZE, OR COLOR.

NO CLAIM IS MADE TO THE EXCLUSIVE RIGHT TO USE "BEARING", APART FROM THE MARK AS SHOWN.

### CLASS 6—METAL GOODS

FOR METAL LOCK NUTS; METAL LOCK NUT WASHERS; STEEL BALLS AND STEEL ROLLERS FOR BEARINGS (U.S. CLS. 2, 12, 13, 14, 23, 25 AND 50).

FIRST USE 4-1-1998; IN COMMERCE 4-1-1998.

### CLASS 7—MACHINERY

FOR CAST IRON, DUCTILE IRON, THERMOPLASTIC AND STAINLESS STEEL MACHINE PARTS, NAMELY, BALL BEARINGS, ROLLER BEARINGS, AND FLANGED BALL AND ROLLER BEARINGS; MACHINE PARTS IN THE NATURE OF MOUNTED UNITS FOR BEARINGS, NAMELY, PILLOW BLOCKS, FLANGE BLOCKS, CARTRIDGE UNITS, TAKE-UP UNITS AND HANGER UNITS; ACCESSORIES FOR USE WITH BALL AND ROLLER BEARINGS, NAMELY, ADAPTER SLEEVES; NON-LAND VEHICLE POWER TRANSMISSION COMPONENTS FOR MACHINES, NAMELY, ROLLER CHAINS AND ATTACHMENT PARTS, SPROCKETS, HUBS, SHAFT COLLARS, PULLEYS, SHEAVES, GEARS, BUSHINGS, COUPLINGS, OIL SEALS, V RINGS AND O RINGS, BELTS AND BELTINGS (U.S. CLS. 13, 19, 21, 23, 31, 34 AND 35).

FIRST USE 4-1-1998; IN COMMERCE 4-1-1998.

CURTIS FRENCH, EXAMINING ATTORNEY

SN 86-087,592. HARMAN INTERNATIONAL INDUSTRIES, INCORPORATED, NORTHRIDGE, CA. FILED 10-9-2013.

## SOUNDCHECK

THE MARK CONSISTS OF STANDARD CHARACTERS WITHOUT CLAIM TO ANY PARTICULAR FONT, STYLE, SIZE, OR COLOR.

### CLASS 35—ADVERTISING AND BUSINESS

FOR PRODUCT DEMONSTRATIONS RELATING TO MUSICAL INSTRUMENTS, SPEAKERS, AMPLIFIERS, SIGNAL PROCESSING EQUIPMENT, DIGITAL EFFECTS PEDALS AND OTHER AUDIO EQUIPMENT (U.S. CLS. 100, 101 AND 102).

### CLASS 41—EDUCATION AND ENTERTAINMENT

FOR ENTERTAINMENT SERVICES IN THE NATURE OF LIVE MUSICAL PERFORMANCES (U.S. CLS. 100, 101 AND 107).

HENRY S. ZAK, EXAMINING ATTORNEY

SN 86-087,787. SOFTOUCH TECHNOLOGIES LTD, GOREY, IRELAND, FILED 10-10-2013.

## WORQ

THE MARK CONSISTS OF STANDARD CHARACTERS WITHOUT CLAIM TO ANY PARTICULAR FONT, STYLE, SIZE, OR COLOR.

**CLASS 9—ELECTRICAL AND SCIENTIFIC APPARATUS**

FOR DOWNLOADABLE MULTI-PLATFORM BUSINESS MANAGEMENT SOFTWARE FOR CENTRALIZING BUSINESS PROCESSES SUCH AS CONTACT MANAGEMENT, JOB AND TIME MANAGEMENT, BUDGETING, SCHEDULING, ORDER PROCESSING, INVENTORY MANAGEMENT, INVOICING, ACCOUNTING, POINT-OF-SALE, EMPLOYEE MANAGEMENT, AND OTHER AREAS OF BUSINESS MANAGEMENT (U.S. CLS. 21, 23, 26, 36 AND 38).

FIRST USE 8-21-2013; IN COMMERCE 8-21-2013.

**CLASS 42—SCIENTIFIC AND COMPUTER SERVICES**

FOR PROVIDING ONLINE, NON-DOWNLOADABLE MULTI-PLATFORM BUSINESS MANAGEMENT SOFTWARE FOR CENTRALIZING BUSINESS PROCESSES SUCH AS CONTACT MANAGEMENT, JOB AND TIME MANAGEMENT, BUDGETING, SCHEDULING, ORDER PROCESSING, INVENTORY MANAGEMENT, INVOICING, ACCOUNTING, POINT-OF-SALE, EMPLOYEE MANAGEMENT, AND OTHER AREAS OF BUSINESS MANAGEMENT (U.S. CLS. 100 AND 101).

FIRST USE 8-21-2013; IN COMMERCE 8-21-2013.

MICHAEL ENGEL, EXAMINING ATTORNEY

SN 86-088,370. WHEATLEY, TERRY, HUGHSON, CA. FILED 10-10-2013.

**GODDESS OF THE VINE**

THE MARK CONSISTS OF STANDARD CHARACTERS WITHOUT CLAIM TO ANY PARTICULAR FONT, STYLE, SIZE, OR COLOR.

**CLASS 3—COSMETICS AND CLEANING PREPARATIONS**

FOR COSMETICS (U.S. CLS. 1, 4, 6, 50, 51 AND 52).

**CLASS 33—WINES AND SPIRITS**

FOR ALCOHOLIC BEVERAGES EXCEPT BEERS (U.S. CLS. 47 AND 49).

ELLEN PERKINS, EXAMINING ATTORNEY

SN 86-089,234. DANCING E, LLC, DBA KLEVER, DURHAM, NC. FILED 10-11-2013.



THE MARK CONSISTS OF THE WORD "KLEVER" IN STYLIZED LOWER CASE LETTERS WITH AN UNDERSCORE BEGINNING BELOW THE "L" AND CONTINUING TWO SPACES TO THE RIGHT OF THE WORD, AND AN INVERTED "V" IMMEDIATELY BELOW THE "V" IN "KLEVER" DEPICTING A FULCRUM POINT.

**CLASS 35—ADVERTISING AND BUSINESS**

FOR BUSINESS CONSULTING SERVICES IN THE FIELD OF KNOWLEDGE MANAGEMENT; PROVIDING AN INTERACTIVE WEBSITE FEATURING INFORMATION IN THE FIELD OF BUSINESS MANAGEMENT, SPECIFICALLY KNOWLEDGE MANAGEMENT (U.S. CLS. 100, 101 AND 102).

FIRST USE 7-2-2013; IN COMMERCE 7-2-2013.

**CLASS 41—EDUCATION AND ENTERTAINMENT**

FOR WORKSHOPS AND SEMINARS IN THE FIELD OF KNOWLEDGE MANAGEMENT, AND DISTRIBUTING COURSE MATERIAL IN CONNECTION THEREWITH; PROVIDING ONLINE NON-DOWNLOADABLE AUDIO AND VIDEO PRESENTATIONS IN THE FIELD OF KNOWLEDGE MANAGEMENT (U.S. CLS. 100, 101 AND 107).

FIRST USE 7-2-2013; IN COMMERCE 7-2-2013.

**CLASS 42—SCIENTIFIC AND COMPUTER SERVICES**

FOR PROVIDING A WEBSITE FEATURING TECHNOLOGY ALLOWING USERS TO ASSESS THEIR ORGANIZATION'S KNOWLEDGE MANAGEMENT READINESS AND FOR DEVELOPMENT OF A PLAN FOR IMPROVED KNOWLEDGE DISCOVERY, RETENTION AND SHARING (U.S. CLS. 100 AND 101).

FIRST USE 7-2-2013; IN COMMERCE 7-2-2013.

EMILY CARLSEN, EXAMINING ATTORNEY

SN 86-089,451. ROYAL STAR FOODS LTD., TIGNISH, P.E.I., CANADA, FILED 10-11-2013.

**ROYAL STAR**

THE MARK CONSISTS OF STANDARD CHARACTERS WITHOUT CLAIM TO ANY PARTICULAR FONT, STYLE, SIZE, OR COLOR.

PRIORITY CLAIMED UNDER SEC. 44(D) ON CANADA APPLICATION NO. 1622096, FILED 4-11-2013, REG. NO. TMA879629, DATED 6-6-2014, EXPIRES 6-6-2029.

**CLASS 29—MEATS AND PROCESSED FOODS**

FOR SEAFOOD, NAMELY, WHOLE COOKED LOBSTER FROZEN IN BRINE, FROZEN WHOLE COOKED LOBSTER IN SHELL, FROZEN WHOLE COOKED LOBSTER VACUUM PACKED, WHOLE RAW LOBSTER FROZEN IN BRINE, FROZEN WHOLE BLANCHED LOBSTER, FROZEN WHOLE LOBSTER BLANCHED AND VACUUM PACKED, FROZEN RAW LOBSTER TAILS, FROZEN BLANCHED LOBSTER TAILS, FROZEN COOKED LOBSTER TAILS, FROZEN COOKED LOBSTER MEAT, FROZEN LOBSTER MINCED MEAT, FROZEN LOBSTER CONCENTRATE, FROZEN COOKED LOBSTER IN SHELL (U.S. CL. 46).

FIRST USE 1-0-1995; IN COMMERCE 1-0-1995.

**CLASS 35—ADVERTISING AND BUSINESS**

FOR WHOLESALE AND RETAIL STORE SERVICES FEATURING FISH (U.S. CLS. 100, 101 AND 102).

FIRST USE 1-0-1995; IN COMMERCE 1-0-1995.

JAY FLOWERS, EXAMINING ATTORNEY

SN 86-089,643. AESYNT INCORPORATED, CRANBERRY, PA. FILED 10-11-2013.

SN 86-090,298. SMITH, CANDACE, R., LOS ANGELES, CA. AND BALDINI, CAMILLE, D., MONTAGUE, CA. AND DAVIS, SHARONDA, Y., SHERMAN OAKS, CA. FILED 10-13-2013.

aesynt

THE MARK CONSISTS OF THE WORD "AESYNT" IN STYLIZED FONT.

**CLASS 7—MACHINERY**

FOR AUTOMATED ROBOTIC STORAGE AND RETRIEVAL SYSTEM NOT FOR LABORATORY USE CONSISTING PRIMARILY OF MECHANICAL MACHINERY, NAMELY, A MULTI-AXIS ROBOTIC AUTOMATION FOR INVENTORY HANDLING SOLUTIONS WITHIN THE PHARMACEUTICAL AND HEALTHCARE INDUSTRY, COMPUTER HARDWARE AND SOFTWARE ALL SOLD TOGETHER AS A UNIT, FOR SORTING, STORING, IDENTIFYING, DISPENSING, STANDARDIZING, TRACKING AND REPLENISHING MEDICATIONS AND SUPPLIES FOR ADMINISTERING MEDICATIONS (U.S. CLS. 13, 19, 21, 23, 31, 34 AND 35).

**CLASS 9—ELECTRICAL AND SCIENTIFIC APPARATUS**

FOR COMPUTER SOFTWARE AND HARDWARE THAT ASSISTS HOSPITAL AND HEALTH SYSTEM PERSONNEL AND PHARMACISTS IN SORTING, STORING, IDENTIFYING, DISPENSING, STANDARDIZING, TRACKING AND REPLENISHING MEDICATIONS AND SUPPLIES FOR ADMINISTERING MEDICATIONS; STORAGE CABINET SPECIALLY ADAPTED FOR USE WITH COMPUTER HARDWARE AND COMPUTER SOFTWARE ALL SOLD TOGETHER AS A UNIT THAT ASSISTS HOSPITAL AND HEALTH SYSTEM PERSONNEL AND PHARMACISTS IN SORTING, STORING, IDENTIFYING, DISPENSING, STANDARDIZING, TRACKING AND REPLENISHING MEDICATIONS AND SUPPLIES FOR ADMINISTERING MEDICATIONS; MACHINES FOR DISPENSING PRE-DETERMINED DOSAGES OF MEDICATION (U.S. CLS. 21, 23, 26, 36 AND 38).

**CLASS 35—ADVERTISING AND BUSINESS**

FOR INVENTORY CONTROL, NAMELY, DESIGNING, BUILDING, IMPLEMENTING AND OPTIMIZING SYSTEMS AND SERVICES FOR MEDICATION AND PHARMACEUTICAL INVENTORY MANAGEMENT; TRACKING OF PACKAGES CONTAINING MEDICATIONS AND SUPPLIES FOR ADMINISTERING MEDICATIONS FOR BUSINESS PURPOSES (U.S. CLS. 100, 101 AND 102).

**CLASS 39—TRANSPORTATION AND STORAGE**

FOR DELIVERY OF MEDICATION AND SUPPLIES FOR WAREHOUSING, STORING, DISPENSING AND ADMINISTERING MEDICATION (U.S. CLS. 100 AND 105).

**CLASS 42—SCIENTIFIC AND COMPUTER SERVICES**

FOR DESIGN AND DEVELOPMENT OF COMPUTER HARDWARE AND SOFTWARE THAT ENABLES USERS TO IMPLEMENT AND OPTIMIZE SYSTEMS AND SERVICES FOR MEDICATION AND PHARMACEUTICAL INVENTORY MANAGEMENT (U.S. CLS. 100 AND 101).  
DEBORAH MEINERS, EXAMINING ATTORNEY

Concrete Blues

THE MARK CONSISTS OF STANDARD CHARACTERS WITHOUT CLAIM TO ANY PARTICULAR FONT, STYLE, SIZE, OR COLOR.

**CLASS 14—JEWELRY**

FOR JEWELRY, NAMELY, NECKLACES, RINGS, BRACELETS, WATCHES, EARRINGS (U.S. CLS. 2, 27, 28 AND 50).

**CLASS 25—CLOTHING**

FOR CLOTHING, NAMELY, SHIRTS, SWEATERS, TOPS, BLOUSES, PANTS, DENIM PANTS, DENIM JACKETS, DRESSES, JUMPERS, COATS, JACKETS, FOOTWEAR, HEADGEAR, NAMELY, HATS, CAPS (U.S. CLS. 22 AND 39).

**CLASS 35—ADVERTISING AND BUSINESS**

FOR RETAIL CONSIGNMENT STORE FEATURING CLOTHING, FOOTWEAR, HEADGEAR; OPERATING AN ON-LINE SHOPPING SITE IN THE FIELD OF CLOTHING, FOOTWEAR, HEADGEAR; RETAIL CLOTHING BOUTIQUE; RETAIL CLOTHING STORES; ON-LINE RETAIL STORE SERVICES FEATURING CLOTHING, FOOTWEAR, HEADGEAR; RETAIL APPAREL STORES (U.S. CLS. 100, 101 AND 102).  
DAVID MURRAY, EXAMINING ATTORNEY

SN 86-090,450. SWANK MOTION PICTURES, INC., ST. LOUIS, MO. FILED 10-14-2013.

CINELINK

THE MARK CONSISTS OF STANDARD CHARACTERS WITHOUT CLAIM TO ANY PARTICULAR FONT, STYLE, SIZE, OR COLOR.

**CLASS 9—ELECTRICAL AND SCIENTIFIC APPARATUS**

FOR DIGITAL HARD DRIVES PRERECORDED WITH MOVIES, TELEVISION PROGRAMS, CONCERTS AND EDUCATIONAL AND TRAINING VIDEOS (U.S. CLS. 21, 23, 26, 36 AND 38).

**CLASS 41—EDUCATION AND ENTERTAINMENT**

FOR RENTAL OF AUDIOVISUAL WORKS FEATURING MOVIES, TELEVISION PROGRAMS, AND CONCERTS; RENTAL OF AUDIOVISUAL WORKS FEATURING EDUCATIONAL AND TRAINING VIDEOS IN THE FIELDS OF HEALTHCARE, STUDENT SAFETY AND CAMPUS LIFE; DISTRIBUTION FOR OTHERS OF MOVIES, TELEVISION PROGRAMS AND OTHER AUDIOVISUAL WORKS FEATURING CONCERTS AND EDUCATIONAL AND TRAINING VIDEOS IN THE FIELDS OF HEALTHCARE, STUDENT SAFETY AND CAMPUS LIFE (U.S. CLS. 100, 101 AND 107).

KRISTIN DAHLING, EXAMINING ATTORNEY

SN 86-091,411. DAMN GOOD DOORMATS, LLC, BALTIMORE, MD. FILED 10-15-2013.

**DAMN GOOD DOORMATS**

THE MARK CONSISTS OF STANDARD CHARACTERS WITHOUT CLAIM TO ANY PARTICULAR FONT, STYLE, SIZE, OR COLOR.

NO CLAIM IS MADE TO THE EXCLUSIVE RIGHT TO USE "GOOD DOORMATS", APART FROM THE MARK AS SHOWN.

**CLASS 27—FLOOR COVERINGS**

FOR DOOR MATS (U.S. CLS. 19, 20, 37, 42 AND 50). FIRST USE 7-15-2009; IN COMMERCE 7-15-2009.

**CLASS 35—ADVERTISING AND BUSINESS**

FOR ON-LINE RETAIL STORE SERVICES FEATURING DOOR MATS (U.S. CLS. 100, 101 AND 102). FIRST USE 7-15-2009; IN COMMERCE 7-15-2009. JUSTINE D. PARKER, EXAMINING ATTORNEY

SN 86-092,247. SPA HEROES, LLC, NOVATO, CA. FILED 10-15-2013.

**BEAUTY HEROES**

THE MARK CONSISTS OF STANDARD CHARACTERS WITHOUT CLAIM TO ANY PARTICULAR FONT, STYLE, SIZE, OR COLOR.

NO CLAIM IS MADE TO THE EXCLUSIVE RIGHT TO USE "BEAUTY", APART FROM THE MARK AS SHOWN.

**CLASS 3—COSMETICS AND CLEANING PREPARATIONS**

FOR SKIN AND BODY CARE PRODUCTS, NAMELY, BODY SCRUB, BODY WASH, BODY LOTION, BODY CREAM, MOISTURIZER, SOAP, FACIAL CLEANSER, FACIAL MUD, FACIAL SCRUB, FACIAL MASKS, FACE LOTION, FACE CREAM, FACIAL SERUM, EYE CREAM, MAKE-UP REMOVER; SUN SCREEN OILS, LOTIONS AND GELS, AFTER SUN LOTIONS, GELS AND BALMS; ANTI-OXIDANT CREAMS, LOTIONS AND GELS; PRODUCTS FOR BLEMISH CONTROL AND TREATMENT OF THE APPEARANCE OF FINE LINES AND WRINKLES OF THE FACE AND SKIN; LIP BALM, NAIL CARE PRODUCTS, NAMELY, NAIL POLISH, NAIL POLISH REMOVER, CUTICLE REMOVING PREPARATIONS, EMERY BOARDS; HAIR CARE PRODUCTS, NAMELY, SHAMPOO, CONDITIONER, STYLING GELS, CREAMS AND LOTIONS; HAIR SERUM, HAIR REPAIR PREPARATIONS; SHAVING PREPARATIONS AND SHAVING CREAM; DEPILATORY PREPARATIONS AND SUBSTANCES; ESSENTIAL OILS FOR AROMATHERAPY USE; NON-MEDICATED SKIN CREAMS WITH ESSENTIAL OILS FOR USE IN AROMATHERAPY; COLOGNES AND PERFUMES; DEODORANT AND ANTI-PERSPIRANT; COSMETICS, NAMELY, CLEANSERS, MOISTURIZERS, FACE TONICS, FACE MASKS, FACE POWDER, FOUNDATION, BLUSHERS, MAS-CARA, EYESHADOW, EYELINER, EYEMAKEUP REMOVER, FALSE EYELASHES; ADHESIVES FOR FALSE EYELASHES, HAIR AND NAILS; LIPSTICKS, LIP PENCILS, EYEBROW PENCILS AND EYEBROW POWDERS (U.S. CLS. 1, 4, 6, 50, 51 AND 52).

**CLASS 35—ADVERTISING AND BUSINESS**

FOR RETAIL STORE SERVICES AND ONLINE RETAIL STORE SERVICES FEATURING A WIDE VARIETY OF SKIN AND BODY CARE PRODUCTS, BATH AND BEAUTY PRODUCTS, HAIR CARE PRODUCTS, AROMATHERAPY PRODUCTS, PERSONAL CARE PRODUCTS, COLOGNES, PERFUMES AND COSMETICS (U.S. CLS. 100, 101 AND 102).

KIMBERLY PERRY, EXAMINING ATTORNEY

SN 86-092,326. URS FEDERAL SERVICES, INC., SAN FRANCISCO, CA. FILED 10-15-2013.

**SAFEUP**

THE MARK CONSISTS OF STANDARD CHARACTERS WITHOUT CLAIM TO ANY PARTICULAR FONT, STYLE, SIZE, OR COLOR.

**CLASS 42—SCIENTIFIC AND COMPUTER SERVICES**

FOR CONSULTING SERVICES IN THE FIELDS OF ENGINEERING AND AEROSPACE ENGINEERING; TECHNICAL CONSULTING IN THE FIELD OF ENVIRONMENTAL ENGINEERING (U.S. CLS. 100 AND 101).

**CLASS 45—PERSONAL AND LEGAL SERVICES**

FOR CONSULTING SERVICES IN THE FIELDS OF MILITARY, DEFENSE, AND THE ENVIRONMENT; REVIEWING STANDARDS AND PRACTICES TO ASSURE COMPLIANCE WITH ENGINEERING, DEFENSE, AEROSPACE, MILITARY AND THE ENVIRONMENT LAWS AND REGULATIONS (U.S. CLS. 100 AND 101).

JOHN DALIER, EXAMINING ATTORNEY

SN 86-092,915. IDEAL STANDARD INTERNATIONAL BVBA, ZAVENTEM, BELGIUM, FILED 10-16-2013.

## CHAMPION

THE MARK CONSISTS OF STANDARD CHARACTERS WITHOUT CLAIM TO ANY PARTICULAR FONT, STYLE, SIZE, OR COLOR.

OWNER OF U.S. REG. NOS. 2,843,945 AND 3,146,752.

### CLASS 6—METAL GOODS

FOR BATHTUB AND SHOWER GRAB BARS OF METAL; TISSUE BOX COVERS OF METAL (U.S. CLS. 2, 12, 13, 14, 23, 25 AND 50).

### CLASS 11—ENVIRONMENTAL CONTROL APPARATUS

FOR PLUMBING FIXTURES, NAMELY, LAVATORIES, BATHTUBS, SHOWER STALLS, URINALS, BIDETS, HAND WASH BASINS IN THE NATURE OF SINKS, VANITY BASINS IN THE NATURE OF SINKS, AND KITCHEN SINKS; PLUMBING FITTINGS, NAMELY, BATHTUB SPOUTS AND SHOWER HEADS; BATHTUB SURROUNDS; SHOWER SURROUNDS; BATHTUB AND SHOWER ENCLOSURES (U.S. CLS. 13, 21, 23, 31 AND 34).

### CLASS 20—FURNITURE AND ARTICLES NOT OTHERWISE CLASSIFIED

FOR BATHROOM VANITIES; BATHROOM CONSOLES IN THE NATURE OF TABLES AND CABINETS; BATHROOM MIRRORS; BATHROOM SHELVING; BATHROOM TABLES; BATHTUB GRAB BARS NOT MADE OF METAL; SHOWER GRAB BARS NOT MADE OF METAL; PORTABLE SHOWER SEATS; PORTABLE BATH SEATS (U.S. CLS. 2, 13, 22, 25, 32 AND 50).

### CLASS 21—HOUSEWARES AND GLASS

FOR TOWEL BARS, TOWEL RINGS, TOILET PAPER HOLDERS, DISPENSERS FOR FACIAL TISSUE, LOTION DISPENSERS AND SOAP DISHES, ALL MADE OF METAL (U.S. CLS. 2, 13, 23, 29, 30, 33, 40 AND 50).  
KIMBERLY FRYE, EXAMINING ATTORNEY

SN 86-092,973. INFOR (US), INC., ALPHARETTA, GA. FILED 10-16-2013.

INFORMING.LE COMMUNITIES

THE MARK CONSISTS OF STANDARD CHARACTERS WITHOUT CLAIM TO ANY PARTICULAR FONT, STYLE, SIZE, OR COLOR.

OWNER OF U.S. REG. NOS. 3,986,817, 4,207,735 AND OTHERS.

NO CLAIM IS MADE TO THE EXCLUSIVE RIGHT TO USE "COMMUNITIES", APART FROM THE MARK AS SHOWN.

### CLASS 9—ELECTRICAL AND SCIENTIFIC APPARATUS

FOR A FEATURE OF COMPUTER SOFTWARE COMPONENT FOR USE WITH ENTERPRISE RESOURCE PLANNING SOFTWARE, NAMELY, SOFTWARE FEATURE THAT ALLOWS USERS TO COMMUNICATE, POST AND SHARE INFORMATION WITH OTHER USERS IN A COMMUNITY GROUP OR DISCUSSION THREAD (U.S. CLS. 21, 23, 26, 36 AND 38).

### CLASS 42—SCIENTIFIC AND COMPUTER SERVICES

FOR A FEATURE OF SOFTWARE AS A SERVICE (SAAS) SERVICES FOR USE WITH ENTERPRISE RESOURCE PLANNING SOFTWARE, NAMELY, SOFTWARE FEATURE THAT ALLOWS USERS TO COMMUNICATE, POST AND SHARE INFORMATION WITH OTHER USERS IN A COMMUNITY GROUP OR DISCUSSION THREAD (U.S. CLS. 100 AND 101).

JOHN GARTNER, EXAMINING ATTORNEY

SN 86-093,052. BELLA BELLISSIMA LTD., HARROW, MIDDLESEX, UNITED KINGDOM, FILED 10-16-2013.

## BELLA BELLISSIMA

THE MARK CONSISTS OF STANDARD CHARACTERS WITHOUT CLAIM TO ANY PARTICULAR FONT, STYLE, SIZE, OR COLOR.

OWNER OF UNITED KINGDOM REG. NO. 2428178, DATED 7-26-2006, EXPIRES 7-26-2016.

THE ENGLISH TRANSLATION OF "BELLA BELLISSIMA" IN THE MARK IS "BEAUTIFUL VERY BEAUTIFUL".

### CLASS 3—COSMETICS AND CLEANING PREPARATIONS

FOR PERFUME; EAU DE PARFUM; EAU DE TOILETTE; COLOGNE (U.S. CLS. 1, 4, 6, 50, 51 AND 52).

### CLASS 4—LUBRICANTS AND FUELS

FOR SCENTED CANDLES (U.S. CLS. 1, 6 AND 15).  
COLLEEN MULCRONE, EXAMINING ATTORNEY

SN 86-093,507. TRIPOD, LLC, BOULDER, CO. FILED 10-16-2013.



THE COLOR(S) LIGHT GREEN AND BLACK IS/ARE CLAIMED AS A FEATURE OF THE MARK.

THE MARK CONSISTS OF THE WORD "TRIPOD" STYLIZED WITH THE FIRST THREE LETTERS, "TRI" IN LIGHT GREEN AND THE DOT ABOVE THE "I" AND THE "POD" IN BLACK.



**CLASS 35—ADVERTISING AND BUSINESS**

FOR BRAND CONCEPT AND BRAND DEVELOPMENT SERVICES FOR CORPORATE AND INDIVIDUAL CLIENTS; BRAND DEVELOPMENT AND EVALUATION SERVICES IN THE FIELD OF RETAIL SALES, CONSULTING SERVICES, FOOD SALES AND ENTERTAINMENT SERVICES; BRANDING SERVICES, NAMELY, CONSULTING, DEVELOPMENT, MANAGEMENT AND MARKETING OF BRANDS FOR BUSINESSES AND/OR INDIVIDUALS; BUSINESS ANALYSIS AND BUSINESS STRATEGIC PLANNING SERVICES IN THE TECHNOLOGY INDUSTRY; BUSINESS CONSULTING SERVICES, NAMELY, PROVIDING ASSISTANCE IN DEVELOPMENT OF BUSINESS STRATEGIES AND CREATIVE IDEATION; BUSINESS DEVELOPMENT CONSULTING SERVICES; BUSINESS MONITORING AND CONSULTING SERVICES, NAMELY, TRACKING WEB SITES AND APPLICATIONS OF OTHERS TO PROVIDE STRATEGY, INSIGHT, MARKETING, SALES, OPERATION, PRODUCT DESIGN, PARTICULARLY SPECIALIZING IN THE USE OF ANALYTIC AND STATISTIC MODELS FOR THE UNDERSTANDING AND PREDICTING OF CONSUMERS, BUSINESSES, AND MARKET TRENDS AND ACTIONS; BUSINESS MONITORING SERVICES, NAMELY, TRACKING WEB SITES OF OTHERS TO PROVIDE DETAILS ABOUT USER CLICK TRAFFIC OR VISITS TO THE WEB SITE; CONSULTATION SERVICES, NAMELY, CREATIVE AND STRATEGIC CONSULTATION REGARDING DEVELOPMENT AND PRODUCTION OF MARKETING CAMPAIGNS FOR OTHERS; CREATIVE MARKETING DESIGN SERVICES; PROVIDING ADVERTISING, MARKETING AND PROMOTIONAL SERVICES, NAMELY, DEVELOPMENT OF ADVERTISING CAMPAIGNS FOR RETAIL SALES, CONSULTING SERVICES, FOOD SALES AND ENTERTAINMENT SERVICES (U.S. CLS. 100, 101 AND 102).

FIRST USE 5-27-2013; IN COMMERCE 7-1-2013.

**CLASS 41—EDUCATION AND ENTERTAINMENT**

FOR CONSULTING SERVICES IN THE FIELD OF PHOTOGRAPHY; DIGITAL IMAGING SERVICES; PHOTOGRAPHY SERVICES; WEDDING PHOTOGRAPHY SERVICES (U.S. CLS. 100, 101 AND 107).

FIRST USE 5-27-2013; IN COMMERCE 7-1-2013.  
DAWN FELDMAN, EXAMINING ATTORNEY

SN 86-093,924. DESIREE CASTELLANO MAUSNER, OVIEDO, FL. FILED 10-17-2013.

**TALIA JOY CASTELLANO**

THE MARK CONSISTS OF STANDARD CHARACTERS WITHOUT CLAIM TO ANY PARTICULAR FONT, STYLE, SIZE, OR COLOR.

THE NAME SHOWN IN THE MARK DOES NOT IDENTIFY A PARTICULAR LIVING INDIVIDUAL.

**CLASS 41—EDUCATION AND ENTERTAINMENT**

FOR PROVIDING A WEBSITE FEATURING BLOGS, NON-DOWNLOADABLE PUBLICATIONS IN THE NATURE OF ARTICLES, RESEARCH REPORTS, AND JOURNALS, AND NON-DOWNLOADABLE VIDEOS, ALL FEATURING PERSONAL NARRATIVE STORIES RELATING TO CANCER, CANCER RECOVERY AND SURVIVAL FOR INSTRUCTIONAL AND ENTERTAINMENT PURPOSES; PROVIDING ENTERTAINMENT INFORMATION VIA BLOGS, TEXT MESSAGING, INSTANT MESSAGING, VOICE MESSAGING; PROVIDING A WEBSITE FEATURING NON-DOWNLOADABLE IMAGES, VIDEOS, MUSIC, AND NEWS ARTICLES IN THE FIELDS OF CANCER, CANCER RECOVERY AND SURVIVAL; INTERACTIVE ONLINE WEB JOURNALS FEATURING USER-DEFINED CONTENT IN THE FIELD OF CANCER, CANCER RECOVERY AND SURVIVAL; ON-LINE NON-DOWNLOADABLE ELECTRONIC NEWSLETTERS DELIVERED BY E-MAIL FEATURING PERSONAL NARRATIVE STORIES RELATING TO CANCER, CANCER RECOVERY AND SURVIVAL (U.S. CLS. 100, 101 AND 107).

**CLASS 44—MEDICAL, BEAUTY AND AGRICULTURAL SERVICES**

FOR PROVIDING MEDICAL INFORMATION IN THE FIELD OF CANCER, CANCER RECOVERY AND CANCER PREVENTION VIA ONLINE WEBSITES, SOCIAL MEDIA WEBSITES, CHAT ROOMS, EMAILS, ONLINE ACCESSIBLE VIDEOS AND THROUGH MOBILE TECHNOLOGY (U.S. CLS. 100 AND 101).

**CLASS 45—PERSONAL AND LEGAL SERVICES**

FOR ONLINE SOCIAL NETWORKING AND SOCIAL MEDIA SERVICES IN THE NATURE OF ONLINE WEBSITES AND SOCIAL MEDIA WEBSITES FEATURING PERSONAL NARRATIVE STORIES RELATING TO CANCER, CANCER RECOVERY AND SURVIVAL AVAILABLE VIA GLOBAL COMPUTER NETWORKS AND MOBILE TECHNOLOGY (U.S. CLS. 100 AND 101).  
ANDREW LEASER, EXAMINING ATTORNEY

SN 86-093,981. INTERNATIONAL PAPER COMPANY, MEMPHIS, TN. FILED 10-17-2013.

**Go paper.  
Grow trees.**

NO CLAIM IS MADE TO THE EXCLUSIVE RIGHT TO USE "PAPER" AND "TREES", APART FROM THE MARK AS SHOWN.

THE MARK CONSISTS OF THE WORDING "GO PAPER. GROW TREES." HAVING THE LETTER "T" IN THE WORD "TREE" STYLIZED IN AN IMAGE OF A TREE.

**CLASS 9—ELECTRICAL AND SCIENTIFIC APPARATUS**

FOR DOWNLOADABLE ELECTRONIC PUBLICATIONS IN THE NATURE OF NEWSLETTERS IN THE FIELD OF THE PAPER AND TREE FARMING INDUSTRIES RELATED TO THE ENVIRONMENT AND RESOURCE SUSTAINABILITY (U.S. CLS. 21, 23, 26, 36 AND 38).

FIRST USE 11-11-2010; IN COMMERCE 11-11-2010.

**CLASS 41—EDUCATION AND ENTERTAINMENT**

FOR EDUCATIONAL SERVICES, NAMELY, CONDUCTING INFORMAL PROGRAMS IN THE FIELDS OF THE PAPER AND TREE FARMING INDUSTRIES AS IT RELATES TO THE ENVIRONMENT AND RESOURCE SUSTAINABILITY USING ON-LINE ACTIVITIES AND INTERACTIVE EXHIBITS, AND PRINTABLE MATERIALS DISTRIBUTED THEREWITH; PROVIDING ON-LINE NON-DOWNLOADABLE PUBLICATIONS IN THE NATURE OF NEWSLETTERS IN THE FIELD OF THE PAPER AND TREE FARMING INDUSTRIES RELATED TO THE ENVIRONMENT AND RESOURCE SUSTAINABILITY (U.S. CLS. 100, 101 AND 107).

FIRST USE 11-11-2010; IN COMMERCE 11-11-2010.  
ARETHA SOMERVILLE, EXAMINING ATTORNEY

**CLASS 9—ELECTRICAL AND SCIENTIFIC APPARATUS**

FOR FLUID DISPENSING SYSTEM COMPRISED OF A NON-METALLIC PESTICIDE CONTAINER WITH A METERING DEVICE FOR DISPENSING MATERIAL FROM THE CONTAINER, FOR USE IN AGRICULTURE, SOLD EMPTY; CONTROL DEVICE FOR CONTROLLING DISPENSING OF MATERIALS FROM A SYSTEM FOR DISPENSING PESTICIDE AND FOR DISPLAYING DATA RELATING TO SAID DISPENSING, FOR USE IN AGRICULTURE; ELECTRONIC DISPENSING SYSTEM FOR DISPENSING PESTICIDES COMPRISING ONE OR TWO CONTAINERS AND A METERING DEVICE FOR DISPENSING MATERIAL FROM ONE CONTAINER, ONE CONTAINER BEING PREFILLED WITH PESTICIDE, FOR USE IN AGRICULTURE; ELECTRONIC DISPENSING SYSTEM FOR USE IN AGRICULTURE COMPRISING ONE OR TWO CONTAINERS, ONE CONTAINER BEING PREFILLED WITH PESTICIDE, A METERING DEVICE FOR DISPENSING MATERIAL FROM ONE CONTAINER, ONE OR MORE SENSORS AND/OR MONITORS FOR SENSING EXTERNAL CONDITIONS AND THE PERFORMANCE OF THE SYSTEM, A CONTROL DEVICE FOR DISPLAYING DATA AND CONTROLLING DISPENSING, AND ONE OR MORE MEMORY DEVICES FOR CALIBRATION AND FOR RECORDING TREATMENT DATA (U.S. CLS. 21, 23, 26, 36 AND 38).

FIRST USE 2-14-1994; IN COMMERCE 2-14-1994.  
CURTIS FRENCH, EXAMINING ATTORNEY

SN 86-094,291. AMVAC CHEMICAL CORPORATION, NEWPORT BEACH, CA. FILED 10-17-2013.



SN 86-094,673. DIGITAL PAYMENT TECHNOLOGIES CORP., BURNABY, B.C., CANADA, FILED 10-17-2013.

OWNER OF U.S. REG. NOS. 1,115,929, 4,361,783 AND 4,444,181.

THE MARK CONSISTS OF THE WORD "AMVAC" TO THE LEFT OF WHICH IS A BEAKER DESIGN WITH A TRIANGLE SHAPE OUTLINED WITH A DARKER TRIANGLE SHAPE AS WELL AS AN UPSIDE DOWN TRIANGLE WITH HORIZONTAL LINES.

**DIGITAL IRIS**

**CLASS 1—CHEMICALS**

FOR PLANT GROWTH REGULATORS AND HORMONES FOR AGRICULTURAL USE (U.S. CLS. 1, 5, 6, 10, 26 AND 46).

FIRST USE 4-23-1978; IN COMMERCE 6-30-1978.

**CLASS 5—PHARMACEUTICALS**

FOR AGRICULTURAL CHEMICALS, NAMELY, INSECTICIDES, PESTICIDES, HERBICIDES, FUNGICIDES, NEMOTOCIDES AND MOLLUSCICIDES FOR COMMERCIAL, AGRICULTURAL, AND HORTICULTURAL USE (U.S. CLS. 6, 18, 44, 46, 51 AND 52).

FIRST USE 4-23-1978; IN COMMERCE 6-30-1978.

**CLASS 7—MACHINERY**

FOR COMPONENT PARTS FOR MECHANICAL AGRICULTURAL CHEMICAL SPREADING MACHINE SYSTEMS, NAMELY, PLASTIC CONTAINERS USED TO STORE THE AGRICULTURAL CHEMICAL BEING APPLIED BY THE SYSTEM; NON-METALLIC PESTICIDE CONTAINER WITHOUT A METERING DEVICE, FOR USE WITH MECHANICAL SPREADERS, FOR DISPENSING MATERIAL FROM THE CONTAINER, FOR USE IN AGRICULTURE, SOLD EMPTY (U.S. CLS. 13, 19, 21, 23, 31, 34 AND 35).

FIRST USE 2-14-1994; IN COMMERCE 2-14-1994.

THE MARK CONSISTS OF STANDARD CHARACTERS WITHOUT CLAIM TO ANY PARTICULAR FONT, STYLE, SIZE, OR COLOR.

NO CLAIM IS MADE TO THE EXCLUSIVE RIGHT TO USE "DIGITAL", APART FROM THE MARK AS SHOWN.

**CLASS 9—ELECTRICAL AND SCIENTIFIC APPARATUS**

FOR COMPUTER SOFTWARE FOR REPORTING, ANALYSIS, AND MONITORING, AND FOR SYSTEMS ADMINISTRATION AND MANAGEMENT, ALL IN THE FIELD OF PARKING OPERATIONS (U.S. CLS. 21, 23, 26, 36 AND 38).

**CLASS 42—SCIENTIFIC AND COMPUTER SERVICES**

FOR SOFTWARE AS A SERVICE (SAAS) SERVICES FEATURING SOFTWARE FOR REPORTING, ANALYSIS, AND MONITORING, AND FOR SYSTEMS ADMINISTRATION AND MANAGEMENT, ALL IN THE FIELD OF PARKING OPERATIONS (U.S. CLS. 100 AND 101).

JONATHAN FALK, EXAMINING ATTORNEY

SN 86-094,715. MEDICAL ELECTRONIC SYSTEMS, LLC,  
LOS ANGELES, CA. FILED 10-17-2013.

Remember it all started  
with a sperm

THE MARK CONSISTS OF STANDARD CHARACTERS WITHOUT CLAIM TO ANY PARTICULAR FONT, STYLE, SIZE, OR COLOR.

#### CLASS 9—ELECTRICAL AND SCIENTIFIC APPARATUS

FOR VALIDATION AND CALIBRATION SYSTEMS, NAMELY, CALIBRATION DEVICES FOR CALIBRATING SPERM QUALITY ANALYZERS FOR MEASURING HUMAN OR ANIMAL SPERM CELL ACTIVITY (U.S. CLS. 21, 23, 26, 36 AND 38).

#### CLASS 10—MEDICAL APPARATUS

FOR MEDICAL AND VETERINARY DEVICES, NAMELY, SPERM QUALITY ANALYZERS FOR MEASURING HUMAN OR ANIMAL SPERM CELL ACTIVITY FOR MEDICAL DIAGNOSTIC USES (U.S. CLS. 26, 39 AND 44).

JAMES LOVELACE, EXAMINING ATTORNEY

SN 86-094,914. CONCEPT FRESH VERTRIEBS GMBH,  
PUCKING, AUSTRIA, FILED 10-18-2013.



NO CLAIM IS MADE TO THE EXCLUSIVE RIGHT TO USE "SIMPLE" AND "DELICIOUS", APART FROM THE MARK AS SHOWN.

THE MARK CONSISTS OF AN ARCHED BANNER CONTAINING THE WORD "GUSTERIA" IN UPPERCASE LETTERING, BELOW WHICH APPEARS THE WORDING "SIMPLE. DELICIOUS." IN LOWER CASE LETTERING AND ALSO INSIDE THE BANNER.

#### CLASS 5—PHARMACEUTICALS

FOR BABY FOOD; BABY FOODS (U.S. CLS. 6, 18, 44, 46, 51 AND 52).

#### CLASS 29—MEATS AND PROCESSED FOODS

FOR CHEESE FOOD; DAIRY-BASED CHOCOLATE FOOD BEVERAGES; DAIRY-BASED FOOD BEVERAGES; DAIRY-BASED FOOD BEVERAGES ALSO CONTAINING COCOA; DAIRY-BASED POWDERS FOR MAKING DAIRY-BASED FOOD BEVERAGES AND SHAKES; DAIRY-BASED SNACK FOODS EXCLUDING ICE CREAM, ICE MILK AND FROZEN YOGURT; DRIED MILK FOR FOOD; FRUIT-BASED RAW FOOD BARS; FRUIT-BASED SNACK FOOD; GAME; NUT-BASED SNACK FOODS; NUT-BASED SNACK FOODS, NAMELY, NUT CLUSTERS; NUT-BASED SNACK FOODS, NAMELY, NUT CRISPS; PEANUT-BASED FOOD BEVERAGES; POTATO-BASED SNACK FOODS; POWDERED MILK FOR FOOD PURPOSES; POWDERED OILS AND FATS; PREPARED FOOD KITS COMPOSED OF MEAT, POULTRY, FISH, SEAFOOD, AND/OR VEGETABLES AND ALSO INCLUDING SAUCES OR SEASONINGS, READY FOR COOKING AND ASSEMBLY AS A MEAL; SNACK FOOD DIPS; SOY-BASED FOOD BARS (U.S. CL. 46).

#### CLASS 30—STAPLE FOODS

FOR CEREAL BASED SNACK FOOD; CEREAL-BASED SNACK FOODS; CHOCOLATE FOOD BEVERAGES NOT BEING DAIRY-BASED OR VEGETABLE BASED; CHOCOLATE-BASED READY-TO-EAT FOOD BARS; COATINGS FOR FOODS MADE OF BREADING; CONFECTIONERIES, NAMELY, SNACK FOODS, NAMELY, CHOCOLATE; FOOD CONDIMENT CONSISTING PRIMARILY OF KETCHUP AND SALSA; FOOD FLAVORINGS, NAMELY, INFUSED OILS, NOT BEING ESSENTIAL OILS; FOOD FLAVOURINGS; FOOD PACKAGE COMBINATIONS CONSISTING PRIMARILY OF BREAD, CRACKERS AND/OR COOKIES; FOOD SEASONINGS; FOOD STARCH; FROZEN FLOUR-FREE FOODS, NAMELY, PANCAKES, CREPES, SANDWICH WRAPS, MUFFINS AND GRIDDLE CAKE SANDWICHES WHICH ARE PROTEIN-ENRICHED; FROZEN FOODS, NAMELY, GRAIN AND BREAD BASED APPETIZERS, HORS D'OEUVRES, AND CANAPES; FRUITOSE FOR FOOD; FRUIT PASTE FOR FLAVOURING OF FOOD; GRAIN-BASED FOOD BEVERAGES; GRAIN-BASED SNACK FOODS; GRASS-BASED FOOD BEVERAGES; HERB TEA; HERBAL FOOD BEVERAGES; HERBAL TEA; HONEY; QUINOA-BASED FOOD BARS; QUINOA-BASED SNACK FOODS; READY TO EAT, CEREAL DERIVED FOOD BARS; RICE-BASED SNACK FOODS; SNACK FOOD CHEWS MADE PRIMARILY FROM BROWN RICE SYRUP; SNACK FOODS, NAMELY, CHOCOLATE-BASED SNACK FOODS; SWEET POTATO STARCH FOR FOOD (U.S. CL. 46).

#### CLASS 31—NATURAL AGRICULTURAL PRODUCTS

FOR BIRD FOOD; BRINE SHRIMP FOR FISH FOOD; CAT FOOD; DOG FOOD; EDIBLE FOOD FOR ANIMALS FOR CHEWING; FISH FOOD (U.S. CLS. 1 AND 46).

#### CLASS 35—ADVERTISING AND BUSINESS

FOR FOOD KIOSK SERVICES; MOBILE FOOD CART SERVICES FEATURING ORGANIC CUPCAKES AND MILKSHAKES; MOBILE FOOD KIOSK SERVICES; MOBILE STREET VENDOR SERVICES FEATURING FOOD AND DRINK (U.S. CLS. 100, 101 AND 102).

#### CLASS 43—HOTEL AND RESTAURANT SERVICES

FOR FAST-FOOD RESTAURANT SERVICES; FAST-FOOD RESTAURANTS (U.S. CLS. 100 AND 101).

#### CLASS 45—PERSONAL AND LEGAL SERVICES

FOR ONLINE SOCIAL NETWORKING IN THE FIELD OF FOOD (U.S. CLS. 100 AND 101).  
EDWARD FENNESSY, EXAMINING ATTORNEY

SN 86-095,133, 1020, SAN FRANCISCO, CA. FILED 10-18-2013.

# PLACECAST

THE MARK CONSISTS OF STANDARD CHARACTERS WITHOUT CLAIM TO ANY PARTICULAR FONT, STYLE, SIZE, OR COLOR.

## CLASS 35—ADVERTISING AND BUSINESS

FOR ADVERTISING AND ADVERTISEMENT SERVICES; ADVERTISING AND COMMERCIAL INFORMATION SERVICES, VIA THE INTERNET AND TELECOMMUNICATIONS NETWORKS; ADVERTISING AND PROMOTION SERVICES AND RELATED CONSULTING; ADVERTISING AND PUBLICITY SERVICES; ADVERTISING AND PUBLICITY SERVICES, NAMELY, PROMOTING THE GOODS, SERVICES, BRAND IDENTITY AND COMMERCIAL INFORMATION AND NEWS OF THIRD PARTIES THROUGH AUDIO, VIDEO, DIGITAL AND ON-LINE MEDIUM; ADVERTISING VIA ELECTRONIC MEDIA AND SPECIFICALLY THE INTERNET; ADVERTISING, INCLUDING PROMOTION RELATING TO THE SALE OF ARTICLES AND SERVICES FOR THIRD PARTIES BY THE TRANSMISSION OF ADVERTISING MATERIAL AND THE DISSEMINATION OF ADVERTISING MESSAGES ON COMPUTER NETWORKS AND TELECOMMUNICATIONS NETWORKS; ADVERTISING, MARKETING AND PROMOTION SERVICES; PROMOTING THE GOODS AND SERVICES OF OTHERS BY PROVIDING HYPERTEXT LINKS TO THE WEB SITES OF OTHERS; PROMOTING THE GOODS AND SERVICES OF OTHERS VIA A GLOBAL COMPUTER NETWORK AND TELECOMMUNICATIONS NETWORKS (U.S. CLS. 100, 101 AND 102).

FIRST USE 6-1-2008; IN COMMERCE 6-1-2008.

## CLASS 42—SCIENTIFIC AND COMPUTER SERVICES

FOR PROVIDING AN ONLINE NON-DOWNLOADABLE SOFTWARE PLATFORM FOR MOBILE MARKETING; PROVIDING ONLINE NON-DOWNLOADABLE SOFTWARE FOR LOCATION-BASED ELECTRONIC COMMUNICATIONS AND ALERTS; PROVIDING ONLINE NON-DOWNLOADABLE SOFTWARE FOR CUSTOMER RELATIONSHIP MANAGEMENT AND DATA ANALYTICS (U.S. CLS. 100 AND 101).

FIRST USE 6-1-2008; IN COMMERCE 6-1-2008.  
EMILY CHUO, EXAMINING ATTORNEY

---

SN 86-095,807, ENTERTAINMENT MAGPIE LIMITED, MACCLESFIELD, UNITED KINGDOM, FILED 10-18-2013.

# DECLUTTR

THE MARK CONSISTS OF STANDARD CHARACTERS WITHOUT CLAIM TO ANY PARTICULAR FONT, STYLE, SIZE, OR COLOR.

## CLASS 35—ADVERTISING AND BUSINESS

FOR ADVERTISING; BUSINESS MANAGEMENT; BUSINESS ADMINISTRATION; PROVISION OF SPACE ON WEB SITES FOR ADVERTISING GOODS AND SERVICES OF OTHERS; PROVISION OF BUSINESS INFORMATION; DATA PROCESSING; AUCTIONEERING; RETAIL STORE SERVICES, ONLINE RETAIL STORE SERVICES AND ONLINE TRADING SERVICES IN WHICH CUSTOMERS PRICE AND SELL PRODUCTS VIA AN INTERNET WEBSITE, ALL CONNECTED WITH THE SALE AND PURCHASE OF HOME ENTERTAINMENT AND PERSONAL ENTERTAINMENT PRODUCTS, TELECOMMUNICATIONS PRODUCTS, PRINTED MATTER, SOUND RECORDINGS, MUSIC RECORDINGS, VIDEO RECORDINGS, AUDIO VISUAL RECORDINGS, CDS, DVDS, DISKS, VIDEO GAMES, COMPUTER GAMES, BOOKS, MOBILE PHONES AND PARTS AND FITTINGS THEREFOR, COMPUTERS AND COMPUTING EQUIPMENT AND PARTS AND FITTINGS THEREFOR, COMPUTER PERIPHERALS, COMPUTER PROGRAMS, COMPUTER SOFTWARE, ELECTRONIC STORAGE MEDIA, MEMORY CARDS, PORTABLE COMPUTERS, LAPTOP, NOTEBOOK AND TABLET COMPUTERS, VIDEO GAME MACHINES AND PARTS AND FITTINGS THEREFOR, APPARATUS FOR RECORDING, TRANSMISSION OR REPRODUCTION OF SOUND OR IMAGES, AUDIO EQUIPMENT AND PARTS AND FITTINGS THEREFOR, VIDEO EQUIPMENT AND PARTS AND FITTINGS THEREFOR, TELEVISIONS AND PARTS AND FITTINGS THEREFOR, RADIOS AND PARTS AND FITTINGS THEREFOR, MUSIC PLAYERS AND RECORDERS AND PARTS AND FITTINGS THEREFOR, VIDEO PLAYERS AND RECORDERS AND PARTS AND FITTINGS THEREFOR, DIGITAL AUDIO VIDEO PLAYERS AND RECORDERS AND PARTS AND FITTINGS THEREFOR, MP3 PLAYERS AND RECORDERS AND PARTS AND FITTINGS THEREFOR, DVD PLAYERS AND RECORDERS AND PARTS AND FITTINGS THEREFOR, CAMERAS AND PARTS AND FITTINGS THEREFOR, VIDEO CAMERAS AND PARTS AND FITTINGS THEREFOR, SPECTACLES AND SUNGLASSES AND FRAMES THEREFOR, BEAUTY PRODUCTS, MACHINES FOR HOUSEHOLD USE, TOOLS, POWER TOOLS, DOMESTIC ELECTRICAL AND ELECTRONIC EQUIPMENT, APPARATUS FOR LIGHTING, HEATING, STEAM GENERATING, DRYING, VENTILATING, CYCLES AND PARTS, COMPONENTS AND FITTINGS THEREFOR, PRAMS AND PARTS, COMPONENTS AND FITTINGS THEREFOR, PUSHCHAIRS AND PARTS, COMPONENTS AND FITTINGS THEREFOR, BABY STROLLERS AND PARTS, COMPONENTS AND FITTINGS THEREFOR, CAR SAFETY SEATS FOR BABIES AND CHILDREN, BABY WALKERS, JEWELLERY, JEWELLERY CHARMS, WATCHES AND CLOCKS AND PARTS AND FITTINGS THEREFOR, COINS AND COPPER TOKENS, MEDALS AND MEDALLIONS, KEY RINGS, TRINKETS AND FOBS, MUSICAL INSTRUMENTS AND PARTS AND FITTINGS THEREFOR, PAPER, CARDBOARD AND GOODS MADE FROM THESE MATERIALS, PHOTOGRAPHS, STATIONERY, INSTRUCTIONAL AND TEACHING MATERIAL, PRINTED PUBLICATIONS, ARTICLES OF LUGGAGE, CASES, BAGS, HANDBAGS, BRIEFCASES, WALLETS, PURSES, CREDIT CARD CASES AND HOLDERS, ID CARD CASES AND HOLDERS, KEYCASES, UMBRELLAS, FURNITURE, MIRRORS, PICTURE FRAMES, PHOTOGRAPH FRAMES, CHILDREN'S FURNITURE, NURSERY FURNITURE, COTS, BEDS, CRIBS, CARRY COTS, MOSES BASKETS, CRADLES, MATTRESSES, COT BUMPER PADS, BABY BOLSTERS, HIGH CHAIRS, BABY CHANGING TABLES, BABY CHANGING MATS, ROCKING CHAIRS, PLAYPENS, TOY BOXES, STORAGE BOXES, CHESTS, SAFETY GATES FOR BABIES AND CHILDREN, FURNITURE PROTECTORS, TRAVEL COTS, SLEEPING BAGS, HOUSEHOLD OR KITCHEN UTENSILS AND CONTAINERS, GLASSWARE, PORCELAIN AND EARTHENWARE, POTTERY, COOKWARE, TABLEWARE, GLASSWARE, DRINKING VESSELS, CUPS, MUGS, BOTTLES, PLATES, BOWLS, CUTLERY, MODELS, ORNAMENTS, DECORATIVE ARTICLES, TENTS, TEXTILES AND TEXTILE GOODS, TEXTILE PIECE GOODS, HOUSEHOLD TEXTILE ARTICLES, TABLE LINEN, BED LINEN, TOWELS, BLANKETS, SOFT FURNISHINGS, FLAGS, BANNERS, PENNANTS, CLOTHING, FOOTWEAR, HEADGEAR, CLOTHING ACCESSORIES, ARTICLES OF CLOTHING, FOOTWEAR AND HEADGEAR FOR BABIES OR CHILDREN, REINS

FOR GUIDING CHILDREN, BADGES, FLOOR COVERINGS, RUGS, WALL HANGINGS, GAMES AND PLAYTHINGS, GYMNAS TIC AND SPORTING ARTICLES, DECORATIONS FOR CHRISTMAS TREES, TOYS, CHILDREN'S ACTIVITY EQUIPMENT AND APPARATUS, BABY TOYS, BABY PLAYTHINGS, BABY SWINGS, BOUNCERS, DOLLS, SOFT TOYS, TEDDY BEARS AND PET PRODUCTS; INFORMATION, ADVISORY AND CONSULTANCY SERVICES IN RELATION TO ALL OF THE AFORESAID (U.S. CLS. 100, 101 AND 102).

### CLASS 36—INSURANCE AND FINANCIAL

FOR CONDUCTING VALUATIONS OF PERSONAL PROPERTY; VALUATION SERVICES IN RELATION TO HOME ENTERTAINMENT AND PERSONAL ENTERTAINMENT PRODUCTS, TELECOMMUNICATIONS PRODUCTS, PRINTED MATTER, SOUND RECORDINGS, MUSIC RECORDINGS, VIDEO RECORDINGS, AUDIO VISUAL RECORDINGS, CDS, DVDS, DISKS, VIDEO GAMES, COMPUTER GAMES, BOOKS, MOBILE PHONES AND PARTS AND FITTINGS THEREFOR, COMPUTERS AND COMPUTING EQUIPMENT AND PARTS AND FITTINGS THEREFOR, COMPUTER PERIPHERALS, COMPUTER PROGRAMS, COMPUTER SOFTWARE, ELECTRONIC STORAGE MEDIA, MEMORY CARDS, PORTABLE COMPUTERS, LAPTOP, NOTEBOOK AND TABLET COMPUTERS, VIDEO GAME MACHINES AND PARTS AND FITTINGS THEREFOR, APPARATUS FOR RECORDING, TRANSMISSION OR REPRODUCTION OF SOUND OR IMAGES, AUDIO EQUIPMENT AND PARTS AND FITTINGS THEREFOR, VIDEO EQUIPMENT AND PARTS AND FITTINGS THEREFOR, TELEVISIONS AND PARTS AND FITTINGS THEREFOR, RADIOS AND PARTS AND FITTINGS THEREFOR, MUSIC PLAYERS AND RECORDERS AND PARTS AND FITTINGS THEREFOR, VIDEO PLAYERS AND RECORDERS AND PARTS AND FITTINGS THEREFOR, DIGITAL AUDIO VIDEO PLAYERS AND RECORDERS AND PARTS AND FITTINGS THEREFOR, MP3 PLAYERS AND RECORDERS AND PARTS AND FITTINGS THEREFOR, DVD PLAYERS AND RECORDERS AND PARTS AND FITTINGS THEREFOR, CAMERAS AND PARTS AND FITTINGS THEREFOR, VIDEO CAMERAS AND PARTS AND FITTINGS THEREFOR, SPECTACLES AND SUNGLASSES AND FRAMES THEREFOR, BEAUTY PRODUCTS, MACHINES FOR HOUSEHOLD USE, TOOLS, POWER TOOLS, DOMESTIC ELECTRICAL AND ELECTRONIC EQUIPMENT, APPARATUS FOR LIGHTING, HEATING, STEAM GENERATING, DRYING, VENTILATING, CYCLES AND PARTS, COMPONENTS AND FITTINGS THEREFOR, PRAMS AND PARTS, COMPONENTS AND FITTINGS THEREFOR, PUSHCHAIRS AND PARTS, COMPONENTS AND FITTINGS THEREFOR, BABY STROLLERS AND PARTS, COMPONENTS AND FITTINGS THEREFOR, CAR SAFETY SEATS FOR BABIES AND CHILDREN, BABY WALKERS, JEWELLERY, JEWELLERY CHARMS, WATCHES AND CLOCKS AND PARTS AND FITTINGS THEREFOR, COINS AND COPPER TOKENS, MEDALS AND MEDALLIONS, KEY RINGS, TRINKETS AND FOBS, MUSICAL INSTRUMENTS AND PARTS AND FITTINGS THEREFOR, PAPER, CARDBOARD AND GOODS MADE FROM THESE MATERIALS, PHOTOGRAPHS, STATIONERY, INSTRUCTIONAL AND TEACHING MATERIAL, PRINTED PUBLICATIONS, ARTICLES OF LUGGAGE, CASES, BAGS, HANDBAGS, BRIEFCASES, WALLETTS, PURSES, CREDIT CARD CASES AND HOLDERS, ID CARD CASES AND HOLDERS, KEYCASES, UMBRELLAS, FURNITURE, MIRRORS, PICTURE FRAMES, PHOTOGRAPH FRAMES, CHILDREN'S FURNITURE, NURSERY FURNITURE, COTS, BEDS, CRIBS, CARRY COTS, MOSES BASKETS, CRADLES, MATTRESSES, COT BUMPER PADS, BABY BOLSTERS, HIGH CHAIRS, BABY CHANGING TABLES, BABY CHANGING MATS, ROCKING CHAIRS, PLAYPENS, TOY BOXES, STORAGE BOXES, CHESTS, SAFETY GATES FOR BABIES AND CHILDREN, FURNITURE PROTECTORS, TRAVEL COTS, SLEEPING BAGS, HOUSEHOLD OR KITCHEN UTENSILS AND CONTAINERS, GLASSWARE, PORCELAIN AND EARTHENWARE, POTTERY, COOKWARE, TABLEWARE, GLASSWARE, DRINKING VESSELS, CUPS, MUGS, BOTTLES, PLATES, BOWLS, CUTLERY, MODELS, ORNAMENTS, DECORATIVE ARTICLES, TENTS, TEXTILES AND TEXTILE GOODS, TEXTILE PIECE GOODS, HOUSEHOLD TEXTILE ARTICLES, TABLE LINEN, BED LINEN, TOWELS, BLANKETS,

SOFT FURNISHINGS, FLAGS, BANNERS, PENNANTS, CLOTHING, FOOTWEAR, HEADGEAR, CLOTHING ACCESSORIES, ARTICLES OF CLOTHING, FOOTWEAR AND HEADGEAR FOR BABIES OR CHILDREN, REINS FOR GUIDING CHILDREN, BADGES, FLOOR COVERINGS, RUGS, WALL HANGINGS, GAMES AND PLAYTHINGS, GYMNAS TIC AND SPORTING ARTICLES, DECORATIONS FOR CHRISTMAS TREES, TOYS, CHILDREN'S ACTIVITY EQUIPMENT AND APPARATUS, BABY TOYS, BABY PLAYTHINGS, BABY SWINGS, BOUNCERS, DOLLS, SOFT TOYS, TEDDY BEARS, PUPPETS AND PET PRODUCTS; ISSUING OF TOKENS OF VALUE; INFORMATION, ADVISORY AND CONSULTANCY SERVICES IN RELATION TO ALL OF THE AFORESAID (U.S. CLS. 100, 101 AND 102).

### CLASS 40—MATERIAL TREATMENT

FOR RECYCLING SERVICES; RECYCLING OF CONSUMER GOODS; INFORMATION, ADVISORY AND CONSULTANCY SERVICES IN RELATION TO ALL OF THE AFORESAID (U.S. CLS. 100, 103 AND 106).  
LINDA E. BLOHM, EXAMINING ATTORNEY

SN 86-095,904. CODY CONSULTING GROUP, INC., LUTZ, FL. FILED 10-18-2013.



NO CLAIM IS MADE TO THE EXCLUSIVE RIGHT TO USE "INVESTIGATIONS MODULE", APART FROM THE MARK AS SHOWN.

THE COLOR(S) ORANGE IS/ARE CLAIMED AS A FEATURE OF THE MARK.

THE MARK CONSISTS OF THREE INTERLINKED RECTANGULAR FRAMES, WHERE ONE OF THE FRAMES IS RELATIVELY DARKER, ONE OF THE FRAMES IS RELATIVELY LIGHTER, AND ONE OF THE FRAMES IS OF A SHADE BETWEEN THE RELATIVELY DARKER FRAME AND THE RELATIVELY LIGHTER FRAME. A SMALL ORANGE CIRCLE IS DISPOSED ON THE RECTANGULAR FRAME AT THE TOP. THE WORD "INVESTIGATIONS" APPEARS IN ORANGE ABOVE THE WORD "MODULE", BOTH OF WHICH ARE DISPOSED BELOW THE FRAMES. THE COLORS LIGHT GRAY AND DARK GRAY ARE NOT CLAIMED AS A FEATURE OF THE MARK AND MERELY SERVE TO SHOW THE PLACEMENT OF THE DESIGN AND WORD "MODULE" IN THE MARK.

### CLASS 9—ELECTRICAL AND SCIENTIFIC APPARATUS

FOR COMPUTER SOFTWARE FOR USE IN THE HEALTHCARE SECTOR, NAMELY, COMPUTER SOFTWARE FOR MANAGING REGULATORY COMPLIANCE MATTERS OF HEALTH PLANS (U.S. CLS. 21, 23, 26, 36 AND 38).

### CLASS 35—ADVERTISING AND BUSINESS

FOR BUSINESS CONSULTATION AND MANAGEMENT IN THE HEALTHCARE SECTOR (U.S. CLS. 100, 101 AND 102).

**CLASS 42—SCIENTIFIC AND COMPUTER SERVICES**

FOR APPLICATION SERVICE PROVIDER, NAMELY, DEVELOPING, MANAGING, AND HOSTING SOFTWARE IN THE HEALTHCARE SECTOR, NAMELY, SOFTWARE FOR MANAGING REGULATORY COMPLIANCE MATTERS OF HEALTH PLANS (U.S. CLS. 100 AND 101).

SHAILA LEWIS, EXAMINING ATTORNEY

SN 86-095,957. SONNY SUROWIEC, TOLUCA LAKE, CA. FILED 10-18-2013.



OWNER OF U.S. REG. NO. 4,380,486.  
THE MARK CONSISTS OF THE WORDS "PRO PAIN", WITH THE WORD "PRO" APPEARING ABOVE THE WORD "PAIN", APPEARING WITHIN A SHIELD DESIGN.

**CLASS 5—PHARMACEUTICALS**

FOR ADHESIVE BANDAGES; ADHESIVE FOR BANDAGES FOR SKIN WOUNDS; AROMATIZED BEVERAGES BASED ON FRUIT, PROTEIN, CORDIAL, SUGAR AND OTHER FLUID NUTRIENTS, NAMELY, MEAL REPLACEMENT DRINKS FOR USE AS A FOOD FILLERS; BANDAGES FOR DRESSINGS; BANDAGES FOR SKIN WOUNDS; DIETARY DRINK MIX FOR USE AS A MEAL REPLACEMENT; DIETARY SUPPLEMENTAL DRINKS; DIETARY SUPPLEMENTAL DRINKS IN THE NATURE OF VITAMIN AND MINERAL BEVERAGES; DIETARY SUPPLEMENTS FOR PETS IN THE NATURE OF A POWDERED DRINK MIX; ENERGY BOOSTING BARS FOR USE AS A MEAL SUBSTITUTE; ENERGY BOOSTING MOUTH DISSOLVABLE FLAVORED EDIBLE FILMS; ENERGY BOOSTING SERUM FOR INJECTION; HERBAL DRINKS USED TO AID IN SLEEP AND RELAXATION; HIGHLY CAFFEINATED ENERGY PILLS; MEAL REPLACEMENT AND DIETARY SUPPLEMENT DRINK MIXES; MEAL REPLACEMENT DRINKS; MEDICINAL DRINKS; NUTRITIONAL SUPPLEMENT IN THE NATURE OF A NUTRIENT-DENSE, PROTEIN BASED DRINK MIX; ORAL SPRAY FOR BOOSTING ENERGY; ORALLY INGESTED GEL FOR BOOSTING ENERGY; POWDERED FRUIT FLAVORED DIETARY SUPPLEMENT DRINK MIX; POWDERED NUTRITIONAL SUPPLEMENT DRINK MIX; SOY PROTEIN FOR USE AS A NUTRITIONAL SUPPLEMENT IN VARIOUS POWDERED AND READY-TO-DRINK BEVERAGES; SURGICAL BANDAGES; NUTRITIONAL DRINKS USED FOR MEAL REPLACEMENT; NUTRITIONAL ENERGY BARS FOR USE AS A MEAL SUBSTITUTE (U.S. CLS. 6, 18, 44, 46, 51 AND 52).  
FIRST USE 5-30-2013; IN COMMERCE 5-30-2013.

**CLASS 10—MEDICAL APPARATUS**

FOR BANDAGES FOR ANATOMICAL JOINTS; COMPRESSION BANDAGES; ELASTIC BANDAGES; ORTHOPAEDIC KNEE BANDAGES; ORTHOPEDIC SUPPORT BANDAGE, NAMELY, WEARABLE PADS FOR THE HANDS; ORTHOPEDIC SUPPORT BANDAGES; SUPPORT BANDAGES; SUPPORTIVE BANDAGES; THERAPEUTIC APPARATUS, NAMELY, CHEMICALLY ACTIVATED ANTI-CELLULITE WRAPS, ICE PACKS, COMPRESSES, AND COMPRESSION BANDAGES (U.S. CLS. 26, 39 AND 44).  
FIRST USE 5-30-2013; IN COMMERCE 5-30-2013.

**CLASS 32—LIGHT BEVERAGES**

FOR NON-ALCOHOLIC BEVERAGES, NAMELY, SPORTS DRINKS, ENERGY DRINKS, RECOVERY DRINKS, FRUIT-BASED BEVERAGES, AND SOFT DRINKS; POWDERS USED IN THE PREPARATION OF SPORTS DRINKS, ENERGY DRINKS, RECOVERY DRINKS, FRUIT-BASED BEVERAGES, AND SOFT DRINKS (U.S. CLS. 45, 46 AND 48).

FIRST USE 5-30-2013; IN COMMERCE 5-30-2013.  
SANJEEV VOHRA, EXAMINING ATTORNEY

SN 86-095,972. AGAVE UNDERGROUND, INC., IRVINE, CA. FILED 10-18-2013.

**AGAVE UNDERGROUND SABROSO**

THE MARK CONSISTS OF STANDARD CHARACTERS WITHOUT CLAIM TO ANY PARTICULAR FONT, STYLE, SIZE, OR COLOR.

OWNER OF U.S. REG. NOS. 3,911,435, 4,002,752 AND 4,002,753.

NO CLAIM IS MADE TO THE EXCLUSIVE RIGHT TO USE "AGAVE" OR "SABROSO", APART FROM THE MARK AS SHOWN.

THE ENGLISH TRANSLATION OF "SABROSO" IN THE MARK IS "DELICIOUS" OR "TASTY".

**CLASS 25—CLOTHING**

FOR CLOTHING, NAMELY, SHIRTS AND HATS (U.S. CLS. 22 AND 39).

**CLASS 33—WINES AND SPIRITS**

FOR DISTILLED SPIRITS; TEQUILA; ALCOHOLIC BEVERAGES EXCEPT BEERS (U.S. CLS. 47 AND 49).  
DAWN FELDMAN, EXAMINING ATTORNEY

SN 86-095,974. PERFECT WORLD ENTERTAINMENT INC., REDWOOD CITY, CA. FILED 10-18-2013.

**ELEMENTAL KINGDOMS**

THE MARK CONSISTS OF STANDARD CHARACTERS WITHOUT CLAIM TO ANY PARTICULAR FONT, STYLE, SIZE, OR COLOR.

**CLASS 9—ELECTRICAL AND SCIENTIFIC APPARATUS**

FOR COMPUTER APPLICATION SOFTWARE FOR MOBILE PHONES, NAMELY, SOFTWARE FOR GAMES AND ENTERTAINMENT FOR PLAYING TRADING CARD STRATEGIC BATTLE GAMES; COMPUTER APPLICATION SOFTWARE FOR MOBILE AND CELLULAR PHONES, TABLETS, AND HAND-HELD COMPUTERS, NAMELY, SOFTWARE FOR GAMES AND ENTERTAINMENT FOR PLAYING TRADING CARD STRATEGIC BATTLE GAMES; COMPUTER GAME PROGRAMMES; COMPUTER GAME PROGRAMMES DOWNLOADABLE VIA THE INTERNET; COMPUTER GAME PROGRAMS; COMPUTER GAME SOFTWARE; COMPUTER SOFTWARE FOR MOBILE AND CELLULAR PHONES, TABLETS, AND HAND-HELD COMPUTERS FOR PLAYING TRADING CARD STRATEGIC BATTLE GAMES; DOWNLOADABLE COMPUTER GAME PROGRAMS; DOWNLOADABLE ELECTRONIC GAME PROGRAMS; DOWNLOADABLE ELECTRONIC GAME SOFTWARE FOR USE ON MOBILE AND CELLULAR PHONES, TABLETS, AND HAND-HELD COMPUTERS; DOWNLOADABLE MOBILE APPLICATIONS FOR GAMES AND ENTERTAINMENT FOR PLAYING TRADING CARD STRATEGIC BATTLE GAMES; DOWNLOADABLE SOFTWARE FOR MOBILE AND CELLULAR PHONES, TABLETS, AND HAND-HELD COMPUTERS; INTERACTIVE GAME SOFTWARE; INTERACTIVE MULTIMEDIA COMPUTER GAME PROGRAMS; INTERACTIVE MULTIMEDIA COMPUTER PROGRAM FOR MOBILE AND CELLULAR PHONES, TABLETS, AND HAND-HELD COMPUTERS; INTERACTIVE VIDEO GAME PROGRAMS; VIDEO GAME SOFTWARE (U.S. CLS. 21, 23, 26, 36 AND 38).

FIRST USE 10-18-2013; IN COMMERCE 10-18-2013.

**CLASS 41—EDUCATION AND ENTERTAINMENT**

FOR ELECTRONIC GAMES SERVICES PROVIDED BY MEANS OF THE INTERNET; ENTERTAINMENT SERVICES, NAMELY, PROVIDING AN ON-LINE COMPUTER GAME; ENTERTAINMENT SERVICES, NAMELY, PROVIDING ONLINE ELECTRONIC GAMES; PROVIDING AN ON-LINE COMPUTER GAME IN THE FIELD OF FREE-TO-PLAY TRADING CARD STRATEGIC BATTLE GAME (U.S. CLS. 100, 101 AND 107).

FIRST USE 10-18-2013; IN COMMERCE 10-18-2013.  
LAURIE MAYES, EXAMINING ATTORNEY

SN 86-096,731. PHILIP CARTER, NEW YORK, NY. FILED 10-21-2013.



NO CLAIM IS MADE TO THE EXCLUSIVE RIGHT TO USE "QUALITY", APART FROM THE MARK AS SHOWN.  
THE MARK CONSISTS OF THE DESIGN OF A ROCK HAVING A GENERALLY OVAL SHAPE WITH THE WORD "QUALITY" WRITTEN THEREON.

**CLASS 16—PAPER GOODS AND PRINTED MATTER**

FOR PAPERWEIGHTS (U.S. CLS. 2, 5, 22, 23, 29, 37, 38 AND 50).

**CLASS 25—CLOTHING**

FOR BASEBALL CAPS AND HATS; HATS; HEADGEAR, NAMELY, HATS WITH LOGO THEREON; SHORT-SLEEVED OR LONG-SLEEVED T-SHIRTS; SPORTS CAPS AND HATS; SWIMWEAR; T-SHIRTS (U.S. CLS. 22 AND 39).

KIMBERLY FRYE, EXAMINING ATTORNEY

SN 86-096,814. FUHU HOLDINGS, INC., EL SEGUNDO, CA. FILED 10-21-2013.

**MOM AND ME**

THE MARK CONSISTS OF STANDARD CHARACTERS WITHOUT CLAIM TO ANY PARTICULAR FONT, STYLE, SIZE, OR COLOR.

NO CLAIM IS MADE TO THE EXCLUSIVE RIGHT TO USE "MOM", APART FROM THE MARK AS SHOWN.

**CLASS 42—SCIENTIFIC AND COMPUTER SERVICES**

FOR PROVIDING A SOCIAL NETWORKING WEBSITE FEATURING TECHNOLOGY FOR YOUTH AND THEIR FAMILIES TO ENABLE PARTICIPATION IN DISCUSSIONS, UPLOAD, EXCHANGE AND SHARE PHOTOS, DRAWINGS, AND VIDEOS; PROVIDING TEMPORARY USE OF NON-DOWNLOADABLE SOFTWARE APPLICATIONS FOR SOCIAL NETWORKING, CREATING A VIRTUAL COMMUNITY, AND TRANSMISSION OF AUDIO, VIDEO, PHOTOGRAPHIC IMAGES, TEXT, GRAPHICS AND DATA (U.S. CLS. 100 AND 101).

**CLASS 45—PERSONAL AND LEGAL SERVICES**

FOR ONLINE SOCIAL NETWORKING SERVICES FOR YOUTH AND THEIR FAMILIES; PROVIDING ON-LINE SOCIAL NETWORKING SERVICES VIA A WEBSITE FOR YOUTH AND THEIR FAMILIES TO PARTICIPATE IN DISCUSSION, UPLOAD, EXCHANGE AND SHARE PHOTOS, DRAWINGS, AND VIDEOS (U.S. CLS. 100 AND 101).

JEAN IM, EXAMINING ATTORNEY

SN 86-096,854. FUHU HOLDINGS, INC., EL SEGUNDO, CA. FILED 10-21-2013.

**GRANDMA AND ME**

THE MARK CONSISTS OF STANDARD CHARACTERS WITHOUT CLAIM TO ANY PARTICULAR FONT, STYLE, SIZE, OR COLOR.

NO CLAIM IS MADE TO THE EXCLUSIVE RIGHT TO USE "GRANDMA", APART FROM THE MARK AS SHOWN.

**CLASS 42—SCIENTIFIC AND COMPUTER SERVICES**

FOR PROVIDING A SOCIAL NETWORKING WEBSITE FEATURING TECHNOLOGY FOR YOUTH AND THEIR FAMILIES TO ENABLE PARTICIPATION IN DISCUSSIONS, UPLOAD, EXCHANGE AND SHARE PHOTOS, DRAWINGS, AND VIDEOS; PROVIDING TEMPORARY USE OF NON-DOWNLOADABLE SOFTWARE APPLICATIONS FOR SOCIAL NETWORKING, CREATING A VIRTUAL COMMUNITY, AND TRANSMISSION OF AUDIO, VIDEO, PHOTOGRAPHIC IMAGES, TEXT, GRAPHICS AND DATA (U.S. CLS. 100 AND 101).

**CLASS 45—PERSONAL AND LEGAL SERVICES**

FOR ONLINE SOCIAL NETWORKING SERVICES FOR YOUTH AND THEIR FAMILIES; PROVIDING ON-LINE SOCIAL NETWORKING SERVICES VIA A WEBSITE FOR YOUTH AND THEIR FAMILIES TO PARTICIPATE IN DISCUSSION, UPLOAD, EXCHANGE AND SHARE PHOTOS, DRAWINGS, AND VIDEOS (U.S. CLS. 100 AND 101).

JÉAN IM, EXAMINING ATTORNEY

SN 86-097,178. OGE ENERGY CORP., OKLAHOMA CITY, OK. FILED 10-21-2013.

# OGE

THE MARK CONSISTS OF STANDARD CHARACTERS WITHOUT CLAIM TO ANY PARTICULAR FONT, STYLE, SIZE, OR COLOR.

OWNER OF U.S. REG. NOS. 3,394,909, 3,628,828 AND OTHERS.

**CLASS 35—ADVERTISING AND BUSINESS**

FOR CUSTOMER SERVICE FOR UTILITIES, NAMELY, STARTING, STOPPING, AND TRANSFERRING SERVICE VIA THE INTERNET, PROVIDING ON-LINE ORDERING SERVICES FOR AN ANTI-SURGE SYSTEM; PROMOTING PUBLIC AWARENESS OF THE EFFICIENT AND SAFE USE OF ELECTRICITY; ASSOCIATION SERVICES, NAMELY, PROMOTING PUBLIC AWARENESS OF ENVIRONMENTAL CONCERNS IN CONNECTION WITH POWER PRODUCTION (U.S. CLS. 100, 101 AND 102).

FIRST USE 12-31-1996; IN COMMERCE 12-31-1996.

**CLASS 36—INSURANCE AND FINANCIAL**

FOR PROVIDING EXTENDED WARRANTIES AGAINST ELECTRICAL SURGE OF CUSTOMERS ELECTRIC, ELECTRONIC OR ELECTRO-MECHANICAL EQUIPMENT; BILL PAYMENT SERVICES AND CREDIT RECOVERY AND COLLECTION SERVICES FEATURING FLEXIBLE PAYMENT PLANS MADE AVAILABLE BY OR THROUGH UTILITY COMPANIES FOR CUSTOMERS TO PAY UTILITY BILLS AND CHARGES; FINANCING LOANS FOR HEAT PUMP EQUIPMENT (U.S. CLS. 100, 101 AND 102).

FIRST USE 12-31-1996; IN COMMERCE 12-31-1996.

**CLASS 39—TRANSPORTATION AND STORAGE**

FOR DISTRIBUTION OF ENERGY; ELECTRICAL SERVICES, NAMELY, PUBLIC UTILITY SERVICES IN THE NATURE OF ELECTRICITY DISTRIBUTION (U.S. CLS. 100 AND 105).

FIRST USE 1-1-1968; IN COMMERCE 1-1-1968.

**CLASS 42—SCIENTIFIC AND COMPUTER SERVICES**

FOR GEOTHERMAL HEATING AND COOLING DESIGN FOR OTHERS IN THE NATURE OF DESIGN OF GEOTHERMAL HEATING AND COOLING SYSTEMS FOR OTHERS; TECHNICAL DESIGN OF ENERGY EFFICIENT HOMES FOR OTHERS (U.S. CLS. 100 AND 101).

FIRST USE 12-31-1996; IN COMMERCE 12-31-1996.  
ELIZABETH KAJUBI, EXAMINING ATTORNEY

SN 86-097,564. HONEYWELL INTERNATIONAL INC., MORRISTOWN, NJ. FILED 10-22-2013.

# LIFE IN TUNE

THE MARK CONSISTS OF STANDARD CHARACTERS WITHOUT CLAIM TO ANY PARTICULAR FONT, STYLE, SIZE, OR COLOR.

**CLASS 9—ELECTRICAL AND SCIENTIFIC APPARATUS**

FOR HOME AND OFFICE AUTOMATION SYSTEMS COMPRISING WIRELESS AND WIRED CONTROLLERS AND CONTROLLED DEVICES FOR LIGHTING, WINDOW SHADES, HVAC, SECURITY, SAFETY AND OTHER HOME AND OFFICE MONITORING AND CONTROL APPLICATIONS; SECURITY EQUIPMENT SOLD INDIVIDUALLY, AS COMPONENTS, OR TOGETHER AS A SYSTEM COMPRISING ONE OR MORE OF THE FOLLOWING: CONTROL PANELS, KEYPADS, TRANSCIEVERS, TRANSMITTERS, SIGNAL RECEIVERS, SIRENS, AUDIO SPEAKERS; SENSORS AND DETECTORS FOR SECURITY, FIRE PROTECTION AND HOME MONITORING, NAMELY ELECTRONIC MAGNETIC CONTACTS, ELECTRONIC INTRUSION DETECTORS, ELECTRONIC GLASSBREAK SENSORS, ELECTRONIC MOTION SENSORS, SMOKE DETECTORS, HEAT DETECTORS, CARBON MONOXIDE DETECTORS, ELECTRONIC SENSORS THAT DETECT THE MOVEMENT OF PHYSICAL OBJECTS, TEMPERATURE, ENVIRONMENTAL CONDITIONS AND WATER LEAKAGE; ELECTRONIC DOOR LOCKS; THERMOSTATS; DIGITAL VIDEO CAMERAS; DIGITAL VIDEO RECORDERS; COMPUTER HARDWARE FOR TRACKING PEOPLE, OBJECTS AND PETS USING GPS DATA ON A DEVICE ON THE TRACKED PEOPLE, OBJECTS AND PETS; COMPUTER SOFTWARE FOR MONITORING, CONTROLLING, AND MANAGING SECURITY, HVAC, FIRE, LIGHTING, LOCKS, PHYSICAL OBJECTS, APPLIANCES AND VEHICLES (U.S. CLS. 21, 23, 26, 36 AND 38).

**CLASS 11—ENVIRONMENTAL CONTROL APPARATUS**

FOR HOUSEHOLD AIR CLEANERS; HUMIDIFIERS; DEHUMIDIFIERS (U.S. CLS. 13, 21, 23, 31 AND 34).

**CLASS 35—ADVERTISING AND BUSINESS**

FOR ENERGY USAGE MANAGEMENT, NAMELY, MANAGING ELECTRIC POWER CONSUMPTION BY THIRD PARTIES, AND CONTROLLING THE USE OF POWER CONSUMING DEVICES/APPLIANCES FOR PURPOSES OF REDUCING ELECTRICAL CONSUMPTION ON BEHALF OF UTILITIES AT CERTAIN TIMES WHEN THE ELECTRICAL GRID IS EXPERIENCING HIGH DEMAND; ELECTRONICALLY GATHERING, ANALYZING AND FORMATTING DATA TO MONITOR AND CONTROL ENERGY USAGE BY CONTROLLING ENERGY CONSUMING APPLIANCES (U.S. CLS. 100, 101 AND 102).



**CLASS 42—SCIENTIFIC AND COMPUTER SERVICES**

FOR SOFTWARE AS A SERVICE (SAAS) SERVICES, NAMELY, HOSTING SOFTWARE FOR USE BY OTHERS FOR USE IN ENERGY EFFICIENCY OR USAGE ANALYSIS AND HOSTING SOFTWARE FOR USE BY OTHERS FOR USE IN HOME ENERGY USAGE MANAGEMENT (U.S. CLS. 100 AND 101).  
KRISTIN DAHLING, EXAMINING ATTORNEY

SN 86-097,887. ZEXTRAS SRL, VICENZA (VI), ITALY, FILED 10-22-2013.

# ZEXTRAS

THE MARK CONSISTS OF STANDARD CHARACTERS WITHOUT CLAIM TO ANY PARTICULAR FONT, STYLE, SIZE, OR COLOR.

SN 86-097,725. THE TRUSTEES OF INDIANA UNIVERSITY, BLOOMINGTON, IN. FILED 10-22-2013.



NO CLAIM IS MADE TO THE EXCLUSIVE RIGHT TO USE THE REPRESENTATION OF THE STATE OF INDIANA, AND THE WORDING "HOOSIER" AND "CLE", APART FROM THE MARK AS SHOWN.

THE COLOR(S) RED, BLACK, BROWN AND WHITE IS/ARE CLAIMED AS A FEATURE OF THE MARK.

THE MARK CONSISTS OF IMAGE OF THE STATE OF INDIANA BROKEN INTO THREE SEGMENTS, INCLUDING AN UPPER RED SEGMENT, A MIDDLE BLACK SEGMENT AND A LOWER BROWN SEGMENT, WITH WHITE CURVING BANDS BETWEEN THE SEGMENTS; AND THE WORDS "HOOSIER" AND "CLE" IN WHITE.

**CLASS 16—PAPER GOODS AND PRINTED MATTER**

FOR PRINTED MATERIALS, NAMELY, ARTICLES, SCHOLARLY PAPERS, SEMINAR HANDOUTS AND PRESENTATIONS, AND COMPILATIONS OF SEMINAR MATERIALS IN THE FIELD OF LEGAL EDUCATION (U.S. CLS. 2, 5, 22, 23, 29, 37, 38 AND 50).

FIRST USE 2-5-2013; IN COMMERCE 2-5-2013.

**CLASS 41—EDUCATION AND ENTERTAINMENT**

FOR EDUCATIONAL SERVICES, NAMELY, PROVIDING LEGAL EDUCATION SEMINARS (U.S. CLS. 100, 101 AND 107).

FIRST USE 2-5-2013; IN COMMERCE 2-5-2013.

HEATHER BIDDULPH, EXAMINING ATTORNEY

**CLASS 9—ELECTRICAL AND SCIENTIFIC APPARATUS**

FOR COMPUTER SOFTWARE FOR USE IN THE DEPLOYMENT OF EMAIL SERVERS TO MANAGE, BACKUP, RESTORE, AND SYNCHRONIZE EMAIL SERVERS WITH MOBILE DEVICES (U.S. CLS. 21, 23, 26, 36 AND 38).

FIRST USE 10-14-2011; IN COMMERCE 10-14-2011.

**CLASS 42—SCIENTIFIC AND COMPUTER SERVICES**

FOR SCIENTIFIC AND TECHNOLOGICAL SERVICES AND RESEARCH AND PLANNING SERVICES RELATED TO THE DEVELOPMENT AND CREATION OF SOFTWARE; ANALYSIS AND INDUSTRY RESEARCH SERVICES RELATED TO THE DEVELOPMENT AND CREATION OF SOFTWARE; PLANNING AND DEVELOPMENT OF COMPUTERS AND COMPUTER PROGRAMS; AND INSTALLATION SERVICES FOR SOFTWARE (U.S. CLS. 100 AND 101).

LINDA QUIGLEY, EXAMINING ATTORNEY

SN 86-099,397. IIC-INTERSPORT INTERNATIONAL CORPORATION GMBH, BERN, SWITZERLAND, FILED 10-23-2013.



PRIORITY CLAIMED UNDER SEC. 44(D) ON SWITZERLAND APPLICATION NO. 58183/2013, FILED 7-3-2013, REG. NO. 650577, DATED 11-4-2013, EXPIRES 7-3-2023.

OWNER OF U.S. REG. NOS. 1,743,175 AND 3,338,071.

THE MARK CONSISTS OF A TRIANGLE IN THE SHAPE OF A SNOW-COVERED MOUNTAIN ON TOP OF THE WORD "MCKINLEY".

**CLASS 18—LEATHER GOODS**

FOR SPORT AND TRAVEL BAGS, MOUNTAIN BAGS FOR CLIMBERS, RUCKSACKS AND BACKPACKS, IN PARTICULAR RUCKSACKS AND BACKPACKS IN WATERPROOF MATERIAL, ESPECIALLY DESIGNED FOR SKIING; SLING BAGS FOR CARRYING INFANTS, RAIN COVERS FOR BAGS; POUCHES MADE OF LEATHER OR CLOTH MATERIAL, WILD ANIMAL GAME BAGS AND RUCKSACKS FOR HUNTING; SADDLERY; WALKING STICKS (U.S. CLS. 1, 2, 3, 22 AND 41).

**CLASS 20—FURNITURE AND ARTICLES NOT OTHERWISE CLASSIFIED**

FOR NON-INFLATABLE AND INFLATABLE MATTRESSES FOR CAMPING, TABLES AND CHAIRS FOR CAMPING, EASY CHAIRS, NON-METALLIC BENCHES FOR FISHING; FISHING CAGES NOT OF METAL FOR COMMERCIAL USE; SLEEPING BAGS FOR CAMPING; CUSHIONS AND PILLOWS; BIVOUAC BAGS, NAMELY, SLEEPING BAGS ESPECIALLY DESIGNED FOR BIVOUAC; CASES OF WOOD AND CASES OF PLASTIC FOR USE IN CAMPING AND MOUNTAINEERING; STAKES AND PEGS NOT OF METAL FOR CAMPING TENTS (U.S. CLS. 2, 13, 22, 25, 32 AND 50).

**CLASS 22—CORDAGE AND FIBERS**

FOR ROPES, STRINGS, NETS, NAMELY, INSECT PROTECTION NETS FOR COMMERCIAL PURPOSES, TENTS, IN PARTICULAR FOR CAMPING, TARPULINS, SAILS (U.S. CLS. 1, 2, 7, 19, 22, 42 AND 50).

**CLASS 25—CLOTHING**

FOR CLOTHING, NAMELY, SOCKS, TROUSERS, PANTS, SHORTS, SHIRTS, T-SHIRTS, POLO SHIRTS, SWEATSHIRTS, PULLOVERS, VESTS, JACKETS, ANORAKS, OVERALLS, SCARVES, FOOTWEAR, GLOVES AND HATS, NAMELY, THOSE FOR WALKING, MOUNTAIN WALKING, MOUNTAINEERING, HUNTING, FISHING, HORSEBACK RIDING, WINTER SPORTS AND SKIING; BOOTS FOR ANGLERS (U.S. CLS. 22 AND 39).

DAVID TAYLOR, EXAMINING ATTORNEY

SN 86-100,845. AMERICA EAST CONFERENCE, CAMBRIDGE, MA. FILED 10-24-2013.



NO CLAIM IS MADE TO THE EXCLUSIVE RIGHT TO USE "CONFERENCE", APART FROM THE MARK AS SHOWN.

THE MARK CONSISTS OF THE INTEGRATED LETTERS "A" AND "E" WITHIN A SHADED QUADRILATERAL. BELOW THE LETTERS ARE THE WORDS "AMERICA EAST CONFERENCE" IN STYLIZED LETTERS.

SEC. 2(F) AS TO "AMERICA EAST".

**CLASS 16—PAPER GOODS AND PRINTED MATTER**

FOR PUBLICATIONS, NAMELY, BOOKS, PAMPHLETS, BROCHURES, NEWSLETTERS, JOURNALS, MAGAZINES, HANDBOOKS, MANUALS AND PROGRAMS, ALL RELATING TO ATHLETIC ACTIVITIES; LETTER OPENERS, NOTEBOOKS, STAPLERS, MONEY CLIPS, PAPERWEIGHTS, PENS, BINDER CLIPS, HIGHLIGHTER PENS, STATIONERY NOTES CONTAINING ADHESIVE ON ONE SIDE FOR ATTACHMENT TO SURFACES (U.S. CLS. 2, 5, 22, 23, 29, 37, 38 AND 50).

FIRST USE 8-20-2013; IN COMMERCE 8-20-2013.

**CLASS 25—CLOTHING**

FOR CLOTHING, NAMELY, HATS, SHIRTS, SWEATSHIRTS, T-SHIRTS, SHORTS, PANTS, JACKETS (U.S. CLS. 22 AND 39).

FIRST USE 8-20-2013; IN COMMERCE 8-20-2013.

**CLASS 35—ADVERTISING AND BUSINESS**

FOR ASSOCIATION SERVICES, NAMELY, PROMOTING THE INTERESTS OF MEMBER COLLEGES AND UNIVERSITIES PARTICIPATING IN INTERCOLLEGIATE ATHLETIC PROGRAMS; PROMOTING THE STANDARDS OF SCHOLARSHIP, SPORTSMANSHIP AND EQUITY INTERESTS OF COLLEGES; PROMOTING THE GOODS AND SERVICES OF OTHERS BY ARRANGING FOR SPONSORS TO AFFILIATE THEIR GOODS AND SERVICES WITH COLLEGE ATHLETIC COMPETITIONS AND CONTESTS; PROMOTING ATHLETIC CONTESTS AND COMPETITIONS FOR OTHERS (U.S. CLS. 100, 101 AND 102).

FIRST USE 8-23-2013; IN COMMERCE 8-23-2013.

**CLASS 38—COMMUNICATION**

FOR TELEVISION BROADCASTING; COMMUNICATIONS SERVICES, NAMELY, BROADCASTING IN THE FORM OF TRANSMITTING LIVE OR TAPED SPORTING AND SCHOLASTIC EVENTS AND TRANSMITTING NEWS, SCORES AND INFORMATION FEATURING SPORTING AND SCHOLASTIC EVENTS VIA THE GLOBAL COMPUTER NETWORK, TELEPHONE NETWORKS AND WIRELESS COMMUNICATION NETWORKS (U.S. CLS. 100, 101 AND 104).

FIRST USE 8-20-2013; IN COMMERCE 8-20-2013.

**CLASS 41—EDUCATION AND ENTERTAINMENT**

FOR ENTERTAINMENT SERVICES, NAMELY, ARRANGING AND CONDUCTING ATHLETIC COMPETITIONS AND PRODUCING TELEVISION PROGRAMS ABOUT ATHLETIC COMPETITIONS AND CONTESTS, AND STORIES ABOUT ACADEMIC SCHOLARSHIP ACHIEVEMENT; CONDUCTING CLINICS AND CLASSES IN THE FIELD OF ATHLETICS AND DRUG ABUSE PREVENTION, AND DISTRIBUTING COURSE MATERIALS IN CONNECTION THEREWITH; ONLINE COMPUTER SERVICES, NAMELY, PROVIDING NEWS, SCORES AND INFORMATION FEATURING SPORTING EVENTS VIA THE GLOBAL COMPUTER NETWORK (U.S. CLS. 100, 101 AND 107).

FIRST USE 8-20-2013; IN COMMERCE 8-20-2013.

MEREDITH MARESCA, EXAMINING ATTORNEY

SN 86-100,847. SEA WORLD LLC, ORLANDO, FL. FILED 10-24-2013.

**INSPIRING GAMERS TO BECOME  
GAME CHANGERS**

THE MARK CONSISTS OF STANDARD CHARACTERS WITHOUT CLAIM TO ANY PARTICULAR FONT, STYLE, SIZE, OR COLOR.

**CLASS 35—ADVERTISING AND BUSINESS**

FOR PROMOTING PUBLIC AWARENESS OF WILDLIFE HABITAT CONSERVATION, NATURAL RESOURCES CONSERVATION, ANIMALS, WILDLIFE, AND ANIMAL HABITATS (U.S. CLS. 100, 101 AND 102).

**CLASS 41—EDUCATION AND ENTERTAINMENT**

FOR ENTERTAINMENT SERVICES, NAMELY, PROVIDING AN ONGOING WEBISODES ABOUT WILDLIFE HABITAT CONSERVATION, NATURAL RESOURCES CONSERVATION, ANIMALS, WILDLIFE, AND ANIMAL HABITATS (U.S. CLS. 100, 101 AND 107).

ALICE BENMAMAN, EXAMINING ATTORNEY

SN 86-101,706. WHEATLEY, TERRY, HUGHSON, CA. FILED 10-25-2013.

**GIRLS FOR GIRLS**

THE MARK CONSISTS OF STANDARD CHARACTERS WITHOUT CLAIM TO ANY PARTICULAR FONT, STYLE, SIZE, OR COLOR.

**CLASS 25—CLOTHING**

FOR CLOTHING, NAMELY, T-SHIRTS, SWEATSHIRTS, JACKETS, SKIRTS, HATS, VISORS AND CAPS (U.S. CLS. 22 AND 39).

**CLASS 36—INSURANCE AND FINANCIAL**

FOR CHARITABLE FUNDRAISING SERVICES (U.S. CLS. 100, 101 AND 102).  
ELLEN PERKINS, EXAMINING ATTORNEY

SN 86-101,714. WHEATLEY, TERRY, HUGHSON, CA. FILED 10-25-2013.

**GIRLS 4 GIRLS**

THE MARK CONSISTS OF STANDARD CHARACTERS WITHOUT CLAIM TO ANY PARTICULAR FONT, STYLE, SIZE, OR COLOR.

**CLASS 25—CLOTHING**

FOR CLOTHING, NAMELY, T-SHIRTS, SWEATSHIRTS, JACKETS, SKIRTS, HATS, VISORS AND CAPS (U.S. CLS. 22 AND 39).

**CLASS 36—INSURANCE AND FINANCIAL**

FOR CHARITABLE FUNDRAISING SERVICES (U.S. CLS. 100, 101 AND 102).  
ELLEN PERKINS, EXAMINING ATTORNEY

SN 86-101,826. TOURENNE JEAN-LUC, PARIS, FRANCE, FILED 10-25-2013.

**ALLOCOMICS**

THE MARK CONSISTS OF STANDARD CHARACTERS WITHOUT CLAIM TO ANY PARTICULAR FONT, STYLE, SIZE, OR COLOR.

**CLASS 9—ELECTRICAL AND SCIENTIFIC APPARATUS**

FOR ELECTRONIC COMIC BOOKS RECORDED ON COMPUTER MEDIA; COMPUTER APPLICATION SOFTWARE FOR MOBILE DEVICES, PHONES, TABLETS FEATURING COMIC BOOKS; COMPUTER SOFTWARE APPLICATION FOR PREVIEWING AND BUYING COMIC BOOKS (U.S. CLS. 21, 23, 26, 36 AND 38).

FIRST USE 9-15-2013; IN COMMERCE 9-20-2013.

**CLASS 41—EDUCATION AND ENTERTAINMENT**

FOR PROVIDING ONLINE NON-DOWNLOADABLE ELECTRONIC COMIC BOOKS; PROVIDING A WEBSITE FEATURING ONLINE NON-DOWNLOADABLE COMIC BOOKS AND GRAPHICAL NOVELS FOR USE BY CONSUMERS AND PUBLISHERS (U.S. CLS. 100, 101 AND 107).

FIRST USE 9-11-2013; IN COMMERCE 9-25-2013.

KHANH LE, EXAMINING ATTORNEY

SN 86-101,941. ZUMTOBEL LIGHTING GMBH, DORNBIRN, AUSTRIA, FILED 10-25-2013.

**LIMBIC LIGHT**

THE MARK CONSISTS OF STANDARD CHARACTERS WITHOUT CLAIM TO ANY PARTICULAR FONT, STYLE, SIZE, OR COLOR.

PRIORITY CLAIMED UNDER SEC. 44(D) ON AUSTRIA APPLICATION NO. AM2485/2013, FILED 5-23-2013, REG. NO. 274770, DATED 9-12-2013, EXPIRES 9-12-2023.

NO CLAIM IS MADE TO THE EXCLUSIVE RIGHT TO USE "LIGHT", APART FROM THE MARK AS SHOWN.

**CLASS 9—ELECTRICAL AND SCIENTIFIC APPARATUS**

FOR ELECTRIC AND ELECTRONIC EQUIPMENT, NAMELY, ELECTRIC LIGHT SWITCHES, LIGHTING CONTROL APPARATUS FOR THE OPERATION OF LAMPS, LIGHT EMITTING DIODES AND ELECTROLUMINESCENT FILM; ELECTRIC BALLASTS AND ELECTRIC IGNITION DEVICES FOR FLUORESCENT LAMPS; ELECTRIC BALLASTS AND ELECTRIC IGNITION DEVICES FOR HIGH-PRESSURE AND LOW-PRESSURE DISCHARGE LAMPS; ELECTRONIC EQUIPMENT FOR LIGHT CONTROLS AND SHADE CONTROLS; LIGHT SENSORS, MOTION DETECTORS, INFRARED REMOTE CONTROLS FOR CONTROLLING LIGHTING, FOR RAISING AND LOWERING WINDOW SHADES, ELECTRIC LIGHT DIMMERS; ELECTRICAL REGULATING AND CONTROL DEVICES AND EQUIPMENT FOR LIGHTING INSTALLATIONS AND LIGHTS; OPTICAL FIBRE LIGHT CONDUITS OF GLASS OR PLASTIC FIBRES; OPTICAL FILTERS AND BARRIER FILTERS; ELECTRICAL LIGHT OUTLETS; LENSES FOR FOCUSING LIGHT, NAMELY, OPTICAL LENSES; LIGHT EMITTING DIODES (U.S. CLS. 21, 23, 26, 36 AND 38).

**CLASS 11—ENVIRONMENTAL CONTROL APPARATUS**

FOR LIGHTING INSTALLATIONS, DEVICES AND EQUIPMENTS AND LIGHTS, NAMELY, ELECTRIC LIGHTING FIXTURES AND LAMPS; FIBRE OPTIC LIGHTING INSTALLATIONS; EXTERIOR LIGHTS, NAMELY, EXTERIOR LIGHTING FIXTURES; STREET LAMPS, FLOOR LAMPS; ELECTRIC LANTERNS; LIGHT MODULES AND LIGHTS WITH LIGHT EMITTING DIODES AS THE MEANS OF LIGHTING, NAMELY, LIGHTING FIXTURES; SOURCES OF LIGHT, NAMELY, LIGHTING FIXTURES, CONTAINING LIGHT EMITTING DIODES; LAMP CASINGS, GRILLES FOR DIRECTING LIGHT, REFLECTORS AND COVERS FOR LIGHTS; ELECTRIC LAMPS; ELECTRIC LAMP SOCKETS; SUSPENSION PENDANTS FOR LIGHTS, NAMELY, LAMP HANGING SUPPORTS; OPTICAL FIBRE LIGHT LINES OF GLASS OR PLASTIC FIBRES IN THE NATURE OF FIBER OPTIC LIGHTING FIXTURES USED IN CONJUNCTION WITH ELECTRICAL ILLUMINATORS (U.S. CLS. 13, 21, 23, 31 AND 34).

**CLASS 42—SCIENTIFIC AND COMPUTER SERVICES**

FOR TECHNICAL DESIGN AND TECHNICAL DESIGN PLANNING OF INSTALLATIONS FOR LIGHTING, AIR CONDITIONING, VENTILATION AND HEATING; PROGRAMMING OF COMPUTING ROUTINES FOR ELECTRONIC DATA PROCESSING EQUIPMENT; SCIENTIFIC AND TECHNOLOGICAL SERVICES, NAMELY, RESEARCH AND DESIGN IN THE FIELDS OF LIGHT PLANNING; RESEARCH PROJECTS AND RELATING DESIGNER SERVICES IN THE FIELDS OF LIGHT PLANNING; SCIENTIFIC AND TECHNOLOGICAL SERVICES, NAMELY, ANALYSIS AND TESTING IN THE FIELDS OF LIGHT PLANNING (U.S. CLS. 100 AND 101).

AMY HELLA, EXAMINING ATTORNEY

SN 86-101,999, FRUGEN LLC, FOUNTAIN VALLEY, CA, FILED 10-25-2013.

# FRÜGEN

THE MARK CONSISTS OF STANDARD CHARACTERS WITHOUT CLAIM TO ANY PARTICULAR FONT, STYLE, SIZE, OR COLOR.

**CLASS 30—STAPLE FOODS**

FOR POWDERED FRAPPÉ BEVERAGE MIX (U.S. CL. 46).  
FIRST USE 10-4-2013; IN COMMERCE 10-4-2013.

**CLASS 32—LIGHT BEVERAGES**

FOR BLENDED ENERGY DRINKS (U.S. CLS. 45, 46 AND 48).  
FIRST USE 10-4-2013; IN COMMERCE 10-4-2013.  
DAVID MURRAY, EXAMINING ATTORNEY

SN 86-102,464, UTOWA CO., LTD., MINATO-KU, TOKYO, JAPAN, FILED 10-26-2013.

# UTOWA

THE MARK CONSISTS OF STANDARD CHARACTERS WITHOUT CLAIM TO ANY PARTICULAR FONT, STYLE, SIZE, OR COLOR.

THE WORDING "UTOWA" HAS NO MEANING IN A FOREIGN LANGUAGE.

**CLASS 3—COSMETICS AND CLEANING PREPARATIONS**

FOR COSMETICS, SOAPS (U.S. CLS. 1, 4, 6, 50, 51 AND 52).

**CLASS 21—HOUSEWARES AND GLASS**

FOR COSMETIC UTENSILS, NAMELY, COMPACTS SOLD EMPTY, NAIL BRUSHES, LIP BRUSHES, EYELASH FORMERS, EYELASH COMB AND COSMETIC SPATULA FOR COSMETIC CREAMS; COSMETIC BRUSHES; EYEBROW BRUSHES; FACIAL SPONGES FOR APPLYING MAKEUP; HAIR BRUSHES; HAIR COMBS; PERFUME SPRAYERS SOLD EMPTY; POWDER PUFFS; FITTED VANITY CASES (U.S. CLS. 2, 13, 23, 29, 30, 33, 40 AND 50).

STEVEN JACKSON, EXAMINING ATTORNEY

SN 86-102,968, ZUMTOBEL LIGHTING GMBH, DORNBIERN, AUSTRIA, FILED 10-28-2013.

# LIMBIC LIGHTING

THE MARK CONSISTS OF STANDARD CHARACTERS WITHOUT CLAIM TO ANY PARTICULAR FONT, STYLE, SIZE, OR COLOR.

PRIORITY CLAIMED UNDER SEC. 44(D) ON AUSTRIA APPLICATION NO. AM2484/2013, FILED 5-23-2013, REG. NO. 274769, DATED 9-12-2013, EXPIRES 9-12-2023.

NO CLAIM IS MADE TO THE EXCLUSIVE RIGHT TO USE "LIGHTING", APART FROM THE MARK AS SHOWN.

**CLASS 9—ELECTRICAL AND SCIENTIFIC APPARATUS**

FOR ELECTRIC AND ELECTRONIC EQUIPMENT, NAMELY, ELECTRIC LIGHT SWITCHES, LIGHTING CONTROL APPARATUS FOR THE OPERATION OF LAMPS, LIGHT EMITTING DIODES AND ELECTROLUMINESCENT FILM; ELECTRIC BALLASTS AND ELECTRIC IGNITION DEVICES FOR FLUORESCENT LAMPS; ELECTRIC BALLASTS AND ELECTRIC IGNITION DEVICES FOR HIGH-PRESSURE AND LOW-PRESSURE DISCHARGE LAMPS; ELECTRONIC EQUIPMENT FOR LIGHT CONTROLS AND SHADE CONTROLS; LIGHT SENSORS, MOTION DETECTORS, INFRARED REMOTE CONTROLS FOR CONTROLLING LIGHTING, FOR RAISING AND LOWERING WINDOW SHADES, ELECTRIC LIGHT DIMMERS; ELECTRICAL REGULATING AND CONTROL DEVICES AND EQUIPMENT FOR LIGHTING INSTALLATIONS AND LIGHTS; OPTICAL FIBRE LIGHT CONDUITS OF GLASS OR PLASTIC FIBRES; OPTICAL FILTERS AND BARRIER FILTERS; ELECTRICAL LIGHT OUTLETS; LENSES FOR FOCUSING LIGHT, NAMELY, OPTICAL LENSES; LIGHT EMITTING DIODES (U.S. CLS. 21, 23, 26, 36 AND 38).

**CLASS 11—ENVIRONMENTAL CONTROL APPARATUS**

FOR LIGHTING INSTALLATIONS, DEVICES AND EQUIPMENTS AND LIGHTS, NAMELY, ELECTRIC LIGHTING FIXTURES AND LAMPS; FIBRE OPTIC LIGHTING INSTALLATIONS; EXTERIOR LIGHTS, NAMELY, EXTERIOR LIGHTING FIXTURES; STREET LAMPS, FLOOR LAMPS; ELECTRIC LANTERNS; LIGHT MODULES AND LIGHTS WITH LIGHT EMITTING DIODES AS THE MEANS OF LIGHTING, NAMELY, LIGHTING FIXTURES; SOURCES OF LIGHT, NAMELY, LIGHTING FIXTURES, CONTAINING LIGHT EMITTING DIODES; LAMP CASINGS, GRILLES FOR DIRECTING LIGHT, REFLECTORS AND COVERS FOR LIGHTS; ELECTRIC LAMPS; ELECTRIC LAMP SOCKETS; SUSPENSION PENDANTS FOR LIGHTS, NAMELY, LAMP HANGING SUPPORTS; OPTICAL FIBRE LIGHT LINES OF GLASS OR PLASTIC FIBRES IN THE NATURE OF FIBER OPTIC LIGHTING FIXTURES USED IN CONJUNCTION WITH ELECTRICAL ILLUMINATORS (U.S. CLS. 13, 21, 23, 31 AND 34).

**CLASS 42—SCIENTIFIC AND COMPUTER SERVICES**

FOR TECHNICAL DESIGN AND TECHNICAL DESIGN PLANNING OF INSTALLATIONS FOR LIGHTING, AIR CONDITIONING, VENTILATION AND HEATING; PROGRAMMING OF COMPUTING ROUTINES FOR ELECTRONIC DATA PROCESSING EQUIPMENT; SCIENTIFIC AND TECHNOLOGICAL SERVICES, NAMELY, RESEARCH AND DESIGN IN THE FIELDS OF LIGHT PLANNING; RESEARCH PROJECTS AND RELATING DESIGNER SERVICES IN THE FIELDS OF LIGHT PLANNING; SCIENTIFIC AND TECHNOLOGICAL SERVICES, NAMELY, ANALYSIS AND TESTING IN THE FIELDS OF LIGHT PLANNING (U.S. CLS. 100 AND 101).

AMY HELLA, EXAMINING ATTORNEY

SN 86-102,990. GENSCRIPT USA INCORPORATED, PISCATAWAY, NJ. FILED 10-28-2013.

# VectorArk

THE MARK CONSISTS OF STANDARD CHARACTERS WITHOUT CLAIM TO ANY PARTICULAR FONT, STYLE, SIZE, OR COLOR.

**CLASS 39—TRANSPORTATION AND STORAGE**

FOR STORAGE OF BIOLOGICAL MATERIALS (U.S. CLS. 100 AND 105).

**CLASS 40—MATERIAL TREATMENT**

FOR BIOLOGICAL MATERIALS PRESERVATION SERVICES (U.S. CLS. 100, 103 AND 106).

**CLASS 42—SCIENTIFIC AND COMPUTER SERVICES**

FOR SCIENTIFIC AND TECHNOLOGICAL SERVICES, NAMELY, SCIENTIFIC RESEARCH IN THE FIELD OF BIOLOGY (U.S. CLS. 100 AND 101).

DOUGLAS LEE, EXAMINING ATTORNEY

SN 86-103,041. CUBIC TRANSPORTATION SYSTEMS, INC., SAN DIEGO, CA. FILED 10-28-2013.

# NEXTLINK

THE MARK CONSISTS OF STANDARD CHARACTERS WITHOUT CLAIM TO ANY PARTICULAR FONT, STYLE, SIZE, OR COLOR.

OWNER OF U.S. REG. NO. 3,079,048.

**CLASS 9—ELECTRICAL AND SCIENTIFIC APPARATUS**

FOR COMPUTER SOFTWARE, COMPUTER OPERATING SYSTEMS AND COMPUTER PERIPHERALS THEREFOR FOR INTEGRATING FARE COLLECTION AND PAYMENT SYSTEM TRANSACTIONS; COMPUTER SOFTWARE, COMPUTER OPERATING SYSTEMS AND COMPUTER PERIPHERALS THEREFOR FOR FARE COLLECTION AND PAYMENT; COMPUTER SOFTWARE, COMPUTER OPERATING SYSTEMS AND COMPUTER PERIPHERALS THEREFOR FOR DATA AND TRANSACTION MANAGEMENT AND ANALYSES; COMPUTER SOFTWARE, COMPUTER OPERATING SYSTEMS AND COMPUTER PERIPHERALS THEREFOR FOR FINANCIAL SETTLEMENT AND CLEARING; COMPUTER SOFTWARE, COMPUTER OPERATING SYSTEMS AND COMPUTER PERIPHERALS THEREFOR FOR TRACKING AND INFLUENCING CONSUMER BEHAVIOR; COMPUTER SOFTWARE, COMPUTER OPERATING SYSTEMS AND COMPUTER PERIPHERALS THEREFOR FOR INFORMING CONSUMERS' TRAVEL DECISIONS, NAMELY, PROVIDING TRAVEL ADVICE AND INFORMATION; COMPUTER SOFTWARE, COMPUTER OPERATING SYSTEMS AND COMPUTER PERIPHERALS THEREFOR FOR TRACKING PEOPLE'S USE OF TRANSPORTATION AND MASS TRANSIT; COMPUTER SOFTWARE, COMPUTER OPERATING SYSTEMS AND COMPUTER PERIPHERALS THEREFOR FOR CUSTOMER RELATIONSHIP MANAGEMENT; COMPUTER SOFTWARE FOR THE USE OF REAL TIME MESSAGING VIA SHORT MESSAGE SERVICE (SMS), MULTIMEDIA MESSAGING SERVICE (MMS), AND PUSH NOTIFICATION; COMPUTER SOFTWARE FOR THE USE OF NEAR FIELD COMMUNICATIONS (NFC) AS AN INTERFACE FOR TRANSIT PAYMENT AND FARE PRODUCT VALIDATION; COMPUTER SOFTWARE FOR THE USE OF NEAR FIELD COMMUNICATIONS (NFC) AS AN INTERFACE FOR CONTACTLESS SMART CARD ENCODING AND FARE PRODUCT UPDATE; COMPUTER SOFTWARE FOR THE USE OF NEAR FIELD COMMUNICATIONS (NFC) AS AN INTERFACE FOR CONTACTLESS SMART CARD DEBITING AND ACCEPTANCE FOR PAYMENT; COMPUTER SOFTWARE FOR THE USE OF BAR CODE TICKETING

IN SUPPORT OF MASS TRANSIT FARE PAYMENT; COMPUTER SOFTWARE FOR DELIVERING OFFERS AND MARKETING CONTENT TO TRANSIT CUSTOMERS; COMPUTER SOFTWARE FOR MANAGING AND MAINTAINING THE INTEGRITY AND SECURITY OF INFORMATION STORED ON SMARTCARDS; COMPUTER SOFTWARE FOR PUBLIC TRANSIT FARE ENFORCEMENT; COMPUTER SOFTWARE FOR TRANSIT SMARTCARD VALIDATION AND SECURITY; COMPUTER SOFTWARE FOR THE USE OF TRANSIT SMARTCARDS FOR PARKING COLLECTION AND PAYMENT; SERIALIZED MEDIA, NAMELY ENCODED SMART CARDS CONTAINING PROGRAMMING USED FOR PAYMENT SYSTEMS IN THE TRANSPORTATION FIELD; MAGNETIC ENCODED CARDS USED FOR DEBIT, CREDIT AND STORED VALUE TRANSACTIONS FOR PAYMENT SYSTEMS IN THE TRANSPORTATION FIELD; RADIO FREQUENCY IDENTIFICATION (RFID) TAGS FOR USE IN CONNECTION WITH PAYMENT FOR SERVICES, NAMELY, CONTACTLESS CREDENTIALS USED FOR PAYMENT SYSTEMS IN THE TRANSPORTATION FIELD; ENCODED SMART CARDS CONTAINING PROGRAMMING FOR USE WITH PAYMENT SYSTEMS IN THE TRANSPORTATION FIELD; RFID TAGS USED AS CONTACTLESS CREDENTIALS FOR ACCOUNT-BASED PAYMENT IN THE TRANSPORTATION FIELD; MAGNETICALLY ENCODED STORED VALUE CARDS FOR USE WITH PAYMENT SYSTEMS IN THE TRANSPORTATION FIELD; SMART CARD READERS; MAGNETIC ENCODED CARD READERS; NEAR FIELD COMMUNICATION (NFC) TECHNOLOGY-ENABLED READERS (U.S. CLS. 21, 23, 26, 36 AND 38).

#### CLASS 42—SCIENTIFIC AND COMPUTER SERVICES

FOR SOFTWARE AS A SERVICE (SAAS) SERVICES FEATURING SOFTWARE FOR INTEGRATING FARE COLLECTION AND PAYMENT SYSTEM TRANSACTIONS; SOFTWARE AS A SERVICE (SAAS) SERVICES FEATURING SOFTWARE FOR FARE COLLECTION AND PAYMENT; SOFTWARE AS A SERVICE (SAAS) SERVICES FEATURING SOFTWARE FOR DATA AND TRANSACTION MANAGEMENT AND ANALYSES; SOFTWARE AS A SERVICE (SAAS) SERVICES FEATURING SOFTWARE FOR FINANCIAL SETTLEMENT AND CLEARING; SOFTWARE AS A SERVICE (SAAS) SERVICES FEATURING SOFTWARE FOR TRACKING AND INFLUENCING CONSUMER BEHAVIOR; SOFTWARE AS A SERVICE (SAAS) SERVICES FEATURING SOFTWARE FOR INFORMING CONSUMERS' TRAVEL DECISIONS, NAMELY, PROVIDING TRAVEL ADVICE AND INFORMATION; SOFTWARE AS A SERVICE (SAAS) SERVICES FEATURING SOFTWARE FOR TRACKING PEOPLE'S USE OF TRANSPORTATION AND MASS TRANSIT; SOFTWARE AS A SERVICE (SAAS) SERVICES FEATURING SOFTWARE FOR CUSTOMER RELATIONSHIP MANAGEMENT; SOFTWARE AS A SERVICE (SAAS) SERVICES FEATURING SOFTWARE FOR THE USE OF REAL TIME MESSAGING VIA SHORT MESSAGE SERVICE (SMS), MULTIMEDIA MESSAGING SERVICE (MMS), AND PUSH NOTIFICATION; SOFTWARE AS A SERVICE (SAAS) SERVICES FEATURING SOFTWARE FOR THE USE OF NEAR FIELD COMMUNICATIONS (NFC) AS AN INTERFACE FOR TRANSIT PAYMENT AND FARE PRODUCT VALIDATION; SOFTWARE AS A SERVICE (SAAS) SERVICES FEATURING SOFTWARE FOR THE USE OF NEAR FIELD COMMUNICATIONS (NFC) AS AN INTERFACE FOR CONTACTLESS SMART CARD ENCODING AND FARE PRODUCT UPDATE; SOFTWARE AS A SERVICE (SAAS) SERVICES FEATURING SOFTWARE FOR THE USE OF NEAR FIELD COMMUNICATIONS (NFC) AS AN INTERFACE FOR CONTACTLESS SMART CARD DEBITING AND ACCEPTANCE FOR PAYMENT; SOFTWARE AS A SERVICE (SAAS) SERVICES FEATURING SOFTWARE FOR THE USE OF BAR CODE TICKETING IN SUPPORT OF MASS TRANSIT FARE PAYMENT; SOFTWARE AS A SERVICE (SAAS) SERVICES FEATURING SOFTWARE FOR DELIVERING OFFERS AND MARKETING CONTENT TO TRANSIT CUSTOMERS; SOFTWARE AS A SERVICE (SAAS) SERVICES FEATURING SOFTWARE FOR MANAGING AND MAINTAINING THE INTEGRITY AND SECURITY OF INFORMATION STORED ON SMARTCARDS; SOFTWARE AS A SERVICE (SAAS) SERVICES FEATURING SOFTWARE FOR PUBLIC TRANSIT FARE ENFORCE-

MENT; SOFTWARE AS A SERVICE (SAAS) SERVICES FEATURING SOFTWARE FOR TRANSIT SMARTCARD VALIDATION AND SECURITY; SOFTWARE AS A SERVICE (SAAS) SERVICES FEATURING SOFTWARE FOR THE USE OF TRANSIT SMARTCARDS FOR PARKING COLLECTION AND PAYMENT (U.S. CLS. 100 AND 101).  
RENEE MCCRAY, EXAMINING ATTORNEY

SN 86-103,157. LOLLY ELLA, LLC, WEST BLOOMFIELD, MI. FILED 10-28-2013.

*LollyElla*  
JEWELRY

NO CLAIM IS MADE TO THE EXCLUSIVE RIGHT TO USE "JEWELRY", APART FROM THE MARK AS SHOWN. THE NAME(S), PORTRAIT(S), AND/OR SIGNATURE(S) SHOWN IN THE MARK DOES NOT IDENTIFY A PARTICULAR LIVING INDIVIDUAL.  
THE MARK CONSISTS OF "LOLLY ELLA" IN STYLIZED SCRIPT ALONG WITH THE WORD "JEWELRY" IN BLOCK LETTERS.

#### CLASS 14—JEWELRY

FOR BRACELETS; JEWELRY; NECKLACES; RINGS (U.S. CLS. 2, 27, 28 AND 50).  
FIRST USE 11-21-2005; IN COMMERCE 11-21-2005.

#### CLASS 18—LEATHER GOODS

FOR HANDBAGS (U.S. CLS. 1, 2, 3, 22 AND 41).  
FIRST USE 11-21-2005; IN COMMERCE 11-21-2005.

#### CLASS 25—CLOTHING

FOR SCARFS (U.S. CLS. 22 AND 39).  
FIRST USE 11-21-2005; IN COMMERCE 11-21-2005.  
MIDGE BUTLER, EXAMINING ATTORNEY

SN 86-103,170. HEALTH PRODUCT DECLARATION COLLABORATIVE, INC., CHARLESTON, SC. FILED 10-28-2013.

HPD

THE MARK CONSISTS OF STANDARD CHARACTERS WITHOUT CLAIM TO ANY PARTICULAR FONT, STYLE, SIZE, OR COLOR.

#### CLASS 9—ELECTRICAL AND SCIENTIFIC APPARATUS

FOR DOWNLOADABLE ELECTRONIC PUBLICATIONS IN THE NATURE OF MANUALS, GUIDES, AND SPREADSHEETS IN THE FIELD OF VOLUNTARY STANDARDS FOR ENVIRONMENTAL PERFORMANCE OF BUILDINGS THROUGH DESIGN, CONSTRUCTION, AND ONGOING OPERATIONS AND MAINTENANCE (U.S. CLS. 21, 23, 26, 36 AND 38).  
FIRST USE 5-31-2011; IN COMMERCE 10-4-2011.

**CLASS 35—ADVERTISING AND BUSINESS**

FOR ASSOCIATION SERVICES, NAMELY, PROMOTING AWARENESS OF ENVIRONMENTALLY RESPONSIBLE BUILDING MATERIALS AND PRODUCTS; ASSOCIATION SERVICES, NAMELY, PROMOTING THE INTERESTS OF THE ENVIRONMENTALLY RESPONSIBLE MANUFACTURERS OF BUILDING MATERIALS AND PRODUCTS; PROVIDING AN ONLINE COMPUTER DATABASE FEATURING BUSINESS AND CONSUMER INFORMATION IN THE FIELD OF ENVIRONMENTALLY HAZARDOUS BUILDING MATERIALS AND PRODUCTS (U.S. CLS. 100, 101 AND 102).

FIRST USE 5-31-2011; IN COMMERCE 10-4-2011.

**CLASS 42—SCIENTIFIC AND COMPUTER SERVICES**

FOR DEVELOPMENT OF VOLUNTARY STANDARDS FOR ENVIRONMENTAL PERFORMANCE OF BUILDINGS THROUGH DESIGN, CONSTRUCTION, AND ONGOING OPERATIONS AND MAINTENANCE; CONSULTING SERVICES IN THE FIELD OF ENVIRONMENTAL ASSESSMENT, NAMELY, PROVIDING A REVIEW PROCESS FOR THE BUILDING INDUSTRY INVOLVING EVALUATION, ANALYSIS, RATING, AND PROFILING OF CHEMICAL HAZARDS AS USED IN BUILDING MATERIALS AND PRODUCTS FOR THE PURPOSE OF CERTIFICATION (U.S. CLS. 100 AND 101).

FIRST USE 5-31-2011; IN COMMERCE 10-4-2011.  
MARK SPARACINO, EXAMINING ATTORNEY

SN 86-103,289. THE PROVIDENCE SERVICE CORPORATION, TUCSON, AZ. FILED 10-28-2013.



OWNER OF U.S. REG. NOS. 2,252,504 AND 3,098,098.  
NO CLAIM IS MADE TO THE EXCLUSIVE RIGHT TO USE "HUMAN SERVICES", APART FROM THE MARK AS SHOWN.

THE COLOR(S) WHITE, BLUE, GREEN, AND GRAY IS/ARE CLAIMED AS A FEATURE OF THE MARK.

THE MARK CONSISTS OF THE LETTERS "P", "H" AND "S" ALL IN A WHITE FONT. THE LETTER "P" IS IN A BLUE SQUARE. THE LETTER "H" IS IN A GREEN SQUARE. THE LETTER "S" IS IN A GRAY SQUARE. THESE THREE SQUARES ARE ARRANGED HORIZONTALLY AND ARE IMMEDIATELY BELOW A TRIANGLE. THE TRIANGLE IS COMPOSED OF SMALLER TRIANGLES, WHICH ARE GREEN, BLUE AND GRAY. THIS ENTIRE DESIGN IS TO THE LEFT OF THE WORDS "PROVIDENCE HUMAN SERVICES", ALL IN GRAY.

SN 86-103,279. THE PROVIDENCE SERVICE CORPORATION, TUCSON, VA. FILED 10-28-2013.



OWNER OF U.S. REG. NOS. 2,252,504 AND 3,098,098.  
THE COLOR(S) BLUE, GREEN, WHITE AND GRAY IS/ARE CLAIMED AS A FEATURE OF THE MARK.

THE MARK CONSISTS OF THE LETTERS "P", "H" AND "S" ALL IN A WHITE FONT. THE LETTER "P" IS IN A BLUE SQUARE. THE LETTER "H" IS IN A GREEN SQUARE. THE LETTER "S" IS IN A GRAY SQUARE. THESE THREE SQUARES ARE ARRANGED HORIZONTALLY AND ARE IMMEDIATELY BELOW A TRIANGLE. THE TRIANGLE IS COMPOSED OF SMALLER TRIANGLES, WHICH ARE GREEN, BLUE AND GRAY.

**CLASS 35—ADVERTISING AND BUSINESS**

FOR DRUG-AND-ALCOHOL ABUSE SERVICES, NAMELY, JOB PLACEMENT; EMPLOYMENT COUNSELING TO ASSIST INDIVIDUALS TO OBTAIN AND RETAIN EMPLOYMENT (U.S. CLS. 100, 101 AND 102).

**CLASS 44—MEDICAL, BEAUTY AND AGRICULTURAL SERVICES**

FOR BEHAVIORAL HEALTH SERVICES (U.S. CLS. 100 AND 101).  
RUDY R. SINGLETON, EXAMINING ATTORNEY

**CLASS 35—ADVERTISING AND BUSINESS**

FOR DRUG-AND-ALCOHOL ABUSE SERVICES, NAMELY, JOB PLACEMENT; EMPLOYMENT COUNSELING TO ASSIST INDIVIDUALS TO OBTAIN AND RETAIN EMPLOYMENT (U.S. CLS. 100, 101 AND 102).

**CLASS 44—MEDICAL, BEAUTY AND AGRICULTURAL SERVICES**

FOR BEHAVIORAL HEALTH SERVICES (U.S. CLS. 100 AND 101).  
RUDY R. SINGLETON, EXAMINING ATTORNEY

SN 86-103,518. WEBROOT INC., BROOMFIELD, CO. FILED 10-28-2013.

# INFRARED

THE MARK CONSISTS OF STANDARD CHARACTERS WITHOUT CLAIM TO ANY PARTICULAR FONT, STYLE, SIZE, OR COLOR.

**CLASS 9—ELECTRICAL AND SCIENTIFIC APPARATUS**

FOR SOFTWARE FOR PROTECTING AND SECURING THE INTEGRITY OF COMPUTING DEVICES, MOBILE PHONES AND NETWORK SYSTEMS; SECURITY SOFTWARE FOR PROTECTING COMPUTERS FROM MALICIOUS SOFTWARE (U.S. CLS. 21, 23, 26, 36 AND 38).

**CLASS 42—SCIENTIFIC AND COMPUTER SERVICES**

FOR COMPUTER SECURITY SERVICES, NAMELY, RESTRICTING ACCESS TO AND BY COMPUTER NETWORKS TO AND OF UNDESIRE WEB SITES, MEDIA AND INDIVIDUALS AND FACILITIES, DETECTING AND ASSESSING THREATS TO COMPUTING DEVICES; COMPUTER SERVICES, NAMELY, PROVIDING INFORMATION REGARDING RISKS AND VULNERABILITIES FOR COMPUTERS, NETWORKS AND MOBILE ELECTRONIC DEVICES; COMPUTER SERVICES FOR PROTECTING AND SECURING THE INTEGRITY OF COMPUTING DEVICES, MOBILE PHONES AND NETWORK SYSTEMS, NAMELY, PROVIDING TEMPORARY USE OF ON-LINE NON-DOWNLOADABLE SOFTWARE FOR PROTECTING AND SECURING THE INTEGRITY OF MOBILE PHONES, COMPUTING DEVICES, AND NETWORK SYSTEMS (U.S. CLS. 100 AND 101).

BRIAN PINO, EXAMINING ATTORNEY

SN 86-103,526. INDIANA HOCKEY CLUB, LLC, INDIANAPOLIS, IN. FILED 10-28-2013.

# FILL 'ER UP

THE MARK CONSISTS OF STANDARD CHARACTERS WITHOUT CLAIM TO ANY PARTICULAR FONT, STYLE, SIZE, OR COLOR.

**CLASS 25—CLOTHING**

FOR CLOTHING FOR MEN, WOMEN, CHILDREN AND INFANTS, NAMELY, SPORTING APPAREL, NAMELY, JERSEYS, HATS, CAPS, SWEATSHIRTS, T-SHIRTS, JACKETS AND COATS, SWEATERS, SWEATPANTS, HEADWEAR, NIGHTSHIRTS, SHORTS, PANTS, SLEEPWEAR, SHIRTS, FOOTWEAR, SOCKS, AND TIES (U.S. CLS. 22 AND 39).

**CLASS 28—TOYS AND SPORTING GOODS**

FOR PROMOTIONAL PRODUCTS, NAMELY, NOVELTY ITEMS, NAMELY, MINIATURE HOCKEY EQUIPMENT IN THE NATURE OF STICKS AND PUCKS, TOYS, NAMELY, PLUSH AND STUFFED TOYS, ACTION FIGURES, AND SPORTING GOODS, NAMELY, HOCKEY STICKS, HOCKEY PUCKS (U.S. CLS. 22, 23, 38 AND 50).

SETH A. RAPPAPORT, EXAMINING ATTORNEY

SN 86-103,542. INDIANA HOCKEY CLUB, LLC, INDIANAPOLIS, IN. FILED 10-28-2013.

# INDY FUEL

THE MARK CONSISTS OF STANDARD CHARACTERS WITHOUT CLAIM TO ANY PARTICULAR FONT, STYLE, SIZE, OR COLOR.

NO CLAIM IS MADE TO THE EXCLUSIVE RIGHT TO USE "INDY", APART FROM THE MARK AS SHOWN.

**CLASS 21—HOUSEWARES AND GLASS**

FOR SPORTS BOTTLES SOLD EMPTY (U.S. CLS. 2, 13, 23, 29, 30, 33, 40 AND 50).

**CLASS 28—TOYS AND SPORTING GOODS**

FOR PROMOTIONAL PRODUCTS, NAMELY, NOVELTY ITEMS, NAMELY, MINIATURE HOCKEY EQUIPMENT IN THE NATURE OF STICKS AND PUCKS, TOYS, NAMELY, PLUSH AND STUFFED TOYS, ACTION FIGURES, AND SPORTING GOODS, NAMELY, HOCKEY STICKS, HOCKEY PUCKS (U.S. CLS. 22, 23, 38 AND 50).

SETH A. RAPPAPORT, EXAMINING ATTORNEY

SN 86-103,932. INDIANA HOCKEY CLUB, LLC, INDIANAPOLIS, IN. FILED 10-29-2013.



NO CLAIM IS MADE TO THE EXCLUSIVE RIGHT TO USE "INDY", APART FROM THE MARK AS SHOWN.

THE MARK CONSISTS OF THE WORD "INDY", APPEARING ABOVE THE WORD "FUEL", APPEARING ABOVE THREE STARS ARRANGED IN A HORIZONTAL LINE, ALL ON THE FACE OF A STYLIZED HOCKEY PUCK.

**CLASS 28—TOYS AND SPORTING GOODS**

FOR PROMOTIONAL PRODUCTS, NAMELY, NOVELTY ITEMS, NAMELY, MINIATURE HOCKEY EQUIPMENT IN THE NATURE OF STICKS AND PUCKS, TOYS, NAMELY, PLUSH AND STUFFED TOYS, ACTION FIGURES, AND SPORTING GOODS, NAMELY, HOCKEY STICKS, HOCKEY PUCKS (U.S. CLS. 22, 23, 38 AND 50).

**CLASS 41—EDUCATION AND ENTERTAINMENT**

FOR ENTERTAINMENT SERVICES IN THE NATURE OF PROFESSIONAL ICE HOCKEY EXHIBITIONS AND GAMES (U.S. CLS. 100, 101 AND 107).

SETH A. RAPPAPORT, EXAMINING ATTORNEY

SN 86-104,093. ST. GEORGE'S UNIVERSITY LLC, GREAT RIVER, NY. FILED 10-29-2013.

# THINK BEYOND

THE MARK CONSISTS OF STANDARD CHARACTERS WITHOUT CLAIM TO ANY PARTICULAR FONT, STYLE, SIZE, OR COLOR.

PRIORITY CLAIMED UNDER SEC. 44(D) ON GRENADA APPLICATION NO. 328/2013, FILED 9-11-2013, REG. NO. 494, DATED 12-30-2013, EXPIRES 9-11-2023.



**CLASS 6—METAL GOODS**

FOR METAL KEY RINGS (U.S. CLS. 2, 12, 13, 14, 23, 25 AND 50).

**CLASS 10—MEDICAL APPARATUS**

FOR MEDICAL BAGS FOR USE BY MEDICAL PERSONNEL ADAPTED FOR AND SOLD WITH MEDICAL AND SURGICAL INSTRUMENTS (U.S. CLS. 26, 39 AND 44).

**CLASS 12—VEHICLES**

FOR LICENSE PLATE HOLDERS (U.S. CLS. 19, 21, 23, 31, 35 AND 44).

**CLASS 16—PAPER GOODS AND PRINTED MATTER**

FOR BUMPER STICKERS; STICKERS; PENS; PENCILS; NOTEBOOKS (U.S. CLS. 2, 5, 22, 23, 29, 37, 38 AND 50).

**CLASS 20—FURNITURE AND ARTICLES NOT OTHERWISE CLASSIFIED**

FOR DIPLOMA FRAMES; PICTURES FRAMES; NON-METAL KEY RINGS (U.S. CLS. 2, 13, 22, 25, 32 AND 50).

**CLASS 21—HOUSEWARES AND GLASS**

FOR DRINKING GLASSES; CUPS; BEVERAGE GLASSWARE; MUGS (U.S. CLS. 2, 13, 23, 29, 30, 33, 40 AND 50).

**CLASS 25—CLOTHING**

FOR CLOTHING, NAMELY, SWEATSHIRTS, JACKETS, SHORTS, TIES, SCARVES, T-SHIRTS, CAPS, HATS (U.S. CLS. 22 AND 39).

**CLASS 28—TOYS AND SPORTING GOODS**

FOR STUFFED AND PLUSH TOYS (U.S. CLS. 22, 23, 38 AND 50).

**CLASS 41—EDUCATION AND ENTERTAINMENT**

FOR PROVIDING COURSE OF INSTRUCTION AT THE COLLEGE AND GRADUATE LEVELS AND DISTRIBUTING COURSE MATERIALS THEREWITH; EDUCATIONAL SERVICES, NAMELY, PROVIDING ONLINE COURSE OF INSTRUCTION AT THE COLLEGE AND GRADUATE LEVELS IN THE FIELD OF MEDICINE AND DISTRIBUTING COURSE MATERIALS THEREWITH; VETERINARY, MEDICAL AND NURSING TEACHING AND TRAINING (U.S. CLS. 100, 101 AND 107).

WON TEAK OH, EXAMINING ATTORNEY

SN 86-104.123. ST. GEORGE'S UNIVERSITY LLC, GREAT RIVER, NY. FILED 10-29-2013.

**SGU**

THE MARK CONSISTS OF STANDARD CHARACTERS WITHOUT CLAIM TO ANY PARTICULAR FONT, STYLE, SIZE, OR COLOR.

PRIORITY CLAIMED UNDER SEC. 44(D) ON GRENADA APPLICATION NO. 330/2013, FILED 9-11-2013, REG. NO. 496, DATED 12-30-2013, EXPIRES 9-11-2023.

**CLASS 6—METAL GOODS**

FOR METAL KEY RINGS (U.S. CLS. 2, 12, 13, 14, 23, 25 AND 50).

**CLASS 10—MEDICAL APPARATUS**

FOR MEDICAL BAGS FOR USE BY MEDICAL PERSONNEL ADAPTED FOR AND SOLD WITH MEDICAL AND SURGICAL INSTRUMENTS (U.S. CLS. 26, 39 AND 44).

**CLASS 12—VEHICLES**

FOR LICENSE PLATE HOLDERS (U.S. CLS. 19, 21, 23, 31, 35 AND 44).

**CLASS 16—PAPER GOODS AND PRINTED MATTER**

FOR BUMPER STICKERS; STICKERS; PENS; PENCILS; NOTEBOOKS (U.S. CLS. 2, 5, 22, 23, 29, 37, 38 AND 50).

**CLASS 20—FURNITURE AND ARTICLES NOT OTHERWISE CLASSIFIED**

FOR DIPLOMA FRAMES; PICTURES FRAMES; NON-METAL KEY RINGS (U.S. CLS. 2, 13, 22, 25, 32 AND 50).

**CLASS 21—HOUSEWARES AND GLASS**

FOR DRINKING GLASSES; CUPS; BEVERAGE GLASSWARE; MUGS (U.S. CLS. 2, 13, 23, 29, 30, 33, 40 AND 50).

**CLASS 25—CLOTHING**

FOR CLOTHING, NAMELY, SWEATSHIRTS, JACKETS, SHORTS, TIES, SCARVES, T-SHIRTS, CAPS, HATS (U.S. CLS. 22 AND 39).

**CLASS 28—TOYS AND SPORTING GOODS**

FOR STUFFED AND PLUSH TOYS (U.S. CLS. 22, 23, 38 AND 50).

**CLASS 41—EDUCATION AND ENTERTAINMENT**

FOR PROVIDING COURSE OF INSTRUCTION AT THE COLLEGE AND GRADUATE LEVELS AND DISTRIBUTING COURSE MATERIALS THEREWITH; EDUCATIONAL SERVICES, NAMELY, PROVIDING ONLINE COURSE OF INSTRUCTION AT THE COLLEGE AND GRADUATE LEVELS IN THE FIELD OF MEDICINE AND DISTRIBUTING COURSE MATERIALS THEREWITH; VETERINARY, MEDICAL AND NURSING TEACHING AND TRAINING (U.S. CLS. 100, 101 AND 107).

WON TEAK OH, EXAMINING ATTORNEY

SN 86-104,490. THANE INTERNATIONAL, INC., EL SEGUNDO, CA. FILED 10-29-2013.

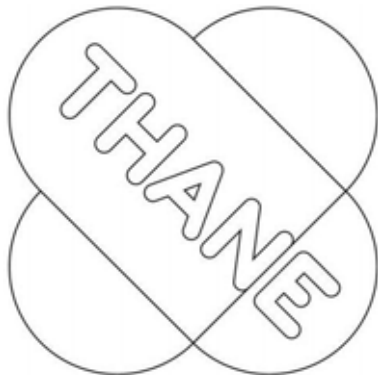

OWNER OF U.S. REG. NOS. 2,731,346 AND 3,543,606.  
THE MARK CONSISTS OF 2 CROSSED ELONGATED OVALS AND THE LITERAL ELEMENT "THANE" WITHIN ONE OVAL.

#### CLASS 7—MACHINERY

FOR ELECTRICALLY-POWERED HOUSEHOLD CLEANING APPLIANCES, NAMELY, MULTI-PURPOSE STEAM CLEANERS AND VACUUM CLEANERS FOR HOUSEHOLD USE; ELECTRIC VACUUM CLEANERS AND THEIR COMPONENTS; STEAM CLEANING MACHINE PARTS, NAMELY, NOZZLES, BRUSHES, HOSES, MOP HEADS, WINDOW CLEANING TOOLS, DUSTER ATTACHMENTS, CARPET GLIDERS, CLEANING PADS; ELECTRIC FOOD BLENDERS; ELECTRIC FOOD CHOPPERS; ELECTRIC FOOD PROCESSORS (U.S. CLS. 13, 19, 21, 23, 31, 34 AND 35).  
FIRST USE 7-17-2013; IN COMMERCE 4-14-2014.

#### CLASS 8—HAND TOOLS

FOR CUTLERY, NAMELY, NON-STICK CUTLERY (U.S. CLS. 23, 28 AND 44).  
FIRST USE 7-17-2013; IN COMMERCE 4-14-2014.

#### CLASS 9—ELECTRICAL AND SCIENTIFIC APPARATUS

FOR PRERECORDED DIGITAL VIDEO DISCS CONCERNING HEALTH, FITNESS, BEAUTY AND LIFESTYLE (U.S. CLS. 21, 23, 26, 36 AND 38).  
FIRST USE 7-17-2013; IN COMMERCE 4-14-2014.

#### CLASS 10—MEDICAL APPARATUS

FOR MASSAGE APPARATUS; HEATING PADS FOR MEDICAL PURPOSES; ELECTRONIC MUSCLE STIMULATORS FOR PHYSICAL THERAPY PURPOSES AND HEALTH PURPOSES (U.S. CLS. 26, 39 AND 44).  
FIRST USE 7-17-2013; IN COMMERCE 4-14-2014.

#### CLASS 11—ENVIRONMENTAL CONTROL APPARATUS

FOR GARMENT STEAMERS; FABRIC STEAMERS; MULTI-PURPOSE, ELECTRIC COUNTERTOP FOOD PREPARATION APPARATUS FOR COOKING, BAKING, BROILING, ROASTING, TOASTING, SEARING, BROWNING, BARBECUING AND GRILLING FOOD; HEATING PADS NOT FOR MEDICAL PURPOSES (U.S. CLS. 13, 21, 23, 31 AND 34).  
FIRST USE 7-17-2013; IN COMMERCE 4-14-2014.

#### CLASS 16—PAPER GOODS AND PRINTED MATTER

FOR RECIPE BOOKS, MEAL PLANNERS, WEIGHT LOSS BOOKS, AND PRINTED INSTRUCTIONAL MATERIAL CONCERNING HEALTH AND LIFESTYLE ISSUES; PERSONAL FITNESS DAILY PLANNERS, COOK BOOKS, AND PERSONAL FITNESS INSTRUCTION BOOKS (U.S. CLS. 2, 5, 22, 23, 29, 37, 38 AND 50).  
FIRST USE 7-17-2013; IN COMMERCE 4-14-2014.

#### CLASS 21—HOUSEWARES AND GLASS

FOR KITCHEN UTENSILS, NAMELY, HIGH HEAT RESISTANT KITCHEN UTENSILS FOR USE ON NON-STICK SURFACES IN THE NATURE OF TONGS, MIXING SPOONS, SLOTTED SPOONS, WHISKS, SPATULAS, STEAMERS; COOKWARE, NAMELY, POTS AND PANS; OVENWARE (U.S. CLS. 2, 13, 23, 29, 30, 33, 40 AND 50).  
FIRST USE 7-17-2013; IN COMMERCE 4-14-2014.

#### CLASS 25—CLOTHING

FOR WOMEN'S UNDERGARMENTS; SHAPEWEAR, NAMELY, GIRDLES, BRAS, CAMISOLES, SLIPS, TANK TOPS, T-SHIRTS, LEGGINGS, SHORTS; FOUNDATION GARMENTS WORN AROUND THE MIDSECTION OR THIGHS TO KEEP THE STOMACH IN AND CREATE A SLIMMING EFFECT (U.S. CLS. 22 AND 39).  
FIRST USE 7-17-2013; IN COMMERCE 4-14-2014.

#### CLASS 28—TOYS AND SPORTING GOODS

FOR MANUALLY-OPERATED EXERCISE MACHINES (U.S. CLS. 22, 23, 38 AND 50).  
FIRST USE 7-17-2013; IN COMMERCE 4-14-2014.

#### CLASS 35—ADVERTISING AND BUSINESS

FOR DIRECT RESPONSE RETAIL SERVICES BY MEANS OF INFOMERCIALS FEATURING CONSUMER PRODUCTS FOR HEALTH, FITNESS, BEAUTY, HOUSEWARES, KITCHEN WARES AND HOUSEHOLD CLEANING; RETAIL ON-LINE DEPARTMENT STORES (U.S. CLS. 100, 101 AND 102).  
FIRST USE 7-17-2013; IN COMMERCE 4-14-2014.  
TINA L. SNAPP, EXAMINING ATTORNEY

SN 86-104,695. RDT BUSINESS ENTERPRISES INC, DBA SYNERGYLABS, FORT LAUDERDALE, FL. FILED S.R. 10-29-2013; AM. P.R. 7-3-2014.



NO CLAIM IS MADE TO THE EXCLUSIVE RIGHT TO USE "DENTAL", APART FROM THE MARK AS SHOWN.  
THE COLOR(S) BLUE, YELLOW, GREEN, AND RED IS/ ARE CLAIMED AS A FEATURE OF THE MARK.

THE MARK CONSISTS OF THE WORDING "SYNERGY LABS" IN BLUE ON A YELLOW SWIRL DESIGN AND THE WORDING "DENTAL FRESH". THE WORD "DENTAL" IS IN YELLOW ON A BLUE, GREEN AND RED STRIPES DESIGN. THE WORD "FRESH" IS IN BLUE. THERE ARE YELLOW AND BLUE DIAMOND STARS AROUND THE DESIGN. THE "SYNERGY LABS" AND DESIGN IS AT THE TOP LEFT OF THE LARGE "DENTAL FRESH" DESIGN.

### CLASS 3—COSMETICS AND CLEANING PREPARATIONS

FOR BREATH FRESHENER FOR PETS (U.S. CLS. 1, 4, 6, 50, 51 AND 52).  
FIRST USE 2-1-1998; IN COMMERCE 2-1-1998.

### CLASS 5—PHARMACEUTICALS

FOR MEDICATED LIQUID PLAQUE AND TARTAR REMOVER FOR PETS (U.S. CLS. 6, 18, 44, 46, 51 AND 52).  
FIRST USE 2-1-1998; IN COMMERCE 2-1-1998.  
DAWN FELDMAN, EXAMINING ATTORNEY

SN 86-104,915. METHANEX CORPORATION, VANCOUVER, BC, CANADA, FILED 10-29-2013.



PRIORITY CLAIMED UNDER SEC. 44(D) ON CANADA APPLICATION NO. 1648791, FILED 10-22-2013.

OWNER OF U.S. REG. NOS. 1,865,492 AND 1,910,929.  
THE MARK CONSISTS OF THE WORD "METHANEX" IN LOWERCASE LETTERS, WITH THE "EX" PORTION OF "METHANEX" IMPOSED ON A STYLIZED GLOBE WITH PARALLEL AND MERIDIAN LINES ON THE LEFT SIDE AND DOTS APPEARING ON THE RIGHT SIDE OF THE STYLIZED GLOBE.

### CLASS 1—CHEMICALS

FOR METHANOL (U.S. CLS. 1, 5, 6, 10, 26 AND 46).

### CLASS 35—ADVERTISING AND BUSINESS

FOR BUSINESS MANAGEMENT SERVICES RELATING TO METHANOL PRODUCTION AND MARKETING, INCLUDING ANALYSIS OF THE MARKET FOR DEMAND AND SUPPLY OF METHANOL, DEFINING THE OVERALL SERVICE DELIVERY STRATEGY, ANALYZING THE COMMERCIAL FEASIBILITY OF PRODUCT APPLICATION OF METHANOL, DEVELOPING BUDGETS AND TRACKING COSTS, MANAGING METHANOL SUPPLIES; NEGOTIATION AND EXECUTION OF CONTRACTS AND COMMERCIAL AGREEMENTS RELATING TO THE SALE, SUPPLY AND DISTRIBUTION OF METHANOL; PROCUREMENT SERVICES, NAMELY, PURCHASING OF METHANOL FOR OTHERS; PROVIDING INDUSTRY EXPERTISE IN THE DEVELOPMENT OF METHANOL MARKETS; BUSINESS OPERATION OF LOADING PORT FACILITIES FOR OTHERS; BUSINESS OPERATION OF METHANOL STORAGE, METHANOL DISTRIBUTION AND METHANOL TRANSPORTATION EQUIPMENT FOR OTHERS; BUSINESS OPERATION OF MATERIAL HANDLING INSTALLATIONS, NAMELY, STORAGE TANK FACILITIES, AND INFRASTRUCTURE FACILITIES ANCILLARY TO THE STORAGE OF METHANOL SITES, FOR OTHERS; PROVISION OF SHIP LOADING PORT FACILITIES, NAMELY, BUSINESS OPERATION OF PORT FACILITIES FOR OTHERS (U.S. CLS. 100, 101 AND 102).

### CLASS 39—TRANSPORTATION AND STORAGE

FOR DISTRIBUTION AND SUPPLY OF METHANOL; STORAGE OF METHANOL IN THE NATURE OF OPERATING STORAGE TERMINALS; PROVISION OF SHIP BERTHING FACILITIES; PROVISION OF SHIP LOADING PORT FACILITIES, NAMELY, RENTAL OF SHIP CARGO LOADING-UNLOADING MACHINES AND APPARATUS; PROVIDING OCEAN, RAIL AND GROUND TRANSPORTATION; SUPPLY CHAIN LOGISTICS, NAMELY, STORAGE, TRANSPORTATION AND DELIVERY OF GOODS FOR OTHERS BY RAIL, SHIP OR TRUCK, STORAGE AND DELIVERY SERVICES OF METHANOL; PROVIDING OCEAN TRANSPORTATION SERVICES OF GASOLINE, FUEL, INFLAMMABLES AND CHEMICALS FOR OTHERS (U.S. CLS. 100 AND 105).

### CLASS 42—SCIENTIFIC AND COMPUTER SERVICES

FOR PROVIDING INDUSTRY EXPERTISE IN THE NATURE OF ENGINEERING FOR THE ENVIRONMENT-FRIENDLY AND SAFE HANDLING OF METHANOL AND PRODUCT APPLICATION OF METHANOL (U.S. CLS. 100 AND 101).  
SUNG IN, EXAMINING ATTORNEY

SN 86-105,444. COMPREHENSIVE SOFTWARE SYSTEMS, LLC, GOLDEN, CO. FILED 10-30-2013.

# TALISYS

THE MARK CONSISTS OF STANDARD CHARACTERS WITHOUT CLAIM TO ANY PARTICULAR FONT, STYLE, SIZE, OR COLOR.

### CLASS 9—ELECTRICAL AND SCIENTIFIC APPARATUS

FOR COMPUTER SOFTWARE FOR FINANCIAL PLANNING (U.S. CLS. 21, 23, 26, 36 AND 38).

### CLASS 36—INSURANCE AND FINANCIAL

FOR FINANCIAL CONSULTING SERVICES (U.S. CLS. 100, 101 AND 102).  
JACQUELINE ABRAMS, EXAMINING ATTORNEY

SN 86-105,767. BEST OF EVERYTHING OF SOUTHWEST FLORIDA, INC., NAPLES, FL. FILED 10-30-2013.

BESTOFEVERYTHINGONLINE.COM

THE MARK CONSISTS OF STANDARD CHARACTERS WITHOUT CLAIM TO ANY PARTICULAR FONT, STYLE, SIZE, OR COLOR.

OWNER OF U.S. REG. NOS. 3,722,800, 3,930,479 AND OTHERS.

**CLASS 14—JEWELRY**

FOR JEWELRY; STERLING SILVER JEWELRY, BRACELETS, NECKLACES, PINS BEING JEWELRY, RINGS BEING JEWELRY, WATCHES (U.S. CLS. 2, 27, 28 AND 50).

**CLASS 35—ADVERTISING AND BUSINESS**

FOR RETAIL JEWELRY STORE SERVICES, RETAIL STERLING SILVER JEWELRY STORE SERVICES AND RETAIL GIFT STORE SERVICES FEATURING JEWELRY, BRACELETS, NECKLACES, RINGS, PINS, WATCHES, GIFT ITEMS, GIFT CARDS, STUFFED ANIMALS, SCARVES, HAIR ACCESSORIES, SUNGLASSES, HANDBAGS, BELTS AND OTHER FASHION ACCESSORIES; ON-LINE RETAIL STORE SERVICES FEATURING JEWELRY, BRACELETS, NECKLACES, RINGS, PINS, WATCHES, GIFT ITEMS, GIFT CARDS, STUFFED ANIMALS, SCARVES, HAIR ACCESSORIES, SUNGLASSES, HANDBAGS, BELTS AND OTHER FASHION ACCESSORIES (U.S. CLS. 100, 101 AND 102).

JULIE GUTTADAURO, EXAMINING ATTORNEY

SN 86-106,203. DORSEY INNOVATIVE PRODUCTS, LLC, BIRMINGHAM, AL. FILED 10-30-2013.

**BIRMINGHAM BLACK BARONS**

THE MARK CONSISTS OF STANDARD CHARACTERS WITHOUT CLAIM TO ANY PARTICULAR FONT, STYLE, SIZE, OR COLOR.

NO CLAIM IS MADE TO THE EXCLUSIVE RIGHT TO USE "BIRMINGHAM", APART FROM THE MARK AS SHOWN.

**CLASS 25—CLOTHING**

FOR CLOTHING AND CLOTHING ACCESSORIES, NAMELY, JEANS, SHIRTS, POLO SHIRTS, COLLARED SHIRTS, T-SHIRTS, JERSEYS, TANK TOPS, SWEAT SHIRTS, SWEAT PANTS, SWEAT SHORTS, TRACK SUITS, JOGGING SUITS, WARM-UP SUITS, TROUSERS, PANTS, SHORTS, DRESSES, BLOUSES, HALTER TOPS, SKIRTS, JACKETS, COATS, HEADWEAR, HATS, CAPS, VISORS; BLAZERS, SUITS, CARDIGANS, PULLOVERS, SWEATERS, VESTS, OVERALLS, SOCKS, GLOVES, UNDERWEAR, BOXER SHORTS, LINGERIE, SLEEPWEAR, PAJAMAS, TUNICS, LOUNGE WEAR, BATHROBES, ROBES, ANORAKS, RAINWEAR, WIND-RESISTANT JACKETS, PARKAS, BELTS, SCARVES, TIES, NECKTIES, BANDANAS, SWEAT BANDS, WRISTBANDS, SWIMWEAR, BEACHWEAR, TENNIS WEAR, DRAW-STRING PANTS, INFANT WEAR, PLAY SUITS, FOOTWEAR, SHOES, ATHLETIC SHOES, SNEAKERS, TENNIS SHOES, RUNNING SHOES, SANDALS, LEATHER SHOES, BOOTS, BERETS, SKULL CAPS, SKI MASKS, DO-RAGS, BEANIES, EARMUFFS, HOODS, HEADBANDS, LEATHER COATS, AND LEATHER JACKETS (U.S. CLS. 22 AND 39).

SN 86-105,810. ETERNAL ACCLAIM INC., NEW YORK, NY. FILED 10-30-2013.



NO CLAIM IS MADE TO THE EXCLUSIVE RIGHT TO USE "PATISSERIE AMERICA", "PATISSERIE ESPRESSO" AND "EST. 2013", APART FROM THE MARK AS SHOWN.

THE MARK CONSISTS OF TWO CONCENTRIC OVAL CIRCLES WITH A SHAPE OF CHEF HAT AT TOP MIDDLE. INSIDE THE CIRCLES ARE THE STYLIZED WORDS "PATISSERIE AMERICA" IN CAPITAL LETTERS, AND UNDERNEATH ARE SUB-TEXT "PATISSERIE" AND "ESPRESSO", WITH A DOT IN BETWEEN; AND UNDERNEATH IS A RIBBON WITH WORDS "EST 2013" INSERTED.

**CLASS 30—STAPLE FOODS**

FOR BAKERY PRODUCTS; COCOA-BASED BEVERAGES; COFFEE; COFFEE BEANS; ESPRESSO DRINKS; PASTRY (U.S. CL. 46).

**CLASS 35—ADVERTISING AND BUSINESS**

FOR FRANCHISING, NAMELY, OFFERING BUSINESS MANAGEMENT ASSISTANCE IN THE ESTABLISHMENT AND/OR OPERATION OF BAKERY AND COFFEE SHOPS, CAFE SERVICE, AND FOOD RELATED SERVICE AND BUSINESS; PASTRY AND DESSERT SHOPS; RETAIL SHOPS FEATURING BAKERY DESERTS, COFFEE, AND RELATED PRODUCTS (U.S. CLS. 100, 101 AND 102).

PRISCILLA MILTON, EXAMINING ATTORNEY

**CLASS 41—EDUCATION AND ENTERTAINMENT**

FOR MUSEUM SERVICES; GUIDED TOURS OF A MUSEUM; EDUCATIONAL SERVICES, NAMELY, CLASSES, SEMINARS, WORKSHOPS IN THE FIELDS OF CULTURE AND HISTORY; ARRANGING AND CONDUCTING EDUCATIONAL CONFERENCES; ENTERTAINMENT SERVICES, NAMELY, ARRANGING AND CONDUCTING CULTURAL AND SOCIAL EVENTS; ORGANIZATION OF CULTURAL EVENTS AND ACTIVITIES; ORGANIZATION OF EXHIBITIONS FOR CULTURAL OR EDUCATIONAL PURPOSES; EDUCATIONAL AND ENTERTAINMENT SERVICES, NAMELY, PROVIDING A WEBSITE FEATURING INFORMATION IN THE FIELDS OF CULTURE AND HISTORY; SPECIAL EVENT PLANNING, NAMELY, PLANNING OF ATHLETIC, CULTURAL, AND EDUCATIONAL EVENTS AND SPORTING EXHIBITIONS; EVENT PLANNING SERVICES, NAMELY, ORGANIZING COMMUNITY SERVICES PROGRAMS, PROJECTS, AND INITIATIVES; EDUCATIONAL SERVICES, NAMELY, PROVIDING CLASSES, SEMINARS, WORKSHOPS, FIELD TRIPS, TUTORING, AND MENTORING FOR PARENTS AND CHILDREN IN THE FIELD OF ACADEMIC AND CULTURAL AWARENESS; PROVIDING EDUCATIONAL MENTORING SERVICES AND PROGRAMS IN THE FIELD OF CULTURAL AWARENESS; PROVIDING A WEBSITE FEATURING RESOURCES, NAMELY, NON-DOWNLOADABLE PUBLICATIONS IN THE NATURE OF BOOKS, MAGAZINES, BROCHURES, ARTICLES AND FLYERS IN THE FIELD OF ENTERTAINMENT; MUSEUM SERVICES, NAMELY, ORGANIZING EXHIBITIONS AND ARRANGING AND CONDUCTING TOURS, COURSES, SEMINARS, FELLOWSHIPS, THEATRE PRESENTATIONS, LECTURES, PROGRAMS, EVENTS, AND WORKSHOPS, AND DEVELOPMENT AND DISTRIBUTION OF EDUCATIONAL MATERIAL IN THE FIELDS OF CULTURE AND HISTORY (U.S. CLS. 100, 101 AND 107).

GIANCARLO CASTRO, EXAMINING ATTORNEY

SN 86-106,539. AVEDA CORPORATION, MINNEAPOLIS, MN. FILED 10-31-2013.

## LEARNAVEDA

THE MARK CONSISTS OF STANDARD CHARACTERS WITHOUT CLAIM TO ANY PARTICULAR FONT, STYLE, SIZE, OR COLOR.

### CLASS 35—ADVERTISING AND BUSINESS

FOR PROVIDING AN INTERNET WEBSITE PORTAL IN THE FIELD OF SALON AND SPA BUSINESS MANAGEMENT AND CUSTOMER RELATIONSHIP MANAGEMENT (U.S. CLS. 100, 101 AND 102).

### CLASS 41—EDUCATION AND ENTERTAINMENT

FOR EDUCATIONAL SERVICES, NAMELY, PROVIDING CLASSES, SEMINARS AND WORKSHOPS IN THE FIELDS OF COSMETOLOGY, ESTHIOLOGY, MASSAGE THERAPY, HAIR CARE AND SKIN CARE, SPA THERAPY, SALON AND SPA MANAGEMENT AND CLIENT RELATIONS; PROVIDING AN EDUCATIONAL INTERNET WEBSITE PORTAL FOR PROVIDING INSTRUCTIONS IN THE FIELDS OF COSMETOLOGY, ESTHIOLOGY, MASSAGE THERAPY, HAIR CARE AND SKIN CARE, SPA THERAPY, SALON AND SPA MANAGEMENT AND CLIENT RELATIONS (U.S. CLS. 100, 101 AND 107).

### CLASS 42—SCIENTIFIC AND COMPUTER SERVICES

FOR PROVIDING A WEBSITE FEATURING TECHNOLOGY WHICH PROVIDES SELF-GUIDED LESSONS IN THE FIELDS OF COSMETOLOGY, ESTHIOLOGY, MASSAGE THERAPY, HAIR CARE AND SKIN CARE, SPA THERAPY, SALON AND SPA MANAGEMENT AND CLIENT RELATIONS (U.S. CLS. 100 AND 101).

### CLASS 44—MEDICAL, BEAUTY AND AGRICULTURAL SERVICES

FOR BEAUTY CONSULTATION SERVICES, NAMELY, PROVIDING GUIDANCE IN THE SELECTION AND USE OF PERSONAL CARE PRODUCTS, COSMETICS, FRAGRANCES, NON-MEDICATED SKIN CARE PRODUCTS AND HAIR CARE PRODUCTS PROVIDED VIA AN ONLINE GLOBAL COMPUTER NETWORK (U.S. CLS. 100 AND 101).

JENNIFER WILLISTON, EXAMINING ATTORNEY

SN 86-106,962. BAYER INTELLECTUAL PROPERTY GMBH, 40789 MONHEIM AM RHEIN, FED REP GERMANY, FILED 10-31-2013.

## YONOA

THE MARK CONSISTS OF STANDARD CHARACTERS WITHOUT CLAIM TO ANY PARTICULAR FONT, STYLE, SIZE, OR COLOR.

### CLASS 1—CHEMICALS

FOR CHEMICALS USED IN AGRICULTURE, HORTICULTURE AND FORESTRY EXCEPT FUNGICIDES, HERBICIDES, INSECTICIDES AND PESTICIDES; PREPARATIONS FOR TREATING SEEDS; PLANT GROWTH REGULATING PREPARATIONS; GENES OF SEEDS FOR AGRICULTURAL PRODUCTION; FERTILIZERS (U.S. CLS. 1, 5, 6, 10, 26 AND 46).

### CLASS 5—PHARMACEUTICALS

FOR PREPARATIONS FOR DESTROYING VERMIN; FUNGICIDES, HERBICIDES (U.S. CLS. 6, 18, 44, 46, 51 AND 52).

### CLASS 31—NATURAL AGRICULTURAL PRODUCTS

FOR AGRICULTURAL SEEDS (U.S. CLS. 1 AND 46).  
SANI KHOURI, EXAMINING ATTORNEY

SN 86-107,126. TEQUILA CUERVO LA ROJENA, S.A. DE C.V., CODIGO, MEXICO, FILED 10-31-2013.

## CUERVORITA

THE MARK CONSISTS OF STANDARD CHARACTERS WITHOUT CLAIM TO ANY PARTICULAR FONT, STYLE, SIZE, OR COLOR.

### CLASS 32—LIGHT BEVERAGES

FOR NON-ALCOHOLIC COCKTAIL MIXES; BEER, NON-ALCOHOLIC MALT BEVERAGES (U.S. CLS. 45, 46 AND 48).

### CLASS 33—WINES AND SPIRITS

FOR ALCOHOLIC BEVERAGES, EXCEPT BEERS; ALCOHOLIC COCKTAIL MIXES (U.S. CLS. 47 AND 49).  
ASMAT KHAN, EXAMINING ATTORNEY

SN 86-107,157. TEQUILA CUERVO LA ROJENA, S.A. DE C.V., CODIGO, MEXICO, FILED 10-31-2013.

## CIDERITA

THE MARK CONSISTS OF STANDARD CHARACTERS WITHOUT CLAIM TO ANY PARTICULAR FONT, STYLE, SIZE, OR COLOR.

### CLASS 32—LIGHT BEVERAGES

FOR NON-ALCOHOLIC FRUIT JUICE BEVERAGES; NON-ALCOHOLIC COCKTAIL MIXES; BEER, NON-ALCOHOLIC MALT BEVERAGES (U.S. CLS. 45, 46 AND 48).

**CLASS 33—WINES AND SPIRITS**

FOR ALCOHOLIC BEVERAGES, EXCEPT BEERS;  
ALCOHOLIC COCKTAIL MIXES (U.S. CLS. 47 AND 49).  
ASMAT KHAN, EXAMINING ATTORNEY

SN 86-107,892. AMAZON TECHNOLOGIES, INC., RENO, NV.  
FILED 11-1-2013.

**KINDLE FIRST**

THE MARK CONSISTS OF STANDARD CHARACTERS  
WITHOUT CLAIM TO ANY PARTICULAR FONT, STYLE,  
SIZE, OR COLOR.

OWNER OF U.S. REG. NOS. 3,694,267, 4,289,293 AND  
4,380,471.

SN 86-107,818. RESPONSE GENETICS, INC., NEW YORK,  
NY. FILED 11-1-2013.

**CLASS 9—ELECTRICAL AND SCIENTIFIC APPARATUS**

FOR DOWNLOADABLE ELECTRONIC PUBLICATIONS  
IN THE NATURE OF SHORT WORKS OF  
FICTION AND NON-FICTION ON A VARIETY OF  
TOPICS (U.S. CLS. 21, 23, 26, 36 AND 38).

**RESPONSEDX: TISSUE OF ORIGIN**

THE MARK CONSISTS OF STANDARD CHARACTERS  
WITHOUT CLAIM TO ANY PARTICULAR FONT, STYLE,  
SIZE, OR COLOR.

OWNER OF U.S. REG. NOS. 4,035,279, 4,207,164 AND  
OTHERS.

NO CLAIM IS MADE TO THE EXCLUSIVE RIGHT TO  
USE "TISSUE OF ORIGIN", APART FROM THE MARK AS  
SHOWN.

**CLASS 35—ADVERTISING AND BUSINESS**

FOR ADMINISTRATION OF A CUSTOMER LOYALTY  
PROGRAM WHICH PROVIDES PROGRAM MEMBERS  
WITH EARLY ACCESS TO NON-PUBLIC DIGITAL  
BOOKS AND ELECTRONIC PUBLICATIONS; RETAIL  
STORE AND ON-LINE RETAIL STORE SERVICES  
FEATURING DIGITAL BOOKS AND ELECTRONIC  
PUBLICATIONS ON A VARIETY OF TOPICS PROVIDED  
VIA GLOBAL COMPUTER NETWORKS, WIRELESS  
NETWORKS, AND ELECTRONIC COMMUNICATIONS  
NETWORKS; ADMINISTRATION OF A PROGRAM  
ENABLING PARTICIPANTS TO GAIN EARLY ACCESS  
TO PURCHASE DIGITAL BOOKS AND ELECTRONIC  
PUBLICATIONS ON A VARIETY OF TOPICS VIA  
GLOBAL COMPUTER NETWORKS, WIRELESS  
NETWORKS, AND ELECTRONIC COMMUNICATIONS  
NETWORKS (U.S. CLS. 100, 101 AND 102).

JUSTINE D. PARKER, EXAMINING ATTORNEY

**CLASS 41—EDUCATION AND ENTERTAINMENT**

FOR EDUCATIONAL SERVICES, NAMELY, PROVIDING  
ONLINE WEBINARS, WORKSHOPS AND SPECIALIZED  
TRAINING IN THE FIELD OF MEDICINE (U.S.  
CLS. 100, 101 AND 107).

SN 86-108,358. JPMORGAN CHASE & CO., NEW YORK, NY.  
FILED 11-1-2013.

**CLASS 42—SCIENTIFIC AND COMPUTER SERVICES**

FOR MEDICAL SERVICES, NAMELY, RESEARCH,  
TESTING AND ANALYSIS OF HUMAN TISSUES AND  
BODY FLUIDS FOR MEDICAL RESEARCH PURPOSES;  
PROVIDING AN ON-LINE COMPUTER DATABASE  
AND INTERFACE IN THE FIELD OF MEDICINE FOR  
RESEARCH PURPOSES; PROVIDING TEMPORARY USE  
OF ONLINE NON-DOWNLOADABLE SOFTWARE FOR  
PROVIDING AN INTERFACE BETWEEN A COMPUTER  
DATABASE FEATURING MEDICAL INFORMATION  
AND THE USER (U.S. CLS. 100 AND 101).

**JPMORGAN SIGNATURE SERIES**

THE MARK CONSISTS OF STANDARD CHARACTERS  
WITHOUT CLAIM TO ANY PARTICULAR FONT, STYLE,  
SIZE, OR COLOR.

OWNER OF U.S. REG. NOS. 3,335,070, 3,408,185 AND  
3,752,981.

NO CLAIM IS MADE TO THE EXCLUSIVE RIGHT TO  
USE "SERIES", APART FROM THE MARK AS SHOWN.

**CLASS 44—MEDICAL, BEAUTY AND AGRICULTURAL SERVICES**

FOR MEDICAL SERVICES, NAMELY, TESTING AND  
ANALYSIS OF HUMAN TISSUES AND BODY FLUIDS  
FOR DIAGNOSTIC AND TREATMENT PURPOSES;  
PROVIDING MEDICAL-RELATED INFORMATION ON  
MEDICAL TREATMENTS, MEDICAL RESULTS, PATIENTS  
AND PHARMACEUTICALS; PROVIDING AN  
ON-LINE COMPUTER DATABASE IN THE FIELD OF  
MEDICINE FOR DIAGNOSTIC AND TREATMENT  
PURPOSES (U.S. CLS. 100 AND 101).

AMY HELLA, EXAMINING ATTORNEY

**CLASS 35—ADVERTISING AND BUSINESS**

FOR PROMOTIONAL SPONSORSHIP OF ART EXHIBITIONS,  
CULTURAL INITIATIVES AND ART EDUCATION  
PROGRAMS (U.S. CLS. 100, 101 AND 102).

**CLASS 36—INSURANCE AND FINANCIAL**

FOR FINANCIAL SPONSORSHIP OF ART EXHIBITIONS,  
CULTURAL INITIATIVES AND ART EDUCATION  
PROGRAMS (U.S. CLS. 100, 101 AND 102).

KRISTINA MORRIS, EXAMINING ATTORNEY

SN 86-108,364. KPMG LLP, NEW YORK, NY. FILED 11-1-2013.

## DATA NEUROSYSTEM

THE MARK CONSISTS OF STANDARD CHARACTERS WITHOUT CLAIM TO ANY PARTICULAR FONT, STYLE, SIZE, OR COLOR.

NO CLAIM IS MADE TO THE EXCLUSIVE RIGHT TO USE "DATA", APART FROM THE MARK AS SHOWN.

### CLASS 35—ADVERTISING AND BUSINESS

FOR BUSINESS CONSULTING AND ADVISORY SERVICES IN THE FIELD OF COMPUTER SOFTWARE DEVELOPMENT, DATA MANAGEMENT AND DATA ANALYTICS (U.S. CLS. 100, 101 AND 102).

### CLASS 42—SCIENTIFIC AND COMPUTER SERVICES

FOR PROVIDING TEMPORARY USE OF A WEB-BASED SOFTWARE APPLICATION FOR GATHERING, COMPILING, ORGANIZING, MANIPULATING, SEARCHING, ANALYZING AND CREATING SEARCHABLE DATABASES OF INFORMATION AND DATA; PROVIDING TEMPORARY USE OF A ON-LINE NON-DOWNLOADABLE CLOUD COMPUTING SOFTWARE FOR GATHERING, COMPILING, ORGANIZING, MANIPULATING, SEARCHING, ANALYZING AND CREATING SEARCHABLE DATABASES OF INFORMATION AND DATA (U.S. CLS. 100 AND 101).

JEFF DEFORD, EXAMINING ATTORNEY

SN 86-108,928. CALLANDS, CATRICE K., DBA CATKIM INDUSTRIES, LANDOVER, MD. FILED 11-3-2013.

## CATKIM

THE MARK CONSISTS OF STANDARD CHARACTERS WITHOUT CLAIM TO ANY PARTICULAR FONT, STYLE, SIZE, OR COLOR.

### CLASS 35—ADVERTISING AND BUSINESS

FOR ADVERTISING AND MARKETING; ADVERTISING AND MARKETING CONSULTANCY; ADVERTISING AND MARKETING SERVICES PROVIDED BY MEANS OF INDIRECT METHODS OF MARKETING COMMUNICATIONS, NAMELY, SOCIAL MEDIA, SEARCH ENGINE MARKETING, INQUIRY MARKETING, INTERNET MARKETING, MOBILE MARKETING, BLOGGING AND OTHER FORMS OF PASSIVE, SHARABLE OR VIRAL COMMUNICATIONS CHANNELS; ADVERTISING AND MARKETING SERVICES, NAMELY, PROMOTING THE GOODS AND SERVICES OF OTHERS; BUSINESS MANAGEMENT AND CONSULTING SERVICES FOR THE HEALTH CARE INDUSTRY, NAMELY, CUSTOMER SERVICE, ACCOUNTING SERVICES, AND WEB-BASED ADVERTISING AND MARKETING SERVICES; COOPERATIVE ADVERTISING AND MARKETING; FASHION SHOW EXHIBITIONS FOR COMMERCIAL PURPOSES; ON-LINE ADVERTISING AND MARKETING SERVICES; ORGANIZATION OF FASHION SHOWS FOR COMMERCIAL PURPOSES; PROMOTING VISUAL AND PERFORMING ARTS EVENTS BY MEANS OF PROVIDING AN ONLINE

EVENTS CALENDAR, ORIGINAL ARTICLES, INTERVIEWS, AND INFORMATION ABOUT ART, ARTISTS AND ARTS EVENTS VIA AN INTERNET WEB SITE, ALL FOR PROMOTIONAL PURPOSES; PROMOTING, ADVERTISING AND MARKETING OF THE BRANDS, PRODUCTS, SERVICES AND ONLINADVERTISING AND MARKETING; ADVERTISING AND MARKETING CONSULTANCY; ADVERTISING AND MARKETING SERVICES PROVIDED BY MEANS OF INDIRECT METHODS OF MARKETING COMMUNICATIONS, NAMELY, SOCIAL MEDIA, SEARCH ENGINE MARKETING, INQUIRY MARKETING, INTERNET MARKETING, MOBILE MARKETING, BLOGGING AND OTHER FORMS OF PASSIVE, SHARABLE OR VIRAL COMMUNICATIONS CHANNELS; ADVERTISING AND MARKETING SERVICES, NAMELY, PROMOTING THE GOODS AND SERVICES OF OTHERS; BUSINESS MANAGEMENT AND CONSULTING SERVICES FOR THE HEALTH CARE INDUSTRY, NAMELY, CUSTOMER SERVICE, ACCOUNTING SERVICES, AND WEB-BASED ADVERTISING AND MARKETING SERVICES; COOPERATIVE ADVERTISING AND MARKETING; FASHION SHOW EXHIBITIONS FOR COMMERCIAL PURPOSES; ON-LINE ADVERTISING AND MARKETING SERVICES; ORGANIZATION OF FASHION SHOWS FOR COMMERCIAL PURPOSES; PROMOTING VISUAL AND PERFORMING ARTS EVENTS BY MEANS OF PROVIDING AN ONLINE EVENTS CALENDAR, ORIGINAL ARTICLES, INTERVIEWS, AND INFORMATION ABOUT ART, ARTISTS AND ARTS EVENTS VIA AN INTERNET WEB SITE, ALL FOR PROMOTIONAL PURPOSES; PROMOTING, ADVERTISING AND MARKETING OF THE BRANDS, PRODUCTS, SERVICES AND ONLINE WEBSITES OF INDIVIDUALS, BUSINESSES AND NONPROFIT ORGANIZATIONS; PROMOTING, ADVERTISING AND MARKETING ON-LINE WEB SITES OF OTHERS; PROMOTING, ADVERTISING AND MARKETING THE ON-LINE DATABASES AND ELECTRONIC PUBLICATIONS OF OTHERS; PROMOTION, ADVERTISING AND MARKETING OF ON-LINE WEBSITE WEBSITES OF INDIVIDUALS, BUSINESSES AND NONPROFIT ORGANIZATIONS; PROMOTING, ADVERTISING AND MARKETING ON-LINE WEB SITES OF OTHERS; PROMOTING, ADVERTISING AND MARKETING THE ON-LINE DATABASES AND ELECTRONIC PUBLICATIONS OF OTHERS; PROMOTION, ADVERTISING AND MARKETING OF ON-LINE WEBSITES (U.S. CLS. 100, 101 AND 102).

FIRST USE 7-9-2011; IN COMMERCE 7-9-2011.

### CLASS 41—EDUCATION AND ENTERTAINMENT

FOR EDUCATION AND ENTERTAINMENT SERVICES, NAMELY, ONGOING TELEVISION PUBLIC SERVICE ANNOUNCEMENTS AND ONGOING TELEVISION PROGRAMS IN THE FIELD OF MARKETING AND BUSINESS DEVELOPMENT; EDUCATIONAL AND ENTERTAINMENT SERVICES, NAMELY, PROVIDING MOTIVATIONAL AND EDUCATIONAL SPEAKERS; EDUCATIONAL AND ENTERTAINMENT SERVICES, NAMELY, PROVIDING MOTIVATIONAL AND EDUCATIONAL SPEAKERS IN THE FIELD OF SELF- AND PERSONAL IMPROVEMENT; ENTERTAINMENT IN THE NATURE OF FASHION SHOWS; ENTERTAINMENT IN THE NATURE OF LIVE PERFORMANCES BY A MUSICAL GROUP; ENTERTAINMENT, NAMELY, LIVE PERFORMANCES BY A MUSICAL BAND; ENTERTAINMENT, NAMELY, LIVE PERFORMANCES BY MUSICAL BANDS; ENTERTAINMENT, NAMELY, LIVE PERFORMANCES BY ROCK GROUPS; FASHION MODELING FOR ENTERTAINMENT PURPOSES; LIVE PERFORMANCES BY A MUSICAL GROUP; LIVE PERFORMANCES FEATURING PRERECORDED VOCAL AND INSTRUMENTAL PERFORMANCES VIEWED ON A BIG SCREEN; PROVISION OF INFORMATION RELATING TO LIVE PERFORMANCES, ROAD SHOWS, LIVE STAGE EVENTS, THEATRICAL PERFORMANCES, LIVE MUSIC CONCERTS AND AUDIENCE PARTICIPATION IN SUCH EVENTS (U.S. CLS. 100, 101 AND 107).

FIRST USE 7-9-2011; IN COMMERCE 7-9-2011.  
GISELLE AGOSTO, EXAMINING ATTORNEY

SN 86-109,021. SAVANT LEARNING SYSTEMS, MARTIN, TN. FILED 11-4-2013.



OWNER OF U.S. REG. NO. 4,389,844.  
NO CLAIM IS MADE TO THE EXCLUSIVE RIGHT TO USE "V-ACADEMY", APART FROM THE MARK AS SHOWN.

THE MARK CONSISTS OF THE WORDING "V-ACADEMY" WRITTEN IN STYLIZED FORM. TO THE LEFT OF THE WORDING IS AN IMAGE OF A SHIELD CONTAINING THE LETTER "V". EMANATING FROM THE CENTER OF THE LETTER "V" AND EXTENDING PARTIALLY ABOVE THE SHIELD IS THE DESIGN OF A FLAME. AROUND THE BOTTOM OF THE SHIELD ARE TWO BRANCHES WITH LEAVES.

#### CLASS 41—EDUCATION AND ENTERTAINMENT

FOR EDUCATION SERVICES, NAMELY, PROVIDING ON-LINE CLASSES, SEMINARS, TRAINING COURSES, AND WORKSHOPS IN THE FIELDS OF BUSINESS AND CRIMINAL JUSTICE FOR USE IN HIGHER EDUCATION (U.S. CLS. 100, 101 AND 107).

FIRST USE 3-1-2013; IN COMMERCE 3-1-2013.

#### CLASS 42—SCIENTIFIC AND COMPUTER SERVICES

FOR SOFTWARE AS A SERVICE (SAAS) SERVICES, NAMELY, HOSTING SOFTWARE FOR USE BY OTHERS FOR USE IN HIGHER EDUCATION, NAMELY, PROVISION OF READING ASSIGNMENTS AND TEXTBOOKS, ONLINE LECTURES, DELIVERY AND REVIEW OF WRITTEN ASSIGNMENTS BY PROFESSORS, AND INSTRUCTOR-LED CLASS DISCUSSIONS, ALL IN THE FIELDS OF BUSINESS AND CRIMINAL JUSTICE; SOFTWARE AS A SERVICE (SAAS) SERVICES, NAMELY, HOSTING SOFTWARE FOR USE BY OTHERS FOR USE IN ONLINE CONTINUING EDUCATION AND SPECIALIZED CERTIFICATE TRAINING FOR LAW ENFORCEMENT PROFESSIONALS AND ENTITIES (U.S. CLS. 100 AND 101).

FIRST USE 3-1-2013; IN COMMERCE 3-1-2013.  
JUHI KAVEESHVAR, EXAMINING ATTORNEY

SN 86-109,803. FLEXSTEEL PIPELINE TECHNOLOGIES, INC., HOUSTON, TX. FILED 11-4-2013.



THE MARK CONSISTS OF A DOUBLE LINE SERPENTINE SHAPE, THE SQUARE SHAPE APPEARING BEHIND THE MARK IS JUST BACKGROUND AND NOT PART OF THE MARK.

#### CLASS 6—METAL GOODS

FOR FLEXIBLE PIPE AND PIPELINE PRODUCTS FOR USE IN THE OIL AND GAS INDUSTRY FOR OIL AND GAS EXPLORATION AND PRODUCTION, TRANSMISSION AND DRILLING, NAMELY, PIPES COMPRISED PRIMARILY OR WHOLLY OF METAL AND METAL FITTINGS THEREFOR; FLEXIBLE PIPES COMPRISED PRIMARILY OR WHOLLY OF METAL FOR CONVEYING NATURAL GAS, OIL, WATER, CARBON DIOXIDE, MINED ORE, JET FUEL, SEWAGE, AND FIBER OPTIC CABLES; PIPE CLIPS, COLLARS, CONNECTORS, COUPLINGS AND JOINTS COMPRISED PRIMARILY OR WHOLLY OF METAL (U.S. CLS. 2, 12, 13, 14, 23, 25 AND 50).

FIRST USE 7-6-2012; IN COMMERCE 7-6-2012.

#### CLASS 17—RUBBER GOODS

FOR FLEXIBLE PIPE AND PIPELINE PRODUCTS FOR USE IN THE OIL AND GAS INDUSTRY FOR OIL AND GAS EXPLORATION AND PRODUCTION, TRANSMISSION AND DRILLING, NAMELY, FLEXIBLE PIPES FOR CONVEYING NATURAL GAS COMPRISED PRIMARILY OR WHOLLY OF PLASTICS; REINFORCED FLEXIBLE THERMOPLASTIC PIPE; FLEXIBLE PIPES COMPRISED PRIMARILY OR WHOLLY OF PLASTICS FOR CONVEYING NATURAL GAS, OIL, WATER, CARBON DIOXIDE, MINED ORE, JET FUEL, SEWAGE, AND FIBER OPTIC CABLES (U.S. CLS. 1, 5, 12, 13, 35 AND 50).

FIRST USE 7-6-2012; IN COMMERCE 7-6-2012.  
LINDA ORNDORFF, EXAMINING ATTORNEY

SN 86-110,199. RYAN, MICHAEL J, COLUMBUS, OH. FILED 11-5-2013.

Villebillies

THE MARK CONSISTS OF STANDARD CHARACTERS WITHOUT CLAIM TO ANY PARTICULAR FONT, STYLE, SIZE, OR COLOR.



**CLASS 35—ADVERTISING AND BUSINESS**

FOR ADMINISTRATION OF A CONSUMER LOYALTY PROGRAM TO PROMOTE RESTAURANT SERVICES AND RETAIL SERVICES OF OTHERS; ADVERTISING SERVICES, NAMELY, PROMOTING AND MARKETING THE GOODS AND SERVICES OF OTHERS IN THE FIELD OF RESTAURANTS VIA PRINT AND ELECTRONIC MEDIA; ASSOCIATION SERVICES, NAMELY, PROMOTING DIVERSITY IN THE RESTAURANT AND HOTEL INDUSTRIES ON BEHALF OF EMPLOYEES, VENDORS, MANAGEMENT, AND OWNERS; BILLING SERVICES IN THE FIELD OF RESTAURANTS; FRANCHISING, NAMELY, OFFERING BUSINESS MANAGEMENT ASSISTANCE IN THE ESTABLISHMENT AND/OR OPERATION OF RESTAURANTS; MARKETING SERVICES IN THE FIELD OF RESTAURANTS; OFFERING BUSINESS MANAGEMENT ASSISTANCE IN THE ESTABLISHMENT AND/OR OPERATION OF RESTAURANTS; OFFERING BUSINESS MANAGEMENT ASSISTANCE IN THE ESTABLISHMENT AND/OR OPERATION OF RESTAURANTS; ONLINE BUSINESS DIRECTORIES FEATURING RESTAURANTS; ON-LINE ORDERING SERVICES IN THE FIELD OF RESTAURANT TAKE-OUT AND DELIVERY; PROMOTIONAL SERVICES, NAMELY, PROMOTING THE GOODS OF OTHERS BY MEANS OF PROVIDING ON-LINE RESTAURANT MENUS; PROMOTIONAL SERVICES, NAMELY, PROMOTING THE GOODS OF OTHERS BY PROVIDING GIFT CARDS, GIFT CERTIFICATES, AND COUPONS TO RESTAURANTS; PROVIDING A WEBSITE FEATURING THE RATINGS, REVIEWS AND RECOMMENDATIONS POSTED BY CONSUMERS ON RESTAURANTS, FOOD AND WINE FOR COMMERCIAL PURPOSES; PROVIDING ON-LINE CONSUMER INFORMATION CONCERNING THE LOCATION OF MOBILE RESTAURANTS; RESTAURANT FRANCHISING, NAMELY, OFFERING BUSINESS MANAGEMENT ASSISTANCE IN THE ESTABLISHMENT AND/OR OPERATION OF RESTAURANTS; RESTAURANT MANAGEMENT FOR OTHERS (U.S. CLS. 100, 101 AND 102).

**CLASS 36—INSURANCE AND FINANCIAL**

FOR FRANCHISING SERVICES NAMELY, PROVIDING FINANCIAL INFORMATION AND ADVICE REGARDING THE ESTABLISHMENT AND/OR OPERATION OF RESTAURANTS (U.S. CLS. 100, 101 AND 102).

KATHERINE CONNOLLY, EXAMINING ATTORNEY

SN 86-111,014. SPARTAN BRANDS, INC., NEW YORK, NY.  
FILED 11-5-2013.

**FRESH PRESSED ENERGY**

THE MARK CONSISTS OF STANDARD CHARACTERS WITHOUT CLAIM TO ANY PARTICULAR FONT, STYLE, SIZE, OR COLOR.

**CLASS 3—COSMETICS AND CLEANING PREPARATIONS**

FOR HAIR CARE PREPARATIONS, NAMELY, SHAMPOOS AND CONDITIONERS, HAIR CREAM, HAIR GEL, HAIR SPRAY; NON-MEDICATED SKIN CARE PREPARATIONS, NAMELY, HAND LOTIONS, FACE AND BODY LOTIONS, SKIN LOTIONS, BODY CREAM, HAND CREAM, SKIN SOAP, BODY WASH FOR HUMANS, FACIAL CLEANSERS, SKIN CLEANSERS, BODY SCRUBS AND FACIAL SCRUBS (U.S. CLS. 1, 4, 6, 50, 51 AND 52).

**CLASS 5—PHARMACEUTICALS**

FOR VITAMINS AND NUTRITIONAL SUPPLEMENTS AND DIETARY AND NUTRITIONAL SUPPLEMENTAL DRINKS IN THE NATURE OF VITAMIN AND MINERAL BEVERAGES (U.S. CLS. 6, 18, 44, 46, 51 AND 52).

DOUGLAS LEE, EXAMINING ATTORNEY

SN 86-111,035. SPARTAN BRANDS, INC., NEW YORK, NY.  
FILED 11-5-2013.

**ENERGETIC ACTIVES**

THE MARK CONSISTS OF STANDARD CHARACTERS WITHOUT CLAIM TO ANY PARTICULAR FONT, STYLE, SIZE, OR COLOR.

NO CLAIM IS MADE TO THE EXCLUSIVE RIGHT TO USE "ACTIVES", APART FROM THE MARK AS SHOWN.

**CLASS 3—COSMETICS AND CLEANING PREPARATIONS**

FOR HAIR CARE PREPARATIONS, NAMELY, SHAMPOOS AND CONDITIONERS, HAIR CREAM, HAIR GEL, HAIR SPRAY; NON-MEDICATED SKIN CARE PREPARATIONS, NAMELY, HAND LOTIONS, FACE AND BODY LOTIONS, SKIN LOTIONS, BODY CREAM, HAND CREAM, SKIN SOAP, BODY WASH FOR HUMANS, FACIAL CLEANSERS, SKIN CLEANSERS, BODY SCRUBS AND FACIAL SCRUBS (U.S. CLS. 1, 4, 6, 50, 51 AND 52).

**CLASS 5—PHARMACEUTICALS**

FOR VITAMINS AND NUTRITIONAL SUPPLEMENTS AND DIETARY AND NUTRITIONAL SUPPLEMENTAL DRINKS IN THE NATURE OF VITAMIN AND MINERAL BEVERAGES (U.S. CLS. 6, 18, 44, 46, 51 AND 52).

DOUGLAS LEE, EXAMINING ATTORNEY

SN 86-111,448. CONOPCO, INC., ENGLEWOOD CLIFFS, NJ.  
FILED 11-6-2013.

**PROJECT SUNLIGHT**

THE MARK CONSISTS OF STANDARD CHARACTERS WITHOUT CLAIM TO ANY PARTICULAR FONT, STYLE, SIZE, OR COLOR.

NO CLAIM IS MADE TO THE EXCLUSIVE RIGHT TO USE "PROJECT", APART FROM THE MARK AS SHOWN.

**CLASS 35—ADVERTISING AND BUSINESS**

FOR PROMOTING PUBLIC AWARENESS OF SUSTAINABLE LIVING INITIATIVES CONCERNING THE ENVIRONMENT, HEALTH AND WELL-BEING AND SUSTAINABLY SOURCED FOOD (U.S. CLS. 100, 101 AND 102).

**CLASS 41—EDUCATION AND ENTERTAINMENT**

FOR PROVIDING INFORMATION ABOUT EDUCATION IN THE FIELD OF SUSTAINABLE LIVING; EDUCATION, NAMELY, CONDUCTING CLASSES, SEMINARS AND WORKSHOPS IN THE FIELD OF SUSTAINABLE LIVING (U.S. CLS. 100, 101 AND 107).

TRACY FLETCHER, EXAMINING ATTORNEY

SN 86-112,664. SINDECUSE, JUDY, ST. CHARLES, MO. FILED 11-7-2013.

**CAPITAL INNOVATORS**

THE MARK CONSISTS OF STANDARD CHARACTERS WITHOUT CLAIM TO ANY PARTICULAR FONT, STYLE, SIZE, OR COLOR.

NO CLAIM IS MADE TO THE EXCLUSIVE RIGHT TO USE "CAPITAL", APART FROM THE MARK AS SHOWN.

**CLASS 35—ADVERTISING AND BUSINESS**

FOR BUSINESS AND PROFESSIONAL NETWORKING SERVICES FOR TECHNOLOGY-ORIENTED COMPANIES (U.S. CLS. 100, 101 AND 102).

FIRST USE 11-1-2010; IN COMMERCE 11-1-2010.

**CLASS 36—INSURANCE AND FINANCIAL**

FOR INVESTMENT MANAGEMENT SERVICES TO SUPPORT TECHNOLOGY-ORIENTED COMPANIES; FINANCIAL INVESTMENT SERVICES IN THE FIELD OF SEED FUNDS FOR TECHNOLOGY-ORIENTED COMPANIES (U.S. CLS. 100, 101 AND 102).

FIRST USE 11-1-2010; IN COMMERCE 11-1-2010.

**CLASS 41—EDUCATION AND ENTERTAINMENT**

FOR BUSINESS EDUCATION AND TRAINING SERVICES, NAMELY PROVIDING MENTORING AND CLASSES TO TECHNOLOGY-ORIENTED COMPANIES (U.S. CLS. 100, 101 AND 107).

FIRST USE 11-1-2010; IN COMMERCE 11-1-2010.

MARYNELLE WILSON, EXAMINING ATTORNEY

SN 86-113,209. LUXO-LED TAIWAN LIMITED, TAIPEI, TAIWAN, FILED 11-8-2013.

we master the color and  
power of led light

THE MARK CONSISTS OF STANDARD CHARACTERS WITHOUT CLAIM TO ANY PARTICULAR FONT, STYLE, SIZE, OR COLOR.

**CLASS 9—ELECTRICAL AND SCIENTIFIC APPARATUS**

FOR LIGHT EMITTING DIODES (LEDS) (U.S. CLS. 21, 23, 26, 36 AND 38).

**CLASS 10—MEDICAL APPARATUS**

FOR LIGHT EMITTING DEVICES, NAMELY, LAMPS AND LED DEVICES FOR TREATMENT OF A VARIETY OF SKIN CONDITIONS; LIGHT EMITTING DIODE (LED) APPARATUS FOR LIGHTING, INCORPORATED INTO MEDICAL INSTRUMENTS; LIGHT EMITTING DIODE (LED) DEVICES FOR ENERGY-EFFICIENT REPLACEMENT OF STANDARD TUNGSTEN-FILAMENT LIGHTING INCORPORATED INTO HAND-HELD MEDICAL INSTRUMENTS (U.S. CLS. 26, 39 AND 44).

**CLASS 11—ENVIRONMENTAL CONTROL APPARATUS**

FOR LED (LIGHT EMITTING DIODE) LIGHTING FIXTURES; LED (LIGHT EMITTING DIODES) LIGHTING FIXTURES FOR USE IN DISPLAY, COMMERCIAL, INDUSTRIAL, RESIDENTIAL, AND ARCHITECTURAL ACCENT LIGHTING APPLICATIONS; LED AND HID LIGHT FIXTURES; LED CANDLES; LED FLOOD LIGHTS AND LED WORK LIGHTS FOR CONSTRUCTION SETTINGS; LED LANDSCAPE LIGHTS; LED LIGHT APPARATUS THAT CLIPS ON TO A HANDBAG, USED TO ILLUMINATE A HANDBAG; LED LIGHT ASSEMBLIES FOR STREET LIGHTS, SIGNS, COMMERCIAL LIGHTING, AUTOMOBILES, BUILDINGS, AND OTHER ARCHITECTURAL USES; LED LIGHT BULBS; LED LIGHT ENGINES; LED LIGHT MACHINES; LED LIGHT STRIPS FOR DECORATIVE PURPOSES; LED LIGHTING FIXTURES FOR INDOOR AND OUTDOOR LIGHTING APPLICATIONS; LED LIGHTING SYSTEMS, NAMELY, LED MODULES, POWER SUPPLIES, AND WIRING; LED LIGHTS FOR LIGHTING PURPOSES INCORPORATED INTO KEY CHAINS, SMALL TOYS OR OTHER SIMILAR PERSONAL ITEMS; LED LIGHTS FOR STRINGS, FLOWERS, BRANCHES AND OTHER ORNAMENTAL DECORATIONS; LED LUMINAIRES; LED STROBE LIGHTS TO BE PLACED ON PUBLIC SAFETY VEHICLES; LED UNDERWATER LIGHTS; LIGHT EMITTING DIODE (LED) PLANT GROW LIGHT; LIGHT EMITTING DIODES (LEDS) INCORPORATED INTO METALLIC AND ADHESIVE PLASTIC REFLECTOR FILM FOR ILLUMINATING TRANSPARENT BALLOONS AND SIMILAR PRODUCTS; LUMINAIRES, USING LIGHT EMITTING DIODES (LEDS) AS A LIGHT SOURCE, FOR STREET OR ROADWAY LIGHTING; OPTICAL LENS COVERS THAT IMPROVE LIGHT OUTPUT AND UNIFORMITY AND PROTECT THE LED, SOLD AS A FEATURE OF AN LED LIGHTING SYSTEM; RED LED FLASHLIGHTS FOR ILLUMINATION PURPOSES; TOOLS, COMPONENTS AND SUPPLIES FOR USE IN MAKING SIGNS, NAMELY, FLUORESCENT, HID, LED AND INCANDESCENT BULBS, LAMPS AND FIXTURES (U.S. CLS. 13, 21, 23, 31 AND 34).

KATHERINE E. HALMEN, EXAMINING ATTORNEY

SN 86-113,300. WASHINGTON BRAVE HEARTS, LLC, POTTOMAC, MD. FILED 11-8-2013.

WASHINGTON BRAVEHEARTS

THE MARK CONSISTS OF STANDARD CHARACTERS WITHOUT CLAIM TO ANY PARTICULAR FONT, STYLE, SIZE, OR COLOR.

NO CLAIM IS MADE TO THE EXCLUSIVE RIGHT TO USE "WASHINGTON", APART FROM THE MARK AS SHOWN.

**CLASS 16—PAPER GOODS AND PRINTED MATTER**

FOR PRINTED MATTER; TRADING CARDS, POSTERS, MAGAZINES AND BOOKS REGARDING FOOTBALL, POSTCARDS, CALENDARS, WRAPPING PAPER, PAPER GIFT BOXES, PAPER STICKERS, PAPER NAPKINS, PAPER TOWELS, POSTER BOOKS, NOTEPADS, PAPER HATS AND GREETING CARDS (U.S. CLS. 2, 5, 22, 23, 29, 37, 38 AND 50).

**CLASS 25—CLOTHING**

FOR CLOTHING AND FOOTWEAR (U.S. CLS. 22 AND 39).  
SUSAN LESLIE DUBOIS, EXAMINING ATTORNEY

SN 86-113,748. LOLO'S INC., PHOENIX, AZ. FILED 11-8-2013.

**LO-LO'S CHICKEN & WAFFLES**

THE MARK CONSISTS OF STANDARD CHARACTERS WITHOUT CLAIM TO ANY PARTICULAR FONT, STYLE, SIZE, OR COLOR.

NO CLAIM IS MADE TO THE EXCLUSIVE RIGHT TO USE "CHICKEN & WAFFLES", APART FROM THE MARK AS SHOWN.

**CLASS 30—STAPLE FOODS**

FOR HOT SAUCE (U.S. CL. 46).  
FIRST USE 9-30-2012; IN COMMERCE 9-30-2012.

**CLASS 43—HOTEL AND RESTAURANT SERVICES**

FOR RESTAURANT AND CATERING SERVICES (U.S. CLS. 100 AND 101).  
FIRST USE 8-31-2002; IN COMMERCE 8-31-2002.  
JENNIFER WILLISTON, EXAMINING ATTORNEY

SN 86-114,238. MITSUBISHI ELECTRIC CORPORATION, CHIYODA-KU, TOKYO, JAPAN, FILED 11-8-2013.

**REAL NET**

THE MARK CONSISTS OF STANDARD CHARACTERS WITHOUT CLAIM TO ANY PARTICULAR FONT, STYLE, SIZE, OR COLOR.

PRIORITY CLAIMED UNDER SEC. 44(D) ON JAPAN APPLICATION NO. 2013-082935, FILED 10-24-2013, REG. NO. 2013-082935, DATED 2-28-2014, EXPIRES 2-29-2024.

OWNER OF JAPAN REG. NO. 5653131, DATED 2-28-2014, EXPIRES 2-29-2024.

NO CLAIM IS MADE TO THE EXCLUSIVE RIGHT TO USE "NET", APART FROM THE MARK AS SHOWN.

**CLASS 9—ELECTRICAL AND SCIENTIFIC APPARATUS**

FOR ELECTRONIC CONTROLS, COMPUTERS, COMPUTER SOFTWARE, COMPUTER MEMORIES, ELECTRIC COMMUNICATION APPARATUS, SEMICONDUCTORS, TRANSISTORS, ELECTRONIC CIRCUITS AND INTEGRATED CIRCUITS, ALL FOR USE IN CONTROLLING AUTOMOBILE PARTS AND FITTINGS, NAMELY, WINDSHIELD WIPERS, WINDOWS, DOORS, AIR-CONDITIONING APPARATUS, MIRRORS, SAFETY BELTS AND LIGHTING APPARATUS (U.S. CLS. 21, 23, 26, 36 AND 38).

**CLASS 12—VEHICLES**

FOR ALTERNATING CURRENT MOTORS AND DIRECT CURRENT MOTORS, ENGINES, TRANSMISSIONS, GEARBOXES, GEARING, SHOCK ABSORBERS, BRAKES, CLUTCHES, WINDSHIELD WIPERS, DOORS, INNER-REARVIEW MIRRORS, OUTER-REARVIEW MIRRORS, VANITY MIRRORS, SAFETY BELTS, ALL FOR AUTOMOBILES (U.S. CLS. 19, 21, 23, 31, 35 AND 44).  
PAM WILLIS, EXAMINING ATTORNEY

SN 86-114,343. NATIONAL ASSOCIATION OF CRIMINAL DEFENSE LAWYERS, WASHINGTON, DC. FILED 11-8-2013.

**NACDL**

THE MARK CONSISTS OF STANDARD CHARACTERS WITHOUT CLAIM TO ANY PARTICULAR FONT, STYLE, SIZE, OR COLOR.

**CLASS 35—ADVERTISING AND BUSINESS**

FOR PROFESSIONAL ASSOCIATION SERVICES IN THE FIELDS OF CRIMINAL DEFENSE LAW, NAMELY, PROMOTING THE INTERESTS OF THE LEGAL PROFESSION AND LAW REFORM IN GENERAL, AND PROMOTING THE INTERESTS OF CRIMINAL DEFENSE ATTORNEYS (U.S. CLS. 100, 101 AND 102).  
FIRST USE 11-30-1972; IN COMMERCE 11-30-1972.

**CLASS 41—EDUCATION AND ENTERTAINMENT**

FOR EDUCATION SERVICES, NAMELY, CONDUCTING CONVENTIONS, CLASSES, CONFERENCES, SEMINARS, WORKSHOPS, AND CONTINUING EDUCATION IN THE FIELD OF LEGAL EDUCATION, NAMELY, CRIMINAL DEFENSE LAW (U.S. CLS. 100, 101 AND 107).  
FIRST USE 7-31-2002; IN COMMERCE 7-31-2002.  
JULIE VEPPUMTHARA, EXAMINING ATTORNEY

SN 86-115,599. JAMES FRANCIS GROUP, INC., DBA D/B/A FROM HOME WITH LOVE, LANDING, NJ. FILED 11-11-2013.

**FROM HOME WITH LOVE**

THE MARK CONSISTS OF STANDARD CHARACTERS WITHOUT CLAIM TO ANY PARTICULAR FONT, STYLE, SIZE, OR COLOR.

OWNER OF U.S. REG. NO. 4,459,983.

**CLASS 21—HOUSEWARES AND GLASS**

FOR INSULATED BAGS FOR FOOD OR BEVERAGE FOR DOMESTIC USE; INSULATED CONTAINERS FOR FOOD OR BEVERAGE FOR DOMESTIC USE; PLASTIC STORAGE CONTAINERS FOR HOUSEHOLD USE (U.S. CLS. 2, 13, 23, 29, 30, 33, 40 AND 50).

FIRST USE 9-20-2013; IN COMMERCE 9-20-2013.

**CLASS 35—ADVERTISING AND BUSINESS**

FOR ON-LINE RETAIL STORE SERVICES FEATURING THERMAL PACKAGING MATERIALS TO ASSIST CUSTOMERS IN SHIPPING HOME-MADE MEALS TO LOVED ONES AND SPECIALIZED PACKAGING MATERIAL WHICH INCLUDE INSULATED SHIPPING CONTAINERS, GEL PACKS, ICE BLANKETS, LEAK PROOF FOOD CONTAINER, AND THERMAL BAG; RETAIL STORE SERVICES FEATURING THERMAL PACKAGING MATERIALS TO ASSIST CUSTOMERS IN SHIPPING HOME-MADE MEALS TO LOVED ONES AND SPECIALIZED PACKAGING MATERIAL WHICH INCLUDE INSULATED SHIPPING CONTAINERS, GEL PACKS, ICE BLANKETS, LEAK PROOF FOOD CONTAINER, THERMAL BAG (U.S. CLS. 100, 101 AND 102).

FIRST USE 9-20-2013; IN COMMERCE 9-20-2013.

**CLASS 39—TRANSPORTATION AND STORAGE**

FOR FOOD DELIVERY (U.S. CLS. 100 AND 105).  
FIRST USE 9-20-2013; IN COMMERCE 9-20-2013.  
BRIDGETT SMITH, EXAMINING ATTORNEY

SN 86-115,896. NATIONAL ASSOCIATION OF CRIMINAL DEFENSE LAWYERS, WASHINGTON, DC. FILED 11-11-2013.



NO CLAIM IS MADE TO THE EXCLUSIVE RIGHT TO USE "NATIONAL ASSOCIATION OF CRIMINAL DEFENSE LAWYERS", THE SCALES OF JUSTICE, AND "1958", APART FROM THE MARK AS SHOWN.

THE MARK CONSISTS OF SCALES INSIDE A CIRCLE WITH THE LETTERS "NACDL" ABOVE THE SCALES AND THE NUMBER "19" TO THE LEFT OF THE SCALES AND THE NUMBER "58" TO THE RIGHT OF THE SCALES AND THE WORDS "NATIONAL ASSOCIATION OF CRIMINAL DEFENSE LAWYERS" AROUND THE OUTSIDE OF THE CIRCLE, WITH A SHADED DOT ON THE RIGHT AND LEFT SIDES OF THE CIRCLE.

**CLASS 35—ADVERTISING AND BUSINESS**

FOR PROFESSIONAL ASSOCIATION SERVICES IN THE FIELDS OF CRIMINAL DEFENSE LAW, NAMELY, PROMOTING THE INTERESTS OF THE LEGAL PROFESSION AND LAW REFORM IN GENERAL, AND PROMOTING THE INTERESTS OF CRIMINAL DEFENSE ATTORNEYS (U.S. CLS. 100, 101 AND 102).

FIRST USE 8-12-1992; IN COMMERCE 8-12-1992.

**CLASS 41—EDUCATION AND ENTERTAINMENT**

FOR EDUCATION SERVICES, NAMELY, CONDUCTING CONVENTIONS, CLASSES, CONFERENCES, SEMINARS, WORKSHOPS, AND CONTINUING EDUCATION IN THE FIELD OF LEGAL EDUCATION, NAMELY, CRIMINAL DEFENSE LAW (U.S. CLS. 100, 101 AND 107).

FIRST USE 11-19-2009; IN COMMERCE 11-19-2009.  
JULIE VEPPUMTHARA, EXAMINING ATTORNEY

SN 86-116,050. NATIONAL ASSOCIATION OF CRIMINAL DEFENSE LAWYERS, WASHINGTON, DC. FILED 11-12-2013.

**LIBERTY'S LAST CHAMPION**

THE MARK CONSISTS OF STANDARD CHARACTERS WITHOUT CLAIM TO ANY PARTICULAR FONT, STYLE, SIZE, OR COLOR.

**CLASS 35—ADVERTISING AND BUSINESS**

FOR PROFESSIONAL ASSOCIATION SERVICES IN THE FIELDS OF CRIMINAL DEFENSE LAW, NAMELY, PROMOTING THE INTERESTS OF THE LEGAL PROFESSION AND LAW REFORM IN GENERAL, AND PROMOTING THE INTERESTS OF CRIMINAL DEFENSE ATTORNEYS (U.S. CLS. 100, 101 AND 102).

FIRST USE 6-0-1983; IN COMMERCE 6-0-1983.

**CLASS 41—EDUCATION AND ENTERTAINMENT**

FOR EDUCATION SERVICES, NAMELY, CONDUCTING CONVENTIONS, CLASSES, CONFERENCES, SEMINARS, WORKSHOPS, AND CONTINUING EDUCATION IN THE FIELD OF LEGAL EDUCATION, NAMELY, CRIMINAL DEFENSE LAW (U.S. CLS. 100, 101 AND 107).

FIRST USE 6-0-1983; IN COMMERCE 6-0-1983.  
JULIE VEPPUMTHARA, EXAMINING ATTORNEY

SN 86-116,292. TD AMERITRADE IP COMPANY, INC.,  
OMAHA, NE. FILED 11-12-2013.

SN 86-116,462. TD AMERITRADE IP COMPANY, INC.,  
OMAHA, NE. FILED 11-12-2013.

THINKORSWIM

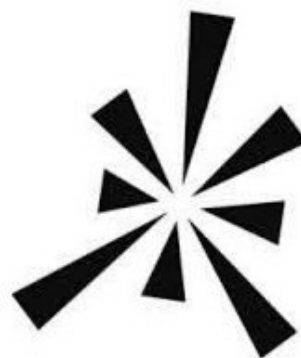

THE MARK CONSISTS OF STANDARD CHARACTERS WITHOUT CLAIM TO ANY PARTICULAR FONT, STYLE, SIZE, OR COLOR.  
OWNER OF U.S. REG. NOS. 2,568,003 AND 3,351,845.

OWNER OF U.S. REG. NOS. 2,568,003 AND 3,351,845.  
THE MARK CONSISTS OF AN ASTERISK DESIGN.

**CLASS 9—ELECTRICAL AND SCIENTIFIC APPARATUS**

FOR COMPUTER SOFTWARE RELATED TO INVESTMENT, NAMELY, ELECTRONIC TRADING SOFTWARE, INVESTMENT PORTFOLIO MANAGEMENT SOFTWARE, FINANCIAL ANALYTICAL SOFTWARE, ELECTRONIC TRADING ORDER MANAGEMENT SOFTWARE, FINANCIAL RISK MODELING SOFTWARE AND SOFTWARE FOR PROVIDING ELECTRONIC CONNECTIVITY TO FINANCIAL EXCHANGES AND MARKETS; DOWNLOADABLE SOFTWARE FOR USE IN ACCESSING INFORMATION ABOUT INVESTMENT PRODUCTS, NAMELY, SECURITIES, FUTURES, AND FOREX; DOWNLOADABLE SOFTWARE FOR USE IN TRADING INVESTMENT PRODUCTS, NAMELY, SECURITIES, FUTURES, AND FOREX (U.S. CLS. 21, 23, 26, 36 AND 38).

FIRST USE 1-11-2001; IN COMMERCE 1-11-2001.

**CLASS 36—INSURANCE AND FINANCIAL**

FOR FINANCIAL SERVICES, NAMELY, PROVIDING INFORMATION, ANALYSIS, NEWS AND COMMENTARY ABOUT INVESTMENT PRODUCTS, NAMELY, SECURITIES, FUTURES, AND FOREX; SECURITIES, FUTURES AND FOREX TRADING FOR OTHERS (U.S. CLS. 100, 101 AND 102).

FIRST USE 12-0-2001; IN COMMERCE 12-0-2001.

**CLASS 38—COMMUNICATION**

FOR BROADCASTING LIVE PROGRAMS FEATURING EDUCATIONAL DISCUSSIONS IN THE FIELDS OF INVESTING AND INVESTMENT PRODUCTS, NAMELY, SECURITIES, FUTURES AND FOREX, VIA A GLOBAL COMPUTER NETWORK (U.S. CLS. 100, 101 AND 104).

FIRST USE 12-0-2002; IN COMMERCE 12-0-2002.

**CLASS 41—EDUCATION AND ENTERTAINMENT**

FOR EDUCATIONAL SERVICES IN THE NATURE OF CONFERENCES, NON-DOWNLOADABLE WEBINARS, WEBCASTS, WORKSHOPS DELIVERED BY MEANS OF LIVE-CHAT BROADCASTS AND SEMINARS ALL IN THE FIELDS OF INVESTING AND INVESTMENT PRODUCTS, NAMELY, SECURITIES, FUTURES AND FOREX; PROVIDING ON-LINE NON-DOWNLOADABLE PUBLICATIONS IN THE NATURE OF MAGAZINES, NEWSLETTERS AND REPORTS IN THE FIELDS OF INVESTING AND INVESTMENT PRODUCTS, NAMELY, SECURITIES, FUTURES AND FOREX, AND COMPUTER SOFTWARE (U.S. CLS. 100, 101 AND 107).

FIRST USE 12-0-2001; IN COMMERCE 12-0-2001.  
EVELYN BRADLEY, EXAMINING ATTORNEY

**CLASS 9—ELECTRICAL AND SCIENTIFIC APPARATUS**

FOR COMPUTER SOFTWARE RELATED TO INVESTMENT, NAMELY, ELECTRONIC TRADING SOFTWARE, INVESTMENT PORTFOLIO MANAGEMENT SOFTWARE, FINANCIAL ANALYTICAL SOFTWARE, ELECTRONIC TRADING ORDER MANAGEMENT SOFTWARE, FINANCIAL RISK MODELING SOFTWARE AND SOFTWARE FOR PROVIDING ELECTRONIC CONNECTIVITY TO FINANCIAL EXCHANGES AND MARKETS; DOWNLOADABLE SOFTWARE FOR USE IN ACCESSING INFORMATION ABOUT INVESTMENT PRODUCTS, NAMELY, SECURITIES, FUTURES, AND FOREX; DOWNLOADABLE SOFTWARE FOR USE IN TRADING INVESTMENT PRODUCTS, NAMELY, SECURITIES, FUTURES, AND FOREX (U.S. CLS. 21, 23, 26, 36 AND 38).

FIRST USE 1-11-2001; IN COMMERCE 1-11-2001.

**CLASS 36—INSURANCE AND FINANCIAL**

FOR FINANCIAL SERVICES, NAMELY, PROVIDING INFORMATION, ANALYSIS, NEWS AND COMMENTARY ABOUT INVESTMENT PRODUCTS, NAMELY, SECURITIES, FUTURES, AND FOREX; SECURITIES, FUTURES AND FOREX TRADING FOR OTHERS (U.S. CLS. 100, 101 AND 102).

FIRST USE 12-0-2001; IN COMMERCE 12-0-2001.

**CLASS 38—COMMUNICATION**

FOR BROADCASTING LIVE PROGRAMS FEATURING EDUCATIONAL DISCUSSIONS IN THE FIELDS OF INVESTING AND INVESTMENT PRODUCTS, NAMELY, SECURITIES, FUTURES AND FOREX, VIA A GLOBAL COMPUTER NETWORK (U.S. CLS. 100, 101 AND 104).

FIRST USE 12-0-2002; IN COMMERCE 12-0-2002.

**CLASS 41—EDUCATION AND ENTERTAINMENT**

FOR EDUCATIONAL SERVICES IN THE NATURE OF CONFERENCES, NON-DOWNLOADABLE WEBINARS, WEBCASTS, WORKSHOPS DELIVERED BY MEANS OF LIVE-CHAT BROADCASTS AND SEMINARS ALL IN THE FIELDS OF INVESTING AND INVESTMENT PRODUCTS, NAMELY, SECURITIES, FUTURES AND FOREX; PROVIDING ON-LINE NON-DOWNLOADABLE PUBLICATIONS IN THE NATURE OF MAGAZINES, NEWSLETTERS AND REPORTS IN THE FIELDS OF INVESTING AND INVESTMENT PRODUCTS, NAMELY, SECURITIES, FUTURES AND FOREX, AND COMPUTER SOFTWARE (U.S. CLS. 100, 101 AND 107).

FIRST USE 12-0-2001; IN COMMERCE 12-0-2001.  
EVELYN BRADLEY, EXAMINING ATTORNEY

SN 86-117,243. SCI DIRECT, LLC, NORTH CANTON, OH. FILED 11-13-2013.

## UNIMAX PICS

THE MARK CONSISTS OF STANDARD CHARACTERS WITHOUT CLAIM TO ANY PARTICULAR FONT, STYLE, SIZE, OR COLOR.

NO CLAIM IS MADE TO THE EXCLUSIVE RIGHT TO USE "PICS", APART FROM THE MARK AS SHOWN.

### CLASS 9—ELECTRICAL AND SCIENTIFIC APPARATUS

FOR ELECTRONIC DEVICES FOR THE PURPOSE OF PRINTING AND TRANSFERRING PICTURES FROM DIGITAL CAMERAS AND SMART PHONES (U.S. CLS. 21, 23, 26, 36 AND 38).

### CLASS 35—ADVERTISING AND BUSINESS

FOR ONLINE RETAIL STORE SERVICES IN THE FIELD OF PHOTOGRAPHY (U.S. CLS. 100, 101 AND 102).

MATTHEW GALAN, EXAMINING ATTORNEY

SN 86-117,491. JOURNOVA, INC., SACRAMENTO, CA. FILED 11-13-2013.

## JOURNOVA

THE MARK CONSISTS OF STANDARD CHARACTERS WITHOUT CLAIM TO ANY PARTICULAR FONT, STYLE, SIZE, OR COLOR.

THE ENGLISH TRANSLATION OF "JOUR" AND "NOVA" IN THE MARK IS "DAY" AND "NEW", RESPECTIVELY.

### CLASS 9—ELECTRICAL AND SCIENTIFIC APPARATUS

FOR BATTERY CASES; BATTERY PACKS; CARRYING CASES, HOLDERS, PROTECTIVE CASES AND STANDS FEATURING POWER SUPPLY CONNECTORS, ADAPTORS, SPEAKERS AND BATTERY CHARGING DEVICES, SPECIALLY ADAPTED FOR USE WITH HANDHELD DIGITAL ELECTRONIC DEVICES, NAMELY, SMARTPHONES, TABLETS AND MEDIA PLAYERS; CHARGERS FOR ELECTRIC BATTERIES; ELECTRIC BATTERIES; RECHARGEABLE ELECTRIC BATTERIES; RENEWABLE BATTERY SYSTEM TO PROVIDE BACKUP POWER (U.S. CLS. 21, 23, 26, 36 AND 38). FIRST USE 6-30-2013; IN COMMERCE 11-4-2013.

### CLASS 18—LEATHER GOODS

FOR BUSINESS CASES; CARRYING CASES; CASES OF IMITATION LEATHER; LEATHER CASES; TRAVEL CASES; TRAVELLING CASES OF LEATHER (U.S. CLS. 1, 2, 3, 22 AND 41).

AHSEN KHAN, EXAMINING ATTORNEY

SN 86-118,036. NATIONAL COMPOUNDING COMPANY, INC., DBA SOOTHE COMPOUNDING PHARMACY, BRADENTON, FL. FILED 11-13-2013.



THE COLOR(S) ORANGE, YELLOW, LIGHT GREEN, BLUE/GREEN, AND GREY IS/ARE CLAIMED AS A FEATURE OF THE MARK.

THE MARK CONSISTS OF OVERLAPPING LEAVES THAT SUGGEST THE FORM OF A FLOWER WHICH APPEAR IN ORANGE, YELLOW, LIGHT GREEN, BLUE/GREEN AND GREY. THE COLOR WHITE IN THE MARK IS FOR BACKGROUND PURPOSES ONLY AND IS NOT A CLAIMED FEATURE OF THE MARK.

### CLASS 42—SCIENTIFIC AND COMPUTER SERVICES

FOR TOXICOLOGY TESTING SERVICES (U.S. CLS. 100 AND 101).

FIRST USE 11-9-2012; IN COMMERCE 11-9-2012.

### CLASS 44—MEDICAL, BEAUTY AND AGRICULTURAL SERVICES

FOR PHARMACEUTICAL COMPOUNDING SERVICES, DISPENSING OF COMPOUNDED AND NON-COMPOUNDED PRESCRIPTION MEDICATIONS, MEDICATION MANAGEMENT IN THE NATURE OF PREPARATION AND DISPENSING OF MEDICATIONS, AND DNA AND GENETIC TESTING FOR MEDICAL PURPOSES (U.S. CLS. 100 AND 101).

FIRST USE 11-9-2012; IN COMMERCE 11-9-2012.

DANIEL CAPSHAW, EXAMINING ATTORNEY

SN 86-118,233. THE PROVIDENCE SERVICE CORPORATION, TUCSON, AZ. FILED 11-13-2013.



OWNER OF U.S. REG. NOS. 2,252,504 AND 3,098,098.

THE COLOR(S) WHITE, BLUE, GREEN AND GRAY IS/ARE CLAIMED AS A FEATURE OF THE MARK.

THE MARK CONSISTS OF THE LETTERS "P", "S" AND "C", ALL IN A WHITE FONT. THE LETTER "P" IS IN A BLUE SQUARE. THE LETTER "S" IS IN A GREEN SQUARE. THE LETTER "C" IS IN A GRAY SQUARE. THESE THREE SQUARES ARE ARRANGED HORIZONTALLY.

**CLASS 35—ADVERTISING AND BUSINESS**

FOR DRUG-AND-ALCOHOL ABUSE SERVICES, NAMELY, JOB PLACEMENT; EMPLOYMENT COUNSELING TO ASSIST INDIVIDUALS TO OBTAIN AND RETAIN EMPLOYMENT (U.S. CLS. 100, 101 AND 102).

**CLASS 39—TRANSPORTATION AND STORAGE**

FOR NON-EMERGENCY MEDICAL TRANSPORTATION SERVICES, NAMELY, PROVIDING TRANSPORTATION FOR PEOPLE BY AMBULANCE, GROUND VEHICLES, AND MEDICAL AIRPLANE (U.S. CLS. 100 AND 105).

**CLASS 44—MEDICAL, BEAUTY AND AGRICULTURAL SERVICES**

FOR BEHAVIORAL HEALTH SERVICES (U.S. CLS. 100 AND 101).  
RUDY R. SINGLETON, EXAMINING ATTORNEY

SN 86-118,484. TERESE CLARK, BELLEVUE, WA. FILED 11-14-2013.

VintageByT

THE MARK CONSISTS OF STANDARD CHARACTERS WITHOUT CLAIM TO ANY PARTICULAR FONT, STYLE, SIZE, OR COLOR.

NO CLAIM IS MADE TO THE EXCLUSIVE RIGHT TO USE "VINTAGE", APART FROM THE MARK AS SHOWN.

**CLASS 35—ADVERTISING AND BUSINESS**

FOR ON-LINE WHOLESALE AND RETAIL STORE SERVICES FEATURING VINTAGE FABRIC, FURNITURE, FURNITURE ACCESSORIES, WORKS OF ART, AND WORKS OF PHOTOGRAPHY (U.S. CLS. 100, 101 AND 102).

FIRST USE 10-28-2013; IN COMMERCE 10-28-2013.

**CLASS 41—EDUCATION AND ENTERTAINMENT**

FOR PHOTOGRAPHY; VIDEO PRODUCTION SERVICES (U.S. CLS. 100, 101 AND 107).

FIRST USE 10-28-2013; IN COMMERCE 10-28-2013.

**CLASS 42—SCIENTIFIC AND COMPUTER SERVICES**

FOR INTERIOR DESIGN SERVICES INCLUDING SPACE PLANNING, FURNITURE SELECTION, MATERIAL AND SURFACE SELECTION (U.S. CLS. 100 AND 101).

FIRST USE 10-28-2013; IN COMMERCE 10-28-2013.  
DAWN HAN, EXAMINING ATTORNEY

SN 86-118,983. TAH TONG TEXTILE CO., LTD., TAIPEI CITY 105, TAIWAN, FILED 11-14-2013.



THE MARK CONSISTS OF A PLURALITY OF OVERLAPPING POLYGONS, ALL OVER THE HIGHLY STYLIZED LETTERS "TAHTONG".

THE WORDING "TAHTONG" OR "TAH TONG" HAS NO MEANING IN A FOREIGN LANGUAGE.

**CLASS 23—YARNS AND THREADS**

FOR HEMP THREAD AND YARN; SPUN COTTON; THREADS OF PLASTIC MATERIALS FOR TEXTILE USE; SPUN THREAD AND YARN (U.S. CL. 43).

FIRST USE 10-4-2013; IN COMMERCE 10-4-2013.

**CLASS 24—FABRICS**

FOR COTTON FABRICS; DRAPERY; TOWELLING COVERLETS; ELASTIC WOVEN FABRICS; FABRICS FOR TEXTILE USE; LINEN CLOTH; MATTRESS COVERS; BED SHEETS (U.S. CLS. 42 AND 50).

FIRST USE 10-4-2013; IN COMMERCE 10-4-2013.

DOUGLAS LEE, EXAMINING ATTORNEY

SN 86-119,536. AUGURY, INC., LOS ANGELES, CA. FILED 11-14-2013.

QUEEN OF SOULS

THE MARK CONSISTS OF STANDARD CHARACTERS WITHOUT CLAIM TO ANY PARTICULAR FONT, STYLE, SIZE, OR COLOR.

**CLASS 9—ELECTRICAL AND SCIENTIFIC APPARATUS**

FOR PRE-RECORDED CDS AND DVDS FEATURING MUSICAL RECORDINGS; DOWNLOADABLE MUSIC AND RING TONES VIA THE INTERNET AND WIRELESS DEVICES (U.S. CLS. 21, 23, 26, 36 AND 38).

**CLASS 41—EDUCATION AND ENTERTAINMENT**

FOR LIVE MUSICAL PERFORMANCES AND MUSIC PRODUCTION SERVICES (U.S. CLS. 100, 101 AND 107).  
BARBARA A. GOLD, EXAMINING ATTORNEY

SN 86-119,720. CONCENTRIC PIPE AND TOOL RENTALS, LLC, HOUMA, LA. FILED 11-15-2013.

SN 86-120,181. DECISION INSIGHT INFORMATION GROUP S.A.R.L., LUXEMBOURG, LUXEMBOURG, FILED 11-15-2013.

# SSWS

THE MARK CONSISTS OF STANDARD CHARACTERS WITHOUT CLAIM TO ANY PARTICULAR FONT, STYLE, SIZE, OR COLOR.

## CLASS 7—MACHINERY

FOR A HAND-HELD PNEUMATIC SAFETY WRENCH SYSTEM COMPRISING PRIMARILY A WRENCH WITH A CLAMPING MECHANISM AND A RATCHETING MECHANISM THAT ENABLES THE USER TO SAFELY TIGHTEN AND LOOSEN HAMMER UNIONS AND SIMILAR HIGH-PRESSURE TEMPORARILY FLOW LINE AND PIPE CONNECTIONS USED IN THE OIL, GAS AND UTILITY INDUSTRY (U.S. CLS. 13, 19, 21, 23, 31, 34 AND 35).

## CLASS 8—HAND TOOLS

FOR A HAND-HELD, MANUALLY OPERATED SAFETY WRENCH SYSTEM COMPRISING PRIMARILY A WRENCH WITH A CLAMPING MECHANISM AND A RATCHETING MECHANISM THAT ENABLES THE USER TO SAFELY TIGHTEN AND LOOSEN HAMMER UNIONS AND SIMILAR HIGH-PRESSURE TEMPORARY FLOW LINE AND PIPE CONNECTIONS USED IN THE OIL, GAS AND UTILITY INDUSTRIES (U.S. CLS. 23, 28 AND 44).

ROGER T. MCDORMAN, EXAMINING ATTORNEY

---

SN 86-120,039. BLUEOCO, LLC, EAST GRAND RAPIDS, MI. FILED 11-15-2013.

# broxan

THE MARK CONSISTS OF STANDARD CHARACTERS WITHOUT CLAIM TO ANY PARTICULAR FONT, STYLE, SIZE, OR COLOR.

## CLASS 3—COSMETICS AND CLEANING PREPARATIONS

FOR CLEANING PREPARATIONS FOR HOUSEHOLD PURPOSES (U.S. CLS. 1, 4, 6, 50, 51 AND 52).

## CLASS 21—HOUSEWARES AND GLASS

FOR CLEANING BRUSHES FOR HOUSEHOLD USE; GLOVES FOR HOUSEHOLD PURPOSES (U.S. CLS. 2, 13, 23, 29, 30, 33, 40 AND 50).

KRISTIN DAHLING, EXAMINING ATTORNEY

# ABSOLUTE VALIDITY

THE MARK CONSISTS OF STANDARD CHARACTERS WITHOUT CLAIM TO ANY PARTICULAR FONT, STYLE, SIZE, OR COLOR.

## CLASS 9—ELECTRICAL AND SCIENTIFIC APPARATUS

FOR COMPUTER SOFTWARE USED TO PROVIDE PROPERTY VALUATION INFORMATION, FINANCIAL VALUATION INFORMATION, INSURANCE RISK INFORMATION, RISK ASSESSMENT INFORMATION, AND BUSINESS INFORMATION (U.S. CLS. 21, 23, 26, 36 AND 38).

## CLASS 16—PAPER GOODS AND PRINTED MATTER

FOR SERIES OF NON-FICTION BOOKS, BOOKLETS, AND NEWSLETTERS CONCERNING PROPERTY VALUATION AND RISK ASSESSMENT (U.S. CLS. 2, 5, 22, 23, 29, 37, 38 AND 50).

## CLASS 36—INSURANCE AND FINANCIAL

FOR INSURANCE AND FINANCIAL SERVICES, NAMELY, PROVIDING PROPERTY VALUATION INFORMATION, REAL PROPERTY GEOCODING LOCATION INFORMATION, AND FINANCIAL AND INSURANCE RISK ASSESSMENT SERVICES (U.S. CLS. 100, 101 AND 102).

## CLASS 42—SCIENTIFIC AND COMPUTER SERVICES

FOR SOFTWARE AS A SERVICE PROVIDING TEMPORARY USE OF ON-LINE NON-DOWNLOADABLE SOFTWARE AND APPLICATIONS FOR COLLECTING, MAINTAINING, AND PROVIDING PROPERTY VALUATION INFORMATION, FINANCIAL VALUATION INFORMATION, INSURANCE RISK INFORMATION, RISK ASSESSMENT INFORMATION, BUSINESS INFORMATION, GEOCODING LOCATION INFORMATION, AND HAZARD RISK INFORMATION (U.S. CLS. 100 AND 101).

TRACY CROSS, EXAMINING ATTORNEY

---

SN 86-121,048. SINGLETON RASHON L, N. CHERSTERFIELD, VA. FILED 11-18-2013.

# Unkle Boo's Southern Smoke BBQ

THE MARK CONSISTS OF STANDARD CHARACTERS WITHOUT CLAIM TO ANY PARTICULAR FONT, STYLE, SIZE, OR COLOR.

NO CLAIM IS MADE TO THE EXCLUSIVE RIGHT TO USE "SOUTHERN SMOKE BBQ", APART FROM THE MARK AS SHOWN.

THE NAME(S), PORTRAIT(S), AND/OR SIGNATURE(S) SHOWN IN THE MARK DOES NOT IDENTIFY A PARTICULAR LIVING INDIVIDUAL.



**CLASS 30—STAPLE FOODS**

FOR (BASED ON INTENT TO USE) BARBECUE SAUCE; HOT SAUCE (U.S. CL. 46).

SN 86-121,511. MARKETINGSUITE.COM, INC., SAN FRANCISCO, CA. FILED 11-18-2013.

**CLASS 43—HOTEL AND RESTAURANT SERVICES**

FOR (BASED ON USE IN COMMERCE) RESTAURANT AND CATERING SERVICES; RESTAURANT SERVICES, INCLUDING SIT-DOWN SERVICE OF FOOD AND TAKE-OUT RESTAURANT SERVICES (U.S. CLS. 100 AND 101).

FIRST USE 12-1-2012; IN COMMERCE 11-1-2013.  
LESLEY LAMOTHE, EXAMINING ATTORNEY

# DAZLE.ME

THE MARK CONSISTS OF STANDARD CHARACTERS WITHOUT CLAIM TO ANY PARTICULAR FONT, STYLE, SIZE, OR COLOR.

**CLASS 35—ADVERTISING AND BUSINESS**

FOR ONLINE BUSINESS NETWORKING SERVICES; ONLINE PROFESSIONAL NETWORKING SERVICES; PROVIDING EMPLOYMENT PLACEMENT AND JOB LISTING SERVICES TO PROSPECTIVE EMPLOYERS AND EMPLOYEES; PROVIDING ONLINE INTERACTIVE COUNSELING IN THE FIELDS OF EMPLOYMENT AND PROFESSIONAL DEVELOPMENT (U.S. CLS. 100, 101 AND 102).

SN 86-121,497. MARKETINGSUITE.COM, INC., SAN FRANCISCO, CA. FILED 11-18-2013.

**CLASS 42—SCIENTIFIC AND COMPUTER SERVICES**

FOR COMPUTER SERVICES, NAMELY, CREATING AN ONLINE COMMUNITY FOR REGISTERED USERS TO PARTICIPATE IN DISCUSSIONS, SHARE INFORMATION AND RESOURCES, AND ENGAGE IN BUSINESS NETWORKING, PROFESSIONAL NETWORKING AND SOCIAL NETWORKING, ALL IN THE FIELDS OF EMPLOYMENT AND CAREER DEVELOPMENT (U.S. CLS. 100 AND 101).

# DAZLE.COM

**CLASS 45—PERSONAL AND LEGAL SERVICES**

FOR ONLINE SOCIAL NETWORKING SERVICES; PROVIDING ONLINE INTERACTIVE COUNSELING IN THE FIELDS OF PERSONAL RELATIONSHIP BUILDING AND SOCIAL NETWORKING (U.S. CLS. 100 AND 101).

THE MARK CONSISTS OF STANDARD CHARACTERS WITHOUT CLAIM TO ANY PARTICULAR FONT, STYLE, SIZE, OR COLOR.

SHAILA LEWIS, EXAMINING ATTORNEY

**CLASS 35—ADVERTISING AND BUSINESS**

FOR ONLINE BUSINESS NETWORKING SERVICES; ONLINE PROFESSIONAL NETWORKING SERVICES; PROVIDING EMPLOYMENT PLACEMENT AND JOB LISTING SERVICES TO PROSPECTIVE EMPLOYERS AND EMPLOYEES; PROVIDING ONLINE INTERACTIVE COUNSELING IN THE FIELDS OF EMPLOYMENT AND PROFESSIONAL DEVELOPMENT (U.S. CLS. 100, 101 AND 102).

SN 86-121,990. HAJOCA CORPORATION, ARDMORE, PA. FILED 11-18-2013.

# POYDRAS

THE MARK CONSISTS OF STANDARD CHARACTERS WITHOUT CLAIM TO ANY PARTICULAR FONT, STYLE, SIZE, OR COLOR.

**CLASS 42—SCIENTIFIC AND COMPUTER SERVICES**

FOR COMPUTER SERVICES, NAMELY, CREATING AN ONLINE COMMUNITY FOR REGISTERED USERS TO PARTICIPATE IN DISCUSSIONS, SHARE INFORMATION AND RESOURCES, AND ENGAGE IN BUSINESS NETWORKING, PROFESSIONAL NETWORKING AND SOCIAL NETWORKING, ALL IN THE FIELDS OF EMPLOYMENT AND CAREER DEVELOPMENT (U.S. CLS. 100 AND 101).

**CLASS 6—METAL GOODS**

FOR METAL HOOKS (U.S. CLS. 2, 12, 13, 14, 23, 25 AND 50).  
FIRST USE 3-0-2011; IN COMMERCE 3-0-2011.

**CLASS 45—PERSONAL AND LEGAL SERVICES**

FOR ONLINE SOCIAL NETWORKING SERVICES; PROVIDING ONLINE INTERACTIVE COUNSELING IN THE FIELDS OF PERSONAL RELATIONSHIP BUILDING AND SOCIAL NETWORKING (U.S. CLS. 100 AND 101).

SHAILA LEWIS, EXAMINING ATTORNEY

**CLASS 11—ENVIRONMENTAL CONTROL APPARATUS**

FOR FAUCETS; HAND-HELD SHOWERS; SHOWER-HEADS (U.S. CLS. 13, 21, 23, 31 AND 34).  
FIRST USE 3-0-2011; IN COMMERCE 3-0-2011.

**CLASS 21—HOUSEWARES AND GLASS**

FOR BATH ACCESSORIES, NAMELY, TOWEL BARS, TOILET PAPER HOLDERS AND TOWEL RINGS (U.S. CLS. 2, 13, 23, 29, 30, 33, 40 AND 50).

FIRST USE 3-0-2011; IN COMMERCE 3-0-2011.  
JACQUELINE ABRAMS, EXAMINING ATTORNEY

SN 86-122,771. NITTA CORPORATION, OSAKA, JAPAN, FILED 11-19-2013.

# NITTA

OWNER OF U.S. REG. NOS. 3,329,257 AND 3,540,441.  
THE MARK CONSISTS OF THE STYLIZED WORD "NITTA".

SN 86-122,114. INTERMOUNTAIN HEALTH CARE, INC., SALT LAKE CITY, UT. FILED 11-18-2013.

## QUALITY BANKS

THE MARK CONSISTS OF STANDARD CHARACTERS WITHOUT CLAIM TO ANY PARTICULAR FONT, STYLE, SIZE, OR COLOR.

**CLASS 9—ELECTRICAL AND SCIENTIFIC APPARATUS**

FOR COMPUTER SOFTWARE FOR USE IN CONNECTION WITH PROVIDING INFORMATION, CONSULTATION, AND TREATMENT SERVICES IN THE FIELD OF MENTAL HEALTHCARE, NAMELY, COMPUTER SOFTWARE FOR MEDICAL CLINICIANS TO ELECTRONICALLY MANAGE AND PROCESS PATIENT HEALTH DATA AND BILL MEDICAL INSURERS FOR COST MANAGEMENT AND PATIENT TREATMENT MANAGEMENT PURPOSES (U.S. CLS. 21, 23, 26, 36 AND 38).

**CLASS 6—METAL GOODS**

FOR TUBES OR HOSES OF METAL; JUNCTIONS OF METAL FOR PIPES; VALVES OF METAL, OTHER THAN PARTS OF MACHINES (U.S. CLS. 2, 12, 13, 14, 23, 25 AND 50).

FIRST USE 4-1-1992; IN COMMERCE 7-1-2003.

**CLASS 17—RUBBER GOODS**

FOR FLEXIBLE TUBES OF PLASTIC; VALVES OF RUBBER OR VULCANIZED FIBER, NOT INCLUDING MACHINE ELEMENTS (U.S. CLS. 1, 5, 12, 13, 35 AND 50).

FIRST USE 4-1-1992; IN COMMERCE 7-1-2003.

**CLASS 19—NON-METALLIC BUILDING MATERIALS**

FOR JUNCTIONS NOT OF METAL FOR FLEXIBLE PIPES (U.S. CLS. 1, 12, 33 AND 50).

FIRST USE 3-19-2010; IN COMMERCE 3-19-2010.  
DANNEAN HETZEL, EXAMINING ATTORNEY

**CLASS 36—INSURANCE AND FINANCIAL**

FOR INTERNET-BASED SERVICES FOR USE IN CONNECTION WITH PROVIDING INSURANCE INFORMATION IN THE FIELD OF MENTAL HEALTHCARE, NAMELY, MEDICAL INSURANCE CASE AND UTILIZATION REVIEW AND INSURANCE CLAIMS ADJUSTMENT SERVICES FOR HEALTHCARE PURCHASERS AND PAYORS AND PROVIDERS AND MEDICARE BENEFICIARIES (U.S. CLS. 100, 101 AND 102).

**CLASS 42—SCIENTIFIC AND COMPUTER SERVICES**

FOR PROVIDING AN ONLINE NON-DOWNLOADABLE INTERNET-BASED SYSTEM APPLICATION FOR USE IN CONNECTION WITH PROVIDING INFORMATION, CONSULTATION, AND TREATMENT SERVICES IN THE FIELD OF MENTAL HEALTHCARE FEATURING TECHNOLOGY ENABLING MEDICAL CLINICIANS TO ELECTRONICALLY MANAGE AND PROCESS PATIENT HEALTH DATA AND BILL MEDICAL INSURERS FOR COST MANAGEMENT AND PATIENT TREATMENT MANAGEMENT PURPOSES (U.S. CLS. 100 AND 101).

**CLASS 44—MEDICAL, BEAUTY AND AGRICULTURAL SERVICES**

FOR INFORMATION, CONSULTATION, AND TREATMENT SERVICES IN THE FIELD OF MENTAL HEALTHCARE (U.S. CLS. 100 AND 101).  
HANNO RITTMER, EXAMINING ATTORNEY

SN 86-122,974. ANNCO, INC., NEW YORK, NY. FILED 11-19-2013.

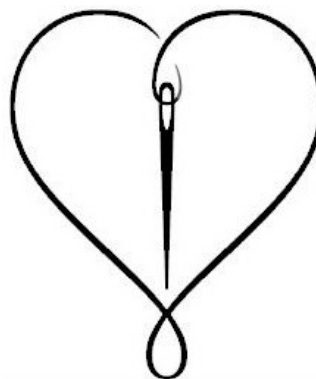

THE MARK CONSISTS OF A STYLIZED DESIGN OF A HEART WITH A STYLIZED DESIGN OF A NEEDLE IN THE CENTER OF THE HEART.

**CLASS 3—COSMETICS AND CLEANING PREPARATIONS**

FOR SOAPS, PERFUMERY, FRAGRANCES, COSMETICS, NON-MEDICATED SKIN CARE PREPARATIONS, NAIL CARE PREPARATIONS, NON-MEDICATED LIP CARE PREPARATIONS, SKIN CLEANSERS (U.S. CLS. 1, 4, 6, 50, 51 AND 52).

**CLASS 9—ELECTRICAL AND SCIENTIFIC APPARATUS**

FOR EYEWEAR; SUNGLASSES; EYEGLASSES; SUNGLASS FRAMES; EYEGGLASS FRAMES; CASES FOR EYEGLASSES; CASES FOR SUNGLASSES; MAGNETIC CODED GIFT CARDS AND ELECTRONIC ENCODED GIFT CERTIFICATES WHICH MAY THEN BE REDEEMED FOR GOODS OR SERVICES (U.S. CLS. 21, 23, 26, 36 AND 38).

**CLASS 14—JEWELRY**

FOR JEWELRY AND WATCHES, HOROLOGICAL AND CHRONOMETRIC INSTRUMENTS, WATCH STRAPS, WATCH BANDS (U.S. CLS. 2, 27, 28 AND 50).

**CLASS 16—PAPER GOODS AND PRINTED MATTER**

FOR STATIONERY, WRITING INSTRUMENTS, NOTE PADS (U.S. CLS. 2, 5, 22, 23, 29, 37, 38 AND 50).

**CLASS 18—LEATHER GOODS**

FOR BAGS, NAMELY, HANDBAGS, POCKETBOOKS, SHOULDER BAGS, EVENING HANDBAGS, COSMETICS CASES SOLD EMPTY, WALLETS, BILL FOLDS, KEY CASES, COIN PURSES, CLUTCH PURSES, CLUTCH BAGS, TOTE BAGS, UMBRELLAS, ROLL BAGS, DRAWSTRING POUCHES, BACKPACKS, SLING BAGS, BRIEFCASES, SATCHELS, MESSENGER BAGS, TRAVEL BAGS, LEATHER CREDIT CARD CASES, LEATHER BUSINESS CARD CASES, BELT BAGS (U.S. CLS. 1, 2, 3, 22 AND 41).

**CLASS 21—HOUSEWARES AND GLASS**

FOR BOWLS, PLATES, MUGS, VASES (U.S. CLS. 2, 13, 23, 29, 30, 33, 40 AND 50).

**CLASS 25—CLOTHING**

FOR CLOTHING, NAMELY, DRESSES, SKIRTS, SUITS, BLOUSES, TOPS, SWEATERS, PANTS, SHORTS, JACKETS, COATS, SOCKS, HOSIERY, BELTS, SCARVES, UNDERWEAR, SWIM WEAR, LOUNGE WEAR, BEACH WEAR, SLEEP WEAR, FOOTWEAR AND HEADWEAR (U.S. CLS. 22 AND 39).

**CLASS 35—ADVERTISING AND BUSINESS**

FOR RETAIL STORE SERVICES AND ONLINE RETAIL STORE SERVICES CLOTHING, FOOTWEAR, CLOTHING ACCESSORIES, HANDBAGS, SMALL LEATHER ACCESSORIES, JEWELRY, TOILETRIES AND COSMETICS, ALL OF WHICH ARE PRODUCED IN A MANNER REPRESENTING SOCIALLY RESPONSIBLE PRINCIPALS; PROVIDING INCENTIVE AWARD PROGRAMS FOR CUSTOMERS BY MEANS OF ISSUANCE OF LOYALTY REWARDS CARDS; PROVIDING AN INCENTIVE AWARD PROGRAM WHEREBY CUSTOMERS ARE AWARDED LOYALTY POINTS FOR PURCHASES OF COMPANY'S GOODS (U.S. CLS. 100, 101 AND 102).

PAUL CROWLEY, EXAMINING ATTORNEY

SN 86-123,034. POINTRIGHT INC., LEXINGTON, MA. FILED 11-19-2013.

**PLSNAPSHOT**

THE MARK CONSISTS OF STANDARD CHARACTERS WITHOUT CLAIM TO ANY PARTICULAR FONT, STYLE, SIZE, OR COLOR.

**CLASS 35—ADVERTISING AND BUSINESS**

FOR PROVIDING BUSINESS REPORTS REGARDING THE INSURANCE BUSINESS; PROVIDING BUSINESS BENCHMARKING INFORMATION AND REPORTS FOR THE INSURANCE INDUSTRY; PROVIDING BUSINESS INFORMATION REGARDING INSURANCE PROFESSIONAL LIABILITY RISK ASSESSMENT AND RISK ANALYSIS FOR UNDERWRITING INSURANCE; PROVIDING BUSINESS INFORMATION AND REPORTS IN INSURANCE MATTERS, NAMELY, COLLECTING, ANALYZING AND REPORTING INFORMATION ON HEALTHCARE FACILITIES AND OTHER HEALTHCARE PROVIDERS TO INSURANCE CARRIERS AND UNDERWRITERS FOR USE IN APPLYING FOR AND UNDERWRITING LIABILITY INSURANCE (U.S. CLS. 100, 101 AND 102).

FIRST USE 5-0-2010; IN COMMERCE 5-0-2010.

**CLASS 36—INSURANCE AND FINANCIAL**

FOR COLLECTING AND ANALYZING LIABILITY CLAIMS DATA FROM HEALTHCARE ORGANIZATIONS FOR USE IN UNDERWRITING INSURANCE (U.S. CLS. 100, 101 AND 102).

FIRST USE 5-0-2010; IN COMMERCE 5-0-2010.

RUDY R. SINGLETON, EXAMINING ATTORNEY

SN 86-123,079. WORLD DANCE COUNCIL, LTD., NEW MALDEN, UNITED KINGDOM, FILED 11-19-2013.

**WDC**

THE MARK CONSISTS OF STANDARD CHARACTERS WITHOUT CLAIM TO ANY PARTICULAR FONT, STYLE, SIZE, OR COLOR.

PRIORITY CLAIMED UNDER SEC. 44(D) ON ERPN CMNTY TM OFC APPLICATION NO. 12217691, FILED 10-11-2013, REG. NO. 12217691, DATED 3-7-2014, EXPIRES 10-11-2023.

**CLASS 16—PAPER GOODS AND PRINTED MATTER**

FOR PRINTED MATTER, NAMELY, PICTURE BOOKS, SONG BOOKS, CALENDARS, GREETING CARDS, MUSIC SHEETS, PRINTED MUSIC BOOKS, POSTERS, POSTCARDS; PRINTED PERIODICALS IN THE FIELD OF DANCE; EDUCATIONAL PUBLICATIONS, NAMELY, BROCHURES, BOOKLETS, AND TEACHING MATERIALS IN THE FIELD OF DANCE AND DANCE INSTRUCTION; EDUCATION AND TRAINING MANUALS, NAMELY, PRINTED INSTRUCTIONAL, EDUCATIONAL, AND TEACHING MATERIALS IN THE FIELD OF DANCE (U.S. CLS. 2, 5, 22, 23, 29, 37, 38 AND 50).

**CLASS 25—CLOTHING**

FOR CLOTHING AND APPAREL, NAMELY, PANTS, SHIRTS, SKIRTS, DRESSES, GOWNS, SUITS, DANCE COSTUMES, TIES, TIGHTS AND LEOTARDS; FOOTWEAR; HEADWEAR (U.S. CLS. 22 AND 39).

**CLASS 41—EDUCATION AND ENTERTAINMENT**

FOR ORGANIZATION AND CONDUCTING OF DANCE CONTESTS, RECITALS AND COMPETITIONS; DANCE EVENTS; DANCE INSTRUCTION, DANCE SCHOOLS; PRODUCTION OF AUDIO-VISUAL WORKS IN THE FIELD OF DANCE (U.S. CLS. 100, 101 AND 107).  
DAVID C. REIHNER, EXAMINING ATTORNEY

SN 86-124,191. ABBVIE BIOTECHNOLOGY LTD., HAMILTON, BERMUDA, FILED 11-20-2013.

**A JOURNEY TO POSSIBILITIES**

THE MARK CONSISTS OF STANDARD CHARACTERS WITHOUT CLAIM TO ANY PARTICULAR FONT, STYLE, SIZE, OR COLOR.

**CLASS 5—PHARMACEUTICALS**

FOR PHARMACEUTICAL PREPARATIONS FOR THE TREATMENT OF AUTOIMMUNE DISEASES (U.S. CLS. 6, 18, 44, 46, 51 AND 52).

**CLASS 16—PAPER GOODS AND PRINTED MATTER**

FOR PAMPHLETS, BROCHURES, NEWSLETTERS AND BOOKS IN THE FIELD OF HEALTHCARE (U.S. CLS. 2, 5, 22, 23, 29, 37, 38 AND 50).

**CLASS 44—MEDICAL, BEAUTY AND AGRICULTURAL SERVICES**

FOR PROVIDING MEDICAL INFORMATION, NAMELY, INFORMATION REGARDING MEDICAL CONDITIONS, TREATMENTS AND PRODUCTS TO PATIENTS AND HEALTHCARE PROFESSIONALS; MEDICAL CONSULTATION, NAMELY, PROVIDING ADVICE TO HEALTHCARE PROFESSIONALS REGARDING MEDICAL CONDITIONS AND TREATMENT (U.S. CLS. 100 AND 101).  
EVIN L. KOZAK, EXAMINING ATTORNEY

SN 86-124,190. ABBVIE BIOTECHNOLOGY LTD., HAMILTON, BERMUDA, FILED 11-20-2013.



THE MARK CONSISTS OF A SHADED CIRCLE AND A DESIGN OF AN ARROW WITH A STARBURST DESIGN.

**CLASS 5—PHARMACEUTICALS**

FOR PHARMACEUTICAL PREPARATIONS FOR THE TREATMENT OF AUTOIMMUNE DISEASES (U.S. CLS. 6, 18, 44, 46, 51 AND 52).

**CLASS 16—PAPER GOODS AND PRINTED MATTER**

FOR PAMPHLETS, BROCHURES, NEWSLETTERS AND BOOKS IN THE FIELD OF HEALTHCARE (U.S. CLS. 2, 5, 22, 23, 29, 37, 38 AND 50).

**CLASS 44—MEDICAL, BEAUTY AND AGRICULTURAL SERVICES**

FOR PROVIDING MEDICAL INFORMATION, NAMELY, INFORMATION REGARDING MEDICAL CONDITIONS, TREATMENTS AND PRODUCTS TO PATIENTS AND HEALTHCARE PROFESSIONALS; MEDICAL CONSULTATION, NAMELY, PROVIDING ADVICE TO HEALTHCARE PROFESSIONALS REGARDING MEDICAL CONDITIONS AND TREATMENT (U.S. CLS. 100 AND 101).  
EVIN L. KOZAK, EXAMINING ATTORNEY

SN 86-124,194. ABBVIE BIOTECHNOLOGY LTD., HAMILTON, BERMUDA, FILED 11-20-2013.

**KNOWLEDGE COUNTS**

THE MARK CONSISTS OF STANDARD CHARACTERS WITHOUT CLAIM TO ANY PARTICULAR FONT, STYLE, SIZE, OR COLOR.

**CLASS 5—PHARMACEUTICALS**

FOR PHARMACEUTICAL PREPARATIONS FOR THE TREATMENT OF AUTOIMMUNE DISEASES (U.S. CLS. 6, 18, 44, 46, 51 AND 52).

**CLASS 16—PAPER GOODS AND PRINTED MATTER**

FOR PAMPHLETS, BROCHURES, NEWSLETTERS AND BOOKS IN THE FIELD OF HEALTHCARE (U.S. CLS. 2, 5, 22, 23, 29, 37, 38 AND 50).

**CLASS 44—MEDICAL, BEAUTY AND AGRICULTURAL SERVICES**

FOR PROVIDING MEDICAL INFORMATION, NAMELY, INFORMATION REGARDING MEDICAL CONDITIONS, TREATMENTS AND PRODUCTS TO PATIENTS AND HEALTHCARE PROFESSIONALS; MEDICAL CONSULTATION, NAMELY, PROVIDING ADVICE TO HEALTHCARE PROFESSIONALS REGARDING MEDICAL CONDITIONS AND TREATMENT (U.S. CLS. 100 AND 101).

EVIN L. KOZAK, EXAMINING ATTORNEY

**CLASS 28—TOYS AND SPORTING GOODS**

FOR (BASED ON 44(E)) (BASED ON INTENT TO USE) GAMES AND PLAYTHINGS, NAMELY, SLOT MACHINES; SCRATCH CARD LOTTERY GAMES; PLAYING CARDS; ELECTRONIC OR ELECTROTECHNICAL GAMING APPARATUS, NAMELY, GAMING MACHINES; MACHINES FOR PLAYING GAMES OF CHANCE; GAMES INVOLVING GAMBLING, NAMELY, SLOT MACHINES AND GAMING MACHINES; SLOT MACHINES OPERATED BY COINS, TOKENS, BANKNOTES, TICKETS OR BY MEANS OF ELECTRONIC, MAGNETIC OR BIOMETRIC STORAGE MEDIA (U.S. CLS. 22, 23, 38 AND 50).

**CLASS 38—COMMUNICATION**

FOR (BASED ON 44(E)) (BASED ON INTENT TO USE) TELECOMMUNICATION SERVICES, NAMELY, ELECTRONIC TRANSMISSION OF STREAMED AND DOWNLOADABLE AUDIO, VIDEO AND GAME FILES VIA COMPUTER AND ELECTRONIC COMMUNICATIONS NETWORKS; PROVIDING ON-LINE CHAT ROOMS AND BULLETIN BOARDS FOR THE TRANSMISSION OF MESSAGES AMONG COMPUTER USERS CONCERNING ENTERTAINMENT, MUSIC, CONCERTS, VIDEOS, RADIO, TELEVISION, FILM, NEWS, SPORTS, GAMES AND CULTURAL EVENTS; WEBCASTING SERVICES; DELIVERY OF MESSAGES BY ELECTRONIC TRANSMISSION; PROVIDING CONNECTIVITY SERVICES AND ACCESS TO ELECTRONIC TELECOMMUNICATIONS NETWORKS FOR TRANSMISSION OR RECEPTION OF AUDIO, VIDEO, GAME OR MULTIMEDIA CONTENT; PROVIDING ACCESS TO COMPUTER DATABASES; PROVIDING ON-LINE FACILITIES, VIA A GLOBAL COMPUTER NETWORK AND OTHER COMPUTER AND ELECTRONIC COMMUNICATION NETWORKS FOR REAL-TIME INTERACTION WITH OTHER COMPUTER USERS TO ENABLE USERS TO ACCESS MULTIMEDIA CONTENT; PROVIDING ACCESS TO DATABASES IN THE FIELD OF COMPUTER GAMES, GAMING AND SOCIAL NETWORKING (U.S. CLS. 100, 101 AND 104).

SN 86-124,454, GAMESYS LIMITED, LONDON, UNITED KINGDOM, FILED 11-20-2013.

**SECRETS OF THE PHOENIX**

THE MARK CONSISTS OF STANDARD CHARACTERS WITHOUT CLAIM TO ANY PARTICULAR FONT, STYLE, SIZE, OR COLOR.

OWNER OF ERPN CMNTY TM OFC REG. NO. 11444544, DATED 5-2-2013, EXPIRES 12-20-2022.

**CLASS 9—ELECTRICAL AND SCIENTIFIC APPARATUS**

FOR (BASED ON 44(E)) (BASED ON INTENT TO USE) COMPUTER GAME SOFTWARE; COMPUTER GAME SOFTWARE FEATURING CARD GAMES, SLOT GAMES, VIDEO GAMES, GAMING, GAMBLING, CASINO, BINGO, INSTANT WIN, LOTTERY AND BETTING ACTIVITIES; COMPUTER HARDWARE RELATING TO GAMES, CARD GAMES, SLOT GAMES, VIDEO GAMES, GAMING, GAMBLING, CASINO, BINGO, INSTANT WIN, LOTTERY AND BETTING ACTIVITIES; COMPUTER SOFTWARE TO ENABLE SEARCHING, BROWSING AND RETRIEVING INFORMATION, WEBSITES, AND OTHER RESOURCES AVAILABLE ON GLOBAL COMPUTER NETWORKS FOR OTHERS; DOWNLOADABLE ONLINE GAME SOFTWARE AND GAME RELATED APPLICATIONS, NAMELY, DOWNLOADABLE COMPUTER GAME PROGRAMS AND DOWNLOADABLE ELECTRONIC GAME PROGRAMS; INTERACTIVE VIDEO GAME PROGRAMS; COMPUTER SOFTWARE TO ENABLE UPLOADING, POSTING, SHOWING, DISPLAYING, TAGGING, BLOGGING, SHARING OR OTHERWISE PROVIDING ELECTRONIC MEDIA AND INFORMATION IN THE FIELDS OF ELECTRONIC GAMING VIA THE INTERNET OR OTHER COMMUNICATIONS NETWORKS; COMPUTER SOFTWARE FOR CONDUCTING AND ADMINISTRATION OF ON-LINE GAMES, GAMBLING AND COMPETITIONS; (BASED ON INTENT TO USE) DOWNLOADABLE ELECTRONIC PUBLICATIONS, NAMELY, MAGAZINES, MANUALS, NEWSLETTERS, ARTICLES, AND MANUALS FEATURING GAMING; ELECTRONIC PUBLICATIONS, NAMELY, DOWNLOADABLE NEWSLETTERS PROVIDED BY ELECTRONIC MAIL IN THE FIELDS OF GAMES, GAMING, GAMBLING, CASINOS, BINGO, INSTANT WIN GAMES, SLOTS, POKER, LOTTERY, AND BETTING (U.S. CLS. 21, 23, 26, 36 AND 38).

**CLASS 41—EDUCATION AND ENTERTAINMENT**

FOR (BASED ON 44(E)) (BASED ON INTENT TO USE) CASINO SERVICES; BETTING SERVICES; GAMBLING SERVICES; PROVIDING OFF TRACK BETTING FACILITIES; ORGANIZATION OF GAMING COMPETITIONS; LOTTERY SERVICES; BINGO SERVICES, NAMELY, LOTTERY AND GAMBLING SERVICES; SLOT MACHINE SERVICES, NAMELY, PROVIDING SLOT MACHINE PARLORS; ELECTRONIC GAME, GAMING QUIZ AND GAMBLING COMPETITION SERVICES PROVIDED BY MEANS OF THE INTERNET OR ON-LINE FROM A COMPUTER NETWORK OR DATABASE, MOBILE TELEPHONE AND TELEVISION; PROVISION OF ONLINE NON-DOWNLOADABLE ELECTRONIC PUBLICATIONS, NAMELY, BOOKS AND NEWSLETTERS IN THE FIELD OF GAMES AND GAMBLING; ENTERTAINMENT SERVICES, NAMELY, PROVIDING ONLINE COMPUTER GAMES, ENHANCEMENTS WITHIN ONLINE COMPUTER GAMES, AND GAME APPLICATIONS WITHIN ONLINE COMPUTER GAMES; ENTERTAINMENT SERVICES, NAMELY, PROVIDING ON-LINE REVIEWS OF COMPUTER GAMES FOR ENTERTAINMENT PURPOSES AND PROVIDING INFORMATION IN THE FIELD OF COMPUTER GAMES; ENTERTAINMENT SERVICES, NAMELY, PROVIDING VIRTUAL ENVIRONMENTS IN WHICH USERS CAN INTERACT THROUGH SOCIAL GAMES FOR RECREATIONAL, LEISURE OR ENTERTAINMENT PURPOSES; CONSULTANCY SERVICES RELATING TO ON-LINE GAMING, NAMELY, GAMING SERVICES CONSULTING IN THE NATURE OF CASINO GAMING; CONSULTANCY, INFORMATION AND ADVISORY SERVICES RELATING TO ALL THE AFORESAID SERVICES; (BASED ON INTENT TO USE) PROVISION OF TRAINING IN THE USE AND OPERATION OF COMPUTER GAME SOFTWARE DEVELOPMENT TOOLS (U.S. CLS. 100, 101 AND 107).

TIMOTHY O. SCHIMPF, EXAMINING ATTORNEY

SN 86-124,457. GAMESYS LIMITED, LONDON, UNITED KINGDOM, FILED 11-20-2013.

## SEARCH FOR THE PHOENIX

THE MARK CONSISTS OF STANDARD CHARACTERS WITHOUT CLAIM TO ANY PARTICULAR FONT, STYLE, SIZE, OR COLOR.

OWNER OF ERPN CMNTY TM OFC REG. NO. 11444684, DATED 5-1-2013, EXPIRES 12-20-2022.

### CLASS 9—ELECTRICAL AND SCIENTIFIC APPARATUS

FOR (BASED ON 44(E)) (BASED ON INTENT TO USE) COMPUTER GAME SOFTWARE; COMPUTER GAME SOFTWARE FEATURING CARD GAMES, SLOT GAMES, VIDEO GAMES, GAMING, GAMBLING, CASINO, BINGO, INSTANT WIN, LOTTERY AND BETTING ACTIVITIES; COMPUTER HARDWARE RELATING TO GAMES, CARD GAMES, SLOT GAMES, VIDEO GAMES, GAMING, GAMBLING, CASINO, BINGO, INSTANT WIN, LOTTERY AND BETTING ACTIVITIES; COMPUTER SOFTWARE TO ENABLE SEARCHING, BROWSING AND RETRIEVING INFORMATION, WEBSITES, AND OTHER RESOURCES AVAILABLE ON GLOBAL COMPUTER NETWORKS FOR OTHERS; DOWNLOADABLE ONLINE GAME SOFTWARE AND GAME RELATED APPLICATIONS, NAMELY, DOWNLOADABLE COMPUTER GAME PROGRAMS AND DOWNLOADABLE ELECTRONIC GAME PROGRAMS; INTERACTIVE VIDEO GAME PROGRAMS; COMPUTER SOFTWARE TO ENABLE UPLOADING, POSTING, SHOWING, DISPLAYING, TAGGING, BLOGGING, SHARING OR OTHERWISE PROVIDING ELECTRONIC MEDIA AND INFORMATION IN THE FIELDS OF ELECTRONIC GAMING VIA THE INTERNET OR OTHER COMMUNICATIONS NETWORKS; COMPUTER SOFTWARE FOR CONDUCTING AND ADMINISTRATION OF ON-LINE GAMES, GAMBLING AND COMPETITIONS; (BASED ON INTENT TO USE) DOWNLOADABLE ELECTRONIC PUBLICATIONS, NAMELY, MAGAZINES, MANUALS, NEWSLETTERS, ARTICLES, AND MANUALS FEATURING GAMING; ELECTRONIC PUBLICATIONS, NAMELY, DOWNLOADABLE NEWSLETTERS PROVIDED BY ELECTRONIC MAIL IN THE FIELDS OF GAMES, GAMING, GAMBLING, CASINOS, BINGO, INSTANT WIN GAMES, SLOTS, POKER, LOTTERY, AND BETTING (U.S. CLS. 21, 23, 26, 36 AND 38).

### CLASS 28—TOYS AND SPORTING GOODS

FOR (BASED ON 44(E)) (BASED ON INTENT TO USE) GAMES AND PLAYTHINGS, NAMELY, SLOT MACHINES; SCRATCH CARD LOTTERY GAMES; PLAYING CARDS; ELECTRONIC OR ELECTROTECHNICAL GAMING APPARATUS, NAMELY, GAMING MACHINES; MACHINES FOR PLAYING GAMES OF CHANCE; GAMES INVOLVING GAMBLING, NAMELY, SLOT MACHINES AND GAMING MACHINES; SLOT MACHINES OPERATED BY COINS, TOKENS, BANKNOTES, TICKETS OR BY MEANS OF ELECTRONIC, MAGNETIC OR BIOMETRIC STORAGE MEDIA (U.S. CLS. 22, 23, 38 AND 50).

### CLASS 38—COMMUNICATION

FOR (BASED ON 44(E)) (BASED ON INTENT TO USE) TELECOMMUNICATION SERVICES, NAMELY, ELECTRONIC TRANSMISSION OF STREAMED AND DOWNLOADABLE AUDIO, VIDEO AND GAME FILES VIA COMPUTER AND ELECTRONIC COMMUNICATIONS NETWORKS; PROVIDING ON-LINE CHAT ROOMS AND BULLETIN BOARDS FOR THE TRANSMISSION OF MESSAGES AMONG COMPUTER USERS CONCERNING ENTERTAINMENT, MUSIC, CONCERTS, VIDEOS, RADIO, TELEVISION, FILM, NEWS, SPORTS, GAMES AND CULTURAL EVENTS; WEBCASTING SERVICES; DELIVERY OF MESSAGES BY ELECTRONIC TRANSMISSION; PROVIDING CONNECTIVITY SERVICES AND ACCESS TO ELECTRONIC TELECOMMUNICATIONS NETWORKS FOR TRANSMISSION OR RECEPTION OF AUDIO, VIDEO, GAME OR MULTIMEDIA CONTENT; PROVIDING ACCESS TO COMPUTER DATABASES; PROVIDING ON-LINE FACILITIES, VIA A GLOBAL COMPUTER NETWORK AND OTHER COMPUTER AND ELECTRONIC COMMUNICATION NETWORKS FOR REAL-TIME INTERACTION WITH OTHER COMPUTER USERS TO ENABLE USERS TO ACCESS MULTIMEDIA CONTENT; PROVIDING ACCESS TO DATABASES IN THE FIELD OF COMPUTER GAMES, GAMING AND SOCIAL NETWORKING (U.S. CLS. 100, 101 AND 104).

### CLASS 41—EDUCATION AND ENTERTAINMENT

FOR (BASED ON 44(E)) (BASED ON INTENT TO USE) CASINO SERVICES; BETTING SERVICES; GAMBLING SERVICES; PROVIDING OFF TRACK BETTING FACILITIES; ORGANIZATION OF GAMING COMPETITIONS; LOTTERY SERVICES; BINGO SERVICES, NAMELY, LOTTERY AND GAMBLING SERVICES; SLOT MACHINE SERVICES, NAMELY, PROVIDING SLOT MACHINE PARLORS; ELECTRONIC GAME, GAMING QUIZ AND GAMBLING COMPETITION SERVICES PROVIDED BY MEANS OF THE INTERNET OR ON-LINE FROM A COMPUTER NETWORK OR DATABASE, MOBILE TELEPHONE AND TELEVISION; PROVISION OF ONLINE NON-DOWNLOADABLE ELECTRONIC PUBLICATIONS, NAMELY, BOOKS AND NEWSLETTERS IN THE FIELD OF GAMES AND GAMBLING; ENTERTAINMENT SERVICES, NAMELY, PROVIDING ONLINE COMPUTER GAMES, ENHANCEMENTS WITHIN ONLINE COMPUTER GAMES, AND GAME APPLICATIONS WITHIN ONLINE COMPUTER GAMES; ENTERTAINMENT SERVICES, NAMELY, PROVIDING ON-LINE REVIEWS OF COMPUTER GAMES FOR ENTERTAINMENT PURPOSES AND PROVIDING INFORMATION IN THE FIELD OF COMPUTER GAMES; ENTERTAINMENT SERVICES, NAMELY, PROVIDING VIRTUAL ENVIRONMENTS IN WHICH USERS CAN INTERACT THROUGH SOCIAL GAMES FOR RECREATIONAL, LEISURE OR ENTERTAINMENT PURPOSES; CONSULTANCY SERVICES RELATING TO ON-LINE GAMING, NAMELY, GAMING SERVICES CONSULTING IN THE NATURE OF CASINO GAMING; CONSULTANCY, INFORMATION AND ADVISORY SERVICES RELATING TO ALL THE AFORESAID SERVICES; (BASED ON INTENT TO USE) PROVISION OF TRAINING IN THE USE AND OPERATION OF COMPUTER GAME SOFTWARE DEVELOPMENT TOOLS (U.S. CLS. 100, 101 AND 107).

TIMOTHY O. SCHIMPF, EXAMINING ATTORNEY

SN 86-124,689. DR. VIE INC., VANCOUVER, CANADA,  
FILED 11-20-2013.

SN 86-126,171. STARWOOD MOTORS, LLC, DALLAS, TX.  
FILED 11-21-2013.

# The Impostor

THE MARK CONSISTS OF STANDARD CHARACTERS WITHOUT CLAIM TO ANY PARTICULAR FONT, STYLE, SIZE, OR COLOR.

## CLASS 9—ELECTRICAL AND SCIENTIFIC APPARATUS

FOR AUDIO BOOKS IN THE FIELD OF SELF DEVELOPMENT; AUDIO AND DOWNLOADABLE BOOKS IN THE NATURE OF NOVELS; DOWNLOADABLE E-BOOKS IN THE FIELD OF SELF DEVELOPMENT; DOWNLOADABLE NON-FICTION BOOKS ON A VARIETY OF TOPICS; ELECTRONIC BOOK READER; ELECTRONIC BOOK READER COVERS; ELECTRONIC PUBLICATIONS, NAMELY, BOOKS, PAMPHLETS, BROCHURES, COURSES, SOFTWARE, ASSESSMENTS AND APPS IN THE FIELD OF SELF DEVELOPMENT (U.S. CLS. 21, 23, 26, 36 AND 38).

## CLASS 35—ADVERTISING AND BUSINESS

FOR ON-LINE RETAIL STORE SERVICES FEATURING PHYSICAL AND VIRTUAL MERCHANDISE FOR USE BY MEMBERS OF AN ONLINE COMMUNITY IN CONNECTION WITH A DESIGNATED WEBSITE FEATURING FICTIONAL CHARACTERS (U.S. CLS. 100, 101 AND 102).

BRIAN NEVILLE, EXAMINING ATTORNEY

---

SN 86-125,205. FONTSMITH LIMITED, LONDON, UNITED KINGDOM, FILED 11-21-2013.

# FONTSMITH

THE MARK CONSISTS OF STANDARD CHARACTERS WITHOUT CLAIM TO ANY PARTICULAR FONT, STYLE, SIZE, OR COLOR.

OWNER OF UNITED KINGDOM REG. NO. UK0000220458, DATED 1-14-2000, EXPIRES 7-31-2019.

## CLASS 9—ELECTRICAL AND SCIENTIFIC APPARATUS

FOR COMPUTER HARDWARE; COMPUTER SOFTWARE FOR USE IN GRAPHIC ART AND TYPOGRAPHIC ACTIVITY; COMPUTER DISKS AND COMPACT DISKS FEATURING TYPOGRAPHIC DATA OR TYPOGRAPHIC MANIPULATION OF PROGRAMS (U.S. CLS. 21, 23, 26, 36 AND 38).

## CLASS 42—SCIENTIFIC AND COMPUTER SERVICES

FOR GRAPHIC ART DESIGN; COMPUTER SITE DESIGN AND COMPUTER SOFTWARE DESIGN FOR OTHERS (U.S. CLS. 100 AND 101).

ALICIA COLLINS, EXAMINING ATTORNEY



NO CLAIM IS MADE TO THE EXCLUSIVE RIGHT TO USE "MOTORS", APART FROM THE MARK AS SHOWN. THE COLOR(S) BLACK AND GOLD IS/ARE CLAIMED AS A FEATURE OF THE MARK.

THE MARK CONSISTS OF A STYLIZED DESIGN CONSISTING OF A STAR SEGMENTED INTO FOUR SECTIONS; THE TOP LEFT SECTION IS OUTLINED IN GOLD, THE TOP RIGHT SECTION IS BLACK, THE BOTTOM RIGHT SECTION IS GOLD, AND THE BOTTOM LEFT SECTION IS BLACK; TO THE LEFT OF THE STAR APPEARS THE WORD "STARWOOD" IN BLACK SMALL-CAPS FONT WITH A STYLIZED LETTER "A" IN BLACK AND GOLD; BENEATH THE WORD "STARWOOD" APPEARS THE WORD "MOTORS" IN BLACK ALL-CAPS FONT.

## CLASS 35—ADVERTISING AND BUSINESS

FOR PROVIDING AUTOMOBILE DEALERSHIPS IN THE FIELD OF AUTOMOBILES (U.S. CLS. 100, 101 AND 102).

FIRST USE 7-30-2011; IN COMMERCE 8-2-2011.

## CLASS 36—INSURANCE AND FINANCIAL

FOR FINANCING RELATING TO AUTOMOBILES (U.S. CLS. 100, 101 AND 102).

FIRST USE 7-30-2011; IN COMMERCE 8-2-2011.

## CLASS 37—CONSTRUCTION AND REPAIR

FOR AUTOMOBILE CUSTOMIZATION, REPAIR, AND MAINTENANCE SERVICES (U.S. CLS. 100, 103 AND 106).

FIRST USE 7-30-2011; IN COMMERCE 8-2-2011.

## CLASS 39—TRANSPORTATION AND STORAGE

FOR LEASING OF AUTOMOBILES (U.S. CLS. 100 AND 105).

FIRST USE 7-30-2011; IN COMMERCE 8-2-2011.

THEODORE MCBRIDE, EXAMINING ATTORNEY

---

SN 86-126,173. STARWOOD MOTORS, LLC, DALLAS, TX.  
FILED 11-21-2013.

# STARWOOD MOTORS

THE MARK CONSISTS OF STANDARD CHARACTERS WITHOUT CLAIM TO ANY PARTICULAR FONT, STYLE, SIZE, OR COLOR.

NO CLAIM IS MADE TO THE EXCLUSIVE RIGHT TO USE "MOTORS", APART FROM THE MARK AS SHOWN.

**CLASS 35—ADVERTISING AND BUSINESS**

FOR PROVIDING AUTOMOBILE DEALERSHIPS IN THE FIELD OF AUTOMOBILES (U.S. CLS. 100, 101 AND 102).

FIRST USE 7-30-2011; IN COMMERCE 8-2-2011.

**CLASS 36—INSURANCE AND FINANCIAL**

FOR FINANCING RELATING TO AUTOMOBILES (U.S. CLS. 100, 101 AND 102).

FIRST USE 7-30-2011; IN COMMERCE 8-2-2011.

**CLASS 37—CONSTRUCTION AND REPAIR**

FOR AUTOMOBILE CUSTOMIZATION, REPAIR, AND MAINTENANCE SERVICES (U.S. CLS. 100, 103 AND 106).

FIRST USE 7-30-2011; IN COMMERCE 8-2-2011.

**CLASS 39—TRANSPORTATION AND STORAGE**

FOR LEASING OF AUTOMOBILES (U.S. CLS. 100 AND 105).

FIRST USE 7-30-2011; IN COMMERCE 8-2-2011.

THEODORE MCBRIDE, EXAMINING ATTORNEY

SN 86-126,402. LIBERTY UNIVERSITY, LYNCHBURG, VA. FILED 11-22-2013.

**FLAMES CLUB**

THE MARK CONSISTS OF STANDARD CHARACTERS WITHOUT CLAIM TO ANY PARTICULAR FONT, STYLE, SIZE, OR COLOR.

OWNER OF U.S. REG. NO. 3,973,164.

NO CLAIM IS MADE TO THE EXCLUSIVE RIGHT TO USE "CLUB", APART FROM THE MARK AS SHOWN.

**CLASS 35—ADVERTISING AND BUSINESS**

FOR ADMINISTRATION OF A CUSTOMER LOYALTY PROGRAM WHICH PROVIDES INCENTIVES IN THE NATURE OF FREE TICKETS, DISCOUNTS, AND LOYALTY POINTS, AND PROVIDING INFORMATION PERTAINING THERETO; ADVERTISEMENT AND PUBLICITY SERVICES BY TELEVISION, RADIO, MAIL; ADVERTISEMENT AND PUBLICITY SERVICES BY E-MAIL, MAIL, TELEVISION, RADIO AND INTERNET; ADVERTISING AND MARKETING; ADVERTISING AND MARKETING SERVICES PROVIDED BY MEANS OF INDIRECT METHODS OF MARKETING COMMUNICATIONS, NAMELY, SOCIAL MEDIA, SEARCH ENGINE MARKETING, INQUIRY MARKETING, INTERNET MARKETING, MOBILE MARKETING, BLOGGING AND OTHER FORMS OF PASSIVE, SHARABLE OR VIRAL COMMUNICATIONS CHANNELS; ADVERTISING AND PUBLICITY SERVICES; ADVERTISING IN PERIODICALS, BROCHURES AND NEWSPAPERS; ADVERTISING VIA ELECTRONIC MEDIA AND SPECIFICALLY THE INTERNET; ADVERTISING, MARKETING AND PROMOTION SERVICES IN THE FIELD OF SPORTS MARKETING; TELEVISION ADVERTISING; THE BRINGING TOGETHER OF CONSUMERS AND PROVIDERS OF A VARIETY OF GOODS AND SERVICES IN THE FIELD OF ATHLETICS FOR COMMERCIAL PURPOSES VIA THE INTERNET (U.S. CLS. 100, 101 AND 102).

FIRST USE 12-31-2001; IN COMMERCE 12-31-2001.

**CLASS 41—EDUCATION AND ENTERTAINMENT**

FOR PROVIDING INFORMATION IN THE FIELD OF COLLEGE ATHLETIC EVENTS (U.S. CLS. 100, 101 AND 107).

FIRST USE 12-1-2001; IN COMMERCE 12-1-2001.

ALLISON SCHRODY, EXAMINING ATTORNEY

SN 86-126,821. NORTH AMERICAN PIPE CORPORATION, HOUSTON, TX. FILED 11-22-2013.

**AMERI-BLOCK**

THE MARK CONSISTS OF STANDARD CHARACTERS WITHOUT CLAIM TO ANY PARTICULAR FONT, STYLE, SIZE, OR COLOR.

OWNER OF U.S. REG. NOS. 3,400,381, 4,260,050 AND 4,366,675.

**CLASS 17—RUBBER GOODS**

FOR INSULATING WATER PROOFING MEMBRANES; WATER PROOFING MEMBRANES FOR FOUNDATIONS OF BUILDINGS; WATERPROOF MEMBRANES FOR FOUNDATIONS OF BUILDINGS OF POLYMERIC MATERIALS; WATERPROOFING MEMBRANES FOR FOUNDATIONS OF BUILDINGS MADE OF HIGH DENSITY POLYETHYLENE (HDPE) OR BITUMINOUS MATERIALS (U.S. CLS. 1, 5, 12, 13, 35 AND 50).

**CLASS 19—NON-METALLIC BUILDING MATERIALS**

FOR FLOORING UNDERLAYMENTS; WATERPROOFING UNDERLAYMENTS FOR FOUNDATIONS, FLOORS, AND WALLS, AND FASTENERS; ADHESIVES SEALANTS FOR USE WITH UNDERLAYMENTS FOR FOUNDATIONS, FLOORS, WALLS AND FASTENERS; WATERPROOF MEMBRANES FOR USE AS A FLOOR UNDERLAYMENT; WATERPROOFING MEMBRANES FOR FLOORS AND WALLS; ADHESIVES SEALANTS FOR USE WITH MEMBRANES FOR FOUNDATIONS, FLOORS, WALLS AND FASTENERS; POLYURETHANE FILM FOR USE AS A MOISTURE BARRIER; POLYURETHANE FILM FOR USE AS WATERPROOFING MOISTURE BARRIERS; POLYURETHANE FILM FOR USE AS WATERPROOFING MOISTURE BARRIERS FOR FOUNDATIONS, FLOORS, AND WALLS, AND FASTENERS; ADHESIVE SEALANTS FOR USE WITH MOISTURE BARRIERS FOR FOUNDATIONS, FLOORS, WALLS, AND FASTENERS; WATERPROOF MEMBRANES FOR USE AS A FLOOR UNDERLAYMENT, AND MOISTURE BARRIERS, ALL MADE OF POLYMERIC MATERIALS; WATERPROOFING MEMBRANES FOR USE AS A FLOOR UNDERLAYMENT, AND MOISTURE BARRIERS, ALL MADE OF HIGH DENSITY POLYETHYLENE (HDPE) OR BITUMINOUS MATERIALS (U.S. CLS. 1, 12, 33 AND 50).

MICHAEL SOUDERS, EXAMINING ATTORNEY



SN 86-127,210. PASS AUTOS, LLC, SCOTTSDALE, AZ. FILED 11-22-2013.



NO CLAIM IS MADE TO THE EXCLUSIVE RIGHT TO USE "AUTOS" AND "RENT-TO-OWN", APART FROM THE MARK AS SHOWN.

THE COLOR(S) BLUE, RED, AND GREY IS/ARE CLAIMED AS A FEATURE OF THE MARK.

THE MARK CONSISTS OF THE WORDS "PASS AUTOS" IN RED, THE WORDS "RENT TO OWN" IN BLUE, AND BLUE AND GREY ARROWS BEHIND THE WORDS "PASS AUTOS".

#### CLASS 35—ADVERTISING AND BUSINESS

FOR RETAIL STORE SERVICES FEATURING AUTOMOTIVES THAT CAN BE PURCHASED UNDER A RENT-TO-OWN CONTRACT (U.S. CLS. 100, 101 AND 102).

FIRST USE 9-1-2013; IN COMMERCE 9-1-2013.

#### CLASS 36—INSURANCE AND FINANCIAL

FOR RENT-TO-OWN FINANCING (U.S. CLS. 100, 101 AND 102).

FIRST USE 9-1-2013; IN COMMERCE 9-1-2013.

NORA BUCHANAN WILL, EXAMINING ATTORNEY

SN 86-128,064. FIGHTERS ONLY LIMITED, GATESHEAD, TYNE AND WE, UNITED KINGDOM, FILED 11-25-2013.



PRIORITY CLAIMED UNDER SEC. 44(D) ON UNITED KINGDOM APPLICATION NO. 3018094, FILED 8-14-2013, REG. NO. 3018094, DATED 11-15-2013, EXPIRES 8-14-2023.

THE COLOR(S) RED AND YELLOW IS/ARE CLAIMED AS A FEATURE OF THE MARK.

THE MARK CONSISTS OF THE WORD "TRAIN" IN RED, STYLIZED LETTERING WITH A YELLOW, FIVE-POINTED STAR IN THE CENTER OF THE LETTER "A".

#### CLASS 9—ELECTRICAL AND SCIENTIFIC APPARATUS

FOR PAMPHLETS, BROCHURES, NEWSLETTERS, NEWSPAPERS AND MAGAZINES DOWNLOADED IN ELECTRONIC FORM FROM THE INTERNET, ALL CONCERNED WITH HEALTH, FITNESS AND NUTRITION OR WITH MARTIAL ARTS; COMPUTER GAME PROGRAMS AND SOFTWARE; COMPUTER GAME PROGRAMS AND SOFTWARE DOWNLOADED VIA THE INTERNET (U.S. CLS. 21, 23, 26, 36 AND 38).

#### CLASS 16—PAPER GOODS AND PRINTED MATTER

FOR PRINTED MATTER, PERIODICAL PUBLICATIONS, BOOKS, MAGAZINES, NEWSLETTERS, ALL CONCERNED WITH HEALTH, FITNESS AND NUTRITION OR WITH MARTIAL ARTS (U.S. CLS. 2, 5, 22, 23, 29, 37, 38 AND 50).

#### CLASS 25—CLOTHING

FOR SPORTSWEAR, NAMELY, SHORTS, SWEAT SHORTS, TEE SHIRTS, SWEAT SHIRTS, SWEAT JACKETS, SWEAT PANTS, TRACK SUITS, LEGGINGS AND LEISURE SUITS; FOOTWEAR FOR SPORTS (U.S. CLS. 22 AND 39).

#### CLASS 28—TOYS AND SPORTING GOODS

FOR EXERCISE AND FITNESS EQUIPMENT, NAMELY, ROWING MACHINES, MANUALLY OPERATED JOGGING MACHINES, STAIR-STEPPING MACHINES, STATIONARY CYCLES, ABDOMINAL BOARDS, CHEST EXPANDERS, CHEST PULLS, ROTARY ABDOMINAL BOARDS, SHOULDER STRETCHER USING RESISTANCE CABLES, INFLATABLE BALLS, NECK AND SHOULDER SUPPORTED WEIGHTS FOR TWISTING AND LIFTING EXERCISES; MANUALLY-OPERATED EXERCISE EQUIPMENT FOR PHYSICAL FITNESS PURPOSES; FITNESS EXERCISE MACHINES (U.S. CLS. 22, 23, 38 AND 50).

#### CLASS 41—EDUCATION AND ENTERTAINMENT

FOR ELECTRONIC GAMES SERVICES PROVIDED BY MEANS OF THE INTERNET; PROVIDING NON-DOWNLOADABLE ELECTRONIC PUBLICATIONS, NAMELY, PAMPHLETS, BROCHURES, NEWSLETTERS, NEWSPAPERS AND MAGAZINES IN THE FIELD OF HEALTH, FITNESS, NUTRITION, AND MARTIAL ARTS; TELEVISION ENTERTAINMENT SERVICES, NAMELY, AN ONGOING TELEVISION PROGRAM IN THE FIELDS OF HEALTH, FITNESS, NUTRITION, AND MARTIAL ARTS; RADIO ENTERTAINMENT SERVICES, NAMELY, AN ONGOING RADIO PROGRAM IN THE FIELDS OF HEALTH, FITNESS, NUTRITION, AND MARTIAL ARTS; ARRANGING AND HOSTING AWARD CEREMONIES, NAMELY, ARRANGING AND CONDUCTING SPORTS AND ATHLETIC COMPETITIONS AND AWARDS PROGRAMS AND ARRANGING AND CONDUCTING INCENTIVE AWARD PROGRAMS TO REWARD PROGRAM PARTICIPANTS WHO EXERCISE, MAKE HEALTHY EATING CHOICES, AND ENGAGE IN OTHER HEALTH-PROMOTING ACTIVITIES; INFORMATION RELATING TO ENTERTAINMENT PROVIDED ON-LINE FROM THE INTERNET (U.S. CLS. 100, 101 AND 107).

MICHAEL ENGEL, EXAMINING ATTORNEY

SN 86-128,674. CULPEPER PHYSICIAN-HOSPITAL ORGANIZATION, INC., CULPEPER, VA. FILED 11-25-2013.

#### PUTTING BUSINESS INTO PRACTICE

THE MARK CONSISTS OF STANDARD CHARACTERS WITHOUT CLAIM TO ANY PARTICULAR FONT, STYLE, SIZE, OR COLOR.

**CLASS 35—ADVERTISING AND BUSINESS**

FOR BUSINESS MANAGEMENT, ADMINISTRATION AND CONSULTATION SERVICES FOR MEDICAL PRACTICES; ADVISORY SERVICES FOR MEDICAL PRACTICES RELATING TO BUSINESS START-UP, BUSINESS MANAGEMENT AND BUSINESS OPERATIONS; GROUP PURCHASING SERVICES, NAMELY, PURCHASING MEDICAL AND HOSPITAL SUPPLIES AND PROFESSIONAL LIABILITY INSURANCE FOR OTHERS; VERIFYING AND MONITORING THE CREDENTIALS OF DOCTORS AND OTHER MEDICAL PROFESSIONALS FOR BUSINESS PURPOSES; PROVIDING ADVICE AND ASSISTANCE TO BUSINESSES RELATING TO ENROLLMENT APPLICATIONS FOR GOVERNMENT PROGRAMS; WORKFLOW ASSESSMENT AND CONSULTATION SERVICES; ADMINISTRATION, BILLING, AND RECONCILIATION OF ACCOUNTS ON BEHALF OF MEDICAL PRACTICES; REVIEW AND NEGOTIATION OF CONTRACTS BETWEEN HEALTHCARE PROVIDERS AND INSURANCE COMPANIES AND AUDITS OF PAYMENTS PURSUANT TO THOSE CONTRACTS; BUSINESS SERVICES PROVIDED TO HEALTHCARE PROVIDERS, NAMELY, THE NEGOTIATION AND EXECUTION OF CONTRACTS WITH HEALTHCARE PAYORS; PROVIDING BUSINESS ADVICE AND ASSISTANCE TO BUSINESSES RELATING TO ELECTRONIC HEALTH RECORDS ADOPTION, SERVICE PROVIDER SELECTION, AND IMPLEMENTATION; BUSINESS CONSULTING SERVICES RELATING TO THE HEALTHCARE EFFECTIVENESS DATA AND INFORMATION SET (HEDIS), PATIENT CENTERED MEDICAL HOME TRANSFORMATION, AND PAY-FOR-PERFORMANCE MEASURES, GUIDELINES, AND INCENTIVES IN THE MEDICAL PRACTICE AND MANAGED CARE INDUSTRIES (U.S. CLS. 100, 101 AND 102).

**CLASS 36—INSURANCE AND FINANCIAL**

FOR FINANCIAL CONSULTING SERVICES; FINANCIAL ANALYSES (U.S. CLS. 100, 101 AND 102).  
ALYSSA STEEL, EXAMINING ATTORNEY

**CLASS 35—ADVERTISING AND BUSINESS**

FOR BUSINESS MANAGEMENT, ADMINISTRATION AND CONSULTATION SERVICES FOR MEDICAL PRACTICES; ADVISORY SERVICES FOR MEDICAL PRACTICES RELATING TO BUSINESS START-UP, BUSINESS MANAGEMENT AND BUSINESS OPERATIONS; GROUP PURCHASING SERVICES, NAMELY, PURCHASING MEDICAL AND HOSPITAL SUPPLIES AND PROFESSIONAL LIABILITY INSURANCE FOR OTHERS; VERIFYING AND MONITORING THE CREDENTIALS OF DOCTORS AND OTHER MEDICAL PROFESSIONALS FOR BUSINESS PURPOSES; PROVIDING ADVICE AND ASSISTANCE TO BUSINESSES RELATING TO ENROLLMENT APPLICATIONS FOR GOVERNMENT PROGRAMS; WORKFLOW ASSESSMENT AND CONSULTATION SERVICES; ADMINISTRATION, BILLING, AND RECONCILIATION OF ACCOUNTS ON BEHALF OF MEDICAL PRACTICES; REVIEW AND NEGOTIATION OF CONTRACTS BETWEEN HEALTHCARE PROVIDERS AND INSURANCE COMPANIES AND AUDITS OF PAYMENTS PURSUANT TO THOSE CONTRACTS; BUSINESS SERVICES PROVIDED TO HEALTHCARE PROVIDERS, NAMELY, THE NEGOTIATION AND EXECUTION OF CONTRACTS WITH HEALTHCARE PAYORS; PROVIDING BUSINESS ADVICE AND ASSISTANCE TO BUSINESSES RELATING TO ELECTRONIC HEALTH RECORDS ADOPTION, SERVICE PROVIDER SELECTION, AND IMPLEMENTATION; BUSINESS CONSULTING SERVICES RELATING TO THE HEALTHCARE EFFECTIVENESS DATA AND INFORMATION SET (HEDIS), PATIENT CENTERED MEDICAL HOME TRANSFORMATION, AND PAY-FOR-PERFORMANCE MEASURES, GUIDELINES, AND INCENTIVES IN THE MEDICAL PRACTICE AND MANAGED CARE INDUSTRIES (U.S. CLS. 100, 101 AND 102).

**CLASS 36—INSURANCE AND FINANCIAL**

FOR FINANCIAL CONSULTING SERVICES; FINANCIAL ANALYSES (U.S. CLS. 100, 101 AND 102).  
ALYSSA STEEL, EXAMINING ATTORNEY

SN 86-128,678. CULPEPER PHYSICIAN-HOSPITAL ORGANIZATION, INC., CULPEPER, VA. FILED 11-25-2013.

**INPHUSE**

THE MARK CONSISTS OF STANDARD CHARACTERS WITHOUT CLAIM TO ANY PARTICULAR FONT, STYLE, SIZE, OR COLOR.

SN 86-128,876. DECISION, INC., STAMFORD, CT. FILED 11-25-2013.

**DECISION 360**

THE MARK CONSISTS OF STANDARD CHARACTERS WITHOUT CLAIM TO ANY PARTICULAR FONT, STYLE, SIZE, OR COLOR.

**CLASS 9—ELECTRICAL AND SCIENTIFIC APPARATUS**

FOR COLLABORATIVE BUSINESS SOFTWARE THAT INTEGRATES ANALYSIS, PLANNING AND EXECUTION IN A UNIFIED ENVIRONMENT; ENTERPRISE BUSINESS SOFTWARE THAT ENABLES THE DEVELOPMENT OF DATA-DRIVEN SOLUTIONS (U.S. CLS. 21, 23, 26, 36 AND 38).

**CLASS 35—ADVERTISING AND BUSINESS**

FOR DATA PROCESSING SERVICES (U.S. CLS. 100, 101 AND 102).

**CLASS 42—SCIENTIFIC AND COMPUTER SERVICES**

FOR SOFTWARE AS A SERVICE (SAAS) SERVICES, NAMELY, HOSTING SOFTWARE FOR USE BY OTHERS; COLLECTION, ANALYSIS, AND REPORTING OF BUSINESS ANALYTICS AND DATA IN REAL TIME (U.S. CLS. 100 AND 101).

DOMINICK J. SALEMI, EXAMINING ATTORNEY

SN 86-130,855. GRUPO AEROMEXICO, S.A.B DE C.V., MEXICO D. F., MEXICO, FILED 11-27-2013.

SN 86-129,183. GLASS HOUSE PARTNERS, INC., NAPERVILLE, IL. FILED 11-26-2013.

**THE FINISHING TOUCH**

THE MARK CONSISTS OF STANDARD CHARACTERS WITHOUT CLAIM TO ANY PARTICULAR FONT, STYLE, SIZE, OR COLOR.

**CLASS 35—ADVERTISING AND BUSINESS**

FOR REAL ESTATE SERVICES, NAMELY, PLANNING AND IMPLEMENTING MOVES OF HOMES IN ORDER TO ASSIST SENIORS IN RELOCATING (U.S. CLS. 100, 101 AND 102).

FIRST USE 11-15-2013; IN COMMERCE 11-15-2013.

**CLASS 36—INSURANCE AND FINANCIAL**

FOR REAL ESTATE SERVICES, NAMELY, REAL ESTATE AGENCY FOR ASSISTING SENIORS IN RELOCATING TO NEW HOMES (U.S. CLS. 100, 101 AND 102).

FIRST USE 11-15-2013; IN COMMERCE 11-15-2013.  
ZACHARY R. SPARER, EXAMINING ATTORNEY

SN 86-129,251. GUNNER TECHNOLOGY, PORT ST. LUCIE, FL. FILED 11-26-2013.

**COUNTRY SHORE**

THE MARK CONSISTS OF STANDARD CHARACTERS WITHOUT CLAIM TO ANY PARTICULAR FONT, STYLE, SIZE, OR COLOR.

**CLASS 25—CLOTHING**

FOR APPAREL, NAMELY, SHIRTS, SHORTS, DRESSES, HATS, TANK TOPS (U.S. CLS. 22 AND 39).

**CLASS 35—ADVERTISING AND BUSINESS**

FOR ON-LINE MARKETING SERVICES OF APPAREL (U.S. CLS. 100, 101 AND 102).

KATHERINE STOIDES, EXAMINING ATTORNEY



PRIORITY CLAIMED UNDER SEC. 44(D) ON MEXICO APPLICATION NO. 1429472, FILED 11-6-2013, REG. NO. 1434768, DATED 2-17-2014, EXPIRES 11-6-2023.

PRIORITY CLAIMED UNDER SEC. 44(D) ON MEXICO APPLICATION NO. 1429471, FILED 11-6-2013, REG. NO. 1443774, DATED 3-27-2014, EXPIRES 11-6-2023.

PRIORITY CLAIMED UNDER SEC. 44(D) ON MEXICO APPLICATION NO. 1429470, FILED 11-6-2013, REG. NO. 144467, DATED 3-28-2014, EXPIRES 11-6-2023.

OWNER OF U.S. REG. NOS. 1,712,266, 2,293,104 AND OTHERS.

NO CLAIM IS MADE TO THE EXCLUSIVE RIGHT TO USE "CONCIERGE", APART FROM THE MARK AS SHOWN.

THE COLOR(S) BLUE AND RED IS/ARE CLAIMED AS A FEATURE OF THE MARK.

THE MARK CONSISTS OF AN EAGLE WARRIOR HEAD IN BLUE FOLLOWED BY THE WORD "AEROMEXICO" IN BLUE LETTERS; A RED CURVED WAVY LINE APPEARS UNDER THE WORD "MEXICO"; THE WORD "CONCIERGE" IN BLUE IS LOCATED TO THE RIGHT AND UNDER THE WORD "AEROMEXICO" FOLLOWED BY A CALL SERVICE BELL, WHICH APPEARS IN RED AT THE TOP, BLUE IN THE MIDDLE AND RED AT THE BOTTOM. ABOVE THE CALL SERVICE BELL APPEARS A RED SILHOUETTE OF A HAND THAT IS BENT OVER THE BELL.

THE WORDING "AEROMEXICO" HAS NO MEANING IN A FOREIGN LANGUAGE.

**CLASS 16—PAPER GOODS AND PRINTED MATTER**

FOR PRINTED MATTER, NAMELY, PRINTED AIRLINE TICKETS, FOLDERS, BLANK AND PARTIALLY PRINTED BUSINESS FORMS; PUBLICATIONS, NAMELY, PRINTED TIMETABLES, MAGAZINES, NEWSPAPERS, BULLETINS, CATALOGS AND MANUALS, BOOKS AND BROCHURES ALL FEATURING INFORMATION ABOUT THE AIRLINE AND TRAVEL INDUSTRY; WRITING PAPER AND PAPER NOTE TABLETS WITH LETTERHEAD; WRITING PAPER; OFFICE SUPPLIES, NAMELY, PENS, PENCIL CASES, PENCILS, NOTEPADS, NOTEBOOKS, ERASERS, FOLDERS FOR DOCUMENTS, CARDBOARD; PAPER BOXES; DECALS; CALENDARS; NOTEBOOKS; POSTERS; PAPER NAPKINS; MAPS; PAPER SIGNBOARDS; CARDBOARD SIGNBOARDS; PAPER POUCHES FOR PACKAGING (U.S. CLS. 2, 5, 22, 23, 29, 37, 38 AND 50).

**CLASS 39—TRANSPORTATION AND STORAGE**

FOR TRANSPORTATION SERVICES, NAMELY, TRANSPORTATION OF PASSENGERS AND GOODS BY AIR; AIR TRANSPORTATION SERVICES FEATURING A FREQUENT FLYER BONUS PROGRAM OF BONUS AWARDS FOR FREQUENT TRAVELERS; TRANSPORTATION OF CARGO AND FREIGHT BY AIR; AIR CARGO STORAGE AND HANDLING SERVICES; PACKING OF GOODS FOR TRANSPORTATION BY AIR, TRUCK, TRAIN, AND SHIP; PARCEL DELIVERY BY AIR, TRUCK, CAR, TRAIN, AND SHIP; AIRCRAFT CHARTERING SERVICES; TRAVEL SERVICES, NAMELY, ARRANGING TRAVEL TOURS AND CRUISES; TRAVEL AGENCY AND BOOKING SERVICES, NAMELY, MAKING RESERVATIONS AND BOOKINGS FOR TRANSPORTATION; ONLINE TRAVEL AGENCY AND BOOKING SERVICES, NAMELY, MAKING RESERVATIONS AND BOOKINGS FOR TRANSPORTATION VIA THE INTERNET; TRAVEL INFORMATION SERVICES; CONSULTING SERVICES RELATED TO AIR TRANSPORTATION AND TRAVEL, NAMELY, TRANSPORTATION CONSULTING SERVICES (U.S. CLS. 100 AND 105).

**CLASS 43—HOTEL AND RESTAURANT SERVICES**

FOR AGENCY SERVICES FOR THE RESERVATION OF TEMPORARY ACCOMMODATION; AGENCY SERVICES FOR BOOKING HOTEL ACCOMMODATION; AGENCY SERVICES FOR RESERVATION OF RESTAURANTS; BAR AND RESTAURANT SERVICES; BOOKING OF CATERING SERVICES FOR OTHERS; BOOKING OF TEMPORARY ACCOMMODATION; CONSULTING SERVICES IN THE FIELD OF HOSPITALITY; CONSULTING SERVICES IN THE FIELD OF CULINARY ARTS; MAKING HOTEL RESERVATIONS FOR OTHERS; MAKING RESERVATIONS AND BOOKINGS FOR RESTAURANTS AND MEALS AT HOTELS AND HEALTH SPAS; PROVIDING A WEBSITE FEATURING INFORMATION IN THE FIELD OF HOTELS AND TEMPORARY ACCOMMODATIONS FOR TRAVELERS; PROVIDING BANQUET AND SOCIAL FUNCTION FACILITIES FOR SPECIAL OCCASIONS, PROVIDING INFORMATION AND ADVICE ON HOTELS AND RESTAURANTS TO TOURISTS AND BUSINESS TRAVELERS; PROVIDING INFORMATION, NEWS AND COMMENTARY IN THE FIELD OF DINING; PROVIDING PERSONALIZED INFORMATION ABOUT HOTELS AND TEMPORARY ACCOMMODATIONS FOR TRAVEL VIA THE INTERNET; RESERVATION OF HOTEL ROOMS FOR TRAVELERS; RESERVATION OF RESTAURANTS (U.S. CLS. 100 AND 101).

WILLIAM VERHOSEK, EXAMINING ATTORNEY

SN 86-131,026. TEAVANA CORPORATION, ATLANTA, GA.  
FILED 11-27-2013.

**STEEP YOUR SOUL**

THE MARK CONSISTS OF STANDARD CHARACTERS WITHOUT CLAIM TO ANY PARTICULAR FONT, STYLE, SIZE, OR COLOR.

**CLASS 5—PHARMACEUTICALS**

FOR HERBAL TEA FOR MEDICINAL PURPOSE, HERBAL SUPPLEMENTS, NUTRITIONALLY FORTIFIED BEVERAGES; MEAL REPLACEMENT AND DIETARY SUPPLEMENT DRINK MIXES; DIETARY FOOD SUPPLEMENTS; DIETARY FIBER SUPPLEMENTS FOR HUMAN CONSUMPTION; POWDERED FRUIT-FLAVORED DIETARY SUPPLEMENT DRINK MIX; POWDERED NUTRITIONAL SUPPLEMENT DRINK MIX; VITAMIN AND MINERAL SUPPLEMENTS; VITAMIN FORTIFIED BEVERAGES (U.S. CLS. 6, 18, 44, 46, 51 AND 52).

**CLASS 11—ENVIRONMENTAL CONTROL APPARATUS**

FOR ELECTRIC TEAPOTS, ELECTRIC WATER HEATERS AND DISPENSERS, ELECTRIC TEA AND ELECTRIC ICE TEA BREWERS FOR DOMESTIC AND COMMERCIAL USE (U.S. CLS. 13, 21, 23, 31 AND 34).

**CLASS 21—HOUSEWARES AND GLASS**

FOR THERMAL INSULATED BEVERAGE CONTAINERS, TEA BALLS, TEA INFUSERS, TEA COZIES, TEA CADDIES; TRIVETS, SERVICE TRAYS; SCULPTURES MADE OF CHINA, PORCELAIN, GLASS, CRYSTAL, EARTHENWARE, OR TERRA COTTA; FIGURINES MADE OF CHINA, PORCELAIN, GLASS, CRYSTAL, EARTHENWARE, OR TERRA COTTA; DECORATIVE ORNAMENTS MADE OF CHINA, PORCELAIN, GLASS, CRYSTAL, EARTHENWARE, OR TERRA COTTA (U.S. CLS. 2, 13, 23, 29, 30, 33, 40 AND 50).

**CLASS 29—MEATS AND PROCESSED FOODS**

FOR MILKSHAKES AND MILK BASED BEVERAGES; SOY BEVERAGES USED AS A MILK SUBSTITUTE; SOY MILK; SOY-BASED FOOD BARS; YOGURT, YOGURT-BASED BEVERAGES; PREPARED NUTS, SEASONED NUTS, ROASTED NUTS; NUT MILK AND NUT JUICE (U.S. CL. 46).

**CLASS 30—STAPLE FOODS**

FOR HERBAL TEA-BASED BEVERAGES; TEA AND HERBAL TEA-BASED BEVERAGES AND CONCENTRATES, WITH FRUIT FLAVORING; FROZEN CONFECTIONS WITH TEA, HERBAL TEA AND FRUIT FLAVORING; COCOA, HERBAL AND NON-HERBAL TEA; TEA, COCOA AND BEVERAGES; BEVERAGES MADE WITH A BASE OF POWDERED CHOCOLATE AND BEVERAGES MADE WITH A BASE OF VANILLA; SAUCES TO ADD TO BEVERAGES; CHOCOLATE SYRUP; FLAVORING SYRUPS TO ADD TO BEVERAGES; READY-TO-DRINK TEA; ICE CREAM AND FROZEN CONFECTIONS, NAMELY, ICE CREAM, ICE MILK, FROZEN YOGURT, FROZEN SOY BASED DESSERTS; CANDY AND CONFECTIONS, NAMELY, CHOCOLATE, SUGAR, CANDY ALMONDS, AND FROZEN CONFECTIONS; BAKED GOODS, NAMELY, MUFFINS, SCONES, BISCUITS, COOKIES, PASTRIES AND BREADS; FOOD BARS, NAMELY, GRAIN-BASED FOOD BARS, AND OAT-BASED FOOD BARS; SUGAR; SPICE; HONEY; AGAVE; FLAVORING SYRUPS FOR MAKING BEVERAGES; TEA-BASED LIQUID AND POWDERED BEVERAGE MIXES FOR MAKING FRUIT-BASED BEVERAGES (U.S. CL. 46).

**CLASS 32—LIGHT BEVERAGES**

FOR NON-ALCOHOLIC BEVERAGES WITH TEA FLAVOR; FRUIT AND JUICE BASED BEVERAGES; FRUIT CONCENTRATES AND PUREES USED AS INGREDIENTS OF BEVERAGES; BEVERAGE CONCENTRATES AND SYRUPS FOR MAKING FROZEN BLENDED FRUIT BASED BEVERAGES; SPARKLING FRUIT AND JUICE BASED BEVERAGES AND SODA BEVERAGES; SODA POP BEVERAGES; ENERGY DRINKS; SOY-BASED BEVERAGES NOT BEING MILK SUBSTITUTES (U.S. CLS. 45, 46 AND 48).

**CLASS 35—ADVERTISING AND BUSINESS**

FOR BUSINESS ADMINISTRATION; BUSINESS MANAGEMENT; FRANCHISE SERVICES, NAMELY, OFFERING BUSINESS MANAGEMENT ASSISTANCE IN THE ESTABLISHMENT AND OPERATION OF RESTAURANTS, CAFES, TEA HOUSES, AND SNACK BARS; RETAIL STORE SERVICES IN THE FIELD OF: COFFEE, COCOA, PACKAGED AND PREPARED FOODS, KITCHENWARE, SCULPTURES, FIGURINES, DECORATIVE ORNAMENTS, INCENSE, HOME FRAGRANCE, PERSONAL CARE PRODUCTS; WHOLESALE DISTRIBUTORSHIPS, WHOLESALE STORES AND WHOLESALE ORDERING SERVICES ALL IN THE FIELD OF COFFEE, TEA, COCOA, PACKAGED AND PREPARED FOODS, TEA-RELATED ELECTRIC AND NON-ELECTRIC APPLIANCES, HOUSEWARES, KITCHENWARE, GLASSWARE, GIFTWARE, PLATES, BOWLS, STORAGE CONTAINERS, SCULPTURES, FIGURINES, DECORATIVE ORNAMENTS, CLOTHING, CANDLES, INCENSE, HOME FRAGRANCE, MUSICAL RECORDINGS AND BOOKS; MAIL ORDER SERVICES AND MAIL ORDER CATALOG SERVICES ALL IN THE FIELD OF: COFFEE, COCOA, PACKAGED AND PREPARED FOODS KITCHENWARE, SCULPTURES, FIGURINES, DECORATIVE ORNAMENTS, CLOTHING, CANDLES, INCENSE, HOME FRAGRANCE; COMPUTERIZED ONLINE ORDERING SERVICES, COMPUTERIZED ONLINE RETAIL SERVICES THROUGH DIRECT SOLICITATION BY SALESPERSONS DIRECTED TO END-USERS, ONLINE ORDERING SERVICES AND ONLINE RETAIL STORE SERVICES ALL IN THE FIELD OF: COFFEE, TEA, COCOA, PACKAGED AND PREPARED FOODS, TEA-RELATED ELECTRIC AND NON-ELECTRIC APPLIANCES, HOUSEWARES, KITCHENWARE, GLASSWARE, GIFTWARE, PLATES, BOWLS, STORAGE CONTAINERS, SCULPTURES, FIGURINES, DECORATIVE ORNAMENTS, CLOTHING, CANDLES, INCENSE, HOME FRAGRANCE, MUSICAL RECORDINGS AND BOOKS; COMPUTERIZED ONLINE GIFT REGISTRY AND GIFT REGISTRY ORDERING SERVICES RELATED THERETO (U.S. CLS. 100, 101 AND 102).

**CLASS 43—HOTEL AND RESTAURANT SERVICES**

FOR RESTAURANT, CAFE, CAFETERIA, SNACK BAR, TEA BAR AND TEA HOUSE, TEA ROOM; CARRY OUT RESTAURANT, AND TAKE OUT RESTAURANT SERVICES; CATERING SERVICES; CONTRACT FOOD SERVICES; FOOD AND BEVERAGE PREPARATION (U.S. CLS. 100 AND 101).  
WILLIAM P. SHANAHAN, EXAMINING ATTORNEY

SN 86-131,560. JUMIO INC., PALO ALTO, CA. FILED 11-27-2013.

**NETSWIPE: THE ONLINE CARD PRESENT TRANSACTION**

THE MARK CONSISTS OF STANDARD CHARACTERS WITHOUT CLAIM TO ANY PARTICULAR FONT, STYLE, SIZE, OR COLOR.  
OWNER OF U.S. REG. NOS. 4,145,189 AND 4,155,691.  
NO CLAIM IS MADE TO THE EXCLUSIVE RIGHT TO USE "THE ONLINE CARD PRESENT TRANSACTION", APART FROM THE MARK AS SHOWN.

**CLASS 9—ELECTRICAL AND SCIENTIFIC APPARATUS**

FOR COMPUTER SOFTWARE FOR PROCESSING ELECTRONIC PAYMENTS AND TRANSFERRING FUNDS TO AND FROM OTHERS AND FOR CREDIT AND DEBIT CARD TRANSACTION PROCESSING (U.S. CLS. 21, 23, 26, 36 AND 38).

**CLASS 36—INSURANCE AND FINANCIAL**

FOR FINANCIAL TRANSACTION SERVICES, NAMELY, PROVIDING SECURE AUTHORIZATION AND SECURE PROCESSING SERVICES FOR ELECTRONIC PAYMENTS, CREDIT CARDS, AND DEBIT CARDS (U.S. CLS. 100, 101 AND 102).  
KIMBERLY FRYE, EXAMINING ATTORNEY

SN 86-131,561. JUMIO INC., PALO ALTO, CA. FILED 11-27-2013.

**JUMIO - WORLD'S FIRST MOBILE CARD PRESENT PAYMENTS**

THE MARK CONSISTS OF STANDARD CHARACTERS WITHOUT CLAIM TO ANY PARTICULAR FONT, STYLE, SIZE, OR COLOR.

OWNER OF U.S. REG. NO. 4,195,166.  
NO CLAIM IS MADE TO THE EXCLUSIVE RIGHT TO USE "WORLD'S FIRST MOBILE CARD PRESENT PAYMENTS", APART FROM THE MARK AS SHOWN.

**CLASS 9—ELECTRICAL AND SCIENTIFIC APPARATUS**

FOR COMPUTER SOFTWARE FOR PROCESSING ELECTRONIC PAYMENTS AND TRANSFERRING FUNDS TO AND FROM OTHERS AND FOR CREDIT AND DEBIT CARD TRANSACTION PROCESSING (U.S. CLS. 21, 23, 26, 36 AND 38).

**CLASS 36—INSURANCE AND FINANCIAL**

FOR FINANCIAL TRANSACTION SERVICES, NAMELY, PROVIDING SECURE AUTHORIZATION AND SECURE PROCESSING SERVICES FOR ELECTRONIC PAYMENTS, CREDIT CARDS, AND DEBIT CARDS (U.S. CLS. 100, 101 AND 102).  
KIMBERLY FRYE, EXAMINING ATTORNEY

SN 86-131,562. JUMIO INC., PALO ALTO, CA. FILED 11-27-2013.

**JUMIO - MOBILE CARD PRESENT PAYMENTS**

THE MARK CONSISTS OF STANDARD CHARACTERS WITHOUT CLAIM TO ANY PARTICULAR FONT, STYLE, SIZE, OR COLOR.

OWNER OF U.S. REG. NO. 4,195,166.  
NO CLAIM IS MADE TO THE EXCLUSIVE RIGHT TO USE "MOBILE CARD PRESENT PAYMENTS", APART FROM THE MARK AS SHOWN.

**CLASS 9—ELECTRICAL AND SCIENTIFIC APPARATUS**

FOR COMPUTER SOFTWARE FOR PROCESSING ELECTRONIC PAYMENTS AND TRANSFERRING FUNDS TO AND FROM OTHERS AND FOR CREDIT AND DEBIT CARD TRANSACTION PROCESSING (U.S. CLS. 21, 23, 26, 36 AND 38).

**CLASS 36—INSURANCE AND FINANCIAL**

FOR FINANCIAL TRANSACTION SERVICES, NAMELY, PROVIDING SECURE AUTHORIZATION AND SECURE PROCESSING SERVICES FOR ELECTRONIC PAYMENTS, CREDIT CARDS, AND DEBIT CARDS (U.S. CLS. 100, 101 AND 102).

KIMBERLY FRYE, EXAMINING ATTORNEY

---

SN 86-131,804. CLASS ACT SPORTS, LLC, LONG BEACH, NY. FILED 11-29-2013.

# Brack Attack

THE MARK CONSISTS OF STANDARD CHARACTERS WITHOUT CLAIM TO ANY PARTICULAR FONT, STYLE, SIZE, OR COLOR.

**CLASS 9—ELECTRICAL AND SCIENTIFIC APPARATUS**

FOR COMPUTER GAME SOFTWARE FOR PROVIDING A FANTASY SPORTS CONTEST FOR USE ON WIRELESS DEVICES; COMPUTER APPLICATION SOFTWARE FOR MOBILE DEVICES AND COMPUTERS, NAMELY, SOFTWARE FOR CREATING AND PLAYING CONTESTS, GAMES AND TRIVIA; COMPUTER GAME SOFTWARE (U.S. CLS. 21, 23, 26, 36 AND 38).

**CLASS 41—EDUCATION AND ENTERTAINMENT**

FOR ENTERTAINMENT SERVICES, NAMELY, PROVIDING SPORTS AND FANTASY SPORTS INFORMATION, ONLINE, NON-DOWNLOADABLE COMPUTER GAMES AND CONTESTS VIA THE INTERNET AND OTHER COMMUNICATIONS NETWORKS IN THE FIELDS OF SPORTS AND FANTASY SPORTS GAMES AND CONTESTS; PROVIDING ONLINE NON-DOWNLOADABLE GAME AND CONTEST SOFTWARE; PROVIDING ONLINE NON-DOWNLOADABLE SOFTWARE FOR PLAYING FANTASY SPORTS GAMES AND CONTESTS (U.S. CLS. 100, 101 AND 107).

**CLASS 42—SCIENTIFIC AND COMPUTER SERVICES**

FOR PROVIDING ONLINE NON-DOWNLOADABLE SOFTWARE FOR USE IN CREATING FANTASY SPORTS GAMES AND CONTESTS (U.S. CLS. 100 AND 101).

DANIEL S. STRINGER, EXAMINING ATTORNEY

---

SN 86-132,386. AGORA MOBILE INC., MONCTON, NEW BRUNSWICK, CANADA, FILED 12-2-2013.

# VIZWIK

THE MARK CONSISTS OF STANDARD CHARACTERS WITHOUT CLAIM TO ANY PARTICULAR FONT, STYLE, SIZE, OR COLOR.

**CLASS 9—ELECTRICAL AND SCIENTIFIC APPARATUS**

FOR MOBILE SOFTWARE TO FACILITATE COMMUNICATING AMONG PEER PROFESSIONALS IN THE ADVERTISING, MARKETING AND BUSINESS SERVICE FIELDS, AND FOR CUSTOMIZING MOBILE SOFTWARE APPLICATION USER INTERFACES; MOBILE SOFTWARE FOR STORING, TRACKING, MANAGING, ANALYZING, AND REPORTING DATA IN THE FIELD OF MARKETING, PROMOTION, SALES, CUSTOMER INFORMATION, CUSTOMER RELATIONSHIP MANAGEMENT, SALES SUPPORT, AND EMPLOYEE EFFICIENCY (U.S. CLS. 21, 23, 26, 36 AND 38).

**CLASS 35—ADVERTISING AND BUSINESS**

FOR BUSINESS MANAGEMENT CONSULTATION AND BRAND IMAGERY CONSULTING SERVICES; PROVIDING A WEBSITE WITH GENERAL INFORMATION OF INTEREST TO THE FIELD OF BUSINESS MANAGEMENT CONSULTING AND ADVISORY SERVICES, OPERATING ONLINE MARKETPLACES FOR BUYING AND SELLING, SHARING, AND OFFERING MOBILE SOFTWARE AND ON-DEMAND APPLICATIONS (U.S. CLS. 100, 101 AND 102).

**CLASS 42—SCIENTIFIC AND COMPUTER SERVICES**

FOR PROVIDING TEMPORARY USE OF ON-LINE NON-DOWNLOADABLE SOFTWARE FOR CUSTOMIZING MOBILE SOFTWARE APPLICATION USER INTERFACES; COMPUTER SERVICES, NAMELY, DESIGNING, DEVELOPING, AND MAINTAINING MOBILE SOFTWARE APPLICATIONS FOR OTHERS AND CONSULTING SERVICES RELATED THERETO; PROVIDING TEMPORARY USE OF ONLINE NON-DOWNLOADABLE MOBILE SOFTWARE APPLICATION DEVELOPMENT TOOLS AND PROGRAMMING LANGUAGE FOR USE IN DEVELOPING, ANALYZING, CODING, CHECKING, AND CONTROLLING OTHER COMPUTER SOFTWARE; PROVIDING TEMPORARY USE OF ONLINE NON-DOWNLOADABLE COMPUTER SOFTWARE THAT IMPLEMENTS A VISUAL DATA FLOW AND PROTOTYPE-ORIENTED PROGRAMMING LANGUAGE; ONLINE HOSTED COMPUTER SERVICES, NAMELY, DESIGNING, DEVELOPING, CUSTOMIZING, AND MAINTAINING MOBILE SOFTWARE APPLICATIONS FOR OTHERS; AND CONSULTING SERVICES RELATED THERETO; PROVIDING USE OF ON-LINE, NON-DOWNLOADABLE SOFTWARE FOR THE CREATION, ACCESS, OPERATION, MAINTENANCE AND MANAGEMENT OF COMPUTERIZED MOBILE APPLICATIONS; PROVIDING TEMPORARY USE OF MOBILE AND ON-LINE NON-DOWNLOADABLE SOFTWARE FOR USE IN COLLECTING, MANAGING, AND SYNCHRONIZING BUSINESS INFORMATION AND CONTACT DATA ACROSS MULTIPLE INDUSTRY FIELDS, ENABLING USERS TO INTERACT AND EXCHANGE BUSINESS DATA WITH A SERVICE VIA A GLOBAL COMPUTER NETWORK AND ACCESS, EXTRACT AND ORGANIZE BUSINESS INFORMATION REGARDING PEOPLE, COMPANIES AND PRODUCTS ACROSS MULTIPLE BUSINESS INDUSTRY FIELDS AND ALSO FOR USE IN COMPUTERIZED MOBILE APPLICATION MANAGEMENT, MAPPING OF BUSINESS ORGANIZATIONS, BUSINESS RESEARCH AND TO FACILITATE BUSINESS COMMUNICATIONS BETWEEN BUSINESS PROFESSIONALS; ON-LINE NON-DOWNLOADABLE COMPUTER SOFTWARE FOR USE IN DEVELOPING, DISTRIBUTING AND CUSTOMIZING MOBILE SOFTWARE APPLICATIONS AND MOBILE SOFTWARE APPLICATION USER INTERFACES; PROVIDING USE OF MOBILE AND ON-LINE, NON-DOWNLOADABLE SOFTWARE FOR USE IN INFORMATION, DATA ASSET AND IDENTITY MANAGEMENT SERVICES, INCLUDING SOFTWARE ENABLING DATA SYNCHRONIZATION, COMMUNICATIONS AND COLLABORATIONS RELATING TO BUSINESS, PRODUCT, INDUSTRY, AND PERSONAL CONTACT INFORMATION; COMPILATION AND REMOTE MANAGEMENT OF COMPUTERIZED MOBILE APPLICATIONS AND CONSULTING SERVICES RELATED THERETO (U.S. CLS. 100 AND 101).

**CLASS 45—PERSONAL AND LEGAL SERVICES**

FOR ON-LINE SOCIAL NETWORKING SERVICES  
(U.S. CLS. 100 AND 101).  
GIANCARLO CASTRO, EXAMINING ATTORNEY

SN 86-133,832. STUDIO 1 INTERIOR DESIGN, INC., DBA  
LUXURY RANCH INTERIOR DESIGN, RAMONA, CA.  
FILED 12-3-2013.



THE MARK CONSISTS OF A JOINED FORM OF THE  
LETTERS "L" AND "R" OVERLAID ON A FILLED REC-  
TANGLE.

**CLASS 14—JEWELRY**

FOR (BASED ON INTENT TO USE) JEWELRY (U.S.  
CLS. 2, 27, 28 AND 50).

**CLASS 20—FURNITURE AND ARTICLES NOT OTHERWISE CLASSIFIED**

FOR (BASED ON USE IN COMMERCE) CUSTOM  
FURNITURE (U.S. CLS. 2, 13, 22, 25, 32 AND 50).  
FIRST USE 9-1-2012; IN COMMERCE 9-1-2012.

**CLASS 42—SCIENTIFIC AND COMPUTER SERVICES**

FOR (BASED ON USE IN COMMERCE) FURNITURE  
DESIGN SERVICES; INTERIOR DESIGN SERVICES;  
INTERIOR DESIGN SERVICES INCLUDING SPACE  
PLANNING, FURNITURE SELECTION, MATERIAL  
AND SURFACE SELECTION (U.S. CLS. 100 AND 101).  
FIRST USE 9-1-2012; IN COMMERCE 9-1-2012.  
STEPHANIE ALI, EXAMINING ATTORNEY

Luxury Ranch Interior  
Design

THE MARK CONSISTS OF STANDARD CHARACTERS  
WITHOUT CLAIM TO ANY PARTICULAR FONT, STYLE,  
SIZE, OR COLOR.

NO CLAIM IS MADE TO THE EXCLUSIVE RIGHT TO  
USE "LUXURY" AND "INTERIOR DESIGN", APART FROM  
THE MARK AS SHOWN.

**CLASS 14—JEWELRY**

FOR (BASED ON INTENT TO USE) JEWELRY (U.S.  
CLS. 2, 27, 28 AND 50).

**CLASS 20—FURNITURE AND ARTICLES NOT OTHERWISE CLASSIFIED**

FOR (BASED ON USE IN COMMERCE) CUSTOM  
FURNITURE (U.S. CLS. 2, 13, 22, 25, 32 AND 50).  
FIRST USE 9-1-2012; IN COMMERCE 9-1-2012.

**CLASS 42—SCIENTIFIC AND COMPUTER SERVICES**

FOR (BASED ON USE IN COMMERCE) FURNITURE  
DESIGN SERVICES; INTERIOR DESIGN SERVICES;  
INTERIOR DESIGN SERVICES INCLUDING SPACE  
PLANNING, FURNITURE SELECTION, MATERIAL  
AND SURFACE SELECTION (U.S. CLS. 100 AND 101).  
FIRST USE 9-1-2012; IN COMMERCE 9-1-2012.  
STEPHANIE ALI, EXAMINING ATTORNEY

SN 86-135,512. SARAH LINDEN, LINCOLN, NE. FILED 12-4-  
2013.

GENERATION V

THE MARK CONSISTS OF STANDARD CHARACTERS  
WITHOUT CLAIM TO ANY PARTICULAR FONT, STYLE,  
SIZE, OR COLOR.

**CLASS 30—STAPLE FOODS**

FOR CARTRIDGES SOLD FILLED WITH CHEMICAL  
FLAVORINGS IN LIQUID FORM FOR ELECTRONIC  
CIGARETTES; CHEMICAL FLAVORINGS IN LIQUID  
FORM USED TO REFILL ELECTRONIC CIGARETTE  
CARTRIDGES; ELECTRONIC CIGARETTE LIQUID (E-  
LIQUID) COMPRISED OF FLAVORINGS IN LIQUID  
FORM USED TO REFILL ELECTRONIC CIGARETTE  
CARTRIDGES (U.S. CL. 46).

**CLASS 35—ADVERTISING AND BUSINESS**

FOR ON-LINE RETAIL STORE SERVICES FEATURING A WIDE VARIETY OF CONSUMER GOODS OF OTHERS; ON-LINE RETAIL STORE SERVICES FEATURING CARTRIDGES FILLED WITH VEGETABLE GLYCOL, CARTRIDGES FILLED WITH PROPYLENE GLYCOL, ELECTRONIC CIGARETTES, ELECTRONIC CIGARETTE LIQUID, ELECTRONIC CIGARETTE ACCESSORIES, ELECTRONIC HOOKAHS, ELECTRONIC CIGARETTE BATTERIES, ELECTRONIC CIGARETTE TANKS, CARTOMIZERS, ATOMIZERS, WICKS AND COILS USED FOR ELECTRONIC CIGARETTES, DRIP TIPS; ON-LINE WHOLESALE AND RETAIL STORE SERVICES FEATURING CARTRIDGES FILLED WITH VEGETABLE GLYCOL, CARTRIDGES FILLED WITH PROPYLENE GLYCOL, ELECTRONIC CIGARETTES, ELECTRONIC CIGARETTE LIQUID, ELECTRONIC CIGARETTE ACCESSORIES, ELECTRONIC HOOKAHS, ELECTRONIC CIGARETTE BATTERIES, ELECTRONIC CIGARETTE TANKS, CARTOMIZERS, ATOMIZERS, WICKS AND COILS USED FOR ELECTRONIC CIGARETTES, DRIP TIPS; RETAIL VARIETY STORES; RETAIL STORE SERVICES FEATURING CARTRIDGES FILLED WITH VEGETABLE GLYCOL, CARTRIDGES FILLED WITH PROPYLENE GLYCOL, ELECTRONIC CIGARETTES, ELECTRONIC CIGARETTE LIQUID, ELECTRONIC CIGARETTE ACCESSORIES, ELECTRONIC HOOKAHS, ELECTRONIC CIGARETTE BATTERIES, ELECTRONIC CIGARETTE TANKS, CARTOMIZERS, ATOMIZERS, WICKS AND COILS USED FOR ELECTRONIC CIGARETTES, DRIP TIPS; RETAIL SHOPS FEATURING CARTRIDGES FILLED WITH VEGETABLE GLYCOL, CARTRIDGES FILLED WITH PROPYLENE GLYCOL, ELECTRONIC CIGARETTES, ELECTRONIC CIGARETTE LIQUID, ELECTRONIC CIGARETTE ACCESSORIES, ELECTRONIC HOOKAHS, ELECTRONIC CIGARETTE BATTERIES, ELECTRONIC CIGARETTE TANKS, CARTOMIZERS, ATOMIZERS, WICKS AND COILS USED FOR ELECTRONIC CIGARETTES, DRIP TIPS; RETAIL STORE SERVICES FEATURING CARTRIDGES FILLED WITH VEGETABLE GLYCOL, CARTRIDGES FILLED WITH PROPYLENE GLYCOL, ELECTRONIC CIGARETTES, ELECTRONIC CIGARETTE LIQUID, ELECTRONIC CIGARETTE ACCESSORIES, ELECTRONIC HOOKAHS, ELECTRONIC CIGARETTE BATTERIES, ELECTRONIC CIGARETTE TANKS, CARTOMIZERS, ATOMIZERS, WICKS AND COILS USED FOR ELECTRONIC CIGARETTES, DRIP TIPS (U.S. CLS. 100, 101 AND 102).

KEVIN CORWIN, EXAMINING ATTORNEY

SN 86-135,903. GLOBAL TRADEMARKS, INC., STOCKERTOWN, PA. FILED 12-5-2013.

**ECO ATELIER**

THE MARK CONSISTS OF STANDARD CHARACTERS WITHOUT CLAIM TO ANY PARTICULAR FONT, STYLE, SIZE, OR COLOR.

OWNER OF U.S. REG. NO. 4,203,051.

NO CLAIM IS MADE TO THE EXCLUSIVE RIGHT TO USE "ATELIER", APART FROM THE MARK AS SHOWN.

**CLASS 6—METAL GOODS**

FOR WORKS OF ART OF COMMON METAL (U.S. CLS. 2, 12, 13, 14, 23, 25 AND 50).

**CLASS 16—PAPER GOODS AND PRINTED MATTER**

FOR FRAMED ART PICTURES; WORKS OF ART MADE OF PAPER (U.S. CLS. 2, 5, 22, 23, 29, 37, 38 AND 50).

**CLASS 20—FURNITURE AND ARTICLES NOT OTHERWISE CLASSIFIED**

FOR WORKS OF ART OF PLASTIC (U.S. CLS. 2, 13, 22, 25, 32 AND 50).

**CLASS 25—CLOTHING**

FOR COVERUPS; SWIMWEAR; T-SHIRTS (U.S. CLS. 22 AND 39).

**CLASS 43—HOTEL AND RESTAURANT SERVICES**

FOR RESTAURANT SERVICES (U.S. CLS. 100 AND 101).

TEJBIR SINGH, EXAMINING ATTORNEY

SN 86-135,949. FERIOLI, JORGELINA, CAPITAL FEDERAL, ARGENTINA, FILED 12-5-2013.

**W**  
**WILLAND**

THE MARK CONSISTS OF THE LETTER "W" AND "WILLAND" IN STYLIZED FONT.

**CLASS 25—CLOTHING**

FOR ATHLETIC FOOTWEAR, PANTS; CLOTHING FOR GYMNASTICS, NAMELY, ATHLETIC PANTS, ATHLETIC SHIRTS, ATHLETIC SHORTS, ATHLETIC TIGHTS, ATHLETIC JUMPERS, LEOTARDS, GYMNASTIC FOOTWEAR AND WARM-UP JACKETS; CLOTHING FOR POLO, NAMELY, ATHLETIC PANTS, POLO SHIRTS, JACKETS, BOOTS AND SOCKS (U.S. CLS. 22 AND 39).

**CLASS 28—TOYS AND SPORTING GOODS**

FOR SPORTING ARTICLES FOR PLAYING POLO, NAMELY, KNEE GUARDS FOR ATHLETIC USE, POLO GLOVES, ELBOW GUARDS FOR ATHLETIC USE, SHIN GUARDS FOR ATHLETIC USE, POLO STICKS, POLO BALLS (U.S. CLS. 22, 23, 38 AND 50).

KRISTIN DAHLING, EXAMINING ATTORNEY

SN 86-136,341. DINSMORE, SCOTT, SAN FRANCISCO, CA. FILED 12-5-2013.

**LIVE YOUR LEGEND**

THE MARK CONSISTS OF STANDARD CHARACTERS WITHOUT CLAIM TO ANY PARTICULAR FONT, STYLE, SIZE, OR COLOR.

**CLASS 35—ADVERTISING AND BUSINESS**

FOR PROVIDING CAREER INFORMATION; PROVIDING A CAREER-DEVELOPMENT WEBSITE FEATURING INFORMATION FOR INDIVIDUALS WHO ARE LOOKING FOR A CHANGE IN CAREER (U.S. CLS. 100, 101 AND 102).

FIRST USE 8-31-2011; IN COMMERCE 8-31-2011.



**CLASS 41—EDUCATION AND ENTERTAINMENT**

FOR ENTERTAINMENT AND EDUCATIONAL SERVICES, NAMELY, MOTIVATIONAL SPEAKING REGARDING WORK, CAREER AND JOB SATISFACTION; CAREER COUNSELING, NAMELY, PROVIDING ADVICE CONCERNING EDUCATION OPTIONS TO PURSUE CAREER OPPORTUNITIES (U.S. CLS. 100, 101 AND 107).

FIRST USE 8-31-2013; IN COMMERCE 8-31-2013.  
WARREN L. OLANDRIA, EXAMINING ATTORNEY

SN 86-136,993. COAST DENTAL SERVICES, INC., TAMPA, FL. FILED 12-6-2013.

**COAST DENTAL & ORTHODONTICS**

THE MARK CONSISTS OF STANDARD CHARACTERS WITHOUT CLAIM TO ANY PARTICULAR FONT, STYLE, SIZE, OR COLOR.

OWNER OF U.S. REG. NOS. 2,132,076, 3,084,892 AND OTHERS.

NO CLAIM IS MADE TO THE EXCLUSIVE RIGHT TO USE "DENTAL & ORTHODONTICS", APART FROM THE MARK AS SHOWN.

SN 86-136,700. PRIVACY SALE, LLC, MIAMI, FL. FILED 12-6-2013.

# Privacy Sale

THE MARK CONSISTS OF STANDARD CHARACTERS WITHOUT CLAIM TO ANY PARTICULAR FONT, STYLE, SIZE, OR COLOR.

NO CLAIM IS MADE TO THE EXCLUSIVE RIGHT TO USE "SALE", APART FROM THE MARK AS SHOWN.

**CLASS 9—ELECTRICAL AND SCIENTIFIC APPARATUS**

FOR AUDIO DISCS FEATURING SALE OR PURCHASE OF REAL ESTATE, PERSONAL PROPERTY, VEHICLES, YAHTS, INTELLECTUAL PROPERTY, AND BUSINESS INSTRUCTION; DOWNLOADABLE MULTIMEDIA FILE CONTAINING ARTWORK, TEXT, AUDIO, VIDEO, GAMES, AND INTERNET WEB LINKS RELATING TO SALE OR PURCHASE OF REAL ESTATE, PERSONAL PROPERTY, VEHICLES, YAHTS, INTELLECTUAL PROPERTY, AND BUSINESS INSTRUCTION; ELECTRONIC PUBLICATIONS, NAMELY, ARTICLES AND BOOKS FEATURING SALE OR PURCHASE OF REAL ESTATE, PERSONAL PROPERTY, VEHICLES, YAHTS, INTELLECTUAL PROPERTY, AND BUSINESS INSTRUCTION RECORDED ON COMPUTER MEDIA; VIDEO DISCS FEATURING SALE OR PURCHASE OF REAL ESTATE, PERSONAL PROPERTY, VEHICLES, YAHTS, INTELLECTUAL PROPERTY, AND BUSINESS INSTRUCTION (U.S. CLS. 21, 23, 26, 36 AND 38).

FIRST USE 8-26-2013; IN COMMERCE 11-22-2013.

**CLASS 35—ADVERTISING AND BUSINESS**

FOR ADVERTISING OF COMMERCIAL OR RESIDENTIAL REAL ESTATE; MARKETING SERVICES FOR THE REAL ESTATE, PERSONAL PROPERTY, VEHICLES, YAHTS, INTELLECTUAL PROPERTY, AND BUSINESSES OF OTHERS; MATCHING CONSUMERS WITH PROFESSIONALS IN THE FIELD OF REAL ESTATE, PERSONAL PROPERTY, VEHICLES, YAHTS, INTELLECTUAL PROPERTY, AND BUSINESSES; REAL ESTATE MARKETING SERVICES IN THE FIELD OF HOMES, APARTMENTS, AND CONDOMINIUMS (U.S. CLS. 100, 101 AND 102).

FIRST USE 7-1-2013; IN COMMERCE 8-29-2013.  
MARK SHINER, EXAMINING ATTORNEY

SN 86-137,084. ACADEMY OF MATHEMATICS AND SCIENCE, INC., TUCSON, AZ. FILED 12-6-2013.



NO CLAIM IS MADE TO THE EXCLUSIVE RIGHT TO USE "POLYMATH SCHOOLS", APART FROM THE MARK AS SHOWN.

THE MARK CONSISTS OF THE WORD "POLYMATH" ABOVE THE WORD "SCHOOLS", WITH A LINE ON EACH SIDE OF "SCHOOLS" AND THE HEAD OF A PERSON IN PROFILE WEARING A TIE TO THE LEFT OF THE WORDS. THE HEAD OF THE PERSON FEATURES A PATTERN OF MULTIPLE CIRCLES.

**CLASS 35—ADVERTISING AND BUSINESS**

FOR BUSINESS OPERATION SERVICES PROVIDED TO PUBLIC SCHOOLS (U.S. CLS. 100, 101 AND 102).

**CLASS 41—EDUCATION AND ENTERTAINMENT**

FOR EDUCATIONAL SERVICES IN THE NATURE OF PROVIDING CLASSROOM INSTRUCTION FOR PRIMARY AND SECONDARY GRADES (U.S. CLS. 100, 101 AND 107).

LINDA ESTRADA, EXAMINING ATTORNEY

SN 86-137,486. H.C. FOODS, CO., COMMERCE, CA. FILED 12-6-2013.

SN 86-138,187. COSMETICS LIMITED, NASSAU, BAHAMAS, FILED 12-9-2013.

## Min Thar Gyi

THE MARK CONSISTS OF STANDARD CHARACTERS WITHOUT CLAIM TO ANY PARTICULAR FONT, STYLE, SIZE, OR COLOR.

THE ENGLISH TRANSLATION OF "MINTHARGYI" IN THE MARK IS "A MALE MAIN ACTOR IN AN OPERA; MALE".

### CLASS 29—MEATS AND PROCESSED FOODS

FOR PROCESSED SEAFOOD (U.S. CL. 46).  
FIRST USE 11-30-2013; IN COMMERCE 11-30-2013.

### CLASS 30—STAPLE FOODS

FOR NOODLES (U.S. CL. 46).  
FIRST USE 11-30-2013; IN COMMERCE 11-30-2013.  
VERNA BETH RIRIE, EXAMINING ATTORNEY



PRIORITY CLAIMED UNDER SEC. 44(D) ON UNITED KINGDOM APPLICATION NO. 3032779, FILED 11-28-2013, REG. NO. 3032779, DATED 3-21-2014, EXPIRES 11-28-2023.

OWNER OF U.S. REG. NOS. 1,678,043 AND 2,664,274.  
NO CLAIM IS MADE TO THE EXCLUSIVE RIGHT TO USE "BIOTECH", APART FROM THE MARK AS SHOWN.

THE MARK CONSISTS OF THE WORD "ELEMIS" OVER THE WORD "BIOTEC", SURROUNDED BY INTERLOCKING OVALS.

SN 86-137,504. HOSPIRA, INC., LAKE FOREST, IL. FILED 12-6-2013.

## 360 ENABLED

THE MARK CONSISTS OF STANDARD CHARACTERS WITHOUT CLAIM TO ANY PARTICULAR FONT, STYLE, SIZE, OR COLOR.

### CLASS 9—ELECTRICAL AND SCIENTIFIC APPARATUS

FOR COMPUTER SOFTWARE FOR MONITORING, MANAGING, AND RECORDING MEDICATION DELIVERY TO PATIENTS (U.S. CLS. 21, 23, 26, 36 AND 38).

### CLASS 10—MEDICAL APPARATUS

FOR MEDICAL DEVICES, NAMELY, INFUSION PUMPS AND ACCESSORIES FOR THE DELIVERY OF MEDICATIONS TO PATIENTS EXCLUDING PUMPS HAVING THE ABILITY TO ROTATE IN ORDER TO DELIVER MEDICATION AT ANY ORIENTATION IN 360 DEGREES OF ROTATION IN A PLANE (U.S. CLS. 26, 39 AND 44).

JOHN E. MICHOS, EXAMINING ATTORNEY

### CLASS 3—COSMETICS AND CLEANING PREPARATIONS

FOR NON-MEDICATED TOILET PREPARATIONS, NAMELY, PERFUMES, COLOGNES, EAU DE COLOGNES, AROMATHERAPY PRODUCTS, NAMELY, ESSENTIAL OILS AND NON-MEDICATED SKIN CREAMS WITH ESSENTIAL OILS FOR USE IN AROMATHERAPY, SOAPS, COSMETIC BATH PREPARATIONS, DEODORANTS AND ANTI-PERSPIRANTS FOR PERSONAL USE, SKIN CREAMS, BODY OILS, BODY LOTIONS, ESSENTIAL OILS AND AROMATIC OILS FOR THE FACE, BODY AND TO BE USED IN THE BATH; NAIL POLISH; NAIL POLISH REMOVER; COSMETICS, NAMELY, FACIAL CREAMS, MOISTURIZERS FOR THE FACE, HANDS AND BODY, BEAUTY MASKS, COSMETIC MASKS, FLORAL TOILET WATER, SKIN BUFF CREAM, CLEANSERS AND TONERS; PREPARATIONS FOR THE HAIR, NAMELY, SHAMPOO, CONDITIONER, POMADES AND FLORAL RINSES; SHAVING AND AFTERSHAVE PREPARATIONS; DENTIFRICES (U.S. CLS. 1, 4, 6, 50, 51 AND 52).

### CLASS 44—MEDICAL, BEAUTY AND AGRICULTURAL SERVICES

FOR BEAUTY TREATMENT SERVICES, NAMELY, PROVIDING A RANGE OF BEAUTY FACIAL TREATMENTS, HAIRDRESSING, MANICURE/PEDICURE, MASSAGE AND AROMATHERAPY SERVICES; BEAUTY SALON SERVICES; HAIRDRESSING SALON SERVICES; MANICURE AND PEDICURE SERVICES; SPA SERVICES, NAMELY, COSMETIC BODY CARE; SPA SERVICES, NAMELY, HEALTH SPA SERVICES FOR HEALTH AND WELLNESS OF THE BODY AND SPIRIT; AROMATHERAPY SERVICES; MASSAGE SERVICES; COSMETIC ELECTROLYSIS AND DEPILATORY HAIR REMOVAL SERVICES; PROVISION OF INFORMATION, CONSULTANCY AND ADVISORY SERVICES RELATING TO THE AFORESAID AND TO HEALTH CARE AND NUTRITION (U.S. CLS. 100 AND 101).

MATTHEW MCDOWELL, EXAMINING ATTORNEY

SN 86-138,400. AWC MANAGEMENT, LLC, GLENDALE, AZ.  
FILED 12-9-2013.



NO CLAIM IS MADE TO THE EXCLUSIVE RIGHT TO USE "AMERICAN" OR "CLINICS", APART FROM THE MARK AS SHOWN.

THE COLOR(S) TURQUOISE AND BLACK IS/ARE CLAIMED AS A FEATURE OF THE MARK.

THE MARK CONSISTS OF THE STYLIZED WORDS "AMERICAN WORLD CLINICS" IN BLACK WITH FOUR SWIRLING LINES IN TURQUOISE APPEARING ABOVE THE AFOREMENTIONED WORDS.

#### CLASS 35—ADVERTISING AND BUSINESS

FOR BUSINESS CONSULTING SERVICES; BUSINESS MANAGEMENT AND CONSULTING SERVICES FOR THE HEALTH CARE INDUSTRY, NAMELY, CUSTOMER SERVICE, ACCOUNTING SERVICES, AND MARKETING SERVICES (U.S. CLS. 100, 101 AND 102).

FIRST USE 11-0-2013; IN COMMERCE 11-0-2013.

#### CLASS 39—TRANSPORTATION AND STORAGE

FOR MEDICAL TOURISM SERVICES, NAMELY, MAKING TRANSPORTATION RESERVATIONS AND BOOKINGS FOR TRAVEL TO ANOTHER COUNTRY IN ORDER TO OBTAIN HEALTH CARE (U.S. CLS. 100 AND 105).

#### CLASS 44—MEDICAL, BEAUTY AND AGRICULTURAL SERVICES

FOR HEALTHCARE AND MEDICAL TOURISM SERVICES, NAMELY, ESTABLISHING AND MAINTAINING A HEALTHCARE PROVIDER NETWORK IN OTHER COUNTRIES FOR THE PROVISION OF HEALTHCARE SERVICES; MEDICAL SERVICES (U.S. CLS. 100 AND 101).

ALLISON SCHRODY, EXAMINING ATTORNEY

SN 86-138,575. OLIVER KÖNIG, DBA WINDFINDER, KIEL,  
FED REP GERMANY, FILED 12-9-2013.



OWNER OF U.S. REG. NO. 4,329,843.

NO CLAIM IS MADE TO THE EXCLUSIVE RIGHT TO USE "WINDFINDER.COM", APART FROM THE MARK AS SHOWN.

THE COLOR(S) RED AND WHITE IS/ARE CLAIMED AS A FEATURE OF THE MARK.

THE MARK CONSISTS OF THE STYLIZED WORDING "WINDFINDER" IN RED, TO THE LEFT OF A RED TRIANGULAR DESIGN CONTAINING THE WORDING ".COM" IN WHITE BENEATH A DESIGN OF A THREE-BLADE FAN IN WHITE.

#### CLASS 9—ELECTRICAL AND SCIENTIFIC APPARATUS

FOR COMPUTER APPLICATION SOFTWARE FOR MOBILE PHONES, NAMELY, SOFTWARE FOR WIND AND WEATHER FORECASTING; DOWNLOADABLE DOCUMENTS IN THE FIELD OF WIND AND WEATHER FORECASTS PROVIDED VIA A WEBSITE; DOWNLOADABLE MOBILE APPLICATIONS FOR THE ACCESS OF INFORMATION RELATED TO WIND AND WEATHER FORECASTS (U.S. CLS. 21, 23, 26, 36 AND 38).

FIRST USE 6-1-2012; IN COMMERCE 6-1-2012.

#### CLASS 41—EDUCATION AND ENTERTAINMENT

FOR EDUCATIONAL SERVICES, NAMELY, PROVIDING ONLINE INSTRUCTION IN THE FIELD OF WIND AND WEATHER FORECASTING FOR THE PURPOSES OF USE BY WINDSURFERS, KITESURFERS, SURFERS, SNOWKITERS, SAILORS, PARAGLIDERS AND OTHER WIND AND WAVE RELATED OUTDOOR ACTIVITIES VIA AN ONLINE WEBSITE (U.S. CLS. 100, 101 AND 107).

MELISSA VALLILLO, EXAMINING ATTORNEY

SN 86-139,429. ULTRAWAVE TECHNOLOGY FOR EMULSION CONTROL LLC, DBA ULTRATEC LLC, HOUSTON, TX. FILED 12-10-2013.

# ULTRATEC

THE MARK CONSISTS OF STANDARD CHARACTERS WITHOUT CLAIM TO ANY PARTICULAR FONT, STYLE, SIZE, OR COLOR.

#### CLASS 7—MACHINERY

FOR APPARATUS FOR OIL RECLAMATION FOR THE SEPARATION OF OIL FROM WATER (U.S. CLS. 13, 19, 21, 23, 31, 34 AND 35).

#### CLASS 37—CONSTRUCTION AND REPAIR

FOR EXTRACTION OF OIL (U.S. CLS. 100, 103 AND 106).

#### CLASS 40—MATERIAL TREATMENT

FOR RECLAMATION PROCESS FOR THE SEPARATION OF OIL FROM WATER (U.S. CLS. 100, 103 AND 106).

JASON TURNER, EXAMINING ATTORNEY

SN 86-139,700. LIBERTY UNIVERSITY, LYNCHBURG, VA.  
FILED 12-10-2013.

SN 86-140,000. SUTRO BIOPHARMA, INC., SOUTH SAN  
FRANCISCO, CA. FILED 12-10-2013.



OWNER OF U.S. REG. NO. 3,973,164.  
NO CLAIM IS MADE TO THE EXCLUSIVE RIGHT TO  
USE "SPORTS NETWORK", APART FROM THE MARK AS  
SHOWN.

THE MARK CONSISTS OF THE STYLIZED WORDING  
"LIBERTY FLAMES" STACKED ABOVE THE STYLIZED  
LETTERS "LFSN". DIRECTLY BELOW IS THE STYLIZED  
WORDING "SPORTS NETWORK" APPEARING IN A REC-  
TANGULAR BAR.

#### CLASS 38—COMMUNICATION

FOR AUDIO AND VIDEO BROADCASTING SERVICES  
OVER THE INTERNET; BROADCAST OF CABLE TELE-  
VISION PROGRAMMES; BROADCASTING OF RADIO  
AND TELEVISION PROGRAMMES; BROADCASTING  
OF VIDEO AND AUDIO PROGRAMMING OVER THE  
INTERNET; ELECTRONIC TRANSMISSION OF VOICE,  
DATA AND IMAGES BY TELEVISION AND VIDEO  
BROADCASTING; INTERNET BROADCASTING SER-  
VICES; SATELLITE TELEVISION BROADCASTING;  
TELEVISION AND RADIO BROADCASTING SERVICES  
(U.S. CLS. 100, 101 AND 104).

FIRST USE 2-25-2013, THE MARK WAS FIRST USED  
ANYWHERE IN A DIFFERENT FORM OTHER THAN  
THAT SOUGHT TO BE REGISTERED AT LEAST AS EARLY  
AS 12/01/2007; IN COMMERCE 2-25-2013, THE MARK WAS  
FIRST USED IN COMMERCE IN A DIFFERENT FORM  
OTHER THAN THAT SOUGHT TO BE REGISTERED AT  
LEAST AS EARLY AS 02/01/2008.

#### CLASS 41—EDUCATION AND ENTERTAIN- MENT

FOR EDUCATING AT UNIVERSITY OR COLLEGES;  
EDUCATION AND ENTERTAINMENT SERVICES;  
NAMELY, ONGOING TELEVISION PUBLIC SERVICE  
ANNOUNCEMENTS AND ONGOING TELEVISION PRO-  
GRAMS IN THE FIELD OF COLLEGE ATHLETICS;  
EDUCATION SERVICES IN THE NATURE OF COURSES  
AT THE UNIVERSITY LEVEL; EDUCATION SERVICES,  
NAMELY, PROVIDING JOURNALISM COURSES IN  
THE FIELD OF MEDIA COVERAGE OF COLLEGE  
ATHLETIC EVENTS; PROVIDING MEDIA COVERAGE  
IN THE FIELD OF COLLEGE ATHLETICS, NAMELY,  
NEWS AND PLAY-BY-PLAY REPORTING ABOUT COL-  
LEGE ATHLETICS; EDUCATIONAL SERVICES,  
NAMELY, CONDUCTING PROGRAMS IN THE FIELD  
OF COLLEGE ATHLETICS; ENTERTAINMENT AND  
EDUCATIONAL SERVICES IN THE NATURE OF COM-  
PETITIONS IN THE FIELD OF ENTERTAINMENT,  
EDUCATION, CULTURE, SPORTS, AND OTHER NON-  
BUSINESS AND NON-COMMERCIAL FIELDS; PHYSI-  
CAL EDUCATION SERVICES (U.S. CLS. 100, 101 AND  
107).

FIRST USE 2-25-2013, THE MARK WAS FIRST USED  
ANYWHERE IN A DIFFERENT FORM OTHER THAN  
THAT SOUGHT TO BE REGISTERED AT LEAST AS EARLY  
AS 12/01/2007; IN COMMERCE 2-25-2013, THE MARK WAS  
FIRST USED IN COMMERCE IN A DIFFERENT FORM  
OTHER THAN THAT SOUGHT TO BE REGISTERED AT  
LEAST AS EARLY AS 02/01/2008.

ALLISON SCHRODY, EXAMINING ATTORNEY

## XPRESS CF+

THE MARK CONSISTS OF STANDARD CHARACTERS  
WITHOUT CLAIM TO ANY PARTICULAR FONT, STYLE,  
SIZE, OR COLOR.

#### CLASS 40—MATERIAL TREATMENT

FOR CUSTOMIZED MANUFACTURE OF THERAPEU-  
TIC PROTEINS FOR THE TREATMENT OR PREVEN-  
TION OF DISEASES BY PHARMACEUTICAL  
COMPOUNDERS (U.S. CLS. 100, 103 AND 106).

#### CLASS 42—SCIENTIFIC AND COMPUTER SERVICES

FOR DRUG DISCOVERY SERVICES FEATURING  
THERAPEUTIC PROTEINS FOR THE TREATMENT OR  
PREVENTION OF DISEASES; CUSTOM DESIGN AND  
DEVELOPMENT OF THERAPEUTIC PROTEINS FOR  
THE TREATMENT OR PREVENTION OF DISEASES  
(U.S. CLS. 100 AND 101).

NAKIA HENRY, EXAMINING ATTORNEY

SN 86-140,663. ORIGIN ELECTRIC CO., LTD., TOKYO,  
JAPAN, FILED 12-11-2013.

## DUONET

THE MARK CONSISTS OF STANDARD CHARACTERS  
WITHOUT CLAIM TO ANY PARTICULAR FONT, STYLE,  
SIZE, OR COLOR.

#### CLASS 1—CHEMICALS

FOR PLASTIC ADHESIVES NOT FOR STATIONERY  
OR HOUSEHOLD PURPOSES; ADHESIVES FOR INDUS-  
TRIAL USE; HARDENING PREPARATIONS, NAMELY,  
COATINGS IN THE NATURE OF INDUSTRIAL SEAL-  
ANTS FOR WATERPROOFING AND HARDENING;  
HARDENING CATALYZER, NAMELY, CATALYSTS  
FOR USE IN THE MANUFACTURE OF INDUSTRIAL  
CHEMICALS, NAMELY, FOR HARDENING COATED  
FILM, ADHESIVES FOR INDUSTRIAL USE; RESIN  
HARDENERS, NAMELY, CHEMICAL PREPARATIONS  
FOR HARDENING RESINS FOR USE IN COATINGS;  
PAINT HARDENERS, NAMELY, CHEMICAL PREPARA-  
TIONS FOR USE IN THE MANUFACTURE OF PAINTS;  
PRIMING PUTTY, NAMELY, GLAZIERS PUTTY (U.S.  
CLS. 1, 5, 6, 10, 26 AND 46).

**CLASS 2—PAINTS**

FOR PAINTS; SYNTHETIC RESIN PAINTS; WATER-BASED METALLIC COATINGS IN THE FORM OF SPRAYS AND LIQUID GELS FOR COATING AUTOMOBILES, HOME ELECTRONICS, CELL-PHONES, BUILDINGS; SOLVENT-BASED PAINTS; DUAL CURE PAINTS; TWO-STEP HARDENER PAINTS; DYESTUFFS; PIGMENTS; COPAL; SANDARAC; SHELLAC; DAMMAR; MASTIC; PINE GUM; WOOD PRESERVATIVES; PRINTING INK; NONFERROUS METALS IN FOIL OR POWDER FORM FOR PAINTERS, DECORATORS, PRINTERS AND ARTISTS; PRECIOUS METALS IN FOIL OR POWDER FORM FOR PAINTERS, DECORATORS, PRINTERS AND ARTISTS; PAINT THINNERS (U.S. CLS. 6, 11 AND 16).

**CLASS 17—RUBBER GOODS**

FOR ELECTRICAL INSULATING PAINTS; INSULATING RESIN PAINTS (U.S. CLS. 1, 5, 12, 13, 35 AND 50).  
DORITT L. CARROLL, EXAMINING ATTORNEY

SN 86-140,818. PRONOVA SOLUTIONS, LLC, KNOXVILLE, TN. FILED 12-11-2013.

# PRONOVA

THE MARK CONSISTS OF STANDARD CHARACTERS WITHOUT CLAIM TO ANY PARTICULAR FONT, STYLE, SIZE, OR COLOR.

**CLASS 10—MEDICAL APPARATUS**

FOR MEDICAL APPARATUS FOR ADMINISTERING PROTON THERAPY USED IN THE TREATMENT OF CANCER (U.S. CLS. 26, 39 AND 44).

**CLASS 44—MEDICAL, BEAUTY AND AGRICULTURAL SERVICES**

FOR MEDICAL AND HEALTHCARE SERVICES (U.S. CLS. 100 AND 101).  
SKYE YOUNG, EXAMINING ATTORNEY

SN 86-141,000. TENNENBAUM, PETER, ROCHESTER, NY, AND TENNENBAUM, JACQUELINE, ROCHESTER, NY. FILED 12-11-2013.

## Sex, Drugs and Rocket Science

THE MARK CONSISTS OF STANDARD CHARACTERS WITHOUT CLAIM TO ANY PARTICULAR FONT, STYLE, SIZE, OR COLOR.

**CLASS 9—ELECTRICAL AND SCIENTIFIC APPARATUS**

FOR DOWNLOADABLE E-BOOKS IN THE FIELD OF SCIENCE AND HUMAN RELATIONS (U.S. CLS. 21, 23, 26, 36 AND 38).

**CLASS 16—PAPER GOODS AND PRINTED MATTER**

FOR BOOKS IN THE FIELD OF SCIENCE AND HUMAN RELATIONS (U.S. CLS. 2, 5, 22, 23, 29, 37, 38 AND 50).

JASON TURNER, EXAMINING ATTORNEY

SN 86-142,176. TRUPOINTE COOPERATIVE, INC., PICQUA, OH. FILED 12-12-2013.

### CUSTOMER DRIVEN. SHARED SUCCESS.

THE MARK CONSISTS OF STANDARD CHARACTERS WITHOUT CLAIM TO ANY PARTICULAR FONT, STYLE, SIZE, OR COLOR.

**CLASS 35—ADVERTISING AND BUSINESS**

FOR PROMOTING THE GOODS OF OTHERS, NAMELY, GRAIN MARKETING SERVICES FOR AGRICULTURAL PRODUCERS OF WHEAT, OATS, CORN, SOYBEANS, AND GRAINS FOR ANIMAL FEED; WHOLESALE DISTRIBUTORSHIP SERVICES OF GRAIN IN THE NATURE OF CORN, SOYBEANS, WHEAT, AND OATS, AND PETROLEUM PRODUCTS IN THE NATURE OF GASOLINE, DIESEL FUEL, LIGHT DISTILLATE HEATING OIL, PROPANE, AND LUBRICANTS; RETAIL DISTRIBUTORSHIP SERVICES FOR ANIMAL FEED, AGRICULTURAL SEED, AGRICULTURAL FERTILIZER, AGRICULTURAL CHEMICALS, GASOLINE, DIESEL FUEL, LIGHT DISTILLATE HEATING OIL AND PROPANE; RETAIL STORES FEATURING FARM SUPPLIES IN THE NATURE OF (A) FENCE, ANIMAL FEEDERS, WORK CLOTHING, AND LIVESTOCK HOUSING, (B) PACKAGED ANIMAL FEED, AGRICULTURAL CHEMICALS, SEED, FERTILIZER, (C) PETROLEUM PRODUCTS IN THE NATURE OF KEROSENE, PROPANE, AND LUBRICANTS, AND (D) TOOLS AND HARDWARE RELATED TO THESE FARM SUPPLIES; AND AGRICULTURAL BUSINESS CONSULTATION, NAMELY, PROVIDING INFORMATION ON MARKETING OF AGRICULTURAL COMMODITIES (U.S. CLS. 100, 101 AND 102).

FIRST USE 0-0-2012; IN COMMERCE 0-0-2012.

**CLASS 39—TRANSPORTATION AND STORAGE**

FOR BULK DELIVERY OF GASOLINE, DIESEL FUEL, LIGHT DISTILLATE HEATING OIL, PROPANE AND PETROLEUM PRODUCTS TO AGRICULTURAL, COMMERCIAL AND RESIDENTIAL CUSTOMERS; BULK DELIVERY OF CROP INPUT PRODUCTS TO AGRICULTURAL CUSTOMERS; TRANSPORTATION OF GRAIN, ANIMAL FEED, FARM SUPPLY PRODUCTS AND PROCESSED AGRICULTURAL COMMODITIES; GRAIN STORAGE FOR AGRICULTURAL PRODUCERS OF WHEAT, OATS, AND OTHER SMALL GRAINS AND CORN, SOYBEANS AND OTHER FEED GRAINS; AND WAREHOUSING SERVICES, NAMELY, GRAIN HANDLING SERVICES FOR AGRICULTURAL PRODUCERS OF WHEAT, OATS, AND OTHER SMALL GRAINS AND CORN, SOYBEANS AND OTHER FEED GRAINS (U.S. CLS. 100 AND 105).

FIRST USE 0-0-2012; IN COMMERCE 0-0-2012.  
LAURIE MAYES, EXAMINING ATTORNEY

SN 86-142,826. TRITON MEDIA, LLC, SHERMAN OAKS, CA.  
FILED 12-13-2013.

## TRITON DIGITAL

THE MARK CONSISTS OF STANDARD CHARACTERS WITHOUT CLAIM TO ANY PARTICULAR FONT, STYLE, SIZE, OR COLOR.

OWNER OF U.S. REG. NOS. 3,333,808, 4,287,580 AND 4,500,367.

NO CLAIM IS MADE TO THE EXCLUSIVE RIGHT TO USE "DIGITAL", APART FROM THE MARK AS SHOWN.

### CLASS 9—ELECTRICAL AND SCIENTIFIC APPARATUS

FOR DOWNLOADABLE SOFTWARE USED FOR STREAMING OF AUDIO, VISUAL, AND AUDIOVISUAL MATERIAL VIA A GLOBAL COMPUTER NETWORK OR THE INTERNET; DOWNLOADABLE SOFTWARE FOR THE TRANSMISSION OF MEDIA SIGNALS ON THE INTERNET AND FOR CONFIGURATION AND MANAGEMENT OF CONTENT ENCODING AND CONTENT REPLACEMENT; DOWNLOADABLE SOFTWARE FOR USE IN CREATING AND MANAGING CUSTOM SIDE CHANNELS FOR AUDIO PUBLISHERS (U.S. CLS. 21, 23, 26, 36 AND 38).

FIRST USE 9-0-2011; IN COMMERCE 9-0-2011.

### CLASS 35—ADVERTISING AND BUSINESS

FOR DEVELOPING AND PLACING ADVERTISEMENTS FOR OTHERS IN THE FIELDS OF SWEEPSTAKES, CONTESTS, INCENTIVE AWARD POINTS, MARKETING REFERRAL PROGRAMS, FAN ENGAGEMENT PROGRAMS, COUPONS, AND PROMOTIONAL PRODUCTS; BUSINESS SERVICES, NAMELY, PROVIDING, DISTRIBUTING, DELIVERING, MANAGING, AND MEASURING DIGITAL AUDIO AND VISUAL ADVERTISING INVENTORY; ADVERTISING AND PUBLICITY SERVICES, NAMELY, PROMOTING THE GOODS, SERVICES, BRAND IDENTITY, AND COMMERCIAL INFORMATION AND NEWS OF THIRD PARTIES THROUGH AUDIO, VISUAL, VIDEO, MOBILE, DIGITAL, AND ONLINE MEDIUMS; PROVIDING FORECASTING AND CAMPAIGN DELIVERY INFORMATION AND ANALYSIS, NAMELY, POST IMPRESSION RESPONSE TRACKING FOR BOTH AUDIO AND VISUAL CAMPAIGNS, AUDIENCE FORECASTING, TRACKING AND REPORTS; BUSINESS CONSULTING AND INFORMATION SERVICES FOR BROADCASTERS AND ONLINE CONTENT PROVIDERS; OPERATING AN ON-LINE MARKETPLACE FOR SELLERS AND BUYERS OF DIGITAL AUDIO INVENTORY FOR THE PURPOSE OF DELIVERING ADVERTISING CAMPAIGNS (U.S. CLS. 100, 101 AND 102).

FIRST USE 8-0-2009; IN COMMERCE 8-0-2009.

### CLASS 36—INSURANCE AND FINANCIAL

FOR PROVIDING FINANCIAL INFORMATION, NAMELY, PROVIDING AN INFORMATION DATABASE THAT FEATURES LISTS OF BID AND OFFER VALUES USED FOR THE PURCHASE OF ADVERTISING CAMPAIGNS AND SALE OF ADVERTISING INVENTORY OF THIRD PARTIES (U.S. CLS. 100, 101 AND 102).

FIRST USE 1-17-2013; IN COMMERCE 1-17-2013.

### CLASS 38—COMMUNICATION

FOR STREAMING OF AUDIO, VISUAL, AND AUDIOVISUAL MATERIAL VIA A GLOBAL COMPUTER NETWORK AND THE INTERNET; MEDIA DISTRIBUTION AND TECHNOLOGY SERVICES, NAMELY, ELECTRONIC TRANSMISSION OF AUDIO, VIDEO CONTENT AND DATA, VIA A GLOBAL COMPUTER NETWORK AND THE INTERNET; ELECTRONIC TRANSMISSION AND STREAMING OF AUDIO, AUDIOVISUAL, DIGITAL MEDIA CONTENT AND MEDIA ADVERTISING COMMUNICATIONS VIA COMPUTER NETWORKS AND GLOBAL COMMUNICATION NETWORKS (U.S. CLS. 100, 101 AND 104).

FIRST USE 3-13-2011; IN COMMERCE 3-13-2011.

### CLASS 42—SCIENTIFIC AND COMPUTER SERVICES

FOR DEVELOPING AND DESIGNING COMPUTER SOFTWARE AS A SERVICE FOR ADVERTISING DISTRIBUTIONS AND OTHER INTERACTIVE SERVICES, NAMELY, EMAIL MARKETING, INCENTIVIZED PROMOTIONS, CONTENT MANAGEMENT SURVEYS, GAME MECHANICS, CONTESTS AND SWEEPSTAKES; SOFTWARE AS A SERVICE (SAAS) FOR MANAGING CONTENT OF ELECTRONIC COMMUNICATIONS, NAMELY, FOR PERSONALIZING AND TARGETING THE CONTENT OF ELECTRONIC COMMUNICATIONS; SOFTWARE AS A SERVICE (SAAS) USED FOR PROMOTING THE GOODS AND SERVICES OF OTHERS THROUGH THE DEVELOPMENT AND IMPLEMENTATION OF ONLINE GAMES, GAME MECHANICS, SURVEYS, MUSIC TESTS, POOLED AND CUSTOM SWEEPSTAKES, CONTESTS, AWARDED POINTS, MARKETING REFERRAL PROGRAMS, COUPONS AND PROMOTIONAL PRODUCTS; SOFTWARE AS A SERVICE (SAAS) USED FOR COMPILING AND ANALYZING THE DATA GATHERED FROM PARTICIPANTS IN SURVEYS, MUSIC TESTS, SWEEPSTAKES, CONTESTS, INCENTIVE AWARD POINTS, GAME MECHANICS, MARKETING REFERRAL PROGRAMS, COUPONS, AND PROMOTIONAL PRODUCTS; SOFTWARE AS A SERVICE (SAAS) USED FOR PROVIDING A POINTS-BASED LOYALTY PROGRAM THAT REWARDS BROADCASTERS' AUDIENCES FOR SUPPORTING THE STATION AND ADVERTISERS; SOFTWARE AS A SERVICE (SAAS) USED FOR PROMOTING THE GOODS AND SERVICES OF OTHERS THROUGH THE DEVELOPMENT AND MANAGEMENT OF PROGRAMS FEATURING GAME MECHANICS, SOCIAL NETWORKING CONSTRUCTS AND ACTIVITY-DRIVEN AFFINITY PROGRAMS, NAMELY, INCENTIVE AWARD PROGRAMS; PROVIDING TEMPORARY USE OF NON-DOWNLOADABLE COMPUTER SOFTWARE ENABLING MARKET RESEARCH AND CONSUMER RESEARCH FOR THE RADIO AND INTERNET STREAMING MEDIA INDUSTRY AND PRINT INDUSTRIES; COMPUTER SERVICES, NAMELY, SOFTWARE AS A SERVICE (SAAS) USED FOR CREATING, MANAGING, AND PUBLISHING ONLINE SURVEYS; COMPUTER SERVICES, NAMELY, SOFTWARE AS A SERVICE (SAAS), ALLOWING USERS TO CREATE AND PUBLISH ONLINE CONTESTS AND SWEEPSTAKES AND TO MANAGE PROMOTIONS OF SERVICES AND GOODS; COMPUTER SERVICES, NAMELY, SOFTWARE AS A SERVICE (SAAS), USED FOR PROVIDING REWARDS PROGRAMS FOR VISITING AND ENGAGING WITH A WEBSITE; COMPUTER SERVICES, NAMELY, SOFTWARE AS A SERVICE (SAAS) USED TO GROW ONLINE TRAFFIC, PAGE VIEWS, USER REGISTRATIONS, AND INCREASED AUDIENCE ENGAGEMENT; APPLICATION SERVICE PROVIDER FEATURING APPLICATION PROGRAMMING INTERFACE (API) SOFTWARE FOR INTEGRATING SOCIAL INTERACTION, GAMING, AND AUDIENCE INCENTIVES INTO WEBSITES; SOFTWARE AS A SERVICE (SAAS) FEATURING SOFTWARE FOR USE IN MANAGING AND TRACKING AUDIENCE REGISTRATIONS AND DATA, ANALYZING DEMOGRAPHICS, AND BUILDING AUDIENCE LISTS BASED ON THOSE DEMOGRAPHICS; PROVIDING TEMPORARY USE OF A WEB-BASED NON-DOWNLOADABLE SOFTWARE APPLICATION FOR COLLECTING, MEASURING AND DELIVERING REAL TIME AUDIENCE DATA, REPORTS FOR INTERNET RADIO AND INTERNET STREAMING MEDIA FEATURING THE NUMBER OF AUDIENCE MEMBERS, DURATION OF STREAMING AND TRANSLATING THEM INTO AUDIENCE

MEASUREMENT METRICS; PROVIDING TEMPORARY USE OF ON-LINE NON-DOWNLOADABLE SOFTWARE AND APPLICATIONS FOR PLAYING AUDIO AND VIDEO CONTENT ON A MULTIMEDIA DEVICE; DESIGNING USER INTERFACE SOFTWARE FOR MULTIMEDIA PLAYERS; DEVELOPING AND DESIGNING MOBILE APPLICATIONS AND SOFTWARE PLATFORMS FOR STREAMING AUDIO AND VIDEO CONTENT AND ADVERTISEMENTS TO MOBILE DEVICES; PROVIDING TEMPORARY USE OF ON-LINE NON-DOWNLOADABLE SOFTWARE AND APPLICATIONS FOR PROVIDING MANAGEMENT SERVICES FOR ADVERTISEMENT AND MARKETING PURPOSES, NAMELY, ADVERTISING PLACEMENT, DELIVERY, BILLING, TRACKING, OPTIMIZATION AND REPORTING; PROVIDING TEMPORARY USE OF ON-LINE NON-DOWNLOADABLE SOFTWARE AND APPLICATIONS FOR COLLECTING, MEASURING, TRACKING, MONITORING, MANAGING, ANALYZING AND REPORTING AUDIO AND VIDEO TRAFFIC DATA OF AUDIENCES; PROVIDING TEMPORARY USE OF ON-LINE NON-DOWNLOADABLE SOFTWARE AND APPLICATIONS FOR COLLECTING, MEASURING, TRACKING, MONITORING, MANAGING, ANALYZING AND REPORTING DEMOGRAPHICS, AUDIENCE BEHAVIORAL INFORMATION, E-COMMERCE ACTIVITY, COMPUTER NETWORK USE AND AUDIENCE RESPONSES TO INTERNET AND AUDIO VIDEO CAMPAIGNS AND DATA; PROVIDING TEMPORARY USE OF ON-LINE NON-DOWNLOADABLE SOFTWARE AND APPLICATIONS FOR ALLOWING THE INSERTION AND REPLACEMENT OF ADVERTISEMENTS WITHIN AN AUDIO OR VIDEO STREAM FOR A GLOBAL AND TARGETED AUDIENCE; WEBSITE AND MEDIA CONTENT MANAGEMENT SERVICES FEATURING NON-DOWNLOADABLE SOFTWARE APPLICATIONS FOR USE IN CREATING, DESIGNING, HOSTING, PUBLISHING, MANAGING AND MAINTAINING CONTENT FOR USE ON THE INTERNET; PROVIDING TEMPORARY USE OF NON-DOWNLOADABLE COMPUTER SOFTWARE FOR USE IN DIGITAL MEDIA MEASUREMENT, WEBSITE AUDIENCE ANALYSIS AND ADVERTISING OPTIMIZATION WHICH TRACKS, MANAGES, MONITORS, ANALYZES AND OPTIMIZES THE PERFORMANCE AND EFFECTIVENESS OF INTERNET VIDEO AND AUDIO CAMPAIGNS AND DATA; COMPUTER SERVICES, NAMELY, SOFTWARE AS A SERVICE (SAAS) USED FOR ANALYZING, COLLECTING, AND REPORTING AUDIENCE DATA; SOFTWARE AS A SERVICE (SAAS) FEATURING SOFTWARE FOR USE IN MANAGING AND SCHEDULING EVENTS, CONTESTS AND PROMOTIONS OF THIRD PARTIES; PROVIDING TEMPORARY USE OF ONLINE NON-DOWNLOADABLE COMPUTER SOFTWARE FOR USE IN PROVIDING A COMPILATION OF REPORTS AND AUDIENCE DATA RELATING TO THE ACCESS, USE, TRANSMISSION AND PERFORMANCE OF THIRD PARTY MATERIAL (U.S. CLS. 100 AND 101).

FIRST USE 8-0-2009; IN COMMERCE 8-0-2009.

#### **CLASS 45—PERSONAL AND LEGAL SERVICES**

FOR LICENSING OF PLAYER FUNCTIONALITIES FOR INTERACTIVE SERVICES, NAMELY, FOR CONTENT DISPLAY AND ADVERTISING DISTRIBUTION OF OTHERS; LICENSING MOBILE APPLICATIONS AND PLATFORMS FOR STREAMING AUDIO AND VIDEO CONTENT AND ADVERTISEMENTS TO MOBILE SERVICES (U.S. CLS. 100 AND 101).

FIRST USE 3-13-2011; IN COMMERCE 3-13-2011.  
PATRICIA EVANKO, EXAMINING ATTORNEY

SN 86-142,827. TRITON MEDIA, LLC, SHERMAN OAKS, CA.  
FILED 12-13-2013.



OWNER OF U.S. REG. NO. 4,287,580.

THE MARK CONSISTS OF THREE, THREE DIMENSIONAL STYLE OVALS CREATING A CIRCULAR PATTERN.

#### **CLASS 9—ELECTRICAL AND SCIENTIFIC APPARATUS**

FOR DOWNLOADABLE SOFTWARE USED FOR STREAMING OF AUDIO, VISUAL, AND AUDIOVISUAL MATERIAL VIA A GLOBAL COMPUTER NETWORK OR THE INTERNET; DOWNLOADABLE SOFTWARE FOR THE TRANSMISSION OF MEDIA SIGNALS ON THE INTERNET AND FOR CONFIGURATION AND MANAGEMENT OF CONTENT ENCODING AND CONTENT REPLACEMENT; DOWNLOADABLE SOFTWARE FOR USE IN CREATING AND MANAGING CUSTOM SIDE CHANNELS FOR AUDIO PUBLISHERS (U.S. CLS. 21, 23, 26, 36 AND 38).

FIRST USE 7-9-2013; IN COMMERCE 7-9-2013.

#### **CLASS 35—ADVERTISING AND BUSINESS**

FOR DEVELOPING AND PLACING ADVERTISEMENTS FOR OTHERS IN THE FIELDS OF SWEEPSTAKES, CONTESTS, INCENTIVE AWARD POINTS, MARKETING REFERRAL PROGRAMS, FAN ENGAGEMENT PROGRAMS, COUPONS, AND PROMOTIONAL PRODUCTS; BUSINESS SERVICES, NAMELY, PROVIDING, DISTRIBUTING, DELIVERING, MANAGING, AND MEASURING DIGITAL AUDIO AND VISUAL ADVERTISING INVENTORY; ADVERTISING AND PUBLICITY SERVICES, NAMELY, PROMOTING THE GOODS, SERVICES, BRAND IDENTITY, AND COMMERCIAL INFORMATION AND NEWS OF THIRD PARTIES THROUGH AUDIO, VISUAL, VIDEO, MOBILE, DIGITAL, AND ONLINE MEDIUMS; PROVIDING FORECASTING AND CAMPAIGN DELIVERY INFORMATION AND ANALYSIS, NAMELY, POST IMPRESSION RESPONSE TRACKING FOR BOTH AUDIO AND VISUAL CAMPAIGNS, AUDIENCE FORECASTING, TRACKING AND REPORTS; BUSINESS CONSULTING AND INFORMATION SERVICES FOR BROADCASTERS AND ONLINE CONTENT PROVIDERS; OPERATING AN ON-LINE MARKETPLACE FOR SELLERS AND BUYERS OF DIGITAL AUDIO INVENTORY FOR THE PURPOSE OF DELIVERING ADVERTISING CAMPAIGNS (U.S. CLS. 100, 101 AND 102).

FIRST USE 7-9-2013; IN COMMERCE 7-9-2013.

#### **CLASS 36—INSURANCE AND FINANCIAL**

FOR PROVIDING FINANCIAL INFORMATION, NAMELY, PROVIDING AN INFORMATION DATABASE THAT FEATURES LISTS OF BID AND OFFER VALUES USED FOR THE PURCHASE OF ADVERTISING CAMPAIGNS AND SALE OF ADVERTISING INVENTORY OF THIRD PARTIES (U.S. CLS. 100, 101 AND 102).

FIRST USE 7-9-2013; IN COMMERCE 7-9-2013.

**CLASS 38—COMMUNICATION**

FOR STREAMING OF AUDIO, VISUAL, AND AUDIO-VISUAL MATERIAL VIA A GLOBAL COMPUTER NETWORK AND THE INTERNET; MEDIA DISTRIBUTION AND TECHNOLOGY SERVICES, NAMELY, ELECTRONIC TRANSMISSION OF AUDIO, VIDEO CONTENT AND DATA, VIA A GLOBAL COMPUTER NETWORK AND THE INTERNET; ELECTRONIC TRANSMISSION AND STREAMING OF AUDIO, AUDIOVISUAL, DIGITAL MEDIA CONTENT AND MEDIA ADVERTISING COMMUNICATIONS VIA COMPUTER NETWORKS AND GLOBAL COMMUNICATION NETWORKS (U.S. CLS. 100, 101 AND 104).

FIRST USE 7-9-2013; IN COMMERCE 7-9-2013.

**CLASS 42—SCIENTIFIC AND COMPUTER SERVICES**

FOR DEVELOPING AND DESIGNING COMPUTER SOFTWARE AS A SERVICE FOR ADVERTISING DISTRIBUTIONS AND OTHER INTERACTIVE SERVICES, NAMELY, EMAIL MARKETING, INCENTIVIZED PROMOTIONS, CONTENT MANAGEMENT SURVEYS, GAME MECHANICS, CONTESTS AND SWEEPSTAKES; SOFTWARE AS A SERVICE (SAAS) FOR MANAGING CONTENT OF ELECTRONIC COMMUNICATIONS, NAMELY, FOR PERSONALIZING AND TARGETING THE CONTENT OF ELECTRONIC COMMUNICATIONS; SOFTWARE AS A SERVICE (SAAS) USED FOR PROMOTING THE GOODS AND SERVICES OF OTHERS THROUGH THE DEVELOPMENT AND IMPLEMENTATION OF ONLINE GAMES, GAME MECHANICS, SURVEYS, MUSIC TESTS, POOLED AND CUSTOM SWEEPSTAKES, CONTESTS, AWARDED POINTS, MARKETING REFERRAL PROGRAMS, COUPONS AND PROMOTIONAL PRODUCTS; SOFTWARE AS A SERVICE (SAAS) USED FOR COMPILING AND ANALYZING THE DATA GATHERED FROM PARTICIPANTS IN SURVEYS, MUSIC TESTS, SWEEPSTAKES, CONTESTS, INCENTIVE AWARD POINTS, GAME MECHANICS, MARKETING REFERRAL PROGRAMS, COUPONS, AND PROMOTIONAL PRODUCTS; SOFTWARE AS A SERVICE (SAAS) USED FOR PROVIDING A POINTS-BASED LOYALTY PROGRAM THAT REWARDS BROADCASTERS' AUDIENCES FOR SUPPORTING THE STATION AND ADVERTISERS; SOFTWARE AS A SERVICE (SAAS) USED FOR PROMOTING THE GOODS AND SERVICES OF OTHERS THROUGH THE DEVELOPMENT AND MANAGEMENT OF PROGRAMS FEATURING GAME MECHANICS, SOCIAL NETWORKING CONSTRUCTS AND ACTIVITY-DRIVEN AFFINITY PROGRAMS, NAMELY, INCENTIVE AWARD PROGRAMS; PROVIDING TEMPORARY USE OF NON-DOWNLOADABLE COMPUTER SOFTWARE ENABLING MARKET RESEARCH AND CONSUMER RESEARCH FOR THE RADIO AND INTERNET STREAMING MEDIA INDUSTRY AND PRINT INDUSTRIES; COMPUTER SERVICES, NAMELY, SOFTWARE AS A SERVICE (SAAS) USED FOR CREATING, MANAGING, AND PUBLISHING ONLINE SURVEYS; COMPUTER SERVICES, NAMELY, SOFTWARE AS A SERVICE (SAAS), ALLOWING USERS TO CREATE AND PUBLISH ONLINE CONTESTS AND SWEEPSTAKES AND TO MANAGE PROMOTIONS OF SERVICES AND GOODS; COMPUTER SERVICES, NAMELY, SOFTWARE AS A SERVICE (SAAS), USED FOR PROVIDING REWARDS PROGRAMS FOR VISITING AND ENGAGING WITH A WEBSITE; COMPUTER SERVICES, NAMELY, SOFTWARE AS A SERVICE (SAAS) USED TO GROW ONLINE TRAFFIC, PAGE VIEWS, USER REGISTRATIONS, AND INCREASED AUDIENCE ENGAGEMENT; APPLICATION SERVICE PROVIDER FEATURING APPLICATION PROGRAMMING INTERFACE (API) SOFTWARE FOR INTEGRATING SOCIAL INTERACTION, GAMING, AND AUDIENCE INCENTIVES INTO WEBSITES; SOFTWARE AS A SERVICE (SAAS) FEATURING SOFTWARE FOR USE IN MANAGING AND TRACKING AUDIENCE REGISTRATIONS AND DATA, ANALYZING DEMOGRAPHICS, AND BUILDING AUDIENCE LISTS BASED ON THOSE DEMOGRAPHICS; PROVIDING TEMPORARY USE OF A WEB-BASED NON-DOWNLOADABLE SOFTWARE APPLICATION FOR COLLECTING, MEASURING AND DELIVERING REAL TIME AUDIENCE DATA, REPORTS FOR INTERNET RADIO AND INTERNET STREAMING MEDIA FEATURING THE NUMBER OF AUDIENCE MEMBERS, DURATION OF STREAMING AND TRANSLATING THEM INTO AUDIENCE

MEASUREMENT METRICS; PROVIDING TEMPORARY USE OF ON-LINE NON-DOWNLOADABLE SOFTWARE AND APPLICATIONS FOR PLAYING AUDIO AND VIDEO CONTENT ON A MULTIMEDIA DEVICE; DESIGNING USER INTERFACE SOFTWARE FOR MULTIMEDIA PLAYERS; DEVELOPING AND DESIGNING MOBILE APPLICATIONS AND SOFTWARE PLATFORMS FOR STREAMING AUDIO AND VIDEO CONTENT AND ADVERTISEMENTS TO MOBILE DEVICES; PROVIDING TEMPORARY USE OF ON-LINE NON-DOWNLOADABLE SOFTWARE AND APPLICATIONS FOR PROVIDING MANAGEMENT SERVICES FOR ADVERTISEMENT AND MARKETING PURPOSES, NAMELY, ADVERTISING PLACEMENT, DELIVERY, BILLING, TRACKING, OPTIMIZATION AND REPORTING; PROVIDING TEMPORARY USE OF ON-LINE NON-DOWNLOADABLE SOFTWARE AND APPLICATIONS FOR COLLECTING, MEASURING, TRACKING, MONITORING, MANAGING, ANALYZING AND REPORTING AUDIO AND VIDEO TRAFFIC DATA OF AUDIENCES; PROVIDING TEMPORARY USE OF ON-LINE NON-DOWNLOADABLE SOFTWARE AND APPLICATIONS FOR COLLECTING, MEASURING, TRACKING, MONITORING, MANAGING, ANALYZING AND REPORTING DEMOGRAPHICS, AUDIENCE BEHAVIORAL INFORMATION, E-COMMERCE ACTIVITY, COMPUTER NETWORK USE AND AUDIENCE RESPONSES TO INTERNET AND AUDIO VIDEO CAMPAIGNS AND DATA; PROVIDING TEMPORARY USE OF ON-LINE NON-DOWNLOADABLE SOFTWARE AND APPLICATIONS FOR ALLOWING THE INSERTION AND REPLACEMENT OF ADVERTISEMENTS WITHIN AN AUDIO OR VIDEO STREAM FOR A GLOBAL AND TARGETED AUDIENCE; WEBSITE AND MEDIA CONTENT MANAGEMENT SERVICES FEATURING NON-DOWNLOADABLE SOFTWARE APPLICATIONS FOR USE IN CREATING, DESIGNING, HOSTING, PUBLISHING, MANAGING AND MAINTAINING CONTENT FOR USE ON THE INTERNET; PROVIDING TEMPORARY USE OF NON-DOWNLOADABLE COMPUTER SOFTWARE FOR USE IN DIGITAL MEDIA MEASUREMENT, WEBSITE AUDIENCE ANALYSIS AND ADVERTISING OPTIMIZATION WHICH TRACKS, MANAGES, MONITORS, ANALYZES AND OPTIMIZES THE PERFORMANCE AND EFFECTIVENESS OF INTERNET VIDEO AND AUDIO CAMPAIGNS AND DATA; COMPUTER SERVICES, NAMELY, SOFTWARE AS A SERVICE (SAAS) USED FOR ANALYZING, COLLECTING, AND REPORTING AUDIENCE DATA; SOFTWARE AS A SERVICE (SAAS) FEATURING SOFTWARE FOR USE IN MANAGING AND SCHEDULING EVENTS, CONTESTS AND PROMOTIONS OF THIRD PARTIES; PROVIDING TEMPORARY USE OF ONLINE NON-DOWNLOADABLE COMPUTER SOFTWARE FOR USE IN PROVIDING A COMPILATION OF REPORTS AND AUDIENCE DATA RELATING TO THE ACCESS, USE, TRANSMISSION AND PERFORMANCE OF THIRD PARTY MATERIAL (U.S. CLS. 100 AND 101).

FIRST USE 7-9-2013; IN COMMERCE 7-9-2013.

**CLASS 45—PERSONAL AND LEGAL SERVICES**

FOR LICENSING OF PLAYER FUNCTIONALITIES FOR INTERACTIVE SERVICES, NAMELY, FOR CONTENT DISPLAY AND ADVERTISING DISTRIBUTION OF OTHERS; LICENSING MOBILE APPLICATIONS AND PLATFORMS FOR STREAMING AUDIO AND VIDEO CONTENT AND ADVERTISEMENTS TO MOBILE SERVICES (U.S. CLS. 100 AND 101).

FIRST USE 7-9-2013; IN COMMERCE 7-9-2013.

PATRICIA EVANKO, EXAMINING ATTORNEY



SN 86-143,372. ZIH CORP., LINCOLNSHIRE, IL. FILED 12-13-2013.

# ZEBRA

THE MARK CONSISTS OF STANDARD CHARACTERS WITHOUT CLAIM TO ANY PARTICULAR FONT, STYLE, SIZE, OR COLOR.

OWNER OF U.S. REG. NOS. 2,173,307, 4,050,058 AND 4,128,951.

## CLASS 9—ELECTRICAL AND SCIENTIFIC APPARATUS

FOR COMPUTER SOFTWARE AND HARDWARE THAT ALLOWS REAL-TIME EXCHANGE OF INFORMATION WITH AND ACCESS TO INFORMATION FROM PEOPLE, DEVICES, MACHINES AND EQUIPMENT; COMPUTER SOFTWARE AND HARDWARE THAT ALLOWS VIEWING, ANALYZING, FILTERING AND MANAGING DATA FROM PEOPLE, DEVICES, MACHINES AND EQUIPMENT; COMPUTER SOFTWARE AND HARDWARE THAT ALLOWS REMOTE UPDATING, MANAGING AND CONFIGURING DEVICES, MACHINES AND EQUIPMENT; COMPUTER SOFTWARE AND HARDWARE USED TO BUILD LOGICAL WORKFLOW FROM DATA; COMPUTER SOFTWARE AND HARDWARE USED TO TRANSFER INFORMATION TO DEVICES WIRELESSLY AND MANAGE WIRELESS DEVICES (U.S. CLS. 21, 23, 26, 36 AND 38).

## CLASS 37—CONSTRUCTION AND REPAIR

FOR CONSULTANCY SERVICES IN THE NATURE OF ADVISING AND ASSISTING WITH INSTALLATION, MODIFICATION AND MAINTENANCE OF COMPUTER HARDWARE THAT ALLOWS REAL-TIME EXCHANGE OF INFORMATION WITH AND ACCESS TO INFORMATION FROM PEOPLE, DEVICES, MACHINES AND EQUIPMENT AND APPLICATIONS THAT INTERACT WITH THAT DATA (U.S. CLS. 100, 103 AND 106).

## CLASS 42—SCIENTIFIC AND COMPUTER SERVICES

FOR SOFTWARE AS A SERVICE (SAAS) SERVICES, NAMELY, HOSTING SOFTWARE THAT ALLOWS REAL-TIME EXCHANGE OF INFORMATION WITH AND ACCESS TO INFORMATION FROM PEOPLE, DEVICES, MACHINES AND EQUIPMENT AND SOFTWARE APPLICATIONS THAT INTERACT WITH THAT DATA; COMPUTER SOFTWARE DEVELOPMENT SERVICES AND COMPUTER CONSULTING SERVICES FOR BUSINESSES; REMOTE MANAGEMENT AND HOSTING OF COMPUTER APPLICATIONS FOR OTHERS; CONSULTANCY SERVICES FOR THE DESIGN, SELECTION, IMPLEMENTATION, MODIFICATION, MAINTENANCE AND USE OF COMPUTER SOFTWARE SYSTEMS; TECHNICAL ADVICE RELATED TO THE INSTALLATION OF COMPUTER SOFTWARE; TECHNICAL SUPPORT SERVICES, NAMELY, TROUBLESHOOTING IN THE NATURE OF DIAGNOSING COMPUTER HARDWARE AND SOFTWARE PROBLEMS; COMPUTER DIAGNOSTIC SERVICES; CONSULTANCY SERVICES IN THE NATURE OF ADVISING AND ASSISTING WITH THE IMPLEMENTATION, INSTALLATION, CONFIGURATION, MODIFICATION AND MAINTENANCE OF COMPUTER SOFTWARE THAT ALLOWS REAL-TIME EXCHANGE OF INFORMATION WITH AND ACCESS TO INFORMATION FROM PEOPLE, DEVICES, MACHINES AND EQUIPMENT AND APPLICATIONS THAT INTERACT WITH THAT DATA. AS WELL AS ADVISING AND ASSISTING WITH THE IMPLEMENTATION AND CONFIGURATION OF COMPUTER HARDWARE THAT ALLOWS REAL-TIME EXCHANGE OF INFORMATION WITH AND ACCESS TO INFORMATION FROM PEOPLE, DEVICES, MACHINES AND EQUIPMENT AND

APPLICATIONS THAT INTERACT WITH THAT DATA; PROVIDING A WEBSITE FEATURING NON-DOWNLOADABLE SOFTWARE FOR ALLOWING USERS AND SOFTWARE APPLICATIONS TO INTERFACE WITH AND MANAGE PEOPLE, DEVICES, MACHINES AND EQUIPMENT AND TO PROVIDE MESSAGING, MANAGEMENT AND MEMORY STORAGE SERVICES; CONSULTING WITH REGARD TO COMPUTER SYSTEMS, COMPUTER NETWORK CONNECTIVITY, AND SOFTWARE APPLICATIONS DESIGN AND DEPLOYMENT; COMPUTER SOFTWARE SERVICES, NAMELY, DEVELOPMENT, MAINTENANCE, REPAIR, AND INSTALLATION OF COMPUTER SOFTWARE, AND TROUBLESHOOTING OF COMPUTER SOFTWARE PROBLEMS; TECHNICAL SUPPORT SERVICES IN THE NATURE OF DIAGNOSING COMPUTER SOFTWARE PROBLEMS; UPGRADE AND UPDATING OF COMPUTER SOFTWARE; AUTHORING, DESIGN AND CUSTOMIZATION OF COMPUTER SOFTWARE AND MIDDLEWARE; PROVIDING INFORMATION IN THE FIELD OF COMPUTER SOFTWARE AND MIDDLEWARE DEVELOPMENT VIA AN ON-LINE WEBSITE; COMPUTER SOFTWARE CONSULTATION IN THE FIELD OF COMPUTER SOFTWARE AND MIDDLEWARE; SUPPORT SERVICES WITH REGARD TO COMPUTER SYSTEMS, COMPUTER NETWORK CONNECTIVITY HARDWARE AND COMPUTER, NAMELY, TROUBLESHOOTING AND DIAGNOSING OF PROBLEMS; COMPUTER SERVICES, NAMELY, PROVIDING REMOTE MANAGEMENT OF REMOTE DEVICES VIA COMPUTER NETWORKS FOR OTHERS (U.S. CLS. 100 AND 101).

SHAUNIA CARLYLE, EXAMINING ATTORNEY

SN 86-144,573. STARBUCKS CORPORATION, DBA STARBUCKS COFFEE COMPANY, SEATTLE, WA. FILED 12-16-2013.



OWNER OF U.S. REG. NOS. 3,306,104 AND 4,415,862. THE COLOR(S) GREEN AND WHITE IS/ARE CLAIMED AS A FEATURE OF THE MARK.

THE MARK CONSISTS OF A GREEN, CIRCULAR SEAL WITH THE DESIGN OF A SIREN (A TWO-TAILED MERMAID) OULINED IN WHITE WEARING A WHITE CROWN WITH A FIVE-POINT, WHITE STAR IN THE MIDDLE OF THE CROWN.

## CLASS 14—JEWELRY

FOR WATCHES AND WRISTWATCHES, JEWELRY (U.S. CLS. 2, 27, 28 AND 50).

FIRST USE 10-31-2011; IN COMMERCE 10-31-2011.

## CLASS 18—LEATHER GOODS

FOR PET CLOTHING; TOTE BAGS, BOOK BAGS, BRIEFCASE-TYPE PORTFOLIOS, AND UMBRELLAS, ALL MADE OF CLOTH, PLASTIC AND LEATHER (U.S. CLS. 1, 2, 3, 22 AND 41).

FIRST USE 10-31-2011; IN COMMERCE 10-31-2011.

**CLASS 25—CLOTHING**

FOR T-SHIRTS, POLO SHIRTS, SWEATSHIRTS, CAPS, HATS, JACKETS, APRONS AND VESTS (U.S. CLS. 22 AND 39).

FIRST USE 3-31-2011; IN COMMERCE 3-31-2011.

**CLASS 28—TOYS AND SPORTING GOODS**

FOR TOYS, NAMELY, TEDDY BEARS, STUFFED TOYS, PLUSH TOYS, DOLLS AND ACCESSORIES THEREFOR, CHRISTMAS TREE ORNAMENTS (U.S. CLS. 22, 23, 38 AND 50).

FIRST USE 3-31-2011; IN COMMERCE 3-31-2011.

**CLASS 36—INSURANCE AND FINANCIAL**

FOR FINANCIAL SERVICES, NAMELY, DEBIT AND STORED-VALUE CARD SERVICES; CHARITABLE FUND RAISING SERVICES (U.S. CLS. 100, 101 AND 102).

FIRST USE 3-31-2011; IN COMMERCE 3-31-2011.

**CLASS 41—EDUCATION AND ENTERTAINMENT**

FOR ENTERTAINMENT SERVICES, NAMELY, THE PROVISION AND ORGANIZATION OF ENTERTAINMENT IN THE NATURE OF MUSICAL PERFORMANCES; ORGANIZATION, PRODUCTION, AND PRESENTATION OF LIVE MUSICAL PERFORMANCES; PUBLISHING AND PRODUCTION OF MUSICAL AND SOUND RECORDINGS; PROVIDING INFORMATION REGARDING MUSIC AND LIVE MUSICAL EVENTS VIA COMMUNICATIONS NETWORKS; MUSIC PUBLISHING SERVICES; MUSIC PRODUCTION SERVICES; ENTERTAINMENT SERVICES, NAMELY, PROVIDING REVIEWS OF MUSIC AND COMMENTARY AND ARTICLES ABOUT MUSIC (U.S. CLS. 100, 101 AND 107).

FIRST USE 3-31-2011; IN COMMERCE 3-31-2011.

CHRISTOPHER BUONGIORNO, EXAMINING ATTORNEY

PORTABLE COMPUTERS, LAPTOP, NOTEBOOK AND TABLET COMPUTERS, VIDEO GAME MACHINES AND PARTS AND FITTINGS THEREFOR, APPARATUS FOR RECORDING, TRANSMISSION OR REPRODUCTION OF SOUND OR IMAGES, AUDIO EQUIPMENT AND PARTS AND FITTINGS THEREFOR, VIDEO EQUIPMENT AND PARTS AND FITTINGS THEREFOR, TELEVISIONS AND PARTS AND FITTINGS THEREFOR, RADIOS AND PARTS AND FITTINGS THEREFOR, MUSIC PLAYERS AND RECORDERS AND PARTS AND FITTINGS THEREFOR, VIDEO PLAYERS AND RECORDERS AND PARTS AND FITTINGS THEREFOR, DIGITAL AUDIO VIDEO PLAYERS AND RECORDERS AND PARTS AND FITTINGS THEREFOR, MP3 PLAYERS AND RECORDERS AND PARTS AND FITTINGS THEREFOR, DVD PLAYERS AND RECORDERS AND PARTS AND FITTINGS THEREFOR, CAMERAS AND PARTS AND FITTINGS THEREFOR, VIDEO CAMERAS AND PARTS AND FITTINGS THEREFOR, SPECTACLES AND SUNGLASSES AND FRAMES THEREFOR, BEAUTY PRODUCTS, MACHINES FOR HOUSEHOLD USE, TOOLS, POWER TOOLS, DOMESTIC ELECTRICAL AND ELECTRONIC EQUIPMENT, APPARATUS FOR LIGHTING, HEATING, STEAM GENERATING, DRYING, VENTILATING, CYCLES AND PARTS, COMPONENTS AND FITTINGS THEREFOR, PRAMS AND PARTS, COMPONENTS AND FITTINGS THEREFOR, PUSHCHAIRS AND PARTS, COMPONENTS AND FITTINGS THEREFOR, BABY STROLLERS AND PARTS, COMPONENTS AND FITTINGS THEREFOR, CAR SAFETY SEATS FOR BABIES AND CHILDREN, BABY WALKERS, JEWELLERY, JEWELLERY CHARMS, WATCHES AND CLOCKS AND PARTS AND FITTINGS THEREFOR, COINS AND COPPER TOKENS, MEDALS AND MEDALLIONS, KEY RINGS, TRINKETS AND FOBS, MUSICAL INSTRUMENTS AND PARTS AND FITTINGS THEREFOR, PAPER, CARDBOARD AND GOODS MADE FROM THESE MATERIALS, PHOTOGRAPHS, STATIONERY, INSTRUCTIONAL AND TEACHING MATERIAL, PRINTED PUBLICATIONS, ARTICLES OF LUGGAGE, CASES, BAGS, HANDBAGS, BRIEFCASES, WALLETS, PURSES, CREDIT CARD CASES AND HOLDERS, ID CARD CASES AND HOLDERS, KEYCASES, UMBRELLAS, FURNITURE, MIRRORS, PICTURE FRAMES, PHOTOGRAPH FRAMES, CHILDREN'S FURNITURE, NURSERY FURNITURE, COTS, BEDS, CRIBS, CARRY COTS, MOSES BASKETS, CRADLES, MATTRESSES, COT BUMPER PADS, BABY BOLSTERS, HIGH CHAIRS, BABY CHANGING TABLES, BABY CHANGING MATS, ROCKING CHAIRS, PLAYPENS, TOY BOXES, STORAGE BOXES, CHESTS, SAFETY GATES FOR BABIES AND CHILDREN, FURNITURE PROTECTORS, TRAVEL COTS, SLEEPING BAGS, HOUSEHOLD OR KITCHEN UTENSILS AND CONTAINERS, GLASSWARE, PORCELAIN AND EARTHENWARE, POTTERY, COOKWARE, TABLEWARE, GLASSWARE, DRINKING VESSELS, CUPS, MUGS, BOTTLES, PLATES, BOWLS, CUTLERY, MODELS, ORNAMENTS, DECORATIVE ARTICLES, TENTS, TEXTILES AND TEXTILE GOODS, TEXTILE PIECE GOODS, HOUSEHOLD TEXTILE ARTICLES, TABLE LINEN, BED LINEN, TOWELS, BLANKETS, SOFT FURNISHINGS, FLAGS, BANNERS, PENNANTS, CLOTHING, FOOTWEAR, HEADGEAR, CLOTHING ACCESSORIES, ARTICLES OF CLOTHING, FOOTWEAR AND HEADGEAR FOR BABIES OR CHILDREN, REINS FOR GUIDING CHILDREN, BADGES, FLOOR COVERINGS, RUGS, WALL HANGINGS, GAMES AND PLAYTHINGS, GYMNASIAC AND SPORTING ARTICLES, DECORATIONS FOR CHRISTMAS TREES, TOYS, CHILDREN'S ACTIVITY EQUIPMENT AND APPARATUS, BABY TOYS, BABY PLAYTHINGS, BABY SWINGS, BOUNCERS, DOLLS, SOFT TOYS, TEDDY BEARS AND PET PRODUCTS; INFORMATION, ADVISORY AND CONSULTANCY SERVICES IN RELATION TO ALL OF THE AFORESAID (U.S. CLS. 100, 101 AND 102).

SN 86-144,613. ENTERTAINMENT MAGPIE LIMITED, MACCLESFIELD, UNITED KINGDOM, FILED 12-16-2013.

decluttr  
make room. make money.

THE MARK CONSISTS OF THE MARK "DECLUTTR" ABOVE THE WORDS "MAKE ROOM. MAKE MONEY."

**CLASS 35—ADVERTISING AND BUSINESS**

FOR ADVERTISING; BUSINESS MANAGEMENT; BUSINESS ADMINISTRATION; PROVISION OF SPACE ON WEB SITES FOR ADVERTISING GOODS AND SERVICES OF OTHERS; PROVISION OF BUSINESS INFORMATION; DATA PROCESSING; AUCTIONEERING; RETAIL STORE SERVICES, ONLINE RETAIL STORE SERVICES AND ONLINE TRADING SERVICES IN WHICH CUSTOMERS PRICE AND SELL PRODUCTS VIA AN INTERNET WEBSITE, ALL CONNECTED WITH THE SALE AND PURCHASE OF HOME ENTERTAINMENT AND PERSONAL ENTERTAINMENT PRODUCTS, TELECOMMUNICATIONS PRODUCTS, PRINTED MATTER, SOUND RECORDINGS, MUSIC RECORDINGS, VIDEO RECORDINGS, AUDIO VISUAL RECORDINGS, CDS, DVDS, DISKS, VIDEO GAMES, COMPUTER GAMES, BOOKS, MOBILE PHONES AND PARTS AND FITTINGS THEREFOR, COMPUTERS AND COMPUTING EQUIPMENT AND PARTS AND FITTINGS THEREFOR, COMPUTER PERIPHERALS, COMPUTER PROGRAMS, COMPUTER SOFTWARE, ELECTRONIC STORAGE MEDIA, MEMORY CARDS,

**CLASS 36—INSURANCE AND FINANCIAL**

FOR CONDUCTING VALUATIONS OF PERSONAL PROPERTY; VALUATION SERVICES IN RELATION TO HOME ENTERTAINMENT AND PERSONAL ENTERTAINMENT PRODUCTS, TELECOMMUNICATIONS PRODUCTS, PRINTED MATTER, SOUND RECORDINGS, MUSIC RECORDINGS, VIDEO RECORDINGS, AUDIO VISUAL RECORDINGS, CDS, DVDS, DISKS, VIDEO GAMES, COMPUTER GAMES, BOOKS, MOBILE PHONES AND PARTS AND FITTINGS THEREFOR, COMPUTERS AND COMPUTING EQUIPMENT AND PARTS AND FITTINGS THEREFOR, COMPUTER PERIPHERALS, COMPUTER PROGRAMS, COMPUTER SOFTWARE, ELECTRONIC STORAGE MEDIA, MEMORY CARDS, PORTABLE COMPUTERS, LAPTOP, NOTEBOOK AND TABLET COMPUTERS, VIDEO GAME MACHINES AND PARTS AND FITTINGS THEREFOR, APPARATUS FOR RECORDING, TRANSMISSION OR REPRODUCTION OF SOUND OR IMAGES, AUDIO EQUIPMENT AND PARTS AND FITTINGS THEREFOR, VIDEO EQUIPMENT AND PARTS AND FITTINGS THEREFOR, TELEVISIONS AND PARTS AND FITTINGS THEREFOR, RADIOS AND PARTS AND FITTINGS THEREFOR, MUSIC PLAYERS AND RECORDERS AND PARTS AND FITTINGS THEREFOR, VIDEO PLAYERS AND RECORDERS AND PARTS AND FITTINGS THEREFOR, DIGITAL AUDIO VIDEO PLAYERS AND RECORDERS AND PARTS AND FITTINGS THEREFOR, MP3 PLAYERS AND RECORDERS AND PARTS AND FITTINGS THEREFOR, DVD PLAYERS AND RECORDERS AND PARTS AND FITTINGS THEREFOR, CAMERAS AND PARTS AND FITTINGS THEREFOR, VIDEO CAMERAS AND PARTS AND FITTINGS THEREFOR, SPECTACLES AND SUNGLASSES AND FRAMES THEREFOR, BEAUTY PRODUCTS, MACHINES FOR HOUSEHOLD USE, TOOLS, POWER TOOLS, DOMESTIC ELECTRICAL AND ELECTRONIC EQUIPMENT, APPARATUS FOR LIGHTING, HEATING, STEAM GENERATING, DRYING, VENTILATING, CYCLES AND PARTS, COMPONENTS AND FITTINGS THEREFOR, PRAMS AND PARTS, COMPONENTS AND FITTINGS THEREFOR, PUSHCHAIRS AND PARTS, COMPONENTS AND FITTINGS THEREFOR, BABY STROLLERS AND PARTS, COMPONENTS AND FITTINGS THEREFOR, CAR SAFETY SEATS FOR BABIES AND CHILDREN, BABY WALKERS, JEWELLERY, JEWELLERY CHARMS, WATCHES AND CLOCKS AND PARTS AND FITTINGS THEREFOR, COINS AND COPPER TOKENS, MEDALS AND MEDALLIONS, KEY RINGS, TRINKETS AND FOBS, MUSICAL INSTRUMENTS AND PARTS AND FITTINGS THEREFOR, PAPER, CARDBOARD AND GOODS MADE FROM THESE MATERIALS, PHOTOGRAPHS, STATIONERY, INSTRUCTIONAL AND TEACHING MATERIAL, PRINTED PUBLICATIONS, ARTICLES OF LUGGAGE, CASES, BAGS, HANDBAGS, BRIEFCASES, WALLETS, PURSES, CREDIT CARD CASES AND HOLDERS, ID CARD CASES AND HOLDERS, KEYCASES, UMBRELLAS, FURNITURE, MIRRORS, PICTURE FRAMES, PHOTOGRAPH FRAMES, CHILDREN'S FURNITURE, NURSERY FURNITURE, COTS, BEDS, CRIBS, CARRY COTS, MOSES BASKETS, CRADLES, MATTRESSES, COT BUMPER PADS, BABY BOLSTERS, HIGH CHAIRS, BABY CHANGING TABLES, BABY CHANGING MATS, ROCKING CHAIRS, PLAYPENS, TOY BOXES, STORAGE BOXES, CHESTS, SAFETY GATES FOR BABIES AND CHILDREN, FURNITURE PROTECTORS, TRAVEL COTS, SLEEPING BAGS, HOUSEHOLD OR KITCHEN UTENSILS AND CONTAINERS, GLASSWARE, PORCELAIN AND EARTHENWARE, POTTERY, COOKWARE, TABLEWARE, GLASSWARE, DRINKING VESSELS, CUPS, MUGS, BOTTLES, PLATES, BOWLS, CUTLERY, MODELS, ORNAMENTS, DECORATIVE ARTICLES, TENTS, TEXTILES AND TEXTILE GOODS, TEXTILE PIECE GOODS, HOUSEHOLD TEXTILE ARTICLES, TABLE LINEN, BED LINEN, TOWELS, BLANKETS, SOFT FURNISHINGS, FLAGS, BANNERS, PENNANTS, CLOTHING, FOOTWEAR, HEADGEAR, CLOTHING ACCESSORIES, ARTICLES OF CLOTHING, FOOTWEAR AND HEADGEAR FOR BABIES OR CHILDREN, REINS FOR GUIDING CHILDREN, BADGES, FLOOR COVERINGS, RUGS, WALL HANGINGS, GAMES AND PLAYTHINGS, GYMNASIAC AND SPORTING ARTICLES, DECORATIONS FOR CHRISTMAS TREES, TOYS, CHILDREN'S ACTIVITY EQUIPMENT AND APPARATUS, BABY TOYS, BABY PLAYTHINGS, BABY SWINGS, BOUNCERS, DOLLS, SOFT TOYS, TEDDY BEARS, PUPPETS AND PET PRODUCTS; ISSUING OF TOKENS

OF VALUE; INFORMATION, ADVISORY AND CONSULTANCY SERVICES IN RELATION TO ALL OF THE AFORESAID (U.S. CLS. 100, 101 AND 102).

**CLASS 40—MATERIAL TREATMENT**

FOR RECYCLING SERVICES; RECYCLING OF CONSUMER GOODS; INFORMATION, ADVISORY AND CONSULTANCY SERVICES IN RELATION TO ALL OF THE AFORESAID (U.S. CLS. 100, 103 AND 106).  
LINDA E. BLOHM, EXAMINING ATTORNEY

SN 86-144,668. ENTERTAINMENT MAGPIE LIMITED, MACCLESFIELD, UNITED KINGDOM, FILED 12-16-2013.

**MAKE ROOM MAKE MONEY**

THE MARK CONSISTS OF STANDARD CHARACTERS WITHOUT CLAIM TO ANY PARTICULAR FONT, STYLE, SIZE, OR COLOR.

**CLASS 35—ADVERTISING AND BUSINESS**

FOR ADVERTISING; BUSINESS MANAGEMENT; BUSINESS ADMINISTRATION; PROVISION OF SPACE ON WEB SITES FOR ADVERTISING GOODS AND SERVICES OF OTHERS; PROVISION OF BUSINESS INFORMATION; DATA PROCESSING; AUCTIONEERING; RETAIL STORE SERVICES, ONLINE RETAIL STORE SERVICES AND ONLINE TRADING SERVICES IN WHICH CUSTOMERS PRICE AND SELL PRODUCTS VIA AN INTERNET WEBSITE, ALL CONNECTED WITH THE SALE AND PURCHASE OF HOME ENTERTAINMENT AND PERSONAL ENTERTAINMENT PRODUCTS, TELECOMMUNICATIONS PRODUCTS, PRINTED MATTER, SOUND RECORDINGS, MUSIC RECORDINGS, VIDEO RECORDINGS, AUDIO VISUAL RECORDINGS, CDS, DVDS, DISKS, VIDEO GAMES, COMPUTER GAMES, BOOKS, MOBILE PHONES AND PARTS AND FITTINGS THEREFOR, COMPUTERS AND COMPUTING EQUIPMENT AND PARTS AND FITTINGS THEREFOR, COMPUTER PERIPHERALS, COMPUTER PROGRAMS, COMPUTER SOFTWARE, ELECTRONIC STORAGE MEDIA, MEMORY CARDS, PORTABLE COMPUTERS, LAPTOP, NOTEBOOK AND TABLET COMPUTERS, VIDEO GAME MACHINES AND PARTS AND FITTINGS THEREFOR, APPARATUS FOR RECORDING, TRANSMISSION OR REPRODUCTION OF SOUND OR IMAGES, AUDIO EQUIPMENT AND PARTS AND FITTINGS THEREFOR, VIDEO EQUIPMENT AND PARTS AND FITTINGS THEREFOR, TELEVISIONS AND PARTS AND FITTINGS THEREFOR, RADIOS AND PARTS AND FITTINGS THEREFOR, MUSIC PLAYERS AND RECORDERS AND PARTS AND FITTINGS THEREFOR, VIDEO PLAYERS AND RECORDERS AND PARTS AND FITTINGS THEREFOR, DIGITAL AUDIO VIDEO PLAYERS AND RECORDERS AND PARTS AND FITTINGS THEREFOR, MP3 PLAYERS AND RECORDERS AND PARTS AND FITTINGS THEREFOR, DVD PLAYERS AND RECORDERS AND PARTS AND FITTINGS THEREFOR, CAMERAS AND PARTS AND FITTINGS THEREFOR, VIDEO CAMERAS AND PARTS AND FITTINGS THEREFOR, SPECTACLES AND SUNGLASSES AND FRAMES THEREFOR, BEAUTY PRODUCTS, MACHINES FOR HOUSEHOLD USE, TOOLS, POWER TOOLS, DOMESTIC ELECTRICAL AND ELECTRONIC EQUIPMENT, APPARATUS FOR LIGHTING, HEATING, STEAM GENERATING, DRYING, VENTILATING, CYCLES AND PARTS, COMPONENTS AND FITTINGS THEREFOR, PRAMS AND PARTS, COMPONENTS AND FITTINGS THEREFOR, PUSHCHAIRS AND PARTS, COMPONENTS AND FITTINGS THEREFOR, BABY STROLLERS AND PARTS, COMPONENTS AND FITTINGS THEREFOR, CAR SAFETY SEATS FOR BABIES AND CHILDREN, BABY WALKERS, JEWELLERY, JEWELLERY CHARMS,

WATCHES AND CLOCKS AND PARTS AND FITTINGS THEREFOR, COINS AND COPPER TOKENS, MEDALS AND MEDALLIONS, KEY RINGS, TRINKETS AND FOBS, MUSICAL INSTRUMENTS AND PARTS AND FITTINGS THEREFOR, PAPER, CARDBOARD AND GOODS MADE FROM THESE MATERIALS, PHOTOGRAPHS, STATIONERY, INSTRUCTIONAL AND TEACHING MATERIAL, PRINTED PUBLICATIONS, ARTICLES OF LUGGAGE, CASES, BAGS, HANDBAGS, BRIEFCASES, WALLETS, PURSES, CREDIT CARD CASES AND HOLDERS, ID CARD CASES AND HOLDERS, KEYCASES, UMBRELLAS, FURNITURE, MIRRORS, PICTURE FRAMES, PHOTOGRAPH FRAMES, CHILDREN'S FURNITURE, NURSERY FURNITURE, COTS, BEDS, CRIBS, CARRY COTS, MOSES BASKETS, CRADLES, MATTRESSES, COT BUMPER PADS, BABY BOLSTERS, HIGH CHAIRS, BABY CHANGING TABLES, BABY CHANGING MATS, ROCKING CHAIRS, PLAYPENS, TOY BOXES, STORAGE BOXES, CHESTS, SAFETY GATES FOR BABIES AND CHILDREN, FURNITURE PROTECTORS, TRAVEL COTS, SLEEPING BAGS, HOUSEHOLD OR KITCHEN UTENSILS AND CONTAINERS, GLASSWARE, PORCELAIN AND EARTHENWARE, POTTERY, COOKWARE, TABLEWARE, GLASSWARE, DRINKING VESSELS, CUPS, MUGS, BOTTLES, PLATES, BOWLS, CUTLERY, MODELS, ORNAMENTS, DECORATIVE ARTICLES, TENTS, TEXTILES AND TEXTILE GOODS, TEXTILE PIECE GOODS, HOUSEHOLD TEXTILE ARTICLES, TABLE LINEN, BED LINEN, TOWELS, BLANKETS, SOFT FURNISHINGS, FLAGS, BANNERS, PENNANTS, CLOTHING, FOOTWEAR, HEADGEAR, CLOTHING ACCESSORIES, ARTICLES OF CLOTHING, FOOTWEAR AND HEADGEAR FOR BABIES OR CHILDREN, REINS FOR GUIDING CHILDREN, BADGES, FLOOR COVERINGS, RUGS, WALL HANGINGS, GAMES AND PLAYTHINGS, GYMNASTIC AND SPORTING ARTICLES, DECORATIONS FOR CHRISTMAS TREES, TOYS, CHILDREN'S ACTIVITY EQUIPMENT AND APPARATUS, BABY TOYS, BABY PLAYTHINGS, BABY SWINGS, BOUNCERS, DOLLS, SOFT TOYS, TEDDY BEARS AND PET PRODUCTS; INFORMATION, ADVISORY AND CONSULTANCY SERVICES IN RELATION TO ALL OF THE AFORESAID (U.S. CLS. 100, 101 AND 102).

### CLASS 36—INSURANCE AND FINANCIAL

FOR CONDUCTING VALUATIONS OF PERSONAL PROPERTY; VALUATION SERVICES IN RELATION TO HOME ENTERTAINMENT AND PERSONAL ENTERTAINMENT PRODUCTS, TELECOMMUNICATIONS PRODUCTS, PRINTED MATTER, SOUND RECORDINGS, MUSIC RECORDINGS, VIDEO RECORDINGS, AUDIO VISUAL RECORDINGS, CDS, DVDS, DISKS, VIDEO GAMES, COMPUTER GAMES, BOOKS, MOBILE PHONES AND PARTS AND FITTINGS THEREFOR, COMPUTERS AND COMPUTING EQUIPMENT AND PARTS AND FITTINGS THEREFOR, COMPUTER PERIPHERALS, COMPUTER PROGRAMS, COMPUTER SOFTWARE, ELECTRONIC STORAGE MEDIA, MEMORY CARDS, PORTABLE COMPUTERS, LAPTOP, NOTEBOOK AND TABLET COMPUTERS, VIDEO GAME MACHINES AND PARTS AND FITTINGS THEREFOR, APPARATUS FOR RECORDING, TRANSMISSION OR REPRODUCTION OF SOUND OR IMAGES, AUDIO EQUIPMENT AND PARTS AND FITTINGS THEREFOR, VIDEO EQUIPMENT AND PARTS AND FITTINGS THEREFOR, TELEVISIONS AND PARTS AND FITTINGS THEREFOR, RADIOS AND PARTS AND FITTINGS THEREFOR, MUSIC PLAYERS AND RECORDERS AND PARTS AND FITTINGS THEREFOR, VIDEO PLAYERS AND RECORDERS AND PARTS AND FITTINGS THEREFOR, DIGITAL AUDIO VIDEO PLAYERS AND RECORDERS AND PARTS AND FITTINGS THEREFOR, MP3 PLAYERS AND RECORDERS AND PARTS AND FITTINGS THEREFOR, DVD PLAYERS AND RECORDERS AND PARTS AND FITTINGS THEREFOR, CAMERAS AND PARTS AND FITTINGS THEREFOR, VIDEO CAMERAS AND PARTS AND FITTINGS THEREFOR, SPECTACLES AND SUNGLASSES AND FRAMES THEREFOR, BEAUTY PRODUCTS, MACHINES FOR HOUSEHOLD USE, TOOLS, POWER TOOLS, DOMESTIC ELECTRICAL AND ELECTRONIC EQUIPMENT, APPARATUS FOR LIGHTING, HEATING, STEAM GENERATING, DRYING, VENTILATING, CYCLES AND PARTS, COMPONENTS AND FITTINGS THEREFOR, PRAMS AND PARTS, COMPONENTS AND FITTINGS THEREFOR, PUSHCHAIRS

AND PARTS, COMPONENTS AND FITTINGS THEREFOR, BABY STROLLERS AND PARTS, COMPONENTS AND FITTINGS THEREFOR, CAR SAFETY SEATS FOR BABIES AND CHILDREN, BABY WALKERS, JEWELLERY, JEWELLERY CHARMS, WATCHES AND CLOCKS AND PARTS AND FITTINGS THEREFOR, COINS AND COPPER TOKENS, MEDALS AND MEDALLIONS, KEY RINGS, TRINKETS AND FOBS, MUSICAL INSTRUMENTS AND PARTS AND FITTINGS THEREFOR, PAPER, CARDBOARD AND GOODS MADE FROM THESE MATERIALS, PHOTOGRAPHS, STATIONERY, INSTRUCTIONAL AND TEACHING MATERIAL, PRINTED PUBLICATIONS, ARTICLES OF LUGGAGE, CASES, BAGS, HANDBAGS, BRIEFCASES, WALLETS, PURSES, CREDIT CARD CASES AND HOLDERS, ID CARD CASES AND HOLDERS, KEYCASES, UMBRELLAS, FURNITURE, MIRRORS, PICTURE FRAMES, PHOTOGRAPH FRAMES, CHILDREN'S FURNITURE, NURSERY FURNITURE, COTS, BEDS, CRIBS, CARRY COTS, MOSES BASKETS, CRADLES, MATTRESSES, COT BUMPER PADS, BABY BOLSTERS, HIGH CHAIRS, BABY CHANGING TABLES, BABY CHANGING MATS, ROCKING CHAIRS, PLAYPENS, TOY BOXES, STORAGE BOXES, CHESTS, SAFETY GATES FOR BABIES AND CHILDREN, FURNITURE PROTECTORS, TRAVEL COTS, SLEEPING BAGS, HOUSEHOLD OR KITCHEN UTENSILS AND CONTAINERS, GLASSWARE, PORCELAIN AND EARTHENWARE, POTTERY, COOKWARE, TABLEWARE, GLASSWARE, DRINKING VESSELS, CUPS, MUGS, BOTTLES, PLATES, BOWLS, CUTLERY, MODELS, ORNAMENTS, DECORATIVE ARTICLES, TENTS, TEXTILES AND TEXTILE GOODS, TEXTILE PIECE GOODS, HOUSEHOLD TEXTILE ARTICLES, TABLE LINEN, BED LINEN, TOWELS, BLANKETS, SOFT FURNISHINGS, FLAGS, BANNERS, PENNANTS, CLOTHING, FOOTWEAR, HEADGEAR, CLOTHING ACCESSORIES, ARTICLES OF CLOTHING, FOOTWEAR AND HEADGEAR FOR BABIES OR CHILDREN, REINS FOR GUIDING CHILDREN, BADGES, FLOOR COVERINGS, RUGS, WALL HANGINGS, GAMES AND PLAYTHINGS, GYMNASTIC AND SPORTING ARTICLES, DECORATIONS FOR CHRISTMAS TREES, TOYS, CHILDREN'S ACTIVITY EQUIPMENT AND APPARATUS, BABY TOYS, BABY PLAYTHINGS, BABY SWINGS, BOUNCERS, DOLLS, SOFT TOYS, TEDDY BEARS, PUPPETS AND PET PRODUCTS; ISSUING OF TOKENS OF VALUE; INFORMATION, ADVISORY AND CONSULTANCY SERVICES IN RELATION TO ALL OF THE AFORESAID (U.S. CLS. 100, 101 AND 102).

### CLASS 40—MATERIAL TREATMENT

FOR RECYCLING SERVICES; RECYCLING OF CONSUMER GOODS; INFORMATION, ADVISORY AND CONSULTANCY SERVICES IN RELATION TO ALL OF THE AFORESAID (U.S. CLS. 100, 103 AND 106).

LINDA E. BLOHM, EXAMINING ATTORNEY

SN 86-145,158. BARBARISE, ANNETTE, NORFOLK, VA. AND BARBARISE, JOHN, NORFOLK, VA. FILED 12-16-2013.



THE MARK CONSISTS OF A DESIGN OF A SEA TURTLE WITH SCUBA DIVING GEAR AND BOONIE HAT WITH THE WORDS "SCUBA-COMMANDER" OVERTOP.

**CLASS 25—CLOTHING**

FOR CLOTHING, NAMELY, T-SHIRTS, SWEAT-SHIRTS, HATS, JACKETS, TANK-TOPS, PANTS, SHORTS, SHIRTS, SOCKS, DRESSES (U.S. CLS. 22 AND 39).

**CLASS 35—ADVERTISING AND BUSINESS**

FOR RETAIL STORE SERVICES AND ON-LINE RETAIL STORE SERVICES FEATURING SCUBA GEAR AND BAGS (U.S. CLS. 100, 101 AND 102).

JAY FLOWERS, EXAMINING ATTORNEY

SN 86-145,887. LISTENER DRIVEN RADIO, LLC, AKA LDR, ROCKY RIVER, OH. FILED 12-17-2013.

#engage

THE MARK CONSISTS OF STANDARD CHARACTERS WITHOUT CLAIM TO ANY PARTICULAR FONT, STYLE, SIZE, OR COLOR.

**CLASS 38—COMMUNICATION**

FOR SERVICES RELATING TO DIGITAL CONTENT OR BROADCAST PROGRAMMING, NAMELY, AUDIO AND VIDEO BROADCASTING OR AUDIO STREAMING WHICH INCORPORATES AUDIENCE INPUT OR DATA FROM SOCIAL MEDIA; TRANSMISSION OF NEWS ITEMS FROM ALL AVAILABLE NEWS SOURCES AND SOCIAL MEDIA OUTLETS TO NEWS GATHERING ORGANIZATIONS, SUCH AS BROADCASTERS, ON TOPICS RELATED TO ENTERTAINMENT, SPORTS, POLITICS, LOCAL MARKET, NATIONAL AND SPANISH NEWS FOR BUSINESS PURPOSES; SERVICES RELATING TO BROADCAST PROGRAMMING, NAMELY, AUDIO BROADCASTING WHICH INCORPORATES AUDIENCE INPUT; COMMUNICATION SERVICES, NAMELY, PROVIDING TELECOMMUNICATION CONNECTIVITY SERVICES FOR THE TRANSFER OF VOICE OR OTHER AUDIO THROUGH A WEB SERVICES PLATFORM FROM THE USER'S DEVICE TO A CLOUD-BASED PLATFORM FOR CONSUMPTION AND SHARING BY OTHER USERS VIA SOCIAL MEDIA, WEBSITES, OR BROADCAST PLATFORMS (U.S. CLS. 100, 101 AND 104).

FIRST USE 12-5-2013; IN COMMERCE 12-9-2013.

**CLASS 41—EDUCATION AND ENTERTAINMENT**

FOR ENTERTAINMENT SERVICES, NAMELY, PROVIDING NON-DOWNLOADABLE PLAYBACK OF MUSIC ACCESSIBLE BY MEANS OF MOBILE APPLICATIONS, WEB-BASED APPLICATIONS AND COMPUTER NETWORKS, BASED ON USERS VOTES AND PASSIVE SOCIAL DATA (U.S. CLS. 100, 101 AND 107).

FIRST USE 12-5-2013; IN COMMERCE 12-9-2013.

**CLASS 42—SCIENTIFIC AND COMPUTER SERVICES**

FOR COMPUTER AND SOFTWARE SERVICES, NAMELY, SOFTWARE AS A SERVICE (SAAS) FEATURING AN INTERACTIVE WEBSITE OR DOWNLOADABLE MOBILE APPLICATION WHICH ALLOWS THE AUDIENCE TO CUSTOMIZE THE BROADCAST, FOR USE IN BROADCASTING; SOFTWARE AS A SERVICE (SAAS) FEATURING NON-DOWNLOADABLE SOFTWARE THAT CREATES CUSTOMIZED PERFORMANCE ANALYTICS AND THAT TRACKS, COMPILES AND PROVIDES REAL TIME INFORMATION FROM ALL AVAILABLE NEWS SOURCES AND SOCIAL MEDIA OUTLETS TO PROVIDE REPORTS, INCLUDING ON-LINE REPORTS TO NEWS GATHERING ORGANIZATIONS SUCH AS BROADCASTERS, ON TOPICS RELATED TO ENTERTAINMENT, SPORTS, POLITICS, LOCAL MARKET, NATIONAL AND SPANISH NEWS; PROVIDING AN ON-LINE, NON-DOWNLOADABLE, INTERNET-BASED INTERACTIVE AUDIO SOFTWARE APPLICATION FOR USE BY RADIO STATIONS THAT ALLOWS LISTENERS TO PROVIDE RATINGS AND FEEDBACK ON MUSIC THAT INFLUENCE WHAT WILL BE BROADCAST OR STREAMED ON A RADIO STATION (U.S. CLS. 100 AND 101).

FIRST USE 12-5-2013; IN COMMERCE 12-9-2013.  
CARYN GLASSER, EXAMINING ATTORNEY

SN 86-146,547. FRANCIS MACHINE INC, WILMINGTON, IL. FILED S.R. 12-17-2013; AM. P.R. 4-14-2014.

Watson Retainer

THE MARK CONSISTS OF STANDARD CHARACTERS WITHOUT CLAIM TO ANY PARTICULAR FONT, STYLE, SIZE, OR COLOR.

NO CLAIM IS MADE TO THE EXCLUSIVE RIGHT TO USE "RETAINER", APART FROM THE MARK AS SHOWN.

**CLASS 7—MACHINERY**

FOR EXTENSION BARS FOR POWER TOOLS; EXTENSIONS FOR POWER TOOLS (U.S. CLS. 13, 19, 21, 23, 31, 34 AND 35).

FIRST USE 11-30-2013; IN COMMERCE 12-12-2013.

**CLASS 8—HAND TOOLS**

FOR EXTENSION BARS FOR HAND TOOLS; EXTENSIONS FOR HAND TOOLS; HAND TOOLS, NAMELY, SOCKET SETS; HAND TOOLS, NAMELY, SOCKET WRENCHES (U.S. CLS. 23, 28 AND 44).

FIRST USE 11-30-2013; IN COMMERCE 12-12-2013.  
ANGELA M. MICHELI, EXAMINING ATTORNEY

SN 86-147,043. HOF'S HUT RESTAURANTS, INC., SIGNAL HILL, CA. FILED 12-18-2013.

LUCILLE'S SMOKEHOUSE  
BAR-B-QUE

THE MARK CONSISTS OF STANDARD CHARACTERS WITHOUT CLAIM TO ANY PARTICULAR FONT, STYLE, SIZE, OR COLOR.

OWNER OF U.S. REG. NOS. 2,350,905, 3,892,919 AND OTHERS.

NO CLAIM IS MADE TO THE EXCLUSIVE RIGHT TO USE "SMOKEHOUSE BAR-B-QUE", APART FROM THE MARK AS SHOWN.

**CLASS 29—MEATS AND PROCESSED FOODS**

FOR PREPARED AND PROCESSED FOOD PRODUCTS, NAMELY, BEEF, PORK, LAMB, FISH AND CHICKEN; SIDE DISHES, NAMELY, POTATO SALAD, PROCESSED POTATOES, FRIED POTATOES AND COOKED VEGETABLES (U.S. CL. 46).

**CLASS 30—STAPLE FOODS**

FOR SIDE DISHES, NAMELY, PASTAS AND RICE (U.S. CL. 46).

**CLASS 31—NATURAL AGRICULTURAL PRODUCTS**

FOR RAW VEGETABLES (U.S. CLS. 1 AND 46).  
JEFF DEFORD, EXAMINING ATTORNEY

SN 86-147,550. GENOSCAPE, LLC, DBA TOADO, SEVEN VALLEYS, PA. FILED 12-18-2013.

Toado

THE MARK CONSISTS OF STANDARD CHARACTERS WITHOUT CLAIM TO ANY PARTICULAR FONT, STYLE, SIZE, OR COLOR.

**CLASS 9—ELECTRICAL AND SCIENTIFIC APPARATUS**

FOR COMMUNICATIONS SOFTWARE FOR CONNECTING SOCIAL NETWORKING PLATFORMS; DOWNLOADABLE MOBILE APPLICATION FOR INSTANT MESSAGING, AUDIO AND VIDEO FILE SHARING, PEER-TO-PEER FILE SHARING SERVICES, AND EXCHANGE OF DIGITAL PHOTOS FOR USE IN SOCIAL NETWORKING; DOWNLOADABLE SOFTWARE FOR INSTANT MESSAGING, AUDIO AND VIDEO FILE SHARING, PEER-TO-PEER FILE SHARING SERVICES, AND EXCHANGE OF DIGITAL PHOTOS FOR USE IN SOCIAL NETWORKING; DOWNLOADABLE SOFTWARE IN THE NATURE OF A MOBILE APPLICATION FOR INSTANT MESSAGING, AUDIO AND VIDEO FILE SHARING, PEER-TO-PEER FILE SHARING SERVICES, AND EXCHANGE OF DIGITAL PHOTOS FOR USE IN SOCIAL NETWORKING (U.S. CLS. 21, 23, 26, 36 AND 38).

**CLASS 38—COMMUNICATION**

FOR COMPUTER SERVICES, NAMELY, PROVIDING ON-LINE FACILITIES FOR REAL-TIME INTERACTION WITH OTHER COMPUTER USERS CONCERNING TOPICS OF GENERAL INTEREST; PEER-TO-PEER NETWORK COMPUTER SERVICES, NAMELY, ELECTRONIC TRANSMISSION OF AUDIO, VIDEO AND OTHER DATA AND DOCUMENTS AMONG COMPUTERS; PEER-TO-PEER PHOTO SHARING SERVICES, NAMELY, ELECTRONIC TRANSMISSION OF DIGITAL PHOTO FILES AMONG INTERNET USERS (U.S. CLS. 100, 101 AND 104).

CORY BOONE, EXAMINING ATTORNEY

SN 86-147,571. GENOSCAPE, LLC, DBA TOADO, SEVEN VALLEYS, PA. FILED 12-18-2013.



THE STIPPLING IS FOR SHADING PURPOSES ONLY. THE MARK CONSISTS OF A STYLIZED DESIGN OF A FISH ABOVE THE WORD "TOADO".

**CLASS 9—ELECTRICAL AND SCIENTIFIC APPARATUS**

FOR COMMUNICATIONS SOFTWARE FOR CONNECTING SOCIAL NETWORKING PLATFORMS; DOWNLOADABLE MOBILE APPLICATION FOR INSTANT MESSAGING, AUDIO AND VIDEO FILE SHARING, PEER-TO-PEER FILE SHARING SERVICES, AND EXCHANGE OF DIGITAL PHOTOS FOR USE IN SOCIAL NETWORKING; DOWNLOADABLE SOFTWARE FOR INSTANT MESSAGING, AUDIO AND VIDEO FILE SHARING, PEER-TO-PEER FILE SHARING SERVICES, AND EXCHANGE OF DIGITAL PHOTOS FOR USE IN SOCIAL NETWORKING; DOWNLOADABLE SOFTWARE IN THE NATURE OF A MOBILE APPLICATION FOR INSTANT MESSAGING, AUDIO AND VIDEO FILE SHARING, PEER-TO-PEER FILE SHARING SERVICES, AND EXCHANGE OF DIGITAL PHOTOS FOR USE IN SOCIAL NETWORKING (U.S. CLS. 21, 23, 26, 36 AND 38).

**CLASS 38—COMMUNICATION**

FOR COMPUTER SERVICES, NAMELY, PROVIDING ON-LINE FACILITIES FOR REAL-TIME INTERACTION WITH OTHER COMPUTER USERS CONCERNING TOPICS OF GENERAL INTEREST; PEER-TO-PEER NETWORK COMPUTER SERVICES, NAMELY, ELECTRONIC TRANSMISSION OF AUDIO, VIDEO AND OTHER DATA AND DOCUMENTS AMONG COMPUTERS; PEER-TO-PEER PHOTO SHARING SERVICES, NAMELY, ELECTRONIC TRANSMISSION OF DIGITAL PHOTO FILES AMONG INTERNET USERS (U.S. CLS. 100, 101 AND 104).

CORY BOONE, EXAMINING ATTORNEY

SN 86-147,657. SOUTHERN GRIND, INC., PEACHTREE CITY, GA. FILED 12-18-2013.

SOUTHERN GRIND

THE MARK CONSISTS OF STANDARD CHARACTERS WITHOUT CLAIM TO ANY PARTICULAR FONT, STYLE, SIZE, OR COLOR.

**CLASS 8—HAND TOOLS**

FOR KNIVES, BLADES FOR HAND OPERATED KNIVES (U.S. CLS. 23, 28 AND 44).  
FIRST USE 10-0-2010; IN COMMERCE 6-13-2011.

**CLASS 18—LEATHER GOODS**

FOR LEATHER GOODS, NAMELY, KEY CHAINS (U.S. CLS. 1, 2, 3, 22 AND 41).  
FIRST USE 3-0-2012; IN COMMERCE 11-4-2012.

**CLASS 21—HOUSEWARES AND GLASS**

FOR LEATHER GOODS, NAMELY, INSULATED SLEEVES FOR BEVERAGES (U.S. CLS. 2, 13, 23, 29, 30, 33, 40 AND 50).  
FIRST USE 3-0-2012; IN COMMERCE 11-4-2012.

**CLASS 25—CLOTHING**

FOR CLOTHING, NAMELY, T-SHIRTS; HEADGEAR, NAMELY, CAPS (U.S. CLS. 22 AND 39).  
FIRST USE 11-0-2010; IN COMMERCE 7-4-2011.  
LIEF MARTIN, EXAMINING ATTORNEY

SN 86-148,326. HOF'S HUT RESTAURANTS, INC., SIGNAL HILL, CA. FILED 12-19-2013.



OWNER OF U.S. REG. NOS. 2,350,905, 3,050,645 AND 3,892,919.

NO CLAIM IS MADE TO THE EXCLUSIVE RIGHT TO USE "SMOKEHOUSE BAR-B-QUE", APART FROM THE MARK AS SHOWN.

THE MARK CONSISTS OF THE WORDING "LUCILLE'S SMOKEHOUSE BAR-B-QUE" WITH THE WORDS SUPERIMPOSED OVER AN OVAL CARRIER, THE WORDS "LUCILLE'S" AND "BAR-B-QUE" SPILLOVER THE EDGES OF THE CARRIER, THE WORD "LUCILLE'S" IS WRITTEN IN CURSIVE LETTERS WITH A THICK BORDER AND APPEARS ABOVE AN ARCHING BANNER CONTAINING THE WORD "SMOKEHOUSE" IN CAPITAL LETTERS, BELOW "LUCILLE'S" AND THE BANNER APPEARS THE WORD "BAR-B-QUE" IN BOLD UPRIGHT OFFSET CAPITAL LETTERS AND DOTS GIVING THE WORD AN APPEARANCE OF THREE DIMENSIONS.

**CLASS 29—MEATS AND PROCESSED FOODS**

FOR PREPARED AND PROCESSED FOOD PRODUCTS, NAMELY, BEEF, PORK, LAMB, FISH AND CHICKEN; SIDE DISHES, NAMELY, POTATO SALAD, PROCESSED POTATOES, FRIED POTATOES AND BAKED POTATOES AND COOKED VEGETABLES (U.S. CL. 46).

**CLASS 30—STAPLE FOODS**

FOR SIDE DISHES, NAMELY, PASTAS AND RICE (U.S. CL. 46).

**CLASS 31—NATURAL AGRICULTURAL PRODUCTS**

FOR RAW VEGETABLES (U.S. CLS. 1 AND 46).  
JEFF DEFORD, EXAMINING ATTORNEY

SN 86-148,328. SUKHINDER PAUL TIMOTHY SINGH GILL, DELTA, B.C., CANADA, FILED 12-19-2013.

**GET BETTER ON YOUR OWN**

THE MARK CONSISTS OF STANDARD CHARACTERS WITHOUT CLAIM TO ANY PARTICULAR FONT, STYLE, SIZE, OR COLOR.

**CLASS 25—CLOTHING**

FOR SPORTS CLOTHING, NAMELY, FOOTWEAR, JERSEYS, SOCKS, T-SHIRTS, VEST, SHORTS, JACKETS, SWEAT PANTS, GLOVES AND HATS; SAND SOCKS (U.S. CLS. 22 AND 39).  
FIRST USE 2-9-2001; IN COMMERCE 2-9-2001.

**CLASS 28—TOYS AND SPORTING GOODS**

FOR ATHLETIC AND SPORTING EQUIPMENT AND TRAINING EQUIPMENT, NAMELY, HURDLES, SPEED LADDERS, BALL BAGS, BALL PUMP, JUMP ROPE, AGILITY BALLS, DISC CONES, CONES, SOCCER EQUIPMENT, NAMELY, GOALS, NETS, BALLS, GLOVES AND GOALIE GLOVES; BASKETBALL EQUIPMENT, NAMELY, REBOUNDERS, MECHANICAL PROJECTILE RETURN EQUIPMENT, BACKBOARDS, HOOPS, BALLS, SHOOTING DEVICE IN THE NATURE OF A BASKETBALL SHOOTING PRACTICE AID WORN ON THE WRIST OF A PLAYER AND ELECTRONIC BASKETBALL BACKBOARD; HOCKEY EQUIPMENT, NAMELY, GOALS, NETS, BALLS, BAGS, AND HOCKEY STICK; LACROSSE EQUIPMENT, NAMELY, REBOUNDERS, GOALS, BALLS, GLOVES, LACROSSE STICK, LACROSSE STICK BAG; BASEBALL AND SOFTBALL EQUIPMENT, NAMELY, REBOUNDERS, BALLS, BATS, GLOVES, BATTING GLOVES; VOLLEYBALL EQUIPMENT, NAMELY, NETS AND BALLS; FOOTBALL EQUIPMENT, NAMELY, GOAL, TARGET MACHINE IN THE NATURE OF A FOOTBALL TARGET AND PRACTICE AID, KICK NET, BALL, NET BALL BAG AND GLOVES (U.S. CLS. 22, 23, 38 AND 50).  
FIRST USE 2-9-2001; IN COMMERCE 2-9-2001.

DAVID ALESKOW, EXAMINING ATTORNEY

SN 86-148,330. SUKHINDER PAUL TIMOTHY SINGH GILL, DELTA, B.C., CANADA, FILED 12-19-2013.

**THERE IS NO OTHER**

THE MARK CONSISTS OF STANDARD CHARACTERS WITHOUT CLAIM TO ANY PARTICULAR FONT, STYLE, SIZE, OR COLOR.

**CLASS 25—CLOTHING**

FOR SPORTS CLOTHING, NAMELY, FOOTWEAR, JERSEYS, SOCKS, T-SHIRTS, VEST, SHORTS, JACKETS, SWEAT PANTS, GLOVES AND HATS; SAND SOCKS (U.S. CLS. 22 AND 39).  
FIRST USE 2-9-2001; IN COMMERCE 2-9-2001.



**CLASS 28—TOYS AND SPORTING GOODS**

FOR ATHLETIC AND SPORTING EQUIPMENT AND TRAINING EQUIPMENT, NAMELY, HURDLES, SPEED LADDERS, BALL BAGS, BALL PUMP, JUMP ROPE, AGILITY BALLS, DISC CONES, CONES, SOCCER EQUIPMENT, NAMELY, GOALS, NETS, BALLS, GLOVES AND GOALIE GLOVES; BASKETBALL EQUIPMENT, NAMELY, REBOUNDERS, MECHANICAL PROJECTILE RETURN EQUIPMENT, BACKBOARDS, HOOPS, BALLS, SHOOTING DEVICE IN THE NATURE OF A BASKETBALL SHOOTING PRACTICE AID WORN ON THE WRIST OF A PLAYER AND ELECTRONIC BASKETBALL BACKBOARD; HOCKEY EQUIPMENT, NAMELY, GOALS, NETS, BALLS, BAGS, AND HOCKEY STICK; LACROSSE EQUIPMENT, NAMELY, REBOUNDERS, GOALS, BALLS, GLOVES, LACROSSE STICK, LACROSSE STICK BAG; BASEBALL AND SOFTBALL EQUIPMENT, NAMELY, REBOUNDERS, BALLS, BATS, GLOVES, BATTING GLOVES; VOLLEYBALL EQUIPMENT, NAMELY, NETS AND BALLS; FOOTBALL EQUIPMENT, NAMELY, GOAL, TARGET MACHINE IN THE NATURE OF A FOOTBALL TARGET AND PRACTICE AID, KICK NET, BALL, NET BALL BAG AND GLOVES (U.S. CLS. 22, 23, 38 AND 50).

FIRST USE 2-9-2001; IN COMMERCE 2-9-2001.  
DAVID ALESKOW, EXAMINING ATTORNEY

---

SN 86-148,331. SUKHINDER PAUL TIMOTHY SINGH GILL,  
DELTA, B.C., CANADA, FILED 12-19-2013.

**TEKK**

THE MARK CONSISTS OF STANDARD CHARACTERS WITHOUT CLAIM TO ANY PARTICULAR FONT, STYLE, SIZE, OR COLOR.

**CLASS 25—CLOTHING**

FOR SPORTS CLOTHING, NAMELY, FOOTWEAR, JERSEYS, SOCKS, T-SHIRTS, VEST, SHORTS, JACKETS, SWEAT PANTS, GLOVES AND HATS; SAND SOCKS (U.S. CLS. 22 AND 39).

FIRST USE 1-3-1999; IN COMMERCE 1-3-1999.

**CLASS 28—TOYS AND SPORTING GOODS**

FOR ATHLETIC AND SPORTING EQUIPMENT AND TRAINING EQUIPMENT, NAMELY, HURDLES, SPEED LADDERS, BALL BAGS, BALL PUMP, JUMP ROPE, AGILITY BALLS, DISC CONES, CONES, SOCCER EQUIPMENT, NAMELY, GOALS, NETS, BALLS, GLOVES AND GOALIE GLOVES; BASKETBALL EQUIPMENT, NAMELY, REBOUNDERS, MECHANICAL PROJECTILE RETURN EQUIPMENT, BACKBOARDS, HOOPS, BALLS, SHOOTING DEVICE IN THE NATURE OF A BASKETBALL SHOOTING PRACTICE AID WORN ON THE WRIST OF A PLAYER AND ELECTRONIC BASKETBALL BACKBOARD; HOCKEY EQUIPMENT, NAMELY, GOALS, NETS, BALLS, BAGS, AND HOCKEY STICK; LACROSSE EQUIPMENT, NAMELY, REBOUNDERS, GOALS, BALLS, GLOVES, LACROSSE STICK, LACROSSE STICK BAG; BASEBALL AND SOFTBALL EQUIPMENT, NAMELY, REBOUNDERS, BALLS, BATS, GLOVES, BATTING GLOVES; VOLLEYBALL EQUIPMENT, NAMELY, NETS AND BALLS; FOOTBALL EQUIPMENT, NAMELY, GOAL, TARGET MACHINE IN THE NATURE OF A FOOTBALL TARGET AND PRACTICE AID, KICK NET, BALL, NET BALL BAG AND GLOVES (U.S. CLS. 22, 23, 38 AND 50).

FIRST USE 1-3-1999; IN COMMERCE 1-3-1999.  
DAVID ALESKOW, EXAMINING ATTORNEY

SN 86-148,880. TAYLOR-LISTUG, INC. D/B/A TAYLOR GUITARS, EL CAJON, CA. FILED 12-19-2013.

**STEP FORWARD. MUSIC IS  
WAITING.**

THE MARK CONSISTS OF STANDARD CHARACTERS WITHOUT CLAIM TO ANY PARTICULAR FONT, STYLE, SIZE, OR COLOR.

**CLASS 15—MUSICAL INSTRUMENTS**

FOR MUSICAL INSTRUMENTS, NAMELY, GUITARS AND CARRYING CASES FOR GUITARS (U.S. CLS. 2, 21 AND 36).

**CLASS 35—ADVERTISING AND BUSINESS**

FOR ADVERTISING SERVICES, NAMELY, PROMOTING THE GOODS OF RETAILERS, DEALERS AND DISTRIBUTORS OF MUSICAL INSTRUMENTS BY PREPARING PRINT AND ON-LINE ADVERTISING FOR THEM (U.S. CLS. 100, 101 AND 102).

NANCY CLARKE, EXAMINING ATTORNEY

---

SN 86-149,888. DISCOVERY COMMUNICATIONS, LLC,  
SILVER SPRING, MD. FILED 12-20-2013.



NO CLAIM IS MADE TO THE EXCLUSIVE RIGHT TO USE "CHANNEL", APART FROM THE MARK AS SHOWN. THE MARK CONSISTS OF THE LETTERS "AHC" WITH A CHEVRON DESIGN BELOW THE LETTER "H" AND A SOLID LINE BELOW THE LETTERS, ALL ABOVE THE WORDING "AMERICAN HEROES CHANNEL".

**CLASS 9—ELECTRICAL AND SCIENTIFIC APPARATUS**

FOR AUDIOTAPES, VIDEOTAPES, DVDS, COMPACT DISCS, AND MULTIMEDIA SOFTWARE RECORDED ON CD-ROM, ALL FEATURING SUBJECTS OF GENERAL HUMAN INTEREST; ELECTRONIC LEARNING GAMES IN THE NATURE OF ELECTRONIC GAME SOFTWARE FOR EDUCATIONAL PURPOSES; VIDEO GAME DISCS; COMPUTER GAME DISCS; ELECTRONIC GAME PROGRAMS; DOWNLOADABLE RING TONES, GRAPHICS, RING BACKS, ANIMATED RINGERS, VIDEO RINGERS AND ANIMATED SCREENSAVERS VIA THE INTERNET AND WIRELESS DEVICES; DIGITAL MEDIA, NAMELY, DOWNLOADABLE PRERECORDED VIDEO CLIPS, PRERECORDED AUDIO CLIPS, TEXT AND GRAPHICS HELD IN ELECTRONIC PERSONAL COMPUTERS AND HANDHELD WIRELESS DEVICES, ALL FEATURING SUBJECTS OF GENERAL HUMAN INTEREST; SUNGLASSES (U.S. CLS. 21, 23, 26, 36 AND 38).



**CLASS 38—COMMUNICATION**

FOR COMMUNICATIONS SERVICES, NAMELY, TRANSMITTING STREAMED SOUND AND AUDIO-VISUAL RECORDINGS VIA THE INTERNET, CABLE NETWORKS, WIRELESS NETWORKS, SATELLITE, OR INTERACTIVE MULTIMEDIA NETWORKS; AUDIO AND VIDEO BROADCASTING SERVICES OVER THE INTERNET; TELEVISION BROADCASTING SERVICES; CABLE TELEVISION BROADCASTING; SATELLITE TELEVISION BROADCASTING; MOBILE MEDIA SERVICES IN THE NATURE OF ELECTRONIC TRANSMISSION OF ENTERTAINMENT MEDIA CONTENT; PROVIDING ON-LINE FORUMS FOR TRANSMISSION OF MESSAGES AMONG COMPUTER USERS (U.S. CLS. 100, 101 AND 104).

**CLASS 41—EDUCATION AND ENTERTAINMENT**

FOR ENTERTAINMENT AND EDUCATIONAL SERVICES, NAMELY, ONGOING MULTIMEDIA PROGRAMS IN THE FIELD OF GENERAL INTEREST, DISTRIBUTED VIA VARIOUS PLATFORMS ACROSS MULTIPLE FORMS OF TRANSMISSION MEDIA; PROVIDING ENTERTAINMENT INFORMATION VIA A GLOBAL COMPUTER NETWORK; PRODUCTION OF TELEVISION PROGRAMS; PRODUCTION OF MULTIMEDIA PROGRAMS (U.S. CLS. 100, 101 AND 107).  
INGRID C. EULIN, EXAMINING ATTORNEY

SN 86-151,065. FELFÖLDI ÉDESSÉGGYÁRTÓ KFT., DEBRECEN, HUNGARY, FILED 12-23-2013.

# QUICK MILK

THE MARK CONSISTS OF STANDARD CHARACTERS WITHOUT CLAIM TO ANY PARTICULAR FONT, STYLE, SIZE, OR COLOR.

NO CLAIM IS MADE TO THE EXCLUSIVE RIGHT TO USE "MILK", APART FROM THE MARK AS SHOWN.

**CLASS 21—HOUSEWARES AND GLASS**

FOR DRINKING STRAWS; DRINKING STRAWS, NAMELY, STRAWS FILLED WITH FLAVORING (U.S. CLS. 2, 13, 23, 29, 30, 33, 40 AND 50).

**CLASS 30—STAPLE FOODS**

FOR FLAVORINGS FOR DRINKS (U.S. CL. 46).  
MARIA-VICTORIA SUAREZ, EXAMINING ATTORNEY

SN 86-151,677. SHANNON SMITH, TOPANGA, CA. FILED 12-23-2013.

# Forte Poesy

THE MARK CONSISTS OF STANDARD CHARACTERS WITHOUT CLAIM TO ANY PARTICULAR FONT, STYLE, SIZE, OR COLOR.

**CLASS 25—CLOTHING**

FOR APPAREL, NAMELY, T-SHIRTS, JACKETS, SWEATSHIRTS, HATS AND CAPS (U.S. CLS. 22 AND 39).

**CLASS 41—EDUCATION AND ENTERTAINMENT**

FOR EDUCATIONAL SERVICES, NAMELY, DEVELOPING CURRICULUM FOR OTHERS IN THE FIELD OF MUSIC, COMPOSITION AND SONGWRITING (U.S. CLS. 100, 101 AND 107).

JASON TURNER, EXAMINING ATTORNEY

SN 86-153,196. WILLIAM COMBES, BOYNTON BEACH, FL. FILED 12-27-2013.

# PASSION AMERICA

THE MARK CONSISTS OF STANDARD CHARACTERS WITHOUT CLAIM TO ANY PARTICULAR FONT, STYLE, SIZE, OR COLOR.

NO CLAIM IS MADE TO THE EXCLUSIVE RIGHT TO USE "AMERICA", APART FROM THE MARK AS SHOWN.

**CLASS 25—CLOTHING**

FOR CLOTHING AND ACCESSORIES, NAMELY, HATS AND T-SHIRTS (U.S. CLS. 22 AND 39).

**CLASS 41—EDUCATION AND ENTERTAINMENT**

FOR EDUCATIONAL SERVICES, NAMELY, PROVIDING DISPLAYS AND EXHIBITS IN THE FIELD OF PHOTOGRAPHY AND VIDEOGRAPHY (U.S. CLS. 100, 101 AND 107).

AISHA CLARKE, EXAMINING ATTORNEY

SN 86-153,373. ALELO, INC., LOS ANGELES, CA. FILED 12-27-2013.

# ALELO

THE MARK CONSISTS OF STANDARD CHARACTERS WITHOUT CLAIM TO ANY PARTICULAR FONT, STYLE, SIZE, OR COLOR.

**CLASS 9—ELECTRICAL AND SCIENTIFIC APPARATUS**

FOR PRERECORDED DVDS AND DOWNLOADABLE AUDIO AND MULTIMEDIA FILES FEATURING INSTRUCTION IN FOREIGN LANGUAGES, CULTURAL AND LINGUISTIC ANTHROPOLOGY, INTERCULTURAL COMMUNICATION, NATURAL LANGUAGE PROCESSING, AND COMPUTATIONAL LINGUISTICS (U.S. CLS. 21, 23, 26, 36 AND 38).

FIRST USE 11-15-2007; IN COMMERCE 11-15-2007.

**CLASS 16—PAPER GOODS AND PRINTED MATTER**

FOR BOOKS PROVIDING INSTRUCTION ON FOREIGN LANGUAGES, CULTURAL AND LINGUISTIC ANTHROPOLOGY, INTERCULTURAL COMMUNICATION, NATURAL LANGUAGE PROCESSING, AND COMPUTATIONAL LINGUISTICS (U.S. CLS. 2, 5, 22, 23, 29, 37, 38 AND 50).

FIRST USE 11-15-2007; IN COMMERCE 11-15-2007.

**CLASS 41—EDUCATION AND ENTERTAINMENT**

FOR PROVIDING ONLINE INSTRUCTION ON FOREIGN LANGUAGES, CULTURAL AND LINGUISTIC ANTHROPOLOGY, INTERCULTURAL COMMUNICATION, NATURAL LANGUAGE PROCESSING, AND COMPUTATIONAL LINGUISTICS VIA AN INTERACTIVE WEBSITE AND INTERACTIVE PHONE APPLICATION (U.S. CLS. 100, 101 AND 107).

FIRST USE 11-15-2007; IN COMMERCE 11-15-2007.

JOHN LINCOSKI, EXAMINING ATTORNEY

SN 86-154,146. SPECIAL PATHOGENS LABORATORY, LLC, PITTSBURGH, PA. FILED 12-30-2013.



OWNER OF U.S. REG. NO. 3,879,140.

THE MARK CONSISTS OF TWO IDENTICAL WAVY HORIZONTAL LINES, ONE ABOVE THE OTHER, INSIDE A SHADED RECTANGULAR DESIGN WITH ROUNDED CORNERS.

SN 86-154,043. MAST BROTHERS, INC., BROOKLYN, NY. FILED 12-30-2013.

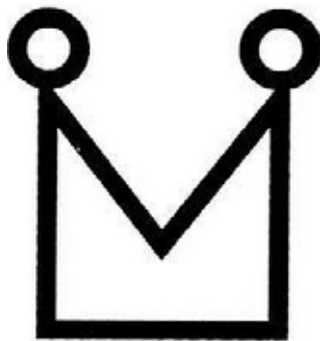

THE MARK CONSISTS OF A STYLIZED CROWN.

**CLASS 30—STAPLE FOODS**

FOR (BASED ON USE IN COMMERCE) CHOCOLATE; CHOCOLATE BARK CONTAINING GROUND COFFEE BEANS; CHOCOLATE BARS; CHOCOLATE CANDIES; CHOCOLATE CHIPS; CHOCOLATE TABLETS; COCOA NIBS; CHOCOLATE COVERED NUTS; CHOCOLATE POWDER; CHOCOLATE SYRUP; CHOCOLATE TOPPING; HOT CHOCOLATE; CHOCOLATE FONDUE; CHOCOLATE MOUSSE; CHOCOLATE PASTES; CHOCOLATE TRUFFLES; CHOCOLATE-BASED FILLINGS FOR CAKES AND PIES; CHOCOLATE-BASED READY-TO-EAT FOOD BARS; MILK CHOCOLATE; CHOCOLATE-BASED SPREAD ALSO CONTAINING NUTS (U.S. CL. 46).

FIRST USE 2-25-2008; IN COMMERCE 5-25-2008.

**CLASS 43—HOTEL AND RESTAURANT SERVICES**

FOR (BASED ON INTENT TO USE) CAFE AND RESTAURANT SERVICES (U.S. CLS. 100 AND 101).

WON TEAK OH, EXAMINING ATTORNEY

**CLASS 9—ELECTRICAL AND SCIENTIFIC APPARATUS**

FOR DOWNLOADABLE ELECTRONIC NEWSLETTERS DELIVERED BY E-MAIL IN THE FIELD OF WATERBORNE PATHOGEN TESTING, DETECTION, AND REMEDIATION (U.S. CLS. 21, 23, 26, 36 AND 38).

FIRST USE 3-7-2014; IN COMMERCE 3-7-2014.

**CLASS 40—MATERIAL TREATMENT**

FOR REMEDIATION AND PREVENTION TREATMENT OF WATERBORNE PATHOGENS, NAMELY, WATER TREATMENT SERVICES (U.S. CLS. 100, 103 AND 106).

FIRST USE 2-5-2014; IN COMMERCE 2-5-2014.

**CLASS 42—SCIENTIFIC AND COMPUTER SERVICES**

FOR LABORATORY RESEARCH SERVICES IN THE FIELD OF WATERBORNE PATHOGENS, NAMELY, WATERBORNE PATHOGEN TESTING, ANALYSIS, AND DETECTION; LABORATORY RESEARCH SERVICES, NAMELY, REPORTING TEST RESULTS OF WATERBORNE PATHOGEN ANALYSIS; SCIENTIFIC RESEARCH FOR MEDICAL PURPOSES AND PUBLIC HEALTH PURPOSES IN THE FIELDS OF INFECTIOUS DISEASES AND MICROBIOLOGY; SCIENTIFIC RESEARCH, NAMELY, REPORTING OF LABORATORY TEST RESULTS OF WATERBORNE PATHOGEN ANALYSIS ELECTRONICALLY VIA THE INTERNET; PRODUCT EVALUATION, NAMELY, CHEMICALS, REAGENTS, FILTERS, AND WATER TREATMENT MACHINERY, IN THE FIELD OF INFECTIOUS DISEASES AND MICROBIOLOGY FOR DETERMINING THE EFFICACY OF MEANS FOR DISINFECTION; PROVIDING MEDICAL RESEARCH AND SCIENTIFIC RESEARCH NEWS AND INFORMATION IN THE FIELD OF MICROBIOLOGY AND INFECTIOUS DISEASES (U.S. CLS. 100 AND 101).

FIRST USE 2-5-2014; IN COMMERCE 2-5-2014.

**CLASS 44—MEDICAL, BEAUTY AND AGRICULTURAL SERVICES**

FOR MEDICAL CONSULTING SERVICES IN FIELD OF DISEASE INFECTION CONTROL RELATING TO WATERBORNE PATHOGENS; PROVIDING MEDICAL NEWS AND INFORMATION RELATING TO MICROBIOLOGY AND INFECTIOUS DISEASES (U.S. CLS. 100 AND 101).

FIRST USE 2-5-2014; IN COMMERCE 2-5-2014.

GENE MACIOL, EXAMINING ATTORNEY

SN 86-155,524. CALIFORNIA RESIDENTIAL MITIGATION PROGRAM, A JOINT EXERCISE OF POWERS AGENCY, SACRAMENTO, CA. FILED 12-31-2013.



NO CLAIM IS MADE TO THE EXCLUSIVE RIGHT TO USE "EARTHQUAKE", APART FROM THE MARK AS SHOWN.

THE MARK CONSISTS OF AN OUTLINE OF A HOUSE WITH A SCREW PARTIALLY IN THE BASE OF THE HOUSE, TO THE RIGHT APPEARS THE STYLIZED WORDING "EARTHQUAKE BRACE + BOLT FUNDS TO STRENGTHEN YOUR FOUNDATION".

#### CLASS 35—ADVERTISING AND BUSINESS

FOR PROVIDING FINANCIAL INCENTIVE AWARDS FOR THE PROMOTION AND ADOPTION OF SEISMIC MITIGATION EFFORTS IN RESIDENTIAL STRUCTURES BY HOMEOWNERS; PROMOTING THE GOODS AND SERVICES OF OTHERS BY PROVIDING AN ONLINE COMPUTER WEB SITE THAT LISTS QUALIFIED HOME CONTRACTORS, INSURERS, AND OTHER BUSINESSES RELATED TO THE STRUCTURAL RETROFITTING OF RESIDENTIAL HOMES (U.S. CLS. 100, 101 AND 102).

FIRST USE 9-23-2013; IN COMMERCE 9-23-2013.

#### CLASS 41—EDUCATION AND ENTERTAINMENT

FOR EDUCATIONAL SERVICES, NAMELY, PROVIDING ONLINE NON-DOWNLOADABLE VIDEOS, CLASSES, SEMINARS, AND WORKSHOPS FEATURING HOME SAFETY, EARTHQUAKE RISK, HOW TO PREPARE FOR AND PROTECT AGAINST EARTHQUAKE RISK, AND HOW TO RETROFIT HOMES; EDUCATIONAL SERVICES, NAMELY, PROVIDING ONLINE NON-DOWNLOADABLE VIDEOS, CLASSES, SEMINARS, AND WORKSHOPS REGARDING SEISMIC RETROFIT EDUCATION (U.S. CLS. 100, 101 AND 107).

FIRST USE 9-23-2013; IN COMMERCE 9-23-2013.  
TRICIA SONNEBORN, EXAMINING ATTORNEY

SN 86-156,297. STUPID CANCER, INC., NEW YORK, NY. FILED 1-2-2014.

#### OMG! CANCER SUMMIT

THE MARK CONSISTS OF STANDARD CHARACTERS WITHOUT CLAIM TO ANY PARTICULAR FONT, STYLE, SIZE, OR COLOR.

NO CLAIM IS MADE TO THE EXCLUSIVE RIGHT TO USE "CANCER SUMMIT" FOR INTERNATIONAL CLASSES 36 AND 41, APART FROM THE MARK AS SHOWN.

#### CLASS 25—CLOTHING

FOR CLOTHING, NAMELY, SHORT-SLEEVED AND LONG-SLEEVED SHIRTS; TANK TOPS; JERSEYS; SWEAT SHIRTS; HOODED SWEAT SHIRTS; TRACK SUITS; THONG UNDERWEAR; CAPS; BABY BOTTOMS; APRONS AND GLOVES (U.S. CLS. 22 AND 39).

#### CLASS 36—INSURANCE AND FINANCIAL

FOR CHARITABLE FUNDRAISING FOR CANCER AWARENESS AND EDUCATIONAL PROGRAMS (U.S. CLS. 100, 101 AND 102).

#### CLASS 41—EDUCATION AND ENTERTAINMENT

FOR EDUCATIONAL SERVICES, NAMELY, PROVIDING, ORGANIZING AND CONDUCTING INFORMAL WORKSHOPS, CONFERENCES AND SEMINARS IN THE FIELDS OF CANCER, CANCER RECOVERY AND SURVIVAL; ENTERTAINMENT SERVICES, NAMELY, PROVIDING A WEBSITE FEATURING PHOTOGRAPHIC, AUDIO, VIDEO AND PROSE PRESENTATIONS FEATURING PERSONAL NARRATIVE STORIES AND NON-DOWNLOADABLE ART AND MUSIC RELATING TO CANCER, CANCER RECOVERY AND SURVIVAL FOR INSTRUCTIONAL AND ENTERTAINMENT PURPOSES (U.S. CLS. 100, 101 AND 107).

PAUL CROWLEY, EXAMINING ATTORNEY

SN 86-156,869. UTILITIES TELECOM COUNCIL, WASHINGTON, DC. FILED 1-3-2014.



NO CLAIM IS MADE TO THE EXCLUSIVE RIGHT TO USE "RURAL BROADBAND" AND "COUNCIL", APART FROM THE MARK AS SHOWN.

THE MARK CONSISTS OF THE LETTERS "RBC" WITH A STYLIZED TARGET DESIGN NEXT TO IT COMPRISED OF FOUR CONCENTRIC CIRCLES HAVING THREE DOTTED LINES AIMED AT THE CENTER; AND THE WORDS "RURAL BROADBAND COUNCIL" BELOW THE LETTERS AND DESIGN.

#### CLASS 35—ADVERTISING AND BUSINESS

FOR TRADE ASSOCIATION SERVICES, NAMELY, PROMOTING THE INTERESTS OF UTILITY COMPANIES PROVIDING BROADBAND SERVICES TO RURAL AMERICA (U.S. CLS. 100, 101 AND 102).

FIRST USE 3-30-2013; IN COMMERCE 3-30-2013.

#### CLASS 42—SCIENTIFIC AND COMPUTER SERVICES

FOR RESEARCH IN THE FIELD OF TELECOMMUNICATIONS TECHNOLOGY FOR UTILITY COMPANIES TO PROVIDE BROADBAND SERVICES TO RURAL AMERICA (U.S. CLS. 100 AND 101).

FIRST USE 3-30-2013; IN COMMERCE 3-13-2013.  
MAYUR VAGHANI, EXAMINING ATTORNEY

SN 86-159,037. PIERRE FABRE DERMO-COSMETIQUE,  
BOULOGNE, FRANCE, FILED 1-7-2014.

# SENSINOL

THE MARK CONSISTS OF STANDARD CHARACTERS  
WITHOUT CLAIM TO ANY PARTICULAR FONT, STYLE,  
SIZE, OR COLOR.

PRIORITY CLAIMED UNDER SEC. 44(D) ON FRANCE  
APPLICATION NO. 134020181, FILED 7-16-2013, REG. NO.  
134020181, DATED 7-16-2013, EXPIRES 7-16-2023.

OWNER OF U.S. REG. NO. 4,367,064.

THE WORDING "SENSINOL" HAS NO MEANING IN A  
FOREIGN LANGUAGE.

## CLASS 3—COSMETICS AND CLEANING PREPARATIONS

FOR COSMETICS; COSMETIC PREPARATIONS (U.S.  
CLS. 1, 4, 6, 50, 51 AND 52).

## CLASS 5—PHARMACEUTICALS

FOR DERMATOLOGICALS; MEDICATED DERMO-  
COSMETIC PREPARATIONS FOR SKIN CARE AND  
SKIN HYGIENE (U.S. CLS. 6, 18, 44, 46, 51 AND 52).

JAMES A. RAUEN, EXAMINING ATTORNEY

SN 86-159,171. FILOLI CENTER, WOODSIDE, CA. FILED 1-7-  
2014.

# FILOLI

THE MARK CONSISTS OF STANDARD CHARACTERS  
WITHOUT CLAIM TO ANY PARTICULAR FONT, STYLE,  
SIZE, OR COLOR.

## CLASS 3—COSMETICS AND CLEANING PREPARATIONS

FOR BAR SOAPS, BATH SOAPS, SACHETS, POT-  
POURRI (U.S. CLS. 1, 4, 6, 50, 51 AND 52).

FIRST USE 1-0-2011; IN COMMERCE 1-0-2011.

## CLASS 9—ELECTRICAL AND SCIENTIFIC APPARATUS

FOR DECORATIVE MAGNETS (U.S. CLS. 21, 23, 26, 36  
AND 38).

FIRST USE 9-0-1999; IN COMMERCE 9-0-1999.

## CLASS 16—PAPER GOODS AND PRINTED MATTER

FOR GREETING CARDS, NOTE CARDS, POSTCARDS,  
NOTE PADS, PENS, PENCILS, PAPERWEIGHTS, BOOK-  
MARKS, RECIPE BOOKS, BOOKS IN THE FIELDS OF  
HISTORY AND GARDENING (U.S. CLS. 2, 5, 22, 23, 29,  
37, 38 AND 50).

FIRST USE 9-0-1999; IN COMMERCE 9-0-1999.

## CLASS 18—LEATHER GOODS

FOR TOTE BAGS, UMBRELLAS (U.S. CLS. 1, 2, 3, 22  
AND 41).

FIRST USE 2-0-2011; IN COMMERCE 2-0-2011.

## CLASS 21—HOUSEWARES AND GLASS

FOR COFFEE MUGS, GARDENING GLOVES (U.S.  
CLS. 2, 13, 23, 29, 30, 33, 40 AND 50).

FIRST USE 4-0-2010; IN COMMERCE 4-0-2010.

## CLASS 25—CLOTHING

FOR CLOTHING, NAMELY, T-SHIRTS, SWEAT-  
SHIRTS, PULLOVERS, HATS, CAPS (U.S. CLS. 22 AND  
39).

FIRST USE 4-0-2005; IN COMMERCE 4-0-2005.

## CLASS 30—STAPLE FOODS

FOR VINEGARS, SPICE BLENDS, DRIED HERBS,  
HONEY, TEA (U.S. CL. 46).

FIRST USE 9-0-2003; IN COMMERCE 9-0-2003.

## CLASS 41—EDUCATION AND ENTERTAINMENT

FOR MUSEUM SERVICES INVOLVING THE PRESER-  
VATION AND DISPLAY OF A HISTORIC MANSION  
AND ADJACENT HISTORIC STRUCTURES, GROUNDS,  
GARDENS AND FURNISHINGS; EDUCATIONAL SER-  
VICES, NAMELY, ARRANGING AND CONDUCTING  
CONFERENCES AND WORKSHOPS IN THE FIELD OF  
HISTORY AND CULTURE OF AN HISTORIC MANSION;  
PROVIDING FACILITIES FOR MUSIC, ART EXHIBITS,  
AND EDUCATIONAL TRAINING (U.S. CLS. 100, 101  
AND 107).

FIRST USE 0-0-1976; IN COMMERCE 0-0-1976.

## CLASS 43—HOTEL AND RESTAURANT SERVICES

FOR RENTAL OF MEETING ROOMS; PROVISION OF  
CONFERENCE AND MEETING FACILITIES; RESTAU-  
RANT AND CATERING SERVICES; CAFE SERVICES  
(U.S. CLS. 100 AND 101).

FIRST USE 0-0-1976; IN COMMERCE 0-0-1976.

WON TEAK OH, EXAMINING ATTORNEY

SN 86-160,873. PERFECT FORMULA LLC, CARLSTADT, NJ.  
FILED 1-8-2014.

# PERFECT FORMULA

THE MARK CONSISTS OF STANDARD CHARACTERS  
WITHOUT CLAIM TO ANY PARTICULAR FONT, STYLE,  
SIZE, OR COLOR.

SEC. 2(F).

**CLASS 3—COSMETICS AND CLEANING PREPARATIONS**

FOR COSMETIC PREPARATIONS FOR NAIL DRYING; COSMETIC PREPARATIONS FOR REMOVING GEL NAILS, ACRYLIC NAILS, AND NAIL POLISH; LOTIONS FOR STRENGTHENING THE NAILS; NAIL BUFFING PREPARATIONS; NAIL CARE KITS COMPRISING NAIL POLISH; NAIL ENAMELS; NAIL ENAMEL REMOVERS; NAIL GROOMING PRODUCTS, NAMELY, TIPS, GLUE, LACQUER AND GLITTER; NAIL HARDENERS; NAIL PAINT; NAIL POLISH; NAIL POLISH BASE COAT; NAIL POLISH TOP COAT; NAIL STRENGTHENERS; NAIL VARNISH; CUTICLE OIL; NAIL OIL (U.S. CLS. 1, 4, 6, 50, 51 AND 52).  
FIRST USE 5-0-2004; IN COMMERCE 5-0-2004.

**CLASS 8—HAND TOOLS**

FOR MANICURE IMPLEMENTS, NAMELY, NAIL FILES AND NAIL BUFFERS (U.S. CLS. 23, 28 AND 44).  
FIRST USE 5-0-2004; IN COMMERCE 5-0-2004.  
ELLEN B. AWRICH, EXAMINING ATTORNEY

SN 86-161,130. CONNECT2CONCEPTS LLC, PEPPER PIKE, OH. FILED 1-9-2014.

# GOBOARD

THE MARK CONSISTS OF STANDARD CHARACTERS WITHOUT CLAIM TO ANY PARTICULAR FONT, STYLE, SIZE, OR COLOR.

**CLASS 9—ELECTRICAL AND SCIENTIFIC APPARATUS**

FOR DOWNLOADABLE CLOUD COMPUTER SOFTWARE FOR TRACKING, RECORDING, AND REPORTING ON OPERATIONS OF A BUSINESS (U.S. CLS. 21, 23, 26, 36 AND 38).  
FIRST USE 6-12-2014; IN COMMERCE 6-12-2014.

**CLASS 42—SCIENTIFIC AND COMPUTER SERVICES**

FOR PROVIDING TEMPORARY USE OF ON-LINE NON-DOWNLOADABLE CLOUD COMPUTING SOFTWARE FOR TRACKING, RECORDING, AND REPORTING ON OPERATIONS OF A BUSINESS (U.S. CLS. 100 AND 101).  
FIRST USE 6-12-2014; IN COMMERCE 6-12-2014.  
SAMUEL PAQUIN, EXAMINING ATTORNEY

SN 86-161,145. CITIGROUP INC., NEW YORK, NY. FILED 1-9-2014.

# WOMEN AND COMPANY

THE MARK CONSISTS OF STANDARD CHARACTERS WITHOUT CLAIM TO ANY PARTICULAR FONT, STYLE, SIZE, OR COLOR.  
OWNER OF U.S. REG. NOS. 2,359,728, 3,920,245 AND OTHERS.

NO CLAIM IS MADE TO THE EXCLUSIVE RIGHT TO USE "WOMEN", APART FROM THE MARK AS SHOWN.

**CLASS 38—COMMUNICATION**

FOR PROVIDING ONLINE ELECTRONIC BULLETIN BOARDS AND CHAT ROOMS FOR TRANSMISSION OF MESSAGES AMONG COMPUTER USERS CONCERNING ELDER CARE, CHILD CARE, PET CARE, NURSING CARE, INTRAFAMILY RELATIONSHIPS, LIFESTYLES, EDUCATION, CAREERS, FINANCES, INSURANCE, CREDIT, TAXES, RETIREMENT PLANNING, BUDGET PLANNING, TECHNOLOGY UPDATES, BUSINESS SERVICES, LEGAL SERVICES, MOVING AND RELOCATION SERVICES, BUYING, SELLING, REMODELING, REFINANCING OF MORTGAGES, CHARITABLE DONATIONS, PHILANTHROPIC DONATIONS, TRUSTS AND INVESTMENTS, AND IDENTITY THEFT PROTECTION (U.S. CLS. 100, 101 AND 104).

**CLASS 41—EDUCATION AND ENTERTAINMENT**

FOR PROVIDING A WEBSITE FEATURING BLOGS AND ONLINE PUBLICATIONS IN THE NATURE OF ARTICLES, DIRECTORIES, MAGAZINES, NEWSLETTERS, REPORTS AND REPORTS ON RESEARCH STUDIES FEATURING NEWS AND CURRENT EVENTS CONCERNING ELDER CARE, CHILD CARE, PET CARE, NURSING CARE, INTRAFAMILY RELATIONSHIPS, LIFESTYLES, EDUCATION, CAREERS, FINANCES, INSURANCE, CREDIT, TAXES, RETIREMENT PLANNING, BUDGET PLANNING, TECHNOLOGY UPDATES, BUSINESS SERVICES, LEGAL SERVICES, MOVING AND RELOCATION SERVICES, BUYING, SELLING, REMODELING, REFINANCING OF MORTGAGES, CHARITABLE DONATIONS, PHILANTHROPIC DONATIONS, TRUSTS AND INVESTMENTS, AND IDENTITY THEFT PROTECTION (U.S. CLS. 100, 101 AND 107).  
DAWN HAN, EXAMINING ATTORNEY

SN 86-161,489. PARCC, INC., WASHINGTON, DC. FILED 1-9-2014.

# PARCC

THE MARK CONSISTS OF STANDARD CHARACTERS WITHOUT CLAIM TO ANY PARTICULAR FONT, STYLE, SIZE, OR COLOR.

**CLASS 35—ADVERTISING AND BUSINESS**

FOR PROMOTING PUBLIC AWARENESS OF A COMMON SET OF K-12 EDUCATIONAL ASSESSMENT CRITERIA AND TESTS; PROVIDING A WEB SITE FOR PUBLIC ADVOCACY TO PROMOTE THE DEVELOPMENT AND ADOPTION OF COMMON CORE K-12 EDUCATIONAL STANDARDS (U.S. CLS. 100, 101 AND 102).  
FIRST USE 2-0-2011; IN COMMERCE 5-0-2011.

**CLASS 41—EDUCATION AND ENTERTAINMENT**

FOR PROVIDING ONLINE INFORMATION REGARDING K-12 EDUCATION STANDARDS; PROVIDING EDUCATIONAL CONSULTING SERVICES TO ASSIST EDUCATORS AND EDUCATION SYSTEMS IN DEVELOPING AND IMPLEMENTING K-12 EDUCATION STANDARDS AND ASSESSMENT TESTING PROCESSES AND REPORTING FORMATS AND MECHANISMS (U.S. CLS. 100, 101 AND 107).  
FIRST USE 2-0-2011; IN COMMERCE 5-0-2011.

**CLASS 42—SCIENTIFIC AND COMPUTER SERVICES**

FOR DESIGN AND DEVELOPMENT OF EDUCATIONAL DEVELOPMENT TECHNOLOGY DELIVERY PLATFORMS FOR EDUCATIONAL ASSESSMENT TESTS, SOFTWARE, DATABASE MANAGEMENT, SCORING METRICS AND TEST ADMINISTRATION; DEVELOPMENT OF K-12 SCIENCE EDUCATION STANDARDS AND ASSESSMENT CRITERIA; DEVELOPMENT OF EDUCATIONAL TEST ADMINISTRATION POLICIES AND PROCEDURES; TECHNOLOGY CONSULTATION SERVICES RELATED TO TECHNOLOGY AND HARDWARE GUIDELINES AND SCHOOL READINESS PLANNING RELATED TO IMPLEMENTATION OF AN ONLINE EDUCATIONAL ASSESSMENT SYSTEM (U.S. CLS. 100 AND 101).

FIRST USE 2-0-2011; IN COMMERCE 5-0-2011.  
DOUGLAS LEE, EXAMINING ATTORNEY

SN 86-161,689. PERFECT FORMULA LLC, CARLSTADT, NJ.  
FILED 1-9-2014.



THE COLOR(S) BROWN, WHITE AND PINK IS/ARE CLAIMED AS A FEATURE OF THE MARK.

THE MARK CONSISTS OF A CIRCULAR DESIGN CONSISTING OF THE SCRIPTED LETTERS "P" AND "F" APPEARING IN WHITE FONT ON A BROWN CIRCULAR BACKGROUND IN THE CENTER, ENCIRCLED BY A THIN PINK CIRCLE, ENCIRCLED BY WHITE SPACE IN WHICH THE ALL-CAPS PRINTED WORDS "PERFECT FORMULA" APPEAR IN BROWN FONT IN AN ARCH AT THE TOP AND "ESSENTIALS FOR PERFECT NAILS" APPEAR IN AN ARCH AT THE BOTTOM, ENCIRCLED BY A FINAL THIN BROWN CIRCLE.

SEC. 2(F) AS TO "PERFECT FORMULA".

**CLASS 3—COSMETICS AND CLEANING PREPARATIONS**

FOR COSMETIC PREPARATIONS FOR NAIL DRYING; COSMETIC PREPARATIONS FOR REMOVING GEL NAILS, ACRYLIC NAILS, AND NAIL POLISH; LOTIONS FOR STRENGTHENING THE NAILS; NAIL BUFFING PREPARATIONS; NAIL CARE KITS COMPRISING NAIL POLISH; NAIL ENAMELS; NAIL ENAMEL REMOVERS; NAIL GROOMING PRODUCTS, NAMELY, TIPS, GLUE, LACQUER AND GLITTER; NAIL HARDENERS; NAIL PAINT; NAIL POLISH; NAIL POLISH BASE COAT; NAIL POLISH TOP COAT; NAIL STRENGTHENERS; NAIL VARNISH; CUTICLE OIL; NAIL OIL (U.S. CLS. 1, 4, 6, 50, 51 AND 52).

FIRST USE 6-0-2005; IN COMMERCE 6-0-2005.

**CLASS 8—HAND TOOLS**

FOR MANICURE IMPLEMENTS, NAMELY, NAIL FILES AND NAIL BUFFERS (U.S. CLS. 23, 28 AND 44).

FIRST USE 6-0-2005; IN COMMERCE 6-0-2005.  
ELLEN B. AWRICH, EXAMINING ATTORNEY

SN 86-163,836. INTELLIGENT EARTH LTD., DOUGLAS, ISLE OF MAN, FILED 1-13-2014.

**METRONATOR**

THE MARK CONSISTS OF STANDARD CHARACTERS WITHOUT CLAIM TO ANY PARTICULAR FONT, STYLE, SIZE, OR COLOR.

**CLASS 9—ELECTRICAL AND SCIENTIFIC APPARATUS**

FOR ELECTRONIC MEASURING APPARATUS AND INSTRUMENTS FOR MEASURING THE SPATIAL LOCATION OF A COMPUTER INPUT CONTROL DEVICE WITH RESPECT TO A USER INTERFACE; COMPUTER GAME SOFTWARE; INTERACTIVE COMPUTER GAME PROGRAMS; COMPUTER SOFTWARE FOR CONTROLLING GRAPHICS AND VIDEO DEVICES; COMPUTER SOFTWARE FOR CONTROLLING COMPUTER PERIPHERALS; COMPUTER MICE, COMPUTER STYLUSES; COMPUTER HARDWARE AND PERIPHERALS (U.S. CLS. 21, 23, 26, 36 AND 38).

**CLASS 16—PAPER GOODS AND PRINTED MATTER**

FOR WRITING AND DRAWING EQUIPMENT, NAMELY, PENS, BRUSHES AND MARKERS (U.S. CLS. 2, 5, 22, 23, 29, 37, 38 AND 50).

**CLASS 28—TOYS AND SPORTING GOODS**

FOR ELECTRONIC GAMES OTHER THAN THOSE ADAPTED FOR USE WITH TELEVISION RECEIVERS ONLY, TOY WEAPONS, INCLUDING TOY SWORDS AND GUNS, AND GAME CONTROLLERS FOR COMPUTER GAMES (U.S. CLS. 22, 23, 38 AND 50).

DOMINIC FATHY, EXAMINING ATTORNEY

SN 86-163,947. CHILTON INVESTMENT COMPANY LLC, STAMFORD, CT. FILED 1-13-2014.

**CHILTON**

THE MARK CONSISTS OF STANDARD CHARACTERS WITHOUT CLAIM TO ANY PARTICULAR FONT, STYLE, SIZE, OR COLOR.

OWNER OF U.S. REG. NO. 2,688,558.  
SEC. 2(F).

**CLASS 35—ADVERTISING AND BUSINESS**

FOR TAX AND TAXATION PLANNING, ADVICE, INFORMATION AND CONSULTANCY SERVICES; FAMILY OFFICE SERVICES, NAMELY, TAX CONSULTATION, PREPARATION, AND FILING SERVICES, AND MANAGEMENT OF TAX FILES (U.S. CLS. 100, 101 AND 102).

FIRST USE 0-0-2010; IN COMMERCE 0-0-2010.

**CLASS 36—INSURANCE AND FINANCIAL**

FOR TRUST SERVICES, NAMELY, INVESTMENT AND TRUST COMPANY SERVICES; FINANCIAL SERVICES, NAMELY, WEALTH MANAGEMENT SERVICES; FIDUCIARY SERVICES, NAMELY, FIDUCIARY REPRESENTATIVE SERVICES; FAMILY OFFICE SERVICES, NAMELY, BUDGET PLANNING, INSURANCE ADVICE, INVESTMENT ADVICE, INVESTMENT MANAGEMENT, INVESTMENT CONSULTATION, INVESTMENT OF FUNDS FOR OTHERS, FIDUCIARY TAX PAYMENT PROCESSING SERVICES, AND TAX PAYMENT PROCESSING SERVICES; TRUSTEE SERVICES; BILL PAYMENT SERVICES; FINANCIAL SERVICES, NAMELY, FINANCIAL ANALYSIS AND CONSULTATION, FORECASTING AND RESEARCH; HEDGE FUNDS AND PRIVATE EQUITY INVESTMENTS; OPTIONS TRADING FOR OTHERS; INVESTMENT ADVISORY SERVICES (U.S. CLS. 100, 101 AND 102).

FIRST USE 0-0-2010; IN COMMERCE 0-0-2010.  
VERNA BETH RIRIE, EXAMINING ATTORNEY

SN 86-165,296. BARTON & ASSOCIATES, INC., PEABODY, MA. FILED 1-14-2014.

# VIRTUVISIT

THE MARK CONSISTS OF STANDARD CHARACTERS WITHOUT CLAIM TO ANY PARTICULAR FONT, STYLE, SIZE, OR COLOR.

**CLASS 42—SCIENTIFIC AND COMPUTER SERVICES**

FOR WEB-BASED NON-DOWNLOADABLE SOFTWARE FOR USE IN ACCESSING PATIENT MEDICAL HISTORY, SCHEDULING APPOINTMENTS, SENDING PRESCRIPTIONS, STORING RECORDS, AND MAKING APPOINTMENTS; PROVIDING ONLINE NON-DOWNLOADABLE SOFTWARE FOR USE BY CONSUMERS IN CONTACTING HEALTH CARE PROFESSIONALS AND OBTAINING HEALTH CARE CONSULTATIONS VIA COMPUTERS AND OTHER ELECTRONIC MEANS; COMPUTER CONSULTING SERVICES REGARDING THE USE OF COMPUTERS IN COMPUTERIZED AND ELECTRONIC ACCESS TO HEALTH CARE (U.S. CLS. 100 AND 101).

FIRST USE 1-6-2014; IN COMMERCE 1-6-2014.

SN 86-164,059. ADVANCE MAGAZINE PUBLISHERS, INC., NEW YORK, NY. FILED 1-13-2014.

## NICK CARTER KILLMASTER

THE MARK CONSISTS OF STANDARD CHARACTERS WITHOUT CLAIM TO ANY PARTICULAR FONT, STYLE, SIZE, OR COLOR.

OWNER OF U.S. REG. NOS. 948,573, 2,875,505 AND 3,815,826.

"NICK CARTER KILLMASTER", "NICK CARTER", OR "KILLMASTER", DOES NOT IDENTIFY A PARTICULAR LIVING INDIVIDUAL.

**CLASS 9—ELECTRICAL AND SCIENTIFIC APPARATUS**

FOR MOTION PICTURE FILMS ABOUT FICTIONAL HEROIC AND VILLAINOUS CHARACTERS (U.S. CLS. 21, 23, 26, 36 AND 38).

**CLASS 16—PAPER GOODS AND PRINTED MATTER**

FOR POSTERS; STORY BOOKS; ACTIVITY BOOKS, NAMELY, STICKER BOOKS; COLORING BOOKS; KITS PRIMARILY COMPRISED OF CRAYONS, MARKERS, PAINTS, PAINT BRUSHES AND PARTS SOLD AS UNITS FOR COLORING AND PAINTING; WRITING SLATES; SCHOOL SUPPLIES, NAMELY, BOOK COVERS, PENCIL CASES, PENCIL SHARPENERS, STAPLERS, BOOK-MARKS; TOILET AND FACIAL TISSUE; PAPER NAPKINS, PAPER PLACEMATS, PAPER TABLECLOTHS; BOOKS FEATURING STORIES OF FICTIONAL HEROIC AND VILLAINOUS CHARACTERS; MAGAZINES FEATURING STORIES OF FICTIONAL HEROIC AND VILLAINOUS CHARACTERS; COMIC BOOKS; GREETING CARDS; TRADING CARDS (U.S. CLS. 2, 5, 22, 23, 29, 37, 38 AND 50).

**CLASS 28—TOYS AND SPORTING GOODS**

FOR PLAYING CARDS; PAPER PARTY HATS (U.S. CLS. 22, 23, 38 AND 50).  
MICHAEL WIENER, EXAMINING ATTORNEY

**CLASS 44—MEDICAL, BEAUTY AND AGRICULTURAL SERVICES**

FOR PROVIDING HEALTHCARE FOR COMPANIES AND THEIR EMPLOYEES REMOTELY OR VIRTUALLY FROM PHYSICIANS, NURSE PRACTITIONERS, AND OTHER HEALTHCARE PROFESSIONALS; PROVIDING HEALTH INFORMATION, NAMELY, PROVIDING ELECTRONIC PERSONAL MEDICAL HISTORY RECORDS AND FILES TO PARTICIPANTS, PATIENTS AND MEDICAL STAFFING PERSONNEL; PROVIDING HEALTH CARE SERVICES FOR CONSUMERS, NAMELY, PROVIDING ONLINE HEALTH CARE SERVICES BY HEALTH CARE PROFESSIONALS VIA COMPUTERS AND OTHER ELECTRONIC MEANS; PROVIDING HEALTH, MEDICAL AND WELLNESS INFORMATION; HEALTH CARE CONSULTING AND INFORMATION SERVICES IN THE FIELDS OF PREVENTATIVE HEALTH CARE AND TOTAL HEALTH MANAGEMENT; MAINTAINING ELECTRONIC PERSONAL MEDICAL HISTORY AND PATIENT MEDICAL RECORDS AND FILES; TELEMEDICINE SERVICES; MEDICAL AND PHARMACEUTICAL CONSULTATION; MEDICAL SERVICES; HEALTH CARE COUNSELING IN THE FIELD OF HEALTH RISK INTERVENTION, HEALTH PROMOTION, HEALTH RISK AND BEHAVIOR MODIFICATION (U.S. CLS. 100 AND 101).

FIRST USE 1-6-2014; IN COMMERCE 1-6-2014.  
MARTHA FROMM, EXAMINING ATTORNEY

SN 86-165,558. PEEKSHARE, INC., SAN FRANCISCO, CA. FILED 1-14-2014.

# PEEKSHARE

THE MARK CONSISTS OF STANDARD CHARACTERS WITHOUT CLAIM TO ANY PARTICULAR FONT, STYLE, SIZE, OR COLOR.

**CLASS 42—SCIENTIFIC AND COMPUTER SERVICES**

FOR PROVIDING A WEBSITE AND VIA MOBILE APPLICATIONS FOR SMART PHONES AND OTHER WIRELESS DEVICES, THAT GIVES USERS THE ABILITY TO REVIEW AND SHARE VARIOUS PRINT, PHOTOGRAPHIC, GRAPHIC IMAGE, AND AUDIO AND VIDEO CONTENT, AND TO UTILIZE A CUSTOM TEMPLATE TO PROVIDE INPUT, LIKES, DISLIKES, EDITS, CHANGES, MODIFICATIONS, OPINIONS, SUGGESTIONS, AND COMMENTS AND ENGAGE IN SOCIAL, BUSINESS, AND COMMUNITY NETWORKING (U.S. CLS. 100 AND 101).

**CLASS 45—PERSONAL AND LEGAL SERVICES**

FOR ON-LINE SOCIAL NETWORKING SERVICES (U.S. CLS. 100 AND 101).  
JOHN HWANG, EXAMINING ATTORNEY

**CLASS 44—MEDICAL, BEAUTY AND AGRICULTURAL SERVICES**

FOR PROVIDING HEALTHCARE FOR COMPANIES AND THEIR EMPLOYEES REMOTELY OR VIRTUALLY FROM PHYSICIANS, NURSE PRACTITIONERS, AND OTHER HEALTHCARE PROFESSIONALS; PROVIDING HEALTH INFORMATION, NAMELY, PROVIDING ELECTRONIC PERSONAL MEDICAL HISTORY RECORDS AND FILES TO PARTICIPANTS, PATIENTS AND MEDICAL STAFFING PERSONNEL; PROVIDING HEALTH CARE SERVICES FOR CONSUMERS, NAMELY, PROVIDING ONLINE HEALTH CARE SERVICES BY HEALTH CARE PROFESSIONALS VIA COMPUTERS AND OTHER ELECTRONIC MEANS; PROVIDING HEALTH, MEDICAL AND WELLNESS INFORMATION; HEALTH CARE CONSULTING AND INFORMATION SERVICES IN THE FIELDS OF PREVENTATIVE HEALTH CARE AND TOTAL HEALTH MANAGEMENT; MAINTAINING ELECTRONIC PERSONAL MEDICAL HISTORY AND PATIENT MEDICAL RECORDS AND FILES; TELEMEDICINE SERVICES; MEDICAL AND PHARMACEUTICAL CONSULTING; MEDICAL SERVICES; HEALTH CARE COUNSELING IN THE FIELD OF HEALTH RISK INTERVENTION, HEALTH PROMOTION, HEALTH RISK AND BEHAVIOR MODIFICATION (U.S. CLS. 100 AND 101).  
FIRST USE 1-6-2014; IN COMMERCE 1-6-2014.  
MARTHA FROMM, EXAMINING ATTORNEY

SN 86-166,015. BARTON & ASSOCIATES, INC., PEABODY, MA. FILED 1-15-2014.

SN 86-166,233. EDATANETWORKS INC., EDMONTON, CANADA, FILED 1-15-2014.



THE MARK CONSISTS OF A CARDIAC SIGNAL APPEARING AT THE CENTER OF A CIRCULAR SHAPE WITH AN OPEN TOP.

**CLASS 42—SCIENTIFIC AND COMPUTER SERVICES**

FOR WEB-BASED NON-DOWNLOADABLE SOFTWARE FOR USE IN ACCESSING PATIENT MEDICAL HISTORY, SCHEDULING APPOINTMENTS, SENDING PRESCRIPTIONS, STORING RECORDS, AND MAKING APPOINTMENTS; PROVIDING ONLINE NON-DOWNLOADABLE SOFTWARE FOR USE BY CONSUMERS IN CONTACTING HEALTH CARE PROFESSIONALS AND OBTAINING HEALTH CARE CONSULTATIONS VIA COMPUTERS AND OTHER ELECTRONIC MEANS; COMPUTER CONSULTING SERVICES REGARDING THE USE OF COMPUTERS IN COMPUTERIZED AND ELECTRONIC ACCESS TO HEALTH CARE (U.S. CLS. 100 AND 101).

FIRST USE 1-6-2014; IN COMMERCE 1-6-2014.

**CLASS 35—ADVERTISING AND BUSINESS**

FOR PROMOTING PUBLIC AWARENESS OF RESEARCH, INNOVATION AND COMMERCIALIZATION IN THE FIELD OF BUSINESS INNOVATION WITH RESPECT TO DIGITAL COMMERCE; BUSINESS CONSULTING SERVICES IN THE FIELD OF BUSINESS INNOVATION WITH RESPECT TO DIGITAL COMMERCE; PROVIDING A WEBSITE FEATURING BUSINESS INFORMATION IN THE FIELD OF BUSINESS INNOVATION WITH RESPECT TO DIGITAL COMMERCE (U.S. CLS. 100, 101 AND 102).

**CLASS 41—EDUCATION AND ENTERTAINMENT**

FOR NON-DOWNLOADABLE ONLINE ELECTRONIC NEWSLETTERS DELIVERED BY EMAIL IN THE FIELD OF BUSINESS INNOVATION WITH RESPECT TO DIGITAL COMMERCE; EDUCATIONAL SERVICES, NAMELY, PROVIDING SEMINARS IN THE FIELD OF EXPLORING COMMON LEARNING AND NETWORKS BETWEEN TECHNOLOGICAL AND BUSINESS INNOVATION AND LEADERSHIP TO BROADER CREATIVE INDUSTRIES AND EVOLVING MODELS OF SOCIAL INNOVATION (U.S. CLS. 100, 101 AND 107).

**CLASS 42—SCIENTIFIC AND COMPUTER SERVICES**

FOR INNOVATION CONSULTING SERVICES, NAMELY, ADVISING OTHERS IN THE AREAS OF PRODUCT DEVELOPMENT IN THE FIELD OF DIGITAL COMMERCE (U.S. CLS. 100 AND 101).

MARK SPARACINO, EXAMINING ATTORNEY



SN 86-167,010. BENTLEY'S SALOON, LLC, ARUNDEL, ME.  
FILED 1-16-2014.



OWNER OF U.S. REG. NO. 3,571,371.  
NO CLAIM IS MADE TO THE EXCLUSIVE RIGHT TO USE "CAMPGROUND & MOTEL", APART FROM THE MARK AS SHOWN.

THE MARK CONSISTS OF THE WORD "BENTLEY'S" WITH TWO WAVING CHECKERED FLAGS ON POLES, ONE FLAG IS COMING OUT OF THE TOP OF THE FIRST LETTER "E" AND THE OTHER FLAG IS COMING OUT OF THE TOP OF THE LETTER "Y", BELOW AND TO THE LEFT OF THE WORD "BENTLEY'S" APPEARS A SILHOUETTE OF A PERSON ON A MOTORCYCLE WITH THE WORDS "CAMPGROUND" STACKED ABOVE "& MOTEL" IN STYLIZED SCRIPT LETTERS TO THE RIGHT OF THE MOTORCYCLE.

#### CLASS 25—CLOTHING

FOR CLOTHING, NAMELY, T-SHIRTS (U.S. CLS. 22 AND 39).

#### CLASS 35—ADVERTISING AND BUSINESS

FOR RETAIL STORE SERVICES FEATURING FOOD, SHIRTS, FLASHLIGHTS, KEY CHAINS, PINS, BANDANAS, HAIR WRAPS, MAGNETS, SWEATSHIRTS, CALENDARS, ADVERTISING, UNIFORMS, HATS, LEATHER, JEWELRY, CLOTHING, ONLINE RETAIL STORE FEATURING FOOD, SHIRTS, FLASHLIGHTS, KEY CHAINS, PINS, BANDANAS, HAIR WRAPS, MAGNETS, SWEATSHIRTS, CALENDARS, ADVERTISING, UNIFORMS, HATS, LEATHER, JEWELRY, CLOTHING (U.S. CLS. 100, 101 AND 102).

#### CLASS 43—HOTEL AND RESTAURANT SERVICES

FOR PROVIDING CAMPGROUND FACILITIES, MOTELS AND RESTAURANTS (U.S. CLS. 100 AND 101).  
JEFF DEFORD, EXAMINING ATTORNEY

SN 86-167,056. BLUESIDE INC., SEONGNAM-SI, GYEONGGI, REPUBLIC OF KOREA, FILED 1-16-2014.

# BLUESIDE

THE MARK CONSISTS OF STANDARD CHARACTERS WITHOUT CLAIM TO ANY PARTICULAR FONT, STYLE, SIZE, OR COLOR.

#### CLASS 9—ELECTRICAL AND SCIENTIFIC APPARATUS

FOR COMPUTER PROGRAMS, NAMELY, GAME SOFTWARE FOR USE ON COMPUTERS AND VIDEO GAME PLAYERS; DOWNLOADABLE SOFTWARE FOR ONLINE GAMES; DOWNLOADABLE GAME SOFTWARE FOR COMPUTERS AND VIDEO GAME PLAYERS; DOWNLOADABLE GRAPHICS VIA A GLOBAL COMPUTER NETWORK (U.S. CLS. 21, 23, 26, 36 AND 38).

#### CLASS 41—EDUCATION AND ENTERTAINMENT

FOR ENTERTAINMENT SERVICES, NAMELY, PRODUCTION OF VIDEO GAMES FOR COMPUTERS AND VIDEO GAME PLAYERS; ENTERTAINMENT SERVICES, NAMELY, PROVIDING ON-LINE COMPUTER GAMES AND CONSOLE GAMES; DIGITAL IMAGING SERVICE; PROVIDING AMUSEMENT CENTERS; TV ENTERTAINMENT SERVICES, NAMELY, ONGOING TELEVISION PROGRAMS IN THE FIELD OF ONLINE COMPUTER AND VIDEO GAMES (U.S. CLS. 100, 101 AND 107).  
DAVID ALESKOW, EXAMINING ATTORNEY

SN 86-167,260. QUANTOMIC, LLC, CONROE, TX. FILED 1-16-2014.

# TAGSPIRE

THE MARK CONSISTS OF STANDARD CHARACTERS WITHOUT CLAIM TO ANY PARTICULAR FONT, STYLE, SIZE, OR COLOR.

#### CLASS 9—ELECTRICAL AND SCIENTIFIC APPARATUS

FOR COMPUTER SOFTWARE AND SOFTWARE APPLICATIONS THAT ENABLE USERS TO CREATE, UPLOAD, BOOKMARK, VIEW, ANNOTATE, AND SHARE DATA, INFORMATION AND MEDIA CONTENT; DOWNLOADABLE MOBILE APPLICATIONS FOR USE IN ENABLING USERS TO CREATE, UPLOAD, BOOKMARK, VIEW, ANNOTATE, SHARE AND DISCOVER DATA, INFORMATION AND MEDIA CONTENT; SOFTWARE TO FACILITATE BUSINESS PROMOTION, CONNECTING SOCIAL-NETWORK USERS WITH BUSINESSES; COMPUTER E-COMMERCE SOFTWARE TO ALLOW USERS TO PERFORM ELECTRONIC BUSINESS TRANSACTIONS VIA A GLOBAL COMPUTER NETWORK (U.S. CLS. 21, 23, 26, 36 AND 38).

#### CLASS 35—ADVERTISING AND BUSINESS

FOR ADVERTISING, MARKETING, AND PROMOTIONAL SERVICES; PROMOTING THE GOODS AND SERVICES OF OTHERS BY MEANS OF OPERATING AN ONLINE PLATFORM WITH HYPERLINKS TO THE GOODS AND SERVICES OF OTHERS; PROVIDING AN ONLINE SEARCHABLE DATABASE FEATURING A WIDE VARIETY OF CONSUMER, BUSINESS, AND INDUSTRIAL GOODS OF OTHERS; ELECTRONIC-COMMERCE SERVICES, NAMELY, PROVIDING INFORMATION ABOUT PRODUCTS AND SERVICES VIA TELECOMMUNICATION NETWORKS FOR ADVERTISING AND SALES PURPOSES (U.S. CLS. 100, 101 AND 102).

**CLASS 42—SCIENTIFIC AND COMPUTER SERVICES**

FOR COMPUTER SERVICES, NAMELY, CREATING AN ONLINE COMMUNITY FOR REGISTERED USERS TO PARTICIPATE IN DISCUSSIONS, GET FEEDBACK FROM THEIR PEERS, FORM VIRTUAL COMMUNITIES, AND ENGAGE IN SOCIAL-NETWORKING SERVICES IN THE FIELD OF GENERAL INTEREST; PROVIDING A WEBSITE THAT ENABLES USERS TO CREATE, UPLOAD, BOOKMARK, VIEW, ANNOTATE, SHARE, AND DISCOVER DATA, INFORMATION, AND MEDIA CONTENT; PROVIDING A PLATFORM THAT ENABLES USERS TO CREATE, UPLOAD, BOOKMARK, VIEW, ANNOTATE, SHARE, AND DISCOVER DATA, INFORMATION, AND MEDIA CONTENT; HOSTING AN INTERACTIVE PLATFORM AND ONLINE NON-DOWNLOADABLE SOFTWARE FOR UPLOADING, POSTING, SHOWING, DISPLAYING, CATEGORIZING, SHARING AND TRANSMITTING MESSAGES, COMMENTS, MULTIMEDIA CONTENT, PHOTOS, PICTURES, IMAGES, TEXT, INFORMATION, AND OTHER USER-GENERATED CONTENT; DEVELOPING AND HOSTING A SERVER ON A GLOBAL COMPUTER NETWORK FOR THE PURPOSE OF FACILITATING E-COMMERCE VIA SUCH A SERVER; PROVIDING NON-DOWNLOADABLE SOFTWARE THAT FACILITATES SHARING AND DISCOVERING INFORMATION AND MEDIA CONTENT VIA LOCAL AND GLOBAL COMPUTER, MOBILE, CELLULAR, ELECTRONIC, WIRELESS, AND DATA COMMUNICATIONS NETWORKS (U.S. CLS. 100 AND 101).

**CLASS 45—PERSONAL AND LEGAL SERVICES**

FOR INTERNET-BASED, SOCIAL-NETWORKING SERVICES (U.S. CLS. 100 AND 101).  
SANJEEV VOHRA, EXAMINING ATTORNEY

SN 86-167,281. IOWA STEEL FABRICATION, LLC, OSCEOLA, IA. FILED 1-16-2014.

COUNTRYSIDE TANK COMPANY

THE MARK CONSISTS OF STANDARD CHARACTERS WITHOUT CLAIM TO ANY PARTICULAR FONT, STYLE, SIZE, OR COLOR.

NO CLAIM IS MADE TO THE EXCLUSIVE RIGHT TO USE "TANK COMPANY", APART FROM THE MARK AS SHOWN.

**CLASS 6—METAL GOODS**

FOR METAL STORAGE TANKS; STATIONARY METAL STORAGE TANKS; METAL PRESSURIZED STORAGE TANKS; METAL PRESSURIZED STORAGE CONTAINERS FOR FERTILIZERS, WATER CHEMICALS, COMPRESSED GASES AND LIQUIDS; CODE COMPLIANT METAL STORAGE TANKS; CODE COMPLIANT METAL STORAGE CONTAINERS FOR FERTILIZERS, WATER CHEMICALS, COMPRESSED GASES AND LIQUIDS (U.S. CLS. 2, 12, 13, 14, 23, 25 AND 50).

**CLASS 12—VEHICLES**

FOR TRAILERS, NAMELY, NAMELY, SEMI-TRACTOR TRAILERS, TRANSPORT TANK TRAILERS, BULK HAULING TRAILERS, WATER VACUUM TRAILERS, TANKER TRAILERS, PRESSURE VESSEL TRAILERS, DEPARTMENT OF TRANSPORTATION COMPLIANT TRAILERS, TRAILERS FOR TANK TRUCKS; TRAILERS IN THE NATURE OF TANKER TRAILERS, NAMELY, PRESSURIZED TANKER TRAILERS FOR USE IN TRANSPORTING FERTILIZERS, WATER CHEMICALS, COMPRESSED GASES, LIQUID PROPANE, AND ANHYDROUS AMMONIA (U.S. CLS. 19, 21, 23, 31, 35 AND 44).  
GRETCHEN ULRICH, EXAMINING ATTORNEY

SN 86-167,305. IOWA STEEL FABRICATION, LLC, OSCEOLA, IA. FILED 1-16-2014.



NO CLAIM IS MADE TO THE EXCLUSIVE RIGHT TO USE "TANK COMPANY", APART FROM THE MARK AS SHOWN.

THE COLOR(S) BLUE, ORANGE AND WHITE IS/ARE CLAIMED AS A FEATURE OF THE MARK.

THE MARK CONSISTS OF A CONCENTRIC CIRCULAR DESIGN WHEREIN THE CENTER CIRCLE IS ORANGE, OUTLINED IN WHITE, AND CONTAINS THE STYLIZED OVERLAPPING WHITE LETTERS "CT". THE BLUE OUTER RING CONTAINS THE STYLIZED WHITE WORDING "COUNTRYSIDE" LOCATED ABOVE THE INNER CIRCLE AND THE STYLIZED WHITE WORDING "TANK COMPANY" LOCATED BELOW THE INNER CIRCLE. THESE TWO PHRASES ARE SEPARATED BY TWO ORANGE CIRCLES. THE MARK IN ITS ENTIRETY APPEARS ON A TRANSPARENT BACKGROUND.

**CLASS 6—METAL GOODS**

FOR METAL STORAGE TANKS; STATIONARY METAL STORAGE TANKS; METAL PRESSURIZED STORAGE TANKS; METAL PRESSURIZED STORAGE CONTAINERS FOR FERTILIZERS, WATER CHEMICALS, COMPRESSED GASES AND LIQUIDS; CODE COMPLIANT METAL STORAGE TANKS; CODE COMPLIANT METAL STORAGE CONTAINERS FOR FERTILIZERS, WATER CHEMICALS, COMPRESSED GASES AND LIQUIDS (U.S. CLS. 2, 12, 13, 14, 23, 25 AND 50).

**CLASS 12—VEHICLES**

FOR TRAILERS, NAMELY, NAMELY, SEMI-TRACTOR TRAILERS, TRANSPORT TANK TRAILERS, BULK HAULING TRAILERS, WATER VACUUM TRAILERS, TANKER TRAILERS, PRESSURE VESSEL TRAILERS, DEPARTMENT OF TRANSPORTATION COMPLIANT TRAILERS, TRAILERS FOR TANK TRUCKS; TRAILERS IN THE NATURE OF TANKER TRAILERS, NAMELY, PRESSURIZED TANKER TRAILERS FOR USE IN TRANSPORTING FERTILIZERS, WATER CHEMICALS, COMPRESSED GASES, LIQUID PROPANE, AND ANHYDROUS AMMONIA (U.S. CLS. 19, 21, 23, 31, 35 AND 44).  
GRETCHEN ULRICH, EXAMINING ATTORNEY

SN 86-167,308. RALLIES ELITE, LLC, DOVER, DE. FILED 1-16-2014.

## RALLIES ELITE

THE MARK CONSISTS OF STANDARD CHARACTERS WITHOUT CLAIM TO ANY PARTICULAR FONT, STYLE, SIZE, OR COLOR.

NO CLAIM IS MADE TO THE EXCLUSIVE RIGHT TO USE "RALLIES" AS TO INTERNATIONAL CLASSES 36, 39 AND 41 ONLY, APART FROM THE MARK AS SHOWN.

### CLASS 35—ADVERTISING AND BUSINESS

FOR BUSINESS NETWORKING OF PEER TO PEER BUSINESS GROUPS OF HIGH NET WORTH INDIVIDUALS (U.S. CLS. 100, 101 AND 102).

### CLASS 36—INSURANCE AND FINANCIAL

FOR CHARITABLE FUNDRAISING SERVICES BY MEANS OF ORGANIZING AUTOMOBILE RACING AND DRIVING EVENTS, AUTOMOBILE EXHIBITIONS AND EXPOSITIONS, AND AUTOMOBILE-RELATED SOCIAL ENTERTAINMENT EVENTS FOR AUTO ENTHUSIASTS (U.S. CLS. 100, 101 AND 102).

### CLASS 39—TRANSPORTATION AND STORAGE

FOR ARRANGING, ORGANIZING AND CONDUCTING TRAVEL TOURS AND EXCURSIONS FOR AUTOMOBILE ENTHUSIASTS (U.S. CLS. 100 AND 105).

### CLASS 41—EDUCATION AND ENTERTAINMENT

FOR ENTERTAINMENT SERVICES IN THE NATURE OF ORGANIZING, ARRANGING AND CONDUCTING AUTOMOBILE RACING AND DRIVING EVENTS AND EXCURSIONS; ENTERTAINMENT SERVICES IN THE NATURE OF AUTOMOBILE COMPETITIONS AND EXHIBITIONS OF PRIVATE AND EXCLUSIVE AUTOMOBILE COLLECTIONS FOR ENTERTAINMENT PURPOSES; ENTERTAINMENT SERVICES IN THE NATURE OF EXPOSITIONS FEATURING AUTOMOBILES FOR ENTERTAINMENT PURPOSES; ORGANIZING, ARRANGING, AND CONDUCTING AUTOMOBILE-RELATED SOCIAL ENTERTAINMENT EVENTS, NAMELY, SOCIAL AND CULTURAL EXPERIENCES; AUTOMOBILE ENTHUSIAST ENTERTAINMENT SERVICES, NAMELY, ORGANIZING AND CONDUCTING SOCIAL ENTERTAINMENT EVENTS, RACING AND DRIVING COMPETITIONS, AND EXHIBITIONS FOR ENTERTAINMENT PURPOSES RELATING TO AUTOMOBILE ENTHUSIASTS (U.S. CLS. 100, 101 AND 107).

JAY FLOWERS, EXAMINING ATTORNEY

SN 86-167,343. RALLIES ELITE, LLC, DOVER, DE. FILED 1-16-2014.

## RALLY ELITE

THE MARK CONSISTS OF STANDARD CHARACTERS WITHOUT CLAIM TO ANY PARTICULAR FONT, STYLE, SIZE, OR COLOR.

NO CLAIM IS MADE TO THE EXCLUSIVE RIGHT TO USE "RALLY" AS TO INTERNATIONAL CLASSES 36, 39 AND 41 ONLY, APART FROM THE MARK AS SHOWN.

### CLASS 35—ADVERTISING AND BUSINESS

FOR BUSINESS NETWORKING OF PEER TO PEER BUSINESS GROUPS OF HIGH NET WORTH INDIVIDUALS (U.S. CLS. 100, 101 AND 102).

### CLASS 36—INSURANCE AND FINANCIAL

FOR CHARITABLE FUNDRAISING SERVICES BY MEANS OF ORGANIZING AUTOMOBILE RACING AND DRIVING EVENTS, AUTOMOBILE EXHIBITIONS AND EXPOSITIONS, AND AUTOMOBILE-RELATED SOCIAL ENTERTAINMENT EVENTS FOR AUTO ENTHUSIASTS (U.S. CLS. 100, 101 AND 102).

### CLASS 39—TRANSPORTATION AND STORAGE

FOR ARRANGING, ORGANIZING AND CONDUCTING TRAVEL TOURS AND EXCURSIONS FOR AUTOMOBILE ENTHUSIASTS (U.S. CLS. 100 AND 105).

### CLASS 41—EDUCATION AND ENTERTAINMENT

FOR ENTERTAINMENT SERVICES IN THE NATURE OF ORGANIZING, ARRANGING AND CONDUCTING AUTOMOBILE RACING AND DRIVING EVENTS AND EXCURSIONS; ENTERTAINMENT SERVICES IN THE NATURE OF AUTOMOBILE COMPETITIONS AND EXHIBITIONS OF PRIVATE AND EXCLUSIVE AUTOMOBILE COLLECTIONS FOR ENTERTAINMENT PURPOSES; ENTERTAINMENT SERVICES IN THE NATURE OF EXPOSITIONS FEATURING AUTOMOBILES FOR ENTERTAINMENT PURPOSES; ORGANIZING, ARRANGING, AND CONDUCTING AUTOMOBILE-RELATED SOCIAL ENTERTAINMENT EVENTS, NAMELY, SOCIAL AND CULTURAL EXPERIENCES; AUTOMOBILE ENTHUSIAST ENTERTAINMENT SERVICES, NAMELY, ORGANIZING AND CONDUCTING SOCIAL ENTERTAINMENT EVENTS, RACING AND DRIVING COMPETITIONS, AND EXHIBITIONS FOR ENTERTAINMENT PURPOSES RELATING TO AUTOMOBILE ENTHUSIASTS (U.S. CLS. 100, 101 AND 107).

JAY FLOWERS, EXAMINING ATTORNEY

SN 86-167,409. DUNDALK INSTITUTE OF TECHNOLOGY, DUNDALK, IE-LH, IRELAND, FILED 1-16-2014.

## MDEVSPICE

THE MARK CONSISTS OF STANDARD CHARACTERS WITHOUT CLAIM TO ANY PARTICULAR FONT, STYLE, SIZE, OR COLOR.

PRIORITY CLAIMED UNDER SEC. 44(D) ON IRELAND APPLICATION NO. 613624, FILED 1-13-2014, REG. NO. 012496741, DATED 5-15-2014, EXPIRES 1-13-2024.

### CLASS 9—ELECTRICAL AND SCIENTIFIC APPARATUS

FOR COMPUTER SOFTWARE FOR MEDICAL DEVICE SOFTWARE PROCESS ASSESSMENT AND TRAINING; ELECTRONIC PRODUCTS FOR THE MANIPULATION OF THE FREQUENCY, TIME, AND AMPLITUDE CHARACTERISTICS OF AUDIO SIGNALS, NAMELY, AUDIO PROCESSORS (U.S. CLS. 21, 23, 26, 36 AND 38).

**CLASS 35—ADVERTISING AND BUSINESS**

FOR CONSULTING SERVICES IN THE FIELD OF MEDICAL PRODUCT APPROVAL FOR COMMERCIAL PURPOSES; COMPILATION OF STATISTICAL DATA RELATING TO MEDICAL RESEARCH; PROVISION OF BUSINESS STATISTICAL INFORMATION RELATING TO MEDICAL MATTERS; ASSESSMENT OF MEDICAL DEVICE SOFTWARE PROCESSES OF OTHERS FOR THE PURPOSE OF DETERMINING BUSINESS PROCESS BENCHMARKING AND CAPABILITY AND COMPLIANCE WITH BEST BUSINESS PRACTICES AND MODELS (U.S. CLS. 100, 101 AND 102).

**CLASS 41—EDUCATION AND ENTERTAINMENT**

FOR MEDICAL EDUCATION SERVICES, NAMELY, COURSES AND SEMINARS IN THE FIELD OF THE DEVELOPMENT OF MEDICAL DEVICES; MEDICAL TRAINING AND TEACHING; PUBLISHING OF MEDICAL PUBLICATIONS; PUBLICATION OF MEDICAL TEXTS; PROVIDING ADVICE IN THE FIELD OF MEDICAL TRAINING; CONDUCTING OF EDUCATIONAL SEMINARS RELATING TO MEDICAL MATTERS; ORGANIZATION OF CONFERENCES AND SYMPOSIA IN THE FIELD OF MEDICAL SCIENCE FOR EDUCATIONAL PURPOSES (U.S. CLS. 100, 101 AND 107).

**CLASS 42—SCIENTIFIC AND COMPUTER SERVICES**

FOR COMPUTER SOFTWARE DESIGN; COMPUTER HARDWARE DESIGN; TECHNICAL SUPPORT SERVICES, NAMELY, TROUBLESHOOTING IN THE NATURE OF DIAGNOSING PROBLEMS WITH MEDICAL EQUIPMENT; DESIGN, ENGINEERING, RESEARCH, DEVELOPMENT AND TESTING SERVICES IN THE FIELD OF POLYMERIC MATERIALS, POLYMER SYNTHESIS, AND MATERIALS CUSTOMIZATION FOR MEDICAL, SCIENTIFIC, AND TECHNOLOGICAL APPLICATIONS; SCIENTIFIC RESEARCH; SCIENTIFIC AND TECHNOLOGICAL SERVICES, NAMELY, RESEARCH AND DESIGN IN THE FIELD OF THE DEVELOPMENT OF MEDICAL DEVICES; MEDICAL RESEARCH SERVICES; CALIBRATION SERVICES RELATING TO MEDICAL APPARATUS; COMPUTER PROGRAMMING IN THE MEDICAL FIELD; WRITING OF COMPUTER PROGRAMS FOR MEDICAL APPLICATIONS; ASSESSMENT OF MEDICAL DEVICE SOFTWARE PROCESSES OF OTHERS FOR QUALITY CONTROL PURPOSES AND FOR DETERMINING COMPLIANCE WITH INTERNATIONAL INDUSTRY STANDARDS; CONSULTANCY AND ADVICE IN RESPECT OF THE ABOVE (U.S. CLS. 100 AND 101).

KIMBERLY FRYE, EXAMINING ATTORNEY

**CLASS 16—PAPER GOODS AND PRINTED MATTER**

FOR PRINTED MATTER AND PRINTED PUBLICATIONS, NAMELY, FINANCIAL REPORTS, BROCHURES, NEWSLETTERS, INDEXES, AND BOOKLETS IN THE FIELD OF FINANCE AND FINANCIAL SERVICES (U.S. CLS. 2, 5, 22, 23, 29, 37, 38 AND 50).

**CLASS 36—INSURANCE AND FINANCIAL**

FOR FINANCIAL AFFAIRS, NAMELY, CONDUCTING AN ELECTRONIC EXCHANGE SECURITIES AND DERIVATIVES AND CONDUCTING A TRADING PLATFORM FOR THE TRADING OF FINANCIAL PRODUCTS; BANKING SERVICES; SECURITIES AND DERIVATIVES CHANGE QUOTATION SERVICES; SECURITIES AND DERIVATIVES TRADING PLATFORM QUOTATION SERVICES; DETERMINATION, CALCULATING AND PROVIDING INFORMATION ON SECURITIES AND DERIVATIVES; PROVIDING ONLINE ELECTRONIC DATABASES IN THE FIELD OF FINANCIAL SERVICES, SECURITIES AND DERIVATIVES EXCHANGES AND A SECURITIES AND DERIVATIVES TRADING PLATFORM FOR THE TRADING OF FINANCIAL PRODUCTS AND BANKING SERVICES; FINANCIAL AFFAIRS, NAMELY, FINANCIAL CLEARINGHOUSE SERVICES, FINANCIAL CLEARING AND SETTLEMENT SERVICES, NAMELY, CLEARING AND SETTLING OF FINANCIAL TRANSACTIONS FOR OTHERS; FINANCIAL RISK MANAGEMENT SERVICES RELATING TO INVESTMENT PORTFOLIOS; PROVIDING ONLINE ELECTRONIC DATABASES IN THE FIELD OF CLEARINGHOUSE SERVICES, FINANCIAL CLEARING AND SETTLEMENT SERVICES, NAMELY, CLEARING AND SETTLING OF FINANCIAL TRANSACTIONS FOR OTHERS; FINANCIAL RISK MANAGEMENT SERVICES RELATING TO INVESTMENT PORTFOLIOS, BANKING SERVICES; INFORMATION AND ADVISORY SERVICES RELATING TO THE AFORESAID SERVICES (U.S. CLS. 100, 101 AND 102).

**CLASS 38—COMMUNICATION**

FOR PROVIDING ACCESS TO GLOBAL TELECOMMUNICATIONS NETWORKS, IN PARTICULAR FOR THE FINANCIAL SERVICES INDUSTRY; PROVIDING ACCESS AND CONNECTIVITY TO ELECTRONIC COMMUNICATIONS NETWORKS AND ELECTRONIC DATABASES, IN PARTICULAR FOR THE FINANCIAL SERVICES INDUSTRY; ELECTRONICALLY CONNECTING FINANCIAL INSTITUTIONS AND FINANCIAL MARKET VENUES WITH ONE ANOTHER ON A GLOBAL SCALE (U.S. CLS. 100, 101 AND 104).

PATRICIA EVANKO, EXAMINING ATTORNEY

SN 86-168,110. DEUTSCHE BÖRSE AG, ESCHBORN, FED REP GERMANY, FILED 1-17-2014.

SN 86-169,575. DUNCAN ENTERPRISES, DBA ILOVE-TOCREATE, FRESNO, CA. FILED 1-19-2014.

**M7**

**Aleene's School Tacky Glue**

THE MARK CONSISTS OF STANDARD CHARACTERS WITHOUT CLAIM TO ANY PARTICULAR FONT, STYLE, SIZE, OR COLOR.

PRIORITY CLAIMED UNDER SEC. 44(D) ON ERP CMNTY TM OFC APPLICATION NO. 012342473, FILED 11-26-2013, REG. NO. 012342473, DATED 4-23-2014, EXPIRES 11-26-2023.

OWNER OF U.S. REG. NOS. 4,417,556, 4,453,611 AND 4,453,739.

THE MARK CONSISTS OF STANDARD CHARACTERS WITHOUT CLAIM TO ANY PARTICULAR FONT, STYLE, SIZE, OR COLOR.

OWNER OF U.S. REG. NOS. 4,101,224, 4,101,228 AND OTHERS.

NO CLAIM IS MADE TO THE EXCLUSIVE RIGHT TO USE "SCHOOL TACKY GLUE", APART FROM THE MARK AS SHOWN.

**CLASS 1—CHEMICALS**

FOR GLUE IN THE NATURE OF A CEMENT FOR HOME AND SCHOOL-CRAFT APPLICATIONS FOR USE IN BONDING TOGETHER FABRIC, FIBERS AND PAPER; GLUE FOR USE BY DECORATORS FOR HOME AND SCHOOL-CRAFT APPLICATIONS FOR USE IN BONDING TOGETHER FABRIC, FIBERS AND PAPER; GLUE FOR USE IN THE SCHOOL CRAFT AND HOBBY INDUSTRIES FOR BONDING TOGETHER FABRIC, FIBERS AND PAPER (U.S. CLS. 1, 5, 6, 10, 26 AND 46).

SN 86-170,479. SWAGELOK COMPANY, SOLON, OH. FILED 1-21-2014.

**CLASS 16—PAPER GOODS AND PRINTED MATTER**

FOR GLUE FOR HOME USE IN BONDING TOGETHER FABRIC, FIBERS AND PAPER; GLUE FOR HOUSEHOLD APPLICATIONS FOR USE IN BONDING TOGETHER FABRIC, FIBERS AND PAPER (U.S. CLS. 2, 5, 22, 23, 29, 37, 38 AND 50).

ALEX KEAM, EXAMINING ATTORNEY



SN 86-169,600. DUNCAN ENTERPRISES, DBA ILOVE-TOCREATE, FRESNO, CA. FILED 1-19-2014.

THE MARK CONSISTS OF THREE CONCENTRIC CIRCLES WITH THE LETTER "S" IN THE CENTER.

---

## Tulip Mini Writers

THE MARK CONSISTS OF STANDARD CHARACTERS WITHOUT CLAIM TO ANY PARTICULAR FONT, STYLE, SIZE, OR COLOR.

OWNER OF U.S. REG. NOS. 2,456,091, 4,442,319 AND OTHERS.

NO CLAIM IS MADE TO THE EXCLUSIVE RIGHT TO USE "MINI WRITERS", APART FROM THE MARK AS SHOWN.

**CLASS 2—PAINTS**

FOR PAINT FOR FABRICS; PAINT FOR CRAFTS (U.S. CLS. 6, 11 AND 16).

**CLASS 16—PAPER GOODS AND PRINTED MATTER**

FOR ARTISTS MATERIALS FOR USE IN THE APPLICATION OF PAINT ONTO FABRIC IN THE FORM OF SMALL PEN-LIKE APPLICATORS TO ALLOW FOR APPLICATION OF PAINT ONTO FABRIC IN SIMILAR MANNER AS IF BEING APPLIED WITH A PEN (U.S. CLS. 2, 5, 22, 23, 29, 37, 38 AND 50).

ALEX KEAM, EXAMINING ATTORNEY

**CLASS 1—CHEMICALS**

FOR CHEMICAL COMPOUND FOR DETECTING LEAKS IN GAS AND FLUID LINES; CHEMICAL COMPOUND WHICH WILL NOT FREEZE AT LOW TEMPERATURES FOR DETECTING LEAKS IN GAS AND FLUID LINES (U.S. CLS. 1, 5, 6, 10, 26 AND 46).

FIRST USE 9-25-2013; IN COMMERCE 9-25-2013.

**CLASS 4—LUBRICANTS AND FUELS**

FOR LUBRICANT OILS FOR GLASS SEALS AND FOR TITANIUM, STAINLESS STEEL, STEEL, AND ALLOY FITTING THREADS, O-RINGS AND GASKETS (U.S. CLS. 1, 6 AND 15).

FIRST USE 9-25-2013; IN COMMERCE 9-25-2013.

**CLASS 6—METAL GOODS**

FOR MANUALLY OPERATED METAL VALVES FOR TUBES, PIPES AND HOSES; METAL VALVES NOT BEING PARTS OF MACHINES; METAL GASKETS, GLANDS, FERRULES AND NUTS FOR TUBES, PIPES AND HOSES; METAL STRAIGHT, ELBOW, TEE AND CROSS FITTINGS FOR TUBES, PIPES AND HOSES; METAL VACUUM FITTINGS FOR TUBES, PIPES AND HOSES; METAL COUPLINGS FOR TUBES, PIPES AND HOSES; METAL REDUCER FITTINGS FOR TUBES, PIPES AND HOSES; METAL ADAPTER FITTINGS FOR TUBES, PIPES AND HOSES; METAL PORT CONNECTOR FITTINGS FOR TUBES, PIPES AND HOSES; METAL QUICK DISCONNECT FITTINGS FOR TUBE, PIPE AND HOSE END CONNECTIONS; METAL TUBING; FLEXIBLE METAL TUBING AND HOSE; METAL CONVOLUTED TUBING; METAL PIPES USED FOR GAS DISTRIBUTION; METAL SEALS FOR TUBES, PIPES AND HOSES; METAL CLAMPS FOR TUBES, PIPES AND HOSES; METAL CAPS FOR TUBES, PIPES AND HOSES; METAL PLUGS FOR TUBES, PIPES AND HOSES; METAL COMPRESSED GAS CYLINDERS SOLD EMPTY FOR USE WITH HYDRAULIC AND PNEUMATIC SYSTEMS; METAL CYLINDERS FOR FLUIDS SOLD EMPTY; METAL THERMOWELLS; METAL MANIFOLDS FOR USE WITH HYDRAULIC AND PNEUMATIC SYSTEMS (U.S. CLS. 2, 12, 13, 14, 23, 25 AND 50).

FIRST USE 9-25-2013; IN COMMERCE 9-25-2013.

**CLASS 7—MACHINERY**

FOR ELECTRICALLY-POWERED MACHINES AND ELECTRICALLY-POWERED TOOLS FOR CUTTING, BENDING, DEBURRING, AND SWAGING TUBE AND HOSE; ELECTRIC TUBE BENDER MACHINE; ELECTRIC ARC WELDING MACHINES, WELDING COOLING PLATES, WELD HEAD BENCH MOUNTING BRACKETS ATTACHED TO WORK BENCHES, WELD HELD FIXTURE TOOL, WELDING COLLETS FOR TUBES, PIPES AND FITTINGS; VALVES AS MACHINE COMPONENTS; PRESSURE TRANSDUCERS AS PARTS OF MACHINES; PNEUMATIC VALVE ACTUATORS; REGULATORS BEING PARTS OF MACHINES; GAS AND LIQUID FILTERS BEING PARTS OF MACHINES; WELDING ELECTRODES (U.S. CLS. 13, 19, 21, 23, 31, 34 AND 35).

FIRST USE 9-25-2013; IN COMMERCE 9-25-2013.

**CLASS 8—HAND TOOLS**

FOR HAND-OPERATED TOOLS FOR CUTTING, SAWING, BENDING, DEBURRING AND SWAGING TUBE AND HOSE; WRENCHES (U.S. CLS. 23, 28 AND 44).

FIRST USE 9-25-2013; IN COMMERCE 9-25-2013.

**CLASS 9—ELECTRICAL AND SCIENTIFIC APPARATUS**

FOR WELDING APPARATUS, NAMELY, REMOTE PENDANT CONTROLS, WELD HEAD CENTERING GAUGES, WELD ARC GAP GAUGES; PRESSURE GAUGES FOR GAS AND FLUID; FITTINGS GAP INSPECTION APPARATUS; ELECTRICAL TRANSDUCER; ELECTRIC OR ELECTRONIC SENSORS FOR SENSING FLOW OF FLUID; PRESSURE TRANSDUCERS AND TRANSMITTERS THAT CONVERT HYDRAULIC OR PNEUMATIC PRESSURE INTO ANALOG ELECTRICAL SIGNALS FOR MONITORING AND CONTROLLING HYDRAULIC OR PNEUMATIC SYSTEMS; CONTROL VALVES FOR REGULATING THE FLOW OF GASES AND LIQUIDS; ELECTRIC VALVE ACTUATORS; PRESSURE RELIEF VALVES FOR FLUID SYSTEMS; THERMOMETERS; FLOWMETERS; CALIBRATION DEVICES FOR CALIBRATING FLUID SYSTEMS (U.S. CLS. 21, 23, 26, 36 AND 38).

FIRST USE 9-25-2013; IN COMMERCE 9-25-2013.

**CLASS 11—ENVIRONMENTAL CONTROL APPARATUS**

FOR PRESSURE REGULATORS FOR GAS INSTALLATIONS (U.S. CLS. 13, 21, 23, 31 AND 34).

FIRST USE 9-25-2013; IN COMMERCE 9-25-2013.

**CLASS 17—RUBBER GOODS**

FOR PIPE JOINT SEALANT; SEALANT COMPOUNDS FOR JOINTS; NON-METAL GASKETS FOR FLUID SYSTEMS; NON-METAL, PLASTIC AND RUBBER HOSES FOR INDUSTRIAL APPLICATIONS; PLASTIC PIPE AND FLEXIBLE PIPE NOT OF METAL; PLASTIC GLANDS AND FERRULES FOR PLASTIC TUBES, FLEXIBLE PIPES AND NON-METAL HOSES; ALL GOODS FOR RESEARCH, INSTRUMENTATION, PHARMACEUTICAL, OIL AND GAS, POWER GENERATION, CHEMICAL, PETROCHEMICAL, SANITARY AND SEMICONDUCTOR INDUSTRY PURPOSES; NON-METALLIC FLEXIBLE PIPES AND HOSE FITTINGS; FLEXIBLE TUBES OF PLASTIC AND PLUGS THEREFOR (U.S. CLS. 1, 5, 12, 13, 35 AND 50).

FIRST USE 9-25-2013; IN COMMERCE 9-25-2013.

**CLASS 19—NON-METALLIC BUILDING MATERIALS**

FOR NON-METAL PIPE COUPLINGS AND JOINTS; NON-METAL TUBING AND TUBING COUPLINGS FOR JOINING AND TERMINATING PIPES (U.S. CLS. 1, 12, 33 AND 50).

**CLASS 20—FURNITURE AND ARTICLES NOT OTHERWISE CLASSIFIED**

FOR PLASTIC VALVES BEING OTHER THAN MACHINE PARTS; PLASTIC NUTS (U.S. CLS. 2, 13, 22, 25, 32 AND 50).

FIRST USE 9-25-2013; IN COMMERCE 9-25-2013.

**CLASS 35—ADVERTISING AND BUSINESS**

FOR LOGISTICS MANAGEMENT, MARKETING, INVENTORY CONTROL, AND CUSTOMER SERVICES MANAGEMENT FOR OTHERS IN THE FIELDS OF BIOPHARMACEUTICAL, FOOD, BEVERAGE, DAIRY, OIL AND GAS, POWER GENERATION, CHEMICAL, PETROCHEMICAL, SHIPBUILDING, PULP AND PAPER, AND SEMI-CONDUCTOR TECHNOLOGIES; BUSINESS MANAGEMENT CONSULTANCY; BUSINESS ORGANIZATION CONSULTANCY; BUSINESS MANAGEMENT ASSISTANCE; BUSINESS INFORMATION; PROCUREMENT, NAMELY, PURCHASING OF FLUID SYSTEMS EQUIPMENT FOR OTHERS USED IN THE PROCESS OF ANALYTICAL INSTRUMENTATION, BIOPHARMACEUTICAL, FOOD, BEVERAGE, DAIRY, OIL AND GAS, POWER GENERATION, CHEMICAL, PETROCHEMICAL, SHIPBUILDING, PULP AND PAPER, AND SEMI-CONDUCTOR INDUSTRIES (U.S. CLS. 100, 101 AND 102).

**CLASS 37—CONSTRUCTION AND REPAIR**

FOR RENTAL OF EQUIPMENT, NAMELY, WELD SYSTEMS, TUBE BENDERS, AND OTHER EQUIPMENT, NAMELY, TUBE FLARING TOOLS, GAP INSPECTION GAUGES, DEPTH MARKING TOOLS AND TUBE CUTTERS FOR THE SUPPORT OF FLUID SYSTEMS TECHNOLOGIES USED IN THE PROCESS AND ANALYTICAL INSTRUMENTATION, BIOPHARMACEUTICAL, FOOD, BEVERAGE, DAIRY, OIL AND GAS, POWER GENERATION, CHEMICAL, PETROCHEMICAL, SHIPBUILDING, PULP AND PAPER, AND SEMI-CONDUCTOR INDUSTRIES (U.S. CLS. 100, 103 AND 106).

**CLASS 39—TRANSPORTATION AND STORAGE**

FOR SHIPPING AND DELIVERY SERVICES, NAMELY, PICKUP AND TRANSPORTATION, AND DELIVERY OF GOODS USED IN THE PROCESS AND ANALYTICAL INSTRUMENTATION, BIOPHARMACEUTICAL, FOOD, BEVERAGE, DAIRY, OIL AND GAS, POWER GENERATION, CHEMICAL, PETROCHEMICAL, SHIPBUILDING, PULP AND PAPER, AND SEMI-CONDUCTOR INDUSTRIES BY VARIOUS MODES OF TRANSPORTATION (U.S. CLS. 100 AND 105).

**CLASS 40—MATERIAL TREATMENT**

FOR TREATMENT OF METAL GOODS USED IN THE PROCESS AND ANALYTICAL INSTRUMENTATION, BIOPHARMACEUTICAL, FOOD, BEVERAGE, DAIRY, OIL AND GAS, POWER GENERATION, CHEMICAL, PETROCHEMICAL, SHIPBUILDING, PULP AND PAPER, AND SEMI-CONDUCTOR INDUSTRIES; ASSEMBLY OF FLUID SYSTEMS FOR OTHERS (U.S. CLS. 100, 103 AND 106).

**CLASS 41—EDUCATION AND ENTERTAINMENT**

FOR EDUCATIONAL TRAINING SERVICES, NAMELY, CONDUCTING CLASSES AND PROVIDING ELECTRONIC AND ON-SITE TRAINING IN THE FIELD OF FLUID SYSTEM TECHNOLOGIES EQUIPMENT FOR GOODS USED IN THE PROCESS AND ANALYTICAL INSTRUMENTATION, BIOPHARMACEUTICAL, FOOD, BEVERAGE, DAIRY, OIL AND GAS, POWER GENERATION, CHEMICAL, PETROCHEMICAL, SHIPBUILDING, PULP AND PAPER, AND SEMI-CONDUCTOR INDUSTRIES, AND DISTRIBUTING COURSE MATERIALS IN CONNECTION THEREWITH (U.S. CLS. 100, 101 AND 107).

**CLASS 42—SCIENTIFIC AND COMPUTER SERVICES**

FOR TESTING, ANALYSIS AND EVALUATION OF THE GOODS OF OTHERS FOR THE PURPOSE OF CERTIFICATION, ENGINEERING CONSULTANCY, CHEMISTRY CONSULTANCY, IN THE FIELDS OF PROCESS AND ANALYTICAL INSTRUMENTATION, BIOPHARMACEUTICAL, FOOD, BEVERAGE, DAIRY, OIL AND GAS, POWER GENERATION, CHEMICAL, PETROCHEMICAL, SHIPBUILDING, PULP AND PAPER, AND SEMI-CONDUCTOR TECHNOLOGIES; QUALITY CONTROL; TECHNICAL SUPPORT SERVICES, NAMELY, TROUBLESHOOTING OF COMPUTER SOFTWARE PROBLEMS (U.S. CLS. 100 AND 101).  
DORITT L. CARROLL, EXAMINING ATTORNEY

SN 86-170,832. PLASTIPACK LIMITED, EAST SUSSEX, UNITED KINGDOM, FILED 1-21-2014.



OWNER OF ERPN CMNTY TM OFC REG. NO. 007323934, DATED 5-14-2009, EXPIRES 10-17-2018.

THE MARK CONSISTS OF THE WORDING "SOL + GUARD" WITH A RIBBON DESIGN ABOVE THE LETTERS "SOL".

**CLASS 17—RUBBER GOODS**

FOR SWIMMING POOL COVER PARTS, NAMELY, SEMI-FINISHED PLASTIC SHEET MATERIALS FOR THE MANUFACTURE OF SWIMMING POOL COVERS; SWIMMING POOL COVER MATERIALS SOLD BY THE PIECE, NAMELY, SEMI-FINISHED PLASTIC SHEET MATERIALS FOR THE MANUFACTURE OF SWIMMING POOL COVERS (U.S. CLS. 1, 5, 12, 13, 35 AND 50).

**CLASS 22—CORDAGE AND FIBERS**

FOR UNFITTED SWIMMING POOL COVERS AND FITTINGS THEREFOR SOLD AS A UNIT (U.S. CLS. 1, 2, 7, 19, 22, 42 AND 50).

B. PARADEWELAI, EXAMINING ATTORNEY

SN 86-171,148. UGLOW LIMITED, CAUSEWAYBAY, HONG KONG, FILED 1-21-2014.

# UGLOW

THE MARK CONSISTS OF STANDARD CHARACTERS WITHOUT CLAIM TO ANY PARTICULAR FONT, STYLE, SIZE, OR COLOR.

**CLASS 9—ELECTRICAL AND SCIENTIFIC APPARATUS**

FOR REFLECTIVE AND ILLUMINATED CLOTHING FOR SAFETY PURPOSES; SAFETY PRODUCTS, NAMELY, REFLECTIVE SAFETY BANDS TO BE WORN ON THE BODY; SAFETY HELMETS; PROTECTIVE HELMETS FOR SPORTS (U.S. CLS. 21, 23, 26, 36 AND 38).

**CLASS 25—CLOTHING**

FOR CLOTHING, NAMELY, LIGHT REFLECTING JACKETS, VESTS, FOOTWEAR AND HEADWEAR (U.S. CLS. 22 AND 39).

STEVEN PEREZ, EXAMINING ATTORNEY

SN 86-171,414. LAYLA GRAYCE, INC., PASADENA, CA, FILED 1-21-2014.



OWNER OF U.S. REG. NO. 4,149,563.

THE NAME(S), PORTRAIT(S), AND/OR SIGNATURE(S) SHOWN IN THE MARK DOES NOT IDENTIFY A PARTICULAR LIVING INDIVIDUAL.

THE COLOR(S) LIGHT BROWN, WHITE, BROWN AND PINK IS/ARE CLAIMED AS A FEATURE OF THE MARK.

THE MARK CONSISTS OF ONE LIGHT BROWN AND WHITE LEAF APPEARING ON THE RIGHT AND LEFT SIDE OF A LIGHT BROWN AND WHITE ROSE ALL APPEARING ABOVE THE WORDS, "LAYLA GRAYCE", IN BROWN APPEARING WITHIN A PINK RIBBON BANNER WITH INVERTED TRIANGLE CUT EDGES.

**CLASS 35—ADVERTISING AND BUSINESS**

FOR (BASED ON USE IN COMMERCE) ON-LINE RETAIL STORE SERVICES FEATURING CLOTHING, HOME DECOR, BEDDING, FURNITURE, SEATING, LIGHTING, BAR AND SERVING PIECES, COASTERS, GLASSWARE, MUGS, SERVING TRAYS, SPOON RESTS, SALE AND PEPPER SHAKERS, TABLE LINENS, FABRIC, RUGS, PILLOWS, WALLPAPER AND WALL DECOR, MIRRORS, SHELVES, ART, WINDOW COVERINGS, BABY GEAR AND ACCESSORIES, BOOKS, JEWELRY, HANDBAGS, HANDICRAFTS, GIFTS, AND WOMEN'S ACCESSORIES (U.S. CLS. 100, 101 AND 102).

FIRST USE 10-22-2004; IN COMMERCE 10-22-2004.

**CLASS 42—SCIENTIFIC AND COMPUTER SERVICES**

FOR (BASED ON INTENT TO USE) DESIGN OF INTERIOR DECOR; DESIGN OF TEXTILES; FURNITURE DESIGN SERVICES; INTERIOR DECORATION CONSULTATION; INTERIOR DESIGN SERVICES; INTERIOR DESIGN SERVICES INCLUDING SPACE PLANNING, FURNITURE SELECTION, MATERIAL AND SURFACE SELECTION (U.S. CLS. 100 AND 101).

ANNE FARRELL, EXAMINING ATTORNEY

SN 86-172,430. PIXOCIATE TECHNOLOGIES KFT., BUDAPEST, HUNGARY, FILED 1-22-2014.

# PIXOCIATE

THE MARK CONSISTS OF STANDARD CHARACTERS WITHOUT CLAIM TO ANY PARTICULAR FONT, STYLE, SIZE, OR COLOR.

PRIORITY CLAIMED UNDER SEC. 44(D) ON HUNGARY APPLICATION NO. M1302118, FILED 7-23-2013, REG. NO. 211746, DATED 1-10-2014, EXPIRES 7-23-2023.

**CLASS 9—ELECTRICAL AND SCIENTIFIC APPARATUS**

FOR COMPUTER SOFTWARE FOR PROVIDING GRAPHICS USER INTERFACE (GUI) AND FUNCTIONS FOR DESIGNING MARKETING CAMPAIGNS, LISTING REPLIES, RATES, VOTES AND STATISTICS OF MARKETING CAMPAIGNS AND SHOWING USER ACTIVITY ON A MAP; COMPUTER SOFTWARE FOR COMMUNICATING WITH MOBILE APPLICATIONS, DOWNLOADING PREDEFINED PICTURE-BASED MARKETING CAMPAIGN DETAILS INCLUDING PICTURES, CAMPAIGN DEADLINES, WELCOME TEXTS AND FOR RECEIVING AND PROCESSING ANSWERS TO QUESTIONS FROM USERS; COMPUTER SOFTWARE DEVELOPMENT TOOLS; COMPUTER SOFTWARE APPLICATIONS FOR MOBILE PHONES FOR ALLOWING INDIVIDUALS TO CAPTURE OR USE PICTURES TO EXPRESS RELATIONS, PREFERENCES, COMPARISONS OR RANKINGS AND THEN TO SHARE THEM TO SOCIAL MEDIA SITES, FOR SUPPORTING PICTURE-BASED FEEDBACK AND FOR PROVIDING CUSTOMER PERCEPTION TO THE CORPORATE ENVIRONMENT (U.S. CLS. 21, 23, 26, 36 AND 38).

**CLASS 35—ADVERTISING AND BUSINESS**

FOR BUSINESS MANAGEMENT CONSULTANCY SERVICES; CONSULTANCY SERVICES RELATING TO MARKETING; MARKET ANALYSIS; MARKETING RESEARCH SERVICES; ANALYZING THE IMPACT OF ADVERTISING IN THE NATURE OF ADVERTISING CONSULTANCY; MEASUREMENT OF CUSTOMER SATISFACTION, NAMELY, CONDUCTING MARKET SURVEYS; ANALYSIS OF MARKET RESEARCH DATA AND STATISTICS; BUSINESS DATA ANALYSIS (U.S. CLS. 100, 101 AND 102).

KERI CANTONE, EXAMINING ATTORNEY

SN 86-172,645. BROWN, NICOLE, CHESTER, VA. FILED 1-22-2014.

**NURSE NICOLE**

THE MARK CONSISTS OF STANDARD CHARACTERS WITHOUT CLAIM TO ANY PARTICULAR FONT, STYLE, SIZE, OR COLOR.

THE NAME(S), PORTRAIT(S), AND/OR SIGNATURE(S) SHOWN IN THE MARK DOES NOT IDENTIFY A PARTICULAR LIVING INDIVIDUAL.

**CLASS 9—ELECTRICAL AND SCIENTIFIC APPARATUS**

FOR PRE-RECORDED DVDS IN THE FIELD OF NURSING AND HEALTH EDUCATION FOR CHILDREN (U.S. CLS. 21, 23, 26, 36 AND 38).

FIRST USE 1-0-2014; IN COMMERCE 1-0-2014.

**CLASS 16—PAPER GOODS AND PRINTED MATTER**

FOR PRINTED MATTER, NAMELY, BOOKS IN THE FIELD OF NURSING AND HEALTH EDUCATION FOR CHILDREN (U.S. CLS. 2, 5, 22, 23, 29, 37, 38 AND 50).

FIRST USE 1-0-2014; IN COMMERCE 1-0-2014.

**CLASS 28—TOYS AND SPORTING GOODS**

FOR DOLLS, DOLL CLOTHING, AND DOLL ACCESSORIES (U.S. CLS. 22, 23, 38 AND 50).

FIRST USE 1-0-2014; IN COMMERCE 1-0-2014.  
JOHN DALIER, EXAMINING ATTORNEY

SN 86-172,727. COLLEGIATE EMPOWERMENT, EASTON, PA. FILED 1-23-2014.

**COLLEGIATE EMPOWERMENT**

THE MARK CONSISTS OF STANDARD CHARACTERS WITHOUT CLAIM TO ANY PARTICULAR FONT, STYLE, SIZE, OR COLOR.

NO CLAIM IS MADE TO THE EXCLUSIVE RIGHT TO USE "COLLEGIATE", APART FROM THE MARK AS SHOWN.

**CLASS 16—PAPER GOODS AND PRINTED MATTER**

FOR A SERIES OF EDUCATIONAL BOOKS AND EDUCATIONAL RESOURCES, NAMELY, PRINTED INSTRUCTIONAL, EDUCATIONAL AND TEACHING MATERIALS IN THE FIELDS OF PERSONAL GROWTH AND DEVELOPMENT AND CO-CURRICULAR EDUCATION FOR UNIVERSITY UNDERGRADUATES, GRADUATE STUDENTS, RECENT UNIVERSITY GRADUATES, AND THE STAFF OF THEIR RESPECTIVE INSTITUTIONS OF HIGHER EDUCATION (U.S. CLS. 2, 5, 22, 23, 29, 37, 38 AND 50).

**CLASS 41—EDUCATION AND ENTERTAINMENT**

FOR EDUCATIONAL SERVICES, NAMELY, DEVELOPING AND CONDUCTING SEMINARS, WORKSHOPS AND CONFERENCES IN THE FIELDS OF PERSONAL GROWTH AND DEVELOPMENT; EDUCATING AT UNIVERSITY OR COLLEGES BY PROVIDING CO-CURRICULAR EDUCATION FOR UNIVERSITY UNDERGRADUATES, GRADUATE STUDENTS, RECENT UNIVERSITY GRADUATES, AND THE STAFF OF THEIR RESPECTIVE INSTITUTIONS OF HIGHER EDUCATION; PERSONAL COACHING SERVICES IN THE FIELD OF PERSONAL GROWTH AND DEVELOPMENT (U.S. CLS. 100, 101 AND 107).

KAPIL BHANOT, EXAMINING ATTORNEY

SN 86-173,789. WELL AWARE RESOURCES, LLC, SHEBOYGAN, WI. FILED 1-23-2014.

**EMPATHOS RESOURCES**

THE MARK CONSISTS OF STANDARD CHARACTERS WITHOUT CLAIM TO ANY PARTICULAR FONT, STYLE, SIZE, OR COLOR.

NO CLAIM IS MADE TO THE EXCLUSIVE RIGHT TO USE "RESOURCES", APART FROM THE MARK AS SHOWN.



**CLASS 9—ELECTRICAL AND SCIENTIFIC APPARATUS**

FOR DOWNLOADABLE ELECTRONIC BOOKS, PAMPHLETS, MAGAZINES AND NEWSLETTERS AND EDUCATIONAL MATERIALS IN THE FIELDS OF VIOLENCE REDUCTION, SAFE AND HEALTHY SCHOOLS AND COMMUNITIES, AND PREVENTION OF SUICIDE; COMPUTER SOFTWARE FOR PRODUCING INTERACTIVE TEMPLATES, FORMS, GUIDELINES AND SPREADSHEETS USED IN THE FIELDS OF VIOLENCE REDUCTION, SAFE AND HEALTHY SCHOOLS AND COMMUNITIES, AND PREVENTION OF SUICIDE; PRE-RECORDED DIGITAL FILES OF INFORMATION ON CD-ROM AND DVD ON BEST PRACTICES FOR VIOLENCE REDUCTION, SAFE AND HEALTHY SCHOOLS AND COMMUNITY ENVIRONMENTS, AND PREVENTION OF SUICIDE; COMPUTER APPLICATION SOFTWARE FOR MOBILE PHONE, PERSONAL DIGITAL ASSISTANTS (PDAS), AND HANDHELD COMPUTERS, NAMELY, SOFTWARE FOR INTERACTIVE TRAINING AND LEARNING APPLICATIONS FOR USE IN THE FIELDS OF VIOLENCE REDUCTION, SAFE AND HEALTHY SCHOOLS AND COMMUNITIES, AND PREVENTION OF SUICIDE; DOWNLOADABLE ELECTRONIC DATA FILES, DISTRIBUTED VIA A COMPANY'S OR ORGANIZATION'S INTERNAL NETWORK OR A GLOBAL COMPUTER INFORMATION NETWORK, FEATURING INFORMATION IN THE FIELDS OF VIOLENCE REDUCTION, SAFE AND HEALTHY SCHOOLS AND COMMUNITIES, AND PREVENTION OF SUICIDE (U.S. CLS. 21, 23, 26, 36 AND 38).

**CLASS 16—PAPER GOODS AND PRINTED MATTER**

FOR SERIES OF BOOKS, TRAINING MANUALS, AND PRINTED INSTRUCTIONAL, EDUCATIONAL, AND TEACHING MATERIALS FOR SCHOOLS, HEALTH CARE, LAW ENFORCEMENT AND OTHER WORKPLACE SETTINGS WITH RELEVANCE TO VIOLENCE REDUCTION, SAFE AND HEALTHY SCHOOLS AND COMMUNITIES, AND PREVENTION OF SUICIDE (U.S. CLS. 2, 5, 22, 23, 29, 37, 38 AND 50).

**CLASS 41—EDUCATION AND ENTERTAINMENT**

FOR ON-LINE ELECTRONIC BOOKS, PAMPHLETS, MAGAZINES AND NEWSLETTERS IN THE FIELDS OF VIOLENCE REDUCTION, SAFE AND HEALTHY SCHOOLS AND COMMUNITIES, AND PREVENTION OF SUICIDE; ON-LINE EDUCATIONAL SERVICES, NAMELY, CONDUCTING CLASSES, SEMINARS, WORKSHOPS AND WEBINARS IN THE FIELDS OF VIOLENCE REDUCTION, SAFE AND HEALTHY SCHOOLS AND COMMUNITIES, AND PREVENTION OF SUICIDE; LEARNING TOOLS AND RESOURCES, NAMELY, ONLINE TRAINING MANUALS, IN THE FIELDS OF VIOLENCE REDUCTION, SAFE AND HEALTHY SCHOOLS AND COMMUNITIES, AND PREVENTION OF SUICIDE; ENTERTAINMENT AND EDUCATIONAL SERVICES IN THE NATURE OF ONLINE NON-DOWNLOADABLE VIDEOS FEATURING CONTENT OF INTEREST TO STUDENTS, EDUCATORS, HEALTH CARE, LAW ENFORCEMENT PROFESSIONALS, AND COMMUNITY MEMBERS; ENTERTAINMENT SERVICES, NAMELY, PRODUCTION OF RADIO PROGRAMS CONCERNING TOPICS RELATED TO VIOLENCE REDUCTION, SAFE AND HEALTHY SCHOOLS AND COMMUNITIES, AND PREVENTION OF SUICIDE (U.S. CLS. 100, 101 AND 107).

**CLASS 42—SCIENTIFIC AND COMPUTER SERVICES**

FOR COMPUTER SERVICES, NAMELY, CREATING AN ON-LINE VIRTUAL COMMUNITY FOR REGISTERED USERS TO ENGAGE IN SOCIAL NETWORKING, AND PARTICIPATE IN DISCUSSIONS REGARDING VIOLENCE REDUCTION, SAFE AND HEALTHY SCHOOLS AND COMMUNITIES, AND PREVENTION OF SUICIDE; ONLINE NON-DOWNLOADABLE SOFTWARE IN THE NATURE OF COMPLIANCE MANAGEMENT TOOLS FOR COMPLYING WITH SCHOOL AND OTHER INSTITUTIONAL REGULATIONS REGARDING TRAINING AND PROFESSIONAL DEVELOPMENT IN THE FIELDS OF VIOLENCE REDUCTION, SAFE AND HEALTHY SCHOOLS AND COMMUNITIES, AND PREVENTION OF SUICIDE; PROVIDING TEMPORARY USE OF NON-DOWNLOADABLE COMPUTER SOFTWARE FOR PRODUCING INTERACTIVE TEMPLATES, FORMS, GUIDELINES AND SPREADSHEETS, FEATURING INFORMATION AND COURSES OF INSTRUCTION FOR SCHOOL, HEALTH CARE, LAW ENFORCEMENT AND OTHER WORKPLACE SETTINGS WITH RELEVANCE TO VIOLENCE REDUCTION, SAFE AND HEALTHY SCHOOLS AND COMMUNITIES, AND PREVENTION OF SUICIDE (U.S. CLS. 100 AND 101).

**CLASS 44—MEDICAL, BEAUTY AND AGRICULTURAL SERVICES**

FOR PROVIDING INFORMATION, INCLUDING ONLINE, VIA A WEBSITE, AND TO MOBILE DEVICE USERS, NAMELY, HEALTH INFORMATION PERTAINING TO STUDENTS AND COMMUNITY MEMBERS; PROVIDING INFORMATION, INCLUDING ONLINE, VIA A WEBSITE, AND TO MOBILE DEVICE USERS, NAMELY, MEDICAL INFORMATION IN THE FIELD OF SUICIDE PREVENTION (U.S. CLS. 100 AND 101).

**CLASS 45—PERSONAL AND LEGAL SERVICES**

FOR ON-LINE SOCIAL NETWORKING SERVICES; PROVIDING INFORMATION, INCLUDING ONLINE, VIA A WEBSITE, AND TO MOBILE DEVICE USERS, IN THE FIELDS OF VIOLENCE REDUCTION, SCHOOL SAFETY, AND COMMUNITY SAFETY; PROVIDING INFORMATION, INCLUDING ONLINE, VIA A WEBSITE, AND TO MOBILE DEVICE USERS, IN THE FIELD OF EMOTIONAL SUPPORT FOR SUICIDE PREVENTION PURPOSES (U.S. CLS. 100 AND 101).  
LIEF MARTIN, EXAMINING ATTORNEY

SN 86-174,314. VOIGT LIGHTING, GARFIELD, NJ. FILED 1-24-2014.

ALL THE WORLD IS A  
STAGE... "I WANT BETTER  
LIGHTING"

THE MARK CONSISTS OF STANDARD CHARACTERS WITHOUT CLAIM TO ANY PARTICULAR FONT, STYLE, SIZE, OR COLOR.

**CLASS 40—MATERIAL TREATMENT**

FOR CUSTOM MANUFACTURE OF LIGHT FIXTURES AND LIGHTING DESIGNS FOR COMMERCIAL AND RESIDENTIAL MARKETS (U.S. CLS. 100, 103 AND 106).

**CLASS 42—SCIENTIFIC AND COMPUTER SERVICES**

FOR PROVIDING LIGHTING DESIGN SERVICES FOR COMMERCIAL AND RESIDENTIAL MARKETS (U.S. CLS. 100 AND 101).

NATALIE KENEALY, EXAMINING ATTORNEY

**CLASS 41—EDUCATION AND ENTERTAINMENT**

FOR EDUCATIONAL SERVICES, NAMELY, CONDUCTING PROGRAMS AND TRAINING FOR BUSINESSES TO INCREASE SALES AND IMPROVE CLIENT RELATIONS (U.S. CLS. 100, 101 AND 107).

FIRST USE 5-0-2005; IN COMMERCE 1-1-2006.  
B. PARADEWELAI, EXAMINING ATTORNEY

SN 86-176,434. ENDRIGO, NANCY J, KEYPORT, WA. FILED 1-27-2014.

SN 86-177,366. RAIN ENTERPRISES, LLC, HOUSATONIC, MA. FILED 1-28-2014.

**Faith not Feelings**

THE MARK CONSISTS OF THE WORDS "FAITH NOT FEELINGS" WHERE THE "T" IN "FAITH" IS IN THE FORM OF A CROSS.

**CLASS 20—FURNITURE AND ARTICLES NOT OTHERWISE CLASSIFIED**

FOR WALL PLAQUES MADE OF WOOD; SIGNS, NAMELY, PLACARDS MADE OF WOOD (U.S. CLS. 2, 13, 22, 25, 32 AND 50).

**CLASS 25—CLOTHING**

FOR CLOTHING, NAMELY, T-SHIRTS, PANTS, HATS (U.S. CLS. 22 AND 39).

DAVID MURRAY, EXAMINING ATTORNEY

SN 86-176,741. PTM SOLUTIONS, LLC, PLYMOUTH MEETING, PA. FILED 1-27-2014.

**The 200% Company**

THE MARK CONSISTS OF STANDARD CHARACTERS WITHOUT CLAIM TO ANY PARTICULAR FONT, STYLE, SIZE, OR COLOR.

NO CLAIM IS MADE TO THE EXCLUSIVE RIGHT TO USE "COMPANY", APART FROM THE MARK AS SHOWN.

**CLASS 35—ADVERTISING AND BUSINESS**

FOR BUSINESS GROWTH CONSULTING, STRATEGIC BUSINESS GROWTH PLANNING CONSULTING, BUSINESS ORGANIZATIONAL AUDITING, SALES MANAGEMENT SERVICES PROVIDED ON AN OUT-SOURCED BASIS; SALES MANAGEMENT CONSULTING SERVICES (U.S. CLS. 100, 101 AND 102).

FIRST USE 5-0-2005; IN COMMERCE 1-1-2006.

**RAIN NEWS**

THE MARK CONSISTS OF STANDARD CHARACTERS WITHOUT CLAIM TO ANY PARTICULAR FONT, STYLE, SIZE, OR COLOR.

NO CLAIM IS MADE TO THE EXCLUSIVE RIGHT TO USE "NEWS", APART FROM THE MARK AS SHOWN.

**CLASS 38—COMMUNICATION**

FOR PROVIDING A WEBSITE FEATURING NEWS AND INFORMATION IN THE FIELD OF RADIO BROADCASTING AND STREAMING OF AUDIO CONTENT VIA INTERNET RADIO (U.S. CLS. 100, 101 AND 104).

FIRST USE 1-0-1999; IN COMMERCE 1-0-1999.

**CLASS 41—EDUCATION AND ENTERTAINMENT**

FOR PROVIDING A WEBSITE FEATURING NEWS AND INFORMATION ON DISTRIBUTION AND PRODUCTION OF RADIO AND INTERNET RADIO CONTENT INCLUDING DIGITAL SERVICES (U.S. CLS. 100, 101 AND 107).

FIRST USE 1-0-1999; IN COMMERCE 1-0-1999.  
KIM SAITO, EXAMINING ATTORNEY

SN 86-178,474. WEISSMANN, ARTHUR, MIAMI BEACH, FL. FILED 1-29-2014.

**PRESENT**

THE MARK CONSISTS OF STANDARD CHARACTERS WITHOUT CLAIM TO ANY PARTICULAR FONT, STYLE, SIZE, OR COLOR.

**CLASS 29—MEATS AND PROCESSED FOODS**

FOR EDIBLE OILS AND FATS; EGGS; FRUIT PRESERVES; JAMS; JELLIES; MEAT; MEAT, FISH, POULTRY AND GAME, NOT LIVE; MILK; MILK PRODUCTS EXCLUDING ICE CREAM, ICE MILK AND FROZEN YOGURT; PRESERVED, DRIED AND COOKED FRUIT AND VEGETABLES (U.S. CL. 46).

**CLASS 30—STAPLE FOODS**

FOR ARTIFICIAL COFFEE; BREAD; BREAKFAST CEREALS; CANDY; CHOCOLATE CONFECTIONS; COCOA; COFFEE; FLOUR; FROZEN CONFECTIONS; HONEY; ICE; MIXES IN THE NATURE OF CONCENTRATES, SYRUPS OR POWDERS USED IN THE PREPARATION OF TEA BASED BEVERAGES; PASTRY; PREPARATIONS MADE FROM CEREALS, NAMELY, BISCUITS, TARTS, CEREAL BARS, CEREAL BASED ENERGY BARS, CEREAL BASED SNACK FOODS, HIGH-PROTEIN CEREAL BARS, CAKES MADE WITH CEREALS; PROCESSED CEREALS; RICE; SAGO; SALAD DRESSINGS; SAUCES; SPICES; SUGAR; TAPIOCA; TEA; TREACLE; YEAST (U.S. CL. 46).

**CLASS 31—NATURAL AGRICULTURAL PRODUCTS**

FOR FRESH FRUIT AND VEGETABLES (U.S. CLS. 1 AND 46).

**CLASS 32—LIGHT BEVERAGES**

FOR BEER; BOTTLED WATER; COCONUT-BASED NON-ALCOHOLIC BEVERAGES NOT BEING MILK SUBSTITUTES; CONCENTRATES AND POWDERS USED IN THE PREPARATION OF ENERGY DRINKS AND FRUIT-FLAVORED BEVERAGES; FRUIT DRINKS AND FRUIT JUICES; FRUIT PUNCH; LEMON JUICE FOR USE IN THE PREPARATION OF BEVERAGES; LIME JUICE FOR USE IN THE PREPARATION OF BEVERAGES; MINERAL AND AERATED WATERS; NON-ALCOHOLIC BEER; NON-ALCOHOLIC BEVERAGES, NAMELY, CARBONATED BEVERAGES; NON-ALCOHOLIC COCKTAILS; NON-ALCOHOLIC DRINKS, NAMELY, ENERGY SHOTS; NON-ALCOHOLIC FRUIT EXTRACTS USED IN THE PREPARATION OF BEVERAGES; NON-ALCOHOLIC FRUIT JUICE BEVERAGES; NON-ALCOHOLIC RICE-BASED BEVERAGES NOT BEING MILK SUBSTITUTES; NON-CARBONATED, NON-ALCOHOLIC FROZEN FLAVORED BEVERAGES; POWDERS USED IN THE PREPARATION OF FRUIT-BASED BEVERAGES; POWDERS USED IN THE PREPARATION OF ISOTONIC SPORTS DRINKS AND SPORTS BEVERAGES; PREPARED ENTREES CONSISTING OF FRUIT DRINKS AND FRUIT JUICES, FRUIT-BASED BEVERAGES, NON-ALCOHOLIC BEVERAGES CONTAINING FRUIT JUICES, NON-ALCOHOLIC FRUIT EXTRACTS USED IN THE PREPARATION OF BEVERAGES, NON-ALCOHOLIC FRUIT JUICE BEVERAGES, VEGETABLE JUICES, VEGETABLE-FRUIT JUICES AND SMOOTHIES; PUNCH; SYRUPS FOR MAKING BEVERAGES (U.S. CLS. 45, 46 AND 48).

**CLASS 33—WINES AND SPIRITS**

FOR ALCOHOLIC BEVERAGES EXCEPT BEERS (U.S. CLS. 47 AND 49).

WON TEAK OH, EXAMINING ATTORNEY

SN 86-178,953. NETWORK HARDWARE RESALE LLC, GOLETA, CA. FILED 1-29-2014.

# CURVATURE

THE MARK CONSISTS OF STANDARD CHARACTERS WITHOUT CLAIM TO ANY PARTICULAR FONT, STYLE, SIZE, OR COLOR.

**CLASS 9—ELECTRICAL AND SCIENTIFIC APPARATUS**

FOR COMPUTER HARDWARE AND PERIPHERALS; NETWORK ACCESS SERVER HARDWARE; COMPUTER NETWORK SERVERS, ADAPTERS, SWITCHES, ROUTERS AND HUBS; COMPUTER WIRELESS ROUTERS; COMPUTER HARDWARE, NAMELY, FIREWALLS; VOICE OVER INTERNET PROTOCOL (VOIP) PHONE ADAPTERS; DIGITAL TELEPHONES, DIGITAL TELEPHONE PLATFORMS AND SWITCHING APPARATUS; OPTICAL FIBRES AND TRANSCEIVERS (U.S. CLS. 21, 23, 26, 36 AND 38).

**CLASS 35—ADVERTISING AND BUSINESS**

FOR ONLINE RETAIL STORE SERVICES IN THE FIELD OF COMPUTERS, COMPUTER HARDWARE AND PERIPHERALS, NETWORK ACCESS SERVER HARDWARE, WIRELESS ROUTERS, TELEPHONES AND OPTICAL FIBRE AND TRANSCEIVERS; DISTRIBUTORSHIP SERVICES FEATURING NEW AND USED COMPUTER HARDWARE, NETWORKING EQUIPMENT AND RELATED PRODUCTS; ONLINE RETAIL SHOP FEATURING COMPUTERS, COMPUTER HARDWARE AND PERIPHERALS, NETWORK ACCESS SERVER HARDWARE, WIRELESS ROUTERS, TELEPHONES AND OPTICAL FIBRE AND TRANSCEIVERS (U.S. CLS. 100, 101 AND 102).

**CLASS 36—INSURANCE AND FINANCIAL**

FOR FINANCIAL VALUATION OF COMPUTER NETWORKING EQUIPMENT AND ACCESSORIES AS WELL AS COMPUTER HARDWARE AND PERIPHERALS (U.S. CLS. 100, 101 AND 102).

**CLASS 37—CONSTRUCTION AND REPAIR**

FOR CONSULTING IN THE FIELD OF MAINTENANCE AND REPAIR OF TELECOMMUNICATIONS NETWORK HARDWARE, APPARATUS, AND INSTRUMENTS; MAINTENANCE OF TELECOMMUNICATIONS NETWORKING HARDWARE, APPARATUS, AND INSTRUMENTS; REPAIR AND MAINTENANCE OF COMPUTER HARDWARE AND PERIPHERALS; RECYCLING SERVICES, NAMELY, COLLECTION, REMOVAL AND DISPOSAL OF UNWANTED, OR DONATED, COMPUTER HARDWARE AND RELATED GOODS FOR REDISTRIBUTION TO VARIOUS ENTITIES, SUCH AS CHARITIES OR COMPUTER HARDWARE WHOLESALERS, OR FOR DISPOSAL OF GOODS IN ECOLOGICALLY FRIENDLY MANNER; TECHNICAL SUPPORT, NAMELY, INSTALLATION AND TROUBLESHOOTING IN THE NATURE OF REPAIR OF COMPUTER NETWORK SYSTEM HARDWARE (U.S. CLS. 100, 103 AND 106).

**CLASS 38—COMMUNICATION**

FOR RENTAL AND LEASING OF TELECOMMUNICATIONS EQUIPMENT; RENTING AND LEASING OF WIRELESS ROUTERS, TELEPHONES AND OPTICAL FIBRE AND TRANSCEIVERS (U.S. CLS. 100, 101 AND 104).

**CLASS 39—TRANSPORTATION AND STORAGE**

FOR TRANSPORT AND STORAGE OF GOODS IN THE NATURE OF ELECTRONICS, TELECOMMUNICATIONS EQUIPMENT, COMPUTERS, COMPUTER HARDWARE AND PERIPHERALS (U.S. CLS. 100 AND 105).

**CLASS 42—SCIENTIFIC AND COMPUTER SERVICES**

FOR TECHNICAL SUPPORT, NAMELY, MONITORING TECHNOLOGICAL AND PERFORMANCE FUNCTIONS OF NETWORK SYSTEMS, SERVERS, WEB AND DATABASE APPLICATIONS; IT CONSULTING SERVICES IN THE FIELD OF NETWORK EQUIPMENT AND RELATED PRODUCTS; COMPUTER SYSTEMS ANALYSIS; RENTAL AND LEASING OF COMPUTERS, COMPUTER HARDWARE, COMPUTER NETWORKING EQUIPMENT AND PERIPHERALS; TECHNICAL SUPPORT, NAMELY, INSTALLATION, ADMINISTRATION, AND TROUBLESHOOTING OF SOFTWARE APPLICATIONS AND COMPUTER NETWORK SOFTWARE SYSTEMS; TESTING OF COMPUTER HARDWARE AND PERIPHERALS FOR THE PURPOSE OF CERTIFICATION AND RE-CERTIFICATION; RENTING AND LEASING OF COMPUTERS, COMPUTER HARDWARE AND PERIPHERALS, NETWORK ACCESS SERVER HARDWARE (U.S. CLS. 100 AND 101).

JOHN DWYER, EXAMINING ATTORNEY

SN 86-180,769. PLUSONE SOLUTIONS, INC., ORLANDO, FL. FILED 1-31-2014.

 The logo for CheckMyBadge.com features the text "CheckMyBadge.com" in a sans-serif font. The word "CheckMy" is in black, "Badge" is in white inside a red rounded rectangle, and ".com" is in black.

THE COLOR(S) BLACK, WHITE AND RED IS/ARE CLAIMED AS A FEATURE OF THE MARK.

THE MARK CONSISTS OF THE FOLLOWING: THE WORDS "CHECKMYBADGE.COM", WITH THE WORDS "CHECKMY" AND ".COM" IN THE COLOR BLACK, WITH THE WORD "BADGE" IN THE COLOR WHITE APPEARING IN A RED BOX REPRESENTING A BADGE-LIKE SHAPE. THERE ARE NO SPACES BETWEEN THE WORDS.

SN 86-179,407. NATIONAL ENVIRONMENTAL EDUCATION FOUNDATION, WASHINGTON, DC. FILED 1-30-2014.

I'm In!

THE MARK CONSISTS OF STANDARD CHARACTERS WITHOUT CLAIM TO ANY PARTICULAR FONT, STYLE, SIZE, OR COLOR.

**CLASS 35—ADVERTISING AND BUSINESS**

FOR PROMOTING PUBLIC AWARENESS OF ENVIRONMENTAL MATTERS SO THAT 300 MILLION AMERICANS WILL ACTIVELY USE ENVIRONMENTAL KNOWLEDGE TO ENSURE THE WELL-BEING OF THE EARTH AND ITS PEOPLE BY 2022 (U.S. CLS. 100, 101 AND 102).

**CLASS 41—EDUCATION AND ENTERTAINMENT**

FOR EDUCATIONAL SERVICES, NAMELY, ONLINE INSTRUCTION ACCESSIBLE BY SOCIAL MEDIA AND VIDEO MEDIA IN THE FIELD OF ENVIRONMENTAL MATTERS AS PART OF A CAMPAIGN TO RAISE PUBLIC AWARENESS ABOUT HOW, BY 2022, 300 MILLION AMERICANS WILL ACTIVELY USE ENVIRONMENTAL KNOWLEDGE TO ENSURE THE WELL-BEING OF THE EARTH AND ITS PEOPLE (U.S. CLS. 100, 101 AND 107).

ELIZABETH CHANG, EXAMINING ATTORNEY

**CLASS 35—ADVERTISING AND BUSINESS**

FOR BUSINESS CONSULTING AND MANAGEMENT SERVICES, NAMELY, PROVIDING HUMAN RESOURCE TYPE FUNCTIONS, NAMELY, THE CREDENTIALING OF CONTRACTOR WORKERS FOR PERFORMANCE OF SERVICES; FINANCIAL RECORD KEEPING FOR REGULATORY COMPLIANCE PURPOSES FOR COMPANIES AND INDUSTRIES USING INDEPENDENT CONTRACTORS; TRACKING AND MONITORING INSURANCE COMPLIANCE FOR BUSINESS PURPOSES (U.S. CLS. 100, 101 AND 102).

**CLASS 45—PERSONAL AND LEGAL SERVICES**

FOR REGULATORY COMPLIANCE CONSULTING SERVICES FOR PERSONAL AND COMPANY REGULATORY COMPLIANCE, PARTICULARLY, THE COLLECTING, RECORDING, AND EVALUATION OF CONTRACTS, INVESTIGATIVE CONSUMER REPORTS, AND VERIFICATION OF INSURANCES, AND LICENSES FOR COMPANIES AND INDUSTRIES USING INDEPENDENT CONTRACTORS (U.S. CLS. 100 AND 101).

JAY FLOWERS, EXAMINING ATTORNEY

SN 86-180,812. DOK, LLC, DBA FRONTLINE OUTDOORS, AUSTIN, TX. FILED 1-31-2014.

FrontLine Outdoors

THE MARK CONSISTS OF STANDARD CHARACTERS WITHOUT CLAIM TO ANY PARTICULAR FONT, STYLE, SIZE, OR COLOR.

NO CLAIM IS MADE TO THE EXCLUSIVE RIGHT TO USE "OUTDOORS", APART FROM THE MARK AS SHOWN.

**CLASS 11—ENVIRONMENTAL CONTROL APPARATUS**

FOR OUTDOOR COOKING AND ENTERTAINING EQUIPMENT AND ACCESSORIES, NAMELY, GRILLS AND BARBECUES, PIZZA OVENS, REFRIGERATORS, COOLERS IN THE NATURE OF BUILT-IN ICE CHESTS, AND ICE MAKING MACHINES (U.S. CLS. 13, 21, 23, 31 AND 34).

FIRST USE 1-1-2010; IN COMMERCE 1-1-2010.

**CLASS 20—FURNITURE AND ARTICLES NOT OTHERWISE CLASSIFIED**

FOR OUTDOOR COOKING AND ENTERTAINING EQUIPMENT, NAMELY, CABINETS FOR USE IN OUTDOOR KITCHENS (U.S. CLS. 2, 13, 22, 25, 32 AND 50).

FIRST USE 1-1-2010; IN COMMERCE 1-1-2010.  
KATHLEEN M. VANSTON, EXAMINING ATTORNEY

**CLASS 41—EDUCATION AND ENTERTAINMENT**

FOR PUBLICATION SERVICES, NAMELY, ONLINE PUBLICATIONS IN THE NATURE OF NEWSLETTERS IN THE FIELDS OF PRODUCTS, SERVICES, ENTERTAINMENT, POPULAR CULTURE, AND LIFESTYLES; PROVIDING INFORMATION RELATING TO CELEBRITIES, ENTERTAINMENT, AND POPULAR CULTURE AND PROVIDING REVIEWS OF VENUES, PRODUCTS AND EVENTS IN CONNECTION THEREWITH; PROVIDING ONLINE NEWSLETTERS IN THE FIELD OF ENTERTAINMENT, CONSUMER PRODUCT INFORMATION, CONSUMER INFORMATION ABOUT THE SERVICES OF OTHERS, POPULAR CULTURE AND LIFESTYLES VIA E-MAIL (U.S. CLS. 100, 101 AND 107).

FIRST USE 10-1-2012; IN COMMERCE 10-1-2012.  
JONATHAN FALK, EXAMINING ATTORNEY

SN 86-181,196. MMETRO.COM LLC, NEW YORK, NY.  
FILED 1-31-2014.

SN 86-181,275. DENDRIFUND, INC., LOUISVILLE, KY.  
FILED 1-31-2014.



OWNER OF U.S. REG. NOS. 3,264,673 AND 3,365,242.  
THE COLOR(S) RED AND BLACK IS/ARE CLAIMED AS A FEATURE OF THE MARK.

THE MARK CONSISTS OF A SPLIT CIRCLE IN RED WITH BLACK CROSSHAIRS WITH THE WORD "THRILLIST" STARTING INSIDE THE RIGHT HAND SIDE OF THE CIRCLE IN BLACK.

**CLASS 35—ADVERTISING AND BUSINESS**

FOR ELECTRONIC COMMERCE SERVICES, NAMELY, PROVIDING INFORMATION ABOUT PRODUCTS AND SERVICES FOR ADVERTISING AND SALE PURPOSES VIA COMPUTER, COMPUTER NETWORKS, THE INTERNET, MOBILE DEVICES, OR ELECTRONIC MAIL; ADVERTISING SERVICES; PROMOTING THE GOODS AND SERVICES OF OTHERS VIA THE INTERNET; ARRANGING AND CONDUCTING MARKETING PROMOTIONAL EVENTS FOR OTHERS; ADVERTISING, MARKETING AND PROMOTION SERVICES; ONLINE RETAIL STORE SERVICES FEATURING CLOTHING, FOOTWEAR, HEADPHONES, SUNGLASSES, HATS, SPEAKERS, AND WATCHES; PROMOTING THE GOODS AND SERVICES OF OTHERS BY PROVIDING A WEBSITE FEATURING DISCOUNTED SALES OF LOCAL SERVICES; ORGANIZATION OF EVENTS AND EXHIBITIONS FOR COMMERCIAL, PROMOTIONAL AND ADVERTISING PURPOSES; PROVIDING INFORMATION AND REVIEWS OF VENUES, PRODUCTS AND EVENTS RELATING TO AUTOMOBILES FOR SALE (U.S. CLS. 100, 101 AND 102).

FIRST USE 10-1-2012; IN COMMERCE 10-1-2012.

THE MARK CONSISTS OF STANDARD CHARACTERS WITHOUT CLAIM TO ANY PARTICULAR FONT, STYLE, SIZE, OR COLOR.

**CLASS 35—ADVERTISING AND BUSINESS**

FOR CHARITABLE SERVICES, NAMELY, PROMOTING PUBLIC AWARENESS OF ENVIRONMENTAL ISSUES RELATED TO SUSTAINABILITY (U.S. CLS. 100, 101 AND 102).

FIRST USE 7-22-2013; IN COMMERCE 7-22-2013.

**CLASS 36—INSURANCE AND FINANCIAL**

FOR PROVIDING FINANCIAL ASSISTANCE TO THOSE UNDERTAKING ENVIRONMENTAL SUSTAINABILITY RESEARCH OR INITIATIVES; CHARITABLE FUNDRAISING SERVICES (U.S. CLS. 100, 101 AND 102).

FIRST USE 7-22-2013; IN COMMERCE 7-22-2013.

**CLASS 41—EDUCATION AND ENTERTAINMENT**

FOR EDUCATIONAL SERVICES, NAMELY, PROVIDING SEMINARS AND WORKSHOPS IN THE FIELD OF ENVIRONMENTAL ISSUES RELATED TO SUSTAINABILITY (U.S. CLS. 100, 101 AND 107).

FIRST USE 7-22-2013; IN COMMERCE 7-22-2013.  
SHAUNIA CARLYLE, EXAMINING ATTORNEY

SN 86-181,291. WILLIAMSON-DICKIE HOLDING COMPANY, FORT WORTH, TX. FILED 1-31-2014.

SN 86-182,219. ALAKEF COFFEE ROASTERS, INC., DULUTH, MN. FILED 2-3-2014.



THE MARK CONSISTS OF THE WORD, "WALLS", WITH THE "W" BEING CAPITALIZED, A BLACK BAR EXTENDS FROM THE END OF THE "W", TO THE END OF THE WORD. THE BLACK BAR MAKES A RIGHT ANGLE AND EXTENDS TO A POSITION ADJACENT TO A LOWER PORTION OF THE LETTER "S".

#### CLASS 9—ELECTRICAL AND SCIENTIFIC APPARATUS

FOR CLOTHING FOR PROTECTION AGAINST ACCIDENTS, IRRADIATION AND FIRE; GLOVES FOR PROTECTION AGAINST ACCIDENTS AND FIRE; PROTECTIVE GLOVES FOR INDUSTRIAL USE; PROTECTIVE FACE MASKS NOT FOR MEDICAL PURPOSES; SAFETY HELMETS; FACE-PROTECTION SHIELDS (U.S. CLS. 21, 23, 26, 36 AND 38).

FIRST USE 1-1-2011; IN COMMERCE 1-1-2011.

#### CLASS 25—CLOTHING

FOR MEN'S, WOMEN'S AND CHILDREN'S CLOTHING, NAMELY, INSULATED AND NON-INSULATED COATS; JACKETS, SWEATSHIRTS, SWEATPANTS, VESTS, SUITS, DUNGAREES, OVERALLS, COVERALLS; WORK PANTS, WORK SHIRTS, DENIM SHIRTS; INSULATED AND THERMAL JACKETS; SHIRTS; PANTS; SHORTS; GLOVES; BELTS, SOCKS BOOTIES AND HOODS; MEN'S, WOMEN'S AND CHILDREN'S CLOTHING, NAMELY, KNIT AND WOVEN SHIRTS, PANTS, JEANS, DUNGAREES, SHORTS; FOOTWEAR; FOOTGEAR, NAMELY, BOOTS; SHOES; HEADGEAR, NAMELY, HATS AND CAPS; HEADWEAR (U.S. CLS. 22 AND 39).

FIRST USE 1-1-2011; IN COMMERCE 1-1-2011.

#### CLASS 35—ADVERTISING AND BUSINESS

FOR ON-LINE RETAIL STORE SERVICES FEATURING CLOTHING, FOOTWEAR, HEADWEAR, AND ACCESSORIES FOR MEN, WOMEN AND CHILDREN (U.S. CLS. 100, 101 AND 102).

FIRST USE 1-1-2011; IN COMMERCE 1-1-2011.  
CHRIS WELLS, EXAMINING ATTORNEY



OWNER OF U.S. REG. NOS. 2,701,326 AND 4,470,146.

THE MARK CONSISTS OF THE PHRASE "TRADED IN FAIRNESS" ARCED OVER AN IMAGE OF TWO RIGHT HANDS CUPPED AROUND A GLOBE (ONE HAND OVER; ONE HAND UNDER) WITH THE PHRASE "RESPECT THE BEAN" ARCED UNDER THAT IMAGE. A SINGLE COFFEE BEAN SEPARATES THE TWO PHRASES, ON EACH SIDE OF THE GLOBE.

#### CLASS 30—STAPLE FOODS

FOR COFFEE BEANS (U.S. CL. 46).

FIRST USE 11-8-2013; IN COMMERCE 11-8-2013.

#### CLASS 35—ADVERTISING AND BUSINESS

FOR ON-LINE WHOLESALE AND RETAIL STORE SERVICES FEATURING COFFEE BEANS, AND COFFEE-BASED PRODUCTS AND ACCESSORIES (U.S. CLS. 100, 101 AND 102).

GIANCARLO CASTRO, EXAMINING ATTORNEY

SN 86-182,264. SWAGELOK COMPANY, SOLON, OH. FILED 2-3-2014.

Engineered to perform  
under pressure

THE MARK CONSISTS OF STANDARD CHARACTERS WITHOUT CLAIM TO ANY PARTICULAR FONT, STYLE, SIZE, OR COLOR.

#### CLASS 1—CHEMICALS

FOR CHEMICAL COMPOUND FOR DETECTING LEAKS IN GAS AND FLUID LINES; CHEMICAL COMPOUND WHICH WILL NOT FREEZE AT LOW TEMPERATURES FOR DETECTING LEAKS IN GAS AND FLUID LINES (U.S. CLS. 1, 5, 6, 10, 26 AND 46).

#### CLASS 4—LUBRICANTS AND FUELS

FOR LUBRICANT OILS FOR GLASS SEALS AND FOR TITANIUM, STAINLESS STEEL, STEEL, AND ALLOY FITTING THREADS, O-RINGS AND GASKETS (U.S. CLS. 1, 6 AND 15).

**CLASS 6—METAL GOODS**

FOR MANUALLY OPERATED METAL VALVES FOR TUBES, PIPES AND HOSES; METAL VALVES NOT BEING PARTS OF MACHINES; METAL GASKETS, GLANDS, FERRULES AND NUTS FOR TUBES, PIPES AND HOSES; METAL STRAIGHT, ELBOW, TEE AND CROSS FITTINGS FOR TUBES, PIPES AND HOSES; METAL VACUUM FITTINGS FOR TUBES, PIPES AND HOSES; METAL COUPLINGS FOR TUBES, PIPES AND HOSES; METAL REDUCER FITTINGS FOR TUBES, PIPES AND HOSES; METAL ADAPTER FITTINGS FOR TUBES, PIPES AND HOSES; METAL PORT CONNECTOR FITTINGS FOR TUBES, PIPES AND HOSES; METAL QUICK DISCONNECT FITTINGS FOR TUBE, PIPE AND HOSE END CONNECTIONS; METAL TUBING; FLEXIBLE METAL TUBING AND HOSE; METAL CONVOLUTED TUBING; METAL PIPES USED FOR GAS DISTRIBUTION; METAL SEALS FOR TUBES, PIPES AND HOSES; METAL CLAMPS FOR TUBES, PIPES AND HOSES; METAL CAPS FOR TUBES, PIPES AND HOSES; METAL PLUGS FOR TUBES, PIPES AND HOSES; METAL COMPRESSED GAS CYLINDERS SOLD EMPTY FOR USE WITH HYDRAULIC AND PNEUMATIC SYSTEMS (U.S. CLS. 2, 12, 13, 14, 23, 25 AND 50).

**CLASS 7—MACHINERY**

FOR ELECTRICALLY-POWERED MACHINES AND ELECTRICALLY-POWERED TOOLS FOR CUTTING, BENDING, DEBURRING, AND SWAGING TUBE AND HOSE; ELECTRIC TUBE BENDER MACHINE; ELECTRIC ARC WELDING MACHINES, WELDING COOLING PLATES, WELD HEAD BENCH MOUNTING BRACKETS ATTACHED TO WORK BENCHES; WELD HELD FIXTURE TOOL, WELDING COLLETS FOR TUBES, PIPES AND FITTINGS; VALVES AS MACHINE COMPONENTS; PRESSURE TRANSDUCERS AS PARTS OF MACHINES; PNEUMATIC VALVE ACTUATORS; REGULATORS BEING PARTS OF MACHINES; FILTERS PARTS OF MACHINES OR ENGINES; GAS AND LIQUID FILTERS BEING PARTS OF MACHINES; WELDING ELECTRODES (U.S. CLS. 13, 19, 21, 23, 31, 34 AND 35).

**CLASS 8—HAND TOOLS**

FOR HAND-OPERATED TOOLS FOR CUTTING, SAWING, BENDING, DEBURRING AND SWAGING TUBE AND HOSE; HAND-OPERATED WRENCHES (U.S. CLS. 23, 28 AND 44).

**CLASS 9—ELECTRICAL AND SCIENTIFIC APPARATUS**

FOR WELDING APPARATUS, NAMELY, REMOTE PENDANT CONTROLS, WELD HEAD CENTERING GAUGES, WELD ARC GAP GAUGES; PRESSURE GAUGES FOR GAS AND FLUID; FITTINGS GAP INSPECTION APPARATUS; ELECTRICAL TRANSDUCER; ELECTRIC OR ELECTRONIC SENSORS FOR SENSING FLOW OF FLUID; PRESSURE TRANSDUCERS AND TRANSMITTERS THAT CONVERT HYDRAULIC OR PNEUMATIC PRESSURE INTO ANALOG ELECTRICAL SIGNALS FOR MONITORING AND CONTROLLING HYDRAULIC OR PNEUMATIC SYSTEMS; CONTROL VALVES FOR REGULATING THE FLOW OF GASES AND LIQUIDS; ELECTRIC VALVE ACTUATORS; PRESSURE RELIEF VALVES FOR FLUID SYSTEMS; THERMOMETERS; FLOWMETERS; CALIBRATION DEVICES FOR CALIBRATING FLUID SYSTEMS (U.S. CLS. 21, 23, 26, 36 AND 38).

**CLASS 11—ENVIRONMENTAL CONTROL APPARATUS**

FOR PRESSURE REGULATORS FOR GAS INSTALLATIONS (U.S. CLS. 13, 21, 23, 31 AND 34).

**CLASS 17—RUBBER GOODS**

FOR PIPE JOINT SEALANT; SEALANT COMPOUNDS FOR JOINTS; NON-METAL GASKETS FOR FLUID SYSTEMS; NON-METAL, PLASTIC AND RUBBER HOSES FOR INDUSTRIAL APPLICATIONS; PLASTIC PIPE AND FLEXIBLE PIPE NOT OF METAL; PLASTIC GLANDS AND FERRULES FOR PLASTIC TUBES, FLEXIBLE PIPES AND NON-METAL HOSES; ALL GOODS FOR RESEARCH, INSTRUMENTATION, PHARMACEUTICAL, OIL AND GAS, POWER GENERATION, CHEMICAL, PETROCHEMICAL, SANITARY AND SEMICONDUCTOR INDUSTRY PURPOSES; NON-METALLIC FLEXIBLE PIPES AND HOSE FITTINGS; FLEXIBLE TUBES OF PLASTIC AND PLUGS THEREFOR (U.S. CLS. 1, 5, 12, 13, 35 AND 50).

**CLASS 19—NON-METALLIC BUILDING MATERIALS**

FOR NON-METAL PIPE COUPLINGS AND JOINTS; NON-METAL TUBING AND TUBING COUPLINGS FOR JOINING AND TERMINATING PIPES (U.S. CLS. 1, 12, 33 AND 50).

**CLASS 20—FURNITURE AND ARTICLES NOT OTHERWISE CLASSIFIED**

FOR PLASTIC VALVES BEING OTHER THAN MACHINE PARTS; PLASTIC CAPS; PLASTIC NUTS; PLUGS, NOT OF METAL (U.S. CLS. 2, 13, 22, 25, 32 AND 50).

**CLASS 35—ADVERTISING AND BUSINESS**

FOR LOGISTICS MANAGEMENT, MARKETING, INVENTORY CONTROL, AND CUSTOMER SERVICES MANAGEMENT FOR OTHERS IN THE FIELDS OF BIOPHARMACEUTICAL, FOOD, BEVERAGE, DAIRY, OIL AND GAS, POWER GENERATION, CHEMICAL, PETROCHEMICAL, SHIPBUILDING, PULP AND PAPER, AND SEMI-CONDUCTOR TECHNOLOGIES; BUSINESS MANAGEMENT CONSULTANCY; BUSINESS ORGANIZATION CONSULTANCY; BUSINESS MANAGEMENT ASSISTANCE; BUSINESS INFORMATION; PROCUREMENT, NAMELY, PURCHASING OF FLUID SYSTEMS TECHNOLOGIES EQUIPMENT FOR OTHERS USED IN THE PROCESS OF ANALYTICAL INSTRUMENTATION, BIOPHARMACEUTICAL, FOOD, BEVERAGE, DAIRY, OIL AND GAS, POWER GENERATION, CHEMICAL, PETROCHEMICAL, SHIPBUILDING, PULP AND PAPER, AND SEMI-CONDUCTOR INDUSTRIES (U.S. CLS. 100, 101 AND 102).

**CLASS 37—CONSTRUCTION AND REPAIR**

FOR RENTAL OF EQUIPMENT, NAMELY, WELD SYSTEMS, TUBE BENDERS, AND OTHER EQUIPMENT, NAMELY, TUBE FLARING TOOLS, GAP INSPECTION GAUGES, DEPTH MARKING TOOLS AND TUBE CUTTERS FOR THE SUPPORT OF FLUID SYSTEMS TECHNOLOGIES USED IN THE PROCESS AND ANALYTICAL INSTRUMENTATION, BIOPHARMACEUTICAL, FOOD, BEVERAGE, DAIRY, OIL AND GAS, POWER GENERATION, CHEMICAL, PETROCHEMICAL, SHIPBUILDING, PULP AND PAPER, AND SEMI-CONDUCTOR INDUSTRIES (U.S. CLS. 100, 103 AND 106).

**CLASS 39—TRANSPORTATION AND STORAGE**

FOR SHIPPING AND DELIVERY SERVICES, NAMELY, PICKUP AND TRANSPORTATION, AND DELIVERY OF GOODS USED IN THE PROCESS AND ANALYTICAL INSTRUMENTATION, BIOPHARMACEUTICAL, FOOD, BEVERAGE, DAIRY, OIL AND GAS, POWER GENERATION, CHEMICAL, PETROCHEMICAL, SHIPBUILDING, PULP AND PAPER, AND SEMI-CONDUCTOR INDUSTRIES BY VARIOUS MODES OF TRANSPORTATION (U.S. CLS. 100 AND 105).

**CLASS 40—MATERIAL TREATMENT**

FOR TREATMENT OF METAL GOODS USED IN THE PROCESS AND ANALYTICAL INSTRUMENTATION, BIOPHARMACEUTICAL, FOOD, BEVERAGE, DAIRY, OIL AND GAS, POWER GENERATION, CHEMICAL, PETROCHEMICAL, SHIPBUILDING, PULP AND PAPER, AND SEMI-CONDUCTOR INDUSTRIES; ASSEMBLY OF FLUID SYSTEMS FOR OTHERS (U.S. CLS. 100, 103 AND 106).

**CLASS 41—EDUCATION AND ENTERTAINMENT**

FOR EDUCATIONAL TRAINING SERVICES, NAMELY, CONDUCTING CLASSES AND PROVIDING ELECTRONIC AND ON-SITE TRAINING IN THE FIELD OF FLUID SYSTEM TECHNOLOGIES EQUIPMENT FOR GOODS USED IN THE PROCESS AND ANALYTICAL INSTRUMENTATION, BIOPHARMACEUTICAL, FOOD, BEVERAGE, DAIRY, OIL AND GAS, POWER GENERATION, CHEMICAL, PETROCHEMICAL, SHIPBUILDING, PULP AND PAPER, AND SEMI-CONDUCTOR INDUSTRIES, AND DISTRIBUTING COURSE MATERIALS IN CONNECTION THEREWITH (U.S. CLS. 100, 101 AND 107).

**CLASS 42—SCIENTIFIC AND COMPUTER SERVICES**

FOR TESTING, ANALYSIS AND EVALUATION OF THE GOODS OF OTHERS FOR THE PURPOSE OF CERTIFICATION, ENGINEERING CONSULTANCY, CHEMISTRY CONSULTANCY, IN THE FIELDS OF PROCESS AND ANALYTICAL INSTRUMENTATION, BIOPHARMACEUTICAL, FOOD, BEVERAGE, DAIRY, OIL AND GAS, POWER GENERATION, CHEMICAL, PETROCHEMICAL, SHIPBUILDING, PULP AND PAPER, AND SEMI-CONDUCTOR TECHNOLOGIES; QUALITY CONTROL; COMPUTER SOFTWARE TECHNICAL SUPPORT SERVICES; TECHNICAL SUPPORT SERVICES, NAMELY, TROUBLESHOOTING OF COMPUTER SOFTWARE PROBLEMS (U.S. CLS. 100 AND 101).

DORITT L. CARROLL, EXAMINING ATTORNEY

SN 86-182,529. AGEL ENTERPRISES, INC., PLEASANT GROVE, UT. FILED 2-3-2014.



THE MARK CONSISTS OF A SMALL RAINDROP CONTAINED WITHIN THE SILHOUTTE OF ANOTHER LARGER RAINDROP.

**CLASS 3—COSMETICS AND CLEANING PREPARATIONS**

FOR NON-MEDICATED SKIN-CARE PREPARATIONS, NAMELY, CLEANERS, FACIAL SCRUBS, TONERS, MOISTURIZERS AND GELS (U.S. CLS. 1, 4, 6, 50, 51 AND 52).

FIRST USE 5-2-2005; IN COMMERCE 5-2-2005.

**CLASS 5—PHARMACEUTICALS**

FOR DIETARY AND NUTRITIONAL SUPPLEMENTS; HERBAL SUPPLEMENTS; VITAMIN AND MINERAL SUPPLEMENTS; ANALGESIC BALM (U.S. CLS. 6, 18, 44, 46, 51 AND 52).

FIRST USE 5-2-2005; IN COMMERCE 5-2-2005.

NICHOLAS COLEMAN, EXAMINING ATTORNEY

SN 86-184,244. HEARTLAND DENTAL, LLC, EFFINGHAM, IL. FILED 2-4-2014.



OWNER OF U.S. REG. NO. 4,445,960.

NO CLAIM IS MADE TO THE EXCLUSIVE RIGHT TO USE "DENTAL", APART FROM THE MARK AS SHOWN.

THE MARK CONSISTS OF THE STYLIZED IMAGE OF A TOOTH WITH TWO CURVED LINES UNDERNEATH. BENEATH THE TOOTH IMAGE IS THE WORD "HEARTLAND" ABOVE THE WORD "DENTAL". HORIZONTAL LINES APPEAR TO THE LEFT AND THE RIGHT OF THE WORD "DENTAL".

**CLASS 35—ADVERTISING AND BUSINESS**

FOR BUSINESS MANAGEMENT AND ADMINISTRATIVE SERVICES FOR DENTISTS AND DENTAL PRACTICES, NAMELY, PROFESSIONAL STAFFING AND RECRUITING SERVICES; HUMAN RESOURCES MANAGEMENT, PROCUREMENT IN THE NATURE OF PURCHASING DENTAL OFFICE SUPPLIES, BUSINESS ADMINISTRATION CONSULTANCY, PAYROLL PROCESSING, ACCOUNTS RECEIVABLES, AND MARKETING (U.S. CLS. 100, 101 AND 102).

**CLASS 36—INSURANCE AND FINANCIAL**

FOR INSURANCE CLAIMS ADMINISTRATION FOR DENTISTS AND DENTAL PRACTICES (U.S. CLS. 100, 101 AND 102).

**CLASS 41—EDUCATION AND ENTERTAINMENT**

FOR PROVIDING CONTINUING PROFESSIONAL EDUCATION COURSES AND MANAGEMENT TRAINING FOR DENTISTS AND DENTAL PRACTICES (U.S. CLS. 100, 101 AND 107).

**CLASS 42—SCIENTIFIC AND COMPUTER SERVICES**

FOR COMPUTER INFORMATION TECHNOLOGY SUPPORT IN THE NATURE OF HELP DESK SERVICES FOR DENTISTS AND DENTAL PRACTICES (U.S. CLS. 100 AND 101).

GEORGE LORENZO, EXAMINING ATTORNEY



SN 86-184,728. FIDELITY NATIONAL INFORMATION SERVICES, INC., JACKSONVILLE, FL. FILED 2-5-2014.



THE MARK CONSISTS OF THE WORD "GENNOW" IN A STYLIZED FONT AND WITH THE SECOND "N" FACING BACKWARDS IN A MIRROR IMAGE OF THE FIRST "N".

**CLASS 9—ELECTRICAL AND SCIENTIFIC APPARATUS**

FOR MAGNETICALLY ENCODED DEBIT CARDS; DOWNLOADABLE SOFTWARE IN THE NATURE OF A MOBILE APPLICATION FOR CONDUCTING FINANCIAL TRANSACTIONS; DOWNLOADABLE SOFTWARE TO CONDUCT ELECTRONIC FUNDS TRANSFERS AND PAYMENT PROCESSING; DOWNLOADABLE SOFTWARE THAT PROVIDES ALERTS REGARDING BALANCES, SPENDING, LOYALTY REWARDS AND OFFERS, AND COMPANION CARD REQUESTS FOR MONEY TRANSFERS; DOWNLOADABLE SOFTWARE THAT TRACKS DEBIT CARD AND OTHER FINANCIAL TRANSACTIONS (U.S. CLS. 21, 23, 26, 36 AND 38).

**CLASS 36—INSURANCE AND FINANCIAL**

FOR FINANCIAL SERVICES, NAMELY, ELECTRONIC BILL PAYMENT, CARD-TO-CARD TRANSFERS, ELECTRONIC REMOTE CHECK DEPOSIT CAPTURE SERVICES, AND BANK ACCOUNT MANAGEMENT SERVICES; PERSONAL FINANCIAL MANAGEMENT BUDGETING SERVICES; ELECTRONIC FUNDS TRANSFER SERVICES; DEBIT CARD SERVICES; ONLINE SERVICES, NAMELY, BANKING SERVICES ACCESSIBLE BY MEANS OF A DOWNLOADABLE MOBILE APPLICATION (U.S. CLS. 100, 101 AND 102).

**CLASS 42—SCIENTIFIC AND COMPUTER SERVICES**

FOR PROVIDING TEMPORARY USE OF ONLINE NON-DOWNLOADABLE SOFTWARE TO FINANCIAL INSTITUTIONS TO CONDUCT FINANCIAL TRANSACTIONS; PROVIDING TEMPORARY USE OF ONLINE NON-DOWNLOADABLE SOFTWARE TO FINANCIAL INSTITUTIONS TO TRACK DEBIT CARD AND OTHER FINANCIAL TRANSACTIONS (U.S. CLS. 100 AND 101).  
LINDA E. BLOHM, EXAMINING ATTORNEY

SN 86-184,736. FIDELITY NATIONAL INFORMATION SERVICES, INC., JACKSONVILLE, FL. FILED 2-5-2014.



THE MARK CONSISTS OF STANDARD CHARACTERS WITHOUT CLAIM TO ANY PARTICULAR FONT, STYLE, SIZE, OR COLOR.

**CLASS 9—ELECTRICAL AND SCIENTIFIC APPARATUS**

FOR MAGNETICALLY ENCODED DEBIT CARDS; DOWNLOADABLE SOFTWARE IN THE NATURE OF A MOBILE APPLICATION FOR CONDUCTING FINANCIAL TRANSACTIONS; DOWNLOADABLE SOFTWARE TO CONDUCT ELECTRONIC FUNDS TRANSFERS AND PAYMENT PROCESSING; DOWNLOADABLE SOFTWARE THAT PROVIDES ALERTS REGARDING BALANCES, SPENDING, LOYALTY REWARDS AND OFFERS, AND COMPANION CARD REQUESTS FOR MONEY TRANSFERS; DOWNLOADABLE SOFTWARE THAT TRACKS DEBIT CARD AND OTHER FINANCIAL TRANSACTIONS (U.S. CLS. 21, 23, 26, 36 AND 38).

**CLASS 36—INSURANCE AND FINANCIAL**

FOR FINANCIAL SERVICES, NAMELY, ELECTRONIC BILL PAYMENT, CARD-TO-CARD TRANSFERS, ELECTRONIC REMOTE CHECK DEPOSIT CAPTURE SERVICES, AND BANK ACCOUNT MANAGEMENT SERVICES; PERSONAL FINANCIAL MANAGEMENT BUDGETING SERVICES; ELECTRONIC FUNDS TRANSFER SERVICES; DEBIT CARD SERVICES; ONLINE SERVICES, NAMELY, BANKING SERVICES ACCESSIBLE BY MEANS OF A DOWNLOADABLE MOBILE APPLICATION (U.S. CLS. 100, 101 AND 102).

**CLASS 42—SCIENTIFIC AND COMPUTER SERVICES**

FOR PROVIDING TEMPORARY USE OF ONLINE NON-DOWNLOADABLE SOFTWARE TO FINANCIAL INSTITUTIONS TO CONDUCT FINANCIAL TRANSACTIONS; PROVIDING TEMPORARY USE OF ONLINE NON-DOWNLOADABLE SOFTWARE TO FINANCIAL INSTITUTIONS TO TRACK DEBIT CARD AND OTHER FINANCIAL TRANSACTIONS (U.S. CLS. 100 AND 101).  
LINDA E. BLOHM, EXAMINING ATTORNEY

SN 86-184,764. SOUTH TEXAS NEON SIGN CO., INC., LAREDO, TX. FILED 2-5-2014.

**SOUTH TEXAS NEON SIGN**

THE MARK CONSISTS OF STANDARD CHARACTERS WITHOUT CLAIM TO ANY PARTICULAR FONT, STYLE, SIZE, OR COLOR.

NO CLAIM IS MADE TO THE EXCLUSIVE RIGHT TO USE "NEON SIGN", APART FROM THE MARK AS SHOWN. SEC. 2(F).

**CLASS 37—CONSTRUCTION AND REPAIR**

FOR REPAIR AND INSTALLATION OF NEON SIGNS (U.S. CLS. 100, 103 AND 106).  
FIRST USE 9-1-1963; IN COMMERCE 9-1-1963.

**CLASS 40—MATERIAL TREATMENT**

FOR MANUFACTURE OF NEON SIGNS TO ORDER AND/OR SPECIFICATION OF OTHERS (U.S. CLS. 100, 103 AND 106).  
FIRST USE 9-1-1963; IN COMMERCE 9-1-1963.  
ELLEN B. AWRICH, EXAMINING ATTORNEY

SN 86-185,077. SOCIAL CHANGE INSTITUTE, LOS ANGELES, CA. FILED 2-5-2014.

## ACTIONLAB

THE MARK CONSISTS OF STANDARD CHARACTERS WITHOUT CLAIM TO ANY PARTICULAR FONT, STYLE, SIZE, OR COLOR.

### CLASS 35—ADVERTISING AND BUSINESS

FOR MATCHING INDIVIDUALS WITH LIKE-MINDED ORGANIZATIONS WHO PROVIDE CHARITABLE ACTIVITIES THROUGH ON-LINE PROFILING SURVEYS AND ANALYSIS; PROMOTING THE CHARITABLE SERVICES OF OTHERS, NAMELY, PROVIDING INDIVIDUALS WITH INFORMATION ABOUT VARIOUS CHARITIES FOR THE PURPOSE OF MAKING DONATIONS TO CHARITIES; PROMOTING THE CHARITABLE GIVING OF OTHERS, NAMELY, TRACKING AND PUBLICIZING CHARITABLE DONATIONS AND RANDOM ACTS OF KINDNESS (U.S. CLS. 100, 101 AND 102).

### CLASS 42—SCIENTIFIC AND COMPUTER SERVICES

FOR COMPUTER SERVICES, NAMELY, ACTING AS AN APPLICATION SERVICE PROVIDER IN THE FIELD OF KNOWLEDGE MANAGEMENT TO HOST COMPUTER APPLICATION SOFTWARE FOR CREATING SEARCHABLE DATABASES OF INFORMATION AND DATA RELATING TO INDIVIDUALS, FILMS, BOOKS, LECTURES, IDEAS, CAUSES AND CHARITABLE ORGANIZATIONS; APPLICATION SERVICE PROVIDER, NAMELY, PROVIDING, HOSTING, MANAGING, DEVELOPING AND MAINTAINING APPLICATIONS, SOFTWARE, WEB SITES AND DATABASES IN THE FIELDS OF KNOWLEDGE MANAGEMENT, WIRELESS COMMUNICATION MOBILE INFORMATION ACCESS AND REMOTE DATA MANAGEMENT FOR WIRELESS DELIVERY OF CONTENT TO HANDHELD COMPUTERS, LAPTOPS AND MOBILE ELECTRONIC DEVICES; COMPUTER SERVICES, NAMELY, PROVIDING SEARCH PLATFORMS TO ALLOW USERS TO REQUEST CONTENT FROM AND RECEIVE CONTENT TO A MOBILE DEVICE (U.S. CLS. 100 AND 101).

STEPHANIE ALI, EXAMINING ATTORNEY

SN 86-185,334. WEST BAY HOUSING CORPORATION, SAN FRANCISCO, CA. FILED 2-5-2014.

## BRILLIANT CORNERS

THE MARK CONSISTS OF STANDARD CHARACTERS WITHOUT CLAIM TO ANY PARTICULAR FONT, STYLE, SIZE, OR COLOR.

### CLASS 35—ADVERTISING AND BUSINESS

FOR PUBLIC HOUSING ADVOCACY TO PROMOTE AWARENESS OF THE NEED FOR HOUSING FOR UNDERSERVED POPULATIONS, PEOPLE WITH DEVELOPMENTAL DISABILITIES, PEOPLE WITH PHYSICAL DISABILITIES OR CHRONIC MEDICAL CONDITIONS, PEOPLE WITH MENTAL ILLNESS, VETERANS, AND PEOPLE MOVING FROM INSTITUTIONS AND OUT OF HOMELESSNESS; BUSINESS MANAGEMENT SERVICES REGARDING PROPERTY (U.S. CLS. 100, 101 AND 102).

### CLASS 36—INSURANCE AND FINANCIAL

FOR REAL ESTATE SERVICES, NAMELY, PROPERTY MANAGEMENT SERVICES FOR APARTMENT BUILDINGS, SINGLE FAMILY HOMES, AND LICENSED CARE FACILITIES; HOUSING AGENCY SERVICES FOR ASSISTING UNDERSERVED POPULATIONS, PEOPLE WITH DEVELOPMENTAL DISABILITIES, PEOPLE WITH PHYSICAL DISABILITIES OR CHRONIC MEDICAL CONDITIONS, PEOPLE WITH MENTAL ILLNESS, VETERANS, AND PEOPLE MOVING FROM INSTITUTIONS AND OUT OF HOMELESSNESS ALL FIND HOUSING; HOUSING AGENCY SERVICES FOR ASSISTING WITH HOUSING PLACEMENT FOR UNDERSERVED POPULATIONS, PEOPLE WITH DEVELOPMENTAL DISABILITIES, PEOPLE WITH PHYSICAL DISABILITIES OR CHRONIC MEDICAL CONDITIONS, PEOPLE WITH MENTAL ILLNESS, VETERANS, AND PEOPLE MOVING FROM INSTITUTIONS AND OUT OF HOMELESSNESS; LEASING OF REAL ESTATE; LEASING OF HOUSING TO UNDERSERVED POPULATIONS, PEOPLE WITH DEVELOPMENTAL DISABILITIES, PEOPLE WITH PHYSICAL DISABILITIES OR CHRONIC MEDICAL CONDITIONS, PEOPLE WITH MENTAL ILLNESS, VETERANS, AND PEOPLE MOVING FROM INSTITUTIONS AND OUT OF HOMELESSNESS; REAL ESTATE RENTAL SERVICES, NAMELY, RENTAL OF RESIDENTIAL HOUSING TO UNDERSERVED POPULATIONS, PEOPLE WITH DEVELOPMENTAL DISABILITIES, PEOPLE WITH PHYSICAL DISABILITIES OR CHRONIC MEDICAL CONDITIONS, PEOPLE WITH MENTAL ILLNESS, VETERANS, AND PEOPLE MOVING FROM INSTITUTIONS AND OUT OF HOMELESSNESS; REAL ESTATE RENTAL SERVICES, NAMELY, RENTAL OF LICENSED RESIDENTIAL HOUSING TO UNDERSERVED POPULATIONS, PEOPLE WITH DEVELOPMENTAL DISABILITIES, PEOPLE WITH PHYSICAL DISABILITIES OR CHRONIC MEDICAL CONDITIONS, PEOPLE WITH MENTAL ILLNESS, VETERANS, AND PEOPLE MOVING FROM INSTITUTIONS AND OUT OF HOMELESSNESS; HOUSING SERVICES, NAMELY, PROVIDING CONSULTING SERVICES IN THE FIELD OF REAL ESTATE RENTAL SERVICES, NAMELY, RENTAL OF RESIDENTIAL HOUSING TO UNDERSERVED POPULATIONS, PEOPLE WITH DEVELOPMENTAL DISABILITIES, PEOPLE WITH PHYSICAL DISABILITIES OR CHRONIC MEDICAL CONDITIONS, PEOPLE WITH MENTAL ILLNESS, VETERANS, AND PEOPLE MOVING FROM INSTITUTIONS AND OUT OF HOMELESSNESS (U.S. CLS. 100, 101 AND 102).

### CLASS 37—CONSTRUCTION AND REPAIR

FOR DEVELOPMENT OF REAL PROPERTY; DEVELOPMENT OF HOUSING IN THE NATURE OF REPAIR, IMPROVEMENT AND NEW CONSTRUCTION OF HOUSING AND REAL ESTATE DEVELOPMENT AND CONSTRUCTION OF PERMANENT SUPPORTIVE HOUSING ACCOMMODATIONS FOR UNDERSERVED POPULATIONS, PEOPLE WITH DEVELOPMENTAL DISABILITIES, PEOPLE WITH PHYSICAL DISABILITIES OR CHRONIC MEDICAL CONDITIONS, PEOPLE WITH MENTAL ILLNESS, VETERANS, AND PEOPLE MOVING FROM INSTITUTIONS AND OUT OF HOMELESSNESS; REAL ESTATE DEVELOPMENT OF PERMANENT HOUSING AND PERMANENT SUPPORTIVE HOUSING FOR USE BY UNDERSERVED POPULATIONS, PEOPLE WITH DEVELOPMENTAL DISABILITIES, PEOPLE WITH PHYSICAL DISABILITIES OR CHRONIC MEDICAL CONDITIONS, PEOPLE WITH MENTAL ILLNESS, VETERANS, AND PEOPLE MOVING FROM INSTITUTIONS AND OUT OF HOMELESSNESS; REAL ESTATE DEVELOPMENT OF PERMANENT LICENSED HOUSING FACILITIES FOR USE BY UNDERSERVED POPULATIONS, PEOPLE WITH DEVELOPMENTAL

DISABILITIES, PEOPLE WITH PHYSICAL DISABILITIES OR CHRONIC MEDICAL CONDITIONS, PEOPLE WITH MENTAL ILLNESS, VETERANS, AND PEOPLE MOVING FROM INSTITUTIONS AND OUT OF HOMELESSNESS; PROVIDING CONSULTING SERVICES IN THE REAL ESTATE DEVELOPMENT OF PERMANENT LOW-INCOME HOUSING FOR USE BY UNDERSERVED POPULATIONS, PEOPLE WITH DEVELOPMENTAL DISABILITIES, PEOPLE WITH PHYSICAL DISABILITIES OR CHRONIC MEDICAL CONDITIONS, PEOPLE WITH MENTAL ILLNESS, VETERANS, AND PEOPLE MOVING FROM INSTITUTIONS AND OUT OF HOMELESSNESS (U.S. CLS. 100, 103 AND 106).

#### **CLASS 45—PERSONAL AND LEGAL SERVICES**

FOR PROVIDING CASE MANAGEMENT SERVICES, NAMELY, COORDINATING MEDICAL, PHYSICAL, SOCIAL, PERSONAL CARE AND PSYCHOLOGICAL SERVICES FOR PEOPLE WITH DEVELOPMENTAL DISABILITIES, PEOPLE WITH PHYSICAL DISABILITIES OR CHRONIC MEDICAL CONDITIONS, PEOPLE WITH MENTAL ILLNESS, VETERANS, AND PEOPLE MOVING FROM INSTITUTIONS AND OUT OF HOMELESSNESS; PROVIDING PATIENT ADVOCATE SERVICES IN THE FIELD OF DEVELOPMENTAL DISABILITIES, PHYSICAL DISABILITIES OR CHRONIC MEDICAL CONDITIONS, MENTAL ILLNESS, AND TREATMENT FOR VETERANS (U.S. CLS. 100 AND 101).

MAYUR VAGHANI, EXAMINING ATTORNEY

#### **CLASS 41—EDUCATION AND ENTERTAINMENT**

FOR PROVIDING NEWS AND INFORMATION IN THE FIELD OF SPORTS; PROVIDING ON-LINE NEWSLETTERS IN THE FIELD OF COLLEGE AND UNIVERSITY ATHLETICS; PROVIDING ON-LINE PUBLICATIONS IN THE NATURE OF PAMPHLETS, BROCHURES, MANUALS, BOOKS, BOOKLETS, LEAFLETS, INFORMATIONAL FLYERS, INFORMATIONAL SHEETS AND NEWSLETTERS IN THE FIELD OF COLLEGE AND UNIVERSITY ATHLETICS (U.S. CLS. 100, 101 AND 107).

FIRST USE 1-1-2004; IN COMMERCE 1-1-2004.  
ALLISON SCHRODY, EXAMINING ATTORNEY

SN 86-185,842. TECHNICARE CONSULTING, LLC, LEXINGTON, KY. FILED 2-6-2014.

# PACSCARE

THE MARK CONSISTS OF STANDARD CHARACTERS WITHOUT CLAIM TO ANY PARTICULAR FONT, STYLE, SIZE, OR COLOR.

#### **CLASS 42—SCIENTIFIC AND COMPUTER SERVICES**

FOR ELECTRONIC DATA STORAGE (U.S. CLS. 100 AND 101).

FIRST USE 1-1-2014; IN COMMERCE 1-1-2014.

#### **CLASS 44—MEDICAL, BEAUTY AND AGRICULTURAL SERVICES**

FOR MEDICAL ASSISTANCE SERVICES IN THE NATURE OF MEDICAL INFORMATION PROVIDED TO MEDICAL PROFESSIONALS FROM REMOTE LOCATIONS VIA THE INTERNET AND GLOBAL COMPUTER NETWORKS THROUGH THE USE OF ARCHIVED MEDICAL IMAGES AND A DATA STORAGE AND RETRIEVAL SYSTEM; MEDICAL RADIOLOGY SERVICES; PROVIDING INFORMATION, ADVICE AND DATA ON MEDICAL IMAGING (U.S. CLS. 100 AND 101).

FIRST USE 1-1-2014; IN COMMERCE 1-1-2014.  
ROBERT C. CLARK JR., EXAMINING ATTORNEY

# FLAMES CLUB

THE MARK CONSISTS OF STANDARD CHARACTERS WITHOUT CLAIM TO ANY PARTICULAR FONT, STYLE, SIZE, OR COLOR.

OWNER OF U.S. REG. NO. 3,973,164.

NO CLAIM IS MADE TO THE EXCLUSIVE RIGHT TO USE "CLUB", APART FROM THE MARK AS SHOWN.

#### **CLASS 16—PAPER GOODS AND PRINTED MATTER**

FOR EDUCATIONAL PUBLICATIONS, NAMELY, BROCHURES, PROGRAMS, TICKETS, CORRESPONDENCE IN THE FIELDS OF COLLEGE AND UNIVERSITY ATHLETICS; NEWSLETTERS IN THE FIELD OF COLLEGE AND UNIVERSITY ATHLETICS; PAMPHLETS IN THE FIELD OF COLLEGE AND UNIVERSITY ATHLETICS; PRINTED PAMPHLETS, BROCHURES, MANUALS, BOOKS, BOOKLETS, LEAFLETS, INFORMATIONAL FLYERS, INFORMATIONAL SHEETS AND NEWSLETTERS, ADHESIVE BACKED STICKERS, AND KITS COMPRISING ONE OR MORE OF THE FOREGOING MATERIALS IN THE FIELD OF COLLEGE AND UNIVERSITY ATHLETICS (U.S. CLS. 2, 5, 22, 23, 29, 37, 38 AND 50).

FIRST USE 1-1-2004; IN COMMERCE 1-1-2004.

SN 86-186,347. CAPPEX.COM, LLC, CHICAGO, IL. FILED 2-6-2014.

# Global Education Exchange

THE MARK CONSISTS OF STANDARD CHARACTERS WITHOUT CLAIM TO ANY PARTICULAR FONT, STYLE, SIZE, OR COLOR.

NO CLAIM IS MADE TO THE EXCLUSIVE RIGHT TO USE "GLOBAL EDUCATION", APART FROM THE MARK AS SHOWN.

**CLASS 35—ADVERTISING AND BUSINESS**

FOR ADVERTISING AND MARKETING SERVICES RELATED TO EDUCATIONAL INSTITUTIONS, BOTH FOR PROFIT AND NON-PROFIT, INCLUDING COLLEGES, UNIVERSITIES AND TRADE SCHOOLS; ADVERTISING AND MARKETING SERVICES FOR OTHERS OF EDUCATIONAL SERVICES SUCH AS CERTIFICATIONS, BADGES AND FREE ONLINE COURSES; ADVERTISING AND MARKETING SERVICES FOR EDUCATION LOANS, GRANTS AND SCHOLARSHIPS; ADVERTISING AND MARKETING SERVICES TO POTENTIAL STUDENTS, INCLUDING FOR COLLEGES, UNIVERSITIES, AND TRADE SCHOOLS; PROVIDING REFERRAL SERVICES TO COMMUNITY-BASED ORGANIZATIONS REGARDING ADVERTISING AND MARKETING TO POTENTIAL STUDENTS AT COLLEGES, UNIVERSITIES AND TRADE SCHOOLS (U.S. CLS. 100, 101 AND 102).

**CLASS 36—INSURANCE AND FINANCIAL**

FOR PROVIDING INFORMATION TO POTENTIAL COLLEGE, UNIVERSITY AND TRADE SCHOOL STUDENTS RELATING TO TUITION, SCHOLARSHIPS, FINANCIAL OPPORTUNITIES AVAILABLE, AND TUITION ASSISTANCE (U.S. CLS. 100, 101 AND 102).

**CLASS 41—EDUCATION AND ENTERTAINMENT**

FOR ASSISTING POTENTIAL STUDENTS IN SEARCHING COLLEGES, UNIVERSITIES AND TRADE SCHOOLS; PROVIDING INFORMATION TO POTENTIAL STUDENT APPLICANTS RELATING TO THE COLLEGE, UNIVERSITY AND TRADE SCHOOL SELECTION PROCESS, ADMISSIONS AND GENERAL INFORMATION ON COLLEGES, UNIVERSITIES AND TRADE SCHOOLS; ONLINE AND OFFLINE PROVISION OF INFORMATION ON COLLEGES, UNIVERSITIES, TRADE SCHOOLS, AND CURRICULUMS (U.S. CLS. 100, 101 AND 107).

REBECCA POVARCHUK, EXAMINING ATTORNEY

SN 86-186,575. SPORTY GIRL LLC, JUPITER, FLORIDA 33477, FL. FILED 2-6-2014.



THE MARK CONSISTS OF A DESIGN OF A HEART COMPRISED OF TWO STYLIZED FISHHOOK DESIGNS.

**CLASS 16—PAPER GOODS AND PRINTED MATTER**

FOR DECALS (U.S. CLS. 2, 5, 22, 23, 29, 37, 38 AND 50). FIRST USE 12-0-2011; IN COMMERCE 12-0-2011.

**CLASS 25—CLOTHING**

FOR CLOTHING GOODS, NAMELY, HEADWEAR, BEANIES, HATS, VISORS, COWBOY HATS, UNDERWEAR, ONE-PIECE GARMENTS FOR BABIES, SCARFS, BIKINIS, SWIMWEAR, LONG-SLEEVE SHIRTS, JACKETS, SWEATERS, SHIRTS, TANK-TOPS, TUBE-TOPS, DRESSES, SKIRTS, SHORTS, PANTS, SWEATPANTS, AND COVER-UPS (U.S. CLS. 22 AND 39).

FIRST USE 12-0-2008; IN COMMERCE 12-0-2008.

PAUL CROWLEY, EXAMINING ATTORNEY

SN 86-186,592. SPORTY GIRL LLC, JUPITER, FL. FILED 2-6-2014.



THE MARK CONSISTS OF A DESIGN OF A HEART COMPRISED OF STYLIZED ANTLER DESIGNS.

**CLASS 16—PAPER GOODS AND PRINTED MATTER**

FOR DECALS (U.S. CLS. 2, 5, 22, 23, 29, 37, 38 AND 50). FIRST USE 2-4-2013; IN COMMERCE 2-4-2013.

**CLASS 25—CLOTHING**

FOR CLOTHING GOODS, NAMELY, HEADWEAR, BEANIES, HATS, VISORS, COWBOY HATS, UNDERWEAR, ONE-PIECE GARMENTS FOR BABIES, SCARFS, BIKINIS, SWIMWEAR, LONG-SLEEVE SHIRTS, JACKETS, SWEATERS, SHIRTS, TANK-TOPS, TUBE-TOPS, DRESSES, SKIRTS, SHORTS, PANTS, SWEATPANTS, AND COVER-UPS (U.S. CLS. 22 AND 39).

FIRST USE 10-0-2010; IN COMMERCE 10-0-2010.

PAUL CROWLEY, EXAMINING ATTORNEY

SN 86-186,603. SPORTY GIRL LLC, JUPITER, FL. FILED 2-6-2014.



THE MARK CONSISTS OF A DESIGN OF A HEART COMPRISED OF A FISH HOOK DESIGN ON ONE SIDE OF THE HEART AND STYLIZED ANTLER DESIGNS ON THE OTHER SIDE OF THE HEART.

#### CLASS 16—PAPER GOODS AND PRINTED MATTER

FOR DECALS (U.S. CLS. 2, 5, 22, 23, 29, 37, 38 AND 50). FIRST USE 2-14-2013; IN COMMERCE 2-14-2013.

#### CLASS 25—CLOTHING

FOR CLOTHING GOODS, NAMELY, HEADWEAR, BEANIES, HATS, VISORS, COWBOY HATS, UNDERWEAR, ONE-PIECE GARMENTS FOR BABIES, SCARFS, BIKINIS, SWIMWEAR, LONG-SLEEVE SHIRTS, JACKETS, SWEATERS, SHIRTS, TANK-TOPS, TUBE-TOPS, DRESSES, SKIRTS, SHORTS, PANTS, SWEATPANTS, AND COVER-UPS (U.S. CLS. 22 AND 39).

FIRST USE 1-0-2012; IN COMMERCE 1-0-2012.  
PAUL CROWLEY, EXAMINING ATTORNEY

SN 86-187,086. GROSAVE, INC., LONE TREE, CO. FILED 2-7-2014.

# GRO SAVE

THE MARK CONSISTS OF STANDARD CHARACTERS WITHOUT CLAIM TO ANY PARTICULAR FONT, STYLE, SIZE, OR COLOR.

NO CLAIM IS MADE TO THE EXCLUSIVE RIGHT TO USE "GROW", APART FROM THE MARK AS SHOWN.

#### CLASS 1—CHEMICALS

FOR FERTILIZERS; ORGANIC SOIL ENHANCEMENT IN THE NATURE OF ORGANIC SOIL ENHANCEMENT POWDERS AND PREPARATIONS (U.S. CLS. 1, 5, 6, 10, 26 AND 46).

FIRST USE 4-2-2013; IN COMMERCE 4-2-2013.

#### CLASS 9—ELECTRICAL AND SCIENTIFIC APPARATUS

FOR ELECTRICAL ENERGY RECYCLING SYSTEMS IN THE NATURE OF METAL ENCLOSED CAPACITOR BANK ASSEMBLIES (U.S. CLS. 21, 23, 26, 36 AND 38).

FIRST USE 4-2-2013; IN COMMERCE 4-2-2013.  
MEGHAN REINHART, EXAMINING ATTORNEY

SN 86-187,679. SATA GMBH & CO. KG, KORNWESTHEIM, FED REP GERMANY, FILED 2-7-2014.

# filter 244

THE MARK CONSISTS OF STANDARD CHARACTERS WITHOUT CLAIM TO ANY PARTICULAR FONT, STYLE, SIZE, OR COLOR.

PRIORITY CLAIMED UNDER SEC. 44(D) ON ERPNTY TM OFC APPLICATION NO. 012058061, FILED 8-9-2013, REG. NO. 012058061, DATED 1-7-2014, EXPIRES 8-9-2023.

NO CLAIM IS MADE TO THE EXCLUSIVE RIGHT TO USE "FILTER", APART FROM THE MARK AS SHOWN.

#### CLASS 7—MACHINERY

FOR CENTRIFUGES; AIR CLEANING FILTERS BEING PARTS OF MACHINES USED IN THE PAINT-SPRAYING INDUSTRY; FILTERS FOR GASES BEING PARTS OF MACHINES USED IN THE PAINT-SPRAYING INDUSTRY; CENTRIFUGAL SEPARATORS; CYCLONES (U.S. CLS. 13, 19, 21, 23, 31, 34 AND 35).

FIRST USE 5-1-2010; IN COMMERCE 5-1-2010.

#### CLASS 11—ENVIRONMENTAL CONTROL APPARATUS

FOR FILTERING MACHINES AND SEPARATORS FOR CLEANING AIR FOR USE IN THE FIELD OF PAINT SPRAYING; AIR FILTERING INSTALLATIONS; AIR CLEANING FILTERS BEING PARTS OF AIR CLEANING MACHINES OR INSTALLATIONS; FILTERS FOR CLEANING GASES SOLD AS INTEGRAL COMPONENT PARTS OF HOUSEHOLD AND INDUSTRIAL AIR CLEANING INSTALLATIONS; FILTERS FOR GAS CONDITIONING FOR HOUSEHOLD OR INDUSTRIAL INSTALLATIONS; AIR FILTERING APPARATUS, NAMELY, AIR FILTERS FOR DOMESTIC USE AND AIR FILTERS FOR INDUSTRIAL INSTALLATIONS; AIR FILTERS FOR INDUSTRIAL INSTALLATIONS AND FOR HOUSEHOLD USE; AIR FILTERS FOR INDUSTRIAL INSTALLATIONS; SEPARATORS FOR PURIFYING GAS; AIR SEPARATION INSTALLATIONS BEING SEPARATORS FOR CLEANING AND PURIFYING AIR; SEPARATORS FOR PURIFYING AIR; AIR DRYERS FOR REMOVING CONDENSATE AND OIL FROM THE AIR FOR USE IN THE FIELD OF PAINT SPRAYING; AIR PURIFYING APPARATUS AND MACHINES; FILTERS FOR CLEANING AIR FOR USE IN THE FIELD OF PAINT SPRAYING; APPARATUS FOR CLEANING AIR, NAMELY, AIR CLEANING UNITS (U.S. CLS. 13, 21, 23, 31 AND 34).

FIRST USE 5-1-2010; IN COMMERCE 5-1-2010.

MAUREEN DALL, EXAMINING ATTORNEY

SN 86-187,990. BENNU OIL & GAS, LLC, HOUSTON, TX. FILED 2-7-2014.

# BENNU OIL & GAS

THE MARK CONSISTS OF STANDARD CHARACTERS WITHOUT CLAIM TO ANY PARTICULAR FONT, STYLE, SIZE, OR COLOR.

NO CLAIM IS MADE TO THE EXCLUSIVE RIGHT TO USE "OIL & GAS", APART FROM THE MARK AS SHOWN.

**CLASS 35—ADVERTISING AND BUSINESS**

FOR MANAGING THE EXPLORATION, PRODUCTION AND OPERATIONS OF NATURAL GAS AND OIL PROPERTIES FOR OTHERS (U.S. CLS. 100, 101 AND 102).

SN 86-189,361. SEARS BRANDS, LLC, HOFFMAN ESTATES, IL. FILED 2-10-2014.

**CLASS 37—CONSTRUCTION AND REPAIR**

FOR OIL AND GAS DRILLING; EXTRACTION OF OIL AND GAS; CONSTRUCTION, MAINTENANCE, AND CONSTRUCTION PROJECT MANAGEMENT SERVICES IN OIL AND GAS FIELDS; CONSTRUCTION AND INSTALLATION OF OFFSHORE OIL AND GAS EXPLORATION AND PRODUCTION EQUIPMENT (U.S. CLS. 100, 103 AND 106).

M2M

THE MARK CONSISTS OF STANDARD CHARACTERS WITHOUT CLAIM TO ANY PARTICULAR FONT, STYLE, SIZE, OR COLOR.

**CLASS 40—MATERIAL TREATMENT**

FOR CONSULTATION IN THE FIELD OF THE PRODUCTION OF OIL AND GAS (U.S. CLS. 100, 103 AND 106).

**CLASS 35—ADVERTISING AND BUSINESS**

FOR RETAIL DEPARTMENT STORE SERVICES AND ONLINE RETAIL DEPARTMENT STORE SERVICES FEATURING TOOLS AND LAWN AND GARDEN EQUIPMENT (U.S. CLS. 100, 101 AND 102).

**CLASS 42—SCIENTIFIC AND COMPUTER SERVICES**

FOR CONSULTATION IN THE FIELD OF EXPLORATION AND SEARCHING OF OIL AND GAS (U.S. CLS. 100 AND 101).

**CLASS 38—COMMUNICATION**

FOR PROVIDING AN ON-LINE FORUM FOR USERS TO SHARE DESIGNS AND IDEAS RELATING TO TOOLS, LAWN AND GARDEN CARE, AND HOME REPAIR AND MAINTENANCE (U.S. CLS. 100, 101 AND 104).

SUZANNE BLANE, EXAMINING ATTORNEY

JILLIAN CANTOR, EXAMINING ATTORNEY

SN 86-188,271. BLACKDOWN SHEPHERD HUTS LTD., ILMINSTER, SOMERSET, UNITED KINGDOM, FILED 2-7-2014.

SN 86-189,429. HAWAIIAN QUILT COLLECTION, INC., HONOLULU, HI. FILED 2-10-2014.

BLACKDOWN



THE MARK CONSISTS OF STANDARD CHARACTERS WITHOUT CLAIM TO ANY PARTICULAR FONT, STYLE, SIZE, OR COLOR.

OWNER OF UNITED KINGDOM REG. NO. 2657978, DATED 7-19-2013, EXPIRES 7-19-2023.

THE MARK CONSISTS OF IN THE CENTER, A CROWN WITH INITIALS "HQC" BELOW, SURROUNDED (BUT WITH A SPACE AT THE TOP) BY A LEI.

**CLASS 19—NON-METALLIC BUILDING MATERIALS**

FOR PREFABRICATED WOODEN BUILDINGS; MOBILE HOMES (U.S. CLS. 1, 12, 33 AND 50).

**CLASS 24—FABRICS**

FOR QUILTS (U.S. CLS. 42 AND 50).

**CLASS 37—CONSTRUCTION AND REPAIR**

FOR CONSTRUCTION SERVICES, NAMELY, ERECTING AND GLAZING BUILDINGS (U.S. CLS. 100, 103 AND 106).

CURTIS FRENCH, EXAMINING ATTORNEY

**CLASS 35—ADVERTISING AND BUSINESS**

FOR RETAIL STORE SERVICES FEATURING HAWAIIAN THEMED QUILTS, PILLOWS, PURSES, BAGS, WALL HANGINGS, BLANKETS, CLOTHING, TOWELS, EYE GLASS CASES AND KITS FOR MAKING QUILTED PRODUCTS (U.S. CLS. 100, 101 AND 102).

ANGELA M. MICHELI, EXAMINING ATTORNEY

SN 86-189,766. NATIONAL PRO FITNESS LEAGUE, LLC,  
SANTA CRUZ, CA. FILED 2-10-2014.

SN 86-190,156. THE MUSIC PROJECT, LLC, PALM HARBOR,  
FL. FILED 2-11-2014.

# NPFL

THE MARK CONSISTS OF STANDARD CHARACTERS WITHOUT CLAIM TO ANY PARTICULAR FONT, STYLE, SIZE, OR COLOR.

## CLASS 35—ADVERTISING AND BUSINESS

FOR PROMOTING ATHLETIC COMPETITIONS AND EXHIBITIONS FOR OTHERS (U.S. CLS. 100, 101 AND 102).

## CLASS 41—EDUCATION AND ENTERTAINMENT

FOR ORGANIZATION OF SPORTS COMPETITIONS; ORGANIZATION OF SPORTS COMPETITIONS IN THE NATURE OF ATHLETIC RACING; ENTERTAINMENT SERVICES ASSOCIATED WITH THE PERFORMANCE OF THE ATHLETIC COMPETITIONS AND EXHIBITIONS, NAMELY, ARRANGING AND CONDUCTING ATHLETIC COMPETITIONS AND ARRANGING AND CONDUCTING HALF-TIME SHOWS FOR ATHLETIC COMPETITIONS; PROVIDING LIVE MEMBER TEAM COMPETITIVE AND EXHIBITION PERFORMANCES, NAMELY, ORGANIZING AND ARRANGING LIVE ATHLETIC COMPETITIONS AND ATHLETIC EXHIBITIONS FOR ENTERTAINMENT PURPOSES; PROVIDING CURRENT EVENT ENTERTAINMENT INFORMATION RELATED TO ATHLETIC COMPETITIONS VIA THE INTERNET, ONLINE COMPUTER SERVICES, AND OTHER MEDIA OUTLETS SUCH AS CABLE, VIDEO, RADIO, BROADCAST TELEVISION, DIGITAL AND OTHER MEANS (U.S. CLS. 100, 101 AND 107).

JAMES MACFARLANE, EXAMINING ATTORNEY

SN 86-190,123. THE MUSIC PROJECT, LLC, PALM HARBOR,  
FL. FILED 2-11-2014.

# Songboard

THE MARK CONSISTS OF STANDARD CHARACTERS WITHOUT CLAIM TO ANY PARTICULAR FONT, STYLE, SIZE, OR COLOR.

## CLASS 38—COMMUNICATION

FOR DELIVERY OF DIGITAL MUSIC BY ELECTRONIC TRANSMISSION (U.S. CLS. 100, 101 AND 104).

## CLASS 41—EDUCATION AND ENTERTAINMENT

FOR ONLINE MUSIC PUBLISHING SERVICES (U.S. CLS. 100, 101 AND 107).

KAREN BRACEY, EXAMINING ATTORNEY

# Mp45

THE MARK CONSISTS OF STANDARD CHARACTERS WITHOUT CLAIM TO ANY PARTICULAR FONT, STYLE, SIZE, OR COLOR.

## CLASS 35—ADVERTISING AND BUSINESS

FOR DISTRIBUTORSHIPS IN THE FIELD OF MUSICAL RECORDINGS (U.S. CLS. 100, 101 AND 102).

## CLASS 41—EDUCATION AND ENTERTAINMENT

FOR ONLINE MUSIC PUBLISHING SERVICES (U.S. CLS. 100, 101 AND 107).

KAREN BRACEY, EXAMINING ATTORNEY

SN 86-190,723. PEAXY, INC., SAN JOSE, CA. FILED 2-11-2014.

# TOTAL DATA ACCESS FOR INDUSTRY

THE MARK CONSISTS OF STANDARD CHARACTERS WITHOUT CLAIM TO ANY PARTICULAR FONT, STYLE, SIZE, OR COLOR.

NO CLAIM IS MADE TO THE EXCLUSIVE RIGHT TO USE "DATA ACCESS" AND "INDUSTRY", APART FROM THE MARK AS SHOWN.

## CLASS 9—ELECTRICAL AND SCIENTIFIC APPARATUS

FOR COMPUTER SOFTWARE FOR AGGREGATION, STORAGE, RETRIEVAL AND MANAGEMENT OF DATA (U.S. CLS. 21, 23, 26, 36 AND 38).

## CLASS 42—SCIENTIFIC AND COMPUTER SERVICES

FOR DESIGN AND DEVELOPMENT OF COMPUTER SOFTWARE FOR OTHERS, NAMELY, DESIGN AND DEVELOPMENT OF AUTOMATED MANAGEMENT TOOLS WITHIN AN ELECTRONIC DATA STORAGE PLATFORM; PROVISION OF AN ELECTRONIC DATA STORAGE PLATFORM (U.S. CLS. 100 AND 101).

LINDA MICKLEBURGH, EXAMINING ATTORNEY

SN 86-190,736. MIRAMAX, LLC, AKA MIRAMAX, SANTA MONICA, CA. FILED 2-11-2014.

# KILL BILL

THE MARK CONSISTS OF STANDARD CHARACTERS WITHOUT CLAIM TO ANY PARTICULAR FONT, STYLE, SIZE, OR COLOR.

## CLASS 9—ELECTRICAL AND SCIENTIFIC APPARATUS

FOR RADIOS INCORPORATING CLOCKS; MAGNETS; DOWNLOADABLE ELECTRONIC BOOKS, NAMELY, A SERIES OF FICTION BOOKS KNOWN AS NOVELIZATIONS, ACTION AND ADVENTURE BOOKS FOR YOUNG ADULTS, DIGITAL TRADING CARDS, DIGITAL COMIC BOOKS AND GRAPHIC NOVELS; COMPUTER AND ELECTRONIC GAME CARTRIDGES, CASSETTES AND/OR DISCS; COMPUTER AND ELECTRONIC GAME SOFTWARE; COMPUTER AND ELECTRONIC GAME SOFTWARE FOR GAMING MACHINES INCLUDING SLOT MACHINES OR VIDEO LOTTERY TERMINALS; COMPUTER AND ELECTRONIC GAME SOFTWARE FOR PERSONAL COMPUTERS AND HOME VIDEO GAME CONSOLES; COMPUTER AND ELECTRONIC GAME SOFTWARE DOWNLOADABLE FROM A GLOBAL COMPUTER NETWORK; COMPUTER AND ELECTRONIC GAME SOFTWARE FOR USE ON MOBILE AND CELLULAR PHONES AND WIRELESS DEVICES; DOWNLOADABLE COMPUTER AND ELECTRONIC GAME PROGRAMS; INTERACTIVE MULTIMEDIA COMPUTER GAME PROGRAMS; VIRTUAL REALITY GAME SOFTWARE; CHARGERS FOR USE IN VEHICLES FOR MOBILE DEVICES, NAMELY, MOBILE PHONES, LAPTOPS, TABLETS, PDAS AND PORTABLE MUSIC PLAYERS; SUN GLASSES AND CASES THEREFOR; HEADPHONES, EAR BUDS, MP3 AND MP4 PLAYERS, BLANK USB FLASH DRIVES, AUDIO SPEAKERS, AUXILIARY POWER CHARGERS AND CARRYING CASES SPECIALLY ADAPTED FOR ALL THE AFOREMENTIONED; CASES FOR MOBILE DEVICES NAMELY, MOBILE PHONES, LAPTOPS, TABLETS, PDAS AND PORTABLE MUSIC PLAYERS AND COMPUTER CASES; CELL PHONE CASES AND COMPUTER JOYSTICKS (U.S. CLS. 21, 23, 26, 36 AND 38).

## CLASS 14—JEWELRY

FOR WATCHES; WATCH CASES; JEWELRY; JEWELRY BOXES; JEWELRY, NAMELY, DOG TAGS FOR WEAR BY HUMANS FOR DECORATIVE PURPOSES; CLOCKS; KEY CHAINS AS JEWELRY AND KEY CHAINS OF PRECIOUS METAL; ORNAMENTAL PINS FOR CLOTHING (U.S. CLS. 2, 27, 28 AND 50).

## CLASS 16—PAPER GOODS AND PRINTED MATTER

FOR BOOK ENDS; CALENDARS; STICKERS; TEMPORARY TATTOO TRANSFERS; BOOKMARKS; POSTERS; ADDRESS BOOKS, NOTEBOOKS; BLANK WRITING JOURNALS AND WRITING TABLETS; WRITING INSTRUMENTS; GREETING CARDS AND NOTE CARDS; PAPER WEIGHTS; BOOKS, NAMELY, ACTION/ADVENTURE BOOKS FOR CHILDREN, ACTION/ADVENTURE BOOKS FOR YOUNG ADULTS AND AS SERIES OF FICTION BOOKS KNOWN AS NOVELIZATIONS; COMIC BOOKS AND COMIC MAGAZINES; COLLECTABLE TRADING CARDS; SERIES OF COMPUTER GAME HINT BOOKS; VEHICLE WINDOW CLINGS SHEETS AND DECALS ON WHICH TEXT AND IMAGES FROM MOTION PICTURES OR IMAGES OF THE CHARACTERS THEREFROM ARE PRINTED; LIFE SIZE PAPER OR CARDBOARD DIE CUT SHAPES OF ANIMATED AND NON-ANIMATED ENTERTAINMENT CHARACTERS AND LANDSCAPE SCENES; LIMITED EDITION AND NON-LIMITED EDITION FRAMED AND UNFRAMED POSTERS, PAINTINGS AND GICLEE PRINTS; AND DESKTOP BUSINESS CARD HOLDERS (U.S. CLS. 2, 5, 22, 23, 29, 37, 38 AND 50).

## CLASS 18—LEATHER GOODS

FOR BACKPACKS; GYM BAGS, BARREL BAGS, HANDBAGS, PURSES, LUGGAGE BAGS, TOTE BAGS; SMALL LEATHER GOODS, NAMELY, SHOULDER BELTS, LEATHER KEY CHAINS, CHANGE PURSES, BILLFOLDS; WALLETS; IDENTIFICATION AND BUSINESS CARD HOLDERS AND CASES IN THE NATURE OF WALLETS AND CREDIT CARD, CALLING CARD, NAME CARD CASES (U.S. CLS. 1, 2, 3, 22 AND 41).

## CLASS 21—HOUSEWARES AND GLASS

FOR SHOT GLASSES; BEVERAGE GLASSWARE; FLASKS; BOTTLE OPENERS; CHARMS FOR ATTACHMENT TO BEVERAGE GLASSWARE; COOKIE JARS; LUNCH BOXES; CUPS AND MUGS; CANDLE HOLDERS; PLASTIC COASTERS AND WINE COASTERS OF PRECIOUS METAL; NON-METALLIC COIN BANKS AND PIGGY BANKS (U.S. CLS. 2, 13, 23, 29, 30, 33, 40 AND 50).

## CLASS 25—CLOTHING

FOR T-SHIRTS; SWEATSHIRTS; HOODIES; CONSTRUCTED APPAREL AND FASHION GARMENTS, NAMELY, KNIT AND WOVEN TOPS, BLOUSES, PANTS, SHORTS, SKIRTS, JEANS, JACKETS; CAPS; BEANIES; HATS; BANDANAS; BOXERS; UNDERWEAR; SLEEPWEAR AND PAJAMAS; LOUNGEWEAR; OUTERWEAR, NAMELY, JACKETS, FLEECE JACKETS AND OUTER SHIRTS AND RAINCOATS; GLOVES, SCARVES AND MITTENS; SOCKS AND HOSIERY; TIES; WRIST BANDS; HALLOWEEN AND MASQUERADE COSTUMES; COSTUMES FOR USE IN CHILDREN'S DRESS UP PLAY; FOOTWEAR, SHOES AND ATHLETIC FOOTWEAR; BELTS (U.S. CLS. 22 AND 39).

## CLASS 28—TOYS AND SPORTING GOODS

FOR ACTION FIGURES AND ACCESSORIES THEREFOR; ACTION FIGURE TOYS; AMUSEMENT GAME MACHINES; AMUSEMENT MACHINES, NAMELY, HAND-HELD ELECTRONIC GAME UNITS ADAPTED FOR USE WITH AN EXTERNAL DISPLAY SCREEN OR MONITOR; AMUSEMENT PARK RIDES; ARCADE GAMES; ARCADE-TYPE ELECTRONIC VIDEO GAMES; ARTICLES OF CLOTHING FOR TOYS; AUDIO AND VISUAL HEADSETS FOR USE IN PLAYING VIDEO GAMES; BATTERY-POWERED COMPUTER GAME WITH LCD SCREEN; BENDABLE TOYS; BILLIARD BALLS; BILLIARD GAME PLAYING EQUIPMENT; BOARD GAMES; BOBBLE HEAD DOLLS; CARD GAMES; ACTION FIGURES SOLD IN BULK, CASES ESPECIALLY ADAPTED FOR HOLDING ACTION FIGURES; CHESS GAMES; CHESS PIECES; CHESS SETS; CHESSBOARDS; CHIPS FOR GAMBLING; CHRISTMAS TREE ORNAMENTS; COLLECTABLE TOY FIGURES; COMPUTER AND VIDEO GAME CONSOLES FOR USE



WITH AN EXTERNAL DISPLAY SCREEN OR MONITOR; COMPUTER GAME AND VIDEO GAME JOYSTICKS; COMPUTERIZED VIDEO TABLE GAMES FOR GAMING PURPOSES; CONSTRUCTION TOYS; COSTUME MASKS; DARTS; DART BOARDS; DART FLIGHTS; DOG TOYS; DOLL ACCESSORIES; DOLL CLOTHING; DOLLS AND ACCESSORIES THEREFOR; ELECTRONIC ACTION TOYS; HAND HELD ELECTRONIC GAMES ADAPTED FOR USE WITH TELEVISION RECEIVERS ONLY; ELECTRONIC GAMING MACHINES, NAMELY, DEVICES WHICH ACCEPT A WAGER; ELECTRONIC INTERACTIVE BOARD GAMES FOR USE WITH EXTERNAL MONITOR; ELECTRONIC TOY VEHICLES; FANTASY CHARACTER TOYS; FITTED PLASTIC FILMS KNOWN AS SKINS FOR COVERING AND PROTECTING ELECTRONIC GAMING APPARATUS, NAMELY, VIDEO GAME CONSOLES, HAND-HELD GAME UNITS; GAMBLING MACHINES; GAME CARDS; GAME CONTROLLERS FOR COMPUTER GAMES; GAMING CHIPS; GAMING DEVICES, NAMELY, GAMING MACHINES, SLOT MACHINES, BINGO MACHINES, WITH OR WITHOUT VIDEO OUTPUT; GAMING MACHINES INCLUDING SLOT MACHINES OR VIDEO LOTTERY TERMINALS; GAME AND GAMING TABLES; HAND-HELD UNITS FOR PLAYING ELECTRONIC GAMES OTHER THAN THOSE ADAPTED FOR USE WITH AN EXTERNAL DISPLAY SCREEN OR MONITOR; HAND-HELD ELECTRONIC GAMES ADAPTED FOR USE WITH TELEVISION RECEIVERS ONLY; HOME VIDEO GAME MACHINES; JIGSAW PUZZLES, PUZZLES AND PUZZLE GAMES; LCD GAME MACHINES; LOTTERY CARDS; LOTTERY TICKETS; MARTIAL ARTS TRAINING EQUIPMENT; MECHANICAL ACTION TOYS; MECHANICAL TOYS; MEMORY GAMES; MODEL TOY VEHICLES; MODELED PLASTIC TOY FIGURINES; MOLDED TOY FIGURES; MUSICAL TOYS; PACHINKOS; PADDLE SURFBOARDS; PET TOYS; PINBALL GAMES; PINBALL MACHINES; PLASTIC CHARACTER TOYS; PLAYING CARDS, PLAYING CARD GAMES AND PLAYING CARD CASES; PLAYING CARD GAME ACCESSORIES, NAMELY, PLAYING CARD HOLDERS, MATS FOR GAMING TABLES, PLAYING CARD SHUFFLING DEVICES AND DICE; PLUSH DOLLS; PLUSH TOYS; POKER CHIPS; PORCELAIN DOLLS; POSITIONABLE TOY FIGURES; PROTECTIVE CARRYING CASES SPECIAL ADAPTED FOR HAND-HELD VIDEO GAMES; PROTECTIVE PADDING FOR SNOWBOARDING AND SKATEBOARDING; PVC TOY FIGURES; REMOTE CONTROL TOYS, NAMELY, CARS, RACE CARS, AIRPLANES, HELICOPTERS, MILITARY AND CONSTRUCTION VEHICLES, BOATS, TRUCKS AND TRAINS; RUBBER CHARACTER TOYS; SCALE MODEL TOY KITS; SCRATCH CARDS FOR PLAYING LOTTERY GAMES; SKATEBOARD DECKS; SKATEBOARDS; SKIS; SLOT MACHINES; SNOWBOARDS; SNOW GLOBES; SPORTS EQUIPMENT FOR BOXING AND MARTIAL ARTS, NAMELY, BOXING GLOVES, BOXING BAGS, PUNCHING MITTS, BELLY PROTECTORS, GROIN PROTECTORS AND SHIN GUARDS; SQUEEZE TOYS; STAND ALONE VIDEO GAME MACHINES; STUFFED AND PLUSH TOYS; SURF BOARDS; TOY ACTION FIGURES AND ACCESSORIES THEREFOR; TOY CLOCKS; TOY BANKS; TOY FIGURES; TOY FIGURES IN THE FORM OF A POTATO; TOY FILM CARTRIDGES AND VIEWERS; TOY MOTION PICTURE PROP REPLICAS; TOY SNOW GLOBES; TOY SWORDS; TOY WEAPONS; TRADING CARD GAMES; TRIVIA GAME PLAYED WITH CARDS AND GAME COMPONENTS; VIDEO GAME INTERACTIVE REMOTE CONTROL UNITS; VIDEO GAME INTERACTIVE HAND-HELD REMOTE CONTROLS FOR PLAYING ELECTRONIC GAMES; VIDEO GAME MACHINES FOR USE WITH EXTERNAL DISPLAY SCREEN OR MONITOR; VIDEO OUTPUT GAME MACHINES FOR USE WITH TELEVISIONS; VINYL DOLLS; VIRTUAL REALITY HEADSETS AND HELMETS ADAPTED FOR USE IN PLAYING VIDEO GAMES; WAKEBOARDS; WATER GLOBES; WATER SKIS; METAL OR PLASTIC 3D TOY DIORAMAS DEPICTING FILM SCENES OR CHARACTERS (U.S. CLS. 22, 23, 38 AND 50).

#### CLASS 41—EDUCATION AND ENTERTAINMENT

FOR PROVIDING ONLINE NON-DOWNLOADABLE COMIC BOOKS, GRAPHIC NOVELS, BOOKS IN THE FIELD OF FICTIONAL ACTION/ADVENTURE STORIES, A SERIES OF FICTION BOOKS KNOWN AS NOVELIZATIONS, ACTION AND ADVENTURE BOOKS FOR YOUNG ADULTS, DIGITAL TRADING CARDS; ENTERTAINMENT SERVICES, NAMELY, PROVIDING ONLINE NON-DOWNLOADABLE FREE TO PLAY NON-WAGERING ELECTRONIC GAMES; ENTERTAINMENT SERVICES, NAMELY, PROVIDING ONLINE COMPUTER GAMES, PROVIDING ONLINE ELECTRONIC AND VIDEO GAMES, PROVIDING TEMPORARY USE OF NON-DOWNLOADABLE ELECTRONIC GAMES, PROVIDING GAMES OF CHANCE VIA THE INTERNET AND CONDUCTING LIVE POKER GAMES; ENTERTAINMENT SERVICES, NAMELY, PROVIDING A WEBSITE FEATURING GAMES AND PUZZLES, ONLINE BOARD GAMES AND ONLINE CARD GAMES (U.S. CLS. 100, 101 AND 107).

ANDREW LEASER, EXAMINING ATTORNEY

SN 86-191,134. CERAGEM TEKNOLOJI VE SANAYI ÜRÜNLERİ PAZARLAMA A.Ş., DBA SHOKKER, ISTANBUL, TURKEY, FILED 2-12-2014.



PRIORITY CLAIMED UNDER SEC. 44(D) ON ERPNCMNTY TM OFC APPLICATION NO. 012542247, FILED 1-28-2014, REG. NO. 012542247, DATED 6-12-2014, EXPIRES 1-28-2024.

THE COLOR(S) BLACK, WHITE, YELLOW, BLUE, AND LIGHT BLUE IS/ARE CLAIMED AS A FEATURE OF THE MARK.

THE MARK CONSISTS OF "SHOKKER" WRITTEN IN CAPS AND IN HEMI HEAD 426 LETTERTYPE. THE WORDING APPEARS IN WHITE BETWEEN TWO IMAGES OF YELLOW LIGHTNING STRIKES. THE WORDING APPEARS OVER A BLACK AND BLUE BACKGROUND COMPOSED OF FREE LINES REPRESENTING ELECTRICITY THAT APPEAR IN WHITE AND SHADES OF LIGHT BLUE.

#### CLASS 9—ELECTRICAL AND SCIENTIFIC APPARATUS

FOR CAMERAS; DIGITAL CAMERAS; DIGITAL VIDEO CAMERAS FOR INDUSTRIAL USE; DIGITAL VIDEO CAMERAS; INFRARED CAMERAS; INTERFACE CIRCUITS FOR VIDEO CAMERAS; MOTION PICTURE CAMERAS; VIDEO CAMERAS; VIDEO INJECTION SYSTEM, NAMELY, OPTICAL AND ELECTRONIC HARDWARE AND COMPUTER SOFTWARE, SIMULATING THE EFFECTS OF TRACER ROUND FLY-OUTS AND BURSTS ON TARGET, WHICH ALLOWS FOR ON-VEHICLE PRECISION GUNNERY WITHOUT EXPENDING ACTUAL AMMUNITION; WIDE-ANGLE LENSES FOR CAMERAS (U.S. CLS. 21, 23, 26, 36 AND 38).

**CLASS 13—FIREARMS**

FOR AIR PISTOLS; AIR PISTOLS; AIR RIFLES; AMMUNITION; AMMUNITION BAGS; AMMUNITION CASINGS; AMMUNITION FOR FIREARMS; AMMUNITION HOISTS; AMMUNITION MAGAZINES AND COMPONENT PARTS FOR AMMUNITION MAGAZINES; AUTOMATIC GUNS; AUTOMATIC PISTOLS; BANDOLIERS FOR HOLDING CARTRIDGES OR AMMUNITION CASES; BELTS ADAPTED FOR AMMUNITION; BUTT PLATES FOR PISTOLS, RIFLES, AND SHOTGUNS; CASE COVERS FOR FIREARMS; COMBINATION PISTOLS AND RIFLES; COMPONENT PARTS FOR GUNS; COMPONENT PARTS FOR PISTOLS; COVERS FOR FIREARMS; DEVICES FOR FIRING SIGNAL CARTRIDGES AND ILLUMINATION CARTRIDGES; EXPLOSIVE CARTRIDGES; EXPLOSIVE HARPOON GUNS; FIREARM ATTACHMENTS, NAMELY, MODULAR EXTERNAL RAIL SYSTEMS FOR ATTACHING ACCESSORIES TO FIREARMS; FIREARM ATTACHMENTS, NAMELY, MODULAR EXTERNAL RAIL SYSTEMS FOR FIREARMS; FIREARM ATTACHMENTS, NAMELY, MOUNTS FOR ATTACHING ACCESSORIES TO A FIREARM; FIREARM ATTACHMENTS, NAMELY, MOUNTS FOR ATTACHING ANCILLARY EQUIPMENT TO A FIREARM; FIREARM ATTACHMENTS, NAMELY, MOUNTS FOR ATTACHING GRIPS TO A FIREARM; FIREARM ATTACHMENTS, NAMELY, MOUNTS FOR ATTACHING GUN SIGHTS TO A FIREARM; FIREARM ATTACHMENTS, NAMELY, MOUNTS FOR ATTACHING LASER POINTING DEVICES TO A FIREARM; FIREARM ATTACHMENTS, NAMELY, MOUNTS FOR ATTACHING LIGHTS TO A FIREARM; FIREARM ATTACHMENTS, NAMELY, MOUNTS FOR ATTACHING NIGHT VISION DEVICES TO A FIREARM; FIREARM ATTACHMENTS, NAMELY, MOUNTS FOR ATTACHING TELESCOPIC SIGHTS TO A FIREARM; FIREARM HAND GUARDS; FIREARM SIGHTS; FIREARM SLINGS; FIREARMS; GUN AND RIFLE CASES; GUN BARRELS; GUN BELTS; GUN CARRIAGES; GUN CARTRIDGES; GUN CASES; GUN LOCKS; GUN MOUNTS; GUNS; HAND GUN ACCESSORIES, NAMELY, BELT CLIPS FOR SECURING A GUN WITHOUT THE USE OF A HOLSTER; HANDLES FOR PISTOLS; HANDLES FOR PISTOLS AND REVOLVERS; HOLSTERS; LOADING CLIPS FOR PISTOLS; MAGAZINES FOR WEAPONS; NAVAL GUNS; PISTOL CAPS; PISTOL CASES; PISTOL GRIPS; PISTOL HOLSTERS; PISTOLS; PISTOLS AND PARTS THEREOF; PROJECTILES; RIFLE AMMUNITION; SHOOTING ACCESSORIES, NAMELY, GUN RESTS; SHOTGUN CARTRIDGES; SHOTSHELL AMMUNITION; SIEGE GUNS; SMALL ARMS AMMUNITION; SPORTING CARTRIDGES; STUN GUNS; SUPPLEMENTAL CHAMBERS FOR FIREARMS; TRIGGER GUARDS FOR GUNS AND RIFLES; WEAPON CASES FOR FIREARMS (U.S. CLS. 2 AND 9).

**CLASS 42—SCIENTIFIC AND COMPUTER SERVICES**

FOR COMPUTER HARDWARE AND SOFTWARE DESIGN; COMPUTER PROGRAMMING AND SOFTWARE DESIGN; COMPUTER SOFTWARE DESIGN; COMPUTER SOFTWARE DESIGN AND UPDATING; COMPUTER SOFTWARE DESIGN, COMPUTER PROGRAMMING, AND MAINTENANCE OF COMPUTER SOFTWARE; DESIGN AND DEVELOPMENT OF COMPUTER HARDWARE AND SOFTWARE; DESIGN AND DEVELOPMENT OF COMPUTER SOFTWARE; DESIGNING OF MACHINES, APPARATUS, INSTRUMENTS OR SYSTEMS COMPOSED OF SUCH MACHINES, APPARATUS AND INSTRUMENTS; RESEARCH AND DEVELOPMENT OF TECHNOLOGY IN THE FIELD OF WEAPONS AND GUNS; RESEARCH IN THE FIELD OF INTELLIGENCE AND SECURITY TECHNOLOGY; SOFTWARE DESIGN AND DEVELOPMENT; UPDATING AND DESIGN OF COMPUTER SOFTWARE; UPDATING, DESIGN AND RENTAL OF SOFTWARE (U.S. CLS. 100 AND 101).

**CLASS 45—PERSONAL AND LEGAL SERVICES**

FOR ADVISORY SERVICES IN THE FIELD OF HOME SECURITY SYSTEMS; CONSULTANCY SERVICES IN THE FIELD OF HOME SECURITY; CONTROL OF BUILDING ENVIRONMENTAL ACCESS AND SECURITY SYSTEMS; PERSONAL SECURITY CONSULTATION; PROVIDING A WEB SITE FEATURING INFORMATION IN THE FIELD OF SECURITY; PROVIDING A WEB SITE FEATURING INFORMATION ON THE DEVELOPMENT OF PRIVACY, SECURITY AND DATA GOVERNANCE LAW; PROVIDING INFORMATION IN THE FIELD OF GUN VIOLENCE PREVENTION AND ILLEGAL GUN TRAFFICKING; PROVIDING INFORMATION IN THE FIELD OF PERSONAL PHYSICAL SECURITY; PROVIDING ONLINE INFORMATION IN THE FIELD OF FIREARM SAFETY; RENTAL OF SECURITY SURVEILLANCE EQUIPMENT; SECURITY CONSULTANCY (U.S. CLS. 100 AND 101).

C. DIONNE CLYBURN, EXAMINING ATTORNEY

SN 86-192,125. IDESIGNEDU, LLC, DALLAS, TX. FILED 2-12-2014.

# IDESIGNEDU

THE MARK CONSISTS OF STANDARD CHARACTERS WITHOUT CLAIM TO ANY PARTICULAR FONT, STYLE, SIZE, OR COLOR.

**CLASS 35—ADVERTISING AND BUSINESS**

FOR DIGITAL MARKETING SERVICES, NAMELY, DEVELOPING CUSTOM DIGITAL MARKETING PLANS (U.S. CLS. 100, 101 AND 102).

FIRST USE 6-15-2013; IN COMMERCE 6-15-2013.

**CLASS 41—EDUCATION AND ENTERTAINMENT**

FOR EDUCATIONAL SERVICES, NAMELY, DEVELOPING CURRICULUM FOR ONLINE COURSES AND DEGREE PROGRAMS FOR EDUCATORS; CONSULTING SERVICES IN THE FIELD OF DEVELOPING CURRICULUM FOR ONLINE INSTRUCTIONAL COURSES AND DEGREE PROGRAMS FOR EDUCATORS (U.S. CLS. 100, 101 AND 107).

FIRST USE 6-15-2013; IN COMMERCE 6-15-2013.

**CLASS 42—SCIENTIFIC AND COMPUTER SERVICES**

FOR WEB SITE DESIGN SERVICES (U.S. CLS. 100 AND 101).

FIRST USE 6-15-2013; IN COMMERCE 6-15-2013.

TIMOTHY O. SCHIMPF, EXAMINING ATTORNEY

SN 86-192,246. IDESIGNEDU, LLC, DALLAS, TX. FILED 2-12-2014.



THE MARK CONSISTS OF THE STYLIZED WORDING "IDESIGNEDU". TO THE LEFT OF THE WORDING IS THE DESIGN OF TWO CONCENTRIC CIRCLES WHERE THE CENTER CIRCLE IS SOLID AND THE OUTER CIRCLE IS COMPRISED OF SHADED ELONGATED OVAL SHAPES AND A SOLID CIRCLE.

#### CLASS 35—ADVERTISING AND BUSINESS

FOR DIGITAL MARKETING SERVICES, NAMELY, DEVELOPING CUSTOM DIGITAL MARKETING PLANS (U.S. CLS. 100, 101 AND 102).

FIRST USE 6-15-2013; IN COMMERCE 6-15-2013.

#### CLASS 41—EDUCATION AND ENTERTAINMENT

FOR EDUCATIONAL SERVICES, NAMELY, DEVELOPING CURRICULUM FOR ONLINE COURSES AND DEGREE PROGRAMS FOR EDUCATORS; CONSULTING SERVICES IN THE FIELD OF DEVELOPING CURRICULUM FOR ONLINE INSTRUCTIONAL COURSES AND DEGREE PROGRAMS FOR EDUCATORS (U.S. CLS. 100, 101 AND 107).

FIRST USE 6-15-2013; IN COMMERCE 6-15-2013.

#### CLASS 42—SCIENTIFIC AND COMPUTER SERVICES

FOR WEB SITE DESIGN SERVICES (U.S. CLS. 100 AND 101).

FIRST USE 6-15-2013; IN COMMERCE 6-15-2013.

TIMOTHY O. SCHIMPF, EXAMINING ATTORNEY

SN 86-192,948. TYR TACTICAL, LLC, PEORIA, AZ. FILED 2-13-2014.

INNOVATE OR DIE

THE MARK CONSISTS OF STANDARD CHARACTERS WITHOUT CLAIM TO ANY PARTICULAR FONT, STYLE, SIZE, OR COLOR.

#### CLASS 9—ELECTRICAL AND SCIENTIFIC APPARATUS

FOR BULLET RESISTANT VESTS; BULLET-PROOF PERSONAL PROTECTION SHIELDS IN THE FORM OF A BACKPACK; BULLET-PROOF VESTS; BULLET-PROOF WAISTCOATS; PROTECTIVE BODY ARMOR, NAMELY, BALLISTIC, BULLET, BLAST, SLASH AND STAB RESISTANT VESTS; PROTECTIVE LOAD BEARING VESTS REINFORCED WITH BALLISTIC ARMOR FOR HOLDING TACTICAL EQUIPMENT; SUPPORT SYSTEM COMPRISING ADJUSTABLE WAIST BELTS, ADJUSTABLE STRAPS, HARNESSSES, SUSPENSION SYSTEM, FRAMING SYSTEM, LOAD DISTRIBUTION ADAPTER SPECIALLY ADAPTED FOR USE WITH BULLET-PROOF VESTS (U.S. CLS. 21, 23, 26, 36 AND 38).

#### CLASS 13—FIREARMS

FOR AUTOMATIC FIREARM AMMUNITION BELTS; BELTS ADAPTED FOR AMMUNITION; BELTS ADAPTED FOR AMMUNITION POUCHES; BELTS ADAPTED FOR MAGAZINE POUCHES IN THE NATURE OF AMMUNITION; CARTRIDGE BELTS; SHELL BELTS; SHOT BELTS; GUN BELTS; LOAD BEARING VESTS ADAPTED PRIMARILY FOR HOLDING GUNS, GRENADES AND AMMUNITION (U.S. CLS. 2 AND 9).

#### CLASS 18—LEATHER GOODS

FOR BELT BAGS; BELT BAGS AND HIP BAGS; TACTICAL BELTS FOR USE PRIMARILY AS BELTS; SUPPORT SYSTEM COMPRISING ADJUSTABLE WAIST BELTS, ADJUSTABLE STRAPS, HARNESSSES, SUSPENSION SYSTEM, FRAMING SYSTEM, LOAD DISTRIBUTION ADAPTER SPECIALLY ADAPTED FOR USE WITH BULLET-PROOF BAGS TO PROTECT CONTENTS OF BAG; SUPPORT SYSTEM COMPRISING ADJUSTABLE WAIST BELTS, ADJUSTABLE STRAPS, HARNESSSES, SUSPENSION SYSTEM, FRAMING SYSTEM, LOAD DISTRIBUTION ADAPTER SPECIALLY ADAPTED FOR USE WITH BULLET-PROOF BACKPACKS TO PROTECT CONTENTS OF BACKPACK (U.S. CLS. 1, 2, 3, 22 AND 41).

JAMES MACFARLANE, EXAMINING ATTORNEY

SN 86-194,030. KUNI ENTERPRISES, INC., VANCOUVER, WA. FILED 2-14-2014.

POWERED BY EXCELLENCE

THE MARK CONSISTS OF STANDARD CHARACTERS WITHOUT CLAIM TO ANY PARTICULAR FONT, STYLE, SIZE, OR COLOR.

#### CLASS 35—ADVERTISING AND BUSINESS

FOR AUTOMOBILE DEALERSHIPS FEATURING NEW AND USED AUTOMOBILES (U.S. CLS. 100, 101 AND 102).

FIRST USE 5-0-2011; IN COMMERCE 5-0-2011.

#### CLASS 37—CONSTRUCTION AND REPAIR

FOR REPAIR AND MAINTENANCE OF AUTOMOBILES AND THE INSTALLATION OF REPLACEMENT PARTS IN AUTOMOBILES (U.S. CLS. 100, 103 AND 106).

FIRST USE 5-0-2011; IN COMMERCE 5-0-2011.

WILLIAM ROSSMAN, EXAMINING ATTORNEY

SN 86-194,069. ENVISAGE TECHNOLOGIES CORPORATION, BLOOMINGTON, IN. FILED 2-14-2014.

FIRSTFORWARD

THE MARK CONSISTS OF STANDARD CHARACTERS WITHOUT CLAIM TO ANY PARTICULAR FONT, STYLE, SIZE, OR COLOR.

**CLASS 35—ADVERTISING AND BUSINESS**

FOR ONLINE BUSINESS NETWORKING SERVICES; ONLINE RETAIL STORE SERVICES FEATURING PRE-RECORDED AND DOWNLOADABLE AUDIOVISUAL FILES, MULTIMEDIA FILES, AND VIDEOS IN THE FIELD OF E-LEARNING FOR LAW ENFORCEMENT AND FIRST RESPONDERS; ONLINE RETAIL STORE SERVICES FEATURING PRE-RECORDED CDS AND DVDS WITH INFORMATION AND COMMENTARY IN THE FIELDS OF TRAINING FOR LAW ENFORCEMENT AND FIRST RESPONDERS; ONLINE RETAIL STORE SERVICES FEATURING A WIDE RANGE OF GEAR FOR LAW ENFORCEMENT AND FIRST RESPONDERS (U.S. CLS. 100, 101 AND 102).

**CLASS 42—SCIENTIFIC AND COMPUTER SERVICES**

FOR COMPUTER SERVICES, NAMELY, CREATING AN ON-LINE COMMUNITY FOR REGISTERED USERS TO PARTICIPATE IN DISCUSSIONS, GET FEEDBACK FROM THEIR PEERS, FORM VIRTUAL COMMUNITIES, AND ENGAGE IN SOCIAL NETWORKING SERVICES (U.S. CLS. 100 AND 101).

AMY KELLY, EXAMINING ATTORNEY

SN 86-194,164. VIC-MACK WORLDWIDE PTY LTD, CARURUM DOWNS VICTORIA, AUSTRALIA, FILED 2-14-2014.

CARRY MASTER

THE MARK CONSISTS OF STANDARD CHARACTERS WITHOUT CLAIM TO ANY PARTICULAR FONT, STYLE, SIZE, OR COLOR.

OWNER OF AUSTRALIA REG. NO. 1325157, DATED 10-12-2009, EXPIRES 10-12-2019.

NO CLAIM IS MADE TO THE EXCLUSIVE RIGHT TO USE "CARRY", APART FROM THE MARK AS SHOWN.

**CLASS 12—VEHICLES**

FOR TROLLEYS, INCLUDING THOSE SPECIFICALLY DESIGNED TO CARRY BAGS, FOR DOMESTIC OR PERSONAL USE; CARTS; SHOPPING TROLLEYS; STROLLERS, PERAMBULATOR IN THE NATURE OF BABY CARRIAGE, TRICYCLE CARRIER FOR VEHICLES; STRUCTURAL PARTS FOR USE IN RELATION TO THE FOREGOING (U.S. CLS. 19, 21, 23, 31, 35 AND 44).

**CLASS 18—LEATHER GOODS**

FOR LUGGAGE; BAGS IN THIS CLASS, NAMELY, MESH SHOPPING BAGS, RE-USABLE MESH SHOPPING BAGS, TEXTILE SHOPPING BAGS, RE-USABLE TEXTILE SHOPPING BAGS, MESH SHOPPING BAGS DESIGNED FOR USE WITH SHOPPING TROLLEYS; MESH SHOPPING BAGS, MESH SHOPPING BAGS WITH HANDLES, WHEELED TEXTILE SHOPPING BAGS; STRUCTURAL PARTS FOR USE IN RELATION TO THE FOREGOING (U.S. CLS. 1, 2, 3, 22 AND 41).

AHSEN KHAN, EXAMINING ATTORNEY

SN 86-194,522. MARINE ENGINE REPAIR CO., INC., DBA MER EQUIPMENT, SEATTLE, WA. FILED 2-14-2014.

BOLLARD

THE MARK CONSISTS OF STANDARD CHARACTERS WITHOUT CLAIM TO ANY PARTICULAR FONT, STYLE, SIZE, OR COLOR.

**CLASS 7—MACHINERY**

FOR MARINE AND INDUSTRIAL ELECTRIC GENERATORS, PROPULSION ENGINES FOR BOATS AND MARINE VEHICLES AND HYDRAULIC POWER UNITS (U.S. CLS. 13, 19, 21, 23, 31, 34 AND 35).

FIRST USE 5-14-2013; IN COMMERCE 6-29-2013.

**CLASS 40—MATERIAL TREATMENT**

FOR CUSTOM BUILDING OF MARINE AND INDUSTRIAL GENERATORS, PROPULSION ENGINES AND HYDRAULIC POWER SYSTEMS (U.S. CLS. 100, 103 AND 106).

FIRST USE 5-14-2013; IN COMMERCE 6-29-2013.

**CLASS 42—SCIENTIFIC AND COMPUTER SERVICES**

FOR CUSTOM DESIGN AND DEVELOPMENT OF MARINE AND INDUSTRIAL GENERATORS, PROPULSION ENGINES AND HYDRAULIC POWER SYSTEMS (U.S. CLS. 100 AND 101).

FIRST USE 5-14-2013; IN COMMERCE 6-29-2013.

MATTHEW KLINE, EXAMINING ATTORNEY

SN 86-194,763. MSIGHTS INCORPORATED, CHARLOTTE, NC. FILED 2-14-2014.

m>sights

OWNER OF U.S. REG. NOS. 3,174,149 AND 3,301,924. THE MARK CONSISTS OF THE LETTER "M" AND THE WORD "SIGHTS" SEPARATED BY AN ARROWHEAD POINTING IN A DIRECTION FROM THE LETTER "M" TOWARD THE WORD "SIGHTS".

**CLASS 35—ADVERTISING AND BUSINESS**

FOR BUSINESS CONSULTING AND INFORMATION SERVICES; BUSINESS MARKETING CONSULTING SERVICES (U.S. CLS. 100, 101 AND 102).

**CLASS 42—SCIENTIFIC AND COMPUTER SERVICES**

FOR PROVIDING A WEBSITE FEATURING NON-DOWNLOADABLE SOFTWARE FOR USE IN MARKETING ANALYSIS AND REPORTING; SOFTWARE AS A SERVICE (SAAS) SERVICES FEATURING SOFTWARE FOR USE IN MARKETING ANALYSIS AND REPORTING; PROVIDING A WEBSITE FEATURING NON-DOWNLOADABLE SOFTWARE FOR USE IN MARKETING MANAGEMENT; SOFTWARE AS A SERVICE (SAAS) SERVICES FEATURING SOFTWARE FOR USE IN MARKETING MANAGEMENT; PROVIDING A WEBSITE FEATURING NON-DOWNLOADABLE SOFTWARE FOR USE BY CORPORATE MARKETERS AND ADVERTISING AGENCIES IN THE FIELD OF MARKETING MANAGEMENT; SOFTWARE AS A SERVICE (SAAS) SERVICES FEATURING SOFTWARE FOR USE BY CORPORATE MARKETERS AND ADVERTISING AGENCIES IN THE FIELD OF MARKETING MANAGEMENT; PROVIDING A WEBSITE FEATURING NON-DOWNLOADABLE SOFTWARE FOR USE IN PROVIDING ON-DEMAND REPORTING AND MARKETING ANALYSIS SERVICES TO CORPORATE MARKETERS AND ADVERTISING AGENCIES; SOFTWARE AS A SERVICE (SAAS) SERVICES FEATURING SOFTWARE FOR USE IN PROVIDING ON-DEMAND REPORTING AND MARKETING ANALYSIS SERVICES TO CORPORATE MARKETERS AND ADVERTISING AGENCIES; PROVIDING A WEBSITE FEATURING NON-DOWNLOADABLE SOFTWARE FOR USE IN BUSINESS MANAGEMENT AND ANALYSIS, NAMELY, COMPUTER SOFTWARE FOR BUSINESS MARKETING PRACTICES; SOFTWARE AS A SERVICE (SAAS) SERVICES FEATURING SOFTWARE FOR USE IN BUSINESS MANAGEMENT AND ANALYSIS, NAMELY, COMPUTER SOFTWARE FOR BUSINESS MARKETING PRACTICES (U.S. CLS. 100 AND 101).

DONALD JOHNSON, EXAMINING ATTORNEY

SN 86-194,829. RTA ASSOCIATES, LLC, VICTOR, NY. FILED 2-15-2014.

**PRONATURAL**

THE MARK CONSISTS OF STANDARD CHARACTERS WITHOUT CLAIM TO ANY PARTICULAR FONT, STYLE, SIZE, OR COLOR.

**CLASS 1—CHEMICALS**

FOR CHEMICAL PREPARATIONS FOR CLEANING PURPOSES FOR USE IN THE FOOD AND FOOD PROCESSING INDUSTRIES; CHEMICAL PREPARATIONS, NAMELY, DEGREASING AND CLEANING SOLVENTS; CHEMICAL PREPARATIONS FOR SANITIZING PURPOSES FOR USE IN THE FOOD AND FOOD PROCESSING INDUSTRIES; CHEMICAL PREPARATIONS FOR CLEANING PURPOSES FOR USE IN CLEANING MEDICAL EQUIPMENT; CHEMICAL PREPARATIONS FOR SANITIZING PURPOSES FOR USE IN SANITIZING MEDICAL EQUIPMENT; CHEMICAL PREPARATIONS FOR CLEANING PURPOSES FOR USE IN CLEANING EQUIPMENT IN THE FOOD AND BEVERAGE PROCESSING INDUSTRY; CHEMICAL PREPARATIONS FOR SANITIZING PURPOSES FOR USE IN SANITIZING EQUIPMENT IN THE FOOD AND BEVERAGE PROCESSING INDUSTRY; CHEMICALS FOR CLEANING, WASHING, OR SANITIZING PURPOSES IN THE FOOD AND BEVERAGE PROCESSING INDUSTRY; CHEMICALS FOR CLEANING, WASHING, OR SANITIZING PURPOSES IN THE MEDICAL INDUSTRY (U.S. CLS. 1, 5, 6, 10, 26 AND 46).

**CLASS 3—COSMETICS AND CLEANING PREPARATIONS**

FOR ALL-PURPOSE CLEANING PREPARATIONS; CLEANING AGENTS AND PREPARATIONS; CLEANING AND WASHING PREPARATIONS FOR USE IN THE FOOD, FOOD PROCESSING, AND MEDICAL INDUSTRIES; IMPREGNATED CLEANING CLOTHS; WIPES IMPREGNATED WITH A CLEANING PREPARATION; ALL-PURPOSE CLEANING AND WASHING PREPARATIONS FOR USE IN MEDICAL AND FOOD/BEVERAGE PROCESSING ESTABLISHMENTS; LAUNDRY DETERGENT (U.S. CLS. 1, 4, 6, 50, 51 AND 52).

**CLASS 5—PHARMACEUTICALS**

FOR SANITIZING PREPARATIONS FOR USE IN THE FOOD AND FOOD PROCESSING INDUSTRIES; IMPREGNATED SANITIZING CLOTHS; WIPES IMPREGNATED WITH A SANITIZING PREPARATION; SANITIZING PREPARATIONS FOR USE IN SANITIZING MEDICAL EQUIPMENT; SANITIZING PREPARATIONS FOR USE IN SANITIZING EQUIPMENT IN THE FOOD AND BEVERAGE PROCESSING INDUSTRY; SANITIZING PREPARATIONS FOR USE IN MEDICAL AND FOOD/BEVERAGE PROCESSING ESTABLISHMENTS (U.S. CLS. 6, 18, 44, 46, 51 AND 52).

KIMBERLY FRYE, EXAMINING ATTORNEY

SN 86-195,297. DISTILLATION TECHNOLOGIES, INC., LEE'S SUMMIT, MO. FILED 2-17-2014.

**PERPETUAL WATER**

THE MARK CONSISTS OF STANDARD CHARACTERS WITHOUT CLAIM TO ANY PARTICULAR FONT, STYLE, SIZE, OR COLOR.

NO CLAIM IS MADE TO THE EXCLUSIVE RIGHT TO USE "WATER", APART FROM THE MARK AS SHOWN.

**CLASS 35—ADVERTISING AND BUSINESS**

FOR BUSINESS CONSULTATION IN THE FIELD OF DESIGN, PLANNING, AND IMPLEMENTATION PROJECT MANAGEMENT OF WASTE WATER PURIFICATION UNITS, WASTE WATER PURIFICATION APPARATUSES, INSTALLATIONS AND TANKS, WATER PURIFICATION INSTALLATIONS, WATER PURIFICATION MACHINES, WATER PURIFICATION TANKS, WATER PURIFICATION UNITS; BUSINESS CONSULTING SERVICES IN THE FIELD OF DESIGN, PLANNING, AND IMPLEMENTATION PROJECT MANAGEMENT OF WASTE WATER PURIFICATION UNITS, WASTE WATER PURIFICATION APPARATUSES, INSTALLATIONS AND TANKS, WATER PURIFICATION INSTALLATIONS, WATER PURIFICATION MACHINES, WATER PURIFICATION TANKS, WATER PURIFICATION UNITS; CONSULTING SERVICES RELATED TO THE ADMINISTRATION OF WATER PURIFICATION STRATEGIES (U.S. CLS. 100, 101 AND 102).

**CLASS 40—MATERIAL TREATMENT**

FOR MANUFACTURING SERVICES FOR OTHERS IN THE FIELD OF WASTE WATER PURIFICATION UNITS, WASTE WATER PURIFICATION APPARATUSES, INSTALLATIONS AND TANKS, WATER PURIFICATION INSTALLATIONS, WATER PURIFICATION MACHINES, WATER PURIFICATION TANKS, WATER PURIFICATION UNITS (U.S. CLS. 100, 103 AND 106).

**CLASS 42—SCIENTIFIC AND COMPUTER SERVICES**

FOR CONSULTING SERVICES FOR OTHERS IN THE FIELD OF DESIGN, PLANNING, AND IMPLEMENTATION PROJECT MANAGEMENT FOR THE PRODUCT DEVELOPMENT OF WASTE WATER PURIFICATION UNITS, WASTE WATER PURIFICATION APPARATUSES, INSTALLATIONS AND TANKS, WATER PURIFICATION INSTALLATIONS, WATER PURIFICATION MACHINES, WATER PURIFICATION TANKS, WATER PURIFICATION UNITS; DESIGN, DEVELOPMENT, AND CONSULTING SERVICES RELATED THERETO IN THE FIELD OF WASTE WATER PURIFICATION UNITS, WASTE WATER PURIFICATION APPARATUSES, INSTALLATIONS AND TANKS, WATER PURIFICATION INSTALLATIONS, WATER PURIFICATION MACHINES, WATER PURIFICATION TANKS, WATER PURIFICATION UNITS; PLANNING AND DESIGN OF WASTE WATER PURIFICATION UNITS, WASTE WATER PURIFICATION APPARATUSES, INSTALLATIONS AND TANKS, WATER PURIFICATION INSTALLATIONS, WATER PURIFICATION MACHINES, WATER PURIFICATION TANKS, WATER PURIFICATION UNITS (U.S. CLS. 100 AND 101).

CHERYL CLAYTON, EXAMINING ATTORNEY

SN 86-196,615. MILLENNIUM PHARMACEUTICALS, INC., CAMBRIDGE, MA. FILED 2-18-2014.

**ENTYVIO CONNECT**

THE MARK CONSISTS OF STANDARD CHARACTERS WITHOUT CLAIM TO ANY PARTICULAR FONT, STYLE, SIZE, OR COLOR.

**CLASS 35—ADVERTISING AND BUSINESS**

FOR ADMINISTRATION OF PATIENT REIMBURSEMENT PROGRAM; ADMINISTERING MEDICATION REIMBURSEMENT PROGRAMS AND SERVICES (U.S. CLS. 100, 101 AND 102).

**CLASS 36—INSURANCE AND FINANCIAL**

FOR PROVIDING INSURANCE AND INSURANCE REIMBURSEMENT INFORMATION (U.S. CLS. 100, 101 AND 102).

**CLASS 42—SCIENTIFIC AND COMPUTER SERVICES**

FOR PROVIDING MEDICAL AND SCIENTIFIC RESEARCH INFORMATION IN THE FIELD OF ULCERATIVE COLITIS AND CROHN'S DISEASE (U.S. CLS. 100 AND 101).

**CLASS 44—MEDICAL, BEAUTY AND AGRICULTURAL SERVICES**

FOR PROVIDING MEDICAL INFORMATION TO PATIENTS RELATING TO THE MANAGEMENT OF ULCERATIVE COLITIS AND CROHN'S DISEASE; PROVIDING INFORMATION REGARDING MEDICAL SERVICES AND THERAPEUTIC PROPERTIES OF PHARMACEUTICAL PRODUCTS TO PATIENTS RELATING TO THE MANAGEMENT OF ULCERATIVE COLITIS AND CROHN'S DISEASE (U.S. CLS. 100 AND 101).

MATTHEW EINSTEIN, EXAMINING ATTORNEY

SN 86-195,919. WHIM EVENTS, LLC, SOMERVILLE, MA. FILED 2-18-2014.

**WHIM EVENTS**

THE MARK CONSISTS OF STANDARD CHARACTERS WITHOUT CLAIM TO ANY PARTICULAR FONT, STYLE, SIZE, OR COLOR.

NO CLAIM IS MADE TO THE EXCLUSIVE RIGHT TO USE "EVENTS", APART FROM THE MARK AS SHOWN.

**CLASS 41—EDUCATION AND ENTERTAINMENT**

FOR ARRANGING AND CONDUCTING SPECIAL EVENTS FOR SOCIAL ENTERTAINMENT PURPOSES; CONSULTATION IN THE FIELD OF SPECIAL EVENT PLANNING FOR SOCIAL ENTERTAINMENT PURPOSES, PROVIDING INFORMATION IN THE FIELD OF WEDDING PARTY PLANNING; PARTY AND WEDDING RECEPTION PLANNING, COORDINATION, AND CONSULTATION SERVICES; FLOWER ARRANGEMENT INSTRUCTION (U.S. CLS. 100, 101 AND 107).

FIRST USE 7-31-2011; IN COMMERCE 7-31-2011.

**CLASS 44—MEDICAL, BEAUTY AND AGRICULTURAL SERVICES**

FOR FLOWER ARRANGEMENT FOR EVENTS (U.S. CLS. 100 AND 101).

FIRST USE 7-31-2011; IN COMMERCE 7-31-2011.

CAITLIN WATTS-FITZGERALD, EXAMINING ATTORNEY

SN 86-197,158. YUMMARI, INC., LOUISVILLE, CO. FILED 2-18-2014.

**YUMMARI**

THE MARK CONSISTS OF STANDARD CHARACTERS WITHOUT CLAIM TO ANY PARTICULAR FONT, STYLE, SIZE, OR COLOR.

**CLASS 29—MEATS AND PROCESSED FOODS**

FOR PEANUT BUTTER (U.S. CL. 46).

FIRST USE 1-15-2014; IN COMMERCE 1-15-2014.

**CLASS 30—STAPLE FOODS**

FOR CEREAL-BASED SNACK FOODS (U.S. CL. 46).

FIRST USE 1-15-2014; IN COMMERCE 1-15-2014.  
MICHAEL WIENER, EXAMINING ATTORNEY

SN 86-197,640. VESSEL, LLC, GENOA, OH. FILED 2-19-2014.

**PACKER CREEK POTTERY**

THE MARK CONSISTS OF STANDARD CHARACTERS WITHOUT CLAIM TO ANY PARTICULAR FONT, STYLE, SIZE, OR COLOR.

NO CLAIM IS MADE TO THE EXCLUSIVE RIGHT TO USE "POTTERY", APART FROM THE MARK AS SHOWN.

**CLASS 21—HOUSEWARES AND GLASS**

FOR POTTERY, NAMELY, BOWLS, VASES, KITCHEN CONTAINERS, PLATES, MUGS, JARS, SERVING PLATTERS, BAKE WARE, TEA KETTLES, FLOWER VASES, SPOON RESTS, COASTERS AND PITCHERS (U.S. CLS. 2, 13, 23, 29, 30, 33, 40 AND 50).

FIRST USE 10-1-1979; IN COMMERCE 7-1-1981.

**CLASS 35—ADVERTISING AND BUSINESS**

FOR ONLINE RETAIL STORE SERVICES AND RETAIL STORE SERVICES FEATURING DECORATIVE HOME FURNISHINGS, DECORATIVE HOME ACCESSORIES, BATH ACCESSORIES, PILLOWS, LIGHTING, LAMPS, RUGS, LINENS AND BEDDING, WINDOW COVERINGS, TABLE LINENS, DINING AND KITCHEN GOODS, TEXTILES, PAINTINGS, AND FURNITURE (U.S. CLS. 100, 101 AND 102).

FIRST USE 10-1-1979; IN COMMERCE 7-1-1981.

DANIEL S. STRINGER, EXAMINING ATTORNEY

SN 86-197,939. AAF HOLDINGS LLC, CORAL GABLES, FL. FILED 2-19-2014.

**BRIGHT LINE**

THE MARK CONSISTS OF STANDARD CHARACTERS WITHOUT CLAIM TO ANY PARTICULAR FONT, STYLE, SIZE, OR COLOR.

NO CLAIM IS MADE TO THE EXCLUSIVE RIGHT TO USE "LINE", APART FROM THE MARK AS SHOWN.

**CLASS 35—ADVERTISING AND BUSINESS**

FOR MANAGEMENT OF RAILROAD SYSTEMS (U.S. CLS. 100, 101 AND 102).

**CLASS 37—CONSTRUCTION AND REPAIR**

FOR CONSTRUCTION OF RAILROAD SYSTEMS (U.S. CLS. 100, 103 AND 106).

**CLASS 39—TRANSPORTATION AND STORAGE**

FOR TRANSPORTATION OF PASSENGERS AND GOODS BY RAIL; PASSENGER AND FREIGHT TRANSPORTATION BY RAIL SERVICES (U.S. CLS. 100 AND 105).

**CLASS 42—SCIENTIFIC AND COMPUTER SERVICES**

FOR DESIGN AND DEVELOPMENT OF RAILROAD SYSTEMS; PLANNING, DESIGN AND IMPLEMENTATION OF RAILROAD COMPUTER TECHNOLOGY SYSTEMS FOR OTHERS (U.S. CLS. 100 AND 101).

TRICIA SONNEBORN, EXAMINING ATTORNEY

SN 86-197,943. INTERNATIONAL MULCH COMPANY, INC., BRIDGETON, MO. FILED 2-19-2014.

**GROUNDSCAPE**

THE MARK CONSISTS OF STANDARD CHARACTERS WITHOUT CLAIM TO ANY PARTICULAR FONT, STYLE, SIZE, OR COLOR.

**CLASS 1—CHEMICALS**

FOR SOIL AMENDMENTS; FERTILIZERS; ORGANIC POTTING AND PLANTING SOIL (U.S. CLS. 1, 5, 6, 10, 26 AND 46).

**CLASS 17—RUBBER GOODS**

FOR RUBBER PRODUCTS, NAMELY, RUBBER MULCH MADE OF RECYCLED RUBBER FOR USE IN LANDSCAPING AND HORTICULTURAL APPLICATIONS; RUBBER CHIPS OR GRANULES FOR USE AS A PLAYGROUND GROUND COVER; MULCH MATS MADE OF RECYCLED RUBBER FOR PREVENTING WEED GROWTH, NAMELY, RUBBER TREE RINGS (U.S. CLS. 1, 5, 12, 13, 35 AND 50).

**CLASS 19—NON-METALLIC BUILDING MATERIALS**

FOR RUBBER SPLASH BLOCKS; RUBBER LANDSCAPE PAVERS; RUBBER LANDSCAPE TIMBERS; GEOTEXTILES, NAMELY, LANDSCAPE FABRIC AND SHEETING FOR PREVENTING WEED GROWTH, FOR PLANT PROTECTION AND FOR USE IN LANDSCAPING TO PROMOTE SEED GERMINATION (U.S. CLS. 1, 12, 33 AND 50).

**CLASS 20—FURNITURE AND ARTICLES NOT OTHERWISE CLASSIFIED**

FOR RUBBER LANDSCAPE BORDERS; RUBBER LANDSCAPE EDGERS; LANDSCAPE FABRIC PINS, NAMELY, PLASTIC AND RUBBER PINS FOR HOLDING DOWN LANDSCAPE FABRIC (U.S. CLS. 2, 13, 22, 25, 32 AND 50).

**CLASS 27—FLOOR COVERINGS**

FOR RUBBER MATS FOR USE ON PLAY AREA SURFACES (U.S. CLS. 19, 20, 37, 42 AND 50).

**CLASS 31—NATURAL AGRICULTURAL PRODUCTS**

FOR GRASS SEED; MULCH (U.S. CLS. 1 AND 46).

TRICIA SONNEBORN, EXAMINING ATTORNEY

SN 86-198,096. SUMMERWOOD CORPORATION, CONSHOHOCKEN, PA. FILED 2-19-2014.

# ZIO GIO

THE MARK CONSISTS OF STANDARD CHARACTERS WITHOUT CLAIM TO ANY PARTICULAR FONT, STYLE, SIZE, OR COLOR.

THE ENGLISH TRANSLATION OF "ZIO" IN THE MARK IS "UNCLE".

## CLASS 35—ADVERTISING AND BUSINESS

FOR FRANCHISING, NAMELY, OFFERING BUSINESS MANAGEMENT ASSISTANCE IN THE ESTABLISHMENT AND/OR OPERATION OF RESTAURANTS; ON-LINE ORDERING SERVICES IN THE FIELD OF RESTAURANT TAKE-OUT AND DELIVERY; RESTAURANT FRANCHISING, NAMELY, OFFERING BUSINESS MANAGEMENT ASSISTANCE IN THE ESTABLISHMENT AND/OR OPERATION OF RESTAURANTS; RESTAURANT MANAGEMENT FOR OTHERS (U.S. CLS. 100, 101 AND 102).

## CLASS 43—HOTEL AND RESTAURANT SERVICES

FOR FAST-FOOD RESTAURANT SERVICES; RESTAURANT AND CAFE SERVICES; RESTAURANT AND CATERING SERVICES; RESTAURANT SERVICES; RESTAURANT SERVICES, INCLUDING SIT-DOWN SERVICE OF FOOD AND TAKE-OUT RESTAURANT SERVICES; RESTAURANT SERVICES, NAMELY, PROVIDING OF FOOD AND BEVERAGES FOR CONSUMPTION ON AND OFF THE PREMISES (U.S. CLS. 100 AND 101).

PAUL CROWLEY, EXAMINING ATTORNEY

SN 86-198,193. MARY A. RIDGEWAY, HAYS, KS. FILED 2-19-2014.

# EQUANCE

THE MARK CONSISTS OF STANDARD CHARACTERS WITHOUT CLAIM TO ANY PARTICULAR FONT, STYLE, SIZE, OR COLOR.

## CLASS 14—JEWELRY

FOR BROACHES; BROOCHES; CHARMS; CHARMS FOR COLLAR JEWELRY AND BRACELET; GEMSTONE JEWELRY; HAIR JEWELRY IN THE NATURE OF JEWELRY FOR USE IN THE HAIR; JEWELRY; JEWELRY AND IMITATION JEWELRY; JEWELRY BROOCHES; JEWELRY FOR THE HEAD; JEWELRY MADE IN WHOLE OR SIGNIFICANT PART OF SILVER AND PRECIOUS GEMS; JEWELRY STICKPINS; JEWELRY, NAMELY, BRACELETS, WRISTBANDS AND NECKLACES THAT ALSO PROVIDES NOTIFICATION TO THE WEARER OF A PENDING MEDICAL RELATED TASK; JEWELRY, NAMELY, STONE PENDANTS; LAPPEL PINS; MEMORIAL JEWELRY; PET JEWELRY; PINS BEING JEWELRY; PRECIOUS AND SEMI-PRECIOUS CRYSTAL STONES AND BEADS FOR USE IN JEWELRY; PRECIOUS METALS FOR USE IN MANUFACTURING JEWELRY FOR HORSES; RINGS; RINGS BEING JEWELRY; SCARF CLIPS BEING JEWELRY; WOMEN'S JEWELRY (U.S. CLS. 2, 27, 28 AND 50).

FIRST USE 11-16-2013; IN COMMERCE 11-16-2013.

## CLASS 18—LEATHER GOODS

FOR PET COLLAR ACCESSORIES, NAMELY, BELLS, SILENCERS, SAFETY LIGHTS AND BLINKERS, PENDANTS AND CHARMS; PET COLLAR ACCESSORIES, NAMELY, BOWS AND CHARMS; PET COLLAR ACCESSORIES, NAMELY, CHARMS; PET HAIR ORNAMENTS; PET TAGS SPECIALLY ADAPTED FOR ATTACHING TO PET LEASHES OR COLLARS (U.S. CLS. 1, 2, 3, 22 AND 41).

FIRST USE 11-16-2013; IN COMMERCE 11-16-2013.

JOHN KELLY, EXAMINING ATTORNEY

SN 86-198,547. HIKARI MISO CO., LTD., NAGANO-KEN, JAPAN, FILED 2-20-2014.



OWNER OF U.S. REG. NO. 4,518,594.

THE MARK CONSISTS OF JAPANESE CHARACTERS. THE ENGLISH TRANSLATION OF THE WORD "ENJUKU" IN THE MARK IS "MELLOWNESS" OR "MATURITY".

THE NON-LATIN CHARACTERS IN THE MARK TRANSLITERATE TO "ENJUKU" AND THIS HAS NO MEANING IN A FOREIGN LANGUAGE.

## CLASS 29—MEATS AND PROCESSED FOODS

FOR SOUP OF SOYBEAN PASTE (U.S. CL. 46).

## CLASS 30—STAPLE FOODS

FOR SOYBEAN PASTE (U.S. CL. 46).

MORGAN WYNNE, EXAMINING ATTORNEY



SN 86-198,970. EPICUREAN GROUP, LOS ALTOS, CA.  
FILED 2-20-2014.

## FRESH. HONEST. LOCAL.

THE MARK CONSISTS OF STANDARD CHARACTERS WITHOUT CLAIM TO ANY PARTICULAR FONT, STYLE, SIZE, OR COLOR.

NO CLAIM IS MADE TO THE EXCLUSIVE RIGHT TO USE "FRESH" AND "LOCAL", APART FROM THE MARK AS SHOWN.

### CLASS 35—ADVERTISING AND BUSINESS

FOR RESTAURANT MANAGEMENT SERVICES FOR OTHERS, FOOD SERVICE MANAGEMENT SERVICES FOR OTHERS, BUSINESS MANAGEMENT SERVICES IN THE FIELDS OF RESTAURANTS, CATERING AND FOOD SERVICE (U.S. CLS. 100, 101 AND 102).  
FIRST USE 3-0-2008; IN COMMERCE 3-0-2008.

### CLASS 43—HOTEL AND RESTAURANT SERVICES

FOR CATERING SERVICES, RESTAURANT SERVICES, PROVIDING RESTAURANT AND CATERING SERVICES TO COMPANIES, DINING COMMUNITIES AND SCHOOLS; CONTRACT FOOD SERVICES, FOOD PREPARATION SERVICES (U.S. CLS. 100 AND 101).  
FIRST USE 3-0-2008; IN COMMERCE 3-0-2008.

ANDREW RHIM, EXAMINING ATTORNEY

SN 86-199,309. BELLOCQ, LLC, BROOKLYN, NY. FILED 2-20-2014.

# BELLOCQ

THE MARK CONSISTS OF STANDARD CHARACTERS WITHOUT CLAIM TO ANY PARTICULAR FONT, STYLE, SIZE, OR COLOR.

### CLASS 4—LUBRICANTS AND FUELS

FOR CANDLES (U.S. CLS. 1, 6 AND 15).  
FIRST USE 1-30-2014; IN COMMERCE 1-30-2014.

### CLASS 8—HAND TOOLS

FOR SILVER COLLECTIBLE SPOONS (U.S. CLS. 23, 28 AND 44).  
FIRST USE 1-30-2012; IN COMMERCE 1-30-2012.

### CLASS 16—PAPER GOODS AND PRINTED MATTER

FOR PAPER PRODUCTS, NAMELY, GREETING CARDS AND POSTCARDS (U.S. CLS. 2, 5, 22, 23, 29, 37, 38 AND 50).  
FIRST USE 1-30-2013; IN COMMERCE 1-30-2013.

### CLASS 21—HOUSEWARES AND GLASS

FOR PORCELAIN CUPS, GLASS TEA POTS, STAINLESS STEEL CONTAINERS FOR HOUSEHOLD USE, NAMELY, FOR STORING TEA AND FOR DECORATION; SILVER TEA STRAINERS, BRASS STRAINERS FOR TEA AND COFFEE; BRASS BOWLS FOR DECORATIVE USES AND DISPLAYING TEA; BRASS CANDLE HOLDERS (U.S. CLS. 2, 13, 23, 29, 30, 33, 40 AND 50).  
FIRST USE 6-5-2013; IN COMMERCE 6-5-2013.

### CLASS 30—STAPLE FOODS

FOR TEAS, POWDERED HOT CHOCOLATE DRINK MIX, COOKIES (U.S. CL. 46).  
FIRST USE 1-30-2012; IN COMMERCE 1-30-2012.

### CLASS 35—ADVERTISING AND BUSINESS

FOR RETAIL AND ONLINE STORE SERVICES FEATURING TEAS, POWDERED HOT CHOCOLATE DRINK MIXES, BAKED GOODS, TEA SERVICE ACCESSORIES, GREETING CARDS AND POSTCARDS, DISHWARE, GLASSWARE, STORAGE CONTAINERS (U.S. CLS. 100, 101 AND 102).  
FIRST USE 6-5-2013; IN COMMERCE 6-5-2013.

### CLASS 43—HOTEL AND RESTAURANT SERVICES

FOR RESTAURANT SERVICES (U.S. CLS. 100 AND 101).  
FIRST USE 6-5-2013; IN COMMERCE 6-5-2013.  
JENNY PARK, EXAMINING ATTORNEY

SN 86-199,568. DER'S CUSTOM BOOTS & SHOES, INC.,  
BROOKLYN, NY. FILED 2-20-2014.

# DER•DAU

THE MARK CONSISTS OF THE WORDS "DER" AND "DAU" WITH A BULLET POINT BETWEEN THE TWO WORDS.

### CLASS 1—CHEMICALS

FOR CHEMICAL SHOE SPRAY FOR STRETCHING SHOES (U.S. CLS. 1, 5, 6, 10, 26 AND 46).  
FIRST USE 12-31-2007; IN COMMERCE 12-31-2007.

### CLASS 3—COSMETICS AND CLEANING PREPARATIONS

FOR SHOE CARE PRODUCTS, NAMELY, POLISHES AND CONDITIONERS (U.S. CLS. 1, 4, 6, 50, 51 AND 52).  
FIRST USE 12-31-2007; IN COMMERCE 12-31-2007.

### CLASS 25—CLOTHING

FOR LEATHER SHOES; SHOES, BOOTS, HATS, SHIRTS, PANTS AND SOCKS (U.S. CLS. 22 AND 39).  
FIRST USE 4-2-1991; IN COMMERCE 4-2-1991.  
ALICE BENMAMAN, EXAMINING ATTORNEY

SN 86-199,665. KBB RECORDS, LLC, LOS ANGELES, CA.  
FILED 2-20-2014.

## KBB RECORDS

THE MARK CONSISTS OF STANDARD CHARACTERS WITHOUT CLAIM TO ANY PARTICULAR FONT, STYLE, SIZE, OR COLOR.

NO CLAIM IS MADE TO THE EXCLUSIVE RIGHT TO USE "RECORDS", APART FROM THE MARK AS SHOWN.

### CLASS 9—ELECTRICAL AND SCIENTIFIC APPARATUS

FOR PRE-RECORDED AUDIO TAPES, DISCS AND CASSETTES, VIDEO TAPES, DISCS AND CASSETTES, DIGITAL AUDIO AND AUDIO VIDEO TAPES AND DISCS, CDS, DVDS, LASER DISCS, AND PHONOGRAPH RECORDS FEATURING MUSIC, SOUNDS AND ENTERTAINMENT; MUSICAL SOUND AND VIDEO RECORDINGS; DOWN LOADABLE RING TONES, MUSIC, SOUNDS, MP3 FILES, GRAPHICS, ELECTRONIC GAMES, IMAGES AND VIDEOS FOR WIRELESS COMMUNICATION DEVICES; DOWNLOADABLE VIDEOS FEATURING MUSIC AND ENTERTAINMENT, MUSIC, SOUNDS, MP3 FILES, GRAPHICS, COMPUTER GAME PROGRAMS AND IMAGES (U.S. CLS. 21, 23, 26, 36 AND 38).

### CLASS 41—EDUCATION AND ENTERTAINMENT

FOR PRODUCTION OF RADIO PROGRAMS; PRODUCTION AND PUBLISHING OF MUSIC; PROVIDING ONLINE ENTERTAINMENT, NAMELY, PROVIDING NON-DOWNLOADABLE SOUND AND VIDEO RECORDINGS IN THE FIELD OF MUSIC AND MUSIC BASED ENTERTAINMENT; ENTERTAINMENT SERVICES, NAMELY, PROVIDING ONLINE NON-DOWNLOADABLE PRERECORDED MUSICAL SOUND AND VIDEO RECORDINGS VIA A GLOBAL COMPUTER NETWORK; FAN CLUBS; DEVELOPMENT AND DISSEMINATION OF EDUCATIONAL MATERIALS OF OTHERS IN THE FIELD OF MUSIC AND ENTERTAINMENT; RADIO ENTERTAINMENT PRODUCTION AND DISTRIBUTION; AUDIO AND SOUND RECORDING AND PRODUCTION; RECORD PRODUCTION; VIDEOTAPE PRODUCTION; ENTERTAINMENT IN THE NATURE OF ONGOING RADIO PROGRAMS IN THE FIELD OF MUSIC; ENTERTAINMENT IN THE NATURE OF LIVE CONCERTS AND PERFORMANCES BY MUSICAL ARTISTS AND GROUPS; ENTERTAINMENT SERVICES, NAMELY, PERSONAL APPEARANCES BY MUSICAL GROUPS, MUSICAL ARTISTS AND CELEBRITIES; ENTERTAINMENT SERVICES IN THE NATURE OF PERFORMANCES RENDERED BY MUSICAL ARTISTS THROUGH THE MEDIUM OF TELEVISION, RADIO, AND AUDIO AND VIDEO RECORDINGS; ENTERTAINMENT SERVICES, NAMELY, PERFORMANCES BY MUSICAL ARTISTS RENDERED LIVE AND RECORDED FOR FUTURE DISTRIBUTION; EDUCATIONAL AND ENTERTAINMENT SERVICES, NAMELY, PRODUCTION AND PRESENTATION OF MUSIC SHOWS AND AWARD SHOWS BEFORE LIVE AUDIENCES WHICH ARE ALL BROADCAST LIVE OR TAPED FOR LATER BROADCAST; ENTERTAINMENT SERVICES, NAMELY, PROVIDING A WEB SITE FEATURING NON-DOWNLOADABLE MUSICAL PERFORMANCES, MUSICAL VIDEOS, PHOTOGRAPHS, AND OTHER MULTIMEDIA MATERIALS FEATURING MUSIC AND ENTERTAINMENT; ENTERTAINMENT SERVICES, NAMELY, PROVIDING PRERECORDED NON-DOWNLOADABLE MUSIC, INFORMATION IN THE FIELD OF MUSIC, AND COMMENTARY AND ARTICLES ABOUT MUSIC, ALL ONLINE VIA A GLOBAL COMPUTER NETWORK; ENTERTAINMENT SERVICES, NAMELY, LIVE, TELEVISED AND MOVIE APPEARANCES BY A PROFESSIONAL ENTERTAINER; PUBLISHING OF WEB MAGAZINES; ONLINE MUSIC SERVICES, NAMELY,

PROVIDING ELECTRONIC LIBRARY SERVICES WHICH FEATURE MUSICAL AND NON-MUSICAL SOUND RECORDINGS VIA AN ONLINE COMPUTER NETWORK; PROVIDING AN ONLINE SEARCHABLE DATABASE FEATURING CATALOGED AND INDEXED RECORDED MUSIC AND SOUNDS; AND PUBLICATION OF MUSIC BOOKS, MUSICAL COMPOSITIONS, MUSICAL ARRANGEMENTS, AND MUSICAL TEXT; AND MUSIC COMPOSITION FOR OTHERS (U.S. CLS. 100, 101 AND 107).

CHERYL CLAYTON, EXAMINING ATTORNEY

SN 86-199,907. THE LIEBER INSTITUTE FOR BRAIN DEVELOPMENT, BALTIMORE, MD. FILED 2-21-2014.

## BrainCloud

THE MARK CONSISTS OF STANDARD CHARACTERS WITHOUT CLAIM TO ANY PARTICULAR FONT, STYLE, SIZE, OR COLOR.

### CLASS 9—ELECTRICAL AND SCIENTIFIC APPARATUS

FOR DOWNLOADABLE COMPUTER SOFTWARE APPLICATION FOR ANALYZING GENETIC DATA AND TEMPORAL DYNAMICS IN THE HUMAN PREFRONTAL CORTEX (U.S. CLS. 21, 23, 26, 36 AND 38).

FIRST USE 0-0-2009; IN COMMERCE 0-0-2011.

### CLASS 42—SCIENTIFIC AND COMPUTER SERVICES

FOR SCIENTIFIC AND MEDICAL RESEARCH INFORMATION PROVIDED ONLINE FROM A COMPUTER DATABASE OR A GLOBAL COMPUTER NETWORK, NAMELY, PROVIDING INFORMATION IN THE FIELD OF NEUROBIOLOGY AND NEUROSCIENCE TO ASSIST IN ANALYZING GENETIC DATA AND TEMPORAL DYNAMICS IN THE HUMAN PREFRONTAL CORTEX (U.S. CLS. 100 AND 101).

FIRST USE 0-0-2009; IN COMMERCE 0-0-2011.

JOSETTE BEVERLY, EXAMINING ATTORNEY

SN 86-200,642. XEBIALABS GROUP B.V., 1213 TL HILVERSUM, NETHERLANDS, FILED 2-21-2014.



THE MARK CONSISTS OF THE LETTERS "XL" APPEARING INSIDE AN INCOMPLETE CIRCLE THAT IS COMPOSED OF AN ARROW.

**CLASS 9—ELECTRICAL AND SCIENTIFIC APPARATUS**

FOR COMPUTER HARDWARE; COMPUTER SOFTWARE FOR APPLICATION DEVELOPMENT, DEPLOYMENT AND MANAGEMENT, DEPLOYMENT AUTOMATION, CONTINUOUS INTEGRATION, APPLICATION RELEASE AUTOMATION (ARA) AND APPLICATION LIFECYCLE MANAGEMENT (ALM) (U.S. CLS. 21, 23, 26, 36 AND 38).

**CLASS 41—EDUCATION AND ENTERTAINMENT**

FOR EDUCATION SERVICES, NAMELY, PROVIDING ONLINE WEBINARS, VIDEOS AND CLASSES IN THE FIELD OF COMPUTERS AND COMPUTER SOFTWARE; PROVIDING TRAINING SERVICES IN THE FIELD OF COMPUTERS AND COMPUTER SOFTWARE (U.S. CLS. 100, 101 AND 107).

**CLASS 42—SCIENTIFIC AND COMPUTER SERVICES**

FOR COMPUTER PROGRAMMING; COMPUTER SOFTWARE DEVELOPMENT, COMPUTER APPLICATION DEVELOPMENT; DESIGN AND DEVELOPMENT OF COMPUTER SYSTEMS AND COMPUTER SOFTWARE; PLATFORM AS A SERVICE (PAAS) FEATURING COMPUTER SOFTWARE PLATFORMS FOR USE IN DEPLOYMENT AUTOMATION, CONTINUOUS INTEGRATION, APPLICATION RELEASE AUTOMATION (ARA) AND APPLICATION LIFECYCLE MANAGEMENT (ALM); SOFTWARE AS A SERVICE (SAAS) SERVICES FEATURING SOFTWARE FOR USE IN DEPLOYMENT AUTOMATION, CONTINUOUS INTEGRATION, APPLICATION RELEASE AUTOMATION (ARA) AND APPLICATION LIFECYCLE MANAGEMENT (ALM); CLOUD COMPUTING FEATURING SOFTWARE FOR USE IN DEPLOYMENT AUTOMATION, CONTINUOUS INTEGRATION, APPLICATION RELEASE AUTOMATION (ARA) AND APPLICATION LIFECYCLE MANAGEMENT (ALM); COMPUTER SOFTWARE CONSULTING; CONSULTING SERVICES IN THE FIELD OF SOFTWARE AS A SERVICE (SAAS), PLATFORM AS A SERVICE (PAAS) AND CLOUD COMPUTING; COMPUTER SERVICES, NAMELY, INTEGRATION OF PRIVATE CLOUD COMPUTING ENVIRONMENTS (U.S. CLS. 100 AND 101).

GRETTA YAO, EXAMINING ATTORNEY

SN 86-201,604. RENEGADE INDUSTRIAL, LLC, PRICE, UT. FILED 2-24-2014.

# RENEGADE

THE MARK CONSISTS OF STANDARD CHARACTERS WITHOUT CLAIM TO ANY PARTICULAR FONT, STYLE, SIZE, OR COLOR.

**CLASS 37—CONSTRUCTION AND REPAIR**

FOR INSTALLATION OF PIPELINE, PIPELINE CONTAINMENT SECTIONS, PIPELINE COMPRESSOR STATIONS AND INJECTION OILFIELD WELL FACILITIES (U.S. CLS. 100, 103 AND 106).

FIRST USE 4-8-2013; IN COMMERCE 4-8-2013.

**CLASS 40—MATERIAL TREATMENT**

FOR CUSTOM FABRICATION AND MANUFACTURE OF OILFIELD PIPELINE, PIPELINE CONTAINMENT SECTIONS, AND PIPELINE COMPRESSOR STATIONS; CUSTOM FABRICATION OF INJECTION OIL WELL FACILITIES; METAL FABRICATION AND FINISHING SERVICES FOR OTHERS (U.S. CLS. 100, 103 AND 106).

FIRST USE 4-8-2013; IN COMMERCE 4-8-2013.

HOWARD B. LEVINE, EXAMINING ATTORNEY

SN 86-201,607. RENEGADE INDUSTRIAL, LLC, PRICE, UT. FILED 2-24-2014.



THE MARK CONSISTS OF AN ARTISTIC REPRESENTATION OF A SKULL AND CROSSBONES.

**CLASS 37—CONSTRUCTION AND REPAIR**

FOR INSTALLATION OF PIPELINE, PIPELINE CONTAINMENT SECTIONS, PIPELINE COMPRESSOR STATIONS AND INJECTION OILFIELD WELL FACILITIES (U.S. CLS. 100, 103 AND 106).

FIRST USE 4-8-2013; IN COMMERCE 4-8-2013.

**CLASS 40—MATERIAL TREATMENT**

FOR CUSTOM FABRICATION AND MANUFACTURE OF OILFIELD PIPELINE, PIPELINE CONTAINMENT SECTIONS, AND PIPELINE COMPRESSOR STATIONS; CUSTOM FABRICATION OF INJECTION OIL WELL FACILITIES; METAL FABRICATION AND FINISHING SERVICES FOR OTHERS (U.S. CLS. 100, 103 AND 106).

FIRST USE 4-8-2013; IN COMMERCE 4-8-2013.

HOWARD B. LEVINE, EXAMINING ATTORNEY

SN 86-201,625. ROLLMAN, AMY, LAS VEGAS, NV. FILED 2-24-2014.



NO CLAIM IS MADE TO THE EXCLUSIVE RIGHT TO USE "FITNESS" FOR CLASS 25 AND "FITNESS NETWORK EXCHANGE" FOR CLASS 42, APART FROM THE MARK AS SHOWN.

THE MARK CONSISTS OF AN OUTER RING WITH LIGHT AND SHADOW EFFECTS, ANOTHER CONCENTRIC RING (APPROXIMATELY THREE TIMES THE WIDTH OF THE OUTER RING), AND A FINAL INNER RING (SAME WIDTH AS THE OUTER-MOST RING) WITH

LIGHT AND SHADOW EFFECTS. THE MIDDLE RING IS COVERED IN A DOT PATTERN AND HAS THE WORDS "FITNESS NETWORK XCHANGE" IN A SEMI-CIRCLE IN THE TOP OF THE MIDDLE RING AND THE TERM "FITNETX.COM" IN A SEMI-CIRCLE IN THE BOTTOM OF THE MIDDLE RING. THE INNER-MOST RING IS FILLED WITH A HONEYCOMB PATTERN OVERLAY WITH SIX DISTINCT RIVETS AT EQUAL INTERVALS AROUND THE EDGE OF THE CIRCLE. A LARGE "X" WITH SHADOW EFFECTS APPEARS OVER THE INNER CIRCLE AND OVERLAPS THE INNER-MOST RING.

#### CLASS 25—CLOTHING

FOR SHIRTS, PANTS, HATS, FOOTWEAR, SOCKS, UNDERWEAR, WRISTBANDS, HEADBANDS, HOODED SWEATSHIRTS, JACKETS, GLOVES, BANDANAS (U.S. CLS. 22 AND 39).

FIRST USE 12-8-2013; IN COMMERCE 12-15-2013.

#### CLASS 42—SCIENTIFIC AND COMPUTER SERVICES

FOR COMPUTER SERVICES, NAMELY, CREATING AN ON-LINE COMMUNITY FOR REGISTERED USERS TO SEARCH, READ, AND POST INFORMATION ABOUT FITNESS INDUSTRY SERVICE PROVIDERS (U.S. CLS. 100 AND 101).

FIRST USE 12-8-2013; IN COMMERCE 12-15-2013.

LINDA QUIGLEY, EXAMINING ATTORNEY

SN 86-201,709. PSYCHED BY MG, LLC, PLYMOUTH, MI. FILED 2-24-2014.

## PSYCHED BY MG

THE MARK CONSISTS OF STANDARD CHARACTERS WITHOUT CLAIM TO ANY PARTICULAR FONT, STYLE, SIZE, OR COLOR.

#### CLASS 9—ELECTRICAL AND SCIENTIFIC APPARATUS

FOR COMPUTER APPLICATION SOFTWARE FOR MOBILE PHONES, PORTABLE MEDIA PLAYERS, AND HANDHELD COMPUTERS, NAMELY, SOFTWARE FOR USE IN DATABASE MANAGEMENT AND INTER-APPLICATION COMMUNICATION VIA TEXT MESSAGING IN THE FIELD OF PERSONAL DEVELOPMENT, SELF-IMPROVEMENT, AND INTERPERSONAL RELATIONSHIPS (U.S. CLS. 21, 23, 26, 36 AND 38).

#### CLASS 16—PAPER GOODS AND PRINTED MATTER

FOR PUBLICATIONS, NAMELY, BOOKS, MANUALS, GUIDES, PERIODICALS AND PAMPHLETS IN THE FIELD OF PERSONAL DEVELOPMENT, SELF-IMPROVEMENT, AND INTERPERSONAL RELATIONSHIPS (U.S. CLS. 2, 5, 22, 23, 29, 37, 38 AND 50).

KEVIN MITTLER, EXAMINING ATTORNEY

SN 86-201,720. PSYCHED BY MG, LLC, PLYMOUTH, MI. FILED 2-24-2014.



THE MARK CONSISTS OF THE SILHOUETTE OF A WOMAN'S FACE WHO IS WEARING GLASSES. TO THE LEFT IS A CONVERSATION BUBBLE CONTAINING THE WORD "PSYCHED" AND UNDERNEATH IS A CONVERSATION BUBBLE CONTAINING THE WORDS "BY MG".

#### CLASS 9—ELECTRICAL AND SCIENTIFIC APPARATUS

FOR COMPUTER APPLICATION SOFTWARE FOR MOBILE PHONES, PORTABLE MEDIA PLAYERS, AND HANDHELD COMPUTERS, NAMELY, SOFTWARE FOR USE IN DATABASE MANAGEMENT AND INTER-APPLICATION COMMUNICATION VIA TEXT MESSAGING IN THE FIELD OF PERSONAL DEVELOPMENT, SELF-IMPROVEMENT, AND INTERPERSONAL RELATIONSHIPS (U.S. CLS. 21, 23, 26, 36 AND 38).

#### CLASS 16—PAPER GOODS AND PRINTED MATTER

FOR PUBLICATIONS, NAMELY, BOOKS, MANUALS, GUIDES, PERIODICALS AND PAMPHLETS IN THE FIELD OF PERSONAL DEVELOPMENT, SELF-IMPROVEMENT, AND INTERPERSONAL RELATIONSHIPS (U.S. CLS. 2, 5, 22, 23, 29, 37, 38 AND 50).

KEVIN MITTLER, EXAMINING ATTORNEY

SN 86-201,866. PRICEWATERHOUSECOOPERS LLP, NEW YORK, NY. FILED 2-24-2014.

## BIG DECISIONS

THE MARK CONSISTS OF STANDARD CHARACTERS WITHOUT CLAIM TO ANY PARTICULAR FONT, STYLE, SIZE, OR COLOR.

#### CLASS 9—ELECTRICAL AND SCIENTIFIC APPARATUS

FOR DOWNLOADABLE DIGITAL PUBLICATIONS, NAMELY, SURVEYS AND REPORTS IN THE AREA OF DATA ANALYTICS AND BUSINESS (U.S. CLS. 21, 23, 26, 36 AND 38).

#### CLASS 41—EDUCATION AND ENTERTAINMENT

FOR PROVIDING ONLINE NON-DOWNLOADABLE DIGITAL PUBLICATIONS, NAMELY, SURVEYS AND REPORTS IN THE AREA OF DATA ANALYTICS AND BUSINESS, VIA THE INTERNET (U.S. CLS. 100, 101 AND 107).

NELSON SNYDER, EXAMINING ATTORNEY

SN 86-202,099. NEW YORK STATE DEPARTMENT OF ECONOMIC DEVELOPMENT, ALBANY, NY. FILED 2-24-2014.



NO CLAIM IS MADE TO THE EXCLUSIVE RIGHT TO USE "BUSINESS MENTOR NY", APART FROM THE MARK AS SHOWN.

THE MARK CONSISTS OF THE WORD "BUSINESS" APPEARING OVER THE WORD "MENTOR"; THE LETTER "M" SHOWING A ROUND DOT AT THE TOP OF THE LEFT LINE OF THE LETTER AND A DOT AT THE TOP OF THE RIGHT LINE OF THE LETTER, DEPICTING TWO PEOPLE HOLDING HANDS; WITH LARGE LETTERS "NY" APPEARING AT THE RIGHT OF THE WORDS "BUSINESS" AND "MENTOR", WITH A STRAIGHT LINE UNDERNEATH THE WORDS "MENTOR" AND "NY"; WITH THE WORDS "REAL WORLD GUIDANCE FROM REAL BUSINESS PROFESSIONALS" APPEARING BENEATH THE STRAIGHT LINE.

#### CLASS 35—ADVERTISING AND BUSINESS

FOR PROMOTING ECONOMIC DEVELOPMENT OF THE STATE OF NEW YORK (U.S. CLS. 100, 101 AND 102).

FIRST USE 1-31-2014; IN COMMERCE 2-3-2014.

#### CLASS 41—EDUCATION AND ENTERTAINMENT

FOR PROVIDING MENTORING PROGRAM IN THE FIELD OF ENTREPRENEURSHIP FOR ASSISTING BUSINESSES AND ENTREPRENEURS (U.S. CLS. 100, 101 AND 107).

FIRST USE 1-31-2014; IN COMMERCE 2-3-2014.  
LAURIE MAYES, EXAMINING ATTORNEY

SN 86-202,290. AIRBLASTER, PORTLAND, OR. FILED 2-24-2014.

# STAY WILD!

THE MARK CONSISTS OF STANDARD CHARACTERS WITHOUT CLAIM TO ANY PARTICULAR FONT, STYLE, SIZE, OR COLOR.

#### CLASS 9—ELECTRICAL AND SCIENTIFIC APPARATUS

FOR EYEWEAR, NAMELY, SNOW GOGGLES, SKI GOGGLES, SNOWBOARD GOGGLES, SUN GLASSES, GLASSES FOR SPORTS, SKI GLASSES, SNOWBOARD GLASSES (U.S. CLS. 21, 23, 26, 36 AND 38).

FIRST USE 2-21-2014; IN COMMERCE 2-21-2014.

#### CLASS 25—CLOTHING

FOR CLOTHING, NAMELY, T-SHIRTS, BUTTON-UP SHIRTS, SWEATSHIRTS, PANTS, JACKETS, HATS, BELTS, GLOVES, UNDERWEAR, LONG UNDERWEAR, SOCKS, SKI MASKS, BEANIES, BALACLAVAS, ONE-PIECE OUTERWEAR SUITS, ONE-PIECE LONG UNDERWEAR, SWEATERS (U.S. CLS. 22 AND 39).

FIRST USE 2-21-2014; IN COMMERCE 2-21-2014.

WILLIAM BRECKENFELD, EXAMINING ATTORNEY

SN 86-202,726. KIM WINSER, LONDON, ENGLAND, FILED 2-24-2014.

# WINSER LONDON

THE MARK CONSISTS OF STANDARD CHARACTERS WITHOUT CLAIM TO ANY PARTICULAR FONT, STYLE, SIZE, OR COLOR.

NO CLAIM IS MADE TO THE EXCLUSIVE RIGHT TO USE "LONDON", APART FROM THE MARK AS SHOWN.

#### CLASS 14—JEWELRY

FOR PRECIOUS METALS AND THEIR ALLOYS AND GOODS IN PRECIOUS METALS OR COATED THEREWITH, NAMELY, AMULETS, IMITATION JEWELRY, EARRINGS, BRACELETS, NECKLACES, BROOCHES, ORNAMENTAL PINS; JEWELRY; WATCHES (U.S. CLS. 2, 27, 28 AND 50).

#### CLASS 18—LEATHER GOODS

FOR BEACH BAGS; HANDBAGS; VANITY CASES SOLD EMPTY; TOILETRY CASES SOLD EMPTY; COSMETIC CASES SOLD EMPTY; PURSES; POUCHES MADE OF TEXTILE; POUCHES OF LEATHER; POUCHES MADE FROM IMITATION LEATHER AND FELT; DRAWSTRING POUCHES MADE FROM SILK, CANVAS, COTTON, LINEN AND SATIN; UMBRELLAS (U.S. CLS. 1, 2, 3, 22 AND 41).

#### CLASS 25—CLOTHING

FOR COATS; JACKETS; PARKAS; WAISTCOATS; RAINCOATS; WRAPS; CARDIGANS; JACKETS MADE IN WHOLE OR IN SUBSTANTIAL PART OF SILK, WOOL, CASHMERE AND COTTON; SWEATERS; SWEATERS MADE IN WHOLE OR IN SUBSTANTIAL PART OF SILK, WOOL, CASHMERE AND COTTON JUMPERS; SWEAT SHIRTS; BLOUSES; SHIRTS; T-SHIRTS; BODY SUITS; COMBINATIONS; JERSEYS; PULLOVERS; SKIRTS; DRESSES; PETTICOATS; APRONS; TROUSERS; SHORTS; PANTS; PLAYSUITS; TRACK SUITS; SWIMWEAR; PAJAMAS; NIGHTWEAR; NIGHTDRESSES; NIGHTGOWNS; NIGHTSHIRTS; NIGHTIES; DRESSING GOWNS; UNDERGARMENTS; UNDERWEAR; BRAS; BRAS; LINGERIE; SLIPS; BRIEFS; BRAS; STOCKINGS; SOCKS; TIGHTS; LEGGINGS; HOSIERY; BATH ROBES; SWIMMING COSTUMES; BIKINIS; BEACHWEAR; BELTS; TIES; CAPS; HATS; CAPES; SHAWLS; SCARVES; SILK SCARVES; CASHMERE SCARVES; SHOULDER WRAPS; MITTENS; MUFFLERS; GLOVES; BATHING COSTUMES FOR WOMEN; TUNICS; FOOTWEAR, EXCLUDING ORTHOPEDIC FOOTWEAR; BOOTS; ANKLE BOOTS; SANDALS; SLIPPERS; SHOES; SANDALS (U.S. CLS. 22 AND 39).

#### CLASS 35—ADVERTISING AND BUSINESS

FOR WHOLESALE DISTRIBUTORSHIP SERVICES, RETAIL OUTLET SERVICES AND RETAIL STORE, RETAIL MAIL ORDER AND ONLINE RETAIL STORE SERVICES IN THE FIELD OF CLOTHING, FOOTWEAR AND HEADGEAR, ALL FOR WOMEN AND FASHION ACCESSORIES, JEWELLERY, WATCHES, LEATHER GOODS AND BAGS, TEXTILES AND TEXTILE GOODS (U.S. CLS. 100, 101 AND 102).

MATTHEW KLINE, EXAMINING ATTORNEY

SN 86-203,443. CLAN SERVERS HOSTING, LLC, MATAWAN, NJ. FILED 2-25-2014.

# VULTR

THE MARK CONSISTS OF STANDARD CHARACTERS WITHOUT CLAIM TO ANY PARTICULAR FONT, STYLE, SIZE, OR COLOR.

## CLASS 9—ELECTRICAL AND SCIENTIFIC APPARATUS

FOR COMPUTER SOFTWARE FOR UPLOADING AND SHARING DATA, DOCUMENTS, FILES, INFORMATION, TEXT, PHOTOS, IMAGES, GRAPHICS, MUSIC, AUDIO, VIDEO, AND MULTIMEDIA CONTENT WITH OTHERS VIA CLOUD-BASED WEB HOSTING SERVICES; COMPUTER SOFTWARE FOR STORING DATA, DOCUMENTS, FILES, INFORMATION, TEXT, PHOTOS, IMAGES, GRAPHICS, MUSIC, AUDIO, VIDEO, AND MULTIMEDIA CONTENT FOR OTHERS FOR USE IN CONJUNCTION WITH DATA SHARING SOFTWARE VIA CLOUD-BASED WEB HOSTING SERVICES (U.S. CLS. 21, 23, 26, 36 AND 38).

FIRST USE 12-20-2013; IN COMMERCE 12-20-2013.

## CLASS 42—SCIENTIFIC AND COMPUTER SERVICES

FOR CLOUD COMPUTING FEATURING SOFTWARE FOR OTHERS FOR USE IN CLOUD-BASED HOSTING AND INFRASTRUCTURE MANAGEMENT OF INTERNET WEBSITES, ELECTRONIC DATABASES, AND OTHER DIGITAL CONTENT; CLOUD COMPUTING FEATURING SOFTWARE FOR OTHERS FOR USE HOSTING E-MAIL, DOCUMENT BACKUP AND ENCRYPTED FILE TRANSFER (U.S. CLS. 100 AND 101).

FIRST USE 12-20-2013; IN COMMERCE 12-20-2013.

TRACY WHITTAKER-BROWN, EXAMINING ATTORNEY

---

SN 86-203,518. CENTRALLO LLC, NEW YORK, NY. FILED 2-25-2014.

# CENTRALLO

THE MARK CONSISTS OF STANDARD CHARACTERS WITHOUT CLAIM TO ANY PARTICULAR FONT, STYLE, SIZE, OR COLOR.

THE WORDING "CENTRALLO" HAS NO MEANING IN A FOREIGN LANGUAGE.

## CLASS 9—ELECTRICAL AND SCIENTIFIC APPARATUS

FOR COMPUTER SOFTWARE FOR USE IN UPLOADING, CAPTURING, ORGANIZING, SEARCHING, INDEXING, STORING, SYNCHRONIZING, RECOGNIZING, SHARING, TRANSMITTING AND DISPLAYING DIGITAL FILES FEATURING AUDIO, VIDEO, TEXT, BINARY, STILL IMAGES, GRAPHICS, MUSIC, DIGITAL CONTENT AND MULTIMEDIA FILES VIA GLOBAL COMPUTER NETWORKS, MOBILE DEVICES, AND OTHER COMMUNICATIONS NETWORKS; COMPUTER SOFTWARE FOR USE IN DATABASE MANAGEMENT, ELECTRONIC SPREADSHEETS, DESIGNING, CREATING, EDITING AND PUBLISHING DOCUMENTS, NOTE TAKING, EMAIL, CALENDARING, SCHEDULING, CONTACT INFORMATION STORAGE AND MANAGEMENT, DOCUMENT MANAGEMENT, DATABASE MANAGEMENT, DATA COLLECTION, WORD PROCESSING AND INSTANT MESSAGING (U.S. CLS. 21, 23, 26, 36 AND 38).

## CLASS 42—SCIENTIFIC AND COMPUTER SERVICES

FOR ELECTRONIC STORAGE OF ELECTRONIC MEDIA, NAMELY, DATA, DOCUMENTS, FILES, TEXT, PHOTOS, IMAGES, GRAPHICS, MUSIC, AUDIO, VIDEO, AND MULTIMEDIA CONTENT, PROVIDING TEMPORARY USE OF NON-DOWNLOADABLE COMPUTER SOFTWARE USED FOR UPLOADING, TRANSFERRING, DOWNLOADING, CAPTURING, ORGANIZING, SEARCHING, INDEXING, STORING, SYNCHRONIZING, RECOGNIZING, SHARING, TRANSMITTING AND DISPLAYING DATA, DOCUMENTS, FILES, INFORMATION, TEXT, PHOTOS, IMAGES, GRAPHICS, MUSIC, AUDIO, VIDEO, AND MULTIMEDIA CONTENT WITH OTHERS VIA GLOBAL COMPUTER NETWORKS, MOBILE DEVICES, AND OTHER COMMUNICATIONS NETWORKS FOR THE PURPOSE OF FILE BACK UP AND SYNCHRONIZATION; HOSTING OF DIGITAL CONTENT ON THE INTERNET; PROVIDING TEMPORARY USE OF NON-DOWNLOADABLE COMPUTER SOFTWARE FOR PUBLISHING AND SHARING DIGITAL MEDIA AND INFORMATION VIA GLOBAL COMPUTER AND COMMUNICATIONS NETWORKS; PROVIDING TEMPORARY USE OF NON-DOWNLOADABLE COMPUTER SOFTWARE FOR CREATING INDEXES OF INFORMATION, INDEXES OF OTHER WEBSITES, AND INDEXES OF INFORMATION RESOURCES; CREATING COMPUTER NETWORK-BASED INDEXES OF INFORMATION, WEBSITES, AND OTHER RESOURCES AVAILABLE ON GLOBAL COMPUTER NETWORKS FOR OTHERS; APPLICATION SERVICE PROVIDER (ASP) SERVICES FEATURING COMPUTER SOFTWARE TO ENABLE UPLOADING, POSTING, SHOWING, DISPLAYING, AND SHARING ELECTRONIC MEDIA OR INFORMATION OVER THE INTERNET OR OTHER COMMUNICATIONS NETWORK; PROVIDING TECHNOLOGICAL INFORMATION RELATING TO COMPUTER SOFTWARE FUNCTIONS ONLINE VIA A GLOBAL COMPUTER NETWORK AND COMMUNICATIONS NETWORKS (U.S. CLS. 100 AND 101).

BRIN ANDERSON, EXAMINING ATTORNEY

---

SN 86-203,560. CLICKBACK INC., ST. CATHARINES, ON, CANADA, FILED 2-25-2014.

# CLICKBACK

THE MARK CONSISTS OF STANDARD CHARACTERS WITHOUT CLAIM TO ANY PARTICULAR FONT, STYLE, SIZE, OR COLOR.

PRIORITY CLAIMED UNDER SEC. 44(D) ON CANADA APPLICATION NO. 1661760, FILED 1-30-2014.

**CLASS 35—ADVERTISING AND BUSINESS**

FOR CONSULTING SERVICES IN THE FIELD OF INTERNET MARKETING; PROVISION OF INTERNET-RELATED DIRECT E-MAIL MARKETING AND ADVERTISING SERVICES FOR OTHERS VIA THE DISTRIBUTION OF MASS AND CUSTOMIZED E-MAILS AND NEWSLETTERS; MARKETING CONSULTING SERVICES IN THE FIELD OF GENERATING MARKETING LEADS THROUGH ELECTRONIC MAIL AS A FORM OF ADVERTISING THE GOODS AND SERVICES OF OTHERS; BUSINESS CONSULTING SERVICES IN THE NATURE OF PROVIDING LEAD GENERATION ADVICE TO BUSINESSES AND INDIVIDUALS (U.S. CLS. 100, 101 AND 102).

**CLASS 42—SCIENTIFIC AND COMPUTER SERVICES**

FOR SOFTWARE AS A SERVICE (SAAS) SERVICES FEATURING MARKETING SOFTWARE FOR CREATING, MANAGING, DELIVERING, AUTOMATING AND MEASURING DIRECT EMAIL AND ONLINE MARKETING CAMPAIGNS AND COLLECTING, ANALYZING AND REPORTING DATA PRODUCED THEREFROM; SOFTWARE AS A SERVICE (SAAS) SERVICES FEATURING PROSPECTIVE-CUSTOMER AND CUSTOMER MANAGEMENT SOFTWARE FOR MANAGING DIRECT-MAIL ELECTRONIC COMMUNICATIONS, PREPARING REPORTS ABOUT PROSPECTIVE AND CURRENT CUSTOMERS, IDENTIFYING SALES OPPORTUNITIES, TRACKING CUSTOMER INTERACTIONS AND PROVIDING RELATED REPORTS; SOFTWARE AS A SERVICE (SAAS), PROVIDING SUBSCRIPTION SERVICES OF NON-DOWNLOADABLE SOFTWARE FOR USE IN E-MAIL MARKETING AND ONLINE MARKETING FOR ADMINISTERING AND MANAGING E-MAIL MARKETING CAMPAIGNS AND THE COLLECTING AND ANALYZING CLIENT DATA COLLECTED FROM SUCH MARKETING; TECHNOLOGY CONSULTATION SERVICES TO IMPROVE CUSTOMER EMAIL DELIVERABILITY AND OPEN RATES, NAMELY, THROUGH CONFIGURATION, CUSTOMIZATION, IMPLEMENTATION, INTEGRATION AND MAINTENANCE SERVICES RELATING TO SOFTWARE FOR DIRECT MARKETING CAMPAIGNS AND CUSTOMER DEVELOPMENT AND RELATIONSHIP MANAGEMENT SOFTWARE (U.S. CLS. 100 AND 101).

BILL DAWE, EXAMINING ATTORNEY

SN 86-203.633. AMERICAN CHEMICAL SOCIETY, WASHINGTON, DC. FILED 2-25-2014.

**AACT**

THE MARK CONSISTS OF STANDARD CHARACTERS WITHOUT CLAIM TO ANY PARTICULAR FONT, STYLE, SIZE, OR COLOR.

**CLASS 16—PAPER GOODS AND PRINTED MATTER**

FOR PRINTED MATERIALS AND PUBLICATIONS, NAMELY, SCIENTIFIC JOURNALS AND PERIODICALS, BROCHURES, PAMPHLETS, MANUALS, BOOKS, CATALOGS, NEWSLETTERS, AND MAGAZINES IN THE FIELDS OF CHEMISTRY AND SCIENCES THAT INVOLVE CHEMISTRY (U.S. CLS. 2, 5, 22, 23, 29, 37, 38 AND 50).

**CLASS 35—ADVERTISING AND BUSINESS**

FOR ASSOCIATION SERVICES, NAMELY, PROMOTING THE INTERESTS OF CHEMISTRY TEACHERS, CHEMISTRY, AND SCIENCES THAT INVOLVE CHEMISTRY (U.S. CLS. 100, 101 AND 102).

**CLASS 41—EDUCATION AND ENTERTAINMENT**

FOR PUBLICATION OF JOURNALS, PERIODICALS, BROCHURES, PAMPHLETS, MANUALS, BOOKS, CATALOGS, NEWSLETTERS, AND MAGAZINES IN THE FIELDS OF CHEMISTRY; EDUCATIONAL SERVICES, NAMELY, CONDUCTING SEMINARS, CLASSES, CONFERENCES, MEETINGS, AND WORKSHOPS IN THE FIELDS OF CHEMISTRY AND SCIENCES THAT INVOLVE CHEMISTRY; PROVIDING ONLINE NEWSLETTERS, MAGAZINES, AND CURRICULAR RESOURCES IN THE NATURE OF LESSON PLANS, LABORATORY EXPERIMENTS, EDUCATIONAL VIDEOS, EDUCATIONAL DEMONSTRATIONS, AND INTERACTIVE, ANIMATED MODELS, ALL IN THE FIELDS OF CHEMISTRY AND SCIENCES THAT INVOLVE CHEMISTRY; DEVELOPING CURRICULUM FOR EDUCATORS FOR PROVIDING EDUCATIONAL STANDARDS AND GUIDELINES IN THE FIELDS OF CHEMISTRY AND SCIENCES THAT INVOLVE CHEMISTRY (U.S. CLS. 100, 101 AND 107).

**CLASS 42—SCIENTIFIC AND COMPUTER SERVICES**

FOR PROVIDING EDUCATIONAL INFORMATION IN THE FIELDS OF CHEMISTRY AND SCIENCES THAT INVOLVE CHEMISTRY (U.S. CLS. 100 AND 101).

SHANNON TWOHIG, EXAMINING ATTORNEY

SN 86-203.815. MATH-U-SEE, INC., DBA DEMME LEARNING, LANCASTER, PA. FILED 2-25-2014.



NO CLAIM IS MADE TO THE EXCLUSIVE RIGHT TO USE "SPELLING", APART FROM THE MARK AS SHOWN. THE MARK CONSISTS OF A PENCIL DRAWING A LINE BENEATH THE WORDS "SPELLING YOU SEE".

**CLASS 9—ELECTRICAL AND SCIENTIFIC APPARATUS**

FOR PRERECORDED VIDEOS FEATURING SPELLING AND LANGUAGE INSTRUCTION (U.S. CLS. 21, 23, 26, 36 AND 38).

FIRST USE 3-15-2014; IN COMMERCE 3-15-2014.

**CLASS 16—PAPER GOODS AND PRINTED MATTER**

FOR EDUCATIONAL MATERIALS IN THE FIELD OF SPELLING AND LANGUAGE CONSISTING PRIMARILY OF EDUCATIONAL BOOKS, WORKSHEETS, WORKBOOKS OR STICKER PACKS (U.S. CLS. 2, 5, 22, 23, 29, 37, 38 AND 50).

FIRST USE 9-15-2013; IN COMMERCE 12-30-2013.

IRA J. GOODSaid, EXAMINING ATTORNEY

SN 86-203,868. EPHRAIM, LLC, DENVER, CO. FILED 2-25-2014.

## TOP OF THE ROCKIES

THE MARK CONSISTS OF STANDARD CHARACTERS WITHOUT CLAIM TO ANY PARTICULAR FONT, STYLE, SIZE, OR COLOR.

### CLASS 25—CLOTHING

FOR CLOTHING, NAMELY, SHIRTS, CAPS, HATS, VISORS, SWEATSHIRTS, HOODIES, T-SHIRTS, JACKETS, UNDERWEAR, SOCKS, BANDANAS, WRIST BANDS, PANTS AND SHORTS (U.S. CLS. 22 AND 39).

### CLASS 41—EDUCATION AND ENTERTAINMENT

FOR ENTERTAINMENT SERVICES, NAMELY, PROVIDING OBSERVATION DECKS AND LONG-DISTANCE VIEWING ATTRACTION SERVICES FROM A SKYSCRAPER FOR THE PURPOSE OF SIGHTSEEING; FIREWORKS DISPLAYS; EDUCATIONAL SERVICES, NAMELY, SEMINARS, WORKSHOPS AND CLASSES ON GEOGRAPHY, HISTORY, METEOROLOGY AND ARCHITECTURE (U.S. CLS. 100, 101 AND 107).

### CLASS 43—HOTEL AND RESTAURANT SERVICES

FOR RESTAURANT, BAR AND CATERING SERVICES; BAR AND COCKTAIL LOUNGE SERVICES; RENTAL OF BANQUET AND SOCIAL FUNCTION FACILITIES FOR SPECIAL OCCASIONS, NAMELY WEDDINGS, BUSINESS MEETINGS, BIRTHDAY PARTIES, ANNIVERSARIES, LUNCHEONS, DINNERS, BANQUETS AND AWARDS CEREMONIES (U.S. CLS. 100 AND 101).

FRED CARL, EXAMINING ATTORNEY

SN 86-203,941. SPY OPTIC, INC., CARLSBAD, CA. FILED 2-25-2014.

## SEE BETTER. FEEL BETTER.

THE MARK CONSISTS OF STANDARD CHARACTERS WITHOUT CLAIM TO ANY PARTICULAR FONT, STYLE, SIZE, OR COLOR.

### CLASS 9—ELECTRICAL AND SCIENTIFIC APPARATUS

FOR SUNGLASSES, EYEGLASSES AND SPORTS GOGGLES; ACCESSORIES FOR SUNGLASSES, EYEGLASSES AND SPORTS GOGGLES, NAMELY, CASES, CHAINS AND LANYARDS; COMPONENTS OF SUNGLASSES, EYEGLASSES AND SPORTS GOGGLES, NAMELY, FRAMES, LENSES AND FACESHIELDS (U.S. CLS. 21, 23, 26, 36 AND 38).

### CLASS 25—CLOTHING

FOR WEARING APPAREL, NAMELY, SHIRTS, T-SHIRTS, SWEATSHIRTS, SWEATERS, JACKETS, PANTS, SHORTS, SKIRTS, HATS, VISORS, CAPS, BELTS, SHOES, FLIP FLOPS, SANDALS (U.S. CLS. 22 AND 39).

KATHERINE CHANG, EXAMINING ATTORNEY

SN 86-203,957. SPY OPTIC, INC., CARLSBAD, CA. FILED 2-25-2014.

## SEE HAPPY

THE MARK CONSISTS OF STANDARD CHARACTERS WITHOUT CLAIM TO ANY PARTICULAR FONT, STYLE, SIZE, OR COLOR.

### CLASS 9—ELECTRICAL AND SCIENTIFIC APPARATUS

FOR SUNGLASSES, EYEGLASSES, SPORTS GOGGLES; ACCESSORIES FOR SUNGLASSES, EYEGLASSES AND SPORTS GOGGLES, NAMELY, CASES, CHAINS AND LANYARDS; COMPONENTS OF SUNGLASSES, EYEGLASSES AND SPORTS GOGGLES, NAMELY, FRAMES, LENSES AND FACESHIELDS (U.S. CLS. 21, 23, 26, 36 AND 38).

### CLASS 25—CLOTHING

FOR WEARING APPAREL, NAMELY, SHIRTS, T-SHIRTS, SWEATSHIRTS, SWEATERS, JACKETS, PANTS, SHORTS, SKIRTS, HATS, VISORS, CAPS, BELTS, SHOES, FLIP FLOPS, SANDALS (U.S. CLS. 22 AND 39).

KATHERINE CHANG, EXAMINING ATTORNEY

SN 86-203,988. SPY OPTIC, INC., CARLSBAD, CA. FILED 2-25-2014.

## HAPPINESS GUARANTEED

THE MARK CONSISTS OF STANDARD CHARACTERS WITHOUT CLAIM TO ANY PARTICULAR FONT, STYLE, SIZE, OR COLOR.

### CLASS 9—ELECTRICAL AND SCIENTIFIC APPARATUS

FOR SUNGLASSES, EYEGLASSES, SPORTS GOGGLES; ACCESSORIES FOR SUNGLASSES, EYEGLASSES AND SPORTS GOGGLES, NAMELY, CASES, CHAINS AND LANYARDS; COMPONENTS OF SUNGLASSES, EYEGLASSES AND SPORTS GOGGLES, NAMELY, FRAMES, LENSES AND FACESHIELDS (U.S. CLS. 21, 23, 26, 36 AND 38).

### CLASS 25—CLOTHING

FOR WEARING APPAREL, NAMELY, SHIRTS, T-SHIRTS, SWEATSHIRTS, SWEATERS, JACKETS, PANTS, SHORTS, SKIRTS, HATS, VISORS, CAPS, BELTS, SHOES, FLIP FLOPS, SANDALS (U.S. CLS. 22 AND 39).



KATHERINE CHANG, EXAMINING ATTORNEY

SN 86-204,897. RED DOG BRANDS LLC, WEST NEW YORK, NJ. FILED 2-26-2014.

SN 86-204,012. REAUCT INC, HACIENDA HEIGHTS, CA. FILED 2-25-2014.

# ReAuct

THE MARK CONSISTS OF STANDARD CHARACTERS WITHOUT CLAIM TO ANY PARTICULAR FONT, STYLE, SIZE, OR COLOR.

#### CLASS 35—ADVERTISING AND BUSINESS

FOR ONLINE TRADING SERVICES IN WHICH SELLERS POST PRODUCTS OR SERVICES TO BE OFFERED FOR SALE, AND PURCHASING OR BIDDING IS DONE VIA THE INTERNET IN ORDER TO FACILITATE THE SALE OF GOODS AND SERVICES BY OTHERS VIA A GLOBAL COMMUNICATIONS NETWORK; ONLINE AUCTIONEERING SERVICES, NAMELY, OPERATING ONLINE MARKETPLACES FOR SELLERS AND BUYERS OF GOODS AND SERVICES; ON-LINE RETAIL STORE AND AUCTION SERVICE IN THE FIELD OF CONSUMER ELECTRONICS, HOUSE WARES, HOME FURNISHINGS, HOME APPLIANCES, TOYS, CONSUMER GOODS, COMPUTER ACCESSORIES, AUTOMOBILE, AUTO PARTS, AND COMPUTERS INCLUDING GAMING COMPUTERS, TABLETS, DESKTOPS PCS, LAPTOPS, PORTABLE GAMING CONSOLES, AND VIDEO GAME CONSOLES; MARKETING, ADVERTISING, PROMOTING, AND AUCTIONING THE GOODS AND SERVICES OF OTHERS BY PROVIDING A WEBSITE FEATURING COUPONS, ON-LINE AUCTION BIDDING PROGRAM FOR OTHERS, REBATES, PRICE-COMPARISON INFORMATION, PRODUCT REVIEWS, LINKS TO THE RETAIL WEBSITES OF OTHERS, AND DISCOUNT INFORMATION; PROVIDING A SEARCHABLE ONLINE ADVERTISING GUIDE FEATURING THE GOODS AND SERVICES OF OTHER ON-LINE VENDORS; PROVIDING EVALUATIVE FEEDBACK AND RATINGS OF THE GOODS AND SERVICES OF SELLERS AND PROVIDERS, BUYERS AND SELLERS' PERFORMANCE, DELIVERY, AND OVERALL TRADING EXPERIENCE IN CONNECTION THEREWITH; PROVIDING A WEB SITE THAT FEATURES AN ON-LINE MARKET FOR USERS TO LIST OFFERED OR WANTED PRODUCT OR SERVICES FOR SALE OF AUCTION TRANSACTED ON THE BASIS OF PREDEFINED PERFORMANCE AND CLOSING TERMS AND CONDITION; INDUSTRIAL ASSET MANAGEMENT SERVICES, NAMELY, AUCTIONING, LIQUIDATING AND REMARKETING INDUSTRIAL ASSETS OF OTHERS OVER AN ON-LINE WEB SITE ACCESSED THROUGH A GLOBAL COMPUTER NETWORK; BUSINESS MANAGEMENT SERVICES, NAMELY, SUPPLY CHAIN LOGISTICS, REVERSE LOGISTICS, PRODUCT DISTRIBUTION PROCESSES AND LIQUIDATION OF GOODS OF OTHERS (U.S. CLS. 100, 101 AND 102).

#### CLASS 45—PERSONAL AND LEGAL SERVICES

FOR ONLINE SOCIAL NETWORKING SERVICES AT WHICH USERS CAN VIEW AND SHARE PRODUCT OR SERVICE INFORMATION (U.S. CLS. 100 AND 101).  
DAVID COLLIER, EXAMINING ATTORNEY

# RUFF HEWN GREY

THE MARK CONSISTS OF STANDARD CHARACTERS WITHOUT CLAIM TO ANY PARTICULAR FONT, STYLE, SIZE, OR COLOR.

OWNER OF U.S. REG. NOS. 1,266,411, 2,983,545 AND OTHERS.

NO CLAIM IS MADE TO THE EXCLUSIVE RIGHT TO USE "GREY", APART FROM THE MARK AS SHOWN.

#### CLASS 14—JEWELRY

FOR PRECIOUS METALS AND THEIR ALLOYS AND GOODS IN PRECIOUS METALS OR COATED THEREWITH, NAMELY, JEWELLERY, HOROLOGICAL AND CHRONOMETRIC INSTRUMENTS; JEWELLERY; PRECIOUS STONES; HOROLOGICAL AND CHRONOMETRIC INSTRUMENTS (U.S. CLS. 2, 27, 28 AND 50).

#### CLASS 18—LEATHER GOODS

FOR LEATHER AND IMITATIONS OF LEATHER, AND GOODS MADE OF THESE MATERIALS, NAMELY, PURSES; ANIMAL SKINS, HIDES; TRUNKS AND TRAVELLING BAGS; UMBRELLAS AND PARASOLS (U.S. CLS. 1, 2, 3, 22 AND 41).

#### CLASS 25—CLOTHING

FOR CLOTHING, NAMELY, DRESSES, SHIRTS, SKIRTS, PANTS, SHORTS, JACKETS, HATS, BELTS, SUSPENDERS, BLAZERS, COATS, SCARVES, SWEATERS, TIES, KERCHIEFS, SOCKS, SHOES, KNIT TOPS, AND BLOUSES; FOOTWEAR; HEADGEAR, NAMELY, HATS, CAPS, HEADWEAR (U.S. CLS. 22 AND 39).

JEAN IM, EXAMINING ATTORNEY

SN 86-204,973. LIFECARE, INC., SHELTON, CT. FILED 2-26-2014.

# THAT'S LIFECARE

THE MARK CONSISTS OF STANDARD CHARACTERS WITHOUT CLAIM TO ANY PARTICULAR FONT, STYLE, SIZE, OR COLOR.

OWNER OF U.S. REG. NOS. 2,516,436, 3,422,908 AND OTHERS.

SEC. 2(F) AS TO "LIFECARE".

**CLASS 16—PAPER GOODS AND PRINTED MATTER**

FOR NEWSLETTERS, PRINTED INFORMATIONAL MATERIALS AND PRINTED EDUCATIONAL MATERIALS, NAMELY, PAMPHLETS AND BROCHURES IN THE FIELDS OF CHILD CARE AND ADULT CARE, HEALTH AND WELLNESS, NUTRITION, MARRIAGE, TRAVEL, PET CARE, EMERGENCY CARE, ELDERCARE, DEPENDENT CARE, ADOPTION, SPECIAL NEEDS CHILDREN, PERSONAL SERVICES, RESPITE CARE, GRIEF AND BEREAVEMENT, DISEASE PREVENTION, HEALTHY AGING, QUALITY OF LIFE ENHANCEMENT, SELF HELP, DIET, GENERAL HEALTH, MEN'S, WOMEN'S, CHILDREN'S AND SENIOR HEALTH, PRENATAL HEALTH, WORKPLACE HEALTH, WORKPLACE SAFETY, CHILD SAFETY, CHILD DEVELOPMENT, CHILD DISABILITIES, GIFTED AND TALENTED CHILDREN, PARENTING, PRENATAL CARE, LACTATION, BREASTFEEDING, AND WEANING, SUMMER CAMP PROGRAMS, WORK AND FAMILY LIFE, ANXIETY, DEPRESSION, EDUCATION, FINANCIAL AID, TUTORING, EXTRACURRICULAR ACTIVITIES, CREDIT/DEBT MANAGEMENT, ESTATE PLANNING, FINANCE, RETIREMENT PLANNING, POST-RETIREMENT PLANNING, POST-RETIREMENT ACTIVITIES, RETIREMENT LIFESTYLE OPTIONS, RELOCATION, EMPLOYMENT, EMPLOYEE FINANCIAL PLANNING, AND WORKPLACE COUNSELING (U.S. CLS. 2, 5, 22, 23, 29, 37, 38 AND 50).

**CLASS 35—ADVERTISING AND BUSINESS**

FOR REFERRAL SERVICES AND ONLINE REFERRAL SERVICES IN THE FIELDS OF CHILD CARE AND ADULT CARE, HEALTH AND WELLNESS, NUTRITION, MARRIAGE, TRAVEL, PET CARE, EMERGENCY CARE, ELDERCARE, DEPENDENT CARE, ADOPTION, SPECIAL NEEDS CHILDREN, PERSONAL SERVICES, RESPITE CARE, GRIEF AND BEREAVEMENT, DISEASE PREVENTION, HEALTHY AGING, QUALITY OF LIFE ENHANCEMENT, SELF HELP, DIET, GENERAL HEALTH, MEN'S, WOMEN'S, CHILDREN'S AND SENIOR HEALTH, PRENATAL HEALTH, WORKPLACE HEALTH, WORKPLACE SAFETY, CHILD SAFETY, CHILD DEVELOPMENT, CHILD DISABILITIES, GIFTED AND TALENTED CHILDREN, PARENTING, PRENATAL CARE, LACTATION, BREASTFEEDING, AND WEANING, SUMMER CAMP PROGRAMS, WORK AND FAMILY LIFE, ANXIETY, DEPRESSION, EDUCATION, FINANCIAL AID, TUTORING, EXTRACURRICULAR ACTIVITIES, CREDIT/DEBT MANAGEMENT, ESTATE PLANNING, FINANCE, RETIREMENT PLANNING, POST-RETIREMENT PLANNING, POST-RETIREMENT ACTIVITIES, RETIREMENT LIFESTYLE OPTIONS, RELOCATION, EMPLOYMENT, EMPLOYEE FINANCIAL PLANNING, AND WORKPLACE COUNSELING; PROVIDING INFORMATION, ON-LINE INFORMATION VIA A COMPUTER NETWORK, TELEPHONE HOTLINE SUPPORT, AND CONSULTATION IN CONNECTION THEREWITH IN THE FIELDS OF CHILD CARE AND ADULT CARE, HEALTH AND WELLNESS, NUTRITION, MARRIAGE, TRAVEL, PET CARE, EMERGENCY CARE, ELDERCARE, DEPENDENT CARE, ADOPTION, SPECIAL NEEDS CHILDREN, PERSONAL SERVICES, RESPITE CARE, GRIEF AND BEREAVEMENT, DISEASE PREVENTION, HEALTHY AGING, QUALITY OF LIFE ENHANCEMENT, SELF HELP, DIET, GENERAL HEALTH, MEN'S, WOMEN'S, CHILDREN'S AND SENIOR HEALTH, PRENATAL HEALTH, WORKPLACE HEALTH, WORKPLACE SAFETY, CHILD SAFETY, CHILD DEVELOPMENT, CHILD DISABILITIES, GIFTED AND TALENTED CHILDREN, PARENTING, PRENATAL CARE, LACTATION, BREASTFEEDING, AND WEANING, SUMMER CAMP PROGRAMS, WORK AND FAMILY LIFE, ANXIETY, DEPRESSION, EDUCATION, FINANCIAL AID, TUTORING, EXTRACURRICULAR ACTIVITIES, CREDIT/DEBT MANAGEMENT, ESTATE PLANNING, FINANCE, RETIREMENT PLANNING, POST-RETIREMENT PLANNING, POST-RETIREMENT ACTIVITIES, RETIREMENT LIFESTYLE OPTIONS, RELOCATION, EMPLOYMENT, EMPLOYEE FINANCIAL PLANNING, AND WORKPLACE COUNSELING; PROVIDING HUMAN RESOURCE INFORMATION VIA A COMPUTER NETWORK (U.S. CLS. 100, 101 AND 102).

PRISCILLA MILTON, EXAMINING ATTORNEY

SN 86-205,343. JILL SEGAL, ST. LOUIS, MO. FILED 2-26-2014.

**JILLY'S ICE CREAM BAR**

THE MARK CONSISTS OF STANDARD CHARACTERS WITHOUT CLAIM TO ANY PARTICULAR FONT, STYLE, SIZE, OR COLOR.

OWNER OF U.S. REG. NO. 3,463,412.

NO CLAIM IS MADE TO THE EXCLUSIVE RIGHT TO USE "ICE CREAM BAR", APART FROM THE MARK AS SHOWN.

**CLASS 30—STAPLE FOODS**

FOR FROZEN CONFECTIONS; FROZEN CONFECTIONS, NAMELY, ICE CREAM, ICE CREAM PIES, ICE CREAM SANDWICHES, ICE CREAM CAKES, SUNDAES AND MALTS (U.S. CL. 46).

**CLASS 43—HOTEL AND RESTAURANT SERVICES**

FOR RESTAURANT SERVICES; RESTAURANT SERVICES FEATURING FROZEN CONFECTIONS AND ICE CREAM (U.S. CLS. 100 AND 101).

LAURA KOVALSKY, EXAMINING ATTORNEY

SN 86-205,523. KEITH ROSSBERG, SOUTH JORDAN, UT. FILED 2-26-2014.

**BOLDEN**

THE MARK CONSISTS OF STANDARD CHARACTERS WITHOUT CLAIM TO ANY PARTICULAR FONT, STYLE, SIZE, OR COLOR.

**CLASS 37—CONSTRUCTION AND REPAIR**

FOR EMERGENCY REPAIR AND PLANNED MAINTENANCE OF PLUMBING FIXTURES, ELECTRICAL SYSTEMS, EMERGENCY GENERATORS, HEATING SYSTEMS, VENTILATION SYSTEMS, AIR CONDITIONING SYSTEMS, BOILERS, ENERGY MANAGEMENT SYSTEMS, REFRIGERATION SYSTEMS, APPLIANCES, FIRE SPRINKLER SYSTEMS, GLASS, DOORS AND LOCKS; CARPENTRY; GENERAL BUILDING REPAIRS AND MAINTENANCE; PARKING LOT REPAIR AND MAINTENANCE; INSTALLING FLOORING; PAINTING; PEST CONTROL; JANITORIAL SERVICES; INSTALLATION AND MAINTENANCE OF DIGITAL SIGNAGE AND AUDIO VISUAL PRODUCTS SOLD THEREWITH; ROOFING REPAIR; SNOW REMOVAL; TECHNICAL ADVICE ON REPAIRS AND REPLACEMENTS FOR PLUMBING FIXTURES, ELECTRICAL SYSTEMS, EMERGENCY GENERATORS, HEATING SYSTEMS, VENTILATION SYSTEMS, AIR CONDITIONING SYSTEMS, BOILERS, ENERGY MANAGEMENT SYSTEMS, REFRIGERATION SYSTEMS, APPLIANCES, FIRE SPRINKLER SYSTEMS, GLASS, DOORS AND LOCKS (U.S. CLS. 100, 103 AND 106).

**CLASS 42—SCIENTIFIC AND COMPUTER SERVICES**

FOR DESIGNING COMPUTER SOFTWARE PROGRAMS FOR FACILITIES MANAGEMENT AND REPAIR (U.S. CLS. 100 AND 101).

FRED CARL, EXAMINING ATTORNEY

---

SN 86-205,547. KEITH ROSSBERG, SOUTH JORDAN, UT. FILED 2-27-2014.

# BOLDEN

THE MARK CONSISTS OF THE WORD "BOLDEN" IN A STYLIZED FORMAT.

**CLASS 37—CONSTRUCTION AND REPAIR**

FOR EMERGENCY REPAIR AND PLANNED MAINTENANCE OF PLUMBING FIXTURES, ELECTRICAL SYSTEMS, EMERGENCY GENERATORS, HEATING SYSTEMS, VENTILATION SYSTEMS, AIR CONDITIONING SYSTEMS, BOILERS, ENERGY MANAGEMENT SYSTEMS, REFRIGERATION SYSTEMS, APPLIANCES, FIRE SPRINKLER SYSTEMS, GLASS, DOORS AND LOCKS; CARPENTRY; GENERAL BUILDING REPAIRS AND MAINTENANCE; PARKING LOT REPAIR AND MAINTENANCE; INSTALLING FLOORING; PAINTING; PEST CONTROL; JANITORIAL SERVICES; INSTALLATION AND MAINTENANCE OF DIGITAL SIGNAGE AND AUDIO VISUAL PRODUCTS SOLD THEREWITH; ROOFING REPAIR; SNOW REMOVAL; TECHNICAL ADVICE ON REPAIRS AND REPLACEMENTS FOR PLUMBING FIXTURES, ELECTRICAL SYSTEMS, EMERGENCY GENERATORS, HEATING SYSTEMS, VENTILATION SYSTEMS, AIR CONDITIONING SYSTEMS, BOILERS, ENERGY MANAGEMENT SYSTEMS, REFRIGERATION SYSTEMS, APPLIANCES, FIRE SPRINKLER SYSTEMS, GLASS, DOORS AND LOCKS (U.S. CLS. 100, 103 AND 106).

**CLASS 42—SCIENTIFIC AND COMPUTER SERVICES**

FOR DESIGNING COMPUTER SOFTWARE PROGRAMS FOR FACILITIES MANAGEMENT AND REPAIR (U.S. CLS. 100 AND 101).

FRED CARL, EXAMINING ATTORNEY

---

SN 86-205,980. MARRONE BIO INNOVATIONS, INC., DAVIS, CA. FILED 2-27-2014.

# HAVEN

THE MARK CONSISTS OF STANDARD CHARACTERS WITHOUT CLAIM TO ANY PARTICULAR FONT, STYLE, SIZE, OR COLOR.

**CLASS 1—CHEMICALS**

FOR PLANT FOOD; PLANT GROWTH REGULATING PREPARATIONS; PLANT GROWTH STIMULATOR; PLANT GROWTH ENHANCER; PLANT NUTRITION PREPARATIONS; SUBSTANCES FOR REGULATING PLANT GROWTH; BIO-BASED PRODUCTS USED IN AGRICULTURE, NAMELY, SUNSCREEN APPLIED TO FRUITS, VEGETABLES, GRAINS, TURFS, AND PLANTS TO PREVENT SUN DAMAGE EXPOSURE AND HEAT STRESS, SUBSTANCES USED AS PLANT STRESS RELIEVERS, AND ANTITRANSPIRANT SPRAYS; ANTI-TRANSPIRANTS FOR PLANTS; SUBSTANCES USED TO INCREASE A PLANTS' TOLERANCE TO WEATHER-INDUCED OR TRANSPLANTATION STRESS CONDITIONS; SUBSTANCES USED AS PLANT STRESS RELIEVERS (U.S. CLS. 1, 5, 6, 10, 26 AND 46).

**CLASS 5—PHARMACEUTICALS**

FOR PESTICIDES FOR PLANTS; INSECT REPELLENTS FOR PLANTS; ANIMAL REPELLENTS FOR PLANTS (U.S. CLS. 6, 18, 44, 46, 51 AND 52).

ALLISON HOLTZ, EXAMINING ATTORNEY

---

SN 86-206,243. APPRISS INC., LOUISVILLE, KY. FILED 2-27-2014.

# CRASHLOGIC

THE MARK CONSISTS OF STANDARD CHARACTERS WITHOUT CLAIM TO ANY PARTICULAR FONT, STYLE, SIZE, OR COLOR.

**CLASS 9—ELECTRICAL AND SCIENTIFIC APPARATUS**

FOR COMPUTER SOFTWARE FOR CONVERTING PAPER GOVERNMENT AND LAW ENFORCEMENT RECORDS INTO AN ELECTRONIC FORMAT; ELECTRONIC DATABASES RECORDED ON COMPUTER MEDIA CONTAINING INFORMATION ABOUT GOVERNMENT AND LAW ENFORCEMENT RECORDS (U.S. CLS. 21, 23, 26, 36 AND 38).

**CLASS 35—ADVERTISING AND BUSINESS**

FOR STATISTICAL ANALYSIS AND REPORTING SERVICES FOR BUSINESS PURPOSES IN THE FIELDS OF GOVERNMENT SERVICES AND LAW ENFORCEMENT (U.S. CLS. 100, 101 AND 102).

**CLASS 38—COMMUNICATION**

FOR ELECTRONIC TRANSMISSION OF DATA RELATED TO GOVERNMENT AND LAW ENFORCEMENT RECORDS FROM ELECTRONIC DATABASES VIA TELECOMMUNICATIONS NETWORKS AND/OR COMPUTER NETWORKS (U.S. CLS. 100, 101 AND 104).

**CLASS 42—SCIENTIFIC AND COMPUTER SERVICES**

FOR COMPUTER SERVICES, NAMELY, APPLICATION SERVICE PROVIDER (ASP) FEATURING SOFTWARE FOR MANAGING GOVERNMENT AND LAW ENFORCEMENT RECORDS; COMPUTER SERVICES, NAMELY, APPLICATION SERVICE PROVIDER (ASP) FEATURING SOFTWARE FOR SEARCHING AND RETRIEVING GOVERNMENT AND LAW ENFORCEMENT RECORDS FROM ELECTRONIC DATABASES; COMPUTER SERVICES, NAMELY, APPLICATION SERVICE PROVIDER (ASP) FEATURING SOFTWARE FOR USE IN THE FIELDS OF GOVERNMENT SERVICES AND LAW ENFORCEMENT TO UPLOAD DATA, PROVIDE STATISTICAL ANALYSIS, AND PRODUCE COMPILATIONS, NOTIFICATIONS, AND REPORTS (U.S. CLS. 100 AND 101).

BRIAN CALLAGHAN, EXAMINING ATTORNEY

**CLASS 29—MEATS AND PROCESSED FOODS**

FOR PROCESSED VEGETABLES AND FRUITS (U.S. CL. 46).  
FIRST USE 1-5-2013; IN COMMERCE 1-5-2013.

**CLASS 31—NATURAL AGRICULTURAL PRODUCTS**

FOR FRESH FRUIT AND VEGETABLES (U.S. CLS. 1 AND 46).  
FIRST USE 1-5-2013; IN COMMERCE 1-5-2013.  
ELLEN BURNS, EXAMINING ATTORNEY

SN 86-206,569. CH2E DELAWARE LLC, MALIBU, CA. FILED 2-27-2014.

CH2E

THE MARK CONSISTS OF STANDARD CHARACTERS WITHOUT CLAIM TO ANY PARTICULAR FONT, STYLE, SIZE, OR COLOR.

**CLASS 4—LUBRICANTS AND FUELS**

FOR FUELS (U.S. CLS. 1, 6 AND 15).

**CLASS 6—METAL GOODS**

FOR STEEL; CARBON STEEL (U.S. CLS. 2, 12, 13, 14, 23, 25 AND 50).

**CLASS 40—MATERIAL TREATMENT**

FOR RECYCLING OF WASTE; RECYCLING AND RECLAMATION OF USABLE MATERIALS FROM WASTE, NAMELY, CONVERSION OF TIRES INTO LIQUID PETROLEUM, METALS AND CARBON; TECHNICAL ADVICE RELATING TO RECYCLING AND RECLAMATION OF USABLE MATERIALS FROM WASTE; CONVERSION OF WASTE TO USABLE PRODUCTS IN THE NATURE OF RECYCLED FUELS, STEEL AND CARBON (U.S. CLS. 100, 103 AND 106).

HENRY S. ZAK, EXAMINING ATTORNEY

SN 86-206,881. SPICE SOLAR, INC., SARATOGA, CA. FILED 2-27-2014.

Spice Solar

THE MARK CONSISTS OF STANDARD CHARACTERS WITHOUT CLAIM TO ANY PARTICULAR FONT, STYLE, SIZE, OR COLOR.

NO CLAIM IS MADE TO THE EXCLUSIVE RIGHT TO USE "SOLAR", APART FROM THE MARK AS SHOWN.

**CLASS 6—METAL GOODS**

FOR METAL HARDWARE STRUCTURES FOR ATTACHING SOLAR PANELS AND PHOTOVOLTAIC MODULES TO OTHER STRUCTURES, NAMELY, FASTENERS, COUPLINGS FOR USE WITH INSTALLATION AND MOUNTING OF SOLAR PANELS, SPLICES, HARDWARE IN THE NATURE OF METAL INTERCONNECTORS AND LOCKING MECHANISMS FOR SOLAR PANELS OR ARRAYS, FEET FOR SUPPORTING SOLAR PANELS OR ARRAYS, ATTACHMENTS, NAMELY, MOUNTS FOR SOLAR PANELS OR ARRAYS, ROOFING AND BUILDING FLASHINGS, STANDOFFS FOR HEIGHT ADJUSTMENT OF SOLAR PANELS OR ARRAYS, ANCHORS, LOCKS, SUPPORTS FOR MOUNTING SOLAR PANELS, AND FOR SUPPORTING SOLAR MODULES, PHOTOVOLTAIC MODULES AND SOLAR COLLECTORS, AND METAL STRUCTURAL CONNECTORS FOR PHOTOVOLTAIC MODULES (U.S. CLS. 2, 12, 13, 14, 23, 25 AND 50).

SN 86-206,670. FORTUNE GROWERS LLC, ELGIN, IL. FILED 2-27-2014.



NO CLAIM IS MADE TO THE EXCLUSIVE RIGHT TO USE "GROWERS", APART FROM THE MARK AS SHOWN. THE MARK CONSISTS OF THE WORDING "FORTUNE GROWERS" IN A STACKED PRESENTATION WITH THE "O" IN "FORTUNE" FORMED BY THE IMAGE OF A CURLING PLANT WITH LEAVES.

**CLASS 9—ELECTRICAL AND SCIENTIFIC APPARATUS**

FOR PHOTOVOLTAIC CELLS; MODULES, NAMELY, PHOTOVOLTAIC MODULES AND SOLAR CELL MODULES; PANELS, NAMELY, PHOTOVOLTAIC PANELS AND SOLAR CELL PANELS; SOLAR BATTERIES; SOLAR CELLS; PHOTOVOLTAIC SOLAR-THERMAL HYBRID MODULES; ELECTRONIC SENSORS FOR MEASURING SOLAR RADIATION; APPARATUS FOR CONVERTING ELECTRONIC RADIATION TO ELECTRICAL ENERGY, NAMELY, PHOTOVOLTAIC ROOFING MEMBERS AND PHOTOVOLTAIC CLADDING PANELS; METAL ELECTRICAL CONNECTING HARDWARE STRUCTURES, NAMELY, ELECTRICAL COUPLINGS FOR USE WITH INSTALLATION AND MOUNTING OF SOLAR PANELS, ELECTRICAL SPLICES, ELECTRICAL CONNECTORS FOR PHOTOVOLTAIC MODULES (U.S. CLS. 21, 23, 26, 36 AND 38).

KAREN DINDAYAL, EXAMINING ATTORNEY

SN 86-207,687. LANDMARK HEALTH LLC, HUNTINGTON BEACH, CA. FILED 2-28-2014.

## COMPLEXIVIST

THE MARK CONSISTS OF STANDARD CHARACTERS WITHOUT CLAIM TO ANY PARTICULAR FONT, STYLE, SIZE, OR COLOR.

### CLASS 35—ADVERTISING AND BUSINESS

FOR MARKETING SERVICES (U.S. CLS. 100, 101 AND 102).

### CLASS 38—COMMUNICATION

FOR VIDEO CONFERENCING SERVICES (U.S. CLS. 100, 101 AND 104).

### CLASS 42—SCIENTIFIC AND COMPUTER SERVICES

FOR PROVIDING A WEBSITE FEATURING TECHNOLOGY THAT ENABLES PHYSICIANS TO GENERATE, MANAGE AND EXCHANGE MEDICAL INFORMATION AND DOCUMENTS REGARDLESS OF MEDICAL ORGANIZATION OR GEOGRAPHIC LOCATION; PROVIDING AN INTERACTIVE WEBSITE FEATURING TECHNOLOGY THAT ENABLES USERS TO ENTER, ACCESS, TRACK, MONITOR AND GENERATE HEALTH AND MEDICAL INFORMATION AND REPORTS (U.S. CLS. 100 AND 101).

### CLASS 44—MEDICAL, BEAUTY AND AGRICULTURAL SERVICES

FOR HEALTHCARE; MEDICAL SERVICES; PROVIDING MEDICAL SERVICES FOR SEVERE AND CRITICALLY ILL PATIENTS; EMERGENCY MEDICAL SERVICES; MEDICAL ASSISTANCE SERVICES; PROVIDING HEALTHCARE INFORMATION; PROVIDING MEDICAL INFORMATION, CONSULTANCY AND ADVISORY SERVICES; PROVIDING A WEBSITE FEATURING INFORMATION IN THE FIELD OF MEDICAL CARE (U.S. CLS. 100 AND 101).

SIDDHARTH JAGANNATHAN, EXAMINING ATTORNEY

SN 86-208,138. ILLINOIS AUTO ELECTRIC CO., AURORA, IL. FILED 2-28-2014.

## RIVET BY IRON BILL

THE MARK CONSISTS OF STANDARD CHARACTERS WITHOUT CLAIM TO ANY PARTICULAR FONT, STYLE, SIZE, OR COLOR.

### CLASS 7—MACHINERY

FOR MOTORCYCLE ENGINE PARTS, NAMELY, AIR CLEANERS, AIR CLEANER COVERS, EXHAUST PIPES (U.S. CLS. 13, 19, 21, 23, 31, 34 AND 35).

### CLASS 12—VEHICLES

FOR MOTORCYCLE PARTS, NAMELY, HANDLEBARS, HANDLE BAR GRIPS, IGNITION POINTS COVERS, GAS CAPS, WHEELS, AND SEATS (U.S. CLS. 19, 21, 23, 31, 35 AND 44).

### CLASS 25—CLOTHING

FOR CASUAL APPAREL, NAMELY, CASUAL SHIRTS, T-SHIRTS, SWEATSHIRTS, HOODIES, LEATHER JACKETS, LEATHER VESTS, SHOES, AND JEANS; ATHLETIC APPAREL, NAMELY SWEAT PANTS, T-SHIRTS, SWEAT SHIRTS, ATHLETIC SHORTS; CLOTHING ACCESSORIES, NAMELY, LEATHER BELTS; BELTS; SHOES; ATHLETIC SHOES (U.S. CLS. 22 AND 39).

TARAH HARDY, EXAMINING ATTORNEY

SN 86-208,644. THE CENTER FOR CAMPUS FIRE SAFETY, INC., NEWBURYPORT, MA. FILED 3-2-2014.

## THE CENTER FOR CAMPUS FIRE SAFETY

THE MARK CONSISTS OF STANDARD CHARACTERS WITHOUT CLAIM TO ANY PARTICULAR FONT, STYLE, SIZE, OR COLOR.

OWNER OF U.S. REG. NOS. 3,529,478 AND 3,569,317.  
SEC. 2(F).

### CLASS 9—ELECTRICAL AND SCIENTIFIC APPARATUS

FOR DOWNLOADABLE ELECTRONIC PUBLICATIONS IN THE NATURE OF GUIDES AND NEWSLETTERS IN THE FIELD OF FIRE PREVENTION AND FIRE SAFETY (U.S. CLS. 21, 23, 26, 36 AND 38).

FIRST USE 10-1-2003; IN COMMERCE 10-1-2003.

### CLASS 41—EDUCATION AND ENTERTAINMENT

FOR EDUCATIONAL SERVICES, NAMELY, CONDUCTING WORKSHOPS AND CONFERENCES IN THE FIELD OF FIRE PREVENTION AND FIRE SAFETY (U.S. CLS. 100, 101 AND 107).

FIRST USE 10-1-2003; IN COMMERCE 10-1-2003.  
JORDAN BAKER, EXAMINING ATTORNEY

SN 86-208,976. TASTY PEACH STUDIOS, MISHAWAKA, IN. FILED 3-3-2014.

## TASTY PEACH STUDIOS

THE MARK CONSISTS OF STANDARD CHARACTERS WITHOUT CLAIM TO ANY PARTICULAR FONT, STYLE, SIZE, OR COLOR.

NO CLAIM IS MADE TO THE EXCLUSIVE RIGHT TO USE "STUDIOS", APART FROM THE MARK AS SHOWN.

**CLASS 14—JEWELRY**

FOR JEWELRY (U.S. CLS. 2, 27, 28 AND 50).  
FIRST USE 8-21-2010; IN COMMERCE 8-21-2010.

**CLASS 25—CLOTHING**

FOR CLOTHING, NAMELY, SHIRTS AND HATS (U.S. CLS. 22 AND 39).  
FIRST USE 8-21-2010; IN COMMERCE 8-21-2010.

**CLASS 28—TOYS AND SPORTING GOODS**

FOR STUFFED AND PLUSH TOYS (U.S. CLS. 22, 23, 38 AND 50).  
FIRST USE 8-21-2010; IN COMMERCE 8-21-2010.  
WON TEAK OH, EXAMINING ATTORNEY

SN 86-209,440. TRADE PRESS MEDIA GROUP, INC., MILWAUKEE, WI. FILED 3-3-2014.

NFMT

THE MARK CONSISTS OF STANDARD CHARACTERS WITHOUT CLAIM TO ANY PARTICULAR FONT, STYLE, SIZE, OR COLOR.

**CLASS 36—INSURANCE AND FINANCIAL**

FOR PROVIDING A WEBSITE FEATURING INFORMATION IN THE FIELD OF BUILDING OPERATING MANAGEMENT (U.S. CLS. 100, 101 AND 102).  
FIRST USE 0-0-2000; IN COMMERCE 0-0-2000.

**CLASS 41—EDUCATION AND ENTERTAINMENT**

FOR ARRANGING AND CONDUCTING EDUCATIONAL CONFERENCES IN THE FIELD OF BUILDING OPERATING MANAGEMENT AND TECHNOLOGY; ONLINE ELECTRONIC NEWSLETTERS DELIVERED BY EMAIL IN THE FIELD OF BUILDING OPERATING MANAGEMENT AND TECHNOLOGY; ENTERTAINMENT SERVICES, NAMELY, PROVIDING WEBCASTS IN THE FIELD OF BUILDING OPERATING MANAGEMENT AND TECHNOLOGY (U.S. CLS. 100, 101 AND 107).  
FIRST USE 0-0-2000; IN COMMERCE 0-0-2000.

**CLASS 42—SCIENTIFIC AND COMPUTER SERVICES**

FOR PROVIDING A WEBSITE FEATURING TECHNOLOGICAL INFORMATION IN THE FIELD OF BUILDING OPERATING MANAGEMENT (U.S. CLS. 100 AND 101).  
FIRST USE 0-0-2000; IN COMMERCE 0-0-2000.  
GRETTA YAO, EXAMINING ATTORNEY

SN 86-209,047. MCGRANN PAPER CORPORATION, CHARLOTTE, NC. FILED 3-3-2014.

MDI

THE MARK CONSISTS OF THE STYLIZED LETTERS "MDI".

**CLASS 16—PAPER GOODS AND PRINTED MATTER**

FOR PAPER PRODUCTS AND PAPER SUBSTITUTES, NAMELY, UNSENSITIZED PHOTO PAPER, POLYESTER FILMS AND FABRICS, CANVAS, POLYESTER SCREEN PRINTING FILMS, AND DYE SUBLIMATION PAPER FOR USE IN SOLVENT, INKJET, ECO-SOLVENT, UV OR LATEX PRINTERS (U.S. CLS. 2, 5, 22, 23, 29, 37, 38 AND 50).  
FIRST USE 11-1-2013; IN COMMERCE 11-1-2013.

**CLASS 17—RUBBER GOODS**

FOR PAPER SUBSTITUTES, NAMELY, POLYPROPYLENE FILMS FOR USE IN SOLVENT, INKJET, ECO-SOLVENT, UV OR LATEX PRINTERS (U.S. CLS. 1, 5, 12, 13, 35 AND 50).  
FIRST USE 11-1-2013; IN COMMERCE 11-1-2013.

**CLASS 20—FURNITURE AND ARTICLES NOT OTHERWISE CLASSIFIED**

FOR PAPER SUBSTITUTES, NAMELY, VINYL BANNERS FOR USE IN SOLVENT, INKJET, ECO-SOLVENT, UV OR LATEX PRINTERS (U.S. CLS. 2, 13, 22, 25, 32 AND 50).  
FIRST USE 11-1-2013; IN COMMERCE 11-1-2013.  
JEFF DEFORD, EXAMINING ATTORNEY

SN 86-209,479. WARTBURG-MT. VERNON, INC., MOUNT VERNON, NY. FILED 3-3-2014.



NO CLAIM IS MADE TO THE EXCLUSIVE RIGHT TO USE "COUNCIL" AND "AGING" AND "LEARNING", APART FROM THE MARK AS SHOWN.

THE COLOR(S) BLUE, GREEN, ORANGE, PURPLE AND WHITE IS/ARE CLAIMED AS A FEATURE OF THE MARK. THE MARK CONSISTS OF THE STYLIZED WORDING "COUNCIL FOR CREATIVE AGING & LIFELONG LEARNING" AND DESIGN. THE DESIGN CONSISTS OF A PURPLE RECTANGLE AND WITHIN THE RECTANGLE AT THE

TOP ARE THE TERMS "COUNCIL FOR" IN PURPLE. BELOW THE WORDING ARE FOUR COLUMNS IN DIFFERENT COLORS. THE COLUMN ON THE FAR LEFT IS BLUE AND WITHIN THE COLUMN IS A WHITE PAINT BRUSH. THE NEXT COLUMN IS GREEN AND WITHIN THE COLUMN IS A WHITE TREBLE CLEF. THE NEXT COLUMN IS ORANGE AND WITHIN THE COLUMN IS PART OF A WHITE SCHOLAR'S CAP. THE LAST COLUMN IS PURPLE AND WITHIN THE COLUMN IS A WHITE NEEDLE AND THREAD. BELOW THE COLUMNS IS THE TERM "CREATIVE" WHICH IS ABOVE THE WORDING "AGING &" WHICH IS ABOVE THE WORDING "LIFELONG LEARNING". ALL ON A WHITE BACKGROUND.

**CLASS 43—HOTEL AND RESTAURANT SERVICES**

FOR PROVIDING ASSISTED LIVING FACILITIES; PROVIDING ELDER CARE; RESPITE CARE SERVICES IN THE NATURE OF ADULT DAY CARE (U.S. CLS. 100 AND 101).

FIRST USE 11-1-2013; IN COMMERCE 11-1-2013.

**CLASS 44—MEDICAL, BEAUTY AND AGRICULTURAL SERVICES**

FOR NURSING CARE; NURSING HOMES; PROVIDING INFORMATION, NEWS AND COMMENTARY IN THE FIELD OF NUTRITION, HEALTH AND WELLNESS; WELLNESS AND HEALTH-RELATED CONSULTING SERVICES (U.S. CLS. 100 AND 101).

FIRST USE 11-1-2013; IN COMMERCE 11-1-2013.  
MARLENE BELL, EXAMINING ATTORNEY

**CLASS 42—SCIENTIFIC AND COMPUTER SERVICES**

FOR INNOVATION CONSULTING SERVICES, NAMELY, ANALYZING TECHNICAL REQUIREMENTS AND DEVELOPING RECOMMENDATIONS FOR COMPUTER SYSTEMS AND OTHER TECHNOLOGY IN THE FIELD OF DISASTER AND EMERGENCY RESPONSE; THINK TANK AND CONSULTING SERVICES, NAMELY, ADVISING COMMUNITIES, NONPROFITS, GOVERNMENTS, AND COUNTRIES IN THE FIELD OF TECHNOLOGY FOR DISASTER RECOVERY AND EMERGENCY RESPONSE; RESEARCH AND DEVELOPMENT AND CONSULTATION RELATED THERETO IN THE FIELD OF DISASTER-RECOVERY AND EMERGENCY-RESPONSE TECHNOLOGY (U.S. CLS. 100 AND 101).

FIRST USE 10-29-2013; IN COMMERCE 10-29-2013.

**CLASS 45—PERSONAL AND LEGAL SERVICES**

FOR COLLABORATION WITH NONPROFITS, COUNTRIES, AND GOVERNMENTS TO DEVELOP SOLUTIONS FOR HANDLING EMERGENCIES AND DISASTERS, NAMELY, PROVIDING CONSULTATION AND INFORMATION IN THE FIELD OF EMERGENCY AND DISASTER RESPONSE FOR COMMUNITIES, GOVERNMENTS, AND COUNTRIES (U.S. CLS. 100 AND 101).

FIRST USE 10-29-2013; IN COMMERCE 10-29-2013.  
DEZMONA MIZELLE, EXAMINING ATTORNEY

SN 86-210,066. GDIG, LLC, HEBER, UT. FILED 3-4-2014.



SN 86-210,254. KIMBERBELL KIDS LLC, NORTH LOGAN, UT. FILED 3-4-2014.

**KIMBERBELL**

THE MARK CONSISTS OF STANDARD CHARACTERS WITHOUT CLAIM TO ANY PARTICULAR FONT, STYLE, SIZE, OR COLOR.

THE MARK CONSISTS OF THE WORD "FIT" WRITTEN IN SYLIZED TYPEFONT WITH THE "T" BEING BACKWARDS AND FACING THE "I".

**CLASS 35—ADVERTISING AND BUSINESS**

FOR SERVICES IN THE FIELD OF PROBLEM SOLVING IN DISASTERS AND EMERGENCIES, NAMELY, ORGANIZING VOLUNTEER GROUPS TO UNDERTAKE CHARITABLE PROJECTS IN THE FIELD OF DISASTER RESPONSE; PROMOTING COLLABORATION WITHIN THE SCIENTIFIC, RESEARCH AND PROVIDER COMMUNITIES TO ACHIEVE ADVANCES IN THE FIELD OF DISASTER AND EMERGENCY RESPONSE (U.S. CLS. 100, 101 AND 102).

FIRST USE 10-29-2013; IN COMMERCE 10-29-2013.

**CLASS 16—PAPER GOODS AND PRINTED MATTER**

FOR PATTERNS FOR EMBROIDERY, QUILTING, AND APPLIQUE; GUIDE BOOKS FEATURING EMBROIDERY, QUILTING, AND APPLIQUE (U.S. CLS. 2, 5, 22, 23, 29, 37, 38 AND 50).

**CLASS 35—ADVERTISING AND BUSINESS**

FOR ON-LINE WHOLESALE AND RETAIL STORE SERVICES FEATURING PRODUCTS AND GOODS FOR EMBROIDERY, QUILTING, AND APPLIQUES (U.S. CLS. 100, 101 AND 102).

ALAIN LAPTER, EXAMINING ATTORNEY

SN 86-210,609. CITYDOG! CLUB, LLC, LOS ANGELES, CA.  
FILED 3-4-2014.

SN 86-211,548. FAIRLEAD CORPORATION, CHARLESTON,  
SC. FILED 3-5-2014.



THE MARK CONSISTS OF A BLACK AND WHITE IMAGE OF A DOG WITH A WHITE COLLAR.

**CLASS 18—LEATHER GOODS**

FOR DOG APPAREL (U.S. CLS. 1, 2, 3, 22 AND 41).

**CLASS 28—TOYS AND SPORTING GOODS**

FOR DOG TOYS (U.S. CLS. 22, 23, 38 AND 50).

**CLASS 31—NATURAL AGRICULTURAL PRODUCTS**

FOR DOG TREATS (U.S. CLS. 1 AND 46).  
IRA J. GOODSAD, EXAMINING ATTORNEY

---

SN 86-211,526. SAFFRON FIELDS VINEYARD, LLC, HOUSTON, TX. FILED 3-5-2014.

## SAFFRON FIELDS

THE MARK CONSISTS OF STANDARD CHARACTERS WITHOUT CLAIM TO ANY PARTICULAR FONT, STYLE, SIZE, OR COLOR.

**CLASS 31—NATURAL AGRICULTURAL PRODUCTS**

FOR FRESH GRAPES FOR WINEMAKING; FRESH WINE GRAPES (U.S. CLS. 1 AND 46).  
FIRST USE 10-0-2009; IN COMMERCE 10-0-2009.

**CLASS 33—WINES AND SPIRITS**

FOR WINE (U.S. CLS. 47 AND 49).  
FIRST USE 7-0-2013; IN COMMERCE 7-0-2013.  
KATHERINE CONNOLLY, EXAMINING ATTORNEY

## JOB MARKET MAKER

THE MARK CONSISTS OF STANDARD CHARACTERS WITHOUT CLAIM TO ANY PARTICULAR FONT, STYLE, SIZE, OR COLOR.

NO CLAIM IS MADE TO THE EXCLUSIVE RIGHT TO USE "JOB MARKET", APART FROM THE MARK AS SHOWN.

**CLASS 35—ADVERTISING AND BUSINESS**

FOR PROVIDING A DATABASE OF RESUMES OF PROSPECTIVE EMPLOYEES; PROVIDING ON-LINE EMPLOYMENT INFORMATION IN THE FIELD OF JOB LISTINGS FOR JOB SEEKERS; PROVIDING ON-LINE EMPLOYMENT PLACEMENT SERVICES, NAMELY, MATCHING RESUMES AND POTENTIAL EMPLOYERS VIA A GLOBAL COMPUTER NETWORK; PROVIDING AN ONLINE SEARCHABLE DATABASE FEATURING EMPLOYMENT OPPORTUNITIES (U.S. CLS. 100, 101 AND 102).

**CLASS 36—INSURANCE AND FINANCIAL**

FOR FINANCIAL SERVICES, NAMELY, MONEY LENDING SERVICES BY INSTITUTIONS OTHER THAN BANKS; FINANCIAL SERVICES, NAMELY, PROVIDING A VIRTUAL CURRENCY FOR USE BY MEMBERS OF AN ON-LINE COMMUNITY VIA A GLOBAL COMPUTER NETWORK (U.S. CLS. 100, 101 AND 102).

**CLASS 41—EDUCATION AND ENTERTAINMENT**

FOR ONLINE EDUCATION AND CREDIT AND DEGREE EVALUATION AND COMPARISON SERVICE; PROVIDING A WEB SITE THAT FEATURES INFORMATION ABOUT ONLINE HIGHER EDUCATION RESOURCES (U.S. CLS. 100, 101 AND 107).

DAWN FELDMAN, EXAMINING ATTORNEY

---

SN 86-211,954. HORIZON GROUP USA, INC., WARREN, NJ.  
FILED 3-5-2014.

## CREATIVE ROOTS

THE MARK CONSISTS OF STANDARD CHARACTERS WITHOUT CLAIM TO ANY PARTICULAR FONT, STYLE, SIZE, OR COLOR.

OWNER OF U.S. REG. NOS. 4,123,146, 4,129,892 AND OTHERS.

**CLASS 21—HOUSEWARES AND GLASS**

FOR BIRDHOUSES; TERRARIUMS FOR PLANTS; STATUES OF CERAMIC (U.S. CLS. 2, 13, 23, 29, 30, 33, 40 AND 50).

**CLASS 26—FANCY GOODS**

FOR ARTIFICIAL PLANTS, NAMELY, DECORATIVE MOSS (U.S. CLS. 37, 39, 40, 42 AND 50).



ROBERT C. CLARK JR., EXAMINING ATTORNEY

SN 86-212,087. NEXT PAGE, INC., KANSAS CITY, MO.  
FILED 3-5-2014.

# NEXTPAGE

THE MARK CONSISTS OF STANDARD CHARACTERS WITHOUT CLAIM TO ANY PARTICULAR FONT, STYLE, SIZE, OR COLOR.

**CLASS 35—ADVERTISING AND BUSINESS**

FOR MARKETING SERVICES; DIRECT MAIL ADVERTISING SERVICES; DIGITAL MARKETING SERVICES; DIGITAL MARKETING CAMPAIGN SERVICES; DATABASE MANAGEMENT SERVICES (U.S. CLS. 100, 101 AND 102).

FIRST USE 11-1-2013; IN COMMERCE 11-1-2013.

**CLASS 40—MATERIAL TREATMENT**

FOR COMMERCIAL PRINTING SERVICES, DIGITAL PRINTING SERVICES (U.S. CLS. 100, 103 AND 106).

FIRST USE 11-1-2013; IN COMMERCE 11-1-2013.  
TASNEEM HUSSAIN, EXAMINING ATTORNEY

SN 86-212,136. ACCESS INTELLIGENCE LLC, ROCKVILLE, MD. FILED 3-5-2014.

# SCREENSTER

THE MARK CONSISTS OF STANDARD CHARACTERS WITHOUT CLAIM TO ANY PARTICULAR FONT, STYLE, SIZE, OR COLOR.

**CLASS 9—ELECTRICAL AND SCIENTIFIC APPARATUS**

FOR DOWNLOADABLE ELECTRONIC NEWSLETTERS IN THE TELEVISION INDUSTRY FIELD AND THE CONTENT CREATION AND DELIVERY INDUSTRY FIELDS (U.S. CLS. 21, 23, 26, 36 AND 38).

**CLASS 38—COMMUNICATION**

FOR PROVIDING A WEBSITE CONTAINING INFORMATION REGARDING THE TELEVISION, CABLE TELEVISION, SATELLITE, AND OVER-THE-AIR BROADCASTING INDUSTRIES, AND PROVIDING A WEBSITE CONTAINING INFORMATION REGARDING ELECTRONIC TRANSMISSION OF DATA IN THE CONTENT DELIVERY INDUSTRY (U.S. CLS. 100, 101 AND 104).

**CLASS 41—EDUCATION AND ENTERTAINMENT**

FOR PROVIDING RECOGNITION BY THE WAY OF AWARDS TO DEMONSTRATE EXCELLENCE IN THE TELEVISION INDUSTRY FIELD AND THE CONTENT CREATION AND DELIVERY INDUSTRY FIELDS (U.S. CLS. 100, 101 AND 107).

JUDITH HELFMAN, EXAMINING ATTORNEY

SN 86-212,361. LONGEVITY MEDICAL CLINIC, PLLC, KIRKLAND, WA. FILED 3-5-2014.

LONGEVITY  MEDICAL CLINIC

OWNER OF U.S. REG. NO. 3,298,814.

NO CLAIM IS MADE TO THE EXCLUSIVE RIGHT TO USE "MEDICAL CLINIC", APART FROM THE MARK AS SHOWN.

THE MARK CONSISTS OF THE TERMS "LONGEVITY" AND "MEDICAL CLINIC" ON EITHER SIDE OF A LEAF DESIGN SUPERIMPOSED OVER A DIAMOND SHAPE.

**CLASS 5—PHARMACEUTICALS**

FOR HORMONE REPLACEMENT THERAPY PREPARATIONS; HORMONES; NUTRITIONAL SUPPLEMENTS (U.S. CLS. 6, 18, 44, 46, 51 AND 52).

FIRST USE 5-0-2010; IN COMMERCE 5-0-2010.

**CLASS 44—MEDICAL, BEAUTY AND AGRICULTURAL SERVICES**

FOR HEALTH CARE SERVICES, NAMELY, MEDICAL AND HORMONE REPLACEMENT THERAPY USING NUTRITIONAL SUPPLEMENTS (U.S. CLS. 100 AND 101).

FIRST USE 5-0-2010; IN COMMERCE 5-0-2010.  
BRENDAN REGAN, EXAMINING ATTORNEY

SN 86-212,370. LONGEVITY MEDICAL CLINIC, PLLC, KIRKLAND, WA. FILED 3-5-2014.

LONGEVITY MEDICAL CLINIC

THE MARK CONSISTS OF STANDARD CHARACTERS WITHOUT CLAIM TO ANY PARTICULAR FONT, STYLE, SIZE, OR COLOR.

OWNER OF U.S. REG. NO. 3,298,814.

NO CLAIM IS MADE TO THE EXCLUSIVE RIGHT TO USE "MEDICAL CLINIC", APART FROM THE MARK AS SHOWN.

**CLASS 5—PHARMACEUTICALS**

FOR HORMONE REPLACEMENT THERAPY PREPARATIONS; HORMONES; NUTRITIONAL SUPPLEMENTS (U.S. CLS. 6, 18, 44, 46, 51 AND 52).

FIRST USE 10-26-2004; IN COMMERCE 10-26-2004.

**CLASS 44—MEDICAL, BEAUTY AND AGRICULTURAL SERVICES**

FOR HEALTH CARE SERVICES, NAMELY, MEDICAL AND HORMONE REPLACEMENT THERAPY USING NUTRITIONAL SUPPLEMENTS (U.S. CLS. 100 AND 101).

FIRST USE 10-26-2004; IN COMMERCE 10-26-2004.

BRENDAN REGAN, EXAMINING ATTORNEY

---

SN 86-212,374. LONGEVITY MEDICAL CLINIC, PLLC, KIRKLAND, WA. FILED 3-5-2014.



OWNER OF U.S. REG. NO. 3,298,814.  
THE MARK CONSISTS OF A LEAF DESIGN SUPERIMPOSED OVER A DIAMOND SHAPE.

#### CLASS 5—PHARMACEUTICALS

FOR HORMONE REPLACEMENT THERAPY PREPARATIONS; HORMONES; NUTRITIONAL SUPPLEMENTS (U.S. CLS. 6, 18, 44, 46, 51 AND 52).  
FIRST USE 0-0-2004; IN COMMERCE 0-0-2004.

#### CLASS 44—MEDICAL, BEAUTY AND AGRICULTURAL SERVICES

FOR HEALTH CARE SERVICES, NAMELY, MEDICAL AND HORMONE REPLACEMENT THERAPY USING NUTRITIONAL SUPPLEMENTS (U.S. CLS. 100 AND 101).  
FIRST USE 0-0-2004; IN COMMERCE 0-0-2004.  
BRENDAN REGAN, EXAMINING ATTORNEY

---

SN 86-212,986. RAAB, SIMON, SANTA BARBARA, CA. FILED 3-6-2014.

PRETTY GRENADE

THE MARK CONSISTS OF STANDARD CHARACTERS WITHOUT CLAIM TO ANY PARTICULAR FONT, STYLE, SIZE, OR COLOR.

#### CLASS 41—EDUCATION AND ENTERTAINMENT

FOR PROVIDING A WEB SITE FEATURING INFORMATION ABOUT ARTS, CULTURE AND ENTERTAINMENT (U.S. CLS. 100, 101 AND 107).

#### CLASS 42—SCIENTIFIC AND COMPUTER SERVICES

FOR PROVIDING A WEBSITE FEATURING A MEDIA AND NEWS AGGREGATOR AND SEARCH ENGINE FOR INTERNET CONTENT; PROVIDING A WEBSITE FEATURING A MEDIA AND NEWS AGGREGATOR AND SEARCH ENGINE FOR INTERNET CONTENT IN THE FIELDS OF ARTS, CULTURE AND ENTERTAINMENT (U.S. CLS. 100 AND 101).  
CHRISTOPHER LAW, EXAMINING ATTORNEY

---

SN 86-213,019. FOREVERGREEN IP, LLC, OREM, UT. FILED 3-6-2014.

FrequenSea

THE MARK CONSISTS OF STANDARD CHARACTERS WITHOUT CLAIM TO ANY PARTICULAR FONT, STYLE, SIZE, OR COLOR.

OWNER OF U.S. REG. NO. 3,318,172.

#### CLASS 3—COSMETICS AND CLEANING PREPARATIONS

FOR AROMATIC BODY CARE PRODUCTS, NAMELY, BODY LOTION, SHOWER GEL, CUTICLE CREAM, SHAMPOO, CONDITIONER, NON-MEDICATED LIP BALM, SOAP, BODY POLISH, BODY AND FOOT SCRUB AND NON-MEDICATED FOOT CREAM; BEAUTY CREAMS FOR BODY CARE; COLOGNES, PERFUMES AND COSMETICS; COSMETIC CREAMS; COSMETIC CREAMS FOR SKIN CARE; COSMETIC MASKS; COSMETIC PREPARATIONS FOR BODY CARE; COSMETIC PREPARATIONS FOR THE CARE OF MOUTH AND TEETH; COSMETIC PREPARATIONS, NAMELY, FIRING CREAMS; COSMETIC PREPARATIONS, NAMELY, FIRING LOTIONS; COSMETIC SOAPS; COSMETIC SUN-PROTECTING PREPARATIONS; COSMETIC SUN-TAN LOTIONS; COSMETICS; DEODORANTS AND ANTIPERSPIRANTS FOR PERSONAL USE; ESSENTIAL OILS FOR PERSONAL USE; FACE CREAMS FOR COSMETIC USE; HAIR CARE CREAMS; HAIR CARE LOTIONS; HAIR CARE PREPARATIONS; HAIR GEL AND HAIR MOUSSE; HAIR RINSES; HAIR SHAMPOOS AND CONDITIONERS; HAIR STYLING GEL; LOTIONS FOR COSMETIC PURPOSES; NUTRITIONAL OILS FOR COSMETIC PURPOSES; PRIVATE LABEL COSMETICS; ROSE OIL FOR COSMETIC PURPOSES; SKIN AND BODY TOPICAL LOTIONS, CREAMS AND OILS FOR COSMETIC USE; SKIN CONDITIONING CREAMS FOR COSMETIC PURPOSES; SOAPS FOR PERSONAL USE (U.S. CLS. 1, 4, 6, 50, 51 AND 52).

FIRST USE 7-1-2010; IN COMMERCE 7-1-2010.

**CLASS 5—PHARMACEUTICALS**

FOR DIETARY AND NUTRITIONAL SUPPLEMENTS; DIETARY BEVERAGE SUPPLEMENTS FOR HUMAN CONSUMPTION IN LIQUID AND DRY MIX FORM FOR THERAPEUTIC PURPOSES; DIETARY FOOD SUPPLEMENTS; DIETARY SUPPLEMENTAL DRINKS; DIETARY SUPPLEMENTAL DRINKS IN THE NATURE OF VITAMIN AND MINERAL BEVERAGES; DIETARY SUPPLEMENTS; FOOD SUPPLEMENTS; HEALTH FOOD SUPPLEMENTS; HERBAL SUPPLEMENTS; MEAL REPLACEMENT DRINK MIXES IN THE NATURE OF DIETARY SUPPLEMENT DRINK MIXES FOR USE AS MEAL REPLACEMENT AND DIETARY SUPPLEMENT DRINK MIXES; MINERAL NUTRITIONAL SUPPLEMENTS; MINERAL SUPPLEMENTS; NUTRITIONAL DRINKS USED FOR MEAL REPLACEMENT IN THE NATURE OF POWDERED NUTRITIONAL SUPPLEMENT DRINK MIXES FOR USE AS MEAL REPLACEMENT; NUTRITIONAL SUPPLEMENTS; POWDERED NUTRITIONAL SUPPLEMENT DRINK MIX; VITAMIN AND MINERAL SUPPLEMENTS; VITAMIN SUPPLEMENTS (U.S. CLS. 6, 18, 44, 46, 51 AND 52).

FIRST USE 7-1-2010; IN COMMERCE 7-1-2010.  
SUNG IN, EXAMINING ATTORNEY

SN 86-213,434. BLUE COLLAR OBJECTS, LLC, FAIRFAX, VA. FILED 3-6-2014.



SN 86-213,412. BLUE COLLAR OBJECTS, LLC, FAIRFAX, VA. FILED 3-6-2014.

**DOLLAR PLACE**

THE MARK CONSISTS OF STANDARD CHARACTERS WITHOUT CLAIM TO ANY PARTICULAR FONT, STYLE, SIZE, OR COLOR.

THE MARK CONSISTS OF A SOLID FIELD WITH AN OUTLINE OF A HOUSE THEREON; WITHIN THE HOUSE IS A DOLLAR SYMBOL.

**CLASS 38—COMMUNICATION**

FOR COMMUNICATIONS SERVICES, NAMELY, PROVIDING MULTIPLE-USER ACCESS TO DATA ON THE INTERNET IN THE FIELD OF CREATING AND MANAGING COMMUNICATIONS AMONG MEMBERS OF AN ONLINE GEOGRAPHICALLY DISPERSED COMMUNITY BY ORGANIZING AND SHARING INFORMATION, COLLECTING PAYMENT FOR ACCESS TO PARTICULAR DATA, COLLECTING REPORTS FOR PAYMENT DATA, MESSAGES, FILES, ALERTS AND NOTICES, INCLUDING, PLACES, TOPIC LISTS, ELECTIONS, CHECKLISTS, CALENDARS, PHOTOS, PERSONAL PROFILES AND NOTIFICATION PREFERENCES (U.S. CLS. 100, 101 AND 104).

**CLASS 38—COMMUNICATION**

FOR COMMUNICATIONS SERVICES, NAMELY, PROVIDING MULTIPLE-USER ACCESS TO DATA ON THE INTERNET IN THE FIELD OF CREATING AND MANAGING COMMUNICATIONS AMONG MEMBERS OF AN ONLINE GEOGRAPHICALLY DISPERSED COMMUNITY BY ORGANIZING AND SHARING INFORMATION, COLLECTING PAYMENT FOR ACCESS TO PARTICULAR DATA, COLLECTING REPORTS FOR PAYMENT DATA, MESSAGES, FILES, ALERTS AND NOTICES, INCLUDING, PLACES, TOPIC LISTS, ELECTIONS, CHECKLISTS, CALENDARS, PHOTOS, PERSONAL PROFILES AND NOTIFICATION PREFERENCES (U.S. CLS. 100, 101 AND 104).

**CLASS 42—SCIENTIFIC AND COMPUTER SERVICES**

FOR ONLINE NON-DOWNLOADABLE SOFTWARE PROVIDED AS A SERVICE FOR DEVELOPING AND ORGANIZING AN ONLINE GEOGRAPHICALLY DISPERSED COMMUNITY TO DEVELOP AND ORGANIZE AND SHARE MESSAGES, FILES, ALERTS AND NOTICES INCLUDING TOPIC LISTS, ELECTIONS, CHECKLISTS, CALENDARS, PHOTOS, PERSONAL PROFILES AND NOTIFICATION PREFERENCES WHILE REQUIRING A FEE FOR ACCESS TO AT LEAST SOME OF THE DATA; ONLINE NON-DOWNLOADABLE SOFTWARE FOR ALLOWING THE READY CONVERSION OF A PORTION OF DATA MAINTAINED BY A USER AN ONLINE GEOGRAPHICALLY DISPERSED COMMUNITY HOSTED ON THE INTERNET INTO DATA THAT REQUIRES PAYMENT FOR ACCESS; PROVIDING TEMPORARY USE OF NON-DOWNLOADABLE E-COMMERCE SOFTWARE TO ALLOW USERS TO PERFORM ELECTRONIC BUSINESS TRANSACTIONS VIA A GLOBAL COMPUTER AND COMMUNICATION NETWORKS (U.S. CLS. 100 AND 101).

ESTHER A. BORSUK, EXAMINING ATTORNEY

**CLASS 42—SCIENTIFIC AND COMPUTER SERVICES**

FOR ONLINE NON-DOWNLOADABLE SOFTWARE PROVIDED AS A SERVICE FOR DEVELOPING AND ORGANIZING AN ONLINE GEOGRAPHICALLY DISPERSED COMMUNITY TO DEVELOP AND ORGANIZE AND SHARE MESSAGES, FILES, ALERTS AND NOTICES INCLUDING TOPIC LISTS, ELECTIONS, CHECKLISTS, CALENDARS, PHOTOS, PERSONAL PROFILES AND NOTIFICATION PREFERENCES WHILE REQUIRING A FEE FOR ACCESS TO AT LEAST SOME OF THE DATA; ONLINE NON-DOWNLOADABLE SOFTWARE FOR ALLOWING THE READY CONVERSION OF A PORTION OF DATA MAINTAINED BY A USER ON AN ONLINE GEOGRAPHICALLY DISPERSED COMMUNITY HOSTED ON THE INTERNET INTO DATA THAT REQUIRES PAYMENT FOR ACCESS; PROVIDING TEMPORARY USE OF NON-DOWNLOADABLE E-COMMERCE SOFTWARE TO ALLOW USERS TO PERFORM ELECTRONIC BUSINESS TRANSACTIONS VIA A GLOBAL COMPUTER AND COMMUNICATION NETWORKS (U.S. CLS. 100 AND 101).

ESTHER A. BORSUK, EXAMINING ATTORNEY

SN 86-213,513. BARNA, MICHAEL LEE, DBA TRADING SYSTEM LAB, SAN JOSE, CA. FILED 3-6-2014.



NO CLAIM IS MADE TO THE EXCLUSIVE RIGHT TO USE "TRADING SYSTEM", APART FROM THE MARK AS SHOWN.

THE COLOR(S) ORANGE IS/ARE CLAIMED AS A FEATURE OF THE MARK.

THE MARK CONSISTS OF THE WORDING "TRADING SYSTEM LAB" IN ORANGE TO THE RIGHT OF AN ORANGE CIRCLE BISECTED BY AN ORANGE DRAWING OF THE DNA DOUBLE HELIX.

#### CLASS 9—ELECTRICAL AND SCIENTIFIC APPARATUS

FOR COMPUTER SOFTWARE FOR GENERATING AN AUTOMATIC FINANCIAL SECURITIES TRADING SYSTEM (U.S. CLS. 21, 23, 26, 36 AND 38).

FIRST USE 10-20-2005; IN COMMERCE 10-20-2005.

#### CLASS 36—INSURANCE AND FINANCIAL

FOR FINANCIAL EVALUATION, TRACKING, ANALYSIS, FORECASTING, CONSULTANCY, ADVISORY AND RESEARCH SERVICES RELATING TO SECURITIES AND OTHER FINANCIAL INSTRUMENTS (U.S. CLS. 100, 101 AND 102).

FIRST USE 10-20-2005; IN COMMERCE 10-20-2005.

JASON TURNER, EXAMINING ATTORNEY

SN 86-213,637. ZAPPONE, HEIDI, SAN CLEMENTE, CA. FILED 3-6-2014.



OWNER OF U.S. REG. NO. 4,283,732.

THE MARK CONSISTS OF THE WORDS "DARE ALLA LUCE" AND ABOVE THE TERM "ALLA" A DRAWING OF A BUTTERFLY.

THE ENGLISH TRANSLATION OF "DARE ALLA LUCE" IN THE MARK IS "TO BRING TO THE LIGHT".

#### CLASS 5—PHARMACEUTICALS

FOR NUTRITIONAL SUPPLEMENTS (U.S. CLS. 6, 18, 44, 46, 51 AND 52).

#### CLASS 14—JEWELRY

FOR JEWELRY (U.S. CLS. 2, 27, 28 AND 50).

#### CLASS 25—CLOTHING

FOR CLOTHING, NAMELY, T-SHIRTS, SHIRTS, TANK TOPS, JACKETS, SWEATERS, YOGA WEAR IN THE NATURE OF YOGA SHIRTS AND YOGA PANTS, PANTS, SHORTS, HEADBANDS; HEADWEAR; FOOTWEAR (U.S. CLS. 22 AND 39).

JULIE VEPPUMTHARA, EXAMINING ATTORNEY

SN 86-213,689. EMPIRE DISPOSAL LTD., FORT WORTH, TX. FILED 3-6-2014.



NO CLAIM IS MADE TO THE EXCLUSIVE RIGHT TO USE "DISPOSAL LTD.", APART FROM THE MARK AS SHOWN.

THE MARK CONSISTS OF THE WORD "EMPIRE" WITH TWO HORIZONTAL BANDS APPEARING ABOVE THE WORD. THE IMAGE OF A ROMAN CENTURION APPEARS BELOW WITHIN A SHADED CIRCLE WITH TWO HORIZONTAL BANDS ON EACH SIDE OF THE CIRCLE AND TWO HORIZONTAL BANDS CONNECTED TO A CURVED BAND OUTLINING THE BOTTOM HALF OF THE CIRCLE. THE WORDS "DISPOSAL LTD." APPEAR IN AN ARCH SHAPE BELOW THE IMAGE OF THE ROMAN CENTURION.

#### CLASS 37—CONSTRUCTION AND REPAIR

FOR WASTE DISPOSAL FOR OTHERS (U.S. CLS. 100, 103 AND 106).

FIRST USE 9-30-2000; IN COMMERCE 9-30-2000.

#### CLASS 39—TRANSPORTATION AND STORAGE

FOR GARBAGE COLLECTION, NAMELY, COLLECTION AND REMOVAL OF WASTE MATERIALS AND DEBRIS FROM COMMERCIAL, INDUSTRIAL, AND CONSTRUCTION LOCATIONS; TRANSPORTATION OF WASTE MATERIALS AND DEBRIS FOR DISPOSAL; TRASH SERVICES, NAMELY, RENTAL OF DUMPSTERS AND WASTE CONTAINERS (U.S. CLS. 100 AND 105).

FIRST USE 9-30-2000; IN COMMERCE 9-30-2000.

JOANNA FIORELLI, EXAMINING ATTORNEY

SN 86-214,235. JACKSON, KIMBERLY, PONTE VEDRA BEACH, FL. FILED 3-7-2014.

#### LILLY AND THE BEE NOVELTIES

THE MARK CONSISTS OF STANDARD CHARACTERS WITHOUT CLAIM TO ANY PARTICULAR FONT, STYLE, SIZE, OR COLOR.

NO CLAIM IS MADE TO THE EXCLUSIVE RIGHT TO USE "NOVELTIES", APART FROM THE MARK AS SHOWN.

#### CLASS 25—CLOTHING

FOR CHILD PRETEND PLAY COSTUMES (U.S. CLS. 22 AND 39).

**CLASS 28—TOYS AND SPORTING GOODS**

FOR DOLL COSTUMES; DOLL CLOTHING; PLAY WANDS; TOY TIARAS; DOLLS (U.S. CLS. 22, 23, 38 AND 50).

CHRISTOPHER LAW, EXAMINING ATTORNEY

**CLASS 41—EDUCATION AND ENTERTAINMENT**

FOR PROVIDING ON-LINE VIDEOS FEATURING DO-IT-YOURSELF PROJECTS IN THE FIELD OF UPCYCLING AND REVAMPING CLOTHES, UPCYCLING AND REVAMPING HOME DECOR, DIY BRIDAL GIFT IDEAS, DECOR, BRIDAL APPAREL AND SHOES, HOUSEHOLD TIPS AND TRICKS, FASHION STYLE GUIDES, TRAVEL, FOOD, BEVERAGE, SPIRITS AKA ALCOHOLIC DRINKS, BAKING AND CAKE DECORATING, FITNESS, YOGA, HEALTH AND BEAUTY, BUDGETING, HAIR AND MAKE-UP, HOSTING PARTIES, HOLIDAY CRAFTS, PETS, NOT DOWNLOADABLE; PROVIDING ON-LINE VIDEOS FEATURING HOW-TO PROJECTS IN THE FIELD OF UPCYCLING AND REVAMPING CLOTHES, UPCYCLING AND REVAMPING HOME DECOR, DIY BRIDAL GIFT IDEAS, DECOR, BRIDAL APPAREL AND SHOES, HOUSEHOLD TIPS AND TRICKS, FASHION STYLE GUIDES, TRAVEL, FOOD, BEVERAGE, SPIRITS AKA ALCOHOLIC DRINKS, BAKING AND CAKE DECORATING, FITNESS, YOGA, HEALTH AND BEAUTY, BUDGETING, HAIR AND MAKE-UP, HOSTING PARTIES, HOLIDAY CRAFTS, PETS, NOT DOWNLOADABLE; PROVIDING ON-LINE VIDEOS FEATURING ARTS AND CRAFTS, DO-IT-YOURSELF ARTS AND CRAFTS, HOME DECOR, DO-IT-YOURSELF HOME DECOR, RENOVATION AND REMODELING, DO-IT-YOURSELF RENOVATION AND REMODELING, FASHION, AND DO-IT-YOURSELF FASHION, NOT DOWNLOADABLE (U.S. CLS. 100, 101 AND 107).

MARGERY A. TIERNEY, EXAMINING ATTORNEY

SN 86-214,263. TAYLOR, ANGELA, REDONDO BEACH, CA.  
FILED 3-7-2014.

HOWTOHOTTIE

THE MARK CONSISTS OF STANDARD CHARACTERS WITHOUT CLAIM TO ANY PARTICULAR FONT, STYLE, SIZE, OR COLOR.

**CLASS 16—PAPER GOODS AND PRINTED MATTER**

FOR STENCILS; STENCILS FOR DECORATING HOME DÉCOR, TRANSFER OF DESIGNS ONTO ANY SURFACE; STENCIL CASES; STENCIL KITS CONTAINING A COMBINATION OF STENCILS, STENCIL PLATES, STENCIL PAPER; STENCIL PLATES; STENCIL PAPER; A SERIES OF INSTRUCTIONAL DO-IT-YOURSELF BOOKS IN THE FIELD OF UPCYCLING AND REVAMPING CLOTHES, UPCYCLING AND REVAMPING HOME DECOR, DIY BRIDAL GIFT IDEAS, DECOR, BRIDAL APPAREL AND SHOES, HOUSEHOLD TIPS AND TRICKS, FASHION STYLE GUIDES, TRAVEL, FOOD, BEVERAGE, SPIRITS AKA ALCOHOLIC DRINKS, BAKING AND CAKE DECORATING, FITNESS, YOGA, HEALTH AND BEAUTY, BUDGETING, HAIR AND MAKE-UP, HOSTING PARTIES, HOLIDAY CRAFTS, PETS; A SERIES OF INSTRUCTIONAL DO-IT-YOURSELF BOOKS IN THE FIELD OF HOME DECOR, ARTS AND CRAFTS, SEWING, FASHION, AND HOME REMODELING; SERIES OF INSTRUCTIONAL/REFERENCE BOOKS IN THE FIELD OF UPCYCLING AND REVAMPING CLOTHES, UPCYCLING AND REVAMPING HOME DECOR, DIY BRIDAL GIFT IDEAS, DECOR, BRIDAL APPAREL AND SHOES, HOUSEHOLD TIPS AND TRICKS, FASHION STYLE GUIDES, TRAVEL, FOOD, BEVERAGE, SPIRITS AKA ALCOHOLIC DRINKS, BAKING AND CAKE DECORATING, FITNESS, YOGA, HEALTH AND BEAUTY, BUDGETING, HAIR AND MAKE-UP, HOSTING PARTIES, HOLIDAY CRAFTS, PETS WHICH ARE INTENDED TO PRESENT NON INTIMIDATING GUIDES FOR READERS NEW TO THE VARIOUS TOPICS COVERED (U.S. CLS. 2, 5, 22, 23, 29, 37, 38 AND 50).

**CLASS 35—ADVERTISING AND BUSINESS**

FOR ONLINE RETAIL STORE SERVICES FEATURING BOOKS, CRAFT SUPPLIES, CRAFT KITS, CLOTHING, SHOES, SHOE ACCESSORIES, ACCESSORY COLLECTION (U.S. CLS. 100, 101 AND 102).

SN 86-214,284. NEXT PAGE, INC., KANSAS CITY, MO.  
FILED 3-7-2014.

**NextPage**

THE COLOR(S) BLACK AND RED IS/ARE CLAIMED AS A FEATURE OF THE MARK.

THE MARK CONSISTS OF THE STYLIZED WORDING "NEXTPAGE". IN THE WORD "NEXT" THE LETTERS "N", "E", AND "T" ARE IN BLACK AND THE "X" IS IN RED AND BLACK; THE WORD "PAGE" IS IN RED.

**CLASS 35—ADVERTISING AND BUSINESS**

FOR MARKETING SERVICES; DIRECT MAIL ADVERTISING SERVICES; DIGITAL MARKETING SERVICES; DIGITAL MARKETING CAMPAIGN SERVICES; DATABASE MANAGEMENT SERVICES (U.S. CLS. 100, 101 AND 102).

FIRST USE 11-1-2013; IN COMMERCE 11-1-2013.

**CLASS 40—MATERIAL TREATMENT**

FOR COMMERCIAL PRINTING SERVICES, DIGITAL PRINTING SERVICES (U.S. CLS. 100, 103 AND 106).

FIRST USE 11-1-2013; IN COMMERCE 11-1-2013.  
TASNEEM HUSSAIN, EXAMINING ATTORNEY

SN 86-214,462. DDR CORP., BEACHWOOD, OH. FILED 3-7-2014.

## WE'VE GOT MORE IN STORE

THE MARK CONSISTS OF STANDARD CHARACTERS WITHOUT CLAIM TO ANY PARTICULAR FONT, STYLE, SIZE, OR COLOR.

### CLASS 36—INSURANCE AND FINANCIAL

FOR FINANCIAL SERVICES, NAMELY, ARRANGING INTERIM AND PERMANENT FINANCING FOR COMMERCIAL AND INDUSTRIAL REAL ESTATE PROPERTIES; LAND EVALUATION AND APPRAISAL SERVICES; LAND ACQUISITION SERVICES; LEASING OF COMMERCIAL REAL ESTATE; AND REAL ESTATE MANAGEMENT FOR OTHERS (U.S. CLS. 100, 101 AND 102).

FIRST USE 2-0-2014; IN COMMERCE 2-0-2014.

### CLASS 37—CONSTRUCTION AND REPAIR

FOR REAL ESTATE DEVELOPMENT SERVICES; REAL ESTATE SITE SELECTION SERVICES; LAND DEVELOPMENT SERVICES, NAMELY, PLANNING AND LAYING OUT OF COMMERCIAL PROPERTIES; AND CONSTRUCTION SERVICES AND SUPERVISING CONSTRUCTION FOR COMMERCIAL AND INDUSTRIAL REAL ESTATE PROPERTIES (U.S. CLS. 100, 103 AND 106).

FIRST USE 2-0-2014; IN COMMERCE 2-0-2014.

DOMINIC J. FERRAIUOLO, EXAMINING ATTORNEY

SN 86-215,075. CHANG, TING-WEI, TAICHUNG CITY 438, TAIWAN, FILED 3-7-2014.



THE COLOR(S) BLUE IS/ARE CLAIMED AS A FEATURE OF THE MARK.

THE MARK CONSISTS OF A HEAD OF RHINO FACING TO THE LEFT OUTLINED IN BLUE. TO THE RIGHT OF THE DESIGN IS THE ITALICIZED WORDING "BOXO" IN BLUE. THE COLOR WHITE REPRESENTS TRANSPARENT AREAS AND IS NOT CLAIMED AS A FEATURE OF THE MARK.

### CLASS 7—MACHINERY

FOR PNEUMATIC HAMMERS; AIR HAMMERS; POWER-OPERATED SCREWDRIVERS; HAND-HELD ELECTRIC HAMMERS; ELECTRICAL DRILLS; POWER-DRIVEN WRENCHES; HAND-HELD ELECTRIC DRILLS; ELECTRIC HAMMERS; SPARK PLUGS; EXTENSION BARS FOR POWER TOOLS; ELECTRIC SCREWDRIVERS; POWER DRILLS; AIR POWERED TOOLS, NAMELY, DRILLS, SCREWDRIVERS, RIVET HAMMERS, AND SAWS; POWER-OPERATED RIVET GUNS, POWER DRILL ACCESSORIES, NAMELY, NON-ELECTRICAL ADAPTERS FOR USE IN JOINING EXTENSIONS AND POWER DRILL BITS (U.S. CLS. 13, 19, 21, 23, 31, 34 AND 35).

### CLASS 8—HAND TOOLS

FOR HAND TOOLS, NAMELY, WRECKING BARS, STRIPPING BARS, SMALL BARS AND NAIL PULLERS, SAN ANGELO BARS, TAMPER BARS, WEDGE POINT BARS, PITCH POINT BARS; HAND TOOLS, NAMELY, STRETCHERS FOR WIRE AND METAL BANDS; HAND TOOLS, NAMELY, PUNCHES; BLADES FOR SHEARS; PRUNING KNIVES; HAND-OPERATED SHEARS; HAND TOOLS, NAMELY, RIVETERS; HAND TOOLS, NAMELY, AUGERS; HAND TOOLS, NAMELY, SCREWDRIVERS; HAND-OPERATED CHISELS; HAND TOOLS, NAMELY, FLARING TOOLS; MATTOCKS; HAND TOOLS, NAMELY, AWLS; HAND TOOLS, NAMELY, DRILLS; HAND TOOLS, NAMELY, EXPANDERS; EXTENSIONS FOR HAND TOOLS; NAIL NIPPERS; HAND TOOLS, NAMELY, SOCKET SETS; HAND TOOLS, NAMELY, SOCKET WRENCHES; HAND TOOLS, NAMELY, RATCHET WRENCHES; EXTENSION BARS FOR HAND TOOLS; HAND SAWS, NAMELY, HACK SAWS; HAND-OPERATED TIN SNIPS; PLIERS; HAND RIVETERS, NAMELY, RIVETERS; HAND TOOLS, NAMELY, HAMMERS; REPLACEMENT PARTS FOR HAND-OPERATED PLANES, NAMELY, BLADES, HANDLES AND KNOBS; TOOL HOLDERS; HAND TOOLS, NAMELY, WRENCHES (U.S. CLS. 23, 28 AND 44).

### CLASS 20—FURNITURE AND ARTICLES NOT OTHERWISE CLASSIFIED

FOR BENCHES; SERVING TROLLEYS; CABINETS; INDUSTRIAL WORK TABLES; METAL DISPLAY STANDS; DESKS; METAL STORAGE CABINETS; DISPLAY RACKS; METAL CABINETS (U.S. CLS. 2, 13, 22, 25, 32 AND 50).

MATTHEW GALAN, EXAMINING ATTORNEY

SN 86-215,227. GIFT CARD, INC., NEWARK, DE. FILED 3-7-2014.



NO CLAIM IS MADE TO THE EXCLUSIVE RIGHT TO USE "A GIFT CARD, INC. COMPANY", APART FROM THE MARK AS SHOWN.

THE MARK CONSISTS OF "BIPIDS" IN LARGER FONT FOLLOWED BY A SMALLER FONT ".COM" UNDERNEATH THE "BIPIDS.COM" AND STARTING TO THE RIGHT OF THE "P" IN BIPIDS, IT STATES "A GIFT CARD, INC. COMPANY".

### CLASS 16—PAPER GOODS AND PRINTED MATTER

FOR CARDS NOT MAGNETICALLY CODED FOR USE IN BUSINESS TRANSACTIONS; NON-MAGNETICALLY ENCODED GIFT CARDS; NON-MAGNETICALLY ENCODED PREPAID PURCHASE CARDS FOR USE AT RETAIL ESTABLISHMENTS FOR GOODS AND SERVICES (U.S. CLS. 2, 5, 22, 23, 29, 37, 38 AND 50).

### CLASS 36—INSURANCE AND FINANCIAL

FOR ISSUING STORED VALUE CARDS; ISSUING STORED VALUE CARDS FOR USE AS ELECTRONIC TRAVEL TICKETS (U.S. CLS. 100, 101 AND 102).

ALYSSA STEEL, EXAMINING ATTORNEY



SN 86-215,410. THE BROOKESIDE GROUP, INC., ACTON, MA. FILED 3-8-2014.

## SALESEQUITY

THE MARK CONSISTS OF STANDARD CHARACTERS WITHOUT CLAIM TO ANY PARTICULAR FONT, STYLE, SIZE, OR COLOR.

### CLASS 35—ADVERTISING AND BUSINESS

FOR BUSINESS MARKETING CONSULTING SERVICES; BUSINESS INFORMATION SERVICES; BUSINESS CONSULTING SERVICES IN THE FIELD OF CLIENT SATISFACTION AND RETENTION; BUSINESS SERVICES, NAMELY, DEVELOPING MARKETING STRATEGIES FOR OTHERS IN THE FIELDS OF GATHERING, ANALYZING AND PROCESSING BUSINESS INFORMATION; BUSINESS SERVICES, NAMELY, DEVELOPING MARKETING STRATEGIES FOR OTHERS IN THE FIELDS OF GATHERING, ANALYZING AND PROCESSING BUSINESS INFORMATION IN CONNECTION WITH COMPETITIVE PRODUCTS AND SERVICES OF THIRD PARTIES, SALES STRATEGY, AND ADVERTISING STRATEGY; CLIENT RELATIONSHIP MANAGEMENT; PROVIDING A WEBSITE FEATURING BUSINESS INFORMATION, NAMELY, BUSINESS INFORMATION IN THE NATURE OF CLIENT MANAGEMENT, SATISFACTION, AND RETENTION (U.S. CLS. 100, 101 AND 102).

### CLASS 41—EDUCATION AND ENTERTAINMENT

FOR EDUCATIONAL SERVICES, NAMELY, CONDUCTING WORKSHOPS AND TRAINING IN THE FIELDS OF SALES STRATEGY, ADVERTISING STRATEGY, CLIENT RELATIONSHIP MANAGEMENT, CLIENT SATISFACTION, AND CLIENT RETENTION (U.S. CLS. 100, 101 AND 107).

MICHELLE DUBOIS, EXAMINING ATTORNEY

SN 86-215,638. NELLIS INVESTMENTS, LLC, AUSTIN, TX. FILED 3-9-2014.

## RoboAgent

THE MARK CONSISTS OF STANDARD CHARACTERS WITHOUT CLAIM TO ANY PARTICULAR FONT, STYLE, SIZE, OR COLOR.

### CLASS 9—ELECTRICAL AND SCIENTIFIC APPARATUS

FOR INTERACTIVE COMPUTER KIOSKS COMPRISING COMPUTERS, COMPUTER HARDWARE, COMPUTER PERIPHERALS, AND COMPUTER OPERATING SOFTWARE, FOR USE IN REAL ESTATE (U.S. CLS. 21, 23, 26, 36 AND 38).

### CLASS 35—ADVERTISING AND BUSINESS

FOR PROVIDING AN INTERACTIVE REAL ESTATE WEBSITE WHICH PROMOTES HOUSING AND APARTMENT PROPERTIES THROUGH OFFERING PROSPECTIVE TENANTS VIDEO WALK THROUGHS, PROPERTY DESCRIPTIONS, TEXT, PRICE, LOCATION, MAPS AND OTHER INFORMATION THAT WOULD BE INFLUENTIAL TO A PROSPECTIVE TENANT IN MAKING A RENTAL DECISION (U.S. CLS. 100, 101 AND 102).

### CLASS 38—COMMUNICATION

FOR PROVIDING ON-LINE FACILITIES FOR REAL-TIME INTERACTION WITH OTHER COMPUTER USERS AND ELECTRONIC BULLETIN BOARDS CONCERNING TOPICS OF INTEREST RELATING TO REAL ESTATE (U.S. CLS. 100, 101 AND 104).

CURTIS FRENCH, EXAMINING ATTORNEY

SN 86-215,969. LIFETIME ENTERTAINMENT SERVICES, LLC, NEW YORK, NY. FILED 3-10-2014.

## FAMOUS YARDSALE

THE MARK CONSISTS OF STANDARD CHARACTERS WITHOUT CLAIM TO ANY PARTICULAR FONT, STYLE, SIZE, OR COLOR.

NO CLAIM IS MADE TO THE EXCLUSIVE RIGHT TO USE "YARD SALE", APART FROM THE MARK AS SHOWN.

### CLASS 9—ELECTRICAL AND SCIENTIFIC APPARATUS

FOR MULTIMEDIA GOODS, NAMELY, PRERECORDED DIGITAL VIDEO DISCS AND DVDS FEATURING SUBJECTS OF GENERAL HUMAN INTEREST; DIGITAL MEDIA, NAMELY, DOWNLOADABLE AUDIO AND VIDEO FILES FEATURING SUBJECTS OF GENERAL HUMAN INTEREST; DOWNLOADABLE WEBCASTS AND PODCASTS FEATURING SUBJECTS OF GENERAL HUMAN INTEREST; DOWNLOADABLE GRAPHICS FOR WIRELESS DEVICES; DOWNLOADABLE ON-LINE DISCUSSION BOARD POSTS FEATURING SUBJECTS OF GENERAL HUMAN INTEREST; COMPUTER GAME SOFTWARE AND VIDEO GAME SOFTWARE; DOWNLOADABLE COMPUTER AND VIDEO GAME SOFTWARE VIA A GLOBAL COMPUTER NETWORK, MOBILE PLATFORMS, AND WIRELESS DEVICES FOR ENTERTAINMENT PURPOSES; DOWNLOADABLE MOBILE APPLICATIONS FOR GAMES (U.S. CLS. 21, 23, 26, 36 AND 38).

**CLASS 41—EDUCATION AND ENTERTAINMENT**

FOR ENTERTAINMENT SERVICES, NAMELY, A MULTIMEDIA PROGRAM SERIES FEATURING SUBJECTS OF GENERAL HUMAN INTEREST DISTRIBUTED VIA VARIOUS PLATFORMS ACROSS MULTIPLE FORMS OF TRANSMISSION MEDIA; ENTERTAINMENT SERVICES, NAMELY, AN ONGOING TELEVISION SERIES FEATURING SUBJECTS OF GENERAL HUMAN INTEREST; PROVIDING A WEBSITE FEATURING ENTERTAINMENT INFORMATION; ENTERTAINMENT SERVICES, NAMELY, OPERATING A REAL-TIME NON-DOWNLOADABLE GAME FOR OTHERS VIA THE INTERNET, MOBILE NETWORK PLATFORMS, AND LOCAL AREA COMPUTER NETWORKS; ELECTRONIC GAME SERVICES, NAMELY, PROVIDING ONLINE ELECTRONIC GAMES BY MEANS OF THE INTERNET, MOBILE NETWORK PLATFORMS, AND LOCAL AREA COMPUTER NETWORKS; ENTERTAINMENT SERVICES, NAMELY, PROVIDING TEMPORARY USE OF NON-DOWNLOADABLE INTERACTIVE GAMES (U.S. CLS. 100, 101 AND 107).

WON TEAK OH, EXAMINING ATTORNEY

SN 86-216,011. ONEHOPE COALITION OF TRANSFORMATIONAL CHURCHES, INC., POMPANO BEACH,, FL. FILED 3-10-2014.



NO CLAIM IS MADE TO THE EXCLUSIVE RIGHT TO USE "MISSION", APART FROM THE MARK AS SHOWN.

THE MARK CONSISTS OF THE WORD "REIMAGINE" IN A STYLIZED FONT POSITIONED ABOVE THE WORD "MISSION" IN SLIGHTLY LARGER LETTERS USING THE SAME STYLIZED FONT, WITH THE TWO WORDS SEPARATED BY A HORIZONTAL LINE AND THE LETTER "I" IN "REIMAGINE" REPLACED WITH A STYLIZED LIGHT BULB DESIGN WITH 5 RAY-LIKE LINE SEGMENTS OUTSIDE THE SURFACE OF THE BULB AS PART OF THE DESIGN TO DEPICT LIGHT EMANATING FROM THE BULB.

**CLASS 9—ELECTRICAL AND SCIENTIFIC APPARATUS**

FOR CDS AND DVDS AND ELECTRONIC TRAINING MATERIALS IN THE NATURE OF CDS, DVDS, AND DOWNLOADABLE AUDIO FILES IN THE FIELD OF RELIGION FOR MISSION AND MINISTRY AND OUTREACH PROGRAM DESIGN (U.S. CLS. 21, 23, 26, 36 AND 38).

FIRST USE 11-19-2013; IN COMMERCE 11-19-2013.

**CLASS 16—PAPER GOODS AND PRINTED MATTER**

FOR PUBLICATIONS, NAMELY, BROCHURES, BOOKLETS, WORKBOOKS AND PRINTED TEACHING MATERIALS IN THE FIELD OF RELIGION FOR USE IN TRAINING CLERGY AND LAY RELIGIOUS LEADERS IN HOW TO CONDUCT MINISTRIES AND MISSIONS (U.S. CLS. 2, 5, 22, 23, 29, 37, 38 AND 50).

FIRST USE 11-19-2013; IN COMMERCE 11-19-2013.

**CLASS 41—EDUCATION AND ENTERTAINMENT**

FOR EDUCATION SERVICES, NAMELY, PROVIDING LIVE AND ON-LINE TRAINING WORKSHOPS TO CLERGY AND LAY RELIGIOUS LEADERS IN HOW TO CONDUCT MINISTRIES AND MISSIONS; PROVIDING A WEBSITE FEATURING INFORMATION ABOUT RELIGIOUS WORKSHOPS TO TRAIN AND ASSIST RELIGIOUS LEADERS, BOTH CLERGY AND LAY, HOW TO CONDUCT MINISTRIES AND MISSIONS (U.S. CLS. 100, 101 AND 107).

FIRST USE 11-19-2013; IN COMMERCE 11-19-2013.

**CLASS 45—PERSONAL AND LEGAL SERVICES**

FOR MINISTERIAL SERVICES, NAMELY, HOLDING SPIRITUAL RETREATS TO ASSIST RELIGIOUS LEADERS, BOTH CLERGY AND LAY, TO DEVELOP AND ENHANCE THEIR SPIRITUAL LIVES; CHARITABLE OUTREACH SERVICES, NAMELY, PROVIDING COUNSELING SERVICES IN THE FIELD OF RELIGION; CHARITABLE OUTREACH SERVICES, NAMELY, PROVIDING COUNSELING SERVICES IN THE FIELD OF RELIGION TO THE NEEDY, THE IMPRISONED, AND THE SICK; CONDUCTING RELIGIOUS PRAYER SERVICES; PROVIDING A WEBSITE FEATURING INFORMATION ABOUT RELIGIOUS BELIEF SYSTEMS; RELIGIOUS AND SPIRITUAL SERVICES, NAMELY, CONDUCTING RELIGIOUS WORSHIP, MARRIAGE CEREMONIES, BAPTISMAL CEREMONIES, BABY DEDICATIONS, BEREAVEMENT CEREMONIES, AND RELIGIOUS COUNSELING; RELIGIOUS AND SPIRITUAL SERVICES, NAMELY, PROVIDING GATHERINGS AND RETREATS TO DEVELOP AND ENHANCE THE SPIRITUAL LIVES OF INDIVIDUALS; RELIGIOUS SERVICES, NAMELY, PRAYER MEETINGS (U.S. CLS. 100 AND 101).

FIRST USE 11-19-2013; IN COMMERCE 11-19-2013.

KALIE KUNG, EXAMINING ATTORNEY

SN 86-216,442. DURAND, FRANCK, PARIS, FRANCE, FILED 3-10-2014.



OWNER OF U.S. REG. NO. 4,173,607.

NO CLAIM IS MADE TO THE EXCLUSIVE RIGHT TO USE "INTERNATIONAL TRAVEL AND STYLE REVIEW", APART FROM THE MARK AS SHOWN.

THE COLOR(S) RED, FUCHSIA, PINK, YELLOW AND BLACK IS/ARE CLAIMED AS A FEATURE OF THE MARK.

THE MARK CONSISTS OF THE WORD "HOLIDAY" IN STYLIZED UPPER CASE LETTERS WITH THE LETTER "H" BEING RED IN COLOR, THE LETTER "O" BEING FUCHSIA, THE LETTERS "L" AND "I" BEING RED, THE LETTER "D" BEING PINK, THE LETTER "A" BEING YELLOW, AND THE LETTER "Y" BEING RED. BELOW THE WORD "HOLIDAY" IS THE LITERAL ELEMENT "INTERNATIONAL TRAVEL AND STYLE REVIEW" WHICH IS IN SMALLER UPPER CASE STYLIZED BLACK LETTERS.

**CLASS 16—PAPER GOODS AND PRINTED MATTER**

FOR JOURNALS, MAGAZINES, NEWSPAPERS, BOOKS, ALL OF THE AFOREMENTIONED GOODS RELATING TO FASHION (U.S. CLS. 2, 5, 22, 23, 29, 37, 38 AND 50).



**CLASS 41—EDUCATION AND ENTERTAINMENT**

FOR PUBLICATION OF BOOKS, JOURNALS, MAGAZINES, NEWSPAPERS, ELECTRONIC DESKTOP PUBLISHING, ALL OF THE AFOREMENTIONED SERVICES RELATING TO FASHION (U.S. CLS. 100, 101 AND 107).  
KATHLEEN KOLACZ, EXAMINING ATTORNEY

SN 86-216,493. SYSTEM OF STRENGTH, GRANDVIEW HEIGHTS, OH. FILED 3-10-2014.



SN 86-216,488. IP ASSOCIATES, LLC, NAPLES, FL. FILED 3-10-2014.

**PROBAR BITE**

THE MARK CONSISTS OF STANDARD CHARACTERS WITHOUT CLAIM TO ANY PARTICULAR FONT, STYLE, SIZE, OR COLOR.

OWNER OF U.S. REG. NOS. 2,861,459, 4,456,516 AND OTHERS.

NO CLAIM IS MADE TO THE EXCLUSIVE RIGHT TO USE "BITE", APART FROM THE MARK AS SHOWN.

**CLASS 5—PHARMACEUTICALS**

FOR MEAL REPLACEMENT BARS FOR MEDICAL PURPOSES, NUTRITIONAL AND DIETARY BARS FOR USE AS A MEAL REPLACEMENT FOR MEDICAL PURPOSES; NUTRITIONAL SUPPLEMENTS; FRUIT-BASED, NUT-BASED, PROTEIN-BASED OR GRANOLA-BASED MEAL REPLACEMENT BARS FOR MEDICAL PURPOSES; FRUIT-BASED, NUT-BASED, PROTEIN-BASED OR GRANOLA-BASED NUTRITIONAL AND DIETARY BARS FOR USE AS A MEAL REPLACEMENT FOR MEDICAL PURPOSES; NUTRITIONAL SUPPLEMENTS IN THE NATURE OF A PROTEIN-BASED, NUTRIENT-DENSE FOOD BAR (U.S. CLS. 6, 18, 44, 46, 51 AND 52).

**CLASS 29—MEATS AND PROCESSED FOODS**

FOR FRUIT-BASED, NUT-BASED OR VEGETABLE-BASED MEAL REPLACEMENT BARS WHICH CONTAIN PROTEIN; FRUIT-BASED, NUT-BASED OR VEGETABLE-BASED NUTRITIONAL AND DIETARY BARS FOR USE AS A MEAL REPLACEMENT WHICH CONTAIN PROTEIN; FRUIT BASED ORGANIC FOOD BARS, FRUIT BASED ORGANIC FOOD BARS ALSO CONTAINING VEGETABLES, NUTS, AND/OR SEEDS; PROCESSED FRUIT-BASED OR VEGETABLE-BASED NUTRIENT DENSE FOOD BARS WHICH CONTAIN PROTEIN, PROCESSED NUT BASED FOOD BARS, PROCESSED NUT AND SEED BASED FOOD BARS (U.S. CL. 46).

**CLASS 30—STAPLE FOODS**

FOR GRANOLA-BASED SNACK BARS; GRANOLA-BASED MEAL REPLACEMENT BARS WITH CONTAIN PROTEIN; GRANOLA-BASED NUTRITIONAL DIETARY BARS FOR USE AS A MEAL REPLACEMENT WHICH CONTAIN PROTEIN (U.S. CL. 46).  
MICHELE SWAIN, EXAMINING ATTORNEY

OWNER OF U.S. REG. NO. 4,521,388.  
THE MARK CONSISTS OF THE LITERAL ELEMENT "SOS" IN A STYLIZED FORMAT. BOTH "S"'S SIT NEXT TO EACH OTHER WITH THE "O" CONNECTING THE TWO AS IN A LINK ON A CHAIN.

**CLASS 35—ADVERTISING AND BUSINESS**

FOR ON-LINE RETAIL STORE SERVICES FEATURING APPAREL, NUTRITIONAL SUPPLEMENTS, AND FITNESS ACCESSORIES; PROVIDING ASSISTANCE, FITNESS EVALUATION AND CONSULTATION TO CORPORATE CLIENTS TO HELP THEIR EMPLOYEES MAKE HEALTH, WELLNESS AND NUTRITIONAL CHANGES IN THEIR DAILY LIVING TO INCREASE PRODUCTIVITY AND LOWER HEALTH CARE COSTS (U.S. CLS. 100, 101 AND 102).

FIRST USE 1-1-2014; IN COMMERCE 1-1-2014.

**CLASS 41—EDUCATION AND ENTERTAINMENT**

FOR CONDUCTING FITNESS CLASSES; CONSULTING SERVICES IN THE FIELDS OF FITNESS AND EXERCISE; PHYSICAL FITNESS INSTRUCTION; PROVIDING A WEB SITE FEATURING INFORMATION ON EXERCISE AND FITNESS; PROVIDING EDUCATION COURSES IN THE FIELD OF FITNESS OFFERED THROUGH ONLINE, NON-DOWNLOADABLE VIDEOS AND INSTRUCTOR ASSISTANCE (U.S. CLS. 100, 101 AND 107).

FIRST USE 1-1-2014; IN COMMERCE 1-1-2014.  
JOANNA FIORELLI, EXAMINING ATTORNEY

SN 86-216,550. INTERNATIONAL FOOD POLICY RESEARCH INSTITUTE, WASHINGTON, DC. FILED 3-10-2014.

**FUTURE HARVEST**

THE MARK CONSISTS OF STANDARD CHARACTERS WITHOUT CLAIM TO ANY PARTICULAR FONT, STYLE, SIZE, OR COLOR.

**CLASS 41—EDUCATION AND ENTERTAINMENT**

FOR ARRANGING AND CONDUCTING EDUCATIONAL CONFERENCES AND LECTURES IN THE FIELD OF SUSTAINABLE AGRICULTURE AND INTERNATIONAL AGRICULTURAL RESEARCH; EDUCATIONAL SERVICES, NAMELY, DEVELOPING CURRICULA AND EDUCATIONAL MATERIALS FOR OTHERS IN THE FIELD OF SUSTAINABLE AGRICULTURE AND INTERNATIONAL AGRICULTURAL RESEARCH AND DISTRIBUTING EDUCATIONAL MATERIALS IN CONNECTION THEREWITH AT EDUCATIONAL CONFERENCES AND LECTURES; PUBLICATION OF ON-LINE BROCHURES, REPORTS, AND/OR NEWSLETTERS, NEWS RELEASES, GLOSSARY OF TERMS AND FACT SHEETS, RELATING TO SUSTAINABLE AGRICULTURE AND INTERNATIONAL AGRICULTURAL RESEARCH; PUBLICATION OF ON-LINE MAGAZINES AND NEWSLETTERS FEATURING INFORMATION IN THE FIELD OF SUSTAINABLE AGRICULTURE AND INTERNATIONAL AGRICULTURAL RESEARCH (U.S. CLS. 100, 101 AND 107).

**CLASS 42—SCIENTIFIC AND COMPUTER SERVICES**

FOR PROVIDING INFORMATION IN THE FIELD OF INTERNATIONAL AGRICULTURAL RESEARCH; PROVIDING A WEBSITE FEATURING INFORMATION IN THE FIELD OF INTERNATIONAL AGRICULTURAL RESEARCH VIA THE GLOBAL COMPUTER NETWORK; PROVIDING AN ON-LINE COMPUTER DATABASE FEATURING INFORMATION IN THE FIELD OF INTERNATIONAL AGRICULTURAL RESEARCH (U.S. CLS. 100 AND 101).

REGINA DRUMMOND, EXAMINING ATTORNEY

SN 86-216,687. HALLMARK LICENSING, LLC, KANSAS CITY, MO. FILED 3-10-2014.

**CHARLIE THE YETI**

THE MARK CONSISTS OF STANDARD CHARACTERS WITHOUT CLAIM TO ANY PARTICULAR FONT, STYLE, SIZE, OR COLOR.

**CLASS 19—NON-METALLIC BUILDING MATERIALS**

FOR NON-LUMINOUS, NON-MECHANICAL SIGNS OF PLASTIC RESIN OR WOOD (U.S. CLS. 1, 12, 33 AND 50).

**CLASS 20—FURNITURE AND ARTICLES NOT OTHERWISE CLASSIFIED**

FOR VINYL APPLIQUES FOR ATTACHMENT TO WINDOWS, MIRRORS, AND OTHER SOLID SURFACES; INFLATABLE YARD DECORATIONS; PLASTIC KEY CHAINS; 3D DECORATIVE CLIPS IN THE NATURE OF ORNAMENTS MADE FROM PLASTIC; PLAQUES MADE OF RESIN OR WOOD (U.S. CLS. 2, 13, 22, 25, 32 AND 50).

THEODORE MCBRIDE, EXAMINING ATTORNEY

SN 86-216,678. HALLMARK LICENSING, LLC, KANSAS CITY, MO. FILED 3-10-2014.

SN 86-216,896. SUSAN PALMER, BROOKLYN, NY. FILED 3-10-2014.

**The Girl In The Little Red Kitchen****CHARLIE THE YETI**

THE MARK CONSISTS OF STANDARD CHARACTERS WITHOUT CLAIM TO ANY PARTICULAR FONT, STYLE, SIZE, OR COLOR.

**CLASS 18—LEATHER GOODS**

FOR DIAPER BAGS; PURSES; KNAPSACKS; BACKPACKS (U.S. CLS. 1, 2, 3, 22 AND 41).

**CLASS 26—FANCY GOODS**

FOR DECORATIVE CHARMS FOR BACKPACKS; DECORATIVE CLIPS FOR BACKPACKS IN THE NATURE OF BACKPACK CHARMS (U.S. CLS. 37, 39, 40, 42 AND 50).

THEODORE MCBRIDE, EXAMINING ATTORNEY

THE MARK CONSISTS OF STANDARD CHARACTERS WITHOUT CLAIM TO ANY PARTICULAR FONT, STYLE, SIZE, OR COLOR.

**CLASS 30—STAPLE FOODS**

FOR BAKERY GOODS (U.S. CL. 46).

**CLASS 35—ADVERTISING AND BUSINESS**

FOR RETAIL BAKERY SHOPS (U.S. CLS. 100, 101 AND 102).

**CLASS 41—EDUCATION AND ENTERTAINMENT**

FOR ONLINE JOURNALS, NAMELY, BLOGS FEATURING FOOD, DRINKS, RECIPES, COOKWARE, TRAVEL; PROVIDING A WEBSITE FEATURING FOOD, DRINKS, RECIPES, COOKWARE, TRAVEL (U.S. CLS. 100, 101 AND 107).

FIRST USE 6-1-2011; IN COMMERCE 6-1-2011.  
LINDA M. KING, EXAMINING ATTORNEY

SN 86-216,904. SUSAN PALMER, BROOKLYN, NY. FILED 3-10-2014.

SN 86-217,094. LORRAINE, KATHLEEN, SAN DIEGO, CA. FILED 3-11-2014.

## Little Red Kitchen

THE MARK CONSISTS OF STANDARD CHARACTERS WITHOUT CLAIM TO ANY PARTICULAR FONT, STYLE, SIZE, OR COLOR.

### CLASS 30—STAPLE FOODS

FOR BAKERY GOODS (U.S. CL. 46).

### CLASS 35—ADVERTISING AND BUSINESS

FOR RETAIL BAKERY SHOPS (U.S. CLS. 100, 101 AND 102).

LINDA M. KING, EXAMINING ATTORNEY

SN 86-216,906. SMITH MICRO SOFTWARE, INC., ALISO VIEJO, CA. FILED 3-10-2014.



THE MARK CONSISTS OF A SMILING FACE WAVING INSIDE A SPEECH BUBBLE ABOVE THE WORD "ANIMATES" WHICH HAS A CAPITAL "A", A CAPITAL "M" AND AN EXCLAMATION POINT.

### CLASS 9—ELECTRICAL AND SCIENTIFIC APPARATUS

FOR COMPUTER SOFTWARE FOR COMPOSING, SENDING, RECEIVING, PREVIEWING, AND POSTING ELECTRONIC MESSAGES VIA SUPPORTED DEVICES, EMAIL AND THIRD PARTY SERVICES (U.S. CLS. 21, 23, 26, 36 AND 38).

### CLASS 38—COMMUNICATION

FOR COMMUNICATION SERVICES, NAMELY, SENDING, RECEIVING, AND POSTING ELECTRONIC MESSAGES VIA SUPPORTED DEVICES, EMAIL AND THIRD PARTY SERVICES; INSTANT MESSAGING SERVICES (U.S. CLS. 100, 101 AND 104).

### CLASS 42—SCIENTIFIC AND COMPUTER SERVICES

FOR ONLINE WEB SITE WITH A NON-DOWNLOADABLE SOFTWARE TOOL FOR ACCESSING, VIEWING, COMPOSING, POSTING, SHARING, RECEIVING AND DELIVERING ELECTRONIC MESSAGES VIA SUPPORTED DEVICES, EMAIL AND THIRD PARTY SERVICES (U.S. CLS. 100 AND 101).

ERIC SABLE, EXAMINING ATTORNEY



THE COLOR(S) BLACK, WHITE, RED, ORANGE, YELLOW, GREEN, BLUE, AND PINK IS/ARE CLAIMED AS A FEATURE OF THE MARK.

THE MARK CONSISTS OF LITERAL ELEMENTS "OUT IS IN." WRITTEN IN STYLIZED FORM WHEREIN THE WORD "OUT" IS PLACED IN BIG FONT IN BLACK COLOR AND ON THE HORIZONTAL LINE OF LETTER "T" THE WORDS "IS IN." WRITTEN IN WHITE COLOR AND A DOOR LIKE IMAGE WITH ORANGE DOT IS PLACED ON THE VERTICAL LINE OF LETTER "T" WHICH IS OF RED, ORANGE, YELLOW, GREEN, BLUE AND PINK COLOR.

### CLASS 16—PAPER GOODS AND PRINTED MATTER

FOR POSTERS; STICKERS; DECALS; BUMPER STICKERS; PAPER FLAGS; PAPER BANNERS (U.S. CLS. 2, 5, 22, 23, 29, 37, 38 AND 50).

### CLASS 24—FABRICS

FOR TEXTILE FLAGS; TEXTILE BANNERS (U.S. CLS. 42 AND 50).

### CLASS 25—CLOTHING

FOR CLOTHING, NAMELY, TOPS, BOTTOMS, PANTS, UNDERGARMENTS, HATS, SOCKS, SWEATSHIRTS, JACKETS (U.S. CLS. 22 AND 39).

MICHAEL KEATING, EXAMINING ATTORNEY

SN 86-217,485. MILTON GLASER, INC., NEW YORK, NY. FILED 3-11-2014.



NO CLAIM IS MADE TO THE EXCLUSIVE RIGHT TO USE "TABLETOP", APART FROM THE MARK AS SHOWN.

THE MARK CONSISTS OF THE TERM "MIXIMOP" OVER THE TERM "TABLETOP" APPEARING ON A RECTANGULAR BACKGROUND WITH THE LETTERS "O" IN EACH TERM FORMED BY A SOLID CIRCLE AND SIX SMALL CIRCLES RANDOMLY PLACED AROUND AND NEAR THE "O" LETTERS.

### CLASS 21—HOUSEWARES AND GLASS

FOR CUPS AND MUGS; DISHES AND PLATES; DRINKING GLASSES; DRINKING GLASSES, NAMELY, TUMBLERS; FRUIT BOWLS OF GLASS; GLASS BEVERAGEWARE; ROASTING DISHES; SERVING DISHES (U.S. CLS. 2, 13, 23, 29, 30, 33, 40 AND 50).

**CLASS 24—FABRICS**

FOR TABLE LINEN; TABLE LINEN OF TEXTILE; TABLE LINEN, NAMELY, COASTERS (U.S. CLS. 42 AND 50).

SETH DENNIS, EXAMINING ATTORNEY

SN 86-217,597. VELCRO INDUSTRIES B.V., CURACAO, NETHERLANDS, FILED 3-11-2014.

# ULTRA-MATE

THE MARK CONSISTS OF STANDARD CHARACTERS WITHOUT CLAIM TO ANY PARTICULAR FONT, STYLE, SIZE, OR COLOR.

OWNER OF U.S. REG. NO. 1,624,838.

**CLASS 17—RUBBER GOODS**

FOR MOLDED AND EXTRUDED PLASTIC MATERIAL HAVING A SURFACE OF HOOKS AND SYNTHETIC FIBER MATERIAL HAVING A SURFACE OF LOOPS, ALL FOR USE IN MANUFACTURE (U.S. CLS. 1, 5, 12, 13, 35 AND 50).

FIRST USE 12-20-1988; IN COMMERCE 12-20-1988.

**CLASS 24—FABRICS**

FOR FABRICS AND TEXTILES AND SUBSTITUTES THEREFOR, NAMELY, WOVEN, MOLDED, NON-WOVEN OR EXTRUDED SYNTHETIC MATERIAL HAVING A SURFACE OF HOOKS AND WOVEN SYNTHETIC MATERIAL HAVING A SURFACE OF LOOPS (U.S. CLS. 42 AND 50).

FIRST USE 12-20-1988; IN COMMERCE 12-20-1988.

**CLASS 26—FANCY GOODS**

FOR SEPARABLE FASTENERS IN THE NATURE OF SNAP FASTENERS AND PRESS FASTENERS; SEPARABLE FASTENERS, NAMELY, HOOK AND LOOP-TYPE FASTENERS AND COMPONENTS THEREOF; HOOK AND LOOP FASTENING TAPE (U.S. CLS. 37, 39, 40, 42 AND 50).

FIRST USE 12-20-1988; IN COMMERCE 12-20-1988.

DORITT L. CARROLL, EXAMINING ATTORNEY

SN 86-218,373. WOMEN IN FILM, LOS ANGELES, CA. FILED 3-12-2014.

# WIF

THE MARK CONSISTS OF STANDARD CHARACTERS WITHOUT CLAIM TO ANY PARTICULAR FONT, STYLE, SIZE, OR COLOR.

OWNER OF U.S. REG. NO. 3,421,978.

**CLASS 35—ADVERTISING AND BUSINESS**

FOR ASSOCIATION SERVICES, NAMELY, PROMOTING THE INTERESTS OF WOMEN IN THE ENTERTAINMENT INDUSTRY (U.S. CLS. 100, 101 AND 102).

FIRST USE 0-0-1973; IN COMMERCE 0-0-1973.

**CLASS 36—INSURANCE AND FINANCIAL**

FOR CHARITABLE FUNDRAISING; PROVIDING GRANTS FOR RESEARCH IN THE ARTS AND FOR ENTERTAINMENT AND MEDIA PRODUCTIONS (U.S. CLS. 100, 101 AND 102).

FIRST USE 0-0-1975; IN COMMERCE 0-0-1975.

**CLASS 41—EDUCATION AND ENTERTAINMENT**

FOR ENTERTAINMENT AND EDUCATIONAL SERVICES, NAMELY, AWARD CEREMONIES IN THE FIELD OF ENTERTAINMENT; PROVIDING RECOGNITION AND INCENTIVES BY WAY OF AWARDS TO DEMONSTRATE EXCELLENCE IN THE FIELD OF ENTERTAINMENT; MOTION PICTURE EXHIBITIONS; CONDUCTING EDUCATIONAL SEMINARS AND COURSES IN THE FIELD OF THE ENTERTAINMENT INDUSTRY; CONTINUING PUBLIC SERVICE PROGRAMS IN THE FIELD OF WOMEN IN THE ENTERTAINMENT INDUSTRY PRODUCED AND DISTRIBUTED OVER TELEVISION, SATELLITE, AUDIO, VIDEO, AND THE INTERNET; AND PRODUCTION OF AUDIOVISUAL RECORDINGS IN THE FIELD OF WOMEN AND THE ENTERTAINMENT INDUSTRY (U.S. CLS. 100, 101 AND 107).

FIRST USE 0-0-1974; IN COMMERCE 0-0-1974.

MELISSA VALLILLO, EXAMINING ATTORNEY

SN 86-218,520. FREE RENTAL FINDER, LLC, BILLINGS, MT. FILED 3-12-2014.

# JASNIA

THE MARK CONSISTS OF STANDARD CHARACTERS WITHOUT CLAIM TO ANY PARTICULAR FONT, STYLE, SIZE, OR COLOR.

**CLASS 35—ADVERTISING AND BUSINESS**

FOR PROVIDING AN INTERACTIVE REAL ESTATE WEBSITE THAT PROMOTES HOUSING AND APARTMENT PROPERTIES THROUGH OFFERING PROSPECTIVE TENANTS ONLINE WALK-THROUGHS, PROPERTY DESCRIPTIONS, LEASE INFORMATION, TEXT, PRICE, LOCATION, MAPS AND OTHER INFORMATION THAT WOULD BE INFLUENTIAL TO A PROSPECTIVE TENANT IN MAKING A RENTAL DECISION (U.S. CLS. 100, 101 AND 102).

**CLASS 42—SCIENTIFIC AND COMPUTER SERVICES**

FOR APPLICATION SERVICE PROVIDER (ASP) FEATURING SOFTWARE FOR MANAGING PROPERTY IN THE FIELD OF RENTAL PROPERTY MANAGEMENT (U.S. CLS. 100 AND 101).

PAUL CROWLEY, EXAMINING ATTORNEY

SN 86-218,602. SAN ANTONIO WINERY, INC., LOS ANGELES, CA. FILED 3-12-2014.

SN 86-218,674. SECURITYCOVERAGE, INC., CEDAR RAPIDS, IA. FILED 3-12-2014.

## STELLA ROSA

THE MARK CONSISTS OF STANDARD CHARACTERS WITHOUT CLAIM TO ANY PARTICULAR FONT, STYLE, SIZE, OR COLOR.

OWNER OF U.S. REG. NOS. 3,663,013, 4,000,417 AND 4,522,059.

THE ENGLISH TRANSLATION OF "STELLA ROSA" IN THE MARK IS "PINK STAR" OR "STAR ROSE".

### CLASS 3—COSMETICS AND CLEANING PREPARATIONS

FOR LIP BALM (U.S. CLS. 1, 4, 6, 50, 51 AND 52).  
FIRST USE 12-15-2013; IN COMMERCE 12-15-2013.

### CLASS 6—METAL GOODS

FOR METAL KEY CHAINS (U.S. CLS. 2, 12, 13, 14, 23, 25 AND 50).

FIRST USE 9-0-2013; IN COMMERCE 9-0-2013.

### CLASS 21—HOUSEWARES AND GLASS

FOR COCKTAIL SHAKERS; ICE BUCKETS (U.S. CLS. 2, 13, 23, 29, 30, 33, 40 AND 50).

FIRST USE 2-28-2011; IN COMMERCE 2-28-2011.  
ZACHARY R. SPARER, EXAMINING ATTORNEY

SN 86-218,667. PM DEV CO, LLC, SAN ANTONIO, TX. FILED 3-12-2014.

## BITE

THE MARK CONSISTS OF STANDARD CHARACTERS WITHOUT CLAIM TO ANY PARTICULAR FONT, STYLE, SIZE, OR COLOR.

### CLASS 9—ELECTRICAL AND SCIENTIFIC APPARATUS

FOR DOWNLOADABLE SOFTWARE IN THE NATURE OF A MOBILE AND WEB BASED APPLICATION FOR PROVIDING RESTAURANTS AN INTERFACE WHICH ALLOWS THE RESTAURANTS TO POST INFORMATION ABOUT THEIR RESTAURANT TO END USERS, AND END USERS CAN ACCESS THE INFORMATION (U.S. CLS. 21, 23, 26, 36 AND 38).

### CLASS 42—SCIENTIFIC AND COMPUTER SERVICES

FOR PROVIDING TEMPORARY USE OF NON-DOWNLOADABLE WEB BASED APPLICATION SOFTWARE FOR PROVIDING RESTAURANTS AN INTERFACE WHICH ALLOWS THE RESTAURANTS TO POST INFORMATION ABOUT THEIR RESTAURANT TO END USERS, AND END USERS CAN ACCESS THE INFORMATION (U.S. CLS. 100 AND 101).

JENNY PARK, EXAMINING ATTORNEY



NO CLAIM IS MADE TO THE EXCLUSIVE RIGHT TO USE "TECH HOME", APART FROM THE MARK AS SHOWN.

THE COLOR(S) GRAY AND GREEN IS/ARE CLAIMED AS A FEATURE OF THE MARK.

THE MARK CONSISTS OF THE WORD "TECH" IN GRAY UPPER CASE LETTERS AND THE WORD "HOME" IN GRAY WITH THE LETTER "O" IN LOWER CASE WITH GREEN CURVED LINES ABOVE AND THE REMAINING LETTERS IN UPPER CASE.

### CLASS 36—INSURANCE AND FINANCIAL

FOR PROVIDING WARRANTIES ON GOODS MANUFACTURED BY OTHERS, NAMELY, COMPUTERS, LAPTOPS, TABLETS, SMART PHONES, TELEVISIONS, AUDIO-VISUAL EQUIPMENT, GAMING SYSTEMS AND OTHER CONNECTED CONSUMER ELECTRONICS (U.S. CLS. 100, 101 AND 102).

FIRST USE 2-15-2014; IN COMMERCE 2-15-2014.

### CLASS 42—SCIENTIFIC AND COMPUTER SERVICES

FOR COMPUTER SERVICES, NAMELY, ACTING AS AN APPLICATION SERVICE PROVIDER IN THE FIELD OF KNOWLEDGE MANAGEMENT TO HOST COMPUTER APPLICATION SOFTWARE FOR THE PURPOSE OF UPLOADING, SECURING, STORING, ORGANIZING, MAINTAINING, ACCESSING, AND MANAGING INFORMATION AND ELECTRONIC DATA FROM MOBILE AND NON-MOBILE DEVICES ON A CLOUD COMPUTING NETWORK; COMPUTER VIRUS PROTECTION SERVICES; COMPUTER TECHNICAL SUPPORT SERVICES, NAMELY, 24/7 SERVICE DESK OR HELP DESK SERVICES FOR OPERATING SYSTEMS, DATABASE SYSTEMS, WEB APPLICATIONS, COMPUTER HARDWARE AND SUPPORT OF CONSUMER ELECTRONIC DEVICES WHICH ARE CONNECTED TO A HOME NETWORK VIA WIRED OR WIRELESS NETWORKING PROTOCOL (U.S. CLS. 100 AND 101).

FIRST USE 2-15-2014; IN COMMERCE 2-15-2014.

### CLASS 45—PERSONAL AND LEGAL SERVICES

FOR ONLINE COMPUTER SERVICES, NAMELY, MONITORING OF ELECTRONIC DEVICES, COMPUTERS, MOBILE PHONES AND COMPUTER TABLET SYSTEMS FOR SECURITY PURPOSES (U.S. CLS. 100 AND 101).

FIRST USE 2-15-2014; IN COMMERCE 2-15-2014.

JENNY PARK, EXAMINING ATTORNEY

SN 86-218,685. SUPER SPROWITZ LLC, BROOKLYN, NY. FILED 3-12-2014.

## FANTASTIC FRUITZ

THE MARK CONSISTS OF STANDARD CHARACTERS WITHOUT CLAIM TO ANY PARTICULAR FONT, STYLE, SIZE, OR COLOR.

NO CLAIM IS MADE TO THE EXCLUSIVE RIGHT TO USE "FRUITS", APART FROM THE MARK AS SHOWN.

#### **CLASS 8—HAND TOOLS**

FOR GARDENING KITS CONTAINING HAND TOOLS USED FOR PLANTING SEEDS, PLANTING MATS, IRRIGATION SYSTEMS, AND SEEDS (U.S. CLS. 23, 28 AND 44).

#### **CLASS 16—PAPER GOODS AND PRINTED MATTER**

FOR BOOKS IN THE FIELD OF NUTRITION AND WELLNESS; CARTOON STRIPS; COMIC BOOKS; GRAPHIC NOVELS; STATIONERY; PRINTED SCHOOL AND OFFICE SUPPLIES, NAMELY, PAPER STATIONERY AND COMPOSITION BOOKS (U.S. CLS. 2, 5, 22, 23, 29, 37, 38 AND 50).

#### **CLASS 28—TOYS AND SPORTING GOODS**

FOR PUPPETS AND STUFFED TOY ANIMALS (U.S. CLS. 22, 23, 38 AND 50).

#### **CLASS 35—ADVERTISING AND BUSINESS**

FOR ON-LINE RETAIL STORE SERVICES FEATURING PUPPETS, STUFFED ANIMALS, GARDENING KITS, SEEDS, BOOKS, AND OTHER MERCHANDISE DIRECTED TOWARDS CHILDREN (U.S. CLS. 100, 101 AND 102).

#### **CLASS 41—EDUCATION AND ENTERTAINMENT**

FOR PROVIDING A SERIES OF SHORT SHOWS AND STORIES FEATURING EDUCATIONAL TOPICS RELATING TO NUTRITION AND WELLNESS PROVIDED THROUGH BROADCAST AND CABLE TELEVISION, MOVIES, AND WEBCASTS (U.S. CLS. 100, 101 AND 107).  
ERIC SABLE, EXAMINING ATTORNEY

SN 86-219,389. AESTHETICALLY WRIGHT I, L.P., PLANO, TX. FILED 3-12-2014.

## **WRIGHT BEAUTY BAR**

THE MARK CONSISTS OF STANDARD CHARACTERS WITHOUT CLAIM TO ANY PARTICULAR FONT, STYLE, SIZE, OR COLOR.

OWNER OF U.S. REG. NOS. 3,321,818 AND 3,450,664.

NO CLAIM IS MADE TO THE EXCLUSIVE RIGHT TO USE "BEAUTY BAR", APART FROM THE MARK AS SHOWN.

#### **CLASS 35—ADVERTISING AND BUSINESS**

FOR RETAIL STORE AND ON-LINE RETAIL STORE SERVICES FEATURING A FULL LINE OF BEAUTY PRODUCTS AND SKIN CARE PRODUCTS; COMMERCIAL INFORMATION IN THE FIELD OF HEALTH AND BEAUTY AS IT RELATES TO COSMETICS, SKIN CARE PRODUCTS AND SKIN CARE TREATMENT SERVICES (U.S. CLS. 100, 101 AND 102).

#### **CLASS 44—MEDICAL, BEAUTY AND AGRICULTURAL SERVICES**

FOR MEDICAL SERVICES, NAMELY, LASER HAIR REMOVAL, AND MICRODERMABRASION; COSMETIC SKIN AND HAIR CARE SERVICES, NAMELY, CHEMICAL PEELS, ACNE TREATMENTS, MICRODERMABRASION TREATMENTS, LASER PROCEDURES FOR THE REMOVAL OF WRINKLES, CAPILLARIES, RED SPOTS, BROWN SPOTS, AGE SPOTS, SPIDER VEINS, FACIAL AND BODY HAIR, LASER PROCEDURES FOR STIMULATING COLLAGEN PRODUCTION, EVENING SKIN TONE AND SKIN RESURFACING; RENDERING CONSULTATION AND ADVISORY SERVICES IN CONNECTION WITH THE AFORESAID; BEAUTY SALON SERVICES; HEALTH SPA SERVICES, NAMELY, MASSAGE SERVICES AND COSMETIC BODY CARE SERVICES; MEDICAL SERVICES FOR COSMETIC PURPOSES; PROVIDING INFORMATION IN THE FIELD OF FACIAL AESTHETIC, COSMETIC SURGERY, PLASTIC SURGERY, MICRODERMABRASION, LASER TREATMENT, NAMELY, SCLEROTHERAPY AND HAIR REMOVAL, TREATMENT OF FATTY DEPOSITS USING ULTRASOUND; MEDICAL DIAGNOSTIC SERVICES, NAMELY, PROVIDING ULTRASOUND SCREENING AND DIAGNOSIS, MEASUREMENT OF SKIN AND HAIR CONDITION; HYGIENIC AND BEAUTY SERVICES FOR SKIN, NAMELY, TREATMENT, HEALTH RESTORATION, CARE THERAPY, TIMED APPLICATION OF GELS, CLEANSERS, LIGHTENERS, EXFOLIANTS, BLENDERS, TONERS AND CREAMS; SKIN CARE SALON; SKIN MASSAGE THERAPY; HEALTH SPA SERVICES FOR BODY AND SKIN TREATMENTS, NAMELY, MESSAGES, APPLICATIONS OF LOTIONS AND COMPOSITIONS INCLUDING SKIN LIGHTENERS, SKIN MASKS, ANTIOXIDANT TREATMENTS, SKIN PEELS, PREOPERATIVE SKIN CARE, POST-OPERATIVE CAMOUFLAGE MAKE-UP, DEEP CLEANSING FACIAL TREATMENTS, MANICURES, PEDICURES, FACE AND BODY WAXING, HAIR DESIGN, COLOR, PERMS AND FULL BODY MASSAGE, FACIALS; BEAUTY SALON SERVICES FOR PROVIDING HAIR CARE, HAIR COLORING, MANICURES, PEDICURES, AND MAKEUP (U.S. CLS. 100 AND 101).  
PARKER HOWARD, EXAMINING ATTORNEY

SN 86-219,869. INNOVATION LOFT, INC., MAHWAH, NJ. FILED 3-13-2014.

## **INNOVATION LOFT**

THE MARK CONSISTS OF STANDARD CHARACTERS WITHOUT CLAIM TO ANY PARTICULAR FONT, STYLE, SIZE, OR COLOR.

NO CLAIM IS MADE TO THE EXCLUSIVE RIGHT TO USE "LOFT", APART FROM THE MARK AS SHOWN.

#### **CLASS 35—ADVERTISING AND BUSINESS**

FOR BUSINESS CONSULTING AND INFORMATION SERVICES; INCUBATION SERVICES, NAMELY, PROVIDING WORK SPACE CONTAINING BUSINESS EQUIPMENT TO FREELANCERS, START-UPS, EXISTING BUSINESSES AND NON-PROFITS; PROVIDING FACILITIES FOR BUSINESS MEETINGS (U.S. CLS. 100, 101 AND 102).

FIRST USE 2-1-2013; IN COMMERCE 8-25-2013.

#### **CLASS 36—INSURANCE AND FINANCIAL**

FOR INCUBATION SERVICES, NAMELY, RENTAL OF OFFICE SPACE TO FREELANCERS, START-UPS, EXISTING BUSINESSES AND NON-PROFITS (U.S. CLS. 100, 101 AND 102).

FIRST USE 2-1-2013; IN COMMERCE 8-25-2013.  
ELLEN PERKINS, EXAMINING ATTORNEY

SN 86-220,026. DHANUKUMAR AND DILCIA RAMROOP,  
COLUMBUS, GA. FILED 3-13-2014.

## IKM Imports and Exports

THE MARK CONSISTS OF STANDARD CHARACTERS WITHOUT CLAIM TO ANY PARTICULAR FONT, STYLE, SIZE, OR COLOR.

NO CLAIM IS MADE TO THE EXCLUSIVE RIGHT TO USE "IMPORTS AND EXPORTS", APART FROM THE MARK AS SHOWN.

### CLASS 18—LEATHER GOODS

FOR HANDBAGS, PURSES AND WALLETS; LEATHER PURSES (U.S. CLS. 1, 2, 3, 22 AND 41).

### CLASS 26—FANCY GOODS

FOR HAIR EXTENSIONS; HAIR ORNAMENTS; HAIR PIECES AND WIGS; HAIR WEAVES (U.S. CLS. 37, 39, 40, 42 AND 50).

CURTIS FRENCH, EXAMINING ATTORNEY

SN 86-220,155. POST-NEWSWEEK STATIONS, INC., DETROIT, MI. FILED 3-13-2014.



THE MARK CONSISTS OF A STYLIZED LETTER "G".

### CLASS 9—ELECTRICAL AND SCIENTIFIC APPARATUS

FOR COMPUTER APPLICATION SOFTWARE FOR MOBILE DEVICES, NAMELY, SOFTWARE FOR VIEWING INFORMATION IN THE FIELDS OF NEWS, POLITICS, WEATHER, SPORTS, BUSINESS, HEALTH, REAL ESTATE, ENTERTAINMENT, TRAVEL, AND CLASSIFIED ADVERTISING (U.S. CLS. 21, 23, 26, 36 AND 38).

### CLASS 35—ADVERTISING AND BUSINESS

FOR PROVIDING A WEBSITE FEATURING INFORMATION IN THE FIELDS OF POLITICS, BUSINESS AND CLASSIFIED ADVERTISING (U.S. CLS. 100, 101 AND 102).

### CLASS 36—INSURANCE AND FINANCIAL

FOR PROVIDING A WEBSITE FEATURING INFORMATION IN THE FIELD OF REAL ESTATE (U.S. CLS. 100, 101 AND 102).

### CLASS 38—COMMUNICATION

FOR TELEVISION BROADCASTING SERVICES (U.S. CLS. 100, 101 AND 104).

### CLASS 39—TRANSPORTATION AND STORAGE

FOR PROVIDING A WEBSITE FEATURING INFORMATION IN THE FIELD OF TRAVEL (U.S. CLS. 100 AND 105).

### CLASS 41—EDUCATION AND ENTERTAINMENT

FOR PROVIDING A WEBSITE FEATURING INFORMATION IN THE FIELD OF SPORTS AND ENTERTAINMENT (U.S. CLS. 100, 101 AND 107).

### CLASS 42—SCIENTIFIC AND COMPUTER SERVICES

FOR PROVIDING A WEBSITE FEATURING INFORMATION IN THE FIELD OF WEATHER (U.S. CLS. 100 AND 101).

### CLASS 44—MEDICAL, BEAUTY AND AGRICULTURAL SERVICES

FOR PROVIDING A WEBSITE FEATURING INFORMATION IN THE FIELD OF HEALTH (U.S. CLS. 100 AND 101).

MARGERY A. TIERNEY, EXAMINING ATTORNEY

SN 86-220,393. BEDESSEE IMPORTS LTD., TORONTO, ONTARIO, CANADA, FILED 3-13-2014.

## DEMERARA GOLD

THE MARK CONSISTS OF STANDARD CHARACTERS WITHOUT CLAIM TO ANY PARTICULAR FONT, STYLE, SIZE, OR COLOR.

OWNER OF CANADA REG. NO. TMA808867, DATED 10-12-2011, EXPIRES 10-12-2026.

NO CLAIM IS MADE TO THE EXCLUSIVE RIGHT TO USE "DEMERARA", APART FROM THE MARK AS SHOWN.

### CLASS 29—MEATS AND PROCESSED FOODS

FOR (BASED ON USE IN COMMERCE) EDIBLE OILS AND FATS; FROZEN FISH, SMOKED FISH, FISH FILLETS (U.S. CL. 46).

FIRST USE 1-31-1984; IN COMMERCE 12-31-1988.

### CLASS 30—STAPLE FOODS

FOR (BASED ON 44(E)) RICE; (BASED ON USE IN COMMERCE) RICE; FLAVOURINGS AND SEASONINGS (U.S. CL. 46).

FIRST USE 1-31-1984; IN COMMERCE 12-31-1990.  
KEVIN MITTLER, EXAMINING ATTORNEY

SN 86-220,428. COLLEGE OF THE HOLY CROSS, WORCESTER, MA. FILED 3-13-2014.

SN 86-220,501. RAW IRON CHOPPERS, LLC, CHARDON, OH. FILED 3-13-2014.

COLLEGIUM A COLLOQUY ON  
FAITH AND INTELLECTUAL LIFE

THE MARK CONSISTS OF STANDARD CHARACTERS WITHOUT CLAIM TO ANY PARTICULAR FONT, STYLE, SIZE, OR COLOR.

NO CLAIM IS MADE TO THE EXCLUSIVE RIGHT TO USE "FAITH", APART FROM THE MARK AS SHOWN.

THE WORDING "COLLEGIUM A" HAS NO MEANING IN A FOREIGN LANGUAGE.

**CLASS 41—EDUCATION AND ENTERTAINMENT**

FOR ARRANGING AND CONDUCTING EDUCATIONAL CONFERENCES IN THE FIELD OF CATHOLICISM AND HIGHER EDUCATION; PROVIDING A WEBSITE FEATURING INFORMATION IN THE FIELD OF HIGHER EDUCATION (U.S. CLS. 100, 101 AND 107).  
FIRST USE 1-0-1992; IN COMMERCE 1-0-1992.

**CLASS 45—PERSONAL AND LEGAL SERVICES**

FOR PROVIDING A WEBSITE FEATURING INFORMATION IN THE FIELD OF CATHOLICISM (U.S. CLS. 100 AND 101).

FIRST USE 9-0-1992; IN COMMERCE 9-0-1992.  
LINDA MICKLEBURGH, EXAMINING ATTORNEY

SN 86-220,469. THETFORD CORPORATION, ANN ARBOR, MI. FILED 3-13-2014.

TOSS-INS

THE MARK CONSISTS OF STANDARD CHARACTERS WITHOUT CLAIM TO ANY PARTICULAR FONT, STYLE, SIZE, OR COLOR.

**CLASS 1—CHEMICALS**

FOR CHEMICAL PREPARATIONS, NAMELY, ODOR ELIMINATING WATER-SOLUBLE FILM SACHETS TO BE DISSOLVED IN WATER FOR USE IN PREVENTING ODOR IN TOILET HOLDING TANKS FOR RECREATIONAL VEHICLES, BOATS, AND CAMPING EQUIPMENT; CHEMICAL ADDITIVES FOR TISSUE DIGESTION IN TOILET HOLDING TANKS FOR RECREATIONAL VEHICLES, BOATS, AND CAMPING EQUIPMENT, NAMELY, WATER SOLUBLE FILM SACHETS TO BE DISSOLVED IN WATER AND USED TO DIGEST ORGANIC WASTE (U.S. CLS. 1, 5, 6, 10, 26 AND 46).  
FIRST USE 1-1-1981; IN COMMERCE 1-1-1981.

**CLASS 5—PHARMACEUTICALS**

FOR ODOR NEUTRALIZING PREPARATIONS FOR USE IN TOILET HOLDING TANKS FOR RECREATIONAL VEHICLES, BOATS, AND CAMPING EQUIPMENT (U.S. CLS. 6, 18, 44, 46, 51 AND 52).

FIRST USE 1-1-1981; IN COMMERCE 1-1-1981.  
PARKER HOWARD, EXAMINING ATTORNEY

RAW IRON CHOPPERS

THE MARK CONSISTS OF STANDARD CHARACTERS WITHOUT CLAIM TO ANY PARTICULAR FONT, STYLE, SIZE, OR COLOR.

NO CLAIM IS MADE TO THE EXCLUSIVE RIGHT TO USE "CHOPPERS", APART FROM THE MARK AS SHOWN.

**CLASS 25—CLOTHING**

FOR SWEATSHIRTS; T-SHIRTS (U.S. CLS. 22 AND 39).  
FIRST USE 8-1-2008; IN COMMERCE 8-1-2008.

**CLASS 40—MATERIAL TREATMENT**

FOR CUSTOM BUILDING OF MOTORCYCLES (U.S. CLS. 100, 103 AND 106).  
FIRST USE 1-23-2004; IN COMMERCE 1-23-2004.  
ELLEN PERKINS, EXAMINING ATTORNEY

SN 86-220,547. GIRLSASKGUYS, L.L.C., ST. LOUIS, MO. FILED 3-13-2014.

ELLASSABEN

THE MARK CONSISTS OF STANDARD CHARACTERS WITHOUT CLAIM TO ANY PARTICULAR FONT, STYLE, SIZE, OR COLOR.

THE ENGLISH TRANSLATION OF THE WORD "ELLASABEN" IN THE MARK IS "THEY KNOW".

**CLASS 9—ELECTRICAL AND SCIENTIFIC APPARATUS**

FOR DOWNLOADABLE MOBILE APPLICATIONS FOR VIEWING AND POSTING QUESTIONS AND OPINIONS ON A VARIETY OF TOPICS (U.S. CLS. 21, 23, 26, 36 AND 38).

**CLASS 42—SCIENTIFIC AND COMPUTER SERVICES**

FOR PROVIDING A WEBSITE FEATURING TECHNOLOGY THAT ENABLES USERS TO COMMUNICATE WITH EACH OTHER ON A RANGE OF TOPICS BY POSTING AND VIEWING QUESTIONS AND OPINIONS (U.S. CLS. 100 AND 101).

SIDDHARTH JAGANNATHAN, EXAMINING ATTORNEY



SN 86-220,786. HOMEFREE NEVADA, DBA ENERGYFIT NEVADA, LAS VEGAS, NV. FILED 3-13-2014.



NO CLAIM IS MADE TO THE EXCLUSIVE RIGHT TO USE "NEVADA", APART FROM THE MARK AS SHOWN. THE COLOR(S) BLUE, RED AND WHITE IS/ARE CLAIMED AS A FEATURE OF THE MARK.

THE MARK CONSISTS OF THE STYLIZED WORDING "ENERGYFIT" WITH "ENERGY" IN BLUE AND "FIT" IN RED. THE STYLIZED WORD "NEVADA" APPEARS BELOW IN RED WITH TWO HORIZONTAL BLUE LINES APPEARING ON EACH SIDE OF THE WORD. ABOVE THE WORDING "ENERGYFIT" IS A DESIGN OF A HOUSE IN WHITE AND BLUE ON TOP OF A BLUE SHADED SQUARE WITH ROUNDED SIDES. THE WHITE AREA BEHIND THE MARK REPRESENTS BACKGROUND OR TRANSPARENCY AND IS NOT A FEATURE OF THE MARK.

#### CLASS 35—ADVERTISING AND BUSINESS

FOR CONSULTING SERVICES IN THE FIELDS OF ENERGY CONSUMPTION AND USAGE CONSERVATION TO IMPROVE ENERGY EFFICIENCY; ENERGY USAGE MANAGEMENT INFORMATION SERVICES; INFORMATION IN THE FIELD OF ENERGY EFFICIENCY; PROVISION OF INFORMATION, ADVICE AND CONSULTANCY IN RELATION TO ENERGY EFFICIENCY (U.S. CLS. 100, 101 AND 102).

FIRST USE 1-1-2012; IN COMMERCE 1-1-2012.

#### CLASS 37—CONSTRUCTION AND REPAIR

FOR HOME ENERGY ASSESSMENT SERVICES FOR THE PURPOSE OF DETERMINING HOME IMPROVEMENTS NEEDED TO IMPROVE ENERGY USE AND EFFICIENCY (U.S. CLS. 100, 103 AND 106).

FIRST USE 1-1-2012; IN COMMERCE 1-1-2012.

DAVID ALESKOW, EXAMINING ATTORNEY

SN 86-221,002. CARESOURCE, DAYTON, OH. FILED 3-14-2014.



OWNER OF U.S. REG. NOS. 3,777,661 AND 3,822,507. THE COLOR(S) PURPLE IS/ARE CLAIMED AS A FEATURE OF THE MARK.

THE MARK CONSISTS OF A HEART IMAGE, WITH ONE HALF BEING A DARKER COLOR PURPLE AND THE OTHER HALF BEING A LIGHTER COLOR PURPLE.

#### CLASS 35—ADVERTISING AND BUSINESS

FOR BUSINESS ADMINISTRATION OF HEALTH MAINTENANCE ORGANIZATIONS; CUSTOMER SERVICES, NAMELY, RESPONDING TO CUSTOMERS INQUIRIES FOR OTHERS IN THE FIELD OF HEALTH INSURANCE, PROVIDED BY MEANS OF A CALL CENTER, THE INTERNET AND THE POSTAL SERVICES; BUSINESS ADMINISTRATION AND MANAGEMENT, NAMELY, ADMINISTRATIVE SERVICES FOR THE PUBLIC HEALTH SECTOR IN THE NATURE OF GENERAL ADMINISTRATION, NAMELY, MANAGEMENT OF HEALTH CARE CLINICS FOR OTHERS; HEALTH CARE UTILIZATION AND REVIEW SERVICES; CASE AND MEDICAL MANAGEMENT, NAMELY, HEALTH CARE COST CONTAINMENT; PROVIDER RELATIONS SERVICES, NAMELY, REQUESTING HEALTH CARE PROVIDER PRIVILEGES FROM HEALTH CARE INSTITUTIONS ON BEHALF OF PHYSICIANS AND HEALTH CARE PROVIDERS; CALL CENTERS SERVICES, NAMELY, OPERATION OF TELEPHONE CALL CENTERS FOR OTHERS; PROVISION OF ADVERTISING SERVICES FOR OTHERS, NAMELY, THE DISTRIBUTION OF ADVERTISEMENTS FOR DISPLAY ON THE INTERNET THROUGH WEBSITES, SOCIAL MEDIA, EMAILS, MICROBLOGS, BLOGS, ELECTRONIC MESSAGES, INSTANT MESSAGES, TEXT MESSAGES, MULTIMEDIA MESSAGES, SOCIAL NETWORKS, STATUS UPDATES, FORUMS, AND ELECTRONIC BULLETIN BOARDS; CONSUMER RESEARCH SERVICES, NAMELY, CONDUCTING BUSINESS SURVEYS AND OUTREACH PROGRAMS TO OBTAIN CONSUMER FEEDBACK; MEDICAID-MANAGED CARE PLAN SERVICES AND MEDICARE/MEDICAID DUAL ELIGIBILITY PLAN SERVICES, NAMELY, RETAIL PHARMACY SERVICES, MAIL ORDER SERVICES FEATURING PRESCRIPTION DRUGS, ON-LINE ORDERING SERVICES FEATURING PRESCRIPTION DRUGS; COST MANAGEMENT FOR THE HEALTH BENEFIT PLANS OF OTHERS; ELECTRONIC PROCESSING OF HEALTH CARE INFORMATION, PHYSICIAN REFERRALS, UTILIZATION REVIEW AND PRE-CERTIFICATION SERVICES, AND BILLING ADMINISTRATION OF ACCOUNTS ON BEHALF OF OTHERS; ARRANGING AND CONDUCTING HEALTH AND WELLNESS INCENTIVE PROGRAMS TO PROMOTE IMPROVEMENT IN OUTCOMES FOR HEALTH PLAN ENROLLEES. DISTRIBUTION OF TANGIBLE OR VIRTUAL INCENTIVE AWARDS TO PROMOTE WELLNESS PROGRAMS AND HEALTHY LIFESTYLES IN THE NATURE OF STORED VALUE CARD SERVICES AND/OR STORED VALUE ELECTRONIC CERTIFICATE SERVICES (U.S. CLS. 100, 101 AND 102).

FIRST USE 4-0-2013; IN COMMERCE 4-0-2013.

#### CLASS 36—INSURANCE AND FINANCIAL

FOR INSURANCE UNDERWRITING IN THE FIELD OF HEALTH CARE IN THE NATURE OF RISK-BASED HEALTH INSURANCE SERVICES FOR LOW-INCOME INDIVIDUALS; ADMINISTRATION OF HEALTH CARE BENEFITS PLANS IN THE NATURE OF HEALTH MAINTENANCE ORGANIZATIONS; ADMINISTRATIVE SERVICES FOR THE PUBLIC HEALTH SECTOR, NAMELY, ADMINISTRATION OF PRE-PAID HEALTH CARE PLANS; HEALTH INSURANCE CLAIMS PROCESSING; PROVIDER RELATIONS, NAMELY, ADMINISTRATION OF PREFERRED PROVIDER PLANS IN THE FIELD OF HEALTH CARE; HEALTH INSURANCE ADMINISTRATION; PROVIDING HEALTH INSURANCE INFORMATION VIA THE INTERNET; PROVIDING FINANCIAL CONSULTATION IN THE FIELDS OF HEALTH CARE PLANS AND HEALTH CARE PLANNING; PROVIDING GRANTS TO ORGANIZATIONS DEDICATED TO ADDRESSING THE NEEDS OF THE UNDERSERVED (U.S. CLS. 100, 101 AND 102).

FIRST USE 4-0-2013; IN COMMERCE 4-0-2013.

**CLASS 41—EDUCATION AND ENTERTAINMENT**

FOR ON-LINE JOURNALS, NAMELY, BLOGS FEATURING INFORMATION AND DISCUSSIONS ABOUT HEALTH, HEALTHCARE PLANS, AND HEALTHCARE SERVICES; EDUCATIONAL SERVICES, NAMELY, PROVIDING WORKSHOPS AND TUTORIALS IN THE FIELD OF HEALTHCARE (U.S. CLS. 100, 101 AND 107).

FIRST USE 4-0-2013; IN COMMERCE 4-0-2013.

**CLASS 42—SCIENTIFIC AND COMPUTER SERVICES**

FOR ADMINISTRATIVE SERVICES FOR THE PUBLIC HEALTH SECTOR, NAMELY, QUALITY CONTROL FOR OTHERS; PROVIDING A WEBSITE FEATURING TECHNOLOGY THAT ENABLES PARTICIPANT MEMBERS TO ACCESS INSURANCE BENEFIT INFORMATION (U.S. CLS. 100 AND 101).

FIRST USE 4-0-2013; IN COMMERCE 4-0-2013.

**CLASS 44—MEDICAL, BEAUTY AND AGRICULTURAL SERVICES**

FOR TELEPHONE HOTLINE COUNSELING, NAMELY, OFFERING MEDICAL AND HEALTHCARE ADVICE; TELEPHONE INFORMATION SERVICE FEATURING INFORMATION IN THE FIELD OF MEDICAL AND HEALTHCARE ADVICE; MEDICAID MANAGED HEALTH CARE SERVICES; HEALTHCARE SERVICES, NAMELY, PROVIDING A HEALTHCARE MANAGEMENT PROGRAM OFFERING INFORMATION IN THE FIELD OF MEDICAL AND HEALTHCARE ADVICE, FITNESS EVALUATION, AND CONSULTATION TO INDIVIDUALS TO IMPROVE THEIR OVERALL HEALTH AND TO HELP ASSIST THEM IN DECISIONS RELATIVE TO HEALTH, WELLNESS, AND NUTRITION (U.S. CLS. 100 AND 101).

FIRST USE 4-0-2013; IN COMMERCE 4-0-2013.

**CLASS 45—PERSONAL AND LEGAL SERVICES**

FOR REGULATORY COMPLIANCE SERVICES, NAMELY, REVIEWING STANDARDS AND PRACTICES TO ASSURE COMPLIANCE WITH HEALTH CARE LAWS AND REGULATIONS (U.S. CLS. 100 AND 101).

FIRST USE 4-0-2013; IN COMMERCE 4-0-2013.

GIANCARLO CASTRO, EXAMINING ATTORNEY

**CLASS 35—ADVERTISING AND BUSINESS**

FOR BUSINESS ADMINISTRATION OF HEALTH MAINTENANCE ORGANIZATIONS; CUSTOMER SERVICES, NAMELY, RESPONDING TO CUSTOMERS INQUIRIES FOR OTHERS IN THE FIELD OF HEALTH INSURANCE, PROVIDED BY MEANS OF A CALL CENTER, THE INTERNET AND THE POSTAL SERVICES; BUSINESS ADMINISTRATION AND MANAGEMENT, NAMELY, ADMINISTRATIVE SERVICES FOR THE PUBLIC HEALTH SECTOR IN THE NATURE OF GENERAL ADMINISTRATION, NAMELY, MANAGEMENT OF HEALTH CARE CLINICS FOR OTHERS; HEALTH CARE UTILIZATION AND REVIEW SERVICES; CASE AND MEDICAL MANAGEMENT, NAMELY, HEALTH CARE COST CONTAINMENT; PROVIDER RELATIONS SERVICES, NAMELY, REQUESTING HEALTH CARE PROVIDER PRIVILEGES FROM HEALTH CARE INSTITUTIONS ON BEHALF OF PHYSICIANS AND HEALTH CARE PROVIDERS; CALL CENTERS SERVICES, NAMELY, OPERATION OF TELEPHONE CALL CENTERS FOR OTHERS; PROVISION OF ADVERTISING SERVICES FOR OTHERS, NAMELY, THE DISTRIBUTION OF ADVERTISEMENTS FOR DISPLAY ON THE INTERNET THROUGH WEBSITES, SOCIAL MEDIA, EMAILS, MICROBLOGS, BLOGS, ELECTRONIC MESSAGES, INSTANT MESSAGES, TEXT MESSAGES, MULTIMEDIA MESSAGES, SOCIAL NETWORKS, STATUS UPDATES, FORUMS, AND ELECTRONIC BULLETIN BOARDS; CONSUMER RESEARCH SERVICES, NAMELY, CONDUCTING BUSINESS SURVEYS AND OUTREACH PROGRAMS TO OBTAIN CONSUMER FEEDBACK; MEDICAID-MANAGED CARE PLAN SERVICES AND MEDICARE/MEDICAID DUAL ELIGIBILITY PLAN SERVICES, NAMELY, RETAIL PHARMACY SERVICES, MAIL ORDER SERVICES FEATURING PRESCRIPTION DRUGS, ON-LINE ORDERING SERVICES FEATURING PRESCRIPTION DRUGS; COST MANAGEMENT FOR THE HEALTH BENEFIT PLANS OF OTHERS; ELECTRONIC PROCESSING OF HEALTH CARE INFORMATION, PHYSICIAN REFERRALS, UTILIZATION REVIEW AND PRE-CERTIFICATION SERVICES, AND BILLING ADMINISTRATION OF ACCOUNTS ON BEHALF OF OTHERS; ARRANGING AND CONDUCTING HEALTH AND WELLNESS INCENTIVE PROGRAMS TO PROMOTE IMPROVEMENT IN OUTCOMES FOR HEALTH PLAN ENROLLEES, DISTRIBUTION OF TANGIBLE OR VIRTUAL INCENTIVE AWARDS TO PROMOTE WELLNESS PROGRAMS AND HEALTHY LIFESTYLES IN THE NATURE OF STORED VALUE CARD SERVICES AND/OR STORED VALUE ELECTRONIC CERTIFICATE SERVICES (U.S. CLS. 100, 101 AND 102).

FIRST USE 4-0-2013; IN COMMERCE 4-0-2013.

SN 86-221,004. CARESOURCE, DAYTON, OH. FILED 3-14-2014.



OWNER OF U.S. REG. NOS. 2,785,521, 3,822,507 AND OTHERS.

THE COLOR(S) PURPLE AND TEAL IS/ARE CLAIMED AS A FEATURE OF THE MARK.

THE MARK CONSISTS OF THE STYLIZED TEXT "CARE-SOURCE" IN TEAL; BETWEEN THE LETTERS "E" AND "S" IS A HEART IMAGE, WITH ONE HALF OF IT BEING LIGHTER PURPLE AND THE OTHER HALF BEING DARKER PURPLE.

**CLASS 36—INSURANCE AND FINANCIAL**

FOR INSURANCE UNDERWRITING IN THE FIELD OF HEALTH CARE IN THE NATURE OF RISK-BASED HEALTH INSURANCE SERVICES FOR LOW-INCOME INDIVIDUALS; ADMINISTRATION OF HEALTH CARE BENEFITS PLANS IN THE NATURE OF HEALTH MAINTENANCE ORGANIZATIONS; ADMINISTRATIVE SERVICES FOR THE PUBLIC HEALTH SECTOR, NAMELY, ADMINISTRATION OF PRE-PAID HEALTH CARE PLANS; HEALTH INSURANCE CLAIMS PROCESSING; PROVIDER RELATIONS, NAMELY, ADMINISTRATION OF PREFERRED PROVIDER PLANS IN THE FIELD OF HEALTH CARE; HEALTH INSURANCE ADMINISTRATION; PROVIDING HEALTH INSURANCE INFORMATION VIA THE INTERNET; PROVIDING FINANCIAL CONSULTATION IN THE FIELDS OF HEALTH CARE PLANS AND HEALTH CARE PLANNING; PROVIDING GRANTS TO ORGANIZATIONS DEDICATED TO ADDRESSING THE NEEDS OF THE UNDERSERVED (U.S. CLS. 100, 101 AND 102).

FIRST USE 4-0-2013; IN COMMERCE 4-0-2013.

**CLASS 41—EDUCATION AND ENTERTAINMENT**

FOR ON-LINE JOURNALS, NAMELY, BLOGS FEATURING INFORMATION AND DISCUSSIONS ABOUT HEALTH, HEALTHCARE PLANS, AND HEALTHCARE SERVICES; EDUCATIONAL SERVICES, NAMELY, PROVIDING WORKSHOPS AND TUTORIALS IN THE FIELD OF HEALTHCARE (U.S. CLS. 100, 101 AND 107).

FIRST USE 4-0-2013; IN COMMERCE 4-0-2013.

**CLASS 42—SCIENTIFIC AND COMPUTER SERVICES**

FOR ADMINISTRATIVE SERVICES FOR THE PUBLIC HEALTH SECTOR, NAMELY, QUALITY CONTROL FOR OTHERS; PROVIDING A WEBSITE FEATURING TECHNOLOGY THAT ENABLES PARTICIPANT MEMBERS TO ACCESS INSURANCE BENEFIT INFORMATION (U.S. CLS. 100 AND 101).

FIRST USE 4-0-2013; IN COMMERCE 4-0-2013.

**CLASS 44—MEDICAL, BEAUTY AND AGRICULTURAL SERVICES**

FOR TELEPHONE HOTLINE COUNSELING, NAMELY, OFFERING MEDICAL AND HEALTHCARE ADVICE; TELEPHONE INFORMATION SERVICE FEATURING INFORMATION IN THE FIELD OF MEDICAL AND HEALTHCARE ADVICE; MEDICAID MANAGED HEALTH CARE SERVICES; HEALTHCARE SERVICES, NAMELY, PROVIDING A HEALTHCARE MANAGEMENT PROGRAM OFFERING INFORMATION IN THE FIELD OF MEDICAL AND HEALTHCARE ADVICE, FITNESS EVALUATION, AND CONSULTATION TO INDIVIDUALS TO IMPROVE THEIR OVERALL HEALTH AND TO HELP ASSIST THEM IN DECISIONS RELATIVE TO HEALTH, WELLNESS, AND NUTRITION (U.S. CLS. 100 AND 101).

FIRST USE 4-0-2013; IN COMMERCE 4-0-2013.

**CLASS 45—PERSONAL AND LEGAL SERVICES**

FOR REGULATORY COMPLIANCE SERVICES, NAMELY, REVIEWING STANDARDS AND PRACTICES TO ASSURE COMPLIANCE WITH HEALTH CARE LAWS AND REGULATIONS (U.S. CLS. 100 AND 101).

FIRST USE 4-0-2013; IN COMMERCE 4-0-2013.

GIANCARLO CASTRO, EXAMINING ATTORNEY

SN 86-221,233. POISON DAWG PRODUCTION, LLC, ALEXANDRIA, VA. FILED 3-14-2014.



NO CLAIM IS MADE TO THE EXCLUSIVE RIGHT TO USE "PRODUCTION", APART FROM THE MARK AS SHOWN.

THE MARK CONSISTS OF THE HEAD OF A DOG IN PARTIAL PROFILE FEATURING SHADOWING ON ITS NOSE, OVER ITS EYES, AND ON ITS JAW LINE. THE DOG WEARS A SPIKED COLLAR, AND THE HEAD IS SUPERIMPOSED UPON A PAIR OF CROSS-BONES. THE DOG HAS ITS MOUTH OPEN EXPOSING ITS TONGUE AND SHARP

TEETH, AND TWO "X"'S COVER ITS EYES. THE WORDS "POISON DAWG" ARE ARRANGED IN CURVED UPPER AND LOWER CASE PRINT ABOVE THE DOG'S HEAD, WITH A PAW PRINT IMAGE AS THE DOT TO THE "I" IN THE WORD "POISON". THE WORD "PRODUCTION", IN SOLID, UPPER AND LOWER CASE PRINT, IS CENTERED DIRECTLY BELOW THE DOG'S HEAD. THE DOG'S HEAD AND COLLAR, AND THE BONES IT IS SUPERIMPOSED UPON, ARE ALL OUTLINED WITH A DOUBLE LINE; THE WORDS "POISON DAWG" ARE OUTLINED WITH A SINGLE LINE.

**CLASS 25—CLOTHING**

FOR BASEBALL CAPS AND HATS; GRAPHIC T-SHIRTS; SPORTS CAPS AND HATS; T-SHIRTS (U.S. CLS. 22 AND 39).

**CLASS 41—EDUCATION AND ENTERTAINMENT**

FOR ENTERTAINMENT SERVICES IN THE NATURE OF RECORDING, PRODUCTION AND POST-PRODUCTION SERVICES IN THE FIELD OF MUSIC; MUSIC PRODUCTION SERVICES; RECORD PRODUCTION (U.S. CLS. 100, 101 AND 107).

ZHALEH DELANEY, EXAMINING ATTORNEY

SN 86-221,553. GENESIS PHYSICAL THERAPY, INC., DENVER, CO. FILED 3-14-2014.

# SymFit

THE MARK CONSISTS OF STANDARD CHARACTERS WITHOUT CLAIM TO ANY PARTICULAR FONT, STYLE, SIZE, OR COLOR.

**CLASS 41—EDUCATION AND ENTERTAINMENT**

FOR PILATES INSTRUCTION; PROVIDING A WEBSITE FEATURING INFORMATION ABOUT FITNESS AND EXERCISE THAT CAN ASSIST IN MAINTAINING A HEALTHY SPINE, ASSIST IN AGING IN A HEALTHY MANNER AND CAN ASSIST WITH INJURY PREVENTION; PROVIDING FITNESS CLASSES AND INSTRUCTION FOCUSED ON MAINTAINING A HEALTHY SPINE, HEALTHY AGING AND INJURY PREVENTION; PROVIDING FITNESS AND EXERCISE CLASSES OFFERED THROUGH ONLINE, NON-DOWNLOADABLE VIDEOS (U.S. CLS. 100, 101 AND 107).

**CLASS 44—MEDICAL, BEAUTY AND AGRICULTURAL SERVICES**

FOR PROVIDING A WEBSITE FEATURING HEALTH CARE INFORMATION TO ASSIST IN MAINTAINING A HEALTHY SPINE, ASSIST IN AGING IN A HEALTHY MANNER AND CAN ASSIST WITH INJURY PREVENTION; PHYSICAL THERAPY SERVICES; WELLNESS AND HEALTH-RELATED CONSULTING SERVICES (U.S. CLS. 100 AND 101).

KELLEY WELLS, EXAMINING ATTORNEY

SN 86-221,870. ONE INC., SALINA, KS. FILED 3-14-2014.

**ONE**  
TV

NO CLAIM IS MADE TO THE EXCLUSIVE RIGHT TO USE "TV", APART FROM THE MARK AS SHOWN. THE MARK CONSISTS OF THE STYLIZED WORDING "ONE TV".

**CLASS 35—ADVERTISING AND BUSINESS**

FOR PROVIDING AN ON-LINE COMPUTER DATABASE FEATURING TRADE INFORMATION IN THE FIELD OF BUILDING, REAL ESTATE, HEALTHCARE, SENIORS, VETERANS, ENERGY, ENVIRONMENTALLY FRIENDLY GOODS AND SERVICES, AND TECHNOLOGY (U.S. CLS. 100, 101 AND 102).

**CLASS 37—CONSTRUCTION AND REPAIR**

FOR HOUSING SERVICES, NAMELY, DEVELOPMENT OF REAL PROPERTY, NAMELY, LOCATION, REPAIR, IMPROVEMENT, AND NEW CONSTRUCTION (U.S. CLS. 100, 103 AND 106).

B. PARADEWELAI, EXAMINING ATTORNEY

SN 86-222,644. NAMBIAR SUDHIR, FREMONT, CA. FILED 3-17-2014.

**Mobinar**

THE MARK CONSISTS OF STANDARD CHARACTERS WITHOUT CLAIM TO ANY PARTICULAR FONT, STYLE, SIZE, OR COLOR.

**CLASS 9—ELECTRICAL AND SCIENTIFIC APPARATUS**

FOR COMPUTER APPLICATION SOFTWARE FOR MOBILE PHONES, NAMELY, SOFTWARE FOR PREPARING, PROVIDING, AND USING SEMINARS AND PRESENTATIONS; COMPUTER SOFTWARE FOR COMMUNICATING WITH USERS OF HAND-HELD COMPUTERS; COMPUTER SOFTWARE FOR CREATING SEARCHABLE DATABASES OF INFORMATION AND DATA; COMPUTER SOFTWARE FOR MANIPULATING DIGITAL AUDIO INFORMATION FOR USE IN AUDIO MEDIA APPLICATIONS; COMPUTER SOFTWARE FOR ORGANIZING AND VIEWING DIGITAL IMAGES AND PHOTOGRAPHS; COMPUTER SOFTWARE FOR THE COLLECTION, EDITING, ORGANIZING, MODIFYING, BOOK MARKING, TRANSMISSION, STORAGE AND SHARING OF DATA AND INFORMATION; COMPUTER SOFTWARE FOR WIRELESS CONTENT DELIVERY; COMPUTER SOFTWARE FOR PREPARING, PROVIDING, AND USING ONLINE SEMINARS AND PRESENTATIONS; COMPUTER SOFTWARE THAT PROVIDES REAL-TIME, INTEGRATED BUSINESS MANAGEMENT INTELLIGENCE BY COMBINING INFORMATION FROM VARIOUS DATABASES AND PRESENTING IT IN AN EASY-TO-UNDERSTAND USER INTERFACE; COMPUTER SOFTWARE TO ENHANCE THE AUDIO-VISUAL CAPABILITIES OF MULTIMEDIA APPLICATIONS, NAMELY, FOR THE INTEGRATION OF TEXT, AUDIO, GRAPHICS, STILL IMAGES AND MOVING PICTURES; DOWNLOADABLE AUDIO FILES, MULTIMEDIA FILES, TEXT FILES, E-MAILS, WRITTEN DOCUMENTS, AUDIO MATERIAL, VIDEO MATERIAL AND GAMES FEATURING INFORMATION IN THE FORM OF DOWNLOADABLE SHORT EDUCATIONAL/ TRAINING COMMUNICATIONS IN THE FIELD OF HUMAN RESOURCE DEVELOPMENT FOR THE PROMOTION OF EMPLOYEE RETENTION, CAREER GROWTH AND INCREASED PRODUCTIVITY FOR EMPLOYEES AND EMPLOYERS; DOWNLOADABLE EDUCATIONAL COURSE MATERIALS IN THE FIELD OF COMPUTERS, FINANCE, BUSINESS, PROFESSIONAL DEVELOPMENT, ARTS, UTILITIES, TRANSPORTATION, CONSTRUCTION; DOWNLOADABLE MOBILE APPLICATIONS FOR PREPARING, PROVIDING, AND USING ONLINE SEMINARS AND PRESENTATIONS; DOWNLOADABLE SOFTWARE IN THE NATURE OF A MOBILE APPLICATION FOR PREPARING, PROVIDING, AND USING ONLINE SEMINARS AND PRESENTATIONS (U.S. CLS. 21, 23, 26, 36 AND 38).

**CLASS 16—PAPER GOODS AND PRINTED MATTER**

FOR PUBLICATIONS, NAMELY, BROCHURES, BOOKLETS, AND TEACHING MATERIALS IN THE FIELD OF COMPUTERS, FINANCE, BUSINESS, PROFESSIONAL DEVELOPMENT, ARTS (U.S. CLS. 2, 5, 22, 23, 29, 37, 38 AND 50).

**CLASS 35—ADVERTISING AND BUSINESS**

FOR AD SERVING, NAMELY, PLACING ADVERTISEMENTS ON WEBSITES FOR OTHERS USING SPECIALIZED COMPUTER SOFTWARE; ADVERTISEMENT AND PUBLICITY SERVICES BY INTERNET; ADVERTISEMENT FOR OTHERS ON THE INTERNET; ADVERTISEMENT VIA MOBILE PHONE NETWORKS; ADVERTISING AND ADVERTISEMENT SERVICES; ADVERTISING AND BUSINESS SERVICES, NAMELY, SECURING AIRTIME ON ALL FORMS OF MEDIA COMMUNICATIONS STATIONS, SYSTEMS, NETWORKS, AND SERVICES FOR THE PURPOSE OF PROMOTING THE GOODS AND SERVICES OF OTHERS; ADVERTISING AND COMMERCIAL INFORMATION SERVICES, VIA THE INTERNET; ADVERTISING AND MARKETING; ADVERTISING AND PROMOTIONAL SERVICES; ADVERTISING AND PUBLICITY SERVICES; ADVERTISING ON THE INTERNET FOR OTHERS; ADVERTISING SERVICES; ADVERTISING VIA ELECTRONIC MEDIA AND SPECIFICALLY THE INTERNET; ADVERTISING, INCLUDING ON-LINE ADVERTISING ON A COMPUTER NETWORK; ADVERTISING, MARKETING AND PROMOTION SERVICES; COMPILATION OF ADVERTISEMENTS FOR USE AS

WEB PAGES ON THE INTERNET; DISSEMINATION OF ADVERTISEMENTS; DISSEMINATION OF ADVERTISING FOR OTHERS VIA AN ON-LINE COMMUNICATIONS NETWORK ON THE INTERNET; DISSEMINATION OF ADVERTISING FOR OTHERS VIA PUBLIC AND PRIVATE WIRELESS NETWORKS FOR DISPLAY ON MOBILE DEVICES; DISSEMINATION OF ADVERTISING FOR OTHERS VIA THE INTERNET; DISSEMINATION OF ADVERTISING MATTER; DISSEMINATION SERVICES OF ADVERTISEMENT MATTER; DISTRIBUTION OF ADVERTISEMENTS AND COMMERCIAL ANNOUNCEMENTS; DISTRIBUTION OF ADVERTISING MATERIALS; ELECTRONIC COMMERCE SERVICES, NAMELY, PROVIDING INFORMATION ABOUT PRODUCTS VIA TELECOMMUNICATION NETWORKS FOR ADVERTISING AND SALES PURPOSES; EVENT PLANNING AND MANAGEMENT FOR MARKETING, BRANDING, PROMOTING OR ADVERTISING THE GOODS AND SERVICES OF OTHERS; INTERNET ADVERTISING SERVICES; MARKETING SERVICES, NAMELY, PROMOTING OR ADVERTISING THE GOODS AND SERVICES OF OTHERS; MARKETING, ADVERTISING, AND PROMOTING THE RETAIL GOODS AND SERVICES OF OTHERS THROUGH WIRELESS ELECTRONIC DEVICES; MARKETING, PROMOTIONAL AND ADVERTISING SERVICES PROVIDED BY MOBILE TELEPHONE CONNECTIONS; ON-LINE ADVERTISING AND MARKETING SERVICES; ON-LINE ADVERTISING ON COMPUTER COMMUNICATION NETWORKS; ON-LINE ADVERTISING ON COMPUTER NETWORKS; ON-LINE ADVERTISING SERVICES FOR OTHERS; ONLINE ADVERTISEMENTS; ONLINE ADVERTISING AND PROMOTIONAL SERVICES; ONLINE ADVERTISING VIA A COMPUTER COMMUNICATIONS NETWORK; ORGANIZING EXHIBITIONS FOR COMMERCIAL OR ADVERTISING PURPOSES IN THE FIELD OF COMPUTERS, FINANCE, BUSINESS, PROFESSIONAL DEVELOPMENT, ARTS, UTILITIES, TRANSPORTATION, CONSTRUCTION; PAY PER CLICK ADVERTISING; PLACING ADVERTISEMENTS FOR OTHERS; PROMOTING THE GOODS AND SERVICES OF OTHERS BY DISTRIBUTING ADVERTISING MATERIALS THROUGH A VARIETY OF METHODS; PROMOTING THE GOODS AND SERVICES OF OTHERS BY MEANS OF DISTRIBUTING ADVERTISING ON THE INTERNET; PROMOTING, ADVERTISING AND MARKETING OF THE BRANDS, PRODUCTS, SERVICES AND ONLINE WEBSITES OF INDIVIDUALS, BUSINESSES AND NONPROFIT ORGANIZATIONS; PROMOTING, ADVERTISING AND MARKETING ON-LINE WEB SITES OF OTHERS; PROMOTING, ADVERTISING AND MARKETING THE ON-LINE DATABASES AND ELECTRONIC PUBLICATIONS OF OTHERS; PROMOTION, ADVERTISING AND MARKETING OF ON-LINE WEBSITES; PROVIDING A SEARCHABLE ON-LINE ADVERTISING WEBSITE AND GUIDE FEATURING THE GOODS AND SERVICES OF OTHER VENDORS VIA THE INTERNET; PROVIDING A WEB SITE WHICH FEATURES ADVERTISEMENTS FOR THE GOODS AND SERVICES OF OTHERS ON A GLOBAL COMPUTER NETWORK; PROVIDING ADVERTISING AND ADVERTISEMENT SERVICES; PROVIDING ADVERTISING SERVICES; PROVIDING AND RENTAL OF ADVERTISING SPACE ON THE INTERNET; PROVIDING ON-LINE BUSINESS INFORMATION OF OTHERS, NAMELY, ADVERTISEMENTS OR SOLICITATIONS; PROVIDING SPACE AT A WEB SITE FOR THE ADVERTISEMENT OF THE GOODS AND SERVICES OF OTHERS; PUBLICITY AND SALES PROMOTION RELATING TO GOODS AND SERVICES, OFFERED AND ORDERED BY TELECOMMUNICATION OR THE ELECTRONIC WAY; RENTAL OF ADVERTISING SPACE (U.S. CLS. 100, 101 AND 102).

#### **CLASS 38—COMMUNICATION**

FOR INTERNET SERVICES, NAMELY, PROVIDING MULTIPLE-USER ACCESS TO INFORMATION ON THE INTERNET CONCERNING THE DEVELOPMENT AND GENERATION OF COMPUTER SOFTWARE FOR USE IN BUSINESSES AS WELL AS THE FUNCTIONS AND APPLICATION OF SUCH BUSINESS SOFTWARE; TELECOMMUNICATION SERVICES, NAMELY, PROVIDING E-MAIL NOTIFICATION ALERTS VIA THE INTERNET; TELECOMMUNICATION SERVICES, NAMELY, TRANSMISSION OF PODCASTS; TELECOMMUNICATION SERVICES, NAMELY, TRANSMISSION OF VOICE, DATA, GRAPHICS, IMAGES, AUDIO AND VIDEO BY MEANS OF TELECOMMUNICATIONS NETWORKS, WIRELESS COMMUNICATION NETWORKS, AND THE INTERNET; TELECOMMUNICATION SERVICES, NAMELY, TRANSMISSION OF VOICE, DATA, GRAPHICS, SOUND AND VIDEO BY MEANS OF BROADBAND POWER LINE OR WIRELESS NETWORKS; TELECOMMUNICATION SERVICES, NAMELY, TRANSMISSION OF WEBCASTS (U.S. CLS. 100, 101 AND 104).

#### **CLASS 41—EDUCATION AND ENTERTAINMENT**

FOR CONTINUING EDUCATION SERVICES, NAMELY, PROVIDING LIVE AND ON-LINE CONTINUING PROFESSIONAL EDUCATION SEMINARS IN THE FIELD OF COMPUTERS, FINANCE, BUSINESS, PROFESSIONAL DEVELOPMENT, ARTS, UTILITIES, TRANSPORTATION, CONSTRUCTION; CONTINUING EDUCATION SERVICES, NAMELY, PROVIDING LIVE AND ON-LINE CONTINUING PROFESSIONAL EDUCATION SEMINARS IN THE LEGAL, MEDICAL, ACCOUNTING, AND REAL ESTATE FIELDS; EDUCATION SERVICES, NAMELY, PROVIDING LIVE AND ON-LINE SEMINARS AND PRESENTATIONS IN THE FIELD OF COMPUTERS, FINANCE, BUSINESS, PROFESSIONAL DEVELOPMENT, ARTS, UTILITIES, TRANSPORTATION, CONSTRUCTION; EDUCATION SERVICES, NAMELY, PROVIDING NON-DOWNLOADABLE WEBINARS IN THE FIELD OF COMPUTERS, FINANCE, BUSINESS, PROFESSIONAL DEVELOPMENT, ARTS, UTILITIES, TRANSPORTATION, CONSTRUCTION; EDUCATIONAL SERVICES, NAMELY, CONDUCTING INFORMAL ON-LINE PROGRAMS IN THE FIELDS OF COMPUTERS, FINANCE, BUSINESS, PROFESSIONAL DEVELOPMENT, ARTS, UTILITIES, TRANSPORTATION, CONSTRUCTION, AND PRINTABLE MATERIALS DISTRIBUTED THEREWITH; EDUCATIONAL SERVICES, NAMELY, CONDUCTING ON LINE AND TELEPHONIC INSTRUCTION AND COURSES IN THE FIELD OF COMPUTERS, FINANCE, BUSINESS, PROFESSIONAL DEVELOPMENT, ARTS, UTILITIES, TRANSPORTATION, CONSTRUCTION; EDUCATIONAL SERVICES, NAMELY, CONDUCTING ON-LINE EXHIBITIONS AND DISPLAYS AND INTERACTIVE EXHIBITS IN THE FIELD OF COMPUTERS, FINANCE, BUSINESS, PROFESSIONAL DEVELOPMENT, ARTS, UTILITIES, TRANSPORTATION, CONSTRUCTION; EDUCATIONAL SERVICES, NAMELY, CONDUCTING ONLINE SEMINARS AND PRESENTATIONS IN THE FIELDS OF COMPUTERS, FINANCE, BUSINESS, PROFESSIONAL DEVELOPMENT, ARTS, UTILITIES, TRANSPORTATION, CONSTRUCTION; EDUCATIONAL SERVICES, NAMELY, CONDUCTING ON-LINE EXHIBITIONS AND DISPLAYS AND INTERACTIVE EXHIBITS IN THE FIELD OF COMPUTERS, FINANCE, BUSINESS, PROFESSIONAL DEVELOPMENT, ARTS, UTILITIES, TRANSPORTATION, CONSTRUCTION AND DISTRIBUTION OF TRAINING MATERIALS IN CONNECTION THEREWITH; EDUCATIONAL SERVICES, NAMELY, PROVIDING CONTINUING PROFESSIONAL EDUCATION COURSES IN THE FIELD OF COMPUTERS, FINANCE, BUSINESS, PROFESSIONAL DEVELOPMENT, ARTS, UTILITIES, TRANSPORTATION, CONSTRUCTION; INFORMATION RELATING TO ENTERTAINMENT AND EDUCATION PROVIDED ON-LINE FROM A COMPUTER DATABASE OR THE INTERNET; PROVIDING A WEBSITE FEATURING RESOURCES, NAMELY, A WEBSITE FEATURING PRIMARILY NON-DOWNLOADABLE PUBLICATIONS IN THE NATURE OF EDUCATIONAL AND TRAINING MATERIALS IN THE FIELD OF COMPUTERS, FINANCE, BUSINESS, PROFESSIONAL DEVELOPMENT, ARTS, UTILITIES, TRANSPORTATION, CONSTRUCTION AND ALSO FEATURING NON-DOWNLOADABLE SOFTWARE FOR

PREPARING, PROVIDING, AND USING ONLINE SEMINARS AND PRESENTATIONS; PROVIDING EDUCATION COURSES IN THE FIELD OF COMPUTERS, FINANCE, BUSINESS, PROFESSIONAL DEVELOPMENT, ARTS, UTILITIES, TRANSPORTATION, CONSTRUCTION OFFERED THROUGH ONLINE, NON-DOWNLOADABLE VIDEOS AND INSTRUCTOR ASSISTANCE; PROVIDING INFORMATION ABOUT ONLINE EDUCATION (U.S. CLS. 100, 101 AND 107).

#### CLASS 42—SCIENTIFIC AND COMPUTER SERVICES

FOR CLOUD COMPUTING FEATURING SOFTWARE FOR USE IN PREPARING, PROVIDING, AND USING ONLINE SEMINARS AND PRESENTATIONS; COMPUTER SOFTWARE CONSULTANCY; COMPUTER SOFTWARE CONSULTING; COMPUTER SOFTWARE DESIGN; COMPUTER SOFTWARE DESIGN, COMPUTER PROGRAMMING, AND MAINTENANCE OF COMPUTER SOFTWARE; COMPUTER SOFTWARE DEVELOPMENT IN THE FIELD OF MOBILE APPLICATIONS; CONSULTING SERVICES IN THE FIELD OF HOSTING COMPUTER SOFTWARE APPLICATIONS; DESIGN AND DEVELOPMENT OF VISUALIZATION TECHNOLOGIES FOR ADVERTISEMENT OF REAL ESTATE, COMMERCIAL PRODUCT AND BUSINESS OF OTHERS; DEVELOPING COMPUTER SOFTWARE; PROVIDING A WEB SITE FEATURING TEMPORARY USE OF NON-DOWNLOADABLE SOFTWARE FOR PREPARING, PROVIDING, AND USING ONLINE SEMINARS AND PRESENTATIONS; SOFTWARE AS A SERVICE (SAAS) SERVICES FEATURING SOFTWARE FOR PREPARING, PROVIDING, AND USING ONLINE SEMINARS AND PRESENTATIONS (U.S. CLS. 100 AND 101).

PAUL CROWLEY, EXAMINING ATTORNEY

SN 86-222,704. CARESOURCE, DAYTON, OH. FILED 3-17-2014.



OWNER OF U.S. REG. NOS. 3,777,661 AND 3,822,507.  
THE COLOR(S) PURPLE IS/ARE CLAIMED AS A FEATURE OF THE MARK.

THE MARK CONSISTS OF A HEART IMAGE, WITH ONE HALF BEING A DARKER COLOR PURPLE AND THE OTHER HALF BEING A LIGHTER COLOR PURPLE.

#### CLASS 9—ELECTRICAL AND SCIENTIFIC APPARATUS

FOR COMPUTER APPLICATION SOFTWARE THAT PROVIDES ACCESS TO INSURANCE BENEFIT INFORMATION AND HEALTHCARE INFORMATION VIA MOBILE PHONES, SMART PHONES, TABLET COMPUTERS, ELECTRONIC TABLETS, PORTABLE MEDIA PLAYERS, ELECTRONIC READING DEVICES, HANDHELD COMPUTERS, HANDHELD ELECTRONIC DEVICES, AND OTHER COMPUTING DEVICES (U.S. CLS. 21, 23, 26, 36 AND 38).

FIRST USE 4-0-2013; IN COMMERCE 4-0-2013.

#### CLASS 16—PAPER GOODS AND PRINTED MATTER

FOR PRINTED MATERIALS, NAMELY, BROCHURES, MANUALS, NEWSLETTERS, INFORMATIONAL SHEETS, COURSE MATERIALS, AND EDUCATIONAL AND INSTRUCTIONAL MATERIALS IN THE FIELD OF INSURANCE BENEFITS AND HEALTHCARE (U.S. CLS. 2, 5, 22, 23, 29, 37, 38 AND 50).

FIRST USE 4-0-2013; IN COMMERCE 4-0-2013.

GIANCARLO CASTRO, EXAMINING ATTORNEY

SN 86-222,717. CARESOURCE, DAYTON, OH. FILED 3-17-2014.



OWNER OF U.S. REG. NOS. 2,785,521, 3,822,507 AND OTHERS.

THE COLOR(S) PURPLE AND TEAL IS/ARE CLAIMED AS A FEATURE OF THE MARK.

THE MARK CONSISTS OF THE STYLIZED TEXT "CARESOURCE" IN TEAL; BETWEEN THE LETTERS "E" AND "S" IS A HEART IMAGE, WITH ONE HALF OF IT BEING LIGHTER PURPLE AND THE OTHER HALF BEING DARKER PURPLE.

#### CLASS 9—ELECTRICAL AND SCIENTIFIC APPARATUS

FOR COMPUTER APPLICATION SOFTWARE THAT PROVIDES ACCESS TO INSURANCE BENEFIT INFORMATION AND HEALTHCARE INFORMATION VIA MOBILE PHONES, SMART PHONES, TABLET COMPUTERS, ELECTRONIC TABLETS, PORTABLE MEDIA PLAYERS, ELECTRONIC READING DEVICES, HANDHELD COMPUTERS, HANDHELD ELECTRONIC DEVICES, AND OTHER COMPUTING DEVICES (U.S. CLS. 21, 23, 26, 36 AND 38).

FIRST USE 4-0-2013; IN COMMERCE 4-0-2013.

#### CLASS 16—PAPER GOODS AND PRINTED MATTER

FOR PRINTED MATERIALS, NAMELY, BROCHURES, MANUALS, NEWSLETTERS, INFORMATIONAL SHEETS, COURSE MATERIALS, AND EDUCATIONAL AND INSTRUCTIONAL MATERIALS IN THE FIELD OF INSURANCE BENEFITS AND HEALTHCARE (U.S. CLS. 2, 5, 22, 23, 29, 37, 38 AND 50).

FIRST USE 4-0-2013; IN COMMERCE 4-0-2013.

GIANCARLO CASTRO, EXAMINING ATTORNEY

SN 86-223,069. PILE PROTECTION TOPS INC, KANSAS CITY, KS. FILED 3-17-2014.

PPT

THE MARK CONSISTS OF STANDARD CHARACTERS WITHOUT CLAIM TO ANY PARTICULAR FONT, STYLE, SIZE, OR COLOR.

**CLASS 6—METAL GOODS**

FOR METAL FASTENERS, NAMELY, CENTRALIZERS FOR USE WITH SOIL NAILS, ANCHORS, REBAR, REBAR CAGES, REINFORCEMENTS STRANDS AND TIE-BACK ANCHORS (U.S. CLS. 2, 12, 13, 14, 23, 25 AND 50).

FIRST USE 12-0-2008; IN COMMERCE 12-0-2008.

**CLASS 35—ADVERTISING AND BUSINESS**

FOR RETAIL STORE SERVICES FEATURING METAL AND NON-METAL FASTENERS, NAMELY, CENTRALIZERS FOR USE WITH SOIL NAILS, ANCHORS, REBAR, REBAR CAGES, REINFORCEMENTS STRANDS AND TIE-BACK ANCHORS, AND FEATURING SPACER WHEELS, AUGER CORKS, STEEL LINES, REBAR IMPALEMENT-PROOF CAPS, AND MOLDS FOR CONCRETE BATCH TESTING; WHOLESALE STORE SERVICES FEATURING METAL AND NON-METAL FASTENERS, NAMELY, CENTRALIZERS FOR USE WITH SOIL NAILS, ANCHORS, REBAR, REBAR CAGES, REINFORCEMENTS STRANDS AND TIE-BACK ANCHORS, AND FEATURING SPACER WHEELS, AUGER CORKS, STEEL LINES, REBAR IMPALEMENT-PROOF CAPS, AND MOLDS FOR CONCRETE BATCH TESTING (U.S. CLS. 100, 101 AND 102).

FIRST USE 12-0-2008; IN COMMERCE 12-0-2008.  
LINDA POWELL, EXAMINING ATTORNEY

SN 86-223,098. ALLERGAN, INC., IRVINE, CA. FILED 3-17-2014.

**MY ANSWERS. MY SUPPORT.**

THE MARK CONSISTS OF STANDARD CHARACTERS WITHOUT CLAIM TO ANY PARTICULAR FONT, STYLE, SIZE, OR COLOR.

**CLASS 41—EDUCATION AND ENTERTAINMENT**

FOR EDUCATIONAL SERVICES, NAMELY, CONDUCTING A CONSUMER EDUCATION PROGRAM TO ENHANCE THE UNDERSTANDING OF OVER-ACTIVE BLADDER AND COMPLIANCE WITH OVER-ACTIVE BLADDER PRESCRIPTION PRODUCTS, AND DISTRIBUTION OF EDUCATIONAL PROGRAM MATERIALS AND PRINTED TREATMENT REMINDERS IN CONNECTION THEREWITH (U.S. CLS. 100, 101 AND 107).

**CLASS 44—MEDICAL, BEAUTY AND AGRICULTURAL SERVICES**

FOR MEDICAL COUNSELING TO ENHANCE THE UNDERSTANDING OF OVER-ACTIVE BLADDER AND COMPLIANCE WITH OVER-ACTIVE BLADDER PRESCRIPTION PRODUCTS (U.S. CLS. 100 AND 101).

ALICIA COLLINS, EXAMINING ATTORNEY

SN 86-223,224. THE A.K. RICE INSTITUTE, PORTLAND, OR. FILED 3-17-2014.

**A.K. RICE INSTITUTE**

THE MARK CONSISTS OF STANDARD CHARACTERS WITHOUT CLAIM TO ANY PARTICULAR FONT, STYLE, SIZE, OR COLOR.

NO CLAIM IS MADE TO THE EXCLUSIVE RIGHT TO USE "INSTITUTE", APART FROM THE MARK AS SHOWN. THE NAME(S), PORTRAIT(S), AND/OR SIGNATURE(S) SHOWN IN THE MARK DOES NOT IDENTIFY A PARTICULAR LIVING INDIVIDUAL.

**CLASS 35—ADVERTISING AND BUSINESS**

FOR BUSINESS CONSULTATION IN THE FIELD OF THE THEORIES AND METHODOLOGIES OF GROUP RELATIONS, FOR GROUPS AND ORGANIZATIONS; DEMOGRAPHIC CONSULTATION AND STUDIES; HUMAN RESOURCE ANALYSIS AND CONSULTING SERVICES; INTERNATIONAL BUSINESS CONSULTING SERVICES RELATING TO THE THEORIES AND METHODOLOGIES OF GROUP RELATIONS, FOR GROUPS AND ORGANIZATIONS; MANAGEMENT CONSULTING AND ADVISORY SERVICES IN THE AREAS OF CORPORATE GROWTH STRATEGY, INNOVATION AND GROWTH PROCESSES, ORGANIZATIONAL TRANSFORMATION, AND TALENT MANAGEMENT AND DEVELOPMENT STRATEGIES (U.S. CLS. 100, 101 AND 102).

FIRST USE 4-7-1975; IN COMMERCE 4-7-1975.

**CLASS 41—EDUCATION AND ENTERTAINMENT**

FOR EDUCATIONAL SERVICES, NAMELY, CONDUCTING CLASSES, SEMINARS, CONFERENCES, SYMPOSIA, AND WORKSHOPS IN THE FIELD OF GROUP RELATIONS, GROUP DYNAMICS, SOCIAL SYSTEMS, LEADERSHIP AND FOLLOWERSHIP, ORGANIZATIONAL DEVELOPMENT, THE TRAINING OF CONSULTANTS TO PRACTICE GROUP RELATIONS CONSULTING, AND PRINTABLE MATERIALS DISTRIBUTED THEREWITH AND DISTRIBUTION OF TRAINING MATERIAL IN CONNECTION THEREWITH; EDUCATIONAL SERVICES, NAMELY, CONDUCTING FORMAL AND INFORMAL ON-LINE PROGRAMS IN THE FIELD OF GROUP RELATIONS, GROUP DYNAMICS, SOCIAL SYSTEMS, LEADERSHIP AND FOLLOWERSHIP, ORGANIZATIONAL DEVELOPMENT, THE TRAINING OF CONSULTANTS TO PRACTICE GROUP RELATIONS CONSULTING, AND PRINTABLE MATERIALS DISTRIBUTED THEREWITH; EDUCATIONAL SERVICES, NAMELY, CONDUCTING CLASSES, SEMINARS, AND WORKSHOPS IN THE FIELD OF GROUP RELATIONS, GROUP DYNAMICS, SOCIAL SYSTEMS, LEADERSHIP AND FOLLOWERSHIP, ORGANIZATIONAL DEVELOPMENT, THE TRAINING OF CONSULTANTS TO PRACTICE GROUP RELATIONS CONSULTING, AND DISTRIBUTION OF PRINTED MATERIALS IN CONNECTION THEREWITH IN HARD COPY OR ELECTRONIC FORMAT ON THE SAME TOPICS; EDUCATIONAL SERVICES, NAMELY, CONDUCTING CLASSES, SEMINARS, CONFERENCES, SYMPOSIA, AND WORKSHOPS IN THE FIELD OF GROUP RELATIONS, GROUP DYNAMICS, SOCIAL SYSTEMS, LEADERSHIP AND FOLLOWERSHIP, ORGANIZATIONAL DEVELOPMENT, THE TRAINING OF CONSULTANTS TO PRACTICE GROUP RELATIONS CONSULTING, AND DISTRIBUTION OF COURSE AND EDUCATIONAL MATERIALS IN CONNECTION THEREWITH; EDUCATIONAL SERVICES, NAMELY, DEVELOPING, ARRANGING, AND CONDUCTING EDUCATIONAL CONFERENCES AND PROGRAMS AND PROVIDING COURSES OF INSTRUCTION IN THE FIELD OF GROUP RELATIONS, GROUP DYNAMICS, SOCIAL SYSTEMS, LEADERSHIP AND FOLLOWERSHIP, ORGANIZATIONAL DEVELOPMENT, THE TRAINING OF CONSULTANTS TO PRACTICE GROUP RELATIONS CONSULTING (U.S. CLS. 100, 101 AND 107).

FIRST USE 4-7-1975; IN COMMERCE 4-7-1975.

**CLASS 42—SCIENTIFIC AND COMPUTER SERVICES**

FOR ACCREDITATION SERVICES, NAMELY, SETTING AND PROVIDING STANDARDS FOR GROUP RELATIONS CONSULTANCY FOR THE PURPOSE OF ACCREDITATION (U.S. CLS. 100 AND 101).

FIRST USE 4-7-1975; IN COMMERCE 4-7-1975.

NAKWAMA ANKRAH, EXAMINING ATTORNEY



SN 86-223,231. STRIDE HEALTH, INC., FORMERLY COVERED, INC., SAN FRANCISCO, CA. FILED 3-17-2014.

SN 86-223,269. INFORMATION TECHNOLOGY INDUSTRY COUNCIL, INC., WASHINGTON, DC. FILED 3-17-2014.

## Stride Health

THE MARK CONSISTS OF STANDARD CHARACTERS WITHOUT CLAIM TO ANY PARTICULAR FONT, STYLE, SIZE, OR COLOR.

NO CLAIM IS MADE TO THE EXCLUSIVE RIGHT TO USE "HEALTH", APART FROM THE MARK AS SHOWN.

### CLASS 9—ELECTRICAL AND SCIENTIFIC APPARATUS

FOR COMPUTER E-COMMERCE SOFTWARE TO ALLOW USERS TO PERFORM ELECTRONIC BUSINESS TRANSACTIONS VIA A GLOBAL COMPUTER NETWORK; COMPUTER SOFTWARE AND FIRMWARE FOR COMPARING, ANALYZING AND PURCHASING INSURANCE PLANS AND RELATED PRODUCTS; COMPUTER SOFTWARE FOR CREATING SEARCHABLE DATABASES OF INFORMATION AND DATA; COMPUTER SOFTWARE FOR PROVIDING AN ON-LINE DATABASE IN THE FIELD OF TRANSACTION PROCESSING TO UPLOAD TRANSACTIONAL DATA, PROVIDE STATISTICAL ANALYSIS, AND PRODUCE NOTIFICATIONS AND REPORTS; COMPUTER SOFTWARE FOR THE DATABASING, VISUALIZATION, MANIPULATION, VIRTUAL REALITY IMMERSION AND INTEGRATION OF GEOGRAPHIC INFORMATION WITH ON-LINE MEMBER COMMUNITIES; COMPUTER SOFTWARE FOR EVALUATING INSURANCE PLANS AND INSTRUCTIONAL USER GUIDES SOLD AS A UNIT; COMPUTER SOFTWARE FOR COMPARING, ANALYZING AND PURCHASING INSURANCE PLANS AND RELATED PRODUCTS THAT MAY BE DOWNLOADED FROM A GLOBAL COMPUTER NETWORK (U.S. CLS. 21, 23, 26, 36 AND 38).

FIRST USE 3-13-2014; IN COMMERCE 3-13-2014.

### CLASS 36—INSURANCE AND FINANCIAL

FOR CONSULTING AND INFORMATION CONCERNING INSURANCE; DESIGN AND DEVELOPMENT OF INSURANCE POLICIES FOR OTHERS; INSURANCE ADMINISTRATION; INSURANCE AGENCY AND BROKERAGE; INSURANCE BROKERAGE SERVICES; INSURANCE CONSULTATION; INSURANCE SERVICES, NAMELY, INSURANCE ELIGIBILITY REVIEW AND VERIFICATION AND CONSULTATION IN THE HEALTHCARE AND LIFE INSURANCE INDUSTRY; INSURANCE SERVICES, NAMELY, PROVIDING INDEPENDENT SCORING SERVICE RELATED TO EXISTING MEDICAL SERVICES IN A SPECIFIC GEOGRAPHIC REGION FOR INSURANCE EVALUATION PURPOSES; PROVIDING INFORMATION ABOUT HEALTHCARE INSURANCE PLANS; PROVIDING INFORMATION IN INSURANCE MATTERS (U.S. CLS. 100, 101 AND 102).

FIRST USE 3-13-2014; IN COMMERCE 3-13-2014.

LYNDSEY KUYKENDALL, EXAMINING ATTORNEY

## IN-NOVATE

THE MARK CONSISTS OF STANDARD CHARACTERS WITHOUT CLAIM TO ANY PARTICULAR FONT, STYLE, SIZE, OR COLOR.

### CLASS 35—ADVERTISING AND BUSINESS

FOR PROVIDING AN IN-PERSON BUSINESS AND COMMERCIAL FORUM IN THE FIELD OF FUTURE TECHNOLOGIES (U.S. CLS. 100, 101 AND 102).

FIRST USE 3-26-2014; IN COMMERCE 3-26-2014.

### CLASS 41—EDUCATION AND ENTERTAINMENT

FOR PROVIDING AN IN-PERSON EDUCATIONAL FORUM IN THE FIELD OF FUTURE TECHNOLOGIES (U.S. CLS. 100, 101 AND 107).

FIRST USE 3-26-2014; IN COMMERCE 3-26-2014.

WON TEAK OH, EXAMINING ATTORNEY

SN 86-223,342. THE WASHINGTON UNIVERSITY, ST. LOUIS, MO. AND BARNES-JEWISH HOSPITAL, ST. LOUIS, MO. FILED 3-17-2014.

## SITEMAN CANCER CENTER

THE MARK CONSISTS OF STANDARD CHARACTERS WITHOUT CLAIM TO ANY PARTICULAR FONT, STYLE, SIZE, OR COLOR.

OWNER OF U.S. REG. NO. 2,824,952.

NO CLAIM IS MADE TO THE EXCLUSIVE RIGHT TO USE "CANCER CENTER", APART FROM THE MARK AS SHOWN.

SEC. 2(F).

### CLASS 41—EDUCATION AND ENTERTAINMENT

FOR EDUCATIONAL SERVICES, NAMELY, CONDUCTING CLASSES, SEMINARS, TRAINING PROGRAMS, WORKSHOPS AND CONFERENCES, ALL IN THE FIELDS OF MEDICINE AND BIOMEDICAL SCIENCES, AND DISTRIBUTING EDUCATIONAL MATERIALS IN CONNECTION THEREWITH (U.S. CLS. 100, 101 AND 107).

FIRST USE 10-0-2000; IN COMMERCE 10-0-2000.

### CLASS 42—SCIENTIFIC AND COMPUTER SERVICES

FOR MEDICAL RESEARCH SERVICES (U.S. CLS. 100 AND 101).

FIRST USE 10-0-2000; IN COMMERCE 10-0-2000.



**CLASS 44—MEDICAL, BEAUTY AND AGRICULTURAL SERVICES**

FOR MEDICAL AND HOSPITAL SERVICES (U.S. CLS. 100 AND 101).  
FIRST USE 10-0-2000; IN COMMERCE 10-0-2000.  
MARTHA FROMM, EXAMINING ATTORNEY

SN 86-223,592. UNIFI COMMUNICATIONS PBC, DOVER, DE. FILED 3-17-2014.

SN 86-223,478. ASSOCIATION OF SURGICAL TECHNOLOGISTS, INC., ENGLEWOOD, CO. FILED 3-17-2014.



NO CLAIM IS MADE TO THE EXCLUSIVE RIGHT TO USE "ASSOCIATION OF SURGICAL TECHNOLOGISTS", APART FROM THE MARK AS SHOWN.

THE MARK CONSISTS OF THE LETTERS "AST" TO THE LEFT OF A TRIANGLE; TRIANGLE HAS A LINE CUT THROUGH THE LEFT HAND SIDE DIAGONALLY; THE WORDS "ASSOCIATION OF SURGICAL TECHNOLOGISTS" BELOW THE TRIANGLE AND THE LETTERS "AST".

**CLASS 16—PAPER GOODS AND PRINTED MATTER**

FOR PRINTED MATERIAL, NAMELY, MAGAZINES, INSTRUCTIONAL BOOKS, BOOKS IN THE FIELD OF SURGICAL TECHNOLOGY (U.S. CLS. 2, 5, 22, 23, 29, 37, 38 AND 50).

FIRST USE 2-19-2014; IN COMMERCE 2-19-2014.

**CLASS 35—ADVERTISING AND BUSINESS**

FOR PROMOTING THE INTERESTS OF SURGICAL TECHNOLOGISTS IN THE HEALTH CARE INDUSTRY; PROMOTING THE INTERESTS OF SURGICAL TECHNOLOGISTS IN THE HEALTH CARE INDUSTRY THROUGH LOBBYING FOR INCREASED AWARENESS, USE AND TRAINING (U.S. CLS. 100, 101 AND 102).

FIRST USE 2-19-2014; IN COMMERCE 2-19-2014.

**CLASS 41—EDUCATION AND ENTERTAINMENT**

FOR CONDUCTING CONTINUING EDUCATION PROGRAM SERVICES FOR SURGICAL TECHNOLOGISTS (U.S. CLS. 100, 101 AND 107).

FIRST USE 2-19-2014; IN COMMERCE 2-19-2014.

**CLASS 200—COLLECTIVE MEMBERSHIP**

FOR INDICATING MEMBERSHIP IN AN ASSOCIATION OF SURGICAL TECHNOLOGISTS.

FIRST USE 2-19-2014; IN COMMERCE 2-19-2014.  
BRIDGETT SMITH, EXAMINING ATTORNEY

# OLUVUS

THE MARK CONSISTS OF STANDARD CHARACTERS WITHOUT CLAIM TO ANY PARTICULAR FONT, STYLE, SIZE, OR COLOR.

THE WORDING "OLUVUS" HAS NO MEANING IN A FOREIGN LANGUAGE.

**CLASS 9—ELECTRICAL AND SCIENTIFIC APPARATUS**

FOR COMPUTER SOFTWARE, NAMELY, COMPUTER SOFTWARE USED FOR TRANSMISSION OF SOUND, IMAGES, VIDEO OR DATA OVER A TELECOMMUNICATIONS NETWORK OR SYSTEM; COMMUNICATIONS SOFTWARE FOR CONNECTING TO COMMUNICATIONS NETWORKS THEREBY ENHANCING AND FACILITATING USE AND ACCESS; COMPUTER OPERATING SYSTEMS; COMPUTER SOFTWARE FOR ACCESSING, SEARCHING, INDEXING AND RETRIEVING INFORMATION AND DATA FROM GLOBAL COMPUTER NETWORKS AND GLOBAL COMMUNICATION NETWORKS, AND FOR BROWSING AND NAVIGATING WEB SITES ON SAID NETWORKS; COMPUTER HARDWARE; TELECOMMUNICATIONS AND TELEPHONE DEVICES, NAMELY, MOBILE PHONES, LAPTOPS, NOTE BOOKS, AND PERSONAL COMPUTERS; COMPUTER PERIPHERALS, NAMELY, PRINTERS; ELECTRONIC APPARATUS, NAMELY, MOBILE PHONES, TABLETS, LAPTOPS, AND PERSONAL COMPUTERS, FOR ORGANIZING, MANIPULATING, PLAYING AND REVIEWING TEXT, DATA, IMAGE, AUDIO AND VIDEO FILES (U.S. CLS. 21, 23, 26, 36 AND 38).

**CLASS 35—ADVERTISING AND BUSINESS**

FOR PROMOTING THE GOODS AND SERVICES OF OTHERS; DISSEMINATION OF ADVERTISING MATERIALS; PROMOTIONAL AND ADVERTISING SERVICES FOR CHARITABLE PURPOSES, NAMELY, PROMOTING THE GOODS AND SERVICES OF OTHERS THROUGH THE USE OF ADVERTISING AND MARKETING CAMPAIGNS FOR THE PURPOSE OF PROMOTING BRINGING INTERNET ACCESS TO POPULATIONS IN NEED; ORGANIZING AND CONDUCTING CHARITY AUCTIONS FOR CHARITABLE FUNDRAISING PURPOSES (U.S. CLS. 100, 101 AND 102).

**CLASS 36—INSURANCE AND FINANCIAL**

FOR CHARITABLE FUNDRAISING; CHARITABLE FUNDRAISING SERVICES (U.S. CLS. 100, 101 AND 102).

**CLASS 38—COMMUNICATION**

FOR TELECOMMUNICATIONS, NAMELY, TELECOMMUNICATION ACCESS SERVICES; CHARITABLE SERVICES, NAMELY, PROVIDING INTERNET ACCESS TO POPULATIONS IN NEED (U.S. CLS. 100, 101 AND 104).

**CLASS 41—EDUCATION AND ENTERTAINMENT**

FOR EDUCATION SERVICES, NAMELY, ARRANGING AND CONDUCTING EDUCATIONAL CONFERENCES, SYMPOSIUMS, AND EXHIBITIONS IN THE FIELD OF HUMANITARIAN RELIEF CONCERNING INTERNET ACCESS FOR POPULATIONS IN NEED AND OTHER HUMANITARIAN RELIEF EFFORTS; ONLINE JOURNALS, NAMELY, BLOGS DISCUSSING AND FOR THE PURPOSE OF PROMOTING AWARENESS ABOUT INTERNET ACCESS FOR POPULATIONS IN NEED AND OTHER HUMANITARIAN EFFORTS (U.S. CLS. 100, 101 AND 107).

**CLASS 45—PERSONAL AND LEGAL SERVICES**

FOR ONLINE SOCIAL NETWORKING SERVICES (U.S. CLS. 100 AND 101).  
SETH DENNIS, EXAMINING ATTORNEY

SN 86-223,784. MADDOX, JEREMIAH J., NEWTON, AL. FILED 3-17-2014.

# WOODSTRONG

THE MARK CONSISTS OF STANDARD CHARACTERS WITHOUT CLAIM TO ANY PARTICULAR FONT, STYLE, SIZE, OR COLOR.

**CLASS 25—CLOTHING**

FOR HATS; SHIRTS (U.S. CLS. 22 AND 39).

**CLASS 41—EDUCATION AND ENTERTAINMENT**

FOR ORGANIZING AND CONDUCTING SPORTING EVENTS IN THE NATURE OF FITNESS RUNS, MUD RUNS, CROSS-COUNTRY RACES, TRAIL RUNS, OBSTACLE COURSES, AND SWIMMING EVENTS; ENTERTAINMENT SERVICES, NAMELY, CONDUCTING POST-EVENT PARTIES (U.S. CLS. 100, 101 AND 107).  
APRIL REEVES, EXAMINING ATTORNEY

SN 86-224,314. PIONEER RESEARCH LABS INC, DBA ISOSENSUALS, BURLINGAME, CA. FILED 3-18-2014.

# IsoSensuals

THE MARK CONSISTS OF STANDARD CHARACTERS WITHOUT CLAIM TO ANY PARTICULAR FONT, STYLE, SIZE, OR COLOR.

**CLASS 3—COSMETICS AND CLEANING PREPARATIONS**

FOR BEAUTY CREAMS FOR BODY CARE (U.S. CLS. 1, 4, 6, 50, 51 AND 52).  
FIRST USE 1-28-2010; IN COMMERCE 1-28-2010.

**CLASS 5—PHARMACEUTICALS**

FOR DIETARY AND NUTRITIONAL SUPPLEMENTS (U.S. CLS. 6, 18, 44, 46, 51 AND 52).  
FIRST USE 1-28-2010; IN COMMERCE 1-28-2010.  
RONALD MCMORROW, EXAMINING ATTORNEY

SN 86-224,671. LIGMINCHA INSTITUTE FOR THE STUDY OF RELIGIONS AND CULTURES OF TIBET, INC., SHIPMAN, VA. FILED 3-18-2014.

# Ligmincha

THE MARK CONSISTS OF STANDARD CHARACTERS WITHOUT CLAIM TO ANY PARTICULAR FONT, STYLE, SIZE, OR COLOR.

**CLASS 41—EDUCATION AND ENTERTAINMENT**

FOR EDUCATIONAL SERVICES, NAMELY, RELIGIOUS/SPIRITUAL EDUCATION CENTERS PROVIDING SEMINARS AND WORKSHOPS ON THE ANCIENT TEACHINGS AND PRACTICES OF THE BON BUDDHIST TRADITION; RELIGIOUS INSTRUCTIONAL SERVICES BASED ON THE PRINCIPLES OF BON BUDDHISM, FOR PRESERVING THE ANCIENT TEACHINGS AND PRACTICES OF THE BON BUDDHIST TRADITION AND INTRODUCING THESE TRADITIONS IN AN AUTHENTIC MANNER TO THE WESTERN WORLD; PROVIDING SEMINARS, CONFERENCES, WORKSHOPS, CLASSES AND TRAINING IN THE FIELDS OF THE ANCIENT TEACHINGS AND PRACTICES OF THE BON BUDDHIST TRADITION; RELIGIOUS INSTRUCTIONAL SERVICES IN THE FIELD OF THE ANCIENT TEACHINGS AND PRACTICES OF THE BON BUDDHIST TRADITION (U.S. CLS. 100, 101 AND 107).  
FIRST USE 12-31-1992; IN COMMERCE 12-31-1992.

**CLASS 45—PERSONAL AND LEGAL SERVICES**

FOR PROVIDING A WEBSITE FEATURING EDUCATIONAL INFORMATION IN THE FIELDS OF THE ANCIENT TEACHINGS AND PRACTICES OF THE BON BUDDHIST TRADITION; PROVIDING A WEB SITE FEATURING INFORMATION ABOUT THE ANCIENT TEACHINGS AND PRACTICES OF THE BON BUDDHIST TRADITION (U.S. CLS. 100 AND 101).  
FIRST USE 12-31-1992; IN COMMERCE 12-31-1992.  
NICHOLAS ALTREE, EXAMINING ATTORNEY

SN 86-224,816. DEAN'S LANDING INC., SPRINGFIELD, OR. FILED 3-18-2014.

# Metro411

THE MARK CONSISTS OF STANDARD CHARACTERS WITHOUT CLAIM TO ANY PARTICULAR FONT, STYLE, SIZE, OR COLOR.

**CLASS 9—ELECTRICAL AND SCIENTIFIC APPARATUS**

FOR DOWNLOADABLE COMPUTER APPLICATION SOFTWARE FOR MOBILE DEVICES, NAMELY, SOFTWARE FOR USE IN ADVERTISING AND MARKETING SERVICES TO PROMOTE THE GOODS AND SERVICES OF OTHERS; DOWNLOADABLE COMPUTER APPLICATION SOFTWARE FOR MOBILE PHONES, PORTABLE MEDIA PLAYERS AND HANDHELD COMPUTERS, NAMELY, SOFTWARE FOR USE IN ADVERTISING AND MARKETING SERVICES TO PROMOTE THE GOODS AND SERVICES OF OTHERS; DOWNLOADABLE COMPUTER SOFTWARE FOR USE IN ADVERTISING AND MARKETING SERVICES TO PROMOTE THE GOODS AND SERVICES OF OTHERS; DOWNLOADABLE COMPUTER SOFTWARE FOR APPLICATION AND DATABASE INTEGRATION; DOWNLOADABLE COMPUTER SOFTWARE FOR CREATING SEARCHABLE DATABASES OF INFORMATION AND DATA; DOWNLOADABLE CLOUD COMPUTER SOFTWARE FOR USE IN ADVERTISING AND MARKETING SERVICES TO PROMOTE THE GOODS AND SERVICES OF OTHERS (U.S. CLS. 21, 23, 26, 36 AND 38).

**CLASS 35—ADVERTISING AND BUSINESS**

FOR ADVERTISING AND MARKETING SERVICES TO PROMOTE THE GOODS AND SERVICES OF OTHERS IN THE FIELD OF RESTAURANTS, BARS, BREW PUBS, BOOKSTORES, SHOPPING, TRAVEL, JEWELERS, HOME CONSTRUCTION AND REMODELING, HOME SECURITY, WEIGHT LOSS, OUTDOOR RECREATION, AUTOMOTIVE, ENTERTAINMENT, RECREATION, ANIMAL AND PET CARE, REAL ESTATE, GROCERY STORE, CONVENIENCE STORE, GARDEN STORE, HARDWARE STORE, LANDSCAPING SERVICES, DENTAL SERVICES, LEGAL SERVICES, PERSONAL CARE SERVICES, HOME AND GARDEN SERVICES, HEALTH CARE SERVICES, HEALTH AND FITNESS, AND TRANSPORTATION VIA TRANSMISSION OF ADVERTISING MATERIAL AND THE DISSEMINATION OF ADVERTISING MESSAGES THROUGH ALL FORMS OF THE TRADITIONAL AND NEW MEDIA COMMUNICATIONS INCLUDING PRINT, THE INTERNET, MOBILE, CELLULAR, AND OTHER COMPUTER AND COMMUNICATIONS NETWORKS, SYSTEMS OR STATIONS FEATURING COUPONS, REBATES, PRICING COMPARISON INFORMATION, INCENTIVES, DISCOUNT INFORMATION AND LINKS TO THE RETAIL WEBSITE OR NETWORKS OF OTHERS; PLACING ADVERTISEMENTS FOR OTHERS (U.S. CLS. 100, 101 AND 102).

MATTHEW EINSTEIN, EXAMINING ATTORNEY

SN 86-224,826. XY WELLNESS, LLC, MADISON, WI. FILED 3-18-2014.



**MR. HAPPY**

OWNER OF U.S. REG. NO. 4,314,879.  
THE MARK CONSISTS OF THE STYLIZED WORDING "MR. HAPPY" BELOW AN IMAGE OF A ROOSTER ABOVE A LINE WITH A SUN NEAR THE FEET OF THE ROOSTER.

**CLASS 5—PHARMACEUTICALS**

FOR DIETARY SUPPLEMENTS (U.S. CLS. 6, 18, 44, 46, 51 AND 52).  
FIRST USE 10-9-2012; IN COMMERCE 10-9-2012.

**CLASS 44—MEDICAL, BEAUTY AND AGRICULTURAL SERVICES**

FOR PROVIDING A WEBSITE FEATURING INFORMATION ABOUT HEALTH AND WELLNESS, NAMELY, MEN'S HEALTH AND NUTRITION (U.S. CLS. 100 AND 101).

FIRST USE 10-9-2012; IN COMMERCE 10-9-2012.  
TIMOTHY O. SCHIMPF, EXAMINING ATTORNEY

SN 86-224,839. MIDAMERICA FINANCIAL CORPORATION, DES MOINES, IA. FILED 3-18-2014.

**BTComplete**

THE MARK CONSISTS OF STANDARD CHARACTERS WITHOUT CLAIM TO ANY PARTICULAR FONT, STYLE, SIZE, OR COLOR.

OWNER OF U.S. REG. NOS. 3,375,245, 4,435,162 AND OTHERS.

**CLASS 35—ADVERTISING AND BUSINESS**

FOR CHARITABLE SERVICES, NAMELY, COORDINATION OF NON-MONETARY CONTRIBUTIONS TO CHARITIES AND NON-PROFITS (U.S. CLS. 100, 101 AND 102).

**CLASS 36—INSURANCE AND FINANCIAL**

FOR ACCEPTING AND ADMINISTERING MONETARY CHARITABLE CONTRIBUTIONS FOR NON-PROFITS; FINANCIAL EVALUATIONS OF DONOR CONTRIBUTIONS FOR NON-PROFITS (U.S. CLS. 100, 101 AND 102).

MARCIE MILONE, EXAMINING ATTORNEY

SN 86-224,917. SPARK INTEGRATION TECHNOLOGIES, INC., VANCOUVER, CANADA, FILED 3-18-2014.

**NETWORKING SIMPLIFIED!**

THE MARK CONSISTS OF STANDARD CHARACTERS WITHOUT CLAIM TO ANY PARTICULAR FONT, STYLE, SIZE, OR COLOR.

NO CLAIM IS MADE TO THE EXCLUSIVE RIGHT TO USE "NETWORKING", APART FROM THE MARK AS SHOWN.

**CLASS 9—ELECTRICAL AND SCIENTIFIC APPARATUS**

FOR COMPUTER SOFTWARE FOR REMOTE INFRASTRUCTURE MONITORING, NETWORK MANAGEMENT, AND INTEGRATION OVER IP AND NON-IP BASED NETWORKS; COMPUTER SOFTWARE FOR ENABLING DIRECT MONITORING AND CONTROL OF PHYSICAL DEVICES, CONTROL SYSTEMS AND IT RESOURCES (U.S. CLS. 21, 23, 26, 36 AND 38).

**CLASS 42—SCIENTIFIC AND COMPUTER SERVICES**

FOR PROVIDING TEMPORARY USE OF NON-DOWNLOADABLE COMPUTER SOFTWARE FOR REMOTE INFRASTRUCTURE MONITORING, NETWORK MANAGEMENT, AND INTEGRATION OVER IP AND NON-IP BASED NETWORKS; PROVIDING TEMPORARY USE OF NON-DOWNLOADABLE COMPUTER SOFTWARE FOR ENABLING DIRECT MONITORING AND CONTROL OF PHYSICAL DEVICES, CONTROL SYSTEMS AND IT RESOURCES (U.S. CLS. 100 AND 101).

CIMMERIAN COLEMAN, EXAMINING ATTORNEY

SN 86-224,994. COUP ENTERTAINMENT LLC, NEW YORK, NY. FILED 3-18-2014.

**COUP ENTERTAINMENT**

THE MARK CONSISTS OF STANDARD CHARACTERS WITHOUT CLAIM TO ANY PARTICULAR FONT, STYLE, SIZE, OR COLOR.

NO CLAIM IS MADE TO THE EXCLUSIVE RIGHT TO USE "ENTERTAINMENT", APART FROM THE MARK AS SHOWN.

**CLASS 35—ADVERTISING AND BUSINESS**

FOR ADVERTISING AND MARKETING; ADVERTISING, MARKETING, AND PROMOTING THE GOODS AND SERVICES OF OTHERS VIA BRANDED VIDEOS AND PRODUCT PLACEMENT WITHIN VIDEOS (U.S. CLS. 100, 101 AND 102).

FIRST USE 7-0-2010; IN COMMERCE 7-0-2010.

**CLASS 41—EDUCATION AND ENTERTAINMENT**

FOR PRODUCTION OF TELEVISION PROGRAMS; VIDEO PRODUCTION SERVICES (U.S. CLS. 100, 101 AND 107).

FIRST USE 7-0-2010; IN COMMERCE 7-0-2010.

KERI CANTONE, EXAMINING ATTORNEY

SN 86-225,021. HAIR CLUB FOR MEN, LTD., INC., BOCA RATON, FL. FILED 3-18-2014.

**EXT EXTREME HAIR THERAPY**

THE MARK CONSISTS OF STANDARD CHARACTERS WITHOUT CLAIM TO ANY PARTICULAR FONT, STYLE, SIZE, OR COLOR.

OWNER OF U.S. REG. NOS. 2,583,786, 2,583,787 AND 2,605,894.

NO CLAIM IS MADE TO THE EXCLUSIVE RIGHT TO USE "HAIR THERAPY", APART FROM THE MARK AS SHOWN.

**CLASS 3—COSMETICS AND CLEANING PREPARATIONS**

FOR HAIR CARE AND STYLING ITEMS, NAMELY, NON-MEDICATED HAIR CARE PREPARATIONS, HAIR CONDITIONERS, HAIR GEL, HAIR MOUSSE, HAIR SPRAY AND HAIR SHAMPOO (U.S. CLS. 1, 4, 6, 50, 51 AND 52).

**CLASS 5—PHARMACEUTICALS**

FOR MEDICATED HAIR CARE PRODUCTS AND PREPARATIONS IN CONNECTION WITH HAIR REPLACEMENT AND HAIR RESTORATION SERVICES, NAMELY, SHAMPOOS, CONDITIONS, HAIR GEL AND HAIR MOUSSE, AND TOPICAL PREPARATIONS TO STIMULATE HAIR GROWTH (U.S. CLS. 6, 18, 44, 46, 51 AND 52).

**CLASS 44—MEDICAL, BEAUTY AND AGRICULTURAL SERVICES**

FOR HAIR REPLACEMENT AND HAIR RESTORATION SERVICES (U.S. CLS. 100 AND 101).

KAMAL PREET, EXAMINING ATTORNEY

SN 86-225,065. ITALPIZZA S.R.L. CON SOCIO UNICO, MODENA, ITALY, FILED 3-18-2014.



OWNER OF U.S. REG. NO. 3,427,185.

THE PORTRAIT SHOWN IN THE MARK DOES NOT IDENTIFY A PARTICULAR LIVING INDIVIDUAL.

THE MARK CONSISTS OF A PIZZA MAKER HOLDING A PIZZA PEEL IN FRONT OF THE MOUTH OF AN OVEN WITH A SEMI-CIRCLE DESIGN ON A SEMI-CIRCULAR BACKGROUND, SURROUNDED BY AN OUTLINE; BELOW THE DESIGN IS THE STYLIZED WORDING "ITALPIZZA" ON A RECTANGULAR BANNER WITH TWO HORIZONTAL BANDS ON EITHER SIDE.

**CLASS 29—MEATS AND PROCESSED FOODS**

FOR FROZEN MEAT IN THE NATURE OF MEAT FILLINGS AND TOPPINGS AND COLD MEAT CUTS FOR USE IN PIZZAS AND PIZZA SNACKS (U.S. CL. 46).

**CLASS 30—STAPLE FOODS**

FOR PIZZAS; CALZONES, PIZZA DOUGH, PIZZA CRUST, PIZZA BASES IN THE NATURE OF PIZZA CRUST MIXES, PIZZA SNACKS, DOUGH BALLS, DOUGH IN THE FORM OF POCKETS AND ROLLS, ALL THESE GOODS WITH FILLINGS AND TOPPINGS CONSISTING PRIMARILY OF VEGETABLES (U.S. CL. 46).

ELIZABETH JACKSON, EXAMINING ATTORNEY

SN 86-225,131. MCCLASKEY, DAVID J., JOHNSON CITY, TN. FILED 3-18-2014.

# Triple 100

THE MARK CONSISTS OF STANDARD CHARACTERS WITHOUT CLAIM TO ANY PARTICULAR FONT, STYLE, SIZE, OR COLOR.

## CLASS 9—ELECTRICAL AND SCIENTIFIC APPARATUS

FOR SERIES OF AUDIO AND VIDEO RECORDINGS DESIGNED TO PROVIDE THE BASIC CONCEPTS IN QUALITY MANAGEMENT AND PERFORMANCE EXCELLENCE FOR IMPROVING BUSINESS OR OVERALL BUSINESS PERFORMANCE (U.S. CLS. 21, 23, 26, 36 AND 38).

FIRST USE 1-24-2012; IN COMMERCE 1-28-2012.

## CLASS 16—PAPER GOODS AND PRINTED MATTER

FOR SERIES OF NON-FICTION BOOKS, MANUALS AND OTHER PRINTED INSTRUCTIONAL MATERIALS DESIGNED TO PROVIDE THE BASIC CONCEPTS IN QUALITY MANAGEMENT AND PERFORMANCE EXCELLENCE FOR IMPROVING BUSINESS OR OVERALL BUSINESS PERFORMANCE (U.S. CLS. 2, 5, 22, 23, 29, 37, 38 AND 50).

FIRST USE 1-24-2012; IN COMMERCE 1-28-2012.

## CLASS 35—ADVERTISING AND BUSINESS

FOR BUSINESS CONSULTING SERVICES IN THE FIELD OF QUALITY MANAGEMENT AND PERFORMANCE EXCELLENCE REGARDING OPERATING A BUSINESS (U.S. CLS. 100, 101 AND 102).

FIRST USE 1-24-2012; IN COMMERCE 1-28-2012.

## CLASS 41—EDUCATION AND ENTERTAINMENT

FOR EDUCATIONAL SERVICES, NAMELY, CONDUCTING CLASSES, SEMINARS, WEBINARS, CONFERENCES, AND WORKSHOPS IN THE FIELD OF QUALITY MANAGEMENT AND PERFORMANCE EXCELLENCE FOR IMPROVING THEIR BUSINESS OR OVERALL BUSINESS PERFORMANCE (U.S. CLS. 100, 101 AND 107).

FIRST USE 1-24-2012; IN COMMERCE 1-28-2012. CHRISTINA SOBRAL, EXAMINING ATTORNEY

SN 86-225,161. DAV EXECUTIVE AUTO GROUP, INC., GLENDALE, CA. FILED 3-18-2014.

# DAV EXECUTIVE AUTO GROUP

THE MARK CONSISTS OF STANDARD CHARACTERS WITHOUT CLAIM TO ANY PARTICULAR FONT, STYLE, SIZE, OR COLOR.

NO CLAIM IS MADE TO THE EXCLUSIVE RIGHT TO USE "AUTO GROUP", APART FROM THE MARK AS SHOWN.

## CLASS 35—ADVERTISING AND BUSINESS

FOR AUTOMOBILE DEALERSHIPS, PROVIDING INFORMATION ABOUT AUTOMOBILES FOR SALE BY MEANS OF THE INTERNET (U.S. CLS. 100, 101 AND 102).

FIRST USE 4-30-2005; IN COMMERCE 4-30-2005.

## CLASS 39—TRANSPORTATION AND STORAGE

FOR LEASING OF AUTOMOBILES; PROVIDING INFORMATION ABOUT AUTOMOBILES FOR LEASE BY MEAN OF THE INTERNET (U.S. CLS. 100 AND 105).

FIRST USE 4-30-2005; IN COMMERCE 4-30-2005. SEAN CROWLEY, EXAMINING ATTORNEY

SN 86-225,308. R SQUARED LLC, PLAINVIEW, NY. FILED 3-19-2014.

# Greybarn

THE MARK CONSISTS OF STANDARD CHARACTERS WITHOUT CLAIM TO ANY PARTICULAR FONT, STYLE, SIZE, OR COLOR.

## CLASS 35—ADVERTISING AND BUSINESS

FOR BUSINESS PLANNING SERVICES IN THE FIELD OF MULTIFAMILY RESIDENTIAL PROJECTS; REAL ESTATE SALES MANAGEMENT (U.S. CLS. 100, 101 AND 102).

## CLASS 36—INSURANCE AND FINANCIAL

FOR FINANCIAL PLANNING SERVICES RELATED TO MULTIFAMILY RESIDENTIAL PROJECTS; REAL ESTATE ACQUISITION SERVICES; REAL ESTATE FINANCING SERVICES; LEASING OF REAL ESTATE; REAL ESTATE PROPERTY MANAGEMENT (U.S. CLS. 100, 101 AND 102).

## CLASS 37—CONSTRUCTION AND REPAIR

FOR REAL ESTATE DEVELOPMENT SERVICES, NAMELY, THE DEVELOPMENT OF MULTIFAMILY RESIDENTIAL PROJECTS AND COMMUNITIES; REAL ESTATE CONSTRUCTION PLANNING SERVICES, NAMELY, THE PLANNING, LAYING OUT AND CONSTRUCTION OF MULTIFAMILY RESIDENTIAL PROJECTS; REAL ESTATE CONSTRUCTION OF MULTIFAMILY RESIDENTIAL PROJECTS AND COMMUNITIES; REAL ESTATE CONSTRUCTION OF COMMERCIAL AND RESIDENTIAL PROPERTY; REAL ESTATE DEVELOPMENT SERVICES (U.S. CLS. 100, 103 AND 106).

MAYUR VAGHANI, EXAMINING ATTORNEY

SN 86-225,366. GIRLSASKGUYS, L.L.C., ST. LOUIS, MO.  
FILED 3-19-2014.

## ELLOSSABEN

THE MARK CONSISTS OF STANDARD CHARACTERS WITHOUT CLAIM TO ANY PARTICULAR FONT, STYLE, SIZE, OR COLOR.

THE ENGLISH TRANSLATION OF "ELLOSSABEN" IN THE MARK IS "THEY KNOW".

### CLASS 9—ELECTRICAL AND SCIENTIFIC APPARATUS

FOR DOWNLOADABLE MOBILE APPLICATIONS FOR VIEWING AND POSTING QUESTIONS AND OPINIONS ON A VARIETY OF TOPICS (U.S. CLS. 21, 23, 26, 36 AND 38).

### CLASS 42—SCIENTIFIC AND COMPUTER SERVICES

FOR PROVIDING A WEBSITE FEATURING TECHNOLOGY THAT ENABLES USERS TO COMMUNICATE WITH EACH OTHER ON A RANGE OF TOPICS BY POSTING AND VIEWING QUESTIONS AND OPINIONS (U.S. CLS. 100 AND 101).

SIDDHARTH JAGANNATHAN, EXAMINING ATTORNEY

SN 86-225,464. BATH & BODY WORKS BRAND MANAGEMENT, INC., REYNOLDSBURG, OH. FILED 3-19-2014.

## PEACE LOVE & DAISIES

THE MARK CONSISTS OF STANDARD CHARACTERS WITHOUT CLAIM TO ANY PARTICULAR FONT, STYLE, SIZE, OR COLOR.

NO CLAIM IS MADE TO THE EXCLUSIVE RIGHT TO USE "DAISIES", APART FROM THE MARK AS SHOWN.

### CLASS 3—COSMETICS AND CLEANING PREPARATIONS

FOR PERSONAL CARE PRODUCTS, NAMELY, ANTI-BACTERIAL SKIN SOAPS AND GELS, BATH GELS, BATH SOAPS IN LIQUID, SOLID OR GEL FORM, BODY BALM, NAMELY, BODY BUTTERS, BODY CREAMS, BODY LOTIONS, BODY POWDER, BODY SCRUB, BODY SPRAY USED AS A PERSONAL DEODORANT AND AS FRAGRANCE, BODY WASHES FOR HUMANS, BUBBLE BATH, COLOGNE, CREAM SOAPS FOR HANDS AND BODY, EAU DE PARFUM, EAU DE TOILETTE, EXFOLIANT CREAMS, FOAM BATH, FOOT SCRUB, HAND CREAMS, HAND LOTIONS, HAND SOAPS, LIP BALM, LIP CREAM, LIP GLOSS, LIP GLOSS PALETTE, MAKE-UP KITS COMPRISED OF LIP BALMS, LIP CREAMS, AND LIP GLOSSES, MASSAGE OILS, PERFUME, SCENTED BODY SPRAY, SHAVING PREPARATIONS, NAMELY, SHAVING CREAMS, SHAVING FOAMS, SHAVING GELS, AND SHAVING LOTIONS, SHOWER GELS; FRAGRANCE EMITTING WICKS FOR ROOM FRAGRANCE, FRAGRANCES FOR AUTOMOBILES, ROOM FRAGRANCES, ROOM FRAGRANCE REFILLS FOR ELECTRIC AND NON-ELECTRIC ROOM FRAGRANCE DISPENSERS, SCENTED LINEN SPRAYS, SCENTED OILS USED TO PRODUCE AROMAS WHEN HEATED, SCENTED ROOM SPRAYS, HOME FRAGRANCE OILS (U.S. CLS. 1, 4, 6, 50, 51 AND 52).

### CLASS 4—LUBRICANTS AND FUELS

FOR CANDLES (U.S. CLS. 1, 6 AND 15).  
ALLISON HOLTZ, EXAMINING ATTORNEY

SN 86-225,477. BATH & BODY WORKS BRAND MANAGEMENT, INC., REYNOLDSBURG, OH. FILED 3-19-2014.

## COOL COCONUT SURF

THE MARK CONSISTS OF STANDARD CHARACTERS WITHOUT CLAIM TO ANY PARTICULAR FONT, STYLE, SIZE, OR COLOR.

NO CLAIM IS MADE TO THE EXCLUSIVE RIGHT TO USE "COCONUT", APART FROM THE MARK AS SHOWN.

### CLASS 3—COSMETICS AND CLEANING PREPARATIONS

FOR PERSONAL CARE PRODUCTS, NAMELY, ANTI-BACTERIAL SKIN SOAPS AND GELS, BATH GELS, BATH SOAPS IN LIQUID, SOLID OR GEL FORM, BODY BALM, NAMELY, BODY BUTTERS, BODY CREAMS, BODY LOTIONS, BODY POWDER, BODY SCRUB, BODY SPRAY USED AS A PERSONAL DEODORANT AND AS FRAGRANCE, BODY WASHES FOR HUMANS, BUBBLE BATH, COLOGNE, CREAM SOAPS FOR HANDS AND BODY, EAU DE PARFUM, EAU DE TOILETTE, EXFOLIANT CREAMS, FOAM BATH, FOOT SCRUB, HAND CREAMS, HAND LOTIONS, HAND SOAPS, LIP BALM, LIP CREAM, LIP GLOSS, LIP GLOSS PALETTE, MAKE-UP KITS COMPRISED OF LIP BALMS, LIP CREAMS, AND LIP GLOSSES, MASSAGE OILS, PERFUME, SCENTED BODY SPRAY, SHAVING PREPARATIONS, NAMELY, SHAVING CREAMS, SHAVING FOAMS, SHAVING GELS, AND SHAVING LOTIONS, SHOWER GELS; FRAGRANCE EMITTING WICKS FOR ROOM FRAGRANCE, FRAGRANCES FOR AUTOMOBILES, ROOM FRAGRANCES, ROOM FRAGRANCE REFILLS FOR ELECTRIC AND NON-ELECTRIC ROOM FRAGRANCE DISPENSERS, SCENTED LINEN SPRAYS, SCENTED OILS USED TO PRODUCE AROMAS WHEN HEATED, SCENTED ROOM SPRAYS, HOME FRAGRANCE OILS (U.S. CLS. 1, 4, 6, 50, 51 AND 52).

**CLASS 4—LUBRICANTS AND FUELS**

FOR CANDLES (U.S. CLS. 1, 6 AND 15).  
ALLISON HOLTZ, EXAMINING ATTORNEY

SN 86-225,544. LIFETIME ENTERTAINMENT SERVICES,  
LLC, NEW YORK, NY. FILED 3-19-2014.

**STUDIO RESCUE**

THE MARK CONSISTS OF STANDARD CHARACTERS  
WITHOUT CLAIM TO ANY PARTICULAR FONT, STYLE,  
SIZE, OR COLOR.

NO CLAIM IS MADE TO THE EXCLUSIVE RIGHT TO  
USE "STUDIO", APART FROM THE MARK AS SHOWN.

**CLASS 9—ELECTRICAL AND SCIENTIFIC  
APPARATUS**

FOR MULTIMEDIA GOODS, NAMELY, PRERE-  
CORDED DIGITAL VIDEO DISCS AND DVDS FEATUR-  
ING SUBJECTS OF GENERAL HUMAN INTEREST;  
DIGITAL MEDIA, NAMELY, DOWNLOADABLE AUDIO  
AND VIDEO FILES FEATURING SUBJECTS OF GEN-  
ERAL HUMAN INTEREST; DOWNLOADABLE WEB-  
CASTS AND PODCASTS FEATURING SUBJECTS OF  
GENERAL HUMAN INTEREST; DOWNLOADABLE  
GRAPHICS FOR WIRELESS DEVICES; DOWNLOA-  
DABLE ON-LINE DISCUSSION BOARD POSTS FEAT-  
URING SUBJECTS OF GENERAL HUMAN INTEREST (U.S.  
CLS. 21, 23, 26, 36 AND 38).

**CLASS 41—EDUCATION AND ENTERTAIN-  
MENT**

FOR ENTERTAINMENT SERVICES, NAMELY, A  
MULTIMEDIA PROGRAM SERIES FEATURING SUB-  
JECTS OF GENERAL HUMAN INTEREST DISTRIBU-  
TED VIA VARIOUS PLATFORMS ACROSS MULTIPLE  
FORMS OF TRANSMISSION MEDIA; ENTERTAIN-  
MENT SERVICES, NAMELY, AN ONGOING TELEVI-  
SION SERIES FEATURING SUBJECTS OF GENERAL  
HUMAN INTEREST; PROVIDING A WEBSITE FEAT-  
URING ENTERTAINMENT INFORMATION (U.S. CLS. 100,  
101 AND 107).  
WON TEAK OH, EXAMINING ATTORNEY

SN 86-226,077. AMERICAN ROAD & TRANSPORTATION  
BUILDERS ASSOCIATION, WASHINGTON, DC. FILED 3-  
19-2014.

**TIAC**

THE MARK CONSISTS OF STANDARD CHARACTERS  
WITHOUT CLAIM TO ANY PARTICULAR FONT, STYLE,  
SIZE, OR COLOR.

**CLASS 35—ADVERTISING AND BUSINESS**

FOR PUBLIC POLICY SERVICES, NAMELY, PROVID-  
ING A WEBSITE FEATURING INFORMATION TO  
ASSIST PRIVATE CITIZENS, LEGISLATORS, ORGANI-  
ZATIONS AND BUSINESSES IN SUCCESSFULLY IN-  
CREASING TRANSPORTATION INFRASTRUCTURE  
INVESTMENT AT THE STATE AND LOCAL LEVELS  
THROUGH THE LEGISLATIVE AND BALLOT INITIA-  
TIVE PROCESSES (U.S. CLS. 100, 101 AND 102).  
FIRST USE 3-14-2014; IN COMMERCE 3-14-2014.

**CLASS 41—EDUCATION AND ENTERTAIN-  
MENT**

FOR EDUCATIONAL SERVICES, NAMELY, WEB-  
BASED INFORMATION RESOURCES DESIGNED TO  
ASSIST PRIVATE CITIZENS, LEGISLATORS, ORGANI-  
ZATIONS AND BUSINESSES IN SUCCESSFULLY IN-  
CREASING TRANSPORTATION INFRASTRUCTURE  
INVESTMENT AT THE STATE AND LOCAL LEVELS  
THROUGH THE LEGISLATIVE AND BALLOT INITIA-  
TIVE PROCESSES, ALONG WITH ONGOING WEBI-  
NARS AND AN ANNUAL WORKSHOP IN  
WASHINGTON, DC (U.S. CLS. 100, 101 AND 107).  
FIRST USE 3-14-2014; IN COMMERCE 3-14-2014.  
SUSAN LESLIE DUBOIS, EXAMINING ATTORNEY

SN 86-226,098. PARKER WALLACE COMPANY, MINDEN,  
NV. FILED 3-19-2014.

**Logline**

THE MARK CONSISTS OF STANDARD CHARACTERS  
WITHOUT CLAIM TO ANY PARTICULAR FONT, STYLE,  
SIZE, OR COLOR.

**CLASS 9—ELECTRICAL AND SCIENTIFIC  
APPARATUS**

FOR COMPUTER SOFTWARE FOR DEVELOPING  
SCREENPLAYS (U.S. CLS. 21, 23, 26, 36 AND 38).  
FIRST USE 4-1-2011; IN COMMERCE 10-19-2011.

**CLASS 42—SCIENTIFIC AND COMPUTER  
SERVICES**

FOR ELECTRONIC STORAGE OF TEXTS, NAMELY,  
SCREENPLAYS; FILE SHARING SERVICES, NAMELY,  
PROVIDING A WEBSITE FEATURING TECHNOLOGY  
ENABLING USERS TO UPLOAD AND DOWNLOAD  
ELECTRONIC FILES IN THE FIELD OF MOTION  
PICTURE DEVELOPMENT (U.S. CLS. 100 AND 101).  
FIRST USE 4-1-2011; IN COMMERCE 10-19-2011.  
MATTHEW MCDOWELL, EXAMINING ATTORNEY

SN 86-226,173. AMERICAN ROAD & TRANSPORTATION BUILDERS ASSOCIATION, WASHINGTON, DC. FILED 3-19-2014.

SN 86-226,521. LETUCHAYA, MARINA, MARINA DEL REY, CA. FILED 3-20-2014.



NO CLAIM IS MADE TO THE EXCLUSIVE RIGHT TO USE "TRANSPORTATION INVESTMENT ADVOCACY CENTER", APART FROM THE MARK AS SHOWN.

THE COLOR(S) RED, WHITE, LIGHT BLUE AND DARK BLUE IS/ARE CLAIMED AS A FEATURE OF THE MARK.

THE MARK CONSISTS OF THE TERM "TRANSPORTATION INVESTMENT ADVOCACY CENTER" IN WHITE LETTERS AGAINST A RECTANGULAR BACKGROUND THAT CONTAINS ELEMENTS OF THE AMERICAN FLAG. THE TOP HALF OF THE DESIGN CONSISTS OF A BLUE BACKGROUND WITH ALTERNATING STARS IN SHADES OF DARK AND LIGHT BLUE, OVER THE BOTTOM HALF OF THE RECTANGLE, WHICH CONSISTS OF ALTERNATING RED AND WHITE STRIPES. THE RECTANGLE IS BISECTED BY A LIGHT BLUE CURVED SWIRL, FEATURING A LINE OF WHITE STARS IN DECREASING SIZE FROM LEFT TO RIGHT.

#### CLASS 35—ADVERTISING AND BUSINESS

FOR PUBLIC POLICY SERVICES, NAMELY, PROVIDING A WEBSITE FEATURING INFORMATION TO ASSIST PRIVATE CITIZENS, LEGISLATORS, ORGANIZATIONS AND BUSINESSES IN SUCCESSFULLY INCREASING TRANSPORTATION INFRASTRUCTURE INVESTMENT AT THE STATE AND LOCAL LEVELS THROUGH THE LEGISLATIVE AND BALLOT INITIATIVE PROCESSES (U.S. CLS. 100, 101 AND 102).

FIRST USE 3-14-2014; IN COMMERCE 3-14-2014.

#### CLASS 41—EDUCATION AND ENTERTAINMENT

FOR EDUCATIONAL SERVICES, NAMELY, WEBINARS, WORKSHOPS AND WEB-BASED TRAINING DESIGNED TO ASSIST PRIVATE CITIZENS, LEGISLATORS, ORGANIZATIONS AND BUSINESSES IN SUCCESSFULLY INCREASING TRANSPORTATION INFRASTRUCTURE INVESTMENT AT THE STATE AND LOCAL LEVELS THROUGH THE LEGISLATIVE AND BALLOT INITIATIVE PROCESSES (U.S. CLS. 100, 101 AND 107).

FIRST USE 3-14-2014; IN COMMERCE 3-14-2014.  
SUSAN LESLIE DUBOIS, EXAMINING ATTORNEY

NO CLAIM IS MADE TO THE EXCLUSIVE RIGHT TO USE "CHILDREN'S FOUNDATION", APART FROM THE MARK AS SHOWN.

THE COLOR(S) GREEN, WHITE, PURPLE, RED, PINK, YELLOW, ORANGE, AND BLUE IS/ARE CLAIMED AS A FEATURE OF THE MARK.

THE MARK CONSISTS OF THE FOLLOWING: A CHILD'S DRAWING OF A GREEN WINGED HEART WITH WHITE ENCLOSED WITHIN THE WINGED HEART DESIGN AND CONTAINING SEVEN (7) SMALLER HEARTS. THE SMALLER HEARTS ARE ALL OUTLINED IN GREEN AND FILLED WITH ONE OF THE FOLLOWING COLORS, BEGINNING WITH THE HEART IN THE TOP RIGHT CORNER AND GOING CLOCKWISE: PURPLE, RED, DARK PINK, LIGHT PINK, YELLOW, ORANGE, AND BLUE. BELOW THE HEART, THE WORDS "FLYING HEARTS" APPEAR IN A LOWER CASE HANDWRITING FONT, WITH THE LETTERS "F" AND "T" IN BLUE, THE LETTERS "L," "Y" AND "G" IN GREEN, THE LETTERS "I" AND "S" IN YELLOW, THE LETTERS "N" AND "E" IN PURPLE, AND THE LETTERS "H," "A" AND "R" IN RED. BELOW "FLYING HEARTS," THE WORDS "CHILDREN'S FOUNDATION" APPEAR IN A GREEN, LOWER CASE HANDWRITING FONT.

#### CLASS 25—CLOTHING

FOR WEARABLE GARMENTS AND CLOTHING, NAMELY, SHIRTS (U.S. CLS. 22 AND 39).

#### CLASS 36—INSURANCE AND FINANCIAL

FOR CHARITABLE FUNDRAISING (U.S. CLS. 100, 101 AND 102).

#### CLASS 45—PERSONAL AND LEGAL SERVICES

FOR PROVIDING EMOTIONAL COUNSELING AND EMOTIONAL SUPPORT SERVICES FOR TROUBLED AND AT-RISK YOUTH AND THEIR FAMILIES (U.S. CLS. 100 AND 101).

ANDREA CORNWELL, EXAMINING ATTORNEY



SN 86-226,916. PREMIER HOSPITALITY, LLC, ALBUQUERQUE, NM. FILED 3-20-2014.



OWNER OF U.S. REG. NO. 4,469,477.  
NO CLAIM IS MADE TO THE EXCLUSIVE RIGHT TO USE "PREMIER HOSPITALITY", APART FROM THE MARK AS SHOWN.

THE MARK CONSISTS OF AN ECLIPSED ARC PASSING THROUGH THE LETTERS "PH" AND EXHIBITING FIVE POINTED RAYS, REPRESENTING SUN RAYS, IN THE BACKGROUND. THE WORDS "PREMIER HOSPITALITY" APPEAR BELOW THE ARC, SUN RAYS, AND THE LETTERS "PH".

#### CLASS 35—ADVERTISING AND BUSINESS

FOR MANAGEMENT OF HOTELS AND MOTELS (U.S. CLS. 100, 101 AND 102).  
FIRST USE 5-1-2005; IN COMMERCE 5-1-2005.

#### CLASS 37—CONSTRUCTION AND REPAIR

FOR CONSTRUCTION OF HOTELS AND MOTELS (U.S. CLS. 100, 103 AND 106).  
FIRST USE 5-1-2005; IN COMMERCE 5-1-2005.  
TEJBIR SINGH, EXAMINING ATTORNEY

SN 86-226,943. THE BOARD OF REGENTS OF THE UNIVERSITY OF TEXAS SYSTEM, AUSTIN, TX. FILED 3-20-2014.

THE UNIVERSITY OF TEXAS  
RIO GRANDE VALLEY

THE MARK CONSISTS OF STANDARD CHARACTERS WITHOUT CLAIM TO ANY PARTICULAR FONT, STYLE, SIZE, OR COLOR.

OWNER OF U.S. REG. NOS. 1,340,787 AND 1,351,805.  
SEC. 2(F).

#### CLASS 41—EDUCATION AND ENTERTAINMENT

FOR EDUCATIONAL SERVICES, NAMELY, PROVIDING COLLEGE, GRADUATE, AND POST-GRADUATE LEVEL COURSES OF INSTRUCTION AND SEMINARS, AND EDUCATIONAL OPPORTUNITIES TO PARTICIPATE IN RESEARCH PROGRAMS; ENTERTAINMENT SERVICES, NAMELY, PROVIDING COLLEGE ATHLETIC AND SPORTING EVENTS, COLLEGE SPORT GAMES AND EVENTS RENDERED LIVE AND VIA A GLOBAL COMPUTER NETWORK, VIA WIRELESS AND MOBILE DEVICES, AND THROUGH THE MEDIUMS OF TELEVISION, AND INTERACTIVE TELEVISION AND RADIO; EDUCATIONAL SERVICES IN THE NATURE OF MEDICAL SCHOOLS; MEDICAL TRAINING AND TEACHING; PROVIDING CONTINUING EDUCATION COURSES IN THE MEDICAL, ACCOUNTING, LEGAL, BUSINESS, AND NURSING FIELDS (U.S. CLS. 100, 101 AND 107).

#### CLASS 44—MEDICAL, BEAUTY AND AGRICULTURAL SERVICES

FOR MEDICAL SERVICES; PROVIDING MEDICAL INFORMATION, CONSULTANCY AND ADVISORY SERVICES (U.S. CLS. 100 AND 101).  
SHARON MEIER, EXAMINING ATTORNEY

SN 86-227,036. BLUESTEM BRANDS, INC., EDEN PRAIRIE, MN. FILED 3-20-2014.

ALCOVE

THE MARK CONSISTS OF STANDARD CHARACTERS WITHOUT CLAIM TO ANY PARTICULAR FONT, STYLE, SIZE, OR COLOR.

#### CLASS 4—LUBRICANTS AND FUELS

FOR CANDLES (U.S. CLS. 1, 6 AND 15).

#### CLASS 7—MACHINERY

FOR ELECTRIC FOOD BLENDERS; ELECTRIC MIXERS; KITCHEN MACHINES, NAMELY, ELECTRIC STANDING MIXERS; ELECTRIC FOOD PROCESSORS (U.S. CLS. 13, 19, 21, 23, 31, 34 AND 35).

#### CLASS 8—HAND TOOLS

FOR FLATWARE, NAMELY, FORKS, KNIVES, AND SPOONS; KITCHEN KNIVES; CHEF KNIVES; HAND TOOLS FOR USE IN THE KITCHEN, NAMELY, HAND HELD CUTTING TOOLS, KNIVES, KNIFE SHARPENERS, TONGS, CAN OPENERS; FIREPLACE TOOLS, NAMELY, SHOVELS, POKERS, RAKES AND A STAND THEREFOR (U.S. CLS. 23, 28 AND 44).

#### CLASS 11—ENVIRONMENTAL CONTROL APPARATUS

FOR ELECTRIC GRIDDLES; ELECTRIC INDOOR GRILLS; GAS GRILLS; ELECTRIC DEEP FRYERS; ELECTRIC SLOW COOKERS; ELECTRIC TOASTERS; ELECTRIC TOASTER OVENS; ELECTRIC COFFEE MAKERS; MICROWAVE OVENS; ELECTRIC BLANKETS NOT FOR MEDICAL PURPOSES; FIREPLACE INSERTS, COMPRISED OF ANDIRONS, ARTIFICIAL LOGS AND ARTIFICIAL EMBERS POWERED BY ELECTRICITY; ELECTRIC CHARCOAL GRILLS; OUTDOOR FIREPLACES; ELECTRIC CANDLES (U.S. CLS. 13, 21, 23, 31 AND 34).

**CLASS 19—NON-METALLIC BUILDING MATERIALS**

FOR FIREPLACE MANTELS; GAZEBOs NOT PRIMARILY OF METAL (U.S. CLS. 1, 12, 33 AND 50).

**CLASS 20—FURNITURE AND ARTICLES NOT OTHERWISE CLASSIFIED**

FOR HOME AND OFFICE FURNITURE; BEDROOM FURNITURE; GARDEN AND PATIO FURNITURE; MIRRORS; DECORATIVE WINDOW FINIALS; DRAPERY HARDWARE, NAMELY, TENSION RODS, ROD SETS, RODS OF WOOD, RODS OF STEEL, POLES, RINGS, TIE BACKS, BRACKETS, DRAPERY RINGS NOT OF METAL; FABRIC STORAGE BIN ORGANIZER; STORAGE AND ORGANIZATION PRODUCTS AND ACCESSORIES, NAMELY, STORAGE SHELVES, STORAGE DRAWERS, STORAGE CARTS, STORAGE RACKS; WOOD AND PLASTIC STORAGE BOXES; TABLES; CHAIRS; SHELVES; BOOKCASES; BOOK STANDS; DESKS; CABINETS; CHESTS OF DRAWERS; DRESSERS; ENTERTAINMENT CENTERS; FILING CABINETS; MAGAZINE RACKS; MEDICINE CABINETS; NIGHTSTANDS; OTTOMANS; HAMPERS; PICTURE FRAMES; HANGERS FOR CLOTHES; PILLOWS; DECORATIVE PILLOWS; STOOLS; SHOWER CURTAIN RINGS; SHOWER CURTAIN HOOKS; SHOWER CURTAIN RODS; SEAT CUSHIONS; MATTRESSES; INDOOR BLINDS; FIRE GUARDS FOR DOMESTIC USE; FIRE SCREENS FOR DOMESTIC USE; FEATHER BEDS; MATTRESS TOPPERS; COAT RACKS; KITCHEN FURNITURE, NAMELY, READY TO ASSEMBLE MOBILE KITCHEN ISLANDS (U.S. CLS. 2, 13, 22, 25, 32 AND 50).

**CLASS 21—HOUSEWARES AND GLASS**

FOR DINNERWARE; STEMWARE; CAKE STANDS; PITCHERS; VASES, CHIP-AND-DIP SETS; BANANA HOLDERS; DISH DRYING RACKS; CROCKERY, NAMELY, POTS, DISHES, DRINKING CUPS AND SAUCERS, BOWLS, SERVING BOWLS AND TRAYS; MUG TREES; FOOD STORAGE CANISTERS SOLD EMPTY; MEAL TRAYS; KITCHEN TOOLS AND ACCESSORIES, NAMELY, BEVERAGE STIRRERS, COOKIE JARS, THERMAL CARAFES, CARAFES, TOWEL HOLDERS, GLASS BOTTLE STOPPERS, BREAD BOXES, SALAD BOWL SETS; COOKWARE, NAMELY, POTS AND PANS, ROASTING PANS; PANS; BAKE WARE; SERVING DISHES, NAMELY, TIERED PLATTERS, SUGAR AND CREAMER SETS, SALT AND PEPPER SHAKERS; TEA POTS NOT OF PRECIOUS METAL; SERVING FORKS; FLATWARE CADDIES; SKILLETS; BEVERAGE WARE; DRINKING GLASSES AND MUGS; MIXING BOWLS; PAPER TOWEL HOLDERS; SOAP DISPENSERS; SOAP DISHES; SHOWER CADDIES; COTTON BALL DISPENSERS; TISSUE HOLDERS; TOILET BRUSHES; TOILET BRUSH HOLDERS; TOOTHBRUSH HOLDERS; CONTAINERS FOR HOUSEHOLD OR KITCHEN USE; CLOTHES DRYING RACKS; TRASH CANS; IRONING BOARDS; TOWEL BARS (U.S. CLS. 2, 13, 23, 29, 30, 33, 40 AND 50).

**CLASS 22—CORDAGE AND FIBERS**

FOR SHOE BAGS FOR STORAGE (U.S. CLS. 1, 2, 7, 19, 22, 42 AND 50).

**CLASS 24—FABRICS**

FOR BATH TOWELS; BED BLANKETS; BED LINEN; BED SPREADS; BLANKET THROWS; COVERS FOR CUSHIONS; DUVET COVERS; FACE TOWELS; WASH CLOTHS; HAND TOWELS; PILLOW COVERS; TOWEL SETS; TOWELS; UNFITTED FABRIC FURNITURE COVERS; UNFITTED FABRIC SLIP COVERS; KITCHEN LINEN; LINENS; SHOWER CURTAINS; SHOWER CURTAIN LINERS; MATTRESS PADS OF COTTON; MATTRESS PADS OF FOAM; BEDDING, NAMELY, COMFORTERS, SHEETS, PILLOW SHAMS, PILLOW CASES, BED SKIRTS, BED SPREADS, BLANKETS, COVERLETS, DUVETS, QUILTS AND THROWS; TABLE LINENS NOT OF PAPER, NAMELY, PLACEMENTS, NAPKINS, TABLECLOTHS, FABRIC TABLE RUNNERS AND FABRIC TABLE TOPPERS; FABRIC WINDOW COVERINGS AND TREATMENTS, NAMELY, CURTAINS, DRAPERIES, SHEERS, SWAGS, VALANCES; DISH CLOTHS; OVEN MITTS (U.S. CLS. 42 AND 50).

**CLASS 25—CLOTHING**

FOR DRESSING GOWNS AND BATH ROBES (U.S. CLS. 22 AND 39).

**CLASS 27—FLOOR COVERINGS**

FOR RUGS; BATH MATS; FABRIC BATH TUB RUGS; ACCENT RUGS; DOOR MATS; WOVEN AREA RUGS; RUGS IN THE NATURE OF FLOOR RUNNERS (U.S. CLS. 19, 20, 37, 42 AND 50).

**CLASS 28—TOYS AND SPORTING GOODS**

FOR ARTIFICIAL CHRISTMAS TREES; ARTIFICIAL CHRISTMAS GARLANDS; BELLS FOR CHRISTMAS TREES; CHRISTMAS TREE ORNAMENTS AND DECORATIONS; PRE-LIT ARTIFICIAL CHRISTMAS TREES; PRE-LIT ARTIFICIAL CHRISTMAS WREATHS; PRE-LIT ARTIFICIAL CHRISTMAS GARLANDS; CHRISTMAS TREE SKIRTS AND STOCKINGS (U.S. CLS. 22, 23, 38 AND 50).

MORGAN WYNNE, EXAMINING ATTORNEY

SN 86-227,056. XTREME DRILLING AND COIL SERVICES, INC., HOUSTON, TX. FILED 3-20-2014.

**KNOWLEDGE BOX**

THE MARK CONSISTS OF STANDARD CHARACTERS WITHOUT CLAIM TO ANY PARTICULAR FONT, STYLE, SIZE, OR COLOR.

**CLASS 9—ELECTRICAL AND SCIENTIFIC APPARATUS**

FOR COMPUTER SOFTWARE FOR COMPANIES ENGAGED IN OIL AND GAS DRILLING AND COMPLETION ACTIVITIES WHICH PROVIDES ACCESS TO OPERATIONAL WORK DETAILS, COMPANY PROCEDURES, POLICY FORMS, AND TRAINING (U.S. CLS. 21, 23, 26, 36 AND 38).

**CLASS 42—SCIENTIFIC AND COMPUTER SERVICES**

FOR PROVIDING SOFTWARE CONSULTING SERVICES FOR COMPANIES ENGAGED IN OIL AND GAS DRILLING AND COMPLETION ACTIVITIES ON THE USE OF SOFTWARE AND A PORTAL FOR USE WITH TOUCH SCREENS WHICH ACCESSES OPERATIONAL WORK DETAILS, COMPANY PROCEDURES, POLICY FORMS, AND TRAINING (U.S. CLS. 100 AND 101).  
CHARLOTTE CORWIN, EXAMINING ATTORNEY

SN 86-227,569. COUP ENTERTAINMENT LLC, NEW YORK, NY. FILED 3-20-2014.

**COUP ADVERTISING**

THE MARK CONSISTS OF STANDARD CHARACTERS WITHOUT CLAIM TO ANY PARTICULAR FONT, STYLE, SIZE, OR COLOR.

NO CLAIM IS MADE TO THE EXCLUSIVE RIGHT TO USE "ADVERTISING", APART FROM THE MARK AS SHOWN.

**CLASS 35—ADVERTISING AND BUSINESS**

FOR ADVERTISING AND MARKETING; ADVERTISING, MARKETING, AND PROMOTING THE GOODS AND SERVICES OF OTHERS VIA BRANDED VIDEOS AND PRODUCT PLACEMENT WITHIN VIDEOS (U.S. CLS. 100, 101 AND 102).

SN 86-227,381. TERGERSON REAL ESTATE, LLC, AUSTIN, TX. FILED 3-20-2014.

**Austin Modern Living****CLASS 41—EDUCATION AND ENTERTAINMENT**

FOR PRODUCTION OF TELEVISION PROGRAMS; VIDEO PRODUCTION SERVICES (U.S. CLS. 100, 101 AND 107).

KERI CANTONE, EXAMINING ATTORNEY

SN 86-227,813. INFUSE CREATIVE, LLC, SANTA MONICA, CA. FILED 3-20-2014.

THE MARK CONSISTS OF STANDARD CHARACTERS WITHOUT CLAIM TO ANY PARTICULAR FONT, STYLE, SIZE, OR COLOR.

NO CLAIM IS MADE TO THE EXCLUSIVE RIGHT TO USE "AUSTIN MODERN", APART FROM THE MARK AS SHOWN.

**LoveLiife**

THE MARK CONSISTS OF STANDARD CHARACTERS WITHOUT CLAIM TO ANY PARTICULAR FONT, STYLE, SIZE, OR COLOR.

**CLASS 35—ADVERTISING AND BUSINESS**

FOR ADVERTISING OF COMMERCIAL OR RESIDENTIAL REAL ESTATE; MATCHING CONSUMERS WITH REAL ESTATE PROFESSIONALS IN THE FIELD OF REAL ESTATE SERVICES VIA COMPUTER NETWORK; NEGOTIATION AND RENEGOTIATION FOR OTHERS OF LEASES AND SUBLEASES AND REAL ESTATE PURCHASE AGREEMENTS; REAL ESTATE ADVERTISING SERVICES; REAL ESTATE MARKETING SERVICES (U.S. CLS. 100, 101 AND 102).

FIRST USE 1-9-2008; IN COMMERCE 1-9-2008.

**CLASS 9—ELECTRICAL AND SCIENTIFIC APPARATUS**

FOR COMPUTER SOFTWARE APPLICATION THAT INTERACTS WITH A WEBSITE, NAMELY, SOFTWARE THAT ALLOWS COUPLES TO TRACK AND CREATE A DETAILED RELATIONSHIP TIMELINE AND COLLECT OTHER DETAILS PERTAINING TO THEIR SHARED RELATIONSHIP HISTORY; WEARABLE DIGITAL ELECTRONIC DEVICES COMPRISED PRIMARILY OF SOFTWARE AND DISPLAY SCREENS THAT ALLOWS COUPLES TO TRACK AND CREATE A DETAILED RELATIONSHIP TIMELINE AND COLLECT OTHER DETAILS PERTAINING TO THEIR SHARED RELATIONSHIP HISTORY (U.S. CLS. 21, 23, 26, 36 AND 38).

**CLASS 36—INSURANCE AND FINANCIAL**

FOR ARRANGING OF LEASES AND RENTAL AGREEMENTS FOR REAL ESTATE; COMMERCIAL AND RESIDENTIAL REAL ESTATE AGENCY SERVICES; LEASING OF REAL ESTATE; LEASING OF REAL PROPERTY; PROVIDING INFORMATION IN THE FIELD OF REAL ESTATE VIA THE INTERNET; PROVIDING REAL ESTATE LISTINGS VIA THE INTERNET; REAL ESTATE AGENCIES; REAL ESTATE BROKERAGE; REAL ESTATE CONSULTATION; REAL ESTATE INVESTMENT SERVICES IN THE NATURE OF PURCHASING AND SELLING OF REAL ESTATE FOR OTHERS; REAL ESTATE LISTING; REAL ESTATE LISTING SERVICES FOR HOUSING RENTALS AND APARTMENT RENTALS; REAL ESTATE RENTAL SERVICES, NAMELY, RENTAL OF RESIDENTIAL HOUSING; RESIDENTIAL REAL ESTATE AGENCY SERVICES (U.S. CLS. 100, 101 AND 102).

FIRST USE 1-9-2008; IN COMMERCE 1-9-2008.  
SOPHIA S. KIM, EXAMINING ATTORNEY

**CLASS 42—SCIENTIFIC AND COMPUTER SERVICES**

FOR PROVIDING AN INTERACTIVE WEBSITE FEATURING TECHNOLOGY THAT ENABLES USERS TO TRACK AND CREATE A DETAILED RELATIONSHIP TIMELINE AND COLLECT OTHER DETAILS PERTAINING TO THEIR SHARED HISTORY; PROVIDING A WEBSITE FEATURING TECHNOLOGY THAT ENABLES USERS TO UPLOAD AND SHARE USER-GENERATED PHOTOGRAPHS, VIDEOS AND OTHER MATERIAL RELATING TO THE USER'S RELATIONSHIPS (U.S. CLS. 100 AND 101).

ZACHARY R. SPARER, EXAMINING ATTORNEY

---

SN 86-227,941, INN FOODS, INC., WATSONVILLE, CA.  
FILED 3-21-2014.

## WISE BROTHER'S FARM

THE MARK CONSISTS OF STANDARD CHARACTERS WITHOUT CLAIM TO ANY PARTICULAR FONT, STYLE, SIZE, OR COLOR.

NO CLAIM IS MADE TO THE EXCLUSIVE RIGHT TO USE "FARM", APART FROM THE MARK AS SHOWN.

### CLASS 29—MEATS AND PROCESSED FOODS

FOR PROCESSED, FROZEN, DRIED OR PRESERVED FRUIT; PRESERVED, PROCESSED, DRIED, FROZEN OR COOKED VEGETABLES; PREPARED ENTREES CONSISTING PRIMARILY OF VEGETABLES, SOUPS, FRUIT SALADS AND VEGETABLE SALADS; ROASTED, SHELLED, SEASONED OR PROCESSED NUTS (U.S. CL. 46).

### CLASS 31—NATURAL AGRICULTURAL PRODUCTS

FOR FRESH VEGETABLES, FRESH FRUIT OR RAW NUTS (U.S. CLS. 1 AND 46).

WARREN L. OLANDRIA, EXAMINING ATTORNEY

---

SN 86-228,030, THE MEN'S WEARHOUSE, INC., HOUSTON, TX. FILED 3-21-2014.



OWNER OF U.S. REG. NOS. 3,897,650, 4,023,622 AND 4,546,365.

THE MARK CONSISTS OF ASIAN INFLUENCED ABSTRACT BRUSHSTROKES MAKING THE BACKWARDS LETTERS "KO" AND THE LETTERS "EGARA" BELOW.

THE ENGLISH TRANSLATION OF THE WORD "EGARA" IN THE MARK IS "PICTURE".

### CLASS 14—JEWELRY

FOR CUFFLINKS; JEWELRY (U.S. CLS. 2, 27, 28 AND 50).

### CLASS 18—LEATHER GOODS

FOR CARRY-ALL BAGS; LEATHER AND IMITATION LEATHER BAGS (U.S. CLS. 1, 2, 3, 22 AND 41).

### CLASS 25—CLOTHING

FOR NECKWEAR; SUITS; VESTS (U.S. CLS. 22 AND 39).

MAYUR VAGHANI, EXAMINING ATTORNEY

---

SN 86-228,040, AUTOZONE PARTS, INC., MEMPHIS, TN.  
FILED 3-21-2014.

## PROVANTAGE WARRANTY

THE MARK CONSISTS OF STANDARD CHARACTERS WITHOUT CLAIM TO ANY PARTICULAR FONT, STYLE, SIZE, OR COLOR.

NO CLAIM IS MADE TO THE EXCLUSIVE RIGHT TO USE "WARRANTY" IN INTERNATIONAL CLASS 36, APART FROM THE MARK AS SHOWN.

### CLASS 35—ADVERTISING AND BUSINESS

FOR CUSTOMER LOYALTY SERVICES AND CUSTOMER CLUB SERVICES, FOR COMMERCIAL, PROMOTIONAL AND/OR ADVERTISING PURPOSES; PROVIDING INCENTIVE AWARD PROGRAMS FOR CUSTOMERS THROUGH THE DISTRIBUTION OF PRIZES, AWARDS AND PROMOTIONAL ITEMS FOR THE PURPOSE OF PROMOTING AND REWARDING LOYALTY (U.S. CLS. 100, 101 AND 102).

### CLASS 36—INSURANCE AND FINANCIAL

FOR PROVIDING AUTOMOTIVE REPAIR WARRANTY SERVICES (U.S. CLS. 100, 101 AND 102).

ANNE FARRELL, EXAMINING ATTORNEY

---

SN 86-228,200, HULL, PETER, FREDERICK, MD. FILED 3-21-2014.

## Frontier Spirit America

THE MARK CONSISTS OF STANDARD CHARACTERS WITHOUT CLAIM TO ANY PARTICULAR FONT, STYLE, SIZE, OR COLOR.

### CLASS 41—EDUCATION AND ENTERTAINMENT

FOR EDUCATIONAL SERVICES, NAMELY, PROVIDING TRAINING IN THE FIELDS OF SKILLS USED FOR PREVENTING, RESPONDING TO, AND RECOVERING FROM DISASTERS, FOR PERSONAL PROTECTION, AND FOR CONTINUITY OF FAMILY, NAMELY, THE PROVIDING OF PERSONAL CARE AND FINANCIAL CARE TO FAMILY MEMBERS FACING CHALLENGES; ARRANGING, ORGANIZING, CONDUCTING, AND HOSTING SOCIAL AND CULTURAL ENTERTAINMENT EVENTS (U.S. CLS. 100, 101 AND 107).

**CLASS 43—HOTEL AND RESTAURANT SERVICES**

FOR PROVIDING OF FOOD AND DRINK; PROVIDING TEMPORARY ACCOMMODATION (U.S. CLS. 100 AND 101).

Laura Fionda, Examining Attorney

SN 86-228,238. H. Brooks and Company LLC, New Brighton, MN. Filed 3-21-2014.



THE MARK CONSISTS OF A STYLIZED DRAWING OF AN APPLE ABOVE THE WORDS "TASTEBUDS BECAUSE LIFE IS DELICIOUS".

**CLASS 29—MEATS AND PROCESSED FOODS**

FOR FRUIT AND VEGETABLE SALADS (U.S. CL. 46).

**CLASS 30—STAPLE FOODS**

FOR SALSA, SEASONINGS, AND SAUCES (U.S. CL. 46).

**CLASS 31—NATURAL AGRICULTURAL PRODUCTS**

FOR FRESH FRUIT AND VEGETABLES (U.S. CLS. 1 AND 46).

Paul Moreno, Examining Attorney

SN 86-228,297. Asian American Hotel Owners Association, AKA AAHOA, Atlanta, GA. Filed 3-21-2014.



OWNER OF U.S. REG. NOS. 2,400,170, 4,477,533 AND OTHERS.

THE MARK CONSISTS OF THE WORD "AAHOA" IN STYLIZED LETTERS, WITH AN ARC EXTENDING THROUGH THE ENTIRE WORD "AAHOA", THE ARC FORMING THE CROSSING LINE FOR THE LETTERS "A" AND THE LETTER "H" BUT HIDDEN BEHIND THE LETTER "O", WITH TWO DIVERGING ARROW LINES FORMING A ROOF ON TOP OF THE LETTER "H", AND WITH FOUR OFFSET BLOCKS SYMBOLICALLY REPRESENTING WINDOWS BELOW THE ROOF AND ABOVE THE ARC INSIDE THE LETTER "H".

**CLASS 16—PAPER GOODS AND PRINTED MATTER**

FOR PRINTED PUBLICATIONS, NAMELY, MAGAZINES AND ARTICLES PUBLISHED PERIODICALLY IN THE FIELD OF HOSPITALITY SERVICES, HOTEL OWNERSHIP, AND HOTEL MANAGEMENT (U.S. CLS. 2, 5, 22, 23, 29, 37, 38 AND 50).

FIRST USE 1-1-2014; IN COMMERCE 1-1-2014.

**CLASS 35—ADVERTISING AND BUSINESS**

FOR TRADE ASSOCIATION SERVICES, NAMELY, PROMOTING THE INTERESTS OF ASIAN-AMERICANS IN THE HOTEL AND HOSPITAL INDUSTRY; LOBBYING SERVICES, NAMELY, PROMOTING THE INTERESTS OF ASIAN-AMERICANS IN THE HOTEL AND HOSPITAL INDUSTRY IN THE FIELDS OF LEGISLATION AND REGULATION; PROVIDING AN ONLINE INTERACTIVE PORTAL TO PROVIDE BUSINESS ADVICE AND INFORMATION, ADVERTISING, AND BUSINESS MANAGEMENT ASSISTANCE TO THE ASIAN-AMERICAN HOTEL AND HOSPITALITY INDUSTRY (U.S. CLS. 100, 101 AND 102).

FIRST USE 1-1-2014; IN COMMERCE 1-1-2014.

**CLASS 41—EDUCATION AND ENTERTAINMENT**

FOR EDUCATIONAL SERVICES AND PROGRAMS, NAMELY, CONDUCTING SEMINARS, CONFERENCES, AND WORKSHOPS IN THE FIELD OF HOSPITALITY SERVICES TO PROMOTE THE INTERESTS OF ASIAN-AMERICANS THE FIELD OF HOSPITALITY SERVICES, HOTEL OWNERSHIP, AND HOTEL MANAGEMENT; PROVIDING ONLINE NON-DOWNLOADABLE ELECTRONIC PUBLICATIONS IN THE NATURE OF MONTHLY NEWSLETTERS AND BLOGS IN THE FIELD OF HOSPITALITY SERVICES, HOTEL OWNERSHIP AND HOTEL MANAGEMENT; PROVIDING ONLINE NEWSLETTERS VIA EMAIL IN THE FIELD OF HOSPITALITY SERVICES, HOTEL OWNERSHIP AND HOTEL MANAGEMENT (U.S. CLS. 100, 101 AND 107).

FIRST USE 1-1-2014; IN COMMERCE 1-1-2014.

Katherine M. Dubray, Examining Attorney

SN 86-228,459. Patriots Energy Group, Rock Hill, SC. Filed 3-21-2014.



OWNER OF U.S. REG. NO. 3,117,466.

NO CLAIM IS MADE TO THE EXCLUSIVE RIGHT TO USE "ENERGY GROUP", APART FROM THE MARK AS SHOWN.

THE COLOR(S) RED, WHITE, BLUE AND BLACK IS/ARE CLAIMED AS A FEATURE OF THE MARK.

THE MARK CONSISTS OF A DESIGN, THE TOP PORTION OF WHICH CONSISTS OF CURVED ALTERNATING RED AND WHITE STRIPES STARTING WITH THE COLOR RED, IN A GENERALLY TRIANGULAR SHAPE. THE BOTTOM PORTION OF THE DESIGN CONSISTS OF A BLUE SEMICIRCLE WITH THREE WHITE FIVE-POINTED STARS. A BLACK PALMETTO TREE IS SUPERIMPOSED OVER THE DESIGN. TO THE RIGHT OF THE DESIGN ARE THE WORDS "PATRIOTS ENERGY GROUP" IN ALL BLUE LETTERS, WITH "PATRIOTS" APPEARING ABOVE "ENERGY GROUP".

**CLASS 35—ADVERTISING AND BUSINESS**

FOR PROCUREMENT, NAMELY, PURCHASING NATURAL GAS FOR OTHERS AND ARRANGING FOR PICKUP, DELIVERY, STORAGE, TRANSPORTATION AND RESELLING OF NATURAL GAS FOR OTHERS (U.S. CLS. 100, 101 AND 102).

FIRST USE 9-12-2001; IN COMMERCE 9-12-2001.

**CLASS 39—TRANSPORTATION AND STORAGE**

FOR TRANSMISSION OF NATURAL GAS THROUGH PIPELINES; PUBLIC UTILITY SERVICES IN THE NATURE OF NATURAL GAS DISTRIBUTION; FREIGHT TRANSPORTATION AND DELIVERY OF NATURAL GAS BY PIPE, RAIL, OR TRUCK; STORAGE OF NATURAL GAS (U.S. CLS. 100 AND 105).

FIRST USE 9-12-2001; IN COMMERCE 9-12-2001.

WILLIAM JACKSON, EXAMINING ATTORNEY

SN 86-228,572. FTS INTERNATIONAL SERVICES, LLC, FORT WORTH, TX. FILED 3-21-2014.



SN 86-228,501. INALCA FOOD & BEVERAGE S.R.L., CASTELVETRO DI MODENA, ITALY, FILED 3-21-2014.



THE MARK CONSISTS OF THE TERMS "MAMMA TINA" INSIDE AN IRREGULAR SQUARE WITH THE TERM "TINA" IN SCRIPT FORMAT AND THE TERM "MAMMA" IN LOWERCASE LETTERING. THE "T" IN "TINA" IS CAPITALIZED AND POSITIONED IN THE INTERIOR LEFT SIDE OF THE BOX. THE TERM "MAMMA" APPEARS UNDER THE "T". THERE IS A LINE UNDER THE LETTERS "INA" AND THE TOP OF THE "I" IS IN THE FORM OF A TRIANGLE.

**CLASS 29—MEATS AND PROCESSED FOODS**

FOR EDIBLE OILS; CONFIT IN THE NATURE OF A COOKED VEGETABLE BASED SPREAD; JELLIES IN THE NATURE OF BREAD SPREADS; VEGETABLE-BASED SPREADS; MEAT, FISH, FRUIT AND VEGETABLE PRESERVES; TOMATO PRESERVES; PICKLED VEGETABLES IN SOY SAUCE, SOYBEAN PASTE OR VINEGAR; COLD CUT MEATS AND PROCESSED OLIVES (U.S. CL. 46).

**CLASS 30—STAPLE FOODS**

FOR SAUCES, NAMELY, ARTICHOKE SAUCE, CHEESE SAUCE, CHOCOLATE SAUCE, PASTA SAUCE, PESTO SAUCE, PIZZA SAUCE, READY-MADE SAUCES, AND TOMATO SAUCE; BAKERY GOODS AND DESERT ITEMS, NAMELY, CAKES, COOKIES, PASTRIES, CANDIES, AND FROZEN CONFECTIONS FOR RETAIL AND WHOLESALE DISTRIBUTION AND CONSUMPTION ON OR OFF THE PREMISES; CHOCOLATE CONFECTIONS; VINEGAR; FROSTINGS; PASTA; AND RICE (U.S. CL. 46).

MICHAEL SOUDERS, EXAMINING ATTORNEY

OWNER OF U.S. REG. NOS. 4,332,747, 4,471,425 AND OTHERS.

NO CLAIM IS MADE TO THE EXCLUSIVE RIGHT TO USE "INTERNATIONAL", APART FROM THE MARK AS SHOWN.

THE MARK CONSISTS OF A STYLIZED LETTER "F" THAT IS FORMED BY INTERLOCKING AND OUTLINED AND CURVED RECTANGULAR DESIGN ELEMENTS. THE LETTER "F" IS LOCATED WITHIN A SQUARE DESIGN ELEMENT WITH CURVED BORDERS. TO THE RIGHT OF THE LETTER "F" AND SQUARE DESIGN IS LOCATED THE WORDING "FTS INTERNATIONAL". THE WORDING "FTS" IS LOCATED ABOVE THE WORDING "INTERNATIONAL". THE STYLIZED LETTER "F", SQUARE DESIGN, AND WORDING "FTS INTERNATIONAL" ARE ALL UNDERLINED. IN THE CENTER OF THE UNDERLINE IS AN UPSIDE DOWN FULCRUM. BENEATH THE UNDERLINE AND FULCRUM ARE THE WORDS "UNCONVENTIONAL BY DESIGN" IN ITALICS.

**CLASS 1—CHEMICALS**

FOR CHEMICALS AND FLUIDS, NAMELY, HYDRAULIC FRACTURING FLUIDS, USED IN OIL AND GAS ENHANCED RECOVERY OPERATIONS (U.S. CLS. 1, 5, 6, 10, 26 AND 46).

FIRST USE 3-20-2014; IN COMMERCE 3-20-2014.

**CLASS 37—CONSTRUCTION AND REPAIR**

FOR WIRELINING FOR OIL AND GAS WELLS; OIL AND GAS WELL CASING, TUBING, AND DRILL PIPE INSTALLATION; OIL AND GAS PIPE RECOVERY SERVICES (U.S. CLS. 100, 103 AND 106).

FIRST USE 3-20-2014; IN COMMERCE 3-20-2014.

**CLASS 40—MATERIAL TREATMENT**

FOR OIL AND GAS WELL TREATMENT; WATER TREATMENT AND PURIFICATION; MANUFACTURING OF OIL AND GAS WELL CONSTRUCTION AND DRILLING EQUIPMENT TO THE ORDER AND SPECIFICATION OF OTHERS (U.S. CLS. 100, 103 AND 106).

FIRST USE 3-20-2014; IN COMMERCE 3-20-2014.

JANET LEE, EXAMINING ATTORNEY

SN 86-228,590. JOAQUIN ORTIZ, MIAMI, FL. FILED 3-21-2014.

SN 86-228,625. SEVENTH GENERATION, INC., BURLINGTON, VT. FILED 3-21-2014.

## PURELY CLEAN



OWNER OF U.S. REG. NO. 4,110,479.  
THE COLOR(S) BLACK, WHITE, GREY AND RED IS/ARE CLAIMED AS A FEATURE OF THE MARK.

THE MARK CONSISTS OF A BLACK CIRCLE ENCOMPASSING THE WHOLE MARK. INSIDE THE BLACK CIRCLE IS A GREY FILLED CIRCLE WITH BLACK WALLS AND IN WHITE LETTERS THE WORDS "CONSCIOUS ACTS" IN THE TOP PORTION AND "OF KINDNESS" IN THE BOTTOM PORTION OF THE GREY CIRCLE. WITHIN THE GREY CIRCLE IS A SOLID WHITE CIRCLE WITH TWO OUT STRETCHED BLACK OUTLINED HANDS HOLDING A RED HEART IN THEIR FINGERTIPS.

### CLASS 25—CLOTHING

FOR BASEBALL CAPS AND HATS; GRAPHIC T-SHIRTS; T-SHIRTS (U.S. CLS. 22 AND 39).  
FIRST USE 4-14-2012; IN COMMERCE 5-30-2012.

### CLASS 35—ADVERTISING AND BUSINESS

FOR CHARITABLE SERVICES, NAMELY, COORDINATION OF NON-MONETARY CONTRIBUTIONS TO CHARITIES AND NON-PROFITS; CHARITABLE SERVICES, NAMELY, COORDINATION OF THE PROCUREMENT AND SALE OF DONOR VEHICLES FOR CHARITIES; ORGANIZING AND CONDUCTING CHARITY AUCTIONS FOR CHARITABLE FUNDRAISING PURPOSES; PROMOTING CHARITABLE GIVING THAT REFLECTS THE CORE VALUES OF THE DONOR BY PROVIDING A METHOD TO IDENTIFY THE DONOR'S CORE VALUES AND TO SELECT CHARITIES THAT FOSTER THOSE VALUES; PROMOTING THE CHARITABLE SERVICES OF OTHERS, NAMELY, PROVIDING INDIVIDUALS WITH INFORMATION ABOUT VARIOUS CHARITIES FOR THE PURPOSE OF MAKING DONATIONS TO CHARITIES; PROMOTIONAL SERVICES, NAMELY, PROMOTING THE CHARITIES OF OTHERS; PROVIDING A WEBSITE FOR MANAGING, CONDUCTING AND ORGANIZING ONLINE AUCTIONS THAT ARE DESIGNED TO RAISE MONEY FOR SELECTED CHARITIES (U.S. CLS. 100, 101 AND 102).

FIRST USE 2-11-2011; IN COMMERCE 2-11-2011.  
KYLE PEETE, EXAMINING ATTORNEY

THE MARK CONSISTS OF STANDARD CHARACTERS WITHOUT CLAIM TO ANY PARTICULAR FONT, STYLE, SIZE, OR COLOR.

NO CLAIM IS MADE TO THE EXCLUSIVE RIGHT TO USE "CLEAN", APART FROM THE MARK AS SHOWN.

### CLASS 3—COSMETICS AND CLEANING PREPARATIONS

FOR LAUNDRY DETERGENTS; FABRIC SOFTENERS FOR LAUNDRY USE, NON-CHLORINE LAUNDRY BLEACH, LAUNDRY CLEANING PREPARATIONS, LAUNDRY PRE-SOAK, LAUNDRY STAIN REMOVAL PREPARATIONS, LAUNDRY STARCH; DISHWASHER RINSE AID, AUTOMATIC DISHWASHER DETERGENTS; DISH WASHING PREPARATIONS; GLASS CLEANING PREPARATIONS, TOILET CLEANING PREPARATIONS, ALL-PURPOSE CLEANING PREPARATIONS FOR HOUSEHOLD USE, HOUSEHOLD SURFACE CLEANING PREPARATIONS, HOUSEHOLD CLEANING PREPARATIONS FOR USE IN NURSERIES; GLASS CLEANING PREPARATIONS, TUB AND TILE CLEANING PREPARATIONS, SHOWER CLEANING PREPARATIONS, CARPET CLEANERS, CLEANERS FOR METAL HOUSEHOLD SURFACES, CLEANERS FOR CERAMIC HOUSEHOLD SURFACES, CLEANERS FOR STONE HOUSEHOLD SURFACES, DISPOSABLE WIPES IMPREGNATED WITH CLEANSING COMPOUNDS FOR HOUSEHOLD CLEANING (U.S. CLS. 1, 4, 6, 50, 51 AND 52).

### CLASS 16—PAPER GOODS AND PRINTED MATTER

FOR PAPER TOWELS; PAPER NAPKINS; TOILET TISSUE; FACIAL TISSUE (U.S. CLS. 2, 5, 22, 23, 29, 37, 38 AND 50).

JULIE VEPPUMTHARA, EXAMINING ATTORNEY

SN 86-228,887. SOYINKA HOLDINGS, UPLAND, CA. FILED 3-21-2014.

## Wole Soyinka

THE MARK CONSISTS OF STANDARD CHARACTERS WITHOUT CLAIM TO ANY PARTICULAR FONT, STYLE, SIZE, OR COLOR.

THE NAME "WOLE SOYINKA" IDENTIFIES A LIVING INDIVIDUAL WHOSE CONSENT IS OF RECORD.

### CLASS 16—PAPER GOODS AND PRINTED MATTER

FOR BOOKS IN THE FIELD OF LITERATURE; EDUCATIONAL BOOKS FEATURING POETRY, PROSE, DRAMA, ESSAYS (U.S. CLS. 2, 5, 22, 23, 29, 37, 38 AND 50).

**CLASS 41—EDUCATION AND ENTERTAINMENT**

FOR EDUCATION SERVICES, NAMELY, PROVIDING PUBLIC LECTURES, CLASSES, SEMINARS, AND WORKSHOPS IN THE FIELDS OF COMPARATIVE LITERATURE; ENTERTAINMENT SERVICES, NAMELY, PROVIDING ADVICE AND INFORMATION FOR MUSIC, VIDEO AND FILM CONCEPT AND SCRIPT DEVELOPMENT; POEM AND LYRIC WRITING; FILM SCRIPT WRITING; TELEVISION SCRIPT WRITING (U.S. CLS. 100, 101 AND 107).

TASHIA BUNCH, EXAMINING ATTORNEY

SN 86-229,091. APFELBAUM, BETH SUE, SAN FRANCISCO, CA. FILED 3-22-2014.

**Mindful Sexuality**

THE MARK CONSISTS OF STANDARD CHARACTERS WITHOUT CLAIM TO ANY PARTICULAR FONT, STYLE, SIZE, OR COLOR.

NO CLAIM IS MADE TO THE EXCLUSIVE RIGHT TO USE "SEXUALITY", APART FROM THE MARK AS SHOWN.

**CLASS 41—EDUCATION AND ENTERTAINMENT**

FOR EDUCATIONAL AND ENTERTAINMENT SERVICES, NAMELY, PROVIDING MOTIVATIONAL AND EDUCATIONAL SPEAKERS IN THE FIELD OF SELF-AND PERSONAL IMPROVEMENT (U.S. CLS. 100, 101 AND 107).

FIRST USE 7-1-2009; IN COMMERCE 7-1-2009.

**CLASS 44—MEDICAL, BEAUTY AND AGRICULTURAL SERVICES**

FOR COUNSELING SERVICES IN THE FIELDS OF HEALTH, NUTRITION AND LIFESTYLE WELLNESS; ENERGY HEALING SERVICES, NAMELY, STRESS MANAGEMENT AND STRESS REDUCTION COUNSELING FOR INDIVIDUALS TO ENHANCE THEIR LIVES; PSYCHOLOGICAL COUNSELING (U.S. CLS. 100 AND 101).

FIRST USE 7-1-2009; IN COMMERCE 7-1-2009.

**CLASS 45—PERSONAL AND LEGAL SERVICES**

FOR MARRIAGE COUNSELING; PERSONAL GROWTH AND MOTIVATION CONSULTING SERVICES; PROVIDING A MOTIVATIONAL WEBSITE THE PRIMARY MISSION OF WHICH IS TO INCREASE PERSONAL HAPPINESS IN TERMS OF PERSONAL RELATIONSHIPS, PERSONAL GROWTH AND MOTIVATION, AND SELF-FULFILLMENT; PROVIDING A WEB SITE FEATURING INFORMATION IN THE FIELDS OF PERSONAL RELATIONSHIPS, PERSONAL GROWTH AND MOTIVATION, AND SELF-FULFILLMENT; PROVIDING BOTH IN-PERSON AND ON-LINE HOLISTIC SPIRITUAL COUNSELING SERVICES; PROVIDING INFORMATION IN THE FIELD OF PERSONAL DEVELOPMENT, NAMELY, PERSONAL IMPROVEMENT; PROVIDING SPIRITUAL RETREATS IN THE FIELD OF SEXUALITY; RELIGIOUS AND SPIRITUAL SERVICES, NAMELY, PROVIDING GATHERINGS AND RETREATS TO DEVELOP AND ENHANCE THE SPIRITUAL LIVES OF INDIVIDUALS; SPIRITUAL COUNSELING (U.S. CLS. 100 AND 101).

FIRST USE 7-1-2009; IN COMMERCE 7-1-2009.  
WILLIAM BRECKENFELD, EXAMINING ATTORNEY

SN 86-229,144. BOOMERSURF LLC, BEND, OR. FILED 3-22-2014.

**BOOMERSURF**

THE MARK CONSISTS OF STANDARD CHARACTERS WITHOUT CLAIM TO ANY PARTICULAR FONT, STYLE, SIZE, OR COLOR.

**CLASS 41—EDUCATION AND ENTERTAINMENT**

FOR PROVIDING ONLINE INSTRUCTION IN THE FIELD OF COMPUTERS TO ALLOW USERS TO PERFORM COMPUTERIZED TASKS, EXECUTE APPLICATIONS, AND TO ACCOMPLISH TASKS ON THEIR COMPUTERS, SMART PHONES, TABLETS, AND OTHER COMPUTERIZED OR ELECTRONIC DEVICES, BOTH NETWORKED AND NON-NETWORKED; PROVIDING A WEBSITE FEATURING NON-DOWNLOADABLE VIDEOS FEATURING INFORMATION ON COMPUTERS TO ALLOW USERS TO PERFORM COMPUTERIZED TASKS, EXECUTE APPLICATIONS, AND TO ACCOMPLISH TASKS ON THEIR COMPUTERS, SMART PHONES, TABLETS, AND OTHER COMPUTERIZED OR ELECTRONIC DEVICES, BOTH NETWORKED AND NON-NETWORKED (U.S. CLS. 100, 101 AND 107).

**CLASS 42—SCIENTIFIC AND COMPUTER SERVICES**

FOR TECHNICAL SUPPORT SERVICES, NAMELY, TROUBLESHOOTING IN THE NATURE OF DIAGNOSING COMPUTER HARDWARE AND SOFTWARE PROBLEMS VIA AUDIO, VIDEO, TEXT, AND COMBINATIONS THEREOF; PROVIDING INFORMATION IN THE FIELD OF COMPUTERS, NAMELY, INFORMATION FOR ASSISTING USERS TO PERFORM COMPUTERIZED TASKS, EXECUTE APPLICATIONS, AND TO ACCOMPLISH TASKS ON THEIR COMPUTERS, SMART PHONES, TABLETS, AND OTHER COMPUTERIZED OR ELECTRONIC DEVICES, BOTH NETWORKED AND NON-NETWORKED (U.S. CLS. 100 AND 101).

MICHAEL KEATING, EXAMINING ATTORNEY

SN 86-229,386. ARCHON CORPORATION, LAS VEGAS, NV. FILED 3-23-2014.

**STONEYS ROCKIN' COUNTRY**

THE MARK CONSISTS OF STANDARD CHARACTERS WITHOUT CLAIM TO ANY PARTICULAR FONT, STYLE, SIZE, OR COLOR.

NO CLAIM IS MADE TO THE EXCLUSIVE RIGHT TO USE "COUNTRY", APART FROM THE MARK AS SHOWN.

**CLASS 41—EDUCATION AND ENTERTAINMENT**

FOR NIGHTCLUBS; ENTERTAINMENT SERVICES IN THE NATURE OF LIVE MUSICAL PERFORMANCES (U.S. CLS. 100, 101 AND 107).

FIRST USE 8-1-2007; IN COMMERCE 8-1-2007.



**CLASS 43—HOTEL AND RESTAURANT SERVICES**

FOR BAR SERVICES (U.S. CLS. 100 AND 101).  
FIRST USE 8-1-2007; IN COMMERCE 8-1-2007.  
AMY C. KEAN, EXAMINING ATTORNEY

SN 86-229,905, CHINA DEVELOPMENT FINANCIAL HOLDING CORPORATION, TAIPEI, TAIWAN, FILED 3-24-2014.



THE COLOR(S) BLUE, ORANGE, YELLOW, WHITE AND GREEN IS/ARE CLAIMED AS A FEATURE OF THE MARK.

THE MARK CONSISTS OF A SQUARE WITH A DIAMOND INSET INSIDE THE SQUARE. THE TRIANGLES CREATED IN THE CORNERS OF THE SQUARE OUTSIDE THE DIAMOND ARE BLUE EXCEPT FOR THE TOP RIGHT CORNER, WHICH IS GREEN. THE LEFT HALF OF THE INSET DIAMOND IS ORANGE GOING FROM LIGHTER YELLOW TO DARKER ORANGE FROM THE CENTER, AND OF THE RIGHT HALF OF THE INSET DIAMOND, THE TOP HALF IS BLUE, GOING FROM LIGHTER TO DARKER FROM THE CENTER, AND THE BOTTOM HALF IS WHITE.

**CLASS 35—ADVERTISING AND BUSINESS**

FOR BUSINESS MANAGEMENT AND ADVICE; COST PRICE ANALYSIS; PRICE COMPARISON SERVICES; PERSONNEL MANAGEMENT CONSULTATION; BUSINESS EFFICIENCY EXPERT SERVICES; CONDUCTING MARKETING STUDIES; BUSINESS APPRAISALS; BUSINESS INVESTIGATIONS; BUSINESS ORGANIZATION CONSULTING; BUSINESS RESEARCH; MARKETING RESEARCH SERVICES; PROFESSIONAL BUSINESS CONSULTATION; ECONOMIC FORECASTING AND ANALYSIS; PUBLIC OPINION POLLING; ADMINISTRATIVE PROCESSING OF PURCHASE ORDERS; COMMERCIAL ADMINISTRATION OF THE LICENSING OF THE GOODS AND SERVICES OF OTHERS; MARKETING SERVICES; GOODS IMPORT-EXPORT AGENCIES; ACCOUNTING SERVICES; BOOKKEEPING; BUSINESS AUDITING; TAX PREPARATION; INVOICING; WRITING OF PUBLICITY TEXTS; COMPILATION OF STATISTICS FOR BUSINESS OR COMMERCIAL PURPOSES; ADVERTISING AGENCIES; DEMONSTRATION OF GOODS; SHOP WINDOW DISPLAY ARRANGEMENT SERVICES; ORGANIZATION OF EXHIBITIONS FOR COMMERCIAL OR ADVERTISING PURPOSES; RENTAL OF ADVERTISING SPACE; SALES PROMOTION FOR THIRD PARTIES; ADVERTISING, INCLUDING ONLINE ADVERTISING ON A COMPUTER NETWORK; LAYOUT SERVICES FOR ADVERTISING PURPOSES; SHORTHAND SERVICES; COMPUTERIZED FILE MANAGEMENT; SHORTHAND SECRETARIAL SERVICES; TELEPHONE ANSWERING SERVICE; WORD PROCESSING; COMPILATION AND SYSTEMIZATION OF INFORMATION INTO COMPUTER DATABASES; NEWS CLIPPING SERVICES; SPONSORSHIP SEARCH; AUCTIONEERING; PUBLIC RELATIONS; RENTAL OF VENDING MACHINES; ARRANGING SUBSCRIPTIONS TO TELECOMMUNICATION SERVICES FOR OTHERS (U.S. CLS. 100, 101 AND 102).

FIRST USE 6-22-2013; IN COMMERCE 6-22-2013.

**CLASS 36—INSURANCE AND FINANCIAL**

FOR BANKING; INSTALLMENT LOANS; DEBT COLLECTION AGENCIES; MUTUAL FUND INVESTMENT; BAIL BONDING; EXCHANGING MONEY; ISSUING OF TRAVELLERS' CHECKS; FINANCIAL CLEARING HOUSES; SAFE DEPOSIT BOX SERVICES; FINANCING OF LOANS; FISCAL ASSESSMENT AND EVALUATION; FINANCIAL EVALUATION, TRACKING, ANALYSIS, FORECASTING, CONSULTANCY, ADVISORY AND RESEARCH SERVICES RELATING TO SECURITIES AND OTHER FINANCIAL INSTRUMENTS; TRUSTEE SERVICES; FIDUCIARY REPRESENTATIVES; FINANCING SERVICES; FINANCIAL MANAGEMENT; HIRE-PURCHASE FINANCING; LEASE-PURCHASE FINANCING; FINANCIAL ANALYSES; CHECK VERIFICATION; CREDIT CARD SERVICES; DEBIT CARD SERVICES; ELECTRONIC FUNDS TRANSFER; ISSUE OF TOKENS OF VALUE; ISSUANCE OF CREDIT CARDS; BUSINESS LIQUIDATION SERVICES; DEBT ADVISORY SERVICES; LEASING OF REAL ESTATE; REAL ESTATE AGENCIES; HOUSING AGENCIES; REAL ESTATE BROKERAGE; REAL ESTATE APPRAISAL; REAL ESTATE MANAGEMENT SERVICES; RENT COLLECTION; INSURANCE BROKERAGE; INSURANCE UNDERWRITING SERVICES FOR ALL TYPES OF INSURANCE; LIFE INSURANCE UNDERWRITING; INSURANCE CONSULTANCY; INSURANCE INFORMATION; SECURITIES BROKERAGE; STOCK EXCHANGE QUOTATIONS; STOCK BROKERAGE SERVICES; CAPITAL INVESTMENT SERVICES; FUND INVESTMENT CONSULTATION; FINANCIAL CONSULTANCY; FINANCIAL INFORMATION; CHARITABLE FUNDRAISING; ANTIQUE APPRAISAL; ART APPRAISAL; JEWELRY APPRAISAL (U.S. CLS. 100, 101 AND 102).

FIRST USE 6-22-2013; IN COMMERCE 6-22-2013.  
JOANNA FIORELLI, EXAMINING ATTORNEY

SN 86-229,961, SOUTH JERSEY INDUSTRIES, FOLSOM, NJ, FILED 3-24-2014.



OWNER OF U.S. REG. NO. 2,441,048.  
THE MARK CONSISTS OF A BROKEN FLAME INSIDE OF A CIRCLE.

**CLASS 35—ADVERTISING AND BUSINESS**

FOR CONSULTING SERVICES IN THE FIELD OF ENERGY USAGE MANAGEMENT AND ENERGY EFFICIENCY; ENERGY USAGE MANAGEMENT; ENERGY USAGE MANAGEMENT INFORMATION SERVICES; PROVIDING A WEB-BASED ON-LINE PORTAL THAT PROVIDES CUSTOMER ACCESS TO THEIR ELECTRIC BILL ACCOUNT INFORMATION, ENERGY USAGE PATTERN INFORMATION, AND ENERGY CONSUMPTION AND USAGE DATA, FOR PURPOSES OF UTILITY ACCOUNT BUSINESS MANAGEMENT AND ENERGY USAGE MANAGEMENT; UTILITY BILL MANAGEMENT SERVICES, NAMELY, TRACKING, REPORTING, ANALYZING AND DELIVERING ENERGY INFORMATION IN THE FORM OF UTILITY BILLS AND UTILITY METER DATA RATE SCHEDULES; CONSULTING SERVICES IN THE FIELDS OF ENERGY CONSUMPTION AND USAGE CONSERVATION TO IMPROVE ENERGY EFFICIENCY FOR UTILITY AND NON-UTILITY INDUSTRIES, ALL RELATING TO IMPROVEMENT OF ENERGY EFFICIENCY AND ALL THE ABOVE IN THE FIELD OF THE GREEN ENERGY INDUSTRY; PROMOTING PUBLIC AWARENESS OF THE NEED FOR GREEN ENERGY (U.S. CLS. 100, 101 AND 102).

FIRST USE 2-1-2008; IN COMMERCE 2-1-2008.

**CLASS 36—INSURANCE AND FINANCIAL**

FOR EQUIPMENT FINANCING SERVICES; FINANCING LOANS FOR EQUIPMENT IN THE FIELD OF THERMAL FACILITIES, COMBINED HEAT AND POWER FACILITIES, DISTRICT HEATING AND COOLING FACILITIES, DISTRIBUTED GENERATION FACILITIES, LANDFILL GAS-TO-ELECTRIC FACILITIES AND SOLAR FACILITIES; PROVIDING INFORMATION AND ADVICE IN THE FIELD OF FINANCE, FINANCIAL INVESTMENTS AND FINANCIAL VALUATIONS; ENERGY BROKERAGE SERVICES, NAMELY, BROKERING NATURAL GAS, ELECTRICITY, HEAT AND POWER, THERMAL AND SOLAR TO RESIDENTIAL AND COMMERCIAL CUSTOMERS THROUGH THE BUNDLING OF CREDITS (U.S. CLS. 100, 101 AND 102).

FIRST USE 4-19-2000; IN COMMERCE 4-19-2000.

**CLASS 37—CONSTRUCTION AND REPAIR**

FOR PLANT CONSTRUCTION, MAINTENANCE AND CONSTRUCTION PROJECT MANAGEMENT SERVICES FOR BUSINESSES IN THE ENERGY PRODUCTION AND TRANSMISSION SECTOR; CONSTRUCTION PROJECT MANAGEMENT SERVICES IN THE FIELD OF CONSTRUCTION OF GAS FACILITIES, ELECTRICAL FACILITIES, THERMAL FACILITIES, COMBINED HEAT AND POWER FACILITIES, DISTRICT HEATING AND COOLING FACILITIES, DISTRIBUTED GENERATION FACILITIES AND LANDFILL GAS-TO-ELECTRIC FACILITIES; INSTALLATION, REPAIR AND MAINTENANCE OF THERMAL FACILITIES, COMBINED HEAT AND POWER FACILITIES, DISTRICT HEATING AND COOLING FACILITIES, DISTRIBUTED GENERATION FACILITIES AND LANDFILL GAS-TO-ELECTRIC FACILITIES (U.S. CLS. 100, 103 AND 106).

FIRST USE 1-1-2008; IN COMMERCE 1-1-2008.

**CLASS 39—TRANSPORTATION AND STORAGE**

FOR DISTRIBUTION OF ENERGY, NAMELY, NATURAL GAS, ELECTRICITY, HEAT AND POWER, THERMAL AND SOLAR; PUBLIC UTILITY SERVICES (U.S. CLS. 100 AND 105).

FIRST USE 4-19-2000; IN COMMERCE 4-19-2000.

**CLASS 42—SCIENTIFIC AND COMPUTER SERVICES**

FOR PUBLIC ENERGY SYSTEM ENGINEERING SERVICES, NAMELY, ENGINEERING, DESIGN AND DEVELOPMENT SERVICES RELATING TO ENERGY SYSTEM PROJECTS, EXCLUDING THE EXPLORATION, PRODUCTION AND DISTRIBUTION OF OIL AND GAS AS DISTINCT SERVICES; COMPUTER SOFTWARE DEVELOPMENT AND COMPUTER PROGRAMMING DEVELOPMENT FOR OTHERS; PLATFORM AS A SERVICE (PAAS) FEATURING COMPUTER SOFTWARE PLATFORMS FOR UTILITY DATA MANAGEMENT AND ANALYSIS (U.S. CLS. 100 AND 101).

FIRST USE 1-1-2008; IN COMMERCE 1-1-2008.

SCOTT BIBB, EXAMINING ATTORNEY

SN 86-230,081. NATIONAL TRADE PRODUCTIONS, INC., ALEXANDRIA, VA. FILED 3-24-2014.



The logo features the letters "MSX" in a large, bold, stylized font. The "S" is particularly prominent, resembling a race track. Below "MSX" is the text "North American MotorSports Expo" in a smaller, sans-serif font.

NO CLAIM IS MADE TO THE EXCLUSIVE RIGHT TO USE "NORTH AMERICAN MOTORSPORTS EXPO", APART FROM THE MARK AS SHOWN.

THE MARK CONSISTS OF THE WORDING "MSX" IN STYLIZED FORM WITH THE "S" RESEMBLING A RACE-TRACK. THE WORDING "NORTH AMERICAN MOTORSPORTS EXPO" APPEARS UNDERNEATH THE "MSX" WORDING.

**CLASS 35—ADVERTISING AND BUSINESS**

FOR ARRANGING AND CONDUCTING TRADE SHOW EXHIBITIONS IN THE FIELD OF MOTORSPORTS; ARRANGING AND CONDUCTING TRADE SHOWS IN THE FIELD OF MOTORSPORTS (U.S. CLS. 100, 101 AND 102).

FIRST USE 3-7-2014; IN COMMERCE 3-7-2014.

**CLASS 41—EDUCATION AND ENTERTAINMENT**

FOR EDUCATIONAL SERVICES, NAMELY, CONDUCTING SEMINARS, CONFERENCES AND WORKSHOPS IN THE FIELD OF MOTORSPORTS AND DISTRIBUTION OF PRINTED MATERIALS IN CONNECTION THEREWITH IN HARD COPY OR ELECTRONIC FORMAT ON THE SAME TOPICS (U.S. CLS. 100, 101 AND 107).

FIRST USE 3-7-2014; IN COMMERCE 3-7-2014.

BRIN ANDERSON, EXAMINING ATTORNEY

SN 86-230,094. SOUTH JERSEY INDUSTRIES, FOLSOM, NJ. FILED 3-24-2014.

**SOUTH JERSEY GAS**

THE MARK CONSISTS OF STANDARD CHARACTERS WITHOUT CLAIM TO ANY PARTICULAR FONT, STYLE, SIZE, OR COLOR.

NO CLAIM IS MADE TO THE EXCLUSIVE RIGHT TO USE "GAS" AS TO CLASS 39, APART FROM THE MARK AS SHOWN.  
SEC. 2(F).

### CLASS 35—ADVERTISING AND BUSINESS

FOR CONSULTING SERVICES IN THE FIELD OF ENERGY USAGE MANAGEMENT AND ENERGY EFFICIENCY; ENERGY USAGE MANAGEMENT; ENERGY USAGE MANAGEMENT INFORMATION SERVICES; PROVIDING A WEB-BASED ON-LINE PORTAL THAT PROVIDES CUSTOMER ACCESS TO THEIR ELECTRIC BILL ACCOUNT INFORMATION, ENERGY USAGE PATTERN INFORMATION, AND ENERGY CONSUMPTION AND USAGE DATA, FOR PURPOSES OF UTILITY ACCOUNT BUSINESS MANAGEMENT AND ENERGY USAGE MANAGEMENT; UTILITY BILL MANAGEMENT SERVICES, NAMELY, TRACKING, REPORTING, ANALYZING AND DELIVERING ENERGY INFORMATION IN THE FORM OF UTILITY BILLS AND UTILITY METER DATA RATE SCHEDULES; CONSULTING SERVICES IN THE FIELDS OF NATURAL GAS DISTRIBUTION AND ELECTRICITY DISTRIBUTION, AND ENERGY MANAGEMENT IN THE NATURE OF ENERGY CONSUMPTION AND USAGE MANAGEMENT FOR UTILITY AND NON-UTILITY INDUSTRIES; CONSULTING SERVICES IN THE FIELDS OF NATURAL GAS DISTRIBUTION AND ELECTRICITY DISTRIBUTION, AND ENERGY MANAGEMENT IN THE NATURE OF ENERGY CONSUMPTION AND USAGE MANAGEMENT, FOR UTILITY AND NON-UTILITY INDUSTRIES, NAMELY CONSULTING SERVICES IN THE FIELD OF ENERGY USAGE MANAGEMENT AND ENERGY EFFICIENCY; CONSULTING SERVICES IN THE FIELDS OF NATURAL GAS DISTRIBUTION AND ELECTRICITY DISTRIBUTION, AND ENERGY MANAGEMENT IN THE NATURE OF ENERGY CONSUMPTION AND USAGE MANAGEMENT FOR UTILITY AND NON-UTILITY INDUSTRIES, NAMELY CONSULTING SERVICES IN THE FIELD OF ENERGY USAGE MANAGEMENT AND ENERGY EFFICIENCY, ALL RELATING TO IMPROVEMENT OF ENERGY EFFICIENCY AND ALL THE ABOVE IN THE FIELD OF THE GREEN ENERGY INDUSTRY; PROMOTING PUBLIC AWARENESS OF THE NEED FOR RENEWABLE ENERGY, CLEAN TECHNOLOGY AND EFFICIENCY (U.S. CLS. 100, 101 AND 102).  
FIRST USE 2-1-2008; IN COMMERCE 2-1-2008.

### CLASS 39—TRANSPORTATION AND STORAGE

FOR DISTRIBUTION OF ENERGY, NAMELY, NATURAL GAS AND ELECTRICITY; PUBLIC UTILITY SERVICES (U.S. CLS. 100 AND 105).  
FIRST USE 1-0-1910; IN COMMERCE 1-0-1910.  
SCOTT BIBB, EXAMINING ATTORNEY

SN 86-230,117. SOUTH JERSEY INDUSTRIES, FOLSOM, NJ.  
FILED 3-24-2014.

**SOUTH JERSEY ENERGY**

THE MARK CONSISTS OF STANDARD CHARACTERS WITHOUT CLAIM TO ANY PARTICULAR FONT, STYLE, SIZE, OR COLOR.

NO CLAIM IS MADE TO THE EXCLUSIVE RIGHT TO USE "ENERGY", APART FROM THE MARK AS SHOWN.  
SEC. 2(F).

### CLASS 35—ADVERTISING AND BUSINESS

FOR CONSULTING SERVICES IN THE FIELD OF ENERGY USAGE MANAGEMENT AND ENERGY EFFICIENCY; ENERGY USAGE MANAGEMENT; ENERGY USAGE MANAGEMENT INFORMATION SERVICES; CONSULTING SERVICES IN THE FIELDS OF NATURAL GAS DISTRIBUTION, ELECTRICITY DISTRIBUTION, THERMAL DISTRIBUTION, COMBINED HEAT AND POWER DISTRIBUTION, HEATING AND COOLING DISTRIBUTION, LANDFILL GAS-TO-ELECTRIC DISTRIBUTION AND SOLAR DISTRIBUTION, AND ENERGY MANAGEMENT IN THE NATURE OF ENERGY CONSUMPTION AND USAGE MANAGEMENT FOR UTILITY AND NON-UTILITY INDUSTRIES, NAMELY CONSULTING SERVICES IN THE FIELD OF ENERGY USAGE MANAGEMENT AND ENERGY EFFICIENCY; CONSULTING SERVICES IN THE FIELDS OF NATURAL GAS DISTRIBUTION, ELECTRICITY DISTRIBUTION, THERMAL DISTRIBUTION, COMBINED HEAT AND POWER DISTRIBUTION, HEATING AND COOLING DISTRIBUTION, LANDFILL GAS-TO-ELECTRIC DISTRIBUTION, SOLAR DISTRIBUTION, AND ENERGY MANAGEMENT IN THE NATURE OF ENERGY CONSUMPTION AND USAGE MANAGEMENT, NAMELY CONSULTING SERVICES IN THE FIELD OF ENERGY USAGE MANAGEMENT AND ENERGY EFFICIENCY, FOR UTILITY AND NON-UTILITY INDUSTRIES, ALL RELATING TO IMPROVEMENT OF ENERGY EFFICIENCY AND ALL THE ABOVE IN THE FIELD OF THE GREEN ENERGY INDUSTRY; PROMOTING PUBLIC AWARENESS OF THE NEED FOR RENEWABLE ENERGY, CLEAN TECHNOLOGY AND EFFICIENCY (U.S. CLS. 100, 101 AND 102).  
FIRST USE 1-0-1973; IN COMMERCE 1-0-1973.

### CLASS 39—TRANSPORTATION AND STORAGE

FOR DISTRIBUTION OF GAS, ELECTRICITY AND SOLAR ENERGY (U.S. CLS. 100 AND 105).  
FIRST USE 1-0-1973; IN COMMERCE 1-0-1973.

### CLASS 42—SCIENTIFIC AND COMPUTER SERVICES

FOR PUBLIC ENERGY SYSTEM ENGINEERING SERVICES, NAMELY, ENGINEERING, DESIGN AND DEVELOPMENT SERVICES RELATING TO ENERGY SYSTEM PROJECTS, EXCLUDING THE EXPLORATION, PRODUCTION AND DISTRIBUTION OF OIL AND GAS AS DISTINCT SERVICES; COMPUTER SOFTWARE DEVELOPMENT AND COMPUTER PROGRAMMING DEVELOPMENT FOR OTHERS; PLATFORM AS A SERVICE (PAAS) FEATURING COMPUTER SOFTWARE PLATFORMS FOR UTILITY DATA MANAGEMENT AND ANALYSIS (U.S. CLS. 100 AND 101).  
FIRST USE 12-0-1985; IN COMMERCE 12-0-1985.  
SCOTT BIBB, EXAMINING ATTORNEY

SN 86-230,142. REDEMPTION SPIRITS LLC, DBA AMERICAN SPIRITS EXCHANGE LIMITED, BRIDGEPORT, PA.  
FILED 3-24-2014.

Grow faster. Focus on the  
big things. Stop  
overpaying.

THE MARK CONSISTS OF STANDARD CHARACTERS WITHOUT CLAIM TO ANY PARTICULAR FONT, STYLE, SIZE, OR COLOR.

**CLASS 35—ADVERTISING AND BUSINESS**

FOR LOGISTICS MANAGEMENT IN THE FIELD OF ALCOHOLIC BEVERAGES; ALCOHOLIC BEVERAGE INDUSTRY RELATED BACK OFFICE PROCESSING, NAMELY, OFFICE ADMINISTRATION SERVICES IN THE NATURE OF PURCHASE ORDER PROCESSING, STATE COMPLIANCE SUBMISSIONS, AND INVOICING (U.S. CLS. 100, 101 AND 102).

FIRST USE 4-10-2011; IN COMMERCE 4-10-2011.

**CLASS 45—PERSONAL AND LEGAL SERVICES**

FOR REGULATORY COMPLIANCE SERVICES IN THE FIELD OF ALCOHOLIC BEVERAGES (U.S. CLS. 100 AND 101).

FIRST USE 4-10-2014; IN COMMERCE 4-10-2014.  
GINA HAYES, EXAMINING ATTORNEY

**CLASS 16—PAPER GOODS AND PRINTED MATTER**

FOR RECIPE BOOKS (U.S. CLS. 2, 5, 22, 23, 29, 37, 38 AND 50).

FIRST USE 1-28-2006; IN COMMERCE 11-14-2008.

**CLASS 43—HOTEL AND RESTAURANT SERVICES**

FOR PROVIDING A DATABASE IN THE FIELD OF RECIPES AND COOKING INFORMATION; PROVIDING A WEBSITE FEATURING INFORMATION IN THE FIELD OF RECIPES AND COOKING; PROVIDING AN ONLINE COMPUTER DATABASE TO CONSUMERS FEATURING INFORMATION ABOUT RECIPES, INGREDIENTS AND COOKING INFORMATION; PROVIDING INFORMATION IN THE NATURE OF RECIPES FOR DRINKS (U.S. CLS. 100 AND 101).

FIRST USE 1-28-2006; IN COMMERCE 1-28-2006.  
JENNY PARK, EXAMINING ATTORNEY

SN 86-230,258. ARIZONA CANES AND GIFTS, LLC, CHANDLER, VA. FILED 3-24-2014.

**THE CANEMAN**

THE MARK CONSISTS OF STANDARD CHARACTERS WITHOUT CLAIM TO ANY PARTICULAR FONT, STYLE, SIZE, OR COLOR.

**CLASS 16—PAPER GOODS AND PRINTED MATTER**

FOR PRINTED PUBLICATIONS, NAMELY, BOOKS IN THE FIELD OF MEMOIRS, HEALTH, AND PERSONAL EMPOWERMENT (U.S. CLS. 2, 5, 22, 23, 29, 37, 38 AND 50).

**CLASS 35—ADVERTISING AND BUSINESS**

FOR RETAIL STORE SERVICES AND ONLINE STORE SERVICES FEATURING WALKING AIDS AND ACCESSORIES, CANES, WALKING STICKS, CLOTHES, HEADWEAR, FOOTWEAR, PRINTED MATTER, BOOKS, GIFTS AND NOVELTIES (U.S. CLS. 100, 101 AND 102).

JILL PRATER, EXAMINING ATTORNEY

SN 86-230,405. STONERS COOKBOOK LLC, AUSTIN, TX. FILED 3-24-2014.

**The Stoner's Cookbook**

THE MARK CONSISTS OF STANDARD CHARACTERS WITHOUT CLAIM TO ANY PARTICULAR FONT, STYLE, SIZE, OR COLOR.

NO CLAIM IS MADE TO THE EXCLUSIVE RIGHT TO USE "COOKBOOK", APART FROM THE MARK AS SHOWN.

SN 86-230,496. INFORMATION TECHNOLOGY INDUSTRY COUNCIL, INC., WASHINGTON, DC. FILED 3-24-2014.



THE COLOR(S) BLUE, GREEN, AND YELLOW IS/ARE CLAIMED AS A FEATURE OF THE MARK.

THE MARK CONSISTS OF A DESIGN ELEMENT THAT CREATES THE IMPRESSION OF A FLAT SURFACE, TRIANGULAR IN SHAPE, WHOSE THREE ANGLES HAVE BEEN TURNED UP TOWARDS ONE ANOTHER SO THEY MEET AT A POINT. SIX SURFACES ARE VISIBLE IN THIS ARRANGEMENT: THREE CONSISTING OF THE BACK SURFACE OF THE TRIANGLE, WHICH ARE VISIBLE BECAUSE THE AFOREMENTIONED ANGLES HAVE BEEN TURNED UP; AND THREE CONSISTING OF THE FRONT SURFACE OF THE TRIANGLE, WHICH REMAIN VISIBLE BEHIND THE TURNED-UP ANGLES. STARTING ON THE LEFT AND PROCEEDING CLOCKWISE, THE SURFACE ON THE LEFT IS BLUE ON THE OUTERMOST EDGE AND BECOMES LIGHTER AS IT EXTENDS TO THE POINT; THE NEXT SURFACE IS YELLOW ON THE OUTERMOST EDGE AND SHADES TO GREEN AS IT EXTENDS TO THE POINT; THE NEXT SURFACE IS GREEN ON THE OUTERMOST EDGE AND SHADES TO YELLOW AS IT EXTENDS TO THE POINT; THE NEXT SURFACE IS BLUE ON THE OUTERMOST EDGE AND BECOMES DARKER AS IT EXTENDS TO THE POINT; THE NEXT SURFACE IS BLUE ON THE OUTERMOST EDGE AND BECOMES LIGHTER AS IT EXTENDS TO THE POINT; AND THE LAST SURFACE IS BLUE ON THE OUTERMOST EDGE AND BECOMES DARKER AS IT EXTENDS TO THE POINT. THE COLOR WHITE IN THE DRAWING REPRESENTS BACKGROUND OR TRANSPARENT AREA, AND IS NOT PART OF THE MARK.

**CLASS 35—ADVERTISING AND BUSINESS**

FOR PROVIDING AN IN-PERSON BUSINESS AND COMMERCIAL FORUM IN THE FIELD OF FUTURE TECHNOLOGIES (U.S. CLS. 100, 101 AND 102).

FIRST USE 3-26-2014; IN COMMERCE 3-26-2014.

**CLASS 41—EDUCATION AND ENTERTAINMENT**

FOR PROVIDING AN IN-PERSON EDUCATIONAL FORUM IN THE FIELD OF FUTURE TECHNOLOGIES (U.S. CLS. 100, 101 AND 107).

FIRST USE 3-26-2014; IN COMMERCE 3-26-2014.  
WON TEAK OH, EXAMINING ATTORNEY

SN 86-230,507. CHARLES VIANCIN GROUP, 74650 CHAVANOD, FRANCE, FILED 3-24-2014.

# SNOWFLAKE

THE MARK CONSISTS OF STANDARD CHARACTERS WITHOUT CLAIM TO ANY PARTICULAR FONT, STYLE, SIZE, OR COLOR.

**CLASS 20—FURNITURE AND ARTICLES NOT OTHERWISE CLASSIFIED**

FOR SILICONE BOTTLE STOPPERS (U.S. CLS. 2, 13, 22, 25, 32 AND 50).

FIRST USE 2-0-2014; IN COMMERCE 2-0-2014.

**CLASS 21—HOUSEWARES AND GLASS**

FOR REUSABLE SELF-SEALING LIDS FOR HOUSEHOLD USE; REUSABLE SELF-SEALING LIDS FOR BOWLS, CUPS, DRINKS, CONTAINERS AND THE STORAGE OF FOOD; SEALING LIDS FOR COOKING USE; REUSABLE SELF-SEALING COVERS FOR CUPS, DRINKS AND BEVERAGE CONTAINERS; COASTERS NOT OF PAPER AND NOT BEING TABLE LINEN (U.S. CLS. 2, 13, 23, 29, 30, 33, 40 AND 50).

FIRST USE 7-0-2013; IN COMMERCE 7-0-2013.  
JAY FLOWERS, EXAMINING ATTORNEY

SN 86-230,854. FLINT HILLS RESOURCES, LLC, WICHITA, KS. FILED 3-25-2014.

OWNER OF U.S. REG. NO. 2,863,210.  
THE MARK CONSISTS OF A STYLIZED LOWER CASE LETTER "F" AND "H", WHEREIN THE LETTER "H" BISECTS THE LOWER PORTION OF THE LETTER "F".

**CLASS 1—CHEMICALS**

FOR CHEMICALS, NAMELY, PURIFIED ISOPHTHALIC ACID, MALEIC ANHYDRIDE AND TRIMELLITIC ANHYDRIDE AND EXPANDABLE POLYSTYRENE; AROMATICS, NAMELY AROMATIC HYDROCARBONS, BENZENE, TOLUENE, XYLENES, CUMENE AND PSEUDOCUMENE; OLEFINS, NAMELY ETHYLENE AND PROPYLENE AND POLYMERS, NAMELY POLYPROPYLENE; AND CHEMICALS USED AS BASE OILS AND ADDITIVES FOR USE IN THE MANUFACTURE OF LUBRICANTS, ELECTRICAL FLUIDS AND FUELS, CROP SPRAY OILS, RUBBER PROCESSING, AUTOMOTIVE PARTS, HEAT TRANSFER OILS, INDUSTRIAL OILS, TEXTILE OILS, WHITE OIL FEEDS, PROCESS OILS, DEFOAMERS, SEALANTS, COATINGS AND ADHESIVES (U.S. CLS. 1, 5, 6, 10, 26 AND 46).

FIRST USE 1-1-2002; IN COMMERCE 1-1-2002.

**CLASS 4—LUBRICANTS AND FUELS**

FOR FUELS, NAMELY, REFINED PETROLEUM PRODUCTS, NAMELY, GASOLINE, AVIATION FUEL, DIESEL FUEL, JET FUEL, RACING FUEL, KEROSENE, HEATING OIL, FUEL OIL, PETROLEUM COKE, VACUUM GAS OIL, NAPHTHA AND OTHER GASOLINE BLEND STOCKS; RENEWABLE FUELS, NAMELY, ETHANOL AND BIODIESELS; NON-FOOD GRADE CORN OIL; LIQUEFIED NATURAL GAS (U.S. CLS. 1, 6 AND 15).

FIRST USE 1-1-2002; IN COMMERCE 1-1-2002.

**CLASS 31—NATURAL AGRICULTURAL PRODUCTS**

FOR DISTILLERS GRAINS FOR ANIMAL CONSUMPTION; CORN CONDENSED DISTILLERS SOLUBLES FOR THE ANIMAL FEED MARKET; FAT PRODUCT-FEED GRADE (U.S. CLS. 1 AND 46).

FIRST USE 9-0-2010; IN COMMERCE 9-0-2010.  
DOMINICK J. SALEMI, EXAMINING ATTORNEY

SN 86-230,873. THE BROADWAY LEAGUE INC., NEW YORK, NY. FILED 3-25-2014.

# THE BROADWAY LEAGUE

THE MARK CONSISTS OF STANDARD CHARACTERS WITHOUT CLAIM TO ANY PARTICULAR FONT, STYLE, SIZE, OR COLOR.

OWNER OF U.S. REG. NOS. 3,578,215 AND 3,699,726.

NO CLAIM IS MADE TO THE EXCLUSIVE RIGHT TO USE "LEAGUE", APART FROM THE MARK AS SHOWN. SEC. 2(F).

**CLASS 35—ADVERTISING AND BUSINESS**

FOR PROMOTING THE LIVE THEATRICAL SHOWS OF OTHERS; TRADE ASSOCIATION SERVICES, NAMELY, PROMOTING THE INTERESTS OF LIVE THEATER AND PROFESSIONALS WHO WORK IN LIVE THEATER; ARRANGING PERSONAL APPEARANCES BY PERSONS WORKING IN THE FIELD OF LIVE THEATRE (U.S. CLS. 100, 101 AND 102).

FIRST USE 12-19-2007; IN COMMERCE 12-19-2007.

**CLASS 41—EDUCATION AND ENTERTAINMENT**

FOR PROVIDING INFORMATION CONCERNING LIVE THEATRE PRODUCTIONS (U.S. CLS. 100, 101 AND 107).

FIRST USE 12-19-2007; IN COMMERCE 12-19-2007.  
BARBARA GAYNOR, EXAMINING ATTORNEY

SN 86-230,895. MARK ANTHONY INTERNATIONAL SRL, ST. MICHAEL, BARBADOS, FILED 3-25-2014.

SN 86-230,983. LAKELAND REGIONAL HEALTH SYSTEMS, INC., LAKELAND, FL. FILED 3-25-2014.

## PALM BREEZE SPRITZ

THE MARK CONSISTS OF STANDARD CHARACTERS WITHOUT CLAIM TO ANY PARTICULAR FONT, STYLE, SIZE, OR COLOR.

NO CLAIM IS MADE TO THE EXCLUSIVE RIGHT TO USE "SPRITZ", APART FROM THE MARK AS SHOWN.

### CLASS 32—LIGHT BEVERAGES

FOR MALT BASED BEVERAGE IN THE NATURE OF A BEER (U.S. CLS. 45, 46 AND 48).

### CLASS 33—WINES AND SPIRITS

FOR FLAVORED ALCOHOLIC MALT BEVERAGE (U.S. CLS. 47 AND 49).

GRETTA YAO, EXAMINING ATTORNEY

SN 86-230,903. JOHNNY'S SELECTED SEEDS, WINSLOW, ME. FILED 3-25-2014.



OWNER OF U.S. REG. NOS. 1,235,101 AND 2,817,334. NO CLAIM IS MADE TO THE EXCLUSIVE RIGHT TO USE "SEEDS", APART FROM THE MARK AS SHOWN.

THE MARK CONSISTS OF THE WORDS "JOHNNY'S SELECTED SEEDS" TO THE RIGHT OF A STYLIZED "J" IN AN OVAL DESIGN.

SEC. 2(F) AS TO "SELECTED SEEDS".

### CLASS 31—NATURAL AGRICULTURAL PRODUCTS

FOR AGRICULTURAL AND HORTICULTURAL SEEDS (U.S. CLS. 1 AND 46).  
FIRST USE 7-1-1975; IN COMMERCE 7-1-1975.

### CLASS 35—ADVERTISING AND BUSINESS

FOR RETAIL AND ON-LINE RETAIL STORE SERVICES FEATURING AGRICULTURAL SEEDS, FRUIT PLANTS, TOOLS AND SUPPLIES FOR FARMING AND GARDENING, AND PEST CONTROL PRODUCTS; CATALOG ORDERING SERVICE FEATURING AGRICULTURAL SEEDS, FRUIT PLANTS, TOOLS AND SUPPLIES FOR FARMING AND GARDENING, AND PEST CONTROL PRODUCTS (U.S. CLS. 100, 101 AND 102).

FIRST USE 7-1-1975; IN COMMERCE 7-1-1975.  
CURTIS FRENCH, EXAMINING ATTORNEY



## Lakeland Regional Health

OWNER OF U.S. REG. NO. 2,728,686.

NO CLAIM IS MADE TO THE EXCLUSIVE RIGHT TO USE "LAKELAND REGIONAL HEALTH", APART FROM THE MARK AS SHOWN.

THE MARK CONSISTS OF THE WORDS "LAKELAND REGIONAL HEALTH" WITH A DESIGN CONSISTING OF THREE CIRCLES OVER THREE V-SHAPED ARCS, REPRESENTING THREE PEOPLE, WITH TWO ADDITIONAL ARCHED LINES ON EITHER SIDE. THE DESIGN ELEMENT APPEARS OVER THE WORDS "REGIONAL HEALTH".

### CLASS 35—ADVERTISING AND BUSINESS

FOR APPOINTMENT SCHEDULING SERVICES; HEALTHCARE MANAGEMENT SERVICE ORGANIZATION (MSO) SERVICES, NAMELY, PROVIDING PRACTICE ORGANIZATION, MANAGEMENT AND ADMINISTRATIVE SUPPORT SERVICES TO INDIVIDUAL PHYSICIANS OR SMALL GROUP PRACTICES; MAIL ORDER PHARMACY SERVICES; PHARMACEUTICAL SERVICES, NAMELY, PROCESSING ONLINE AND TELEPHONE PRESCRIPTION ORDERS IN RETAIL AND CENTRAL FILL PHARMACIES; PROMOTING PUBLIC AWARENESS OF HEALTHCARE ISSUES AND PHYSICAL HEALTH AND WELLNESS; PROVIDING AN INTERNET-BASED DATABASE OF PATIENT MEDICAL INFORMATION DESIGNED TO FACILITATE PATIENT-AUTHORIZED, HIPAA-COMPLIANT SHARING AND MAINTENANCE OF PATIENT MEDICAL INFORMATION AMONGST A PATIENT'S DOCTORS SUCH THAT THIS INFORMATION CAN BE DIRECTLY INSERTED INTO THE DOCTOR'S MEDICAL REPORTS AS A MEANS OF INCREASING MEDICAL RECORD GENERATION EFFICIENCY AND ACCURACY; RETAIL PHARMACY SERVICES (U.S. CLS. 100, 101 AND 102).

### CLASS 44—MEDICAL, BEAUTY AND AGRICULTURAL SERVICES

FOR DISPENSING OF PHARMACEUTICALS; HEALTHCARE; HOSPITALS; MAINTAINING PATIENT MEDICAL RECORDS AND FILES; MEDICAL CLINICS; MEDICAL CONSULTATIONS; MEDICAL IMAGING SERVICES; MEDICAL INFORMATION SERVICES, NAMELY, REPORTING OF CONSUMER AUTHORIZED CLINICAL TESTING RESULTS DIRECTLY TO THE PATIENT; MEDICAL SERVICES; PHARMACEUTICAL ADVICE; PHARMACISTS' SERVICES TO MAKE UP PRESCRIPTIONS; PRESCRIPTION REFILL REMINDER SERVICES (U.S. CLS. 100 AND 101).

LAURA GOLDEN, EXAMINING ATTORNEY

SN 86-231,034. SOUTH JERSEY INDUSTRIES, FOLSOM, NJ. FILED 3-25-2014.

## MARINA ENERGY

THE MARK CONSISTS OF STANDARD CHARACTERS WITHOUT CLAIM TO ANY PARTICULAR FONT, STYLE, SIZE, OR COLOR.

NO CLAIM IS MADE TO THE EXCLUSIVE RIGHT TO USE "ENERGY", APART FROM THE MARK AS SHOWN.

#### CLASS 35—ADVERTISING AND BUSINESS

FOR CONSULTING SERVICES IN THE FIELD OF ENERGY USAGE MANAGEMENT AND ENERGY EFFICIENCY; ENERGY USAGE MANAGEMENT; ENERGY USAGE MANAGEMENT INFORMATION SERVICES; CONSULTING SERVICES IN THE FIELD OF ENERGY USAGE MANAGEMENT AND ENERGY EFFICIENCY FOR UTILITY AND NON-UTILITY INDUSTRIES, ALL RELATING TO IMPROVEMENT OF ENERGY EFFICIENCY AND ALL THE ABOVE IN THE FIELD OF THE GREEN ENERGY INDUSTRY; PROMOTING PUBLIC AWARENESS OF THE NEED FOR RENEWABLE ENERGY, CLEAN TECHNOLOGY AND EFFICIENCY (U.S. CLS. 100, 101 AND 102).

FIRST USE 10-0-2000; IN COMMERCE 1-0-2001.

#### CLASS 36—INSURANCE AND FINANCIAL

FOR EQUIPMENT FINANCING SERVICES; FINANCING LOANS FOR EQUIPMENT IN THE FIELD OF THERMAL FACILITIES, COMBINED HEAT AND POWER FACILITIES, DISTRICT HEATING AND COOLING FACILITIES, DISTRIBUTED GENERATION FACILITIES AND LANDFILL GAS-TO-ELECTRIC FACILITIES; PROVIDING INFORMATION AND ADVICE IN THE FIELD OF FINANCE, FINANCIAL INVESTMENTS AND FINANCIAL VALUATIONS (U.S. CLS. 100, 101 AND 102).

FIRST USE 10-0-2000; IN COMMERCE 1-0-2001.

#### CLASS 37—CONSTRUCTION AND REPAIR

FOR PLANT CONSTRUCTION, MAINTENANCE AND CONSTRUCTION PROJECT MANAGEMENT SERVICES FOR BUSINESSES IN THE ENERGY PRODUCTION AND TRANSMISSION SECTOR; CONSTRUCTION PROJECT MANAGEMENT SERVICES IN THE FIELD OF CONSTRUCTION OF GAS FACILITIES, ELECTRICAL FACILITIES, THERMAL FACILITIES, COMBINED HEAT AND POWER FACILITIES, DISTRICT HEATING AND COOLING FACILITIES, DISTRIBUTED GENERATION FACILITIES AND LANDFILL GAS-TO-ELECTRIC FACILITIES; INSTALLATION, REPAIR AND MAINTENANCE OF THERMAL FACILITIES, COMBINED HEAT AND POWER FACILITIES, DISTRICT HEATING AND COOLING FACILITIES, DISTRIBUTED GENERATION FACILITIES AND LANDFILL GAS-TO-ELECTRIC FACILITIES (U.S. CLS. 100, 103 AND 106).

FIRST USE 10-0-2000; IN COMMERCE 1-0-2001.

#### CLASS 42—SCIENTIFIC AND COMPUTER SERVICES

FOR PUBLIC ENERGY SYSTEM ENGINEERING SERVICES, NAMELY, ENGINEERING, DESIGN AND DEVELOPMENT SERVICES RELATING TO ENERGY SYSTEM PROJECTS, EXCLUDING THE EXPLORATION, PRODUCTION AND DISTRIBUTION OF OIL AND GAS AS DISTINCT SERVICES (U.S. CLS. 100 AND 101).

FIRST USE 10-0-2000; IN COMMERCE 1-0-2001.

SCOTT BIBB, EXAMINING ATTORNEY

SN 86-231,053. SOUTH JERSEY INDUSTRIES, FOLSOM, NJ. FILED 3-25-2014.

OPEN FLOW ENERGY

THE MARK CONSISTS OF STANDARD CHARACTERS WITHOUT CLAIM TO ANY PARTICULAR FONT, STYLE, SIZE, OR COLOR.

NO CLAIM IS MADE TO THE EXCLUSIVE RIGHT TO USE "ENERGY", APART FROM THE MARK AS SHOWN.

#### CLASS 35—ADVERTISING AND BUSINESS

FOR CONSULTING SERVICES IN THE FIELD OF ENERGY USAGE MANAGEMENT AND ENERGY EFFICIENCY; ENERGY USAGE MANAGEMENT; ENERGY USAGE MANAGEMENT INFORMATION SERVICES; CONSULTING SERVICES IN THE FIELDS OF ENERGY CONSUMPTION AND USAGE CONSERVATION TO IMPROVE ENERGY EFFICIENCY ALL RELATING TO IMPROVEMENT OF ENERGY EFFICIENCY AND ALL THE ABOVE IN THE FIELD OF THE GREEN ENERGY INDUSTRY; PROMOTING PUBLIC AWARENESS OF THE NEED FOR RENEWABLE ENERGY, CLEAN TECHNOLOGY AND EFFICIENCY (U.S. CLS. 100, 101 AND 102).

FIRST USE 11-2-2006; IN COMMERCE 11-2-2006.

#### CLASS 39—TRANSPORTATION AND STORAGE

FOR DISTRIBUTION OF ENERGY, NAMELY, NATURAL GAS (U.S. CLS. 100 AND 105).

FIRST USE 11-2-2006; IN COMMERCE 11-2-2006.

SCOTT BIBB, EXAMINING ATTORNEY

SN 86-231,131. FP FASHIONS LLC, TENAFLY, NJ. FILED 3-25-2014.

FACINE

THE MARK CONSISTS OF STANDARD CHARACTERS WITHOUT CLAIM TO ANY PARTICULAR FONT, STYLE, SIZE, OR COLOR.

THE WORDING "FACINE" HAS NO MEANING IN A FOREIGN LANGUAGE.

#### CLASS 9—ELECTRICAL AND SCIENTIFIC APPARATUS

FOR CARRYING CASES FOR CELL PHONES; CARRYING CASES FOR MOBILE COMPUTERS; PROTECTIVE CASES FOR SMARTPHONES; PROTECTIVE COVERS AND CASES FOR CELL PHONES, LAPTOPS AND PORTABLE MEDIA PLAYERS; PROTECTIVE COVERS AND CASES FOR TABLET COMPUTERS (U.S. CLS. 21, 23, 26, 36 AND 38).

#### CLASS 14—JEWELRY

FOR JEWELRY (U.S. CLS. 2, 27, 28 AND 50).

#### CLASS 18—LEATHER GOODS

FOR ALL-PURPOSE CARRYING BAGS; BACKPACKS; BRIEFCASES; HANDBAGS; LEATHER CASES; LUGGAGE; PURSES; TOTE BAGS; UMBRELLAS; WALLETS (U.S. CLS. 1, 2, 3, 22 AND 41).

#### CLASS 25—CLOTHING

FOR BOTTOMS; COATS; DRESSES; FOOTWEAR; GLOVES; HEADWEAR; HOSIERY; JACKETS; PANTS; SCARVES; SHIRTS; SKIRTS; SLEEPWEAR; SOCKS; SWIMWEAR; TIES; TOPS; UNDERWEAR (U.S. CLS. 22 AND 39).



**CLASS 35—ADVERTISING AND BUSINESS**

FOR ON-LINE RETAIL STORE SERVICES FEATURING CONSUMER ELECTRONICS ACCESSORIES, JEWELRY, HANDBAGS, PURSES, WALLETS, BAGS, CLOTHING AND CLOTHING ACCESSORIES, FOOTWEAR AND HEADWEAR; RETAIL STORES FEATURING CONSUMER ELECTRONICS ACCESSORIES, JEWELRY, HANDBAGS, PURSES, WALLETS, BAGS, CLOTHING AND CLOTHING ACCESSORIES, FOOTWEAR AND HEADWEAR (U.S. CLS. 100, 101 AND 102).  
NELSON SNYDER, EXAMINING ATTORNEY

SN 86-231,153. SOUTH JERSEY INDUSTRIES, FOLSOM, NJ.  
FILED 3-25-2014.



OWNER OF U.S. REG. NO. 3,783,192.  
THE COLOR(S) BROWN, WHITE, PURPLE, BLUE, GREEN, YELLOW, ORANGE IS/ARE CLAIMED AS A FEATURE OF THE MARK.

THE MARK CONSISTS OF THE WORD "ENERGENIC" IN WHITE LETTERS TO THE RIGHT OF MULTI-COLORED FLAMES, THE OVERLAPPING FLAMES APPEAR, IN ORDER FROM LEFT TO RIGHT, IN PURPLE, BLUE, GREEN, YELLOW, AND ORANGE, ALL ON A BROWN RECTANGULAR BACKGROUND.

**CLASS 35—ADVERTISING AND BUSINESS**

FOR CONSULTING SERVICES IN THE FIELD OF ENERGY USAGE MANAGEMENT AND ENERGY EFFICIENCY; ENERGY USAGE MANAGEMENT; ENERGY USAGE MANAGEMENT INFORMATION SERVICES; PROVIDING A WEB-BASED ON-LINE PORTAL THAT PROVIDES CUSTOMER ACCESS TO THEIR ELECTRIC BILL ACCOUNT INFORMATION, ENERGY USAGE PATTERN INFORMATION, AND ENERGY CONSUMPTION AND USAGE DATA, FOR PURPOSES OF UTILITY ACCOUNT BUSINESS MANAGEMENT AND ENERGY USAGE MANAGEMENT (U.S. CLS. 100, 101 AND 102).  
FIRST USE 1-1-2008; IN COMMERCE 1-1-2008.

**CLASS 36—INSURANCE AND FINANCIAL**

FOR EQUIPMENT FINANCING SERVICES; FINANCING LOANS FOR EQUIPMENT IN THE FIELD OF THERMAL FACILITIES, COMBINED HEAT AND POWER FACILITIES, DISTRICT HEATING AND COOLING FACILITIES, DISTRIBUTED GENERATION FACILITIES AND LANDFILL GAS-TO-ELECTRIC FACILITIES; PROVIDING INFORMATION AND ADVICE IN THE FIELD OF FINANCE, FINANCIAL INVESTMENTS AND FINANCIAL VALUATIONS (U.S. CLS. 100, 101 AND 102).

FIRST USE 1-1-2008; IN COMMERCE 1-1-2008.

**CLASS 37—CONSTRUCTION AND REPAIR**

FOR PLANT CONSTRUCTION, MAINTENANCE AND CONSTRUCTION PROJECT MANAGEMENT SERVICES FOR BUSINESSES IN THE ENERGY PRODUCTION AND TRANSMISSION SECTOR; CONSTRUCTION PROJECT MANAGEMENT SERVICES IN THE FIELD OF CONSTRUCTION OF GAS FACILITIES, ELECTRICAL FACILITIES, THERMAL FACILITIES, COMBINED HEAT AND POWER FACILITIES, DISTRICT HEATING AND COOLING FACILITIES, DISTRIBUTED GENERATION FACILITIES AND LANDFILL GAS-TO-ELECTRIC FACILITIES; INSTALLATION, REPAIR AND MAINTENANCE OF THERMAL FACILITIES, COMBINED HEAT AND POWER FACILITIES, DISTRICT HEATING AND COOLING FACILITIES, DISTRIBUTED GENERATION FACILITIES AND LANDFILL GAS-TO-ELECTRIC FACILITIES (U.S. CLS. 100, 103 AND 106).

FIRST USE 1-1-2008; IN COMMERCE 1-1-2008.

**CLASS 42—SCIENTIFIC AND COMPUTER SERVICES**

FOR PUBLIC ENERGY SYSTEM ENGINEERING SERVICES, NAMELY, ENGINEERING, DESIGN AND DEVELOPMENT SERVICES RELATING TO ENERGY SYSTEM PROJECTS, EXCLUDING THE EXPLORATION, PRODUCTION AND DISTRIBUTION OF OIL AND GAS AS DISTINCT SERVICES (U.S. CLS. 100 AND 101).

FIRST USE 1-1-2008; IN COMMERCE 1-1-2008.  
SCOTT BIBB, EXAMINING ATTORNEY

SN 86-231,179. KENDALL, URSULA U, ATLANTA, GA.  
FILED 3-25-2014.



THE COLOR(S) PURPLE, YELLOW, AND GREEN IS/ARE CLAIMED AS A FEATURE OF THE MARK.

THE MARK CONSISTS OF A TWO-TONED GREEN CIRCLE, FRAMED YELLOW BOX, PURPLE DANCER IMAGE AND STYLIZED "SHE CREATED IT" WORDING IN YELLOW.

**CLASS 18—LEATHER GOODS**

FOR BACKPACKS, BOOK BAGS, SPORTS BAGS, BUM BAGS, WALLETS AND HANDBAGS (U.S. CLS. 1, 2, 3, 22 AND 41).

FIRST USE 9-28-2013; IN COMMERCE 9-28-2013.

**CLASS 25—CLOTHING**

FOR APPAREL FOR DANCERS, NAMELY, TEE SHIRTS, SWEATSHIRTS, PANTS, LEGGINGS, SHORTS AND JACKETS; ATHLETIC APPAREL, NAMELY, SHIRTS, PANTS, JACKETS, FOOTWEAR, HATS AND CAPS, ATHLETIC UNIFORMS (U.S. CLS. 22 AND 39).

FIRST USE 9-17-2011; IN COMMERCE 9-17-2011.

HENRY S. ZAK, EXAMINING ATTORNEY

SN 86-231,230. WELLTRINSIC SLEEP NETWORK, INC.,  
DARIEN, IL. FILED 3-25-2014.

**WELLTRINSIC SLEEP NETWORK**

THE MARK CONSISTS OF STANDARD CHARACTERS WITHOUT CLAIM TO ANY PARTICULAR FONT, STYLE, SIZE, OR COLOR.

NO CLAIM IS MADE TO THE EXCLUSIVE RIGHT TO USE "SLEEP NETWORK", APART FROM THE MARK AS SHOWN.



**CLASS 35—ADVERTISING AND BUSINESS**

FOR ARRANGING AND NEGOTIATING OF MANAGED CARE CONTRACTUAL SERVICES IN THE FIELD OF HOME HEALTHCARE, DURABLE MEDICAL EQUIPMENT, AND DIAGNOSTIC LAB SERVICES OFFERED BY SLEEP SPECIALISTS AND SLEEP CENTERS; HEALTHCARE MANAGEMENT SERVICES, NAMELY, PROVIDING PRACTICE ORGANIZATION, MANAGEMENT AND ADMINISTRATIVE SUPPORT SERVICES TO THE DOCTORS OR HEALTH CARE PROVIDERS OF A NETWORK OF HEALTH CARE PROVIDERS (U.S. CLS. 100, 101 AND 102).

**CLASS 38—COMMUNICATION**

FOR ELECTRONIC EXCHANGE OF MEDICAL RECORDS ACROSS A NATIONWIDE HEALTH INFORMATION NETWORK (U.S. CLS. 100, 101 AND 104).

**CLASS 44—MEDICAL, BEAUTY AND AGRICULTURAL SERVICES**

FOR HEALTH CARE SERVICES OFFERED THROUGH A NETWORK OF HEALTH CARE PROVIDERS ON A CONTRACT BASIS; TELEMEDICINE SERVICES IN THE FIELD OF SLEEP MEDICINE (U.S. CLS. 100 AND 101).  
JERI J. FICKES, EXAMINING ATTORNEY

SN 86-231,248. SOUTH JERSEY INDUSTRIES, FOLSOM, NJ. FILED 3-25-2014.

**SOUTH JERSEY ENERGY  
SERVICE PLUS**

THE MARK CONSISTS OF STANDARD CHARACTERS WITHOUT CLAIM TO ANY PARTICULAR FONT, STYLE, SIZE, OR COLOR.

NO CLAIM IS MADE TO THE EXCLUSIVE RIGHT TO USE "ENERGY SERVICE", APART FROM THE MARK AS SHOWN.

SEC. 2(F).

**CLASS 35—ADVERTISING AND BUSINESS**

FOR CONSULTING SERVICES IN THE FIELD OF ENERGY USAGE MANAGEMENT AND ENERGY EFFICIENCY; ENERGY USAGE MANAGEMENT; ENERGY USAGE MANAGEMENT INFORMATION SERVICES; CONSULTING SERVICES IN THE FIELDS OF ENERGY MANAGEMENT IN THE NATURE OF ENERGY CONSUMPTION AND USAGE MANAGEMENT FOR UTILITY AND NON-UTILITY INDUSTRIES; CONSULTING SERVICES IN THE FIELD OF ENERGY MANAGEMENT IN THE NATURE OF ENERGY CONSUMPTION AND USAGE MANAGEMENT, FOR UTILITY AND NON-UTILITY INDUSTRIES, ALL RELATING TO IMPROVEMENT OF ENERGY EFFICIENCY AND ALL THE ABOVE IN THE FIELD OF THE GREEN ENERGY INDUSTRY; PROMOTING PUBLIC AWARENESS OF THE NEED FOR RENEWABLE ENERGY, CLEAN TECHNOLOGY AND EFFICIENCY (U.S. CLS. 100, 101 AND 102).

FIRST USE 2-0-2003; IN COMMERCE 1-0-2004.

**CLASS 37—CONSTRUCTION AND REPAIR**

FOR HVAC CONTRACTOR SERVICES; INSTALLATION, REPAIR AND MAINTENANCE OF HVAC SYSTEMS, APPLIANCES, PLUMBING, SOLAR ELECTRIC, WATER HEATING AND PROPANE-FUELED EQUIPMENT (U.S. CLS. 100, 103 AND 106).

FIRST USE 2-0-2003; IN COMMERCE 2-0-2003.  
SCOTT BIBB, EXAMINING ATTORNEY

SN 86-231,366. SUGAR HOLLOW SOLAR, INC., FAIRVIEW, NC. FILED 3-25-2014.

**SUGAR HOLLOW SOLAR**

THE MARK CONSISTS OF STANDARD CHARACTERS WITHOUT CLAIM TO ANY PARTICULAR FONT, STYLE, SIZE, OR COLOR.

NO CLAIM IS MADE TO THE EXCLUSIVE RIGHT TO USE "SOLAR", APART FROM THE MARK AS SHOWN.

**CLASS 37—CONSTRUCTION AND REPAIR**

FOR INSTALLATION AND MAINTENANCE OF RENEWABLE AND ALTERNATIVE ENERGY SYSTEMS, NAMELY, SOLAR ELECTRIC SYSTEMS, SOLAR HOT WATER SYSTEMS, HYDRONIC HEATING SYSTEMS, AND MICRO HYDRO POWER SYSTEMS (U.S. CLS. 100, 103 AND 106).

FIRST USE 12-18-2013; IN COMMERCE 12-18-2013.

**CLASS 42—SCIENTIFIC AND COMPUTER SERVICES**

FOR DESIGN SERVICES FOR RENEWABLE AND ALTERNATIVE ENERGY SYSTEMS, NAMELY, SOLAR ELECTRIC SYSTEMS, SOLAR HOT WATER SYSTEMS, HYDRONIC HEATING SYSTEMS, AND MICRO HYDRO POWER SYSTEMS (U.S. CLS. 100 AND 101).

FIRST USE 12-18-2013; IN COMMERCE 12-18-2013.

JOANNA DUKOVIC, EXAMINING ATTORNEY

SN 86-231,386. NATURE'S MARK, LLC, HOUSTON, TX. FILED 3-25-2014.



NO CLAIM IS MADE TO THE EXCLUSIVE RIGHT TO USE "HOME", APART FROM THE MARK AS SHOWN.

THE NAME(S), PORTRAIT(S), AND/OR SIGNATURE(S) SHOWN IN THE MARK DOES NOT IDENTIFY A PARTICULAR LIVING INDIVIDUAL.

THE MARK CONSISTS OF THE WORDS "SOPHIA ELAN" IN A BOX AGAINST A CURLICUE DESIGN AND THE WORD "HOME" BENEATH THE BOX.

**CLASS 11—ENVIRONMENTAL CONTROL APPARATUS**

FOR ORNAMENTAL TABLE FOUNTAINS; LED CANDLES (U.S. CLS. 13, 21, 23, 31 AND 34).

**CLASS 21—HOUSEWARES AND GLASS**

FOR CANDLE HOLDERS (U.S. CLS. 2, 13, 23, 29, 30, 33, 40 AND 50).

KIM SAITO, EXAMINING ATTORNEY

SN 86-231,406. DERINGER, ERIK, SAN JOSE, CA. FILED 3-25-2014.

SN 86-231,514. CARLOS CRESPO, MIAMI, FL. FILED 3-25-2014.

# COMA

THE MARK CONSISTS OF STANDARD CHARACTERS WITHOUT CLAIM TO ANY PARTICULAR FONT, STYLE, SIZE, OR COLOR.

## CLASS 18—LEATHER GOODS

FOR BAGS, NAMELY, BACKPACKS, LUGGAGE, SOFT LUGGAGE, ALL-PURPOSE CARRYING BAGS, DUFFEL BAGS, BOOK BAGS COURIER BAGS, MESSENGER BAGS, TOTE BAGS, KNAPSACKS, RUCKSACKS, BEACH BAGS, FANNY PACKS, TRAVEL BAGS, BAGS AND HOLD-ALLS FOR SPORTS CLOTHING, SHOULDER BAGS, WALLETS, SLING BAGS, SCHOOL BAGS, DRAWSTRING BAGS, ALL-PURPOSE ATHLETIC BAGS, BAGS FOR SPORTS, AND ALL-PURPOSE SPORT BAGS (U.S. CLS. 1, 2, 3, 22 AND 41).  
FIRST USE 3-1-2013; IN COMMERCE 4-18-2013.

## CLASS 25—CLOTHING

FOR CLOTHING, NAMELY, T-SHIRTS, TOPS, SHIRTS, SWEATSHIRTS, HOODED SWEATSHIRTS, SWEATPANTS, JACKETS, BOTTOMS, PANTS, JEANS, SHORTS, VESTS, SLEEPWEAR, UNDERWEAR, SCARVES, SOCKS, GLOVES, BELTS; HEADWEAR, HATS, CAPS (U.S. CLS. 22 AND 39).  
FIRST USE 3-1-2013; IN COMMERCE 4-18-2013.  
NAAKWAMA ANKRAH, EXAMINING ATTORNEY

SN 86-231,506. NATIONAL WOMEN'S HALL OF FAME, INC., SENECA FALLS, NY. FILED 3-25-2014.

# National Women's Hall of Fame

THE MARK CONSISTS OF STANDARD CHARACTERS WITHOUT CLAIM TO ANY PARTICULAR FONT, STYLE, SIZE, OR COLOR.

NO CLAIM IS MADE TO THE EXCLUSIVE RIGHT TO USE "HALL OF FAME" FOR INTERNATIONAL CLASS 41, APART FROM THE MARK AS SHOWN.  
SEC. 2(F).

## CLASS 35—ADVERTISING AND BUSINESS

FOR RETAIL GIFT SHOPS (U.S. CLS. 100, 101 AND 102).  
FIRST USE 4-30-1972; IN COMMERCE 4-30-1972.

## CLASS 41—EDUCATION AND ENTERTAINMENT

FOR CONDUCTING EDUCATIONAL EXHIBITIONS IN THE NATURE OF SHOWCASING GREAT WOMEN; MUSEUM SERVICES (U.S. CLS. 100, 101 AND 107).  
FIRST USE 4-30-1972; IN COMMERCE 4-30-1972.  
ALLISON SCHRODY, EXAMINING ATTORNEY

# LA FAMA

THE MARK CONSISTS OF STANDARD CHARACTERS WITHOUT CLAIM TO ANY PARTICULAR FONT, STYLE, SIZE, OR COLOR.

THE ENGLISH TRANSLATION OF "LA FAMA" IN THE MARK IS "THE FAME".

## CLASS 35—ADVERTISING AND BUSINESS

FOR COMPUTERIZED ON-LINE RETAIL STORE SERVICES IN THE FIELD OF CLOTHING AND APPAREL ACCESSORIES, SUCH AS SHIRTS, HATS, PANTS, CAPS; DISCOUNT STORES IN THE FIELD OF CLOTHING AND APPAREL ACCESSORIES, SUCH AS SHIRTS, HATS, PANTS, CAPS; FRANCHISING, NAMELY, OFFERING BUSINESS MANAGEMENT ASSISTANCE IN THE ESTABLISHMENT AND/OR OPERATION OF RETAIL SHOPS FEATURING CLOTHING AND APPAREL ACCESSORIES, SUCH AS SHIRTS, HATS, PANTS, CAPS; MARKETING, ADVERTISING, AND PROMOTING THE RETAIL GOODS AND SERVICES OF OTHERS THROUGH WIRELESS ELECTRONIC DEVICES; RETAIL AND ON-LINE GROCERY STORE SERVICES FEATURING HOME DELIVERY SERVICE; RETAIL APPAREL STORES; RETAIL AUTOMOBILE PARTS AND ACCESSORIES STORES; RETAIL BAKERY SHOPS; RETAIL BOOK STORE SERVICES; RETAIL CANDY STORES; RETAIL CLOTHING BOUTIQUES; RETAIL CLOTHING STORES; RETAIL CONVENIENCE STORES; RETAIL CUPCAKE SHOPS; RETAIL DEPARTMENT STORE SERVICES; RETAIL DEPARTMENT STORES; RETAIL DISCOUNT STORE SERVICES IN THE FIELD OF CLOTHING AND APPAREL ACCESSORIES; RETAIL FLORIST SHOPS; RETAIL FRUIT STANDS; RETAIL GIFT SHOPS; RETAIL JEWELRY STORES; RETAIL MUSIC AND RECORD STORES; RETAIL SHOPS FEATURING CLOTHING AND APPAREL ACCESSORIES, SUCH AS SHIRTS, HATS, PANTS, CAPS; RETAIL STORE SERVICES FEATURING A WIDE VARIETY OF CONSUMER GOODS OF OTHERS; RETAIL STORE SERVICES FEATURING VIRTUAL GOODS, NAMELY, CLOTHING AND APPAREL ACCESSORIES, SUCH AS SHIRTS, HATS, PANTS, CAPS FOR USE IN ONLINE VIRTUAL WORLDS; RETAIL STORES FEATURING CLOTHING AND APPAREL ACCESSORIES, SUCH AS SHIRTS, HATS, PANTS, CAPS; RETAIL VARIETY STORES; RETAIL CLOTHING STORES (U.S. CLS. 100, 101 AND 102).  
FIRST USE 1-1-2012; IN COMMERCE 5-1-2012.

## CLASS 44—MEDICAL, BEAUTY AND AGRICULTURAL SERVICES

FOR BARBER SHOP SERVICES; BARBERING SERVICES; RENTAL OF MACHINES AND APPARATUS FOR USE IN BEAUTY SALONS OR BARBERS' SHOPS; SHOPPING MALL KIOSKS FOR PROVIDING MEN'S BARBER SERVICES (U.S. CLS. 100 AND 101).  
FIRST USE 1-1-2012; IN COMMERCE 5-1-2012.  
JANICE L. MCMORROW, EXAMINING ATTORNEY

SN 86-231,616. TBC TRADEMARKS, LLC, LAS VEGAS, NV.  
FILED 3-25-2014.

## TIRE KINGDOM

THE MARK CONSISTS OF STANDARD CHARACTERS WITHOUT CLAIM TO ANY PARTICULAR FONT, STYLE, SIZE, OR COLOR.

OWNER OF U.S. REG. NOS. 1,838,215, 2,850,390 AND 2,864,332.

NO CLAIM IS MADE TO THE EXCLUSIVE RIGHT TO USE "TIRE", APART FROM THE MARK AS SHOWN.

### CLASS 12—VEHICLES

FOR TIRES (U.S. CLS. 19, 21, 23, 31, 35 AND 44).  
FIRST USE 5-5-1978; IN COMMERCE 5-5-1978.

### CLASS 35—ADVERTISING AND BUSINESS

FOR RETAIL STORE SERVICES AND ONLINE RETAIL STORE SERVICES FEATURING AUTOMOBILE PRODUCTS, VEHICLE WHEELS AND TIRES (U.S. CLS. 100, 101 AND 102).  
FIRST USE 5-5-1978; IN COMMERCE 5-5-1978.

### CLASS 37—CONSTRUCTION AND REPAIR

FOR TIRE BALANCING AND TIRE ROTATION SERVICES; VEHICLE REPAIR AND MAINTENANCE SERVICES (U.S. CLS. 100, 103 AND 106).

FIRST USE 5-5-1978; IN COMMERCE 5-5-1978.  
JUSTINE D. PARKER, EXAMINING ATTORNEY

SN 86-231,649. ENERHEALTH BOTANICALS, LLC, EVERGREEN, CO. FILED 3-25-2014.



THE COLOR(S) BLACK AND GOLD IS/ARE CLAIMED AS A FEATURE OF THE MARK.

THE MARK CONSISTS OF A BLACK CAPITAL "E" FACING DOWNWARDS AND OVERLAYED ONTO A CAPITAL "H" IN BLACK WITH A STYLIZED SUNBURST IN GOLD OVER THE "E/H" GRAPHIC.

### CLASS 5—PHARMACEUTICALS

FOR ANTIOXIDANT ENRICHED COFFEE; FOOD SUPPLEMENTS; HEALTH FOOD SUPPLEMENTS; NATURAL HERBAL SUPPLEMENTS (U.S. CLS. 6, 18, 44, 46, 51 AND 52).

FIRST USE 1-12-2006; IN COMMERCE 1-12-2006.

### CLASS 30—STAPLE FOODS

FOR COCOA-BASED CONDIMENTS AND SEASONINGS FOR FOOD AND DRINK; COFFEE; ROASTED COFFEE BEANS (U.S. CL. 46).

FIRST USE 1-12-2006; IN COMMERCE 1-12-2006.  
JUSTINE D. PARKER, EXAMINING ATTORNEY

SN 86-231,712. LIONS HEAD LLC, VAIL, CO. FILED 3-25-2014.

## The Lion at Vail

THE MARK CONSISTS OF STANDARD CHARACTERS WITHOUT CLAIM TO ANY PARTICULAR FONT, STYLE, SIZE, OR COLOR.

NO CLAIM IS MADE TO THE EXCLUSIVE RIGHT TO USE "AT VAIL", APART FROM THE MARK AS SHOWN.

### CLASS 36—INSURANCE AND FINANCIAL

FOR REAL ESTATE BROKERAGE; REAL ESTATE MANAGEMENT SERVICES (U.S. CLS. 100, 101 AND 102).

### CLASS 37—CONSTRUCTION AND REPAIR

FOR REAL ESTATE DEVELOPMENT AND CONSTRUCTION OF COMMERCIAL, RESIDENTIAL AND HOTEL PROPERTY (U.S. CLS. 100, 103 AND 106).  
NICHOLAS ALTREE, EXAMINING ATTORNEY

SN 86-231,993. EISAI INC., WOODCLIFF LAKE, NJ. FILED 3-25-2014.

## MY HEALTHY

THE MARK CONSISTS OF STANDARD CHARACTERS WITHOUT CLAIM TO ANY PARTICULAR FONT, STYLE, SIZE, OR COLOR.

NO CLAIM IS MADE TO THE EXCLUSIVE RIGHT TO USE "HEALTHY", APART FROM THE MARK AS SHOWN.

### CLASS 16—PAPER GOODS AND PRINTED MATTER

FOR PRINTED EDUCATIONAL MATERIALS IN THE FIELD OF WEIGHT LOSS AND/OR WEIGHT MANAGEMENT, DIET AND EXERCISE (U.S. CLS. 2, 5, 22, 23, 29, 37, 38 AND 50).

### CLASS 35—ADVERTISING AND BUSINESS

FOR PROMOTING PUBLIC AWARENESS OF THE BENEFITS OF MAINTAINING A HEALTHY LIFESTYLE AND LOSING WEIGHT (U.S. CLS. 100, 101 AND 102).

**CLASS 44—MEDICAL, BEAUTY AND AGRICULTURAL SERVICES**

FOR PROVIDING A WEB SITE FEATURING MEDICAL INFORMATION; PROVIDING A WEBSITE FEATURING INFORMATION AND ADVICE IN THE FIELDS OF DIET, WEIGHT LOSS, DIET PLANNING AND LIFESTYLE WELLNESS; PROVIDING A WEBSITE FEATURING INFORMATION REGARDING HEALTHY LIVING AND LIFESTYLE WELLNESS; PROVIDING INFORMATION ON MAINTAINING A HEALTHY LIFESTYLE AND LOSING WEIGHT; PROVIDING MEDICAL INFORMATION IN THE FIELD OF WEIGHT LOSS AND/OR WEIGHT MANAGEMENT, DIET AND EXERCISE (U.S. CLS. 100 AND 101).

JOHN GARTNER, EXAMINING ATTORNEY

SN 86-232,107. DUADIKOS LLC, SOMERVILLE, MA. FILED 3-26-2014.

**PLAY WITH YOUR MIND**

THE MARK CONSISTS OF STANDARD CHARACTERS WITHOUT CLAIM TO ANY PARTICULAR FONT, STYLE, SIZE, OR COLOR.

**CLASS 9—ELECTRICAL AND SCIENTIFIC APPARATUS**

FOR COMPUTER GAME DISCS; COMPUTER GAME PROGRAMMES; COMPUTER GAME PROGRAMMES DOWNLOADABLE VIA THE INTERNET; COMPUTER GAME PROGRAMS; COMPUTER GAME SOFTWARE FOR PERSONAL COMPUTERS AND HOME VIDEO GAME CONSOLES; COMPUTER GAME SOFTWARE FOR USE ON MOBILE AND CELLULAR PHONES; COMPUTER GAME SOFTWARE FOR USE WITH PERSONAL COMPUTERS, HOME VIDEO GAME CONSOLES USED WITH TELEVISIONS AND ARCADE-BASED VIDEO GAME CONSOLES; COMPUTER PROGRAMS FOR VIDEO AND COMPUTER GAMES; COMPUTER SOFTWARE, NAMELY, GAME ENGINE SOFTWARE FOR VIDEO GAME DEVELOPMENT AND OPERATION; DOWNLOADABLE COMPUTER GAME PROGRAMS; INTERACTIVE MULTIMEDIA COMPUTER GAME PROGRAMS; INTERACTIVE VIDEO GAME PROGRAMS; VIDEO AND COMPUTER GAME PROGRAMS; VIDEO GAME DISCS; VIDEO GAME SOFTWARE (U.S. CLS. 21, 23, 26, 36 AND 38).

FIRST USE 10-15-2013; IN COMMERCE 10-15-2013.

SN 86-231,997. EISAI INC., WOODCLIFF LAKE, NJ. FILED 3-25-2014.



NO CLAIM IS MADE TO THE EXCLUSIVE RIGHT TO USE "HEALTHY", APART FROM THE MARK AS SHOWN.

THE MARK CONSISTS OF THE WORDING "MY" NEXT TO THE WORDING "HEALTHY" AND THE DESIGNS OF AN APPLE, SHOE AND FIRST AID KIT IN SHADED CIRCLES.

**CLASS 16—PAPER GOODS AND PRINTED MATTER**

FOR PRINTED EDUCATIONAL MATERIALS IN THE FIELD OF WEIGHT LOSS AND/OR WEIGHT MANAGEMENT, DIET AND EXERCISE (U.S. CLS. 2, 5, 22, 23, 29, 37, 38 AND 50).

**CLASS 35—ADVERTISING AND BUSINESS**

FOR PROMOTING PUBLIC AWARENESS OF THE BENEFITS OF MAINTAINING A HEALTHY LIFESTYLE AND LOSING WEIGHT (U.S. CLS. 100, 101 AND 102).

**CLASS 44—MEDICAL, BEAUTY AND AGRICULTURAL SERVICES**

FOR PROVIDING A WEB SITE FEATURING MEDICAL INFORMATION; PROVIDING A WEBSITE FEATURING INFORMATION AND ADVICE IN THE FIELDS OF DIET, WEIGHT LOSS, DIET PLANNING AND LIFESTYLE WELLNESS; PROVIDING A WEBSITE FEATURING INFORMATION REGARDING HEALTHY LIVING AND LIFESTYLE WELLNESS; PROVIDING INFORMATION ON MAINTAINING A HEALTHY LIFESTYLE AND LOSING WEIGHT; PROVIDING MEDICAL INFORMATION IN THE FIELD OF WEIGHT LOSS AND/OR WEIGHT MANAGEMENT, DIET AND EXERCISE (U.S. CLS. 100 AND 101).

JOHN GARTNER, EXAMINING ATTORNEY

SN 86-232,111. DUADIKOS LLC, SOMERVILLE, MA. FILED 3-26-2014.

**DUADIKOS**

THE MARK CONSISTS OF STANDARD CHARACTERS WITHOUT CLAIM TO ANY PARTICULAR FONT, STYLE, SIZE, OR COLOR.

**CLASS 9—ELECTRICAL AND SCIENTIFIC APPARATUS**

FOR COMPUTER GAME DISCS; COMPUTER GAME PROGRAMMES; COMPUTER GAME PROGRAMMES DOWNLOADABLE VIA THE INTERNET; COMPUTER GAME PROGRAMS; COMPUTER GAME SOFTWARE; COMPUTER GAME SOFTWARE FOR PERSONAL COMPUTERS AND HOME VIDEO GAME CONSOLES; COMPUTER GAME SOFTWARE FOR USE ON MOBILE AND CELLULAR PHONES; COMPUTER SOFTWARE, NAMELY, GAME ENGINE SOFTWARE FOR VIDEO GAME DEVELOPMENT AND OPERATION; DOWNLOADABLE COMPUTER GAME PROGRAMS; INTERACTIVE VIDEO GAME PROGRAMS; VIDEO AND COMPUTER GAME PROGRAMS; VIDEO GAME DISCS; VIDEO GAME SOFTWARE (U.S. CLS. 21, 23, 26, 36 AND 38).

FIRST USE 10-15-2013; IN COMMERCE 10-15-2013.

**CLASS 28—TOYS AND SPORTING GOODS**

FOR BOARD GAMES; CUPS FOR DICE; DICE; DICE GAMES; EQUIPMENT SOLD AS A UNIT FOR PLAYING BOARD GAMES; EQUIPMENT SOLD AS A UNIT FOR PLAYING CARD GAMES; GAMING PAPER, NAMELY, PAPER PRINTED WITH REGULAR GRID AND HEXAGON PATTERNS FOR USE IN PLAYING WAR GAMES, ROLE PLAYING GAMES AND MINIATURE GAMES; PLAYING CARDS AND CARD GAMES; ROLE PLAYING GAMES; TABLETOP GAMES; TABLETOP HOBBY BATTLE GAMES IN THE NATURE OF BATTLE, WAR AND SKIRMISH GAMES, AND FANTASY GAMES, AND PLAYING EQUIPMENT SOLD AS A UNIT THEREWITH; TABLETOP UNITS FOR PLAYING ELECTRONIC GAMES OTHER THAN IN CONJUNCTION WITH A TELEVISION OR COMPUTER (U.S. CLS. 22, 23, 38 AND 50).

FIRST USE 10-15-2013; IN COMMERCE 10-15-2013.  
ALEXANDER L. POWERS, EXAMINING ATTORNEY

SN 86-232,307. DETROIT GUITAR LLC, BIRMINGHAM, MI. FILED 3-26-2014.



NO CLAIM IS MADE TO THE EXCLUSIVE RIGHT TO USE "DETROIT", APART FROM THE MARK AS SHOWN.

THE MARK CONSISTS OF STYLIZED DISTRESSED WORD "DETROIT" WITH A OPEN CROWN OVER THE TOP CORNER OF THE "D" AND LIGHTENING BOLT AT THE BOTTOM. SMALLER LETTERS SPELL "GUITAR" ON LOWER LINE. THERE IS SMALL DISTRESSED DOTS SURROUNDING THE WORDS.

**CLASS 25—CLOTHING**

FOR T-SHIRTS (U.S. CLS. 22 AND 39).  
FIRST USE 3-3-2011; IN COMMERCE 3-3-2011.

**CLASS 28—TOYS AND SPORTING GOODS**

FOR SKATEBOARD DECKS (U.S. CLS. 22, 23, 38 AND 50).  
FIRST USE 3-3-2011; IN COMMERCE 3-3-2011.  
WARREN L. OLANDRIA, EXAMINING ATTORNEY

SN 86-232,407. CHARLES VIANCIN GROUP, 74650 CHAVANOD, FRANCE, FILED 3-26-2014.

# DAHLIA

THE MARK CONSISTS OF STANDARD CHARACTERS WITHOUT CLAIM TO ANY PARTICULAR FONT, STYLE, SIZE, OR COLOR.

**CLASS 20—FURNITURE AND ARTICLES NOT OTHERWISE CLASSIFIED**

FOR SILICONE BOTTLE STOPPERS (U.S. CLS. 2, 13, 22, 25, 32 AND 50).  
FIRST USE 10-0-2013; IN COMMERCE 10-0-2013.

**CLASS 21—HOUSEWARES AND GLASS**

FOR REUSABLE SELF-SEALING LIDS FOR HOUSEHOLD USE; REUSABLE SELF-SEALING LIDS FOR BOWLS, CUPS, DRINKS, CONTAINERS AND THE STORAGE OF FOOD; SEALING LIDS FOR COOKING USE; REUSABLE SELF-SEALING COVERS FOR CUPS, DRINKS AND BEVERAGE CONTAINERS (U.S. CLS. 2, 13, 23, 29, 30, 33, 40 AND 50).  
FIRST USE 9-0-2013; IN COMMERCE 9-0-2013.  
JAY FLOWERS, EXAMINING ATTORNEY

SN 86-232,536. EQUINOX HOLDINGS, INC., NEW YORK, NY. FILED 3-26-2014.



OWNER OF U.S. REG. NOS. 1,796,108, 3,377,795 AND OTHERS.

THE MARK CONSISTS OF AN OVAL THAT IS HALF BLACK AND HALF WHITE WITH THE WORD "EQUINOX" WRITTEN IN BLACK AND WHITE LETTERS WITH AN ELLIPTICAL BROKEN OVAL CIRCLE PLACED ON AN ANGLE OVER THE MAIN OVAL.

**CLASS 41—EDUCATION AND ENTERTAINMENT**

FOR GYM FACILITIES IN THE NATURE OF FITNESS AND EXERCISE FACILITIES PROVIDED IN A HOTEL (U.S. CLS. 100, 101 AND 107).

**CLASS 43—HOTEL AND RESTAURANT SERVICES**

FOR HOTELS FOCUSED ON LIFESTYLE, WELLNESS AND FITNESS (U.S. CLS. 100 AND 101).  
KIMBERLY PARKS, EXAMINING ATTORNEY

SN 86-232,554. BOSSIER, TODD, GREENWELL SPRINGS, LA. FILED 3-26-2014.

SN 86-232,776. JOHNSON & JOHNSON, NEW BRUNSWICK, NJ. FILED 3-26-2014.

## DISRUPTIVESTRONG

THE MARK CONSISTS OF STANDARD CHARACTERS WITHOUT CLAIM TO ANY PARTICULAR FONT, STYLE, SIZE, OR COLOR.

### CLASS 28—TOYS AND SPORTING GOODS

FOR PHYSICAL FITNESS EQUIPMENT, NAMELY, PUNCHING BAGS, BOXING GLOVES, BOXING BAGS, PUNCHING MITTS, DUMBBELLS, MANUALLY OPERATED EXERCISE EQUIPMENT UTILIZING A GLIDING MOTION, SPORTS TRAINING SLEDS AND JUMP ROPES (U.S. CLS. 22, 23, 38 AND 50).

### CLASS 41—EDUCATION AND ENTERTAINMENT

FOR PERSONAL FITNESS TRAINING SERVICES AND CONSULTANCY, PROVIDING A WEBSITE WITH INFORMATION IN THE FIELD OF FITNESS (U.S. CLS. 100, 101 AND 107).

ZHALEH DELANEY, EXAMINING ATTORNEY



OWNER OF U.S. REG. NOS. 2,863,261, 3,048,411 AND OTHERS.

THE MARK CONSISTS OF A DESIGN OF A DANCING COW.

### CLASS 5—PHARMACEUTICALS

FOR DIETARY AID, NAMELY, A LACTASE ENZYME USED TO REDUCE OR REMOVE THE LACTOSE IN MILK (U.S. CLS. 6, 18, 44, 46, 51 AND 52).

### CLASS 29—MEATS AND PROCESSED FOODS

FOR COTTAGE CHEESE, MILK, NON-ALCOHOLIC EGG NOG (U.S. CL. 46).

### CLASS 30—STAPLE FOODS

FOR ICE CREAM (U.S. CL. 46).  
MEREDITH MARESCA, EXAMINING ATTORNEY

SN 86-232,677. AYALA CANTU, JOSE ANTONIO, MONTERREY, N.L., MEXICO, FILED 3-26-2014.



NO CLAIM IS MADE TO THE EXCLUSIVE RIGHT TO USE "TECHNOLOGY", APART FROM THE MARK AS SHOWN.

THE MARK CONSISTS OF FIVE SLANTED LINES FOLLOWED BY THE WORDING "POTTER'S TECHNOLOGY" IN STYLIZED LETTERS.

### CLASS 8—HAND TOOLS

FOR ELECTRIC HAIR STRAIGHTENER; ELECTRIC HAIR STRAIGHTENING IRONS; HAIR CUTTING SCISSORS (U.S. CLS. 23, 28 AND 44).

### CLASS 11—ENVIRONMENTAL CONTROL APPARATUS

FOR ELECTRIC HAIR DRYERS (U.S. CLS. 13, 21, 23, 31 AND 34).

CHARLOTTE CORWIN, EXAMINING ATTORNEY

SN 86-232,782. TED DREWES, INC., ST. LOUIS, MO. FILED 3-26-2014.



OWNER OF U.S. REG. NOS. 2,830,152 AND 2,897,174.  
NO CLAIM IS MADE TO THE EXCLUSIVE RIGHT TO USE "FROZEN CUSTARD", APART FROM THE MARK AS SHOWN.

THE NAME "TED DREWES" IDENTIFIES A LIVING INDIVIDUAL WHOSE CONSENT IS OF RECORD.

THE MARK CONSISTS OF THE WORDS "TED DREWES FROZEN CUSTARD" IN STYLIZED LETTERING PLACED UNDERNEATH THE DESIGN OF A ICICLE-LADEN ROOF.

### CLASS 30—STAPLE FOODS

FOR FROZEN CUSTARDS (U.S. CL. 46).  
FIRST USE 12-31-1988; IN COMMERCE 12-31-1988.

### CLASS 35—ADVERTISING AND BUSINESS

FOR RETAIL STORE SERVICES FEATURING FROZEN CUSTARD DESSERTS FOR CONSUMPTION ON OR OFF THE PREMISES (U.S. CLS. 100, 101 AND 102).

FIRST USE 12-31-1988; IN COMMERCE 12-31-1988.  
CATHERINE TARCU, EXAMINING ATTORNEY

SN 86-232,831. MEDICATION CONTROL SYSTEMS, LLC,  
RICHMOND, VA. FILED 3-26-2014.

# PILLPOD

THE MARK CONSISTS OF STANDARD CHARACTERS WITHOUT CLAIM TO ANY PARTICULAR FONT, STYLE, SIZE, OR COLOR.

## CLASS 9—ELECTRICAL AND SCIENTIFIC APPARATUS

FOR ELECTRONIC AUTOMATED PILL DISPENSERS TO ASSIST AND SUPPORT COMPLIANCE WITH MEDICATION TREATMENT REGIMENS, NAMELY, ELECTRONIC PROGRAMMABLE MEDICATION PILL DISPENSERS WITH SECURE ACCESSING, MONITORING, REMINDING, MESSAGING, AND REPORTING FEATURES (U.S. CLS. 21, 23, 26, 36 AND 38).

## CLASS 38—COMMUNICATION

FOR ELECTRONIC TRANSMISSION OF MESSAGES TO HELP PATIENTS COMPLY WITH MEDICATION TREATMENT REGIMENS (U.S. CLS. 100, 101 AND 104).

## CLASS 44—MEDICAL, BEAUTY AND AGRICULTURAL SERVICES

FOR INTERACTIVE MEDICAL MONITORING AND ALERT SERVICE VIA ELECTRONIC WIRELESS DEVICES TO HELP PATIENTS COMPLY WITH MEDICATION TREATMENT REGIMENS, INCLUDING FOR REMINDING PATIENTS OF MEDICAL DOSAGES (U.S. CLS. 100 AND 101).  
ZHALEH DELANEY, EXAMINING ATTORNEY

SN 86-232,922. MEDICATION CONTROL SYSTEMS, LLC,  
RICHMOND, VA. FILED 3-26-2014.

# MULTIPOD

THE MARK CONSISTS OF STANDARD CHARACTERS WITHOUT CLAIM TO ANY PARTICULAR FONT, STYLE, SIZE, OR COLOR.

## CLASS 9—ELECTRICAL AND SCIENTIFIC APPARATUS

FOR ELECTRONIC AUTOMATED PILL DISPENSERS TO ASSIST AND SUPPORT COMPLIANCE WITH MEDICATION TREATMENT REGIMENS, NAMELY, ELECTRONIC PROGRAMMABLE MEDICATION PILL DISPENSERS WITH SECURE ACCESSING, MONITORING, REMINDING, MESSAGING, AND REPORTING FEATURES (U.S. CLS. 21, 23, 26, 36 AND 38).

## CLASS 38—COMMUNICATION

FOR ELECTRONIC TRANSMISSION OF MESSAGES TO HELP PATIENTS COMPLY WITH MEDICATION TREATMENT REGIMENS (U.S. CLS. 100, 101 AND 104).

## CLASS 44—MEDICAL, BEAUTY AND AGRICULTURAL SERVICES

FOR INTERACTIVE MEDICAL MONITORING AND ALERT SERVICE VIA ELECTRONIC WIRELESS DEVICES TO HELP PATIENTS COMPLY WITH MEDICATION TREATMENT REGIMENS, INCLUDING FOR REMINDING PATIENTS OF MEDICAL DOSAGES (U.S. CLS. 100 AND 101).  
ZHALEH DELANEY, EXAMINING ATTORNEY

SN 86-233,202. MILLER, MICHAEL, DENVER, CO. FILED 3-26-2014.

# Urban Brain

THE MARK CONSISTS OF STANDARD CHARACTERS WITHOUT CLAIM TO ANY PARTICULAR FONT, STYLE, SIZE, OR COLOR.

## CLASS 35—ADVERTISING AND BUSINESS

FOR CUSTOM WRITING OF COPY AND TEXT FOR ADVERTISING AND MARKETING PURPOSES (U.S. CLS. 100, 101 AND 102).  
FIRST USE 8-17-2006; IN COMMERCE 1-1-2008.

## CLASS 41—EDUCATION AND ENTERTAINMENT

FOR FILM PRODUCTION; WRITING OF SCREENPLAYS FOR NON-ADVERTISING PURPOSES; WRITING SERVICES FOR OTHERS FOR NON-ADVERTISING PURPOSES (U.S. CLS. 100, 101 AND 107).  
FIRST USE 8-17-2006; IN COMMERCE 1-1-2008.  
KRISTINA MORRIS, EXAMINING ATTORNEY

SN 86-233,312. FOOTPRINTS MD, INC., SAN DIEGO, CA.  
FILED 3-26-2014.

# GLOGGER

THE MARK CONSISTS OF STANDARD CHARACTERS WITHOUT CLAIM TO ANY PARTICULAR FONT, STYLE, SIZE, OR COLOR.

## CLASS 9—ELECTRICAL AND SCIENTIFIC APPARATUS

FOR DOWNLOADABLE SOFTWARE IN THE NATURE OF A MOBILE APPLICATION FEATURING GEO-FENCING AND LOCATION-BASED NOTIFICATIONS FOR OPTIMIZING THE EFFECTIVENESS OF FIELD REPRESENTATIVE EFFORTS (U.S. CLS. 21, 23, 26, 36 AND 38).

**CLASS 42—SCIENTIFIC AND COMPUTER SERVICES**

FOR PROVIDING A SECURE ELECTRONIC ONLINE SYSTEM FEATURING TECHNOLOGY WHICH ALLOWS FOR MONITORING AND MEASURING FIELD REPRESENTATIVE ACTIVITIES AND EFFECTIVENESS VIA THE WEB AND COMMUNICATING WITH FIELD REPRESENTATIVES (U.S. CLS. 100 AND 101).  
JOHN SCHUYLER YARD, EXAMINING ATTORNEY

SN 86-233,620. ROKA CAPITAL, LLC, NORTH BETHESDA, MD. FILED 3-27-2014.

**THE ART OF INCOME**

THE MARK CONSISTS OF STANDARD CHARACTERS WITHOUT CLAIM TO ANY PARTICULAR FONT, STYLE, SIZE, OR COLOR.

NO CLAIM IS MADE TO THE EXCLUSIVE RIGHT TO USE "INCOME", APART FROM THE MARK AS SHOWN.

SN 86-233,543. GALLERY SALONS, L.L.C., NEWTON, MA. FILED 3-27-2014.

**GALLERY SALONS**

THE MARK CONSISTS OF STANDARD CHARACTERS WITHOUT CLAIM TO ANY PARTICULAR FONT, STYLE, SIZE, OR COLOR.

NO CLAIM IS MADE TO THE EXCLUSIVE RIGHT TO USE "SALONS", APART FROM THE MARK AS SHOWN.

**CLASS 36—INSURANCE AND FINANCIAL**

FOR FINANCIAL INVESTMENT BROKERAGE SERVICES; FINANCIAL RESEARCH; FINANCIAL INFORMATION AND EVALUATIONS; FINANCIAL FORECASTING; FINANCIAL ASSET MANAGEMENT; FINANCIAL ANALYSIS AND CONSULTATION (U.S. CLS. 100, 101 AND 102).

**CLASS 41—EDUCATION AND ENTERTAINMENT**

FOR EDUCATIONAL SERVICES, NAMELY, CONDUCTING CLASSES, CONFERENCES, SEMINARS AND WORKSHOPS IN THE FIELD OF FINANCE AND THE DISTRIBUTION OF PRINTED MATERIALS IN CONNECTION THEREWITH (U.S. CLS. 100, 101 AND 107).

SUZANNE BLANE, EXAMINING ATTORNEY

**CLASS 36—INSURANCE AND FINANCIAL**

FOR LEASING OF FULLY-EQUIPPED BEAUTY SALON SUITES IN A MULTI-SALON SETTING TO HAIR-STYLISTS, COSMETOLOGISTS, BARBERS, NAIL TECHNICIANS, AESTHETICIANS, MASSAGE THERAPISTS AND OTHER LICENSED BEAUTY PROFESSIONALS (U.S. CLS. 100, 101 AND 102).

**CLASS 44—MEDICAL, BEAUTY AND AGRICULTURAL SERVICES**

FOR BEAUTY SALON SERVICES (U.S. CLS. 100 AND 101).

ROSELLE HERRERA, EXAMINING ATTORNEY

SN 86-233,704. STILA STYLES, LLC, GLENDALE, CA. FILED 3-27-2014.

SN 86-233,597. HJC CONSULTING, INC., STUART, FL. FILED 3-27-2014.

**HOW BIG IS YOUR BRAVE**

THE MARK CONSISTS OF STANDARD CHARACTERS WITHOUT CLAIM TO ANY PARTICULAR FONT, STYLE, SIZE, OR COLOR.

**CLASS 16—PAPER GOODS AND PRINTED MATTER**

FOR STICKERS (U.S. CLS. 2, 5, 22, 23, 29, 37, 38 AND 50).

FIRST USE 3-15-2014; IN COMMERCE 3-15-2014.

**CLASS 25—CLOTHING**

FOR SHIRTS (U.S. CLS. 22 AND 39).

FIRST USE 3-15-2014; IN COMMERCE 3-15-2014.  
SEAN CROWLEY, EXAMINING ATTORNEY

**CLASS 3—COSMETICS AND CLEANING PREPARATIONS**

FOR COSMETICS; MAKE-UP; NON-MEDICATED SKINCARE PREPARATIONS; NAIL ENAMELS; HAIR CARE PREPARATIONS; FRAGRANCES (U.S. CLS. 1, 4, 6, 50, 51 AND 52).

**CLASS 14—JEWELRY**

FOR JEWELRY (U.S. CLS. 2, 27, 28 AND 50).



THE MARK CONSISTS OF 3 STYLIZED AND CONNECTED "S".



**CLASS 18—LEATHER GOODS**

FOR COSMETIC BAGS SOLD EMPTY; COSMETIC CASES SOLD EMPTY (U.S. CLS. 1, 2, 3, 22 AND 41).

**CLASS 21—HOUSEWARES AND GLASS**

FOR COSMETIC BRUSHES; COMPACTS SOLD EMPTY (U.S. CLS. 2, 13, 23, 29, 30, 33, 40 AND 50).

**CLASS 35—ADVERTISING AND BUSINESS**

FOR ON-LINE RETAIL STORE SERVICES FEATURING COSMETICS, MAKE-UP, NON-MEDICATED SKINCARE PREPARATIONS, NAIL ENAMELS, HAIR CARE PREPARATIONS, FRAGRANCES, JEWELRY, COSMETIC BAGS SOLD EMPTY, COSMETIC CASES SOLD EMPTY, COSMETIC BRUSHES AND COMPACTS SOLD EMPTY; RETAIL STORE SERVICES FEATURING COSMETICS, MAKE-UP, NON-MEDICATED SKINCARE PREPARATIONS, NAIL ENAMELS, HAIR CARE PREPARATIONS, FRAGRANCES, JEWELRY, COSMETIC BAGS SOLD EMPTY, COSMETIC CASES SOLD EMPTY, COSMETIC BRUSHES AND COMPACTS SOLD EMPTY (U.S. CLS. 100, 101 AND 102).

**CLASS 44—MEDICAL, BEAUTY AND AGRICULTURAL SERVICES**

FOR BEAUTY CONSULTATION SERVICES; PROVIDING INFORMATION ABOUT BEAUTY (U.S. CLS. 100 AND 101).

HEATHER THOMPSON, EXAMINING ATTORNEY

**CLASS 35—ADVERTISING AND BUSINESS**

FOR ON-LINE RETAIL STORE SERVICES FEATURING COSMETICS, MAKE-UP, NON-MEDICATED SKINCARE PREPARATIONS, NAIL ENAMELS, HAIR CARE PREPARATIONS, FRAGRANCES, COSMETIC BAGS SOLD EMPTY, COSMETIC CASES SOLD EMPTY, COSMETIC BRUSHES AND COMPACTS SOLD EMPTY; RETAIL STORE SERVICES FEATURING COSMETICS, MAKE-UP, NON-MEDICATED SKINCARE PREPARATIONS, NAIL ENAMELS, HAIR CARE PREPARATIONS, FRAGRANCES, COSMETIC BAGS SOLD EMPTY, COSMETIC CASES SOLD EMPTY, COSMETIC BRUSHES AND COMPACTS SOLD EMPTY (U.S. CLS. 100, 101 AND 102).

FIRST USE 2-5-2001; IN COMMERCE 2-5-2001.

**CLASS 44—MEDICAL, BEAUTY AND AGRICULTURAL SERVICES**

FOR BEAUTY CONSULTATION SERVICES; PROVIDING INFORMATION ABOUT BEAUTY (U.S. CLS. 100 AND 101).

FIRST USE 2-5-2001; IN COMMERCE 2-5-2001.

HEATHER THOMPSON, EXAMINING ATTORNEY

SN 86-233,774. STILA STYLES, LLC, GLENDALE, CA. FILED 3-27-2014.

SN 86-233,727. STILA STYLES, LLC, GLENDALE, CA. FILED 3-27-2014.

stila

STILA

OWNER OF U.S. REG. NOS. 2,024,328, 2,565,973 AND OTHERS.

THE MARK CONSISTS OF THE LETTERS "STILA" IN STYLIZED FORM.

THE MARK CONSISTS OF STANDARD CHARACTERS WITHOUT CLAIM TO ANY PARTICULAR FONT, STYLE, SIZE, OR COLOR.

OWNER OF U.S. REG. NOS. 2,024,328, 2,565,973 AND OTHERS.

**CLASS 3—COSMETICS AND CLEANING PREPARATIONS**

FOR COSMETICS; MAKE-UP; NON-MEDICATED SKINCARE PREPARATIONS; NAIL ENAMELS; HAIR CARE PREPARATIONS; FRAGRANCES (U.S. CLS. 1, 4, 6, 50, 51 AND 52).

FIRST USE 11-1-1994; IN COMMERCE 11-1-1994.

**CLASS 3—COSMETICS AND CLEANING PREPARATIONS**

FOR COSMETICS; MAKE-UP; NON-MEDICATED SKINCARE PREPARATIONS; NAIL ENAMELS; HAIR CARE PREPARATIONS; FRAGRANCES (U.S. CLS. 1, 4, 6, 50, 51 AND 52).

FIRST USE 11-1-1994; IN COMMERCE 11-1-1994.

**CLASS 18—LEATHER GOODS**

FOR COSMETIC BAGS SOLD EMPTY; COSMETIC CASES SOLD EMPTY (U.S. CLS. 1, 2, 3, 22 AND 41).

FIRST USE 11-0-1996; IN COMMERCE 11-0-1996.

**CLASS 18—LEATHER GOODS**

FOR COSMETIC BAGS SOLD EMPTY; COSMETIC CASES SOLD EMPTY (U.S. CLS. 1, 2, 3, 22 AND 41).

FIRST USE 11-0-1996; IN COMMERCE 11-0-1996.

**CLASS 21—HOUSEWARES AND GLASS**

FOR COSMETIC BRUSHES; COMPACTS SOLD EMPTY (U.S. CLS. 2, 13, 23, 29, 30, 33, 40 AND 50).

FIRST USE 8-0-1996; IN COMMERCE 8-0-1996.

**CLASS 21—HOUSEWARES AND GLASS**

FOR COSMETIC BRUSHES; COMPACTS SOLD EMPTY (U.S. CLS. 2, 13, 23, 29, 30, 33, 40 AND 50).

FIRST USE 8-0-1996; IN COMMERCE 8-0-1996.

**CLASS 35—ADVERTISING AND BUSINESS**

FOR ON-LINE RETAIL STORE SERVICES FEATURING COSMETICS, MAKE-UP, NON-MEDICATED SKINCARE PREPARATIONS, NAIL ENAMELS, HAIR CARE PREPARATIONS, FRAGRANCES, COSMETIC BAGS SOLD EMPTY, COSMETIC CASES SOLD EMPTY, COSMETIC BRUSHES AND COMPACTS SOLD EMPTY; RETAIL STORE SERVICES FEATURING COSMETICS, MAKE-UP, NON-MEDICATED SKINCARE PREPARATIONS, NAIL ENAMELS, HAIR CARE PREPARATIONS, FRAGRANCES, COSMETIC BAGS SOLD EMPTY, COSMETIC CASES SOLD EMPTY, COSMETIC BRUSHES AND COMPACTS SOLD EMPTY (U.S. CLS. 100, 101 AND 102).

FIRST USE 2-5-2001; IN COMMERCE 2-5-2001.

**CLASS 44—MEDICAL, BEAUTY AND AGRICULTURAL SERVICES**

FOR BEAUTY CONSULTATION SERVICES; PROVIDING INFORMATION ABOUT BEAUTY (U.S. CLS. 100 AND 101).

FIRST USE 2-5-2001; IN COMMERCE 2-5-2001.

HEATHER THOMPSON, EXAMINING ATTORNEY

**CLASS 35—ADVERTISING AND BUSINESS**

FOR ON-LINE RETAIL STORE SERVICES FEATURING COSMETICS, MAKE-UP, NON-MEDICATED SKINCARE PREPARATIONS, NAIL ENAMELS, HAIR CARE PREPARATIONS, FRAGRANCES, JEWELRY, COSMETIC BAGS SOLD EMPTY, COSMETIC CASES SOLD EMPTY, COSMETIC BRUSHES AND COMPACTS SOLD EMPTY; RETAIL STORE SERVICES FEATURING COSMETICS, MAKE-UP, NON-MEDICATED SKINCARE PREPARATIONS, NAIL ENAMELS, HAIR CARE PREPARATIONS, FRAGRANCES, JEWELRY, COSMETIC BAGS SOLD EMPTY, COSMETIC CASES SOLD EMPTY, COSMETIC BRUSHES AND COMPACTS SOLD EMPTY (U.S. CLS. 100, 101 AND 102).

**CLASS 44—MEDICAL, BEAUTY AND AGRICULTURAL SERVICES**

FOR BEAUTY CONSULTATION SERVICES; PROVIDING INFORMATION ABOUT BEAUTY (U.S. CLS. 100 AND 101).

HEATHER THOMPSON, EXAMINING ATTORNEY

SN 86-233,811. STILA STYLES, LLC, GLENDALE, CA. FILED 3-27-2014.



THE COLOR(S) ROSE, GOLD AND SILVER IS/ARE CLAIMED AS A FEATURE OF THE MARK.

THE MARK CONSISTS OF 3 STYLIZED AND CONNECTED "S" LETTERS, WITH THE UPPERMOST "S" IN ROSE, THE CENTER "S" IN GOLD AND THE BOTTOM "S" IN SILVER.

**CLASS 3—COSMETICS AND CLEANING PREPARATIONS**

FOR COSMETICS; MAKE-UP; NON-MEDICATED SKINCARE PREPARATIONS; NAIL ENAMELS; HAIR CARE PREPARATIONS; FRAGRANCES (U.S. CLS. 1, 4, 6, 50, 51 AND 52).

**CLASS 14—JEWELRY**

FOR JEWELRY (U.S. CLS. 2, 27, 28 AND 50).

**CLASS 18—LEATHER GOODS**

FOR COSMETIC BAGS SOLD EMPTY; COSMETIC CASES SOLD EMPTY (U.S. CLS. 1, 2, 3, 22 AND 41).

**CLASS 21—HOUSEWARES AND GLASS**

FOR COSMETIC BRUSHES; COMPACTS SOLD EMPTY (U.S. CLS. 2, 13, 23, 29, 30, 33, 40 AND 50).

SN 86-233,820. THROWBACK LEGACY, LTD, WALLED LAKE, MI. FILED 3-27-2014.

**THROWBACK LEGACY**

THE MARK CONSISTS OF STANDARD CHARACTERS WITHOUT CLAIM TO ANY PARTICULAR FONT, STYLE, SIZE, OR COLOR.

**CLASS 14—JEWELRY**

FOR JEWELRY, NAMELY, BRACELETS, ANKLE BRACELETS, NECKLACES, EARRINGS, AND DOG TAGS FOR WEAR BY HUMANS FOR DECORATIVE PURPOSES; HAIR JEWELRY IN THE NATURE OF JEWELRY FOR USE IN THE HAIR; RUBBER OR SILICONE WRISTBANDS IN THE NATURE OF A BRACELET (U.S. CLS. 2, 27, 28 AND 50).

**CLASS 18—LEATHER GOODS**

FOR GYM BAGS, HARD-SIDED AND SOFT-SIDED CARRY-ON BAGS AND GYM BAGS; TOTE BAGS; WHEELED TOTE BAGS; SHOULDER BAGS; BACKPACKS; SACK PACKS, NAMELY, DRAWSTRING BAGS USED AS BACKPACKS; BACKPACKS, BOOK BAGS, SPORTS BAGS, BUM BAGS, WALLETS AND HANDBAGS (U.S. CLS. 1, 2, 3, 22 AND 41).

**CLASS 25—CLOTHING**

FOR CLOTHING, NAMELY, SHIRTS, T-SHIRTS, SWEATSHIRTS, POLO SHIRTS, JERSEYS, TANK-TOPS, SKIRTS, PANTS, SOCKS, SLIPPERS, JACKETS, COATS, HATS, SCARFS, GLOVES, HEADBANDS, HOODS, WRAPS, SWEAT BANDS, AND WRISTBANDS (U.S. CLS. 22 AND 39).

SCOTT BIBB, EXAMINING ATTORNEY

SN 86-233,829. NIC & ZOE COMPANY, NATICK, MA. FILED 3-27-2014.

SN 86-234,114. WORLD RELIEF CORPORATION OF NATIONAL ASSOCIATION OF EVANGELICALS, DBA WORLD RELIEF, BALTIMORE, MD. FILED 3-27-2014.

# NIC+ZOE

THE MARK CONSISTS OF STANDARD CHARACTERS WITHOUT CLAIM TO ANY PARTICULAR FONT, STYLE, SIZE, OR COLOR.

OWNER OF U.S. REG. NO. 3,132,504.

## CLASS 14—JEWELRY

FOR JEWELRY (U.S. CLS. 2, 27, 28 AND 50).

## CLASS 18—LEATHER GOODS

FOR HANDBAGS (U.S. CLS. 1, 2, 3, 22 AND 41).  
WARREN L. OLANDRIA, EXAMINING ATTORNEY

---

SN 86-234,096. CHARLES VIANCIN GROUP, 74650 CHAVANOD, FRANCE, FILED 3-27-2014.

# CHERRY BLOSSOM

THE MARK CONSISTS OF STANDARD CHARACTERS WITHOUT CLAIM TO ANY PARTICULAR FONT, STYLE, SIZE, OR COLOR.

## CLASS 20—FURNITURE AND ARTICLES NOT OTHERWISE CLASSIFIED

FOR SILICONE BOTTLE STOPPERS (U.S. CLS. 2, 13, 22, 25, 32 AND 50).  
FIRST USE 2-0-2014; IN COMMERCE 2-0-2014.

## CLASS 21—HOUSEWARES AND GLASS

FOR REUSABLE SELF-SEALING LIDS FOR HOUSEHOLD USE; REUSABLE SELF-SEALING LIDS FOR BOWLS, CUPS, DRINKS, CONTAINERS AND THE STORAGE OF FOOD; SEALING LIDS FOR COOKING USE; REUSABLE SELF-SEALING COVERS FOR CUPS, DRINKS AND BEVERAGE CONTAINERS; COASTERS NOT OF PAPER AND NOT BEING TABLE LINEN (U.S. CLS. 2, 13, 23, 29, 30, 33, 40 AND 50).

FIRST USE 2-0-2014; IN COMMERCE 2-0-2014.  
JAY FLOWERS, EXAMINING ATTORNEY

# The Justice Conference

THE MARK CONSISTS OF STANDARD CHARACTERS WITHOUT CLAIM TO ANY PARTICULAR FONT, STYLE, SIZE, OR COLOR.

NO CLAIM IS MADE TO THE EXCLUSIVE RIGHT TO USE "CONFERENCE", APART FROM THE MARK AS SHOWN.

## CLASS 35—ADVERTISING AND BUSINESS

FOR CHARITABLE SERVICES, NAMELY, THE RAISING OF AWARENESS OF AND ADVOCATING FOR ASSISTANCE AND AID TO THE VULNERABLE, POOR, AND OPPRESSED PEOPLES NATIONALLY AND GLOBALLY THROUGH THE USE OF AN ANNUAL MULTI-SITE CONFERENCE OF SPEAKERS AND FILMS WHICH DISCUSS AND DEPICT THOSE INDIVIDUALS WITH ATTENDEES (U.S. CLS. 100, 101 AND 102).

FIRST USE 1-11-2010; IN COMMERCE 1-11-2010.

## CLASS 41—EDUCATION AND ENTERTAINMENT

FOR EDUCATIONAL SERVICES, NAMELY, THE FACILITATION AND PRESENTATION OF AN ANNUAL MULTI-SITE CONFERENCE OF SPEAKERS AND FILMS DISCUSSING AND DEPICTING THE PLIGHT OF THE VULNERABLE, POOR, AND OPPRESSED ON THE NATIONAL AND GLOBAL LEVEL (U.S. CLS. 100, 101 AND 107).

FIRST USE 1-11-2010; IN COMMERCE 1-11-2010.  
AISHA CLARKE, EXAMINING ATTORNEY

---

SN 86-234,174. MADE IN SPACE, INC., MOFFET FIELD, CA. FILED 3-27-2014.

# MADE IN

THE MARK CONSISTS OF STANDARD CHARACTERS WITHOUT CLAIM TO ANY PARTICULAR FONT, STYLE, SIZE, OR COLOR.

OWNER OF U.S. REG. NO. 4,552,331.

## CLASS 9—ELECTRICAL AND SCIENTIFIC APPARATUS

FOR THREE DIMENSIONAL (3D) PRINTERS; SATELLITE COMPONENTS AND PORTIONS THEREOF, NAMELY, SATELLITE DISHES, TRANSMITTERS, RECEIVERS, BUS COMPONENTS, AND SATELLITE STRUCTURAL COMPONENTS; SOFTWARE FOR FACILITATING THE DOWNLOADING, MODIFICATION AND SHARING OF THREE DIMENSIONAL DESIGNS FOR USE IN CONNECTION WITH THREE DIMENSIONAL PRINTERS; AUTOMATED PROCESSORS OF THREE DIMENSIONAL (3D) PRINTER FEEDSTOCK; SPACE-BASED ADDITIVE MANUFACTURING DEVICES (U.S. CLS. 21, 23, 26, 36 AND 38).

**CLASS 40—MATERIAL TREATMENT**

FOR FABRICATION AND FINISHING SERVICES, NAMELY, PLASTIC, POLYMER, COMPOSITE AND METAL FABRICATION AND POST PRODUCTION FINISHING OF PARTS, JIGS, FIXTURES, TOOLS, COLLECTIBLES, MEMORABILIA, COMPUTER PERIPHERALS AND COMPUTER EQUIPMENT (U.S. CLS. 100, 103 AND 106).

ROBIN CHOSID, EXAMINING ATTORNEY

SN 86-234,329. MADE IN SPACE, INC., MOFFET FIELD, CA. FILED 3-27-2014.

**MADE  
IN**

OWNER OF U.S. REG. NO. 4,552,331.  
THE MARK CONSISTS OF THE WORDS "MADE" AND "IN" IN A STYLIZED FONT, THE FIRST VERTICAL ARM OF THE "M" OF "MADE" BEING CONNECTED TO THE "I" OF "IN".

**CLASS 9—ELECTRICAL AND SCIENTIFIC APPARATUS**

FOR THREE DIMENSIONAL (3D) PRINTERS; SATELLITE COMPONENTS AND PORTIONS THEREOF, NAMELY, SATELLITE DISHES, TRANSMITTERS, RECEIVERS, BUS COMPONENTS, AND SATELLITE STRUCTURAL COMPONENTS; SOFTWARE FOR FACILITATING THE DOWNLOADING, MODIFICATION AND SHARING OF THREE DIMENSIONAL DESIGNS FOR USE IN CONNECTION WITH THREE DIMENSIONAL PRINTERS; AUTOMATED PROCESSORS OF THREE DIMENSIONAL (3D) PRINTER FEEDSTOCK; SPACE-BASED ADDITIVE MANUFACTURING DEVICES (U.S. CLS. 21, 23, 26, 36 AND 38).

**CLASS 40—MATERIAL TREATMENT**

FOR FABRICATION AND FINISHING SERVICES, NAMELY, PLASTIC, POLYMER, COMPOSITE AND METAL FABRICATION AND POST PRODUCTION FINISHING OF PARTS, JIGS, FIXTURES, TOOLS, COLLECTIBLES, MEMORABILIA, COMPUTER PERIPHERALS AND COMPUTER EQUIPMENT (U.S. CLS. 100, 103 AND 106).

ROBIN CHOSID, EXAMINING ATTORNEY

SN 86-234,394. BULL CREST LLC, NEW YORK, NY. FILED 3-27-2014.



THE MARK CONSISTS OF A SIDEWAYS-FACING BUCKLING BULL OUTLINED IN BLACK AND CENTERED OVER A HORIZONTAL LINE WHICH IS BISECTED BY THE BULL'S REAR LEGS. THE WORDS "BULL CREST" ARE CENTERED OVER THE WORDS "RISE HIGHER", WHICH ARE CENTERED OVER A HORIZONTAL LINE.

**CLASS 6—METAL GOODS**

FOR METAL KEY CHAINS (U.S. CLS. 2, 12, 13, 14, 23, 25 AND 50).

**CLASS 14—JEWELRY**

FOR KEY CHAINS OF PRECIOUS METAL (U.S. CLS. 2, 27, 28 AND 50).

**CLASS 18—LEATHER GOODS**

FOR ATHLETIC BAGS; IMITATION LEATHER KEY CHAINS; LEATHER KEY CHAINS; LUGGAGE (U.S. CLS. 1, 2, 3, 22 AND 41).

**CLASS 20—FURNITURE AND ARTICLES NOT OTHERWISE CLASSIFIED**

FOR NON-METAL AND NON-LEATHER KEY CHAINS; PLASTIC KEY CHAINS (U.S. CLS. 2, 13, 22, 25, 32 AND 50).

**CLASS 25—CLOTHING**

FOR ATHLETIC SHORTS; ATHLETIC UNIFORMS; COATS; GLOVES; HATS; JACKETS; SOCKS; SWEATPANTS; SWEATSHIRTS; T-SHIRTS (U.S. CLS. 22 AND 39).

**CLASS 35—ADVERTISING AND BUSINESS**

FOR ON-LINE RETAIL STORE SERVICES FEATURING APPAREL, KEY CHAINS, LUGGAGE AND ATHLETIC BAGS; RETAIL STORE SERVICES FEATURING APPAREL, KEY CHAINS, LUGGAGE AND ATHLETIC BAGS (U.S. CLS. 100, 101 AND 102).

JUDITH HELFMAN, EXAMINING ATTORNEY

SN 86-234,453. WHEELED COACH INDUSTRIES, INC., DBA U.S. AMBULANCE CORPORATION, WINTER PARK, FL. FILED 3-27-2014.



NO CLAIM IS MADE TO THE EXCLUSIVE RIGHT TO USE "U.S. AMBULANCE CORPORATION", APART FROM THE MARK AS SHOWN.

THE MARK CONSISTS OF AN IMAGE OF AN AMBULANCE WHICH INCLUDES A WAVING FLAG DESIGN WITH THE WORDS "U.S. AMBULANCE CORPORATION" UNDERNEATH THE IMAGE.

**CLASS 12—VEHICLES**

FOR AMBULANCES, AUTOMOBILES, TRUCKS AND VANS FOR HEALTHCARE, EMERGENCY AND RESCUE TRANSPORTATION; TELECOMMUNICATIONS VEHICLES IN THE NATURE OF AMBULANCES, AUTOMOBILES, TRUCKS AND VANS FOR HEALTHCARE, EMERGENCY AND RESCUE TRANSPORTATION (U.S. CLS. 19, 21, 23, 31, 35 AND 44).

**CLASS 35—ADVERTISING AND BUSINESS**

FOR WHOLESALE DISTRIBUTORSHIP SERVICES FOR AMBULANCES, AUTOMOBILES, TRUCKS, VANS AND TELECOMMUNICATIONS VEHICLES FOR HEALTHCARE, EMERGENCY AND RESCUE TRANSPORTATION (U.S. CLS. 100, 101 AND 102).

FIRST USE 9-1-2013; IN COMMERCE 9-1-2013.

**CLASS 37—CONSTRUCTION AND REPAIR**

FOR MAINTENANCE AND REPAIR OF AMBULANCES, AUTOMOBILES, TRUCKS, VANS AND TELECOMMUNICATIONS VEHICLES FOR HEALTH CARE, EMERGENCY AND RESCUE TRANSPORTATION, AND AUTOMOTIVE CONVERSION SERVICES, NAMELY, INSTALLING SPECIALTY AUTOMOTIVE EQUIPMENT IN POLICE AUTOMOBILES (U.S. CLS. 100, 103 AND 106).

**CLASS 40—MATERIAL TREATMENT**

FOR CUSTOM MANUFACTURING OF AMBULANCES, AUTOMOBILES, TRUCKS, VANS AND TELECOMMUNICATIONS VEHICLES FOR HEALTHCARE, EMERGENCY AND RESCUE TRANSPORTATION (U.S. CLS. 100, 103 AND 106).

FIRST USE 9-1-2013; IN COMMERCE 9-1-2013.  
JAMES LOVELACE, EXAMINING ATTORNEY

**CLASS 41—EDUCATION AND ENTERTAINMENT**

FOR EDUCATIONAL SERVICES, NAMELY, THE FACILITATION AND PRESENTATION OF AN ANNUAL MULTI-SITE CONFERENCE OF SPEAKERS AND FILMS DISCUSSING AND DEPICTING THE PLIGHT OF THE VULNERABLE, POOR, AND OPPRESSED ON THE NATIONAL AND GLOBAL LEVEL (U.S. CLS. 100, 101 AND 107).

FIRST USE 1-11-2010; IN COMMERCE 1-11-2010.  
AISHA CLARKE, EXAMINING ATTORNEY

SN 86-234,681. BAKERCORP, SEAL BEACH, CA. FILED 3-27-2014.

SN 86-234,576. WORLD RELIEF CORPORATION OF NATIONAL ASSOCIATION OF EVANGELICALS, DBA WORLD RELIEF, BALTIMORE, MD. FILED 3-27-2014.



NO CLAIM IS MADE TO THE EXCLUSIVE RIGHT TO USE "CONFERENCE", APART FROM THE MARK AS SHOWN.

THE COLOR(S) RED AND BLACK IS/ARE CLAIMED AS A FEATURE OF THE MARK.

THE MARK CONSISTS OF A RED FLOWER WITH A BLACK OUTLINE WHICH CONSISTS OF ONE FLOWER AND A SECOND BULB JUST BELOW AND TO THE LEFT OF THE FLOWER. TO THE RIGHT AND BELOW OF THE FLOWER IS A STEM ARM WHICH TAKES THE APPEARANCE OF A PIECE OF BARBED WIRE. THE FLOWER STEM CHANGES INTO A STRING OF BARBED WIRE WHICH LOOPS OVER ITSELF FROM THE LEFT TO THE RIGHT AND ENDS IN A SECOND INCOMPLETE LOOP DIRECTLY BELOW THE FLOWER. UNDER THE FLOWER AND THE WORD "THE" IS IMPRINTED VERTICALLY IN BLACK CAPITAL LETTERS. IMMEDIATELY TO ITS RIGHT AND AT THE SAME SIZE IS THE WORD "JUSTICE" IN THE SAME BLACK CAPITAL LETTERS BUT IN A FONT SIZE EQUAL TO THE HEIGHT OF THE VERTICAL "THE". IMMEDIATELY BELOW THE PHRASE "THE JUSTICE" IS THE WORD "CONFERENCE" IN BLACK CAPITAL LETTERS.

**CLASS 35—ADVERTISING AND BUSINESS**

FOR CHARITABLE SERVICES, NAMELY, THE RAISING OF AWARENESS AND ADVOCATING FOR ASSISTANCE AND AID TO THE VULNERABLE, POOR, AND OPPRESSED PEOPLES NATIONALLY AND GLOBALLY THROUGH THE USE OF AN ANNUAL MULTI-SITE CONFERENCE OF SPEAKERS AND FILMS WHICH DISCUSS AND DEPICT THOSE INDIVIDUALS WITH ATTENDEES (U.S. CLS. 100, 101 AND 102).

FIRST USE 1-11-2010; IN COMMERCE 1-11-2010.

**BAKERMOD**

THE MARK CONSISTS OF STANDARD CHARACTERS WITHOUT CLAIM TO ANY PARTICULAR FONT, STYLE, SIZE, OR COLOR.

OWNER OF U.S. REG. NOS. 3,165,824, 4,186,968 AND 4,338,919.

**CLASS 6—METAL GOODS**

FOR METAL STORAGE TANKS FOR INDUSTRIAL USE (U.S. CLS. 2, 12, 13, 14, 23, 25 AND 50).

**CLASS 20—FURNITURE AND ARTICLES NOT OTHERWISE CLASSIFIED**

FOR NON-METAL STORAGE TANKS FOR INDUSTRIAL USE (U.S. CLS. 2, 13, 22, 25, 32 AND 50).  
TARAH HARDY, EXAMINING ATTORNEY

SN 86-234,718. BLAIR, JOHN, GRANITE BAY, CA. FILED 3-27-2014.

**PURE PRIDE**

THE MARK CONSISTS OF STANDARD CHARACTERS WITHOUT CLAIM TO ANY PARTICULAR FONT, STYLE, SIZE, OR COLOR.

NO CLAIM IS MADE TO THE EXCLUSIVE RIGHT TO USE "PURE", APART FROM THE MARK AS SHOWN.

**CLASS 32—LIGHT BEVERAGES**

FOR BEER (U.S. CLS. 45, 46 AND 48).

**CLASS 33—WINES AND SPIRITS**

FOR ALCOHOLIC BEVERAGES EXCLUDING BEER; DISTILLED SPIRITS; WINE (U.S. CLS. 47 AND 49).  
ROBIN CHOSID, EXAMINING ATTORNEY

SN 86-234,729. W&W NURSERY & LANDSCAPING, INC.,  
APALACHIN, NY. FILED 3-27-2014.

## The Street Smart Gardener

THE MARK CONSISTS OF STANDARD CHARACTERS WITHOUT CLAIM TO ANY PARTICULAR FONT, STYLE, SIZE, OR COLOR.

NO CLAIM IS MADE TO THE EXCLUSIVE RIGHT TO USE "GARDENER", APART FROM THE MARK AS SHOWN.

### CLASS 41—EDUCATION AND ENTERTAINMENT

FOR EDUCATION SERVICES, NAMELY, PROVIDING A WEBSITE FEATURING ON-LINE NON-DOWNLOADABLE VIDEOS IN THE FIELD OF GARDENING AND THE LIFESTYLES OF GARDENING; EDUCATIONAL AND ENTERTAINMENT SERVICES, NAMELY, A CONTINUING PROGRAM ABOUT GARDENING AND THE LIFESTYLES OF GARDENING ACCESSIBLE BY MEANS OF VIDEO, PODCASTS, WEBISODES AND WEB-BASED APPLICATIONS; PROVIDING A WEB SITE FEATURING NON-DOWNLOADABLE INSTRUCTIONAL VIDEOS IN THE FIELD OF GARDENING AND THE LIFESTYLES OF GARDENING; PROVIDING ON-LINE VIDEOS FEATURING GARDENING AND THE LIFESTYLES OF GARDENING, NOT DOWNLOADABLE (U.S. CLS. 100, 101 AND 107).

FIRST USE 1-1-2013; IN COMMERCE 1-1-2013.

### CLASS 44—MEDICAL, BEAUTY AND AGRICULTURAL SERVICES

FOR GARDENER AND GARDENING SERVICES; LANDSCAPE GARDENING; PROVIDING INFORMATION ABOUT GARDENING (U.S. CLS. 100 AND 101).

FIRST USE 1-1-2013; IN COMMERCE 1-1-2013.  
AMY C. KEAN, EXAMINING ATTORNEY

SN 86-234,778. BILLS.COM, LLC, SAN MATEO, CA. FILED 3-27-2014.

## THE EASYLOAN SITE

THE MARK CONSISTS OF STANDARD CHARACTERS WITHOUT CLAIM TO ANY PARTICULAR FONT, STYLE, SIZE, OR COLOR.

NO CLAIM IS MADE TO THE EXCLUSIVE RIGHT TO USE "SITE", APART FROM THE MARK AS SHOWN.

### CLASS 35—ADVERTISING AND BUSINESS

FOR CONNECTING BUYERS AND SELLERS OF MORTGAGES; PROMOTING THE GOODS AND SERVICES OF OTHERS BY PROVIDING A WEBSITE FEATURING PRICE-COMPARISON INFORMATION, PRODUCT AND SERVICE REVIEWS, AND LINKS TO THE RETAIL WEBSITES OF OTHERS; PROVIDING A WEBSITE AND PORTAL WHERE CONSUMERS CAN COMPARISON SHOP FOR PRODUCTS AND SERVICES IN THE FIELDS OF PERSONAL FINANCE AND MORTGAGES (U.S. CLS. 100, 101 AND 102).

FIRST USE 2-8-2007; IN COMMERCE 2-8-2007.

### CLASS 36—INSURANCE AND FINANCIAL

FOR PROVIDING A WEBSITE AND PORTAL FEATURING NEWS AND INFORMATION IN THE FIELDS OF PERSONAL FINANCE AND MORTGAGES; PROVIDING A WEBSITE AND PORTAL WHERE CONSUMERS CAN LEARN ABOUT FINANCIAL ISSUES; FINANCIAL INFORMATION SERVICES, NAMELY, PROVIDING INFORMATION IN RESPONSE TO QUERIES BY CONSUMERS VIA A GLOBAL COMPUTER NETWORK (U.S. CLS. 100, 101 AND 102).

FIRST USE 2-8-2007; IN COMMERCE 2-8-2007.

### CLASS 42—SCIENTIFIC AND COMPUTER SERVICES

FOR PERSONAL FINANCE AND BUDGETING TOOLS, NAMELY, PROVIDING TEMPORARY USE OF A WEB-BASED SOFTWARE APPLICATION FOR USE IN PERSONAL FINANCE (U.S. CLS. 100 AND 101).

FIRST USE 2-8-2007; IN COMMERCE 2-8-2007.

REBECCA POVARCHUK, EXAMINING ATTORNEY

SN 86-234,794. TWO VIEW ART CORP., LYNBROOK, NY.  
FILED 3-27-2014.

## TWO VIEW ART

THE MARK CONSISTS OF STANDARD CHARACTERS WITHOUT CLAIM TO ANY PARTICULAR FONT, STYLE, SIZE, OR COLOR.

NO CLAIM IS MADE TO THE EXCLUSIVE RIGHT TO USE "ART", APART FROM THE MARK AS SHOWN.

### CLASS 16—PAPER GOODS AND PRINTED MATTER

FOR FRAMED ART PICTURES; FRAMED ART PRINTS; LENTICULAR PRINTS; VIGNOLA ANAMORPHOSIS PRINTS (U.S. CLS. 2, 5, 22, 23, 29, 37, 38 AND 50).

### CLASS 35—ADVERTISING AND BUSINESS

FOR ONLINE RETAIL STORE SERVICES FEATURING FRAMED ART AND PRINTS (U.S. CLS. 100, 101 AND 102).

CHRISTOPHER LAW, EXAMINING ATTORNEY

SN 86-234,801. TWO VIEW ART CORP., LYNBROOK, NY.  
FILED 3-27-2014.



NO CLAIM IS MADE TO THE EXCLUSIVE RIGHT TO USE "ART", APART FROM THE MARK AS SHOWN.

THE COLOR(S) GRAY, BROWN AND WHITE IS/ARE CLAIMED AS A FEATURE OF THE MARK.

THE MARK CONSISTS OF A SERIES OF CONNECTED RECTANGLES IN THE COLORS GRAY AND BROWN DISPLAYED VERTICALLY WHICH GIVE THE APPEARANCE OF A THREE DIMENSIONAL DISPLAY. IN FRONT OF THE RECTANGLES ARE THE WORDS "TWO VIEW" IN A STYLIZED FONT IN BROWN AT THE TOP AND TRANSITIONING TO WHITE AND THE BOTTOM. IMMEDIATELY TO THE LOWER RIGHT OF THE "W" IN THE WORD "VIEW" IS THE WORD "ART" DISPLAYED IN A SMALLER STYLIZED FONT IN WHITE.

**CLASS 16—PAPER GOODS AND PRINTED MATTER**

FOR FRAMED ART PICTURES; FRAMED ART PRINTS; LENTICULAR PRINTS; VIGNOLA ANAMORPHOSIS PRINTS (U.S. CLS. 2, 5, 22, 23, 29, 37, 38 AND 50).

**CLASS 35—ADVERTISING AND BUSINESS**

FOR ONLINE RETAIL STORE SERVICES FEATURING FRAMED ART AND PRINTS (U.S. CLS. 100, 101 AND 102).

CHRISTOPHER LAW, EXAMINING ATTORNEY

APRIL ROACH, EXAMINING ATTORNEY

SN 86-234,815. H.G. KEIT, LLC, LITTLE NECK, NY. FILED 3-27-2014.

Moving Across Town, Across  
The Country or Around The  
World - We Make Moving  
Easy!

SN 86-234,808. SCOOTER'S COFFEE, LLC, OMAHA, NE. FILED 3-27-2014.



OWNER OF U.S. REG. NOS. 3,182,703, 4,249,693 AND OTHERS.

NO CLAIM IS MADE TO THE EXCLUSIVE RIGHT TO USE "WORLD CLASS COFFEE" AND "EST. 1998", APART FROM THE MARK AS SHOWN.

THE MARK CONSISTS OF OUTER CIRCLE HAVING A SOLID BORDER THAT DISPLAYS THE LITERAL ELEMENT, "WORLD-CLASS COFFEE" AT THE TOP OF THE CIRCLE AND THE LITERAL ELEMENT, "ROOTED IN QUALITY", AT THE BOTTOM OF THE CIRCLE AND THE MARK ALSO CONSISTS OF AN INNER CIRCLE WHICH DEPICTS A STIR STICK AND SPOON, THE LITERAL ELEMENT, "EST. 1998" AND A PARTIALLY ENCLOSED RECTANGLE THAT CONTAINS THE LITERAL ELEMENT, "SCOOTER'S".

**CLASS 35—ADVERTISING AND BUSINESS**

FOR DRIVE-THROUGH RETAIL STORE SERVICES FEATURING COFFEE, SMOOTHIES, AND RELATED GOODS; FRANCHISE SERVICES, NAMELY, OFFERING BUSINESS MANAGEMENT ASSISTANCE IN THE ESTABLISHMENT AND OPERATION OF COFFEE SHOPS AND COFFEEHOUSES (U.S. CLS. 100, 101 AND 102).

FIRST USE 8-0-2013; IN COMMERCE 8-0-2013.

**CLASS 43—HOTEL AND RESTAURANT SERVICES**

FOR RESTAURANT SERVICES; SNACK BAR SERVICES; COFFEE SHOPS; COFFEEHOUSE SERVICES FEATURING COFFEE, SMOOTHIES, AND RELATED GOODS (U.S. CLS. 100 AND 101).

FIRST USE 8-0-2013; IN COMMERCE 8-0-2013.

THE MARK CONSISTS OF STANDARD CHARACTERS WITHOUT CLAIM TO ANY PARTICULAR FONT, STYLE, SIZE, OR COLOR.

**CLASS 35—ADVERTISING AND BUSINESS**

FOR REAL ESTATE ADVERTISING SERVICES; REAL ESTATE RELOCATION SERVICES, NAMELY, EMPLOYEE RELOCATION; REAL ESTATE MOVING AND RELOCATION SERVICES, NAMELY, PLANNING AND IMPLEMENTING MOVES OF HOMES AND OFFICES (U.S. CLS. 100, 101 AND 102).

FIRST USE 4-1-2007; IN COMMERCE 4-1-2007.

**CLASS 36—INSURANCE AND FINANCIAL**

FOR REAL ESTATE LISTING SERVICES FOR HOUSING RENTALS AND APARTMENT RENTALS; RESIDENTIAL REAL ESTATE AGENCY SERVICES (U.S. CLS. 100, 101 AND 102).

FIRST USE 4-1-2007; IN COMMERCE 4-1-2007.

SKYE YOUNG, EXAMINING ATTORNEY

SN 86-234,830. RECORD MOB, INC., EDMONTON, CANADA, FILED 3-27-2014.

RECORD MOB

THE MARK CONSISTS OF STANDARD CHARACTERS WITHOUT CLAIM TO ANY PARTICULAR FONT, STYLE, SIZE, OR COLOR.

NO CLAIM IS MADE TO THE EXCLUSIVE RIGHT TO USE "RECORD", APART FROM THE MARK AS SHOWN.

**CLASS 9—ELECTRICAL AND SCIENTIFIC APPARATUS**

FOR DOWNLOADABLE SOFTWARE IN THE NATURE OF A MOBILE APPLICATION FOR USE IN ACCESSING, DOWNLOADING AND PURCHASING OF MUSIC, VIDEOS AND OTHER DIGITAL RECORDINGS IN THE FIELD OF MUSIC; COMPUTER SOFTWARE TO ENABLE USERS TO PROGRAM AND DISTRIBUTE AUDIO, VIDEO, TEXT AND OTHER MULTIMEDIA CONTENT, NAMELY, MUSIC, CONCERTS, VIDEOS, AND ENTERTAINMENT-RELATED PROGRAMS VIA COMMUNICATION NETWORKS; COMPUTER SOFTWARE FOR ONLINE ACCESSING AND PURCHASING OF MUSIC, VIDEOS AND OTHER DIGITAL RECORDINGS; DOWNLOADABLE DIGITAL FILES, DIGITAL RECORDINGS, ONLINE DISCUSSION BOARDS, WEBCASTS, PODCASTS, AND WEBINARS ALL IN THE FIELD OF MUSIC; DOWNLOADABLE VIDEO RECORDINGS FEATURING MUSIC AND ENTERTAINMENT-RELATED CONTENT; COMPUTER SOFTWARE FOR ACCESSING, BROWSING AND SEARCHING ONLINE DATABASES OF MUSIC FILES; COMPUTER SOFTWARE TO ENABLE AUTHORIZING, POSTING, UPLOADING, DOWNLOADING, TRANSMITTING, RECEIVING, EDITING, EXTRACTING, ENCODING, DECODING, PLAYING, STORING, ORGANIZING, SHOWING, DISPLAYING, TAGGING, BLOGGING, SHARING OR OTHERWISE PROVIDING ELECTRONIC MEDIA OR INFORMATION OVER THE INTERNET OR OTHER COMMUNICATIONS NETWORK; COMPUTER SOFTWARE FOR USE IN RECORDING, ORGANIZING, TRANSMITTING, MANIPULATING, AND REVIEWING TEXT, DATA, AUDIO FILES, VIDEO FILES IN CONNECTION WITH TV, COMPUTERS, MUSIC PLAYERS, VIDEO PLAYERS, MEDIA PLAYERS, MOBILE PHONES, AND PORTABLE AND HANDHELD DIGITAL ELECTRONIC DEVICES (U.S. CLS. 21, 23, 26, 36 AND 38).

**CLASS 35—ADVERTISING AND BUSINESS**

FOR RETAIL STORE SERVICES IN THE FIELD OF ENTERTAINMENT, NAMELY, MUSICAL AND AUDIO-VISUAL WORKS PROVIDED VIA THE INTERNET AND OTHER COMPUTER AND ELECTRONIC COMMUNICATION NETWORKS; PROMOTING AND MARKETING THE CHARITABLE SERVICES AND MUSIC OF OTHERS IN THE FIELD OF MUSIC AND CHARITY; PROMOTING AND MARKETING THE GOODS AND SERVICES OF OTHERS BY DISTRIBUTING ADVERTISING IN THE FIELDS OF MUSIC AND CHARITY VIA SOCIAL MEDIA; PROMOTING PUBLIC AWARENESS OF CHARITABLE CAUSES OF INTEREST TO MUSICIANS BY ORGANIZING AND CONDUCTING CHARITY EVENTS (U.S. CLS. 100, 101 AND 102).

**CLASS 38—COMMUNICATION**

FOR TELECOMMUNICATION SERVICES, NAMELY, ELECTRONIC TRANSMISSION OF STREAMED AND DOWNLOADABLE AUDIO, VIDEO AND MULTIMEDIA FILES VIA COMPUTER AND OTHER COMMUNICATIONS NETWORKS; ELECTRONIC TRANSMISSION OF MUSIC AND VIDEO INFORMATION VIA AN INTERNET-BASED DATABASE; PROVIDING ON-LINE CHAT ROOMS, BULLETIN BOARDS AND COMMUNITY FORUMS FOR THE TRANSMISSION OF MESSAGES AMONG COMPUTER USERS CONCERNING ENTERTAINMENT, MUSIC, CONCERTS, VIDEOS, NEWS, AND CULTURAL AND CHARITABLE EVENTS; WEB CASTING SERVICES; BROADCASTING PRE-RECORDED VIDEOS FEATURING MUSIC, CONCERTS AND ENTERTAINMENT-RELATED PROGRAMS VIA COMPUTER AND OTHER COMMUNICATIONS NETWORKS; ELECTRONIC TRANSMISSION OF STREAMED AND DOWNLOADABLE AUDIO AND VIDEO FILES VIA COMPUTER AND OTHER COMMUNICATIONS NETWORKS; TRANSMISSION AND DISTRIBUTION OF DATA AND AUDIO-VISUAL IMAGES VIA A GLOBAL COMPUTER NETWORK OF THE INTERNET; DELIVERY OF DIGITAL MUSIC BY TELECOMMUNICATIONS (U.S. CLS. 100, 101 AND 104).

**CLASS 41—EDUCATION AND ENTERTAINMENT**

FOR ENTERTAINMENT SERVICES, NAMELY, PROVIDING A WEB SITE AND DATABASE FEATURING MUSIC, VIDEOS, ENTERTAINMENT NEWS, AND MUSIC ENTERTAINMENT PROGRAMS; ENTERTAINMENT SERVICES, NAMELY, PROVIDING NON-DOWNLOADABLE PRERECORDED AUDIO AND AUDIOVISUAL CONTENT, INFORMATION AND COMMENTARY IN THE FIELDS OF MUSIC, CONCERTS, VIDEOS, AND ENTERTAINMENT NEWS, ALL ON-LINE VIA A GLOBAL COMPUTER NETWORK; INFORMATION RELATING TO MUSIC ENTERTAINMENT, PROVIDED ON-LINE FROM LOCAL OR GLOBAL COMMUNICATIONS NETWORKS, INCLUDING THE INTERNET, INTRANETS, EXTRANETS, TELEVISION, MOBILE COMMUNICATION, CELLULAR AND SATELLITE NETWORKS; PROVIDING SERVICES RELATING TO DIGITAL VIDEO AUDIO AND MULTIMEDIA ENTERTAINMENT PUBLISHING SERVICES, NAMELY, MUSIC PUBLISHING; MUSIC LIBRARY SERVICES (U.S. CLS. 100, 101 AND 107).

**CLASS 42—SCIENTIFIC AND COMPUTER SERVICES**

FOR PROVIDING SEARCH ENGINES FOR OBTAINING DATA VIA COMMUNICATIONS NETWORKS IN THE FIELD OF MUSIC; PROVIDING TEMPORARY USE OF ON-LINE NON-DOWNLOADABLE SOFTWARE TO ENABLE USERS TO PROGRAM AUDIO, VIDEO AND OTHER MULTIMEDIA CONTENT; PROVIDING A WEB SITE, VIA A GLOBAL COMPUTER NETWORK, TO ENABLE USERS TO PROGRAM AUDIO, VIDEO, AND OTHER MULTIMEDIA CONTENT, INCLUDING MUSIC, CONCERTS, VIDEOS, AND ENTERTAINMENT-RELATED PROGRAMS; APPLICATION SERVICE PROVIDER (ASP) FEATURING SOFTWARE FOR USE IN CONNECTION WITH ONLINE MUSIC SUBSCRIPTION, DOWNLOAD AND STREAMING SERVICES, SOFTWARE THAT ENABLES USERS TO PLAY AND PROGRAM MUSIC AND ENTERTAINMENT-RELATED AUDIO; ONLINE NON-DOWNLOADABLE SOFTWARE FEATURING MUSICAL SOUND RECORDINGS AND ENTERTAINMENT-RELATED AUDIO; COMPUTER SERVICES, NAMELY, ACTING AS AN APPLICATION SERVICE PROVIDER IN THE FIELDS OF ENTERTAINMENT AND SOCIAL MEDIA TO HOST COMPUTER APPLICATION SOFTWARE VIA SMARTPHONES OR OTHER WIRELESS DEVICES FOR DISTRIBUTING, SELECTING, PURCHASING AND PLAYING AUDIO AND VIDEO RECORDINGS; PROVIDING ONLINE TEMPORARY USE OF NON-DOWNLOADABLE COMPUTER SOFTWARE FOR DISTRIBUTING, SELECTING, PRICING, SELLING AND PLAYING AUDIO AND VIDEO RECORDINGS; PROVIDING ONLINE TEMPORARY USE OF NON-DOWNLOADABLE COMPUTER SOFTWARE FOR ENABLING THE DESIGNATION OF AND DISTRIBUTION TO CHARITIES OF PROFITS MADE FROM THE SALE OF AUDIO AND VIDEO RECORDINGS (U.S. CLS. 100 AND 101).

ROBIN CHOSID, EXAMINING ATTORNEY

SN 86-234,941. MOTIV FISHING, DUNEDIN, FL. FILED 3-28-2014.

# GEOBASS

THE MARK CONSISTS OF STANDARD CHARACTERS WITHOUT CLAIM TO ANY PARTICULAR FONT, STYLE, SIZE, OR COLOR.



**CLASS 16—PAPER GOODS AND PRINTED MATTER**

FOR STICKERS; POSTERS; DECALS (U.S. CLS. 2, 5, 22, 23, 29, 37, 38 AND 50).  
FIRST USE 3-14-2014; IN COMMERCE 3-14-2014.

**CLASS 25—CLOTHING**

FOR CLOTHING, NAMELY, TOPS, BOTTOMS, SHIRTS, T-SHIRTS, SWEATSHIRTS, CAPS, HATS, JACKETS, PANTS, HOODED SWEATSHIRTS, UNDERWEAR, SWIMWEAR, BEACH COVER-UPS, LONG UNDERWEAR, THERMAL UNDERWEAR, FISHING WADERS; BOOTS; FISHING VESTS; HIP-GUARDS ESPECIALLY MADE FOR FISHING; FISHING SHIRTS (U.S. CLS. 22 AND 39).  
FIRST USE 3-14-2014; IN COMMERCE 3-14-2014.

**CLASS 28—TOYS AND SPORTING GOODS**

FOR FISHING TACKLE; FISHING LINES; FISHING RODS; FISHING REELS; FISHING TACKLE BOXES; FISHING TACKLE BAGS; FISHING BAIT HOLDER; FISHING FLIES; HAND-HELD FISHING NETS; FISHING LURES; FISHING ROD CASES; FISHING ROD RACKS; INFLATABLE FLOAT TUBES FOR FISHING; SPEARS FOR USE IN FISHING; FISHING STOOLS; FISHING BUOYS (U.S. CLS. 22, 23, 38 AND 50).

**CLASS 41—EDUCATION AND ENTERTAINMENT**

FOR ENTERTAINMENT SERVICES IN THE NATURE OF AN ONGOING REALITY BASED TELEVISION PROGRAM; ENTERTAINMENT SERVICES, NAMELY, AN ONGOING SERIES FEATURING FISHING, FLY FISHING, ADVENTURE TRAVEL, AND SURVIVAL TRAVEL PROVIDED THROUGH TELEVISION AND WEBCASTS; ENTERTAINMENT SERVICES, NAMELY, PROVIDING ONGOING WEBISODES FEATURING FISHING, FLY FISHING, ADVENTURE TRAVEL, AND SURVIVAL TRAVEL VIA A GLOBAL COMPUTER NETWORK; ENTERTAINMENT IN THE NATURE OF ONGOING TELEVISION PROGRAMS IN THE FIELD OF FISHING, FLY FISHING, ADVENTURE TRAVEL, AND SURVIVAL TRAVEL; PROVIDING A WEBSITE FOR ENTERTAINMENT PURPOSES FEATURING PHOTOS AND VIDEOS ABOUT FISHING, FLY FISHING, AND ADVENTURE TRAVEL; PROVIDING INFORMATION ABOUT RECREATIONAL FISHING AND FLY FISHING (U.S. CLS. 100, 101 AND 107).

FIRST USE 3-14-2014; IN COMMERCE 3-14-2014.  
ESTHER QUEEN, EXAMINING ATTORNEY

SN 86-234,952. E:COUNTABLE, LLC, NORFOLK, VA. FILED 3-28-2014.



OWNER OF U.S. REG. NO. 4,400,719.

THE MARK CONSISTS OF A STYLIZED IMAGE IN THE FORM OF A TIE AND PEN IN WHICH THE NIB OF THE PEN CONTAINS A GRAPHIC OF A COMPUTER MOUSE AND THE UPPER PART OF THE PEN BARREL BEGINS IN GREATER PIXELATION BUT BY THE LOWER PART OF THE PEN BARREL FOCUSES AND CLARIFIES TO THE NIB WHICH IS IN FIRM FOCUS.

**CLASS 35—ADVERTISING AND BUSINESS**

FOR ACCOUNTING SERVICES; BUSINESS AND ACCOUNT AUDITING SERVICES; TAX PREPARATION AND CONSULTING SERVICES; BUSINESS MANAGEMENT AND CONSULTING SERVICES; BUSINESS CONSULTING; BUSINESS PROCESS MANAGEMENT AND CONSULTING; BUSINESS MARKETING CONSULTING SERVICES; PROVIDING INFORMATION IN THE FIELDS OF BUSINESS MANAGEMENT, BUSINESS MARKETING, BUSINESS ACQUISITIONS AND MERGERS CONSULTING; BUSINESS ACQUISITIONS CONSULTING; ANALYSIS SERVICES, NAMELY, MARKET ANALYSIS AND FINANCIAL ANALYSIS; BUSINESS APPRAISALS; CONDUCTING BUSINESS AND MARKET RESEARCH SURVEYS; BUSINESS INFORMATION SERVICES IN THE FIELD OF BUSINESS CHANGE MANAGEMENT, BUSINESS PROCESS MANAGEMENT, BUSINESS STRATEGIC MANAGEMENT AND PLANNING SERVICES, AND BUSINESS TECHNOLOGY; BUSINESS MANAGEMENT PLANNING; BUSINESS MERGER CONSULTATION; BUSINESS NETWORKING; CONDUCTING BUSINESS RESEARCH AND SURVEYS; BUSINESS SUPERVISION; COMMERCIAL AND INDUSTRIAL MANAGEMENT ASSISTANCE; ECONOMIC FORECASTING AND ANALYSIS; PERSONNEL MANAGEMENT CONSULTATION; PREPARING BUSINESS REPORTS; BUSINESS CONSULTING IN THE FIELDS OF ENTERPRISE MANAGEMENT, HUMAN RESOURCE MANAGEMENT, CUSTOMER SERVICE MANAGEMENT, CORPORATE AND MERGER STRATEGY AND POST-MERGER INTEGRATION STRATEGY, SUPPLY CHAIN AND INVENTORY, OUTSOURCING OF BUSINESS FUNCTIONS AND PROCESSES, ORGANIZATIONAL CHANGE MANAGEMENT, CUSTOMER RELATIONSHIP MANAGEMENT; CONSULTING IN THE FIELD OF FINANCIAL INFORMATION MANAGEMENT; NEW BUSINESS VENTURE DEVELOPMENT AND FORMATION CONSULTING SERVICE; MANAGEMENT AND OPERATION ASSISTANCE TO COMMERCIAL BUSINESSES; BUSINESS MANAGEMENT CONSULTATION IN THE FIELD OF EXECUTIVE AND LEADERSHIP DEVELOPMENT, AND HUMAN RESOURCES DEVELOPMENT AND MANAGEMENT; ORGANIZATIONAL SERVICES, NAMELY, SERVICES FOR ORGANIZING AND COORDINATING TALENT MANAGEMENT, NAMELY, PLACEMENT OF EXECUTIVES; CAREER MANAGEMENT, NAMELY, MANAGEMENT OF EXECUTIVES IN THE FIELDS OF BUSINESS AND HUMAN RESOURCES; EMPLOYMENT COUNSELING AND CONSULTATION IN THE FIELD OF EXECUTIVE RECRUITMENT; EMPLOYMENT HIRING, RECRUITING, PLACEMENT, STAFFING AND CAREER NETWORKING SERVICES; EMPLOYMENT COUNSELING AND RECRUITMENT; EXECUTIVE SEARCH, RECRUITMENT AND PLACEMENT SERVICES; ARRANGING AND CONDUCTING CONFERENCES AND TRADE SHOWS IN THE FIELDS OF ACCOUNTING, BUSINESS AND ACCOUNT AUDITING AND BUSINESS MANAGEMENT (U.S. CLS. 100, 101 AND 102).

FIRST USE 10-13-2011; IN COMMERCE 10-13-2011.

**CLASS 36—INSURANCE AND FINANCIAL**

FOR FINANCIAL ANALYSIS AND CONSULTATION; CONSULTING IN THE FIELD OF FINANCIAL INFORMATION MANAGEMENT; FINANCIAL MANAGEMENT; FINANCIAL AFFAIRS AND MONETARY AFFAIRS, NAMELY, FINANCIAL INFORMATION, MANAGEMENT AND ANALYSIS SERVICES; FINANCIAL ANALYSES; FINANCIAL CONSULTING; FINANCIAL ANALYSIS AND RESEARCH SERVICES; FINANCIAL CONSULTING SERVICES, NAMELY, EXPERT ANALYSIS IN FINANCE; FINANCIAL PLANNING; FINANCIAL ADVICE, NAMELY, BUDGET PLANNING; MANAGEMENT AND CONSULTING SERVICES IN THE FIELD OF FINANCE; PROVIDING FINANCIAL INFORMATION; FINANCIAL SERVICES, NAMELY, CREDIT AGENCIES FEATURING CREDIT PROCESSING, NAMELY, CREDIT CHECKING, CREDIT ANALYZING, AND FINANCIAL REPORTING SERVICES (U.S. CLS. 100, 101 AND 102).

FIRST USE 10-13-2011; IN COMMERCE 10-13-2011.

**CLASS 41—EDUCATION AND ENTERTAINMENT**

FOR ARRANGING AND CONDUCTING COURSES, SEMINARS, WORKSHOPS, AND CLASSES IN THE FIELDS OF ACCOUNTING, BUSINESS AND ACCOUNT AUDITING AND BUSINESS MANAGEMENT (U.S. CLS. 100, 101 AND 107).

FIRST USE 10-13-2011; IN COMMERCE 10-13-2011.

**CLASS 42—SCIENTIFIC AND COMPUTER SERVICES**

FOR CONSULTING IN THE FIELD OF INFORMATION TECHNOLOGY; PLANNING, DESIGN AND MANAGEMENT OF INFORMATION TECHNOLOGY SYSTEMS; CONSULTING SERVICES IN THE FIELD OF DESIGN, SELECTION, IMPLEMENTATION AND USE OF COMPUTER HARDWARE AND SOFTWARE SYSTEMS FOR OTHERS; COMPUTER CONSULTING SERVICES FOR PLANNING, DESIGN, AND ANALYSIS OF INFORMATION PROCESSES, SYSTEMS, AND BUSINESS REENGINEERING; ANALYSIS AND DESIGN OF COMPUTER SYSTEMS, SOFTWARE AND INFORMATION SYSTEMS FOR OTHERS; DESIGN FOR OTHERS OF SOFTWARE APPLICATIONS ON LOCAL AND INTERNAL COMPUTER NETWORKS AND THE INTERNET; PROVIDING DESIGN AND DEVELOPMENT FOR OTHERS' COMPUTER NETWORKS; MAINTENANCE OF SOFTWARE AND SOFTWARE SYSTEMS; COMPUTER CONSULTATION ON THE COMPUTER-RELATED ASPECTS OF INFORMATION TECHNOLOGY SECURITY (U.S. CLS. 100 AND 101).

FIRST USE 10-13-2011; IN COMMERCE 10-13-2011.

EDWARD NELSON, EXAMINING ATTORNEY

**CLASS 9—ELECTRICAL AND SCIENTIFIC APPARATUS**

FOR AUDIO AND VIDEO RECORDINGS FEATURING MUSICAL PERFORMANCES; DIGITAL MATERIALS, NAMELY, CDS, DVDS, AND DOWNLOADABLE AUDIO FILES FEATURING MUSICAL PERFORMANCES (U.S. CLS. 21, 23, 26, 36 AND 38).

FIRST USE 0-0-2012, THE MARK WAS FIRST USED ANYWHERE IN A DIFFERENT FORM OTHER THAN THAT SOUGHT TO BE REGISTERED AT LEAST AS EARLY AS 00/00/1944; IN COMMERCE 0-0-2012, THE MARK WAS FIRST USED IN COMMERCE IN A DIFFERENT FORM OTHER THAN THAT SOUGHT TO BE REGISTERED AT LEAST AS EARLY AS 00/00/1944.

**CLASS 16—PAPER GOODS AND PRINTED MATTER**

FOR PAPER GOODS AND PRINTED MATERIALS, NAMELY, POSTERS, FOLDERS, NOTEBOOKS, STATIONERY, POSTCARDS, DECALS, STICKERS, BUMPER STICKERS, WRITING PADS, ENVELOPES, CALENDARS, PHOTOGRAPHS, BOTH MOUNTED AND UNMOUNTED; CATALOGS, BROCHURES AND MAGAZINES IN THE FIELD OF EDUCATION, STUDENT RECRUITMENT, ALUMNI RELATIONS AND FUNDRAISING WITHIN HIGHER EDUCATION; WRITING INSTRUMENTS, NAMELY, PENS AND PENCILS (U.S. CLS. 2, 5, 22, 23, 29, 37, 38 AND 50).

FIRST USE 8-31-2010, THE MARK WAS FIRST USED ANYWHERE IN A DIFFERENT FORM OTHER THAN THAT SOUGHT TO BE REGISTERED AT LEAST AS EARLY AS 00/00/1944.; IN COMMERCE 8-31-2010, THE MARK WAS FIRST USED IN COMMERCE IN A DIFFERENT FORM OTHER THAN THAT SOUGHT TO BE REGISTERED AT LEAST AS EARLY AS 00/00/1944..

SN 86-235.030. RIDER UNIVERSITY, LAWRENCE TOWNSHIP, NJ. FILED 3-28-2014.



NO CLAIM IS MADE TO THE EXCLUSIVE RIGHT TO USE "CHOIR COLLEGE", APART FROM THE MARK AS SHOWN.

THE MARK CONSISTS OF THE WORDING "WESTMINSTER CHOIR COLLEGE" BESIDE A SHIELD FEATURING THREE ROSETTES ON A BAND ABOVE A LYRE.

**CLASS 25—CLOTHING**

FOR CLOTHING, NAMELY, SHIRTS, SWEATERS, SWEATSHIRTS, T-SHIRTS, TANK TOPS, PANTS, SHORTS, GYM SHORTS, RUNNING SHORTS, SWEATSUITS, GYM SUITS, JACKETS, GLOVES, SCARVES, SOCKS, HATS, CAPS (U.S. CLS. 22 AND 39).

FIRST USE 12-0-2010, THE MARK WAS FIRST USED ANYWHERE IN A DIFFERENT FORM OTHER THAN THAT SOUGHT TO BE REGISTERED AT LEAST AS EARLY AS 00/00/1944; IN COMMERCE 12-0-2010, THE MARK WAS FIRST USED IN COMMERCE IN A DIFFERENT FORM OTHER THAN THAT SOUGHT TO BE REGISTERED AT LEAST AS EARLY AS 00/00/1944.

**CLASS 41—EDUCATION AND ENTERTAINMENT**

FOR EDUCATIONAL SERVICES, NAMELY, PROVIDING COURSES OF INSTRUCTION AND TRAINING AT THE COLLEGIATE AND GRADUATE LEVEL; EDUCATIONAL SERVICES, NAMELY, PROVIDING COURSES OF INSTRUCTION AND TRAINING AT THE COLLEGIATE AND GRADUATE LEVEL IN THE FIELDS OF MUSIC, MUSIC EDUCATION, MUSIC THEORY AND COMPOSITION, SACRED MUSIC, VOICE, ORGAN, AND PIANO PERFORMANCE AND PEDAGOGY, CHORAL CONDUCTING, AND PIANO ACCOMPANYING AND COACHING; ENTERTAINMENT SERVICES IN THE NATURE OF LIVE MUSICAL PERFORMANCES, NAMELY, INSTRUMENTAL, CHORAL, RECITALS, MUSICAL THEATER, AND OPERA; ORGANIZING AND CONDUCTING MUSICAL CONCERTS AND SHOWCASES FOR CULTURAL OR EDUCATIONAL PURPOSES; ENTERTAINMENT SERVICES, NAMELY, PROVIDING PODCASTS IN THE FIELD OF MUSIC EDUCATION; PROVIDING A WEBSITE FEATURING NON-DOWNLOADABLE VIDEOS AND SLIDESHOWS IN THE FIELD OF MUSIC EDUCATION; MULTIMEDIA ENTERTAINMENT SERVICES IN THE NATURE OF RECORDING, PRODUCTION AND POST-PRODUCTION SERVICES IN THE FIELD OF MUSIC, VIDEO AND FILMS (U.S. CLS. 100, 101 AND 107).

FIRST USE 8-31-2010, THE MARK WAS FIRST USED ANYWHERE IN A DIFFERENT FORM OTHER THAN THAT SOUGHT TO BE REGISTERED AT LEAST AS EARLY AS 00/00/1944.; IN COMMERCE 8-31-2010, THE MARK WAS FIRST USED IN COMMERCE IN A DIFFERENT FORM OTHER THAN THAT SOUGHT TO BE REGISTERED AT LEAST AS EARLY AS 00/00/1944..

ESTHER QUEEN, EXAMINING ATTORNEY

SN 86-235,249. TEACHING CLEVELAND FOUNDATION, UNIVERSITY HEIGHTS, OH. FILED S.R. 3-28-2014; AM. P.R. 7-1-2014.



NO CLAIM IS MADE TO THE EXCLUSIVE RIGHT TO USE "TEACHING CLEVELAND", APART FROM THE MARK AS SHOWN.

THE MARK CONSISTS OF A CONNECTED, ARCHED SKYLINE FEATURING BUILDINGS WITH THE TALLEST TOWER IN THE MIDDLE. THE WORDS "TEACHING CLEVELAND" ARE CENTERED UNDERNEATH THE SKYLINE.

**CLASS 36—INSURANCE AND FINANCIAL**

FOR CHARITABLE FUNDRAISING SERVICES FOR PROMOTING RESEARCH, EDUCATION AND OTHER ACTIVITIES RELATING TO LOCAL HISTORY, ECONOMICS, PUBLIC POLICY, AND YOUTH ENGAGEMENT (U.S. CLS. 100, 101 AND 102).

FIRST USE 9-17-2010; IN COMMERCE 9-17-2010.

**CLASS 41—EDUCATION AND ENTERTAINMENT**

FOR CHARITABLE DONATION SERVICES, NAMELY, PROVIDING EDUCATIONAL PROFESSIONAL DEVELOPMENT WORKSHOPS IN THE FIELD OF LOCAL HISTORY, ECONOMICS, PUBLIC POLICY, AND YOUTH ENGAGEMENT; CHARITABLE SERVICES, NAMELY, PROVIDING EDUCATIONAL MATERIALS IN THE NATURE OF PRINTED MATERIALS AND ONLINE LESSON PLANS TO STUDENTS K-12; EDUCATION SERVICES, NAMELY, PROVIDING ON-LINE CURRICULAR RESOURCES IN THE FIELD OF LOCAL HISTORY, ECONOMICS, PUBLIC POLICY, AND YOUTH ENGAGEMENT; EDUCATION SERVICES, NAMELY, PROVIDING PANEL DISCUSSIONS IN THE FIELD OF LOCAL HISTORY, ECONOMICS, PUBLIC POLICY, AND YOUTH ENGAGEMENT; EDUCATION SERVICES, NAMELY, TRAINING EDUCATORS TO TEACH THROUGH SERVICE LEARNING AND CIVIC ENGAGEMENT AND PROVIDING CURRICULA IN CONNECTION THEREWITH; EDUCATIONAL SERVICES, NAMELY, DEVELOPING CURRICULUM FOR EDUCATORS; EDUCATIONAL SERVICES, NAMELY, DEVELOPING CURRICULUM FOR OTHERS IN THE FIELD OF LOCAL HISTORY, ECONOMICS, PUBLIC POLICY, AND YOUTH ENGAGEMENT; EDUCATIONAL SERVICES, NAMELY, DEVELOPING, ARRANGING, AND CONDUCTING EDUCATIONAL CONFERENCES AND PROGRAMS AND PROVIDING COURSES OF INSTRUCTION IN THE FIELD OF LOCAL HISTORY, ECONOMICS, PUBLIC POLICY, AND YOUTH ENGAGEMENT; EDUCATIONAL SERVICES, NAMELY, PROVIDING EDUCATIONAL SPEAKERS IN THE FIELD OF LOCAL HISTORY, ECONOMICS, PUBLIC POLICY, AND YOUTH ENGAGEMENT (U.S. CLS. 100, 101 AND 107).

FIRST USE 9-17-2010; IN COMMERCE 9-17-2010.  
BRIAN PINO, EXAMINING ATTORNEY

SN 86-235,121. SEWALL PARTNERS, LLC, CHICAGO, IL. FILED 3-28-2014.

# Jesus Sees Us

THE MARK CONSISTS OF STANDARD CHARACTERS WITHOUT CLAIM TO ANY PARTICULAR FONT, STYLE, SIZE, OR COLOR.

NO CLAIM IS MADE TO THE EXCLUSIVE RIGHT TO USE "JESUS", APART FROM THE MARK AS SHOWN.

**CLASS 9—ELECTRICAL AND SCIENTIFIC APPARATUS**

FOR AUDIO BOOKS IN THE NATURE OF NOVELS; DOWNLOADABLE E-BOOKS IN THE FIELD OF LIFE OF JESUS CHRIST; INTERACTIVE GAME SOFTWARE (U.S. CLS. 21, 23, 26, 36 AND 38).

**CLASS 16—PAPER GOODS AND PRINTED MATTER**

FOR BOOKS IN THE FIELD OF LIFE OF JESUS CHRIST (U.S. CLS. 2, 5, 22, 23, 29, 37, 38 AND 50).

**CLASS 28—TOYS AND SPORTING GOODS**

FOR DOLLS (U.S. CLS. 22, 23, 38 AND 50).  
TARAH HARDY, EXAMINING ATTORNEY

SN 86-235,323. DERB E CIGS LLC, LOUISVILLE, KY. FILED 3-28-2014.

## DERB E CIGS

THE MARK CONSISTS OF STANDARD CHARACTERS WITHOUT CLAIM TO ANY PARTICULAR FONT, STYLE, SIZE, OR COLOR.

NO CLAIM IS MADE TO THE EXCLUSIVE RIGHT TO USE "E CIGS", APART FROM THE MARK AS SHOWN.

### CLASS 30—STAPLE FOODS

FOR ELECTRONIC CIGARETTE LIQUID (E-LIQUID) COMPRISED OF FLAVORINGS IN LIQUID FORM USED TO REFILL ELECTRONIC CIGARETTE CARTRIDGES (U.S. CL. 46).

FIRST USE 8-5-2013; IN COMMERCE 8-5-2013.

### CLASS 34—SMOKERS' ARTICLES

FOR ELECTRONIC CIGARETTE REFILL CARTRIDGES SOLD EMPTY; ELECTRONIC CIGARETTES; ELECTRONIC CIGARETTES FOR USE AS AN ALTERNATIVE TO TRADITIONAL CIGARETTES (U.S. CLS. 2, 8, 9 AND 17).

FIRST USE 8-5-2013; IN COMMERCE 8-5-2013.

### CLASS 35—ADVERTISING AND BUSINESS

FOR RETAIL STORE SERVICES FEATURING ELECTRONIC CIGARETTES, VAPORIZERS, CHEMICAL FLAVOR IN LIQUID FORM USED IN ELECTRONIC CIGARETTE (U.S. CLS. 100, 101 AND 102).

FIRST USE 8-5-2013; IN COMMERCE 8-5-2013.

KIMBERLY PERRY, EXAMINING ATTORNEY

SN 86-235,460. FAIRFIELD PROCESSING CORPORATION, DANBURY, CT. FILED 3-28-2014.

## WE MAKE FOR GOOD

THE MARK CONSISTS OF STANDARD CHARACTERS WITHOUT CLAIM TO ANY PARTICULAR FONT, STYLE, SIZE, OR COLOR.

### CLASS 36—INSURANCE AND FINANCIAL

FOR CHARITABLE FUNDRAISING; FUNDRAISING SERVICES, BY MEANS OF ORGANIZING FUNDRAISERS FOR SCHOOLS AND OTHER GROUPS; PROVIDING FUNDRAISING INFORMATION REGARDING CHARITABLE OR HUMANITARIAN ORGANIZATIONS (U.S. CLS. 100, 101 AND 102).

### CLASS 41—EDUCATION AND ENTERTAINMENT

FOR ARRANGING AND CONDUCTING EDUCATIONAL CONFERENCES; ARRANGING OF CONTESTS; ARRANGING OF SEMINARS; ARRANGING PROFESSIONAL WORKSHOP AND TRAINING COURSES; ART EXHIBITIONS; AWARDS PROGRAM FOR MAJOR CORPORATIONS AND INDIVIDUALS WHO HAVE MADE SIGNIFICANT CHARITABLE CONTRIBUTIONS; CHARITABLE DONATION SERVICES, NAMELY, PROVIDING EDUCATIONAL WORKSHOPS AND SEMINARS IN THE FIELD OF DIY, SEWING AND QUILTING; CHARITABLE SERVICES, NAMELY, PROVIDING TOYS TO NEEDY CHILDREN; CHARITABLE SERVICES, NAMELY, PROVIDING ARTS AND CRAFTS AND EDUCATIONAL MATERIALS IN THE NATURE OF RECYCLED MANUFACTURING BY-PRODUCTS TO NEEDY AND UNDERPRIVILEGED CHILDREN; CHARITABLE SERVICES, NAMELY, PROVIDING HANDMADE DOLLS TO CHILDREN; DO-IT-YOURSELF ARTS AND CRAFTS STUDIO THAT PROVIDES THE USE OF SUPPLIES AND EQUIPMENT TO INDIVIDUALS FOR MAKING THEIR OWN ARTS AND CRAFTS; EDUCATION SERVICES, NAMELY, PROVIDING WORKSHOPS AND SEMINARS IN THE FIELD OF DIY, SEWING AND QUILTING; EDUCATION SERVICES, NAMELY, PROVIDING ON-LINE WORKSHOPS AND SEMINARS IN THE FIELD OF DIY, SEWING AND QUILTING; EDUCATIONAL SERVICES, NAMELY, DEVELOPING, ARRANGING, AND CONDUCTING EDUCATIONAL CONFERENCES AND PROGRAMS AND PROVIDING COURSES OF INSTRUCTION IN THE FIELD OF DIY, SEWING AND QUILTING; EDUCATIONAL SERVICES, NAMELY, CONDUCTING INFORMAL PROGRAMS IN THE FIELDS OF DIY, SEWING AND QUILTING, USING ON-LINE ACTIVITIES AND INTERACTIVE EXHIBITS, AND PRINTABLE MATERIALS DISTRIBUTED THEREWITH; EDUCATIONAL SERVICES, NAMELY, CONDUCTING WORKSHOPS AND SEMINARS IN THE FIELD OF DIY, SEWING AND QUILTING AND DISTRIBUTION THEREWITH IN HARD COPY OR ELECTRONIC FORMAT ON THE SAME TOPICS; ENTERTAINMENT AND RECREATIONAL SERVICES, NAMELY, ORGANIZING AND CONDUCTING A SEWING/QUILTING EVENT THE PROCEEDS OF WHICH ARE DONATED TO CHARITY; ON-LINE JOURNALS, NAMELY, BLOGS FEATURING DIY, SEWING AND QUILTING; ORGANIZING, ARRANGING, AND CONDUCTING DIY, SEWING AND QUILTING EVENTS; PROVIDING A WEB SITE THAT FEATURES INFORMAL INSTRUCTION ON DIY, SEWING AND QUILTING; PROVIDING A WEBSITE FEATURING NON-DOWNLOADABLE ARTICLES IN THE FIELD OF DIY, SEWING AND QUILTING; PROVIDING CLASSES, SEMINARS, WORKSHOPS, AND TRAINING FOR PARENTS, INSTRUCTORS, AND OTHER INDIVIDUALS IN THE FIELD OF EDUCATION FOR INDIVIDUALS WITH AUTISM AND OTHER DEVELOPMENTAL DISORDERS; PROVIDING CLASSES, WORKSHOPS, SEMINARS AND CAMPS IN THE FIELD OF DIY, SEWING AND QUILTING; PROVIDING EDUCATION COURSES IN THE FIELD OF DIY, SEWING AND QUILTING OFFERED THROUGH ONLINE, NON-DOWNLOADABLE VIDEOS AND INSTRUCTOR ASSISTANCE; PROVIDING EDUCATIONAL DEMONSTRATIONS; PROVIDING ON-LINE DIGITAL PUBLICATIONS IN THE NATURE OF BLOGS, NEWSLETTERS AND ARTICLES IN THE FIELD OF DIY, SEWING AND QUILTING VIA THE INTERNET, NOT DOWNLOADABLE; PROVIDING ON-LINE NEWSLETTERS IN THE FIELD OF DIY, SEWING AND QUILTING; PUBLICATION AND EDITING OF PRINTED MATTER; PUBLICATION OF BOOKS, WORKSHEETS AND VIDEOS; PUBLICATION OF BOOKS, OF MAGAZINES, OF JOURNALS, OF NEWSPAPERS, OF PERIODICALS, OF CATALOGS, OF BROCHURES; PUBLICATION OF LEAFLETS; PUBLICATION OF PRINTED MATTER; PUBLISHING OF ELECTRONIC PUBLICATIONS; SOCIAL CLUB SERVICES, NAMELY, ARRANGING, ORGANIZING, AND HOSTING SOCIAL EVENTS, GET-TOGETHERS, AND PARTIES FOR CLUB MEMBERS; WORKSHOPS AND SEMINARS IN THE FIELD OF DIY, SEWING AND QUILTING (U.S. CLS. 100, 101 AND 107).

CHERYL CLAYTON, EXAMINING ATTORNEY

SN 86-235,639. TIGASE, INC., SAN FRANCISCO, CA. FILED 3-28-2014.

# TIGASE

THE MARK CONSISTS OF STANDARD CHARACTERS WITHOUT CLAIM TO ANY PARTICULAR FONT, STYLE, SIZE, OR COLOR.

## CLASS 9—ELECTRICAL AND SCIENTIFIC APPARATUS

FOR DOWNLOADABLE COMPUTER SOFTWARE, NAMELY, INSTANT MESSAGING AND COMMUNICATIONS SOFTWARE FOR CONNECTING COMPUTER NETWORK USERS; SOFTWARE FOR INSTANT MESSAGING; COMMUNICATIONS SOFTWARE FOR PROVIDING ACCESS TO THE INTERNET; DOWNLOADABLE MOBILE APPLICATIONS FOR INSTANT MESSAGING; DOWNLOADABLE MOBILE APPLICATIONS FOR COMMUNICATIONS, NAMELY, COMPUTER SOFTWARE FOR DATA COMMUNICATION AND TRANSLATING AND TRANSMITTING DATA (U.S. CLS. 21, 23, 26, 36 AND 38).

FIRST USE 11-21-2005; IN COMMERCE 11-21-2005.

## CLASS 38—COMMUNICATION

FOR INSTANT MESSAGING SERVICES (U.S. CLS. 100, 101 AND 104).

FIRST USE 9-15-2008; IN COMMERCE 9-15-2008.

## CLASS 42—SCIENTIFIC AND COMPUTER SERVICES

FOR PROVIDING TECHNICAL SUPPORT SERVICES REGARDING THE USAGE OF SOFTWARE FOR COMMUNICATIONS AND INSTANT MESSAGING, NAMELY, DIAGNOSING AND TROUBLESHOOTING COMPUTER SOFTWARE PROBLEMS; COMPUTER PROGRAMMING AND SOFTWARE DESIGN; COMPUTER PROGRAM ANALYSIS FOR OTHERS; MAINTENANCE OF COMPUTER PROGRAMS FOR OTHERS; COMPUTER SOFTWARE DESIGN AND DEVELOPMENT (U.S. CLS. 100 AND 101).

FIRST USE 11-14-2007; IN COMMERCE 11-14-2007.  
AMY C. KEAN, EXAMINING ATTORNEY

SN 86-235,666. CADILLAC JACK, INC., DULUTH, GA. FILED 3-28-2014.

# SPIRIT OWL

THE MARK CONSISTS OF STANDARD CHARACTERS WITHOUT CLAIM TO ANY PARTICULAR FONT, STYLE, SIZE, OR COLOR.

## CLASS 9—ELECTRICAL AND SCIENTIFIC APPARATUS

FOR COMPUTER GAME SOFTWARE FOR GAMING MACHINES INCLUDING SLOT MACHINES OR VIDEO LOTTERY TERMINALS; GAMING SOFTWARE THAT GENERATES OR DISPLAYS WAGER OUTCOMES OF GAMING MACHINES (U.S. CLS. 21, 23, 26, 36 AND 38).

## CLASS 28—TOYS AND SPORTING GOODS

FOR GAMING MACHINES THAT GENERATE OR DISPLAY WAGER OUTCOMES; RECONFIGURABLE CASINO AND LOTTERY GAMING EQUIPMENT, NAMELY, GAMING MACHINES AND OPERATIONAL COMPUTER GAME SOFTWARE THEREFOR SOLD AS A UNIT (U.S. CLS. 22, 23, 38 AND 50).

DOMINIC FATHY, EXAMINING ATTORNEY

SN 86-235,849. USA ENTERPRISES, LLC, LAKEWOOD, NJ. FILED 3-28-2014.

# BELLEMAIN

THE MARK CONSISTS OF STANDARD CHARACTERS WITHOUT CLAIM TO ANY PARTICULAR FONT, STYLE, SIZE, OR COLOR.

## CLASS 20—FURNITURE AND ARTICLES NOT OTHERWISE CLASSIFIED

FOR CUTLERY ORGANIZERS IN THE NATURE OF DRAWER ORGANIZERS FOR SILVERWARE (U.S. CLS. 2, 13, 22, 25, 32 AND 50).

FIRST USE 12-9-2013; IN COMMERCE 12-9-2013.

## CLASS 21—HOUSEWARES AND GLASS

FOR CUPS, NOT OF PRECIOUS METAL; GRILL PRESSES; KNIFE BLOCKS; METAL COOKING PANS; SHOT GLASSES; SPICE RACKS (U.S. CLS. 2, 13, 23, 29, 30, 33, 40 AND 50).

FIRST USE 12-9-2013; IN COMMERCE 12-9-2013.  
ELIZABETH CHANG, EXAMINING ATTORNEY

SN 86-235,903. AUTO EXPRESSIONS, LLC, COMPTON, CA. FILED 3-28-2014.

# SMART RELEASE

THE MARK CONSISTS OF STANDARD CHARACTERS WITHOUT CLAIM TO ANY PARTICULAR FONT, STYLE, SIZE, OR COLOR.

NO CLAIM IS MADE TO THE EXCLUSIVE RIGHT TO USE "RELEASE", APART FROM THE MARK AS SHOWN.

## CLASS 3—COSMETICS AND CLEANING PREPARATIONS

FOR AIR FRAGRANCING PREPARATIONS (U.S. CLS. 1, 4, 6, 50, 51 AND 52).

## CLASS 5—PHARMACEUTICALS

FOR AIR DEODORIZING PREPARATIONS (U.S. CLS. 6, 18, 44, 46, 51 AND 52).

KAMAL PREET, EXAMINING ATTORNEY

SN 86-236,285. KEE WORLD TRADING CO., INC., DBA KEE WORLD GROUP, STAFFORD, VA. FILED 3-29-2014.



OWNER OF U.S. REG. NO. 4,501,047.

THE MARK CONSISTS OF THREE HOLLOW CIRCLES THAT TOUCH ONE ANOTHER AND FORM A ROUGHLY TRIANGULAR DESIGN WITH THE POINT OF THE TRIANGULAR DESIGN POINTING TO THE LEFT AND THE BASE OF THE TRIANGULAR DESIGN TO THE RIGHT. THE WORD "KEEWORLDGROUP" IS TO THE RIGHT OF THE DESIGN AND THE PHRASE "EXPAND YOUR VISION." IS LOCATED BELOW THE WORD "KEEWORLDGROUP".

#### CLASS 35—ADVERTISING AND BUSINESS

FOR WHOLESALE DISTRIBUTORSHIPS FEATURING DRY FOOD GOODS, FROZEN FOOD GOODS, ALCOHOLIC BEVERAGES, NON-ALCOHOLIC BEVERAGES, AND NON-FOOD PRODUCTS IN THE NATURE OF SANITARY FACE SHIELDS AND FIRE EXTINGUISHING SPRAYS (U.S. CLS. 100, 101 AND 102).

FIRST USE 3-23-2007; IN COMMERCE 3-23-2007.

#### CLASS 39—TRANSPORTATION AND STORAGE

FOR IMPORT AND EXPORT SERVICES, NAMELY, TRANSPORTATION OF THE MERCHANDISE OF OTHERS IN THE NATURE OF DRY FOOD GOODS, FROZEN FOOD GOODS, ALCOHOLIC BEVERAGES, NON-ALCOHOLIC BEVERAGES, AND NON-FOOD PRODUCTS IN THE NATURE OF SANITARY FACE SHIELDS AND FIRE EXTINGUISHING SPRAYS (U.S. CLS. 100 AND 105).

FIRST USE 3-23-2007; IN COMMERCE 3-23-2007.  
ANNIE NOBLE, EXAMINING ATTORNEY

SN 86-236,519. EDGEMAKERS, INC., SAN FRANCISCO, CA. FILED 3-30-2014.

# EDGEMAKERS

THE MARK CONSISTS OF STANDARD CHARACTERS WITHOUT CLAIM TO ANY PARTICULAR FONT, STYLE, SIZE, OR COLOR.

#### CLASS 9—ELECTRICAL AND SCIENTIFIC APPARATUS

FOR COMPUTER SOFTWARE USED BY TEACHERS AND SCHOOLS FOR CURRICULUM DEVELOPMENT AND MANAGEMENT, MANAGING CLASSROOM ACTIVITIES, COMPILING, ASSIGNING, REVIEWING, AND GRADING HOMEWORK, ASSIGNMENTS, TESTS AND EXAMS, COMMUNICATING WITH STUDENTS AND OTHER TEACHERS AND COMPILING AND PREPARING REPORTS ON STUDENTS; COMPUTER SOFTWARE USED BY STUDENTS FOR ACCESSING COURSE MATERIALS, ACCESSING AND COMPLETING EDUCATIONAL SIMULATIONS AND GAMES, VIEWING VIDEO, LISTENING TO AUDIO, ACCESSING, COMPLETING AND SUBMITTING HOMEWORK, ASSIGNMENTS, TESTS AND EXAMS, AND COMMUNICATING WITH TEACHERS AND OTHER STUDENTS (U.S. CLS. 21, 23, 26, 36 AND 38).

#### CLASS 41—EDUCATION AND ENTERTAINMENT

FOR EDUCATION SERVICES, NAMELY, PROVIDING LIVE AND ON-LINE CLASSES, SEMINARS, AND WORKSHOPS IN THE FIELDS OF CREATIVITY, INNOVATION, ENTREPRENEURSHIP, DESIGN, PROJECT MANAGEMENT, STARTUPS, AND PRODUCT DEVELOPMENT; EDUCATIONAL SERVICES, NAMELY, DEVELOPING CURRICULUM FOR EDUCATORS; PROVIDING RECOGNITION AND INCENTIVES BY THE WAY OF AWARDS AND CONTESTS TO DEMONSTRATE EXCELLENCE IN THE FIELDS OF INNOVATION AND PROBLEM SOLVING; PROVIDING TEMPORARY USE OF NON-DOWNLOADABLE EDUCATIONAL COMPUTER GAME SOFTWARE FOR STUDENTS (U.S. CLS. 100, 101 AND 107).

#### CLASS 42—SCIENTIFIC AND COMPUTER SERVICES

FOR PROVIDING TEMPORARY USE OF NON-DOWNLOADABLE COMPUTER SOFTWARE USED BY TEACHERS AND SCHOOLS FOR CURRICULUM DEVELOPMENT AND MANAGEMENT, MANAGING CLASSROOM ACTIVITIES, COMPILING, ASSIGNING, REVIEWING, AND GRADING HOMEWORK, ASSIGNMENTS, TESTS AND EXAMS, COMMUNICATING WITH STUDENTS AND OTHER TEACHERS AND COMPILING AND PREPARING REPORTS ON STUDENTS VIA ELECTRONIC, OPTICAL AND WIRELESS NETWORKS; PROVIDING TEMPORARY USE OF NON-DOWNLOADABLE COMPUTER SOFTWARE USED BY STUDENTS FOR ACCESSING COURSE MATERIALS, ACCESSING AND COMPLETING EDUCATIONAL SIMULATIONS, VIEWING VIDEO, LISTENING TO AUDIO, ACCESSING, COMPLETING AND SUBMITTING HOMEWORK, ASSIGNMENTS, TESTS AND EXAMS, AND COMMUNICATING AND COLLABORATING WITH TEACHERS AND OTHER STUDENTS VIA ELECTRONIC, OPTICAL AND WIRELESS NETWORKS (U.S. CLS. 100 AND 101).

LAURA GOLDEN, EXAMINING ATTORNEY

SN 86-236,642. SUNFLOWER MEADOWS HERB FARM LLC, KANOSH, UT. FILED 3-31-2014.



THE COLOR(S) BROWN AND YELLOW IS/ARE CLAIMED AS A FEATURE OF THE MARK.

THE MARK CONSISTS OF A DEPICTION OF A SUNFLOWER IN THE COLORS BROWN AND YELLOW, SUPERIMPOSED, IN PART, OVER A YELLOW CIRCLE; THE AREAS OF THE FLOWER SHOWN IN WHITE ARE NOT PART OF THE MARK AND ARE TRANSPARENT.

#### CLASS 5—PHARMACEUTICALS

FOR HERBAL SUPPLEMENTS AND MEDICINAL HERBAL PREPARATIONS (U.S. CLS. 6, 18, 44, 46, 51 AND 52).

#### CLASS 30—STAPLE FOODS

FOR HERBAL TEA AND HERBAL FOOD BEVERAGES (U.S. CL. 46).

**CLASS 32—LIGHT BEVERAGES**

FOR HERBAL JUICES (U.S. CLS. 45, 46 AND 48).  
KAPIL BHANOT, EXAMINING ATTORNEY

SN 86-236,658. SUNFLOWER MEADOWS HERB FARM LLC,  
KANOSH, UT. FILED 3-31-2014.

SN 86-236,645. THE MOODY BIBLE INSTITUTE OF CHICA-  
GO, CHICAGO, IL. FILED 3-31-2014.

SUNFLOWER MEADOWS HERB FARM

**THE 5 LOVE LANGUAGES**

THE MARK CONSISTS OF STANDARD CHARACTERS  
WITHOUT CLAIM TO ANY PARTICULAR FONT, STYLE,  
SIZE, OR COLOR.

OWNER OF U.S. REG. NO. 3,810,681.

THE MARK CONSISTS OF STANDARD CHARACTERS  
WITHOUT CLAIM TO ANY PARTICULAR FONT, STYLE,  
SIZE, OR COLOR.

NO CLAIM IS MADE TO THE EXCLUSIVE RIGHT TO  
USE "HERB FARM", APART FROM THE MARK AS  
SHOWN.

**CLASS 9—ELECTRICAL AND SCIENTIFIC APPARATUS**

FOR ELECTRONIC PUBLICATIONS, NAMELY,  
DOWNLOADABLE E-BOOKS IN THE FIELD OF PERSONAL  
SKILLS AND RELATIONSHIPS; DOWNLOADABLE  
SOFTWARE IN THE NATURE OF A MOBILE APPLICATION  
REGARDING PERSONAL SKILLS AND RELATIONSHIPS;  
AUDIO AND VIDEO RECORDINGS FEATURING  
INFORMATION AND ADVICE ABOUT PERSONAL SKILLS  
AND RELATIONSHIPS; AUDIO BOOKS IN THE FIELD OF  
PERSONAL SKILLS AND RELATIONSHIPS; PRE-RECORDED  
DVDs FEATURING INFORMATION AND ADVICE ABOUT  
PERSONAL SKILLS AND RELATIONSHIPS (U.S. CLS. 21,  
23, 26, 36 AND 38).

FIRST USE 0-0-2010; IN COMMERCE 0-0-2010.

**CLASS 5—PHARMACEUTICALS**

FOR HERBAL SUPPLEMENTS AND MEDICINAL  
HERBAL PREPARATIONS (U.S. CLS. 6, 18, 44, 46, 51  
AND 52).

**CLASS 30—STAPLE FOODS**

FOR HERBAL TEA AND HERBAL FOOD BEVERAGES  
(U.S. CL. 46).

**CLASS 16—PAPER GOODS AND PRINTED MATTER**

FOR SERIES OF PUBLICATIONS, NAMELY, BOOKS,  
PAMPHLETS, BROCHURES RELATED TO PERSONAL  
SKILLS AND RELATIONSHIPS; PRINTED MATERIALS,  
NAMELY, CALENDARS AND GREETING CARDS CONTAINING  
THEMES RELATED TO PERSONAL SKILLS AND  
RELATIONSHIPS (U.S. CLS. 2, 5, 22, 23, 29, 37, 38  
AND 50).

FIRST USE 0-0-2010; IN COMMERCE 0-0-2010.

**CLASS 32—LIGHT BEVERAGES**

FOR HERBAL JUICES (U.S. CLS. 45, 46 AND 48).  
KAPIL BHANOT, EXAMINING ATTORNEY

SN 86-237,082. HDPB SYSTEM INTERNACIONAL, S.A.,  
MIAMI, FL. FILED 3-31-2014.

**PIC BOX C****CLASS 41—EDUCATION AND ENTERTAINMENT**

FOR PROVIDING A WEBSITE FEATURING BLOGS  
AND NON-DOWNLOADABLE PUBLICATIONS IN THE  
NATURE OF ARTICLES AND STUDY GUIDES IN THE  
FIELDS OF PERSONAL SKILLS AND RELATIONSHIPS;  
PROVIDING A WEBSITE FEATURING NON-DOWNLOADABLE  
VIDEOS AND AUDIO RECORDINGS CONCERNING  
INFORMATION AND ADVICE ABOUT PERSONAL SKILLS  
AND; EDUCATIONAL SERVICES, NAMELY, CONDUCTING  
CONFERENCES, SEMINARS, WEBINARS IN THE FIELD  
OF PERSONAL SKILLS AND RELATIONSHIPS (U.S. CLS.  
100, 101 AND 107).

FIRST USE 0-0-2010; IN COMMERCE 0-0-2010.

THE MARK CONSISTS OF STANDARD CHARACTERS  
WITHOUT CLAIM TO ANY PARTICULAR FONT, STYLE,  
SIZE, OR COLOR.

NO CLAIM IS MADE TO THE EXCLUSIVE RIGHT TO  
USE "PIC" FOR CLASSES 016 AND 040 AND PICTURE  
FRAMES IN CLASS 020., APART FROM THE MARK AS  
SHOWN.

**CLASS 45—PERSONAL AND LEGAL SERVICES**

FOR PROVIDING A WEBSITE FEATURING INFORMATION  
AND ADVICE ABOUT PERSONAL SKILLS AND  
RELATIONSHIPS, NOT FOR ENTERTAINMENT  
PURPOSES (U.S. CLS. 100 AND 101).

FIRST USE 0-0-2010; IN COMMERCE 0-0-2010.

SIDDHARTH JAGANNATHAN, EXAMINING ATTORNEY

**CLASS 16—PAPER GOODS AND PRINTED MATTER**

FOR PRINTED MATTER, NAMELY, ADVERTISING  
CATALOGUES; CALENDARS; HANDBOOKS, NAMELY,  
MANUALS IN THE FIELD OF PHOTOGRAPHY; POSTERS;  
PLASTIC FILMS AND BAGS FOR PACKAGING;  
PHOTOGRAPHS; PRINTS; PRINT ENGRAVINGS; STATIONERY;  
PHOTOGRAPH ALBUMS (U.S. CLS. 2, 5, 22,  
23, 29, 37, 38 AND 50).

**CLASS 20—FURNITURE AND ARTICLES NOT OTHERWISE CLASSIFIED**

FOR FURNITURE, MIRRORS, PICTURE FRAMES  
(U.S. CLS. 2, 13, 22, 25, 32 AND 50).

**CLASS 40—MATERIAL TREATMENT**

FOR DIGITAL PRINTING, PHOTOGRAPHIC PRINTING, PRINTING OF ADVERTISING MATERIAL, PRINTING OF BOOKS; PHOTOMONTAGE IN THE NATURE OF ALTERATION AND RETOUCHING OF PHOTOGRAPHIC IMAGES; FINE ART PRINTING SERVICES; SCREEN PRINTING; RENTAL OF IMAGE PRINTING MACHINES AND APPARATUS (U.S. CLS. 100, 103 AND 106).

KAPIL BHANOT, EXAMINING ATTORNEY

SN 86-237,083. MACDONALD, JOHN A., LOWELL, MA. FILED 3-31-2014.

**Big Decisions, LLC.**

THE MARK CONSISTS OF STANDARD CHARACTERS WITHOUT CLAIM TO ANY PARTICULAR FONT, STYLE, SIZE, OR COLOR.

NO CLAIM IS MADE TO THE EXCLUSIVE RIGHT TO USE "LLC.", APART FROM THE MARK AS SHOWN.

**CLASS 35—ADVERTISING AND BUSINESS**

FOR ADVICE IN THE FIELD OF BUSINESS MANAGEMENT; PROVIDING ONLINE BUSINESS MANAGEMENT SERVICES IN THE FIELDS OF ACCOUNTING, BUSINESS PROJECT MANAGEMENT, AND BUSINESS DEVELOPMENT; PROVIDING PUBLIC SECTOR BUSINESS INTELLIGENCE (U.S. CLS. 100, 101 AND 102).

**CLASS 41—EDUCATION AND ENTERTAINMENT**

FOR TRAINING COURSES IN STRATEGIC PLANNING RELATING TO BUSINESS (U.S. CLS. 100, 101 AND 107).

DAVID MURRAY, EXAMINING ATTORNEY

SN 86-237,121. JRINKR, FOUNTAIN VALLEY, CA. FILED 3-31-2014.

**jrindr**

THE MARK CONSISTS OF STANDARD CHARACTERS WITHOUT CLAIM TO ANY PARTICULAR FONT, STYLE, SIZE, OR COLOR.

**CLASS 9—ELECTRICAL AND SCIENTIFIC APPARATUS**

FOR DOWNLOADABLE SOFTWARE IN THE NATURE OF A MOBILE APPLICATION IN THE FIELD OF SOCIAL MEDIA FOR INTERNET-BASED USERS TO POST RATINGS, REVIEWS, DIGITAL PICTURE AND MEDIA UPLOADS, REFERRALS AND RECOMMENDATIONS RELATING TO RESTAURANTS, BAR BUSINESSES, AND BAR RELATED EVENTS; DOWNLOADABLE SOFTWARE FOR PROVIDING CONSUMER INFORMATION, NAMELY, RATINGS, REVIEWS, REFERRALS, RECOMMENDATIONS, BUSINESS INFORMATION, NAMELY, BAR BUSINESSES, RESTAURANTS, AND BAR RELATED EVENTS; DOWNLOADABLE SOFTWARE FOR DISPLAYING, SHARING, FINDING, AND LOCATING A USER'S LOCATION TO INTERACT WITH OTHER USERS AND PLACES AND ALLOWS SOCIAL ENGAGEMENT BETWEEN USERS, NAMELY, MESSAGING, SHARING, TAGGING, AND CHECKING (U.S. CLS. 21, 23, 26, 36 AND 38).

**CLASS 42—SCIENTIFIC AND COMPUTER SERVICES**

FOR PROVIDING A WEBSITE FEATURING TECHNOLOGY IN THE FIELD OF SOCIAL MEDIA THAT ALLOWS USERS TO POST RATINGS, REVIEWS, DIGITAL PICTURES AND MEDIA UPLOADS, REFERRALS AND RECOMMENDATIONS RELATING TO RESTAURANTS, BAR BUSINESSES AND BAR RELATED EVENTS; PROVIDING A WEBSITE FEATURING TECHNOLOGY WHICH ENABLES USERS TO MEET ONLINE THROUGH DISPLAYING, SHARING, FINDING AND LOCATING A USER'S LOCATION WITH OTHER USERS AND PLACES AND CREATES AN ONLINE COMMUNITY FOR REGISTERED USERS THAT ALLOWS ENGAGEMENT IN SOCIAL NETWORKING SERVICES, NAMELY, MESSAGING, SHARING, TAGGING, AND CHECKING-IN FOR BAR BUSINESSES AND BAR RELATED EVENTS (U.S. CLS. 100 AND 101).

DANIEL S. STRINGER, EXAMINING ATTORNEY

SN 86-237,157. FRIENDS OF THE HUNLEY, INC, CHARLESTON, SC. FILED 3-31-2014.

**THE H. L. HUNLEY COMPANY**

THE MARK CONSISTS OF STANDARD CHARACTERS WITHOUT CLAIM TO ANY PARTICULAR FONT, STYLE, SIZE, OR COLOR.

OWNER OF U.S. REG. NOS. 2,604,493 AND 2,607,515. NO CLAIM IS MADE TO THE EXCLUSIVE RIGHT TO USE "COMPANY", APART FROM THE MARK AS SHOWN.

THE NAME(S), PORTRAIT(S), AND/OR SIGNATURE(S) SHOWN IN THE MARK DOES NOT IDENTIFY A PARTICULAR LIVING INDIVIDUAL.

**CLASS 11—ENVIRONMENTAL CONTROL APPARATUS**

FOR ELECTRIC LANTERNS (U.S. CLS. 13, 21, 23, 31 AND 34).

FIRST USE 1-31-2014; IN COMMERCE 1-31-2014.

**CLASS 25—CLOTHING**

FOR BASEBALL CAPS (U.S. CLS. 22 AND 39).

FIRST USE 1-31-2014; IN COMMERCE 1-31-2014. CRISTIANA SCHWAB, EXAMINING ATTORNEY



SN 86-237,169. KABUSHIKI KAISHA JUN, AKA JUN CO., LTD., TOKYO, JAPAN, FILED 3-31-2014.

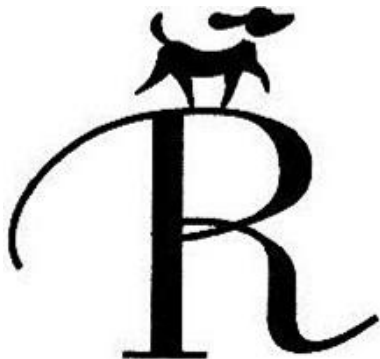

THE MARK CONSISTS OF A DOG CHARACTER ABOVE THE LETTER "R" IN STYLIZED FORM.

#### CLASS 14—JEWELRY

FOR PRECIOUS METALS; KEY RINGS OF PRECIOUS METAL; PERSONAL ORNAMENTS OF PRECIOUS METAL; PERSONAL JEWELRY ORNAMENTS; UNWROUGHT AND SEMI-WROUGHT PRECIOUS STONES AND THEIR IMITATIONS, CLOCKS AND WATCHES, JEWEL CASES (U.S. CLS. 2, 27, 28 AND 50).

#### CLASS 18—LEATHER GOODS

FOR HANDBAG FRAMES, PURSE FRAMES, HORSESHOES, INDUSTRIAL PACKAGING CONTAINERS OF LEATHER, CLOTHING FOR DOMESTIC PETS; CLUTCH BAGS; CANVAS SHOPPING BAGS; CARRY-ALL BAGS; CARRY-ON BAGS; DRAWSTRING BAGS; LEATHER AND IMITATION LEATHER BAGS; SHOULDER BAGS; BACKPACKS, BOOK BAGS, SPORTS BAGS, BUM BAGS, WALLETS AND HANDBAGS; DRAWSTRING POUCHES; FELT POUCHES; JEWELRY POUCHES; KEY POUCHES; LEATHER AND IMITATION LEATHER POUCHES; POUCHES FOR HOLDING MAKE-UP, KEYS AND OTHER PERSONAL ITEMS; POUCHES TEXTILE AND CLOTH; WAIST POUCHES; WEARABLE STRAP-ON POUCH; UNFITTED VANITY CASES; VANITY CASES SOLD EMPTY; UMBRELLAS AND THEIR PARTS, WALKING STICKS, CANES, METAL PARTS OF CANES AND WALKING STICKS, HANDLES FOR CANES AND WALKING STICKS, RAWHIDES, RAW SKINS, TANNED LEATHER; FUR PELTS; ARTIFICIAL FUR (U.S. CLS. 1, 2, 3, 22 AND 41).

#### CLASS 25—CLOTHING

FOR CLOTHING, NAMELY, SHIRTS, SHORTS, PANTS, JACKETS, COATS, SWEATSHIRTS, SWEATPANTS, TOPS, BOTTOMS, SOCKS, HATS AND CAPS; GARTERS, SOCK SUSPENDERS, SUSPENDERS, WAISTBANDS, BELTS FOR CLOTHING, FOOTWEAR, MASQUERADE COSTUMES; CLOTHES FOR SPORTS, NAMELY, UNIFORMS AND OVERUNIFORMS; ATHLETIC APPAREL FOR SPORTS, NAMELY, SHIRTS, PANTS, JACKETS, FOOTWEAR, HATS AND CAPS, ATHLETIC UNIFORMS; SPECIAL FOOTWEAR FOR SPORTS (U.S. CLS. 22 AND 39).

#### CLASS 30—STAPLE FOODS

FOR CONFECTIONERY, NAMELY, CHOCOLATE CONFECTIONS, CONFECTIONERY MADE OF SUGAR, PASTILLES, FONDANTS, BAKERY DESSERTS; FROZEN CONFECTIONERY; BREAD AND BUNS, SANDWICHES, TEA, COFFEE AND COCOA, BOXED LUNCHESES CONSISTING OF RICE WITH ADDED MEAT OR FISH OR VEGETABLES (U.S. CL. 46).

#### CLASS 35—ADVERTISING AND BUSINESS

FOR PROVIDING INFORMATION CONCERNING COMMERCIAL SALES; RETAIL AND WHOLESALE STORE SERVICES FEATURING WOVEN FABRICS, BEDDINGS, CLOTHING, FOOTWEAR, OTHER THAN SPECIAL FOOTWEAR FOR SPORTS, BAGS AND POUCHES, PERSONAL ARTICLES, COSMETICS, TOILETRIES, DENTIFRICES, SOAPS AND DETERGENTS, CONFECTIONERY, BREAD AND BUNS, SANDWICHES, TEA, COFFEE AND COCOA, AND BOXED LUNCHESES CONSISTING OF RICE WITH ADDED MEAT OR FISH OR VEGETABLES (U.S. CLS. 100, 101 AND 102).

VERNA BETH RIRIE, EXAMINING ATTORNEY

SN 86-237,303. INTERNET PIPELINE, INC., DBA IPIPELINE, EXTON, PA. FILED 3-31-2014.



OWNER OF U.S. REG. NOS. 3,799,398 AND 4,515,634.  
NO CLAIM IS MADE TO THE EXCLUSIVE RIGHT TO USE "INSURANCE", APART FROM THE MARK AS SHOWN.

#### CLASS 9—ELECTRICAL AND SCIENTIFIC APPARATUS

FOR DOWNLOADABLE SOFTWARE FOR EXPEDITING AND FACILITATING THE MARKETING, SELLING AND PROCESSING OF INSURANCE AND FINANCIAL PRODUCTS FOR THE INSURANCE INDUSTRY (U.S. CLS. 21, 23, 26, 36 AND 38).

#### CLASS 42—SCIENTIFIC AND COMPUTER SERVICES

FOR PROVIDING TEMPORARY USE OF NON-DOWNLOADABLE SOFTWARE FOR EXPEDITING AND FACILITATING THE MARKETING, SELLING AND PROCESSING OF INSURANCE AND FINANCIAL PRODUCTS FOR THE INSURANCE INDUSTRY (U.S. CLS. 100 AND 101).

KRISTIN DAHLING, EXAMINING ATTORNEY

SN 86-237,341. ULM, AMY DELYLA, WASHINGTON ISLAND, WI. FILED 3-31-2014.



**AUTISM LOVE**

NO CLAIM IS MADE TO THE EXCLUSIVE RIGHT TO USE "AUTISM", APART FROM THE MARK AS SHOWN.

THE MARK CONSISTS OF A DESIGN OF AN ABSTRACT CHICKEN INSIDE OF A SQUARE WITH THE STYLIZED TEXT "AUTISM LOVE" BENEATH THE SQUARE.

**CLASS 16—PAPER GOODS AND PRINTED MATTER**

FOR SERIES OF NON-FICTION BOOKS IN THE FIELD OF AUTISM (U.S. CLS. 2, 5, 22, 23, 29, 37, 38 AND 50).

**CLASS 41—EDUCATION AND ENTERTAINMENT**

FOR PROVIDING A WEBSITE FEATURING NON-DOWNLOADABLE ARTICLES IN THE FIELD OF AUTISM (U.S. CLS. 100, 101 AND 107).

**CLASS 42—SCIENTIFIC AND COMPUTER SERVICES**

FOR PROVIDING A WEB SITE FEATURING TECHNOLOGY THAT ENABLES USERS TO SUBMIT AND UPLOAD PERSONAL STORIES AND ANECDOTES ABOUT AUTISM (U.S. CLS. 100 AND 101).

JENNY PARK, EXAMINING ATTORNEY

SN 86-237,344. BELLINI JUVENILE DESIGNER FURNITURE CORPORATION, SCARSDALE, NY. FILED 3-31-2014.

MOONSICLES

THE MARK CONSISTS OF STANDARD CHARACTERS WITHOUT CLAIM TO ANY PARTICULAR FONT, STYLE, SIZE, OR COLOR.

**CLASS 5—PHARMACEUTICALS**

FOR BABY DIAPERS (U.S. CLS. 6, 18, 44, 46, 51 AND 52).

**CLASS 18—LEATHER GOODS**

FOR DIAPER BAGS (U.S. CLS. 1, 2, 3, 22 AND 41).

**CLASS 25—CLOTHING**

FOR FOOTWEAR; CLOTHING, NAMELY, TOPS, BOTTOMS, PANTS, INFANTWEAR, UNDERWEAR, BODYSUITS, UNDERCLOTHES AND SLEEPWEAR; SOCKS, HEADWEAR (U.S. CLS. 22 AND 39).

**CLASS 28—TOYS AND SPORTING GOODS**

FOR TOYS, NAMELY, INFANT TOYS, TEETHING TOYS, NAMELY, BABY RATTLES INCORPORATING TEETHING RINGS, PULL TOYS, SQUEEZABLE TOYS, BABY MULTIPLE ACTIVITY TOYS, BUILDING TOYS, NAMELY, TOY BUILDING BLOCKS, RATTLES, BATH TOYS, DOLLS, STUFFED ANIMALS (U.S. CLS. 22, 23, 38 AND 50).

KAREN K. BUSH, EXAMINING ATTORNEY

SN 86-237,443. PREFER PRODUCTS BRANDS, INC., WARREN, MI. FILED 3-31-2014.



OWNER OF U.S. REG. NO. 4,229,053.  
THE COLOR(S) RED AND WHITE IS/ARE CLAIMED AS A FEATURE OF THE MARK.

THE MARK CONSISTS OF A RED OVAL ENCIRCLED BY A WHITE RING WITH THE WORD "PREFER" IN WHITE APPEARING IN THE OVAL; THE GREYSCALE BACKGROUND IS NOT CLAIMED AS A FEATURE OF THE MARK, BUT IS INTENDED TO SHOW THE WHITE RING SURROUNDING THE OVAL.

**CLASS 6—METAL GOODS**

FOR (BASED ON USE IN COMMERCE) ALUMINIUM FOIL (U.S. CLS. 2, 12, 13, 14, 23, 25 AND 50).  
FIRST USE 6-30-2003; IN COMMERCE 6-30-2003.

**CLASS 16—PAPER GOODS AND PRINTED MATTER**

FOR (BASED ON INTENT TO USE) GARBAGE BAGS OF PLASTIC (U.S. CLS. 2, 5, 22, 23, 29, 37, 38 AND 50).

**CLASS 29—MEATS AND PROCESSED FOODS**

FOR (BASED ON USE IN COMMERCE) CANNED FISH; LEMON JUICE FOR COOKING PURPOSES; VEGETABLE OILS (U.S. CL. 46).  
FIRST USE 6-30-2003; IN COMMERCE 6-30-2003.

**CLASS 30—STAPLE FOODS**

FOR (BASED ON INTENT TO USE) PANCAKE SYRUP; SALT (U.S. CL. 46).  
BRENDAN REGAN, EXAMINING ATTORNEY

SN 86-237,530. BIG PARKA PRODUCTIONS INC., DBA LITTLE JACKET, CLEVELAND, OH. FILED 3-31-2014.

LITTLE JACKET

THE MARK CONSISTS OF STANDARD CHARACTERS WITHOUT CLAIM TO ANY PARTICULAR FONT, STYLE, SIZE, OR COLOR.

**CLASS 35—ADVERTISING AND BUSINESS**

FOR ADVERTISING AND MARKETING; BRAND CONCEPT AND BRAND DEVELOPMENT SERVICES FOR CORPORATE AND INDIVIDUAL CLIENTS (U.S. CLS. 100, 101 AND 102).

FIRST USE 7-1-2004; IN COMMERCE 7-1-2004.

**CLASS 42—SCIENTIFIC AND COMPUTER SERVICES**

FOR GRAPHIC DESIGN FOR OTHERS, WEBSITE DESIGN FOR OTHERS, GRAPHIC ILLUSTRATION SERVICES FOR OTHERS (U.S. CLS. 100 AND 101).  
FIRST USE 7-1-2004; IN COMMERCE 7-1-2004.  
MARC LEIPZIG, EXAMINING ATTORNEY

SN 86-237,540. SOUTH CAROLINA ASSOCIATION OF CERTIFIED PUBLIC ACCOUNTANTS, AKA SCACPA, WEST COLUMBIA, SC. FILED 3-31-2014.

## Where CPAs Thrive

THE MARK CONSISTS OF STANDARD CHARACTERS WITHOUT CLAIM TO ANY PARTICULAR FONT, STYLE, SIZE, OR COLOR.

**CLASS 35—ADVERTISING AND BUSINESS**

FOR ASSOCIATION SERVICES, NAMELY, PROMOTING THE PROFESSIONAL INTERESTS OF FINANCIAL PLANNERS; PROVIDING PROFESSIONAL RESOURCES FOR FINANCIAL PLANNERS, NAMELY, PROVIDING AN ONLINE MEMBER DIRECTORY, BUSINESS NETWORKING SERVICES, BUSINESS NETWORKING REFERRAL SERVICES IN THE NATURE OF PROVIDING REFERRALS AMONG ASSOCIATION MEMBERS, AND PROVIDING AN ONLINE MARKETPLACE FEATURING GOODS AND SERVICES FOR USE BY FINANCIAL PLANNERS IN THE OPERATION OF THEIR BUSINESSES (U.S. CLS. 100, 101 AND 102).

**CLASS 41—EDUCATION AND ENTERTAINMENT**

FOR EDUCATIONAL SERVICES, NAMELY, PROVIDING CONTINUING PROFESSIONAL EDUCATION COURSES IN THE FIELD OF FINANCIAL PLANNING (U.S. CLS. 100, 101 AND 107).  
KIMBERLY FRYE, EXAMINING ATTORNEY

SN 86-237,553. SOUTH CAROLINA ASSOCIATION OF CERTIFIED PUBLIC ACCOUNTANTS, AKA SCACPA, WEST COLUMBIA, SC. FILED 3-31-2014.



NO CLAIM IS MADE TO THE EXCLUSIVE RIGHT TO USE "SOUTH CAROLINA CPAs", APART FROM THE MARK AS SHOWN.

THE COLOR(S) BLACK, GREY AND GREEN IS/ARE CLAIMED AS A FEATURE OF THE MARK.

THE MARK CONSISTS OF THE WORDS "SOUTH CAROLINA CPAs" WITH THE WORDS "SOUTH CAROLINA" IN BLACK AND "CPAs" IN GREEN, ABOVE THE WORDING "WHERE CPAs THRIVE" IN GREY, NEXT TO A SUBSTANTIALLY SQUARE PENROSE SHAPE FORMED BY ALTERNATING AND OVERLAPPING GREEN, GREY AND BLACK LINES. THE WHITE IN THE MARK REPRESENTS TRANSPARENCY AND IS NOT CLAIMED AS A FEATURE OF THE MARK.

**CLASS 35—ADVERTISING AND BUSINESS**

FOR ASSOCIATION SERVICES, NAMELY, PROMOTING THE PROFESSIONAL INTERESTS OF CERTIFIED PUBLIC ACCOUNTANTS; PROVIDING PROFESSIONAL RESOURCES FOR CERTIFIED PUBLIC ACCOUNTANTS, NAMELY, PROVIDING AN ONLINE MEMBER DIRECTORY, BUSINESS NETWORKING SERVICES, BUSINESS NETWORKING REFERRAL SERVICES IN THE NATURE OF PROVIDING REFERRALS AMONG ASSOCIATION MEMBERS, AND PROVIDING AN ONLINE MARKETPLACE FEATURING GOODS AND SERVICES FOR USE BY ACCOUNTANTS IN THE OPERATION OF THEIR BUSINESSES (U.S. CLS. 100, 101 AND 102).

**CLASS 41—EDUCATION AND ENTERTAINMENT**

FOR EDUCATIONAL SERVICES, NAMELY, PROVIDING CONTINUING PROFESSIONAL EDUCATION COURSES IN THE FIELD OF ACCOUNTING (U.S. CLS. 100, 101 AND 107).  
KIMBERLY FRYE, EXAMINING ATTORNEY

SN 86-237,556. NGUYEN, LAN, HOUSTON, TX. FILED 3-31-2014.

## ELLA EYES

THE MARK CONSISTS OF STANDARD CHARACTERS WITHOUT CLAIM TO ANY PARTICULAR FONT, STYLE, SIZE, OR COLOR.

NO CLAIM IS MADE TO THE EXCLUSIVE RIGHT TO USE "EYES", APART FROM THE MARK AS SHOWN.

**CLASS 35—ADVERTISING AND BUSINESS**

FOR RETAIL OPTICAL STORES (U.S. CLS. 100, 101 AND 102).

**CLASS 44—MEDICAL, BEAUTY AND AGRICULTURAL SERVICES**

FOR OPTOMETRY SERVICES; OPTICIAN SERVICES; OPTICAL SERVICES, NAMELY, FITTING OF OPTICAL LENSES (U.S. CLS. 100 AND 101).  
KIMBERLY FRYE, EXAMINING ATTORNEY

SN 86-237,631. TRANSLATOR ADVISOR INC, DULUTH, GA. FILED 3-31-2014.

## translatoradvisor

THE MARK CONSISTS OF STANDARD CHARACTERS WITHOUT CLAIM TO ANY PARTICULAR FONT, STYLE, SIZE, OR COLOR.

**CLASS 35—ADVERTISING AND BUSINESS**

FOR PROVIDING AN ONLINE COMMERCIAL DATABASE OF TRANSLATORS AND TRANSLATOR PROFILES (U.S. CLS. 100, 101 AND 102).

FIRST USE 3-28-2014; IN COMMERCE 3-28-2014.

**CLASS 42—SCIENTIFIC AND COMPUTER SERVICES**

FOR PROVIDING A WEB SITE FEATURING TECHNOLOGY THAT ENABLES USERS TO PROVIDE REVIEWS OF TRANSLATORS WHOSE SERVICES THEY HAVE USED (U.S. CLS. 100 AND 101).

FIRST USE 3-28-2014; IN COMMERCE 3-28-2014.

LINDA POWELL, EXAMINING ATTORNEY

SN 86-237,632. HAPPINESS GLUE, LLC, LOS ANGELES, CA. FILED 3-31-2014.

**DUGGIE SCOTT WALKER**

THE MARK CONSISTS OF STANDARD CHARACTERS WITHOUT CLAIM TO ANY PARTICULAR FONT, STYLE, SIZE, OR COLOR.

THE NAME "DUGGIE SCOTT WALKER" DOES NOT IDENTIFY A LIVING INDIVIDUAL.

**CLASS 25—CLOTHING**

FOR CLOTHING, NAMELY, SHIRTS, SWEATSHIRTS, AND HATS (U.S. CLS. 22 AND 39).

**CLASS 28—TOYS AND SPORTING GOODS**

FOR TOYS, NAMELY, BOBBLE HEAD DOLLS, PLUSH DOLLS, PUPPETS, AND VENTRILOQUIST'S DUMMIES (U.S. CLS. 22, 23, 38 AND 50).

**CLASS 41—EDUCATION AND ENTERTAINMENT**

FOR ENTERTAINMENT SERVICES, NAMELY, LIVE MUSICAL, COMEDY, AND VENTRILOQUIST PERFORMANCES (U.S. CLS. 100, 101 AND 107).

LINDA POWELL, EXAMINING ATTORNEY

SN 86-237,843. ONE INC., SALINA, KS. FILED 3-31-2014.

**ONE TAXI**

THE MARK CONSISTS OF STANDARD CHARACTERS WITHOUT CLAIM TO ANY PARTICULAR FONT, STYLE, SIZE, OR COLOR.

NO CLAIM IS MADE TO THE EXCLUSIVE RIGHT TO USE "TAXI", APART FROM THE MARK AS SHOWN.

**CLASS 9—ELECTRICAL AND SCIENTIFIC APPARATUS**

FOR DOWNLOADABLE COMPUTER SOFTWARE FOR COORDINATING TRANSPORTATION SERVICES, NAMELY, SOFTWARE FOR THE AUTOMATED SCHEDULING AND DISPATCH OF MOTORIZED VEHICLES; DOWNLOADABLE MOBILE APPLICATIONS FOR COORDINATING TRANSPORTATION SERVICES, NAMELY, SOFTWARE FOR THE AUTOMATED SCHEDULING AND DISPATCH OF MOTORIZED VEHICLES (U.S. CLS. 21, 23, 26, 36 AND 38).

**CLASS 38—COMMUNICATION**

FOR TELECOMMUNICATIONS SERVICES, NAMELY, ROUTING CALLS, SMS MESSAGES, AND PUSH-NOTIFICATIONS TO LOCAL THIRD-PARTY MOTORIZED VEHICLE DISPATCHERS IN THE VICINITY OF THE CALLER USING MOBILE PHONES (U.S. CLS. 100, 101 AND 104).

**CLASS 39—TRANSPORTATION AND STORAGE**

FOR PROVIDING A WEBSITE FEATURING INFORMATION REGARDING TRANSPORTATION SERVICES AND BOOKINGS FOR TRANSPORTATION SERVICES (U.S. CLS. 100 AND 105).

**CLASS 42—SCIENTIFIC AND COMPUTER SERVICES**

FOR PROVIDING TEMPORARY USE OF ONLINE NON-DOWNLOADABLE SOFTWARE FOR PROVIDING TRANSPORTATION SERVICES, BOOKINGS FOR TRANSPORTATION SERVICES AND DISPATCHING MOTORIZED VEHICLES TO CUSTOMERS (U.S. CLS. 100 AND 101).

B. PARADEWELAI, EXAMINING ATTORNEY

SN 86-237,993. CASTLE HILL HOLDING LLC, CHARLOTTEVILLE, VA. FILED 3-31-2014.

**CASTLE HILL GAMING**

THE MARK CONSISTS OF STANDARD CHARACTERS WITHOUT CLAIM TO ANY PARTICULAR FONT, STYLE, SIZE, OR COLOR.

NO CLAIM IS MADE TO THE EXCLUSIVE RIGHT TO USE "GAMING", APART FROM THE MARK AS SHOWN.

**CLASS 28—TOYS AND SPORTING GOODS**

FOR ELECTRONIC GAMING MACHINES, NAMELY, DEVICES WHICH ACCEPT A WAGER; GAMING DEVICES, NAMELY, GAMING MACHINES, SLOT MACHINES, BINGO MACHINES, WITH OR WITHOUT VIDEO OUTPUT; GAMING EQUIPMENT, NAMELY, SLOT MACHINES WITH OR WITHOUT VIDEO OUTPUT; GAMING MACHINES; GAMING MACHINES FEATURING A DEVICE THAT ACCEPTS WAGERS; GAMING MACHINES FOR GAMBLING; GAMING MACHINES INCLUDING SLOT MACHINES OR VIDEO LOTTERY TERMINALS; GAMING MACHINES THAT GENERATE OR DISPLAY WAGER OUTCOMES; GAMING MACHINES, NAMELY SLOT MACHINES AND VIDEO LOTTERY TERMINALS; GAMING MACHINES, NAMELY, DEVICES WHICH ACCEPT A WAGER; RECONFIGURABLE CASINO AND LOTTERY GAMING EQUIPMENT, NAMELY, GAMING MACHINES AND OPERATIONAL COMPUTER GAME SOFTWARE THEREFOR SOLD AS A UNIT; RECONFIGURABLE CASINO GAMING MACHINES AND OPERATIONAL GAME SOFTWARE THEREFOR SOLD AS A UNIT; SLOT MACHINES (U.S. CLS. 22, 23, 38 AND 50).

**CLASS 41—EDUCATION AND ENTERTAINMENT**

FOR ENTERTAINMENT SERVICES, NAMELY, PROVIDING ONLINE ELECTRONIC GAMES; LEASING OF CASINO GAMES; PROVIDING ONLINE NON-DOWNLOADABLE GAME SOFTWARE (U.S. CLS. 100, 101 AND 107).

CURTIS FRENCH, EXAMINING ATTORNEY

**CLASS 41—EDUCATION AND ENTERTAINMENT**

FOR CASINOS; CONDUCTING AND PROVIDING FACILITIES FOR CASINO AND GAMING CONTESTS AND TOURNAMENTS; ENTERTAINMENT SERVICES, NAMELY, CASINO GAMING; ENTERTAINMENT SERVICES, NAMELY, PROVIDING ONLINE ELECTRONIC GAMES; GAMING SERVICES IN THE NATURE OF CASINO GAMING; LEASING OF CASINO GAMES; PROVIDING ONLINE NON-DOWNLOADABLE GAME SOFTWARE (U.S. CLS. 100, 101 AND 107).

PARKER HOWARD, EXAMINING ATTORNEY

SN 86-238,028. CASTLE HILL HOLDING LLC, CHARLOTTEVILLE, VA. FILED 3-31-2014.

SN 86-238,018. CASTLE HILL HOLDING LLC, CHARLOTTEVILLE, VA. FILED 3-31-2014.

**ARCTIC CASH**

THE MARK CONSISTS OF STANDARD CHARACTERS WITHOUT CLAIM TO ANY PARTICULAR FONT, STYLE, SIZE, OR COLOR.

NO CLAIM IS MADE TO THE EXCLUSIVE RIGHT TO USE "CASH", APART FROM THE MARK AS SHOWN.

**CLASS 28—TOYS AND SPORTING GOODS**

FOR ELECTRONIC GAMING MACHINES, NAMELY, DEVICES WHICH ACCEPT A WAGER; GAMING DEVICES, NAMELY, GAMING MACHINES, SLOT MACHINES, BINGO MACHINES, WITH OR WITHOUT VIDEO OUTPUT; GAMING EQUIPMENT, NAMELY, SLOT MACHINES WITH OR WITHOUT VIDEO OUTPUT; GAMING MACHINES; GAMING MACHINES FEATURING A DEVICE THAT ACCEPTS WAGERS; GAMING MACHINES FOR GAMBLING; GAMING MACHINES INCLUDING SLOT MACHINES OR VIDEO LOTTERY TERMINALS; GAMING MACHINES THAT GENERATE OR DISPLAY WAGER OUTCOMES; GAMING MACHINES, NAMELY SLOT MACHINES AND VIDEO LOTTERY TERMINALS; GAMING MACHINES, NAMELY, DEVICES WHICH ACCEPT A WAGER; RECONFIGURABLE CASINO AND LOTTERY GAMING EQUIPMENT, NAMELY, GAMING MACHINES AND OPERATIONAL COMPUTER GAME SOFTWARE THEREFOR SOLD AS A UNIT; RECONFIGURABLE CASINO GAMING MACHINES AND OPERATIONAL GAME SOFTWARE THEREFOR SOLD AS A UNIT; SLOT MACHINES (U.S. CLS. 22, 23, 38 AND 50).

**CLASS 28—TOYS AND SPORTING GOODS**

FOR ELECTRONIC GAMING MACHINES, NAMELY, DEVICES WHICH ACCEPT A WAGER; GAMING DEVICES, NAMELY, GAMING MACHINES, SLOT MACHINES, BINGO MACHINES, WITH OR WITHOUT VIDEO OUTPUT; GAMING EQUIPMENT, NAMELY, SLOT MACHINES WITH OR WITHOUT VIDEO OUTPUT; GAMING MACHINES; GAMING MACHINES FEATURING A DEVICE THAT ACCEPTS WAGERS; GAMING MACHINES FOR GAMBLING; GAMING MACHINES INCLUDING SLOT MACHINES OR VIDEO LOTTERY TERMINALS; GAMING MACHINES THAT GENERATE OR DISPLAY WAGER OUTCOMES; GAMING MACHINES, NAMELY SLOT MACHINES AND VIDEO LOTTERY TERMINALS; GAMING MACHINES, NAMELY, DEVICES WHICH ACCEPT A WAGER; RECONFIGURABLE CASINO AND LOTTERY GAMING EQUIPMENT, NAMELY, GAMING MACHINES AND OPERATIONAL COMPUTER GAME SOFTWARE THEREFOR SOLD AS A UNIT; RECONFIGURABLE CASINO GAMING MACHINES AND OPERATIONAL GAME SOFTWARE THEREFOR SOLD AS A UNIT; SLOT MACHINES (U.S. CLS. 22, 23, 38 AND 50).

**CLASS 41—EDUCATION AND ENTERTAINMENT**

FOR CASINOS; CONDUCTING AND PROVIDING FACILITIES FOR CASINO AND GAMING CONTESTS AND TOURNAMENTS; ENTERTAINMENT SERVICES, NAMELY, CASINO GAMING; GAMING SERVICES IN THE NATURE OF CASINO GAMING; LEASING OF CASINO GAMES; PROVIDING ONLINE NON-DOWNLOADABLE GAMING SOFTWARE (U.S. CLS. 100, 101 AND 107).

PARKER HOWARD, EXAMINING ATTORNEY

**NEW MONEY**

THE MARK CONSISTS OF STANDARD CHARACTERS WITHOUT CLAIM TO ANY PARTICULAR FONT, STYLE, SIZE, OR COLOR.

SN 86-238,036. CASTLE HILL HOLDING LLC, CHARLOTTEVILLE, VA. FILED 4-1-2014.

## THE WINNER CHANNEL

THE MARK CONSISTS OF STANDARD CHARACTERS WITHOUT CLAIM TO ANY PARTICULAR FONT, STYLE, SIZE, OR COLOR.

NO CLAIM IS MADE TO THE EXCLUSIVE RIGHT TO USE "CHANNEL" AS TO CLASS 41, APART FROM THE MARK AS SHOWN.

### CLASS 28—TOYS AND SPORTING GOODS

FOR ELECTRONIC GAMING MACHINES, NAMELY, DEVICES WHICH ACCEPT A WAGER; GAMING DEVICES, NAMELY, GAMING MACHINES, SLOT MACHINES, BINGO MACHINES, WITH OR WITHOUT VIDEO OUTPUT; GAMING EQUIPMENT, NAMELY, SLOT MACHINES WITH OR WITHOUT VIDEO OUTPUT; GAMING MACHINES; GAMING MACHINES FEATURING A DEVICE THAT ACCEPTS WAGERS; GAMING MACHINES FOR GAMBLING; GAMING MACHINES INCLUDING SLOT MACHINES OR VIDEO LOTTERY TERMINALS; GAMING MACHINES THAT GENERATE OR DISPLAY WAGER OUTCOMES; GAMING MACHINES, NAMELY SLOT MACHINES AND VIDEO LOTTERY TERMINALS; GAMING MACHINES, NAMELY, DEVICES WHICH ACCEPT A WAGER; RECONFIGURABLE CASINO AND LOTTERY GAMING EQUIPMENT, NAMELY, GAMING MACHINES AND OPERATIONAL COMPUTER GAME SOFTWARE THEREFOR SOLD AS A UNIT; RECONFIGURABLE CASINO GAMING MACHINES AND OPERATIONAL GAME SOFTWARE THEREFOR SOLD AS A UNIT; SLOT MACHINES (U.S. CLS. 22, 23, 38 AND 50).

### CLASS 41—EDUCATION AND ENTERTAINMENT

FOR CASINOS; CONDUCTING AND PROVIDING FACILITIES FOR CASINO AND GAMING CONTESTS AND TOURNAMENTS; ENTERTAINMENT SERVICES, NAMELY, CASINO GAMING; ENTERTAINMENT SERVICES, NAMELY, PROVIDING ONLINE ELECTRONIC GAMES; GAMING SERVICES IN THE NATURE OF CASINO GAMING; LEASING OF CASINO GAMES; PROVIDING ONLINE NON-DOWNLOADABLE GAME SOFTWARE (U.S. CLS. 100, 101 AND 107).

PARKER HOWARD, EXAMINING ATTORNEY

SN 86-238,176. BALLYHOO, INC., WEST PITTSBURGH, PA. FILED 4-1-2014.

## BALLYHOO

THE MARK CONSISTS OF STANDARD CHARACTERS WITHOUT CLAIM TO ANY PARTICULAR FONT, STYLE, SIZE, OR COLOR.

THE WORDING "BALLYHOO" HAS NO MEANING IN A FOREIGN LANGUAGE.

### CLASS 35—ADVERTISING AND BUSINESS

FOR RETAIL CANDY STORES (U.S. CLS. 100, 101 AND 102).

FIRST USE 0-0-2011; IN COMMERCE 0-0-2011.

### CLASS 43—HOTEL AND RESTAURANT SERVICES

FOR ICE CREAM PARLORS (U.S. CLS. 100 AND 101). FIRST USE 0-0-2011; IN COMMERCE 0-0-2011.

KATHERINE CHANG, EXAMINING ATTORNEY

SN 86-238,225. INTERNATIONAL WHOLESALERS CORPORATION, WASHINGTON, DC. FILED 4-1-2014.

## PAQUITA

THE MARK CONSISTS OF STANDARD CHARACTERS WITHOUT CLAIM TO ANY PARTICULAR FONT, STYLE, SIZE, OR COLOR.

THE NAME(S), PORTRAIT(S), AND/OR SIGNATURE(S) SHOWN IN THE MARK DOES NOT IDENTIFY A PARTICULAR LIVING INDIVIDUAL.

### CLASS 29—MEATS AND PROCESSED FOODS

FOR FROZEN FRUITS; FROZEN VEGETABLES; PROCESSED EDIBLE FLOWERS AND LEAVES (U.S. CL. 46).

FIRST USE 8-22-2008; IN COMMERCE 8-22-2008.

### CLASS 30—STAPLE FOODS

FOR TAMALES; TORTILLAS (U.S. CL. 46).

FIRST USE 8-22-2008; IN COMMERCE 8-22-2008.

GENE MACIOL, EXAMINING ATTORNEY

SN 86-238,446. DDJ INVESTMENTS, LLC, DBA TECHHUB, DENVER, CO. FILED 4-1-2014.

## TECH HUB

THE MARK CONSISTS OF STANDARD CHARACTERS WITHOUT CLAIM TO ANY PARTICULAR FONT, STYLE, SIZE, OR COLOR.

NO CLAIM IS MADE TO THE EXCLUSIVE RIGHT TO USE "TECH", APART FROM THE MARK AS SHOWN.

### CLASS 9—ELECTRICAL AND SCIENTIFIC APPARATUS

FOR NEW AND USED ELECTRONIC DEVICES, NAMELY, SMART PHONES, MOBILE PHONES, ELECTRONIC HANDHELD UNITS AND PERSONAL DIGITAL ASSISTANTS (PDA) FOR WIRELESS TRANSMISSION OF DATA AND VOICE SIGNALS, COMPUTERS AND TABLETS, AND PARTS AND ACCESSORIES FOR SAME (U.S. CLS. 21, 23, 26, 36 AND 38).

FIRST USE 2-5-2014; IN COMMERCE 2-5-2014.

### CLASS 37—CONSTRUCTION AND REPAIR

FOR ELECTRONIC EQUIPMENT REPAIR SERVICES, NAMELY, SMART PHONE, MOBILE DEVICE, COMPUTER AND TABLET REPAIR (U.S. CLS. 100, 103 AND 106).

FIRST USE 2-5-2014; IN COMMERCE 2-5-2014.

JOHN HWANG, EXAMINING ATTORNEY

SN 86-238,462. CONDUIT LTD., NESS ZIONA, ISRAEL,  
FILED 4-1-2014.

SN 86-238,463. CITADEL ENVIRONMENTAL SERVICES,  
INC., GLENDALE, CA. FILED 4-1-2014.



OWNER OF U.S. REG. NO. 4,333,377.  
THE MARK CONSISTS OF THE LETTER "U" IN STY-  
LIZED FONT.

#### **CLASS 9—ELECTRICAL AND SCIENTIFIC APPARATUS**

FOR BROWSER SOFTWARE FOR MOBILE PHONES, HAND HELD COMPUTERS, TABLET COMPUTERS, TELEVISIONS, WEARABLE DEVICES AND DESKTOP COMPUTERS, INCLUDING COMPUTER SEARCH ENGINE SOFTWARE; INTERNET BROWSERS IN THE NATURE OF COMPUTER SEARCH ENGINE SOFTWARE; SOFTWARE PROGRAMS FOR COMPUTERS, TELEVISIONS AND VARIOUS MOBILE DEVICES FOR PROVIDING ACCESS TO THE INTERNET; SOFTWARE PROGRAMS FOR COMPUTERS, TELEVISIONS AND VARIOUS MOBILE DEVICES FOR CONTROLLING, VIEWING, ACCESSING, SEARCHING, BROWSING AND UTILIZING GLOBAL COMPUTER, COMMUNICATION AND ENTERTAINMENT NETWORKS; SOFTWARE PROGRAMS THAT RUN ON VARIOUS OPERATING SYSTEMS OF COMPUTERS, TELEVISIONS AND VARIOUS MOBILE DEVICES, AND CAPABLE OF SYNCING AND COMMUNICATING WITH ONE ANOTHER OR CONTEXTUALIZING ACROSS VARIOUS DEVICES AND ENVIRONMENTS (U.S. CLS. 21, 23, 26, 36 AND 38).

FIRST USE 2-29-2012; IN COMMERCE 2-29-2012.

#### **CLASS 42—SCIENTIFIC AND COMPUTER SERVICES**

FOR APPLICATION SERVICES PROVIDER (ASP), NAMELY, HOSTING PROVIDING COMPUTER, TELEVISION AND MOBILE SOFTWARE AND APPLICATIONS FOR USERS, PUBLISHERS AND DEVELOPERS TO ENABLE THEM TO VIEW, ACCESS, SEARCH, INTERACT, BROWSE AND TRANSMIT VIDEOS, PICTURES, CONTENT AND DATA VIA GLOBAL COMPUTER, COMMUNICATION AND ENTERTAINMENT NETWORKS; PROVIDING SOFTWARE PLATFORM, DATA OR TOOLS FOR PUBLISHERS AND DEVELOPERS TO DEVELOP, USE AND IMPLEMENT COMPUTER, TELEVISION AND MOBILE SOFTWARE AND APPLICATIONS; PROVIDING SOFTWARE PROGRAMS AND SOFTWARE DEVELOPMENT TOOLS THAT RUN ON VARIOUS OPERATING SYSTEMS OF COMPUTERS, TELEVISIONS AND VARIOUS MOBILE DEVICES, AND CAPABLE OF SYNCING AND COMMUNICATING WITH ONE ANOTHER OR CONTEXTUALIZING ACROSS VARIOUS DEVICES AND ENVIRONMENTS (U.S. CLS. 100 AND 101).

FIRST USE 2-29-2012; IN COMMERCE 2-29-2012.  
JOHN HWANG, EXAMINING ATTORNEY

#### **CITADEL ENVIRONMENTAL SERVICES, INC.**

THE MARK CONSISTS OF STANDARD CHARACTERS WITHOUT CLAIM TO ANY PARTICULAR FONT, STYLE, SIZE, OR COLOR.

NO CLAIM IS MADE TO THE EXCLUSIVE RIGHT TO USE "ENVIRONMENTAL SERVICES, INC.", APART FROM THE MARK AS SHOWN.

#### **CLASS 37—CONSTRUCTION AND REPAIR**

FOR CONSTRUCTION SERVICES, NAMELY, INSTALLATION OF ENVIRONMENTAL CONTAINMENT SYSTEMS; CONSULTATION SERVICES IN THE FIELD OF CONSTRUCTION OF ENVIRONMENTALLY-CONSCIOUS BUILDINGS; ENVIRONMENTAL CONTAINMENT, NAMELY, LOCALIZATION, DRYING AND CLEANING OF PARTICULATE AND MOISTURE CONTAMINANTS FOR BUILDINGS AND CONTENTS THEREIN; INSTALLATION OF ENVIRONMENTALLY COMPLIANT REMEDIATION EQUIPMENT; PROVIDING NEWS AND INFORMATION IN THE FIELD OF ENVIRONMENTALLY-CONSCIOUS BUILDING CONSTRUCTION; REPAIR AND INSTALLATION SERVICES, NAMELY, THE INSTALLATION OF HEATING, COOLING AND ENVIRONMENTAL CONTROL SYSTEMS PRIMARILY USING SOLAR ENERGY, RENEWABLE ENERGY RESOURCES AND RAINWATER (U.S. CLS. 100, 103 AND 106).

#### **CLASS 42—SCIENTIFIC AND COMPUTER SERVICES**

FOR CONDUCTING FEASIBILITY STUDIES IN THE FIELD OF ENVIRONMENTAL ENGINEERING; CONDUCTING WELLBORE SURVEY SERVICES FOR THE OIL AND GAS, ENERGY, MINING, ENVIRONMENTAL AND CONSTRUCTION INDUSTRIES; CONSULTING SERVICES IN THE FIELD OF ENVIRONMENTAL ASSESSMENT AND PLANNING; ENGINEERING SERVICES IN THE FIELD OF ENVIRONMENTAL COMPLIANCE; ENVIRONMENTAL AUTOMOBILE EMISSION TESTING AND INSPECTION SERVICES; ENVIRONMENTAL ENGINEERING, TESTING AND INSPECTION SERVICES; ENVIRONMENTAL SERVICES, NAMELY, DESIGN FOR OTHERS IN THE FIELD OF ENVIRONMENTAL ENGINEERING; ENVIRONMENTAL SERVICES, NAMELY, TECHNICAL CONSULTATION IN THE FIELD OF ENVIRONMENTAL SCIENCE; ENVIRONMENTAL SERVICES, NAMELY, TECHNICAL CONSULTATION IN THE FIELD OF ENVIRONMENTAL SCIENCE, ENGINEERING SERVICES AND DESIGN FOR OTHERS IN THE FIELD OF ENVIRONMENTAL ENGINEERING; ENVIRONMENTAL TESTING AND INSPECTION SERVICES; EVALUATING AND TESTING THE ENVIRONMENTAL QUALITIES AND IMPACT OF CONSUMER PRODUCTS OF OTHERS; PROFESSIONAL CONSULTING SERVICES IN THE FIELDS OF ENGINEERING, LAND USE PLANNING, SURVEYING, LANDSCAPE ARCHITECTURE, AND ENVIRONMENTAL SCIENCES; PROVIDING A WEBSITE FEATURING ENVIRONMENTAL INFORMATION ABOUT CLIMATE CHANGE AND BIO-DIVERSITY; PROVIDING TECHNOLOGICAL AND SCIENTIFIC INFORMATION ABOUT ENVIRONMENTALLY-CONSCIOUS AND GREEN INNOVATIONS; PROVIDING TECHNOLOGICAL INFORMATION ABOUT ENVIRONMENTALLY-CONSCIOUS AND GREEN INNOVATIONS; RESEARCH AND DEVELOPMENT OF ENVIRONMENTALLY FRIENDLY FORMS OF ENERGY AND POWER; RESEARCH IN THE AREA OF ENVIRONMENTAL PROTECTION; RESEARCH IN THE FIELD OF ENVIRONMENTAL PROTECTION; RESEARCH RELATING TO ENVIRONMENTAL PROTECTION; SCIENTIFIC RESEARCH RELATING TO THE IMPACT OF CONSUMER AND INDUSTRIAL PRODUCTS ON ENVIRONMENTAL PRESERVATION; TECH-

NICAL CONSULTANCY IN THE FIELD OF ENVIRONMENTAL SCIENCE; TECHNICAL CONSULTATION IN THE FIELD OF ENVIRONMENTAL SCIENCE, ENGINEERING SERVICES, DESIGN FOR OTHERS IN THE FIELD OF ENERGY ENGINEERING, DESIGNING AND TESTING OF ENERGY PRODUCTS FOR OTHERS; TECHNICAL CONSULTATION IN THE FIELD OF ENVIRONMENTAL SCIENCE, ENGINEERING SERVICES, DESIGN FOR OTHERS IN THE FIELD OF ENVIRONMENTAL ENGINEERING, DESIGNING AND TESTING OF NEW ENVIRONMENTALLY FRIENDLY PRODUCTS FOR OTHERS; TECHNICAL CONSULTING IN THE FIELD OF ENVIRONMENTAL ENGINEERING; WETLAND HABITAT DEVELOPMENT AND PRESERVATION SERVICES, NAMELY, MONITORING, TESTING AND ANALYZING ECOLOGICAL SUCCESS IN THE FIELD OF ENVIRONMENTALLY SENSITIVE HABITAT CONSERVATION AND PRESERVATION OF NATIVE PLANTS AND WILDLIFE (U.S. CLS. 100 AND 101).

#### **CLASS 45—PERSONAL AND LEGAL SERVICES**

FOR ADVICE AND CONSULTANCY ON ENVIRONMENTAL REGULATORY MATTERS; CONTROL OF BUILDING ENVIRONMENTAL ACCESS AND SECURITY SYSTEMS; PERMITTING, NAMELY, OBTAINING ENVIRONMENTAL, DESIGN, ZONING AND OTHER GOVERNMENTAL PERMITS FOR DEVELOPMENT PROJECTS; REVIEWING ENVIRONMENTAL DATA, ANALYZING THE DATA IN CONNECTION WITH ENVIRONMENTAL LAWS AND REGULATIONS, AND PREPARING ENVIRONMENTAL COMPLIANCE REPORTS; REVIEWING STANDARDS AND PRACTICES TO ASSURE COMPLIANCE WITH ENVIRONMENTAL HEALTH SAFETY AND SUSTAINABILITY LAWS AND REGULATIONS (U.S. CLS. 100 AND 101).

JOHN HWANG, EXAMINING ATTORNEY

SN 86-238,465. DDJ INVESTMENTS, LLC, DBA TECHHUB, DENVER, CO. FILED 4-1-2014.



THE COLOR(S) TEAL AND WHITE IS/ARE CLAIMED AS A FEATURE OF THE MARK.

THE MARK CONSISTS OF A WHITE EIGHT-POINT GEAR CONTAINING A TEAL INNER CIRCLE WITH THE WORDS "TECH HUB" IN WHITE LETTERING, IN WHICH THE WORD "TECH" IS SET VERTICALLY IN SMALLER TEXT TO THE LEFT OF THE WORD "HUB" SET HORIZONTALLY IN LARGER TEXT.

#### **CLASS 9—ELECTRICAL AND SCIENTIFIC APPARATUS**

FOR NEW AND USED ELECTRONIC DEVICES NAMELY, SMART PHONES, MOBILE PHONES, ELECTRONIC HANDHELD UNITS AND PERSONAL DIGITAL ASSISTANTS (PDA) FOR WIRELESS TRANSMISSION OF DATA AND VOICE SIGNALS, COMPUTERS AND TABLETS, AND PARTS AND ACCESSORIES FOR SAME (U.S. CLS. 21, 23, 26, 36 AND 38).

FIRST USE 2-5-2014; IN COMMERCE 2-5-2014.

#### **CLASS 37—CONSTRUCTION AND REPAIR**

FOR ELECTRONIC EQUIPMENT REPAIR SERVICES, NAMELY, SMART PHONE, MOBILE DEVICE, COMPUTER AND TABLET REPAIR (U.S. CLS. 100, 103 AND 106).

FIRST USE 2-5-2014; IN COMMERCE 2-5-2014.

JOHN HWANG, EXAMINING ATTORNEY

SN 86-238,498. AMERICAN PETROLEUM INSTITUTE, WASHINGTON, DC. FILED 4-1-2014.

Q1

THE MARK CONSISTS OF STANDARD CHARACTERS WITHOUT CLAIM TO ANY PARTICULAR FONT, STYLE, SIZE, OR COLOR.

OWNER OF U.S. REG. NOS. 3,159,641 AND 3,409,522.

#### **CLASS 35—ADVERTISING AND BUSINESS**

FOR ASSOCIATION SERVICES, NAMELY, PROMOTION OF THE INTERESTS, GENERAL DEVELOPMENT, AND IMPROVEMENT OF THE AMERICAN PETROLEUM INDUSTRY BY PROMOTING THE DEVELOPMENT AND DISSEMINATION OF PETROLEUM TECHNOLOGY, DISTRIBUTING OF INFORMATION REGARDING LEGISLATION AND OF INFORMATION ABOUT AND OF INTEREST TO THE PETROLEUM INDUSTRY (U.S. CLS. 100, 101 AND 102).

#### **CLASS 41—EDUCATION AND ENTERTAINMENT**

FOR EDUCATIONAL SERVICES, NAMELY, SEMINARS AND CONFERENCES IN THE FIELD OF SAFETY AND QUALITY FOR GOODS AND SERVICES IN THE PETROLEUM AND NATURAL GAS INDUSTRY (U.S. CLS. 100, 101 AND 107).

#### **CLASS 42—SCIENTIFIC AND COMPUTER SERVICES**

FOR PROVIDING QUALITY ASSURANCE SERVICES IN THE FIELD OF PETROLEUM PRODUCTS AND EQUIPMENT, PETROLEUM DRILLING PRODUCTS AND EQUIPMENT, PETROLEUM REFINING PRODUCTS AND EQUIPMENT, AND PETROLEUM EXPLORATION PRODUCTS AND EQUIPMENT; DEVELOPING SAFETY AND QUALITY STANDARDS IN THE FIELD OF THE PETROLEUM AND NATURAL GAS INDUSTRY; TESTING, ANALYSIS, INSPECTION, AND EVALUATION OF PETROLEUM EXPLORATION, DRILLING, EXPLORATION AND REFINING EQUIPMENT AND PRODUCTS AND SERVICES OF OTHERS FOR THE PURPOSE OF CERTIFICATION (U.S. CLS. 100 AND 101).

BRENDAN MCCAULEY, EXAMINING ATTORNEY



SN 86-238,536. THE JOHN D. WALSH COMPANY, INC.,  
RINGWOOD, NJ. FILED 4-1-2014.

THE JOHN D. WALSH COMPANY

THE MARK CONSISTS OF STANDARD CHARACTERS WITHOUT CLAIM TO ANY PARTICULAR FONT, STYLE, SIZE, OR COLOR.

NO CLAIM IS MADE TO THE EXCLUSIVE RIGHT TO USE "COMPANY", APART FROM THE MARK AS SHOWN.

THE NAME(S), PORTRAIT(S), AND/OR SIGNATURE(S) SHOWN IN THE MARK DOES NOT IDENTIFY A PARTICULAR LIVING INDIVIDUAL.

#### CLASS 1—CHEMICALS

FOR CHEMICAL ADDITIVES FOR USE IN THE MANUFACTURE OF FLAVORINGS, FRAGRANCES, TOILETRIES, COSMETICS, HOUSEHOLD CLEANERS, DEODORIZERS, DETERGENTS, CANDLES, PHARMACEUTICALS, NUTRACEUTICALS, AND FOOD SUPPLEMENTS (U.S. CLS. 1, 5, 6, 10, 26 AND 46).

FIRST USE 2-1-1942; IN COMMERCE 2-1-1942.

#### CLASS 3—COSMETICS AND CLEANING PREPARATIONS

FOR ESSENTIAL OILS, INCLUDING CONCRETES AND ABSOLUTES, USED IN THE MANUFACTURING OF FLAVORINGS, FRAGRANCES, TOILETRIES, COSMETICS, HOUSEHOLD CLEANERS, DEODORIZERS, DETERGENTS, CANDLES, PHARMACEUTICALS, NUTRACEUTICALS, AND FOOD SUPPLEMENTS (U.S. CLS. 1, 4, 6, 50, 51 AND 52).

FIRST USE 2-1-1942; IN COMMERCE 2-1-1942.

#### CLASS 30—STAPLE FOODS

FOR FLAVORINGS FOR USE IN COFFEE, TEA AND JUICE BASED BEVERAGES, AND FOR USE IN FOOD, CONFECTIONERY, PHARMACEUTICALS, AND NUTRACEUTICALS APPLICATIONS (U.S. CL. 46).

FIRST USE 2-1-1942; IN COMMERCE 2-1-1942.

GENE MACIOL, EXAMINING ATTORNEY

SN 86-238,747. BIO CREATIVE ENTERPRISES, INC., LONG BEACH, CA. FILED 4-1-2014.

BCL Be Care Love

THE MARK CONSISTS OF STANDARD CHARACTERS WITHOUT CLAIM TO ANY PARTICULAR FONT, STYLE, SIZE, OR COLOR.

OWNER OF U.S. REG. NOS. 4,433,457 AND 4,518,805.

#### CLASS 3—COSMETICS AND CLEANING PREPARATIONS

FOR BEAUTY CREAMS; BEAUTY CREAMS FOR BODY CARE; BEAUTY LOTIONS; BODY CREAM; BODY LOTION; BODY MASK LOTION; BODY MASKS; BODY MILK; BODY WASH; CONDITIONERS; COSMETICS; EXFOLIANT CREAMS; EXFOLIANTS FOR BODY, HAND AND FOOT; EYE MAKE-UP REMOVER; FACIAL CLEANSERS; FACIAL MASKS; FACIAL SCRUBS; FOOT SCRUBS; HAIR CONDITIONERS; HAIR LOTION; HAND CREAM; HAND LOTIONS; HAND SCRUBS; MAKE-UP REMOVER; MOISTURIZING CREAMS; NON-MEDICATED BODY SOAKS; NON-MEDICATED FOOT CREAM; NON-MEDICATED FOOT LOTIONS; NON-MEDICATED FOOT SOAKS; NON-MEDICATED SKIN TONERS; PRE-MOISTENED COSMETIC WIPES; SHAMPOOS; SKIN CARE PREPARATION, NAMELY, BODY POLISH; SKIN LOTION; SKIN MASKS; SKIN MOISTURIZER; SKIN MOISTURIZER MASKS (U.S. CLS. 1, 4, 6, 50, 51 AND 52).

#### CLASS 25—CLOTHING

FOR CLOTHING, NAMELY, SHIRTS, SHORTS, PANTS, SKIRTS, DRESSES, HATS, CAPS, BELTS, JACKETS, JERSEYS AND COATS (U.S. CLS. 22 AND 39).

#### CLASS 35—ADVERTISING AND BUSINESS

FOR ON-LINE RETAIL STORE SERVICES AND RETAIL STORE SERVICES FEATURING CLOTHING AND SKIN AND BODY CARE PRODUCTS (U.S. CLS. 100, 101 AND 102).

DAVID MURRAY, EXAMINING ATTORNEY

SN 86-238,828. BREITLING ENERGY CORPORATION, DALLAS, TX. FILED 4-1-2014.

Frackmaster

THE MARK CONSISTS OF STANDARD CHARACTERS WITHOUT CLAIM TO ANY PARTICULAR FONT, STYLE, SIZE, OR COLOR.

#### CLASS 9—ELECTRICAL AND SCIENTIFIC APPARATUS

FOR CHILDREN'S EDUCATIONAL MUSIC CDS AND DVDS; DOWNLOADABLE COMIC STRIPS; DOWNLOADABLE MULTIMEDIA FILE CONTAINING ARTWORK, TEXT, AUDIO, VIDEO, GAMES, AND INTERNET WEB LINKS RELATING TO ALTERNATIVE ENERGY SOURCES; INTERACTIVE VIDEO GAME PROGRAMS; VIDEO DISKS AND VIDEO TAPES WITH RECORDED ANIMATED CARTOONS; VIDEO GAME CARTRIDGES; VIDEO GAME CARTRIDGES AND CASSETTES; VIDEO GAME CARTRIDGES AND DISCS; VIDEO GAME DISCS (U.S. CLS. 21, 23, 26, 36 AND 38).

#### CLASS 16—PAPER GOODS AND PRINTED MATTER

FOR CARTOON PRINTS; CARTOON STRIPS; CHILDREN'S BOOKS; COMIC BOOKS; COMIC MAGAZINES; COMIC STRIPS; COMIC STRIPS' COMIC FEATURES; COMICS (U.S. CLS. 2, 5, 22, 23, 29, 37, 38 AND 50).

**CLASS 28—TOYS AND SPORTING GOODS**

FOR ACTION FIGURE TOYS; ACTION FIGURES; ACTION FIGURES AND ACCESSORIES THEREFOR; ARCADE-TYPE ELECTRONIC EDUCATION VIDEO GAMES; COLLECTABLE TOY FIGURES; EDUCATIONAL TOY FOR THE PURPOSE OF THE DEMONSTRATION OF ALTERNATIVE ENERGY SOURCES; ELECTRONIC ACTION TOYS; ELECTRONIC LEARNING TOYS; ELECTRONIC NOVELTY TOYS, NAMELY, TOYS THAT ELECTRONICALLY RECORD, PLAY BACK, AND DISTORT OR MANIPULATE VOICES AND SOUNDS; FANTASY CHARACTER TOYS; MOLDED TOY FIGURES; PLAY FIGURES; PLAY SETS FOR ACTION FIGURES; POSITIONABLE TOY FIGURES; RUBBER CHARACTER TOYS; TALKING ELECTRONIC PRESS-DOWN TOY; TALKING TOYS; TOY ACTION FIGURES; TOY ACTION FIGURES AND ACCESSORIES THEREFOR; TOY FIGURES (U.S. CLS. 22, 23, 38 AND 50).

CIMMERIAN COLEMAN, EXAMINING ATTORNEY

SN 86-238,864. TPR EDUCATION IP HOLDINGS, LLC, NATICK, MA. FILED 4-1-2014.

**CLASS 41—EDUCATION AND ENTERTAINMENT**

FOR TEST PREPARATION CLASSES AND TUTORING SERVICES FOR PERSONS TAKING STANDARDIZED EXAMINATIONS; PROVIDING TUTORING AND CLASSES TO IMPROVE ACADEMIC PERFORMANCE OF STUDENTS AND FOR PROFESSIONAL DEVELOPMENT OF TEACHERS; PROVIDING INFORMATION ONLINE ON ATTENDING COLLEGE, GRADUATE SCHOOL AND PROFESSIONAL SCHOOL WITH AN EMPHASIS ON PROSPECTIVE STUDENTS; ADMISSION CONSULTING SERVICES, NAMELY, CONSULTING IN THE FIELD OF COLLEGE, GRADUATE SCHOOL AND PROFESSIONAL SCHOOL ADMISSIONS, SPECIFICALLY, COLLEGE, GRADUATE SCHOOL AND PROFESSIONAL SCHOOL SELECTION, COMPLETING ADMISSIONS APPLICATIONS, AND PREPARATION FOR COLLEGE, GRADUATE SCHOOL AND PROFESSIONAL SCHOOL ADMISSION INTERVIEWS; PROVIDING ON-LINE INSTRUCTION FOR STUDENTS AND TEACHERS VIA THE INTERNET IN THE FIELDS OF PREPARATION FOR ACADEMIC ACHIEVEMENT, TEST PREPARATION, ACADEMIC ASSESSMENT, ADMISSIONS AND APTITUDE TESTS FOR PROFESSIONAL LICENSING; CLASSES, GROUP SESSIONS AND ONE-ON-ONE COUNSELING PROVIDING INFORMATION AND GUIDANCE ON COLLEGE ADMISSIONS, AND GRADUATE AND PROFESSIONAL SCHOOL ADMISSIONS (U.S. CLS. 100, 101 AND 107).

GEOFFREY FOSDICK, EXAMINING ATTORNEY

Your Goals. Our Expertise.

SN 86-238,926. MINTO COMMUNITIES, LLC, NAPLES, FL. FILED 4-1-2014.

THE MARK CONSISTS OF STANDARD CHARACTERS WITHOUT CLAIM TO ANY PARTICULAR FONT, STYLE, SIZE, OR COLOR.

**CLASS 9—ELECTRICAL AND SCIENTIFIC APPARATUS**

FOR AUDIO RECORDINGS, VIDEO RECORDINGS AND CD-ROMS FEATURING INFORMATION AND INSTRUCTION FOR PREPARING FOR STANDARDIZED EXAMINATIONS; DOWNLOADABLE SOFTWARE IN THE NATURE OF A MOBILE APPLICATION FOR USE IN AND FEATURING INFORMATION, INSTRUCTION AND PREPARATION FOR STANDARDIZED TESTS, COLLEGE READINESS AND COLLEGE ADMISSIONS; DIGITAL MEDIA, NAMELY, PRE-RECORDED DVDS, DOWNLOADABLE AUDIO AND VIDEO RECORDINGS, AND CDS FEATURING INFORMATION, PREPARATION AND INSTRUCTION FOR STANDARDIZED TESTS, COLLEGE READINESS, COLLEGE AND GRADUATE SCHOOL ADMISSIONS AND FINANCIAL AID (U.S. CLS. 21, 23, 26, 36 AND 38).

**CLASS 16—PAPER GOODS AND PRINTED MATTER**

FOR BOOKS ON DEVELOPING STUDY SKILLS; GUIDEBOOKS FOR OBTAINING FINANCIAL AID FOR HIGHER LEARNING; GUIDE BOOKS ON SELECTING COLLEGES, GRADUATE SCHOOLS AND PROFESSIONAL SCHOOLS; GUIDE BOOKS FOR PREPARING FOR STANDARDIZED TESTS; GUIDE BOOKS FOR IMPROVING LANGUAGE AND MATH SKILLS; EDUCATIONAL PUBLICATIONS, NAMELY, TEXTBOOKS, EDUCATIONAL LEARNING CARDS, FLASH CARDS, ACTIVITY CARDS, WORKBOOKS, TEXTBOOKS, MANUALS, AND EDUCATIONAL BOOKLETS IN THE FIELD OF TEST PREPARATION, TUTORING, COLLEGE AND GRADUATE SCHOOL ADMISSIONS, AND FINANCIAL AID (U.S. CLS. 2, 5, 22, 23, 29, 37, 38 AND 50).

PORTOSOL

THE MARK CONSISTS OF STANDARD CHARACTERS WITHOUT CLAIM TO ANY PARTICULAR FONT, STYLE, SIZE, OR COLOR.

THE ENGLISH TRANSLATION OF THE WORD "PORTOSOL" IN THE MARK IS "PORT SUN".

**CLASS 36—INSURANCE AND FINANCIAL**

FOR REAL ESTATE SERVICES, NAMELY, BROKERAGE, LEASING AND MANAGEMENT OF RESIDENTIAL PROPERTY; REAL ESTATE PROPERTY MANAGEMENT; RESIDENTIAL COMMUNITY PROPERTY MANAGEMENT SERVICES; REAL ESTATE LISTING SERVICES (U.S. CLS. 100, 101 AND 102).

FIRST USE 3-0-2007; IN COMMERCE 3-0-2007.

**CLASS 37—CONSTRUCTION AND REPAIR**

FOR CONSTRUCTION, REAL ESTATE AND LAND DEVELOPMENT SERVICES, NAMELY, CONSTRUCTION, PLANNING AND LAYING OUT OF RESIDENTIAL COMMUNITIES HAVING AMENITIES INCLUDING A COMMUNITY CENTER, SWIMMING POOL, NATURE PRESERVE, CONSERVATION AREA, NATURE TRAILS, LAKES AND FITNESS FACILITIES (U.S. CLS. 100, 103 AND 106).

FIRST USE 3-0-2007; IN COMMERCE 3-0-2007.

CIMMERIAN COLEMAN, EXAMINING ATTORNEY

SN 86-239,028. HAR MASPETH CORP., MASPETH, NY.  
FILED 4-1-2014.

SN 86-239,030. SYSTEMS PAVING, INC., DBA SYSTEM  
PAVERS, SANTA ANA, CA. FILED 4-1-2014.

## KIMCHI LOVERS

THE MARK CONSISTS OF STANDARD CHARACTERS WITHOUT CLAIM TO ANY PARTICULAR FONT, STYLE, SIZE, OR COLOR.

NO CLAIM IS MADE TO THE EXCLUSIVE RIGHT TO USE "KIMCHI", APART FROM THE MARK AS SHOWN.

### CLASS 29—MEATS AND PROCESSED FOODS

FOR KOREAN SIDE DISHES, NAMELY, FERMENTED VEGETABLES (KIMCHI), FERMENTED SOY BEANS, PROCESSED VEGETABLES, PICKLED VEGETABLES, VEGETABLE PUREE, SALTED VEGETABLES, DRIED VEGETABLES, PRESERVED VEGETABLES, SEASONED VEGETABLES, FRIED VEGETABLES, STEWED VEGETABLES, VEGETABLE CROQUETTES, POTATO SALAD, OMELETS, JELLIES, PROCESSED SEAFOOD, PICKLED SEAFOOD, SALTED SEAFOOD, FERMENTED SEAFOOD, FRIED SEAFOOD, DRIED SLICED SEAFOOD, SEASONED SEAFOOD, SAUTÉED SEAFOOD, STEWED SEAFOOD, BOILED SEAFOOD, GRILLED SEAFOOD, CRAB CAKES, FISH CROQUETTES, TOFU; VEGETABLE BASED SNACK FOODS; VEGETABLE PANCAKE, GINGER PUREE, AND SOY BEAN SOUP PASTE (U.S. CL. 46).

### CLASS 30—STAPLE FOODS

FOR KOREAN STYLE RICE CAKES; KOREAN STYLE RICE PORRIDGE (U.S. CL. 46).  
ELIZABETH JACKSON, EXAMINING ATTORNEY

SN 86-239,029. EPAYSPOT, MISSION VIEJO, CA. FILED 4-1-2014.

## EPAYSPOT

THE MARK CONSISTS OF STANDARD CHARACTERS WITHOUT CLAIM TO ANY PARTICULAR FONT, STYLE, SIZE, OR COLOR.

### CLASS 9—ELECTRICAL AND SCIENTIFIC APPARATUS

FOR COMPUTER SOFTWARE FOR ELECTRONIC BILLING, CREDIT AND DEBIT CARD TRANSACTION PROCESSING AND AUTOMATED CLEARING HOUSE (ACH) TRANSACTION PROCESSING (U.S. CLS. 21, 23, 26, 36 AND 38).

FIRST USE 10-1-2009; IN COMMERCE 10-1-2009.

### CLASS 36—INSURANCE AND FINANCIAL

FOR PAYMENT PROCESSING SERVICES, NAMELY, CREDIT AND DEBIT CARD TRANSACTION PROCESSING SERVICES AND AUTOMATED CLEARING HOUSE (ACH) TRANSACTION PROCESSING SERVICES ON BEHALF OF MERCHANTS (U.S. CLS. 100, 101 AND 102).

FIRST USE 8-19-2009; IN COMMERCE 8-19-2009.  
JAMES LOVELACE, EXAMINING ATTORNEY



THE MARK CONSISTS OF DESIGNS OF FIRE ON A DIAMOND SHAPE, A WATER DROPLET ON A DIAMOND SHAPE, GRILLING UTENSILS ON A DIAMOND SHAPE AND A MUSIC NOTE ON A DIAMOND SHAPE, ALL ARRANGED IN THE SHAPE OF A DIAMOND.

### CLASS 37—CONSTRUCTION AND REPAIR

FOR INSTALLATION OF PAVERS OR PAVING STONES FOR PATIOS; INSTALLATION OF BARBECUES, LANDSCAPE WATER FEATURES, ARTIFICIAL TURF, FIRE PITS, OUTDOOR FIREPLACES, MAILBOXES, WALLS, PILLARS, MAILBOXES AND PERGOLAS; INSTALLATION OF OUTDOOR LIGHTING SYSTEMS; INSTALLATION OF OUTDOOR HOME THEATRES AND RELATED STRUCTURED WIRING (U.S. CLS. 100, 103 AND 106).

FIRST USE 3-30-2014; IN COMMERCE 3-30-2014.

### CLASS 42—SCIENTIFIC AND COMPUTER SERVICES

FOR LANDSCAPE LIGHTING DESIGN; PLANNING AND DESIGN OF OUTDOOR LIVING PRODUCTS AND INTERLOCKING PAVING STONES FOR DRIVEWAYS, WALKWAYS, POOLS AND DECKS (U.S. CLS. 100 AND 101).

FIRST USE 3-30-2014; IN COMMERCE 3-30-2014.

### CLASS 44—MEDICAL, BEAUTY AND AGRICULTURAL SERVICES

FOR LANDSCAPE DESIGN (U.S. CLS. 100 AND 101).  
FIRST USE 3-30-2014; IN COMMERCE 3-30-2014.  
JUSTINE D. PARKER, EXAMINING ATTORNEY

SN 86-239,046. SYSTEMS PAVING, INC., DBA SYSTEM  
PAVERS, SANTA ANA, CA. FILED 4-1-2014.



THE MARK CONSISTS OF A DESIGN OF TURF ON A DIAMOND-SHAPED BACKGROUND.

**CLASS 37—CONSTRUCTION AND REPAIR**

FOR INSTALLATION OF PAVERS OR PAVING STONES FOR PATIOS; INSTALLATION OF BARBEQUES, LANDSCAPE WATER FEATURES, ARTIFICIAL TURF, FIRE PITS, OUTDOOR FIREPLACES, MAILBOXES, WALLS, PILLARS, MAILBOXES AND PERGOLAS; INSTALLATION OF OUTDOOR LIGHTING SYSTEMS; INSTALLATION OF OUTDOOR HOME THEATRES AND RELATED STRUCTURED WIRING (U.S. CLS. 100, 103 AND 106).

FIRST USE 3-30-2014; IN COMMERCE 3-30-2014.

**CLASS 42—SCIENTIFIC AND COMPUTER SERVICES**

FOR LANDSCAPE LIGHTING DESIGN; PLANNING AND DESIGN OF OUTDOOR LIVING PRODUCTS AND INTERLOCKING PAVING STONES FOR DRIVEWAYS, WALKWAYS, POOLS AND DECKS (U.S. CLS. 100 AND 101).

FIRST USE 3-30-2014; IN COMMERCE 3-30-2014.

**CLASS 44—MEDICAL, BEAUTY AND AGRICULTURAL SERVICES**

FOR LANDSCAPE DESIGN (U.S. CLS. 100 AND 101).  
FIRST USE 3-30-2014; IN COMMERCE 3-30-2014.  
JUSTINE D. PARKER, EXAMINING ATTORNEY

SN 86-239,059. SYSTEMS PAVING, INC., DBA SYSTEM PAVERS, SANTA ANA, CA. FILED 4-1-2014.



THE MARK CONSISTS OF A DESIGN OF A PERGOLA ON A DIAMOND-SHAPED BACKGROUND.

**CLASS 37—CONSTRUCTION AND REPAIR**

FOR INSTALLATION OF PAVERS OR PAVING STONES FOR PATIOS; INSTALLATION OF BARBEQUES, LANDSCAPE WATER FEATURES, ARTIFICIAL TURF, FIRE PITS, OUTDOOR FIREPLACES, MAILBOXES, WALLS, PILLARS, MAILBOXES AND PERGOLAS; INSTALLATION OF OUTDOOR LIGHTING SYSTEMS; INSTALLATION OF OUTDOOR HOME THEATRES AND RELATED STRUCTURED WIRING (U.S. CLS. 100, 103 AND 106).

FIRST USE 3-30-2014; IN COMMERCE 3-30-2014.

**CLASS 42—SCIENTIFIC AND COMPUTER SERVICES**

FOR LANDSCAPE LIGHTING DESIGN; PLANNING AND DESIGN OF OUTDOOR LIVING PRODUCTS AND INTERLOCKING PAVING STONES FOR DRIVEWAYS, WALKWAYS, POOLS AND DECKS (U.S. CLS. 100 AND 101).

FIRST USE 3-30-2014; IN COMMERCE 3-30-2014.

**CLASS 44—MEDICAL, BEAUTY AND AGRICULTURAL SERVICES**

FOR LANDSCAPE DESIGN (U.S. CLS. 100 AND 101).  
FIRST USE 3-30-2014; IN COMMERCE 3-30-2014.  
JUSTINE D. PARKER, EXAMINING ATTORNEY

SN 86-239,136. SYSTEMS PAVING, INC., DBA SYSTEM PAVERS, SANTA ANA, CA. FILED 4-1-2014.



THE MARK CONSISTS OF A DESIGN OF LIGHTING ON TURF ALL ON A DIAMOND-SHAPED BACKGROUND.

**CLASS 37—CONSTRUCTION AND REPAIR**

FOR INSTALLATION OF PAVERS OR PAVING STONES FOR PATIOS; INSTALLATION OF BARBEQUES, LANDSCAPE WATER FEATURES, ARTIFICIAL TURF, FIRE PITS, OUTDOOR FIREPLACES, MAILBOXES, WALLS, PILLARS, MAILBOXES AND PERGOLAS; INSTALLATION OF OUTDOOR LIGHTING SYSTEMS; INSTALLATION OF OUTDOOR HOME THEATRES AND RELATED STRUCTURED WIRING (U.S. CLS. 100, 103 AND 106).

FIRST USE 3-30-2014; IN COMMERCE 3-30-2014.

**CLASS 42—SCIENTIFIC AND COMPUTER SERVICES**

FOR LANDSCAPE LIGHTING DESIGN; PLANNING AND DESIGN OF OUTDOOR LIVING PRODUCTS AND INTERLOCKING PAVING STONES FOR DRIVEWAYS, WALKWAYS, POOLS AND DECKS (U.S. CLS. 100 AND 101).

FIRST USE 3-30-2014; IN COMMERCE 3-30-2014.

**CLASS 44—MEDICAL, BEAUTY AND AGRICULTURAL SERVICES**

FOR LANDSCAPE DESIGN (U.S. CLS. 100 AND 101).  
FIRST USE 3-30-2014; IN COMMERCE 3-30-2014.  
JUSTINE D. PARKER, EXAMINING ATTORNEY

SN 86-239,292. T-REX GLOBAL INCORPORATED, FREMONT, CA. FILED 4-1-2014.

# SIMPLIFYEM

THE MARK CONSISTS OF STANDARD CHARACTERS WITHOUT CLAIM TO ANY PARTICULAR FONT, STYLE, SIZE, OR COLOR.

**CLASS 9—ELECTRICAL AND SCIENTIFIC APPARATUS**

FOR TAX MANAGEMENT SOFTWARE; CREDIT AND TENANT SCREENING SOFTWARE; ACCOUNTING SOFTWARE; PROPERTY MANAGEMENT SOFTWARE; DOWNLOADABLE ELECTRONIC DATA FILES FEATURING FORMS FOR PROPERTY MANAGEMENT; MOBILE APPLICATION SOFTWARE FOR USE IN TAX MANAGEMENT, CREDIT AND TENANT SCREENING, ACCOUNTING, PROPERTY MANAGEMENT AND SEARCHING AND LOCATING FORMS FOR PROPERTY MANAGEMENT (U.S. CLS. 21, 23, 26, 36 AND 38).

**CLASS 42—SCIENTIFIC AND COMPUTER SERVICES**

FOR SOFTWARE AS A SERVICE (SAAS) SERVICES FEATURING SOFTWARE FOR TAX MANAGEMENT, CREDIT AND TENANT SCREENING, ACCOUNTING, PROPERTY MANAGEMENT, SEARCHING AND LOCATING FORMS FOR USE IN PROPERTY MANAGEMENT (U.S. CLS. 100 AND 101).

JEAN IM, EXAMINING ATTORNEY

SN 86-239,679. BUNKER, BRIAN, SPOKANE, WA. FILED 4-2-2014.

# ARCHERESS

THE MARK CONSISTS OF STANDARD CHARACTERS WITHOUT CLAIM TO ANY PARTICULAR FONT, STYLE, SIZE, OR COLOR.

**CLASS 14—JEWELRY**

FOR JEWELRY, NAMELY, IMITATION JEWELRY AND JEWELRY OF PRECIOUS METAL AND STONES (U.S. CLS. 2, 27, 28 AND 50).

**CLASS 25—CLOTHING**

FOR CLOTHING, NAMELY, PANTS, SHIRTS, SHORTS, GLOVES, HATS, JACKETS, FOOTWEAR AND HEADWEAR (U.S. CLS. 22 AND 39).

SUSAN STIGLITZ, EXAMINING ATTORNEY

SN 86-239,508. TAGRR, INC., JENKINTOWN, PA. FILED 4-2-2014.

# TAGRR

THE MARK CONSISTS OF STANDARD CHARACTERS WITHOUT CLAIM TO ANY PARTICULAR FONT, STYLE, SIZE, OR COLOR.

**CLASS 9—ELECTRICAL AND SCIENTIFIC APPARATUS**

FOR COMPUTER APPLICATION SOFTWARE FOR MOBILE PHONES, NAMELY, SOFTWARE FOR FOR USE IN DATABASE MANAGEMENT, FILE LABEL MANAGEMENT, AND FILE METADATA MANAGEMENT; COMPUTER APPLICATION SOFTWARE FOR MOBILE PHONES, PORTABLE MEDIA PLAYERS, HANDHELD COMPUTERS, PERSONAL COMPUTERS, NAMELY, SOFTWARE FOR FOR USE IN DATABASE MANAGEMENT, FILE LABEL MANAGEMENT, AND FILE METADATA MANAGEMENT; DOWNLOADABLE CLOUD COMPUTER SOFTWARE FOR USE IN DATABASE MANAGEMENT, FILE LABEL MANAGEMENT, AND FILE METADATA MANAGEMENT (U.S. CLS. 21, 23, 26, 36 AND 38).

**CLASS 42—SCIENTIFIC AND COMPUTER SERVICES**

FOR PROVIDING TEMPORARY USE OF ON-LINE NON-DOWNLOADABLE CLOUD COMPUTING SOFTWARE FOR USE IN DATABASE MANAGEMENT, FILE LABEL MANAGEMENT, AND FILE METADATA MANAGEMENT (U.S. CLS. 100 AND 101).

MARK SPARACINO, EXAMINING ATTORNEY

SN 86-239,689. DELCOM TELECOMMUNICATIONS, LLC, POMPAÑO BEACH, FL. FILED 4-2-2014.

# Delcom

THE MARK CONSISTS OF STANDARD CHARACTERS WITHOUT CLAIM TO ANY PARTICULAR FONT, STYLE, SIZE, OR COLOR.

**CLASS 38—COMMUNICATION**

FOR TELECOMMUNICATIONS SERVICES, NAMELY, TELEVISION TRANSMISSION SERVICES, PROVIDING INTERNET ACCESS, TELEPHONE COMMUNICATION SERVICES, AND TRANSMISSION OF VOICE, VIDEO, AND DATA VIA TELECOMMUNICATIONS NETWORKS (U.S. CLS. 100, 101 AND 104).

**CLASS 42—SCIENTIFIC AND COMPUTER SERVICES**

FOR DESIGN FOR OTHERS OF TELECOMMUNICATIONS INFRASTRUCTURE (U.S. CLS. 100 AND 101).

ALEX KEAM, EXAMINING ATTORNEY

SN 86-239,706. DELCOM TELECOMMUNICATIONS, LLC, POMPAÑO BEACH, FL. FILED 4-2-2014.

# the future of fast

THE MARK CONSISTS OF STANDARD CHARACTERS WITHOUT CLAIM TO ANY PARTICULAR FONT, STYLE, SIZE, OR COLOR.

**CLASS 38—COMMUNICATION**

FOR TELECOMMUNICATIONS SERVICES, NAMELY, TELEVISION TRANSMISSION SERVICES, PROVIDING INTERNET ACCESS, TELEPHONE COMMUNICATION SERVICES, AND TRANSMISSION OF VOICE, VIDEO, AND DATA VIA TELECOMMUNICATIONS NETWORKS (U.S. CLS. 100, 101 AND 104).

**CLASS 42—SCIENTIFIC AND COMPUTER SERVICES**

FOR DESIGN FOR OTHERS OF TELECOMMUNICATIONS INFRASTRUCTURE (U.S. CLS. 100 AND 101).  
ALEX KEAM, EXAMINING ATTORNEY

SN 86-239,750. TODD, JED, NEWARK, DE. AND TODD, CLAUDIA R, NEWARK, DE. FILED 4-2-2014.

## Content Critter

THE MARK CONSISTS OF STANDARD CHARACTERS WITHOUT CLAIM TO ANY PARTICULAR FONT, STYLE, SIZE, OR COLOR.  
OWNER OF U.S. REG. NOS. 3,601,651 AND 3,633,001.

**CLASS 44—MEDICAL, BEAUTY AND AGRICULTURAL SERVICES**

FOR DOG WALKING SERVICES (U.S. CLS. 100 AND 101).  
FIRST USE 7-25-2008; IN COMMERCE 3-1-2014.

**CLASS 45—PERSONAL AND LEGAL SERVICES**

FOR PET SITTING (U.S. CLS. 100 AND 101).  
FIRST USE 7-25-2008; IN COMMERCE 3-1-2014.  
MORGAN WYNNE, EXAMINING ATTORNEY

SN 86-239,769. THE COCA-COLA COMPANY, ATLANTA, GA. FILED 4-2-2014.

## COKE PIRATES

THE MARK CONSISTS OF STANDARD CHARACTERS WITHOUT CLAIM TO ANY PARTICULAR FONT, STYLE, SIZE, OR COLOR.

**CLASS 35—ADVERTISING AND BUSINESS**

FOR BUSINESS MANAGEMENT FOR LEGAL SERVICES WITH RELATION TO INNOVATION, INTELLECTUAL PROPERTY, STRATEGY, MARKETING, SALES, COMMUNICATION, OPERATION, PRODUCT DESIGN, NAMELY, SPECIALIZING IN THE USE OF VARIOUS MODELS FOR THE UNDERSTANDING, UTILIZING AND COMMUNICATING WITH EMPLOYEES (U.S. CLS. 100, 101 AND 102).

**CLASS 41—EDUCATION AND ENTERTAINMENT**

FOR EDUCATIONAL SERVICES, NAMELY, DEVELOPING AND CONDUCTING WORKSHOPS, ON-LINE TRAINING, PRESENTATIONS, SEMINARS, TRAINING COURSES AND RETREATS, FOR EMPLOYEE DEVELOPMENT IN THE INTELLECTUAL PROPERTY AND LEGAL SUBJECT AREAS (U.S. CLS. 100, 101 AND 107).  
TIMOTHY FINNEGAN, EXAMINING ATTORNEY

SN 86-240,217. IP ASSOCIATES, LLC, NAPLES, FL. FILED 4-2-2014.

## SIMPLY REAL

THE MARK CONSISTS OF STANDARD CHARACTERS WITHOUT CLAIM TO ANY PARTICULAR FONT, STYLE, SIZE, OR COLOR.  
OWNER OF U.S. REG. NO. 3,750,681.

**CLASS 5—PHARMACEUTICALS**

FOR MEAL REPLACEMENT BARS FOR MEDICAL PURPOSES, NUTRITIONAL AND DIETARY BARS FOR USE AS A MEAL REPLACEMENT FOR MEDICAL PURPOSES; NUTRITIONAL SUPPLEMENTS; NUTRITIONAL SUPPLEMENTS IN THE NATURE OF NUTRITIONALLY FORTIFIED SOFT CHEWS; FRUIT-BASED, NUT-BASED, PROTEIN-BASED OR GRANOLA-BASED MEAL REPLACEMENT BARS FOR MEDICAL PURPOSES; FRUIT-BASED, NUT-BASED, PROTEIN-BASED OR GRANOLA-BASED NUTRITIONAL AND DIETARY BARS FOR USE AS A MEAL REPLACEMENT FOR MEDICAL PURPOSES; NUTRITIONAL SUPPLEMENTS IN THE NATURE OF A PROTEIN-BASED, NUTRIENT-DENSE FOOD BAR (U.S. CLS. 6, 18, 44, 46, 51 AND 52).  
FIRST USE 11-6-2009; IN COMMERCE 11-6-2009.

**CLASS 29—MEATS AND PROCESSED FOODS**

FOR FRUIT BASED, NUT-BASED OR VEGETABLE-BASED MEAL REPLACEMENT BARS, FRUIT-BASED, NUT-BASED OR VEGETABLE-BASED NUTRITIONAL AND DIETARY BARS FOR USE AS A MEAL REPLACEMENT; SNACK FOOD CHEWS MADE PRIMARILY FROM FRUIT; SNACK FOOD CHEWS MADE PRIMARILY FROM VEGETABLES; SNACK FOOD CHEWS MADE PRIMARILY FROM FRUITS, VEGETABLES, FOR USE IN CONJUNCTION WITH ATHLETIC ACTIVITIES; SNACK FOOD CHEWS MADE PRIMARILY FROM FRUITS, VEGETABLES, AND ENHANCED WITH VITAMINS; FRUIT-BASED, NUT-BASED OR VEGETABLE-BASED MEAL REPLACEMENT BARS WHICH CONTAIN PROTEIN; FRUIT-BASED, NUT-BASED OR VEGETABLE-BASED NUTRITIONAL AND DIETARY BARS FOR USE AS A MEAL REPLACEMENT WHICH CONTAIN PROTEIN; FRUIT BASED ORGANIC FOOD BARS, FRUIT BASED ORGANIC FOOD BARS ALSO CONTAINING VEGETABLES, NUTS, AND/OR SEEDS; PROCESSED FRUIT-BASED OR VEGETABLE-BASED NUTRIENT DENSE FOOD BARS WHICH CONTAIN PROTEIN, PROCESSED NUT BASED FOOD BARS, PROCESSED NUT AND SEED BASED FOOD BARS (U.S. CL. 46).

FIRST USE 11-6-2009; IN COMMERCE 11-6-2009.

**CLASS 30—STAPLE FOODS**

FOR SNACK FOOD CHEWS MADE PRIMARILY FROM TAPIOCA SYRUP; SNACK FOOD CHEWS MADE PRIMARILY FROM GRAIN; SNACK FOOD CHEWS MADE PRIMARILY FROM GRAINS OR TAPIOCA SYRUP, FOR USE IN CONJUNCTION WITH ATHLETIC ACTIVITIES; SNACK FOOD CHEWS MADE PRIMARILY FROM GRAINS OR TAPIOCA SYRUP, ALSO CONTAINING FRUITS AND VEGETABLES AND ENHANCED WITH VITAMINS; GRANOLA-BASED SNACK BARS; GRANOLA-BASED MEAL REPLACEMENT BARS WHICH CONTAIN PROTEIN; GRANOLA-BASED NUTRITIONAL DIETARY BARS FOR USE AS A MEAL REPLACEMENT WHICH CONTAIN PROTEIN (U.S. CL. 46).

FIRST USE 11-6-2009; IN COMMERCE 11-6-2009.  
MICHELE SWAIN, EXAMINING ATTORNEY

SN 86-240,357. DELCOM TELECOMMUNICATIONS, LLC, POMPANO BEACH, FL. FILED 4-2-2014.



THE COLOR(S) RED, ORANGE, BLUE AND WHITE IS/ ARE CLAIMED AS A FEATURE OF THE MARK.

THE MARK CONSISTS OF A RED HEXAGON, A BLUE HEXAGON, AN ORANGE HEXAGON AND A WHITE HEXAGON.

SN 86-240,338. DELCOM TELECOMMUNICATIONS, LLC, POMPANO BEACH, FL. FILED 4-2-2014.

**CLASS 38—COMMUNICATION**

FOR TELECOMMUNICATIONS SERVICES, NAMELY, TELEVISION TRANSMISSION SERVICES, PROVIDING INTERNET ACCESS, TELEPHONE COMMUNICATION SERVICES, AND TRANSMISSION OF VOICE, VIDEO, AND DATA VIA TELECOMMUNICATIONS NETWORKS (U.S. CLS. 100, 101 AND 104).

**CLASS 42—SCIENTIFIC AND COMPUTER SERVICES**

FOR DESIGN FOR OTHERS OF TELECOMMUNICATIONS INFRASTRUCTURE (U.S. CLS. 100 AND 101).  
ALEX KEAM, EXAMINING ATTORNEY



THE COLOR(S) RED, ORANGE, BLUE, BLACK AND WHITE IS/ARE CLAIMED AS A FEATURE OF THE MARK.

THE MARK CONSISTS OF A RED HEXAGON, A BLUE HEXAGON, AN ORANGE HEXAGON AND A WHITE HEXAGON, ALL NEXT TO THE WORD "DELCOM" IN BLACK CAPITALIZED LETTERS WITH THE FOLLOWING WORDS UNDERNEATH "THE FUTURE OF FAST" IN BLACK LOWERCASE LETTERS.

**CLASS 38—COMMUNICATION**

FOR TELECOMMUNICATIONS SERVICES, NAMELY, TELEVISION TRANSMISSION SERVICES, PROVIDING INTERNET ACCESS, TELEPHONE COMMUNICATION SERVICES, AND TRANSMISSION OF VOICE, VIDEO, AND DATA VIA TELECOMMUNICATIONS NETWORKS (U.S. CLS. 100, 101 AND 104).

**CLASS 42—SCIENTIFIC AND COMPUTER SERVICES**

FOR DESIGN FOR OTHERS OF TELECOMMUNICATIONS INFRASTRUCTURE (U.S. CLS. 100 AND 101).  
ALEX KEAM, EXAMINING ATTORNEY

SN 86-240,430. ROBMAR, LLC, GAITHERSBURG, MD. FILED 4-2-2014.

**MAXI'S DESIGNS**

THE MARK CONSISTS OF STANDARD CHARACTERS WITHOUT CLAIM TO ANY PARTICULAR FONT, STYLE, SIZE, OR COLOR.

NO CLAIM IS MADE TO THE EXCLUSIVE RIGHT TO USE "DESIGNS", APART FROM THE MARK AS SHOWN.

**CLASS 16—PAPER GOODS AND PRINTED MATTER**

FOR LUNCH BAGS; PENCIL CASES (U.S. CLS. 2, 5, 22, 23, 29, 37, 38 AND 50).

**CLASS 18—LEATHER GOODS**

FOR BACKPACKS; GENERAL PURPOSE SPORT TROLLEY BAGS; SCHOOL BAGS; SPORTS BAGS; TRAVEL BAGS (U.S. CLS. 1, 2, 3, 22 AND 41).  
REBECCA SMITH, EXAMINING ATTORNEY

SN 86-240,672. ATEAM HQ INC., CHANDLER, AZ. FILED 4-2-2014.

## A Team HQ

THE MARK CONSISTS OF STANDARD CHARACTERS WITHOUT CLAIM TO ANY PARTICULAR FONT, STYLE, SIZE, OR COLOR.

### CLASS 35—ADVERTISING AND BUSINESS

FOR BUSINESS ADMINISTRATION AND OFFICE WORK; BUSINESS MANAGEMENT SERVICES, NAMELY, ADMINISTRATION OF THE EMPLOYMENT PROCESS INCLUDING RESUME REVIEW, SCHEDULING OF INTERVIEWS, REFERENCE CHECKING, EMPLOYMENT APPLICATION ACQUISITION, AND PERSONNEL RECRUITMENT FOR OTHERS; BUSINESS PROJECT MANAGEMENT SERVICES FOR OTHERS IN THE FIELD OF CUSTOM WRITING OF PROPOSALS AND OFFICE POLICIES; OFFICE ADMINISTRATION SERVICES; PROVIDING VIRTUAL ON-LINE OFFICE SUPPORT STAFF SERVICES FOR BUSINESSES; ACCOUNTING SERVICES; ADMINISTRATION OF BUSINESS PAYROLL FOR OTHERS; BOOKKEEPING; EMPLOYEE ADMINISTRATION SERVICES; PAYROLL ADMINISTRATION AND MANAGEMENT SERVICES; SERVING AS A HUMAN RESOURCES DEPARTMENT FOR OTHERS (U.S. CLS. 100, 101 AND 102).

### CLASS 42—SCIENTIFIC AND COMPUTER SERVICES

FOR COMPUTER WEBSITE DESIGN; TECHNICAL SUPPORT SERVICES, NAMELY, REMOTE ADMINISTRATION AND MANAGEMENT OF IN-HOUSE AND HOSTED DATACENTERS, PERSONAL MOBILE DEVICES, DATABASES, COMPUTERS, LAPTOPS AND SOFTWARE APPLICATIONS; TECHNICAL SUPPORT SERVICES, NAMELY, INSTALLATION, ADMINISTRATION, AND TROUBLESHOOTING OF WEB AND DATABASE APPLICATIONS; INSTALLATION OF COMPUTER SOFTWARE FOR OTHERS (U.S. CLS. 100 AND 101).

### CLASS 45—PERSONAL AND LEGAL SERVICES

FOR PERSONAL CONCIERGE SERVICES FOR OTHERS COMPRISING MAKING REQUESTED PERSONAL ARRANGEMENTS, APPOINTMENTS AND RESERVATIONS AND PROVIDING CUSTOMER-SPECIFIC INFORMATION TO MEET INDIVIDUAL NEEDS (U.S. CLS. 100 AND 101).

DAVID MURRAY, EXAMINING ATTORNEY

SN 86-241,207. ISTAR FINANCIAL INC., NEW YORK, NY. FILED 4-3-2014.

## ISTAR RESIDENTIAL

THE MARK CONSISTS OF STANDARD CHARACTERS WITHOUT CLAIM TO ANY PARTICULAR FONT, STYLE, SIZE, OR COLOR.

OWNER OF U.S. REG. NOS. 2,484,891 AND 2,516,785.

NO CLAIM IS MADE TO THE EXCLUSIVE RIGHT TO USE "RESIDENTIAL", APART FROM THE MARK AS SHOWN.

### CLASS 36—INSURANCE AND FINANCIAL

FOR RESIDENTIAL REAL ESTATE INVESTMENT AND FINANCING SERVICES, LOAN SERVICING, ASSET MANAGEMENT, AND PROPERTY MANAGEMENT SERVICES; RESIDENTIAL PROPERTY DEVELOPMENT FINANCING; REAL ESTATE BROKERAGE SERVICES SPECIALIZING IN RESIDENTIAL CONDOMINIUM PROJECTS (U.S. CLS. 100, 101 AND 102).

FIRST USE 3-1-2011; IN COMMERCE 3-1-2011.

### CLASS 37—CONSTRUCTION AND REPAIR

FOR REAL ESTATE DEVELOPMENT AND CONSTRUCTION OF RESIDENTIAL PROPERTY (U.S. CLS. 100, 103 AND 106).

FIRST USE 3-1-2011; IN COMMERCE 3-1-2011.

B. PARADEWELAI, EXAMINING ATTORNEY

SN 86-241,343. COLUMBIA SPORTSWEAR NORTH AMERICA, INC., PORTLAND, OR. FILED 4-3-2014.

## OMNI-HEAT

THE MARK CONSISTS OF STANDARD CHARACTERS WITHOUT CLAIM TO ANY PARTICULAR FONT, STYLE, SIZE, OR COLOR.

OWNER OF U.S. REG. NOS. 3,878,153, 4,070,939 AND 4,164,890.

### CLASS 20—FURNITURE AND ARTICLES NOT OTHERWISE CLASSIFIED

FOR PILLOWS (U.S. CLS. 2, 13, 22, 25, 32 AND 50).

### CLASS 24—FABRICS

FOR BED BLANKETS; BED SHEETS; BED SKIRTS; BED THROWS; BLANKET THROWS; BLANKETS FOR OUTDOOR USE; COMFORTERS; DUVETS; PILLOW CASES; SHAMS; TOWELS (U.S. CLS. 42 AND 50).

CAITLIN WATTS-FITZGERALD, EXAMINING ATTORNEY

SN 86-241,443. DMG HOLDINGS MIAMI, INC., HIALEAH, FL. FILED 4-3-2014.

## SHAVER AID

THE MARK CONSISTS OF STANDARD CHARACTERS WITHOUT CLAIM TO ANY PARTICULAR FONT, STYLE, SIZE, OR COLOR.

NO CLAIM IS MADE TO THE EXCLUSIVE RIGHT TO USE "SHAVER", APART FROM THE MARK AS SHOWN.

### CLASS 3—COSMETICS AND CLEANING PREPARATIONS

FOR NON-MEDICATED SHAVE LOTION; CLEANER FOR USE ON ELECTRIC SHAVERS (U.S. CLS. 1, 4, 6, 50, 51 AND 52).

FIRST USE 4-0-1986; IN COMMERCE 4-0-1986.



**CLASS 8—HAND TOOLS**

FOR ELECTRIC SHAVER REPLACEMENT PARTS, NAMELY, SHAVER HEADS, SCREEN FOILS, AND CUTTER BLADES; ELECTRIC SHAVER CLEANING BRUSHES (U.S. CLS. 23, 28 AND 44).

FIRST USE 4-0-1986; IN COMMERCE 4-0-1986.

JEFF DEFORD, EXAMINING ATTORNEY

SN 86-241,455. JORDAN BURROUGHS, LINCOLN, NE.  
FILED 4-3-2014.

**ALL I SEE IS GOLD**

THE MARK CONSISTS OF STANDARD CHARACTERS WITHOUT CLAIM TO ANY PARTICULAR FONT, STYLE, SIZE, OR COLOR.

**CLASS 25—CLOTHING**

FOR CLOTHING, NAMELY, SHIRTS, PANTS, UNDERWEAR, JACKETS, TOPS, BOTTOMS, FOOTWEAR, SOCKS, HATS AND CAPS (U.S. CLS. 22 AND 39).

**CLASS 28—TOYS AND SPORTING GOODS**

FOR PHYSICAL FITNESS EQUIPMENT, NAMELY, FOAM ROLLERS (U.S. CLS. 22, 23, 38 AND 50).

MARTHA FROMM, EXAMINING ATTORNEY

SN 86-241,542. COMITÉ INTERNATIONAL OLYMPIQUE,  
AKA INTERNATIONAL OLYMPIC COMMITTEE, 1007  
LAUSANNE, SWITZERLAND, FILED 4-3-2014.



**LAUSANNE**  
**2020**

PRIORITY CLAIMED UNDER SEC. 44(D) ON SWITZERLAND APPLICATION NO. 64206/2013, FILED 11-26-2013, REG. NO. 655119, DATED 2-20-2014, EXPIRES 11-26-2023.

OWNER OF U.S. REG. NO. 4,524,813.

THE MARK CONSISTS OF FIVE INTERLOCKING RINGS SUPERIMPOSED UPON A RECTANGULAR BACKGROUND WITH THE UPPER RIGHT HAND CORNER THEREOF MISSING, WHICH ARE FOLLOWED BY "LAUSANNE" UNDER WHICH APPEARS "2020".

**CLASS 35—ADVERTISING AND BUSINESS**

FOR ADVERTISING; DISSEMINATION OF ADVERTISING MATTER VIA ALL MEDIA, NAMELY, IN THE FORM OF THEMATIC MESSAGES CENTERED ON HUMAN VALUES; PROMOTION OF PRODUCTS AND SERVICES OF THIRD PARTIES THROUGH SPONSORING ARRANGEMENTS AND LICENSE AGREEMENTS RELATING TO INTERNATIONAL SPORTS' EVENTS; BUSINESS MANAGEMENT; BUSINESS ADMINISTRATION; PROVIDING OFFICE FUNCTIONS; PROMOTING THE GOODS AND SERVICES OF OTHERS BY MEANS OF CONTRACTUAL AGREEMENTS, NAMELY, ARRANGING FOR SPONSORS TO AFFILIATE THEIR GOODS AND SERVICES WITH AN AWARDS PROGRAM, A SPORTS COMPETITION AND SPORTING ACTIVITIES AND LICENSING AGREEMENTS RELATING TO INTERNATIONAL SPORTS' EVENTS TO ENABLE PARTNERS TO GAIN ADDITIONAL NOTORIETY AND/OR IMAGE DERIVED FROM THOSE OF CULTURAL AND SPORTING EVENTS, IN PARTICULAR INTERNATIONAL SPORTING EVENTS; PROMOTING THE GOODS AND SERVICES OF OTHERS BY MEANS OF IMAGE TRANSFER, NAMELY, MAKING THE PARTNERS' PRODUCTS AND SERVICES BENEFIT FROM THE NOTORIETY AND ATTRACTIVENESS OF SPORTING EVENTS AND COMPETITIONS; RENTAL OF ADVERTISING SPACE OF ALL KINDS AND ON ALL CARRIERS, DIGITAL OR NOT; BUSINESS MANAGEMENT SERVICES, NAMELY, ADMINISTRATION OF COMPETITIONS FOR THE PARTICIPATION OF NATIONAL TEAMS TO AN INTERNATIONAL ATHLETIC COMPETITION, AND PROMOTING THE SUPPORT TO SAID TEAMS WITH THE PUBLIC AND THE CONCERNED CIRCLES BY MEANS OF PROMOTIONAL CAMPAIGNS IN THE MEDIA; INVENTORY CONTROL SERVICES; CONSULTATION IN THE FIELD OF INVENTORY CONTROL SERVICES; BUSINESS ACQUISITION INTEGRATION SERVICES; DIRECT MARKETING ADVERTISING FOR OTHERS FEATURING DATABASE MARKETING; CONSULTATION IN THE FIELD OF DIRECT MARKETING ADVERTISING FOR OTHERS FEATURING DATABASE MARKETING; BUSINESS REORGANIZATION CONSULTING SERVICES; TRUCK AND AUTOMOBILE FLEET MANAGEMENT SERVICES, NAMELY, VOYAGE REPORTING AND INVOICING VIA A GLOBAL COMPUTER NETWORK; CONSULTATION IN THE FIELD OF TRUCK AND AUTOMOBILE FLEET MANAGEMENT SERVICES; BUSINESS ADMINISTRATION CONSULTING SERVICES; OPERATION AND MANAGEMENT OF POWER PLANTS OF OTHERS; CONSULTATION IN THE FIELD OF OPERATION AND MANAGEMENT OF POWER PLANTS, BUSINESS SERVICES, NAMELY, THE ADMINISTRATION OF REPAIR AND SERVICES CONTRACTS, SUPPLY CHAIN MANAGEMENT AND CONSULTING SERVICES IN THE AREAS OF CHEMICAL PRODUCT AND SERVICE SOURCING AND PROCUREMENT, PRODUCT INVENTORY AND SUPPLY MANAGEMENT AND COST; CONSULTING, MARKETING, COST AND PRICING ANALYSIS RELATING TO ELECTROCHEMICAL LIQUID PURIFICATION UNITS FOR USE IN THE INDUSTRIAL SECTOR; ADMINISTRATIVE, COMMERCIAL AND TECHNICAL COMPUTERIZED FILE MANAGEMENT; DATA ENTRY AND DATA PROCESSING SERVICES; CONSULTANCY IN COMPUTERIZED DATABASE AND FILE MANAGEMENT; THE BRINGING TOGETHER, FOR THE BENEFIT OF OTHERS, OF A VARIETY OF GOODS AND SERVICES, ENABLING CUSTOMERS TO CONVENIENTLY VIEW AND PURCHASE THOSE GOODS AND SERVICES FROM AN INTERNET WEB SITE PARTICULARLY SPECIALIZING IN THE MARKETING OF THE SALE OF GOODS AND SERVICES OF OTHERS; BUSINESS INFORMATION, COMMERCIAL INFORMATION AGENCIES, RENTAL OF PHOTOCOPYING MACHINES; PROMOTING THE SALE OF GOODS AND SERVICES OF OTHERS BY MEANS OF ADVERTISEMENTS, PROMOTIONAL CONTESTS, DISCOUNTS AND INCENTIVES IN THE NATURE OF SWEEPSTAKES, REBATES, REWARD POINTS, AND VALUE ADDED OFFERS GENERATED IN CONNECTION WITH THE USE OF PAYMENT CARDS; PROMOTING SPORTS COMPETITIONS AND EVENTS OF OTHERS; PROMOTING CONCERTS AND CULTURAL EVENTS OF OTHERS, ORGANIZATION OF EXPOSITIONS HAVING COMMERCIAL OR ADVERTISING PURPOSES; THE PROVISION OF DOCUMENTATION, NAMELY, DIRECT MAIL ADVERTISING, DISSEMINATION OF ADVERTISING MATTER, DISTRI-

BUTION OF SAMPLES, DOCUMENT REPRODUCTION; ADVERTISING REGARDING COMMERCIAL SALES PROMOTION OF GOODS AND SERVICES AT THE RETAIL LEVEL; PROVIDING CONSUMER PRODUCT INFORMATION REGARDING PURCHASE OF GOODS AND SERVICES ON-LINE VIA THE INTERNET AND OTHER COMPUTER NETWORKS; ADVERTISING SERVICES, NAMELY, ADVERTISING FOR TRANSPORT, TRAVEL, HOTELS, LODGING, FOOD AND MEALS, SPORTS, ENTERTAINMENT AND SIGHTSEEING, FOR TOURIST AGENCIES SERVICES; CONSULTATION IN THE FIELD OF DATA PROCESSING, IN PARTICULAR, IN REGARD TO FINANCIAL TRANSACTIONS (U.S. CLS. 100, 101 AND 102).

#### **CLASS 41—EDUCATION AND ENTERTAINMENT**

FOR PROVIDING OF TRAINING SERVICES IN THE FIELDS OF BIATHLON, BOBSLEIGH, CURLING, ICE HOCKEY, LUGE, SKATING, SKIING, AND SHOOTING; ENTERTAINMENT IN THE NATURE OF INTERNATIONAL SPORTING EVENTS, NAMELY, BIATHLON PERFORMANCES, BOBSLEIGH PERFORMANCES, CURLING PERFORMANCES, ICE HOCKEY PERFORMANCES, LUGE PERFORMANCES, SKATING PERFORMANCES, SKIING PERFORMANCES, AND SHOOTING PERFORMANCES; ORGANIZING INTERNATIONAL COMMUNITY SPORTING AND CULTURAL EVENTS, TELEVISION SHOW PRODUCTION IN THE FIELD OF SPORTING AND CULTURAL ENTERTAINMENT; ORGANIZATION OF CULTURAL AND EDUCATIONAL EXHIBITIONS IN THE FIELD OF SPORTS; ORGANIZATION OF LOTTERIES; BETTING AND GAMBLING SERVICES RELATING TO OR IN CONJUNCTION WITH SPORT; ENTERTAINMENT SERVICES PROVIDED AT OR RELATING TO SPORTS EVENTS, NAMELY, PRESENTATION OF LIVE SHOW PERFORMANCES IN THE NATURE OF OPENING AND CLOSING CEREMONIES OF INTERNATIONAL SPORTS EVENTS; ORGANIZATION OF INTERNATIONAL COMMUNITY SPORTING AND CULTURAL EVENTS; ORGANIZATION OF SPORTING COMPETITIONS, NAMELY, BIATHLON, BOBSLEIGH, CURLING, ICE HOCKEY, LUGE, SKATING, SKIING, AND SHOOTING COMPETITIONS; MANAGEMENT OF SPORTING FACILITIES, NAMELY, PROVIDING SPORTS FACILITIES; RENTAL OF AUDIO AND VIDEO EQUIPMENT; PRODUCTION AND DISTRIBUTION OF MOTION PICTURE FILMS; PRODUCTION OF VIDEO TAPES AND AUDIO SOUNDS RECORDINGS; RENTAL OF FILMS AND VIDEO TAPES AND SOUNDS RECORDINGS; RENTAL OF INTERACTIVE EDUCATION AND ENTERTAINMENT VIDEO-TAPES IN THE FIELD OF SPORTS; PRODUCTION OF RADIO AND TELEVISION PROGRAMS FEATURING COVERAGE OF SPORTS AND SPORTING EVENTS; RADIO AND TELEVISION PROGRAM AND VIDEO TAPE PRODUCTION SERVICES; PRODUCTION OF ANIMATED MOTION PICTURE FILMS; PRODUCTION OF ANIMATED TELEVISION PROGRAMS; SEAT BOOKING SERVICES FOR SHOWS AND SPORTING EVENTS; TIMING OF SPORTS EVENTS; ORGANIZATION OF BEAUTY CONTESTS; ON-LINE GAMBLING SERVICES; PROVIDING OF GAMES OVER THE INTERNET, NAMELY, ON-LINE COMPUTER GAMES; PROVIDING OF RAFFLE SERVICES IN THE NATURE OF A LOTTERY; PROVIDING INFORMATION RELATING TO SPORTS ENTERTAINMENT AND EDUCATION, PROVIDED ON-LINE FROM A COMPUTER DATABASE OR THE INTERNET; ELECTRONIC GAMES SERVICES PROVIDED BY MEANS OF THE INTERNET, NAMELY, PROVIDING ON-LINE COMPUTER GAMES; PROVIDING ON-LINE ELECTRONIC PUBLICATIONS, NAMELY, PUBLICATION OF ELECTRONIC MAGAZINES AND NEWSPAPERS; PUBLICATION OF ELECTRONIC BOOKS, REVIEWS, JOURNALS, MAGAZINES, TEXTS OTHER THAN PUBLICITY TEXTS; ON-LINE PUBLICATION OF ELECTRONIC BOOKS, REVIEWS, JOURNALS, MAGAZINES, TEXTS OTHER THAN PUBLICITY TEXTS; PROVIDING NON-DOWNLOADABLE DIGITAL MUSIC ON THE INTERNET VIA A GLOBAL COMPUTER NETWORK; PROVIDING NON-DOWNLOADABLE DIGITAL MUSIC BY MEANS OF MP3 INTERNET WEB SITES ON A GLOBAL COMPUTER NETWORK; PROVIDING SPORT RECORDS AND STATISTICAL INFORMATION IN CONNECTION WITH SPORTS AND SPORTING EVENTS; LEASING OF RECORDED SOUND AND IMAGES, NAMELY, AUDIO,

VIDEO AND PHOTOGRAPHIC ARCHIVES RELATING TO SPORT COMPETITIONS AND RELATED EVENTS, AUDIO PRODUCTION SERVICES; PROVIDING INFORMATION IN THE FIELD OF SPORTS, NAMELY, PROVIDING SPORTING RESULTS; PROVIDING INFORMATION RELATED TO SPORTING EVENTS PROVIDED ON-LINE FROM A COMPUTER DATABASE OR FROM THE INTERNET; MUSIC PUBLISHING AND PRODUCTION SERVICES; PROVIDING NON-DOWNLOADABLE DIGITAL MUSIC, NAMELY, MUSIC FROM THE OPENING AND CLOSING CEREMONIES OF INTERNATIONAL SPORTING EVENTS, VIA THE INTERNET; PROVIDING STATISTICAL INFORMATION IN RELATION TO SPORTS RESULTS AND AUDIENCE RATINGS FOR SPORTS COMPETITIONS; TRAINING IN THE USE AND OPERATION OF SIGNALING AND CROSS-WARNING SYSTEMS FOR THE RAIL AND TRANSIT INDUSTRIES; EDUCATIONAL SERVICES IN THE FIELD OF MEDICAL IMAGING AND DIAGNOSTICS, NAMELY, HOLDING SEMINARS, CONFERENCES, SYMPOSIUMS OR WORKSHOPS RELATING TO THE PHARMACEUTICAL INDUSTRY, FOR MEDICAL PRACTITIONERS AND EMPLOYEES OF PHARMACEUTICAL COMPANIES; EDUCATIONAL SERVICES, NAMELY, HOLDING SEMINARS, CONFERENCES, SYMPOSIUMS OR WORKSHOPS IN THE FIELD OF LIFE SCIENCE AND BIOTECHNOLOGY FOR SCIENTISTS AND RESEARCHERS; CONDUCTING SEMINARS RELATED TO INDUSTRIAL WATER TREATMENT PROBLEMS; PROVIDING TRAINING SERVICES FOR ALL THE AFORESAID; PROVIDING TRAINING SERVICES IN MANAGEMENT AND THE MEDICAL FIELD THROUGH THE USE OF INSTRUCTIONS AND DEMONSTRATIONS PROVIDED ONLINE, THROUGH THE INTERNET, INTRANET AND EXTRANETS; EDUCATION SERVICES, NAMELY, CONDUCTING PRACTICAL TRAINING WORKSHOPS, CLASSES AND SEMINARS FEATURING DEMONSTRATIONS IN THE FIELD OF MANAGEMENT AND MEDICINE; DESIGN, ORGANIZATION AND CONDUCTING OF EDUCATIONAL COURSES, SEMINARS AND TRAINING IN THE FIELD OF COMPUTERS; ORGANIZING AND CONDUCTING MUSICAL CONCERTS; BOOKING OF SEATS FOR SHOWS AND CINEMA PRESENTATIONS; ENTERTAINMENT INFORMATION; FILM PRODUCTION; PRODUCTION OF TELEVISION AND RADIO SHOWS; ENTERTAINMENT SERVICES IN THE NATURE OF THEATRE PRODUCTIONS; PROVIDING GOLF FACILITIES; HEALTH CLUB SERVICES, NAMELY, PROVIDING INSTRUCTION AND EQUIPMENT IN THE FIELD OF PHYSICAL EXERCISE; SPORT CAMP SERVICES; PRESENTATION OF LIVE SHOW PERFORMANCES; MOVIE THEATRES; ORGANIZATION OF CULTURAL SHOWS; HOLIDAY CAMP SERVICES; MOVIE STUDIOS; NEWS REPORTERS SERVICES; PROVIDING ON-LINE NON-DOWNLOADABLE PUBLICATIONS, IN THE NATURE OF BOOKS, MAGAZINES, REVIEWS IN THE FIELD OF SPORTS; EDUCATION SERVICES, NAMELY, CONDUCTING CLASSES, SEMINARS, PRESENTATIONS, VIDEO PRESENTATIONS IN THE FIELD OF SPORTS, PROVISION OF EDUCATIONAL MATERIAL, NAMELY, DEVELOPMENT AND DISSEMINATION OF EDUCATIONAL MATERIALS IN THE AREA OF FINANCIAL LITERACY; EDUCATIONAL SERVICES IN THE TOURIST FIELD, NAMELY, PROVIDING SEMINARS, CONFERENCES, SYMPOSIUMS AND WORKSHOPS IN THE FIELD OF BOOKING TRAVEL AND ENTERTAINMENT TICKETS; INFORMATION SERVICES IN THE TOURIST FIELD, NAMELY, TICKET RESERVATION INFORMATION IN THE NATURE OF PROVIDING INFORMATION CONCERNING TICKET RESERVATIONS FOR SHOWS AND OTHER ENTERTAINMENT EVENTS ENTERTAINMENT; INFORMATION SERVICES IN THE TOURIST FIELD, NAMELY, ENTERTAINMENT INFORMATION SERVICES; INFORMATION SERVICES IN THE TOURIST FIELD, NAMELY, PROVIDING ACTIVITY SCHEDULING INFORMATION SERVICES FOR SPORTS, CULTURE AND OTHER ENTERTAINMENT EVENTS; SERVICES IN REGARD TO ENTERTAINMENT FOR THE ASSISTANCE OF TOURISTS, NAMELY, TOURIST ASSISTANCE SERVICES IN THE NATURE OF ACTIVITY SCHEDULING FOR SPORTING, CULTURAL AND OTHER ENTERTAINMENT EVENTS; TOURIST RESERVATION SERVICES, NAMELY, TICKET RESERVATION SERVICES FOR SPORTING, CULTURAL AND OTHER ENTERTAINMENT EVENTS; TOURIST RESERVATION

SERVICES, NAMELY, TICKET RESERVATION SERVICES FOR SPORTING, CULTURAL AND OTHER ENTERTAINMENT EVENTS (U.S. CLS. 100, 101 AND 107).  
JEFFERY COWARD, EXAMINING ATTORNEY

SN 86-241,985. MBPT, LLC, PLYMOUTH, MI. FILED 4-3-2014.

SN 86-241,707. PROJECT 529, INC., PORTLAND, OR. FILED 4-3-2014.



## PROJECT 529

THE MARK CONSISTS OF STANDARD CHARACTERS WITHOUT CLAIM TO ANY PARTICULAR FONT, STYLE, SIZE, OR COLOR.

### CLASS 9—ELECTRICAL AND SCIENTIFIC APPARATUS

FOR COMPUTER APPLICATION SOFTWARE FOR MOBILE PHONES, HANDHELD COMPUTERS, AND PCS, NAMELY, SOFTWARE FOR COLLECTING AND SHOWING LOCATION-BASED INFORMATION, AUDIO, VIDEO, PHOTOGRAPHIC AND OR PROSE PRESENTATIONS (U.S. CLS. 21, 23, 26, 36 AND 38).

### CLASS 35—ADVERTISING AND BUSINESS

FOR BICYCLE REGISTRATION SERVICES, NAMELY, NATIONAL BICYCLE REGISTRY SERVICES RENDERED VIA A GLOBAL COMPUTER NETWORK FOR NOTIFICATION OF RECOVERY OF LOST OR STOLEN BICYCLES (U.S. CLS. 100, 101 AND 102).

### CLASS 41—EDUCATION AND ENTERTAINMENT

FOR PROVIDING INFORMATION IN THE FIELD OF SPORTS AND OUTDOOR RECREATIONAL ACTIVITIES, NAMELY, BICYCLING (U.S. CLS. 100, 101 AND 107).

### CLASS 45—PERSONAL AND LEGAL SERVICES

FOR PROVIDING ONLINE SOCIAL NETWORKING SERVICES IN THE FIELD OF SPORTS AND OUTDOOR RECREATIONAL ACTIVITIES, NAMELY, BICYCLING (U.S. CLS. 100 AND 101).  
MATTHEW GALAN, EXAMINING ATTORNEY

OWNER OF U.S. REG. NO. 3,857,874.

THE COLOR(S) BLACK AND RED IS/ARE CLAIMED AS A FEATURE OF THE MARK.

THE MARK CONSISTS OF A DRAGON SHOWN FROM THE NECK UP, WITH ITS NECK AND HEAD CURLING TO ITS LEFT, SHOWING A PROFILE OF THE LEFT SIDE OF THE DRAGON'S HEAD, AND WITH THE DRAGON'S TALONS RESTING ON THE DRAGON'S NECK. THE LETTERS "BM" APPEAR ON THE UPPER PORTION OF THE DRAGON'S NECK, WITH THE LETTER "B" IN BLACK AND THE LETTER "M" IN RED.

### CLASS 9—ELECTRICAL AND SCIENTIFIC APPARATUS

FOR DIGITAL MEDIA, NAMELY, PRE-RECORDED VIDEO CASSETTES, DIGITAL VIDEO DISCS, DIGITAL VERSATILE DISCS, DOWNLOADABLE AUDIO AND VIDEO RECORDINGS, DVDS, AND HIGH DEFINITION DIGITAL DISCS FEATURING STRENGTH AND CONDITIONING TRAINING (U.S. CLS. 21, 23, 26, 36 AND 38).  
FIRST USE 11-1-2009; IN COMMERCE 3-1-2010.

### CLASS 16—PAPER GOODS AND PRINTED MATTER

FOR PUBLICATIONS, NAMELY, BOOKS, MANUALS AND GUIDES IN THE FIELDS OF STRENGTH AND CONDITIONING TRAINING (U.S. CLS. 2, 5, 22, 23, 29, 37, 38 AND 50).  
FIRST USE 11-1-2009; IN COMMERCE 11-1-2009.

### CLASS 25—CLOTHING

FOR ATHLETIC APPAREL, NAMELY, SHIRTS, PANTS, JACKETS, FOOTWEAR, HATS AND CAPS, ATHLETIC UNIFORMS (U.S. CLS. 22 AND 39).  
FIRST USE 11-1-2009; IN COMMERCE 2-1-2010.  
MARGERY A. TIERNEY, EXAMINING ATTORNEY

SN 86-242,119. BIRCHBOX, INC., NEW YORK, NY. FILED 4-3-2014.



THE MARK CONSISTS OF THE STYLIZED DESIGN OF THE OUTLINE OF THE LETTER "B" IN THE CENTER OF A DIAMOND. IN ADDITION, A SINGLE, SMALLER DIAMOND SHAPE APPEARS CENTERED WITHIN THE LETTER "B" AND IS THE ONLY ELEMENT CONTAINED WITHIN THE LETTER "B".

#### CLASS 35—ADVERTISING AND BUSINESS

FOR RETAIL STORE SERVICES FEATURING COSMETIC, BEAUTY, PERFUMERY, MAKE-UP, TOILETRY, LIFESTYLE, SKIN, HAIR AND PERSONAL CARE PRODUCTS AND ACCESSORIES, BATH AND BODY PRODUCTS AND ACCESSORIES, FOOD, COFFEE, TEA, NON-ALCOHOLIC BEVERAGES, APPAREL, BAGS, HOUSEWARES, HOME ACCESSORIES, TABLEWARE, CLOCKS, WATCHES, JEWELRY, CANDLES, PICTURE FRAMES AND STATIONERY (U.S. CLS. 100, 101 AND 102).

#### CLASS 44—MEDICAL, BEAUTY AND AGRICULTURAL SERVICES

FOR PROVIDING ON-SITE BEAUTY SERVICES, NAMELY, HAIR STYLING, NAIL CARE AND MAKE-UP APPLICATION SERVICES, AND BEAUTY CONSULTATION SERVICES (U.S. CLS. 100 AND 101).

GEORGE LORENZO, EXAMINING ATTORNEY

SN 86-242,156. BIRCHBOX, INC., NEW YORK, NY. FILED 4-4-2014.



THE MARK CONSISTS OF THE STYLIZED DESIGN OF THE OUTLINE OF THE LETTER "B". IN ADDITION, A SINGLE DIAMOND SHAPE APPEARS CENTERED WITHIN THE LETTER "B" AND IS THE ONLY ELEMENT CONTAINED WITHIN THE LETTER "B".

#### CLASS 35—ADVERTISING AND BUSINESS

FOR RETAIL STORE SERVICES FEATURING COSMETIC, BEAUTY, PERFUMERY, MAKE-UP, TOILETRY, LIFESTYLE, SKIN, HAIR AND PERSONAL CARE PRODUCTS AND ACCESSORIES, BATH AND BODY PRODUCTS AND ACCESSORIES, FOOD, COFFEE, TEA, NON-ALCOHOLIC BEVERAGES, APPAREL, BAGS, HOUSEWARES, HOME ACCESSORIES, TABLEWARE, CLOCKS, WATCHES, JEWELRY, CANDLES, PICTURE FRAMES AND STATIONERY (U.S. CLS. 100, 101 AND 102).

#### CLASS 44—MEDICAL, BEAUTY AND AGRICULTURAL SERVICES

FOR PROVIDING ON-SITE BEAUTY SERVICES, NAMELY, HAIR STYLING, NAIL CARE AND MAKE-UP APPLICATION SERVICES, AND BEAUTY CONSULTATION SERVICES (U.S. CLS. 100 AND 101).

GEORGE LORENZO, EXAMINING ATTORNEY

SN 86-242,381. CONVENTION INDUSTRY COUNCIL, ALEXANDRIA, VA. FILED 4-4-2014.



OWNER OF U.S. REG. NOS. 3,205,007 AND 3,372,978. NO CLAIM IS MADE TO THE EXCLUSIVE RIGHT TO USE "HEALTHCARE", APART FROM THE MARK AS SHOWN.

THE MARK CONSISTS OF A DIAMOND-SHAPED FIGURE, WITH TWO SMALLER TRIANGLES ON EITHER SIDE, WITH THE LETTERS "CMP" UNDERNEATH, ALL ENCLOSED WITHIN A TRIANGLE BORDER; DIRECTLY BENEATH THE TRIANGLE BORDER IS THE WORD "HEALTHCARE" WITH THE "H" AND THE "C" CAPITALIZED.

#### CLASS 35—ADVERTISING AND BUSINESS

FOR ASSOCIATION SERVICES, NAMELY, PROMOTING THE INTERESTS OF MEETING, CONVENTION AND EXHIBITION PLANNING PROFESSIONALS (U.S. CLS. 100, 101 AND 102).

FIRST USE 4-1-2014; IN COMMERCE 4-1-2014.

#### CLASS 42—SCIENTIFIC AND COMPUTER SERVICES

FOR TESTING, ANALYSIS AND EVALUATION OF THE SERVICES OF OTHERS FOR THE PURPOSE OF CERTIFICATION RELATING TO THE MEETING, CONVENTION AND EXHIBITION PLANNING INDUSTRY (U.S. CLS. 100 AND 101).

FIRST USE 4-1-2014; IN COMMERCE 4-1-2014. ANNE MADDEN, EXAMINING ATTORNEY

SN 86-243,276. HY IP HOLDING COMPANY LLC, NEW YORK, NY. FILED 4-4-2014.

SN 86-243,527. META IMPLANT, INC., SAN FRANCISCO, CA. FILED 4-5-2014.

# 50 HY

THE MARK CONSISTS OF STANDARD CHARACTERS WITHOUT CLAIM TO ANY PARTICULAR FONT, STYLE, SIZE, OR COLOR.

## CLASS 36—INSURANCE AND FINANCIAL

FOR REAL ESTATE MANAGEMENT AND LEASING SERVICES; REAL ESTATE MANAGEMENT AND LEASING SERVICES FOR COMMERCIAL AND BUSINESS OFFICES, RETAIL FACILITIES, RESTAURANTS, CULTURAL, AND ENTERTAINMENT FACILITIES (U.S. CLS. 100, 101 AND 102).

## CLASS 37—CONSTRUCTION AND REPAIR

FOR REAL ESTATE DEVELOPMENT (U.S. CLS. 100, 103 AND 106).

## CLASS 43—HOTEL AND RESTAURANT SERVICES

FOR BAR AND RESTAURANT SERVICES (U.S. CLS. 100 AND 101).  
DAVID BROOKSHIRE, EXAMINING ATTORNEY

---

SN 86-243,438. SHENZHEN SIGELEI TECHNOLOGY CO., LTD, BAOAN DISTRICT, SHENZHEN, CHINA, FILED 4-4-2014.

# SIGELEI

THE MARK CONSISTS OF STANDARD CHARACTERS WITHOUT CLAIM TO ANY PARTICULAR FONT, STYLE, SIZE, OR COLOR.

## CLASS 9—ELECTRICAL AND SCIENTIFIC APPARATUS

FOR BATTERIES (U.S. CLS. 21, 23, 26, 36 AND 38).  
FIRST USE 4-21-2012; IN COMMERCE 4-21-2012.

## CLASS 34—SMOKERS' ARTICLES

FOR ELECTRONIC CIGARETTES; ELECTRONIC CIGARS; CARTOMIZERS, NAMELY, COMBINATION ELECTRONIC CIGARETTE REFILL CARTRIDGES SOLD EMPTY AND ATOMIZERS SOLD AS A COMPONENT OF ELECTRONIC CIGARETTES; SMOKELESS CIGARETTE VAPORIZER PIPES (U.S. CLS. 2, 8, 9 AND 17).

FIRST USE 4-21-2012; IN COMMERCE 4-21-2012.  
LINDA MICKLEBURGH, EXAMINING ATTORNEY

# META IMPLANT

THE MARK CONSISTS OF STANDARD CHARACTERS WITHOUT CLAIM TO ANY PARTICULAR FONT, STYLE, SIZE, OR COLOR.

NO CLAIM IS MADE TO THE EXCLUSIVE RIGHT TO USE "IMPLANT", APART FROM THE MARK AS SHOWN.

## CLASS 10—MEDICAL APPARATUS

FOR DENTAL IMPLANTS; DENTAL PROSTHESES; IMPLANTABLE DENTAL DEVICES FOR IMPLANTING WITHIN A SUBJECT'S MOUTH, COMPRISING A MESHWORK STRUCTURE CONFIGURED TO PROMOTE BONE GROWTH AND HAVING INTERCONNECTED CELLS CONFIGURED FOR RECEIVING BONE GRAFT MATERIAL THEREIN, THE MESHWORK STRUCTURE CONFIGURED FOR PERMANENT PLACEMENT WITHIN THE PATIENT'S JAW BONE; ROOT FORM IMPLANTS AND FIXATING PLATE(S) FORMED INTEGRAL WITH THE MESHWORK STRUCTURE THAT ATTACH TO THE STRUCTURE OF A PATIENT'S JAWBONE (U.S. CLS. 26, 39 AND 44).

## CLASS 40—MATERIAL TREATMENT

FOR CUSTOM MANUFACTURE OF DENTAL IMPLANTS; CUSTOM MANUFACTURE OF DENTAL IMPLANTS WITH PROSTHETIC COMPONENTS; CUSTOM MANUFACTURE OF DENTAL PROSTHESES; CUSTOM MANUFACTURE OF APPARATUSES COMPRISED OF MESHWORKS, FIXATING PLATES, AND ROOT FORM IMPLANTS FOR FACILITATING THE FIXATION OF DENTAL IMPLANTS TO A PATIENT'S JAW BONE (U.S. CLS. 100, 103 AND 106).

## CLASS 44—MEDICAL, BEAUTY AND AGRICULTURAL SERVICES

FOR ORAL SURGERY AND DENTAL IMPLANT SERVICES; DENTAL SERVICES, NAMELY, PERFORMING RESTORATIVE AND COSMETIC PROCEDURES; SERVICES RELATED TO IMPLANTING DENTAL IMPLANTS WITH PROSTHETIC COMPONENT(S) ATTACHED TO SUPPORT CUSTOM PROSTHESES, COMPRISING IDENTIFYING A PATIENT SUITABLE FOR RECEIVING A DENTAL IMPLANT, COMMISSIONING A THREE DIMENSIONAL IMAGE OF A TARGET AREA OF THE PATIENT'S BODY FOR RECEIVING THE IMPLANT, COMMISSIONING A DESIGN OF THE IMPLANT USING COMPUTER MODELING, COMMISSIONING THE CONSTRUCTION OF THE IMPLANT USING DEPOSITION METHOD, AND AFFIXING THE DENTAL IMPLANT IN THE PATIENT'S JAW (U.S. CLS. 100 AND 101).

BRITTNEY COGAN, EXAMINING ATTORNEY

SN 86-243,608. AMERICAN JEWEL, LLC, VALENCIA, CA.  
FILED 4-5-2014.

## GENERATION US

THE MARK CONSISTS OF STANDARD CHARACTERS WITHOUT CLAIM TO ANY PARTICULAR FONT, STYLE, SIZE, OR COLOR.

### CLASS 14—JEWELRY

FOR BRACELETS; BROACHES; CAMEOS; CHARMS; CHILDREN'S JEWELRY; COSTUME JEWELRY; CUFFLINKS; EARRINGS; HAIR JEWELRY IN THE NATURE OF JEWELRY FOR USE IN THE HAIR; JEWELRY; JEWELRY AND IMITATION JEWELRY; JEWELRY FOR ATTACHMENT TO CLOTHING; JEWELRY FOR THE HEAD; JEWELRY IN THE NATURE OF ARMBANDS; JEWELRY TO BE AFFIXED TO BIKINIS; JEWELRY, NAMELY, AMULETS; JEWELRY, NAMELY, ANKLETS; JEWELRY, NAMELY, ARM CUFFS; LEATHER JEWELRY AND ACCESSORY BOXES; NECKLACES; RINGS; WOMEN'S JEWELRY (U.S. CLS. 2, 27, 28 AND 50).

### CLASS 25—CLOTHING

FOR BANDANAS; COATS; DRESSES; GLOVES; HATS; LEGGINGS; MITTENS; PANTS; SCARFS; SHIRTS; SHOES; SHORTS; SLIPPERS; SNEAKERS; SOCKS; STOCKINGS; SUITS; TIGHTS; VESTS (U.S. CLS. 22 AND 39).

### CLASS 26—FANCY GOODS

FOR HAIR ACCESSORIES, NAMELY, TWISTERS; HAIR BANDS; HAIR BARRETTES; HAIR BOWS; HAIR BUCKLES; HAIR CHOPSTICKS; HAIR CLAMPS; HAIR CLIPS; HAIR ELASTICS; HAIR GRIPS; HAIR NETS; HAIR ORNAMENTS; HAIR PINS; HAIR RIBBONS; HAIR RODS; HAIR SCRUNCHIES; HAIR SLIDES; RUBBER BANDS FOR HAIR (U.S. CLS. 37, 39, 40, 42 AND 50).  
TASHIA BUNCH, EXAMINING ATTORNEY

SN 86-243,646. CULVER DESIGN GROUP LLC, CULVER CITY, CA. FILED 4-5-2014.

## IVI ŌNO

THE MARK CONSISTS OF STANDARD CHARACTERS WITHOUT CLAIM TO ANY PARTICULAR FONT, STYLE, SIZE, OR COLOR.

THE NAME(S), PORTRAIT(S), AND/OR SIGNATURE(S) SHOWN IN THE MARK DOES NOT IDENTIFY A PARTICULAR LIVING INDIVIDUAL.

THE WORDING "IVI ŌNO" HAS NO MEANING IN A FOREIGN LANGUAGE.

### CLASS 18—LEATHER GOODS

FOR ALL PURPOSE SPORT BAGS; ALL-PURPOSE ATHLETIC BAGS; ALL-PURPOSE CARRYING BAGS; AMENITY BAGS SOLD EMPTY; BACKPACKS, BOOK BAGS, SPORTS BAGS, BUM BAGS, WALLETS AND HANDBAGS; BOOK BAGS; CARRY-ALL BAGS; CLUTCH BAGS; COIN PURSES; HANDBAGS; PURSES (U.S. CLS. 1, 2, 3, 22 AND 41).

### CLASS 25—CLOTHING

FOR BELTS; COATS; COLLARED SHIRTS; DRESS SHIRTS; DRESSES; FOOTWEAR; GYM PANTS; HOODED SWEATSHIRTS; KNIT SHIRTS; LONG-SLEEVED SHIRTS; PANTS; PONCHOS; SARONGS; SHIRTS; SHOES; SHORT-SLEEVED OR LONG-SLEEVED T-SHIRTS; SHORT-SLEEVED SHIRTS; SKIRTS; SPORTS SHIRTS; SWEAT SHIRTS; SWEATERS; T-SHIRTS (U.S. CLS. 22 AND 39).

JENNIFER RICHARDSON, EXAMINING ATTORNEY

SN 86-244,165. CHATWAL HOTELS & RESORTS, LLC, NEW YORK, NY. FILED 4-7-2014.



THE COLOR(S) GOLD IS/ARE CLAIMED AS A FEATURE OF THE MARK.

THE MARK CONSISTS OF A CAPITAL LETTER "H"-SHAPED DESIGN IN GOLD WITH TWO DOTS IN GOLD IN THE MIDDLE OF THE "H", WHICH IS SURROUNDED BY A GOLD RECTANGLE.

### CLASS 36—INSURANCE AND FINANCIAL

FOR REAL ESTATE SERVICES, NAMELY, LISTING, BROKERAGE AND MANAGEMENT OF HOTELS AND CONDOMINIUM RESIDENTIAL UNITS; REAL ESTATE FINANCING (U.S. CLS. 100, 101 AND 102).

FIRST USE 1-1-2014; IN COMMERCE 1-1-2014.

### CLASS 43—HOTEL AND RESTAURANT SERVICES

FOR HOTEL SERVICES; RESTAURANT, CATERING, BAR AND COCKTAIL LOUNGE SERVICES; RESORT LODGING SERVICES; PROVISION OF GENERAL-PURPOSE FACILITIES FOR MEETINGS, CONFERENCES AND EXHIBITIONS; PROVISION OF BANQUET AND SOCIAL FUNCTION FACILITIES FOR SPECIAL OCCASIONS; AND RESERVATIONS SERVICES FOR HOTEL ACCOMMODATIONS FOR OTHERS (U.S. CLS. 100 AND 101).

FIRST USE 1-1-2014; IN COMMERCE 1-1-2014.  
GISELLE AGOSTO, EXAMINING ATTORNEY

SN 86-244,386. DROPCAST, LLC, MESA, AZ. FILED 4-7-2014.

# ONCAST

THE MARK CONSISTS OF STANDARD CHARACTERS WITHOUT CLAIM TO ANY PARTICULAR FONT, STYLE, SIZE, OR COLOR.

## CLASS 9—ELECTRICAL AND SCIENTIFIC APPARATUS

FOR DOWNLOADABLE COMPUTER SOFTWARE APPLICATION TO ENABLE CAPTURING, EDITING, UPLOADING, POSTING, SHARING AND LIVE STREAMING OF ELECTRONIC MEDIA OR INFORMATION INCLUDING USER-GENERATED DIGITAL VISUAL IMAGES, AUDIO FILES, AND DIGITAL VIDEOS OVER THE INTERNET OR OTHER COMMUNICATIONS NETWORK THROUGH THE USE OF A MOBILE COMPUTING DEVICE (U.S. CLS. 21, 23, 26, 36 AND 38).

## CLASS 42—SCIENTIFIC AND COMPUTER SERVICES

FOR PROVIDING A WEBSITE FEATURING NON-DOWNLOADABLE SOFTWARE AND TECHNOLOGY THAT ENABLES USERS TO ELECTRONICALLY VIEW, DISPLAY, SHARE, AND ARCHIVE ELECTRONIC MEDIA OR INFORMATION INCLUDING USER-GENERATED DIGITAL VISUAL IMAGES, AUDIO FILES, AND DIGITAL VIDEOS OVER THE INTERNET OR OTHER COMMUNICATIONS NETWORK (U.S. CLS. 100 AND 101).

BERNICE MIDDLETON, EXAMINING ATTORNEY

---

SN 86-244,408. ELECTRIC CLOUD, INC., SUNNYVALE, CA. FILED 4-7-2014.

# ELECTRICFLOW

THE MARK CONSISTS OF STANDARD CHARACTERS WITHOUT CLAIM TO ANY PARTICULAR FONT, STYLE, SIZE, OR COLOR.

## CLASS 9—ELECTRICAL AND SCIENTIFIC APPARATUS

FOR COMPUTER SOFTWARE DEVELOPMENT TOOLS; COMPUTER SOFTWARE FOR COMPUTER SYSTEM AND APPLICATION DEVELOPMENT, TESTING, DEPLOYMENT, AND MANAGEMENT; COMPUTER SOFTWARE FOR ENABLING THE AUTOMATED BUILD, TEST, RELEASE, AND DEPLOYMENT OF SOFTWARE AND APPLICATIONS TO PRE-PRODUCTION AND PRODUCTION ENVIRONMENTS (U.S. CLS. 21, 23, 26, 36 AND 38).

## CLASS 42—SCIENTIFIC AND COMPUTER SERVICES

FOR CLOUD COMPUTING FEATURING SOFTWARE FOR USE FOR DEVELOPMENT TOOLS; CLOUD COMPUTING FEATURING SOFTWARE FOR USE FOR APPLICATION DEVELOPMENT, TESTING, DEPLOYMENT, AND MANAGEMENT; PROVIDING ONLINE NON-DOWNLOADABLE COMPUTER SOFTWARE FOR ENABLING THE AUTOMATED BUILD, TEST, RELEASE AND DEPLOYMENT OF SOFTWARE AND APPLICATIONS TO PRE-PRODUCTION AND PRODUCTION ENVIRONMENTS (U.S. CLS. 100 AND 101).

ZACHARY BELLO, EXAMINING ATTORNEY

---

SN 86-244,478. ELECTRONIC CONTROLS COMPANY, BOISE, ID. FILED 4-7-2014.



OWNER OF U.S. REG. NOS. 1,301,314, 3,968,362 AND OTHERS.

THE MARK CONSISTS OF THE WORDS "ECCO PASSIONATE ABOUT SAFETY" WITH A STYLIZED ALARM GRILL CONSISTING OF AN ARCHING LINE PARTIALLY ENCLOSING CROSSING LINES THAT FORM A DIAMOND PATTERN.

## CLASS 9—ELECTRICAL AND SCIENTIFIC APPARATUS

FOR HOUSE MARK FOR SIGNALING AND WARNING LIGHTS, NAMELY, ELECTRIC WARNING LIGHTS, FLASHING SAFETY LIGHTS, SAFETY BEACON LIGHTS, ROTATING LIGHTS; HOUSE MARK FOR SIGNALING, WARNING AND SAFETY PRODUCTS, NAMELY, SOUND ALARMS, PROXIMITY SENSORS, ELECTRIC SWITCHES, CAMERAS; VIDEO MONITORS; SECURITY AND WARNING PRODUCTS, NAMELY, AUDIO SPEAKERS AND SIRENS; VEHICLE SAFETY EQUIPMENT, NAMELY, AN ON-BOARD VEHICULAR SURVEILLANCE SYSTEM COMPRISED OF CAMERAS AND MONITORS FOR EXPOSING AND ELIMINATING THE BLIND SPOTS ON BOTH SIDES OF VEHICLES; COMPONENTS, PARTS AND ACCESSORIES FOR ALL THE FOREGOING GOODS, NAMELY, CONTROL UNITS FOR REGULATING START-UP ELECTRIC MOTORS, DUST COVERS FOR MONITORS, ELECTRIC CABLES, ADAPTER PLUGS, ELECTRIC CONNECTORS, MOUNTING DEVICES FOR MONITORS (U.S. CLS. 21, 23, 26, 36 AND 38).

## CLASS 11—ENVIRONMENTAL CONTROL APPARATUS

FOR HOUSE MARK FOR VEHICLE LIGHTS; LIGHTING PRODUCTS, NAMELY, LIGHT BULBS, HIGH INTENSITY SEARCH LIGHTS, BACKUP LIGHTS FOR LAND VEHICLES, FLASHING STROBE LIGHTING APPARATUS, LED LIGHT ASSEMBLIES FOR VEHICLES; LIGHT BARS AND PANELS FOR VEHICLES, NAMELY, VEHICLES AND MACHINERY EMPLOYED IN CONSTRUCTION, MAINTENANCE, MATERIAL HANDLING, SAFETY AND SECURITY, AND TRANSPORTATION INDUSTRIES; COMPONENTS, PARTS AND ACCESSORIES FOR ALL THE FOREGOING GOODS, NAMELY, LIGHT REFLECTORS, INFRARED LAMP FIXTURES, AND OPTICAL LENS COVERS THAT IMPROVES LIGHT OUTPUT AND UNIFORMITY AND PROTECTS THE LED, SOLD AS A FEATURE OF AN LED LIGHTING SYSTEM (U.S. CLS. 13, 21, 23, 31 AND 34).



**CLASS 12—VEHICLES**

FOR HOUSE MARK FOR VEHICLE ACCESSORIES, NAMELY, BACK-UP WARNING ALARMS FOR VEHICLES; HORNS FOR VEHICLES; VEHICLE CAMERA MOUNTS (U.S. CLS. 19, 21, 23, 31, 35 AND 44).  
ELI HELLMAN, EXAMINING ATTORNEY

SN 86-244,521. ELECTRONIC CONTROLS COMPANY, BOISE, ID. FILED 4-7-2014.



OWNER OF U.S. REG. NO. 3,310,361.  
THE MARK CONSISTS OF A STYLIZED ALARM GRILL CONSISTING OF AN ARCHING LINE PARTIALLY ENCLOSING CROSSING LINES THAT FORM A DIAMOND PATTERN.

**CLASS 9—ELECTRICAL AND SCIENTIFIC APPARATUS**

FOR HOUSE MARK FOR SIGNALING AND WARNING LIGHTS, NAMELY, ELECTRIC WARNING LIGHTS, FLASHING SAFETY LIGHTS, SAFETY BEACON LIGHTS, ROTATING LIGHTS; HOUSE MARK FOR SIGNALING, WARNING AND SAFETY PRODUCTS, NAMELY, SOUND ALARMS, PROXIMITY SENSORS, ELECTRIC SWITCHES, CAMERAS; VIDEO MONITORS; SECURITY AND WARNING PRODUCTS, NAMELY, AUDIO SPEAKERS AND SIRENS; VEHICLE SAFETY EQUIPMENT, NAMELY, AN ON-BOARD VEHICULAR SURVEILLANCE SYSTEM COMPRISED OF CAMERAS AND MONITORS FOR EXPOSING AND ELIMINATING THE BLIND SPOTS ON BOTH SIDES OF VEHICLES; COMPONENTS, PARTS AND ACCESSORIES FOR ALL THE FOREGOING GOODS, NAMELY, CONTROL UNITS FOR REGULATING START-UP ELECTRIC MOTORS, DUST COVERS FOR MONITORS, ELECTRIC CABLES, ADAPTER PLUGS, ELECTRIC CONNECTORS, MOUNTING DEVICES FOR MONITORS (U.S. CLS. 21, 23, 26, 36 AND 38).

**CLASS 11—ENVIRONMENTAL CONTROL APPARATUS**

FOR HOUSE MARK FOR VEHICLE LIGHTS; LIGHTING PRODUCTS, NAMELY, LIGHT BULBS, HIGH INTENSITY SEARCH LIGHTS, BACKUP LIGHTS FOR LAND VEHICLES, FLASHING STROBE LIGHTING APPARATUS, LED LIGHT ASSEMBLIES FOR VEHICLES; LIGHT BARS AND PANELS FOR VEHICLES, NAMELY, VEHICLES AND MACHINERY EMPLOYED IN CONSTRUCTION, MAINTENANCE, MATERIAL HANDLING, SAFETY AND SECURITY, AND TRANSPORTATION INDUSTRIES; COMPONENTS, PARTS AND ACCESSORIES FOR ALL THE FOREGOING GOODS, NAMELY, LIGHT REFLECTORS, INFRARED LAMP FIXTURES, AND OPTICAL LENS COVERS THAT IMPROVES LIGHT OUTPUT AND UNIFORMITY AND PROTECTS THE LED, SOLD AS A FEATURE OF AN LED LIGHTING SYSTEM (U.S. CLS. 13, 21, 23, 31 AND 34).

**CLASS 12—VEHICLES**

FOR HOUSE MARK FOR VEHICLE ACCESSORIES, NAMELY, BACK-UP WARNING ALARMS FOR VEHICLES; HORNS FOR VEHICLES; VEHICLE CAMERA MOUNTS (U.S. CLS. 19, 21, 23, 31, 35 AND 44).  
ELI HELLMAN, EXAMINING ATTORNEY

SN 86-244,552. FASTENAL IP COMPANY, WINONA, MN. FILED 4-7-2014.

**FPAS**

THE MARK CONSISTS OF STANDARD CHARACTERS WITHOUT CLAIM TO ANY PARTICULAR FONT, STYLE, SIZE, OR COLOR.

**CLASS 6—METAL GOODS**

FOR METAL FASTENERS, NAMELY, CLAMPS, BOLTS, SCREWS, SOCKET SCREWS, NUTS, WASHERS, AND CONCRETE ANCHORS (U.S. CLS. 2, 12, 13, 14, 23, 25 AND 50).

**CLASS 8—HAND TOOLS**

FOR MANUALLY-OPERATED EPOXY ADHESIVE DISPENSING GUNS AND NOZZLES AND BITS FOR SAME; HAND TOOLS, NAMELY, SETTING TOOLS FOR DROP ANCHORS (U.S. CLS. 23, 28 AND 44).  
MARK T. MULLEN, EXAMINING ATTORNEY

SN 86-244,645. PEACE LOVE WORLD, LLC, MIAMI, FL. FILED 4-7-2014.

**I LOVE SUNDAYS**

THE MARK CONSISTS OF STANDARD CHARACTERS WITHOUT CLAIM TO ANY PARTICULAR FONT, STYLE, SIZE, OR COLOR.

**CLASS 9—ELECTRICAL AND SCIENTIFIC APPARATUS**

FOR CELL PHONE CASES; CELL PHONE COVERS; PROTECTIVE COVERS AND CASES FOR CELL PHONES, LAPTOPS AND PORTABLE MEDIA PLAYERS; PROTECTIVE COVERS FOR SMARTPHONES (U.S. CLS. 21, 23, 26, 36 AND 38).  
FIRST USE 7-1-2013; IN COMMERCE 7-1-2013.

**CLASS 25—CLOTHING**

FOR HOODED SWEAT SHIRTS; HOODED SWEATSHIRTS; LONG-SLEEVED SHIRTS; SHIRTS; SHIRTS AND SHORT-SLEEVED SHIRTS; SHORT-SLEEVED OR LONG-SLEEVED T-SHIRTS; SHORT-SLEEVED SHIRTS; SWEAT SHIRTS; SWEATERS; SWEATSHIRTS; T-SHIRTS; TEE SHIRTS (U.S. CLS. 22 AND 39).  
FIRST USE 7-1-2013; IN COMMERCE 7-1-2013.  
CASSONDRANDERSON, EXAMINING ATTORNEY



SN 86-244,653. NAZZAL, FARRIS, LOS ANGELES, CA. FILED 4-7-2014.

SN 86-244,846. RCRV, INC., LOS ANGELES, CA. FILED 4-7-2014.

RED LINGERIE



THE MARK CONSISTS OF STANDARD CHARACTERS WITHOUT CLAIM TO ANY PARTICULAR FONT, STYLE, SIZE, OR COLOR.

**CLASS 35—ADVERTISING AND BUSINESS**

FOR ON-LINE RETAIL STORE SERVICES FEATURING MUSICAL RECORDINGS (U.S. CLS. 100, 101 AND 102).

**CLASS 41—EDUCATION AND ENTERTAINMENT**

FOR ENTERTAINMENT IN THE NATURE OF LIVE PERFORMANCES BY A MUSIC PRODUCER AND DJ (U.S. CLS. 100, 101 AND 107).

SAMUEL PAQUIN, EXAMINING ATTORNEY

THE MARK CONSISTS OF TWO STYLIZED "R"'S FACING EACH OTHER WITH THE FIRST "R" FACING RIGHT AND THE SECOND "R" FACING LEFT TO CREATE A FLEUR DE LIS BETWEEN THE TWO LETTERS.

**CLASS 18—LEATHER GOODS**

FOR HANDBAGS; PURSES; WALLETS; AND BACKPACKS (U.S. CLS. 1, 2, 3, 22 AND 41).

**CLASS 25—CLOTHING**

FOR CLOTHING, NAMELY, PANTS, JEANS, TROUSERS, SHORTS, JACKETS, SHIRTS, TOPS, T-SHIRTS, HATS, BASEBALL HATS AND CAPS, AND UNDERWEAR (U.S. CLS. 22 AND 39).

FIRST USE 12-2-2013; IN COMMERCE 12-2-2013.

**CLASS 35—ADVERTISING AND BUSINESS**

FOR ON-LINE RETAIL STORE SERVICES FEATURING APPAREL (U.S. CLS. 100, 101 AND 102).

FIRST USE 2-3-2014; IN COMMERCE 2-3-2014.

ALAIN LAPTER, EXAMINING ATTORNEY

SN 86-244,794. RON & KELLY ANDERSON, SANTA CRUZ, CA. FILED 4-7-2014.

SN 86-244,864. GNU FOODS, LLC, NEW YORK, NY. FILED 4-7-2014.

Dirty Locust

FiberLoco

THE MARK CONSISTS OF STANDARD CHARACTERS WITHOUT CLAIM TO ANY PARTICULAR FONT, STYLE, SIZE, OR COLOR.

**CLASS 35—ADVERTISING AND BUSINESS**

FOR RETAIL STORE SERVICES FEATURING NURSERY PRODUCTS (U.S. CLS. 100, 101 AND 102).

**CLASS 41—EDUCATION AND ENTERTAINMENT**

FOR EDUCATION SERVICES, NAMELY, PROVIDING CLASSES, SEMINARS, WORKSHOPS, AND LECTURES IN THE FIELD OF BONSAI EDUCATION (U.S. CLS. 100, 101 AND 107).

SANJEEV VOHRA, EXAMINING ATTORNEY

THE MARK CONSISTS OF STANDARD CHARACTERS WITHOUT CLAIM TO ANY PARTICULAR FONT, STYLE, SIZE, OR COLOR.

**CLASS 29—MEATS AND PROCESSED FOODS**

FOR FRUIT AND NUT-BASED FOOD BARS (U.S. CL. 46).

**CLASS 30—STAPLE FOODS**

FOR CEREAL AND GRAIN-BASED FOOD BARS (U.S. CL. 46).

MICHAEL P EISNACH, EXAMINING ATTORNEY

SN 86-245,125. MOUNTAIN MAFIA ENTERTAINMENT, LLC, SANDPOINT, ID. FILED 4-7-2014.

## Mountain Mafia

THE MARK CONSISTS OF STANDARD CHARACTERS WITHOUT CLAIM TO ANY PARTICULAR FONT, STYLE, SIZE, OR COLOR.

### CLASS 16—PAPER GOODS AND PRINTED MATTER

FOR BUMPER STICKERS; DECALS AND STICKERS FOR USE AS HOME DECOR; DECORATIVE STICKERS FOR HELMETS; MAGNETIC BUMPER STICKERS; STICKERS (U.S. CLS. 2, 5, 22, 23, 29, 37, 38 AND 50).

### CLASS 21—HOUSEWARES AND GLASS

FOR INSULATING SLEEVE HOLDERS FOR BEVERAGE CANS (U.S. CLS. 2, 13, 23, 29, 30, 33, 40 AND 50).

### CLASS 25—CLOTHING

FOR BUTTON DOWN SHIRTS; GRAPHIC T-SHIRTS; HOODED SWEAT SHIRTS; LONG-SLEEVED SHIRTS; POLO SHIRTS; SPORTS CAPS AND HATS; T-SHIRTS (U.S. CLS. 22 AND 39).

KATHLEEN KOLACZ, EXAMINING ATTORNEY

SN 86-245,136. MY DAMN CHANNEL, INC., LONG BEACH, CA. FILED 4-7-2014.

## Omnivision Entertainment, Inc.

THE MARK CONSISTS OF STANDARD CHARACTERS WITHOUT CLAIM TO ANY PARTICULAR FONT, STYLE, SIZE, OR COLOR.

NO CLAIM IS MADE TO THE EXCLUSIVE RIGHT TO USE "ENTERTAINMENT, INC.", APART FROM THE MARK AS SHOWN.

### CLASS 41—EDUCATION AND ENTERTAINMENT

FOR ENTERTAINMENT SERVICES, NAMELY, PROVIDING A WEB SITE FEATURING PHOTOGRAPHIC, AUDIO, VIDEO AND PROSE PRESENTATIONS FEATURING COMEDY, MUSIC, MOVIES, DRAMA AND OTHER NEWS; ENTERTAINMENT SERVICES, NAMELY, PROVIDING ON-LINE REVIEWS OF COMEDY, MUSIC, MOVIES, DRAMA AND NEWS; ENTERTAINMENT SERVICES, NAMELY, PROVIDING ONGOING WEBSISODES FEATURING COMEDY, MUSIC, MOVIES, DRAMA, AND NEWS VIA A GLOBAL COMPUTER NETWORK; ENTERTAINMENT, NAMELY, PRODUCTION OF COMEDY SHOWS, LIVE MUSIC SHOWS, MOVIES, DRAMAS, AND NEWS SHOWS (U.S. CLS. 100, 101 AND 107).

FIRST USE 3-31-2014; IN COMMERCE 4-4-2014.

### CLASS 42—SCIENTIFIC AND COMPUTER SERVICES

FOR COMPUTER SERVICES, NAMELY, HOSTING AND MAINTAINING AN ON-LINE WEB SITE FOR OTHERS FOR COMEDY, MUSIC, MOVIES, DRAMA, AND NEWS (U.S. CLS. 100 AND 101).

FIRST USE 3-31-2014; IN COMMERCE 4-4-2014.

KEVON CHISOLM, EXAMINING ATTORNEY

SN 86-245,247. ASSOCIATED ENDOSCOPY INC., ARCADIA, CA. FILED 4-8-2014.

## AEI

THE MARK CONSISTS OF STANDARD CHARACTERS WITHOUT CLAIM TO ANY PARTICULAR FONT, STYLE, SIZE, OR COLOR.

### CLASS 35—ADVERTISING AND BUSINESS

FOR DISTRIBUTORSHIP SERVICES IN THE FIELD OF MEDICAL EQUIPMENT; RESELLER SERVICES, NAMELY, DISTRIBUTORSHIP SERVICES IN THE FIELD OF MEDICAL EQUIPMENT (U.S. CLS. 100, 101 AND 102).

### CLASS 37—CONSTRUCTION AND REPAIR

FOR MAINTENANCE AND REPAIR OF MEDICAL EQUIPMENT (U.S. CLS. 100, 103 AND 106).

NAAKWAMA ANKRAH, EXAMINING ATTORNEY

SN 86-245,314. SANTOS, ANDRÉ CASTRO, DBA ANDRÉ CASTRO SANTOS, LISBOA, PORTUGAL, FILED 4-8-2014.

## VALUMA

THE MARK CONSISTS OF STANDARD CHARACTERS WITHOUT CLAIM TO ANY PARTICULAR FONT, STYLE, SIZE, OR COLOR.

### CLASS 9—ELECTRICAL AND SCIENTIFIC APPARATUS

FOR DIGITAL MEDIA HUBS; ELECTRONIC PUBLICATIONS, NAMELY, AUDIO-VISUAL CONTENT FEATURING SEA/OCEAN/WATER RECORDED ON COMPUTER MEDIA; PRE-RECORDED ELECTRONIC AND DIGITAL MEDIA FEATURING SEA/OCEAN/WATER; VIDEO MAGAZINE RECORDED ON ELECTRONIC MEDIA FEATURING SEA/OCEAN/WATER (U.S. CLS. 21, 23, 26, 36 AND 38).

### CLASS 39—TRANSPORTATION AND STORAGE

FOR TRAVEL GUIDE AND TRAVEL INFORMATION SERVICES (U.S. CLS. 100 AND 105).

DOMINICK J. SALEMI, EXAMINING ATTORNEY

SN 86-245.362. MILD TO WILD LTD, TA PSYCHO JUICE, BRISTOL, UNITED KINGDOM, FILED 4-8-2014.

# Psycho Juice

THE MARK CONSISTS OF STANDARD CHARACTERS WITHOUT CLAIM TO ANY PARTICULAR FONT, STYLE, SIZE, OR COLOR.

OWNER OF UNITED KINGDOM REG. NO. 2629618, DATED 10-26-2012, EXPIRES 7-25-2022.

## CLASS 25—CLOTHING

FOR A-SHIRTS; APPAREL FOR DANCERS, NAMELY, TEE SHIRTS, SWEATSHIRTS, PANTS, LEGGINGS, SHORTS AND JACKETS; ATHLETIC APPAREL, NAMELY, SHIRTS, PANTS, JACKETS, FOOTWEAR, HATS AND CAPS, ATHLETIC UNIFORMS; ATHLETIC SHIRTS; BODY SHIRTS; BUSINESS WEAR, NAMELY, SUITS, JACKETS, TROUSERS, BLAZERS, BLOUSES, SHIRTS, SKIRTS, DRESSES AND FOOTWEAR; BUTTON DOWN SHIRTS; BUTTON-FRONT ALOHA SHIRTS; CAMOUFLAGE SHIRTS; CAMP SHIRTS; CLOTHING FOR ATHLETIC USE, NAMELY, PADDED SHIRTS; CLOTHING FOR BABIES, TODDLERS AND CHILDREN, TREATED WITH FIRE AND HEAT RETARDANTS, NAMELY, PAJAMAS, JACKETS, SHIRTS, PANTS, JUMPERS; CLOTHING SHIELDS, NAMELY, PADS APPLIED TO THE UNDERARMS OF SHIRTS, BLOUSES AND SWEATERS; COLLARED SHIRTS; DRESS SHIRTS; FISHING SHIRTS; GOLF PANTS, SHIRTS AND SKIRTS; GOLF SHIRTS; GRAPHIC T-SHIRTS; HOODED SWEAT SHIRTS; HUNTING SHIRTS; KNIT SHIRTS; LEATHER SHIRTS; LONG-SLEEVED SHIRTS; MOISTURE-WICKING SPORTS SHIRTS; NIGHT SHIRTS; OPEN-NECKED SHIRTS; OVER SHIRTS; PIQUE SHIRTS; POLO SHIRTS; RAMIE SHIRTS; RUGBY SHIRTS; SHIRT FRONTS; SHIRT INSERTS, NAMELY, DICKIES; SHIRT YOKES; SHIRTS; SHIRTS AND SHORT-SLEEVED SHIRTS; SHIRTS AND SLIPS; SHIRTS FOR INFANTS, BABIES, TODDLERS AND CHILDREN; SHIRTS FOR SUITS; SHIRTS FOR BABIES, ADULTS, CHILDREN, WOMEN, MEN; SHORT-SLEEVED OR LONG-SLEEVED T-SHIRTS; SHORT-SLEEVED SHIRTS; SLEEP SHIRTS; SLEEVES WORN SEPARATE AND APART FROM BLOUSES, SHIRTS AND OTHER TOPS; SNAP CROTCH SHIRTS FOR INFANTS AND TODDLERS; SPORT SHIRTS; SPORTS SHIRTS; SPORTS SHIRTS WITH SHORT SLEEVES; SUN PROTECTIVE CLOTHING, NAMELY, SHIRTS, PANTS; SWEAT SHIRTS; T-SHIRTS; T-SHIRTS FOR BABIES, ADULTS, CHILDREN, WOMEN, MEN; TEE SHIRTS; TRIATHLON CLOTHING, NAMELY, TRIATHLON TIGHTS, TRIATHLON SHORTS, TRIATHLON SINGLET, TRIATHLON SHIRTS, TRIATHLON SUITS; TURTLE NECK SHIRTS; WEARABLE GARMENTS AND CLOTHING, NAMELY, SHIRTS; WIND SHIRTS; WOMEN'S CLOTHING, NAMELY, SHIRTS, DRESSES, SKIRTS, BLOUSES; YOGA SHIRTS (U.S. CLS. 22 AND 39).

## CLASS 30—STAPLE FOODS

FOR ARTICHOKE SAUCE; BARBECUE SAUCE; BARBEQUE SAUCE; CARAMEL SAUCE; CHEESE SAUCE; CHICKEN WING SAUCE; CHILI OIL FOR USE AS A SEASONING OR CONDIMENT; CHILI PASTE FOR USE AS A SEASONING; CHILI PODS FOR USE AS A SEASONING; CHILI POWDERS; CHILI SAUCE; CHILI SEASONING; CHIMICHURRI SAUCE; CHINESE MABO TOFU SAUCE; CHOCOLATE SAUCE; COCKTAIL SAUCES; CONDIMENT, NAMELY, OYSTER SAUCE; CONDIMENT, NAMELY, PEPPER SAUCE; COOKING SAUCES; CURRY SAUCE; DIPPING SAUCES; DRIED CHILI PEPPERS; FISH SAUCE; FRUIT SAUCES EXCLUDING CRANBERRY SAUCE AND APPLESAUCE; GARLIC-BASED SAUCES; GRILLING SAUCES; HONEY MUSTARD SAUCE; HOT CHILI PEPPER SAUCE; HOT SAUCE; JERK SAUCE; MIX FOR MAKING COMBINED NOODLE AND SAUCE DISH; NOODLES AND SAUCE MIXES COMBINED IN UNITARY PACKAGES; NOO-

DLES, SAUCE, AND PROCESSED VEGETABLES COMBINED IN UNITARY PACKAGES; NOODLES, SAUCE, AND SEASONING TOPPINGS COMBINED IN UNITARY PACKAGES; NOODLES, SAUCE, AND TOPPING COMBINED IN UNITARY PACKAGES; NOODLES, SAUCE, DEHYDRATED VEGETABLES, AND TOPPING COMBINED IN UNITARY PACKAGES; ORGANIC CURRY SAUCES; PASTA SAUCE; PESTO SAUCE; PICANTE SAUCE; PICO DE GALLO SAUCE; PIZZA SAUCE; READY-MADE SAUCES; SALAD SAUCES; SAUCE MIXES; SAUCES; SAUCES FOR BARBECUED MEAT; SLOPPY JOE SAUCE; SOY SAUCE; SOY SAUCE; SPAGHETTI SAUCE; SRIRACHA HOT CHILI SAUCE; STEAK SAUCE; TARTAR SAUCE; TERIYAKI SAUCE; TOMATO SAUCE; WORCESTERSHIRE SAUCE (U.S. CL. 46).

DOMINIC J. FERRAIUOLO, EXAMINING ATTORNEY

SN 86-245.418. VISIONARY WILD, LLC, WASHINGTON, DC, FILED 4-8-2014.



THE COLOR(S) RED, ORANGE, WHITE, BLACK IS/ARE CLAIMED AS A FEATURE OF THE MARK.

THE MARK CONSISTS OF A RED CIRCULAR RING ENCLOSED A STYLIZED LANDSCAPE CONTAINING ORANGE AND WHITE MOUNTAINS, SUN, CLOUD, AND STREAM. UNDERNEATH THE DESIGN ARE THE WORDS "VISIONARY" IN BLACK AND "WILD" IN RED.

## CLASS 39—TRANSPORTATION AND STORAGE

FOR TRAVEL AGENCY SERVICES, NAMELY, MAKING RESERVATIONS AND BOOKINGS FOR TRANSPORTATION FOR PEOPLE; TRAVEL GUIDE SERVICES; TRAVEL TOUR GUIDE SERVICES; TRAVEL TOUR OPERATING (U.S. CLS. 100 AND 105).

FIRST USE 4-7-2011; IN COMMERCE 5-13-2011.

## CLASS 41—EDUCATION AND ENTERTAINMENT

FOR ARRANGING PROFESSIONAL WORKSHOP AND TRAINING COURSES; CONSULTING SERVICES IN THE FIELD OF PHOTOGRAPHY; EDUCATION SERVICES, NAMELY, PROVIDING WORKSHOPS IN THE FIELD OF PHOTOGRAPHY; PROVIDING CLASSES, WORKSHOPS, SEMINARS AND CAMPS IN THE FIELD OF PHOTOGRAPHY (U.S. CLS. 100, 101 AND 107).

FIRST USE 4-7-2011; IN COMMERCE 5-13-2011. KEVON CHISOLM, EXAMINING ATTORNEY

SN 86-245,458. PEACE LOVE WORLD, LLC, MIAMI, FL.  
FILED 4-8-2014.

SN 86-245,700. ROBERT ROSENHECK, LOS ANGELES., CA.  
FILED 4-8-2014.

I AM GENTLEMAN  
n. respectful, selfless,  
and true. Acts not for his  
own gain, but for the  
consideration of all  
others.

THE MARK CONSISTS OF STANDARD CHARACTERS  
WITHOUT CLAIM TO ANY PARTICULAR FONT, STYLE,  
SIZE, OR COLOR.

**CLASS 9—ELECTRICAL AND SCIENTIFIC  
APPARATUS**

FOR CELL PHONE CASES; CELL PHONE COVERS;  
PROTECTIVE COVERS AND CASES FOR CELL  
PHONES, LAPTOPS AND PORTABLE MEDIA PLAYERS;  
PROTECTIVE COVERS FOR SMARTPHONES (U.S. CLS.  
21, 23, 26, 36 AND 38).

FIRST USE 2-14-2014; IN COMMERCE 2-14-2014.

**CLASS 25—CLOTHING**

FOR HOODED SWEAT SHIRTS; HOODED SWEAT-  
SHIRTS; SHIRTS; SHIRTS AND SHORT-SLEEVED  
SHIRTS; SHORT-SLEEVED OR LONG-SLEEVED T-  
SHIRTS; SHORT-SLEEVED SHIRTS; T-SHIRTS; TEE  
SHIRTS (U.S. CLS. 22 AND 39).

FIRST USE 2-14-2014; IN COMMERCE 2-14-2014.  
CASSONDRRA ANDERSON, EXAMINING ATTORNEY

## LORD JONES

THE MARK CONSISTS OF STANDARD CHARACTERS  
WITHOUT CLAIM TO ANY PARTICULAR FONT, STYLE,  
SIZE, OR COLOR.

THE NAME(S), PORTRAIT(S), AND/OR SIGNATURE(S)  
SHOWN IN THE MARK DOES NOT IDENTIFY A PARTI-  
CULAR LIVING INDIVIDUAL.

**CLASS 30—STAPLE FOODS**

FOR BAKERY GOODS, NAMELY, CAKES AND  
COOKIES; CANDY; CHOCOLATE; CHOCOLATE CAN-  
DIES (U.S. CL. 46).

**CLASS 34—SMOKERS' ARTICLES**

FOR HERBS FOR SMOKING (U.S. CLS. 2, 8, 9 AND  
17).

SAMUEL PAQUIN, EXAMINING ATTORNEY

SN 86-245,714. SIMPLE FINANCE TECHNOLOGY CORP.,  
PORTLAND, OR. FILED 4-8-2014.

SN 86-245,613. MAINSTREAM FASHIONS FRANCHISING,  
INC., MINNEAPOLIS, MN. FILED 4-8-2014.

## MAC AND ME

THE MARK CONSISTS OF STANDARD CHARACTERS  
WITHOUT CLAIM TO ANY PARTICULAR FONT, STYLE,  
SIZE, OR COLOR.

**CLASS 14—JEWELRY**

FOR WOMEN'S JEWELRY (U.S. CLS. 2, 27, 28 AND 50).

**CLASS 25—CLOTHING**

FOR WOMEN'S CLOTHING, NAMELY, SHIRTS,  
BLOUSES, DRESSES, PANTS AND JACKETS; WOMEN'S  
HATS; SCARVES (U.S. CLS. 22 AND 39).

JOANNA FIORELLI, EXAMINING ATTORNEY

## BANKSIMPLE

THE MARK CONSISTS OF STANDARD CHARACTERS  
WITHOUT CLAIM TO ANY PARTICULAR FONT, STYLE,  
SIZE, OR COLOR.

**CLASS 35—ADVERTISING AND BUSINESS**

FOR CUSTOMER SERVICE IN THE FIELD OF ON-  
LINE BANKING; PROVIDING LEAD GENERATION  
ACTIVITIES AND SERVICES FOR FINANCIAL SER-  
VICES PROVIDERS; PROVIDING AN ON-LINE COMPU-  
TER WEB SITE THAT PROVIDES BANKING AND  
FINANCIAL TRANSACTION DATA, ACCOUNT MAN-  
AGEMENT, FINANCIAL REPORTING, ACCOUNTING  
FEATURES AND RELATED REFERENCE INFORMATION  
IN THE FIELD OF RETAIL BANKING (U.S. CLS.  
100, 101 AND 102).

**CLASS 36—INSURANCE AND FINANCIAL**

FOR BANKING AND FINANCING SERVICES; ON-  
LINE BANKING SERVICES; ELECTRONIC BANKING  
VIA A GLOBAL COMPUTER NETWORK, NAMELY,  
INTERNET BANKING; BANKING SERVICES PRO-  
VIDED BY MOBILE TELEPHONE CONNECTIONS; BILL  
PAYMENT SERVICES; CREDIT CARD AND DEBIT  
CARD SERVICES; ELECTRONIC FUNDS TRANSFER;  
FINANCING AND LOAN SERVICES; PROVIDING WEB-  
BASED PERSONAL FINANCIAL MANAGEMENT SER-  
VICES, NAMELY, MANAGEMENT OF FINANCIAL  
ACCOUNTS INCLUDING MONITORING OF TRANSAC-  
TIONS, ACCOUNT BALANCES, AND BUDGET AND  
SPENDING REPORTING (U.S. CLS. 100, 101 AND 102).

**CLASS 42—SCIENTIFIC AND COMPUTER SERVICES**

FOR APPLICATION SERVICE PROVIDER FEATURING APPLICATION PROGRAMMING INTERFACE (API) SOFTWARE FOR ALLOWING DATA RETRIEVAL, UPLOAD, ACCESS AND MANAGEMENT; APPLICATION SERVICE PROVIDER (ASP) FEATURING SOFTWARE FOR USE IN ONLINE BANKING AND FINANCIAL ANALYSIS; COMPUTER SERVICES, NAMELY, CREATING AN ON-LINE COMMUNITY FOR REGISTERED USERS TO PARTICIPATE IN DISCUSSIONS, SHARE BANKING TRANSACTION INFORMATION AND FINANCIAL SERVICES INFORMATION, AND ENGAGE IN SOCIAL NETWORKING IN THE FIELDS OF RETAIL BAKING, ONLINE BANKING AND PERSONAL FINANCE (U.S. CLS. 100 AND 101).

JACLYN KIDWELL WALKER, EXAMINING ATTORNEY

SN 86-245,734. SCG CHARACTERS LLC, LOS ANGELES, CA.  
FILED 4-8-2014.

**PRINCESS TIME**

THE MARK CONSISTS OF STANDARD CHARACTERS WITHOUT CLAIM TO ANY PARTICULAR FONT, STYLE, SIZE, OR COLOR.

**CLASS 28—TOYS AND SPORTING GOODS**

FOR TOYS, GAMES, PLAYTHINGS, AND SPORTING GOODS, NAMELY, BASKETBALL BACKBOARDS; TOY SCOOTERS; SKATEBOARDS AND SKATEBOARD BAGS; BENDABLE PLAY FIGURES AND ACCESSORIES THEREFORE; TOY ACTION FIGURES AND ACCESSORIES THEREFORE; SPORTS BOARD GAMES; BALLS, NAMELY, BALLS FOR GAMES; BASKETBALLS; PLAYGROUND BALLS; RUBBER BALLS; SPORTS BALLS; FOAM ACTION BALLS; TOY HOOP SETS; TOY BANKS; TOY WATCHES; BATH TUB TOYS; CHILDREN'S MULTIPLE ACTIVITY TOYS; TOY MAGIC TRICKS; WATER SQUIRTING TOYS; WIND-UP TOYS; SQUEEZE TOYS; JUMP ROPES; SLING SHOTS; TOY WALKIE-TALKIES; ACTION SKILL GAMES; TALKING DOLLS; TOY 3-D VIEWERS AND REELS; BOARD GAMES; CARD GAMES; HAND HELD UNITS FOR PLAYING ELECTRONIC GAMES; STAND ALONE VIDEOGAME MACHINES AND PROGRAMS THEREFORE SOLD AS A UNIT; ELECTRONIC GAME EQUIPMENT WITH A WATCH FUNCTION; HAND HELD LCD GAME MACHINES; COIN AND NON-COIN OPERATED GAME TABLES; PINBALL MACHINES AND PINBALL-TYPE GAMES; JIGSAW PUZZLES; MANIPULATIVE PUZZLES; MECHANICAL ACTION TOYS; BATTERY-OPERATED ACTION TOYS; PUPPETS; DOLLS; PLAYSETS FOR DOLLS; DOLL CLOTHING; DOLL COSTUMES; CHILDREN'S PLAY COSMETICS; ROLE PLAYING GAMES; ACTION-TYPE TARGET SHOOTING GAME SETS COMPRISING TOY GUN, TOY SUCTION DARTS AND TARGET; TOY WEAPONS; SQUIRT GUNS; KITES; PLASTIC PARTY FAVORS IN THE NATURE OF SMALL TOYS AND NOISEMAKERS; BALLOONS; STUFFED AND PLUSH TOYS; LATEX SQUEEZE TOY FIGURES; MUSICAL TOYS; INFLATABLE BATH TOYS; SWIMMING AND INFLATABLE RIDE-IN TOYS; TOY VEHICLES; TRANSFORMING ROBOTIC TOY VEHICLES; NON-MOTORIZED RIDE-IN TOYS; INFLATABLE PLAY SWIMMING POOLS; TOY PLAY HOUSES AND TOY PLAY TENTS; SURF BOARDS, KICK BOARD FLOATATION DEVICES, BODY BOARDS AND LEASHES THEREFORE FOR RECREATIONAL USE; TOY SAND BOXES AND SAND TOYS, SNOW SLEDS, TOBOGGANS, SNOW SAUCERS AND SNOW BOARDS FOR RECREATIONAL USE; TOY BUILDING BLOCKS; MOBILES FOR CHILDREN; CHRISTMAS TREE ORNAMENTS THAT ARE NEITHER CONFECTIONERY NOR ILLUMINATED; TOY CRAFT KITS COMPRISING MOLDS AND MOULDINGS FOR

MAKING TOY FIGURES; PLASTIC ACTION FIGURE MODELS; FLYING DISCS; PET TOYS; MARBLES; YO-YOS; AND PLAYING CARDS; PAPER PARTY HATS; APPARATUS FOR GAMES ADAPTED FOR USE WITH TELEVISION RECEIVERS; PAPER PARTY FAVORS IN THE NATURE OF SMALL TOYS AND NOISEMAKERS; BOWS AND ARROWS (U.S. CLS. 22, 23, 38 AND 50).

**CLASS 41—EDUCATION AND ENTERTAINMENT**

FOR ENTERTAINMENT SERVICES, NAMELY, THE PRODUCTION AND DISTRIBUTION OF ONGOING TELEVISION PROGRAMS IN THE FIELD OF CHILDREN'S ENTERTAINMENT; ON-LINE ENTERTAINMENT SERVICES OFFERED OVER A WORLDWIDE COMMUNICATION NETWORK, NAMELY, PROVIDING A WEBSITE FEATURING NON-DOWNLOADABLE VIDEO AND AUDIO CLIPS, GAMES, INFORMATION RELATING TO TELEVISION PROGRAMS, AND OTHER MULTIMEDIA MATERIALS RELATING TO TELEVISION PROGRAMS; ENTERTAINMENT SERVICES, NAMELY, LIVE PERFORMANCES AND PERSONAL APPEARANCES BY INDIVIDUALS AND CHARACTERS ASSOCIATED WITH TELEVISION PROGRAMS; PERSONAL APPEARANCES BY CHARACTERS ASSOCIATED WITH TELEVISION PROGRAMS (U.S. CLS. 100, 101 AND 107).

KELLY BOULTON, EXAMINING ATTORNEY

SN 86-245,784. TROPIC MAGAZINE, INC., FORT LAUDERDALE, FL. FILED 4-8-2014.

**MODWEEKEND**

THE MARK CONSISTS OF STANDARD CHARACTERS WITHOUT CLAIM TO ANY PARTICULAR FONT, STYLE, SIZE, OR COLOR.

**CLASS 35—ADVERTISING AND BUSINESS**

FOR ORGANIZATION OF EVENTS, EXHIBITIONS, FAIRS AND SHOWS FOR COMMERCIAL, PROMOTIONAL AND ADVERTISING PURPOSES IN THE FIELDS OF ARCHITECTURE, HISTORY, PHOTOGRAPHY AND FILM (U.S. CLS. 100, 101 AND 102).

FIRST USE 1-0-2013; IN COMMERCE 1-0-2013.

**CLASS 41—EDUCATION AND ENTERTAINMENT**

FOR ENTERTAINMENT SERVICES, NAMELY, PLANNING AND CONDUCTING FAIRS FOR NON-COMMERCIAL PURPOSES, PLANNING AND CONDUCTING CAR SHOWS FOR NON-COMMERCIAL PURPOSES, PLANNING AND CONDUCTING A SERIES OF FILM FESTIVALS AND LECTURES IN THE FIELDS OF ARCHITECTURE, HISTORY AND FILM, PLANNING AND CONDUCTING PHOTOGRAPHY EXHIBITIONS; EDUCATIONAL SERVICES, NAMELY, PROVIDING LECTURES IN THE FIELDS OF ARCHITECTURE, HISTORY AND FILM (U.S. CLS. 100, 101 AND 107).

FIRST USE 1-0-2013; IN COMMERCE 1-0-2013.

PATRICIA EVANKO, EXAMINING ATTORNEY

SN 86-245,816. GEM MOTORSPORTS, LLC, MARENGO, OH.  
FILED 4-8-2014.

Racing is my passion,  
firesuits are my fashion

THE MARK CONSISTS OF STANDARD CHARACTERS WITHOUT CLAIM TO ANY PARTICULAR FONT, STYLE, SIZE, OR COLOR.

**CLASS 16—PAPER GOODS AND PRINTED MATTER**

FOR DECALS (U.S. CLS. 2, 5, 22, 23, 29, 37, 38 AND 50).

**CLASS 25—CLOTHING**

FOR HATS; HEADBANDS; HOODED SWEATSHIRTS; JACKETS; SHORTS; SWEATPANTS; T-SHIRTS; TANK TOPS (U.S. CLS. 22 AND 39).

KELLY BOULTON, EXAMINING ATTORNEY

---

SN 86-245,830. MONDAYS AT RACINE, INC., ISLIP, NY.  
FILED 4-8-2014.

MONDAYS AT RACINE

THE MARK CONSISTS OF STANDARD CHARACTERS WITHOUT CLAIM TO ANY PARTICULAR FONT, STYLE, SIZE, OR COLOR.

**CLASS 3—COSMETICS AND CLEANING PREPARATIONS**

FOR NON-MEDICATED BODY CARE PRODUCTS, NAMELY, BALMS, SALVES, MENDING OILS, CREAMS, MOISTURE LOTIONS AND MISTS (U.S. CLS. 1, 4, 6, 50, 51 AND 52).

FIRST USE 1-31-2014; IN COMMERCE 1-31-2014.

**CLASS 41—EDUCATION AND ENTERTAINMENT**

FOR YOGA INSTRUCTION; MEDITATION TRAINING (U.S. CLS. 100, 101 AND 107).

FIRST USE 7-30-2013; IN COMMERCE 7-30-2013.

**CLASS 44—MEDICAL, BEAUTY AND AGRICULTURAL SERVICES**

FOR HAIR SALON SERVICES; HEALTH SPA SERVICES FOR HEALTH AND WELLNESS OF THE BODY AND SPIRIT, NAMELY, PROVIDING MASSAGE, FACIAL AND BODY TREATMENT SERVICES, AND COSMETIC BODY CARE SERVICES; MASSAGE THERAPY SERVICES; REIKI HEALING SERVICES; REFLEXOLOGY SERVICES (U.S. CLS. 100 AND 101).

FIRST USE 7-30-2011; IN COMMERCE 7-30-2011.  
MICHAEL WEBSTER, EXAMINING ATTORNEY

SN 86-245,888. DAIRY GOAT CO-OPERATIVE (NZ) LIMITED, HAMILTON, NEW ZEALAND, FILED 4-8-2014.

CAPRICARE

THE MARK CONSISTS OF STANDARD CHARACTERS WITHOUT CLAIM TO ANY PARTICULAR FONT, STYLE, SIZE, OR COLOR.

OWNER OF NEW ZEALAND REG. NO. 833919, DATED 11-26-2010, EXPIRES 11-26-2020.

**CLASS 5—PHARMACEUTICALS**

FOR POWDERED INFANT FORMULAS; MILK BASED FOODS AND BEVERAGES FOR INFANTS; INFANT FORMULAS CONTAINING GOATS' MILK; POWDERED GOATS' MILK FORTIFIED WITH ADDED NUTRIENTS, VITAMINS, MINERALS AND/OR INGREDIENTS TO ASSIST DIGESTION, ABSORPTION OF VITAMINS AND MINERALS FOR INFANTS (U.S. CLS. 6, 18, 44, 46, 51 AND 52).

**CLASS 29—MEATS AND PROCESSED FOODS**

FOR MILK AND MILK PRODUCTS, INCLUDING BEVERAGES WITH A MILK BASE, UHT MILK, POWDERED MILK, AND MILK PRODUCTS FORTIFIED WITH ADDED NUTRIENTS, VITAMINS AND/OR MINERALS; GOATS' MILK AND MILK PRODUCTS DERIVED FROM GOATS' MILK. ALL THE FOREGOING EXCLUDING ICE CREAM, ICE MILK AND FROZEN YOGURT (U.S. CL. 46).

DANIEL S. STRINGER, EXAMINING ATTORNEY

---

SN 86-245,955. LIGHTWELL INC., DUBLIN, OH. FILED 4-8-2014.

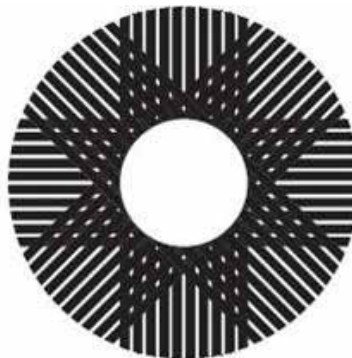

THE MARK CONSISTS OF A CIRCLE CONSISTING OF EIGHT SETS OF INTERSECTING LINES WITH THE MIDDLE A BLANK CIRCLE. THE INTERSECTING LINES FORMING A STAR WITH EIGHT POINTS.

**CLASS 35—ADVERTISING AND BUSINESS**

FOR PERSONNEL PLACEMENT OF INDIVIDUALS WITH INFORMATION TECHNOLOGY SKILLS TO BUSINESSES ON A TEMPORARY AND FULL-TIME BASIS (U.S. CLS. 100, 101 AND 102).

FIRST USE 5-8-2014; IN COMMERCE 5-8-2014.

**CLASS 42—SCIENTIFIC AND COMPUTER SERVICES**

FOR CLOUD COMPUTING FEATURING SOFTWARE FOR USE IN CONDUCTING BUSINESS TO BUSINESS COMMERCE, ELECTRONIC DATA INTERCHANGE (EDI), MANAGED FILE TRANSFER, ORDER MANAGEMENT, WAREHOUSE MANAGEMENT, AND E-COMMERCE; COMPUTER SERVICES, NAMELY, REMOTE AND ON-SITE MANAGEMENT OF THE INFORMATION TECHNOLOGY (IT) SYSTEMS AND THE SOFTWARE APPLICATIONS OF OTHERS RELATING TO BUSINESS TO BUSINESS COMMERCE, ELECTRONIC DATA INTERCHANGE (EDI), MANAGED FILE TRANSFER, ORDER MANAGEMENT, WAREHOUSE MANAGEMENT, AND E-COMMERCE; INSTALLATION AND MAINTENANCE OF COMPUTER SOFTWARE; CONSULTING SERVICES IN THE FIELDS OF INFORMATION TECHNOLOGY, COMPUTER HARDWARE AND SOFTWARE, NAMELY, CONSULTING SERVICES, IN THE NATURE OF TECHNICAL ADVICE TO OTHERS PROVIDED DIRECTLY THROUGH INDIVIDUAL CONSULTANTS AND THROUGH MANAGED TECHNICAL PROJECTS AND STRATEGIC TECHNICAL SERVICES; INFORMATION TECHNOLOGY (IT) CONSULTING SERVICES (U.S. CLS. 100 AND 101).

FIRST USE 5-8-2014; IN COMMERCE 5-8-2014.  
ZACHARY BELLO, EXAMINING ATTORNEY

SN 86-246,110. EVEREADY BATTERY COMPANY, INC., ST. LOUIS, MO. FILED 4-8-2014.

**SUNCOMFORT**

THE MARK CONSISTS OF STANDARD CHARACTERS WITHOUT CLAIM TO ANY PARTICULAR FONT, STYLE, SIZE, OR COLOR.

**CLASS 3—COSMETICS AND CLEANING PREPARATIONS**

FOR NON-MEDICATED SKIN CARE PREPARATIONS; NON-MEDICATED SUN CARE PREPARATIONS; SUN BLOCK; SUN BLOCK PREPARATIONS; SUN CARE LOTIONS AND SPRAYS; SUN SCREEN; SUN SCREEN PREPARATIONS; SUN-BLOCK LOTIONS AND SPRAYS; SUN-TANNING PREPARATIONS; SUNSCREEN CREAMS (U.S. CLS. 1, 4, 6, 50, 51 AND 52).

**CLASS 5—PHARMACEUTICALS**

FOR MEDICATED SUN CARE PREPARATIONS; MEDICATED SUN SCREEN (U.S. CLS. 6, 18, 44, 46, 51 AND 52).

ESTHER QUEEN, EXAMINING ATTORNEY

SN 86-246,123. A TO Z 4 YOU, LLC., WEST DES MOINES, IA. FILED 4-8-2014.

**The Picker Knows**

THE MARK CONSISTS OF STANDARD CHARACTERS WITHOUT CLAIM TO ANY PARTICULAR FONT, STYLE, SIZE, OR COLOR.

**CLASS 25—CLOTHING**

FOR CLOTHING AND HEADGEAR, NAMELY, T-SHIRTS, SHIRTS, HATS AND CAPS (U.S. CLS. 22 AND 39).

FIRST USE 3-1-2014; IN COMMERCE 3-1-2014.

**CLASS 35—ADVERTISING AND BUSINESS**

FOR RETAIL STORE SERVICES FEATURING ANTIQUES AND COLLECTIBLES (U.S. CLS. 100, 101 AND 102).

FIRST USE 3-1-2014; IN COMMERCE 3-1-2014.

CRISTIANA SCHWAB, EXAMINING ATTORNEY

SN 86-246,316. D'AMORE, CHRISTIANA, MALIBU, CA. FILED 4-8-2014.

**MALIBEAUTIES**

THE MARK CONSISTS OF STANDARD CHARACTERS WITHOUT CLAIM TO ANY PARTICULAR FONT, STYLE, SIZE, OR COLOR.

**CLASS 25—CLOTHING**

FOR CLOTHING, NAMELY, T-SHIRTS, PANTS, UNDERWEAR AND HATS (U.S. CLS. 22 AND 39).

**CLASS 41—EDUCATION AND ENTERTAINMENT**

FOR ENTERTAINMENT, NAMELY, PRODUCTION OF TELEVISION SHOWS; ENTERTAINMENT, NAMELY, A CONTINUING REALITY SHOW BROADCAST OVER TELEVISION, SATELLITE, RADIO AND THE INTERNET (U.S. CLS. 100, 101 AND 107).

TASNEEM HUSSAIN, EXAMINING ATTORNEY

SN 86-246,430. DJO, LLC, VISTA, CA. FILED 4-8-2014.



THE MARK CONSISTS OF THE STYLIZED TEXT "TRIZONE" WITH A DESIGN ELEMENT OF AN ENLARGED "Z" AND A PYRAMID-LIKE SHAPE SUBSTANTIALLY IN THE CENTER.

**CLASS 10—MEDICAL APPARATUS**

FOR CARBON BAMBOO ORTHOPEDIC BRACES FOR THE KNEE, ANKLE, OR ELBOW HAVING DIRECTIONAL WICKING FIBERS (U.S. CLS. 26, 39 AND 44).

**CLASS 28—TOYS AND SPORTING GOODS**

FOR BRACES TO BE WORN ON KNEES, ANKLES, OR ELBOWS FOR SUPPORT WHEN PLAYING SPORTS (U.S. CLS. 22, 23, 38 AND 50).

LINDA E. BLOHM, EXAMINING ATTORNEY

---

SN 86-246,546. GAMAGA, INC., SANTIAGO, CHILE, FILED 4-9-2014.

## GAMAGA

THE MARK CONSISTS OF STANDARD CHARACTERS WITHOUT CLAIM TO ANY PARTICULAR FONT, STYLE, SIZE, OR COLOR.

THE WORDING "GAMAGA" HAS NO MEANING IN A FOREIGN LANGUAGE.

### CLASS 9—ELECTRICAL AND SCIENTIFIC APPARATUS

FOR COMPUTER GAME PROGRAMMES; COMPUTER GAME PROGRAMMES DOWNLOADABLE VIA THE INTERNET; COMPUTER GAME SOFTWARE; COMPUTER GAME SOFTWARE FOR USE ON MOBILE AND CELLULAR PHONES; COMPUTER PROGRAMS FOR VIDEO AND COMPUTER GAMES; DOWNLOADABLE COMPUTER GAME PROGRAMS; DOWNLOADABLE COMPUTER GAME SOFTWARE VIA A GLOBAL COMPUTER NETWORK AND WIRELESS DEVICES; DOWNLOADABLE VIRTUAL GOODS, NAMELY, COMPUTER PROGRAMS FEATURING IN-GAME RESOURCES, TOKENS, AND DIGITAL CURRENCY FOR USE IN ON-LINE VIRTUAL WORLDS; INTERACTIVE VIDEO GAME PROGRAMS; VIDEO AND COMPUTER GAME PROGRAMS (U.S. CLS. 21, 23, 26, 36 AND 38).

FIRST USE 7-1-2009; IN COMMERCE 7-1-2009.

### CLASS 41—EDUCATION AND ENTERTAINMENT

FOR ENTERTAINMENT SERVICES, NAMELY, PROVIDING ON-LINE COMPUTER GAMES; ENTERTAINMENT SERVICES, NAMELY, PROVIDING VIRTUAL ENVIRONMENTS IN WHICH USERS CAN INTERACT FOR RECREATIONAL, LEISURE OR ENTERTAINMENT PURPOSES; PRODUCTION OF VIDEO AND COMPUTER GAME SOFTWARE; PROVIDING ON-LINE COMPUTER GAMES; PROVISION OF INFORMATION RELATING TO ELECTRONIC COMPUTER GAMES PROVIDED VIA THE INTERNET (U.S. CLS. 100, 101 AND 107).

FIRST USE 7-1-2009; IN COMMERCE 7-1-2009.  
SCOTT BIBB, EXAMINING ATTORNEY

---

SN 86-246,611. MARYANN LORUSSO, SAN FRANCISCO, CA. FILED 4-9-2014.

## STRIKE A PROSE

THE MARK CONSISTS OF STANDARD CHARACTERS WITHOUT CLAIM TO ANY PARTICULAR FONT, STYLE, SIZE, OR COLOR.

### CLASS 16—PAPER GOODS AND PRINTED MATTER

FOR BOOKS IN THE FIELD OF GENERAL HUMAN INTEREST; PRINTED MAGAZINES AND NEWSLETTERS IN THE FIELD OF GENERAL HUMAN INTEREST (U.S. CLS. 2, 5, 22, 23, 29, 37, 38 AND 50).

### CLASS 25—CLOTHING

FOR T-SHIRTS (U.S. CLS. 22 AND 39).

### CLASS 41—EDUCATION AND ENTERTAINMENT

FOR PROVIDING A WEBSITE FEATURING BLOGS AND NON-DOWNLOADABLE PUBLICATIONS IN THE NATURE OF ARTICLES IN THE FIELD(S) OF ISSUES OF INTEREST TO WOMEN; PROVIDING ON-LINE NON-DOWNLOADABLE GENERAL FEATURE MAGAZINES (U.S. CLS. 100, 101 AND 107).

FIRST USE 1-1-2011; IN COMMERCE 1-1-2011.  
LIEF MARTIN, EXAMINING ATTORNEY

---

SN 86-246,613. MARYANN LORUSSO, SAN FRANCISCO, CA. FILED 4-9-2014.

## RED TYPEWRITER

THE MARK CONSISTS OF STANDARD CHARACTERS WITHOUT CLAIM TO ANY PARTICULAR FONT, STYLE, SIZE, OR COLOR.

### CLASS 16—PAPER GOODS AND PRINTED MATTER

FOR BOOKS IN THE FIELD OF GENERAL HUMAN INTEREST; PRINTED MAGAZINES AND NEWSLETTERS IN THE FIELD OF GENERAL HUMAN INTEREST (U.S. CLS. 2, 5, 22, 23, 29, 37, 38 AND 50).

### CLASS 25—CLOTHING

FOR T-SHIRTS (U.S. CLS. 22 AND 39).

### CLASS 41—EDUCATION AND ENTERTAINMENT

FOR PROVIDING A WEBSITE FEATURING BLOGS AND NON-DOWNLOADABLE PUBLICATIONS IN THE NATURE OF ARTICLES IN THE FIELD(S) OF ISSUES OF INTEREST TO WOMEN; PROVIDING ON-LINE NON-DOWNLOADABLE GENERAL FEATURE MAGAZINES (U.S. CLS. 100, 101 AND 107).

FIRST USE 1-1-2011; IN COMMERCE 1-1-2011.  
LIEF MARTIN, EXAMINING ATTORNEY



SN 86-246,734. BH PET GEAR LLC, BROOKLYN, NY. FILED 4-9-2014.

DOMINICK J. SALEMI, EXAMINING ATTORNEY

## KEEP CALM and BARK ON

THE MARK CONSISTS OF STANDARD CHARACTERS WITHOUT CLAIM TO ANY PARTICULAR FONT, STYLE, SIZE, OR COLOR.

### CLASS 18—LEATHER GOODS

FOR DOG APPAREL; DOG CLOTHING; DOG LEASHES (U.S. CLS. 1, 2, 3, 22 AND 41).

### CLASS 24—FABRICS

FOR THROWS (U.S. CLS. 42 AND 50).

### CLASS 28—TOYS AND SPORTING GOODS

FOR DOG TOYS (U.S. CLS. 22, 23, 38 AND 50).  
TIMOTHY O. SCHIMPF, EXAMINING ATTORNEY

SN 86-246,739. ACE LIGHTING SERVICES, LLC, BROOK PARK, OH. FILED 4-9-2014.

## SUNSOURCE

THE MARK CONSISTS OF STANDARD CHARACTERS WITHOUT CLAIM TO ANY PARTICULAR FONT, STYLE, SIZE, OR COLOR.

### CLASS 10—MEDICAL APPARATUS

FOR ELECTRONIC AESTHETIC SKIN TREATMENT DEVICES USING LIGHT EMITTING DIODES, NAMELY, INFRARED, RED, ORANGE, YELLOW, GREEN, AND BLUE WAVELENGTHS FOR GENERATING LIGHT RAYS; ELECTRONIC LIGHT THERAPY APPARATUS FOR THE SKIN; LIGHT EMITTING DEVICES, NAMELY, LAMPS AND LED DEVICES FOR TREATMENT OF A VARIETY OF SKIN CONDITIONS; PHOTOTHERAPEUTIC APPARATUS FOR MEDICAL PURPOSES, NAMELY, A LED (LIGHT-EMITTING DIODE) LIGHT SOURCE FOR MEDICAL AND AESTHETIC SKIN TREATMENTS (U.S. CLS. 26, 39 AND 44).

### CLASS 11—ENVIRONMENTAL CONTROL APPARATUS

FOR AQUARIUM LIGHTS; CULTIVATION LAMPS AND PARTS THEREOF, NAMELY, HIGH PRESSURE SODIUM (HPS), METAL HALIDE, PLASMA, AND LIGHT EMITTING DIODE (LED); ELECTRIC LIGHT BULBS; LED (LIGHT EMITTING DIODE) LIGHTING FIXTURES; LED (LIGHT EMITTING DIODES) LIGHTING FIXTURES FOR USE IN DISPLAY, COMMERCIAL, INDUSTRIAL, RESIDENTIAL, AND ARCHITECTURAL ACCENT LIGHTING APPLICATIONS; LED LIGHT ENGINES; LED LIGHTING FIXTURES FOR INDOOR AND OUTDOOR LIGHTING APPLICATIONS; LED LIGHTING SYSTEMS, NAMELY, LED MODULES, POWER SUPPLIES, AND WIRING; LED UNDERWATER LIGHTS; LIGHT BULBS; LIGHT EMITTING DIODE (LED) PLANT GROW LIGHT (U.S. CLS. 13, 21, 23, 31 AND 34).

SN 86-246,853. HEMPWIRE, LLC, SAN DIEGO, CA. FILED 4-9-2014.

## HempWire

THE MARK CONSISTS OF STANDARD CHARACTERS WITHOUT CLAIM TO ANY PARTICULAR FONT, STYLE, SIZE, OR COLOR.

### CLASS 5—PHARMACEUTICALS

FOR MEDICATED LOTION FOR SKIN/HAIR/SUN-BURN/FACE/BODY, HERBAL TOPICAL CREAMS/SALVES/OINTMENTS FOR THE RELIEF OF ACHE AND PAIN, DIETARY AND NUTRITIONAL SUPPLEMENTS, NEUTRACEUTICALS FOR USE AS A DIETARY SUPPLEMENT DRINK MIXES, NUTRACEUTICALS FOR USE AS DIETARY SUPPLEMENT, NUTRITION SUPPLEMENTS IN DROP FORM, CAPSULE FORM, AND LIQUID FORM, EDIBLE HEMP OIL FOR USE AS A DIETARY SUPPLEMENT; ALL THE FOREGOING CONTAINING HEMP (U.S. CLS. 6, 18, 44, 46, 51 AND 52).

### CLASS 30—STAPLE FOODS

FOR CANDIES, NAMELY, CHEWABLE CANDIES, HARD CANDIES, FRUIT CANDIES, CANDIES FLAVORED WITH PLANTS, LOLLIPOPS, CANDY BARS; CONFECTIONERY, NAMELY, CAKES, PASTRIES, SCONES, COOKIES; GUM, NAMELY, FLAVORED CHEWING GUM; PREPARED MEALS, NAMELY, GRANOLA BARS, CEREAL BARS, NUT BARS, ALL THE FOREGOING CONTAINING HEMP (U.S. CL. 46).

### CLASS 32—LIGHT BEVERAGES

FOR NON-ALCOHOLIC BEVERAGES, NAMELY, BEVERAGES WITH VEGETABLE OR FRUIT FLAVORS, FRUIT JUICE, FRUIT EXTRACTS, VEGETABLE JUICE; BEER, NAMELY, BEER WITH VEGETABLE OR FRUIT FLAVORS, ALL THE FOREGOING CONTAINING HEMP (U.S. CLS. 45, 46 AND 48).

### CLASS 35—ADVERTISING AND BUSINESS

FOR ON-LINE RETAIL STORE SERVICES IN THE FIELD OF DIETARY AND NUTRITIONAL SUPPLEMENTS, FOOD STUFFS AND BEVERAGES, BODY CARE AND TOILETRY PRODUCTS ALL OF WHICH CONTAIN HEMP; WHOLESALE DISTRIBUTORSHIP SERVICES FEATURING DIETARY AND NUTRITIONAL SUPPLEMENTS, AND FOOD STUFFS AND BEVERAGES, BODY CARE AND TOILETRY PRODUCTS ALL OF WHICH CONTAIN HEMP; RETAIL STORE SERVICES FEATURING DIETARY AND NUTRITIONAL SUPPLEMENTS, FOOD STUFFS AND BEVERAGES, BODY CARE AND TOILETRY PRODUCTS ALL OF WHICH CONTAIN HEMP AND WHICH IS ACCESSIBLE ON-LINE AND BY TELEPHONE, FACSIMILE, AND MAIL ORDER (U.S. CLS. 100, 101 AND 102).

JEFFREY LOOK, EXAMINING ATTORNEY

SN 86-247,021. HERR HOLDINGS, INC., WILMINGTON, DE. FILED 4-9-2014.



THE MARK CONSISTS OF THE STYLIZED WORDING "GO LITE" WITH A STYLIZED EXCLAMATION MARK WITHIN A CLOUD DESIGN WITH SHADING ON THE BOTTOM AND ON THE RIGHT TO GIVE THE WORDING A THREE DIMENSIONAL APPEARANCE.

**CLASS 29—MEATS AND PROCESSED FOODS**

FOR POPPED POTATO CHIPS; POPPED CASSAVA CHIPS; BAKED POTATO CRISPS (U.S. CL. 46).

**CLASS 30—STAPLE FOODS**

FOR POPCORN; POPPED CORN CHIPS; CEREAL BARS (U.S. CL. 46).  
CHRISTOPHER REAMS, EXAMINING ATTORNEY

SN 86-247,056. NATERA, INC., SAN CARLOS, CA. FILED 4-9-2014.



THE MARK CONSISTS OF STANDARD CHARACTERS WITHOUT CLAIM TO ANY PARTICULAR FONT, STYLE, SIZE, OR COLOR.

**CLASS 42—SCIENTIFIC AND COMPUTER SERVICES**

FOR MEDICAL AND SCIENTIFIC RESEARCH AND ANALYSIS IN THE FIELD OF GENETIC TESTING; PROVIDING MEDICAL AND SCIENTIFIC RESEARCH INFORMATION IN THE FIELD OF GENETIC TESTING; MEDICAL LABORATORY SERVICES; GENETIC TESTING FOR SCIENTIFIC RESEARCH AND ANALYSIS PURPOSES; GENETIC TESTING FOR SCIENTIFIC RESEARCH AND ANALYSIS PURPOSES IN THE FIELD OF HUMAN REPRODUCTION; PROVIDING A WEBSITE FEATURING INFORMATION IN THE FIELD OF GENETIC TESTING FOR SCIENTIFIC PURPOSES; GENETIC TESTING OF FETAL REMAINS FOR SCIENTIFIC RESEARCH AND ANALYSIS PURPOSES (U.S. CLS. 100 AND 101).

**CLASS 44—MEDICAL, BEAUTY AND AGRICULTURAL SERVICES**

FOR GENETIC TESTING FOR MEDICAL PURPOSES; GENETIC COUNSELING; GENETIC TESTING FOR MEDICAL PURPOSES AND GENETIC COUNSELING IN THE FIELD OF HUMAN REPRODUCTION; PROVIDING A WEBSITE FEATURING INFORMATION ABOUT GENETIC TESTING FOR MEDICAL PURPOSES AND GENETIC COUNSELING; GENETIC TESTING OF FETAL REMAINS FOR MEDICAL PURPOSES (U.S. CLS. 100 AND 101).  
ANDREA BUTLER, EXAMINING ATTORNEY

SN 86-247,066. CONNECTED MINISTRIES, ROCKFORD, IL. FILED 4-9-2014.

**GOD'S BEST VERSION OF YOU**

THE MARK CONSISTS OF STANDARD CHARACTERS WITHOUT CLAIM TO ANY PARTICULAR FONT, STYLE, SIZE, OR COLOR.

**CLASS 9—ELECTRICAL AND SCIENTIFIC APPARATUS**

FOR PRERECORDED CDS AND DVDS FEATURING TRAINING AND EDUCATION MATERIAL ABOUT A HEALTH AND WELLNESS PROGRAM (U.S. CLS. 21, 23, 26, 36 AND 38).

**CLASS 16—PAPER GOODS AND PRINTED MATTER**

FOR PRINTED MATERIALS, NAMELY, PAMPHLETS, BOOKS, MAGAZINES, NEWSLETTERS AND TEACHING MATERIALS IN THE FIELD OF A HEALTH AND WELLNESS PROGRAM (U.S. CLS. 2, 5, 22, 23, 29, 37, 38 AND 50).

**CLASS 41—EDUCATION AND ENTERTAINMENT**

FOR EDUCATIONAL AND TRAINING SERVICES, NAMELY, CONDUCTING ONLINE AND LIVE SEMINARS, WORKSHOPS AND CLASSES IN THE FIELD OF A HEALTH AND WELLNESS PROGRAM; PROVIDING AN EDUCATIONAL WEBSITE IN THE FIELD OF A HEALTH AND WELLNESS PROGRAM (U.S. CLS. 100, 101 AND 107).  
ERIC SABLE, EXAMINING ATTORNEY

SN 86-247,185. MIND OVER MATTER AI, LLC, GILBERT, AZ. FILED 4-9-2014.



THE MARK CONSISTS OF STANDARD CHARACTERS WITHOUT CLAIM TO ANY PARTICULAR FONT, STYLE, SIZE, OR COLOR.

**CLASS 9—ELECTRICAL AND SCIENTIFIC APPARATUS**

FOR COMPUTER HARDWARE; COMPUTER SOFTWARE FOR USE IN DATA PROCESSING AND ANALYSIS (U.S. CLS. 21, 23, 26, 36 AND 38).

**CLASS 42—SCIENTIFIC AND COMPUTER SERVICES**

FOR SCIENTIFIC RESEARCH AND DEVELOPMENT; SCIENTIFIC AND TECHNOLOGICAL SERVICES, NAMELY, RESEARCH, DESIGN, AND DEVELOPMENT OF TECHNOLOGIES IN THE FIELDS OF PHYSICS AND COGNITIVE SCIENCE (U.S. CLS. 100 AND 101).

GINA HAYES, EXAMINING ATTORNEY

**CLASS 44—MEDICAL, BEAUTY AND AGRICULTURAL SERVICES**

FOR PROVIDING MEDICAL EVALUATION OF PERSONAL INJURIES AND COMPREHENSIVE TREATMENT PLANS; MEDICAL CONSULTATION SERVICES RESPECTING PERSONAL INJURY; OPERATION OF A MEDICAL CLINIC AND SURGICAL CARE CLINIC; SURGERY SERVICES (U.S. CLS. 100 AND 101).

LEIGH CAROLINE CASE, EXAMINING ATTORNEY

SN 86-247,202. MIND OVER MATTER AI, LLC, GILBERT, AZ. FILED 4-9-2014.

QMIND

THE MARK CONSISTS OF STANDARD CHARACTERS WITHOUT CLAIM TO ANY PARTICULAR FONT, STYLE, SIZE, OR COLOR.

**CLASS 9—ELECTRICAL AND SCIENTIFIC APPARATUS**

FOR COMPUTER HARDWARE; COMPUTER SOFTWARE FOR USE IN DATA PROCESSING AND ANALYSIS (U.S. CLS. 21, 23, 26, 36 AND 38).

**CLASS 42—SCIENTIFIC AND COMPUTER SERVICES**

FOR SCIENTIFIC RESEARCH AND DEVELOPMENT; SCIENTIFIC AND TECHNOLOGICAL SERVICES, NAMELY, RESEARCH, DESIGN, AND DEVELOPMENT OF TECHNOLOGIES IN THE FIELDS OF PHYSICS AND COGNITIVE SCIENCE (U.S. CLS. 100 AND 101).

GINA HAYES, EXAMINING ATTORNEY

SN 86-247,227. SOUTH COAST MEDICAL MANAGEMENT, LLC, NEWPORT BEACH, CA. FILED 4-9-2014.

PLEDGE MEDICAL

THE MARK CONSISTS OF STANDARD CHARACTERS WITHOUT CLAIM TO ANY PARTICULAR FONT, STYLE, SIZE, OR COLOR.

NO CLAIM IS MADE TO THE EXCLUSIVE RIGHT TO USE "MEDICAL", APART FROM THE MARK AS SHOWN.

**CLASS 36—INSURANCE AND FINANCIAL**

FOR PROVIDING INFORMATION IN THE FIELD OF WORKERS' COMPENSATION (U.S. CLS. 100, 101 AND 102).

SN 86-247,295. TSANG, MARK, SAN FRANCISCO, CA. FILED 4-9-2014.

Cascade

THE MARK CONSISTS OF STANDARD CHARACTERS WITHOUT CLAIM TO ANY PARTICULAR FONT, STYLE, SIZE, OR COLOR.

**CLASS 9—ELECTRICAL AND SCIENTIFIC APPARATUS**

FOR DOWNLOADABLE MOBILE APPLICATIONS FOR UPLOADING IMAGES VIDEOS, AUDIO-VISUAL, TEXT, AND OTHER MULTIMEDIA CONTENT; DOWNLOADABLE SOFTWARE IN THE NATURE OF A MOBILE APPLICATION FOR ENABLING USERS TO PARTICIPATE IN FULLY AUTOMATED CONTESTS; SOFTWARE THAT ENABLES USERS TO PARTICIPATE IN MULTI-LEVEL PHOTO AND VIDEO CONTESTS, AS WELL AS WRITING, DESIGN, ART AND ESSAY CONTESTS (U.S. CLS. 21, 23, 26, 36 AND 38).

**CLASS 42—SCIENTIFIC AND COMPUTER SERVICES**

FOR PROVIDING A WEB SITE FEATURING TECHNOLOGY THAT ENABLES USERS TO UPLOAD IMAGES, VIDEOS, TEXT, AUDIO-VISUAL AND OTHER MULTIMEDIA CONTENT; PROVIDING A WEBSITE FEATURING ON-LINE NON-DOWNLOADABLE SOFTWARE THAT ENABLES USERS TO PARTICIPATE IN FULLY AUTOMATED CONTESTS AND FEATURING ON-LINE NON-DOWNLOADABLE SOFTWARE THAT ENABLES USERS TO PARTICIPATE IN MULTI-LEVEL PHOTO AND VIDEO CONTESTS, AS WELL AS WRITING, DESIGN, ART AND ESSAY CONTESTS (U.S. CLS. 100 AND 101).

SEAN CROWLEY, EXAMINING ATTORNEY

SN 86-247,299. FREENOTE, LLC, DANA POINT, CA. FILED 4-9-2014.



THE MARK CONSISTS OF A MULTIPOINT-SHAPED SYMBOL CUT OUT OF A DARK CIRCLE.

#### CLASS 18—LEATHER GOODS

FOR WALLETS, BACKPACKS, AND LUGGAGE (U.S. CLS. 1, 2, 3, 22 AND 41).

#### CLASS 25—CLOTHING

FOR CLOTHING, NAMELY JACKETS, SHIRTS, VESTS, FLEECE PULLOVERS, SWEATSHIRTS, WOVEN TOPS, BUTTON DOWN SHIRTS, JEANS, PANTS, SHORTS, SWIM TRUNKS, HATS, BEANIES, BELTS FOR CLOTHING, SOCKS, AND SCARVES (U.S. CLS. 22 AND 39).

GEORGE LORENZO, EXAMINING ATTORNEY

SN 86-247,305. HEARST COMMUNICATIONS, INC., NEW YORK, NY. FILED 4-9-2014.

### ESQUIRE EAT LIKE A MAN

THE MARK CONSISTS OF STANDARD CHARACTERS WITHOUT CLAIM TO ANY PARTICULAR FONT, STYLE, SIZE, OR COLOR.

OWNER OF U.S. REG. NOS. 313,768, 3,858,001 AND OTHERS.

#### CLASS 29—MEATS AND PROCESSED FOODS

FOR FRESH AND FROZEN BEEF STEAKS; DIPS; DAIRY-BASED DIPS; SPINACH DIP; ARTICHOKE DIP; SOUPS; FRESH, PREPARED, PRE-PACKAGED AND FROZEN APPETIZERS CONSISTING PRIMARILY OF MEAT, POULTRY, VEGETABLES, POTATOES, SEAFOOD AND/OR CHEESE; FRESH, PREPARED, PRE-PACKAGED AND FROZEN ENTREES AND MEALS CONSISTING PRIMARILY OF MEAT, POULTRY, VEGETABLES, POTATOES, SEAFOOD AND/OR CHEESE; POTATO SKINS; POTATO FRIES; ONION RINGS; POTATO CHIPS; PREPARED FOODS, NAMELY, SIDE DISHES AND CASSEROLES MAINLY CONSISTING OF VEGETABLES, POTATOES, BEANS OR FRUIT; FOOD PACKAGE COMBINATIONS CONSISTING PRIMARILY OF CHEESE, MEAT AND/OR PROCESSED FRUIT; BACON; BEEF; BEEF JERKY; BEEF STICK SNACK FOODS; SAUSAGE; BRATWURST; CHEESE; CHICKEN; CORNED BEEF; CRAB CAKES; CRABS; DIPS; FISH FILLETS; FISH; FRANKFURTERS (U.S. CL. 46).

#### CLASS 30—STAPLE FOODS

FOR SAUCES, NAMELY, BBQ SAUCE, STEAK SAUCE, MARINADES; SPRING ROLLS; SEASONINGS; CONDIMENTS, NAMELY, MUSTARD, HORSERADISH, KETCHUP AND RELISH; DRY SPICE RUB FOR MEATS AND FISH; BREAKFAST BURRITOS (U.S. CL. 46).

KIMBERLY PERRY, EXAMINING ATTORNEY

SN 86-247,342. PRICELINE.COM LLC, NORWALK, CT. FILED 4-9-2014.



THE COLOR(S) WHITE, BLUE, AND DARK BLUE IS/ARE CLAIMED AS A FEATURE OF THE MARK.

THE MARK CONSISTS OF THE LETTER "P" IN WHITE IN A BLUE SQUARE WITH DARK BLUE RAYS EMANATING FROM THE CENTER OF THE LETTER "P".

#### CLASS 9—ELECTRICAL AND SCIENTIFIC APPARATUS

FOR DOWNLOADABLE SOFTWARE IN THE NATURE OF MOBILE APPLICATIONS FOR MAKING RESERVATIONS AND BOOKINGS FOR TEMPORARY LODGING AND ACCOMMODATIONS; DOWNLOADABLE SOFTWARE IN THE NATURE OF MOBILE APPLICATIONS FOR MATCHING PURCHASERS AND POTENTIAL PURCHASERS OF HOTEL, RESORT AND HOLIDAY ACCOMMODATIONS WITH PARTICULAR HOTELS AND RESORTS; DOWNLOADABLE SOFTWARE IN THE NATURE OF MOBILE APPLICATIONS FOR PROVIDING HOTEL, RESORT AND ACCOMMODATION RATE COMPARISON INFORMATION; DOWNLOADABLE SOFTWARE IN THE NATURE OF MOBILE APPLICATIONS THAT PROVIDE INFORMATION ON HOTEL, RESORT AND HOLIDAY ACCOMMODATIONS (U.S. CLS. 21, 23, 26, 36 AND 38).

FIRST USE 1-12-2013; IN COMMERCE 1-12-2013.

#### CLASS 35—ADVERTISING AND BUSINESS

FOR ADVERTISING AND BUSINESS SERVICES, NAMELY, ADVERTISING, MARKETING AND PROMOTIONAL SERVICES FOR THE TRANSPORTATION, TRAVEL, AIRLINE, HOTEL AND RESORT INDUSTRIES; PUBLICITY AND SALES PROMOTION SERVICES FOR THE TRANSPORTATION, TRAVEL, AIRLINE, HOTEL AND RESORT INDUSTRIES; ADVERTISING AND MARKETING SERVICES PROVIDED BY MEANS OF SOCIAL MEDIA; PROVIDING RATE COMPARISON INFORMATION FOR THE HOTEL AND RESORT INDUSTRIES; MATCHING POTENTIAL PURCHASERS OF HOTEL, RESORT AND HOLIDAY ACCOMMODATIONS WITH PARTICULAR PROVIDERS OF SUCH SERVICES (U.S. CLS. 100, 101 AND 102).

FIRST USE 1-12-2013; IN COMMERCE 1-12-2013.

**CLASS 43—HOTEL AND RESTAURANT SERVICES**

SN 86-247,383. MOOCHO, INC., MIAMI, FL. FILED 4-9-2014.

FOR TRAVEL AGENCY SERVICES, NAMELY, MAKING RESERVATIONS AND BOOKINGS FOR TEMPORARY LODGING (U.S. CLS. 100 AND 101).

FIRST USE 1-12-2013; IN COMMERCE 1-12-2013.  
JESSICA A. POWERS, EXAMINING ATTORNEY

**MOOCHO**

SN 86-247,361. DENNIS BOUFFARD, DBA ATARAXIC, MARLBOROUGH, MA. FILED 4-9-2014.

THE MARK CONSISTS OF STANDARD CHARACTERS WITHOUT CLAIM TO ANY PARTICULAR FONT, STYLE, SIZE, OR COLOR.

**FREEDOM FROM DEMAND****CLASS 35—ADVERTISING AND BUSINESS**

THE MARK CONSISTS OF STANDARD CHARACTERS WITHOUT CLAIM TO ANY PARTICULAR FONT, STYLE, SIZE, OR COLOR.

FOR PROMOTING THE GOODS AND SERVICES OF OTHERS BY MEANS OF COUPONS, DISCOUNTS, ADMINISTRATION OF INCENTIVE AWARDS PROGRAMS, REBATES, AND VOUCHERS, VIA WIRELESS NETWORK, MOBILE TELECOMMUNICATION DEVICES, GLOBAL COMPUTER NETWORK; DISSEMINATION OF ADVERTISING FOR OTHERS VIA WIRELESS NETWORK, MOBILE TELECOMMUNICATION DEVICES, GLOBAL COMPUTER NETWORK (U.S. CLS. 100, 101 AND 102).

FIRST USE 7-19-2011; IN COMMERCE 7-22-2011.

**CLASS 25—CLOTHING**

FOR HATS; T-SHIRTS (U.S. CLS. 22 AND 39).  
FIRST USE 3-21-2014; IN COMMERCE 3-21-2014.

**CLASS 36—INSURANCE AND FINANCIAL****CLASS 35—ADVERTISING AND BUSINESS**

FOR ON-LINE RETAIL STORE SERVICES FEATURING CLOTHING AND HATS (U.S. CLS. 100, 101 AND 102).

FIRST USE 3-21-2014; IN COMMERCE 3-21-2014.  
ELIZABETH CHANG, EXAMINING ATTORNEY

FOR FINANCIAL TRANSACTION SERVICES, NAMELY, PROVIDING SECURE COMMERCIAL TRANSACTIONS AND PAYMENT OPTIONS; PROVISION OF ELECTRONIC CONTACTLESS PAYMENT SERVICES, NAMELY, PROCESSING ELECTRONIC PAYMENTS MADE THROUGH PREPAID CARDS; FINANCIAL TRANSACTION SERVICES, NAMELY, PROVIDING SECURE COMMERCIAL TRANSACTIONS AND PAYMENT OPTIONS USING A MOBILE DEVICE AT A POINT OF SALE (U.S. CLS. 100, 101 AND 102).

FIRST USE 7-19-2011; IN COMMERCE 7-22-2011.  
JORDAN BAKER, EXAMINING ATTORNEY

SN 86-247,376. DENNIS BOUFFARD, DBA ATARAXIC, MARLBOROUGH, MA. FILED 4-9-2014.

SN 86-247,403. SOCIALWHIRLED, LLC, PHOENIX, AZ. FILED 4-9-2014.

**SOCIALWHIRLED**

THE MARK CONSISTS OF A SHADOWED LETTER "A" WITH A PARTIAL STAR OUTLINE.

THE MARK CONSISTS OF STANDARD CHARACTERS WITHOUT CLAIM TO ANY PARTICULAR FONT, STYLE, SIZE, OR COLOR.

**CLASS 25—CLOTHING**

FOR HATS; T-SHIRTS (U.S. CLS. 22 AND 39).  
FIRST USE 3-21-2014; IN COMMERCE 3-21-2014.

**CLASS 35—ADVERTISING AND BUSINESS**

FOR MARKETING SERVICES, NAMELY, CONDUCTING MARKETING CAMPAIGNS AND COLLECTING DATA ACROSS MOBILE DEVICES, SOCIAL PLATFORMS AND WEBSITES (U.S. CLS. 100, 101 AND 102).

FIRST USE 11-7-2011; IN COMMERCE 11-7-2011.

**CLASS 35—ADVERTISING AND BUSINESS**

FOR ON-LINE RETAIL STORE SERVICES FEATURING CLOTHING AND HATS (U.S. CLS. 100, 101 AND 102).

FIRST USE 3-21-2014; IN COMMERCE 3-21-2014.  
ELIZABETH CHANG, EXAMINING ATTORNEY

**CLASS 42—SCIENTIFIC AND COMPUTER SERVICES**

FOR SOFTWARE AS A SERVICE (SAAS) SERVICES FEATURING SOFTWARE FOR PUBLISHING MARKETING CAMPAIGNS AND COLLECTING DATA ACROSS MOBILE DEVICES, SOCIAL PLATFORMS AND WEBSITES (U.S. CLS. 100 AND 101).

FIRST USE 11-7-2011; IN COMMERCE 11-7-2011.  
ERNEST SHOSHO, EXAMINING ATTORNEY

SN 86-247,481. NECROMONGER, LLC, PLANO, TX. FILED 4-9-2014.

## BATTLEBORN

THE MARK CONSISTS OF STANDARD CHARACTERS WITHOUT CLAIM TO ANY PARTICULAR FONT, STYLE, SIZE, OR COLOR.

### CLASS 9—ELECTRICAL AND SCIENTIFIC APPARATUS

FOR COMPUTER GAME SOFTWARE; COMPUTER PROGRAMS FOR VIDEO AND COMPUTER GAMES; VIDEO GAME SOFTWARE; DOWNLOADABLE ELECTRONIC PUBLICATIONS FEATURING SCENES OR CHARACTERS BASED ON VIDEO GAMES OR COMPUTER GAMES; DOWNLOADABLE DIGITAL MEDIA FILES, NAMELY PRE-RECORDED AUDIO, VIDEO AND AUDIOVISUAL GAMING CONTENT, AND ARTWORK; DOWNLOADABLE VIDEO GAME SOFTWARE AND DOWNLOADABLE COMPUTER GAME SOFTWARE; COMPUTER GAME SOFTWARE FOR USE ON MOBILE AND CELLULAR PHONES (U.S. CLS. 21, 23, 26, 36 AND 38).

### CLASS 16—PAPER GOODS AND PRINTED MATTER

FOR PUBLICATIONS, NAMELY, BOOKS, COMIC BOOKS AND MAGAZINES FEATURING SCENES OR CHARACTERS BASED ON VIDEO OR COMPUTER GAMES; STICKERS; TRADING CARDS; POSTERS; PRINTS; PRINTED ART REPRODUCTIONS (U.S. CLS. 2, 5, 22, 23, 29, 37, 38 AND 50).

### CLASS 28—TOYS AND SPORTING GOODS

FOR ACTION FIGURES AND ACCESSORIES THEREFOR; MECHANICAL ACTION TOYS; MODELED PLASTIC TOY FIGURINES; SCALE-MODEL VEHICLES (U.S. CLS. 22, 23, 38 AND 50).

THEODORE MCBRIDE, EXAMINING ATTORNEY

SN 86-247,573. KILDUFF, ALBERT, EDGEWOOD, MD. FILED 4-9-2014.

## FACE DANCER

THE MARK CONSISTS OF STANDARD CHARACTERS WITHOUT CLAIM TO ANY PARTICULAR FONT, STYLE, SIZE, OR COLOR.

### CLASS 9—ELECTRICAL AND SCIENTIFIC APPARATUS

FOR MUSICAL SOUND RECORDINGS (U.S. CLS. 21, 23, 26, 36 AND 38).

FIRST USE 5-2-1977; IN COMMERCE 5-2-1977.

### CLASS 41—EDUCATION AND ENTERTAINMENT

FOR ENTERTAINMENT, NAMELY, LIVE MUSIC CONCERTS; ENTERTAINMENT, NAMELY, LIVE PERFORMANCES BY A MUSICAL BAND (U.S. CLS. 100, 101 AND 107).

FIRST USE 5-2-1977; IN COMMERCE 5-2-1977.

ALYSSA STEEL, EXAMINING ATTORNEY

SN 86-247,609. APTIV SOLUTIONS, INC., RESTON, VA. FILED 4-9-2014.

## APTIVINSITE

THE MARK CONSISTS OF STANDARD CHARACTERS WITHOUT CLAIM TO ANY PARTICULAR FONT, STYLE, SIZE, OR COLOR.

OWNER OF U.S. REG. NOS. 4,132,792 AND 4,502,195.

### CLASS 35—ADVERTISING AND BUSINESS

FOR PROVIDING INDEPENDENT REVIEW OF CLINICAL TRIALS FOR BUSINESS PURPOSES (U.S. CLS. 100, 101 AND 102).

FIRST USE 6-20-2013; IN COMMERCE 6-20-2013.

### CLASS 42—SCIENTIFIC AND COMPUTER SERVICES

FOR PROVIDING MEDICAL AND SCIENTIFIC RESEARCH INFORMATION IN THE FIELD OF CLINICAL TRIALS; PROVIDING REVIEW AND MONITORING OF MEDICAL AND SCIENTIFIC RESEARCH DATA IN CLINICAL TRIALS (U.S. CLS. 100 AND 101).

FIRST USE 6-20-2013; IN COMMERCE 6-20-2013.

DAVID COLLIER, EXAMINING ATTORNEY

SN 86-247,692. KOSE CORPORATION, TOKYO, JAPAN. FILED 4-9-2014.

## PREDIA

THE MARK CONSISTS OF STANDARD CHARACTERS WITHOUT CLAIM TO ANY PARTICULAR FONT, STYLE, SIZE, OR COLOR.

### CLASS 3—COSMETICS AND CLEANING PREPARATIONS

FOR COSMETICS; PERFUMES; COSMETIC SOAPS; COTTON WOOL FOR COSMETIC PURPOSES AND HAIR CARE PREPARATIONS (U.S. CLS. 1, 4, 6, 50, 51 AND 52).

### CLASS 21—HOUSEWARES AND GLASS

FOR EYEBROW BRUSHES; CHEEK BRUSHES; EYE SHADOW BRUSHES; MASCARA COMBS; COMPACTS SOLD EMPTY; LIP BRUSHES; POWDER PUFFS AND MAKE-UP SPONGES (U.S. CLS. 2, 13, 23, 29, 30, 33, 40 AND 50).

THEODORE MCBRIDE, EXAMINING ATTORNEY

SN 86-247,729. BARBELLS FOR BOOBS, COSTA MESA, CA.  
FILED 4-9-2014.

SN 86-247,841. GUTWIZDOM, LLC, NEW YORK, NY. FILED  
4-10-2014.

EVERYONE HAS A RIGHT TO  
KNOW

THE MARK CONSISTS OF STANDARD CHARACTERS  
WITHOUT CLAIM TO ANY PARTICULAR FONT, STYLE,  
SIZE, OR COLOR.

**CLASS 25—CLOTHING**

FOR T-SHIRTS; TOPS; WEARABLE GARMENTS AND  
CLOTHING, NAMELY, SHIRTS (U.S. CLS. 22 AND 39).

**CLASS 36—INSURANCE AND FINANCIAL**

FOR CHARITABLE FUNDRAISING SERVICES; PRO-  
VIDING GRANTS TO ORGANIZATIONS IN THE  
FIELDS OF PUBLIC HEALTH, CANCER, CANCER  
RECOVERY AND SURVIVAL (U.S. CLS. 100, 101 AND  
102).

**CLASS 44—MEDICAL, BEAUTY AND AGRI-  
CULTURAL SERVICES**

FOR PROVIDING A WEBSITE VIA A GLOBAL COM-  
PUTER NETWORK FEATURING INFORMATION IN  
THE FIELDS OF HEALTH, CANCER, CANCER RECOV-  
ERY AND SURVIVAL (U.S. CLS. 100 AND 101).  
CHRIS WELLS, EXAMINING ATTORNEY

---

SN 86-247,785. BIRS GROUP, LTD., TORTOLA, BR.VIRGIN  
ISLANDS, FILED 4-9-2014.

SMOKE X MIRRORS

THE MARK CONSISTS OF STANDARD CHARACTERS  
WITHOUT CLAIM TO ANY PARTICULAR FONT, STYLE,  
SIZE, OR COLOR.

**CLASS 9—ELECTRICAL AND SCIENTIFIC  
APPARATUS**

FOR EYEWEAR, NAMELY, SUNGLASSES, EYE-  
GLASSES AND OPHTHALMIC FRAMES AND CASES  
THEREFOR (U.S. CLS. 21, 23, 26, 36 AND 38).

**CLASS 35—ADVERTISING AND BUSINESS**

FOR ON-LINE RETAIL STORE SERVICES FEATUR-  
ING SUNGLASSES, GLASSES AND FRAMES (U.S. CLS.  
100, 101 AND 102).  
ANNE E. GUSTASON, EXAMINING ATTORNEY

GutwiZdom

THE MARK CONSISTS OF STANDARD CHARACTERS  
WITHOUT CLAIM TO ANY PARTICULAR FONT, STYLE,  
SIZE, OR COLOR.

**CLASS 16—PAPER GOODS AND PRINTED  
MATTER**

FOR A SERIES OF BOOKS, WRITTEN ARTICLES,  
HANDOUTS AND WORKSHEETS IN THE FIELD OF  
INSPIRATION AND SELF-ESTEEM; MAGAZINES IN  
THE FIELD OF INSPIRATION AND SELF-ESTEEM  
(U.S. CLS. 2, 5, 22, 23, 29, 37, 38 AND 50).

**CLASS 25—CLOTHING**

FOR ATHLETIC APPAREL, NAMELY, SHIRTS,  
PANTS, JACKETS, FOOTWEAR, HATS AND CAPS,  
ATHLETIC UNIFORMS; CLOTHING FOR BABIES, TOD-  
DLERS AND CHILDREN, TREATED WITH FIRE AND  
HEAT RETARDANTS, NAMELY, PAJAMAS, JACKETS,  
SHIRTS, PANTS, JUMPERS; COLLARED SHIRTS; GOLF  
SHIRTS; GRAPHIC T-SHIRTS; HOODED SWEAT  
SHIRTS; JACKETS; JEANS; JERSEYS; LONG-SLEEVED  
SHIRTS; NIGHT SHIRTS; POLO SHIRTS; SHORT SETS;  
SKIRTS; SLEEPWEAR; SWEATERS; T-SHIRTS; TANK-  
TOPS; WEARABLE GARMENTS AND CLOTHING,  
NAMELY, SHIRTS; WOMEN'S CLOTHING, NAMELY,  
SHIRTS, DRESSES, SKIRTS, BLOUSES; WRAPS (U.S.  
CLS. 22 AND 39).

**CLASS 35—ADVERTISING AND BUSINESS**

FOR BUSINESS CONSULTING AND INFORMATION  
SERVICES (U.S. CLS. 100, 101 AND 102).

**CLASS 41—EDUCATION AND ENTERTAIN-  
MENT**

FOR EDUCATIONAL SERVICES, NAMELY, CON-  
DUCTING SEMINARS, LECTURES AND WORKSHOPS  
IN THE FIELD OF MOTIVATIONAL DEVELOPMENT;  
PRODUCTION OF TELEVISION PROGRAMS (U.S. CLS.  
100, 101 AND 107).  
KIMBERLY PERRY, EXAMINING ATTORNEY

---

SN 86-247,853. BEGLAMMED LLC, LOS ANGELES, CA.  
FILED 4-10-2014.

BEGLAMMED

THE MARK CONSISTS OF STANDARD CHARACTERS  
WITHOUT CLAIM TO ANY PARTICULAR FONT, STYLE,  
SIZE, OR COLOR.

**CLASS 9—ELECTRICAL AND SCIENTIFIC APPARATUS**

FOR COMPUTER APPLICATION SOFTWARE FOR COMPUTERS, MOBILE PHONES AND HANDHELD COMPUTERS, NAMELY, SOFTWARE FOR USE IN COORDINATING PROFESSIONAL BEAUTY SERVICES, NAMELY, THE AUTOMATED SCHEDULING AND DISPATCH OF BEAUTY AND HAIR PROFESSIONALS (U.S. CLS. 21, 23, 26, 36 AND 38).

**CLASS 44—MEDICAL, BEAUTY AND AGRICULTURAL SERVICES**

FOR BEAUTY CONSULTATION SERVICES; MAKING RESERVATIONS AND BOOKINGS FOR OTHERS FOR PHYSICAL AND BEAUTY TREATMENTS AT HEALTH SPAS; PROVIDING INFORMATION ABOUT BEAUTY; PROVIDING ON-SITE BEAUTY SERVICES, NAMELY, HAIR STYLING AND MAKE-UP APPLICATION SERVICES (U.S. CLS. 100 AND 101).

IRA J. GOODSaid, EXAMINING ATTORNEY

SN 86-247,935. TEA FORTE, INC., CONCORD, MA. FILED 4-10-2014.

**STEEP & CHILL**

THE MARK CONSISTS OF STANDARD CHARACTERS WITHOUT CLAIM TO ANY PARTICULAR FONT, STYLE, SIZE, OR COLOR.

**CLASS 21—HOUSEWARES AND GLASS**

FOR NON-ELECTRIC TEA MAKERS; PITCHERS (U.S. CLS. 2, 13, 23, 29, 30, 33, 40 AND 50).

**CLASS 30—STAPLE FOODS**

FOR TEA; ICED TEA; HERBAL INFUSIONS, OTHER THAN FOR MEDICINAL USE; INFUSIONS CONSISTING OF TEA, HERBS, FRUITS, SPICES OR FLAVORINGS OR A COMBINATION OF THESE PRODUCTS, OTHER THAN FOR MEDICINAL USE (U.S. CL. 46).

GEOFFREY FOSDICK, EXAMINING ATTORNEY

SN 86-247,864. FOKUS INC., MILPITAS, CA. FILED 4-10-2014.

**Performance Meets Science**

THE MARK CONSISTS OF STANDARD CHARACTERS WITHOUT CLAIM TO ANY PARTICULAR FONT, STYLE, SIZE, OR COLOR.

**CLASS 5—PHARMACEUTICALS**

FOR ADHESIVE TAPES FOR MEDICAL PURPOSES (U.S. CLS. 6, 18, 44, 46, 51 AND 52).

**CLASS 10—MEDICAL APPARATUS**

FOR CHEMICALLY ACTIVATED HOT AND/OR COLD COMPRESSES; COMPRESSION BANDAGES; ELECTRONIC STIMULATION APPARATUS FOR MUSCLES FOR PHYSICAL THERAPY PURPOSES; FOAM POSITIONING PADS FOR MEDICAL AND PHYSICAL THERAPY USE; FOAM ROLLERS FOR USE IN PHYSICAL THERAPY; MANUALLY-OPERATED EXERCISE EQUIPMENT FOR PHYSICAL THERAPY PURPOSES; MANUALLY-OPERATED RESISTANCE BANDS FOR PHYSICAL THERAPY PURPOSES; MANUALLY-OPERATED RESISTANCE TUBING FOR PHYSICAL THERAPY PURPOSES; NON-MEDICATED COMPRESSES; THERAPEUTIC APPARATUS, NAMELY, BODY LIMB THERMAL COMPRESSION UNDERGARMENTS FOR RELIEF OF MUSCULAR AND JOINT PAIN THROUGH TARGETED THERMAL APPLICATION AND COMPRESSION; THERAPEUTIC HOT AND COLD COMPRESSION WRAPS; THERMO-ELECTRIC COMPRESSES (U.S. CLS. 26, 39 AND 44).

**CLASS 28—TOYS AND SPORTING GOODS**

FOR ATHLETIC TAPE (U.S. CLS. 22, 23, 38 AND 50).  
IRA J. GOODSaid, EXAMINING ATTORNEY

SN 86-248,125. SPECAT COMPANIES, SAN FRANCISCO, CA. FILED 4-10-2014.

**GOGO FETCH FUEL**

THE MARK CONSISTS OF STANDARD CHARACTERS WITHOUT CLAIM TO ANY PARTICULAR FONT, STYLE, SIZE, OR COLOR.

**CLASS 5—PHARMACEUTICALS**

FOR DIETARY PET SUPPLEMENTS IN THE FORM OF PET TREATS; DIETARY SUPPLEMENTS FOR PETS; VITAMINS FOR PETS (U.S. CLS. 6, 18, 44, 46, 51 AND 52).

**CLASS 31—NATURAL AGRICULTURAL PRODUCTS**

FOR ELECTROLYTE DRINK MIX FOR PETS; PET BEVERAGES; PET FOOD; PET TREATS (U.S. CLS. 1 AND 46).

JOANNA DUKOVIC, EXAMINING ATTORNEY

SN 86-248,224. MERCURY ONE, INC., IRVING, TX. FILED 4-10-2014.

**GOD, GUNS & GIVING**

THE MARK CONSISTS OF STANDARD CHARACTERS WITHOUT CLAIM TO ANY PARTICULAR FONT, STYLE, SIZE, OR COLOR.



**CLASS 35—ADVERTISING AND BUSINESS**

FOR CHARITABLE SERVICES, NAMELY, ORGANIZING AND CONDUCTING VOLUNTEER PROGRAMS AND COMMUNITY SERVICE PROJECTS (U.S. CLS. 100, 101 AND 102).

SN 86-248,291. GONZALEZ, SAUL, SANTA ANA, CA. FILED 4-10-2014.

**CLASS 36—INSURANCE AND FINANCIAL**

FOR CHARITABLE FUNDRAISING (U.S. CLS. 100, 101 AND 102).  
DEBORAH MEINERS, EXAMINING ATTORNEY

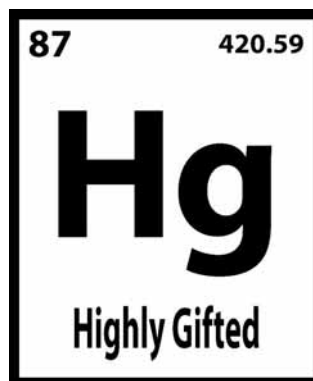

THE MARK CONSISTS OF A PERIODIC TABLE DESIGN "HG" STANDING FOR "HIGHLY GIFTED", "87" ON TOP LEFT CORNER AND "420.59" ON TOP RIGHT CORNER, "HG" IN THE MIDDLE "HIGHLY GIFTED" UNDER THE "HG" IN THE MIDDLE.

SN 86-248,227. SURVIVOR INDUSTRIES, INC., OXNARD, CA. FILED 4-10-2014.

# MAINSTAY

THE MARK CONSISTS OF STANDARD CHARACTERS WITHOUT CLAIM TO ANY PARTICULAR FONT, STYLE, SIZE, OR COLOR.

**CLASS 16—PAPER GOODS AND PRINTED MATTER**

FOR DECALS (U.S. CLS. 2, 5, 22, 23, 29, 37, 38 AND 50).

**CLASS 30—STAPLE FOODS**

FOR EMERGENCY FOOD RATIONS, NAMELY, FLOUR-BASED FOOD BARS (U.S. CL. 46).  
FIRST USE 0-0-1984; IN COMMERCE 0-0-1984.

**CLASS 25—CLOTHING**

FOR BEANIES; HATS; SHIRTS; SOCKS; UNDERWEAR (U.S. CLS. 22 AND 39).  
CAITLIN WATTS-FITZGERALD, EXAMINING ATTORNEY

**CLASS 32—LIGHT BEVERAGES**

FOR EMERGENCY DRINKING WATER (U.S. CLS. 45, 46 AND 48).  
FIRST USE 0-0-1984; IN COMMERCE 0-0-1984.  
LAURA GOLDEN, EXAMINING ATTORNEY

SN 86-248,310. QS WHOLESALE, INC., HUNTINGTON BEACH, CA. FILED 4-10-2014.

SN 86-248,288. FIREBIRDS INTERNATIONAL LLC, CHARLOTTE, NC. FILED 4-10-2014.

# SPARK SOMETHING



THE MARK CONSISTS OF A STYLIZED LETTER "A".

THE MARK CONSISTS OF STANDARD CHARACTERS WITHOUT CLAIM TO ANY PARTICULAR FONT, STYLE, SIZE, OR COLOR.

**CLASS 30—STAPLE FOODS**

FOR SPICES, SPICE BLENDS, SPICES FOR COOKING, SPICE RUBS, SEASONING SALTS, SEASONING SPICES, AND SEASONING MIXES (U.S. CL. 46).

**CLASS 18—LEATHER GOODS**

FOR ALL-PURPOSE CARRYING BAGS; ATHLETIC BAGS; BACKPACKS; DUFFEL BAGS; FANNY PACKS; KEY CASES; LUGGAGE; TOTE BAGS; UMBRELLAS; WALLETS (U.S. CLS. 1, 2, 3, 22 AND 41).

**CLASS 43—HOTEL AND RESTAURANT SERVICES**

FOR RESTAURANT AND BAR SERVICES (U.S. CLS. 100 AND 101).  
CAITLIN WATTS-FITZGERALD, EXAMINING ATTORNEY

**CLASS 25—CLOTHING**

FOR BELTS; COATS; FOOTWEAR; GLOVES; HATS; HEADBANDS; HEADWEAR; JACKETS; JEANS; JERSEYS; PANTS; SHIRTS; SHORTS; SOCKS; SPORTS BRAS; SWEATERS; SWEATSHIRTS; SWIMWEAR; TIGHTS; UNDERGARMENTS; VESTS; VISORS; WARM-UP SUITS (U.S. CLS. 22 AND 39).  
MICHAEL WIENER, EXAMINING ATTORNEY

SN 86-248,331. QS WHOLESALE, INC., HUNTINGTON BEACH, CA. FILED 4-10-2014.



THE MARK CONSISTS OF A STYLIZED LETTER "A" WITH THE WORD "AMPLA" BELOW.

#### CLASS 18—LEATHER GOODS

FOR ALL-PURPOSE CARRYING BAGS; ATHLETIC BAGS; BACKPACKS; DUFFEL BAGS; FANNY PACKS; KEY CASES; LUGGAGE; TOTE BAGS; UMBRELLAS; WALLETS (U.S. CLS. 1, 2, 3, 22 AND 41).

#### CLASS 25—CLOTHING

FOR BELTS; COATS; FOOTWEAR; GLOVES; HATS; HEADBANDS; HEADWEAR; JACKETS; JEANS; JERSEYS; PANTS; SHIRTS; SHORTS; SOCKS; SPORTS BRAS; SWEATERS; SWEATSHIRTS; SWIMWEAR; TIGHTS; UNDERGARMENTS; VESTS; VISORS; WARM-UP SUITS (U.S. CLS. 22 AND 39).

MICHAEL WIENER, EXAMINING ATTORNEY

SN 86-248,343. DOLIGHTFUL, INC., SAN FRANCISCO, CA. FILED 4-10-2014.

# KangaDo

THE MARK CONSISTS OF STANDARD CHARACTERS WITHOUT CLAIM TO ANY PARTICULAR FONT, STYLE, SIZE, OR COLOR.

#### CLASS 9—ELECTRICAL AND SCIENTIFIC APPARATUS

FOR DOWNLOADABLE SOFTWARE IN THE NATURE OF A MOBILE APPLICATION TO ALLOW USERS TO COMMUNICATE WITH EACH OTHER AND SHARE REQUESTS AND CALENDARS; DOWNLOADABLE MOBILE APPLICATION SOFTWARE FOR MESSAGING; DOWNLOADABLE MOBILE APPLICATION SOFTWARE TO ALLOW USERS TO EXCHANGE MESSAGES AND SHARE REQUESTS AND CALENDARS, SCHEDULES, PHOTOS, AND GEO-LOCATION INFORMATION; DOWNLOADABLE SOFTWARE THAT GENERATES AND DISPLAYS GROUPS BASED ON GEO-LOCATION AND DEMOGRAPHIC INDICATORS AND WHICH ALLOWS USERS TO JOIN EXISTING GROUPS AND CREATE NEW GROUPS TO ALLOW USERS TO FORM AND MANAGE COMMUNITIES AND TO COMMUNICATE, EXCHANGE MESSAGES, AND SHARE REQUESTS AND CALENDARS, SCHEDULES, PHOTOS, AND GEO-LOCATION INFORMATION (U.S. CLS. 21, 23, 26, 36 AND 38).

FIRST USE 12-15-2012; IN COMMERCE 12-15-2012.

#### CLASS 42—SCIENTIFIC AND COMPUTER SERVICES

FOR PROVIDING TEMPORARY USE OF NON-DOWNLOADABLE SOFTWARE IN THE NATURE OF AN APPLICATION TO ALLOW USERS TO COMMUNICATE WITH EACH OTHER AND SHARE REQUESTS AND CALENDARS; PROVIDING TEMPORARY USE OF NON-DOWNLOADABLE WEB APPLICATION SOFTWARE FOR MESSAGING; PROVIDING TEMPORARY USE OF A NON-DOWNLOADABLE WEB APPLICATION TO ALLOW USERS TO EXCHANGE MESSAGES AND SHARE REQUESTS AND CALENDARS, SCHEDULES, PHOTOS, AND GEO-LOCATION INFORMATION; PROVIDING TEMPORARY USE OF NON-DOWNLOADABLE SOFTWARE THAT GENERATES AND DISPLAYS GROUPS BASED ON GEO-LOCATION AND DEMOGRAPHIC INDICATORS AND WHICH ALLOWS USERS TO JOIN EXISTING GROUPS AND CREATE NEW GROUPS TO ALLOW USERS TO FORM AND MANAGE COMMUNITIES AND TO COMMUNICATE, EXCHANGE MESSAGES, AND SHARE REQUESTS AND CALENDARS, SCHEDULES, PHOTOS, AND GEO-LOCATION INFORMATION (U.S. CLS. 100 AND 101).

TARAH HARDY, EXAMINING ATTORNEY

SN 86-248,358. WAKIN UP WAGGIN, LLC, DBA WAKIN UP WAGGIN, MYTIC, CT. FILED 4-10-2014.

# Wakin' up Waggin'

THE MARK CONSISTS OF STANDARD CHARACTERS WITHOUT CLAIM TO ANY PARTICULAR FONT, STYLE, SIZE, OR COLOR.

#### CLASS 21—HOUSEWARES AND GLASS

FOR CUPS AND MUGS (U.S. CLS. 2, 13, 23, 29, 30, 33, 40 AND 50).

#### CLASS 25—CLOTHING

FOR ATHLETIC SHIRTS (U.S. CLS. 22 AND 39).

JAY FLOWERS, EXAMINING ATTORNEY

SN 86-248,376. NTREEGE, LLC, SAN JUAN CAPISTRANO, CA. FILED 4-10-2014.

# INTRIGUE

THE MARK CONSISTS OF STANDARD CHARACTERS WITHOUT CLAIM TO ANY PARTICULAR FONT, STYLE, SIZE, OR COLOR.

**CLASS 9—ELECTRICAL AND SCIENTIFIC APPARATUS**

FOR COMPUTER APPLICATION SOFTWARE FOR MOBILE PHONES, HANDHELD COMPUTERS AND OTHER WIRELESS ELECTRONIC DEVICES, NAMELY, SOFTWARE THAT ALLOWS USERS TO CREATE PERSONAL PROFILES AND TO ACCESS CURATED AESTHETIC ARTICLES AND TRENDS BY PROVIDING NON-BIASED AESTHETIC TREATMENT CONTENT THAT CAN BE LINKED TO PROVIDERS AND RANKING SCALES REFLECTIVE OF COMMUNITY ACCEPTANCE; AND TO LOCATE SERVICE PROVIDERS, TRACK, MANAGE AND SHARE INFORMATION IN THE AREA OF PLASTIC SURGERY AND OTHER AESTHETIC TREATMENTS AND PROCEDURES (U.S. CLS. 21, 23, 26, 36 AND 38).

**CLASS 42—SCIENTIFIC AND COMPUTER SERVICES**

FOR PROVIDING AN INTERACTIVE WEBSITE FEATURING TECHNOLOGY THAT ALLOWS USERS TO CREATE PERSONAL PROFILES AND TO ACCESS CURATED AESTHETIC ARTICLES AND TRENDS BY PROVIDING NON-BIASED AESTHETIC TREATMENT CONTENT THAT CAN BE LINKED TO PROVIDERS AND RANKING SCALES REFLECTIVE OF COMMUNITY ACCEPTANCE; AND TO LOCATE SERVICE PROVIDERS, TRACK, MANAGE AND SHARE INFORMATION IN THE AREA OF PLASTIC SURGERY AND OTHER AESTHETIC TREATMENTS AND PROCEDURES (U.S. CLS. 100 AND 101).

WILLIAM BRECKENFELD, EXAMINING ATTORNEY

SN 86-248,388. CRIMSON TRACE CORPORATION, WILSONVILLE, OR. FILED 4-10-2014.

**CONDITION CRIMSON**

THE MARK CONSISTS OF STANDARD CHARACTERS WITHOUT CLAIM TO ANY PARTICULAR FONT, STYLE, SIZE, OR COLOR.

OWNER OF U.S. REG. NOS. 2,205,041, 3,354,759 AND OTHERS.

**CLASS 6—METAL GOODS**

FOR METAL KEY CHAINS (U.S. CLS. 2, 12, 13, 14, 23, 25 AND 50).

**CLASS 9—ELECTRICAL AND SCIENTIFIC APPARATUS**

FOR TACTICAL LASER SIGHTS (U.S. CLS. 21, 23, 26, 36 AND 38).

**CLASS 11—ENVIRONMENTAL CONTROL APPARATUS**

FOR FLASHLIGHTS (U.S. CLS. 13, 21, 23, 31 AND 34).

**CLASS 13—FIREARMS**

FOR FIREARM ATTACHMENTS, NAMELY, MOUNTS FOR ATTACHING ACCESSORIES TO A FIREARM; FIREARM SIGHTS (U.S. CLS. 2 AND 9).

**CLASS 16—PAPER GOODS AND PRINTED MATTER**

FOR PENS (U.S. CLS. 2, 5, 22, 23, 29, 37, 38 AND 50).

**CLASS 21—HOUSEWARES AND GLASS**

FOR MUGS (U.S. CLS. 2, 13, 23, 29, 30, 33, 40 AND 50).

**CLASS 25—CLOTHING**

FOR CAPS; HATS; SHIRTS; T-SHIRTS (U.S. CLS. 22 AND 39).

JAY FLOWERS, EXAMINING ATTORNEY

SN 86-248,393. NTREEGE, LLC, SAN JUAN CAPISTRANO, CA. FILED 4-10-2014.

**GLANNCE**

THE MARK CONSISTS OF STANDARD CHARACTERS WITHOUT CLAIM TO ANY PARTICULAR FONT, STYLE, SIZE, OR COLOR.

**CLASS 9—ELECTRICAL AND SCIENTIFIC APPARATUS**

FOR COMPUTER APPLICATION SOFTWARE FOR MOBILE PHONES, HANDHELD COMPUTERS AND OTHER WIRELESS ELECTRONIC DEVICES, NAMELY, SOFTWARE THAT ALLOWS USERS TO CREATE PERSONAL PROFILES AND TO ACCESS CURATED AESTHETIC ARTICLES AND TRENDS BY PROVIDING NON-BIASED AESTHETIC TREATMENT CONTENT THAT CAN BE LINKED TO PROVIDERS AND RANKING SCALES REFLECTIVE OF COMMUNITY ACCEPTANCE; AND TO LOCATE SERVICE PROVIDERS, TRACK, MANAGE AND SHARE INFORMATION IN THE AREA OF PLASTIC SURGERY AND OTHER AESTHETIC TREATMENTS AND PROCEDURES (U.S. CLS. 21, 23, 26, 36 AND 38).

**CLASS 42—SCIENTIFIC AND COMPUTER SERVICES**

FOR PROVIDING AN INTERACTIVE WEBSITE FEATURING TECHNOLOGY THAT ALLOWS USERS TO CREATE PERSONAL PROFILES AND TO ACCESS CURATED AESTHETIC ARTICLES AND TRENDS BY PROVIDING NON-BIASED AESTHETIC TREATMENT CONTENT THAT CAN BE LINKED TO PROVIDERS AND RANKING SCALES REFLECTIVE OF COMMUNITY ACCEPTANCE; AND TO LOCATE SERVICE PROVIDERS, TRACK, MANAGE AND SHARE INFORMATION IN THE AREA OF PLASTIC SURGERY AND OTHER AESTHETIC TREATMENTS AND PROCEDURES (U.S. CLS. 100 AND 101).

WILLIAM BRECKENFELD, EXAMINING ATTORNEY

SN 86-248,403. IT MANAGEMENT, LLC, WOODLAND PARK, NJ. FILED 4-10-2014.

# TECHFOX

THE MARK CONSISTS OF STANDARD CHARACTERS WITHOUT CLAIM TO ANY PARTICULAR FONT, STYLE, SIZE, OR COLOR.

## CLASS 41—EDUCATION AND ENTERTAINMENT

FOR IT TRAINING SERVICES (U.S. CLS. 100, 101 AND 107).

## CLASS 42—SCIENTIFIC AND COMPUTER SERVICES

FOR COMPUTER SECURITY SERVICE, NAMELY, RESTRICTING ACCESS TO AND BY COMPUTER NETWORKS TO AND OF UNDESIRE WEB SITES, MEDIA AND INDIVIDUALS AND FACILITIES; COMPUTER SERVICES, NAMELY, REMOTE AND ON-SITE MANAGEMENT OF THE INFORMATION TECHNOLOGY (IT) SYSTEMS OF OTHERS; COMPUTER SERVICES, NAMELY, REMOTE MANAGEMENT OF COMPUTER NETWORKS, TECHNICAL MONITORING AND SOFTWARE MAINTENANCE FOR OTHERS; COMPUTER TECHNICAL SUPPORT SERVICES, NAMELY, 24/7 SERVICE DESK OR HELP DESK SERVICES FOR IT INFRASTRUCTURE, OPERATING SYSTEMS, DATABASE SYSTEMS, AND WEB APPLICATIONS; COMPUTER VIRUS PROTECTION SERVICES; CONSULTING SERVICES IN THE DESIGN AND IMPLEMENTATION OF COMPUTER-BASED INFORMATION SYSTEMS FOR BUSINESSES; DESIGNING WEBSITES FOR OTHERS; MANAGING WEB SITES FOR OTHERS; MONITORING OF COMPUTER SYSTEMS BY REMOTE ACCESS TO ENSURE PROPER FUNCTIONING; PROVIDING TEMPORARY USE OF NON-DOWNLOADABLE COMPUTER SOFTWARE FOR SHIPMENT PROCESSING OVER COMPUTER NETWORKS, COMPUTER SECURITY SERVICE, NAMELY, RESTRICTING ACCESS TO AND BY COMPUTER NETWORKS TO AND OF UNDESIRE WEB SITES, MEDIA AND INDIVIDUALS AND FACILITIES; COMPUTER SERVICES, NAMELY, REMOTE AND ON-SITE MANAGEMENT OF THE INFORMATION TECHNOLOGY (IT) SYSTEMS OF OTHERS; COMPUTER SERVICES, NAMELY, REMOTE MANAGEMENT OF COMPUTER NETWORKS, TECHNICAL MONITORING AND SOFTWARE MAINTENANCE FOR OTHERS; COMPUTER TECHNICAL SUPPORT SERVICES, NAMELY, 24/7 SERVICE DESK OR HELP DESK SERVICES FOR IT INFRASTRUCTURE, OPERATING SYSTEMS, DATABASE SYSTEMS, AND WEB APPLICATIONS; COMPUTER VIRUS PROTECTION SERVICES; CONSULTING SERVICES IN THE DESIGN AND IMPLEMENTATION OF COMPUTER-BASED INFORMATION SYSTEMS FOR BUSINESSES; DESIGNING WEBSITES FOR OTHERS; MANAGING WEB SITES FOR OTHERS; MONITORING OF COMPUTER SYSTEMS BY REMOTE ACCESS TO ENSURE PROPER FUNCTIONING; PROVIDING TEMPORARY USE OF NON-DOWNLOADABLE COMPUTER SOFTWARE FOR SHIPMENT PROCESSING OVER COMPUTER NETWORKS, INTRANETS AND THE INTERNET; TECHNICAL SUPPORT SERVICES, NAMELY, REMOTE AND ON-SITE INFRASTRUCTURE MANAGEMENT SERVICES FOR MONITORING, ADMINISTRATION AND MANAGEMENT OF PUBLIC AND PRIVATE CLOUD COMPUTING IT AND APPLICATION SYSTEMS; TECHNICAL SUPPORT SERVICES, NAMELY, TROUBLESHOOTING IN THE NATURE OF DIAGNOSING COMPUTER HARDWARE AND SOFTWARE PROBLEMS; UPDATING OF COMPUTER SOFTWARE RELATING TO COMPUTER SECURITY AND PREVENTION OF COMPUTER RISKS; WEBSITE DESIGN AND DEVELOPMENT FOR OTHERS; INTRANETS AND THE INTERNET; TECHNICAL SUPPORT SERVICES, NAMELY, REMOTE AND ON-SITE INFRA-

STRUCTURE MANAGEMENT SERVICES FOR MONITORING, ADMINISTRATION AND MANAGEMENT OF PUBLIC AND PRIVATE CLOUD COMPUTING IT AND APPLICATION SYSTEMS; TECHNICAL SUPPORT SERVICES, NAMELY, TROUBLESHOOTING IN THE NATURE OF DIAGNOSING COMPUTER HARDWARE AND SOFTWARE PROBLEMS; UPDATING OF COMPUTER SOFTWARE RELATING TO COMPUTER SECURITY AND PREVENTION OF COMPUTER RISKS; WEBSITE DESIGN AND DEVELOPMENT FOR OTHERS (U.S. CLS. 100 AND 101).

ANNE E. GUSTASON, EXAMINING ATTORNEY

SN 86-248,552. HOME RUN CONSULTANTS, WILMETTE, IL. FILED 4-10-2014.

# Theme My Run

THE MARK CONSISTS OF STANDARD CHARACTERS WITHOUT CLAIM TO ANY PARTICULAR FONT, STYLE, SIZE, OR COLOR.

## CLASS 35—ADVERTISING AND BUSINESS

FOR PROMOTING THE PARTIES AND SPECIAL EVENTS OF OTHERS (U.S. CLS. 100, 101 AND 102).

## CLASS 36—INSURANCE AND FINANCIAL

FOR CHARITABLE FUNDRAISING SERVICES BY MEANS OF ORGANIZING AND CONDUCTING SPECIAL EVENTS; CHARITABLE FUNDRAISING SERVICES BY MEANS OF RUNNING AND WALKING EVENTS (U.S. CLS. 100, 101 AND 102).

JOHN DALIER, EXAMINING ATTORNEY

SN 86-248,616. 4R SHORES, LLC, STUART, FL. FILED 4-10-2014.



THE COLOR(S) BLUE AND YELLOW IS/ARE CLAIMED AS A FEATURE OF THE MARK.

THE MARK CONSISTS OF THE NUMBER "4" APPEARING IN BLUE, THE LETTER "R" APPEARING IN BLUE, THE WORD "SHORES" APPEARING IN YELLOW WITH THE LETTER "O" IN THE SHAPE OF A YELLOW SUN WITH BLUE WATER BELOW THE SUN DESIGN.

## CLASS 16—PAPER GOODS AND PRINTED MATTER

FOR STICKERS (U.S. CLS. 2, 5, 22, 23, 29, 37, 38 AND 50).

FIRST USE 12-31-2012; IN COMMERCE 12-31-2012.

**CLASS 25—CLOTHING**

FOR HATS; SHIRTS (U.S. CLS. 22 AND 39).  
FIRST USE 3-30-2013; IN COMMERCE 3-30-2013.  
ELLEN B. AWRICH, EXAMINING ATTORNEY

SN 86-248,748. THERMO MANUFACTURING SYSTEMS,  
LLC, LINDALE, TX. FILED 4-10-2014.

SN 86-248,690, ND INDUSTRIES, INC., CLAWSON, MI.  
FILED 4-10-2014.

**DAM GOOD**

THE MARK CONSISTS OF STANDARD CHARACTERS  
WITHOUT CLAIM TO ANY PARTICULAR FONT, STYLE,  
SIZE, OR COLOR.  
OWNER OF U.S. REG. NO. 4,307,694.

**CLASS 1—CHEMICALS**

FOR ALL PURPOSE INDUSTRIAL GLUE (U.S. CLS. 1,  
5, 6, 10, 26 AND 46).  
FIRST USE 5-0-2010; IN COMMERCE 5-0-2010.

**CLASS 16—PAPER GOODS AND PRINTED  
MATTER**

FOR ALL PURPOSE HOUSEHOLD GLUE (U.S. CLS. 2,  
5, 22, 23, 29, 37, 38 AND 50).  
FIRST USE 5-0-2010; IN COMMERCE 5-0-2010.  
MORGAN WYNNE, EXAMINING ATTORNEY

SN 86-248,734. THERMO MANUFACTURING SYSTEMS,  
LLC, LINDALE, TX. FILED 4-10-2014.

**THERMOTHANE**

THE MARK CONSISTS OF STANDARD CHARACTERS  
WITHOUT CLAIM TO ANY PARTICULAR FONT, STYLE,  
SIZE, OR COLOR.

**CLASS 2—PAINTS**

FOR ROOFING MATERIALS, NAMELY, RUBBER  
AND ELASTOMERIC BASED SURFACE COATINGS  
(U.S. CLS. 6, 11 AND 16).

**CLASS 17—RUBBER GOODS**

FOR ROOFING MATERIALS, NAMELY, LIQUID AC-  
RYLIC AND URETHANE BASED SURFACE COATINGS  
(U.S. CLS. 1, 5, 12, 13, 35 AND 50).  
HOWARD SMIGA, EXAMINING ATTORNEY

**THERMOPOXY**

THE MARK CONSISTS OF STANDARD CHARACTERS  
WITHOUT CLAIM TO ANY PARTICULAR FONT, STYLE,  
SIZE, OR COLOR.

**CLASS 2—PAINTS**

FOR ROOFING MATERIALS, NAMELY, RUBBER  
AND ELASTOMERIC BASED SURFACE COATINGS  
(U.S. CLS. 6, 11 AND 16).

**CLASS 17—RUBBER GOODS**

FOR ROOFING MATERIALS, NAMELY, LIQUID AC-  
RYLIC AND URETHANE BASED SURFACE COATINGS  
(U.S. CLS. 1, 5, 12, 13, 35 AND 50).  
HOWARD SMIGA, EXAMINING ATTORNEY

SN 86-248,750. IDEA NUOVA, INC., NEW YORK, NY. FILED  
4-10-2014.

**Jump & Dream**

THE MARK CONSISTS OF STANDARD CHARACTERS  
WITHOUT CLAIM TO ANY PARTICULAR FONT, STYLE,  
SIZE, OR COLOR.

**CLASS 11—ENVIRONMENTAL CONTROL AP-  
PARATUS**

FOR ELECTRIC LAMPS; ELECTRIC NIGHT LIGHTS  
(U.S. CLS. 13, 21, 23, 31 AND 34).

**CLASS 16—PAPER GOODS AND PRINTED  
MATTER**

FOR ART PRINTS (U.S. CLS. 2, 5, 22, 23, 29, 37, 38 AND  
50).

**CLASS 20—FURNITURE AND ARTICLES NOT  
OTHERWISE CLASSIFIED**

FOR ACCENT PILLOWS; BEAN BAG CHAIRS;  
CHAIRS; OTTOMANS; SLUMBER BAGS (U.S. CLS. 2,  
13, 22, 25, 32 AND 50).

**CLASS 24—FABRICS**

FOR BED BLANKETS; BED SPREADS; BED TROWS;  
PILLOW SHAMS (U.S. CLS. 42 AND 50).  
WILLIAM VERHOSEK, EXAMINING ATTORNEY

SN 86-248,793. ROMAN AND WILLIAMS INC., NEW YORK, NY. FILED 4-10-2014.

SN 86-248,875. EXCELERIDE CYCLE & FITNESS LLC, WHITE PLAINS, NY. FILED 4-10-2014.

## ROMAN AND WILLIAMS

THE MARK CONSISTS OF STANDARD CHARACTERS WITHOUT CLAIM TO ANY PARTICULAR FONT, STYLE, SIZE, OR COLOR.

### **CLASS 20—FURNITURE AND ARTICLES NOT OTHERWISE CLASSIFIED**

FOR FURNITURE (U.S. CLS. 2, 13, 22, 25, 32 AND 50). FIRST USE 0-0-2012; IN COMMERCE 0-0-2012.

### **CLASS 35—ADVERTISING AND BUSINESS**

FOR BRANDING SERVICES, NAMELY, CONSULTING, DEVELOPMENT, MANAGEMENT AND MARKETING OF BRANDS FOR BUSINESSES AND/OR INDIVIDUALS (U.S. CLS. 100, 101 AND 102). FIRST USE 0-0-2010; IN COMMERCE 0-0-2010.

### **CLASS 42—SCIENTIFIC AND COMPUTER SERVICES**

FOR INTERIOR DESIGN; EXTERIOR FACADE AESTHETIC CONSULTANCY SERVICES; DESIGN OF SETS FOR MOTION PICTURES, VIDEOS, COMMERCIALS, AND MOVIE TRAILERS (U.S. CLS. 100 AND 101). FIRST USE 6-19-1998; IN COMMERCE 6-19-1998. ESTHER A. BORSUK, EXAMINING ATTORNEY

SN 86-248,857. HAUTE CAKETURE, HOUSTON, TX. FILED 4-10-2014.

## Caketure

THE MARK CONSISTS OF STANDARD CHARACTERS WITHOUT CLAIM TO ANY PARTICULAR FONT, STYLE, SIZE, OR COLOR.

### **CLASS 35—ADVERTISING AND BUSINESS**

FOR ONLINE RETAIL STORE SERVICES FEATURING APPAREL, STATIONERY, HOME GOODS, CALENDARS, AND BOOKS (U.S. CLS. 100, 101 AND 102). FIRST USE 5-1-2008; IN COMMERCE 5-1-2008.

### **CLASS 40—MATERIAL TREATMENT**

FOR CUSTOM CAKE DECORATING SERVICES (U.S. CLS. 100, 103 AND 106). FIRST USE 5-1-2008; IN COMMERCE 5-1-2008. STEPHANIE ALI, EXAMINING ATTORNEY

## Exceleride

THE MARK CONSISTS OF STANDARD CHARACTERS WITHOUT CLAIM TO ANY PARTICULAR FONT, STYLE, SIZE, OR COLOR.

### **CLASS 25—CLOTHING**

FOR ATHLETIC APPAREL, NAMELY, SHIRTS, PANTS, JACKETS, FOOTWEAR, HATS AND CAPS, ATHLETIC UNIFORMS (U.S. CLS. 22 AND 39). FIRST USE 11-13-2013; IN COMMERCE 2-1-2014.

### **CLASS 41—EDUCATION AND ENTERTAINMENT**

FOR PHYSICAL FITNESS INSTRUCTION; PROVIDING FITNESS AND EXERCISE FACILITIES; PROVIDING A WEBSITE FEATURING INFORMATION ON EXERCISE AND FITNESS; PROVIDING AN INTERACTIVE WEBSITE FEATURING INFORMATION AND LINKS RELATING TO FITNESS (U.S. CLS. 100, 101 AND 107). FIRST USE 11-13-2013; IN COMMERCE 2-1-2014. SANI KHOURI, EXAMINING ATTORNEY

SN 86-248,895. GIGGLING PAWS, VIRGINIA BEACH, VA. FILED 4-10-2014.

## Giggling paws

THE MARK CONSISTS OF STANDARD CHARACTERS WITHOUT CLAIM TO ANY PARTICULAR FONT, STYLE, SIZE, OR COLOR.

### **CLASS 9—ELECTRICAL AND SCIENTIFIC APPARATUS**

FOR COMPUTER APPLICATION SOFTWARE FOR MOBILE PHONES, NAMELY, SOFTWARE FOR THE STORAGE, MODIFICATION, SHARING, AND TRANSMISSION OF PHOTOGRAPHS (U.S. CLS. 21, 23, 26, 36 AND 38).

### **CLASS 42—SCIENTIFIC AND COMPUTER SERVICES**

FOR COMPUTER SERVICES, NAMELY, CREATING AN ON-LINE COMMUNITY FOR REGISTERED USERS TO SHARE PHOTOGRAPHS AND ENGAGE IN SOCIAL NETWORKING (U.S. CLS. 100 AND 101). RONALD MCMORROW, EXAMINING ATTORNEY

SN 86-248,937. COLDANI OLIVE RANCH, LLC, LODI, CA.  
FILED 4-10-2014.

SN 86-248,980. NTREEGE, LLC, SAN JUAN CAPISTRANO,  
CA. FILED 4-10-2014.



THE MARK CONSISTS OF THE FANCIFUL REPRESENTATION OF A VINE FEATURING A SINGLE LEAF.

**CLASS 29—MEATS AND PROCESSED FOODS**

FOR OLIVE OIL (U.S. CL. 46).  
FIRST USE 11-30-2009; IN COMMERCE 11-30-2009.

**CLASS 30—STAPLE FOODS**

FOR SPICES; VINEGAR (U.S. CL. 46).  
FIRST USE 11-30-2009; IN COMMERCE 11-30-2009.  
ANDREA CORNWELL, EXAMINING ATTORNEY

SN 86-248,942. FURNEX, LLC, NEW CANAAN, CT. FILED 4-10-2014.

**FURNEX**

THE MARK CONSISTS OF STANDARD CHARACTERS WITHOUT CLAIM TO ANY PARTICULAR FONT, STYLE, SIZE, OR COLOR.

**CLASS 35—ADVERTISING AND BUSINESS**

FOR OPERATING ON-LINE MARKETPLACES FOR SELLERS AND BUYERS OF GOODS AND/OR SERVICES (U.S. CLS. 100, 101 AND 102).

**CLASS 39—TRANSPORTATION AND STORAGE**

FOR TRANSPORT AND DELIVERY OF GOODS (U.S. CLS. 100 AND 105).  
COLLEEN MULCRONE, EXAMINING ATTORNEY

**nTrigue**

THE MARK CONSISTS OF STANDARD CHARACTERS WITHOUT CLAIM TO ANY PARTICULAR FONT, STYLE, SIZE, OR COLOR.

**CLASS 9—ELECTRICAL AND SCIENTIFIC APPARATUS**

FOR COMPUTER APPLICATION SOFTWARE FOR MOBILE PHONES, HANDHELD COMPUTERS AND OTHER WIRELESS ELECTRONIC DEVICES, NAMELY, SOFTWARE THAT ALLOWS USERS TO CREATE PERSONAL PROFILES AND TO ACCESS CURATED AESTHETIC ARTICLES AND TRENDS BY PROVIDING NON-BIASED AESTHETIC TREATMENT CONTENT THAT CAN BE LINKED TO PROVIDERS AND RANKING SCALES REFLECTIVE OF COMMUNITY ACCEPTANCE; AND TO LOCATE SERVICE PROVIDERS, TRACK, MANAGE AND SHARE INFORMATION IN THE AREA OF PLASTIC SURGERY AND OTHER AESTHETIC TREATMENTS AND PROCEDURES (U.S. CLS. 21, 23, 26, 36 AND 38).

**CLASS 42—SCIENTIFIC AND COMPUTER SERVICES**

FOR PROVIDING AN INTERACTIVE WEBSITE FEATURING TECHNOLOGY THAT ALLOWS USERS TO CREATE PERSONAL PROFILES AND TO ACCESS CURATED AESTHETIC ARTICLES AND TRENDS BY PROVIDING NON-BIASED AESTHETIC TREATMENT CONTENT THAT CAN BE LINKED TO PROVIDERS AND RANKING SCALES REFLECTIVE OF COMMUNITY ACCEPTANCE; AND TO LOCATE SERVICE PROVIDERS, TRACK, MANAGE AND SHARE INFORMATION IN THE AREA OF PLASTIC SURGERY AND OTHER AESTHETIC PROCEDURES (U.S. CLS. 100 AND 101).

WILLIAM BRECKENFELD, EXAMINING ATTORNEY

SN 86-249,025. EMMANUEL OGUNBIYI, CHICAGO, IL.  
FILED 4-10-2014.

**MAPWORDS**

THE MARK CONSISTS OF STANDARD CHARACTERS WITHOUT CLAIM TO ANY PARTICULAR FONT, STYLE, SIZE, OR COLOR.

**CLASS 35—ADVERTISING AND BUSINESS**

FOR ON-LINE ADVERTISING SERVICES FOR OTHERS (U.S. CLS. 100, 101 AND 102).

**CLASS 45—PERSONAL AND LEGAL SERVICES**

FOR INTERNET-BASED SOCIAL NETWORKING SERVICES (U.S. CLS. 100 AND 101).  
GINA HAYES, EXAMINING ATTORNEY

SN 86-249,191. XOVA LABS LLC, LOS ALTOS, CA. FILED 4-11-2014.

SN 86-249,268. PETRO HOLDINGS, INC., STAMFORD, CT. FILED 4-11-2014.

# XOVA

THE MARK CONSISTS OF STANDARD CHARACTERS WITHOUT CLAIM TO ANY PARTICULAR FONT, STYLE, SIZE, OR COLOR.

## CLASS 35—ADVERTISING AND BUSINESS

FOR BUSINESS DEVELOPMENT SERVICES, NAMELY, PROVIDING COMPANIES WITH START-UP SUPPORT SERVICES (U.S. CLS. 100, 101 AND 102).

## CLASS 36—INSURANCE AND FINANCIAL

FOR CAPITAL INVESTMENT SERVICES; EQUITY CAPITAL INVESTMENT; FINANCIAL AND INVESTMENT SERVICES, NAMELY, ASSET AND INVESTMENT ACQUISITION, CONSULTATION, ADVISORY AND DEVELOPMENT; FINANCIAL INVESTMENT IN THE FIELD OF TECHNOLOGY COMPANIES (U.S. CLS. 100, 101 AND 102).

ESTHER A. BORSUK, EXAMINING ATTORNEY

---

SN 86-249,240. FINLAYSON, JESSICA, TITUSVILLE, FL. FILED 4-11-2014.

CALLED TO BE PROSPEROUS

THE MARK CONSISTS OF STANDARD CHARACTERS WITHOUT CLAIM TO ANY PARTICULAR FONT, STYLE, SIZE, OR COLOR.

## CLASS 25—CLOTHING

FOR CLOTHING, NAMELY, HEADWEAR, FOOTWEAR, TOPS, BOTTOMS; CLOTHING, NAMELY, T-SHIRTS, SHIRTS, CARDIGANS, BLOUSES, COATS, JACKETS, PANTS, SKIRTS, DRESSES, HATS, SCARF, SUITS, SLEEPWEAR; DENIM CLOTHING, NAMELY, JEANS, SKIRTS, SHIRTS, HATS, SHORTS, DRESSES, TROUSERS, JACKETS AND COATS; LINEN CLOTHING, NAMELY, DRESSES, TROUSERS, JACKETS, SHIRTS, BLOUSES; KNIT WEAR, NAMELY, SWIMWEAR, BIKINIS, SWEATERS, HOODS, HOODED SWEATERS, WIND RESISTANT JACKETS, TANK TOPS, SLIPPERS, NECKWEAR; FOOTWEAR, NAMELY, FLIP FLOPS, SANDALS, DRESS SHOES, ATHLETIC SHOES, BOOTS, SNEAKERS (U.S. CLS. 22 AND 39).

## CLASS 35—ADVERTISING AND BUSINESS

FOR ON-LINE RETAIL STORE SERVICES FEATURING CLOTHING; ON-LINE RETAIL STORE SERVICES FEATURING DOWNLOADABLE PRE-RECORDED MUSIC AND VIDEO (U.S. CLS. 100, 101 AND 102).

CHRISTOPHER BUONGIORNO, EXAMINING ATTORNEY

# MAREX

THE MARK CONSISTS OF STANDARD CHARACTERS WITHOUT CLAIM TO ANY PARTICULAR FONT, STYLE, SIZE, OR COLOR.

## CLASS 37—CONSTRUCTION AND REPAIR

FOR INSTALLATION, MAINTENANCE AND REPAIR OF SECURITY ALARM SYSTEMS FOR RESIDENTIAL AND COMMERCIAL USE (U.S. CLS. 100, 103 AND 106).

## CLASS 45—PERSONAL AND LEGAL SERVICES

FOR ALARM RESPONSE AND MONITORING SERVICES (U.S. CLS. 100 AND 101).

HAI-LY LAM, EXAMINING ATTORNEY

---

SN 86-249,307. OGER SARL, PARIS, FRANCE, FILED 4-11-2014.

# HISTORIAE

THE MARK CONSISTS OF STANDARD CHARACTERS WITHOUT CLAIM TO ANY PARTICULAR FONT, STYLE, SIZE, OR COLOR.

OWNER OF FRANCE REG. NO. 103762559, DATED 8-27-2010, EXPIRES 8-27-2020.

## CLASS 3—COSMETICS AND CLEANING PREPARATIONS

FOR SOAPS, PERFUMERY, ESSENTIAL OILS, COSMETICS, HAIR LOTIONS, DENTIFRICES, DEPILATORY PREPARATIONS, MAKE-UP REMOVING PREPARATIONS, LIPSTICK, BEAUTY MASKS, SHAVING PREPARATIONS (U.S. CLS. 1, 4, 6, 50, 51 AND 52).

## CLASS 4—LUBRICANTS AND FUELS

FOR CANDLES, LIGHTING WICKS, GAS FOR LIGHTING (U.S. CLS. 1, 6 AND 15).

ANDREA K. NADELMAN, EXAMINING ATTORNEY



SN 86-249,523. GANART TECHNOLOGIES, INC., CARROLLTON, TX. FILED 4-11-2014.

## MONEY EARNED

THE MARK CONSISTS OF STANDARD CHARACTERS WITHOUT CLAIM TO ANY PARTICULAR FONT, STYLE, SIZE, OR COLOR.

### CLASS 9—ELECTRICAL AND SCIENTIFIC APPARATUS

FOR COMPUTER E-COMMERCE SOFTWARE IN THE NATURE OF A TRANSACTION ENGINE TO ALLOW USERS TO PERFORM ELECTRONIC BUSINESS TRANSACTIONS FOR THE ELECTRONIC TRANSFER AND DELIVERY OF FINANCIAL INSTRUMENTS VIA GLOBAL COMPUTER NETWORK AND/OR TELECOMMUNICATIONS NETWORK AND FOR THE DELIVERY OF FINANCIAL SERVICES VIA A GLOBAL COMPUTER NETWORK AND/OR TELECOMMUNICATIONS NETWORK AND TO ALLOW MANAGING THE AFORESAID ELECTRONIC BUSINESS TRANSACTIONS; NETWORK-CONNECTED APPARATUS FEATURING DISPLAY, INPUT AND OUTPUT DEVICES, NAMELY, SECURE TERMINALS, TABLET COMPUTERS, PERSONAL COMPUTERS, NOTEBOOK COMPUTERS, NETBOOK COMPUTERS AND HANDHELD WIRELESS COMMUNICATION DEVICES FOR ELECTRONIC TRANSACTIONS, NAMELY, THE ELECTRONIC TRANSFER AND DELIVERY OF FINANCIAL INSTRUMENTS OVER A COMPUTER NETWORK AND/OR TELECOMMUNICATIONS NETWORK AND FOR THE DELIVERY OF FINANCIAL SERVICES VIA A COMPUTER NETWORK AND/OR TELECOMMUNICATIONS NETWORK AND TO ALLOW MANAGING THE AFORESAID ELECTRONIC BUSINESS TRANSACTIONS; DOWNLOADABLE COMPUTER SOFTWARE PLATFORM, NAMELY, A SOFTWARE PLATFORM FOR VALUE EXCHANGE WHICH ALLOWS USERS TO ACCESS THE SERVICES OF THIRD PARTIES OVER A COMPUTER NETWORK AND/OR TELECOMMUNICATION NETWORK (U.S. CLS. 21, 23, 26, 36 AND 38).

FIRST USE 4-20-2011; IN COMMERCE 4-20-2011.

### CLASS 36—INSURANCE AND FINANCIAL

FOR BUSINESS SERVICES, NAMELY, ELECTRONIC TRANSFER OF FINANCIAL INSTRUMENTS, NAMELY, MONEY ORDERS AND WIRE TRANSFERS OF FUNDS; ELECTRONIC FUNDS TRANSFER, NAMELY, ELECTRONIC PROCESSING AND PAYMENT OF BILLS AND INVOICES AND ELECTRONIC TRANSFER OF MONEY, CONSULTATION SERVICES FOR ALL OF THE FOREGOING PROVIDED VIA A GLOBAL COMPUTER NETWORK, ELECTRONIC FUNDS TRANSFER (U.S. CLS. 100, 101 AND 102).

FIRST USE 9-7-2010; IN COMMERCE 9-7-2010.

RON FAIRBANKS, EXAMINING ATTORNEY

SN 86-249,684. NEXGEN RXMARKETING, LLC, BENSALLEM, PA. FILED 4-11-2014.

## SPEAKERDIRECT

THE MARK CONSISTS OF STANDARD CHARACTERS WITHOUT CLAIM TO ANY PARTICULAR FONT, STYLE, SIZE, OR COLOR.

### CLASS 9—ELECTRICAL AND SCIENTIFIC APPARATUS

FOR COMPUTER SOFTWARE FOR TRACKING DATA TO HELP GROW AND MANAGE A PORTFOLIO OF BRANDS AND AND CONDUCT RELATED BRAND DATA ANALYSIS AND PHARMACEUTICAL MARKETING AND SALES, WEB-BASED RECRUITING AND TRACKING OF THE HIRING PROCESS, INTEGRATION OF INTERNAL AND EXTERNAL RECRUITMENT SOURCES, STREAMLINING THE HIRING PROCESS, STREAMLINING MULTI-STAGE HIRING PROCESSES, TRACKING INTERVIEWS, DRUG SCREENINGS, AND BACKGROUND CHECKS, ORGANIZE AND OUTPUT CONTRACT COMPLIANCE REPORTING, INTEGRATING DATABASE SETS AND PERFORMANCE METRICS, CONSOLIDATE AND STREAMLINE THE TALENT MANAGEMENT PROCESS, INTEGRATION OF INTERNAL AND EXTERNAL HIRING FEEDS, CENTRALIZE HIRING DATA, FULL-SCALE HUMAN RESOURCES MANAGEMENT SYSTEMS, STREAM INFORMATION ABOUT APPROVAL, HIRING, EMPLOYMENT, AND OTHER HUMAN RESOURCES INFORMATION, ORGANIZATION OF PERSONNEL INFORMATION, TRACKING OF WORK PERFORMANCE, TRACKING OF EMPLOYEE TIME SHEETS, SURVEYING EMPLOYEE THERAPEUTIC CLASS SALES EXPERIENCE, AGGREGATING AND REPORTING SURVEY RESULTS, USE AS A ROLLOVER TOOL FOR CONTRACT SALES TEAMS AND DRAFTING, EDITING, SENDING AND RECEIVING E-MAIL AND WIRELESS E-MAIL AND FOR ANALYZING MARKET SHARE USING SPREADSHEETS AND CHARTS AS POPULATED BY INFORMATION IN THE DATABASE IN THE FIELD OF BRANDS AND CUSTOMERS, PROVIDING TARGETED SEGMENTATION TO FACILITATE STRATEGIC BRAND GROWTH AND FOR ANALYZING DATA AND RETURN ON INVESTMENT USING SPREADSHEETS AND CHARTS AS POPULATED BY INFORMATION IN DATABASE TO HELP ANALYZE AND TRACK CORPORATE PROMOTIONAL ACTIVITIES AND PROFITABILITY, IDENTIFY AND RECOMMEND BEST BUSINESS PRACTICES, AND TO HELP BUSINESSES AVOID COMMON PITFALLS AND INSTRUCTIONAL USER GUIDES SOLD AS A UNIT; COMPUTER SOFTWARE FOR TRACKING DATA TO HELP GROW AND MANAGE A PORTFOLIO OF BRANDS AND AND CONDUCT RELATED BRAND DATA ANALYSIS AND PHARMACEUTICAL MARKETING AND SALES, WEB-BASED RECRUITING AND TRACKING OF THE HIRING PROCESS, INTEGRATION OF INTERNAL AND EXTERNAL RECRUITMENT SOURCES, STREAMLINING THE HIRING PROCESS, STREAMLINING MULTI-STAGE HIRING PROCESSES, TRACKING INTERVIEWS, DRUG SCREENINGS, AND BACKGROUND CHECKS, ORGANIZE AND OUTPUT CONTRACT COMPLIANCE REPORTING, INTEGRATING DATABASE SETS AND PERFORMANCE METRICS, CONSOLIDATE AND STREAMLINE THE TALENT MANAGEMENT PROCESS, INTEGRATION OF INTERNAL AND EXTERNAL HIRING FEEDS, CENTRALIZE HIRING DATA, FULL-SCALE HUMAN RESOURCES MANAGEMENT SYSTEMS, STREAM INFORMATION ABOUT APPROVAL, HIRING, EMPLOYMENT, AND OTHER HUMAN RESOURCES INFORMATION, ORGANIZATION OF PERSONNEL INFORMATION, TRACKING OF WORK PERFORMANCE, TRACKING OF EMPLOYEE TIME SHEETS, SURVEYING EMPLOYEE THERAPEUTIC CLASS SALES EXPERIENCE, AGGREGATING AND REPORTING SURVEY RESULTS, USE AS A ROLLOVER TOOL FOR CONTRACT SALES TEAMS AND DRAFTING, EDITING, SENDING AND RECEIVING E-MAIL AND WIRELESS E-MAIL AND FOR ANALYZING MARKET SHARE USING SPREADSHEETS AND CHARTS AS POPULATED BY INFORMATION IN THE DATABASE IN THE FIELD OF BRANDS AND CUSTOMERS, PROVIDING TARGETED SEGMENTATION TO FACILITATE STRATEGIC BRAND GROWTH AND FOR ANALYZING DATA AND RETURN ON INVESTMENT USING SPREADSHEETS AND CHARTS AS POPULATED BY INFORMATION IN DATABASE TO HELP ANALYZE AND TRACK CORPORATE PROMOTIONAL ACTIVITIES AND PROFITABILITY, IDENTIFY AND RECOMMEND BEST BUSINESS PRACTICES, AND TO HELP BUSINESSES AVOID COMMON PITFALLS; COMPUTER SOFTWARE FOR TRACKING DATA TO HELP GROW AND MANAGE A PORTFOLIO OF BRANDS AND AND CONDUCT RELATED BRAND DATA ANALYSIS AND PHARMACEUTICAL MARKETING AND SALES, WEB-BASED RECRUITING AND



NIZATION OF PERSONNEL INFORMATION, TRACKING OF WORK PERFORMANCE, TRACKING OF EMPLOYEE TIME SHEETS, SURVEYING EMPLOYEE THERAPEUTIC CLASS SALES EXPERIENCE, AGGREGATING AND REPORTING SURVEY RESULTS, USE AS A ROLLOVER TOOL FOR CONTRACT SALES TEAMS AND DRAFTING, EDITING, SENDING AND RECEIVING E-MAIL AND WIRELESS E-MAIL AND FOR ANALYZING MARKET SHARE USING SPREADSHEETS AND CHARTS AS POPULATED BY INFORMATION IN THE DATABASE IN THE FIELD OF BRANDS AND CUSTOMERS, PROVIDING TARGETED SEGMENTATION TO FACILITATE STRATEGIC BRAND GROWTH AND FOR ANALYZING DATA AND RETURN ON INVESTMENT USING SPREADSHEETS AND CHARTS AS POPULATED BY INFORMATION IN DATABASE TO HELP ANALYZE AND TRACK CORPORATE PROMOTIONAL ACTIVITIES AND PROFITABILITY, IDENTIFY AND RECOMMEND BEST BUSINESS PRACTICES, AND TO HELP BUSINESSES AVOID COMMON PITFALLS; DOWNLOADABLE SOFTWARE IN THE NATURE OF A MOBILE APPLICATION FOR TRACKING DATA TO HELP GROW AND MANAGE A PORTFOLIO OF BRANDS AND AND CONDUCT RELATED BRAND DATA ANALYSIS AND PHARMACEUTICAL MARKETING AND SALES, WEB-BASED RECRUITING AND TRACKING OF THE HIRING PROCESS, INTEGRATION OF INTERNAL AND EXTERNAL RECRUITMENT SOURCES, STREAMLINING THE HIRING PROCESS, STREAMLINING MULTI-STAGE HIRING PROCESSES, TRACKING INTERVIEWS, DRUG SCREENINGS, AND BACKGROUND CHECKS, ORGANIZE AND OUTPUT CONTRACT COMPLIANCE REPORTING, INTEGRATING DATABASE SETS AND PERFORMANCE METRICS, CONSOLIDATE AND STREAMLINE THE TALENT MANAGEMENT PROCESS, INTEGRATION OF INTERNAL AND EXTERNAL HIRING FEEDS, CENTRALIZE HIRING DATA, FULL-SCALE HUMAN RESOURCES MANAGEMENT SYSTEMS, STREAM INFORMATION ABOUT APPROVAL, HIRING, EMPLOYMENT, AND OTHER HUMAN RESOURCES INFORMATION, ORGANIZATION OF PERSONNEL INFORMATION, TRACKING OF WORK PERFORMANCE, TRACKING OF EMPLOYEE TIME SHEETS, SURVEYING EMPLOYEE THERAPEUTIC CLASS SALES EXPERIENCE, AGGREGATING AND REPORTING SURVEY RESULTS, USE AS A ROLLOVER TOOL FOR CONTRACT SALES TEAMS AND DRAFTING, EDITING, SENDING AND RECEIVING E-MAIL AND WIRELESS E-MAIL AND FOR ANALYZING MARKET SHARE USING SPREADSHEETS AND CHARTS AS POPULATED BY INFORMATION IN THE DATABASE IN THE FIELD OF BRANDS AND CUSTOMERS, PROVIDING TARGETED SEGMENTATION TO FACILITATE STRATEGIC BRAND GROWTH AND FOR ANALYZING DATA AND RETURN ON INVESTMENT USING SPREADSHEETS AND CHARTS AS POPULATED BY INFORMATION IN DATABASE TO HELP ANALYZE AND TRACK CORPORATE PROMOTIONAL ACTIVITIES AND PROFITABILITY, IDENTIFY AND RECOMMEND BEST BUSINESS PRACTICES, AND TO HELP BUSINESSES AVOID COMMON PITFALLS (U.S. CLS. 21, 23, 26, 36 AND 38).

#### **CLASS 35—ADVERTISING AND BUSINESS**

FOR ADVERTISING AND ADVERTISEMENT SERVICES; ADVERTISING AND BUSINESS MANAGEMENT CONSULTANCY; ADVERTISING AND MARKETING; ADVERTISING AND MARKETING CONSULTANCY; ADVERTISING AND MARKETING SERVICES, NAMELY, PROMOTING THE GOODS AND SERVICES OF OTHERS; ADVERTISING SERVICES; ADVERTISING SERVICES IN THE FIELD OF PHARMACEUTICALS AND MEDICAL INDUSTRY PRODUCTS; ADVERTISING SERVICES, NAMELY, PROMOTING AND MARKETING THE GOODS AND SERVICES OF OTHERS IN THE FIELD OF PHARMACEUTICALS AND MEDICAL INDUSTRY PRODUCTS VIA PRINT AND ELECTRONIC MEDIA; ADVERTISING SERVICES, NAMELY, PROMOTING AND MARKETING THE GOODS AND SERVICES OF OTHERS THROUGH ALL PUBLIC COMMUNICATION MEANS; ADVERTISING, MARKETING AND PROMOTION SERVICES; ADVICE IN THE FIELD OF BUSINESS MANAGEMENT AND MARKETING; BRANDING SERVICES, NAMELY, CONSULTING, DEVELOPMENT, MANAGEMENT AND MARKETING OF BRANDS FOR BUSINESSES AND/OR INDIVIDUALS; BUSINESS MANAGEMENT CONSULTANCY AND AD-

VISORY SERVICES; BUSINESS MANAGEMENT CONSULTATION IN THE FIELD OF PHARMACEUTICALS AND MEDICAL INDUSTRY PRODUCTS; BUSINESS MANAGEMENT CONSULTING; BUSINESS MANAGEMENT CONSULTING AND ADVISORY SERVICES; BUSINESS MANAGEMENT CONSULTING AND ADVISORY SERVICES FOR THE PHARMACEUTICAL AND MEDICAL INDUSTRY; BUSINESS MANAGEMENT CONSULTING SERVICES IN THE FIELD OF PHARMACEUTICALS AND MEDICAL INDUSTRY PRODUCTS; BUSINESS MANAGEMENT CONSULTING WITH RELATION TO STRATEGY, MARKETING, PRODUCTION, PERSONNEL AND RETAIL SALE MATTERS; BUSINESS MANAGEMENT CONSULTING WITH RELATION TO STRATEGY, MARKETING, SALES, OPERATION, PRODUCT DESIGN PARTICULARLY SPECIALIZING IN THE USE OF ANALYTIC AND STATISTIC MODELS FOR THE UNDERSTANDING AND PREDICTING OF CONSUMERS, BUSINESSES, AND MARKET TRENDS AND ACTIONS; BUSINESS MARKETING CONSULTING SERVICES; BUSINESS TO BUSINESS DIRECT MARKETING SERVICES; CONSUMER MARKETING RESEARCH AND CONSULTING RELATED THERETO; DEVELOPMENT OF MARKETING STRATEGIES AND CONCEPTS; DIRECT MAIL ADVERTISING SERVICES; DIRECT MARKETING ADVERTISING FOR OTHERS; DIRECT MARKETING CONSULTING SERVICES; DIRECT MARKETING SERVICES; MARKETING AND BRANDING SERVICES, NAMELY, PROVIDING CUSTOMIZED COMMUNICATION PROGRAMS TO OBTAIN CONSUMER INSIGHTS AND DEVELOP BRANDING STRATEGIES; MARKETING CONSULTATION IN THE FIELD OF PHARMACEUTICALS AND MEDICAL INDUSTRY PRODUCTS; MARKETING CONSULTING; ON-LINE ADVERTISING AND MARKETING SERVICES; PROVIDING BUSINESS MARKETING INFORMATION; PROVIDING MARKETING CONSULTING IN THE FIELD OF SOCIAL MEDIA; PROVISION OF MARKETING REPORTS; SOCIAL MEDIA STRATEGY AND MARKETING CONSULTANCY FOCUSING ON HELPING CLIENTS CREATE AND EXTEND THEIR PRODUCT AND BRAND STRATEGIES BY BUILDING VIRALLY ENGAGING MARKETING SOLUTIONS; STATISTICAL EVALUATIONS OF MARKETING DATA (U.S. CLS. 100, 101 AND 102).

#### **CLASS 42—SCIENTIFIC AND COMPUTER SERVICES**

FOR COMPUTER SERVICES, NAMELY, ACTING AS AN APPLICATION SERVICE PROVIDER IN THE FIELD OF INFORMATION MANAGEMENT TO HOST COMPUTER APPLICATION SOFTWARE FOR THE PURPOSE OF HOSTING ON-LINE WEB FACILITIES FOR OTHERS FOR ORGANIZING AND CONDUCTING ONLINE MEETINGS, GATHERINGS, AND INTERACTIVE DISCUSSIONS; COMPUTER SERVICES, NAMELY, ACTING AS AN APPLICATION SERVICE PROVIDER IN THE FIELD OF KNOWLEDGE MANAGEMENT TO HOST COMPUTER APPLICATION SOFTWARE FOR THE PURPOSE OF HOSTING ON-LINE WEB FACILITIES FOR OTHERS FOR ORGANIZING AND CONDUCTING ONLINE MEETINGS, GATHERINGS, AND INTERACTIVE DISCUSSIONS; COMPUTER SERVICES, NAMELY, CREATING AN ON-LINE COMMUNITY FOR REGISTERED USERS TO ORGANIZE AND CONDUCT ON-LINE MEETINGS, GATHERINGS, AND INTERACTIVE DISCUSSIONS; COMPUTER SERVICES, NAMELY, CREATING AN ON-LINE VIRTUAL ENVIRONMENT FOR ORGANIZE AND CONDUCT ONLINE MEETINGS, GATHERINGS, AND INTERACTIVE DISCUSSIONS; CONSULTING SERVICES IN THE FIELD OF SOFTWARE AS A SERVICE (SAAS); PLATFORM AS A SERVICE (PAAS) FEATURING COMPUTER SOFTWARE PLATFORMS FOR TRACKING DATA TO HELP GROW AND MANAGE A PORTFOLIO OF BRANDS AND AND CONDUCT RELATED BRAND DATA ANALYSIS AND PHARMACEUTICAL MARKETING AND SALES, WEB-BASED RECRUITING AND TRACKING OF THE HIRING PROCESS, INTEGRATION OF INTERNAL AND EXTERNAL RECRUITMENT SOURCES, STREAMLINING THE HIRING PROCESS, STREAMLINING MULTI-STAGE HIRING PROCESSES, TRACKING INTERVIEWS, DRUG SCREENINGS, AND BACKGROUND CHECKS, ORGANIZE AND OUTPUT CONTRACT COMPLIANCE REPORTING, INTEGRATING DATABASE SETS AND PERFORMANCE METRICS, CONSOLIDATE AND STREAMLINE THE TALENT MANAGEMENT PROCESS,

INTEGRATION OF INTERNAL AND EXTERNAL HIRING FEEDS, CENTRALIZE HIRING DATA, FULL-SCALE HUMAN RESOURCES MANAGEMENT SYSTEMS, STREAM INFORMATION ABOUT APPROVAL, HIRING, EMPLOYMENT, AND OTHER HUMAN RESOURCES INFORMATION, ORGANIZATION OF PERSONNEL INFORMATION, TRACKING OF WORK PERFORMANCE, TRACKING OF EMPLOYEE TIME SHEETS, SURVEYING EMPLOYEE THERAPEUTIC CLASS SALES EXPERIENCE, AGGREGATING AND REPORTING SURVEY RESULTS, USE AS A ROLLOVER TOOL FOR CONTRACT SALES TEAMS AND DRAFTING, EDITING, SENDING AND RECEIVING E-MAIL AND WIRELESS E-MAIL AND FOR ANALYZING MARKET SHARE USING SPREADSHEETS AND CHARTS AS POPULATED BY INFORMATION IN THE DATABASE IN THE FIELD OF BRANDS AND CUSTOMERS, PROVIDING TARGETED SEGMENTATION TO FACILITATE STRATEGIC BRAND GROWTH AND FOR ANALYZING DATA AND RETURN ON INVESTMENT USING SPREADSHEETS AND CHARTS AS POPULATED BY INFORMATION IN DATABASE TO HELP ANALYZE AND TRACK CORPORATE PROMOTIONAL ACTIVITIES AND PROFITABILITY, IDENTIFY AND RECOMMEND BEST BUSINESS PRACTICES, AND TO HELP BUSINESSES AVOID COMMON PITFALLS; PROVIDING TEMPORARY USE OF ON-LINE NON-DOWNLOADABLE CLOUD COMPUTING SOFTWARE FOR TRACKING DATA TO HELP GROW AND MANAGE A PORTFOLIO OF BRANDS AND AND CONDUCT RELATED BRAND DATA ANALYSIS AND PHARMACEUTICAL MARKETING AND SALES, WEB-BASED RECRUITING AND TRACKING OF THE HIRING PROCESS, INTEGRATION OF INTERNAL AND EXTERNAL RECRUITMENT SOURCES, STREAMLINING THE HIRING PROCESS, STREAMLINING MULTI-STAGE HIRING PROCESSES, TRACKING INTERVIEWS, DRUG SCREENINGS, AND BACKGROUND CHECKS, ORGANIZE AND OUTPUT CONTRACT COMPLIANCE REPORTING, INTEGRATING DATABASE SETS AND PERFORMANCE METRICS, CONSOLIDATE AND STREAMLINE THE TALENT MANAGEMENT PROCESS, INTEGRATION OF INTERNAL AND EXTERNAL HIRING FEEDS, CENTRALIZE HIRING DATA, FULL-SCALE HUMAN RESOURCES MANAGEMENT SYSTEMS, STREAM INFORMATION ABOUT APPROVAL, HIRING, EMPLOYMENT, AND OTHER HUMAN RESOURCES INFORMATION, ORGANIZATION OF PERSONNEL INFORMATION, TRACKING OF WORK PERFORMANCE, TRACKING OF EMPLOYEE TIME SHEETS, SURVEYING EMPLOYEE THERAPEUTIC CLASS SALES EXPERIENCE, AGGREGATING AND REPORTING SURVEY RESULTS, USE AS A ROLLOVER TOOL FOR CONTRACT SALES TEAMS AND DRAFTING, EDITING, SENDING AND RECEIVING E-MAIL AND WIRELESS E-MAIL AND FOR ANALYZING MARKET SHARE USING SPREADSHEETS AND CHARTS AS POPULATED BY INFORMATION IN THE DATABASE IN THE FIELD OF BRANDS AND CUSTOMERS, PROVIDING TARGETED SEGMENTATION TO FACILITATE STRATEGIC BRAND GROWTH AND FOR ANALYZING DATA AND RETURN ON INVESTMENT USING SPREADSHEETS AND CHARTS AS POPULATED BY INFORMATION IN DATABASE TO HELP ANALYZE AND TRACK CORPORATE PROMOTIONAL ACTIVITIES AND PROFITABILITY, IDENTIFY AND RECOMMEND BEST BUSINESS PRACTICES, AND TO HELP BUSINESSES AVOID COMMON PITFALLS; SOFTWARE AS A SERVICE (SAAS) SERVICES FEATURING SOFTWARE FOR TRACKING DATA TO HELP GROW AND MANAGE A PORTFOLIO OF BRANDS AND AND CONDUCT RELATED BRAND DATA ANALYSIS AND PHARMACEUTICAL MARKETING AND SALES, WEB-BASED RECRUITING AND TRACKING OF THE HIRING PROCESS, INTEGRATION OF INTERNAL AND EXTERNAL RECRUITMENT SOURCES, STREAMLINING THE HIRING PROCESS, STREAMLINING MULTI-STAGE HIRING PROCESSES, TRACKING INTERVIEWS, DRUG SCREENINGS, AND BACKGROUND CHECKS, ORGANIZE AND OUTPUT CONTRACT COMPLIANCE REPORTING, INTEGRATING DATABASE SETS AND PERFORMANCE METRICS, CONSOLIDATE AND STREAMLINE THE TALENT MANAGEMENT PROCESS, INTEGRATION OF INTERNAL AND EXTERNAL HIRING FEEDS, CENTRALIZE HIRING DATA, FULL-SCALE HUMAN RESOURCES MANAGEMENT SYSTEMS, STREAM INFORMATION ABOUT APPROVAL, HIRING, EMPLOYMENT, AND OTHER HUMAN RESOURCES INFORMATION, ORGANIZATION OF PERSONNEL INFORMATION, TRACKING OF WORK PERFORMANCE, TRACKING OF EMPLOYEE TIME SHEETS, SURVEYING EMPLOYEE THERAPEUTIC CLASS SALES EXPERIENCE, AGGREGATING AND REPORTING SURVEY RESULTS, USE AS A ROLLOVER TOOL FOR CONTRACT SALES TEAMS AND DRAFTING, EDITING, SENDING AND RECEIVING E-MAIL AND WIRELESS E-MAIL AND FOR ANALYZING MARKET SHARE USING SPREADSHEETS AND CHARTS AS POPULATED BY INFORMATION IN THE DATABASE IN THE FIELD OF BRANDS AND CUSTOMERS, PROVIDING TARGETED SEGMENTATION TO FACILITATE STRATEGIC BRAND GROWTH AND FOR ANALYZING DATA AND RETURN ON INVESTMENT USING SPREADSHEETS AND CHARTS AS POPULATED BY INFORMATION IN DATABASE TO HELP ANALYZE AND TRACK CORPORATE PROMOTIONAL ACTIVITIES AND PROFITABILITY, IDENTIFY AND RECOMMEND BEST BUSINESS PRACTICES, AND TO HELP BUSINESSES AVOID COMMON PITFALLS (U.S. CLS. 100 AND 101).

SONNEL INFORMATION, TRACKING OF WORK PERFORMANCE, TRACKING OF EMPLOYEE TIME SHEETS, SURVEYING EMPLOYEE THERAPEUTIC CLASS SALES EXPERIENCE, AGGREGATING AND REPORTING SURVEY RESULTS, USE AS A ROLLOVER TOOL FOR CONTRACT SALES TEAMS AND DRAFTING, EDITING, SENDING AND RECEIVING E-MAIL AND WIRELESS E-MAIL AND FOR ANALYZING MARKET SHARE USING SPREADSHEETS AND CHARTS AS POPULATED BY INFORMATION IN THE DATABASE IN THE FIELD OF BRANDS AND CUSTOMERS, PROVIDING TARGETED SEGMENTATION TO FACILITATE STRATEGIC BRAND GROWTH AND FOR ANALYZING DATA AND RETURN ON INVESTMENT USING SPREADSHEETS AND CHARTS AS POPULATED BY INFORMATION IN DATABASE TO HELP ANALYZE AND TRACK CORPORATE PROMOTIONAL ACTIVITIES AND PROFITABILITY, IDENTIFY AND RECOMMEND BEST BUSINESS PRACTICES, AND TO HELP BUSINESSES AVOID COMMON PITFALLS; SOFTWARE AS A SERVICE (SAAS) SERVICES FEATURING SOFTWARE FOR TRACKING DATA TO HELP GROW AND MANAGE A PORTFOLIO OF BRANDS AND AND CONDUCT RELATED BRAND DATA ANALYSIS AND PHARMACEUTICAL MARKETING AND SALES, WEB-BASED RECRUITING AND TRACKING OF THE HIRING PROCESS, INTEGRATION OF INTERNAL AND EXTERNAL RECRUITMENT SOURCES, STREAMLINING THE HIRING PROCESS, STREAMLINING MULTI-STAGE HIRING PROCESSES, TRACKING INTERVIEWS, DRUG SCREENINGS, AND BACKGROUND CHECKS, ORGANIZE AND OUTPUT CONTRACT COMPLIANCE REPORTING, INTEGRATING DATABASE SETS AND PERFORMANCE METRICS, CONSOLIDATE AND STREAMLINE THE TALENT MANAGEMENT PROCESS, INTEGRATION OF INTERNAL AND EXTERNAL HIRING FEEDS, CENTRALIZE HIRING DATA, FULL-SCALE HUMAN RESOURCES MANAGEMENT SYSTEMS, STREAM INFORMATION ABOUT APPROVAL, HIRING, EMPLOYMENT, AND OTHER HUMAN RESOURCES INFORMATION, ORGANIZATION OF PERSONNEL INFORMATION, TRACKING OF WORK PERFORMANCE, TRACKING OF EMPLOYEE TIME SHEETS, SURVEYING EMPLOYEE THERAPEUTIC CLASS SALES EXPERIENCE, AGGREGATING AND REPORTING SURVEY RESULTS, USE AS A ROLLOVER TOOL FOR CONTRACT SALES TEAMS AND DRAFTING, EDITING, SENDING AND RECEIVING E-MAIL AND WIRELESS E-MAIL AND FOR ANALYZING MARKET SHARE USING SPREADSHEETS AND CHARTS AS POPULATED BY INFORMATION IN THE DATABASE IN THE FIELD OF BRANDS AND CUSTOMERS, PROVIDING TARGETED SEGMENTATION TO FACILITATE STRATEGIC BRAND GROWTH AND FOR ANALYZING DATA AND RETURN ON INVESTMENT USING SPREADSHEETS AND CHARTS AS POPULATED BY INFORMATION IN DATABASE TO HELP ANALYZE AND TRACK CORPORATE PROMOTIONAL ACTIVITIES AND PROFITABILITY, IDENTIFY AND RECOMMEND BEST BUSINESS PRACTICES, AND TO HELP BUSINESSES AVOID COMMON PITFALLS (U.S. CLS. 100 AND 101).

FRED CARL, EXAMINING ATTORNEY

SN 86-249,685. ROBBIE GOULD, NEW YORK, NY. FILED 4-11-2014.



THE NAME(S), PORTRAIT(S), AND/OR SIGNATURE(S) SHOWN IN THE MARK IDENTIFIES "ROBBIE GOULD", WHOSE CONSENT(S) TO REGISTER IS MADE OF RECORD.

THE MARK CONSISTS OF A DESIGN OF A FOOTBALL WITH A SMALL LINE AT THE TOP, THE NUMBER "9" IN THE MIDDLE AND A SMALL LINE AT THE BOTTOM WITHIN THE FOOTBALL AND THE WORDS "ROBBIE GOULD" UNDER THE FOOTBALL.

#### CLASS 24—FABRICS

FOR GOLF TOWELS (U.S. CLS. 42 AND 50).

#### CLASS 25—CLOTHING

FOR CLOTHING, NAMELY, T-SHIRTS, SWEAT-SHIRTS, HATS, SOCKS AND JACKETS (U.S. CLS. 22 AND 39).

#### CLASS 28—TOYS AND SPORTING GOODS

FOR GOLF BALLS AND GOLF CLUB COVERS (U.S. CLS. 22, 23, 38 AND 50).

#### CLASS 35—ADVERTISING AND BUSINESS

FOR ADVERTISING AND MARKETING SERVICES, NAMELY, PROMOTING THE GOODS AND SERVICES OF OTHERS (U.S. CLS. 100, 101 AND 102).

#### CLASS 41—EDUCATION AND ENTERTAINMENT

FOR ENTERTAINMENT SERVICES, NAMELY, PERSONAL APPEARANCES BY A FOOTBALL PLAYER (U.S. CLS. 100, 101 AND 107).

ALYSSA STEEL, EXAMINING ATTORNEY

SN 86-249,874. ANNIKKEN PTE. LTD., SINGAPORE, SINGAPORE, FILED 4-11-2014.

ANNIKKEN

THE MARK CONSISTS OF STANDARD CHARACTERS WITHOUT CLAIM TO ANY PARTICULAR FONT, STYLE, SIZE, OR COLOR.

#### CLASS 9—ELECTRICAL AND SCIENTIFIC APPARATUS

FOR CARDS AND MICROPROCESSORS FOR COMPUTERS; COMMUNICATIONS SOFTWARE FOR CONNECTING MOBILE DEVICES TO A GLOBAL COMPUTER NETWORK; COMPUTER APPLICATION SOFTWARE FOR MOBILE PHONES, NAMELY, SOFTWARE FOR USE IN WIRELESS MACHINE-TO-MACHINE COMMUNICATIONS; COMPUTER HARDWARE; COMPUTER HARDWARE AND SOFTWARE SYSTEMS FOR WIRELESS MACHINE-TO-MACHINE COMMUNICATIONS; COMPUTER HARDWARE FOR COMMUNICATING AUDIO, VIDEO AND DATA BETWEEN COMPUTERS VIA A GLOBAL COMPUTER NETWORK, WIDE-AREA COMPUTER NETWORKS, AND PEER-TO-PEER COMPUTER NETWORKS; COMPUTER OPERATING PROGRAMS; COMPUTER OPERATING SOFTWARE; COMPUTER OPERATING SYSTEMS; COMPUTER PROGRAMS FOR CONNECTING REMOTELY TO COMPUTERS OR COMPUTER NETWORKS; COMPUTER SOFTWARE FOR COMPUTER SYSTEM AND APPLICATION DEVELOPMENT, DEPLOYMENT AND MANAGEMENT; COMPUTER SOFTWARE FOR USE IN WIRELESS MACHINE-TO-MACHINE COMMUNICATIONS; COMPUTER SOFTWARE PLATFORMS FOR WIRELESS CONTENT DELIVERY AND MANAGING WIRELESS MACHINE-TO-MACHINE COMMUNICATIONS; COMPUTER SOFTWARE THAT PROVIDES WEB-BASED ACCESS TO APPLICATIONS AND SERVICES THROUGH A WEB OPERATING SYSTEM OR PORTAL INTERFACE; INTERFACES AND PERIPHERAL DEVICES FOR COMPUTERS; SOFTWARE FOR MONITORING AND CONTROLLING COMMUNICATION BETWEEN COMPUTERS AND AUTOMATED MACHINE SYSTEMS (U.S. CLS. 21, 23, 26, 36 AND 38).

FIRST USE 7-1-2013; IN COMMERCE 8-7-2013.

#### CLASS 42—SCIENTIFIC AND COMPUTER SERVICES

FOR APPLICATION SERVICE PROVIDER, NAMELY, HOSTING, MANAGING, DEVELOPING, ANALYZING, AND MAINTAINING APPLICATIONS, SOFTWARE AND WEB SITES OF OTHERS IN THE FIELDS OF WIRELESS COMMUNICATION, MOBILE INFORMATION ACCESS, AND REMOTE DATA MANAGEMENT FOR WIRELESS DELIVERY OF CONTENT TO HANDHELD COMPUTERS, LAPTOPS, AND MOBILE DEVICES; COMPUTER HARDWARE AND SOFTWARE DESIGN; COMPUTER PROGRAMMING SERVICES FOR OTHERS IN THE FIELD OF SOFTWARE CONFIGURATION MANAGEMENT; COMPUTER SOFTWARE DESIGN, COMPUTER PROGRAMMING, AND MAINTENANCE OF COMPUTER SOFTWARE; COMPUTER SOFTWARE DEVELOPMENT IN THE FIELD OF MOBILE APPLICATIONS; COMPUTER SYSTEMS INTEGRATION SERVICES; CONSULTING SERVICES IN THE FIELD OF DESIGN, SELECTION, IMPLEMENTATION AND USE OF COMPUTER HARDWARE AND SOFTWARE SYSTEMS FOR OTHERS; PROVIDING A WEBSITE FEATURING NON-DOWNLOADABLE SOFTWARE FOR IMPLEMENTING AND MANAGING WIRELESS COMMUNICATION; PROVIDING A WEBSITE THAT FEATURES TECHNOLOGY THAT ENABLES THE SECURE EXCHANGE OF INFORMATION BY USERS; PROVIDING AN INTERNET WEBSITE PORTAL IN THE FIELDS OF TECHNOLOGY AND SOFTWARE DEVELOPMENT; PROVIDING VIRTUAL COMPUTER SYSTEMS AND VIRTUAL COMPUTER ENVIRONMENTS THROUGH CLOUD COMPUTING; TECHNICAL SUPPORT SERVICES, NAMELY, TROUBLESHOOTING IN THE NATURE OF DIAGNOSING COMPUTER HARDWARE AND SOFTWARE PROBLEMS (U.S. CLS. 100 AND 101).

FIRST USE 7-1-2013; IN COMMERCE 8-7-2013.  
TEJBIR SINGH, EXAMINING ATTORNEY

SN 86-249,919. MERCURY ONE, INC., IRVING, TX. FILED 4-11-2014.

DOING MORE SO GOVERNMENT  
CAN DO LESS

THE MARK CONSISTS OF STANDARD CHARACTERS WITHOUT CLAIM TO ANY PARTICULAR FONT, STYLE, SIZE, OR COLOR.

**CLASS 35—ADVERTISING AND BUSINESS**

FOR CHARITABLE SERVICES, NAMELY, ORGANIZING AND CONDUCTING VOLUNTEER PROGRAMS AND COMMUNITY SERVICE PROJECTS (U.S. CLS. 100, 101 AND 102).

**CLASS 36—INSURANCE AND FINANCIAL**

FOR CHARITABLE FUNDRAISING (U.S. CLS. 100, 101 AND 102).  
DEBORAH MEINERS, EXAMINING ATTORNEY

SN 86-250,230. SUITE 2375 SEVEN, LLC, HOUSTON, TX. FILED 4-11-2014.

BrainPrep

THE MARK CONSISTS OF STANDARD CHARACTERS WITHOUT CLAIM TO ANY PARTICULAR FONT, STYLE, SIZE, OR COLOR.

**CLASS 9—ELECTRICAL AND SCIENTIFIC APPARATUS**

FOR COMPUTER SOFTWARE FEATURING MATERIALS FOR STANDARDIZED TEST PREPARATION, SCHOOL ADMISSIONS, NAMELY PRIVATE SECONDARY SCHOOL, UNDERGRADUATE AND GRADUATE SCHOOL SELECTION, ELECTRONIC APPLICATIONS, SCHOLARSHIPS AND FINANCIAL AID AND CAREERS, NAMELY INTEREST ASSESSMENT, JOB SEARCH, JOB PLANNING, JOB SELECTION AND CAREER DEVELOPMENT; COMPUTER APPLICATION SOFTWARE FOR MOBILE PHONES, NAMELY, SOFTWARE FOR STANDARDIZED TEST PREPARATION (U.S. CLS. 21, 23, 26, 36 AND 38).

**CLASS 16—PAPER GOODS AND PRINTED MATTER**

FOR PRINTED MATERIALS, NAMELY WORKBOOKS, TEXTBOOKS, AND INSTRUCTORS' GUIDES FOR STANDARDIZED TEST PREPARATION (U.S. CLS. 2, 5, 22, 23, 29, 37, 38 AND 50).

**CLASS 41—EDUCATION AND ENTERTAINMENT**

FOR EDUCATIONAL SERVICES, NAMELY, CONDUCTING LIVE AND ONLINE COURSES IN THE FIELD OF TEST PREPARATION, ADMISSIONS PREPARATION, AND CONTINUING EDUCATION, AND DISTRIBUTION OF EDUCATIONAL MATERIALS IN CONNECTION THEREWITH (U.S. CLS. 100, 101 AND 107).

**CLASS 42—SCIENTIFIC AND COMPUTER SERVICES**

FOR PROVIDING TEMPORARY USE OF ON-LINE, NON-DOWNLOADABLE COMPUTER SOFTWARE FOR STANDARDIZED TEST PREPARATION (U.S. CLS. 100 AND 101).  
SAMUEL E. SHARPER JR., EXAMINING ATTORNEY

SN 86-250,269. WAITS, COREY, ATLANTA, GA. FILED 4-11-2014.

**NOBRAINER**  
**INSTITUTE**  
Here to Help Elevate the Innovation of Artistry

THE MARK CONSISTS OF THE STYLIZED TEXT "NOBRAINER INSTITUTE" WITH A "NO" IN THE "O" AND "HERE TO HELP ELEVATE THE INNOVATION OF ARTISTRY" ON THE SECOND LINE.

**CLASS 16—PAPER GOODS AND PRINTED MATTER**

FOR ART PRINTS; ART PRINTS ON CANVAS; PAINTINGS; WORKS OF ART MADE OF PAPER (U.S. CLS. 2, 5, 22, 23, 29, 37, 38 AND 50).  
FIRST USE 3-24-2010; IN COMMERCE 3-24-2010.

**CLASS 25—CLOTHING**

FOR BELTS; HATS; HOODED SWEATSHIRTS; JACKETS; JEANS; PANTS; POLO SHIRTS; SCARVES; SKULLIES; SWEATSHIRTS; T-SHIRTS (U.S. CLS. 22 AND 39).  
FIRST USE 3-24-2010; IN COMMERCE 3-24-2010.  
KAPIL BHANOT, EXAMINING ATTORNEY

SN 86-250,289. MERCURY ONE, INC., IRVING, TX. FILED 4-11-2014.

IF WE WANT GOVERNMENT TO  
DO LESS, WE NEED TO DO MORE

THE MARK CONSISTS OF STANDARD CHARACTERS WITHOUT CLAIM TO ANY PARTICULAR FONT, STYLE, SIZE, OR COLOR.

**CLASS 35—ADVERTISING AND BUSINESS**

FOR CHARITABLE SERVICES, NAMELY, ORGANIZING AND CONDUCTING VOLUNTEER PROGRAMS AND COMMUNITY SERVICE PROJECTS (U.S. CLS. 100, 101 AND 102).

**CLASS 36—INSURANCE AND FINANCIAL**

FOR CHARITABLE FUNDRAISING (U.S. CLS. 100, 101 AND 102).  
DEBORAH MEINERS, EXAMINING ATTORNEY

SN 86-250,314. SUITED POKER GEAR, LLC, CAVE CREEK, AZ. FILED 4-11-2014.

SPG

THE MARK CONSISTS OF STANDARD CHARACTERS WITHOUT CLAIM TO ANY PARTICULAR FONT, STYLE, SIZE, OR COLOR.

**CLASS 18—LEATHER GOODS**

FOR BACKPACKS, BOOK BAGS, SPORTS BAGS, WALLETS, HANDBAGS, TRAVEL BAGS, BELT BAGS, DUFFEL BAGS, SLING BAGS AND SHOULDER BAGS (U.S. CLS. 1, 2, 3, 22 AND 41).

**CLASS 25—CLOTHING**

FOR CLOTHING, NAMELY, SHIRTS, PANTS, JACKETS, SWEATSHIRTS, HATS, VISORS AND CAPS (U.S. CLS. 22 AND 39).

GIANCARLO CASTRO, EXAMINING ATTORNEY

**CLASS 41—EDUCATION AND ENTERTAINMENT**

FOR ENTERTAINMENT SERVICES, NAMELY, A MULTIMEDIA PROGRAM SERIES FEATURING SUBJECTS OF GENERAL HUMAN INTEREST DISTRIBUTED VIA VARIOUS PLATFORMS ACROSS MULTIPLE FORMS OF TRANSMISSION MEDIA; ENTERTAINMENT SERVICES, NAMELY, AN ONGOING TELEVISION SERIES FEATURING SUBJECTS OF GENERAL HUMAN INTEREST; PROVIDING A WEBSITE FEATURING ENTERTAINMENT INFORMATION; ENTERTAINMENT SERVICES, NAMELY, OPERATING A REAL-TIME NON-DOWNLOADABLE GAME FOR OTHERS VIA THE INTERNET, MOBILE NETWORK PLATFORMS, AND LOCAL AREA COMPUTER NETWORKS; ELECTRONIC GAME SERVICES, NAMELY, PROVIDING ONLINE ELECTRONIC GAMES BY MEANS OF THE INTERNET, MOBILE NETWORK PLATFORMS, AND LOCAL AREA COMPUTER NETWORKS; ENTERTAINMENT SERVICES, NAMELY, PROVIDING TEMPORARY USE OF NON-DOWNLOADABLE INTERACTIVE GAMES (U.S. CLS. 100, 101 AND 107).

GIANCARLO CASTRO, EXAMINING ATTORNEY

SN 86-250,322. TREND NATION LLC, LAS VEGAS, NV. FILED 4-11-2014.

SN 86-250,316. A&E TELEVISION NETWORKS, LLC, NEW YORK, NY. FILED 4-11-2014.

PAWNOGRAPHY

THE MARK CONSISTS OF STANDARD CHARACTERS WITHOUT CLAIM TO ANY PARTICULAR FONT, STYLE, SIZE, OR COLOR.

**CLASS 9—ELECTRICAL AND SCIENTIFIC APPARATUS**

FOR MULTIMEDIA GOODS, NAMELY, PRERECORDED DIGITAL VIDEO DISCS AND DVDS FEATURING SUBJECTS OF GENERAL HUMAN INTEREST; DIGITAL MEDIA, NAMELY, DOWNLOADABLE AUDIO AND VIDEO FILES FEATURING SUBJECTS OF GENERAL HUMAN INTEREST; DOWNLOADABLE WEBCASTS AND PODCASTS FEATURING SUBJECTS OF GENERAL HUMAN INTEREST; DOWNLOADABLE GRAPHICS FOR WIRELESS DEVICES; DOWNLOADABLE ON-LINE DISCUSSION BOARD POSTS FEATURING SUBJECTS OF GENERAL HUMAN INTEREST; COMPUTER GAME SOFTWARE AND VIDEO GAME SOFTWARE; DOWNLOADABLE COMPUTER AND VIDEO GAME SOFTWARE VIA A GLOBAL COMPUTER NETWORK, MOBILE PLATFORMS, AND WIRELESS DEVICES FOR ENTERTAINMENT PURPOSES; DOWNLOADABLE MOBILE APPLICATIONS FOR GAMES (U.S. CLS. 21, 23, 26, 36 AND 38).

THE MARK CONSISTS OF STANDARD CHARACTERS WITHOUT CLAIM TO ANY PARTICULAR FONT, STYLE, SIZE, OR COLOR.

**CLASS 16—PAPER GOODS AND PRINTED MATTER**

FOR POSTERS; POSTERS MADE OF PAPER; UNMOUNTED POSTERS (U.S. CLS. 2, 5, 22, 23, 29, 37, 38 AND 50).

**CLASS 18—LEATHER GOODS**

FOR ALL-PURPOSE CARRYING BAGS; CANVAS SHOPPING BAGS; CARRY-ALL BAGS; DRAWSTRING BAGS; TOTE BAGS (U.S. CLS. 1, 2, 3, 22 AND 41).

**CLASS 25—CLOTHING**

FOR ATHLETIC SHIRTS; GRAPHIC T-SHIRTS; HOODED SWEAT SHIRTS; LONG-SLEEVED SHIRTS; NIGHT SHIRTS; SHIRTS; SHORT-SLEEVED OR LONG-SLEEVED T-SHIRTS; SHORT-SLEEVED SHIRTS; SLEEP SHIRTS; SNAP CROTCH SHIRTS FOR INFANTS AND TODDLERS; SPORT SHIRTS; SWEAT SHIRTS; T-SHIRTS; TEE SHIRTS (U.S. CLS. 22 AND 39).

GIANCARLO CASTRO, EXAMINING ATTORNEY

Printopoly

SN 86-250,363. SHIPE, KIM L, MESA, AZ. FILED 4-11-2014.

SN 86-250,386. BACKBONE ENTERTAINMENT, IRVINE, CA. FILED 4-11-2014.

uWrap

THE MARK CONSISTS OF STANDARD CHARACTERS WITHOUT CLAIM TO ANY PARTICULAR FONT, STYLE, SIZE, OR COLOR.

**CLASS 10—MEDICAL APPARATUS**

FOR COMPRESSION BANDAGES (U.S. CLS. 26, 39 AND 44).

**CLASS 41—EDUCATION AND ENTERTAINMENT**

FOR MEDICAL TRAINING AND TEACHING (U.S. CLS. 100, 101 AND 107).  
ZHALEH DELANEY, EXAMINING ATTORNEY

SN 86-250,375. KOSTALNICK, CATHERINE, LIVERMORE, CA. FILED 4-11-2014.

ALCHO-LETE

THE MARK CONSISTS OF STANDARD CHARACTERS WITHOUT CLAIM TO ANY PARTICULAR FONT, STYLE, SIZE, OR COLOR.

**CLASS 21—HOUSEWARES AND GLASS**

FOR BEER MUGS; MUGS; SHOT GLASSES; WINE GLASSES (U.S. CLS. 2, 13, 23, 29, 30, 33, 40 AND 50).

**CLASS 25—CLOTHING**

FOR HATS; HOODED SWEATSHIRTS; T-SHIRTS (U.S. CLS. 22 AND 39).  
ZHALEH DELANEY, EXAMINING ATTORNEY



OWNER OF U.S. REG. NOS. 3,480,068 AND 3,480,069.  
THE MARK CONSISTS OF THE WORD "PIPEWORKS" AND A COMET TAIL ENCIRCLING THE LETTER "P", UPRIGHT, AND THE LETTER "S", TURNED ON ITS SIDE.

**CLASS 9—ELECTRICAL AND SCIENTIFIC APPARATUS**

FOR HOME VIDEO GAME SOFTWARE AND RELATED PRODUCTS, NAMELY, VIDEO GAME CARTRIDGES, CD-ROM DISCS, AND DIGITAL VIDEO DISCS FEATURING VIDEO GAME PROGRAMS AND VIDEO GAME INSTRUCTION MANUALS ALL SOLD AS A UNIT THEREWITH; ELECTRONIC GAMES AND PLAYTHINGS, NAMELY, VIDEO GAME MACHINES FOR USE WITH EXTERNAL DISPLAY SCREEN OR MONITOR, PORTABLE VIDEO-GAME MACHINES FOR USE WITH EXTERNAL DISPLAY SCREEN OR MONITOR; VIDEO GAME SOFTWARE STORED ON VARIOUS MEDIA FOR USE IN CONNECTION WITH HOME COMPUTERS, LAPTOP COMPUTERS, AND NOTEBOOK COMPUTERS; CONSOLE GAME MACHINES USED IN CONJUNCTION WITH TELEVISION SETS; COMPUTER SOFTWARE FOR VIDEO GAMES THAT MAY BE DOWNLOADED FROM A GLOBAL COMPUTER NETWORK; AND ELECTRONIC GAME SOFTWARE USED IN CONNECTION WITH CELLULAR OR MOBILE TELEPHONES (U.S. CLS. 21, 23, 26, 36 AND 38).  
FIRST USE 1-15-2007; IN COMMERCE 1-15-2007.

**CLASS 28—TOYS AND SPORTING GOODS**

FOR ARCADE TYPE ELECTRONIC VIDEO GAMES; ELECTRONIC GAMES AND PLAYTHINGS, NAMELY, STAND ALONE VIDEO GAME MACHINES, PORTABLE VIDEO-GAME MACHINES IN THE NATURE OF HAND HELD UNITS FOR PLAYING ELECTRONIC GAMES (U.S. CLS. 22, 23, 38 AND 50).  
FIRST USE 1-15-2007; IN COMMERCE 1-15-2007.

**CLASS 42—SCIENTIFIC AND COMPUTER SERVICES**

FOR DESIGN, DEVELOPMENT AND MAINTENANCE OF COMPUTER SOFTWARE FOR OTHERS, NAMELY, DEVELOPMENT OF COMPUTER GAMES SOFTWARE FOR PERSONAL COMPUTERS, LAPTOP COMPUTERS, NOTEBOOK COMPUTERS, CELLULAR AND MOBILE TELEPHONES, PERSONAL ELECTRONIC DEVICES, AND CONSOLE GAME MACHINES USED IN CONJUNCTION WITH TELEVISION SETS AND VIDEO MONITORS (U.S. CLS. 100 AND 101).  
FIRST USE 1-15-2007; IN COMMERCE 1-15-2007.  
SUSAN STIGLITZ, EXAMINING ATTORNEY



SN 86-250,402. GHS INTERACTIVE SECURITY, LLC, SACRAMENTO, CA. FILED 4-11-2014.

**SAVING LIVES AND MAKING A DIFFERENCE**

THE MARK CONSISTS OF STANDARD CHARACTERS WITHOUT CLAIM TO ANY PARTICULAR FONT, STYLE, SIZE, OR COLOR.

**CLASS 37—CONSTRUCTION AND REPAIR**

FOR INSTALLATION AND MAINTENANCE OF HOME SECURITY AND ALARM SYSTEMS (U.S. CLS. 100, 103 AND 106).

**CLASS 45—PERSONAL AND LEGAL SERVICES**

FOR MONITORING HOME SECURITY AND ALARM SYSTEMS (U.S. CLS. 100 AND 101).  
DAVID ELTON, EXAMINING ATTORNEY

SN 86-250,463. JACKSON, CONSTANCE L., ROLLING HILLS ESTATES, CA. FILED 4-11-2014.

**ADVAITA**

THE MARK CONSISTS OF STANDARD CHARACTERS WITHOUT CLAIM TO ANY PARTICULAR FONT, STYLE, SIZE, OR COLOR.

**CLASS 9—ELECTRICAL AND SCIENTIFIC APPARATUS**

FOR COMPUTER APPLICATION SOFTWARE FOR MOBILE PHONES AND HANDHELD COMPUTERS, NAMELY, SOFTWARE FOR STORING AND ACCESSING MEDICAL RECORDS; COMPUTER APPLICATION SOFTWARE FOR MOBILE PHONES AND HANDHELD COMPUTERS, NAMELY, SOFTWARE ENABLING PATIENTS TO COMMUNICATE ELECTRONICALLY WITH MEDICAL SERVICE PROVIDERS AND FAMILY MEMBERS; COMPUTER APPLICATION SOFTWARE FOR MOBILE PHONES AND HANDHELD COMPUTERS, NAMELY, SOFTWARE FOR USE BY HEALTH CARE PROVIDERS IN PROVIDING INFORMATION ON MEDICAL CONDITIONS TO PATIENTS; COMPUTER APPLICATION SOFTWARE FOR MOBILE PHONES AND HANDHELD COMPUTERS, NAMELY, SOFTWARE FOR PATIENTS TO RECEIVE INSTRUCTIONS ON TREATING THEIR MEDICAL CONDITION AND INSTRUCTIONS ON THE MEDICATION THEY ARE TAKING; COMPUTER APPLICATION SOFTWARE FOR MOBILE PHONES AND HANDHELD COMPUTERS, NAMELY, SOFTWARE FOR MEDICAL PATIENTS TO TRACK GOALS RELATING TO THEIR CONDITION AND/OR DISEASE (U.S. CLS. 21, 23, 26, 36 AND 38).

**CLASS 42—SCIENTIFIC AND COMPUTER SERVICES**

FOR PROVIDING ON-LINE NON-DOWNLOADABLE SOFTWARE FOR STORING AND ACCESSING MEDICAL RECORDS; PROVIDING ONLINE NON-DOWNLOADABLE TELECOMMUNICATIONS SOFTWARE ENABLING PATIENTS TO COMMUNICATE ELECTRONICALLY WITH MEDICAL SERVICE PROVIDERS AND FAMILY MEMBERS; PROVIDING ON-LINE NON-DOWNLOADABLE COMMUNICATIONS SOFTWARE FOR USE BY HEALTH CARE PROVIDERS IN PROVIDING INFORMATION ON MEDICAL CONDITIONS TO THEIR PATIENTS; PROVIDING ON-LINE NON-DOWNLOADABLE COMMUNICATIONS SOFTWARE ENABLING PATIENTS TO RECEIVE INSTRUCTIONS ON TREATING THEIR MEDICAL CONDITION AND INSTRUCTIONS ON THE MEDICATION THEY ARE TAKING; PROVIDING ON-LINE NON-DOWNLOADABLE SOFTWARE FOR USE BY MEDICAL PATIENTS ON TRACKING GOALS RELATING TO THEIR CONDITION AND/OR DISEASE (U.S. CLS. 100 AND 101).  
JANICE L. MCMORROW, EXAMINING ATTORNEY

SN 86-250,540. LUCAS, JOSE, LABELLE, FL. FILED 4-12-2014.

**FLOPRIDE**

THE MARK CONSISTS OF STANDARD CHARACTERS WITHOUT CLAIM TO ANY PARTICULAR FONT, STYLE, SIZE, OR COLOR.

**CLASS 25—CLOTHING**

FOR CLOTHING NAMELY T-SHIRTS, SHIRTS, TOPS, SWEATERS, SWEATSHIRTS, HOODED SWEATSHIRTS; COATS, JERSEYS, JACKETS; BOTTOMS, PANTS, TROUSERS, JEANS, SHORTS, SWEATPANTS, PAJAMAS; DRESSES; SKIRTS; BLOUSES; UNDERWEAR; SWIMWEAR; HEADWEAR; FOOTWEAR; BELTS, TIES, GLOVES, SOCKS (U.S. CLS. 22 AND 39).

**CLASS 45—PERSONAL AND LEGAL SERVICES**

FOR ON-LINE SOCIAL NETWORKING SERVICES (U.S. CLS. 100 AND 101).  
ANNE E. GUSTASON, EXAMINING ATTORNEY

SN 86-251,590. UNITED PET GROUP, INC., CINCINNATI, OH. FILED 4-14-2014.

**NATURE'S MIRACLE**

THE MARK CONSISTS OF STANDARD CHARACTERS WITHOUT CLAIM TO ANY PARTICULAR FONT, STYLE, SIZE, OR COLOR.  
OWNER OF U.S. REG. NOS. 1,321,689, 2,727,180 AND 2,791,077.

**CLASS 18—LEATHER GOODS**

FOR ANIMAL CARRIERS (U.S. CLS. 1, 2, 3, 22 AND 41).  
FIRST USE 3-0-2011; IN COMMERCE 3-0-2011.

SN 86-251,742. CENTER FOR THE ADVANCEMENT OF PERIODONTICS, REGENERATION & IMPLANTS, LLC, ROBBINSVILLE, NJ. FILED 4-14-2014.

**CLASS 20—FURNITURE AND ARTICLES NOT OTHERWISE CLASSIFIED**

FOR PET CRATES AND PORTABLE PET BEDS (U.S. CLS. 2, 13, 22, 25, 32 AND 50).  
FIRST USE 3-0-2001; IN COMMERCE 3-0-2001.  
EDWARD NELSON, EXAMINING ATTORNEY

# LAPIMP

SN 86-251,655. EXECUTIVE FLIGHT SERVICES, INC., KANSAS CITY, MO. FILED 4-14-2014.

THE MARK CONSISTS OF STANDARD CHARACTERS WITHOUT CLAIM TO ANY PARTICULAR FONT, STYLE, SIZE, OR COLOR.

**CLASS 41—EDUCATION AND ENTERTAINMENT**

FOR EDUCATION SERVICES, NAMELY, PROVIDING MENTORING, TUTORING, CLASSES, SEMINARS AND WORKSHOPS IN THE FIELD OF LASER DENTAL IMPLANT PROCEDURES; TRAINING IN THE USE AND OPERATION OF LASERS FOR DENTAL IMPLANT PROCEDURES AND CONSULTATION RELATING THERETO (U.S. CLS. 100, 101 AND 107).

**CLASS 44—MEDICAL, BEAUTY AND AGRICULTURAL SERVICES**

FOR CONSULTING SERVICES IN THE FIELD OF MEDICAL CARE; MEDICAL ASSISTANCE CONSULTANCY PROVIDED BY DOCTORS AND OTHER SPECIALIZED MEDICAL PERSONNEL; MEDICAL SERVICES, NAMELY, ORAL SURGERY AND LASER DENTAL IMPLANT SERVICES; PROVIDING MEDICAL INFORMATION, CONSULTANCY AND ADVISORY SERVICES (U.S. CLS. 100 AND 101).  
AHSEN KHAN, EXAMINING ATTORNEY

THE MARK CONSISTS OF A SERIES OF VERTICAL AND HORIZONTAL LINES DEPICTING A WINGED OBJECT.

**CLASS 35—ADVERTISING AND BUSINESS**

FOR BUSINESS MANAGEMENT SERVICES, NAMELY, AIRCRAFT MANAGEMENT FOR OTHERS (U.S. CLS. 100, 101 AND 102).  
FIRST USE 8-20-2012; IN COMMERCE 8-20-2012.

SN 86-251,792. GBA MATTRESS, LLC, DBA GBA MATTRESS, MAPLE SHADE, NJ. FILED 4-14-2014.

**CLASS 36—INSURANCE AND FINANCIAL**

FOR AIRCRAFT BROKERAGE; AIRCRAFT FINANCING SERVICES; FORMATION, BROKERAGE AND MANAGEMENT OF TIME SHARE INTERESTS IN AIRCRAFT; OFFERING AIRCRAFT FRACTIONAL OWNERSHIP PROGRAMS TO OTHERS (U.S. CLS. 100, 101 AND 102).  
FIRST USE 8-20-2012; IN COMMERCE 8-20-2012.

# GBA MATTRESS

**CLASS 39—TRANSPORTATION AND STORAGE**

FOR LEASING OF AIRCRAFT; RENTAL OF AIRCRAFT; RENTAL OF AIRPLANES; TRANSPORT BY AIRCRAFT, NAMELY, USING PRIVATELY CHARTERED AIR TRANSPORT FOR EXECUTIVE CLASS TRAVELERS THE FOREGOING BEING LIMITED TO PRIVATE AIRCRAFT NOT INVOLVING SINGLE TICKET PURCHASERS (U.S. CLS. 100 AND 105).  
FIRST USE 8-20-2012; IN COMMERCE 8-20-2012.  
KEVIN DINALLO, EXAMINING ATTORNEY

THE MARK CONSISTS OF STANDARD CHARACTERS WITHOUT CLAIM TO ANY PARTICULAR FONT, STYLE, SIZE, OR COLOR.  
NO CLAIM IS MADE TO THE EXCLUSIVE RIGHT TO USE "MATTRESS", APART FROM THE MARK AS SHOWN.

**CLASS 20—FURNITURE AND ARTICLES NOT OTHERWISE CLASSIFIED**

FOR AIR MATTRESSES FOR USE WHEN CAMPING; BED BASES; BED FRAMES; BED HEADBOARDS; BED PILLOWS; BED RAILS; BED RESTS; BEDS, MATTRESSES, PILLOWS AND BOLSTERS; BOX SPRINGS; BUNK BEDS; FEATHER BEDS; FIBER BEDS; FOLDING BEDS; FUTON MATTRESSES; FUTONS; INFANT BEDS; INFLATABLE MATTRESSES FOR USE WHEN CAMPING; INFLATABLE PILLOWS; MATTRESS COMPONENT, NAMELY, ELASTIC GEL MATERIAL LOCATED IN THE TOP UPHOLSTERY LAYER OF MATTRESSES SOLD AS AN INTEGRAL COMPONENT OF THE MATTRESSES; MATTRESS CUSHIONS; MATTRESS FOUNDATIONS; MATTRESS TOPPERS; NON-METAL BED FITTINGS; PLASTIC FASTENERS FOR HOLDING BED SHEETS AND LINENS IN PLACE; RODS FOR BEDS; SLEEP PRODUCTS, NAMELY, MATTRESSES, SPRING MATTRESSES, BOX SPRINGS AND MATTRESS FOUNDATIONS; SLEEPER SOFAS; SOFA BEDS; SPRING MATTRESSES; WATER BEDS NOT FOR MEDICAL PURPOSES; WOODEN BEDS (U.S. CLS. 2, 13, 22, 25, 32 AND 50).

**CLASS 24—FABRICS**

FOR BABY BEDDING, NAMELY, BUNDLE BAGS, SWADDLING BLANKETS, CRIB BUMPERS, FITTED CRIB SHEETS, CRIB SKIRTS, CRIB BLANKETS, AND DIAPER CHANGING PAD COVERS NOT OF PAPER; BABY BLANKETS; BED BLANKETS; BED CANOPIES; BED COVERS; BED LINEN; BED PADS; BED SHEETS; BED SKIRTS; BED SPREADS; BED THROWS; BLANKET THROWS; CASHMERE BLANKETS; CHILDREN'S BED SHEETS, PILLOW CASES, AND BLANKETS; COMFORTERS; CRIB SHEETS; FITTED BED SHEETS; FLAT BED SHEETS; FLEECE BLANKETS; PILLOW CASES; PILLOW COVERS; PILLOW SHAMS; PILLOW-TOP, LOW-PROFILE BED SKIRTS; SHAMS; SHEET SETS; SILK BED BLANKETS; SWADDLING BLANKETS; TABLE AND BED LINEN; THROWS (U.S. CLS. 42 AND 50).

CHRISTINA SOBRAL, EXAMINING ATTORNEY

SN 86-251,875. A&E TELEVISION NETWORKS, LLC, NEW YORK, NY. FILED 4-14-2014.

**SONS OF LIBERTY**

THE MARK CONSISTS OF STANDARD CHARACTERS WITHOUT CLAIM TO ANY PARTICULAR FONT, STYLE, SIZE, OR COLOR.

**CLASS 9—ELECTRICAL AND SCIENTIFIC APPARATUS**

FOR MULTIMEDIA GOODS, NAMELY, PRERECORDED DIGITAL VIDEO DISCS AND DVDS ON THE TOPIC OF HISTORICAL EVENTS AND FIGURES DURING THE UNITED STATES REVOLUTIONARY WAR ERA; DIGITAL MEDIA, NAMELY, DOWNLOADABLE AUDIO AND VIDEO FILES ON THE TOPIC OF HISTORICAL EVENTS AND FIGURES AROUND THE UNITED STATES REVOLUTIONARY WAR ERA; DOWNLOADABLE WEBCASTS AND PODCASTS ON THE TOPIC OF HISTORICAL EVENTS AND FIGURES AROUND THE UNITED STATES REVOLUTIONARY WAR ERA (U.S. CLS. 21, 23, 26, 36 AND 38).

**CLASS 41—EDUCATION AND ENTERTAINMENT**

FOR ENTERTAINMENT SERVICES, NAMELY, A MULTIMEDIA PROGRAM SERIES ON THE TOPIC OF HISTORICAL EVENTS AND FIGURES DURING THE UNITED STATES REVOLUTIONARY WAR ERA; ENTERTAINMENT SERVICES, NAMELY, AN ONGOING TELEVISION SERIES ON THE TOPIC OF HISTORICAL EVENTS AND FIGURES DURING THE UNITED STATES REVOLUTIONARY WAR ERA (U.S. CLS. 100, 101 AND 107).

GIANCARLO CASTRO, EXAMINING ATTORNEY

SN 86-251,892. BODY BLU, A NATUROPATHIC PROFESSIONAL CORPORATION, CARDIFF BY THE SEA, CA. FILED 4-14-2014.



THE MARK CONSISTS OF THE STYLIZED IMAGE OF A FEMALE'S UPPER TORSO AND HEAD INSIDE A CIRCLE WITH HER LEFT ARM STRETCHED OUT AND HER HANDS IN THE FORM OF TWO LEAVES. BELOW THE TORSO A WAIVE COMES IN FROM THE RIGHT SIDE ATTACHED TO THE BREASTS OF THE FEMALE IMAGE WITH TWO LEAVES FORMING HER RIGHT ARM AND HAND.

**CLASS 25—CLOTHING**

FOR CLOTHING, NAMELY, HEADWEAR, FOOTWEAR, TOPS, BOTTOMS; CLOTHING, NAMELY, T-SHIRTS, SHIRTS, CARDIGANS, BLOUSES, BODY SUITS, COATS, JACKETS, PANTS, SKIRTS, DRESSES, BELTS, HATS, SCARF, GLOVES, KIMONOS, MUFFS, SUITS, TUNICS, WAISTCOATS, VESTS, SLEEPWEAR; DENIM CLOTHING, NAMELY, JEANS, SKIRTS, SHIRTS, HATS, SHORTS, DRESSES, TROUSERS, JACKETS AND COATS; SUEDE AND LEATHER CLOTHING, NAMELY, GLOVES, TROUSERS, SKIRTS, JACKETS, COATS, HATS, BELTS, SHIRTS, DRESSES, LINGERIE; LINEN CLOTHING, NAMELY, DRESSES, TROUSERS, JACKETS, SHIRTS, BLOUSES; KNIT WEAR, NAMELY, JERSEY AND HEAVY KNITWEAR; JUMPSUITS, SHORTS, SWEATSHIRTS, UNDERWEAR, PAJAMAS, LINGERIE, CORSETS, BRAS, BUSTIERS, BODY STOCKINGS, HOT PANTS, CAMISOLES, SUSPENDERS, CHEMISES, HOSIERY, THIGH HIGH STOCKINGS, GARTER BELTS, PANTYHOSE, LEGGINGS, TIGHTS, SOCKS, STOCKINGS, LONG JOHNS, SINGLET, SWIMWEAR, BIKINIS, SARONGS, PONCHOS, PULLOVERS, BANDANAS, POLO SHIRTS, FAKE FUR JACKETS AND COATS, SWEATERS, HOODS, ANORAKS, HOODED SWEATERS, WIND RESISTANT JACKETS, TANK TOPS, SLIPPERS, NECKWEAR, MITTENS, RAINWEAR, PARKAS, OVERALLS, JOGGING SUITS, SKIWEAR, MASQUERADE COSTUMES; FOOTWEAR, NAMELY, FLIP FLOPS, SANDALS, DRESS SHOES, ATHLETIC SHOES, BOOTS, SNEAKERS (U.S. CLS. 22 AND 39).

FIRST USE 1-2-2012; IN COMMERCE 1-2-2012.

**CLASS 35—ADVERTISING AND BUSINESS**

FOR RETAIL AND ONLINE RETAIL STORE SERVICES FEATURING GENERAL MERCHANDISE AND A WIDE VARIETY OF CONSUMER GOODS OF OTHERS; RETAIL AND ONLINE RETAIL STORE SERVICES FEATURING ESSENTIAL OILS, COSMETICS, FACIAL OILS, SKIN LOTIONS, FACE AND BODY LOTIONS, FRAGRANCES, SKIN OIL FRAGRANCES, PERFUME, ROOM FRAGRANCES, BATH OILS, BODY OILS, ESSENTIAL OILS, ESSENTIAL OIL DIFFUSERS, BODY WASHES, BODY SPRITZERS, PROBIOTIC COMPOSITIONS, VITAMINS, DIETARY SUPPLEMENTS, NEUTRACEUTICALS, MINERAL SUPPLEMENTS, SHAMPOO, CONDITIONER, SOAP, SKIN CLEANSERS, SKIN SCRUBS, SKIN TONING LOTION, EXFOLIANTS, SKIN THERAPY FACIAL MASKS, FACIAL SERUMS, EYE BALMS, LIP BALMS, ACNE CREAM, CUTICLE BALM, EYE CREAMS, SKIN TONING MACHINES, ELECTRIC POWERED SKIN CARE DEVICES, PHOTO-THERAPEUTIC DEVICES FOR SKIN CARE, SKIN BRUSH MACHINES, HAIR REMOVAL MACHINES, SKIN CLEANSING MACHINES, MICRODERM MACHINES, EYE AND LIP TONING MACHINES, SKIN PORE CLEANSING MACHINES, DERMA ROLLERS, FAN BRUSHES, SKIN LIGHT THERAPY MACHINES, EPILATOR MACHINES, PEDICURE DISCS, EXCLUDING CLOTHING, JEWELRY, AND HAND-BAGS (U.S. CLS. 100, 101 AND 102).

FIRST USE 1-2-2012; IN COMMERCE 1-2-2012.

MARGERY A. TIERNEY, EXAMINING ATTORNEY

---

SN 86-251,905. ANGEL SERVICE DOGS INC., DBA LIBERTY SERVICE DOGS, COLORADO SPRINGS, CO. FILED 4-14-2014.

**LIBERTY SERVICE DOGS**

THE MARK CONSISTS OF STANDARD CHARACTERS WITHOUT CLAIM TO ANY PARTICULAR FONT, STYLE, SIZE, OR COLOR.

OWNER OF U.S. REG. NOS. 3,996,126 AND 4,131,686.

NO CLAIM IS MADE TO THE EXCLUSIVE RIGHT TO USE "SERVICE DOGS", APART FROM THE MARK AS SHOWN.

**CLASS 31—NATURAL AGRICULTURAL PRODUCTS**

FOR DOGS (U.S. CLS. 1 AND 46).

**CLASS 41—EDUCATION AND ENTERTAINMENT**

FOR CHARITABLE SERVICES, NAMELY, PROVIDING TRAINING IN THE FIELD OF DOG TRAINING STANDARDS FOR SERVICE DOGS; DOG TRAINING; PROVIDING INFORMATION AND ADVICE IN THE FIELD OF PET TRAINING; TRAINING ANIMALS FOR OTHERS; TRAINING SERVICES IN THE FIELD OF DOG TRAINING STANDARDS FOR SERVICE DOGS (U.S. CLS. 100, 101 AND 107).

**CLASS 44—MEDICAL, BEAUTY AND AGRICULTURAL SERVICES**

FOR CHARITABLE SERVICES, NAMELY, PROVIDING TRAINED SERVICE DOGS TO DISABLED OR CHALLENGED PEOPLE (U.S. CLS. 100 AND 101).

MORGAN WYNNE, EXAMINING ATTORNEY

SN 86-251,936. WICK COMPANIES, L.L.C., WOODBRIDGE, NJ. FILED 4-14-2014.

**Wick**

THE MARK CONSISTS OF STANDARD CHARACTERS WITHOUT CLAIM TO ANY PARTICULAR FONT, STYLE, SIZE, OR COLOR.

**CLASS 36—INSURANCE AND FINANCIAL**

FOR REAL ESTATE SERVICES, NAMELY, RENTAL, BROKERAGE, LEASING AND MANAGEMENT OF COMMERCIAL PROPERTY, OFFICES AND OFFICE SPACE (U.S. CLS. 100, 101 AND 102).

FIRST USE 11-1-1960; IN COMMERCE 11-1-1960.

**CLASS 37—CONSTRUCTION AND REPAIR**

FOR REAL ESTATE DEVELOPMENT (U.S. CLS. 100, 103 AND 106).

FIRST USE 11-1-1960; IN COMMERCE 11-1-1960.

KEVIN CORWIN, EXAMINING ATTORNEY

---

SN 86-252,339. PEPSICO, INC., PURCHASE, NY. FILED 4-15-2014.

**WE'VE GOT YOUR BACK**

THE MARK CONSISTS OF STANDARD CHARACTERS WITHOUT CLAIM TO ANY PARTICULAR FONT, STYLE, SIZE, OR COLOR.

**CLASS 29—MEATS AND PROCESSED FOODS**

FOR DIPS; NUT-BASED SNACK FOODS; POTATO-BASED SNACK FOODS; PROCESSED EDIBLE SEEDS; PROCESSED NUTS; SOY-BASED SNACK FOODS (U.S. CL. 46).

**CLASS 30—STAPLE FOODS**

FOR CEREAL-BASED SNACK FOODS; COOKIES; CORN-BASED SNACK FOODS; CRACKERS; FLOUR-BASED CHIPS; GRAIN-BASED SNACK FOODS; GRANOLA; GRANOLA SNACKS; OATMEAL; PRETZELS; READY TO EAT, CEREAL DERIVED FOOD BARS; READY-TO-EAT CEREALS; RICE-BASED SNACK FOODS; SALSA; WHEAT-BASED SNACK FOODS (U.S. CL. 46).

**CLASS 32—LIGHT BEVERAGES**

FOR DRINKING WATER; ENERGY DRINKS; FRUIT JUICES; NON-ALCOHOLIC BEVERAGES CONTAINING FRUIT JUICES; SMOOTHIES; SOFT DRINKS; SPORTS DRINKS; VEGETABLE DRINKS; VEGETABLE JUICES (U.S. CLS. 45, 46 AND 48).

JENNIFER RICHARDSON, EXAMINING ATTORNEY

SN 86-252,432. ARKANSAS BEST CORPORATION, FORT SMITH, AR. FILED 4-15-2014.

### PANTHER PREMIUM LOGISTICS

THE MARK CONSISTS OF STANDARD CHARACTERS WITHOUT CLAIM TO ANY PARTICULAR FONT, STYLE, SIZE, OR COLOR.

OWNER OF U.S. REG. NOS. 4,075,485, 4,107,649 AND OTHERS.

NO CLAIM IS MADE TO THE EXCLUSIVE RIGHT TO USE "PREMIUM LOGISTICS", APART FROM THE MARK AS SHOWN.

### CLASS 35—ADVERTISING AND BUSINESS

FOR SUPPLY CHAIN MANAGEMENT SERVICES AND TRANSPORTATION MANAGEMENT OF DOMESTIC AND INTERNATIONAL SHIPMENTS; AND CONSULTATION AND LOGISTICAL SERVICES IN THE FIELD OF TRANSPORTATION MANAGEMENT, SHIPMENT PLANNING, ADMINISTRATION FOR FREIGHT BILL AUDITING, PAYMENT INVOICING AND REPORTING; PROVIDING ELECTRONIC TRACKING AND MONITORING OF FREIGHT INFORMATION TO OTHERS FOR BUSINESS ADMINISTRATION PURPOSES (U.S. CLS. 100, 101 AND 102).

### CLASS 39—TRANSPORTATION AND STORAGE

FOR PICK-UP, TRANSPORTATION, STORAGE AND DELIVERY OF DOCUMENTS, PACKAGES AND FREIGHT BY LAND, OCEAN AND AIR; LIFE SCIENCE LOGISTIC SERVICES, NAMELY, THE TRANSPORTATION OF BIOLOGICAL, MEDICAL AND PHARMACEUTICAL MATERIAL (U.S. CLS. 100 AND 105).

BRENDAN MCCAULEY, EXAMINING ATTORNEY

SN 86-252,546. BATH & BODY WORKS BRAND MANAGEMENT, INC., REYNOLDSBURG, OH. FILED 4-15-2014.

### CIDER CHEER

THE MARK CONSISTS OF STANDARD CHARACTERS WITHOUT CLAIM TO ANY PARTICULAR FONT, STYLE, SIZE, OR COLOR.

NO CLAIM IS MADE TO THE EXCLUSIVE RIGHT TO USE "CIDER", APART FROM THE MARK AS SHOWN.

### CLASS 3—COSMETICS AND CLEANING PREPARATIONS

FOR PERSONAL CARE PRODUCTS, NAMELY, ANTI-BACTERIAL SKIN SOAPS AND GELS, BATH GELS, BATH SOAPS IN LIQUID, SOLID OR GEL FORM, BODY BALM, NAMELY, BODY BUTTERS, BODY CREAMS, BODY LOTIONS, BODY POWDER, BODY SCRUB, BODY SPRAY USED AS A PERSONAL DEODORANT AND AS FRAGRANCE, BODY WASHES FOR HUMANS, BUBBLE BATH, COLOGNE, CREAM SOAPS FOR HANDS AND BODY, EAU DE PARFUM, EAU DE TOILETTE, EXFOLIANT CREAMS, FOAM BATH, FOOT SCRUB, HAND CREAMS, HAND LOTIONS, HAND SOAPS, LIP BALM, LIP CREAM, LIP GLOSS, LIP GLOSS PALETTE, MAKE-UP KITS COMPRISED OF LIP BALMS, LIP CREAMS, AND LIP GLOSSES, MASSAGE OILS, PERFUME, SCENTED BODY SPRAY, SHAVING PREPARATIONS, NAMELY, SHAVING CREAMS, SHAVING FOAMS, SHAVING GELS, AND SHAVING LOTIONS, SHOWER GELS; FRAGRANCE EMITTING WICKS FOR ROOM FRAGRANCE, FRAGRANCES FOR AUTOMOBILES, ROOM FRAGRANCES, ROOM FRAGRANCE REFILLS FOR ELECTRIC AND NON-ELECTRIC ROOM FRAGRANCE DISPENSERS, SCENTED LINEN SPRAYS, SCENTED OILS USED TO PRODUCE AROMAS WHEN HEATED, SCENTED ROOM SPRAYS, HOME FRAGRANCE OILS (U.S. CLS. 1, 4, 6, 50, 51 AND 52).

### CLASS 4—LUBRICANTS AND FUELS

FOR CANDLES (U.S. CLS. 1, 6 AND 15).  
ALLISON HOLTZ, EXAMINING ATTORNEY

SN 86-252,676. TRIANGLE FINANCIAL SERVICES, LLC, AVENTURA, FL. FILED 4-15-2014.

### MIAMI MIDNITES HOOPS FOR KIDS

THE MARK CONSISTS OF STANDARD CHARACTERS WITHOUT CLAIM TO ANY PARTICULAR FONT, STYLE, SIZE, OR COLOR.

NO CLAIM IS MADE TO THE EXCLUSIVE RIGHT TO USE "MIAMI" AND "HOOPS FOR KIDS", APART FROM THE MARK AS SHOWN.

### CLASS 36—INSURANCE AND FINANCIAL

FOR CHARITABLE FUND RAISING SERVICES FOR SENDING UNDERPRIVILEGED CHILDREN TO PROFESSIONAL BASKETBALL GAMES (U.S. CLS. 100, 101 AND 102).

### CLASS 41—EDUCATION AND ENTERTAINMENT

FOR CHARITABLE SERVICES, NAMELY, SENDING UNDERPRIVILEGED CHILDREN TO PROFESSIONAL BASKETBALL GAMES (U.S. CLS. 100, 101 AND 107).  
DOUGLAS LEE, EXAMINING ATTORNEY

SN 86-252,966. WARM WATER COMMUNICATIONS, INC., LEMONT, IL. FILED 4-15-2014.

SN 86-253,677. BOEHRINGER INGELHEIM VETMEDICA GMBH, INGELHEIM 55218, FED REP GERMANY, FILED 4-16-2014.

## What You Would Say

THE MARK CONSISTS OF STANDARD CHARACTERS WITHOUT CLAIM TO ANY PARTICULAR FONT, STYLE, SIZE, OR COLOR.

### **CLASS 9—ELECTRICAL AND SCIENTIFIC APPARATUS**

FOR DOWNLOADABLE MOBILE APPLICATIONS FOR ALLOWING USERS TO RESPOND TO PARTICULAR SITUATIONS AND QUESTIONS, WHICH PIQUE THEIR CURIOSITY (U.S. CLS. 21, 23, 26, 36 AND 38).

### **CLASS 42—SCIENTIFIC AND COMPUTER SERVICES**

FOR PROVIDING AN INTERACTIVE WEBSITE FEATURING TECHNOLOGY THAT ALLOWS USERS TO RESPOND TO PARTICULAR SITUATIONS AND QUESTIONS, WHICH PIQUE THEIR CURIOSITY (U.S. CLS. 100 AND 101).

MATTHEW GALAN, EXAMINING ATTORNEY

## FIXCOMBO

THE MARK CONSISTS OF STANDARD CHARACTERS WITHOUT CLAIM TO ANY PARTICULAR FONT, STYLE, SIZE, OR COLOR.

### **CLASS 5—PHARMACEUTICALS**

FOR VACCINES FOR SWINE (U.S. CLS. 6, 18, 44, 46, 51 AND 52).

### **CLASS 16—PAPER GOODS AND PRINTED MATTER**

FOR PRINTED MATTER, NAMELY, BOOKS, BROCHURES, PRESS RELEASES ALL IN THE FIELD OF VACCINES; INSTRUCTIONAL AND TEACHING MATERIALS, NAMELY, NEWSLETTERS AND INFORMATIONAL BROCHURES IN THE FIELD OF VETERINARY MEDICINE (U.S. CLS. 2, 5, 22, 23, 29, 37, 38 AND 50).

MAYUR VAGHANI, EXAMINING ATTORNEY

SN 86-253,360. MICROSOFT CORPORATION, REDMOND, WA. FILED 4-16-2014.

SN 86-254,328. MERCURY ONE, INC., IRVING, TX. FILED 4-16-2014.

## EDEN FALLS

THE MARK CONSISTS OF STANDARD CHARACTERS WITHOUT CLAIM TO ANY PARTICULAR FONT, STYLE, SIZE, OR COLOR.

PRIORITY CLAIMED UNDER SEC. 44(D) ON SOUTH AFRICA APPLICATION NO. 2013/35418, FILED 12-19-2013.

### **CLASS 9—ELECTRICAL AND SCIENTIFIC APPARATUS**

FOR GAME SOFTWARE (U.S. CLS. 21, 23, 26, 36 AND 38).

### **CLASS 41—EDUCATION AND ENTERTAINMENT**

FOR ENTERTAINMENT SERVICES, NAMELY, PROVIDING AN ON-LINE COMPUTER GAME (U.S. CLS. 100, 101 AND 107).

DOMINIC FATHY, EXAMINING ATTORNEY

## MERCURY ONE

THE MARK CONSISTS OF STANDARD CHARACTERS WITHOUT CLAIM TO ANY PARTICULAR FONT, STYLE, SIZE, OR COLOR.

### **CLASS 35—ADVERTISING AND BUSINESS**

FOR CHARITABLE SERVICES, NAMELY, ORGANIZING AND CONDUCTING VOLUNTEER PROGRAMS AND COMMUNITY SERVICE PROJECTS (U.S. CLS. 100, 101 AND 102).

FIRST USE 11-8-2011; IN COMMERCE 11-8-2011.

### **CLASS 36—INSURANCE AND FINANCIAL**

FOR CHARITABLE FUNDRAISING (U.S. CLS. 100, 101 AND 102).

FIRST USE 11-8-2011; IN COMMERCE 11-8-2011.  
DEBORAH MEINERS, EXAMINING ATTORNEY

SN 86-254,455. CARHARTT, INC., DEARBORN, MI. FILED 4-16-2014.

SN 86-255,062. EDIBLE ARRANGEMENTS, LLC, WALLINGFORD, CT. FILED 4-17-2014.

## BUILD YOUR OWN BEER

THE MARK CONSISTS OF STANDARD CHARACTERS WITHOUT CLAIM TO ANY PARTICULAR FONT, STYLE, SIZE, OR COLOR.

### CLASS 9—ELECTRICAL AND SCIENTIFIC APPARATUS

FOR FLAME RESISTANT SHIRTS, PANTS, JACKETS, COATS, BIB OVERALLS, SAFETY GLASSES (U.S. CLS. 21, 23, 26, 36 AND 38).

### CLASS 18—LEATHER GOODS

FOR DUFFLE BAGS, TOTE BAGS, WALLETS (U.S. CLS. 1, 2, 3, 22 AND 41).

### CLASS 25—CLOTHING

FOR SHIRTS, PANTS, JACKETS, COATS, BIB OVERALLS, FOOTWEAR, GLOVES, BELTS, SUSPENDERS AND SOCKS (U.S. CLS. 22 AND 39).

### CLASS 35—ADVERTISING AND BUSINESS

FOR RETAIL STORE SERVICES FEATURING CLOTHING, FOOTWEAR, HEADWEAR AND CLOTHING-RELATED ACCESSORIES; ONLINE RETAIL STORE SERVICES FEATURING CLOTHING, FOOTWEAR, HEADWEAR AND CLOTHING-RELATED ACCESSORIES (U.S. CLS. 100, 101 AND 102).  
MIAH ROSENBERG, EXAMINING ATTORNEY

SN 86-254,498. GOGI'S ADVENTURES LLC, DORAL, FL. FILED 4-17-2014.



THE MARK CONSISTS OF A SPEECH BALLOON WITH THE WORDS "GOGI'S ADVENTURES" WITH A DRAWING OF A MARTIAN DRESSED LIKE A SUPER HERO THAT HAS A G IN THE CHEST PORTION OF THE MARTIAN TO THE RIGHT OF THE SPEECH BALLOON.

### CLASS 25—CLOTHING

FOR CAPS; SANDALS; SHIRTS; SHORTS; SWEAT JACKETS; SWEAT PANTS; SWEAT SHIRTS; SWEATERS; T-SHIRTS (U.S. CLS. 22 AND 39).

### CLASS 28—TOYS AND SPORTING GOODS

FOR BENDABLE TOYS; FANTASY CHARACTER TOYS; STUFFED TOYS; TEDDY BEARS; TOY ACTION FIGURES; TOY ACTION FIGURES AND ACCESSORIES THEREFOR (U.S. CLS. 22, 23, 38 AND 50).  
DAVID TAYLOR, EXAMINING ATTORNEY

## EASTER BUNNY CELEBRATION

THE MARK CONSISTS OF STANDARD CHARACTERS WITHOUT CLAIM TO ANY PARTICULAR FONT, STYLE, SIZE, OR COLOR.

OWNER OF U.S. REG. NO. 3,542,903.  
NO CLAIM IS MADE TO THE EXCLUSIVE RIGHT TO USE "EASTER BUNNY", APART FROM THE MARK AS SHOWN.

### CLASS 29—MEATS AND PROCESSED FOODS

FOR FRESH FRUIT CUT INTO SHAPES AND ARRANGED IN CONTAINERS AS FLORAL DESIGNS; PROCESSED FRUITS; ARRANGEMENTS MADE OF PROCESSED FRUITS (U.S. CL. 46).  
FIRST USE 3-0-2013; IN COMMERCE 3-0-2013.

### CLASS 30—STAPLE FOODS

FOR FRESH FRUIT CUT INTO SHAPES AND COATED WITH CHOCOLATE; FRESH FRUIT CUT INTO SHAPES AND COATED WITH CHOCOLATE AND ARRANGED IN CONTAINERS AS FLORAL DESIGNS; PROCESSED FRUITS COATED WITH CHOCOLATE; ARRANGEMENTS MADE OF FRESH PROCESSED FRUIT COATED WITH CHOCOLATE (U.S. CL. 46).  
FIRST USE 3-0-2013; IN COMMERCE 3-0-2013.  
ANNE MADDEN, EXAMINING ATTORNEY

SN 86-257,344. MAJOR LEAGUE FISHING, LLC, TULSA, OK. FILED 4-21-2014.



OWNER OF U.S. REG. NO. 4,242,866.  
NO CLAIM IS MADE TO THE EXCLUSIVE RIGHT TO USE "FISHING" FOR INTERNATIONAL CLASS 25 AND "MAJOR LEAGUE FISHING" FOR INTERNATIONAL CLASS 41, APART FROM THE MARK AS SHOWN.

THE COLOR(S) RED, WHITE, GRAY AND BLACK IS/ARE CLAIMED AS A FEATURE OF THE MARK.

THE MARK CONSISTS OF THE LETTERS "MLF" IN WHITE AND GRAY ON A RED BACKGROUND AND THE WORDS "MAJOR LEAGUE FISHING" IN GRAY BELOW, ALL ENCASED IN A GRAY AND BLACK SHIELD, FIVE WHITE STARS AT THE TOP ENCASED IN A RED BACKGROUND, AND TWO GRAY CROSSED FISH HOOKS AT THE BOTTOM ENCASED IN A RED OVAL.

### CLASS 25—CLOTHING

FOR CLOTHING, NAMELY, SHIRTS, JACKETS, VESTS, HATS, WADERS (U.S. CLS. 22 AND 39).

**CLASS 41—EDUCATION AND ENTERTAINMENT**

FOR ENTERTAINMENT SERVICES, NAMELY, CONDUCTING FISHING TOURNAMENTS; A CONTINUING PROGRAM ABOUT FISHING ACCESSIBLE BY RADIO, TELEVISION, SATELLITE, AUDIO, VIDEO AND COMPUTER NETWORKS (U.S. CLS. 100, 101 AND 107).  
MICHAEL ENGEL, EXAMINING ATTORNEY

SN 86-257,370. JOHNSON & JOHNSON, NEW BRUNSWICK, NJ. FILED 4-21-2014.



OWNER OF U.S. REG. NOS. 2,863,261, 4,486,433 AND OTHERS.  
THE MARK CONSISTS OF A HUMAN FORM DANCING WITH A COW.

**CLASS 29—MEATS AND PROCESSED FOODS**

FOR RICOTTA CHEESE, CREAM CHEESE, SOUR CREAM, CONDENSED MILK; SOUP (U.S. CL. 46).

**CLASS 30—STAPLE FOODS**

FOR PIZZA, PUDDING; CHEESECAKE, SALAD DRESSING; MACARONI AND CHEESE; DESSERT MOUSSE; DAIRY BASED FROZEN NOVELTIES, NAMELY ICE CREAM AND FROZEN CAKES (U.S. CL. 46).  
MEREDITH MARESCA, EXAMINING ATTORNEY

SN 86-258,031. BATH & BODY WORKS BRAND MANAGEMENT, INC., REYNOLDSBURG, OH. FILED 4-21-2014.

**CIDER WONDERLAND**

THE MARK CONSISTS OF STANDARD CHARACTERS WITHOUT CLAIM TO ANY PARTICULAR FONT, STYLE, SIZE, OR COLOR.

NO CLAIM IS MADE TO THE EXCLUSIVE RIGHT TO USE "CIDER", APART FROM THE MARK AS SHOWN.

**CLASS 3—COSMETICS AND CLEANING PREPARATIONS**

FOR PERSONAL CARE PRODUCTS, NAMELY, ANTI-BACTERIAL SKIN SOAPS AND GELS, BATH GELS, BATH SOAPS IN LIQUID, SOLID OR GEL FORM, BODY BALM, NAMELY, BODY BUTTERS, BODY CREAMS, BODY LOTIONS, BODY POWDER, BODY SCRUB, BODY SPRAY USED AS A PERSONAL DEODORANT AND AS FRAGRANCE, BODY WASHES FOR HUMANS, BUBBLE BATH, COLOGNE, CREAM SOAPS FOR HANDS AND BODY, EAU DE PARFUM, EAU DE TOILETTE, EXFOLIANT CREAMS, FOAM BATH, FOOT SCRUB, HAND CREAMS, HAND LOTIONS, HAND SOAPS, LIP BALM, LIP CREAM, LIP GLOSS, LIP GLOSS PALETTE, MAKE-UP KITS COMPRISED OF LIP BALMS, LIP CREAMS, AND LIP GLOSSES, MASSAGE OILS, PERFUME, SCENTED BODY SPRAY, SHAVING PREPARATIONS, NAMELY, SHAVING CREAMS, SHAVING FOAMS, SHAVING GELS, AND SHAVING LOTIONS, SHOWER GELS; FRAGRANCE EMITTING WICKS FOR ROOM FRAGRANCE, FRAGRANCES FOR AUTOMOBILES, ROOM FRAGRANCES, ROOM FRAGRANCE REFILLS FOR ELECTRIC AND NON-ELECTRIC ROOM FRAGRANCE DISPENSERS, SCENTED LINEN SPRAYS, SCENTED OILS USED TO PRODUCE AROMAS WHEN HEATED, SCENTED ROOM SPRAYS, HOME FRAGRANCE OILS (U.S. CLS. 1, 4, 6, 50, 51 AND 52).

**CLASS 4—LUBRICANTS AND FUELS**

FOR CANDLES (U.S. CLS. 1, 6 AND 15).  
ALLISON HOLTZ, EXAMINING ATTORNEY

SN 86-258,685. RILEY, SUNDAY S, HOUSTON, TX. FILED 4-22-2014.

**Weekend Warrior**

THE MARK CONSISTS OF STANDARD CHARACTERS WITHOUT CLAIM TO ANY PARTICULAR FONT, STYLE, SIZE, OR COLOR.

**CLASS 3—COSMETICS AND CLEANING PREPARATIONS**

FOR BODY AND BEAUTY CARE COSMETICS; FACIAL MAKE-UP; NON-MEDICATED PREPARATIONS ALL FOR THE CARE OF SKIN, HAIR AND SCALP; SKIN MASKS; SKIN WHITENING PREPARATIONS; WIPES IMPREGNATED WITH A SKIN CLEANSER (U.S. CLS. 1, 4, 6, 50, 51 AND 52).

**CLASS 5—PHARMACEUTICALS**

FOR MEDICATED SKIN CARE PREPARATIONS, NAMELY, CREAMS, LOTIONS, GELS, TONERS, CLEANSERS AND PEELS (U.S. CLS. 6, 18, 44, 46, 51 AND 52).

**CLASS 21—HOUSEWARES AND GLASS**

FOR FACIAL BUFFING PADS; FACIAL CLEANSING SPONGES (U.S. CLS. 2, 13, 23, 29, 30, 33, 40 AND 50).

**CLASS 44—MEDICAL, BEAUTY AND AGRICULTURAL SERVICES**

FOR COSMETIC SKIN CARE SERVICES, NAMELY, FACIALS, PEELS, MICRODERMABRASION, ANTI-AGING TREATMENT, MAKEUP APPLICATION (U.S. CLS. 100 AND 101).

GIANCARLO CASTRO, EXAMINING ATTORNEY



SN 86-259,093. CUPRUM LXV AG, ZUG, SWITZERLAND,  
FILED 4-22-2014.

SN 86-259,740. FEEL LIFE BIOSCIENCE INTERNATIONAL  
CO., LIMITED, WANCHAI, HONG KONG, FILED 4-23-  
2014.

## SOLUTIONS FOR LIFE

THE MARK CONSISTS OF STANDARD CHARACTERS  
WITHOUT CLAIM TO ANY PARTICULAR FONT, STYLE,  
SIZE, OR COLOR.

NO CLAIM IS MADE TO THE EXCLUSIVE RIGHT TO  
USE "SOLUTIONS", APART FROM THE MARK AS  
SHOWN.

### CLASS 1—CHEMICALS

FOR NUTRIENT-BASED SOLUTIONS FOR APPLICA-  
TIONS IN MEDICINE AND LIFE SCIENCES RESEARCH  
WHICH REQUIRE THE SUPPORT OF LIFE-PROVIDING  
SYSTEMS IN CELLS, TISSUES AND ORGANS (U.S. CLS.  
1, 5, 6, 10, 26 AND 46).

### CLASS 5—PHARMACEUTICALS

FOR NUTRIENT-BASED SOLUTIONS FOR MEDICAL  
USE TO STORE AND TREAT CELLS, ISSUES, AND  
ORGANS, IN ORDER TO SUSTAIN LIFE-PROVIDING  
SYSTEMS CONTAINED THEREIN (U.S. CLS. 6, 18, 44, 46,  
51 AND 52).

AMY KELLY, EXAMINING ATTORNEY

SN 86-259,478. MERCURY ONE, INC., IRVING, TX. FILED 4-  
22-2014.

## MERCURY ONE MALICE TOWARDS NONE AND CHARITY FOR ALL

THE MARK CONSISTS OF STANDARD CHARACTERS  
WITHOUT CLAIM TO ANY PARTICULAR FONT, STYLE,  
SIZE, OR COLOR.

### CLASS 35—ADVERTISING AND BUSINESS

FOR CHARITABLE SERVICES, NAMELY, ORGANIZ-  
ING AND CONDUCTING VOLUNTEER PROGRAMS  
AND COMMUNITY SERVICE PROJECTS (U.S. CLS.  
100, 101 AND 102).

FIRST USE 11-8-2011; IN COMMERCE 11-8-2011.

### CLASS 36—INSURANCE AND FINANCIAL

FOR CHARITABLE FUNDRAISING (U.S. CLS. 100, 101  
AND 102).

FIRST USE 11-8-2011; IN COMMERCE 11-8-2011.  
DEBORAH MEINERS, EXAMINING ATTORNEY

# HANSMIX

THE MARK CONSISTS OF WORDING "HANSMIX" IN  
STYLIZED FONT.

THE WORDING "HANSMIX" HAS NO MEANING IN A  
FOREIGN LANGUAGE.

### CLASS 3—COSMETICS AND CLEANING PRE- PARATIONS

FOR AIR FRAGRANCING PREPARATIONS; BATH-  
ING LOTIONS; CAKES OF TOILET SOAP; CLEANING  
AND WASHING PREPARATIONS; CLEANING PRE-  
PARATIONS; COSMETICS; COSMETICS FOR ANIMALS;  
DENTIFRICES; ESSENTIAL OILS; FRAGRANCES AND  
PERFUMERY; HAIR LOTIONS; INCENSE; POLISHING  
PREPARATIONS; POLISHING, SCOURING AND ABRA-  
SIVE PREPARATIONS; WASHING POWDER (U.S. CLS.  
1, 4, 6, 50, 51 AND 52).

FIRST USE 1-7-2014; IN COMMERCE 1-7-2014.

### CLASS 34—SMOKERS' ARTICLES

FOR ASHTRAYS FOR SMOKERS; CHEWING TOBAC-  
CO; CIGARETTE CASES; CIGARETTE FILTERS; CI-  
GARETTE HOLDERS; CIGARETTES; CIGARETTES  
CONTAINING TOBACCO SUBSTITUTES NOT FOR  
MEDICAL PURPOSES; CIGARS; ELECTRIC CIGAR-  
ETTES; HERBS FOR SMOKING; LIGHTERS FOR SMO-  
KERS; MATCHES; TOBACCO; TOBACCO FILTERS;  
TOBACCO PIPES (U.S. CLS. 2, 8, 9 AND 17).

FIRST USE 1-7-2014; IN COMMERCE 1-7-2014.

KATHY DE JONGE, EXAMINING ATTORNEY

SN 86-260,543. MENARD, INC., EAU CLAIRE, WI. FILED 4-  
23-2014.

# FLORCRAFT

THE MARK CONSISTS OF STANDARD CHARACTERS  
WITHOUT CLAIM TO ANY PARTICULAR FONT, STYLE,  
SIZE, OR COLOR.

OWNER OF U.S. REG. NOS. 3,307,968, 3,790,626 AND  
OTHERS.

### CLASS 8—HAND TOOLS

FOR MANUALLY-OPERATED HAND TOOLS,  
NAMELY, TROWELS, FLOATS FOR GROUT, MORTAR  
OR CEMENT, TILE CUTTERS, CLAMPS, TAPPING  
BLOCKS USED FOR INSTALLATION OF WOOD AND  
LAMINATE FLOORING, AND PULL BARS USED TO  
PULL IN END PIECES AND TIGHTEN PIECES IN  
AREAS DIFFICULT TO REACH DURING INSTALLA-  
TION OF LAMINATE AND WOOD FLOORING (U.S.  
CLS. 23, 28 AND 44).

FIRST USE 7-1-2006; IN COMMERCE 7-1-2006.

**CLASS 17—RUBBER GOODS**

FOR ADHESIVE SEALANTS, CAULKING AND BUILDING SEALANTS FOR USE IN THE MAINTENANCE AND INSTALLATION OF FLOORING AND FLOOR COVERINGS (U.S. CLS. 1, 5, 12, 13, 35 AND 50).  
FIRST USE 7-1-2006; IN COMMERCE 7-1-2006.  
ELLEN B. AWRICH, EXAMINING ATTORNEY

SN 86-261,077. A&E TELEVISION NETWORKS, LLC, NEW YORK, NY. FILED 4-24-2014.

**PLEASE SAVE OUR DATE**

THE MARK CONSISTS OF STANDARD CHARACTERS WITHOUT CLAIM TO ANY PARTICULAR FONT, STYLE, SIZE, OR COLOR.

SN 86-260,547. GHC ND LICENSING, LTD., CASTRIES, ST.LUCIA, FILED 4-23-2014.

**GREENTECH**

THE MARK CONSISTS OF STANDARD CHARACTERS WITHOUT CLAIM TO ANY PARTICULAR FONT, STYLE, SIZE, OR COLOR.

**CLASS 5—PHARMACEUTICALS**

FOR DIETARY AND NUTRITIONAL SUPPLEMENTS; FUNGAL EXTRACTS SOLD AS A COMPONENT INGREDIENT OF NUTRITIONAL SUPPLEMENTS AND VITAMINS; MEDICINAL HERB EXTRACTS; NUTRACEUTICALS FOR USE AS A DIETARY SUPPLEMENT; NUTRITIONAL FOOD ADDITIVES FOR MEDICAL PURPOSES IN THE NATURE OF NATURAL FOOD EXTRACTS DERIVED FROM PLANTS, FUNGUS, AND MINERALS; PLANT EXTRACTS FOR MEDICAL, VETERINARY AND PHARMACEUTICAL PURPOSES; VITAMIN SUPPLEMENTS (U.S. CLS. 6, 18, 44, 46, 51 AND 52).

**CLASS 40—MATERIAL TREATMENT**

FOR BIOMANUFACTURING FOR OTHERS, NAMELY, MANUFACTURING OF DIETARY AND NUTRITIONAL SUPPLEMENTS USING BIOLOGICAL ORGANISMS IN THE MANUFACTURING PROCESS; CUSTOM MANUFACTURE OF DIETARY AND NUTRITIONAL SUPPLEMENTS; MANUFACTURE OF GENERAL PRODUCT LINES IN THE FIELD OF DIETARY AND NUTRITIONAL SUPPLEMENTS TO THE ORDER AND SPECIFICATION OF OTHERS (U.S. CLS. 100, 103 AND 106).

**CLASS 42—SCIENTIFIC AND COMPUTER SERVICES**

FOR PRODUCT DESIGN AND DEVELOPMENT IN THE FIELD OF DIETARY AND NUTRITIONAL SUPPLEMENTS; PRODUCT DEVELOPMENT AND ENGINEERING SERVICES FOR OTHERS IN THE FIELD OF DIETARY AND NUTRITIONAL SUPPLEMENTS (U.S. CLS. 100 AND 101).  
JEANIE LEE, EXAMINING ATTORNEY

**CLASS 9—ELECTRICAL AND SCIENTIFIC APPARATUS**

FOR MULTIMEDIA GOODS, NAMELY, PRERECORDED DIGITAL VIDEO DISCS AND DVDS FEATURING SUBJECTS OF GENERAL HUMAN INTEREST; DIGITAL MEDIA, NAMELY, DOWNLOADABLE AUDIO AND VIDEO FILES FEATURING SUBJECTS OF GENERAL HUMAN INTEREST; DOWNLOADABLE WEBCASTS AND PODCASTS FEATURING SUBJECTS OF GENERAL HUMAN INTEREST; DOWNLOADABLE GRAPHICS FOR WIRELESS DEVICES; DOWNLOADABLE ON-LINE DISCUSSION BOARD POSTS FEATURING SUBJECTS OF GENERAL HUMAN INTEREST; COMPUTER GAME SOFTWARE AND VIDEO GAME SOFTWARE; DOWNLOADABLE COMPUTER AND VIDEO GAME SOFTWARE VIA A GLOBAL COMPUTER NETWORK, MOBILE PLATFORMS, AND WIRELESS DEVICES FOR ENTERTAINMENT PURPOSES; DOWNLOADABLE MOBILE APPLICATIONS FOR GAMES (U.S. CLS. 21, 23, 26, 36 AND 38).

**CLASS 41—EDUCATION AND ENTERTAINMENT**

FOR ENTERTAINMENT SERVICES, NAMELY, A MULTIMEDIA PROGRAM SERIES FEATURING SUBJECTS OF GENERAL HUMAN INTEREST DISTRIBUTED VIA VARIOUS PLATFORMS ACROSS MULTIPLE FORMS OF TRANSMISSION MEDIA; ENTERTAINMENT SERVICES, NAMELY, AN ONGOING TELEVISION SERIES FEATURING SUBJECTS OF GENERAL HUMAN INTEREST; PROVIDING A WEBSITE FEATURING ENTERTAINMENT INFORMATION; ENTERTAINMENT SERVICES, NAMELY, OPERATING A REAL-TIME NON-DOWNLOADABLE GAME FOR OTHERS VIA THE INTERNET, MOBILE NETWORK PLATFORMS, AND LOCAL AREA COMPUTER NETWORKS; ELECTRONIC GAME SERVICES, NAMELY, PROVIDING ONLINE ELECTRONIC GAMES BY MEANS OF THE INTERNET, MOBILE NETWORK PLATFORMS, AND LOCAL AREA COMPUTER NETWORKS; ENTERTAINMENT SERVICES, NAMELY, PROVIDING TEMPORARY USE OF NON-DOWNLOADABLE INTERACTIVE GAMES (U.S. CLS. 100, 101 AND 107).  
GIANCARLO CASTRO, EXAMINING ATTORNEY

SN 86-261,079. A&E TELEVISION NETWORKS, LLC, NEW YORK, NY. FILED 4-24-2014.

**STITCH MASTERS**

THE MARK CONSISTS OF STANDARD CHARACTERS WITHOUT CLAIM TO ANY PARTICULAR FONT, STYLE, SIZE, OR COLOR.

**CLASS 9—ELECTRICAL AND SCIENTIFIC APPARATUS**

FOR MULTIMEDIA GOODS, NAMELY, PRERECORDED DIGITAL VIDEO DISCS AND DVDS FEATURING SUBJECTS OF GENERAL HUMAN INTEREST; DIGITAL MEDIA, NAMELY, DOWNLOADABLE AUDIO AND VIDEO FILES FEATURING SUBJECTS OF GENERAL HUMAN INTEREST; DOWNLOADABLE WEBCASTS AND PODCASTS FEATURING SUBJECTS OF GENERAL HUMAN INTEREST; DOWNLOADABLE GRAPHICS FOR WIRELESS DEVICES; DOWNLOADABLE ON-LINE DISCUSSION BOARD POSTS FEATURING SUBJECTS OF GENERAL HUMAN INTEREST; COMPUTER GAME SOFTWARE AND VIDEO GAME SOFTWARE; DOWNLOADABLE COMPUTER AND VIDEO GAME SOFTWARE VIA A GLOBAL COMPUTER NETWORK, MOBILE PLATFORMS, AND WIRELESS DEVICES FOR ENTERTAINMENT PURPOSES; DOWNLOADABLE MOBILE APPLICATIONS FOR GAMES (U.S. CLS. 21, 23, 26, 36 AND 38).

**CLASS 9—ELECTRICAL AND SCIENTIFIC APPARATUS**

FOR MULTIMEDIA GOODS, NAMELY, PRERECORDED DIGITAL VIDEO DISCS AND DVDS FEATURING SUBJECTS OF GENERAL HUMAN INTEREST; DIGITAL MEDIA, NAMELY, DOWNLOADABLE AUDIO AND VIDEO FILES FEATURING SUBJECTS OF GENERAL HUMAN INTEREST; DOWNLOADABLE WEBCASTS AND PODCASTS FEATURING SUBJECTS OF GENERAL HUMAN INTEREST; DOWNLOADABLE GRAPHICS FOR WIRELESS DEVICES; DOWNLOADABLE ON-LINE DISCUSSION BOARD POSTS FEATURING SUBJECTS OF GENERAL HUMAN INTEREST; COMPUTER GAME SOFTWARE AND VIDEO GAME SOFTWARE; DOWNLOADABLE COMPUTER AND VIDEO GAME SOFTWARE VIA A GLOBAL COMPUTER NETWORK, MOBILE PLATFORMS, AND WIRELESS DEVICES FOR ENTERTAINMENT PURPOSES; DOWNLOADABLE MOBILE APPLICATIONS FOR GAMES (U.S. CLS. 21, 23, 26, 36 AND 38).

**CLASS 41—EDUCATION AND ENTERTAINMENT**

FOR ENTERTAINMENT SERVICES, NAMELY, A MULTIMEDIA PROGRAM SERIES FEATURING SUBJECTS OF GENERAL HUMAN INTEREST DISTRIBUTED VIA VARIOUS PLATFORMS ACROSS MULTIPLE FORMS OF TRANSMISSION MEDIA; ENTERTAINMENT SERVICES, NAMELY, AN ONGOING TELEVISION SERIES FEATURING SUBJECTS OF GENERAL HUMAN INTEREST; PROVIDING A WEBSITE FEATURING ENTERTAINMENT INFORMATION; ENTERTAINMENT SERVICES, NAMELY, OPERATING A REAL-TIME NON-DOWNLOADABLE GAME FOR OTHERS VIA THE INTERNET, MOBILE NETWORK PLATFORMS, AND LOCAL AREA COMPUTER NETWORKS; ELECTRONIC GAME SERVICES, NAMELY, PROVIDING ONLINE ELECTRONIC GAMES BY MEANS OF THE INTERNET, MOBILE NETWORK PLATFORMS, AND LOCAL AREA COMPUTER NETWORKS; ENTERTAINMENT SERVICES, NAMELY, PROVIDING TEMPORARY USE OF NON-DOWNLOADABLE INTERACTIVE GAMES (U.S. CLS. 100, 101 AND 107).  
GIANCARLO CASTRO, EXAMINING ATTORNEY

**CLASS 41—EDUCATION AND ENTERTAINMENT**

FOR ENTERTAINMENT SERVICES, NAMELY, A MULTIMEDIA PROGRAM SERIES FEATURING SUBJECTS OF GENERAL HUMAN INTEREST DISTRIBUTED VIA VARIOUS PLATFORMS ACROSS MULTIPLE FORMS OF TRANSMISSION MEDIA; ENTERTAINMENT SERVICES, NAMELY, AN ONGOING TELEVISION SERIES FEATURING SUBJECTS OF GENERAL HUMAN INTEREST; PROVIDING A WEBSITE FEATURING ENTERTAINMENT INFORMATION; ENTERTAINMENT SERVICES, NAMELY, OPERATING A REAL-TIME NON-DOWNLOADABLE GAME FOR OTHERS VIA THE INTERNET, MOBILE NETWORK PLATFORMS, AND LOCAL AREA COMPUTER NETWORKS; ELECTRONIC GAME SERVICES, NAMELY, PROVIDING ONLINE ELECTRONIC GAMES BY MEANS OF THE INTERNET, MOBILE NETWORK PLATFORMS, AND LOCAL AREA COMPUTER NETWORKS; ENTERTAINMENT SERVICES, NAMELY, PROVIDING TEMPORARY USE OF NON-DOWNLOADABLE INTERACTIVE GAMES (U.S. CLS. 100, 101 AND 107).  
GIANCARLO CASTRO, EXAMINING ATTORNEY

SN 86-261,134. A&E TELEVISION NETWORKS, LLC, NEW YORK, NY. FILED 4-24-2014.

SN 86-261,381. AMAZON TECHNOLOGIES, INC., RENO, NV. FILED 4-24-2014.

**MY CITY'S JUST NOT THAT INTO ME**

THE MARK CONSISTS OF STANDARD CHARACTERS WITHOUT CLAIM TO ANY PARTICULAR FONT, STYLE, SIZE, OR COLOR.

**AMAZON FASHION**

THE MARK CONSISTS OF STANDARD CHARACTERS WITHOUT CLAIM TO ANY PARTICULAR FONT, STYLE, SIZE, OR COLOR.  
OWNER OF U.S. REG. NOS. 2,078,496, 2,884,547 AND OTHERS.  
NO CLAIM IS MADE TO THE EXCLUSIVE RIGHT TO USE "FASHION", APART FROM THE MARK AS SHOWN.

**CLASS 35—ADVERTISING AND BUSINESS**

FOR PROVIDING ONLINE RETAIL STORE SERVICES IN THE FIELD OF CLOTHING, CLOTHING ACCESSORIES, HEADGEAR, JEWELRY AND FOOTWEAR; ADVERTISING AND PROMOTIONAL SERVICES; ADVERTISING AND MARKETING SERVICES, NAMELY, PROMOTING THE GOODS OF OTHERS IN THE NATURE OF CLOTHING, CLOTHING ACCESSORIES, JEWELRY AND FOOTWEAR; ELECTRONIC COMMERCE SERVICES, NAMELY, PROVIDING INFORMATION ABOUT CLOTHING, CLOTHING ACCESSORIES, JEWELRY AND FOOTWEAR VIA TELECOMMUNICATION NETWORKS FOR ADVERTISING AND SALES PURPOSES; PROVIDING AN ONLINE SEARCHABLE DATABASE FEATURING PRODUCT INFORMATION ABOUT THE GOODS OF OTHERS FOR THE PURPOSE OF SELECTING, REVIEWING AND CATEGORIZING CLOTHING, CLOTHING ACCESSORIES, JEWELRY AND FOOTWEAR TO MEET CONSUMER'S SPECIFICATIONS (U.S. CLS. 100, 101 AND 102).

FIRST USE 12-31-2013; IN COMMERCE 12-31-2013.

**CLASS 45—PERSONAL AND LEGAL SERVICES**

FOR PROVIDING NEWS AND INFORMATION IN THE FIELD OF FASHION INCLUDING TEXT, VIDEO, AUDIO AND IMAGES IN THE FIELD OF FASHION; PROVIDING A WEBSITE FEATURING INFORMATION ON FASHION INCLUDING REVIEWS AND COMMENTARY ON FASHION; ONLINE SOCIAL NETWORKING SERVICES; PROVIDING SOCIAL NETWORKING SERVICES FOR PURPOSES OF COMMENTARY, COMPARISON, COLLABORATION, CONSULTATION, ADVICE, DISCUSSION, RESEARCH, INFORMATION SHARING, INDEXING, INFORMATION LOCATION, ENTERTAINMENT, ALL RELATED TO FASHION, PROVIDED VIA A WEBSITE (U.S. CLS. 100 AND 101).

FIRST USE 12-31-2013; IN COMMERCE 12-31-2013.

DAVID COLLIER, EXAMINING ATTORNEY

SN 86-261,466. DYNAMIC BRANDS, LLC, RICHMOND, VA. FILED 4-24-2014.

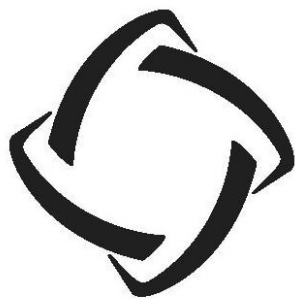

THE MARK CONSISTS OF A SQUARE SHAPE CONSISTING OF FOUR IDENTICAL GEOMETRIC FIGURES.

**CLASS 18—LEATHER GOODS**

FOR GENERAL PURPOSE BAGS, LUGGAGE, TROLLEY BAGS AND CASES WITH WHEELS FOR CARRYING TRADESHOW AND CONFERENCE DISPLAYS, PRODUCT SAMPLES AND TENTS (U.S. CLS. 1, 2, 3, 22 AND 41).

**CLASS 25—CLOTHING**

FOR CLOTHING, SPORTS CLOTHING, AND APPAREL, NAMELY, PANTS, SHORTS, SHIRTS, T-SHIRTS, SHOES, PULLOVERS, SWEAT SHIRTS, SWEAT PANTS, SKIRTS, SWEATERS, JACKETS, COATS, SOCKS, HEADWEAR, GLOVES, BELTS, COATS, AND VESTS (U.S. CLS. 22 AND 39).

**CLASS 28—TOYS AND SPORTING GOODS**

FOR BAGS, TROLLEY BAGS AND CASES WITH WHEELS SPECIALLY ADAPTED FOR SPORTS EQUIPMENT, NAMELY, GOLF EQUIPMENT, BASEBALL EQUIPMENT, FOOTBALL EQUIPMENT, SOFTBALL EQUIPMENT, LACROSSE EQUIPMENT, FIELD HOCKEY EQUIPMENT, ICE HOCKEY EQUIPMENT, BASKETBALL EQUIPMENT, VOLLEYBALL EQUIPMENT, SKIING AND SNOWBOARDING EQUIPMENT, SOCCER, BOWLING, MOTOCROSS EQUIPMENT AND TENNIS EQUIPMENT (U.S. CLS. 22, 23, 38 AND 50).

BRIAN NEVILLE, EXAMINING ATTORNEY

SN 86-262,036. NORTH AMERICAN SALT COMPANY, OVERLAND PARK, KS. FILED 4-24-2014.

# SALTSMART

THE MARK CONSISTS OF STANDARD CHARACTERS WITHOUT CLAIM TO ANY PARTICULAR FONT, STYLE, SIZE, OR COLOR.

**CLASS 1—CHEMICALS**

FOR PACKAGED WATER CONDITIONING PRODUCTS, NAMELY, SALT AND SALT BLENDS AND POTASSIUM CHLORIDE; PACKAGED DE-ICING AND ICE PREVENTION PREPARATION FOR ROADWAYS AND SIDEWALKS AND OTHER PAVED SURFACES (U.S. CLS. 1, 5, 6, 10, 26 AND 46).

**CLASS 31—NATURAL AGRICULTURAL PRODUCTS**

FOR PACKAGED SALT AND TRACE MINERAL SALT FOR ANIMAL CONSUMPTION (U.S. CLS. 1 AND 46).

THEODORE MCBRIDE, EXAMINING ATTORNEY

SN 86-262,739. THE LANDTEK GROUP, INC., AMITYVILLE, NY. FILED 4-25-2014.

# LandTek

THE MARK CONSISTS OF STANDARD CHARACTERS WITHOUT CLAIM TO ANY PARTICULAR FONT, STYLE, SIZE, OR COLOR.

OWNER OF U.S. REG. NOS. 4,149,376 AND 4,367,914.

**CLASS 37—CONSTRUCTION AND REPAIR**

FOR CONSTRUCTION AND INSTALLATION OF ATHLETIC FIELDS AND TRACKS; SPORTS EQUIPMENT INSTALLATION; CONSTRUCTION SERVICES, NAMELY, CONCRETE PAVING, SITE CLEARING, EXCAVATION, GRADING, ASPHALT PAVING, CONSTRUCTION AND INSTALLATION OF MASONRY WALLS AND STRUCTURES, FLAT WORK PAVER TILE INSTALLATION, VERTICAL BRICK INSTALLATION, BRICKLAYING, ROAD CONSTRUCTION, PARKING LOT CONSTRUCTION, PRECAST CONCRETE INSTALLATION, UTILITY LINE INSTALLATION, INSTALLATION OF CHAIN LINK, WOOD, ORNAMENTAL, GUARD RAIL, AND GUIDE RAIL FENCING; GENERAL CONSTRUCTION CONTRACTING SERVICES, NAMELY, CARPENTRY AND STRUCTURE BUILDING; INSTALLATION OF SOLAR ENERGY PANELS AND SOLAR ENERGY SYSTEMS; INSTALLATION OF GRASS FIELD AND SUBSURFACE DRAINAGE SYSTEMS; INSTALLATION OF STORM DRAINAGE SYSTEMS (U.S. CLS. 100, 103 AND 106).

FIRST USE 10-4-1988; IN COMMERCE 10-4-1988.

**CLASS 42—SCIENTIFIC AND COMPUTER SERVICES**

FOR LAND AND ROAD SURVEYING; DESIGN OF ATHLETIC FIELDS AND TRACKS (U.S. CLS. 100 AND 101).

FIRST USE 10-4-1988; IN COMMERCE 10-4-1988.

**CLASS 44—MEDICAL, BEAUTY AND AGRICULTURAL SERVICES**

FOR LAWN CARE, NAMELY, NATURAL GRASS AND SYNTHETIC GRASS FIELD CARE AND LAWN MAINTENANCE SERVICES; LANDSCAPING SERVICES, NAMELY, LANDSCAPE GARDENING AND LANDSCAPE DESIGN (U.S. CLS. 100 AND 101).

FIRST USE 10-4-1988; IN COMMERCE 10-4-1988.  
ALISON POLLACK, EXAMINING ATTORNEY

SN 86-263,333. A&E TELEVISION NETWORKS, LLC, NEW YORK, NY. FILED 4-25-2014.

**HOUSE VS HOUSE**

THE MARK CONSISTS OF STANDARD CHARACTERS WITHOUT CLAIM TO ANY PARTICULAR FONT, STYLE, SIZE, OR COLOR.

**CLASS 9—ELECTRICAL AND SCIENTIFIC APPARATUS**

FOR MULTIMEDIA GOODS, NAMELY, PRERECORDED DIGITAL VIDEO DISCS AND DVDS FEATURING SUBJECTS OF GENERAL HUMAN INTEREST; DIGITAL MEDIA, NAMELY, DOWNLOADABLE AUDIO AND VIDEO FILES FEATURING SUBJECTS OF GENERAL HUMAN INTEREST; DOWNLOADABLE WEBCASTS AND PODCASTS FEATURING SUBJECTS OF GENERAL HUMAN INTEREST; DOWNLOADABLE GRAPHICS FOR WIRELESS DEVICES; DOWNLOADABLE ON-LINE DISCUSSION BOARD POSTS FEATURING SUBJECTS OF GENERAL HUMAN INTEREST; COMPUTER GAME SOFTWARE AND VIDEO GAME SOFTWARE; DOWNLOADABLE COMPUTER AND VIDEO GAME SOFTWARE VIA A GLOBAL COMPUTER NETWORK, MOBILE PLATFORMS, AND WIRELESS DEVICES FOR ENTERTAINMENT PURPOSES; DOWNLOADABLE MOBILE APPLICATIONS FOR GAMES (U.S. CLS. 21, 23, 26, 36 AND 38).

**CLASS 41—EDUCATION AND ENTERTAINMENT**

FOR ENTERTAINMENT SERVICES, NAMELY, A MULTIMEDIA PROGRAM SERIES FEATURING SUBJECTS OF GENERAL HUMAN INTEREST DISTRIBUTED VIA VARIOUS PLATFORMS ACROSS MULTIPLE FORMS OF TRANSMISSION MEDIA; ENTERTAINMENT SERVICES, NAMELY, AN ONGOING TELEVISION SERIES FEATURING SUBJECTS OF GENERAL HUMAN INTEREST; PROVIDING A WEBSITE FEATURING ENTERTAINMENT INFORMATION; ENTERTAINMENT SERVICES, NAMELY, OPERATING A REAL-TIME NON-DOWNLOADABLE GAME FOR OTHERS VIA THE INTERNET, MOBILE NETWORK PLATFORMS, AND LOCAL AREA COMPUTER NETWORKS; ELECTRONIC GAME SERVICES, NAMELY, PROVIDING ONLINE ELECTRONIC GAMES BY MEANS OF THE INTERNET, MOBILE NETWORK PLATFORMS, AND LOCAL AREA COMPUTER NETWORKS; ENTERTAINMENT SERVICES, NAMELY, PROVIDING TEMPORARY USE OF NON-DOWNLOADABLE INTERACTIVE GAMES (U.S. CLS. 100, 101 AND 107).

GIANCARLO CASTRO, EXAMINING ATTORNEY

SN 86-263,403. LANDTEK GROUP, INC., THE, AMITYVILLE, NY. FILED 4-25-2014.

**LandSite**

THE MARK CONSISTS OF STANDARD CHARACTERS WITHOUT CLAIM TO ANY PARTICULAR FONT, STYLE, SIZE, OR COLOR.

OWNER OF U.S. REG. NOS. 4,149,376 AND 4,367,914.

**CLASS 37—CONSTRUCTION AND REPAIR**

FOR CONSTRUCTION AND INSTALLATION OF ATHLETIC FIELDS AND TRACKS; SPORTS EQUIPMENT INSTALLATION; CONSTRUCTION SERVICES, NAMELY, CONCRETE PAVING, SITE CLEARING, EXCAVATION, GRADING, ASPHALT PAVING, CONSTRUCTION AND INSTALLATION OF MASONRY WALLS AND STRUCTURES, FLAT WORK PAVER TILE INSTALLATION, VERTICAL BRICK INSTALLATION, BRICKLAYING, ROAD CONSTRUCTION, PARKING LOT CONSTRUCTION, PRECAST CONCRETE INSTALLATION, UTILITY LINE INSTALLATION, INSTALLATION OF CHAIN LINK, WOOD, ORNAMENTAL, GUARD RAIL, AND GUIDE RAIL FENCING; GENERAL CONSTRUCTION CONTRACTING SERVICES, NAMELY, CARPENTRY AND STRUCTURE BUILDING; INSTALLATION OF SOLAR ENERGY PANELS AND SOLAR ENERGY SYSTEMS; INSTALLATION OF GRASS FIELD AND SUBSURFACE DRAINAGE SYSTEMS; INSTALLATION OF STORM DRAINAGE SYSTEMS (U.S. CLS. 100, 103 AND 106).

**CLASS 42—SCIENTIFIC AND COMPUTER SERVICES**

FOR LAND AND ROAD SURVEYING; DESIGN OF ATHLETIC FIELDS AND TRACKS (U.S. CLS. 100 AND 101).

**CLASS 44—MEDICAL, BEAUTY AND AGRICULTURAL SERVICES**

FOR LAWN CARE, NAMELY, NATURAL GRASS AND SYNTHETIC GRASS FIELD CARE AND LAWN MAINTENANCE SERVICES; LANDSCAPING SERVICES, NAMELY, LANDSCAPE GARDENING AND LANDSCAPE DESIGN (U.S. CLS. 100 AND 101).

ALISON POLLACK, EXAMINING ATTORNEY

SN 86-264,428. DQC INTERNATIONAL, CORP., TAMPA, FL.  
FILED 4-28-2014.

## KP Killer Penguin

THE MARK CONSISTS OF STANDARD CHARACTERS WITHOUT CLAIM TO ANY PARTICULAR FONT, STYLE, SIZE, OR COLOR.

### CLASS 25—CLOTHING

FOR FISHING SHIRTS; HATS (U.S. CLS. 22 AND 39).

### CLASS 28—TOYS AND SPORTING GOODS

FOR FISHING POLES; FISHING REELS; FISHING RODS; REELS FOR FISHING; RODS FOR FISHING (U.S. CLS. 22, 23, 38 AND 50).  
RAMONA ORTIGA, EXAMINING ATTORNEY

SN 86-265,634. NOVARTIS AG, BASEL, SWITZERLAND,  
FILED 4-29-2014.



OWNER OF U.S. REG. NO. 4,372,842.  
NO CLAIM IS MADE TO THE EXCLUSIVE RIGHT TO USE "ADULTS", APART FROM THE MARK AS SHOWN.  
THE MARK CONSISTS OF THE WORD "ADULTS" OVER THE WORD "PATRO" WITH THE "T" IN "PATRO" FORMED BY A STYLIZED IMAGE OF A PERSON; THE COLOR GRAY IS INTENDED TO SHOW SHADING OR CONTRAST ONLY AND IS NOT PART OF THE MARK.

### CLASS 16—PAPER GOODS AND PRINTED MATTER

FOR PRINTED MATTER, NAMELY, NEWSLETTERS, BOOKLETS AND MAGAZINES IN THE FIELD OF PHARMACEUTICALS AND MEDICAL TREATMENT; PRINTED PUBLICATIONS, NAMELY, NEWSLETTERS, BROCHURES, RESEARCH REPORTS AND BOOKLETS IN THE FIELD OF PHARMACEUTICALS AND MEDICAL TREATMENT; BOOKS IN THE FIELD OF PHARMACEUTICALS AND MEDICAL TREATMENT; AND PRINTED INSTRUCTIONAL AND TEACHING MATERIALS IN THE FIELD OF PHARMACEUTICALS AND MEDICAL TREATMENT (U.S. CLS. 2, 5, 22, 23, 29, 37, 38 AND 50).

### CLASS 42—SCIENTIFIC AND COMPUTER SERVICES

FOR PROVIDING AN INTERACTIVE WEB SITE FEATURING TECHNOLOGY THAT ENABLES USERS TO ENTER, ACCESS, TRACK, MANAGE, MONITOR AND GENERATE MEDICAL, PATIENT AND PHARMACEUTICAL INFORMATION AND REPORTS; MEDICAL AND PHARMACEUTICAL RESEARCH AND DEVELOPMENT (U.S. CLS. 100 AND 101).

### CLASS 44—MEDICAL, BEAUTY AND AGRICULTURAL SERVICES

FOR PROVIDING MEDICAL INFORMATION AND ADVISORY SERVICES (U.S. CLS. 100 AND 101).  
JUHI KAVEESHVAR, EXAMINING ATTORNEY

SN 86-265,880. SMITH & CULT, LLC, MIAMI, FL. FILED 4-29-2014.



THE MARK CONSISTS OF A STYLIZED SCRIPT CAPITAL LETTER "S" FOLLOWED BY A STYLIZED AMPERSAND FOLLOWED BY A STYLIZED SCRIPT CAPITAL LETTER "C".

### CLASS 3—COSMETICS AND CLEANING PREPARATIONS

FOR NAIL CARE KITS COMPRISING NAIL POLISH; NAIL GLITTER; NAIL POLISH; NAIL TIPS (U.S. CLS. 1, 4, 6, 50, 51 AND 52).

### CLASS 8—HAND TOOLS

FOR MANICURE SETS; NAIL BUFFERS; NAIL CLIPPERS; NAIL FILES; NAIL SCISSORS (U.S. CLS. 23, 28 AND 44).

### CLASS 35—ADVERTISING AND BUSINESS

FOR ON-LINE RETAIL STORE SERVICES FEATURING NAIL CARE KITS COMPRISING NAIL POLISH, NAIL GLITTER, NAIL POLISH, NAIL TIPS, MANICURE SETS, NAIL BUFFERS, NAIL CLIPPERS, NAIL FILES, NAIL SCISSORS; RETAIL STORE SERVICES FEATURING NAIL CARE KITS COMPRISING NAIL POLISH, NAIL GLITTER, NAIL POLISH, NAIL TIPS, MANICURE SETS, NAIL BUFFERS, NAIL CLIPPERS, NAIL FILES, NAIL SCISSORS (U.S. CLS. 100, 101 AND 102).  
STEVEN JACKSON, EXAMINING ATTORNEY

SN 86-265,892. SMITH & CULT, LLC, MIAMI, FL. FILED 4-29-2014.



THE MARK CONSISTS OF A STYLIZED SCRIPT WORD "SMITH" WITH A CAPITAL LETTER "S" FOLLOWED BY A STYLIZED AMPERSAND FOLLOWED BY A STYLIZED SCRIPT WORD "CULT" WITH A CAPITAL LETTER "C".

**CLASS 3—COSMETICS AND CLEANING PREPARATIONS**

FOR NAIL CARE KITS COMPRISING NAIL POLISH; NAIL GLITTER; NAIL POLISH; NAIL TIPS (U.S. CLS. 1, 4, 6, 50, 51 AND 52).

**CLASS 8—HAND TOOLS**

FOR MANICURE SETS; NAIL BUFFERS; NAIL CLIPPERS; NAIL FILES; NAIL SCISSORS (U.S. CLS. 23, 28 AND 44).

**CLASS 35—ADVERTISING AND BUSINESS**

FOR ON-LINE RETAIL STORE SERVICES FEATURING NAIL CARE KITS COMPRISING NAIL POLISH, NAIL GLITTER, NAIL POLISH, NAIL TIPS, MANICURE SETS, NAIL BUFFERS, NAIL CLIPPERS, NAIL FILES, NAIL SCISSORS; RETAIL STORE SERVICES FEATURING NAIL CARE KITS COMPRISING NAIL POLISH, NAIL GLITTER, NAIL POLISH, NAIL TIPS, MANICURE SETS, NAIL BUFFERS, NAIL CLIPPERS, NAIL FILES, NAIL SCISSORS (U.S. CLS. 100, 101 AND 102).  
STEVEN JACKSON, EXAMINING ATTORNEY

SN 86-266,828. CARGILL, INCORPORATED, WAYZATA, MN. FILED 4-30-2014.

**SUNNY FRESH**

THE MARK CONSISTS OF STANDARD CHARACTERS WITHOUT CLAIM TO ANY PARTICULAR FONT, STYLE, SIZE, OR COLOR.  
OWNER OF U.S. REG. NOS. 1,849,499, 3,521,851 AND OTHERS.  
NO CLAIM IS MADE TO THE EXCLUSIVE RIGHT TO USE "FRESH", APART FROM THE MARK AS SHOWN.

**CLASS 29—MEATS AND PROCESSED FOODS**

FOR EGGS (U.S. CL. 46).  
FIRST USE 8-14-1985; IN COMMERCE 8-14-1985.

**CLASS 30—STAPLE FOODS**

FOR FRENCH TOAST (U.S. CL. 46).  
FIRST USE 8-19-1993; IN COMMERCE 8-19-1993.  
APRIL HESIK, EXAMINING ATTORNEY

SN 86-268,285. A&E TELEVISION NETWORKS, LLC, NEW YORK, NY. FILED 5-1-2014.

**MIDNIGHT FEAST**

THE MARK CONSISTS OF STANDARD CHARACTERS WITHOUT CLAIM TO ANY PARTICULAR FONT, STYLE, SIZE, OR COLOR.

**CLASS 9—ELECTRICAL AND SCIENTIFIC APPARATUS**

FOR MULTIMEDIA GOODS, NAMELY, PRERECORDED DIGITAL VIDEO DISCS AND DVDS FEATURING SUBJECTS OF GENERAL HUMAN INTEREST; DIGITAL MEDIA, NAMELY, DOWNLOADABLE AUDIO AND VIDEO FILES FEATURING SUBJECTS OF GENERAL HUMAN INTEREST; DOWNLOADABLE WEBCASTS AND PODCASTS FEATURING SUBJECTS OF GENERAL HUMAN INTEREST; DOWNLOADABLE GRAPHICS FOR WIRELESS DEVICES; DOWNLOADABLE ON-LINE DISCUSSION BOARD POSTS FEATURING SUBJECTS OF GENERAL HUMAN INTEREST; COMPUTER GAME SOFTWARE AND VIDEO GAME SOFTWARE; DOWNLOADABLE COMPUTER AND VIDEO GAME SOFTWARE VIA A GLOBAL COMPUTER NETWORK, MOBILE PLATFORMS, AND WIRELESS DEVICES FOR ENTERTAINMENT PURPOSES; DOWNLOADABLE MOBILE APPLICATIONS FOR GAMES (U.S. CLS. 21, 23, 26, 36 AND 38).

**CLASS 41—EDUCATION AND ENTERTAINMENT**

FOR ENTERTAINMENT SERVICES, NAMELY, A MULTIMEDIA PROGRAM SERIES FEATURING SUBJECTS OF GENERAL HUMAN INTEREST DISTRIBUTED VIA VARIOUS PLATFORMS ACROSS MULTIPLE FORMS OF TRANSMISSION MEDIA; ENTERTAINMENT SERVICES, NAMELY, AN ONGOING TELEVISION SERIES FEATURING SUBJECTS OF GENERAL HUMAN INTEREST; PROVIDING A WEBSITE FEATURING ENTERTAINMENT INFORMATION; ENTERTAINMENT SERVICES, NAMELY, OPERATING A REAL-TIME NON-DOWNLOADABLE GAME FOR OTHERS VIA THE INTERNET, MOBILE NETWORK PLATFORMS, AND LOCAL AREA COMPUTER NETWORKS; ELECTRONIC GAME SERVICES, NAMELY, PROVIDING ONLINE ELECTRONIC GAMES BY MEANS OF THE INTERNET, MOBILE NETWORK PLATFORMS, AND LOCAL AREA COMPUTER NETWORKS; ENTERTAINMENT SERVICES, NAMELY, PROVIDING TEMPORARY USE OF NON-DOWNLOADABLE INTERACTIVE GAMES (U.S. CLS. 100, 101 AND 107).  
GIANCARLO CASTRO, EXAMINING ATTORNEY

SN 86-268,549. CLEARBRIDGE BIOPHOTONICS, CARLSBAD, CA. FILED 5-1-2014.

**FPM**

THE MARK CONSISTS OF STANDARD CHARACTERS WITHOUT CLAIM TO ANY PARTICULAR FONT, STYLE, SIZE, OR COLOR.

**CLASS 9—ELECTRICAL AND SCIENTIFIC APPARATUS**

FOR AUTOMATED MICROSCOPE AND OPERATING SOFTWARE SOLD AS A UNIT FOR USE IN LABORATORY OPERATIONS; BIOLOGICAL MICROSCOPES; DIAGNOSTIC APPARATUS FOR THE DETECTION OF PATHOGENS FOR LABORATORY OR RESEARCH USE (U.S. CLS. 21, 23, 26, 36 AND 38).

**CLASS 10—MEDICAL APPARATUS**

FOR HEMATOLOGY ANALYZERS FOR MEDICAL DIAGNOSTIC USES; MEDICAL APPARATUS AND INSTRUMENT FOR DIAGNOSTIC USE, NAMELY, APPARATUS FOR MEDICAL DIAGNOSTIC TESTING IN THE FIELDS OF CANCER OR OTHER TISSUE-BASED DIAGNOSTIC TESTING, CYTOLOGY AND CELL-BASED TESTING; MEDICAL DIAGNOSTIC INSTRUMENTS FOR THE ANALYSIS OF BODY FLUIDS (U.S. CLS. 26, 39 AND 44).

INGRID C. EULIN, EXAMINING ATTORNEY

SN 86-271,226. MCGRAW-HILL SCHOOL EDUCATION HOLDINGS, LLC, NEW YORK, NY. FILED 5-5-2014.

**MUSIC STUDIO**

NO CLAIM IS MADE TO THE EXCLUSIVE RIGHT TO USE "MUSIC STUDIO", APART FROM THE MARK AS SHOWN.

THE MARK CONSISTS OF THE WORDING "MUSIC STUDIO" WITH A PLAY BUTTON DESIGN INSIDE THE "O".

**CLASS 9—ELECTRICAL AND SCIENTIFIC APPARATUS**

FOR EDUCATION SOFTWARE FEATURING INSTRUCTION IN MUSIC; DOWNLOADABLE MOBILE APPLICATION SOFTWARE FEATURING EDUCATIONAL CONTENT FOR INSTRUCTION IN MUSIC; DOWNLOADABLE E-BOOKS IN THE FIELD OF MUSIC AND MUSIC INSTRUCTIONS (U.S. CLS. 21, 23, 26, 36 AND 38).

**CLASS 16—PAPER GOODS AND PRINTED MATTER**

FOR PRINTED EDUCATIONAL MATERIALS IN THE FIELD OF MUSIC AND MUSIC INSTRUCTION (U.S. CLS. 2, 5, 22, 23, 29, 37, 38 AND 50).

**CLASS 42—SCIENTIFIC AND COMPUTER SERVICES**

FOR PROVIDING AN INTERACTIVE WEBSITE FEATURING NON-DOWNLOADABLE SOFTWARE FEATURING EDUCATIONAL MATERIALS FOR LEARNING AND TEACHING MUSIC (U.S. CLS. 100 AND 101).

DAVID HOFFMAN, EXAMINING ATTORNEY

SN 86-273,437. SIMPLE FINANCE TECHNOLOGY CORP., PORTLAND, OR. FILED 5-6-2014.

**SIMPLE-TO-SIMPLE**

THE MARK CONSISTS OF STANDARD CHARACTERS WITHOUT CLAIM TO ANY PARTICULAR FONT, STYLE, SIZE, OR COLOR.

**CLASS 36—INSURANCE AND FINANCIAL**

FOR ELECTRONIC FUND TRANSFERS; PROVIDING ELECTRONIC PROCESSING OF ELECTRONIC FUNDS TRANSFERS, ACH, CREDIT CARD, DEBIT CARD, ELECTRONIC CHECK AND ELECTRONIC PAYMENTS; PROVIDING AN INTERNET WEBSITE PORTAL IN THE FIELD OF FINANCIAL TRANSACTION AND PAYMENT PROCESSING SERVICES; ELECTRONIC COMMERCE PAYMENT SERVICES; FINANCIAL TRANSACTION SERVICES, NAMELY, PROVIDING SECURE COMMERCIAL TRANSACTION AND PAYMENT OPTIONS (U.S. CLS. 100, 101 AND 102).

**CLASS 45—PERSONAL AND LEGAL SERVICES**

FOR PROVIDING USER AUTHENTICATION OF ELECTRONIC FUND TRANSFER, CREDIT AND DEBIT CARD AND ELECTRONIC CHECK TRANSACTIONS VIA A GLOBAL COMPUTER NETWORK (U.S. CLS. 100 AND 101).

JACLYN KIDWELL WALKER, EXAMINING ATTORNEY

SN 86-273,468. TRUJILLO, FAVIOLA, IMPERIAL, CA. AND SALGADO, VICTOR, IMPERIAL, CA. FILED 5-6-2014.

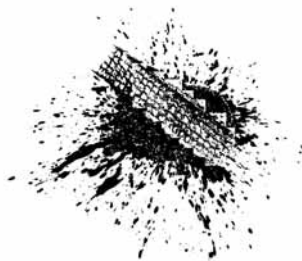

THE MARK CONSISTS OF A MUD SPLATTER WITH A TIRE MARK ROLLED THROUGH IT.

**CLASS 25—CLOTHING**

FOR CLOTHING, NAMELY SHIRTS, SWEATERS AND PANTS; HATS; BEANIES (U.S. CLS. 22 AND 39).

**CLASS 35—ADVERTISING AND BUSINESS**

FOR ON-LINE RETAIL STORE SERVICES FEATURING SHIRTS, SWEATERS, PANTS, HATS AND BEANIES (U.S. CLS. 100, 101 AND 102).

THEODORE MCBRIDE, EXAMINING ATTORNEY

SN 86-274,397. GERAKARIS, NICHOLE, SUNNYSIDE, NY. FILED 5-7-2014.

**Luxy Lady**

THE MARK CONSISTS OF STANDARD CHARACTERS WITHOUT CLAIM TO ANY PARTICULAR FONT, STYLE, SIZE, OR COLOR.

NO CLAIM IS MADE TO THE EXCLUSIVE RIGHT TO USE "LADY", APART FROM THE MARK AS SHOWN.



**CLASS 35—ADVERTISING AND BUSINESS**

FOR RETAIL STORE SERVICES IN THE FIELD OF BEAUTY SUPPLIES AND EQUIPMENT (U.S. CLS. 100, 101 AND 102).

**CLASS 41—EDUCATION AND ENTERTAINMENT**

FOR ARRANGING, ORGANIZING, CONDUCTING, AND HOSTING SOCIAL ENTERTAINMENT EVENTS; HOSTING SOCIAL ENTERTAINMENT EVENTS, NAMELY, PARTIES, FOR OTHERS (U.S. CLS. 100, 101 AND 107).

**CLASS 44—MEDICAL, BEAUTY AND AGRICULTURAL SERVICES**

FOR HAIR SALON SERVICES; HAIR STYLING; APPLY CLIP-IN HAIR EXTENSIONS; SELL CLIP-IN EXTENSIONS; PROVIDING ONLINE ADVICE AND INFORMATION IN THE FIELDS OF HAIRSTYLING, HAIRCARE, AND HAIR MAINTENANCE; NAIL CARE SERVICES; DAY SPA SERVICES, NAMELY, NAIL CARE, MANICURES, PEDICURES AND NAIL ENHANCEMENTS (U.S. CLS. 100 AND 101).  
SUNG IN, EXAMINING ATTORNEY

---

SN 86-274,426. METROPOLITAN LIFE INSURANCE COMPANY, NEW YORK, NY. FILED 5-7-2014.

**CHOICE EXPRESS**

THE MARK CONSISTS OF STANDARD CHARACTERS WITHOUT CLAIM TO ANY PARTICULAR FONT, STYLE, SIZE, OR COLOR.

**CLASS 36—INSURANCE AND FINANCIAL**

FOR INSURANCE AND FINANCIAL SERVICES, NAMELY, UNDERWRITING AND ADMINISTRATION OF AUTO, RECREATIONAL VEHICLE, MOTOR HOME, MOTORCYCLE, AND ANTIQUE/COLLECTIBLE VEHICLE INSURANCE COVERAGE; ASSESSING AND PROCESSING INSURANCE CLAIMS, NAMELY, IN THE FIELD OF PROPERTY AND CASUALTY INSURANCE, PROVIDING ADMINISTRATIVE SERVICES AND PROCESSING AND ADJUSTING INSURANCE CLAIMS MADE BY POLICYHOLDERS; PROVIDING CUSTOMERS ELECTRONIC PAYMENT OF CLAIMS, NAMELY, ELECTRONIC PROCESSING AND TRANSMISSION OF ELECTRONIC FUNDS TRANSFER PAYMENTS AND PAYMENT DATA (U.S. CLS. 100, 101 AND 102).  
FIRST USE 11-17-2013; IN COMMERCE 11-17-2013.

**CLASS 42—SCIENTIFIC AND COMPUTER SERVICES**

FOR PROVIDING ONLINE NON-DOWNLOADABLE SOFTWARE THAT ALLOWS CUSTOMERS AND CLAIMANTS TO CREATE CLAIMS AND SEND LOSS AND DAMAGE INFORMATION TO THE COMPANY ON MOBILE DEVICES AND PERSONAL COMPUTERS VIA A GLOBAL COMPUTER NETWORK (U.S. CLS. 100 AND 101).  
FIRST USE 11-17-2013; IN COMMERCE 11-17-2013.  
LEIGH CAROLINE CASE, EXAMINING ATTORNEY

SN 86-275,599. SHOWTIME NETWORKS INC., NEW YORK, NY. FILED 5-8-2014.

**SHO SYNC**

THE MARK CONSISTS OF STANDARD CHARACTERS WITHOUT CLAIM TO ANY PARTICULAR FONT, STYLE, SIZE, OR COLOR.

**CLASS 9—ELECTRICAL AND SCIENTIFIC APPARATUS**

FOR COMPUTER APPLICATION SOFTWARE FOR INTERACTIVE TELEVISION, NAMELY, SOFTWARE FOR THE DELIVERY OF REAL TIME TELEVISION BROADCAST CONTENT AND INFORMATION, AND FOR INTERACTIVE GAMES AND/OR QUIZZES; COMPUTER APPLICATION E-COMMERCE SOFTWARE TO ALLOW USERS TO CONDUCT ELECTRONIC BUSINESS TRANSACTIONS IN ONLINE MARKETPLACES VIA A GLOBAL COMPUTER NETWORK, FOR USE BY VIEWERS OF A DIGITAL TELEVISION CHANNEL FOR THE VIEWING AND PURCHASE OF GOODS AND SERVICES (U.S. CLS. 21, 23, 26, 36 AND 38).  
FIRST USE 9-22-2012; IN COMMERCE 9-22-2012.

**CLASS 41—EDUCATION AND ENTERTAINMENT**

FOR ENTERTAINMENT SERVICES, NAMELY, PROVIDING TEMPORARY USE OF NON-DOWNLOADABLE INTERACTIVE GAMES; PROVIDING A WEBSITE FEATURING INFORMATIONAL, NON-DOWNLOADABLE PHOTOGRAPHIC, AUDIO, AND VIDEO PRESENTATIONS IN THE FIELD OF ENTERTAINMENT AND ON-SCREEN INTERACTIVE ACTIVITIES IN REAL TIME FOR TELEVISION VIEWERS, NAMELY, CONDUCTING USER-GENERATED POLLS, INTEGRATION WITH OTHER SOCIAL NETWORKING SITES AND CELEBRITY SITES, VIDEOS, PHOTOS, AND FACTS (U.S. CLS. 100, 101 AND 107).  
FIRST USE 9-22-2012; IN COMMERCE 9-22-2012.  
MATTHEW KLINE, EXAMINING ATTORNEY

---

SN 86-276,349. ELECTRONIC CONTROLS COMPANY, BOISE, ID. FILED 5-8-2014.

**ESG**

THE MARK CONSISTS OF STANDARD CHARACTERS WITHOUT CLAIM TO ANY PARTICULAR FONT, STYLE, SIZE, OR COLOR.

**CLASS 9—ELECTRICAL AND SCIENTIFIC APPARATUS**

FOR HOUSE MARK FOR SIGNALING AND WARNING LIGHTS, NAMELY, ELECTRIC WARNING LIGHTS, FLASHING SAFETY LIGHTS, SAFETY BEACON LIGHTS, ROTATING LIGHTS; HOUSE MARK FOR SIGNALING, WARNING AND SAFETY PRODUCTS, NAMELY, SOUND ALARMS, PROXIMITY SENSORS, ELECTRIC SWITCHES, CAMERAS; VIDEO MONITORS; SECURITY AND WARNING PRODUCTS, NAMELY, AUDIO SPEAKERS AND SIRENS; VEHICLE SAFETY EQUIPMENT, NAMELY, AN ON-BOARD VEHICULAR SURVEILLANCE SYSTEM COMPRISED OF CAMERAS AND MONITORS FOR EXPOSING AND ELIMINATING THE BLIND SPOTS ON BOTH SIDES OF VEHICLES; COMPONENTS, PARTS AND ACCESSORIES FOR ALL THE FOREGOING GOODS, NAMELY, CONTROL UNITS FOR REGULATING START-UP ELECTRIC MOTORS, DUST COVERS FOR MONITORS, ELECTRIC CABLES, ADAPTER PLUGS, ELECTRIC CONNECTORS, MOUNTING DEVICES FOR MONITORS (U.S. CLS. 21, 23, 26, 36 AND 38).

**CLASS 11—ENVIRONMENTAL CONTROL APPARATUS**

FOR HOUSE MARK FOR VEHICLE LIGHTS; LIGHTING PRODUCTS, NAMELY, PORTABLE WORK LIGHTS AND WORK LAMPS, LIGHT BULBS, HIGH INTENSITY SEARCH LIGHTS, BACKUP LIGHTS FOR LAND VEHICLES, FLASHING STROBE LIGHTING APPARATUS, LED LIGHT ASSEMBLIES FOR VEHICLES; LIGHT BARS AND PANELS FOR VEHICLES, NAMELY, VEHICLES AND MACHINERY EMPLOYED IN CONSTRUCTION, MAINTENANCE, MATERIAL HANDLING, SAFETY AND SECURITY, AND TRANSPORTATION INDUSTRIES; COMPONENTS, PARTS AND ACCESSORIES FOR ALL THE FOREGOING GOODS, NAMELY, LIGHT REFLECTORS, INFRARED LAMP FIXTURES, AND OPTICAL LENS COVERS THAT IMPROVES LIGHT OUTPUT AND UNIFORMITY AND PROTECTS THE LED, SOLD AS A FEATURE OF AN LED LIGHTING SYSTEM; SCENE LIGHTS, NAMELY, PORTABLE LIGHTING SYSTEMS FOR LIGHTING UP EMERGENCY SCENES (U.S. CLS. 13, 21, 23, 31 AND 34).

**CLASS 12—VEHICLES**

FOR HOUSE MARK FOR VEHICLE ACCESSORIES, NAMELY, BACK-UP WARNING ALARMS FOR VEHICLES; HORNS FOR VEHICLES; VEHICLE CAMERA MOUNTS (U.S. CLS. 19, 21, 23, 31, 35 AND 44).  
ELI HELLMAN, EXAMINING ATTORNEY

SN 86-277,424. CNU ONLINE HOLDINGS, LLC, CHICAGO, IL. FILED 5-9-2014.

**HEADWAY CAPITAL**  
CREDIT FOR SMALL BUSINESSES

NO CLAIM IS MADE TO THE EXCLUSIVE RIGHT TO USE "CAPITAL" AND "CREDIT FOR SMALL BUSINESSES", APART FROM THE MARK AS SHOWN.

THE MARK CONSISTS OF THE WORD "HEADWAY" IN BOLD BLOCK LETTERS TOGETHER WITH THE WORD "CAPITAL" IN SANS-SERIF BLOCK LETTERS, APPEARING OVER THE WORDS "CREDIT FOR SMALL BUSINESSES" IN SMALLER SANS-SERIF BLOCK LETTERS.

**CLASS 9—ELECTRICAL AND SCIENTIFIC APPARATUS**

FOR DOWNLOADABLE SOFTWARE IN THE NATURE OF A MOBILE APPLICATION FOR USE IN CONDUCTING AND MANAGING LOANS IN THE FIELD OF FINANCIAL SERVICES AND MONEY LENDING (U.S. CLS. 21, 23, 26, 36 AND 38).

**CLASS 36—INSURANCE AND FINANCIAL**

FOR ARRANGING OF LOANS; CREDIT AND LOAN SERVICES; ELECTRONIC LOAN ORIGATION SERVICES; ELECTRONIC LOAN PREPARATION SERVICES; FINANCIAL LOAN CONSULTATION; FINANCIAL SERVICES, NAMELY, MONEY LENDING; FINANCING AND LOAN SERVICES; FINANCING LOANS FOR SMALL BUSINESSES (U.S. CLS. 100, 101 AND 102).

NORA BUCHANAN WILL, EXAMINING ATTORNEY

SN 86-278,680. TAASERA, INC., ERIE, PA. FILED 5-12-2014.

**FAAR SIGHT**

THE MARK CONSISTS OF STANDARD CHARACTERS WITHOUT CLAIM TO ANY PARTICULAR FONT, STYLE, SIZE, OR COLOR.

**CLASS 9—ELECTRICAL AND SCIENTIFIC APPARATUS**

FOR DOWNLOADABLE COMPUTER SOFTWARE, NAMELY, SOFTWARE FOR PREVENTING UNAUTHORIZED ACCESS TO COMPUTER SYSTEMS; COMPUTER UTILITY SOFTWARE; SOFTWARE FOR THE DETECTION AND REMOVAL OF COMPUTER VIRUSES AND THREATS; SOFTWARE FOR MANAGING AND FILTERING ELECTRONIC COMMUNICATIONS; SOFTWARE FOR PROTECTING AND SECURING COMPUTER NETWORKS AND APPLICATIONS; SOFTWARE FOR ENCRYPTING AND AUTHENTICATING DATA; SOFTWARE FOR DETECTING AND REPAIRING COMPUTER SOFTWARE AND HARDWARE PROBLEMS; AND MANUALS FOR SUCH SOFTWARE PACKAGED AS A UNIT (U.S. CLS. 21, 23, 26, 36 AND 38).

**CLASS 42—SCIENTIFIC AND COMPUTER SERVICES**

FOR COMPUTER CONSULTING SERVICES; TECHNICAL CONSULTING AND RESEARCH SERVICES FOR OTHERS IN THE FIELDS OF COMPUTER, DATA, AND NETWORK SECURITY; MONITORING OF NETWORK SYSTEMS; APPLICATION SERVICE PROVIDER FEATURING SOFTWARE FOR THE DETECTION AND REMOVAL OF COMPUTER VIRUSES AND THREATS, PROTECTING AND SECURING COMPUTER NETWORKS AND APPLICATIONS, ENCRYPTING AND AUTHENTICATING DATA, AND MANAGING AND FILTERING OF ELECTRONIC COMMUNICATIONS; PROVIDING INFORMATION IN THE FIELDS OF NETWORK, DATA, AND COMPUTER SECURITY (U.S. CLS. 100 AND 101).

TARAH HARDY, EXAMINING ATTORNEY

SN 86-279,144. KEECO, LLC, HAYWARD, CA. FILED 5-12-2014.

## SO-SOFT COLLECTION

THE MARK CONSISTS OF STANDARD CHARACTERS WITHOUT CLAIM TO ANY PARTICULAR FONT, STYLE, SIZE, OR COLOR.

NO CLAIM IS MADE TO THE EXCLUSIVE RIGHT TO USE "COLLECTION", APART FROM THE MARK AS SHOWN.

### CLASS 20—FURNITURE AND ARTICLES NOT OTHERWISE CLASSIFIED

FOR PILLOWS (U.S. CLS. 2, 13, 22, 25, 32 AND 50).

### CLASS 24—FABRICS

FOR BED SHEETS; BED SKIRTS; BLANKET THROWS; COMFORTERS; COVERLETS; FABRIC WINDOW COVERINGS AND TREATMENTS, NAMELY, CURTAINS, DRAPERIES, SHEERS, SWAGS AND VALANCES; MATTRESS PADS; PILLOW CASES; PILLOW SHAMS; QUILTS (U.S. CLS. 42 AND 50).

STEVEN JACKSON, EXAMINING ATTORNEY

SN 86-279,363. LIFETIME ENTERTAINMENT SERVICES, LLC, NEW YORK, NY. FILED 5-13-2014.

## B.A.P.S.

THE MARK CONSISTS OF STANDARD CHARACTERS WITHOUT CLAIM TO ANY PARTICULAR FONT, STYLE, SIZE, OR COLOR.

### CLASS 9—ELECTRICAL AND SCIENTIFIC APPARATUS

FOR MULTIMEDIA GOODS, NAMELY, PRERECORDED DIGITAL VIDEO DISCS AND DVDS FEATURING SUBJECTS OF GENERAL HUMAN INTEREST; DIGITAL MEDIA, NAMELY, DOWNLOADABLE AUDIO AND VIDEO FILES FEATURING SUBJECTS OF GENERAL HUMAN INTEREST; DOWNLOADABLE WEBCASTS AND PODCASTS FEATURING SUBJECTS OF GENERAL HUMAN INTEREST; DOWNLOADABLE GRAPHICS FOR WIRELESS DEVICES; DOWNLOADABLE ON-LINE DISCUSSION BOARD POSTS FEATURING SUBJECTS OF GENERAL HUMAN INTEREST; COMPUTER GAME SOFTWARE AND VIDEO GAME SOFTWARE; DOWNLOADABLE COMPUTER AND VIDEO GAME SOFTWARE VIA A GLOBAL COMPUTER NETWORK, MOBILE PLATFORMS, AND WIRELESS DEVICES FOR ENTERTAINMENT PURPOSES; DOWNLOADABLE MOBILE APPLICATIONS FOR GAMES (U.S. CLS. 21, 23, 26, 36 AND 38).

### CLASS 41—EDUCATION AND ENTERTAINMENT

FOR ENTERTAINMENT SERVICES, NAMELY, A MULTIMEDIA PROGRAM SERIES FEATURING SUBJECTS OF GENERAL HUMAN INTEREST DISTRIBUTED VIA VARIOUS PLATFORMS ACROSS MULTIPLE FORMS OF TRANSMISSION MEDIA; ENTERTAINMENT SERVICES, NAMELY, AN ONGOING TELEVISION SERIES FEATURING SUBJECTS OF GENERAL HUMAN INTEREST; PROVIDING A WEBSITE FEATURING ENTERTAINMENT INFORMATION; ENTERTAINMENT SERVICES, NAMELY, OPERATING A REAL-TIME NON-DOWNLOADABLE GAME FOR OTHERS VIA THE INTERNET, MOBILE NETWORK PLATFORMS, AND LOCAL AREA COMPUTER NETWORKS; ELECTRONIC GAME SERVICES, NAMELY, PROVIDING ONLINE ELECTRONIC GAMES BY MEANS OF THE INTERNET, MOBILE NETWORK PLATFORMS, AND LOCAL AREA COMPUTER NETWORKS; ENTERTAINMENT SERVICES, NAMELY, PROVIDING TEMPORARY USE OF NON-DOWNLOADABLE INTERACTIVE GAMES (U.S. CLS. 100, 101 AND 107).

WON TEAK OH, EXAMINING ATTORNEY

SN 86-279,524. CHITIMACHA TRIBE OF LOUISIANA, CHARENTON, LA. FILED 5-13-2014.



THE COLOR(S) RED, YELLOW, BROWN, BLUE, GREEN, ORANGE, WHITE, AND BLACK IS/ARE CLAIMED AS A FEATURE OF THE MARK.

THE MARK CONSISTS OF A ROUND LOGO OF RED AND YELLOW IN WHICH THE OUTERMOST RING CONTAINS THE WORDS "SOVEREIGN NATION OF THE CHITIMACHA" IN YELLOW ON A RED BACKGROUND. THERE IS A SECOND RING WHICH CONTAINS GEOMETRIC BASKET WEAVE DESIGN CALLED THE BEAR'S EAR / EARRING IN BLACK AGAINST A BROWN BACKGROUND. SUPERIMPOSED OVER BOTH RINGS AT THE BOTTOM OF THE LOGO ARE FOUR BLACK-AND-WHITE EAGLE FEATHERS WITH BLACK AND YELLOW STEMS SIGNIFYING THE FOUR DIRECTIONS. THE CENTER CIRCLE OF THE LOGO CONTAINS A BROWN CYPRESS TREE OUTLINED IN BLACK ON A GREEN PATCH, REPRESENTING THE TRIBE'S SACRED CYPRESS TREES, WITH GREEN LIMBS AND BROWN CYPRESS KNEES OUTLINED IN BLACK SURROUND BY GREEN IN THE BLUE WATER. TO THE RIGHT OF THE TREE IN THE CENTER CIRCLE IS AN ORANGE RISING SUN IN THE EAST SIGNIFYING THE DAWN OF A NEW DAY. IN THE CENTER CIRCLE HORIZONTALLY ACROSS THE TREE IS A BROWN PIPE OUTLINED IN BLACK SIGNIFYING PEACE.

### CLASS 35—ADVERTISING AND BUSINESS

FOR PROMOTING ECONOMIC DEVELOPMENT IN CHARENTON, LOUISIANA (U.S. CLS. 100, 101 AND 102). FIRST USE 4-30-1996; IN COMMERCE 4-30-1996.

**CLASS 36—INSURANCE AND FINANCIAL**

FOR PROVIDING COLLEGE SCHOLARSHIPS; PROVIDING EDUCATIONAL SCHOLARSHIPS; HOUSING AGENCIES (U.S. CLS. 100, 101 AND 102).

FIRST USE 4-30-1996; IN COMMERCE 4-30-1996.

**CLASS 39—TRANSPORTATION AND STORAGE**

FOR MASS TRANSIT FOR THE GENERAL PUBLIC; PUBLIC UTILITY SERVICES; CHARITABLE SERVICES, NAMELY, PROVIDING TRANSPORTATION TO THE ELDERLY OR HANDICAPPED PERSONS (U.S. CLS. 100 AND 105).

FIRST USE 4-30-1996; IN COMMERCE 4-30-1996.

**CLASS 41—EDUCATION AND ENTERTAINMENT**

FOR PROVIDING RECREATION FACILITIES; RECREATIONAL CAMPS; RECREATIONAL PARK SERVICES, NAMELY, FISHING AND BOATING; MUSEUMS; PROVIDING COURSES OF INSTRUCTION AT THE PRIMARY AND HIGH SCHOOL LEVEL; ENTERTAINMENT SERVICES, NAMELY, LIVE MUSICAL CONCERTS AND MUSICAL SHOWS (U.S. CLS. 100, 101 AND 107).

FIRST USE 4-30-1996; IN COMMERCE 4-30-1996.

**CLASS 43—HOTEL AND RESTAURANT SERVICES**

FOR PROVIDING TEMPORARY HOUSING ACCOMMODATIONS; PUBLIC HOUSING SERVICES; EMERGENCY SHELTER SERVICES, NAMELY, PROVIDING TEMPORARY HOUSING; PROVIDING DAY CARE TO CHILDREN (U.S. CLS. 100 AND 101).

FIRST USE 4-30-1996; IN COMMERCE 4-30-1996.

**CLASS 44—MEDICAL, BEAUTY AND AGRICULTURAL SERVICES**

FOR HEALTH CARE; PHYSICAL REHABILITATION; PROVIDING MENTAL REHABILITATION FACILITIES; REHABILITATION OF ALCOHOL ADDICTED PATIENTS; REHABILITATION OF DRUG-ADDICTED PATIENTS; REHABILITATION OF NARCOTIC ADDICTED PATIENTS; FOOD NUTRITION CONSULTATION; PSYCHOLOGICAL COUNSELING (U.S. CLS. 100 AND 101).

FIRST USE 4-30-1996; IN COMMERCE 4-30-1996.

**CLASS 45—PERSONAL AND LEGAL SERVICES**

FOR CASE MANAGEMENT SERVICES, NAMELY, COORDINATION OF LEGAL, SOCIAL, AND PSYCHOLOGICAL SERVICES FOR DOMESTICALLY ABUSED PERSONS; POLICE AND CIVIL PROTECTION SERVICES; POLICE PROTECTION; FIRE FIGHTING; LEGAL SERVICES; NON-MEDICAL IN-HOME PERSONAL CARE SERVICES FOR ASSISTING WITH DAILY LIVING ACTIVITIES OF THE ELDERLY (U.S. CLS. 100 AND 101).

FIRST USE 4-30-1996; IN COMMERCE 4-30-1996.

KATHLEEN M. VANSTON, EXAMINING ATTORNEY

SN 86-280,338. KEECO, LLC, HAYWARD, CA. FILED 5-13-2014.



THE COLOR(S) GREY AND WHITE IS/ARE CLAIMED AS A FEATURE OF THE MARK.

THE MARK CONSISTS OF THE LITERAL ELEMENT "SIMPLE SOLUTIONS" IN GREY ON A WHITE BACKGROUND WHERE "SOLUTIONS" IS INVERSED. THE LITERAL ELEMENT "SIMPLE SOLUTIONS" IS INSIDE A GREY CIRCLE AND GOING AROUND JUST INSIDE THE CIRCLE. IN THE CENTER OF THE CIRCLE IS ANOTHER GREY CIRCLE BROKEN ON THE LEFT AND RIGHT SIDE. INSIDE THIS MIDDLE CIRCLE IS THE DESIGN ELEMENT OF TWO SKELETON KEYS IN GREY CRISSCROSSING.

**CLASS 20—FURNITURE AND ARTICLES NOT OTHERWISE CLASSIFIED**

FOR PILLOWS (U.S. CLS. 2, 13, 22, 25, 32 AND 50).

**CLASS 24—FABRICS**

FOR BATH TOWELS; BED SHEETS; BED SKIRTS; COMFORTERS; MATTRESS PADS; PILLOW SHAMS; QUILTS; SHAMS (U.S. CLS. 42 AND 50).

STEVEN JACKSON, EXAMINING ATTORNEY

SN 86-280,908. AMERICAN TEXTILE COMPANY, DUESNE, PA. FILED 5-14-2014.

**ALLEREASE**

THE MARK CONSISTS OF STANDARD CHARACTERS WITHOUT CLAIM TO ANY PARTICULAR FONT, STYLE, SIZE, OR COLOR.

OWNER OF U.S. REG. NOS. 2,080,165, 3,319,027 AND OTHERS.

**CLASS 20—FURNITURE AND ARTICLES NOT OTHERWISE CLASSIFIED**

FOR BEDS FOR HOUSEHOLD PETS; PORTABLE BEDS FOR PETS (U.S. CLS. 2, 13, 22, 25, 32 AND 50).

**CLASS 24—FABRICS**

FOR FITTED BED SHEETS FOR PETS; PET BLANKETS (U.S. CLS. 42 AND 50).

SHAVELL MCPHERSON, EXAMINING ATTORNEY

SN 86-282,678. EISAI INC., WOODCLIFF LAKE, NJ. FILED 5-15-2014.

SN 86-284,738. MOUTH FOODS, INC., BROOKLYN, NY. FILED 5-19-2014.

READY, SET, CHANGE TOOLKIT

THE MARK CONSISTS OF STANDARD CHARACTERS WITHOUT CLAIM TO ANY PARTICULAR FONT, STYLE, SIZE, OR COLOR.

NO CLAIM IS MADE TO THE EXCLUSIVE RIGHT TO USE "TOOLKIT", APART FROM THE MARK AS SHOWN.

**CLASS 9—ELECTRICAL AND SCIENTIFIC APPARATUS**

FOR DOWNLOADABLE ELECTRONIC PUBLICATIONS IN THE NATURE OF BOOKLETS, WORKBOOKS, GUIDES, PAMPHLETS OR BROCHURES IN THE FIELD OF WEIGHT LOSS AND/OR WEIGHT MANAGEMENT, DIET AND EXERCISE (U.S. CLS. 21, 23, 26, 36 AND 38).

**CLASS 44—MEDICAL, BEAUTY AND AGRICULTURAL SERVICES**

FOR PROVIDING A WEB SITE FEATURING MEDICAL INFORMATION; PROVIDING INFORMATION ON MAINTAINING A HEALTHY LIFESTYLE AND LOSING WEIGHT; PROVIDING MEDICAL INFORMATION IN THE FIELD OF WEIGHT LOSS AND/OR WEIGHT MANAGEMENT, DIET AND EXERCISE (U.S. CLS. 100 AND 101).

JOHN GARTNER, EXAMINING ATTORNEY

SN 86-282,829. GRAVES, CHERYL, GRESHAM, OR. FILED 5-15-2014.

People Love Buds

THE MARK CONSISTS OF STANDARD CHARACTERS WITHOUT CLAIM TO ANY PARTICULAR FONT, STYLE, SIZE, OR COLOR.

**CLASS 29—MEATS AND PROCESSED FOODS**

FOR EDIBLE OILS (U.S. CL. 46).

**CLASS 30—STAPLE FOODS**

FOR COOKIES; CRACKERS; SPICES; TEA (U.S. CL. 46).

ANDREA K. NADELMAN, EXAMINING ATTORNEY

MOUTH

THE MARK CONSISTS OF STANDARD CHARACTERS WITHOUT CLAIM TO ANY PARTICULAR FONT, STYLE, SIZE, OR COLOR.

**CLASS 29—MEATS AND PROCESSED FOODS**

FOR CANDIED FRUIT SNACKS; CHOCOLATE NUT BUTTER; COOKED FRUITS AND VEGETABLES; DEHYDRATED FRUIT SNACKS; DRIED VEGETABLES; EDIBLE OILS AND FATS, PRESERVES AND PICKLES; FERMENTED VEGETABLES, FRUIT CONSERVES, FRUIT LEATHERS, FRUIT PASTE, FRUIT PEEL, FRUIT PRESERVES, FRUIT PUREES, FRUIT SPREADS, FRUITS PRESERVED IN ALCOHOL, GLAZED FRUITS; MEAT, FISH, FRUIT AND VEGETABLE JELLIES, JAMS, PRESERVES; NUT- AND DRIED FRUIT-BASED SNACK BARS; NUT- AND SEED-BASED SNACK BARS; NUT BUTTERS; NUT MEATS; NUT TOPPING; OLIVE OIL; OLIVE PASTES; PICKLED FRUITS; PICKLED VEGETABLES; PICKLES; PREPARED NUTS; PRESERVED MEATS AND SAUSAGES; PRESERVED, DRIED AND COOKED FRUIT AND VEGETABLES; PRESERVED, DRIED AND COOKED OLIVES; PROCESSED NUTS; PROCESSED STUFFED OLIVES; ROASTED NUTS; SAUSAGES; SEASONED NUTS; SHELLED NUTS; SNACK DIPS; SNACK MIX CONSISTING PRIMARILY OF PROCESSED NUTS, SEEDS, DRIED FRUIT AND ALSO INCLUDING CHOCOLATE; TRAIL MIX CONSISTING PRIMARILY OF PROCESSED NUTS, SEEDS, DRIED FRUIT AND ALSO INCLUDING CHOCOLATE; VEGETABLE CHIPS; VEGETABLE PASTE; VEGETABLE PUREE; VEGETABLES IN VINEGAR; VEGETABLE-BASED SNACK FOODS (U.S. CL. 46).

**CLASS 30—STAPLE FOODS**

FOR CEREAL BASED SNACK FOOD; CHILI SAUCES; CHOCOLATE AND CHOCOLATES; CHOCOLATE BARS; CHOCOLATE COVERED POTATO CHIPS; CHOCOLATE COVERED NUTS; CHOCOLATE COVERED DRIED FRUITS; CHOCOLATE COVERED COOKIES; CHOCOLATE COVERED ROASTED COFFEE BEANS; CHOCOLATE SAUCE; COCKTAIL SAUCES; COFFEE; COOKIES; COOKING SAUCES; CRACKERS; DIPPING SAUCES; FRUIT SAUCES EXCLUDING CRANBERRY SAUCE AND APPLESAUCE; PASTA; PASTA SAUCE, POPCORN; READY-MADE SAUCES; SAUCES; SNACK FOODS, NAMELY, CHOCOLATE-BASED SNACK FOODS; SPICE BLENDS; SPICE RUBS; SPICES; SUGARED NUTS (U.S. CL. 46).

LEIGH LOWRY, EXAMINING ATTORNEY

SN 86-286,070. TSA STORES, INC., ENGLEWOOD, CO. FILED 5-20-2014.

NATURALLY CENTERED

THE MARK CONSISTS OF STANDARD CHARACTERS WITHOUT CLAIM TO ANY PARTICULAR FONT, STYLE, SIZE, OR COLOR.

**CLASS 25—CLOTHING**

FOR LADIES APPAREL, NAMELY, SHIRTS, SHORTS, PANTS, TIGHTS AND HOSIERY (U.S. CLS. 22 AND 39).

**CLASS 28—TOYS AND SPORTING GOODS**

FOR SPORTING GOODS, NAMELY, YOGA MATS, YOGA STRAPS, YOGA BLOCKS, YOGA CUSHIONS, YOGA BOLSTERS, YOGA BOARDS; BAGS SPECIALLY ADAPTED TO CARRY YOGA EQUIPMENT (U.S. CLS. 22, 23, 38 AND 50).

KAREN SEVERSON, EXAMINING ATTORNEY

SN 86-286,818. FOREST LABORATORIES, INC., NEW YORK, NY. FILED 5-20-2014.



THE MARK CONSISTS OF TWO ASCENDING THREE DIMENSIONAL TOWERS IN THE SHAPE OF THE LETTER V WITH SIX CIRCLES FORMING A CURVING LINE AT THE BOTTOM.

SN 86-286,286. A&E TELEVISION NETWORKS, LLC, NEW YORK, NY. FILED 5-20-2014.

**UNITED STUFF OF AMERICA**

THE MARK CONSISTS OF STANDARD CHARACTERS WITHOUT CLAIM TO ANY PARTICULAR FONT, STYLE, SIZE, OR COLOR.

OWNER OF U.S. REG. NO. 4,191,434.

**CLASS 9—ELECTRICAL AND SCIENTIFIC APPARATUS**

FOR MULTIMEDIA GOODS, NAMELY, PRERECORDED DIGITAL VIDEO DISCS AND DVDS FEATURING SUBJECTS OF GENERAL HUMAN INTEREST; DIGITAL MEDIA, NAMELY, DOWNLOADABLE AUDIO AND VIDEO FILES FEATURING SUBJECTS OF GENERAL HUMAN INTEREST; DOWNLOADABLE WEBCASTS AND PODCASTS FEATURING SUBJECTS OF GENERAL HUMAN INTEREST; DOWNLOADABLE GRAPHICS FOR WIRELESS DEVICES; DOWNLOADABLE ON-LINE DISCUSSION BOARD POSTS FEATURING SUBJECTS OF GENERAL HUMAN INTEREST; COMPUTER GAME SOFTWARE AND VIDEO GAME SOFTWARE; DOWNLOADABLE COMPUTER AND VIDEO GAME SOFTWARE VIA A GLOBAL COMPUTER NETWORK, MOBILE PLATFORMS, AND WIRELESS DEVICES FOR ENTERTAINMENT PURPOSES; DOWNLOADABLE MOBILE APPLICATIONS FOR GAMES (U.S. CLS. 21, 23, 26, 36 AND 38).

**CLASS 41—EDUCATION AND ENTERTAINMENT**

FOR ENTERTAINMENT SERVICES, NAMELY, A MULTIMEDIA PROGRAM SERIES FEATURING SUBJECTS OF GENERAL HUMAN INTEREST DISTRIBUTED VIA VARIOUS PLATFORMS ACROSS MULTIPLE FORMS OF TRANSMISSION MEDIA; ENTERTAINMENT SERVICES, NAMELY, AN ONGOING TELEVISION SERIES FEATURING SUBJECTS OF GENERAL HUMAN INTEREST; PROVIDING A WEBSITE FEATURING ENTERTAINMENT INFORMATION; ENTERTAINMENT SERVICES, NAMELY, PROVIDING TEMPORARY USE OF A REAL-TIME, NON-DOWNLOADABLE GAME FOR OTHERS VIA THE INTERNET, MOBILE NETWORK PLATFORMS, AND LOCAL AREA COMPUTER NETWORKS; ELECTRONIC GAME SERVICES, NAMELY, PROVIDING ONLINE ELECTRONIC GAMES BY MEANS OF THE INTERNET, MOBILE NETWORK PLATFORMS, AND LOCAL AREA COMPUTER NETWORKS; ENTERTAINMENT SERVICES, NAMELY, PROVIDING TEMPORARY USE OF NON-DOWNLOADABLE INTERACTIVE GAMES (U.S. CLS. 100, 101 AND 107).

MICHAEL P EISNACH, EXAMINING ATTORNEY

**CLASS 44—MEDICAL, BEAUTY AND AGRICULTURAL SERVICES**

FOR MEDICAL INFORMATION SERVICES, NAMELY, PROVIDING HEALTH INFORMATION IN THE FIELD OF BACTERIAL INFECTIONS VIA A GLOBAL COMPUTER NETWORK (U.S. CLS. 100 AND 101).

GEORGE LORENZO, EXAMINING ATTORNEY

SN 86-288,717. RARE ANTIBODY ANTIGEN SUPPLY, INC., AGOURA HILLS, CA. FILED 5-22-2014.

**KUNAKIN**

THE MARK CONSISTS OF STANDARD CHARACTERS WITHOUT CLAIM TO ANY PARTICULAR FONT, STYLE, SIZE, OR COLOR.

THE WORDING "KUNAKIN" HAS NO MEANING IN A FOREIGN LANGUAGE.

**CLASS 5—PHARMACEUTICALS**

FOR SOY PROTEIN FOR USE AS A NUTRITIONAL SUPPLEMENT IN VARIOUS POWDERED AND READY-TO-DRINK BEVERAGES (U.S. CLS. 6, 18, 44, 46, 51 AND 52).

**CLASS 29—MEATS AND PROCESSED FOODS**

FOR SOY-BASED FOOD BEVERAGE USED AS A MILK SUBSTITUTE (U.S. CL. 46).

**CLASS 32—LIGHT BEVERAGES**

FOR SOY-BASED BEVERAGES NOT BEING MILK SUBSTITUTES (U.S. CLS. 45, 46 AND 48).  
JOHN HWANG, EXAMINING ATTORNEY

SN 86-288,790. RARE ANTIBODY ANTIGEN SUPPLY, INC.,  
AGOURA HILLS, CA. FILED 5-22-2014.

SN 86-288,727. RARE ANTIBODY ANTIGEN SUPPLY, INC.,  
AGOURA HILLS, CA. FILED 5-22-2014.

---

# HIDENKA

THE MARK CONSISTS OF STANDARD CHARACTERS WITHOUT CLAIM TO ANY PARTICULAR FONT, STYLE, SIZE, OR COLOR.

THE ENGLISH TRANSLATION OF "HIDENKA" IS "PRINCESS".

**CLASS 32—LIGHT BEVERAGES**

FOR BEER; BOTTLED WATER; CONCENTRATES FOR MAKING FRUIT DRINKS; GRAPE JUICE; GRAPE JUICE BEVERAGES; SOY-BASED BEVERAGES NOT BEING MILK SUBSTITUTES (U.S. CLS. 45, 46 AND 48).

**CLASS 33—WINES AND SPIRITS**

FOR ALCOHOLIC COCKTAIL MIXES, NAMELY, MARGARITA MIXES; LIQUOR; SAKE; TEQUILA; WINE (U.S. CLS. 47 AND 49).

JOHN HWANG, EXAMINING ATTORNEY

SN 86-288,751. RARE ANTIBODY ANTIGEN SUPPLY, INC.,  
AGOURA HILLS, CA. FILED 5-22-2014.

---

# TENNO

THE MARK CONSISTS OF STANDARD CHARACTERS WITHOUT CLAIM TO ANY PARTICULAR FONT, STYLE, SIZE, OR COLOR.

THE ENGLISH TRANSLATION OF "TENNO" IS "HEAVENLY SOVEREIGN".

**CLASS 30—STAPLE FOODS**

FOR COFFEE; COFFEE-BASED BEVERAGES; TEA (U.S. CL. 46).

**CLASS 32—LIGHT BEVERAGES**

FOR BEER; BOTTLED WATER; CONCENTRATES FOR MAKING FRUIT DRINKS; GRAPE JUICE; GRAPE JUICE BEVERAGES; SOY-BASED BEVERAGES NOT BEING MILK SUBSTITUTES (U.S. CLS. 45, 46 AND 48).

**CLASS 33—WINES AND SPIRITS**

FOR LIQUOR; SAKE; TEQUILA; WINE (U.S. CLS. 47 AND 49).

JOHN HWANG, EXAMINING ATTORNEY

# OHHI

THE MARK CONSISTS OF STANDARD CHARACTERS WITHOUT CLAIM TO ANY PARTICULAR FONT, STYLE, SIZE, OR COLOR.

THE WORDING "OHHI" HAS NO MEANING IN A FOREIGN LANGUAGE.

**CLASS 29—MEATS AND PROCESSED FOODS**

FOR EDIBLE BIRD'S NESTS (U.S. CL. 46).

**CLASS 32—LIGHT BEVERAGES**

FOR BEER; BOTTLED WATER; CONCENTRATES FOR MAKING FRUIT DRINKS; GRAPE JUICE; GRAPE JUICE BEVERAGES; SOY-BASED BEVERAGES NOT BEING MILK SUBSTITUTES (U.S. CLS. 45, 46 AND 48).

**CLASS 33—WINES AND SPIRITS**

FOR ALCOHOLIC COCKTAIL MIXES, NAMELY, MARGARITA MIXES; LIQUOR; SAKE; TEQUILA; WINE (U.S. CLS. 47 AND 49).

JOHN HWANG, EXAMINING ATTORNEY

SN 86-288,844. RARE ANTIBODY ANTIGEN SUPPLY, INC.,  
AGOURA HILLS, CA. FILED 5-22-2014.

---

# RAAS NUTRITIONALS

THE MARK CONSISTS OF STANDARD CHARACTERS WITHOUT CLAIM TO ANY PARTICULAR FONT, STYLE, SIZE, OR COLOR.

NO CLAIM IS MADE TO THE EXCLUSIVE RIGHT TO USE "NUTRITIONALS", APART FROM THE MARK AS SHOWN.

**CLASS 5—PHARMACEUTICALS**

FOR DIETARY AND NUTRITIONAL SUPPLEMENTS; DIETARY SUPPLEMENT BEVERAGE FOR AIDING SLEEP; FOOD FOR INFANTS; HERBAL DRINKS USED TO AID IN SLEEP AND RELAXATION; LIQUID NUTRITIONAL SUPPLEMENT; NATURAL SLEEP AID PREPARATIONS; POWDERED NUTRITIONAL SUPPLEMENT CONCENTRATE; SOY PROTEIN FOR USE AS A NUTRITIONAL SUPPLEMENT IN VARIOUS POWDERED AND READY-TO-DRINK BEVERAGES (U.S. CLS. 6, 18, 44, 46, 51 AND 52).

**CLASS 29—MEATS AND PROCESSED FOODS**

FOR DRIED MILK POWDER; MILK POWDER; MILK POWDER FOR NUTRITIONAL PURPOSES (U.S. CL. 46).

JOHN HWANG, EXAMINING ATTORNEY

SN 86-289,809. BRAND ENFORCEMENT SERVICES LIMITED, HONG KONG, HONG KONG, FILED 5-22-2014.

## SIMILAR LOOK

THE MARK CONSISTS OF STANDARD CHARACTERS WITHOUT CLAIM TO ANY PARTICULAR FONT, STYLE, SIZE, OR COLOR.

### CLASS 35—ADVERTISING AND BUSINESS

FOR PROVIDING AN ADVERTISING WEBSITE FEATURING DIRECTORY INFORMATION ABOUT WEBSITES BASED ON ANALYSIS AND COMPILATION OF DATA FROM RESOURCES AVAILABLE ON GLOBAL INFORMATION NETWORKS; BUSINESS CONSULTATION, NAMELY, ONLINE ANALYSIS AND RANKING OF RELATIONSHIPS BETWEEN WEBSITES FOR BUSINESS PURPOSES; BUSINESS SERVICES, NAMELY, PROVIDING A WEBSITE FEATURING INFORMATION ABOUT THE MANAGEMENT OF INTELLECTUAL PROPERTY (U.S. CLS. 100, 101 AND 102).

### CLASS 42—SCIENTIFIC AND COMPUTER SERVICES

FOR APPLICATION SERVICE PROVIDER SERVICES FEATURING SOFTWARE FOR USE IN RESEARCHING INTERNET DOMAIN NAMES; COMPUTER SERVICES IN THE NATURE OF PROVIDING SOFTWARE AS A SERVICE FEATURING SOFTWARE FOR SEARCHING, TRACKING AND MONITORING OF BRANDS, DOMAINS AND TRADEMARKS, FOR THE PURPOSE OF FACILITATING USERS IN PROTECTING THEIR BRANDS, DOMAINS AND TRADEMARKS (U.S. CLS. 100 AND 101).

### CLASS 45—PERSONAL AND LEGAL SERVICES

FOR INTELLECTUAL PROPERTY CONSULTATION FEATURING INTELLECTUAL PROPERTY RESEARCH AND STRATEGY SUPPORT SERVICES PROVIDED VIA A WEBSITE FEATURING INFORMATION DERIVED FROM RESOURCES AVAILABLE ON GLOBAL INFORMATION NETWORKS; LEGAL SERVICES, NAMELY, PROVIDING A WEBSITE WHERE USERS CAN CONDUCT SEARCHES FOR THE PURPOSE OF BRAND NAME PROTECTION (U.S. CLS. 100 AND 101).  
EVELYN BRADLEY, EXAMINING ATTORNEY

SN 86-289,836. BRAND ENFORCEMENT SERVICES LIMITED, HONG KONG, HONG KONG, FILED 5-22-2014.

## SIMILAR CONTENT

THE MARK CONSISTS OF STANDARD CHARACTERS WITHOUT CLAIM TO ANY PARTICULAR FONT, STYLE, SIZE, OR COLOR.

### CLASS 35—ADVERTISING AND BUSINESS

FOR PROVIDING AN ADVERTISING WEBSITE FEATURING DIRECTORY INFORMATION ABOUT WEBSITES BASED ON ANALYSIS AND COMPILATION OF DATA FROM RESOURCES AVAILABLE ON GLOBAL INFORMATION NETWORKS; BUSINESS CONSULTATION, NAMELY, ONLINE ANALYSIS AND RANKING OF RELATIONSHIPS BETWEEN WEBSITES FOR BUSINESS PURPOSES; BUSINESS SERVICES, NAMELY, PROVIDING A WEBSITE FEATURING INFORMATION ABOUT THE MANAGEMENT OF INTELLECTUAL PROPERTY (U.S. CLS. 100, 101 AND 102).

### CLASS 42—SCIENTIFIC AND COMPUTER SERVICES

FOR APPLICATION SERVICE PROVIDER SERVICES FEATURING SOFTWARE FOR USE IN RESEARCHING INTERNET DOMAIN NAMES; COMPUTER SERVICES IN THE NATURE OF PROVIDING SOFTWARE AS A SERVICE FEATURING SOFTWARE FOR SEARCHING, TRACKING AND MONITORING OF BRANDS, DOMAINS AND TRADEMARKS, FOR THE PURPOSE OF FACILITATING USERS IN PROTECTING THEIR BRANDS, DOMAINS AND TRADEMARKS (U.S. CLS. 100 AND 101).

### CLASS 45—PERSONAL AND LEGAL SERVICES

FOR INTELLECTUAL PROPERTY CONSULTATION FEATURING INTELLECTUAL PROPERTY RESEARCH AND STRATEGY SUPPORT SERVICES PROVIDED VIA A WEBSITE FEATURING INFORMATION DERIVED FROM RESOURCES AVAILABLE ON GLOBAL INFORMATION NETWORKS; LEGAL SERVICES, NAMELY, PROVIDING A WEBSITE WHERE USERS CAN CONDUCT SEARCHES FOR THE PURPOSE OF BRAND NAME PROTECTION (U.S. CLS. 100 AND 101).  
EVELYN BRADLEY, EXAMINING ATTORNEY

SN 86-289,907. CARLON HOLDINGS, INDIANAPOLIS, IN. FILED 5-22-2014.

## Drop it Like it's

THE MARK CONSISTS OF STANDARD CHARACTERS WITHOUT CLAIM TO ANY PARTICULAR FONT, STYLE, SIZE, OR COLOR.

### CLASS 32—LIGHT BEVERAGES

FOR NON-ALCOHOLIC COCKTAIL MIXES (U.S. CLS. 45, 46 AND 48).

### CLASS 33—WINES AND SPIRITS

FOR ALCOHOLIC COCKTAIL MIXES; PREPARED ALCOHOLIC COCKTAIL; SPIRITS AND LIQUEURS (U.S. CLS. 47 AND 49).  
DAVID MURRAY, EXAMINING ATTORNEY



SN 86-290,136. TRUE VALUE COMPANY, CHICAGO, IL. FILED 5-23-2014.

## TRUE VALUE RENTAL

THE MARK CONSISTS OF STANDARD CHARACTERS WITHOUT CLAIM TO ANY PARTICULAR FONT, STYLE, SIZE, OR COLOR.

NO CLAIM IS MADE TO THE EXCLUSIVE RIGHT TO USE "RENTAL", APART FROM THE MARK AS SHOWN.

### CLASS 35—ADVERTISING AND BUSINESS

FOR RETAIL STORE SERVICES FEATURING PARTY EQUIPMENT AND SUPPLIES, PARTY BOXES, ICE SCULPTURES AND LIGHTED TRAY DISPLAYS; RENTAL OF OFFICE EQUIPMENT (U.S. CLS. 100, 101 AND 102).

### CLASS 37—CONSTRUCTION AND REPAIR

FOR RENTAL OF CONSTRUCTION EQUIPMENT FOR PARTIES; RENTAL OF PAINTING EQUIPMENT FOR PARTIES; RENTAL OF FLOOR CLEANING MACHINES FOR PARTIES; RENTAL OF HAND AND POWER TOOLS FOR PARTIES; RENTAL OF PAPERING APPURTENANCES, PAINTING SUPPLIES, AUTOMOTIVE TOOLS AND EQUIPMENT, HOUSEHOLD REPAIR, CLEANING AND MAINTENANCE EQUIPMENT, AND PLUMBING EQUIPMENT; RENTAL OF CARPET CLEANING MACHINES, FLOOR SCRUBBERS, POLISHERS AND SANDERS; RENTAL OF PORTABLE GAS OR AIR COMPRESSORS; RENTAL OF TRASH PUMPS AND PRESSURE WASHERS; RENTAL OF CONTRACTOR'S EQUIPMENT (U.S. CLS. 100, 103 AND 106).

### CLASS 39—TRANSPORTATION AND STORAGE

FOR RENTAL OF MOVING EQUIPMENT AND SUPPLIES FOR PARTIES, NAMELY, MOVING PADS, BLANKETS, PALLET JACKS, DOLLIES, BOXES, AND HAND TRUCKS (U.S. CLS. 100 AND 105).

### CLASS 40—MATERIAL TREATMENT

FOR RENTAL OF ELECTRIC POWER GENERATORS AND ELECTRICITY GENERATORS; RENTAL OF AIR TREATING APPLIANCES (U.S. CLS. 100, 103 AND 106).

### CLASS 41—EDUCATION AND ENTERTAINMENT

FOR RENTAL OF EVENT SCENERY, NAMELY, WEDDING ARCHES AND CANDELABRAS; RENTAL OF PORTABLE SUPPORT STRUCTURES FOR DANCE AND OTHER EXERCISES; RENTAL OF PARTY EQUIPMENT AND SUPPLIES, NAMELY, BOUNCE HOUSES AND SLIDES; RENTAL OF BANQUET SUPPLIES, RENTAL OF SPORTS AND RECREATIONAL EQUIPMENT AND EXERCISE APPARATUS; RENTAL OF AUDIO-VISUAL EQUIPMENT (U.S. CLS. 100, 101 AND 107).

### CLASS 43—HOTEL AND RESTAURANT SERVICES

FOR RENTAL OF BARBECUE GRILLS; RENTAL OF COTTON CANDY MACHINES; RENTAL OF TENTS AND CANOPIES; RENTAL OF FURNITURE; RENTAL OF FOLDING CHAIRS AND TABLES; AND RENTAL OF FOOD SERVICE EQUIPMENT; RENTAL OF TABLE LINENS, TABLEWARE SILVERWARE, DISHES AND TABLE ACCESSORIES FOR SPECIAL EVENTS; RENTAL OF WATER AND BEVERAGE DISPENSERS, POPCORN AND FROZEN DRINK MACHINES; RENTAL OF CAMPING EQUIPMENT, NAMELY TENTS AND STOVES (U.S. CLS. 100 AND 101).

### CLASS 44—MEDICAL, BEAUTY AND AGRICULTURAL SERVICES

FOR RENTAL OF LAWN AND GARDENING EQUIPMENT AND TOOLS FOR PARTIES; RENTAL OF LAWN MOWERS; RENTAL OF LEAF BLOWERS, AERATORS, GARDEN TILLERS, LAWN EDGERS, TURF RAKES, SOD CUTTERS, LOG SPLITTERS, STUMP GRINDERS, AUGERS AND CHAIN SAWS (U.S. CLS. 100 AND 101). ANNE MADDEN, EXAMINING ATTORNEY

SN 86-291,093. SEARCH OPTICS, LLC, FERNDALE, MI. FILED 5-23-2014.

## UPTIC MEDIA

THE MARK CONSISTS OF STANDARD CHARACTERS WITHOUT CLAIM TO ANY PARTICULAR FONT, STYLE, SIZE, OR COLOR.

NO CLAIM IS MADE TO THE EXCLUSIVE RIGHT TO USE "MEDIA", APART FROM THE MARK AS SHOWN.

### CLASS 35—ADVERTISING AND BUSINESS

FOR ADVERTISING, MARKETING AND PROMOTION SERVICES (U.S. CLS. 100, 101 AND 102).

### CLASS 42—SCIENTIFIC AND COMPUTER SERVICES

FOR COMPUTER SERVICES, NAMELY, DESIGNING AND IMPLEMENTING WEB SITES FOR OTHERS (U.S. CLS. 100 AND 101).

CHERYL CLAYTON, EXAMINING ATTORNEY

SN 86-291,095. SEARCH OPTICS, LLC, FERNDALE, MI. FILED 5-23-2014.

## UPACCESS MEDIA

THE MARK CONSISTS OF STANDARD CHARACTERS WITHOUT CLAIM TO ANY PARTICULAR FONT, STYLE, SIZE, OR COLOR.

NO CLAIM IS MADE TO THE EXCLUSIVE RIGHT TO USE "MEDIA", APART FROM THE MARK AS SHOWN.

**CLASS 35—ADVERTISING AND BUSINESS**

FOR ADVERTISING, MARKETING AND PROMOTION SERVICES (U.S. CLS. 100, 101 AND 102).

**CLASS 42—SCIENTIFIC AND COMPUTER SERVICES**

FOR COMPUTER SERVICES, NAMELY, DESIGNING AND IMPLEMENTING WEB SITES FOR OTHERS (U.S. CLS. 100 AND 101).

CHERYL CLAYTON, EXAMINING ATTORNEY

SN 86-292,027. FABARA, LUIS, MIAMI, FL. FILED 5-27-2014.



NO CLAIM IS MADE TO THE EXCLUSIVE RIGHT TO USE "CAFE & LOUNGE", APART FROM THE MARK AS SHOWN.

THE COLOR(S) BROWN, BLUE, ORANGE, WHITE AND GRAY IS/ARE CLAIMED AS A FEATURE OF THE MARK.

THE MARK CONSISTS OF THE STYLIZED WORDING "SOMEWHERE" APPEARING IN WHITE ON VERTICAL WOODEN BOARDS OF VARYING LENGTHS WITH THE BOARDS BEHIND THE LETTERS "S", "W" AND "E" IN "SOMEWHERE" APPEARING IN BROWN, THE BOARDS BEHIND THE LETTERS "O", "E" AND "R" APPEARING IN BLUE, THE BOARDS BEHIND THE LETTERS "M", "H" AND "E" APPEARING IN ORANGE, WITH THREE SMALL ORANGE TILES FORMING AN ELLIPSIS AFTER "SOMEWHERE", THE STYLIZED WORD "ELSE" APPEARING IN WHITE ON A BROWN WOODEN BOARD ANGLED ABOVE THE LAST LETTER "E" IN "SOMEWHERE", AND WITH THE STYLIZED WORDING "CAFE & LOUNGE" APPEARING ON A HORIZONTAL BROWN WOODEN BOARD BELOW THE RIGHT PORTION OF THE WORD "SOMEWHERE" WITH THE WORDS "CAFÉ" AND "LOUNGE" APPEARING IN WHITE AND WITH THE "&" APPEARING IN GRAY.

SN 86-291,589. GAMAGA, INC., SANTIAGO, CHILE, FILED 5-26-2014.

**FOLLOW TUTO**

THE MARK CONSISTS OF STANDARD CHARACTERS WITHOUT CLAIM TO ANY PARTICULAR FONT, STYLE, SIZE, OR COLOR.

THE NAME(S), PORTRAIT(S), AND/OR SIGNATURE(S) SHOWN IN THE MARK DOES NOT IDENTIFY A PARTICULAR LIVING INDIVIDUAL.

THE WORDING "TUTO" HAS NO MEANING IN A FOREIGN LANGUAGE.

**CLASS 9—ELECTRICAL AND SCIENTIFIC APPARATUS**

FOR COMPUTER GAME PROGRAMS; COMPUTER GAME SOFTWARE; COMPUTER GAME SOFTWARE DOWNLOADABLE FROM A GLOBAL COMPUTER NETWORK; COMPUTER GAME SOFTWARE FOR USE ON MOBILE AND CELLULAR PHONES; DOWNLOADABLE COMPUTER GAME PROGRAMS; DOWNLOADABLE COMPUTER GAME SOFTWARE VIA A GLOBAL COMPUTER NETWORK AND WIRELESS DEVICES; ELECTRONIC GAME SOFTWARE FOR CELLULAR TELEPHONES; ELECTRONIC GAME SOFTWARE FOR HANDHELD ELECTRONIC DEVICES; ELECTRONIC GAME SOFTWARE FOR WIRELESS DEVICES; GAME SOFTWARE; INTERACTIVE VIDEO GAME PROGRAMS; VIDEO GAME SOFTWARE (U.S. CLS. 21, 23, 26, 36 AND 38).

FIRST USE 5-26-2014; IN COMMERCE 5-26-2014.

**CLASS 41—EDUCATION AND ENTERTAINMENT**

FOR ENTERTAINMENT SERVICES, NAMELY, PROVIDING A WEBSITE FEATURING GAMES AND PUZZLES; ENTERTAINMENT SERVICES, NAMELY, PROVIDING AN ON-LINE COMPUTER GAME; ENTERTAINMENT SERVICES, NAMELY, PROVIDING BRAIN TRAINING GAMES ON-LINE AND IN MOBILE WIRELESS FORM; ENTERTAINMENT SERVICES, NAMELY, PROVIDING ONLINE ELECTRONIC GAMES; ENTERTAINMENT SERVICES, NAMELY, PROVIDING ONLINE VIDEO GAMES (U.S. CLS. 100, 101 AND 107).

FIRST USE 5-26-2014; IN COMMERCE 5-26-2014.  
SCOTT BIBB, EXAMINING ATTORNEY

**CLASS 25—CLOTHING**

FOR HATS; HEAD SWEATBANDS; SWIM SUITS; T-SHIRTS; TANK-TOPS (U.S. CLS. 22 AND 39).

**CLASS 30—STAPLE FOODS**

FOR BARBEQUE SAUCE; CHILI SAUCE; COFFEE; HOT CHILI PEPPER SAUCE; HOT SAUCE; JERK SAUCE; TEA (U.S. CL. 46).

**CLASS 43—HOTEL AND RESTAURANT SERVICES**

FOR BAR AND RESTAURANT SERVICES; TAKE-OUT RESTAURANT SERVICES (U.S. CLS. 100 AND 101).

AMY KERTGATE, EXAMINING ATTORNEY

SN 86-294,237. THREAT STREAM INC., REDWOOD CITY, CA. FILED 5-28-2014.



THE MARK CONSISTS OF THE WORD "THREAT-STREAM" NEXT TO AN HOURGLASS.

**CLASS 9—ELECTRICAL AND SCIENTIFIC APPARATUS**

FOR COMPUTER SOFTWARE FOR PROVIDING COMPUTER AND NETWORK SECURITY; COMPUTER SOFTWARE PLATFORMS FOR LOCATING, ASSESSING, MEASURING AND REMEDIATION OF SUSPECTED MALWARE AND PROVIDING NETWORK SECURITY; DOWNLOADABLE COMPUTER SOFTWARE FOR PROVIDING COMPUTER AND NETWORK SECURITY, ANTI-VIRUS PROTECTION, FOR THE DETECTION OF INTERNET THREATS AND ATTACKS, AND FOR PROVIDING SECURE TRANSMISSION OF COMMUNICATIONS, DATA, SOUND AND IMAGES VIA COMPUTER NETWORKS (U.S. CLS. 21, 23, 26, 36 AND 38).

**CLASS 42—SCIENTIFIC AND COMPUTER SERVICES**

FOR COMPUTER SECURITY CONSULTANCY IN THE FIELD OF SCANNING AND PENETRATION TESTING OF COMPUTERS AND NETWORKS TO ASSESS INFORMATION SECURITY VULNERABILITY; COMPUTER SECURITY SERVICE, NAMELY, RESTRICTING ACCESS TO AND BY COMPUTER NETWORKS TO AND OF UNDESIRE WEB SITES, MEDIA AND INDIVIDUALS AND FACILITIES; COMPUTER SECURITY SERVICES, NAMELY, ENFORCING, RESTRICTING AND CONTROLLING ACCESS PRIVILEGES OF USERS OF COMPUTING RESOURCES FOR CLOUD, MOBILE OR NETWORK RESOURCES BASED ON ASSIGNED CREDENTIALS; DESIGN AND DEVELOPMENT OF ELECTRONIC DATA SECURITY SYSTEMS; DEVELOPMENT OF SECURITY SYSTEMS AND CONTINGENCY PLANNING FOR INFORMATION SYSTEMS; MAINTENANCE OF COMPUTER SOFTWARE RELATING TO COMPUTER SECURITY AND PREVENTION OF COMPUTER RISKS; SOFTWARE AS A SERVICE (SAAS) SERVICES FEATURING SOFTWARE FOR COMPUTER SECURITY; UPDATING OF COMPUTER SOFTWARE RELATING TO COMPUTER SECURITY AND PREVENTION OF COMPUTER RISKS (U.S. CLS. 100 AND 101).

JENNIFER RICHARDSON, EXAMINING ATTORNEY

SN 86-295,688. AMERICAN READING COMPANY, KING OF PRUSSIA, PA. FILED 5-30-2014.

**EIRLA**

THE MARK CONSISTS OF STANDARD CHARACTERS WITHOUT CLAIM TO ANY PARTICULAR FONT, STYLE, SIZE, OR COLOR.

OWNER OF U.S. REG. NO. 3,423,682.

**CLASS 41—EDUCATION AND ENTERTAINMENT**

FOR EDUCATION SERVICES, NAMELY, PROVIDING ONLINE COGNITIVE ASSESSMENTS AND TRAINING PROGRAMS THAT HELP IDENTIFY COGNITIVE STRENGTHS AND WEAKNESSES OF AN INDIVIDUAL; EDUCATIONAL SERVICES, NAMELY, A READING PROGRAM FOR PRE-KINDERGARTEN THROUGH SECONDARY SCHOOL AND A PROGRAM FOR ASSESSING THE LEVEL OF DIFFICULTY OF BOOKS AS PART OF A READING PROGRAM; EDUCATIONAL SERVICES, NAMELY, NAMELY, AN ONLINE READING PROGRAM FOR PRE-KINDERGARTEN THROUGH SECONDARY SCHOOL AND A PROGRAM FOR ASSESSING THE LEVEL OF DIFFICULTY OF BOOKS AS PART OF A READING PROGRAM; EDUCATIONAL SERVICES, NAMELY, PROVIDING ONLINE COURSES OF INSTRUCTION AT THE PRIMARY AND SECONDARY LEVEL AND DISTRIBUTION OF COURSE MATERIAL IN CONNECTION THEREWITH (U.S. CLS. 100, 101 AND 107).

FIRST USE 8-9-2010; IN COMMERCE 8-9-2010.

**CLASS 42—SCIENTIFIC AND COMPUTER SERVICES**

FOR PROVIDING TEMPORARY USE OF ON-LINE NON-DOWNLOADABLE SOFTWARE DEVELOPMENT TOOLS FOR USE IN DATABASE MANAGEMENT, FOR USE AS A SPREADSHEET, FOR USE IN WORD PROCESSING IN THE FIELD OF EDUCATION; PROVIDING A WEB SITE FEATURING TEMPORARY USE OF NON-DOWNLOADABLE SOFTWARE FOR USE IN DATABASE MANAGEMENT, FOR USE AS A SPREADSHEET, FOR USE IN WORD PROCESSING IN THE FIELD OF EDUCATION; SOFTWARE AS A SERVICE (SAAS) SERVICES, NAMELY, HOSTING SOFTWARE FOR USE BY OTHERS FOR USE IN DATABASE MANAGEMENT, FOR USE AS A SPREADSHEET, FOR USE IN WORD PROCESSING IN THE FIELD OF EDUCATION (U.S. CLS. 100 AND 101).

FIRST USE 8-9-2010; IN COMMERCE 8-9-2010.

SHAILA LEWIS, EXAMINING ATTORNEY

SN 86-296,384. KITZ CORPORATION, CHIBA-KEN, JAPAN, FILED 5-30-2014.

**PROTKEEP**

OWNER OF JAPAN REG. NO. 5504272, DATED 6-29-2012, EXPIRES 6-29-2022.

OWNER OF U.S. REG. NO. 2,696,997.

THE MARK CONSISTS OF STYLIZED AND CAPITALIZED WORDING "PROTKEEP".

THE WORDING "PROTKEEP" HAS NO MEANING IN A FOREIGN LANGUAGE.

**CLASS 1—CHEMICALS**

FOR CHEMICAL AGENTS FOR USE IN METAL SURFACE FILM FORMATION FOR REDUCING LIXIVIATION OF METAL COMPONENT; CHEMICAL AGENTS, NAMELY, METAL SURFACE FILM FORMATION AGENT FOR LIXIVIATION REDUCTION OF CADMIUM, COPPER, AND ZINC; CHEMICALS, NAMELY, CHEMICAL AGENTS FOR USE IN THE MANUFACTURE OF METAL; ADHESIVES NOT FOR STATIONERY OR HOUSEHOLD PURPOSES, BUT FOR USE IN THE MANUFACTURE OF METAL; HIGHER FATTY ACIDS FOR USE IN THE MANUFACTURE OF METAL; NON-FERROUS METALS, NAMELY, ANTIMONY, SILICON, CERIUM, AND TELLURIUM; NON-METALLIC MINERALS, NAMELY, SULPHUR; UNPROCESSED PLASTICS IN PRIMARY FORM (U.S. CLS. 1, 5, 6, 10, 26 AND 46).

**CLASS 6—METAL GOODS**

FOR IRON AND STEEL; NONFERROUS METALS AND THEIR ALLOYS, NAMELY, ALLOYS OF COMMON METAL; METAL MATERIALS FOR BUILDING AND CONSTRUCTION, NAMELY, WATER PIPES, HINGES, BARS FOR RAILINGS, WALL PANELS, CEILING PANELS, DOORS, BEAMS, WINDOWS, GATES, FLOOR BOARDS, WINDOW SHUTTERS, TILES AND HANDLES FOR DOORS; METAL PULLEYS, SPRINGS AND VALVES NOT INCLUDING MACHINE ELEMENTS; METAL JUNCTIONS FOR PIPES; METAL FLANGES; METAL HARDWARE, NAMELY, METAL SPRINGS; INDUSTRIAL PACKAGING CONTAINERS OF METAL (U.S. CLS. 2, 12, 13, 14, 23, 25 AND 50).

**CLASS 40—MATERIAL TREATMENT**

FOR METAL SURFACE FILM FORMATION TREATMENT FOR ANTI-RUST OR POLISHING; METAL SURFACE FILM FORMATION TREATMENT FOR LIXIVIATION REDUCTION OF CADMIUM, COPPER, OR ZINC; TREATMENT OF METAL; CERAMIC PROCESSING; WATER TREATING; RECYCLING OF WASTE; RENTAL OF METAL TREATING MACHINES AND TOOLS; RENTAL OF CHEMICAL PROCESSING MACHINES AND APPARATUS (U.S. CLS. 100, 103 AND 106).

JOANNA FIORELLI, EXAMINING ATTORNEY

SN 86-298,411. CUBISM INC., MEGURO-KU, TOKYO, JAPAN, FILED 6-3-2014.



THE MARK CONSISTS OF A HAT.

**CLASS 18—LEATHER GOODS**

FOR BAGS, NAMELY, ALL-PURPOSE CARRYING BAGS AND BACKPACKS; POUCHES, NAMELY, LEATHER POUCHES AND TEXTILE POUCHES; PORTABLE MAKE-UP POUCHES SOLD EMPTY; WALLETS NOT OF PRECIOUS METALS; UMBRELLAS; LEATHER STRAPS; UNWORKED LEATHER (U.S. CLS. 1, 2, 3, 22 AND 41).

**CLASS 25—CLOTHING**

FOR CLOTHING, NAMELY, COATS, JACKETS, SUITS, SWEATERS, VESTS, CARDIGANS, SHIRTS, POLO SHIRTS, SWEAT SHIRTS, DRESS SHIRTS, BLOUSES, T-SHIRTS, TUNICS, PULLOVERS, PONCHOS, TANK TOPS, SHORTS, PANTS, SKIRTS, DRESSES, RAINWEAR, SWIMWEAR, SOCKS, UNDERWEAR, NECKTIES, MUFFLERS, SCARVES, STOLEES, GLOVES, BANDANAS, EARMUFFS, HATS, CAPS, AND BELTS; FOOTWEAR EXCLUDING ORTHOPEDIC FOOTWEAR; SHOES; SANDALS; BOOTS, NAMELY, HALF-BOOTS, RACE BOOTS, TREKKING BOOTS, RAIN BOOTS, AND LEATHER BOOTS (U.S. CLS. 22 AND 39).

GINA HAYES, EXAMINING ATTORNEY

SN 86-297,446. CAPITOL WHOLESALE MEATS, INC., MCCOOK, IL. FILED 6-2-2014.

PIE'S THE LIMIT

THE MARK CONSISTS OF STANDARD CHARACTERS WITHOUT CLAIM TO ANY PARTICULAR FONT, STYLE, SIZE, OR COLOR.

**CLASS 29—MEATS AND PROCESSED FOODS**

FOR MEAT; CHEESE; COOKED VEGETABLES (U.S. CL. 46).

**CLASS 30—STAPLE FOODS**

FOR PIZZA CRUST; PIZZA DOUGH; PIZZA SAUCE; SANDWICHES; COOKING SAUCES (U.S. CL. 46).

BARBARA BROWN, EXAMINING ATTORNEY

SN 86-298,614. BARBELLS FOR BOOBS, COSTA MESA, CA. FILED 6-3-2014.

FUNDRAISE. DETECT. SAVE.

THE MARK CONSISTS OF STANDARD CHARACTERS WITHOUT CLAIM TO ANY PARTICULAR FONT, STYLE, SIZE, OR COLOR.

**CLASS 25—CLOTHING**

FOR T-SHIRTS; TOPS; WEARABLE GARMENTS AND CLOTHING, NAMELY, SHIRTS (U.S. CLS. 22 AND 39).

**CLASS 36—INSURANCE AND FINANCIAL**

FOR CHARITABLE FUNDRAISING SERVICES; PROVIDING GRANTS TO ORGANIZATIONS IN THE FIELDS OF PUBLIC HEALTH, CANCER, CANCER RECOVERY AND SURVIVAL (U.S. CLS. 100, 101 AND 102).

**CLASS 44—MEDICAL, BEAUTY AND AGRICULTURAL SERVICES**

FOR PROVIDING A WEBSITE VIA A GLOBAL COMPUTER NETWORK FEATURING INFORMATION IN THE FIELDS OF HEALTH, CANCER, CANCER RECOVERY AND SURVIVAL (U.S. CLS. 100 AND 101).  
CHRIS WELLS, EXAMINING ATTORNEY

SN 86-299,857. NOVEN THERAPEUTICS, LLC, MIAMI, FL.  
FILED 6-4-2014.

SN 86-299,172. ST. JUDE MEDICAL, INC., ST. PAUL, MN.  
FILED 6-3-2014.

**SIMPLESTIM**

THE MARK CONSISTS OF STANDARD CHARACTERS WITHOUT CLAIM TO ANY PARTICULAR FONT, STYLE, SIZE, OR COLOR.

**CLASS 9—ELECTRICAL AND SCIENTIFIC APPARATUS**

FOR PAIN MANAGEMENT DIAGNOSTIC AND PROGRAMMING COMPUTER SOFTWARE AND HARDWARE FOR CONTROLLING A NEUROSTIMULATION SYSTEM (U.S. CLS. 21, 23, 26, 36 AND 38).

**CLASS 10—MEDICAL APPARATUS**

FOR MEDICAL DEVICES FOR USE IN NEUROSTIMULATION, NAMELY, TISSUE AND NEURAL TISSUE STIMULATORS AND CONTROLLERS AND PROGRAMMERS FOR NEURAL TISSUE STIMULATORS (U.S. CLS. 26, 39 AND 44).  
MARC LEIPZIG, EXAMINING ATTORNEY

SN 86-299,846. CONAGRA FOODS RDM, INC., OMAHA, NE.  
FILED 6-4-2014.

**TIME TO SAVOR**

THE MARK CONSISTS OF STANDARD CHARACTERS WITHOUT CLAIM TO ANY PARTICULAR FONT, STYLE, SIZE, OR COLOR.

**CLASS 29—MEATS AND PROCESSED FOODS**

FOR FROZEN, PREPARED OR PRE-PACKAGED DINNERS, MEALS, ENTREES AND SIDE DISHES CONSISTING PRIMARILY OF MEAT, FISH, POULTRY OR VEGETABLES; SOUPS (U.S. CL. 46).

**CLASS 30—STAPLE FOODS**

FOR FRUIT COBBLERS; PIES; POT PIES; FROZEN, PREPARED OR PRE-PACKAGED DINNERS, MEALS, ENTREES AND SIDE DISHES CONSISTING PRIMARILY OF PASTA OR RICE (U.S. CL. 46).  
SUE LAWRENCE, EXAMINING ATTORNEY

**MY BRISDELLE**

THE MARK CONSISTS OF STANDARD CHARACTERS WITHOUT CLAIM TO ANY PARTICULAR FONT, STYLE, SIZE, OR COLOR.

OWNER OF U.S. REG. NOS. 4,482,387 AND 4,496,258.

**CLASS 35—ADVERTISING AND BUSINESS**

FOR ADMINISTRATION OF A CO-PAY SUPPORT PROGRAM FOR ENABLING PARTICIPANTS TO OBTAIN SAVINGS AND DISCOUNTS ON PRESCRIPTION PHARMACEUTICALS (U.S. CLS. 100, 101 AND 102).  
FIRST USE 11-30-2013; IN COMMERCE 11-30-2013.

**CLASS 44—MEDICAL, BEAUTY AND AGRICULTURAL SERVICES**

FOR PATIENT SUPPORT PROGRAM RELATING TO TREATMENT OF MENOPAUSE, NAMELY, PROVIDING INFORMATION TO PATIENTS ABOUT MENOPAUSE AND PROVIDING LINKS TO THE WEB SITES OF OTHERS FEATURING INFORMATION ABOUT MENOPAUSE (U.S. CLS. 100 AND 101).  
FIRST USE 11-30-2013; IN COMMERCE 11-30-2013.

JAMES GRIFFIN, EXAMINING ATTORNEY

SN 86-301,650. LIFETIME ENTERTAINMENT SERVICES, LLC, NEW YORK, NY. FILED 6-5-2014.

**SIXTH SENSE FOR MURDER**

THE MARK CONSISTS OF STANDARD CHARACTERS WITHOUT CLAIM TO ANY PARTICULAR FONT, STYLE, SIZE, OR COLOR.

**CLASS 9—ELECTRICAL AND SCIENTIFIC APPARATUS**

FOR MULTIMEDIA GOODS, NAMELY, PRERECORDED DIGITAL VIDEO DISCS AND DVDS FEATURING SUBJECTS OF GENERAL HUMAN INTEREST; DIGITAL MEDIA, NAMELY, DOWNLOADABLE AUDIO AND VIDEO FILES FEATURING SUBJECTS OF GENERAL HUMAN INTEREST; DOWNLOADABLE WEBCASTS AND PODCASTS FEATURING SUBJECTS OF GENERAL HUMAN INTEREST; DOWNLOADABLE GRAPHICS FOR WIRELESS DEVICES; DOWNLOADABLE ON-LINE DISCUSSION BOARD POSTS FEATURING SUBJECTS OF GENERAL HUMAN INTEREST (U.S. CLS. 21, 23, 26, 36 AND 38).

**CLASS 41—EDUCATION AND ENTERTAINMENT**

FOR ENTERTAINMENT SERVICES, NAMELY, A MULTIMEDIA PROGRAM SERIES FEATURING SUBJECTS OF GENERAL HUMAN INTEREST DISTRIBUTED VIA VARIOUS PLATFORMS ACROSS MULTIPLE FORMS OF TRANSMISSION MEDIA; ENTERTAINMENT SERVICES, NAMELY, AN ONGOING TELEVISION SERIES FEATURING SUBJECTS OF GENERAL HUMAN INTEREST; PROVIDING A WEBSITE FEATURING ENTERTAINMENT INFORMATION (U.S. CLS. 100, 101 AND 107).

WON TEAK OH, EXAMINING ATTORNEY

SN 86-302,078. CARLON HOLDINGS, INDIANAPOLIS, IN. FILED 6-6-2014.

# Mix-a-lot

THE MARK CONSISTS OF STANDARD CHARACTERS WITHOUT CLAIM TO ANY PARTICULAR FONT, STYLE, SIZE, OR COLOR.

**CLASS 32—LIGHT BEVERAGES**

FOR NON-ALCOHOLIC COCKTAIL MIXES (U.S. CLS. 45, 46 AND 48).

**CLASS 33—WINES AND SPIRITS**

FOR ALCOHOLIC COCKTAIL MIXES; PREPARED ALCOHOLIC COCKTAIL; SPIRITS AND LIQUEURS (U.S. CLS. 47 AND 49).

DAVID MURRAY, EXAMINING ATTORNEY

SN 86-302,655. TSA STORES, INC., ENGLEWOOD, CO. FILED 6-6-2014.



THE MARK CONSISTS OF PARALLELOGRAM DESIGN ELEMENT WITH ROUNDED SIDES THAT COME TO A POINT ON THE TOP RIGHT AND BOTTOM LEFT, WITH AN OVAL CUT OUT SECTION IN THE MIDDLE.

**CLASS 9—ELECTRICAL AND SCIENTIFIC APPARATUS**

FOR LIFE VESTS (U.S. CLS. 21, 23, 26, 36 AND 38).

**CLASS 20—FURNITURE AND ARTICLES NOT OTHERWISE CLASSIFIED**

FOR BEACH CHAIRS (U.S. CLS. 2, 13, 22, 25, 32 AND 50).

**CLASS 25—CLOTHING**

FOR SANDALS, WATER SOCKS, BOARD SHORTS, AND RASH GUARDS (U.S. CLS. 22 AND 39).

**CLASS 28—TOYS AND SPORTING GOODS**

FOR INFLATABLE INNER TUBES AND RAFTS FOR AQUATIC RECREATIONAL USE, WATER TOYS (U.S. CLS. 22, 23, 38 AND 50).

KAREN SEVERSON, EXAMINING ATTORNEY

SN 86-305,220. BARBELLS FOR BOOBS, COSTA MESA, CA. FILED 6-10-2014.

# BOX DROP

THE MARK CONSISTS OF STANDARD CHARACTERS WITHOUT CLAIM TO ANY PARTICULAR FONT, STYLE, SIZE, OR COLOR.

**CLASS 25—CLOTHING**

FOR T-SHIRTS; TOPS; WEARABLE GARMENTS AND CLOTHING, NAMELY, SHIRTS (U.S. CLS. 22 AND 39).

**CLASS 36—INSURANCE AND FINANCIAL**

FOR CHARITABLE FUNDRAISING SERVICES; PROVIDING GRANTS TO ORGANIZATIONS IN THE FIELDS OF PUBLIC HEALTH, CANCER, CANCER RECOVERY AND SURVIVAL (U.S. CLS. 100, 101 AND 102).

**CLASS 44—MEDICAL, BEAUTY AND AGRICULTURAL SERVICES**

FOR PROVIDING A WEBSITE VIA A GLOBAL COMPUTER NETWORK FEATURING INFORMATION IN THE FIELDS OF HEALTH, CANCER, CANCER RECOVERY AND SURVIVAL (U.S. CLS. 100 AND 101).

CHRIS WELLS, EXAMINING ATTORNEY

SN 86-305,227. BARBELLS FOR BOOBS, COSTA MESA, CA. FILED 6-10-2014.

# CHECK YOUR PECKS

THE MARK CONSISTS OF STANDARD CHARACTERS WITHOUT CLAIM TO ANY PARTICULAR FONT, STYLE, SIZE, OR COLOR.

**CLASS 25—CLOTHING**

FOR T-SHIRTS; TOPS; WEARABLE GARMENTS AND CLOTHING, NAMELY, SHIRTS (U.S. CLS. 22 AND 39).

**CLASS 36—INSURANCE AND FINANCIAL**

FOR CHARITABLE FUNDRAISING SERVICES; PROVIDING GRANTS TO ORGANIZATIONS IN THE FIELDS OF PUBLIC HEALTH, CANCER, CANCER RECOVERY AND SURVIVAL (U.S. CLS. 100, 101 AND 102).

**CLASS 44—MEDICAL, BEAUTY AND AGRICULTURAL SERVICES**

FOR PROVIDING A WEBSITE VIA A GLOBAL COMPUTER NETWORK FEATURING INFORMATION IN THE FIELDS OF HEALTH, CANCER, CANCER RECOVERY AND SURVIVAL (U.S. CLS. 100 AND 101).  
CHRIS WELLS, EXAMINING ATTORNEY

ALEX KEAM, EXAMINING ATTORNEY

SN 86-306,944. SOCIALWHIRLED, LLC, PHOENIX, AZ.  
FILED 6-11-2014.

SN 86-306,895. ASSURANT, INC., NEW YORK, NY. FILED 6-11-2014.

**MARKETING AT THE SPEED OF IDEAS****GEEK TIPS**

THE MARK CONSISTS OF STANDARD CHARACTERS WITHOUT CLAIM TO ANY PARTICULAR FONT, STYLE, SIZE, OR COLOR.

NO CLAIM IS MADE TO THE EXCLUSIVE RIGHT TO USE "TIPS", APART FROM THE MARK AS SHOWN.

THE MARK CONSISTS OF STANDARD CHARACTERS WITHOUT CLAIM TO ANY PARTICULAR FONT, STYLE, SIZE, OR COLOR.

**CLASS 35—ADVERTISING AND BUSINESS**

FOR MARKETING SERVICES, NAMELY, CONDUCTING MARKETING CAMPAIGNS AND COLLECTING DATA ACROSS MOBILE DEVICES, SOCIAL PLATFORMS AND WEBSITES (U.S. CLS. 100, 101 AND 102).  
FIRST USE 5-23-2014; IN COMMERCE 5-23-2014.

**CLASS 9—ELECTRICAL AND SCIENTIFIC APPARATUS**

FOR DOWNLOADABLE COMPUTER SOFTWARE APPLICATION THAT ALLOWS MOBILE DEVICE USERS TO ACCESS ON-DEVICE SELF-HELP AND TECHNICAL SUPPORT AND EXPEDITED SMART CALL CENTER ROUTING; DOWNLOADABLE COMPUTER SOFTWARE APPLICATION THAT ALLOWS WIRELESS CARRIERS TO PROVIDE DEVICE MONITORING, DEVICE MANAGEMENT AND ON-LINE TECHNICAL SUPPORT (U.S. CLS. 21, 23, 26, 36 AND 38).

**CLASS 42—SCIENTIFIC AND COMPUTER SERVICES**

FOR SOFTWARE AS A SERVICES (SAAS) SERVICES FEATURING SOFTWARE FOR PUBLISHING MARKETING CAMPAIGNS AND COLLECTING DATA ACROSS MOBILE DEVICES, SOCIAL PLATFORMS AND WEBSITES (U.S. CLS. 100 AND 101).  
FIRST USE 5-23-2014; IN COMMERCE 5-23-2014.  
ERNEST SHOSHO, EXAMINING ATTORNEY

**CLASS 36—INSURANCE AND FINANCIAL**

FOR INSURANCE SERVICES, NAMELY, PROVIDING EXTENDED WARRANTIES BY CONTRACT FOR MOBILE DEVICES, NAMELY, WIRELESS TELEPHONES, PAGERS, LAPTOP COMPUTERS AND PERSONAL DIGITAL ASSISTANTS; ADMINISTRATION OF EXTENDED WARRANTY CONTRACTS AND REPAIR AND REPLACEMENT CONTRACTS FOR WIRELESS TELEPHONES, PAGERS, LAPTOP COMPUTERS AND PERSONAL DIGITAL ASSISTANTS (U.S. CLS. 100, 101 AND 102).

SN 86-307,732. MINTO COMMUNITIES, LLC, NAPLES, FL.  
FILED 6-12-2014.

**CLASS 38—COMMUNICATION**

FOR PROVIDING ONLINE FACILITIES FOR REAL-TIME INTERACTION BETWEEN MOBILE DEVICE USERS AND TECHNICAL SUPPORT PERSONNEL; COMMUNICATION SERVICES, NAMELY, TRANSMITTING, RECEIVING, DOWNLOADING, STREAMING, BROADCASTING OF TEXT, IMAGES, AUDIO, VIDEO AND DATA VIA MOBILE DEVICES (U.S. CLS. 100, 101 AND 104).

THE MARK CONSISTS OF THE STYLIZED WORDS "LAKE PARK" WITH TWO SEPARATE BLACK RECTANGLES NEXT TO EACH OTHER AND ABOVE THE WORDS. THE BLACK RECTANGLES ARE CONNECTED BY A WHITE WAVY LINE THAT INTERSECTS BOTH RECTANGLES.

**CLASS 42—SCIENTIFIC AND COMPUTER SERVICES**

FOR PROVIDING TECHNICAL SUPPORT SERVICES, NAMELY, INSTALLATION, MAINTENANCE AND UPDATING OF COMPUTER SOFTWARE FOR MOBILE DEVICES; TECHNICAL SUPPORT SERVICES, NAMELY, MONITORING MOBILE DEVICES, COMMUNICATING RELEVANT ALERTS AND RECOMMENDATIONS TO USERS OF MOBILE DEVICES AND PROVIDING REAL-TIME DATA TO CUSTOMER SERVICES REPRESENTATIVES TO FACILITATE BETTER TECHNICAL SUPPORT SERVICE CALLS USING CUSTOMER-SPECIFIC AND DEVICE-SPECIFIC BEHAVIORAL INFORMATION; TROUBLESHOOTING OF COMPUTER HARDWARE AND SOFTWARE PROBLEMS (U.S. CLS. 100 AND 101).

**CLASS 36—INSURANCE AND FINANCIAL**

FOR REAL ESTATE SERVICES, NAMELY, BROKERAGE, LEASING AND MANAGEMENT OF RESIDENTIAL PROPERTY; REAL ESTATE PROPERTY MANAGEMENT; RESIDENTIAL COMMUNITY PROPERTY MANAGEMENT; REAL ESTATE LISTING SERVICES (U.S. CLS. 100, 101 AND 102).

**CLASS 37—CONSTRUCTION AND REPAIR**

FOR CONSTRUCTION, REAL ESTATE AND LAND DEVELOPMENT SERVICES, NAMELY, CONSTRUCTION, PLANNING AND LAYING OUT OF RESIDENTIAL COMMUNITIES HAVING AMENITIES INCLUDING SWIMMING POOLS, TENNIS COURTS, NATURE AREAS, A COMMUNITY CENTER AND WATERFRONT RECREATIONAL ACTIVITIES (U.S. CLS. 100, 103 AND 106).

CIMMERIAN COLEMAN, EXAMINING ATTORNEY

SN 86-310,893. FIRST DATA CORPORATION, GREENWOOD VILLAGE, CO. FILED 6-16-2014.

**INSIGHTICS**

THE MARK CONSISTS OF STANDARD CHARACTERS WITHOUT CLAIM TO ANY PARTICULAR FONT, STYLE, SIZE, OR COLOR.

**CLASS 9—ELECTRICAL AND SCIENTIFIC APPARATUS**

FOR COMPUTER APPLICATION SOFTWARE FOR MOBILE DEVICES, NAMELY, SOFTWARE FOR USE IN PROVIDING BUSINESS PERFORMANCE AND CONSUMER INTELLIGENCE ANALYTICS (U.S. CLS. 21, 23, 26, 36 AND 38).

**CLASS 35—ADVERTISING AND BUSINESS**

FOR MARKETING SERVICES, NAMELY, CONDUCTING CONSUMER TRACKING BEHAVIOR RESEARCH AND CONSUMER TREND ANALYSIS; PROVIDING BUSINESS INTELLIGENCE SERVICES; PROVIDING MARKET INTELLIGENCE SERVICES (U.S. CLS. 100, 101 AND 102).

**CLASS 42—SCIENTIFIC AND COMPUTER SERVICES**

FOR SOFTWARE AS A SERVICE (SAAS) SERVICES FEATURING SOFTWARE FOR CONDUCTING BUSINESS PERFORMANCE AND CONSUMER INTELLIGENCE ANALYTICS (U.S. CLS. 100 AND 101).

PATRICIA EVANKO, EXAMINING ATTORNEY

SN 86-312,221. BZB ENTERPRISES INC., DEERFIELD, IL. FILED 6-17-2014.

**ABSOLUTE BLOWOUT WINNER**

THE MARK CONSISTS OF STANDARD CHARACTERS WITHOUT CLAIM TO ANY PARTICULAR FONT, STYLE, SIZE, OR COLOR.

**CLASS 16—PAPER GOODS AND PRINTED MATTER**

FOR NEWSLETTERS, BROCHURES, AND MAGAZINES IN THE FIELDS OF SECURITIES, OPTIONS, BONDS AND OTHER FINANCIAL INSTRUMENTS (U.S. CLS. 2, 5, 22, 23, 29, 37, 38 AND 50).

**CLASS 36—INSURANCE AND FINANCIAL**

FOR PROVIDING INFORMATION ON TRADING OPTIONS AND ON PROFITING FROM THE TIME DELAY OF OPTIONS (U.S. CLS. 100, 101 AND 102).

BARNEY CHARLON, EXAMINING ATTORNEY

SN 86-313,490. LOKAI HOLDINGS LLC, NEW YORK, NY. FILED 6-18-2014.

**LIVE LOKAI**

THE MARK CONSISTS OF STANDARD CHARACTERS WITHOUT CLAIM TO ANY PARTICULAR FONT, STYLE, SIZE, OR COLOR.

OWNER OF U.S. REG. NO. 4,429,129.

**CLASS 14—JEWELRY**

FOR BRACELETS; JEWELRY; RUBBER OR SILICONE WRISTBANDS IN THE NATURE OF A BRACELET (U.S. CLS. 2, 27, 28 AND 50).

**CLASS 25—CLOTHING**

FOR ATHLETIC APPAREL, NAMELY, SHIRTS, PANTS, JACKETS, FOOTWEAR, HATS AND CAPS, ATHLETIC UNIFORMS (U.S. CLS. 22 AND 39).

**CLASS 35—ADVERTISING AND BUSINESS**

FOR RETAIL STORE SERVICES FEATURING JEWELRY (U.S. CLS. 100, 101 AND 102).

JUSTIN SEVERSON, EXAMINING ATTORNEY

SN 86-315,791. RARE ANTIBODY ANTIGEN SUPPLY, INC., AGOURA HILLS, CA. FILED 6-20-2014.

**RAAS NUTRITIONALS HEALTHY INFANT FORMULAS**

THE MARK CONSISTS OF STANDARD CHARACTERS WITHOUT CLAIM TO ANY PARTICULAR FONT, STYLE, SIZE, OR COLOR.

NO CLAIM IS MADE TO THE EXCLUSIVE RIGHT TO USE "NUTRITIONALS HEALTHY INFANT FORMULAS", APART FROM THE MARK AS SHOWN.

**CLASS 5—PHARMACEUTICALS**

FOR FOOD FOR INFANTS; INFANT FORMULA (U.S. CLS. 6, 18, 44, 46, 51 AND 52).

**CLASS 29—MEATS AND PROCESSED FOODS**

FOR DRIED MILK POWDER; MILK POWDER; MILK POWDER FOR NUTRITIONAL PURPOSES (U.S. CL. 46).

JOHN HWANG, EXAMINING ATTORNEY



SN 86-318,288. SHENZHEN FIRST UNION TECHNOLOGY CO., LTD., SHENZHEN, CHINA, FILED 6-24-2014.

# FIRSTUNION

THE MARK CONSISTS OF STANDARD CHARACTERS WITHOUT CLAIM TO ANY PARTICULAR FONT, STYLE, SIZE, OR COLOR.

### CLASS 3—COSMETICS AND CLEANING PREPARATIONS

FOR ETHEREAL OILS; STAIN REMOVERS; ETHEREAL ESSENCES; PERFUMERY; DENTIFRICES; COSMETICS; INCENSE; DISH DETERGENTS; LAUNDRY DETERGENT; DETERGENTS FOR HOUSEHOLD USE; PERFUMES FOR INDUSTRIAL PURPOSES (U.S. CLS. 1, 4, 6, 50, 51 AND 52).  
FIRST USE 4-13-2011; IN COMMERCE 1-8-2013.

### CLASS 9—ELECTRICAL AND SCIENTIFIC APPARATUS

FOR COMPUTER PERIPHERAL DEVICES; ELECTRIC NAVIGATIONAL INSTRUMENTS; CAMERAS; PHOTOGRAPHIC CAMERAS; AUTOMATIC INDICATORS OF LOW PRESSURE IN TYRES; INTEGRATED CIRCUITS; PERSONAL SECURITY ALARMS; BATTERIES, ELECTRIC; SOLAR BATTERIES; PERSONAL STEREO (U.S. CLS. 21, 23, 26, 36 AND 38).  
FIRST USE 4-13-2011; IN COMMERCE 1-8-2013.

### CLASS 34—SMOKERS' ARTICLES

FOR TOBACCO; CIGARETTES CONTAINING TOBACCO SUBSTITUTES, NOT FOR MEDICAL PURPOSES; CIGARETTES; HERBS FOR SMOKING; TOBACCO PIPES; CIGARETTE CASES; CIGARETTE HOLDERS; MATCH BOXES; LIGHTERS FOR SMOKERS; CIGARETTE FILTERS; CIGARETTE PAPER; MATCHES; ASHTRAYS FOR SMOKERS; CIGAR HOLDERS; FLAVORED TOBACCO (U.S. CLS. 2, 8, 9 AND 17).  
FIRST USE 4-13-2011; IN COMMERCE 1-8-2013.  
JORDAN BAKER, EXAMINING ATTORNEY

SN 86-318,870. UNITED STATES POSTAL SERVICE, WASHINGTON, DC. FILED 6-24-2014.

# A GOOD FIT FOR BUSINESS

THE MARK CONSISTS OF STANDARD CHARACTERS WITHOUT CLAIM TO ANY PARTICULAR FONT, STYLE, SIZE, OR COLOR.

### CLASS 35—ADVERTISING AND BUSINESS

FOR MAILING SERVICES, NAMELY, SORTING, HANDLING, AND RECEIVING PACKAGES AND LETTERS (U.S. CLS. 100, 101 AND 102).  
FIRST USE 5-0-2014; IN COMMERCE 5-0-2014.

### CLASS 39—TRANSPORTATION AND STORAGE

FOR DELIVERY SERVICES, NAMELY, PICKUP, TRANSPORTATION AND DELIVERY OF PACKAGES AND DOCUMENTS BY VARIOUS MODES OF TRANSPORTATION (U.S. CLS. 100 AND 105).  
FIRST USE 5-0-2014; IN COMMERCE 5-0-2014.  
JEFFERY COWARD, EXAMINING ATTORNEY

SN 86-320,373. SOCIETE BIC, CLICHY, FRANCE, FILED 6-25-2014.

# FLICK IT SAFELY

THE MARK CONSISTS OF STANDARD CHARACTERS WITHOUT CLAIM TO ANY PARTICULAR FONT, STYLE, SIZE, OR COLOR.

### CLASS 11—ENVIRONMENTAL CONTROL APPARATUS

FOR LIGHTERS PRIMARILY FOR LIGHTING GRILLS, FIREPLACES AND CANDLES (U.S. CLS. 13, 21, 23, 31 AND 34).

### CLASS 34—SMOKERS' ARTICLES

FOR CIGARETTE LIGHTERS NOT OF PRECIOUS METALS AND CASES THEREFORE (U.S. CLS. 2, 8, 9 AND 17).

### CLASS 35—ADVERTISING AND BUSINESS

FOR PUBLIC ADVOCACY TO PROMOTE AWARENESS OF FIRE SAFETY (U.S. CLS. 100, 101 AND 102).  
DOMINIC J. FERRAIUOLO, EXAMINING ATTORNEY

SN 86-321,120. NOVARTIS AG, BASEL, SWITZERLAND, FILED 6-26-2014.

# OUR VOICE IN SONG

THE MARK CONSISTS OF STANDARD CHARACTERS WITHOUT CLAIM TO ANY PARTICULAR FONT, STYLE, SIZE, OR COLOR.

**CLASS 9—ELECTRICAL AND SCIENTIFIC APPARATUS**

FOR DOWNLOADABLE MUSIC FILES; DOWNLOADABLE VIDEO RECORDINGS FEATURING TOPICS AND INFORMATION RELATED TO NEUROLOGICAL DISEASES AND DISORDERS; MULTIMEDIA SOFTWARE RECORDED ON CD-ROM FEATURING TOPICS AND INFORMATION RELATED TO NEUROLOGICAL DISEASES AND DISORDERS; MUSICAL RECORDINGS; PRE-RECORDED CDS, VIDEO TAPES, LASER DISKS AND DVDS FEATURING TOPICS AND INFORMATION RELATED TO NEUROLOGICAL DISEASES AND DISORDERS; PRERECORDED AUDIO TAPES FEATURING MUSIC; PRERECORDED VIDEO TAPES FEATURING MUSIC; SOUND RECORDINGS FEATURING TOPICS AND INFORMATION RELATED TO NEUROLOGICAL DISEASES AND DISORDERS; VIDEO RECORDINGS FEATURING TOPICS AND INFORMATION RELATED TO NEUROLOGICAL DISEASES AND DISORDERS (U.S. CLS. 21, 23, 26, 36 AND 38).

**CLASS 35—ADVERTISING AND BUSINESS**

FOR PROMOTING PUBLIC AWARENESS OF THE NEED FOR TREATMENT AND MANAGEMENT OF NEUROLOGICAL DISEASES AND DISORDERS (U.S. CLS. 100, 101 AND 102).

**CLASS 41—EDUCATION AND ENTERTAINMENT**

FOR EDUCATIONAL SERVICES, NAMELY, CONDUCTING PROGRAMS FOR PATIENTS AND RELATIVES IN THE FIELD OF NEUROLOGICAL DISEASES AND DISORDERS AND THE MANAGEMENT OF SAID DISEASES AND DISORDERS (U.S. CLS. 100, 101 AND 107).

**CLASS 44—MEDICAL, BEAUTY AND AGRICULTURAL SERVICES**

FOR MEDICAL SERVICES, NAMELY, PROVIDING MEDICAL INFORMATION RELATING TO NEUROLOGICAL DISEASES AND DISORDERS AND THE MANAGEMENT OF SAID DISEASES AND DISORDERS (U.S. CLS. 100 AND 101).

ALLISON SCHRÖDY, EXAMINING ATTORNEY

SN 86-321,226. ATTENDS HEALTHCARE PRODUCTS, INC., GREENVILLE, NC. FILED 6-26-2014.

**ATTENDS DISCRETE**

THE MARK CONSISTS OF STANDARD CHARACTERS WITHOUT CLAIM TO ANY PARTICULAR FONT, STYLE, SIZE, OR COLOR.

OWNER OF U.S. REG. NOS. 1,100,540, 1,439,799 AND 3,704,000.

**CLASS 5—PHARMACEUTICALS**

FOR INCONTINENCE DIAPERS; INCONTINENCE GARMENTS; INCONTINENCE PADS (U.S. CLS. 6, 18, 44, 46, 51 AND 52).

**CLASS 10—MEDICAL APPARATUS**

FOR INCONTINENCE BED PADS (U.S. CLS. 26, 39 AND 44).

BRENDAN REGAN, EXAMINING ATTORNEY

SN 86-321,249. ATTENDS HEALTHCARE PRODUCTS, INC., GREENVILLE, NC. FILED 6-26-2014.

**ATTENDS DISCREET**

THE MARK CONSISTS OF STANDARD CHARACTERS WITHOUT CLAIM TO ANY PARTICULAR FONT, STYLE, SIZE, OR COLOR.

OWNER OF U.S. REG. NOS. 1,100,540, 1,439,799 AND 3,704,000.

**CLASS 5—PHARMACEUTICALS**

FOR INCONTINENCE DIAPERS; INCONTINENCE GARMENTS; INCONTINENCE PADS (U.S. CLS. 6, 18, 44, 46, 51 AND 52).

**CLASS 10—MEDICAL APPARATUS**

FOR INCONTINENCE BED PADS (U.S. CLS. 26, 39 AND 44).

BRENDAN REGAN, EXAMINING ATTORNEY

SN 86-323,821. GIVAUDAN SA, CH - 1214 VERNIER, SWITZERLAND, FILED 6-30-2014.

**ACTISCULPT**

THE MARK CONSISTS OF STANDARD CHARACTERS WITHOUT CLAIM TO ANY PARTICULAR FONT, STYLE, SIZE, OR COLOR.

OWNER OF ERP CMNTY TM OFC REG. NO. 004272605, DATED 3-1-2006, EXPIRES 3-4-2015.

**CLASS 1—CHEMICALS**

FOR SYNTHETIC AROMA CHEMICALS FOR USE IN THE MANUFACTURE OF PERFUMERY, FLAVORINGS, COSMETICS, TOILETRIES AND HOUSEHOLD PRODUCTS; CHEMICAL PREPARATIONS FOR USE IN THE MANUFACTURE OF FRAGRANCES, FRAGRANCE INGREDIENTS AND FRAGRANCE COMPOUNDS; CHEMICALS FOR USE IN THE FORMULATION OF FRAGRANCES; CHEMICALS FOR USE IN THE MANUFACTURE OF PERFUMES AND PERFUMED PRODUCTS; CHEMICALS FOR USE IN THE MANUFACTURE OF COSMETIC AND TOILET PREPARATIONS; CHEMICALS FOR USE IN THE MANUFACTURE OF AIR-FRESHENING AND DEODORIZING PREPARATIONS; CHEMICAL FRAGRANCES FOR USE IN THE MANUFACTURE OF ORAL CARE PREPARATIONS; CHEMICAL FRAGRANCES FOR IMPREGNATION IN TEXTILES; CHEMICAL FRAGRANCES FOR USE IN THE MANUFACTURE OF HOUSE-HOLD CLEANSERS, DEODORIZERS AND DISINFECTANTS; FRAGRANCES FOR USE IN THE MANUFACTURE OF PERFUMES, COSMETICS, TOILETRIES, HAIR, BODY AND SKINCARE PREPARATIONS, DEODORIZING AND AIR FRESHENING PREPARATIONS, CLEANING AND LAUNDRY PRODUCTS; CHEMICALS FOR USE IN THE MANUFACTURE OF ODOR NEUTRALIZING PREPARATIONS (U.S. CLS. 1, 5, 6, 10, 26 AND 46).

**CLASS 3—COSMETICS AND CLEANING PREPARATIONS**

FOR ESSENTIAL OILS FOR USE IN THE MANUFACTURE OF PERFUMERY, FLAVORINGS, COSMETICS, TOILETRIES AND HOUSEHOLD PRODUCTS; PERFUMES; ESSENTIAL OILS FOR PERSONAL USE; ETHEREAL ESSENCES AND OILS FOR PERSONAL USE; COSMETICS; NON-MEDICATED TOILETRIES; DEODORANTS AND ANTIPERSPIRANTS FOR THE BODY; PERFUMED SOAPS; DEPILATORIES AND DEPILATORY PREPARATIONS AND SUBSTANCES; DENTIFRICES; DYES FOR COSMETIC PURPOSES; MAKE-UP REMOVING PREPARATIONS; CLEANSING PREPARATIONS FOR PERSONAL USE; NAIL CARE PREPARATIONS AND SUBSTANCES; EXFOLIANT PREPARATIONS FOR PERSONAL USE; SHAVING PREPARATIONS; HAIR CARE PREPARATIONS; HAND AND BODY CREAMS AND LOTIONS; DETERGENTS FOR GENERAL HOUSEHOLD USE; LAUNDRY PREPARATIONS NAMELY LAUNDRY SOAP; DETERGENTS FOR COSMETIC PURPOSES; SOAKING PREPARATIONS FOR LAUNDRY USE; STAIN REMOVERS; FRAGRANCES, NAMELY ESSENTIAL OILS FOR USE IN THE MANUFACTURE OF PERFUMES, COSMETICS, TOILETRIES, HAIR, BODY AND SKINCARE PREPARATIONS, DEODORIZING AND AIR FRESHENING PREPARATIONS, CLEANING AND LAUNDRY PRODUCTS (U.S. CLS. 1, 4, 6, 50, 51 AND 52).

EDWARD FENNESSY, EXAMINING ATTORNEY

SN 86-325,432. SOCIETE BIC, CLICHY, FRANCE, FILED 7-1-2014.

**MORE FOR YOUR  
MONEY...ALWAYS!**

THE MARK CONSISTS OF STANDARD CHARACTERS WITHOUT CLAIM TO ANY PARTICULAR FONT, STYLE, SIZE, OR COLOR.

**CLASS 8—HAND TOOLS**

FOR SHAVERS, NAMELY, RAZORS AND RAZOR BLADES (U.S. CLS. 23, 28 AND 44).

FIRST USE 1-1-2013; IN COMMERCE 1-1-2013.

**CLASS 11—ENVIRONMENTAL CONTROL APPARATUS**

FOR LIGHTERS PRIMARILY FOR LIGHTING GRILLS, FIREPLACES AND CANDLES (U.S. CLS. 13, 21, 23, 31 AND 34).

FIRST USE 1-1-2013; IN COMMERCE 1-1-2013.

**CLASS 16—PAPER GOODS AND PRINTED MATTER**

FOR WRITING INSTRUMENTS, NAMELY, PENS, PENCILS, MARKERS AND HIGHLIGHTING MARKERS (U.S. CLS. 2, 5, 22, 23, 29, 37, 38 AND 50).

FIRST USE 1-1-2013; IN COMMERCE 1-1-2013.

**CLASS 34—SMOKERS' ARTICLES**

FOR CIGARETTE LIGHTERS NOT OF PRECIOUS METALS AND CASES THEREFORE (U.S. CLS. 2, 8, 9 AND 17).

FIRST USE 1-1-2013; IN COMMERCE 1-1-2013.

DOMINIC J. FERRAIUOLO, EXAMINING ATTORNEY

SN 86-327,058. WILLIAMSON-DICKIE MANUFACTURING COMPANY, FORT WORTH, TX. FILED 7-2-2014.

**DICKIES**

THE MARK CONSISTS OF STANDARD CHARACTERS WITHOUT CLAIM TO ANY PARTICULAR FONT, STYLE, SIZE, OR COLOR.

OWNER OF U.S. REG. NOS. 2,946,584 AND 4,473,451.

**CLASS 18—LEATHER GOODS**

FOR PET APPAREL, NAMELY, CLOTHING FOR DOGS; PET RESTRAINING DEVICES, NAMELY, LEASHES, COLLARS, HARNESSES, RESTRAINING STRAPS AND LEASHES WITH LOCKING DEVICES, ELECTRONIC COLLARS (U.S. CLS. 1, 2, 3, 22 AND 41).

FIRST USE 11-1-2013; IN COMMERCE 11-1-2013.

**CLASS 20—FURNITURE AND ARTICLES NOT OTHERWISE CLASSIFIED**

FOR BEDS FOR HOUSEHOLD PETS; PORTABLE BEDS FOR PETS; PET CUSHIONS (U.S. CLS. 2, 13, 22, 25, 32 AND 50).

FIRST USE 11-1-2013; IN COMMERCE 11-1-2013.

**CLASS 28—TOYS AND SPORTING GOODS**

FOR PET TOYS (U.S. CLS. 22, 23, 38 AND 50).

FIRST USE 11-1-2013; IN COMMERCE 11-1-2013.

APRIL ROACH, EXAMINING ATTORNEY

SN 86-327,075. WILLIAMSON-DICKIE MANUFACTURING COMPANY, FORT WORTH, TX. FILED 7-2-2014.



OWNER OF U.S. REG. NOS. 2,444,583, 2,946,584 AND OTHERS.

THE MARK CONSISTS OF AN ELONGATED CIRCLE CONTAINING THE DRAWING OF A HORSESHOE AND A PARALLELOGRAM CENTERED ACROSS THE CIRCLE AND THE HORSESHOE, LEFT TO RIGHT. THE TITLE-CASE, ITALICIZED WORD "DICKIES" IS CENTERED INSIDE THE PARALLELOGRAM. THE CIRCLE AND PARALLELOGRAM IS OUTLINED IN A THICK, WHITE LINE. COLOR IS NOT A CLAIMED FEATURE OF THE MARK.

**CLASS 18—LEATHER GOODS**

FOR PET APPAREL, NAMELY, CLOTHING FOR DOGS; PET RESTRAINING DEVICES, NAMELY, LEASHES, COLLARS, HARNESSES, RESTRAINING STRAPS AND LEASHES WITH LOCKING DEVICES, ELECTRONIC COLLARS (U.S. CLS. 1, 2, 3, 22 AND 41).

FIRST USE 11-1-2013; IN COMMERCE 11-1-2013.

**CLASS 20—FURNITURE AND ARTICLES NOT OTHERWISE CLASSIFIED**

FOR BEDS FOR HOUSEHOLD PETS; PORTABLE BEDS FOR PETS; PET CUSHIONS (U.S. CLS. 2, 13, 22, 25, 32 AND 50).

FIRST USE 11-1-2013; IN COMMERCE 11-1-2013.

**CLASS 28—TOYS AND SPORTING GOODS**

FOR PET TOYS (U.S. CLS. 22, 23, 38 AND 50).

FIRST USE 11-1-2013; IN COMMERCE 11-1-2013.

APRIL ROACH, EXAMINING ATTORNEY

SN 86-334,041. UNION OF ANGELS, DELAPHANE, VA. FILED 7-10-2014.

**UNION OF ANGELS**

THE MARK CONSISTS OF STANDARD CHARACTERS WITHOUT CLAIM TO ANY PARTICULAR FONT, STYLE, SIZE, OR COLOR.

**CLASS 3—COSMETICS AND CLEANING PREPARATIONS**

FOR BODY AND BEAUTY CARE COSMETICS; COLOGNE; COLOGNES, PERFUMES AND COSMETICS; COSMETICS AND MAKE-UP; EAU DE COLOGNES; EAU DE PERFUME; EAU DE TOILETTE AND EAU DE COLOGNE; PERFUME; PERFUMED CREAMS; PERFUMED SOAP; PERFUMES; PERFUMES AND COLOGNES (U.S. CLS. 1, 4, 6, 50, 51 AND 52).

**CLASS 14—JEWELRY**

FOR ANKLE BRACELETS; BANGLE BRACELETS; BANGLES; BRACELETS; BRACELETS; CHARMS; COSTUME JEWELRY; JEWELRY; JEWELRY AND IMITATION JEWELRY; JEWELRY CASES; JEWELRY FOR THE HEAD; JEWELRY IN THE NATURE OF ARMBANDS; JEWELRY WATCHES; JEWELRY, NAMELY, ANKLETS; JEWELRY, NAMELY, ARM CUFFS; LEATHER JEWELRY AND ACCESSORY BOXES; NECKLACES; PENDANTS; RINGS; RINGS; RINGS BEING JEWELRY; WATCHES AND JEWELRY; WATCHES, CLOCKS, JEWELRY AND IMITATION JEWELRY; WOMEN'S JEWELRY (U.S. CLS. 2, 27, 28 AND 50).

**CLASS 18—LEATHER GOODS**

FOR BACKPACKS; BACKPACKS, BOOK BAGS, SPORTS BAGS, BUM BAGS, WALLETS AND HANDBAGS; CARD WALLETS; CHANGE PURSES; CLUTCH BAGS; CLUTCH PURSES; CLUTCHES; COIN PURSES; DIAPER BAGS; FASHION HANDBAGS; GARMENT BAGS FOR TRAVEL; HANDBAGS; HANDBAGS, PURSES AND WALLETS; LEATHER BAGS, SUITCASES AND WALLETS; LEATHER CREDIT CARD WALLETS; LEATHER HANDBAGS; LEATHER PURSES; LUGGAGE; LUGGAGE AND TRUNKS; LUGGAGE TAGS; MILITARY DUFFLE BAGS, GARMENT BAGS FOR TRAVEL, TOTE BAGS, SHOULDER BAGS AND BACKPACKS; MINAUDIERES IN THE NATURE OF SMALL CLUTCH PURSES; MULTI-PURPOSE PURSES; MULTI-STRANDED, BEADED CLIP THAT ATTACHES TO THE OUTSIDE OF A WOMEN'S PURSE AS A DECORATIVE ACCESSORY; POCKET WALLETS; PURSES; PURSES AND WALLETS; SHOULDER BAGS; SMALL BACKPACKS; SMALL CLUTCH PURSES; SMALL PURSES; TOTE BAGS; TRUNKS AND SUITCASES; WALLETS; WALLETS INCLUDING CARD HOLDERS; WALLETS MADE OF LEATHER OR OTHER MATERIALS; WRIST MOUNTED PURSES (U.S. CLS. 1, 2, 3, 22 AND 41).

**CLASS 25—CLOTHING**

FOR BOOTS; FOOTWEAR; FOOTWEAR FOR MEN; FOOTWEAR FOR MEN AND WOMEN; FOOTWEAR FOR WOMEN; FOOTWEAR, NAMELY, PUMPS; LEATHER BOOTS; LEATHER SHOES; PUMPS; SANDALS; SHOES; WOMEN'S SHOES (U.S. CLS. 22 AND 39).

DAVID COLLIER, EXAMINING ATTORNEY

SN 86-327,154. FIRST DATA CORPORATION, GREENWOOD VILLAGE, CO. FILED 7-2-2014.

**PAYLUCKY**

THE MARK CONSISTS OF STANDARD CHARACTERS WITHOUT CLAIM TO ANY PARTICULAR FONT, STYLE, SIZE, OR COLOR.

**CLASS 9—ELECTRICAL AND SCIENTIFIC APPARATUS**

FOR MAGNETIC CODED CARDS FOR PREPAID, STORED VALUE, AND LOYALTY PROGRAMS (U.S. CLS. 21, 23, 26, 36 AND 38).

**CLASS 36—INSURANCE AND FINANCIAL**

FOR FINANCIAL TRANSACTION SERVICES, NAMELY, PROVIDING SECURE COMMERCIAL TRANSACTIONS AND PAYMENT OPTIONS; MERCHANT SERVICES, NAMELY, PAYMENT TRANSACTION PROCESSING SERVICES; ON-LINE PREPAID CARD SERVICES; PROVIDING ELECTRONIC PROCESSING OF ELECTRONIC FUNDS TRANSFER, ACH, CREDIT CARD, DEBIT CARD, ELECTRONIC CHECK AND ELECTRONIC PAYMENTS; STORED VALUE PREPAID CARD SERVICES, NAMELY, PROCESSING ELECTRONIC PAYMENTS MADE THROUGH PREPAID CARDS (U.S. CLS. 100, 101 AND 102).

**CLASS 41—EDUCATION AND ENTERTAINMENT**

FOR GAMBLING SERVICES (U.S. CLS. 100, 101 AND 107).

**CLASS 42—SCIENTIFIC AND COMPUTER SERVICES**

FOR SOFTWARE AS A SERVICE (SAAS) SERVICES FEATURING SOFTWARE FOR PAYMENT PROCESSING IN THE GAMING AND GAMBLING FIELDS (U.S. CLS. 100 AND 101).

PATRICIA EVANKO, EXAMINING ATTORNEY

SN 86-975,146. JAMGLEJAM, INC., TOKYO, JAPAN, FILED 7-29-2013.



THE MARK CONSISTS OF THE STYLIZED WORD "BANKS" BELOW TWO FOUR-SIDED FIGURES.

**CLASS 9—ELECTRICAL AND SCIENTIFIC APPARATUS**

FOR EYEWEAR (U.S. CLS. 21, 23, 26, 36 AND 38).

**CLASS 14—JEWELRY**

FOR SILVER JEWELRY (U.S. CLS. 2, 27, 28 AND 50).

**CLASS 18—LEATHER GOODS**

FOR TRAVEL BAGS (U.S. CLS. 1, 2, 3, 22 AND 41).

**CLASS 24—FABRICS**

FOR BLANKET THROWS AND BATH TOWELS (U.S. CLS. 42 AND 50).  
NICOLE A NGUYEN, EXAMINING ATTORNEY

SN 86-975,392. HARD SCOOP, INC., MOUNT PLEASANT, SC. FILED 12-12-2013.



THE MARK CONSISTS OF STANDARD CHARACTERS WITHOUT CLAIM TO ANY PARTICULAR FONT, STYLE, SIZE, OR COLOR.

**CLASS 25—CLOTHING**

FOR CLOTHING, NAMELY, SHIRTS AND HATS (U.S. CLS. 22 AND 39).  
FIRST USE 5-1-2014; IN COMMERCE 5-1-2014.

**CLASS 33—WINES AND SPIRITS**

FOR ALCOHOLIC BEVERAGES EXCLUDING BEER, ALCOHOL SPIRITS INFUSED WITH FROZEN OR CHILLED FOOD PRODUCTS, NAMELY, MILK SHAKES, ICE CREAM, FLAVORED WATER (U.S. CLS. 47 AND 49).  
FIRST USE 5-1-2014; IN COMMERCE 5-1-2014.  
KERI CANTONE, EXAMINING ATTORNEY

\* \* \* \* \*

## SECTION 2.— INTERNATIONAL CLASSIFICATION

The short titles associated below with the international class numbers are terms designed merely for quick identification and are not an official part of the international classification. The full names of international classes are given in section 6.1 of the trademark rules of practice.

The designation "U.S. Cl." appearing in this section refers to the U.S. class in effect prior to Sep. 1, 1973 rather than the international class which applies to applications filed on or after that date. For adoption of international classification see notice in the OFFICIAL GAZETTE of Jun. 26, 1973 (911 O.G. TM 210).

### Application in one class

#### CLASS 1—CHEMICALS

SN 79-137,046. MOTUL, FRANCE, FILED 7-30-2013.

**ESTER Core**

THE MARK CONSISTS OF STANDARD CHARACTERS WITHOUT CLAIM TO ANY PARTICULAR FONT, STYLE, SIZE, OR COLOR.

PRIORITY DATE OF 5-13-2013 IS CLAIMED.

OWNER OF INTERNATIONAL REGISTRATION 1177873 DATED 7-30-2013, EXPIRES 7-30-2023.

NO CLAIM IS MADE TO THE EXCLUSIVE RIGHT TO USE "ESTER", APART FROM THE MARK AS SHOWN.

FOR CHEMICAL PRODUCTS FOR COOLING LIQUIDS, NAMELY, COOLANTS; CHEMICAL PRODUCTS, NAMELY, CHEMICAL ADDITIVES FOR USE AS INGREDIENTS FOR THE COMPOSITION OF LUBRICANTS; CHEMICAL ADDITIVES FOR MOTOR FUEL; CHEMICAL PRODUCTS, NAMELY, CHEMICALS FOR USE IN INDUSTRY, SCIENCE, PHOTOGRAPHY; UNPROCESSED ARTIFICIAL RESINS, UNPROCESSED PLASTICS; FIRE EXTINGUISHING COMPOSITIONS; TEMPERING AND SOLDERING PREPARATIONS; CHEMICAL SUBSTANCES FOR PRESERVING FOODSTUFFS; TANNING SUBSTANCES, NAMELY, TANNING AGENTS FOR USE IN THE MANUFACTURE OF LEATHER; ADHESIVES FOR USE IN INDUSTRY; WATERPROOFING PRODUCTS, NAMELY, WATERPROOFING CHEMICAL COMPOSITIONS, ANTI-FREEZE, SCALE REMOVERS OTHER THAN FOR HOUSEHOLD USE (U.S. CLS. 1, 5, 6, 10, 26 AND 46).

NATALIE POLZER, EXAMINING ATTORNEY

#### CLASS 1—(Continued).

SN 79-140,832. THOR SPECIALITIES (UK) LTD, UNITED KINGDOM, FILED 11-13-2013.

**MICROCARE**

THE MARK CONSISTS OF STANDARD CHARACTERS WITHOUT CLAIM TO ANY PARTICULAR FONT, STYLE, SIZE, OR COLOR.

PRIORITY DATE OF 10-24-2013 IS CLAIMED.

OWNER OF INTERNATIONAL REGISTRATION 1187755 DATED 11-13-2013, EXPIRES 11-13-2023.

OWNER OF U.S. REG. NO. 2,852,264.

FOR CHEMICALS USED IN INDUSTRY AND SCIENCE AS WELL AS IN AGRICULTURE EXCEPT FUNGICIDES, HERBICIDES, INSECTICIDES AND PARASITICIDES, ALL BEING CHEMICAL INGREDIENTS FOR USE IN PERSONAL CARE PRODUCTS; CHEMICAL SUBSTANCES FOR PRESERVING FOODSTUFFS; SILICONE AND SILICONE BASED CHEMICALS USED IN THE PERSONAL CARE INDUSTRIES; CHEMICALS USED IN THE PHARMACEUTICAL INDUSTRIES; EMULSIFIERS AND EMOLLIENTS USED AS INGREDIENTS IN THE MANUFACTURE OF COSMETICS; CHEMICAL PRODUCTS FOR COSMETIC INDUSTRIES; ANTIMICROBIAL PRESERVATIVES FOR COSMETICS, TOILETRIES AND PERSONAL CARE PRODUCTS (U.S. CLS. 1, 5, 6, 10, 26 AND 46).

KEVIN MITTLER, EXAMINING ATTORNEY

SN 79-142,073. SPOLEK PRO CHEMICKOU A HUTNÍ VYROBU, AKCIOVA SPOLECNOST, USTÍ NAD LABEM, CZECH REPUBLIC, FILED 9-12-2013.

**CHS-EPOXY**

THE MARK CONSISTS OF STANDARD CHARACTERS WITHOUT CLAIM TO ANY PARTICULAR FONT, STYLE, SIZE, OR COLOR.

OWNER OF INTERNATIONAL REGISTRATION 1191004 DATED 9-12-2013, EXPIRES 9-12-2023.

THE WORD(S) "CHS" HAS NO MEANING IN A FOREIGN LANGUAGE.

FOR EPOXY-BASED RESIN CHEMICAL PRODUCTS, NAMELY, UNPROCESSED EPOXY RESIN AND EPOXY RESINS WITH ADDITIVES FOR COMPOSITES, ELECTRONICS, ELECTRICAL COMPONENTS, CONSTRUCTION AND CIVIL ENGINEERING (U.S. CLS. 1, 5, 6, 10, 26 AND 46).

WENDY JUN, EXAMINING ATTORNEY

**CLASS 1—(Continued).**

SN 79-142,715. SAILING TECHNOLOGIES, S.L., SPAIN, FILED 1-17-2014.



OWNER OF INTERNATIONAL REGISTRATION 1192491 DATED 1-17-2014, EXPIRES 1-17-2024.

THE NAME(S), PORTRAIT(S), AND/OR SIGNATURE(S) SHOWN IN THE MARK DOES NOT IDENTIFY A PARTICULAR LIVING INDIVIDUAL.

THE COLOR(S) GRAY, DARK BLUE AND LIGHT BLUE IS/ARE CLAIMED AS A FEATURE OF THE MARK.

THE MARK CONSISTS OF THE WORDING "DR SAILS" IN GRAY STYLIZED FONT. TO THE LEFT OF THE WORDING IS A DESIGN CONSISTING OF ONE DARK BLUE BAND AND ONE LIGHT BLUE BAND CURVING TOWARDS EACH OTHER.

FOR CHEMICAL PRODUCTS FOR USE IN INDUSTRY, SCIENCE AND PHOTOGRAPHY, AS WELL AS IN AGRICULTURE, HORTICULTURE AND FORESTRY, NAMELY, A TWO-COMPONENT EXPOXY BASED ADHESIVE; UNPROCESSED ARTIFICIAL RESINS, UNPROCESSED PLASTICS; SOIL FERTILIZERS; FIRE EXTINGUISHING COMPOSITIONS; TEMPERING PREPARATIONS AND SOLDERING CHEMICALS; CHEMICAL PREPARATIONS FOR PRESERVING FOODSTUFFS; TANNING SUBSTANCES, NAMELY, TANNING AGENTS FOR USE IN MANUFACTURE OF LEATHER; ADHESIVES FOR INDUSTRIAL PURPOSES (U.S. CLS. 1, 5, 6, 10, 26 AND 46).

COLLEEN MULCRONE, EXAMINING ATTORNEY

**CLASS 1—(Continued).**

SN 79-145,327. LAFFORT, BORDEAUX, FRANCE, FILED 2-24-2014.

VR Grape

THE MARK CONSISTS OF STANDARD CHARACTERS WITHOUT CLAIM TO ANY PARTICULAR FONT, STYLE, SIZE, OR COLOR.

PRIORITY DATE OF 9-18-2013 IS CLAIMED.

OWNER OF INTERNATIONAL REGISTRATION 1198810 DATED 2-24-2014, EXPIRES 2-24-2024.

OWNER OF U.S. REG. NOS. 3,032,522 AND 3,683,370.

NO CLAIM IS MADE TO THE EXCLUSIVE RIGHT TO USE "GRAPE", APART FROM THE MARK AS SHOWN.

FOR CHEMICAL PRODUCTS, NAMELY, WINE PRODUCTS, NAMELY, WINE-MAKING CHEMICAL USED IN THE WINE-MAKING PROCESS (U.S. CLS. 1, 5, 6, 10, 26 AND 46).

DANIEL CAPSHAW, EXAMINING ATTORNEY

SN 79-145,316. NANTONG SUN-GREEN BIO-TECH CO., LTD., JIANGSU PROVINCE, CHINA, FILED 1-27-2014.



OWNER OF INTERNATIONAL REGISTRATION 1198791 DATED 1-27-2014, EXPIRES 1-27-2024.

THE COLOR(S) GREEN AND WHITE IS/ARE CLAIMED AS A FEATURE OF THE MARK.

THE MARK CONSISTS OF THE WORDING "SUN-GREEN" WITH "SUN" IN WHITE, "GREEN" IN GREEN AND THE HYPHEN IN WHITE AND GREEN, COMBINED WITH A WHITE LEAF DESIGN. THE BACKGROUND IS HALF GREEN AND HALF WHITE.

FOR ANIMAL AND VEGETABLE ALBUMIN IN RAW MATERIAL FORM FOR USE IN THE MANUFACTURE OF FOOD PRODUCTS; PROTEIN IN RAW MATERIAL FORM FOR INDUSTRIAL USE, FOR USE IN THE MANUFACTURE OF FOOD PRODUCTS AND FOR SCIENTIFIC AND MEDICAL RESEARCH; LECITHIN IN RAW MATERIAL FORM FOR USE IN THE MANUFACTURE OF FOOD PRODUCTS; PHOTOGRAPHIC CHEMICALS, NAMELY, IODISED ALBUMEN; CASEIN FOR INDUSTRIAL PURPOSES; CHEMICAL SUBSTANCES FOR PRESERVING FOODSTUFFS; MEAT TENDERIZERS FOR INDUSTRIAL PURPOSES (U.S. CLS. 1, 5, 6, 10, 26 AND 46).

KIM MONINGHOFF, EXAMINING ATTORNEY

SN 79-145,968. BIOMAGIC LIMITED, NEW ZEALAND, FILED 1-30-2014.



OWNER OF INTERNATIONAL REGISTRATION 1200451 DATED 1-30-2014, EXPIRES 1-30-2024.

NO CLAIM IS MADE TO THE EXCLUSIVE RIGHT TO USE "TURF" AND "SOIL OXIDANT", APART FROM THE MARK AS SHOWN.

THE COLOR(S) BLACK, WHITE AND GREEN IS/ARE CLAIMED AS A FEATURE OF THE MARK.

THE MARK CONSISTS OF THE STYLIZED WHITE TEXT "TURF" TO THE LEFT OF THE STYLIZED GREEN AND WHITE TEXT "X" ALL ABOVE THE STYLIZED WHITE TEXT "SOIL OXIDANT" ALL ON A BLACK RECTANGLE WITH CURVED CORNERS WHICH IS SURROUNDED BY A WHITE BAND WHICH IS SURROUNDED BY A BLACK BAND.

FOR CHEMICALS USED IN AGRICULTURE, HORTICULTURE AND FORESTRY EXCEPT FUNGICIDES, HERBICIDES, INSECTICIDES AND PARASITICIDES (U.S. CLS. 1, 5, 6, 10, 26 AND 46).

KEVIN MITTLER, EXAMINING ATTORNEY

**CLASS 1—(Continued).**

SN 85-863,210. FIREFLY BIOWORKS, INC., CAMBRIDGE, MA. FILED 2-28-2013.

# MIRSELECT

THE MARK CONSISTS OF STANDARD CHARACTERS WITHOUT CLAIM TO ANY PARTICULAR FONT, STYLE, SIZE, OR COLOR.

FOR REAGENTS AND ASSAYS FOR SCIENTIFIC OR RESEARCH PURPOSES; ENCODED PARTICLES FOR MULTI-PLEXED DETECTION OF PROTEINS AND NUCLEIC ACIDS FOR SCIENTIFIC OR RESEARCH USE; DIAGNOSTIC KITS CONSISTING PRIMARILY OF REAGENTS, PARTICLES, VIALS AND BUFFERS FOR SCIENTIFIC OR RESEARCH USE; ASSAYS FOR MONITORING, DETECTING, AND QUANTIFYING BIOLOGICAL MOLECULES FOR SCIENTIFIC OR RESEARCH USE; DIAGNOSTIC KITS CONSISTING PRIMARILY OF REAGENTS, PARTICLES, VIALS AND BUFFERS FOR MONITORING, DETECTING, AND QUANTIFYING BIOLOGICAL MOLECULES FOR SCIENTIFIC OR RESEARCH USE; MULTI-PLEXED ASSAYS FOR ANALYSIS OF PROTEINS AND NUCLEIC ACIDS FOR SCIENTIFIC OR RESEARCH USE (U.S. CLS. 1, 5, 6, 10, 26 AND 46).

JOANNA FIORELLI, EXAMINING ATTORNEY

SN 86-026,595. CLIFFSTAR LLC, TAMPA, FL. FILED 8-1-2013.

# SCIOCRAN

THE MARK CONSISTS OF STANDARD CHARACTERS WITHOUT CLAIM TO ANY PARTICULAR FONT, STYLE, SIZE, OR COLOR.

FOR PHYTONUTRIENTS AND CRANBERRY POWDER FOR USE IN THE MANUFACTURE OF DIETARY AND NUTRITIONAL SUPPLEMENTS (U.S. CLS. 1, 5, 6, 10, 26 AND 46).

MARK SHINER, EXAMINING ATTORNEY

SN 86-026,612. CLIFFSTAR LLC, TAMPA, FL. FILED 8-1-2013.

# SCIOCRAN 90

THE MARK CONSISTS OF STANDARD CHARACTERS WITHOUT CLAIM TO ANY PARTICULAR FONT, STYLE, SIZE, OR COLOR.

NO CLAIM IS MADE TO THE EXCLUSIVE RIGHT TO USE "90", APART FROM THE MARK AS SHOWN.

FOR PHYTONUTRIENTS AND CRANBERRY POWDER FOR USE IN THE MANUFACTURE OF DIETARY AND NUTRITIONAL SUPPLEMENTS (U.S. CLS. 1, 5, 6, 10, 26 AND 46).

MARK SHINER, EXAMINING ATTORNEY

**CLASS 1—(Continued).**

SN 86-053,497. LIDOCHEM, INC., HAZLET, NJ. FILED 9-1-2013.

# Argosy

THE MARK CONSISTS OF THE WORD "ARGOSY" ADJACENT TO A STRIP SWIRL SHAPED INTO A SPHERE. FOR ADJUVANT FOR USE WITH AGRICULTURAL CHEMICALS (U.S. CLS. 1, 5, 6, 10, 26 AND 46).

CAROL SPILLS, EXAMINING ATTORNEY

SN 86-057,480. ENVIROLOGIX INC, PORTLAND, ME. FILED 9-6-2013.

# RNABLE

THE MARK CONSISTS OF STANDARD CHARACTERS WITHOUT CLAIM TO ANY PARTICULAR FONT, STYLE, SIZE, OR COLOR.

FOR CHEMICALS USED IN INDUSTRY AND SCIENCE, AS WELL AS AGRICULTURE, HORTICULTURE, VETERINARY, FOOD SCIENCE AND BIOTECHNOLOGY, AND FORESTRY EXCEPT FUNGICIDES, HERBICIDES, INSECTICIDES AND PARASITICIDES; TESTING KITS COMPRISING CHEMICALS USED IN GENETIC AND MOLECULAR BIOLOGICAL SCIENCE; TESTING KITS COMPRISING AN ISOTHERMAL NUCLEIC ACID AMPLIFICATION DETECTION SYSTEM COMPRISED OF REVERSE TRANSCRIPTASE, NICKING ENZYME AND POLYMERASE FOR RAPID DETECTION OF RNA SEQUENCES NOT FOR MEDICAL PURPOSES (U.S. CLS. 1, 5, 6, 10, 26 AND 46).

JAY FLOWERS, EXAMINING ATTORNEY

SN 86-066,486. DANISCO US INC., PALO ALTO, CA. FILED 9-17-2013.

# FERMGEN

THE MARK CONSISTS OF STANDARD CHARACTERS WITHOUT CLAIM TO ANY PARTICULAR FONT, STYLE, SIZE, OR COLOR.

FOR ENZYMES AND ENZYME PREPARATIONS FOR INDUSTRIAL USE, NAMELY, FOR USE IN THE GRAIN PROCESSING INDUSTRY (U.S. CLS. 1, 5, 6, 10, 26 AND 46).

FIRST USE 6-21-2006; IN COMMERCE 6-21-2006.

EUGENIA MARTIN, EXAMINING ATTORNEY



**CLASS 1—(Continued).**

SN 86-094,646. KAO KABUSHIKI KAISHA, TA KAO CORPORATION, CHUO-KU, TOKYO, JAPAN, FILED 10-17-2013.

# VINYCIZER

THE MARK CONSISTS OF STANDARD CHARACTERS WITHOUT CLAIM TO ANY PARTICULAR FONT, STYLE, SIZE, OR COLOR.

FOR CHEMICAL PRODUCTS FOR PREPARATION OF ARTIFICIAL AND SYNTHETIC LEATHER FOR USE IN INDUSTRY, AUTOMOBILES, FOOTWEAR, AND MATERIALS FOR ELECTRICAL WIRES AND CABLES; UNPROCESSED ARTIFICIAL AND SYNTHETIC RESINS; PLASTICS IN UNPROCESSED FORM OF POWDERS, LIQUIDS AND PASTE FORMS FOR INDUSTRIAL USE; PLASTICIZERS (U.S. CLS. 1, 5, 6, 10, 26 AND 46).

WON TEAK OH, EXAMINING ATTORNEY

SN 86-109,669. GARDENER'S LIVING SOIL, LLC, CADIZ, KY. FILED 11-4-2013.



NO CLAIM IS MADE TO THE EXCLUSIVE RIGHT TO USE "GARDENER'S LIVING SOIL", APART FROM THE MARK AS SHOWN.

THE MARK CONSISTS OF THE WORD "GARDENER'S". THE WORDS "LIVING SOIL" APPEAR CENTERED UNDER THE WORD "GARDENER'S". A LEAF PATTERN APPEARS IN THE BACKGROUND.

FOR COMPOST (U.S. CLS. 1, 5, 6, 10, 26 AND 46).  
DEIRDRE ROBERTSON, EXAMINING ATTORNEY

SN 86-127,581. ESPINOSA, JESUS, DORAL, FL. FILED 11-23-2013.



THE COLOR(S) WHITE, BLACK, YELLOW, MAGENTA, CYAN, AND OLIVE GREEN IS/ARE CLAIMED AS A FEATURE OF THE MARK.

THE MARK CONSISTS OF THE WORD "CENT" IN THE COLOR WHITE IMMEDIATELY FOLLOWED BY THE CAPITAL LETTER "Q" IN THE COLOR WHITE WITH TWO DESIGNS BENEATH IT. THE FIRST DESIGN CON-

**CLASS 1—(Continued).**

SISTS OF TWO OPEN HANDS IN THE COLOR WHITE HOLDING A CUBE/DIAMOND WITH FOUR STRIPES OF COLOR IN THE FOLLOWING ORDER: YELLOW, MAGENTA, CYAN, AND COMBINED BLACK AND WHITE. DIRECTLY BESIDE THE FIRST DESIGN IS A SECOND DESIGN WHICH CONSISTS OF TWO OPEN HANDS IN THE COLOR WHITE HOLDING A CUBE/DIAMOND WITH FOUR STRIPES OF COLOR IN THE FOLLOWING ORDER: YELLOW, MAGENTA, CYAN, AND BLACK, ALL APPEARING ON AN OLIVE GREEN RECTANGLE.

FOR CHEMICALS FOR USE IN THE MANUFACTURE OF PAPER, PRINTING PAPER, PHOTOGRAPHIC PAPER, AND PHOTOCOPY PAPER (U.S. CLS. 1, 5, 6, 10, 26 AND 46).

MIDGE BUTLER, EXAMINING ATTORNEY

SN 86-157,096. PEL-FREEZ HOLDINGS, INC., FRIDAY HARBOR, WA. FILED 1-3-2014.



OWNER OF U.S. REG. NOS. 758,200, 1,209,924 AND 1,705,207.

NO CLAIM IS MADE TO THE EXCLUSIVE RIGHT TO USE "BIOLOGICALS", APART FROM THE MARK AS SHOWN.

THE COLOR(S) AZURE, BLUE, RED, GREEN, YELLOW, ORANGE AND IS/ARE CLAIMED AS A FEATURE OF THE MARK.

THE MARK CONSISTS OF AN AZURE DOUBLE-HELIX-SHAPED "S" DESIGN WITH A BLUE OUTLINE AND WITH RED, GREEN, YELLOW AND ORANGE HORIZONTAL STRIPES WITH BLUE LINES SEPARATING THEM WITHIN THE DESIGN; TO THE RIGHT OF THE DESIGN ARE THE WORDS "PEL FREEZ" IN BLUE WITH AN AZURE DOT BETWEEN "PEL" AND "FREEZ"; THE WORD "BIOLOGICALS", IN BLUE, IS DIRECTLY UNDERNEATH "FREEZ".

FOR DIAGNOSTIC PREPARATIONS COMPRISING REAGENTS FOR SCIENTIFIC RESEARCH AND CLINICAL OR MEDICAL LABORATORY USE; ANIMAL TISSUE, FLUIDS AND ORGANS FOR CLINICAL, SCIENTIFIC OR MEDICAL RESEARCH USE; DIAGNOSTIC PREPARATIONS AND REAGENTS FOR MEDICAL LABORATORY RESEARCH USE (U.S. CLS. 1, 5, 6, 10, 26 AND 46).

KRISTINA MORRIS, EXAMINING ATTORNEY

**CLASS 1—(Continued).**

SN 86-161,121. ROYAL GROUP, INC., WOODBRIDGE, ON, CANADA, FILED 1-9-2014.

**ROYALBLEND**

THE MARK CONSISTS OF STANDARD CHARACTERS WITHOUT CLAIM TO ANY PARTICULAR FONT, STYLE, SIZE, OR COLOR.

FOR VINYL CHLORIDE COMPOUNDS AND POLYMER COMPOUNDS USED IN THE MANUFACTURE OF EXTRUDED PVC WINDOW AND DOOR PROFILES (U.S. CLS. 1, 5, 6, 10, 26 AND 46).

EMILY CHUO, EXAMINING ATTORNEY

---

SN 86-165,283. WESTERN LITHIUM CORPORATION, RENO, CO. FILED 1-14-2014.

**GELFAST**

THE MARK CONSISTS OF STANDARD CHARACTERS WITHOUT CLAIM TO ANY PARTICULAR FONT, STYLE, SIZE, OR COLOR.

FOR CLAY-CONTAINING CHEMICAL ADDITIVES FOR OIL-WELL DRILLING FLUID THAT ENHANCE THE RATE OF GELLING (U.S. CLS. 1, 5, 6, 10, 26 AND 46).

SEAN CROWLEY, EXAMINING ATTORNEY

---

SN 86-179,564. JOHNSON MATTHEY PUBLIC LIMITED COMPANY, EC4A 4AB LONDON, UNITED KINGDOM, FILED 1-30-2014.

**ECO-CAT**

THE MARK CONSISTS OF STANDARD CHARACTERS WITHOUT CLAIM TO ANY PARTICULAR FONT, STYLE, SIZE, OR COLOR.

OWNER OF UNITED KINGDOM REG. NO. UK0000302107, DATED 12-6-2013, EXPIRES 9-6-2023.

OWNER OF U.S. REG. NOS. 2,061,667 AND 2,708,932.

FOR WOVEN AND/OR KNITTED PRECIOUS METAL GAUZE PACKS BEING CATALYSTS FOR USE IN NITRIC OXIDE PRODUCTION FOR INDUSTRIAL USE, NOT FOR LABORATORY USE (U.S. CLS. 1, 5, 6, 10, 26 AND 46).

LAURIE MAYES, EXAMINING ATTORNEY

**CLASS 1—(Continued).**

SN 86-185,251. PERK PRODUCTS & CHEMICAL CO., INC., NASHVILLE, TN. FILED 2-5-2014.

**SURE SEAL**

THE MARK CONSISTS OF STANDARD CHARACTERS WITHOUT CLAIM TO ANY PARTICULAR FONT, STYLE, SIZE, OR COLOR.

NO CLAIM IS MADE TO THE EXCLUSIVE RIGHT TO USE "SEAL", APART FROM THE MARK AS SHOWN.

FOR CHEMICAL COMPOUNDS FOR CURING AND SEALING CONCRETE AND CONCRETE SURFACES (U.S. CLS. 1, 5, 6, 10, 26 AND 46).

FIRST USE 6-0-1996; IN COMMERCE 6-0-1996.

INGA ERVIN, EXAMINING ATTORNEY

---

SN 86-198,821. WELCH D TRAYLON, DBA ING CLOTHING LINE - I NEED GOD, MESQUITE, TX. FILED 2-20-2014.



NO CLAIM IS MADE TO THE EXCLUSIVE RIGHT TO USE "CLOTHING LINE", APART FROM THE MARK AS SHOWN.

THE MARK CONSISTS OF THE LETTERS "ING" WITH THE WORDS "CLOTHING LINE" WRITTEN ACROSS THE MIDDLE OF THE LETTERS, AND THE WORDS "I NEED GOD" BENEATH THE LETTERS; THE COLOR GRAY IN THE BACKGROUND REPRESENT SHADING AND IS NOT A PART OF THE MARK.

FOR POLYMER BASE COMPOSITIONS USED IN THE MANUFACTURE OF GOODS, NAMELY, CLOTHING, EXERCISE APPAREL, COMPRESSION GARMENTS, HOME FURNISHING (U.S. CLS. 1, 5, 6, 10, 26 AND 46).

GINA HAYES, EXAMINING ATTORNEY

**CLASS 1—(Continued).**

SN 86-210,674. SOLUTIONS 4 EARTH, LLC, HENDERSON, NV. FILED 3-4-2014.



NO CLAIM IS MADE TO THE EXCLUSIVE RIGHT TO USE "GREEN", APART FROM THE MARK AS SHOWN.

THE COLOR(S) GREEN, LIGHT GRAY, DARK GRAY, AND BLACK IS/ARE CLAIMED AS A FEATURE OF THE MARK.

THE MARK CONSISTS OF A GREEN SQUARE BORDER WITH A GREEN FIST IN THE CENTER WITH ALTERNATING LIGHT GRAY AND DARK GRAY RAYS RADIATING FROM BEHIND THE GREEN FIST, THE WORD "GREEN" IN ALL BLACK CAPITAL LETTERS ATOP THE WORD "PUNCH" IN ALL BLACK CAPITAL LETTERS APPEARS TO THE RIGHT OF THE SQUARE.

FOR FERTILIZERS; FERTILIZERS FOR AGRICULTURAL USE; SOIL ADDITIVES; SOIL AMENDMENTS; SOIL IMPROVING AGENTS; ALL PRECEDING COMPOSED IN PART OF ENVIRONMENTALLY FRIENDLY, OR "GREEN", CONSTITUENTS (U.S. CLS. 1, 5, 6, 10, 26 AND 46).

FIRST USE 7-9-2013; IN COMMERCE 7-9-2013.

TIMOTHY FINNEGAN, EXAMINING ATTORNEY

---

SN 86-221,121. CHAMPION BRANDS, LLC, CLINTON, MO. FILED 3-14-2014.

**BIODIESEL GUARD**

THE MARK CONSISTS OF STANDARD CHARACTERS WITHOUT CLAIM TO ANY PARTICULAR FONT, STYLE, SIZE, OR COLOR.

NO CLAIM IS MADE TO THE EXCLUSIVE RIGHT TO USE "BIODIESEL", APART FROM THE MARK AS SHOWN.

FOR CHEMICAL ADDITIVES FOR LUBRICANTS; CHEMICAL ENGINE TREATMENTS AND ADDITIVES FOR ENGINE OILS, GASOLINE AND DIESEL FUELS, TRANSMISSION FLUIDS AND COOLING SYSTEMS; CHEMICAL MOTOR OIL ADDITIVES (U.S. CLS. 1, 5, 6, 10, 26 AND 46).

GILBERT SWIFT, EXAMINING ATTORNEY

**CLASS 1—(Continued).**

SN 86-226,256. FTS INTERNATIONAL SERVICES, LLC, FORT WORTH, TX. FILED 3-19-2014.

**Diamond**

THE MARK CONSISTS OF STANDARD CHARACTERS WITHOUT CLAIM TO ANY PARTICULAR FONT, STYLE, SIZE, OR COLOR.

OWNER OF U.S. REG. NO. 4,451,132.

FOR CHEMICALS AND FLUIDS, NAMELY, HYDRAULIC FRACTURING FLUIDS, USED IN OIL AND GAS ENHANCED RECOVERY OPERATIONS (U.S. CLS. 1, 5, 6, 10, 26 AND 46).

FIRST USE 3-1-2013; IN COMMERCE 3-1-2013.

JANET LEE, EXAMINING ATTORNEY

---

SN 86-228,735. FLOW POLYMERS, LLC, CLEVELAND, OH. FILED 3-21-2014.

**PROFILE**

THE MARK CONSISTS OF STANDARD CHARACTERS WITHOUT CLAIM TO ANY PARTICULAR FONT, STYLE, SIZE, OR COLOR.

FOR CHEMICAL ADDITIVES FOR GENERAL INDUSTRIAL USE IN THE MANUFACTURE OF A WIDE VARIETY OF RUBBER AND TIRE PRODUCTS (U.S. CLS. 1, 5, 6, 10, 26 AND 46).

FIRST USE 3-3-2014; IN COMMERCE 3-3-2014.

MICHAEL TANNER, EXAMINING ATTORNEY

---

SN 86-233,111. MCVICKER, AUTIE, KEMAH, TX. FILED 3-26-2014.

**Tank Tamer**

THE MARK CONSISTS OF STANDARD CHARACTERS WITHOUT CLAIM TO ANY PARTICULAR FONT, STYLE, SIZE, OR COLOR.

NO CLAIM IS MADE TO THE EXCLUSIVE RIGHT TO USE "TANK", APART FROM THE MARK AS SHOWN.

FOR BACTERIA FOR WASTE WATER TREATMENT (U.S. CLS. 1, 5, 6, 10, 26 AND 46).

FIRST USE 2-1-1992; IN COMMERCE 2-1-1992.

TIMOTHY O. SCHIMPF, EXAMINING ATTORNEY

**CLASS 1—(Continued).**

SN 86-235,368. BEACON ANALYTICAL SYSTEMS, INC., SACO, ME. FILED 3-28-2014.

**Beacon Analytical Systems,  
Inc.**

THE MARK CONSISTS OF STANDARD CHARACTERS WITHOUT CLAIM TO ANY PARTICULAR FONT, STYLE, SIZE, OR COLOR.

NO CLAIM IS MADE TO THE EXCLUSIVE RIGHT TO USE "ANALYTICAL SYSTEMS, INC.", APART FROM THE MARK AS SHOWN.

FOR DIAGNOSTIC REAGENTS FOR SCIENTIFIC OR RESEARCH USE (U.S. CLS. 1, 5, 6, 10, 26 AND 46).

FIRST USE 6-13-1996; IN COMMERCE 6-13-1996.  
NATALIE POLZER, EXAMINING ATTORNEY

**CLASS 1—(Continued).**

SN 86-237,036. GEMINI INDUSTRIES, INC., EL RENO, OK. FILED 3-31-2014.

## MASTERPIECE

THE MARK CONSISTS OF STANDARD CHARACTERS WITHOUT CLAIM TO ANY PARTICULAR FONT, STYLE, SIZE, OR COLOR.

OWNER OF U.S. REG. NO. 1,830,064.

FOR CHEMICAL SOLVENTS, NAMELY, PAINT THIN- NERS, MINERAL SPIRITS, BRUSH CLEANER, DE- GREASER, SILK PLANT CLEANERS, AND GENERAL PURPOSE CLEANERS (U.S. CLS. 1, 5, 6, 10, 26 AND 46).

FIRST USE 12-31-1993; IN COMMERCE 12-31-1993.

KEVIN MITTLER, EXAMINING ATTORNEY

SN 86-239,041. SPC RESOURCES, INC., HARTSVILLE, SC. FILED 4-1-2014.

## ZERO BENCH-TIME

THE MARK CONSISTS OF STANDARD CHARACTERS WITHOUT CLAIM TO ANY PARTICULAR FONT, STYLE, SIZE, OR COLOR.

FOR PHASE CHANGE MATERIALS, NAMELY, CHE- MICAL COMPOSITIONS FOR USE IN CONTROLLING TEMPERATURE IN PORTABLE INSULATED SHIPPING CONTAINERS (U.S. CLS. 1, 5, 6, 10, 26 AND 46).

JAMES LOVELACE, EXAMINING ATTORNEY

SN 86-236,972. BETTY'S AZALEA RANCH INC., FAIRFAX, VA. FILED 3-31-2014.



NO CLAIM IS MADE TO THE EXCLUSIVE RIGHT TO USE "EARTH", APART FROM THE MARK AS SHOWN.

THE MARK CONSISTS OF A SPOON HOLDING FLOW- ERS WITH THE ADDITION OF A POT WITH FLOWERS AND THE WORDING "SWEET EARTH" LOCATED OVER THE POT AND SPOON.

FOR SOIL CONDITIONING PREPARATIONS (U.S. CLS. 1, 5, 6, 10, 26 AND 46).

FIRST USE 7-1-1998; IN COMMERCE 7-1-1998.

PAUL E. FAHRENKOPF, EXAMINING ATTORNEY

SN 86-242,359. HYDRITE CHEMICAL CO., BROOKFIELD, WI. FILED 4-4-2014.

## HYDRITE

THE MARK CONSISTS OF STANDARD CHARACTERS WITHOUT CLAIM TO ANY PARTICULAR FONT, STYLE, SIZE, OR COLOR.

FOR CHEMICALS AND CHEMICAL COMPOSITIONS FOR INDUSTRIAL AND LABORATORY USE, IN ANY EVENT EXCLUDING CLAYS AND KAOLINS (U.S. CLS. 1, 5, 6, 10, 26 AND 46).

FIRST USE 12-31-1928; IN COMMERCE 12-31-1928.

HENRY S. ZAK, EXAMINING ATTORNEY

**CLASS 1—(Continued).**

SN 86-244,038. SHISEIDO COMPANY, LIMITED, TOKYO 104-0061, JAPAN, FILED 4-7-2014.

**IMUMOISTURE EXTRACT**

THE MARK CONSISTS OF STANDARD CHARACTERS WITHOUT CLAIM TO ANY PARTICULAR FONT, STYLE, SIZE, OR COLOR.

NO CLAIM IS MADE TO THE EXCLUSIVE RIGHT TO USE "EXTRACT", APART FROM THE MARK AS SHOWN. FOR CHEMICALS USED IN THE COSMETICS, SOAPS, AND PERFUMERY INDUSTRY (U.S. CLS. 1, 5, 6, 10, 26 AND 46).

DANIEL CAPSHAW, EXAMINING ATTORNEY

---

SN 86-246,203. VERDESIAN LIFE SCIENCES U.S., LLC, VISALIA, CA. FILED 4-8-2014.

**PRESIDE**

THE MARK CONSISTS OF STANDARD CHARACTERS WITHOUT CLAIM TO ANY PARTICULAR FONT, STYLE, SIZE, OR COLOR.

FOR SEED INOCULANT (U.S. CLS. 1, 5, 6, 10, 26 AND 46).

B. PARADEWELAI, EXAMINING ATTORNEY

---

SN 86-246,906. CHEMICAL UNIVERSE INC., NORTH KANSAS CITY, MO. FILED 4-9-2014.

**LOCKNLOAD**

THE MARK CONSISTS OF STANDARD CHARACTERS WITHOUT CLAIM TO ANY PARTICULAR FONT, STYLE, SIZE, OR COLOR.

FOR CHEMICAL PREPARATIONS, NAMELY, DEGREASING AND CLEANING SOLVENTS; CHEMICAL PREPARATIONS FOR CLEANING PURPOSES IN THE FOOD AND FOOD PROCESSING INDUSTRIES (U.S. CLS. 1, 5, 6, 10, 26 AND 46).

FIRST USE 1-7-2009; IN COMMERCE 1-7-2009.

JULIE WATSON, EXAMINING ATTORNEY

**CLASS 1—(Continued).**

SN 86-247,179. KINETIC FUEL TECHNOLOGY, INC., YOUNGSTOWN, NY. FILED 4-9-2014.



THE MARK CONSISTS OF THE LITERAL ELEMENT "K100" WRITTEN IN STYLIZED FORM AND PLACED INSIDE AN OVAL.

FOR CHEMICAL ADDITIVES FOR FUEL; CHEMICAL ADDITIVES FOR FUEL TREATMENT; CHEMICAL ENGINE TREATMENTS AND ADDITIVES FOR ENGINE OILS, GASOLINE AND DIESEL FUELS, TRANSMISSION FLUIDS AND COOLING SYSTEMS (U.S. CLS. 1, 5, 6, 10, 26 AND 46).

FIRST USE 3-22-1999; IN COMMERCE 3-22-1999.

MARYNELLE WILSON, EXAMINING ATTORNEY

---

SN 86-247,285. DREXEL CHEMICAL COMPANY, MEMPHIS, TN. FILED 4-9-2014.

**Holzit**

THE MARK CONSISTS OF STANDARD CHARACTERS WITHOUT CLAIM TO ANY PARTICULAR FONT, STYLE, SIZE, OR COLOR.

FOR AMMONIUM SULPHATE; DEFOAMING AGENTS (U.S. CLS. 1, 5, 6, 10, 26 AND 46).

FIRST USE 4-5-2007; IN COMMERCE 4-5-2007.

GEORGE LORENZO, EXAMINING ATTORNEY

---

SN 86-248,362. INNEVAPE, LLC, HUDSON, FL. FILED 4-10-2014.

**LIVE LONG AND VAPOR**

THE MARK CONSISTS OF STANDARD CHARACTERS WITHOUT CLAIM TO ANY PARTICULAR FONT, STYLE, SIZE, OR COLOR.

FOR ELECTRONIC CIGARETTE LIQUID (E-LIQUID) COMPRISED OF PROPYLENE GLYCOL; ELECTRONIC CIGARETTE LIQUID (E-LIQUID) COMPRISED OF VEGETABLE GLYCERIN (U.S. CLS. 1, 5, 6, 10, 26 AND 46).

FIRST USE 4-1-2013; IN COMMERCE 4-1-2013.

JAY FLOWERS, EXAMINING ATTORNEY

**CLASS 1—(Continued).**

SN 86-248,495. DANISE & ASSOCIATES, INC., DBA SOUTHERN ORGANICS & SUPPLY, MONROE, NC. FILED 4-10-2014.



THE MARK CONSISTS OF THE OUTLINE OF A WORM HOLDING A SIGN WITH THE WORDS "WILL WORK FOR FOOD".

FOR ORGANIC FERTILIZER AND SOIL CONDITIONER FOR PLANTS, TREES, SHRUBS, FLOWERS, VEGETABLES, FRUITS AND LAWNS (U.S. CLS. 1, 5, 6, 10, 26 AND 46).

CHRIS WELLS, EXAMINING ATTORNEY

SN 86-250,023. FLORATINE PRODUCTS GROUP, INC., AKA FLORATINE, FPG, COLLIERVILLE, TN. FILED 4-11-2014.

# VOLATEX

THE MARK CONSISTS OF STANDARD CHARACTERS WITHOUT CLAIM TO ANY PARTICULAR FONT, STYLE, SIZE, OR COLOR.

FOR ADJUVANT FOR USE WITH AGRICULTURAL CHEMICALS; CHEMICAL FERTILIZERS; CHEMICALLY CONVERTED COMPOUND FERTILIZERS; CHEMICALS FOR USE IN AGRICULTURE, HORTICULTURE AND FORESTRY EXCEPT FUNGICIDES, HERBICIDES, INSECTICIDES AND PARASITICIDES; COMPLEX FERTILIZER; COMPLEX FERTILIZERS; FERTILIZERS; FERTILIZERS FOR AGRICULTURAL USE; FERTILIZERS FOR DOMESTIC USE; HORTICULTURAL SOIL AMENDMENTS THAT ARE INCORPORATED INTO OR ONTO A TURF, LAWN OR SOIL PROFILE; MIXED FERTILIZERS; NATURAL FERTILIZERS; NON-CHEMICAL BIO-FERTILIZERS; NUTRITIVE ADDITIVE TO ENHANCE THE BIOLOGICAL ACTIVITY OF WATER, SOIL, SEEDS AND PLANTS FOR PURPOSES OF FERTILIZATION AND BIOREMEDIATION OF POLLUTANTS; ORGANIC FERTILIZERS; PLANT NUTRIENTS; PLANT NUTRITION PREPARATIONS; SOIL CONDITIONERS FOR AGRICULTURAL USE; UREA FERTILIZER (U.S. CLS. 1, 5, 6, 10, 26 AND 46).

ZACHARY R. SPARER, EXAMINING ATTORNEY

**CLASS 1—(Continued).**

SN 86-250,241. MEADWESTVACO CORPORATION, RICHMOND, VA. FILED 4-11-2014.

# ENVACOR

THE MARK CONSISTS OF STANDARD CHARACTERS WITHOUT CLAIM TO ANY PARTICULAR FONT, STYLE, SIZE, OR COLOR.

FOR DERIVATIVES OF TALL OIL FATTY ACIDS FOR USE IN CORROSION INHIBITOR FORMULATIONS (U.S. CLS. 1, 5, 6, 10, 26 AND 46).

FIRST USE 10-8-2012; IN COMMERCE 10-8-2012.

ALLISON HOLTZ, EXAMINING ATTORNEY

SN 86-251,506. ADVANCED CARBONATE TECHNOLOGIES, LLC, FERNLEY, NV. FILED 4-14-2014.

# ActProMin

THE MARK CONSISTS OF STANDARD CHARACTERS WITHOUT CLAIM TO ANY PARTICULAR FONT, STYLE, SIZE, OR COLOR.

FOR CALCIUM CARBONATE; CALCIUM NITRATE; CALCIUM PHOSPHATE; CALCIUM SUPERPHOSPHATE FERTILIZER (U.S. CLS. 1, 5, 6, 10, 26 AND 46).

SAIMA MAKHDOOM, EXAMINING ATTORNEY

SN 86-251,693. MEADWESTVACO CORPORATION, RICHMOND, VA. FILED 4-14-2014.

# ENVAMUL

THE MARK CONSISTS OF STANDARD CHARACTERS WITHOUT CLAIM TO ANY PARTICULAR FONT, STYLE, SIZE, OR COLOR.

FOR DERIVATIVES OF CRUDE TALL OIL, DISTILLED TALL OIL, AND TALL OIL FATTY ACIDS FOR USE IN FORMULATING EMULSIFIERS USED IN THE OIL AND GAS INDUSTRY (U.S. CLS. 1, 5, 6, 10, 26 AND 46).

FIRST USE 10-3-2012; IN COMMERCE 10-3-2012.

ALLISON HOLTZ, EXAMINING ATTORNEY

**CLASS 1—(Continued).**

SN 86-273,857. MEADWESTVACO CORPORATION, RICHMOND, VA. FILED 5-7-2014.

# ENVAWET

THE MARK CONSISTS OF STANDARD CHARACTERS WITHOUT CLAIM TO ANY PARTICULAR FONT, STYLE, SIZE, OR COLOR.

FOR CHEMICAL ADDITIVES USED FOR ALTERING SURFACE PROPERTIES IN THE OIL AND GAS INDUSTRY (U.S. CLS. 1, 5, 6, 10, 26 AND 46).

ALLISON HOLTZ, EXAMINING ATTORNEY

**CLASS 1—(Continued).**

SN 86-314,358. MULTI-CHEM GROUP, LLC, SAN ANGELO, TX. FILED 6-19-2014.

SN 86-280,170. MATHESON TRI-GAS, INC., BASKING RIDGE, NJ. FILED 5-13-2014.



# SOURSHIELD

OWNER OF U.S. REG. NOS. 3,331,364, 3,946,222 AND OTHERS.

THE MARK CONSISTS OF THE WORDS "MATHESON ASK...THE GAS PROFESSIONALS" AND AN OVERLAPPING CIRCLES DESIGN.

FOR GASES FOR GENERAL INDUSTRIAL USE, NAMELY, NITROGEN (U.S. CLS. 1, 5, 6, 10, 26 AND 46). BRIDGETT SMITH, EXAMINING ATTORNEY

SN 86-290,137. MEADWESTVACO CORPORATION, RICHMOND, VA. FILED 5-23-2014.

# WESTRACK

THE MARK CONSISTS OF STANDARD CHARACTERS WITHOUT CLAIM TO ANY PARTICULAR FONT, STYLE, SIZE, OR COLOR.

FOR CHEMICAL ADDITIVES FOR USE AS TACKIFIERS IN THE MANUFACTURE OF TIRES AND OTHER RUBBER PRODUCTS (U.S. CLS. 1, 5, 6, 10, 26 AND 46).

ALLISON HOLTZ, EXAMINING ATTORNEY

THE MARK CONSISTS OF STANDARD CHARACTERS WITHOUT CLAIM TO ANY PARTICULAR FONT, STYLE, SIZE, OR COLOR.

FOR MICROBIOLOGICAL CHEMICAL TREATMENTS USED TO TREAT, CONTROL, AND REDUCE MICROORGANISM GROWTH IN OIL AND GAS WELL OPERATIONS (U.S. CLS. 1, 5, 6, 10, 26 AND 46).

ESTHER QUEEN, EXAMINING ATTORNEY

**CLASS 2—PAINTS**

SN 79-141,522. HLS PAINT (SHANGHAI) CO., LTD, CHINA, FILED 9-16-2013.



**CLASS 2—(Continued).**

SN 79-143,278. ALFRED CLOUTH LACKFABRIK GMBH & CO. KG, 63073 OFFENBACH, FED REP GERMANY, FILED 12-20-2013.

**CLOU**

OWNER OF INTERNATIONAL REGISTRATION 0415673 DATED 4-25-1975, EXPIRES 4-25-2015.

THE ENGLISH TRANSLATION OF THE WORD "CLOU" IN THE MARK IS "NAIL".

FOR LACQUERS IN THE NATURE OF A COATING; LACQUERS IN THE FORM OF AEROSOL SPRAYS OR FOR USE IN AUTOMATIC SPRAYING APPARATUS; LACQUERS FOR ULTRAVIOLET RADIATION ABSORBENT PAINTING BEING BASE COATINGS FOR ABSORBING ULTRAVIOLET RADIATION; PRIMING LACQUERS AND PRIMING VARNISHES; MORDANTS FOR WOOD FOR USE IN FURNITURE AND CONSTRUCTION MATERIALS (U.S. CLS. 6, 11 AND 16).  
BERNICE MIDDLETON, EXAMINING ATTORNEY

SN 85-889,996. NATIONAL GLAZING SOLUTIONS LLC, ROSWELL, GA. FILED 3-29-2013.



OWNER OF INTERNATIONAL REGISTRATION 1189590 DATED 9-16-2013, EXPIRES 9-16-2023.

THE MARK CONSISTS OF A SHADED RECTANGLE THAT CONTAINS THE STYLIZED WORDING "HY" IN THE TOP-CENTER OF THE RECTANGLE ABOVE A SMALLER RECTANGULAR ELEMENT THAT CONTAINS THE STYLIZED WORDING "HAOLISEN". BENEATH THE RECTANGLES ARE THREE STYLIZED CHINESE CHARACTERS THAT TRANSLITERATE TO "HAO", "LI", AND "SEN", RESPECTIVELY.

THE ENGLISH TRANSLATION OF THE FOREIGN WORDING IN THE MARK IS AS FOLLOWS: THE FIRST CHINESE CHARACTER WHICH TRANSLITERATES TO "HAO" TRANSLATES AS "GREAT"; THE SECOND CHINESE CHARACTER WHICH TRANSLITERATES TO "LI" TRANSLATES AS "POWER"; THE THIRD CHINESE CHARACTER WHICH TRANSLITERATES TO "SEN" TRANSLATES AS "FOREST"; THE LATIN CHARACTERS "HAOLISEN" ARE PINYIN OF THE CHINESE CHARACTERS AND HAVE NO MEANING IN COMBINATION.

THE TRANSLITERATION OF THE NON-LATIN CHARACTERS IN THE MARK IS: "HAO LI SEN".

FOR PAINTS; COATINGS, NAMELY, PAINTS; LACQUERS; WHITE COLORANTS AND PAINTS; DYES, NAMELY, ALCOHOL SOLUBLE DYES, OIL SOLUBLE DYES, AND DYES FOR USE IN THE MANUFACTURE OF AUTOMOBILE PARTS, METAL PARTS OF AUTOMOBILE, HOME APPLIANCES; COLORANTS; DYE-STUFFS; PRINTING INK; ANTI-CORROSIVE PRESERVATIVE OILS AND COATINGS; UNPROCESSED NATURAL MASTIC RESINS (U.S. CLS. 6, 11 AND 16).  
WENDELL PHILLIPS, EXAMINING ATTORNEY

THE COLOR(S) AQUA, BLACK AND WHITE IS/ARE CLAIMED AS A FEATURE OF THE MARK.

THE MARK CONSISTS OF THREE TRIANGLES CONFIGURED TOGETHER WITH THE TOP TRIANGLE BEING AQUA AND THE TWO BOTTOM TRIANGLES BEING BLACK. THE WORDING "TRI-SHIELD", IN BLACK SEEN BELOW. THE ENTIRE MARK IS SET ON A WHITE BACKGROUND.

FOR GLASS COATINGS AND TINT LAMINATIONS (U.S. CLS. 6, 11 AND 16).  
FIRST USE 3-14-2013; IN COMMERCE 3-14-2013.  
BRITTANY ESTELL, EXAMINING ATTORNEY



**CLASS 2—(Continued).**

SN 86-004,470. SKC ACQUISITION CORP., GETTYSBURG, PA. FILED 7-8-2013.

**WAM**

THE MARK CONSISTS OF STANDARD CHARACTERS WITHOUT CLAIM TO ANY PARTICULAR FONT, STYLE, SIZE, OR COLOR.

FOR MATERIAL TREATMENT COATINGS FOR APPLICATION TO PAPER PRODUCTS, NAMELY, NON-WAX POLYMER COATINGS FOR APPLICATION TO CORRUGATED MEDIUM, LINER, AND KRAFT, AND NON-WAX POLYMER COATINGS FOR APPLICATION TO PAPER PRODUCTS (U.S. CLS. 6, 11 AND 16).

FIRST USE 9-0-1992; IN COMMERCE 9-0-1992.  
SETH A. RAPPAPORT, EXAMINING ATTORNEY

SN 86-005,370. SKC ACQUISITION CORP., GETTYSBURG, PA. FILED 7-9-2013.



THE MARK CONSISTS OF THE LETTERS "WAM" INSIDE OF A TRIANGLE FORMED BY THREE CONSECUTIVE ARROWS WHICH LOOP AROUND EACH CORNER OF THE TRIANGLE.

FOR MATERIAL TREATMENT COATINGS FOR APPLICATION TO PAPER PRODUCTS, NAMELY, NON-WAX POLYMER COATINGS FOR APPLICATION TO CORRUGATED MEDIUM, LINER, AND KRAFT, AND NON-WAX POLYMER COATINGS FOR APPLICATION TO PAPER PRODUCTS (U.S. CLS. 6, 11 AND 16).  
SETH A. RAPPAPORT, EXAMINING ATTORNEY

**CLASS 2—(Continued).**

SN 86-070,176. VAPOR TECHNOLOGIES, INC., LONGMONT, CO. FILED 9-20-2013.

**ZROC**

THE MARK CONSISTS OF STANDARD CHARACTERS WITHOUT CLAIM TO ANY PARTICULAR FONT, STYLE, SIZE, OR COLOR.

FOR PROTECTIVE COATINGS AND FINISHES FOR METALS, PLASTICS AND CERAMICS (U.S. CLS. 6, 11 AND 16).

KAPIL BHANOT, EXAMINING ATTORNEY

SN 86-073,108. CHROMA INC., LITITZ, PA. FILED 9-24-2013.

**Atelier Classic  
Professional Artists'  
Acrylics**

THE MARK CONSISTS OF STANDARD CHARACTERS WITHOUT CLAIM TO ANY PARTICULAR FONT, STYLE, SIZE, OR COLOR.

OWNER OF U.S. REG. NO. 2,194,766.

NO CLAIM IS MADE TO THE EXCLUSIVE RIGHT TO USE "ATELIER" AND "PROFESSIONAL ARTISTS' ACRYLICS", APART FROM THE MARK AS SHOWN.

THE ENGLISH TRANSLATION OF "ATELIER" IN THE MARK IS "WORKSHOP" OR "STUDIO".

FOR ACRYLIC PAINTS; PAINT FOR ARTISTS; PAINTS FOR FINE ART, INCLUDING PAINTING MEDIUMS FOR THINNING AND THICKENING PAINTS; VARNISHES (U.S. CLS. 6, 11 AND 16).

KELLY TRUSILO, EXAMINING ATTORNEY

SN 86-237,298. HANDY ART, INC., MILTON, WI. FILED 3-31-2014.

**HANDY Art**

OWNER OF U.S. REG. NOS. 1,667,301, 2,123,612 AND 2,123,637.

NO CLAIM IS MADE TO THE EXCLUSIVE RIGHT TO USE "ART", APART FROM THE MARK AS SHOWN.

THE MARK CONSISTS OF THE WORDS "HANDY ART" IN STYLIZED FONT.

FOR PAINTS (U.S. CLS. 6, 11 AND 16).

MARILYN IZZI, EXAMINING ATTORNEY

**CLASS 2—(Continued).**

SN 86-237,305. HANDY ART, INC., MILTON, WI. FILED 3-31-2014.



OWNER OF U.S. REG. NOS. 3,889,629 AND 4,154,158.  
THE MARK CONSISTS OF STYLIZED WORDS "LITTLE MASTERS" WITH THE WORD "LITTLE" HOUSED UNDER THE CAPITAL "M" IN "MASTERS".  
FOR PAINTS (U.S. CLS. 6, 11 AND 16).  
MARILYN IZZI, EXAMINING ATTORNEY

---

SN 86-244,636. AXALTA COATING SYSTEMS IP CO. LLC, WILMINGTON, DE. FILED 4-7-2014.



THE MARK CONSISTS OF A SPLASH OF LIQUID OVER THE WORDING "AQUAEC".  
FOR ANTI-CORROSIVE PROTECTIVE COATINGS FOR AUTOMOTIVE AND INDUSTRIAL USERS (U.S. CLS. 6, 11 AND 16).  
WENDELL PHILLIPS, EXAMINING ATTORNEY

---

SN 86-248,707. MATSUI INTERNATIONAL CO., INC., GARDENA, CA. FILED 4-10-2014.



THE MARK CONSISTS OF STANDARD CHARACTERS WITHOUT CLAIM TO ANY PARTICULAR FONT, STYLE, SIZE, OR COLOR.  
FOR WATER-BASED INJET PRINTING INK (U.S. CLS. 6, 11 AND 16).  
DOUGLAS LEE, EXAMINING ATTORNEY

**CLASS 2—(Continued).**

SN 86-323,277. AXALTA COATING SYSTEMS IP CO. LLC, WILMINGTON, DE. FILED 6-27-2014.



THE MARK CONSISTS OF STANDARD CHARACTERS WITHOUT CLAIM TO ANY PARTICULAR FONT, STYLE, SIZE, OR COLOR.

FOR PAINTS AND COATINGS IN THE NATURE OF PRIMING POWDERS AND PRIMERS (U.S. CLS. 6, 11 AND 16).  
WENDELL PHILLIPS, EXAMINING ATTORNEY

**CLASS 3—COSMETICS AND CLEANING PREPARATIONS**

---

SN 76-716,057. OLD PURPLE, CHAGRIN FALLS, OH. FILED 3-24-2014.



THE MARK CONSISTS OF STANDARD CHARACTERS WITHOUT CLAIM TO ANY PARTICULAR FONT, STYLE, SIZE, OR COLOR.

FOR MOLD POLISH FOR POLISHING AND CLEANING OF STAINLESS STEEL, CHROME-PLATED AND ALUMINUM ALLOY MOLD SURFACES AND TOOL STEELS (U.S. CLS. 1, 4, 6, 50, 51 AND 52).

FIRST USE 0-0-1975; IN COMMERCE 0-0-1975.  
DARRYL SPRUILL, EXAMINING ATTORNEY

**CLASS 3—(Continued).**

SN 77-218,196. RWACHSBERG HOLDINGS INC., TORONTO, ONTARIO, CANADA, FILED 6-28-2007.

**GREEN LIVING**

THE MARK CONSISTS OF STANDARD CHARACTERS WITHOUT CLAIM TO ANY PARTICULAR FONT, STYLE, SIZE, OR COLOR.

PRIORITY CLAIMED UNDER SEC. 44(D) ON CANADA APPLICATION NO. 1313199, FILED 6-28-2007, REG. NO. TMA745258, DATED 8-12-2009, EXPIRES 8-12-2024.

PRIORITY CLAIMED UNDER SEC. 44(D) ON CANADA APPLICATION NO. 1353649, FILED 6-28-2007, REG. NO. TMA817621, DATED 2-14-2012, EXPIRES 2-14-2027.

NO CLAIM IS MADE TO THE EXCLUSIVE RIGHT TO USE "GREEN", APART FROM THE MARK AS SHOWN.

FOR NON-MEDICATED PERSONAL CARE PRODUCTS, NAMELY, SHAMPOOS AND HAIR CONDITIONERS, SKIN MOISTURIZERS, SKIN LOTION, BODY LOTION, BODY CREAM, SKIN CREAM, ANTI-AGING CREAM, NON-MEDICATED STRETCH MARK SKIN CREAMS, NON-MEDICATED COSMETIC LOTIONS AND CREAMS FOR NAILS, HAIR, AND VARICOSE VEINS, DEPILATORY LOTIONS AND CREAMS, SHAVING LOTIONS AND CREAMS, NON-MEDICATED SKIN CARE PREPARATIONS, NAMELY, ANTI-WRINKLE LOTIONS AND CREAMS, AND LOTIONS AND CREAMS FOR TREATING DRY AND DAMAGED SKIN, FOR ANTI-AGING, FOR SKIN FIRMLING, FOR STRETCH MARKS, AND UNDER EYE AND EYELID FIRMLING; NON-MEDICATED SKIN CARE PREPARATIONS IN GEL FORM, NAMELY, DEPILATORY GELS, SHAVING GELS, SHOWER GELS, MOISTURIZING AND ANTI-AGING GELS, AND STRETCH MARK GELS; OILS, NAMELY, BATH OILS, BODY OILS, COSMETIC OILS, AND NUTRITIONAL OILS FOR COSMETIC PURPOSES, NON-MEDICATED SKIN AND BEAUTY SERUMS, PETROLEUM JELLY FOR COSMETIC PURPOSES, LIQUID SOAPS, ANTI-BACTERIAL LIQUID SOAPS, HUMAN BODY SPRAYS, REFRESHING BODY SPRAYS, BODY WASHING SOAPS, BUBBLE BATH, BODY AND FACIAL SCRUBS, MASKS, NAMELY, BEAUTY MASKS, FACIAL MASKS, BODY MASKS, GEL EYE MASKS, SKIN MASKS, AND SKIN MOISTURIZER MASKS, NON-MEDICATED SKIN CARE PREPARATIONS IN THE NATURE OF FACE PEELS, NON-MEDICATED SKIN CARE PREPARATIONS, AND WRINKLE REMOVING SKIN CARE PREPARATIONS, AFTER-SUN LOTIONS WITH OR WITHOUT SPF, SELF-TANNING CREAMS AND LOTIONS, TALCUM POWDERS, PERSONAL DEODORANTS, HAND SOAPS, DISPOSABLE WIPES IN SHEET FORM IMPREGNATED WITH CHEMICALS OR COMPOUNDS FOR USE ON HUMAN SKIN, PRE-MOISTENED COSMETIC WIPES IN SHEET FORM, NON-MEDICATED SKIN CARE PREPARATIONS FOR ANTI-AGING, ANTI-WRINKLES, SKIN CONDITIONING AND SKIN FIRMLING, NAMELY, DAYTIME AND NIGHTTIME PILLS, CAPSULES, GEL CAPS AND TABLETS (U.S. CLS. 1, 4, 6, 50, 51 AND 52).

ZHALEH DELANEY, EXAMINING ATTORNEY

**CLASS 3—(Continued).**

SN 77-817,198. SANTE SEMPRINI CESARI, UNION CITY, NJ, FILED 9-1-2009.



THE MARK CONSISTS OF THE LETTER "M" IN BOLD ON TOP OF TWO SHAPES THAT TOGETHER FORM AN "X".

FOR HAIR BLEACHING PREPARATIONS; HAIR CARE CREAMS; HAIR CARE LOTIONS; HAIR GEL AND HAIR MOUSSE; HAIR LACQUERS; HAIR SHAMPOOS AND CONDITIONERS; HAIR SPRAY; HAIR WAVING LOTION; HAIR WAX; NON-MEDICATED HAIR SERUMS (U.S. CLS. 1, 4, 6, 50, 51 AND 52).

FIRST USE 11-1-2007; IN COMMERCE 11-1-2007.

CHERYL CLAYTON, EXAMINING ATTORNEY

SN 79-137,526. MÄURER & WIRTZ GMBH & CO. KG, 52224 STOLBERG, FED REP GERMANY, FILED 8-12-2013.

**Nautic Spirit**

THE MARK CONSISTS OF STANDARD CHARACTERS WITHOUT CLAIM TO ANY PARTICULAR FONT, STYLE, SIZE, OR COLOR.

PRIORITY DATE OF 2-14-2013 IS CLAIMED.

OWNER OF INTERNATIONAL REGISTRATION 1179148 DATED 8-12-2013, EXPIRES 8-12-2023.

FOR BLEACHING PREPARATIONS AND OTHER SUBSTANCES FOR LAUNDRY USE, NAMELY, DETERGENTS, SIZING STARCH, FABRIC CONDITIONERS, STAIN REMOVERS; CLEANING, POLISHING, SCOURING AND ABRASIVE PREPARATIONS; SOAPS; COSMETICS; PERFUMERIES; ESSENTIAL OILS; HAIR LOTIONS; DENTIFRICES (U.S. CLS. 1, 4, 6, 50, 51 AND 52).

KAREN SEVERSON, EXAMINING ATTORNEY

**CLASS 3—(Continued).**

SN 79-138,249. CASTER, FRANCE, FILED 9-27-2013.

# LIERAC MAGNIFICENCE

THE MARK CONSISTS OF STANDARD CHARACTERS WITHOUT CLAIM TO ANY PARTICULAR FONT, STYLE, SIZE, OR COLOR.

PRIORITY DATE OF 4-25-2013 IS CLAIMED.

OWNER OF INTERNATIONAL REGISTRATION 1181238 DATED 9-27-2013, EXPIRES 9-27-2023.

FOR COSMETIC PRODUCTS FOR ANTI-AGE CARE, NAMELY, ANTI-AGING CREAM, ANTI-WRINKLE CREAM, ANTI-AGING TONER, ANTI-AGING MOISTURIZER, ANTI-AGING CLEANSER, AND NON-MEDICATED ANTI-AGING SERUM (U.S. CLS. 1, 4, 6, 50, 51 AND 52).

MICHAEL KEATING, EXAMINING ATTORNEY

SN 79-138,833. KIRMIZIGÜL KOZMETİK VE TURİZM SANAYİ TİCARET LİMİTED SİRKETİ, TEKİRDAĞ, TURKEY, FILED 6-18-2013.

# REDONE

THE MARK CONSISTS OF STANDARD CHARACTERS WITHOUT CLAIM TO ANY PARTICULAR FONT, STYLE, SIZE, OR COLOR.

OWNER OF INTERNATIONAL REGISTRATION 1182652 DATED 6-18-2013, EXPIRES 6-18-2023.

FOR BLEACHING PREPARATIONS FOR LAUNDRY USE; SUBSTANCES FOR LAUNDRY USE, NAMELY, LAUNDRY DETERGENT, LAUNDRY STARCH, LAUNDRY FABRIC CONDITIONER; CLEANING, POLISHING, SCOURING AND ABRASIVE PREPARATIONS; CLEANING PREPARATIONS; FURNITURE POLISH; SOAPS; PERFUMERY; ESSENTIAL OILS; COSMETICS; HAIR LOTIONS; DENTIFRICES; COSMETIC CREAMS (U.S. CLS. 1, 4, 6, 50, 51 AND 52).

NATALIE KENEALY, EXAMINING ATTORNEY

SN 79-139,288. BURBERRY LİMİTED, UNITED KINGDOM, FILED 9-6-2013.

# BURBERRY WHITE GLOW

THE MARK CONSISTS OF STANDARD CHARACTERS WITHOUT CLAIM TO ANY PARTICULAR FONT, STYLE, SIZE, OR COLOR.

PRIORITY DATE OF 7-8-2013 IS CLAIMED.

OWNER OF INTERNATIONAL REGISTRATION 1183765 DATED 9-6-2013, EXPIRES 9-6-2023.

OWNER OF U.S. REG. NOS. 2,629,931, 4,223,739 AND OTHERS.

FOR NON-MEDICATED TOILETRIES; COSMETICS; COSMETIC PREPARATIONS FOR THE BATH AND SHOWER; COSMETIC BODY AND SKIN CARE PREPARATIONS; HAIR CARE AND STYLING PREPARATIONS; NAIL CARE PREPARATIONS AND POLISH; FALSE NAILS; SKIN SOAPS; ANTI-PERSPIRANTS, DEODORANTS FOR PERSONAL USE; PERFUMES, EAU DE COLOGNE, EAU DE TOILETTE AND TOILET WATER; ESSENTIAL OILS, MASSAGE OIL; POTPOURRI, ROOM FRAGRANCES AND INCENSE (U.S. CLS. 1, 4, 6, 50, 51 AND 52).

AMY HELLA, EXAMINING ATTORNEY

**CLASS 3—(Continued).**

SN 79-140,027. GUANGZHOU CITY BAIYUN LIANJIA FINE CHEMICAL FACTORY, GUANGZHOU CITY, GUANGDONG, CHINA, FILED 6-22-2013.



OWNER OF INTERNATIONAL REGISTRATION 1185689 DATED 6-22-2013, EXPIRES 6-22-2023.

THE MARK CONSISTS OF TWO CHINESE CHARACTERS ABOVE THE STYLIZED WORDING "DANZI" ALL OF WHICH ARE SURROUNDED BY CONCENTRIC RECTANGLES.

THE ENGLISH TRANSLATION OF THE FOREIGN WORD(S) IN THE MARK IS: THE FIRST CHINESE CHARACTER MEANS "RED", THE SECOND CHINESE CHARACTER MEANS "POSTURE".

THE TRANSLITERATION OF THE NON-LATIN CHARACTERS IN THE MARK IS: THE FIRST CHINESE CHARACTER IS TRANSLITERATED AS "DAN", THE SECOND CHINESE CHARACTER IS TRANSLITERATED AS "ZI".

FOR COSMETIC SUNSCREEN PREPARATIONS; COSMETIC PREPARATIONS FOR SLIMMING PURPOSES; MACULE-REMOVING CREAM; HAIR TREATMENT CREAM; TALCUM POWDER; CREAM FOR WHITENING THE SKIN; HAIR SPRAY; COSMETIC PREPARATIONS FOR SKIN CARE; NON-MEDICATED ACNE CREAM; BOOT CREAM; ESSENTIAL OILS; COSMETICS; LIPSTICKS; BEAUTY MASKS; HAIR DYES; COSMETIC CREAMS; PERFUMES; TOILET WATER; DEPILATORIES; SOAP; HAIR LOTIONS; SHAMPOOS; CAKES OF SOAP; HAIR CONDITIONER; FACIAL CLEANSER; COSMETIC HAND LOTIONS WITH ANTIBACTERIAL PROPERTIES; WASHING PREPARATIONS (U.S. CLS. 1, 4, 6, 50, 51 AND 52).

MATTHEW EINSTEIN, EXAMINING ATTORNEY

SN 79-141,318. SBH SAS, FRANCE, FILED 11-15-2013.

# KADALYS

THE MARK CONSISTS OF STANDARD CHARACTERS WITHOUT CLAIM TO ANY PARTICULAR FONT, STYLE, SIZE, OR COLOR.

OWNER OF INTERNATIONAL REGISTRATION 1189007 DATED 11-15-2013, EXPIRES 11-15-2023.

FOR SOAPS; PERFUMES, COSMETICS, HAIR LOTIONS; MAKE-UP REMOVING PRODUCTS, NAMELY, MAKE-UP REMOVING PREPARATIONS AND CLEANSING GELS; BEAUTY MASKS (U.S. CLS. 1, 4, 6, 50, 51 AND 52).

SANI KHOURI, EXAMINING ATTORNEY

**CLASS 3—(Continued).**

SN 79-142,894. INTERNATIONAL TRADE CORPORATION LIMITED, WATFORD, HERTFORDSHIRE, UNITED KINGDOM, FILED 12-7-2013.

**CELUTONE**  
Xavier Laurent

PRIORITY DATE OF 6-10-2013 IS CLAIMED.  
OWNER OF INTERNATIONAL REGISTRATION 1192969 DATED 12-7-2013, EXPIRES 12-7-2023.

OWNER OF U.S. REG. NOS. 3,602,797 AND 3,647,755.  
THE NAME(S), PORTRAIT(S), AND/OR SIGNATURE(S) SHOWN IN THE MARK DOES NOT IDENTIFY A PARTICULAR LIVING INDIVIDUAL.

FOR SUNSCREEN CREAM; SUN BLOCK; SUN TANNING AND SELF-TANNING PREPARATIONS; ESSENTIAL OILS; NON-MEDICATED TOILET PREPARATIONS; COSMETICS; NON-MEDICATED PREPARATIONS FOR THE CARE OF THE SKIN; SKIN EXFOLIANTS; BODY EMULSIONS, SKIN MOISTURIZING GELS, SKIN MOUSSES AND BODY OILS FOR USE ON THE SKIN; BODY LOTIONS AND SKIN MOISTURIZERS; SKIN CREAMS; SKIN LOTIONS; CREAMS, SKIN MOUSSES, LOTIONS AND OILS FOR CELLULITE REDUCTION; CREAMS, MOUSSES, LOTIONS AND OILS FOR SELF-TANNING OR TANNING AND CELLULITE REDUCTION (U.S. CLS. 1, 4, 6, 50, 51 AND 52).

SHAVELL MCPHERSON, EXAMINING ATTORNEY

SN 79-145,212. PARFUMS PAROUR, PARIS, FRANCE, FILED 1-28-2014.

**PARFUM D'OR**

OWNER OF INTERNATIONAL REGISTRATION 0632083 DATED 2-21-1995, EXPIRES 2-21-2015.

NO CLAIM IS MADE TO THE EXCLUSIVE RIGHT TO USE "PARFUM", APART FROM THE MARK AS SHOWN.  
THE ENGLISH TRANSLATION OF "PARFUM D'OR" IN THE MARK IS "GOLDEN PERFUME".

FOR BLEACHING PREPARATIONS AND OTHER SUBSTANCES FOR LAUNDRY USE, NAMELY, LAUNDRY SOAP, LAUNDRY BLEACH; CLEANING, POLISHING, DEGREASING AND ABRASIVE PREPARATIONS, SOAPS, PERFUMERY, ESSENTIAL OILS, COSMETICS, HAIR LOTIONS, DENTIFRICES (U.S. CLS. 1, 4, 6, 50, 51 AND 52).

RON FAIRBANKS, EXAMINING ATTORNEY

**CLASS 3—(Continued).**

SN 79-145,215. NIPPON MENARD COSMETIC CO., LTD., AICHI 451-0071, JAPAN, FILED 1-29-2014.

**BEAUNESS**

OWNER OF INTERNATIONAL REGISTRATION 0802746 DATED 4-14-2003, EXPIRES 4-14-2023.

OWNER OF U.S. REG. NO. 1,856,513.

FOR SOAPS, NAMELY, SOAPS FOR PERSONAL USE, LIQUID SOAP, BATH SOAP, SKIN SOAPS AND MEDICATED SOAPS; DENTIFRICES; COSMETICS; NATURAL PERFUMERY PREPARED FROM VEGETABLES; NATURAL PERFUMERY PREPARED FROM ANIMALS; SYNTHETIC PERFUMERY; COMPOUND PERFUMERY; INCENSES AND FRAGRANCES (U.S. CLS. 1, 4, 6, 50, 51 AND 52).

JAMES MACFARLANE, EXAMINING ATTORNEY

SN 79-145,940. INTERNATIONAL TRADE CORPORATION LIMITED, UNITED KINGDOM, FILED 12-9-2013.

**CELUTAN**  
Xavier Laurent

PRIORITY DATE OF 8-29-2013 IS CLAIMED.

OWNER OF INTERNATIONAL REGISTRATION 1200375 DATED 12-9-2013, EXPIRES 12-9-2023.

OWNER OF U.S. REG. NOS. 3,602,797 AND 3,647,755.

THE NAME(S), PORTRAIT(S), AND/OR SIGNATURE(S) SHOWN IN THE MARK DOES NOT IDENTIFY A PARTICULAR LIVING INDIVIDUAL.

FOR SUNSCREEN; SUN BLOCK; SUN TANNING AND SELF-TAN PREPARATIONS; ESSENTIAL OILS; NON-MEDICATED TOILET PREPARATIONS, NAMELY, NON-MEDICATED SKIN AND BODY CREAMS, SKIN AND BODY CLEANSERS, SKIN AND BODY LOTIONS, SKIN AND BODY ASTRINGENTS; COSMETICS; NON-MEDICATED PREPARATIONS FOR THE CARE OF THE SKIN; SKIN EXFOLIANTS; NON-MEDICATED EMULSIONS, GELS, MOUSSES AND OILS FOR USE ON THE SKIN; BODY LOTIONS AND MOISTURIZERS; SKIN CREAMS; SKIN LOTIONS; CREAMS, MOUSSES, LOTIONS AND OILS FOR CELLULITE REDUCTION; SELF-TANNING AND TANNING CREAMS, MOUSSES, LOTIONS AND OILS WITH CELLULITE REDUCTION PROPERTIES (U.S. CLS. 1, 4, 6, 50, 51 AND 52).

MATTHEW GALAN, EXAMINING ATTORNEY

SN 79-146,873. TETRAHEDRON, VINCENNES, FRANCE, FILED 1-31-2014.

**BIONEINE**

THE MARK CONSISTS OF STANDARD CHARACTERS WITHOUT CLAIM TO ANY PARTICULAR FONT, STYLE, SIZE, OR COLOR.

OWNER OF INTERNATIONAL REGISTRATION 1202835 DATED 1-31-2014, EXPIRES 1-31-2024.

FOR PERFUMES; ESSENTIAL OILS; COSMETICS; HAIR LOTIONS; MAKE-UP REMOVING PREPARATIONS (U.S. CLS. 1, 4, 6, 50, 51 AND 52).

MICHELLE DUBOIS, EXAMINING ATTORNEY

**CLASS 3—(Continued).**

SN 85-244,036. HOLLYWOOD ALLIANCE CANADA INC., TORONTO, ONTARIO, CANADA, FILED 2-16-2011.

**SUN PIRATES**

THE MARK CONSISTS OF STANDARD CHARACTERS WITHOUT CLAIM TO ANY PARTICULAR FONT, STYLE, SIZE, OR COLOR.

PRIORITY CLAIMED UNDER SEC. 44(D) ON CANADA APPLICATION NO. 1,515,415, FILED 2-15-2011.

NO CLAIM IS MADE TO THE EXCLUSIVE RIGHT TO USE "SUN", APART FROM THE MARK AS SHOWN.

FOR SUNBLOCK PREPARATIONS, SUN SCREEN PREPARATIONS, SUN TAN GELS, SUN TAN OILS, SUN TAN LOTIONS, SUN TANNING PREPARATIONS, AFTER SUN LOTIONS, AND SUNLESS SELF-TANNING PREPARATIONS (U.S. CLS. 1, 4, 6, 50, 51 AND 52).

WILLIAM BRECKENFELD, EXAMINING ATTORNEY

SN 85-355,315. MARCHESA HOLDINGS, LLC, NEW YORK, NY. FILED 6-24-2011.

**MARCHESA ISOLA**

THE MARK CONSISTS OF STANDARD CHARACTERS WITHOUT CLAIM TO ANY PARTICULAR FONT, STYLE, SIZE, OR COLOR.

OWNER OF U.S. REG. NOS. 3,111,629, 3,201,569 AND OTHERS.

THE ENGLISH TRANSLATION OF "ISOLA" IN THE MARK IS "ISLAND".

FOR SOAPS, PERFUMERY, ESSENTIAL OILS, COSMETICS (U.S. CLS. 1, 4, 6, 50, 51 AND 52).

MELISSA VALLILLO, EXAMINING ATTORNEY

SN 85-371,059. OLIVERI, JOE, RANCHO PALOS VERDES, CA. FILED 7-14-2011.

**URGENT CURE**

THE MARK CONSISTS OF STANDARD CHARACTERS WITHOUT CLAIM TO ANY PARTICULAR FONT, STYLE, SIZE, OR COLOR.

OWNER OF U.S. REG. NO. 4,451,737.

FOR HAIR SHAMPOOS AND CONDITIONERS (U.S. CLS. 1, 4, 6, 50, 51 AND 52).

KRISTIN DAHLING, EXAMINING ATTORNEY

**CLASS 3—(Continued).**

SN 85-693,225. LORNAMEAD, INC., TONAWANDA, NY. FILED 8-2-2012.

**RADIANT WHITE**

THE MARK CONSISTS OF STANDARD CHARACTERS WITHOUT CLAIM TO ANY PARTICULAR FONT, STYLE, SIZE, OR COLOR.

NO CLAIM IS MADE TO THE EXCLUSIVE RIGHT TO USE "WHITE", APART FROM THE MARK AS SHOWN.

FOR CLEANING PREPARATIONS FOR THE TEETH; TOOTH PASTE; WHITENING TOOTH PASTE; DENTIFRICES; MOUTHWASH; DENTAL BLEACHING GEL; WHITENING DENTAL FLOSS (U.S. CLS. 1, 4, 6, 50, 51 AND 52).

FIRST USE 11-0-2011; IN COMMERCE 11-0-2011.

WILLIAM BRECKENFELD, EXAMINING ATTORNEY

SN 85-705,491. COSMETICS LIMITED, NASSAU, BAHAMAS, FILED 8-16-2012.

**LaTHÉRAPIE**

THE MARK CONSISTS OF THE WORDS "LA THÉRAPIE" IN STYLIZED LETTERS.

THE ENGLISH TRANSLATION OF "LA THÉRAPIE" IN THE MARK IS "THE THERAPY".

FOR NON-MEDICATED SKIN CARE CREAMS, LOTIONS, GELS, SERUMS AND PREPARATIONS; SKIN CLEANSERS AND TONERS; BODY AND FACE SCRUBS AND EXFOLIANTS FOR SKIN; EYE CREAMS, GELS AND NON-MEDICATED CLEANERS; NON-MEDICATED NECK CREAMS; FACIAL MASKS; SUNSCREEN CREAMS, COSMETIC SUNSCREEN PREPARATIONS (U.S. CLS. 1, 4, 6, 50, 51 AND 52).

FIRST USE 7-31-2003; IN COMMERCE 7-31-2003.

GEOFFREY FOSDICK, EXAMINING ATTORNEY

SN 85-751,188. CWACHSBERG HOLDINGS INC., TORONTO, ONTARIO, CANADA, FILED 10-11-2012.

**DISCOVER THE MOVEMENT**

THE MARK CONSISTS OF STANDARD CHARACTERS WITHOUT CLAIM TO ANY PARTICULAR FONT, STYLE, SIZE, OR COLOR.

PRIORITY CLAIMED UNDER SEC. 44(D) ON CANADA APPLICATION NO. 1588505, FILED 8-1-2012, REG. NO. TMA876,912, DATED 5-1-2014, EXPIRES 5-1-2029.

FOR HAIR CARE PREPARATIONS (U.S. CLS. 1, 4, 6, 50, 51 AND 52).

ZACHARY BELLO, EXAMINING ATTORNEY

**CLASS 3—(Continued).**

SN 85-792,146. HOTEL EMPORIUM, INC., GARDENA, CA. FILED 11-30-2012.

# O2 Oxygen

THE MARK CONSISTS OF STANDARD CHARACTERS WITHOUT CLAIM TO ANY PARTICULAR FONT, STYLE, SIZE, OR COLOR.

OWNER OF U.S. REG. NO. 3,241,089.

NO CLAIM IS MADE TO THE EXCLUSIVE RIGHT TO USE "O2", APART FROM THE MARK AS SHOWN. SEC. 2(F).

FOR HOTEL BATHROOM AMENITIES, NAMELY, NON-MEDICATED BODY CARE PRODUCTS AND COSMETICS, NAMELY, BATH GEL, BODY LOTION, BODY WASH, HAIR CONDITIONER, HAIR LOTION, SHAMPOO-CONDITIONERS, SHAMPOOS, SOAPS, AND FRAGRANCES FOR COMPLIMENTARY HOTEL DISTRIBUTION (U.S. CLS. 1, 4, 6, 50, 51 AND 52).

FIRST USE 6-3-2009; IN COMMERCE 6-3-2009.

JENNY PARK, EXAMINING ATTORNEY

SN 85-802,298. LANGHAM HOTELS INTERNATIONAL LIMITED, WANCHAI, HONG KONG, FILED 12-13-2012.



PRIORITY CLAIMED UNDER SEC. 44(D) ON HONG KONG APPLICATION NO. 302464434, FILED 12-12-2012, REG. NO. 302464434, DATED 12-12-2012, EXPIRES 12-12-2022.

OWNER OF U.S. REG. NOS. 3,595,895 AND 4,281,832.

NO CLAIM IS MADE TO THE EXCLUSIVE RIGHT TO USE "SPA", APART FROM THE MARK AS SHOWN.

THE MARK CONSISTS OF THREE VERTICAL PAINT BRUSH STROKES, ONE MEDIUM BRUSH STROKE ON THE LEFT, ONE SMALL BRUSH STROKE IN THE MIDDLE AND ONE LARGE BRUSH STROKE ON THE RIGHT WITH THE WORDS "CHUAN SPA" BELOW THE MEDIUM AND SMALL BRUSH STROKE AND TO THE LEFT OF THE LARGE BRUSH STROKE.

THE ENGLISH TRANSLATION OF THE WORD "CHUAN" IN THE MARK IS "RIVER".

FOR COSMETICS AND BODY CARE PRODUCTS; NON-MEDICATED BODY POWDER; SKIN SOAPS; BATH GEL, BATH OILS, BATH SALTS, BATH BEADS, AND BATH FIZZIES; NON-MEDICATED SKIN CARE PREPARATIONS; HAIR CARE AND HAIR STYLING PREPARATIONS; PERSONAL DEODORANTS; SUN-TANNING PREPARATIONS; SUNSCREEN OILS AND LOTIONS; SHAVING PREPARATIONS; DENTIFRICES; PERFUMES, EAU DE TOILETTE, ESSENTIAL OILS FOR PERSONAL USE, PERFUME OILS; NAIL CARE PREPARATIONS; NAIL ENAMEL; POWDERED COSMETIC TISSUES (U.S. CLS. 1, 4, 6, 50, 51 AND 52).

RON FAIRBANKS, EXAMINING ATTORNEY

**CLASS 3—(Continued).**

SN 85-848,361. RECKITT & COLMAN (OVERSEAS) LIMITED, HULL HU8 7DS, ENGLAND, FILED 2-13-2013.

# THERMACREME

THE MARK CONSISTS OF STANDARD CHARACTERS WITHOUT CLAIM TO ANY PARTICULAR FONT, STYLE, SIZE, OR COLOR.

PRIORITY CLAIMED UNDER SEC. 44(D) ON UNITED KINGDOM APPLICATION NO. UK0000265204, FILED 2-12-2013, REG. NO. UK0000265204, DATED 2-12-2013, EXPIRES 2-12-2023.

FOR DEPILATORY PREPARATIONS; DEPILATORY CREAMS; DEPILATORY WAXES; COSMETIC HAIR REGROWTH INHIBITING PREPARATIONS; NON-MEDICATED SKIN CARE PREPARATIONS, NAMELY, CREAMS, GELS AND MOUSSES, FOR USE BEFORE, DURING AND AFTER SHAVING OR HAIR REMOVAL; WARMING HAIR REMOVAL CREAMS; DEPILATORY WIPES (U.S. CLS. 1, 4, 6, 50, 51 AND 52).

CIMMERIAN COLEMAN, EXAMINING ATTORNEY

SN 85-869,313. SRDG LIMITED, LONDON, WC1B 3HH, UNITED KINGDOM, FILED 3-7-2013.



THE NAME(S), PORTRAIT(S), AND/OR SIGNATURE(S) SHOWN IN THE MARK IDENTIFIES "DANIEL GALVIN JR", WHOSE CONSENT(S) TO REGISTER IS MADE OF RECORD.

THE COLOR(S) WHITE, BLACK, BROWN AND GRAY IS/ARE CLAIMED AS A FEATURE OF THE MARK.

THE MARK CONSISTS OF THE WORDING "DGJ DANIEL GALVIN JR" WITH THE INITIALS "DGJ" IN WHITE ON A STYLIZED DESIGN OF THE UNION JACK SHOWN IN BROWN AND BLACK WITH A GRAY BORDER. THE NAME "DANIEL GALVIN JR" IS SHOWN IN BLACK.

FOR NON-MEDICATED TOILETRIES; CLEANING PREPARATIONS FOR THE HANDS AND BODY; SOAPS; HAIR PRODUCTS, NAMELY, HAIR BALSAM, HAIR CARE CREAMS, HAIR CARE LOTIONS, HEAT PROTECTION SPRAYS, HAIR COLOR REMOVERS, HAIR COLORING AND DYES, HAIR CURLING PREPARATIONS, HAIR EMOLLIENTS, HAIR FIXERS, HAIR FROSTS, HAIR MOUSSE, HAIR GLAZE, HAIR LACQUERS, HAIR LIGHTENERS, HAIR MASCARA, HAIR MASKS, HAIR NOURISHERS, HAIR OILS, HAIR POMADES, HAIR RELAXERS, HAIR SPRAY, HAIR STRAIGHTENING PREPARATIONS, HAIR STYLING FIXATIVE IN THE NATURE OF HAIR WAX, HAIR TONIC, AND STYLING CLAY FOR HAIR; SHAMPOOS; SHAMPOOS FOR CHILDREN; HAIR CONDITIONERS; HAIR CONDITIONERS FOR CHILDREN; BODY WASH; BODY WASH FOR CHILDREN; SKIN CLEANSERS; SKIN CLEANSERS FOR CHILDREN (U.S. CLS. 1, 4, 6, 50, 51 AND 52).

FRED CARL, EXAMINING ATTORNEY

**CLASS 3—(Continued).**

SN 85-896,729. DREW MARINE USA, INC., WHIPPANY, NJ. FILED 4-5-2013.

**DREW MARINE CREW CARE**

THE MARK CONSISTS OF STANDARD CHARACTERS WITHOUT CLAIM TO ANY PARTICULAR FONT, STYLE, SIZE, OR COLOR.

OWNER OF U.S. REG. NOS. 2,049,903 AND 4,471,075.

NO CLAIM IS MADE TO THE EXCLUSIVE RIGHT TO USE "MARINE", APART FROM THE MARK AS SHOWN.

FOR CLEANING PREPARATIONS FOR KITCHEN, BATHROOM, LAUNDRY AND SLEEPING QUARTERS ONBOARD SHIPS (U.S. CLS. 1, 4, 6, 50, 51 AND 52).

CHARLES L. JENKINS, EXAMINING ATTORNEY

SN 85-906,947. KRYOLAN GMBH CHEMISCHE FABRIK, BERLIN, FED REP GERMANY, FILED 4-17-2013.

**AQUACOLOR**

THE MARK CONSISTS OF STANDARD CHARACTERS WITHOUT CLAIM TO ANY PARTICULAR FONT, STYLE, SIZE, OR COLOR.

OWNER OF ERPN CMNTY TM OFC REG. NO. 000074088, DATED 10-29-1998, EXPIRES 4-1-2016.

FOR WET MAKE-UP FOR THEATRICAL COSMETICS (U.S. CLS. 1, 4, 6, 50, 51 AND 52).

FIRST USE 1-1-1947; IN COMMERCE 1-1-1971.

CHRISTOPHER REAMS, EXAMINING ATTORNEY

SN 86-023,110. PIRAMAL ENTERPRISES LIMITED, MUMBAI, INDIA, FILED 7-30-2013.



NO CLAIM IS MADE TO THE EXCLUSIVE RIGHT TO USE "CALAMINE", APART FROM THE MARK AS SHOWN. THE MARK CONSISTS OF "LC LACTO CALAMINE" IN STYLIZED LETTERS.

FOR ANTI-AGING CREAM, FACE LOTION, FACE WASH, AND SUNSCREEN (U.S. CLS. 1, 4, 6, 50, 51 AND 52).

PAUL MORENO, EXAMINING ATTORNEY

**CLASS 3—(Continued).**

SN 86-023,112. PIRAMAL ENTERPRISES LIMITED, MUMBAI, INDIA, FILED 7-30-2013.



NO CLAIM IS MADE TO THE EXCLUSIVE RIGHT TO USE "CALAMINE", APART FROM THE MARK AS SHOWN. THE MARK CONSISTS OF "LC LACTO CALAMINE RENEU" IN STYLIZED LETTERS.

FOR ANTI-AGING CREAM, FACE LOTION, FACE WASH, AND SUNSCREEN (U.S. CLS. 1, 4, 6, 50, 51 AND 52).

PAUL MORENO, EXAMINING ATTORNEY

SN 86-025,456. STUSSY, INC., IRVINE, CA. FILED 7-31-2013.

**STUSSY**

THE MARK CONSISTS OF STANDARD CHARACTERS WITHOUT CLAIM TO ANY PARTICULAR FONT, STYLE, SIZE, OR COLOR.

OWNER OF U.S. REG. NOS. 3,112,126, 4,410,371 AND OTHERS.

SEC. 2(F).

FOR BODY WASH; HAIR SHAMPOO; HAIR SHAMPOOS AND CONDITIONERS; NON-MEDICATED BALMS FOR USE ON SKIN; PERFUME; PERFUMES IN SOLID FORM (U.S. CLS. 1, 4, 6, 50, 51 AND 52).

FIRST USE 4-28-2011; IN COMMERCE 4-28-2011.

WANDA KAY PRICE, EXAMINING ATTORNEY

SN 86-028,019. OPUS GAIA LLC, DBA ADORATHERAPY, DENVER, NJ. FILED 8-3-2013.

**Adore Yourself**

THE MARK CONSISTS OF STANDARD CHARACTERS WITHOUT CLAIM TO ANY PARTICULAR FONT, STYLE, SIZE, OR COLOR.

FOR ESSENTIAL OILS FOR AROMATHERAPY USE; ESSENTIAL OILS FOR USE IN AROMATHERAPY; ESSENTIAL OILS FOR USE IN MANUFACTURING OF PERSONAL CARE COSMETICS; ESSENTIAL OILS FOR USE IN THE MANUFACTURE OF SCENTED PRODUCTS (U.S. CLS. 1, 4, 6, 50, 51 AND 52).

FIRST USE 4-13-2013; IN COMMERCE 6-7-2013.

TEJBIR SINGH, EXAMINING ATTORNEY



**CLASS 3—(Continued).**

SN 86-030,904. VITA LIBERATA LIMITED, BALLYCLARE, CO. ANTRIM, NORTHERN IRELAND, FILED 8-7-2013.

SKIN  
S<sup>[rɪˈspɛkt]</sup>respect  
N

PRIORITY CLAIMED UNDER SEC. 44(D) ON UNITED KINGDOM APPLICATION NO. 0003016464, FILED 8-2-2013, REG. NO. 00003016464, DATED 11-1-2013, EXPIRES 8-2-2023.

NO CLAIM IS MADE TO THE EXCLUSIVE RIGHT TO USE "SKIN", APART FROM THE MARK AS SHOWN.

THE MARK CONSISTS OF THE WORD "RESPECT" INSIDE THE WORD "SKIN" WITH THE PRONUNCIATION SYMBOL OF THE LETTERS "RI SPEKT" IN A STYLIZED FORM INSIDE BRACKETS.

FOR TANNING PREPARATIONS, NAMELY, SELF TANNING LOTIONS, SELF TANNING OILS, SELF TANNING CREAMS, SELF TANNING GELS; SUN CARE PRODUCTS, NAMELY, SUNTAN LOTIONS, SUNTAN OILS, SUNTAN CREAMS, SUNTAN GELS, SUNBLOCK LOTIONS, SUNBLOCK OILS, SUNBLOCK CREAMS, SUNBLOCK GELS; NON-MEDICATED PRODUCTS FOR USE IN ALLEVIATING SUNBURN AND MOISTURIZING THE SKIN, NAMELY, LOTIONS, OILS, CREAMS AND GELS FOR APPLICATION TO THE SKIN, FACE AND BODY; NON-MEDICATED PREPARATIONS FOR USE IN PROLONGING SUNTAN, NAMELY, LOTIONS, OILS, CREAMS AND GELS FOR APPLICATION TO THE SKIN, FACE AND BODY; LIP BALMS; COSMETICS; SKINCARE PRODUCTS, NAMELY, NON-MEDICATED PREPARATIONS FOR MOISTURIZING THE SKIN, NON-MEDICATED PREPARATIONS FOR TONING THE SKIN, NON-MEDICATED PREPARATIONS FOR PLUMPING THE SKIN, NON-MEDICATED PREPARATIONS FOR POLISHING THE SKIN, AND NON-MEDICATED PREPARATIONS FOR CLEANSING THE SKIN (U.S. CLS. 1, 4, 6, 50, 51 AND 52).

MARILYN IZZI, EXAMINING ATTORNEY

SN 86-048,793. R.F. TECHNOLOGY CONSULTANTS, INC., HOLLYWOOD, FL. FILED 8-27-2013.

**BLEND-TO-TONE**

THE MARK CONSISTS OF STANDARD CHARACTERS WITHOUT CLAIM TO ANY PARTICULAR FONT, STYLE, SIZE, OR COLOR.

FOR SKIN CARE PREPARATIONS, NAMELY, COSMETICS, MOISTURIZERS, CLEANSERS, TONERS, EXFOLIANTS, FACIAL MASKS, BODY MASKS, EYE CREAMS, BODY SCRUBS, HAND CREAMS, FOOT SCRUBS, FOOT MASKS, MASSAGE OILS, ESSENTIAL OILS FOR PERSONAL USE, HAIR CARE PREPARATIONS, SUN BLOCK PREPARATIONS, SUN SCREEN PREPARATIONS, GELS FOR SKIN, PEELS, LIP CARE PREPARATIONS AND SKIN CLARIFIERS (U.S. CLS. 1, 4, 6, 50, 51 AND 52).

ANGELA M. MICHELI, EXAMINING ATTORNEY

**CLASS 3—(Continued).**

SN 86-048,802. R.F. TECHNOLOGY CONSULTANTS, INC., HOLLYWOOD, FL. FILED 8-27-2013.

**BLEND-2-TONE**

THE MARK CONSISTS OF STANDARD CHARACTERS WITHOUT CLAIM TO ANY PARTICULAR FONT, STYLE, SIZE, OR COLOR.

FOR SKIN CARE PREPARATIONS, NAMELY, COSMETICS, MOISTURIZERS, CLEANSERS, TONERS, EXFOLIANTS, FACIAL MASKS, BODY MASKS, EYE CREAMS, BODY SCRUBS, HAND CREAMS, FOOT SCRUBS, FOOT MASKS, MASSAGE OILS, ESSENTIAL OILS FOR PERSONAL USE, HAIR CARE PREPARATIONS, SUN BLOCK PREPARATIONS, SUN SCREEN PREPARATIONS, GELS FOR SKIN, PEELS, LIP CARE PREPARATIONS AND SKIN CLARIFIERS (U.S. CLS. 1, 4, 6, 50, 51 AND 52).

ANGELA M. MICHELI, EXAMINING ATTORNEY

SN 86-049,469. NOVABELLA, INC., LA PORTE, IN. FILED 8-27-2013.

**SMARTBLEACH**

THE MARK CONSISTS OF STANDARD CHARACTERS WITHOUT CLAIM TO ANY PARTICULAR FONT, STYLE, SIZE, OR COLOR.

FOR DRY BLEACH IN GRANULAR AND TABLET FORM FOR LAUNDRY AND GENERAL HOUSEHOLD, COMMERCIAL, AND INDUSTRIAL PURPOSES (U.S. CLS. 1, 4, 6, 50, 51 AND 52).

CURTIS FRENCH, EXAMINING ATTORNEY

SN 86-052,339. AVLON INDUSTRIES, INC., MELROSE PARK, IL. FILED 8-30-2013.

**MoisturRight**

THE MARK CONSISTS OF STANDARD CHARACTERS WITHOUT CLAIM TO ANY PARTICULAR FONT, STYLE, SIZE, OR COLOR.

FOR CLARIFYING SHAMPOO; MOISTURIZING SHAMPOO; MOISTURIZING SHAMPOO; LEAVE-IN HAIR DETANGLING MIST; FOAM WRAP WAVE-SET LOTIONS WITH PHYTO-OIL-COMPLEX; INTENSIVE HAIR MOISTURIZING MASQUE; HAIR OIL RICH IN PHYTOSTEROILS; HAIR OIL SHEEN SPRAY WITH HUMIDITY GUARD; CREAM COSMETIC HAIR DRESSING PREPARATIONS (U.S. CLS. 1, 4, 6, 50, 51 AND 52).

KELLY BOULTON, EXAMINING ATTORNEY

**CLASS 3—(Continued).**

SN 86-055,285. PUNCH INDUSTRIES, DUBLIN 15, IRELAND, FILED 9-4-2013.



OWNER OF IRELAND REG. NO. 227484, DATED 6-24-2003, EXPIRES 6-24-2023.

OWNER OF U.S. REG. NO. 3,267,689.

THE MARK CONSISTS OF THE WORDS "KEEP IT BRIGHT" WITH A LARGE BUBBLE WITHIN A LARGER BUBBLE TO THE LEFT AND OTHER SMALLER BUBBLES OF VARIOUS SIZES AND SHAPES FLOWING BETWEEN THE "KEEP IT" AND "BRIGHT".

FOR TREATED SYNTHETIC CELLULOSE NON-WOVEN APERTURE SHEETS IMPREGNATED WITH DETERGENT AND/OR DIRT AND DYE ATTRACTORS FOR USE IN WASHING; LAUNDRY FABRIC CONDITIONERS, SOFTENERS, DIRT AND DYE ATTRACTORS; BLEACHING PREPARATIONS FOR LAUNDRY USE; CLEANING AND POLISHING PREPARATIONS (U.S. CLS. 1, 4, 6, 50, 51 AND 52).

DAWN HAN, EXAMINING ATTORNEY

**CLASS 3—(Continued).**

SN 86-063,294. ANDERSON, RICHARD, HOLLYWOOD, CA. FILED 9-12-2013.

SMART COLOR CORRECTOR  
TECHNOLOGY

THE MARK CONSISTS OF STANDARD CHARACTERS WITHOUT CLAIM TO ANY PARTICULAR FONT, STYLE, SIZE, OR COLOR.

OWNER OF U.S. REG. NO. 4,031,796.

NO CLAIM IS MADE TO THE EXCLUSIVE RIGHT TO USE "COLOR AND TECHNOLOGY", APART FROM THE MARK AS SHOWN.

FOR COSMETIC PREPARATIONS FOR SKIN CARE; COSMETICS AND MAKE-UP (U.S. CLS. 1, 4, 6, 50, 51 AND 52).

FIRST USE 6-25-2013; IN COMMERCE 6-25-2013.

DOMINICK J. SALEMI, EXAMINING ATTORNEY

SN 86-061,708. ALBERTO-CULVER INTERNATIONAL, INC., MELROSE PARK, IL. FILED 9-11-2013.

EXPERT SELECTION

THE MARK CONSISTS OF STANDARD CHARACTERS WITHOUT CLAIM TO ANY PARTICULAR FONT, STYLE, SIZE, OR COLOR.

FOR SOAPS; PERFUMERY; ESSENTIAL OILS; DEODORANTS AND ANTIPERSPIRANTS; HAIR CARE PREPARATIONS; HAIR COLORANTS, HAIR DYES, HAIR LOTIONS, HAIR WAVING PREPARATIONS, SHAMPOOS, CONDITIONERS, HAIR SPRAYS, HAIR DRESSINGS, HAIR LACQUERS, HAIR MOUSSES, HAIR GLAZES, HAIR GELS, HAIR MOISTURIZERS, HAIR PRESERVATION TREATMENTS, HAIR CARE CREAMS, MOISTURIZING PREPARATIONS FOR THE HAIR AND SCALP, HAIR NOURISHERS; HAIR OILS, HAIR TONIC, HAIR CREAMS, PREPARATIONS FOR THE BATH OR SHOWER, NAMELY, SHOWER AND BATH GEL, SHOWER CREAMS, SHOWER AND BATH FOAM, COSMETIC PREPARATIONS FOR BATH AND SHOWER; NON-MEDICATED SKIN CARE PREPARATIONS; COSMETICS (U.S. CLS. 1, 4, 6, 50, 51 AND 52).

MICHAEL TANNER, EXAMINING ATTORNEY

SN 86-064,206. PRL USA HOLDINGS, INC., NEW YORK, NY. FILED 9-13-2013.

SEDONA LEATHER

THE MARK CONSISTS OF STANDARD CHARACTERS WITHOUT CLAIM TO ANY PARTICULAR FONT, STYLE, SIZE, OR COLOR.

NO CLAIM IS MADE TO THE EXCLUSIVE RIGHT TO USE "LEATHER", APART FROM THE MARK AS SHOWN.

FOR FRAGRANCES, NAMELY, EAU DE PARFUM, EAU DE TOILETTE, PERFUME, PERFUMED SOAPS, AND SCENTED BODY LOTIONS AND CREAMS (U.S. CLS. 1, 4, 6, 50, 51 AND 52).

DEZMONA MIZELLE, EXAMINING ATTORNEY

**CLASS 3—(Continued).**

SN 86-068,500. SANCTUARY PILATES, LLC, NEW YORK, NY. FILED 9-18-2013.



OWNER OF U.S. REG. NOS. 4,197,086 AND 4,197,371.  
NO CLAIM IS MADE TO THE EXCLUSIVE RIGHT TO USE "PILATES", APART FROM THE MARK AS SHOWN.

THE MARK CONSISTS OF THE WORDS "SANCTUARY PILATES AND WELLNESS" APPEARING OVER A CIRCULAR SHAPE AND THE DESIGN OF A SWALLOW.

FOR LIP BALMS, BODY SCRUBS AND NON-AEROSOL SPRAYS FOR CLEANING EXERCISE MATS (U.S. CLS. 1, 4, 6, 50, 51 AND 52).

FIRST USE 10-2-2010; IN COMMERCE 10-2-2010.  
AISHA CLARKE, EXAMINING ATTORNEY

**CLASS 3—(Continued).**

SN 86-076,685. RODIAL LIMITED, LONDON, UNITED KINGDOM, FILED 9-27-2013.

**GLAMOBROW**

THE MARK CONSISTS OF STANDARD CHARACTERS WITHOUT CLAIM TO ANY PARTICULAR FONT, STYLE, SIZE, OR COLOR.

OWNER OF UNITED KINGDOM REG. NO. 00003023657, DATED 12-20-2013, EXPIRES 12-20-2023.

FOR COSMETICS AND TOILETRIES FOR USE ON AND AROUND THE EYES, NAMELY, EYEBROW COSMETICS, EYEBROW COLORS; MASCARA; EYE MAKE-UP (U.S. CLS. 1, 4, 6, 50, 51 AND 52).

WANDA KAY PRICE, EXAMINING ATTORNEY

SN 86-081,792. HIGH BELEM CHEMISTRY CO., LTD., TAICHUNG CITY, TAIWAN, FILED 10-3-2013.



SN 86-074,202. AMERICAN INTERNATIONAL INDUSTRIES, COMMERCE, CA. FILED 9-25-2013.

**ARDELL TOUCH OF COLOR**

THE MARK CONSISTS OF STANDARD CHARACTERS WITHOUT CLAIM TO ANY PARTICULAR FONT, STYLE, SIZE, OR COLOR.

OWNER OF U.S. REG. NOS. 3,549,146 AND 4,523,142.  
NO CLAIM IS MADE TO THE EXCLUSIVE RIGHT TO USE "COLOR", APART FROM THE MARK AS SHOWN.

FOR COSMETIC PREPARATIONS FOR THE HAIR AND SCALP; COSMETICS AND COSMETIC PREPARATIONS; HAIR BLEACHING PREPARATIONS; HAIR CARE CREAMS; HAIR CARE LOTIONS; HAIR CARE PREPARATIONS; HAIR COLOURING AND DYES; HAIR COLOURING PREPARATIONS; HAIR LIGHTENERS; HAIR RINSES (U.S. CLS. 1, 4, 6, 50, 51 AND 52).

ERIN FALK, EXAMINING ATTORNEY

THE MARK CONSISTS OF CHINESE CHARACTERS THAT TRANSLITERATE TO "SHANG-SHAN-CHAI-YAO", WHICH TRANSLATES IN ENGLISH TO "UP MOUNTAIN GATHER HERB PLANT", ABOVE THE WORDING "TSAIO" WHICH APPEARS WITHIN A HORIZONTAL RECTANGULAR BAR. A DESIGN CONSISTING OF AN OVAL PLACED OVER THE RECTANGULAR BAR AND TO THE LEFT OF THE WORDING "TSAIO" CONTAINS THE ABSTRACT IMAGE OF A MAN WEARING A HAT AND HOLDING A LONG TOOL ABOVE HIS SHOULDER.

THE ENGLISH TRANSLATION OF "TSAIO" IN THE MARK IS AN ACRONYM OR ABBREVIATION OF FIVE ENGLISH WORDS: (1) "TREATMENT" (2) "SOOTHE" (3) "AROMA" (4) "IMAGE" AND (5) "ORGANIC".

THE NON-LATIN CHARACTERS IN THE MARK TRANSLITERATE TO "SHANG-SHAN-CHAI-YAO" AND THIS MEANS "UP MOUNTAIN GATHER MEDICINE" IN ENGLISH.

FOR COSMETICS AND MAKE-UP; MAKE-UP REMOVER; MAKE-UP SETS; BODY AND BEAUTY CARE COSMETICS; COSMETIC MASKS; COSMETIC PENCILS; COSMETIC SUNSCREEN PREPARATIONS; COSMETICS AND MAKE-UP; NAIL PAINT BEING COSMETICS; SKIN AND BODY TOPICAL LOTIONS, CREAMS AND OILS FOR COSMETIC USE; DOUCHING PREPARATIONS FOR PERSONAL SANITARY OR DEODORANT PURPOSES BEING TOILETRIES; HAIR RINSES BEING SHAMPOO-CONDITIONERS; SHAMPOOS; BAR SOAP; BATH SOAPS; BATH SOAPS IN LIQUID, SOLID OR GEL FORM; COSMETIC SOAPS (U.S. CLS. 1, 4, 6, 50, 51 AND 52).

ALLISON SCHRODY, EXAMINING ATTORNEY

**CLASS 3—(Continued).**

SN 86-086,036. FISH LONDON LIMITED, TEDDINGTON, MIDDLESEX, UNITED KINGDOM, FILED 10-8-2013.

# FISH

THE MARK CONSISTS OF STANDARD CHARACTERS WITHOUT CLAIM TO ANY PARTICULAR FONT, STYLE, SIZE, OR COLOR.

OWNER OF ERPN CMNTY TM OFC REG. NO. 004685772, DATED 10-10-2006, EXPIRES 10-14-2015.

FOR NON-MEDICATED SKIN CARE PREPARATIONS; BODY WASHES; SHOWER GELS; HAIR CARE PREPARATIONS; SHAMPOOS; HAIR GELS; HAIR PUTTY; HAIR MUDS; HAIR WAXES; STYLING CLAYS; AND HAIR CREAMS (U.S. CLS. 1, 4, 6, 50, 51 AND 52).  
KEVON CHISOLM, EXAMINING ATTORNEY

SN 86-086,373. WHEATLEY, TERRY, HUGHSON, CA. FILED 10-8-2013.

# SISTERHOOD

THE MARK CONSISTS OF STANDARD CHARACTERS WITHOUT CLAIM TO ANY PARTICULAR FONT, STYLE, SIZE, OR COLOR.

FOR COSMETICS (U.S. CLS. 1, 4, 6, 50, 51 AND 52).  
ELLEN PERKINS, EXAMINING ATTORNEY

SN 86-086,378. WHEATLEY, TERRY, HUGHSON, CA. FILED 10-8-2013.

# GODDESS OF THE VALLEY

THE MARK CONSISTS OF STANDARD CHARACTERS WITHOUT CLAIM TO ANY PARTICULAR FONT, STYLE, SIZE, OR COLOR.

FOR COSMETICS (U.S. CLS. 1, 4, 6, 50, 51 AND 52).  
ELLEN PERKINS, EXAMINING ATTORNEY

**CLASS 3—(Continued).**

SN 86-087,471. DIVERSEY, INC., STURTEVANT, WI. FILED 10-9-2013.

# JP 2'N 1

THE MARK CONSISTS OF STANDARD CHARACTERS WITHOUT CLAIM TO ANY PARTICULAR FONT, STYLE, SIZE, OR COLOR.

NO CLAIM IS MADE TO THE EXCLUSIVE RIGHT TO USE "2'N 1", APART FROM THE MARK AS SHOWN.

FOR CLEANING AND DEGREASING PREPARATIONS FOR USE ON HARD SURFACES, NAMELY, FLOORS, WALLS AND COUNTERTOPS AND POT AND PAN DETERGENTS BOTH FOR COMMERCIAL, INDUSTRIAL AND INSTITUTIONAL USE; GLASS CLEANERS; AND ALL-PURPOSE CLEANERS (U.S. CLS. 1, 4, 6, 50, 51 AND 52).

NATALIE POLZER, EXAMINING ATTORNEY

SN 86-089,747. BRUNO MARS MUSIC, LLC, LOS ANGELES, CA. FILED 10-11-2013.

# LA JUNGLA

THE MARK CONSISTS OF STANDARD CHARACTERS WITHOUT CLAIM TO ANY PARTICULAR FONT, STYLE, SIZE, OR COLOR.

THE ENGLISH TRANSLATION OF "LA JUNGLA" IN THE MARK IS "THE JUNGLE".

FOR PERFUME, PERFUME OILS, COLOGNE, EAU DE TOILETTE, EAU DE PERFUME, EAU DE COLOGNE, TOILETTE WATER, BODY FRAGRANCES, AND FRAGRANCES FOR PERSONAL USE; COSMETICS; FACIAL MAKEUP, CONCEALERS, BLUSHERS, FACIAL POWDERS, FOUNDATION MAKEUP, EYE MAKEUP, EYE PENCILS, EYEBROW PENCILS, MASCARA, FALSE EYELASHES, FACE AND BODY GLITTER, COSMETIC COMPACTS, COSMETIC PENCILS, LIPSTICK, LIPSTICK CASES, LIPSTICK HOLDERS, LIP GLOSS, LIP POMADES, LIP PENCILS, MAKEUP REMOVERS, MAKEUP APPLICATORS IN THE NATURE OF COTTON SWABS FOR COSMETIC PURPOSES, EYE CREAMS, FACIAL CLEANSERS, TONERS, FACIAL EXFOLIANTS AND SCRUBS, FACIAL CREAMS, FACIAL MOISTURIZERS, AND FACIAL LOTIONS; NON-MEDICATED FACIAL TREATMENTS, NAMELY, NON-MEDICATED FACIAL EMULSIONS, NON-MEDICATED FACIAL MASKS, NON-MEDICATED ACNE TREATMENT PREPARATIONS, AND NON-MEDICATED OINTMENTS FOR THE PREVENTION AND TREATMENT OF SUNBURN; WRINKLE REMOVING SKIN CARE PREPARATIONS, NAIL POLISHES, NAIL POLISH BASE COAT, NAIL POLISH TOP COAT, NAIL STRENGTHENERS, NAIL HARDENERS, NAIL POLISH REMOVERS, NAIL CREAMS, CUTICLE REMOVING PREPARATIONS, NAIL TIPS, AND NAIL BUFFING PREPARATIONS; BEAUTY MILKS, SKIN MOISTURIZERS AND SKIN MOISTURIZER MASKS, SKIN CONDITIONERS, HAND CREAMS, MASSAGE OILS, ESSENTIAL OILS FOR PERSONAL USE, TALCUM POWDER, PERFUMED POWDERS, BATH BEADS, BATH CRYSTALS, BATH FOAM, BATH GELS, BATH OILS, BATH POWDERS, BATH SALTS, FACE WASH, SKIN CLEANSERS, SKIN HIGHLIGHTER IN THE NATURE OF A SKIN BRONZER, BODY SCRUBS, BODY AND HAND LOTIONS; BODY GELS, NAMELY, SHOWER GELS, SUN TAN GELS, BATH GELS, BEAUTY GELS AND SHOWER

**CLASS 3—(Continued).**

GELS; BODY OILS, BODY POWDERS, BODY EXFOLIANTS, BODY MASKS, BODY MASK CREAMS AND LOTIONS, SHAVING PREPARATIONS, AFTER SHAVE LOTIONS, SHAVING BALM, SHAVING CREAM, SHAVING GEL, SKIN ABRASIVE PREPARATIONS, NON-MEDICATED SKIN CREAMS AND SKIN LOTIONS FOR RELIEVING RAZOR BURNS, NON-MEDICATED LIP CARE PREPARATIONS, LIP CREAM, SUNSCREEN PREPARATIONS, SUNTANNING PREPARATIONS AND AFTER-SUN LOTIONS; COSMETIC SUN-PROTECTING PREPARATIONS; SUN TAN OILS; SELF-TANNING PREPARATIONS, NAMELY, SELF TANNING MILK AND CREAM, ACCELERATED TANNING CREAM, SELF-TANNING LOTIONS, GELS AND SPRAYS; TOOTH-PASTE, DEODORANT AND ANTIPERSPIRANT; COSMETIC PADS, PRE-MOISTENED COSMETIC WIPES, PRE-MOISTENED COSMETIC TISSUES AND TOWELLETTES; COTTON STICKS FOR COSMETIC PURPOSES; ALL PURPOSE COTTON SWABS FOR PERSONAL USE AND COSMETIC PURPOSES; NON-MEDICATED TOPICAL OINTMENTS FOR THE PREVENTION AND TREATMENT OF SUNBURN; NON-MEDICATED TOPICAL SKIN CREAMS, GELS, TONERS, LOTIONS, SPRAYS AND POWDERS, ALL FOR COSMETIC USE; HAIR CARE PRODUCTS, NAMELY, SHAMPOOS, CONDITIONERS, MOUSSE, GELS, FROSTS, CREAMS, RINSES, SPRAYS, HAIR COLOR, HAIR WAVING LOTION, PERMANENT WAVE PREPARATIONS, HAIR LIGHTENERS, HAIR DYES, HAIR EMOLLIENTS, HAIR MASCARA, HAIR POMADES, HAIR COLOR REMOVERS, HAIR RELAXING PREPARATIONS, HAIR STYLING PREPARATIONS, HAIR REMOVING CREAM, AND HAIR CARE PREPARATIONS; ASTRINGENTS FOR COSMETIC PURPOSES; BABY WIPES; DISPOSABLE WIPES IMPREGNATED WITH CHEMICALS OR COMPOUNDS FOR PERSONAL HYGIENE AND HOUSEHOLD USE; INCENSE; ROOM FRAGRANCES; FRAGRANCE EMITTING WICKS FOR ROOM FRAGRANCES; SACHETS; SACHET-LIKE EYE PILLOWS CONTAINING FRAGRANCES; SCENTED CERAMIC STONES; SCENTED LINEN SPRAYS AND SCENTED ROOM SPRAYS; SCENTED OILS USED TO PRODUCE AROMAS WHEN HEATED; SCENTED PINE CONES; POTPOURRI (U.S. CLS. 1, 4, 6, 50, 51 AND 52).  
VIVIAN MICZNIK FIRST, EXAMINING ATTORNEY

---

SN 86-093,065. NOVABELLA, INC., LA PORTE, IN. FILED 10-16-2013.

**THE SMART WAY TO BLEACH**

THE MARK CONSISTS OF STANDARD CHARACTERS WITHOUT CLAIM TO ANY PARTICULAR FONT, STYLE, SIZE, OR COLOR.  
NO CLAIM IS MADE TO THE EXCLUSIVE RIGHT TO USE "BLEACH", APART FROM THE MARK AS SHOWN.  
FOR DRY BLEACH FOR LAUNDRY AND GENERAL HOUSEHOLD, COMMERCIAL, AND INDUSTRIAL CLEANING PURPOSES (U.S. CLS. 1, 4, 6, 50, 51 AND 52).  
CURTIS FRENCH, EXAMINING ATTORNEY

**CLASS 3—(Continued).**

SN 86-099,118. N.V. PERRICONE LLC, MERIDEN, CT. FILED 10-23-2013.

**CHLORO PLASMA**

THE MARK CONSISTS OF STANDARD CHARACTERS WITHOUT CLAIM TO ANY PARTICULAR FONT, STYLE, SIZE, OR COLOR.  
OWNER OF U.S. REG. NOS. 3,670,677, 4,404,467 AND OTHERS.  
FOR BEAUTY SERUMS; COSMETIC CREAMS FOR SKIN CARE; COSMETIC PREPARATIONS FOR SKIN RENEWAL; SKIN CLEANSERS; SKIN CONDITIONERS; SKIN CREAM; SKIN LOTION; SKIN MOISTURIZER; SKIN TONERS (U.S. CLS. 1, 4, 6, 50, 51 AND 52).  
JANICE L. MCMORROW, EXAMINING ATTORNEY

---

SN 86-102,912. VG ECO DESIGNS, LLC., ALBUQUERQUE, NM. FILED 10-28-2013.

**Wholesome Wool Tumballs**

THE MARK CONSISTS OF STANDARD CHARACTERS WITHOUT CLAIM TO ANY PARTICULAR FONT, STYLE, SIZE, OR COLOR.  
NO CLAIM IS MADE TO THE EXCLUSIVE RIGHT TO USE "WOOL", APART FROM THE MARK AS SHOWN.  
FOR FABRIC SOFTENERS MADE OF WOOL FOR LAUNDRY USE (U.S. CLS. 1, 4, 6, 50, 51 AND 52).  
FIRST USE 3-1-2013; IN COMMERCE 3-1-2013.  
TASNEEM HUSSAIN, EXAMINING ATTORNEY

**CLASS 3—(Continued).**

SN 86-106,743. AMOREPACIFIC CORPORATION, SEOUL, REPUBLIC OF KOREA, FILED 10-31-2013.



NO CLAIM IS MADE TO THE EXCLUSIVE RIGHT TO USE "THE UNIVERSAL RECYCLING SYMBOL", APART FROM THE MARK AS SHOWN.

THE COLOR(S) GREEN, LIGHT GREEN AND DARK GREEN IS/ARE CLAIMED AS A FEATURE OF THE MARK.

THE MARK CONSISTS OF THREE GREEN ARROWS, EACH ARROW POINTING TO THE NEXT, FORMING A CIRCULAR FLOWER DESIGN ABOVE TWO PETALS, WITH THE WORDING "GREENCYCLE" APPEARING BELOW THE DESIGN; THE COLORING OF THE LETTERS IS AS FOLLOWS: THE "G", SECOND "E", AND "N" ARE IN LIGHT GREEN, AND THE REST OF THE LETTERING IS IN DARK GREEN.

FOR COSMETIC PREPARATIONS FOR BATH AND SHOWER; COSMETIC PREPARATIONS FOR BODY CARE; COSMETIC PREPARATIONS FOR SKIN CARE; COSMETIC SUNSCREEN PREPARATIONS; COSMETICS; DENTIFRICES; HAIR SHAMPOO; MAKE-UP PREPARATIONS; PERFUME; PET SHAMPOO (U.S. CLS. 1, 4, 6, 50, 51 AND 52).

DEBORAH LOBO, EXAMINING ATTORNEY

SN 86-108,216. SMART COSMETICS, INC., COLUMBUS, OH. FILED 11-1-2013.

# MYRRHACLE

THE MARK CONSISTS OF STANDARD CHARACTERS WITHOUT CLAIM TO ANY PARTICULAR FONT, STYLE, SIZE, OR COLOR.

FOR COSMETICS (U.S. CLS. 1, 4, 6, 50, 51 AND 52).

KEVIN CORWIN, EXAMINING ATTORNEY

**CLASS 3—(Continued).**

SN 86-111,366. RRI FINANCIAL, INC., COLUMBUS, OH. FILED 11-6-2013.



OWNER OF U.S. REG. NOS. 984,159, 2,586,181 AND OTHERS.

THE COLOR(S) RED, BROWN, BEIGE AND WHITE IS/ARE CLAIMED AS A FEATURE OF THE MARK.

THE MARK CONSISTS OF THE WORDS "TRUE RED" APPEARING IN THE COLOR RED, BELOW WHICH ARE SEVEN HORIZONTAL LINES OF VARYING THICKNESS APPEARING IN THE COLORS, FROM TOP TO BOTTOM, OF RED, BEIGE, BROWN, BEIGE, WHITE, RED, AND WHITE.

FOR PERSONAL CARE PRODUCTS, NAMELY, BODY LOTIONS; FACE AND BODY CLEANSERS AND SOAPS; HAIR SHAMPOOS AND CONDITIONERS (U.S. CLS. 1, 4, 6, 50, 51 AND 52).

JOHN DWYER, EXAMINING ATTORNEY

SN 86-113,291. MALCO PRODUCTS, INC., BARBERTON, OH. FILED 11-8-2013.

## GOLD SEAL GLASS WAX

THE MARK CONSISTS OF STANDARD CHARACTERS WITHOUT CLAIM TO ANY PARTICULAR FONT, STYLE, SIZE, OR COLOR.

NO CLAIM IS MADE TO THE EXCLUSIVE RIGHT TO USE "GLASS WAX", APART FROM THE MARK AS SHOWN.

FOR ALL PURPOSE CLEANING PREPARATIONS (U.S. CLS. 1, 4, 6, 50, 51 AND 52).

DOUGLAS LEE, EXAMINING ATTORNEY

**CLASS 3—(Continued).**

SN 86-127,838. LJ CREATIONS LLC, VAN NUYS, CA. FILED 11-25-2013.



NO CLAIM IS MADE TO THE EXCLUSIVE RIGHT TO USE "CALI" AND "THE DESCRIPTIVE DESIGN OF THE STATE OF CALIFORNIA", APART FROM THE MARK AS SHOWN.

THE MARK CONSISTS OF A PAPER DIE CUT OF THE SHAPE OF THE STATE OF CALIFORNIA WITH THE WORDS "CALI LIFE" ON IT.

SEC. 2(F).

FOR PAPER AIR FRESHENERS COMPRISING AIR FRAGRANCING PREPARATIONS EMBEDDED IN PAPER FOR THE PURPOSE OF DISTRIBUTING FRAGRANCE IN THE AIR (U.S. CLS. 1, 4, 6, 50, 51 AND 52).  
SHAILA LEWIS, EXAMINING ATTORNEY

**CLASS 3—(Continued).**

SN 86-131,737. LJ CREATIONS LLC, VAN NUYS, CA. FILED 11-29-2013.



NO CLAIM IS MADE TO THE EXCLUSIVE RIGHT TO USE "FLORIDA" AND "THE DESCRIPTIVE DESIGN OF THE STATE OF FLORIDA", APART FROM THE MARK AS SHOWN.

THE MARK CONSISTS OF A PAPER DIE CUT OF THE SHAPE OF THE STATE OF FLORIDA WITH THE WORDS "FLORIDA LIFE" ON IT.

FOR PAPER AIR FRESHENERS COMPRISING AIR FRAGRANCING PREPARATIONS EMBEDDED IN PAPER FOR THE PURPOSE OF DISTRIBUTING FRAGRANCE IN THE AIR (U.S. CLS. 1, 4, 6, 50, 51 AND 52).  
SHAILA LEWIS, EXAMINING ATTORNEY

SN 86-128,111. PAULA ALDERS, MIDWAY, TX. FILED 11-25-2013.

## Botanika Naturals

THE MARK CONSISTS OF STANDARD CHARACTERS WITHOUT CLAIM TO ANY PARTICULAR FONT, STYLE, SIZE, OR COLOR.

NO CLAIM IS MADE TO THE EXCLUSIVE RIGHT TO USE "NATURALS", APART FROM THE MARK AS SHOWN.

FOR BAR SOAP; BATH LOTION; BATH OIL; BATH POWDER; BATH SALTS; BATH SOAPS; BEAUTY SOAP; BODY LOTION; BODY SCRUB (U.S. CLS. 1, 4, 6, 50, 51 AND 52).

ANNE MADDEN, EXAMINING ATTORNEY

SN 86-133,612. MODEL'S SECRET, INC., POCASSET, MA. FILED 12-3-2013.

## MODEL'S SECRET

THE MARK CONSISTS OF STANDARD CHARACTERS WITHOUT CLAIM TO ANY PARTICULAR FONT, STYLE, SIZE, OR COLOR.

FOR COSMETICS AND NON-MEDICATED SKIN CARE PREPARATIONS FOR WOMEN, MEN, AND CHILDREN (U.S. CLS. 1, 4, 6, 50, 51 AND 52).

FIRST USE 9-2-2012; IN COMMERCE 9-2-2012.

DAVID BROOKSHIRE, EXAMINING ATTORNEY

**CLASS 3—(Continued).**

SN 86-140,280. TRI-COASTAL DESIGN GROUP, INC., WHARTON, NJ. FILED 12-11-2013.

**CHERRY KISS**

THE MARK CONSISTS OF STANDARD CHARACTERS WITHOUT CLAIM TO ANY PARTICULAR FONT, STYLE, SIZE, OR COLOR.

NO CLAIM IS MADE TO THE EXCLUSIVE RIGHT TO USE "CHERRY", APART FROM THE MARK AS SHOWN.

FOR BATH GEL; BATH SALTS; BATH SOAPS; BODY CREAM; BODY LOTION; BODY OIL; BODY SCRUB; BODY SPRAYS; BUBBLE BATH; DUSTING POWDER; FOOT SCRUBS; LIP BALM; LIP GLOSS; LIQUID SOAP (U.S. CLS. 1, 4, 6, 50, 51 AND 52).

FIRST USE 10-23-2010; IN COMMERCE 10-23-2010.  
PAUL MORENO, EXAMINING ATTORNEY

**CLASS 3—(Continued).**

SN 86-150,559. LJ CREATIONS LLC, VAN NUYS, CA. FILED 12-22-2013.



NO CLAIM IS MADE TO THE EXCLUSIVE RIGHT TO USE "ILLINOIS" AND THE DESCRIPTIVE DESIGN OF THE STATE OF ILLINOIS, APART FROM THE MARK AS SHOWN.

THE MARK CONSISTS OF A PAPER DIE CUT OF THE SHAPE OF THE STATE OF ILLINOIS WITH THE WORDS "ILLINOIS LIFE" ON IT.

FOR PAPER AIR FRESHENERS COMPRISING AIR FRAGRANCING PREPARATIONS EMBEDDED IN PAPER FOR THE PURPOSE OF DISTRIBUTING FRAGRANCE IN THE AIR (U.S. CLS. 1, 4, 6, 50, 51 AND 52).  
SHAILA LEWIS, EXAMINING ATTORNEY

SN 86-149,645. LANCOME PARFUMS ET BEAUTE & CIE, PARIS, FRANCE, FILED 12-20-2013.

**LA BASE PAUPIERES PRO  
AQUATIQUE**

PRIORITY CLAIMED UNDER SEC. 44(D) ON ERPN CMNTY TM OFC APPLICATION NO. 012029435, FILED 7-31-2013, REG. NO. 012029435, DATED 12-11-2013, EXPIRES 7-31-2023.

NO CLAIM IS MADE TO THE EXCLUSIVE RIGHT TO USE "LA BASE PAUPIERES PRO", APART FROM THE MARK AS SHOWN.

THE MARK CONSISTS OF "LA BASE PAUPIERES PRO AQUATIQUE" IN STYLIZED FORM.

THE ENGLISH TRANSLATION OF "LA BASE PAUPIERES PRO AQUATIQUE" IN THE MARK IS "EYELID MAKEUP PRIMER PRO AQUATIC".

FOR COSMETICS AND MAKE-UP PREPARATIONS (U.S. CLS. 1, 4, 6, 50, 51 AND 52).

MIAH ROSENBERG, EXAMINING ATTORNEY

SN 86-160,150. LJ CREATIONS LLC, VAN NUYS, CA. FILED 1-8-2014.



NO CLAIM IS MADE TO THE EXCLUSIVE RIGHT TO USE "HAWAII" AND THE DESCRIPTIVE DESIGN OF THE STATE OF HAWAII, APART FROM THE MARK AS SHOWN.

THE MARK CONSISTS OF A PAPER DIE CUT OF THE SHAPE OF THE STATE OF HAWAII WITH THE WORDS "HAWAII LIFE" ON IT.

FOR PAPER AIR FRESHENERS COMPRISING AIR FRAGRANCING PREPARATIONS EMBEDDED IN PAPER FOR THE PURPOSE OF DISTRIBUTING FRAGRANCE IN THE AIR (U.S. CLS. 1, 4, 6, 50, 51 AND 52).  
SHAILA LEWIS, EXAMINING ATTORNEY



**CLASS 3—(Continued).**

SN 86-161,038. LUSA ORGANICS LLC, VIROQUA, WI. FILED 1-9-2014.

# Booty Balm

THE MARK CONSISTS OF STANDARD CHARACTERS WITHOUT CLAIM TO ANY PARTICULAR FONT, STYLE, SIZE, OR COLOR.

NO CLAIM IS MADE TO THE EXCLUSIVE RIGHT TO USE "BALM", APART FROM THE MARK AS SHOWN.

FOR NON-MEDICATED DIAPER RASH OINTMENTS, NON-MEDICATED SKIN CREAMS, NON-MEDICATED SKIN BALMS, NON-MEDICATED SKIN POWDERS, NON-MEDICATED SKIN OILS, AND NON-MEDICATED SKIN LOTIONS; ORGANIC COSMETIC PREPARATIONS FOR SKIN CARE; ORGANIC COSMETICS; BEAUTY OINTMENTS, BEAUTY CREAMS, BEAUTY BALMS, BEAUTY POWDERS, BEAUTY OILS, AND BEAUTY LOTIONS; BABY WIPES; BAR SOAP (U.S. CLS. 1, 4, 6, 50, 51 AND 52).

FIRST USE 1-5-2002; IN COMMERCE 12-15-2004.  
DANIEL CAPSHAW, EXAMINING ATTORNEY

SN 86-167,351. PEANUTS WORLDWIDE LLC, NEW YORK, NY. FILED 1-16-2014.



OWNER OF U.S. REG. NOS. 1,256,900, 1,267,166 AND OTHERS.

THE MARK CONSISTS OF TWO PARTIALLY OBLITATED STYLIZED DOG FACES MOSTLY WITHIN A SQUARE WITH THE AMPERSAND SYMBOL BETWEEN THE DOG FACES. THE WORDING "SNOOPY" ALONG THE LEFT SIDE OF THE SQUARE, AND THE WORDING "HIS SISTER BELLE" ALONG THE RIGHT SIDE OF THE SQUARE.

FOR BLEACHING PREPARATIONS FOR LAUNDRY USE; WASHING PREPARATIONS AND FABRIC SOFTENERS FOR LAUNDRY USE; CLEANING, POLISHING, SCOURING AND ABRASIVE PREPARATIONS; SOAPS; PERFUMERY, ESSENTIAL OILS, COSMETICS, HAIR LOTIONS; DENTIFRICES; NON-MEDICATED TOILETRIES; CREAMS AND LOTIONS FOR HAND, BODY AND FACE; BABY POWDERS, FACE POWDERS; SHAMPOO AND CONDITIONER; HAIR CARE PREPARATIONS; FRAGRANCES, LIP GLOSS, LIP BALM, NAIL POLISH, MOUTHWASH; AIR FRAGRANCE PREPARATIONS, BUBBLE BATH; BATH AND SHOWER GELS; ALL-PURPOSE COTTON SWABS FOR PERSONAL USE; PET SHAMPOO AND PET CONDITIONER (U.S. CLS. 1, 4, 6, 50, 51 AND 52).

MIAH ROSENBERG, EXAMINING ATTORNEY

**CLASS 3—(Continued).**

SN 86-169,320. WHITE, MATTHEW, RENO, NV. FILED 1-18-2014.

# NAKARA

THE MARK CONSISTS OF STANDARD CHARACTERS WITHOUT CLAIM TO ANY PARTICULAR FONT, STYLE, SIZE, OR COLOR.

THE WORDING "NAKARA" HAS NO MEANING IN A FOREIGN LANGUAGE.

FOR SHAVING SOAP; SOAP; DEODORANT FOR PERSONAL USE; LIP BALM; BODY SCRUBS; LOTIONS FOR SKIN, FACE, BODY; BATH BOMBS; PERFUME; BATH MILK, AND BODY BUTTER (U.S. CLS. 1, 4, 6, 50, 51 AND 52).

FIRST USE 6-1-2013; IN COMMERCE 6-1-2013.  
ALYSSA STEEL, EXAMINING ATTORNEY

SN 86-176,975. LANCOME PARFUMS ET BEAUTE & CIE, PARIS, FRANCE, FILED 1-28-2014.

# ABSOLU VOYAGE

THE MARK CONSISTS OF STANDARD CHARACTERS WITHOUT CLAIM TO ANY PARTICULAR FONT, STYLE, SIZE, OR COLOR.

PRIORITY CLAIMED UNDER SEC. 44(D) ON ERP/CMNTY TM OFC APPLICATION NO. 012110491, FILED 9-3-2013, REG. NO. 012110491, DATED 1-14-2014, EXPIRES 9-3-2023.

OWNER OF U.S. REG. NOS. 3,874,012, 4,457,927 AND OTHERS.

THE ENGLISH TRANSLATION OF "ABSOLU" IN THE MARK IS "ABSOLUTE".

FOR COSMETICS AND MAKE-UP PREPARATIONS (U.S. CLS. 1, 4, 6, 50, 51 AND 52).

JULIE WATSON, EXAMINING ATTORNEY

SN 86-178,303. MASQLINE LLC, DOVER, DE. FILED 1-29-2014.

# MASQLINE

THE MARK CONSISTS OF STANDARD CHARACTERS WITHOUT CLAIM TO ANY PARTICULAR FONT, STYLE, SIZE, OR COLOR.

FOR BODY CREAM; SKIN CREAM (U.S. CLS. 1, 4, 6, 50, 51 AND 52).

DAVID MURRAY, EXAMINING ATTORNEY

**CLASS 3—(Continued).**

SN 86-195,066. PURE JOYS ORGANICS, LIMITED LIABILITY COMPANY, VERNON, NJ. FILED 2-16-2014.



NO CLAIM IS MADE TO THE EXCLUSIVE RIGHT TO USE "SKINCARE", APART FROM THE MARK AS SHOWN.

THE MARK CONSISTS OF THE STYLIZED WORDS "PURE JOYS" IN ALL CAPITAL LETTERS ABOVE THE STYLIZED WORDS "FRESH COUTURE SKINCARE" IN ALL LOWER CASE LETTERS. BEHIND THE WORDS IS A REPRESENTATION OF A WATER SPLASH WITH TWO STYLIZED CURLS RESEMBLING OCEAN WAVES CRESTING OVER AND TWO STYLIZED CURLS RESEMBLING OCEAN WAVES CRESTING BELOW THE WORDING IN THE CENTER. THE FOUR CURLS INTERSECT IN THE MIDDLE BEHIND THE WORDING TO FORM AN INFINITY SYMBOL.

FOR BODY BUTTER; BODY SCRUB (U.S. CLS. 1, 4, 6, 50, 51 AND 52).

FIRST USE 9-1-2012; IN COMMERCE 1-1-2013.

MARK SPARACINO, EXAMINING ATTORNEY

SN 86-200,534. SQUARE ONE ENTERTAINMENT, INC., MIAMI BEACH, FL. FILED 2-21-2014.



OWNER OF U.S. REG. NO. 4,489,358.

THE COLOR(S) RED, WHITE, LIGHT BLUE, DARK BLUE, AND BLUE IS/ARE CLAIMED AS A FEATURE OF THE MARK.

THE MARK CONSISTS OF THE LETTERS "INVINCIBLE" IN OUTLINED FORMAT EMBEDDED IN A 3D BANNER FORMAT WITH A LIGHT BLUE FILL AND A DARK BLUE BAND AT THE BOTTOM OF THE BANNER.

**CLASS 3—(Continued).**

THE FIRST "IN" IN THE WORD AND THE LETTERS "ABLE" ARE IN RED COLOR WITH A BLUE OUTLINE. THE LETTERS "VINCE" APPEAR IN WHITE COLOR WITH A BLUE OUTLINE. THE LETTER "V" IS APPROXIMATELY 25% LARGER THAN THE OTHER LETTERS AND EXTENDS ABOVE AND BELOW THE BANNER. THE LETTER "V" HAS A WHITE SPARKLE ON THE TOP RIGHT SIDE. THE LETTER "A" HAS A WHITE SPARKLE ON THE TOP LEFT SIDE. BOTH SPARKLES EXTEND OUTSIDE OF THE BANNER FORMAT.

FOR ALL PURPOSE HOUSEHOLD CLEANING PREPARATIONS; ALL-PURPOSE HOUSEHOLD AND AUTOMOTIVE CLEANERS; AUTOMOBILE CARPET AND UPHOLSTERY CLEANING PREPARATIONS; AUTOMOTIVE CLEANING PREPARATIONS; CLEANING AGENTS FOR CLEANING HOUSEHOLD AND AUTOMOTIVE SURFACES; HOUSEHOLD AND AUTOMOTIVE CLEANING AND POLISHING PREPARATIONS; HOUSEHOLD AND AUTOMOTIVE CLEANING AND WASHING PREPARATIONS; CLEANING PREPARATIONS FOR CLEANING HOUSEHOLD AND AUTOMOTIVE SURFACES; CLEANING PREPARATIONS FOR HOUSEHOLD PURPOSES; STAIN REMOVING PREPARATIONS (U.S. CLS. 1, 4, 6, 50, 51 AND 52).

FIRST USE 10-30-2013; IN COMMERCE 10-30-2013.

MATTHEW GALAN, EXAMINING ATTORNEY

SN 86-205,152. ALPINE MADE LLC, SOUTH WALES, NY. FILED 2-26-2014.



THE MARK CONSISTS OF A WHITE GOAT HEAD IN FRONT OF A BLACK BACKGROUND WITH "ALPINE MADE" IN BLACK TEXT ON A WHITE BACKGROUND.

FOR SOAPS MADE FROM GOAT'S MILK (U.S. CLS. 1, 4, 6, 50, 51 AND 52).

FIRST USE 8-1-2012; IN COMMERCE 8-1-2012.

MARTHA FROMM, EXAMINING ATTORNEY

**CLASS 3—(Continued).**

SN 86-205,866. INBEAUTY INC., ROCKVILLE, MD. FILED 2-27-2014.

**CICI & SISI**

THE MARK CONSISTS OF STANDARD CHARACTERS WITHOUT CLAIM TO ANY PARTICULAR FONT, STYLE, SIZE, OR COLOR.

THE NAME(S), PORTRAIT(S), AND/OR SIGNATURE(S) SHOWN IN THE MARK DOES NOT IDENTIFY A PARTICULAR LIVING INDIVIDUAL.

FOR BAR SOAP; BATH SOAPS; BEAUTY CREAMS; BEAUTY LOTIONS; BEAUTY SERUMS; BEAUTY SOAP; COSMETIC CREAMS; COSMETIC CREAMS FOR SKIN CARE; COSMETIC HAND CREAMS; COSMETIC MASKS; COSMETIC OILS; COSMETIC PENCILS; COSMETIC PREPARATIONS; COSMETIC PREPARATIONS FOR BATH AND SHOWER; COSMETIC PREPARATIONS FOR BODY CARE; COSMETIC PREPARATIONS FOR SKIN CARE; COSMETIC PREPARATIONS FOR SKIN RENEWAL; COSMETIC PREPARATIONS FOR THE HAIR AND SCALP; COSMETIC SOAPS; COSMETICS, NAMELY, NAIL ART STAMPING PLATES; COSMETICS AND MAKE-UP; EYE MAKE-UP; FACIAL MAKE-UP; MAKE UP FOUNDATIONS; MAKE-UP; MAKE-UP PENCILS; MAKE-UP POWDER; MAKE-UP PREPARATIONS; MAKE-UP REMOVER; MAKE-UP SETS (U.S. CLS. 1, 4, 50, 51 AND 52).

FIRST USE 5-1-2013; IN COMMERCE 7-1-2013.  
EMILY CHUO, EXAMINING ATTORNEY

**CLASS 3—(Continued).**

SN 86-211,507. LANCOME PARFUMS ET BEAUTE &amp; CIE, PARIS, FRANCE, FILED 3-5-2014.

**BIENFAIT  
PURE FOCUS**

OWNER OF U.S. REG. NOS. 2,031,775, 3,164,356 AND 3,241,356.

THE MARK CONSISTS OF "BIENFAIT PURE FOCUS" IN STYLIZED FONT.

THE ENGLISH TRANSLATION OF "BIENFAIT" IN THE MARK IS "BENEFIT".

FOR COSMETICS, NAMELY, CREAMS, MILKS, LOTIONS, GELS AND POWDERS FOR THE BODY, THE FACE AND THE HANDS (U.S. CLS. 1, 4, 6, 50, 51 AND 52).

JULIE WATSON, EXAMINING ATTORNEY

SN 86-214,056. REVLON CONSUMER PRODUCTS CORPORATION, NEW YORK, NY. FILED 3-7-2014.

SN 86-206,150. KICTEAM, INC., AUBURN, ME. FILED 2-27-2014.



THE MARK CONSISTS OF THE WORD "ENVANISH" WITH THE "I" STYLIZED AS A CANDLE FLAME, AND A SWIRL ABOVE THE WORD.

FOR CHEMICAL SOLUTIONS IN THE NATURE OF CLEANING SOLUTIONS USED TO CLEAN ELECTRONIC INSTRUMENTS (U.S. CLS. 1, 4, 6, 50, 51 AND 52).

TASHIA BUNCH, EXAMINING ATTORNEY

**BARE BUFF**

THE MARK CONSISTS OF STANDARD CHARACTERS WITHOUT CLAIM TO ANY PARTICULAR FONT, STYLE, SIZE, OR COLOR.

NO CLAIM IS MADE TO THE EXCLUSIVE RIGHT TO USE "BUFF", APART FROM THE MARK AS SHOWN.

FOR COSMETICS AND MAKE-UP (U.S. CLS. 1, 4, 6, 50, 51 AND 52).

FIRST USE 12-31-2005; IN COMMERCE 12-31-2005.  
TOBY BULLOFF, EXAMINING ATTORNEY

**CLASS 3—(Continued).**

SN 86-214,154. BIENTINA, LLC, FRISCO, TX. FILED 3-7-2014.



THE MARK CONSISTS OF THE LETTER "B" INSIDE OF A POLYGON EMBLEM ON TOP OF A SQUARE WITH FLATTENED CORNERS.

FOR SUN BLOCK PREPARATION, SUN SCREEN PREPARATION, SUNSCREEN CREAM, SUN TANNING PREPARATIONS, SKIN BRONZING CREAMS, SELF-TANNING PREPARATION, SELF-TANNING SPRAYS, SELF-TANNING LOTIONS, AND SELF-TANNING CREAMS, AFTER SUN SOOTHING MOISTURIZING LOTION, AFTER SUN CREAM AND GEL; FACIAL MOISTURIZER WITH SPF; SKIN EMOLLIENT, SKIN LOTION, SKIN CREAM, SKIN MOISTURIZER, BODY LOTION, BODY CREAM, NON-MEDICATED SKIN CLEANSER, SKIN CLEANSING LOTION, SKIN CLEANSING CREAM, NON-MEDICATED BODY CLEANSER, SKIN EXFOLIANT, MOISTURIZING SOLUTIONS FOR THE SKIN, HAND CREAM, EYE CREAM, EYE LOTION, EYE GEL, GEL EYE MASKS, FACIAL LOTION, FACIAL CREAM, FACIAL MOISTURIZER, FACIAL BEAUTY GEL, NON-MEDICATED FACIAL CLEANSER, FACIAL HYDRATING SPRAY, FACIAL HYDRATOR BEING A MOISTURIZING SOLUTION FOR THE SKIN, NON-MEDICATED FACIAL SKIN SERUMS, FACE OIL, FACIAL SCRUB, FACIAL MASKS, FACE POWDERS, FACIAL CLEANSERS, FACIAL SOAP, SKIN TONER, SKIN CLARIFIERS, SKIN LIGHTENER, SKIN SPOT REMOVERS BEING AGE SPOT REDUCING CREAMS, SKIN CONDITIONER, SKIN REFRESHER BEING A COSMETIC PREPARATION FOR SKIN CARE; FACIAL EXFOLIATING PREPARATIONS, NAMELY, FACIAL SKIN CLEANSERS; NON-MEDICATED SKIN CARE PREPARATION; SKIN CARE PREPARATIONS, NAMELY, SKIN PEELS; FRAGRANCED AND NON-FRAGRANCED CREAMS, GELS AND LOTIONS FOR THE HANDS, FACE AND BODY; ASTRINGENTS FOR COSMETIC PURPOSES, BEAUTY MASKS, WRINKLE REMOVING SKIN CARE PREPARATIONS, ANTI-AGING CREAM, ANTI-WRINKLE CREAM, FACE AND BODY WRINKLE REMOVING SKIN CARE PREPARATION; SKIN BALANCING LOTIONS, CREAMS AND GELS, NAMELY, SKIN TONERS AND SKIN-TONE CORRECTORS; FACIAL SKIN OIL CONTROLLERS FOR COSMETIC USE, NAMELY, LOTIONS, CREAMS, GELS, OILS, SPRAYS, AND COSMETIC FACIAL BLOT- TING PAPERS; COSMETIC SKIN FIRING LOTIONS; NON-MEDICATED SKIN RENEWAL CREAM, NAMELY, COSMETIC SKIN RENEWAL PREPARATIONS; FACIAL CLEANING PREPARATION, NAMELY, SALICYLIC ACNE CLEANSER NOT FOR MEDICAL PURPOSES; NON-MEDICATED ACNE TREATMENT PREPARATION; BEAUTY SERUMS; NON-MEDICATED SKIN SERUMS; NON-MEDICATED ANTI-AGING SERUM, NON-MEDICATED FACIAL AND EYE SERUM, CREAMS FOR CELLULITE REDUCTION AND BODY FIRING CREAMS, LOTIONS, SERUMS AND SPRAYS FOR THE FACE AND BODY; COSMETICS SOLD AS AN INTEGRAL COMPONENT INGREDIENT IN COSMETIC AND NON-MEDICATED SKINCARE PREPARATIONS; COSMETICS; COSMETICS, NAMELY, NON-MEDI- CATED LIP BALM, LIP GLOSS, TINTED LIP GLOSS, LIPSTICK, LIP LINER, LIP PENCIL, LIP SCRUB, LIP CONDITIONING SKIN CREAMS AND GELS FOR COS- METIC PURPOSES, LIP GLOSS PALETTES, BLUSH,

**CLASS 3—(Continued).**

ROUGE, SKIN BRONZER; SKIN BRONZING POWDERS, CREAMS AND LOTIONS FOR THE FACE AND BODY; FOUNDATION, EYE MAKEUP, EYE MAKEUP REMOV- ER, EYE PENCILS, EYE SHADOW, EYE SHADOW PENCILS, EYELINER, EYEBROW PENCILS, ARTIFI- CIAL EYELASHES, EYE SHADOW PALETTES, MAS- CARA, FACIAL CONCEALER, UNDER-EYE CONCEALER, MAKE-UP PRIMER, FACIAL POWDER, PRESSED FACE POWDER, LOOSE FACE POWDER, NON-MEDICATED TINTED LIP CONDITIONER BEING NON-MEDICATED LIP CARE PREPARATIONS, TINTED EYELASH CONDITIONER BEING EYELASH TINT, LASH ENHANCING OR PRIMING PREPARATIONS BEING COSMETIC PREPARATIONS FOR EYE LASHES, LIQUID MAKEUP, EYE AND FACIAL MAKEUP, MA- KEUP REMOVER, NAIL CARE PREPARATIONS, NAIL POLISH, NAIL ENAMEL, NAIL POLISH REMOVER, PRE-SOAKED NAIL POLISH REMOVER PADS, NAIL AND CUTICLE CREAMS, COMPACTS CONTAINING MAKE-UP; APPLICATOR STICKS FOR APPLYING MAKE-UP, AND MAKE-UP BRUSHES, FOAM MAKE- UP APPLICATORS, AND FACIAL SPONGES FOR AP- PLYING MAKE-UP ALL SOLD AS INTEGRAL COMPO- NENTS OF MAKEUP; PRE-SHAVE CREAM, PRE-SHAVE FACE OILS; AFTER-SHAVE LOTION, AFTER-SHAVE BALM, AFTER-SHAVE CONDITIONER, AFTER-SHAVE PREPARATION; SHAVING BALM, SHAVING GEL, SHAVING CREAM, SHAVING FOAM, SHAVING LO- TION, SHAVING SOAP, SHAVING PREPARATION, SHAVE FACE OIL; NON-MEDICATED SKIN CARE AND SHAVING PREPARATIONS FOR CONTROLLING INGROWN HAIRS, RAZOR BURNS AND RAZOR BUMPS, INGROWN HAIR REMOVER BEING DEPILA- TORIES, NON-MEDICATED SKIN PREPARATIONS FOR THE PREVENTION OF INGROWN HAIR AND SHAV- ING BURNS, NON-MEDICATED SKIN CARE LOTIONS FOR RELIEF OF IRRITATION ASSOCIATED WITH SHAVING, INCLUDING BUMPS AND BURNS, NON- MEDICATED LOTION FOR TREATMENT OF RAZOR CAUSED SKIN BUMPS; HAIR STYLING PREPARA- TION, HAIR CARE PREPARATIONS, HAIR POMADE, HAIR GEL, HAIR LOTION, HAIR OIL, HAIR SHAMPOO, HAIR CONDITIONER, HAIR SPRAY, HAIR MOUSSE, HAIR GLOSS BEING A HAIR CARE PREPARATION, NON-MEDICATED HAIR REVITALIZING TREATMENT BEING A HAIR CARE PREPARATION, HAIR THICK- ENERS BEING A HAIR CARE PREPARATION; FRA- GRANCES FOR PERSONAL USE, ESSENTIAL OILS FOR PERSONAL USE, COLOGNE, PERFUME, TOILET WATER, SCENTED SKIN AND BODY LOTIONS AND MOISTURIZERS AND BATH GELS, FRAGRANCES, NAMELY, POTPOURRI, SACHETS, AND POMANDER; BATH OIL, BATH GEL, BATH CRYSTALS, SHOWER GEL, BODY SCRUB, BODY WASH, SKIN SOAP, BAR SOAP, LIQUID SOAPS FOR HANDS, FACE AND BODY, FACIAL SOAPS, SOAPS FOR BODY CARE, SOAPS FOR PERSONAL USE, BATH SOAPS IN LIQUID, SOLID OR GEL FORM, ANTIBACTERIAL SOAP, DEODORANT SOAP, HAND SOAPS, 3-IN-1 SOAP BARS FOR USE AS SOAP, SHAMPOO AND CONDITIONER, NON-MEDI- CATED BATH PREPARATION, NON-MEDICATED BATH SALT; NAIL CUTICLE OIL, BODY OIL, BODY OIL FOR THE FEET, FACIAL OIL, MASSAGE OIL, AROMATIC OIL, ESSENTIAL OILS; MASSAGE GELS AND LOTIONS OTHER THAN FOR MEDICAL PUR- POSES; BODY POWDER, NON-MEDICATED FOOT POWDER; TALCUM POWDER; BODY SPRAYS; BUBBLE BATH; ANTIPERSPIRANT, PERSONAL DEODORANT; COTTON FOR COSMETIC PURPOSES; PRE-MOIS- TENED COSMETIC TISSUE; PRE-MOISTENED COS- METIC TOWELETTES; PRE-MOISTENED COSMETIC WIPES; SKIN CLEANSING WIPES BEING DISPOSABLE CLEANSING COMPOUNDS FOR PERSONAL HYGIENE; CUSTOM BLENDED SKIN CARE PREPARATIONS, CUSTOM BLENDED COSMETICS, CUSTOM BLENDED FRAGRANCES (U.S. CLS. 1, 4, 6, 50, 51 AND 52).

JAMES STEIN, EXAMINING ATTORNEY

**CLASS 3—(Continued).**

SN 86-216,356. MAURO PET CARE, LLC, BEVERLY HILLS, CA. FILED 3-10-2014.



THE MARK CONSISTS OF THE CAPITAL LETTER "M" SURROUNDED BY LAUREL LEAVES.

FOR NON-MEDICATED GROOMING PREPARATIONS FOR DOGS, NAMELY, HAIR CLEANING PREPARATIONS, HAIR SHAMPOO AND CONDITIONER, HAIR STYLING PREPARATIONS, HAIR STYLING GEL AND HAIR STYLING SPRAY; NON-MEDICATED GROOMING PREPARATIONS FOR DOGS, NAMELY, SHAMPOO, CONDITIONER, BODY MIST, AND NON-MEDICATED SKIN CARE SOLUTION FOR TREATING AND HEALING DERMATITIS IN THE NATURE OF HOT SPOTS; SCENTED FABRIC REFRESHER SPRAY (U.S. CLS. 1, 4, 6, 50, 51 AND 52).

FIRST USE 1-1-1994; IN COMMERCE 8-1-1995.  
KATHERINE CHANG, EXAMINING ATTORNEY

SN 86-216,394. MAURO PET CARE, LLC, BEVERLY HILLS, CA. FILED 3-10-2014.



NO CLAIM IS MADE TO THE EXCLUSIVE RIGHT TO USE "NATURAL DOG CARE", APART FROM THE MARK AS SHOWN.

THE MARK CONSISTS OF THE WORD "MAURO" IN CAPITAL LETTERS ABOVE THE CAPITAL LETTER "M" SURROUNDED BY LAUREL LEAVES. UNDERNEATH THE "M" SURROUNDED BY LAUREL LEAVES IS A LARGER CAPITAL LETTER "M" ABOVE THE WORDING "NATURAL DOG CARE" IN CAPITAL LETTERS.

THE WORDING "MAURO" HAS NO MEANING IN A FOREIGN LANGUAGE.

FOR NON-MEDICATED GROOMING PREPARATIONS FOR DOGS, NAMELY, SHAMPOO, CONDITIONER, BODY MIST, AND NON-MEDICATED SKIN CARE SOLUTION FOR TREATING AND HEALING DERMATITIS IN THE NATURE OF HOT SPOTS; SCENTED FABRIC REFRESHER SPRAY; ALL OF THE FOREGOING GOODS MADE IN SIGNIFICANT PART OF NATURAL INGREDIENTS (U.S. CLS. 1, 4, 6, 50, 51 AND 52).

FIRST USE 2-1-2013; IN COMMERCE 2-1-2013.  
KATHERINE CHANG, EXAMINING ATTORNEY

**CLASS 3—(Continued).**

SN 86-216,415. MAURO PET CARE, LLC, BEVERLY HILLS, CA. FILED 3-10-2014.



NO CLAIM IS MADE TO THE EXCLUSIVE RIGHT TO USE "NATURAL DOG CARE", APART FROM THE MARK AS SHOWN.

THE MARK CONSISTS OF THE CAPITAL LETTER "M" SURROUNDED BY LAUREL LEAVES WITH ALL OF THE FOREGOING ON A CIRCULAR BACKGROUND. TO THE RIGHT IS THE WORD "NATURAL" ABOVE THE WORDING "DOG CARE", ALL IN CAPITAL LETTERS.

FOR NON-MEDICATED GROOMING PREPARATIONS FOR DOGS, NAMELY, SHAMPOO, CONDITIONER, BODY MIST, AND NON-MEDICATED SKIN CARE SOLUTION FOR TREATING AND HEALING DERMATITIS IN THE NATURE OF HOT SPOTS; SCENTED FABRIC REFRESHER SPRAY; ALL OF THE FOREGOING GOODS MADE IN SIGNIFICANT PART OF NATURAL INGREDIENTS (U.S. CLS. 1, 4, 6, 50, 51 AND 52).

FIRST USE 2-1-2013; IN COMMERCE 2-1-2013.  
KATHERINE CHANG, EXAMINING ATTORNEY

SN 86-217,175. DANIELLE REY, F-31200 TOULOUSE, FRANCE, FILED 3-11-2014.

# FURIOSA

THE MARK CONSISTS OF STANDARD CHARACTERS WITHOUT CLAIM TO ANY PARTICULAR FONT, STYLE, SIZE, OR COLOR.

THE ENGLISH TRANSLATION OF "FURIOSA" IN THE MARK IS "FURIOUS, ANGRY OR FRANTIC".

FOR PERFUMES; PERFUMERY; EAU DE TOILETTE; EAU DE PARFUM; BODY MILK; SHOWER GEL; PERSONAL DEODORANT (U.S. CLS. 1, 4, 6, 50, 51 AND 52).  
KATHERINE CHANG, EXAMINING ATTORNEY

SN 86-217,388. PURA NATURALS LLC, LAKE FOREST, CA. FILED 3-11-2014.

## Tiny Sponge, Mighty Clean!

THE MARK CONSISTS OF STANDARD CHARACTERS WITHOUT CLAIM TO ANY PARTICULAR FONT, STYLE, SIZE, OR COLOR.

NO CLAIM IS MADE TO THE EXCLUSIVE RIGHT TO USE "SPONGE", APART FROM THE MARK AS SHOWN.

FOR SPONGES IMPREGNATED WITH CLEANING PREPARATIONS (U.S. CLS. 1, 4, 6, 50, 51 AND 52).  
KATHLEEN LORENZO, EXAMINING ATTORNEY

**CLASS 3—(Continued).**

SN 86-217,444. PERSONAL CARE PRODUCTS, LLC, TROY, MI. FILED 3-11-2014.



NO CLAIM IS MADE TO THE EXCLUSIVE RIGHT TO USE "HEALTHY PET", APART FROM THE MARK AS SHOWN.

THE MARK CONSISTS OF THE WORD "HEALTHY" IN A STYLIZED FORMAT WITH THE WORD "PET" IN BOLD LETTERS DIRECTLY UNDERNEATH. THERE IS A FAINT PAW PRINT IN THE BACKGROUND OF THE WORDS.

FOR SHAMPOOS AND CONDITIONERS FOR PETS (U.S. CLS. 1, 4, 6, 50, 51 AND 52).

MATTHEW GALAN, EXAMINING ATTORNEY

**CLASS 3—(Continued).**

SN 86-221,988. KISS MY FACE, LLC, LOS ANGELES, CA. FILED 3-14-2014.

**ONE KISS IS ALL IT TAKES**

THE MARK CONSISTS OF STANDARD CHARACTERS WITHOUT CLAIM TO ANY PARTICULAR FONT, STYLE, SIZE, OR COLOR.

FOR PERSONAL CARE PRODUCTS, NAMELY, ALL PURPOSE SOAP, MOISTURIZING SOAP, NON-MEDICATED ALPHA-HYDROXY ACID HAND, FACIAL, AND BODY LOTION, BAR SOAP, BATH AND SHOWER GEL, BODY LOTION, BODY CREAM, BODY BALM, BODY WASH, COSMETICS, TINTED LIP GLOSS, LIP TINT, TINTED FACIAL MOISTURIZER, DEODORANT FOR PERSONAL USE, EXFOLIATING BODY AND FACIAL CLEANSER, FACIAL CLEANSER, FACIAL LOTION, CREAM, AND GEL, FACIAL MASKS, FOAMING SOAP, NON-MEDICATED FOOT CREAM, FOOT SCRUB, SHAMPOO, HAIR CONDITIONER, HAIR DETANGLER, HAIR STYLING GEL, HAND LOTION, HAND CREAM, LIQUID SOAP, MOISTURIZING SHOWER GEL, MOUTHWASH, NON-MEDICATED LIP BALM, SHAVING CREAM, MOISTURIZING SHAVING CREAM, SKIN TONER, NON-MEDICATED SUN CARE PREPARATIONS, AFTER SUN MOISTURIZER, CREAM, LOTION, AND GEL PREPARATIONS, COSMETIC TANNING PREPARATIONS, TOOTHPASTE, AND TOOTHPASTE GEL (U.S. CLS. 1, 4, 6, 50, 51 AND 52).

FIRST USE 3-3-2014; IN COMMERCE 3-3-2014.

CATHERINE TARCU, EXAMINING ATTORNEY

SN 86-220,341. ELCO, PARIS, FRANCE, FILED 3-13-2014.

**AROVITA**

THE MARK CONSISTS OF STANDARD CHARACTERS WITHOUT CLAIM TO ANY PARTICULAR FONT, STYLE, SIZE, OR COLOR.

OWNER OF U.S. REG. NO. 3,392,079.

FOR NON-MEDICATED SKIN CARE PREPARATIONS (U.S. CLS. 1, 4, 6, 50, 51 AND 52).

DAVID HOFFMAN, EXAMINING ATTORNEY

SN 86-222,246. FIGO USA, BLOOMFIELD HILLS, MI. FILED 3-15-2014.

**FIGO**

THE MARK CONSISTS OF STANDARD CHARACTERS WITHOUT CLAIM TO ANY PARTICULAR FONT, STYLE, SIZE, OR COLOR.

OWNER OF U.S. REG. NO. 4,462,488.

THE ENGLISH TRANSLATION OF "FIGO" IN THE MARK IS "COOL".

FOR FRAGRANCES AND PERFUMERY (U.S. CLS. 1, 4, 6, 50, 51 AND 52).

FIRST USE 1-7-2013; IN COMMERCE 1-7-2013.

DANIEL S. STRINGER, EXAMINING ATTORNEY

**CLASS 3—(Continued).**

SN 86-222,490. WHIP-IT INVENTIONS, INC., MILTON, FL. FILED 3-16-2014.

**Hyperspec Technology**

THE MARK CONSISTS OF STANDARD CHARACTERS WITHOUT CLAIM TO ANY PARTICULAR FONT, STYLE, SIZE, OR COLOR.

NO CLAIM IS MADE TO THE EXCLUSIVE RIGHT TO USE "TECHNOLOGY", APART FROM THE MARK AS SHOWN.

FOR ALL PURPOSE CLEANING PREPARATION WITH DEODORIZING PROPERTIES; ALL PURPOSE CLEANING PREPARATIONS; ALL-PURPOSE CLEANERS; CARPET CLEANERS; CARPET CLEANERS WITH DEODORIZER; DE-GREASING PREPARATIONS FOR HOUSEHOLD PURPOSES; GLASS CLEANERS; UPHOLSTERY CLEANERS (U.S. CLS. 1, 4, 6, 50, 51 AND 52).

FIRST USE 9-7-2011; IN COMMERCE 6-12-2012.

TIMOTHY O. SCHIMPF, EXAMINING ATTORNEY

**CLASS 3—(Continued).**

SN 86-225,771. RICH, DOUGLAS, NORCO, CA. AND RICH, SCHERRY, NORCO, CA. FILED 3-19-2014.

**BIG MARE**

THE MARK CONSISTS OF STANDARD CHARACTERS WITHOUT CLAIM TO ANY PARTICULAR FONT, STYLE, SIZE, OR COLOR.

NO CLAIM IS MADE TO THE EXCLUSIVE RIGHT TO USE "MARE", APART FROM THE MARK AS SHOWN.

FOR BODY WASHES FOR ANIMALS; NON-MEDICATED SKIN CARE PREPARATIONS FOR ANIMALS; SHAMPOOS FOR ANIMALS; LOTIONS, NAMELY, SKIN LOTION FOR ANIMALS; NON-MEDICATED SKIN CARE GELS FOR ANIMALS, AND DISPOSABLE WIPES IMPREGNATED WITH CLEANSING CHEMICALS OR COMPOUNDS FOR ANIMAL HYGIENE (U.S. CLS. 1, 4, 6, 50, 51 AND 52).

ALLISON HOLTZ, EXAMINING ATTORNEY

SN 86-225,823. RICH, DOUGLAS, NORCO, CA. AND RICH, SCHERRY, NORCO, CA. FILED 3-19-2014.

SN 86-223,590. MCBRIDE RESEARCH LABORATORY, INC., DECATUR, GA. FILED 3-17-2014.

**CURLY BABY**

THE MARK CONSISTS OF STANDARD CHARACTERS WITHOUT CLAIM TO ANY PARTICULAR FONT, STYLE, SIZE, OR COLOR.

NO CLAIM IS MADE TO THE EXCLUSIVE RIGHT TO USE "BABY", APART FROM THE MARK AS SHOWN.

FOR BABY HAIR CONDITIONER; BABY SHAMPOO; HAIR CONDITIONERS; HAIR CONDITIONERS FOR BABIES; HAIR SHAMPOOS AND CONDITIONERS; HAIR STYLING GEL; HAIR STYLING PREPARATIONS; HAIR STYLING SPRAY; SHAMPOO-CONDITIONERS; SHAMPOOS; SHAMPOOS FOR BABIES (U.S. CLS. 1, 4, 6, 50, 51 AND 52).

ANGELA M. MICHELI, EXAMINING ATTORNEY



NO CLAIM IS MADE TO THE EXCLUSIVE RIGHT TO USE "MARE", APART FROM THE MARK AS SHOWN.

THE MARK CONSISTS OF A HORSE'S HEAD AND MANE FORMING THE LEFT HALF OF A HEART SHAPE, AND A DOG'S HEAD AND NECK FORMING THE RIGHT HALF OF A HEART SHAPE. THE WORDS "BIG MARE" APPEAR BELOW THE HEART SHAPE.

FOR BODY WASHES FOR ANIMALS; NON-MEDICATED SKIN CARE PREPARATIONS FOR ANIMALS; SHAMPOOS FOR ANIMALS; LOTIONS, NAMELY, SKIN LOTION FOR ANIMALS; NON-MEDICATED SKIN CARE GELS FOR ANIMALS, AND DISPOSABLE WIPES IMPREGNATED WITH CLEANSING CHEMICALS OR COMPOUNDS FOR ANIMAL HYGIENE (U.S. CLS. 1, 4, 6, 50, 51 AND 52).

ALLISON HOLTZ, EXAMINING ATTORNEY



**CLASS 3—(Continued).**

SN 86-226,511. PRICE, DEBORAH, LOS ANGELES, CA. FILED 3-20-2014.

## TWEEN TOWN

THE MARK CONSISTS OF STANDARD CHARACTERS WITHOUT CLAIM TO ANY PARTICULAR FONT, STYLE, SIZE, OR COLOR.

NO CLAIM IS MADE TO THE EXCLUSIVE RIGHT TO USE "TWEEN", APART FROM THE MARK AS SHOWN.

FOR MAKE UP; MAKE UP FOUNDATIONS; COSMETIC PREPARATIONS; BLUSH; MASCARA; LIP GLOSS; LIPSTICK; FACE AND BODY BEAUTY CREAMS; SHAMPOOS; SKIN TONERS; SOAPS FOR BODY CARE; NON-MEDICATED SKIN CARE PREPARATIONS (U.S. CLS. 1, 4, 6, 50, 51 AND 52).

TARAH HARDY, EXAMINING ATTORNEY

SN 86-226,537. PROVAN, LEEANA, P, SOUTH DAYTONA, FL. FILED 3-20-2014.

## LOVE LEEANA SOAPS

THE MARK CONSISTS OF STANDARD CHARACTERS WITHOUT CLAIM TO ANY PARTICULAR FONT, STYLE, SIZE, OR COLOR.

NO CLAIM IS MADE TO THE EXCLUSIVE RIGHT TO USE "SOAPS", APART FROM THE MARK AS SHOWN.

FOR AROMATIC BODY CARE PRODUCTS, NAMELY, BODY LOTION, SHOWER GEL, CUTICLE CREAM, SHAMPOO, CONDITIONER, NON-MEDICATED LIP BALM, SOAP, BODY POLISH, BODY AND FOOT SCRUB AND NON-MEDICATED FOOT CREAM; BAR SOAP; BATH SOAPS; BATH SOAPS IN LIQUID, SOLID OR GEL FORM; BEAUTY SOAP; BODY CREAM SOAP; CAKES OF TOILET SOAP; COSMETIC SOAPS; CREAM SOAPS (U.S. CLS. 1, 4, 6, 50, 51 AND 52).

KATHRYN COWARD, EXAMINING ATTORNEY

**CLASS 3—(Continued).**

SN 86-226,602. JOHNSON & JOHNSON, NEW BRUNSWICK, NJ. FILED 3-20-2014.



OWNER OF U.S. REG. NOS. 1,825,726, 3,872,156 AND OTHERS.

THE COLOR(S) CREAM, PURPLE AND BLACK IS/ARE CLAIMED AS A FEATURE OF THE MARK.

THE MARK CONSISTS OF A THREE-DIMENSIONAL CONFIGURATION OF A CYLINDER SHAPED BOTTLE WITH A PUMP CAP. THE PUMP CAP IS PURPLE, AND THE CYLINDER PORTION OF THE BOTTLE FEATURES GRADATIONS OF THE COLOR PURPLE, WITH PURPLE BEING DARKEST AT THE BOTTOM OF THE BOTTLE AND GETTING LIGHTER AS IT MOVES TO THE MIDDLE OF THE BOTTLE. THE WORDING "AVEENO ACTIVE NATURALS" APPEARS ON THE TOP OF THE CYLINDER PORTION OF THE BOTTLE, WITH "AVEENO" ON A LINE ABOVE "ACTIVE NATURALS". THE WORDING IS IN BLACK. THE MIDDLE TO THE TOP OF THE BOTTLE IS A CREAM COLOR. THE MATTER SHOWN BY THE DOTTED LINES IS NOT A PART OF THE MARK AND SERVES ONLY TO SHOW THE PLACEMENT OF THE MARK.

FOR NON-MEDICATED SKIN CARE PRODUCTS, NAMELY, NIGHT AND DAY CREAM, FACIAL AND BODY MOISTURIZER, FACIAL AND BODY CLEANSER, ANTI-AGING SERUM, EYE CREAM, AND ANTI-AGING PRODUCTS IN THE NATURE OF ANTI-AGING CLEANSER, ANTI-AGING CREAM, ANTI-AGING MOISTURIZER, ANTI-AGING TONER (U.S. CLS. 1, 4, 6, 50, 51 AND 52).

MEREDITH MARESCA, EXAMINING ATTORNEY

SN 86-228,127. LANCOME PARFUMS ET BEAUTE & CIE, PARIS, FRANCE, FILED 3-21-2014.

## HYPNÔSE *mini Maxi*

OWNER OF U.S. REG. NOS. 4,294,690, 4,367,235 AND OTHERS.

THE MARK CONSISTS OF "HYPNOSE MINI MAXI" STYLIZED.

THE ENGLISH TRANSLATION OF "HYPNOSE" IN THE MARK IS "HYPNOSIS".

FOR MASCARA (U.S. CLS. 1, 4, 6, 50, 51 AND 52).

JULIE WATSON, EXAMINING ATTORNEY



**CLASS 3—(Continued).**

SN 86-229,485. PURE FIJI EXPORT LTD., SUVA, FIJI, FILED 3-24-2014.



OWNER OF U.S. REG. NO. 4,257,482.

NO CLAIM IS MADE TO THE EXCLUSIVE RIGHT TO USE "FIJI", APART FROM THE MARK AS SHOWN.

THE MARK CONSISTS OF A STYLIZED LEAF, AND BELOW, THE WORDING "PURE FIJI".

SEC. 2(F) AS TO PURE.

FOR ANTI-AGING CREAM; BATH SOAPS; BEAUTY CREAMS; BODY BUTTER; BODY LOTIONS; BODY OILS; BODY SCRUB; EXFOLIANT CREAMS; EYE CREAM; FACIAL CLEANSERS; FACIAL CREAMS; FACIAL OILS; FACIAL SCRUBS; HAIR CONDITIONERS; NON-MEDICATED BODY SOAKS; SHAMPOOS; SUGAR RUBS, NAMELY, EXFOLIANTS COMPRISED OF COCONUT OIL, SUGAR CANE CRYSTALS, AND NUT EXTRACTS FOR THE BODY, SKIN, HANDS, AND FEET; COSMETICS CONTAINING DILO OIL, NAMELY, BODY GELS, BODY BUTTERS, BODY SPRAYS, AND FACIAL OILS (U.S. CLS. 1, 4, 6, 50, 51 AND 52).

FIRST USE 10-23-2007; IN COMMERCE 11-20-2007.

JAMES MACFARLANE, EXAMINING ATTORNEY

SN 86-231,180. DEVOTED CREATIONS, INC., OLDSMAR, FL. FILED 3-25-2014.

## The Perfect Tan

THE MARK CONSISTS OF STANDARD CHARACTERS WITHOUT CLAIM TO ANY PARTICULAR FONT, STYLE, SIZE, OR COLOR.

NO CLAIM IS MADE TO THE EXCLUSIVE RIGHT TO USE "TAN", APART FROM THE MARK AS SHOWN.

FOR AFTER-SUN GELS; AFTER-SUN MILKS; AFTER-SUN OILS; ALMOND MILK FOR COSMETIC PURPOSES; ALOE VERA GEL FOR COSMETIC PURPOSES; ARGAN OIL FOR COSMETIC PURPOSES; ASTRINGENTS FOR COSMETIC PURPOSES; BATH OILS FOR COSMETIC PURPOSES; BLEACHING PREPARATIONS FOR COSMETIC PURPOSES; BODY AND BEAUTY CARE COSMETICS; CHEMICALS SOLD AS COMPONENTS OF COSMETICS; CLEANER FOR COSMETIC BRUSHES; CLEANSING CREAMS; CLEANSING MILK FOR COSMETIC PURPOSES; COCOA BUTTER FOR COSMETIC PURPOSES; COCONUT OIL FOR COSMETIC PURPOSES; COLOGNES, PERFUMES AND COSMETICS; COLORING PREPARATIONS FOR COSMETIC PURPOSES; CONCEALERS; COSMETIC BALLS; COSMETIC BATH SALTS; COSMETIC COTTON WOOL; COSMETIC CREAMS; COSMETIC CREAMS FOR SKIN CARE; COSMETIC FACIAL BLOTTERING PAPERS; COSMETIC HAIR DRESSING PREPARATIONS; COSMETIC HAIR FILLING POWDERS FOR COVERING BALD AND THINNING SPOTS ON THE SCALP; COSMETIC HAIR REGROWTH INHIBITING PREPARATIONS; COSMETIC HAND CREAMS; COSMETIC MASKS; COSMETIC MASSAGE CREAMS; COSMETIC MILKS; COSMETIC NOURISHING CREAMS; COSMETIC OILS; COSMETIC OILS FOR THE EPIDERMIS; COSMETIC OLIVE OIL FOR THE

**CLASS 3—(Continued).**

FACE AND BODY; COSMETIC PADS; COSMETIC PENCILS; COSMETIC PREPARATIONS; COSMETIC PREPARATIONS AGAINST SUNBURN; COSMETIC PREPARATIONS FOR BATH AND SHOWER; COSMETIC PREPARATIONS FOR BODY CARE; COSMETIC PREPARATIONS FOR EYE LASHES; COSMETIC PREPARATIONS FOR NAIL DRYING; COSMETIC PREPARATIONS FOR PROTECTING THE SKIN FROM THE SUN'S RAYS; COSMETIC PREPARATIONS FOR REMOVING GEL NAILS, ACRYLIC NAILS, AND NAIL POLISH; COSMETIC PREPARATIONS FOR SKIN CARE; COSMETIC PREPARATIONS FOR SKIN RENEWAL; COSMETIC PREPARATIONS FOR SLIMMING PURPOSES; COSMETIC PREPARATIONS FOR THE CARE OF MOUTH AND TEETH; COSMETIC PREPARATIONS FOR THE HAIR AND SCALP; COSMETIC PREPARATIONS, NAMELY, FIRMING CREAMS; COSMETIC PREPARATIONS, NAMELY, FIRMING LOTIONS; COSMETIC PREPARATIONS, NAMELY, SKIN BALMS; COSMETIC PRODUCTS IN THE FORM OF AEROSOLS FOR SKIN CARE; COSMETIC PRODUCTS IN THE FORM OF AEROSOLS FOR SKINCARE; COSMETIC PRODUCTS TAKEN ORALLY, NAMELY, PILLS THAT INDUCE BRONZING OF THE SKIN; COSMETIC ROUGES; COSMETIC SKIN FRESHENERS; COSMETIC SOAPS; COSMETIC SUN MILK LOTIONS; COSMETIC SUN OILS; COSMETIC SUN-PROTECTING PREPARATIONS; COSMETIC SUN-TANNING PREPARATIONS; COSMETIC SUNSCREEN PREPARATIONS; COSMETIC SUNTAN LOTIONS; COSMETIC SUNTAN PREPARATIONS; COSMETIC TANNING PREPARATIONS; LIP STAINS; LOTIONS FOR COSMETIC PURPOSES; RETINOL CREAM FOR COSMETIC PURPOSES; ROSE OIL FOR COSMETIC PURPOSES; SELF-TANNING PREPARATIONS; SHAVING STONES; SHEA BUTTER FOR COSMETIC PURPOSES; SKIN AND BODY TOPICAL LOTIONS, CREAMS AND OILS FOR COSMETIC USE; SKIN CONDITIONING CREAMS FOR COSMETIC PURPOSES; SKIN FRESHENERS; SOAPS; SOLID POWDER FOR COMPACTS; SPIRIT GUM FOR COSMETIC USE; SUNTAN OILS FOR COSMETIC PURPOSES; TANNING AND AFTER-SUN MILKS, GELS AND OILS; TANNING GELS; TANNING MILKS; TANNING OILS; TEETH WHITENING STRIPS IMPREGNATED WITH TEETH WHITENING PREPARATIONS; TEMPORARY TATTOO TRANSFERS FOR USE AS COSMETICS; TISSUES IMPREGNATED WITH COSMETIC LOTIONS; TONERS; TOPICAL SKIN SPRAYS FOR COSMETIC PURPOSES; WRINKLE-MINIMIZING COSMETIC PREPARATIONS FOR TOPICAL FACIAL USE (U.S. CLS. 1, 4, 6, 50, 51 AND 52).

HENRY S. ZAK, EXAMINING ATTORNEY

**CLASS 3—(Continued).**

SN 86-231,525. ONE LOVE ORGANICS, INC., SAINT SIMONS ISLAND, GA. FILED 3-25-2014.

**ONE LOVE SKINCARE**

THE MARK CONSISTS OF STANDARD CHARACTERS WITHOUT CLAIM TO ANY PARTICULAR FONT, STYLE, SIZE, OR COLOR.

OWNER OF U.S. REG. NO. 3,938,537.

NO CLAIM IS MADE TO THE EXCLUSIVE RIGHT TO USE "SKINCARE", APART FROM THE MARK AS SHOWN.

FOR SKIN CARE PREPARATIONS FOR COSMETIC USE, NAMELY, FACIAL AND BODY BALMS, OILS, NON-MEDICATED SERUMS, LOTIONS, CREAMS, MOISTURIZERS, CLEANSERS, EXFOLIATORS, AND BODY, FACIAL, AND FOOT SCRUBS; EYE PRODUCTS, NAMELY, CREAMS AND NON-MEDICATED SERUMS; ANTI-AGING PRODUCTS, NAMELY, FACE AND BODY POWDERS, SKIN AND FACIAL MOISTURIZERS, BODY MISTS, SPONGES IMPREGNATED WITH OR INCORPORATING A SKIN CLEANSER; NON-MEDICATED LIP BALMS (U.S. CLS. 1, 4, 6, 50, 51 AND 52).

BRIN ANDERSON, EXAMINING ATTORNEY

SN 86-231,575. ONE LOVE ORGANICS, INC., SAINT SIMONS ISLAND, GA. FILED 3-25-2014.

**ONE LOVE**  
SKINCARE

OWNER OF U.S. REG. NO. 3,938,537.  
NO CLAIM IS MADE TO THE EXCLUSIVE RIGHT TO USE "SKINCARE", APART FROM THE MARK AS SHOWN.  
THE COLOR(S) BLACK AND PINK IS/ARE CLAIMED AS A FEATURE OF THE MARK.

THE MARK CONSISTS OF THE WORDS "ONE LOVE" IN STYLIZED BLACK FONT WITH A PINK HEART DEPICTED BETWEEN "ONE" AND "LOVE". THE WORD "SKINCARE" APPEARS IN SMALLER STYLIZED BLACK FONT BELOW THE PHRASE "ONE LOVE". WHITE IS NOT CLAIMED AS A FEATURE OF THE MARK AND MERELY REPRESENTS BACKGROUND OR TRANSPARENT AREAS.

FOR SKIN CARE PREPARATIONS FOR COSMETIC USE, NAMELY, FACIAL AND BODY BALMS, OILS, NON-MEDICATED SERUMS, LOTIONS, CREAMS, MOISTURIZERS, CLEANSERS, EXFOLIATORS, AND BODY, FACIAL, AND FOOT SCRUBS; EYE PRODUCTS, NAMELY, CREAMS AND NON-MEDICATED SERUMS; ANTI-AGING PRODUCTS, NAMELY, FACE AND BODY POWDERS, SKIN AND FACIAL MOISTURIZERS, BODY MISTS, SPONGES IMPREGNATED WITH OR INCORPORATING A SKIN CLEANSER; NON-MEDICATED LIP BALMS (U.S. CLS. 1, 4, 6, 50, 51 AND 52).

BRIN ANDERSON, EXAMINING ATTORNEY

**CLASS 3—(Continued).**

SN 86-231,736. DIAL CORPORATION, THE, SCOTTSDALE, AZ. FILED 3-25-2014.

**CLINICAL HEAT SHIELD**

THE MARK CONSISTS OF STANDARD CHARACTERS WITHOUT CLAIM TO ANY PARTICULAR FONT, STYLE, SIZE, OR COLOR.

NO CLAIM IS MADE TO THE EXCLUSIVE RIGHT TO USE "CLINICAL", APART FROM THE MARK AS SHOWN.

FOR ANTIPERSPIRANTS AND DEODORANTS FOR PERSONAL USE (U.S. CLS. 1, 4, 6, 50, 51 AND 52).

NAAKWAMA ANKRAH, EXAMINING ATTORNEY

SN 86-233,198. JADE IMPORTACAO E EXPORTACAO DE MANUFATURADOS LTDA, LONDRINA / PR, BRAZIL, FILED 3-26-2014.

**JADE**  
NAIL POLISH

NO CLAIM IS MADE TO THE EXCLUSIVE RIGHT TO USE "NAIL POLISH", APART FROM THE MARK AS SHOWN.

FOR BLUSH; EYE-SHADOW; EYEBROW PENCILS; EYELINER; HAIR CONDITIONER; HAIR SHAMPOO; LIP GLOSS; LIPSTICKS; MASCARA; MOUTHWASH; NAIL POLISH; TOOTHPASTE (U.S. CLS. 1, 4, 6, 50, 51 AND 52).

MARIA-VICTORIA SUAREZ, EXAMINING ATTORNEY

SN 86-234,073. BAB PRODUCTS, LLC, KENT, CT. FILED 3-27-2014.

**BAB**

THE MARK CONSISTS OF STYLIZED LETTERS "BAB" WITH THE FIRST LETTER "B" APPEARING BACKWARDS AND THE MIDDLE HORIZONTAL LINE OF LETTER "A" EXTENDING TO THE BOTTOM PORTION OF THE BACKWARD LETTER "B".

FOR SOAP FOR PERSONAL AND HOUSEHOLD USE (U.S. CLS. 1, 4, 6, 50, 51 AND 52).

HEATHER THOMPSON, EXAMINING ATTORNEY

**CLASS 3—(Continued).**

SN 86-234,120. XTREME TOOLS INTERNATIONAL, INC., MIAMI, FL. FILED 3-27-2014.

## Polished Edges

THE MARK CONSISTS OF STANDARD CHARACTERS WITHOUT CLAIM TO ANY PARTICULAR FONT, STYLE, SIZE, OR COLOR.

NO CLAIM IS MADE TO THE EXCLUSIVE RIGHT TO USE "EDGES", APART FROM THE MARK AS SHOWN.

FOR 3-IN-1 HAIR CONDITIONERS; 3-IN-1 HAIR SHAMPOOS; BLEACHING PREPARATIONS FOR THE HAIR; COSMETIC HAIR DRESSING PREPARATIONS; HAIR CARE CREAMS; HAIR CARE LOTIONS; HAIR CARE PREPARATIONS; HAIR CONDITIONER; HAIR CREAMS; HAIR GEL AND HAIR MOUSSE; HAIR LOTION; HAIR OILS; HAIR RELAXERS; HAIR RELAXING PREPARATIONS; HAIR SHAMPOO; HAIR SPRAYS AND HAIR GELS; HAIR STYLING FIXATIVE IN THE NATURE OF HAIR WAX; HAIR STYLING GEL; HAIR WAX; NON-MEDICATED HAIR TREATMENT PREPARATIONS FOR COSMETIC PURPOSES (U.S. CLS. 1, 4, 6, 50, 51 AND 52).

FIRST USE 12-7-2010; IN COMMERCE 12-7-2010.  
WANDA KAY PRICE, EXAMINING ATTORNEY

**CLASS 3—(Continued).**

SN 86-236,356. ATRIUM MEDIA INC., BROOKLYN, NY. FILED 3-29-2014.



NO CLAIM IS MADE TO THE EXCLUSIVE RIGHT TO USE "MAT" AND "MIST", APART FROM THE MARK AS SHOWN.

THE MARK CONSISTS OF BETWEEN THE WORDS "MAT" AND "MIST" IS A SINGLE CIRCLE, SINGLE SQUARE, AND INTERSECTING TRIANGLES COMBINING TO COMPLETE THE MARK.

FOR ESSENTIAL OILS FOR USE IN THE MANUFACTURE OF SCENTED PRODUCTS; ESSENTIAL OIL-BASED LIQUID BLENDS SPRAYED FOR USE IN CLEANING AND AROMATHERAPY (U.S. CLS. 1, 4, 6, 50, 51 AND 52).

FIRST USE 6-1-2013; IN COMMERCE 3-1-2014.  
JOHN DWYER, EXAMINING ATTORNEY

SN 86-237,390. IDOWU, EMMANUEL D., DBA SHEMG, BALITMORE, MD. FILED 3-31-2014.



NO CLAIM IS MADE TO THE EXCLUSIVE RIGHT TO USE "CO", APART FROM THE MARK AS SHOWN.

THE COLOR(S) RED, BLACK, AND PURPLE IS/ARE CLAIMED AS A FEATURE OF THE MARK.

THE MARK CONSISTS OF THE STYLIZED WORD "SHEMG" IN RED WITH A BLACK SHADOW OUTLINE. BELOW THE "G" IN SMALL BLACK LETTERS IS THE WORDING "& CO". THE FOREGOING APPEARS ON A PURPLE RECTANGULAR BACKGROUND.

FOR COSMETICS AND MAKE-UP (U.S. CLS. 1, 4, 6, 50, 51 AND 52).

KATHERINE CHANG, EXAMINING ATTORNEY

SN 86-235,591. RAZA, ALIA, LOS ANGELES, CA. AND WOODS, EZRA, LOS ANGELES, CA. FILED 3-28-2014.

## Régime des Fleurs

THE MARK CONSISTS OF STANDARD CHARACTERS WITHOUT CLAIM TO ANY PARTICULAR FONT, STYLE, SIZE, OR COLOR.

THE ENGLISH TRANSLATION OF "RÉGIME DES FLEURS" IS "GOVERNMENT OF FLOWERS" OR "REGIME OF FLOWERS".

FOR PERFUME (U.S. CLS. 1, 4, 6, 50, 51 AND 52).  
ESTHER BELENKER, EXAMINING ATTORNEY

SN 86-237,795. CHAU, JOHN, SCOTTSDALE, AZ. FILED 3-31-2014.

## the lion gel

THE MARK CONSISTS OF STANDARD CHARACTERS WITHOUT CLAIM TO ANY PARTICULAR FONT, STYLE, SIZE, OR COLOR.

NO CLAIM IS MADE TO THE EXCLUSIVE RIGHT TO USE "GEL", APART FROM THE MARK AS SHOWN.

FOR NAIL ENAMELS; NAIL GEL; NAIL POLISH (U.S. CLS. 1, 4, 6, 50, 51 AND 52).

FIRST USE 4-1-2010; IN COMMERCE 7-28-2012.  
ANDREA CORNWELL, EXAMINING ATTORNEY

**CLASS 3—(Continued).**

SN 86-238,275. JACK BLACK, L.L.C., CARROLLTON, TX.  
FILED 4-1-2014.

# TURBO GEAR

THE MARK CONSISTS OF STANDARD CHARACTERS WITHOUT CLAIM TO ANY PARTICULAR FONT, STYLE, SIZE, OR COLOR.

OWNER OF U.S. REG. NOS. 3,968,398 AND 4,336,289.

NO CLAIM IS MADE TO THE EXCLUSIVE RIGHT TO USE "GEAR", APART FROM THE MARK AS SHOWN.

FOR KITS AND GIFT SETS CONSISTING OF ONE OR MORE OF BODY WASHES, BATH GEL, SHOWER GEL, FACIAL CLEANSERS, HAIR SHAMPOO, HAIR CONDITIONER, BAR SOAP, SOAPS FOR PERSONAL USE, ANTIBACTERIAL SOAP, BATH SOAPS IN LIQUID, SOLID OR GEL FORM, SOAPS FOR BODY CARE, 3-IN-1 SOAP BARS FOR USE AS SOAP, SHAMPOO AND CONDITIONER, NON-MEDICATED BATH PREPARATION, NON-MEDICATED SKIN CARE PREPARATIONS, FRAGRANCES FOR PERSONAL USE, DEODORANTS, AND ANTIPERSPIRANTS SOLD AS A UNIT OR PACKAGE (U.S. CLS. 1, 4, 6, 50, 51 AND 52).

FIRST USE 4-23-2014; IN COMMERCE 4-28-2014.  
KAREN K. BUSH, EXAMINING ATTORNEY

---

SN 86-238,568. CEQUENT CONSUMER PRODUCTS, INC.,  
SOLON, OH. FILED 4-1-2014.



THE MARK CONSISTS OF THE STYLIZED LETTER "W" POSITIONED BETWEEN TWO CURVED DROPLETS.

FOR CLEANING PREPARATIONS FOR HOUSEHOLD, MARINE AND AUTOMOTIVE PURPOSES (U.S. CLS. 1, 4, 6, 50, 51 AND 52).

LYNDSEY KUYKENDALL, EXAMINING ATTORNEY

**CLASS 3—(Continued).**

SN 86-239,335. KING'S FLAIR MARKETING LIMITED,  
TORTOLA, BR. VIRGIN ISLANDS, FILED 4-1-2014.

THE MARK CONSISTS OF LITERAL ELEMENT "ALEYBO" AND A SPECIAL DESIGN OF THE LETTER "A" ON THE LEFT SIDE OF THE LITERAL ELEMENT "ALEYBO".

THE WORDING "ALEYBO" HAS NO MEANING IN A FOREIGN LANGUAGE.

FOR AIR FRAGRANCING PREPARATIONS; BATH SOAPS; BEAUTY MASKS; CLEANSING MILK FOR TOILET PURPOSES; COSMETICS; COSMETICS FOR ANIMALS; COTTON FOR COSMETIC PURPOSES; COTTON STICKS FOR COSMETIC PURPOSES; COTTON SWABS FOR COSMETIC PURPOSES; DENTIFRICES; DISINFECTANT SOAP; ESSENTIAL OILS; ETHEREAL OILS; HAIR BLEACH; HAIR COLORANTS; HAIR DYE; HAND SOAPS; INCENSE; LAUNDRY BLEACH; LAUNDRY DETERGENTS; LEATHER POLISHES; LEATHER PRESERVING POLISHES; LIQUID SOAPS FOR HANDS, FACE AND BODY; NON-SLIPPING WAX FOR FLOORS; PERFUMES; POLISHING PREPARATIONS; POTPOURRI; SCALE REMOVING PREPARATIONS FOR HOUSEHOLD PURPOSES; SOAPS FOR BODY CARE; SOAPS FOR HOUSEHOLD USE; SOAPS FOR PERSONAL USE; TOOTH WHITENING PREPARATIONS (U.S. CLS. 1, 4, 6, 50, 51 AND 52).

FIRST USE 10-20-2013; IN COMMERCE 3-5-2014.  
ELIZABETH JACKSON, EXAMINING ATTORNEY

---

SN 86-239,415. B.I.M. IMAGING, FENTON, MI. FILED 4-2-2014.

# AFFLUENZA

THE MARK CONSISTS OF STANDARD CHARACTERS WITHOUT CLAIM TO ANY PARTICULAR FONT, STYLE, SIZE, OR COLOR.

OWNER OF U.S. REG. NO. 4,527,325.  
FOR FRAGRANCES AND PERFUMERY (U.S. CLS. 1, 4, 6, 50, 51 AND 52).

ELLEN B. AWRICH, EXAMINING ATTORNEY

**CLASS 3—(Continued).**

SN 86-239,542. SHISEIDO COMPANY, LIMITED, TOKYO 104-0061, JAPAN, FILED 4-2-2014.

**SYNACTIF EYE CARE RITUAL**

THE MARK CONSISTS OF STANDARD CHARACTERS WITHOUT CLAIM TO ANY PARTICULAR FONT, STYLE, SIZE, OR COLOR.

OWNER OF U.S. REG. NO. 3,706,690.

NO CLAIM IS MADE TO THE EXCLUSIVE RIGHT TO USE "EYE CARE", APART FROM THE MARK AS SHOWN.

FOR SOAPS, PERFUMERIES, AND COSMETICS; NON-MEDICATED SKIN CARE PREPARATIONS, HAIR CARE PREPARATIONS, BODY CARE COSMETICS, AND MAKE-UP (U.S. CLS. 1, 4, 6, 50, 51 AND 52).

DANIEL CAPSHAW, EXAMINING ATTORNEY

SN 86-239,555. SHISEIDO COMPANY, LIMITED, TOKYO 104-0061, JAPAN, FILED 4-2-2014.

**SYNACTIF RITUEL SOIN YEUX**

THE MARK CONSISTS OF STANDARD CHARACTERS WITHOUT CLAIM TO ANY PARTICULAR FONT, STYLE, SIZE, OR COLOR.

OWNER OF U.S. REG. NO. 3,706,690.

NO CLAIM IS MADE TO THE EXCLUSIVE RIGHT TO USE "SOIN YEUX", APART FROM THE MARK AS SHOWN.

THE ENGLISH TRANSLATION OF "RITUEL SOIN YEUX" IN THE MARK IS "EYE CARE RITUAL".

FOR SOAPS, PERFUMERIES, AND COSMETICS; NON-MEDICATED SKIN CARE PREPARATIONS, HAIR CARE PREPARATIONS, BODY CARE COSMETICS, AND MAKE-UP (U.S. CLS. 1, 4, 6, 50, 51 AND 52).

DANIEL CAPSHAW, EXAMINING ATTORNEY

SN 86-239,560. SHISEIDO COMPANY, LIMITED, TOKYO 104-0061, JAPAN, FILED 4-2-2014.

**VOILE ELÉGANCE**

THE MARK CONSISTS OF STANDARD CHARACTERS WITHOUT CLAIM TO ANY PARTICULAR FONT, STYLE, SIZE, OR COLOR.

OWNER OF U.S. REG. NOS. 2,805,537 AND 3,854,307.

THE ENGLISH TRANSLATION OF "VOILE" IN THE MARK IS "VEIL".

FOR SOAPS, PERFUMERIES, AND COSMETICS; NON-MEDICATED SKIN CARE PREPARATIONS, HAIR CARE PREPARATIONS, BODY CARE COSMETICS, AND MAKE-UP (U.S. CLS. 1, 4, 6, 50, 51 AND 52).

DANIEL CAPSHAW, EXAMINING ATTORNEY

**CLASS 3—(Continued).**

SN 86-239,639. BAB PRODUCTS, LLC, KENT, CT. FILED 4-2-2014.

**BAB**

THE MARK CONSISTS OF STANDARD CHARACTERS WITHOUT CLAIM TO ANY PARTICULAR FONT, STYLE, SIZE, OR COLOR.

FOR SOAP FOR PERSONAL AND HOUSEHOLD USE (U.S. CLS. 1, 4, 6, 50, 51 AND 52).

HEATHER THOMPSON, EXAMINING ATTORNEY

SN 86-242,265. SHISEIDO COMPANY, LIMITED, TOKYO 104-0061, JAPAN, FILED 4-4-2014.

**IMUMOISTURE EXTRACT**

THE MARK CONSISTS OF STANDARD CHARACTERS WITHOUT CLAIM TO ANY PARTICULAR FONT, STYLE, SIZE, OR COLOR.

NO CLAIM IS MADE TO THE EXCLUSIVE RIGHT TO USE "EXTRACT", APART FROM THE MARK AS SHOWN.

FOR SOAPS, PERFUMERIES, AND COSMETICS; NON-MEDICATED SKIN CARE PREPARATIONS, HAIR CARE PREPARATIONS, BODY CARE COSMETICS, AND MAKE-UP (U.S. CLS. 1, 4, 6, 50, 51 AND 52).

DANIEL CAPSHAW, EXAMINING ATTORNEY

SN 86-242,270. SHISEIDO COMPANY, LIMITED, TOKYO 104-0061, JAPAN, FILED 4-4-2014.

**POWER INFUSING EYE  
CONCENTRATE**

THE MARK CONSISTS OF STANDARD CHARACTERS WITHOUT CLAIM TO ANY PARTICULAR FONT, STYLE, SIZE, OR COLOR.

NO CLAIM IS MADE TO THE EXCLUSIVE RIGHT TO USE "EYE CONCENTRATE", APART FROM THE MARK AS SHOWN.

FOR SOAPS, PERFUMERIES, AND COSMETICS; NON-MEDICATED SKIN CARE PREPARATIONS, HAIR CARE PREPARATIONS, BODY CARE COSMETICS, AND MAKE-UP (U.S. CLS. 1, 4, 6, 50, 51 AND 52).

DANIEL CAPSHAW, EXAMINING ATTORNEY

**CLASS 3—(Continued).**

SN 86-242,276. SHISEIDO COMPANY, LIMITED, TOKYO 104-0061, JAPAN, FILED 4-4-2014.

**CONCENTRÉ ACTIVATEUR YEUX  
ENERGISANT**

THE MARK CONSISTS OF STANDARD CHARACTERS WITHOUT CLAIM TO ANY PARTICULAR FONT, STYLE, SIZE, OR COLOR.

OWNER OF U.S. REG. NO. 4,380,625.

NO CLAIM IS MADE TO THE EXCLUSIVE RIGHT TO USE "CONCENTRÉ" AND "YEUX", APART FROM THE MARK AS SHOWN.

THE ENGLISH TRANSLATION OF "CONCENTRÉ ACTIVATEUR YEUX ENERGISANT" IN THE MARK IS "ENERGIZING ACTIVATOR EYE CONCENTRATE".

FOR SOAPS, PERFUMERIES, AND COSMETICS; NON-MEDICATED SKIN CARE PREPARATIONS, HAIR CARE PREPARATIONS, BODY CARE COSMETICS, AND MAKE-UP (U.S. CLS. 1, 4, 6, 50, 51 AND 52).

DANIEL CAPSHAW, EXAMINING ATTORNEY

---

SN 86-243,058. ABERCROMBIE & FITCH TRADING CO., NEW ALBANY, OH. FILED 4-4-2014.

**BLUSHED ABERCROMBIE & FITCH**

THE MARK CONSISTS OF STANDARD CHARACTERS WITHOUT CLAIM TO ANY PARTICULAR FONT, STYLE, SIZE, OR COLOR.

OWNER OF U.S. REG. NOS. 1,999,665, 3,381,675 AND OTHERS.

FOR BODY SPRAYS; BODY WASH; DEODORANT FOR PERSONAL USE; FRAGRANCES; NON-MEDICATED SKIN CARE CREAMS AND LOTIONS; NON-MEDICATED SKIN CARE PREPARATION, NAMELY, BODY MIST; PERFUMES; SHAMPOOS (U.S. CLS. 1, 4, 6, 50, 51 AND 52).

CHRISTOPHER LAW, EXAMINING ATTORNEY

---

SN 86-243,162. SEVENTH GENERATION, INC., BURLINGTON, VT. FILED 4-4-2014.

**100% CLEAN 0% TOXIC**

THE MARK CONSISTS OF STANDARD CHARACTERS WITHOUT CLAIM TO ANY PARTICULAR FONT, STYLE, SIZE, OR COLOR.

NO CLAIM IS MADE TO THE EXCLUSIVE RIGHT TO USE "0% TOXIC", APART FROM THE MARK AS SHOWN.

FOR LAUNDRY DETERGENTS, LAUNDRY CLEANING PREPARATIONS, DISHWASHING DETERGENTS, DISHWASHING PREPARATIONS (U.S. CLS. 1, 4, 6, 50, 51 AND 52).

FIRST USE 3-5-2014; IN COMMERCE 3-5-2014.

JULIE VEPPUMTHARA, EXAMINING ATTORNEY

**CLASS 3—(Continued).**

SN 86-244,410. MORNINGSTAR DESIGN INC., DBA SAVAGE SOAPS, FREDERICK, MD. FILED 4-7-2014.



OWNER OF U.S. REG. NO. 2,876,174.

NO CLAIM IS MADE TO THE EXCLUSIVE RIGHT TO USE "SOAPS", APART FROM THE MARK AS SHOWN.

THE MARK CONSISTS OF "SAVAGE SOAPS GET WET WITH SAVAGE!"

FOR AROMATIC BODY CARE PRODUCTS, NAMELY, BODY LOTION, SHOWER GEL, CUTICLE CREAM, SHAMPOO, CONDITIONER, NON-MEDICATED LIP BALM, SOAP, BODY POLISH, BODY AND FOOT SCRUB AND NON-MEDICATED FOOT CREAM; BAR SOAP (U.S. CLS. 1, 4, 6, 50, 51 AND 52).

FIRST USE 10-11-2002; IN COMMERCE 10-11-2002.

HEATHER SAPP, EXAMINING ATTORNEY

---

SN 86-244,952. STARLUME, INC. DBA ILLUME, BLOOMINGTON, MN. FILED 4-7-2014.

**MOMENTARY ESCAPE**

THE MARK CONSISTS OF STANDARD CHARACTERS WITHOUT CLAIM TO ANY PARTICULAR FONT, STYLE, SIZE, OR COLOR.

FOR PERSONAL CARE PRODUCTS, NAMELY, PERFUMES, PERFUMES IN SOLID FORM, HAND AND BODY LOTIONS, BATH SALTS, BAR SOAPS, LIQUID SOAPS, BODY BUTTERS, SHOWER GEL, SHOWER FOAM, SHOWER CREAM, BUBBLE BATH, BODY OILS, NON-MEDICATED BODY SERUMS, BODY BALMS, NON-MEDICATED FOOT LOTIONS, BODY SCRUBS, BODY POLISH, BODY SHIMMER LOTION, NON-MEDICATED SKIN CARE PREPARATIONS, NAMELY, BODY SHIMMER MISTS AND BODY MISTS; REEDS AND SCENTED OILS SOLD AS A UNIT FOR USE IN ROOM SCENT DIFFUSERS (U.S. CLS. 1, 4, 6, 50, 51 AND 52).

TIFFANY CHIANG, EXAMINING ATTORNEY

**CLASS 3—(Continued).**

SN 86-245,292. MASON, CALVIN, INMAN, SC. FILED 4-8-2014.

**ABSOLUTE POWER**

THE MARK CONSISTS OF STANDARD CHARACTERS WITHOUT CLAIM TO ANY PARTICULAR FONT, STYLE, SIZE, OR COLOR.

FOR ALL PURPOSE CLEANER AND DEGREASER (U.S. CLS. 1, 4, 6, 50, 51 AND 52).  
DOMINICK J. SALEMI, EXAMINING ATTORNEY

**CLASS 3—(Continued).**

SN 86-245,890. THE SUN PRODUCTS CORPORATION, WILTON, CT. FILED 4-8-2014.

**FRESH SPRING FLOWERS**

THE MARK CONSISTS OF STANDARD CHARACTERS WITHOUT CLAIM TO ANY PARTICULAR FONT, STYLE, SIZE, OR COLOR.

OWNER OF U.S. REG. NO. 4,172,542.  
FOR FABRIC CONDITIONERS (U.S. CLS. 1, 4, 6, 50, 51 AND 52).  
ELI HELLMAN, EXAMINING ATTORNEY

SN 86-245,317. SAMARA, MOHAMMAD, AMMAN, JORDAN, FILED 4-8-2014.

**MIZK**

THE MARK CONSISTS OF STANDARD CHARACTERS WITHOUT CLAIM TO ANY PARTICULAR FONT, STYLE, SIZE, OR COLOR.

FOR COSMETICS AND COSMETIC PREPARATIONS (U.S. CLS. 1, 4, 6, 50, 51 AND 52).  
DOMINICK J. SALEMI, EXAMINING ATTORNEY

SN 86-246,923. YOUN KWANG JUNG, SEOUL 121-764, REPUBLIC OF KOREA, FILED 4-9-2014.

**SKINMISO**

THE MARK CONSISTS OF STANDARD CHARACTERS WITHOUT CLAIM TO ANY PARTICULAR FONT, STYLE, SIZE, OR COLOR.

OWNER OF REPUBLIC OF KOREA REG. NO. 0815628, DATED 3-3-2010, EXPIRES 3-3-2020.

FOR (BASED ON INTENT TO USE) ADHESIVES FOR COSMETIC USE; BEAUTY SOAP; COSMETICS; COTTON STICKS FOR COSMETIC PURPOSES; COTTON WOOL FOR COSMETIC PURPOSES; FALSE EYELASHES; FALSE NAILS; PERFUMERY; SOAPS FOR PERSONAL USE (BASED ON 44(E)) ADHESIVES FOR COSMETIC USE; BEAUTY SOAP; COSMETICS; COTTON STICKS FOR COSMETIC PURPOSES; COTTON WOOL FOR COSMETIC PURPOSES; FALSE EYELASHES; FALSE NAILS; PERFUMERY; SOAPS FOR PERSONAL USE (U.S. CLS. 1, 4, 6, 50, 51 AND 52).  
JULIE WATSON, EXAMINING ATTORNEY

SN 86-245,542. L'OREAL, PARIS, FRANCE, FILED 4-8-2014.

**FLUIDISSIME**

THE MARK CONSISTS OF STANDARD CHARACTERS WITHOUT CLAIM TO ANY PARTICULAR FONT, STYLE, SIZE, OR COLOR.

PRIORITY CLAIMED UNDER SEC. 44(D) ON FRANCE APPLICATION NO. 13/4051455, FILED 12-2-2013, REG. NO. 13/4051455, DATED 12-2-2013, EXPIRES 12-2-2023.

FOR SHAMPOOS; GELS, POWDERS, SPRAYS, MOUSSES, NON-MEDICATED BALMS, CREAMS, LOTIONS, NON-MEDICATED SERUMS AND WAX FOR HAIR STYLING AND HAIR CARE; HAIR LACQUERS; HAIR COLOURING AND HAIR DECOLORANT PREPARATIONS; HAIR COLOR TREATMENT, NAMELY, PROTECTIVE COLOUR FOR TREATED HAIR; PERMANENT HAIR WAVING AND HAIR CURLING PREPARATIONS; HAIR STRENGTHENER PREPARATIONS; ESSENTIAL OILS FOR PERSONAL USE (U.S. CLS. 1, 4, 6, 50, 51 AND 52).  
ZACHARY CROMER, EXAMINING ATTORNEY

SN 86-247,482. HORNER, BRANDIE, ROYAL PALM BEACH, FL. FILED 4-9-2014.

**SKINTILLATING**

THE MARK CONSISTS OF STANDARD CHARACTERS WITHOUT CLAIM TO ANY PARTICULAR FONT, STYLE, SIZE, OR COLOR.

FOR COSMETIC PREPARATIONS; COSMETICS; NON-MEDICATED SKIN CARE PREPARATIONS (U.S. CLS. 1, 4, 6, 50, 51 AND 52).  
THEODORE MCBRIDE, EXAMINING ATTORNEY

**CLASS 3—(Continued).**

SN 86-247,530. SEATTLE GOURMET FOODS, INC., KENT, WA. FILED 4-9-2014.

**ORAL FIXATION**

THE MARK CONSISTS OF STANDARD CHARACTERS WITHOUT CLAIM TO ANY PARTICULAR FONT, STYLE, SIZE, OR COLOR.

OWNER OF U.S. REG. NO. 2,832,902.  
FOR BREATH MINTS FOR USE AS A BREATH FRESHENER (U.S. CLS. 1, 4, 6, 50, 51 AND 52).  
FIRST USE 8-1-2003; IN COMMERCE 12-1-2003.  
DAVID COLLIER, EXAMINING ATTORNEY

---

SN 86-247,566. LASIO, INC., LONG ISLAND CITY, NY. FILED 4-9-2014.

**Lasio Color Pro**

THE MARK CONSISTS OF STANDARD CHARACTERS WITHOUT CLAIM TO ANY PARTICULAR FONT, STYLE, SIZE, OR COLOR.

OWNER OF U.S. REG. NO. 3,891,111.  
NO CLAIM IS MADE TO THE EXCLUSIVE RIGHT TO USE "COLOR", APART FROM THE MARK AS SHOWN.  
FOR HAIR CARE KITS COMPRISING NON-MEDICATED HAIR CARE PREPARATIONS, NAMELY, FOR STRAIGHTENING; HAIR CARE PREPARATIONS; HAIR CONDITIONERS; HAIR GLAZE; HAIR SHAMPOO; HAIR STRAIGHTENING PREPARATIONS (U.S. CLS. 1, 4, 6, 50, 51 AND 52).  
MIDGE BUTLER, EXAMINING ATTORNEY

---

SN 86-248,029. THE STEPHAN CO., TAMPA, FL. FILED 4-10-2014.

**LOVE YOUR CURLS**

THE MARK CONSISTS OF STANDARD CHARACTERS WITHOUT CLAIM TO ANY PARTICULAR FONT, STYLE, SIZE, OR COLOR.

FOR HAIR CARE PREPARATIONS; HAIR CURLING PREPARATIONS; HAIR STYLING PREPARATIONS; HAIR STYLING SPRAY (U.S. CLS. 1, 4, 6, 50, 51 AND 52).  
DANIEL S. STRINGER, EXAMINING ATTORNEY

**CLASS 3—(Continued).**

SN 86-248,123. ABERCROMBIE & FITCH TRADING CO., NEW ALBANY, OH. FILED 4-10-2014.

**HOLLISTER CALIFORNIA SKYLER**

THE MARK CONSISTS OF STANDARD CHARACTERS WITHOUT CLAIM TO ANY PARTICULAR FONT, STYLE, SIZE, OR COLOR.

OWNER OF U.S. REG. NOS. 3,627,568, 3,804,831 AND 3,804,832.  
NO CLAIM IS MADE TO THE EXCLUSIVE RIGHT TO USE "CALIFORNIA", APART FROM THE MARK AS SHOWN.

FOR BODY SPRAYS; BODY WASH; DEODORANT FOR PERSONAL USE; FRAGRANCES; NON-MEDICATED SKIN CARE CREAMS AND LOTIONS; NON-MEDICATED SKIN CARE PREPARATION, NAMELY, BODY MIST; PERFUMES; SHAMPOOS (U.S. CLS. 1, 4, 6, 50, 51 AND 52).  
CHRISTOPHER LAW, EXAMINING ATTORNEY

---

SN 86-248,422. INDEVCO FLEXIBLE PACKAGING, INC., ARLINGTON, VA. FILED 4-10-2014.

**GIPSY**

THE MARK CONSISTS OF STANDARD CHARACTERS WITHOUT CLAIM TO ANY PARTICULAR FONT, STYLE, SIZE, OR COLOR.

FOR DISPOSABLE WIPES IMPREGNATED WITH CLEANSING CHEMICALS OR COMPOUNDS (U.S. CLS. 1, 4, 6, 50, 51 AND 52).  
MICHAEL ENGEL, EXAMINING ATTORNEY

---

SN 86-248,722. COSMEDICAL TECHNOLOGIES, INC., DAVIE, FL. FILED 4-10-2014.

**C-STEM**

THE MARK CONSISTS OF STANDARD CHARACTERS WITHOUT CLAIM TO ANY PARTICULAR FONT, STYLE, SIZE, OR COLOR.

FOR NON-MEDICATED SKIN CARE PREPARATIONS (U.S. CLS. 1, 4, 6, 50, 51 AND 52).  
FIRST USE 8-31-2013; IN COMMERCE 8-31-2013.  
SOPHIA S. KIM, EXAMINING ATTORNEY



**CLASS 3—(Continued).**

SN 86-248,841. COSMEDICAL TECHNOLOGIES, INC., DAVIE, FL. FILED 4-10-2014.

# STEMULOUS

THE MARK CONSISTS OF STANDARD CHARACTERS WITHOUT CLAIM TO ANY PARTICULAR FONT, STYLE, SIZE, OR COLOR.  
FOR NON-MEDICATED SKIN CARE PREPARATIONS (U.S. CLS. 1, 4, 6, 50, 51 AND 52).  
FIRST USE 8-31-2013; IN COMMERCE 8-31-2013.  
SOPHIA S. KIM, EXAMINING ATTORNEY

---

SN 86-248,969. JO MILANO PARIS INC, NEW YORK, NY. FILED 4-10-2014.

# GOL'DEN DIAMOND

THE MARK CONSISTS OF STANDARD CHARACTERS WITHOUT CLAIM TO ANY PARTICULAR FONT, STYLE, SIZE, OR COLOR.  
FOR EAU DE PERFUME; FRAGRANCES; FRAGRANCES AND PERFUMERY; FRAGRANCES FOR PERSONAL USE; PERFUMERY; PERFUMES; PERFUMES AND COGNES (U.S. CLS. 1, 4, 6, 50, 51 AND 52).  
FIRST USE 0-0-2013; IN COMMERCE 0-0-2013.  
TINA L. SNAPP, EXAMINING ATTORNEY

---

SN 86-249,007. JO MILANO PARIS INC, NEW YORK, NY. FILED 4-10-2014.

# RICH & SEXY

THE MARK CONSISTS OF STANDARD CHARACTERS WITHOUT CLAIM TO ANY PARTICULAR FONT, STYLE, SIZE, OR COLOR.  
FOR EAU DE PERFUME; FRAGRANCES; FRAGRANCES AND PERFUMERY; FRAGRANCES FOR PERSONAL USE; PERFUMERY; PERFUMES; PERFUMES AND COGNES (U.S. CLS. 1, 4, 6, 50, 51 AND 52).  
TINA L. SNAPP, EXAMINING ATTORNEY

**CLASS 3—(Continued).**

SN 86-249,015. LIVE BY BEAUTY CORP, BROOKLYN, NY. FILED 4-10-2014.

# LIVE BY BEAUTY

THE MARK CONSISTS OF STANDARD CHARACTERS WITHOUT CLAIM TO ANY PARTICULAR FONT, STYLE, SIZE, OR COLOR.  
FOR BEAUTY CREAMS; BEAUTY MASKS; BEAUTY SERUMS (U.S. CLS. 1, 4, 6, 50, 51 AND 52).  
JOHN WILKE, EXAMINING ATTORNEY

---

SN 86-249,582. VOWTO INC., DENVER, CO. FILED 4-11-2014.

# VowTo Nurture

THE MARK CONSISTS OF STANDARD CHARACTERS WITHOUT CLAIM TO ANY PARTICULAR FONT, STYLE, SIZE, OR COLOR.  
FOR NON-MEDICATED SKIN CARE PREPARATIONS (U.S. CLS. 1, 4, 6, 50, 51 AND 52).  
GINA HAYES, EXAMINING ATTORNEY

---

SN 86-249,688. SOMATIKA INCORPORATED, NORMANDY PARK, WA. FILED 4-11-2014.

# Somatika

THE MARK CONSISTS OF STANDARD CHARACTERS WITHOUT CLAIM TO ANY PARTICULAR FONT, STYLE, SIZE, OR COLOR.  
FOR BODY AND BEAUTY CARE COSMETICS (U.S. CLS. 1, 4, 6, 50, 51 AND 52).  
SCOTT BIBB, EXAMINING ATTORNEY

**CLASS 3—(Continued).**

SN 86-249,798. WHISH BODY PRODUCTS, L.L.C., SCOTTS-DALE, AZ. FILED 4-11-2014.

**WHISH PRELUDE**

THE MARK CONSISTS OF STANDARD CHARACTERS WITHOUT CLAIM TO ANY PARTICULAR FONT, STYLE, SIZE, OR COLOR.

OWNER OF U.S. REG. NOS. 3,595,393 AND 4,192,632. FOR SHAVING PREPARATIONS (U.S. CLS. 1, 4, 6, 50, 51 AND 52).

CAITLIN WATTS-FITZGERALD, EXAMINING ATTORNEY

SN 86-249,821. CHRISALYN PHILLIPS, PALOS VERDES, CA. AND WILLIAM PHILLIPS, PALOS VERDES, CA. FILED 4-11-2014.

**Chrisalyn**

THE MARK CONSISTS OF STANDARD CHARACTERS WITHOUT CLAIM TO ANY PARTICULAR FONT, STYLE, SIZE, OR COLOR.

FOR COSMETICS, NON-MEDICATED SKIN CARE PREPARATIONS (U.S. CLS. 1, 4, 6, 50, 51 AND 52).

FIRST USE 9-30-2012; IN COMMERCE 12-31-2012. MICHAEL ENGEL, EXAMINING ATTORNEY

SN 86-249,827. WHISH BODY PRODUCTS, L.L.C., SCOTTS-DALE, AZ. FILED 4-11-2014.

**WHISH FLAWLESS**

THE MARK CONSISTS OF STANDARD CHARACTERS WITHOUT CLAIM TO ANY PARTICULAR FONT, STYLE, SIZE, OR COLOR.

OWNER OF U.S. REG. NOS. 3,595,393 AND 4,192,632. FOR SHAVING PREPARATIONS (U.S. CLS. 1, 4, 6, 50, 51 AND 52).

CAITLIN WATTS-FITZGERALD, EXAMINING ATTORNEY

**CLASS 3—(Continued).**

SN 86-249,979. JO MILANO PARIS INC, NEW YORK, NY. FILED 4-11-2014.

**SEXY & JUICE**

THE MARK CONSISTS OF STANDARD CHARACTERS WITHOUT CLAIM TO ANY PARTICULAR FONT, STYLE, SIZE, OR COLOR.

FOR EAU DE PERFUME; FRAGRANCES; FRAGRANCES AND PERFUMERY; FRAGRANCES FOR PERSONAL USE; PERFUMERY; PERFUMES; PERFUMES AND COGNES (U.S. CLS. 1, 4, 6, 50, 51 AND 52).

TINA L. SNAPP, EXAMINING ATTORNEY

SN 86-250,000. PIEDADE, FRANCIS RUMENOS, PIRACICABA, SP, BRAZIL, FILED 4-11-2014.

**Liquifloss**

THE MARK CONSISTS OF STANDARD CHARACTERS WITHOUT CLAIM TO ANY PARTICULAR FONT, STYLE, SIZE, OR COLOR.

FOR ANTI-CAVITY MOUTH RINSES; COSMETIC PREPARATIONS FOR THE CARE OF MOUTH AND TEETH; MOUTH WASHES; NON-MEDICATED DENTAL RINSE; NON-MEDICATED MOUTH RINSE; NON-MEDICATED MOUTH WASH AND RINSE; NON-MEDICATED MOUTH WASHES (U.S. CLS. 1, 4, 6, 50, 51 AND 52).

ALISON KEELEY, EXAMINING ATTORNEY

SN 86-251,713. ACATAC, INC., LOS ANGELES, CA. FILED 4-14-2014.

**SKLEER**

THE MARK CONSISTS OF STANDARD CHARACTERS WITHOUT CLAIM TO ANY PARTICULAR FONT, STYLE, SIZE, OR COLOR.

OWNER OF U.S. REG. NO. 4,564,153. FOR COSMETIC PREPARATIONS FOR BODY CARE; COSMETIC PREPARATIONS FOR SKIN CARE; COSMETICS; NON-MEDICATED SERUMS FOR USE ON THE SKIN; NON-MEDICATED SKIN CARE PREPARATIONS; SKIN CONDITIONERS; SKIN CONDITIONING CREAMS FOR COSMETIC PURPOSES; SKIN MOISTURIZER; SKIN TEXTURIZERS; SKIN TONERS; WRINKLE-MINIMIZING COSMETIC PREPARATIONS FOR TOPICAL FACIAL USE (U.S. CLS. 1, 4, 6, 50, 51 AND 52).

EMILY CHUO, EXAMINING ATTORNEY

**CLASS 3—(Continued).**

SN 86-252,757. TANGERINE LOTIONS AND COSMETICS, INC., RICHMOND, KY. FILED 4-15-2014.

# MARSCOTÁ

THE MARK CONSISTS OF STANDARD CHARACTERS WITHOUT CLAIM TO ANY PARTICULAR FONT, STYLE, SIZE, OR COLOR.

FOR COSMETIC PREPARATIONS FOR SKIN CARE; BEAUTY CREAMS; BEAUTY LOTIONS; SKIN MOISTURIZER; SKIN MOISTURIZER GEL; SKIN CREAMS; SKIN LOTIONS; SKIN MASK; COSMETIC PREPARATIONS FOR BATH AND SHOWER; BODY CREAMS; NATURAL COCOA BUTTER BASED PERSONAL CARE PRODUCTS, NAMELY, BODY LOTION, SHOWER GEL, SOAP, BODY POLISH, BODY AND FOOT SCRUB AND NON-MEDICATED SKIN CREAMS; COCOA BUTTER FOR COSMETIC PURPOSES; HAND CREAMS; HAND LOTIONS; COSMETIC PREPARATIONS FOR SLIMMING PURPOSES; COSMETIC PREPARATIONS, NAMELY, FIRMLING CREAMS; COSMETIC PREPARATIONS, NAMELY, FIRMLING LOTIONS; COSMETIC CREAMS FOR CELLULITE REDUCTION; LOTIONS FOR CELLULITE REDUCTION; SUN CARE LOTIONS; SUN CREAMS; COSMETIC SUN-PROTECTING PREPARATIONS; COSMETIC PREPARATIONS AGAINST SUNBURN; SUN SCREEN; SUNSCREEN CREAMS; SUN BLOCK PREPARATIONS; COSMETIC SUNTAN PREPARATIONS; SUNTAN LOTIONS; COSMETIC TANNING PREPARATIONS; SKIN BRONZING CREAMS; AFTER SUN MOISTURIZERS; AFTER SUN CREAMS; AFTER SUN LOTIONS; DEODORANTS AND ANTIPERSPIRANTS; DEODORANT FOR PERSONAL USE; EAU DE TOILETTE (U.S. CLS. 1, 4, 6, 50, 51 AND 52).

KATHERINE CHANG, EXAMINING ATTORNEY

SN 86-253,916. ABERCROMBIE & FITCH TRADING CO., NEW ALBANY, OH. FILED 4-16-2014.

## PERFUME NO. 1 BARE

THE MARK CONSISTS OF STANDARD CHARACTERS WITHOUT CLAIM TO ANY PARTICULAR FONT, STYLE, SIZE, OR COLOR.

OWNER OF U.S. REG. NO. 4,415,225.  
NO CLAIM IS MADE TO THE EXCLUSIVE RIGHT TO USE "PERFUME", APART FROM THE MARK AS SHOWN.  
FOR FRAGRANCES; PERFUMES (U.S. CLS. 1, 4, 6, 50, 51 AND 52).

CHRISTOPHER LAW, EXAMINING ATTORNEY

**CLASS 3—(Continued).**

SN 86-253,924. ABERCROMBIE & FITCH TRADING CO., NEW ALBANY, OH. FILED 4-16-2014.

## PERFUME NO. 1 MOMENT

THE MARK CONSISTS OF STANDARD CHARACTERS WITHOUT CLAIM TO ANY PARTICULAR FONT, STYLE, SIZE, OR COLOR.

OWNER OF U.S. REG. NO. 4,415,225.  
NO CLAIM IS MADE TO THE EXCLUSIVE RIGHT TO USE "PERFUME", APART FROM THE MARK AS SHOWN.  
FOR FRAGRANCES; PERFUMES (U.S. CLS. 1, 4, 6, 50, 51 AND 52).

CHRISTOPHER LAW, EXAMINING ATTORNEY

SN 86-256,461. PERSONAL CARE PRODUCTS, LLC, TROY, MI. FILED 4-18-2014.

## FAMILY CHOICE

THE MARK CONSISTS OF STANDARD CHARACTERS WITHOUT CLAIM TO ANY PARTICULAR FONT, STYLE, SIZE, OR COLOR.

OWNER OF U.S. REG. NO. 1,833,599.  
FOR HAIR SHAMPOOS; HAIR CONDITIONERS; NON-MEDICATED SKIN CARE LOTIONS AND TOILET PREPARATIONS, NAMELY, PERSONAL DEODORANTS, AND SHOWER AND BATH POWDERS (U.S. CLS. 1, 4, 6, 50, 51 AND 52).

MATTHEW GALAN, EXAMINING ATTORNEY

SN 86-256,467. PRIMAL PRODUCTS, LLC, TAMPA, GA. FILED 4-18-2014.

## Primal Paste

THE MARK CONSISTS OF STANDARD CHARACTERS WITHOUT CLAIM TO ANY PARTICULAR FONT, STYLE, SIZE, OR COLOR.

NO CLAIM IS MADE TO THE EXCLUSIVE RIGHT TO USE "PASTE", APART FROM THE MARK AS SHOWN.  
FOR DEODORANT FOR PERSONAL USE (U.S. CLS. 1, 4, 6, 50, 51 AND 52).

ALLISON HOLTZ, EXAMINING ATTORNEY

**CLASS 3—(Continued).**

SN 86-256,481. PRIMAL PRODUCTS, LLC, TAMPA, GA.  
FILED 4-18-2014.

# Pit Pump

THE MARK CONSISTS OF STANDARD CHARACTERS WITHOUT CLAIM TO ANY PARTICULAR FONT, STYLE, SIZE, OR COLOR.

NO CLAIM IS MADE TO THE EXCLUSIVE RIGHT TO USE "PUMP", APART FROM THE MARK AS SHOWN.

FOR DEODORANT FOR PERSONAL USE (U.S. CLS. 1, 4, 6, 50, 51 AND 52).

ALLISON HOLTZ, EXAMINING ATTORNEY

**CLASS 3—(Continued).**

SN 86-261,764. NATURE'S GIFTS INTERNATIONAL, LLC,  
KNOXVILLE, TN. FILED 4-24-2014.

# REJUCENATE YOUR SKIN

THE MARK CONSISTS OF STANDARD CHARACTERS WITHOUT CLAIM TO ANY PARTICULAR FONT, STYLE, SIZE, OR COLOR.

FOR PERSONAL CARE PRODUCTS, NAMELY, BODY LOTION BARS, BODY LOTION, LIP BALM, DEODORANT, COSMETICS, SOLID PERFUMES, SHAMPOO, HAIR CONDITIONER, TALCUM POWDER, SHAVING CREAM, SKIN CREAM, AND COSMETIC PREPARATIONS FOR BATH, NAMELY, HEAT TREATMENT WAX FOR BATHS (U.S. CLS. 1, 4, 6, 50, 51 AND 52).

SHAILA LEWIS, EXAMINING ATTORNEY

SN 86-256,907. PURE MD, BUFORD, GA. FILED 4-19-2014.

# NAKED BLISS

THE MARK CONSISTS OF STANDARD CHARACTERS WITHOUT CLAIM TO ANY PARTICULAR FONT, STYLE, SIZE, OR COLOR.

FOR COSMETIC PREPARATIONS FOR SKIN CARE; ANTI-AGING CREAMS; NON-MEDICATED ACNE TREATMENT PREPARATIONS (U.S. CLS. 1, 4, 6, 50, 51 AND 52).

FIRST USE 2-1-2014; IN COMMERCE 2-1-2014.

YAT SYE, LEE, EXAMINING ATTORNEY

SN 86-261,787. THOSE CHARACTERS FROM CLEVELAND, INC., CLEVELAND, OH. FILED 4-24-2014.

# Care♥Bears

OWNER OF U.S. REG. NOS. 1,270,509, 3,767,824 AND OTHERS.

NO CLAIM IS MADE TO THE EXCLUSIVE RIGHT TO USE "BEARS", APART FROM THE MARK AS SHOWN.

THE MARK CONSISTS OF A DESIGN OF A HEART BETWEEN THE WORDS CARE AND BEARS.

FOR ANTI-BACTERIAL SOAP; BODY CREAM; BODY GLITTER; BODY WASH; BUBBLE BATH; HAIR CONDITIONERS; HAIR GEL; HAIR MOUSSE; LIP BALM; NAIL POLISH; PERFUMES; SHAMPOOS (U.S. CLS. 1, 4, 6, 50, 51 AND 52).

LESLIE RICHARDS, EXAMINING ATTORNEY

SN 86-261,089. MSD CONSUMER CARE, INC., MEMPHIS, TN. FILED 4-24-2014.

# SheerDelight

THE MARK CONSISTS OF STANDARD CHARACTERS WITHOUT CLAIM TO ANY PARTICULAR FONT, STYLE, SIZE, OR COLOR.

FOR NON-MEDICATED SUN CARE PREPARATIONS; SUN BLOCK PREPARATIONS; SUN SCREEN PREPARATIONS; SUN-TANNING PREPARATIONS (U.S. CLS. 1, 4, 6, 50, 51 AND 52).

PAUL E. FAHRENKOPF, EXAMINING ATTORNEY

SN 86-262,207. KOSE CORPORATION, TOKYO, JAPAN, FILED 4-24-2014.

# COSME DECORTE

THE MARK CONSISTS OF STANDARD CHARACTERS WITHOUT CLAIM TO ANY PARTICULAR FONT, STYLE, SIZE, OR COLOR.

OWNER OF JAPAN REG. NO. 5479029, DATED 3-16-2012, EXPIRES 3-16-2022.

OWNER OF U.S. REG. NOS. 1,289,673 AND 4,247,769.  
FOR COSMETICS; PERFUMES; COSMETIC SOAPS; COTTON WOOL FOR COSMETIC PURPOSES AND HAIR CARE PREPARATIONS (U.S. CLS. 1, 4, 6, 50, 51 AND 52).  
THEODORE MCBRIDE, EXAMINING ATTORNEY

**CLASS 3—(Continued).**

SN 86-262,886. NATURE'S GIFTS INTERNATIONAL, LLC,  
KNOXVILLE, TN. FILED 4-25-2014.

**ENVIRONMENTAL GUARDIANS**

THE MARK CONSISTS OF STANDARD CHARACTERS WITHOUT CLAIM TO ANY PARTICULAR FONT, STYLE, SIZE, OR COLOR.

NO CLAIM IS MADE TO THE EXCLUSIVE RIGHT TO USE "ENVIRONMENTAL", APART FROM THE MARK AS SHOWN.

FOR ENVIRONMENTALLY-FRIENDLY PERSONAL CARE PRODUCTS, NAMELY, BODY LOTION BARS, BODY LOTION, LIP BALM, DEODORANT, COSMETICS, SOLID PERFUMES, SHAMPOO, HAIR CONDITIONER, TALCUM POWDER, SHAVING CREAM, SKIN CREAM, AND COSMETIC PREPARATIONS FOR BATH, NAMELY, HEAT TREATMENT WAX FOR BATHS (U.S. CLS. 1, 4, 6, 50, 51 AND 52).

SHAILA LEWIS, EXAMINING ATTORNEY

SN 86-264,182. SKINVISIBLE PHARMACEUTICALS, INC.,  
LAS VEGAS, NV. FILED 4-28-2014.

**skinbrella**

THE MARK CONSISTS OF STANDARD CHARACTERS WITHOUT CLAIM TO ANY PARTICULAR FONT, STYLE, SIZE, OR COLOR.

FOR AFTER SUN CREAMS; AFTER SUN MOISTURISERS; AFTER-SUN GELS; AFTER-SUN LOTIONS; AFTER-SUN MILKS; AFTER-SUN OILS; AROMATIC BODY CARE PRODUCTS, NAMELY, BODY LOTION, SHOWER GEL, CUTICLE CREAM, SHAMPOO, CONDITIONER, NON-MEDICATED LIP BALM, SOAP, BODY POLISH, BODY AND FOOT SCRUB AND NON-MEDICATED FOOT CREAM; BEAUTY CREAMS FOR BODY CARE; BODY AND BEAUTY CARE COSMETICS; CONCEALERS FOR SKIN; COSMETIC CREAMS FOR SKIN CARE; COSMETIC PREPARATIONS FOR BODY CARE; COSMETIC PREPARATIONS FOR PROTECTING THE SKIN FROM THE SUN'S RAYS; COSMETIC PREPARATIONS FOR SKIN CARE; COSMETIC PREPARATIONS FOR SKIN RENEWAL; COSMETIC PREPARATIONS, NAMELY, SKIN BALSAMS; COSMETIC PRODUCTS IN THE FORM OF AEROSOLS FOR SKIN CARE; COSMETIC PRODUCTS IN THE FORM OF AEROSOLS FOR SKINCARE; COSMETIC SKIN FRESHENERS; COSMETIC SUN MILK LOTIONS; COSMETIC SUN OILS; COSMETIC SUN-PROTECTING PREPARATIONS; COSMETIC SUN-TANNING PREPARATIONS; DEODORANTS FOR BODY CARE; EXFOLIANTS FOR SKIN; FRAGRANCED BODY CARE PREPARATIONS, NAMELY, SKIN LOTIONS; FRAGRANCED FACE CARE PREPARATIONS, NAMELY, SKIN LOTIONS; INDOOR SUN TANNING PREPARATIONS; LOTIONS FOR FACE AND BODY CARE; LOTIONS FOR SKIN CARE; MOISTURIZING PREPARATIONS FOR THE SKIN; MOISTURIZING SOLUTIONS FOR THE SKIN; MOUSSE FOR SKIN CARE; NON-FOAMING COSMETIC PREPARATIONS FOR SKIN; NON-MEDICATED BALMS FOR USE ON SKIN; NON-MEDICATED CLEANSERS FOR PERSONAL USE, NAMELY, SKIN CLEANSERS; NON-MEDICATED CLEANSERS, NAMELY, SKIN CLEANSERS; NON-MEDICATED COSMETIC SKIN CARE PREPARATIONS CONSISTING OF ORGANIC COCONUT VIRGIN OIL AND COCONUT VIRGIN OIL; NON-MEDICATED HERBAL BODY CARE PRODUCTS, NAMELY, BODY OILS,

**CLASS 3—(Continued).**

SALVES, AND LIP BALMS; NON-MEDICATED HERBAL BODY CARE PRODUCTS, NAMELY, SKIN CREAMS AND LOTIONS; NON-MEDICATED LIP CARE PREPARATIONS; NON-MEDICATED PREPARATIONS ALL FOR THE CARE OF SKIN, HAIR AND SCALP; NON-MEDICATED SERUMS FOR USE ON SKIN; NON-MEDICATED SKIN CARE CREAMS AND LOTIONS; NON-MEDICATED SKIN CARE PREPARATION, NAMELY, BODY MIST; NON-MEDICATED SKIN CARE PREPARATIONS; NON-MEDICATED SKIN CARE PREPARATIONS, NAMELY, CREAMS, LOTIONS, GELS, TONERS, CLEANERS AND PEELS; NON-MEDICATED SKIN CARE PREPARATIONS, NAMELY, SKIN LOTIONS AND CREAMS; NON-MEDICATED SKIN CREAM FOR GENERAL SKIN RASH AND IRRITATION RESULTING FROM SKIN SHINGLES; NON-MEDICATED SKIN CREAMS; NON-MEDICATED SKIN CREAMS WITH ESSENTIAL OILS FOR USE IN AROMATHERAPY; NON-MEDICATED SKIN TONERS; NON-MEDICATED STIMULATING LOTIONS FOR THE SKIN; NON-MEDICATED SUN CARE PREPARATIONS; NON-MEDICATED SKIN CARE PREPARATIONS; PATCHES CONTAINING SUN SCREEN AND SUN BLOCK FOR USE ON THE SKIN; SKIN ABRASIVE PREPARATIONS; SKIN AND BODY TOPICAL LOTIONS, CREAMS AND OILS FOR COSMETIC USE; SKIN BRONZER; SKIN BRONZING CREAMS; SKIN CARE PREPARATION, NAMELY, BODY POLISH; SKIN CARE PREPARATIONS, NAMELY, BODY BALM; SKIN CARE PREPARATIONS, NAMELY, CHEMICAL PEELS FOR SKIN; SKIN CARE PREPARATIONS, NAMELY, FRUIT ACID PEELS FOR SKIN; SKIN CARE PREPARATIONS, NAMELY, SKIN PEELS; SKIN CARE PRODUCTS, NAMELY, NON-MEDICATED SKIN SERUM; SKIN CLARIFIERS; SKIN CLEANSER IN LIQUID SPRAY FORM FOR USE AS A BABY WIPE ALTERNATIVE; SKIN CLEANSERS; SKIN CLEANSING CREAM; SKIN CLEANSING LOTION; SKIN CONDITIONERS; SKIN CONDITIONING CREAMS FOR COSMETIC PURPOSES; SKIN CREAM; SKIN CREAMS; SKIN CREAMS IN LIQUID AND IN SOLID FORM; SKIN CREAMS IN LIQUID AND SOLID; SKIN CREAMS IN LIQUID AND SOLID FORM; SKIN EMOLLIENTS; SKIN FRESHENERS; SKIN GELS FOR ACCELERATING, ENHANCING OR EXTENDING TANS; SKIN LIGHTENERS; SKIN LIGHTENING CREAMS; SKIN LOTION; SKIN LOTIONS; SKIN MASKS; SKIN MOISTURIZER; SKIN MOISTURIZER MASKS; SKIN MOISTURIZING GEL; SKIN WHITENING CREAMS; SKIN WHITENING PREPARATIONS; SPF SUN BLOCK SPRAYS; SPF SUN BLOCK TOWELETES; SUN BLOCK; SUN BLOCK PREPARATIONS; SUN CARE LOTIONS; SUN CREAMS; SUN SCREEN; SUN SCREEN PREPARATIONS; SUN TAN GEL; SUN TAN LOTION; SUN TAN OIL; SUN-BLOCK LOTIONS; SUN-TANNING OILS; SUN-TANNING OILS AND LOTIONS; SUN-TANNING PREPARATIONS; TANNING AND AFTER-SUN MILKS, GELS AND OILS; TOPICAL SKIN SPRAYS FOR COSMETIC PURPOSES; WRINKLE REMOVING SKIN CARE PREPARATIONS (U.S. CLS. 1, 4, 6, 50, 51 AND 52).

JIM RINGLE, EXAMINING ATTORNEY

**CLASS 3—(Continued).**

SN 86-265,109. UNILIN FLOORING NC, LLC, CALHOUN, GA. FILED 4-29-2014.

## RENEWAL REVITALIZING SOLUTION

THE MARK CONSISTS OF STANDARD CHARACTERS WITHOUT CLAIM TO ANY PARTICULAR FONT, STYLE, SIZE, OR COLOR.

NO CLAIM IS MADE TO THE EXCLUSIVE RIGHT TO USE "REVITALIZING SOLUTION", APART FROM THE MARK AS SHOWN.

FOR CLEANING PREPARATIONS FOR HARDWOOD (U.S. CLS. 1, 4, 6, 50, 51 AND 52).

FIRST USE 1-12-2014; IN COMMERCE 1-12-2014.  
JENNIFER DIXON, EXAMINING ATTORNEY

---

SN 86-265,667. THE SUN PRODUCTS CORPORATION, WILTON, CT. FILED 4-29-2014.

## ISLAND DREAMS

THE MARK CONSISTS OF STANDARD CHARACTERS WITHOUT CLAIM TO ANY PARTICULAR FONT, STYLE, SIZE, OR COLOR.

FOR LAUNDRY ADDITIVE IN THE NATURE OF FRAGRANCE ENHANCERS (U.S. CLS. 1, 4, 6, 50, 51 AND 52).

ELI HELLMAN, EXAMINING ATTORNEY

---

SN 86-268,199. SHURFINE FOODS, INC., TIGARD, OR. FILED 4-30-2014.

## SHUR SAVING

THE MARK CONSISTS OF STANDARD CHARACTERS WITHOUT CLAIM TO ANY PARTICULAR FONT, STYLE, SIZE, OR COLOR.

OWNER OF U.S. REG. NOS. 1,237,527, 1,711,996 AND OTHERS.

FOR ALL-PURPOSE CLEANERS; SPRAY CLEANERS FOR USE ON TILE AND VINYL; PINE CLEANERS; ANTIBACTERIAL SOAP; HAND SOAPS; LIQUID SOAPS FOR HANDS AND BODY; BODY WASH; ALL-PURPOSE COTTON SWABS FOR PERSONAL USE; BABY WIPES; DISH DETERGENTS (U.S. CLS. 1, 4, 6, 50, 51 AND 52).

FIRST USE 4-1-2014; IN COMMERCE 4-1-2014.  
MICHAEL P EISNACH, EXAMINING ATTORNEY

**CLASS 3—(Continued).**

SN 86-268,667. PERSONAL CARE PRODUCTS, LLC, TROY, MI. FILED 5-1-2014.

## PURE ESSENCE

THE MARK CONSISTS OF STANDARD CHARACTERS WITHOUT CLAIM TO ANY PARTICULAR FONT, STYLE, SIZE, OR COLOR.

FOR HAIR SHAMPOOS; HAIR CONDITIONERS; NON-MEDICATED SKIN CARE LOTIONS AND TOILET PREPARATIONS, NAMELY, PERSONAL DEODORANTS, AND SHOWER AND BATH POWDERS (U.S. CLS. 1, 4, 6, 50, 51 AND 52).

MATTHEW GALAN, EXAMINING ATTORNEY

---

SN 86-270,554. INTERNATIONAL COMMERCIAL TELEVISION, INC., WAYNE, PA. FILED 5-2-2014.

## DAY NOURISH

THE MARK CONSISTS OF STANDARD CHARACTERS WITHOUT CLAIM TO ANY PARTICULAR FONT, STYLE, SIZE, OR COLOR.

FOR NON-MEDICATED SKIN CARE PREPARATIONS, NAMELY, CREAM (U.S. CLS. 1, 4, 6, 50, 51 AND 52).

GINA HAYES, EXAMINING ATTORNEY

---

SN 86-270,564. INTERNATIONAL COMMERCIAL TELEVISION, INC., WAYNE, PA. FILED 5-2-2014.

## NIGHT NOURISH

THE MARK CONSISTS OF STANDARD CHARACTERS WITHOUT CLAIM TO ANY PARTICULAR FONT, STYLE, SIZE, OR COLOR.

FOR NON-MEDICATED SKIN CARE PREPARATIONS, NAMELY, CREAM (U.S. CLS. 1, 4, 6, 50, 51 AND 52).

GINA HAYES, EXAMINING ATTORNEY

**CLASS 3—(Continued).**

SN 86-270,714. COLGATE-PALMOLIVE COMPANY, NEW YORK, NY. FILED 5-2-2014.

**THE GOOD FOR YOU ESCAPE**

THE MARK CONSISTS OF STANDARD CHARACTERS WITHOUT CLAIM TO ANY PARTICULAR FONT, STYLE, SIZE, OR COLOR.

FOR PERSONAL CARE PRODUCTS, NAMELY, NON-MEDICATED SKIN AND BODY CARE PREPARATIONS (U.S. CLS. 1, 4, 6, 50, 51 AND 52).

JULIE VEPPUMTHARA, EXAMINING ATTORNEY

SN 86-271,199. PRICE, DEBORAH, LOS ANGELES, CA. FILED 5-5-2014.

**MALE MADNESS**

THE MARK CONSISTS OF STANDARD CHARACTERS WITHOUT CLAIM TO ANY PARTICULAR FONT, STYLE, SIZE, OR COLOR.

NO CLAIM IS MADE TO THE EXCLUSIVE RIGHT TO USE "MALE", APART FROM THE MARK AS SHOWN.

FOR COSMETIC PREPARATIONS FOR SKIN CARE; SHAVING PREPARATIONS; SHAVING BALMS; CREAMS, FOAM, GELS, LOTIONS, MOUSSE, SOAPS; SHAVING SPRITZ IN THE NATURE OF A MOISTURIZING SOLUTION FOR SHAVING; SHAVING STONES; COSMETIC PREPARATIONS FOR THE HAIR AND SCALP; COSMETIC HAIR DRESSING PREPARATIONS; COSMETIC HAIR REGROWTH INHIBITING PREPARATIONS; HAIR CARE PREPARATIONS; HAIR CLEANING PREPARATIONS; HAIR COLORING PREPARATIONS; HAIR SHAMPOOS AND CONDITIONERS; HAIR SPRAYS AND HAIR GELS; HAIR STRAIGHTENING PREPARATIONS; HAIR STYLING PREPARATIONS; HAIR-WASHING POWDER; NON-MEDICATED HAIR SERUMS (U.S. CLS. 1, 4, 6, 50, 51 AND 52).

TARAH HARDY, EXAMINING ATTORNEY

SN 86-271,380. HEALTHY DIRECTIONS, LLC, BETHESDA, MD. FILED 5-5-2014.

**OXYRUB**

THE MARK CONSISTS OF STANDARD CHARACTERS WITHOUT CLAIM TO ANY PARTICULAR FONT, STYLE, SIZE, OR COLOR.

OWNER OF U.S. REG. NOS. 3,675,910 AND 4,523,459.

FOR MASSAGE OIL (U.S. CLS. 1, 4, 6, 50, 51 AND 52). FIRST USE 3-0-2014; IN COMMERCE 3-0-2014.

DANIEL CAPSHAW, EXAMINING ATTORNEY

**CLASS 3—(Continued).**

SN 86-271,762. AEROPOSTALE PROCUREMENT COMPANY, INC., NEW YORK, NY. FILED 5-5-2014.

**AEROPOSTALE PRIME**

THE MARK CONSISTS OF STANDARD CHARACTERS WITHOUT CLAIM TO ANY PARTICULAR FONT, STYLE, SIZE, OR COLOR.

OWNER OF U.S. REG. NOS. 3,285,335, 3,709,721 AND OTHERS.

THE ENGLISH TRANSLATION OF "AEROPOSTALE" IN THE MARK IS "AIR MAIL".

FOR BODY SPRAYS; COLOGNE (U.S. CLS. 1, 4, 6, 50, 51 AND 52).

KATHY DE JONGE, EXAMINING ATTORNEY

SN 86-273,197. AMOREPACIFIC CORPORATION, SEOUL, REPUBLIC OF KOREA, FILED 5-6-2014.

**AIRCELL**

THE MARK CONSISTS OF STANDARD CHARACTERS WITHOUT CLAIM TO ANY PARTICULAR FONT, STYLE, SIZE, OR COLOR.

FOR COSMETICS; COSMETICS FOR MAKE-UP; COSMETICS, NAMELY, SOLID POWDER FOR COMPACTS; COSMETIC PREPARATIONS FOR SKIN CARE; PERFUMES; EYE SHADOWS; LIPSTICKS; DENTIFRICES; HAIR SHAMPOO (U.S. CLS. 1, 4, 6, 50, 51 AND 52).

HENRY S. ZAK, EXAMINING ATTORNEY

SN 86-273,523. CONAIR CORPORATION, STAMFORD, CT. FILED 5-6-2014.

**RUSK**  
fashion×culture×attitude

OWNER OF U.S. REG. NOS. 3,472,146, 3,621,710 AND 4,095,387.

THE MARK CONSISTS OF THE MARK "RUSK" ABOVE THE WORDS "FASHION CULTURE ATTITUDE" WHICH ARE SEPARATED BY SCISSORS.

FOR HAIR CARE PREPARATIONS; HAIR STYLING PREPARATIONS (U.S. CLS. 1, 4, 6, 50, 51 AND 52).

KRISTINA MORRIS, EXAMINING ATTORNEY

**CLASS 3—(Continued).**

SN 86-276,594. THE SUN PRODUCTS CORPORATION, WILTON, CT. FILED 5-9-2014.

**FIBER SHIELD**

THE MARK CONSISTS OF STANDARD CHARACTERS WITHOUT CLAIM TO ANY PARTICULAR FONT, STYLE, SIZE, OR COLOR.

FOR LAUNDRY DETERGENT (U.S. CLS. 1, 4, 6, 50, 51 AND 52).

ELI HELLMAN, EXAMINING ATTORNEY

SN 86-280,746. MILKFACE BABIES, INC., LOS ANGELES, CA. FILED 5-14-2014.

**SUGARTUSH**

THE MARK CONSISTS OF STANDARD CHARACTERS WITHOUT CLAIM TO ANY PARTICULAR FONT, STYLE, SIZE, OR COLOR.

FOR NON-MEDICATED BABY BALMS FOR DIAPER RASH; NON-MEDICATED DIAPER RASH OINTMENTS, LOTIONS AND CREAMS; SKIN CARE PREPARATIONS, NAMELY, BODY BALM (U.S. CLS. 1, 4, 6, 50, 51 AND 52). FIRST USE 2-0-2011; IN COMMERCE 2-0-2011.

RONALD DELGIZZI, EXAMINING ATTORNEY

SN 86-283,139. KENDYL JAMESON, LLC, BOCA RATON, FL. FILED 5-16-2014.

**Skin Booty**

THE MARK CONSISTS OF STANDARD CHARACTERS WITHOUT CLAIM TO ANY PARTICULAR FONT, STYLE, SIZE, OR COLOR.

NO CLAIM IS MADE TO THE EXCLUSIVE RIGHT TO USE "SKIN", APART FROM THE MARK AS SHOWN.

FOR BODY LOTION; BODY SCRUB; COSMETICS AND COSMETIC PREPARATIONS; EYE SHADOW; HAIR CARE PREPARATIONS; LIP BALM; LIP CREAM; LIP GLOSS; NON-MEDICATED LIP CARE PREPARATIONS (U.S. CLS. 1, 4, 6, 50, 51 AND 52).

DARRYL SPRUILL, EXAMINING ATTORNEY

**CLASS 3—(Continued).**

SN 86-290,402. BEAUMONT PRODUCTS, INC., KENNESAW, GA. FILED 5-23-2014.

**ORGANIC FARMERS' MARKET**

THE MARK CONSISTS OF STANDARD CHARACTERS WITHOUT CLAIM TO ANY PARTICULAR FONT, STYLE, SIZE, OR COLOR.

OWNER OF U.S. REG. NO. 3,797,457.

NO CLAIM IS MADE TO THE EXCLUSIVE RIGHT TO USE "ORGANIC", APART FROM THE MARK AS SHOWN.

FOR ORGANIC BATH SOAPS (U.S. CLS. 1, 4, 6, 50, 51 AND 52).

LEE HUNT, EXAMINING ATTORNEY

SN 86-296,994. KIM KEARNEY, VAN NUYS, CA. FILED 5-31-2014.

**FACEMAX**

THE MARK CONSISTS OF STANDARD CHARACTERS WITHOUT CLAIM TO ANY PARTICULAR FONT, STYLE, SIZE, OR COLOR.

FOR CLEANER FOR COSMETIC BRUSHES; CLEANSING CREAMS; COLOGNES, PERFUMES AND COSMETICS; COSMETIC BODY SCRUBS FOR THE FACE, HANDS, FEET, BODY; COSMETIC CREAMS; COSMETIC CREAMS FOR SKIN CARE; COSMETIC HAND CREAMS; COSMETIC MASKS; COSMETIC MASSAGE CREAMS; COSMETIC NOURISHING CREAMS; COSMETIC OILS; COSMETIC PADS; COSMETIC PENCILS; COSMETIC PREPARATIONS; COSMETIC PREPARATIONS AGAINST SUNBURN; COSMETIC PREPARATIONS FOR BATH AND SHOWER; COSMETIC PREPARATIONS FOR BODY CARE; COSMETIC PREPARATIONS FOR EYE LASHES; COSMETIC PREPARATIONS FOR NAIL DRYING; COSMETIC PREPARATIONS FOR REMOVING GEL NAILS, ACRYLIC NAILS, AND NAIL POLISH; COSMETIC PREPARATIONS FOR SKIN CARE; COSMETIC PREPARATIONS FOR SKIN RENEWAL; COSMETIC PREPARATIONS FOR THE CARE OF MOUTH AND TEETH; COSMETIC PREPARATIONS FOR THE HAIR AND SCALP; COSMETIC PREPARATIONS, NAMELY, FIRMSING CREAMS; COSMETIC PREPARATIONS, NAMELY, FIRMSING LOTIONS; COSMETIC PREPARATIONS, NAMELY, SKIN BALSAMS; COSMETIC SKIN FRESHENERS; COSMETIC SOAPS; COSMETIC SUN OILS; COSMETIC SUN-PROTECTING PREPARATIONS; COSMETIC SUN-TANNING PREPARATIONS; COSMETICS; COSMETICS AND COSMETIC PREPARATIONS; COSMETICS AND MAKE-UP; COSMETICS, NAMELY, LIP PRIMER; COSMETICS, NAMELY, LIP REPAIRERS; COTTON BALLS FOR COSMETIC PURPOSES; COTTON PUFFS FOR COSMETIC PURPOSES; COTTON SWABS FOR COSMETIC PURPOSES; EYE COMPRESSES FOR COSMETIC PURPOSES; EYEBROW COSMETICS; FACE CREAMS FOR COSMETIC USE; FLOWER ESSENCES FOR COSMETIC PURPOSES; FOAMS CONTAINING COSMETICS AND SUNSCREENS; GAUZE FOR COSMETIC PURPOSES; GELS FOR COSMETIC PURPOSES; GLITTER FOR COSMETIC PURPOSES; HENNA FOR COSMETIC PURPOSES; LIP STAINS; LOTIONS FOR COSMETIC PURPOSES; MAKE-UP KITS COMPRISED OF EYESHADOWS, FOUNDATIONS, PRIMERS, BLUSH, LIPSTICKS, LIP GLOSSES, CONCEALERS, POWDERS, EYELINER PENCILS, LIPLINER PENCILS, MASCARA, EYELASHES, EYELINER



**CLASS 3—(Continued).**

PENS, CONCEALERS, MOISTURIZERS, GLITTERS, BRONZERS, BODY PAINT.; MASK PACK FOR COSMETIC PURPOSES; MILK FOR COSMETIC PURPOSES; MINERAL POWDER FOR USE IN COSMETIC BODY WRAP APPLICATIONS; NAIL PAINT; NAIL VARNISH FOR COSMETIC PURPOSES; NON-FOAMING COSMETIC PREPARATIONS FOR FACE, HANDS, FEET, BODY; NUTRITIONAL OILS FOR COSMETIC PURPOSES; PARAFFIN WAX FOR COSMETIC PURPOSES; PENCILS FOR COSMETIC PURPOSES; PERFUME OILS FOR THE MANUFACTURE OF COSMETIC PREPARATIONS; PRE-MOISTENED COSMETIC TISSUES; PRE-MOISTENED COSMETIC TOWELETTE; PRE-MOISTENED COSMETIC WIPES; PRIVATE LABEL COSMETICS; RETINOL CREAM FOR COSMETIC PURPOSES; SELF-TANNING PREPARATIONS; SKIN AND BODY TOPICAL LOTIONS, CREAMS AND OILS FOR COSMETIC USE; SKIN CONDITIONING CREAMS FOR COSMETIC PURPOSES; SKIN FRESHENERS; SUNTAN OILS FOR COSMETIC PURPOSES; TEETH WHITENING STRIPS IMPREGNATED WITH TEETH WHITENING PREPARATIONS (U.S. CLS. 1, 4, 6, 50, 51 AND 52).

EDWARD NELSON, EXAMINING ATTORNEY

SN 86-308,896. FORSYTHE COSMETIC GROUP, LTD., LAWRENCE, NY. FILED 6-13-2014.

**PLAYBOOK**

THE MARK CONSISTS OF STANDARD CHARACTERS WITHOUT CLAIM TO ANY PARTICULAR FONT, STYLE, SIZE, OR COLOR.

FOR NAIL POLISH, LIP GLOSS, BODY GLITTER, NAIL ENAMEL, NAIL HARDENER, NAIL GLITTER, NAIL LACQUER, NAIL STRENGTHENER, NAIL CARE PREPARATIONS, CUTICLE REMOVING PREPARATIONS, NAIL POLISH TOP COAT, NAIL POLISH BASE COAT, NAIL VARNISH, NAIL ART, NAMELY, FINGER-NAIL DECALS, NAIL ART STICKERS, NAIL ART ADHESIVE GEMS, NAIL GROOMING PRODUCTS, NAMELY, MATTE TOPCOAT, NAIL LACQUER SEALER, DECORATIVE NAIL ART PEARLS, NAIL ART STRIPERS, NAMELY, REMOVING PREPARATIONS, DECORATIVE NAIL ART BEADS, DECORATIVE NAIL ART STUDS, NAIL ART GLITTER, NAIL ART GLUE, NAIL ART REMOVING PREPARATIONS, NAMELY, STRIPING TAPE, DISPOSABLE PUMICE FOR NAILS, GEL NAIL POLISH (U.S. CLS. 1, 4, 6, 50, 51 AND 52).

KEVIN DINALLO, EXAMINING ATTORNEY

SN 86-322,401. NEW MILANI GROUP, INC., LOS ANGELES, CA. FILED 6-27-2014.

**MILANI FIERCE FOILS**

THE MARK CONSISTS OF STANDARD CHARACTERS WITHOUT CLAIM TO ANY PARTICULAR FONT, STYLE, SIZE, OR COLOR.

OWNER OF U.S. REG. NO. 3,641,687.  
FOR COSMETICS (U.S. CLS. 1, 4, 6, 50, 51 AND 52).  
DORITT L. CARROLL, EXAMINING ATTORNEY

**CLASS 4—LUBRICANTS AND FUELS**

SN 76-715,954. HALOCARBON PRODUCTS CORPORATION, RIVER EDGE, NJ. FILED 3-5-2014.

**SAFETOL**

THE MARK CONSISTS OF STANDARD CHARACTERS WITHOUT CLAIM TO ANY PARTICULAR FONT, STYLE, SIZE, OR COLOR.

FOR INDUSTRIAL SYNTHETIC OILS, GENERAL PURPOSE GREASE (U.S. CLS. 1, 6 AND 15).

ANDREW LEASER, EXAMINING ATTORNEY

SN 86-067,208. MARTIN OPERATING PARTNERSHIP L.P., KILGORE, TX. FILED 9-17-2013.

**MOLYGARD**

THE MARK CONSISTS OF STANDARD CHARACTERS WITHOUT CLAIM TO ANY PARTICULAR FONT, STYLE, SIZE, OR COLOR.

OWNER OF U.S. REG. NOS. 3,721,742, 3,721,746 AND 3,739,202.

FOR AUTOMOBILE LUBRICANTS AND MOTOR VEHICULAR LUBRICANTS, AUTOMOTIVE GREASES, AND INDUSTRIAL AND GENERAL PURPOSE GREASES CONTAINING MOLYBDENUM DISULFIDE ADDITIVE FOR USE IN AUTOMOTIVE, HEAVY DUTY TRUCKING, FARM, CONSTRUCTION, AND LOGGING APPLICATIONS (U.S. CLS. 1, 6 AND 15).

SAIMA MAKHDOOM, EXAMINING ATTORNEY

SN 86-089,961. BIOSYNTHETIC TECHNOLOGIES, LLC, FORMERLY LUBRIGREEN BIOSYNTHETICS, LLC, IRVINE, CA. FILED 10-11-2013.

**Where Sustainability &  
High Performance Converge**

THE MARK CONSISTS OF STANDARD CHARACTERS WITHOUT CLAIM TO ANY PARTICULAR FONT, STYLE, SIZE, OR COLOR.

FOR BASE OILS FOR USE IN THE MANUFACTURE OF OTHER PRODUCTS, NAMELY, BIO-BASED OILS FOR USE IN THE FORMULATION OF FINISHED LUBRICANTS, GREASES, COSMETICS, PERSONAL CARE PRODUCTS, DIELECTRIC FLUIDS, DRILLING FLUIDS, INDUSTRIAL FLUIDS, FOOD ADDITIVES, FUEL ADDITIVES, CLEANSING MATERIALS, OIL-BASED PRODUCTS, AND A WIDE VARIETY OF GOODS (U.S. CLS. 1, 6 AND 15).

LIEF MARTIN, EXAMINING ATTORNEY

**CLASS 4—(Continued).**

SN 86-167,364. PEANUTS WORLDWIDE LLC, NEW YORK, NY. FILED 1-16-2014.



OWNER OF U.S. REG. NOS. 1,256,900, 1,267,166 AND OTHERS.

THE MARK CONSISTS OF TWO PARTIALLY OBSCURED STYLIZED DOG FACES MOSTLY WITHIN A SQUARE WITH THE AMPERSAND SYMBOL BETWEEN THE DOG FACES, THE WORDING "SNOOPY" ALONG THE LEFT SIDE OF THE SQUARE, AND THE WORDING "HIS SISTER BELLE" ALONG THE RIGHT SIDE OF THE SQUARE.

FOR CANDLES (U.S. CLS. 1, 6 AND 15).  
MIAH ROSENBERG, EXAMINING ATTORNEY

**CLASS 4—(Continued).**

SN 86-208,032. NZR RETAIL OF TOLEDO INC, AKA NZR FUEL SUPPLY AND DISTRIBUTION, TOLEDO, OH. FILED 2-28-2014.

## NZR FUEL SUPPLY AND DISTRIBUTION

THE MARK CONSISTS OF STANDARD CHARACTERS WITHOUT CLAIM TO ANY PARTICULAR FONT, STYLE, SIZE, OR COLOR.

NO CLAIM IS MADE TO THE EXCLUSIVE RIGHT TO USE "FUEL SUPPLY AND DISTRIBUTION", APART FROM THE MARK AS SHOWN.

FOR AVIATION FUEL; BENZENE FUEL; BIODIESEL FUEL; DIESEL FUEL; ETHANOL FUELS; FUEL FOR MOTOR VEHICLES, NAMELY, MOTOR FUEL; FUEL FROM CRUDE OIL; FUEL GAS (U.S. CLS. 1, 6 AND 15).  
FIRST USE 6-1-2013; IN COMMERCE 6-1-2013.

SHAUNIA CARLYLE, EXAMINING ATTORNEY

SN 86-208,882. RENEWABLE HEAT PRODUCTS, LLC, WATERBURY, CT. FILED 3-3-2014.

SN 86-176,829. HAFERD HIGH TECH LUBRICATING OIL INC., WILMINGTON, DE. FILED 1-28-2014.

# 哈弗·原动力



THE MARK CONSISTS OF FIVE CHINESE CHARACTERS WITH A DOT BETWEEN THE SECOND AND THIRD CHARACTERS.

THE FIRST TWO NON-LATIN CHARACTERS IN THE MARK TRANSLITERATE TO "HAFERD" OR "HARVARD" AND IT HAS NO MEANING IN A FOREIGN LANGUAGE. THE FINAL THREE NON-LATIN CHARACTERS IN THE MARK TRANSLITERATE TO "YUAN DONG LI" AND THIS MEANS "ORIGINAL POWER" IN ENGLISH.

FOR CUTTING OILS, ENGINE OILS, LUBRICATING OILS, LUBRICATING OILS AND GREASES, INDUSTRIAL LUBRICANTS, GEAR OILS, MOTOR FUEL, NON-CHEMICAL ADDITIVES FOR ENGINE OILS (U.S. CLS. 1, 6 AND 15).

FIRST USE 10-1-2012; IN COMMERCE 10-1-2012.  
ELIZABETH CHANG, EXAMINING ATTORNEY

OWNER OF U.S. REG. NO. 4,458,387.

NO CLAIM IS MADE TO THE EXCLUSIVE RIGHT TO USE "BAG", APART FROM THE MARK AS SHOWN.

THE COLOR(S) GREEN, ORANGE, RED, YELLOW AND WHITE IS/ARE CLAIMED AS A FEATURE OF THE MARK. THE MARK CONSISTS OF THE WORD "HOT" WITH THE "O" BEING IN THE SHAPE OF A RED, ORANGE AND YELLOW FLAME OUTLINED IN GREEN, AND THE LETTERS "H" AND "T" IN YELLOW AND ALSO OUTLINED IN GREEN, ABOVE THE PHRASE "BAG OF FIRE" IN GREEN, ALL ABOVE A GREEN AND WHITE FLAME.

FOR BRIQUETTES OF WOOD (U.S. CLS. 1, 6 AND 15).  
FIRST USE 2-24-2014; IN COMMERCE 2-24-2014.

ROBERT STRUCK, EXAMINING ATTORNEY

**CLASS 4—(Continued).**

SN 86-213,209. CANDLE GROUP INC., BROOKLYN, NY.  
FILED 3-6-2014.

**WOOD CRAFT**

THE MARK CONSISTS OF STANDARD CHARACTERS WITHOUT CLAIM TO ANY PARTICULAR FONT, STYLE, SIZE, OR COLOR.

NO CLAIM IS MADE TO THE EXCLUSIVE RIGHT TO USE "WOOD", APART FROM THE MARK AS SHOWN. FOR CANDLES (U.S. CLS. 1, 6 AND 15).  
GRETCHEN ULRICH, EXAMINING ATTORNEY

**CLASS 4—(Continued).**

SN 86-234,819. HOME DELIGHTS, INC., HOUSTON, TX.  
FILED 3-27-2014.

**TREASURED WAX**

THE MARK CONSISTS OF STANDARD CHARACTERS WITHOUT CLAIM TO ANY PARTICULAR FONT, STYLE, SIZE, OR COLOR.

NO CLAIM IS MADE TO THE EXCLUSIVE RIGHT TO USE "WAX", APART FROM THE MARK AS SHOWN. FOR SCENTED CANDLES (U.S. CLS. 1, 6 AND 15).  
FIRST USE 3-1-2014; IN COMMERCE 3-1-2014.  
CHRISTOPHER LAW, EXAMINING ATTORNEY

SN 86-217,067. EL-SIBAI, FATME, STATEN ISLAND, NY.  
FILED 3-11-2014.

**COCO LAVA**

THE MARK CONSISTS OF STANDARD CHARACTERS WITHOUT CLAIM TO ANY PARTICULAR FONT, STYLE, SIZE, OR COLOR.

NO CLAIM IS MADE TO THE EXCLUSIVE RIGHT TO USE "COCO", APART FROM THE MARK AS SHOWN. FOR COCONUT CHARCOAL FOR FUEL (U.S. CLS. 1, 6 AND 15).  
ZACHARY R. SPARER, EXAMINING ATTORNEY

SN 86-244,958. STARLUME, INC. DBA ILLUME, BLOOMINGTON, MN. FILED 4-7-2014.

**MOMENTARY ESCAPE**

THE MARK CONSISTS OF STANDARD CHARACTERS WITHOUT CLAIM TO ANY PARTICULAR FONT, STYLE, SIZE, OR COLOR.

FOR CANDLES; SCENTED CANDLES; COLORED CANDLES; NATURAL AND PARAFFIN CANDLES; VOTIVE CANDLES; PILLAR CANDLES; DECORATIVE CANDLES (U.S. CLS. 1, 6 AND 15).  
TIFFANY CHIANG, EXAMINING ATTORNEY

SN 86-229,152. VIVIAN LE, DALLAS, TX. FILED 3-22-2014.

**Good Day Candles**

THE MARK CONSISTS OF STANDARD CHARACTERS WITHOUT CLAIM TO ANY PARTICULAR FONT, STYLE, SIZE, OR COLOR.

NO CLAIM IS MADE TO THE EXCLUSIVE RIGHT TO USE "CANDLES", APART FROM THE MARK AS SHOWN. FOR AROMATHERAPY FRAGRANCE CANDLES; CANDLES; CANDLES AND WICKS FOR CANDLES FOR LIGHTING; CANDLES FOR LIGHTING; PERFUMED CANDLES; SCENTED CANDLES (U.S. CLS. 1, 6 AND 15).  
BRIAN PINO, EXAMINING ATTORNEY

SN 86-269,656. GIBSON BRANDS, INC., NASHVILLE, TN.  
FILED 5-2-2014.

**PRO-EASE**

THE MARK CONSISTS OF STANDARD CHARACTERS WITHOUT CLAIM TO ANY PARTICULAR FONT, STYLE, SIZE, OR COLOR.

FOR LUBRICANT FOR MUSICAL INSTRUMENTS (U.S. CLS. 1, 6 AND 15).  
CAITLIN WATTS-FITZGERALD, EXAMINING ATTORNEY

**CLASS 4—(Continued).**

SN 86-287,880. STARLUME, INC. DBA ILLUME, BLOOMINGTON, MN. FILED 5-21-2014.

## GO BE LOVELY

THE MARK CONSISTS OF STANDARD CHARACTERS WITHOUT CLAIM TO ANY PARTICULAR FONT, STYLE, SIZE, OR COLOR.

FOR CANDLES; SCENTED CANDLES; NATURAL AND PARAFFIN CANDLES; DECORATIVE CANDLES; JAR CANDLES; SOY CANDLES (U.S. CLS. 1, 6 AND 15).  
FIRST USE 1-0-2014; IN COMMERCE 1-0-2014.  
TIFFANY CHIANG, EXAMINING ATTORNEY

**CLASS 5—(Continued).**

SN 76-716,000. TIME ENGINEERED TECHNOLOGIES, LLC, OGDEN, UT. FILED 3-18-2014.

## EASYUP

THE MARK CONSISTS OF STANDARD CHARACTERS WITHOUT CLAIM TO ANY PARTICULAR FONT, STYLE, SIZE, OR COLOR.

FOR DELAYED-RELEASE CAFFEINE-BASED NUTRITIONAL SUPPLEMENTS THAT FACILITATE WAKING UP (U.S. CLS. 6, 18, 44, 46, 51 AND 52).  
FIRST USE 3-1-2012; IN COMMERCE 4-1-2012.  
MARY ROSSMAN, EXAMINING ATTORNEY

**CLASS 5—PHARMACEUTICALS**

SN 76-514,737. THE CONCEPT FOUNDATION, PATHUMTHANI, THAILAND, FILED 5-16-2003.

## CYCLOFEM

OWNER OF THAILAND REG. NO. KOR99669, DATED 10-17-1989, EXPIRES 10-16-2019.

FOR INJECTABLE CONTRACEPTIVES (U.S. CLS. 6, 18, 44, 46, 51 AND 52).  
ODESSA BIBBINS, EXAMINING ATTORNEY

SN 76-716,141. FITTS, JANE GALE, WASHINGTON, DC. FILED 4-7-2014.

## MOBOCET

THE MARK CONSISTS OF STANDARD CHARACTERS WITHOUT CLAIM TO ANY PARTICULAR FONT, STYLE, SIZE, OR COLOR.

FOR NARCOTIC PAIN RELIEVER AND MOBILITY ENHANCER (U.S. CLS. 6, 18, 44, 46, 51 AND 52).  
LINDA POWELL, EXAMINING ATTORNEY

SN 76-715,985. RELIANCE DENTAL MFG. COMPANY, WORTH, IL. FILED 3-12-2014.

## DURALAY

THE MARK CONSISTS OF STANDARD CHARACTERS WITHOUT CLAIM TO ANY PARTICULAR FONT, STYLE, SIZE, OR COLOR.

FOR DENTAL INLAY PATTERN MATERIAL, COMPRISING RESINOUS POWDER AND LIQUID TO BE COMBINED TO FORM A RESINOUS PRODUCT FOR USE IN MAKING INLAY PATTERNS (U.S. CLS. 6, 18, 44, 46, 51 AND 52).

FIRST USE 12-27-1951; IN COMMERCE 12-27-1951.  
JESSICA A. POWERS, EXAMINING ATTORNEY

SN 76-716,142. FITTS, JANE GALE, WASHINGTON, DC. FILED 4-7-2014.

## NAPROCET

THE MARK CONSISTS OF STANDARD CHARACTERS WITHOUT CLAIM TO ANY PARTICULAR FONT, STYLE, SIZE, OR COLOR.

FOR NARCOTIC PAIN RELIEVER AND MOBILITY ENHANCER (U.S. CLS. 6, 18, 44, 46, 51 AND 52).  
LINDA POWELL, EXAMINING ATTORNEY

**CLASS 5—(Continued).**

SN 77-851,902. MEDASANI MUNISEKHAR, JACKSONVILLE, FL. FILED 10-19-2009.

# D-Stress

THE MARK CONSISTS OF STANDARD CHARACTERS WITHOUT CLAIM TO ANY PARTICULAR FONT, STYLE, SIZE, OR COLOR.

FOR ANIMAL FEED ADDITIVE FOR USE AS A NUTRITIONAL SUPPLEMENT FOR MEDICAL PURPOSES; ANIMAL FEED SUPPLEMENTS; DIETARY AND NUTRITIONAL SUPPLEMENTS; DIETARY AND NUTRITIONALLY FORTIFIED FOOD PRODUCTS ADAPTED FOR MEDICAL USE; DIETARY FIBER AS AN ADDITIVE FOR FOOD PRODUCTS; DIETARY FOOD SUPPLEMENTS; DIETARY PET SUPPLEMENTS IN THE FORM OF PET TREATS; DIETARY SUPPLEMENTS; DIETARY SUPPLEMENTS FOR ANIMALS; DIETARY SUPPLEMENTS FOR CONTROLLING CHOLESTEROL; DIETARY SUPPLEMENTS FOR HUMAN CONSUMPTION; DIETARY SUPPLEMENTS FOR PETS; HERBAL SUPPLEMENTS; LECITHIN FOR USE AS A DIETARY SUPPLEMENT; LIQUID NUTRITIONAL SUPPLEMENT; NATURAL HERBAL SUPPLEMENTS; NATURAL SUPPLEMENTS FOR TREATING DEPRESSION AND ANXIETY; NATURAL SUPPLEMENTS FOR TREATING ERECTILE DYSFUNCTION; NUTRACEUTICALS FOR USE AS A DIETARY SUPPLEMENT; PROTEIN SUPPLEMENTS; VITAMIN AND MINERAL SUPPLEMENTS (U.S. CLS. 6, 18, 44, 46, 51 AND 52).

FIRST USE 3-25-2009; IN COMMERCE 3-25-2009.  
CURTIS FRENCH, EXAMINING ATTORNEY

**CLASS 5—(Continued).**

CONDITIONS; PHARMACEUTICAL PREPARATIONS FOR THE TREATMENT OF HEART RHYTHM DISORDERS; PHARMACEUTICAL PREPARATIONS FOR THE TREATMENT OF IMMUNE SYSTEM RELATED DISEASES AND DISORDERS; PHARMACEUTICAL PREPARATIONS FOR THE TREATMENT OF KIDNEY DISEASES; PHARMACEUTICAL PREPARATIONS FOR TREATING DIABETES; PHARMACEUTICAL PREPARATIONS FOR TREATING HYPERTENSION; PHARMACEUTICAL PREPARATIONS FOR TREATING SKIN DISORDERS; PHARMACEUTICAL PREPARATIONS FOR USE IN DERMATOLOGY; PHARMACEUTICAL PREPARATIONS FOR USE IN UROLOGY; PHARMACEUTICAL PRODUCTS FOR OPHTHALMOLOGICAL USE; PHARMACEUTICAL PRODUCTS FOR THE PREVENTION AND TREATMENT OF CANCER; PHARMACEUTICAL PRODUCTS FOR THE TREATMENT OF BONE DISEASES; PHARMACEUTICAL PRODUCTS FOR TREATING RESPIRATORY DISEASES; PHARMACEUTICAL PRODUCTS FOR TREATING RESPIRATORY DISEASES AND ASTHMA (U.S. CLS. 6, 18, 44, 46, 51 AND 52).

MICHAEL WEBSTER, EXAMINING ATTORNEY

SN 79-142,777. APR APPLIED PHARMA RESEARCH SA, BALERNA, SWITZERLAND, FILED 1-23-2014.

SN 79-139,587. NOVARTIS AG, SWITZERLAND, FILED 10-1-2013.

# NVR

# NEXODYN

THE MARK CONSISTS OF STANDARD CHARACTERS WITHOUT CLAIM TO ANY PARTICULAR FONT, STYLE, SIZE, OR COLOR.

PRIORITY DATE OF 8-29-2013 IS CLAIMED.  
OWNER OF INTERNATIONAL REGISTRATION 1184463 DATED 10-1-2013, EXPIRES 10-1-2023.

FOR PHARMACEUTICAL PRODUCTS, NAMELY, ANTI-INFECTIVES; ANTI-INFLAMMATORIES; ANTIBACTERIAL PHARMACEUTICALS; ANTIBIOTICS; ANTIFUNGAL PREPARATIONS; ANTIVIRALS; CARDIOVASCULAR PHARMACEUTICALS; DERMATOLOGICAL PHARMACEUTICAL PRODUCTS; INHALED PHARMACEUTICAL PREPARATIONS FOR THE TREATMENT OF RESPIRATORY DISEASES AND DISORDERS; PHARMACEUTICAL PREPARATIONS ACTING ON THE CENTRAL NERVOUS SYSTEM; PHARMACEUTICAL PREPARATIONS AND SUBSTANCES FOR THE TREATMENT OF GASTRO-INTESTINAL DISEASES; PHARMACEUTICAL PREPARATIONS FOR THE TREATMENT AND PREVENTION OF DISEASES AND DISORDERS OF THE AUTOIMMUNE SYSTEM, THE METABOLIC SYSTEM, THE MUSCULOSKELETAL SYSTEM AND THE GENITOURINARY SYSTEM; PHARMACEUTICAL PREPARATIONS FOR USE IN HEMATOLOGY AND IN TISSUE AND ORGAN TRANSPLANTATION; PHARMACEUTICAL PREPARATIONS FOR THE TREATMENT OF EYE DISEASES AND

THE MARK CONSISTS OF STANDARD CHARACTERS WITHOUT CLAIM TO ANY PARTICULAR FONT, STYLE, SIZE, OR COLOR.

OWNER OF INTERNATIONAL REGISTRATION 1192666 DATED 1-23-2014, EXPIRES 1-23-2024.

FOR PHARMACEUTICAL PREPARATIONS FOR THE TREATMENT OF WOUNDS AND BURNS, NAMELY, WOUND DRESSINGS, BURN DRESSINGS, BURN RELIEF MEDICATIONS, ANTIBIOTIC PREPARATIONS; DISINFECTANTS FOR THE TREATMENT OF WOUNDS AND BURNS, CONTACT LENSES, HYGIENE PURPOSES, MEDICAL PURPOSES; MATERIAL FOR DRESSINGS, NAMELY, GAUZE, BANDAGES FOR DRESSINGS, ADHESIVE BANDAGES, SURGICAL BANDAGES, BANDAGES FOR SKIN WOUNDS AND BURNS, WADDING, SURGICAL DRESSINGS; BANDAGES FOR DRESSINGS, GAUZE FOR MEDICAL USE AND MEDICATED PLASTERS (U.S. CLS. 6, 18, 44, 46, 51 AND 52).

NATALIE KENEALY, EXAMINING ATTORNEY

**CLASS 5—(Continued).**

SN 79-143,066. QUANTEC LIMITED, HAMILTON 3240, NEW ZEALAND, FILED 11-8-2013.

# EPIIOLOGY

THE MARK CONSISTS OF STANDARD CHARACTERS WITHOUT CLAIM TO ANY PARTICULAR FONT, STYLE, SIZE, OR COLOR.

PRIORITY DATE OF 5-13-2013 IS CLAIMED.

OWNER OF INTERNATIONAL REGISTRATION 1193275 DATED 11-8-2013, EXPIRES 11-8-2023.

FOR MEDICATED SKIN CREAMS; SUN BLOCKING CREAM FOR MEDICAL USE; MEDICATED CREAMS FOR TREATING DERMATOLOGICAL CONDITIONS; MEDICATED MOISTURIZING CREAMS FOR THE SKIN; MEDICATED WOUND HEALING CREAMS; MEDICATED PAIN RELIEVING CREAMS; MEDICATED CREAMS FOR SOOTHING THE SKIN; MEDICATED CREAMS FOR SOFTENING THE SKIN; MEDICATED CREAMS FOR PROTECTION OF THE SKIN; MEDICATED CREAMS FOR PROTECTION AGAINST THE SUN; MEDICATED CREAMS FOR PERSONAL SKIN CARE; MEDICATED DIAPER RASH CREAM FOR BABIES; MEDICATED BODY CREAMS FOR THE TREATMENT OF SKIN CONDITIONS (U.S. CLS. 6, 18, 44, 46, 51 AND 52).

DANIEL CAPSHAW, EXAMINING ATTORNEY

SN 79-143,546. XIANJU PURE PHARMACEUTICAL CO., LTD., XIANJU, ZHEJIANG, CHINA, FILED 11-28-2013.



OWNER OF INTERNATIONAL REGISTRATION 1194419 DATED 11-28-2013, EXPIRES 11-28-2023.

THE NAME(S), PORTRAIT(S), AND/OR SIGNATURE(S) SHOWN IN THE MARK DOES NOT IDENTIFY A PARTICULAR LIVING INDIVIDUAL.

THE MARK CONSISTS OF THE NAME "PURUI" LOCATED BENEATH THE LETTER "b" INSIDE A GEOMETRIC DESIGN ABOVE A CHEVRON.

THE WORDING "PURUI" HAS NO MEANING IN A FOREIGN LANGUAGE.

FOR PHARMACEUTICAL PREPARATIONS IN INJECTION, TABLET, AND LIQUID FOR TREATING ALLERGIC RHINITIS AND ASTHMA, DIABETES, SKIN DISORDERS, ALLERGIES, HYPERTENSION; CHINESE MEDICINE IN THE NATURE OF MEDICINAL HERBS; MEDICINAL ALCOHOL; PESTICIDES; HORMONES, NAMELY, EPLERENONE FOR TREATING HYPERTENSION; FLUTICASONE PROPIONATE FOR PREVENTING AND TREATING ALLERGIC RHINITIS; TOPICAL CORTICOSTEROID PREPARATIONS, NAMELY, DIFLUCORTOLONE FOR TOPICAL CORTICOSTEROIDS ANTI-INFLAMMATORY; DEFLAZACORT FOR TREATING ADRENAL CORTICAL HYPOFUNCTION, AUTOIMMUNE DISEASE, ALLERGIC DISEASES AND DISEASES OF THE BLOOD SYSTEM, BETAMETHASONE FOR TREATING ALLERGIC AND AUTOIMMUNE INFLAMMATORY DISEASES, ACTIVE RHEUMATISM, RHEUMATOID ARTHRITIS, LUPUS ERYTHEMATOSUS, SEVERE BRONCHIAL ASTHMA, SEVERE DERMATITIS, AND ACUTE LEUKEMIA; DEXAMETHASONE FOR TREATING AUTOIMMUNE DISEASES, ALLERGY, INFLAMMATION, ASTHMA AND OPHTHALMOLOGY DISEASE; DEXAMETHASONE FOR TREATING INFLAMMATORY AND ALLERGIC DISEASES; DEXA-

**CLASS 5—(Continued).**

METHASONE SODIUM PHOSPHATE FOR TREATING FEVER, 6-METHYL PREDNISOLONE FOR TREATING INFLAMMATION; STEROID HORMONES, NAMELY, CORTISOL FOR TREATING ADRENAL INSUFFICIENCY, ARTHRITIS PAUPERUM, RHEUMATIC FEVER, ARTHROLITHIASIS, BRONCHIAL ASTHMA, ALLERGIC DERMATITIS, SEBORRHEIC DERMATITIS, PRURITUS, IRIDOCYCLITIS, CONJUNCTIVITIS, KERATITIS, SCLERITIS, TUBERCULOUS MENINGITIS, ARTHRITIS, PLEURISY, TENOSYNOVITIS, ACUTE AND CHRONIC SPRAIN, AND TENDON STRAIN; HYDROCORTISONE ACETATE FOR TREATING RHEUMATIC ARTHRITIS, ACUTE ARTICULAR RHEUMATISM, ARTHROLITHIASIS, BRONCHIAL ASTHMA, TUBERCULOUS, PURULENT MENINGITIS, TUBERCULOUS PLEURISY, PYOTHORAX, ARTHRITIS, PERITENDINITIS, SPRAIN, HYDE'S DISEASE, AND LICHEN PLANUS; MEDROXYPROGESTERONE ACETATE FOR TREATING ALGOMENORRHEA, FUNCTIONAL AMENORRHEA, DYSFUNCTIONAL UTERINE BLEEDING, THREATENED ABORTION AND HABITUAL ABORTION, ENDOMETRIOSIS UTERINE, MAMMARY CANCER, ADENOCARCINOMA OF ENDOMETRIUM, AND RENAL CARCINOMA; CYPROTERONE ACETATE FOR TREATING PROSTATIC CARCINOMA, HIRSUTISM, AND ANDROGENETIC ALOPECIA; PREDNISOLONE FOR TREATING ALLERGIC AND INFLAMMATORY DISEASES; PREDNISOLONE ACETATE FOR TREATING DERMATITIS, ECZEMA, LICHEN PLANUS CIRCUMSCRIPTUS, SEBORRHEIC DERMATITIS, RHEUMATISM, ARTHRITIS DEFORMANS, BIETT'S DISEASE, BRONCHIAL ASTHMA, DROPSICAL NEPHRITIS, ESSENTIAL THROMBOPENIA, GRANULOCYTOPENIA, ACUTE LYMPHATIC LEUKEMIA, ADRENAL INSUFFICIENCY, AND DERMATITIS EXFOLIATIVA; ASTENILE FOR TREATING ADVANCED CERVIX MATURE INSUFFICIENCY; TRENBOLONE ACETATE FOR TREATING CHRONIC WASTING DISEASE, ILL AND FRAIL THIN, FRAIL AFTER OPERATION, OSTEOPOROSIS, CHILDREN DYSPLASIA, AND APLASTIC ANEMIA; STANAZOLOL FOR TREATING HEREDITARY ANGIO-NEUROTIC EDEMA, AND CACOTROPHY; OXYMETHOLONE FOR TREATING CHRONIC WASTING DISEASE, INFIRM, SICK AND POSTOPERATIVE WEAK THIN, NAUSEA, EDEMA, LIVER DYSFUNCTION AND JAUNDICE; ESTRADIOL FOR TREATING ESTROGEN DEFICIENCY, METASTATIC BREAST CANCER, ADVANCED PROSTATE CANCER, ACNE, ALEUCOCYTOSIS, AND POSTCOITAL CONTRACEPTION; ESTRIOL FOR TREATING CERVICITIS, AUXILIARY MEDICINE AND ABORTION OF MIDTRIMESTER INDUCTION OF LABOR, PROSTATAUXE, PROSTATIC CARCINOMA, ALEUCOCYTOSIS, AND HAEMORRHAGE (U.S. CLS. 6, 18, 44, 46, 51 AND 52).

ROBERT C. CLARK JR., EXAMINING ATTORNEY

SN 79-146,229. FUJIFILM KYOWA KIRIN BIOLOGICS CO., LTD., TOKYO 100-8185, JAPAN, FILED 2-20-2014.

# ADALMEA

THE MARK CONSISTS OF STANDARD CHARACTERS WITHOUT CLAIM TO ANY PARTICULAR FONT, STYLE, SIZE, OR COLOR.

PRIORITY DATE OF 2-4-2014 IS CLAIMED.

OWNER OF INTERNATIONAL REGISTRATION 1201141 DATED 2-20-2014, EXPIRES 2-20-2024.

THE WORDING "ADALMEA" HAS NO MEANING IN A FOREIGN LANGUAGE.

FOR PHARMACEUTICAL PREPARATIONS FOR TREATMENT OF AUTOIMMUNE DISEASES; PHARMACEUTICAL PREPARATIONS COMPRISING AN ANTI-TUMOR NECROSIS FACTOR (TNF) ALPHA MONOCLONAL ANTIBODY (U.S. CLS. 6, 18, 44, 46, 51 AND 52).

WARREN L. OLANDRIA, EXAMINING ATTORNEY

**CLASS 5—(Continued).**

SN 79-146,264. FUJIFILM KYOWA KIRIN BIOLOGICS CO., LTD., TOKYO 100-8185, JAPAN, FILED 2-20-2014.

# ONVIADA

THE MARK CONSISTS OF STANDARD CHARACTERS WITHOUT CLAIM TO ANY PARTICULAR FONT, STYLE, SIZE, OR COLOR.

PRIORITY DATE OF 2-4-2014 IS CLAIMED.

OWNER OF INTERNATIONAL REGISTRATION 1201250 DATED 2-20-2014, EXPIRES 2-20-2024.

THE WORDING "ONVIADA" HAS NO MEANING IN A FOREIGN LANGUAGE.

FOR PHARMACEUTICAL PREPARATIONS FOR TREATMENT OF AUTOIMMUNE DISEASES; PHARMACEUTICAL PREPARATIONS COMPRISING AN ANTI-TUMOR NECROSIS FACTOR (TNF) ALPHA MONOCLONAL ANTIBODY (U.S. CLS. 6, 18, 44, 46, 51 AND 52).

WARREN L. OLANDRIA, EXAMINING ATTORNEY

SN 79-146,691. FUJIFILM KYOWA KIRIN BIOLOGICS; CO., LTD., JAPAN, FILED 2-20-2014.

# ADAQLIRA

THE MARK CONSISTS OF STANDARD CHARACTERS WITHOUT CLAIM TO ANY PARTICULAR FONT, STYLE, SIZE, OR COLOR.

PRIORITY DATE OF 2-4-2014 IS CLAIMED.

OWNER OF INTERNATIONAL REGISTRATION 1202360 DATED 2-20-2014, EXPIRES 2-20-2024.

THE WORDING "ADAQLIRA" HAS NO MEANING IN A FOREIGN LANGUAGE.

FOR PHARMACEUTICAL PREPARATIONS FOR TREATMENT OF AUTOIMMUNE DISEASES; PHARMACEUTICAL PREPARATIONS COMPRISING AN ANTI-TUMOR NECROSIS FACTOR (TNF) ALPHA MONOCLONAL ANTIBODY (U.S. CLS. 6, 18, 44, 46, 51 AND 52).

WARREN L. OLANDRIA, EXAMINING ATTORNEY

SN 79-146,879. FUJIFILM KYOWA KIRIN BIOLOGICS CO., LTD., TOKYO, JAPAN, FILED 2-20-2014.

# HEQUAL

THE MARK CONSISTS OF STANDARD CHARACTERS WITHOUT CLAIM TO ANY PARTICULAR FONT, STYLE, SIZE, OR COLOR.

PRIORITY DATE OF 2-4-2014 IS CLAIMED.

OWNER OF INTERNATIONAL REGISTRATION 1202852 DATED 2-20-2014, EXPIRES 2-20-2024.

THE WORDING "HEQUAL" HAS NO MEANING IN A FOREIGN LANGUAGE.

FOR PHARMACEUTICAL PREPARATIONS FOR TREATMENT OF AUTOIMMUNE DISEASES; PHARMACEUTICAL PREPARATIONS COMPRISING AN ANTI-TUMOR NECROSIS FACTOR (TNF) ALPHA MONOCLONAL ANTIBODY (U.S. CLS. 6, 18, 44, 46, 51 AND 52).

WARREN L. OLANDRIA, EXAMINING ATTORNEY

**CLASS 5—(Continued).**

SN 79-148,978. NOVARTIS AG, SWITZERLAND, FILED 4-2-2014.

# RESKAPE

THE MARK CONSISTS OF STANDARD CHARACTERS WITHOUT CLAIM TO ANY PARTICULAR FONT, STYLE, SIZE, OR COLOR.

PRIORITY DATE OF 3-25-2014 IS CLAIMED.

OWNER OF INTERNATIONAL REGISTRATION 1207474 DATED 4-2-2014, EXPIRES 4-2-2024.

FOR PHARMACEUTICAL PREPARATIONS FOR THE PREVENTION OR TREATMENT OF DISEASES AND DISORDERS OF THE NERVOUS SYSTEM, THE IMMUNE SYSTEM, THE CARDIOVASCULAR SYSTEM, THE METABOLIC SYSTEM, THE RESPIRATORY SYSTEM, THE MUSCULO-SKELETAL SYSTEM AND THE UROGENITAL SYSTEM; PHARMACEUTICAL PREPARATIONS FOR THE TREATMENT OF INFLAMMATORY DISORDERS; PHARMACEUTICAL PREPARATIONS FOR USE IN DERMATOLOGY, ONCOLOGY, HEMATOLOGY AND IN TISSUE AND ORGAN TRANSPLANTATION, IN OPHTHALMOLOGY AND FOR GASTRO-ENTEROLOGICAL DISORDERS; PHARMACEUTICAL PREPARATIONS FOR THE PREVENTION AND TREATMENT OF OCULAR DISORDERS AND DISEASES; PHARMACEUTICAL PREPARATIONS FOR THE TREATMENT OF DISEASES AND DISORDERS CAUSED BY BACTERIA, AUTOIMMUNE DISEASES AND DISORDERS, KIDNEY DISEASES AND DISORDERS, DIABETES; ANTIFUNGAL, ANTI-INFECTIVE, ANTIVIRAL PREPARATIONS AND ANTIBIOTICS (U.S. CLS. 6, 18, 44, 46, 51 AND 52).

ALLISON SCHRODY, EXAMINING ATTORNEY

SN 85-670,513. RESERVE LIFE ORGANICS LLC, DBA RESERVEAGE, GAINESVILLE, FL. FILED 7-6-2012.

# ADAPTOSTRESS<sup>3</sup> ENERGY

NO CLAIM IS MADE TO THE EXCLUSIVE RIGHT TO USE "ENERGY", APART FROM THE MARK AS SHOWN.

THE MARK CONSISTS OF THE WORD "ADAPTOSTRESS" FOLLOWED BY A SUPERSCRIPED NUMBER "3" ABOVE THE WORD "ENERGY".

FOR DIETARY AND NUTRITIONAL SUPPLEMENTS (U.S. CLS. 6, 18, 44, 46, 51 AND 52).

FIRST USE 2-13-2012; IN COMMERCE 2-13-2012.

ELLEN BURNS, EXAMINING ATTORNEY

**CLASS 5—(Continued).**

SN 85-890,777. VITALON FOODS CO., LTD., TAICHUNG, TAIWAN, FILED 3-29-2013.

**ROYAL SHINE**

THE MARK CONSISTS OF STANDARD CHARACTERS WITHOUT CLAIM TO ANY PARTICULAR FONT, STYLE, SIZE, OR COLOR.

OWNER OF TAIWAN REG. NO. 01598727, DATED 9-16-2013, EXPIRES 9-15-2023.

FOR NUTRITIONAL SUPPLEMENTS; NUTRITIONAL SUPPLEMENTS IN LOTION FORM SOLD AS A COMPONENT OF NUTRITIONAL SKIN CARE PRODUCTS; ALBUMIN DIETARY SUPPLEMENTS; ALGINATE DIETARY SUPPLEMENTS; DIETARY SUPPLEMENTS; ENZYME DIETARY SUPPLEMENTS; BEE POLLEN FOR USE AS A DIETARY FOOD SUPPLEMENT; ENZYME FOOD SUPPLEMENTS; CASEIN DIETARY SUPPLEMENTS; DIETARY SUPPLEMENT DRINK MIXES; FLAXSEED DIETARY SUPPLEMENTS; FLAXSEED OIL DIETARY SUPPLEMENTS; GLUCOSE DIETARY SUPPLEMENTS; HEALTH FOOD SUPPLEMENTS; LECITHIN FOR USE AS A DIETARY SUPPLEMENT; LINSEED DIETARY SUPPLEMENTS; LINSEED OIL DIETARY SUPPLEMENTS; LIQUID VITAMIN SUPPLEMENTS; MINERAL NUTRITIONAL SUPPLEMENTS; NUTRITIONAL SUPPLEMENTS, NAMELY, PROBIOTIC COMPOSITIONS; POLLEN DIETARY SUPPLEMENTS; PROPOLIS DIETARY SUPPLEMENTS; PROTEIN DIETARY SUPPLEMENTS; ROYAL JELLY DIETARY SUPPLEMENTS; YEAST DIETARY SUPPLEMENTS; VITAMIN AND MINERAL SUPPLEMENTS; SOY PROTEIN FOR USE AS A NUTRITIONAL SUPPLEMENT IN VARIOUS POWDERED AND READY-TO-DRINK BEVERAGES (U.S. CLS. 6, 18, 44, 46, 51 AND 52).

MARYNELLE WILSON, EXAMINING ATTORNEY

SN 85-920,973. ANIMAL SUPPLY COMPANY, FEDERAL WAY, WA. FILED 5-2-2013.

**ENHANCEDVITALITY**

THE MARK CONSISTS OF STANDARD CHARACTERS WITHOUT CLAIM TO ANY PARTICULAR FONT, STYLE, SIZE, OR COLOR.

FOR PET NUTRITIONAL SUPPLEMENTS (U.S. CLS. 6, 18, 44, 46, 51 AND 52).

JANICE KIM, EXAMINING ATTORNEY

**CLASS 5—(Continued).**

SN 85-920,997. ANIMAL SUPPLY COMPANY, FEDERAL WAY, WA. FILED 5-2-2013.



THE COLOR(S) GREEN AND BLUE IS/ARE CLAIMED AS A FEATURE OF THE MARK.

THE MARK CONSISTS OF THE LITERAL ELEMENTS "ENHANCEDVITALITY" WRITTEN IN STYLIZED FORM WHEREIN THE LETTERS "ENHANCED" AND "LITY" ARE WRITTEN IN GREEN COLOR AND THE LETTERS "VITA" ARE WRITTEN IN BLUE COLOR. A BLUE CURVED LINE IS PLACED OVER THE LETTER "D" TO LETTER "L" WITH AN IMAGE OF BLUE JUMPING CAT HAVING BLUE AND GREEN COLORED LEGS AS SHOWN IN THE MARK.

FOR PET NUTRITIONAL SUPPLEMENTS (U.S. CLS. 6, 18, 44, 46, 51 AND 52).

JANICE KIM, EXAMINING ATTORNEY

SN 85-928,697. MEDIMPEX UNITED INC., BENSLEM, PA. FILED 5-10-2013.

**MEDITESTS**

THE MARK CONSISTS OF STANDARD CHARACTERS WITHOUT CLAIM TO ANY PARTICULAR FONT, STYLE, SIZE, OR COLOR.

FOR ON-SITE RAPID TESTING KITS, NAMELY, PREGNANCY TEST KITS AND OVULATION TEST KITS FOR HOME USE, AND DRUG TESTING KITS COMPOSED OF MEDICAL DIAGNOSTIC REAGENTS AND ASSAYS FOR TESTING BODY FLUIDS (U.S. CLS. 6, 18, 44, 46, 51 AND 52).

FIRST USE 1-0-2001; IN COMMERCE 1-0-2001.

ELISSA GARBER KON, EXAMINING ATTORNEY

SN 85-938,898. FRITZ, BOB, MARTINEZ, CA. FILED 5-21-2013.

**VITAMIN S**

THE MARK CONSISTS OF STANDARD CHARACTERS WITHOUT CLAIM TO ANY PARTICULAR FONT, STYLE, SIZE, OR COLOR.

NO CLAIM IS MADE TO THE EXCLUSIVE RIGHT TO USE "VITAMIN", APART FROM THE MARK AS SHOWN.

FOR ORGANIC DIETARY AND NUTRITIONAL SUPPLEMENTS CONTAINING VITAMINS FOR AIDING SLEEP (U.S. CLS. 6, 18, 44, 46, 51 AND 52).

DAWN HAN, EXAMINING ATTORNEY



**CLASS 5—(Continued).**

SN 85-944,267. BIOTHERA, INC., EAGAN, MN. FILED 5-28-2013.

**Imprime PGG**

THE MARK CONSISTS OF STANDARD CHARACTERS WITHOUT CLAIM TO ANY PARTICULAR FONT, STYLE, SIZE, OR COLOR.

OWNER OF U.S. REG. NOS. 3,393,014 AND 4,298,761.  
FOR PHARMACEUTICALS IN THE NATURE OF IMMUNOTHERAPEUTIC AGENTS AND PHARMACEUTICAL PREPARATIONS FOR MODULATING CELLS OF THE IMMUNE SYSTEM, ALL OF WHICH CONTAIN POLY-(1-6)-BETA-GLUCOTRIOSYL-(1-3)-BETA-GLUCOPYRANOSE GLUCAN (U.S. CLS. 6, 18, 44, 46, 51 AND 52).  
FIRST USE 10-24-2005; IN COMMERCE 10-24-2005.  
LAURA GOLDEN, EXAMINING ATTORNEY

SN 85-944,271. BIOTHERA, INC., EAGAN, MN. FILED 5-28-2013.

**Imprime WGP**

THE MARK CONSISTS OF STANDARD CHARACTERS WITHOUT CLAIM TO ANY PARTICULAR FONT, STYLE, SIZE, OR COLOR.

OWNER OF U.S. REG. NOS. 2,807,439, 3,393,014 AND 4,298,761.  
FOR PHARMACEUTICALS IN THE NATURE OF IMMUNOTHERAPEUTIC AGENTS AND PHARMACEUTICAL PREPARATIONS FOR MODULATING CELLS OF THE IMMUNE SYSTEM, ALL OF WHICH CONTAIN WHOLE GLUCAN PARTICLES (U.S. CLS. 6, 18, 44, 46, 51 AND 52).  
FIRST USE 9-24-2011; IN COMMERCE 9-24-2011.  
LAURA GOLDEN, EXAMINING ATTORNEY

SN 85-962,440. PANTON MCLEOD AMERICAS, LLC, GROTON, MA. FILED 6-18-2013.

**PANTONITE**

THE MARK CONSISTS OF STANDARD CHARACTERS WITHOUT CLAIM TO ANY PARTICULAR FONT, STYLE, SIZE, OR COLOR.

FOR DISINFECTANT PRODUCTS FOR WATER STORAGE FACILITIES AND WATER WELLS (U.S. CLS. 6, 18, 44, 46, 51 AND 52).  
FIRST USE 1-1-2009; IN COMMERCE 1-1-2009.  
JANET LEE, EXAMINING ATTORNEY

**CLASS 5—(Continued).**

SN 85-964,492. GFR HEALTH LTD., MAPLE RIDGE, BC, CANADA, FILED 6-19-2013.

**LEANFIT**

THE MARK CONSISTS OF STANDARD CHARACTERS WITHOUT CLAIM TO ANY PARTICULAR FONT, STYLE, SIZE, OR COLOR.

OWNER OF CANADA REG. NO. TMA646,101, DATED 8-18-2005, EXPIRES 8-18-2020.  
FOR NUTRITIONAL AND HERBAL SUPPLEMENTS (U.S. CLS. 6, 18, 44, 46, 51 AND 52).  
FIRST USE 4-9-2003; IN COMMERCE 7-15-2005.  
ANNE FARRELL, EXAMINING ATTORNEY

SN 86-003,595. CREATIVE MEDICAL HEALTH, INC, PHOENIX, AZ. FILED 7-7-2013.

**NATURAL REST Sleep the way  
nature intended**

THE MARK CONSISTS OF STANDARD CHARACTERS WITHOUT CLAIM TO ANY PARTICULAR FONT, STYLE, SIZE, OR COLOR.

OWNER OF U.S. REG. NO. 4,467,884.  
FOR NATURAL SLEEP AID PREPARATIONS; NUTRACEUTICALS FOR THE TREATMENT OF SLEEP; NUTRACEUTICALS FOR USE AS A DIETARY SUPPLEMENT; NUTRACEUTICALS FOR USE AS A DIETARY SUPPLEMENT FOR SLEEP; SLEEPING PILLS/TABLETS (U.S. CLS. 6, 18, 44, 46, 51 AND 52).  
FIRST USE 4-1-2013; IN COMMERCE 4-1-2013.  
DOMINICK J. SALEMI, EXAMINING ATTORNEY

SN 86-003,849. BARI LIFE BARIATRIC SUPPLEMENTS, LLC, KNOXVILLE, TN. FILED 7-8-2013.



NO CLAIM IS MADE TO THE EXCLUSIVE RIGHT TO USE "BARIATRIC SUPPLEMENTS", APART FROM THE MARK AS SHOWN.

THE MARK CONSISTS OF THE TERM "BARILIFE" IN A PARTICULAR FONT WHEREIN A FIRST, SECOND, AND THIRD ELONGATE PARALLELOGRAM EXTEND FROM

**CLASS 5—(Continued).**

THE LEFT SIDE OF THE DOT OF THE "I", A FOURTH AND FIFTH ELONGATE PARALLELOGRAM EXTEND FROM THE RIGHT OF THE DOT OF THE "I" WHEREIN THE FOURTH AND FIFTH PARALLELOGRAMS MIRROR THE SECOND AND THIRD PARALLELOGRAMS RESPECTIVELY, AND A "W" SHAPED SET OF MARKINGS LOCATED DIRECTLY ABOVE THE DOT OF THE "I"; AND THE PHRASE "BARIATRIC SUPPLEMENTS" CENTERED DIRECTLY BELOW THE TERM "BARILIFE" IN A SMALLER FONT SIZE.

FOR DIETARY FOOD SUPPLEMENTS FOR USE AFTER BARIATRIC SURGERY; VITAMINS FOR USE AFTER BARIATRIC SURGERY (U.S. CLS. 6, 18, 44, 46, 51 AND 52).

FRANK LATTUCA, EXAMINING ATTORNEY

---

SN 86-010,208. BIOMEDICAL RESEARCH LABORATORIES, LLC, WILMINGTON, DE. FILED 7-15-2013.

**LOOK GOOD NAKED**

THE MARK CONSISTS OF STANDARD CHARACTERS WITHOUT CLAIM TO ANY PARTICULAR FONT, STYLE, SIZE, OR COLOR.

FOR DIETARY AND NUTRITIONAL SUPPLEMENTS (U.S. CLS. 6, 18, 44, 46, 51 AND 52).

RAUL CORDOVA, EXAMINING ATTORNEY

---

SN 86-029,166. GRANT, JEREMY, SAN ANTONIO, TX. FILED 8-5-2013.



NO CLAIM IS MADE TO THE EXCLUSIVE RIGHT TO USE "NUTRITION", "SUPPLEMENTS" AND "ATHLETES", APART FROM THE MARK AS SHOWN.

THE MARK CONSISTS OF THE DESIGN OF A BARBELL WITH A DOUBLE CAPITAL "A" DESIGN SURROUNDING THE LEFT SIDE OF THE BARBELL, THE STYLIZED WORDING "BIGGER FASTER STRONGER" ABOVE THE BAR OF THE BARBELL, AND THE STYLIZED WORDING "NUTRITION HARDCORE SUPPLEMENTS HARDCORE ATHLETES", BELOW THE BAR OF THE BARBELL.

FOR DIETARY AND NUTRITIONAL SUPPLEMENTS FOR ENDURANCE SPORTS; PROTEIN SUPPLEMENTS (U.S. CLS. 6, 18, 44, 46, 51 AND 52).

FIRST USE 6-1-2012; IN COMMERCE 6-1-2012.

BARBARA A. GOLD, EXAMINING ATTORNEY

**CLASS 5—(Continued).**

SN 86-038,547. JJBD, LLC, MERIDIAN, ID. FILED 8-15-2013.

**EPHEDRA POWERED**

NO CLAIM IS MADE TO THE EXCLUSIVE RIGHT TO USE "EPHEDRA", APART FROM THE MARK AS SHOWN. THE MARK CONSISTS OF "EPHEDRA POWERED".

FOR DIETARY AND NUTRITIONAL SUPPLEMENTS WHICH CONTAIN EPHEDRA (U.S. CLS. 6, 18, 44, 46, 51 AND 52).

FIRST USE 1-9-2012; IN COMMERCE 1-9-2012.

LINDA ORNDORFF, EXAMINING ATTORNEY

---

SN 86-048,323. BRISTOL-MYERS SQUIBB COMPANY, NEW YORK, NY. FILED 8-26-2013.

**RENZOPA**

THE MARK CONSISTS OF STANDARD CHARACTERS WITHOUT CLAIM TO ANY PARTICULAR FONT, STYLE, SIZE, OR COLOR.

FOR PHARMACEUTICAL PREPARATIONS FOR HUMAN USE FOR THE TREATMENT AND PREVENTION OF OBESITY, DIABETES, INCONTINENCE, CARDIOVASCULAR DISEASES, CENTRAL NERVOUS SYSTEM DISEASES AND DISORDERS, METABOLIC DISORDERS, STROKE, CANCER, INFLAMMATION AND INFLAMMATORY DISEASES, RESPIRATORY AND INFECTIOUS DISEASES, AUTO-IMMUNE DISEASES, SOLID ORGAN TRANSPLANT REJECTION; PHARMACEUTICAL PREPARATIONS FOR HUMAN USE, NAMELY, ANTIBIOTICS, ANTI-FUNGALS, ANTI-VIRALS, IMMUNOSUPPRESSANTS AND PHARMACEUTICAL ANTIBODIES (U.S. CLS. 6, 18, 44, 46, 51 AND 52).

BARNEY CHARLON, EXAMINING ATTORNEY

---

SN 86-048,327. BRISTOL-MYERS SQUIBB COMPANY, NEW YORK, NY. FILED 8-26-2013.

**BRELCAPA**

THE MARK CONSISTS OF STANDARD CHARACTERS WITHOUT CLAIM TO ANY PARTICULAR FONT, STYLE, SIZE, OR COLOR.

FOR PHARMACEUTICAL PREPARATIONS FOR HUMAN USE FOR THE TREATMENT AND PREVENTION OF OBESITY, DIABETES, INCONTINENCE, CARDIOVASCULAR DISEASES, CENTRAL NERVOUS SYSTEM DISEASES AND DISORDERS, METABOLIC DISORDERS, STROKE, CANCER, INFLAMMATION AND INFLAMMATORY DISEASES, RESPIRATORY AND INFECTIOUS DISEASES, AUTO-IMMUNE DISEASES, SOLID ORGAN TRANSPLANT REJECTION; PHARMACEUTICAL PREPARATIONS FOR HUMAN USE, NAMELY, ANTIBIOTICS, ANTI-FUNGALS, ANTI-VIRALS, IMMUNOSUPPRESSANTS AND PHARMACEUTICAL ANTIBODIES (U.S. CLS. 6, 18, 44, 46, 51 AND 52).

BARNEY CHARLON, EXAMINING ATTORNEY

**CLASS 5—(Continued).**

SN 86-048,331. BRISTOL-MYERS SQUIBB COMPANY, NEW YORK, NY. FILED 8-26-2013.

# ARPIQUA

THE MARK CONSISTS OF STANDARD CHARACTERS WITHOUT CLAIM TO ANY PARTICULAR FONT, STYLE, SIZE, OR COLOR.

FOR PHARMACEUTICAL PREPARATIONS FOR HUMAN USE FOR THE TREATMENT AND PREVENTION OF OBESITY, DIABETES, INCONTINENCE, CARDIOVASCULAR DISEASES, CENTRAL NERVOUS SYSTEM DISEASES AND DISORDERS, METABOLIC DISORDERS, STROKE, CANCER, INFLAMMATION AND INFLAMMATORY DISEASES, RESPIRATORY AND INFECTIOUS DISEASES, AUTO-IMMUNE DISEASES, SOLID ORGAN TRANSPLANT REJECTION; PHARMACEUTICAL PREPARATIONS FOR HUMAN USE, NAMELY, ANTIBIOTICS, ANTI-FUNGALS, ANTI-VIRALS, IMMUNOSUPPRESSANTS AND PHARMACEUTICAL ANTIBODIES (U.S. CLS. 6, 18, 44, 46, 51 AND 52).

BARNEY CHARLON, EXAMINING ATTORNEY

---

SN 86-053,783. PRISTINE NUTRACEUTICALS, LLC, FORT LAUDERDALE, FL. FILED 9-3-2013.

# DIGESTACURE

THE MARK CONSISTS OF STANDARD CHARACTERS WITHOUT CLAIM TO ANY PARTICULAR FONT, STYLE, SIZE, OR COLOR.

OWNER OF U.S. REG. NO. 4,071,047.  
FOR DIETARY AND NUTRITIONAL SUPPLEMENTS FOR HUMANS (U.S. CLS. 6, 18, 44, 46, 51 AND 52).  
FIRST USE 8-27-2008; IN COMMERCE 8-27-2008.  
SARA BENJAMIN, EXAMINING ATTORNEY

---

SN 86-055,523. SKINCENTIAL SCIENCES, INC., SAN DIEGO, CA. FILED 9-4-2013.

# SKINCENTIALS

THE MARK CONSISTS OF STANDARD CHARACTERS WITHOUT CLAIM TO ANY PARTICULAR FONT, STYLE, SIZE, OR COLOR.

FOR CHEMICAL PREPARATIONS FOR MEDICAL AND VETERINARY PURPOSES FOR SOLUBILIZING TISSUE FOR COSMETIC PURPOSES AND THERAPEUTIC PURPOSES (U.S. CLS. 6, 18, 44, 46, 51 AND 52).

JILLIAN CANTOR, EXAMINING ATTORNEY

**CLASS 5—(Continued).**

SN 86-056,179. AMERASIA MY-A TRADING CORPORATION, WESTMINSTER, CA. FILED 9-5-2013.



NO CLAIM IS MADE TO THE EXCLUSIVE RIGHT TO USE "HEALTH NUTRITION", APART FROM THE MARK AS SHOWN.

THE NAME(S), PORTRAIT(S), AND/OR SIGNATURE(S) SHOWN IN THE MARK DOES NOT IDENTIFY A PARTICULAR LIVING INDIVIDUAL.

THE COLOR(S) RED, BLACK, LIGHT GOLD, GOLD, BROWNISH GOLD AND REDDISH GOLD IS/ARE CLAIMED AS A FEATURE OF THE MARK.

THE MARK CONSISTS OF: ON THE UPPER CENTER OF THE LOGO, THERE ARE TWO GOLD-COLORED WORDS "LANA GOLD", WHICH IS BORDERED WITH BLACK COLORED LINE. THESE TWO WORDS ARE SURROUNDED BY A RIBBON, THE RIBBON HAS THE OUTERMOST RIM COLORED RED, AND THE INNER RIM COLORED GOLD, AND MAJORITY OF THE MIDDLE GROUND COLORED LIGHT GOLD, THE COLOR TURNS TO SLIGHTLY BROWNISH GOLD ON TWO SIDES. THE RIBBON IS FOLDED PARTIALLY BACKWARD ON BOTH SIDES, AND THE COLOR ON THE BACKWARD PART OF THE RIBBON TURNS TO REDDISH GOLD AND BROWNISH GOLD AT SOME SPOTS. IN THE MIDDLE OF THE RIBBON, THERE ARE TWO WORDS "HEALTH NUTRITION" COLORED IN BLACK AND BORDERED WITH WHITE LINE.

FOR DIETARY FOOD SUPPLEMENTS (U.S. CLS. 6, 18, 44, 46, 51 AND 52).

FIRST USE 4-25-2012; IN COMMERCE 4-25-2012.

CIMMERIAN COLEMAN, EXAMINING ATTORNEY

---

SN 86-058,837. NOVARTIS AG, BASEL, SWITZERLAND, FILED 9-9-2013.

# FILGATENZ

THE MARK CONSISTS OF STANDARD CHARACTERS WITHOUT CLAIM TO ANY PARTICULAR FONT, STYLE, SIZE, OR COLOR.

FOR PHARMACEUTICAL PREPARATIONS FOR THE TREATMENT OF NEUTROPENIA (U.S. CLS. 6, 18, 44, 46, 51 AND 52).

MICHAEL WEBSTER, EXAMINING ATTORNEY

**CLASS 5—(Continued).**

SN 86-066,933. FERNANDEZ, ANTONIO N, DBA BIOMEDI-  
ZIN USA, WINDERMERE, FL. FILED 9-17-2013.

**CARDIOZIN**

THE MARK CONSISTS OF STANDARD CHARACTERS  
WITHOUT CLAIM TO ANY PARTICULAR FONT, STYLE,  
SIZE, OR COLOR.  
FOR DIETARY AND NUTRITIONAL SUPPLEMENTS  
(U.S. CLS. 6, 18, 44, 46, 51 AND 52).  
FIRST USE 9-16-2013; IN COMMERCE 9-16-2013.  
DARRYL SPRUILL, EXAMINING ATTORNEY

SN 86-074,843. DAVID D KIM, MD, COLLEYVILLE, TX.  
FILED 9-25-2013.

**BariComplete**

THE MARK CONSISTS OF STANDARD CHARACTERS  
WITHOUT CLAIM TO ANY PARTICULAR FONT, STYLE,  
SIZE, OR COLOR.  
FOR MULTI-VITAMIN PREPARATIONS (U.S. CLS. 6,  
18, 44, 46, 51 AND 52).  
FIRST USE 4-1-2013; IN COMMERCE 4-1-2013.  
JEFFREY LOOK, EXAMINING ATTORNEY

**CLASS 5—(Continued).**

SN 86-083,446. NOVARTIS AG, BASEL, SWITZERLAND,  
FILED 10-4-2013.



THE COLOR(S) GREEN, LIGHT GREEN AND WHITE IS/  
ARE CLAIMED AS A FEATURE OF THE MARK.  
THE MARK CONSISTS OF THE IMAGE OF HEAD,  
TORSO, LEFT ARM AND UPPER LEGS OF THE BODY OF  
A MAN STANDING UPRIGHT IN THE COLOR GREEN  
AND WITH A GLOWING WHITE SPOT ON THE ABDOM-  
INAL AREA. THE IMAGE OF THE MAN IS OUTLINED IN  
WHITE ON A LIGHT GREEN BACKGROUND AND THERE  
IS A RECTANGLE OF GREEN ON THE RIGHT SIDE OF  
THE LIGHT GREEN BACKGROUND AND A WHITE  
VERTICAL LINE WITHIN THE GREEN RECTANGLE.  
FOR PHARMACEUTICAL PREPARATIONS FOR DI-  
GESTIVE HEALTH (U.S. CLS. 6, 18, 44, 46, 51 AND 52).  
JENNY PARK, EXAMINING ATTORNEY

SN 86-086,077. L. PERRIGO COMPANY, ALLEGAN, MI.  
FILED 10-8-2013.

**TOMORROW'S OPTION**

THE MARK CONSISTS OF STANDARD CHARACTERS  
WITHOUT CLAIM TO ANY PARTICULAR FONT, STYLE,  
SIZE, OR COLOR.  
OWNER OF U.S. REG. NO. 4,295,894.  
FOR ORAL CONTRACEPTIVES (U.S. CLS. 6, 18, 44, 46,  
51 AND 52).  
ESTHER A. BORSUK, EXAMINING ATTORNEY

**CLASS 5—(Continued).**

SN 86-086,083. L. PERRIGO COMPANY, ALLEGAN, MI. FILED 10-8-2013.

TOMORROW'S CONTRACEPTIVE

THE MARK CONSISTS OF STANDARD CHARACTERS WITHOUT CLAIM TO ANY PARTICULAR FONT, STYLE, SIZE, OR COLOR.

NO CLAIM IS MADE TO THE EXCLUSIVE RIGHT TO USE "CONTRACEPTIVE", APART FROM THE MARK AS SHOWN.

FOR ORAL CONTRACEPTIVES (U.S. CLS. 6, 18, 44, 46, 51 AND 52).

ESTHER A. BORSUK, EXAMINING ATTORNEY

SN 86-086,399. ONDINE INTERNATIONAL HOLDINGS, LTD., ST. MICHAEL, BARBADOS, FILED 10-8-2013.

SOLACIN

THE MARK CONSISTS OF STANDARD CHARACTERS WITHOUT CLAIM TO ANY PARTICULAR FONT, STYLE, SIZE, OR COLOR.

FOR PHOTOSENSITIZING AGENTS FOR MEDICAL APPLICATIONS, NAMELY, PHARMACEUTICALS FOR PHOTODYNAMIC THERAPY AND/OR PHOTO DISINFECTION; LIGHT-ACTIVATED DISINFECTANT COMPOSITIONS FOR KILLING DISEASE-CAUSING MICROORGANISMS; LIGHT ACTIVATED PHOTOSENSITIZING COMPOSITIONS FOR KILLING TUMOR CELLS (U.S. CLS. 6, 18, 44, 46, 51 AND 52).

LUCY ARANT, EXAMINING ATTORNEY

SN 86-088,329. K10 HOLDINGS, LLC, NEW YORK, NY. FILED 10-10-2013.

10+

THE MARK CONSISTS OF STANDARD CHARACTERS WITHOUT CLAIM TO ANY PARTICULAR FONT, STYLE, SIZE, OR COLOR.

OWNER OF U.S. REG. NO. 4,258,560. FOR DIETARY SUPPLEMENTS FOR PETS (U.S. CLS. 6, 18, 44, 46, 51 AND 52).

WILLIAM VERHOSEK, EXAMINING ATTORNEY

**CLASS 5—(Continued).**

SN 86-091,344. STAFFORD, DAMON, TAMPA, FL. FILED 10-15-2013.

Dr.S Total Health RX

THE MARK CONSISTS OF STANDARD CHARACTERS WITHOUT CLAIM TO ANY PARTICULAR FONT, STYLE, SIZE, OR COLOR.

NO CLAIM IS MADE TO THE EXCLUSIVE RIGHT TO USE "HEALTH RX", APART FROM THE MARK AS SHOWN.

FOR NUTRITIONAL SUPPLEMENTS; VITAMINS (U.S. CLS. 6, 18, 44, 46, 51 AND 52).

KIMBERLY PERRY, EXAMINING ATTORNEY

SN 86-091,456. PHIBRO ANIMAL HEALTH CORPORATION, TEANECK, NJ. FILED 10-15-2013.

COXISTAC

THE MARK CONSISTS OF STANDARD CHARACTERS WITHOUT CLAIM TO ANY PARTICULAR FONT, STYLE, SIZE, OR COLOR.

FOR VETERINARY PREPARATION FOR USE IN THE PREVENTION, CONTROL AND TREATMENT OF ENTERIC, RESPIRATORY AND SYSTEMIC DISEASES IN ANIMALS (U.S. CLS. 6, 18, 44, 46, 51 AND 52).

TAMARA FRAZIER, EXAMINING ATTORNEY

SN 86-091,996. BRISTOL-MYERS SQUIBB COMPANY, NEW YORK, NY. FILED 10-15-2013.

VALOREY

THE MARK CONSISTS OF STANDARD CHARACTERS WITHOUT CLAIM TO ANY PARTICULAR FONT, STYLE, SIZE, OR COLOR.

FOR PHARMACEUTICAL PREPARATIONS FOR HUMAN USE FOR THE TREATMENT AND PREVENTION OF OBESITY, DIABETES, INCONTINENCE, CARDIOVASCULAR DISEASES, CENTRAL NERVOUS SYSTEM DISEASES AND DISORDERS, METABOLIC DISORDERS, STROKE, CANCER, INFLAMMATION AND INFLAMMATORY DISEASES, RESPIRATORY AND INFECTIOUS DISEASES, AUTO-IMMUNE DISEASES, SOLID ORGAN TRANSPLANT REJECTION; PHARMACEUTICAL PREPARATIONS FOR HUMAN USE, NAMELY, ANTIBIOTICS, ANTI-FUNGALS, ANTI-VIRALS, IMMUNOSUPPRESSANTS AND PHARMACEUTICAL ANTIBODIES (U.S. CLS. 6, 18, 44, 46, 51 AND 52).

CYNTHIA RINALDI, EXAMINING ATTORNEY

**CLASS 5—(Continued).**

SN 86-092,002. BRISTOL-MYERS SQUIBB COMPANY, NEW YORK, NY. FILED 10-15-2013.

# REYPRIMA

THE MARK CONSISTS OF STANDARD CHARACTERS WITHOUT CLAIM TO ANY PARTICULAR FONT, STYLE, SIZE, OR COLOR.

FOR PHARMACEUTICAL PREPARATIONS FOR HUMAN USE FOR THE TREATMENT AND PREVENTION OF OBESITY, DIABETES, INCONTINENCE, CARDIOVASCULAR DISEASES, CENTRAL NERVOUS SYSTEM DISEASES AND DISORDERS, METABOLIC DISORDERS, STROKE, CANCER, INFLAMMATION AND INFLAMMATORY DISEASES, RESPIRATORY AND INFECTIOUS DISEASES, AUTO-IMMUNE DISEASES, SOLID ORGAN TRANSPLANT REJECTION; PHARMACEUTICAL PREPARATIONS FOR HUMAN USE, NAMELY, ANTIBIOTICS, ANTI-FUNGALS, ANTI-VIRALS, IMMUNOSUPPRESSANTS AND PHARMACEUTICAL ANTIBODIES (U.S. CLS. 6, 18, 44, 46, 51 AND 52).

CYNTHIA RINALDI, EXAMINING ATTORNEY

**CLASS 5—(Continued).**

SN 86-092,032. BRISTOL-MYERS SQUIBB COMPANY, NEW YORK, NY. FILED 10-15-2013.

# ADVOREY

THE MARK CONSISTS OF STANDARD CHARACTERS WITHOUT CLAIM TO ANY PARTICULAR FONT, STYLE, SIZE, OR COLOR.

FOR PHARMACEUTICAL PREPARATIONS FOR HUMAN USE FOR THE TREATMENT AND PREVENTION OF OBESITY, DIABETES, INCONTINENCE, CARDIOVASCULAR DISEASES, CENTRAL NERVOUS SYSTEM DISEASES AND DISORDERS, METABOLIC DISORDERS, STROKE, CANCER, INFLAMMATION AND INFLAMMATORY DISEASES, RESPIRATORY AND INFECTIOUS DISEASES, AUTO-IMMUNE DISEASES, SOLID ORGAN TRANSPLANT REJECTION; PHARMACEUTICAL PREPARATIONS FOR HUMAN USE, NAMELY, ANTIBIOTICS, ANTI-FUNGALS, ANTI-VIRALS, IMMUNOSUPPRESSANTS AND PHARMACEUTICAL ANTIBODIES (U.S. CLS. 6, 18, 44, 46, 51 AND 52).

CYNTHIA RINALDI, EXAMINING ATTORNEY

---

SN 86-092,017. BRISTOL-MYERS SQUIBB COMPANY, NEW YORK, NY. FILED 10-15-2013.

# INPIRITAZ

THE MARK CONSISTS OF STANDARD CHARACTERS WITHOUT CLAIM TO ANY PARTICULAR FONT, STYLE, SIZE, OR COLOR.

FOR PHARMACEUTICAL PREPARATIONS FOR HUMAN USE FOR THE TREATMENT AND PREVENTION OF OBESITY, DIABETES, INCONTINENCE, CARDIOVASCULAR DISEASES, CENTRAL NERVOUS SYSTEM DISEASES AND DISORDERS, METABOLIC DISORDERS, STROKE, CANCER, INFLAMMATION AND INFLAMMATORY DISEASES, RESPIRATORY AND INFECTIOUS DISEASES, AUTO-IMMUNE DISEASES, SOLID ORGAN TRANSPLANT REJECTION; PHARMACEUTICAL PREPARATIONS FOR HUMAN USE, NAMELY, ANTIBIOTICS, ANTI-FUNGALS, ANTI-VIRALS, IMMUNOSUPPRESSANTS AND PHARMACEUTICAL ANTIBODIES (U.S. CLS. 6, 18, 44, 46, 51 AND 52).

CYNTHIA RINALDI, EXAMINING ATTORNEY

---

SN 86-092,667. SOUTHWEST ENVIROTX PARTNERS LLC, DBA ENVIROTX, JONESTOWN, TX. FILED 10-16-2013.

# Enviro Equine

THE MARK CONSISTS OF STANDARD CHARACTERS WITHOUT CLAIM TO ANY PARTICULAR FONT, STYLE, SIZE, OR COLOR.

NO CLAIM IS MADE TO THE EXCLUSIVE RIGHT TO USE "EQUINE", APART FROM THE MARK AS SHOWN.

FOR VETERINARY PHARMACEUTICAL COMPOUNDS FOR EQUINE USE TO TREAT CONDITIONS OF THE LEG, HOOF, EAR, NOSE AND THROAT (U.S. CLS. 6, 18, 44, 46, 51 AND 52).

FIRST USE 9-1-2013; IN COMMERCE 9-1-2013.

KAREN SEVERSON, EXAMINING ATTORNEY

**CLASS 5—(Continued).**

SN 86-098,780. GENSCO LABORATORIES, LLC, MIRAMAR, FL. FILED 10-23-2013.

# NitroTranz

THE MARK CONSISTS OF STANDARD CHARACTERS WITHOUT CLAIM TO ANY PARTICULAR FONT, STYLE, SIZE, OR COLOR.

FOR PHARMACEUTICAL TOPICAL GELS AND OINTMENTS FOR TRANSDERMAL DELIVERY OF ANALGESICS, ANTI-INFLAMMATORIES, ANTINEOPLASTIC AGENTS FOR THE TREATMENT OF CANCER, MUSCLE RELAXANTS, ANAESTHETICS, PROTEINS FOR THE TREATMENT OF WOUNDS, GROWTH FACTORS FOR THE TREATMENT OF BURNS, HORMONES, SUBSTANCE P ANTAGONISTS FOR THE PREVENTION OF NAUSEA AND VOMITING, ANTIFUNGAL PREPARATIONS, ANTIVIRALS, ANTIBACTERIAL SUBSTANCES FOR MEDICAL PURPOSES, ANTI-OBESITY DRUGS, ANTIANGINAL MEDICATIONS, HAIR GROWTH STIMULANTS, HAIR GROWTH RETARDANTS, NUTRITIONAL SUPPLEMENTS, AND ANTIMETABOLITES FOR THE TREATMENT OF CANCER (U.S. CLS. 6, 18, 44, 46, 51 AND 52).

KATHERINE CHANG, EXAMINING ATTORNEY

SN 86-098,783. GENSCO LABORATORIES, LLC, MIRAMAR, FL. FILED 10-23-2013.

# Boundless

THE MARK CONSISTS OF STANDARD CHARACTERS WITHOUT CLAIM TO ANY PARTICULAR FONT, STYLE, SIZE, OR COLOR.

FOR PHARMACEUTICAL TOPICAL GELS AND OINTMENTS FOR TRANSDERMAL DELIVERY OF ANALGESICS, ANTI-INFLAMMATORIES, ANTINEOPLASTIC AGENTS FOR THE TREATMENT OF CANCER, MUSCLE RELAXANTS, ANAESTHETICS, PROTEINS FOR THE TREATMENT OF WOUNDS, GROWTH FACTORS FOR THE TREATMENT OF BURNS, HORMONES, SUBSTANCE P ANTAGONISTS FOR THE PREVENTION OF NAUSEA AND VOMITING, ANTIFUNGAL PREPARATIONS, ANTIVIRALS, ANTIBACTERIAL SUBSTANCES FOR MEDICAL PURPOSES, ANTI-OBESITY DRUGS, ANTIANGINAL MEDICATIONS, HAIR GROWTH STIMULANTS, HAIR GROWTH RETARDANTS, NUTRITIONAL SUPPLEMENTS, AND ANTIMETABOLITES FOR THE TREATMENT OF CANCER (U.S. CLS. 6, 18, 44, 46, 51 AND 52).

KATHERINE CHANG, EXAMINING ATTORNEY

**CLASS 5—(Continued).**

SN 86-099,539. SAN JAMAR, INC., ELKHORN, WI. FILED 10-23-2013.

# MANI-KARE

THE MARK CONSISTS OF STANDARD CHARACTERS WITHOUT CLAIM TO ANY PARTICULAR FONT, STYLE, SIZE, OR COLOR.

FOR ADHESIVE BANDAGES; BANDAGES FOR SKIN WOUNDS (U.S. CLS. 6, 18, 44, 46, 51 AND 52).

ALEXANDER L. POWERS, EXAMINING ATTORNEY

SN 86-101,154. JT GLOBAL ENTERPRISE CO., LTD., TAIPEI CITY, TAIWAN, FILED 10-25-2013.

# OPUS IX

THE MARK CONSISTS OF STANDARD CHARACTERS WITHOUT CLAIM TO ANY PARTICULAR FONT, STYLE, SIZE, OR COLOR.

FOR MEDICINAL HERBS; MEDICINAL DRINKS; MINERAL NUTRITIONAL SUPPLEMENTS; PROTEIN SUPPLEMENTS; NUTRITIONAL SUPPLEMENTS CONSISTING PRIMARILY OF PLANT CELLULOSE; NUTRITIONAL FOOD ADDITIVES FOR MEDICAL PURPOSES IN THE NATURE OF NATURAL FOOD EXTRACTS DERIVED FROM YATSA GUNBU; FOOD SUPPLEMENTS; VITAMIN AND MINERAL (U.S. CLS. 6, 18, 44, 46, 51 AND 52).

JOHN HWANG, EXAMINING ATTORNEY

SN 86-103,201. TERRAMERA, INC., VANCOUVER, B.C., CANADA, FILED 10-28-2013.

# INSPIRIUM

THE MARK CONSISTS OF STANDARD CHARACTERS WITHOUT CLAIM TO ANY PARTICULAR FONT, STYLE, SIZE, OR COLOR.

FOR PESTICIDES, BIOPESTICIDES, INSECTICIDES, AND OVICIDES (U.S. CLS. 6, 18, 44, 46, 51 AND 52).

MARK SHINER, EXAMINING ATTORNEY

**CLASS 5—(Continued).**

SN 86-104,952. PLAYTEX MARKETING CORPORATION, NEW YORK, NY. FILED 10-29-2013.

# PLAYTEX

THE MARK CONSISTS OF STANDARD CHARACTERS WITHOUT CLAIM TO ANY PARTICULAR FONT, STYLE, SIZE, OR COLOR.

OWNER OF U.S. REG. NOS. 3,442,845, 4,350,959 AND OTHERS.

FOR DIAPERS, NAMELY, BABY DIAPERS, ADULT DIAPERS, INFANT CLOTH DIAPERS OR INCONTINENCE DIAPERS (U.S. CLS. 6, 18, 44, 46, 51 AND 52).

ELLEN PERKINS, EXAMINING ATTORNEY

SN 86-106,664. LEGG LAWN CARE, INC., DECATUR, AL. FILED 10-31-2013.

## SUPERIOR MOSQUITO DEFENSE

THE MARK CONSISTS OF STANDARD CHARACTERS WITHOUT CLAIM TO ANY PARTICULAR FONT, STYLE, SIZE, OR COLOR.

NO CLAIM IS MADE TO THE EXCLUSIVE RIGHT TO USE "MOSQUITO", APART FROM THE MARK AS SHOWN.

FOR INSECT REPELLENT AGENTS; INSECT REPELLENTS; INSECT-REPELLENTS; PREPARATIONS FOR REPELLING ANIMALS, BIRDS AND INSECTS; PREPARATIONS FOR REPELLING MOSQUITOES AND INSECTS (U.S. CLS. 6, 18, 44, 46, 51 AND 52).

FIRST USE 10-15-2012; IN COMMERCE 10-15-2012.

CHRISTOPHER LAW, EXAMINING ATTORNEY

SN 86-106,700. AMGEN INC., THOUSAND OAKS, CA. FILED 10-31-2013.

# CENPROVA

THE MARK CONSISTS OF STANDARD CHARACTERS WITHOUT CLAIM TO ANY PARTICULAR FONT, STYLE, SIZE, OR COLOR.

FOR PHARMACEUTICAL PREPARATIONS FOR THE TREATMENT OF ONCOLOGICAL DISEASES AND DISORDERS, AND COMPLICATIONS ASSOCIATED THEREWITH (U.S. CLS. 6, 18, 44, 46, 51 AND 52).

DARRYL SPRUILL, EXAMINING ATTORNEY

**CLASS 5—(Continued).**

SN 86-124,061. DANIEL BAUM COMPANY, LANCASTER, PA. FILED 11-20-2013.



OWNER OF U.S. REG. NO. 3,254,531.

THE MARK CONSISTS OF THE WORDING "FIRST ARRIVAL" TO THE RIGHT OF DESIGNS CONSISTING OF FOUR QUARTER-CIRCLE SHAPES SPIRALING TOGETHER TO FORM A LARGER PNIWHEEL-SHAPED SQUARE.

FOR ANIMAL FEED SUPPLEMENTS (U.S. CLS. 6, 18, 44, 46, 51 AND 52).

FIRST USE 10-1-2010; IN COMMERCE 10-1-2010.

CORY BOONE, EXAMINING ATTORNEY

SN 86-130,263. BIOTROPICS MALAYSIA BERHAD, SELANGOR DARUL EHSAN, MALAYSIA, FILED 11-26-2013.



THE MARK CONSISTS OF THE STYLIZED WORD "LINEMINUS" WITH A DESIGN OF FOUR LEAVES LOCATED ABOVE THE LETTER "M".

THE WORDING "LINEMINUS" HAS NO MEANING IN A FOREIGN LANGUAGE.

FOR DIETARY SUPPLEMENTS; DIETETIC FOOD, NAMELY, HERBS, ADAPTED FOR MEDICAL USE; DIETARY SUPPLEMENT BEVERAGES, NAMELY, LIQUID HERBAL SUPPLEMENTS FOR ANTIOXIDANT, BEAUTY AND LONGEVITY; NUTRITIONAL SUPPLEMENTS; MEDICINAL HERB EXTRACTS; PLANT EXTRACTS FOR MEDICAL PURPOSES; HERBAL SUPPLEMENTS FOR IMPROVING COGNITIVE RESPONSES; NUTRACEUTICALS FOR USE AS A DIETARY SUPPLEMENT; ORAL PREPARATIONS FOR PROMOTING GENERAL HEALTH, NAMELY, NUTRITIONAL SUPPLEMENTS IN THE NATURE OF BOTANICAL TABLETS, NUTRITIONAL SUPPLEMENTS IN THE FORM OF CAPSULES, LIQUID NUTRITIONAL SUPPLEMENT, NUTRITIONAL SUPPLEMENTS IN THE FORM OF POWDER (U.S. CLS. 6, 18, 44, 46, 51 AND 52).

DAVID ALESKOW, EXAMINING ATTORNEY



**CLASS 5—(Continued).**

SN 86-136,931. BAYER HEALTHCARE LLC, SHAWNEE, KS. FILED 12-6-2013.

# NUVIATECH

THE MARK CONSISTS OF STANDARD CHARACTERS WITHOUT CLAIM TO ANY PARTICULAR FONT, STYLE, SIZE, OR COLOR.

FOR VETERINARY PREPARATIONS FOR DOGS AND CATS, NAMELY PREPARATIONS FOR PAIN RELIEF; PREPARATIONS FOR THE TREATMENT OF HEART DISEASE, PREPARATIONS FOR DESTROYING PARASITES, AND ANTI-INFECTIVES (U.S. CLS. 6, 18, 44, 46, 51 AND 52).

MIDGE BUTLER, EXAMINING ATTORNEY



SN 86-136,936. BAYER HEALTHCARE LLC, SHAWNEE, KS. FILED 12-6-2013.

# NUVIA-TECH

THE MARK CONSISTS OF STANDARD CHARACTERS WITHOUT CLAIM TO ANY PARTICULAR FONT, STYLE, SIZE, OR COLOR.

FOR VETERINARY PREPARATIONS FOR DOGS AND CATS, NAMELY, PREPARATIONS FOR PAIN RELIEF; PREPARATIONS FOR THE TREATMENT OF HEART DISEASE, PREPARATIONS FOR DESTROYING PARASITES, AND ANTI-INFECTIVES (U.S. CLS. 6, 18, 44, 46, 51 AND 52).

MIDGE BUTLER, EXAMINING ATTORNEY



SN 86-138,150. MISS SMARTY PANTS ENTERPRISES, INC., LOS ANGELES, CA. FILED 12-9-2013.

# Dr. Edna's

THE MARK CONSISTS OF STANDARD CHARACTERS WITHOUT CLAIM TO ANY PARTICULAR FONT, STYLE, SIZE, OR COLOR.

THE NAME(S), PORTRAIT(S), AND/OR SIGNATURE(S) SHOWN IN THE MARK IDENTIFIES "DR. EDNA" MA, WHOSE CONSENT(S) TO REGISTER IS MADE OF RECORD.

FOR TOPICAL ANALGESIC CREAMS; TOPICAL AN-ALGESICS (U.S. CLS. 6, 18, 44, 46, 51 AND 52).

FIRST USE 1-31-2013; IN COMMERCE 1-31-2013.  
COLLEEN DOMBROW, EXAMINING ATTORNEY

**CLASS 5—(Continued).**

SN 86-141,567. WYETH LLC, NEW YORK, NY. FILED 12-12-2013.

## COUGH DROPS FROM THE COUGH EXPERTS

THE MARK CONSISTS OF STANDARD CHARACTERS WITHOUT CLAIM TO ANY PARTICULAR FONT, STYLE, SIZE, OR COLOR.

NO CLAIM IS MADE TO THE EXCLUSIVE RIGHT TO USE "COUGH DROPS", APART FROM THE MARK AS SHOWN.

FOR COUGH LOZENGES (U.S. CLS. 6, 18, 44, 46, 51 AND 52).

HENRY S. ZAK, EXAMINING ATTORNEY



SN 86-148,942. KOWA COMPANY, LTD., AICHI-KEN, JAPAN, FILED 12-19-2013.



OWNER OF JAPAN REG. NO. 1817876, DATED 10-31-1985, EXPIRES 10-31-2015.

OWNER OF U.S. REG. NOS. 2,855,437, 4,100,634 AND 4,381,759.

THE COLOR(S) RED IS/ARE CLAIMED AS A FEATURE OF THE MARK.

THE MARK CONSISTS OF THE WORD "KOWA" IN STYLIZED LETTERS WITHIN AN OVAL, ALL IN RED. THE COLOR WHITE REPRESENTS BACKGROUND AREA AND IS NOT PART OF THE MARK.

FOR PESTICIDE (U.S. CLS. 6, 18, 44, 46, 51 AND 52).  
MEREDITH MARESCA, EXAMINING ATTORNEY

**CLASS 5—(Continued).**

SN 86-150,858. MEMPHIS POOL SUPPLY, INC., MEMPHIS, TN. FILED 12-23-2013.



THE MARK CONSISTS OF A STYLIZED DRAWING OF A SEA HORSE.

FOR ALGAEICIDE CHEMICALS FOR SWIMMING POOLS; ALGAEICIDES (U.S. CLS. 6, 18, 44, 46, 51 AND 52).

FIRST USE 5-28-1995; IN COMMERCE 5-28-1995.  
NAKIA HENRY, EXAMINING ATTORNEY

**CLASS 5—(Continued).**

SN 86-162,152. DOGGESTIVE DAILY LLC, MISSOULA, MO. FILED 1-10-2014.

**NUPATH**

THE MARK CONSISTS OF STANDARD CHARACTERS WITHOUT CLAIM TO ANY PARTICULAR FONT, STYLE, SIZE, OR COLOR.

FOR VETERINARY PRODUCTS FOR LIVESTOCK, HORSES AND DOMESTIC ANIMALS, NAMELY, NUTRITIONAL AND DIETARY SUPPLEMENTS AND HEALTH FEED SUPPLEMENTS ADMINISTERED ORALLY; NUTRITIONAL AND DIETARY SUPPLEMENTS AND HEALTH FEED SUPPLEMENTS IN THE FORM OF ANIMAL TREATS (U.S. CLS. 6, 18, 44, 46, 51 AND 52).

FIRST USE 12-22-2013; IN COMMERCE 12-22-2013.  
HAI-LY LAM, EXAMINING ATTORNEY

SN 86-161,768. WISCONSIN PHARMACAL COMPANY, LLC, JACKSON, WI. FILED 1-9-2014.

**POTABLE AQUA**

THE MARK CONSISTS OF STANDARD CHARACTERS WITHOUT CLAIM TO ANY PARTICULAR FONT, STYLE, SIZE, OR COLOR.

OWNER OF U.S. REG. NO. 1,194,490.  
SEC. 2(F).  
FOR DRINKING WATER GERMICIDAL TABLETS (U.S. CLS. 6, 18, 44, 46, 51 AND 52).  
FIRST USE 4-0-1951; IN COMMERCE 4-0-1951.  
TARAH HARDY, EXAMINING ATTORNEY

SN 86-174,785. ABBVIE INC., NORTH CHICAGO, IL. FILED 1-24-2014.



THE MARK CONSISTS OF A STYLIZED BUTTERFLY IN FLIGHT ABOVE THREE SHADED CIRCLES. THE FIRST CIRCLE APPEARS DIRECTLY BELOW THE BUTTERFLY AND IS THE LARGEST CIRCLE. THE SECOND CIRCLE IS MEDIUM-SIZED AND APPEARS TO THE LOWER RIGHT OF THE FIRST CIRCLE. THE THIRD CIRCLE IS THE SMALLEST CIRCLE AND APPEARS TO THE RIGHT OF THE SECOND CIRCLE.

FOR PHARMACEUTICAL PREPARATIONS, NAMELY, PULMONARY SURFACTANT FOR THE TREATMENT OF LUNG CONDITIONS (U.S. CLS. 6, 18, 44, 46, 51 AND 52).  
TIMOTHY O. SCHIMPF, EXAMINING ATTORNEY

**CLASS 5—(Continued).**

SN 86-174,963. B & D DENTAL CORP., WEST VALLEY CITY, UT. FILED 1-24-2014.

**FLUORIGHT**

THE MARK CONSISTS OF STANDARD CHARACTERS WITHOUT CLAIM TO ANY PARTICULAR FONT, STYLE, SIZE, OR COLOR.

FOR DENTAL RESTORATION COMPOUNDS (U.S. CLS. 6, 18, 44, 46, 51 AND 52).

MICHAEL KEATING, EXAMINING ATTORNEY

SN 86-180,495. EQUIPT4 LLC, POTOMAC, MD. FILED 1-30-2014.

**PET FIT FOR LIFE**

THE MARK CONSISTS OF STANDARD CHARACTERS WITHOUT CLAIM TO ANY PARTICULAR FONT, STYLE, SIZE, OR COLOR.

NO CLAIM IS MADE TO THE EXCLUSIVE RIGHT TO USE "PET", APART FROM THE MARK AS SHOWN.

FOR DIETARY SUPPLEMENTS FOR PETS (U.S. CLS. 6, 18, 44, 46, 51 AND 52).

FIRST USE 1-24-2014; IN COMMERCE 1-24-2014.

BRIAN CALLAGHAN, EXAMINING ATTORNEY

SN 86-183,272. BIOMODE ORGANICS LLC, LOCUST VALLEY, NY. FILED 2-3-2014.

**BIOMODE SENTINEL**

THE MARK CONSISTS OF STANDARD CHARACTERS WITHOUT CLAIM TO ANY PARTICULAR FONT, STYLE, SIZE, OR COLOR.

OWNER OF U.S. REG. NOS. 4,309,856, 4,309,858 AND 4,325,147.

FOR PESTICIDES; INSECT EXTERMINATING AGENTS; BED BUG EXTERMINATING AGENTS (U.S. CLS. 6, 18, 44, 46, 51 AND 52).

CURTIS FRENCH, EXAMINING ATTORNEY

**CLASS 5—(Continued).**

SN 86-183,739. SPECIAL NUTRIENTS, INC., MIAMI, FL. FILED 2-4-2014.

**MYCOAD A-Z**

THE MARK CONSISTS OF STANDARD CHARACTERS WITHOUT CLAIM TO ANY PARTICULAR FONT, STYLE, SIZE, OR COLOR.

OWNER OF U.S. REG. NOS. 2,158,669 AND 3,244,360. FOR NON-NUTRITIONAL ANIMAL FEED ADDITIVE FOR THE ABSORPTION OF MYCOTOXINS (U.S. CLS. 6, 18, 44, 46, 51 AND 52).

FIRST USE 0-0-2002; IN COMMERCE 0-0-2002.

KEVIN MITTLER, EXAMINING ATTORNEY

SN 86-183,757. SPECIAL NUTRIENTS, INC., MIAMI, FL. FILED 2-4-2014.

**MYCO-AD**

THE MARK CONSISTS OF STANDARD CHARACTERS WITHOUT CLAIM TO ANY PARTICULAR FONT, STYLE, SIZE, OR COLOR.

OWNER OF U.S. REG. NOS. 2,158,669 AND 3,244,360. FOR NON-NUTRITIONAL ANIMAL FEED ADDITIVE FOR THE ABSORPTION OF MYCOTOXINS (U.S. CLS. 6, 18, 44, 46, 51 AND 52).

FIRST USE 3-0-1992; IN COMMERCE 1-0-1993.

KEVIN MITTLER, EXAMINING ATTORNEY

SN 86-188,478. MOROCCAN ECO-BIOLOGICS, LLC, SAINT PAUL, MN. FILED 2-8-2014.



NO CLAIM IS MADE TO THE EXCLUSIVE RIGHT TO USE "MOROCCAN" OR "ECO-BIOLOGICS", APART FROM THE MARK AS SHOWN.

THE COLOR(S) RED, GREEN, LIGHT GREEN, BLUE, GRAY, AND LIGHT GRAY IS/ARE CLAIMED AS A FEATURE OF THE MARK.

THE MARK CONSISTS OF THE STYLIZED WORD "MOROCCAN" IN RED AND UNDERNEATH IT, THE STYLIZED WORDING "ECO-BIOLOGICS" IN BLUE; TO THE RIGHT SIDE OF THE WORDING ARE FOUR LIGHT GREEN STYLIZED ARGAN SEEDS, SURROUNDED BY SIX GREEN LEAVES OUTLINED IN GRAY; A LIGHT GRAY LINE REPRESENTING A THIN ROOT EXITS THE ARGAN SEEDS AND UNDERLINES THE WORDING.

FOR ARGAN OIL FOR MEDICAL PURPOSES; MEDICINAL CREAMS FOR SKIN CARE; MEDICINAL HAIR GROWTH PREPARATIONS; MEDICINAL OILS; MEDICINAL PREPARATIONS FOR STIMULATING HAIR GROWTH (U.S. CLS. 6, 18, 44, 46, 51 AND 52).

JAMES A. RAUEN, EXAMINING ATTORNEY

**CLASS 5—(Continued).**

SN 86-198,016. RT HOLDINGS MM STRIPS LLC, TEMPE, AZ. FILED 2-19-2014.

# Moxi

THE MARK CONSISTS OF STANDARD CHARACTERS WITHOUT CLAIM TO ANY PARTICULAR FONT, STYLE, SIZE, OR COLOR.

FOR DELIVERY AGENTS IN THE FORM OF DIS-SOLVABLE STRIPS, LIQUID SHOTS, LIQUID DROPS AND GELS CONTAINING NUTRACEUTICAL, PHAR-MACEUTICAL AND OVER-THE-COUNTER ACTIVE INGREDIENTS (U.S. CLS. 6, 18, 44, 46, 51 AND 52).

JOHN WILKE, EXAMINING ATTORNEY

SN 86-199,859. ULTIMATE SURVIVAL TECHNOLOGIES, FORMERLY REVERE SUPPLY COMPANY, INC., JACK-SONVILLE, FL. FILED 2-21-2014.



THE MARK CONSISTS OF THREE CONCENTRIC CIR-CLES WITH THE LETTERS "UST" STYLIZED IN THE COMMON CENTER CIRCLE.

FOR FIRST AID KITS (U.S. CLS. 6, 18, 44, 46, 51 AND 52).

FIRST USE 3-1-2007; IN COMMERCE 3-1-2007.  
LINDA LAVACHE, EXAMINING ATTORNEY

SN 86-200,092. HERITAGE TECHNOLOGIES, LLC, INDIA-NAPOLIS, IN. FILED 2-21-2014.

# INTELLIBOND VITAL 4

THE MARK CONSISTS OF STANDARD CHARACTERS WITHOUT CLAIM TO ANY PARTICULAR FONT, STYLE, SIZE, OR COLOR.

OWNER OF U.S. REG. NO. 4,016,877.

FOR PARTICULATE MATERIAL COMPRISING TRACE MINERALS AND ONE OR MORE CHEMICALLY STABLE INGREDIENTS FOR ADDITION TO ANIMAL FEED (U.S. CLS. 6, 18, 44, 46, 51 AND 52).

TOBY BULLOFF, EXAMINING ATTORNEY

**CLASS 5—(Continued).**

SN 86-200,799. ELYSIUM HEALTH, DELRAY BEACH, FL. FILED 2-21-2014.

# Metavitamin

THE MARK CONSISTS OF STANDARD CHARACTERS WITHOUT CLAIM TO ANY PARTICULAR FONT, STYLE, SIZE, OR COLOR.

FOR DIETARY AND NUTRITIONAL SUPPLEMENTS CONTAINING VITAMINS (U.S. CLS. 6, 18, 44, 46, 51 AND 52).

JASON BLAIR, EXAMINING ATTORNEY

SN 86-201,678. BIOLIFE KALI 3 LLC, BALDWIN PARK, CA. FILED 2-24-2014.



NO CLAIM IS MADE TO THE EXCLUSIVE RIGHT TO USE "HERBAL SUPPLEMENTS", APART FROM THE MARK AS SHOWN.

THE COLOR(S) GREEN, YELLOW, ORANGE, PURPLE, BLACK, AND WHITE IS/ARE CLAIMED AS A FEATURE OF THE MARK.

THE MARK CONSISTS OF AN ORANGE AND YELLOW SUN BEHIND GREEN AND WHITE MOUNTAINS FEATURING BLACK OUTLINING. THE WORD "EXELIFE" APPEARS IN GREEN AND PURPLE ON THE MOUNTAINS WITH "EXE" IN PURPLE, THE LETTER "L" IN GREEN, AND "IFE" IN PURPLE. A GREEN AND WHITE LEAF APPEARS ABOVE THE LETTER "I" IN "EXELIFE". THE WORDS "HERBAL SUPPLEMENTS" APPEAR IN BLACK BELOW WITH TWO PURPLE LINES ABOVE AND BELOW.

FOR DIETARY AND NUTRITIONAL SUPPLEMENTS CONTAINING HERBS (U.S. CLS. 6, 18, 44, 46, 51 AND 52).

JOANNA FIORELLI, EXAMINING ATTORNEY

SN 86-203,309. NUTRACEUTICAL EVOLUTION INC., POM-PANO BEACH, FL. FILED 2-25-2014.

# NUTRACEUTICAL EVOLUTION SLENDER MAGIC COFFEE

THE MARK CONSISTS OF STANDARD CHARACTERS WITHOUT CLAIM TO ANY PARTICULAR FONT, STYLE, SIZE, OR COLOR.

NO CLAIM IS MADE TO THE EXCLUSIVE RIGHT TO USE "NUTRACEUTICAL" AND "COFFEE", APART FROM THE MARK AS SHOWN.

FOR NUTRACEUTICALS FOR USE AS A DIETARY SUPPLEMENT CONTAINING COFFEE (U.S. CLS. 6, 18, 44, 46, 51 AND 52).

ALICIA COLLINS, EXAMINING ATTORNEY

**CLASS 5—(Continued).**

SN 86-205,429. IMMUNOCLIN LTD., LONDON, UNITED KINGDOM, FILED 2-26-2014.

**GastroWellBeing (GWB)**

THE MARK CONSISTS OF STANDARD CHARACTERS WITHOUT CLAIM TO ANY PARTICULAR FONT, STYLE, SIZE, OR COLOR.  
FOR DIETARY AND NUTRITIONAL SUPPLEMENTS; DIETARY FOOD SUPPLEMENTS; DIETARY SUPPLEMENTS; NUTRITIONAL SUPPLEMENTS (U.S. CLS. 6, 18, 44, 46, 51 AND 52).  
ALISON POLLACK, EXAMINING ATTORNEY

SN 86-206,213. ORGANICAWORLD, LLC, GROVELAND, FL. FILED 2-27-2014.

**TAKE IT ON**

THE MARK CONSISTS OF STANDARD CHARACTERS WITHOUT CLAIM TO ANY PARTICULAR FONT, STYLE, SIZE, OR COLOR.  
FOR DIETARY AND NUTRITIONAL SUPPLEMENTS; DIETARY SUPPLEMENTAL DRINKS (U.S. CLS. 6, 18, 44, 46, 51 AND 52).  
FIRST USE 1-8-2014; IN COMMERCE 2-17-2014.  
CRISTIANA SCHWAB, EXAMINING ATTORNEY

SN 86-206,263. ORGANICAWORLD, LLC, GROVELAND, FL. FILED 2-27-2014.

**ATOMIC TONIC**

THE MARK CONSISTS OF STANDARD CHARACTERS WITHOUT CLAIM TO ANY PARTICULAR FONT, STYLE, SIZE, OR COLOR.  
NO CLAIM IS MADE TO THE EXCLUSIVE RIGHT TO USE "TONIC", APART FROM THE MARK AS SHOWN.  
FOR DIETARY AND NUTRITIONAL SUPPLEMENTS; DIETARY SUPPLEMENTAL DRINKS (U.S. CLS. 6, 18, 44, 46, 51 AND 52).  
FIRST USE 1-8-2014; IN COMMERCE 2-17-2014.  
CRISTIANA SCHWAB, EXAMINING ATTORNEY

**CLASS 5—(Continued).**

SN 86-207,977. BKK PHARMACEUTICALS, LLC, WILMINGTON, DE. FILED 2-28-2014.

**CARMOL**

THE MARK CONSISTS OF STANDARD CHARACTERS WITHOUT CLAIM TO ANY PARTICULAR FONT, STYLE, SIZE, OR COLOR.  
FOR DERMATOLOGICAL PHARMACEUTICAL PREPARATIONS (U.S. CLS. 6, 18, 44, 46, 51 AND 52).  
ZACHARY BELLO, EXAMINING ATTORNEY

SN 86-213,134. AVADOR BUSINESS GROUP INC, NEW YORK, NY. FILED 3-6-2014.

**Avador Nutrition**

THE MARK CONSISTS OF STANDARD CHARACTERS WITHOUT CLAIM TO ANY PARTICULAR FONT, STYLE, SIZE, OR COLOR.  
NO CLAIM IS MADE TO THE EXCLUSIVE RIGHT TO USE "NUTRITION", APART FROM THE MARK AS SHOWN.  
FOR DIETARY AND NUTRITIONAL SUPPLEMENTS (U.S. CLS. 6, 18, 44, 46, 51 AND 52).  
SUSAN LESLIE DUBOIS, EXAMINING ATTORNEY

SN 86-218,961. RARE ANTIBODY ANTIGEN SUPPLY, INC., AGOURA HILLS, CA. FILED 3-12-2014.

**RAAS NUTRITIONALS**

THE MARK CONSISTS OF STANDARD CHARACTERS WITHOUT CLAIM TO ANY PARTICULAR FONT, STYLE, SIZE, OR COLOR.  
NO CLAIM IS MADE TO THE EXCLUSIVE RIGHT TO USE "NUTRITIONALS", APART FROM THE MARK AS SHOWN.  
FOR FOOD FOR INFANTS (U.S. CLS. 6, 18, 44, 46, 51 AND 52).  
JOHN HWANG, EXAMINING ATTORNEY

**CLASS 5—(Continued).**

SN 86-224,452. VESPA POWER PRODUCTS, LLC, DAVIS, CA. FILED 3-18-2014.



THE COLOR(S) YELLOW, BLACK AND WHITE IS/ARE CLAIMED AS A FEATURE OF THE MARK.  
 THE MARK CONSISTS OF THE FOLLOWING: A HEAD ON VIEW OF A YELLOW AND BLACK WASP WITH WHITE WINGS OUTLINED IN BLACK.  
 FOR DIETARY AND NUTRITIONAL SUPPLEMENTS (U.S. CLS. 6, 18, 44, 46, 51 AND 52).  
 FIRST USE 12-11-1998; IN COMMERCE 12-31-1998.  
 LUCY ARANT, EXAMINING ATTORNEY

SN 86-224,477. CONNOR, KYM, WESTLAKE VILLAGE, CA. FILED 3-18-2014.

**TINX PROTECTION**

THE MARK CONSISTS OF STANDARD CHARACTERS WITHOUT CLAIM TO ANY PARTICULAR FONT, STYLE, SIZE, OR COLOR.  
 NO CLAIM IS MADE TO THE EXCLUSIVE RIGHT TO USE "PROTECTION", APART FROM THE MARK AS SHOWN.  
 FOR INCONTINENCE PADS (U.S. CLS. 6, 18, 44, 46, 51 AND 52).  
 ALICIA COLLINS, EXAMINING ATTORNEY

SN 86-224,674. MICHAEL ROJAS, LAGUNA BEACH, CA. FILED 3-18-2014.

**Real Recovery**

THE MARK CONSISTS OF STANDARD CHARACTERS WITHOUT CLAIM TO ANY PARTICULAR FONT, STYLE, SIZE, OR COLOR.  
 NO CLAIM IS MADE TO THE EXCLUSIVE RIGHT TO USE "RECOVERY", APART FROM THE MARK AS SHOWN.  
 FOR CASEIN DIETARY SUPPLEMENTS; DIETARY AND NUTRITIONAL SUPPLEMENTS FOR ENDURANCE SPORTS; DIETARY AND NUTRITIONAL SUPPLEMENTS USED FOR WEIGHT LOSS; DIETARY BEVERAGE SUPPLEMENTS FOR HUMAN CONSUMPTION IN LIQUID AND DRY MIX FORM FOR THERAPEUTIC PURPOSES; DIETARY FOOD SUPPLEMENTS; DIETARY SUPPLEMENTAL DRINK MIXES; DIETARY SUPPLEMENTAL DRINKS IN THE NATURE OF VITAMIN AND MINERAL BEVERAGES; DIETARY SUPPLEMENTS; DIETARY AND NUTRITIONAL SUPPLEMENTS (U.S. CLS. 6, 18, 44, 46, 51 AND 52).  
 STEVEN PEREZ, EXAMINING ATTORNEY

**CLASS 5—(Continued).**

SN 86-225,808. YE, XIANG, TEMPLE CITY, CA. FILED 3-19-2014.



THE COLOR(S) BLUE, ORANGE, PURPLE, AND WHITE IS/ARE CLAIMED AS A FEATURE OF THE MARK.  
 THE MARK CONSISTS OF TWO CONCENTRIC CIRCLES, THE OUTER CIRCLE IS A BAND WHICH IS MOSTLY ORANGE-COLORED, WITHIN THE OUTER CIRCLE, THERE IS A BLUE-COLORED SICKLE SITS ON ITS UPPER LEFT SIDE IN A STRAIGHT UP AND DOWN FASHION, ADJACENT TO THE BLUE-COLORED SICKLE, THERE IS A PURPLE-COLORED SICKLE SITS ON ITS LOWER LEFT SIDE EXTENDING SLIGHTLY TO THE RIGHT SIDE OF THE OUTER CIRCLE. THE INNER CIRCLE IS COLORED WHITE, UNDERNEATH AND OUTSIDE OF THE CONCENTRIC CIRCLES, THERE IS AN ENGLISH WORD "OLYMBAY" IN ORANGE SITS HORIZONTALLY FROM LEFT TO RIGHT.  
 FOR CASEIN DIETARY SUPPLEMENTS; DIETARY AND NUTRITIONAL SUPPLEMENTS; DIETARY AND NUTRITIONAL SUPPLEMENTS FOR ENDURANCE SPORTS; DIETARY BEVERAGE SUPPLEMENTS FOR HUMAN CONSUMPTION IN LIQUID AND DRY MIX FORM FOR THERAPEUTIC PURPOSES; DIETARY FOOD SUPPLEMENTS; DIETARY SUPPLEMENT DRINK MIXES; DIETARY SUPPLEMENTAL DRINKS; DIETARY SUPPLEMENTAL DRINKS IN THE NATURE OF VITAMIN AND MINERAL BEVERAGES; DIETARY SUPPLEMENTS; DIETARY SUPPLEMENTS FOR HUMAN CONSUMPTION; FOOD SUPPLEMENTS; HERBAL SUPPLEMENTS (U.S. CLS. 6, 18, 44, 46, 51 AND 52).  
 FIRST USE 7-19-2013; IN COMMERCE 7-19-2013.  
 MARIA-VICTORIA SUAREZ, EXAMINING ATTORNEY

SN 86-225,944. SUN, DEYU, EL MONTE, CA. FILED 3-19-2014.



NO CLAIM IS MADE TO THE EXCLUSIVE RIGHT TO USE "U.S.A.", APART FROM THE MARK AS SHOWN.  
 THE COLOR(S) BLACK, GREEN, YELLOW, RED, WHITE AND GOLD IS/ARE CLAIMED AS A FEATURE OF THE MARK.  
 THE MARK CONSISTS OF THE WORDING "DE YU TANG" IN BLACK TO THE LEFT OF BLACK CHINESE

**CLASS 5—(Continued).**

CHARACTERS THAT TRANSLITERATE TO "DE YU TANG" AND THIS MEANS "VIRTUE JADE HALL" IN ENGLISH. THE WORDING APPEARS OF A DESIGN OF A YELLOW CIRCLE WITH A RED "S" INSIDE, A WHITE SHINE APPEARS ON TOP OF THE LETTER "S". GREEN LEAVES SURROUND THE CIRCLE ON EACH SIDE. A GOLD BANNER WITH THE WORDING "U.S.A." IN BLACK INSIDE OF IT APPEARS BELOW THE YELLOW CIRCLE. THE DESIGN ELEMENTS AND THE WORDING ALL APPEAR INSIDE A BLACK CIRCLE.

THE ENGLISH TRANSLATION OF THE WORD "DE YU TANG" IN THE MARK IS "VIRTUE JADE HALL".

THE NON-LATIN CHARACTERS IN THE MARK TRANSLITERATE TO "DE YU TANG" AND THIS MEANS "VIRTUE JADE HALL" IN ENGLISH.

FOR DIETARY AND NUTRITIONAL SUPPLEMENTS; DIETARY FOOD SUPPLEMENTS; DIETARY SUPPLEMENTS; FOOD SUPPLEMENTS; HERBAL SUPPLEMENTS (U.S. CLS. 6, 18, 44, 46, 51 AND 52).

FIRST USE 12-26-2012; IN COMMERCE 12-26-2012.

SETH A. RAPPAPORT, EXAMINING ATTORNEY

---

SN 86-230,061. GREEN STAR INDUSTRIAL SUPPLY INC., FAIRFIELD, NJ. FILED 3-24-2014.

**GREEN STAR ODOR ELIMINATOR**

THE MARK CONSISTS OF STANDARD CHARACTERS WITHOUT CLAIM TO ANY PARTICULAR FONT, STYLE, SIZE, OR COLOR.

NO CLAIM IS MADE TO THE EXCLUSIVE RIGHT TO USE "GREEN" AND "ODOR ELIMINATOR", APART FROM THE MARK AS SHOWN.

FOR ODOR NEUTRALIZING PREPARATIONS FOR GENERAL USE ON VARIOUS SURFACES (U.S. CLS. 6, 18, 44, 46, 51 AND 52).

INGRID C. EULIN, EXAMINING ATTORNEY

---

SN 86-230,241. JOHNSON & JOHNSON, NEW BRUNSWICK, NJ. FILED 3-24-2014.

**SONJOIR**

THE MARK CONSISTS OF STANDARD CHARACTERS WITHOUT CLAIM TO ANY PARTICULAR FONT, STYLE, SIZE, OR COLOR.

THE WORDING "SONJOIR" HAS NO MEANING IN A FOREIGN LANGUAGE.

FOR HUMAN PHARMACEUTICAL PREPARATIONS FOR THE PREVENTION AND TREATMENT OF VIRAL DISEASES, AUTO-IMMUNE AND INFLAMMATORY DISEASES, CARDIOVASCULAR DISEASES, CENTRAL NERVOUS SYSTEM DISEASES AND PAIN, DERMATOLOGIC DISEASES, GASTRO-INTESTINAL DISEASES, INFECTIOUS-RELATED DISEASES, METABOLIC DISEASES, ONCOLOGIC DISEASES, OPHTHALMIC DISEASES, AND RESPIRATORY DISEASES (U.S. CLS. 6, 18, 44, 46, 51 AND 52).

MEREDITH MARESCA, EXAMINING ATTORNEY

**CLASS 5—(Continued).**

SN 86-230,243. JOHNSON & JOHNSON, NEW BRUNSWICK, NJ. FILED 3-24-2014.

**SPANZAR**

THE MARK CONSISTS OF STANDARD CHARACTERS WITHOUT CLAIM TO ANY PARTICULAR FONT, STYLE, SIZE, OR COLOR.

THE WORDING "SPANZAR" HAS NO MEANING IN A FOREIGN LANGUAGE.

FOR HUMAN PHARMACEUTICAL PREPARATIONS FOR THE PREVENTION AND TREATMENT OF VIRAL DISEASES, AUTO-IMMUNE AND INFLAMMATORY DISEASES, CARDIOVASCULAR DISEASES, CENTRAL NERVOUS SYSTEM DISEASES AND PAIN, DERMATOLOGIC DISEASES, GASTRO-INTESTINAL DISEASES, INFECTIOUS-RELATED DISEASES, METABOLIC DISEASES, ONCOLOGIC DISEASES, OPHTHALMIC DISEASES, AND RESPIRATORY DISEASES (U.S. CLS. 6, 18, 44, 46, 51 AND 52).

MEREDITH MARESCA, EXAMINING ATTORNEY

---

SN 86-230,346. BRISTOL-MYERS SQUIBB COMPANY, NEW YORK, NY. FILED 3-24-2014.

**DANVIART**

THE MARK CONSISTS OF STANDARD CHARACTERS WITHOUT CLAIM TO ANY PARTICULAR FONT, STYLE, SIZE, OR COLOR.

FOR PHARMACEUTICAL PREPARATIONS FOR HUMAN USE FOR THE TREATMENT AND PREVENTION OF OBESITY, DIABETES, INCONTINENCE, CARDIOVASCULAR DISEASES, CENTRAL NERVOUS SYSTEM DISEASES AND DISORDERS, METABOLIC DISORDERS, STROKE, CANCER, INFLAMMATION AND INFLAMMATORY DISEASES, RESPIRATORY AND INFECTIOUS DISEASES, AUTO-IMMUNE DISEASES, SOLID ORGAN TRANSPLANT REJECTION; PHARMACEUTICAL PREPARATIONS FOR HUMAN USE, NAMELY, ANTIBIOTICS, ANTI-FUNGALS, ANTI-VIRALS, IMMUNOSUPPRESSANTS AND PHARMACEUTICAL ANTIBODIES (U.S. CLS. 6, 18, 44, 46, 51 AND 52).

KAREN K. BUSH, EXAMINING ATTORNEY



**CLASS 5—(Continued).**

SN 86-230,358. BRISTOL-MYERS SQUIBB COMPANY, NEW YORK, NY. FILED 3-24-2014.

# XIMENCY

THE MARK CONSISTS OF STANDARD CHARACTERS WITHOUT CLAIM TO ANY PARTICULAR FONT, STYLE, SIZE, OR COLOR.

FOR PHARMACEUTICAL PREPARATIONS FOR HUMAN USE FOR THE TREATMENT AND PREVENTION OF VIRAL DISEASES, INCLUDING HEPATITIS (U.S. CLS. 6, 18, 44, 46, 51 AND 52).

KAREN K. BUSH, EXAMINING ATTORNEY

**CLASS 5—(Continued).**

SN 86-231,046. IPSEN S.A., BOULOGNE BILLANCOURT, FRANCE, FILED 3-25-2014.



SN 86-230,723. DICERNA PHARMACEUTICALS, INC., WATERTOWN, MA. FILED 3-24-2014.

## DICERNA PHARMACEUTICALS

THE MARK CONSISTS OF STANDARD CHARACTERS WITHOUT CLAIM TO ANY PARTICULAR FONT, STYLE, SIZE, OR COLOR.

NO CLAIM IS MADE TO THE EXCLUSIVE RIGHT TO USE "PHARMACEUTICALS", APART FROM THE MARK AS SHOWN.

FOR PHARMACEUTICAL PREPARATIONS FOR THE TREATMENT OF CANCER; PHARMACEUTICAL PREPARATIONS FOR THE TREATMENT OF RARE DISEASES DEFINED BY GENETICS, PRIMARY HYPEROXALURIA, ALPHA 1 ANTI-TRYPsin DEFICIENCY, AND MAPLE SYRUP URINE DISEASE; PHARMACEUTICAL PREPARATIONS FOR THE PURPOSE OF INCREASING THE EFFECTIVENESS OF OTHER PHARMACEUTICAL PRODUCTS; DRUG DELIVERY AGENTS CONSISTING OF COMPOUNDS THAT FACILITATE DELIVERY OF A WIDE RANGE OF PHARMACEUTICALS (U.S. CLS. 6, 18, 44, 46, 51 AND 52).

JUSTINE D. PARKER, EXAMINING ATTORNEY

OWNER OF FRANCE REG. NO. 033248041, DATED 9-24-2003, EXPIRES 9-24-2023.

OWNER OF U.S. REG. NOS. 3,055,541, 3,251,886 AND OTHERS.

THE COLOR(S) DARK BLUE (PANTONE 281C) AND LIGHT BLUE (PANTONE 7461C) IS/ARE CLAIMED AS A FEATURE OF THE MARK.

THE MARK CONSISTS OF A VERTICAL S-SHAPED CURVED LINE APPEARING IN DARK BLUE (PANTONE 281C) WHICH IS DISSECTED BY TWO HORIZONTAL CURVED LINES APPEARING IN LIGHT BLUE (PANTONE 7461C) WITH A LIGHT BLUE (PANTONE 7461C) DOT TO THE RIGHT OF THE CURVATURE OF THE UPPER HORIZONTAL LINE.

FOR FULL LINE OF PHARMACEUTICAL PREPARATIONS, NAMELY, PHARMACEUTICAL PREPARATIONS FOR USE IN THE TREATMENT OF GASTROINTESTINAL DISEASES, LAXATIVES AND PURGATIVE AGENTS, PHARMACEUTICAL PREPARATIONS FOR IN USE IN THE TREATMENT OF CARDIOVASCULAR DISEASES, CIRCULATORY DISORDERS, CANCER, NEUROLOGICAL DISEASES, UROLOGICAL DISEASES, HORMONAL DISORDERS, PHARMACEUTICAL PREPARATIONS COMPRISING PEPTIDES FOR HORMONAL TREATMENT AND TUMOR TREATMENT; PHARMACEUTICAL PREPARATIONS FOR USE IN THE TREATMENT OF BLOOD DISEASES, MUSCLE DISORDERS, AGE-RELATED DISORDERS, DIABETES, DIABETES-RELATED DISORDERS, RESPIRATORY DISORDERS, OPHTHAMOLOGICAL DISORDERS, ENDOCRINE DISORDERS, ACROMEGALIA AND CARCINOID TUMORS, GASTROINTESTINAL BLEEDING DISORDERS, COUGH, VERTIGO, NAUSEA, VOMITING AND MIGRAINE, DISORDERS AND DISEASES OF THE REPRODUCTIVE SYSTEM, GLABELLAR LINES, FACIAL WRINKLES, ASYMETRIES AND DEFECTS AND CONDITIONS OF THE HUMAN SKIN, AND GOUT (U.S. CLS. 6, 18, 44, 46, 51 AND 52).

JOANNA FIORELLI, EXAMINING ATTORNEY



**CLASS 5—(Continued).**

SN 86-231,050. NOVEN THERAPEUTICS, LLC, MIAMI, FL.  
FILED 3-25-2014.



OWNER OF U.S. REG. NO. 4,496,258.  
THE MARK CONSISTS OF A GRAPHIC DESIGN OF  
THREE S-LIKE SHAPES THAT TOGETHER, RESEMBLE A  
BIRD IN FLIGHT.

FOR PHARMACEUTICAL PREPARATIONS AND SUB-  
STANCES FOR USE IN THE TREATMENT, ALLEVI-  
ATION AND PREVENTION OF THERMOREGULATORY  
DYSFUNCTIONS AND VASOMOTOR SYMPTOMS IN-  
CLUDING HOT FLASHES, HOT FLUSHES, NIGHT  
AWAKENINGS, NIGHT SWEATS, AND SUCH DISOR-  
DERS AND CONDITIONS ASSOCIATED WITH PERIME-  
NOPAUSE, MENOPAUSE AND HORMONAL  
DEFICIENCIES (U.S. CLS. 6, 18, 44, 46, 51 AND 52).

FIRST USE 10-7-2013; IN COMMERCE 10-7-2013.  
JAMES GRIFFIN, EXAMINING ATTORNEY

SN 86-231,605. NUTRI-DYN MIDWEST, INC., MAPLE  
PLAIN, MN. FILED 3-25-2014.

**DYNAMIC FRUITS & GREENS**

THE MARK CONSISTS OF STANDARD CHARACTERS  
WITHOUT CLAIM TO ANY PARTICULAR FONT, STYLE,  
SIZE, OR COLOR.

NO CLAIM IS MADE TO THE EXCLUSIVE RIGHT TO  
USE "FRUITS & GREENS", APART FROM THE MARK AS  
SHOWN.

FOR POWDERED NUTRITIONAL SUPPLEMENTS  
PRIMARILY COMPRISING NATURAL FRUIT AND  
VEGETABLE EXTRACTS, VITAMINS, FLAX LIGNANS,  
IONIC TRACE MINERALS, ENZYMES, ANTIOXI-  
DANTS, PHYTONUTRIENTS, PROBIOTICS, AND FIBER  
(U.S. CLS. 6, 18, 44, 46, 51 AND 52).

FIRST USE 12-5-2012; IN COMMERCE 12-5-2012.  
KHANH LE, EXAMINING ATTORNEY

**CLASS 5—(Continued).**

SN 86-232,811. HEALTH MANAGEMENT OF GUANGZHOU  
HEALTH LIFE, LTD., GUANGZHOU, GUANGDONG,  
CHINA, FILED 3-26-2014.



THE COLOR(S) GREEN, LIGHT BLUE, ORANGE,  
BRIGHT RED, MAROON, AND DARK BLUE IS/ARE  
CLAIMED AS A FEATURE OF THE MARK.

THE MARK CONSISTS OF THE WORD "AKSO", WITH  
AN ARC OF FIVE MULTI-COLORED HEXAGONS THAT  
DECREASE IN SIZE EACH SUCCESSIVE HEXAGON.  
THESE FOUR LETTERS ARE IN BOLD, UPPER CASE  
AND GREEN. THE FIRST AND LARGEST HEXAGON IS  
LIGHT BLUE AND PLACED AT THE BOTTOM LEFT OF  
THE MARK, WITH THE FOUR LETTERS PLACED TO THE  
RIGHT OF THE HEXAGON MATCHING ITS HEIGHT. THIS  
HEXAGON IS ORIENTED IN SUCH A WAY THAT THE TOP  
AND BOTTOM FACES ARE PARALLEL TO THE HORI-  
ZONTAL AXIS OF THE MARK, WHILE THE SUBSE-  
QUENTLY SMALLER HEXAGONS ARE SHIFTED 45  
DEGREES, SUCH THAT THEIR RIGHT AND LEFT FACES  
ARE PERPENDICULAR TO THE MARK'S HORIZONTAL  
AXIS. SIMILAR TO THE LARGE LIGHT BLUE HEXAGON, THE  
TOP AND BOTTOM FACES OF THE FOUR LETTERS ARE  
PARALLEL TO THE MARK'S HORIZONTAL AXIS, SUCH  
THAT THE TOP AND BOTTOMS OF THE "S" AND "O"  
LETTERS, WHICH WOULD OTHERWISE BE ROUNDED,  
ARE CUT OFF SO THAT THEY ARE FLAT. THE TOP  
RIGHT LIMB OF THE "K" IS COLORED THE SAME LIGHT  
BLUE AS THE LARGEST HEXAGON, AND STYLIZED  
SUCH THAT THE STROKE CONTINUES THROUGH THE  
MIDDLE OF THE "K" AND OUT OF THE LETTER'S  
LEFTMOST BOUNDARY INTO THE BOTTOM RIGHT OF  
THE LETTER "A". INSIDE THE "O" IS A STYLIZED GREEN  
DESIGN CONSISTING OF FIVE DOWNWARDS LINES  
THAT HUG THE CURVES OF THE "O", AND THREE  
SIMILARLY CURVED SIDEWAYS LINES. SPECIFICALLY,  
OF THE DOWNWARDS LINES THE LEFTMOST TWO  
CURVE RIGHT INTO THE MIDDLE OF THE "O", THE  
MIDDLE LINE IS PERPENDICULAR TO THE HORIZON-  
TAL AXIS OF THE MARK, WHILE THE RIGHTMOST TWO  
CURVE LEFT INTO THE MIDDLE OF THE "O". THIS  
EFFECT IS THE SAME IN THE THREE SIDEWAYS LINES,  
WITH THE LINE IN THE MIDDLE BEING PARALLEL TO  
THE MARK'S HORIZONTAL AXIS. THE FIRST HEXAGON  
BRANCHING OUT OF THE LARGEST LIGHT BLUE  
HEXAGON IS ORANGE AND POSITIONED TO THE LIGHT  
BLUE HEXAGON'S TOP RIGHT, DIRECTLY ABOVE THE  
LEFT TWO-THIRDS OF THE "A". THE NEXT HEXAGON IS  
BRIGHT RED AND PLACED ABOVE THE LEFT HALF OF  
THE "K", AND TO THE TOP RIGHT OF THE ORANGE  
HEXAGON, ALTHOUGH AT A FLATTER ANGLE COM-  
PARED TO THAT OF THE LINE BETWEEN THE LIGHT  
BLUE AND ORANGE HEXAGONS. THE NEXT HEXAGON  
IS MAROON AND CENTERED HORIZONTALLY TO THE  
BRIGHT RED HEXAGON, PLACED RIGHT ABOVE THE  
LEFT HALF OF THE "S". THE LAST AND SMALLEST  
HEXAGON IS DARK BLUE, AND IS PLACED TOWARDS  
THE LOWER RIGHT OF THE MAROON HEXAGON,  
RIGHT ABOVE THE LEFTMOST PORTION OF THE "O".

FOR DIETARY AND NUTRITIONAL SUPPLEMENTS  
(U.S. CLS. 6, 18, 44, 46, 51 AND 52).

FIRST USE 3-12-2014; IN COMMERCE 3-12-2014.  
ANDREA BUTLER, EXAMINING ATTORNEY

**CLASS 5—(Continued).**

SN 86-233,669. BRISTOL-MYERS SQUIBB COMPANY, NEW YORK, NY. FILED 3-27-2014.

# ORKEPA

THE MARK CONSISTS OF STANDARD CHARACTERS WITHOUT CLAIM TO ANY PARTICULAR FONT, STYLE, SIZE, OR COLOR.

FOR PHARMACEUTICAL PREPARATIONS FOR HUMAN USE FOR THE TREATMENT AND PREVENTION OF VIRAL DISEASES, INCLUDING HEPATITIS (U.S. CLS. 6, 18, 44, 46, 51 AND 52).

KAREN K. BUSH, EXAMINING ATTORNEY

SN 86-233,946. COLSON, WENDY, CARLSBAD, CA. FILED 3-27-2014.

# Boobie Bar

THE MARK CONSISTS OF STANDARD CHARACTERS WITHOUT CLAIM TO ANY PARTICULAR FONT, STYLE, SIZE, OR COLOR.

NO CLAIM IS MADE TO THE EXCLUSIVE RIGHT TO USE "BAR", APART FROM THE MARK AS SHOWN.

FOR NUTRITIONAL SUPPLEMENTS (U.S. CLS. 6, 18, 44, 46, 51 AND 52).

FIRST USE 8-30-2011; IN COMMERCE 10-30-2012.

BARBARA BROWN, EXAMINING ATTORNEY

SN 86-234,323. NATURAL PRODUCT DESIGN, LLC, CLARKDALE, AZ. FILED 3-27-2014.

# Castor Oil Easy Pack

THE MARK CONSISTS OF STANDARD CHARACTERS WITHOUT CLAIM TO ANY PARTICULAR FONT, STYLE, SIZE, OR COLOR.

NO CLAIM IS MADE TO THE EXCLUSIVE RIGHT TO USE "CASTOR OIL" AND "PACK", APART FROM THE MARK AS SHOWN.

FOR CASTOR OIL FOR MEDICAL PURPOSES (U.S. CLS. 6, 18, 44, 46, 51 AND 52).

JOHN SCHUYLER YARD, EXAMINING ATTORNEY

**CLASS 5—(Continued).**

SN 86-235,551. JOBEN BIO-MEDICAL CO., LTD., CHANGZHI, PINGTUNG CO., TAIWAN, FILED 3-28-2014.



NO CLAIM IS MADE TO THE EXCLUSIVE RIGHT TO USE THE NON-LATIN CHARACTERS THAT TRANSLITERATE TO "NIU ZHANG ZHI", APART FROM THE MARK AS SHOWN.

THE COLOR(S) DARK ORANGE, ORANGE, BLUE, AND BLACK IS/ARE CLAIMED AS A FEATURE OF THE MARK.

THE MARK CONSISTS OF A FUNGUS-LIKE SHAPE IN DARK ORANGE AND ORANGE COLORS, THREE BLACK CHINESE CHARACTERS LAID OVER THE FUNGUS-LIKE SHAPE, THREE BLUE LETTERS "JBM" AT THE UPPER-LEFT CORNER OF THE MARK, AND A SMALL DARK ORANGE SPIRAL SYMBOL TO THE LEFT OF THE LETTERS "JBM".

THE NON-LATIN CHARACTERS IN THE MARK TRANSLITERATE TO "NIU ZHANG ZHI" AND THIS MEANS "CATTLE", "CAMPHOR TREE", "A FRAGRANT PURPLISH HERB OR FUNGUS" IN ENGLISH.

FOR DIETARY AND NUTRITIONAL SUPPLEMENTS; FUNGAL EXTRACTS SOLD AS A COMPONENT INGREDIENT OF NUTRITIONAL SUPPLEMENTS AND VITAMINS; HEALTH FOOD SUPPLEMENTS; NUTRACEUTICALS FOR USE AS A DIETARY SUPPLEMENT; NUTRITIONAL FOOD ADDITIVES FOR MEDICAL PURPOSES IN THE NATURE OF NATURAL FOOD EXTRACTS DERIVED FROM ANTRODIA CAMPHORATE; NUTRITIONAL SUPPLEMENTS; PHARMACEUTICAL PREPARATIONS FOR THE PREVENTION AND TREATMENT OF DISORDERS OF THE NERVOUS SYSTEM, THE IMMUNE SYSTEM, THE CARDIO-VASCULAR SYSTEM, THE METABOLIC SYSTEM, THE RESPIRATORY SYSTEM, THE MUSCULO-SKELETAL SYSTEM, THE GENITOURINARY SYSTEM; PHARMACEUTICAL PREPARATIONS FOR THE TREATMENT OF INFLAMMATORY DISORDERS; PHARMACEUTICAL PREPARATIONS FOR USE IN DERMATOLOGY, ONCOLOGY, HEMATOLOGY AND IN TISSUE AND ORGAN TRANSPLANTATION, IN OPHTHALMOLOGY AND FOR GASTROENTEROLOGICAL DISORDERS; POWDERED NUTRITIONAL SUPPLEMENT CONCENTRATE; PRESCRIPTION AND NON-PRESCRIPTION MEDICINES, NAMELY, PILLS, TABLETS, CAPSULES, CAPLETS, LIQUID DROPS, SACHETS AND PHARMACEUTICAL PREPARATIONS FOR THE TREATMENT OF CARDIOVASCULAR DISORDERS; THERAPEUTIC PHARMACEUTICAL FOR THE TREATMENT OF HEPATOPROTECTIVE, CHOLESTEROL-LOWERING, PROMOTING BLOOD CIRCULATION AND BOOSTING METABOLISM, REGULATION IN BLOOD PRESSURE, REGULATION IN BLOOD LIPIDS, REGULATION IN BLOOD SUGAR, IMMUNOMODULATORY, PROMOTING IMMUNE SYSTEM, REGULATION OF ALLERGY (U.S. CLS. 6, 18, 44, 46, 51 AND 52).

WILLIAM P. SHANAHAN, EXAMINING ATTORNEY

**CLASS 5—(Continued).**

SN 86-236,237. HARVEY HEALTH CENTERS, INC., AMARILLO, TX. FILED 3-29-2014.

**TOTAL TOOTH SOLUTION**

THE MARK CONSISTS OF STANDARD CHARACTERS WITHOUT CLAIM TO ANY PARTICULAR FONT, STYLE, SIZE, OR COLOR.

NO CLAIM IS MADE TO THE EXCLUSIVE RIGHT TO USE "TOOTH SOLUTION", APART FROM THE MARK AS SHOWN.

FOR MEDICATED DENTAL CARE PREPARATIONS FOR PREVENTION AND REMOVAL OF PLAQUE AND BACTERIA, FOR REMINERALIZATION OF TOOTH ENAMEL, FOR PROTECTION OF ENAMEL AND GINGIVAL TISSUE, FOR TEETH WHITENING, FOR GUM TISSUE GROWTH, FOR PREVENTING PERIODONTAL DISEASE, FOR PREVENTING GINGIVITIS, AND FOR TIGHTENING LOOSE TEETH, NAMELY, MEDICATED DENTAL DENTIFRICES AND DENTAL POWDERS; MEDICATED ORAL CARE PREPARATIONS SOLD OVER THE COUNTER (U.S. CLS. 6, 18, 44, 46, 51 AND 52).

JAMES GRIFFIN, EXAMINING ATTORNEY

---

SN 86-236,790. DURACAP LABS LLC, NORCROSS, GA. FILED 3-31-2014.

**Silverback Nutrition**

THE MARK CONSISTS OF STANDARD CHARACTERS WITHOUT CLAIM TO ANY PARTICULAR FONT, STYLE, SIZE, OR COLOR.

NO CLAIM IS MADE TO THE EXCLUSIVE RIGHT TO USE "NUTRITION", APART FROM THE MARK AS SHOWN.

FOR DIETARY SUPPLEMENTS (U.S. CLS. 6, 18, 44, 46, 51 AND 52).

FIRST USE 12-1-2013; IN COMMERCE 12-1-2013.

PAUL E. FAHRENKOPF, EXAMINING ATTORNEY

---

SN 86-237,154. HORSEY CULINARY, LLC, SMILEY, TX. FILED 3-31-2014.

**HORSEY CULINARY SWOOSH FLY SWIPES**

THE MARK CONSISTS OF STANDARD CHARACTERS WITHOUT CLAIM TO ANY PARTICULAR FONT, STYLE, SIZE, OR COLOR.

NO CLAIM IS MADE TO THE EXCLUSIVE RIGHT TO USE "HORSEY" AND "FLY", APART FROM THE MARK AS SHOWN.

FOR ANTI FLY LOTION; ANTI-HORSE-FLY OILS (U.S. CLS. 6, 18, 44, 46, 51 AND 52).

FIRST USE 7-1-2013; IN COMMERCE 7-1-2013.

ANDREA CORNWELL, EXAMINING ATTORNEY

**CLASS 5—(Continued).**

SN 86-237,788. MARRYHEALTH ENTERPRISES NORTH AMERICA INC., VANCOUVER, BC, CANADA, FILED 3-31-2014.



THE MARK CONSISTS OF THE TERM "MARRY-HEALTH" IN STYLIZED LETTERING, WITH THE LETTERS "M" AND "H" CAPITALIZED. TO THE LEFT OF THE WORD ARE THE STYLIZED LETTERS "MH", JOINED AND SHARING A COMMON VERTICAL ELEMENT BETWEEN THE LETTERS, WITH A LEAF DESIGN APPEARING AT THE TOP OF THE LETTER "H".

FOR BABY FOOD; DIETARY AND NUTRITIONAL SUPPLEMENTS USED FOR WEIGHT LOSS; DIETARY SUPPLEMENTAL DRINKS; DIETARY SUPPLEMENTS IN THE NATURE OF WEIGHT LOSS POWDERS; ENZYME DIETARY SUPPLEMENTS; ENZYME FOOD SUPPLEMENTS; ENZYMES FOR MEDICAL PURPOSES; FOOD SUPPLEMENTS; HERBAL PILLS AND MIXES FOR THE PSYCHOLOGICAL BENEFIT OF CLEANSING ONE'S KARMA; HERBAL SUPPLEMENTS; HERBS FOR MEDICINAL PURPOSES; NUTRITIONAL SUPPLEMENTS; NUTRITIONALLY FORTIFIED WATER; VITAMIN AND MINERAL SUPPLEMENTS (U.S. CLS. 6, 18, 44, 46, 51 AND 52).

HENRY S. ZAK, EXAMINING ATTORNEY

---

SN 86-237,812. VICTORIA PRINCIPAL PRODUCTIONS, INC., LOS ANGELES, CA. FILED 3-31-2014.

**SERENE INTESTINAL STRENGTH**

THE MARK CONSISTS OF STANDARD CHARACTERS WITHOUT CLAIM TO ANY PARTICULAR FONT, STYLE, SIZE, OR COLOR.

NO CLAIM IS MADE TO THE EXCLUSIVE RIGHT TO USE "INTESTINAL", APART FROM THE MARK AS SHOWN.

FOR DIETARY SUPPLEMENTS FORMULATED TO PROMOTE HEALTHY BALANCE OF PROBIOTIC BACTERIA IN THE INTESTINES; NUTRITIONAL SUPPLEMENTS, NAMELY PROBIOTIC COMPOSITIONS (U.S. CLS. 6, 18, 44, 46, 51 AND 52).

JILLIAN CANTOR, EXAMINING ATTORNEY

**CLASS 5—(Continued).**

SN 86-237,865. BARLOW HERBAL SPECIALTIES, SANDY, UT. FILED 3-31-2014.

**LDM-100**

THE MARK CONSISTS OF STANDARD CHARACTERS WITHOUT CLAIM TO ANY PARTICULAR FONT, STYLE, SIZE, OR COLOR.

FOR MEDICINAL HERBAL EXTRACT OF LOMATIUM DISSECTUM FOR USE AS A NUTRITIONAL SUPPLEMENT FOR MEDICAL PURPOSES (U.S. CLS. 6, 18, 44, 46, 51 AND 52).

FIRST USE 1-1-1976; IN COMMERCE 1-1-1976.  
DAVID MURRAY, EXAMINING ATTORNEY

**CLASS 5—(Continued).**

SN 86-239,405. FARIA LIMITED LLC, DBA DR. SHEFFIELD PHARMACEUTICALS, NEW LONDON, CT. FILED 4-2-2014.

**BLACK-DRAUGHT**

THE MARK CONSISTS OF STANDARD CHARACTERS WITHOUT CLAIM TO ANY PARTICULAR FONT, STYLE, SIZE, OR COLOR.

FOR CATHARTIC MEDICINE FOR ACCELERATING DEFECATION AND LAXATIVE MEDICINE (U.S. CLS. 6, 18, 44, 46, 51 AND 52).

FIRST USE 9-30-1931; IN COMMERCE 9-30-1931.  
ANN E. SAPPENFIELD, EXAMINING ATTORNEY

SN 86-238,016. THREE LOLLIES LLC, WEST HILLS, CA. FILED 3-31-2014.

**Queasy Naturals**

THE MARK CONSISTS OF STANDARD CHARACTERS WITHOUT CLAIM TO ANY PARTICULAR FONT, STYLE, SIZE, OR COLOR.

OWNER OF U.S. REG. NOS. 2,809,228 AND 3,308,463.  
NO CLAIM IS MADE TO THE EXCLUSIVE RIGHT TO USE "NATURALS", APART FROM THE MARK AS SHOWN.  
FOR DIETARY AND NUTRITIONAL SUPPLEMENTS (U.S. CLS. 6, 18, 44, 46, 51 AND 52).

ELLEN BURNS, EXAMINING ATTORNEY

SN 86-239,517. SCHEL, CHARLES L., DBA DIETARY SUPPLEMENT SYSTEMS GLOBAL, LLC, MC CORMICK, SC. FILED 4-2-2014.

**BENEQUINE**

THE MARK CONSISTS OF STANDARD CHARACTERS WITHOUT CLAIM TO ANY PARTICULAR FONT, STYLE, SIZE, OR COLOR.

FOR ANIMAL FEED SUPPLEMENTS; DIETARY AND NUTRITIONAL SUPPLEMENTS; DIETARY AND NUTRITIONAL SUPPLEMENTS CONTAINING BREWER'S YEAST DERIVED NUCLEOTIDES; NUTRITIONAL SUPPLEMENTS, NAMELY, PROBIOTIC COMPOSITIONS; DIETARY PET SUPPLEMENTS IN THE FORM OF PET TREATS; DIETARY SUPPLEMENTS; DIETARY SUPPLEMENTS FOR ANIMALS; DIETARY SUPPLEMENTS FOR PETS; NUTRITIONAL SUPPLEMENTS (U.S. CLS. 6, 18, 44, 46, 51 AND 52).

LESLIE RICHARDS, EXAMINING ATTORNEY

SN 86-238,925. ARGENT AQUACULTURE, LLC, REDMOND, WA. FILED 4-1-2014.

**FINQUEL**

THE MARK CONSISTS OF STANDARD CHARACTERS WITHOUT CLAIM TO ANY PARTICULAR FONT, STYLE, SIZE, OR COLOR.

FOR PHARMACEUTICAL PREPARATIONS FOR FISH AND OTHER AQUATIC ORGANISMS, NAMELY, SEDATIVES (U.S. CLS. 6, 18, 44, 46, 51 AND 52).

CIMMERIAN COLEMAN, EXAMINING ATTORNEY

SN 86-241,880. BIO TRUST NUTRITION, LLC, AUSTIN, TX. FILED 4-3-2014.

**GLUTEN GUARD**

THE MARK CONSISTS OF STANDARD CHARACTERS WITHOUT CLAIM TO ANY PARTICULAR FONT, STYLE, SIZE, OR COLOR.

NO CLAIM IS MADE TO THE EXCLUSIVE RIGHT TO USE "GLUTEN", APART FROM THE MARK AS SHOWN.  
FOR DIETARY AND NUTRITIONAL SUPPLEMENTS (U.S. CLS. 6, 18, 44, 46, 51 AND 52).

FIRST USE 12-7-2009; IN COMMERCE 12-7-2009.  
PAUL CROWLEY, EXAMINING ATTORNEY

**CLASS 5—(Continued).**

SN 86-242,316. EMERGENT PROTECTIVE PRODUCTS CANADA ULC, NS, CANADA, FILED 4-4-2014.



THE MARK CONSISTS OF FLOWER CENTERED INSIDE THE BIOLOGICAL HAZARD SYMBOL.  
FOR TOPICALLY APPLIED SKIN PREPARATION FOR NEUTRALIZING CHEMICAL AGENTS AND/OR TOXINS (U.S. CLS. 6, 18, 44, 46, 51 AND 52).  
KAMAL PREET, EXAMINING ATTORNEY

SN 86-242,365. NEOMEND, INC., IRVINE, CA. FILED 4-4-2014.

**PROGEL PLATINUM**

THE MARK CONSISTS OF STANDARD CHARACTERS WITHOUT CLAIM TO ANY PARTICULAR FONT, STYLE, SIZE, OR COLOR.  
OWNER OF U.S. REG. NO. 3,811,322.  
FOR SURGICAL SEALANT AND ADHESION BARRIER KITS COMPRISED OF INGREDIENTS FOR A HYDROGEL AND AN APPLICATOR FOR THE HYDROGEL (U.S. CLS. 6, 18, 44, 46, 51 AND 52).  
HENRY S. ZAK, EXAMINING ATTORNEY

**CLASS 5—(Continued).**

SN 86-242,663. DR. LOPO'S SKIN SOLUTIONS, TARZANA, CA. FILED 4-4-2014.



THE NAME(S), PORTRAIT(S), AND/OR SIGNATURE(S) SHOWN IN THE MARK IDENTIFIES DR. ALINA LOPO, WHOSE CONSENT(S) TO REGISTER IS MADE OF RECORD.

THE COLOR(S) BLACK, GREEN, AND BROWN IS/ARE CLAIMED AS A FEATURE OF THE MARK.

THE MARK CONSISTS OF THE WORDS "DR. LOPO'S" IN BLACK SANS SERIF SCRIPT WITH THE WORD "ELITE" IN GREEN, PLACED UNDER AND IMMEDIATELY BENEATH THE WORD "LOPO'S" WITH A GREEN SNAKE HAVING AN EXTENDED TONGUE WRAPPED AROUND A BROWN STAFF TO THE LEFT OF ALL WORDS.

FOR DIETARY AND NUTRITIONAL SUPPLEMENTS (U.S. CLS. 6, 18, 44, 46, 51 AND 52).

FIRST USE 1-12-2012; IN COMMERCE 1-12-2012.

GRETTA YAO, EXAMINING ATTORNEY

SN 86-242,905. LO VI POR TV, HIALEEAH, FL. FILED 4-4-2014.

**Maxenafil**

THE MARK CONSISTS OF STANDARD CHARACTERS WITHOUT CLAIM TO ANY PARTICULAR FONT, STYLE, SIZE, OR COLOR.

FOR HERBAL MALE ENHANCEMENT CAPSULES; HERBAL SUPPLEMENTS; HERBAL SUPPLEMENTS FOR SEXUAL ACTIVITY; NATURAL HERBAL SUPPLEMENTS (U.S. CLS. 6, 18, 44, 46, 51 AND 52).

FIRST USE 10-30-2013; IN COMMERCE 10-30-2013.

KATHY WANG, EXAMINING ATTORNEY

**CLASS 5—(Continued).**

SN 86-243,967. FOREST LABORATORIES, INC., NEW YORK, NY. FILED 4-7-2014.

# C-AVI

THE MARK CONSISTS OF STANDARD CHARACTERS WITHOUT CLAIM TO ANY PARTICULAR FONT, STYLE, SIZE, OR COLOR.

FOR PHARMACEUTICAL PREPARATIONS FOR THE TREATMENT OF BACTERIAL INFECTIONS (U.S. CLS. 6, 18, 44, 46, 51 AND 52).

SANJEEV VOHRA, EXAMINING ATTORNEY

---

SN 86-243,970. FOREST LABORATORIES, INC., NEW YORK, NY. FILED 4-7-2014.

# COMBACTIB

THE MARK CONSISTS OF STANDARD CHARACTERS WITHOUT CLAIM TO ANY PARTICULAR FONT, STYLE, SIZE, OR COLOR.

FOR PHARMACEUTICAL PREPARATIONS FOR THE TREATMENT OF BACTERIAL INFECTIONS (U.S. CLS. 6, 18, 44, 46, 51 AND 52).

SANJEEV VOHRA, EXAMINING ATTORNEY

---

SN 86-243,974. FOREST LABORATORIES, INC., NEW YORK, NY. FILED 4-7-2014.

# EXZALTI

THE MARK CONSISTS OF STANDARD CHARACTERS WITHOUT CLAIM TO ANY PARTICULAR FONT, STYLE, SIZE, OR COLOR.

FOR PHARMACEUTICAL PREPARATIONS FOR THE TREATMENT OF BACTERIAL INFECTIONS (U.S. CLS. 6, 18, 44, 46, 51 AND 52).

SANJEEV VOHRA, EXAMINING ATTORNEY

**CLASS 5—(Continued).**

SN 86-244,731. BAYER INTELLECTUAL PROPERTY GMBH, 40789 MONHEIM AM RHEIN, FED REP GERMANY, FILED 4-7-2014.

PROUD SPONSOR OF MIND AND  
BODY

THE MARK CONSISTS OF STANDARD CHARACTERS WITHOUT CLAIM TO ANY PARTICULAR FONT, STYLE, SIZE, OR COLOR.

FOR VITAMIN MINERAL SUPPLEMENTS; DIETARY SUPPLEMENTS (U.S. CLS. 6, 18, 44, 46, 51 AND 52).

FIRST USE 3-24-2014; IN COMMERCE 3-24-2014.

ADA HAN, EXAMINING ATTORNEY

---

SN 86-245,290. QINGDAO TIAN HE XIANG TEXTILE CO.,LTD., SHANDONG, CHINA, FILED 4-8-2014.



THE MARK CONSISTS OF STYLIZED LETTERS "BALE & JESSEE".

FOR BABIES' DIAPERS OF PAPER; BABIES' NAPKIN-PANTS; BABIES' NAPKINS; BABY DIAPERS; DIAPERS FOR INCONTINENCE; DISPOSABLE BABY DIAPERS; DISPOSABLE DIAPERS FOR INCONTINENCE; FOOD FOR BABIES; INCONTINENCE DIAPERS; PANTY LINERS; POWDERED MILK FOR BABIES; SANITARY NAPKINS; SANITARY PADS; SANITARY PANTIES (U.S. CLS. 6, 18, 44, 46, 51 AND 52).

FIRST USE 8-6-2013; IN COMMERCE 8-6-2013.

JOHN WILKE, EXAMINING ATTORNEY

**CLASS 5—(Continued).**

SN 86-245,485. JOHNSON & JOHNSON, NEW BRUNSWICK, NJ. FILED 4-8-2014.

**DOKTOR MOM**

THE MARK CONSISTS OF STANDARD CHARACTERS WITHOUT CLAIM TO ANY PARTICULAR FONT, STYLE, SIZE, OR COLOR.

FOR PHARMACEUTICAL AND MEDICAL HERBAL PREPARATIONS FOR THE RELIEF AND PREVENTION OF UPPER RESPIRATORY, SORE THROAT, AND COUGH AND COLD SYMPTOMS (U.S. CLS. 6, 18, 44, 46, 51 AND 52).

MEREDITH MARESCA, EXAMINING ATTORNEY



SN 86-245,514. VITALAST LLC, POUND RIDGE, NY. FILED 4-8-2014.

**BrighterDay**

THE MARK CONSISTS OF STANDARD CHARACTERS WITHOUT CLAIM TO ANY PARTICULAR FONT, STYLE, SIZE, OR COLOR.

FOR DIETARY AND NUTRITIONAL SUPPLEMENTS (U.S. CLS. 6, 18, 44, 46, 51 AND 52).

APRIL HESIK, EXAMINING ATTORNEY



SN 86-245,620. MODUS3, LLC, DBA HUMANOLABS, LAS VEGAS, NV. FILED 4-8-2014.

**HUMANOLABS**

THE MARK CONSISTS OF STANDARD CHARACTERS WITHOUT CLAIM TO ANY PARTICULAR FONT, STYLE, SIZE, OR COLOR.

FOR DIETARY SUPPLEMENTS; NUTRITIONAL SUPPLEMENTS (U.S. CLS. 6, 18, 44, 46, 51 AND 52).

FIRST USE 10-25-2013; IN COMMERCE 10-25-2013.

HEATHER SAPP, EXAMINING ATTORNEY

**CLASS 5—(Continued).**

SN 86-245,623. TRIBRAVUS ENTERPRISES, LLC, DBA IFORCE NUTRITION, VISTA, CA. FILED 4-8-2014.

**MAX OUT**

THE MARK CONSISTS OF STANDARD CHARACTERS WITHOUT CLAIM TO ANY PARTICULAR FONT, STYLE, SIZE, OR COLOR.

FOR DIETARY AND NUTRITIONAL SUPPLEMENTS (U.S. CLS. 6, 18, 44, 46, 51 AND 52).

DAVID TAYLOR, EXAMINING ATTORNEY



SN 86-246,074. CEPHAM INC, PISCATAWAY, NJ. FILED 4-8-2014.

**Suppressatite**

THE MARK CONSISTS OF STANDARD CHARACTERS WITHOUT CLAIM TO ANY PARTICULAR FONT, STYLE, SIZE, OR COLOR.

FOR DIETARY AND NUTRITIONAL SUPPLEMENTS; DIETARY SUPPLEMENTAL DRINKS; DIETARY SUPPLEMENTAL DRINKS IN THE NATURE OF VITAMIN AND MINERAL BEVERAGES; DIETARY SUPPLEMENTS; DIETARY SUPPLEMENTS FOR CONTROLLING CHOLESTEROL; DIETARY SUPPLEMENTS FOR HUMAN CONSUMPTION; FOOD SUPPLEMENTS; HEALTH FOOD SUPPLEMENTS; HERBAL SUPPLEMENTS; LIQUID HERBAL SUPPLEMENTS; LIQUID NUTRITIONAL SUPPLEMENT; NATURAL HERBAL SUPPLEMENTS; NUTRITIONAL AND DIETARY SUPPLEMENTS FORMED AND PACKAGED AS BARS; NUTRITIONAL SUPPLEMENT MEAL REPLACEMENT BARS FOR BOOSTING ENERGY; NUTRITIONAL SUPPLEMENT SHAKES; POWDERED NUTRITIONAL SUPPLEMENT CONCENTRATE; POWDERED NUTRITIONAL SUPPLEMENT DRINK MIX (U.S. CLS. 6, 18, 44, 46, 51 AND 52).

DAWN FELDMAN, EXAMINING ATTORNEY

**CLASS 5—(Continued).**

SN 86-246,407. ACOUSYS BIODEVICES INC, PITTSBURGH, PA. FILED 4-8-2014.

# ACOUSYS

THE MARK CONSISTS OF STANDARD CHARACTERS WITHOUT CLAIM TO ANY PARTICULAR FONT, STYLE, SIZE, OR COLOR.

FOR DIAGNOSTIC PRODUCTS, NAMELY, REAGENTS AND ASSAYS, FOR PREPARING AND ANALYZING SAMPLES FOR USE IN DETECTING, ENUMERATING, ANALYZING, CHARACTERIZING AND CAPTURING CIRCULATING TUMOR CELLS AND PATHOGENS, NAMELY, BACTERIA, FUNGI, PARASITES AND VIRUSES FOR MEDICAL PURPOSES; CHEMICAL, BIOCHEMICAL AND BIOLOGICAL SUBSTANCES, REAGENTS AND PREPARATIONS FOR THE DETECTION AND IDENTIFICATION OF PATHOGENS, NAMELY, BACTERIA, FUNGI, PARASITES AND VIRUSES, FOR MEDICAL PURPOSES (U.S. CLS. 6, 18, 44, 46, 51 AND 52).

DOUGLAS LEE, EXAMINING ATTORNEY

SN 86-246,639. THE NATURAL VET LLC, UNICOI, TN. FILED 4-9-2014.

# NATURE FOR LIFE

THE MARK CONSISTS OF STANDARD CHARACTERS WITHOUT CLAIM TO ANY PARTICULAR FONT, STYLE, SIZE, OR COLOR.

FOR FOOD SUPPLEMENTS FOR HUMANS AND ANIMALS (U.S. CLS. 6, 18, 44, 46, 51 AND 52).  
FIRST USE 3-1-2005; IN COMMERCE 4-1-2005.  
LINDA M. KING, EXAMINING ATTORNEY

SN 86-246,707. LYCORED CORP., ORANGE, NJ. FILED 4-9-2014.

# NOVAHUE

THE MARK CONSISTS OF STANDARD CHARACTERS WITHOUT CLAIM TO ANY PARTICULAR FONT, STYLE, SIZE, OR COLOR.

FOR DIETARY SUPPLEMENTS (U.S. CLS. 6, 18, 44, 46, 51 AND 52).

DOMINICK J. SALEMI, EXAMINING ATTORNEY

**CLASS 5—(Continued).**

SN 86-246,738. LYCORED CORP., ORANGE, NJ. FILED 4-9-2014.

# CAR-O-BLENDS

THE MARK CONSISTS OF STANDARD CHARACTERS WITHOUT CLAIM TO ANY PARTICULAR FONT, STYLE, SIZE, OR COLOR.

FOR DIETARY SUPPLEMENTS (U.S. CLS. 6, 18, 44, 46, 51 AND 52).

DOMINICK J. SALEMI, EXAMINING ATTORNEY

SN 86-246,756. Y-TEX CORPORATION, CODY, WY. FILED 4-9-2014.

# FBP23

THE MARK CONSISTS OF STANDARD CHARACTERS WITHOUT CLAIM TO ANY PARTICULAR FONT, STYLE, SIZE, OR COLOR.

FOR INSECTICIDES (U.S. CLS. 6, 18, 44, 46, 51 AND 52).

DOMINICK J. SALEMI, EXAMINING ATTORNEY

SN 86-247,020. LIVE WELL ALTERNATIVES, LLC, MAPLE GROVE, MN. FILED 4-9-2014.

# Live Well Alternatives

THE MARK CONSISTS OF STANDARD CHARACTERS WITHOUT CLAIM TO ANY PARTICULAR FONT, STYLE, SIZE, OR COLOR.

FOR INSECT REPELLENT AGENTS; INSECT REPELLENTS (U.S. CLS. 6, 18, 44, 46, 51 AND 52).

ELLEN PERKINS, EXAMINING ATTORNEY



**CLASS 5—(Continued).**

SN 86-247,055. INDEVCO FLEXIBLE PACKAGING, INC.,  
ARLINGTON, VA. FILED 4-9-2014.

# ELEGANCE

THE MARK CONSISTS OF STANDARD CHARACTERS  
WITHOUT CLAIM TO ANY PARTICULAR FONT, STYLE,  
SIZE, OR COLOR.

FOR ADULT DIAPERS (U.S. CLS. 6, 18, 44, 46, 51 AND  
52).  
MICHAEL ENGEL, EXAMINING ATTORNEY



SN 86-247,328. 24 HR, RENO, NV. FILED 4-9-2014.

# OVER IT

THE MARK CONSISTS OF STANDARD CHARACTERS  
WITHOUT CLAIM TO ANY PARTICULAR FONT, STYLE,  
SIZE, OR COLOR.

FOR COLD SORE TREATMENT PREPARATIONS (U.S.  
CLS. 6, 18, 44, 46, 51 AND 52).  
ALISON KEELEY, EXAMINING ATTORNEY



SN 86-247,624. ROBERT EDWARDS, VANCOUVER, BC,  
CANADA, FILED 4-9-2014.

# TRIPLE RIPPLE

THE MARK CONSISTS OF STANDARD CHARACTERS  
WITHOUT CLAIM TO ANY PARTICULAR FONT, STYLE,  
SIZE, OR COLOR.

FOR NUTRITIONAL SUPPLEMENTS (U.S. CLS. 6, 18,  
44, 46, 51 AND 52).  
FIRST USE 3-7-2014; IN COMMERCE 3-7-2014.  
B. PARADEWELAI, EXAMINING ATTORNEY

**CLASS 5—(Continued).**

SN 86-248,158. INDEVCO FLEXIBLE PACKAGING, INC.,  
ARLINGTON, VA. FILED 4-10-2014.

# BABY DREAMS

THE MARK CONSISTS OF STANDARD CHARACTERS  
WITHOUT CLAIM TO ANY PARTICULAR FONT, STYLE,  
SIZE, OR COLOR.

NO CLAIM IS MADE TO THE EXCLUSIVE RIGHT TO  
USE "BABY", APART FROM THE MARK AS SHOWN.  
FOR DIAPERS (U.S. CLS. 6, 18, 44, 46, 51 AND 52).  
MICHAEL ENGEL, EXAMINING ATTORNEY



SN 86-248,366. JOHNSON & JOHNSON, NEW BRUNSWICK,  
NJ. FILED 4-10-2014.

# BRINFORT

THE MARK CONSISTS OF STANDARD CHARACTERS  
WITHOUT CLAIM TO ANY PARTICULAR FONT, STYLE,  
SIZE, OR COLOR.

FOR HUMAN PHARMACEUTICAL PREPARATIONS  
FOR THE PREVENTION OR TREATMENT OF VIRAL  
DISEASES, AUTO-IMMUNE AND INFLAMMATORY  
DISEASES, CARDIOVASCULAR DISEASES, CENTRAL  
NERVOUS SYSTEM DISEASES, PAIN, DERMATOLOGIC  
DISEASES, GASTRO-INTESTINAL DISEASES, INFEC-  
TIOUS-RELATED DISEASES, METABOLIC DISEASES,  
ONCOLOGIC DISEASES, OPHTHALMIC DISEASES,  
AND RESPIRATORY DISEASES (U.S. CLS. 6, 18, 44, 46,  
51 AND 52).  
JAMES LOVELACE, EXAMINING ATTORNEY



SN 86-248,368. JOHNSON & JOHNSON, NEW BRUNSWICK,  
NJ. FILED 4-10-2014.

# CALEQUE

THE MARK CONSISTS OF STANDARD CHARACTERS  
WITHOUT CLAIM TO ANY PARTICULAR FONT, STYLE,  
SIZE, OR COLOR.

FOR HUMAN PHARMACEUTICAL PREPARATIONS  
FOR THE PREVENTION OR TREATMENT OF VIRAL  
DISEASES, AUTO-IMMUNE AND INFLAMMATORY  
DISEASES, CARDIOVASCULAR DISEASES, CENTRAL  
NERVOUS SYSTEM DISEASES, PAIN, DERMATOLOGIC  
DISEASES, GASTRO-INTESTINAL DISEASES, INFEC-  
TIOUS-RELATED DISEASES, METABOLIC DISEASES,  
ONCOLOGIC DISEASES, OPHTHALMIC DISEASES,  
AND RESPIRATORY DISEASES (U.S. CLS. 6, 18, 44, 46,  
51 AND 52).  
JAMES LOVELACE, EXAMINING ATTORNEY

**CLASS 5—(Continued).**

SN 86-248,370. JOHNSON & JOHNSON, NEW BRUNSWICK, NJ. FILED 4-10-2014.

**COMPREON**

THE MARK CONSISTS OF STANDARD CHARACTERS WITHOUT CLAIM TO ANY PARTICULAR FONT, STYLE, SIZE, OR COLOR.

FOR HUMAN PHARMACEUTICAL PREPARATIONS FOR THE PREVENTION OR TREATMENT OF VIRAL DISEASES, AUTO-IMMUNE AND INFLAMMATORY DISEASES, CARDIOVASCULAR DISEASES, CENTRAL NERVOUS SYSTEM DISEASES, PAIN, DERMATOLOGIC DISEASES, GASTRO-INTESTINAL DISEASES, INFECTIOUS-RELATED DISEASES, METABOLIC DISEASES, ONCOLOGIC DISEASES, OPHTHALMIC DISEASES, AND RESPIRATORY DISEASES (U.S. CLS. 6, 18, 44, 46, 51 AND 52).

JAMES LOVELACE, EXAMINING ATTORNEY

SN 86-248,373. JOHNSON & JOHNSON, NEW BRUNSWICK, NJ. FILED 4-10-2014.

**ECCELIO**

THE MARK CONSISTS OF STANDARD CHARACTERS WITHOUT CLAIM TO ANY PARTICULAR FONT, STYLE, SIZE, OR COLOR.

FOR HUMAN PHARMACEUTICAL PREPARATIONS FOR THE PREVENTION OR TREATMENT OF VIRAL DISEASES, AUTO-IMMUNE AND INFLAMMATORY DISEASES, CARDIOVASCULAR DISEASES, CENTRAL NERVOUS SYSTEM DISEASES, PAIN, DERMATOLOGIC DISEASES, GASTRO-INTESTINAL DISEASES, INFECTIOUS-RELATED DISEASES, METABOLIC DISEASES, ONCOLOGIC DISEASES, OPHTHALMIC DISEASES, AND RESPIRATORY DISEASES (U.S. CLS. 6, 18, 44, 46, 51 AND 52).

JAMES LOVELACE, EXAMINING ATTORNEY

**CLASS 5—(Continued).**

SN 86-248,374. JOHNSON & JOHNSON, NEW BRUNSWICK, NJ. FILED 4-10-2014.

**EFRIDOM**

THE MARK CONSISTS OF STANDARD CHARACTERS WITHOUT CLAIM TO ANY PARTICULAR FONT, STYLE, SIZE, OR COLOR.

FOR HUMAN PHARMACEUTICAL PREPARATIONS FOR THE PREVENTION OR TREATMENT OF VIRAL DISEASES, AUTO-IMMUNE AND INFLAMMATORY DISEASES, CARDIOVASCULAR DISEASES, CENTRAL NERVOUS SYSTEM DISEASES, PAIN, DERMATOLOGIC DISEASES, GASTRO-INTESTINAL DISEASES, INFECTIOUS-RELATED DISEASES, METABOLIC DISEASES, ONCOLOGIC DISEASES, OPHTHALMIC DISEASES, AND RESPIRATORY DISEASES (U.S. CLS. 6, 18, 44, 46, 51 AND 52).

JAMES LOVELACE, EXAMINING ATTORNEY

SN 86-248,378. JOHNSON & JOHNSON, NEW BRUNSWICK, NJ. FILED 4-10-2014.

**VIANEER**

THE MARK CONSISTS OF STANDARD CHARACTERS WITHOUT CLAIM TO ANY PARTICULAR FONT, STYLE, SIZE, OR COLOR.

FOR HUMAN PHARMACEUTICAL PREPARATIONS FOR THE PREVENTION OR TREATMENT OF VIRAL DISEASES, AUTO-IMMUNE AND INFLAMMATORY DISEASES, CARDIOVASCULAR DISEASES, CENTRAL NERVOUS SYSTEM DISEASES, PAIN, DERMATOLOGIC DISEASES, GASTRO-INTESTINAL DISEASES, INFECTIOUS-RELATED DISEASES, METABOLIC DISEASES, ONCOLOGIC DISEASES, OPHTHALMIC DISEASES, AND RESPIRATORY DISEASES (U.S. CLS. 6, 18, 44, 46, 51 AND 52).

JAMES LOVELACE, EXAMINING ATTORNEY

SN 86-248,680. VINCO, INC, EVANS CITY, PA. FILED 4-10-2014.

**Goutch**

THE MARK CONSISTS OF STANDARD CHARACTERS WITHOUT CLAIM TO ANY PARTICULAR FONT, STYLE, SIZE, OR COLOR.

FOR HEALTH FOOD SUPPLEMENTS (U.S. CLS. 6, 18, 44, 46, 51 AND 52).

FIRST USE 4-1-2014; IN COMMERCE 4-1-2014.

MARC LEIPZIG, EXAMINING ATTORNEY

**CLASS 5—(Continued).**

SN 86-248,818. CROSS VETPHARM GROUP LIMITED, DUBLIN 24, IRELAND, FILED 4-10-2014.

# DERRACOX

THE MARK CONSISTS OF STANDARD CHARACTERS WITHOUT CLAIM TO ANY PARTICULAR FONT, STYLE, SIZE, OR COLOR.  
FOR VETERINARY PHARMACEUTICAL PREPARATIONS AND SUBSTANCES, NAMELY, ANALGESICS AND ANTI-INFLAMMATORY AGENTS (U.S. CLS. 6, 18, 44, 46, 51 AND 52).  
MEGHAN REINHART, EXAMINING ATTORNEY

**CLASS 5—(Continued).**

SN 86-249,060. EVERGREEN HERBS INTERNATIONAL, LLC, CITY OF INDUSTRY, CA. FILED 4-10-2014.

# DERMATROL

THE MARK CONSISTS OF STANDARD CHARACTERS WITHOUT CLAIM TO ANY PARTICULAR FONT, STYLE, SIZE, OR COLOR.  
FOR DIETARY SUPPLEMENTS (U.S. CLS. 6, 18, 44, 46, 51 AND 52).  
FIRST USE 4-0-2002; IN COMMERCE 4-0-2002.  
JENNIFER BUTTON, EXAMINING ATTORNEY

SN 86-248,825. CROSS VETPHARM GROUP LIMITED, DUBLIN 24, IRELAND, FILED 4-10-2014.

# PANAZOLE

THE MARK CONSISTS OF STANDARD CHARACTERS WITHOUT CLAIM TO ANY PARTICULAR FONT, STYLE, SIZE, OR COLOR.  
FOR VETERINARY PHARMACEUTICAL PREPARATIONS AND SUBSTANCES, NAMELY, ANTHELMINTICS (U.S. CLS. 6, 18, 44, 46, 51 AND 52).  
MEGHAN REINHART, EXAMINING ATTORNEY

SN 86-249,718. CROSS VETPHARM GROUP LIMITED, DUBLIN 24, IRELAND, FILED 4-11-2014.

# DEXDOMED

THE MARK CONSISTS OF STANDARD CHARACTERS WITHOUT CLAIM TO ANY PARTICULAR FONT, STYLE, SIZE, OR COLOR.  
FOR VETERINARY PHARMACEUTICAL PREPARATIONS AND SUBSTANCES, NAMELY, ANXIOLYTICS, ANALGESICS AND SEDATIVES (U.S. CLS. 6, 18, 44, 46, 51 AND 52).  
MEGHAN REINHART, EXAMINING ATTORNEY

SN 86-248,826. CROSS VETPHARM GROUP LIMITED, DUBLIN 24, IRELAND, FILED 4-10-2014.

# KEFAMAST

THE MARK CONSISTS OF STANDARD CHARACTERS WITHOUT CLAIM TO ANY PARTICULAR FONT, STYLE, SIZE, OR COLOR.  
FOR VETERINARY PHARMACEUTICAL PREPARATIONS AND SUBSTANCES, NAMELY, ANTIBACTERIAL AGENTS (U.S. CLS. 6, 18, 44, 46, 51 AND 52).  
MEGHAN REINHART, EXAMINING ATTORNEY

SN 86-250,003. MSD CONSUMER CARE, INC., MEMPHIS, TN. FILED 4-11-2014.

# ALLERGEDDON

THE MARK CONSISTS OF STANDARD CHARACTERS WITHOUT CLAIM TO ANY PARTICULAR FONT, STYLE, SIZE, OR COLOR.  
FOR ANTI-ALLERGY PREPARATIONS; ANTIHISTAMINE PREPARATIONS; AND DECONGESTANT PREPARATIONS (U.S. CLS. 6, 18, 44, 46, 51 AND 52).  
PAUL E. FAHRENKOPF, EXAMINING ATTORNEY

**CLASS 5—(Continued).**

SN 86-250,067. CROSS VETPHARM GROUP LIMITED, DUBLIN 24, IRELAND, FILED 4-11-2014.

## EPRIMECTIN

THE MARK CONSISTS OF STANDARD CHARACTERS WITHOUT CLAIM TO ANY PARTICULAR FONT, STYLE, SIZE, OR COLOR.

FOR VETERINARY PHARMACEUTICAL PREPARATIONS AND SUBSTANCES, NAMELY, ANTHELMINTICS (U.S. CLS. 6, 18, 44, 46, 51 AND 52).  
MEGHAN REINHART, EXAMINING ATTORNEY

**CLASS 5—(Continued).**

SN 86-250,222. PERFORMANCE RESEARCH LABORATORIES, INC., ANAHEIM, CA. FILED 4-11-2014.

## breathreanu

THE MARK CONSISTS OF STANDARD CHARACTERS WITHOUT CLAIM TO ANY PARTICULAR FONT, STYLE, SIZE, OR COLOR.

FOR NUTRACEUTICALS FOR USE AS A DIETARY SUPPLEMENT FOR LUNG SUPPORT (U.S. CLS. 6, 18, 44, 46, 51 AND 52).  
FIRST USE 4-1-2014; IN COMMERCE 4-1-2014.  
JENNIFER BUTTON, EXAMINING ATTORNEY

SN 86-250,070. CROSS VETPHARM GROUP LIMITED, DUBLIN 24, IRELAND, FILED 4-11-2014.

## BIMOXYL

THE MARK CONSISTS OF STANDARD CHARACTERS WITHOUT CLAIM TO ANY PARTICULAR FONT, STYLE, SIZE, OR COLOR.

FOR VETERINARY PHARMACEUTICAL PREPARATIONS AND SUBSTANCES, NAMELY, ANTIBACTERIAL AGENTS (U.S. CLS. 6, 18, 44, 46, 51 AND 52).  
MEGHAN REINHART, EXAMINING ATTORNEY

SN 86-250,657. SAN MILLAN FRANCISCO, MEXICO, MEXICO, FILED 4-12-2014.

## MOREMOTION

THE MARK CONSISTS OF STANDARD CHARACTERS WITHOUT CLAIM TO ANY PARTICULAR FONT, STYLE, SIZE, OR COLOR.

FOR DIETARY AND NUTRITIONAL SUPPLEMENTS (U.S. CLS. 6, 18, 44, 46, 51 AND 52).  
DANIEL CAPSHAW, EXAMINING ATTORNEY

SN 86-250,147. VOWTO INC., DENVER, CO. FILED 4-11-2014.

## VowTo Nourish

THE MARK CONSISTS OF STANDARD CHARACTERS WITHOUT CLAIM TO ANY PARTICULAR FONT, STYLE, SIZE, OR COLOR.

FOR DIETARY AND NUTRITIONAL SUPPLEMENTS; NUTRITIONAL SUPPLEMENT SHAKES (U.S. CLS. 6, 18, 44, 46, 51 AND 52).  
GINA HAYES, EXAMINING ATTORNEY

SN 86-250,705. SPIELBERG, MAX, LOS ANGELES, CA. FILED 4-13-2014.

## COUGH CRUSH

THE MARK CONSISTS OF STANDARD CHARACTERS WITHOUT CLAIM TO ANY PARTICULAR FONT, STYLE, SIZE, OR COLOR.

NO CLAIM IS MADE TO THE EXCLUSIVE RIGHT TO USE "COUGH", APART FROM THE MARK AS SHOWN.  
FOR DIETARY AND NUTRITIONAL SUPPLEMENTS (U.S. CLS. 6, 18, 44, 46, 51 AND 52).  
COLLEEN DOMBROW, EXAMINING ATTORNEY

**CLASS 5—(Continued).**

SN 86-250,754. SCHELLING, CHRISTIANNE, THREE RIVERS, CA. FILED 4-13-2014.

**ACNECEUTICALS**

THE MARK CONSISTS OF STANDARD CHARACTERS WITHOUT CLAIM TO ANY PARTICULAR FONT, STYLE, SIZE, OR COLOR.

OWNER OF U.S. REG. NO. 4,125,625.  
FOR ACNE TREATMENT PREPARATIONS (U.S. CLS. 6, 18, 44, 46, 51 AND 52).  
FIRST USE 12-1-2003; IN COMMERCE 12-1-2003.  
TEJBIR SINGH, EXAMINING ATTORNEY

SN 86-250,803. GUERRERO, CRISTOBAL, PALM SPRINGS, FL. FILED 4-13-2014.

**GREENACID**

THE MARK CONSISTS OF STANDARD CHARACTERS WITHOUT CLAIM TO ANY PARTICULAR FONT, STYLE, SIZE, OR COLOR.

FOR ANTACIDS; DIGESTIVES FOR PHARMACEUTICAL PURPOSES (U.S. CLS. 6, 18, 44, 46, 51 AND 52).  
FIRST USE 1-21-2014; IN COMMERCE 1-21-2014.  
JENNY PARK, EXAMINING ATTORNEY

SN 86-251,472. SMM MANUFACTURING INC., LOS ANGELES, CA. FILED 4-14-2014.

**Auto Shocker**

THE MARK CONSISTS OF STANDARD CHARACTERS WITHOUT CLAIM TO ANY PARTICULAR FONT, STYLE, SIZE, OR COLOR.

OWNER OF U.S. REG. NO. 3,997,408.  
NO CLAIM IS MADE TO THE EXCLUSIVE RIGHT TO USE "AUTO", APART FROM THE MARK AS SHOWN.  
FOR CAR DEODORIZER; DEODORIZER FOR AUTOMOBILES (U.S. CLS. 6, 18, 44, 46, 51 AND 52).  
FIRST USE 8-1-2008; IN COMMERCE 8-1-2008.  
JESSICA A. POWERS, EXAMINING ATTORNEY

**CLASS 5—(Continued).**

SN 86-251,546. CROSS VETPHARM GROUP LIMITED, DUBLIN 24, IRELAND, FILED 4-14-2014.

**ANTISEDAMED**

THE MARK CONSISTS OF STANDARD CHARACTERS WITHOUT CLAIM TO ANY PARTICULAR FONT, STYLE, SIZE, OR COLOR.

FOR VETERINARY PHARMACEUTICAL PREPARATIONS AND SUBSTANCES, NAMELY, AGENTS FOR REVERSING THE EFFECTS OF ANALGESICS AND SEDATIVES (U.S. CLS. 6, 18, 44, 46, 51 AND 52).  
MEGHAN REINHART, EXAMINING ATTORNEY

SN 86-251,562. BAYER INTELLECTUAL PROPERTY GMBH, MONHEIM AM RHEIN, FED REP GERMANY, FILED 4-14-2014.



OWNER OF ERPN CMNTY TM OFC REG. NO. 011521333, DATED 6-24-2013, EXPIRES 1-28-2023.

THE COLORS SILVER, GREY, ORANGE AND RED ARE CLAIMED AS A FEATURE OF THE MARK.

THE MARK CONSISTS OF TWO OVERLAPPING CURVE DESIGNS WITH THE COLORS RED AND ORANGE ON THE EXTERIOR SURFACE OF THE CURVES AND THE COLORS GREY AND SILVER ON THE INTERIOR SURFACE OF THE CURVES.

FOR PHARMACEUTICAL PREPARATIONS FOR THE TREATMENT OF PULMONARY HYPERTENSION AND CARDIOVASCULAR DISEASES (U.S. CLS. 6, 18, 44, 46, 51 AND 52).

ADA HAN, EXAMINING ATTORNEY

SN 86-251,965. MACULAR HEALTH, LLC, GARDENDALE, AL. FILED 4-14-2014.

**BLEPHADEX**

THE MARK CONSISTS OF STANDARD CHARACTERS WITHOUT CLAIM TO ANY PARTICULAR FONT, STYLE, SIZE, OR COLOR.

FOR EYELID CLEANSER FOR MEDICAL USE, NAMELY, EYELID CLEANSER FOR USE IN THE TREATMENT OF BLEPHARITIS AND DEMODEX (U.S. CLS. 6, 18, 44, 46, 51 AND 52).

ELLEN B. AWRICH, EXAMINING ATTORNEY

**CLASS 5—(Continued).**

SN 86-254,860. HEALTHY DIRECTIONS, LLC, BETHESDA, MD. FILED 4-17-2014.

# OXYJOINT

THE MARK CONSISTS OF STANDARD CHARACTERS WITHOUT CLAIM TO ANY PARTICULAR FONT, STYLE, SIZE, OR COLOR.

FOR DIETARY AND NUTRITIONAL SUPPLEMENTS; DIETARY AND NUTRITIONAL SUPPLEMENTS FOR JOINT SUPPORT; NONE OF THE ABOVE FOR SKIN CARE AND ACNE CARE (U.S. CLS. 6, 18, 44, 46, 51 AND 52).

DANIEL CAPSHAW, EXAMINING ATTORNEY

**CLASS 5—(Continued).**

SN 86-265,677. WOODBOLT DISTRIBUTION, LLC, BRYAN, TX. FILED 4-29-2014.

# SIEGE

THE MARK CONSISTS OF STANDARD CHARACTERS WITHOUT CLAIM TO ANY PARTICULAR FONT, STYLE, SIZE, OR COLOR.

FOR DIETARY AND NUTRITIONAL SUPPLEMENTS (U.S. CLS. 6, 18, 44, 46, 51 AND 52).

FIRST USE 6-1-2013; IN COMMERCE 6-1-2013.

SETH A. RAPPAPORT, EXAMINING ATTORNEY

SN 86-261,678. IMAGE SPORTS, LLC, HOLLYWOOD, FL. FILED 4-24-2014.

# FAST WHEY

THE MARK CONSISTS OF STANDARD CHARACTERS WITHOUT CLAIM TO ANY PARTICULAR FONT, STYLE, SIZE, OR COLOR.

NO CLAIM IS MADE TO THE EXCLUSIVE RIGHT TO USE "WHEY", APART FROM THE MARK AS SHOWN.

FOR DIETARY AND NUTRITIONAL SUPPLEMENTS CONTAINING WHEY (U.S. CLS. 6, 18, 44, 46, 51 AND 52).

JAMES GRIFFIN, EXAMINING ATTORNEY

SN 86-266,494. SPIELBERG, MAX, LOS ANGELES, CA. FILED 4-29-2014.

# PAIN CRUSH

THE MARK CONSISTS OF STANDARD CHARACTERS WITHOUT CLAIM TO ANY PARTICULAR FONT, STYLE, SIZE, OR COLOR.

NO CLAIM IS MADE TO THE EXCLUSIVE RIGHT TO USE "PAIN", APART FROM THE MARK AS SHOWN.

FOR DIETARY AND NUTRITIONAL SUPPLEMENTS (U.S. CLS. 6, 18, 44, 46, 51 AND 52).

COLLEEN DOMBROW, EXAMINING ATTORNEY

SN 86-262,976. PURDUE PHARMA L.P., STAMFORD, CT. FILED 4-25-2014.



The logo for TARGINIQ ER features a stylized diamond shape on the left, composed of two interlocking curved triangles. To the right of this symbol, the words "TARGINIQ ER" are written in a bold, sans-serif font.

NO CLAIM IS MADE TO THE EXCLUSIVE RIGHT TO USE "ER", APART FROM THE MARK AS SHOWN.

THE MARK CONSISTS OF THE TERMS "TARGINIQ ER" TO THE RIGHT OF A DESIGN OF INTERLOCKING CURVED TRIANGLES WHICH FORM A DIAMOND IN THE MIDDLE.

FOR ANALGESICS (U.S. CLS. 6, 18, 44, 46, 51 AND 52).  
RONALD AIKENS, EXAMINING ATTORNEY

SN 86-266,974. CINTAS HOLDINGS LLC, MASON, OH. FILED 4-30-2014.

# QUIKHEAL

THE MARK CONSISTS OF STANDARD CHARACTERS WITHOUT CLAIM TO ANY PARTICULAR FONT, STYLE, SIZE, OR COLOR.

FOR ADHESIVE BANDAGES; BANDAGES FOR SKIN WOUNDS (U.S. CLS. 6, 18, 44, 46, 51 AND 52).

FIRST USE 10-30-2010; IN COMMERCE 10-30-2010.

APRIL HESIK, EXAMINING ATTORNEY

**CLASS 5—(Continued).**

SN 86-267,687. RARE ANTIBODY ANTIGEN SUPPLY, INC.,  
AGOURA HILLS, CA. FILED 4-30-2014.

**KH POWER DRINKS**

THE MARK CONSISTS OF STANDARD CHARACTERS  
WITHOUT CLAIM TO ANY PARTICULAR FONT, STYLE,  
SIZE, OR COLOR.

NO CLAIM IS MADE TO THE EXCLUSIVE RIGHT TO  
USE "DRINKS", APART FROM THE MARK AS SHOWN.

FOR DIETARY AND NUTRITIONAL SUPPLEMENTS;  
LIQUID NUTRITIONAL SUPPLEMENT; POWDERED  
NUTRITIONAL SUPPLEMENT CONCENTRATE (U.S.  
CLS. 6, 18, 44, 46, 51 AND 52).

JOHN HWANG, EXAMINING ATTORNEY

SN 86-268,561. CROSS VETPHARM GROUP LIMITED,  
DUBLIN 24, IRELAND, FILED 5-1-2014.

**PROSTAMED**

THE MARK CONSISTS OF STANDARD CHARACTERS  
WITHOUT CLAIM TO ANY PARTICULAR FONT, STYLE,  
SIZE, OR COLOR.

FOR VETERINARY PHARMACEUTICAL PREPARA-  
TIONS AND SUBSTANCES, NAMELY, ABORTIFA-  
CIENTS AND AGENTS FOR INDUCTION OF LABOUR  
(U.S. CLS. 6, 18, 44, 46, 51 AND 52).

MEGHAN REINHART, EXAMINING ATTORNEY

SN 86-269,108. MAXIMUM HUMAN PERFORMANCE, LLC,  
FAIRFIELD, NJ. FILED 5-1-2014.

**MUSCLE MEAT**

THE MARK CONSISTS OF STANDARD CHARACTERS  
WITHOUT CLAIM TO ANY PARTICULAR FONT, STYLE,  
SIZE, OR COLOR.

NO CLAIM IS MADE TO THE EXCLUSIVE RIGHT TO  
USE "MUSCLE", APART FROM THE MARK AS SHOWN.

FOR DIETARY AND NUTRITIONAL SUPPLEMENTS  
(U.S. CLS. 6, 18, 44, 46, 51 AND 52).

JAY FLOWERS, EXAMINING ATTORNEY

**CLASS 5—(Continued).**

SN 86-271,720. AMS HEALTH SCIENCES LLC, OKLAHOMA  
CITY, OK. FILED 5-5-2014.

**SKINNY5000**

THE MARK CONSISTS OF STANDARD CHARACTERS  
WITHOUT CLAIM TO ANY PARTICULAR FONT, STYLE,  
SIZE, OR COLOR.

FOR DIETARY AND NUTRITIONAL SUPPLEMENTS  
(U.S. CLS. 6, 18, 44, 46, 51 AND 52).

JENNIFER BUTTON, EXAMINING ATTORNEY

SN 86-272,605. CHURCH & DWIGHT CO., INC., EWING, NJ.  
FILED 5-6-2014.

**IMMUNE WELL**

THE MARK CONSISTS OF STANDARD CHARACTERS  
WITHOUT CLAIM TO ANY PARTICULAR FONT, STYLE,  
SIZE, OR COLOR.

NO CLAIM IS MADE TO THE EXCLUSIVE RIGHT TO  
USE "IMMUNE", APART FROM THE MARK AS SHOWN.

FOR DIETARY AND NUTRITIONAL SUPPLEMENTS;  
MINERAL SUPPLEMENTS; VITAMINS (U.S. CLS. 6, 18,  
44, 46, 51 AND 52).

TARAH HARDY, EXAMINING ATTORNEY

SN 86-273,653. MEDTECH PRODUCTS INC., TARRYTOWN,  
NY. FILED 5-6-2014.

**LIQUID-FAST**

THE MARK CONSISTS OF STANDARD CHARACTERS  
WITHOUT CLAIM TO ANY PARTICULAR FONT, STYLE,  
SIZE, OR COLOR.

FOR ANALGESIC PREPARATIONS (U.S. CLS. 6, 18, 44,  
46, 51 AND 52).

FIRST USE 10-31-2013; IN COMMERCE 10-31-2013.

JAY FLOWERS, EXAMINING ATTORNEY

**CLASS 5—(Continued).**

SN 86-274,054. EMPOWERS PERFORMANCE, SCOTTS-DALE, AZ. FILED 5-7-2014.



THE COLOR(S) GREEN AND BLUE IS/ARE CLAIMED AS A FEATURE OF THE MARK.

THE MARK CONSISTS OF THE LETTER "P" IN THE COLOR GREEN, CIRCLED BY A GREEN AND BLUE ARROW, FOLLOWED BY THE WORD "POWER" IN GREEN, FOLLOWED BY THE WORD "DOWN" IN BLUE, WITH THE LETTER "N" IN "DOWN" BEING COMPLETED BY A DOWNWARD POINTING ARROW. UNDERNEATH THE WORDS "POWER DOWN" THE WORDS "FUELING RECOVERY" ARE WRITTEN IN BLUE.

FOR DIETARY AND NUTRITIONAL SUPPLEMENTS; DIETARY AND NUTRITIONAL SUPPLEMENTS FOR ENDURANCE SPORTS; DIETARY SUPPLEMENTAL DRINKS; DIETARY SUPPLEMENTAL DRINKS IN THE NATURE OF VITAMIN AND MINERAL BEVERAGES; HEALTH FOOD SUPPLEMENTS; LIQUID NUTRITIONAL SUPPLEMENT; LIQUID PROTEIN SUPPLEMENTS; LIQUID VITAMIN SUPPLEMENTS; NUTRACEUTICALS FOR USE AS A DIETARY SUPPLEMENT; NUTRITIONAL AND DIETARY SUPPLEMENTS FORMED AND PACKAGED AS BARS; NUTRITIONAL SUPPLEMENTS; NUTRITIONAL SUPPLEMENTS, NAMELY, CARBOHYDRATES IN POWDERED FORM; POWDERED NUTRITIONAL SUPPLEMENT CONCENTRATE; POWDERED NUTRITIONAL SUPPLEMENT DRINK MIX; POWDERED NUTRITIONAL SUPPLEMENT DRINK MIX AND CONCENTRATE; PROTEIN DIETARY SUPPLEMENTS; PROTEIN SUPPLEMENT SHAKES; PROTEIN SUPPLEMENTS; VITAMIN AND MINERAL SUPPLEMENTS; VITAMIN SUPPLEMENTS; WEIGHT MANAGEMENT SUPPLEMENTS (U.S. CLS. 6, 18, 44, 46, 51 AND 52).

CAROLINE WOOD, EXAMINING ATTORNEY

SN 86-275,349. SOMAHLUTION, LLC, JUPITER, FL. FILED 5-8-2014.

# VasoVivo

THE MARK CONSISTS OF STANDARD CHARACTERS WITHOUT CLAIM TO ANY PARTICULAR FONT, STYLE, SIZE, OR COLOR.

THE WORDING "VASOVIVO" HAS NO MEANING IN A FOREIGN LANGUAGE.

FOR SALINE SOLUTION FOR PRESERVING BLOOD VESSELS (U.S. CLS. 6, 18, 44, 46, 51 AND 52).

JEANIE LEE, EXAMINING ATTORNEY

**CLASS 5—(Continued).**

SN 86-277,901. VIVEX BIOMEDICAL, INC., MARIETTA, GA. FILED 5-10-2014.

# VIAGRAFT

THE MARK CONSISTS OF STANDARD CHARACTERS WITHOUT CLAIM TO ANY PARTICULAR FONT, STYLE, SIZE, OR COLOR.

FOR BONE GROWTH MEDIA CONSISTING OF BIOLOGICAL MATERIALS FOR MEDICAL PURPOSES (U.S. CLS. 6, 18, 44, 46, 51 AND 52).

SAIMA MAKHDUM, EXAMINING ATTORNEY

SN 86-283,014. BELIMED INC., CHARLESTON, SC. FILED 5-16-2014.

# CHALLENGER BD

THE MARK CONSISTS OF STANDARD CHARACTERS WITHOUT CLAIM TO ANY PARTICULAR FONT, STYLE, SIZE, OR COLOR.

FOR BIOLOGICAL AND CHEMICAL INDICATORS FOR MONITORING STERILIZATION PROCESSES FOR MEDICAL AND VETERINARY PURPOSES (U.S. CLS. 6, 18, 44, 46, 51 AND 52).

LINDA E. BLOHM, EXAMINING ATTORNEY

SN 86-283,468. BELIMED INC., CHARLESTON, SC. FILED 5-16-2014.

# CHALLENGER 5

THE MARK CONSISTS OF STANDARD CHARACTERS WITHOUT CLAIM TO ANY PARTICULAR FONT, STYLE, SIZE, OR COLOR.

FOR BIOLOGICAL AND CHEMICAL INDICATORS FOR MONITORING STERILIZATION PROCESSES FOR MEDICAL AND VETERINARY PURPOSES (U.S. CLS. 6, 18, 44, 46, 51 AND 52).

LINDA E. BLOHM, EXAMINING ATTORNEY



**CLASS 5—(Continued).**

SN 86-285,117. GENERAL NUTRITION INVESTMENT COMPANY, WILMINGTON, DE. FILED 5-19-2014.

**LIFE ELEMENTS**

THE MARK CONSISTS OF STANDARD CHARACTERS WITHOUT CLAIM TO ANY PARTICULAR FONT, STYLE, SIZE, OR COLOR.

FOR DIETARY AND NUTRITIONAL SUPPLEMENTS (U.S. CLS. 6, 18, 44, 46, 51 AND 52).

PAUL E. FAHRENKOPF, EXAMINING ATTORNEY

**CLASS 5—(Continued).**

SN 86-292,319. VIVEX BIOMEDICAL, INC., MARIETTA, GA. FILED 5-27-2014.

**ProAmnion**

THE MARK CONSISTS OF STANDARD CHARACTERS WITHOUT CLAIM TO ANY PARTICULAR FONT, STYLE, SIZE, OR COLOR.

FOR BIOLOGICAL AMNIOTIC TISSUE INTENDED FOR SUBSEQUENT IMPLANTATION (U.S. CLS. 6, 18, 44, 46, 51 AND 52).

SAIMA MAKHDOOM, EXAMINING ATTORNEY

SN 86-286,568. KIM KEARNEY, VAN NUYS, CA. FILED 5-20-2014.

**HAIRNAMICS**

THE MARK CONSISTS OF STANDARD CHARACTERS WITHOUT CLAIM TO ANY PARTICULAR FONT, STYLE, SIZE, OR COLOR.

FOR VITAMIN SUPPLEMENTS; VITAMIN TABLETS; VITAMINS (U.S. CLS. 6, 18, 44, 46, 51 AND 52).

FIRST USE 4-24-2014; IN COMMERCE 4-24-2014.  
EDWARD NELSON, EXAMINING ATTORNEY

SN 86-293,420. GENOMMA LAB INTERNACIONAL, S.A.B. DE C.V., JUAREZ MEXICO, DF, MEXICO, FILED 5-28-2014.

**NASALUB MAX**

THE MARK CONSISTS OF STANDARD CHARACTERS WITHOUT CLAIM TO ANY PARTICULAR FONT, STYLE, SIZE, OR COLOR.

OWNER OF MEXICO REG. NO. 1106866, DATED 6-1-2009, EXPIRES 6-1-2019.

FOR NASAL LUBRICANT MEDICATION (U.S. CLS. 6, 18, 44, 46, 51 AND 52).

JOHN WILKE, EXAMINING ATTORNEY

SN 86-291,798. BEAUMONT PRODUCTS, INC., KENNESAW, GA. FILED 5-27-2014.

**ORGANIC CITRUS MAGIC**

THE MARK CONSISTS OF STANDARD CHARACTERS WITHOUT CLAIM TO ANY PARTICULAR FONT, STYLE, SIZE, OR COLOR.

OWNER OF U.S. REG. NOS. 1,638,853, 3,939,159 AND OTHERS.

NO CLAIM IS MADE TO THE EXCLUSIVE RIGHT TO USE "ORGANIC CITRUS", APART FROM THE MARK AS SHOWN.

FOR ORGANIC AIR DEODORIZING PREPARATIONS (U.S. CLS. 6, 18, 44, 46, 51 AND 52).

LEE HUNT, EXAMINING ATTORNEY

SN 86-299,125. RECKITT BENCKISER LLC, PARSIPPANY, NJ. FILED 6-3-2014.

**CLEAR BURST**

THE MARK CONSISTS OF STANDARD CHARACTERS WITHOUT CLAIM TO ANY PARTICULAR FONT, STYLE, SIZE, OR COLOR.

FOR PHARMACEUTICAL PREPARATIONS AND SUBSTANCES FOR THE TREATMENT OF COUGHS AND THE SYMPTOMS OF COLDS AND INFLUENZA; PREPARATIONS FOR THE TREATMENT OF RESPIRATORY AND PULMONARY CONDITIONS; EXPECTORANTS; DECONGESTANTS; PHARMACEUTICAL ANTITUSSIVE-COLD PREPARATIONS; PREPARATIONS FOR TREATING COLDS (U.S. CLS. 6, 18, 44, 46, 51 AND 52).

MARY CRAWFORD, EXAMINING ATTORNEY

**CLASS 5—(Continued).**

SN 86-302,911. BIOFARMA, SURESNES CEDEX, FRANCE, FILED 6-6-2014.

# ARPARIAL

THE MARK CONSISTS OF STANDARD CHARACTERS WITHOUT CLAIM TO ANY PARTICULAR FONT, STYLE, SIZE, OR COLOR.

OWNER OF FRANCE REG. NO. 063454588, DATED 10-5-2006, EXPIRES 10-5-2016.

OWNER OF U.S. REG. NO. 3,445,514.

THE WORDING "ARPARIAL" HAS NO MEANING IN A FOREIGN LANGUAGE.

FOR PHARMACEUTICAL PREPARATIONS FOR THE PREVENTION AND TREATMENT OF DISORDERS OF THE CARDIOVASCULAR SYSTEM (U.S. CLS. 6, 18, 44, 46, 51 AND 52).

JULIE VEPPUMTHARA, EXAMINING ATTORNEY

---

SN 86-303,777. VINCO, INC, EVANS CITY, PA. FILED 6-9-2014.

# N2GOUT

THE MARK CONSISTS OF STANDARD CHARACTERS WITHOUT CLAIM TO ANY PARTICULAR FONT, STYLE, SIZE, OR COLOR.

FOR HEALTH FOOD SUPPLEMENTS (U.S. CLS. 6, 18, 44, 46, 51 AND 52).

FIRST USE 6-2-2014; IN COMMERCE 6-2-2014.

MARC LEIPZIG, EXAMINING ATTORNEY

---

SN 86-304,208. MONSANTO TECHNOLOGY LLC, ST. LOUIS, MO. FILED 6-9-2014.



MONSANTO  
BioAg

OWNER OF U.S. REG. NOS. 2,766,879, 2,769,375 AND 4,470,392.

NO CLAIM IS MADE TO THE EXCLUSIVE RIGHT TO USE BIOAG, APART FROM THE MARK AS SHOWN.

THE MARK CONSISTS OF THE WORD "MONSANTO" IN ALL CAPS ABOVE THE WORD "BIOAG" IN LARGER TEXT WITH A CAPITAL "B" AND "A". TO THE RIGHT OF THE MARK IS A LEAF DESIGN WITH A HALF ARCH STARTING AT THE OPPOSITE END OF THE PEAK OF THE LEAF.

FOR INSECTICIDES; FUNGICIDES; BIOLOGICAL FUNGICIDES (U.S. CLS. 6, 18, 44, 46, 51 AND 52).

DORITT L. CARROLL, EXAMINING ATTORNEY

**CLASS 5—(Continued).**

SN 86-304,275. MONSANTO TECHNOLOGY LLC, ST. LOUIS, MO. FILED 6-9-2014.



MONSANTO  
BioAg

OWNER OF U.S. REG. NOS. 2,766,879, 2,769,375 AND 4,470,392.

NO CLAIM IS MADE TO THE EXCLUSIVE RIGHT TO USE "BIOAG", APART FROM THE MARK AS SHOWN.

THE COLOR(S) LIGHT GREEN, DARK GREEN, WHITE IS/ARE CLAIMED AS A FEATURE OF THE MARK.

THE MARK CONSISTS OF THE WORD "MONSANTO" IN ALL CAPS AND IN A DARK GREEN LETTERING ABOVE THE WORD "BIOAG" IN LARGER TEXT WITH A CAPITAL "B" AND "A"; "BIO" IS IN A LIGHT GREEN COLOR AND "AG" IS IN A DARK GREEN COLOR. TO THE RIGHT OF THE MARK IS A LEAF DESIGN IN A LIGHT GREEN COLOR WITH A HALF ARCH STARTING AT THE OPPOSITE END OF THE PEAK OF THE LEAF WHICH IS WHITE.

FOR INSECTICIDES, FUNGICIDES, BIOLOGICAL FUNGICIDES (U.S. CLS. 6, 18, 44, 46, 51 AND 52).

DORITT L. CARROLL, EXAMINING ATTORNEY

---

SN 86-319,743. VIANA MULLER, NEW YORK, NY. FILED 6-25-2014.

# WHOLE WORLD BOTANICALS

THE MARK CONSISTS OF STANDARD CHARACTERS WITHOUT CLAIM TO ANY PARTICULAR FONT, STYLE, SIZE, OR COLOR.

NO CLAIM IS MADE TO THE EXCLUSIVE RIGHT TO USE "BOTANICALS", APART FROM THE MARK AS SHOWN.

FOR HERBAL NUTRITIONAL SUPPLEMENTS (U.S. CLS. 6, 18, 44, 46, 51 AND 52).

FIRST USE 4-0-1999; IN COMMERCE 4-0-1999.

MATTHEW KLINE, EXAMINING ATTORNEY

**CLASS 5—(Continued).**

SN 86-322,221. NOVARTIS AG, BASEL, SWITZERLAND,  
FILED 6-27-2014.

# HABITROL

THE MARK CONSISTS OF STANDARD CHARACTERS WITHOUT CLAIM TO ANY PARTICULAR FONT, STYLE, SIZE, OR COLOR.

THE WORDING "HABITROL" HAS NO MEANING IN A FOREIGN LANGUAGE.

FOR SMOKING CESSATION PREPARATIONS (U.S. CLS. 6, 18, 44, 46, 51 AND 52).

FIRST USE 12-3-1991; IN COMMERCE 12-3-1991.  
ALLISON SCHRODY, EXAMINING ATTORNEY

SN 86-325,351. WOODBOLT DISTRIBUTION, LLC, BRYAN,  
TX. FILED 7-1-2014.

# SUPERHDX

THE MARK CONSISTS OF STANDARD CHARACTERS WITHOUT CLAIM TO ANY PARTICULAR FONT, STYLE, SIZE, OR COLOR.

OWNER OF U.S. REG. NO. 4,274,443.  
FOR DIETARY AND NUTRITIONAL SUPPLEMENTS  
(U.S. CLS. 6, 18, 44, 46, 51 AND 52).

CYNTHIA RINALDI, EXAMINING ATTORNEY

SN 86-325,364. WOODBOLT DISTRIBUTION, LLC, BRYAN,  
TX. FILED 7-1-2014.

# SUPERHD ELITE

THE MARK CONSISTS OF STANDARD CHARACTERS WITHOUT CLAIM TO ANY PARTICULAR FONT, STYLE, SIZE, OR COLOR.

OWNER OF U.S. REG. NO. 4,274,443.  
FOR DIETARY AND NUTRITIONAL SUPPLEMENTS  
(U.S. CLS. 6, 18, 44, 46, 51 AND 52).

CYNTHIA RINALDI, EXAMINING ATTORNEY

**CLASS 6—METAL GOODS**

SN 79-136,682. SERTO HOLDING AG, FRAUENFELD,  
SWITZERLAND, FILED 8-7-2013.

# Jacoflon

THE MARK CONSISTS OF STANDARD CHARACTERS WITHOUT CLAIM TO ANY PARTICULAR FONT, STYLE, SIZE, OR COLOR.

PRIORITY DATE OF 2-21-2013 IS CLAIMED.

OWNER OF INTERNATIONAL REGISTRATION 1176994  
DATED 8-7-2013, EXPIRES 8-7-2023.

THE WORDING "JACOFLO" HAS NO MEANING IN A FOREIGN LANGUAGE.

FOR FLEXIBLE METAL PIPES, PARTICULARLY IN THE FIELD OF INSTALLATION AND CONNECTION WORK, INSTALLATION OF AIR-CONDITIONING APPARATUS, THE AGRI-FOOD INDUSTRY, MEDICAL AND LABORATORY TECHNOLOGY, WATER TREATMENT, THE AEROSPACE AND AUTOMOBILE INDUSTRY (U.S. CLS. 2, 12, 13, 14, 23, 25 AND 50).

RAUL CORDOVA, EXAMINING ATTORNEY

SN 79-137,025. GAME OVER CYCLES STANISLAW MYSZ-  
KOWSKI, POLAND, FILED 5-14-2013.



OWNER OF INTERNATIONAL REGISTRATION 1177819  
DATED 5-14-2013, EXPIRES 5-14-2023.

NO CLAIM IS MADE TO THE EXCLUSIVE RIGHT TO USE "CYCLES", APART FROM THE MARK AS SHOWN.

THE COLOR(S) BLACK AND WHITE IS/ARE CLAIMED AS A FEATURE OF THE MARK.

THE MARK CONSISTS OF A BLACK RING. INSIDE THE RING IS A WHITE INNER CIRCLE WITH A DESIGN OF A SKULL WEARING SUNGLASSES AND A BANDANA IN WHITE WITH THE OUTLINE AND FACIAL FEATURE AND PART OF THE SUNGLASSES IN BLACK. THE RING CONTAINS THE WORDING "GAME OVER" AND "CYCLES" SEPARATED BY TWO MALTESE CROSSES IN WHITE, NEAR THE OUTER BORDER OF THE BLACK RING IS A DASHED LINE WHITE CIRCLE.

FOR BADGES OF METAL FOR VEHICLES; CRAMPONS OF METAL; METAL RINGS FOR KEYS; LETTERS AND NUMERALS OF COMMON METAL, EXCEPT TYPE; GENERAL PURPOSE METALLIC STORAGE CONTAINERS; BUCKLES OF COMMON METAL BEING HARDWARE; SIGNBOARDS OF METAL; WORKS OF ART OF COMMON METAL; IDENTITY PLATES OF METAL; BRONZES WORKS OF ART (U.S. CLS. 2, 12, 13, 14, 23, 25 AND 50).

CARYN GLASSER, EXAMINING ATTORNEY

**CLASS 6—(Continued).**

SN 79-147,028. USHA MARTIN UK LIMITED, NOTTINGHAMSHIRE, UNITED KINGDOM, FILED 2-25-2014.

# OCEANMAX

THE MARK CONSISTS OF STANDARD CHARACTERS WITHOUT CLAIM TO ANY PARTICULAR FONT, STYLE, SIZE, OR COLOR.

PRIORITY DATE OF 9-4-2013 IS CLAIMED.

OWNER OF INTERNATIONAL REGISTRATION 1203156 DATED 2-25-2014, EXPIRES 2-25-2024.

FOR NON-ELECTRIC CABLES AND WIRES OF COMMON METAL; NON-ELECTRIC RODS, NAMELY, STEEL RODS; WIRE ROPES; WIRE CORDS BEING WIRE ROPES; NON-ELECTRIC WIRE STRANDS; SPIRAL WIRE ROPES; MULTI-STRANDED WIRE ROPES (U.S. CLS. 2, 12, 13, 14, 23, 25 AND 50).

CARYN GLASSER, EXAMINING ATTORNEY

---

SN 85-682,461. TENARIS CONNECTIONS BV, AMSTERDAM, NETHERLANDS, FILED 7-20-2012.

# BLUEDOCK

THE MARK CONSISTS OF STANDARD CHARACTERS WITHOUT CLAIM TO ANY PARTICULAR FONT, STYLE, SIZE, OR COLOR.

OWNER OF ERPNTM CMNTY TM OFC REG. NO. 011055209, DATED 3-11-2014, EXPIRES 7-19-2022.

FOR METAL PIPE CONNECTORS (U.S. CLS. 2, 12, 13, 14, 23, 25 AND 50).

RONALD DELGIZZI, EXAMINING ATTORNEY

---

SN 85-848,944. TOME VELAZQUEZ, GUSTAVO FELIPE, IRAPUATO, GUANAJUATO, MEXICO, FILED 2-13-2013.



NO CLAIM IS MADE TO THE EXCLUSIVE RIGHT TO USE "ACP", APART FROM THE MARK AS SHOWN.

THE MARK CONSISTS OF TWO CROSSING CHECK MARK LIKE ABSTRACT FIGURES FOLLOWED BY THE WORDING "ACP ALUTEC" IN STYLIZED LETTERS.

FOR METAL PANELS IN THE NATURE OF ALUMINUM AND POLYETHYLENE OF LOW DENSITY USED FOR SIGNAGE, ADS, STANDS, AS WELL AS TO COVER AND COAT INTERIOR AND EXTERIOR FACADES OF WALLS AND BUILDINGS (U.S. CLS. 2, 12, 13, 14, 23, 25 AND 50).

ANNE E. GUSTASON, EXAMINING ATTORNEY

**CLASS 6—(Continued).**

SN 85-962,251. GEORG SHANDOR HAYDE, FELDAFING 82340, FED REP GERMANY, FILED 6-17-2013.

# TRACK, JR.

THE MARK CONSISTS OF STANDARD CHARACTERS WITHOUT CLAIM TO ANY PARTICULAR FONT, STYLE, SIZE, OR COLOR.

NO CLAIM IS MADE TO THE EXCLUSIVE RIGHT TO USE "TRACK", APART FROM THE MARK AS SHOWN.

SEC. 2(F).

FOR METAL HANGERS FOR SECURING AND LEVELING THE HANGING OF WORKS OF ART (U.S. CLS. 2, 12, 13, 14, 23, 25 AND 50).

FIRST USE 1-31-2000; IN COMMERCE 1-31-2000.

DAWN HAN, EXAMINING ATTORNEY

---

SN 86-050,935. ACORN ENGINEERING COMPANY, DBA ELMDOR/STONEMAN, CITY OF INDUSTRY, CA. FILED S.R. 8-28-2013; AM. P.R. 9-11-2013.

# ELMDOR/STONEMAN

THE MARK CONSISTS OF STANDARD CHARACTERS WITHOUT CLAIM TO ANY PARTICULAR FONT, STYLE, SIZE, OR COLOR.

OWNER OF U.S. REG. NOS. 1,472,827 AND 3,284,712.

FOR METAL PLUMBING ACCESS DOORS, METAL ROOF FLASHING AND METAL ROOF HATCHES (U.S. CLS. 2, 12, 13, 14, 23, 25 AND 50).

FIRST USE 0-0-1989; IN COMMERCE 0-0-1995.

MICHAEL TANNER, EXAMINING ATTORNEY

---

SN 86-062,639. EDG HOLDCO LLC, BATON ROUGE, LA. FILED 9-12-2013.

# BOURLAND & LEVERICH

THE MARK CONSISTS OF STANDARD CHARACTERS WITHOUT CLAIM TO ANY PARTICULAR FONT, STYLE, SIZE, OR COLOR.

FOR TUBULAR METAL GOODS, NAMELY, TUBULAR METAL CASING AND TUBING FOR OIL AND GAS OPERATIONS; METAL CONNECTIONS FOR CONNECTING CASING AND TUBING FOR OIL AND GAS OPERATIONS; METAL JOINTS FOR USE WITH CASING AND/OR TUBING USED WITH OIL AND GAS OPERATIONS; TUBULAR METAL GOODS, NAMELY, LINE PIPE, GATHERING PIPE, AND TRANSMISSION PIPE, FOR OIL AND GAS OPERATIONS (U.S. CLS. 2, 12, 13, 14, 23, 25 AND 50).

FIRST USE 1-1-1936; IN COMMERCE 1-1-1936.

REGINA DRUMMOND, EXAMINING ATTORNEY

**CLASS 6—(Continued).**

SN 86-065,760. Z-SHADE CO. LTD., BALDWIN PARK, CA. FILED 9-16-2013.

# HORIZON

THE MARK CONSISTS OF STANDARD CHARACTERS WITHOUT CLAIM TO ANY PARTICULAR FONT, STYLE, SIZE, OR COLOR.

FOR PORTABLE SHELTERS, NAMELY, PORTABLE SHELTERS HAVING METAL FRAMEWORK (U.S. CLS. 2, 12, 13, 14, 23, 25 AND 50).

SCOTT BIBB, EXAMINING ATTORNEY

**CLASS 6—(Continued).**

SN 86-079,442. TOMARCO CONTRACTOR SPECIALTIES, INC., LA MIRADA, CA. FILED 10-1-2013.

# PUSH ROD

THE MARK CONSISTS OF STANDARD CHARACTERS WITHOUT CLAIM TO ANY PARTICULAR FONT, STYLE, SIZE, OR COLOR.

NO CLAIM IS MADE TO THE EXCLUSIVE RIGHT TO USE "ROD", APART FROM THE MARK AS SHOWN.

FOR FASTENERS, NAMELY, METAL, INTERNALLY THREADED INSERT HANGERS FOR POURED IN PLACE CONCRETE CEILINGS (U.S. CLS. 2, 12, 13, 14, 23, 25 AND 50).

KELLY TRUSILO, EXAMINING ATTORNEY

SN 86-072,417. STRATEGIC PARTNERS, INC., CHATSWORTH, CA. FILED 9-23-2013.

# Curo

THE MARK CONSISTS OF STANDARD CHARACTERS WITHOUT CLAIM TO ANY PARTICULAR FONT, STYLE, SIZE, OR COLOR.

THE ENGLISH TRANSLATION OF "CURO" IN THE MARK IS "TO HEAL".

FOR METAL RINGS AND CHAINS FOR KEYS (U.S. CLS. 2, 12, 13, 14, 23, 25 AND 50).

DANNEAN HETZEL, EXAMINING ATTORNEY

SN 86-108,565. JIM TJERRILD, FRESNO, CA. FILED 11-1-2013.

# SANISTRUT

THE MARK CONSISTS OF STANDARD CHARACTERS WITHOUT CLAIM TO ANY PARTICULAR FONT, STYLE, SIZE, OR COLOR.

FOR METAL SUPPORTS FOR PIPE, CONDUIT, AND TUBING; METAL CONSTRUCTION HARDWARE, NAMELY, STRUTS; METAL SUPPORT SYSTEMS AND COMPONENTS FOR PIPE, CONDUIT, AND TUBING, NAMELY, FRAMING CHANNELS, CLAMPS, NUTS, PLATES, BRACKETS, BOLTS, NUTS, AND WASHERS (U.S. CLS. 2, 12, 13, 14, 23, 25 AND 50).

FIRST USE 4-9-2009; IN COMMERCE 4-16-2009.  
CAROLINE WOOD, EXAMINING ATTORNEY

SN 86-073,210. INTERMET METALS SERVICES, INC., SCHAUMBURG, IL. FILED 9-24-2013.

# INTERBRONZE

THE MARK CONSISTS OF STANDARD CHARACTERS WITHOUT CLAIM TO ANY PARTICULAR FONT, STYLE, SIZE, OR COLOR.

OWNER OF U.S. REG. NO. 3,312,471.

FOR METAL PRODUCTS MADE WHOLLY OR SIGNIFICANTLY IN PART OF BRONZE, NAMELY, METAL BARS, TUBES, SHEETS, PLATES, COILS AND WIRE (U.S. CLS. 2, 12, 13, 14, 23, 25 AND 50).

FIRST USE 10-4-1991; IN COMMERCE 10-4-1991.

EVIN L. KOZAK, EXAMINING ATTORNEY

SN 86-116,096. AMERICAN OUTDOOR PRODUCTS, LLC, KNOXVILLE, TN. FILED 11-12-2013.



THE MARK CONSISTS OF A SUBSTANTIALLY RECTANGULAR CONFIGURATION WITH ARCUATE SEC-

**CLASS 6—(Continued).**

TIONS EXTENDING OUTWARDLY PROXIMATE THE MID-POINT OF EACH SIDE OF THE RECTANGLE, THE DESIGN IS OUTLINED BY A BOLD LINE ON THE PERIMETER OF THE CONFIGURATION WHICH CIRCUMSCRIBES THE TERM "PLATEMATES". THE LETTERS "P" AND "M" ARE CONNECTED BY ONE SINGLE LINE AND THE LETTERS "T" AND "S" ARE CONNECTED BY ANOTHER SINGLE LINE. A HORIZONTAL LINE APPEARS BELOW THE MARK AND THE RECTANGULAR CONFIGURATION.

FOR METAL YARD SIGN HOLDERS AND NON-LUMINOUS AND NON-MECHANICAL METAL SIGNS (U.S. CLS. 2, 12, 13, 14, 23, 25 AND 50).

DAVID COLLIER, EXAMINING ATTORNEY

---

SN 86-123,672. DEEPAK FASTENERS LIMITED, DBA DEEPAK FASTENERS LIMITED, LUDHIANA, INDIA, FILED 11-20-2013.

# DEEPAK

THE MARK CONSISTS OF STANDARD CHARACTERS WITHOUT CLAIM TO ANY PARTICULAR FONT, STYLE, SIZE, OR COLOR.

OWNER OF U.S. REG. NO. 3,169,460.

THE ENGLISH TRANSLATION OF "DEEPAK" IN THE MARK IS "LAMP".

FOR METAL HARDWARE, NAMELY, ANCHOR BOLTS OF METAL, BOLTS OF METAL, METAL EYE BOLTS, FIXING BOLTS OF METAL, SCREW BOLTS OF METAL, LOCK NUTS OF METAL, METAL NUTS, THREADED NUTS OF METAL, WING NUTS OF METAL, SCREWS OF METAL, SELF TAPPING SCREWS OF METAL, SOCKET SET SCREWS OF METAL, SOCKET HEAD CAP SCREWS OF METAL, SOCKET HEAD SHOULDER SCREWS OF METAL, SQUARE SET SCREWS OF METAL, COUNTERSUNK SOCKET SCREWS OF METAL, METAL WASHERS, SPRING WASHERS OF METAL, DOWEL PINS OF METAL, SPRING PINS OF METAL, HIGH TENSILE BOLTS OF METAL, LOW HEAD CAP SCREWS OF METAL, CON ROD BOLTS OF METAL, WHEEL BOLTS OF METAL, TWELVE POINT BOLTS OF METAL, BALL STUDS OF METAL, TRACK SHOE BOLTS OF METAL, TRACK SHOE NUTS OF METAL, SOCKET BUTTON HEAD SCREWS OF METAL, HEXAGON HEAD SCREWS OF METAL, HEXAGON HEAD BOLTS OF METAL, HEX NUTS OF METAL, THREADED RODS OF METAL, HIGH STRENGTH STRUCTURAL BOLTS OF METAL, HIGH STRENGTH STRUCTURAL NUTS OF METAL, HIGH STRENGTH STRUCTURAL WASHERS OF METAL (U.S. CLS. 2, 12, 13, 14, 23, 25 AND 50).

FIRST USE 8-7-2005; IN COMMERCE 8-7-2005.

KAPIL BHANOT, EXAMINING ATTORNEY

**CLASS 6—(Continued).**

SN 86-151,520. EARTH CONTACT PRODUCTS, L.L.C., OLATHE, KS. FILED 12-23-2013.

# ECP

THE MARK CONSISTS OF STANDARD CHARACTERS WITHOUT CLAIM TO ANY PARTICULAR FONT, STYLE, SIZE, OR COLOR.

OWNER OF U.S. REG. NOS. 2,434,932, 2,572,217 AND OTHERS.

FOR METAL FOUNDATION PIERS AND PILES USED TO SUPPORT THE FOUNDATIONS OF RESIDENCES AND COMMERCIAL STRUCTURES (U.S. CLS. 2, 12, 13, 14, 23, 25 AND 50).

FIRST USE 9-1-1999; IN COMMERCE 9-1-1999.

JULIE GUTTADAURO, EXAMINING ATTORNEY

---

SN 86-151,536. EARTH CONTACT PRODUCTS, L.L.C., OLATHE, KS. FILED 12-23-2013.

# ECP UTILITY

THE MARK CONSISTS OF STANDARD CHARACTERS WITHOUT CLAIM TO ANY PARTICULAR FONT, STYLE, SIZE, OR COLOR.

OWNER OF U.S. REG. NOS. 2,434,932, 2,572,217 AND OTHERS.

NO CLAIM IS MADE TO THE EXCLUSIVE RIGHT TO USE "UTILITY", APART FROM THE MARK AS SHOWN.

FOR METAL FOUNDATION PIERS AND PILES USED TO SUPPORT THE FOUNDATIONS OF RESIDENCES AND COMMERCIAL STRUCTURES (U.S. CLS. 2, 12, 13, 14, 23, 25 AND 50).

FIRST USE 7-1-2007; IN COMMERCE 7-1-2007.

JULIE GUTTADAURO, EXAMINING ATTORNEY

---

SN 86-156,305. STUPID CANCER, INC., NEW YORK, NY. FILED 1-2-2014.

# STPDCNCR

THE MARK CONSISTS OF STANDARD CHARACTERS WITHOUT CLAIM TO ANY PARTICULAR FONT, STYLE, SIZE, OR COLOR.

OWNER OF U.S. REG. NO. 3,453,463.

FOR METAL NOVELTY LICENSE PLATES (U.S. CLS. 2, 12, 13, 14, 23, 25 AND 50).

PAUL CROWLEY, EXAMINING ATTORNEY

**CLASS 6—(Continued).**

SN 86-168,216. NANZ CUSTOM HARDWARE, INC., NEW YORK, NY. FILED 1-17-2014.

**EVERY-DOOR**

THE MARK CONSISTS OF STANDARD CHARACTERS WITHOUT CLAIM TO ANY PARTICULAR FONT, STYLE, SIZE, OR COLOR.

FOR DOOR HARDWARE, NAMELY, METAL HANDLES, METAL LOCKS AND METAL HINGES (U.S. CLS. 2, 12, 13, 14, 23, 25 AND 50).

KRISTIN CARLSON, EXAMINING ATTORNEY

SN 86-172,885. DK SMITH INTERNATIONAL TRADE INC., PORT COQUITLAM, CANADA, FILED 1-23-2014.

**EZ  
OIL DRAIN  
VALVE**

OWNER OF U.S. REG. NO. 4,417,852.  
NO CLAIM IS MADE TO THE EXCLUSIVE RIGHT TO USE "OIL DRAIN VALVE", APART FROM THE MARK AS SHOWN.

THE MARK CONSISTS OF THE WORDS "EZ OIL DRAIN VALVE" AT A 45 DEGREE ANGLE.

FOR MANUALLY OPERATED METAL VALVES (U.S. CLS. 2, 12, 13, 14, 23, 25 AND 50).

FIRST USE 8-24-2009. THE MARK WAS FIRST USED ANYWHERE IN A DIFFERENT FORM OTHER THAN THAT SOUGHT TO BE REGISTERED AT LEAST AS EARLY AS 08/24/2009; IN COMMERCE 11-6-2012. THE MARK WAS FIRST USED IN COMMERCE IN A DIFFERENT FORM OTHER THAN THAT SOUGHT TO BE REGISTERED AT LEAST AS EARLY AS 11/06/2012.

JOHN HWANG, EXAMINING ATTORNEY

**CLASS 6—(Continued).**

SN 86-178,601. SAFE-T-TANK CORP., MERIDEN, CT. FILED 1-29-2014.



THE MARK CONSISTS OF A STYLIZED IMAGE OF A STORAGE TANK WITH A STYLIZED FISH UNDERNEATH. FOR METAL STORAGE TANKS FOR LIQUIDS AND WASTE LIQUIDS SOLD EMPTY (U.S. CLS. 2, 12, 13, 14, 23, 25 AND 50).

FIRST USE 12-31-1987; IN COMMERCE 12-31-1987.

SUE LAWRENCE, EXAMINING ATTORNEY

SN 86-191,682. BOCARISA HOLDING LIMITED, LIMASSOL, CYPRUS, FILED 2-12-2014.

**GLOBAL PIPING SOLUTIONS**

THE MARK CONSISTS OF STANDARD CHARACTERS WITHOUT CLAIM TO ANY PARTICULAR FONT, STYLE, SIZE, OR COLOR.

NO CLAIM IS MADE TO THE EXCLUSIVE RIGHT TO USE "GLOBAL PIPING", APART FROM THE MARK AS SHOWN.

FOR CORROSION-RESISTANT METAL OVERLAYS AND ALLOYS FOR FITTINGS, FLANGES, AND PIPING COMPONENTS; METAL FLANGES; METAL CLAD PIPES; METAL PIPES AND METAL FITTINGS THEREFOR; STEEL PIPES; STAINLESS STEEL PIPES; ELBOWS OF METAL FOR PIPES INCLUDING THOSE FROM ALLOY STEEL AND TITANIUM; CLAD STEEL PLATES AND SHEETS; METAL JUNCTIONS FOR PIPES; BRANCHING PIPES OF METAL (U.S. CLS. 2, 12, 13, 14, 23, 25 AND 50).

SALLY SHIH, EXAMINING ATTORNEY

**CLASS 6—(Continued).**

SN 86-198,761. MCR OIL TOOLS, LLC, ARLINGTON, TX. FILED 2-20-2014.

**PHANTOM PLUG**

THE MARK CONSISTS OF STANDARD CHARACTERS WITHOUT CLAIM TO ANY PARTICULAR FONT, STYLE, SIZE, OR COLOR.

NO CLAIM IS MADE TO THE EXCLUSIVE RIGHT TO USE "PLUG", APART FROM THE MARK AS SHOWN.

FOR OIL AND GAS WELL EQUIPMENT, SPECIFICALLY, DOWNHOLE METAL WELL PLUGS (U.S. CLS. 2, 12, 13, 14, 23, 25 AND 50).

GEOFFREY FOSDICK, EXAMINING ATTORNEY

---

SN 86-217,100. CST INDUSTRIES, INC., LENEXA, KS. FILED 3-11-2014.



THE MARK CONSISTS OF THREE SILO DESIGN ELEMENTS NEXT TO EACH OTHER WITH THE MIDDLE SILO DESIGN ELEMENT BEING TALLER THAN THE OUTER SILO DESIGN ELEMENTS, WITH TWO SETS OF TWO DIAGONAL LINES ON THE LEFT AND RIGHT UNDER THE SILO THAT MEET UNDER THE MIDDLE SILO WHICH REPRESENT FARMLAND.

FOR METAL SILOS (U.S. CLS. 2, 12, 13, 14, 23, 25 AND 50).

FIRST USE 0-0-2007; IN COMMERCE 0-0-2007.  
ALICE BENMAMAN, EXAMINING ATTORNEY

---

SN 86-234,697. 3FORM, LLC, SALT LAKE CITY, UT. FILED 3-27-2014.

**LEVELGLASS**

THE MARK CONSISTS OF STANDARD CHARACTERS WITHOUT CLAIM TO ANY PARTICULAR FONT, STYLE, SIZE, OR COLOR.

FOR METAL ARCHITECTURAL HARDWARE, NAMELY, MOUNTING HARDWARE FOR USE WITH WALL CLADDING IN THE NATURE OF BRACKETS AND FASTENERS (U.S. CLS. 2, 12, 13, 14, 23, 25 AND 50).

TARAH HARDY, EXAMINING ATTORNEY

**CLASS 6—(Continued).**

SN 86-234,699. 3FORM, LLC, SALT LAKE CITY, UT. FILED 3-27-2014.

**SLIDE07**

THE MARK CONSISTS OF STANDARD CHARACTERS WITHOUT CLAIM TO ANY PARTICULAR FONT, STYLE, SIZE, OR COLOR.

FOR METAL ARCHITECTURAL HARDWARE, NAMELY, HARDWARE FOR USE WITH DOOR SYSTEMS IN THE NATURE OF TRACKS, RAILS, ROLLERS, HANDLES, GUIDES, LATCHES AND LOCKS (U.S. CLS. 2, 12, 13, 14, 23, 25 AND 50).

TARAH HARDY, EXAMINING ATTORNEY

---

SN 86-234,702. 3FORM, LLC, SALT LAKE CITY, UT. FILED 3-27-2014.

**SLIDE08**

THE MARK CONSISTS OF STANDARD CHARACTERS WITHOUT CLAIM TO ANY PARTICULAR FONT, STYLE, SIZE, OR COLOR.

FOR METAL ARCHITECTURAL HARDWARE, NAMELY, HARDWARE FOR USE WITH DOOR SYSTEMS IN THE NATURE OF TRACKS, RAILS, ROLLERS, HANDLES, GUIDES, LATCHES AND LOCKS (U.S. CLS. 2, 12, 13, 14, 23, 25 AND 50).

TARAH HARDY, EXAMINING ATTORNEY

---

SN 86-235,398. AK STEEL CORPORATION, WEST CHESTER, OH. FILED 3-28-2014.

**CHROMESHIELD**

THE MARK CONSISTS OF STANDARD CHARACTERS WITHOUT CLAIM TO ANY PARTICULAR FONT, STYLE, SIZE, OR COLOR.

FOR CORROSION RESISTANT COILED AND SLIT FLAT-ROLLED SPECIALTY FERRITIC STAINLESS STEEL MADE IN SIGNIFICANT PART OF CHROMIUM (U.S. CLS. 2, 12, 13, 14, 23, 25 AND 50).

FIRST USE 3-1-2014; IN COMMERCE 3-1-2014.

KATHLEEN M. VANSTON, EXAMINING ATTORNEY



**CLASS 6—(Continued).**

SN 86-236,685. EGW UTILITIES, INC., CARROLLTON, TX.  
FILED 3-31-2014.

**WHITE RHINO TUFF**

THE MARK CONSISTS OF STANDARD CHARACTERS WITHOUT CLAIM TO ANY PARTICULAR FONT, STYLE, SIZE, OR COLOR.

NO CLAIM IS MADE TO THE EXCLUSIVE RIGHT TO USE "TOUGH", APART FROM THE MARK AS SHOWN.

FOR BOLTS MADE OF METAL, NUTS MADE OF METAL, ALL OF THE FOREGOING FOR USE IN NATURAL GAS DISTRIBUTION, WATERWORKS, SEWER, PLUMBING, OILFIELD, OR PIPELINE FIELDS; MAGNETIZED TRACER STATIONS, NAMELY, MAGNETIZED CONNECTORS MADE OF METAL SPECIALLY ADAPTED FOR NON-ELECTRIC PIPELINE TRACER WIRES OF METAL THAT ARE BURIED BELOW GROUND LEVEL FOR USE IN LOCATING THE PIPELINE TRACER WIRES (U.S. CLS. 2, 12, 13, 14, 23, 25 AND 50).

FIRST USE 1-31-2010; IN COMMERCE 6-30-2011.  
CRISTIANA SCHWAB, EXAMINING ATTORNEY

SN 86-236,686. EGW UTILITIES, INC., CARROLLTON, TX.  
FILED 3-31-2014.

**WHITE RHINO TUFF**

THE MARK CONSISTS OF STANDARD CHARACTERS WITHOUT CLAIM TO ANY PARTICULAR FONT, STYLE, SIZE, OR COLOR.

NO CLAIM IS MADE TO THE EXCLUSIVE RIGHT TO USE "TOUGH", APART FROM THE MARK AS SHOWN.

FOR NON-ELECTRIC PIPELINE TRACER WIRE MADE OF COPPER (U.S. CLS. 2, 12, 13, 14, 23, 25 AND 50).

CRISTIANA SCHWAB, EXAMINING ATTORNEY

SN 86-237,371. DOG IS GOOD, LLC, LOS ALAMITOS, CA.  
FILED 3-31-2014.

**It's All Fun And Games  
Until Someone Ends Up In A  
Cone**

THE MARK CONSISTS OF STANDARD CHARACTERS WITHOUT CLAIM TO ANY PARTICULAR FONT, STYLE, SIZE, OR COLOR.

OWNER OF U.S. REG. NOS. 4,358,177, 4,498,243 AND OTHERS.

FOR NON-LUMINOUS AND NON-MECHANICAL METAL SIGNS; WALL PLAQUES MADE OF COMMON METAL; METAL LICENSE PLATES (U.S. CLS. 2, 12, 13, 14, 23, 25 AND 50).

JACLYN KIDWELL WALKER, EXAMINING ATTORNEY

**CLASS 6—(Continued).**

SN 86-239,323. WENCON DEVELOPMENT, INC., DBA QUICK MOUNT PV, WALNUT CREEK, CA. FILED 4-1-2014.

**DIRECT MOUNT**

THE MARK CONSISTS OF STANDARD CHARACTERS WITHOUT CLAIM TO ANY PARTICULAR FONT, STYLE, SIZE, OR COLOR.

OWNER OF U.S. REG. NO. 3,508,754.

NO CLAIM IS MADE TO THE EXCLUSIVE RIGHT TO USE "MOUNT", APART FROM THE MARK AS SHOWN.

FOR CONSTRUCTION ELEMENTS MADE OF METAL, NAMELY, SUPPORTS; METAL BUILDING FLASHING (U.S. CLS. 2, 12, 13, 14, 23, 25 AND 50).

SIMON TENG, EXAMINING ATTORNEY

SN 86-239,326. WENCON DEVELOPMENT, INC., DBA QUICK MOUNT PV, WALNUT CREEK, CA. FILED 4-1-2014.

**DIRECT MOUNT PV**

THE MARK CONSISTS OF STANDARD CHARACTERS WITHOUT CLAIM TO ANY PARTICULAR FONT, STYLE, SIZE, OR COLOR.

OWNER OF U.S. REG. NO. 3,508,754.

NO CLAIM IS MADE TO THE EXCLUSIVE RIGHT TO USE "MOUNT PV", APART FROM THE MARK AS SHOWN.

FOR CONSTRUCTION ELEMENTS MADE OF METAL, NAMELY, SUPPORTS; METAL BUILDING FLASHING (U.S. CLS. 2, 12, 13, 14, 23, 25 AND 50).

SIMON TENG, EXAMINING ATTORNEY

**CLASS 6—(Continued).**

SN 86-246,792. ALUMABRIDGE, LLC, ANN ARBOR, MI.  
FILED 4-9-2014.

**ALUMABRIDGE**

THE MARK CONSISTS OF STANDARD CHARACTERS WITHOUT CLAIM TO ANY PARTICULAR FONT, STYLE, SIZE, OR COLOR.

FOR METAL STRUCTURAL PANELS AND DECK PANELS FOR USE IN BRIDGE BUILDING; METAL STRUCTURAL PANELS AND DECK PANELS FOR USE IN BUILDING HIGHWAY BRIDGES, MOVEABLE BRIDGES, EMERGENCY DEPLOYMENT BRIDGES, MILITARY AND TEMPORARY BRIDGES; METAL STRUCTURAL PANELS AND DECK PANELS FOR USE IN BUILDING BRIDGES FOR VEHICLE AND PEDESTRIAN USE; METAL STRUCTURAL PANELS AND DECK PANELS FOR USE IN BUILDING MARINE DECKING; METAL STRUCTURAL PANELS AND DECK PANELS FOR USE IN BUILDING CONSTRUCTION PLATFORMS; METAL PREFABRICATED BRIDGE DECKING USED FOR RAPID BRIDGE DEPLOYMENT (U.S. CLS. 2, 12, 13, 14, 23, 25 AND 50).

FIRST USE 12-16-2013; IN COMMERCE 12-16-2013.  
ANNIE NOBLE, EXAMINING ATTORNEY

SN 86-248,672. THERMADUCT, LLC, PERRYSBURG, OH.  
FILED 4-10-2014.

**THERMAROUND**

THE MARK CONSISTS OF STANDARD CHARACTERS WITHOUT CLAIM TO ANY PARTICULAR FONT, STYLE, SIZE, OR COLOR.

FOR VENTILATING DUCTS OF METAL; METAL HEATING DUCTS; METAL AIR CONDITIONING DUCTS; INSULATED VENTILATING DUCTS OF METAL; INSULATED HEATING DUCTS OF METAL; INSULATED AIR CONDITIONING DUCTS OF METAL (U.S. CLS. 2, 12, 13, 14, 23, 25 AND 50).

MEREDITH MARESCA, EXAMINING ATTORNEY

SN 86-250,082. HOWARD, ROBERT, SIGNAL MOUNTAIN, TN. FILED 4-11-2014.

**LEFT2PASS**

THE MARK CONSISTS OF STANDARD CHARACTERS WITHOUT CLAIM TO ANY PARTICULAR FONT, STYLE, SIZE, OR COLOR.

FOR METAL NOVELTY LICENSE PLATES (U.S. CLS. 2, 12, 13, 14, 23, 25 AND 50).

DANIEL S. STRINGER, EXAMINING ATTORNEY

**CLASS 6—(Continued).**

SN 86-275,742. TOP KNOBS USA, INC., BELLE MEAD, NJ.  
FILED 5-8-2014.

**FINALE**

THE MARK CONSISTS OF STANDARD CHARACTERS WITHOUT CLAIM TO ANY PARTICULAR FONT, STYLE, SIZE, OR COLOR.

FOR METAL HANDLES, PULLS AND KNOBS FOR CABINETS, DRAWERS AND FURNITURE (U.S. CLS. 2, 12, 13, 14, 23, 25 AND 50).

MICHAEL ENGEL, EXAMINING ATTORNEY

**CLASS 7—MACHINERY**

SN 79-129,428. TRIPLE R INDUSTRY CO., LTD., TOKYO 120-0003, JAPAN, FILED 3-18-2013.



PRIORITY DATE OF 2-14-2013 IS CLAIMED.  
OWNER OF INTERNATIONAL REGISTRATION 1158423  
DATED 3-18-2013, EXPIRES 3-18-2023.  
OWNER OF U.S. REG. NO. 1,717,495.

NO CLAIM IS MADE TO THE EXCLUSIVE RIGHT TO USE "CORPORATION", APART FROM THE MARK AS SHOWN.

THE MARK CONSISTS OF THE STYLIZED WORDING "TRIPLE R CORPORATION" INSIDE A SINGLE LINE RECTANGLE.

FOR OIL FILTERING MACHINES; FILTERS AND FILTER ELEMENTS FOR OIL FILTERING MACHINES; CENTRIFUGES; FILTERING MACHINES FOR CHEMICAL PROCESSING THAT CONSIST IN PART OF A VACUUM DEHYDRATOR THAT REMOVES BUBBLES FROM LIQUIDS AND OILS; LOADING AND UNLOADING MACHINES; OIL FILTERS AND THEIR ELEMENTS FOR INTERNAL COMBUSTION ENGINES; OIL SEPARATORS; FILTERS FOR OIL-WATER SEPARATORS; FILTERS FOR OIL SEPARATORS; OIL FILTERING MACHINES FOR INTERNAL COMBUSTION ENGINES; FILTERS AND FILTER ELEMENTS FOR OIL FILTERING MACHINES FOR INTERNAL COMBUSTION ENGINES (U.S. CLS. 13, 19, 21, 23, 31, 34 AND 35).

VERNA BETH RIRIE, EXAMINING ATTORNEY

**CLASS 7—(Continued).**

SN 79-130,971. NE SEAL CORP., OKAYAMA, JAPAN, FILED 3-15-2013.

**kibi**  
kibi Gaskets

OWNER OF INTERNATIONAL REGISTRATION 1162377 DATED 3-15-2013, EXPIRES 3-15-2023.

NO CLAIM IS MADE TO THE EXCLUSIVE RIGHT TO USE "GASKETS", APART FROM THE MARK AS SHOWN.

THE MARK CONSISTS OF THE WORDING "KIBI KIBI GASKETS" WITH THE FIRST "KIBI" BEING SURROUNDED BY A RECTANGULAR BORDER WHICH CONNECTS TO, AND FORMS PART OF, THE BOTTOM OF THE LETTERS.

FOR METAL ENGINE GASKETS FOR VEHICLES; SEALING JOINTS BEING PARTS OF ENGINES; SEALS FOR INTERNAL COMBUSTION ENGINES FOR LAND VEHICLES; BEARING SEALS BEING MACHINE PARTS, NOT FOR LAND VEHICLES; MECHANICAL SEALS OF METAL; MECHANICAL SEALS (U.S. CLS. 13, 19, 21, 23, 31, 34 AND 35).

CHRISTINE MARTIN, EXAMINING ATTORNEY

**CLASS 7—(Continued).**

SN 79-138,026. MEIKO MASCHINENBAU GMBH & CO. KG, 77652 OFFENBURG, FED REP GERMANY, FILED 7-22-2013.

**M-iClean**

THE MARK CONSISTS OF STANDARD CHARACTERS WITHOUT CLAIM TO ANY PARTICULAR FONT, STYLE, SIZE, OR COLOR.

PRIORITY DATE OF 2-5-2013 IS CLAIMED.

OWNER OF INTERNATIONAL REGISTRATION 1180520 DATED 7-22-2013, EXPIRES 7-22-2023.

FOR INDUSTRIAL DISH WASHING MACHINES, AS UNDERCOUNTER WASHING MACHINES, HOOD TYPE WASHING MACHINES, UTENSIL WASHERS, GLASS WASHERS (U.S. CLS. 13, 19, 21, 23, 31, 34 AND 35).

ANDREW LEASER, EXAMINING ATTORNEY

SN 79-135,536. ALLGAIER WERKE GMBH, FED REP GERMANY, FILED 4-23-2013.

**Variotempo**

THE MARK CONSISTS OF STANDARD CHARACTERS WITHOUT CLAIM TO ANY PARTICULAR FONT, STYLE, SIZE, OR COLOR.

PRIORITY DATE OF 10-23-2012 IS CLAIMED.

OWNER OF INTERNATIONAL REGISTRATION 1174001 DATED 4-23-2013, EXPIRES 4-23-2023.

FOR PRESS MACHINES FOR INDUSTRIAL PURPOSES; BLANKING PRESSES; MACHINE TOOLS FOR COMPRESSION, CUTTING AND FORMING OF MATERIALS; METALWORKING MACHINE TOOLS; MOULDING MACHINES, NAMELY, COMPRESSION MOULDING MACHINES, EXTRUSION MOULDING MACHINES, INJECTION MOULDING MACHINES; DEEP-DRAWING MACHINES, NAMELY, MACHINES FOR DEEP DRAWING OF SHEETS OF PLASTIC, WOOD OR METAL; PUNCHING MACHINES, NAMELY, PUNCHING PRESSES, PISTON SPRING PLATES; MACHINE PARTS, NAMELY, TOOLS TO OBTAIN DEEP-DRAWN METAL PIECES, REAMERS, PISTON RODS, CENTRIFUGES, BEARINGS AND BUSHINGS; PRESSED PARTS AND MOULDED PARTS, NAMELY, BEARINGS, AS PARTS OF MACHINES; DISC SPRINGS AS BEING MACHINE PARTS (U.S. CLS. 13, 19, 21, 23, 31, 34 AND 35).

ALICE BENMAMAN, EXAMINING ATTORNEY

SN 79-139,098. ZHEJIANG WUYI MACHINERY CO., LTD., ZHEJIANG PROVINCE, CHINA, FILED 10-8-2013.



OWNER OF INTERNATIONAL REGISTRATION 1183281 DATED 10-8-2013, EXPIRES 10-8-2023.

THE MARK CONSISTS OF A CIRCLE WITHIN WHICH ARE TWO FLYING BIRDS BELOW TWO ASIAN CHARACTERS, AT THE BOTTOM IS A BANNER WITH THE WORDING "SHUANG GE" IN IT.

THE ENGLISH TRANSLATION OF "SHUANG GE" IN THE MARK IS "DOUBLE DOVE".

THE NON-LATIN CHARACTERS IN THE MARK TRANSLITERATE TO "SHUANG GE" AND THIS MEANS "DOUBLE DOVE" IN ENGLISH.

FOR CAPSTANS; HOISTS; ELEVATING APPARATUS IN THE NATURE OF ELEVATING WORK PLATFORMS; HANDLING APPARATUS FOR LOADING AND UNLOADING IN THE NATURE OF LOADING AND UNLOADING MACHINES; CRANES USED FOR LIFTING AND HOISTING; LIFTING AND HOISTING APPARATUS IN THE NATURE OF MECHANICAL AND HYDRAULIC LIFTS AND HOISTS; HOIST TACKLE (U.S. CLS. 13, 19, 21, 23, 31, 34 AND 35).

SUE LAWRENCE, EXAMINING ATTORNEY

**CLASS 7—(Continued).**

SN 79-140,529. ZARD S.R.L., ITALY, FILED 10-18-2013.



OWNER OF INTERNATIONAL REGISTRATION 1186959 DATED 10-18-2013, EXPIRES 10-18-2023.

NO CLAIM IS MADE TO THE EXCLUSIVE RIGHT TO USE "OFFICINE ITALIANE", APART FROM THE MARK AS SHOWN.

THE COLOR(S) WHITE, BLACK, GREEN AND RED IS/ ARE CLAIMED AS A FEATURE OF THE MARK.

THE MARK CONSISTS OF THE FOLLOWING: THE TERM "ZARD" WRITTEN IN DISTINCTIVE BLOCK CAPITAL LETTERS APPEARING IN THE COLOR WHITE WITH BACKGROUND/OUTLINING IN THE COLOR BLACK; THE LAST LETTER "D" HAS A DROPLET DESIGN IN COLOR BLACK WITH A WHITE RIM IN THE UPPER RIGHT; THE WORD "ZARD" IS UNDERLINED BY A HORIZONTAL STRIPE WITH THE FIRST PART ON THE LEFT SIDE IN COLOR GREEN, THE CENTRAL PART IN COLOR WHITE AND THE LAST PART ON THE RIGHT SIDE IN THE COLOR RED, AND OUTLINE WITH THIN BLACK LINES; UNDER THE STRIPE THERE ARE THE WORDS "OFFICINE ITALIANE ZARD" IN BLACK AND IN SMALLER FONT.

THE ENGLISH TRANSLATION OF THE FOREIGN WORD(S) IN THE MARK IS: THE ENGLISH TRANSLATION OF "OFFICINE ITALIANE" IS "ITALIAN WORKSHOPS", "ZARD" HAS NO MEANING AND THEREFORE CANNOT BE TRANSLATED.

FOR EXHAUSTS FOR MOTORS AND ENGINES (U.S. CLS. 13, 19, 21, 23, 31, 34 AND 35).

CURTIS FRENCH, EXAMINING ATTORNEY

SN 79-143,651. BLEISTAHL-PRODUKTIONS GMBH & CO KG., FED REP GERMANY, FILED 12-27-2013.

**COMO**

THE MARK CONSISTS OF STANDARD CHARACTERS WITHOUT CLAIM TO ANY PARTICULAR FONT, STYLE, SIZE, OR COLOR.

PRIORITY DATE OF 7-3-2013 IS CLAIMED. OWNER OF INTERNATIONAL REGISTRATION 1194659 DATED 12-27-2013, EXPIRES 12-27-2023.

THE ENGLISH TRANSLATION OF THE WORD "COMO" IN THE MARK IS "AS" OR "LIKE".

FOR VALVE SEATS FOR COMBUSTION ENGINES (U.S. CLS. 13, 19, 21, 23, 31, 34 AND 35).

MARC LEIPZIG, EXAMINING ATTORNEY

**CLASS 7—(Continued).**

SN 79-145,207. SOLIOS ENVIRONNEMENT, SAINT GERMAIN EN LAYE, FRANCE, FILED 2-5-2014.

**TGT**

THE MARK CONSISTS OF STANDARD CHARACTERS WITHOUT CLAIM TO ANY PARTICULAR FONT, STYLE, SIZE, OR COLOR.

PRIORITY DATE OF 8-26-2013 IS CLAIMED.

OWNER OF INTERNATIONAL REGISTRATION 1198579 DATED 2-5-2014, EXPIRES 2-5-2024.

FOR FILTERS, NAMELY, AIR FILTERS FOR INDUSTRIAL DEDUSTING, FILTERS FOR CEMENT PROCESSING MACHINES, FILTERS FOR MINERAL PROCESSING MACHINES, FILTERS FOR METAL PROCESSING MACHINES; GAS FILTERING MACHINES FOR CHEMICAL PROCESSING (U.S. CLS. 13, 19, 21, 23, 31, 34 AND 35).

GENE MACIOL, EXAMINING ATTORNEY

SN 85-844,356. MTD PRODUCTS INC, VALLEY CITY, OH. FILED 2-8-2013.

**SPRINGASSIST**

THE MARK CONSISTS OF STANDARD CHARACTERS WITHOUT CLAIM TO ANY PARTICULAR FONT, STYLE, SIZE, OR COLOR.

FOR TRIMMERS, NAMELY, POWER-OPERATED LAWN AND GARDEN STRING TRIMMERS (U.S. CLS. 13, 19, 21, 23, 31, 34 AND 35).

DAWN HAN, EXAMINING ATTORNEY

**CLASS 7—(Continued).**

SN 86-024,877. GUMWAND INC., FARMINGDALE, NY.  
FILED 7-31-2013.



NO CLAIM IS MADE TO THE EXCLUSIVE RIGHT TO USE "GUM", APART FROM THE MARK AS SHOWN.

THE COLOR(S) WHITE, GREEN, RED, DARK GREEN AND LIGHT GREEN IS/ARE CLAIMED AS A FEATURE OF THE MARK.

THE MARK CONSISTS OF THE WORDS "GUM WAND" IN WHITE INSIDE A GREEN BUBBLE THAT HAS A LIGHT GREEN HIGHLIGHT AND RED SHADOWING, A DARK GREEN BORDER AND RED CIRCLES.

FOR MOBILE FLUID CLEANING MACHINERY (U.S. CLS. 13, 19, 21, 23, 31, 34 AND 35).

FIRST USE 9-5-2013; IN COMMERCE 9-5-2013.

MICHAEL KEATING, EXAMINING ATTORNEY

**CLASS 7—(Continued).**

SN 86-069,509. NISUS CORPORATION, ROCKFORD, TN.  
FILED 9-19-2013.

# TRUETECH

THE MARK CONSISTS OF STANDARD CHARACTERS WITHOUT CLAIM TO ANY PARTICULAR FONT, STYLE, SIZE, OR COLOR.

FOR COMMERCIAL POWER-OPERATED PESTICIDE APPLICATION EQUIPMENT, NAMELY, FOAMERS AND SPRAYERS, SOLD TO PEST CONTROL PROFESSIONALS (U.S. CLS. 13, 19, 21, 23, 31, 34 AND 35).

MARYNELLE WILSON, EXAMINING ATTORNEY

SN 86-070,131. SHENK AG. ENTERPRISES LLC, HOME-DALE, ID. FILED 9-20-2013.

SN 86-063,021. FUEL MOTO, INC., LITTLE CHUTE, WI.  
FILED 9-12-2013.



NO CLAIM IS MADE TO THE EXCLUSIVE RIGHT TO USE "FUEL MOTO", APART FROM THE MARK AS SHOWN.

THE MARK CONSISTS OF THE STYLIZED WORDING "FUEL MOTO" FEATURING A STYLIZED THREE-LEAF CLOVER CENTERED BETWEEN THE WORDS ALL ON AN OVAL BACKGROUND. THE BACKGROUND PORTION BEHIND "FUEL" IS SHADED.

FOR MOTORCYCLE PARTS, NAMELY, ELECTRONIC FUEL INJECTION MODULES (U.S. CLS. 13, 19, 21, 23, 31, 34 AND 35).

FIRST USE 10-20-2004; IN COMMERCE 10-20-2004.

BERYL GARDNER, EXAMINING ATTORNEY

# MAX-A-MILL

THE MARK CONSISTS OF STANDARD CHARACTERS WITHOUT CLAIM TO ANY PARTICULAR FONT, STYLE, SIZE, OR COLOR.

FOR GRAIN HANDLING EQUIPMENT, NAMELY, EQUIPMENT FOR GRINDING AND PROCESSING GRAIN, NAMELY, MACHINES FOR PROCESSING GRAIN, HANDLING MACHINES FOR HANDLING GRAIN, SCREENING EQUIPMENT FOR SCREENING GRAIN, MACHINES FOR SCREENING GRAINS AFTER GRINDING, CENTRIFUGAL GRINDING MACHINES FOR GRAINS, ELECTRIC GRAIN GRINDERS FOR INDUSTRIAL USE, AND MACHINES FOR POWERING GRAIN AND HAY HANDLING EQUIPMENT (U.S. CLS. 13, 19, 21, 23, 31, 34 AND 35).

MIAH ROSENBERG, EXAMINING ATTORNEY

**CLASS 7—(Continued).**

SN 86-072,860. TALLERES ZB, S.A., RENTERIA (GUIPÚZCOA), SPAIN, FILED 9-24-2013.



OWNER OF SPAIN REG. NO. 3010365, DATED 11-19-2011, EXPIRES 11-19-2021.

NO CLAIM IS MADE TO THE EXCLUSIVE RIGHT TO USE "GROUP", APART FROM THE MARK AS SHOWN.

THE COLOR(S) ORANGE AND GRAY IS/ARE CLAIMED AS A FEATURE OF THE MARK.

THE MARK CONSISTS OF THE LETTERS "ZB" IN STYLIZED TEXT DISPLAYED IN ORANGE OVER THE WORDING "ZB GROUP" IN A FADING, GRAY FONT.

FOR ROCK AND GRAVEL CRUSHING AND SORTING MACHINES; MACHINERY FOR THE RECYCLING AND SORTING OF CONSTRUCTION AND DEMOLITION WASTE; MACHINERY FOR THE RECYCLING AND SORTING OF METAL WASTE; MACHINERY FOR THE RECYCLING AND SORTING OF BATTERIES; MOBILE EQUIPMENT USED FOR THE OPERATION OF ROCK AND GRAVEL CRUSHING MACHINES AND RECYCLING MACHINES, NAMELY, MOBILE MACHINERY FOR CRUSHING AND PULVERIZING ROCK AND GRAVEL AND MOBILE MACHINERY FOR SHREDDING, SORTING AND RECYCLING OF AGGREGATES, IRON SCRAP AND DEMOLITION AND CONSTRUCTION DEBRIS (U.S. CLS. 13, 19, 21, 23, 31, 34 AND 35).  
JANICE KIM, EXAMINING ATTORNEY

SN 86-078,469. THE CHARLES MACHINE WORKS, INC., PERRY, OK. FILED 9-30-2013.

## DURATOOTH

THE MARK CONSISTS OF STANDARD CHARACTERS WITHOUT CLAIM TO ANY PARTICULAR FONT, STYLE, SIZE, OR COLOR.

FOR PARTS FOR POWER-OPERATED DIGGING CHAINS USED IN UNDERGROUND CONSTRUCTION, NAMELY CUTTING TEETH (U.S. CLS. 13, 19, 21, 23, 31, 34 AND 35).

FIRST USE 11-0-2010; IN COMMERCE 11-0-2010.  
ALEXANDER L. POWERS, EXAMINING ATTORNEY

**CLASS 7—(Continued).**

SN 86-088,413. HENGST SE & CO. KG, MUNSTER, FED REP GERMANY, FILED 10-10-2013.

## Blue·tron

PRIORITY CLAIMED UNDER SEC. 44(D) ON ERPN CMNTY TM OFC APPLICATION NO. 011729993, FILED 4-11-2013, REG. NO. 011729993, DATED 10-18-2013, EXPIRES 4-11-2023.

THE MARK CONSISTS OF THE STYLIZED WORDING "BLUE" AND "TRON" WITH A DOT CENTERED BETWEEN THE WORDS.

FOR MOTORS AND ENGINES, EXCEPT FOR LAND VEHICLES, PARTS OF MOTORS AND ENGINES, EXCEPT FOR LAND VEHICLES, IN PARTICULAR DISK SEPARATORS; PARTS FOR ENGINES AND MOTORS FOR VEHICLES, IN PARTICULAR DISK SEPARATORS (U.S. CLS. 13, 19, 21, 23, 31, 34 AND 35).

TEJBIR SINGH, EXAMINING ATTORNEY

SN 86-095,411. REACHMASTER, INC., HUMBLE, TX. FILED 10-18-2013.

## REACHMASTER

THE MARK CONSISTS OF STANDARD CHARACTERS WITHOUT CLAIM TO ANY PARTICULAR FONT, STYLE, SIZE, OR COLOR.

OWNER OF U.S. REG. NO. 2,866,324.  
FOR MOBILE CRANES AND ELEVATING WORK PLATFORMS (U.S. CLS. 13, 19, 21, 23, 31, 34 AND 35).  
FIRST USE 11-30-1994; IN COMMERCE 1-31-1995.  
JOHN DWYER, EXAMINING ATTORNEY

SN 86-105,693. HONDA MOTOR CO., LTD., TOKYO, JAPAN, FILED 10-30-2013.

## HONDA GP

THE MARK CONSISTS OF STANDARD CHARACTERS WITHOUT CLAIM TO ANY PARTICULAR FONT, STYLE, SIZE, OR COLOR.

OWNER OF U.S. REG. NOS. 1,002,188, 4,019,898 AND OTHERS.

FOR MOTORS AND ENGINES NOT FOR LAND VEHICLES, FOR THE GENERATION OF ELECTRICITY, AND PARTS AND FITTING THEREFOR; WATER PUMPS FOR USE IN MOTORS AND ENGINES NOT FOR LAND VEHICLES, AND PARTS AND FITTING THEREFOR (U.S. CLS. 13, 19, 21, 23, 31, 34 AND 35).

APRIL REEVES, EXAMINING ATTORNEY

**CLASS 7—(Continued).**

SN 86-109,476. TRITECH INDUSTRIES, INC., UNION, NJ. FILED 11-4-2013.

**TriTech Industries, Inc.**

THE MARK CONSISTS OF STANDARD CHARACTERS WITHOUT CLAIM TO ANY PARTICULAR FONT, STYLE, SIZE, OR COLOR.

NO CLAIM IS MADE TO THE EXCLUSIVE RIGHT TO USE "INDUSTRIES, INC.", APART FROM THE MARK AS SHOWN.

FOR (BASED ON USE IN COMMERCE) PAINT SPRAYING APPARATUS, NAMELY, AIRLESS PAINT SPRAY GUNS, SPRAY NOZZLES FOR AIRLESS PAINT SPRAY GUNS, SPRAY NOZZLE EXTENSIONS FOR AIRLESS PAINT SPRAY GUNS, SAFETY GUARDS FOR AIRLESS PAINT SPRAY NOZZLES, POLE EXTENSIONS FOR AIRLESS PAINT SPRAY GUNS, HIGH PRESSURE FLUID HOSES FOR AIRLESS PAINT SPRAYING SYSTEMS, PAINT FILTERS FOR AIRLESS PAINT SPRAY GUNS, ACCESSORIES, NAMELY, REPAIR KITS FOR AIRLESS PAINT SPRAY GUNS COMPRISED OF STRUCTURAL REPLACEMENT PARTS FOR AIRLESS PAINT SPRAY GUNS; (BASED ON INTENT TO USE) PUMPS FOR AIRLESS PAINT SPRAYING SYSTEMS (U.S. CLS. 13, 19, 21, 23, 31, 34 AND 35).

FIRST USE 12-31-2005; IN COMMERCE 12-31-2005.  
APRIL ROACH, EXAMINING ATTORNEY

SN 86-117,982. M.D. MANUFACTURING, INC., BAKERSFIELD, CA. FILED 11-13-2013.

**MODERN DAY**

THE MARK CONSISTS OF STANDARD CHARACTERS WITHOUT CLAIM TO ANY PARTICULAR FONT, STYLE, SIZE, OR COLOR.

OWNER OF U.S. REG. NO. 1,810,589.  
FOR CENTRAL VACUUM CLEANING INSTALLATIONS (U.S. CLS. 13, 19, 21, 23, 31, 34 AND 35).  
FIRST USE 11-30-1992; IN COMMERCE 11-30-1992.  
FLORENTINA BLANDU, EXAMINING ATTORNEY

SN 86-118,007. M.D. MANUFACTURING, INC., BAKERSFIELD, CA. FILED 11-13-2013.

**SILENTMASTER**

THE MARK CONSISTS OF STANDARD CHARACTERS WITHOUT CLAIM TO ANY PARTICULAR FONT, STYLE, SIZE, OR COLOR.

OWNER OF U.S. REG. NO. 1,804,275.  
FOR CENTRAL VACUUM CLEANING INSTALLATIONS (U.S. CLS. 13, 19, 21, 23, 31, 34 AND 35).  
FIRST USE 11-30-1992; IN COMMERCE 11-30-1992.  
FLORENTINA BLANDU, EXAMINING ATTORNEY

**CLASS 7—(Continued).**

SN 86-123,288. GENERAC POWER SYSTEMS, INC., WAUKESHA, WI. FILED 11-19-2013.

**CENTURION**

THE MARK CONSISTS OF STANDARD CHARACTERS WITHOUT CLAIM TO ANY PARTICULAR FONT, STYLE, SIZE, OR COLOR.

OWNER OF U.S. REG. NO. 3,380,066.  
FOR ELECTRIC GENERATORS AND RELATED EQUIPMENT, NAMELY, AUTOMATIC STANDBY ELECTRIC GENERATOR SETS (U.S. CLS. 13, 19, 21, 23, 31, 34 AND 35).

FIRST USE 6-11-2003; IN COMMERCE 6-11-2003.  
TEJBIR SINGH, EXAMINING ATTORNEY

SN 86-123,324. GENERAC POWER SYSTEMS, INC., WAUKESHA, WI. FILED 11-19-2013.

**PROTECTOR**

THE MARK CONSISTS OF STANDARD CHARACTERS WITHOUT CLAIM TO ANY PARTICULAR FONT, STYLE, SIZE, OR COLOR.

FOR STANDBY ELECTRICAL GENERATORS (U.S. CLS. 13, 19, 21, 23, 31, 34 AND 35).  
FIRST USE 10-31-2013; IN COMMERCE 10-31-2013.  
TEJBIR SINGH, EXAMINING ATTORNEY

SN 86-142,711. ANDERSON-AMERICA CORPORATION, PINEVILLE, NC. FILED 12-13-2013.



NO CLAIM IS MADE TO THE EXCLUSIVE RIGHT TO USE "SYSTEMS INC.", APART FROM THE MARK AS SHOWN.

THE COLOR(S) BLACK AND ORANGE IS/ARE CLAIMED AS A FEATURE OF THE MARK.

THE MARK CONSISTS OF THE FOLLOWING: THE BLACK STYLIZED WORDING "OMNITECH" APPEARING OVER THE GRAPHIC REPRESENTATION OF AN ORANGE LINE, APPEARING OVER THE BLACK WORDING "SYSTEMS INC.", APPEARING TO THE LEFT OF THE GRAPHIC REPRESENTATION OF SIX ORANGE POLYGONS, WHITE IN THE DRAWING REPRESENTS BACKGROUND AREA AND IS NOT PART OF THE MARK.

FOR MACHINE TOOLS, NAMELY, CNC ROUTERS (U.S. CLS. 13, 19, 21, 23, 31, 34 AND 35).  
FIRST USE 12-31-2002; IN COMMERCE 12-31-2002.  
CHRISTOPHER REAMS, EXAMINING ATTORNEY

**CLASS 7—(Continued).**

SN 86-148,407. HYUNDAI WIA CORPORATION, GYEONG-SANGNAM-DO, REPUBLIC OF KOREA, FILED 12-19-2013.

**HYUNDAI  
WIA i-CUT**

PRIORITY CLAIMED UNDER SEC. 44(D) ON REPUBLIC OF KOREA APPLICATION NO. 2013-0074830, FILED 11-11-2013, REG. NO. 1028537, DATED 3-20-2014, EXPIRES 3-20-2024.

THE MARK CONSISTS OF THE WORD "HYUNDAI" IN BLOCK PRINT FONT, AND BEGINNING UNDER THE "U" IN "HYUNDAI" APPEARS THE WORD "WIA" IN BOLD BLOCK PRINT FONT, WITH AN UPSIDE DOWN V APPEARING INSTEAD OF THE "A", AND TO THE RIGHT OF "WIA" IS THE WORD "I-CUT" WITH A LOWER CASE "I" AND "CUT" APPEARING IN UPPER CASE.

THE WORDING "HYUNDAI" AND "WIA" HAS NO MEANING IN A FOREIGN LANGUAGE.

FOR MACHINE TOOLS, NAMELY, BORING MACHINES; METALWORKING MACHINES; MACHINE PART, NAMELY, TOOLHOLDERS FOR METALWORKING MACHINES; MECHANICAL PRESSES FOR METALWORKING; ROLLING MILLS FOR METALWORKING; HYDRAULIC PRESSES FOR METALWORKING; SHEARING MACHINES FOR METALWORKING; CUTTING MACHINES FOR METALWORKING; TUBING MILLS FOR METALWORKING; PERFORATING MACHINES FOR METALWORKING; PUNCHING PRESSES FOR METALWORKING; PLANING MACHINES FOR METALWORKING; SHAPING MACHINES FOR METALWORKING; HORNING MACHINES FOR METALWORKING; DRILLING MACHINES; LAPPING MACHINES FOR METALWORKING; MACHINING CENTERS; MILLING MACHINES; BENDING MACHINES FOR METALWORKING; BROACHING MACHINES FOR METALWORKING; LATHES FOR METALWORKING; GRINDING MACHINES FOR METALWORKING; TAPPING MACHINES FOR METAL WORKING (U.S. CLS. 13, 19, 21, 23, 31, 34 AND 35).

JANICE L. MCMORROW, EXAMINING ATTORNEY

SN 86-148,466. GENERAC POWER SYSTEMS, INC., WAUKESHA, WI. FILED 12-19-2013.

**VERSA-TECH**

THE MARK CONSISTS OF STANDARD CHARACTERS WITHOUT CLAIM TO ANY PARTICULAR FONT, STYLE, SIZE, OR COLOR.

FOR PRESSURE WASHER MACHINE PARTS, NAMELY, HOSES (U.S. CLS. 13, 19, 21, 23, 31, 34 AND 35).

TEJBIR SINGH, EXAMINING ATTORNEY

**CLASS 7—(Continued).**

SN 86-148,528. HYUNDAI WIA CORPORATION, GYEONG-SANGNAM-DO, REPUBLIC OF KOREA, FILED 12-19-2013.

**WIA i-CUT**

THE MARK CONSISTS OF THE WORD "WIA" IN BOLD BLOCK PRINT FONT, WITH AN UPSIDE DOWN V APPEARING INSTEAD OF THE "A", AND TO THE RIGHT OF "WIA" IS THE WORD "I-CUT" WITH A LOWER CASE "I" AND "CUT" APPEARING IN UPPER CASE.

THE WORDING "WIA" HAS NO MEANING IN A FOREIGN LANGUAGE.

FOR MACHINE TOOLS, NAMELY, BORING MACHINES; METALWORKING MACHINES; MACHINE PART, NAMELY, TOOLHOLDERS FOR METALWORKING MACHINES; MECHANICAL PRESSES FOR METALWORKING; ROLLING MILLS FOR METALWORKING; HYDRAULIC PRESSES FOR METALWORKING; SHEARING MACHINES FOR METALWORKING; CUTTING MACHINES FOR METALWORKING; TUBING MILLS FOR METALWORKING; PERFORATING MACHINES FOR METALWORKING; PUNCHING PRESSES FOR METALWORKING; PLANING MACHINES FOR METALWORKING; SHAPING MACHINES FOR METALWORKING; HORNING MACHINES FOR METALWORKING; DRILLING MACHINES; LAPPING MACHINES FOR METALWORKING; MACHINING CENTERS; MILLING MACHINES; BENDING MACHINES FOR METALWORKING; BROACHING MACHINES FOR METALWORKING; LATHES FOR METALWORKING; GRINDING MACHINES FOR METALWORKING; TAPPING MACHINES FOR METAL WORKING (U.S. CLS. 13, 19, 21, 23, 31, 34 AND 35).

JANICE L. MCMORROW, EXAMINING ATTORNEY



**CLASS 7—(Continued).**

SN 86-148,620. HYUNDAI WIA CORPORATION, GYEONG-SANGNAM-DO, REPUBLIC OF KOREA, FILED 12-19-2013.

# i-CUT

THE MARK CONSISTS OF THE WORD "I-CUT" WITH A LOWER CASE "I" AND "CUT" APPEARING IN UPPER CASE.

FOR MACHINE TOOLS, NAMELY, BORING MACHINES; METALWORKING MACHINES; MACHINE PART NAMELY, TOOLHOLDERS FOR METALWORKING MACHINES; MECHANICAL PRESSES FOR METALWORKING; ROLLING MILLS FOR METALWORKING; HYDRAULIC PRESSES FOR METALWORKING; SHEARING MACHINES FOR METALWORKING; CUTTING MACHINES FOR METALWORKING; TUBING MILLS FOR METALWORKING; PERFORATING MACHINES FOR METALWORKING; PUNCHING PRESSES FOR METALWORKING; PLANING MACHINES FOR METALWORKING; SHAPING MACHINES FOR METALWORKING; HORNING MACHINES FOR METALWORKING; DRILLING MACHINES; LAPPING MACHINES FOR METALWORKING; MACHINING CENTERS; MILLING MACHINES; BENDING MACHINES FOR METALWORKING; BROACHING MACHINES FOR METALWORKING; LATHES FOR METALWORKING; GRINDING MACHINES FOR METALWORKING; TAPPING MACHINES FOR METAL WORKING (U.S. CLS. 13, 19, 21, 23, 31, 34 AND 35).

JANICE L. MCMORROW, EXAMINING ATTORNEY

SN 86-155,596. TOLER JR., JIMMY E., MESA, AZ. FILED 12-31-2013.

# ACCUCAM

THE MARK CONSISTS OF STANDARD CHARACTERS WITHOUT CLAIM TO ANY PARTICULAR FONT, STYLE, SIZE, OR COLOR.

FOR EARTH DRILLING EQUIPMENT AND PARTS THEREFOR, NAMELY, EARTH DRILLING MACHINES AND PARTS FOR USE IN DEEP HOLE DRILLING OPERATIONS (U.S. CLS. 13, 19, 21, 23, 31, 34 AND 35).

KIMBERLY PERRY, EXAMINING ATTORNEY

**CLASS 7—(Continued).**

SN 86-156,400. GENERAC POWER SYSTEMS, INC., WAUKESHA, WI. FILED 1-2-2014.

# CONTROL YOUR POWER. YOUR LIFE.

THE MARK CONSISTS OF THE TERM "CONTROL" TO THE LEFT OF THE PHRASE "YOUR POWER." ABOVE THE PHRASE "YOUR LIFE."

FOR ELECTRIC GENERATORS AND RELATED EQUIPMENT, NAMELY, BACKUP AND STANDBY ELECTRIC GENERATOR SETS AND PARTS THEREFOR (U.S. CLS. 13, 19, 21, 23, 31, 34 AND 35).

FIRST USE 12-31-2007; IN COMMERCE 12-31-2007.  
BILL DAWE, EXAMINING ATTORNEY

SN 86-164,783. GENERAC POWER SYSTEMS, INC., WAUKESHA, WI. FILED 1-14-2014.

# SYNERGY

THE MARK CONSISTS OF STANDARD CHARACTERS WITHOUT CLAIM TO ANY PARTICULAR FONT, STYLE, SIZE, OR COLOR.

FOR ELECTRIC GENERATORS AND RELATED EQUIPMENT, NAMELY, BACKUP AND STANDBY ELECTRIC GENERATOR SETS AND PARTS THEREFOR (U.S. CLS. 13, 19, 21, 23, 31, 34 AND 35).

BILL DAWE, EXAMINING ATTORNEY

SN 86-173,739. KEMAICO USA CORPORATION, LINCOLNSHIRE, IL. FILED 1-23-2014.



OWNER OF CHINA REG. NO. 9090665, DATED 2-7-2012, EXPIRES 2-6-2022.

THE COLOR(S) BLACK AND BLUE IS/ARE CLAIMED AS A FEATURE OF THE MARK.

THE MARK CONSISTS OF THE WORD "KEMAICO" IN BLACK ON THE RIGHT SIDE OF A DESIGN OF A THREE 60° EVENLY DISCONNECTED ARC LENGTH IN A CIRCLE FORMATION IN BLUE, WITH ANOTHER SOLID CIRCLE INSIDE, LIKE A DRILLING BIT HEAD. BLUE COLOR LIGHT FROM LEFT SIDE GRADUALLY TURN TO DARK BLUE TO THE RIGHT SIDE OF THE LOGO.

FOR BITS FOR POWER DRILLS; CONNECTING RODS FOR MACHINES, MOTORS AND ENGINES; DRILL BITS FOR ROCK DRILLING; ELECTRIC HAMMERS (U.S. CLS. 13, 19, 21, 23, 31, 34 AND 35).

FIRST USE 1-1-2010; IN COMMERCE 1-1-2010.  
JAY FLOWERS, EXAMINING ATTORNEY

**CLASS 7—(Continued).**

SN 86-178,329. GENERAC POWER SYSTEMS, INC., WAUKESHA, WI. FILED 1-29-2014.

**REAL HOMES DON'T BLACK OUT**

THE MARK CONSISTS OF STANDARD CHARACTERS WITHOUT CLAIM TO ANY PARTICULAR FONT, STYLE, SIZE, OR COLOR.

OWNER OF U.S. REG. NO. 3,375,034.  
FOR AUTOMATIC STANDBY ELECTRIC GENERATOR SETS AND PARTS THEREFOR (U.S. CLS. 13, 19, 21, 23, 31, 34 AND 35).

BILL DAWE, EXAMINING ATTORNEY

SN 86-191,271. JASON INCORPORATED, BROOKLYN HEIGHTS, OH. FILED 2-12-2014.

**BROOMATE**

THE MARK CONSISTS OF STANDARD CHARACTERS WITHOUT CLAIM TO ANY PARTICULAR FONT, STYLE, SIZE, OR COLOR.

FOR ATTACHMENTS FOR VEHICLES, NAMELY, VEHICLE MOUNTED BROOMS FOR NON-HOUSEHOLD USE (U.S. CLS. 13, 19, 21, 23, 31, 34 AND 35).

FIRST USE 7-26-2013; IN COMMERCE 8-26-2013.  
KAREN BRACEY, EXAMINING ATTORNEY

SN 86-201,944. OMAX CORPORATION, KENT, WA. FILED 2-24-2014.

**MAXIEM ABRASIVE WATERJETS**

THE MARK CONSISTS OF STANDARD CHARACTERS WITHOUT CLAIM TO ANY PARTICULAR FONT, STYLE, SIZE, OR COLOR.

OWNER OF U.S. REG. NOS. 3,826,091, 3,829,226 AND OTHERS.

NO CLAIM IS MADE TO THE EXCLUSIVE RIGHT TO USE "ABRASIVE WATERJETS", APART FROM THE MARK AS SHOWN.

FOR COMPUTER-CONTROLLED, POWER-OPERATED MACHINE TOOL FOR ABRASIVE JET CUTTING AND MACHINING; MACHINES AND MACHINE TOOLS FOR THE CUTTING AND FORMING OF MATERIALS (U.S. CLS. 13, 19, 21, 23, 31, 34 AND 35).

ALLISON HOLTZ, EXAMINING ATTORNEY

**CLASS 7—(Continued).**

SN 86-201,969. OMAX CORPORATION, KENT, WA. FILED 2-24-2014.

**OMAX ABRASIVE WATERJETS**

THE MARK CONSISTS OF STANDARD CHARACTERS WITHOUT CLAIM TO ANY PARTICULAR FONT, STYLE, SIZE, OR COLOR.

OWNER OF U.S. REG. NOS. 1,992,387, 4,471,035 AND OTHERS.

NO CLAIM IS MADE TO THE EXCLUSIVE RIGHT TO USE "ABRASIVE WATERJETS", APART FROM THE MARK AS SHOWN.

FOR COMPUTER-CONTROLLED, POWER-OPERATED MACHINE TOOL FOR ABRASIVE JET CUTTING AND MACHINING; MACHINES AND MACHINE TOOLS FOR THE CUTTING AND FORMING OF MATERIALS (U.S. CLS. 13, 19, 21, 23, 31, 34 AND 35).

ALLISON HOLTZ, EXAMINING ATTORNEY

SN 86-203,474. TENNSMITH INC., MCMINNVILLE, TN. FILED 2-25-2014.

**AUTOBRAKE**

THE MARK CONSISTS OF STANDARD CHARACTERS WITHOUT CLAIM TO ANY PARTICULAR FONT, STYLE, SIZE, OR COLOR.

SEC. 2(F).  
FOR SHEET METAL WORKING MACHINES FOR BENDING AND TRIMMING SHEET METAL (U.S. CLS. 13, 19, 21, 23, 31, 34 AND 35).

FIRST USE 5-31-1991; IN COMMERCE 5-31-1991.  
LAURIE MAYES, EXAMINING ATTORNEY

SN 86-205,881. C & T TARLTON, INC., TA NATIONAL EQUIPMENT&DESIGN CO./NEDCO CONVEYORS, UNION, NJ. FILED 2-27-2014.



OWNER OF U.S. REG. NO. 1,778,688.  
THE MARK CONSISTS OF THE WORDING "NEDCO" INSIDE AN ARROW DESIGN.

FOR CHAIN CONVEYORS; CONVEYOR LINES; CONVEYORS (U.S. CLS. 13, 19, 21, 23, 31, 34 AND 35).

FIRST USE 6-30-1972; IN COMMERCE 6-30-1972.  
EMILY CHUO, EXAMINING ATTORNEY

**CLASS 7—(Continued).**

SN 86-206,313. BENTON GRAPHICS, INC., TRENTON, NJ.  
FILED 2-27-2014.

**MICROLOY**

THE MARK CONSISTS OF STANDARD CHARACTERS WITHOUT CLAIM TO ANY PARTICULAR FONT, STYLE, SIZE, OR COLOR.

FOR STEEL ALLOY SOLD AS AN INTEGRAL COMPONENT OF DOCTOR BLADES, SAID BLADES FOR USE WITH PRINTING MACHINES IN THE PRINTING INDUSTRY (U.S. CLS. 13, 19, 21, 23, 31, 34 AND 35).

FIRST USE 2-16-2000; IN COMMERCE 9-26-2001.  
LAURIE MAYES, EXAMINING ATTORNEY

SN 86-218,844. J.R. CLANCY, INC., SYRACUSE, NY. FILED  
3-12-2014.

**VARION**

THE MARK CONSISTS OF STANDARD CHARACTERS WITHOUT CLAIM TO ANY PARTICULAR FONT, STYLE, SIZE, OR COLOR.

FOR HOIST AND RIGGING SYSTEMS FOR THEATERS, ARENAS, AND STAGES COMPRISED OF MOTORIZED HOISTS OR HOIST EQUIPMENT FOR MOTORIZING COUNTERWEIGHT RIGGING SYSTEMS (U.S. CLS. 13, 19, 21, 23, 31, 34 AND 35).

DOUGLAS LEE, EXAMINING ATTORNEY

SN 86-218,855. J.R. CLANCY, INC., SYRACUSE, NY. FILED  
3-12-2014.

**PERFORMER**

THE MARK CONSISTS OF STANDARD CHARACTERS WITHOUT CLAIM TO ANY PARTICULAR FONT, STYLE, SIZE, OR COLOR.

FOR HOIST AND RIGGING SYSTEMS FOR THEATERS, ARENAS, AND STAGES COMPRISED OF MOTORIZED HOISTS OR HOIST EQUIPMENT FOR MOTORIZING COUNTERWEIGHT RIGGING SYSTEMS (U.S. CLS. 13, 19, 21, 23, 31, 34 AND 35).

DOUGLAS LEE, EXAMINING ATTORNEY

**CLASS 7—(Continued).**

SN 86-227,412. SEARS BRANDS, LLC, HOFFMAN ESTATES, IL. FILED 3-20-2014.

**ACCELA WASH**

THE MARK CONSISTS OF STANDARD CHARACTERS WITHOUT CLAIM TO ANY PARTICULAR FONT, STYLE, SIZE, OR COLOR.

OWNER OF U.S. REG. NO. 4,227,123.

NO CLAIM IS MADE TO THE EXCLUSIVE RIGHT TO USE "WASH", APART FROM THE MARK AS SHOWN.

FOR CLOTHES WASHING MACHINES; COMPONENT FEATURE OF CLOTHES WASHING MACHINES, NAMELY, ALLOWING FOR A SHORTENED WASH CYCLE (U.S. CLS. 13, 19, 21, 23, 31, 34 AND 35).

JILLIAN CANTOR, EXAMINING ATTORNEY

SN 86-230,572. SILVA TECHNOLOGIES INC., ROCKVILLE, MD. FILED 3-24-2014.

**A.S. ENGINES**

THE MARK CONSISTS OF STANDARD CHARACTERS WITHOUT CLAIM TO ANY PARTICULAR FONT, STYLE, SIZE, OR COLOR.

NO CLAIM IS MADE TO THE EXCLUSIVE RIGHT TO USE "ENGINES", APART FROM THE MARK AS SHOWN.

FOR ENGINES AND MOTORS FOR MODEL VEHICLES, AIRCRAFT, AND BOATS; ENGINES AND MOTORS, OTHER THAN FOR LAND VEHICLES; PARTS AND FITTINGS FOR ALL OF THE AFOREMENTIONED GOODS (U.S. CLS. 13, 19, 21, 23, 31, 34 AND 35).

LINDA MICKLEBURGH, EXAMINING ATTORNEY

SN 86-230,613. SILVA TECHNOLOGIES INC., ROCKVILLE, MD. FILED 3-24-2014.



NO CLAIM IS MADE TO THE EXCLUSIVE RIGHT TO USE "ENGINES", APART FROM THE MARK AS SHOWN.

THE MARK CONSISTS OF AN OVAL SHAPE WITH THE LETTERS "A" AND "S" WITHIN THE OVAL; A PROPELLER DESIGN IMPOSED ACROSS THE LETTERS "A" AND "S"; AND THE WORD "ENGINES" ABOVE THE OVAL.

FOR ENGINES AND MOTORS FOR MODEL VEHICLES, AIRCRAFT, AND BOATS; ENGINES AND MOTORS, OTHER THAN FOR LAND VEHICLES; PARTS AND FITTINGS FOR ALL OF THE AFOREMENTIONED GOODS (U.S. CLS. 13, 19, 21, 23, 31, 34 AND 35).

LINDA MICKLEBURGH, EXAMINING ATTORNEY

**CLASS 7—(Continued).**

SN 86-231,891. MARK D. ROMERO, SPRING, TX. FILED 3-25-2014.



THE MARK CONSISTS OF A BLACK HOLLOW CIRCLE WITH SIX BLACK ROUNDED MOUNDS PROTRUDING FROM THE OUTER CIRCUMFERENCE.

FOR PRINTING MACHINES FOR WEB PRODUCTS, PARTICULARLY WALLPAPER, FLOOR COVERINGS AND FILMS, PARTS FOR THE AFOREMENTIONED MACHINES AND LINES COMPOSED THEREOF, NAMELY, GRAVURE PRINTING LINES, SCREEN PRINTING LINES, FLEXO PRINTING LINES AND COMBINATIONS OF THE AFOREMENTIONED LINES (U.S. CLS. 13, 19, 21, 23, 31, 34 AND 35).

ELIZABETH JACKSON, EXAMINING ATTORNEY

---

SN 86-232,081. SILVA TECHNOLOGIES INC., ROCKVILLE, MD. FILED 3-25-2014.

**GRYPHON DIESEL ENGINES**

THE MARK CONSISTS OF STANDARD CHARACTERS WITHOUT CLAIM TO ANY PARTICULAR FONT, STYLE, SIZE, OR COLOR.

NO CLAIM IS MADE TO THE EXCLUSIVE RIGHT TO USE "DIESEL ENGINES", APART FROM THE MARK AS SHOWN.

FOR DIESEL ENGINES NOT FOR LAND VEHICLES; PARTS AND FITTINGS FOR THE AFOREMENTIONED GOODS (U.S. CLS. 13, 19, 21, 23, 31, 34 AND 35).

LINDA MICKLEBURGH, EXAMINING ATTORNEY

**CLASS 7—(Continued).**

SN 86-232,897. AMMBUSHER, INC, DILLSBORO, IN. FILED 3-26-2014.

**AMMBUSHER**

THE MARK CONSISTS OF STANDARD CHARACTERS WITHOUT CLAIM TO ANY PARTICULAR FONT, STYLE, SIZE, OR COLOR.

FOR AGRICULTURAL MACHINERY AND ATTACHMENTS THEREFOR, NAMELY, ROTARY MOWERS, BOX SCRAPERS, AND THREE-POINT ATTACHMENTS; CONSTRUCTION MACHINERY AND ATTACHMENTS THEREFOR, NAMELY, FENCING MACHINERY IN THE NATURE OF POST PULLERS, POST DRIVERS, AND FENCE STRETCHERS (U.S. CLS. 13, 19, 21, 23, 31, 34 AND 35).

FIRST USE 3-23-1992; IN COMMERCE 3-23-1992.  
KRISTINA MORRIS, EXAMINING ATTORNEY

---

SN 86-234,172. BELANGER, INC., NORTHVILLE, MI. FILED 3-27-2014.

**Foam Bullet**

THE MARK CONSISTS OF STANDARD CHARACTERS WITHOUT CLAIM TO ANY PARTICULAR FONT, STYLE, SIZE, OR COLOR.

NO CLAIM IS MADE TO THE EXCLUSIVE RIGHT TO USE "FOAM", APART FROM THE MARK AS SHOWN.

FOR AUTOMATIC VEHICLE WASHING EQUIPMENT, NAMELY, SOAP AND CHEMICAL APPLICATORS USED TO APPLY SOLUTIONS FOR CLEANING, WAXING AND DRYING (U.S. CLS. 13, 19, 21, 23, 31, 34 AND 35).

TINA MAI, EXAMINING ATTORNEY

---

SN 86-234,188. BELANGER, INC., NORTHVILLE, MI. FILED 3-27-2014.

**H2Air**

THE MARK CONSISTS OF STANDARD CHARACTERS WITHOUT CLAIM TO ANY PARTICULAR FONT, STYLE, SIZE, OR COLOR.

FOR AUTOMATIC VEHICLE WASHING EQUIPMENT, NAMELY, A CAR WASH ARCH THAT DISPENSES A COMBINATION OF AIR AND WATER TO RINSE AND DRY VEHICLES (U.S. CLS. 13, 19, 21, 23, 31, 34 AND 35).

TINA MAI, EXAMINING ATTORNEY

**CLASS 7—(Continued).**

SN 86-235,369. RI CARBIDE TOOL CO, DBA RI CARBIDE TOOL CO, SMITHFIELD, RI. FILED 3-28-2014.

# Wild Mill

THE MARK CONSISTS OF STANDARD CHARACTERS WITHOUT CLAIM TO ANY PARTICULAR FONT, STYLE, SIZE, OR COLOR.

NO CLAIM IS MADE TO THE EXCLUSIVE RIGHT TO USE "MILL", APART FROM THE MARK AS SHOWN.

FOR MILLING CUTTERS; MILLING CUTTERS FOR MILLING MACHINES (U.S. CLS. 13, 19, 21, 23, 31, 34 AND 35).

FIRST USE 8-2-2011; IN COMMERCE 8-2-2011.  
NATALIE POLZER, EXAMINING ATTORNEY

SN 86-236,430. BELANGER, INC., NORTHVILLE, MI. FILED 3-30-2014.

# Roll-A-Grate

THE MARK CONSISTS OF STANDARD CHARACTERS WITHOUT CLAIM TO ANY PARTICULAR FONT, STYLE, SIZE, OR COLOR.

FOR AUTOMATIC VEHICLE WASH EQUIPMENT, NAMELY, GRATING FOR DRAINS THAT ROLLS UP FOR ACCESS FOR MAINTENANCE AND ROLLS DOWN TO RESTRICT ACCESS FOR VEHICLE WASHES (U.S. CLS. 13, 19, 21, 23, 31, 34 AND 35).

TINA MAI, EXAMINING ATTORNEY

SN 86-237,805. LUMINAR PRODUCTS, LLC, NAMPA, ID. FILED 3-31-2014.

# makerboss

THE MARK CONSISTS OF STANDARD CHARACTERS WITHOUT CLAIM TO ANY PARTICULAR FONT, STYLE, SIZE, OR COLOR.

FOR MULTI-MANUFACTURING MACHINES, NAMELY, INJECTION MOLDING MACHINES AND MILLING MACHINES (U.S. CLS. 13, 19, 21, 23, 31, 34 AND 35).

DAVID GEARHART, EXAMINING ATTORNEY

**CLASS 7—(Continued).**

SN 86-238,569. LEVY, URIEL, LOS ANGELES, CA. FILED 4-1-2014.



NO CLAIM IS MADE TO THE EXCLUSIVE RIGHT TO USE "USA", APART FROM THE MARK AS SHOWN.

THE COLOR(S) BLUE IS/ARE CLAIMED AS A FEATURE OF THE MARK.

THE MARK CONSISTS OF THE STYLIZED WORD "ATLAS" IN BLUE FOLLOWED BY "USA" IN STYLIZED SMALLER PRINT IN DARKER BLUE.

FOR SEWING MACHINERY; SEWING MACHINES; SEWING MACHINES FOR HOUSEHOLD PURPOSES (U.S. CLS. 13, 19, 21, 23, 31, 34 AND 35).

LINDA POWELL, EXAMINING ATTORNEY

SN 86-238,695. COMEAU, TOM, SAN MARCOS, CA. FILED 4-1-2014.



THE COLOR(S) YELLOW, BLACK AND WHITE IS/ARE CLAIMED AS A FEATURE OF THE MARK.

THE MARK CONSISTS OF THE WORDING "SOOTBUDDY" WITH THE LETTER "S" SHOWN AS A BLACK HOSE. EXTENDING FROM THE LETTER "S" ON BOTH ENDS IS A VARIEGATED HOSE IN BLACK AND WHITE. AT THE BOTTOM END OF THE LETTER "S", THE HOSE UNDERLINES THE WORDING. AT THE TOP END OF THE LETTER "S", THE HOSE EXTENDS TO A CONIC NOZZLE SHOWN IN YELLOW AND WHITE WITH BLACK OUTLINE. THE LETTERS "OOTBU" AND "Y" APPEAR IN YELLOW WITH BLACK OUTLINING. THE LETTERS "DD" ARE FORMED WITH THE BOTTOM PORTIONS IN BLACK, AND THE TOP PORTIONS FORMED BY PIPES APPEARING IN BLACK AND WHITE. TWO SMOKE CLOUDS APPEAR IN WHITE WITH BLACK OUTLINE COMING OUT OF THE PIPES AND BEING SUCKED TOWARDS THE CONIC NOZZLE.

FOR MOBILE DIESEL PARTICULATE FILTER CLEANING MACHINE (U.S. CLS. 13, 19, 21, 23, 31, 34 AND 35).

FIRST USE 8-30-2013; IN COMMERCE 8-30-2013.  
JOANNA DUKOVIC, EXAMINING ATTORNEY

**CLASS 7—(Continued).**

SN 86-239,351. WENZHOU RENQIAN FUEL PUMP CO., LTD, RUIAN CITY, CHINA, FILED 4-1-2014.

# CRQ

THE MARK CONSISTS OF WORDING "CRQ" IN STY-  
LIZED FONT.

THE WORDING "CRQ" HAS NO MEANING IN A  
FOREIGN LANGUAGE.

FOR BACK PRESSURE VALVES AS PARTS OF MA-  
CHINES; DYNAMOS; FANS FOR MOTORS AND EN-  
GINES; FUEL INJECTOR PARTS FOR LAND AND  
WATER VEHICLE ENGINES; HYDRAULIC CONTROLS  
FOR MACHINES, MOTORS AND ENGINES; IGNITION  
PARTS FOR INTERNAL COMBUSTION ENGINES,  
NAMELY, CONDENSERS; IGNITION WIRES FOR MO-  
TOR VEHICLES; OIL PUMPS FOR LAND VEHICLES;  
PUMPS AS PARTS OF MACHINES, MOTORS AND  
ENGINES; STARTERS FOR MOTORS AND ENGINES;  
VALVES BEING PARTS OF MACHINES (U.S. CLS. 13, 19,  
21, 23, 31, 34 AND 35).

FIRST USE 11-14-2004; IN COMMERCE 10-8-2008.

RUSS HERMAN, EXAMINING ATTORNEY

SN 86-244,054. THE BLACK & DECKER CORPORATION,  
TOWSON, MD. FILED 4-7-2014.

## SHOCKS ACTIVE VIBRATION CONTROL

THE MARK CONSISTS OF STANDARD CHARACTERS  
WITHOUT CLAIM TO ANY PARTICULAR FONT, STYLE,  
SIZE, OR COLOR.

OWNER OF U.S. REG. NOS. 3,263,766 AND 3,421,053.  
SEC. 2(F).

FOR ANTI-VIBRATION FEATURE OF A POWER  
TOOL NAMELY A ROTARY HAMMER (U.S. CLS. 13,  
19, 21, 23, 31, 34 AND 35).

FIRST USE 11-30-2005; IN COMMERCE 11-30-2005.

LOURDES AYALA, EXAMINING ATTORNEY

**CLASS 7—(Continued).**

SN 86-244,381. BOYD AND SONS MACHINERY LLC,  
WASHINGTON, IN. FILED 4-7-2014.

# Warrior Tracks

THE MARK CONSISTS OF STANDARD CHARACTERS  
WITHOUT CLAIM TO ANY PARTICULAR FONT, STYLE,  
SIZE, OR COLOR.

NO CLAIM IS MADE TO THE EXCLUSIVE RIGHT TO  
USE "TRACKS", APART FROM THE MARK AS SHOWN.

FOR RUBBER TRACKS BEING PARTS OF AN EX-  
CAVATING MACHINE OR SKID STEER, NAMELY,  
COMPACT TRACK LOADER (U.S. CLS. 13, 19, 21, 23,  
31, 34 AND 35).

LUCY ARANT, EXAMINING ATTORNEY

SN 86-245,277. EVERWIN PNEUMATIC CORP., TAICHUNG  
CITY, TAIWAN, FILED 4-8-2014.

# EVERWIN

THE MARK CONSISTS OF STANDARD CHARACTERS  
WITHOUT CLAIM TO ANY PARTICULAR FONT, STYLE,  
SIZE, OR COLOR.

FOR PNEUMATIC HAMMERS; PNEUMATIC DRILLS;  
PNEUMATIC SCREWDRIVERS; POWER-OPERATED  
STAPLE GUNS; PNEUMATIC STAPLE GUNS; POWER-  
DRIVEN WRENCHES (U.S. CLS. 13, 19, 21, 23, 31, 34 AND  
35).

FIRST USE 11-20-2013; IN COMMERCE 2-8-2014.

KATHRYN COWARD, EXAMINING ATTORNEY

SN 86-245,605. SIMMONS ENGINEERING CORPORATION,  
WHEELING, IL. FILED 4-8-2014.



THE MARK CONSISTS OF THE TRADEMARK "SIM-  
MONS" IN ALL-CAPS AND AN ITALICIZED FONT, SET IN  
AN OVAL AND FRAMED ON ONE SIDE BY AN INVERTED  
STYLIZED TRIANGLE, AND ABOVE AND BELOW BY  
THREE HORIZONTAL LINES OF DIFFERENT THICK-  
NESSES.

FOR BLADES FOR POWER SAWS; MACHINE PARTS,  
NAMELY, BLADES; POWER SAW BLADES (U.S. CLS. 13,  
19, 21, 23, 31, 34 AND 35).

FIRST USE 12-1-1993; IN COMMERCE 12-1-1993.

JEFF DEFORD, EXAMINING ATTORNEY

**CLASS 7—(Continued).**

SN 86-245,825. TECHTRONIC FLOOR CARE TECHNOLOGY LIMITED, ROAD TOWN TORTOLA, BR.VIRGIN ISLANDS, FILED 4-8-2014.

# SteamStream

THE MARK CONSISTS OF STANDARD CHARACTERS WITHOUT CLAIM TO ANY PARTICULAR FONT, STYLE, SIZE, OR COLOR.

FOR CARPET CLEANING MACHINES; CLEANING APPLIANCES UTILIZING STEAM; ELECTRIC VACUUM CLEANERS AND THEIR COMPONENTS; FLOOR CLEANING MACHINES; FLOOR SCRUBBING MACHINES; FLOOR WASHING MACHINES; MULTI-PURPOSE STEAM CLEANERS; STEAM CLEANING MACHINES; VACUUM CLEANERS (U.S. CLS. 13, 19, 21, 23, 31, 34 AND 35).

THEODORE MCBRIDE, EXAMINING ATTORNEY

---

SN 86-245,829. TECHTRONIC FLOOR CARE TECHNOLOGY LIMITED, ROAD TOWN TORTOLA, BR.VIRGIN ISLANDS, FILED 4-8-2014.

# FloorSense

THE MARK CONSISTS OF STANDARD CHARACTERS WITHOUT CLAIM TO ANY PARTICULAR FONT, STYLE, SIZE, OR COLOR.

FOR CARPET CLEANING MACHINES; CLEANING APPLIANCES UTILIZING STEAM; ELECTRIC VACUUM CLEANERS AND THEIR COMPONENTS; FLOOR CLEANING MACHINES; FLOOR SCRUBBING MACHINES; FLOOR WASHING MACHINES; MULTI-PURPOSE STEAM CLEANERS; STEAM CLEANING MACHINES; VACUUM CLEANERS (U.S. CLS. 13, 19, 21, 23, 31, 34 AND 35).

THEODORE MCBRIDE, EXAMINING ATTORNEY

---

SN 86-246,956. INSCERCO MFG. INC., CRESTWOOD, IL, FILED 4-9-2014.

# MAILCRAFTERS

THE MARK CONSISTS OF STANDARD CHARACTERS WITHOUT CLAIM TO ANY PARTICULAR FONT, STYLE, SIZE, OR COLOR.

FOR ENVELOPE INSERTING AND MAILING MACHINES (U.S. CLS. 13, 19, 21, 23, 31, 34 AND 35).  
FIRST USE 1-31-1982; IN COMMERCE 1-31-1982.  
ANDREA CORNWELL, EXAMINING ATTORNEY

**CLASS 7—(Continued).**

SN 86-247,769. FLORIDA ENGINES & MACHINERY, DORAL, FL. FILED 4-9-2014.

# MTR

THE MARK CONSISTS OF STANDARD CHARACTERS WITHOUT CLAIM TO ANY PARTICULAR FONT, STYLE, SIZE, OR COLOR.

FOR COOLING RADIATORS FOR MOTORS AND ENGINES; FILTERS FOR CLEANING COOLING AIR, FOR ENGINES; FUEL FILTERS; FUEL INJECTOR PARTS FOR LAND AND WATER VEHICLE ENGINES; FUEL INJECTORS; FUEL PUMPS FOR LAND VEHICLES; GASKETS FOR INTERNAL COMBUSTION ENGINES; HEADERS AS PART OF VEHICLE EXHAUST SYSTEM; HYDRAULIC CONTROLS FOR MACHINES, MOTORS AND ENGINES; HYDRAULIC ENGINES AND MOTORS; HYDRAULIC EXCAVATORS; HYDRAULIC PUMPS; HYDRAULIC PUMPS AND MOTORS FOR HYDROSTATIC SYSTEMS, COMPRISED OF PUMPS, MOTORS, VALVES, SWITCHES, SENSORS AND ELECTRONIC CONTROLS, FOR HYDRAULIC DRIVES AND FORCE TRANSMISSION IN MACHINES, MACHINE TOOLS, GRINDING AND FOOD PROCESSING MACHINES AND IN OFF-ROAD-VEHICLES; MACHINE PARTS, NAMELY, CYLINDERS; MACHINE PARTS, NAMELY, GEAR DRIVES; MECHANICAL ELEMENTS FOR USE WITH LAND VEHICLES, NAMELY, AUTOMOBILE TURNTABLES AND THEIR ROTATING DEVICES FOR MECHANICAL PARTY SYSTEMS AND GARAGES; METAL ENGINE GASKETS FOR VEHICLES; SELF-LUBRICATING MECHANICAL FRICTION PARTS, ESPECIALLY OF COMPOSITE MATERIALS, NAMELY, WEAR RINGS, WASHERS, BUSHINGS, SPHERICAL BEARINGS, BEARING PADS, SLIDING BLOCKS AND MACHINE TRANSMISSION GEARS ALL FOR LOAD BEARING MACHINES, CONVEYORS, HANDLING TRUCKS AND MACHINES, LIFTING MACHINES, AGRICULTURAL MACHINERY, CONSTRUCTION EQUIPMENT MACHINES AND HYDRAULIC TURBINES (U.S. CLS. 13, 19, 21, 23, 31, 34 AND 35).

KAPIL BHANOT, EXAMINING ATTORNEY

---

SN 86-249,082. SASE COMPANY, INC., KENT, WA. FILED 4-10-2014.

# TRI-FORCE

THE MARK CONSISTS OF STANDARD CHARACTERS WITHOUT CLAIM TO ANY PARTICULAR FONT, STYLE, SIZE, OR COLOR.

FOR FLOOR POLISHING MACHINES (U.S. CLS. 13, 19, 21, 23, 31, 34 AND 35).  
FIRST USE 1-21-2013; IN COMMERCE 1-21-2013.  
RON FAIRBANKS, EXAMINING ATTORNEY

**CLASS 7—(Continued).**

SN 86-249,391. CONAIR CORPORATION, STAMFORD, CT.  
FILED 4-11-2014.

# WARING

THE MARK CONSISTS OF STANDARD CHARACTERS WITHOUT CLAIM TO ANY PARTICULAR FONT, STYLE, SIZE, OR COLOR.

OWNER OF U.S. REG. NOS. 2,843,844, 3,607,179 AND OTHERS.

FOR ELECTRIC KNIVES (U.S. CLS. 13, 19, 21, 23, 31, 34 AND 35).

KRISTINA MORRIS, EXAMINING ATTORNEY

**CLASS 7—(Continued).**

SN 86-263,001. BELANGER, INC., NORTHVILLE, MI. FILED 4-25-2014.

# Sparklewheelz

THE MARK CONSISTS OF STANDARD CHARACTERS WITHOUT CLAIM TO ANY PARTICULAR FONT, STYLE, SIZE, OR COLOR.

FOR AUTOMATIC VEHICLE WASHING EQUIPMENT, NAMELY, ROTARY WASHERS WITH ILLUMINATED STRUCTURES (U.S. CLS. 13, 19, 21, 23, 31, 34 AND 35).

TINA MAI, EXAMINING ATTORNEY

SN 86-273,508. FASTENAL IP COMPANY, WINONA, MN.  
FILED 5-6-2014.

# ROCK RIVER

THE MARK CONSISTS OF STANDARD CHARACTERS WITHOUT CLAIM TO ANY PARTICULAR FONT, STYLE, SIZE, OR COLOR.

OWNER OF U.S. REG. NOS. 4,163,652, 4,479,079 AND OTHERS.

FOR ELECTRIC POWER TOOLS, NAMELY, DRILLS AND IMPACT DRIVERS (U.S. CLS. 13, 19, 21, 23, 31, 34 AND 35).

MARK T. MULLEN, EXAMINING ATTORNEY

SN 86-274,582. HARNISCHFEGER TECHNOLOGIES, INC., WILMINGTON, DE. FILED 5-7-2014.

# P&H

THE MARK CONSISTS OF STANDARD CHARACTERS WITHOUT CLAIM TO ANY PARTICULAR FONT, STYLE, SIZE, OR COLOR.

OWNER OF U.S. REG. NOS. 1,058,988, 4,490,445 AND OTHERS.

FOR MINING TRUCK WHEEL MOTORS AND MINING TRUCK WHEEL MOTOR PARTS (U.S. CLS. 13, 19, 21, 23, 31, 34 AND 35).

FIRST USE 3-20-2014; IN COMMERCE 3-20-2014.  
MAYUR VAGHANI, EXAMINING ATTORNEY

SN 86-254,821. BELANGER, INC., NORTHVILLE, MI. FILED 4-17-2014.

# GLOWHEELZ

THE MARK CONSISTS OF STANDARD CHARACTERS WITHOUT CLAIM TO ANY PARTICULAR FONT, STYLE, SIZE, OR COLOR.

FOR AUTOMATIC VEHICLE WASH EQUIPMENT, NAMELY, ROTARY WASHERS WITH ILLUMINATED STRUCTURES (U.S. CLS. 13, 19, 21, 23, 31, 34 AND 35).

TINA MAI, EXAMINING ATTORNEY

SN 86-262,985. BELANGER, INC., NORTHVILLE, MI. FILED 4-25-2014.

# Blizzwheelz

THE MARK CONSISTS OF STANDARD CHARACTERS WITHOUT CLAIM TO ANY PARTICULAR FONT, STYLE, SIZE, OR COLOR.

FOR AUTOMATIC VEHICLE WASHING EQUIPMENT, NAMELY, ROTARY WASHERS WITH ILLUMINATED STRUCTURES (U.S. CLS. 13, 19, 21, 23, 31, 34 AND 35).

TINA MAI, EXAMINING ATTORNEY



**CLASS 8—HAND TOOLS**

SN 79-143,818. TUSA PRECISION TOOLS SA, SWITZERLAND, FILED 1-21-2014.



OWNER OF INTERNATIONAL REGISTRATION 1195168 DATED 1-21-2014, EXPIRES 1-21-2024.

THE WORDING "TUSA" HAS NO MEANING IN A FOREIGN LANGUAGE.

FOR HAND-OPERATED TOOLS, NAMELY, DRILLS, REAMERS, MILLING CUTTERS, AND CUTTING TOOLS MADE OF TUNGSTEN CARBIDE AND OTHER METALS; DRILL BITS FOR HAND DRILLS (U.S. CLS. 23, 28 AND 44).

AMY KELLY, EXAMINING ATTORNEY

SN 85-384,885. WEI BIN INDUSTRIAL CO., LTD., TAI-CHUNG CITY 412, TAIWAN, FILED 7-29-2011.



OWNER OF U.S. REG. NO. 3,542,345.

NO CLAIM IS MADE TO THE EXCLUSIVE RIGHT TO USE "TOOLS", APART FROM THE MARK AS SHOWN.

THE MARK CONSISTS OF THE HIGHLY STYLIZED LETTERING "T&E TOOLS".

FOR HAND TOOLS, NAMELY, SCREWDRIVERS, SOCKET SETS, WRENCHES, PLIERS, JACKS, NAIL PULLERS, RATCHET WRENCHES, HAMMERS, BITS FOR HAND DRILLS (U.S. CLS. 23, 28 AND 44).

FIRST USE 3-1-2002; IN COMMERCE 3-1-2002.  
STEVEN JACKSON, EXAMINING ATTORNEY

SN 85-697,947. CORTEX USA, INC., DBA CORTEX INTERNATIONAL, MIAMI GARDENS, FL. FILED 8-8-2012.



THE MARK CONSISTS OF STANDARD CHARACTERS WITHOUT CLAIM TO ANY PARTICULAR FONT, STYLE, SIZE, OR COLOR.

NO CLAIM IS MADE TO THE EXCLUSIVE RIGHT TO USE "PROFESSIONAL", APART FROM THE MARK AS SHOWN.

FOR ELECTRIC HAIR STRAIGHTENING IRONS; BAGS AND CASES SPECIALLY ADAPTED FOR HOLDING OR CARRYING ELECTRIC HAIR STRAIGHTENING IRONS; ELECTRIC HAIR CURLING IRONS; HEAT RESISTANT MAT FOR RESTING ELECTRIC HAIR STRAIGHTENING IRONS (U.S. CLS. 23, 28 AND 44).

FIRST USE 1-1-2012; IN COMMERCE 1-1-2012.  
ALICIA COLLINS, EXAMINING ATTORNEY

**CLASS 8—(Continued).**

SN 85-698,011. CORTEX USA, INC., DBA CORTEX INTERNATIONAL, MIAMI GARDENS, FL. FILED 8-8-2012.



THE MARK CONSISTS OF STANDARD CHARACTERS WITHOUT CLAIM TO ANY PARTICULAR FONT, STYLE, SIZE, OR COLOR.

NO CLAIM IS MADE TO THE EXCLUSIVE RIGHT TO USE "INTERNATIONAL", APART FROM THE MARK AS SHOWN.

FOR ELECTRIC HAIR STRAIGHTENING IRONS; BAGS AND CASES SPECIALLY ADAPTED FOR HOLDING OR CARRYING ELECTRIC HAIR STRAIGHTENING IRONS; ELECTRIC HAIR CURLING IRONS; HEAT RESISTANT MAT FOR RESTING ELECTRIC HAIR STRAIGHTENING IRONS (U.S. CLS. 23, 28 AND 44).

FIRST USE 9-1-2008; IN COMMERCE 9-1-2008.  
ALICIA COLLINS, EXAMINING ATTORNEY

SN 85-814,094. KING OF INK, INC., ST. JAMES, NY. FILED 1-2-2013.



THE MARK CONSISTS OF STANDARD CHARACTERS WITHOUT CLAIM TO ANY PARTICULAR FONT, STYLE, SIZE, OR COLOR.

FOR TATTOO EQUIPMENT AND SUPPLIES, NAMELY, TATTOOING NEEDLES, TUBES AND GRIPS (U.S. CLS. 23, 28 AND 44).

THEODORE MCBRIDE, EXAMINING ATTORNEY

SN 85-852,379. WOODPECKERS, INC., NORTH ROYALTON, OH. FILED 2-18-2013.



THE MARK CONSISTS OF STANDARD CHARACTERS WITHOUT CLAIM TO ANY PARTICULAR FONT, STYLE, SIZE, OR COLOR.

NO CLAIM IS MADE TO THE EXCLUSIVE RIGHT TO USE "TOOL", APART FROM THE MARK AS SHOWN.

FOR HAND TOOLS FOR LAYING OUT, MARKING, AND MEASURING WOOD, NAMELY, SQUARES, DOWELING JIGS, MALLETS, MITER BOXES, MITER CUTTERS, CARPENTER'S CLAMPS, AND CLAMPING CAULS, SPECIFICALLY, AN ELONGATED BAR USED WHEN CLAMPING OBJECTS TOGETHER (U.S. CLS. 23, 28 AND 44).

JUHI KAVEESHVAR, EXAMINING ATTORNEY

**CLASS 8—(Continued).**

SN 85-901,205. HOLT, LINCOLN ELIJAH, HAVRE, MT. FILED 4-11-2013.



NO CLAIM IS MADE TO THE EXCLUSIVE RIGHT TO USE "1889", APART FROM THE MARK AS SHOWN.

THE MARK CONSISTS OF A ROUND RUSTIC LOGO WITH THE WORDS "MONTANA HAMMER". IN THE CENTER OF THE LOGO IS A BISON SKULL. "MONTANA" ABOVE, "HAMMER" BELOW. TWO RIFLE BULLET SHELLS ON THE SIDES SURROUNDED IN LEAFING, "1889" ON THE RIGHT SIDE OF THE LOGO, "308 WIN" IN THE LEFT LEAFING, AND "308 WIN" IN THE RIGHT LEAFING.

FOR HAND-CRAFTED RUSTIC HUNTING AND KITCHEN KNIVES, WITH HANDLES MADE FROM VARIOUS FORMS OF ANTLER, COPPER, STEEL, BRASS SPACERS, AS WELL AS VARIOUS FORMS OF FINE WOODS (U.S. CLS. 23, 28 AND 44).

FIRST USE 9-1-2012; IN COMMERCE 9-1-2012.  
INGA ERVIN, EXAMINING ATTORNEY

SN 86-110,666. EVEREADY BATTERY COMPANY, INC., ST. LOUIS, MO. FILED 11-5-2013.

**TRIAD 3**

THE MARK CONSISTS OF STANDARD CHARACTERS WITHOUT CLAIM TO ANY PARTICULAR FONT, STYLE, SIZE, OR COLOR.

FOR RAZOR BLADES; RAZORS (U.S. CLS. 23, 28 AND 44).

THEODORE MCBRIDE, EXAMINING ATTORNEY

**CLASS 8—(Continued).**

SN 86-110,691. I-V PRODUCTS, INC., SEATTLE, WA. FILED 11-5-2013.

**I-V**

THE MARK CONSISTS OF STANDARD CHARACTERS WITHOUT CLAIM TO ANY PARTICULAR FONT, STYLE, SIZE, OR COLOR.

OWNER OF U.S. REG. NO. 996,090.

SEC. 2(F).

FOR HAND TOOLS, NAMELY, PLIERS, SCREWDRIVERS AND COMMUNICATIONS PROBES NAMELY TOOLS USED TO LOCATE A WIRE, PULL THE WIRE AND FORM OR REFORM A HARNESS (U.S. CLS. 23, 28 AND 44).

FIRST USE 12-31-1974; IN COMMERCE 12-31-1974.

LINDA M. KING, EXAMINING ATTORNEY

SN 86-113,906. I-V PRODUCTS, INC., SEATTLE, WA. FILED 11-8-2013.



OWNER OF U.S. REG. NO. 996,090.

THE MARK CONSISTS OF "I-V" INSIDE OF TWO CIRCLES.

SEC. 2(F).

FOR HAND TOOLS, NAMELY, PLIERS, SCREWDRIVERS AND COMMUNICATIONS PROBES NAMELY TOOLS USED TO LAOCATE A WIRE, PULL THE WIRE, FORM OR REFORM A HARNESS (U.S. CLS. 23, 28 AND 44).

FIRST USE 7-1-1995; IN COMMERCE 7-1-1995.

LINDA M. KING, EXAMINING ATTORNEY

**CLASS 8—(Continued).**

SN 86-179,531. POHL FORCE GMBH, BURSCHIED, FED REP GERMANY, FILED 1-30-2014.

**POHL FORCE**

FOR CUTLERY, NAMELY, KNIVES, THROWING KNIVES, FISHING KNIVES, SPORT KNIVES, WORKING KNIVES, DIVING KNIVES, WHITTLING KNIVES, FOLDING KNIVES, HAND-OPERATED KNIFE TO AID IN SKINNING AN ANIMAL, HUNTING KNIVES, JACK KNIVES, PEN KNIVES, POCKET KNIVES; SIDEARMS, NOT INCLUDING FIREARMS, NAMELY, KNIVES FOR MILITARY PURPOSES AND FOR POLICE SERVICES; BLADES FOR THROWING KNIVES, FISHING KNIVES, SPORT KNIVES, WORKING KNIVES, DIVING KNIVES, WHITTLING KNIVES, FOLDING KNIVES, HAND-OPERATED KNIFE TO AID IN SKINNING AN ANIMAL, HUNTING KNIVES, JACK KNIVES, PEN KNIVES, POCKET KNIVES; HAND TOOLS, NAMELY, KNIFE SHARPENERS, MANUALLY-OPERATED KNIFE SHARPENING WHEELS, MANUALLY-OPERATED GUIDES FOR KNIVES; KNIFE BAGS, KNIFE SHEATHS, KNIFE SHEATHS OF LEATHER (U.S. CLS. 23, 28 AND 44).

FIRST USE 4-24-2013; IN COMMERCE 4-24-2013.  
MARIA-VICTORIA SUAREZ, EXAMINING ATTORNEY

SN 86-200,266. DECTRONIQUE 1984 INC., AKA DECTRO INTERNATIONAL, QUEBEC, CANADA, FILED 2-21-2014.

**APILUS**

THE MARK CONSISTS OF "APILUS" IN CAPITAL LETTERS WITH A WAVE (REPRESENTING A HAIR) ONTO THE LETTER "A".

FOR ELECTROLYSIS APPARATUS FOR HAIR REMOVAL (U.S. CLS. 23, 28 AND 44).

FIRST USE 1-1-1976; IN COMMERCE 8-9-1989.  
BRITTANY ESTELL, EXAMINING ATTORNEY

SN 86-210,187. EGW UTILITIES, INC., CARROLLTON, TX, FILED 3-4-2014.

**WHITE RHINO**

THE MARK CONSISTS OF STANDARD CHARACTERS WITHOUT CLAIM TO ANY PARTICULAR FONT, STYLE, SIZE, OR COLOR.

FOR HAND TOOLS, NAMELY, VALVE WRENCHES FOR USE IN NATURAL GAS DISTRIBUTION, WATERWORKS, SEWER, PLUMBING, OILFIELD, OR PIPELINE FIELDS (U.S. CLS. 23, 28 AND 44).

FIRST USE 10-31-2013; IN COMMERCE 10-31-2013.  
CRISTIANA SCHWAB, EXAMINING ATTORNEY

**CLASS 8—(Continued).**

SN 86-229,349. HIGHROAD DESIGNS INC., LOUISVILLE, CO. FILED 3-23-2014.

**Ice Slicer**

THE MARK CONSISTS OF STANDARD CHARACTERS WITHOUT CLAIM TO ANY PARTICULAR FONT, STYLE, SIZE, OR COLOR.

NO CLAIM IS MADE TO THE EXCLUSIVE RIGHT TO USE "ICE", APART FROM THE MARK AS SHOWN.

FOR HAND TOOLS, NAMELY, SCRAPERS (U.S. CLS. 23, 28 AND 44).

TOBY BULLOFF, EXAMINING ATTORNEY

SN 86-229,624. ENGINEER INC., OSAKA, JAPAN, FILED 3-24-2014.

**Neji-saurus**

THE MARK CONSISTS OF STANDARD CHARACTERS WITHOUT CLAIM TO ANY PARTICULAR FONT, STYLE, SIZE, OR COLOR.

OWNER OF JAPAN REG. NO. 5412932, DATED 5-20-2011, EXPIRES 5-20-2021.

FOR PLIERS, TWEEZERS, HAND-OPERATED EDGING TOOLS, SCREW DRIVERS (U.S. CLS. 23, 28 AND 44).

CURTIS FRENCH, EXAMINING ATTORNEY

SN 86-230,457. DIY FLORAL, LLC, PORTLAND, OR, FILED 3-24-2014.

**DIY Floral**

THE MARK CONSISTS OF STANDARD CHARACTERS WITHOUT CLAIM TO ANY PARTICULAR FONT, STYLE, SIZE, OR COLOR.

NO CLAIM IS MADE TO THE EXCLUSIVE RIGHT TO USE "FLORAL", APART FROM THE MARK AS SHOWN.

FOR HAND TOOLS, NAMELY, TOOLS FOR ARRANGING FLOWERS (U.S. CLS. 23, 28 AND 44).

BRIAN PINO, EXAMINING ATTORNEY

**CLASS 8—(Continued).**

SN 86-232,458. ROONEY, BRUCE, LOUISBURG, KS. FILED 3-26-2014.

# V-Drill

THE MARK CONSISTS OF STANDARD CHARACTERS WITHOUT CLAIM TO ANY PARTICULAR FONT, STYLE, SIZE, OR COLOR.

OWNER OF U.S. REG. NO. 4,466,390.  
FOR HAND TOOLS, NAMELY, GUIDES, DRILL GUIDES, AND TAP GUIDES (U.S. CLS. 23, 28 AND 44).  
FIRST USE 10-1-2012; IN COMMERCE 10-1-2012.  
ESTHER BELENKER, EXAMINING ATTORNEY

SN 86-232,749. ROONEY, BRUCE, LOUISBURG, KS. FILED 3-26-2014.

# V-TapGuide

THE MARK CONSISTS OF STANDARD CHARACTERS WITHOUT CLAIM TO ANY PARTICULAR FONT, STYLE, SIZE, OR COLOR.

OWNER OF U.S. REG. NO. 4,466,390.  
FOR HAND TOOLS, NAMELY, GUIDES, DRILL GUIDES, AND TAP GUIDES (U.S. CLS. 23, 28 AND 44).  
FIRST USE 5-1-2005; IN COMMERCE 5-1-2005.  
ESTHER BELENKER, EXAMINING ATTORNEY

**CLASS 8—(Continued).**

SN 86-233,589. THE ORIGINAL SCREED BRACKET LLC, PERKINS, OK. FILED 3-27-2014.



NO CLAIM IS MADE TO THE EXCLUSIVE RIGHT TO USE THE DESIGN OF A SCREED BRACKET AND "THE ORIGINAL SCREED BRACKET", APART FROM THE MARK AS SHOWN.

THE COLOR(S) BLACK, WHITE AND TAN IS/ARE CLAIMED AS A FEATURE OF THE MARK.

THE MARK CONSISTS OF A SERIES OF WHITE CONCENTRIC CIRCLES OUTLINED IN BLACK WITH THE WORD "SCREED" IN BLACK AT THE TOP AND "BRACKET" IN BLACK AT THE BOTTOM WITH A WHITE BANNER OUTLINED IN BLACK AND THE WORDS "THE ORIGINAL" IN BLACK THROUGH THE CENTER OF THE CIRCLE, AND A TAN PIECE OF WOOD WITH BLACK BRACKETS AND TAN HANDLES ACROSS THE FRONT.

FOR HAND TOOLS FOR PUTTING A FINISH ON CONCRETE, NAMELY, CONCRETE BRUSHES AND COMBS; HAND TOOLS, NAMELY, CONCRETE MOVERS (U.S. CLS. 23, 28 AND 44).

FIRST USE 7-23-2013; IN COMMERCE 10-25-2013.  
NICHOLAS COLEMAN, EXAMINING ATTORNEY

SN 86-236,687. EGW UTILITIES, INC., CARROLLTON, TX. FILED 3-31-2014.

# WHITE RHINO TUFF

THE MARK CONSISTS OF STANDARD CHARACTERS WITHOUT CLAIM TO ANY PARTICULAR FONT, STYLE, SIZE, OR COLOR.

NO CLAIM IS MADE TO THE EXCLUSIVE RIGHT TO USE "TOUGH", APART FROM THE MARK AS SHOWN.

FOR HAND TOOLS, NAMELY, VALVE WRENCHES FOR USE IN NATURAL GAS DISTRIBUTION, WATERWORKS, SEWER, PLUMBING, OILFIELD, OR PIPELINE FIELDS (U.S. CLS. 23, 28 AND 44).

FIRST USE 10-31-2013; IN COMMERCE 10-31-2013.  
CRISTIANA SCHWAB, EXAMINING ATTORNEY

**CLASS 8—(Continued).**

SN 86-238,085. ZUREK, RONALD CHRISTOPHER, ETIWANDA, CA. AND HORELLE, LONA SUSAN, VICTORVILLE, CA. FILED 4-1-2014.

**Currency Buddy**

THE MARK CONSISTS OF STANDARD CHARACTERS WITHOUT CLAIM TO ANY PARTICULAR FONT, STYLE, SIZE, OR COLOR.

NO CLAIM IS MADE TO THE EXCLUSIVE RIGHT TO USE "CURRENCY", APART FROM THE MARK AS SHOWN.

FOR HAND TOOLS, NAMELY, CLAMPS (U.S. CLS. 23, 28 AND 44).

GRETTA YAO, EXAMINING ATTORNEY

SN 86-240,292. MARUT ENTERPRISES LLC, MIAMI BEACH, FL. FILED 4-2-2014.

**PRIVATE GROOMER**

THE MARK CONSISTS OF STANDARD CHARACTERS WITHOUT CLAIM TO ANY PARTICULAR FONT, STYLE, SIZE, OR COLOR.

OWNER OF U.S. REG. NO. 3,579,563.

NO CLAIM IS MADE TO THE EXCLUSIVE RIGHT TO USE "GROOMER", APART FROM THE MARK AS SHOWN.

FOR HAIR CLIPPERS; HAIR TRIMMERS; ELECTRIC HAIR CUTTERS; ELECTRIC RAZORS; ELECTRIC SHAVERS (U.S. CLS. 23, 28 AND 44).

IRA J. GOODSID, EXAMINING ATTORNEY

SN 86-253,025. RUCCI, INC., LOS ANGELES, CA. FILED 4-15-2014.



THE MARK CONSISTS OF THE TRADE DRESS CHARACTERIZING PACKAGING FOR THE GOODS. THE PACKAGING COMPRISES A VERTICALLY ORIENTED GENERALLY RECTANGULAR ENCLOSURE, WITH THE TOP END OF THE ENCLOSURE BEING ANGLED Laterally. WITHIN THE GENERALLY RECTANGULAR ENCLOSURE IS A SECOND ENCLOSURE CONFIGURED TO CONTAIN THE LOWER BODY PORTION OF THE NIPPER PRODUCT (NOT SHOWN). THE SECOND ENCLOSURE EXTENDS VERTICALLY UPWARD FROM THE GENERALLY RECTANGULAR ENCLOSURE BOTTOM AND INCLUDES A GENERALLY CONCAVE TOP END DEFINING AN APERTURE FOR RECEIVING THERETHROUGH THE TOP END OF NIPPERS.

FOR NIPPERS (U.S. CLS. 23, 28 AND 44).

MIDGE BUTLER, EXAMINING ATTORNEY

**CLASS 8—(Continued).**

SN 86-255,530. SHELTER DISTRIBUTORS INC, COMMERCE, CA. FILED 4-17-2014.

**HUNT-DOWN**

THE MARK CONSISTS OF THE STYLIZED LETTERS "HUNT-DOWN" WITH A BIRD FLYING BETWEEN "HUNT" AND "DOWN". ALSO THERE IS A TARGET AIMED AT BIRD.

FOR CUTLERY; HAND-OPERATED CUTTING TOOLS; KNIVES; KNIVES FOR HOBBY USE (U.S. CLS. 23, 28 AND 44).

FIRST USE 1-1-2006; IN COMMERCE 1-1-2006.

KELLY BOULTON, EXAMINING ATTORNEY

SN 86-279,707. MARUT ENTERPRISES LLC, MIAMI BEACH, FL. FILED 5-13-2014.

**HYDRASPIN**

THE MARK CONSISTS OF STANDARD CHARACTERS WITHOUT CLAIM TO ANY PARTICULAR FONT, STYLE, SIZE, OR COLOR.

FOR ELECTRIC SHAVERS; HAIR TRIMMERS; MUSTACHE AND BEARD TRIMMERS (U.S. CLS. 23, 28 AND 44).

IRA J. GOODSID, EXAMINING ATTORNEY

SN 86-292,378. SOCIETE BIC, CLICHY, FRANCE, FILED 5-27-2014.

**SUN TWIST**

THE MARK CONSISTS OF STANDARD CHARACTERS WITHOUT CLAIM TO ANY PARTICULAR FONT, STYLE, SIZE, OR COLOR.

FOR SHAVERS, NAMELY, RAZORS AND RAZOR BLADES (U.S. CLS. 23, 28 AND 44).

DOMINIC J. FERRAIUOLO, EXAMINING ATTORNEY

**CLASS 9—ELECTRICAL AND SCIENTIFIC APPARATUS**

SN 76-714,877. VOITH PATENT GMBH, INC., D-89522 HEIDENHEIM, FED REP GERMANY, FILED 9-4-2013.

# LINKTRONIK

THE MARK CONSISTS OF STANDARD CHARACTERS WITHOUT CLAIM TO ANY PARTICULAR FONT, STYLE, SIZE, OR COLOR.

FOR COMPUTER SOFTWARE FOR USE WITH PAPER MACHINES, NAMELY, COMPUTER SOFTWARE FOR USE WITH PAPER MACHINES TO CONTROL A MOISTURE CROSS PROFILE OVER A PAPER WEB PRODUCED IN THE PAPER MACHINES (U.S. CLS. 21, 23, 26, 36 AND 38).

FIRST USE 5-5-2012; IN COMMERCE 5-5-2012.  
JOSETTE BEVERLY, EXAMINING ATTORNEY

SN 76-715,190. NATIONAL FEDERATION OF INDEPENDENT BUSINESS, NASHVILLE, TN. FILED 10-17-2013.

# SMALLBIZ TODAY

THE MARK CONSISTS OF STANDARD CHARACTERS WITHOUT CLAIM TO ANY PARTICULAR FONT, STYLE, SIZE, OR COLOR.

NO CLAIM IS MADE TO THE EXCLUSIVE RIGHT TO USE "SMALL BIZ", APART FROM THE MARK AS SHOWN.

FOR DOWNLOADABLE COMPUTER SOFTWARE FOR MOBILE DEVICES, PERSONAL COMPUTERS, TABLETS FOR USE IN READING, SEARCHING AND DISPLAYING IMAGES, TEXT AND GRAPHICS IN THE FIELD OF ISSUES AFFECTING SMALL BUSINESS, ENTREPRENEURS AND INDEPENDENTLY OWNED COMPANIES; DOWNLOADABLE SOFTWARE APPLICATIONS FOR USE IN READING, SEARCHING AND DISPLAYING IMAGES, TEXT AND GRAPHICS IN THE FIELD OF ISSUES AFFECTING SMALL BUSINESS, ENTREPRENEURS AND INDEPENDENTLY OWNED COMPANIES; AND DOWNLOADABLE ELECTRONIC MEDIA CONTENT, NAMELY, TEXTS, GRAPHICS AND IMAGES RELATED TO ISSUES AFFECTING SMALL BUSINESS, ENTREPRENEURS AND INDEPENDENTLY OWNED COMPANIES (U.S. CLS. 21, 23, 26, 36 AND 38).

DANIEL CAPSHAW, EXAMINING ATTORNEY

**CLASS 9—(Continued).**

SN 76-715,205. KAISHA TAITO, KABUSHIKI, TOKYO, 160-8447, JAPAN, FILED 10-18-2013.

# ELEVATOR ACTION

THE MARK CONSISTS OF STANDARD CHARACTERS WITHOUT CLAIM TO ANY PARTICULAR FONT, STYLE, SIZE, OR COLOR.

OWNER OF JAPAN REG. NO. 5185343, DATED 12-5-2008, EXPIRES 12-5-2018.

FOR GAME PROGRAMS FOR MOBILE TELEPHONES AND SMARTPHONES; DOWNLOADABLE GAME PROGRAMS FOR MOBILE TELEPHONES AND SMARTPHONES; GAME PROGRAMS FOR PERSONAL COMPUTERS; DOWNLOADABLE GAME PROGRAMS FOR PERSONAL COMPUTERS; VIDEO GAME PROGRAMS FOR HOME VIDEO GAME MACHINES; ROM CARTRIDGES, DISCS AND TAPES ON WHICH VIDEO GAME PROGRAMS ARE PRERECORDED FOR HOME VIDEO GAME MACHINES; DOWNLOADABLE VIDEO GAME PROGRAMS FOR HOME VIDEO GAME MACHINES (U.S. CLS. 21, 23, 26, 36 AND 38).

MATTHEW GALAN, EXAMINING ATTORNEY

SN 76-715,932. HICONVERSION, INC., BOCA RATON, FL. FILED 3-4-2014.

# REAL OPTIMIZATION

THE MARK CONSISTS OF STANDARD CHARACTERS WITHOUT CLAIM TO ANY PARTICULAR FONT, STYLE, SIZE, OR COLOR.

NO CLAIM IS MADE TO THE EXCLUSIVE RIGHT TO USE "OPTIMIZATION", APART FROM THE MARK AS SHOWN.

FOR COMPUTER SOFTWARE FOR INCREASING THE EFFECTIVENESS OF WEBSITES WITH RESPECT TO THE RATES AT WHICH WEBSITE VISITORS ENGAGE IN DESIRED CONTEMPORANEOUS OR SUBSEQUENT ACTIVITIES (U.S. CLS. 21, 23, 26, 36 AND 38).

EVELYN BRADLEY, EXAMINING ATTORNEY

SN 77-412,295. TELEPHONICS CORPORATION, FARMINGDALE, NY. FILED 3-4-2008.

# Netcom

THE MARK CONSISTS OF STANDARD CHARACTERS WITHOUT CLAIM TO ANY PARTICULAR FONT, STYLE, SIZE, OR COLOR.

FOR AUDIO AND DATA INTERCOMMUNICATIONS SYSTEMS COMPRISED OF RADIO TRANSMITTERS AND RECEIVERS FOR MISSION CREWS IN MILITARY VEHICLES OR OTHER GROUND CONTROL APPLICATIONS FOR MILITARY AND HOMELAND SECURITY (U.S. CLS. 21, 23, 26, 36 AND 38).

CHARLES L. JENKINS, EXAMINING ATTORNEY

**CLASS 9—(Continued).**

SN 79-131,463. GKE-GMBH, 65529 WALDEMS, FED REP GERMANY, FILED 4-24-2013.

**gke Steri-Record Bio-C-PCD**

THE MARK CONSISTS OF STANDARD CHARACTERS WITHOUT CLAIM TO ANY PARTICULAR FONT, STYLE, SIZE, OR COLOR.

OWNER OF INTERNATIONAL REGISTRATION 1163732 DATED 4-24-2013, EXPIRES 4-24-2023.

OWNER OF U.S. REG. NOS. 3,307,477 AND 4,062,025.

FOR LABORATORY DEVICES, NAMELY, DEVICES TO CONTROL STERILIZATION PROCESSES FOR MEDICAL, PHARMACEUTICAL AND/OR MICROBIOLOGICAL RESEARCH PURPOSES (U.S. CLS. 21, 23, 26, 36 AND 38).

BERNICE MIDDLETON, EXAMINING ATTORNEY

**CLASS 9—(Continued).**

INSTRUMENTS FOR WEAK-CURRENT ENGINEERING, NAMELY, ALARM APPARATUS AND EQUIPMENT, WARNING APPARATUS AND EQUIPMENT, SIGNAL TRANSMISSION AND PROCESSING APPARATUS AND EQUIPMENT; APPARATUS AND INSTRUMENTS FOR WEAK-CURRENT ENGINEERING, NAMELY, TELECOMMUNICATIONS AND HIGH-FREQUENCY ENGINEERING; APPARATUS AND INSTRUMENTS FOR POWER ENGINEERING, NAMELY, FOR CONDUCTING, CASING, STORING, REGULATING AND CONTROL; ELECTRIC AMPLIFIERS AND SIGNAL CONVERTERS; APPARATUS AND EQUIPMENT FOR DATA TRANSMISSION, NAMELY, ELECTRONIC UNITS USED IN DATA TRANSMISSION NETWORKS, NAMELY, INTERFACES, COUPLERS AND TRANSCEIVERS, INCLUDING INSTALLATIONS CONSISTING THEREOF; SOFTWARE FOR RUNNING AND MONITORING THE PERFORMANCE OF ELECTRONIC AND OPTO-ELECTRONIC COMPONENTS AND UNITS BASED ON SEMICONDUCTOR TECHNOLOGY (U.S. CLS. 21, 23, 26, 36 AND 38).

MARILYN IZZI, EXAMINING ATTORNEY

SN 79-133,619. ELMOS SEMICONDUCTOR AKTIENGESELLSCHAFT, FED REP GERMANY, FILED 6-11-2013.



PRIORITY DATE OF 12-14-2012 IS CLAIMED.  
OWNER OF INTERNATIONAL REGISTRATION 1169366 DATED 6-11-2013, EXPIRES 6-11-2023.

THE MARK CONSISTS OF THREE SHADED SQUARES, WITH TWO ON ONE LINE AND ONE BENEATH THE RIGHT TOP SQUARE. BENEATH THE SQUARES, THE STYLIZED LETTERS "EA" APPEAR WITH THE LETTER "E" BEING LARGER THAN THE LETTER "A" AND IN LOWER CASE WITH THE LETTER "A" IS SMALLER AND IN UPPER CASE.

FOR INTEGRATED-CIRCUIT CHIPS; SEMICONDUCTORS, INCLUDED IN THIS CLASS; ELECTRIC AND ELECTRONIC COMPONENTS AND UNITS, INCLUDED IN THIS CLASS, IN PARTICULAR PRINTED CIRCUITS, SEMICONDUCTOR COMPONENTS, RESISTORS, CAPACITORS, COILS, FILTERS, TRANSISTORS, DIODES, PHOTOGRAPHIC SEMICONDUCTORS, PHOTO-RESISTORS, TRANSFORMERS, RELAYS, MAGNETIC SWITCHES, FUSES, ELECTRIC CONTACTS, SWITCH CLOCKS, MICROPROCESSORS, ACTUATORS, SENSORS, TRANSDUCERS AND SIGNAL SENSORS, IN PARTICULAR FOR THE ACQUISITION OF TEMPERATURE, LENGTH, FILLING LEVEL, FLOW RATE, WEIGHT, FREQUENCY, NOISE, PRESSURE, ACCELERATION, VELOCITY, BRIGHTNESS, TREMORS, GAS, SMOKE, CURRENT, REVOLUTION SPEED, VOLTAGE, RESISTANCE, CAPACITANCE, INDUCTION, MAGNETIC FIELDS; APPARATUS AND INSTRUMENTS FOR WEAK-CURRENT ENGINEERING, NAMELY, FOR CONTROL ENGINEERING, IN PARTICULAR ELECTRONIC CONTROL SYSTEMS; APPARATUS AND

SN 79-137,280. PV DIRECT LIMITED, WAIUKU, NEW ZEALAND, FILED 9-18-2013.



THE MARK CONSISTS OF STANDARD CHARACTERS WITHOUT CLAIM TO ANY PARTICULAR FONT, STYLE, SIZE, OR COLOR.

OWNER OF INTERNATIONAL REGISTRATION 1178555 DATED 9-18-2013, EXPIRES 9-18-2023.

FOR SOLAR ENERGY OPERATING APPARATUS, NAMELY, SOLAR PANELS FOR PRODUCTION OF ELECTRICITY (U.S. CLS. 21, 23, 26, 36 AND 38).

CHARLOTTE CORWIN, EXAMINING ATTORNEY

**CLASS 9—(Continued).**

SN 79-137,405. LOGIC 3 INTERNATIONAL LIMITED, WATFORD WD24 4YW, UNITED KINGDOM, FILED 9-6-2013.

# SONITUS

THE MARK CONSISTS OF STANDARD CHARACTERS WITHOUT CLAIM TO ANY PARTICULAR FONT, STYLE, SIZE, OR COLOR.

OWNER OF INTERNATIONAL REGISTRATION 1178804 DATED 9-6-2013, EXPIRES 9-6-2023.

THE WORDING "SONITUS" HAS NO MEANING IN A FOREIGN LANGUAGE.

FOR POWER ADAPTERS; BATTERY ADAPTERS; ELECTRICAL APPARATUS FOR THE RECORDING, TRANSMISSION OR REPRODUCTION OF SOUND AND IMAGES; ELECTRICAL AND ELECTRONIC APPARATUS FOR LEISURE AND ENTERTAINMENT, NAMELY, RADIOS AND TELEVISIONS, TELEVISION APPARATUS AND INSTRUMENTS, NAMELY, TELEVISION MONITORS; TELEVISION TUNERS, NAMELY, TELEVISION RECEIVERS; HOME CINEMA AND HOME THEATRE APPARATUS AND INSTRUMENTS, NAMELY, DVD PLAYERS, AUDIO AMPLIFIERS, AUDIO SPEAKERS, LCD PROJECTORS; AUDIO PLAYERS, NAMELY, CD PLAYERS, DIGITAL AUDIO PLAYERS; MP3 PLAYERS; AUDIO ACCESSORIES, NAMELY, AUDIO CABLES; AUDIO TRANSMITTERS AND RECEIVERS; WIRELESS AUDIO TRANSMITTERS AND RECEIVERS; HI-FI SYSTEMS CONSISTING PRIMARILY OF RADIO RECEIVERS, AUDIO VISUAL RECEIVERS AND DIGITAL AUDIO PLAYERS; HEADPHONES, EARPHONES AND MICROPHONES; COMPUTERS; APPARATUS AND INSTRUMENTS FOR USE WITH COMPUTERS, NAMELY, COMPUTER CAMERAS, COMPUTER HARDWARE; COMPUTERS PERIPHERALS; HARD DISK DRIVES; SOUND CARDS; MEMORY CARDS; ELECTRICAL ADAPTERS; ELECTRICAL CONNECTORS; ELECTRICAL CABLES AND HUBS, NAMELY, COMMUNICATION HUBS, COMPUTER NETWORK HUBS AND USB HUBS; DOCKING STATIONS; TELEPHONE APPARATUS; MOBILE PHONES; PHONE ACCESSORIES, NAMELY, CARRYING CASES FOR CELL PHONES, CELL PHONE COVERS; SMARTCARD READERS AND WRITERS; DATA STORAGE DEVICES, NAMELY, BLANK DIGITAL STORAGE MEDIA, BLANK MAGNETIC DATA CARRIERS; LOUDSPEAKERS; LOUDSPEAKERS ADAPTED FOR USE WITH PERSONAL COMPUTERS; LOUDSPEAKERS ADAPTED FOR USE WITH VISUAL DISPLAY APPARATUS; SPEAKER SYSTEMS FOR USE WITH ELECTRONIC DEVICES INCLUDING AUDIO PLAYERS CONSISTING PRIMARILY OF AUDIO SPEAKERS; SPEAKER SYSTEMS INCORPORATING DOCKING STATIONS CONSISTING PRIMARILY OF AUDIO SPEAKERS AND ELECTRONIC DOCKING STATIONS; CHARGING APPARATUS, NAMELY, ELECTRIC CHARGING CABLES, BATTERY CHARGERS, BATTERY CHARGE DEVICES; BATTERY CHARGERS FOR AUDIO PLAYERS; COMPUTER CONTROLLERS; COMPUTER JOYSTICKS; PLUG-IN COMPUTER GAME CARDS, NAMELY, MEMORY CARDS; COMPUTER MICE; MOUSE MATS, NAMELY, MOUSE PADS; HAND-HELD SCANNERS; WIRELESS CONTROLLERS AND OTHER INPUT DEVICES FOR USE WITH COMPUTERS OR COMPUTER GAMES EQUIPMENT, NAMELY, WIRELESS COMPUTER CONTROLLERS, WIRELESS COMPUTER JOYSTICKS, WIRELESS COMPUTER KEYBOARDS AND WIRELESS COMPUTER MICE; PARTS AND FITTINGS FOR ALL THE AFORESAID GOODS; GAMES SOFTWARE; WALLETS, POUCHES, BAGS AND CASES ADAPTED FOR ANY OF THE AFORESAID GOODS (U.S. CLS. 21, 23, 26, 36 AND 38).

KATHRYN COWARD, EXAMINING ATTORNEY

**CLASS 9—(Continued).**

SN 79-137,658. SECUFN, INC. SEONGDONG-GU SEOUL, REPUBLIC OF KOREA, FILED 8-20-2013.

# DOCUTRUST

THE MARK CONSISTS OF STANDARD CHARACTERS WITHOUT CLAIM TO ANY PARTICULAR FONT, STYLE, SIZE, OR COLOR.

PRIORITY DATE OF 6-13-2013 IS CLAIMED.

OWNER OF INTERNATIONAL REGISTRATION 1179647 DATED 8-20-2013, EXPIRES 8-20-2023.

FOR OPERATING SYSTEM PROGRAMS (U.S. CLS. 21, 23, 26, 36 AND 38).

ANDREW LEASER, EXAMINING ATTORNEY

SN 79-137,842. CONDUIT LTD., 74140 NESS ZIONA, ISRAEL, FILED 4-9-2013.

# FLING

THE MARK CONSISTS OF STANDARD CHARACTERS WITHOUT CLAIM TO ANY PARTICULAR FONT, STYLE, SIZE, OR COLOR.

PRIORITY DATE OF 4-8-2013 IS CLAIMED.

OWNER OF INTERNATIONAL REGISTRATION 1180055 DATED 4-9-2013, EXPIRES 4-9-2023.

FOR COMPUTER SOFTWARE APPLICATION COMPONENT FOR THE COMPUTER SOFTWARE APPLICATIONS OF OTHERS, NAMELY, CUSTOMIZED, DIRECTIONAL, NAMELY, RIGHT, LEFT, UP, AND DOWN, FINGER SWIPE ACCESS APPLICATION COMPONENTS FOR CONTENT PROVIDERS THAT ALLOW MOBILE COMMUNICATION DEVICE USERS TO ACCESS CONTENT ON LOCK SCREENS AND HOME SCREENS OF SMARTPHONES, TABLETS AND HANDHELD COMPUTERS (U.S. CLS. 21, 23, 26, 36 AND 38).

APRIL ROACH, EXAMINING ATTORNEY

SN 79-137,896. CARTADIS, F-94120 FONTENAY-SOUS-BOIS, FRANCE, FILED 9-12-2013.

# GESPAGE

THE MARK CONSISTS OF STANDARD CHARACTERS WITHOUT CLAIM TO ANY PARTICULAR FONT, STYLE, SIZE, OR COLOR.

PRIORITY DATE OF 5-6-2013 IS CLAIMED.

OWNER OF INTERNATIONAL REGISTRATION 1180186 DATED 9-12-2013, EXPIRES 9-12-2023.

THE WORDING "GESPAGE" HAS NO MEANING IN A FOREIGN LANGUAGE.

FOR RECORDED SOFTWARE PROGRAMS FOR PRINTING AND PHOTOCOPYING; MANAGEMENT SOFTWARE FOR PRINTING AND PHOTOCOPYING (U.S. CLS. 21, 23, 26, 36 AND 38).

YAT SYE, LEE, EXAMINING ATTORNEY



**CLASS 9—(Continued).**

SN 79-138,101. PARK, JIN WOO, REPUBLIC OF KOREA, FILED 7-23-2013.

# JOWATECH

THE MARK CONSISTS OF STANDARD CHARACTERS WITHOUT CLAIM TO ANY PARTICULAR FONT, STYLE, SIZE, OR COLOR.

OWNER OF INTERNATIONAL REGISTRATION 1180731 DATED 7-23-2013, EXPIRES 7-23-2023.

FOR SOCKETS FOR ELECTRICAL CONNECTORS; WIRE TO BOARD ELECTRICAL CONNECTORS; MEMORY CARD ELECTRICAL CONNECTORS; ELECTRIC CONNECTORS; ELECTRICITY CONNECTORS; PLUG CONNECTORS; ELECTRIC CONNECTIONS, NAMELY, SOCKETS, PLUGS, AND CONTACTS; ELECTRIC CONTACTS; ELECTRICAL CONNECTORS FOR INTERFACES FOR DETECTORS; ELECTRICAL CONNECTORS FOR ELECTRIC POWER DISTRIBUTION MACHINE (U.S. CLS. 21, 23, 26, 36 AND 38).

CHRISTOPHER BUONGIORNO, EXAMINING ATTORNEY

SN 79-140,038. SOFRANE, F-75008 PARIS, FRANCE, FILED 9-5-2013.

# Paul & Joe

PRIORITY DATE OF 3-5-2013 IS CLAIMED. OWNER OF INTERNATIONAL REGISTRATION 1185717 DATED 9-5-2013, EXPIRES 9-5-2023.

OWNER OF U.S. REG. NO. 4,104,456. THE NAMES "PAUL" AND "JOE" DO NOT IDENTIFY LIVING INDIVIDUALS.

FOR TELEPHONE APPARATUS, TELEPHONES, MOBILE TELEPHONES AND TELEPHONE HANDSETS; ADAPTERS FOR TELEPHONES; BATTERY CHARGERS FOR TELEPHONES, HOLDERS FOR TELEPHONE HANDSETS INSTALLED IN CARS; HANDS-FREE KITS FOR TELEPHONES; BAGS AND CASES SPECIALLY DESIGNED TO HOLD OR CARRY PORTABLE TELEPHONES AND TELEPHONE EQUIPMENT AND ACCESSORIES, COVERS, CASES AND BAGS FOR COMPUTERS AND MOBILE ELECTRONIC OFFICE EQUIPMENT, PROTECTIVE CASES FOR HANDHELD ELECTRONIC DEVICES, NAMELY, PORTABLE MUSIC PLAYERS, MOBILE TELEPHONES, PORTABLE VIDEO PLAYERS, DIGITAL TABLETS AND COMPUTERS; CARRYING CASES SPECIALLY ADAPTED FOR COMPUTERS (U.S. CLS. 21, 23, 26, 36 AND 38).

MICHAEL WIENER, EXAMINING ATTORNEY

**CLASS 9—(Continued).**

SN 79-140,478. JACOB KILSGAARD, DK-8000 ARHUS C, DENMARK, FILED 5-3-2013.

# KILSGAARD

THE MARK CONSISTS OF STANDARD CHARACTERS WITHOUT CLAIM TO ANY PARTICULAR FONT, STYLE, SIZE, OR COLOR.

OWNER OF INTERNATIONAL REGISTRATION 1186829 DATED 5-3-2013, EXPIRES 5-3-2023.

SEC. 2(F). FOR SPECTACLE FRAMES, SPECTACLES OPTICS, SPECTACLE LENSES, OPTICAL CORRECTING LENSES, ANTI-GLARE GLASSES, GOGGLES FOR SPORTS, EYE-GLASS CASES (U.S. CLS. 21, 23, 26, 36 AND 38).

SCOTT BIBB, EXAMINING ATTORNEY

SN 79-140,687. BOE TECHNOLOGY GROUP CO., LTD., 100016 BEIJING, CHINA, FILED 3-30-2012.

# BOE

OWNER OF INTERNATIONAL REGISTRATION 1055089 DATED 8-17-2010, EXPIRES 8-17-2020.

OWNER OF U.S. REG. NOS. 3,226,977, 3,226,978 AND 4,252,163.

THE MARK CONSISTS OF THE LETTERS "BOE" IN STYLIZED FORM.

THE WORDING "BOE" HAS NO MEANING IN A FOREIGN LANGUAGE.

FOR SEMICONDUCTOR DEVICES; NOTEBOOK COMPUTERS; LAPTOP COMPUTERS; ELECTRIC SWITCHES; ELECTRON TUBES; ELECTRONIC CARD READERS; X-RAYS TUBES NOT FOR MEDICAL PURPOSES; INTEGRATED CIRCUITS; INTEGRATED CIRCUIT CARDS; INTEGRATED CIRCUIT MODULES; COMPUTERS; COMPUTER KEYBOARDS; COMPUTER SOFTWARE FOR USE IN DATABASE MANAGEMENT; COMPUTER PERIPHERALS; COMPUTER MOUSE; COMPUTER MONITORS; THIN FILM TRANSISTOR LIQUID CRYSTAL DISPLAY (TFT LCD) TELEVISIONS; ORGANIC LIGHT-EMITTING DIODE (OLED) TELEVISIONS; CAMERAS; TRANSISTORS; FLUORESCENT VIDEO AND PROJECTION SCREENS; TELEVISION SETS; LIQUID CRYSTAL DISPLAY TELEVISIONS (LCD TV); THIN FILM TRANSISTOR LIQUID CRYSTAL DISPLAY (TFT LCD) PANELS; THIN FILM TRANSISTOR LIQUID CRYSTAL DISPLAY (TFT LCD) MODULES; LIQUID CRYSTAL DISPLAY (LCD) MONITORS; PERSONAL DIGITAL ASSISTANTS (PDA); ELECTRONIC APPARATUS, NAMELY, PLASMA DISPLAY PANELS, PLASMA DISPLAY PANELS (PDP) FOR TELEVISIONS, PLASMA DISPLAY PANELS (PDP) FOR COMPUTER MONITORS; ORGANIC LIGHT-EMITTING DIODE (OLED) DISPLAY PANEL (U.S. CLS. 21, 23, 26, 36 AND 38).

MARY ROSSMAN, EXAMINING ATTORNEY

**CLASS 9—(Continued).**

SN 79-140,904. MALAL SECURITY SYSTEMS LTD., YEHUD, ISRAEL, FILED 9-17-2013.

**CLASS 9—(Continued).**

SN 79-141,372. A. SCHWEIGER GMBH, SAUERLACH, FED REP GERMANY, FILED 11-29-2013.

**FENSOR** **EcoM** **MOLDED**  
by Schweiger

THE MARK CONSISTS OF STANDARD CHARACTERS WITHOUT CLAIM TO ANY PARTICULAR FONT, STYLE, SIZE, OR COLOR.

OWNER OF INTERNATIONAL REGISTRATION 1187960 DATED 9-17-2013, EXPIRES 9-17-2023.

FOR FENCE-MOUNTED DETECTION SYSTEM FOR DETECTING INTRUSIONS, NAMELY, ELECTRIC SENSORS, ELECTRIC FENCES, ANTI-INTRUSION ALARMS, MOTION DETECTORS, AND PARTS AND FITTINGS THEREOF (U.S. CLS. 21, 23, 26, 36 AND 38).

KRISTIN CARLSON, EXAMINING ATTORNEY

PRIORITY DATE OF 6-3-2013 IS CLAIMED.

OWNER OF INTERNATIONAL REGISTRATION 1189215 DATED 11-29-2013, EXPIRES 11-29-2023.

FOR ELECTRICAL SIGNALLING LINES, NAMELY, FIBER OPTIC CABLES AND ELECTRIC CABLES AND WIRES, CONDUCTORS AND CONNECTION FITTINGS THEREFOR; MOTOR AND POWER LEADS, NAMELY, ELECTRIC CABLE LEADS AND CABLE JUMP LEADS; BRAKE CABLE CONTROLLERS; TRANSMITTER LINES IN THE NATURE OF CABLES FOR ELECTRICAL AND OPTICAL SIGNAL TRANSMISSION, ELECTRICAL AND OPTICAL CABLES, COAXIAL CABLES, CONNECTION CABLES, ELECTRICAL CABLES FOR USE IN CONNECTIONS, ELECTRICAL INTERCONNECT CABLES, CABLE CONNECTORS; ENCODER LINES IN THE NATURE OF ENCODERS; RESOLVER LINES IN THE NATURE OF ELECTRICAL RESOLVERS AND ELECTRONIC RESOLVERS; MEASURING LEADS AND EXTENSION LEADS, NAMELY, ELECTRICAL EXTENSION LEADS AND EXTENSION LEADS FOR ELECTRICAL APPARATUS; READY-MADE ELECTRICAL CABLES WITH PLUGS; ELECTRICAL CONNECTORS (U.S. CLS. 21, 23, 26, 36 AND 38).

MIAH ROSENBERG, EXAMINING ATTORNEY

SN 79-141,159. CENTRO STYLE S.P.A., VEDANO OLONA (VA), ITALY, FILED 10-14-2013.

**CENTROSTYLE**

THE MARK CONSISTS OF STANDARD CHARACTERS WITHOUT CLAIM TO ANY PARTICULAR FONT, STYLE, SIZE, OR COLOR.

PRIORITY DATE OF 9-3-2013 IS CLAIMED.

OWNER OF INTERNATIONAL REGISTRATION 1188661 DATED 10-14-2013, EXPIRES 10-14-2023.

OWNER OF U.S. REG. NO. 2,330,482.

FOR OPTICAL APPARATUS AND INSTRUMENTS, NAMELY, EYEWEAR, SPECTACLES, SUNGLASSES, CLIP-ON SUNGLASSES, BINOCULARS AND PARTS AND FITTINGS THEREFOR; LENSES FOR EYEWEAR, OPTICAL LENSES, MAGNIFYING GLASSES, PARTS AND FITTINGS THEREFOR; CONTACT LENSES, PARTS AND FITTINGS THEREFOR; CONTACT LENS CASES AND PARTS AND FITTINGS THEREFOR; EYEGLASSES FRAMES; EYEGLASSES CASES; EYEGLASSES CORDS AND CHAINS; SWIM GOGGLES; DIVERS' MASKS; GOGGLES FOR SPORT; PROTECTIVE EYEGLASSES; INSTRUMENTS FOR MEASURING TEMPERATURE, HUMIDITY, BAROMETRIC PRESSURE AND WIND SPEED (U.S. CLS. 21, 23, 26, 36 AND 38).

CAROLINE WOOD, EXAMINING ATTORNEY

SN 79-141,800. POWERSOFT S.P.A., I-50018 SCANDICCI (FI), ITALY, FILED 10-30-2013.

**POWERSOFTAUDIO**

THE MARK CONSISTS OF STANDARD CHARACTERS WITHOUT CLAIM TO ANY PARTICULAR FONT, STYLE, SIZE, OR COLOR.

PRIORITY DATE OF 7-16-2013 IS CLAIMED.

OWNER OF INTERNATIONAL REGISTRATION 1190312 DATED 10-30-2013, EXPIRES 10-30-2023.

FOR AMPLIFIERS (U.S. CLS. 21, 23, 26, 36 AND 38).

EVELYN BRADLEY, EXAMINING ATTORNEY

**CLASS 9—(Continued).**

SN 79-142,035. VITZROCELL CO.,LTD, REPUBLIC OF KOREA, FILED 10-8-2013.



OWNER OF INTERNATIONAL REGISTRATION 1190920 DATED 10-8-2013, EXPIRES 10-8-2023.

OWNER OF U.S. REG. NO. 3,606,566.

THE COLOR(S) BLUE IS/ARE CLAIMED AS A FEATURE OF THE MARK.

THE MARK CONSISTS OF THE FOLLOWING: THE STYLIZED WORDING "VITZROCAP" IN THE COLOR BLUE.

FOR DRY CELLS, NAMELY, BATTERIES; FUEL CELLS; MOBILE TELEPHONE BATTERIES; CONDENSERS, NAMELY, CAPACITORS; ACCUMULATORS, NAMELY, BATTERIES; RECHARGERS FOR ELECTRIC ACCUMULATORS; BATTERY CHARGE DEVICES; SOLAR BATTERIES; NICKEL-CADMIUM STORAGE BATTERIES; ELECTRIC CAPACITORS; LITHIUM ION BATTERIES; LITHIUM POLYMER BATTERIES (U.S. CLS. 21, 23, 26, 36 AND 38).

ELLEN B. AWRICH, EXAMINING ATTORNEY

SN 79-142,760. CANOR, SPOL. S R.O., SK-080 06 PRESOV, SLOVAKIA, FILED 10-23-2013.



OWNER OF INTERNATIONAL REGISTRATION 1192619 DATED 10-23-2013, EXPIRES 10-23-2023.

THE MARK CONSISTS OF TWO HALF CIRCLES THAT MELD TOGETHER AT THE BOTTOM OF THE HALF CIRCLES. THIS DESIGN APPEARS ABOVE A HORIZONTAL LINE. THE WORDING "CANOR" APPEARS IN STYLIZED LETTERING BELOW THE HORIZONTAL LINE.

THE WORDING "CANOR" HAS NO MEANING IN A FOREIGN LANGUAGE.

FOR SOUND REPRODUCTION APPARATUS AND THEIR ACCESSORIES, NAMELY, AMPLIFIERS, PREAMPLIFIERS, SOUND REPRODUCTION APPARATUS, LOUDSPEAKERS, LOUDSPEAKER SYSTEMS PRIMARILY COMPRISED OF LOUDSPEAKERS AND THEIR ELECTRIC CABLES; ELECTRIC CABLES FOR SIGNAL TRANSMISSION; ELECTROMAGNETIC COILS; TRANSFORMERS; ACOUSTIC CONDUITS; ELECTRIC CHOKING COILS FOR IMPEDANCE; ELECTRIC CABLES; CONDENSERS; ELECTRIC CONVERTERS; SOUND TRANSMISSION DEVICES, NAMELY, SOUND TRANSMITTING APPARATUS, CD PLAYER, MP3 PLAYERS, AMPLIFIERS, PREAMPLIFIERS; ELECTRICITY ANTI-INTERFERENCE DEVICES, NAMELY, TRANSFORMERS; AUDIOVISUAL APPARATUS AND INSTALLATIONS, NAMELY, AUDIOVISUAL RECEIVERS, AUDIO TUBE AMPERAGE TESTERS, AUDIO VACUUM TUBES; ELECTRIC RECORD PLAYERS; TONE ARMS FOR RECORD PLAYERS; RECORD PLAYER NEEDLES; SPEED REGULATORS FOR RECORD PLAYERS; COMPACT DISC PLAYERS; DVD PLAYERS; MP3 PLAYERS; MICROPHONES; EARPHONES; ELECTRONIC AND AUDIO VACUUM TUBES FOR RADIOS; THERMIONIC TUBES; AMPLIFYING PROJECTOR LAMPS; COMPUTER SOFTWARE FOR DOWNLOADING, CREATING, EDITING AND ORGANIZING AUDIO FILES RECORDED ON RECORDABLE MEDIA; COMPUTER SOFTWARE FOR CONTROLLING THE OPERATION

**CLASS 9—(Continued).**

OF AUDIO AND VIDEO DEVICES; COMPUTER SOFTWARE TO CONTROL AND IMPROVE COMPUTER AND AUDIO EQUIPMENT SOUND QUALITY; RECORDED COMPUTER PROGRAMS FOR THE INTEGRATION OF TEXT, AUDIO, GRAPHICS, STILL IMAGES AND MOVING PICTURES INTO AN INTERACTIVE DELIVERY FOR MULTIMEDIA APPLICATIONS; ELECTRIC RESISTANCES; SOUND RECORDING APPARATUS; AUDIOVISUAL PLAYERS, NAMELY, DIGITAL AUDIO AND VIDEO PLAYERS; HOLDERS FOR ELECTRIC COILS; COMPACT DISCS FEATURING MUSIC; INTEGRATED CIRCUITS; SEMI-CONDUCTORS; ELECTRIC CONDUCTORS; ACOUSTIC COUPLERS; MODEMS; ELECTRIC CONNECTORS; REMOTE CONTROL APPARATUS, NAMELY, REMOTE CONTROLS FOR RADIOS, TELEVISIONS; ELECTRIC INSTALLATIONS FOR THE REMOTE CONTROL OF INDUSTRIAL OPERATIONS, NAMELY, REMOTE CONTROLS FOR AMPLIFIERS AND CD-PLAYERS; VOLTAGE SURGE PROTECTORS; AUDIO AND VIDEO RECEIVERS; CASH REGISTERS; ELECTRICITY SWITCHBOXES (U.S. CLS. 21, 23, 26, 36 AND 38).

SETH A. RAPPAPORT, EXAMINING ATTORNEY

SN 79-143,187. BYSS MOBILE SPÓLKA JAWNA MARCIN KRAKOWIAK, TOMASZ SARNOWSKI, GRZEGORZ MOZDZIERZ, PL-70-372 SZCZECIN, POLAND, FILED 1-14-2014.



THE MARK CONSISTS OF STANDARD CHARACTERS WITHOUT CLAIM TO ANY PARTICULAR FONT, STYLE, SIZE, OR COLOR.

OWNER OF INTERNATIONAL REGISTRATION 1193621 DATED 1-14-2014, EXPIRES 1-14-2024.

FOR COMPUTER SOFTWARE FOR MODIFYING THE APPEARANCE AND ENABLING TRANSMISSION OF PHOTOGRAPHS; SOFTWARE AND SOFTWARE APPLICATIONS FOR MOBILE DEVICES, NAMELY, FOR MODIFYING THE APPEARANCE AND ENABLING TRANSMISSION OF PHOTOGRAPHS; GAMES SOFTWARE (U.S. CLS. 21, 23, 26, 36 AND 38).

CHRISTOPHER BUONGIORNO, EXAMINING ATTORNEY

SN 79-145,258. FUJIAN NAN'AN BAO FENG ELECTRONIC CO., LTD., NANAN CITY 362302 FUJIAN PROVINCE, CHINA, FILED 2-7-2014.



OWNER OF INTERNATIONAL REGISTRATION 1198655 DATED 2-7-2014, EXPIRES 2-7-2024.

THE MARK CONSISTS OF THE WORDING "POFUNG" IN STYLIZED FONT.

THE WORDING "POFUNG" HAS NO MEANING IN A FOREIGN LANGUAGE.

FOR QUANTITY INDICATORS, NAMELY, LEVEL INDICATORS; PHOTOGRAPHIC, ELECTROSTATIC, AND THERMIC PHOTOCOPIERS; SCALES; SPEAKING TUBES; RADIOTELEPHONY SETS; TELEPHONE APPARATUS; PORTABLE TELEPHONES; ACOUSTIC SOUND ALARMS; ELECTRIC BATTERIES (U.S. CLS. 21, 23, 26, 36 AND 38).

CYNTHIA RINALDI, EXAMINING ATTORNEY

**CLASS 9—(Continued).**

SN 79-147,761. UVEX WINTER HOLDING GMBH & CO. KG, FED REP GERMANY, FILED 4-8-2014.

# SAGA

THE MARK CONSISTS OF STANDARD CHARACTERS WITHOUT CLAIM TO ANY PARTICULAR FONT, STYLE, SIZE, OR COLOR.

PRIORITY DATE OF 10-24-2013 IS CLAIMED.  
OWNER OF INTERNATIONAL REGISTRATION 1205228 DATED 4-8-2014, EXPIRES 4-8-2024.  
FOR SKI GOGGLES (U.S. CLS. 21, 23, 26, 36 AND 38).  
STEVEN JACKSON, EXAMINING ATTORNEY

SN 79-147,797. UVEX WINTER HOLDING GMBH & CO. KG, FED REP GERMANY, FILED 4-14-2014.

# MARY JANE

THE MARK CONSISTS OF STANDARD CHARACTERS WITHOUT CLAIM TO ANY PARTICULAR FONT, STYLE, SIZE, OR COLOR.

PRIORITY DATE OF 10-23-2013 IS CLAIMED.  
OWNER OF INTERNATIONAL REGISTRATION 1205307 DATED 4-14-2014, EXPIRES 4-14-2024.  
FOR SKI GOGGLES, PROTECTIVE HELMETS, INDUSTRIAL SAFETY HELMETS, SPORTS HELMETS (U.S. CLS. 21, 23, 26, 36 AND 38).  
STEVEN JACKSON, EXAMINING ATTORNEY

SN 79-149,132. TOKYO SEIMITSU CO., LTD., JAPAN, FILED 4-9-2014.

# Opt-measure

THE MARK CONSISTS OF STANDARD CHARACTERS WITHOUT CLAIM TO ANY PARTICULAR FONT, STYLE, SIZE, OR COLOR.

PRIORITY DATE OF 1-7-2014 IS CLAIMED.  
OWNER OF INTERNATIONAL REGISTRATION 1195637 DATED 1-17-2014, EXPIRES 1-17-2024.  
FOR INTERFEROMETERS (U.S. CLS. 21, 23, 26, 36 AND 38).  
LINDA LAVACHE, EXAMINING ATTORNEY

**CLASS 9—(Continued).**

SN 85-084,854. GATEWAY SAFETY, INC., CLEVELAND, OH, FILED 7-14-2010.

# COBRA

THE MARK CONSISTS OF STANDARD CHARACTERS WITHOUT CLAIM TO ANY PARTICULAR FONT, STYLE, SIZE, OR COLOR.

FOR PROTECTIVE EYEWEAR (U.S. CLS. 21, 23, 26, 36 AND 38).  
FIRST USE 1-0-2001; IN COMMERCE 1-0-2001.  
TRACY WHITTAKER-BROWN, EXAMINING ATTORNEY

SN 85-266,850. SOLOCLOUDS, LLC., DBA SOLOCLOUDS, SEATTLE, WA. FILED 3-15-2011.

# CloudBook

THE MARK CONSISTS OF STANDARD CHARACTERS WITHOUT CLAIM TO ANY PARTICULAR FONT, STYLE, SIZE, OR COLOR.

FOR COMPUTER HARDWARE; COMPUTER OPERATING PROGRAMS AND COMPUTER OPERATING SYSTEMS; COMPUTER PERIPHERALS; COMPUTERS; COMPUTERS, NAMELY, NETBOOKS; HANDHELD PERSONAL COMPUTERS; NOTEBOOK AND LAPTOP COMPUTERS; NOTEBOOK COMPUTERS; PERSONAL COMPUTERS (U.S. CLS. 21, 23, 26, 36 AND 38).  
ANN E. SAPPENFIELD, EXAMINING ATTORNEY

SN 85-481,895. PROSPER, INC., PROVO, UT. FILED 11-28-2011.

# PROSPERING

THE MARK CONSISTS OF STANDARD CHARACTERS WITHOUT CLAIM TO ANY PARTICULAR FONT, STYLE, SIZE, OR COLOR.

OWNER OF U.S. REG. NOS. 3,113,045, 3,688,384 AND OTHERS.

FOR PRE-RECORDED ELECTRONIC MEDIA PRODUCTS, NAMELY, AUDIOTAPES, VIDEOTAPES, CDS, DVDS, AND MULTIMEDIA COMPUTER SOFTWARE FOR TRAINING AND EDUCATION, COMPUTER APPLICATION SOFTWARE FOR MOBILE PHONES, PORTABLE COMPUTERS AND DESKTOP COMPUTERS FOR TRAINING AND EDUCATION, ALL IN THE FIELDS OF BUSINESS AND INVESTING, INCLUDING ECOMMERCE, REAL ESTATE INVESTING, STOCK MARKET INVESTING, PERSONAL FINANCE, SMALL BUSINESS AND STARTING A HOME BUSINESS (U.S. CLS. 21, 23, 26, 36 AND 38).

FIRST USE 11-12-2011; IN COMMERCE 11-12-2011.  
LINDA ESTRADA, EXAMINING ATTORNEY

**CLASS 9—(Continued).**

SN 85-561,826. BRITANNIA PETROLEUM LIMITED, LONDON, UNITED KINGDOM, FILED 3-6-2012.



PRIORITY CLAIMED UNDER SEC. 44(D) ON ERPNTY TM OFC APPLICATION NO. 010245298, FILED 9-7-2011, REG. NO. 010245298, DATED 3-16-2012, EXPIRES 9-7-2021.

NO CLAIM IS MADE TO THE EXCLUSIVE RIGHT TO USE "PETROLEUM", APART FROM THE MARK AS SHOWN.

THE COLOR(S) BLUE, RED, WHITE AND YELLOW IS/ARE CLAIMED AS A FEATURE OF THE MARK.

THE MARK CONSISTS OF THE WORD "BRITANNIA" IN BLUE LETTERS WITH A STYLIZED FLAME, IN THE COLORS BLUE, YELLOW AND RED, DOTTING THE SECOND "I". UNDERNEATH THE WORD "BRITANNIA" IS A RED RECTANGLE WITH THE WORD "PETROLEUM" IN WHITE LETTERS WITHIN THE RED RECTANGLE. EXCEPT WHERE OTHERWISE NOTED, THE COLOR WHITE IN THE MARK REPRESENTS BACKGROUND AND/OR TRANSPARENT ONLY AND IS NOT CLAIMED AS A FEATURE OF THE MARK.

FOR ELECTRICAL AND ELECTRONIC POWER CONTROL SYSTEMS FOR USE IN CONNECTION WITH DRILLING APPARATUS AND RIGS FOR OIL AND GAS EXPLORATION AND PRODUCTION; ELECTRICAL AND ELECTRONIC COMPONENTS FOR USE IN SUCH POWER CONTROL SYSTEMS, NAMELY, AC CONTROL MODULES, DC CONTROL MODULES, DIGITAL DC MODULES, POWER SUPPLY UNITS, DRILLING POWER CONTROL SYSTEMS, PRINTED CIRCUIT BOARDS (U.S. CLS. 21, 23, 26, 36 AND 38).

KATHLEEN KOLACZ, EXAMINING ATTORNEY

SN 85-579,853. DIGITAL POWER CORPORATION, FREMONT, CA. FILED 3-26-2012.



NO CLAIM IS MADE TO THE EXCLUSIVE RIGHT TO USE "DIGITAL POWER", APART FROM THE MARK AS SHOWN.

THE MARK CONSISTS OF THE LETTERS "DP" INSIDE A BOX NEXT TO THE TERMS "DIGITAL POWER".

FOR ELECTRONIC POWER SUPPLIES (U.S. CLS. 21, 23, 26, 36 AND 38).

FIRST USE 4-0-2002; IN COMMERCE 4-0-2002.

WENDY GOODMAN, EXAMINING ATTORNEY

**CLASS 9—(Continued).**

SN 85-618,353. GREENWAVE SCIENTIFIC, INC., DBA MOHU, INC., RALEIGH, NC. FILED 5-7-2012.

# HIVE

THE MARK CONSISTS OF STANDARD CHARACTERS WITHOUT CLAIM TO ANY PARTICULAR FONT, STYLE, SIZE, OR COLOR.

FOR DIGITAL VIDEO DEVICE COMPRISING TELEVISION TUNERS; COMPUTER SOFTWARE FOR VIEWING AND STORING TELEVISION PROGRAMMING; COMPUTER SOFTWARE FOR USE IN GENERATING, DISPLAYING AND MANIPULATING VISUAL MEDIA (U.S. CLS. 21, 23, 26, 36 AND 38).

VIVIAN MICZNIK FIRST, EXAMINING ATTORNEY

SN 85-740,069. THE TRAVEL CHANNEL, LLC, CHEVY CHASE, MD. FILED 9-27-2012.

# QUIT YOUR JOB

THE MARK CONSISTS OF STANDARD CHARACTERS WITHOUT CLAIM TO ANY PARTICULAR FONT, STYLE, SIZE, OR COLOR.

FOR PRERECORDED VIDEO DISKS, AUDIO-VISUAL RECORDINGS, DOWNLOADABLE AUDIO AND VIDEO RECORDINGS, AND DVDS ALL FEATURING CONTENT IN THE FIELDS OF TRAVEL AND LEISURE, CULTURE, COOKING AND FOOD, RESTAURANTS, AND LIFESTYLE; DOWNLOADABLE SOFTWARE APPLICATIONS FOR PROVIDING INFORMATION AND PRE-RECORDED TELEVISION PROGRAMS, IN THE FIELDS OF TRAVEL AND LEISURE, CULTURE, COOKING AND FOOD, RESTAURANTS, AND LIFESTYLE (U.S. CLS. 21, 23, 26, 36 AND 38).

SUSAN BILLHEIMER, EXAMINING ATTORNEY

SN 85-751,759. LQM PETROLEUM SERVICES, INC., CRESSKILL, NJ. FILED 10-11-2012.

# BunkerVision

THE MARK CONSISTS OF STANDARD CHARACTERS WITHOUT CLAIM TO ANY PARTICULAR FONT, STYLE, SIZE, OR COLOR.

FOR AUTOMATED SYSTEMS, NAMELY, SOFTWARE, HARDWARE AND COMMUNICATIONS DEVICES FOR PLANNING, SCHEDULING, CONTROLLING, MONITORING AND PROVIDING INFORMATION ON TRANSPORTATION ASSETS AND PARTS THEREOF; COMPUTER SOFTWARE THAT PROVIDES WEB-BASED ACCESS TO APPLICATIONS AND SERVICES THROUGH A WEB OPERATING SYSTEM OR PORTAL INTERFACE (U.S. CLS. 21, 23, 26, 36 AND 38).

FIRST USE 10-1-2012; IN COMMERCE 10-1-2012.

PAUL MORENO, EXAMINING ATTORNEY

**CLASS 9—(Continued).**

SN 85-769,827. MANDO CORPORATION, KYUNGKI-DO, REPUBLIC OF KOREA, FILED 11-2-2012.

# MANDO

PRIORITY CLAIMED UNDER SEC. 44(D) ON REPUBLIC OF KOREA APPLICATION NO. 2012-0057475, FILED 9-13-2012, REG. NO. 40-1005724, DATED 11-7-2013, EXPIRES 11-7-2023.

THE MARK CONSISTS OF THE STYLIZED WORD "MANDO".

FOR OPTICAL APPARATUS AND INSTRUMENTS, NAMELY, OPTICAL INSPECTION APPARATUS, OPTICAL FILTERS, OPTICAL CABLES, OPTICAL SCANNERS; MULTIPLE PURPOSE CAMERAS, MULTIFRAME VIEW CAMERAS, DIGITAL CAMERAS, CAMERA CONTAINING A LINEAR IMAGE SENSOR, INFRARED CAMERAS, ACCELEROMETERS, ACCELERATION SENSORS, RANGE FINDERS, SPEED INDICATORS, SPEED CHECKING APPARATUS FOR VEHICLES, KILOMETER RECORDERS FOR VEHICLES, AUTOMATIC INDICATORS OF LOW PRESSURE IN VEHICLE TIRES, PRESSURE SENSORS, AUTOMATIC PRESSURE CONTROL MACHINES AND INSTRUMENTS, PRESSURE MEASURING APPARATUS, NAMELY, PRESSURE GAUGES, TYRE-PRESSURE MEASURERS, PRESSURE SENSORS, TEMPERATURE SENSORS, GYROMETERS, BICYCLE SPEEDOMETERS, ALARMS, NAMELY, SMOKE ALARMS, SOUND ALARMS, GAS ALARMS; ATTENUATORS, VOLTAGE REGULATORS FOR VEHICLES, ELECTRICAL TRANSFORMERS, ELECTRIC SWITCHES, ELECTRIC REGULATING LIGHT DIMMERS, ELECTRIC REGULATING APPARATUS, NAMELY, APPARATUS FOR REGULATING ELECTRIC CURRENT, ELECTRICITY ADAPTERS, ELECTRICITY, ELECTRICITY INVERTERS, ELECTRICITY CONTROL PANELS, ARMATURES FOR USE IN ELECTRICAL APPARATUS, ELECTRIC RESISTANCES, ELECTRIC CONVERTERS, ELECTRIC CONNECTIONS, ELECTRIC CONTACTS, ELECTRICAL CONTROLLERS, ELECTRICAL CONTROLLING DEVICES, ELECTRIC COILS, CURRENT CONVERTERS, ELECTRIC CURRENT SWITCHES, ELECTRIC CURRENT CONTROL DEVICES, NAMELY, ELECTRICITY CURRENT LIMITERS, VOLTAGE STABILIZING POWER SUPPLY, VOLTAGE STABILIZERS, VOLTAGE REGULATORS, POWER SWITCHES, ELECTROMAGNETIC COILS, CURRENT RECTIFIERS, RECTIFIER MODULES, ELECTRIC APPARATUS FOR COMMUTATION, NAMELY, COMMUTATORS, POWER TRANSFORMERS FOR AMPLIFICATION, CIRCUIT BREAKERS, DIFFERENTIAL SWITCHES, CHOKING COILS FOR USE IN ELECTRICAL APPARATUS, CONDENSERS, BATTERY CHARGE DEVICES, ELECTRIC ACCUMULATORS FOR VEHICLES, BATTERY CASES, ELECTRIC ACCUMULATORS, WAVEMETERS, CAR VIDEO RECORDERS, DETECTORS, NAMELY, GAMMA RAY DETECTORS, LASER SPEED DETECTORS, MOTION DETECTORS, INTERFACES FOR DETECTORS, HIGH-FREQUENCY APPARATUS, NAMELY, HIGH-FREQUENCY SWITCHES, HIGH-FREQUENCY SWITCHING POWER SUPPLIES, ULTRASONIC SENSORS, DIODES, SEMI-CONDUCTORS, SEMI-CONDUCTOR MEMORIES, SEMI-CONDUCTOR MEMORY UNITS, SEMICONDUCTOR POWER ELEMENTS, SEMI-CONDUCTOR WAFERS, SEMICONDUCTOR POWER ELEMENTS, LIGHT EMITTING DIODES LED, SILICON SLICE WAFERS, PRINTED CIRCUIT BOARDS, TESTING APPARATUS FOR TESTING PRINTED CIRCUIT BOARDS, ELECTRONIC CIRCUIT BOARD, CONNECTORS FOR ELECTRONIC CIRCUITS, INTEGRATED CIRCUITS, CIRCUIT BOARDS PROVIDED WITH INTEGRATED CIRCUITS, INTEGRATED CIRCUIT MODULE, INTEGRATED CIRCUIT CHIPS FOR DIGITAL VIDEO COMPRESSION AND DECOMPRESSION, FOR ENCODING AND DECODING DIGITAL VIDEO, TRANSISTORS, PRINTED CIRCUITS, CIRCUIT BOARDS (U.S. CLS. 21, 23, 26, 36 AND 38).

GRETTA YAO, EXAMINING ATTORNEY

**CLASS 9—(Continued).**

SN 85-773,108. FXCONNECTX, LLC, LOS ANGELES, CA, FILED 11-6-2012.

# CUT THE CORD

THE MARK CONSISTS OF STANDARD CHARACTERS WITHOUT CLAIM TO ANY PARTICULAR FONT, STYLE, SIZE, OR COLOR.

FOR AUDIO EQUIPMENT, NAMELY, WIRELESS AND WIRED SYSTEMS COMPRISED OF SIGNAL PROCESSORS, TRANSMITTERS, SWITCHES, RECEIVERS AND RELAYS FOR REMOTE CONTROL, CONNECTION, AND SWITCHING OF MUSICAL EFFECTS PEDALS, VOLUME CONTROLS, AMPLIFIERS AND MUTE FUNCTIONS; AUDIO SWITCHING EQUIPMENT, NAMELY, WIRELESS AND WIRED SYSTEMS COMPRISED OF SIGNAL PROCESSORS, TRANSMITTERS, SWITCHES, RECEIVERS AND RELAYS FOR REMOTE CONTROL AND SWITCHING OF MUSICAL EFFECTS PEDALS, AMPLIFIERS AND MUTE FUNCTIONS; SIGNAL PROCESSING EQUIPMENT FOR AUDIO SIGNALS, NAMELY, WIRELESS AND WIRED SYSTEMS COMPRISED OF SIGNAL PROCESSORS, TRANSMITTERS, SWITCHES, RECEIVERS AND RELAYS FOR REMOTE CONTROL, CONNECTION, AND SWITCHING OF MUSICAL EFFECTS PEDALS, VOLUME CONTROLS, AMPLIFIERS AND MUTE FUNCTIONS; CONTROL UNITS FOR AUDIO SWITCHING AND SIGNAL PROCESSING EQUIPMENT, NAMELY, WIRELESS AND WIRED SYSTEMS COMPRISED OF SIGNAL PROCESSORS, TRANSMITTERS, SWITCHES, RECEIVERS AND RELAYS FOR REMOTE CONTROL, CONNECTION, AND SWITCHING OF MUSICAL EFFECTS PEDALS, VOLUME CONTROLS, AMPLIFIERS, AND MUTE FUNCTIONS (U.S. CLS. 21, 23, 26, 36 AND 38).

SAIMA MAKHDOOM, EXAMINING ATTORNEY

SN 85-800,836. A.D.C. AUTOMOTIVE DISTANCE CONTROL SYSTEMS GMBH, LINDAU, FED REP GERMANY, FILED 12-12-2012.

# SMFC

THE MARK CONSISTS OF STANDARD CHARACTERS WITHOUT CLAIM TO ANY PARTICULAR FONT, STYLE, SIZE, OR COLOR.

OWNER OF ERPN CMNTY TM OFC REG. NO. 011358711, DATED 5-22-2013, EXPIRES 11-20-2022.

FOR SENSORS FOR CONTROL AND STEERING OF VEHICLE BRAKES, GEARS AND CHASSIS; VEHICLE DETECTION EQUIPMENT, NAMELY, DISPLAY MONITORS, COMPUTERS, IMAGE SENSORS, VIDEO CAMERAS, AND OPERATING SYSTEM AND APPLICATION SOFTWARE TO DETECT VEHICLE LOCATION (U.S. CLS. 21, 23, 26, 36 AND 38).

JORDAN BAKER, EXAMINING ATTORNEY

**CLASS 9—(Continued).**

SN 85-809,712. ACCUMULATORENWERKE HOPPECKE CARL ZOELLNER & SOHN GMBH, BRILON, FED REP GERMANY, FILED 12-21-2012.

# DriTop

THE MARK CONSISTS OF CAPITAL "D" FOLLOWED BY LOWER CASE "RI" FOLLOWED BY CAPITAL "T" FOLLOWED BY LOWER CASE "OP".

THE WORD(S) "DRITOP" HAS NO MEANING IN A FOREIGN LANGUAGE.

FOR ACCUMULATORS; CHARGERS AND RECHARGING TECHNOLOGY FOR ACCUMULATORS, NAMELY, BATTERY CHARGERS; SECONDARY BATTERIES; CHARGERS AND RECHARGING TECHNOLOGY FOR SECONDARY BATTERIES, NAMELY, RECHARGEABLE BATTERIES AND BATTERIES THAT HAVE ELECTROCHEMICAL REACTIONS THAT ARE ELECTRICALLY REVERSIBLE; RECHARGEABLE ENERGY STORAGE IN THE NATURE OF ELECTROCHEMICAL AND OR ELECTRICAL STORAGE, NAMELY, STORAGE BATTERIES, HYDROGEN STORAGE, FLOW BATTERIES; CHARGERS AND RECHARGING TECHNOLOGY FOR RECHARGEABLE ENERGY STORAGE, NAMELY, DEVICES OR PHYSICAL MEDIA THAT STORE ENERGY TO BE USED AT A LATER DATE IN THE NATURE OF STORAGE BATTERIES, ELECTRICAL BATTERIES, FLOW BATTERIES, HYDROGEN, LIQUID NITROGEN, POWER TO GAS SYSTEM FOR CONVERTING ELECTRICAL POWER TO GAS FUEL COMPOSED OF ELECTRIC POWER CONVERTERS; ACCUMULATOR JARS; ACCUMULATOR BOXES; ACCUMULATOR CASES; ACCUMULATOR CAPS; CELL CASES AND CELL CAPS; APPARATUS AND INSTRUMENTS FOR THE MAINTENANCE AND REPROCESSING OF THE AFOREMENTIONED GOODS AND THEIR COMPONENTS IN THE NATURE OF CHECKING AND TESTING DEVICES AND TESTING EQUIPMENT, NAMELY, BATTERY TESTERS; BATTERY MANAGEMENT SYSTEMS COMPRISED OF MECHANICAL AND ELECTRICAL COMPONENTS FOR PROTECTING A BATTERY FROM OPERATING OUTSIDE ITS SAFE OPERATING AREA, FOR MONITORING ITS STATE, CALCULATING SECONDARY DATA, REPORTING THAT DATA, CONTROLLING ITS ENVIRONMENT, AUTHENTICATING AND BALANCING IT, MONITORING BATTERIES IN VIEW OF THE CHARGING VOLTAGE, TEMPERATURE, CAPACITY, CONTROL OF THE CHARGING PROCESS AND ANALYSIS; BATTERY MANAGEMENT SYSTEM IN THE NATURE OF BATTERY PERFORMANCE MONITORS THAT MAY BE ATTACHED TO A BATTERY TO MONITOR THE PERFORMANCE OF THE BATTERY AND OPERATING SOFTWARE FOR USE THEREWITH (U.S. CLS. 21, 23, 26, 36 AND 38).

ELIZABETH KAJUBI, EXAMINING ATTORNEY

**CLASS 9—(Continued).**

SN 85-831,158. LOAN SYNDICATIONS AND TRADING ASSOCIATION, INC., NEW YORK, NY. FILED 1-24-2013.

# LSTA

THE MARK CONSISTS OF STANDARD CHARACTERS WITHOUT CLAIM TO ANY PARTICULAR FONT, STYLE, SIZE, OR COLOR.

OWNER OF U.S. REG. NOS. 2,634,485 AND 2,648,381.

FOR DOWNLOADABLE PUBLICATIONS, NAMELY, NEWSLETTERS, RESOURCE GUIDES AND BROCHURES THAT ARE ACCESSIBLE FROM THE INTERNET IN THE FIELD OF CORPORATE LOAN TRADING, THIRD PARTY MARK-TO-MARKET PRICING SERVICE, THIRD PARTY LOAN INDICES AND MODEL PROVISIONS AND OTHER STANDARDIZED DOCUMENTATION FOR ORIGINATING AND TRADING PAR AND DISTRESSED LOAN ASSETS (U.S. CLS. 21, 23, 26, 36 AND 38).

FIRST USE 12-31-1998; IN COMMERCE 12-31-1998.

DAWN HAN, EXAMINING ATTORNEY

---

SN 85-850,245. PATRICIA S. MCLAUGHLIN, DBA BLUSH 'N BRUSH, DALLAS, TX. AND ANGUS M. BROWN III, DBA BLUSH 'N BRUSH, DALLAS, TX. FILED 2-14-2013.

# BLUSH 'N BRUSH

THE MARK CONSISTS OF STANDARD CHARACTERS WITHOUT CLAIM TO ANY PARTICULAR FONT, STYLE, SIZE, OR COLOR.

FOR COMPUTER APPLICATION SOFTWARE FOR SMARTPHONES, NAMELY, SOFTWARE FOR SELECTING COSMETIC PRODUCTS AND STORING USERS' COSMETICS PREFERENCES (U.S. CLS. 21, 23, 26, 36 AND 38).

DAWN HAN, EXAMINING ATTORNEY

**CLASS 9—(Continued).**

SN 85-857,547. SKYHIGH NETWORKS, INC., CUPERTINO, CA. FILED 2-22-2013.

SKYHIGH

THE MARK CONSISTS OF STANDARD CHARACTERS WITHOUT CLAIM TO ANY PARTICULAR FONT, STYLE, SIZE, OR COLOR.

FOR COMPUTER SOFTWARE, NAMELY, COMPUTER SOFTWARE FOR PROVIDING SECURITY FOR CLOUD COMPUTING SERVICES, WITH FUNCTIONS CONSISTING OF DATA SECURITY, INFORMATION PROTECTION, DATA LOSS PREVENTION, DATA AUTHENTICATION, MANAGEMENT OF SECURITY POLICIES, NETWORK MANAGEMENT, NETWORK MONITORING, MONITORING CLOUD SERVICES USAGE, CONTROLLING EMPLOYEE ACCESS, CONTROLLING USER ACCESS, MONITORING AND AUDITING CLOUD SERVICES, GOVERNANCE AND AUDITING OF PUBLIC AND PRIVATE IT CLOUD SERVICES, AND MONITORING THE SECURITY OF REMOTE COMPUTERS AND MOBILE ELECTRONIC DEVICES; COMPUTER SOFTWARE, NAMELY, ENCRYPTION SOFTWARE TO ENABLE SECURE TRANSMISSION OF DIGITAL INFORMATION; COMPUTER SOFTWARE TO INTEGRATE MANAGED SECURITY SERVICES, WITH EXISTING COMMUNICATIONS NETWORKS, SOFTWARE AND SERVICES; COMPUTER SOFTWARE FOR DATA COMMUNICATIONS APPLICATIONS, AND FOR THE ENCRYPTION AND AUTHENTICATION OF DIGITAL INFORMATION AND DATA; COMPUTER SOFTWARE FOR AUTHENTICATION AND IDENTITY MANAGEMENT INFORMATION SECURITY (U.S. CLS. 21, 23, 26, 36 AND 38).

MIAH ROSENBERG, EXAMINING ATTORNEY

**CLASS 9—(Continued).**

SN 85-858,165. SKYHIGH NETWORKS, INC., CUPERTINO, CA. FILED 2-22-2013.

SKYHIGH NETWORKS

THE MARK CONSISTS OF STANDARD CHARACTERS WITHOUT CLAIM TO ANY PARTICULAR FONT, STYLE, SIZE, OR COLOR.

NO CLAIM IS MADE TO THE EXCLUSIVE RIGHT TO USE "NETWORKS", APART FROM THE MARK AS SHOWN.

FOR COMPUTER SOFTWARE, NAMELY, COMPUTER SOFTWARE FOR PROVIDING SECURITY FOR CLOUD COMPUTING SERVICES, WITH FUNCTIONS CONSISTING OF DATA SECURITY, INFORMATION PROTECTION, DATA LOSS PREVENTION, DATA AUTHENTICATION, MANAGEMENT OF SECURITY POLICIES, NETWORK MANAGEMENT, NETWORK MONITORING, MONITORING CLOUD SERVICES USAGE, CONTROLLING EMPLOYEE ACCESS, CONTROLLING USER ACCESS, MONITORING AND AUDITING CLOUD SERVICES, GOVERNANCE AND AUDITING OF PUBLIC AND PRIVATE IT CLOUD SERVICES, AND MONITORING THE SECURITY OF REMOTE COMPUTERS AND MOBILE ELECTRONIC DEVICES; COMPUTER SOFTWARE, NAMELY, ENCRYPTION SOFTWARE TO ENABLE SECURE TRANSMISSION OF DIGITAL INFORMATION AND DATA; COMPUTER SOFTWARE TO INTEGRATE MANAGED SECURITY SERVICES, WITH EXISTING COMMUNICATIONS NETWORKS, SOFTWARE AND SERVICES; COMPUTER SOFTWARE FOR DATA COMMUNICATIONS APPLICATIONS, AND FOR THE ENCRYPTION AND AUTHENTICATION OF DIGITAL INFORMATION AND DATA; COMPUTER SOFTWARE FOR AUTHENTICATION AND IDENTITY MANAGEMENT INFORMATION SECURITY (U.S. CLS. 21, 23, 26, 36 AND 38).

MIAH ROSENBERG, EXAMINING ATTORNEY

SN 85-870,533. NOMNOM NATION LLC, CINCINNATI, OH. FILED 3-8-2013.

THE COLOR(S) (S) YELLOW-ORANGE, SCARLET RED, BLUE AND BLACK IS/ARE CLAIMED AS A FEATURE OF THE MARK.

THE MARK CONSISTS OF THE WORDING "NOMNOM" IN STYLIZED FONT OUTLINED IN BLACK. THE FIRST SET OF LETTERS "NOM" IS IN YELLOW-ORANGE, THE SECOND SET OF "NOM" IS IN SCARLET RED. BELOW THIS IS THE WORDING "NATION" IN BLUE STYLIZED FONT OUTLINED IN BLACK.

FOR COMPUTER APPLICATION SOFTWARE FOR MOBILE PHONES, PORTABLE MEDIA PLAYERS, HANDHELD COMPUTERS, NAMELY, SOFTWARE FOR MAKING FOOD DONATIONS TO FOOD SHELTERS (U.S. CLS. 21, 23, 26, 36 AND 38).

NAKWAMA ANKRAH, EXAMINING ATTORNEY



**CLASS 9—(Continued).**

SN 85-891,320. DURAND, JORGE, HOUSTON, TX. FILED 3-31-2013.

**Hawk Vision Systems**

THE MARK CONSISTS OF STANDARD CHARACTERS WITHOUT CLAIM TO ANY PARTICULAR FONT, STYLE, SIZE, OR COLOR.

NO CLAIM IS MADE TO THE EXCLUSIVE RIGHT TO USE "VISION SYSTEMS", APART FROM THE MARK AS SHOWN.

FOR AUTOMATED PROCESS CONTROL SYSTEM, NAMELY, MICRO-PROCESSOR BASED HARDWARE AND SOFTWARE USED TO MONITOR POWER GENERATION AND ELECTRICAL DISTRIBUTION, AND OIL AND GAS TEMPERATURE, VOLUME, FLOW, AND PRESSURE; FLOWMETERS FOR USE IN OIL PIPELINES (U.S. CLS. 21, 23, 26, 36 AND 38).

CAITLIN WATTS-FITZGERALD, EXAMINING ATTORNEY

SN 85-891,377. DURAND, JORGE, HOUSTON, TX. FILED 3-31-2013.



NO CLAIM IS MADE TO THE EXCLUSIVE RIGHT TO USE "VISION SYSTEMS", APART FROM THE MARK AS SHOWN.

THE COLOR(S) RED, GRAY, WHITE, AND BLACK IS/ARE CLAIMED AS A FEATURE OF THE MARK.

THE MARK CONSISTS OF A BLACK BOX WITH A GRAY RAISED BORDER, CONTAINING A STYLISTIC HAWK DESIGN COMPRISED OF RED THICK LINES, CENTERED ABOVE THE WORDS, "HAWK VISION", IN A WHITE STYLIZED FONT, CENTERED ABOVE THE WORD, "SYSTEMS", IN A RED OUTLINE FONT.

FOR AUTOMATED PROCESS CONTROL SYSTEM, NAMELY, MICRO-PROCESSOR BASED HARDWARE AND SOFTWARE USED TO MONITOR POWER GENERATION AND ELECTRICAL DISTRIBUTION, AND OIL AND GAS TEMPERATURE, VOLUME, FLOW, AND PRESSURE; FLOWMETERS FOR USE IN OIL PIPELINES (U.S. CLS. 21, 23, 26, 36 AND 38).

CAITLIN WATTS-FITZGERALD, EXAMINING ATTORNEY

**CLASS 9—(Continued).**

SN 85-895,812. SOCIALRADAR INC., WASHINGTON, DC. FILED 4-4-2013.

**SOCIALRADAR**

THE MARK CONSISTS OF STANDARD CHARACTERS WITHOUT CLAIM TO ANY PARTICULAR FONT, STYLE, SIZE, OR COLOR.

FOR COMPUTER AND MOBILE TELEPHONE SOFTWARE USED FOR LOCATION BASED TRACKING AND IDENTIFICATION OF OTHER USERS (U.S. CLS. 21, 23, 26, 36 AND 38).

FIRST USE 5-0-2012; IN COMMERCE 5-0-2012.  
MARK SPARACINO, EXAMINING ATTORNEY

SN 85-906,232. ENUSTECH., INC, SEOUL, REPUBLIC OF KOREA, FILED 4-16-2013.



PRIORITY CLAIMED UNDER SEC. 44(D) ON REPUBLIC OF KOREA APPLICATION NO. 40-2012-0076, FILED 12-7-2012, REG. NO. 1032219, DATED 4-9-2014, EXPIRES 4-9-2024.

THE COLOR(S) BLUE, GREY, AND WHITE IS/ARE CLAIMED AS A FEATURE OF THE MARK.

THE MARK CONSISTS OF A LIGHT BLUE LETTER OF "B", A DARK GREY WORD OF "CODA" NEXT TO THE LETTER "B", AND A BLUE LIGHT TARGET SYMBOL AT THE UPPER RIGHT OF THE LETTER OF "A", ALL INSIDE A WHITE BACKGROUND.

FOR BLANK USB FLASH DRIVES; DATA PROCESSING APPARATUS; MICROPHONES; DEVICES FOR WIRELESS RADIO TRANSMISSION; VIDEO TRANSMISSION APPARATUS; PORTABLE VIDEO CAMERAS WITH BUILT-IN VIDEOCASSETTE RECORDERS; PHOTOGRAPHIC APPARATUS AND INSTRUMENTS, NAMELY, PHOTOGRAPHIC CAMERAS; AUDIOVISUAL RECEIVERS; APPARATUS FOR TRANSMITTING AND REPRODUCING SOUND OR IMAGES; COMPUTER APPLICATION SOFTWARE FOR MOBILE PHONES, NAMELY, FOR SHARING AND TRANSMITTING FILES IN THE MOBILE-PHONE WITH ACCESSORIES/PERIPHERALS; CASES FOR MOBILE PHONES; DEVICES FOR HANDS-FREE USE OF MOBILE PHONES; ELECTRON TUBES; ELECTRIC BATTERIES; COMPUTERS; COMPUTER SOFTWARE FOR DATA TRANSMITTING; TABLET COMPUTERS; SOLAR BATTERIES (U.S. CLS. 21, 23, 26, 36 AND 38).

ALICE BENMAMAN, EXAMINING ATTORNEY

**CLASS 9—(Continued).**

SN 85-914,077. RODICHOK, MICHAEL R., JOHNSTOWN, OH. FILED 4-24-2013.

**CLASS 9—(Continued).**

SN 85-931,556. LG CORP., SEOUL 150-721, REPUBLIC OF KOREA, FILED 5-14-2013.

## Sugar Creek Bluegrass

THE MARK CONSISTS OF STANDARD CHARACTERS WITHOUT CLAIM TO ANY PARTICULAR FONT, STYLE, SIZE, OR COLOR.

NO CLAIM IS MADE TO THE EXCLUSIVE RIGHT TO USE "BLUEGRASS", APART FROM THE MARK AS SHOWN.

FOR AUDIO RECORDINGS FEATURING MUSIC; COMPACT DISCS FEATURING MUSIC (U.S. CLS. 21, 23, 26, 36 AND 38).

FIRST USE 7-1-2012; IN COMMERCE 4-1-2013.  
FRED CARL, EXAMINING ATTORNEY

---

SN 85-919,970. UQ INC., SAN FRANCISCO, CA. FILED 5-1-2013.

## LG G Prix

## UQ LIFE

THE MARK CONSISTS OF STANDARD CHARACTERS WITHOUT CLAIM TO ANY PARTICULAR FONT, STYLE, SIZE, OR COLOR.

FOR COMPUTER GAME SOFTWARE; COMPUTER SOFTWARE DEVELOPMENT TOOLS; COMPUTER SOFTWARE FOR COMPILING, ANALYZING, STORING, SORTING, ORGANIZING AND DISTRIBUTING DEMOGRAPHIC, LIFESTYLE AND BEHAVIORAL DATA AND INFORMATION; COMPUTER SOFTWARE PLATFORMS FOR ONLINE NETWORKING IN THE FIELD OF SOCIAL NETWORKING AND CASUAL ONLINE GAMING (U.S. CLS. 21, 23, 26, 36 AND 38).

FIRST USE 4-30-2013; IN COMMERCE 4-30-2013.  
SUSAN STIGLITZ, EXAMINING ATTORNEY

---

SN 85-930,494. KABUSHIKI KAISHA TOSHIBA, TA TOSHIBA CORPORATION, TOKYO, JAPAN, FILED 5-13-2013.

## REGZA

THE MARK CONSISTS OF STANDARD CHARACTERS WITHOUT CLAIM TO ANY PARTICULAR FONT, STYLE, SIZE, OR COLOR.

OWNER OF JAPAN REG. NO. 5411028, DATED 5-13-2011, EXPIRES 5-13-2021.

OWNER OF U.S. REG. NO. 3,369,753.  
FOR TELEVISION SETS (U.S. CLS. 21, 23, 26, 36 AND 38).

KEVIN DINALLO, EXAMINING ATTORNEY

THE MARK CONSISTS OF STANDARD CHARACTERS WITHOUT CLAIM TO ANY PARTICULAR FONT, STYLE, SIZE, OR COLOR.

OWNER OF U.S. REG. NOS. 4,311,564, 4,374,353 AND OTHERS.

FOR TELEPHONE SETS; PORTABLE APPARATUS FOR THE TRANSMISSION OF COMMUNICATIONS; MOBILE PHONES; HEADSETS FOR MOBILE PHONES; PERSONAL DIGITAL ASSISTANTS; MPEG AUDIO LAYER-3 PLAYERS; TELEVISION RECEIVERS; TELEVISION MONITORS; CHARGERS FOR BATTERIES; DIGITAL VERSATILE DISC PLAYERS; APPARATUS FOR RECORDING, TRANSMISSION OR REPRODUCTION OF SOUND AND IMAGES; AUDIO-VIDEO RECEIVERS; TELECOMMUNICATION DEVICES AND APPARATUS, NAMELY, ELECTRIC CAPACITORS, FUSES, MICROPHONES, PICKUPS; NOTEBOOK COMPUTERS; HANDHELD COMPUTERS; COMPUTERS; COMPUTER APPLICATION SOFTWARE FOR MOBILE PHONE FOR RECEIVING AND TRANSMISSION OF MESSAGE IN THE NATURE OF DATA, TEXT, LANGUAGE, SOUND, IMAGE AND VIDEO; RECORDED COMPUTER OPERATING PROGRAMMES; DOWN-LOADABLE COMPUTER OPERATING PROGRAMS (U.S. CLS. 21, 23, 26, 36 AND 38).

ALAIN LAPTER, EXAMINING ATTORNEY

**CLASS 9—(Continued).**

SN 85-936,512. MAYO FOUNDATION FOR MEDICAL EDUCATION AND RESEARCH, ROCHESTER, MN. FILED 5-20-2013.

# MAYO CLINIC

THE MARK CONSISTS OF STANDARD CHARACTERS WITHOUT CLAIM TO ANY PARTICULAR FONT, STYLE, SIZE, OR COLOR.

OWNER OF U.S. REG. NOS. 1,614,853, 3,634,120 AND OTHERS.

SEC. 2(F) AS TO "CLINIC".

FOR COMPUTER APPLICATION SOFTWARE, NAMELY, SOFTWARE FOR TABLET COMPUTERS, SMARTPHONES, CELL PHONES AND OTHER MOBILE ELECTRONIC DEVICES FOR THE COLLECTION, EDITING, ORGANIZING, MODIFYING, BOOK MARKING, TRANSMISSION, STORAGE AND SHARING OF DATA AND INFORMATION IN THE FIELDS OF MEDICINE, HEALTHCARE, WELLNESS AND MENTAL HEALTH; COMPUTER APPLICATION SOFTWARE, NAMELY, SOFTWARE FOR TABLET COMPUTERS, SMARTPHONES, CELL PHONES, AND OTHER MOBILE ELECTRONIC DEVICES FOR SCHEDULING AND TRACKING MEDICAL APPOINTMENTS, VIEWING MEDICAL TEST RESULTS, ACCESSING PATIENT MEDICAL RECORDS, SENDING AND RECEIVING MESSAGES BETWEEN PATIENTS AND THEIR HEALTH CARE PROVIDERS AND SENDING, RECEIVING AND ACCESSING NEWS, PUBLICATIONS AND HEALTH-RELATED INFORMATION IN THE FIELDS OF MEDICINE, HEALTHCARE, WELLNESS AND MENTAL HEALTH; DIGITAL MEDIA, NAMELY, PRE-RECORDED DVDS AND DOWNLOADABLE AUDIO AND VISUAL RECORDINGS FEATURING INFORMATION IN THE FIELDS OF MEDICINE, HEALTHCARE, WELLNESS AND MENTAL HEALTH; DOWNLOADABLE MP3 FILES, MP3 RECORDINGS, ON-LINE DISCUSSION BOARD POSTS, WEBCASTS, WEBINARS AND PODCASTS FEATURING INFORMATION IN THE FIELDS OF MEDICINE, HEALTHCARE, WELLNESS AND MENTAL HEALTH; DOWNLOADABLE EDUCATIONAL COMPUTER SOFTWARE FEATURING INSTRUCTION AND PRE-RECORDED TUTORIALS IN MEDICINE AND HEALTHCARE (U.S. CLS. 21, 23, 26, 36 AND 38).

FIRST USE 12-29-2009; IN COMMERCE 12-29-2009.

DAVID YONTEF, EXAMINING ATTORNEY

SN 85-942,805. CARL ZEISS AG, OBERKOCHEN, FED REP GERMANY, FILED 5-25-2013.

# Metroscope

THE MARK CONSISTS OF STANDARD CHARACTERS WITHOUT CLAIM TO ANY PARTICULAR FONT, STYLE, SIZE, OR COLOR.

PRIORITY CLAIMED UNDER SEC. 44(D) ON FED REP GERMANY APPLICATION NO. 302013018460, FILED 2-21-2013, REG. NO. 302013018460, DATED 10-18-2013, EXPIRES 2-28-2023.

FOR MICROSCOPES AND PARTS THEREOF (U.S. CLS. 21, 23, 26, 36 AND 38).

JUSTINE D. PARKER, EXAMINING ATTORNEY

**CLASS 9—(Continued).**

SN 85-955,617. ROSMARIN, MICHELLE, WELLESLEY, MA. FILED 6-10-2013.



OWNER OF U.S. REG. NO. 3,135,679.

NO CLAIM IS MADE TO THE EXCLUSIVE RIGHT TO USE "CONTRACTOR'S CUSHION", APART FROM THE MARK AS SHOWN.

THE MARK CONSISTS OF A DESIGN OF A CONTRACTOR WEARING OVERALLS AND A CAP, RECLINING ON A CUSHION AND HOLDING A WRENCH. ABOVE THE DESIGN OF THE CONTRACTOR, THE STYLIZED WORDING "CONTRACTOR'S" APPEARS, IN AN ARC. BENEATH THE DESIGN, THE WORDING "CUSHION" APPEARS. BENEATH THE WORDING "CUSHION", THE WORDING "FOR COMFORT ON THE JOB" APPEARS.

FOR SAFETY CUSHIONS TO PROVIDE BODY PROTECTION WHILE LAYING DOWN, SITTING, OR KNEELING FOR CONTRACTORS WHILE WORKING (U.S. CLS. 21, 23, 26, 36 AND 38).

MARILYN IZZI, EXAMINING ATTORNEY

SN 85-960,422. ROSMARIN, MICHELLE, WELLESLEY, MA. FILED 6-14-2013.



OWNER OF U.S. REG. NO. 3,135,679.

NO CLAIM IS MADE TO THE EXCLUSIVE RIGHT TO USE "MECHANIC'S MAT", APART FROM THE MARK AS SHOWN.

THE MARK CONSISTS OF A DESIGN OF A MECHANIC WEARING OVERALLS AND A CAP, RECLINING ON A MAT AND HOLDING A WRENCH. ABOVE THE DESIGN OF THE MECHANIC, THE STYLIZED WORDING "MECHANIC'S MAT" APPEARS IN AN ARC. BENEATH THE DESIGN, THE WORDING "MAT" APPEARS. BENEATH THE WORDING "MAT", THE WORDING "FOR LAYING DOWN ON THE JOB" APPEARS.

FOR PROTECTIVE SAFETY CUSHION TO BE USED BY A MECHANIC (U.S. CLS. 21, 23, 26, 36 AND 38).

MARILYN IZZI, EXAMINING ATTORNEY

**CLASS 9—(Continued).**

SN 85-964,282. RELIURE CONCEPT INC., BOUCHERVILLE, QUEBEC, CANADA, FILED 6-19-2013.

# TOOGOOD

THE MARK CONSISTS OF STANDARD CHARACTERS WITHOUT CLAIM TO ANY PARTICULAR FONT, STYLE, SIZE, OR COLOR.

PRIORITY CLAIMED UNDER SEC. 44(D) ON CANADA APPLICATION NO. 1608011, FILED 12-21-2012, REG. NO. TMA880,349, DATED 6-18-2014, EXPIRES 6-18-2029.

FOR PROTECTIVE COVERS, CASES, CUSTOM-MADE CASES, SLEEVES, PROTECTIVE SKINS AND ACCESSORIES FOR TABLET COMPUTERS, LAPTOP COMPUTERS, CELL PHONES, PORTABLE MEDIA PLAYERS AND ELECTRONIC BOOK READERS, NAMELY, STYLUS, SCREEN PROTECTIVE FILMS, BLANK USB FLASH DRIVES, USB WALL CHARGER, KEYBOARDS, KEYBOARD COVERS, LAPTOP COOLING PADS, COMPUTER CABLES, ELECTRIC NETWORK CABLES, CABLE ADAPTERS, BATTERIES, ELECTRIC BATTERY CHARGERS, BATTERY CHARGERS FOR USE IN A CAR, POWER ADAPTERS, ELECTRIC DATA COMMUNICATION CABLES, HEADSETS, EARPHONES, MOUSE, MOUSE PAD; BRIEFCASES, PORTFOLIOS, BOOK BAGS, MESSENGER BAGS, ALL SPECIALLY ADAPTED FOR HOLDING TABLET COMPUTERS, LAPTOP COMPUTERS, CELL PHONES, PORTABLE MEDIA PLAYERS AND ELECTRONIC BOOK READERS (U.S. CLS. 21, 23, 26, 36 AND 38).

DEBORAH MEINERS, EXAMINING ATTORNEY

---

SN 85-966,438. NEXTIVITY, INC., SAN DIEGO, CA. FILED 6-21-2013.

# CEL-FI

THE MARK CONSISTS OF STANDARD CHARACTERS WITHOUT CLAIM TO ANY PARTICULAR FONT, STYLE, SIZE, OR COLOR.

OWNER OF U.S. REG. NOS. 3,566,124 AND 3,578,189. SEC. 2(F). FOR CELLULAR REPEATERS (U.S. CLS. 21, 23, 26, 36 AND 38).

FIRST USE 12-6-2007; IN COMMERCE 12-6-2007. JAY FLOWERS, EXAMINING ATTORNEY

**CLASS 9—(Continued).**

SN 85-968,661. MARVEL CHARACTERS, INC., BURBANK, CA. FILED 6-24-2013.

# GUARDIANS OF THE GALAXY

THE MARK CONSISTS OF STANDARD CHARACTERS WITHOUT CLAIM TO ANY PARTICULAR FONT, STYLE, SIZE, OR COLOR.

OWNER OF U.S. REG. NO. 3,562,304.

FOR APPARATUS FOR RECORDING, TRANSMISSION OR REPRODUCTION OF SOUND OR IMAGES; AUDIO BOOKS IN THE NATURE OF NOVELS; AUDIO RECORDINGS FEATURING MUSIC, STORIES, DRAMATIC PERFORMANCES, NON-DRAMATIC PERFORMANCES, LEARNING ACTIVITIES FOR CHILDREN AND GAMES; DOWNLOADABLE RINGTONES AND SOUND RECORDINGS FEATURING MUSIC, STORIES, DRAMATIC PERFORMANCES, NON-DRAMATIC PERFORMANCES, LEARNING ACTIVITIES FOR CHILDREN AND GAMES, ALL FOR WIRELESS COMMUNICATIONS DEVICES; AUDIO AND VISUAL RECORDINGS FEATURING LIVE-ACTION ENTERTAINMENT, ANIMATED ENTERTAINMENT, MUSIC, STORIES AND GAMES FOR CHILDREN; MUSICAL RECORDINGS; VIDEO GAME SOFTWARE; COMPUTER GAME SOFTWARE AND COMPUTER GAME PROGRAMS; CONSUMER ELECTRONICS, NAMELY, COMPUTER SOFTWARE FEATURING LEARNING ACTIVITIES FOR CHILDREN, COMPUTER CHIPS, COMPUTER HARDWARE AND PERIPHERAL DEVICES, MOUSE PADS, WRIST AND ARM RESTS FOR USE WITH COMPUTERS, CALCULATORS, ELECTRICAL AND OPTICAL CABLES, ELECTRONIC PERSONAL ORGANIZERS, PERSONAL DIGITAL ASSISTANTS, CAMCORDERS, CAMERAS, DIGITAL CAMERAS, OPTICAL AND MAGNETO-OPTICAL DISC PLAYERS AND RECORDERS FOR AUDIO, VIDEO AND COMPUTER DATA, RADIOS, TELEVISION SETS, AUDIO SPEAKERS, HEADPHONES, EARPHONES, WALKIE-TALKIES, TELEPHONES, VIDEOPHONES, HEAD SETS FOR CELLULAR TELEPHONES, ADAPTERS FOR CELLULAR TELEPHONES, BATTERIES FOR CELLULAR TELEPHONES, CASES FOR CELLULAR TELEPHONES, CELL PHONE FACEPLATES, EYEGLASSES, SUNGLASSES, EYEGLASS AND SUNGLASS CASES; BINOCULARS; DECORATIVE MAGNETS; GRADUATED RULERS (U.S. CLS. 21, 23, 26, 36 AND 38).

DAVID YONTEF, EXAMINING ATTORNEY

**CLASS 9—(Continued).**

SN 86-009,398. RESCUECOM CORPORATION, SYRACUSE, NY. FILED 7-12-2013.

**NOW!**

THE COLOR(S) RED IS/ARE CLAIMED AS A FEATURE OF THE MARK.

THE MARK CONSISTS OF THE WORD "NOW" IN RED ITALICIZED WITH AN EXCLAMATION POINT.

FOR COMPUTER ANTI-VIRUS SOFTWARE; COMPUTER OPERATING SOFTWARE; COMPUTER SOFTWARE AND FIRMWARE FOR OPERATING SYSTEM PROGRAMS; COMPUTER SOFTWARE FOR ADMINISTRATION OF COMPUTER LOCAL AREA NETWORKS; COMPUTER SOFTWARE FOR ADMINISTRATION OF COMPUTER NETWORKS; COMPUTER SOFTWARE FOR APPLICATION AND DATABASE INTEGRATION; COMPUTER SOFTWARE FOR COMPUTER SYSTEM AND APPLICATION DEVELOPMENT, DEPLOYMENT AND MANAGEMENT; COMPUTER SOFTWARE FOR CONTROLLING AND MANAGING ACCESS SERVER APPLICATIONS; COMPUTER SOFTWARE FOR ENCRYPTION; COMPUTER SOFTWARE FOR PC PROTECTION AND DIAGNOSTICS; COMPUTER SOFTWARE THAT PROVIDES WEB-BASED ACCESS TO APPLICATIONS AND SERVICES THROUGH A WEB OPERATING SYSTEM OR PORTAL INTERFACE; DATABASE MANAGEMENT SOFTWARE FOR PC PROTECTION AND DIAGNOSTICS; DOWNLOADABLE COMPUTER SOFTWARE FOR PC PROTECTION AND DIAGNOSTICS (U.S. CLS. 21, 23, 26, 36 AND 38).

FIRST USE 6-25-2013; IN COMMERCE 6-25-2013.  
DAWN FELDMAN, EXAMINING ATTORNEY

SN 86-014,871. KLEIN, PHILIP E., NEW YORK, NY. FILED 7-19-2013.

**BINDLE**

THE MARK CONSISTS OF STANDARD CHARACTERS WITHOUT CLAIM TO ANY PARTICULAR FONT, STYLE, SIZE, OR COLOR.

FOR CARRYING CASES, HOLDERS, PROTECTIVE CASES AND STANDS FEATURING POWER SUPPLY CONNECTORS, ADAPTORS, SPEAKERS AND BATTERY CHARGING DEVICES, SPECIALLY ADAPTED FOR USE WITH HANDHELD DIGITAL ELECTRONIC DEVICES, NAMELY, TABLET COMPUTERS, CELL PHONES, MP3 PLAYERS AND PERSONAL DIGITAL ASSISTANTS (U.S. CLS. 21, 23, 26, 36 AND 38).

GRETCHEN ULRICH, EXAMINING ATTORNEY

**CLASS 9—(Continued).**

SN 86-020,596. WELL RESOLUTIONS TECHNOLOGY, INC., HOUSTON, TX. FILED 7-26-2013.

**BOUNDARY TRACKER**

THE MARK CONSISTS OF STANDARD CHARACTERS WITHOUT CLAIM TO ANY PARTICULAR FONT, STYLE, SIZE, OR COLOR.

NO CLAIM IS MADE TO THE EXCLUSIVE RIGHT TO USE "BOUNDARY", APART FROM THE MARK AS SHOWN.

FOR OIL AND GAS WELL DOWNHOLE SURVEY AND MEASUREMENT EQUIPMENT, NAMELY, AZIMUTHAL RESISTIVITY MEASUREMENT TOOL USED IN WELLBORE DRILLING AND GEOSTEERING, AND AZIMUTHAL ELECTROMAGNETIC RESISTIVITY MEASUREMENT TOOL USED IN IMAGING-WHILE-DRILLING (U.S. CLS. 21, 23, 26, 36 AND 38).

LEE-ANNE BERNIS, EXAMINING ATTORNEY

SN 86-022,208. JONES, JOY K, OAK PARK, IL. FILED 7-29-2013.

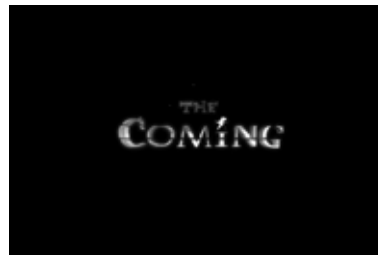

FOR A SERIES OF PRERECORDED VIDEO DISCS FEATURING A TELEVISION PROGRAM AND MOTION PICTURE FILMS, ALL ABOUT THE BOOK OF REVELATION AND THE SECOND COMING OF JESUS CHRIST (U.S. CLS. 21, 23, 26, 36 AND 38).

FIRST USE 5-23-2013; IN COMMERCE 5-23-2013.  
MARY CRAWFORD, EXAMINING ATTORNEY

**CLASS 9—(Continued).**

SN 86-028,301. KAMAL KARMAKAR, BEDFORD, NH.  
FILED 8-5-2013.

**CLASS 9—(Continued).**

SN 86-028,310. KAMAL KARMAKAR, BEDFORD, NH.  
FILED 8-5-2013.

# iVend POS iVend Retail

THE MARK CONSISTS OF STANDARD CHARACTERS WITHOUT CLAIM TO ANY PARTICULAR FONT, STYLE, SIZE, OR COLOR.

NO CLAIM IS MADE TO THE EXCLUSIVE RIGHT TO USE "POS", APART FROM THE MARK AS SHOWN.

SEC. 2(F).

FOR COMPUTER OPERATING SYSTEM PROGRAMS AND UTILITY SOFTWARE; COMPUTER APPLICATION SOFTWARE FOR WIRELESS TELECOMMUNICATIONS FOR USE WITH WIRELESS DEVICES; COMPUTER SOFTWARE TO ENABLE UPLOADING, DOWNLOADING, ACCESSING, POSTING, DISPLAYING, TAGGING, BLOGGING, STREAMING, LINKING, SHARING OR OTHERWISE PROVIDING ELECTRONIC MEDIA OR INFORMATION VIA COMPUTER AND COMMUNICATION NETWORKS; SOFTWARE FOR ALLOWING COMMUNICATION AND INTERACTION BETWEEN PHONES, MOBILE DEVICES, TELEVISIONS, VIDEO GAME CONSOLES, MEDIA PLAYERS, COMPUTERS, DIGITAL MEDIA HUBS, AND AUDIOVISUAL DEVICES; COMPUTER SOFTWARE FOR USE BY COMPUTER NETWORK ADMINISTRATORS TO DEPLOY AND MANAGE APPLICATION SOFTWARE AND NETWORK SERVER SOFTWARE; COMPUTER NETWORK SERVER SOFTWARE FOR MANAGING USER CONTENT ON COMPUTER NETWORKS AND GLOBAL COMPUTER NETWORKS; COMPUTER SOFTWARE FOR MANAGING SECURE COMMUNICATIONS OVER COMPUTER NETWORKS AND GLOBAL COMPUTER NETWORKS; COMPUTER SOFTWARE FOR DEVELOPING, MANAGING AND OPERATING INTRANET SITES; COMPUTER NETWORK OPERATING SOFTWARE AND UTILITY SOFTWARE; COMPUTER SOFTWARE DEVELOPMENT TOOLS FOR NETWORK SERVERS AND APPLICATIONS; COMPUTER SOFTWARE FOR INVENTORYING AND MONITORING COMPUTER HARDWARE AND SOFTWARE ASSETS AND USE WITHIN AN ORGANIZATION; COMPUTER APPLICATION PROGRAMS AND OPERATING SYSTEM PROGRAMS FOR USE WITH COMMUNICATIONS SERVERS; COMPUTER PROGRAMS FOR MANAGING COMMUNICATIONS AND DATA EXCHANGE BETWEEN COMPUTERS AND ELECTRONIC DEVICES; OPERATING SYSTEMS SOFTWARE FOR USE IN PLAYING ELECTRONIC GAMES; COMPUTER HARDWARE AND PERIPHERALS; COMPUTER KEYBOARDS; COMPUTER MICE AND WIRELESS COMPUTER MICE; WIRELESS COMMUNICATIONS DEVICES, NAMELY, MOBILE PHONES, CELLULAR TELEPHONES, PERSONAL DIGITAL ASSISTANTS, AND HAND-HELD COMPUTERS; HARDWARE FOR TELECOMMUNICATIONS FOR CONNECTING DEVICES VIA IN-HOME PHONE AND ELECTRICAL WIRING, NAMELY, COMPUTER NETWORKS HUBS, COMPUTER SERVERS, SET-TOP BOXES, COMPUTER SWITCHES AND COMPUTER ROUTERS DESIGNED TO PROVIDE IN-HOME VOICE OVER INTERNET PROTOCOL (VOIP) COMMUNICATIONS; COMPUTER AND VIDEO GAME SYSTEMS DEVICES, NAMELY, ELECTRONIC SENSOR DEVICES, CAMERAS, PROJECTORS, HEADPHONES, AND MICROPHONES (U.S. CLS. 21, 23, 26, 36 AND 38).

FIRST USE 2-16-2004; IN COMMERCE 2-16-2004.

DAVID C. REIHNER, EXAMINING ATTORNEY

THE MARK CONSISTS OF STANDARD CHARACTERS WITHOUT CLAIM TO ANY PARTICULAR FONT, STYLE, SIZE, OR COLOR.

NO CLAIM IS MADE TO THE EXCLUSIVE RIGHT TO USE "RETAIL", APART FROM THE MARK AS SHOWN.

SEC. 2(F).

FOR COMPUTER OPERATING SYSTEM PROGRAMS AND UTILITY SOFTWARE; COMPUTER APPLICATION SOFTWARE FOR WIRELESS TELECOMMUNICATIONS FOR USE WITH WIRELESS DEVICES; COMPUTER SOFTWARE TO ENABLE UPLOADING, DOWNLOADING, ACCESSING, POSTING, DISPLAYING, TAGGING, BLOGGING, STREAMING, LINKING, SHARING OR OTHERWISE PROVIDING ELECTRONIC MEDIA OR INFORMATION VIA COMPUTER AND COMMUNICATION NETWORKS; SOFTWARE FOR ALLOWING COMMUNICATION AND INTERACTION BETWEEN PHONES, MOBILE DEVICES, TELEVISIONS, VIDEO GAME CONSOLES, MEDIA PLAYERS, COMPUTERS, DIGITAL MEDIA HUBS, AND AUDIOVISUAL DEVICES; COMPUTER SOFTWARE FOR USE BY COMPUTER NETWORK ADMINISTRATORS TO DEPLOY AND MANAGE APPLICATION SOFTWARE AND NETWORK SERVER SOFTWARE; COMPUTER NETWORK SERVER SOFTWARE FOR MANAGING USER CONTENT ON COMPUTER NETWORKS AND GLOBAL COMPUTER NETWORKS; COMPUTER SOFTWARE FOR MANAGING SECURE COMMUNICATIONS OVER COMPUTER NETWORKS AND GLOBAL COMPUTER NETWORKS; COMPUTER SOFTWARE FOR DEVELOPING, MANAGING AND OPERATING INTRANET SITES; COMPUTER NETWORK OPERATING SOFTWARE AND UTILITY SOFTWARE; COMPUTER SOFTWARE DEVELOPMENT TOOLS FOR NETWORK SERVERS AND APPLICATIONS; COMPUTER SOFTWARE FOR INVENTORYING AND MONITORING COMPUTER HARDWARE AND SOFTWARE ASSETS AND USE WITHIN AN ORGANIZATION; COMPUTER APPLICATION PROGRAMS AND OPERATING SYSTEM PROGRAMS FOR USE WITH COMMUNICATIONS SERVERS; COMPUTER PROGRAMS FOR MANAGING COMMUNICATIONS AND DATA EXCHANGE BETWEEN COMPUTERS AND ELECTRONIC DEVICES; OPERATING SYSTEMS SOFTWARE FOR USE IN PLAYING ELECTRONIC GAMES; COMPUTER HARDWARE AND PERIPHERALS; COMPUTER KEYBOARDS; COMPUTER MICE AND WIRELESS COMPUTER MICE; WIRELESS COMMUNICATIONS DEVICES, NAMELY, MOBILE PHONES, CELLULAR TELEPHONES, PERSONAL DIGITAL ASSISTANTS, AND HAND-HELD COMPUTERS; HARDWARE FOR TELECOMMUNICATIONS FOR CONNECTING DEVICES VIA IN-HOME PHONE AND ELECTRICAL WIRING, NAMELY, COMPUTER NETWORKS HUBS, COMPUTER SERVERS, SET-TOP BOXES, COMPUTER SWITCHES AND COMPUTER ROUTERS DESIGNED TO PROVIDE IN-HOME VOICE OVER INTERNET PROTOCOL (VOIP) COMMUNICATIONS; COMPUTER AND VIDEO GAME SYSTEMS DEVICES, NAMELY, ELECTRONIC SENSOR DEVICES, CAMERAS, PROJECTORS, HEADPHONES, AND MICROPHONES (U.S. CLS. 21, 23, 26, 36 AND 38).

FIRST USE 2-16-2004; IN COMMERCE 2-16-2004.

DAVID C. REIHNER, EXAMINING ATTORNEY

**CLASS 9—(Continued).**

SN 86-035,588. SOURCEONE SOLUTIONS, WILLMAR, MN. FILED 8-12-2013.

# SOLOGIC

THE MARK CONSISTS OF STANDARD CHARACTERS WITHOUT CLAIM TO ANY PARTICULAR FONT, STYLE, SIZE, OR COLOR.

FOR COMPUTER SOFTWARE USED FOR PROCESSING CUSTOMER BILLING AND PAYMENTS IN THE TELECOMMUNICATIONS AND UTILITIES INDUSTRIES (U.S. CLS. 21, 23, 26, 36 AND 38).

DAVID ALESKOW, EXAMINING ATTORNEY

SN 86-035,650. OLTIS SECURITY SYSTEMS INTERNATIONAL, LLC, WAUKESHA, WI. FILED 8-12-2013.

# READYAXS

THE MARK CONSISTS OF STANDARD CHARACTERS WITHOUT CLAIM TO ANY PARTICULAR FONT, STYLE, SIZE, OR COLOR.

FOR SECURITY ACCESS CONTROL SYSTEMS COMPRISED OF COMPUTER PROCESSOR BOARDS AND COMPUTER SOFTWARE FOR OPERATING BUILDING ACCESS CONTROL SYSTEMS; COMPUTER PROCESSOR BOARDS; COMPUTER SOFTWARE FOR OPERATING BUILDING ACCESS CONTROL SYSTEMS (U.S. CLS. 21, 23, 26, 36 AND 38).

KATHERINE CHANG, EXAMINING ATTORNEY

SN 86-035,653. NEW HOPE CHARITABLE FOUNDATION, DEL MAR, CA. FILED 8-12-2013.

# DRAWING OUT GENIUS

THE MARK CONSISTS OF STANDARD CHARACTERS WITHOUT CLAIM TO ANY PARTICULAR FONT, STYLE, SIZE, OR COLOR.

FOR AUDIO AND VIDEO RECORDINGS FEATURING FICTIONAL STORIES, PARENTING SKILLS, CLASSROOM MANAGEMENT, SETTING CHILDREN UP FOR SUCCESS, IMPROVING LEARNING, CORE SUBJECT REMEDIATION, FACTORS AND SKILLS FOR SUCCESSFUL LEARNING, CHILD, YOUTH, TEEN, AND YOUNG ADULT CULTURE, CAREER EXPLORATION AND OPPORTUNITY, INTEREST EXPLORATION AND OPPORTUNITIES, SELF-AWARENESS, COMMUNITY AWARENESS, LEADERSHIP, TEAM WORK, CLEAR COMMUNICATION, SELF-RESPECT AND RESPECT FOR OTHERS, CONFIDENCE, AND GOAL SETTING AND ACHIEVEMENT; AUDIO BOOKS IN THE FIELD OF FICTIONAL STORIES, PARENTING SKILLS, CLASSROOM MANAGEMENT, SETTING CHILDREN UP FOR SUCCESS, IMPROVING LEARNING, CORE SUBJECT REMEDIATION, FACTORS AND SKILLS FOR SUCCESSFUL LEARNING, CHILD, YOUTH, TEEN, AND YOUNG ADULT CULTURE, CAREER EXPLORATION AND OPPORTUNITY, INTEREST EXPLORATION AND OPPORTUNITIES, SELF-AWARENESS, COMMUNITY AWARENESS, LEADERSHIP, TEAM WORK, CLEAR COMMUNICATION, SELF-RESPECT AND RESPECT FOR OTHERS, CONFIDENCE, AND GOAL SETTING AND ACHIEVEMENT; COMPUTER GAME SOFTWARE; DECORATIVE MAGNETS; DOWNLOADABLE PODCASTS IN THE FIELD OF FICTIONAL STORIES; MOTION PICTURE FILMS ABOUT FICTIONAL STORIES, PARENTING SKILLS, CLASSROOM MANAGEMENT, SETTING CHILDREN UP FOR SUCCESS, IMPROVING LEARNING, CORE SUBJECT REMEDIATION, FACTORS AND SKILLS FOR SUCCESSFUL LEARNING, CHILD, YOUTH, TEEN, AND YOUNG ADULT CULTURE, CAREER EXPLORATION AND OPPORTUNITY, INTEREST EXPLORATION AND OPPORTUNITIES, SELF-AWARENESS, COMMUNITY AWARENESS, LEADERSHIP, TEAM WORK, CLEAR COMMUNICATION, SELF-RESPECT AND RESPECT FOR OTHERS, CONFIDENCE, AND GOAL SETTING AND ACHIEVEMENT (U.S. CLS. 21, 23, 26, 36 AND 38).

**CLASS 9—(Continued).**

CESSFUL LEARNING, CHILD, YOUTH, TEEN, AND YOUNG ADULT CULTURE, CAREER EXPLORATION AND OPPORTUNITY, INTEREST EXPLORATION AND OPPORTUNITIES, SELF-AWARENESS, COMMUNITY AWARENESS, LEADERSHIP, TEAM WORK, CLEAR COMMUNICATION, SELF-RESPECT AND RESPECT FOR OTHERS, CONFIDENCE, AND GOAL SETTING AND ACHIEVEMENT; COMPUTER GAME SOFTWARE; DECORATIVE MAGNETS; DOWNLOADABLE PODCASTS IN THE FIELD OF FICTIONAL STORIES; MOTION PICTURE FILMS ABOUT FICTIONAL STORIES, PARENTING SKILLS, CLASSROOM MANAGEMENT, SETTING CHILDREN UP FOR SUCCESS, IMPROVING LEARNING, CORE SUBJECT REMEDIATION, FACTORS AND SKILLS FOR SUCCESSFUL LEARNING, CHILD, YOUTH, TEEN, AND YOUNG ADULT CULTURE, CAREER EXPLORATION AND OPPORTUNITY, INTEREST EXPLORATION AND OPPORTUNITIES, SELF-AWARENESS, COMMUNITY AWARENESS, LEADERSHIP, TEAM WORK, CLEAR COMMUNICATION, SELF-RESPECT AND RESPECT FOR OTHERS, CONFIDENCE, AND GOAL SETTING AND ACHIEVEMENT (U.S. CLS. 21, 23, 26, 36 AND 38).

KATHLEEN M. VANSTON, EXAMINING ATTORNEY

SN 86-037,137. GIULIANA HAIK PAIM DE ANDRADE, AKA GIULIANA ANDRADE, SYDNEY, AUSTRALIA, FILED 8-14-2013.

# inout

THE MARK CONSISTS OF STANDARD CHARACTERS WITHOUT CLAIM TO ANY PARTICULAR FONT, STYLE, SIZE, OR COLOR.

FOR COMMUNICATIONS SOFTWARE FOR CONNECTING USERS INTERESTED IN BUSINESS, EDUCATIONAL AND SOCIAL EVENTS, LIVE ENTERTAINMENT, EXHIBITIONS AND PERFORMANCE EVENTS; COMPUTER E-COMMERCE SOFTWARE TO ALLOW USERS TO PERFORM ELECTRONIC BUSINESS TRANSACTIONS VIA A GLOBAL COMPUTER NETWORK; COMPUTER SOFTWARE FOR PROVIDING AN ON-LINE DATABASE IN THE FIELD OF TRANSACTION PROCESSING TO UPLOAD TRANSACTIONAL DATA, PROVIDE STATISTICAL ANALYSIS, AND PRODUCE NOTIFICATIONS AND REPORTS (U.S. CLS. 21, 23, 26, 36 AND 38).

MELISSA VALLILLO, EXAMINING ATTORNEY

SN 86-037,976. TRANSITIONS OPTICAL, INC., PINELLAS PARK, FL. FILED 8-14-2013.



OWNER OF U.S. REG. NOS. 1,576,217, 4,354,238 AND OTHERS.

NO CLAIM IS MADE TO THE EXCLUSIVE RIGHT TO USE "ADAPTIVE SUNGLASSES", APART FROM THE MARK AS SHOWN.

THE MARK CONSISTS OF THE LITERAL ELEMENT "TRANSITIONS ADAPTIVE SUNGLASSES", WITH "TRANSITIONS", IN STYLIZED LETTERS AND A SWIRL DESIGN IN PLACE OF THE LETTER "O", BEING ABOVE THE

**CLASS 9—(Continued).**

WORDS "ADAPTIVE SUNGLASSES" IN STYLIZED UPPER CASE LETTERS. THE ENTIRETY OF THE LITERAL ELEMENT IS TO THE RIGHT OF DESIGN ELEMENT CONSISTING OF A SHADED SPHERE WITH THE APPEARANCE OF A MOON ORBITING A LARGER SHADED SPHERE WITH THE APPEARANCE OF A PLANET, THE SMALLER SHADED SPHERE APPEARING TO THE TOP RIGHT AND PARTIALLY OBSCURING A PORTION OF THE LARGER SHADED SPHERE. THE MARK APPEARS ON A SHADED, TRANSPARENT BACKGROUND THAT IS NOT CLAIMED AS A FEATURE OF THE MARK.

FOR OPTICAL LENSES; OPHTHALMIC LENSES; SPECTACLE LENS BLANKS; SPECTACLES, NAMELY, EYEGASSES AND GOGGLES; EYEGASS FRAMES; SUNGLASSES; VISORS FOR HELMETS AND GOGGLES (U.S. CLS. 21, 23, 26, 36 AND 38).

KATHLEEN KOLACZ, EXAMINING ATTORNEY

---

SN 86-038,954. STRATUS ANALYTICS, LLC., GREENWICH, CT. FILED 8-15-2013.

# HIST

THE MARK CONSISTS OF STANDARD CHARACTERS WITHOUT CLAIM TO ANY PARTICULAR FONT, STYLE, SIZE, OR COLOR.

FOR ANALYTICAL SOFTWARE FOR USE BY INVESTORS IN ANALYZING HISTORICAL RETURN AND RISK CHARACTERISTICS OF AIRCRAFT SELECTION, INVESTMENT STRUCTURING, AND RISK DIVERSIFICATION ALTERNATIVES APPLIED RETROSPECTIVELY TO THE HISTORICAL WORLD AIRCRAFT FLEET (U.S. CLS. 21, 23, 26, 36 AND 38).

LAURA GOLDEN, EXAMINING ATTORNEY

---

SN 86-039,784. THE CARTOON NETWORK, INC., ATLANTA, GA. FILED 8-16-2013.

# TOME OF THE UNKNOWN

THE MARK CONSISTS OF STANDARD CHARACTERS WITHOUT CLAIM TO ANY PARTICULAR FONT, STYLE, SIZE, OR COLOR.

FOR COMPACT DISCS FEATURING MUSIC; PORTABLE AUDIO SPEAKERS, HEADPHONES, EARPHONES, MOUSE PADS; DECORATIVE MAGNETS, DIGITAL PHOTO FRAMES; PROTECTIVE HELMETS FOR SPORTS, SNORKEL TUBES, SWIM MASKS, SWIM GOGGLES; EYEGASSES, SUNGLASSES, FRAMES AND CASES THEREFOR; VIDEO GAME CARTRIDGES, VIDEO GAME SOFTWARE; PROTECTIVE SLEEVES, COVERS AND CASES FOR CELL PHONES, LAPTOPS, TABLET COMPUTERS, DIGITAL CAMERAS (U.S. CLS. 21, 23, 26, 36 AND 38).

ANDREW RHIM, EXAMINING ATTORNEY

**CLASS 9—(Continued).**

SN 86-042,304. SYSTECH ELECTRONICS LTD., HONG KONG, HONG KONG, FILED 8-20-2013.

# D + Oi

PRIORITY CLAIMED UNDER SEC. 44(D) ON HONG KONG APPLICATION NO. 302708811, FILED 8-19-2013, REG. NO. 302708811, DATED 8-19-2013, EXPIRES 8-18-2023.

THE MARK CONSISTS OF THE WORDING "D+OI" IN A STYLIZED FORM.

FOR CAMERAS; CAMCORDERS; COMPUTER PERIPHERAL DEVICES; COMPUTER PROGRAMS FOR THE PURPOSE OF MANAGING WIRELESS LOCAL AREA NETWORKING CONNECTIONS WITH CONTROL AND IMAGE PROCESSING; ELECTRIC DOOR BELLS; GLOBAL POSITIONING SYSTEM APPARATUS; COMBINATION WIRELESS CONTROLLER AND NETWORK HUB USED TO MONITOR AND CONTROL THE FUNCTIONING OF OTHER WIRELESS ELECTRONIC DEVICES; ELECTRIC MEASURING DEVICES, NAMELY, HOME USE DEVICES AND CONSUMER USE DEVICES FOR MEASUREMENT OF POWER CONSUMPTION; MEASURING INSTRUMENTS, NAMELY, INSTRUMENTS FOR MEASURING TEMPERATURE, HUMIDITY AND POWER CONSUMPTION; COMPUTER MOUSE; ELECTRICAL CONTACTS, NAMELY, ELECTRIC PLUGS AND OUTLETS; SCANNERS; SOUND ALARMS (U.S. CLS. 21, 23, 26, 36 AND 38).

JOANNA DUKOVIC, EXAMINING ATTORNEY

---

SN 86-047,293. TENABLE NETWORK SECURITY, INC., COLUMBIA, MD. FILED 8-25-2013.

# LCE

THE MARK CONSISTS OF STANDARD CHARACTERS WITHOUT CLAIM TO ANY PARTICULAR FONT, STYLE, SIZE, OR COLOR.

SEC. 2(F).  
FOR COMPUTER NETWORK SECURITY SOFTWARE (U.S. CLS. 21, 23, 26, 36 AND 38).

FIRST USE 7-1-2006; IN COMMERCE 7-1-2006.

DOMINIC J. FERRAIUOLO, EXAMINING ATTORNEY



**CLASS 9—(Continued).**

SN 86-047,331. PLANT AUTOMATION SERVICES, INC., HOUSTON, TX. FILED 8-25-2013.

# Integrity

THE MARK CONSISTS OF STANDARD CHARACTERS WITHOUT CLAIM TO ANY PARTICULAR FONT, STYLE, SIZE, OR COLOR.

SEC. 2(F).  
FOR COMPUTER APPLICATION SOFTWARE FOR COMPUTERS IN INDUSTRIAL MANUFACTURING FACILITIES, NAMELY, SOFTWARE FOR USE IN DOCUMENTING THE DATABASES OF PROPRIETARY INDUSTRIAL DISTRIBUTED CONTROL SYSTEMS IN A PERSONAL COMPUTER; IT PROVIDES SEARCHES AND QUERIES THAT ENABLE A PROCESS PLANT ENGINEER TO QUICKLY AND ACCURATELY LOCATE CONTROL SYSTEMS RELATED INFORMATION, IDENTIFY DATA INTEGRITY ISSUES, MAP PROCESS EQUIPMENT, IDENTIFY AND ALLOCATE SYSTEM CAPACITY, DISCOVER UNKNOWN SYSTEM MODIFICATIONS, TRACK AND MANAGE PROCESS CHANGES, AND SUPPORT OSHA 1910.119 AND FDA CFR PART 11 REGULATIONS; IT ALSO IDENTIFIES CHANGES BETWEEN VARIOUS VERSIONS OF THE SAME DATABASE (U.S. CLS. 21, 23, 26, 36 AND 38).

FIRST USE 3-1-2006; IN COMMERCE 3-1-2006.  
SAMUEL E. SHARPER JR., EXAMINING ATTORNEY

---

SN 86-048,210. MONSTER, INC., BRISBANE, CA. FILED 8-26-2013.

# POWERCARD

THE MARK CONSISTS OF STANDARD CHARACTERS WITHOUT CLAIM TO ANY PARTICULAR FONT, STYLE, SIZE, OR COLOR.

FOR RECHARGEABLE POWERCELLS; BATTERY CHARGERS (U.S. CLS. 21, 23, 26, 36 AND 38).

CIMMERIAN COLEMAN, EXAMINING ATTORNEY

---

SN 86-049,757. HALBAUER, STEWART, BOCA RATON, FL. FILED 8-28-2013.

# RAYG

THE MARK CONSISTS OF THE LITERAL ELEMENTS "RAYG" WRITTEN IN STYLIZED FORM AND ATTACHED TO EACH OTHER.

FOR SUNGLASSES, DIFFRACTION GLASSES, OPTICAL GLASSES; OPTICAL LENSES; OPHTHALMIC LENSES; SPECTACLE LENSES (U.S. CLS. 21, 23, 26, 36 AND 38).

FIRST USE 8-13-2011; IN COMMERCE 2-28-2013.  
ZACHARY CROMER, EXAMINING ATTORNEY

**CLASS 9—(Continued).**

SN 86-054,756. SILVER SPRING NETWORKS, INC., REDWOOD CITY, CA. FILED 9-3-2013.

# SSNSOR

THE MARK CONSISTS OF STANDARD CHARACTERS WITHOUT CLAIM TO ANY PARTICULAR FONT, STYLE, SIZE, OR COLOR.

FOR COMPUTER SOFTWARE FOR ENABLING CONSUMERS, INCLUDING UTILITY AND INFRASTRUCTURE CUSTOMERS, TO TRACK, VIEW, AND MONITOR UTILITY AND INFRASTRUCTURE OPERATIONAL AND COMMODITY CONSUMPTION INFORMATION, NAMELY, INFORMATION RELATED TO USAGE ANALYSIS, COST ANALYSIS, BILL ANALYSIS, BILL ESTIMATION, ENERGY BUDGETING, NEIGHBORHOOD COMPARISONS, COMMUNITY ANALYSIS, ENVIRONMENTAL ANALYSIS, RATE COMPARISONS, WEATHER MODELING, AND HVAC MODELING, AS WELL AS TO RECEIVE RELATED REPORTS; COMPUTER HARDWARE; COMPUTER SOFTWARE AND NETWORKING EQUIPMENT, NAMELY, NETWORK HARDWARE AND SOFTWARE FOR DEVELOPING, SECURING, MONITORING, CONFIGURING AND MANAGING MACHINE TO MACHINE NETWORKS; COMPUTER SOFTWARE AND NETWORKING EQUIPMENT, NAMELY, NETWORK HARDWARE AND SOFTWARE FOR SECURING, MONITORING AND MANAGING ENERGY IN THE PUBLIC UTILITIES, GAS UTILITIES, ELECTRIC UTILITIES AND WATER UTILITIES INDUSTRIES AS WELL AS IN MANAGING OPERATIONAL AND COMMODITY INFORMATION IN THE UTILITY AND INFRASTRUCTURE INDUSTRIES; COMPUTER SOFTWARE AND NETWORKING EQUIPMENT, NAMELY, NETWORK HARDWARE AND SOFTWARE FOR DATA COLLECTION APPLICATIONS, NAMELY, DISTRIBUTION AUTOMATION AND DEMAND SIDE MANAGEMENT APPLICATIONS; COMMUNICATIONS NETWORKING SYSTEMS CONSISTING OF COMPUTER HARDWARE, WAN (WIDE AREA NETWORK) OPERATING SOFTWARE, AND SOFTWARE ENABLING CUSTOMERS TO COMMUNICATE WITH, MANAGE, CONFIGURE, PROVIDE SECURITY FOR, AND CONTROL IN HOME APPLIANCES AND ELECTRONIC DEVICES AND DISTRIBUTION AUTOMATION COMMUNICATIONS DEVICES; RADIO FREQUENCY WIRELESS COMMUNICATIONS TECHNOLOGY, NAMELY, NETWORK INTERFACE DEVICES, RELAYS, ACCESS POINTS, AND COMPUTER NETWORK BRIDGES; ONE-WAY AND TWO-WAY AUTOMATED METER READING DEVICES FOR USE IN THE ENERGY, UTILITY, PARKING, WATER TREATMENT, AND OTHER MUNICIPAL INFRASTRUCTURE FIELDS; COMPUTER HARDWARE AND SOFTWARE FOR USE IN TRANSMITTING DATA ONE-WAY AND TWO-WAY BETWEEN A DATA COMPUTING NETWORK AND REMOTE COMMUNICATIONS DEVICES, NAMELY, WIRELESS NETWORK REPEATERS, ROUTERS, PERSONAL COMPUTERS, LAPTOP COMPUTERS, CELLULAR PHONES AND HANDHELD COMPUTERS; ELECTRONIC INTERFACE MODULES FOR RECEIVING AND TRANSMITTING UTILITY AND INFRASTRUCTURE OPERATIONAL AND COMMODITY USAGE-RELATED INFORMATION AND REQUESTS BETWEEN AND AMONG COMMODITY METERS, ELECTRONIC VEHICLE CHARGING STATIONS, ELECTRONIC DEVICES AND A HOST COMPUTER OVER A WIDE AREA NETWORK AND A LOCAL AREA NETWORK; COMPUTER DATABASE MANAGEMENT SOFTWARE USED FOR RECEIVING AND MONITORING UTILITY AND INFRASTRUCTURE OPERATIONAL AND COMMODITY USAGE INFORMATION FROM MULTIPLE REMOTE COMMODITY METERS IN THE PUBLIC UTILITIES, GAS UTILITIES, ELECTRIC UTILITIES, WATER UTILITIES, AND INFRASTRUCTURE INDUSTRIES; ELECTRIC UTILITY METERS, NAMELY, GAS METERS, ELECTRIC METERS, AND WATER METERS; NETWORK INTERFACE CARDS; GATEWAY ROUTERS IN THE NATURE OF COMPUTER CONTROL HARDWARE; ELECTRONIC

**CLASS 9—(Continued).**

DEVICES, NAMELY, RADIO FREQUENCY REPEATERS USED IN LONG RANGE COMMUNICATION FOR TRACKING AND MONITORING UTILITY AND INFRASTRUCTURE OPERATIONAL AND COMMODITY USAGE AND ADVANCED METER READING DATA; ADVANCED METER COMMUNICATIONS DEVICES, NAMELY, TRANSMITTERS, RECEIVERS AND ANTENNAS USED TO COLLECT, STORE AND PROCESS CONSUMPTION DATA, DISTRIBUTION AUTOMATION DATA, DEMAND RESPONSE DATA AND OTHER INFORMATION IN THE UTILITY AND INFRASTRUCTURE FIELDS; COMPUTER INTERFACE BOARDS; COMPUTER NETWORK INTERFACE DEVICES; INTERFACE CARDS FOR DATA PROCESSING EQUIPMENT IN THE FORM OF PRINTED CIRCUITS; INTERFACES AND PERIPHERAL DEVICES FOR COMPUTERS; INTERFACES FOR COMPUTERS; INTERFACES FOR METERS; PERIPHERAL COMPONENT INTERFACE (PCI) HARDWARE; UPI (UNIVERSAL PERIPHERAL INTERFACE) HARDWARE (U.S. CLS. 21, 23, 26, 36 AND 38).

APRIL REEVES, EXAMINING ATTORNEY

**CLASS 9—(Continued).**

SN 86-058,698. BEERSEEKER LLC, SEATTLE, WA. FILED 9-8-2013.

**BEERSEEKER**

THE MARK CONSISTS OF STANDARD CHARACTERS WITHOUT CLAIM TO ANY PARTICULAR FONT, STYLE, SIZE, OR COLOR.

FOR SOFTWARE THAT PROVIDES WEB BASED ACCESS THROUGH A MOBILE APP OR A PORTAL INTERFACE TO APPLICATIONS AND SERVICES FOR THE BEER INDUSTRY AND THE WINE INDUSTRY AND FOR PEOPLE WHO CONSUME BEER AND WINE (U.S. CLS. 21, 23, 26, 36 AND 38).

NATALIE KENEALY, EXAMINING ATTORNEY

SN 86-058,356. RICOH INNOVATIONS CORPORATION, MENLO PARK, CA. FILED 9-6-2013.



THE MARK CONSISTS OF AN UPRIGHT TRIANGLE WITH ROUNDED CORNERS AND INSIDE IS A DESIGN OF A MAGNIFYING GLASS WITH AN OFFSET, SMALL CIRCLE INSIDE OF THE LENS.

FOR COMPUTER SOFTWARE DEVELOPMENT TOOLS; COMPUTER SOFTWARE, NAMELY, SOFTWARE DEVELOPMENT TOOLS FOR THE CREATION OF VISUAL SEARCH FUNCTIONALITY INTO OTHER COMPUTER SOFTWARE; COMPUTER SOFTWARE THAT ALLOWS FOR VISUAL SEARCH FUNCTIONALITY; COMPUTER VISUAL SEARCH ENGINE SOFTWARE (U.S. CLS. 21, 23, 26, 36 AND 38).

FIRST USE 6-28-2013; IN COMMERCE 6-28-2013.

CHRISTOPHER BUONGIORNO, EXAMINING ATTORNEY

SN 86-059,617. BROTHER INDUSTRIES, LTD., NAGOYA-SHI 467-8561, JAPAN, FILED 9-9-2013.



PRIORITY CLAIMED UNDER SEC. 44(D) ON JAPAN APPLICATION NO. 2013-059871, FILED 8-1-2013, REG. NO. 5637898, DATED 12-20-2013, EXPIRES 12-20-2023.

THE COLOR(S) BLUE, WHITE AND GRAY IS/ARE CLAIMED AS A FEATURE OF THE MARK.

THE MARK CONSISTS OF A DESIGN DEPICTING A BLUE SQUARE WITH A WHITE DOCUMENT DISPLAYED ON ONE SIDE, A WHITE PENCIL DISPLAYED ON ANOTHER SIDE AND A WHITE CLOUD DISPLAYED ON THE TOP, WITH GRAY SHADING BELOW THE SQUARE.

FOR PRINTERS; FACSIMILE MACHINES; PHOTOCOPYING MACHINES; MULTIFUNCTION ELECTRONIC DEVICES FOR USE IN COPYING, PRINTING, SCANNING, VIDEO CAPTURING AND/OR TRANSMITTING DOCUMENTS AND IMAGES; COMPUTER SOFTWARE FOR PROCESSING DIGITAL IMAGES; DOWNLOADABLE COMPUTER SOFTWARE FOR DATA PROCESSING FOR USE WITH PRINTERS, PHOTOCOPYING MACHINES, FACSIMILE MACHINES, AND MULTIFUNCTION ELECTRONIC DEVICES FOR USE IN PRINTING, COPYING, SCANNING, VIDEO CAPTURING AND/OR TRANSMITTING DOCUMENTS AND IMAGES; DOWNLOADABLE COMPUTER SOFTWARE FOR DATA PROCESSING FOR USE WITH SCANNERS; SCANNERS (U.S. CLS. 21, 23, 26, 36 AND 38).

FIRST USE 7-7-2013; IN COMMERCE 7-7-2013.

INGRID C. EULIN, EXAMINING ATTORNEY

**CLASS 9—(Continued).**

SN 86-060,501. POWERIT SOLUTIONS, LLC, SEATTLE, WA.  
FILED 9-10-2013.

## SPARA DEMAND DIAGNOSTICS

THE MARK CONSISTS OF STANDARD CHARACTERS WITHOUT CLAIM TO ANY PARTICULAR FONT, STYLE, SIZE, OR COLOR.

OWNER OF U.S. REG. NOS. 3,790,860 AND 3,796,505.

NO CLAIM IS MADE TO THE EXCLUSIVE RIGHT TO USE "DEMAND DIAGNOSTICS", APART FROM THE MARK AS SHOWN.

THE ENGLISH TRANSLATION OF "SPARA" IN THE MARK IS "SAVE".

FOR ENERGY MANAGEMENT SYSTEMS COMPRISING ELECTRICAL CONTROLLERS, COMPUTER PERIPHERALS, NAMELY, REMOTE INPUT/OUTPUT DEVICES, AND COMMUNICATION DEVICES, NAMELY, COMMUNICATIONS SERVERS AND SOFTWARE FOR ANALYZING, EVALUATING, IMPLEMENTING, MONITORING AND CONTROLLING ENERGY DEMAND AND CONSUMPTION, INCLUDING ELECTRICAL ENERGY DEMAND AND CONSUMPTION IN COMMERCIAL AND INDUSTRIAL SETTINGS (U.S. CLS. 21, 23, 26, 36 AND 38).

FIRST USE 2-5-2013; IN COMMERCE 3-0-2013.

CIMMERIAN COLEMAN, EXAMINING ATTORNEY

SN 86-062,973. DAVID G. WILDE, HOUSTON, TX. FILED 9-12-2013.

## THE GUZZLERS

THE MARK CONSISTS OF STANDARD CHARACTERS WITHOUT CLAIM TO ANY PARTICULAR FONT, STYLE, SIZE, OR COLOR.

OWNER OF U.S. REG. NOS. 4,383,923 AND 4,383,948.

FOR PRE-RECORDED CDS AND DOWNLOADABLE AUDIO AND VIDEO RECORDINGS FEATURING MUSICAL PERFORMANCES (U.S. CLS. 21, 23, 26, 36 AND 38).

MATTHEW EINSTEIN, EXAMINING ATTORNEY

**CLASS 9—(Continued).**

SN 86-064,090. UNIVERSAL LOGIC, LLC, NASHVILLE, TN.  
FILED 9-13-2013.

## UNIVERSAL LOGIC

THE MARK CONSISTS OF STANDARD CHARACTERS WITHOUT CLAIM TO ANY PARTICULAR FONT, STYLE, SIZE, OR COLOR.

NO CLAIM IS MADE TO THE EXCLUSIVE RIGHT TO USE "LOGIC", APART FROM THE MARK AS SHOWN.

FOR COMPUTER SOFTWARE AND RELATED FIRMWARE THAT AUTOMATES INTELLIGENCE, PROVIDES SELF-LEARNING, AND SYNTHESIZES SYSTEM SENSOR DATA, DATA OR MACHINE PROCESSING, AND COMMUNICATIONS IN AN ADVANCED FRAMEWORK, IN ORDER TO ADAPT TO SITUATIONS, DIAGNOSE PHENOMENA, DISCOVER ANOMALIES OR PATTERNS, CONTROL MACHINES AND EQUIPMENT, MAKE DECISIONS, AND MONITOR ACTIVITY, FOR USE IN A WIDE VARIETY OF MECHANICAL, PHYSICAL, BIOLOGICAL, COGNITIVE, OR SOCIAL FIELDS THAT HAVE PHYSICAL OR VIRTUAL CYBERNETIC PROCESSES (U.S. CLS. 21, 23, 26, 36 AND 38).

ANGELA M. MICHELI, EXAMINING ATTORNEY

SN 86-064,199. M.H. CORBIN, INC., PLAIN CITY, OH. FILED 9-13-2013.

## INTELLIZONE

THE MARK CONSISTS OF STANDARD CHARACTERS WITHOUT CLAIM TO ANY PARTICULAR FONT, STYLE, SIZE, OR COLOR.

OWNER OF U.S. REG. NO. 3,442,336.

FOR MOBILE COMMUNICATIONS SYSTEMS, NAMELY, PORTABLE TRAFFIC SENSORS USED TO MEASURE TRAFFIC VOLUME AND SPEED, A MOBILE CONTROL UNIT THAT IS MOUNTED ON A TRAILER, AND A VARIABLE ELECTRONIC MESSAGE SIGN (U.S. CLS. 21, 23, 26, 36 AND 38).

JULIE WATSON, EXAMINING ATTORNEY

**CLASS 9—(Continued).**

SN 86-064,630. NOHSN CO., LTD., JEOLLABUK-DO, REPUBLIC OF KOREA, FILED 9-13-2013.

# NOHSN

THE MARK CONSISTS OF STANDARD CHARACTERS WITHOUT CLAIM TO ANY PARTICULAR FONT, STYLE, SIZE, OR COLOR.

FOR PROGRAMMABLE LOGIC CONTROLLER (PLC); HEAT DETECTION SYSTEMS COMPRISED PRIMARILY OF ULTRASOUND HEAT DETECTORS; BATTERY CHARGE DEVICES; ELECTRIC CONTROL PANELS; RESISTANCE MEASURING INSTRUMENTS; NOTEBOOK COMPUTERS; MICROPROCESSORS; SEMICONDUCTORS; COMPUTER CENTRAL PROCESSING UNITS; INTEGRATED CIRCUITS; DNA CHIPS; AIR ANALYSIS APPARATUS; ACCELERATION SENSORS; RANGE FINDERS; METAL DETECTORS; TEMPERATURE SENSORS; ELECTRIC CONTROLLING DEVICES FOR POWER SUPPLY MANAGEMENT; PHOTOVOLTAIC CELLS; ELECTROMAGNETIC APPARATUS USED TO GENERATE OR MEASURE MAGNETIC FIELDS; DIGITAL MULTIMETERS; ANALOG MULTIMETERS; WAVEMETERS; APPARATUS FOR TRANSMITTING AND REPRODUCING SOUND OR IMAGES; ELECTRONIC APPARATUS FOR THE REMOTE CONTROL OF INDUSTRIAL OPERATIONS; REMOTE CONTROLS FOR MEDICAL EQUIPMENT AND COMPUTER SYSTEMS, AND MONITORS; APPARATUS FOR WIRELESS TRANSMISSION OF ACOUSTIC INFORMATION; MOBILE PHONES; COMPUTER APPLICATION SOFTWARE FOR MOBILE PHONES FOR MEDICAL IMAGING AND COLLECTING, STORING AND SEARCHING PATIENT MEDICAL INFORMATION; COMPUTER SOFTWARE FOR MEDICAL IMAGING AND COLLECTING, STORING AND SEARCHING PATIENT MEDICAL INFORMATION; SONAR; ULTRASONIC SENSORS; TABLET COMPUTER; COMMUNICATIONS COMPUTERS; MICRO PROCESSORS; HOLOGRAM APPARATUS; PRINTED CIRCUIT BOARDS; ELECTRICAL CIRCUIT BOARDS; INTEGRATED CIRCUIT MODULES; ELECTRONIC CHIPS FOR THE MANUFACTURER OF INTEGRATED CIRCUITS (U.S. CLS. 21, 23, 26, 36 AND 38).

ELLEN PERKINS, EXAMINING ATTORNEY

SN 86-066,831. SAMSUNG ELECTRO-MECHANICS CO., LTD., SUWON-SI, KYUNGKI-DO, REPUBLIC OF KOREA, FILED 9-17-2013.

## Starry Night Camera

THE MARK CONSISTS OF STANDARD CHARACTERS WITHOUT CLAIM TO ANY PARTICULAR FONT, STYLE, SIZE, OR COLOR.

PRIORITY CLAIMED UNDER SEC. 44(D) ON REPUBLIC OF KOREA APPLICATION NO. 40-2013-0043, FILED 7-2-2013, REG. NO. 1031533, DATED 4-7-2014, EXPIRES 7-7-2024.

NO CLAIM IS MADE TO THE EXCLUSIVE RIGHT TO USE "CAMERA", APART FROM THE MARK AS SHOWN.

FOR CAMERAS; CAMERA MODULES; MULTIPLE PURPOSE CAMERAS; WEBCAM; TV CAMERAS; CAMERAS FOR CCTVS; DIGITAL CAMERAS; CAMERAS FOR VEHICLES; CAMERA MODULES FOR MOBILE TELEPHONES; CAMERA MODULES FOR COMPUTERS (U.S. CLS. 21, 23, 26, 36 AND 38).

PAUL E. FAHRENKOPF, EXAMINING ATTORNEY

**CLASS 9—(Continued).**

SN 86-067,251. LUCEY CORPORATION, ST. PETERSBURG, FL. FILED 9-17-2013.

# BEAM

THE MARK CONSISTS OF STANDARD CHARACTERS WITHOUT CLAIM TO ANY PARTICULAR FONT, STYLE, SIZE, OR COLOR.

FOR SOFTWARE FOR MONITORING AND AUTOMATICALLY CORRECTING ERROR CONDITIONS IN OTHER SOFTWARE SYSTEMS (U.S. CLS. 21, 23, 26, 36 AND 38).

FIRST USE 4-22-2013; IN COMMERCE 4-22-2013.  
DONALD JOHNSON, EXAMINING ATTORNEY

SN 86-068,437. CELLCO PARTNERSHIP, DBA VERIZON WIRELESS, BASKING RIDGE, NJ. FILED 9-18-2013.

# SWIVEO

THE MARK CONSISTS OF STANDARD CHARACTERS WITHOUT CLAIM TO ANY PARTICULAR FONT, STYLE, SIZE, OR COLOR.

FOR WIRELESS TELECOMMUNICATIONS DEVICE FEATURING TRANSMISSION OF VOICE, DATA, IMAGE AND VIDEO, INCLUDING VOICE, TEXT, PICTURE AND VIDEO MESSAGING, INTERNET ACCESS, ACCESS TO NAVIGATION AND DIRECTIONAL SERVICE OVER THE AIR, THE ABILITY TO DOWNLOAD MUSIC, VIDEOS AND APPLICATIONS OVER THE AIR, AND WHICH HAS A MUSIC PLAYER AND A STILL IMAGE AND VIDEO CAMERA; TABLET COMPUTERS; WIRELESS COMMUNICATIONS DEVICE FOR ESTABLISHING A LOCAL WIRELESS NETWORK; USB MODEMS; AUDIO HEADSETS AND EARPHONES; DOCKING STATIONS FOR ELECTRONIC DEVICES; CAR MOUNTS FOR ELECTRONIC DEVICES; PHONE CHARGERS; BATTERY CHARGERS; CELL PHONE AND TABLET COMPUTER CASES; CELL PHONE HOLSTERS; TELECOMMUNICATION ROUTERS; ANTI-GLARE PHONE DISPLAY PROTECTORS; ANTI-SCRATCH PHONE DISPLAY PROTECTORS; WIRELESS AND MOBILE AUDIO SPEAKERS (U.S. CLS. 21, 23, 26, 36 AND 38).

FONG HSU, EXAMINING ATTORNEY

**CLASS 9—(Continued).**

SN 86-070,749. THE LAUNDRY CHUTE LLC, PALM BEACH GARDENS, FL. FILED 9-20-2013.

**THE LAUNDRY CHUTE**

THE MARK CONSISTS OF STANDARD CHARACTERS WITHOUT CLAIM TO ANY PARTICULAR FONT, STYLE, SIZE, OR COLOR.

FOR MOBILE APPLICATION AND WEB-BASED APPLICATION SOFTWARE FOR ENABLING INDEPENDENT LAUNDRY AND DRY CLEANING SERVICE PROVIDERS TO MANAGE CUSTOMERS AND WORKLOAD FOR THE COLLEGE, INSTITUTIONAL, AND HOSPITALITY MARKETS, INCLUDING REAL-TIME TRACKING OF WORK ORDER STATUS, PROCESSING OUTPUT, AND STAFFING (U.S. CLS. 21, 23, 26, 36 AND 38).

LINDA MICKLEBURGH, EXAMINING ATTORNEY

**CLASS 9—(Continued).**

SN 86-071,969. AGCO CORPORATION, DULUTH, GA. FILED 9-23-2013.

**TASKDOC**

THE MARK CONSISTS OF STANDARD CHARACTERS WITHOUT CLAIM TO ANY PARTICULAR FONT, STYLE, SIZE, OR COLOR.

FOR DOCUMENTATION MANAGEMENT SYSTEM, COMPRISED PRIMARILY OF COMPUTER HARDWARE AND SOFTWARE, THAT ENABLES FILE TRANSFER BETWEEN AGRICULTURAL MACHINES AND THE BACK OFFICE, ACCURATE DOCUMENTATION OF FIELD DATA AND RECORDS, EASY TASK DATA EXCHANGE VIA CELLULAR OR OTHER WIRELESS MEANS OF DATA TRANSFER (U.S. CLS. 21, 23, 26, 36 AND 38).

CYNTHIA RINALDI, EXAMINING ATTORNEY

SN 86-071,067. XENON CORPORATION, WILMINGTON, MA. FILED 9-20-2013.

**SINTERON**

THE MARK CONSISTS OF STANDARD CHARACTERS WITHOUT CLAIM TO ANY PARTICULAR FONT, STYLE, SIZE, OR COLOR.

FOR ELECTRONIC APPARATUS, NAMELY, PULSED LIGHT SYSTEM COMPOSED PRIMARILY OF A HIGH POWER XENON FLASH LAMP, OPTICAL REFLECTOR, HIGH VOLTAGE CAPACITOR BANK, POWER SUPPLY, CONTROL ELECTRONICS AND COMPUTER SOFTWARE FOR MELTING METALLIC NANOPARTICLES INTO CONDUCTIBLE MATERIAL FOR USE IN THE ELECTRONICS INDUSTRY TO FABRICATE CIRCUIT BOARDS AND CIRCUIT BOARD ELECTRONIC COMPONENTS (U.S. CLS. 21, 23, 26, 36 AND 38).

FIRST USE 7-17-2013; IN COMMERCE 7-17-2013.  
MARY ROSSMAN, EXAMINING ATTORNEY

SN 86-072,378. DHS SYSTEMS LLC, ORANGEBURG, NY. FILED 9-23-2013.

**DRASH**

THE MARK CONSISTS OF STANDARD CHARACTERS WITHOUT CLAIM TO ANY PARTICULAR FONT, STYLE, SIZE, OR COLOR.

OWNER OF U.S. REG. NO. 2,347,223.  
FOR PROJECTOR SYSTEMS COMPRISED OF MULTIMEDIA PROJECTORS, SNAP ON VINYL PROJECTION SURFACES, ALUMINUM FRAMEWORKS TO SUPPORT THE PROJECTORS AND PROJECTION SURFACES, VIDEO AND POWER CABLES, AND AUDIO-VISUAL SWITCHING SYSTEMS COMPRISED OF TOUCH PANEL CONTROL SYSTEMS, GRAPHICAL USER INTERFACE SOFTWARE FOR CONTROLLING INTEGRATED SYSTEM SUBCOMPONENTS, AUDIO MATRIX MIXER, MULTI-WINDOW DIGITAL SIGNAL PROCESSORS, VIDEO MATRIX SWITCHER, AUDIO SPEAKERS, VIDEO TRANSMITTERS AND RECEIVERS AND TRANSPORT CASES, BOTH FOR FUSING MULTIPLE FEEDS OF INFORMATION ON TO SINGLE OR MULTIPLE DISPLAYS (U.S. CLS. 21, 23, 26, 36 AND 38).

FIRST USE 9-0-2005; IN COMMERCE 9-0-2005.  
LUCY ARANT, EXAMINING ATTORNEY

**CLASS 9—(Continued).**

SN 86-072,454. STRATEGIC PARTNERS, INC., CHATSWORTH, CA. FILED 9-23-2013.

# Curo

THE MARK CONSISTS OF STANDARD CHARACTERS WITHOUT CLAIM TO ANY PARTICULAR FONT, STYLE, SIZE, OR COLOR.

THE ENGLISH TRANSLATION OF "CURO" IN THE MARK IS "TO HEAL".

FOR FACE-PROTECTION SHIELDS; PROTECTIVE EYEWEAR (U.S. CLS. 21, 23, 26, 36 AND 38).

DANNEAN HETZEL, EXAMINING ATTORNEY

---

SN 86-072,495. SUNTIGER, INC., CALABASAS, CA. FILED 9-23-2013.

# VET SPECS

THE MARK CONSISTS OF STANDARD CHARACTERS WITHOUT CLAIM TO ANY PARTICULAR FONT, STYLE, SIZE, OR COLOR.

NO CLAIM IS MADE TO THE EXCLUSIVE RIGHT TO USE "SPECS", APART FROM THE MARK AS SHOWN.

FOR EYEGLASS FRAMES; EYEGLASS LENSES; EYEGLASSES; EYEWEAR; PROTECTIVE EYEWEAR; SPECTACLES; SPORTS EYEWEAR; SUNGLASS LENSES; SUNGLASSES (U.S. CLS. 21, 23, 26, 36 AND 38).

GIANCARLO CASTRO, EXAMINING ATTORNEY

---

SN 86-074,877. ZOWEE MARKETING CO. LTD., FO TAN SHATIN NT, HONG KONG, FILED 9-25-2013.



THE COLOR(S) BLACK AND YELLOW IS/ARE CLAIMED AS A FEATURE OF THE MARK.

THE MARK CONSISTS OF THE WORD "NOBIS" IN BLACK AND YELLOW. THE LETTERS "N", "B", PART OF THE "I", AND "S" ARE IN BLACK AND THE "O" AND DOT ABOVE THE LETTER "I" ARE IN YELLOW.

FOR TABLET COMPUTER (U.S. CLS. 21, 23, 26, 36 AND 38).

THEODORE MCBRIDE, EXAMINING ATTORNEY

**CLASS 9—(Continued).**

SN 86-074,993. LYNDA WARD PIERCE, SAN FRANCISCO, CA. FILED 9-25-2013.

# CompSavvy

THE MARK CONSISTS OF STANDARD CHARACTERS WITHOUT CLAIM TO ANY PARTICULAR FONT, STYLE, SIZE, OR COLOR.

FOR BUSINESS SOFTWARE FOR MANAGING, ORGANIZING, ANALYZING, COLLECTING, PRESENTING, AND ADMINISTERING HUMAN RESOURCE DATA, BENEFITS DATA, TAX DATA, AND PAYROLL DATA FOR INDIVIDUALS AND ENTITIES FOR HUMAN RESOURCE PURPOSES, PAYROLL PREPARATION AND PROCESSING, COMPENSATION MANAGEMENT, BENEFITS ADMINISTRATION, AND FOR TAX PLANNING (U.S. CLS. 21, 23, 26, 36 AND 38).

ANDREW LEASER, EXAMINING ATTORNEY

---

SN 86-075,166. PIERCE MANUFACTURING INC., APPLETON, WI. FILED 9-26-2013.

# HAWK EXTREME

THE MARK CONSISTS OF STANDARD CHARACTERS WITHOUT CLAIM TO ANY PARTICULAR FONT, STYLE, SIZE, OR COLOR.

FOR CHASSIS FOR LAND VEHICLES SPECIFICALLY ADAPTED AND EQUIPPED FOR FIREFIGHTING (U.S. CLS. 21, 23, 26, 36 AND 38).

JUDITH HELFMAN, EXAMINING ATTORNEY

---

SN 86-076,331. KOSLOFF, STEPHEN, BROOKLYN, NY. FILED 9-27-2013.

# HAUSFRAU

THE MARK CONSISTS OF STANDARD CHARACTERS WITHOUT CLAIM TO ANY PARTICULAR FONT, STYLE, SIZE, OR COLOR.

THE ENGLISH TRANSLATION OF "HAUSFRAU" IN THE MARK IS "HOUSE WIFE".

FOR DOWNLOADABLE MOBILE APPLICATION FEATURING A SERIES OF STORYTELLING MAGAZINES OF FICTIONAL SATIRE TARGETED TO THE GENERAL PUBLIC, NOT RELATING TO HOUSEWIVES AS A SUBJECT MATTER AND NOT SPECIFICALLY TARGETED TO HOUSEWIVES AS THE INTENDED AUDIENCE (U.S. CLS. 21, 23, 26, 36 AND 38).

FIRST USE 9-24-2013; IN COMMERCE 9-24-2013.

LAURIE MAYES, EXAMINING ATTORNEY

**CLASS 9—(Continued).**

SN 86-077,135. SECURITY FIRST CORP., DBA SECURITY FIRST, RANCHO SANTA MARGARITA, CA. FILED 9-27-2013.

**SPx**

THE MARK CONSISTS OF STANDARD CHARACTERS WITHOUT CLAIM TO ANY PARTICULAR FONT, STYLE, SIZE, OR COLOR.

FOR COMPUTER SOFTWARE AND FIRMWARE FOR DATA PROTECTION AND HIGH AVAILABILITY (U.S. CLS. 21, 23, 26, 36 AND 38).

MICHAEL SOUDERS, EXAMINING ATTORNEY

**CLASS 9—(Continued).**

SN 86-078,009. NGW LLC, WASHINGTON, DC. FILED 9-30-2013.

**T.T. TOPPERZ**

THE MARK CONSISTS OF STANDARD CHARACTERS WITHOUT CLAIM TO ANY PARTICULAR FONT, STYLE, SIZE, OR COLOR.

FOR DECORATIVE RECORD PLAYER ACCESSORIES, NAMELY, ORNAMENTS SPECIALLY ADAPTED FOR RECORD PLAYER SPINDLES AND PLATTERS (U.S. CLS. 21, 23, 26, 36 AND 38).

HAI-LY LAM, EXAMINING ATTORNEY

SN 86-077,369. AOL INC., DULLES, VA. FILED 9-27-2013.

**GROUPSYNC**

THE MARK CONSISTS OF STANDARD CHARACTERS WITHOUT CLAIM TO ANY PARTICULAR FONT, STYLE, SIZE, OR COLOR.

FOR DOWNLOADABLE MOBILE APPLICATION FOR USE IN CREATING AND SHARING CALENDARS AND SCHEDULES, IDENTIFYING GEOGRAPHICAL LOCATIONS, CUSTOMIZED MAPPING, MAP DISPLAY, DRIVING DIRECTIONS, AND MESSAGING (U.S. CLS. 21, 23, 26, 36 AND 38).

LINDA LAVACHE, EXAMINING ATTORNEY

SN 86-078,510. JBRL LLC, IRVINE, CA. FILED 9-30-2013.

**IN THE POOL**

THE MARK CONSISTS OF STANDARD CHARACTERS WITHOUT CLAIM TO ANY PARTICULAR FONT, STYLE, SIZE, OR COLOR.

FOR DOWNLOADABLE COMPUTER SOFTWARE GAME FEATURING AN INTERACTIVE GAME OF CHANCE USING IDENTIFIABLE EVENTS, OCCURRENCES, OR MILESTONES DURING THE PLAY OF AN ACTUAL SPORTING EVENT FOR ENTERTAINMENT PURPOSES AT PARTIES, ASSEMBLIES, OR GATHERINGS (U.S. CLS. 21, 23, 26, 36 AND 38).

FIRST USE 5-13-2011; IN COMMERCE 5-13-2011.  
PATRICIA EVANKO, EXAMINING ATTORNEY

SN 86-077,937. VISTA, RIO DE JANEIRO, BRAZIL, FILED 9-30-2013.

**niivo**

THE MARK CONSISTS OF STANDARD CHARACTERS WITHOUT CLAIM TO ANY PARTICULAR FONT, STYLE, SIZE, OR COLOR.

THE WORDING "NIIVO" HAS NO MEANING IN A FOREIGN LANGUAGE.

FOR CELLULAR PHONES; MOBILE PHONES; TELEPHONES (U.S. CLS. 21, 23, 26, 36 AND 38).

ALEX KEAM, EXAMINING ATTORNEY

SN 86-079,139. MARTIN, PHILLIP ALAN, DBA SODANCEA-BIT, LOS ALAMITOS, CA. FILED 10-1-2013.

**STEP INTO FITNESS**

THE MARK CONSISTS OF STANDARD CHARACTERS WITHOUT CLAIM TO ANY PARTICULAR FONT, STYLE, SIZE, OR COLOR.

NO CLAIM IS MADE TO THE EXCLUSIVE RIGHT TO USE "FITNESS", APART FROM THE MARK AS SHOWN.

FOR DIGITAL MATERIALS, NAMELY, PRE-RECORDED VIDEO CASSETTES, MUSIC CASSETTES, CDS AND DVDS FEATURING DANCE, DANCE INSTRUCTION, FITNESS AND MUSIC FOR DANCE AND FITNESS (U.S. CLS. 21, 23, 26, 36 AND 38).

FIRST USE 5-7-1988; IN COMMERCE 5-7-1988.  
BRITTANY ESTELL, EXAMINING ATTORNEY

**CLASS 9—(Continued).**

SN 86-079,145. GLENAIR, INC., GLENDALE, CA. FILED 10-1-2013.

# Eye-Beam

THE MARK CONSISTS OF STANDARD CHARACTERS WITHOUT CLAIM TO ANY PARTICULAR FONT, STYLE, SIZE, OR COLOR.

FOR FIBER OPTIC CONNECTORS (U.S. CLS. 21, 23, 26, 36 AND 38).

FIRST USE 11-20-2011; IN COMMERCE 11-20-2011.

MARC LEIPZIG, EXAMINING ATTORNEY

**CLASS 9—(Continued).**

SN 86-080,337. HANCOCK, CHRISTOPHER R, PALM SPRINGS, CA. FILED 10-2-2013.



NO CLAIM IS MADE TO THE EXCLUSIVE RIGHT TO USE "MEDICAL IMAGES", APART FROM THE MARK AS SHOWN.

THE COLOR(S) BLUE, WHITE, GREEN AND GRAY IS/ARE CLAIMED AS A FEATURE OF THE MARK.

THE MARK CONSISTS OF THE WORDING "MYMED-IMAGE MEDICAL IMAGES FOR EVERYONE" THE IMAGE OF A GREEK CROSS FORMED BY TWO GREEN SQUARES AND A BLUE SHEET OF PAPER WITH WHITE OUT-LINING. "MY" AND "IMAGE" APPEAR IN BLUE, "MED" APPEARS IN GREEN, AND "MEDICAL IMAGES FOR EVERYONE" APPEARS IN GRAY.

FOR MEDICAL SOFTWARE FOR UPLOADING, PROCESSING, ARCHIVING, TRANSMITTING, DOWNLOADING, DIAGNOSING, AND CONSULTING MEDICAL IMAGE STUDIES THROUGH MEDICAL IMAGE NETWORKS AND EMRS (U.S. CLS. 21, 23, 26, 36 AND 38).

FIRST USE 5-7-2008; IN COMMERCE 10-22-2012.

SEAN CROWLEY, EXAMINING ATTORNEY

SN 86-080,072. ZHAI, HONGSHENG, MANLIUS, NY. FILED 10-1-2013.

# i-Ever

THE MARK CONSISTS OF STANDARD CHARACTERS WITHOUT CLAIM TO ANY PARTICULAR FONT, STYLE, SIZE, OR COLOR.

FOR MOBILE DEVICE ACCESSORIES, NAMELY, EXTERNAL BATTERIES AND BATTERY CHARGERS FOR MOBILE PHONES, MOBILE PHONE CASES, MOBILE PHONE CABLES AND ADAPTERS; COMPUTER APPLICATION SOFTWARE FOR MOBILE DEVICES, NAMELY, WIRELESS EARPHONES, ELECTRONIC LOCKS, AND WIRELESS CAMERAS, FOR USE IN ELECTRONIC STORAGE OF DATA (U.S. CLS. 21, 23, 26, 36 AND 38).

FIRST USE 7-1-2013; IN COMMERCE 7-1-2013.

TEJBIR SINGH, EXAMINING ATTORNEY

SN 86-082,320. OLSEN, JUSTIN BENNETT, BURBANK, CA. FILED 10-3-2013.

# wormwood

THE MARK CONSISTS OF STANDARD CHARACTERS WITHOUT CLAIM TO ANY PARTICULAR FONT, STYLE, SIZE, OR COLOR.

SEC. 2(F).

FOR (BASED ON USE) DIGITAL MEDIA, NAMELY, MUSICAL AUDIO RECORDINGS, DOWNLOADABLE MUSICAL AUDIO RECORDINGS, AUDIOVISUAL RECORDINGS FEATURING MUSIC AND MUSICAL ENTERTAINMENT, DOWNLOADABLE RINGTONES AND GRAPHICS FOR MOBILE PHONES AND WIRELESS DEVICES; (BASED ON INTENT TO USE) DOWNLOADABLE AUDIOVISUAL RECORDINGS, DOWNLOADABLE ELECTRONIC SHEET MUSIC (U.S. CLS. 21, 23, 26, 36 AND 38).

FIRST USE 11-24-2007; IN COMMERCE 11-24-2007.

PATRICIA EVANKO, EXAMINING ATTORNEY



**CLASS 9—(Continued).**

SN 86-082,656. SAMSUNG ELECTRONICS CO., LTD., SUWON-SI, GYEONGGI-DO, REPUBLIC OF KOREA, FILED 10-4-2013.

**SAMSUNG DREAM**

THE MARK CONSISTS OF STANDARD CHARACTERS WITHOUT CLAIM TO ANY PARTICULAR FONT, STYLE, SIZE, OR COLOR.

OWNER OF ERPN CMNTY TM OFC REG. NO. 012194163, DATED 2-17-2014, EXPIRES 3-10-2023.

THE ENGLISH TRANSLATION OF THE WORD "SAMSUNG" IN THE MARK IS "THREE STARS".

FOR COMPUTER SOFTWARE FOR ENCODING AND DECODING OF VOICE AND AUDIO SIGNALS; ANALOG AND DIGITAL SOUND ENHANCING SOFTWARE FOR PROCESSING, RECORDING, CAPTURING, RECEIVING, TRANSMITTING, RENDERING AND STORING VOICE AND AUDIO SIGNALS, FILES AND SOUNDS; AUDIO AMPLIFIERS; AUDIO SPEAKERS; BLANK UNIVERSAL SERIAL BUS (USB) FLASH MEMORY DRIVE; BUILT-IN WIRELESS AUDIO AND VIDEO RECEIVERS AND ELECTRONIC DOCKING STATIONS FOR USE WITH ELECTRONIC BOOK READERS, TABLET COMPUTERS, MP3 PLAYERS, MP4 PLAYERS, MOBILE PHONES AND SMART PHONES; CAMCORDERS; COMPUTER AND MOBILE DEVICE SOFTWARE TO PERSONALIZE WIDGETS AND MOBILE APPLICATIONS; COMPUTER APPLICATION SOFTWARE FOR MOBILE PHONES, PORTABLE MEDIA PLAYERS AND HANDHELD COMPUTERS, NAMELY, SOFTWARE FOR USE IN VOICE RECOGNITION; COMPUTER GAME SOFTWARE; COMPUTER MONITORS; COMPUTER NETWORK HUBS, SWITCHES AND ROUTERS; COMPUTER SOFTWARE EMBEDDED ON PORTABLE PHONES AND/OR PORTABLE COMPUTERS THAT ALLOWS USERS TO PLAY AND DOWNLOAD ELECTRONIC GAMES, LISTEN TO AND DOWNLOAD RING TONES AND MUSIC, AND VIEW AND DOWNLOAD SCREEN SAVERS AND WALLPAPERS; COMPUTER SOFTWARE FOR CONTROLLING HOME APPLIANCES; COMPUTER SOFTWARE FOR INSTANT MESSAGING, SENDING AND RECEIVING EMAILS AND CONTACT INFORMATION, SCHEDULE SHARING AND CONTENTS SHARING; COMPUTER SOFTWARE FOR MANAGING AND ORGANIZING VARIOUS DIGITAL READING CONTENTS NAMELY DIGITAL ELECTRONIC-BOOKS, DIGITAL ELECTRONIC-NEWSPAPERS, THESIS, AND DIGITAL ELECTRONIC-MAGAZINES; COMPUTER SOFTWARE FOR PERSONAL INFORMATION MANAGEMENT; COMPUTER SOFTWARE FOR PLAYING, SHARING AND MANAGING MULTIMEDIA FILES; COMPUTER SOFTWARE FOR PURCHASING, DOWNLOADING, PLAYING OR LISTENING TO MUSIC; COMPUTER SOFTWARE FOR PURCHASING, SUBSCRIBING, DOWNLOADING, PLAYING OR LISTENING TO DIGITAL READING CONTENTS NAMELY DIGITAL ELECTRONIC-BOOKS, DIGITAL ELECTRONIC-NEWSPAPERS, THESIS AND DIGITAL ELECTRONIC-MAGAZINES AND ELECTRONIC GAMES; COMPUTER SOFTWARE FOR TRAVEL INFORMATION SYSTEMS FOR THE PROVISION OR RENDERING OF TRAVEL ADVICE AND FOR INFORMATION CONCERNING HOTELS, LANDMARKS, MUSEUMS, PUBLIC TRANSPORTATION, RESTAURANTS AND OTHER INFORMATION REGARDING TRAVEL AND TRANSPORT; COMPUTER SOFTWARE FOR TRAVEL INFORMATION SYSTEMS FOR THE PROVISION OR RENDERING OF TRAVEL ADVICE AND FOR INFORMATION CONCERNING HOTELS, LANDMARKS, MUSEUMS, PUBLIC TRANSPORTATION, RESTAURANTS AND OTHER INFORMATION REGARDING TRAVEL AND TRANSPORT; COMPUTER SOFTWARE FOR USE IN RECORDING, ORGANIZING, TRANSMITTING, MANIPULATING, AND REVIEWING TEXT, AUDIO FILES, VIDEO FILES AND COMPUTER GAME PROGRAMS IN CONNECTION WITH TELEVISIONS, COMPUTERS, MUSIC PLAYERS, VIDEO PLAYERS, MEDIA PLAYERS AND MOBILE PHONES; COMPUTER SOFTWARE FOR

**CLASS 9—(Continued).**

USE IN SEARCHING FOR, BROWSING, AND PURCHASING SOFTWARE ON AN ELECTRONIC DATABASE; COMPUTER SOFTWARE FOR USE WITH SATELLITE AND GLOBAL POSITIONING SYSTEM (GPS) NAVIGATION SYSTEMS FOR NAVIGATION, ROUTE AND TRIP PLANNING, AND ELECTRONIC MAPPING; COMPUTER SOFTWARE SUGGESTING THE MOST SUITABLE PEN-INPUT APPLICATIONS FOR THE MOBILE DEVICE; COMPUTER SOFTWARE TO ACCESS INTERNET AND VARIOUS APPLICATIONS; COMPUTER SOFTWARE TO BE USED FOR VIEWING AND DOWNLOADING ELECTRONIC MAPS; COMPUTER SOFTWARE TO EDIT DAILY ACTIVITIES, ADDRESS BOOK, CALENDAR, MEMOS, AND MULTIMEDIA CONTENTS STORED IN MOBILE DEVICES; COMPUTER SOFTWARE TO ENABLE AUTHORING, POSTING, UPLOADING, DOWNLOADING, TRANSMITTING, RECEIVING, EDITING, EXTRACTING, ENCODING, DECODING, PLAYING, STORING, ORGANIZING, SHOWING, DISPLAYING, TAGGING, BLOGGING AND/OR SHARING ELECTRONIC MEDIA AND INFORMATION OVER THE INTERNET, LOCAL AREA NETWORK OR TELECOMMUNICATION NETWORK; COMPUTER SOFTWARE TO ENABLE USERS TO PROGRAM AND DISTRIBUTE AUDIO, VIDEO, TEXT AND OTHER MULTIMEDIA CONTENT, NAMELY, MUSIC, CONCERTS, VIDEOS, RADIO, TELEVISION, NEWS, SPORTS, GAMES, CULTURAL EVENTS, AND ENTERTAINMENT-RELATED AND EDUCATIONAL PROGRAMS VIA COMMUNICATION NETWORK; COMPUTER SOFTWARE TO RECEIVE, TRANSPORT, ENCODE, DECODE, DECRYPT, ENCRYPT, TRANSMIT, MULTIPLEX, DEMULTIPLEX, AND MANIPULATE VIDEO, AUDIO AND TEXT IN DIGITAL FORMAT TO DELIVER TELEVISION AND OTHER VIDEO PROGRAMMING TO APPROPRIATE VIDEO DEVICES FOR DISTRIBUTION OF TELEVISION PROGRAMMING FOR VIEWING ON TELEVISION SETS AND COMPUTER MONITORS; COMPUTER SOFTWARE USED TO ENHANCE AND OPTIMIZE AUDIO AND VIDEO SOUND; COMPUTERS; DIGITAL CAMERAS; DIGITAL PHOTO ALBUMS FOR DISPLAYING DIGITAL PICTURES, VIDEO CLIPS AND MUSIC; DIGITAL PHOTO FRAMES FOR DISPLAYING DIGITAL PICTURES, VIDEO CLIPS AND MUSIC; DIGITAL SET-TOP BOXES, NAMELY DIGITAL MEDIA RECEIVERS AND DECODERS, CABLE TELEVISION CONVERTERS, ETHERNET STREAMING MEDIA CONVERTERS; DOWNLOADABLE DIGITAL IMAGES, NAMELY, PHOTOGRAPHIC OR VIDEO IMAGES IN THE FIELD OF ARCHITECTURE, BALLET DANCERS, COSTUMES, MUSICAL INSTRUMENTS, SET DESIGNS, COMMUNICATION EQUIPMENT, SOUND WAVES, POLITICAL FIGURES, POVERTY, MOUNTAINS, LAKES, ROCK STRATA, SOLDIERS, HISTORICAL FIGURES AND PLACES, COURTHOUSES, LAWYERS, COURT SCENES, JUDGES, CRIMINALS, MANUSCRIPTS, BOOKS, BOOK COVER ART, ORCHESTRAS, ROCK BANDS, SINGERS, GUITAR PLAYERS, GUITARS, PHILOSOPHERS, PRINTING PRESSES, NEWSPAPERS, NEWSROOMS, LABORATORIES, SCIENCE LABS, SPACE, PLANETS, GALAXIES, THE MOON, PLANTS, SPACE ALIENS, SPACE SHIPS, SCIENCE FICTION CREATURES, CARS AND COMPUTERS; DOWNLOADABLE RING TONES FOR MOBILE PHONES AND TABLET COMPUTERS; DVD PLAYERS; ELECTRONIC WHITEBOARDS; FACSIMILE MACHINES; HARD DISK DRIVES; INTERCOM KEY PHONE TERMINALS FOR CONNECTION TO A TELEPHONE NETWORK; INTERNET PROTOCOL PHONES; INTERNET PROTOCOL PRIVATE BRANCH EXCHANGE (PBX) SWITCHBOARDS; KEY PHONE OPERATING SYSTEM SOFTWARE; KEY PHONE SWITCH BOARDS; LOCAL AREA NETWORK (LAN) SWITCHES; MOBILE APPLICATION SOFTWARE; MOBILE PHONE AND TABLET COMPUTER ACCESSORIES NAMELY BATTERIES, ELECTRIC BATTERY CHARGERS, DATA COMMUNICATION CABLES, HEADSETS, EAR PHONES, BATTERY CHARGERS FOR USE IN A CAR, LEATHER CASES ADAPTED FOR MOBILE PHONES AND TABLET COMPUTERS, FLIP COVERS FOR MOBILE PHONES AND TABLET COMPUTERS, HANDS FREES KITS AND SNAP ON CASES ADAPTED FOR MOBILE PHONES AND TABLET COMPUTERS, STYLUS, AUDIO DOCKING STATIONS, SCREEN PROTECTIVE FILMS ADAPTED FOR MOBILE PHONES AND TABLET COMPUTERS AND PORTABLE SPEAKERS; MOBILE PHONE OPERATING SYSTEM SOFTWARE; MOBILE TELEPHONES; MP3 PLAYERS;

**CLASS 9—(Continued).**

NETWORK ACCESS SERVER HARDWARE; NETWORK ACCESS SERVER OPERATING SOFTWARE; OPTICAL DISK DRIVES; OPTICAL DISK PLAYERS; PERSONAL DIGITAL ASSISTANTS (PDAS); PORTABLE COMPUTERS; PORTABLE MEDIA PLAYER; PRINTERS FOR COMPUTERS; SEMICONDUCTORS; SMART PHONES; STEREO AUDIO SPEAKERS; STYLUS FOR PORTABLE ELECTRONIC DEVICES; TABLET COMPUTER OPERATING SYSTEM SOFTWARE; TABLET COMPUTERS; TELEPHONES; TELEPHONES USED AS TERMINAL DEVICES FOR INTERNET PROTOCOL (IP) PRIVATE BRANCH EXCHANGE (PBX); TELEVISION RECEIVERS; THREE DIMENSIONAL (3D) EYEGLASSES; WIDE AREA NETWORK(WAN) ROUTERS (U.S. CLS. 21, 23, 26, 36 AND 38).

KATINA MISTER, EXAMINING ATTORNEY

SN 86-082,896. GROUPON, INC., CHICAGO, IL. FILED 10-4-2013.

ONTEK

THE MARK CONSISTS OF STANDARD CHARACTERS WITHOUT CLAIM TO ANY PARTICULAR FONT, STYLE, SIZE, OR COLOR.

FOR ELECTRONIC GOODS, NAMELY, PHONE CHARGERS, BATTERY CHARGERS, PORTABLE POWER CHARGERS, USB CHARGERS FOR PHONES AND MOBILE DEVICES, USB CHARGING PORT WITH BUILT-IN FLASHLIGHT, PORTABLE BATTERY PACKS, MOBILE PHONE CASE WITH BUILT-IN PHONE CHARGER, AUDIO SPEAKERS, PORTABLE AUDIO SPEAKERS, WIRELESS SPEAKERS, INDUCTIVE AUDIO SPEAKERS, CABLES, CONNECTION CABLES, POWER CABLES, CHARGING CABLES, USB CABLES, HIGH DEFINITION MULTIMEDIA INTERFACE CABLES, USB CHARGING PORTS FOR USE IN VEHICLES, LED-LIT ARMBAND SPECIALLY ADAPTED FOR PERSONAL ELECTRONIC DEVICES, NAMELY, MOBILE PHONES AND MUSIC PLAYERS; AUDIO HEADSETS, NAMELY, HEADSETS FOR USE WITH COMPUTERS, HEADSETS FOR USE WITH PHONE, EARPHONES (U.S. CLS. 21, 23, 26, 36 AND 38).

JORDAN BAKER, EXAMINING ATTORNEY

**CLASS 9—(Continued).**

SN 86-083,332. K M MOONEY PROD., INC., ELLENTON, FL. FILED 10-4-2013.

KMARIE

THE MARK CONSISTS OF STANDARD CHARACTERS WITHOUT CLAIM TO ANY PARTICULAR FONT, STYLE, SIZE, OR COLOR.

THE NAME(S), PORTRAIT(S), AND/OR SIGNATURE(S) SHOWN IN THE MARK IDENTIFIES KELSEY MARIE MOONEY, WHOSE CONSENT(S) TO REGISTER IS MADE OF RECORD.

FOR DVDS, CDS, AND AUDIO AND VISUAL SOUND RECORDINGS FEATURING MUSICAL PERFORMANCES; MUSICAL SOUND RECORDINGS; COMPUTER APPLICATION SOFTWARE FOR MOBILE PHONES, PORTABLE MEDIA PLAYERS, AND HANDHELD COMPUTERS FOR USE IN DOWNLOADING MUSIC, RING TONES AND VIDEO GAMES; HANDHELD AND MOBILE DIGITAL ELECTRONIC DEVICES, NAMELY, TABLET PCS, CELLULAR PHONES, LAPTOPS, PORTABLE MEDIA PLAYERS, HANDHELD COMPUTERS; CASES AND COVERS FOR MOBILE PHONES AND MOBILE DIGITAL ELECTRONIC DEVICES, NAMELY, LAPTOPS, CELL PHONES, RADIO PAGERS, MOBILE COMPUTERS; DOWNLOADABLE APPLICATION SOFTWARE IN THE NATURE OF A MOBILE APPLICATION DOWNLOADABLE TO HANDHELD AND MOBILE DIGITAL ELECTRONIC DEVICES THAT CAN ACCESS THE INTERNET FOR USE IN DOWNLOADING MUSIC, RING TONES AND VIDEO GAMES; DECORATIVE MAGNETS, COMPUTER BAGS; GRADUATED GLASSWARE; EYEGLASSES AND EYEGLASS FRAMES; SUNGLASSES AND SUNGLASS FRAMES; CLIP-ON SUNGLASSES; SPECTACLES AND SPECTACLE FRAMES; LENSES FOR EYEGLASSES, SUNGLASSES AND SPECTACLES; EYEGLASS, SUNGLASS AND SPECTACLE CASES; EYEGLASS, SUNGLASS AND SPECTACLE STRAPS; GOGGLES FOR SPORTS; MOTORCYCLE GOGGLES AND NIGHT VISION GOGGLES; EYEGLASS, SUNGLASS AND SPECTACLE CHAINS (U.S. CLS. 21, 23, 26, 36 AND 38).

KAMAL PREET, EXAMINING ATTORNEY

SN 86-083,522. GIZMOBIES, INC., LAS VEGAS, NV. FILED 10-4-2013.



THE MARK CONSISTS OF THE WORD "GIZMOBIES" IN STYLIZED FONT, WITH A CAPITAL "G" AND LOWER CASE FOR ALL OTHER LETTERS, WITH EACH LETTER SLANTED SLIGHTLY FROM BOTTOM LEFT TO TOP RIGHT, AND WITH EACH SUCCESSIVE LETTER IN SLIGHTLY SMALLER FONT SIZE, RESULTING IN A TAPERED FORM THAT IS WIDER AT THE "G" AND SMALLEST AT THE "S", ALSO WITH A CHRISTMAS-TREE SHAPED ANTENNA FIGURE IMMEDIATELY ABOVE AND TOUCHING THE TOP OF THE "G" AND A SMALL SQUARE IN THE PLACE OF THE DOT OVER THE FIRST "I" AND STYLIZED SIX-POINTED STAR IN THE PLACE OF THE

**CLASS 9—(Continued).**

DOT OVER THE SECOND "I", ALL WITHIN A CONTINUOUS FOUR-SIDED STRAIGHT-LINE, ROUNDED CORNER, SOLID BORDER FITTING THE TAPERED SHAPE OF THE WORD, WITH THE LEFT SIDE BORDER LINE SLANTED LEFT TOP TO RIGHT BOTTOM, WITH THE RIGHT SIDE BORDER SLANTED BOTTOM LEFT TO TOP RIGHT, WITH THE TOP SIDE BORDER LINE SLANTED FROM TOP LEFT TO BOTTOM RIGHT, AND BOTTOM SIDE BORDER LINE SLANTED FROM BOTTOM LEFT TO TOP RIGHT.

FOR PROTECTIVE CASES AND DECORATIVE COVERS MADE OF VINYL, PLASTIC FILM, PLASTIC LAMINATES, METAL, PLASTIC AND RUBBER SPECIALLY ADAPTED FOR SMART PHONES, CELL PHONES, PORTABLE MUSIC PLAYERS, PORTABLE VIDEO PLAYERS, COMPUTERS, TABLET COMPUTERS, LAPTOPS, NOTEBOOK COMPUTERS, KEYBOARDS, MP3 PLAYERS, PORTABLE SATELLITE RADIOS, PERSONAL DIGITAL ASSISTANTS, REMOTE CONTROLS, AND SATELLITE RECORDERS; FITTED PLASTIC FILMS KNOWN AS SKINS FOR COVERING AND PROVIDING A SCRATCH-PROOF BARRIER AND PROTECTION FOR ELECTRONIC DEVICES, NAMELY, SMART PHONES, CELL PHONES, PORTABLE MUSIC PLAYERS, PORTABLE VIDEO PLAYERS, COMPUTERS, TABLET COMPUTERS, LAPTOPS, NOTEBOOK COMPUTERS, KEYBOARDS, MP3 PLAYERS, PORTABLE SATELLITE RADIOS, PERSONAL DIGITAL ASSISTANTS, REMOTE CONTROLS, AND SATELLITE RECORDERS; PAINTED CELL PHONE COVERS (U.S. CLS. 21, 23, 26, 36 AND 38).

FIRST USE 7-12-2006; IN COMMERCE 7-14-2006.  
RUSS HERMAN, EXAMINING ATTORNEY

SN 86-086,498. ELEGANI LLC, FORT LEE, NJ. FILED 10-9-2013.

elegani

THE MARK CONSISTS OF STANDARD CHARACTERS WITHOUT CLAIM TO ANY PARTICULAR FONT, STYLE, SIZE, OR COLOR.

FOR 3D CAMERA SYSTEMS, NAMELY, ADAPTERS FOR ALLOWING 3D SHOOTING; ABDOMINAL BELTS CONTAINING BUILT-IN SPEAKERS FOR PURPOSES OF TRANSMITTING MUSIC/SOUNDS/EDUCATIONAL MATERIAL TO A FETUS AND BUILT-IN POCKETS IN WHICH TO CARRY AUDIO TRANSMITTERS; ACCUMULATORS; ACCUMULATORS AND BATTERIES; ACIDIMETERS FOR BATTERIES; ADAPTER PLUGS; ADAPTER RINGS FOR ATTACHING OBJECTIVES ON CAMERAS; ADAPTERS; ADJUSTABLE SMARTPHONE AND PC TABLET STABILIZERS AND MOUNTS; AERIAL CABLES FOR HEAVY CURRENTS; ANALOG TO DIGITAL CONVERTER (ADCS); ANODE BATTERIES; ANTI-THEFT LOCKS SPECIALLY ADAPTED TO PERSONAL ELECTRONIC DEVICES, NAMELY, TABLETS; APPARATUS FOR CONVERTING ELECTRONIC RADIATION TO ELECTRICAL ENERGY, NAMELY, PHOTOVOLTAIC CLADDING PANELS; APPARATUS FOR CONVERTING ELECTRONIC RADIATION TO ELECTRICAL ENERGY, NAMELY, PHOTOVOLTAIC ROOFING MEMBERS; APPARATUS FOR CONVERTING ELECTRONIC RADIATION TO ELECTRICAL ENERGY, NAMELY, PHOTOVOLTAIC SOLAR HYBRID MODULES; APPARATUS FOR CONVERTING ELECTRONIC RADIATION TO ELECTRICAL ENERGY, NAMELY, PHOTOVOLTAIC SOLAR MODULES; APPARATUS FOR CONVERTING ELECTRONIC RADIATION TO ELECTRICAL ENERGY, NAMELY, PHOTOVOLTAIC THERMAL HYBRID MODULE; APPARATUS FOR CONVERTING ELECTRONIC RADIATION TO ELECTRICAL ENERGY, NAMELY, PHOTOVOLTAIC THERMAL MODULE; APPARATUS FOR CONVERTING ELECTRONIC RADIATION TO ELECTRICAL ENERGY,

**CLASS 9—(Continued).**

NAMELY, PVT (PHOTOVOLTAIC THERMAL) MODULE; APPARATUS FOR CONVERTING THERMAL ENERGY TO ELECTRICAL ENERGY, NAMELY, THERMOELECTRIC CONVERTERS; AUDIO CABLES; BACKPACKS ESPECIALLY ADAPTED FOR HOLDING LAPTOPS; BACKPACKS ESPECIALLY ADAPTED FOR HOLDING LAPTOPS AND NOTEBOOK COMPUTERS; BAGS ADAPTED FOR LAPTOPS; BAGS AND CASES SPECIALLY ADAPTED FOR HOLDING OR CARRYING PORTABLE TELEPHONES AND TELEPHONE EQUIPMENT AND ACCESSORIES; BAGS SPECIALLY ADAPTED FOR PROTECTIVE HELMETS; BAGS SPECIALLY ADAPTED FOR UNDERWATER CAMERA HOUSINGS; BATTERIES; BATTERIES AND BATTERY CHARGERS; BATTERIES AND BATTERY CHARGERS FOR INTRAVENOUS FLUID DELIVERY APPARATUS; BATTERIES FOR LIGHTING; BATTERIES FOR POCKETLAMPS; BATTERIES FOR USE IN HEARING AIDS; BATTERIES FOR VEHICLES; BATTERIES, ELECTRIC; BATTERIES, ELECTRIC, FOR VEHICLES; BATTERY BOXES; BATTERY CABLES; BATTERY CASES; BATTERY CHARGE DEVICES; BATTERY CHARGERS; BATTERY CHARGERS FOR USE WITH TELEPHONES; BATTERY JUMP STARTERS; BATTERY MONITORING DEVICES THAT MAY BE ATTACHED TO A BATTERY TO MONITOR THE PERFORMANCE OF THE BATTERY AND OPERATING SOFTWARE FOR USE THEREWITH, SOLD AS A UNIT; BATTERY MONITORS; BATTERY PACKS; BATTERY PACKS FOR TABLETS AND SMARTPHONES; BATTERY PERFORMANCE MONITORS; BATTERY POWER SUPPLIES FOR MEDICAL VENTILATORS; BATTERY POWERED METER FOR MEASURING THE MOISTURE CONTENT OF COFFEE BEANS; BATTERY TERMINAL CONNECTOR CLAMPS; BATTERY TESTERS; BEEPER CARRYING CASES; BLANK INTEGRATED CIRCUIT CARDS FOR RECORDING, TRANSMITTING, AND REPRODUCING SOUND AND IMAGES IN MOBILE TELEPHONE SERVICES; BOXES SPECIALLY ADAPTED FOR HOUSING AUDIO EQUIPMENT; BRACKETS SPECIALLY ADAPTED FOR SETTING UP FLAT SCREEN TV SETS; BRIEFCASES SPECIALLY ADAPTED FOR HOLDING LAPTOP COMPUTERS; CABLE AND WIRING PLATES IN THE NATURE OF PROTECTIVE SHEATHS FOR ELECTRICAL CABLE AND WIRING; CABLE BROADCAST TRANSMISSION MACHINES AND APPARATUS; CABLE CONNECTORS; CABLE JUMP LEADS; CABLE MODEMS; CABLE TELEVISION CONVERTERS; CABLE TELEVISION TRANSMITTERS; CABLES AND FIBRES FOR THE TRANSMISSION OF SOUNDS AND IMAGES; CABLES FOR ELECTRICAL AND OPTICAL SIGNAL TRANSMISSION SYSTEMS; CABLES FOR ELECTRICAL OR OPTICAL SIGNAL TRANSMISSION; CABLES FOR OPTICAL SIGNAL TRANSMISSION; CABLES, ELECTRIC; CAMERA CASES; CARRYING CASES AND CONTAINERS FOR CONTACT LENSES; CARRYING CASES FOR CELL PHONES; CARRYING CASES FOR MOBILE COMPUTERS; CARRYING CASES FOR RADIO PAGERS; CARRYING CASES SPECIALLY ADAPTED FOR ELECTRONIC EQUIPMENT, NAMELY, TABLETS AND SMARTPHONES; CARRYING CASES SPECIALLY ADAPTED FOR POCKET CALCULATORS AND CELLPHONES; CARRYING CASES, HOLDERS, PROTECTIVE CASES AND STANDS FEATURING POWER SUPPLY CONNECTORS, ADAPTORS, SPEAKERS AND BATTERY CHARGING DEVICES, SPECIALLY ADAPTED FOR USE WITH HANDHELD DIGITAL ELECTRONIC DEVICES, NAMELY, TABLETS AND SMARTPHONES; CASES FITTED WITH DISSECTING INSTRUMENTS FOR SCIENTIFIC OR RESEARCH PURPOSES; CASES FITTED WITH DISSECTING INSTRUMENTS NOT FOR MEDICAL USE; CASES FOR CHILDREN'S EYE GLASSES; CASES FOR CONTACT LENSES; CASES FOR DISKETTES AND COMPACT DISKS; CASES FOR ELECTRONIC DIARIES; CASES FOR EYEGASSES AND SUNGLASSES; CASES FOR MOBILE PHONES; CASES FOR MUSIC, AUDIO AND RELATED ELECTRONIC EQUIPMENT, NAMELY, CASES FOR AUDIO TUNERS, AUDIO RECEIVERS, AMPLIFIERS, TAPE PLAYERS, COMPACT DISC PLAYERS, MP3 CONTROLLERS/PLAYERS, AUDIO MIXERS, AUDIO SPEAKERS IN THE NATURE OF MUSIC STUDIO MONITORS, MICROPHONES, AUDIO SPEAKERS, COMPACT DISCS, AUDIO TAPES, PORTABLE COMPUTERS, ANTENNAS, PHONOGRAPHIC RECORD PLAYERS, AUDIO RECORDING EQUIPMENT, AND THE CABLES ASSOCIATED WITH ALL OF THE FOREGOING EQUIPMENT; CASES FOR

**CLASS 9—(Continued).**

PHOTOGRAPHIC APPARATUS; CASES FOR POCKET CALCULATORS; CASES FOR SPECTACLES AND SUNGLASSES; CASES FOR SPECTACLES, FOR PINCE-NEZ AND FOR CONTACT LENSES; CASES FOR TELEPHONES; CASINGS AND CASING PARTS FOR ELECTRICAL EQUIPMENT, NAMELY, HOUSING FOR SWITCHING APPARATUS; CD CASES; CELL PHONE BACKPLATES; CELL PHONE BATTERY CHARGERS; CELL PHONE BATTERY CHARGERS FOR USE IN VEHICLES; CELL PHONE CASES; CELL PHONE COVERS; CELL PHONE FACEPLATES; CELL PHONE HAVING LARGE KEYS AND NUMBERS THAT ASSIST USERS HAVING IMPAIRED VISION OR DEXTERITY; CELL PHONE STRAPS; CELL PHONES; CELLULAR PHONE ACCESSORY CHARMS; CELLULAR PHONE USAGE DETECTION SYSTEM COMPRISING A CAMERA AND A MOBILE PHONE SIGNAL RECEIVING DEVICE; CELLULAR PHONES; CHARGERS FOR BATTERIES; CHARGERS FOR ELECTRIC BATTERIES; CHIPSETS FOR CONNECTING MULTIMEDIA HOME DEVICES, HOME AND VOIP PHONES AND DIGITAL CORDLESS PHONE DEVICES; CLEAR PROTECTIVE COVERS SPECIALLY ADAPTED FOR PERSONAL ELECTRONIC DEVICES, NAMELY, TABLETS AND SMARTPHONES; COAXIAL CABLES; COAXIAL CABLES INCORPORATING FILTERS; COMMUNICATIONS HEADSETS FOR USE WITH COMMUNICATION RADIOS, INTERCOM SYSTEMS, OR OTHER COMMUNICATIONS NETWORK TRANSCEIVERS; COMPACT DISC CASES; COMPONENT PARTS OF BATTERIES, NAMELY, VENT CAPS; COMPONENT VIDEO CABLES; COMPUTER APPARATUS, NAMELY, A CONVERTER THAT SUPERIMPOSES AN ETHERNET SIGNAL ON AN EXISTING CABLE; COMPUTER CABLES; COMPUTER CARD ADAPTER; COMPUTER CARRYING CASES; COMPUTER CURSOR CONTROL DEVICES, NAMELY, COMPUTER MOUSE; COMPUTER CURSOR CONTROL DEVICES, NAMELY, DIGITIZER TABLETS; COMPUTER GAME CARTRIDGES; COMPUTER GAME CARTRIDGES AND DISCS; COMPUTER GAME CASSETTES; COMPUTER GAME DISCS; COMPUTER GAME EQUIPMENT, NAMELY, DISCS; COMPUTER GAME PROGRAMMES; COMPUTER GAME PROGRAMMES DOWNLOADABLE VIA THE INTERNET; COMPUTER GAME PROGRAMS; COMPUTER GAME PROGRAMS, CARTRIDGES, AND CASSETTES; COMPUTER GAME SOFTWARE; COMPUTER GAME SOFTWARE DOWNLOADABLE FROM A GLOBAL COMPUTER NETWORK; COMPUTER GAME SOFTWARE FOCUSING ON ACHIEVING A SET OF GOALS, POSITIONS, OWNERSHIP, AND CREDENTIALS, AND PROFESSIONAL AND SOCIAL STATUS, AND GOOD FORTUNE NECESSARY TO SUCCEED PROFESSIONALLY AND PERSONALLY, AND NOT REFERRING EITHER TO A GROUP OF SOFTWARE FOR USE IN COMMERCE OR TO A GROUP OF OFFICES; COMPUTER GAME SOFTWARE FOR GAMING MACHINES INCLUDING SLOT MACHINES OR VIDEO LOTTERY TERMINALS; COMPUTER GAME SOFTWARE FOR GAMING MACHINES, NAMELY, SLOT MACHINES AND VIDEO LOTTERY TERMINALS; COMPUTER GAME SOFTWARE FOR PERSONAL COMPUTERS AND HOME VIDEO GAME CONSOLES; COMPUTER GAME SOFTWARE FOR USE ON MOBILE AND CELLULAR PHONES; COMPUTER GAME SOFTWARE FOR USE WITH PERSONAL COMPUTERS, HOME VIDEO GAME CONSOLES USED WITH TELEVISIONS AND ARCADE-BASED VIDEO GAME CONSOLES; COMPUTER GAME TAPES; COMPUTER KEYBOARD CONTROLLERS; COMPUTER KEYBOARDS; COMPUTER MOUSE; COMPUTER MOUSE IN THE NATURE OF A TRACKPAD; COMPUTER MOUSE, NAMELY, TOUCHPADS; COMPUTER MOUSE, NAMELY, TRACKBALLS; COMPUTER NETWORK ADAPTERS; COMPUTER NETWORK ADAPTERS, SWITCHES, ROUTERS AND HUBS; COMPUTER PROGRAMS FOR PRE-RECORDED GAMES; COMPUTER PROGRAMS FOR VIDEO AND COMPUTER GAMES; COMPUTER SOFTWARE AND FIRMWARE FOR GAMES OF CHANCE ON ANY COMPUTERIZED PLATFORM, INCLUDING DEDICATED GAMING CONSOLES, VIDEO BASED SLOT MACHINES, REEL BASED SLOT MACHINES, AND VIDEO LOTTERY TERMINALS; COMPUTER SOFTWARE TO ENABLE THE TRANSMISSION OF PHOTOGRAPHS TO MOBILE TELEPHONES; COMPUTER SOFTWARE, NAMELY, AN APPLICATION ALLOWING SALES AND FIELD SERVICE EMPLOYEES TO UPDATE AND RECEIVE DATA STORED IN AN ENTERPRISE'S COMPUTER DATA-

**CLASS 9—(Continued).**

BASES IN REAL TIME, USING A MOBILE DEVICE, WITH FULL TELEPHONY INTEGRATION WITH THE TELEPHONE AND/OR SOFTWARE FEATURES OF THE MOBILE DEVICE; COMPUTER SOFTWARE, NAMELY, ELECTRONIC FINANCIAL PLATFORM THAT ACCOMMODATES MULTIPLE TYPES OF PAYMENT AND DEBT TRANSACTIONS IN AN INTEGRATED MOBILE PHONE, PDA, AND WEB BASED ENVIRONMENT; COMPUTER SOFTWARE, NAMELY, GAME ENGINE SOFTWARE FOR VIDEO GAME DEVELOPMENT AND OPERATION; COMPUTER SOFTWARE, NAMELY, SOFTWARE DEVELOPMENT TOOLS FOR THE CREATION OF MOBILE INTERNET APPLICATIONS AND CLIENT INTERFACES; COMPUTER TERMINALS, KEYBOARDS AND PRINTERS; COMPUTER-GAMING SOFTWARE; CONDUCTIVE FIBERS, NAMELY, HIGH POWER FIBERS FOR CONDUCTING LASER BEAMS IN THE MID INFRARED WAVELENGTH RANGE; CONNECTING DEVICES FOR PHOTOGRAPHIC EQUIPMENT, NAMELY, CABLE CONNECTORS; CONNECTING ELECTRICAL CABLES; CONNECTION CABLES; CONSUMER ELECTRONIC PRODUCTS, NAMELY, AUDIO AMPLIFIERS, AUDIO SPEAKERS, AUDIO RECEIVERS, ELECTRICAL AUDIO AND SPEAKER CABLES AND CONNECTORS, AUDIO DECODERS, VIDEO DECODERS, SPEAKERS, POWER CONVERSION DEVICES, POWER CONVERTERS, AND POWER INVERTERS; CONTACT LENS CASES; CONTINGENCY RESPONSE COMMUNICATION SYSTEM DESIGNED TO PROVIDE RADIO INTEROPERABILITY, STREAMING VIDEO, WIRELESS INTERNET, AND VOIP PHONE; CONTROL CABINETS SPECIALLY ADAPTED FOR TRAFFIC CONTROL EQUIPMENT; CONTROL CABINETS SPECIALLY ADAPTED FOR VEHICLE TRAFFIC CONTROL EQUIPMENT; CONVERTERS; CONVERTERS FOR ELECTRIC PLUGS; CURRENT CONVERTERS; CUSHIONED SUPPORT BASE SPECIALLY ADAPTED TO PROP UP LAPTOP COMPUTERS; DATA SYNCHRONIZATION CABLES; DC/AC POWER CONVERTERS; DEVICES FOR HANDS-FREE USE OF MOBILE PHONES; DIGITAL CELLULAR PHONES; DIGITAL ENTERTAINMENT SYSTEMS FOR WATCHING, STORING AND SHARING DIGITAL CONTENT ON A HOME COMPUTER NETWORK; DIGITAL PHONES; DIGITAL PHOTO IMAGE CONVERTERS; DIGITAL TO ANALOG CONVERTERS (DACs); DISPLAY SCREEN FILTERS ADAPTED FOR USE WITH TABLETS AND SMARTPHONES; DISPLAY SCREEN PROTECTORS FOR PROVIDING SHADE AND PRIVACY SPECIALLY ADAPTED TO ELECTRONIC DEVICES, NAMELY, TABLETS AND SMARTPHONES; DISPOSABLE KEYBOARD COVERS; DOWNLOADABLE GRAPHICS FOR MOBILE PHONES; DOWNLOADABLE RING TONES AND GRAPHICS FOR MOBILE PHONES; DOWNLOADABLE RING TONES FOR MOBILE PHONES; DRY CELLS AND BATTERIES; DUCTING FOR ELECTRIC CABLES; DVD CASES; EAR PHONES; EARPHONE ACCESSORIES, NAMELY, EARPHONE CUSHIONS, EARPHONE PADS, CORD MANAGEMENT SYSTEMS, EARPHONE CASES, AND EARPHONE EXTENSION CORDS; ELECTRIC BATTERIES; ELECTRIC CABLES; ELECTRIC CABLES AND WIRES; ELECTRIC CABLES, WIRES, CONDUCTORS AND CONNECTION FITTINGS THEREFOR; ELECTRIC CHARGING CABLES; ELECTRIC CONVERTERS; ELECTRIC POWER CONVERTERS; ELECTRIC SHAVER CHARGERS; ELECTRIC STORAGE BATTERIES; ELECTRIC WIRE AND CABLE; ELECTRIC WIRES AND CABLES; ELECTRICAL AND OPTICAL CABLES; ELECTRICAL CABLES; ELECTRICAL CABLES AND CORDSETS; ELECTRICAL CABLES FOR MUSICAL INSTRUMENTS; ELECTRICAL CABLES FOR USE IN CONNECTIONS; ELECTRICAL CABLES WITH INTEGRATED FITTINGS, NAMELY, CORDSETS; ELECTRICAL CELLS AND BATTERIES; ELECTRICAL INTERCONNECT CABLES; ELECTRICAL PLUG DEVICE ENABLING CONNECTION AND DISCONNECTION OF POWER AND/OR CONTROL CABLES; ELECTRICAL SHIELDING SPACERS FOR CABLES AND CABLE ASSEMBLIES; ELECTRICAL STORAGE BATTERIES; ELECTRONIC AND OPTICAL COMMUNICATIONS INSTRUMENTS AND COMPONENTS, NAMELY, CABLE TELEVISION TRANSMITTERS; ELECTRONIC AND OPTICAL COMMUNICATIONS INSTRUMENTS AND COMPONENTS, NAMELY, DIGITAL TRANSMITTERS; ELECTRONIC AND OPTICAL COMMUNICATIONS INSTRUMENTS AND COMPONENTS, NAMELY, OPTICAL TRANSMITTERS; ELECTRONIC

**CLASS 9—(Continued).**

ANIMAL CONFINEMENT UNIT COMPRISING TRANSMITTERS, ELECTRICAL TRANSFORMERS, WIRES, AND RECEIVER COLLARS; ELECTRONIC CABLES; ELECTRONIC CHARGING DEVICES FOR TABLET PCS THAT ALSO INCLUDE FEATURES TO SECURE AND DISINFECT THE TABLET PCS; ELECTRONIC CIGAR BATTERIES; ELECTRONIC CIGARETTE BATTERIES; ELECTRONIC COMPONENTS IN THE NATURE OF INFRARED DETECTORS FOR USE IN FURTHER MANUFACTURE; ELECTRONIC CONTROLLERS FOR USE WITH POWER CONVERTERS; ELECTRONIC CURRENT CONVERTERS; ELECTRONIC DETECTORS FOR OBSERVING AND MEASURING THE INFRARED SPECTRUM, NAMELY, INFRARED DETECTORS; ELECTRONIC DEVICE TO CHARGE AND SECURE TABLET PCS; ELECTRONIC EQUIPMENT FOR POINT-OF-SALES (POS) SYSTEMS, NAMELY, POINT-OF-SALE TERMINALS, BAR CODE READERS, OPTICAL READERS, ADVERTISEMENT DISPLAY MONITORS, KEYBOARDS, PRINTERS, SCANNERS, RADIO TRANSMITTERS, RADIO RECEIVERS, COMPUTER HARDWARE, AND COMPUTER OPERATING SOFTWARE; ELECTRONIC EQUIPMENT, NAMELY, TRANSFORMERS, BALUNS, CABLES USED IN CONNECTION WITH COMPUTERS, COMPUTER PERIPHERAL DEVICES, TELEVISIONS, AUDIO-VIDEO EQUIPMENT, CLOSED-CIRCUIT TV EQUIPMENT AND TELECOMMUNICATION EQUIPMENT; ELECTRONIC FREQUENCY CONVERTERS FOR HIGH VELOCITY ELECTRO MOTORS; ELECTRONIC TEST AND MEASUREMENT DEVICES FOR USE IN THE FIELDS OF NETWORKS AND TELECOMMUNICATIONS, NAMELY, INSTRUMENTATION USED TO TEST AND CERTIFY NEW AND EXISTING DATA AND VOICE COMMUNICATION CABLE AND COAXIAL CABLE; ELECTRONIC TRANSMITTERS AND RECEIVERS FOR AUDIO; ELECTRONIC TRANSMITTERS AND RECEIVERS USED TO LOCATE LOST CHILDREN; ELECTRONIC TRANSMITTERS FOR JAMMING SIGNALS; ELECTRONIC WRITING TABLETS; EMERGENCY AUTO KITS COMPRISED OF A BATTERY CHARGER AND A HAND HELD SPOTLIGHT; ENTERTAINMENT SYSTEM COMPRISING A COMPUTER, MULTIPLE IMAGE DISPLAY SCREEN, MULTIPLE INPUT DEVICES AND A PRINTER; ENVIRONMENTAL ENCLOSURES, NAMELY, STRUCTURES SPECIALLY ADAPTED TO HOLD AND PROTECT CAMERAS FROM OUTDOOR ELEMENTS AND TAMPERING; ETHERNET ADAPTERS; ETHERNET CABLES; EXTENSION CABLES; EYE GLASS CASES; EYEGLASS CASES; EYEWEAR CASES; EYEWEAR, NAMELY, SUNGLASSES, EYEGLASSES AND OPHTHALMIC FRAMES AND CASES THEREFOR; FIBER OPTIC CABLES; FIBRE-OPTIC CABLES; FITTED PLASTIC FILMS KNOWN AS SKINS FOR COVERING AND PROTECTING ELECTRONIC APPARATUS, NAMELY, TABLETS AND SMARTPHONES; FITTED PLASTIC FILMS KNOWN AS SKINS FOR COVERING AND PROVIDING A SCRATCH PROOF BARRIER OR PROTECTION FOR ELECTRONIC DEVICES, NAMELY, MP3 PLAYERS, MOBILE TELEPHONES, SMART TELEPHONES, DIGITAL CAMERAS, GLOBAL POSITIONING SYSTEMS AND PERSONAL DIGITAL ASSISTANTS; FLASH CARD ADAPTERS; FLEXIBLE PVC COVERING SPECIALLY ADAPTED FOR ELECTRICAL CORDS THAT IS INFUSED WITH CITRUS TO PREVENT PET DAMAGE; FM MODULES; FREE-SPACE OPTICS TRANSMISSION SYSTEMS, ETHERNET SWITCHES AND ROUTERS, AND SOFTWARE SOLD BOTH AS COMPONENTS THEREOF AND SEPARATELY, NAMELY, SOFTWARE ADAPTED AND ARRANGED FOR OPERATING, INSTALLING, TESTING, DIAGNOSING AND MANAGING THE FORGOING TELECOMMUNICATION EQUIPMENT; FREQUENCY CONVERTER FOR ACTUATORS; FREQUENCY CONVERTERS; GALVANIC BATTERIES; GATE OPERATORS POWERED BY BATTERY, ELECTRICITY OR SOLAR POWER; GLOBAL POSITIONING SYSTEM (GPS) CONSISTING OF COMPUTERS, COMPUTER SOFTWARE, TRANSMITTERS, RECEIVERS, AND NETWORK INTERFACE DEVICES; GRIDS FOR BATTERIES; GUITAR CABLES; HANDS FREE DEVICES FOR MOBILE PHONES; HANDS FREE KITS FOR PHONES; HARDENED UNITS COMPOSED OF MICROPROCESSORS AND INTEGRATED TRANSMITTERS AND RECEIVERS INSTALLED IN THE FIELD AND ON BOARD BOTH MOBILE AND STATIONARY EQUIPMENT IN LARGE SCALE MINING, CONSTRUCTION, AND INDUSTRIAL OPERATIONS TO COLLECT DATA FROM VARIOUS

**CLASS 9—(Continued).**

APPLICATIONS, TO TRANSMIT THE DATA TO CENTRAL PROCESSING FACILITIES, AND TO RECEIVE DATA TRANSMISSIONS DIRECTED TO THE APPLICATIONS AND EQUIPMENT; HARDENED UNITS COMPOSED OF MICROPROCESSORS AND INTEGRATED TRANSMITTERS AND RECEIVERS INSTALLED IN THE FIELD AT LARGE SCALE MINING, CONSTRUCTION, AND INDUSTRIAL SITES TO COLLECT DATA FROM MONITORING AND CONTROL INSTALLATIONS, TO TRANSMIT THE DATA TO CENTRAL PROCESSING FACILITIES, AND TO RECEIVE DATA TRANSMISSIONS DIRECTED TO THE INSTALLATIONS; HARDENED UNITS COMPOSED OF MICROPROCESSORS AND INTEGRATED TRANSMITTERS AND RECEIVERS INSTALLED IN THE FIELD, AFFIXED TO EQUIPMENT, OR WORN BY PERSONNEL AT LARGE SCALE MINING, CONSTRUCTION, AND INDUSTRIAL SITES TO TRANSMIT TELEMETRY DATA ON EQUIPMENT AND PERSONNEL TO CENTRAL PROCESSING FACILITIES AND TO RECEIVE AUTOMATED PROXIMITY ALERTS OF OTHER EQUIPMENT OR PERSONNEL FOR OPERATIONS AND SAFETY MANAGEMENT SYSTEMS; HARDWARE AND SOFTWARE ADAPTER FOR COUPLING A GPS RECEIVER TO THE MICROPHONE INPUT OF A DIGITAL CAMCORDER; HARNESSES SPECIALLY ADAPTED FOR HOLDING ELECTRONIC DEVICES, NAMELY, TABLETS AND SMARTPHONES; HEAD-CLIP CELL PHONE HOLDERS; HEADSETS FOR CELLULAR OR MOBILE PHONES; HEADSETS FOR MOBILE TELEPHONES; HEADSETS FOR TELEPHONES; HEADSETS FOR USE WITH COMPUTERS; HIGH DEFINITION MULTIMEDIA INTERFACE CABLES; HIGH FREQUENCY MOBILE AND SEA-BASED COMMUNICATION ANTENNAS; HIGH PERFORMANCE COMPUTER HARDWARE WITH SPECIALIZED FEATURES FOR ENHANCED GAME PLAYING ABILITY; HIGH TENSION BATTERIES; HOST BUS ADAPTERS; IGNITION BATTERIES; INFRARED CAMERAS; INFRARED DETECTORS FOR USE IN MILITARY, LAW ENFORCEMENT, CIVIL, SCIENTIFIC AND INDUSTRIAL APPLICATIONS; INTEGRATED BATTERY BACKUP SYSTEMS COMPRISING A BATTERY, AN ELECTRONIC MEASUREMENT APPARATUS FOR USE IN THE MEASUREMENT OF BATTERY HEALTH AND PERFORMANCE, AND A REMOTE COMPUTER SOFTWARE PROGRAM THAT USES THE FOREGOING DATA TO TREND, PREDICT, AND STORE DATA RELATED TO THE HEALTH OF THE BATTERY; INTEGRATED CIRCUIT MODULES FOR USE WITH INFRARED DETECTORS; INTEGRATED CIRCUITS FOR USE IN THE MANUFACTURE OF INFRARED DETECTORS; INTERPHONE PHONES; INTEROPERABLE COMMUNICATION SYSTEM DESIGNED TO PROVIDE RADIO, STREAMING VIDEO, WIRELESS INTERNET, AND VOIP PHONE; JUMP START CABLES; JUMPER CABLES; JUNCTION SLEEVES FOR ELECTRIC CABLES; KEYBOARD AND PRINT OUT APPARATUS FOR USE WITH COMPUTERS; KEYBOARD COVERS; KEYBOARDS; KEYBOARDS FOR MOBILE PHONES; KITS COMPRISED PRIMARILY OF A FIRE HOSE AND ALSO INCLUDING A FIRE NOZZLE AND NON-METALLIC FIRE HOSE ADAPTER SOLD AS A UNIT; LAPTOP CARRYING CASES; LEATHER PROTECTIVE COVERS SPECIALLY ADAPTED FOR PERSONAL ELECTRONIC DEVICES, NAMELY, TABLETS AND SMARTPHONES; LITHIUM ION BATTERIES; LITHIUM IRON PHOSPHATE BATTERIES; LITHIUM PHOSPHATE BATTERIES; MAGNETS ARRANGED FOR CONVERTING HUMAN EFFORT INTO MECHANICAL POWER; MESSENGER BAGS ESPECIALLY ADAPTED FOR HOLDING ELECTRONIC BOOK READERS; MESSENGER BAGS ESPECIALLY ADAPTED FOR HOLDING LAPTOPS; METAL CABINETS SPECIALLY ADAPTED TO PROTECT TELECOMMUNICATIONS EQUIPMENT IN THE NATURE OF FIBER OPTIC CABLES; METAL DEPOSITORY HOUSING SOLD EMPTY THAT IS SPECIALLY ADAPTED TO CONTAIN PHOTOGRAPHIC AND COMPUTER COMPONENTS; METAL GROUNDING BUSHINGS AND METAL GROUNDING CLAMPS, BOTH FOR USE ONLY AS PARTS AND FITTINGS FOR COAXIAL CABLE, AND NOT FOR NON-ELECTRIC CABLE OR MACHINERY OR MACHINE PARTS; METAL TOWER CART WITH WHEELS SPECIALLY ADAPTED FOR COMPUTERS; MICROPHONE CABLES; MINERAL INSULATED ELECTRIC CABLES; MOBILE COMPUTERS; MOBILE COMPUTING AND OPERATING PLATFORMS CONSISTING OF DATA TRANSCIEVERS,

**CLASS 9—(Continued).**

WIRELESS NETWORKS AND GATEWAYS FOR COLLECTION AND MANAGEMENT OF DATA; MOBILE DATA RECEIVERS; MOBILE DATA TERMINAL (MDT); MOBILE OR PORTABLE FAX MACHINES; MOBILE PHONE STRAPS; MOBILE PHONES; MOBILE RADIOS; MOBILE TELEPHONE ACCESSORIES, NAMELY, BELT CLIPS; MOBILE TELEPHONE APPARATUS WITH BUILT-IN FACSIMILE SYSTEMS; MOBILE TELEPHONE BATTERIES; MOBILE TELEPHONES; MODEM CABLES; MONITORING DEVICES FOR MONITORING BATTERY PERFORMANCE CHARACTERISTICS; MOTION PICTURE FILMS AND FILMS FOR TELEVISION FEATURING CHILDREN'S ENTERTAINMENT; MOTION PICTURE FILMS FEATURING CHILDREN'S ENTERTAINMENT; MOTORCYCLE CHARGER FAULT DETECTOR; MOUSE PADS; MULTIFUNCTION KEYBOARDS; NICKEL-CADMIUM STORAGE BATTERIES; NOTEBOOK COMPUTER CARRYING CASES; OPTICAL APPARATUS AND INSTRUMENTS, NAMELY, OPTICAL PORTS FOR UNDERWATER PHOTOGRAPHY, DOME PORTS FOR UNDERWATER PHOTOGRAPHY, WET DIOPTERS, ADAPTER LENSES FOR UNDERWATER PHOTOGRAPHY; OPTICAL CABLES; OPTICAL FIBER CABLES; OPTICAL FIBERS SOLD AS A COMPONENT OF FIBER OPTICAL CABLES; OPTICAL SIGNALING CABLES; OVERLAYS SPECIALLY ADAPTED FOR TOUCHSCREEN DISPLAYS; PARTS FOR ANTI-THEFT AUTOMOTIVE ALARMS, NAMELY, ELECTRONIC SENSORS, REMOTE CONTROL TRANSMITTERS AND RECEIVERS FOR REMOTELY OPERATING LAND VEHICLES; PC TABLET MOUNTS; PC TABLET STABILIZERS; PC TABLETS; PHOTOVOLTAIC SYSTEMS THAT CONVERT SUNLIGHT INTO ELECTRIC AND THERMAL ENERGY; PIPELINE COMMUNICATION SYSTEMS FOR TRANSFERRING DATA OVER OIL, GAS, WATER AND HEAT DISTRIBUTION PIPELINE NETWORKS, COMPRISED OF COMPUTER HARDWARE, SOFTWARE, MODEMS AND COMMUNICATION CABLES; PLASTIC AND CARDBOARD CASES FOR STORING RECORD ALBUMS; PLASTIC CASE USED AS A SECURITY DEVICE FOR PROTECTING AND SECURING DVDS AND OTHER MAGNETIC AND ELECTRONIC MEDIA FROM THEFT; PLASTIC CASES SPECIALLY ADAPTED HOLDING COMPACT DISCS, DVDS AND OTHER ELECTRONIC MEDIA; PLASTIC MOLDED SUPPORT BASE SPECIALLY ADAPTED TO PROP UP LAPTOP COMPUTERS; PLATES FOR BATTERIES; PORTABLE PHOTOGRAPHY EQUIPMENT, NAMELY, REFLECTORS, TRIPODS, LIGHT STANDS AND SUPPORTS AND BAGS SPECIALLY ADAPTED FOR THESE GOODS; POWER ADAPTERS; POWER ADAPTERS FOR COMPUTERS; POWER CABLES; PRESSURE TRANSDUCERS AND TRANSMITTERS THAT CONVERT HYDRAULIC OR PNEUMATIC PRESSURE INTO ANALOG ELECTRICAL SIGNALS FOR MONITORING AND CONTROLLING HYDRAULIC OR PNEUMATIC SYSTEMS; PRESSURE TRANSMITTERS; PRINTER CABLES; PRINTER CARRYING CASES; PROJECTORS PARTICULARLY PROJECTORS FOR THE ENTERTAINMENT INDUSTRY; PROTECTIVE CARRYING CASES FOR PORTABLE MUSIC PLAYERS; PROTECTIVE CARRYING CASES SPECIALLY ADAPTED FOR GLOBAL POSITIONING SYSTEM (GPS) APPARATUS; PROTECTIVE CARRYING CASES SPECIALLY ADAPTED FOR PERSONAL DIGITAL ASSISTANTS (PDA); PROTECTIVE CASES FOR SMARTPHONES; PROTECTIVE COVERS AND CASES FOR CELL PHONES, LAPTOPS AND PORTABLE MEDIA PLAYERS; PROTECTIVE COVERS AND CASES FOR TABLET COMPUTERS; PROTECTIVE DISPLAY SCREEN COVERS ADAPTED FOR USE WITH TABLETS AND SMARTPHONES; PROTECTIVE SHEATHS FOR FIBER OPTICAL CABLES; PUBLIC ADDRESS (PA) AND SOUND SYSTEM ACCESSORIES, NAMELY, MICROPHONE STANDS, SPEAKER STANDS, MICROPHONE CABLES, SPEAKER CABLES, SPEAKER BOXES AND SOUND MIXERS; RADIO RECEIVERS AND TRANSMITTERS; RADIO RECEIVERS AND TRANSMITTERS FOR MONITORING AND CONTROLLING LIGHT EMITTING DIODES IN A NETWORK OF STREET LIGHTS AND FOR PROCESSING EMERGENCY SIGNALS TRANSMITTED TO INDIVIDUAL STREET LIGHTS; RADIO RELAY CABLES; RADIO TRANSMITTERS; RADIO TRANSMITTERS AND RECEIVERS; RADIO TRANSMITTERS AND RECEIVERS FOR REMOTE CONTROLS, RADIO CONTROLS; RADIO TRANSMITTERS, RECEIVERS, AND CONTROLLERS FOR MONITORING AND CONTROL-

**CLASS 9—(Continued).**

LING PUBLIC LIGHTING; RECEIVERS FOR RECEIVING CABLE TELEVISION; RECHARGEABLE ELECTRIC BATTERIES; REMOTE CONTROL TRANSMITTER FOR RADIO-CONTROLLED DEVICES; REMOTE SENSORS FOR USE IN MEASURING THERMAL AND INFRARED RADIATION ENERGY WAVES; REMOTELY-CONTROLLED SUB-AQUATIC VIDEO CAMERA CONTAINING A TV CAMERA, TRANSMITTER, RECEIVER AND MICROPHONE TO RECORD, DETECT, MEASURE, SURVEY AND LOCATE OBJECTS UNDERWATER; RENEWABLE BATTERY SYSTEM TO PROVIDE BACKUP POWER; RF TUNING DEVICES, NAMELY, RESONATORS; ROLLING CASES ESPECIALLY ADAPTED FOR HOLDING LAPTOPS AND NOTEBOOK COMPUTERS; ROTARY CONVERTERS; SATELLITE TRANSMITTERS AND RECEIVERS; SECURITY DEVICES, NAMELY, MOBILE IMAGE PROJECTION DEVICE FOR DISPLAYING RETINAL IMAGES; SHEATHS FOR ELECTRIC CABLES; SHIELD CASES FOR MAGNETIC DISKS; SOLAR BATTERIES; SOLAR RECHARGING BATTERY PACK FOR DIGITAL CAMERAS; SPECIALLY ADAPTED COMPUTER INPUT DEVICE COVER FEATURING A DISINFECTING CAPABILITY; SPECIALTY HOLSTERS ADAPTED FOR CARRYING PERSONAL ELECTRONIC DEVICES, NAMELY, TABLETS AND SMARTPHONES; SPECTACLE CASES; SPECTACLES, FRAMES AND CASES; STABILIZERS FOR PC TABLETS WITH PROTECTIVE CASES; STABILIZERS FOR SMARTPHONES WITH PROTECTIVE CASES; STANDS FOR HANDHELD DIGITAL ELECTRONIC DEVICES, NAMELY, SMARTPHONE STANDS; STANDS FOR PERSONAL DIGITAL ELECTRONIC DEVICES, NAMELY, TABLET STANDS; STANDS SPECIALLY ADAPTED FOR STEREO AND AUDIO SPEAKERS; STEREO CABLES; STRAPS FOR MOBILE PHONES; TABLET COMPUTER; TELECOMMUNICATION CABLES; TELECOMMUNICATIONS CABLES; TELECOMMUNICATIONS EQUIPMENT, NAMELY, FIBER-OPTIC TRANSCEIVERS, FIBER OPTIC REPEATERS, CONVERTERS AND OPTIMIZERS, WAVE DIVISION MULTIPLEXERS, FREE-SPACE OPTICS TRANSMISSION SYSTEMS, SWITCHES INCLUDING ETHERNET SWITCHES AND ROUTERS, FIBER-TO-THE-HOME AND ETHERNET-OVER-VDSL ACCESS AGGREGATORS, TERMINATORS AND REPEATERS, AND REMOTE PRESENCE MANAGEMENT PRODUCTS, NAMELY, SWITCHES, AND CONSOLE, ALARM, SENSOR AND POWER MANAGEMENT DEVICES; TELECOMMUNICATIONS TRANSMITTERS; TELEMATICS APPARATUS, NAMELY, WIRELESS INTERNET DEVICES WHICH PROVIDE TELEMATIC SERVICES AND HAVE A CELLULAR PHONE FUNCTION; TELEPHONE CALL ROUTER, FOR HOME AND OFFICE TOUCH-TONE PHONES, FOR INTERNATIONAL AND LONG DISTANCE CALLS MADE FROM VARIOUS TELEPHONE PLATFORMS INCLUDING VOIP PLATFORM WITHOUT THE REQUIREMENT FOR INTERNET; TELEPHONE CALL ROUTERS FOR LONG DISTANCE CALLS MADE THROUGH PSTN AND VOIP PLATFORMS FROM ANY TOUCH-TONE PHONE WITHOUT A REQUIREMENT FOR INTERNET ACCESS; TELEPHONE HEADSETS; TELEPHONE SETS WITH SCREEN AND KEYBOARD; TELEPHONE TRANSMITTERS; TELEVISION AND VIDEO CONVERTERS; TELEVISION TRANSMITTERS; TEMPERATURE TRANSMITTERS; TEST ADAPTERS FOR TESTING PRINTED CIRCUIT BOARDS; THIN-FILM SOLAR (TFS), VERTICAL AXIS WIND TURBINE (VAWT) AND HYBRID TFS VAWT OFF-GRID POWER AND DEEP CYCLE BATTERY STORAGE SYSTEMS COMPOSED OF BATTERIES, CHARGE CONTROLLERS AND INVERTERS WITH INTEGRATED LED BULBS AND LED LIGHT FIXTURES; THREADED CABLE CONNECTORS OF METAL; TRANSMITTER AND RECEIVER USED TO LOCATE LOST PETS; TRANSMITTERS AND RECEIVERS FOR AUDIO AND VIDEO SIGNALS FOR TRANSMISSION OVER TWISTED PAIR CABLES; TRANSMITTERS OF ELECTRONIC SIGNALS; USB CABLES; USB CABLES FOR CELLPHONES; VEHICLE LOCATING, TRACKING AND SECURITY SYSTEM COMPRISED OF AN ANTENNA AND RADIO TRANSMITTER TO BE PLACED IN A VEHICLE; VEHICLE TRACKING DEVICES COMPRISED OF CELLULAR RADIO MODULES, COMPUTER SOFTWARE AND COMPUTER HARDWARE, SENSORS, TRANSMITTERS, RECEIVERS AND GLOBAL POSITIONING SATELLITE RECEIVERS, ALL FOR USE IN CONNECTION WITH VEHICLE TRACKING, VEHICLE MONITORING AND ANTI-THEFT VEHICLE ALARMS; VIBRATING ALARM

**CLASS 9—(Continued).**

INCORPORATED INTO PLASTIC MEDICATION CASES SOLD EMPTY AS A REMINDER TO TAKE MEDICATION; VIDEO CABLES; VIDEO GAME CARTRIDGES; VIDEO GAME CARTRIDGES AND CASSETTES; VIDEO GAME CARTRIDGES AND DISCS; VIDEO GAME DISCS; VIDEO GAME TAPE CASSETTES; VIDEO PHONES; VINYL COVERS SPECIALLY ADAPTED FOR CELL PHONES, MP3 PLAYERS, LAPTOPS, COMPUTERS, PORTABLE SATELLITE RADIOS, PERSONAL DIGITAL ASSISTANTS, REMOTE CONTROLS, AND TELEVISION SATELLITE RECORDERS; VOICE OVER INTERNET PROTOCOL (VOIP) PHONE ADAPTER; WEBCAMS; WET CELL BATTERIES; WHEELED BACKPACKS ESPECIALLY ADAPTED FOR HOLDING LAPTOPS; WHEELED MESSENGER BAGS ESPECIALLY ADAPTED FOR HOLDING LAPTOPS; WIND SLEEVES; WIND SLEEVES; WIRELESS ADAPTERS FOR COMPUTERS; WIRELESS ADAPTERS USED TO LINK COMPUTERS TO A TELECOMMUNICATIONS NETWORK; WIRELESS CELLULAR PHONE HEADSETS; WIRELESS COMMUNICATION DEVICE FEATURING VOICE, DATA AND IMAGE TRANSMISSION INCLUDING VOICE, TEXT AND PICTURE MESSAGING, A VIDEO AND STILL IMAGE CAMERA, ALSO FUNCTIONAL TO PURCHASE MUSIC, GAMES, VIDEO AND SOFTWARE APPLICATIONS OVER THE AIR FOR DOWNLOADING TO THE DEVICE; WIRELESS CONTROLLERS TO MONITOR AND CONTROL THE FUNCTIONING OF OTHER ELECTRONIC DEVICES; WIRELESS DIGITAL ELECTRONIC APPARATUS TO SECURE AND PROTECT DATA AND IMAGES ON ALL FORMS OF WIRELESS EQUIPMENT INCLUDING MOBILE TELECOMMUNICATIONS EQUIPMENT USING AN AUTOMATIC SYNCHRONIZATION PROCESS AND ALARM NOTIFICATION OF THE LOSS OR THEFT OF THE WIRELESS EQUIPMENT INCLUDING MOBILE TELECOMMUNICATIONS EQUIPMENT; WIRELESS RECEIVERS AND TRANSMITTERS FOR PORTABLE MEDIA PLAYERS; WIRELESS TRANSMITTERS AND RECEIVERS; WRIST RESTS FOR COMPUTER MOUSE USERS; WRIST SUPPORTS FOR COMPUTER MOUSE USERS; FM TRANSMITTERS (U.S. CLS. 21, 23, 26, 36 AND 38).  
FIRST USE 5-7-2013; IN COMMERCE 9-10-2013.  
THEODORE MCBRIDE, EXAMINING ATTORNEY

**CLASS 9—(Continued).**

SN 86-086,572. NIKON CORPORATION, TOKYO, JAPAN, FILED 10-9-2013.



THE MARK CONSISTS OF THE TERM "D610" IN STYLIZED FORM.

FOR CAMERAS; DIGITAL CAMERAS; RECHARGEABLE BATTERIES FOR CAMERAS AND DIGITAL CAMERAS; BATTERY CHARGERS FOR CAMERAS AND DIGITAL CAMERAS; STRAPS FOR CAMERAS AND DIGITAL CAMERAS; CAPS FOR CAMERA BODIES; HOT SHOE COVERS FOR CAMERAS; COMPUTER SOFTWARE COMPRISED OF ELECTRONIC INSTRUCTION MANUALS FOR DIGITAL CAMERAS; COMPUTER SOFTWARE FOR EDITING AND MANAGING OF PHOTOGRAPHS AND MOVIES; COMPUTER SOFTWARE FOR TRANSFERRING PHOTOGRAPHS AND MOVIES FROM A CAMERA OR MEMORY CARD TO A BACKUP FOLDER; COMPUTER SOFTWARE FOR UPLOADING PHOTOGRAPHS AND MOVIES TO AN IMAGE STORAGE AND SHARING SERVICE; COMPUTER SOFTWARE FOR ADDING GPS DATA TO PHOTOGRAPH AND MOVIE FILES; COMPUTER SOFTWARE FOR POSTING THE LOCATIONS OF PHOTOGRAPH AND MOVIE FILES ON A WORLD MAP USING GPS DATA; CAMERA LENSES; LENS CAPS FOR CAMERAS; EYEPIECE CAPS FOR CAMERAS; EYECUPS FOR CAMERAS; USB CABLES; AUDIO VIDEO CABLES; LCD MONITOR COVERS; EYEPIECES FOR CAMERAS; CABLE CLIPS FOR USB CABLES; FERRITE CORES FOR CAMERAS; TERMINAL COVERS FOR STEREO MINI PLUG CABLES; BATTERY CHAMBER COVERS FOR CAMERAS; ELECTRONIC PUBLICATIONS, NAMELY, DOWNLOADABLE INSTRUCTION MANUAL FOR DIGITAL CAMERA; ALL OF THE FOREGOING GOODS NOT FOR USE IN RELATION TO TELECOMMUNICATIONS DEVICES (U.S. CLS. 21, 23, 26, 36 AND 38).

KHANH LE, EXAMINING ATTORNEY

SN 86-087,070. STEINER ELECTRIC COMPANY, ELK GROVE VILLAGE, IL. FILED 10-9-2013.



THE MARK CONSISTS OF STANDARD CHARACTERS WITHOUT CLAIM TO ANY PARTICULAR FONT, STYLE, SIZE, OR COLOR.

OWNER OF U.S. REG. NOS. 2,766,264, 3,783,332 AND 3,783,333.

SEC. 2(F).

FOR POWER SYSTEMS AND EQUIPMENT, NAMELY, TAP BOXES, ELECTRICAL EXTENSION CORDS, AND ELECTRICAL EXTENSION CORDS WITH VOLTAGE STEP-DOWN AND BOOSTER TRANSFORMERS; SOFTWARE FOR MANAGING INVENTORY; SOFTWARE FOR TRACKING ASSETS, NAMELY, SOFTWARE FOR TRACKING THE LOCATION OF EQUIPMENT, PERSONAL PROPERTY, PACKAGES AND/OR DOCUMENTS; SOFTWARE FOR TRACKING DOCUMENTS, NAMELY, SOFTWARE FOR TRACKING THE LOCATION OF DOCUMENTS; AND SOFTWARE FOR OPERATING BAR CODING SYSTEMS AND EQUIPMENT (U.S. CLS. 21, 23, 26, 36 AND 38).

JASON BLAIR, EXAMINING ATTORNEY

**CLASS 9—(Continued).**

SN 86-089,762. BRUNO MARS MUSIC, LLC, LOS ANGELES, CA. FILED 10-11-2013.

# LA JUNGLA

THE MARK CONSISTS OF STANDARD CHARACTERS WITHOUT CLAIM TO ANY PARTICULAR FONT, STYLE, SIZE, OR COLOR.

THE ENGLISH TRANSLATION OF "LA JUNGLA" IN THE MARK IS "THE JUNGLE".

FOR MUSICAL SOUND RECORDINGS; AUDIO-VISUAL RECORDINGS, NAMELY, COMPACT DISCS, TAPE CASSETTES, AUDIO CASSETTES, AUDIO TAPES, AUDIO DISCS, PHONOGRAPH RECORDS, CD-ROMS, VIDEO TAPES, VIDEO CASSETTES, VIDEO DISCS, DVDS, DIGITAL AUDIO TAPES (DATS), DOWNLOADABLE MP3 FILES, AND LASER DISCS, ALL FEATURING MUSIC AND SOUND TRACKS; DOWNLOADABLE MUSICAL SOUND RECORDINGS; DOWNLOADABLE VIDEO RECORDINGS FEATURING MUSIC; DOWNLOADABLE ELECTRONIC PUBLICATIONS IN THE NATURE OF BOOKS, BOOKLETS, MAGAZINES, JOURNALS, MANUALS, BROCHURES, LEAFLETS, PAMPHLETS AND NEWSLETTERS, ALL IN THE FIELD OF MUSIC, ENTERTAINMENT, TELEVISION, FILM, THE ARTS, FASHION, LIFESTYLES, CULTURE, SOCIAL ISSUES AND POLITICS; ELECTRONIC PUBLICATIONS, NAMELY, BOOKS, BOOKLETS, MAGAZINES, JOURNALS, MANUALS, BROCHURES, LEAFLETS, PAMPHLETS AND NEWSLETTERS, ALL IN THE FIELD OF MUSIC, ENTERTAINMENT, TELEVISION, FILM, THE ARTS, FASHION, LIFESTYLES, CULTURE, SOCIAL ISSUES AND POLITICS, RECORDED ON CD-ROMS, DISKETTES, FLOPPY DISKS, VIDEO CASSETTES, AND MAGNETIC TAPES; MAGNETS; DECORATIVE MAGNETS; REFRIGERATOR MAGNETS; NOVELTY MAGNETS; MOUSE PADS; COMPACT DISC CASES AND COVERS; FACE PLATES FOR CELL PHONES; JACKETS FOR VIDEO CASSETTES, TAPES AND DISCS; FITTED CASES FOR STORAGE AND TRANSPORTATION, NAMELY, CASES FOR COMPACT DISCS, AUDIO CASSETTES, VIDEO CASSETTES, CD-ROMS, COMPUTERS, CAMERAS, CAMCORDERS AND PORTABLE PHONES; COMPUTER CARRYING CASES; WRIST RESTS AND SUPPORTS FOR COMPUTER MOUSE USERS; WRIST RESTS FOR COMPUTERS AND COMPUTER ACCESSORIES; COMPUTER KEYBOARD WRIST PADS; PROTECTIVE EYEWEAR; EYEGLASSES AND EYEGGLASS FRAMES; SUNGLASSES AND SUNGLASS FRAMES; CLIP-ON SUNGLASSES; SPECTACLES AND SPECTACLE FRAMES; LENSES FOR EYEGLASSES, SUNGLASSES AND SPECTACLES; EYEGGLASS, SUNGLASS AND SPECTACLE CASES; EYEGGLASS, SUNGLASS AND SPECTACLE STRAPS; GOGGLES FOR SPORTS; MOTORCYCLE GOGGLES AND NIGHT VISION GOGGLES; EYEGGLASS, SUNGLASS AND SPECTACLE CHAINS; BINOCULARS; MAGNIFYING GLASSES; DOG, SIGNAL AND SPORT WHISTLES; DOWNLOADABLE MUSIC, RING TONES, GRAPHICS, AND ELECTRONIC GAMES VIA THE INTERNET AND WIRELESS DEVICES; DOWNLOADABLE WIRELESS GAME SOFTWARE; DOWNLOADABLE WIRELESS ENTERTAINMENT VIA THE INTERNET AND WIRELESS DEVICES, NAMELY, RING TONES, SCREEN SAVERS, IMAGES, AND WALLPAPER; COMPUTER GAME CARTRIDGES, DISCS, CASSETTES, TAPES, JOYSTICKS, PROGRAMS AND SOFTWARE; HAND HELD JOY STICK UNITS FOR PLAYING VIDEO GAMES; VIDEO GAME CARTRIDGES, VIDEO GAME DISCS, VIDEO GAME TAPE CASSETTES, VIDEO GAME SOFTWARE, VIDEO GAME PROGRAMS, AND VIDEO GAME JOYSTICKS; INTERACTIVE MULTIMEDIA COMPUTER GAME PROGRAM; INTERACTIVE VIDEO

**CLASS 9—(Continued).**

GAME PROGRAMS; INTERACTIVE AUDIO GAME DISCS CONTAINING ACTION GAMES AND ROLE PLAYING GAMES; INTERACTIVE VIDEO GAMES OF VIRTUAL REALITY COMPRISED OF COMPUTER HARDWARE AND SOFTWARE; VIRTUAL REALITY GAME SOFTWARE; MULTI-MEDIA SOFTWARE RECORDED ON CD-ROM FEATURING MUSIC, ENTERTAINMENT, AND GAMES; COMPUTER SOFTWARE FOR USE IN THE DESIGN, DEVELOPMENT AND EXECUTION OF WIRELESS GAME AND ENTERTAINMENT PROGRAMS AND APPLICATIONS (U.S. CLS. 21, 23, 26, 36 AND 38).

VIVIAN MICZNIK FIRST, EXAMINING ATTORNEY

SN 86-091,497. SPICON INDUSTRIES PTY LTD, SEAFORD, VICTORIA, AUSTRALIA, FILED 10-15-2013.

# LINEAR MATRIX

THE MARK CONSISTS OF STANDARD CHARACTERS WITHOUT CLAIM TO ANY PARTICULAR FONT, STYLE, SIZE, OR COLOR.

FOR LUMINOUS SIGNS (U.S. CLS. 21, 23, 26, 36 AND 38).

LINDA ORNDORFF, EXAMINING ATTORNEY

SN 86-093,926. VECTORSOFT AG, HEUSENSTAMM, FED REP GERMANY, FILED 10-17-2013.

# LyraVis

THE MARK CONSISTS OF STANDARD CHARACTERS WITHOUT CLAIM TO ANY PARTICULAR FONT, STYLE, SIZE, OR COLOR.

PRIORITY CLAIMED UNDER SEC. 44(D) ON FED REP GERMANY APPLICATION NO. 302013006342, FILED 9-12-2013, REG. NO. 302013006342, DATED 11-20-2013, EXPIRES 11-20-2023.

FOR PROGRAMS FOR DATA PROCESSING EQUIPMENT, NAMELY, DATABASE MANAGEMENT SOFTWARE FOR GENERAL USE; PROGRAM DEVELOPMENT SYSTEMS, NAMELY, COMPUTER APPLICATION SOFTWARE DEVELOPMENT TOOLS; DATABASE PROGRAMS, NAMELY, COMPUTER SOFTWARE FOR CREATING SEARCHABLE DATABASES OF INFORMATION AND DATA AND PROGRAMS ACCESSING THE DATABASE; DATA-PROCESSING EQUIPMENT; PARTS OF DATA PROCESSING INSTALLATIONS, NAMELY, COMPUTER HARDWARE (U.S. CLS. 21, 23, 26, 36 AND 38).

CHRIS WELLS, EXAMINING ATTORNEY



**CLASS 9—(Continued).**

SN 86-094,992. KRZYSZTOF WIAROWSKI, ZYWIEC, POLAND, FILED 10-18-2013.



PRIORITY CLAIMED UNDER SEC. 44(D) ON ERP CMNTY TM OFC APPLICATION NO. 012228615, FILED 10-16-2013, REG. NO. 012228615, DATED 4-11-2014, EXPIRES 10-16-2023.

NO CLAIM IS MADE TO THE EXCLUSIVE RIGHT TO USE "BUSINESS CARD BOOK", APART FROM THE MARK AS SHOWN.

THE COLOR(S) RED, ORANGE, BLACK AND WHITE IS/ ARE CLAIMED AS A FEATURE OF THE MARK.

THE MARK CONSISTS OF TWO INTERLOCKING TRIANGLES POINTING TO THE RIGHT THAT FORM A STYLISTIC LETTER "B", ONE TRIANGLE POINTING TO THE LEFT THAT FORMS THE STYLISTIC LETTER "C", AND ANOTHER SET OF TWO INTERLOCKING TRIANGLES POINTING TO THE RIGHT THAT FORM ANOTHER STYLISTIC LETTER "B"; THE COLOR OF THE TRIANGLES FADES FROM RED ON THE LEFT TO ORANGE ON THE RIGHT; AND THE WORDS "BUSINESS CARD BOOK" APPEAR BELOW THE DESIGN IN BLACK; ALL ON A WHITE BACKGROUND.

FOR COMPUTER SOFTWARE, NAMELY, SOFTWARE DEVELOPMENT TOOLS FOR THE CREATION OF MOBILE INTERNET APPLICATIONS AND CLIENT INTERFACES (U.S. CLS. 21, 23, 26, 36 AND 38).

MICHELLE DUBOIS, EXAMINING ATTORNEY

SN 86-096,513. QUALITY VISION INTERNATIONAL, INC., ROCHESTER, NY. FILED 10-21-2013.

# EVOLVE

THE MARK CONSISTS OF STANDARD CHARACTERS WITHOUT CLAIM TO ANY PARTICULAR FONT, STYLE, SIZE, OR COLOR.

FOR SOFTWARE FOR DIMENSIONAL MEASUREMENT AND INSPECTION OF MANUFACTURED PARTS FOR QUALITY CONTROL PURPOSES; COMPUTER SOFTWARE RELATING TO METROLOGY FOR THE PURPOSE OF MEASUREMENT AND INSPECTION OF MANUFACTURED PARTS FOR QUALITY CONTROL PURPOSES (U.S. CLS. 21, 23, 26, 36 AND 38).

ALEX KEAM, EXAMINING ATTORNEY

**CLASS 9—(Continued).**

SN 86-099,089. HARMAN INTERNATIONAL INDUSTRIES, INCORPORATED, NORTHRIDGE, CA. FILED 10-23-2013.



OWNER OF U.S. REG. NOS. 1,166,266, 4,061,882 AND OTHERS.

THE MARK CONSISTS OF THE WORDING "HARMAN" IN A RECTANGULAR BOX.

SEC. 2(F).

FOR FULL LINE OF AUDIO SOUND EQUIPMENT, NAMELY, APPARATUS AND INSTRUMENTS FOR RECORDING, TRANSMISSION, RECEPTION, PROCESSING, RETRIEVAL, REPRODUCTION AND MANIPULATION OF SOUND AND/OR AUDIO SIGNALS AND EFFECTS, SIGNAL PROCESSORS, AMPLIFIERS, POWER AMPLIFIERS, OPTICAL MEDIA PLAYERS, EQUALIZERS, MICROPHONES, SOUND EFFECTS PEDALS FOR MUSICAL INSTRUMENTS, NETWORKING DEVICES, NAMELY, COMPUTER SOFTWARE FOR REMOTE CONTROL OF ONE OR MORE AUDIO PRODUCTS, NAMELY, MICROPHONES, MIXERS, AMPLIFIERS, SIGNAL PROCESSORS AND SPEAKERS THAT IS USED FOR CONTROL AND CONFIGURING SAID AUDIO PRODUCTS, ELECTRONIC AUDIO EFFECTS APPARATUS, MIXING CONSOLES, MASTER AUDIO MIXING DESKS FOR USE IN AN AUDIO RECORDING STUDIO, ELECTRONIC MUSICAL RECORDING APPARATUS, NAMELY, EFFECTS PEDALS FOR MUSICAL INSTRUMENTS, SOUND ADAPTION APPARATUS FOR USE WITH MUSICAL INSTRUMENTS FOR CREATING AND REPRODUCING A VARIETY OF SOUND, SOUND AMPLIFIERS FOR MUSICAL INSTRUMENTS AND PARTS AND FITTINGS THEREOF, SOUND REINFORCEMENT AND/OR REPRODUCING APPARATUS IN THE NATURE OF BASS PROCESSORS, MICROPHONES, MIXING CONSOLES, SIGNAL PROCESSORS, AND CABLES FOR ELECTRICAL AND OPTICAL SIGNAL TRANSMISSION CONTROL APPARATUS FOR AUDIO SIGNALS, SIGNAL, SOUND, SURROUND, EFFECTS AND/OR VOICE PROCESSORS, HEADPHONES, EAR BUDS, LOUDSPEAKERS, AUDIO LOUDSPEAKER SYSTEMS, TRANSDUCERS, STUDIO MONITORS, TRANSMITTERS, DOCKING STATIONS, REMOTE CONTROLS, AUDIO AND VIDEO PLAYING AND RECORDING EQUIPMENT, COMPUTER SOFTWARE AND HARDWARE FOR OPERATING AND CONTROLLING AUDIO SOUND SYSTEMS AND MUSICAL AND SOUND REPRODUCING INSTRUMENTS, VEHICLE MULTIMEDIA AND AUDIO SYSTEMS AND COMPONENTS, NAMELY, AUDIO SPEAKERS, AMPLIFIERS, MULTIMEDIA CONNECTORS, MOBILE PHONE CONNECTORS, NAVIGATION SYSTEMS, CONTROL UNITS FOR AMPLIFIERS, MULTIMEDIA CONNECTORS, MOBILE PHONE CONNECTORS, NAVIGATION SYSTEMS, AND AUDIO SPEAKER SYSTEMS, PORTABLE NAVIGATION DEVICES, AUDIO AND VIDEO TRANSMITTING APPARATUS, NAMELY, ELECTRONIC MICROPHONE SPLITTERS, ELECTRONIC SIGNAL DISTRIBUTION SYSTEMS PRIMARILY USED FOR THE DISTRIBUTION OF AUDIO AND VIDEO SIGNALS, AND AUDIO TIME DELAY UNITS, APPARATUS FOR ALTERING THE TONAL CHARACTERISTICS OF AN AUDIO SIGNAL, NAMELY, AUDIO COMPRESSORS, EXPANDERS, DYNAMIC CHARACTERISTICS MODIFIERS, NOISE GATES, LIMITERS, ELECTRONIC AUDIO CROSSEOVERS, AND AUDIO TEST APPARATUS, NAMELY, PHASE CHECKERS, AUDIO ANALYZERS AND CABLE TESTERS, AUDIO EQUALIZERS, SOUND AMPLIFIERS, AND COMPUTER HARDWARE AND SOFTWARE FOR CONTROLLING AUDIO AND VIDEO EQUIPMENT, NONE OF THE AFORESAID GOODS UTILIZING SATELLITE TRANSMISSIONS, SIGNAL COMPRESSORS AND EXPANDERS, SIGNAL COMPRESSOR LIMITERS, ANALOG SIGNAL PROCESSORS, DIGITAL SIGNAL PROCESSORS, AUDIO NOISE REDUCERS, VOLTAGE CONTROLLED AMPLIFIERS, PROGRAMMED AUDIO SIGNAL ROUTE SELECTORS, MICROPROCESSOR

**CLASS 9—(Continued).**

CONTROLLED LOUDSPEAKER EQUALIZERS, AND AUDIO SIGNAL RANGE EXPANDERS AND RESTORERS, COMPUTER SOFTWARE THAT ENABLES THE WIRELESS TRANSMISSION AND PROVISION OF REAL-TIME INFORMATION REGARDING TRAFFIC, ROAD CONDITIONS, POINTS OF INTEREST, TOPICS OF GENERAL INTEREST AND ONLINE CONTENT VIA WIRELESS TRANSMISSIONS TO MOBILE COMMUNICATIONS DEVICES, MOBILE PHONES, AND ELECTRONIC DEVICES INSTALLED IN AUTOMOBILES AND OTHER VEHICLES, AND TO ENABLE AUTOMOBILE AND VEHICLE DRIVERS AND PASSENGERS TO COMMUNICATE WITH EACH OTHER AND SHARE REAL-TIME DATA, INFORMATION, OBSERVATIONS, COMMENTARY, OPINIONS, AND MULTIMEDIA AND ONLINE CONTENT VIA WIRELESS COMMUNICATIONS DEVICES MOBILE PHONES, AND ELECTRONIC DEVICES INSTALLED IN AUTOMOBILES AND OTHER VEHICLES, AND TO AGGREGATE SUCH DATA, INFORMATION, OBSERVATIONS, COMMENTARY, OPINIONS, AND OTHER CONTENT FOR TRANSMISSION OR BROADCAST BY OTHERS VIA THE INTERNET, RADIO OR TELEVISION, LED (LIGHT EMITTING DIODE) DISPLAYS, LED (LIGHT EMITTING DIODE) PANELS FOR DISPLAYING VIDEO OR IMAGES, ELECTRONIC REGULATING AND CONTROL DEVICES FOR THE OPERATION OF LEDS (LIGHT EMITTING DIODES), APPARATUS AND INSTRUMENTS FOR CONTROLLING LIGHTING, NAMELY APPARATUS AND INSTRUMENTS FOR CONTROLLING STAGE LIGHTING, APPARATUS AND INSTRUMENTS FOR OPERATION, CONTROLLING AND SUPERVISION OF LIGHTING, APPARATUS AND INSTRUMENTS FOR OPERATION, CONTROLLING AND SUPERVISION OF APPARATUS FOR LIGHTING AND OF LIGHTING SYSTEMS, COMPUTER HARDWARE AND COMPUTER SOFTWARE FOR OPERATION, CONTROLLING AND SUPERVISION OF LIGHTING, APPARATUS AND INSTRUMENTS FOR OPERATION, CONTROLLING AND SUPERVISION OF APPARATUS FOR LIGHTING AND OF LIGHTING SYSTEMS, COMPUTER HARDWARE AND COMPUTER SOFTWARE FOR ERROR DETECTION, ERROR DIAGNOSING AND ERROR REPORTING OF APPARATUS FOR LIGHTING AND OF LIGHTING SYSTEMS, COMPUTER CONTROLS FOR LIGHTING APPARATUS AND INSTRUMENTS, CONTROL CONSOLES FOR LIGHTING APPARATUS AND INSTRUMENTS, PROGRAMMABLE CONTROLS FOR LIGHTING APPARATUS AND INSTRUMENTS, REMOTE CONTROL APPARATUS FOR LIGHTING APPARATUS AND INSTRUMENTS, AUDIO SENSITIVE CONTROLS FOR LIGHTING APPARATUS AND INSTRUMENTS, LIGHTING CONTROL SOFTWARE NAMELY LIGHTING CONTROL SOFTWARE FOR USE IN COMMERCIAL AND INDUSTRIAL FACILITIES, IN THEATRES, IN NIGHT CLUBS AND AT CONCERTS, LIGHTING CONTROL SOFTWARE FOR USE IN STAGE LIGHTING APPARATUS AND INSTRUMENTS AND FOR CONTROLLING STAGE LIGHTING APPARATUS AND INSTRUMENTS, CABLES, CONNECTORS AND SWITCHES FOR STAGE LIGHTING APPARATUS AND INSTRUMENTS, IMAGE PROJECTORS FOR PROJECTION OF PATTERNS, IMAGES, LOGOS, TEXT OR SHAPES, CARRYING CASES AND FLIGHT CASES SPECIALLY ADAPTED FOR INSTRUMENTS FOR CONTROLLING LIGHTING APPARATUS (U.S. CLS. 21, 23, 26, 36 AND 38).

FIRST USE 4-0-2010; IN COMMERCE 4-0-2010.  
HENRY S. ZAK, EXAMINING ATTORNEY

**CLASS 9—(Continued).**

SN 86-099,935. TYLER JOSEPH WHITING, PANAMA CITY, FL. FILED 10-24-2013.

# Shout London

THE MARK CONSISTS OF STANDARD CHARACTERS WITHOUT CLAIM TO ANY PARTICULAR FONT, STYLE, SIZE, OR COLOR.

FOR AUDIO RECORDINGS FEATURING A MUSIC BAND; DIGITAL MEDIA, NAMELY, PRE-RECORDED DVDS, DOWNLOADABLE AUDIO AND VIDEO RECORDINGS, AND CDS FEATURING AND PROMOTING A MUSIC BAND; DIGITAL MEDIA, NAMELY, PRE-RECORDED VIDEO CASSETTES, DIGITAL VIDEO DISCS, DIGITAL VERSATILE DISCS, DOWNLOADABLE AUDIO AND VIDEO RECORDINGS, DVDS, AND HIGH DEFINITION DIGITAL DISCS FEATURING A MUSIC BAND; DOWNLOADABLE MP3 FILES AND MP3 RECORDINGS FEATURING A MUSIC BAND; DOWNLOADABLE MUSICAL SOUND RECORDINGS; DOWNLOADABLE VIDEO RECORDINGS FEATURING A MUSIC BAND; ELECTRONIC PUBLICATIONS, NAMELY, AUDIO FILES FEATURING A MUSIC BAND RECORDED ON COMPUTER MEDIA; MUSICAL RECORDINGS; MUSICAL SOUND RECORDINGS; MUSICAL VIDEO RECORDINGS; PRE-RECORDED CDS FEATURING A MUSIC BAND; PRE-RECORDED CDS, VIDEO TAPES, LASER DISKS AND DVDS FEATURING A MUSIC BAND; PRE-RECORDED DIGITAL MEDIA FEATURING A MUSIC BAND; PRE-RECORDED DIGITAL VIDEO DISCS FEATURING A MUSIC BAND; PRE-RECORDED DVDS FEATURING A MUSIC BAND; VISUAL AND AUDIO RECORDINGS FEATURING A MUSIC BAND (U.S. CLS. 21, 23, 26, 36 AND 38).

FIRST USE 3-2-2013; IN COMMERCE 3-3-2013.  
WILLIAM VERHOSEK, EXAMINING ATTORNEY

SN 86-100,832. FIRST TEXAS PRODUCTS, LLC, EL PASO, TX. FILED 10-24-2013.

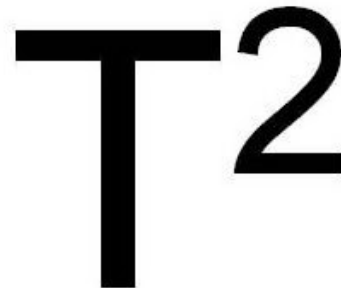

THE MARK CONSISTS OF THE LETTER "T" WITH SUPERSCRIP "2".  
FOR METAL DETECTORS (U.S. CLS. 21, 23, 26, 36 AND 38).  
FIRST USE 7-0-2005; IN COMMERCE 7-0-2005.  
DAVID ELTON, EXAMINING ATTORNEY

**CLASS 9—(Continued).**

SN 86-101,099. OMNIPOTENCE LLC, CHARLESTOWN, ST. KITTS-NEVIS, FILED 10-24-2013.

**MR. HOW-NOT-TOO**

THE MARK CONSISTS OF STANDARD CHARACTERS WITHOUT CLAIM TO ANY PARTICULAR FONT, STYLE, SIZE, OR COLOR.

FOR DOWNLOADABLE FILM RECORDINGS FEATURING COMEDIC ROUTINES (U.S. CLS. 21, 23, 26, 36 AND 38).

ALICIA COLLINS, EXAMINING ATTORNEY

SN 86-103,344. NCR CORPORATION, DULUTH, GA. FILED 10-29-2013.

**PACESETTER**

THE MARK CONSISTS OF STANDARD CHARACTERS WITHOUT CLAIM TO ANY PARTICULAR FONT, STYLE, SIZE, OR COLOR.

FOR BARCODE SCANNING SOFTWARE THAT ENABLES READING OF DEFECTIVE BARCODES (U.S. CLS. 21, 23, 26, 36 AND 38).

FIRST USE 12-31-1991; IN COMMERCE 12-31-1991.  
HENRY S. ZAK, EXAMINING ATTORNEY

SN 86-104,342. LIGHTRICKS LTD., JERUSALEM, ISRAEL, FILED 10-29-2013.

**FACETUNE**

THE MARK CONSISTS OF STANDARD CHARACTERS WITHOUT CLAIM TO ANY PARTICULAR FONT, STYLE, SIZE, OR COLOR.

FOR COMPUTER SOFTWARE AND DOWNLOADABLE COMPUTER SOFTWARE APPLICATIONS FOR PHOTO, VIDEO AND IMAGE EDITING, TOUCH UP AND ENHANCEMENT (U.S. CLS. 21, 23, 26, 36 AND 38).

FIRST USE 3-7-2013; IN COMMERCE 3-7-2013.  
CYNTHIA TRIPI, EXAMINING ATTORNEY

**CLASS 9—(Continued).**

SN 86-104,522. LEBOFF, JAY, BEDFORD, NY. FILED 10-29-2013.

**EDU-STATION**

THE COLOR(S) BLUE AND GREEN IS/ARE CLAIMED AS A FEATURE OF THE MARK.

THE MARK CONSISTS OF THE WORDS "EDU" IN BLUE AND "STATION" IN GREEN WITH BLUE CENTER BARS IN THE LETTERS "T", IN A STYLIZED CHARACTER FORM WITH A BLUE HYPHEN BETWEEN THE WORDS.

FOR PORTABLE VEHICLE OR AIRCRAFT SIMULATOR COMPRISING COMPUTER HARDWARE AND SOFTWARE FOR TRAINING IN THE USE AND OPERATION OF VEHICLES OR AIRCRAFT (U.S. CLS. 21, 23, 26, 36 AND 38).

DOMINIC J. FERRAIUOLO, EXAMINING ATTORNEY

SN 86-105,399. MULTIMEDIA GAMES, INC., AUSTIN, TX. FILED 10-30-2013.

**WILD PAIRS**

THE MARK CONSISTS OF STANDARD CHARACTERS WITHOUT CLAIM TO ANY PARTICULAR FONT, STYLE, SIZE, OR COLOR.

NO CLAIM IS MADE TO THE EXCLUSIVE RIGHT TO USE "PAIRS", APART FROM THE MARK AS SHOWN.

FOR COMPUTER GAME SOFTWARE FOR GAMING MACHINES INCLUDING SLOT MACHINES OR VIDEO LOTTERY TERMINALS; COMPUTER SOFTWARE AND FIRMWARE FOR GAMES OF CHANCE ON ANY COMPUTERIZED PLATFORM, INCLUDING DEDICATED GAMING CONSOLES, VIDEO BASED SLOT MACHINES, REEL BASED SLOT MACHINES, AND VIDEO LOTTERY TERMINALS; GAMING SOFTWARE THAT GENERATES OR DISPLAYS WAGER OUTCOMES OF GAMING MACHINES (U.S. CLS. 21, 23, 26, 36 AND 38).

ELIZABETH JACKSON, EXAMINING ATTORNEY

**CLASS 9—(Continued).**

SN 86-105,804. ECTOR, ELLEN, ATLANTA, GA. AND ECTOR, CHALANA, ATLANTA, GA. AND ECTOR, ROBERT, ATLANTA, GA. FILED 10-30-2013.



THE MARK CONSISTS OF A SQUARE BOX INSIDE OF WHICH IS THE WORDING "SNATCH IT BACK". FOR DVDS FEATURING WORKOUT VIDEOS (U.S. CLS. 21, 23, 26, 36 AND 38).  
ERIN FALK, EXAMINING ATTORNEY

SN 86-107,253. AINSWORTH GAME TECHNOLOGY LIMITED, NEWINGTON, AUSTRALIA, FILED 10-31-2013.

# 7TH HEAVEN

THE MARK CONSISTS OF STANDARD CHARACTERS WITHOUT CLAIM TO ANY PARTICULAR FONT, STYLE, SIZE, OR COLOR.

FOR COMPUTER SOFTWARE AND FIRMWARE FOR GAMES OF CHANCE ON ANY COMPUTERIZED PLATFORM, INCLUDING DEDICATED GAMING CONSOLES, VIDEO BASED SLOT MACHINES, REEL BASED SLOT MACHINES, AND VIDEO LOTTERY TERMINALS (U.S. CLS. 21, 23, 26, 36 AND 38).  
JEFFREY LOOK, EXAMINING ATTORNEY

**CLASS 9—(Continued).**

SN 86-107,718. AUTOMATED QUALITY TECHNOLOGIES, INC., SHOREVIEW, MN. FILED 11-1-2013.



NO CLAIM IS MADE TO THE EXCLUSIVE RIGHT TO USE "SPINDLE ERROR ANALYZER", APART FROM THE MARK AS SHOWN.

THE MARK CONSISTS OF CROSS HAIRS AXIALLY DISPOSED WITHIN THREE CONCENTRIC CIRCLES, WITH A CIRCULAR ARROW DISPOSED BETWEEN THE FIRST AND SECOND INNERMOST CIRCLES, AND A PAIR OF IRREGULAR CIRCULAR LINES DISPOSED OVER THE SECOND INNER MOST CIRCLE, AND WITH THE WORDS "SPINDLE ERROR ANALYZER" STACKED TO THE CENTER RIGHT HAND SIDE OF THE CIRCLES.

FOR COMPUTER SYSTEMS COMPRISING COMPUTER HARDWARE AND SOFTWARE FOR MEASURING AND ANALYZING THE ACCURACY OF ROTATING SPINDLES (U.S. CLS. 21, 23, 26, 36 AND 38).

KATHRYN COWARD, EXAMINING ATTORNEY

SN 86-108,320. KPMG LLP, NEW YORK, NY. FILED 11-1-2013.

# DATA NEUROSYSTEM

THE MARK CONSISTS OF STANDARD CHARACTERS WITHOUT CLAIM TO ANY PARTICULAR FONT, STYLE, SIZE, OR COLOR.

NO CLAIM IS MADE TO THE EXCLUSIVE RIGHT TO USE "DATA", APART FROM THE MARK AS SHOWN.

FOR COMPUTER SOFTWARE FOR GATHERING, COMPILING, ORGANIZING, MANIPULATING, SEARCHING, ANALYZING AND CREATING SEARCHABLE DATABASES OF INFORMATION AND DATA, AND FOR COMPUTING AND PROCESSING INFORMATION AND DATA; DOWNLOADABLE SOFTWARE FOR GATHERING, COMPILING, ORGANIZING, MANIPULATING, SEARCHING, ANALYZING AND CREATING SEARCHABLE DATABASES OF INFORMATION AND DATA (U.S. CLS. 21, 23, 26, 36 AND 38).

FIRST USE 10-28-2013; IN COMMERCE 10-28-2013.

JEFF DEFORD, EXAMINING ATTORNEY

**CLASS 9—(Continued).**

SN 86-108,589. TELEMUNDO NETWORK GROUP LLC, HIALEAH, FL. FILED 11-1-2013.

**SUELTA LA SOPA**

THE MARK CONSISTS OF STANDARD CHARACTERS WITHOUT CLAIM TO ANY PARTICULAR FONT, STYLE, SIZE, OR COLOR.

THE ENGLISH TRANSLATION OF "SUELTA LA SOPA" IN THE MARK IS "SPILL THE BEANS".

FOR DIGITAL MEDIA, NAMELY, DOWNLOADABLE AUDIO, VIDEO AND AUDIOVISUAL FILES AND MULTIMEDIA ENTERTAINMENT CONTENT IN THE FIELD OF COMMENTARY, INTERVIEWS AND INFORMATION IN THE FIELD OF ENTERTAINMENT; DOWNLOADABLE APPLICATION SOFTWARE FOR MOBILE, PORTABLE AND HANDHELD DEVICES THAT ALLOW USERS TO VIEW AND PLAY AUDIO, VISUAL AND AUDIOVISUAL ELEMENTS AND INFORMATION RELATING TO CONTENT IN THE FIELD OF ENTERTAINMENT; COMPUTER APPLICATION SOFTWARE FOR MOBILE, PORTABLE AND HANDHELD DEVICES FOR USE IN DISTRIBUTION AND VIEWING OF AUDIO, VIDEO, AND AUDIOVISUAL ELEMENTS AND INFORMATION RELATING TO CONTENT IN THE FIELD OF ENTERTAINMENT; DOWNLOADABLE ELECTRONIC PUBLICATIONS, NAMELY, INFORMATIONAL SHEETS, INFORMATIONAL FLYERS, LEAFLETS, NEWSLETTERS, PERIODICALS, BOOKS AND MANUALS FEATURING INFORMATION RELATING TO AUDIOVISUAL AND MULTIMEDIA ENTERTAINMENT CONTENT (U.S. CLS. 21, 23, 26, 36 AND 38).

JOHN E. MICHOS, EXAMINING ATTORNEY

**CLASS 9—(Continued).**

SN 86-112,012. BIMBA MANUFACTURING COMPANY, MONEE, IL. FILED 11-6-2013.

**INTELLIVALVE**

THE MARK CONSISTS OF STANDARD CHARACTERS WITHOUT CLAIM TO ANY PARTICULAR FONT, STYLE, SIZE, OR COLOR.

OWNER OF U.S. REG. NO. 3,908,777.

FOR SOFTWARE AND PRESSURE AND/OR TEMPERATURE SENSORS FOR OPERATING FLUID CONTROL VALVES THAT MANAGE FLUID POWERED SYSTEMS AND MACHINES INVOLVED IN FACTORY AUTOMATION (U.S. CLS. 21, 23, 26, 36 AND 38).

CYNTHIA TRIPI, EXAMINING ATTORNEY

SN 86-112,050. BIMBA MANUFACTURING COMPANY, MONEE, IL. FILED 11-6-2013.

SN 86-110,986. BELDEN INC., ST. LOUIS, MO. FILED 11-5-2013.

**BRILLIANCE**

THE MARK CONSISTS OF STANDARD CHARACTERS WITHOUT CLAIM TO ANY PARTICULAR FONT, STYLE, SIZE, OR COLOR.

OWNER OF U.S. REG. NOS. 1,938,770, 2,133,223 AND 2,974,489.

FOR WIRE, NAMELY, ELECTRIC WIRE, ELECTRIC CORDS, ELECTRICAL AND COMMUNICATION CABLES, FIBER OPTIC CABLES, AND CABLE CONNECTORS FOR USE WITH FIBER OPTIC CABLES AND ELECTRONIC CABLE PREPARATION AND TERMINATION; MOLDED CABLE ASSEMBLIES, NAMELY CABLES SOLD WITH CONNECTORS, PLUGS OR TERMINALS ATTACHED (U.S. CLS. 21, 23, 26, 36 AND 38).

FIRST USE 1-0-2010; IN COMMERCE 1-0-2010.

HEATHER BIDDULPH, EXAMINING ATTORNEY

**PNEUMATICS 2.0**

THE MARK CONSISTS OF STANDARD CHARACTERS WITHOUT CLAIM TO ANY PARTICULAR FONT, STYLE, SIZE, OR COLOR.

NO CLAIM IS MADE TO THE EXCLUSIVE RIGHT TO USE "PNEUMATICS", APART FROM THE MARK AS SHOWN.

FOR SOFTWARE AND PRESSURE AND/OR TEMPERATURE SENSORS FOR MANAGING FLUID POWERED SYSTEMS AND MACHINES INVOLVED IN FACTORY AUTOMATION (U.S. CLS. 21, 23, 26, 36 AND 38).

CYNTHIA TRIPI, EXAMINING ATTORNEY

**CLASS 9—(Continued).**

SN 86-112,370. 1STPAYGATEWAY, LLC, FORT WORTH, TX. FILED 11-6-2013.

# 1stPayTerminal

THE MARK CONSISTS OF STANDARD CHARACTERS WITHOUT CLAIM TO ANY PARTICULAR FONT, STYLE, SIZE, OR COLOR.

OWNER OF U.S. REG. NOS. 3,203,268, 4,452,518 AND 4,452,519.

FOR ELECTRONIC PAYMENT TERMINAL AND POINT OF SALE PAYMENT PROCESSING EQUIPMENT, NAMELY, PAYMENT CARD TERMINALS, PIN PADS, BAR CODE AND QR CODE READERS, MAGNETIC STRIPE READERS, EMV READERS, NFC READERS, ELECTRONIC WALLET READERS, CHECK SCANNERS AND READERS, CASH DRAWERS, PRINTERS, AND POINT-OF-SALE SYSTEMS CONSISTING OF SOME COMBINATION OF THE FOREGOING EQUIPMENT IN CONJUNCTION WITH A COMPUTER-BASED OR TABLET-BASED OPERATING SYSTEM (U.S. CLS. 21, 23, 26, 36 AND 38).

ZACHARY CROMER, EXAMINING ATTORNEY

SN 86-113,351. SAMSUNG ELECTRONICS CO., LTD., GYEONGGI-DO, REPUBLIC OF KOREA, FILED 11-8-2013.



OWNER OF U.S. REG. NOS. 3,503,660, 4,486,912 AND OTHERS.

THE MARK CONSISTS OF THE WORDS "GALAXY 11" ABOVE A STYLIZED "G11" AND THE WORDS "SAMSUNG GALAXY" BELOW.

THE ENGLISH TRANSLATION OF "SAMSUNG" IN THE MARK IS "THREE STARS".

FOR MOBILE APPLICATION SOFTWARE FOR MOBILE PHONES, SMART PHONES AND TABLET COMPUTERS TO ENABLE AUTHORIZING, POSTING, UPLOADING, DOWNLOADING, TRANSMITTING, RECEIVING, EDITING, EXTRACTING, ENCODING, DECODING, PLAYING, STORING, ORGANIZING, SHOWING, DISPLAYING, TAGGING, BLOGGING AND SHARING ELECTRONIC MEDIA AND INFORMATION OVER THE INTERNET, LOCAL AREA NETWORK OR TELECOMMUNICATION NETWORK IN THE FIELD OF SOCIAL AND LEAGUE SPORTS GAMES AND SPORTING EVENTS; COMPUTER SOFTWARE FOR MOBILE PHONES, SMART PHONES AND TABLET COMPUTERS TO ENABLE AUTHORIZING, POSTING, UPLOADING, DOWNLOADING, TRANSMITTING, RECEIVING, EDITING, EXTRACTING, ENCODING, DECODING, PLAYING, STORING, ORGANIZING, SHOWING, DISPLAYING, TAGGING, BLOGGING AND SHARING ELECTRONIC MEDIA AND INFORMATION OVER THE

**CLASS 9—(Continued).**

INTERNET, LOCAL AREA NETWORK OR TELECOMMUNICATION NETWORK IN THE FIELD OF SOCIAL AND LEAGUE SPORTS GAMES AND SPORTING EVENTS; COMPUTER PROGRAM FOR MOBILE PHONES, SMART PHONES AND TABLET COMPUTERS TO ENABLE AUTHORIZING, POSTING, UPLOADING, DOWNLOADING, TRANSMITTING, RECEIVING, EDITING, EXTRACTING, ENCODING, DECODING, PLAYING, STORING, ORGANIZING, SHOWING, DISPLAYING, TAGGING, BLOGGING AND SHARING ELECTRONIC MEDIA AND INFORMATION OVER THE INTERNET, LOCAL AREA NETWORK OR TELECOMMUNICATION NETWORK IN THE FIELD OF SOCIAL AND LEAGUE SPORTS GAMES AND SPORTING EVENTS; DIGITAL CAMERAS; MOBILE TELEPHONES; PORTABLE MEDIA PLAYERS; PORTABLE COMPUTERS; RECHARGEABLE BATTERIES; SMART PHONES; TABLET COMPUTERS; WIRELESS HEADSETS FOR MOBILE PHONES AND TABLET COMPUTERS; BATTERY CHARGERS; LEATHER CASES SPECIALLY ADAPTED FOR MOBILE PHONES, SMART PHONES AND TABLET COMPUTERS; FLIP COVERS FOR MOBILE PHONES, SMART PHONES AND TABLET COMPUTERS; DISPLAY SCREEN PROTECTORS IN THE NATURE OF FILMS SPECIALLY ADAPTED FOR MOBILE PHONES, SMART PHONES AND TABLET COMPUTERS; TELEVISION RECEIVERS (U.S. CLS. 21, 23, 26, 36 AND 38).

MICHAEL TANNER, EXAMINING ATTORNEY

SN 86-115,578. MASCOTTE HOLDINGS, INC., NEW YORK, NY. FILED 11-11-2013.

# YEEZUS

THE MARK CONSISTS OF STANDARD CHARACTERS WITHOUT CLAIM TO ANY PARTICULAR FONT, STYLE, SIZE, OR COLOR.

FOR MUSICAL SOUND RECORDINGS; AUDIO-VISUAL RECORDINGS, NAMELY, COMPACT DISCS, TAPE CASSETTES, AUDIO CASSETTES, AUDIO TAPES, AUDIO DISCS, PHONOGRAPH RECORDS, CD-ROMS, VIDEO TAPES, VIDEO CASSETTES, VIDEO DISCS, DVDS, DIGITAL AUDIO TAPES (DATS), DOWNLOADABLE MP3 FILES, AND LASER DISCS, ALL FEATURING MUSIC AND SOUND TRACKS; DOWNLOADABLE MUSICAL SOUND RECORDINGS; DOWNLOADABLE VIDEO RECORDINGS FEATURING MUSIC; DOWNLOADABLE ELECTRONIC PUBLICATIONS IN THE NATURE OF BOOKS, BOOKLETS, MAGAZINES, JOURNALS, MANUALS, BROCHURES, LEAFLETS, PAMPHLETS AND NEWSLETTERS, ALL IN THE FIELD OF MUSIC, ENTERTAINMENT, TELEVISION, FILM, THE ARTS, FASHION, LIFESTYLES, CULTURE, SOCIAL ISSUES AND POLITICS; ELECTRONIC PUBLICATIONS, NAMELY, BOOKS, BOOKLETS, MAGAZINES, JOURNALS, MANUALS, BROCHURES, LEAFLETS, PAMPHLETS AND NEWSLETTERS, ALL IN THE FIELD OF MUSIC, ENTERTAINMENT, TELEVISION, FILM, THE ARTS, FASHION, LIFESTYLES, CULTURE, SOCIAL ISSUES AND POLITICS, RECORDED ON CD-ROMS, DISKETTES, FLOPPY DISKS, VIDEO CASSETTES, AND MAGNETIC TAPES; MAGNETS; DECORATIVE MAGNETS; REFRIGERATOR MAGNETS; NOVELTY MAGNETS; MOUSE PADS; COMPACT DISC CASES AND COVERS; FACE PLATES IN THE NATURE OF COVERS FOR CELL PHONES; JACKETS FOR VIDEO CASSETTES, TAPES AND DISCS; FITTED CASES FOR STORAGE AND TRANSPORTATION, NAMELY, CASES FOR COMPACT DISCS, AUDIO CASSETTES, VIDEO CASSETTES, CD-ROMS, COMPUTERS, CAMERAS, CAMCORDERS AND PORTABLE PHONES; COMPUTER CARRYING CASES; WRIST RESTS AND SUPPORTS FOR COMPUTER MOUSE USERS; WRIST RESTS FOR USE WITH COMPUTERS AND COMPUTER ACCESSORIES; COM-

**CLASS 9—(Continued).**

PUTER KEYBOARD WRIST PADS; PROTECTIVE EYEWEAR; EYEGLASSES AND EYEGGLASS FRAMES; SUNGLASSES AND SUNGLASS FRAMES; CLIP-ON SUNGLASSES; SPECTACLES AND SPECTACLE FRAMES; LENSES FOR EYEGLASSES, SUNGLASSES AND SPECTACLES; EYEGGLASS, SUNGLASS AND SPECTACLE CASES; EYEWEAR ACCESSORIES, NAMELY, EYEGGLASS, SUNGLASS AND SPECTACLE STRAPS WHICH RESTRAIN EYEWEAR FROM MOVEMENT ON A WEARER; GOGGLES FOR SPORTS; MOTORCYCLE GOGGLES AND NIGHT VISION GOGGLES; EYEGGLASS, SUNGLASS AND SPECTACLE CHAINS; BINOCULARS; MAGNIFYING GLASSES; DOWNLOADABLE MUSIC, RING TONES, GRAPHICS, AND ELECTRONIC GAMES VIA THE INTERNET AND WIRELESS DEVICES; DOWNLOADABLE WIRELESS GAME SOFTWARE ACCESSIBLE VIA THE INTERNET AND WIRELESS DEVICES; DOWNLOADABLE WIRELESS ENTERTAINMENT VIA THE INTERNET AND WIRELESS DEVICES, NAMELY, RING TONES, AND DOWNLOADABLE COMPUTER SOFTWARE FEATURING SCREEN SAVERS, IMAGES, AND WALLPAPER; COMPUTER GAME CARTRIDGES, DISCS, PROGRAMS AND SOFTWARE; VIDEO GAME CARTRIDGES, VIDEO GAME DISCS, VIDEO GAME TAPE CASSETTES, VIDEO GAME SOFTWARE AND VIDEO GAME PROGRAMS; INTERACTIVE MULTIMEDIA COMPUTER GAME PROGRAM; INTERACTIVE VIDEO GAME PROGRAMS; INTERACTIVE AUDIO GAME DISCS CONTAINING ACTION GAMES AND ROLE PLAYING GAMES; INTERACTIVE VIDEO GAMES OF VIRTUAL REALITY COMPRISED OF COMPUTER HARDWARE AND SOFTWARE; VIRTUAL REALITY GAME SOFTWARE; MULTI-MEDIA SOFTWARE RECORDED ON CD-ROM FEATURING MUSIC, ENTERTAINMENT, AND GAMES; COMPUTER SOFTWARE FOR USE IN THE DESIGN, DEVELOPMENT AND EXECUTION OF WIRELESS GAME AND ENTERTAINMENT PROGRAMS AND APPLICATIONS (U.S. CLS. 21, 23, 26, 36 AND 38).

JONATHAN FALK, EXAMINING ATTORNEY

**CLASS 9—(Continued).**

SN 86-116,607. ALFRED FRANKS & BARTLETT PLC, HERTFORDSHIRE, UNITED KINGDOM, FILED 11-12-2013.

# SISKIN

THE MARK CONSISTS OF STANDARD CHARACTERS WITHOUT CLAIM TO ANY PARTICULAR FONT, STYLE, SIZE, OR COLOR.

PRIORITY CLAIMED UNDER SEC. 44(D) ON UNITED KINGDOM APPLICATION NO. 3030123, FILED 11-11-2013, REG. NO. 3030123, DATED 3-7-2014, EXPIRES 11-11-2023.

FOR CASES AND PROTECTIVE CASES FOR MOBILE TELEPHONES AND PORTABLE MEDIA PLAYERS; PROTECTIVE COVERS FOR MOBILE TELEPHONES AND PORTABLE MEDIA PLAYERS; HEADPHONES, EARPHONES, AUDIO SPEAKERS, PORTABLE AUDIO SPEAKERS; SCREEN PROTECTORS SPECIALLY ADAPTED FOR MOBILE TELEPHONES AND PORTABLE MEDIA PLAYERS; BATTERY CHARGERS, TRAVEL BATTERY CHARGERS, IN-CAR BATTERY CHARGERS AND PORTABLE BATTERY CHARGERS, ALL FOR MOBILE TELEPHONES, PORTABLE MEDIA PLAYERS AND SATELLITE NAVIGATION DEVICES; CRADLES, STANDS, HOLDERS AND IN-CAR HOLDERS FOR MOBILE TELEPHONES, PORTABLE MEDIA PLAYERS AND SATELLITE NAVIGATION DEVICES; ARMBANDS SPECIALLY ADAPTED FOR PERSONAL ELECTRONIC DEVICES, NAMELY, FOR ATTACHING MOBILE TELEPHONES AND PORTABLE MEDIA PLAYERS TO THE BODY; PARTS AND FITTINGS FOR ALL THE AFORESAID GOODS SOLD AS COMPONENTS WITH THE GOODS (U.S. CLS. 21, 23, 26, 36 AND 38).

ELIZABETH KAJUBI, EXAMINING ATTORNEY

SN 86-116,392. GRAPESEED MEDIA LTD., CENTRAL, HONG KONG, FILED 11-12-2013.

# GRAPELEAF

THE MARK CONSISTS OF STANDARD CHARACTERS WITHOUT CLAIM TO ANY PARTICULAR FONT, STYLE, SIZE, OR COLOR.

FOR DOWNLOADABLE SOFTWARE FOR CREATING, ASSESSING, TRACKING, MONITORING, MANAGING, AND ANALYZING EDUCATIONAL LEARNING PROGRESS AND RESULTS FOR USE BY STUDENTS, TEACHERS, ADMINISTRATORS, AND PARENTS; DOWNLOADABLE COMPUTER SOFTWARE FOR GENERATING LESSON PLANS (U.S. CLS. 21, 23, 26, 36 AND 38).

LESLEY LAMOTHE, EXAMINING ATTORNEY

SN 86-117,845. UNIVERSITY OF NORTHERN IOWA, CEDAR FALLS, IA. FILED 11-13-2013.



## Name That!

NO CLAIM IS MADE TO THE EXCLUSIVE RIGHT TO USE "NAME THAT", APART FROM THE MARK AS SHOWN.

THE MARK CONSISTS OF A SOLID HEAD WITH A PUZZLE PIECE SUSPENDED WITHIN. A DIALOGUE BALLOON DIRECTLY OPPOSITE THE SOLID HEAD'S MOUTH. IN THE DIALOGUE BALLOON IS A PUZZLE PIECE. THE WORDS "NAME THAT" FOLLOWED BY AN EXCLAMATION MARK APPEAR TO THE RIGHT OF THE SOLID HEAD AND BELOW THE DIALOGUE BALLOON. THE "N" ON "NAME" AND THE "T" ON "THAT" ARE IN CAPITAL LETTERS WHILE THE REST OF EACH WORD IS IN LOWERCASE. THE FONT FOR "NAME THAT!" IS BERTHOLD IMAGO EXTRA BOLD.

FOR DOWNLOADABLE MOBILE APPLICATION FOR HELPING PEOPLE WITH APHASIA AND INDIVIDUALS WITH SPECIAL NEEDS TO IMPROVE THEIR NAMING, WORD-FINDING, AND DESCRIBING ABILITIES (U.S. CLS. 21, 23, 26, 36 AND 38).

FIRST USE 10-1-2013; IN COMMERCE 10-12-2013.

LINDA ORNDORFF, EXAMINING ATTORNEY

**CLASS 9—(Continued).**

SN 86-119,408. LANCE NEWQUIST, KIHEI, HI. AND ROBERT MITCHELL, ALPINE, CA. FILED 11-14-2013.

# SAFEHAWK

THE MARK CONSISTS OF STANDARD CHARACTERS WITHOUT CLAIM TO ANY PARTICULAR FONT, STYLE, SIZE, OR COLOR.

FOR EMERGENCY CATASTROPHIC COMMUNICATIONS SYSTEM FOR USE IN THE CIVILIAN MARKET COMPRISED OF AIRBORNE AND SATELLITE RADIO FREQUENCY RECEIVERS, TRANSMITTERS, ANTENNAS, AMPLIFIERS, COMPUTER HARDWARE AND COMPUTER SOFTWARE (U.S. CLS. 21, 23, 26, 36 AND 38).

ANDREW LEASER, EXAMINING ATTORNEY

SN 86-120,786. CHANFUL VOICE TECHNIC CO., LTD., TAICHUNG CITY, TAIWAN, FILED 11-16-2013.

# AV-ART

THE MARK CONSISTS OF THE STYLIZED LETTERS "AV-ART".

FOR MICROPHONES, HEADPHONES, RADIO TRANSMITTERS, RADIO RECEIVERS, PROTECTIVE COVERS FOR MICROPHONES, LOUDSPEAKERS (U.S. CLS. 21, 23, 26, 36 AND 38).

FIRST USE 9-21-2013; IN COMMERCE 9-21-2013.

KATHERINE STOIDES, EXAMINING ATTORNEY

SN 86-120,885. FLEX BOOTH, INC., IRVINE, CA. FILED 11-16-2013.

# FLEXBOOTH

THE MARK CONSISTS OF THE WORDS "FLEXBOOTH" WITH THE LETTER "X" HAVING A CIRCLE ABOVE IT, REPRESENTING A PERSON THAT IS FLEXING HIS ARMS AND LEGS.

FOR APPARATUS FOR BROADCASTING, RECORDING, TRANSMISSION OR REPRODUCTION OF SOUND OR IMAGES; APPARATUS FOR RECORDING AND REPRODUCTION OF SOUND, IMAGES OR DATA; APPARATUS FOR RECORDING, TRANSMISSION AND REPRODUCTION OF IMAGES; APPARATUS FOR RECORDING, TRANSMISSION OR REPRODUCTION OF SOUND AND IMAGES; APPARATUS FOR RECORDING, TRANSMISSION, PROCESSING AND REPRODUCTION OF SOUND, IMAGES OR DATA; APPARATUS FOR RECORDING, TRANSMITTING AND REPRODUCING SOUND AND IMAGES; APPARATUS FOR THE RECORDING, TRANSMISSION AND REPRODUCTION OF SOUND AND IMAGES; APPARATUS FOR TRANSMIT-

**CLASS 9—(Continued).**

TING AND REPRODUCING SOUND OR IMAGES; CABLES AND FIBRES FOR THE TRANSMISSION OF SOUNDS AND IMAGES; CAMERA CONTAINING A LINEAR IMAGE SENSOR; CENTRAL PROCESSING UNITS FOR PROCESSING INFORMATION, DATA, SOUND OR IMAGES; COMPUTER HARDWARE AND COMPUTER SOFTWARE PROGRAMS FOR THE INTEGRATION OF TEXT, AUDIO, GRAPHICS, STILL IMAGES AND MOVING PICTURES INTO AN INTERACTIVE DELIVERY FOR MULTIMEDIA APPLICATIONS; COMPUTER HARDWARE AND SOFTWARE FOR MEDICAL IMAGING APPARATUS; COMPUTER PROCESSING SOFTWARE TO PROCESS THE IMAGE COLORS WITH THE COLOR AND INTENSITY AND INTERPRET THE RESULTS AS TENDENCIES OF THE ORGANS, GLANDS AND TISSUES ACCORDING TO THE IRIDOLOGY CHARTS; COMPUTER PROGRAMS FOR EDITING IMAGES, SOUND AND VIDEO; COMPUTER SOFTWARE FOR INTERPRETATION OF NEURO AND BRAIN SCANS PROVIDED BY DIAGNOSTIC IMAGING EQUIPMENT; COMPUTER SOFTWARE FOR ORGANIZING AND VIEWING DIGITAL IMAGES AND PHOTOGRAPHS; COMPUTER SOFTWARE FOR PROCESSING DIGITAL IMAGES; COMPUTER SOFTWARE FOR USE IN RELATION TO DIGITAL ANIMATION AND SPECIAL EFFECTS OF IMAGES; COMPUTER SOFTWARE FOR USE IN THE ENCRYPTION AND DECRYPTION OF DIGITAL FILES, INCLUDING AUDIO, VIDEO, TEXT, BINARY, STILL IMAGES, GRAPHICS AND MULTIMEDIA FILES; COMPUTER SOFTWARE TO ENHANCE THE AUDIO-VISUAL CAPABILITIES OF MULTIMEDIA APPLICATIONS, NAMELY, FOR THE INTEGRATION OF TEXT, AUDIO, GRAPHICS, STILL IMAGES AND MOVING PICTURES; COUNTDOWN TIMER(S) AND ALARMS TO REMIND A PERSON TO TAKE OR GIVE A MEDICATION(S) AND/OR TO REMIND A PERSON TO DO A DAILY ROUTINE(S) INCORPORATED INTO A WRISTBAND; DIGITAL CAMERA ACCESSORY IN THE NATURE OF A DIGITAL PHOTO VIEWER; DIGITAL PHOTO FRAMES; DIGITAL PHOTO IMAGE CONVERTERS; DOWNLOADABLE IMAGE FILE CONTAINING ARTWORK, TEXT, AUDIO, VIDEO, GAMES AND INTERNET WEB LINKS RELATING TO SPORTING AND CULTURAL ACTIVITIES; DRUM UNITS FOR PRINTERS, FACSIMILE MACHINES, SCANNERS, COPYING MACHINES AND MULTIFUNCTION ELECTRONIC DEVICES FOR USE IN COPYING, PRINTING, SCANNING, VIDEO CAPTURE AND/OR TRANSMITTING DOCUMENTS AND IMAGES; ELECTRONIC APPARATUS, NAMELY, STAND ALONE DISPLAYS FOR MEDICAL IMAGES; ELECTRONIC CARDS FOR PROCESSING IMAGES; ELECTRONIC IMAGING APPARATUS IN THE FIELD OF IRIDOLOGY, SCLEROSIS, RAYID AND EYOLOGY NOT FOR MEDICAL USE; ELECTRONIC IMAGING PLATFORMS IN THE FIELD OF INSPECTION OF SEMICONDUCTOR MATERIALS, NAMELY, SEMICONDUCTOR WAFERS AND RETICLES; ENTERTAINMENT SYSTEM COMPRISING A COMPUTER, MULTIPLE IMAGE DISPLAY SCREEN, MULTIPLE INPUT DEVICES AND A PRINTER; FIBER OPTIC LIGHT AND IMAGE CONDUITS; FINGERPRINT IMAGERS; IMAGE FUSER UNITS FOR COMPUTER PRINTERS COMPRISING ELECTRO-MECHANICAL ROLLERS FOR THE PURPOSE OF TRANSFERRING TONER ONTO PAPER; INTERACTIVE PHOTO KIOSKS FOR CAPTURING, PRINTING AND UPLOADING DIGITAL IMAGES FOR FUTURE USE; LIGHTING DEVICES FOR TAKING PICTURES; MAGNETIC DOOR COVERS WITH A PRINTED IMAGE THEREON FOR AFFIXING TO METAL DOORS; MEDICAL IMAGING APPARATUS FOR SMALL ANIMALS, IN A RESEARCH LABORATORY ENVIRONMENT; MEDICAL IMAGING SOFTWARE THAT RECORDS, MONITORS AND ANALYZES DATA USING A CATHETER BASED ULTRASOUND IMAGING PROBE; MEDICAL RESEARCH EQUIPMENT, NAMELY, COMPUTERS, GAMMA CAMERAS, COLLIMATORS, APERTURE PLATES AND COMPUTER SOFTWARE, ALL SOLD TOGETHER AS A UNIT FOR USE IN HIGH RESOLUTION, HIGH SENSITIVITY TOMOGRAPHIC IMAGE PROCESSING AND IMAGING IN THE FIELD OF NUCLEAR MEDICINE; MEDICAL SOFTWARE FOR PROCESSING AND DISPLAYING BREAST IMAGES ON MEDICAL RESONANCE IMA-



**CLASS 9—(Continued).**

GING MACHINES (MRI'S); MEDICAL SOFTWARE FOR PROCESSING AND DISPLAYING IMAGES ON ULTRASOUND MEDICAL IMAGING MACHINES; MEDICAL WORKSTATION COMPRISED OF COMPUTER HARDWARE AND SOFTWARE FOR GATHERING AND TRANSMITTING PATIENT IMAGE DATA FOR USE DURING SURGICAL PROCEDURES; MULTIFUNCTION ELECTRONIC DEVICES FOR USE IN COPYING, PRINTING, SCANNING, VIDEO CAPTURING AND/OR TRANSMITTING DOCUMENTS AND IMAGES; NUCLEAR MEDICAL RESEARCH IMAGING APPARATUS; NUCLEAR MEDICINE IMAGING APPARATUS FOR RESEARCH PURPOSES; PHOTO PRINTERS; PHOTOCOPYING MACHINES; POCKET COMPUTERS FOR NOTE-TAKING; PORTABLE AND HANDHELD DIGITAL ELECTRONIC DEVICES FOR RECORDING, ORGANIZING, TRANSMITTING, MANIPULATING, AND REVIEWING TEXT, DATA, IMAGE, AND AUDIO FILES; RADIO TOMOGRAPHIC IMAGING APPARATUS FOR TRACKING MOVEMENT; RASTER IMAGE PROCESSORS; RECORDING AND PLAYING DEVICES FOR SOUND AND IMAGE CARRIERS; REMOTE CONTROLLED THERMAL IMAGING SYSTEMS, NOT FOR MEDICAL USE; REMOTE VIDEO MONITORING SYSTEM CONSISTING PRIMARILY OF A CAMERA AND VIDEO MONITOR FOR RECORDING AND TRANSMITTING IMAGES TO A REMOTE LOCATION; SOFTWARE FOR MEDICAL IMAGING EQUIPMENT, NAMELY, FOR INTERPRETING THE RESULTS OF CT SCANNERS; SOFTWARE FOR PROCESSING DIGITAL IMAGES OF THE ANATOMY FOR DIAGNOSIS AND TREATMENT; SOFTWARE FOR PROCESSING IMAGES, GRAPHICS AND TEXT; SOLID STATE LIGHT BASED EMISSIVE IMAGERS; TIME LAPSE IMAGE RECORDER; WIRELESS COMMUNICATION DEVICE FEATURING VOICE, DATA AND IMAGE TRANSMISSION INCLUDING VOICE, TEXT AND PICTURE MESSAGING, A VIDEO AND STILL IMAGE CAMERA, ALSO FUNCTIONAL TO PURCHASE MUSIC, GAMES, VIDEO AND SOFTWARE APPLICATIONS OVER THE AIR FOR DOWNLOADING TO THE DEVICE; WIRELESS COMMUNICATION DEVICES FOR TRANSMITTING IMAGES TAKEN BY A CAMERA; WIRELESS COMMUNICATION DEVICES FOR VOICE, DATA OR IMAGE TRANSMISSION; WIRELESS DIGITAL ELECTRONIC APPARATUS TO SECURE AND PROTECT DATA AND IMAGES ON ALL FORMS OF WIRELESS EQUIPMENT INCLUDING MOBILE TELECOMMUNICATIONS EQUIPMENT USING AN AUTOMATIC SYNCHRONIZATION PROCESS AND ALARM NOTIFICATION OF THE LOSS OR THEFT OF THE WIRELESS EQUIPMENT INCLUDING MOBILE TELECOMMUNICATIONS EQUIPMENT (U.S. CLS. 21, 23, 26, 36 AND 38).

FIRST USE 3-15-2013; IN COMMERCE 3-15-2013.  
ERIN FALK, EXAMINING ATTORNEY

SN 86-121,214. IPEK SPEZIAL TV GMBH, SULZBERG, AUSTRIA, FILED 11-18-2013.

**ULTRAVISION**

THE MARK CONSISTS OF STANDARD CHARACTERS WITHOUT CLAIM TO ANY PARTICULAR FONT, STYLE, SIZE, OR COLOR.

FOR A REMOTE CONTROL DEVICE FOR THE INSPECTION OF PIPES AND SEWER SYSTEMS COMPRISING COMPUTER HARDWARE, CONNECTION CABLES, VIDEO DISPLAY SCREENS AND ELECTRICAL CONTROLLING DEVICES AND SOFTWARE FOR THE INSPECTION OF PIPES AND SEWER SYSTEMS (U.S. CLS. 21, 23, 26, 36 AND 38).

ERIN FALK, EXAMINING ATTORNEY

**CLASS 9—(Continued).**

SN 86-124,362. SBE HOTEL LICENSING, LLC, LAS VEGAS, NV. FILED 11-20-2013.

THE KEY UNLOCKS YOUR DOOR,  
THE CODE UNLOCKS YOUR  
EXPERIENCE

THE MARK CONSISTS OF STANDARD CHARACTERS WITHOUT CLAIM TO ANY PARTICULAR FONT, STYLE, SIZE, OR COLOR.

FOR COMPUTER APPLICATION SOFTWARE FOR MOBILE AND TABLET DEVICES, NAMELY, SOFTWARE FOR USE IN LOCATING HOTELS, MAKING RESERVATIONS, THE PROVISION OR RENDERING OF TRAVEL ADVICE AND FOR INFORMATION CONCERNING HOTELS, BARS, NIGHTCLUBS, LANDMARKS, RESTAURANTS AND OTHER INFORMATION REGARDING TRAVEL AND TRANSPORT, ALLOWING USERS TO POST COMMENTS, SOCIAL NETWORKING FOR HOTEL, NIGHTCLUB, BAR AND RESTAURANT GOERS, CHECKING FOR CURRENT WEATHER AND FINDING NEARBY SERVICES, NAMELY, TAXIS, HAPPY HOURS, GAS, PETROL AND HOTELS, BOOK, MANAGE AND PAY FOR VIP TABLES THROUGH MOBILE AND TABLET DEVICES, VIEW VENUE VIDEOS AND PHOTO ALBUMS, VIEW AND MANAGE UPCOMING EVENTS AND SHARE EVENT NOTICES ON SOCIAL NETWORKS, TO ALLOW NIGHTCLUB, BAR AND RESTAURANT GOERS TO REQUEST A SONG FOR A DJ TO PLAY BY USING THEIR MOBILE AND TABLET DEVICES, JOIN AND MANAGE A VIP GUEST LIST, AND TO VIEW AND MANAGE DRINK SPECIALS AND RATE RESTAURANT FOODS, AND MANAGEMENT OF LOYALTY REWARD POINTS FOR HOTEL, CASINO, RESTAURANT, BAR, AND NIGHTCLUB SERVICES AND FOR RELATED LOYALTY REWARDS PROGRAMS (U.S. CLS. 21, 23, 26, 36 AND 38).

KEVIN DINALLO, EXAMINING ATTORNEY

SN 86-125,116. KABUSHIKI KAISHA TOSHIBA, TA TOSHIBA CORPORATION, TOKYO, JAPAN, FILED 11-21-2013.

**Silmee Engine**

THE MARK CONSISTS OF STANDARD CHARACTERS WITHOUT CLAIM TO ANY PARTICULAR FONT, STYLE, SIZE, OR COLOR.

OWNER OF JAPAN REG. NO. 5632359, DATED 11-22-2013, EXPIRES 11-22-2023.

NO CLAIM IS MADE TO THE EXCLUSIVE RIGHT TO USE "ENGINE", APART FROM THE MARK AS SHOWN.

FOR INTEGRATED CIRCUIT (IC) CHIPS FOR WIRELESS VITAL DATA MONITORING SENSORS USED IN MEDICAL FIELD; INTEGRATED CIRCUIT (IC) CHIPS FOR WIRELESS VITAL DATA MONITORING SENSORS (U.S. CLS. 21, 23, 26, 36 AND 38).

TARAH HARDY, EXAMINING ATTORNEY

**CLASS 9—(Continued).**

SN 86-128,962. UNDERSEA PRODUCTIONS TRUST, AKA UNDERSEA PRODUCTIONS, TEWANTIN, AUSTRALIA, FILED 11-25-2013.

## Undersea Productions

THE MARK CONSISTS OF STANDARD CHARACTERS WITHOUT CLAIM TO ANY PARTICULAR FONT, STYLE, SIZE, OR COLOR.

NO CLAIM IS MADE TO THE EXCLUSIVE RIGHT TO USE "PRODUCTIONS", APART FROM THE MARK AS SHOWN.

SEC. 2(F).

FOR CINEMATOGRAPHIC FILMS FEATURING NATURE, TRAVEL, TOURISM, OCEAN, BIOLOGY, AND CONSERVATION; DIGITAL MEDIA, NAMELY, PRE-RECORDED DVDS, DOWNLOADABLE AUDIO AND VIDEO RECORDINGS, AND CDS FEATURING AND PROMOTING NATURE, TRAVEL, TOURISM, OCEAN, BIOLOGY, AND CONSERVATION; DIGITAL MEDIA, NAMELY, PRE-RECORDED VIDEO CASSETTES, DIGITAL VIDEO DISCS, DIGITAL VERSATILE DISCS, DOWNLOADABLE AUDIO AND VIDEO RECORDINGS, DVDS, AND HIGH DEFINITION DIGITAL DISCS FEATURING NATURE, TRAVEL, TOURISM, OCEAN, BIOLOGY, AND CONSERVATION; DOWNLOADABLE FILMS AND MOVIES FEATURING NATURE, TRAVEL, TOURISM, OCEAN, BIOLOGY, AND CONSERVATION PROVIDED VIA A VIDEO-ON-DEMAND SERVICE; DOWNLOADABLE FILMS AND TELEVISION PROGRAMS FEATURING NATURE, TRAVEL, TOURISM, OCEAN, BIOLOGY, AND CONSERVATION PROVIDED VIA A VIDEO-ON-DEMAND SERVICE; DOWNLOADABLE MULTIMEDIA FILE CONTAINING VIDEO RELATING TO NATURE, TRAVEL, TOURISM, OCEAN, BIOLOGY, AND CONSERVATION; DOWNLOADABLE VIDEO RECORDINGS FEATURING NATURE, TRAVEL, TOURISM, OCEAN, BIOLOGY, AND CONSERVATION; MOTION PICTURE FILMS ABOUT NATURE, TRAVEL, TOURISM, OCEAN, BIOLOGY, AND CONSERVATION; MUSICAL VIDEO RECORDINGS; PRE-RECORDED CDS, VIDEO TAPES, LASER DISKS AND DVDS FEATURING NATURE, TRAVEL, TOURISM, OCEAN, BIOLOGY, AND CONSERVATION; PRE-RECORDED DIGITAL VIDEO DISCS FEATURING NATURE, TRAVEL, TOURISM, OCEAN, BIOLOGY, AND CONSERVATION; PRE-RECORDED VIDEO DISCS, DIGITAL VERSATILE DISCS, DIGITAL VIDEO DISCS, DIGITAL VIDEO RECORDINGS, DVDS, AND HIGH DEFINITION DIGITAL DISCS FEATURING NATURE, TRAVEL, TOURISM, OCEAN, BIOLOGY, AND CONSERVATION (U.S. CLS. 21, 23, 26, 36 AND 38).

FIRST USE 0-0-2006; IN COMMERCE 0-0-2006.  
BRIN ANDERSON, EXAMINING ATTORNEY

**CLASS 9—(Continued).**

SN 86-129,067. YEN, DANIEL P. PASADENA, CA. AND WU, LONG, PASADENA, CA. FILED 11-26-2013.

## Spiker

THE MARK CONSISTS OF STANDARD CHARACTERS WITHOUT CLAIM TO ANY PARTICULAR FONT, STYLE, SIZE, OR COLOR.

FOR AUDIO HEADPHONES; AUDIO SPEAKERS; BATTERIES; BATTERY CHARGERS FOR USE WITH TELEPHONES; BATTERY PACKS; CARRYING CASES FOR CELL PHONES; CARRYING CASES FOR MOBILE COMPUTERS; EARPHONES AND HEADPHONES (U.S. CLS. 21, 23, 26, 36 AND 38).

KHANH LE, EXAMINING ATTORNEY

SN 86-131,501. ATHENA SPA, ALONTE (VI), ITALY, FILED 11-27-2013.



THE COLOR(S) ORANGE, BLUE, WHITE, AND BLACK IS/ARE CLAIMED AS A FEATURE OF THE MARK.

THE MARK CONSISTS OF THE TERM "GET" IN BLUE BLOCK LETTERS OUTLINED IN WHITE WITHIN AN ORANGE RECTANGLE HAVING ROUNDED CORNERS. THE RECTANGLE IS BORDERED IN BLUE, WHITE, AND BLACK MOVING OUTWARD.

FOR ELECTRONIC EQUIPMENT FOR THE AUTOMOBILE SECTOR, NAMELY, ELECTRONIC CONTROL UNITS (ECUS), HOUR METERS FOR ENGINES, GAS PATH ANALYSIS SWITCHES FOR ENGINES, POWER INTERFACE ECU-TO-COMPUTER CONNECTION INTERFACES, MANUAL CONFIGURATORS FOR CONFIGURING ENGINE CONTROL UNITS, LAP TIMERS; ELECTRONIC EQUIPMENT FOR LEISURE TIME AND ENTERTAINMENT, NAMELY, STILL CAMERAS AND VIDEO CAMERAS; ELECTRONIC EQUIPMENT FOR SPORTING AND RECREATIONAL PURPOSES, NAMELY, ELECTRONIC ENGINE CONTROL UNITS FOR MANAGING ELECTRONIC INJECTION ENGINES FOR CARS, MOTORBIKES, WATERCRAFT, QUAD BIKES, SCOOTERS; SYSTEMS FOR ACQUIRING DATA AND VIDEOS FOR THE MOTORSPORT SECTOR, AND FOR SPORTS IN GENERAL IN THE NATURE OF LAP TIMERS, STILL CAMERAS, VIDEO CAMERAS, GPS TRACKING DEVICES; ELECTRONIC SYSTEMS FOR TIMING AND DETECTING POSITIONAL DATA VIA GPS TECHNOLOGY, NAMELY, GPS TRACKING DEVICES (U.S. CLS. 21, 23, 26, 36 AND 38).

MICHAEL KEATING, EXAMINING ATTORNEY

**CLASS 9—(Continued).**

SN 86-132,489. GENERAC POWER SYSTEMS, INC., WAUKESHA, WI. FILED 12-2-2013.

# QUIETSOURCE

THE MARK CONSISTS OF STANDARD CHARACTERS WITHOUT CLAIM TO ANY PARTICULAR FONT, STYLE, SIZE, OR COLOR.

OWNER OF U.S. REG. NO. 3,654,729.  
FOR ELECTRICAL GENERATORS AND RELATED EQUIPMENT, NAMELY, AUTOMATIC STANDBY GENERATOR SETS (U.S. CLS. 21, 23, 26, 36 AND 38).  
FIRST USE 11-1-2003; IN COMMERCE 3-1-2004.  
TEJBIR SINGH, EXAMINING ATTORNEY

---

SN 86-133,323. SAKAR INTERNATIONAL, INC., EDISON, NJ. FILED 12-3-2013.

# STEREO SYNC

THE MARK CONSISTS OF STANDARD CHARACTERS WITHOUT CLAIM TO ANY PARTICULAR FONT, STYLE, SIZE, OR COLOR.

NO CLAIM IS MADE TO THE EXCLUSIVE RIGHT TO USE "STEREO", APART FROM THE MARK AS SHOWN.  
FOR AUDIO SPEAKERS (U.S. CLS. 21, 23, 26, 36 AND 38).  
FIRST USE 11-0-2013; IN COMMERCE 11-0-2013.  
KEVON CHISOLM, EXAMINING ATTORNEY

---

SN 86-136,900. INFOR (US), INC., ALPHARETTA, GA. FILED 12-6-2013.

# INFOR THRU-PUT

THE MARK CONSISTS OF STANDARD CHARACTERS WITHOUT CLAIM TO ANY PARTICULAR FONT, STYLE, SIZE, OR COLOR.

OWNER OF U.S. REG. NOS. 3,986,817, 4,207,735 AND OTHERS.  
FOR COMPUTER SOFTWARE FOR PLANNING AND SCHEDULING MANUFACTURING PRODUCTION (U.S. CLS. 21, 23, 26, 36 AND 38).  
JOHN GARTNER, EXAMINING ATTORNEY

**CLASS 9—(Continued).**

SN 86-137,407. AMBURGEY, BRYAN, LONG BEACH, CA. FILED 12-6-2013.

# ARtv

THE MARK CONSISTS OF STANDARD CHARACTERS WITHOUT CLAIM TO ANY PARTICULAR FONT, STYLE, SIZE, OR COLOR.

FOR COMPUTER APPLICATION SOFTWARE FOR MOBILE DEVICES, WEARABLE DEVICES, MOBILE PHONES, PORTABLE MEDIA PLAYERS, HANDHELD COMPUTERS, AND TABLET COMPUTERS, NAMELY, SOFTWARE FOR DISTRIBUTION OF SHORT AND LONG FORM VIDEO CONTENT BY SCANNING A PRE SET IMAGE (U.S. CLS. 21, 23, 26, 36 AND 38).  
KEVIN MITTLER, EXAMINING ATTORNEY

---

SN 86-137,468. HAVI AUDIO TECHNOLOGY LLC, MICKLETON, NJ. FILED 12-6-2013.

THE MARK CONSISTS OF THE WORDING "HAVI" IN CAPITAL BLOCK LETTERS PRECEDED BY A DESIGN ELEMENT OF A SQUARE FORMED BY 2 TRIANGLES PLACED OPPOSITE EACH OTHER, THE UPPER TRIANGLE LARGER THAN THE LOWER.

THE ENGLISH TRANSLATION OF THE WORD "HAVI" IN THE MARK IS "POWERFUL SOUND".  
FOR EARPHONES AND HEADPHONES (U.S. CLS. 21, 23, 26, 36 AND 38).  
FIRST USE 11-15-2013; IN COMMERCE 11-15-2013.  
ALLISON SCHRODY, EXAMINING ATTORNEY

**CLASS 9—(Continued).**

SN 86-138,728. MICROSOFT CORPORATION, REDMOND, WA. FILED 12-9-2013.

**WINDOWS MOD**

THE MARK CONSISTS OF STANDARD CHARACTERS WITHOUT CLAIM TO ANY PARTICULAR FONT, STYLE, SIZE, OR COLOR.

PRIORITY CLAIMED UNDER SEC. 44(D) ON SOUTH AFRICA APPLICATION NO. 2013/15,334, FILED 6-10-2013.

OWNER OF U.S. REG. NOS. 1,989,386, 3,765,517 AND OTHERS.

SEC. 2(F) AS TO "WINDOWS".

FOR COMPUTER OPERATING SYSTEM SOFTWARE; COMPUTER SOFTWARE FOR MANAGING AND CONTROLLING SERVERS FOR BACKUP, STORAGE AND ORGANIZATION OF FILES AND DATA; COMPUTER PROGRAMS FOR OPERATING AND MANAGING NETWORK SERVERS; COMPUTER NETWORK OPERATING SOFTWARE; COMPUTER SOFTWARE FOR USE BY COMPUTER NETWORK ADMINISTRATORS TO DEPLOY AND MANAGE APPLICATION SOFTWARE AND NETWORK SERVER SOFTWARE; COMPUTER NETWORK SERVER SOFTWARE FOR MANAGING USER CONTENT ON COMPUTER NETWORKS AND GLOBAL COMPUTER NETWORKS; COMPUTER SOFTWARE FOR MANAGING SECURE COMMUNICATIONS OVER COMPUTER NETWORKS AND GLOBAL COMPUTER NETWORKS; COMPUTER SOFTWARE FOR MANAGING COMMUNICATIONS BETWEEN COMPUTER NETWORKS AND WIRELESS NETWORKS; COMPUTER SOFTWARE FOR DEVELOPING, MANAGING AND OPERATING INTRANET SITES; COMPUTER SOFTWARE DEVELOPMENT TOOLS FOR NETWORK SERVERS AND APPLICATIONS; COMPUTER SOFTWARE FOR DOWNLOADING, STREAMING, AND PLAYING MUSIC, AUDIO, VIDEOS AND INTERNET RADIO BROADCASTS; COMPUTER SOFTWARE FOR STORING, ACCESSING AND SYNCHRONIZING DOCUMENTS, PHOTOS AND DATA; COMPUTER SOFTWARE FOR RESTRICTING AND MONITORING COMPUTER AND INTERNET USE; COMPUTER SOFTWARE FOR CREATING DVDS; WEBSITE DEVELOPMENT SOFTWARE; COMPUTER SOFTWARE THAT PROVIDES WEB-BASED ACCESS TO APPLICATIONS AND SERVICES THROUGH A WEB OPERATING SYSTEM OR PORTAL INTERFACE; COMPUTER SOFTWARE FOR DEVELOPING AND OPERATING CLOUD COMPUTER NETWORKS AND APPLICATIONS; COMPUTER SOFTWARE PLATFORMS FOR CLOUD COMPUTING NETWORKS AND APPLICATIONS; COMPUTER SOFTWARE FOR USE IN DATABASE MANAGEMENT, ELECTRONIC SPREADSHEETS, DESIGNING, CREATING, EDITING AND PUBLISHING DOCUMENTS, NOTE TAKING, EMAIL, CALENDARING, SCHEDULING, CONTACT INFORMATION STORAGE AND MANAGEMENT, ACCOUNTING, CUSTOMER RELATIONSHIP MANAGEMENT, PROJECT MANAGEMENT, PRESENTATION GRAPHICS, DESKTOP PUBLISHING, WEB PUBLISHING, DOCUMENT MANAGEMENT, DATABASE MANAGEMENT, DATA COLLECTION, DATA ANALYSIS, GRAPHICS, PHOTO AND VIDEO EDITING, PRESENTATION GRAPHICS, WORD PROCESSING, INSTANT MESSAGING, VOICE OVER INTERNET PROTOCOL (VOIP), VIDEO CONFERENCING, AUDIO CONFERENCING, WEB CONFERENCING AND DOCUMENT SHARING, APPLICATION SHARING, COMPUTER DESKTOP SHARING, FILE TRANSFER, SENSING AND PROVIDING USER PRESENCE INFORMATION, TELEPHONY, REAL-TIME COMMUNICATIONS FEATURING INSTANT MESSAGING, AUDIO, VIDEO AND DATA EXCHANGE, MAPPING GEOGRAPHICAL LOCATIONS, MANIPULATING VIDEO, AUDIO AND GRAPHICS; COMMUNICATIONS SOFTWARE FOR MANAGING THE EXCHANGE OF COMMUNICATIONS AND DATA AND INFORMATION OVER COMPUTER NETWORKS, WIRELESS NETWORKS, AND GLOBAL COMMUNICATIONS NETWORKS; COMPUTER COMMUNICATIONS SOFTWARE

**CLASS 9—(Continued).**

FOR USE IN ACCESSING WEB SITES AND EXCHANGING INFORMATION AND DATA AND OBTAINING SERVICES FROM WEB SITES; COMPUTER SOFTWARE FOR USE IN DEVELOPING WEB SITES, OPERATING ELECTRONIC MAIL AND PROVIDING COMPUTER SECURITY; COMPUTER SOFTWARE FOR RECORDING, ORGANIZING, EDITING AND TRANSMITTING INFORMATION IN TYPED WRITTEN AND VOICE FORMAT; COMPUTER COMMUNICATIONS SOFTWARE FOR ACCESSING WEB MESSAGING AND SHARED DOCUMENTS FROM WEB SITES ON THE INTERNET; COMPUTER SECURITY AND AUTHENTICATION SOFTWARE FOR CONTROLLING ACCESS TO AND COMMUNICATIONS WITH COMPUTERS; COMPUTER SOFTWARE FOR COMPUTER NETWORK SECURITY, ANTI-VIRUS PROTECTION, AND INTRUSION DETECTION AND PREVENTION; COMPUTER GAME SOFTWARE; COMPUTER HARDWARE; COMPUTER PERIPHERALS; MOBILE COMPUTING DEVICES; MOBILE COMMUNICATION DEVICES, NAMELY, CELLULAR PHONES, MOBILE PHONES, SMART PHONES, PORTABLE COMPUTERS, AND TABLET DEVICES (U.S. CLS. 21, 23, 26, 36 AND 38).

JORDAN BAKER, EXAMINING ATTORNEY

SN 86-141,698. COLINK DIGITAL TECHNOLOGY CO., LTD, BEIJING, CHINA, FILED 12-12-2013.

**NewClass**

THE MARK CONSISTS OF THE LITERAL ELEMENT "NEWCLASS" WITH A TRIANGLE FORMED UNDER THE "W".

FOR VIDEOPHONE TELECONFERENCING TERMINAL AND COMPUTER SERVER HARDWARE FOR EDUCATION; COMPUTER HARDWARE FOR TELECOMMUNICATIONS FOR EDUCATION; COMPUTER LANGUAGE LAB LESSON SOFTWARE FOR EDUCATION; VIDEO TELEPHONES FOR EDUCATION (U.S. CLS. 21, 23, 26, 36 AND 38).

FIRST USE 1-0-2003; IN COMMERCE 1-0-2003.

EUGENIA MARTIN, EXAMINING ATTORNEY

SN 86-141,718. COLINK DIGITAL TECHNOLOGY CO., LTD, BEIJING, CHINA, FILED 12-12-2013.

**NEWCLASS**

THE MARK CONSISTS OF STANDARD CHARACTERS WITHOUT CLAIM TO ANY PARTICULAR FONT, STYLE, SIZE, OR COLOR.

FOR VIDEOPHONE TELECONFERENCING TERMINAL AND COMPUTER SERVER HARDWARE FOR EDUCATION; COMPUTER HARDWARE FOR TELECOMMUNICATIONS FOR EDUCATION; COMPUTER LANGUAGE LAB LESSON SOFTWARE FOR EDUCATION; VIDEO TELEPHONES FOR EDUCATION (U.S. CLS. 21, 23, 26, 36 AND 38).

FIRST USE 1-0-2003; IN COMMERCE 1-0-2003.

EUGENIA MARTIN, EXAMINING ATTORNEY

**CLASS 9—(Continued).**

SN 86-141,742. COLINK DIGITAL TECHNOLOGY CO., LTD, BEIJING, CHINA, FILED 12-12-2013.

# COLINK

THE MARK CONSISTS OF STANDARD CHARACTERS WITHOUT CLAIM TO ANY PARTICULAR FONT, STYLE, SIZE, OR COLOR.

FOR VIDEOPHONE TELECONFERENCING TERMINAL AND COMPUTER SERVER HARDWARE; COMPUTER HARDWARE FOR TELECOMMUNICATIONS; APPLICATION SOFTWARE FOR TELECONFERENCING; VIDEO TELEPHONES (U.S. CLS. 21, 23, 26, 36 AND 38).

FIRST USE 10-8-2013; IN COMMERCE 10-8-2013.  
EUGENIA MARTIN, EXAMINING ATTORNEY

---

SN 86-142,630. SHENZHEN KAVID COMMUNICATION APPARATUS CO.,LTD., SHENZHEN CITY, CHINA, FILED 12-13-2013.



THE MARK CONSISTS OF THE WORD "DOOGEE" IN STYLIZED LETTERING WITH THE "O"S JOINED TOGETHER FOLLOWED BY THE CHINESE CHARACTERS WHICH TRANSLITERATE TO "DAO GE".

THE WORDING "DOOGEE" HAS NO MEANING IN A FOREIGN LANGUAGE.

THE NON-LATIN CHARACTERS IN THE MARK TRANSLITERATE TO "DAO GE" AND THIS HAS NO MEANING IN A FOREIGN LANGUAGE.

FOR BATTERIES, ELECTRIC; CASES FOR TELEPHONES; COMPUTER PERIPHERAL DEVICES; EAR PLUGS FOR DIVERS; EARPHONES; MOBILE PHONES; NOTEBOOK COMPUTERS; RADIOTELEPHONY SETS; TELEPHONE APPARATUS; THEFT ALARMS; VOLTAGE STABILIZING POWER SUPPLY (U.S. CLS. 21, 23, 26, 36 AND 38).

FIRST USE 6-1-2010; IN COMMERCE 10-1-2010.  
DAVID BROOKSHIRE, EXAMINING ATTORNEY

**CLASS 9—(Continued).**

SN 86-147,391. OMNIPOTENCE LLC, CHARLESTOWN, ST.KITTS-NEVIS, FILED 12-18-2013.

# HOW-NOT-TO

THE MARK CONSISTS OF STANDARD CHARACTERS WITHOUT CLAIM TO ANY PARTICULAR FONT, STYLE, SIZE, OR COLOR.

FOR DIGITAL MEDIA IN THE NATURE OF DOWNLOADABLE ELECTRONIC NON-FICTION PUBLICATIONS, NAMELY, BOOKS, BOOKLETS, PAMPHLETS, ARTICLES AND MANUALS FEATURING SUBJECTS IN THE FIELDS SELF-HELP, PERSONAL EMPOWERMENT, PERSONAL IMPROVEMENT, PERSONAL DEVELOPMENT AND INTERPERSONAL COMMUNICATION (U.S. CLS. 21, 23, 26, 36 AND 38).

FIRST USE 5-11-2014; IN COMMERCE 5-11-2014.  
ALICIA COLLINS, EXAMINING ATTORNEY

---

SN 86-148,074. KABUSHIKI KAISHA TOSHIBA, TA TOSHIBA CORPORATION, TOKYO, JAPAN, FILED 12-19-2013.

# Visconti

THE MARK CONSISTS OF STANDARD CHARACTERS WITHOUT CLAIM TO ANY PARTICULAR FONT, STYLE, SIZE, OR COLOR.

OWNER OF JAPAN REG. NO. 4713134, DATED 9-26-2003, EXPIRES 9-26-2023.

FOR IMAGE RECOGNITION PROCESSOR LSI (U.S. CLS. 21, 23, 26, 36 AND 38).

TARAH HARDY, EXAMINING ATTORNEY

**CLASS 9—(Continued).**

SN 86-148,180. RICHARD D. WARREN, RANCHO SANTA MARGARITA, CA. FILED 12-19-2013.

**CLASS 9—(Continued).**

SN 86-149,633. PANASONIC CORPORATION, OSAKA, JAPAN, FILED 12-20-2013.



# Life<sup>+</sup> Screen

NO CLAIM IS MADE TO THE EXCLUSIVE RIGHT TO USE "SCREEN", APART FROM THE MARK AS SHOWN.

THE MARK CONSISTS OF THE WORD "LIFE", FOLLOWED BY A SUPERSCRIP PLUS SYMBOL, FOLLOWED BY THE WORD "SCREEN".

FOR TELEVISION SETS (U.S. CLS. 21, 23, 26, 36 AND 38).

JASON BLAIR, EXAMINING ATTORNEY

OWNER OF U.S. REG. NO. 4,402,876.  
THE MARK CONSISTS OF THE LETTER "D" WITH A CROSS DESIGN INSIDE THE LETTER.

FOR DOWNLOADABLE SOFTWARE IN THE NATURE OF A MOBILE APPLICATION FOR USE IN ACCESSING AND MANAGING INFORMATION IN THE FIELDS OF FAITH, FOOD, FITNESS, FRIENDS, FOCUS, NUTRITION, WEIGHT MANAGEMENT, AND ACHIEVING PERSONAL GOALS; DOWNLOADABLE WEBCASTS IN THE FIELDS OF FAITH, FOOD, FITNESS, FRIENDS, FOCUS, NUTRITION, WEIGHT MANAGEMENT AND ACHIEVING PERSONAL GOALS; ELECTRONIC PUBLICATIONS, NAMELY, BOOKS, WORKBOOKS, JOURNALS AND COOKBOOKS IN THE FIELDS OF FAITH, FOOD, FITNESS, FRIENDS, FOCUS, NUTRITION, WEIGHT MANAGEMENT, AND ACHIEVING PERSONAL GOALS; AUDIO RECORDINGS, VIDEO RECORDINGS, DVDS AND CDS IN THE FIELDS OF FAITH, FOOD, FITNESS, FRIENDS, FOCUS, NUTRITION, WEIGHT MANAGEMENT AND ACHIEVING PERSONAL GOALS; DOWNLOADABLE ELECTRONIC NEWSLETTERS DELIVERED BY EMAIL IN THE FIELDS OF FAITH, FOOD, FITNESS, FRIENDS, FOCUS, NUTRITION, WEIGHT MANAGEMENT, AND ACHIEVING PERSONAL GOALS; DOWNLOADABLE MOBILE APPLICATIONS FOR DEVELOPING AND MONITORING PERSONAL ACTIVITY AND EXERCISE PLANS, TRAINING GOALS AND GIVING FEEDBACK ON THE ACHIEVED RESULTS; COMPUTER SOFTWARE AND DOWNLOADABLE SOFTWARE FOR MOBILE DEVICES FOR USE IN RECORDING, TRACKING AND MONITORING INFORMATION RELATING TO FAITH, FOOD, FITNESS, FRIENDS, FOCUS, NUTRITION, WEIGHT MANAGEMENT AND ACHIEVING PERSONAL GOALS; SCALES (U.S. CLS. 21, 23, 26, 36 AND 38).

B. PARADEWELAI, EXAMINING ATTORNEY

SN 86-149,936. IGROUND, LLC, APOPKA, FL. FILED 12-20-2013.

# Intelliground

THE MARK CONSISTS OF STANDARD CHARACTERS WITHOUT CLAIM TO ANY PARTICULAR FONT, STYLE, SIZE, OR COLOR.

FOR ELECTRICAL OUTLET TESTER (U.S. CLS. 21, 23, 26, 36 AND 38).

FIRST USE 12-1-2013; IN COMMERCE 12-16-2013.  
DEBORAH MEINERS, EXAMINING ATTORNEY

**CLASS 9—(Continued).**

SN 86-153,495. UNIA, GOYANG-SI, GYEONGGI-DO, REPUBLIC OF KOREA, FILED 12-27-2013.



THE MARK CONSISTS OF THE WORDING "MOTOMO" APPEARING IN STYLIZED FONT AFTER TWO DOTS. THE WORDING "MOTOMO" HAS NO MEANING IN A FOREIGN LANGUAGE.

FOR PROTECTIVE CASES AND COVERS FOR SMARTPHONES; SMARTPHONE ACCESSORIES, NAMELY, SCREEN PROTECTORS, DECORATIVE HOME BUTTONS, SMART PHONE COOLING PADS, AND SUPPLY ORGANIZERS CONTAINING A USB PORT, SPECIALLY ADAPTED FOR HOLDING SMARTPHONES AND SMARTPHONE ACCESSORIES (U.S. CLS. 21, 23, 26, 36 AND 38).  
MARTHA SANTOMARTINO, EXAMINING ATTORNEY

SN 86-153,498. UNIA, GOYANG-SI, GYEONGGI-DO, REPUBLIC OF KOREA, FILED 12-27-2013.



THE MARK CONSISTS OF STANDARD CHARACTERS WITHOUT CLAIM TO ANY PARTICULAR FONT, STYLE, SIZE, OR COLOR.

THE WORDING "MOTOMO" HAS NO MEANING IN A FOREIGN LANGUAGE.  
FOR PROTECTIVE CASES AND COVERS FOR SMARTPHONES; SMARTPHONE ACCESSORIES, NAMELY, SCREEN PROTECTORS, DECORATIVE HOME BUTTONS, SMART PHONE COOLING PADS, AND SUPPLY ORGANIZERS CONTAINING A USB PORT, SPECIALLY ADAPTED FOR HOLDING SMARTPHONES AND SMARTPHONE ACCESSORIES (U.S. CLS. 21, 23, 26, 36 AND 38).  
MARTHA SANTOMARTINO, EXAMINING ATTORNEY

**CLASS 9—(Continued).**

SN 86-154,346. REED ELSEVIER PROPERTIES INC., WILMINGTON, DE. FILED 12-30-2013.



OWNER OF U.S. REG. NOS. 2,936,593, 4,498,080 AND OTHERS.

THE MARK CONSISTS OF A CIRCLE CONTAINING FIVE CURVED BANDS WHICH ORIGINATE ON THE LEFT HAND SIDE OF THE CIRCLE AND GRADUALLY REDUCE IN SIZE UNTIL CONVERGING AT A AN EPICENTER IN THE UPPER RIGHT-HAND PORTION OF THE CIRCLE AND THEN CONTINUE TO THE EDGE OF THE CIRCLE.

FOR DOWNLOADABLE COMPUTER APPLICATION SOFTWARE FOR MOBILE DEVICES, NAMELY, COMPUTER SOFTWARE OFFERING LEGAL RESEARCH, NEWS, EMERGING ISSUES AND BUSINESS INSIGHTS, PRACTICE MANAGEMENT AND MARKETING INFORMATION, AND LITIGATION ASSISTANCE (U.S. CLS. 21, 23, 26, 36 AND 38).  
FIRST USE 10-31-2009; IN COMMERCE 10-31-2009.

MICHELLE DUBOIS, EXAMINING ATTORNEY

SN 86-157,886. HANIF, ZAHRA A., DORAL, FL. FILED 1-6-2014.



THE MARK CONSISTS OF STANDARD CHARACTERS WITHOUT CLAIM TO ANY PARTICULAR FONT, STYLE, SIZE, OR COLOR.

NO CLAIM IS MADE TO THE EXCLUSIVE RIGHT TO USE "INC.", APART FROM THE MARK AS SHOWN.  
FOR COMPUTER SOFTWARE, NAMELY, SOFTWARE DEVELOPMENT TOOLS FOR THE CREATION OF MOBILE INTERNET APPLICATIONS AND CLIENT INTERFACES (U.S. CLS. 21, 23, 26, 36 AND 38).  
EMILY CHUO, EXAMINING ATTORNEY

**CLASS 9—(Continued).**

SN 86-158,817. RAZER (ASIA-PACIFIC) PTE.LTD, SINGAPORE, SINGAPORE, FILED 1-7-2014.

# NABU

THE MARK CONSISTS OF STANDARD CHARACTERS WITHOUT CLAIM TO ANY PARTICULAR FONT, STYLE, SIZE, OR COLOR.

THE WORDING "NABU" HAS NO MEANING IN A FOREIGN LANGUAGE.

FOR WEARABLE COMPUTER PERIPHERALS; COMPUTER HARDWARE FOR RECORDING, ORGANIZING, TRANSMITTING, MANIPULATING, REVIEWING, AND RECEIVING PHONE CALLS, DATA, AUDIO AND VIDEO; COMPUTER PERIPHERALS FOR RECORDING, ORGANIZING, TRANSMITTING, MANIPULATING, REVIEWING, AND RECEIVING DATA; COMPUTER PERIPHERALS FOR MOBILE DEVICES FOR RECORDING, ORGANIZING, TRANSMITTING, MANIPULATING, REVIEWING, AND RECEIVING PHONE CALLS, DATA, AUDIO AND VIDEO, NAMELY, PERIPHERALS WORN ON THE WRIST FOR MOBILE DEVICES FOR RECORDING, ORGANIZING, TRANSMITTING, MANIPULATING, REVIEWING, AND RECEIVING PHONE CALLS, DATA, AUDIO AND VIDEO; COMPUTER HARDWARE FOR DISPLAYING PHONE CALLS, DATA, AUDIO AND VIDEO; COMPUTER PERIPHERALS FOR DISPLAYING PHONE CALLS, DATA, AUDIO AND VIDEO; COMPUTER PERIPHERALS FOR MOBILE DEVICES FOR DISPLAYING PHONE CALLS, DATA, AUDIO AND VIDEO, NAMELY, PERIPHERALS WORN ON THE WRIST FOR MOBILE DEVICES FOR DISPLAYING DATA AND VIDEO; COMPUTER SOFTWARE USED FOR RECORDING, ORGANIZING, TRANSMITTING, RECEIVING, AND REVIEWING TEXT, DATA, IMAGES AND AUDIO FILES; DOWNLOADABLE COMPUTER SOFTWARE, NAMELY, DOWNLOADABLE MOBILE APPLICATION FOR SETTING UP, CONFIGURING, AND CONTROLLING WEARABLE COMPUTER HARDWARE AND WEARABLE COMPUTER PERIPHERALS (U.S. CLS. 21, 23, 26, 36 AND 38).

ERIN FALK, EXAMINING ATTORNEY

---

SN 86-160,725. SRC, INC., N. SYRACUSE, NY. FILED 1-8-2014.

# OPTIARMOR

THE MARK CONSISTS OF STANDARD CHARACTERS WITHOUT CLAIM TO ANY PARTICULAR FONT, STYLE, SIZE, OR COLOR.

FOR CONTENT INSPECTION AND ROUTING COMPUTER SOFTWARE THAT ALLOWS FOR SECURE SHARING OF CRITICAL INFORMATION BETWEEN AUTHORIZED SYSTEMS, AND PROVIDES THE CAPACITY TO EFFICIENTLY INTERCEPT, AUTHENTICATE, VALIDATE AND FORWARD CRITICAL DATA FLOWS WITHOUT INTRODUCING CYBER VULNERABILITIES (U.S. CLS. 21, 23, 26, 36 AND 38).

FIRST USE 1-8-2014; IN COMMERCE 1-8-2014.  
MIDGE BUTLER, EXAMINING ATTORNEY

**CLASS 9—(Continued).**

SN 86-162,421. HEIWA SEIKI KOGYO CO., LTD., SAITAMA, JAPAN, FILED 1-10-2014.

# ALLEX

THE MARK CONSISTS OF STANDARD CHARACTERS WITHOUT CLAIM TO ANY PARTICULAR FONT, STYLE, SIZE, OR COLOR.

FOR TRIPOD, TRIPOD HEAD AND CAMERA SLIDER (U.S. CLS. 21, 23, 26, 36 AND 38).

MICHELLE DUBOIS, EXAMINING ATTORNEY

---

SN 86-162,723. ASA ELECTRONICS, LLC, ELKHART, IN. FILED 1-10-2014.

# LEDC

THE MARK CONSISTS OF STANDARD CHARACTERS WITHOUT CLAIM TO ANY PARTICULAR FONT, STYLE, SIZE, OR COLOR.

FOR TELEVISIONS AND TELEVISION APPARATUS FOR PROJECTION PURPOSES (U.S. CLS. 21, 23, 26, 36 AND 38).

FIRST USE 11-1-2010; IN COMMERCE 11-1-2010.  
KATHRYN COWARD, EXAMINING ATTORNEY

---

SN 86-163,933. SOFT COMPUTER CONSULTANTS, INC., DBA SCC SOFT COMPUTER, CLEARWATER, FL. FILED 1-13-2014.

# SCC's Genetics Information Systems Suite

THE MARK CONSISTS OF STANDARD CHARACTERS WITHOUT CLAIM TO ANY PARTICULAR FONT, STYLE, SIZE, OR COLOR.

OWNER OF U.S. REG. NOS. 2,892,837 AND 3,273,266.

NO CLAIM IS MADE TO THE EXCLUSIVE RIGHT TO USE "GENETICS INFORMATION SYSTEMS SUITE", APART FROM THE MARK AS SHOWN.

FOR COMPUTER APPLICATION SOFTWARE FOR MANAGING GENETICS INFORMATION SYSTEMS THAT CAN BE INTEGRATED WITH HOSPITAL INFORMATION SYSTEMS IN THE FIELDS OF CYTOGENETICS, MOLECULAR GENETICS, FLOW CYTOMETRY, BIOCHEMISTRY, DIAGNOSTIC PATHOLOGY, AND IMMUNOGENETICS (U.S. CLS. 21, 23, 26, 36 AND 38).

TEJBIR SINGH, EXAMINING ATTORNEY



**CLASS 9—(Continued).**

SN 86-164,641. SOFT COMPUTER CONSULTANTS, INC., DBA SCC SOFT COMPUTER, CLEARWATER, FL. FILED 1-14-2014.

## SCC'S Blood Services Information Systems Suite

THE MARK CONSISTS OF STANDARD CHARACTERS WITHOUT CLAIM TO ANY PARTICULAR FONT, STYLE, SIZE, OR COLOR.

OWNER OF U.S. REG. NOS. 2,892,837 AND 3,273,266.

NO CLAIM IS MADE TO THE EXCLUSIVE RIGHT TO USE "BLOOD SERVICES INFORMATION SYSTEMS SUITE", APART FROM THE MARK AS SHOWN.

FOR COMPUTER APPLICATION SOFTWARE FOR BLOOD SERVICES INFORMATION SYSTEMS THAT MANAGES BLOOD TRANSFUSION SERVICES (U.S. CLS. 21, 23, 26, 36 AND 38).

TEJBIR SINGH, EXAMINING ATTORNEY

SN 86-164,693. SOFT COMPUTER CONSULTANTS, INC., DBA SCC SOFT COMPUTER, CLEARWATER, FL. FILED 1-14-2014.

## SCC's Laboratory Information Systems Suite

THE MARK CONSISTS OF STANDARD CHARACTERS WITHOUT CLAIM TO ANY PARTICULAR FONT, STYLE, SIZE, OR COLOR.

OWNER OF U.S. REG. NOS. 2,892,837 AND 3,273,266.

NO CLAIM IS MADE TO THE EXCLUSIVE RIGHT TO USE "LABORATORY INFORMATION SYSTEMS SUITE", APART FROM THE MARK AS SHOWN.

FOR COMPUTER APPLICATION SOFTWARE FOR LABORATORY INFORMATION SYSTEMS THAT PROVIDES CONNECTIVITY TO LABORATORY INSTRUMENTS, ROBOTICS AND OTHER INFORMATION SYSTEMS (U.S. CLS. 21, 23, 26, 36 AND 38).

TEJBIR SINGH, EXAMINING ATTORNEY

SN 86-165,934. ARROW FLYNN MUSIC, WEST HOLLYWOOD, CA. FILED 1-15-2014.

## Tunideo

THE MARK CONSISTS OF STANDARD CHARACTERS WITHOUT CLAIM TO ANY PARTICULAR FONT, STYLE, SIZE, OR COLOR.

THE WORDING "TUNIDEO" HAS NO MEANING IN A FOREIGN LANGUAGE.

FOR DIGITAL MEDIA, NAMELY, CDS, DVDS, DOWNLOADABLE AUDIO FILES, AND DOWNLOADABLE VIDEO FILES FEATURING MUSIC (U.S. CLS. 21, 23, 26, 36 AND 38).

FIRST USE 1-28-2014; IN COMMERCE 1-28-2014.

ELI HELLMAN, EXAMINING ATTORNEY

**CLASS 9—(Continued).**

SN 86-167,847. SECUREINSTALLS, LLLP, AKA SECUREINSTALLS, ENGLEWOOD, CO. FILED 1-16-2014.



NO CLAIM IS MADE TO THE EXCLUSIVE RIGHT TO USE "SECURE INSTALLS", APART FROM THE MARK AS SHOWN.

THE COLOR(S) BLUE AND ORANGE IS/ARE CLAIMED AS A FEATURE OF THE MARK.

THE MARK CONSISTS OF AN "S" SHAPED BLUE DESIGN REPRESENTING A SHIELD WITH THREE ORANGE TRIANGLES IN THE LOWER CENTER OF THE SHIELD POINTING DOWNWARD. THE WORD "SECURE" IN BLUE TO THE RIGHT OF THE SHIELD AND THE WORD "INSTALLS" IN ORANGE TO THE RIGHT OF THE SHIELD BENEATH THE WORD "SECURE".

FOR COMPUTER SEARCH ENGINE SOFTWARE (U.S. CLS. 21, 23, 26, 36 AND 38).

FIRST USE 12-12-2012; IN COMMERCE 10-13-2013.

WON TEAK OH, EXAMINING ATTORNEY

SN 86-169,628. DOCPOD CORP., TORONTO, CANADA, FILED 1-19-2014.

## DocPod

THE MARK CONSISTS OF STANDARD CHARACTERS WITHOUT CLAIM TO ANY PARTICULAR FONT, STYLE, SIZE, OR COLOR.

FOR COMPUTER HARDWARE AND SOFTWARE, FOR USE WITH MEDICAL PATIENT MONITORING EQUIPMENT, FOR RECEIVING, PROCESSING, TRANSMITTING AND DISPLAYING DATA; COMPUTER SOFTWARE FOR CONTROLLING AND MANAGING PATIENT MEDICAL INFORMATION; COMPUTER SOFTWARE FOR CONTROLLING SELF-SERVICE TERMINALS (U.S. CLS. 21, 23, 26, 36 AND 38).

FIRST USE 6-10-2013; IN COMMERCE 1-2-2014.

DANIEL CAPSHAW, EXAMINING ATTORNEY

**CLASS 9—(Continued).**

SN 86-170,898. CAROLANNE OLSEN, BRANDON, FL. FILED 1-21-2014.

**SNAPPY STRAP**

THE MARK CONSISTS OF STANDARD CHARACTERS WITHOUT CLAIM TO ANY PARTICULAR FONT, STYLE, SIZE, OR COLOR.

NO CLAIM IS MADE TO THE EXCLUSIVE RIGHT TO USE "STRAP", APART FROM THE MARK AS SHOWN.

FOR EYEWEAR; EYEWEAR CASES; EYEWEAR PROTECTIVE CASES; EYEWEAR ACCESSORIES, NAMELY, STRAPS, NECK CORDS, HEAD STRAPS, AND LEASHES; SUNGLASSES; SUNGLASSES CASES; SUNGLASSES PROTECTIVE CASES; SUNGLASSES ACCESSORIES, NAMELY, STRAPS, NECK CORDS, HEAD STRAPS, AND LEASHES; EYE GLASSES; EYE GLASSES CASES; EYE GLASSES PROTECTIVE CASES; EYE GLASSES ACCESSORIES, NAMELY, STRAPS, NECK CORDS, HEAD STRAPS, AND LEASHES (U.S. CLS. 21, 23, 26, 36 AND 38).

WILLIAM JACKSON, EXAMINING ATTORNEY

**CLASS 9—(Continued).**

SN 86-173,526. THIS OLD HOUSE VENTURES, INC., NEW YORK, NY. FILED 1-23-2014.

**THIS OLD HOUSE**

THE MARK CONSISTS OF STANDARD CHARACTERS WITHOUT CLAIM TO ANY PARTICULAR FONT, STYLE, SIZE, OR COLOR.

OWNER OF U.S. REG. NOS. 2,326,190, 4,227,312 AND OTHERS.

NO CLAIM IS MADE TO THE EXCLUSIVE RIGHT TO USE "HOUSE", APART FROM THE MARK AS SHOWN.

FOR COMPUTER GAME CARTRIDGES AND DISCS; COMPUTER GAME PROGRAMS; COMPUTER SOFTWARE FOR UPLOADING, POSTING, SHOWING, DISPLAYING, TAGGING, BLOGGING, SHARING OR OTHERWISE PROVIDING INFORMATION IN THE FIELD OF VIRTUAL COMMUNITIES, ELECTRONIC GAMING AND ENTERTAINMENT VIA THE INTERNET OR OTHER COMMUNICATIONS NETWORKS WITH THIRD PARTIES; COMPUTER SOFTWARE PLATFORMS FOR SOCIAL NETWORKING; DOWNLOADABLE COMPUTER GAME SOFTWARE VIA A GLOBAL COMPUTER NETWORK AND WIRELESS DEVICES; DOWNLOADABLE ELECTRONIC GAME SOFTWARE FOR USE ON SOCIAL NETWORKING THAT MAY BE ACCESSED VIA THE INTERNET, COMPUTERS AND WIRELESS DEVICES, NAMELY LAPTOP COMPUTERS, MOBILE PHONES, TABLET COMPUTERS AND HANDHELD COMPUTERS; ELECTRONIC GAME PROGRAMS; INTERACTIVE VIDEO GAME PROGRAMS; VIDEO GAME SOFTWARE (U.S. CLS. 21, 23, 26, 36 AND 38).

DAVID I, EXAMINING ATTORNEY

SN 86-172,326. DIXON, JOHN, HERNDON, VA. FILED 1-22-2014.

**Auto Commander**

THE MARK CONSISTS OF STANDARD CHARACTERS WITHOUT CLAIM TO ANY PARTICULAR FONT, STYLE, SIZE, OR COLOR.

NO CLAIM IS MADE TO THE EXCLUSIVE RIGHT TO USE "AUTO", APART FROM THE MARK AS SHOWN.

FOR ELECTRONIC CONTROLS FOR AFTER-MARKET ELECTRICAL DEVICES ON AN AUTOMOBILE, NAMELY, FOR LIGHTS, AIR COMPRESSORS, WINCHES, HORNS, EMERGENCY SIRENS, SNOW PLOWS AND RADIOS (U.S. CLS. 21, 23, 26, 36 AND 38).

KATHERINE CHANG, EXAMINING ATTORNEY

SN 86-174,718. DOMINGUEZ, RICARDO CARMAN, DBA CITY IN COLOR, SANTA BARBARA, CA. FILED 1-24-2014.



THE COLOR(S) BLACK, WHITE, ORANGE, RED, OLIVE, MAGENTA, PURPLE, AND CYAN IS/ARE CLAIMED AS A FEATURE OF THE MARK.

THE MARK CONSISTS OF A SMALL WHITE "C" WITHIN A BIGGER WHITE "C" WITH A BLACK "C" IN THE

**CLASS 9—(Continued).**

MIDDLE. AROUND AND WITHIN THE "C"'S ARE SIX WEDGE SHAPES THAT ARE SEGMENTED AND START FROM A DARKER COLOR TO A LIGHTER COLOR AND END WITH A THICK BLACK BAND AND THE ENTIRE WEDGE HAS A WHITE OUTLINE. THE WEDGES VARY IN SIZE. THE COLOR OF THE WEDGES VARIES FROM TOP TO BOTTOM GOING ORANGE, OLIVE, CYAN, PURPLE, MAGENTA, AND RED. THE REMAINING BLACK REPRESENTS BACKGROUND AREA ONLY AND IS NOT CLAIMED AS A FEATURE OF THE MARK.

FOR COMPUTER APPLICATION SOFTWARE FOR SMARTPHONES, TABLET COMPUTERS AND COMPUTERS, NAMELY, SOFTWARE FOR SOCIAL NETWORKING (U.S. CLS. 21, 23, 26, 36 AND 38).

FIRST USE 6-1-2013; IN COMMERCE 1-22-2014.  
JONATHAN FALK, EXAMINING ATTORNEY

SN 86-175,005. FROG'S TUNG, LLC, BOZEMAN, MT. FILED 1-24-2014.



THE MARK CONSISTS OF OVAL "FROG'S TUNG" WRITTEN ALSO HAS A SITTING FROG WITH AN EXTENDED TONGUE GOING AROUND ON THE INSIDE OF THE OVAL.

FOR ELECTRONIC DEVICE ACCESSORY USED TO PREVENT A USER FROM LOSING OR HAVING ITS ELECTRONIC DEVICES STOLEN, NAMELY, A CLIP THAT ATTACHES TO BELT, PURSE, OR BACKPACK AND CONNECTS VIA A CABLE THAT IS ADHERED TO A MOBILE ELECTRONIC DEVICE IN THE NATURE OF CELL PHONE, PORTABLE MUSIC PLAYER OR HAND HELD GAME POD (U.S. CLS. 21, 23, 26, 36 AND 38).

CHRISTINA SOBRAL, EXAMINING ATTORNEY

SN 86-177,763. NIKON CORPORATION, TOKYO, JAPAN, FILED 1-28-2014.

## Creative Palette

THE MARK CONSISTS OF STANDARD CHARACTERS WITHOUT CLAIM TO ANY PARTICULAR FONT, STYLE, SIZE, OR COLOR.

PRIORITY CLAIMED UNDER SEC. 44(D) ON JAPAN APPLICATION NO. 2014-4588, FILED 1-27-2014, REG. NO. 5676689, DATED 6-13-2014, EXPIRES 6-13-2024.

FOR DIGITAL CAMERAS (U.S. CLS. 21, 23, 26, 36 AND 38).

ELISSA GARBER KON, EXAMINING ATTORNEY

**CLASS 9—(Continued).**

SN 86-177,893. ECCN INC., MANASSAS PARK, VA. FILED 1-28-2014.



NO CLAIM IS MADE TO THE EXCLUSIVE RIGHT TO USE "INC.", APART FROM THE MARK AS SHOWN.

THE COLOR(S) BLUE AND ORANGE IS/ARE CLAIMED AS A FEATURE OF THE MARK.

THE MARK CONSISTS OF 4 C SHAPE CRESCENTS OR CURVES THAT EXTEND OUTWARDS STARTING FROM LEFT TO RIGHT WITH THE FOLLOWING ORDER OF COLORS BLUE ORANGE BLUE ORANGE. THESE 4 CRESCENTS OR CURVES DECREASE IN SIZE FROM LEFT TO RIGHT GRADUALLY. THE "ECCN INC." LETTERS ARE REPRESENTED IN BLUE COLOR TO THE RIGHT SIDE OF THE CURVES WITH THE FOLLOWING DISTINCTIONS, LETTERS "ECCN" ARE CAPITALIZED AND ONLY "I" IN THE WORD "INC." IS CAPITALIZED WITH A PERIOD AT THE END. BLUE VERTICAL LINE SEPARATES THE WORD "ECCN" FROM THE WORD "INC.". THESE LETTERS ARE SAME IN SIZE AND STYLE WITHOUT ANY ASSOCIATED FONT.

FOR CAMERA HARDWARE SYSTEMS FOR IP (INTERNET PROTOCOL) VIDEO SURVEILLANCE; CLOSED CIRCUIT TV SYSTEMS FOR SECURITY AND SURVEILLANCE, NAMELY, CAMERAS, SWITCHERS, MONITORS, MICROPHONES, AND RECORDERS; COMPUTER HARDWARE FOR IP VIDEO SURVEILLANCE; DIGITAL VIDEO RECORDING SOFTWARE FOR IP (INTERNET PROTOCOL) VIDEO SURVEILLANCE; ELECTRONIC VIDEO SURVEILLANCE PRODUCTS, NAMELY, ELECTRONIC COMPONENTS OF SECURITY SYSTEMS; ENTRY/EXIT SECURITY PORTAL COMPRISED OF AN ELECTRONIC PASSAGEWAY EQUIPPED WITH BIOMETRIC DEVICES FOR IDENTIFICATION VERIFICATION AND DETECTION OF IMPERMISSIBLE ITEMS BEING CARRIED THROUGH; FIBER OPTICS; HOME AND OFFICE AUTOMATION SYSTEMS COMPRISING WIRELESS AND WIRED CONTROLLERS, CONTROLLED DEVICES, AND SOFTWARE FOR LIGHTING, HVAC, SECURITY, SAFETY AND OTHER HOME AND OFFICE MONITORING AND CONTROL APPLICATIONS; IP (INTERNET PROTOCOL) CAMERAS; IP (INTERNET PROTOCOL) SPEED DOME CAMERAS; IP VIDEO SERVERS; NETWORK VIDEO RECORDING SOFTWARE FOR IP (INTERNET PROTOCOL) VIDEO SURVEILLANCE; SECURITY ALARM CONTROLLERS; SECURITY AND FIRE ALARMS; SECURITY CONTROL PANELS AND MOTION DETECTORS; VEHICLE LOCATING, TRACKING AND SECURITY SYSTEM COMPRISED OF AN ANTENNA AND RADIO TRANSMITTER TO BE PLACED IN A VEHICLE (U.S. CLS. 21, 23, 26, 36 AND 38).

FIRST USE 1-1-2011; IN COMMERCE 11-1-2011.

MORGAN WYNNE, EXAMINING ATTORNEY

**CLASS 9—(Continued).**

SN 86-179,381. INCENT GAMES LLC, AKA FANTASYSALESTEAM, AUSTIN, TX. FILED 1-30-2014.

# FantasySales

THE MARK CONSISTS OF STANDARD CHARACTERS WITHOUT CLAIM TO ANY PARTICULAR FONT, STYLE, SIZE, OR COLOR.

FOR COMPUTER GAME SOFTWARE, NOT DOWNLOADABLE (U.S. CLS. 21, 23, 26, 36 AND 38).

FIRST USE 6-13-2014; IN COMMERCE 6-13-2014.  
SEAN CROWLEY, EXAMINING ATTORNEY

**CLASS 9—(Continued).**

OF PUZZLE PIECES FITTING TOGETHER WITH DOVETAIL JOINTS. THE TOP, LEFT AND BOTTOM CORNERS OF THE INNER SQUARE FORM ARROWS POINTING OUTWARD. THE ARROWS WHICH POINT UP AND DOWN HAVE THE TIPS CUT OFF BY THE TOP AND BOTTOM EDGES OF THE OUTER SQUARE WITH THE ROUNDED CORNERS. THE CORNER OF THE INNER SQUARE POINTING TO THE VIEWER'S LEFT POINTS TO THE CENTER OF THE THREE EQUALLY-SPACED HORIZONTAL LINES. THE CORNER POINTING TO THE VIEWER'S RIGHT IS CUT OFF AT A 45-DEGREE ANGLE BELOW WHERE THE ARROW WOULD BE FORMED BY THE INTERSECTION OF THE DOVETAIL JOINTS.

FOR CUSTOMIZABLE METAL STANDS SPECIALLY ADAPTED FOR USE WITH POINT-OF-SALE COMPUTING DEVICES FOR RETAIL TRANSACTIONS AND OTHER ELECTRONIC COMPUTER AND TABLET DEVICES (U.S. CLS. 21, 23, 26, 36 AND 38).

FIRST USE 1-5-2012; IN COMMERCE 1-5-2012.  
BRIDGETT SMITH, EXAMINING ATTORNEY

SN 86-180,006. MAILSTORE SOFTWARE GMBH, VIERSEN, FED REP GERMANY, FILED 1-30-2014.

# MailStore Home

THE MARK CONSISTS OF STANDARD CHARACTERS WITHOUT CLAIM TO ANY PARTICULAR FONT, STYLE, SIZE, OR COLOR.

OWNER OF U.S. REG. NOS. 3,443,247, 4,204,322 AND OTHERS.

SEC. 2(F).

FOR SOFTWARE FOR EMAIL ARCHIVING (U.S. CLS. 21, 23, 26, 36 AND 38).

FIRST USE 12-31-2007; IN COMMERCE 12-31-2007.  
MATTHEW EINSTEIN, EXAMINING ATTORNEY

SN 86-181,444. BARSOCIAL, LLC, HOBOKEN, NJ. FILED 1-31-2014.

SN 86-180,262. SOURCE COMMUNICATIONS, LLP, BROOMFIELD, CO. FILED 1-30-2014.



**MPS**  
Modular Pole Systems

NO CLAIM IS MADE TO THE EXCLUSIVE RIGHT TO USE "MODULAR POLE SYSTEMS", APART FROM THE MARK AS SHOWN.

THE MARK CONSISTS OF THE UPPER CASE LETTERS "MPS", IN A BOLD-FACED TYPE, WHICH ARE CENTERED ABOVE THE WORDS "MODULAR POLE SYSTEMS" IN A SMALLER-SIZED FONT. TO THE LEFT OF THE VERBAL PORTION OF THE MARK IS A SQUARE WITH ROUNDED CORNERS. STARTING AT THE LEFT SIDE OF THE SQUARE AND EXTENDING TO THE RIGHT ARE THREE EQUALLY-SPACED HORIZONTAL LINES WHICH END WHERE THEY INTERSECT WITH THE LEFT-HAND CORNER OF AN INNER SQUARE. THE INNER SQUARE, FORMED BY HEAVY LINES, IS TURNED 45 DEGREES SO THAT IT APPEARS TO BE RESTING ON THE BOTTOM CORNER WHICH IS CUT OFF AT A 45-DEGREE ANGLE BY THE LOWER EDGE OF THE OUTER SQUARE. THE INNER EDGES OF THE INNER SQUARE ARE NOTCHED IN SUCH A WAY THAT IT CREATES THE APPEARANCE



NO CLAIM IS MADE TO THE EXCLUSIVE RIGHT TO USE "NYC", APART FROM THE MARK AS SHOWN.

THE MARK CONSISTS OF A CITY SKYLINE AS A THE BACKGROUND FOR THE WORDING "BARSOCIAL", WITH THE WORD "NYC" IN A THOUGHT CLOUD ABOVE THE LETTERS "O" AND "C", WITH THE WORDING "CHECK IN TO NIGHTLIFE" BENEATH THE SKYLINE DESIGN.

FOR COMPUTER APPLICATION SOFTWARE FOR MOBILE PHONES, NAMELY, SOFTWARE FOR ALLOWING USERS TO POST COMMENTS AND REQUEST FOR RECOMMENDATIONS FOR NIGHTLIFE VENUES SUCH AS BARS AND CLUBS (U.S. CLS. 21, 23, 26, 36 AND 38).

LAURA KOVALSKY, EXAMINING ATTORNEY

**CLASS 9—(Continued).**

SN 86-182,931. ETRAK CORP., DALLAS, TX. FILED 2-3-2014.

NO CLAIM IS MADE TO THE EXCLUSIVE RIGHT TO USE "CARTRAK", APART FROM THE MARK AS SHOWN. THE COLOR(S) GREEN AND WHITE IS/ARE CLAIMED AS A FEATURE OF THE MARK.

THE MARK CONSISTS OF THE STYLIZED WORDING "CARTRAK" WITH THE LETTER "K" FOLLOWED BY TWO CHEVRONS; THE TERM "CAR" IS IN GREEN, WHILE THE "TRAK" AND THE CHEVRON DESIGNS ARE IN WHITE; THE BLACK OUTLINE IS MERELY TO INDICATE WHERE THE COLOR WHITE APPEARS AND IS NOT CLAIMED AS A FEATURE OF THE MARK.

FOR ELECTRONIC DEVICES USED FOR LOCATING PERSONS AND PROPERTY BY MEANS OF GPS, CELLULAR AND WIRELESS NETWORK LOCATION DATA (U.S. CLS. 21, 23, 26, 36 AND 38).

SUE LAWRENCE, EXAMINING ATTORNEY

SN 86-182,980. ETRAK CORP., DALLAS, TX. FILED 2-3-2014.

NO CLAIM IS MADE TO THE EXCLUSIVE RIGHT TO USE "PETTRAK", APART FROM THE MARK AS SHOWN. THE COLOR(S) GREEN AND WHITE IS/ARE CLAIMED AS A FEATURE OF THE MARK.

THE MARK CONSISTS OF THE STYLIZED WORDING "PETTRAK" WITH THE LETTER "K" FOLLOWED BY TWO CHEVRONS; THE TERM "PET" IS IN GREEN, WHILE THE "TRAK" AND THE CHEVRON DESIGNS ARE IN WHITE; THE BLACK OUTLINE IS MERELY TO INDICATE WHERE THE COLOR WHITE APPEARS AND IS NOT CLAIMED AS A FEATURE OF THE MARK.

FOR ELECTRONIC DEVICES USED FOR LOCATING PERSONS AND PROPERTY BY MEANS OF GPS, CELLULAR AND WIRELESS NETWORK LOCATION DATA (U.S. CLS. 21, 23, 26, 36 AND 38).

SUE LAWRENCE, EXAMINING ATTORNEY

SN 86-184,502. TRANSCARE HOLDINGS CORPORATION, COPPELL, TX. FILED 2-4-2014.

# HOTTHINGZ

THE MARK CONSISTS OF STANDARD CHARACTERS WITHOUT CLAIM TO ANY PARTICULAR FONT, STYLE, SIZE, OR COLOR.

FOR COMPUTER E-COMMERCE SOFTWARE TO ALLOW USERS TO PERFORM ELECTRONIC BUSINESS TRANSACTIONS VIA A GLOBAL COMPUTER NETWORK (U.S. CLS. 21, 23, 26, 36 AND 38).

STEVEN JACKSON, EXAMINING ATTORNEY

**CLASS 9—(Continued).**

SN 86-184,506. TRANSCARE HOLDINGS CORPORATION, COPPELL, TX. FILED 2-4-2014.

## If it's hot, it's in the box!

THE MARK CONSISTS OF STANDARD CHARACTERS WITHOUT CLAIM TO ANY PARTICULAR FONT, STYLE, SIZE, OR COLOR.

FOR COMPUTER E-COMMERCE SOFTWARE TO ALLOW USERS TO PERFORM ELECTRONIC BUSINESS TRANSACTIONS VIA A GLOBAL COMPUTER NETWORK (U.S. CLS. 21, 23, 26, 36 AND 38).

STEVEN JACKSON, EXAMINING ATTORNEY

SN 86-184,637. MAESTRANO PTY LTD, DBA MAESTRANO, SURRY HILLS, SYDNEY, AUSTRALIA, FILED 2-5-2014.

THE COLOR(S) GREEN, WHITE AND BLACK IS/ARE CLAIMED AS A FEATURE OF THE MARK.

THE MARK CONSISTS OF THE WORD "MAESTRANO" WRITTEN IN BLACK WITH THE EXCEPTION OF THE LETTER "E" WRITTEN IN GREEN AND A DIAMOND SHAPE COLOURED IN THE SAME GREEN AS THE LETTER "E" WITH WHITE DOTS IN THE CENTER OF THE DIAMOND LOOKING LIKE A WATER SPURT.

THE WORDING "MAESTRANO" HAS NO MEANING IN A FOREIGN LANGUAGE.

FOR COMPUTER SOFTWARE THAT PROVIDES WEB-BASED ACCESS TO APPLICATIONS AND SERVICES THROUGH A WEB OPERATING SYSTEM OR PORTAL INTERFACE (U.S. CLS. 21, 23, 26, 36 AND 38).

FIRST USE 9-8-2012; IN COMMERCE 1-3-2013.

ESTHER A. BORSUK, EXAMINING ATTORNEY

SN 86-185,484. GUNNARSSON, FREDRIK, KARLSTAD, SWEDEN, FILED 2-5-2014.

## Sound Dimension

THE MARK CONSISTS OF STANDARD CHARACTERS WITHOUT CLAIM TO ANY PARTICULAR FONT, STYLE, SIZE, OR COLOR.

NO CLAIM IS MADE TO THE EXCLUSIVE RIGHT TO USE "SOUND", APART FROM THE MARK AS SHOWN.

FOR AMPLIFIERS; APPARATUS FOR RECORDING, TRANSMISSION OR REPRODUCTION OF SOUND AND IMAGES; CABLES, ELECTRIC; INTEGRATED CIRCUITS; LOUDSPEAKERS, HEADPHONES, MICROPHONES AND CD PLAYERS (U.S. CLS. 21, 23, 26, 36 AND 38).

ANNE MADDEN, EXAMINING ATTORNEY

**CLASS 9—(Continued).**

SN 86-186,352. TASTY TECH LTD., TORONTO, ONTARIO, CANADA, FILED 2-6-2014.

## Smile Designer Pro

THE MARK CONSISTS OF STANDARD CHARACTERS WITHOUT CLAIM TO ANY PARTICULAR FONT, STYLE, SIZE, OR COLOR.

NO CLAIM IS MADE TO THE EXCLUSIVE RIGHT TO USE "SMILE DESIGNER", APART FROM THE MARK AS SHOWN.

FOR COMPUTER APPLICATION SOFTWARE FOR MOBILE PHONES, TABLETS, HANDHELD COMPUTERS, DESKTOP COMPUTERS, NAMELY, SOFTWARE FOR DENTAL TREATMENT PLANNING (U.S. CLS. 21, 23, 26, 36 AND 38).

FIRST USE 8-7-2013; IN COMMERCE 9-13-2013.  
LAURIE MAYES, EXAMINING ATTORNEY

**CLASS 9—(Continued).**

SN 86-187,291. ENVISIONBODY LLC, BELLEAIR BLUFFS, FL. FILED 2-7-2014.

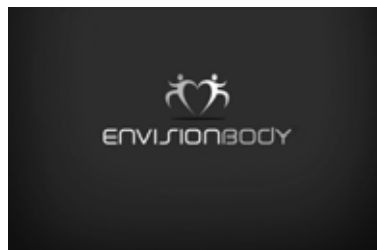

THE MARK CONSISTS OF AN ABSTRACT DESIGN OF TWO PEOPLE ABOVE A HORIZONTAL LINE WITH THE WORDING "ENVISIONBODY" BELOW THE HORIZONTAL LINE.

FOR COMPUTER SOFTWARE, NAMELY, COMPUTER SOFTWARE THAT RECEIVES DATA AND PRODUCES A MOTIVATIONAL VIDEO IMAGE OF AN EXERCISER LOOKING MORE FIT ON A VIDEO DISPLAY AND COMPILES DATA INTO A USEFUL FORMAT FOR TRACKING EXERCISE PERFORMED AND WELLNESS FACTORS ATTAINED (U.S. CLS. 21, 23, 26, 36 AND 38).  
MARC LEIPZIG, EXAMINING ATTORNEY

SN 86-188,802. TECHLAND SP. Z O.O., DBA TECHLAND SP. Z O.O., OSTROW WIELKOPOLSKI, POLAND, FILED 2-10-2014.

## HUMALO

THE MARK CONSISTS OF STANDARD CHARACTERS WITHOUT CLAIM TO ANY PARTICULAR FONT, STYLE, SIZE, OR COLOR.

THE WORDING "HUMALO" HAS NO MEANING IN A FOREIGN LANGUAGE.

FOR COMPUTER SOFTWARE PROGRAMS FOR THE INTEGRATION OF TEXT, AUDIO, GRAPHICS, STILL IMAGES AND MOVING PICTURES INTO AN INTERACTIVE DELIVERY FOR MULTIMEDIA APPLICATIONS; COMPUTER SOFTWARE DEVELOPMENT TOOLS; COMPUTER SOFTWARE FOR USE AS AN APPLICATION PROGRAMMING INTERFACE (API); APPLICATION PROGRAMMING INTERFACE (API) FOR COMPUTER SOFTWARE WHICH FACILITATES ONLINE SERVICES FOR SOCIAL NETWORKING, BUILDING SOCIAL NETWORKING APPLICATIONS AND FOR ALLOWING DATA RETRIEVAL, UPLOAD, DOWNLOAD, ACCESS AND MANAGEMENT; COMPUTER SOFTWARE TO ENABLE UPLOADING, DOWNLOADING, ACCESSING, POSTING, DISPLAYING, TAGGING, BLOGGING, STREAMING, LINKING, SHARING OR OTHERWISE PROVIDING ELECTRONIC MEDIA OR INFORMATION VIA COMPUTER AND COMMUNICATION NETWORKS (U.S. CLS. 21, 23, 26, 36 AND 38).

KEVIN DINALLO, EXAMINING ATTORNEY

SN 86-186,524. TACO, INC., CRANSTON, RI. FILED 2-6-2014.

## OneTouch ProBalance

THE MARK CONSISTS OF STANDARD CHARACTERS WITHOUT CLAIM TO ANY PARTICULAR FONT, STYLE, SIZE, OR COLOR.

NO CLAIM IS MADE TO THE EXCLUSIVE RIGHT TO USE "PROBALANCE", APART FROM THE MARK AS SHOWN.

FOR SOFTWARE PROGRAM THAT ALLOWS USERS THE SINGLE AUTOMATIC OPTION DISPLAYED ON A SCREEN TO PERFORM AUTOMATIC CALIBRATION OF PRODUCTS, NAMELY, CIRCULATOR PUMPS, ELECTRONIC CONTROL DEVICES, AIR SEPARATORS, EXPANSION TANKS AND HEAT EXCHANGERS (U.S. CLS. 21, 23, 26, 36 AND 38).

C. DIONNE CLYBURN, EXAMINING ATTORNEY

**CLASS 9—(Continued).**

SN 86-189,354. ZIVIX LLC, MINNEAPOLIS, MN. FILED 2-10-2014.

Zivix

THE MARK CONSISTS OF STANDARD CHARACTERS WITHOUT CLAIM TO ANY PARTICULAR FONT, STYLE, SIZE, OR COLOR.

FOR WIRELESS MUSICAL INSTRUMENT DIGITAL INTERFACE CONTROLLER AND OPERATING SOFTWARE FOR MAKING MUSIC; INTERACTIVE MULTIMEDIA COMPUTER PROGRAM FOR MUSIC COMPOSITION, PERFORMANCE AND COLLABORATION; INTERACTIVE VIDEO GAME PROGRAMS; VIDEO AND COMPUTER GAME PROGRAMS; VIDEO GAME CARTRIDGES AND DISCS (U.S. CLS. 21, 23, 26, 36 AND 38).

FIRST USE 2-17-2006; IN COMMERCE 8-10-2010.  
TRACY CROSS, EXAMINING ATTORNEY

**CLASS 9—(Continued).**

SN 86-191,410. SHENZHEN AEE TECHNOLOGY CO., LTD., SHENZHEN, GUANGDONG, CHINA, FILED 2-12-2014.

AEE

OWNER OF U.S. REG. NO. 3,308,595.

THE MARK CONSISTS OF THE WORDING "AEE" WITH A CURVED LINE RUNNING FROM THE BOTTOM LEFT SIDE OF THE LETTER "A" AND HORIZONTALLY THROUGH THE UPPER HALF OF THE LETTERS "E".

FOR DIGITAL VIDEO CAMERAS; CAMCORDER; PORTABLE VIDEO CAMERAS WITH BUILT-IN VIDEO-CASSETTE RECORDERS; CAMERAS; DIGITAL CAMERAS; LENSES FOR CAMERAS; COMPUTER MONITORS; ANTENNAS; TELECOMMUNICATIONS TRANSMITTERS; BURGLAR ALARMS; FIRE ALARMS; SMOKE ALARMS; PERSONAL SECURITY ALARMS; SMOKE DETECTORS; RADAR DETECTORS; RADON DETECTORS; PHOTOGRAPHIC LENSES (U.S. CLS. 21, 23, 26, 36 AND 38).

FIRST USE 3-1-2006; IN COMMERCE 3-1-2006.  
JUHI KAVEESHVAR, EXAMINING ATTORNEY

SN 86-189,841. JOYFUL PIXELS LLC, FAIRBANKS, AK. FILED 2-11-2014.

Joyful Pixels

THE MARK CONSISTS OF STANDARD CHARACTERS WITHOUT CLAIM TO ANY PARTICULAR FONT, STYLE, SIZE, OR COLOR.

FOR DOWNLOADABLE MULTIMEDIA FILE CONTAINING ARTWORK, TEXT, AUDIO, VIDEO, GAMES, AND INTERNET WEB LINKS RELATING TO ENTERTAINMENT, BUSINESS AND EDUCATION (U.S. CLS. 21, 23, 26, 36 AND 38).

FIRST USE 1-19-2014; IN COMMERCE 2-4-2014.  
MARIA-VICTORIA SUAREZ, EXAMINING ATTORNEY

SN 86-193,039. BIGGS, BRANDON, WYLIE, TX. FILED 2-13-2014.

Brandon Biggs

THE MARK CONSISTS OF STANDARD CHARACTERS WITHOUT CLAIM TO ANY PARTICULAR FONT, STYLE, SIZE, OR COLOR.

THE NAME "BRANDON BIGGS" IDENTIFIES A LIVING INDIVIDUAL WHOSE CONSENT IS OF RECORD.

FOR DOWNLOADABLE COMPUTER GAME SOFTWARE VIA A GLOBAL COMPUTER NETWORK; WIRELESS DEVICES, NAMELY, HEAD-MOUNTED VIDEO DISPLAYS, SMARTPHONES; DOWNLOADABLE COMPUTER GRAPHICS (U.S. CLS. 21, 23, 26, 36 AND 38).

GILBERT SWIFT, EXAMINING ATTORNEY



**CLASS 9—(Continued).**

SN 86-193,738. HARVARD BIOSCIENCE, INC., HOLLISTON, MA. FILED 2-14-2014.



THE COLOR(S) BLUE, RED, AND GRAY IS/ARE CLAIMED AS A FEATURE OF THE MARK.

THE MARK CONSISTS OF A BLUE CRESCENT ABOVE AND TO THE LEFT OF THE LETTER "H" WRITTEN IN RED WHICH SLIGHTLY OVERLAPS THE LETTER "A" WRITTEN IN GRAY.

FOR HOUSEMARK FOR A FULL LINE OF LABORATORY EQUIPMENT AND SUPPLIES, NAMELY, SYRINGE AND PERISTALTIC PUMPS AND SURGICAL AND ANESTHESIA EQUIPMENT FOR RESEARCH (U.S. CLS. 21, 23, 26, 36 AND 38).

LINDA ORNDORFF, EXAMINING ATTORNEY

SN 86-196,885. JDS UNIPHASE CORPORATION, MILPITAS, CA. FILED 2-18-2014.

# VARIO

THE MARK CONSISTS OF STANDARD CHARACTERS WITHOUT CLAIM TO ANY PARTICULAR FONT, STYLE, SIZE, OR COLOR.

FOR ELECTRO-OPTIC COUPLING DEVICE, NAMELY, A LASER COUPLING SYSTEM COMPRISED OF A FIBER-TO-FIBER COUPLER AND PROCESS FIBER FOR ELECTRICALLY CONTROLLED IN-PROCESS LASER BEAM SHAPE ADJUSTMENT FOR USE IN CUTTING, WELDING AND MATERIAL DEPOSITION PROCESSES; LASER COUPLING SYSTEM COMPRISED OF A FIBER-TO-FIBER COUPLER AND PROCESS FIBER; EQUIPMENT FOR LASERS, NAMELY COUPLERS AND OPTICAL FIBERS; LASER EQUIPMENT FOR NON-MEDICAL PURPOSES (U.S. CLS. 21, 23, 26, 36 AND 38).

MATTHEW KLINE, EXAMINING ATTORNEY

**CLASS 9—(Continued).**

SN 86-197,113. BROCADE COMMUNICATIONS SYSTEMS, INC., SAN JOSE, CA. FILED 2-18-2014.

# FABRIC VISION

THE MARK CONSISTS OF STANDARD CHARACTERS WITHOUT CLAIM TO ANY PARTICULAR FONT, STYLE, SIZE, OR COLOR.

NO CLAIM IS MADE TO THE EXCLUSIVE RIGHT TO USE "FABRIC", APART FROM THE MARK AS SHOWN.

FOR COMPUTER SOFTWARE AND FIRMWARE FOR CREATING, OPERATING AND MANAGING NETWORKS; COMPUTER SOFTWARE FOR ADMINISTRATION OF COMPUTER NETWORKS; LAN (LOCAL AREA NETWORK) OPERATING SOFTWARE; NETWORK ACCESS SERVER OPERATING SOFTWARE; VPN (VIRTUAL PRIVATE NETWORK) OPERATING SOFTWARE; WAN (WIDE AREA NETWORK) OPERATING SOFTWARE (U.S. CLS. 21, 23, 26, 36 AND 38).

LIEF MARTIN, EXAMINING ATTORNEY

SN 86-201,512. MOSSGREG E-COMMERCE CO., LIMITED, HONGKONG, CHINA, FILED 2-24-2014.



THE NAME(S), PORTRAIT(S), AND/OR SIGNATURE(S) SHOWN IN THE MARK DOES NOT IDENTIFY A PARTICULAR LIVING INDIVIDUAL.

THE MARK CONSISTS OF A FLOWER TO THE LEFT OF THE WORDING "MOSSGREG" IN STYLIZED LETTERING.

THE WORDING "MOSSGREG" HAS NO MEANING IN A FOREIGN LANGUAGE.

FOR BACKUP DRIVES FOR COMPUTERS; BATTERIES; CASES FOR MOBILE PHONES; COMPUTER PERIPHERAL DEVICES; DEVICES FOR HANDS-FREE USE OF MOBILE PHONES; ELECTRONIC LED SIGNS; KEYBOARDS; KEYBOARDS FOR MOBILE PHONES; LIGHT EMITTING DIODES (LEDS) (U.S. CLS. 21, 23, 26, 36 AND 38).

FIRST USE 2-10-2012; IN COMMERCE 2-10-2012.

ELISSA GARBER KON, EXAMINING ATTORNEY



**CLASS 9—(Continued).**

SN 86-202,833. MICHELLE VANGIE CANDELARIA, MESA, AZ. FILED 2-24-2014.

# Cupapp

THE MARK CONSISTS OF STANDARD CHARACTERS WITHOUT CLAIM TO ANY PARTICULAR FONT, STYLE, SIZE, OR COLOR.

FOR COMPUTER APPLICATION SOFTWARE FOR MOBILE PHONES, NAMELY, SOFTWARE FOR COMMUNITY CMS (COMPUTER MANAGEMENT SYSTEM) WEBSITE; COMPUTER GAME SOFTWARE FOR USE ON MOBILE AND CELLULAR PHONES; COMPUTER SOFTWARE, NAMELY, SOFTWARE DEVELOPMENT TOOLS FOR THE CREATION OF MOBILE INTERNET APPLICATIONS AND CLIENT INTERFACES (U.S. CLS. 21, 23, 26, 36 AND 38).

DEBORAH LOBO, EXAMINING ATTORNEY

---

SN 86-204,472. NAIL, RYAN, AUSTIN, TX. FILED 2-26-2014.

# Corefitx

THE MARK CONSISTS OF STANDARD CHARACTERS WITHOUT CLAIM TO ANY PARTICULAR FONT, STYLE, SIZE, OR COLOR.

FOR DIGITAL MATERIALS, NAMELY, DVDS AND DOWNLOADABLE VIDEO FILES FEATURING FITNESS INSTRUCTION (U.S. CLS. 21, 23, 26, 36 AND 38).

ERNEST SHOSHO, EXAMINING ATTORNEY

---

SN 86-205,002. SPEEDWAY LLC, ENON, OH. FILED 2-26-2014.

# SPEEDY WALLET

THE MARK CONSISTS OF STANDARD CHARACTERS WITHOUT CLAIM TO ANY PARTICULAR FONT, STYLE, SIZE, OR COLOR.

OWNER OF U.S. REG. NOS. 2,667,115 AND 4,227,895.

NO CLAIM IS MADE TO THE EXCLUSIVE RIGHT TO USE "WALLET", APART FROM THE MARK AS SHOWN.

FOR MOBILE SOFTWARE ALLOWING CUSTOMERS TO INTERACT WITH THE POS AND FUEL DISPENSER, NAMELY, TO MAKE PAYMENTS, PURCHASE GOODS, PARTICIPATE IN A LOYALTY PROGRAM; MOBILE SOFTWARE ALLOWING CUSTOMERS TO PARTICIPATE IN A LOYALTY PROGRAM, ACCESS CUSTOMER'S LOYALTY ACCOUNT AND ACCOUNT BALANCES, AND VIEW ELECTRONIC RECEIPTS (U.S. CLS. 21, 23, 26, 36 AND 38).

DOMINICK J. SALEMI, EXAMINING ATTORNEY

**CLASS 9—(Continued).**

SN 86-205,792. PARTNER SOFTWARE, INC., ATHENS, GA. FILED 2-27-2014.

# PARTNER SOFTWARE

THE MARK CONSISTS OF STANDARD CHARACTERS WITHOUT CLAIM TO ANY PARTICULAR FONT, STYLE, SIZE, OR COLOR.

NO CLAIM IS MADE TO THE EXCLUSIVE RIGHT TO USE "SOFTWARE", APART FROM THE MARK AS SHOWN.

FOR COMPUTER APPLICATION SOFTWARE FOR MAP VIEWING AND FIELD DATA COLLECTION ON DESKTOP AND LAPTOP COMPUTERS, MOBILE PHONES, HAND-HELD COMPUTERS, TABLET COMPUTERS; SOFTWARE FOR FIELD DATA COLLECTION; COMPUTER SOFTWARE FOR THE COLLECTION, EDITING, ORGANIZING, MODIFYING, BOOK MARKING, TRANSMISSION, STORAGE AND SHARING OF DATA AND INFORMATION; COMPUTER SOFTWARE PLATFORMS FOR MAP VIEWING AND FIELD DATA COLLECTION; COMPUTER SOFTWARE, NAMELY, AN APPLICATION ALLOWING SALES AND FIELD SERVICE EMPLOYEES TO UPDATE AND RECEIVE DATA STORED IN AN ENTERPRISE'S COMPUTER DATABASES IN REAL TIME, USING A MOBILE DEVICE, WITH SOFTWARE FEATURES ON THE MOBILE DEVICE (U.S. CLS. 21, 23, 26, 36 AND 38).

FIRST USE 2-28-1997; IN COMMERCE 9-30-1997.

TINA L. SNAPP, EXAMINING ATTORNEY

---

SN 86-206,208. ZYNO MEDICAL LLC, NATICK, MA. FILED 2-27-2014.

# ZYNOFLO

THE MARK CONSISTS OF STANDARD CHARACTERS WITHOUT CLAIM TO ANY PARTICULAR FONT, STYLE, SIZE, OR COLOR.

FOR COMPUTER SOFTWARE FOR USE WITH INFUSION PUMP DEVICE, FOR MEDICATION ADMINISTRATION MANAGEMENT (U.S. CLS. 21, 23, 26, 36 AND 38).

FIRST USE 7-1-2013; IN COMMERCE 7-1-2013.

MARY CRAWFORD, EXAMINING ATTORNEY

**CLASS 9—(Continued).**

SN 86-207,927. HOTEL, GABRIEL N, AKA MEK, MIAMI, FL. FILED 2-28-2014.

# MEK

THE MARK CONSISTS OF STANDARD CHARACTERS WITHOUT CLAIM TO ANY PARTICULAR FONT, STYLE, SIZE, OR COLOR.

THE NAME "MEK" IDENTIFIES A LIVING INDIVIDUAL WHOSE CONSENT IS OF RECORD.

FOR MUSICAL SOUND RECORDINGS (U.S. CLS. 21, 23, 26, 36 AND 38).

FIRST USE 2-11-2000; IN COMMERCE 4-25-2000.

JOANNA FIORELLI, EXAMINING ATTORNEY

SN 86-207,959. INFOBELT, LLC, CHARLOTTE, NC. FILED 2-28-2014.



THE COLOR(S) GREEN AND WHITE IS/ARE CLAIMED AS A FEATURE OF THE MARK.

THE MARK CONSISTS OF THE DESIGN OF TWO CONCENTRIC CIRCLES COMPOSED OF A WHITE CIRCLE INSIDE A GREEN CIRCLE WHICH IS INSIDE AN INCOMPLETE WHITE CIRCLE INSIDE AN INCOMPLETE GREEN CIRCLE WITH WHITE HORIZONTAL LINES.

FOR COMPUTER SOFTWARE FOR USE IN INFORMATION MANAGEMENT, NAMELY, LIFECYCLE, ARCHIVING, DISPOSITION, ANALYTICS, STORAGE, REPLICATION, BACKUP, DATA MANAGEMENT, CONTENT MANAGEMENT, INFORMATION INTEGRATION, BUSINESS INTELLIGENCE FUNCTIONS, SEARCH AND DISCOVERY OF DATA; AND INSTRUCTION MANUALS SOLD AS A UNIT THEREWITH (U.S. CLS. 21, 23, 26, 36 AND 38).

FIRST USE 1-1-2013; IN COMMERCE 1-1-2013.

DAVID C. REIHNER, EXAMINING ATTORNEY

**CLASS 9—(Continued).**

SN 86-208,214. HOTEL, GABRIEL N, AKA MEK, MIAMI, FL. FILED 2-28-2014.

**ABM ENTERTAINMENT WORLDWIDE**

THE MARK CONSISTS OF STANDARD CHARACTERS WITHOUT CLAIM TO ANY PARTICULAR FONT, STYLE, SIZE, OR COLOR.

NO CLAIM IS MADE TO THE EXCLUSIVE RIGHT TO USE "ENTERTAINMENT WORLDWIDE", APART FROM THE MARK AS SHOWN.

FOR MUSICAL SOUND RECORDINGS (U.S. CLS. 21, 23, 26, 36 AND 38).

FIRST USE 2-15-2000; IN COMMERCE 5-21-2005.

JOANNA FIORELLI, EXAMINING ATTORNEY

SN 86-208,576. BEDZ COMPANY, LLC, DBA BEDZ COMPANY, LLC, NATICK, MA. AND PHILANDEN, INC., DBA PHILANDEN, INC., MELVILLE, NY. FILED 3-2-2014.

## iFlex Remote

THE MARK CONSISTS OF STANDARD CHARACTERS WITHOUT CLAIM TO ANY PARTICULAR FONT, STYLE, SIZE, OR COLOR.

NO CLAIM IS MADE TO THE EXCLUSIVE RIGHT TO USE "REMOTE", APART FROM THE MARK AS SHOWN.

FOR COMPUTER APPLICATION SOFTWARE FOR HANDHELD MOBILE PHONES, HANDHELD COMPUTERS, PORTABLE PADS AND TABLETS, NAMELY, SOFTWARE FOR USE IN REMOTELY CONTROLLING SETTINGS IN ADJUSTABLE BEDS (U.S. CLS. 21, 23, 26, 36 AND 38).

DAVID MURRAY, EXAMINING ATTORNEY

SN 86-208,582. BEDZ COMPANY, LLC, DBA BEDZ COMPANY, LLC, NATICK, MA. AND PHILANDEN, INC., DBA PHILANDEN, INC., MELVILLE, NY. FILED 3-2-2014.

## iFlex Lumbar Remote

THE MARK CONSISTS OF STANDARD CHARACTERS WITHOUT CLAIM TO ANY PARTICULAR FONT, STYLE, SIZE, OR COLOR.

NO CLAIM IS MADE TO THE EXCLUSIVE RIGHT TO USE "LUMBAR REMOTE", APART FROM THE MARK AS SHOWN.

FOR COMPUTER APPLICATION SOFTWARE FOR HANDHELD MOBILE PHONES, HANDHELD COMPUTERS, PORTABLE PADS AND TABLETS, NAMELY, SOFTWARE FOR USE IN REMOTELY CONTROLLING SETTINGS IN ADJUSTABLE BEDS (U.S. CLS. 21, 23, 26, 36 AND 38).

DAVID MURRAY, EXAMINING ATTORNEY

**CLASS 9—(Continued).**

SN 86-208,704. HELGERSON SCOTT M, DBA H-1 VIDEO PRODUCTIONS, LA CROSSE, WI. FILED 3-2-2014.

**H-1 video productions**

THE MARK CONSISTS OF STANDARD CHARACTERS WITHOUT CLAIM TO ANY PARTICULAR FONT, STYLE, SIZE, OR COLOR.

NO CLAIM IS MADE TO THE EXCLUSIVE RIGHT TO USE "VIDEO PRODUCTIONS", APART FROM THE MARK AS SHOWN.

FOR AUDIO AND VIDEO CASSETTE RECORDERS; AUDIO AND VIDEO RECORDINGS FEATURING FOOTAGE OF NATURE, CITIES, TOWNS AND NATURAL OR MAN-MADE OBJECTS; DIGITAL AUDIO AND VIDEO RECORDERS AND PLAYERS; DIGITAL MEDIA, NAMELY, PRE-RECORDED VIDEO CASSETTES, DIGITAL VIDEO DISCS, DIGITAL VERSATILE DISCS, DOWNLOADABLE AUDIO AND VIDEO RECORDINGS, DVDS, AND HIGH DEFINITION DIGITAL DISCS FEATURING FOOTAGE OF NATURE, CITIES, TOWNS AND NATURAL OR MAN-MADE OBJECTS; DIGITAL VIDEO CAMERAS; DIGITAL VIDEO RECORDERS; DISTRIBUTION AMPLIFIERS FOR AUDIO AND VIDEO SIGNALS; DOWNLOADABLE FILMS AND MOVIES FEATURING FOOTAGE OF NATURE, CITIES, TOWNS AND NATURAL OR MAN-MADE OBJECTS PROVIDED VIA A VIDEO-ON-DEMAND SERVICE; DOWNLOADABLE FILMS AND TELEVISION PROGRAMS FEATURING FOOTAGE OF NATURE, CITIES, TOWNS AND NATURAL OR MAN-MADE OBJECTS PROVIDED VIA A VIDEO-ON-DEMAND SERVICE (U.S. CLS. 21, 23, 26, 36 AND 38).  
HEATHER THOMPSON, EXAMINING ATTORNEY

SN 86-209,653. RAMSELL CORPORATION, OAKLAND, CA. FILED 3-3-2014.

**SMARTMATCH**

THE MARK CONSISTS OF STANDARD CHARACTERS WITHOUT CLAIM TO ANY PARTICULAR FONT, STYLE, SIZE, OR COLOR.

FOR CASE MANAGEMENT SOFTWARE FOR RECORDING, COMPILING, STORING, PLANNING, RETRIEVING, TRACKING, MONITORING, AND REPORTING DATA AND INFORMATION RELATED TO THE MEDICAL AND SOCIAL INTEGRATION, REHABILITATION, AND TREATMENT OF FORMERLY INCARCERATED OFFENDERS, PAROLEES, PROBATIONERS, AND OTHER PERSONS WHO ARE SUBJECT TO CORRECTIONAL SUPERVISION, MENTAL HEALTH PATIENTS, CHILDREN AND FAMILIES IN THE FOSTER CARE SYSTEM, HOMELESS PERSONS, AND THOSE IN NEED OF SOCIALLY OR MEDICALLY SUPPORTIVE SERVICES (U.S. CLS. 21, 23, 26, 36 AND 38).

KATHLEEN M. VANSTON, EXAMINING ATTORNEY

**CLASS 9—(Continued).**

SN 86-209,696. CONSTANCE MESSMER, LLC DBA C.A.M.P., CHILMARK, MA. FILED 3-3-2014.

**c.a.m.p. shorts**

THE MARK CONSISTS OF STANDARD CHARACTERS WITHOUT CLAIM TO ANY PARTICULAR FONT, STYLE, SIZE, OR COLOR.

NO CLAIM IS MADE TO THE EXCLUSIVE RIGHT TO USE "SHORTS", APART FROM THE MARK AS SHOWN.

FOR DOWNLOADABLE SERIES OF FICTION BOOKS (U.S. CLS. 21, 23, 26, 36 AND 38).

FIRST USE 6-17-2011; IN COMMERCE 7-22-2011.  
WON TEAK OH, EXAMINING ATTORNEY

SN 86-209,893. TG INCORPORATED, DUBAI, UNITED ARAB EMIR., FILED 3-4-2014.

**7 mobile**

THE MARK CONSISTS OF STANDARD CHARACTERS WITHOUT CLAIM TO ANY PARTICULAR FONT, STYLE, SIZE, OR COLOR.

NO CLAIM IS MADE TO THE EXCLUSIVE RIGHT TO USE "MOBILE", APART FROM THE MARK AS SHOWN.

FOR CELLULAR PHONES; CELLULAR TELEPHONE APPARATUSES; CELLULAR TELEPHONES (U.S. CLS. 21, 23, 26, 36 AND 38).

FIRST USE 9-1-2013; IN COMMERCE 10-1-2013.  
ANTHONY RINKER, EXAMINING ATTORNEY

SN 86-210,320. SAFEHEAD INC., TORTOLA, BR.VIRGIN ISLANDS, FILED 3-4-2014.

**safehead**  
Freedom for Little Explorers

THE MARK CONSISTS OF THE LITERAL ELEMENTS "SAFEHEAD FREEDOM FOR LITTLE EXPLORERS" WRITTEN IN STYLIZED FORM WHEREIN AT THE END OF THE LETTER "D" OF "SAFEHEAD" THERE IS A LEAF LIKE IMAGE IS PLACED WITH DEW DROPS AND A LADYBUG LIKE IMAGE UPON IT AND WORDS "FREEDOM FOR LITTLE EXPLORERS" ARE WRITTEN BELLOW THE WORD "SAFEHEAD".

FOR PROTECTIVE HEADGEAR IN THE NATURE OF PADDED HELMETS FOR CHILDREN FOR THE PREVENTION OF ACCIDENT OR INJURY; HEADGEAR IN THE NATURE OF PADDED HELMETS FOR PROTECTION AGAINST ACCIDENT OR INJURY; SAFETY HEADGEAR IN THE NATURE OF PADDED HELMETS (U.S. CLS. 21, 23, 26, 36 AND 38).

FIRST USE 7-28-2011; IN COMMERCE 12-12-2013.  
KYLE PEETE, EXAMINING ATTORNEY

**CLASS 9—(Continued).**

SN 86-210,474. HIGHLINE SOFTWARE, INC., NEW YORK, NY. FILED 3-4-2014.



THE COLOR(S) BLUE AND ORANGE IS/ARE CLAIMED AS A FEATURE OF THE MARK.

THE MARK CONSISTS OF THE WORD "HIGH" IN BLUE ON ONE PLANE, WITH THE WORD "LINE" IN BLUE ON A SLIGHTLY ELEVATED PLANE ABOVE AND TO THE RIGHT OF THE "HIGH" WORDING. THE "LINE" WORDING IS SURROUNDED ON THREE SIDES BY AN INCOMPLETE ORANGE RECTANGLE.

FOR COMPUTER APPLICATION SOFTWARE FOR MOBILE PHONES AND HANDHELD COMPUTERS, NAMELY, SOFTWARE FOR USE IN DATABASE MANAGEMENT BY RETAIL BUSINESSES; COMPUTER SOFTWARE FOR APPLICATION AND DATABASE INTEGRATION; COMPUTER SOFTWARE THAT PROVIDES WEB-BASED ACCESS TO APPLICATIONS AND SERVICES THROUGH A WEB OPERATING SYSTEM OR PORTAL INTERFACE; COMPUTER SOFTWARE, NAMELY, AN APPLICATION ALLOWING SALES AND FIELD SERVICE EMPLOYEES TO UPDATE AND RECEIVE DATA STORED IN AN ENTERPRISE'S COMPUTER DATABASES IN REAL TIME, USING A MOBILE DEVICE, WITH FULL TELEPHONY INTEGRATION WITH THE TELEPHONE AND/OR SOFTWARE FEATURES OF THE MOBILE DEVICE; DOWNLOADABLE MOBILE APPLICATIONS FOR USE IN DATABASE MANAGEMENT BY RETAIL BUSINESSES (U.S. CLS. 21, 23, 26, 36 AND 38).

FIRST USE 1-1-2014; IN COMMERCE 1-1-2014.  
MICHAEL TANNER, EXAMINING ATTORNEY

SN 86-211,308. BEST ACTION ENTERPRISES LIMITED, TOPSFIELD, MA. FILED 3-5-2014.

## CLEER AV

THE MARK CONSISTS OF STANDARD CHARACTERS WITHOUT CLAIM TO ANY PARTICULAR FONT, STYLE, SIZE, OR COLOR.

NO CLAIM IS MADE TO THE EXCLUSIVE RIGHT TO USE "AV", APART FROM THE MARK AS SHOWN.

FOR CABLES, ELECTRIC; FIBRE-OPTIC CABLES; COMPACT DISC PLAYERS; EAR PLUGS FOR DIVERS; HEADPHONES; JUKE BOXES, MUSICAL; LOUDSPEAKERS; DVD PLAYERS; RADIO; AUDIO-VIDEO RECEIVERS; AUDIO-RECEIVERS AND VIDEO-RECEIVERS; RECORD PLAYERS; AMPLIFIERS; TV MONITORS; TELEVISION RECEIVERS; WIRELESS INDOOR AND OUTDOOR SPEAKERS (U.S. CLS. 21, 23, 26, 36 AND 38).

FIRST USE 1-7-2014; IN COMMERCE 1-7-2014.  
LESLEY LAMOTHE, EXAMINING ATTORNEY

**CLASS 9—(Continued).**

SN 86-211,661. THE RETHINK GROUP, INC., CUMMING, GA. FILED 3-5-2014.

## PARENT CUE

THE MARK CONSISTS OF STANDARD CHARACTERS WITHOUT CLAIM TO ANY PARTICULAR FONT, STYLE, SIZE, OR COLOR.

OWNER OF U.S. REG. NOS. 3,971,769, 3,971,770 AND 4,003,494.

NO CLAIM IS MADE TO THE EXCLUSIVE RIGHT TO USE "PARENT", APART FROM THE MARK AS SHOWN.

FOR ELECTRONIC DOWNLOADABLE RELIGIOUS INSTRUCTIONAL AND TEACHING MATERIALS, AND DOWNLOADABLE MOBILE APPLICATIONS AND PODCASTS, ALL IN THE FIELDS OF SPIRITUAL FORMATION AND PARENTING (U.S. CLS. 21, 23, 26, 36 AND 38).

FIRST USE 4-0-2011; IN COMMERCE 4-0-2011.  
ELLEN BURNS, EXAMINING ATTORNEY

SN 86-212,480. BONG, HENDRA, HAYWARD, CA. FILED 3-6-2014.

## RADIUS CASE

THE MARK CONSISTS OF STANDARD CHARACTERS WITHOUT CLAIM TO ANY PARTICULAR FONT, STYLE, SIZE, OR COLOR.

NO CLAIM IS MADE TO THE EXCLUSIVE RIGHT TO USE "CASE", APART FROM THE MARK AS SHOWN.

FOR CASES FOR MOBILE PHONES (U.S. CLS. 21, 23, 26, 36 AND 38).

FIRST USE 10-1-2012; IN COMMERCE 10-1-2012.  
CURTIS FRENCH, EXAMINING ATTORNEY

**CLASS 9—(Continued).**

SN 86-213,889. VELOSTI TECHNOLOGY LTD., SHEUNG WAN, HONG KONG, FILED 3-6-2014.

# VELOSTI

THE MARK CONSISTS OF STANDARD CHARACTERS WITHOUT CLAIM TO ANY PARTICULAR FONT, STYLE, SIZE, OR COLOR.

THE WORDING "VELOSTI" HAS NO MEANING IN A FOREIGN LANGUAGE.

FOR (BASED ON USE IN COMMERCE) INTEGRATED CIRCUITS, NAMELY, ELECTRONIC CONTROLLERS FOR COMPUTER MEMORIES AND COMPUTER PERIPHERALS; COMPUTER STORAGE DEVICES, NAMELY, BLANK FLASH DRIVES SOLD WITH BUILT-IN COMPUTER SOFTWARE FOR ENABLING ACCESS OR ENTRY CONTROL FOR THE SECURE STORAGE AND RETRIEVAL OF DATA ON THOSE FLASH DRIVES; (BASED ON INTENT TO USE) TRANSISTORS; BLANK FLASH DRIVES; COMPUTER SOFTWARE FOR ENABLING ACCESS OR ENTRY CONTROL FOR THE SECURE STORAGE AND RETRIEVAL OF DATA ON FLASH DRIVES; DIGITAL PHOTO FRAMES (U.S. CLS. 21, 23, 26, 36 AND 38).

FIRST USE 7-1-2012; IN COMMERCE 7-13-2013.  
LINDA QUIGLEY, EXAMINING ATTORNEY

**CLASS 9—(Continued).**

SN 86-214,153. PIXEL PRESS TECHNOLOGY, LLC, ST. LOUIS, MO. FILED 3-7-2014.



SN 86-214,148. PIXEL PRESS TECHNOLOGY, LLC, ST. LOUIS, MO. FILED 3-7-2014.

THE COLOR(S) WHITE, GREY, BLUE, GREEN AND MAGENTA IS/ARE CLAIMED AS A FEATURE OF THE MARK.

THE MARK CONSISTS OF THE WORD "FLOORS" IN WHITE LOWER CASE LETTERS WITH A DARK GREY BORDER, WHERE THE LETTER "L" IS COMPRISED A BLUE RECTANGLE OVERLAPPING AN OFFSET GREEN RECTANGLE AND AN OFFSET MAGENTA RECTANGLE; THE WHITE COLOR BACKGROUND IS INTENDED AS A BACKGROUND AND IS NOT PART OF THE MARK.

FOR ELECTRONIC GAME PROGRAMS AND SOFTWARE FOR USE ON MOBILE DEVICES, COMPUTERS, CONSOLES, AND TABLETS; DOWNLOADABLE GAME PROGRAMS AND SOFTWARE; COMPUTER AND VIDEO GAME PROGRAMS AND SOFTWARE; INTERACTIVE GAME PROGRAMS AND SOFTWARE; INTERACTIVE GAME PROGRAMS AND SOFTWARE FOR USE ON NETWORK CONNECTABLE COMPUTING PLATFORMS; COMPUTER SOFTWARE FOR GENERATING PLAYABLE VIDEO GAME CONTENT, NAMELY, VIDEO AND COMPUTER GAME LEVEL DATA AND FILES; COMPUTER SOFTWARE FOR EDITING VIDEO GAME LEVEL DATA AND FILES; SOFTWARE FOR SHARING AND DISTRIBUTING USER-GENERATED VIDEO GAME CONTENT, NAMELY, GAME LEVEL DATA AND FILES, OVER A COMMUNICATION NETWORK (U.S. CLS. 21, 23, 26, 36 AND 38).

SETH DENNIS, EXAMINING ATTORNEY

THE COLOR(S) BLUE, GREEN AND MAGENTA IS/ARE CLAIMED AS A FEATURE OF THE MARK.

THE MARK CONSISTS OF A NINE SQUARES IN A 3X3 GRID. THE LEFTMOST COLUMN OF SQUARES ARE IN THREE SHADES OF GRADUALLY LIGHTENING BLUE, THE CENTRAL COLUMN OF SQUARES ARE IN THREE SHADES OF GRADUALLY LIGHTENING GREEN, AND THE RIGHTMOST COLUMN OF SQUARES ARE IN THREE SHADES OF GRADUALLY LIGHTENING MAGENTA.

FOR ELECTRONIC GAME PROGRAMS AND SOFTWARE FOR USE ON MOBILE DEVICES, COMPUTERS, CONSOLES, AND TABLETS; DOWNLOADABLE GAME PROGRAMS AND SOFTWARE; COMPUTER AND VIDEO GAME PROGRAMS AND SOFTWARE; INTERACTIVE GAME PROGRAMS AND SOFTWARE; COMPUTER AND VIDEO GAME SOFTWARE FOR USE ON NETWORK CONNECTABLE COMPUTING PLATFORMS; COMPUTER SOFTWARE FOR IMAGING HAND-DRAWN ARTWORK; COMPUTER SOFTWARE FOR GENERATING PLAYABLE VIDEO GAME CONTENT, NAMELY, VIDEO AND COMPUTER GAME LEVEL DATA AND FILES; COMPUTER SOFTWARE FOR EDITING VIDEO GAME LEVEL DATA AND FILES; SOFTWARE FOR SHARING AND DISTRIBUTING USER-GENERATED VIDEO GAME CONTENT, NAMELY, GAME LEVEL DATA AND FILES, OVER A COMMUNICATION NETWORK (U.S. CLS. 21, 23, 26, 36 AND 38).

SETH DENNIS, EXAMINING ATTORNEY

**CLASS 9—(Continued).**

SN 86-214,156. PIXEL PRESS TECHNOLOGY, LLC, ST. LOUIS, MO. FILED 3-7-2014.

## PIXEL PRESS

THE MARK CONSISTS OF STANDARD CHARACTERS WITHOUT CLAIM TO ANY PARTICULAR FONT, STYLE, SIZE, OR COLOR.

FOR ELECTRONIC GAME PROGRAMS AND SOFTWARE FOR USE ON MOBILE DEVICES, COMPUTERS, CONSOLES, AND TABLETS; DOWNLOADABLE GAME PROGRAMS AND SOFTWARE; COMPUTER AND VIDEO GAME PROGRAMS AND SOFTWARE; INTERACTIVE GAME PROGRAMS AND SOFTWARE; COMPUTER AND VIDEO GAME SOFTWARE FOR USE ON NETWORK CONNECTABLE COMPUTING PLATFORMS; COMPUTER SOFTWARE FOR IMAGING HAND-DRAWN ARTWORK; COMPUTER SOFTWARE FOR GENERATING PLAYABLE VIDEO GAME CONTENT, NAMELY, VIDEO AND COMPUTER GAME LEVEL DATA AND FILES; COMPUTER SOFTWARE FOR EDITING VIDEO GAME LEVEL DATA AND FILES; SOFTWARE FOR SHARING AND DISTRIBUTING USER-GENERATED VIDEO GAME CONTENT, NAMELY, GAME LEVEL DATA AND FILES, OVER A COMMUNICATION NETWORK (U.S. CLS. 21, 23, 26, 36 AND 38).

SETH DENNIS, EXAMINING ATTORNEY

SN 86-215,056. HALLMARK LICENSING, LLC, KANSAS CITY, MO. FILED 3-7-2014.

## SNOWBY

THE MARK CONSISTS OF STANDARD CHARACTERS WITHOUT CLAIM TO ANY PARTICULAR FONT, STYLE, SIZE, OR COLOR.

FOR PRE-RECORDED DVDS FEATURING CHILDREN'S STORIES; VIDEO GAMES AND COMPUTER GAME PROGRAMS ALL FEATURING CHILDREN'S STORYBOOKS FOR MOBILE DEVICES, PERSONAL COMPUTERS, AND PC TABLETS; ELECTRONIC GAME PROGRAMS FEATURING CHILDREN'S STORYBOOKS; DOWNLOADABLE ELECTRONIC GAME PROGRAMS FEATURING CHILDREN'S STORYBOOKS; ELECTRONIC COMPUTER GAME SOFTWARE FEATURING CHILDREN'S STORYBOOKS; DOWNLOADABLE ELECTRONIC COMPUTER GAME PROGRAMS FEATURING CHILDREN'S STORYBOOKS; INTERACTIVE GAME PROGRAMS FEATURING CHILDREN'S STORYBOOKS; INTERACTIVE COMPUTER GAME SOFTWARE FEATURING CHILDREN'S STORYBOOKS; DOWNLOADABLE ELECTRONIC CHILDREN'S STORYBOOKS (U.S. CLS. 21, 23, 26, 36 AND 38).

KATHLEEN KOLACZ, EXAMINING ATTORNEY

**CLASS 9—(Continued).**

SN 86-215,636. RHODIUM INC., WEEKI WACHEE, FL. FILED 3-9-2014.

## ChemiCalc

THE MARK CONSISTS OF STANDARD CHARACTERS WITHOUT CLAIM TO ANY PARTICULAR FONT, STYLE, SIZE, OR COLOR.

FOR COMPUTER APPLICATION SOFTWARE FOR MOBILE PHONES, NAMELY, SOFTWARE FOR CALCULATING AND CONVERTING SCIENTIFIC UNITS (U.S. CLS. 21, 23, 26, 36 AND 38).

FIRST USE 2-1-2014; IN COMMERCE 2-18-2014.

CURTIS FRENCH, EXAMINING ATTORNEY

SN 86-216,637. RSCC WIRE & CABLE LLC, EAST GRANBY, CT. FILED 3-10-2014.

## ROCK-FLEX

THE MARK CONSISTS OF STANDARD CHARACTERS WITHOUT CLAIM TO ANY PARTICULAR FONT, STYLE, SIZE, OR COLOR.

OWNER OF U.S. REG. NO. 4,238,259.

FOR ELECTRICAL CABLES; ELECTRICAL WIRES (U.S. CLS. 21, 23, 26, 36 AND 38).

ALISON POLLACK, EXAMINING ATTORNEY

SN 86-216,651. HALLMARK LICENSING, LLC, KANSAS CITY, MO. FILED 3-10-2014.

## CHARLIE THE YETI

THE MARK CONSISTS OF STANDARD CHARACTERS WITHOUT CLAIM TO ANY PARTICULAR FONT, STYLE, SIZE, OR COLOR.

FOR PRE-RECORDED DVDS FEATURING CHILDREN'S STORIES; VIDEO GAME SOFTWARE OR DISCS AND COMPUTER GAME PROGRAMS ALL FEATURING CHILDREN'S STORYBOOKS FOR MOBILE DEVICES, PERSONAL COMPUTERS, PC TABLETS; ELECTRONIC GAME PROGRAMS FEATURING CHILDREN'S STORYBOOKS; DOWNLOADABLE ELECTRONIC GAME PROGRAMS FEATURING CHILDREN'S STORYBOOKS; ELECTRONIC COMPUTER GAME SOFTWARE FEATURING CHILDREN'S STORYBOOKS; DOWNLOADABLE ELECTRONIC COMPUTER GAME PROGRAMS FEATURING CHILDREN'S STORYBOOKS; INTERACTIVE GAME PROGRAMS FEATURING CHILDREN'S STORYBOOKS; INTERACTIVE COMPUTER GAME SOFTWARE FEATURING CHILDREN'S STORYBOOKS; DOWNLOADABLE ELECTRONIC CHILDREN'S STORYBOOKS (U.S. CLS. 21, 23, 26, 36 AND 38).

THEODORE MCBRIDE, EXAMINING ATTORNEY

**CLASS 9—(Continued).**

SN 86-216,714. KWIXIN INC., LONG BEACH, CA. FILED 3-10-2014.



THE COLOR(S) WHITE, BLACK, LIGHT PINK, PINK, YELLOW, DARK YELLOW, LIGHT YELLOW, GREEN, ORANGE, BROWN, RED, AND DARK RED IS/ARE CLAIMED AS A FEATURE OF THE MARK.

THE MARK CONSISTS OF THE WORDING "ABRACAVID" IN PINK WITH WHITE AND LIGHT PINK OUTLINING, AND THE DESIGN OF A CIRCULAR DESIGN CONTAINING A RABBIT HOLDING A WAND WITH STARS EMANATING FROM IT. THE CIRCULAR DESIGN APPEARS IN YELLOW AND IS COMPOSED OF SMALLER RECTANGLES AND CIRCLES. THE RABBIT IS OUTLINED IN BLACK AND APPEARS IN YELLOW, DARK YELLOW, LIGHT YELLOW AND WHITE, WITH WHITE, LIGHT PINK, DARK RED, BLACK, GREEN, AND BROWN FACIAL FEATURES. THE WAND APPEARS IN ORANGE AND RED, AND THE STARS ARE YELLOW, DARK YELLOW AND LIGHT YELLOW WITH BLACK OUTLINING.

FOR COMPUTER APPLICATION SOFTWARE FOR MOBILE PHONES, NAMELY, SOFTWARE FOR PROCESSING, MANAGING, EDITING PHOTOGRAPHIC, OPTICAL, AND CINEMATOGRAPHIC IMAGES AND DATA, AND FOR TRANSMISSION OR REPRODUCTION OF SOUND OR IMAGES (U.S. CLS. 21, 23, 26, 36 AND 38).

FIRST USE 3-0-2013; IN COMMERCE 3-0-2013.  
SEAN CROWLEY, EXAMINING ATTORNEY

SN 86-217,061. MISSION: PIC, LLC, OAKLAND, CA. FILED 3-11-2014.

## MISSION: PIC

THE MARK CONSISTS OF STANDARD CHARACTERS WITHOUT CLAIM TO ANY PARTICULAR FONT, STYLE, SIZE, OR COLOR.

NO CLAIM IS MADE TO THE EXCLUSIVE RIGHT TO USE "PIC", APART FROM THE MARK AS SHOWN.

FOR COMPUTER APPLICATION SOFTWARE FOR MOBILE PHONES, PORTABLE MEDIA PLAYERS, HANDHELD COMPUTERS, NAMELY, PHOTOGRAPHY SOFTWARE THAT ENABLES EDITING, MODIFICATION, TRANSMISSION AND SHARING OF IMAGES; DOWNLOADABLE COMPUTER SOFTWARE THAT ENABLES EDITING, MODIFICATION, TRANSMISSION AND SHARING OF IMAGES VIA COMPUTER AND COMMUNICATION NETWORKS (U.S. CLS. 21, 23, 26, 36 AND 38).

ZACHARY R. SPARER, EXAMINING ATTORNEY

**CLASS 9—(Continued).**

SN 86-217,431. WORDEN ENTERPRISES, INC., MIAMI, FL. FILED 3-11-2014.



OWNER OF U.S. REG. NO. 4,359,364.

THE MARK CONSISTS OF THE WORD "POPCLIK" APPEARING ABOVE THE WORDS "LOUD BY NATURE", ALL APPEARING BELOW THE DESIGN OF A MONKEY.

FOR CELLULAR TELEPHONE ACCESSORIES, NAMELY, HEADSETS, EAR BUDS, DEVICES FOR HANDS FREE USE OF CELLULAR TELEPHONES (U.S. CLS. 21, 23, 26, 36 AND 38).

TINA L. SNAPP, EXAMINING ATTORNEY

SN 86-218,775. DIGITAL AND POS ENTERPRISES INC., DORAL, FL. FILED 3-12-2014.

## Advanced

THE MARK CONSISTS OF THE WORD "ADVANCED" IN FRANKLIN GOTHIC DEMI FONT. THERE ARE 5 LINES PARALLEL TO THE LEFT SIDE OF THE LETTER "A". IN THE MIDDLE OF THE WORD "ADVANCED" THERE IS A HORIZONTAL LINE.

FOR ELECTRONIC POINT OF SALE TERMINALS COMPRISED OF COMPUTER TERMINALS AND CASH REGISTERS; CASH REGISTERS AND ASSOCIATED PERIPHERAL DEVICES, NAMELY, BAR CODE SCANNERS; MAGNETIC CARD STRIP READER; CASH DRAWERS; PROGRAMMABLE AND NON-PROGRAMMABLE ELECTRONIC KEYBOARDS; RECEIPT AND JOURNAL PRINTERS; ELECTRONIC TOUCH SCREEN DISPLAYS; POLE-MOUNTED ELECTRONIC DISPLAYS, NAMELY, LCD PANELS; CAMERAS AND DIGITAL VIDEO RECORDER; COMPUTER HARDWARE FOR TIME, ATTENDANCE AND ACCESS CONTROL; ELECTRONIC DATA COLLECTORS (U.S. CLS. 21, 23, 26, 36 AND 38).

ALYSSA STEEL, EXAMINING ATTORNEY



**CLASS 9—(Continued).**

SN 86-218,827. DIGITAL AND POS ENTERPRISES INC., DORAL, FL. FILED 3-12-2014.



THE COLOR(S) BLUE, RED AND BLACK IS/ARE CLAIMED AS A FEATURE OF THE MARK.

THE MARK CONSISTS OF THE WORD "ADVANCED" IN BLUE FRANKLIN GOTHIC DEMI FONT, ON THE LEFT SIDE THERE ARE 5 BLACK LINES PARALLEL TO THE LETTER "A". IN THE MIDDLE OF THE WORD "ADVANCED" THERE IS A HORIZONTAL RED LINE.

FOR ELECTRONIC POINT OF SALE TERMINALS COMPRISED OF COMPUTER TERMINALS AND CASH REGISTERS; CASH REGISTERS AND ASSOCIATED PERIPHERAL DEVICES, NAMELY, BAR CODE SCANNERS; MAGNETIC CARD STRIP READER; CASH DRAWERS; PROGRAMMABLE AND NON-PROGRAMMABLE ELECTRONIC KEYBOARDS; RECEIPT AND JOURNAL PRINTERS; ELECTRONIC TOUCH SCREEN DISPLAYS; POLE-MOUNTED ELECTRONIC DISPLAYS, NAMELY, LCD PANELS; CAMERAS AND DIGITAL VIDEO RECORDER; COMPUTER HARDWARE FOR TIME, ATTENDANCE AND ACCESS CONTROL; ELECTRONIC DATA COLLECTORS (U.S. CLS. 21, 23, 26, 36 AND 38).

ALYSSA STEEL, EXAMINING ATTORNEY

SN 86-220,003. RABIN, JARED, IRVINE, CA. FILED 3-13-2014.

# Hang-o-matic

THE MARK CONSISTS OF STANDARD CHARACTERS WITHOUT CLAIM TO ANY PARTICULAR FONT, STYLE, SIZE, OR COLOR.

FOR ADJUSTABLE INSTRUMENT FOR MEASURING HORIZONTAL AND VERTICAL LENGTH THAT ALLOW PERFECT SPACING AND ALIGNMENT FOR HANGING OR ANCHOR POINTS FOR PICTURES OR ANY ITEM HUNG ON A WALL (U.S. CLS. 21, 23, 26, 36 AND 38).

FIRST USE 9-8-2008; IN COMMERCE 2-17-2014.  
CAROLINE WOOD, EXAMINING ATTORNEY

**CLASS 9—(Continued).**

SN 86-220,004. CONFIDENCE THROUGH CHARACTERS, INC., DEL MAR, CA. FILED 3-13-2014.

# Confidence Through Characters

THE MARK CONSISTS OF STANDARD CHARACTERS WITHOUT CLAIM TO ANY PARTICULAR FONT, STYLE, SIZE, OR COLOR.

FOR DOWNLOADABLE MOBILE APPLICATIONS FEATURING CHILDREN'S BOOKS AND INTERACTIVE STORY-BASED ENTERTAINMENT AND EDUCATION (U.S. CLS. 21, 23, 26, 36 AND 38).

FIRST USE 7-29-2013; IN COMMERCE 2-15-2014.  
CAROLINE WOOD, EXAMINING ATTORNEY

SN 86-220,053. ZENMONICS, CHARLOTTE, NC. FILED 3-13-2014.

# channelUNITED

THE MARK CONSISTS OF STANDARD CHARACTERS WITHOUT CLAIM TO ANY PARTICULAR FONT, STYLE, SIZE, OR COLOR.

FOR COMMUNICATIONS SOFTWARE FOR CONNECTING DEVICES TO TRANSACTIONAL DATABASES; COMPUTER APPLICATION SOFTWARE FOR MOBILE PHONES, NAMELY, SOFTWARE FOR ACCESSING FINANCIAL DATA AND ACCOUNTS; COMPUTER APPLICATION SOFTWARE FOR MOBILE BANKING, NAMELY, SOFTWARE FOR ACCESSING ACCOUNT DATABASES; COMPUTER COMMUNICATIONS SOFTWARE TO ALLOW CUSTOMERS TO ACCESS BANK ACCOUNT INFORMATION AND TRANSACT BANK BUSINESS; COMPUTER E-COMMERCE SOFTWARE TO ALLOW USERS TO PERFORM ELECTRONIC BUSINESS TRANSACTIONS VIA A GLOBAL COMPUTER NETWORK; COMPUTER GRAPHICS SOFTWARE; COMPUTER HARDWARE AND COMPUTER SOFTWARE PROGRAMS FOR THE INTEGRATION OF TEXT, AUDIO, GRAPHICS, STILL IMAGES AND MOVING PICTURES INTO AN INTERACTIVE DELIVERY FOR MULTIMEDIA APPLICATIONS; COMPUTER HARDWARE AND PERIPHERAL DEVICES AND COMPUTER SOFTWARE FOR DATA COMMUNICATION AND TRANSLATING AND TRANSMITTING DATA SOLD THEREWITH; COMPUTER HARDWARE AND SOFTWARE SYSTEM FOR TRACKING PEOPLE, OBJECTS AND PETS USING GPS DATA ON A DEVICE ON THE TRACKED PEOPLE, OBJECTS AND PETS; COMPUTER HARDWARE AND SOFTWARE SYSTEMS FOR ELECTRONIC BUSINESS TRANSACTIONS; COMPUTER PROGRAMS AND COMPUTER SOFTWARE FOR ELECTRONICALLY TRADING SECURITIES; COMPUTER SOFTWARE AND FIRMWARE FOR ACCESSING BRANCH BANKING SYSTEMS; COMPUTER SOFTWARE AND HARDWARE FOR BANKING; COMPUTER SOFTWARE DEVELOPMENT TOOLS; COMPUTER SOFTWARE FOR ACCESSING INFORMATION DIRECTORIES THAT MAY BE DOWNLOADED FROM THE GLOBAL COMPUTER NETWORK; COMPUTER SOFTWARE FOR APPLICATION AND DATABASE INTEGRATION; COMPUTER SOFTWARE FOR COMMUNICATING WITH USERS OF HAND-HELD COMPUTERS; COMPUTER SOFTWARE FOR COMPUTER SYSTEM AND APPLICATION DEVELOPMENT, DEPLOYMENT AND MANAGEMENT; COMPUTER SOFTWARE FOR CONTROLLING AND MANAGING



**CLASS 9—(Continued).**

ACCESS SERVER APPLICATIONS; COMPUTER SOFTWARE FOR CREATING SEARCHABLE DATABASES OF INFORMATION AND DATA; COMPUTER SOFTWARE FOR PROVIDING AN ON-LINE DATABASE IN THE FIELD OF TRANSACTION PROCESSING TO UPLOAD TRANSACTIONAL DATA, PROVIDE STATISTICAL ANALYSIS, AND PRODUCE NOTIFICATIONS AND REPORTS; COMPUTER SOFTWARE FOR THE COLLECTION, EDITING, ORGANIZING, MODIFYING, BOOK MARKING, TRANSMISSION, STORAGE AND SHARING OF DATA AND INFORMATION; COMPUTER SOFTWARE FOR THE DATABASING, VISUALIZATION, MANIPULATION, VIRTUAL REALITY IMMERSION AND INTEGRATION OF GEOGRAPHIC INFORMATION WITH ON-LINE MEMBER COMMUNITIES; COMPUTER SOFTWARE FOR USE IN CUSTOMER RELATIONSHIP MANAGEMENT (CRM); COMPUTER SOFTWARE FOR CONDUCTING FINANCIAL TRANSACTIONS THAT MAY BE DOWNLOADED FROM A GLOBAL COMPUTER NETWORK; COMPUTER SOFTWARE PLATFORMS FOR BANKING; COMPUTER SOFTWARE THAT PROVIDES REAL-TIME, INTEGRATED BUSINESS MANAGEMENT INTELLIGENCE BY COMBINING INFORMATION FROM VARIOUS DATABASES AND PRESENTING IT IN AN EASY-TO-UNDERSTAND USER INTERFACE; COMPUTER SOFTWARE THAT PROVIDES WEB-BASED ACCESS TO APPLICATIONS AND SERVICES THROUGH A WEB OPERATING SYSTEM OR PORTAL INTERFACE; COMPUTER SOFTWARE TO AUTOMATE DATA WAREHOUSING; COMPUTER SOFTWARE, NAMELY, ELECTRONIC FINANCIAL PLATFORM THAT ACCOMMODATES MULTIPLE TYPES OF PAYMENT AND DEBT TRANSACTIONS IN AN INTEGRATED MOBILE PHONE, PDA, AND WEB BASED ENVIRONMENT; COMPUTER SOFTWARE, NAMELY, SOFTWARE DEVELOPMENT TOOLS FOR THE CREATION OF MOBILE INTERNET APPLICATIONS AND CLIENT INTERFACES; CREDIT SCREENING SOFTWARE; DATABASE MANAGEMENT SOFTWARE FOR FINANCIAL RECORDS; DOWNLOADABLE COMPUTER SOFTWARE FOR BANKING; DOWNLOADABLE MOBILE APPLICATIONS FOR ACCESSING FINANCIAL DATA; DOWNLOADABLE SOFTWARE FOR ACCESSING FINANCIAL DATABASES; DOWNLOADABLE SOFTWARE IN THE NATURE OF A MOBILE APPLICATION FOR ACCESSING FINANCIAL DATABASES; ELECTRONIC SOFTWARE UPDATES, NAMELY, DOWNLOADABLE COMPUTER SOFTWARE AND ASSOCIATED DATA FILES FOR UPDATING COMPUTER SOFTWARE IN THE FIELDS OF BANKING, PROVIDED VIA COMPUTER AND COMMUNICATION NETWORKS; TAX MANAGEMENT DATA COLLECTION SOFTWARE; TAX MANAGEMENT SOFTWARE; TAX PREPARATION SOFTWARE (U.S. CLS. 21, 23, 26, 36 AND 38).

FIRST USE 1-2-2014; IN COMMERCE 1-2-2014.  
THOMAS MANOR, EXAMINING ATTORNEY

**CLASS 9—(Continued).**

SN 86-220,400. MINIARD, JERRY, FLORENCE, KY. FILED 3-13-2014.

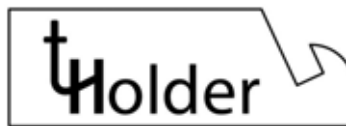

THE MARK CONSISTS OF A POLYGON OUTLINED WITH A SINGLE BLACK LINE SHOWING A NOTCH AND CONTAINING THE WORD "THOLDER".

FOR STANDS SPECIALLY ADAPTED FOR SUPPORTING SMART PHONES, PORTABLE MUSIC PLAYERS, ELECTRONIC TABLETS, DIGITAL PICTURE FRAMES, AND ELECTRONIC FLAT SCREEN DISPLAYS (U.S. CLS. 21, 23, 26, 36 AND 38).

ANNIE NOBLE, EXAMINING ATTORNEY

SN 86-220,708. AWESOME COOL AND FUN FREE GAMES LLC, REDONDO BEACH, CA. FILED 3-13-2014.

# FUAMS

THE MARK CONSISTS OF STANDARD CHARACTERS WITHOUT CLAIM TO ANY PARTICULAR FONT, STYLE, SIZE, OR COLOR.

FOR DOWNLOADABLE SOFTWARE IN THE NATURE OF A MOBILE APPLICATION FOR UPLOADING, DOWNLOADING, ACCESSING, POSTING, DISPLAYING, BLOGGING, LINKING, SHARING OR OTHERWISE PROVIDING ELECTRONIC MEDIA OR INFORMATION VIA COMPUTER, THE INTERNET AND OTHER COMMUNICATION NETWORKS; COMPUTER APPLICATION SOFTWARE FOR MOBILE PHONES AND TABLET COMPUTERS, NAMELY, SOFTWARE TO ENABLE UPLOADING, DOWNLOADING, ACCESSING, POSTING, DISPLAYING, BLOGGING, LINKING, SHARING OR OTHERWISE PROVIDING ELECTRONIC MEDIA OR INFORMATION VIA COMPUTER AND COMMUNICATION NETWORKS; DOWNLOADABLE SOFTWARE FOR COMPUTERS, PORTABLE HANDHELD DIGITAL ELECTRONIC COMMUNICATION DEVICES, MOBILE COMMUNICATION DEVICES, AND WIRED AND WIRELESS COMMUNICATION DEVICES FOR SOCIAL NETWORKING; DOWNLOADABLE SOFTWARE IN THE NATURE OF A MOBILE APPLICATION FOR USE WITH PORTABLE HANDHELD DIGITAL ELECTRONIC COMMUNICATION DEVICES AND MOBILE PHONES FOR CREATING, SHARING, AND POSTING CONTENT AND BLOGS ON THE INTERNET; COMPUTER SOFTWARE DEVELOPMENT TOOLS; COMPUTER SOFTWARE FOR USE AS AN APPLICATION PROGRAMMING INTERFACE (API) FOR USE IN DEVELOPING OTHER APPLICATIONS SOFTWARE (U.S. CLS. 21, 23, 26, 36 AND 38).

KATHERINE CHANG, EXAMINING ATTORNEY

**CLASS 9—(Continued).**

SN 86-220,716. THE ESTATE OF WHITNEY HOUSTON, ALPHA RETTA, GA. FILED 3-13-2014.

**WHITNEY HOUSTON**

THE MARK CONSISTS OF STANDARD CHARACTERS WITHOUT CLAIM TO ANY PARTICULAR FONT, STYLE, SIZE, OR COLOR.

THE NAME(S), PORTRAIT(S), AND/OR SIGNATURE(S) SHOWN IN THE MARK DOES NOT IDENTIFY A PARTICULAR LIVING INDIVIDUAL.

FOR SERIES OF MUSICAL SOUND RECORDINGS; SERIES OF MUSICAL VIDEO RECORDINGS; DOWNLOADABLE MUSICAL SOUND RECORDINGS; DOWNLOADABLE MUSIC VIDEO RECORDINGS FEATURING MUSIC AND ENTERTAINMENT; AUDIOVISUAL RECORDINGS FEATURING MUSIC AND ENTERTAINMENT; DOWNLOADABLE AUDIOVISUAL RECORDINGS FEATURING MUSIC AND ENTERTAINMENT; DOWNLOADABLE RINGTONES FOR MOBILE PHONES AND WIRELESS DEVICES (U.S. CLS. 21, 23, 26, 36 AND 38).

FIRST USE 2-14-1985; IN COMMERCE 2-14-1985.  
MICHAEL WIENER, EXAMINING ATTORNEY

SN 86-220,972. BODI WULIAN TECHNOLOGY CO LTD, SHENZHEN, CHINA, FILED 3-14-2014.



THE MARK CONSISTS OF THE WORDING "IBODY" IN STYLIZED FONT.

THE WORDING "IBODY" HAS NO MEANING IN A FOREIGN LANGUAGE.

FOR AIR ANALYSIS APPARATUS; COMPUTER OPERATING PROGRAMS; COMPUTER OPERATING SOFTWARE; DIAGNOSTIC APPARATUS FOR TESTING FOOD; EYE GLASSES; MOBILE PHONES; Pedometers; RECONFIGURABLE PROCESSORS FOR USE IN WIRELESS COMMUNICATION HANDSETS AND NETWORK EQUIPMENT IN THE FIELD OF WIDEBAND COMMUNICATIONS; TEMPERATURE SENSORS USED IN THE MEDICAL FIELD TO MEASURE TEMPERATURE OF MEDICAL SOLUTIONS; WEIGHING APPARATUS AND INSTRUMENTS (U.S. CLS. 21, 23, 26, 36 AND 38).

FIRST USE 10-1-2013; IN COMMERCE 2-1-2014.  
GINA FINK, EXAMINING ATTORNEY

**CLASS 9—(Continued).**

SN 86-221,645. RF SURGICAL SYSTEMS, INC., CARLSBAD, CA. FILED 3-14-2014.

**VERISPHERE**

THE MARK CONSISTS OF STANDARD CHARACTERS WITHOUT CLAIM TO ANY PARTICULAR FONT, STYLE, SIZE, OR COLOR.

FOR ELECTRONIC DEVICES AND ACCESSORIES, NAMELY, A HANDHELD SCANNING WAND AND A CONSOLE POWER CONTROLLER FOR DETECTING TAGGED MEDICAL DISPOSABLE GOODS AND GENERATING AN AUDIBLE SIGNAL WHEN SUCH GOODS ARE DETECTED (U.S. CLS. 21, 23, 26, 36 AND 38).

DEIRDRE ROBERTSON, EXAMINING ATTORNEY

SN 86-222,680. HME, INCORPORATED, WYOMING, MI. FILED 3-17-2014.

**SUPERFOX**

THE MARK CONSISTS OF STANDARD CHARACTERS WITHOUT CLAIM TO ANY PARTICULAR FONT, STYLE, SIZE, OR COLOR.

OWNER OF U.S. REG. NOS. 2,715,830 AND 2,717,606.

FOR FIRE TRUCKS (U.S. CLS. 21, 23, 26, 36 AND 38).  
AMY C. KEAN, EXAMINING ATTORNEY

SN 86-222,943. NEONODE, INC., SANTA CLARA, CA. FILED 3-17-2014.

**ZFORCE AIR**

THE MARK CONSISTS OF STANDARD CHARACTERS WITHOUT CLAIM TO ANY PARTICULAR FONT, STYLE, SIZE, OR COLOR.

OWNER OF U.S. REG. NO. 3,904,622.

FOR INTEGRATED CIRCUITS, APPLICATION SPECIFIC INTEGRATED CIRCUITS, PROGRAMMABLE INTEGRATED CIRCUITS, INTEGRATED CIRCUIT MODULES FOR TOUCH SCREEN CONTROLLERS AND PROXIMITY SENSOR CONTROLLERS; SOFTWARE FOR RUNNING, PROGRAMMING AND CONTROLLING ALL OF THE FOREGOING; OPERATING SOFTWARE FOR INTEGRATED CIRCUITS AND MODULES FOR TOUCH SCREEN CONTROLLERS AND PROXIMITY SENSOR CONTROLLERS; GRAPHICAL USER INTERFACE SOFTWARE FOR TOUCH SCREENS AND FOR PROXIMITY SENSORS; INTERFACE SOFTWARE FOR TOUCH-SENSITIVE OR PROXIMITY-SENSITIVE COMPUTER SCREENS AND DISPLAYS; OPERATING SOFTWARE FOR TOUCH-SENSITIVE OR PROXIMITY-SENSITIVE COMPUTER SCREENS AND DISPLAYS; COMPUTER CHIPS, SEMICONDUCTORS, COMPUTER OPERATING SOFTWARE, ELECTRONIC CONTROLLERS FOR TOUCH SCREENS; ELECTRONIC PROXIMITY SENSORS AND SWITCHES; ELECTRONIC TOUCH SENSITIVE SWITCHES; PROXIMITY SENSORS; TOUCH PADS; TOUCH PANELS; TOUCH SCREENS; TOUCHSCREEN MONITORS; TOUCHSCREEN SEN-

**CLASS 9—(Continued).**

SORS; PROTECTIVE COVERS AND CASES FOR CELL PHONES, LAPTOPS AND PORTABLE MEDIA PLAYERS; PROTECTIVE COVERS FOR SMARTPHONES; ELECTRICAL CONTROL SYSTEMS FOR HOUSEHOLD APPLIANCES, NAMELY, REFRIGERATORS, FREEZERS, OVENS, COOKTOPS, DISHWASHING MACHINES, CLOTHES WASHING MACHINES AND CLOTHES DRYERS, COMPRISED OF PROXIMITY SENSORS, TOUCH PADS, TOUCH PANELS AND VIRTUAL DISPLAYS FOR USE IN CONNECTION WITH ACTIVATION CONTROLS, TEMPERATURE CONTROLS, ENERGY CONTROLS, WASH CYCLE CONTROLS AND DRY CYCLE CONTROLS; ELECTRICAL CONTROL SYSTEMS FOR AUTOMOTIVE VEHICLES COMPRISED OF PROXIMITY SENSORS, TOUCH PADS, TOUCH PANELS AND VIRTUAL DISPLAYS FOR USE IN CONNECTION WITH ON-BOARD ENGINE CONTROLS, STABILITY CONTROLS, BRAKING CONTROLS, ENERGY CONTROLS, AUDIO FEATURES, DISPLAY FEATURES, LIGHTING FEATURES AND COMFORT CONTROL FEATURES; LIQUID CRYSTAL DISPLAYS, VIDEO SCREENS, COMPUTER TOUCHSCREENS FOR MOBILE TELEPHONES, PORTABLE TELEPHONES, WIRELESS TELEPHONES, AND MOBILE TELEPHONES WITH DIGITAL CAMERAS (U.S. CLS. 21, 23, 26, 36 AND 38).

JULIE VEPPUMTHARA, EXAMINING ATTORNEY

**CLASS 9—(Continued).**

SN 86-223,543. RYTOONS LLC, HONOLULU, HI. FILED 3-17-2014.



SN 86-223,001. NEONODE, INC., SANTA CLARA, CA. FILED 3-17-2014.

## ZFORCE NEMO

THE MARK CONSISTS OF STANDARD CHARACTERS WITHOUT CLAIM TO ANY PARTICULAR FONT, STYLE, SIZE, OR COLOR.

OWNER OF U.S. REG. NO. 3,904,622.

FOR INTERFACE SOFTWARE FOR TOUCH-SENSITIVE OR PROXIMITY-SENSITIVE COMPUTER SCREENS AND DISPLAYS; OPERATING SOFTWARE FOR TOUCH-SENSITIVE OR PROXIMITY-SENSITIVE COMPUTER SCREENS AND DISPLAYS; COMPUTER CHIPS, SEMICONDUCTORS, COMPUTER OPERATING SOFTWARE, ELECTRONIC CONTROLLERS FOR TOUCH SCREENS; ELECTRONIC PROXIMITY SENSORS AND SWITCHES; ELECTRONIC TOUCH SENSITIVE SWITCHES; TOUCH PADS; TOUCH PANELS; TOUCH SCREENS; TOUCHSCREEN SENSORS; PROTECTIVE COVERS AND CASES FOR CELL PHONES, LAPTOPS AND PORTABLE MEDIA PLAYERS; PROTECTIVE COVERS FOR SMARTPHONES; LIQUID CRYSTAL DISPLAYS, VIDEO SCREENS, COMPUTER TOUCHSCREENS FOR MOBILE TELEPHONES, PORTABLE TELEPHONES, WIRELESS TELEPHONES, AND MOBILE TELEPHONES WITH DIGITAL CAMERAS (U.S. CLS. 21, 23, 26, 36 AND 38).

JULIE VEPPUMTHARA, EXAMINING ATTORNEY

THE MARK CONSISTS OF THE HAIR AND HEAD AND TORSO OF A BOY. HIS HAIR IS FLAT ON THE TOP AND HAS A WIDOWS PEAK AND TWO PIECES OF HAIR STICKING OUT FROM THE LEFT SIDE OF HIS HEAD AND TWO PIECES OF HAIR STICKING OUT FROM THE RIGHT SIDE OF HIS HEAD. HIS FACE IS SHAPED LIKE THE LETTER V. HIS TORSO IS SHAPED LIKE A RECTANGLE WITH ITS SHORT SIDES ON THE TOP AND BOTTOM. THE TORSO RECTANGLE HAS A SLIGHT BEND.

FOR AUDIO BOOKS IN THE FIELD OF CHILDREN'S EDUCATION AND ENTERTAINMENT; AUDIO BOOKS IN THE NATURE OF SHORT STORIES; CHILDREN'S EDUCATIONAL MUSIC CDS AND DVDS; CHILDREN'S EDUCATIONAL SOFTWARE; COMPUTER GAME PROGRAMMES; COMPUTER GAME PROGRAMMES DOWNLOADABLE VIA THE INTERNET; COMPUTER GAME PROGRAMS; COMPUTER GAME SOFTWARE; DOWNLOADABLE E-BOOKS IN THE FIELD OF CHILDREN'S EDUCATION AND ENTERTAINMENT; DOWNLOADABLE ELECTRONIC BOOKS IN THE FIELD OF CHILDREN'S EDUCATION AND ENTERTAINMENT; DOWNLOADABLE MP3 FILES AND MP3 RECORDINGS FEATURING MUSIC FROM MOTION PICTURE FILMS AND AUDIO BOOKS FEATURING CHILDREN'S EDUCATION AND ENTERTAINMENT; MOTION PICTURE FILMS AND FILMS FOR TELEVISION FEATURING CHILDREN'S ENTERTAINMENT; MOTION PICTURE FILMS FEATURING CHILDREN'S ENTERTAINMENT (U.S. CLS. 21, 23, 26, 36 AND 38).

FIRST USE 3-14-2014; IN COMMERCE 3-14-2014.

JUSTINE D. PARKER, EXAMINING ATTORNEY

**CLASS 9—(Continued).**

SN 86-223,712. LALITUDE LLC, HACIENDA HEIGHTS, CA.  
FILED 3-17-2014.

# SoundLuv

THE MARK CONSISTS OF STANDARD CHARACTERS WITHOUT CLAIM TO ANY PARTICULAR FONT, STYLE, SIZE, OR COLOR.

FOR CARRYING CASES, HOLDERS, PROTECTIVE CASES AND STANDS FEATURING POWER SUPPLY CONNECTORS, ADAPTORS, SPEAKERS AND BATTERY CHARGING DEVICES, SPECIALLY ADAPTED FOR USE WITH HANDHELD DIGITAL ELECTRONIC DEVICES, NAMELY, CELL PHONES, MP3 PLAYERS, MP4 PLAYERS, PERSONAL DIGITAL ASSISTANTS, GLOBAL POSITIONING SYSTEM (GPS), TABLET COMPUTERS, ELECTRONIC BOOK READERS, LAPTOPS, DIGITAL MUSIC AND MOVIE PLAYERS; AUDIO SPEAKERS; EARPHONES AND HEADPHONES; LOUDSPEAKERS, HEADPHONES, MICROPHONES AND CD PLAYERS; MUSIC HEADPHONES; PLUG-IN CONNECTORS FOR CAR USE; ACCESSORIES AND PERIPHERALS FOR COMPUTERS, NAMELY, HEADSETS, KEYBOARDS, MOUSE PADS, COMPUTER MICE; EXTERNAL BACK UP BATTERY FOR USE WITH HANDHELD DIGITAL ELECTRONIC DEVICES, NAMELY, CELL PHONES AND MEDIA PLAYERS (U.S. CLS. 21, 23, 26, 36 AND 38).

FIRST USE 3-2-2014; IN COMMERCE 3-2-2014.  
KIM SAITO, EXAMINING ATTORNEY

SN 86-224,097. PARACHUTE WORLDWIDE, DBA PARACHUTE, KIFISSIA, GREECE, FILED 3-18-2014.

# Bague

THE MARK CONSISTS OF STANDARD CHARACTERS WITHOUT CLAIM TO ANY PARTICULAR FONT, STYLE, SIZE, OR COLOR.

THE ENGLISH TRANSLATION OF "BAGUE" IN THE MARK IS "RING".

FOR TYPEFACE FONTS RECORDED ON MAGNETIC MEDIA (U.S. CLS. 21, 23, 26, 36 AND 38).

FIRST USE 10-8-2010; IN COMMERCE 1-29-2013.  
KRISTINA MORRIS, EXAMINING ATTORNEY

**CLASS 9—(Continued).**

SN 86-224,152. ETHOS PRODUCTIONS LLC, NEW YORK, NY. FILED 3-18-2014.



THE MARK CONSISTS OF THE LETTERS "EN" AND A SWIRL WITH TWO DOTS ON EITHER SIDE.

FOR SOUND RECORDINGS FEATURING ELECTRONIC DANCE MUSIC (U.S. CLS. 21, 23, 26, 36 AND 38).

FIRST USE 4-25-2013; IN COMMERCE 4-25-2013.  
TIMOTHY FINNEGAN, EXAMINING ATTORNEY

SN 86-224,216. ETHOS PRODUCTIONS LLC, NEW YORK, NY. FILED 3-18-2014.



THE MARK CONSISTS OF A SWIRL WITH TWO DOTS ON EITHER SIDE.

FOR SOUND RECORDINGS FEATURING ELECTRONIC DANCE MUSIC (U.S. CLS. 21, 23, 26, 36 AND 38).

FIRST USE 4-25-2013; IN COMMERCE 4-25-2013.  
TIMOTHY FINNEGAN, EXAMINING ATTORNEY

SN 86-224,415. CONFIDENCE THROUGH CHARACTERS, INC., DEL MAR, CA. FILED 3-18-2014.

# My Parents Are Crazy

THE MARK CONSISTS OF STANDARD CHARACTERS WITHOUT CLAIM TO ANY PARTICULAR FONT, STYLE, SIZE, OR COLOR.

FOR DOWNLOADABLE MOBILE APPLICATIONS FEATURING CHILDREN'S BOOKS AND INTERACTIVE STORY-BASED ENTERTAINMENT AND EDUCATION (U.S. CLS. 21, 23, 26, 36 AND 38).

FIRST USE 2-15-2014; IN COMMERCE 2-15-2014.  
CAROLINE WOOD, EXAMINING ATTORNEY

**CLASS 9—(Continued).**

SN 86-225,418. COMMUNICATION APPETITUDE, LLC, CO-LUMBIA, MD. FILED 3-19-2014.



The logo for InferCabulary features the word "InferCabulary" in a bold, sans-serif font. The letter "C" in "Cabulary" is stylized with a checkmark inside it.

THE MARK CONSISTS OF THE STYLIZED WORDS "INFERCABULARY" WITH THE WORD "INFER", WITH A CAPITAL "I" AND THE WORD-PART "CABULARY" WITH A CAPITAL "C" TOGETHER WITH NO SPACE BETWEEN AND WITH A CHECK MARK DISPLAYED SUPERIMPOSED ON THE LETTER "C".

FOR COMPUTER APPLICATION SOFTWARE FOR HANDHELD TABLETS, MOBILE PHONES, PORTABLE MEDIA PLAYERS, HANDHELD COMPUTERS, NAMELY, SOFTWARE FOR EDUCATION FEATURING INSTRUCTION IN LANGUAGE ARTS, READING AND VOCABULARY; CHILDREN'S EDUCATIONAL SOFTWARE; COMPUTER SOFTWARE FOR EDUCATION IN THE NATURE OF INSTRUCTION IN THE FIELD OF LANGUAGE ARTS, READING AND VOCABULARY (U.S. CLS. 21, 23, 26, 36 AND 38).

FIRST USE 4-1-2012; IN COMMERCE 1-31-2014.  
NATALIE KENEALY, EXAMINING ATTORNEY

**CLASS 9—(Continued).**

SN 86-225,952. ISOTROPIC NETWORKS, INC, SPRINGFIELD, WI. FILED 3-19-2014.



The logo for Connected Planet Alliance consists of the words "Connected Planet Alliance" in a clean, sans-serif font.

THE MARK CONSISTS OF STANDARD CHARACTERS WITHOUT CLAIM TO ANY PARTICULAR FONT, STYLE, SIZE, OR COLOR.

NO CLAIM IS MADE TO THE EXCLUSIVE RIGHT TO USE "CONNECTED" AND "ALLIANCE", APART FROM THE MARK AS SHOWN.

FOR COMMUNICATION HUBS; COMMUNICATION SOFTWARE FOR PROVIDING ACCESS TO THE INTERNET; COMMUNICATIONS COMPUTERS; HIGH FREQUENCY MOBILE AND SEA-BASED COMMUNICATION ANTENNAS; PIPELINE COMMUNICATION SYSTEMS FOR TRANSFERRING DATA OVER OIL, GAS, WATER AND HEAT DISTRIBUTION PIPELINE NETWORKS, COMPRISED OF COMPUTER HARDWARE, SOFTWARE, MODEMS AND COMMUNICATION CABLES; RECEIVERS FOR SATELLITES; SATELLITE COMPONENTS, NAMELY, FEED HORNS; SATELLITE DISHES; SATELLITE DISHES FOR SATELLITE TRANSMISSIONS; SATELLITE NAVIGATIONAL SYSTEM, NAMELY, A GLOBAL POSITIONING SYSTEM (GPS); SATELLITE PROCESSORS; SATELLITE RADIOS; SATELLITE RECEIVERS; SATELLITE TELEPHONES; SATELLITE TRANSMITTERS AND RECEIVERS; SATELLITE-AIDED NAVIGATION SYSTEMS; SATELLITES; SATELLITES FOR SCIENTIFIC PURPOSES (U.S. CLS. 21, 23, 26, 36 AND 38).

JENNIFER MARTIN, EXAMINING ATTORNEY

SN 86-225,886. MAGNATONE, LLC, ST. LOUIS, MO. FILED 3-19-2014.



The logo for MAGNATONE features a stylized letter "M" with two chevron arrows pointing downwards from its top center. Below the "M" is the word "MAGNATONE" in a bold, sans-serif font.

OWNER OF U.S. REG. NOS. 2,830,280 AND 3,872,047.  
THE MARK CONSISTS OF A STYLIZED "M" WITH TWO CHEVRON ARROWS POINTING DOWN TOWARDS THE CENTER OF THE "M"'S DIP, WITH THE STYLIZED WORD "MAGNATONE" RESIDING BELOW THE LETTER "M".  
FOR ELECTRONIC MUSICAL INSTRUMENT AMPLIFIERS (U.S. CLS. 21, 23, 26, 36 AND 38).

FIRST USE 12-15-2003; IN COMMERCE 12-15-2003.  
SETH A. RAPPAPORT, EXAMINING ATTORNEY

SN 86-226,201. COMNEZ, INC., CEDAR RAPIDS, IA. FILED 3-19-2014.



The logo for XNOTIFY consists of the word "XNOTIFY" in a bold, serif font.

THE MARK CONSISTS OF STANDARD CHARACTERS WITHOUT CLAIM TO ANY PARTICULAR FONT, STYLE, SIZE, OR COLOR.

FOR COMPUTER APPLICATION SOFTWARE FOR MOBILE PHONES, NAMELY, SOFTWARE FOR GROUP OR EVENT NOTIFICATIONS (U.S. CLS. 21, 23, 26, 36 AND 38).

FIRST USE 3-11-2014; IN COMMERCE 3-11-2014.  
LINDA POWELL, EXAMINING ATTORNEY

**CLASS 9—(Continued).**

SN 86-226,365. INTERSOURCE OEM, INC., TORRANCE, CA. FILED 3-19-2014.

**The Filler Detective**

THE MARK CONSISTS OF STANDARD CHARACTERS WITHOUT CLAIM TO ANY PARTICULAR FONT, STYLE, SIZE, OR COLOR.

NO CLAIM IS MADE TO THE EXCLUSIVE RIGHT TO USE "FILLER", APART FROM THE MARK AS SHOWN.

FOR ELECTROMAGNETIC APPARATUS USED TO DETECT IMPERFECTIONS ON HARD SURFACES, NAMELY, AUTOMOTIVE EXTERIORS (U.S. CLS. 21, 23, 26, 36 AND 38).

FIRST USE 1-1-2011; IN COMMERCE 1-1-2011.  
DAVID TOOLEY, EXAMINING ATTORNEY

---

SN 86-226,551. BBEWBREW, PEARLAND, TX. FILED 3-20-2014.

**Adventurer Manager**

THE MARK CONSISTS OF STANDARD CHARACTERS WITHOUT CLAIM TO ANY PARTICULAR FONT, STYLE, SIZE, OR COLOR.

FOR COMPUTER GAME SOFTWARE AND APPLICATION FOR USE ON MOBILE DEVICES, TABLETS, CONSOLES, AND COMPUTERS (U.S. CLS. 21, 23, 26, 36 AND 38).

FIRST USE 6-15-2013; IN COMMERCE 3-1-2014.  
JILLIAN CANTOR, EXAMINING ATTORNEY

---

SN 86-227,189. I.D.E.A. LLC, ST. LOUIS, MO. FILED 3-20-2014.

**INSTAVEME**

THE MARK CONSISTS OF STANDARD CHARACTERS WITHOUT CLAIM TO ANY PARTICULAR FONT, STYLE, SIZE, OR COLOR.

FOR DOWNLOADABLE COMPUTER SOFTWARE FOR CREATING AND EDITING VIDEOS AND UPLOADING VIDEOS TO THE INTERNET IN CREATING INTERNET VIDEO MEMES (U.S. CLS. 21, 23, 26, 36 AND 38).

ZACHARY CROMER, EXAMINING ATTORNEY

**CLASS 9—(Continued).**

SN 86-227,202. MOJIX, INC., LOS ANGELES, CA. FILED 3-20-2014.

**OmniSenseRF**

THE MARK CONSISTS OF STANDARD CHARACTERS WITHOUT CLAIM TO ANY PARTICULAR FONT, STYLE, SIZE, OR COLOR.

FOR RADIO-FREQUENCY IDENTIFICATION (RFID) READERS; SIGNAL PROCESSORS FOR WIRELESS APPLICATIONS, NAMELY, RADIO-FREQUENCY IDENTIFICATION (RFID) APPLICATIONS; SOFTWARE FOR USE WITH RADIO-FREQUENCY IDENTIFICATION (RFID) READERS; SOFTWARE FOR USE IN SUPPLY CHAIN MANAGEMENT AND INVENTORY APPLICATIONS; SOFTWARE FOR MONITORING AND IDENTIFYING RADIO-FREQUENCY IDENTIFICATION (RFID) TAGS; SOFTWARE FOR INVENTORY CONTROL (U.S. CLS. 21, 23, 26, 36 AND 38).

MIROSLAV NOVAKOVIC, EXAMINING ATTORNEY

---

SN 86-227,647. KEEPSAYK, LLC, CHICAGO, IL. FILED 3-20-2014.

**Rich Sharing**

THE MARK CONSISTS OF STANDARD CHARACTERS WITHOUT CLAIM TO ANY PARTICULAR FONT, STYLE, SIZE, OR COLOR.

NO CLAIM IS MADE TO THE EXCLUSIVE RIGHT TO USE "SHARING", APART FROM THE MARK AS SHOWN.

FOR DOWNLOADABLE COMPUTER SOFTWARE FOR VIEWING DIGITAL IMAGES AND PHOTOGRAPHS, AND FOR THE COLLECTION, EDITING, ORGANIZING, MODIFYING, BOOK MARKING, TRANSMISSION, STORAGE, AND SHARING OF DATA AND INFORMATION (U.S. CLS. 21, 23, 26, 36 AND 38).

DAVID MURRAY, EXAMINING ATTORNEY

**CLASS 9—(Continued).**

SN 86-228,399. ZUWM, INC., PORT WASHINGTON, NY. FILED 3-21-2014.

# WINGS UP!

THE MARK CONSISTS OF STANDARD CHARACTERS WITHOUT CLAIM TO ANY PARTICULAR FONT, STYLE, SIZE, OR COLOR.

FOR COMPUTER GAME PROGRAMMES; COMPUTER GAME PROGRAMMES DOWNLOADABLE VIA THE INTERNET; COMPUTER GAME PROGRAMS; COMPUTER GAME SOFTWARE; COMPUTER PROGRAMS FOR VIDEO AND COMPUTER GAMES; COMPUTER SOFTWARE, NAMELY, GAME ENGINE SOFTWARE FOR VIDEO GAME DEVELOPMENT AND OPERATION; DOWNLOADABLE COMPUTER GAME PROGRAMS; DOWNLOADABLE COMPUTER GAME SOFTWARE VIA A GLOBAL COMPUTER NETWORK AND WIRELESS DEVICES; DOWNLOADABLE ELECTRONIC GAME PROGRAMS; DOWNLOADABLE ELECTRONIC GAME SOFTWARE FOR USE ON COMPUTERS, TABLETS AND SMARTPHONES RUNNING MOBILE BROWSERS THAT READ FLASH AND INTERACTIVE TOUCHSCREEN KIOSKS; INTERACTIVE GAME PROGRAMS; INTERACTIVE GAME SOFTWARE; INTERACTIVE MULTIMEDIA COMPUTER GAME PROGRAMS; INTERACTIVE VIDEO GAME PROGRAMS; VIDEO AND COMPUTER GAME PROGRAMS; VIDEO GAME SOFTWARE (U.S. CLS. 21, 23, 26, 36 AND 38).

FIRST USE 3-13-2014; IN COMMERCE 3-13-2014.  
KELLY BOULTON, EXAMINING ATTORNEY

SN 86-228,401. DAVID SPIRO, LIVINGSTON, NJ. FILED 3-21-2014.

# ELEVATR

THE MARK CONSISTS OF STANDARD CHARACTERS WITHOUT CLAIM TO ANY PARTICULAR FONT, STYLE, SIZE, OR COLOR.

FOR COMPUTER APPLICATION SOFTWARE FOR COMPUTERS, NAMELY, SOFTWARE FOR BUSINESS ORGANIZATION (U.S. CLS. 21, 23, 26, 36 AND 38).  
FIRST USE 5-10-2013; IN COMMERCE 3-21-2014.  
KIMBERLY PARKS, EXAMINING ATTORNEY

**CLASS 9—(Continued).**

SN 86-228,442. CELL-NERDS LLC, MIAMI, FL. FILED 3-21-2014.

# NerdShield

THE MARK CONSISTS OF STANDARD CHARACTERS WITHOUT CLAIM TO ANY PARTICULAR FONT, STYLE, SIZE, OR COLOR.

FOR PROTECTIVE CASES AND COVERS FOR PORTABLE COMMUNICATION DEVICES, NAMELY, CELL PHONES, SMART PHONES, AND PERSONAL DATA ASSISTANTS; PROTECTIVE CASES AND COVERS FOR NOTEBOOK COMPUTERS, PORTABLE COMPUTERS, PORTABLE MUSIC OR VIDEO PLAYERS, PORTABLE STORAGE DEVICES, AND PORTABLE TABLETS (U.S. CLS. 21, 23, 26, 36 AND 38).

FIRST USE 1-1-2012; IN COMMERCE 1-1-2012.  
ANDREA CORNWELL, EXAMINING ATTORNEY

SN 86-228,711. NAGIOS ENTERPRISES, LLC, ST. PAUL, MN. FILED 3-21-2014.

# Nagios

OWNER OF U.S. REG. NO. 3,255,661.

THE MARK CONSISTS OF A STYLIZED FORM OF THE WORD "NAGIOS". THE "N" IN THE WORD "NAGIOS" IS UNDERLINED.

FOR COMPUTER SOFTWARE FOR USE IN MONITORING AND REPORTING THE AVAILABILITY AND OPERATIONAL STATE OF COMPUTER SYSTEMS, COMPUTER SOFTWARE, NETWORK OPERATING SYSTEMS, AND NETWORK SERVICES (U.S. CLS. 21, 23, 26, 36 AND 38).

FIRST USE 5-3-2001; IN COMMERCE 7-3-2001.  
SIDDHARTH JAGANNATHAN, EXAMINING ATTORNEY

SN 86-228,747. KATRINA A FREIRE, DBA QUICK CLAIMS PRO, MIAMI, FL. FILED 3-21-2014.

# Quick Claims Pro

THE MARK CONSISTS OF STANDARD CHARACTERS WITHOUT CLAIM TO ANY PARTICULAR FONT, STYLE, SIZE, OR COLOR.

NO CLAIM IS MADE TO THE EXCLUSIVE RIGHT TO USE "QUICK CLAIMS", APART FROM THE MARK AS SHOWN.

FOR DOWNLOADABLE PICTURES IN THE FIELD OF AUTOMOBILES (U.S. CLS. 21, 23, 26, 36 AND 38).  
ALEXANDER L. POWERS, EXAMINING ATTORNEY

**CLASS 9—(Continued).**

SN 86-228,972. PETER LEVY, MONTE SERENO, CA. FILED 3-21-2014.

# CARJOJO

THE MARK CONSISTS OF STANDARD CHARACTERS WITHOUT CLAIM TO ANY PARTICULAR FONT, STYLE, SIZE, OR COLOR.

FOR COMPUTER APPLICATION SOFTWARE FOR MOBILE PHONES, PORTABLE MEDIA PLAYERS, HANDHELD COMPUTERS, NAMELY, SOFTWARE FEATURING INFORMATION IN THE FIELDS OF VEHICLE PRICING AND VEHICULAR INVENTORY MANAGEMENT, INFORMATION ON VEHICLES TO HELP GUIDE CONSUMERS IN THEIR PURCHASE OF A NEW OR USED VEHICLE, INFORMATION ABOUT VEHICLES FOR SALE, RANKINGS, RATINGS, AND REVIEWS IN THE FIELD OF VEHICLES; COMPUTER APPLICATION SOFTWARE FOR MOBILE PHONES, PORTABLE MEDIA PLAYERS, HANDHELD COMPUTERS, NAMELY, SOFTWARE TO ASSIST CUSTOMERS IN LOCATING AUTOMOTIVE DEALERS AND TO MATCH CONSUMER REQUESTS FOR VEHICLE PRICING AND INFORMATION TO AUTOMOTIVE DEALERS (U.S. CLS. 21, 23, 26, 36 AND 38).

MARY CRAWFORD, EXAMINING ATTORNEY

SN 86-229,030. VALUE SHARK, INC., MENLO PARK, CA. FILED 3-21-2014.

# STATRICKS

THE MARK CONSISTS OF STANDARD CHARACTERS WITHOUT CLAIM TO ANY PARTICULAR FONT, STYLE, SIZE, OR COLOR.

FOR COMPUTER SOFTWARE FOR PROVIDING INFORMATION RELATED TO MARKET VALUES, PRICING TRENDS AND DEPRECIATION SCHEDULES FOR A WIDE VARIETY OF USED GOODS; DOWNLOADABLE COMPUTER SOFTWARE, NAMELY, AN APPLICATION PROGRAMMING INTERFACE (API) THAT ALLOWS USERS TO ACCESS DATA PRICING ANALYTICS FOR A WIDE VARIETY OF PRODUCTS (U.S. CLS. 21, 23, 26, 36 AND 38).

NATALIE KENEALY, EXAMINING ATTORNEY

**CLASS 9—(Continued).**

SN 86-229,743. STRATCOM SYSTEMS, INC., DBA SIMS SOFTWARE, SOLANA BEACH, CA. FILED 3-24-2014.

# FASET FIRE & SAFETY EQUIPMENT TRACKER

THE MARK CONSISTS OF STANDARD CHARACTERS WITHOUT CLAIM TO ANY PARTICULAR FONT, STYLE, SIZE, OR COLOR.

OWNER OF U.S. REG. NOS. 3,506,601 AND 3,903,903.

NO CLAIM IS MADE TO THE EXCLUSIVE RIGHT TO USE "FIRE & SAFETY EQUIPMENT TRACKER", APART FROM THE MARK AS SHOWN.

FOR DATABASE SOFTWARE FOR TRACKING FIRE SAFETY EQUIPMENT AND MATERIALS (U.S. CLS. 21, 23, 26, 36 AND 38).

FIRST USE 8-21-2006; IN COMMERCE 8-21-2006.

INGRID C. EULIN, EXAMINING ATTORNEY

SN 86-229,744. MADLOVE, INC., NEW YORK, NY. FILED 3-24-2014.

# MADLOVE

THE MARK CONSISTS OF STANDARD CHARACTERS WITHOUT CLAIM TO ANY PARTICULAR FONT, STYLE, SIZE, OR COLOR.

OWNER OF U.S. REG. NOS. 4,110,532 AND 4,373,656.

FOR EYEWEAR, NAMELY, SUNGLASSES AND THEIR CASES (U.S. CLS. 21, 23, 26, 36 AND 38).

INGRID C. EULIN, EXAMINING ATTORNEY

SN 86-229,917. PALISADE CORPORATION, ITHACA, NY. FILED 3-24-2014.

# BIGPICTURE

THE MARK CONSISTS OF STANDARD CHARACTERS WITHOUT CLAIM TO ANY PARTICULAR FONT, STYLE, SIZE, OR COLOR.

FOR COMPUTER SOFTWARE FOR DATA ANALYSIS AND FOR CREATING DRAWINGS AND GRAPHICS IN THE FIELD OF MIND MAPPING (U.S. CLS. 21, 23, 26, 36 AND 38).

KRISTIN DAHLING, EXAMINING ATTORNEY



**CLASS 9—(Continued).**

SN 86-230,032. MANGO FAMILY, LLC, WILMINGTON, DE. FILED 3-25-2014.

# BANG UP BOX

THE MARK CONSISTS OF STANDARD CHARACTERS WITHOUT CLAIM TO ANY PARTICULAR FONT, STYLE, SIZE, OR COLOR.

NO CLAIM IS MADE TO THE EXCLUSIVE RIGHT TO USE "BOX", APART FROM THE MARK AS SHOWN.

FOR COMPUTER APPLICATION SOFTWARE FOR MOBILE PHONES, TABLETS, AND COMPUTERS, NAMELY, SOFTWARE FOR ENTERTAINMENT; COMPUTER GAME SOFTWARE; COMPUTER GAME SOFTWARE FOR USE ON MOBILE AND CELLULAR PHONES; DOWNLOADABLE COMPUTER GAME PROGRAMS; ELECTRONIC GAME SOFTWARE; GAME SOFTWARE; VIDEO GAME SOFTWARE (U.S. CLS. 21, 23, 26, 36 AND 38).

DOMINICK J. SALEMI, EXAMINING ATTORNEY

**CLASS 9—(Continued).**

SN 86-230,639. YJ LINK, DALSEONG-GUN, DAEGU, REPUBLIC OF KOREA, FILED 3-24-2014.



OWNER OF REPUBLIC OF KOREA REG. NO. 45-0040820, DATED 7-6-2012, EXPIRES 7-26-2022.

NO CLAIM IS MADE TO THE EXCLUSIVE RIGHT TO USE "LINK", APART FROM THE MARK AS SHOWN.

THE MARK CONSISTS OF THE WORDS "YJ LINK" WITH AN "I" HAVING A WAVE DESIGN.

FOR CIRCUIT BOARDS; CIRCUIT BOARDS PROVIDED WITH INTEGRATED CIRCUITS; DATA PROCESSING APPARATUS; DIGITAL COLOUR COPIERS; DIGITAL COLOUR PRINTERS; DIGITAL INPUT AND OUTPUT SCANNERS; DIGITAL SIGNAL PROCESSORS; ELECTRONIC CIRCUIT BOARD; ELECTRONIC COMPONENTS IN THE NATURE OF ELECTRONIC SEMICONDUCTORS; INTEGRATED CIRCUIT MODULES; INTEGRATED CIRCUITS; INTERFACE CARDS FOR DATA PROCESSING EQUIPMENT IN THE FORM OF PRINTED CIRCUITS; LCD LARGE-SCREEN DISPLAYS; LCD PANELS; PRINTED CIRCUITS; SEMI-CONDUCTOR MEMORIES; SEMI-CONDUCTOR MEMORY UNITS; SEMI-CONDUCTORS; SEMICONDUCTOR POWER ELEMENTS; SILICON WAFERS; STRUCTURED SEMI-CONDUCTOR WAFERS; TESTING APPARATUS FOR TESTING PRINTED CIRCUIT BOARDS; WAFERS FOR INTEGRATED CIRCUITS (U.S. CLS. 21, 23, 26, 36 AND 38).

DAVID HOFFMAN, EXAMINING ATTORNEY

SN 86-230,377. CODAI, INC., DENVER, CO. FILED 3-24-2014.



THE MARK CONSISTS OF AN ICON WITH A CHECK-MARK IN IT TO THE LEFT OF THE TEXT, SOMEWHAT RESEMBLING A PERSON WITH OUTSTRETCHED ARMS. TO THE RIGHT IS THE WORD "VENATO" IN STYLIZED FONT.

THE ENGLISH TRANSLATION OF THE WORD "VENATO" IN THE MARK IS "TRACKER".

FOR COMPUTER SOFTWARE FOR ALLOWING HOSPITALS TO MANAGE COMPLIANCE REQUIREMENTS AND MONITOR THE COMPLIANCE OF MEDICAL PRACTITIONERS, ACCORDINGLY (U.S. CLS. 21, 23, 26, 36 AND 38).

FIRST USE 1-6-2014; IN COMMERCE 1-6-2014.

JANICE KIM, EXAMINING ATTORNEY

SN 86-230,852. MANGO FAMILY, LLC, WILMINGTON, DE. FILED 3-25-2014.



NO CLAIM IS MADE TO THE EXCLUSIVE RIGHT TO USE "BOX", APART FROM THE MARK AS SHOWN.

THE MARK CONSISTS OF THE WORDS "BANG UP BOX" DISPLAYED IN FRONT OF A CANNON SHOOTING FOUR CIRCULAR OBJECTS WITH AN IMAGE OF AN EXPLOSION IN THE BACKGROUND.

FOR COMPUTER APPLICATION SOFTWARE FOR MOBILE PHONES, TABLETS, AND COMPUTERS, NAMELY, SOFTWARE FOR ENTERTAINMENT; COMPUTER GAME SOFTWARE FOR USE ON MOBILE AND CELLULAR PHONES; DOWNLOADABLE COMPUTER GAME PROGRAMS; ELECTRONIC GAME PROGRAMS; GAME SOFTWARE; VIDEO GAME SOFTWARE (U.S. CLS. 21, 23, 26, 36 AND 38).

DOMINICK J. SALEMI, EXAMINING ATTORNEY

**CLASS 9—(Continued).**

SN 86-231,159. COOLCAD ELECTRONICS LLC, COLLEGE PARK, MD. FILED 3-25-2014.



THE COLOR(S) BLUE, WHITE AND BLACK IS/ARE CLAIMED AS A FEATURE OF THE MARK.

THE MARK CONSISTS OF A DRAWING OF A COMPUTER WITH A KEYHOLE, AND A KEY-RING ATTACHED TO IT. IT CONTAINS BLUE, WHITE AND BLACK COLORS. THE COMPUTER IS LIGHT BLUE AT THE TOP AND DARK BLUE AT THE BOTTOM WITH A SMOOTH GRADIENT. THE KEYHOLE IS BLACK IN COLOR. THE KEY RING IS WHITE WITH SHADES OF BLUE AND BLACK. THE COMPUTER SHOWS A WHITE BORDER AND A BLUE OUTLINE.

FOR COMPUTER PERIPHERAL DEVICES; DEVICES FOR WIRELESS RADIO TRANSMISSION; ELECTRONIC DEVICES USED TO LOCATED LOST OBJECTS EMPLOYING RADIO FREQUENCY; INTERFACES AND PERIPHERAL DEVICES FOR COMPUTERS; WIRELESS COMPUTER PERIPHERALS; WIRELESS POS (POINT OF SERVICE) DEVICES; WIRELESS TRANSCEIVER RADIO; WIRELESS TRANSMITTERS AND RECEIVERS (U.S. CLS. 21, 23, 26, 36 AND 38).

HENRY S. ZAK, EXAMINING ATTORNEY

SN 86-231,438. DESIREE MCDOWELL-WHITE, LOS ANGELES, CA. FILED 3-25-2014.

**BLIND DEBIT**

THE MARK CONSISTS OF STANDARD CHARACTERS WITHOUT CLAIM TO ANY PARTICULAR FONT, STYLE, SIZE, OR COLOR.

NO CLAIM IS MADE TO THE EXCLUSIVE RIGHT TO USE "DEBIT", APART FROM THE MARK AS SHOWN.

FOR COMPUTER E-COMMERCE SOFTWARE TO ALLOW USERS TO PERFORM ELECTRONIC BUSINESS TRANSACTIONS VIA A GLOBAL COMPUTER NETWORK; COMPUTER SOFTWARE FOR PROVIDING AN ON-LINE DATABASE IN THE FIELD OF TRANSACTION PROCESSING TO UPLOAD TRANSACTIONAL DATA, PROVIDE STATISTICAL ANALYSIS, AND PRODUCE NOTIFICATIONS AND REPORTS; COMPUTER SOFTWARE, NAMELY, ELECTRONIC FINANCIAL PLATFORM THAT ACCOMMODATES MULTIPLE TYPES OF PAYMENT AND DEBT TRANSACTIONS IN AN INTEGRATED MOBILE PHONE, PDA, AND WEB BASED ENVIRONMENT; ELECTRONIC MACHINES FOR READING CREDIT CARDS AND RECORDING FINANCIAL OPERATIONS; ELECTRONIC PAYMENT TERMINAL; SECURE TERMINALS FOR ELECTRONIC TRANSACTIONS (U.S. CLS. 21, 23, 26, 36 AND 38).

EVIN L. KOZAK, EXAMINING ATTORNEY

**CLASS 9—(Continued).**

SN 86-232,010. MEDOW, JOSHUA E., MADISON, WI. FILED 3-25-2014.

**DIGITAL INTERN**

THE MARK CONSISTS OF STANDARD CHARACTERS WITHOUT CLAIM TO ANY PARTICULAR FONT, STYLE, SIZE, OR COLOR.

NO CLAIM IS MADE TO THE EXCLUSIVE RIGHT TO USE "DIGITAL", APART FROM THE MARK AS SHOWN.

FOR COMPUTER SOFTWARE FOR ANALYZING PATIENT INFORMATION AND ADVISING MEDICAL PROFESSIONALS (U.S. CLS. 21, 23, 26, 36 AND 38).

KIM MONINGHOFF, EXAMINING ATTORNEY

SN 86-232,596. FORUM SYSTEMS, INC, NEWTON, MA. FILED 3-26-2014.

**Forum Sentry**

THE MARK CONSISTS OF STANDARD CHARACTERS WITHOUT CLAIM TO ANY PARTICULAR FONT, STYLE, SIZE, OR COLOR.

NO CLAIM IS MADE TO THE EXCLUSIVE RIGHT TO USE "FORUM", APART FROM THE MARK AS SHOWN.

FOR COMPUTER HARDWARE AND PERIPHERAL DEVICES AND COMPUTER SOFTWARE FOR DATA COMMUNICATION AND TRANSLATING AND TRANSMITTING DATA SOLD THEREWITH (U.S. CLS. 21, 23, 26, 36 AND 38).

FIRST USE 10-31-2002; IN COMMERCE 10-31-2002.

ANDREA K. NADELMAN, EXAMINING ATTORNEY

**CLASS 9—(Continued).**

SN 86-232,734. GHOST OF JASON MOLINA, LLC, NASHVILLE, TN. FILED 3-26-2014.

**CLASS 9—(Continued).**

SN 86-232,735. RDIO, INC., SAN FRANCISCO, CA. FILED 3-26-2014.

# SONGS: OHIA

# YOUFM

THE MARK CONSISTS OF STANDARD CHARACTERS WITHOUT CLAIM TO ANY PARTICULAR FONT, STYLE, SIZE, OR COLOR.

NO CLAIM IS MADE TO THE EXCLUSIVE RIGHT TO USE "SONGS", APART FROM THE MARK AS SHOWN.

FOR MUSICAL SOUND RECORDINGS; PRERECORDED AUDIO-VISUAL MEDIA, NAMELY, COMPACT DISCS, TAPE CASSETTES, AUDIO CASSETTES, AUDIO TAPES, AUDIO DISCS, RECORDS, CD-ROMS, VIDEO TAPES, VIDEO CASSETTES, VIDEO DISCS, DVDS, DATS, AND LASER DISCS, ALL FEATURING MUSIC AND MUSIC-BASED ENTERTAINMENT; PRERECORDED AUDIO AND AUDIO/VISUAL MEDIA IN DIGITAL FORMATS, NAMELY, DOWNLOADABLE AUDIO AND AUDIO/VISUAL FILES FEATURING MUSIC AND MUSIC-BASED ENTERTAINMENT; DOWNLOADABLE RINGTONES VIA A GLOBAL COMPUTER NETWORK AND WIRELESS DEVICES; DOWNLOADABLE VIDEO RECORDINGS FEATURING MUSIC; DOWNLOADABLE ELECTRONIC PUBLICATIONS IN THE NATURE OF BOOKS, BOOKLETS, MAGAZINES, JOURNALS, BROCHURES, PAMPHLETS AND NEWSLETTERS, ALL IN THE FIELDS OF MUSIC AND MUSIC-BASED ENTERTAINMENT; ELECTRONIC PUBLICATIONS, NAMELY, BOOKS, BOOKLETS, MAGAZINES, JOURNALS, MANUALS, BROCHURES, LEAFLETS, PAMPHLETS AND NEWSLETTERS, ALL IN THE FIELDS OF MUSIC AND MUSIC-BASED ENTERTAINMENT, ALL RECORDED ON CD-ROMS, DISKETTES, FLOPPY DISKS, VIDEO CASSETTES, AND MAGNETIC TAPES; MOUSE PADS; COMPACT DISC CASES; FITTED CASES FOR STORAGE AND TRANSPORTATION, NAMELY, CASES FOR COMPACT DISCS, AUDIO CASSETTES, VIDEO CASSETTES, CD-ROMS, HOME VIDEO GAMES, HOME VIDEO GAME ACCESSORIES, AND PORTABLE PHONES; COMPUTER GAME CARTRIDGES, CASSETTES, TAPES, DISCS, PROGRAMS AND SOFTWARE; VIDEO GAME CARTRIDGES, TAPE CASSETTES, DISCS, PROGRAMS AND SOFTWARE; ELECTRONIC GAME PROGRAMS (U.S. CLS. 21, 23, 26, 36 AND 38).

FIRST USE 1-30-1996; IN COMMERCE 1-30-1996.  
HOWARD SMIGA, EXAMINING ATTORNEY

THE MARK CONSISTS OF STANDARD CHARACTERS WITHOUT CLAIM TO ANY PARTICULAR FONT, STYLE, SIZE, OR COLOR.

FOR COMPUTER SOFTWARE FOR USE IN DOWNLOADING, TRANSMITTING, RECEIVING, EXTRACTING, DECODING AND PLAYING AUDIO DATA; COMPUTER SOFTWARE FOR USE IN DOWNLOADING AND STREAMING AUDIO MATERIALS VIA THE INTERNET, MOBILE DEVICES, WIRELESS INTERNET NETWORKS OR SYSTEMS AND OTHER COMPUTER AND ELECTRONIC COMMUNICATION NETWORKS; COMPUTER SOFTWARE FOR USE IN DOWNLOADING, TRANSMITTING, RECEIVING, EXTRACTING, DECODING AND PLAYING AUDIO FILES; SOFTWARE THAT ENABLES USERS TO PLAY AND PROGRAM MUSIC AND ENTERTAINMENT RELATED AUDIO; SOFTWARE FEATURING MUSICAL SOUND RECORDINGS AND ENTERTAINMENT-RELATED AUDIO RECORDINGS IN THE FIELD OF MUSIC (U.S. CLS. 21, 23, 26, 36 AND 38).

HAI-LY LAM, EXAMINING ATTORNEY

**CLASS 9—(Continued).**

SN 86-233,033. GHOST OF JASON MOLINA, LLC, NASHVILLE, TN. FILED 3-26-2014.

**MAGNOLIA ELECTRIC CO.**

THE MARK CONSISTS OF STANDARD CHARACTERS WITHOUT CLAIM TO ANY PARTICULAR FONT, STYLE, SIZE, OR COLOR.

NO CLAIM IS MADE TO THE EXCLUSIVE RIGHT TO USE "CO.", APART FROM THE MARK AS SHOWN.

FOR MUSICAL SOUND RECORDINGS; PRERECORDED AUDIO-VISUAL MEDIA, NAMELY, COMPACT DISCS, TAPE CASSETTES, AUDIO CASSETTES, AUDIO TAPES, AUDIO DISCS, RECORDS, CD-ROMS, VIDEO TAPES, VIDEO CASSETTES, VIDEO DISCS, DVDS, DATS, AND LASER DISCS, ALL FEATURING MUSIC AND MUSIC-BASED ENTERTAINMENT; PRERECORDED AUDIO AND AUDIO/VISUAL MEDIA IN DIGITAL FORMATS, NAMELY, DOWNLOADABLE AUDIO AND AUDIO/VISUAL FILES FEATURING MUSIC AND MUSIC-BASED ENTERTAINMENT; DOWNLOADABLE RINGTONES VIA A GLOBAL COMPUTER NETWORK AND WIRELESS DEVICES; DOWNLOADABLE VIDEO RECORDINGS FEATURING MUSIC; DOWNLOADABLE ELECTRONIC PUBLICATIONS IN THE NATURE OF BOOKS, BOOKLETS, MAGAZINES, JOURNALS, BROCHURES, PAMPHLETS AND NEWSLETTERS, ALL IN THE FIELDS OF MUSIC AND MUSIC-BASED ENTERTAINMENT; ELECTRONIC PUBLICATIONS, NAMELY, BOOKS, BOOKLETS, MAGAZINES, JOURNALS, MANUALS, BROCHURES, LEAFLETS, PAMPHLETS AND NEWSLETTERS, ALL IN THE FIELDS OF MUSIC AND MUSIC-BASED ENTERTAINMENT, ALL RECORDED ON CD-ROMS, DISKETTES, FLOPPY DISKS, VIDEO CASSETTES, AND MAGNETIC TAPES; MOUSE PADS; COMPACT DISC CASES; FITTED CASES FOR STORAGE AND TRANSPORTATION, NAMELY, CASES FOR COMPACT DISCS, AUDIO CASSETTES, VIDEO CASSETTES, CD-ROMS, HOME VIDEO GAMES, HOME VIDEO GAME ACCESSORIES, AND PORTABLE PHONES; COMPUTER GAME CARTRIDGES, CASSETTES, TAPES, DISCS, PROGRAMS AND SOFTWARE; VIDEO GAME CARTRIDGES, TAPE CASSETTES, DISCS, PROGRAMS AND SOFTWARE; ELECTRONIC GAME PROGRAMS (U.S. CLS. 21, 23, 26, 36 AND 38).

FIRST USE 1-18-2005; IN COMMERCE 1-18-2005.  
HOWARD SMIGA, EXAMINING ATTORNEY

SN 86-233,110. EDUARR ENTERPRISES LLC, DBA LOUD LENSES, ARLINGTON, TX. FILED 3-26-2014.

**Loud Lenses**

THE MARK CONSISTS OF STANDARD CHARACTERS WITHOUT CLAIM TO ANY PARTICULAR FONT, STYLE, SIZE, OR COLOR.

NO CLAIM IS MADE TO THE EXCLUSIVE RIGHT TO USE "LENSES", APART FROM THE MARK AS SHOWN.

FOR EYEWEAR (U.S. CLS. 21, 23, 26, 36 AND 38).  
FIRST USE 4-1-2013; IN COMMERCE 4-1-2013.  
SUE LAWRENCE, EXAMINING ATTORNEY

**CLASS 9—(Continued).**

SN 86-233,424. WEB MARKETING, INC., COOS BAY, OR. FILED 3-26-2014.

**BeaconFinder**

THE MARK CONSISTS OF STANDARD CHARACTERS WITHOUT CLAIM TO ANY PARTICULAR FONT, STYLE, SIZE, OR COLOR.

SEC. 2(F).

FOR COMPUTER APPLICATION SOFTWARE FOR MOBILE DEVICES, NAMELY, SOFTWARE FOR LOCATING WIRELESS HOTSPOTS (U.S. CLS. 21, 23, 26, 36 AND 38).

FIRST USE 3-18-2004; IN COMMERCE 3-18-2004.  
NAKIA HENRY, EXAMINING ATTORNEY

SN 86-233,839. CONFIDENCE THROUGH CHARACTERS, INC., DEL MAR, CA. FILED 3-27-2014.



THE MARK CONSISTS OF A FACE OF A BOY NEXT TO A FACE OF A GIRL. THE FACE OF THE BOY IS ON THE LEFT AND THE FACE OF THE GIRL IS ON THE RIGHT. THE BOY AND GIRL ARE SMILING. RIBBON IS VISIBLE IN THE GIRL'S HAIR. BELOW THE FACES IS THE WORD "CONFIDENCE" ON ONE LINE. ON THE LINE BELOW "CONFIDENCE" ARE THE WORDS "THROUGH CHARACTERS". BELOW THE WORDS "THROUGH CHARACTERS" IS A LINE AT AN ANGLE. THE WORDS ARE CONTAINED IN A CLOUD SHAPE. THE BORDER OF THE CLOUD SHAPE EXTENDS FROM THE LEFT SIDE OF THE FACE OF THE BOY, AROUND THE WORDS BELOW THE FACES, AND TO THE RIGHT SIDE OF THE GIRL'S FACE.

FOR DOWNLOADABLE MOBILE APPLICATIONS FEATURING CHILDREN'S BOOKS AND INTERACTIVE STORY-BASED ENTERTAINMENT AND EDUCATION (U.S. CLS. 21, 23, 26, 36 AND 38).

FIRST USE 2-15-2014; IN COMMERCE 2-15-2014.  
CAROLINE WOOD, EXAMINING ATTORNEY

**CLASS 9—(Continued).**

SN 86-233,993. RX-360 INTERNATIONAL PHARMACEUTICAL SUPPLY CHAIN CONSORTIUM, WASHINGTON, DC. FILED 3-27-2014.

# RX-360

THE MARK CONSISTS OF STANDARD CHARACTERS WITHOUT CLAIM TO ANY PARTICULAR FONT, STYLE, SIZE, OR COLOR.

FOR DOWNLOADABLE ELECTRONIC PUBLICATIONS, NAMELY, WHITE PAPERS, MODEL FORMS, AUDIT GUIDELINES, AND REPORTS IN THE FIELD OF PHARMACEUTICAL SUPPLY CHAIN SECURITY (U.S. CLS. 21, 23, 26, 36 AND 38).

FIRST USE 0-0-2009; IN COMMERCE 0-0-2009.  
KELLEY WELLS, EXAMINING ATTORNEY

**CLASS 9—(Continued).**

SN 86-234,322. TRS QUALITY, INC., FORT WORTH, TX. FILED 3-27-2014.

# Optimus

THE MARK CONSISTS OF STANDARD CHARACTERS WITHOUT CLAIM TO ANY PARTICULAR FONT, STYLE, SIZE, OR COLOR.

OWNER OF U.S. REG. NO. 3,503,983.

FOR AUDIO HEADPHONES; AUDIO SPEAKERS; AUDIO-RECEIVERS AND VIDEO-RECEIVERS; EARPHONES AND HEADPHONES; HEADPHONES; HEADPHONES INCLUDING ATTACHED LANYARD; LOUDSPEAKERS, HEADPHONES, MICROPHONES AND CD PLAYERS; MUSIC HEADPHONES; PERSONAL HEADPHONES FOR SOUND TRANSMITTING APPARATUS; PERSONAL HEADPHONES FOR USE WITH SOUND TRANSMITTING SYSTEMS; RADIOS; SOUND AMPLIFIERS; SOUND BOARDS; STEREO HEADPHONES (U.S. CLS. 21, 23, 26, 36 AND 38).

MATTHEW CUCCIAS, EXAMINING ATTORNEY

SN 86-235,250. LEWANDOWSKI, MARK, PROSPECT HEIGHTS, IL. FILED 3-28-2014.

# Jugem's Cloud

THE MARK CONSISTS OF STANDARD CHARACTERS WITHOUT CLAIM TO ANY PARTICULAR FONT, STYLE, SIZE, OR COLOR.

FOR DIGITAL MEDIA, NAMELY, CDS, DVDS, AND DOWNLOADABLE AUDIO FILES FEATURING ORIGINAL MUSIC AND BAND-RELATED CONTENT (U.S. CLS. 21, 23, 26, 36 AND 38).

KEVIN CRENNAN, EXAMINING ATTORNEY

SN 86-234,178. DEFENDER SECURITY COMPANY, INDIANAPOLIS, IN. FILED 3-27-2014.

# HOME DEFENDER

THE MARK CONSISTS OF STANDARD CHARACTERS WITHOUT CLAIM TO ANY PARTICULAR FONT, STYLE, SIZE, OR COLOR.

OWNER OF U.S. REG. NO. 3,144,080.

NO CLAIM IS MADE TO THE EXCLUSIVE RIGHT TO USE "HOME", APART FROM THE MARK AS SHOWN.

FOR ALARM INSTALLATIONS AND ALARMS; HOME AND OFFICE AUTOMATION SYSTEMS COMPRISING WIRELESS AND WIRED CONTROLLERS, CONTROLLED DEVICES, AND SOFTWARE FOR LIGHTING, HVAC, SECURITY, SAFETY AND OTHER HOME AND OFFICE MONITORING AND CONTROL APPLICATIONS (U.S. CLS. 21, 23, 26, 36 AND 38).

FIRST USE 5-5-2014; IN COMMERCE 5-5-2014.  
SHAUNIA CARLYLE, EXAMINING ATTORNEY

SN 86-235,500. D B INDUSTRIES, LLC, DBA CAPITAL SAFETY USA, RED WING, MN. FILED 3-28-2014.

# SEAT BELT

THE MARK CONSISTS OF STANDARD CHARACTERS WITHOUT CLAIM TO ANY PARTICULAR FONT, STYLE, SIZE, OR COLOR.

NO CLAIM IS MADE TO THE EXCLUSIVE RIGHT TO USE "BELT", APART FROM THE MARK AS SHOWN.

FOR FALL ARREST AND FALL PROTECTION EQUIPMENT, IN THE NATURE OF, LINEMAN BELTS, NAMELY, SUPPORT BELTS FOR WORKERS (U.S. CLS. 21, 23, 26, 36 AND 38).

SHAVELL MCPHERSON, EXAMINING ATTORNEY

**CLASS 9—(Continued).**

SN 86-235,873. FRESHETECH, LLC, ORLANDO, FL. FILED 3-28-2014.

**ALL-TERRAIN SOUND**

THE MARK CONSISTS OF STANDARD CHARACTERS WITHOUT CLAIM TO ANY PARTICULAR FONT, STYLE, SIZE, OR COLOR.

NO CLAIM IS MADE TO THE EXCLUSIVE RIGHT TO USE "SOUND", APART FROM THE MARK AS SHOWN. FOR AUDIO SPEAKERS (U.S. CLS. 21, 23, 26, 36 AND 38).

CHARLES HISER, EXAMINING ATTORNEY

---

SN 86-236,245. B & E SERVICES, INC., NORTHBROOK, IL. FILED 3-29-2014.



NO CLAIM IS MADE TO THE EXCLUSIVE RIGHT TO USE "SANI", APART FROM THE MARK AS SHOWN.

THE MARK CONSISTS OF THE HEAD OF A HAWK WITH A BEAK CONNECTED TO A TOP OF THE LETTER "S" AS PART OF THE MARK "SANI HAWK".

FOR WAREWASHING SANITATION MONITORING SYSTEM COMPOSED OF AN ELECTRIC CONTROL CIRCUIT AND AN ALARM, AN AUTOMATED SANITIZER DISPENSER AND A MIXING CHAMBER (U.S. CLS. 21, 23, 26, 36 AND 38).

FIRST USE 11-20-2013; IN COMMERCE 11-20-2013.  
PARKER HOWARD, EXAMINING ATTORNEY

**CLASS 9—(Continued).**

SN 86-236,295. HVAC BUSINESS & TECHNICAL INSTITUTE, KENT, WA. FILED 3-29-2014.

**Tech Ready Mobile**

THE MARK CONSISTS OF STANDARD CHARACTERS WITHOUT CLAIM TO ANY PARTICULAR FONT, STYLE, SIZE, OR COLOR.

NO CLAIM IS MADE TO THE EXCLUSIVE RIGHT TO USE "TECH" AND "MOBILE", APART FROM THE MARK AS SHOWN.

FOR COMPUTER SOFTWARE THAT PROVIDES WEB-BASED ACCESS TO APPLICATIONS AND SERVICES THROUGH A WEB OPERATING SYSTEM OR PORTAL INTERFACE; COMPUTER SOFTWARE, NAMELY, AN APPLICATION ALLOWING SALES AND FIELD SERVICE EMPLOYEES TO UPDATE AND RECEIVE DATA STORED IN AN ENTERPRISE'S COMPUTER DATABASES IN REAL TIME, USING A MOBILE DEVICE, WITH FULL TELEPHONY INTEGRATION WITH THE TELEPHONE AND/OR SOFTWARE FEATURES OF THE MOBILE DEVICE; COMPUTER SOFTWARE, NAMELY, ELECTRONIC FINANCIAL PLATFORM THAT ACCOMMODATES MULTIPLE TYPES OF PAYMENT AND DEBT TRANSACTIONS IN AN INTEGRATED MOBILE PHONE, PDA, AND WEB BASED ENVIRONMENT; COMPUTER SOFTWARE, NAMELY, SOFTWARE DEVELOPMENT TOOLS FOR THE CREATION OF MOBILE INTERNET APPLICATIONS AND CLIENT INTERFACES; CUSTOMER SELF SERVICE ELECTRONIC CHECKOUT STATIONS FOR POINT OF SALE (U.S. CLS. 21, 23, 26, 36 AND 38).

KAPIL BHANOT, EXAMINING ATTORNEY

---

SN 86-236,482. SIMON KING'S UTILITIES GROUP PTY LTD., SYDNEY, AUSTRALIA, FILED 3-30-2014.

**Stacker**

THE MARK CONSISTS OF STANDARD CHARACTERS WITHOUT CLAIM TO ANY PARTICULAR FONT, STYLE, SIZE, OR COLOR.

FOR COMPUTER PROGRAMS FOR LIVE, TRANSPARENT, FULL DISK DATA COMPRESSION; DATA COMPRESSION SOFTWARE (U.S. CLS. 21, 23, 26, 36 AND 38).

ANDREA K. NADELMAN, EXAMINING ATTORNEY

**CLASS 9—(Continued).**

SN 86-236,496. YONG HONG PENG, SHENZHEN, GUANGDONG, CHINA, FILED 3-30-2014.

**lomji**  
Smarter Energy

NO CLAIM IS MADE TO THE EXCLUSIVE RIGHT TO USE "ENERGY", APART FROM THE MARK AS SHOWN.

THE MARK CONSISTS OF STYLIZED LETTERS "LOMJI SMARTER ENERGY" IN TWO LINES.

FOR AUDIO-RECEIVERS AND VIDEO-RECEIVERS; BATTERIES AND BATTERY CHARGERS; CAMERAS; COMPUTER PERIPHERALS AND PARTS THEREOF; ELECTRONIC EDUCATIONAL APPARATUS, NAMELY, COMMUNICATION BLOCKS THAT MANIPULATE AND CONVEY INFORMATION ELECTRONICALLY BASED ON THEIR ARRANGEMENT AND ARE USED FOR COGNITIVE DEVELOPMENT IN DISCIPLINES SUCH AS COUNTING, SPELLING OR QUANTITATIVE; EYE GLASSES; FILM CAMERAS; GPS NAVIGATION DEVICE; LABORATORY EQUIPMENT AND SUPPLIES, NAMELY, CALIPERS; LABORATORY EQUIPMENT AND SUPPLIES, NAMELY, INCUBATORS; LABORATORY EQUIPMENT AND SUPPLIES, NAMELY, TEST TUBES; LABORATORY EQUIPMENT AND SUPPLIES, NAMELY, THERMOMETERS; LABORATORY EQUIPMENT, NAMELY, CRUCIBLES; LABORATORY EQUIPMENT, NAMELY, CUPELS; LABORATORY EQUIPMENT, NAMELY, DUCTLESS FUME ENCLOSURES AND FORENSIC DRYING CABINETS; LABORATORY EQUIPMENT, NAMELY, ELECTRIC BATH HEATERS; LABORATORY EQUIPMENT, NAMELY, FUNNELS; LABORATORY EQUIPMENT, NAMELY, MICROARRAYS; LABORATORY EQUIPMENT, NAMELY, MICROSCOPE SLIDES; LABORATORY EQUIPMENT, NAMELY, PIPETTE RACKS; LABORATORY EQUIPMENT, NAMELY, PLASTIC, RUBBER AND ELASTOMER CLOSURES, SEALS AND STOPPERS FOR LABORATORY BOTTLES; LABORATORY EQUIPMENT, NAMELY, SPECTROSCOPES; SCIENTIFIC INSTRUMENTATION FOR MEASURING WEIGHT, NOT FOR MEDICAL USE; TOOL MEASURING INSTRUMENTS (U.S. CLS. 21, 23, 26, 36 AND 38).

FIRST USE 3-1-2013; IN COMMERCE 3-1-2013.  
KIMBERLY PERRY, EXAMINING ATTORNEY

**CLASS 9—(Continued).**

SN 86-236,583. CHEN YIGANG, GUANGDONG PROVINCE,, CHINA, FILED 3-31-2014.

**MOOBOM**

THE MARK CONSISTS OF THE UNDERLINED STYLIZED WORDING "MOOBOM" WITH THREE CURVED LINES.

THE WORDING "MOOBOM" HAS NO MEANING IN A FOREIGN LANGUAGE.

FOR AUDIO-RECEIVERS AND VIDEO-RECEIVERS; BAGS AND CASES SPECIALLY ADAPTED FOR HOLDING OR CARRYING PORTABLE TELEPHONES AND TELEPHONE EQUIPMENT AND ACCESSORIES; CAMERAS; CHARGERS FOR ELECTRIC BATTERIES; COMPUTER HARDWARE AND PERIPHERAL DEVICES AND COMPUTER SOFTWARE FOR DATA COMMUNICATION AND TRANSLATING AND TRANSMITTING DATA SOLD THEREWITH; COMPUTER KEYBOARDS; ELECTRIC NAVIGATIONAL INSTRUMENTS; FLUORESCENT SCREENS; HANDS FREE KITS FOR PHONES; INTEGRATED CIRCUIT CARDS AND COMPONENTS; LAPTOP COMPUTERS; PORTABLE MEDIA PLAYERS; RADIOTELEPHONY SETS; TELEPHONE APPARATUS; VIDEO TELEPHONES; WIRELESS COMMUNICATION DEVICES FOR VOICE, DATA OR IMAGE TRANSMISSION (U.S. CLS. 21, 23, 26, 36 AND 38).

FIRST USE 11-16-2013; IN COMMERCE 3-1-2014.

JOHN E. MICHOS, EXAMINING ATTORNEY

SN 86-236,667. NORTHEAST POWER SYSTEMS, INC., AKA NEPSI, QUEENSBURY, NY. FILED 3-31-2014.

**actiVAR**

THE MARK CONSISTS OF STANDARD CHARACTERS WITHOUT CLAIM TO ANY PARTICULAR FONT, STYLE, SIZE, OR COLOR.

THE ENGLISH TRANSLATION OF THE WORD "ACTIVAR" IN THE MARK IS "ACTIVATE".

FOR ELECTRICAL POWER DISTRIBUTION UNITS; MEDIUM VOLTAGE POWER DISTRIBUTION AND PROTECTION COMPONENT SYSTEM COMPOSED OF BREAKERS AND SWITCHGEARS (U.S. CLS. 21, 23, 26, 36 AND 38).

TIFFANY CHIANG, EXAMINING ATTORNEY

**CLASS 9—(Continued).**

SN 86-237,402. DATURA, LLC, HOWELL, MI. FILED 3-31-2014.



THE MARK CONSISTS OF A DESIGN WITH THE OVERALL SHAPE OF A DIAMOND WHERE THE LEFT SIDE OF THE DIAMOND IS SEPARATED BY A LINE FORMING A SHADED TRIANGLE. IN THE CENTER OF THE DIAMOND ARE FOUR INTERSECTING TRIANGLES.

FOR COMPUTER SOFTWARE FEATURING PRE-PACKAGED DATA STRUCTURES FOR USE IN DATABASE MANAGEMENT; COMPUTER SOFTWARE FOR USE IN DATABASE MANAGEMENT (U.S. CLS. 21, 23, 26, 36 AND 38).

FIRST USE 2-22-2009; IN COMMERCE 2-22-2009.  
TIMOTHY O. SCHIMPF, EXAMINING ATTORNEY

SN 86-237,534. SENSIBLE BABY, SOMERVILLE, MA. FILED 3-31-2014.

**Sensible Baby**

THE MARK CONSISTS OF STANDARD CHARACTERS WITHOUT CLAIM TO ANY PARTICULAR FONT, STYLE, SIZE, OR COLOR.

NO CLAIM IS MADE TO THE EXCLUSIVE RIGHT TO USE "BABY", APART FROM THE MARK AS SHOWN.

FOR BABY MONITORS (U.S. CLS. 21, 23, 26, 36 AND 38).

DAVID GEARHART, EXAMINING ATTORNEY

**CLASS 9—(Continued).**

SN 86-237,579. ABLESYS CORPORATION, HAYWARD, CA. FILED 3-31-2014.



THE MARK CONSISTS OF THE STYLIZED WORD "ABLESYS" TO THE RIGHT OF A CIRCLE WITH A STYLIZED LETTER "A".

FOR COMPUTER SOFTWARE FOR TRADING STOCKS, FUTURES AND FOREIGN CURRENCY (U.S. CLS. 21, 23, 26, 36 AND 38).

FIRST USE 6-1-2007, THE MARK WAS FIRST USED ANYWHERE IN A DIFFERENT FORM OTHER THAN THAT SOUGHT TO BE REGISTERED AT LEAST AS EARLY AS 00/00/1995.; IN COMMERCE 6-1-2007, THE MARK WAS FIRST USED IN COMMERCE IN A DIFFERENT FORM OTHER THAN THAT SOUGHT TO BE REGISTERED AT LEAST AS EARLY AS 00/00/1995..

JOANNA DUKOVIC, EXAMINING ATTORNEY

SN 86-237,609. VAGAL THOUGHTS, MADISON HEIGHTS, MI. FILED 3-31-2014.

**BOKA'S NOTES**

NO CLAIM IS MADE TO THE EXCLUSIVE RIGHT TO USE "NOTES", APART FROM THE MARK AS SHOWN.

THE MARK CONSISTS OF "BOKA'S NOTES" IN STYLIZED FONT.

FOR COMPUTER APPLICATION SOFTWARE FOR MOBILE PHONES, PORTABLE MEDIA PLAYERS, HANDHELD COMPUTERS, AND TABLET COMPUTERS, NAMELY, SOFTWARE FOR MEDICAL EDUCATION (U.S. CLS. 21, 23, 26, 36 AND 38).

FIRST USE 4-1-2010; IN COMMERCE 7-1-2012.

VIVIAN MICZNIK FIRST, EXAMINING ATTORNEY



**CLASS 9—(Continued).**

SN 86-237,658. CARL SALMON, BROOKLYN, NY. FILED 3-31-2014.

**CASSU**

THE MARK CONSISTS OF STANDARD CHARACTERS WITHOUT CLAIM TO ANY PARTICULAR FONT, STYLE, SIZE, OR COLOR.

FOR ELECTRIC CIRCUIT SWITCHES; ELECTRIC CURRENT SWITCHES; ELECTRIC LIGHT DIMMERS; ELECTRIC LIGHT SWITCHES; ELECTRIC OUTLET COVERS; ELECTRIC PLUGS; ELECTRIC SOCKETS; ELECTRIC SWITCHES; ELECTRICAL OUTLET PLATES; ELECTRICAL OUTLET TESTER; ELECTRICAL OUTLETS; ELECTRICAL PLUG DEVICE ENABLING CONNECTION AND DISCONNECTION OF POWER AND/OR CONTROL CABLES; ELECTRICAL PLUGS; ELECTRICAL PLUGS AND SOCKETS; ELECTRICAL RECEPTACLES; ELECTRICAL SOCKETS; ELECTRICAL SWITCHES; ELECTRONIC COMPONENTS IN THE NATURE OF CONNECTORS, SWITCHES, CIRCUITS, TRANSFORMERS; MULTI-OUTLET SOCKET BLOCKS; POWER SWITCHES; SWITCH BOXES (U.S. CLS. 21, 23, 26, 36 AND 38).

DAVID BROOKSHIRE, EXAMINING ATTORNEY

SN 86-237,808. ELEMNO INC., PORTLAND, OR. FILED 3-31-2014.

**CIRCLE**

THE MARK CONSISTS OF STANDARD CHARACTERS WITHOUT CLAIM TO ANY PARTICULAR FONT, STYLE, SIZE, OR COLOR.

FOR COMPUTER SOFTWARE FOR MANAGING ACCESS AND USE OF ONLINE CONTENT; ELECTRONIC DEVICES FOR INTERFACING WITH A ROUTER TO MANAGE ACCESS AND USE OF INTERNET AND WIRELESS CONTENT ACCESSIBLE FROM THE ROUTER; COMPUTER SOFTWARE FOR USE IN MONITORING AND RESTRICTING INTERNET AND COMPUTER ACTIVITY ACROSS GLOBAL AND PRIVATE COMPUTER NETWORKS, WIRELESS NETWORKS, AND ELECTRONIC COMMUNICATIONS NETWORKS; PARENTAL CONTROL SOFTWARE FOR USE IN MONITORING AND RESTRICTING INTERNET AND COMPUTER ACTIVITY ACROSS GLOBAL AND PRIVATE COMPUTER NETWORKS, WIRELESS NETWORKS, AND ELECTRONIC COMMUNICATIONS NETWORKS; ELECTRONIC DEVICES AND COMPUTER HARDWARE FOR USE IN MONITORING AND RESTRICTING INTERNET AND COMPUTER ACTIVITY ACROSS GLOBAL AND PRIVATE COMPUTER NETWORKS, WIRELESS NETWORKS, AND ELECTRONIC COMMUNICATIONS NETWORKS; COMPUTER SOFTWARE THAT PROVIDES AN INTERNET CONTENT FILTER OR OTHER INTERNET SAFETY FEATURE TO PERSONAL COMPUTING, MOBILE COMMUNICATION, AND INFORMATION DEVICES; ELECTRONIC DEVICES AND COMPUTER HARDWARE THAT PROVIDES AN INTERNET CONTENT FILTER OR OTHER INTERNET SAFETY FEATURE TO PERSONAL COMPUTING, MOBILE COMMUNICATION, AND INFORMATION DEVICES (U.S. CLS. 21, 23, 26, 36 AND 38).

DAVID MURRAY, EXAMINING ATTORNEY

**CLASS 9—(Continued).**

SN 86-237,858. BARTOL, JR, ROBERT J., BOISE, ID. FILED 3-31-2014.

**BARTOL MAG-PROBE**

THE MARK CONSISTS OF STANDARD CHARACTERS WITHOUT CLAIM TO ANY PARTICULAR FONT, STYLE, SIZE, OR COLOR.

OWNER OF U.S. REG. NO. 2,110,663.

FOR PROBES FOR SENSING FIELD CHARACTERISTICS, NAMELY, MAGNETIC FIELDS GENERATED BY PERMANENT MAGNETIC ELECTROMAGNETIC OR RANDOM MAGNETIC FIELDS, AND MAGNETIC POLARITY OF NORTH AND SOUTH POLES (U.S. CLS. 21, 23, 26, 36 AND 38).

FIRST USE 11-1-2013; IN COMMERCE 11-1-2013.

ESTHER QUEEN, EXAMINING ATTORNEY

SN 86-238,717. NETWORK OPTIX, BURBANK, CA. FILED 4-1-2014.

**HD Swarm**

THE MARK CONSISTS OF STANDARD CHARACTERS WITHOUT CLAIM TO ANY PARTICULAR FONT, STYLE, SIZE, OR COLOR.

NO CLAIM IS MADE TO THE EXCLUSIVE RIGHT TO USE "HD", APART FROM THE MARK AS SHOWN.

FOR DOWNLOADABLE CLOUD COMPUTER ENTERPRISE-SCALE SOFTWARE FOR MANAGEMENT OF VIDEOS (U.S. CLS. 21, 23, 26, 36 AND 38).

TEJBIR SINGH, EXAMINING ATTORNEY

SN 86-238,742. NETWORK OPTIX, BURBANK, CA. FILED 4-1-2014.

**Cloud Swarm**

THE MARK CONSISTS OF STANDARD CHARACTERS WITHOUT CLAIM TO ANY PARTICULAR FONT, STYLE, SIZE, OR COLOR.

NO CLAIM IS MADE TO THE EXCLUSIVE RIGHT TO USE "CLOUD", APART FROM THE MARK AS SHOWN.

FOR DOWNLOADABLE CLOUD COMPUTER ENTERPRISE-SCALE SOFTWARE FOR MANAGEMENT OF VIDEOS (U.S. CLS. 21, 23, 26, 36 AND 38).

TEJBIR SINGH, EXAMINING ATTORNEY

**CLASS 9—(Continued).**

SN 86-238,816. POWER MAGNETICS, INC., TRENTON, NJ. FILED 4-1-2014.



THE MARK CONSISTS OF A CIRCULAR DESIGN WITH THREE VERTICAL SHADOWED RECTANGLES IN FRONT OF, AND PROTRUDING BELOW, THE CIRCLE, WITH THE TWO RECTANGLES TO THE RIGHT HAVING ROUNDED EDGES, AND A HORIZONTAL SHADOWED LINE ACROSS THIS ENTIRE DESIGN.

FOR ELECTRICAL TRANSFORMERS, AND AC REACTORS AND DC INDUCTORS (U.S. CLS. 21, 23, 26, 36 AND 38).

FIRST USE 0-0-2011; IN COMMERCE 0-0-2011.  
NICHOLAS COLEMAN, EXAMINING ATTORNEY

**CLASS 9—(Continued).**

SN 86-240,733. HUANG ZHIFANG, SURREY, CANADA, FILED 4-2-2014.

**JBtek**

THE MARK CONSISTS OF STANDARD CHARACTERS WITHOUT CLAIM TO ANY PARTICULAR FONT, STYLE, SIZE, OR COLOR.

FOR BATTERIES AND BATTERY CHARGERS; BATTERY CHARGERS; CABLE CONNECTORS; CABLE JUMP LEADS; CAMERAS SHUTTERS; CELL PHONE BATTERY CHARGERS; CELL PHONE BATTERY CHARGERS FOR USE IN VEHICLES; CHARGERS FOR BATTERIES; CHARGERS FOR ELECTRIC BATTERIES; EARPHONES; EARPHONES AND HEADPHONES; FM MODULATORS (U.S. CLS. 21, 23, 26, 36 AND 38).  
GEOFFREY FOSDICK, EXAMINING ATTORNEY

SN 86-240,880. KELLER PROVOST MEDIA LLC, NEW YORK, NY. FILED 4-3-2014.

**BellyGuard**

THE MARK CONSISTS OF STANDARD CHARACTERS WITHOUT CLAIM TO ANY PARTICULAR FONT, STYLE, SIZE, OR COLOR.

FOR VIDEO RECORDINGS FEATURING PRENATAL EXERCISE (U.S. CLS. 21, 23, 26, 36 AND 38).  
FIRST USE 5-9-2013; IN COMMERCE 5-9-2013.  
EMILY CHUO, EXAMINING ATTORNEY

SN 86-239,999. INVIS-A-BEAM, LLC, NAPLES, FL. FILED 4-2-2014.

**GET IT STRAIGHT!**

THE MARK CONSISTS OF STANDARD CHARACTERS WITHOUT CLAIM TO ANY PARTICULAR FONT, STYLE, SIZE, OR COLOR.

FOR INFRARED LIGHT BEAM EMITTING DEVICE FOR ALIGNING OBJECTS (U.S. CLS. 21, 23, 26, 36 AND 38).

MIROSLAV NOVAKOVIC, EXAMINING ATTORNEY

SN 86-241,105. SHARP KABUSHIKI KAISHA, TA SHARP CORPORATION, OSAKA, JAPAN, FILED 4-3-2014.

**AQUOS**

THE MARK CONSISTS OF STANDARD CHARACTERS WITHOUT CLAIM TO ANY PARTICULAR FONT, STYLE, SIZE, OR COLOR.

OWNER OF U.S. REG. NOS. 2,830,322, 4,203,965 AND 4,355,782.

FOR CELL PHONES, SMART PHONES; TABLET COMPUTERS (U.S. CLS. 21, 23, 26, 36 AND 38).

MIROSLAV NOVAKOVIC, EXAMINING ATTORNEY

**CLASS 9—(Continued).**

SN 86-241,565. IOTTIE, INC., HACKENSACK, NJ. FILED 4-3-2014.

# Rapid VOLT

THE MARK CONSISTS OF STANDARD CHARACTERS WITHOUT CLAIM TO ANY PARTICULAR FONT, STYLE, SIZE, OR COLOR.

NO CLAIM IS MADE TO THE EXCLUSIVE RIGHT TO USE "VOLT", APART FROM THE MARK AS SHOWN.

FOR BATTERIES AND BATTERY CHARGERS; BATTERY CHARGERS; BATTERY CHARGERS FOR USE WITH TELEPHONES; CARRYING CASES, HOLDERS, PROTECTIVE CASES AND STANDS FEATURING POWER SUPPLY CONNECTORS, ADAPTORS, SPEAKERS AND BATTERY CHARGING DEVICES, SPECIALLY ADAPTED FOR USE WITH HANDHELD DIGITAL ELECTRONIC DEVICES, NAMELY, CELL PHONES, LAPTOPS, TABLETS, AND OTHER PORTABLE MEDIA PLAYERS; CELL PHONE BATTERY CHARGERS; CELL PHONE BATTERY CHARGERS FOR USE IN VEHICLES; CHARGERS FOR BATTERIES; CHARGERS FOR ELECTRIC BATTERIES; CHARGING APPLIANCES FOR RECHARGEABLE EQUIPMENT (U.S. CLS. 21, 23, 26, 36 AND 38).

FIRST USE 4-1-2014; IN COMMERCE 4-1-2014.  
RAUL CORDOVA, EXAMINING ATTORNEY

SN 86-242,159. SPANGLER, JONATHAN D., DEL MAR, CA. FILED 4-4-2014.

# Anchor Eye

THE MARK CONSISTS OF STANDARD CHARACTERS WITHOUT CLAIM TO ANY PARTICULAR FONT, STYLE, SIZE, OR COLOR.

FOR REMOTE VIDEO MONITORING SYSTEM CONSISTING PRIMARILY OF A CAMERA AND VIDEO MONITOR FOR RECORDING AND TRANSMITTING IMAGES TO A REMOTE LOCATION; UNDERWATER CAMERAS; VIDEO CAMERAS; VIDEO MONITORS; VIDEO RECEIVERS; VIDEO TRANSMISSION APPARATUS; WIRELESS COMMUNICATION DEVICES FOR TRANSMITTING IMAGES TAKEN BY A CAMERA (U.S. CLS. 21, 23, 26, 36 AND 38).

BARBARA BROWN, EXAMINING ATTORNEY

**CLASS 9—(Continued).**

SN 86-242,256. SONNLEITNER, PHILIPP, GLEISDORF, AUSTRIA, FILED 4-4-2014.

# MIKME

THE MARK CONSISTS OF STANDARD CHARACTERS WITHOUT CLAIM TO ANY PARTICULAR FONT, STYLE, SIZE, OR COLOR.

FOR MICROPHONES; AUDIO CABLES; AUDIO AMPLIFIERS; AUDIO HEADPHONES; AUDIO RECORDERS; AUDIO SPEAKERS; ELECTRIC AUDIO PLAYBACK UNITS; DIGITAL AUDIO PLAYERS; COMPUTER HARDWARE AND SOFTWARE FOR RECORDING, PLAYING, EDITING AND MANIPULATING AUDIO AND MUSIC; COMPUTER APPLICATION SOFTWARE FOR MOBILE PHONES AND TABLETS, NAMELY, SOFTWARE FOR RECORDING, PLAYING, EDITING AND MANIPULATING AUDIO AND MUSIC (U.S. CLS. 21, 23, 26, 36 AND 38).

JAY FLOWERS, EXAMINING ATTORNEY

SN 86-242,315. VU, HAI T., SAN JOSE, CA. FILED 4-4-2014.

# OPENWEARABLES

THE MARK CONSISTS OF STANDARD CHARACTERS WITHOUT CLAIM TO ANY PARTICULAR FONT, STYLE, SIZE, OR COLOR.

FOR COMPUTER SOFTWARE PLATFORMS FOR DEVELOPING APPLICATIONS FOR WEARABLE DEVICES (U.S. CLS. 21, 23, 26, 36 AND 38).

CHRIS WELLS, EXAMINING ATTORNEY

SN 86-242,749. BONNIER ACTIVE MEDIA, INC., WINTER PARK, FL. FILED 4-4-2014.

# DIRT RIDER

THE MARK CONSISTS OF STANDARD CHARACTERS WITHOUT CLAIM TO ANY PARTICULAR FONT, STYLE, SIZE, OR COLOR.

OWNER OF U.S. REG. NO. 2,688,174.  
FOR GAME SOFTWARE, VIDEO GAME SOFTWARE, ELECTRONIC GAME PROGRAMS, DOWNLOADABLE ELECTRONIC GAME PROGRAMS, COMPUTER GAME SOFTWARE FOR USE ON MOBILE AND CELLULAR PHONES (U.S. CLS. 21, 23, 26, 36 AND 38).

FIRST USE 4-1-2014; IN COMMERCE 4-1-2014.

JESSICA FATHY, EXAMINING ATTORNEY

**CLASS 9—(Continued).**

SN 86-244,188. LAURAN MARIE GUIJARRO, MIAMI, FL. FILED 4-7-2014.

# CartLess

THE MARK CONSISTS OF STANDARD CHARACTERS WITHOUT CLAIM TO ANY PARTICULAR FONT, STYLE, SIZE, OR COLOR.

FOR COMPUTER SOFTWARE FOR CREATING SEARCHABLE DATABASES OF INFORMATION AND DATA; COMPUTER SOFTWARE FOR THE COLLECTION, EDITING, ORGANIZING, MODIFYING, BOOK MARKING, TRANSMISSION, STORAGE AND SHARING OF DATA AND INFORMATION; COMPUTER SOFTWARE PLATFORMS FOR PURCHASING IN STORE PRODUCT FOR PICK UP/DELIVERY (U.S. CLS. 21, 23, 26, 36 AND 38).

JASON MALASHEVICH, EXAMINING ATTORNEY

SN 86-244,214. URTSO, MICHAEL, PLANO, TX. AND URTSO, JORDAN, PLANO, TX. FILED 4-7-2014.

# SHAMELESS

THE MARK CONSISTS OF STANDARD CHARACTERS WITHOUT CLAIM TO ANY PARTICULAR FONT, STYLE, SIZE, OR COLOR.

FOR COMPUTER SOFTWARE FOR UPLOADING, DOWNLOADING, ACCESSING, POSTING, DISPLAYING, TAGGING, BLOGGING, STREAMING, LINKING, SHARING OR OTHERWISE PROVIDING ELECTRONIC MEDIA OR INFORMATION VIA COMPUTER AND COMMUNICATION NETWORKS; COMPUTER SOFTWARE FOR ENABLING OR FACILITATING THE UPLOADING, DOWNLOADING, STREAMING, POSTING, DISPLAYING, BLOGGING, LINKING, TRANSMITTING, AND SHARING OF TEXT AND PHOTOGRAPHIC IMAGES; COMPUTER SOFTWARE FOR CREATING ONLINE VIRTUAL COMMUNITIES FOR REGISTERED USERS TO PUBLISH AND SHARE QUOTES AND PHOTOGRAPHIC IMAGES; COMPUTER SOFTWARE FOR ENABLING USERS TO SHARE PERSONAL IDENTITY DATA WITH AND AMONG MULTIPLE SITES, CREATE PERSONAL PROFILES FEATURING SOCIAL NETWORKING INFORMATION AND TRANSFER AND SHARE SUCH INFORMATION AMONG MULTIPLE WEBSITES; COMPUTER SOFTWARE FOR ENABLING, FACILITATING, OR ENHANCING SOCIAL NETWORKING BY SHARING TEXT, IMAGES, AUDIO AND VIDEO CONTENT (U.S. CLS. 21, 23, 26, 36 AND 38).

JUSTINE D. PARKER, EXAMINING ATTORNEY

**CLASS 9—(Continued).**

SN 86-244,226. SOUTHWIRE COMPANY, LLC, CARROLLTON, GA. FILED 4-7-2014.

# American MUSTANG



OWNER OF U.S. REG. NOS. 3,668,152, 3,854,192 AND OTHERS.

THE MARK CONSISTS OF THE TERMS AMERICAN MUSTANG AND THE DESIGN OF A HORSE HEAD.

FOR PORTABLE POWER CABLES AND ELECTRICAL CORDS (U.S. CLS. 21, 23, 26, 36 AND 38).

FIRST USE 8-13-2012; IN COMMERCE 8-13-2012.

ESTHER QUEEN, EXAMINING ATTORNEY

SN 86-244,335. AJA VIDEO SYSTEMS, INC., GRASS VALLEY, CA. FILED 4-7-2014.

# CION

THE MARK CONSISTS OF STANDARD CHARACTERS WITHOUT CLAIM TO ANY PARTICULAR FONT, STYLE, SIZE, OR COLOR.

FOR DIGITAL VIDEO CAMERAS FOR USE BY VIDEO PROFESSIONALS TO PRODUCE VIDEO, TELEVISION OR FILM (U.S. CLS. 21, 23, 26, 36 AND 38).

ANNIE NOBLE, EXAMINING ATTORNEY

SN 86-244,499. GLASSES.COM, MASON, OH. FILED 4-7-2014.

# OLIVIA & ROWE

THE MARK CONSISTS OF STANDARD CHARACTERS WITHOUT CLAIM TO ANY PARTICULAR FONT, STYLE, SIZE, OR COLOR.

FOR EYEWEAR, NAMELY EYEGASSES AND SUNGLASSES (U.S. CLS. 21, 23, 26, 36 AND 38).

BRIAN NEVILLE, EXAMINING ATTORNEY

**CLASS 9—(Continued).**

SN 86-245,286. URBAN, DAN, POINT PLEASANT BEACH, NJ. FILED 4-8-2014.

**SURVEYSHOT**

THE MARK CONSISTS OF STANDARD CHARACTERS WITHOUT CLAIM TO ANY PARTICULAR FONT, STYLE, SIZE, OR COLOR.

FOR DOWNLOADABLE SOFTWARE, NAMELY, A MOBILE APPLICATION FEATURING GPS LOCATION DATA (U.S. CLS. 21, 23, 26, 36 AND 38).

HOWARD SMIGA, EXAMINING ATTORNEY

SN 86-245,441. XPLORE TECHNOLOGIES CORPORATION OF AMERICA, AUSTIN, TX. FILED 4-8-2014.

**XC6**

THE MARK CONSISTS OF STANDARD CHARACTERS WITHOUT CLAIM TO ANY PARTICULAR FONT, STYLE, SIZE, OR COLOR.

FOR COMPUTERS (U.S. CLS. 21, 23, 26, 36 AND 38).

CURTIS FRENCH, EXAMINING ATTORNEY

SN 86-245,462. MACKTRACK MEDIA LLC, HIALEAH, FL. FILED 4-8-2014.

**Macktrack**

THE MARK CONSISTS OF STANDARD CHARACTERS WITHOUT CLAIM TO ANY PARTICULAR FONT, STYLE, SIZE, OR COLOR.

FOR DOWNLOADABLE COMPUTER SOFTWARE FOR MODIFYING THE APPEARANCE AND ENABLING TRANSMISSION OF PHOTOGRAPHS AND VIDEO; COMPUTER SOFTWARE FOR THE COLLECTION, EDITING, ORGANIZING, MODIFYING, TRANSMISSION, STORAGE AND SHARING OF DATA AND INFORMATION; COMPUTER SOFTWARE FOR USE AS AN APPLICATION PROGRAMMING INTERFACE (API); COMPUTER SOFTWARE IN THE NATURE OF AN APPLICATION PROGRAMMING INTERFACE (API) FOR COMPUTER SOFTWARE WHICH FACILITATES ONLINE SERVICES FOR SOCIAL NETWORKING, BUILDING SOCIAL NETWORKING APPLICATIONS AND FOR ALLOWING DATA RETRIEVAL, UPLOAD, DOWNLOAD, ACCESS AND MANAGEMENT; COMPUTER SOFTWARE TO ENABLE UPLOADING, DOWNLOADING, MESSAGING, ACCESSING, POSTING, DISPLAYING, TAGGING, BLOGGING, STREAMING, LINKING, SHARING OR OTHERWISE PROVIDING ELECTRONIC MEDIA OR INFORMATION VIA COMPUTER AND COMMUNICATION NETWORKS (U.S. CLS. 21, 23, 26, 36 AND 38).

FIRST USE 3-1-2014; IN COMMERCE 3-15-2014.

PRISCILLA MILTON, EXAMINING ATTORNEY

**CLASS 9—(Continued).**

SN 86-245,496. ANGEL ARMOR, LLC, FORT COLLINS, CO. FILED 4-8-2014.



THE MARK CONSISTS OF A TRIANGLE WITH ANGULAR SIDEBARS.

FOR BULLET-PROOF VESTS, CLOTHING AND PROTECTIVE HELMETS (U.S. CLS. 21, 23, 26, 36 AND 38).

JOANNA DUKOVIC, EXAMINING ATTORNEY

SN 86-245,590. ATRENTA, INC., SAN JOSE, CA. FILED 4-8-2014.

**BUGSCOPE**

THE MARK CONSISTS OF STANDARD CHARACTERS WITHOUT CLAIM TO ANY PARTICULAR FONT, STYLE, SIZE, OR COLOR.

FOR COMPUTER SOFTWARE TO IMPROVE SEMICONDUCTOR DESIGN (U.S. CLS. 21, 23, 26, 36 AND 38).

FIRST USE 5-5-2010; IN COMMERCE 9-30-2010.

WILLIAM JACKSON, EXAMINING ATTORNEY

SN 86-245,688. VIASAT, INC., CARLSBAD, CA. FILED 4-8-2014.

**EXEDE**

THE MARK CONSISTS OF STANDARD CHARACTERS WITHOUT CLAIM TO ANY PARTICULAR FONT, STYLE, SIZE, OR COLOR.

OWNER OF U.S. REG. NO. 4,194,330.

FOR SATELLITE REFLECTORS; ANALOG TELEPHONE ADAPTERS (U.S. CLS. 21, 23, 26, 36 AND 38).

FIRST USE 9-1-2012; IN COMMERCE 9-1-2012.

CAROLINE WOOD, EXAMINING ATTORNEY

**CLASS 9—(Continued).**

SN 86-245,711. ELEMENT CASE, INC., SAN CARLOS, CA. FILED 4-8-2014.

# RECON

THE MARK CONSISTS OF STANDARD CHARACTERS WITHOUT CLAIM TO ANY PARTICULAR FONT, STYLE, SIZE, OR COLOR.

FOR CARRYING CASES, HOLDERS, PROTECTIVE CASES, COVERS AND STANDS SPECIALLY ADAPTED FOR MOBILE PHONES, TABLET COMPUTERS, LAPTOP COMPUTERS AND PORTABLE MEDIA PLAYERS (U.S. CLS. 21, 23, 26, 36 AND 38).

FIRST USE 4-25-2014; IN COMMERCE 4-25-2014.  
JILLIAN CANTOR, EXAMINING ATTORNEY

---

SN 86-245,877. WISETHINK CONSULTING, MABLETON, GA. FILED 4-8-2014.



THE MARK CONSISTS OF A STYLIZED WORD "WISECONNECT" WITH A PARTIAL SPHERE TO THE LEFT OF THE WORD, ALONG WITH THE PHRASE "THE POWER OF HEALTH" UNDERNEATH THE WORD "WISECONNECT".

FOR DOWNLOADABLE MOBILE APPLICATION FOR NUTRITION, EXERCISE, HEALTH, AND WELLNESS MANAGEMENT (U.S. CLS. 21, 23, 26, 36 AND 38).

KRISTIN CARLSON, EXAMINING ATTORNEY

**CLASS 9—(Continued).**

SN 86-246,101. BAYLOR SCOTT & WHITE HOLDINGS, DALLAS, TX. FILED 4-8-2014.

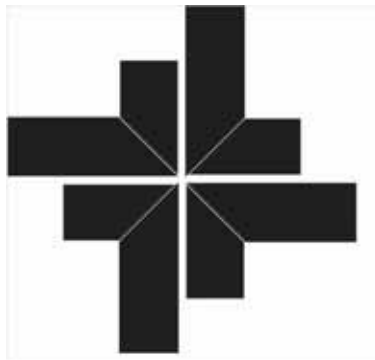

THE MARK CONSISTS OF AN ABSTRACT DIAMOND DESIGN COMPRISED OF FOUR "L" SHAPED POLYGONS. EACH OF THE FOUR "L" SHAPED POLYGONS ARE COMPRISED OF ONE LONG SOLID QUADRILATERAL AND ONE SHORT SOLID QUADRILATERAL.

FOR COMPUTER APPLICATION SOFTWARE, NAMELY, SOFTWARE FOR TABLET COMPUTERS, SMARTPHONES, CELL PHONES AND OTHER MOBILE DEVICES FOR SENDING, RECEIVING AND ACCESSING HEALTH CARE INFORMATION IN THE FIELDS OF MEDICINE, HEALTHCARE, AND WELLNESS; DOWNLOADABLE AUDIO AND VISUAL RECORDINGS FEATURING INFORMATION IN THE FIELDS OF MEDICINE, HEALTHCARE, AND WELLNESS; DOWNLOADABLE EDUCATIONAL COMPUTER SOFTWARE FEATURING INSTRUCTION AND PRE-RECORDED TUTORIALS IN THE FIELDS OF MEDICINE AND HEALTHCARE; COMPUTER APPLICATION SOFTWARE, NAMELY, SOFTWARE FOR TABLET COMPUTERS, SMARTPHONES, CELL PHONES, AND OTHER MOBILE ELECTRONIC DEVICES FOR SCHEDULING AND TRACKING MEDICAL APPOINTMENTS, VIEWING MEDICAL TEST RESULTS, ACCESSING PATIENT MEDICAL RECORDS, AND SENDING AND RECEIVING MESSAGES BETWEEN PATIENTS AND THEIR HEALTH CARE PROVIDERS (U.S. CLS. 21, 23, 26, 36 AND 38).

SARA KUNKLEMAN, EXAMINING ATTORNEY

---

SN 86-246,181. THE UNIVERSITY OF CHICAGO, CHICAGO, IL. FILED 4-8-2014.

# LAPPD

THE MARK CONSISTS OF STANDARD CHARACTERS WITHOUT CLAIM TO ANY PARTICULAR FONT, STYLE, SIZE, OR COLOR.

FOR PHOTODETECTOR; SCIENTIFIC APPARATUS AND INSTRUMENTS FOR MEASURING THE TIME OF ARRIVAL AND POSITION OF PHOTONS; SCIENTIFIC APPARATUS AND INSTRUMENTS FOR MEASURING THE TIME OF ARRIVAL AND POSITION OF RELATIVISTIC PARTICLES (U.S. CLS. 21, 23, 26, 36 AND 38).

DAVID HOFFMAN, EXAMINING ATTORNEY

**CLASS 9—(Continued).**

SN 86-246,348. NICOLALDE R&D LLC, LEXINGTON, KY.  
FILED 4-8-2014.

**MRENDERING**

THE MARK CONSISTS OF STANDARD CHARACTERS WITHOUT CLAIM TO ANY PARTICULAR FONT, STYLE, SIZE, OR COLOR.

FOR DOWNLOADABLE SOFTWARE FOR DIGITAL DELIVERY, DISPLAY, AND TRACKING USE OF DOCUMENTS, MANUALS, BOOKS, GUIDES, AND PUBLICATIONS (U.S. CLS. 21, 23, 26, 36 AND 38).

FIRST USE 4-3-2014; IN COMMERCE 4-3-2014.  
SIDDHARTH JAGANNATHAN, EXAMINING ATTORNEY

SN 86-246,353. LAWRENCE FINE, HASTINGS-ON-HUDSON, NY. FILED 4-8-2014.

**MURDERING LAWYERS**

THE MARK CONSISTS OF STANDARD CHARACTERS WITHOUT CLAIM TO ANY PARTICULAR FONT, STYLE, SIZE, OR COLOR.

FOR COMPUTER GAME SOFTWARE; COMPUTER GAME SOFTWARE FOR USE ON MOBILE AND CELLULAR PHONES; DOWNLOADABLE COMPUTER GAME SOFTWARE VIA A GLOBAL COMPUTER NETWORK AND WIRELESS DEVICES (U.S. CLS. 21, 23, 26, 36 AND 38).

ALYSSA STEEL, EXAMINING ATTORNEY

SN 86-246,412. ACOUSYS BIODEVICES INC, PITTSBURGH, PA. FILED 4-8-2014.

**ACOUSYS**

THE MARK CONSISTS OF STANDARD CHARACTERS WITHOUT CLAIM TO ANY PARTICULAR FONT, STYLE, SIZE, OR COLOR.

FOR LABORATORY INSTRUMENTS, DEVICES, EQUIPMENT AND SOFTWARE FOR THE DETECTION, ENUMERATION, ANALYSIS, CHARACTERIZATION AND CAPTURE OF CIRCULATING TUMOR CELLS AND PATHOGENS, NAMELY, BACTERIA, FUNGI, PARASITES AND VIRUSES, FOR SCIENTIFIC, LABORATORY AND GENERAL RESEARCH USES; LABORATORY INSTRUMENTS, DEVICES AND EQUIPMENT FOR USE IN THE ENVIRONMENTAL MONITORING OF SEAWATER AND FRESH WATER FOR BIOLOGICAL AND PATHOGENIC ORGANISMS (U.S. CLS. 21, 23, 26, 36 AND 38).

DOUGLAS LEE, EXAMINING ATTORNEY

**CLASS 9—(Continued).**

SN 86-246,420. SMOTROFF, MARK, SAN FRANCISCO, CA.  
FILED 4-8-2014.

**GROOVE RUNNER**

THE MARK CONSISTS OF STANDARD CHARACTERS WITHOUT CLAIM TO ANY PARTICULAR FONT, STYLE, SIZE, OR COLOR.

FOR COMPUTER GAME PROGRAMMES DOWNLOADABLE VIA THE INTERNET; DOWNLOADABLE ELECTRONIC GAME SOFTWARE FOR USE ON MOBILE AND HANDHELD DEVICES; ELECTRONIC GAME SOFTWARE FOR HANDHELD ELECTRONIC DEVICES; GAME SOFTWARE; VIDEO GAME DISCS; VIDEO GAME SOFTWARE (U.S. CLS. 21, 23, 26, 36 AND 38).

DOUGLAS LEE, EXAMINING ATTORNEY

SN 86-246,422. MEDIWARE INFORMATION SYSTEMS, INC., LENEXA, KS. FILED 4-8-2014.

**CARETEND**

THE MARK CONSISTS OF STANDARD CHARACTERS WITHOUT CLAIM TO ANY PARTICULAR FONT, STYLE, SIZE, OR COLOR.

FOR SOFTWARE FOR USE IN PROCESSING TRANSACTIONS AND CREATING AND MAINTAINING RECORDS AND INFORMATION WITHIN THE HOME HEALTH, HOME MEDICAL EQUIPMENT AND HOME INFUSION INDUSTRIES (U.S. CLS. 21, 23, 26, 36 AND 38).

DOUGLAS LEE, EXAMINING ATTORNEY

SN 86-246,445. BAKER & DABOLL, LLC, CINCINNATI, OH.  
FILED 4-8-2014.

**DAUGHTERS IN CHARGE**

THE MARK CONSISTS OF STANDARD CHARACTERS WITHOUT CLAIM TO ANY PARTICULAR FONT, STYLE, SIZE, OR COLOR.

FOR DOWNLOADABLE ELECTRONIC BOOKS IN THE FIELD OF FAMILY BUSINESSES (U.S. CLS. 21, 23, 26, 36 AND 38).

FIRST USE 11-0-2013; IN COMMERCE 11-0-2013.  
SUNG IN, EXAMINING ATTORNEY

**CLASS 9—(Continued).**

SN 86-246,477. OSBASE LLC, DBA OSBASE, BELLEVUE, WA.  
FILED 4-8-2014.

# mDisplay

THE MARK CONSISTS OF STANDARD CHARACTERS WITHOUT CLAIM TO ANY PARTICULAR FONT, STYLE, SIZE, OR COLOR.

FOR COMPUTER SOFTWARE FOR THE MANAGEMENT, MONITORING, CONTROL AND DISTRIBUTION OF VARIOUS SIGNALS TO AND AMONG VARIOUS COMPUTER PERIPHERALS (U.S. CLS. 21, 23, 26, 36 AND 38).

FIRST USE 6-4-2013; IN COMMERCE 6-4-2013.  
TINA L. SNAPP, EXAMINING ATTORNEY

**CLASS 9—(Continued).**

SN 86-246,547. HONGKONG RUI XIANG COMMUNICATION TECHNOLOGY CO., LIMITED, WAN KLN, HONG KONG, FILED 4-9-2014.

# JIAXIUFEN

THE MARK CONSISTS OF STANDARD CHARACTERS WITHOUT CLAIM TO ANY PARTICULAR FONT, STYLE, SIZE, OR COLOR.

THE WORDING "JIAXIUFEN" HAS NO MEANING IN A FOREIGN LANGUAGE.

FOR BAGS ADAPTED FOR LAPTOPS; BATTERY CHARGERS; BLANK USB FLASH DRIVES; CASES ADAPTED FOR COMPUTERS; CASES ADAPTED FOR MOBILE PHONES; CASES FOR MOBILE PHONES; CASES FOR PHOTOGRAPHIC APPARATUS; CASES FOR TELEPHONES; COMPACT DISC CASES; COMPUTER CARRYING CASES; COMPUTER MOUSE; ELECTRONIC DEVICES FOR READING, ENCODING AND PROGRAMMING TRANSPONDER KEYS; ELECTRONIC PENS; LAPTOP CARRYING CASES; LAPTOP COMPUTERS; MOBILE TELEPHONE ACCESSORIES, NAMELY, BELT CLIPS; PROTECTIVE COVERS FOR ELECTRONIC READING DEVICES (U.S. CLS. 21, 23, 26, 36 AND 38).

FIRST USE 7-23-2013; IN COMMERCE 8-8-2013.  
AMY HELLA, EXAMINING ATTORNEY

SN 86-246,532. STRAT HOLDINGS LLC, WOODBURY, MN.  
FILED 4-9-2014.

# ConfiPad

THE MARK CONSISTS OF STANDARD CHARACTERS WITHOUT CLAIM TO ANY PARTICULAR FONT, STYLE, SIZE, OR COLOR.

FOR ALARM THAT UTILIZES PRESSURE SENSITIVE PADS TO MONITOR PATIENTS OR RESIDENT MOVEMENT; ELECTRICAL SENSOR APPARATUS FOR SENSING THE PRESENCE OR ABSENCE OF INDIVIDUALS OR OBJECTS BY CONTACT OR PRESSURE (U.S. CLS. 21, 23, 26, 36 AND 38).

LINDA MICKLEBURGH, EXAMINING ATTORNEY

SN 86-246,552. SHENZHEN HUANI ELECTRONICS CO., LTD., SHENZHEN, GUANGDONG, CHINA, FILED 4-9-2014.

# koo-power

THE MARK CONSISTS OF STANDARD CHARACTERS WITHOUT CLAIM TO ANY PARTICULAR FONT, STYLE, SIZE, OR COLOR.

FOR GALVANIC BATTERIES; SOLAR BATTERIES; BATTERIES FOR LIGHTING; PHOTOVOLTAIC CELLS; CABINETS FOR LOUDSPEAKERS; LOUDSPEAKERS; PORTABLE MEDIA PLAYERS; CHARGERS FOR ELECTRIC BATTERIES; ELECTRIC BATTERIES; BATTERY ACCUMULATORS (U.S. CLS. 21, 23, 26, 36 AND 38).

FIRST USE 9-20-2012; IN COMMERCE 4-4-2014.  
SAIMA MAKHDOOM, EXAMINING ATTORNEY



**CLASS 9—(Continued).**

SN 86-246,590. SHENZHEN TECHONE TECH CO., LTD., SHENZHEN, CHINA, FILED 4-9-2014.

# IBLITZ

THE MARK CONSISTS OF STANDARD CHARACTERS WITHOUT CLAIM TO ANY PARTICULAR FONT, STYLE, SIZE, OR COLOR.

FOR BATTERIES; COMMUTATORS; CURRENT RECTIFIERS; ELECTRIC LIGHT DIMMERS; LIGHTING BALLASTS; OPTICAL INSPECTION APPARATUS; OPTICAL LAMPS; THERMIONIC TUBES; TRAFFIC-LIGHT APPARATUS; VOLTAGE STABILIZING POWER SUPPLY (U.S. CLS. 21, 23, 26, 36 AND 38).

SETH A. RAPPAPORT, EXAMINING ATTORNEY

---

SN 86-246,673. ECLIPSE.ORG FOUNDATION, INC., OTTAWA, ONTARIO, CANADA, FILED 4-9-2014.

# POLARSYS

THE MARK CONSISTS OF STANDARD CHARACTERS WITHOUT CLAIM TO ANY PARTICULAR FONT, STYLE, SIZE, OR COLOR.

FOR COMPUTER SOFTWARE, NAMELY, AN OPEN SOURCE TOOL FOR EMBEDDED SYSTEMS (U.S. CLS. 21, 23, 26, 36 AND 38).

FIRST USE 9-21-2012; IN COMMERCE 9-21-2012.  
BERNICE MIDDLETON, EXAMINING ATTORNEY

---

SN 86-246,767. BOTTLES WAITING INC., SUNNYVALE, CA, FILED 4-9-2014.

# BOTTLES WAITING

THE MARK CONSISTS OF STANDARD CHARACTERS WITHOUT CLAIM TO ANY PARTICULAR FONT, STYLE, SIZE, OR COLOR.

FOR DOWNLOADABLE SOFTWARE FOR RESERVATION AND BOOKING SERVICES FOR BARS, DAY CLUBS AND NIGHTCLUBS (U.S. CLS. 21, 23, 26, 36 AND 38).

DOMINICK J. SALEMI, EXAMINING ATTORNEY

**CLASS 9—(Continued).**

SN 86-246,768. HOLST, BETH ANNE, SPRINGFIELD, VA, FILED 4-9-2014.

# ACUDEMIC

THE MARK CONSISTS OF STANDARD CHARACTERS WITHOUT CLAIM TO ANY PARTICULAR FONT, STYLE, SIZE, OR COLOR.

FOR ELECTRONIC AND OPTICAL SYSTEMS FOR MONITORING A PERSON'S EYE MOVEMENT AND FIELD OF VIEW COMPRISING A CAMERA MOUNTED ON HEADWEAR AND EYEWEAR FOR RECORDING IMAGES AND CONVERTING RECORDED IMAGES TO ELECTRONIC SIGNALS, AND A TRANSMITTER FOR TRANSMITTING ELECTRONIC SIGNALS (U.S. CLS. 21, 23, 26, 36 AND 38).

DOMINICK J. SALEMI, EXAMINING ATTORNEY

---

SN 86-246,849. MARIO LONDONO, BOGOTA, COLOMBIA, FILED 4-9-2014.

# BATTLE CATS

THE MARK CONSISTS OF STANDARD CHARACTERS WITHOUT CLAIM TO ANY PARTICULAR FONT, STYLE, SIZE, OR COLOR.

FOR DOWNLOADABLE ELECTRONIC COMIC BOOKS AND GRAPHIC NOVELS; ELECTRONIC BOOKS IN THE FIELD OF CHILDREN'S ENTERTAINMENT, EDUCATION AND LEARNING RECORDED ON COMPUTER MEDIA; ELECTRONIC PUBLICATIONS, NAMELY, E-ZINES FEATURING GRAPHIC NOVELS AND COMICS; VIDEO GAME SOFTWARE; ELECTRONIC GAME SOFTWARE FOR CELLULAR TELEPHONES; ELECTRONIC GAME SOFTWARE FOR WIRELESS DEVICES; ELECTRONIC GAME SOFTWARE FOR HANDHELD ELECTRONIC DEVICES; DOWNLOADABLE AUDIO-VISUAL MEDIA CONTENT IN THE FIELD OF ENTERTAINMENT FEATURING ANIMATED MOTION PICTURES AND TELEVISION SERIES; SOFTWARE THAT ENABLES USERS TO PLAY ENTERTAINMENT-RELATED MULTI-MEDIA CONTENT; COMPUTER APPLICATION SOFTWARE FOR STREAMING AND STORING VISUAL MEDIA CONTENT (U.S. CLS. 21, 23, 26, 36 AND 38).

THOMAS MANOR, EXAMINING ATTORNEY

**CLASS 9—(Continued).**

SN 86-246,857. CARFIDANT.COM, INC., MONROE, NY.  
FILED 4-9-2014.

**milPRO**

THE MARK CONSISTS OF THE WORD "MILPRO" IN STYLIZED LETTERING. THE FIRST THREE LETTERS ("MIL") APPEAR IN LOWER CASE LETTERING AND THE SECOND THREE LETTERS ("PRO") APPEAR IN UPPER-CASE LETTERING.

FOR ELECTRICAL EDDY CURRENT TEST EQUIPMENT; ELECTROMAGNETIC APPARATUS USED TO GENERATE OR MEASURE MAGNETIC FIELDS; ELECTRONIC DATA PROCESSING APPARATUS; MAGNETIC INDUCTION TESTERS (U.S. CLS. 21, 23, 26, 36 AND 38).  
SANI KHOURI, EXAMINING ATTORNEY

SN 86-246,917. ECHOSPAWN STUDIOS, ORLANDO, FL.  
FILED 4-9-2014.

**Lumora**

THE MARK CONSISTS OF STANDARD CHARACTERS WITHOUT CLAIM TO ANY PARTICULAR FONT, STYLE, SIZE, OR COLOR.

FOR ELECTRONIC GAME SOFTWARE; ELECTRONIC GAME SOFTWARE FOR HANDHELD ELECTRONIC DEVICES (U.S. CLS. 21, 23, 26, 36 AND 38).

WILLIAM BRECKENFELD, EXAMINING ATTORNEY

SN 86-246,972. DORM COMPANY DBA DORMCO, CLARENCE, NY. FILED 4-9-2014.

**IRON BRICK SAFE**

THE MARK CONSISTS OF STANDARD CHARACTERS WITHOUT CLAIM TO ANY PARTICULAR FONT, STYLE, SIZE, OR COLOR.

NO CLAIM IS MADE TO THE EXCLUSIVE RIGHT TO USE "SAFE", APART FROM THE MARK AS SHOWN.

FOR LAPTOP CARRYING CASES (U.S. CLS. 21, 23, 26, 36 AND 38).

FIRST USE 4-8-2014; IN COMMERCE 4-8-2014.  
TEJBIR SINGH, EXAMINING ATTORNEY

**CLASS 9—(Continued).**

SN 86-246,984. XPLORE TECHNOLOGIES CORPORATION OF AMERICA, AUSTIN, TX. FILED 4-9-2014.

**RANGERX**

THE MARK CONSISTS OF STANDARD CHARACTERS WITHOUT CLAIM TO ANY PARTICULAR FONT, STYLE, SIZE, OR COLOR.

FOR COMPUTERS (U.S. CLS. 21, 23, 26, 36 AND 38).  
CURTIS FRENCH, EXAMINING ATTORNEY

SN 86-247,004. BLUME, RYAN P, FORT COLLINS, CO.  
FILED 4-9-2014.

**6-4-3**

THE MARK CONSISTS OF STANDARD CHARACTERS WITHOUT CLAIM TO ANY PARTICULAR FONT, STYLE, SIZE, OR COLOR.

FOR COMPUTER APPLICATION SOFTWARE FOR MOBILE PHONES, TABLETS, AND COMPUTERS, NAMELY, SOFTWARE FOR RECORDING EVENTS AND TABULATING STATISTICS FOR BASEBALL AND SOFTBALL GAMES (U.S. CLS. 21, 23, 26, 36 AND 38).

FIRST USE 3-21-2010; IN COMMERCE 5-12-2010.

DOUGLAS LEE, EXAMINING ATTORNEY

SN 86-247,012. PANASONIC CORPORATION OF NORTH AMERICA, NEWARK, NJ. FILED 4-9-2014.

**3E**

THE MARK CONSISTS OF STANDARD CHARACTERS WITHOUT CLAIM TO ANY PARTICULAR FONT, STYLE, SIZE, OR COLOR.

FOR LAPTOPS, TABLET COMPUTERS AND COMPUTERS (U.S. CLS. 21, 23, 26, 36 AND 38).

JASON TURNER, EXAMINING ATTORNEY

**CLASS 9—(Continued).**

SN 86-247,024. GUAN SHENG OPTICAL CO., LTD., HSINCHU HSIEN, TAIWAN, FILED 4-9-2014.



THE MARK CONSISTS OF "GSO" STYLIZED. FOR BODY-TUBES FOR TELESCOPES, NAMELY, LENS BARRELS; LENSES FOR TELESCOPES; MERIDIAN TRANSIT TELESCOPES; PRISMS FOR TELESCOPES; REFLECTORS FOR TELESCOPES; TELESCOPES; TRIPODS FOR TELESCOPES; ZENITH TELESCOPES; OPTICAL LENSES (U.S. CLS. 21, 23, 26, 36 AND 38).  
HOWARD SMIGA, EXAMINING ATTORNEY

SN 86-247,057. XPLORE TECHNOLOGIES CORPORATION OF AMERICA, AUSTIN, TX. FILED 4-9-2014.

## XDIM G2

THE MARK CONSISTS OF STANDARD CHARACTERS WITHOUT CLAIM TO ANY PARTICULAR FONT, STYLE, SIZE, OR COLOR.  
FOR COMPUTER DOCKING STATIONS (U.S. CLS. 21, 23, 26, 36 AND 38).  
CURTIS FRENCH, EXAMINING ATTORNEY

SN 86-247,081. ACC LABEL INC., MONTREAL, QUEBEC, CANADA, FILED 4-9-2014.

## MESURACC

THE MARK CONSISTS OF STANDARD CHARACTERS WITHOUT CLAIM TO ANY PARTICULAR FONT, STYLE, SIZE, OR COLOR.  
FOR TYPOGRAPHICAL RULER USED IN FOOD LABELLING (U.S. CLS. 21, 23, 26, 36 AND 38).  
MICHAEL ENGEL, EXAMINING ATTORNEY

**CLASS 9—(Continued).**

SN 86-247,294. ANDERSON, TIMOTHY, SHERMAN OAKS, CA. AND TA, KENNY, SHERMAN OAKS, CA. FILED 4-9-2014.

## CurveForward

THE MARK CONSISTS OF STANDARD CHARACTERS WITHOUT CLAIM TO ANY PARTICULAR FONT, STYLE, SIZE, OR COLOR.

FOR COMPUTER APPLICATION SOFTWARE FOR DEVICES, TABLETS, MOBILE PHONES, PORTABLE MEDIA PLAYERS, HANDHELD COMPUTERS, LAPTOP COMPUTERS, AND DESKTOP COMPUTERS, NAMELY, SOFTWARE FOR PUSHING CUSTOMIZED CONTENTS TO A DEVICE BASED ON A SPECIFIC USER'S GEOGRAPHIC AND DEMOGRAPHIC DATA (U.S. CLS. 21, 23, 26, 36 AND 38).  
SALLY SHIH, EXAMINING ATTORNEY

SN 86-247,297. MX COMPANY PTY LTD, FERNY GROVE, AUSTRALIA, FILED 4-9-2014.

## PREVALERT

THE MARK CONSISTS OF STANDARD CHARACTERS WITHOUT CLAIM TO ANY PARTICULAR FONT, STYLE, SIZE, OR COLOR.

FOR CARBON MONOXIDE DETECTORS; SMOKE DETECTORS; HEAT DETECTORS; GAS DETECTORS FOR DETECTING THE PRESENCE OF GAS; LEAK DETECTING DEVICE FOR WATER SUPPLIED HOME APPLIANCES CONSISTING OF WATER SENSOR, CONTROL UNIT WITH AUDIBLE ALARM AND WATER VALVES (U.S. CLS. 21, 23, 26, 36 AND 38).  
FIRST USE 12-6-2013; IN COMMERCE 2-3-2014.  
LESLIE RICHARDS, EXAMINING ATTORNEY

SN 86-247,314. OBJECTIVE SYSTEMS INTEGRATORS, INC., FOLSOM, CA. FILED 4-9-2014.

## LTEXPERT

THE MARK CONSISTS OF STANDARD CHARACTERS WITHOUT CLAIM TO ANY PARTICULAR FONT, STYLE, SIZE, OR COLOR.

FOR COMPUTER SOFTWARE FOR USE IN NETWORK OPERATIONAL AND SUPPORT MANAGEMENT (U.S. CLS. 21, 23, 26, 36 AND 38).  
HEATHER SAPP, EXAMINING ATTORNEY

**CLASS 9—(Continued).**

SN 86-247,339. PIVOS TECHNOLOGY GROUP, INC., FREMONT, CA. FILED 4-9-2014.

**TOFU**

THE MARK CONSISTS OF STANDARD CHARACTERS WITHOUT CLAIM TO ANY PARTICULAR FONT, STYLE, SIZE, OR COLOR.

FOR MEDIA PLAYERS (U.S. CLS. 21, 23, 26, 36 AND 38).

FIRST USE 4-1-2014; IN COMMERCE 4-1-2014.  
ZACHARY BELLO, EXAMINING ATTORNEY

SN 86-247,340. THE PEOPLE DECIDE, INC., LAS VEGAS, NV. FILED 4-9-2014.

**Instavote**

THE MARK CONSISTS OF STANDARD CHARACTERS WITHOUT CLAIM TO ANY PARTICULAR FONT, STYLE, SIZE, OR COLOR.

FOR COMPUTER APPLICATION SOFTWARE FOR MOBILE PHONES, PORTABLE MEDIA PLAYERS, HANDHELD COMPUTERS, TABLETS, LAPTOP COMPUTERS, DESKTOP COMPUTERS, AND INTERNET-ACCESSIBLE DEVICES, NAMELY, SOFTWARE FOR COMPILING AND TRACKING STATISTICAL DATA FOR CURRENT EVENTS (U.S. CLS. 21, 23, 26, 36 AND 38).

ZACHARY BELLO, EXAMINING ATTORNEY

SN 86-247,429. KALB, LAWRENCE M, SAN FRANCISCO, CA. FILED 4-9-2014.

**SWIZZILLE TRIP**

THE MARK CONSISTS OF STANDARD CHARACTERS WITHOUT CLAIM TO ANY PARTICULAR FONT, STYLE, SIZE, OR COLOR.

FOR DOWNLOADABLE MUSICAL SOUND RECORDINGS; MUSICAL RECORDINGS; MUSICAL SOUND RECORDINGS (U.S. CLS. 21, 23, 26, 36 AND 38).

HANNO RITTNER, EXAMINING ATTORNEY

**CLASS 9—(Continued).**

SN 86-247,571. LMI TECHNOLOGIES LIMITED, DUBLIN, IRELAND, FILED 4-9-2014.

**METRION**

THE MARK CONSISTS OF STANDARD CHARACTERS WITHOUT CLAIM TO ANY PARTICULAR FONT, STYLE, SIZE, OR COLOR.

FOR HANDHELD NON-CONTACT OPTICAL 3D SCANNER (U.S. CLS. 21, 23, 26, 36 AND 38).

CYNTHIA TRIPI, EXAMINING ATTORNEY

SN 86-247,601. PETER PERKETT, SOUTH BURLINGTON, VT. FILED 4-9-2014.

**TUBBY BIRD**

THE MARK CONSISTS OF STANDARD CHARACTERS WITHOUT CLAIM TO ANY PARTICULAR FONT, STYLE, SIZE, OR COLOR.

FOR VIDEO GAMES FOR MOBILE DEVICES, PERSONAL COMPUTERS, CONSOLES, TABLETS; ELECTRONIC GAME PROGRAMS; DOWNLOADABLE ELECTRONIC GAME PROGRAMS; ELECTRONIC GAME SOFTWARE; COMPUTER GAME PROGRAMS; DOWNLOADABLE COMPUTER GAME PROGRAMS; INTERACTIVE GAME PROGRAMS; INTERACTIVE GAME SOFTWARE; GAME SOFTWARE ADAPTED FOR USE WITH TELEVISION RECEIVERS; PRE-RECORDED MOTION PICTURE, TELEVISION, AND ANIMATION FILMS (U.S. CLS. 21, 23, 26, 36 AND 38).

JANICE L. MCMORROW, EXAMINING ATTORNEY

SN 86-247,659. BULL, ADA MARIE, SUNNYVALE, CA. FILED 4-9-2014.

**Nudge Me Once**

THE MARK CONSISTS OF STANDARD CHARACTERS WITHOUT CLAIM TO ANY PARTICULAR FONT, STYLE, SIZE, OR COLOR.

FOR PORTABLE ARM, WRIST OR ANKLE MOUNTED DIGITAL ELECTRONIC DEVICE, NAMELY, A SMALL VIBRATING DISC ATTACHED TO A NARROW BAND WITH A PRE-PROGRAMMED TIMER USED IN HELPING TRAIN ONE TO REMEMBER TO STAND UP ONCE EVERY HOUR OR TO DO EXERCISE FOR THE KEGEL METHOD EXERCISE TO AVOID URINARY AND PROSTATE PROBLEMS (U.S. CLS. 21, 23, 26, 36 AND 38).

JANICE L. MCMORROW, EXAMINING ATTORNEY

**CLASS 9—(Continued).**

SN 86-247,705. PROSOFT ENGINEERING, INC., LIVERMORE, CA. FILED 4-9-2014.

**PICTURE RESCUE**

THE MARK CONSISTS OF STANDARD CHARACTERS WITHOUT CLAIM TO ANY PARTICULAR FONT, STYLE, SIZE, OR COLOR.

OWNER OF U.S. REG. NO. 4,285,588.  
NO CLAIM IS MADE TO THE EXCLUSIVE RIGHT TO USE "PICTURE", APART FROM THE MARK AS SHOWN.  
FOR IMAGE AND PICTURE RECOVERY SOFTWARE (U.S. CLS. 21, 23, 26, 36 AND 38).

MARGERY A. TIERNEY, EXAMINING ATTORNEY

SN 86-247,733. WOYNAROWSKI, DAVID M., FLEETWOOD, PA. FILED 4-9-2014.

**MAGNETIC WEALTH ATTRACTION**

THE MARK CONSISTS OF STANDARD CHARACTERS WITHOUT CLAIM TO ANY PARTICULAR FONT, STYLE, SIZE, OR COLOR.

FOR AUDIO AND VIDEO RECORDINGS FEATURING CONTENT IN THE FIELD OF HYPNOSIS (U.S. CLS. 21, 23, 26, 36 AND 38).

CHRIS WELLS, EXAMINING ATTORNEY

SN 86-247,779. BIRS GROUP, LTD., TORTOLA, BR. VIRGIN ISLANDS, FILED 4-9-2014.



THE MARK CONSISTS OF THE WORDS "SMOKE & MIRRORS" IN A STYLIZED FONT.

FOR EYEWEAR, NAMELY, SUNGLASSES, EYEGLASSES AND OPHTHALMIC FRAMES AND CASES THEREFOR (U.S. CLS. 21, 23, 26, 36 AND 38).

FIRST USE 3-0-2013; IN COMMERCE 8-1-2013.

ANNE E. GUSTASON, EXAMINING ATTORNEY

**CLASS 9—(Continued).**

SN 86-247,862. SHENZHEN DANALE TECHNOLOGY CO., LTD, SHENZHEN CITY, CHINA, FILED 4-10-2014.



THE MARK CONSISTS OF THE STYLIZED WORD DANALE.

THE WORDING "DANALE" HAS NO MEANING IN A FOREIGN LANGUAGE.

FOR CAMERAS SHUTTERS; COMPUTER OPERATING PROGRAMS, RECORDED; COMPUTER SOFTWARE FOR CONTROLLING AND MANAGING ACCESS SERVER APPLICATIONS; DOWNLOADABLE COMPUTER GAME PROGRAMS; ELECTRONIC TAGS FOR GOODS; INTEGRATED CIRCUITS; OPTICAL LANTERNS; PHOTOTELEGRAPHY APPARATUS; SMOKE DETECTORS; TELEPHONE APPARATUS (U.S. CLS. 21, 23, 26, 36 AND 38).

DAWN FELDMAN, EXAMINING ATTORNEY

SN 86-247,933. SOFTDOCS, INC., COLUMBIA, SC. FILED 4-10-2014.



THE MARK CONSISTS OF STANDARD CHARACTERS WITHOUT CLAIM TO ANY PARTICULAR FONT, STYLE, SIZE, OR COLOR.

FOR COMPUTER SOFTWARE FOR ELECTRONIC DOCUMENT MANAGEMENT, NAMELY, SOFTWARE FOR DOCUMENT IMAGING, CONVERSION, ARCHIVING, ACCESSING, ROUTING, HISTORY RECORDING, IMPORTING, EXPORTING, AND DELIVERY FOR OTHERS; RENTAL OF COMPUTER SOFTWARE FOR ELECTRONIC DOCUMENT MANAGEMENT, NAMELY, SOFTWARE FOR DOCUMENT IMAGING, CONVERSION, ARCHIVING, ACCESSING, ROUTING, HISTORY RECORDING, IMPORTING, EXPORTING, AND DELIVERY FOR OTHERS (U.S. CLS. 21, 23, 26, 36 AND 38).

FIRST USE 9-23-2013; IN COMMERCE 3-24-2014.

MARGERY A. TIERNEY, EXAMINING ATTORNEY

SN 86-247,948. KINGSISLE ENTERTAINMENT, INC., PLANO, TX. FILED 4-10-2014.



THE MARK CONSISTS OF STANDARD CHARACTERS WITHOUT CLAIM TO ANY PARTICULAR FONT, STYLE, SIZE, OR COLOR.

FOR DOWNLOADABLE ELECTRONIC GAME SOFTWARE AND UPDATES FOR USE ON COMPUTERS, MOBILE DEVICES AND HANDHELD DEVICES (U.S. CLS. 21, 23, 26, 36 AND 38).

HEATHER SAPP, EXAMINING ATTORNEY

**CLASS 9—(Continued).**

SN 86-247,952. ARKANSAS INTEGRATED COMMUNITY HEALTH NETWORK, INC., TEXARKANA, TX. FILED 4-10-2014.



THE MARK CONSISTS OF THE LETTERS "SYM" TO THE LEFT OF THE CHECK SYMBOL.  
FOR SOFTWARE APPLICATION FOR NURSING DECISION SUPPORT, PATIENT CARE ESCALATION AND REPORTING (U.S. CLS. 21, 23, 26, 36 AND 38).  
LEE-ANNE BERNS, EXAMINING ATTORNEY

SN 86-248,062. LIU YU HUA, YONGSHUN COUNTY, HUNAN, CHINA, FILED 4-10-2014.

**JANDM**

THE MARK CONSISTS OF STANDARD CHARACTERS WITHOUT CLAIM TO ANY PARTICULAR FONT, STYLE, SIZE, OR COLOR.

THE WORDING "JANDM" HAS NO MEANING IN A FOREIGN LANGUAGE.

FOR BATTERY CHARGERS; CELL PHONE CASES; CELL PHONE COVERS; PROTECTIVE COVERS AND CASES FOR CELL PHONES, LAPTOPS AND PORTABLE MEDIA PLAYERS; PROTECTIVE COVERS AND CASES FOR TABLET COMPUTERS; PROTECTIVE COVERS FOR SMARTPHONES; USB CABLES (U.S. CLS. 21, 23, 26, 36 AND 38).

FIRST USE 4-9-2014; IN COMMERCE 4-9-2014.  
CHRISTOPHER REAMS, EXAMINING ATTORNEY

SN 86-248,614. TEACHER CREATED RESOURCES, INC., WESTMINSTER, CA. FILED 4-10-2014.

**CLASS RESPONDER**

THE MARK CONSISTS OF STANDARD CHARACTERS WITHOUT CLAIM TO ANY PARTICULAR FONT, STYLE, SIZE, OR COLOR.

NO CLAIM IS MADE TO THE EXCLUSIVE RIGHT TO USE "CLASS", APART FROM THE MARK AS SHOWN.

FOR SOFTWARE USED IN CONJUNCTION WITH ELECTRONIC HARDWARE FOR POLLING AN AUDIENCE OR QUIZZING AN INDIVIDUAL (U.S. CLS. 21, 23, 26, 36 AND 38).

ESTHER BELENKER, EXAMINING ATTORNEY

**CLASS 9—(Continued).**

SN 86-248,629. MG SYSTEMS CONSULTORIA E SISTEMAS LTDA, SÃO PAULO, BRAZIL, FILED 4-10-2014.



THE MARK CONSISTS OF THE LETTER "W" ABOVE THREE CURVED LINES.

FOR COMPUTER APPLICATION SOFTWARE FOR MOBILE PHONES, NAMELY, SOFTWARE FOR MANAGING CARD PAYMENT AND ACH PAYMENTS FOR MERCHANTS, ORGANIZATIONS, AND CORPORATIONS, INCLUDING E-COMMERCE SHOPPING CART COMPONENTS FOR ORDERING GOODS AND SERVICES (U.S. CLS. 21, 23, 26, 36 AND 38).

CHRISTINA SOBRAL, EXAMINING ATTORNEY

SN 86-248,712. ATLANTIS COMPUTING, INC., MOUNTAIN VIEW, CA. FILED 4-10-2014.

**Atlantis ILIO USX**

THE MARK CONSISTS OF STANDARD CHARACTERS WITHOUT CLAIM TO ANY PARTICULAR FONT, STYLE, SIZE, OR COLOR.

OWNER OF U.S. REG. NOS. 4,093,021, 4,093,022 AND 4,444,469.

FOR COMPUTER SOFTWARE FOR VIRTUALIZATION OF SOFTWARE APPLIANCES, OPERATING SYSTEMS AND HARDWARE SYSTEMS (U.S. CLS. 21, 23, 26, 36 AND 38).

FIRST USE 2-11-2014; IN COMMERCE 2-11-2014.  
DOUGLAS LEE, EXAMINING ATTORNEY

**CLASS 9—(Continued).**

SN 86-248,861. JOHNNY RHYMES WITH CONNIE, LLC,  
ROSEVILLE, MN. FILED 4-11-2014.

# SLINGGRIP

THE MARK CONSISTS OF STANDARD CHARACTERS  
WITHOUT CLAIM TO ANY PARTICULAR FONT, STYLE,  
SIZE, OR COLOR.

FOR MOBILE PHONE STRAPS (U.S. CLS. 21, 23, 26, 36  
AND 38).

FIRST USE 6-30-2013; IN COMMERCE 6-30-2013.  
ESTHER A. BORSUK, EXAMINING ATTORNEY

**CLASS 9—(Continued).**

SN 86-248,913. SABIA, INCORPORATED, SAN DIEGO, CA.  
FILED 4-10-2014.

# X-1 LiNX

THE MARK CONSISTS OF STANDARD CHARACTERS  
WITHOUT CLAIM TO ANY PARTICULAR FONT, STYLE,  
SIZE, OR COLOR.

FOR MEASUREMENT APPARATUS FOR TESTING  
AND DETERMINING THE ELEMENTAL COMPONENTS  
OF BULK RAW MATERIALS (U.S. CLS. 21, 23, 26, 36  
AND 38).

ANDREA CORNWELL, EXAMINING ATTORNEY

SN 86-248,872. GRITNESS, INC., AUSTIN, TX. FILED 4-10-  
2014.

# Gritness

THE MARK CONSISTS OF STANDARD CHARACTERS  
WITHOUT CLAIM TO ANY PARTICULAR FONT, STYLE,  
SIZE, OR COLOR.

FOR COMMUNICATIONS SOFTWARE FOR CON-  
NECTING GROUP FITNESS ACTIVITY PARTICIPANTS  
(U.S. CLS. 21, 23, 26, 36 AND 38).

FIRST USE 2-28-2013; IN COMMERCE 3-4-2013.  
STEPHANIE ALI, EXAMINING ATTORNEY

SN 86-248,916. HOROPPA LABS, LLC, SANTA CLARA, CA.  
FILED 4-10-2014.

# VPBD

THE MARK CONSISTS OF STANDARD CHARACTERS  
WITHOUT CLAIM TO ANY PARTICULAR FONT, STYLE,  
SIZE, OR COLOR.

FOR COMPUTER SOFTWARE FOR COMPUTER SYS-  
TEM AND APPLICATION DEVELOPMENT, DEPLOY-  
MENT AND MANAGEMENT (U.S. CLS. 21, 23, 26, 36  
AND 38).

EMILY CHUO, EXAMINING ATTORNEY

SN 86-248,904. SELECT MIX, INC., LAS VEGAS, NV. FILED  
4-10-2014.

# SELECT ESSENTIALS

THE MARK CONSISTS OF STANDARD CHARACTERS  
WITHOUT CLAIM TO ANY PARTICULAR FONT, STYLE,  
SIZE, OR COLOR.

FOR MUSICAL SOUND RECORDINGS (U.S. CLS. 21,  
23, 26, 36 AND 38).

FIRST USE 0-0-2003; IN COMMERCE 0-0-2003.  
RONALD MCMORROW, EXAMINING ATTORNEY

SN 86-249,125. EYEFLUENCE, INC., RENO, NV. FILED 4-10-  
2014.

# EYESELECT

THE MARK CONSISTS OF STANDARD CHARACTERS  
WITHOUT CLAIM TO ANY PARTICULAR FONT, STYLE,  
SIZE, OR COLOR.

FOR COMPUTER HARDWARE AND SOFTWARE FOR  
PROVIDING A USER INTERFACE INVOLVING EYE  
TRACKING AND/OR EYE MOVEMENT FOR WEAR-  
ABLE DEVICES (U.S. CLS. 21, 23, 26, 36 AND 38).

BERNICE MIDDLETON, EXAMINING ATTORNEY

**CLASS 9—(Continued).**

SN 86-249,169. PINSER, LLC, FORT LAUDERDALE, FL. FILED 4-10-2014.

**PINSER**

THE MARK CONSISTS OF STANDARD CHARACTERS WITHOUT CLAIM TO ANY PARTICULAR FONT, STYLE, SIZE, OR COLOR.

FOR SOCIAL NETWORKING SOFTWARE APPLICATIONS DOWNLOADABLE VIA THE INTERNET AND OTHER COMMUNICATION NETWORKS FOR USE WITH MOBILE TELEPHONES, SMART PHONES, COMPUTERS AND TABLET COMPUTERS, FOR THE PURPOSE OF UPLOADING, POSTING, SHOWING, DISPLAYING, TAGGING, BLOGGING, SHARING AND PROVIDING ELECTRONIC MEDIA AND INFORMATION IN THE FIELDS OF ENTERTAINMENT AND GENERAL INTEREST (U.S. CLS. 21, 23, 26, 36 AND 38).  
 NAAKWAMA ANKRAH, EXAMINING ATTORNEY

**CLASS 9—(Continued).**

SN 86-249,224. CHANGZHOU ALMADEN CO., LTD., CHANGZHOU, JIANGSU, CHINA, FILED 4-11-2014.

**EagleLite**

THE MARK CONSISTS OF STYLIZED WORDING "EAGLELITE".

FOR ANTI-DAZZLE SPECTACLES; ANTI-GLARE GLASSES; GLASS COVERED WITH AN ELECTRICAL CONDUCTOR; OPTICAL CHARACTER RECOGNITION (OCR) APPARATUS; OPTICAL FIBERS; OPTICAL GLASSES; OPTICAL INSPECTION APPARATUS; PLATES FOR BATTERIES; SOLAR BATTERIES (U.S. CLS. 21, 23, 26, 36 AND 38).  
 FIRST USE 1-8-2013; IN COMMERCE 1-8-2013.  
 JOHN HWANG, EXAMINING ATTORNEY

SN 86-249,335. ITT CORPORATION, WHITE PLAINS, NY. FILED 4-11-2014.

**veam**

THE MARK CONSISTS OF THE WORD "VEAM" IN LOWERCASE LETTERS, WITH THREE DOTS ARRANGED IN A TRIANGULAR PATTERN INSIDE THE "A" SUGGESTING THE PRONGS OR RECEPTACLES OF AN ELECTRICAL CONNECTOR.

FOR ELECTRICAL CONNECTORS (U.S. CLS. 21, 23, 26, 36 AND 38).  
 ELISSA GARBER KON, EXAMINING ATTORNEY

SN 86-249,206. CHINA MACHINERY ENGINEERING WUXI CO., LTD., WUXI, JIANGSU, CHINA, FILED 4-11-2014.



THE MARK CONSISTS OF THE WORD "BESTYLE" INSIDE AN OVAL WITH THE LETTER "B" IN STYLIZED FONT.

THE WORDING "BESTYLE" HAS NO MEANING IN A FOREIGN LANGUAGE.

FOR COMMUTATORS; CONNECTIONS FOR ELECTRIC LINES; ELECTRIC CONVERTERS; ELECTRIC COUPLINGS; ELECTRIC LIGHT DIMMERS; ELECTRIC SWITCHES; ELECTRICAL PLUGS AND SOCKETS; JUNCTION BOXES; LIGHTING BALLASTS; REMOTE CONTROLS FOR RADIOS, TELEVISIONS, STEREO (U.S. CLS. 21, 23, 26, 36 AND 38).

ANDREA K. NADELMAN, EXAMINING ATTORNEY

SN 86-249,341. ITT CORPORATION, WHITE PLAINS, NY. FILED 4-11-2014.

**veam**

THE COLOR(S) BRIGHT RED IS/ARE CLAIMED AS A FEATURE OF THE MARK.

THE MARK CONSISTS OF THE WORD "VEAM" IN LOWERCASE LETTERS IN A BRIGHT RED COLOR, WITH THREE DOTS ARRANGED IN A TRIANGULAR PATTERN INSIDE THE "A" SUGGESTING THE PRONGS OR RECEPTACLES OF AN ELECTRICAL CONNECTOR.

FOR ELECTRICAL CONNECTORS (U.S. CLS. 21, 23, 26, 36 AND 38).

ELISSA GARBER KON, EXAMINING ATTORNEY



**CLASS 9—(Continued).**

SN 86-249,365. STARKEY LABORATORIES, INC., EDEN PRAIRIE, MN. FILED 4-11-2014.

TruLink

THE MARK CONSISTS OF STANDARD CHARACTERS WITHOUT CLAIM TO ANY PARTICULAR FONT, STYLE, SIZE, OR COLOR.

FOR SOFTWARE APPLICATIONS FOR PROVIDING AN AUDIO CONNECTION BETWEEN A COMPUTER DEVICE, IN PARTICULAR A MOBILE PHONE OR A TABLET COMPUTER TO A SOUND REPRODUCING DEVICE, NAMELY HEARING AIDS (U.S. CLS. 21, 23, 26, 36 AND 38).

BRITTANY ESTELL, EXAMINING ATTORNEY

**CLASS 9—(Continued).**

SN 86-249,447. DROPOFF, INC., AUSTIN, TX. FILED 4-11-2014.



SN 86-249,433. DROPOFF, INC., AUSTIN, TX. FILED 4-11-2014.

DROPOFF

THE MARK CONSISTS OF STANDARD CHARACTERS WITHOUT CLAIM TO ANY PARTICULAR FONT, STYLE, SIZE, OR COLOR.

FOR DOWNLOADABLE MOBILE APPLICATIONS AND SOFTWARE FOR BOOKING COURIER SERVICES (U.S. CLS. 21, 23, 26, 36 AND 38).

DAVID MURRAY, EXAMINING ATTORNEY

THE MARK CONSISTS OF THE LETTER "D" IN LOWERCASE; THE LOOP OF THE LETTER "D" ENDS IN AN ARROW FORMED BY A CIRCLE THAT CURVES COUNTERCLOCKWISE AND ULTIMATELY POINTS TO THE RIGHT. THE LETTER "D" IS CONTAINED WITHIN A LARGER CIRCLE, WHICH IS BROKEN AT THE TOP BY THE HIGHEST POINT OF THE LETTER "D".

FOR DOWNLOADABLE MOBILE APPLICATIONS AND SOFTWARE FOR BOOKING COURIER SERVICES (U.S. CLS. 21, 23, 26, 36 AND 38).

DAVID MURRAY, EXAMINING ATTORNEY

SN 86-249,441. DROPOFF, INC., AUSTIN, TX. FILED 4-11-2014.



THE MARK CONSISTS OF THE WORD "DROPOFF" IN STYLIZED LOWERCASE LETTERING; THE LOOP OF THE LETTER "D" ENDS IN AN ARROW FORMED BY A CIRCLE THAT CURVES COUNTERCLOCKWISE AND ULTIMATELY POINTS TO THE RIGHT. THE LETTER "D" IS ITSELF CONTAINED WITHIN A LARGER CIRCLE, WHICH IS BROKEN AT THE TOP BY THE HIGHEST POINT OF THE LETTER "D" AND AT THE BOTTOM RIGHT BY THE LETTER "R".

FOR DOWNLOADABLE MOBILE APPLICATIONS AND SOFTWARE FOR BOOKING COURIER SERVICES (U.S. CLS. 21, 23, 26, 36 AND 38).

DAVID MURRAY, EXAMINING ATTORNEY

SN 86-249,626. MIND-OUT LLC, MILLIS, MA. FILED 4-11-2014.

CHILL OUTZ

THE MARK CONSISTS OF STANDARD CHARACTERS WITHOUT CLAIM TO ANY PARTICULAR FONT, STYLE, SIZE, OR COLOR.

FOR COMPUTER APPLICATION SOFTWARE FOR PERSONAL COMPUTERS, LAPTOP COMPUTERS, TABLETS, MOBILE PHONES, AND PORTABLE MEDIA PLAYERS, NAMELY, SOFTWARE FOR ASSISTING INDIVIDUALS WITH PROGRESSIVE RELAXATION, BREATHING AND MOOD CHANGES (U.S. CLS. 21, 23, 26, 36 AND 38).

ODESSA BIBBINS, EXAMINING ATTORNEY

**CLASS 9—(Continued).**

SN 86-249,631. MIND-OUT LLC, MILLIS, MA. FILED 4-11-2014.

MOVING FROM TIME-OUTS TO  
CHILL OUTZ

THE MARK CONSISTS OF STANDARD CHARACTERS WITHOUT CLAIM TO ANY PARTICULAR FONT, STYLE, SIZE, OR COLOR.

FOR COMPUTER APPLICATION SOFTWARE FOR PERSONAL COMPUTERS, LAPTOP COMPUTERS, TABLETS, MOBILE PHONES, AND PORTABLE MEDIA PLAYERS, NAMELY, SOFTWARE FOR ASSISTING INDIVIDUALS WITH PROGRESSIVE RELAXATION, BREATHING AND MOOD CHANGES (U.S. CLS. 21, 23, 26, 36 AND 38).

ODESSA BIBBINS, EXAMINING ATTORNEY

SN 86-249,636. MIND-OUT LLC, MILLIS, MA. FILED 4-11-2014.

MIND-OUT

THE MARK CONSISTS OF STANDARD CHARACTERS WITHOUT CLAIM TO ANY PARTICULAR FONT, STYLE, SIZE, OR COLOR.

FOR COMPUTER APPLICATION SOFTWARE FOR PERSONAL COMPUTERS, LAPTOP COMPUTERS, TABLETS, MOBILE PHONES, AND PORTABLE MEDIA PLAYERS, NAMELY, SOFTWARE FOR ASSISTING INDIVIDUALS WITH PROGRESSIVE RELAXATION, BREATHING AND MOOD CHANGES (U.S. CLS. 21, 23, 26, 36 AND 38).

ODESSA BIBBINS, EXAMINING ATTORNEY

SN 86-249,733. OPTEX CO., LTD., SHIGA, JAPAN, FILED 4-11-2014.

BLUEZONE

THE MARK CONSISTS OF STANDARD CHARACTERS WITHOUT CLAIM TO ANY PARTICULAR FONT, STYLE, SIZE, OR COLOR.

FOR ELECTRONIC SENSORS FOR THE OPERATION OF AUTOMATIC DOORS AND ROLLING SHUTTERS; TOUCH SENSITIVE SWITCHES AND TOUCHLESS SWITCHES FOR THE OPERATION OF AUTOMATIC DOORS AND ROLLING SHUTTERS (U.S. CLS. 21, 23, 26, 36 AND 38).

JEAN IM, EXAMINING ATTORNEY

**CLASS 9—(Continued).**

SN 86-249,922. LONELY FEW, LLC, COVINA, CA. FILED 4-11-2014.

bendoku

THE MARK CONSISTS OF STANDARD CHARACTERS WITHOUT CLAIM TO ANY PARTICULAR FONT, STYLE, SIZE, OR COLOR.

FOR COMPUTER GAME SOFTWARE; COMPUTER GAME SOFTWARE DOWNLOADABLE FROM A GLOBAL COMPUTER NETWORK; COMPUTER GAME SOFTWARE FOR PERSONAL COMPUTERS AND HOME VIDEO GAME CONSOLES; COMPUTER GAME SOFTWARE FOR USE ON MOBILE AND CELLULAR PHONES; DOWNLOADABLE COMPUTER GAME SOFTWARE VIA A GLOBAL COMPUTER NETWORK AND WIRELESS DEVICES; ELECTRONIC GAME SOFTWARE FOR HANDHELD ELECTRONIC DEVICES (U.S. CLS. 21, 23, 26, 36 AND 38).

TRACY WHITTAKER-BROWN, EXAMINING ATTORNEY

SN 86-249,962. CENTRIC GROUP, LLC, ST. LOUIS, MO. FILED 4-11-2014.



THE MARK CONSISTS OF THREE HORIZONTAL LINES. FOR PC TABLETS (U.S. CLS. 21, 23, 26, 36 AND 38). JESSICA A. POWERS, EXAMINING ATTORNEY

SN 86-250,039. WATCHDOG GROUP LC, ST. LOUIS, MO. FILED 4-11-2014.

FLIP N SLIDE

THE MARK CONSISTS OF STANDARD CHARACTERS WITHOUT CLAIM TO ANY PARTICULAR FONT, STYLE, SIZE, OR COLOR.

FOR CONTACT LENS CASES (U.S. CLS. 21, 23, 26, 36 AND 38).

FIRST USE 4-16-2013; IN COMMERCE 4-16-2013. DANIEL S. STRINGER, EXAMINING ATTORNEY

**CLASS 9—(Continued).**

SN 86-250,060. DATASPEED, INC., TROY, MI. FILED 4-11-2014.

# ENABLET

THE MARK CONSISTS OF STANDARD CHARACTERS WITHOUT CLAIM TO ANY PARTICULAR FONT, STYLE, SIZE, OR COLOR.

FOR SOFTWARE FOR CONTROLLING ROBOTIC AND AUTONOMOUS MACHINES (U.S. CLS. 21, 23, 26, 36 AND 38).

MARGARET POWER, EXAMINING ATTORNEY

**CLASS 9—(Continued).**

SN 86-250,173. BIG SHINY GAMES LLC, LAKESIDE, CA. FILED 4-11-2014.

# Retro Assault

THE MARK CONSISTS OF STANDARD CHARACTERS WITHOUT CLAIM TO ANY PARTICULAR FONT, STYLE, SIZE, OR COLOR.

FOR COMPUTER GAME SOFTWARE FOR USE ON MOBILE AND CELLULAR PHONES; DOWNLOADABLE SOFTWARE IN THE NATURE OF A MOBILE APPLICATION FOR GAMES; INTERACTIVE GAME PROGRAMS; INTERACTIVE VIDEO GAME PROGRAMS; VIDEO GAME SOFTWARE (U.S. CLS. 21, 23, 26, 36 AND 38).

JAMES A. RAUEN, EXAMINING ATTORNEY

SN 86-250,074. DG ROCK LLC, BROOKLYN, NY. FILED 4-11-2014.

# Dgrock

THE MARK CONSISTS OF STANDARD CHARACTERS WITHOUT CLAIM TO ANY PARTICULAR FONT, STYLE, SIZE, OR COLOR.

FOR WIRELESS CELLULAR PHONE HEADSETS; WIRELESS INDOOR AND OUTDOOR SPEAKERS (U.S. CLS. 21, 23, 26, 36 AND 38).

DANIEL S. STRINGER, EXAMINING ATTORNEY

SN 86-250,233. SWIFT AUTO PARTS, EL MONTE, CA. FILED 4-11-2014.

# ISUMO

THE MARK CONSISTS OF STANDARD CHARACTERS WITHOUT CLAIM TO ANY PARTICULAR FONT, STYLE, SIZE, OR COLOR.

FOR AUDIO EQUIPMENT FOR VEHICLES, NAMELY, LOUD SPEAKERS FOR AUTOMOTIVE AUDIO SYSTEMS; AUTOMOTIVE MEASURING INSTRUMENTS, NAMELY, WATER TEMPERATURE GAUGES, AIR FUEL/RATIO GAUGES, BOOST GAUGES, VACUUM GAUGES AND EXHAUST GAS TEMPERATURE GAUGES; AUTOMOTIVE TESTING EQUIPMENT, NAMELY, TRANSMISSION TESTING AND BRAKE TESTING EQUIPMENT; AUTOMOTIVE, INDUSTRIAL, CONSTRUCTION, LOCOMOTIVE, AVIATION, NAVIGATION AND MARINE SAFETY-WARNING LIGHTS, NAMELY, STROBES, ROTATING LIGHTS AND BAR LIGHTS; HUMIDITY SENSOR WITH INTEGRATED DIGITAL AND ANALOG OUTPUT CIRCUITRY USED IN AUTOMOTIVE, APPLIANCE AND LIGHT INDUSTRIAL APPLICATIONS TO SENSE BOTH RELATIVE HUMIDITY AND TEMPERATURE ENVIRONMENTAL CONDITIONS; KEYLESS ENTRY SYSTEM AND KEYLESS IGNITION SWITCH SYSTEM FOR AUTOMOTIVE VEHICLES COMPRISED OF A MICROPROCESSOR, ELECTRONIC SIGNAL RECEIVER, AND KEYFOB WITH ELECTRONIC SIGNAL TRANSPONDER; PARTS FOR ANTI-THEFT AUTOMOTIVE ALARMS, NAMELY, ELECTRONIC SENSORS, REMOTE CONTROL TRANSMITTERS AND RECEIVERS FOR REMOTELY OPERATING LAND VEHICLES; SENSORS AND DETECTOR UNITS FOR USE IN CONTROLLING THE ACTUATION AND OPERATION OF AUTOMOTIVE SAFETY APPARATUS AND EQUIPMENT; TELESCOPIC INSPECTION MIRRORS FOR AUTOMOTIVE USE (U.S. CLS. 21, 23, 26, 36 AND 38).

FIRST USE 6-10-2013; IN COMMERCE 6-10-2013. SAMUEL E. SHARPER JR., EXAMINING ATTORNEY

SN 86-250,081. WATCHDOG GROUP LC, ST. LOUIS, MO. FILED 4-11-2014.

# EZCASE

THE MARK CONSISTS OF STANDARD CHARACTERS WITHOUT CLAIM TO ANY PARTICULAR FONT, STYLE, SIZE, OR COLOR.

FOR CONTACT LENS CASES (U.S. CLS. 21, 23, 26, 36 AND 38).

DANIEL S. STRINGER, EXAMINING ATTORNEY

**CLASS 9—(Continued).**

SN 86-250,404. FND MOBILE SEARCH, INC., PASADENA, CA. FILED 4-11-2014.

# FND

THE MARK CONSISTS OF STANDARD CHARACTERS WITHOUT CLAIM TO ANY PARTICULAR FONT, STYLE, SIZE, OR COLOR.

FOR COMPUTER APPLICATION SOFTWARE FOR MOBILE PHONES, TABLETS AND PORTABLE DEVICES, NAMELY, SOFTWARE FOR SEARCHING, ORGANIZING AND SHARING PREFERENCES AND SUGGESTIONS, WEB BROWSING, ONLINE FINANCIAL TRANSACTIONS AND E-COMMERCE TRANSACTIONS, LOCATION BASED SEARCHING, MOBILE PAYMENTS, SPEECH RECOGNITION, DATA STORAGE AND RETRIEVAL, DATABASE MANAGEMENT, RESERVATIONS, TRAVEL AND ENTERTAINMENT; COMPUTER E-COMMERCE SOFTWARE TO ALLOW USERS TO PERFORM ELECTRONIC BUSINESS TRANSACTIONS VIA A GLOBAL COMPUTER NETWORK; COMPUTER SEARCH ENGINE SOFTWARE; COMPUTER SOFTWARE, NAMELY, ELECTRONIC FINANCIAL PLATFORM THAT ACCOMMODATES MULTIPLE TYPES OF PAYMENT AND DEBT TRANSACTIONS IN AN INTEGRATED MOBILE PHONE, PDA, AND WEB BASED ENVIRONMENT; COMPUTER SOFTWARE, NAMELY, SOFTWARE DEVELOPMENT TOOLS FOR THE CREATION OF MOBILE INTERNET APPLICATIONS AND CLIENT INTERFACES; DOWNLOADABLE MOBILE APPLICATIONS FOR SEARCHING, ORGANIZING AND SHARING PREFERENCES AND SUGGESTIONS, WEB BROWSING, ONLINE FINANCIAL TRANSACTIONS AND E-COMMERCE TRANSACTIONS, LOCATION BASED SEARCHING, MOBILE PAYMENTS, SPEECH RECOGNITION, DATA STORAGE AND RETRIEVAL, DATABASE MANAGEMENT, RESERVATIONS, TRAVEL AND ENTERTAINMENT; DOWNLOADABLE RING TONES AND GRAPHICS FOR MOBILE PHONES (U.S. CLS. 21, 23, 26, 36 AND 38).

EVIN L. KOZAK, EXAMINING ATTORNEY

SN 86-250,446. GLIMPSE LABS, INC., OAKLAND GARDENS, NY. FILED 4-11-2014.

# LIFE CYCLE EPHEMERALITY

THE MARK CONSISTS OF STANDARD CHARACTERS WITHOUT CLAIM TO ANY PARTICULAR FONT, STYLE, SIZE, OR COLOR.

FOR COMPUTER APPLICATION SOFTWARE FOR MOBILE PHONES, PORTABLE MEDIA PLAYERS, HANDHELD COMPUTERS, AND DESKTOP COMPUTERS, NAMELY, SOFTWARE FOR THE TRANSMISSION OF DIGITAL PHOTOS, IMAGES, DATA AND TEXT VIA A GLOBAL COMPUTER NETWORK; DOWNLOADABLE SOFTWARE FOR THE FACILITATION OF COMMUNICATION AND DATA TRANSMISSION IN THE FIELD OF SOCIAL NETWORKING; DOWNLOADABLE SOFTWARE FOR REAL-TIME SENDING AND RECEIVING OF DATA, TEXT, PHOTOGRAPHS AND IMAGES; DOWNLOADABLE SOFTWARE IN THE NATURE OF A MOBILE APPLICATION FOR SOCIAL NETWORKING (U.S. CLS. 21, 23, 26, 36 AND 38).

TEJBIR SINGH, EXAMINING ATTORNEY

**CLASS 9—(Continued).**

SN 86-250,482. LUCAS LLACH, BUENOS AIRES, ARGENTINA, FILED 4-11-2014.

# TipType

THE MARK CONSISTS OF STANDARD CHARACTERS WITHOUT CLAIM TO ANY PARTICULAR FONT, STYLE, SIZE, OR COLOR.

FOR KEYBOARDS FOR MOBILE PHONES (U.S. CLS. 21, 23, 26, 36 AND 38).

BRITNEY COGAN, EXAMINING ATTORNEY

SN 86-250,555. KREATIVE LAND INTERNATIONAL, INC., ROAD TOWN, TORTOLA, BR.VIRGIN ISLANDS, FILED 4-12-2014.

# Hello Pal

THE MARK CONSISTS OF STANDARD CHARACTERS WITHOUT CLAIM TO ANY PARTICULAR FONT, STYLE, SIZE, OR COLOR.

FOR DOWNLOADABLE SOFTWARE FOR USE ON MOBILE AND DESKTOP PLATFORMS FOR SOCIAL NETWORKING, COMMUNICATING WITH OTHERS IN A FOREIGN LANGUAGE, AND LEARNING ANOTHER LANGUAGE; DOWNLOADABLE SOFTWARE FOR LEARNING ANOTHER LANGUAGE; DOWNLOADABLE SOFTWARE FOR SOCIAL NETWORKING; DOWNLOADABLE SOFTWARE FOR USE IN COMMUNICATING WITH OTHER PEOPLE IN A FOREIGN LANGUAGE (U.S. CLS. 21, 23, 26, 36 AND 38).

MARC LEIPZIG, EXAMINING ATTORNEY

SN 86-250,575. BALLANTYNE, BRUCE, DBA BRIT VIDEO SYSTEMS, CUMBERLAND, RI. FILED 4-12-2014.

# BRIT VIDEO SYSTEMS



NO CLAIM IS MADE TO THE EXCLUSIVE RIGHT TO USE "VIDEO SYSTEMS", APART FROM THE MARK AS SHOWN.

THE MARK CONSISTS OF THE WORDS "BRIT VIDEO SYSTEMS" IN CAPITAL LETTERS, ABOVE A WAVED LINE, ABOVE A LINE WITH 8 BOXED EDGES WHICH CLOSES THE WAVED LINE AT EACH SIDE.

FOR ELECTRONIC EQUIPMENT, NAMELY, CONVERTORS, PROCESSORS, ROUTERS, AND DISTRIBUTION SYSTEMS COMPRISED OF DISTRIBUTION AMPLIFIERS, SYNCHRONIZERS, ENCODERS, DECODERS, AND TRANSCIEVERS THAT CONVERT ANALOG BROADCAST SIGNALS TO DIGITAL BROADCAST SIGNALS USED MAINLY BY TELEVISION STATIONS (U.S. CLS. 21, 23, 26, 36 AND 38).

FIRST USE 1-1-2001; IN COMMERCE 1-1-2001.

JOHN WILKE, EXAMINING ATTORNEY

**CLASS 9—(Continued).**

SN 86-250,751. XSKY INC, VALENCIA, CA. FILED 4-13-2014.

# xSky

THE MARK CONSISTS OF STANDARD CHARACTERS WITHOUT CLAIM TO ANY PARTICULAR FONT, STYLE, SIZE, OR COLOR.

FOR COMPUTER APPLICATION SOFTWARE FOR MOBILE PHONES, NAMELY, SOFTWARE FOR FOR SEARCHING, IDENTIFYING, DISPLAYING AND DESCRIBING CELESTIAL OBJECTS (U.S. CLS. 21, 23, 26, 36 AND 38).

FIRST USE 4-5-2014; IN COMMERCE 4-5-2014.  
ERIN FALK, EXAMINING ATTORNEY

**CLASS 9—(Continued).**

SN 86-250,844. CLASSIC PUBLISHING SYSTEMS LTD, HONG KONG, HONG KONG, FILED 4-14-2014.



SN 86-250,787. MTCOMPANY, AMSTERDAM, NETHERLANDS, FILED 4-13-2014.

# UseClark

THE MARK CONSISTS OF STANDARD CHARACTERS WITHOUT CLAIM TO ANY PARTICULAR FONT, STYLE, SIZE, OR COLOR.

FOR DOCUMENT READER SOFTWARE USED TO FACILITATE READING SPEED AND COMPREHENSION (U.S. CLS. 21, 23, 26, 36 AND 38).

MICHAEL WIENER, EXAMINING ATTORNEY

THE MARK CONSISTS OF A GRAPHIC PANDA BEAR FACE WITH A SHOOTING STAR THAT IS CIRCLING ITS HEAD AND HAS THE PHRASE "PANDA PLANET" WRITTEN ON THE STREAM FROM THE STAR.

FOR CHILDREN'S EDUCATIONAL MUSIC CDS AND DVDS; COMPUTER APPLICATION SOFTWARE FOR MOBILE PHONES, NAMELY, SOFTWARE FOR INTERACTIVE COMPUTER GAMES; COMPUTER APPLICATION SOFTWARE FOR MOBILE PHONES, PERSONAL COMPUTERS, TABLETS AND WIRELESS DEVICES, NAMELY, SOFTWARE FOR INTERACTIVE COMPUTER GAMES; COMPUTER GAME PROGRAMMES DOWNLOADABLE VIA THE INTERNET; COMPUTER GAME PROGRAMS; COMPUTER GAME SOFTWARE FOR USE WITH PERSONAL COMPUTERS, HOME VIDEO GAME CONSOLES USED WITH TELEVISIONS AND ARCADE-BASED VIDEO GAME CONSOLES; DIGITAL MEDIA, NAMELY, PRE-RECORDED VIDEO CASSETTES, DIGITAL VIDEO DISCS, DIGITAL VERSATILE DISCS, DOWNLOADABLE AUDIO AND VIDEO RECORDINGS, DVDS, AND HIGH DEFINITION DIGITAL DISCS FEATURING 3D CARTOON ANIMATED STORIES; DOWNLOADABLE COMIC STRIPS; DOWNLOADABLE COMPUTER GAME PROGRAMS; DOWNLOADABLE COMPUTER GAME SOFTWARE VIA A GLOBAL COMPUTER NETWORK AND WIRELESS DEVICES; DOWNLOADABLE E-BOOKS IN THE FIELD OF 3D CARTOON ANIMAL CHARACTERS; DOWNLOADABLE ELECTRONIC BOOKS IN THE FIELD OF 3D CARTOON ANIMAL CHARACTERS; DOWNLOADABLE ELECTRONIC GAME SOFTWARE FOR USE ON MOBILE AND CELLULAR PHONES, HANDHELD COMPUTERS; DOWNLOADABLE SOFTWARE IN THE NATURE OF A MOBILE APPLICATION FOR INTERACTIVE COMPUTER GAMES; INTERACTIVE GAME PROGRAMS; INTERACTIVE MULTIMEDIA COMPUTER GAME PROGRAMS; INTERACTIVE VIDEO GAME PROGRAMS; MAGNETS; MOTION PICTURE FILMS AND FILMS FOR TELEVISION FEATURING CHILDREN'S ENTERTAINMENT; MUSICAL VIDEO RECORDINGS (U.S. CLS. 21, 23, 26, 36 AND 38).

KATHERINE M. DUBRAY, EXAMINING ATTORNEY

SN 86-250,790. JOHNSON, FRED M., FULLERTON, CA. FILED 4-13-2014.

# GS-1

THE MARK CONSISTS OF STANDARD CHARACTERS WITHOUT CLAIM TO ANY PARTICULAR FONT, STYLE, SIZE, OR COLOR.

FOR TRIBOMETERS (U.S. CLS. 21, 23, 26, 36 AND 38).  
ELLEN B. AWRICH, EXAMINING ATTORNEY

**CLASS 9—(Continued).**

SN 86-252,516. PARTNER SOFTWARE, INC., ATHENS, GA. FILED 4-15-2014.

**POWERED BY PARTNER**

THE MARK CONSISTS OF STANDARD CHARACTERS WITHOUT CLAIM TO ANY PARTICULAR FONT, STYLE, SIZE, OR COLOR.

FOR COMPUTER APPLICATION SOFTWARE FOR MAP VIEWING AND FIELD DATA COLLECTION ON DESKTOP AND LAPTOP COMPUTERS, MOBILE PHONES, HAND-HELD COMPUTERS, TABLET COMPUTERS; SOFTWARE FOR FIELD DATA COLLECTION; COMPUTER SOFTWARE FOR THE COLLECTION, EDITING, ORGANIZING, MODIFYING, BOOK MARKING, TRANSMISSION, STORAGE AND SHARING OF DATA AND INFORMATION; COMPUTER SOFTWARE PLATFORMS FOR MAP VIEWING AND FIELD DATA COLLECTION; COMPUTER SOFTWARE, NAMELY, AN APPLICATION ALLOWING SALES AND FIELD SERVICE EMPLOYEES TO UPDATE AND RECEIVE DATA STORED IN AN ENTERPRISE'S COMPUTER DATABASES IN REAL TIME, USING A MOBILE DEVICE, WITH SOFTWARE FEATURES ON THE MOBILE DEVICE (U.S. CLS. 21, 23, 26, 36 AND 38).

FIRST USE 11-30-2008; IN COMMERCE 2-28-2009.  
TINA L. SNAPP, EXAMINING ATTORNEY

**CLASS 9—(Continued).**

SN 86-255,252. BC MEDIA, INC., PIEDMONT, SC. FILED 4-17-2014.



NO CLAIM IS MADE TO THE EXCLUSIVE RIGHT TO USE "CAMERA CRANE", APART FROM THE MARK AS SHOWN.

THE MARK CONSISTS OF A WHEEL THAT IS ANGLED HAVING TRAPEZOIDAL WEDGE SHAPED PIECES WITH THE "O" AND "R" OF THE WORD "ORION" ON TOP OF A PORTION OF THE WHEEL, THE STYLIZED WORD "ORION" HAVING THE STYLIZED WORDS "CAMERA CRANE" BELOW THE WORD "ORION".

FOR CAMERA CRANES, NAMELY, TRIPOD MOUNTED CAMERA CRANES (U.S. CLS. 21, 23, 26, 36 AND 38).

FIRST USE 2-0-2014; IN COMMERCE 2-0-2014.  
CHERYL CLAYTON, EXAMINING ATTORNEY

SN 86-255,073. BC MEDIA, INC., PIEDMONT, SC. FILED 4-17-2014.



NO CLAIM IS MADE TO THE EXCLUSIVE RIGHT TO USE "JIB", APART FROM THE MARK AS SHOWN.

THE MARK CONSISTS OF THE STYLIZED WORDS "CARRYON JIB" THAT ARE OUTLINED AND IN WHICH PART OF THE OUTLINE FORMS WINGS TO THE LEFT AND RIGHT OF THE WORDS "CARRYON JIB".

FOR CAMERA CRANES, NAMELY, TRIPOD MOUNTED CAMERA CRANES (U.S. CLS. 21, 23, 26, 36 AND 38).

CHERYL CLAYTON, EXAMINING ATTORNEY

SN 86-258,820. SHARP KABUSHIKI KAISHA, TA SHARP CORPORATION, OSAKA, JAPAN, FILED 4-22-2014.

**AQUOS CRYSTAL**

THE MARK CONSISTS OF STANDARD CHARACTERS WITHOUT CLAIM TO ANY PARTICULAR FONT, STYLE, SIZE, OR COLOR.

OWNER OF U.S. REG. NOS. 2,830,322, 4,203,965 AND 4,355,782.

FOR CELL PHONES; SMART PHONES; TABLET COMPUTERS (U.S. CLS. 21, 23, 26, 36 AND 38).

MIROSLAV NOVAKOVIC, EXAMINING ATTORNEY

**CLASS 9—(Continued).**

SN 86-259,298. NVIDIA CORPORATION, SANTA CLARA, CA. FILED 4-22-2014.

# DABBLER

THE MARK CONSISTS OF STANDARD CHARACTERS WITHOUT CLAIM TO ANY PARTICULAR FONT, STYLE, SIZE, OR COLOR.

FOR COMPUTER SOFTWARE FOR CREATING, VIEWING, EDITING, PROCESSING, MANIPULATING, MANAGING, STORING, ORGANIZING, IMPORTING, AND EXPORTING DIGITAL IMAGES, DIGITAL ARTWORK, AND DATA; COMPUTER SOFTWARE FOR DIGITAL DRAWING, SKETCHING, AND PAINTING; COMPUTER SOFTWARE FOR USE IN GRAPHIC DESIGN, DRAWING, PAINTING, AND ENHANCEMENT OF IMAGES; COMPUTER SOFTWARE, NAMELY, GRAPHICS PROCESSING UNIT SOFTWARE, SOFTWARE FOR PROCESSING AND DISPLAY OF MULTIMEDIA CONTENT, AND SOFTWARE FOR OPERATING AND MANAGING INTEGRATED CIRCUIT COMPONENTS; COMPUTER SOFTWARE FOR THE DISPLAY OF DIGITAL MEDIA (U.S. CLS. 21, 23, 26, 36 AND 38).  
MARILYN IZZI, EXAMINING ATTORNEY

**CLASS 9—(Continued).**

SN 86-260,520. MOJIX, INC., LOS ANGELES, CA. FILED 4-23-2014.



OWNER OF U.S. REG. NOS. 3,540,618 AND 3,542,073.  
THE MARK CONSISTS OF THE WORD "MOJIX" SURROUNDED BY TWO ARCS COMPRISING INCOMPLETE OVALS.

FOR RADIO-FREQUENCY IDENTIFICATION (RFID) READERS; SIGNAL PROCESSORS FOR WIRELESS APPLICATIONS, NAMELY, RADIO-FREQUENCY IDENTIFICATION (RFID) APPLICATIONS; SOFTWARE FOR USE WITH RADIO-FREQUENCY IDENTIFICATION (RFID) READERS; SOFTWARE FOR USE IN SUPPLY CHAIN MANAGEMENT AND INVENTORY APPLICATIONS; SOFTWARE FOR MONITORING AND IDENTIFYING RADIO-FREQUENCY IDENTIFICATION (RFID) TAGS; SOFTWARE FOR INVENTORY CONTROL (U.S. CLS. 21, 23, 26, 36 AND 38).

FIRST USE 10-14-2008; IN COMMERCE 10-14-2008.  
MIROSLAV NOVAKOVIC, EXAMINING ATTORNEY

SN 86-260,691. LEADING SOFTWARE MANIACS, MILL CREEK, WA. FILED 4-23-2014.

# Spresso

THE MARK CONSISTS OF STANDARD CHARACTERS WITHOUT CLAIM TO ANY PARTICULAR FONT, STYLE, SIZE, OR COLOR.

FOR DOWNLOADABLE COMPUTER SOFTWARE APPLICATIONS DESIGNED TO PROVIDE PRODUCTIVITY IMPROVEMENTS IN THE NATURE OF MANAGING FILES IN A SERIES OF VERSION BACKUPS OR MANAGING THE DOCUMENT REVIEW PROCESS FOR USE ON DESKTOP COMPUTERS, LAPTOP COMPUTERS AND SMARTPHONES (U.S. CLS. 21, 23, 26, 36 AND 38).

FIRST USE 6-1-2013; IN COMMERCE 7-5-2013.  
KAREN BRACEY, EXAMINING ATTORNEY

SN 86-260,060. NEXT AUDIO LABS, LLC., ALISO VIEJO, CA. FILED 4-23-2014.



THE MARK CONSISTS OF A SYLIZED VINYL TURNTABLE WITH A SQUARE BASE AND ROUNDED CORNERS, ROUNDED STYLIZED TONE-ARM.

FOR COMPUTER SOFTWARE FOR PROCESSING DIGITAL MUSIC FILES (U.S. CLS. 21, 23, 26, 36 AND 38).  
KAPIL BHANOT, EXAMINING ATTORNEY

SN 86-261,164. SHELBY GROUP INTERNATIONAL, INC., COLLIERVILLE, TN. FILED 4-24-2014.

# PREDAGRIP

THE MARK CONSISTS OF STANDARD CHARACTERS WITHOUT CLAIM TO ANY PARTICULAR FONT, STYLE, SIZE, OR COLOR.

FOR PROTECTIVE GLOVES FOR INDUSTRIAL USE (U.S. CLS. 21, 23, 26, 36 AND 38).

REBECCA GILBERT, EXAMINING ATTORNEY

**CLASS 9—(Continued).**

SN 86-264,228. ZEIKOS INC., EDISON, NJ. FILED 4-28-2014.

**ENERGY FOR MUSIC**

THE MARK CONSISTS OF STANDARD CHARACTERS WITHOUT CLAIM TO ANY PARTICULAR FONT, STYLE, SIZE, OR COLOR.

FOR ADAPTER PLUGS; AUDIO CABLES; AUDIO SPEAKERS; BATTERY CASES; BATTERY CHARGE DEVICES; BATTERY CHARGERS; DIGITAL CAMERAS; EARPHONES AND HEADPHONES; FITTED PLASTIC FILMS KNOWN AS SKINS FOR COVERING AND PROVIDING A SCRATCH PROOF BARRIER OR PROTECTION FOR ELECTRONIC DEVICES, NAMELY, MP3 PLAYERS, MOBILE TELEPHONES, SMART TELEPHONES, DIGITAL CAMERAS, GLOBAL POSITIONING SYSTEMS AND PERSONAL DIGITAL ASSISTANTS; GLOBAL POSITIONING SYSTEM (GPS); MOBILE RADIOS; MP3 PLAYERS; PERSONAL DIGITAL ASSISTANTS (PDA); PERSONAL STEREO; PORTABLE MEDIA PLAYERS; PORTABLE RADIOS; POWER CABLES; PROTECTIVE CARRYING CASES FOR PORTABLE MUSIC PLAYERS; SMARTPHONES; SPECIALTY HOLSTERS ADAPTED FOR CARRYING PERSONAL ELECTRONIC DEVICES, NAMELY, MP3 PLAYERS, RADIO TRANSMITTERS, RADIOS; USB CABLES; WIRELESS INDOOR AND OUTDOOR SPEAKERS (U.S. CLS. 21, 23, 26, 36 AND 38).

FIRST USE 4-1-2014; IN COMMERCE 4-1-2014.  
PATRICIA EVANKÓ, EXAMINING ATTORNEY

SN 86-265,079. STAR ASSET INTERNATIONAL LIMITED, THE VALLEY, ANGUILLA, FILED 4-29-2014.

**Willsonite**

THE MARK CONSISTS OF STANDARD CHARACTERS WITHOUT CLAIM TO ANY PARTICULAR FONT, STYLE, SIZE, OR COLOR.

FOR EYEGLASS CASES, EYEGLASS CHAINS, EYEGLASS CASES, EYEGLASS FRAMES, EYEGLASSES, EYEPIECES, GÖGGLES FOR SPORTS, DIVERS' MASKS, OPTICAL LENSES, SUNGLASSES (U.S. CLS. 21, 23, 26, 36 AND 38).

FIRST USE 2-1-2014; IN COMMERCE 2-1-2014.  
WILLIAM ROSSMAN, EXAMINING ATTORNEY

SN 86-267,287. SHARP KABUSHIKI KAISHA, TA SHARP CORPORATION, OSAKA, JAPAN, FILED 4-30-2014.

**AQUOS Crystal**

OWNER OF U.S. REG. NOS. 2,830,322, 4,203,965 AND 4,355,782.

THE MARK CONSISTS OF THE WORDING "AQUOS CRYSTAL" WITH THE WORD "AQUOS" IN ALL CAPS AND THE WORD "CRYSTAL" IN INITIAL CAPS.

FOR CELL PHONES; SMART PHONES; TABLET COMPUTERS (U.S. CLS. 21, 23, 26, 36 AND 38).  
MIROSLAV NOVAKOVIC, EXAMINING ATTORNEY

**CLASS 9—(Continued).**

SN 86-267,349. MAZIK GLOBAL TECHNOLOGIES, INC., PARK RIDGE, IL. FILED 4-30-2014.

**MAZIKAX FOR CHEMICAL**

THE MARK CONSISTS OF STANDARD CHARACTERS WITHOUT CLAIM TO ANY PARTICULAR FONT, STYLE, SIZE, OR COLOR.

NO CLAIM IS MADE TO THE EXCLUSIVE RIGHT TO USE "FOR CHEMICAL", APART FROM THE MARK AS SHOWN.

THE WORDING "MAZIKAX" HAS NO MEANING IN A FOREIGN LANGUAGE.

FOR DOWNLOADABLE CLOUD COMPUTER SOFTWARE AND COMPUTER SOFTWARE FOR CONTROLLING, MEASURING AND MANAGING COMPANY OPERATIONS IN THE FIELDS OF BUSINESS AND PROJECT MANAGEMENT, SOFTWARE DEVELOPMENT, MANUFACTURING PROCESS CONTROL AND ENTERPRISE RESOURCE PLANNING SERVICES FOR THE CHEMICAL MANUFACTURING AND HEALTH-CARE INDUSTRIES (U.S. CLS. 21, 23, 26, 36 AND 38).

KEVON CHISOLM, EXAMINING ATTORNEY

SN 86-268,489. CONFIDENCE THROUGH CHARACTERS, INC., DEL MAR, CA. FILED 5-1-2014.

**Girls Got Guts**

THE MARK CONSISTS OF STANDARD CHARACTERS WITHOUT CLAIM TO ANY PARTICULAR FONT, STYLE, SIZE, OR COLOR.

FOR DOWNLOADABLE MOBILE APPLICATIONS FEATURING CHILDREN'S BOOKS AND INTERACTIVE STORY-BASED ENTERTAINMENT AND EDUCATION (U.S. CLS. 21, 23, 26, 36 AND 38).

CAROLINE WOOD, EXAMINING ATTORNEY

SN 86-268,510. CONFIDENCE THROUGH CHARACTERS, INC., DEL MAR, CA. FILED 5-1-2014.

**Girlz Got Gutz**

THE MARK CONSISTS OF STANDARD CHARACTERS WITHOUT CLAIM TO ANY PARTICULAR FONT, STYLE, SIZE, OR COLOR.

FOR DOWNLOADABLE MOBILE APPLICATIONS FEATURING CHILDREN'S BOOKS AND INTERACTIVE STORY-BASED ENTERTAINMENT AND EDUCATION (U.S. CLS. 21, 23, 26, 36 AND 38).

CAROLINE WOOD, EXAMINING ATTORNEY



**CLASS 9—(Continued).**

SN 86-270,084. TEKTRONIX, INC., BEAVERTON, OR. FILED 5-2-2014.

# TEKBOX

THE MARK CONSISTS OF STANDARD CHARACTERS WITHOUT CLAIM TO ANY PARTICULAR FONT, STYLE, SIZE, OR COLOR.

FOR ELECTRONIC TEST AND MEASUREMENT APPARATUS, NAMELY, APPARATUS IN THE NATURE OF A WIRELESS SIGNAL INTERFACE CONVERTER FOR CONNECTING ELECTRONIC TEST AND MEASUREMENT INSTRUMENTS TO A COMMUNICATIONS NETWORK (U.S. CLS. 21, 23, 26, 36 AND 38).

SIDDHARTH JAGANNATHAN, EXAMINING ATTORNEY

SN 86-270,269. ELECTRIC CLOUD, INC., SUNNYVALE, CA. FILED 5-2-2014.

ELECTRICACCELERATOR HUDDLE

THE MARK CONSISTS OF STANDARD CHARACTERS WITHOUT CLAIM TO ANY PARTICULAR FONT, STYLE, SIZE, OR COLOR.

FOR COMPUTER SOFTWARE DEVELOPMENT TOOLS; COMPUTER SOFTWARE USED TO AUTOMATE THE PROCESS OF BUILDING COMPUTER SOFTWARE; COMPUTER SOFTWARE FOR USE IN THE COMPILING AND LINKING PROCESS OF SOFTWARE DEVELOPMENT; COMPUTER SOFTWARE FOR MONITORING, MANAGING, ANALYZING, AND REPORTING ON THE DEVELOPMENT AND BUILDING OF COMPUTER SOFTWARE (U.S. CLS. 21, 23, 26, 36 AND 38).

ZACHARY BELLO, EXAMINING ATTORNEY

**CLASS 9—(Continued).**

SN 86-271,336. HUANG, HETAO, SAN FRANCISCO, CA. AND SONG, TINGYONG, BEIJING, CHINA, FILED 5-5-2014.

# eLink Pro

THE MARK CONSISTS OF STANDARD CHARACTERS WITHOUT CLAIM TO ANY PARTICULAR FONT, STYLE, SIZE, OR COLOR.

NO CLAIM IS MADE TO THE EXCLUSIVE RIGHT TO USE "ELINK", APART FROM THE MARK AS SHOWN.

FOR AUDIO AMPLIFIERS, AUDIO SPEAKERS, AUDIO RECEIVERS, ELECTRICAL AUDIO AND SPEAKER CABLES AND CONNECTORS, AUDIO DECODERS, VIDEO DECODERS, SPEAKERS, POWER CONVERSION DEVICES, POWER CONVERTERS, AND POWER INVERTERS; CELL PHONE BATTERY CHARGERS; CHARGERS FOR BATTERIES; HEADPHONES; HEADSETS FOR CELLULAR OR MOBILE PHONES; HEADSETS FOR USE WITH COMPUTERS; INTEROPERABLE COMMUNICATION SYSTEM DESIGNED TO PROVIDE RADIO, STREAMING VIDEO, WIRELESS INTERNET, AND VOIP PHONE; RADIOS; MICROPHONES; ELECTRICAL OUTLETS; ELECTRICAL POWER DEVICES, NAMELY, MULTIMEDIA OUTLETS; POWER ADAPTERS; EARPHONE; EARPHONE ACCESSORIES, NAMELY, EARPHONE CUSHIONS, EARPHONE PADS, CORD MANAGEMENT SYSTEMS, EARPHONE CASES, AND EARPHONE EXTENSION CORDS; TWO-WAY RADIOS; LIGHT EMITTING DIODE (LED) DISPLAYS; LIGHT EMITTING DIODES (LED); LIGHTING CONTROLS; LCD PANELS; EYEGLASSES; CONVERTERS, ANALOG TO DIGITAL CONVERTER; ANALOGUE TO DIGITAL CONVERTERS; CABLE TELEVISION CONVERTERS; COMPUTER APPARATUS, NAMELY, A CONVERTER THAT SUPERIMPOSES AN ETHERNET SIGNAL ON AN EXISTING CABLE; CONVERTERS FOR ELECTRIC PLUGS; CURRENT CONVERTERS; DC/AC POWER CONVERTERS; DIGITAL PHOTO IMAGE CONVERTERS, HIGH DEFINITION MULTIMEDIA INTERFACE CABLES; DUCTING FOR ELECTRIC CABLES; ELECTRIC CABLES, WIRES, CONDUCTORS AND CONNECTION FITTINGS THEREFOR; ELECTRIC CHARGING CABLES; ELECTRICAL CABLES FOR MUSICAL INSTRUMENTS; ELECTRICAL CABLES WITH INTEGRATED FITTINGS, NAMELY, CORDSETS; ELECTRONIC AND OPTICAL COMMUNICATIONS INSTRUMENTS AND COMPONENTS, NAMELY, CABLE TELEVISION TRANSMITTERS; ETHERNET CABLES; EXTENSION CABLES; JUMP START CABLES; MICROPHONE CABLES; GUITAR CABLES; COMPUTER KEYBOARD CONTROLLERS; COMPUTER KEYBOARDS; COMPUTER MOUSE; MOUSE MATS; MOUSE PADS; USB CABLES; USB HUBS; USB CARD READERS; USB COMPUTER ACCESS CONTROL KEY; COMPUTER NETWORK ADAPTERS, SWITCHES, ROUTERS AND HUBS; WIRELESS COMPUTER MICE; ARM RESTS FOR USE WITH COMPUTERS; WRIST RESTS FOR USE WITH COMPUTERS; BLANK HARD DRIVES FOR COMPUTERS; BROADBAND POWER LINE COMMUNICATION SYSTEMS FOR TRANSFERRING BROADBAND DATA OVER ELECTRICAL POWER LINES, COMPRISED OF COMPUTER HARDWARE, SOFTWARE AND MODEMS; CARDS AND MICROPROCESSORS FOR COMPUTERS; COMPUTER CABLES; COMPUTER CAMERAS; COMPUTER CARD ADAPTER; COMPUTER HARDWARE; WEBCAMS; ELECTRONIC RODENT CONTROL UNIT ELECTRONIC BOOK READER; ELECTRONIC CARD READERS; ELECTRONIC MEMORY CARD READERS; FLASH CARD READERS; FLASH CARD ADAPTERS; SMART CARD READERS; USB CARD READERS; BAR CODE READERS; BAR CODE SCANNERS; DIGITAL BOOK READERS; MEDIA PLAYERS; DIGITAL AUDIO PLAYERS; DVD PLAYERS; MP3 PLAYERS; PROTECTIVE COVERS AND CASES FOR CELL PHONES, LAPTOPS AND PORTABLE MEDIA PLAYERS; PROTECTIVE COVERS AND CASES FOR TABLET COMPUTERS; PROTECTIVE COVERS FOR ELECTRONIC READING DEVICES; PROTECTIVE COV-

**CLASS 9—(Continued).**

ERS FOR SMARTPHONES; CELL PHONE COVERS; CLEAR PROTECTIVE COVERS SPECIALLY ADAPTED FOR PERSONAL ELECTRONIC DEVICES; LAPTOP CARRYING CASES; NOTEBOOK COMPUTER CARRYING CASES; BAGS AND CASES SPECIALLY ADAPTED FOR HOLDING OR CARRYING PORTABLE TELEPHONES AND TELEPHONE EQUIPMENT AND ACCESSORIES; BAGS FOR CAMERAS AND PHOTOGRAPHIC EQUIPMENT; BRIEFCASES SPECIALLY ADAPTED FOR HOLDING LAPTOP COMPUTERS; CAMERA CASES; EYEWEAR CASES; EYEGLASS CASES; CAMERA CASES; BACKPACKS ESPECIALLY ADAPTED FOR HOLDING LAPTOPS AND NOTEBOOK COMPUTERS; BACKPACKS ESPECIALLY ADAPTED FOR HOLDING LAPTOPS; CAMERA HANDLES; CAMERA MOUNTS AND SUPPORTS; CAMERA TRIPODS; WIRELESS RECEIVERS AND TRANSMITTERS FOR PORTABLE MEDIA PLAYERS; WIRELESS ROUTERS; WIRELESS TELEPHONES (U.S. CLS. 21, 23, 26, 36 AND 38).

ROBERT C. CLARK JR., EXAMINING ATTORNEY

---

SN 86-271,374. PANAMA JACK INTERNATIONAL, INC., ORLANDO, FL. FILED 5-5-2014.

**PJ OUTFITTER**

THE MARK CONSISTS OF STANDARD CHARACTERS WITHOUT CLAIM TO ANY PARTICULAR FONT, STYLE, SIZE, OR COLOR.

NO CLAIM IS MADE TO THE EXCLUSIVE RIGHT TO USE "OUTFITTER", APART FROM THE MARK AS SHOWN.

FOR SUNGLASSES, CASES FOR EYEGLASSES AND SUNGLASSES, EYEGLASSES, EYEGLASS FRAMES AND EYEGLASS ACCESSORIES NAMELY, CORDS AND NOSE PADS (U.S. CLS. 21, 23, 26, 36 AND 38).

CAROLINE WOOD, EXAMINING ATTORNEY

---

SN 86-271,403. PANAMA JACK INTERNATIONAL, INC., ORLANDO, FL. FILED 5-5-2014.

**PANAMA JACK OUTFITTERS**

THE MARK CONSISTS OF STANDARD CHARACTERS WITHOUT CLAIM TO ANY PARTICULAR FONT, STYLE, SIZE, OR COLOR.

OWNER OF U.S. REG. NOS. 1,325,935, 1,328,519 AND 1,354,252.

NO CLAIM IS MADE TO THE EXCLUSIVE RIGHT TO USE "OUTFITTERS", APART FROM THE MARK AS SHOWN.

THE NAME(S), PORTRAIT(S), AND/OR SIGNATURE(S) SHOWN IN THE MARK DOES NOT IDENTIFY A PARTICULAR LIVING INDIVIDUAL.

FOR SUNGLASSES, CASES FOR EYEGLASSES AND SUNGLASSES, EYEGLASSES, EYEGLASS FRAMES AND EYEGLASS ACCESSORIES NAMELY, CORDS AND NOSE PADS (U.S. CLS. 21, 23, 26, 36 AND 38).

CAROLINE WOOD, EXAMINING ATTORNEY

**CLASS 9—(Continued).**

SN 86-272,368. EYEFLUENCE, INC., RENO, NV. FILED 5-5-2014.

**EYEUI**

THE MARK CONSISTS OF STANDARD CHARACTERS WITHOUT CLAIM TO ANY PARTICULAR FONT, STYLE, SIZE, OR COLOR.

FOR COMPUTER HARDWARE AND SOFTWARE FOR PROVIDING A USER INTERFACE INVOLVING EYE TRACKING AND/OR EYE MOVEMENT FOR WEARABLE DEVICES (U.S. CLS. 21, 23, 26, 36 AND 38).

BERNICE MIDDLETON, EXAMINING ATTORNEY

---

SN 86-275,289. SPECULATIVE PRODUCT DESIGN, LLC, DBA SPECK PRODUCTS, MOUNTAIN VIEW, CA. FILED 5-8-2014.

**SHOWFOLIO**

THE MARK CONSISTS OF STANDARD CHARACTERS WITHOUT CLAIM TO ANY PARTICULAR FONT, STYLE, SIZE, OR COLOR.

FOR PROTECTIVE CARRYING CASES FOR PORTABLE ELECTRONIC LISTENING DEVICES AND MUSIC PLAYERS, NAMELY, MP3 PLAYERS, AND FOR PORTABLE COMPUTERS, GLOBAL POSITIONING SYSTEMS (GPS DEVICES), MOBILE AND CELLULAR TELEPHONES, PORTABLE MEDIA PLAYERS, AND PERSONAL DIGITAL ASSISTANTS (U.S. CLS. 21, 23, 26, 36 AND 38).

CYNTHIA RINALDI, EXAMINING ATTORNEY

---

SN 86-279,671. MONSTER, INC., BRISBANE, CA. FILED 5-13-2014.

**MYOS**

THE MARK CONSISTS OF STANDARD CHARACTERS WITHOUT CLAIM TO ANY PARTICULAR FONT, STYLE, SIZE, OR COLOR.

FOR ELECTRICAL CONTROL COMPONENTS AND ACCESSORIES, NAMELY, POWER CONDITIONERS, POWER CELL RE-CHARGERS, POWER AMPLIFIERS, VOLTAGE STABILIZERS, CURRENT STABILIZERS, ELECTRICAL SURGE PROTECTORS, CIRCUIT CHARGERS AND CIRCUIT BREAKERS; POWERSTRIPS; UNINTERRUPTIBLE POWER SUPPLY DEVICES; CONTROL PROTOCOL SOFTWARE FEATURING INTEROPERABILITY STANDARDS, HARDWARE, AND CONTROLLERS FOR CENTRALIZED HOME CONTROL, NAMELY, FOR CONTROLLING RESIDENTIAL LIGHTING, TELEPHONE SYSTEMS, HEATING, VENTILATION, AIR CONDITIONING SYSTEMS, AND AUDIO AND VIDEO DEVICES (U.S. CLS. 21, 23, 26, 36 AND 38).

JOHN DALIER, EXAMINING ATTORNEY

**CLASS 9—(Continued).**

SN 86-281,393. WOOLLEY, BRETT H. GILBERT, AZ. AND WOOLLEY, CARLY R. GILBERT, AZ. FILED 5-14-2014.



THE COLOR(S) GREEN, PINK, ORANGE, BLUE, YELLOW, RED, PURPLE, AND LIGHT BLUE IS/ARE CLAIMED AS A FEATURE OF THE MARK.

THE MARK CONSISTS OF THE WORDING "SQUARE BUNNIES" IN STYLIZED FONT. THE LETTER "Q" APPEARS UPSIDE DOWN AND IN PINK FONT. THE REMAINING LETTERS IN THE WORDING ARE COLORED AS FOLLOWS: THE LETTER "S" IN "SQUARE" APPEARS IN GREEN, THE LETTER "U" IN "SQUARE" APPEARS IN ORANGE, THE LETTER "A" IN "SQUARE" APPEARS IN BLUE, THE LETTER "R" IN "SQUARE" APPEARS IN YELLOW, THE LETTER "E" IN "SQUARE" APPEARS IN RED, THE LETTER "B" IN "BUNNIES" APPEARS IN ORANGE, THE LETTER "U" IN "BUNNIES" APPEARS IN YELLOW, THE FIRST LETTER "N" IN "BUNNIES" APPEARS IN LIGHT BLUE, THE SECOND LETTER "N" IN "BUNNIES" APPEARS IN PURPLE, THE LETTER "I" IN "BUNNIES" APPEARS IN BLUE, THE LETTER "E" IN "BUNNIES" APPEARS IN GREEN, AND THE LETTER "S" IN "BUNNIES" APPEARS IN PINK.

FOR DOWNLOADABLE COMPUTER GRAPHICS (U.S. CLS. 21, 23, 26, 36 AND 38).

FIRST USE 4-8-2014; IN COMMERCE 5-10-2014.  
MATTHEW GALAN, EXAMINING ATTORNEY

SN 86-281,448. MONSTER, INC., BRISBANE, CA. FILED 5-14-2014.

YOU'VE GOT TO HEAR IT TO  
BELIEVE IT

THE MARK CONSISTS OF STANDARD CHARACTERS WITHOUT CLAIM TO ANY PARTICULAR FONT, STYLE, SIZE, OR COLOR.

FOR ELECTRICAL AND ELECTROMAGNETIC SIGNAL TRANSMITTING, AMPLIFYING, RECEIVING, AND CONVERTING DEVICES, NAMELY, CABLES, WIRES, CONNECTORS, AND CONTROL DEVICES FOR USE WITH ELECTRICAL, ELECTRONIC, AND COMPUTER DEVICES; ELECTRICAL AND ELECTRONIC SIGNAL WIRELESS REMOTE CONTROLLERS AND SIGNAL PROCESSORS, SENDERS, AND RECEIVERS FOR SENDING RECEIVING, AND CONTROLLING AUDIO, VIDEO, COMPUTER, APPLIANCES, COMPUTERS, HEATING AND AIR, AND SECURITY SYSTEMS; COMPUTER COMPONENTS AND ACCESSORIES, NAMELY COMPUTER PERIPHERALS, COMPUTER CABLES, AND COMPUTER CONNECTORS; AUDIO EQUIPMENT AND ACCESSORIES, NAMELY SPEAKERS, SUBWOOFERS, POWER AMPLIFIERS, AUDIO

**CLASS 9—(Continued).**

SIGNAL EQUALIZERS; VIDEO EQUIPMENT AND ACCESSORIES, NAMELY DIGITAL MEDIA RECORDERS AND DIGITAL MEDIA PLAYERS; SPEAKERS; SPEAKER DOCKS, LAPTOP CASES; CELL PHONE CASES AND ACCESSORIES, NAMELY CELL PHONE CASES, CHARGERS, AND CONNECTING CABLES; MOUNTING DEVICES FOR FLAT SCREEN VIDEO DISPLAYS; VIDEO CAPTURE SYSTEMS NAMELY, DRIVES AND MEDIA FOR VIDEO STORAGE; DIGITAL AUDIO PLAYERS; MEDIA PLAYERS; ELECTRICAL POWER CONTROL COMPONENTS AND ACCESSORIES, NAMELY POWER CONDITIONERS, POWER CELL RE-CHARGERS, POWER AMPLIFIERS, VOLTAGE STABILIZERS, CURRENT STABILIZERS, ELECTRICAL SURGE PROTECTORS, CIRCUIT CHARGERS AND CIRCUIT BREAKERS; POWER LINE COMMUNICATION EQUIPMENT, NAMELY SIGNAL PROCESSORS, SENDERS, AND RECEIVERS FOR TRANSMITTING AND RECEIVING AUDIO, VIDEO, AND DATA OVER POWER LINES; EYEWEAR; HEADPHONES; ELECTRONIC DOCKING STATIONS (U.S. CLS. 21, 23, 26, 36 AND 38).

JOHN DALIER, EXAMINING ATTORNEY

SN 86-286,855. ARGENTO SC, NEW YORK, NY. FILED 5-20-2014.

DESIGN NATION

THE MARK CONSISTS OF STANDARD CHARACTERS WITHOUT CLAIM TO ANY PARTICULAR FONT, STYLE, SIZE, OR COLOR.

FOR PROTECTIVE CARRYING CASES FOR PORTABLE MUSIC PLAYERS; PROTECTIVE CARRYING CASES SPECIALLY ADAPTED FOR GLOBAL POSITIONING SYSTEM (GPS) APPARATUS; CARRYING CASES FOR CELL PHONES AND MOBILE PHONES; PROTECTIVE CARRYING CASES SPECIALLY ADAPTED FOR PERSONAL DIGITAL ASSISTANTS (PDA); AUDIO SPEAKERS (U.S. CLS. 21, 23, 26, 36 AND 38).

COLLEEN DOMBROW, EXAMINING ATTORNEY

**CLASS 9—(Continued).**

SN 86-286,903. ARGENTO SC, NEW YORK, NY. FILED 5-20-2014.



THE MARK CONSISTS OF THE LITERAL ELEMENTS "DESIGN NATION DN" WRITTEN IN A STYLIZED FORM WITH THE WORD "NATION" PLACED BELOW THE WORD "DESIGN AND TO THE RIGHT OF IT, THE LETTERS "DN" WRITTEN IN LOWER CASE ARE PLACED WITHIN A RECTANGLE WITH A HORIZONTAL SOLID LINE PLACED ABOVE THE RECTANGLE.

FOR PROTECTIVE CARRYING CASES FOR PORTABLE MUSIC PLAYERS; PROTECTIVE CARRYING CASES SPECIALLY ADAPTED FOR GLOBAL POSITIONING SYSTEM (GPS) APPARATUS; CARRYING CASES FOR CELL PHONES AND MOBILE PHONES; PROTECTIVE CARRYING CASES SPECIALLY ADAPTED FOR PERSONAL DIGITAL ASSISTANTS (PDA); AUDIO SPEAKERS (U.S. CLS. 21, 23, 26, 36 AND 38).

COLLEEN DOMBROW, EXAMINING ATTORNEY

SN 86-288,868. RAPHAEL BEZERRA DE MIRANDA, RIO DE JANEIRO (RJ), BRAZIL, FILED 5-22-2014.



THE COLOR(S) BLUE, ORANGE, WHITE AND DARK BLUE IS/ARE CLAIMED AS A FEATURE OF THE MARK.

THE MARK CONSISTS OF THE WORDING "WEMUSIC" IN WHITE ON A BLUE RECTANGULAR BACKGROUND, AND THE DESIGN OF A HAND LINED IN DARK BLUE WITH AN UPWARDLY EXTENDED FOREFINGER AND PINKY IN ORANGE INSIDE A WHITE SQUARE WITH CURVED CORNERS, LOCATED TO THE LEFT OF THE WORD.

FOR COMPUTER APPLICATION SOFTWARE FOR MOBILE PHONES, NAMELY, SOFTWARE FOR RECORDING MUSIC; DOWNLOADABLE SOFTWARE IN THE NATURE OF A MOBILE APPLICATION FOR CREATING, EDITING, RECORDING, DUBBING, REPRODUCTION, SEQUENCING, TRANSMISSION, DOWNLOAD AND PLAYBACK OF AUDIO IN THE FIELD OF MUSIC; DOWNLOADABLE SOFTWARE IN THE FIELD OF INTERACTIVE MUSIC THAT ALLOWS THE CONSUMERS TO ENTERTAIN THEMSELVES BY PLAYING, CREATING, RECORDING AND DOWNLOADING MUSIC (U.S. CLS. 21, 23, 26, 36 AND 38).

ODESSA BIBBINS, EXAMINING ATTORNEY

**CLASS 9—(Continued).**

SN 86-289,928. SECRET HEADQUARTERS, INC., DBA GAME ACADEMY, LA JOLLA, CA. FILED 5-22-2014.



THE MARK CONSISTS OF FOUR GREY AND WHITE RECTANGLES ORGANIZED IN A SQUARE. UNDERNEATH THE RECTANGLES ARE THE WORDS "BUILD-BOX" IN GREY.

FOR COMPUTER GAME SOFTWARE; COMPUTER PROGRAMS FOR VIDEO AND COMPUTER GAMES; COMPUTER SOFTWARE DEVELOPMENT TOOLS (U.S. CLS. 21, 23, 26, 36 AND 38).

MEGHAN REINHART, EXAMINING ATTORNEY

SN 86-289,930. SECRET HEADQUARTERS, INC., DBA GAME ACADEMY, LA JOLLA, CA. FILED 5-22-2014.



THE MARK CONSISTS OF A PARTIAL BOX WITH CERTAIN PARTS OF THREE SIDES REMOVED, IN THE COLORS GREY AND WHITE. UNDERNEATH THE BOX ARE THE WORDS "ZEROBOX" IN GREY.

FOR COMPUTER GAME SOFTWARE; COMPUTER PROGRAMS FOR VIDEO AND COMPUTER GAMES; COMPUTER SOFTWARE DEVELOPMENT TOOLS (U.S. CLS. 21, 23, 26, 36 AND 38).

MEGHAN REINHART, EXAMINING ATTORNEY

**CLASS 9—(Continued).**

SN 86-290,968. POLK AUDIO, LLC, BALTIMORE, MD. FILED 5-23-2014.

## LOVE OUT LOUD

THE MARK CONSISTS OF STANDARD CHARACTERS WITHOUT CLAIM TO ANY PARTICULAR FONT, STYLE, SIZE, OR COLOR.

FOR LOUDSPEAKERS (U.S. CLS. 21, 23, 26, 36 AND 38).

NANCY CLARKE, EXAMINING ATTORNEY

SN 86-292,355. MINDAPTIV, LLC, CENTENNIAL, CO. FILED 5-27-2014.

## illumin8 | TV

THE MARK CONSISTS OF STANDARD CHARACTERS WITHOUT CLAIM TO ANY PARTICULAR FONT, STYLE, SIZE, OR COLOR.

NO CLAIM IS MADE TO THE EXCLUSIVE RIGHT TO USE "TV", APART FROM THE MARK AS SHOWN.

FOR COMPUTER SOFTWARE AND HARDWARE FOR REDUCING VIDEO DATA TRANSMITTED, STORED, AND POWER CONSUMPTION, WHILE INCREASING VIDEO RESOLUTION; COMPUTER SOFTWARE AND HARDWARE FOR ENABLING USERS TO INTERACT WITH OBJECTS WITHIN DATA STREAMS, SUCH AS VIDEO, AUDIO, IMAGES, AND TEXT; COMPUTER SOFTWARE FOR COMPRESSING, ENCODING, ENCRYPTING, AND DECODING DATA OF MANY TYPES, SUCH AS VIDEO, AUDIO, IMAGES, AND TEXT ALL OF THE FOREGOING SPECIFICALLY EXCLUDING SOFTWARE USED IN THE FIELDS OF GENETICS, MEDICAL DIAGNOSIS OR TREATMENT, AND SCIENTIFIC OR CLINICAL RESEARCH (U.S. CLS. 21, 23, 26, 36 AND 38).

SUNG IN, EXAMINING ATTORNEY

**CLASS 9—(Continued).**

SN 86-301,869. HY IP HOLDING COMPANY LLC, NEW YORK, NY. FILED 6-5-2014.

## HUDSON YARDS NOW

THE MARK CONSISTS OF STANDARD CHARACTERS WITHOUT CLAIM TO ANY PARTICULAR FONT, STYLE, SIZE, OR COLOR.

FOR SOFTWARE FOR MOBILE DEVICES FOR SHARING OF DATA AND INFORMATION OVER COMPUTER NETWORKS AND SECURE PRIVATE NETWORKS; SOFTWARE FOR USE IN SOCIAL NETWORKING; SOFTWARE THAT ENABLES USERS TO ENTER, TRACK, MANAGE, CALENDAR, MONITOR, GENERATE, AND SHARE INFORMATION; SOFTWARE IN THE NATURE OF A MOBILE APPLICATION FOR DISPLAYING AND SHARING A USER'S LOCATION, AND FINDING AND LOCATING OTHER USERS; SOFTWARE FOR PROVIDING CONSUMER INFORMATION, NAMELY, COMPILATIONS, RANKINGS, RATINGS, REVIEWS, REFERRALS, INFORMATION, AND RECOMMENDATIONS RELATING TO BUSINESSES, RESTAURANTS, SERVICE PROVIDERS, EVENTS, PUBLIC SERVICES AND GOVERNMENT AGENCIES, PARKS AND RECREATIONAL AREAS, RELIGIOUS ORGANIZATIONS AND NONPROFIT ORGANIZATIONS; SOFTWARE FOR DISPLAYING AND SHARING A USER'S LOCATION AND FINDING, LOCATING, AND INTERACTING WITH OTHER USERS AND PLACES; AUGMENTED REALITY SOFTWARE FOR USE IN MOBILE DEVICES FOR INTEGRATING ELECTRONIC DATA WITH REAL WORLD ENVIRONMENTS FOR THE PURPOSE OF LOCATING VEHICLES, LOCATING EVENTS, RECEIVING NEWS AND NOTICES, CREATING MAPS, AND LEARNING ABOUT CURRENT CULTURAL AND SOCIAL DEVELOPMENTS (U.S. CLS. 21, 23, 26, 36 AND 38).

MELISSA VALLILLO, EXAMINING ATTORNEY

SN 86-304,047. IOTTIE, INC., HACKENSACK, NJ. FILED 6-9-2014.

## Click, Tap & Drive Safely

THE MARK CONSISTS OF STANDARD CHARACTERS WITHOUT CLAIM TO ANY PARTICULAR FONT, STYLE, SIZE, OR COLOR.

FOR CARRYING CASES FOR CELL PHONES; CARRYING CASES, HOLDERS, PROTECTIVE CASES AND STANDS FEATURING POWER SUPPLY CONNECTORS, ADAPTORS, SPEAKERS AND BATTERY CHARGING DEVICES, SPECIALLY ADAPTED FOR USE WITH HANDHELD DIGITAL ELECTRONIC DEVICES, NAMELY, CELL PHONES, SMARTPHONES, LAPTOPS, AND PORTABLE MEDIA PLAYERS (U.S. CLS. 21, 23, 26, 36 AND 38).

FIRST USE 4-1-2014; IN COMMERCE 4-1-2014.  
RAUL CORDOVA, EXAMINING ATTORNEY

**CLASS 9—(Continued).**

SN 86-308,791. ATLANTIS COMPUTING, INC., MOUNTAIN VIEW, CA. FILED 6-13-2014.

**HYPERDUPE**

THE MARK CONSISTS OF STANDARD CHARACTERS WITHOUT CLAIM TO ANY PARTICULAR FONT, STYLE, SIZE, OR COLOR.

FOR COMPUTER APPLICATION SOFTWARE TO FACILITATE THE ELECTRONIC STORAGE OF DATA (U.S. CLS. 21, 23, 26, 36 AND 38).

DOUGLAS LEE, EXAMINING ATTORNEY

SN 86-312,582. AINSWORTH GAME TECHNOLOGY LIMITED, NEWINGTON, AUSTRALIA, FILED 6-18-2014.

**FIREPOWER FEVER**

THE MARK CONSISTS OF STANDARD CHARACTERS WITHOUT CLAIM TO ANY PARTICULAR FONT, STYLE, SIZE, OR COLOR.

FOR COMPUTER SOFTWARE AND FIRMWARE FOR GAMES OF CHANCE ON ANY COMPUTERIZED PLATFORM, INCLUDING DEDICATED GAMING CONSOLES, VIDEO BASED SLOT MACHINES, REEL BASED SLOT MACHINES, AND VIDEO LOTTERY TERMINALS (U.S. CLS. 21, 23, 26, 36 AND 38).

VIVIAN MICZNIK FIRST, EXAMINING ATTORNEY

SN 86-320,153. PLANITMAPPER LLC, SANTA FE, NM. FILED 6-25-2014.

**PLANITMAPPER**

THE MARK CONSISTS OF STANDARD CHARACTERS WITHOUT CLAIM TO ANY PARTICULAR FONT, STYLE, SIZE, OR COLOR.

FOR DOWNLOADABLE MOBILE APPLICATIONS FOR THE SEARCH AND COORDINATION OF OUTDOOR ADVENTURE ACTIVITIES WITH OTHER USERS (U.S. CLS. 21, 23, 26, 36 AND 38).

DARRYL SPRUILL, EXAMINING ATTORNEY

**CLASS 9—(Continued).**

SN 86-323,150. QUALCOMM INCORPORATED, SAN DIEGO, CA. FILED 6-27-2014.

**CHROMAFLASH**

THE MARK CONSISTS OF STANDARD CHARACTERS WITHOUT CLAIM TO ANY PARTICULAR FONT, STYLE, SIZE, OR COLOR.

FOR COMPUTER HARDWARE AND SOFTWARE FOR IMPROVING THE QUALITY OF PHOTOGRAPHY IN MOBILE DEVICES (U.S. CLS. 21, 23, 26, 36 AND 38).

JORDAN BAKER, EXAMINING ATTORNEY

SN 86-325,110. JC WORLD BELL WHOLESALE, HACKENSACK, NJ. FILED 7-1-2014.

**CR**

THE MARK CONSISTS OF STANDARD CHARACTERS WITHOUT CLAIM TO ANY PARTICULAR FONT, STYLE, SIZE, OR COLOR.

FOR DIGITAL SCALES (U.S. CLS. 21, 23, 26, 36 AND 38).

JULIE WATSON, EXAMINING ATTORNEY

SN 86-325,679. ARTS OPTICAL COMPANY LIMITED, KWUN TONG, KOWLOON, HONG KONG, FILED 7-1-2014.



THE MARK CONSISTS OF THE LETTERS "U N I Z" IN STYLIZED FONT, ALL AGAINST A BACKGROUND OF SHADED PARALLELOGRAMS.

FOR EYEWEAR, NAMELY, SUNGLASSES, EYEGLASSES AND OPHTHALMIC FRAMES AND CASES THEREFOR, SPECTACLES, OPTICAL FRAMES, CONTACT LENSES, SUNGLASS LENSES, EYEGLASS LENSES, EYEWEAR CASES, EYEWEAR ACCESSORIES, NAMELY, STRAPS, NECK CORDS AND HEAD STRAPS WHICH RESTRAIN EYEWEAR FROM MOVEMENT ON A WEARER (U.S. CLS. 21, 23, 26, 36 AND 38).

MAYUR VAGHANI, EXAMINING ATTORNEY

**CLASS 9—(Continued).**

SN 86-326,408. JC WORLD BELL WHOLESALE, HACKENSACK, NJ. FILED 7-2-2014.

# ZIQ

THE MARK CONSISTS OF STANDARD CHARACTERS WITHOUT CLAIM TO ANY PARTICULAR FONT, STYLE, SIZE, OR COLOR.

FOR PROTECTIVE WORK GLOVES; EXTENSION CORDS; JUMPER CABLES (U.S. CLS. 21, 23, 26, 36 AND 38).

JULIE WATSON, EXAMINING ATTORNEY

SN 86-326,853. DEPANNEUR, INC., SAN FRANCISCO, CA. FILED 7-2-2014.

# YUMBIN

THE MARK CONSISTS OF STANDARD CHARACTERS WITHOUT CLAIM TO ANY PARTICULAR FONT, STYLE, SIZE, OR COLOR.

FOR CUSTOMER SELF SERVICE ELECTRONIC CHECKOUT STATIONS FOR POINT OF SALE (U.S. CLS. 21, 23, 26, 36 AND 38).

SKYE YOUNG, EXAMINING ATTORNEY

SN 86-328,844. EDMONDSON, MICHAEL, LAWRENCE, KS. FILED 7-4-2014.

# FLASH-ON

THE MARK CONSISTS OF STANDARD CHARACTERS WITHOUT CLAIM TO ANY PARTICULAR FONT, STYLE, SIZE, OR COLOR.

FOR COMPUTER APPLICATION SOFTWARE FOR MOBILE PHONES, LAPTOP COMPUTERS, TABLET COMPUTERS, AND COMPUTERS, NAMELY, FOR VOTING, COMMENTARY AND DISCUSSION ON FASHION, FASHION TRENDS, APPAREL, AND ACCESSORIES (U.S. CLS. 21, 23, 26, 36 AND 38).

JORDAN BAKER, EXAMINING ATTORNEY

**CLASS 10—MEDICAL APPARATUS**

SN 79-135,365. XI'AN FOCUSLIGHT TECHNOLOGIES CO., LTD., 710119 SHAANXI, CHINA, FILED 8-7-2013.

# Never stop exploring

OWNER OF INTERNATIONAL REGISTRATION 1173567 DATED 8-7-2013, EXPIRES 8-7-2023.

THE MARK CONSISTS OF THE ENGLISH WORDING "NEVER STOP EXPLORING".

FOR KNIVES FOR SURGICAL PURPOSES; LASERS FOR MEDICAL PURPOSES; ARTIFICIAL SKIN FOR SURGICAL PURPOSES; SUTURE MATERIALS (U.S. CLS. 26, 39 AND 44).

JACLYN KIDWELL WALKER, EXAMINING ATTORNEY

SN 79-137,317. SHENZHEN CE LINK LIMITED, CHINA, FILED 9-6-2013.

# CUPID ENVY

OWNER OF INTERNATIONAL REGISTRATION 1178639 DATED 9-6-2013, EXPIRES 9-6-2023.

THE MARK CONSISTS OF THE WORDS "CUPID ENVY" IN STYLIZED FORM.

FOR BLOOD PRESSURE MEASURING APPARATUS; HEMATOLOGY ANALYZERS FOR MEDICAL DIAGNOSTIC USES; STETHOSCOPES; BLOOD PRESSURE AND DIABETIC DIAGNOSTIC MEDICAL DEVICES; DIAGNOSTIC APPARATUS FOR THE DETECTION OF PERIODONTAL DISEASE; DIAGNOSTIC APPARATUS FOR THE DETECTION OF CANCER; ELECTROMAGNETIC MEDICAL DIAGNOSTIC IMAGING APPARATUS; MEDICAL APPARATUS AND INSTRUMENTS FOR DIAGNOSTIC RADIOPHARMACEUTICAL USE; MRI DIAGNOSTIC APPARATUS; BODY REHABILITATION APPARATUS FOR MEDICAL PURPOSES; MANUALLY-OPERATED EXERCISE EQUIPMENT FOR PHYSICAL THERAPY PURPOSES; PHYSICAL EXERCISE APPARATUS, FOR MEDICAL PURPOSES; DENTAL AND MEDICAL DRILL BITS FOR CUTTING TEETH OR BONE; DENTAL DRILLS; DENTAL INSTRUMENTS, NAMELY, ORAL IRRIGATORS; DENTAL OPERATING LAMPS; HEARING AIDS; ORTHOPEDIC DEVICES FOR DIAGNOSTIC AND THERAPEUTIC USE; THREAD FOR MEDICAL USE; SURGICAL IMPLANTS COMPRISING ARTIFICIAL MATERIAL (U.S. CLS. 26, 39 AND 44).

DAWN FELDMAN, EXAMINING ATTORNEY

SN 79-138,540. FINAPRES MEDICAL SYSTEMS B.V., OLDENZAAL, NETHERLANDS, FILED 8-14-2013.

# FINAPRES NOVA

THE MARK CONSISTS OF STANDARD CHARACTERS WITHOUT CLAIM TO ANY PARTICULAR FONT, STYLE, SIZE, OR COLOR.

PRIORITY DATE OF 3-5-2013 IS CLAIMED.

OWNER OF INTERNATIONAL REGISTRATION 1181940 DATED 8-14-2013, EXPIRES 8-14-2023.

OWNER OF U.S. REG. NO. 3,288,350.

FOR PATIENT MEDICAL MONITORS FOR MONITORING BLOOD PRESSURE, SPHYGMOTENSIO-METERS; HEART RATE MONITORS (U.S. CLS. 26, 39 AND 44).

MICHAEL TANNER, EXAMINING ATTORNEY

**CLASS 10—(Continued).**

SN 79-138,928. INERVENTIONS AB, SE-171 67 SOLNA, SWEDEN, FILED 9-19-2013.

# Mollii

THE MARK CONSISTS OF STANDARD CHARACTERS WITHOUT CLAIM TO ANY PARTICULAR FONT, STYLE, SIZE, OR COLOR.

PRIORITY DATE OF 3-25-2013 IS CLAIMED.

OWNER OF INTERNATIONAL REGISTRATION 1182856 DATED 9-19-2013, EXPIRES 9-19-2023.

FOR MEDICAL APPARATUS, NAMELY, MUSCLE STIMULATION GARMENTS FOR THE PURPOSE OF ELECTRICALLY STIMULATING THE MUSCLES, RELAXING SPASTIC, TENSE AND ACHING MUSCLES, AND ACTIVATING WEAK MUSCULATURE (U.S. CLS. 26, 39 AND 44).

RON FAIRBANKS, EXAMINING ATTORNEY

---

SN 79-140,773. ASALUS MEDICAL INSTRUMENTS LIMITED, CARDIFF, UNITED KINGDOM, FILED 6-21-2013.

# ULTRAVISION

THE MARK CONSISTS OF STANDARD CHARACTERS WITHOUT CLAIM TO ANY PARTICULAR FONT, STYLE, SIZE, OR COLOR.

PRIORITY DATE OF 12-24-2012 IS CLAIMED.

OWNER OF INTERNATIONAL REGISTRATION 1187616 DATED 6-21-2013, EXPIRES 6-21-2023.

FOR IONIZING APPARATUS, NAMELY, ELECTROSTATIC PRECIPITATORS, FOR USE DURING MINIMALLY INVASIVE MEDICAL AND SURGICAL PROCEDURES AND PARTS AND ACCESSORIES THEREFOR; AIRBORNE PARTICLE REMOVAL APPARATUS, NAMELY, ELECTROSTATIC PRECIPITATORS FOR USE DURING MINIMALLY INVASIVE MEDICAL AND SURGICAL PROCEDURES AND PARTS AND ACCESSORIES THEREFOR (U.S. CLS. 26, 39 AND 44).

JORDAN BAKER, EXAMINING ATTORNEY

**CLASS 10—(Continued).**

SN 79-140,878. MIZUHO IKAKOGYO CO., LTD., TOKYO 113-0033, JAPAN, FILED 7-10-2013.

PRIORITY DATE OF 5-16-2013 IS CLAIMED.

OWNER OF INTERNATIONAL REGISTRATION 1187899 DATED 7-10-2013, EXPIRES 7-10-2023.

OWNER OF U.S. REG. NOS. 3,156,641, 3,285,552 AND 4,401,354.

THE COLOR(S) BLUE IS/ARE CLAIMED AS A FEATURE OF THE MARK.

THE MARK CONSISTS OF THE WORD "MIZUHO" IN STYLIZED LETTERING IN THE COLOR BLUE.

THE ENGLISH TRANSLATION OF THE FOREIGN WORD(S) IN THE MARK IS: "MIZUHO" IS AN ARCHAIC JAPANESE TERM MEANING "GOLDEN EARS OF RICE".

FOR SURGICAL AND MEDICAL APPARATUS AND INSTRUMENTS FOR USE IN GENERAL SURGERY; SURGICAL AND MEDICAL APPARATUS AND INSTRUMENTS FOR USE IN ORTHOPEDIC SURGERY; SURGICAL AND MEDICAL APPARATUS AND INSTRUMENTS FOR USE IN SPINAL SURGERY; SURGICAL DOPPLER TRANSCIVERS AND PROBES; HEAD FRAMES FOR HEAD STABILIZATION DURING MEDICAL PROCEDURES AND ACCESSORIES IN THE NATURE OF SNAKE ARM RETRACTORS, BRAIN SPATULAS, COTTON TRAY, INSTRUMENT RECEPTACLE, AND HAND RESTS; SURGICAL TABLES; SURGICAL INSTRUMENT TRAYS; ANEURYSM CLIP AND APPLIERS; SURGICAL CLIPS; SUCTION TUBES; MICRO SCISSORS FOR MEDICAL AND SURGICAL USE; SURGICAL SCISSORS; TISSUE DISSECTORS; RONGEURS; CRANIAL HEADREST SYSTEMS FOR POSITIONING THE HEAD DURING MEDICAL PROCEDURES; ARTIFICIAL BIOMATERIALS FOR DURA SUBSTITUTE; ANASTOMOSIS CLIPS AND APPLIERS; MEDICAL AND SURGICAL KNIVES AND CUTTERS FOR CUTTING HUMAN TISSUE AND ORGANS; MRI DIAGNOSTIC APPARATUS; BONE SCREWS; GOODS OF METAL FOR MEDICAL USE, NAMELY, SCREWS, PLATES, PINS AND PIVOTS; MEDICAL IMPLANTS MADE OF ARTIFICIAL MATERIALS; SURGICAL LIGHTS; MICROSCOPES FOR SURGICAL OPERATIONS (U.S. CLS. 26, 39 AND 44).

ELISSA GARBER KON, EXAMINING ATTORNEY

---

SN 79-145,196. HOME HEALTH PRODUCTS, AFGEKORT HHP, BESLOTEN VENNOOTSCHAP MET BEPERKTE AANSPRAKELIJKHEID, B-9700 OUDENAARDE, BELGIUM, FILED 1-7-2014.

# ANDUBED

PRIORITY DATE OF 10-18-2013 IS CLAIMED.

OWNER OF INTERNATIONAL REGISTRATION 1198533 DATED 1-7-2014, EXPIRES 1-7-2024.

THE MARK CONSISTS OF THE STYLIZED WORDING "ANDUBED".

FOR MASSAGE DEVICES; MASSAGE BEDS, MASSAGE MATTRESSES, MASSAGE BLANKETS AND MASSAGE CHAIRS ALL FOR MEDICAL PURPOSES; MEDICAL PRODUCTS, NAMELY, THERAPEUTIC MATTRESSES, BEDS, SEATS AND CUSHIONS (U.S. CLS. 26, 39 AND 44).

JONATHAN FALK, EXAMINING ATTORNEY



**CLASS 10—(Continued).**

SN 79-148,640. SCOLIOSIS CLINICS AUSTRALIA PTY LTD, AUSTRALIA, FILED 4-4-2014.

# ScoliBrace

THE MARK CONSISTS OF STANDARD CHARACTERS WITHOUT CLAIM TO ANY PARTICULAR FONT, STYLE, SIZE, OR COLOR.

OWNER OF INTERNATIONAL REGISTRATION 1207488 DATED 4-4-2014, EXPIRES 4-4-2024.

FOR ORTHOPAEDIC BRACES, NAMELY, SPINAL ORTHOSIS FOR TREATMENT OF SCOLIOSIS OF THE SPINE (U.S. CLS. 26, 39 AND 44).

BARBARA BROWN, EXAMINING ATTORNEY

---

SN 85-052,298. HOTSPUR TECHNOLOGIES, INC., MOUNTAIN VIEW, CA. FILED 6-1-2010.

# VISIOVALVE

THE MARK CONSISTS OF STANDARD CHARACTERS WITHOUT CLAIM TO ANY PARTICULAR FONT, STYLE, SIZE, OR COLOR.

FOR FLUID INJECTION SYSTEM CONSISTING PRIMARILY OF VALVES SOLD AS A COMPONENT OF CATHETERS (U.S. CLS. 26, 39 AND 44).

FIRST USE 9-0-2012; IN COMMERCE 9-0-2012.

NAKIA HENRY, EXAMINING ATTORNEY

---

SN 85-711,731. HAMAMATSU PHOTONICS K.K., SHIZUOKA, JAPAN, FILED 8-23-2012.

# PDE

THE MARK CONSISTS OF STANDARD CHARACTERS WITHOUT CLAIM TO ANY PARTICULAR FONT, STYLE, SIZE, OR COLOR.

OWNER OF JAPAN REG. NO. 4890119, DATED 8-26-2005, EXPIRES 8-26-2015.

FOR NEAR-INFRARED RAY CAMERAS FOR MEDICAL PURPOSES; ENDOSCOPY CAMERAS; RIGID AND FLEXIBLE MEDICAL ENDOSCOPES; ENDOSCOPIC EQUIPMENT; SURGICAL INSTRUMENTS AND APPARATUS (U.S. CLS. 26, 39 AND 44).

DEBORAH MEINERS, EXAMINING ATTORNEY

**CLASS 10—(Continued).**

SN 85-913,962. R2T2 SOLUTIONS LLC, SAG HARBOR, NY. FILED 4-24-2013.

# THERMAL POWER

THE MARK CONSISTS OF STANDARD CHARACTERS WITHOUT CLAIM TO ANY PARTICULAR FONT, STYLE, SIZE, OR COLOR.

NO CLAIM IS MADE TO THE EXCLUSIVE RIGHT TO USE "THERMAL", APART FROM THE MARK AS SHOWN.

FOR MASSAGE AND COMPRESSION DEVICE FOR MEDICAL, THERAPEUTIC, AND ATHLETIC PERFORMANCE ENHANCEMENT (U.S. CLS. 26, 39 AND 44).

JESSICA FATHY, EXAMINING ATTORNEY

---

SN 85-927,271. KONINKLIJKE PHILIPS N.V., 5656 AE EINDHOVEN, NETHERLANDS, FILED 5-9-2013.

# ANATOMICAL INTELLIGENCE

THE MARK CONSISTS OF STANDARD CHARACTERS WITHOUT CLAIM TO ANY PARTICULAR FONT, STYLE, SIZE, OR COLOR.

NO CLAIM IS MADE TO THE EXCLUSIVE RIGHT TO USE "ANATOMICAL", APART FROM THE MARK AS SHOWN.

FOR MEDICAL APPARATUS AND INSTRUMENTS, NAMELY, X-RAY, MRI, ULTRASOUND AND COMPUTED TOMOGRAPHY (CT) BASED APPARATUS AND SYSTEMS COMPRISED PRIMARILY OF ULTRASOUND PROBES, ULTRASOUND TRANSDUCERS, X-RAY CT SCANNERS, ULTRASOUND, CT, X-RAY AND MRI IMAGERS, AND ALSO INCLUDING ULTRASOUND, CT, X-RAY AND MRI CONSOLES, ULTRASOUND, CT, X-RAY AND MRI USER INTERFACE HARDWARE AND SOFTWARE, ULTRASOUND, CT, X-RAY AND MRI DATA PROCESSORS, AND ULTRASOUND, CT, X-RAY AND MRI CONTROLLERS, ALL FOR MEDICAL DIAGNOSTIC AND INTERVENTIONAL IMAGING APPLICATIONS (U.S. CLS. 26, 39 AND 44).

APRIL ROACH, EXAMINING ATTORNEY

**CLASS 10—(Continued).**

SN 85-962,967. C. R. BARD, INC., MURRAY HILL, NJ. FILED 6-18-2013.

# OptiFix

THE MARK CONSISTS OF STANDARD CHARACTERS WITHOUT CLAIM TO ANY PARTICULAR FONT, STYLE, SIZE, OR COLOR.

OWNER OF U.S. REG. NOS. 1,448,324 AND 1,639,642.  
FOR MEDICAL AND SURGICAL DEVICES AND APPARATUS, NAMELY, SURGICAL INSTRUMENTS FOR REAPPROXIMATION OF SOFT TISSUE DURING HERNIA REPAIR, AND FASTENING DEVICES FOR USE WITH HERNIA MESH PRODUCTS AND PARTS AND FITTINGS THEREFOR (U.S. CLS. 26, 39 AND 44).  
NORA BUCHANAN WILL, EXAMINING ATTORNEY

SN 86-037,553. MINI COMFORT FRANCHISE SYSTEMS, LLC, DBA MINI COMFORT, AKRON, OH. FILED 8-14-2013.

# Mini Comfort

THE MARK CONSISTS OF STANDARD CHARACTERS WITHOUT CLAIM TO ANY PARTICULAR FONT, STYLE, SIZE, OR COLOR.

NO CLAIM IS MADE TO THE EXCLUSIVE RIGHT TO USE "MINI", APART FROM THE MARK AS SHOWN.  
FOR OCCLUSAL BITE GUARD (U.S. CLS. 26, 39 AND 44).  
FIRST USE 1-10-2011; IN COMMERCE 1-10-2011.  
TASHIA BUNCH, EXAMINING ATTORNEY

SN 86-043,268. ZIIP LLC, JACKSON, WY. FILED 8-20-2013.

# ziip

THE MARK CONSISTS OF STANDARD CHARACTERS WITHOUT CLAIM TO ANY PARTICULAR FONT, STYLE, SIZE, OR COLOR.

FOR PORTABLE HAND-HELD SKIN CARE DEVICE THAT USES ELECTRICAL CURRENTS ON THE SKIN FOR SKIN REPAIR AND REJUVENATION (U.S. CLS. 26, 39 AND 44).  
ELLEN B. AWRICH, EXAMINING ATTORNEY

**CLASS 10—(Continued).**

SN 86-046,843. ST. GEORGE MEDICAL MACHINE COMPANY, DBA CATH-TIP, INC., ST. GEORGE, UT. FILED 8-23-2013.

# CATH-TIP

THE MARK CONSISTS OF STANDARD CHARACTERS WITHOUT CLAIM TO ANY PARTICULAR FONT, STYLE, SIZE, OR COLOR.

OWNER OF U.S. REG. NO. 4,438,595.  
FOR CATHETERS; MEDICAL AND SURGICAL CATHETERS; MEDICAL DEVICE FOR ACCESSING SUBCUTANEOUS STRUCTURES OF THE HUMAN BODY FOR THE PURPOSE OF ADMINISTERING MEDICAL TREATMENT; MEDICINAL CATHETERS (U.S. CLS. 26, 39 AND 44).  
FIRST USE 6-1-2001; IN COMMERCE 4-0-2013.  
NATALIE KENEALY, EXAMINING ATTORNEY

SN 86-050,913. DEXCOM, INC., SAN DIEGO, CA. FILED 8-28-2013.

# DEXCOM ONE STEP AHEAD

THE MARK CONSISTS OF STANDARD CHARACTERS WITHOUT CLAIM TO ANY PARTICULAR FONT, STYLE, SIZE, OR COLOR.

OWNER OF U.S. REG. NO. 3,895,549.  
FOR MEDICAL DEVICES, NAMELY, MEDICAL SENSORS THAT ARE IMPLANTED OR INSERTED INTO THE HUMAN BODY FOR USE IN DETERMINING THE CONCENTRATION OF GLUCOSE IN THE HUMAN BODY AND ACCESSORIES THEREFOR, INCLUDING, RECEIVERS, SENSOR HOUSINGS AND SENSOR INSERTION DEVICES (U.S. CLS. 26, 39 AND 44).  
DAVID ALESKOW, EXAMINING ATTORNEY

SN 86-061,355. MERZ NORTH AMERICA, INC., GREENSBORO, NC. FILED 9-11-2013.

# VOTHERA

THE MARK CONSISTS OF STANDARD CHARACTERS WITHOUT CLAIM TO ANY PARTICULAR FONT, STYLE, SIZE, OR COLOR.

FOR ARTIFICIAL IMPLANTABLE MATERIAL, NAMELY, BIOCOMPATIBLE INJECTABLE MATERIAL FOR USE AS A VOCAL FOLD AUGMENTATION MATERIAL IN LARYNGEAL SURGICAL PROCEDURES FOR VOCAL FOLD WEAKNESS, INSUFFICIENCY OR PARALYSIS, ALL THE AFORESAID FOR MEDICAL USE (U.S. CLS. 26, 39 AND 44).  
JOHN E. MICHOS, EXAMINING ATTORNEY

**CLASS 10—(Continued).**

SN 86-072,393. STRATEGIC PARTNERS, INC., CHATSWORTH, CA. FILED 9-23-2013.

# Curo

THE MARK CONSISTS OF STANDARD CHARACTERS WITHOUT CLAIM TO ANY PARTICULAR FONT, STYLE, SIZE, OR COLOR.

THE ENGLISH TRANSLATION OF "CURO" IN THE MARK IS "TO HEAL".

FOR BELTS FOR MEDICAL PURPOSES; CASES FITTED FOR MEDICAL INSTRUMENTS AND/OR FOR USE BY DOCTORS; FORCEPS FOR MEDICAL USE; HUMAN FACE PROTECTORS, NAMELY, TRANSPARENT FACE SHIELDS FOR USE IN THE MEDICAL AND DENTAL FIELDS; MEDICAL DEVICES, NAMELY, PULSE OXIMETERS; MEDICAL GLOVES; MEDICAL GOWNS; MEDICAL SCISSORS; MEDICAL TREATMENT APPAREL; MEDICAL WEARING APPAREL, NAMELY, CAPS; MEDICAL WEARING APPAREL, NAMELY, SCRUB PANTS; MEDICAL WEARING APPAREL, NAMELY, SCRUB TOPS; MEDICAL WEARING APPAREL, NAMELY, SHOES; OTOSCOPES; REFLEX HAMMERS; SPHYGMOMANOMETERS; STETHOSCOPES; THERMOMETERS FOR MEDICAL PURPOSES (U.S. CLS. 26, 39 AND 44).

DANNEAN HETZEL, EXAMINING ATTORNEY

SN 86-072,635. DERMA DREAM GROUP LTD., TORTOLA, BR. VIRGIN ISLANDS, FILED 9-24-2013.

# SensiLight

THE MARK CONSISTS OF STANDARD CHARACTERS WITHOUT CLAIM TO ANY PARTICULAR FONT, STYLE, SIZE, OR COLOR.

FOR COSMETIC APPARATUS, NAMELY, LIGHT BASED DEVICES PROVIDING MAINLY PULSED LIGHT FOR PERFORMING NON-ABLATIVE AESTHETIC SKIN TREATMENT PROCEDURES; ELECTRONIC LIGHT THERAPY APPARATUS FOR THE SKIN; LIGHT EMITTING DEVICES, NAMELY, LAMPS AND LED DEVICES FOR TREATMENT OF A VARIETY OF SKIN CONDITIONS; MEDICAL DEVICES FOR NONSURGICAL COSMETIC TREATMENTS (U.S. CLS. 26, 39 AND 44).

JANICE KIM, EXAMINING ATTORNEY

**CLASS 10—(Continued).**

SN 86-112,077. YOUNG DENTAL MANUFACTURING I, LLC, EARTH CITY, MO. FILED 11-6-2013.

# CHEETAH CHERRY

THE MARK CONSISTS OF STANDARD CHARACTERS WITHOUT CLAIM TO ANY PARTICULAR FONT, STYLE, SIZE, OR COLOR.

NO CLAIM IS MADE TO THE EXCLUSIVE RIGHT TO USE "CHERRY", APART FROM THE MARK AS SHOWN.

FOR LATEX AND NITRILE GLOVES FOR MEDICAL USE; DISPOSABLE PROPHY ANGLES (U.S. CLS. 26, 39 AND 44).

CYNTHIA TRIPI, EXAMINING ATTORNEY

SN 86-131,144. R.I.M. MEDICAL, LTD., MALVERN, PA. FILED 11-27-2013.

# VES

THE MARK CONSISTS OF STANDARD CHARACTERS WITHOUT CLAIM TO ANY PARTICULAR FONT, STYLE, SIZE, OR COLOR.

FOR MEDICAL SYSTEMS AND MEDICAL DEVICES, NAMELY, THERAPEUTIC APPARATUS NAMELY, COMPRESSION SLEEVES AND PUMPS FOR THE INTERMITTENT COMPRESSION OF LIMBS AND OTHER AREAS OF THE BODY TO REDUCE EDEMA, TREAT THROMBOSIS, ACCELERATE EPIDERMAL WOUND CARE, AND ENHANCE THE REHABILITATION OF AND RECOVERY FROM MEDICAL CONDITIONS, SPORTS RELATED INJURIES, AND MUSCLE RECOVERY (U.S. CLS. 26, 39 AND 44).

ANTHONY RINKER, EXAMINING ATTORNEY

SN 86-149,025. KOWA COMPANY, LTD., AICHI-KEN, JAPAN, FILED 12-19-2013.

# Cutestep

THE MARK CONSISTS OF STANDARD CHARACTERS WITHOUT CLAIM TO ANY PARTICULAR FONT, STYLE, SIZE, OR COLOR.

FOR MEDICAL APPARATUS AND INSTRUMENTS, NAMELY, ORTHOTIC INSERTS FOR FOOTWEAR IN THE NATURE OF INSOLES (U.S. CLS. 26, 39 AND 44).

KAREN SEVERSON, EXAMINING ATTORNEY

**CLASS 10—(Continued).**

SN 86-155,652. PDC RESTORER LLC, MORRESVILLE, NC.  
FILED 12-31-2013.



NO CLAIM IS MADE TO THE EXCLUSIVE RIGHT TO USE "PDC", APART FROM THE MARK AS SHOWN.

THE COLOR(S) BLUE AND LIGHT BLUE IS/ARE CLAIMED AS A FEATURE OF THE MARK.

THE MARK CONSISTS OF THE LETTERS "P", "D" AND "C" IN ALL CAPS AND IN THE COLOR BLUE SITUATED IN FRONT OF FOUR ELONGATED TRIANGULAR MOUNTAIN SHAPES WHICH APPEAR IN THE BACKGROUND IN LIGHT BLUE. DIRECTLY BENEATH THESE LETTERS IS THE WORD "RESTORER" IN ALL CAPS AND IN BLUE WITH A LIGHT BLUE LINE UNDERLINING THIS WORDING. THE MARK APPEARS ON A TRANSPARENT BACKGROUND AND NO OTHER COLORS ARE CLAIMED AS A FEATURE OF THE MARK.

FOR ELECTRODES FOR MEDICAL USE; MEDICAL ELECTRODES; MEDICAL EQUIPMENT ACCESSORIES, NAMELY, ELECTRODIAGNOSTIC AUTOMATED CONSTANT CURRENT SINUSOID WAVEFORM NEUROSELECTIVE SENSORY NERVE TESTING DEVICES, NAMELY, DISPOSABLE ELECTRODES (U.S. CLS. 26, 39 AND 44).

FIRST USE 9-1-2013; IN COMMERCE 9-1-2013.  
LEE-ANNE BERNIS, EXAMINING ATTORNEY

SN 86-159,529. MYLAN LABORATORIES LIMITED, HYDERABAD-500034, INDIA, FILED 1-7-2014.

## MYT4

THE MARK CONSISTS OF STANDARD CHARACTERS WITHOUT CLAIM TO ANY PARTICULAR FONT, STYLE, SIZE, OR COLOR.

FOR MEDICAL TESTING DEVICE FOR USE AT THE POINT OF CARE FOR TESTING THE NUMBER OF CD4 CELLS (T-CELLS) IN BLOOD SAMPLES (U.S. CLS. 26, 39 AND 44).

BRIAN PINO, EXAMINING ATTORNEY

**CLASS 10—(Continued).**

SN 86-159,602. VIKON SURGICAL, LLC, BIRMINGHAM, AL.  
FILED 1-7-2014.



OWNER OF U.S. REG. NO. 3,846,207.

THE MARK CONSISTS OF THE LETTER "V" INSIDE A CIRCLE WITH THE LEFT LEG OF THE "V" EXTENDING A LITTLE HIGHER THAN THE RIGHT LEG OF THE "V" WITH THE WORD "VIKON" TO THE RIGHT.

FOR MEDICAL INSTRUMENTS FOR USE IN GENERAL SURGERY, NAMELY, STAINLESS STEEL INSTRUMENTS; SURGICAL INSTRUMENTS, NAMELY, RONGEURS; SURGICAL LAMPS (U.S. CLS. 26, 39 AND 44).

MATTHEW EINSTEIN, EXAMINING ATTORNEY

SN 86-180,106. MERETE MEDICAL GMBH, BERLIN, FED REP GERMANY, FILED 1-30-2014.

## OSTEOBRIDGE

THE MARK CONSISTS OF STANDARD CHARACTERS WITHOUT CLAIM TO ANY PARTICULAR FONT, STYLE, SIZE, OR COLOR.

OWNER OF U.S. REG. NO. 3,354,525.  
SEC. 2(F).

FOR ORTHOPEDIC IMPLANTS, NAMELY, BONE REPLACEMENT METALLIC IMPLANTS COMPOSED OF ARTIFICIAL MATERIAL; ENDOPROSTHETIC COMPONENTS IN THE NATURE OF ARTIFICIAL MATERIALS FOR USE IN THE REPLACEMENT OF BONES; SURGICAL ORTHOPEDIC INSTRUMENTS FOR USE IN ORTHOPEDIC SURGERY (U.S. CLS. 26, 39 AND 44).

FIRST USE 3-10-2004; IN COMMERCE 3-10-2004.  
MATTHEW EINSTEIN, EXAMINING ATTORNEY

SN 86-187,416. JOHN M. AGEE, DBA HAND BIOMECHANICS LAB, SACRAMENTO, CA. FILED 2-7-2014.

## DIGIT WIDGET

THE MARK CONSISTS OF STANDARD CHARACTERS WITHOUT CLAIM TO ANY PARTICULAR FONT, STYLE, SIZE, OR COLOR.

FOR MEDICAL AND SURGICAL DEVICES, NAMELY, AN ORTHOPEDIC EXTERNAL FIXATION DEVICE FOR USE ON THE JOINTS OF THE FINGERS (U.S. CLS. 26, 39 AND 44).

FIRST USE 5-1-1999; IN COMMERCE 3-20-2000.  
PRISCILLA MILTON, EXAMINING ATTORNEY

**CLASS 10—(Continued).**

SN 86-190,654. SALT CHAMBER, LLC, BOCA RATON, FL. FILED 2-11-2014.

# S.A.L.T. FX

THE MARK CONSISTS OF STANDARD CHARACTERS WITHOUT CLAIM TO ANY PARTICULAR FONT, STYLE, SIZE, OR COLOR.

NO CLAIM IS MADE TO THE EXCLUSIVE RIGHT TO USE "SALT", APART FROM THE MARK AS SHOWN.

FOR EQUIPMENT USED IN CONNECTION WITH HEALTH SPA SERVICES FOR HEALTH AND WELLNESS OF THE BODY AND SPIRIT, NAMELY, APPARATUS FOR DISPENSING NON-MEDICAL SALT PARTICLES FOR THERAPEUTIC PURPOSES (U.S. CLS. 26, 39 AND 44).

FIRST USE 1-1-2013; IN COMMERCE 6-1-2013.  
KEVIN MITTLER, EXAMINING ATTORNEY

**CLASS 10—(Continued).**

SN 86-197,901. MOXIMED, INC., HAYWARD, CA. FILED 2-19-2014.

# PEEK ELEMENT

THE MARK CONSISTS OF STANDARD CHARACTERS WITHOUT CLAIM TO ANY PARTICULAR FONT, STYLE, SIZE, OR COLOR.

FOR IMPLANTS CONSISTING OF ARTIFICIAL MATERIALS; MEDICAL AND SURGICAL APPARATUS AND INSTRUMENTS, NAMELY, ORTHOPEDIC FIXATION DEVICE USED IN ORTHOPEDIC TRANSPLANT AND/OR IMPLANT SURGERY; ORTHOPEDIC JOINT IMPLANTS MADE OF ARTIFICIAL MATERIALS; SHOCK ABSORBER ORTHOTICS FOR THE KNEE FOR ORTHOPEDIC AND MEDICAL PURPOSES (U.S. CLS. 26, 39 AND 44).

JOHN WILKE, EXAMINING ATTORNEY

SN 86-215,324. MASTERS, EZRA M, MIAMI, FL. FILED 3-8-2014.

SN 86-192,420. HANGZHOU KANGJI MEDICAL INSTRUMENTS CO., LTD., HANGZHOU, CHINA, FILED 2-13-2014.

# KANGJI

THE MARK CONSISTS OF WORD "KANGJI" IN STYLIZED FONT.

THE WORDING "KANGJI" HAS NO MEANING IN A FOREIGN LANGUAGE.

FOR MEDICAL, SURGICAL AND ORTHOPAEDIC IMPLANTS MADE OF ARTIFICIAL MATERIALS; SURGICAL AND MEDICAL APPARATUS AND INSTRUMENTS FOR USE IN GENERAL SURGERY; SURGICAL APPARATUS AND INSTRUMENTS FOR MEDICAL, DENTAL OR VETERINARY USE; SURGICAL IMPLANTS COMPRISING ARTIFICIAL MATERIAL; SURGICAL MIRRORS; SUTURE MATERIALS (U.S. CLS. 26, 39 AND 44).

FIRST USE 10-12-2004; IN COMMERCE 10-11-2006.  
MATTHEW KLINE, EXAMINING ATTORNEY



OWNER OF U.S. REG. NO. 4,284,660.

THE MARK CONSISTS OF ILLUSTRATION OF A HORSE FROM CHEST UPWARD WITH AN INDICATION OF THE HORSE IN MOVEMENT GIVEN HAIR POSITION AND MUSCULATURE. THE WORDS "WELL ENDOWED" ARE WRITTEN IN THE SPACE BENEATH CHIN AND THROAT LINE. THE GRAPHIC AND TEXT ARE ENCLOSED IN THE OUTLINE OF A SQUARE.

FOR CONDOMS (U.S. CLS. 26, 39 AND 44).  
ALYSSA STEEL, EXAMINING ATTORNEY

**CLASS 10—(Continued).**

SN 86-216,576. BELLEFIT, INC., SUNRISE, FL. FILED 3-10-2014.

**TIGHTY WIFEY**

THE MARK CONSISTS OF STANDARD CHARACTERS WITHOUT CLAIM TO ANY PARTICULAR FONT, STYLE, SIZE, OR COLOR.

FOR POST-PREGNANCY ABDOMINAL SUPPORT AND COMPRESSION UNDERGARMENTS, GIRDLES AND UNDERWEAR FOR MEDICAL PURPOSES (U.S. CLS. 26, 39 AND 44).

FIRST USE 2-1-2013; IN COMMERCE 4-17-2013.  
MATTHEW GALAN, EXAMINING ATTORNEY

**CLASS 10—(Continued).**

SN 86-222,492. MYOLYN, LLC, GAINESVILLE, FL. FILED 3-16-2014.

**MYOLYN**  
*Powering Your Potential.*

THE MARK CONSISTS OF THE WORD "MYOLYN" WHEREIN THE "O" IS IN STYLIZED FORM THAT ENCLOSES THE DESIGN OF A NEURON, ABOVE THE WORDS "POWERING YOUR POTENTIAL" IN A HORIZONTAL LINE.

FOR MEDICAL DEVICES, NAMELY, POWERED ELECTRICAL MUSCLE STIMULATION DEVICES FOR PERSONS WITH NEUROLOGICAL CONDITIONS (U.S. CLS. 26, 39 AND 44).

ELIZABETH CHANG, EXAMINING ATTORNEY

SN 86-220,976. BODI WULIAN TECHNOLOGY CO LTD, SHENZHEN, CHINA, FILED 3-14-2014.

**ibody**

THE MARK CONSISTS OF THE WORDING "IBODY" IN STYLIZED FONT.

THE WORDING "IBODY" HAS NO MEANING IN A FOREIGN LANGUAGE.

FOR APPARATUS FOR BLOOD ANALYSIS; BLOOD TESTING APPARATUS; CLINICAL THERMOMETERS; ELECTRIC MASSAGE APPLIANCES, NAMELY, ELECTRIC VIBRATING MASSAGER; MEDICAL APPARATUS AND INSTRUMENTS FOR TREATING CARDIOVASCULAR DISEASE; MEDICAL DIAGNOSTIC APPARATUS, ANALYTICAL APPARATUS FOR MEDICAL PURPOSES AND BLOOD PRESSURE MEASURING APPARATUS; PHYSICAL REHABILITATION, PHYSICAL THERAPY AND SPORTS MEDICINE EQUIPMENT ALL DESIGNED SPECIFICALLY FOR MEDICAL USE, NAMELY, SHOULDER STRETCHER USING RESISTANCE CABLES; PULSE METERS; SANITARY MASKS FOR VIRUS ISOLATION PURPOSES; SANITIZATION UNITS FOR STETHOSCOPES (U.S. CLS. 26, 39 AND 44).

FIRST USE 10-1-2013; IN COMMERCE 2-1-2014.  
GINA FINK, EXAMINING ATTORNEY

SN 86-226,092. SOMERSAULT ORTHOPEDICS, INC., PLEASANTON, CA. FILED 3-19-2014.

**Somersault** Knee



NO CLAIM IS MADE TO THE EXCLUSIVE RIGHT TO USE "KNEE", APART FROM THE MARK AS SHOWN.

THE MARK CONSISTS OF A SILHOUETTE OF A PERSON LEANING BACKWARDS WITH ARMS OUTSTRETCHED DOING A FLIP WITH A CIRCLE OVER THE KNEE AREA, ALL ABOVE THE WORD "SOMERSAULT" AND THE WORD "KNEE" TYPED VERTICALLY TO THE RIGHT.

FOR SURGICAL AND MEDICAL APPARATUS AND INSTRUMENTS FOR USE IN ORTHOPEDIC SURGERY (U.S. CLS. 26, 39 AND 44).

MATTHEW MCDOWELL, EXAMINING ATTORNEY

**CLASS 10—(Continued).**

SN 86-226,182. SOMERSAULT ORTHOPEDICS, INC., PLEASANTON, CA. FILED 3-19-2014.



NO CLAIM IS MADE TO THE EXCLUSIVE RIGHT TO USE "SHOULDER", APART FROM THE MARK AS SHOWN. THE MARK CONSISTS OF A SILHOUETTE OF A PERSON LEANING BACKWARDS WITH ARMS OUTSTRETCHED DOING A FLIP WITH A CIRCLE OVER THE SHOULDER AREA, ALL ABOVE THE WORD "SOMERSAULT" AND THE WORD "SHOULDER" TYPED VERTICALLY TO THE RIGHT.

FOR SURGICAL AND MEDICAL APPARATUS AND INSTRUMENTS FOR USE IN ORTHOPEDIC SURGERY (U.S. CLS. 26, 39 AND 44).

MATTHEW MCDOWELL, EXAMINING ATTORNEY

**CLASS 10—(Continued).**

SN 86-226,630. MICROMAR INDUSTRIA E COMERCIO LTDA, DIADEMA, SP, BRAZIL, FILED 3-20-2014.

EasyDrill

NO CLAIM IS MADE TO THE EXCLUSIVE RIGHT TO USE "DRILL", APART FROM THE MARK AS SHOWN.

THE MARK CONSISTS OF THE WORDING "EASY DRILL" IN STYLIZED LETTERS.

FOR SURGICAL AND MEDICAL APPARATUS AND INSTRUMENTS FOR USE IN GENERAL SURGERY; SURGICAL APPARATUS AND INSTRUMENTS FOR MEDICAL, DENTAL OR VETERINARY USE (U.S. CLS. 26, 39 AND 44).

TOBY BULLOFF, EXAMINING ATTORNEY

SN 86-226,204. SOMERSAULT ORTHOPEDICS, INC., PLEASANTON, CA. FILED 3-19-2014.



NO CLAIM IS MADE TO THE EXCLUSIVE RIGHT TO USE "HIP", APART FROM THE MARK AS SHOWN.

THE MARK CONSISTS OF A SILHOUETTE OF A PERSON LEANING BACKWARDS WITH ARMS OUTSTRETCHED DOING A FLIP WITH A CIRCLE OVER THE HIP AREA, ALL ABOVE THE WORD "SOMERSAULT" AND THE WORD "HIP" TYPED VERTICALLY TO THE RIGHT.

FOR SURGICAL AND MEDICAL APPARATUS AND INSTRUMENTS FOR USE IN ORTHOPEDIC SURGERY (U.S. CLS. 26, 39 AND 44).

MATTHEW MCDOWELL, EXAMINING ATTORNEY

SN 86-227,406. SONOCINE, INC., RENO, NV. FILED 3-20-2014.

SONOCINE AWBUS

THE MARK CONSISTS OF STANDARD CHARACTERS WITHOUT CLAIM TO ANY PARTICULAR FONT, STYLE, SIZE, OR COLOR.

OWNER OF U.S. REG. NOS. 2,553,776, 2,553,777 AND 2,658,956.

FOR MEDICAL IMAGE GENERATION, STORAGE AND VIEWING SYSTEMS, NAMELY, ULTRASOUND APPARATUS FOR MEDICAL USE (U.S. CLS. 26, 39 AND 44).

JUHI KAVEESHVAR, EXAMINING ATTORNEY

**CLASS 10—(Continued).**

SN 86-230,128. LE BELLE INTERNATIONAL, INC., DESTIN, FL. FILED 3-24-2014.

# LE BELLE

THE MARK CONSISTS OF STANDARD CHARACTERS WITHOUT CLAIM TO ANY PARTICULAR FONT, STYLE, SIZE, OR COLOR.

THE ENGLISH TRANSLATION OF "LE BELLE" IN THE MARK IS "THE BEAUTIFUL".

FOR AESTHETICS MACHINES FOR COSMETIC USE FOR DEEP CLEANSING, SKIN REJUVENATION, SKIN REGENERATION, AND SKIN PRODUCT PENETRATION; FACIAL MACHINES FOR COSMETIC USE FOR DEEP CLEANSING, SKIN REJUVENATION, SKIN REGENERATION, AND SKIN PRODUCT PENETRATION; HAND HELD AESTHETICS MACHINES FOR COSMETIC USE FOR DEEP CLEANSING, SKIN REJUVENATION, SKIN REGENERATION, AND SKIN PRODUCT PENETRATION; HAND HELD FACIAL MACHINES FOR COSMETIC USE FOR DEEP CLEANSING, SKIN REJUVENATION, SKIN REGENERATION, AND SKIN PRODUCT PENETRATION (U.S. CLS. 26, 39 AND 44).

FIRST USE 12-1-1999; IN COMMERCE 12-1-1999.  
APRIL HESIK, EXAMINING ATTORNEY

SN 86-230,151. LE BELLE INTERNATIONAL, INC., DESTIN, FL. FILED 3-24-2014.

# LE BELLE PRO

THE MARK CONSISTS OF STANDARD CHARACTERS WITHOUT CLAIM TO ANY PARTICULAR FONT, STYLE, SIZE, OR COLOR.

NO CLAIM IS MADE TO THE EXCLUSIVE RIGHT TO USE "PRO", APART FROM THE MARK AS SHOWN.

THE ENGLISH TRANSLATION OF "LE BELLE" IN THE MARK IS "THE BEAUTIFUL".

FOR AESTHETICS MACHINES FOR COSMETIC USE FOR DEEP CLEANSING, SKIN REJUVENATION, SKIN REGENERATION, AND SKIN PRODUCT PENETRATION SOLD ONLY TO AND FOR USE ONLY BY BEAUTY PROFESSIONALS; FACIAL MACHINES FOR COSMETIC USE FOR DEEP CLEANSING, SKIN REJUVENATION, SKIN REGENERATION, AND SKIN PRODUCT PENETRATION SOLD ONLY TO AND FOR USE ONLY BY BEAUTY PROFESSIONALS (U.S. CLS. 26, 39 AND 44).

FIRST USE 10-0-2000; IN COMMERCE 10-0-2000.  
APRIL HESIK, EXAMINING ATTORNEY

**CLASS 10—(Continued).**

SN 86-235,187. THE SPECTRANETICS CORPORATION, COLORADO SPRINGS, CO. FILED 3-28-2014.

# TIGHTRAIL MINI

THE MARK CONSISTS OF STANDARD CHARACTERS WITHOUT CLAIM TO ANY PARTICULAR FONT, STYLE, SIZE, OR COLOR.

NO CLAIM IS MADE TO THE EXCLUSIVE RIGHT TO USE "MINI", APART FROM THE MARK AS SHOWN.

FOR MEDICAL DEVICE, NAMELY, ROTARY DILATORS AND SHEATHS FOR USE IN LEAD EXTRACTION PROCEDURES FOR SEPARATING LEADS FROM TISSUE IN A PATIENT'S VASCULAR SYSTEM (U.S. CLS. 26, 39 AND 44).

LAUREN BURKE, EXAMINING ATTORNEY

SN 86-235,670. TERRAMED LLC, SAN DIEGO, CA. FILED 3-28-2014.



THE MARK CONSISTS OF THE STYLIZED TEXT "TERRAMED" WITH "JUST THINK COMFORT" BELOW IT TO THE LEFT OF A DESIGN OF A HAND HOLDING EARTH.

FOR MEDICAL COMPRESSION SOCKS, STOCKINGS, TIGHTS, ARM SLEEVES AND LEG SLEEVES FOR LEGS, THIGHS, ANKLES, KNEES, BACK, ABDOMINAL, WRISTS, SHOULDERS, ELBOWS, NECK, AND MATERNITY FOR MEDICAL USE (U.S. CLS. 26, 39 AND 44).

FIRST USE 12-1-2013; IN COMMERCE 12-1-2013.  
CIMMERIAN COLEMAN, EXAMINING ATTORNEY

SN 86-239,039. DIGITAL DOC LLC, EL DORADO HILLS, CA. FILED 4-1-2014.



OWNER OF U.S. REG. NO. 4,328,921.  
NO CLAIM IS MADE TO THE EXCLUSIVE RIGHT TO USE "DIGITAL", APART FROM THE MARK AS SHOWN.

THE MARK CONSISTS OF REPRESENTATION OF A TOOTH INSIDE OF A CIRCLE, THE TOOTH BEING LOCATED NEXT TO THE WORDING "DIGITAL DOC".

FOR DENTAL AND MEDICAL VIDEO DIAGNOSTIC APPARATUS, NAMELY, VIDEO CAMERAS EMPLOYED FOR INTRA-ORAL DENTAL AND MEDICAL EXAMINATIONS (U.S. CLS. 26, 39 AND 44).

FIRST USE 1-1-1999; IN COMMERCE 1-1-1999.  
JAMES LOVELACE, EXAMINING ATTORNEY



**CLASS 10—(Continued).**

SN 86-239,271. GEORGI, KAMARA, CARLSBAD, CA. AND BERGER, MATTHEW, CARLSBAD, CA. FILED 4-1-2014.

# My Fidget

THE MARK CONSISTS OF STANDARD CHARACTERS WITHOUT CLAIM TO ANY PARTICULAR FONT, STYLE, SIZE, OR COLOR.

FOR THERAPEUTIC HAND MANIPULATORS, NAMELY, MANUALLY MANIPULATED HAND-HELD SHAPED MEMORY FOAM FOR THERAPEUTIC USE IN THE NATURE OF INCREASING USERS FOCUS AND CONCENTRATION AND ALLEVIATING STRESS (U.S. CLS. 26, 39 AND 44).

FIRST USE 3-3-2014; IN COMMERCE 3-3-2014.  
LESLEY LAMOTHE, EXAMINING ATTORNEY

**CLASS 10—(Continued).**

SN 86-245,288. AQUAQUINTA AG, VADUZ, LIECHTENSTEIN, FILED 4-8-2014.

# SOUND OF SOUL

THE MARK CONSISTS OF STANDARD CHARACTERS WITHOUT CLAIM TO ANY PARTICULAR FONT, STYLE, SIZE, OR COLOR.

FOR ELECTROCARDIOGRAPHS (U.S. CLS. 26, 39 AND 44).

FIRST USE 9-27-2013; IN COMMERCE 9-27-2013.  
ALYSSA STEEL, EXAMINING ATTORNEY

SN 86-240,898. STARKEY LABORATORIES, INC., EDEN PRAIRIE, MN. FILED 4-3-2014.

# Halo

THE MARK CONSISTS OF STANDARD CHARACTERS WITHOUT CLAIM TO ANY PARTICULAR FONT, STYLE, SIZE, OR COLOR.

FOR BIOMEDICAL APPARATUS, NAMELY, HEARING AIDS AND STRUCTURAL PARTS THEREFOR (U.S. CLS. 26, 39 AND 44).

BRITTANY ESTELL, EXAMINING ATTORNEY

SN 86-245,363. ROBERT E. HARADEN, LIBERTYVILLE, IL. FILED 4-8-2014.

# HEMABAND

THE MARK CONSISTS OF STANDARD CHARACTERS WITHOUT CLAIM TO ANY PARTICULAR FONT, STYLE, SIZE, OR COLOR.

FOR DENTAL INSTRUMENTS, NAMELY, DENTAL BANDS TO FIT AROUND A TOOTH; SURGICAL APPARATUS AND INSTRUMENTS FOR MEDICAL, DENTAL OR VETERINARY USE (U.S. CLS. 26, 39 AND 44).

DOMINIC J. FERRAIUOLO, EXAMINING ATTORNEY

SN 86-245,276. XUYAO ZHANG, BEIJING, CHINA, FILED 4-8-2014.

# Prodent

THE MARK CONSISTS OF STANDARD CHARACTERS WITHOUT CLAIM TO ANY PARTICULAR FONT, STYLE, SIZE, OR COLOR.

FOR ACUPUNCTURE INSTRUMENTS; AIR MATTRESSES FOR MEDICAL PURPOSES; BREAST PUMPS; DENTAL APPARATUS, NAMELY, INTRA-ORAL LIGHT SYSTEMS; DENTAL MIRRORS; ELASTIC STOCKINGS; INSTRUMENTS AND APPARATUS PROVIDED EMPTY USED FOR THE INHALATION OF PHARMACEUTICALS; MASSAGE APPARATUS; MEDICAL APPARATUS AND INSTRUMENTS FOR USE IN SURGERY; ORTHODONTIC MACHINES AND INSTRUMENTS (U.S. CLS. 26, 39 AND 44).

FIRST USE 3-1-2013; IN COMMERCE 3-1-2013.  
EDWARD NELSON, EXAMINING ATTORNEY

SN 86-245,568. IVOCLAR VIVADENT, INC., AMHERST, NY. FILED 4-8-2014.

# ORTHOLINGUAL DCL

THE MARK CONSISTS OF STANDARD CHARACTERS WITHOUT CLAIM TO ANY PARTICULAR FONT, STYLE, SIZE, OR COLOR.

FOR APPARATUS, TOOLS AND INSTRUMENTS USED IN DENTISTRY, NAMELY, SHADE GUIDES; ARTIFICIAL TEETH (U.S. CLS. 26, 39 AND 44).

FIRST USE 0-0-2002; IN COMMERCE 0-0-2002.  
JAMES LOVELACE, EXAMINING ATTORNEY

**CLASS 10—(Continued).**

SN 86-246,064. GUILLET, MARC A., PALO ALTO, CA. FILED 4-8-2014.

# LeverUp

THE MARK CONSISTS OF STANDARD CHARACTERS WITHOUT CLAIM TO ANY PARTICULAR FONT, STYLE, SIZE, OR COLOR.

FOR INVALID LIFTS (U.S. CLS. 26, 39 AND 44).  
DAWN FELDMAN, EXAMINING ATTORNEY

SN 86-246,400. AEQUOR, INC., OCEANSIDE, CA. FILED 4-8-2014.

# AEQUOR

THE MARK CONSISTS OF STANDARD CHARACTERS WITHOUT CLAIM TO ANY PARTICULAR FONT, STYLE, SIZE, OR COLOR.

FOR SURGICAL, MEDICAL, DENTAL AND VETERINARY APPARATUS AND INSTRUMENTS, NAMELY, IN-DWELLING MEDICAL DEVICES, NAMELY CATHETERS, PROSTHESES FOR LIMB, JOINT, HIP, BONE, EYE, DENTAL, BREAST, AND HAND, IMPLANTS CONSISTING OF ARTIFICIAL MATERIALS, ARTIFICIAL EYES AND TEETH; MEDICAL FABRIC WITH ANTI-BIOFILM COATINGS FOR USE IN MEDICAL SURGERY, TRANSPLANT SURGERY, WOUND TREATMENT, BURN TREATMENT, BONE REPAIR SURGERY, DENTAL REPAIR, DENTAL TREATMENT, DENTAL SURGERY, ORAL SURGERY, COSMETIC SURGERY, PLASTIC SURGERY, RECONSTRUCTIVE SURGERY, CORONARY SURGERY, AND SUTURE MATERIALS WITH ANTI-BIOFILM COATINGS (U.S. CLS. 26, 39 AND 44).

DOUGLAS LEE, EXAMINING ATTORNEY

**CLASS 10—(Continued).**

SN 86-246,416. ACOUSYS BIODEVICES INC, PITTSBURGH, PA. FILED 4-8-2014.

# ACOUSYS

THE MARK CONSISTS OF STANDARD CHARACTERS WITHOUT CLAIM TO ANY PARTICULAR FONT, STYLE, SIZE, OR COLOR.

FOR SCIENTIFIC AND MEDICAL DIAGNOSTIC APPARATUS, INSTRUMENTS AND EQUIPMENT FOR THE DETECTION, ENUMERATION, ANALYSIS, CHARACTERIZATION AND CAPTURE OF CIRCULATING TUMOR CELLS AND PATHOGENS, NAMELY, BACTERIA, FUNGI, PARASITES AND VIRUSES, FOR MEDICAL, CLINICAL, AND MEDICAL DIAGNOSTIC USES; SCIENTIFIC AND MEDICAL DIAGNOSTIC APPARATUS, INSTRUMENTS AND EQUIPMENT FOR SCREENING BLOOD FOR THE DETECTION AND IDENTIFICATION OF PATHOGENIC ORGANISMS (U.S. CLS. 26, 39 AND 44).

DOUGLAS LEE, EXAMINING ATTORNEY

SN 86-247,552. SECURISYN MEDICAL, LLC, HIGHLANDS RANCH, CO. FILED 4-9-2014.



THE COLOR(S) BLUE, GREEN, AND GREY IS/ARE CLAIMED AS A FEATURE OF THE MARK.

THE MARK CONSISTS OF THE WORD "SOLIDAIRITY" IN AROMA LT ITALIC FONT, COMPRISED OF THE LETTERS "SOLID" IN GREEN, THE LETTERS "AIR" IN BLUE, AND THE LETTERS "ITY" IN GREEN. THE LETTERS "AIR" ARE CONTAINED INSIDE THE HOLLOW OF A GREY CYLINDER THAT IS LYING ON ITS SIDE IN THE HORIZONTAL PLANE AT A 60 DEGREE OBLIQUE ANGLE WITH THE FRONT TO THE RIGHT. THE EXTERIOR OF THE CYLINDER IS COMPRISED OF A SERIES OF ALTERNATING RIBS AND RECESSES. THE APEX OF A BLUE FLATTENED, CURVED CONIC SECTION WITH THE CONVEX EDGE TO THE RIGHT BEGINS IN THE UPPER LEFT CORNER AND ENTERS THE BACK OF THE HOLLOW CYLINDER AT THE UPPER INSIDE SURFACE FROM 10 TO 12 O'CLOCK. AN INVERTED MIRROR IMAGE OF THE BLUE CONIC SECTION EXITS THE FRONT OF THE HOLLOW CYLINDER AT THE LOWER INSIDE SURFACE FROM 4 TO 6 O'CLOCK WITH THE CONVEX EDGE TO THE LEFT AND THE APEX IN THE LOWER RIGHT CORNER. AS THE BLUE CONIC SECTIONS APPROACH THE HOLLOW OF THE CYLINDER, THEIR COLOR INTENSIFIES.

FOR MEDICAL ENDOTRACHEAL TUBE WITH SECURING DEVICE (U.S. CLS. 26, 39 AND 44).

KEVIN DINALLO, EXAMINING ATTORNEY

**CLASS 10—(Continued).**

SN 86-247,562. MILES LANDIS, SEATTLE, WA. FILED 4-9-2014.

**JAWMAKER**

THE MARK CONSISTS OF STANDARD CHARACTERS WITHOUT CLAIM TO ANY PARTICULAR FONT, STYLE, SIZE, OR COLOR.

FOR MOUTH EXERCISER FOR USE IN EXERCISING AND STRENGTHENING MOUTH AND FACIAL MUSCLES FOR MEDICAL AND BEAUTY BENEFITS (U.S. CLS. 26, 39 AND 44).

KEVIN DINALLO, EXAMINING ATTORNEY

**CLASS 10—(Continued).**

SN 86-248,518. DEFIBTECH, LLC, GUILFORD, CT. FILED 4-10-2014.

**DEFIBTECH**

THE MARK CONSISTS OF STANDARD CHARACTERS WITHOUT CLAIM TO ANY PARTICULAR FONT, STYLE, SIZE, OR COLOR.

OWNER OF U.S. REG. NOS. 2,830,686 AND 3,378,547.  
FOR MEDICAL DEVICE, NAMELY, A DEVICE FOR MECHANICALLY APPLYING CPR (U.S. CLS. 26, 39 AND 44).

TINA MAI, EXAMINING ATTORNEY

SN 86-248,483. MARBLES HOLDINGS, INC., CHICAGO, IL. FILED 4-10-2014.

**The Brain Tickler**

THE MARK CONSISTS OF STANDARD CHARACTERS WITHOUT CLAIM TO ANY PARTICULAR FONT, STYLE, SIZE, OR COLOR.

FOR MANUAL HEAD MASSAGER (U.S. CLS. 26, 39 AND 44).

FIRST USE 11-9-2012; IN COMMERCE 11-9-2012.  
MIAH ROSENBERG, EXAMINING ATTORNEY

SN 86-248,632. MEDLINE INDUSTRIES, INC., MUNDELEIN, IL. FILED 4-10-2014.

**COMFORT GLIDE**

THE MARK CONSISTS OF STANDARD CHARACTERS WITHOUT CLAIM TO ANY PARTICULAR FONT, STYLE, SIZE, OR COLOR.

OWNER OF U.S. REG. NO. 4,548,861.  
NO CLAIM IS MADE TO THE EXCLUSIVE RIGHT TO USE "COMFORT", APART FROM THE MARK AS SHOWN.  
FOR MEDICAL APPARATUS, NAMELY, FOAM WEDGES AND UNDERPADS FOR USE WITH LOW-FRICTION SHEETS FOR USE IN MOVING, POSITIONING AND TRANSFER OF PATIENTS TO, FROM, OR ON A BED, STRETCHER, GURNEY OR FLOOR (U.S. CLS. 26, 39 AND 44).

FIRST USE 10-21-2013; IN COMMERCE 10-21-2013.  
JOHN SCHUYLER YARD, EXAMINING ATTORNEY

SN 86-248,516. DEFIBTECH, LLC, GUILFORD, CT. FILED 4-10-2014.

**DEFIBTECH**

THE MARK CONSISTS OF STANDARD CHARACTERS WITHOUT CLAIM TO ANY PARTICULAR FONT, STYLE, SIZE, OR COLOR.

OWNER OF U.S. REG. NOS. 2,830,686 AND 3,378,547.  
FOR AUTOMATED EXTERNAL DEFIBRILLATORS AND ACCESSORIES, NAMELY, ELECTRODES (U.S. CLS. 26, 39 AND 44).

FIRST USE 6-0-2002; IN COMMERCE 1-31-2003.  
TINA MAI, EXAMINING ATTORNEY

SN 86-248,699. KUB TECHNOLOGIES, INC., AKA KUBTEC, MILFORD, CT. FILED 4-10-2014.

**MOZART**

THE MARK CONSISTS OF STANDARD CHARACTERS WITHOUT CLAIM TO ANY PARTICULAR FONT, STYLE, SIZE, OR COLOR.

FOR X-RAY APPARATUS FOR MEDICAL USE; X-RAY DIAGNOSTIC APPARATUS (U.S. CLS. 26, 39 AND 44).

FIRST USE 4-10-2014; IN COMMERCE 4-10-2014.  
TINA MAI, EXAMINING ATTORNEY

**CLASS 10—(Continued).**

SN 86-248,721. ACTINA FZCO, DUBAI, UNITED ARAB EMIR., FILED 4-10-2014.

- Shin Balance -

THE MARK CONSISTS OF THE STYLIZED WORDING "SHIN BALANCE" WITH A HYPHEN-LIKE LINE EXTENDING HORIZONTALLY FROM EACH SIDE OF THE WORDING.

THE ENGLISH TRANSLATION OF THE WORD "SHIN" IN THE MARK IS "HEART".

FOR MASSAGE APPARATUS (U.S. CLS. 26, 39 AND 44).

ELLEN B. AWRICH, EXAMINING ATTORNEY

SN 86-250,033. ABC ACROMION, LLC, DBA VALERIS MEDICAL, WOODSTOCK, GA. FILED 4-11-2014.

ForceBraid

THE MARK CONSISTS OF STANDARD CHARACTERS WITHOUT CLAIM TO ANY PARTICULAR FONT, STYLE, SIZE, OR COLOR.

FOR SURGICAL SUTURES; SUTURE MATERIALS; SUTURES (U.S. CLS. 26, 39 AND 44).

JOHN E. MICHOS, EXAMINING ATTORNEY

SN 86-250,599. SCHULZ, GREGORY W., DBA PAINDICATOR, SAN JOSE, CA. FILED 4-12-2014.

Paindicator

THE MARK CONSISTS OF STANDARD CHARACTERS WITHOUT CLAIM TO ANY PARTICULAR FONT, STYLE, SIZE, OR COLOR.

THE WORDING "PAINDICATOR" HAS NO MEANING IN A FOREIGN LANGUAGE.

FOR ILLUSTRATION BOARDS DISPLAYING WORDS, PHRASES, AND PICTURES FOR USE BY PATIENTS TO COMMUNICATE WITH HEALTH CARE PROVIDERS ABOUT THEIR PHYSICAL CONDITION WHEN UNABLE TO DO SO VERBALLY (U.S. CLS. 26, 39 AND 44).

DANIEL S. STRINGER, EXAMINING ATTORNEY

**CLASS 10—(Continued).**

SN 86-256,609. KCI LICENSING, INC., SAN ANTONIO, TX. FILED 4-18-2014.

V.A.C.RX4

THE MARK CONSISTS OF STANDARD CHARACTERS WITHOUT CLAIM TO ANY PARTICULAR FONT, STYLE, SIZE, OR COLOR.

OWNER OF U.S. REG. NOS. 1,982,349, 2,940,436 AND OTHERS.

FOR NEGATIVE PRESSURE WOUND THERAPY DEVICE, NAMELY, A SUBATMOSPHERIC PRESSURE SOURCE AND RELATED TUBING, ALL FOR USE WITH WOUND INTERFACE DRAINAGE RECEPTACLES, AND ALL FOR PROMOTING WOUND HEALING (U.S. CLS. 26, 39 AND 44).

TARA BHUPATHI, EXAMINING ATTORNEY

SN 86-257,492. MEDLINE INDUSTRIES, INC., MUNDELEIN, IL. FILED 4-21-2014.

PROFESSIONAL

NO CLAIM IS MADE TO THE EXCLUSIVE RIGHT TO USE "PROFESSIONAL", APART FROM THE MARK AS SHOWN.

THE MARK CONSISTS OF THE WORD "PROFESSIONAL" IN STYLIZED FONT SUPERIMPOSED OVER FIVE SEMI-CONNECTED HEXAGONS, A SMALLER HEXAGON APPEARING INSIDE A LARGE HEXAGON OVER THE LETTER "R", WHERE THE FIRST "O" APPEARS IN THE FORM OF A HEXAGON DESIGN.

FOR MEDICAL EXAMINATION GLOVES (U.S. CLS. 26, 39 AND 44).

FIRST USE 12-31-2013; IN COMMERCE 12-31-2013.

JOHN SCHUYLER YARD, EXAMINING ATTORNEY

SN 86-265,770. GENEWEAVE BIOSCIENCES, INC., LOS GATOS, CA. FILED 4-29-2014.

GENEWEAVE

THE MARK CONSISTS OF STANDARD CHARACTERS WITHOUT CLAIM TO ANY PARTICULAR FONT, STYLE, SIZE, OR COLOR.

FOR MEDICAL EQUIPMENT, NAMELY, A DEVICE FOR BIOANALYSIS INCORPORATING A TEST KIT FOR DETECTION AND ANALYSIS OF INFECTIOUS DISEASE AND INFECTIOUS DISEASE AGENTS (U.S. CLS. 26, 39 AND 44).

DOUGLAS LEE, EXAMINING ATTORNEY

**CLASS 10—(Continued).**

SN 86-265,785. GENEWEAVE BIOSCIENCES, INC., LOS GATOS, CA. FILED 4-29-2014.

**CLASS 10—(Continued).**

SN 86-283,021. BELIMED INC., CHARLESTON, SC. FILED 5-16-2014.

**VIVODX**

THE MARK CONSISTS OF STANDARD CHARACTERS WITHOUT CLAIM TO ANY PARTICULAR FONT, STYLE, SIZE, OR COLOR.

FOR MEDICAL EQUIPMENT, NAMELY, A DEVICE FOR BIOANALYSIS INCORPORATING A TEST KIT FOR DETECTION AND ANALYSIS OF INFECTIOUS DISEASE AND INFECTIOUS DISEASE AGENTS (U.S. CLS. 26, 39 AND 44).  
DOUGLAS LEE, EXAMINING ATTORNEY



SN 86-269,745. DANE CHAPIN, ENCINITAS, CA. FILED 5-2-2014.

**UNCLE SAMZ**

**CHALLENGER PCD**

THE MARK CONSISTS OF STANDARD CHARACTERS WITHOUT CLAIM TO ANY PARTICULAR FONT, STYLE, SIZE, OR COLOR.

FOR CONDOMS (U.S. CLS. 26, 39 AND 44).  
APRIL REEVES, EXAMINING ATTORNEY



SN 86-269,765. DANE CHAPIN, ENCINITAS, CA. FILED 5-2-2014.

**SAMZ**

THE MARK CONSISTS OF STANDARD CHARACTERS WITHOUT CLAIM TO ANY PARTICULAR FONT, STYLE, SIZE, OR COLOR.

NO CLAIM IS MADE TO THE EXCLUSIVE RIGHT TO USE "PCD", APART FROM THE MARK AS SHOWN.  
FOR MEDICAL EQUIPMENT FOR USE IN CONNECTION WITH STEAM STERILIZERS, NAMELY, A PROCESS CHALLENGE DEVICE (U.S. CLS. 26, 39 AND 44).  
LINDA E. BLOHM, EXAMINING ATTORNEY

THE MARK CONSISTS OF STANDARD CHARACTERS WITHOUT CLAIM TO ANY PARTICULAR FONT, STYLE, SIZE, OR COLOR.

FOR CONDOMS (U.S. CLS. 26, 39 AND 44).  
APRIL REEVES, EXAMINING ATTORNEY

**CLASS 11—ENVIRONMENTAL CONTROL APPARATUS**

SN 79-132,271. SEDAL, S.L., SPAIN, FILED 4-10-2013.



PRIORITY DATE OF 12-28-2012 IS CLAIMED.

OWNER OF INTERNATIONAL REGISTRATION 1165821 DATED 4-10-2013, EXPIRES 4-10-2023.

THE COLOR(S) GREEN AND GRAY IS/ARE CLAIMED AS A FEATURE OF THE MARK.

THE MARK CONSISTS OF TWO CURVED LINES IN GREEN WITH A GRAY RAINDROP INSIDE WITH THE LANGUAGE "SEDAL" IN GREEN TO THE RIGHT OF THE CURVED LINES. BENEATH "SEDAL" IS THE LANGUAGE "THE FAUCET'S HEART" IN GRAY.

THE ENGLISH TRANSLATION OF "SEDAL" IN THE MARK IS "FISHING LINE".

FOR SANITARY AND AIR CONDITIONING APPARATUS AND INSTALLATIONS, NAMELY, CONNECTING HOSES BEING COMPONENT PARTS OF SAUNA BATHS AND AIR CONDITIONERS, SAUNA BATH INSTALLATIONS, AIR-CONDITIONING INSTALLATIONS THAT ARE SPECIALLY ADAPTED FOR AN SOLD AS A COMPONENT PART OF THE SAUNA BATHS, AIR CONDITIONERS AND SAUNA BATH INSTALLATIONS; SANITARY FITTINGS FOR INSTALLATIONS FOR WATER DISTRIBUTION, HOT WATER CONDITIONING, BATH, SHOWER, WASHBASIN, CISTERN, BIDET AND TOILET INSTALLATIONS, NAMELY, VALVES, BATH SHOWER ACCESSORIES, NAMELY, SHOWER ARMS BEING FAUCET EXTENSIONS, SHOWER RAILS BEING SHOWER SURROUNDS, SHOWER SUPPORTS BEING SHOWER BASES, DRAINS, FLOW REGULATORS BEING HYDRAULIC COMPENSATORS, FITTED LINERS FOR BATHS AND SHOWERS AND ALL MIXER FAUCET COMPONENTS, NAMELY, FAUCET AERATORS AND SPRAYERS, MIXER FAUCETS FOR WATER PIPES; FILTERS BEING PARTS OF HOUSEHOLD OR INDUSTRIAL INSTALLATIONS, NAMELY, FAUCET AERATORS FOR SANITARY USING; STOP VALVES AND CONTROL VALVES BEING PLUMBING FITTINGS; PIPES BEING PARTS OF SANITARY FACILITIES; SHOWER CUBICLES; BATHTUBS; TOILETS AND WATER-CLOSETS; TOILETS SEATS; SHOWERS; SHOWER COLUMNS, NAMELY, SHOWER PANELS; WATER FOUNTAINS; WATER STERILIZERS; HYDRANTS; BOILERS, NAMELY, ELECTRIC BOILERS, HEATING BOILERS AND FURNACE BOILERS; WATER, WASTE WATER AND GAS PURIFICATION INSTALLATIONS; ELECTRIC HAND DRYING APPARATUS FOR WASHROOMS (U.S. CLS. 13, 21, 23, 31 AND 34).

LAURIE MAYES, EXAMINING ATTORNEY

**CLASS 11—(Continued).**

SN 79-135,829. LIGHTTHERM OY, FI-90570 OULU, FINLAND, FILED 7-31-2013.

# Molded Core

THE MARK CONSISTS OF STANDARD CHARACTERS WITHOUT CLAIM TO ANY PARTICULAR FONT, STYLE, SIZE, OR COLOR.

PRIORITY DATE OF 1-31-2013 IS CLAIMED.

OWNER OF INTERNATIONAL REGISTRATION 1174779 DATED 7-31-2013, EXPIRES 7-31-2023.

FOR APPARATUS FOR LIGHTING, HEATING, STEAM GENERATING, COOKING, REFRIGERATING, DRYING, VENTILATING, WATER SUPPLY AND SANITARY PURPOSES, NAMELY, LAMPS, LIGHTING FIXTURES, LIGHT BULBS, LIGHT DIFFUSERS, LUMINARIES; ANTI-DAZZLE DEVICES FOR AUTOMOBILES, NAMELY, LAMP FITTINGS; AQUARIUM LIGHTS; ARC LAMPS; CEILING LIGHTS; CURLING LAMPS; ELECTRIC LAMPS; HEADLIGHTS FOR AUTOMOBILES; LABORATORY LAMPS; LAMP CASINGS; LAMP GLASSES; LAMP REFLECTORS; LAMP GLOBES; LAMP SHADES; LAMPS; LAMP SHADE HOLDERS; LANTERNS FOR LIGHTING; LIGHT BULBS; LIGHT DIFFUSERS; LIGHT-EMITTING DIODES LED LIGHTING APPARATUS, NAMELY, LED LAMPS, LED LIGHT BULBS, LED LIGHT FIXTURES, LED LIGHT ENGINES, LED LIGHT MACHINES, LED LIGHTING SYSTEMS, NAMELY, LED MODULES, LED POWER SUPPLIES, AND LED WIRING, LED CANDLES, LED FLOOD LIGHTS, LED WORK LIGHTS FOR CONSTRUCTION SETTINGS, LED LANDSCAPE LIGHTS, LED LIGHT STRIPS FOR DECORATIVE PURPOSES, LED LUMINAIRES, LED UNDERWATER LIGHTS, LED LIGHT ASSEMBLIES FOR STREET LIGHTS, SIGNS, COMMERCIAL LIGHTING, AUTOMOBILES, BUILDINGS, AND OTHER ARCHITECTURAL USES; LIGHTING APPARATUS FOR VEHICLES; LIGHTING APPARATUS, NAMELY, LIGHTING INSTALLATIONS (U.S. CLS. 13, 21, 23, 31 AND 34).

DAVID ALESKOW, EXAMINING ATTORNEY

SN 79-140,447. KONINKLIJKE PHILIPS N.V., NETHERLANDS, FILED 10-31-2013.

# Gran Baristo

PRIORITY DATE OF 5-24-2013 IS CLAIMED.

OWNER OF INTERNATIONAL REGISTRATION 1186742 DATED 10-31-2013, EXPIRES 10-31-2023.

THE ENGLISH TRANSLATION OF "GRAN" IN THE MARK IS "GREAT".

FOR ELECTRIC COFFEE MAKERS AND MACHINES, ELECTRIC COFFEE PERCOLATORS, ELECTRIC ESPRESSO MACHINES; ELECTRICAL APPARATUS FOR MAKING HOT BEVERAGES, NAMELY, COFFEE, TEA, CHOCOLATE, SOUP, BROTH (U.S. CLS. 13, 21, 23, 31 AND 34).

MELISSA VALLILLO, EXAMINING ATTORNEY

**CLASS 11—(Continued).**

SN 79-140,824. VITA VORTEX GMBH, 80809 MÜNCHEN, FED REP GERMANY, FILED 9-13-2013.

# Magic7

THE MARK CONSISTS OF STANDARD CHARACTERS WITHOUT CLAIM TO ANY PARTICULAR FONT, STYLE, SIZE, OR COLOR.

PRIORITY DATE OF 3-13-2013 IS CLAIMED. OWNER OF INTERNATIONAL REGISTRATION 1187743 DATED 9-13-2013, EXPIRES 9-13-2023.

FOR SHOWER HEADS; FAUCET AERATORS; HOUSEHOLD PLUMBING FITTINGS, NAMELY, WATER SWIRLERS AND WATER ATOMIZERS (U.S. CLS. 13, 21, 23, 31 AND 34).

KELLY TRUSILO, EXAMINING ATTORNEY

**CLASS 11—(Continued).**

SN 79-144,196. KONINKLIJKE PHILIPS N.V., NETHERLANDS, FILED 1-22-2014.

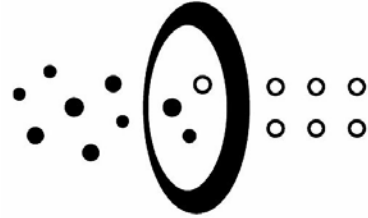

## VitaShield IPS

PRIORITY DATE OF 9-5-2013 IS CLAIMED. OWNER OF INTERNATIONAL REGISTRATION 1196103 DATED 1-22-2014, EXPIRES 1-22-2024.

THE MARK CONSISTS OF THE STYLIZED WORDING "VITASHIELD IPS" BELOW A PLAIN SINGLE LINE CIRCLE THAT HAS SIX UNSHADED SMALLER CIRCLES TO THE RIGHT, SEVEN SHADED SMALLER CIRCLES TO THE LEFT AND TWO SMALLER SHADED CIRCLES AND ONE SMALLER UNSHADED CIRCLE IN THE MIDDLE OF THE PLAIN LINE CIRCLE.

FOR APPARATUS FOR THE TREATMENT OF AIR, NAMELY, AIR PURIFYING APPARATUS, AIR FILTERING APPARATUS, AIR HUMIDIFYING APPARATUS; AIR FILTERS FOR THE AFORESAID APPARATUS (U.S. CLS. 13, 21, 23, 31 AND 34).

DEBORAH MEINERS, EXAMINING ATTORNEY

SN 85-081,432. CITY ELECTRIC SUPPLY CO., ORLANDO, FL. FILED 7-9-2010.

SN 79-141,908. KONINKLIJKE PHILIPS N.V., NETHERLANDS, FILED 11-20-2013.

# VITASHIELD

THE MARK CONSISTS OF STANDARD CHARACTERS WITHOUT CLAIM TO ANY PARTICULAR FONT, STYLE, SIZE, OR COLOR.

PRIORITY DATE OF 6-6-2013 IS CLAIMED. OWNER OF INTERNATIONAL REGISTRATION 1190644 DATED 11-20-2013, EXPIRES 11-20-2023.

FOR APPARATUS FOR THE TREATMENT OF AIR, NAMELY, AIR PURIFYING APPARATUS, AIR FILTERING APPARATUS, AIR HUMIDIFYING APPARATUS; AIR FILTERS FOR THE AFORESAID APPARATUS (U.S. CLS. 13, 21, 23, 31 AND 34).

HAI-LY LAM, EXAMINING ATTORNEY



THE MARK CONSISTS OF THE TERM "EXTERRA" WITH LEAVES EXTENDING FROM THE TOP OF THE "T". FOR LIGHTING FIXTURES USED FOR OUTDOOR FIXED LIGHTING, NAMELY, LED AND HID LIGHT FIXTURES (U.S. CLS. 13, 21, 23, 31 AND 34).

FIRST USE 7-0-2007; IN COMMERCE 7-0-2007. TRACY WHITTAKER-BROWN, EXAMINING ATTORNEY

**CLASS 11—(Continued).**

SN 85-511,813. GABE COSCARELLA, EDMONTON, ALBERTA, CANADA, FILED 1-9-2012.

**TERMEX**

THE MARK CONSISTS OF STANDARD CHARACTERS WITHOUT CLAIM TO ANY PARTICULAR FONT, STYLE, SIZE, OR COLOR.

PRIORITY CLAIMED UNDER SEC. 44(D) ON CANADA APPLICATION NO. 1535018, FILED 7-8-2011, REG. NO. TMA880,888, DATED 6-26-2014, EXPIRES 6-26-2029.

FOR PARTS OF PLUMBING SYSTEMS, NAMELY, DRAINAGE VALVES AND FITTING THEREFORE (U.S. CLS. 13, 21, 23, 31 AND 34).

ELI HELLMAN, EXAMINING ATTORNEY

**CLASS 11—(Continued).**

SN 85-717,187. CLEARBROOK, L.L.C., MOBILE, AL. FILED 8-30-2012.

**CLEARBROOK**

THE MARK CONSISTS OF STANDARD CHARACTERS WITHOUT CLAIM TO ANY PARTICULAR FONT, STYLE, SIZE, OR COLOR.

FOR WATER-FILTERS; WASTE WATER PURIFICATION UNITS; AND WATER PURIFICATION UNITS (U.S. CLS. 13, 21, 23, 31 AND 34).

FIRST USE 0-0-1984; IN COMMERCE 0-0-1984.

GRETCHEN ULRICH, EXAMINING ATTORNEY

SN 85-680,814. TO INTERNATIONAL INDUSTRIAL CORPORATION, VANCOUVER, B.C., CANADA, FILED 7-18-2012.



OWNER OF CANADA REG. NO. TMA847,901, DATED 4-8-2013, EXPIRES 4-8-2028.

THE MARK CONSISTS OF THE WORDS "LIGHT UP THE NIGHT" WHICH ARC ABOVE A CANDLE DESIGN THAT COMPRISES THE "I" OF THE LETTERS "IOED" THAT APPEAR AGAINST A DARK BACKGROUND.

FOR LIGHT EMITTING DIODES (LEDS), LIGHT BULBS, LIGHTING FIXTURES (U.S. CLS. 13, 21, 23, 31 AND 34).

MICHELLE DUBOIS, EXAMINING ATTORNEY

SN 85-789,084. TEMPAK INTERATIONAL PTY LTD., MEL-ROSE PARK, NSW 2114, AUSTRALIA, FILED 11-28-2012.

**ONEDER**

THE MARK CONSISTS OF STANDARD CHARACTERS WITHOUT CLAIM TO ANY PARTICULAR FONT, STYLE, SIZE, OR COLOR.

FOR TEMPERATURE CONTROLLED BEVERAGE DISPENSER, AND COMPONENTS THEREOF (U.S. CLS. 13, 21, 23, 31 AND 34).

MARTHA SANTOMARTINO, EXAMINING ATTORNEY

SN 85-697,977. CORTEX USA, INC., DBA CORTEX INTERNATIONAL, MIAMI GARDENS, FL. FILED 8-8-2012.

**CORTEX PROFESSIONAL**

THE MARK CONSISTS OF STANDARD CHARACTERS WITHOUT CLAIM TO ANY PARTICULAR FONT, STYLE, SIZE, OR COLOR.

NO CLAIM IS MADE TO THE EXCLUSIVE RIGHT TO USE "PROFESSIONAL", APART FROM THE MARK AS SHOWN.

FOR HAND-HELD ELECTRIC HAIR DRYERS (U.S. CLS. 13, 21, 23, 31 AND 34).

FIRST USE 1-1-2012; IN COMMERCE 1-1-2012.

ALICIA COLLINS, EXAMINING ATTORNEY

SN 85-842,725. SAMSUNG ELECTRONICS CO., LTD., SU-WON-SI, GYEONGGI-DO, REPUBLIC OF KOREA, FILED 2-6-2013.

**SAMSUNG SMART OVEN**

THE MARK CONSISTS OF STANDARD CHARACTERS WITHOUT CLAIM TO ANY PARTICULAR FONT, STYLE, SIZE, OR COLOR.

OWNER OF U.S. REG. NOS. 2,882,774, 2,929,523 AND OTHERS.

NO CLAIM IS MADE TO THE EXCLUSIVE RIGHT TO USE "SMART OVEN", APART FROM THE MARK AS SHOWN.

THE ENGLISH TRANSLATION OF "SAMSUNG" IN THE MARK IS "THREE STARS".

FOR ELECTRIC COOKING OVENS; MICROWAVE OVENS (U.S. CLS. 13, 21, 23, 31 AND 34).

SUNG IN, EXAMINING ATTORNEY



**CLASS 11—(Continued).**

SN 85-847,319. CROWN SUPPLY CO.,INC, PROVIDENCE, RI.  
FILED 2-12-2013.

**Home Lighting Makeover**

THE MARK CONSISTS OF STANDARD CHARACTERS WITHOUT CLAIM TO ANY PARTICULAR FONT, STYLE, SIZE, OR COLOR.

NO CLAIM IS MADE TO THE EXCLUSIVE RIGHT TO USE "HOME LIGHTING", APART FROM THE MARK AS SHOWN.

FOR LIGHTING FIXTURES (U.S. CLS. 13, 21, 23, 31 AND 34).

FIRST USE 12-6-2012; IN COMMERCE 2-5-2013.  
BRIAN NEVILLE, EXAMINING ATTORNEY

SN 85-893,477. VENTAMATIC, LTD., MINERAL WELLS, TX.  
FILED 4-2-2013.

**MAXX AIR**

THE MARK CONSISTS OF STANDARD CHARACTERS WITHOUT CLAIM TO ANY PARTICULAR FONT, STYLE, SIZE, OR COLOR.

NO CLAIM IS MADE TO THE EXCLUSIVE RIGHT TO USE "AIR", APART FROM THE MARK AS SHOWN.

FOR VENTILATING, HIGH-VELOCITY FIXED EXHAUST FANS FOR COMMERCIAL AND AGRICULTURAL USE; VENTILATING, HIGH-VELOCITY PORTABLE EXHAUST FANS FOR COMMERCIAL AND AGRICULTURAL USE (U.S. CLS. 13, 21, 23, 31 AND 34).

FIRST USE 1-31-1998; IN COMMERCE 1-31-1998.  
LAURIE MAYES, EXAMINING ATTORNEY

SN 85-969,809. TREVI SYSTEMS INC., DBA TREVI SYSTEMS INC., PETALUMA, CA. FILED S.R. 6-25-2013; AM. P.R. 6-27-2014.



NO CLAIM IS MADE TO THE EXCLUSIVE RIGHT TO USE "SYSTEMS", APART FROM THE MARK AS SHOWN.

THE COLOR(S) LIGHT BLUE, DARK BLUE AND WHITE IS/ARE CLAIMED AS A FEATURE OF THE MARK.

THE MARK CONSISTS OF "TREVI SYSTEMS" WORDING IN A DARK BLUE COLOR IN THE MIDDLE OF AN OVAL FIGURE THAT IS NOT CONNECTED TO COMPLETE THE

**CLASS 11—(Continued).**

OVAL. THE OVAL STARTS AT THE "T" IN "TREVI", ON THE LEFT, AND ENDS AT THE WATER AND SPIRAL DESIGN, ON THE RIGHT. THE OVAL IS IN A GRADIENT BLUE COLOR, CHANGING FROM DARK BLUE TO LIGHT BLUE AS YOU LOOK LEFT TO RIGHT. THERE IS A LIGHT BLUE, DARK BLUE AND WHITE SPIRAL FIGURE WITH A LIGHT BLUE, DARK BLUE, AND WHITE WATER DROP IN THE MIDDLE, ON THE RIGHT. ALL OF THE MARK APPEARS ON A WHITE BACKGROUND, AND IS NOT PART OF THE MARK.

FOR DESALINATION UNITS (U.S. CLS. 13, 21, 23, 31 AND 34).

BRITTANY ESTELL, EXAMINING ATTORNEY

SN 86-002,807. SANIPROTEX INC., VARENNES, QUEBEC, CANADA, FILED 7-4-2013.

**EPURA TECH**

THE MARK CONSISTS OF STANDARD CHARACTERS WITHOUT CLAIM TO ANY PARTICULAR FONT, STYLE, SIZE, OR COLOR.

PRIORITY CLAIMED UNDER SEC. 44(D) ON CANADA APPLICATION NO. 1611904, FILED 1-30-2013, REG. NO. TMA871,385, DATED 2-14-2014, EXPIRES 2-14-2029.

NO CLAIM IS MADE TO THE EXCLUSIVE RIGHT TO USE "TECH", APART FROM THE MARK AS SHOWN.

THE ENGLISH TRANSLATION OF "EPURA" IN THE MARK IS "PURIFIES".

FOR NEGATIVE PRESSURE FILTRATION SUCTION HEAD WHERE THE WASTE WATERS ARE SUCKED AND WHERE THE LIQUID MATERIAL IS SEPARATED FROM SEMI-LIQUID MATERIAL (U.S. CLS. 13, 21, 23, 31 AND 34).

KIM MONINGHOFF, EXAMINING ATTORNEY

SN 86-022,965. FEELUX CO., LTD., GYEONGGIDO, REPUBLIC OF KOREA, FILED 7-30-2013.

**SPOT FREE**

THE MARK CONSISTS OF STANDARD CHARACTERS WITHOUT CLAIM TO ANY PARTICULAR FONT, STYLE, SIZE, OR COLOR.

FOR ELECTRIC LAMPS; ELECTRIC LIGHTING FIXTURES; FLUORESCENT LAMPS; LIGHTING APPARATUS, NAMELY, LIGHTING INSTALLATIONS; LIGHTING FIXTURES; STANDS FOR ELECTRIC LIGHTING FIXTURES; ; LED LIGHT BULBS; LED LIGHTING FIXTURES (U.S. CLS. 13, 21, 23, 31 AND 34).

MATTHEW MCDOWELL, EXAMINING ATTORNEY

**CLASS 11—(Continued).**

SN 86-046,183. MEREDITH CORPORATION, DES MOINES, IA. FILED 8-23-2013.

# PARENTS

THE MARK CONSISTS OF STANDARD CHARACTERS WITHOUT CLAIM TO ANY PARTICULAR FONT, STYLE, SIZE, OR COLOR.

OWNER OF U.S. REG. NOS. 2,550,977, 3,688,209 AND OTHERS.

FOR ELECTRIC BABY BOTTLE WARMERS; ELECTRIC BABY FOOD WARMERS (U.S. CLS. 13, 21, 23, 31 AND 34).

DORITT L. CARROLL, EXAMINING ATTORNEY

SN 86-046,616. MEREDITH CORPORATION, DES MOINES, IA. FILED 8-23-2013.

# Parents

OWNER OF U.S. REG. NOS. 2,550,977, 4,286,674 AND OTHERS.

THE MARK CONSISTS OF A STYLIZED VERSION OF THE WORD "PARENTS".

FOR ELECTRIC BABY BOTTLE WARMERS; ELECTRIC BABY FOOD WARMERS (U.S. CLS. 13, 21, 23, 31 AND 34).

DORITT L. CARROLL, EXAMINING ATTORNEY

SN 86-052,858. HELD, MICHAEL P., WEST SENECA, NY. FILED 8-31-2013.

# Glow Valance

THE MARK CONSISTS OF STANDARD CHARACTERS WITHOUT CLAIM TO ANY PARTICULAR FONT, STYLE, SIZE, OR COLOR.

FOR LIGHTING FIXTURE, NAMELY, LED LIGHTS POSITIONED BETWEEN LAYERS OF FABRIC TO PROVIDE INDIRECT LIGHTING (U.S. CLS. 13, 21, 23, 31 AND 34).

RONALD AIKENS, EXAMINING ATTORNEY

**CLASS 11—(Continued).**

SN 86-065,574. C2 DEVELOPMENT, INC., AMES, IA. FILED 9-16-2013.

# Sprout

THE MARK CONSISTS OF STANDARD CHARACTERS WITHOUT CLAIM TO ANY PARTICULAR FONT, STYLE, SIZE, OR COLOR.

FOR LED (LIGHT EMITTING DIODE) LIGHTING FIXTURES FOR AQUARIA, VIVARIA AND HORTICULTURE (U.S. CLS. 13, 21, 23, 31 AND 34).

HENRY S. ZAK, EXAMINING ATTORNEY

SN 86-065,877. NEWGENSAUNA CO., LTD., DAEJEON, REPUBLIC OF KOREA, FILED 9-16-2013.



THE MARK CONSISTS OF THE STYLIZED WORDING "NEWGEN" OVER THE DESIGN OF FOUR LARGE SQUARES. THE SQUARES ARE IN A TWO SQUARE BY TWO SQUARE FORMATION WHERE EACH SQUARE CONTAINS THE OUTLINE OF A SMALLER SQUARE.

FOR ELECTRIC SAUNAS, INFRARED SAUNAS, SAUNAS FOR DOMESTIC USE, FAR-INFRARED SAUNAS, SAUNA BATH INSTALLATIONS, HALF-BATH SAUNAS FOR DOMESTIC USE, DRY TYPE SAUNAS (U.S. CLS. 13, 21, 23, 31 AND 34).

KIM SAITO, EXAMINING ATTORNEY

SN 86-066,686. FELLOWES, INC., ITASCA, IL. FILED 9-17-2013.

# AERAMAX

THE MARK CONSISTS OF STANDARD CHARACTERS WITHOUT CLAIM TO ANY PARTICULAR FONT, STYLE, SIZE, OR COLOR.

FOR AIR PURIFIERS FOR USE WITH HOME AND OFFICE (U.S. CLS. 13, 21, 23, 31 AND 34).

FIRST USE 5-31-2013; IN COMMERCE 5-31-2013.

HEATHER THOMPSON, EXAMINING ATTORNEY

**CLASS 11—(Continued).**

SN 86-072,408. STRATEGIC PARTNERS, INC., CHATSWORTH, CA. FILED 9-23-2013.

# Curo

THE MARK CONSISTS OF STANDARD CHARACTERS WITHOUT CLAIM TO ANY PARTICULAR FONT, STYLE, SIZE, OR COLOR.

THE ENGLISH TRANSLATION OF "CURO" IN THE MARK IS "TO HEAL".  
FOR FLASHLIGHTS (U.S. CLS. 13, 21, 23, 31 AND 34).  
DANNEAN HETZEL, EXAMINING ATTORNEY

---

SN 86-072,627. NTFB COMBUSTION EQUIPMENT USA, INC., FREMONT, CA. FILED 9-24-2013.



OWNER OF U.S. REG. NO. 3,808,432.  
NO CLAIM IS MADE TO THE EXCLUSIVE RIGHT TO USE "COMBUSTION EQUIPMENT USA, INC.", APART FROM THE MARK AS SHOWN.

THE MARK CONSISTS OF THE LITERAL ELEMENTS "NTFB COMBUSTION EQUIPMENT USA, INC." WHEREAS THERE IS AN IMAGE TO THE LEFT SIDE REPRESENTING AN ABSTRACT BURNER FLAME WHICH IS CROSSING OVER LETTER "N".

FOR HEATING BOILERS AND BOILER ROOM EQUIPMENT, NAMELY, HEAT PIPES TO COOL HEAT PRODUCING COMPONENTS, HEATING SYSTEMS FOR RESIDENTIAL OR COMMERCIAL BUILDINGS COMPRISED OF BOILERS, VALVES, PIPES, MANIFOLDS, CONTROL PANELS, SWITCHES AND ELECTRICAL WIRE, ALL SOLD AS A UNIT (U.S. CLS. 13, 21, 23, 31 AND 34).

KATHLEEN M. VANSTON, EXAMINING ATTORNEY

---

SN 86-074,866. STELLA LIGHTING INC., EUGENE, OR. FILED 9-25-2013.



THE MARK CONSISTS OF A CIRCLE FORMED BY EIGHT FOUR-SIDED SHAPES TO THE LEFT OF THE WORDS "STELLA EDGE".

FOR LIGHTING FIXTURES (U.S. CLS. 13, 21, 23, 31 AND 34).

TARAH HARDY, EXAMINING ATTORNEY

**CLASS 11—(Continued).**

SN 86-075,013. EVRIHOLDER ACQUISITION CO., LLC, ANAHEIM, CA. FILED 9-25-2013.

# HOT STONE THERAPY

THE MARK CONSISTS OF STANDARD CHARACTERS WITHOUT CLAIM TO ANY PARTICULAR FONT, STYLE, SIZE, OR COLOR.

NO CLAIM IS MADE TO THE EXCLUSIVE RIGHT TO USE "THERAPY", APART FROM THE MARK AS SHOWN.

FOR HEATING AND COOLING PACKS FILLED WITH CHEMICAL SUBSTANCES THAT REACT WHEN REQUIRED TO WARM OR COOL THE BODY AND CONTAIN HERBS AND AROMATHERAPY MATERIALS (U.S. CLS. 13, 21, 23, 31 AND 34).

TEJBIR SINGH, EXAMINING ATTORNEY

---

SN 86-097,165. EVOQUA WATER TECHNOLOGIES LLC, ALPHARETTA, GA. FILED 10-21-2013.

# MEMRACK

THE MARK CONSISTS OF STANDARD CHARACTERS WITHOUT CLAIM TO ANY PARTICULAR FONT, STYLE, SIZE, OR COLOR.

FOR WATER FILTRATION APPARATUS INTEGRATING WATER FEED, PRESSURIZED AIR, FILTRATE WITH FILTER MODULE HOUSINGS, AND WASTE HEADERS INTO ONE APPARATUS (U.S. CLS. 13, 23, 31 AND 34).

B. PARADEWELAI, EXAMINING ATTORNEY

---

SN 86-106,423. EVOLUTION LIGHTING, LLC, MIAMI LAKES, FL. FILED 10-31-2013.

# ALSY

THE MARK CONSISTS OF STANDARD CHARACTERS WITHOUT CLAIM TO ANY PARTICULAR FONT, STYLE, SIZE, OR COLOR.

OWNER OF U.S. REG. NO. 1,701,647.

FOR ELECTRIC LIGHTING FIXTURES (U.S. CLS. 13, 21, 23, 31 AND 34).

GEORGE LORENZO, EXAMINING ATTORNEY

**CLASS 11—(Continued).**

SN 86-123,526. ACROSENTEC CO., LTD., UIWANG CITY, KYUNGGIDO, REPUBLIC OF KOREA, FILED 11-19-2013.



THE COLOR(S) ORANGE, GREEN, BLUE AND BLACK IS/ARE CLAIMED AS A FEATURE OF THE MARK.

THE MARK CONSISTS OF THE WORDS "MORE THAN JUST TECHNOLOGY" OVER THE WORD "ACROSENTEC" IN BLACK LETTERS WHICH IS TO THE RIGHT OF A DESIGN MADE UP OF THREE SETS OF 16 DOTS, ONE SET IS GREEN, ONE SET IS BLUE, ONE SET IS ORANGE. THE THREE SETS OF DOTS ARE CONFIGURED IN A WAY TO FORM AN OPEN SPACE TRIANGLE IN THE CENTER OF THEM.

FOR LED LIGHTING, NAMELY, LED FIXTURES FOR INDOOR AND OUTDOOR LIGHTING APPLICATIONS, LED MODULES, POWER SUPPLIES, AND WIRING, LED DISPLAYS; ENERGY RELATED PRODUCTS, NAMELY, SOLAR COLLECTORS, SOLAR HEATING PANELS AND WIND TURBINES FOR USE WITH CONVERTING SOLAR AND WIND ENERGY INTO ELECTRICITY FOR LED LIGHTING FIXTURES (U.S. CLS. 13, 21, 23, 31 AND 34).

HOWARD SMIGA, EXAMINING ATTORNEY

**CLASS 11—(Continued).**

SN 86-135,006. DOORFILTER TECHNOLOGIES LIMITED, WOODBRIDGE, CANADA, FILED 12-4-2013.



NO CLAIM IS MADE TO THE EXCLUSIVE RIGHT TO USE "DOOR FILTER", APART FROM THE MARK AS SHOWN.

THE COLOR(S) WHITE, BLUE, GREEN AND GRAY IS/ARE CLAIMED AS A FEATURE OF THE MARK.

THE MARK CONSISTS OF THE LITERAL ELEMENTS "PURUS AERO DOOR FILTER BY PURUS AERO" WRITTEN IN STYLIZED FORM WHEREIN WORD "PURUS AERO" WRITTEN IN WHITE COLOR DEPICTED IN LETTER "D" WRITTEN IN BLUE COLOR. THERE ARE TWO GREEN LEAVES, ONE INSIDE THE LETTER "D" AND ONE ABOVE THE LETTER "O". THE WORD "DOOR FILTER" WRITTEN IN BLUE AND GRAY COLOR AND WORD "BY PURUS AERO" WRITTEN IN GRAY COLOR PLACED AT BELOW.

FOR AIR FILTERING INSTALLATIONS; AIR FILTERS FOR INDUSTRIAL INSTALLATIONS; AIR FILTERS FOR DOMESTIC USE; FILTERS AND FILTERING DEVICES FOR FILTERING AIR THAT PASSES AROUND DOORS (U.S. CLS. 13, 21, 23, 31 AND 34).

MEGHAN REINHART, EXAMINING ATTORNEY

SN 86-128,685. SALOMON, LYAT, OCEAN, NJ. FILED 11-25-2013.



THE MARK CONSISTS OF AN OUTLINE OF A HANGING LIGHT BULB HAVING A SINGLE COIL AT THE TOP AND PARTIALLY ENCIRCLING A "+" AND A "-".

FOR LIGHTING FIXTURES MANUFACTURED AND DISTRIBUTED FOR PERMANENT OR TEMPORARY ARCHITECTURAL, THEATRICAL, ENTERTAINMENT, COMMERCIAL OR RESIDENTIAL APPLICATIONS (U.S. CLS. 13, 21, 23, 31 AND 34).

TINA MAI, EXAMINING ATTORNEY

**CLASS 11—(Continued).**

SN 86-141,246. LONGEVITY RESOURCES INC., VICTORIA, B.C., CANADA, FILED 12-11-2013.



The logo for Longevity Resources features the word "Longevity" in a bold, sans-serif font. The letter "o" is stylized with a blue globe icon. Below "Longevity" is the word "RESOURCES" in a smaller, all-caps, sans-serif font.

THE COLOR(S) BLACK, BLUE AND WHITE IS/ARE CLAIMED AS A FEATURE OF THE MARK.

THE MARK CONSISTS OF THE WORDS "LONGEVITY RESOURCES" IN BLACK, EXCEPT FOR THE LETTER "O" IN "LONGEVITY" WHICH IS BLUE WITH WHITE HIGHLIGHTING.

FOR AIR CLEANING UNITS CONTAINING AN AIR FILTER, ULTRAVIOLET LIGHTS AND A PHOTOCATALYTIC FILTER; COMBINATION OZONE SANITIZER AND ELECTRIC DEODORIZING UNITS; DISINFECTING ULTRAVIOLET LAMPS HOUSED IN A CONTAINER OR COVER FOR DISINFECTING OBJECTS PLACED THEREIN; EMISSION CONTROL SYSTEMS COMPRISED PRIMARILY OF INDIRECT CONTACT HEAT EXCHANGERS AND OZONE-BASED CONTROL DEVICES USING GAS AND VAPOR CONDENSING TO CONTROL AND TREAT EMISSIONS; OXYGEN CONCENTRATORS FOR USE WITH FUEL CELLS USED IN HEATING, VENTILATION, AIR CONDITIONING, LIGHTING, AND POWER SYSTEMS FOR BUILDINGS; OXYGEN GENERATOR BASED ON THERMAL DECOMPOSITION OF OXYGEN RICH SALTS; OXYGEN GENERATOR FOR PROCESSING WATER BY INCREASING OXYGEN CONTENT IN THE WATER; OZONE GENERATORS THAT KILL MOLD AND MILDEW; OZONE SANITIZERS FOR AIR AND WATER; SANITIZING APPARATUS FOR LINENS USING ULTRAVIOLET LIGHT, OZONE STERILIZATION AND LOW PRESSURE TECHNIQUES; SANITIZING APPARATUS USING ULTRAVIOLET LIGHT FOR SANITIZING AIR AND WATER NOT FOR MEDICAL PURPOSES; ULTRAVIOLET LAMPS NOT FOR MEDICAL PURPOSES; WATER TREATMENT EQUIPMENT, NAMELY, ULTRAVIOLET STERILIZATION UNITS (U.S. CLS. 13, 21, 23, 31 AND 34).

FIRST USE 1-22-1997; IN COMMERCE 1-22-1997.  
PATRICIA EVANKO, EXAMINING ATTORNEY

SN 86-170,676. APPLIED ENERGY COMPANY, LLC, CARROLLTON, TX. FILED 1-21-2014.



The logo for DµRT HOG features the word "DµRT" in a large, bold, serif font, followed by the word "HOG" in a smaller, bold, serif font.

THE MARK CONSISTS OF STANDARD CHARACTERS WITHOUT CLAIM TO ANY PARTICULAR FONT, STYLE, SIZE, OR COLOR.

FOR FLUID FILTRATION APPARATUS FOR SEPARATION OF OIL AND WATER; SEPARATORS FOR PURIFICATION OF LIQUIDS (U.S. CLS. 13, 21, 23, 31 AND 34).

FIRST USE 5-7-2012; IN COMMERCE 5-7-2012.  
DAVID MURRAY, EXAMINING ATTORNEY

**CLASS 11—(Continued).**

SN 86-197,834. HYDROXYGEN, INC., BRIGHAM CITY, UT. FILED 2-19-2014.



The logo for Global Solution to Pollution features the words "GLOBAL SOLUTION TO POLLUTION" in a bold, sans-serif font, arranged in three lines.

THE MARK CONSISTS OF STANDARD CHARACTERS WITHOUT CLAIM TO ANY PARTICULAR FONT, STYLE, SIZE, OR COLOR.

FOR HYDROGEN GENERATORS; HYDROGEN-GENERATION EQUIPMENT AND COMPONENTS, NAMELY, HYDROGEN GENERATORS, HYDROGEN PURIFIERS, HYDROGEN PURIFICATION MEMBRANES, FUEL PROCESSORS, AND STEAM REFORMERS (U.S. CLS. 13, 21, 23, 31 AND 34).

ANDREW RHIM, EXAMINING ATTORNEY

SN 86-198,716. WATERWORLD USA, INC., HOUSTON, TX. FILED 2-20-2014.



The logo for Waterworld USA features the words "WATERWORLD USA" in a bold, sans-serif font.

THE MARK CONSISTS OF STANDARD CHARACTERS WITHOUT CLAIM TO ANY PARTICULAR FONT, STYLE, SIZE, OR COLOR.

NO CLAIM IS MADE TO THE EXCLUSIVE RIGHT TO USE "USA", APART FROM THE MARK AS SHOWN.

FOR WATER FILTRATION AND PURIFICATION APPARATUS AND COMPONENT PARTS THEREOF (U.S. CLS. 13, 21, 23, 31 AND 34).

FIRST USE 1-1-1996; IN COMMERCE 1-1-1996.  
ROBERT C. CLARK JR., EXAMINING ATTORNEY

**CLASS 11—(Continued).**

SN 86-199,642. DELITE PRODUCTS, INC., SIMI VALLEY, CA. FILED 2-20-2014.



NO CLAIM IS MADE TO THE EXCLUSIVE RIGHT TO USE "MODS USA" AND "MADE IN USA", APART FROM THE MARK AS SHOWN.

THE MARK CONSISTS OF A STYLIZED "T" WITHIN STYLIZED CROSSHAIRS WITH THE WORDS "TAC MODS USA" ON THE TOP RIGHT AND "MADE IN USA" ON THE BOTTOM LEFT.

FOR ELECTRIC VAPORIZERS (U.S. CLS. 13, 21, 23, 31 AND 34).

FIRST USE 12-28-2013; IN COMMERCE 12-28-2013.  
STEVEN JACKSON, EXAMINING ATTORNEY

SN 86-201,977. CLEARWATER SYSTEMS CORPORATION, MIDDLETOWN, CT. FILED 2-24-2014.



OWNER OF U.S. REG. NO. 2,712,367.  
NO CLAIM IS MADE TO THE EXCLUSIVE RIGHT TO USE "CLEARWATER SYSTEMS", APART FROM THE MARK AS SHOWN.

THE MARK CONSISTS OF A CIRCULAR DESIGN MADE OF A DOLPHIN JUMPING OVER THE LOWER HALF OF THE DESIGN, WITH THE WORDS "CLEARWATER SYSTEMS" TO THE RIGHT OF THE DESIGN.

FOR ELECTRIC LIQUID TREATMENT DEVICES AND ELECTRIC LIQUID PRE-TREATMENT DEVICES FOR MEMBRANE FILTRATION SYSTEMS AND UV LIGHT SYSTEMS, NAMELY, WATER TREATMENT UNITS FOR GENERATING OSCILLATING ELECTROMAGNETIC FLUX TO PREVENT SCALE DEPOSITS AND INHIBIT MICROORGANISM AND MICROBIAL GROWTH COMPRISING PIPING FEATURING ELECTRICAL INDUCTION COILS, AND ASSOCIATED ELECTRICAL POWER SUPPLY UNITS FOR USE IN COMMERCIAL AND INDUSTRIAL SETTINGS, NAMELY, CIRCULATING WATER IN COMMERCIAL HEATING AND AIR CONDITIONING SYSTEMS; AND PRE-TREATMENT OF LIQUIDS MEMBRANE FILTRATION SYSTEMS AND UV LIGHT SYSTEMS (U.S. CLS. 13, 21, 23, 31 AND 34).

ALLISON HOLTZ, EXAMINING ATTORNEY

**CLASS 11—(Continued).**

SN 86-204,147. NANODER TECHNOLOGY GROUP INC, NEW YORK, NY. FILED 2-25-2014.



THE COLOR(S) BLUE, DARK BLUE AND LIGHT BLUE IS/ARE CLAIMED AS A FEATURE OF THE MARK.

THE MARK CONSISTS OF A DESIGN OF RECTANGLES FORMING A WAVE IN THE COLORS BLUE, DARK BLUE AND LIGHT BLUE OVER THE WORDING "NANODER" IN DARK BLUE.

THE WORDING "NANODER" HAS NO MEANING IN A FOREIGN LANGUAGE.

FOR DISH DISINFECTANT APPARATUS FOR INDUSTRIAL PURPOSES; IONISATION APPARATUS FOR THE TREATMENT OF AIR; PURIFICATION INSTALLATIONS FOR SEWAGE; WASTE WATER PURIFICATION APPARATUS, INSTALLATIONS AND TANKS; WATER FILTERING APPARATUS; WATER FILTERING DEVICES, NAMELY, WATER PURIFICATION INSTALLATIONS FOR WASTE WATER AND SEWAGE CONSISTING OF CURTAINS AND TEXTILE FABRICS; WATER PURIFICATION INSTALLATIONS; WATER PURIFYING APPARATUS; WATER SOFTENING APPARATUS AND INSTALLATIONS; WATER STERILIZERS (U.S. CLS. 13, 21, 23, 31 AND 34).

FIRST USE 1-10-2014; IN COMMERCE 2-13-2014.  
LINDA M. KING, EXAMINING ATTORNEY

SN 86-207,078. DV SYSTEMS INC., BARRIE, CANADA, FILED 2-28-2014.

# ProDry

THE MARK CONSISTS OF STANDARD CHARACTERS WITHOUT CLAIM TO ANY PARTICULAR FONT, STYLE, SIZE, OR COLOR.

OWNER OF CANADA REG. NO. TMA620,807, DATED 9-28-2004, EXPIRES 9-28-2019.

FOR DRYERS FOR THE REMOVAL OF WATER VAPOR FROM COMPRESSED AIR AND GASES; DRYERS USED FOR THE REMOVAL OF SOLID, LIQUID AND VAPOR CONTAMINANTS FROM COMPRESSED AIR AND GASES (U.S. CLS. 13, 21, 23, 31 AND 34).

KIMBERLY FRYE, EXAMINING ATTORNEY

**CLASS 11—(Continued).**

SN 86-214,627. CLEAVER-BROOKS, INC., THOMASVILLE, GA. FILED 3-7-2014.



NO CLAIM IS MADE TO THE EXCLUSIVE RIGHT TO USE "INDUSTRIAL COMBUSTION", APART FROM THE MARK AS SHOWN.

THE MARK CONSISTS OF THE WORDS "INDUSTRIAL COMBUSTION" IN STYLIZED LETTERING WITH A FLAME DESIGN IN THE FIRST LETTER "O" IN "COMBUSTION".

FOR OIL BURNERS, GAS BURNERS, AND COMBINATION OIL AND GAS BURNERS FOR COMMERCIAL AND INDUSTRIAL USE; FUEL OIL HEATERS (U.S. CLS. 13, 21, 23, 31 AND 34).

FIRST USE 12-0-2010; IN COMMERCE 12-0-2010.  
PAUL CROWLEY, EXAMINING ATTORNEY

SN 86-214,659. CLEAVER-BROOKS, INC., THOMASVILLE, GA. FILED 3-7-2014.



OWNER OF U.S. REG. NO. 1,529,586.

THE MARK CONSISTS OF THE STYLIZED LETTERS "IC" WITH A FLAME DESIGN INSIDE OF A CIRCLE THAT IS SUPERIMPOSED OVER PORTIONS OF THE LETTERS.

FOR OIL BURNERS, GAS BURNERS, AND COMBINATION OIL AND GAS BURNERS FOR COMMERCIAL AND INDUSTRIAL USE; FUEL OIL HEATERS (U.S. CLS. 13, 21, 23, 31 AND 34).

FIRST USE 9-0-2010; IN COMMERCE 9-0-2010.  
PAUL CROWLEY, EXAMINING ATTORNEY

SN 86-215,627. OIL SOLUTIONS GROUP, INC., COLLEYVILLE, TX. FILED 3-9-2014.



THE MARK CONSISTS OF STANDARD CHARACTERS WITHOUT CLAIM TO ANY PARTICULAR FONT, STYLE, SIZE, OR COLOR.

FOR FILTRATION UNIT FOR FILTERING AND TREATING COOKING OIL BEING PART OF COMMERCIAL DEEP FRYERS (U.S. CLS. 13, 21, 23, 31 AND 34).

FIRST USE 6-15-2009; IN COMMERCE 6-15-2009.  
CURTIS FRENCH, EXAMINING ATTORNEY

**CLASS 11—(Continued).**

SN 86-217,016. JATIN V MEHTA, CHERRY HILL, NJ. FILED 3-11-2014.



NO CLAIM IS MADE TO THE EXCLUSIVE RIGHT TO USE "PRL LED LIGHTING", APART FROM THE MARK AS SHOWN.

THE MARK CONSISTS OF THE WORDING "PRL" ABOVE THE WORDING "LED LIGHTING" ABOVE THE WORDING "WWW.RAVILIGHTS.COM". NEXT TO THE WORDING APPEARS A STYLIZED DEPICTION OF THE SUN.

THE ENGLISH TRANSLATION OF "RAVI" IS "SUN".  
FOR ELECTRIC BULBS; ELECTRIC LIGHT BULBS; LED (LIGHT EMITTING DIODE) LIGHTING FIXTURES; LED (LIGHT EMITTING DIODES) LIGHTING FIXTURES FOR USE IN DISPLAY, COMMERCIAL, INDUSTRIAL, RESIDENTIAL, AND ARCHITECTURAL ACCENT LIGHTING APPLICATIONS; LED LIGHT ASSEMBLIES FOR STREET LIGHTS, SIGNS, COMMERCIAL LIGHTING, AUTOMOBILES, BUILDINGS, AND OTHER ARCHITECTURAL USES; LED LIGHT BULBS; LED LIGHT ENGINES; LED LIGHT MACHINES; LED LIGHTING SYSTEMS, NAMELY, LED MODULES, POWER SUPPLIES, AND WIRING; LIGHT BULBS (U.S. CLS. 13, 21, 23, 31 AND 34).

JIM RINGLE, EXAMINING ATTORNEY

SN 86-219,800. INGENIOUS DESIGNS LLC, ST. PETERSBURG, FL. FILED 3-13-2014.

**FOREVER FRAGRANT AIRFLOW**

THE MARK CONSISTS OF STANDARD CHARACTERS WITHOUT CLAIM TO ANY PARTICULAR FONT, STYLE, SIZE, OR COLOR.

OWNER OF U.S. REG. NOS. 3,716,803 AND 3,759,257.  
NO CLAIM IS MADE TO THE EXCLUSIVE RIGHT TO USE "FRAGRANT AIRFLOW", APART FROM THE MARK AS SHOWN.

FOR AIR PURIFIERS (U.S. CLS. 13, 21, 23, 31 AND 34).  
SIDDHARTH JAGANNATHAN, EXAMINING ATTORNEY



**CLASS 11—(Continued).**

SN 86-223,611. KEYCOLOUR INC., PHOENIX, AZ. FILED 3-17-2014.

## Lake FX

THE MARK CONSISTS OF STANDARD CHARACTERS WITHOUT CLAIM TO ANY PARTICULAR FONT, STYLE, SIZE, OR COLOR.

NO CLAIM IS MADE TO THE EXCLUSIVE RIGHT TO USE "LAKE", APART FROM THE MARK AS SHOWN.

FOR A BIOLOGICAL BLEND OF NATURALLY OCCURRING BACTERIA AND FUNGI TO AUGMENT EXISTING POPULATIONS OF MICROORGANISMS IN HYDROFOIL TO INCREASE THE RATE OF DECAY OF DEAN PLANT MATTER AND OTHER COMPONENTS OF ORGANIC SEDIMENTS IN AQUATIC ENVIRONMENT FOR USE IN THE TREATMENT OF LAKES AND PONDS (U.S. CLS. 13, 21, 23, 31 AND 34).

ALLISON SCHRODY, EXAMINING ATTORNEY

**CLASS 11—(Continued).**

SN 86-228,085. ALLMAND BROS., INC., HOLDREGE, NE. FILED 3-21-2014.

## MINE SPEC

THE MARK CONSISTS OF STANDARD CHARACTERS WITHOUT CLAIM TO ANY PARTICULAR FONT, STYLE, SIZE, OR COLOR.

NO CLAIM IS MADE TO THE EXCLUSIVE RIGHT TO USE "MINE", APART FROM THE MARK AS SHOWN.

FOR A PORTABLE LIGHT TOWER MODEL DESIGNED AND MANUFACTURED WITH FEATURES REQUIRED OR SPECIFICALLY APPROPRIATE FOR THE MINING MARKETS (U.S. CLS. 13, 21, 23, 31 AND 34).

FIRST USE 9-30-2012; IN COMMERCE 3-31-2013.

DAVID MURRAY, EXAMINING ATTORNEY

SN 86-225,951. SHAPIRO, STEPHEN, TORRANCE, CA. AND SHAPIRO, MARIA, TORRANCE, CA. FILED 3-19-2014.

## Sink Buddy

THE MARK CONSISTS OF STANDARD CHARACTERS WITHOUT CLAIM TO ANY PARTICULAR FONT, STYLE, SIZE, OR COLOR.

NO CLAIM IS MADE TO THE EXCLUSIVE RIGHT TO USE "SINK", APART FROM THE MARK AS SHOWN.

FOR ERGONOMIC FAUCET ATTACHMENTS FOR BATHROOM SINKS (U.S. CLS. 13, 21, 23, 31 AND 34).

JENNIFER MARTIN, EXAMINING ATTORNEY

SN 86-229,817. INSTANT-OFF, INC., CLEARWATER, FL. FILED 3-24-2014.

## Innovative Hydraulic Technology

THE MARK CONSISTS OF STANDARD CHARACTERS WITHOUT CLAIM TO ANY PARTICULAR FONT, STYLE, SIZE, OR COLOR.

NO CLAIM IS MADE TO THE EXCLUSIVE RIGHT TO USE "HYDRAULIC TECHNOLOGY", APART FROM THE MARK AS SHOWN.

FOR FAUCET AERATORS, FAUCETS AND PLUMBING FIXTURES, NAMELY, FAUCETS AND WATER SAVING DEVICES AS ATTACHMENTS FOR FAUCETS (U.S. CLS. 13, 21, 23, 31 AND 34).

DAVID MURRAY, EXAMINING ATTORNEY

SN 86-228,043. ALLMAND BROS., INC., HOLDREGE, NE. FILED 3-21-2014.

## RIG SPEC

THE MARK CONSISTS OF STANDARD CHARACTERS WITHOUT CLAIM TO ANY PARTICULAR FONT, STYLE, SIZE, OR COLOR.

NO CLAIM IS MADE TO THE EXCLUSIVE RIGHT TO USE "RIG", APART FROM THE MARK AS SHOWN.

FOR A PORTABLE LIGHT TOWER MODEL DESIGNED AND MANUFACTURED WITH FEATURES REQUIRED OR SPECIFICALLY APPROPRIATE FOR THE OIL AND GAS MARKET (U.S. CLS. 13, 21, 23, 31 AND 34).

FIRST USE 9-30-2012; IN COMMERCE 6-30-2013.

DAVID MURRAY, EXAMINING ATTORNEY

SN 86-231,564. TEXAS CUSTOM GRILLS, LLC, DBA FIRE DISC GRILLS, KATY, TX. FILED 3-25-2014.

## Quality You Can Cook On!

THE MARK CONSISTS OF STANDARD CHARACTERS WITHOUT CLAIM TO ANY PARTICULAR FONT, STYLE, SIZE, OR COLOR.

FOR BARBECUE GRILLS; BARBECUES; BARBECUES AND GRILLS (U.S. CLS. 13, 21, 23, 31 AND 34).

FIRST USE 1-1-2010; IN COMMERCE 1-1-2010.

GRETTA YAO, EXAMINING ATTORNEY



**CLASS 11—(Continued).**

SN 86-234,267. SUNBEAM PRODUCTS, INC., BOCA RATON, FL. FILED 3-27-2014.



OWNER OF U.S. REG. NOS. 928,614, 3,644,324 AND OTHERS.

THE MARK CONSISTS OF THE LITERAL ELEMENT "CROCK POT", WITH A DIAMOND BETWEEN THE WORDS "CROCK" AND "POT", AND WITH STEAM VAPORS EMANATING FROM THE TOP VIEW OF A SLOW COOKER SERVING AS THE "O" IN THE WORD "POT".

FOR ELECTRIC COOKING APPLIANCES, NAMELY, WARMING TRAYS (U.S. CLS. 13, 21, 23, 31 AND 34).

WILLIAM JACKSON, EXAMINING ATTORNEY

**CLASS 11—(Continued).**

SN 86-237,517. YORK NEW ENERGY CO., INC., NEW YORK, NY. FILED 3-31-2014.

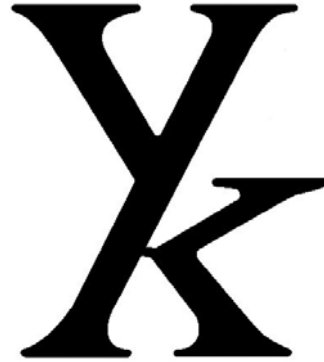

THE MARK CONSISTS OF THE STYLIZED LETTERS "YK" FORMED BY COMBINING THE LETTERS TOGETHER WITHOUT SPACES.

FOR LED (LIGHT EMITTING DIODE) LIGHTING FIXTURES; LED LIGHT BULBS; LED LAMPS; LED LUMINAIRES; LIGHT BULBS; LIGHTING FIXTURES; SPOTLIGHTS; FLASHLIGHTS; LANTERNS FOR LIGHTING; OUTDOOR PORTABLE LIGHTING PRODUCTS, NAMELY, HEADLAMPS; ELECTRIC TRACK LIGHTING UNITS; ELECTRIC LIGHTING FIXTURES (U.S. CLS. 13, 21, 23, 31 AND 34).

EDWARD NELSON, EXAMINING ATTORNEY

SN 86-235,088. ELVARIA, LLC, GAINESVILLE, VA. FILED 3-28-2014.

**ELVARIA**

THE MARK CONSISTS OF STANDARD CHARACTERS WITHOUT CLAIM TO ANY PARTICULAR FONT, STYLE, SIZE, OR COLOR.

OWNER OF U.S. REG. NO. 4,510,684.

FOR FREEZERS AND CHILLERS FOR USE IN COMMERCIAL AND INDUSTRIAL FOOD OR BEVERAGE PROCESSING (U.S. CLS. 13, 21, 23, 31 AND 34).

HANNO RITTNER, EXAMINING ATTORNEY

SN 86-237,920. WESTIN AUTOMOTIVE PRODUCTS, INC., SAN DIMAS, CA. FILED 3-31-2014.

**WESTIN**

THE MARK CONSISTS OF STANDARD CHARACTERS WITHOUT CLAIM TO ANY PARTICULAR FONT, STYLE, SIZE, OR COLOR.

OWNER OF U.S. REG. NOS. 4,500,551 AND 4,500,603.

FOR AUTOMOTIVE ACCESSORIES, NAMELY, LIGHTS, LIGHT GUARDS AND LIGHT COVERS IN THE NATURE OF LIGHT CASINGS AND LIGHT BARS FOR TRUCKS, VANS, SPORTS UTILITY VEHICLES; EXTERIOR ACCESSORIES FOR VEHICLES, NAMELY, LIGHTS, LIGHT GUARDS AND LIGHT COVERS IN THE NATURE OF LIGHT CASINGS AND LIGHT BARS FOR TRUCKS, VANS, SPORTS UTILITY VEHICLES; ACCESSORIES FOR TRUCKS AND SUVs, NAMELY, LIGHTS, LIGHT BARS AND LIGHT GUARDS AND LIGHT COVERS IN THE NATURE OF LIGHT CASINGS (U.S. CLS. 13, 21, 23, 31 AND 34).

FIRST USE 1-0-2005; IN COMMERCE 1-0-2005.

KERI CANTONE, EXAMINING ATTORNEY

**CLASS 11—(Continued).**

SN 86-239,767. PREMARK FEG L.L.C., GLENVIEW, IL.  
FILED 4-2-2014.

EVEN. BETTER. COOKING.

THE MARK CONSISTS OF STANDARD CHARACTERS  
WITHOUT CLAIM TO ANY PARTICULAR FONT, STYLE,  
SIZE, OR COLOR.

NO CLAIM IS MADE TO THE EXCLUSIVE RIGHT TO  
USE "COOKING", APART FROM THE MARK AS SHOWN.  
FOR COOKING OVENS (U.S. CLS. 13, 21, 23, 31 AND  
34).

JORDAN BAKER, EXAMINING ATTORNEY

SN 86-240,634. ALLIANCE SPORTS GROUP, L.P., GRAND  
PRAIRIE, TX. FILED 4-2-2014.

LUMO

THE MARK CONSISTS OF STANDARD CHARACTERS  
WITHOUT CLAIM TO ANY PARTICULAR FONT, STYLE,  
SIZE, OR COLOR.

FOR FLASHLIGHTS (U.S. CLS. 13, 21, 23, 31 AND 34).  
FIRST USE 1-15-2014; IN COMMERCE 1-15-2014.

TOBY BULLOFF, EXAMINING ATTORNEY

SN 86-241,385. HOMER TLC, INC., WILMINGTON, DE.  
FILED 4-3-2014.

COTTONPORT

THE MARK CONSISTS OF STANDARD CHARACTERS  
WITHOUT CLAIM TO ANY PARTICULAR FONT, STYLE,  
SIZE, OR COLOR.

FOR ELECTRIC LIGHTING FIXTURES (U.S. CLS. 13,  
21, 23, 31 AND 34).

JEAN IM, EXAMINING ATTORNEY

**CLASS 11—(Continued).**

SN 86-241,437. 4FRONT ENGINEERED SOLUTIONS, INC.,  
CARROLTON, TX. FILED 4-3-2014.

WAVE

THE MARK CONSISTS OF STANDARD CHARACTERS  
WITHOUT CLAIM TO ANY PARTICULAR FONT, STYLE,  
SIZE, OR COLOR.

FOR ELECTRIC FANS FOR COMMERCIAL, INDUS-  
TRIAL AND WAREHOUSE USE (U.S. CLS. 13, 21, 23, 31  
AND 34).

CIMMERIAN COLEMAN, EXAMINING ATTORNEY

SN 86-241,561. 4FRONT ENGINEERED SOLUTIONS, INC.,  
CARROLTON, TX. FILED 4-3-2014.

ATEC

THE MARK CONSISTS OF STANDARD CHARACTERS  
WITHOUT CLAIM TO ANY PARTICULAR FONT, STYLE,  
SIZE, OR COLOR.

FOR ELECTRIC FANS FOR COMMERCIAL, INDUS-  
TRIAL AND WAREHOUSE USE (U.S. CLS. 13, 21, 23, 31  
AND 34).

CIMMERIAN COLEMAN, EXAMINING ATTORNEY

SN 86-244,385. CANNAHYDRO LLC, FORMERLY TETRA-  
HYDRO LLC, LAS VEGAS, NV. FILED 4-7-2014.

VICCS

THE MARK CONSISTS OF STANDARD CHARACTERS  
WITHOUT CLAIM TO ANY PARTICULAR FONT, STYLE,  
SIZE, OR COLOR.

THE ACRONYM "VICCS" HAS NO MEANING IN THE  
RELEVANT TRADE OR INDUSTRY, OR AS APPLIED TO  
THE GOODS, AND NO MEANING OTHER THAN TRADE-  
MARK SIGNIFICANCE.

FOR HYDROPONICS GROW BOX IN THE NATURE  
OF A CLOSED ENVIRONMENT EQUIPPED WITH  
LIGHTS, EXHAUST SYSTEM, HYDROPONICS GROW-  
ING CONTAINER AND ODOR CONTROL SYSTEM (U.S.  
CLS. 13, 21, 23, 31 AND 34).

ALEXANDER L. POWERS, EXAMINING ATTORNEY

**CLASS 11—(Continued).**

SN 86-246,423. AEQUOR, INC., OCEANSIDE, CA. FILED 4-8-2014.

# AEQUOR

THE MARK CONSISTS OF STANDARD CHARACTERS WITHOUT CLAIM TO ANY PARTICULAR FONT, STYLE, SIZE, OR COLOR.

FOR APPARATUS FOR LIGHTING, HEATING, STEAM GENERATING, COOKING, REFRIGERATING, DRYING, VENTILATING, WATER SUPPLY AND SANITARY PURPOSES, NAMELY, WATER CONDITIONING AND COOLING UNIT, COMPRISING WATER PIPES, WATER FILTRATION FILTERS, REFRIGERATION CONDENSERS, WATER COOLING TOWERS AND UNIT HOUSING CONTAINERS, ALL WITH AN ANTI-FOULING COATING AND SOLD TOGETHER AS A UNIT (U.S. CLS. 13, 21, 23, 31 AND 34).

DOUGLAS LEE, EXAMINING ATTORNEY

SN 86-246,653. BAILEY, MARK, SLACKS CREEKS, AUSTRALIA, AND BAILEY, KAJIRA, SLACKS CREEK, AUSTRALIA, FILED 4-9-2014.

# SPARKLE RIBBON

THE MARK CONSISTS OF STANDARD CHARACTERS WITHOUT CLAIM TO ANY PARTICULAR FONT, STYLE, SIZE, OR COLOR.

FOR LIGHTED PARTY-THEMED DECORATIONS, ELECTRIC LIGHT DECORATIVE STRINGS; LIGHTING APPARATUS, DEVICES AND FIXTURES FOR THE FLORAL, BALLOON, PARTY AND SPECIAL EVENT INDUSTRIES; LED (LIGHT EMITTING DIODE) LIGHTING FIXTURES; LED CANDLES; LED LANDSCAPE LIGHTS; LED LIGHT STRIPS FOR DECORATIVE PURPOSES; LED LUMINAIRES; LIGHTED PARTY-THEMED DECORATIONS, ELECTRIC LIGHT DECORATIVE STRINGS (U.S. CLS. 13, 21, 23, 31 AND 34).

FIRST USE 2-1-2012; IN COMMERCE 2-1-2012.  
HEATHER SAPP, EXAMINING ATTORNEY

SN 86-247,027. NATIONAL REFRIGERATION & AIR CONDITIONING PRODUCTS, INC., BENSALEM, PA. FILED 4-9-2014.

# COMFORT PACK

THE MARK CONSISTS OF STANDARD CHARACTERS WITHOUT CLAIM TO ANY PARTICULAR FONT, STYLE, SIZE, OR COLOR.

FOR HEATING, VENTILATION AND AIR CONDITIONING UNITS FOR COMMERCIAL AND RESIDENTIAL USE (U.S. CLS. 13, 21, 23, 31 AND 34).

FIRST USE 12-31-2008; IN COMMERCE 12-31-2008.  
MARIA-VICTORIA SUAREZ, EXAMINING ATTORNEY

**CLASS 11—(Continued).**

SN 86-247,459. C & A INTERNATIONAL, INC., POMONA, CA. FILED 4-9-2014.

# KONESOON

THE MARK CONSISTS OF STANDARD CHARACTERS WITHOUT CLAIM TO ANY PARTICULAR FONT, STYLE, SIZE, OR COLOR.

FOR AIR PURIFIERS; AIR PURIFYING APPARATUS; BAKING OVENS; COOKING OVENS (U.S. CLS. 13, 21, 23, 31 AND 34).

GEORGE LORENZO, EXAMINING ATTORNEY

SN 86-247,557. PLH PRODUCTS, INC., BUENA PARK, CA. FILED 4-9-2014.

# TECOLOY

THE MARK CONSISTS OF STANDARD CHARACTERS WITHOUT CLAIM TO ANY PARTICULAR FONT, STYLE, SIZE, OR COLOR.

FOR SAUNAS, NAMELY, ELECTRIC SAUNA, INFRARED SAUNA, STEAM SAUNA, DRY SAUNA, HALF-BODY SAUNAS, SMALL SIZE SAUNAS, AND PORTABLE SAUNAS FOR HEATING PURPOSES; ELECTRIC HEATERS FOR SAUNAS AND FOR WALL PANELS; ELECTRIC SPACE HEATERS; ELECTRIC PORTABLE HEATERS; AND ELECTRIC INFRARED HEATERS (U.S. CLS. 13, 21, 23, 31 AND 34).

KEVIN DINALLO, EXAMINING ATTORNEY

SN 86-247,713. MEGALOWMART HOLDINGS, LLC, DIAMOND BAR, CA. FILED 4-9-2014.

# AON

THE MARK CONSISTS OF THREE LETTERS "A", "O" AND "N" WHERE THE HORIZONTAL LINE OF LETTER "A" PIERCING INTO LETTER "O".

FOR LED LIGHT BULBS (U.S. CLS. 13, 21, 23, 31 AND 34).

FIRST USE 3-1-2014; IN COMMERCE 3-1-2014.  
TINA MAI, EXAMINING ATTORNEY

**CLASS 11—(Continued).**

SN 86-247,894. BEIJING CONNOISSEUR CULTURAL RELIC IDENTIFICATION EQUIPMENT AND TECHNOLOGY CO., LTD., BEIJING, CHINA, FILED 4-10-2014.

*CONNOISSEUR*

THE MARK CONSISTS OF THE STYLIZED WORD "CONNOISSEUR".

FOR DIVING LIGHTS; FLASHLIGHTS; LIGHT BULBS; LIGHTING APPARATUS, NAMELY, LIGHTING INSTALLATIONS; LIGHTING INSTALLATIONS FOR VEHICLES; LIGHTING TUBES; OVEN GAS IGNITERS; POCKET SEARCH LIGHTS; ULTRAVIOLET RAY LAMPS, NOT FOR MEDICAL PURPOSES (U.S. CLS. 13, 21, 23, 31 AND 34).

PATRICIA EVANKO, EXAMINING ATTORNEY

SN 86-249,208. CHINA MACHINERY ENGINEERING WUXI CO., LTD., WUXI, JIANGSU, CHINA, FILED 4-11-2014.

*BESTYLE*

THE MARK CONSISTS OF THE WORD "BESTYLE" INSIDE AN OVAL WITH THE LETTER "B" IN STYLIZED FONT.

THE WORDING BESTYLE HAS NO MEANING IN A FOREIGN LANGUAGE.

FOR BURNERS FOR LAMPS; CEILING LIGHTS; CHANDELIERS; ELECTRIC CHINESE LANTERNS; ELECTRIC LIGHTS FOR CHRISTMAS TREES; LAMP CASINGS; LAMPS; LIGHT BULBS; LIGHT DIFFUSERS; LIGHTING APPARATUS, NAMELY, LIGHTING INSTALLATIONS; STREET LAMPS (U.S. CLS. 13, 21, 23, 31 AND 34).

ANDREA K. NADELMAN, EXAMINING ATTORNEY

SN 86-250,727. KES HOME (U.S.) LIMITED, KWUN TONG, HONG KONG, FILED 4-13-2014.

**KES**

THE MARK CONSISTS OF STYLIZED LETTERS "KES".  
FOR FAUCET AERATORS; FAUCET HANDLES; FAUCET SPRAYERS; FAUCETS; KITCHEN SINKS; SHOWER BASES; SHOWER HEADS; SHOWER MIXING VALVES; SHOWER STANDS; SHOWERS; SINKS; VANITY TOP SINKS; WATER CONTROL VALVES FOR FAUCETS (U.S. CLS. 13, 21, 23, 31 AND 34).

FIRST USE 2-1-2013; IN COMMERCE 2-1-2013.

TEJBIR SINGH, EXAMINING ATTORNEY

**CLASS 11—(Continued).**

SN 86-250,991. CONAIR CORPORATION, STAMFORD, CT. FILED 4-14-2014.

CONAIRPRO

THE MARK CONSISTS OF STANDARD CHARACTERS WITHOUT CLAIM TO ANY PARTICULAR FONT, STYLE, SIZE, OR COLOR.

OWNER OF U.S. REG. NOS. 2,333,387, 3,598,435 AND OTHERS.

FOR HAIR DRYER DIFFUSERS (U.S. CLS. 13, 21, 23, 31 AND 34).

FIRST USE 4-30-2001; IN COMMERCE 4-30-2001.

KRISTINA MORRIS, EXAMINING ATTORNEY

SN 86-251,815. SUNDANCE SPAS, INC., CHINO HILLS, CA. FILED 4-14-2014.

FLUIDIX

THE MARK CONSISTS OF STANDARD CHARACTERS WITHOUT CLAIM TO ANY PARTICULAR FONT, STYLE, SIZE, OR COLOR.

FOR JETS FOR SPAS AND HOT TUBS (U.S. CLS. 13, 21, 23, 31 AND 34).

SIMON TENG, EXAMINING ATTORNEY

SN 86-252,630. PIEDADE, FRANCIS RUMENOS, PIRACICABA, SP, BRAZIL, FILED 4-15-2014.

ONNO

THE MARK CONSISTS OF STANDARD CHARACTERS WITHOUT CLAIM TO ANY PARTICULAR FONT, STYLE, SIZE, OR COLOR.

FOR ELECTRIC LUMINAIRES; LED LANDSCAPE LIGHTS; LED LIGHT ASSEMBLIES FOR STREET LIGHTS; SIGNS, COMMERCIAL LIGHTING, AUTOMOBILES, BUILDINGS, AND OTHER ARCHITECTURAL USES; LED LIGHT BULBS; LED LIGHTING SYSTEMS, NAMELY, LED MODULES, POWER SUPPLIES, AND WIRING; LED LUMINAIRES; LIGHT POST LUMINAIRES; LUMINAIRE REFRACTORS; LUMINAIRES, USING LIGHT EMITTING DIODES (LEDS) AS A LIGHT SOURCE, FOR STREET OR ROADWAY LIGHTING (U.S. CLS. 13, 21, 23, 31 AND 34).

ALISON KEELEY, EXAMINING ATTORNEY

**CLASS 11—(Continued).**

SN 86-258,257. YIN, HSUEH CHENG, GARDENA, CA. FILED 4-21-2014.

asmodus

THE MARK CONSISTS OF STANDARD CHARACTERS WITHOUT CLAIM TO ANY PARTICULAR FONT, STYLE, SIZE, OR COLOR.  
FOR ELECTRIC VAPORIZERS (U.S. CLS. 13, 21, 23, 31 AND 34).  
ALISON POLLACK, EXAMINING ATTORNEY

SN 86-258,270. SUNDANCE SPAS, INC., CHINO HILLS, CA. FILED 4-21-2014.

PROCLEAR

THE MARK CONSISTS OF STANDARD CHARACTERS WITHOUT CLAIM TO ANY PARTICULAR FONT, STYLE, SIZE, OR COLOR.  
FOR FILTERS FOR HOT TUBS AND SPAS (U.S. CLS. 13, 21, 23, 31 AND 34).  
SIMON TENG, EXAMINING ATTORNEY

SN 86-266,261. PLH PRODUCTS, INC., BUENA PARK, CA. FILED 4-29-2014.

TRUE INFRA

THE MARK CONSISTS OF STANDARD CHARACTERS WITHOUT CLAIM TO ANY PARTICULAR FONT, STYLE, SIZE, OR COLOR.  
FOR SAUNAS, NAMELY, ELECTRIC SAUNA, INFRARED SAUNA, STEAM SAUNA, DRY SAUNA, HALF-BODY SAUNAS, SMALL SIZE SAUNAS, AND PORTABLE SAUNAS FOR HEATING PURPOSES; ELECTRIC HEATERS FOR SAUNAS AND FOR WALL PANELS; ELECTRIC SPACE HEATERS; ELECTRIC PORTABLE HEATERS; AND ELECTRIC INFRARED HEATERS (U.S. CLS. 13, 21, 23, 31 AND 34).  
KEVIN DINALLO, EXAMINING ATTORNEY

**CLASS 11—(Continued).**

SN 86-271,771. YIN, HSUEH CHENG, GARDENA, CA. FILED 5-5-2014.



THE MARK CONSISTS OF A BRUSHSTROKE, CIRCULAR DESIGN FORMING AN OUTER CIRCULAR BORDER, AND THE WORDS "ASMODUS" IS POSITIONED IN A CIRCULAR SEAL ON THE INSIDE OF THE CIRCLE.  
FOR ELECTRIC VAPORIZERS (U.S. CLS. 13, 21, 23, 31 AND 34).  
ALISON POLLACK, EXAMINING ATTORNEY

SN 86-275,990. AXALTA COATING SYSTEMS IP CO. LLC, WILMINGTON, DE. FILED 5-8-2014.

LIGHTCOAT

THE MARK CONSISTS OF STANDARD CHARACTERS WITHOUT CLAIM TO ANY PARTICULAR FONT, STYLE, SIZE, OR COLOR.  
FOR ULTRAVIOLET LAMP FOR CURING PAINTS AND COATINGS (U.S. CLS. 13, 21, 23, 31 AND 34).  
WENDELL PHILLIPS, EXAMINING ATTORNEY

SN 86-279,233. DREAMLINE, WARMINSTER, PA. FILED 5-13-2014.

CLEARMAX

THE MARK CONSISTS OF STANDARD CHARACTERS WITHOUT CLAIM TO ANY PARTICULAR FONT, STYLE, SIZE, OR COLOR.  
FOR BATHTUBS; SHOWERS; SHOWER DOORS; HOT TUBS (U.S. CLS. 13, 21, 23, 31 AND 34).  
SAIMA MAKHDOOM, EXAMINING ATTORNEY

**CLASS 11—(Continued).**

SN 86-283,776. CALIFORNIA FAUCETS, INC., HUNTINGTON BEACH, CA. FILED 5-16-2014.

**HERMOSA**

THE MARK CONSISTS OF STANDARD CHARACTERS WITHOUT CLAIM TO ANY PARTICULAR FONT, STYLE, SIZE, OR COLOR.

FOR FAUCET AERATORS; FAUCET HANDLES; FAUCET SPRAYERS; FAUCETS; FLEXIBLE PIPES BEING PARTS OF BATH PLUMBING INSTALLATIONS; FLEXIBLE PIPES BEING PARTS OF SHOWER PLUMBING INSTALLATIONS; MANUALLY-OPERATED PLUMBING VALVES; PLUMBING FITTINGS, NAMELY, SHOWERHEADS, TUB FAUCETS, PLUMBING WALL STABILIZERS, SHOWER AND TUB MOUNTING KITS COMPRISED OF FAUCETS, VALVES, AND SCREWS; SHOWER AND TUB VALVES, SPOUTS, HANDLES; PLUMBING FITTINGS, NAMELY, AERATORS FOR FAUCETS; PLUMBING FITTINGS, NAMELY, FAUCET FILTERS; PLUMBING FITTINGS, NAMELY, SHOWER CONTROL VALVES; PLUMBING FITTINGS, NAMELY, SPOUTS; PLUMBING FITTINGS, NAMELY, TUB CONTROL VALVES; PLUMBING FITTINGS, NAMELY, VALVES; PLUMBING FIXTURES, NAMELY, SHOWER SPRAYERS; PLUMBING FIXTURES, NAMELY, SINK SPRAYERS; SHOWER FAUCET EXTENSIONS; TAP WATER FAUCETS; TUB SPOUTS; WATER CONTROL VALVES FOR FAUCETS; WATER FAUCET SPOUT (U.S. CLS. 13, 21, 23, 31 AND 34).

KAREN K. BUSH, EXAMINING ATTORNEY

SN 86-283,781. CALIFORNIA FAUCETS, INC., HUNTINGTON BEACH, CA. FILED 5-16-2014.

**ASILOMAR**

THE MARK CONSISTS OF STANDARD CHARACTERS WITHOUT CLAIM TO ANY PARTICULAR FONT, STYLE, SIZE, OR COLOR.

FOR FAUCET AERATORS; FAUCET HANDLES; FAUCET SPRAYERS; FAUCETS; FLEXIBLE PIPES BEING PARTS OF BATH PLUMBING INSTALLATIONS; FLEXIBLE PIPES BEING PARTS OF SHOWER PLUMBING INSTALLATIONS; MANUALLY-OPERATED PLUMBING VALVES; PLUMBING FITTINGS, NAMELY, SHOWERHEADS, TUB FAUCETS, PLUMBING WALL STABILIZERS, SHOWER AND TUB MOUNTING KITS COMPRISED OF FAUCETS, VALVES, AND SCREWS; SHOWER AND TUB VALVES, SPOUTS, HANDLES; PLUMBING FITTINGS, NAMELY, AERATORS FOR FAUCETS; PLUMBING FITTINGS, NAMELY, FAUCET FILTERS; PLUMBING FITTINGS, NAMELY, SHOWER CONTROL VALVES; PLUMBING FITTINGS, NAMELY, SPOUTS; PLUMBING FITTINGS, NAMELY, TUB CONTROL VALVES; PLUMBING FITTINGS, NAMELY, VALVES; PLUMBING FIXTURES, NAMELY, SHOWER SPRAYERS; PLUMBING FIXTURES, NAMELY, SINK SPRAYERS; SHOWER FAUCET EXTENSIONS; TAP WATER FAUCETS; TUB SPOUTS; WATER CONTROL VALVES FOR FAUCETS; WATER FAUCET SPOUT (U.S. CLS. 13, 21, 23, 31 AND 34).

KAREN K. BUSH, EXAMINING ATTORNEY

**CLASS 11—(Continued).**

SN 86-286,507. RESPONSE PRODUCTS LTD., WANCHAI, HONG KONG, FILED 5-20-2014.

**IONIC PRO TURBO**

THE MARK CONSISTS OF STANDARD CHARACTERS WITHOUT CLAIM TO ANY PARTICULAR FONT, STYLE, SIZE, OR COLOR.

SEC. 2(F).

FOR AIR PURIFIERS (U.S. CLS. 13, 21, 23, 31 AND 34). FIRST USE 9-30-2006; IN COMMERCE 9-30-2006.

MAYUR VAGHANI, EXAMINING ATTORNEY

**CLASS 12—VEHICLES**

SN 76-715,988. MONTELLA, MICHAEL J., GLEN MILLS, PA. FILED 3-13-2014.

**Mototape**

THE MARK CONSISTS OF STANDARD CHARACTERS WITHOUT CLAIM TO ANY PARTICULAR FONT, STYLE, SIZE, OR COLOR.

FOR SPECIALIZED FRICTION GRIP TAPE FOR USE ON MOTORCYCLES (U.S. CLS. 19, 21, 23, 31, 35 AND 44).

MARK SHINER, EXAMINING ATTORNEY

SN 79-135,776. KAWASAKI JUKOGYO KABUSHIKI KAISHA, DBA KAWASAKI HEAVY INDUSTRIES, LTD., JAPAN, FILED 1-28-2013.



OWNER OF INTERNATIONAL REGISTRATION 1174587 DATED 1-28-2013, EXPIRES 1-28-2023.

THE MARK CONSISTS OF THE STYLIZED LETTERS "ZX".

FOR MOTORCYCLES; MOPEDS; SCOOTERS; FAIRINGS FOR TWO-WHEELED VEHICLES, NAMELY, FOR BICYCLES, SCOOTERS, MOPEDS AND MOTORCYCLES (U.S. CLS. 19, 21, 23, 31, 35 AND 44).

KATHERINE CHANG, EXAMINING ATTORNEY

**CLASS 12—(Continued).**

SN 79-137,741. MIFA MITTELDEUTSCHE FAHRRADWERKE AG, FED REP GERMANY, FILED 9-3-2013.



PRIORITY DATE OF 3-23-2013 IS CLAIMED.  
OWNER OF INTERNATIONAL REGISTRATION 1179786 DATED 9-3-2013, EXPIRES 9-3-2023.  
THE COLOR(S) BLACK, RED, BLUE, PURPLE, WHITE, GREEN AND YELLOW IS/ARE CLAIMED AS A FEATURE OF THE MARK.

THE MARK CONSISTS OF THE STYLIZED WORDING "GRACE" IN BLACK, WITH THE IMAGE OF THREE OVERLAPPING CIRCULAR DESIGNS IN RED, BLUE, PURPLE, WHITE, GREEN AND YELLOW.

FOR TWO-WHEELED VEHICLES, NAMELY, BICYCLES AND ELECTRIC MOTOR-DRIVEN BICYCLES; COMPONENTS AND ACCESSORY PARTS THEREFOR, NAMELY, PEDAL CLIPS, BRAKES, CHAINS, HANDLE BARS, STABILIZERS IN THE NATURE OF TRAINING WHEELS, SADDLES, TIRES, WHEELS, BELLS, HORNS, KICKSTANDS, HANDLE BAR ENDS, PUMPS, WHEEL HUBS, CHAIN STAY PROTECTORS, CHAIN STAY FITTED NEOPRENE PROTECTIVE COVERS FOR BICYCLE SUSPENSION FORKS, AND CHAIN PROTECTORS FOR CHAIN RINGS (U.S. CLS. 19, 21, 23, 31, 35 AND 44).

ROBERT STRUCK, EXAMINING ATTORNEY

SN 79-138,147. INNTECK S.R.L., ITALY, FILED 9-13-2013.



OWNER OF INTERNATIONAL REGISTRATION 1180908 DATED 9-13-2013, EXPIRES 9-13-2023.

THE TRADEMARK CONSISTS OF THE WORDING "INNTECK" WRITTEN IN DISTINCTIVE BLOCK GRAPHIC CHARACTERS; THE LETTER "T" IS HIGHLIGHTED IN BOLD; THE WORDING IS CONTAINED WITHIN AN OVAL FORMED FROM FOUR STYLIZED HALF-MOON SHAPES OF DIFFERENT THICKNESSES.

FOR MOTOR VEHICLES, NAMELY, CONCEPT MOTOR VEHICLES; BRAKES FOR VEHICLES (U.S. CLS. 19, 21, 23, 31, 35 AND 44).

DAVID HOFFMAN, EXAMINING ATTORNEY

**CLASS 12—(Continued).**

SN 79-139,014. VALEO SYSTEMES D'ESSUYAGE, LA VERRIÈRE, FRANCE, FILED 10-24-2013.

# PYRAMID

THE MARK CONSISTS OF STANDARD CHARACTERS WITHOUT CLAIM TO ANY PARTICULAR FONT, STYLE, SIZE, OR COLOR.

PRIORITY DATE OF 4-24-2013 IS CLAIMED.

OWNER OF INTERNATIONAL REGISTRATION 1183082 DATED 10-24-2013, EXPIRES 10-24-2023.

FOR WINDSHIELD WIPER BLADES; FASTENERS SPECIALLY ADAPTED FOR CONNECTING WINDSHIELD WIPER BLADES; WINDSHIELD WIPER ARMS; WINDSHIELD WIPER DEFLECTORS (U.S. CLS. 19, 21, 23, 31, 35 AND 44).

LINDA LAVACHE, EXAMINING ATTORNEY

SN 79-141,317. KASHIYAMA SHOUTEN, NAGANO-PREF., JAPAN, FILED 10-29-2013.



OWNER OF INTERNATIONAL REGISTRATION 1189005 DATED 10-29-2013, EXPIRES 10-29-2023.

THE MARK CONSISTS OF THE STYLIZED AND UNDERLINED WORD "WINMAX".

FOR PARTS AND FITTINGS FOR AUTOMOBILES, NAMELY, BRAKE ROTORS, BRAKE SHOES AND BRAKE PADS (U.S. CLS. 19, 21, 23, 31, 35 AND 44).

CHRISTOPHER BUONGIORNO, EXAMINING ATTORNEY

SN 79-144,939. TYREMAX PTY LTD, AUSTRALIA, FILED 1-10-2014.

# ACETRAK

THE MARK CONSISTS OF STANDARD CHARACTERS WITHOUT CLAIM TO ANY PARTICULAR FONT, STYLE, SIZE, OR COLOR.

PRIORITY DATE OF 12-17-2013 IS CLAIMED.

OWNER OF INTERNATIONAL REGISTRATION 1197826 DATED 1-10-2014, EXPIRES 1-10-2024.

FOR TYRES FOR MOTOR VEHICLES; TYRES FOR TRUCKS; TYRES FOR TWO-WHEELED VEHICLES; TYRES FOR LAND VEHICLES; TREADS FOR RETREADING TIRES; REPAIR MATERIALS FOR TYRES, NAMELY, TYRE REPAIR PATCHES, TYRE INFLATORS AND TYRE RETREADING CAPS; WHEELS FOR VEHICLES; VEHICLE WHEEL RIMS; INNER TUBES (U.S. CLS. 19, 21, 23, 31, 35 AND 44).

TINA BROWN, EXAMINING ATTORNEY

**CLASS 12—(Continued).**

SN 79-146,011. ROAD SCENERY IMP & EXP; (BEIJING) CO., LTD, BEIJING, CHINA, FILED 2-6-2014.

**ROAD SCENERY**

OWNER OF INTERNATIONAL REGISTRATION 1200524 DATED 2-6-2014, EXPIRES 2-6-2024.

NO CLAIM IS MADE TO THE EXCLUSIVE RIGHT TO USE "ROAD", APART FROM THE MARK AS SHOWN.

THE MARK CONSISTS OF THE STYLIZED WORDING "ROAD SCENERY" UNDERLINED.

FOR INNER TUBES FOR VEHICLES; VEHICLE TYRES; TYRES FOR VEHICLES; CASINGS FOR PNEUMATIC TIRES; PNEUMATIC TIRES; TYRES, SOLID, FOR VEHICLE WHEELS; VEHICLE WHEEL TIRES; AUTOMOBILE TIRES; AUTOMOBILE STRUCTURAL PARTS, NAMELY, AUTOMOBILE HINGES; ANTI-SKID CHAINS FOR VEHICLE TIRES (U.S. CLS. 19, 21, 23, 31, 35 AND 44).

ALISON POLLACK, EXAMINING ATTORNEY

SN 85-776,093. YANMAR AMERICA CORPORATION, ADAIRSVILLE, GA. FILED 11-9-2012.

**PERFORMANCE LINK TECHNOLOGY**

THE MARK CONSISTS OF STANDARD CHARACTERS WITHOUT CLAIM TO ANY PARTICULAR FONT, STYLE, SIZE, OR COLOR.

NO CLAIM IS MADE TO THE EXCLUSIVE RIGHT TO USE "TECHNOLOGY", APART FROM THE MARK AS SHOWN.

FOR TRACTORS; TRACTORS FOR AGRICULTURAL PURPOSES; UTILITY TRACTORS; TRACTORS AND STRUCTURAL PARTS THEREOF; COMPACT TRACTORS; SUB-COMPACT TRACTORS (U.S. CLS. 19, 21, 23, 31, 35 AND 44).

FIRST USE 1-1-2012; IN COMMERCE 1-1-2012.

JEFF DEFORD, EXAMINING ATTORNEY

SN 86-051,253. NATIONAL ELECTRIC VEHICLE SWEDEN AB, TROLLHATTAN, SWEDEN, FILED 8-29-2013.

**XWVD**

THE MARK CONSISTS OF STANDARD CHARACTERS WITHOUT CLAIM TO ANY PARTICULAR FONT, STYLE, SIZE, OR COLOR.

OWNER OF U.S. REG. NO. 3,996,002.

FOR STRUCTURAL PARTS FOR AUTOMOBILES, SPORT UTILITY VEHICLES, TRUCKS, AND VANS (U.S. CLS. 19, 21, 23, 31, 35 AND 44).

ESTHER BELENKER, EXAMINING ATTORNEY

**CLASS 12—(Continued).**

SN 86-055,135. RING POWER CORPORATION, ST. AUGUSTINE, FL. FILED 9-4-2013.



OWNER OF U.S. REG. NOS. 3,401,520, 3,494,697 AND 3,616,437.

NO CLAIM IS MADE TO THE EXCLUSIVE RIGHT TO USE "TACTICAL SOLUTIONS", APART FROM THE MARK AS SHOWN.

THE MARK CONSISTS OF THE WORDS "RING POWER" ABOVE A SHIELD DESIGN CONTAINING THE STYLIZED WORDS "THE ROOK" IN THE TOP OF THE SHIELD. THE SHIELD HAS FOUR QUADRANTS BELOW THE WORDS "THE ROOK". CENTERED IN THE FRONT OF THE SHIELD IS A DESIGN COMBINING A ROOK CHESS PIECE WITH THE HULL AND TREADS OF A TANK-LIKE VEHICLE. BEHIND THE SHIELD DESIGN ARE TWO CROSSED LIGHTNING BOLTS. BENEATH THE SHIELD DESIGN IS A BANNER CONTAINING THE WORDS "TACTICAL SOLUTIONS".

FOR ARMoured LAND VEHICLES; UTILITY TERRAIN VEHICLES (UTVS) (U.S. CLS. 19, 21, 23, 31, 35 AND 44).

FIRST USE 1-1-2005; IN COMMERCE 1-1-2006.

STEVEN PEREZ, EXAMINING ATTORNEY

SN 86-060,654. PREMIER PROTECTION, SALT LAKE CITY, UT. FILED 9-10-2013.

**PREMIER PROTECTION  
AUTOMOTIVE INTERIOR FILMS**

THE MARK CONSISTS OF STANDARD CHARACTERS WITHOUT CLAIM TO ANY PARTICULAR FONT, STYLE, SIZE, OR COLOR.

NO CLAIM IS MADE TO THE EXCLUSIVE RIGHT TO USE "PROTECTION AUTOMOTIVE INTERIOR FILMS", APART FROM THE MARK AS SHOWN.

FOR FITTED PLASTIC FILM, NAMELY, FOR COVERING AND DECORATING AUTOMOTIVE INTERIORS AND EXTERIORS (U.S. CLS. 19, 21, 23, 31, 35 AND 44).

ELLEN BURNS, EXAMINING ATTORNEY



**CLASS 12—(Continued).**

SN 86-094,308. BLAC-RAC MANUFACTURING, INC., MERIDIAN, ID. FILED 10-17-2013.

# BLAC-RAC

THE MARK CONSISTS OF STANDARD CHARACTERS WITHOUT CLAIM TO ANY PARTICULAR FONT, STYLE, SIZE, OR COLOR.

OWNER OF U.S. REG. NO. 3,464,678.  
SEC. 2(F).  
FOR GUN RACKS FOR VEHICLES (U.S. CLS. 19, 21, 23, 31, 35 AND 44).  
FIRST USE 1-31-2008; IN COMMERCE 1-31-2008.  
RENEE MCCRAY, EXAMINING ATTORNEY

---

SN 86-104,552. MASERATI S.P.A., MODENA, ITALY, FILED 10-29-2013.

**THE ANTIDOTE TO CONFORMITY**

THE MARK CONSISTS OF STANDARD CHARACTERS WITHOUT CLAIM TO ANY PARTICULAR FONT, STYLE, SIZE, OR COLOR.

PRIORITY CLAIMED UNDER SEC. 44(D) ON ERPN CMNTY TM OFC APPLICATION NO. 12238549, FILED 10-21-2013, REG. NO. 12238549, DATED 3-6-2014, EXPIRES 10-21-2023.

FOR AUTOMOBILES; AUTOMOBILE PARTS, ACCESSORIES AND COMPONENTS, NAMELY, STEERING WHEELS, SPEED CHANGE GEARS, TRANSMISSION GEARS, SUSPENSION GEARS, AUTOMOBILE BODIES, RUBBER TRANSMISSION AND DRIVE BELTS, HEATERS, BUMPERS, TIRE PUMPS, CLUTCHES, DOOR HANDLES, REAR VIEW MIRRORS, DIRECTION INDICATORS, HORNS, AIR PUMPS, CHASSIS, WIND SCREEN BLOCKERS TO BE AFFIXED IN THE PASSENGER AREA, RUNNING BOARDS, TORSION BARS, SAFETY BELTS, RIMS FOR WHEELS, GEAR BOXES, ALL SPECIALLY ADAPTED FOR AUTOMOBILES; SAFETY SEATS FOR CHILDREN FOR AUTOMOBILES, SEAT COVERS FOR AUTOMOBILES, SOFT TOPS FOR AUTOMOBILES, ROOF RACKS FOR AUTOMOBILES, LUGGAGE CARRIERS FOR AUTOMOBILES, SAFETY DEVICES FOR AUTOMOBILES, NAMELY, AIRBAGS, ANTILOCK BRAKING SYSTEMS FOR AUTOMOBILES (ABS), ANTI-THEFT LOCKS FOR USE ON AUTOMOBILES, SUN BLINDS ADAPTED FOR AUTOMOBILES, SUNROOFS FOR AUTOMOBILES, INTERIOR TRIM FOR AUTOMOBILES, GLOVE BOXES FOR AUTOMOBILES, CIGAR LIGHTERS FOR AUTOMOBILES AND COMPONENTS THEREFOR (U.S. CLS. 19, 21, 23, 31, 35 AND 44).

ZACHARY R. SPARER, EXAMINING ATTORNEY

**CLASS 12—(Continued).**

SN 86-112,542. BAYERISCHE MOTOREN WERKE AKTIENGESELLSCHAFT, 80809 MUNICH, FED REP GERMANY, FILED 11-7-2013.

# HP4

THE MARK CONSISTS OF STANDARD CHARACTERS WITHOUT CLAIM TO ANY PARTICULAR FONT, STYLE, SIZE, OR COLOR.

OWNER OF FED REP GERMANY REG. NO. 30438838, DATED 8-5-2004, RENEWED AS REG. NO. 30438838, DATED 4-25-2014, EXPIRES 6-30-2024.  
FOR MOTORCYCLES (U.S. CLS. 19, 21, 23, 31, 35 AND 44).  
FIRST USE 1-31-2013; IN COMMERCE 1-31-2013.  
ANTHONY RINKER, EXAMINING ATTORNEY

---

SN 86-123,522. HONDA MOTOR CO., LTD., TOKYO, JAPAN, FILED 11-19-2013.

# RIDE RED

THE MARK CONSISTS OF STANDARD CHARACTERS WITHOUT CLAIM TO ANY PARTICULAR FONT, STYLE, SIZE, OR COLOR.

FOR MOTOR VEHICLES, NAMELY, MOTORCYCLES, ALL-TERRAIN VEHICLES, SIDE-BY-SIDE VEHICLES, MOTORSCOOTERS, AND THEIR STRUCTURAL PARTS (U.S. CLS. 19, 21, 23, 31, 35 AND 44).

APRIL REEVES, EXAMINING ATTORNEY

**CLASS 12—(Continued).**

SN 86-131,486. CUP INSERTS, INC., WOODLAND HILLS, CA. FILED 11-27-2013.



THE COLOR(S) RED AND GRAY IS/ARE CLAIMED AS A FEATURE OF THE MARK.

THE MARK CONSISTS OF A GRAY LETTER "C" WITH A SIDEWAYS LOWERCASE GRAY LETTER "I" WITH A RED DOT INSERTED IN THE OPENING.

FOR METAL AIRCRAFT CUP HOLDER ADAPTER IN THE FORM OF AN INSERT USED TO SECURE SUCH ITEMS AS WATER BOTTLES, GLASSWARE, STEAMWARE, CANS, WINE BOTTLES, ASHTRAYS AND THE LIKE INTO EXISTING CUP HOLDERS (U.S. CLS. 19, 21, 23, 31, 35 AND 44).

FIRST USE 2-1-2011; IN COMMERCE 2-1-2011.  
B. PARADEWELAI, EXAMINING ATTORNEY

SN 86-143,516. CHRISTOPHER WYCHE, NEWBURY PARK, CA. FILED 12-13-2013.



THE MARK CONSISTS OF THE LETTERS "CBW" IN STYLIZED LETTERING, WITH AN ARROW FORMED AT THE TOP OF THE LETTER "C".

FOR BICYCLE BELLS (U.S. CLS. 19, 21, 23, 31, 35 AND 44).  
FIRST USE 2-7-2012; IN COMMERCE 2-7-2012.  
FRED CARL, EXAMINING ATTORNEY

**CLASS 12—(Continued).**

SN 86-158,822. WYLIN AUTOMOTIVE, INC., EDISON, NJ. FILED 1-7-2014.

**WYLIN**

THE MARK CONSISTS OF STANDARD CHARACTERS WITHOUT CLAIM TO ANY PARTICULAR FONT, STYLE, SIZE, OR COLOR.

FOR AUTOMOTIVE PARTS, NAMELY, AUTOMOBILE CHASSIS, STEERING INNER AND OUTER TIE ROD ENDS, STEERING TIE ROD END ADJUSTING SLEEVES, STEERING IDLER ARMS, STEERING GEAR BELLOWS, SUSPENSION BALL JOINTS, SUSPENSION CONTROL ARMS, TRAILING ARMS AND TRACK BARS, SUSPENSION BUSHINGS AND SUSPENSION SWAY BAR LINKS (U.S. CLS. 19, 21, 23, 31, 35 AND 44).

INGRID C. EULIN, EXAMINING ATTORNEY

SN 86-158,827. WYLIN AUTOMOTIVE, INC., EDISON, NJ. FILED 1-7-2014.

**HONSSION**

THE MARK CONSISTS OF STANDARD CHARACTERS WITHOUT CLAIM TO ANY PARTICULAR FONT, STYLE, SIZE, OR COLOR.

FOR AUTOMOTIVE PARTS, NAMELY, AUTOMOBILE CHASSIS, STEERING INNER AND OUTER TIE ROD ENDS, STEERING TIE ROD END ADJUSTING SLEEVES, STEERING IDLER ARMS, STEERING GEAR BELLOWS, SUSPENSION BALL JOINTS, SUSPENSION CONTROL ARMS, TRAILING ARMS AND TRACK BARS, SUSPENSION BUSHINGS AND SUSPENSION SWAY BAR LINKS (U.S. CLS. 19, 21, 23, 31, 35 AND 44).

INGRID C. EULIN, EXAMINING ATTORNEY

SN 86-160,631. VISION WHEEL, INC., DECATUR, AL. FILED 1-8-2014.



OWNER OF U.S. REG. NO. 2,872,348.

THE MARK CONSISTS OF THE STYLIZED WORD, "MILANNI", WITH A THICK HORIZONTAL BAR ABOVE AND BELOW THE WORD; THE RECTANGULAR BACKGROUND IS ONLY TO SHOW CONTRAST AND IS NOT PART OF THE MARK

FOR CUSTOM WHEELS FOR VEHICLES (U.S. CLS. 19, 21, 23, 31, 35 AND 44).  
SUNG IN, EXAMINING ATTORNEY

**CLASS 12—(Continued).**

SN 86-167,384. MARINE INDUSTRIES CORPORATION,  
JEFFERSONVILLE, IN. FILED 1-16-2014.

**WEARGUARD**

THE MARK CONSISTS OF STANDARD CHARACTERS  
WITHOUT CLAIM TO ANY PARTICULAR FONT, STYLE,  
SIZE, OR COLOR.

FOR STRUCTURAL PARTS FOR BOATS (U.S. CLS. 19,  
21, 23, 31, 35 AND 44).

FIRST USE 10-9-2013; IN COMMERCE 10-9-2013.

JAY FLOWERS, EXAMINING ATTORNEY

**CLASS 12—(Continued).**

SN 86-195,526. RONIN MOTOR WORKS, LLC, DENVER, CO.  
FILED 2-17-2014.



NO CLAIM IS MADE TO THE EXCLUSIVE RIGHT TO  
USE "47", APART FROM THE MARK AS SHOWN.

THE MARK CONSISTS OF THE NUMBER "47" IN  
STYLIZED FONT WITHIN A CIRCLE.

FOR MOTORCYCLES; STRUCTURAL PARTS FOR  
MOTORCYCLES (U.S. CLS. 19, 21, 23, 31, 35 AND 44).

GINA FINK, EXAMINING ATTORNEY

SN 86-195,855. GEISER BROS. DESIGN & DEVELOPMENT,  
INC., DBA GEISER BROS., PHOENIX, AZ. FILED 2-17-  
2014.

**GEISER BROS.**

THE MARK CONSISTS OF STANDARD CHARACTERS  
WITHOUT CLAIM TO ANY PARTICULAR FONT, STYLE,  
SIZE, OR COLOR.

NO CLAIM IS MADE TO THE EXCLUSIVE RIGHT TO  
USE "BROS.", APART FROM THE MARK AS SHOWN.

SEC. 2(F).

FOR OFF-ROAD VEHICLES; RACING CARS (U.S.  
CLS. 19, 21, 23, 31, 35 AND 44).

FIRST USE 8-1-1995; IN COMMERCE 8-1-1995.

PRISCILLA MILTON, EXAMINING ATTORNEY

SN 86-194,623. KOKOPELLI RAFT CO., DBA KOKOPELLI  
RAFT CO., DENVER, CO. FILED 2-14-2014.



**Kokopelli Raft Co.**

SN 86-203,145. MICHELIN NORTH AMERICA, INC.,  
GREENVILLE, SC. FILED 2-25-2014.

**MICHELIN**

NO CLAIM IS MADE TO THE EXCLUSIVE RIGHT TO  
USE "RAFT CO.", APART FROM THE MARK AS SHOWN.

THE MARK CONSISTS OF TWO LINES IN A ALMOND  
SHAPED FORM DEPICTING RAFT WITH 4 LINES OFF OF  
LEFT SIDE OF RAFT INDICATING WATER. "KOKOPELLI  
RAFT CO." LETTERING POSITIONED BELOW.

FOR RAFTS (U.S. CLS. 19, 21, 23, 31, 35 AND 44).

FIRST USE 5-11-2013; IN COMMERCE 7-11-2013.

NICHOLAS ALTREE, EXAMINING ATTORNEY

THE MARK CONSISTS OF STANDARD CHARACTERS  
WITHOUT CLAIM TO ANY PARTICULAR FONT, STYLE,  
SIZE, OR COLOR.

OWNER OF U.S. REG. NOS. 892,045, 4,246,952 AND  
OTHERS.

FOR TRACK BELTS FOR TRACKED LAND VEHI-  
CLES (U.S. CLS. 19, 21, 23, 31, 35 AND 44).

PAUL CROWLEY, EXAMINING ATTORNEY

**CLASS 12—(Continued).**

SN 86-216,299. WHEELED COACH INDUSTRIES, INC., WINTER PARK, FL. FILED 3-10-2014.



OWNER OF U.S. REG. NOS. 1,413,260, 1,424,769 AND 2,050,808.

THE MARK CONSISTS OF A THREE STRIPED WING DESIGN WITHIN A CIRCLE.

FOR AMBULANCES, AUTOMOBILES, TRUCKS AND VANS FOR HEALTHCARE, EMERGENCY AND RESCUE TRANSPORTATION; TELECOMMUNICATIONS VEHICLES IN THE NATURE OF AMBULANCES, AUTOMOBILES, TRUCKS AND VANS FOR HEALTHCARE, EMERGENCY AND RESCUE TRANSPORTATION (U.S. CLS. 19, 21, 23, 31, 35 AND 44).

FIRST USE 1-1-1985; IN COMMERCE 1-1-1985.  
JAMES LOVELACE, EXAMINING ATTORNEY

SN 86-216,334. WHEELED COACH INDUSTRIES, INC., WINTER PARK, FL. FILED 3-10-2014.



OWNER OF U.S. REG. NOS. 1,413,260, 4,180,746 AND OTHERS.

NO CLAIM IS MADE TO THE EXCLUSIVE RIGHT TO USE "WHEELED COACH", APART FROM THE MARK AS SHOWN.

THE MARK CONSISTS OF THE WORDS "WHEELED COACH" WITH A WINGED DESIGN COMING OFF THE "W" AND THE "C".

FOR AMBULANCES, AUTOMOBILES, TRUCKS AND VANS FOR HEALTHCARE, EMERGENCY AND RESCUE TRANSPORTATION; TELECOMMUNICATIONS VEHICLES IN THE NATURE OF AMBULANCES, AUTOMOBILES, TRUCKS AND VANS FOR HEALTHCARE, EMERGENCY AND RESCUE TRANSPORTATION (U.S. CLS. 19, 21, 23, 31, 35 AND 44).

FIRST USE 1-1-1981; IN COMMERCE 1-1-1981.  
JAMES LOVELACE, EXAMINING ATTORNEY

**CLASS 12—(Continued).**

SN 86-227,050. EBIUS TRADING AND DISTRIBUTING, DBA EASTERN BIKES, INC., CARY, NC. FILED 3-20-2014.



NO CLAIM IS MADE TO THE EXCLUSIVE RIGHT TO USE "BIKES", APART FROM THE MARK AS SHOWN.

THE MARK CONSISTS OF THE STYLIZED LETTERS "EB" ADJACENT TO THE WORDS "EASTERN BIKES".

FOR BICYCLE PEDAL ACCESSORIES, NAMELY, FRAMES, SEATS, SEAT POSTS, CRANKS, FORKS, HANDLEBARS, PEGS, WHEELS, STEMS, SPROCKETS AND GUARDS, GRIPS PEDALS, CHAINS AND HUBS (U.S. CLS. 19, 21, 23, 31, 35 AND 44).

FIRST USE 6-30-2003, THE MARK WAS FIRST USED ANYWHERE IN A DIFFERENT FORM OTHER THAN THAT SOUGHT TO BE REGISTERED AT LEAST AS EARLY AS 06/30/2003; IN COMMERCE 6-30-2003, THE MARK WAS FIRST USED IN COMMERCE IN A DIFFERENT FORM OTHER THAN THAT SOUGHT TO BE REGISTERED AT LEAST AS EARLY AS 06/30/2003.

MORGAN WYNNE, EXAMINING ATTORNEY

SN 86-228,048. AUTOZONE PARTS, INC., MEMPHIS, TN. FILED 3-21-2014.

**DURALAST AERO BLADE**

THE MARK CONSISTS OF STANDARD CHARACTERS WITHOUT CLAIM TO ANY PARTICULAR FONT, STYLE, SIZE, OR COLOR.

OWNER OF U.S. REG. NOS. 4,151,614, 4,151,759 AND OTHERS.

NO CLAIM IS MADE TO THE EXCLUSIVE RIGHT TO USE "BLADE", APART FROM THE MARK AS SHOWN.

FOR WINDSHIELD WIPER BLADES (U.S. CLS. 19, 21, 23, 31, 35 AND 44).

FIRST USE 9-2-2013; IN COMMERCE 9-2-2013.  
ANNE FARRELL, EXAMINING ATTORNEY

SN 86-232,617. TIRE MART, INC., SAINT LOUIS, MO. FILED 3-26-2014.

**PIT BULL**

THE MARK CONSISTS OF STANDARD CHARACTERS WITHOUT CLAIM TO ANY PARTICULAR FONT, STYLE, SIZE, OR COLOR.

OWNER OF U.S. REG. NOS. 2,007,072, 2,020,321 AND 2,893,211.

FOR TIRES, WHEELS, AND INNER TUBES FOR TIRES (U.S. CLS. 19, 21, 23, 31, 35 AND 44).

FIRST USE 3-26-2003; IN COMMERCE 3-26-2003.  
SANJEEV VOHRA, EXAMINING ATTORNEY

**CLASS 12—(Continued).**

SN 86-233,199. BARLAND, MICHAEL, CHULA VISTA, CA. FILED 3-26-2014.

**MGP CALIPER COVERS**

THE MARK CONSISTS OF STANDARD CHARACTERS WITHOUT CLAIM TO ANY PARTICULAR FONT, STYLE, SIZE, OR COLOR.

NO CLAIM IS MADE TO THE EXCLUSIVE RIGHT TO USE "CALIPER COVERS", APART FROM THE MARK AS SHOWN.

FOR BRAKE HARDWARE FOR VEHICLES (U.S. CLS. 19, 21, 23, 31, 35 AND 44).

FIRST USE 9-1-2008; IN COMMERCE 9-1-2008.

MARIA-VICTORIA SUAREZ, EXAMINING ATTORNEY

**CLASS 12—(Continued).**

SN 86-237,464. CRESTING WAVE VENTURES LLC, LOS ANGELES, CA. FILED 3-31-2014.

**CALIVEIL**

THE MARK CONSISTS OF STANDARD CHARACTERS WITHOUT CLAIM TO ANY PARTICULAR FONT, STYLE, SIZE, OR COLOR.

FOR AUTOMOTIVE SUN AND WIND DRIVER AND PASSENGER PROTECTION SHADES SPECIALLY DESIGNED FOR USE IN AUTOMOBILES WITH OPEN ROOFS (U.S. CLS. 19, 21, 23, 31, 35 AND 44).

REBECCA GILBERT, EXAMINING ATTORNEY

SN 86-234,980. RILEY, LINDA, EAST GREENWICH, RI. AND KORDANA, KRISTIE, CHESHIRE, MA. AND BOORMAN, ZACHARY, NEWINGTON, CT. AND STANLEY, ADAM, LITCHFIELD, CT. AND FREITAS, RICHARD, PEMBROKE, MA. FILED 3-28-2014.

SN 86-237,837. DZINESQUARE, INC., DBA 2 CRAVE, LA MIRADA, CA. FILED 3-31-2014.



NO CLAIM IS MADE TO THE EXCLUSIVE RIGHT TO USE "COLLAPSIBLE KID", APART FROM THE MARK AS SHOWN.

THE COLOR(S) BLUE AND YELLOW IS/ARE CLAIMED AS A FEATURE OF THE MARK.

THE MARK CONSISTS OF BLUE BACKGROUND WITH YELLOW LETTERING OF THE WORDS "COLLAPSIBLE KID CRUISER".

FOR CHILD CARRYING TRAILERS FOR USE IN TRANSPORTING CHILDREN WHILE HIKING, JOGGING, WALKING, SKIING, SNOW SHOEING OR SKATING (U.S. CLS. 19, 21, 23, 31, 35 AND 44).

DANIEL CAPSHAW, EXAMINING ATTORNEY



THE COLOR(S) RED AND BLACK IS/ARE CLAIMED AS A FEATURE OF THE MARK.

THE MARK CONSISTS OF THE DESIGN OF TWO "H" CHARACTERS IN BLACK SUPERIMPOSED ON A RED FIGURE SUGGESTIVE OF A DIAGONAL LINE TO THE LEFT OF THE WORDING "HEAVY HITTERS" IN BLACK, WITH A RED FIGURE SUGGESTIVE OF A DIAGONAL LINE TO THE RIGHT OF THE WORDING "HEAVY".

FOR VEHICLE WHEEL RIMS; VEHICLE WHEEL RIMS AND STRUCTURAL PARTS THEREFOR; VEHICLE WHEELS; WHEEL RIMS; WHEEL RIMS FOR MOTOR CARS (U.S. CLS. 19, 21, 23, 31, 35 AND 44).

KRISTIN DAHLING, EXAMINING ATTORNEY

**CLASS 12—(Continued).**

SN 86-238,268. RICK FAIRLESS PARTS, INC., DBA RF CUSTOM PARTS, DALLAS, TX. FILED 4-1-2014.

## RF Custom Parts

THE MARK CONSISTS OF STANDARD CHARACTERS WITHOUT CLAIM TO ANY PARTICULAR FONT, STYLE, SIZE, OR COLOR.

NO CLAIM IS MADE TO THE EXCLUSIVE RIGHT TO USE "CUSTOM PARTS", APART FROM THE MARK AS SHOWN.

FOR MOTORCYCLE ACCESSORIES, NAMELY, FRONT AND SIDE PLATES; MOTORCYCLE FOOT PEGS; MOTORCYCLE KICKSTANDS; MOTORCYCLE PARTS, NAMELY, BRACKETS FOR MOUNTING MOTORCYCLE SADDLEBAGS TO MOTORCYCLES; MOTORCYCLE PARTS, NAMELY, HEEL GUARDS; MOTORCYCLE SPROCKETS; MOTORCYCLE SWING ARMS; MOTORCYCLES AND STRUCTURAL PARTS THEREFOR; PARTS OF MOTORCYCLES, NAMELY, FRONT DASH PANELS; PARTS OF MOTORCYCLES, NAMELY, HANDLE BAR GRIPS; PARTS OF MOTORCYCLES, NAMELY, HANDLE BARS; PARTS OF MOTORCYCLES, NAMELY, HEADLIGHT MOUNTS; PARTS OF MOTORCYCLES, NAMELY, SHIFT LEVERS; SISSY BARS FOR MOTORCYCLES; STRUCTURAL PARTS FOR MOTORCYCLES (U.S. CLS. 19, 21, 23, 31, 35 AND 44).

FIRST USE 2-24-2012; IN COMMERCE 2-24-2012.

JORDAN BAKER, EXAMINING ATTORNEY

**CLASS 12—(Continued).**

SN 86-246,542. SHENGTAI GROUP CO., LTD., SHANDONG PROVINCE, CHINA, FILED 4-9-2014.

## *Rapid*

THE MARK CONSISTS OF THE STYLIZED WORD "RAPID".

FOR ANTI-SKID STUDS FOR VEHICLE TIRES; AUTOMOBILES; CASINGS FOR PNEUMATIC TIRES; ELECTRIC BICYCLES; INNER TUBES FOR VEHICLE TIRES; TIRES; TIRES FOR VEHICLE WHEELS; TIRES FOR VEHICLES; VEHICLE WHEEL RIMS; VEHICLE WHEELS (U.S. CLS. 19, 21, 23, 31, 35 AND 44).

NAAKWAMA ANKRAH, EXAMINING ATTORNEY

SN 86-246,544. SHENGTAI GROUP CO., LTD., SHANDONG PROVINCE, CHINA, FILED 4-9-2014.

SN 86-244,923. GREENBALL CORPORATION, ANAHEIM, CA. FILED 4-7-2014.

## TRAIL HOG

THE MARK CONSISTS OF STANDARD CHARACTERS WITHOUT CLAIM TO ANY PARTICULAR FONT, STYLE, SIZE, OR COLOR.

FOR TIRES (U.S. CLS. 19, 21, 23, 31, 35 AND 44).

FIRST USE 1-23-2014; IN COMMERCE 1-23-2014.

DOUGLAS LEE, EXAMINING ATTORNEY

## *Aoteli*

THE MARK CONSISTS OF THE STYLIZED WORD "AOTELI".

FOR AEROPLANES; AUTOMOBILES; LOCOMOTIVES; MOTOR SCOOTERS; MOTORCYCLES; TIRES FOR VEHICLE WHEELS; TIRES FOR VEHICLES; TREADS FOR RETREADING TYRES; TROLLEYS; VEHICLE WHEELS (U.S. CLS. 19, 21, 23, 31, 35 AND 44).

NAAKWAMA ANKRAH, EXAMINING ATTORNEY

**CLASS 12—(Continued).**

SN 86-246,652. MOMENTUM USA, INC., RICHMOND, VA. FILED 4-9-2014.

**AMERIPRO**

THE MARK CONSISTS OF STANDARD CHARACTERS WITHOUT CLAIM TO ANY PARTICULAR FONT, STYLE, SIZE, OR COLOR.

FOR BRAKE PADS FOR VEHICLES (U.S. CLS. 19, 21, 23, 31, 35 AND 44).

SAMUEL PAQUIN, EXAMINING ATTORNEY



SN 86-247,424. INTERNATIONAL TRUCK INTELLECTUAL PROPERTY COMPANY, LLC, LISLE, IL. FILED 4-9-2014.

**DIAMOND RENEWED**

THE MARK CONSISTS OF STANDARD CHARACTERS WITHOUT CLAIM TO ANY PARTICULAR FONT, STYLE, SIZE, OR COLOR.

OWNER OF U.S. REG. NOS. 2,571,452, 2,814,132 AND OTHERS.

FOR MOTOR VEHICLES, SPECIFICALLY USED COMMERCIAL TRUCKS (U.S. CLS. 19, 21, 23, 31, 35 AND 44).

DANIEL S. STRINGER, EXAMINING ATTORNEY



SN 86-247,524. LAPLANT, ROGER, PACIFIC PALISADES, CA. FILED 4-9-2014.

**Liferak**

THE MARK CONSISTS OF STANDARD CHARACTERS WITHOUT CLAIM TO ANY PARTICULAR FONT, STYLE, SIZE, OR COLOR.

FOR AUTOMOBILE ROOF RACKS (U.S. CLS. 19, 21, 23, 31, 35 AND 44).

SEAN CROWLEY, EXAMINING ATTORNEY

**CLASS 12—(Continued).**

SN 86-247,794. PACIFIC COACHWORKS, INC., PERRIS, CA. FILED 4-9-2014.

**PACIFICA**

THE MARK CONSISTS OF STANDARD CHARACTERS WITHOUT CLAIM TO ANY PARTICULAR FONT, STYLE, SIZE, OR COLOR.

FOR RECREATIONAL VEHICLES, NAMELY, FIFTH WHEEL TRAILERS; RECREATIONAL VEHICLES, NAMELY, FIFTH WHEELS; RECREATIONAL VEHICLES, NAMELY, MOTOR HOMES; RECREATIONAL VEHICLES, NAMELY, PARK TRAILERS; RECREATIONAL VEHICLES, NAMELY, TOWABLE TRAILERS; RECREATIONAL VEHICLES, NAMELY, TOY HAULERS; RECREATIONAL VEHICLES, NAMELY, TRAVEL TRAILERS; RECREATIONAL VEHICLES, NAMELY, TRUCK CAMPERS (U.S. CLS. 19, 21, 23, 31, 35 AND 44).

PAUL CROWLEY, EXAMINING ATTORNEY



SN 86-248,394. MASTERCRAFT BOAT COMPANY, LLC, VONORE, TN. FILED 4-10-2014.

**X23**

THE MARK CONSISTS OF STANDARD CHARACTERS WITHOUT CLAIM TO ANY PARTICULAR FONT, STYLE, SIZE, OR COLOR.

OWNER OF U.S. REG. NOS. 2,746,144, 2,905,813 AND OTHERS.

FOR BOATS (U.S. CLS. 19, 21, 23, 31, 35 AND 44).

JAY FLOWERS, EXAMINING ATTORNEY



SN 86-249,783. SUMMIT TIRE AND BATTERY, INC., WENTZVILLE, MO. FILED 4-11-2014.

**HI-ROAD ST**

THE MARK CONSISTS OF STANDARD CHARACTERS WITHOUT CLAIM TO ANY PARTICULAR FONT, STYLE, SIZE, OR COLOR.

FOR TIRES FOR VEHICLES (U.S. CLS. 19, 21, 23, 31, 35 AND 44).

JAMES STEIN, EXAMINING ATTORNEY

**CLASS 12—(Continued).**

SN 86-250,646. VIRGINIA KING, LOMITA, CA. FILED 4-12-2014.

# Millennium

THE MARK CONSISTS OF STANDARD CHARACTERS WITHOUT CLAIM TO ANY PARTICULAR FONT, STYLE, SIZE, OR COLOR.

FOR CARS; ELECTRIC CARS (U.S. CLS. 19, 21, 23, 31, 35 AND 44).

CHRISTINA SOBRAL, EXAMINING ATTORNEY

SN 86-263,040. GRACO CHILDREN'S PRODUCTS INC., ATLANTA, GA. FILED 4-25-2014.

# MILESTONE

THE MARK CONSISTS OF STANDARD CHARACTERS WITHOUT CLAIM TO ANY PARTICULAR FONT, STYLE, SIZE, OR COLOR.

FOR CAR SEATS FOR INFANTS AND CHILDREN (U.S. CLS. 19, 21, 23, 31, 35 AND 44).

ELISSA GARBER KON, EXAMINING ATTORNEY

SN 86-264,528. XTI AIRCRAFT COMPANY, GREENWOOD VILLAGE, CO. FILED 4-28-2014.



THE MARK CONSISTS OF A DESIGN OF GEOMETRIC SHAPES FORMED BY DIFFERENT SIZED TRIANGLES.

FOR AIRCRAFT; HELICOPTERS AND STRUCTURAL PARTS THEREFOR (U.S. CLS. 19, 21, 23, 31, 35 AND 44).

KIM MONINGHOFF, EXAMINING ATTORNEY

**CLASS 12—(Continued).**

SN 86-271,955. PACIFIC COACHWORKS, INC., PERRIS, CA. FILED 5-5-2014.

# BLAZE'N

THE MARK CONSISTS OF STANDARD CHARACTERS WITHOUT CLAIM TO ANY PARTICULAR FONT, STYLE, SIZE, OR COLOR.

FOR RECREATIONAL VEHICLES, NAMELY, CAMPER; RECREATIONAL VEHICLES, NAMELY, FIFTH WHEEL TRAILERS; RECREATIONAL VEHICLES, NAMELY, FIFTH WHEELS; RECREATIONAL VEHICLES, NAMELY, MOTOR HOMES; RECREATIONAL VEHICLES, NAMELY, PARK TRAILERS; RECREATIONAL VEHICLES, NAMELY, TOWABLE TRAILERS; RECREATIONAL VEHICLES, NAMELY, TOY HAULERS; RECREATIONAL VEHICLES, NAMELY, TRAVEL TRAILERS; RECREATIONAL VEHICLES, NAMELY, TRUCK CAMPERS (U.S. CLS. 19, 21, 23, 31, 35 AND 44).

PAUL CROWLEY, EXAMINING ATTORNEY

**CLASS 13—FIREARMS**

SN 76-716,115. SYLVESTER, DEAN E, BOISE, ID. AND MACDONAGH, DEAN E., BOISE, ID. FILED 3-31-2014.

TURN THE RIFLE YOU HAVE INTO THE RIFLE YOU WANT

THE MARK CONSISTS OF STANDARD CHARACTERS WITHOUT CLAIM TO ANY PARTICULAR FONT, STYLE, SIZE, OR COLOR.

FOR FIREARMS (U.S. CLS. 2 AND 9).

ANDREA CORNWELL, EXAMINING ATTORNEY

SN 79-138,109. ARMSAN SILAH; SANAYI VE TICARET A.S., TURKEY, FILED 8-26-2013.

# PHENOMA

THE MARK CONSISTS OF STANDARD CHARACTERS WITHOUT CLAIM TO ANY PARTICULAR FONT, STYLE, SIZE, OR COLOR.

OWNER OF INTERNATIONAL REGISTRATION 1180764 DATED 8-26-2013, EXPIRES 8-26-2023.

THE WORDING "PHENOMA" HAS NO MEANING IN A FOREIGN LANGUAGE.

FOR FIREARMS, AIR PISTOLS WEAPONS, SPRING-LOADED FIREARMS, ADAPTED CASES AND SHOULDER STRAPS THEREFOR; HEAVY WEAPONS, MORTARS AND ROCKETS; FIREWORKS; SPRAYS FOR PERSONAL DEFENCE PURPOSES (U.S. CLS. 2 AND 9).

LINDA MICKLEBURGH, EXAMINING ATTORNEY



**CLASS 13—(Continued).**

SN 85-854,834. LWRC INTERNATIONAL, LLC, CAMBRIDGE, MD. FILED 2-20-2013.



NO CLAIM IS MADE TO THE EXCLUSIVE RIGHT TO USE "SIX 8", APART FROM THE MARK AS SHOWN.

THE MARK CONSISTS OF THE WORD "SIX" IN STYLIZED LETTERS OVER A STYLIZED NUMBER "8" INSIDE OF AN IRREGULARLY SHAPED CIRCLE, WHICH IS SURROUNDED BY A SECOND IRREGULARLY SHAPED CIRCLE, AND WHICH IS IN TURN SURROUNDED BY TWO ROUND CONCENTRIC CIRCLES.

FOR AUTOMATIC RIFLES (U.S. CLS. 2 AND 9).  
FIRST USE 8-22-2012; IN COMMERCE 1-31-2013.  
PAUL CROWLEY, EXAMINING ATTORNEY

SN 86-163,164. DOUBLE A INDUSTRIES INC, LAS VEGAS, NV. FILED 1-11-2014.

**ARES ARMOR**

THE MARK CONSISTS OF STANDARD CHARACTERS WITHOUT CLAIM TO ANY PARTICULAR FONT, STYLE, SIZE, OR COLOR.

NO CLAIM IS MADE TO THE EXCLUSIVE RIGHT TO USE "ARMOR", APART FROM THE MARK AS SHOWN.  
FOR COMPONENT PARTS FOR GUNS (U.S. CLS. 2 AND 9).

FIRST USE 1-1-2011; IN COMMERCE 1-1-2011.  
LINDA MICKLEBURGH, EXAMINING ATTORNEY

**CLASS 13—(Continued).**

SN 86-169,354. HELL FIRE ARMORY LLC, WILMINGTON, NC. FILED 1-18-2014.

**Hell Fire Armory**

THE MARK CONSISTS OF STANDARD CHARACTERS WITHOUT CLAIM TO ANY PARTICULAR FONT, STYLE, SIZE, OR COLOR.

NO CLAIM IS MADE TO THE EXCLUSIVE RIGHT TO USE "ARMORY", APART FROM THE MARK AS SHOWN.

FOR (BASED ON USE IN COMMERCE) COMPONENT PARTS FOR RIFLES; RIFLES AND PARTS THEREOF; SPORTING RIFLES (BASED ON INTENT TO USE) AMMUNITION FOR FIREARMS; BARREL REFLECTORS FOR FIREARMS; BUTT PLATES FOR PISTOLS, RIFLES, AND SHOTGUNS; CASE COVERS FOR FIREARMS; CLEANING RODS FOR FIREARMS; COMBINATION PISTOLS AND RIFLES; COVERS FOR FIREARMS; FIREARMS; GUN AND RIFLE CASES; HUNTING RIFLES; MILITARY RIFLES; RIFLE BARRELS; RIFLE CASES; RIFLE HAND GUARDS; RIFLE MAGAZINE CLAMPS; RIFLE MOUNTS; RIFLE RAILS; RIFLES; SILENCERS FOR FIREARMS; TRIGGER GUARDS FOR GUNS AND RIFLES; WEAPON CASES FOR FIREARMS (U.S. CLS. 2 AND 9).

FIRST USE 6-1-2013; IN COMMERCE 6-1-2013.  
ANTHONY RINKER, EXAMINING ATTORNEY

SN 86-200,477. TRISTAR SPORTING ARMS, LTD., NORTH KANSAS CITY, MO. FILED 2-21-2014.



THE MARK CONSISTS OF THE WORDING "TRISTAR", WITH A STAR APPEARING AS THE DOT IN THE LETTER "I" AND AN ELLIPSE COMING OFF THE STAR, AROUND THE RIGHT SIDE OF "TRISTAR" AND DOWN TOWARD THE BASE OF THE LETTER "R".

FOR GUNS; COMPONENT PARTS FOR GUNS (U.S. CLS. 2 AND 9).  
FIRST USE 12-20-2013; IN COMMERCE 12-20-2013.  
PAM WILLIS, EXAMINING ATTORNEY

SN 86-233,720. OVERSIGHT SHOOTING TECHNOLOGIES, LLC, BLACKFOOT, ID. FILED 3-27-2014.

**SEE ALL**

THE MARK CONSISTS OF STANDARD CHARACTERS WITHOUT CLAIM TO ANY PARTICULAR FONT, STYLE, SIZE, OR COLOR.

FOR FIREARM SIGHTS; NON-TELESCOPIC GUN SIGHTS FOR FIREARMS (U.S. CLS. 2 AND 9).  
FIRST USE 12-31-2013; IN COMMERCE 12-31-2013.  
ELLEN BURNS, EXAMINING ATTORNEY

**CLASS 13—(Continued).**

SN 86-240,289. WILLIAM BO BARNES, CEDAR PARK, TX.  
FILED 4-2-2014.

# AK SOC

THE MARK CONSISTS OF STANDARD CHARACTERS WITHOUT CLAIM TO ANY PARTICULAR FONT, STYLE, SIZE, OR COLOR.

NO CLAIM IS MADE TO THE EXCLUSIVE RIGHT TO USE "AK", APART FROM THE MARK AS SHOWN.  
FOR COVERS FOR FIREARMS (U.S. CLS. 2 AND 9).  
MAYUR VAGHANI, EXAMINING ATTORNEY

**CLASS 13—(Continued).**

SN 86-245,305. BATTLE ARMS DEVELOPMENT, INC.,  
HENDERSON, NV. FILED 4-8-2014.

# BAD762

THE MARK CONSISTS OF STANDARD CHARACTERS WITHOUT CLAIM TO ANY PARTICULAR FONT, STYLE, SIZE, OR COLOR.

FOR COMPONENT PARTS FOR GUNS; FIREARMS (U.S. CLS. 2 AND 9).  
LEIGH CAROLINE CASE, EXAMINING ATTORNEY

SN 86-241,184. WILLIAM BO BARNES, CEDAR PARK, TX.  
FILED 4-3-2014.

# AR SOC

THE MARK CONSISTS OF STANDARD CHARACTERS WITHOUT CLAIM TO ANY PARTICULAR FONT, STYLE, SIZE, OR COLOR.

NO CLAIM IS MADE TO THE EXCLUSIVE RIGHT TO USE "AR", APART FROM THE MARK AS SHOWN.  
FOR COVERS FOR FIREARMS (U.S. CLS. 2 AND 9).  
MAYUR VAGHANI, EXAMINING ATTORNEY

SN 86-245,306. BATTLE ARMS DEVELOPMENT, INC.,  
HENDERSON, NV. FILED 4-8-2014.

# BAD556

THE MARK CONSISTS OF STANDARD CHARACTERS WITHOUT CLAIM TO ANY PARTICULAR FONT, STYLE, SIZE, OR COLOR.

FOR COMPONENT PARTS FOR GUNS; FIREARMS (U.S. CLS. 2 AND 9).  
LEIGH CAROLINE CASE, EXAMINING ATTORNEY

SN 86-245,304. BATTLE ARMS DEVELOPMENT, INC.,  
HENDERSON, NV. FILED 4-8-2014.

# BAD-10

THE MARK CONSISTS OF STANDARD CHARACTERS WITHOUT CLAIM TO ANY PARTICULAR FONT, STYLE, SIZE, OR COLOR.

FOR COMPONENT PARTS FOR GUNS; FIREARMS (U.S. CLS. 2 AND 9).  
LEIGH CAROLINE CASE, EXAMINING ATTORNEY

SN 86-245,312. BATTLE ARMS DEVELOPMENT, INC.,  
HENDERSON, NV. FILED 4-8-2014.

# BAD-CASS

THE MARK CONSISTS OF STANDARD CHARACTERS WITHOUT CLAIM TO ANY PARTICULAR FONT, STYLE, SIZE, OR COLOR.

FOR COMPONENT PARTS FOR GUNS (U.S. CLS. 2 AND 9).  
FIRST USE 4-9-2009; IN COMMERCE 8-5-2010.  
LEIGH CAROLINE CASE, EXAMINING ATTORNEY

**CLASS 13—(Continued).**

SN 86-247,484. INTELLIGUN, LLC, CHULA VISTA, CA.  
FILED 4-9-2014.

# INTELLIGUN

THE MARK CONSISTS OF STANDARD CHARACTERS  
WITHOUT CLAIM TO ANY PARTICULAR FONT, STYLE,  
SIZE, OR COLOR.

FOR FIREARM SAFETY PRODUCTS, NAMELY BIO-  
METRIC GUN LOCKS (U.S. CLS. 2 AND 9).  
THEODORE MCBRIDE, EXAMINING ATTORNEY

---

SN 86-249,066. HUNTING TITAN, INC., PAMPA, TX. FILED  
4-10-2014.

# KNOCKOUT

THE MARK CONSISTS OF STANDARD CHARACTERS  
WITHOUT CLAIM TO ANY PARTICULAR FONT, STYLE,  
SIZE, OR COLOR.

FOR SHAPED EXPLOSIVE CHARGES FOR USE IN  
THE OIL AND GAS INDUSTRY (U.S. CLS. 2 AND 9).  
JENNIFER BUTTON, EXAMINING ATTORNEY

---

SN 86-250,021. STURM, RUGER & COMPANY, INC.,  
SOUTHPORT, CT. FILED 4-11-2014.

# SR-556TD

THE MARK CONSISTS OF STANDARD CHARACTERS  
WITHOUT CLAIM TO ANY PARTICULAR FONT, STYLE,  
SIZE, OR COLOR.

OWNER OF U.S. REG. NOS. 546,918, 4,085,245 AND  
OTHERS.

FOR FIREARMS (U.S. CLS. 2 AND 9).  
ANNE E. GUSTASON, EXAMINING ATTORNEY

---

SN 86-250,025. STURM, RUGER & COMPANY, INC.,  
SOUTHPORT, CT. FILED 4-11-2014.

# BX-15

THE MARK CONSISTS OF STANDARD CHARACTERS  
WITHOUT CLAIM TO ANY PARTICULAR FONT, STYLE,  
SIZE, OR COLOR.

OWNER OF U.S. REG. NO. 4,047,959.  
FOR FIREARM ACCESSORIES, NAMELY, GUN MA-  
GAZINES (U.S. CLS. 2 AND 9).  
ANNE E. GUSTASON, EXAMINING ATTORNEY

**CLASS 13—(Continued).**

SN 86-250,287. LONG RANGE PRECISION ARMS, LLC, DBA  
THE GUN VAULT, SOUTH JORDAN, UT. FILED 4-11-  
2014.



NO CLAIM IS MADE TO THE EXCLUSIVE RIGHT TO  
USE "ARMS", APART FROM THE MARK AS SHOWN.

THE MARK CONSISTS OF "LRP" IN STYLIZED CAPITAL  
LETTERS WITH "ARMS" UNDER THE "RP" OF "LRP". A  
RIFLE ROUND IS VERTICALLY ORIENTED BEHIND THE  
"L" OF "LRP".

FOR FIREARMS (U.S. CLS. 2 AND 9).  
FIRST USE 3-21-2011; IN COMMERCE 6-15-2011.  
CARYN GLASSER, EXAMINING ATTORNEY

---

SN 86-292,710. THE ALLEN COMPANY, INC., BROOM-  
FIELD, CO. FILED 5-27-2014.

# HARDLINE

THE MARK CONSISTS OF STANDARD CHARACTERS  
WITHOUT CLAIM TO ANY PARTICULAR FONT, STYLE,  
SIZE, OR COLOR.

FOR GUN CASES; AMMUNITION BAGS; BAGS SPE-  
CIALY ADAPTED TO HOLD FIREARMS (U.S. CLS. 2  
AND 9).

MICHAEL P EISNACH, EXAMINING ATTORNEY

**CLASS 14—JEWELRY**

SN 79-139,348. VAN CLEEF & ARPELS SA, CH-1752 VIL-LARS-SUR-GLANE, SWITZERLAND, FILED 10-31-2013.

**POETIC ASTRONOMY**

THE MARK CONSISTS OF STANDARD CHARACTERS WITHOUT CLAIM TO ANY PARTICULAR FONT, STYLE, SIZE, OR COLOR.

PRIORITY DATE OF 6-3-2013 IS CLAIMED.

OWNER OF INTERNATIONAL REGISTRATION 1183930 DATED 10-31-2013, EXPIRES 10-31-2023.

NO CLAIM IS MADE TO THE EXCLUSIVE RIGHT TO USE "ASTRONOMY", APART FROM THE MARK AS SHOWN.

FOR JEWELRY; WATCHES (U.S. CLS. 2, 27, 28 AND 50).

MAYUR VAGHANI, EXAMINING ATTORNEY

SN 79-143,697. ALEJANDRO GAYUBO, S.A., SPAIN, FILED 2-5-2014.

**GAYUBO**

OWNER OF INTERNATIONAL REGISTRATION 1194784 DATED 2-5-2014, EXPIRES 2-5-2024.

THE COLOR(S) BLACK IS/ARE CLAIMED AS A FEATURE OF THE MARK.

THE MARK CONSISTS OF THE STYLIZED WORDING "GAYUBO" IN THE COLOR BLACK.

FOR PRECIOUS METALS AND THEIR ALLOYS AND GOODS MADE OF THESE MATERIALS OR COATED THEREWITH NOT INCLUDED IN OTHER CLASSES, NAMELY, NECKLACES, PENDANTS, RINGS, BRACELETS, BROOCHES, ARMBANDS; JEWELRY, PRECIOUS STONES; TIMEPIECES AND CHRONOMETRIC INSTRUMENTS (U.S. CLS. 2, 27, 28 AND 50).

GENE MACIOL, EXAMINING ATTORNEY

SN 85-971,476. EYAL, R.D. GEMS CORP, GREAT NECK, NY, FILED 6-27-2013.

**COCO KALLATI**

THE MARK CONSISTS OF STANDARD CHARACTERS WITHOUT CLAIM TO ANY PARTICULAR FONT, STYLE, SIZE, OR COLOR.

OWNER OF U.S. REG. NOS. 2,681,841 AND 4,336,112.

THE NAME(S), PORTRAIT(S), AND/OR SIGNATURE(S) SHOWN IN THE MARK DOES NOT IDENTIFY A PARTICULAR LIVING INDIVIDUAL.

FOR JEWELRY (U.S. CLS. 2, 27, 28 AND 50).

FIRST USE 10-15-2013; IN COMMERCE 10-15-2013.

MICHELLE DUBOIS, EXAMINING ATTORNEY

**CLASS 14—(Continued).**

SN 86-034,684. 1762448 ONTARIO INC., DBA JOSEPH NO-GUCCI, TORONTO, CANADA, FILED 8-12-2013.



NO CLAIM IS MADE TO THE EXCLUSIVE RIGHT TO USE "CHARMBALLA", APART FROM THE MARK AS SHOWN.

THE COLOR(S) GRAY IS/ARE CLAIMED AS A FEATURE OF THE MARK.

THE MARK CONSISTS OF THE WORD "CHARMBALLA" IN THE COLOR GRAY, WHICH APPEARS TO THE RIGHT OF AN IMAGE OF A BEARDED CELESTIAL BEING IN THE COLOR GRAY WHOSE FACE AND BEARD HUG THE INSIDE OF A CONCENTRIC CIRCLE DESIGN IN GRAY. WITHIN THE CIRCLE IS ALSO A STYLIZED IMAGE OF AN AUM SYMBOL IN GRAY.

THE WORDING "CHARMBALLA" HAS NO MEANING IN A FOREIGN LANGUAGE.

THE NON-LATIN CHARACTERS IN THE MARK TRANSLITERATE TO "CHARMBALLA" AND THIS HAS NO MEANING IN A FOREIGN LANGUAGE.

FOR BRACELETS; BRACELETS; BRACELETS MADE OF PLATED BEADS AND NYLON; CHARITY BRACELETS; NYLON BRACELETS (U.S. CLS. 2, 27, 28 AND 50). FIRST USE 6-1-2013; IN COMMERCE 6-1-2013.

ANDREW RHIM, EXAMINING ATTORNEY

SN 86-051,940. REEDY, ROBERT, HOUSTON, TX, FILED 8-29-2013.



NO CLAIM IS MADE TO THE EXCLUSIVE RIGHT TO USE "2 TROY OZ. OF .999 FINE SILVER" AND "REDEEM FOR \$250 AT 1-855-USOWNED WWW.PRICEQUOTEINTERNATIONAL.COM", APART FROM THE MARK AS SHOWN.

THE MARK CONSISTS OF TWO PLAIN SINGLE LINE CONCENTRIC CIRCLES OF DIFFERENT WIDTHS. WITHIN THE ANNULUS READS: "GLOBAL SEAL OF PRICE QUOTE GLOBAL AUTHORITY" "S \$" 2, TWO BAR DOLLAR SIGNS AND "ONE PRICE QUOTE DOLLAR". A TWO PIECE PYRAMID, WITH THE TOP OF WHICH CONTAINS A CENTERED TWO BAR DOLLAR SIGN. THE LOWER PART OF THE PYRAMID IS DIVIDED INTO SEVEN SECTIONS; IN ASCENDING ORDER, THEY ARE "TOWN", "CITY", "COUNTY", "STATE", "FEDERAL", "U.S." AND "U.N.",

**CLASS 14—(Continued).**

"CAPITALISM STARTS HERE" IS LOCATED ABOVE THE TOP OF THE PYRAMID. SUN, CLOUDS AND MOON. THERE ARE FOUR, 5 POINTED STARS. "2 TROY OZ. OF .999 FINE SILVER" AND "WE TRUST YOU" ARE LOCATED MID WAY OF THE LOWER PART OF THE DIVIDED PYRAMID. A MINT DATE OF "2013" IS LOCATED ON THE RIGHT SIDE AT THE BASE OF THE LOWER DIVIDED PYRAMID. BELOW THE LOWER DIVIDED PYRAMID IT READS: "REDEEM FOR \$250 AT 1-855-USOWNED WWW.PRICEQUOTEINTERNATIONAL.COM".

FOR MEDALLIONS (U.S. CLS. 2, 27, 28 AND 50).  
CAROLINE WOOD, EXAMINING ATTORNEY

---

SN 86-063,980. AMERICAN GIRL, LLC, EL SEGUNDO, CA. FILED 9-13-2013.

## TRULY ME

THE MARK CONSISTS OF STANDARD CHARACTERS WITHOUT CLAIM TO ANY PARTICULAR FONT, STYLE, SIZE, OR COLOR.

OWNER OF U.S. REG. NO. 3,406,707.

FOR JEWELRY, WATCHES, CLOCKS, BRACELETS, CHARMS, JEWELRY MAKING KITS, LOCKETS, JEWELRY ORGANIZER CASES (U.S. CLS. 2, 27, 28 AND 50).  
MICHELE SWAIN, EXAMINING ATTORNEY

---

SN 86-072,431. STRATEGIC PARTNERS, INC., CHATSWORTH, CA. FILED 9-23-2013.

## Curo

THE MARK CONSISTS OF STANDARD CHARACTERS WITHOUT CLAIM TO ANY PARTICULAR FONT, STYLE, SIZE, OR COLOR.

THE ENGLISH TRANSLATION OF "CURO" IN THE MARK IS "TO HEAL".

FOR WATCHES (U.S. CLS. 2, 27, 28 AND 50).  
DANNEAN HETZEL, EXAMINING ATTORNEY

**CLASS 14—(Continued).**

SN 86-073,755. RIFE, CHERIE, LAKE FOREST, CA. FILED 9-24-2013.



THE NAME(S), PORTRAIT(S), AND/OR SIGNATURE(S) SHOWN IN THE MARK IDENTIFIES "CHERIE RIFE", WHOSE CONSENT(S) TO REGISTER IS MADE OF RECORD.

THE MARK CONSISTS OF A MARK CONTAINING A STYLIZED CAPITAL "C" AND A STYLIZED CAPITAL "R" AND THE LITERAL ELEMENT OF "CHERIE RIFE" INSIDE OF A RECTANGLE.

FOR JEWELRY AND PRECIOUS STONES (U.S. CLS. 2, 27, 28 AND 50).

JAY FLOWERS, EXAMINING ATTORNEY

---

SN 86-090,149. SECRET LABS LLC, NEW YORK, NY. FILED 10-12-2013.

## SECRET LABS

THE MARK CONSISTS OF STANDARD CHARACTERS WITHOUT CLAIM TO ANY PARTICULAR FONT, STYLE, SIZE, OR COLOR.

OWNER OF U.S. REG. NO. 4,522,177.

NO CLAIM IS MADE TO THE EXCLUSIVE RIGHT TO USE "LABS", APART FROM THE MARK AS SHOWN.

FOR SMART WATCHES; WATCHES AND JEWELRY (U.S. CLS. 2, 27, 28 AND 50).

PARKER HOWARD, EXAMINING ATTORNEY

**CLASS 14—(Continued).**

SN 86-122,961. NATIONAL HOCKEY LEAGUE, NEW YORK, NY. FILED 11-19-2013.

## STANLEY CUP

THE MARK CONSISTS OF STANDARD CHARACTERS WITHOUT CLAIM TO ANY PARTICULAR FONT, STYLE, SIZE, OR COLOR.

OWNER OF U.S. REG. NOS. 888,872, 3,961,015 AND OTHERS.

FOR ITEMS MADE OF PRECIOUS AND NON-PRECIOUS METALS, NAMELY, COMMEMORATIVE COINS, AND MEDALS; KEY CHAINS MADE OF PRECIOUS METALS; JEWELRY, CHARMS, EARRINGS, MEDALLIONS, RINGS, NECKLACES, TIE TACKS, PINS IN THE NATURE OF JEWELRY; CHRONOMETRIC INSTRUMENTS IN THE NATURE OF DOCKS AND CLOCKS (U.S. CLS. 2, 27, 28 AND 50).

FIRST USE 12-31-1991; IN COMMERCE 12-31-1991.  
EMILY CARLSEN, EXAMINING ATTORNEY

SN 86-128,583. DIAMINTANGIBLES INTERNATIONAL, LTD., NASSAU, BAHAMAS, FILED 11-25-2013.

## THE IDEAL DIAMOND FOR THE IDEAL WOMAN AT THE IDEAL PRICE

THE MARK CONSISTS OF STANDARD CHARACTERS WITHOUT CLAIM TO ANY PARTICULAR FONT, STYLE, SIZE, OR COLOR.

NO CLAIM IS MADE TO THE EXCLUSIVE RIGHT TO USE "DIAMOND", APART FROM THE MARK AS SHOWN.

FOR DIAMONDS; DIAMOND JEWELRY (U.S. CLS. 2, 27, 28 AND 50).

LINDA ORNDORFF, EXAMINING ATTORNEY

SN 86-151,867. BOSSKU INVESTMENTS LIMITED, CHAI WAN, HONG KONG, FILED 12-24-2013.

## KUTOUR

THE MARK CONSISTS OF STANDARD CHARACTERS WITHOUT CLAIM TO ANY PARTICULAR FONT, STYLE, SIZE, OR COLOR.

PRIORITY CLAIMED UNDER SEC. 44(D) ON HONG KONG APPLICATION NO. 302803239, FILED 11-14-2013, REG. NO. 302803239, DATED 11-14-2013, EXPIRES 11-14-2023.

THE WORDING "KUTOUR" HAS NO MEANING IN A FOREIGN LANGUAGE.

FOR JEWELRY; JEWELRY, NAMELY, NECKLACES; PRECIOUS STONES; JEWELRY, NAMELY, RINGS; SEMI-PRECIOUS STONES; PRECIOUS STONES, NAMELY, SPINEL; WATCHES; WRISTWATCHES (U.S. CLS. 2, 27, 28 AND 50).

DAVID ELTON, EXAMINING ATTORNEY

**CLASS 14—(Continued).**

SN 86-167,400. PEANUTS WORLDWIDE LLC, NEW YORK, NY. FILED 1-16-2014.



OWNER OF U.S. REG. NOS. 1,256,900, 1,260,740 AND 1,267,166.

THE MARK CONSISTS OF TWO PARTIALLY OBSCURED STYLIZED DOG FACES MOSTLY WITHIN A SQUARE WITH THE AMPERSAND SYMBOL BETWEEN THE DOG FACES, THE WORDING "SNOOPY" ALONG THE LEFT SIDE OF THE SQUARE, AND THE WORDING "HIS SISTER BELLE" ALONG THE RIGHT SIDE OF THE SQUARE.

FOR CLOCKS; JEWELRY; WATCHES (U.S. CLS. 2, 27, 28 AND 50).

MAH ROSENBERG, EXAMINING ATTORNEY

SN 86-174,056. GLOBAL MAINLAND INTERNATIONAL LLC, DBA GLOBAL MAINLAND INTERNATIONAL LLC, MARKHAM, ONTARIO, CANADA, FILED 1-24-2014.

## KING WILL

THE COLOR(S) YELLOW IS/ARE CLAIMED AS A FEATURE OF THE MARK.

THE MARK CONSISTS OF THE STYLIZED WORDING "KING WILL" APPEARING IN YELLOW.

FOR BEADS FOR MAKING JEWELRY; BEADS FOR USE IN THE MANUFACTURE OF JEWELRY; BODY JEWELRY; BRACELETS; BRACELETS AND JEWELRY FEATURING ELECTRONIC CHIPS FOR ATTRACTING ENERGY TO THE BODY WHEREIN THE ELECTRONIC CHIPS INCREASE IN POWER IN THE PRESENCE OF ELECTROMAGNETIC FIELDS, FOR THE PURPOSE OF RE-BALANCING THE HUMAN ENERGY FIELD; BROACHES; BRONZE JEWELRY; BROOCHES; CAMEOS; CHARMS; CHARMS FOR COLLAR JEWELRY AND BRACELET; CHILDREN'S JEWELRY; CLASPS FOR JEWELRY; COSTUME JEWELRY (U.S. CLS. 2, 27, 28 AND 50).

FIRST USE 10-20-2013; IN COMMERCE 10-30-2013.

ASMAT KHAN, EXAMINING ATTORNEY

**CLASS 14—(Continued).**

SN 86-196,486. PEDELABORDE, SEANA, DBA A MANO TRADING, SONOMA, CA. FILED 2-18-2014.

# Amano Studio

THE MARK CONSISTS OF STANDARD CHARACTERS WITHOUT CLAIM TO ANY PARTICULAR FONT, STYLE, SIZE, OR COLOR.

NO CLAIM IS MADE TO THE EXCLUSIVE RIGHT TO USE "STUDIO", APART FROM THE MARK AS SHOWN.

THE ENGLISH TRANSLATION OF "AMANO" IN THE MARK IS "BY HAND".

FOR JEWELLERY AND IMITATION JEWELLERY (U.S. CLS. 2, 27, 28 AND 50).

FIRST USE 1-1-2010; IN COMMERCE 1-1-2010.

ARETHA SOMERVILLE, EXAMINING ATTORNEY

**CLASS 14—(Continued).**

METAL FOR BRACELETS; JEWELRY CLIPS FOR ADAPTING PIERCED EARRINGS TO CLIP-ON EARRINGS; JEWELRY RING HOLDERS; JEWELRY, NAMELY, BRACELETS, WRISTBANDS AND NECKLACES THAT ALSO PROVIDES NOTIFICATION TO THE WEARER OF A PENDING MEDICAL RELATED TASK; JEWELRY, NAMELY, MAGNETIC NECKLACES; JEWELRY, NAMELY, MAGNETIC PENDANTS; JEWELRY, NAMELY, STONE PENDANTS; NECKLACE AND EARRING COMBINATIONS THAT CAN BE WORN SEPARATELY OR AS ONE PIECE; NECKLACES; NECKLACES MADE OF METALS, JEWEL; NYLON ANKLE BRACELETS; NYLON BRACELETS; PEARLS; PENDANTS; PLASTIC BRACELETS IN THE NATURE OF JEWELRY; PRECIOUS AND SEMI-PRECIOUS CRYSTAL STONES AND BEADS FOR USE IN JEWELRY; RINGS; RUBBER OR SILICONE WRISTBANDS IN THE NATURE OF A BRACELET; STAINLESS STEEL JEWELRY BRACELETS; STRAPS FOR WRISTWATCHES; WATCH BANDS AND STRAPS; WATCH BRACELETS (U.S. CLS. 2, 27, 28 AND 50).

JASON BLAIR, EXAMINING ATTORNEY

SN 86-204,344. ULTIMATE SURVIVAL TECHNOLOGIES, FORMERLY REVERE SUPPLY COMPANY, INC., JACKSONVILLE, FL. FILED 2-26-2014.

SN 86-201,497. LIN, CHING-TSAI, TAOYUAN, TAIWAN, FILED 2-24-2014.

# LOCHES LYNN

THE MARK CONSISTS OF STANDARD CHARACTERS WITHOUT CLAIM TO ANY PARTICULAR FONT, STYLE, SIZE, OR COLOR.

THE NAME "LOCHES LYNN" DOES NOT IDENTIFY A LIVING INDIVIDUAL.

FOR BEADS FOR MAKING JEWELRY; BEADS FOR USE IN THE MANUFACTURE OF JEWELRY; BODY JEWELRY; BODY-PIERCING RINGS; BRACELETS; BRACELETS AND JEWELRY FEATURING ELECTRONIC CHIPS FOR ATTRACTING ENERGY TO THE BODY WHEREIN THE ELECTRONIC CHIPS INCREASE IN POWER IN THE PRESENCE OF ELECTROMAGNETIC FIELDS, FOR THE PURPOSE OF RE-BALANCING THE HUMAN ENERGY FIELD; BRACELETS MADE OF METALS, JEWEL; BRACELETS OF PRECIOUS METAL; BROACHES; BRONZE JEWELRY; BROOCHES; CAMEOS; CHARITY BRACELETS; CHARMS; CHARMS FOR COLLAR JEWELRY AND BRACELET; CHILDREN'S JEWELRY; CLASPS FOR JEWELRY; CLIP EARRINGS; COSTUME JEWELRY; DIAMOND JEWELRY; EAR CLIPS; EAR STUDS; EARRINGS; GEMSTONE JEWELRY; GOLD THREAD JEWELRY; HAIR JEWELRY IN THE NATURE OF JEWELRY FOR USE IN THE HAIR; JEWEL PENDANTS; JEWELLERY CHAIN OF PRECIOUS



THE MARK CONSISTS OF THREE CONCENTRIC CIRCLES WITH THE LETTERS "UST" STYLIZED IN THE COMMON CENTER CIRCLE.

FOR BRACELETS MADE OF PARACORD AND/OR NYLON MATERIAL; NYLON BRACELETS (U.S. CLS. 2, 27, 28 AND 50).

FIRST USE 3-1-2007; IN COMMERCE 3-1-2007.

LINDA LAVACHE, EXAMINING ATTORNEY

**CLASS 14—(Continued).**

SN 86-208,908. ZERGERAN DIAMOND, INC., YONKERS, NY. FILED 3-3-2014.



NO CLAIM IS MADE TO THE EXCLUSIVE RIGHT TO USE "DIAMOND", APART FROM THE MARK AS SHOWN. THE MARK CONSISTS OF A STYLIZED LETTER "Z" ABOVE THE WORDING "ZERGERAN DIAMOND". THERE IS A SMALL DIAMOND-SHAPED BALL ON THE UPPER LEFT SIDE OF THE LETTER "Z".

THE WORDING "ZERGERAN" HAS NO MEANING IN A FOREIGN LANGUAGE.

FOR BRACELETS; BROACHES; CUT DIAMONDS; DIAMOND JEWELRY; DIAMONDS; JEWELRY; JEWELRY BOXES; JEWELRY MADE IN WHOLE OR SIGNIFICANT PART OF DIAMONDS AND PRECIOUS METALS; JEWELRY WATCHES; KEY CHAINS AS JEWELRY; PRECIOUS METALS AND THEIR ALLOYS; PRECIOUS METALS FOR USE IN MANUFACTURING JEWELRY; PRECIOUS STONES; RINGS; RINGS MADE IN WHOLE OR SIGNIFICANT PART OF DIAMONDS AND PRECIOUS METALS; WATCHES AND JEWELRY; WATCHES MADE IN WHOLE OR SIGNIFICANT PART OF DIAMONDS AND PRECIOUS METALS; WOMEN'S JEWELRY, ALL OF THE ABOVE MADE IN WHOLE OR SIGNIFICANT PART OF DIAMONDS (U.S. CLS. 2, 27, 28 AND 50).

FIRST USE 10-1-2009; IN COMMERCE 5-1-2013.  
KAREN K. BUSH, EXAMINING ATTORNEY

SN 86-210,153. SELECT JEWELRY, INC., LONG ISLAND CITY, NY. FILED 3-4-2014.

EVERY GREAT MOMENT BEGINS  
WITH A WISH

THE MARK CONSISTS OF STANDARD CHARACTERS WITHOUT CLAIM TO ANY PARTICULAR FONT, STYLE, SIZE, OR COLOR.

FOR JEWELRY, NAMELY, WEDDING BANDS, RINGS, BRACELETS, PENDANTS, EARRINGS, NECKLACES, BROOCHES AND JEWELRY PINS (U.S. CLS. 2, 27, 28 AND 50).

JULIE VEPPUMTHARA, EXAMINING ATTORNEY

**CLASS 14—(Continued).**

SN 86-212,513. COSTELLO, MARRIN, ALAMEDA, CA. FILED 3-6-2014.



THE MARK CONSISTS OF A STYLIZED LETTER "M" ROTATED 90 DEGREES CLOCKWISE, FOLLOWED BY A STYLIZED LETTER "C".

FOR JEWELRY (U.S. CLS. 2, 27, 28 AND 50).  
FIRST USE 6-0-2008; IN COMMERCE 7-26-2008.  
KAREN SEVERSON, EXAMINING ATTORNEY

SN 86-213,106. E.L. DIAMOND CORP, REGO PARK, NY. FILED 3-6-2014.



E.L. DIAMOND CORP

NO CLAIM IS MADE TO THE EXCLUSIVE RIGHT TO USE "DIAMOND CORP", APART FROM THE MARK AS SHOWN.

THE MARK CONSISTS OF THE WORDING "E.L. DIAMOND CORP" ABOVE WHICH IS A REPRESENTATION OF DIAMOND WITH A THIN OUTLINE AND A DARKER INTERIOR LINE GIVING IT A THREE-DIMENSIONAL LOOK.

FOR DIAMOND JEWELRY (U.S. CLS. 2, 27, 28 AND 50).

FIRST USE 7-15-2013; IN COMMERCE 7-15-2013.  
SUE LAWRENCE, EXAMINING ATTORNEY

SN 86-216,432. THE MARFO COMPANY, DBA MARSALA MANUFACTURING COMPANY, COLUMBUS, OH. FILED 3-10-2014.



THE MARK CONSISTS OF THE WORD "NEVERENDING" IN STYLIZED SCRIPT POSITIONED ABOVE THE WORD "LOVE", ALSO IN STYLIZED SCRIPT, WITH THE LETTER "G" IN "NEVERENDING" BEING ALIGNED ABOVE THE LETTER "O" IN "LOVE". A VERTICAL



**CLASS 14—(Continued).**

INFINITY SYMBOL, THE UPPER LOOP OF WHICH IS COMPRISED OF A STYLIZED HEART DESIGN WITH TWO SHADED CIRCLES, ONE ON EACH OF THE OUTER EDGES OF ROUNDED UPPER ARCS OF THE HEART REPRESENTING A PARENT AND A CHILD, IS PLACED AFTER THE SECOND LETTER "N" IN "NEVERENDING" AND FORMS THE LETTER "G" IN THE WORD "NEVER-ENDING" WITH THE BOTTOM OF THE INFINITY SYMBOL ALSO FORMING THE LETTER "O" IN THE WORD "LOVE".

FOR JEWELRY (U.S. CLS. 2, 27, 28 AND 50).  
FIRST USE 3-6-2014; IN COMMERCE 3-6-2014.  
KATHLEEN KOLACZ, EXAMINING ATTORNEY

SN 86-219,438. JULIA KNIGHT, INC., MINNEAPOLIS, MN.  
FILED 3-12-2014.

**JULIA KNIGHT**

THE MARK CONSISTS OF STANDARD CHARACTERS WITHOUT CLAIM TO ANY PARTICULAR FONT, STYLE, SIZE, OR COLOR.

OWNER OF U.S. REG. NO. 3,901,315.  
THE NAME "JULIA KNIGHT" IDENTIFIES A LIVING INDIVIDUAL WHOSE CONSENT IS PRESUMED FROM THE SIGNATURE IN THE RECORD.

FOR BANGLE BRACELETS; BRACELETS; BRACELETS; BRACELETS MADE OF METAL WITH ENAMEL; CLIP EARRINGS; EARRINGS; GEMSTONE JEWELRY; JEWELRY; JEWELRY BOXES; JEWELRY CHAINS; NECKLACE AND EARRING COMBINATIONS THAT CAN BE WORN SEPARATELY OR AS ONE PIECE; NECKLACES; NECKLACES MADE OF METAL WITH ENAMEL (U.S. CLS. 2, 27, 28 AND 50).

FIRST USE 6-8-2013; IN COMMERCE 6-8-2013.  
CORY BOONE, EXAMINING ATTORNEY

SN 86-221,080. WATCHES LLC, LAKEWOOD, NJ. FILED 3-14-2014.

**CONQUEROR**

THE COLOR(S) GOLD AND PURPLE IS/ARE CLAIMED AS A FEATURE OF THE MARK.

THE MARK CONSISTS OF A GOLD SHIELD WITH PURPLE OUTLINING CONTAINING THE GOLD AND PURPLE PROFILE OF A LION IN THE CENTER, PLACED ABOVE THE PURPLE TERM "CONQUEROR".

FOR WATCHES (U.S. CLS. 2, 27, 28 AND 50).  
JOHN DWYER, EXAMINING ATTORNEY

**CLASS 14—(Continued).**

SN 86-232,000. TEAH M. MAZZONI, DBA ANCHOR ME BRACELET, MATTAPOISETT, MA. FILED 3-25-2014.



NO CLAIM IS MADE TO THE EXCLUSIVE RIGHT TO USE "BRACELET", APART FROM THE MARK AS SHOWN. THE COLOR(S) BROWN, WHITE AND TAN IS/ARE CLAIMED AS A FEATURE OF THE MARK.

THE MARK CONSISTS OF THE WORDING "ANCHOR ME BRACELET" IN BROWN LETTERS; TO THE LEFT OF THE WORDING IS A WHITE ANCHOR DESIGN AGAINST A TAN CIRCULAR BACKGROUND.

FOR BRACELETS (U.S. CLS. 2, 27, 28 AND 50).  
FIRST USE 6-1-2013; IN COMMERCE 6-1-2013.  
JOHN GARTNER, EXAMINING ATTORNEY

SN 86-232,002. GIRALT, ANDREA C., DBA UNEQUAL DESIGNS, HOUSTON, TX. FILED 3-25-2014.



NO CLAIM IS MADE TO THE EXCLUSIVE RIGHT TO USE "DESIGNS", APART FROM THE MARK AS SHOWN.

THE MARK CONSISTS OF THE WORD "UN" FOLLOWED BY THE NOT EQUAL SIGN AND THEN THE WORD "EQUAL", ALL ABOVE THE WORD "DESIGNS", ALL IN A STYLIZED FONT.

FOR BRACELETS; BROACHES; BROOCHES; COSTUME JEWELRY; JEWELRY; JEWELRY AND IMITATION JEWELRY; JEWELRY CHAINS; JEWELRY IN THE NATURE OF ARMBANDS; PASTE JEWELRY; PINS BEING JEWELRY; PLASTIC BRACELETS IN THE NATURE OF JEWELRY; PRECIOUS AND SEMI-PRECIOUS CRYSTAL STONES AND BEADS FOR USE IN JEWELRY; WOMEN'S JEWELRY (U.S. CLS. 2, 27, 28 AND 50).  
MARK SHINER, EXAMINING ATTORNEY

SN 86-232,189. AGC, LLC, CLEVELAND, OH. FILED 3-26-2014.

**MOMENTOS OF THE HEART**

THE MARK CONSISTS OF STANDARD CHARACTERS WITHOUT CLAIM TO ANY PARTICULAR FONT, STYLE, SIZE, OR COLOR.

NO CLAIM IS MADE TO THE EXCLUSIVE RIGHT TO USE "MOMENTOS", APART FROM THE MARK AS SHOWN.

FOR JEWELRY (U.S. CLS. 2, 27, 28 AND 50).  
ELLEN BURNS, EXAMINING ATTORNEY

**CLASS 14—(Continued).**

SN 86-232,637. WORNELL, RONALD, GLENDORA, CA. FILED 3-26-2014.

MOON SHADOW HANDCRAFTED  
JEWELRY

THE MARK CONSISTS OF STANDARD CHARACTERS WITHOUT CLAIM TO ANY PARTICULAR FONT, STYLE, SIZE, OR COLOR.

NO CLAIM IS MADE TO THE EXCLUSIVE RIGHT TO USE "HANDCRAFTED JEWELRY", APART FROM THE MARK AS SHOWN.

FOR JEWELRY (U.S. CLS. 2, 27, 28 AND 50).  
KEVIN DINALLO, EXAMINING ATTORNEY

SN 86-233,980. FUZION CREATIONS INTERNATIONAL, LLC, BROOKLYN, NY. FILED 3-27-2014.

FZN

THE MARK CONSISTS OF STANDARD CHARACTERS WITHOUT CLAIM TO ANY PARTICULAR FONT, STYLE, SIZE, OR COLOR.

FOR JEWELRY AND IMITATION JEWELRY; NAMELY, ANKLETS, AMULETS, AND BRACELETS; BROOCHES; BRONZE, GOLD AND SILVER JEWELRY; BROOCHES; CHARMS; COSTUME JEWELRY; DIAMOND JEWELRY; GEMSTONE JEWELRY; IDENTIFICATION BRACELETS; IMITATION JEWELLERY; WATCHES; JEWELLERY CHAINS; JEWELLERY PLATED WITH PRECIOUS METALS; JEWELRY FOR ATTACHMENT TO CLOTHING; LAPEL PINS; NECKLACES; PEARLS; ORNAMENTAL PINS; PINS BEING JEWELRY; RINGS; STAINLESS STEEL NECKLACES AND BRACELETS; EARRINGS (U.S. CLS. 2, 27, 28 AND 50).

FIRST USE 1-1-2006; IN COMMERCE 1-1-2006.  
LEIGH LOWRY, EXAMINING ATTORNEY

SN 86-236,425. TIDY TIE COMPANY, JERSEY CITY, NJ. FILED 3-30-2014.

TIDY TIE

NO CLAIM IS MADE TO THE EXCLUSIVE RIGHT TO USE "TIE", APART FROM THE MARK AS SHOWN.

THE MARK CONSISTS OF THE WORDS "TIDY TIE" AND THEY ARE SPELLED OUT WITH THE "I" IN "TIE" REPLACED BY A UNIQUE LOGO OF A TIE.

FOR CUFF LINKS AND TIE CLIPS; NECK CHAINS; NECKTIE FASTENERS; TIE BARS; TIE CLIPS; TIE CLIPS OF PRECIOUS METAL; TIE FASTENERS; TIE PINS; TIE TACKS; TIE-PINS OF PRECIOUS METAL (U.S. CLS. 2, 27, 28 AND 50).

MARC LEIPZIG, EXAMINING ATTORNEY

**CLASS 14—(Continued).**

SN 86-236,990. SANDEEP DIAMOND CORPORATION, NEW YORK, NY. FILED 3-31-2014.

FAIRYTALE PROMISE

THE MARK CONSISTS OF STANDARD CHARACTERS WITHOUT CLAIM TO ANY PARTICULAR FONT, STYLE, SIZE, OR COLOR.

FOR JEWELRY (U.S. CLS. 2, 27, 28 AND 50).

LYNDESEY KUYKENDALL, EXAMINING ATTORNEY

SN 86-239,038. ROBLES, CARLOS, MINNEAPOLIS, MN. FILED 4-1-2014.

Lovely Lapels

THE MARK CONSISTS OF STANDARD CHARACTERS WITHOUT CLAIM TO ANY PARTICULAR FONT, STYLE, SIZE, OR COLOR.

NO CLAIM IS MADE TO THE EXCLUSIVE RIGHT TO USE "LAPELS", APART FROM THE MARK AS SHOWN.

FOR LAPEL PINS; ORNAMENTAL LAPEL PINS (U.S. CLS. 2, 27, 28 AND 50).

FIRST USE 1-1-2014; IN COMMERCE 1-1-2014.

JAMES LOVELACE, EXAMINING ATTORNEY

SN 86-239,975. KING'S FLAIR MARKETING LIMITED, TORTOLA, BR. VIRGIN ISLANDS, FILED 4-2-2014.



THE MARK CONSISTS OF LITERAL ELEMENT "ALEYBO" AND A SPECIAL DESIGN OF THE LETTER "A" ON THE LEFT SIDE OF THE LITERAL ELEMENT "ALEYBO".

THE WORDING "ALEYBO" HAS NO MEANING IN A FOREIGN LANGUAGE.

FOR AGATE AS JEWELLERY; ALARM CLOCKS; BOXES OF PRECIOUS METAL; BRACELETS; CASES FOR WATCHES AND CLOCKS; CASKETS FOR CLOCKS AND JEWELS; CHARMS; CHRONOMETERS; CLOCKS AND WATCHES; INGOTS OF PRECIOUS METAL; JEWELLERY CASES; JEWELRY BROOCHES; METAL WIRE FOR USE IN THE MAKING OF JEWELRY, NAMELY, JEWELRY CABLE; NECKLACES; ORNAMENTS OF PRECIOUS METAL IN THE NATURE OF JEWELRY; RINGS BEING JEWELRY; SILVER AND ITS ALLOYS; STOPWATCHES; WORKS OF ART OF PRECIOUS METAL; WRISTWATCHES (U.S. CLS. 2, 27, 28 AND 50).

FIRST USE 10-20-2013; IN COMMERCE 3-5-2014.

ELIZABETH JACKSON, EXAMINING ATTORNEY

**CLASS 14—(Continued).**

SN 86-244,023. LOKAI HOLDINGS LLC, NEW YORK, NY.  
FILED 4-7-2014.



THE MARK CONSISTS OF TWO CONCENTRIC STYLIZED WATER DROPLETS CONTAINING TWO CIRCLES.  
FOR BRACELETS; JEWELRY; RUBBER OR SILICON WRISTBANDS IN THE NATURE OF A BRACELET (U.S. CLS. 2, 27, 28 AND 50).

FIRST USE 1-0-2014; IN COMMERCE 1-0-2014.  
JUSTIN SEVERSON, EXAMINING ATTORNEY

SN 86-245,054. LAZULINE SKY LLC, SHORT HILLS, NJ.  
FILED 4-7-2014.

## S. A. Peck

THE MARK CONSISTS OF STANDARD CHARACTERS WITHOUT CLAIM TO ANY PARTICULAR FONT, STYLE, SIZE, OR COLOR.

THE WORDING "S. A. PECK" HAS NO MEANING IN A FOREIGN LANGUAGE.

FOR JEWELRY (U.S. CLS. 2, 27, 28 AND 50).  
FIRST USE 1-8-2013; IN COMMERCE 4-2-2014.  
THEODORE MCBRIDE, EXAMINING ATTORNEY

SN 86-245,086. LISA STEWART STUDIO, INC., BEVERLY HILLS, CA. FILED 4-7-2014.

## Reminders in Recovery

THE MARK CONSISTS OF STANDARD CHARACTERS WITHOUT CLAIM TO ANY PARTICULAR FONT, STYLE, SIZE, OR COLOR.

FOR BRACELETS; BROACHES; CHARMS; IDENTIFICATION BRACELETS; JEWELRY; JEWELRY BROOCHES; JEWELRY IN THE NATURE OF ARMBANDS; JEWELRY, NAMELY, ARM CUFFS; RINGS; WATCHES AND JEWELRY; WOMEN'S JEWELRY (U.S. CLS. 2, 27, 28 AND 50).

PAULA MAHONEY, EXAMINING ATTORNEY

**CLASS 14—(Continued).**

SN 86-245,789. SZPONDOWSKI, KARA L., CHICAGO, IL.  
FILED 4-8-2014.

## CoverBand

THE MARK CONSISTS OF STANDARD CHARACTERS WITHOUT CLAIM TO ANY PARTICULAR FONT, STYLE, SIZE, OR COLOR.

FOR BANGLE BRACELETS; BRACELETS; BRACELETS (U.S. CLS. 2, 27, 28 AND 50).  
LINDA LAVACHE, EXAMINING ATTORNEY

SN 86-246,818. STELLA & DOT LLC, SAN BRUNO, CA.  
FILED 4-9-2014.



THE MARK CONSISTS OF THE WORD "KEEP" IN LARGE FONT, CENTERED ABOVE THE WORD "COLLECTIVE" IN SMALLER FONT; BOTH FRAMED AND CENTERED WITHIN TWO CONCENTRIC RECTANGULAR BORDERS; THE IMAGE OF A KEY IS CENTERED BELOW THE WORD "COLLECTIVE" LAYING HORIZONTALLY AS PART OF AND WITHIN A SPACE IN THE BOTTOM SEGMENT OF THE INNER BORDER.

FOR JEWELRY (U.S. CLS. 2, 27, 28 AND 50).  
LOKSYE G LEE RISO, EXAMINING ATTORNEY

SN 86-247,311. LISA PAIGE LLC, DBA CHEWBEADS, NEW YORK, NY. FILED 4-9-2014.

## CB BY CHEWBEADS

THE MARK CONSISTS OF STANDARD CHARACTERS WITHOUT CLAIM TO ANY PARTICULAR FONT, STYLE, SIZE, OR COLOR.

OWNER OF U.S. REG. NOS. 3,925,037, 4,391,800 AND OTHERS.

FOR BRACELETS MADE OF RUBBER SILICON; JEWELRY AND IMITATION JEWELRY; NECKLACES MADE OF RUBBER SILICON (U.S. CLS. 2, 27, 28 AND 50).

JENNIFER BUTTON, EXAMINING ATTORNEY

**CLASS 14—(Continued).**

SN 86-247,607. BOBOWSKI, LAUREN K., DBA LALA JEWELRY, TAHOE CITY, CA. FILED 4-9-2014.

**TWO LOVERS**

THE MARK CONSISTS OF STANDARD CHARACTERS WITHOUT CLAIM TO ANY PARTICULAR FONT, STYLE, SIZE, OR COLOR.

FOR JEWELRY (U.S. CLS. 2, 27, 28 AND 50).  
ROGER T. MCDORMAN, EXAMINING ATTORNEY

---

SN 86-247,856. SAELEE, PHAY, DBA SAELEE, PHAY, ROCKLIN, CA. FILED 4-10-2014.

**P.H.A.Y.  
Pretty Hot and Yummy**

THE MARK CONSISTS OF STANDARD CHARACTERS WITHOUT CLAIM TO ANY PARTICULAR FONT, STYLE, SIZE, OR COLOR.

FOR BRACELETS (U.S. CLS. 2, 27, 28 AND 50).  
LAURA GOLDEN, EXAMINING ATTORNEY

---

SN 86-248,337. ALMAR SALES CO., INC., NEW YORK, NY. FILED 4-10-2014.

**D.I.Y. DO IT YOURSELF**

THE MARK CONSISTS OF STANDARD CHARACTERS WITHOUT CLAIM TO ANY PARTICULAR FONT, STYLE, SIZE, OR COLOR.

FOR BRACELETS; JEWELRY MAKING KITS; NECKLACES; RINGS; RUBBER OR SILICONE WRISTBANDS IN THE NATURE OF A BRACELET (U.S. CLS. 2, 27, 28 AND 50).

FIRST USE 8-1-2013; IN COMMERCE 8-1-2013.  
TOBY BULLOFF, EXAMINING ATTORNEY

**CLASS 14—(Continued).**

SN 86-249,061. BRILLIANCE LLC, BOYNTON BEACH, FL. FILED 4-10-2014.

**Mangagement**

THE MARK CONSISTS OF STANDARD CHARACTERS WITHOUT CLAIM TO ANY PARTICULAR FONT, STYLE, SIZE, OR COLOR.

FOR JEWELRY MADE IN WHOLE OR SIGNIFICANT PART OF DIAMONDS; RINGS; RINGS MADE IN WHOLE OR SIGNIFICANT PART OF DIAMONDS; WEDDING RINGS (U.S. CLS. 2, 27, 28 AND 50).

COLLEEN MULCRONE, EXAMINING ATTORNEY

---

SN 86-249,239. BAIR, CAMERON, GLENDALE, AZ. FILED 4-11-2014.

**YESJ**

THE MARK CONSISTS OF STANDARD CHARACTERS WITHOUT CLAIM TO ANY PARTICULAR FONT, STYLE, SIZE, OR COLOR.

FOR JEWELRY; RINGS; RINGS MADE OF SILICONE (U.S. CLS. 2, 27, 28 AND 50).

FIRST USE 8-16-2010; IN COMMERCE 8-16-2010.  
JOHN HWANG, EXAMINING ATTORNEY

**CLASS 14—(Continued).**

SN 86-250,127. TANNER, ANDRE, SCHINDELLEGI, SWITZERLAND, FILED 4-11-2014.

# ALPRAUSCH

THE MARK CONSISTS OF STANDARD CHARACTERS WITHOUT CLAIM TO ANY PARTICULAR FONT, STYLE, SIZE, OR COLOR.

OWNER OF U.S. REG. NOS. 3,002,229 AND 3,725,042.

FOR CLOCKS, ALARM CLOCKS, AUTOMOBILE CLOCKS, CLOCKS INCORPORATING RADIOS, PENDULUM CLOCKS, SMALL CLOCKS, TABLE CLOCKS, WALL CLOCKS, CASES FOR CLOCK AND WATCH-MAKING, CASES FOR CLOCKS AND WATCHES, CLOCK AND WATCH HANDS, CLOCK CABINETS, CLOCK DIALS, CLOCK HOUSINGS, DIALS FOR CLOCK- AND WATCH-MAKING, PARTS FOR CLOCKS, PARTS FOR WATCHES, WATCH AND CLOCK SPRINGS, WATCHES, WRIST WATCHES, CHRONOGRAPHS FOR USE AS WATCHES OR TIME PIECES, DIVING WATCHES, JEWELRY WATCHES, MECHANICAL AND AUTOMATIC WATCHES, POCKET WATCHES, STOP WATCHES, WATCHES CONTAINING AN ELECTRONIC GAME FUNCTION, WATCH BANDS, WATCH STRAPS, WATCH BOXES, WATCH BRACELETS, WATCH CHAINS, WATCH CLASPS, WATCH CROWNS, WATCH FACES, WATCH FOBS, WATCH GLASSES, WATCH MOVEMENTS, WATCH POUCHES, WATCH STRAPS MADE OF METAL OR LEATHER OR PLASTIC, WATCH WINDERS, WATCH WINDING BUTTONS (U.S. CLS. 2, 27, 28 AND 50).

GINA HAYES, EXAMINING ATTORNEY

SN 86-251,314. DOVE'S JEWELRY DESIGNS, INC., GREAT NECK, NY. FILED 4-14-2014.

## DOVES BY DORON PALOMA

THE MARK CONSISTS OF STANDARD CHARACTERS WITHOUT CLAIM TO ANY PARTICULAR FONT, STYLE, SIZE, OR COLOR.

THE NAME(S), PORTRAIT(S), AND/OR SIGNATURE(S) SHOWN IN THE MARK IDENTIFIES DORON HAKIMIAN, WHOSE CONSENT(S) TO REGISTER IS MADE OF RECORD.

FOR JEWELRY (U.S. CLS. 2, 27, 28 AND 50).

FIRST USE 4-19-2013; IN COMMERCE 4-19-2013.

WARREN L. OLANDRIA, EXAMINING ATTORNEY

**CLASS 14—(Continued).**

SN 86-251,418. DOVE'S JEWELRY DESIGNS, INC., GREAT NECK, NY. FILED 4-14-2014.



THE NAME(S), PORTRAIT(S), AND/OR SIGNATURE(S) SHOWN IN THE MARK IDENTIFIES DORON HAKIMIAN, WHOSE CONSENT(S) TO REGISTER IS MADE OF RECORD.

THE MARK CONSISTS OF THE LITERAL ELEMENTS "DOVES BY DORON PALOMA" WRITTEN IN A STYLIZED FORM WITH THE WORD "DOVES" PLACED AT THE TOP, BELOW THAT THE WORD "BY" IS PLACED WITH TWO HORIZONTAL LINES AT BOTH SIDES AND THE WORDS "DORON PALOMA" WRITTEN AT THE BOTTOM AND RIGHT FACING DOVE BIRD LIKE IMAGE PLACED AT THE LEFT SIDE OF THE LITERAL ELEMENTS.

FOR JEWELRY (U.S. CLS. 2, 27, 28 AND 50).

FIRST USE 4-19-2013; IN COMMERCE 4-19-2013.

WARREN L. OLANDRIA, EXAMINING ATTORNEY

SN 86-251,937. C & R PRODUCTIONS, LLC, SHERMAN OAKS, CA. FILED 4-14-2014.



THE MARK CONSISTS OF A FLOWER VINE DESIGN ABOVE THE WORD "HOMAGE" WITH THE CENTER OF THE VINE CONTAINING THE LETTERS "CVC", AND ANOTHER SMALL FLOWER VINE BELOW THE WORD.

FOR BRACELETS; BROACHES; EARRINGS; JEWELRY; NECKLACES; RINGS (U.S. CLS. 2, 27, 28 AND 50).

SETH A. RAPPAPORT, EXAMINING ATTORNEY

SN 86-251,950. CROOKS, MONICA, GRANITE BAY, CA. FILED 4-14-2014.

# CREATRESS

THE MARK CONSISTS OF STANDARD CHARACTERS WITHOUT CLAIM TO ANY PARTICULAR FONT, STYLE, SIZE, OR COLOR.

FOR JEWELRY (U.S. CLS. 2, 27, 28 AND 50).

LAUREN BURKE, EXAMINING ATTORNEY

**CLASS 14—(Continued).**

SN 86-251,960. CROOKS, MONICA, GRANITE BAY, CA.  
FILED 4-14-2014.

## ANAMONICA

THE MARK CONSISTS OF STANDARD CHARACTERS  
WITHOUT CLAIM TO ANY PARTICULAR FONT, STYLE,  
SIZE, OR COLOR.

FOR JEWELRY (U.S. CLS. 2, 27, 28 AND 50).  
LAUREN BURKE, EXAMINING ATTORNEY

**CLASS 14—(Continued).**

SN 86-261,198. AYA INTERNATIONAL, LLC, NEW YORK,  
NY. FILED 4-24-2014.

## SILIX

THE MARK CONSISTS OF STANDARD CHARACTERS  
WITHOUT CLAIM TO ANY PARTICULAR FONT, STYLE,  
SIZE, OR COLOR.

FOR JEWELRY (U.S. CLS. 2, 27, 28 AND 50).  
TOBY BULLOFF, EXAMINING ATTORNEY

SN 86-256,539. LEMA J, LLC, ORLANDO, FL. FILED 4-18-  
2014.

LEMA J  
HANDMADE SHAGREEN CUFFS

NO CLAIM IS MADE TO THE EXCLUSIVE RIGHT TO  
USE "HANDMADE SHAGREEN CUFFS", APART FROM  
THE MARK AS SHOWN.

THE NAME(S), PORTRAIT(S), AND/OR SIGNATURE(S)  
SHOWN IN THE MARK DOES NOT IDENTIFY A PARTI-  
CULAR LIVING INDIVIDUAL.

THE COLOR(S) BLACK AND ORANGE IS/ARE CLAIMED  
AS A FEATURE OF THE MARK.

THE MARK CONSISTS OF THE STYLIZED LITERAL  
ELEMENT "LEMA" RENDERED IN BLACK LETTERING,  
FOLLOWED BY A SINGLE ORANGE DOT FOLLOWED BY  
THE STYLIZED LITERAL ELEMENT "J" RENDERED IN  
BLACK LETTERING ALL ON TOP OF THE STYLIZED  
LITERAL ELEMENT "HANDMADE SHAGREEN CUFFS"  
RENDERED IN BLACK LETTERING.

FOR BRACELETS MADE OF SHAGREEN, LAMBSKIN  
AND OTHER LEATHER AND HIDES (U.S. CLS. 2, 27, 28  
AND 50).

FIRST USE 4-18-2014; IN COMMERCE 4-18-2014.  
STEVEN JACKSON, EXAMINING ATTORNEY

SN 86-277,507. LAZULINE SKY LLC, SHORT HILLS, NJ.  
FILED 5-9-2014.

## Amberley West

THE MARK CONSISTS OF STANDARD CHARACTERS  
WITHOUT CLAIM TO ANY PARTICULAR FONT, STYLE,  
SIZE, OR COLOR.

FOR JEWELRY (U.S. CLS. 2, 27, 28 AND 50).  
FIRST USE 1-8-2010; IN COMMERCE 1-8-2010.  
THEODORE MCBRIDE, EXAMINING ATTORNEY

SN 86-278,212. MAURICES INCORPORATED, DULUTH,  
MN. FILED 5-12-2014.

SN 86-259,151. AYA INTERNATIONAL, LLC, NEW YORK,  
NY. FILED 4-22-2014.

## SILIX BY AYA

THE MARK CONSISTS OF STANDARD CHARACTERS  
WITHOUT CLAIM TO ANY PARTICULAR FONT, STYLE,  
SIZE, OR COLOR.

OWNER OF U.S. REG. NOS. 1,817,419, 3,269,044 AND  
OTHERS.

FOR JEWELRY (U.S. CLS. 2, 27, 28 AND 50).  
TOBY BULLOFF, EXAMINING ATTORNEY



THE MARK CONSISTS OF A STYLIZED FLOWER.

FOR JEWELRY, NAMELY COSTUME JEWELRY, BRA-  
CELETS, EARRINGS, NECKLACES, PENDANTS, PINS,  
RINGS AND WATCHES; IMITATION JEWELRY (U.S.  
CLS. 2, 27, 28 AND 50).

WILLIAM P. SHANAHAN, EXAMINING ATTORNEY

**CLASS 14—(Continued).**

SN 86-278,356. SAMUEL AARON, INC., LONG ISLAND CITY, NY. FILED 5-12-2014.

**VIVA LAS VEGAS**

THE MARK CONSISTS OF STANDARD CHARACTERS WITHOUT CLAIM TO ANY PARTICULAR FONT, STYLE, SIZE, OR COLOR.

NO CLAIM IS MADE TO THE EXCLUSIVE RIGHT TO USE "LAS VEGAS", APART FROM THE MARK AS SHOWN. FOR JEWELRY (U.S. CLS. 2, 27, 28 AND 50). FIRST USE 1-0-2004; IN COMMERCE 1-0-2004. JEFF DEFORD, EXAMINING ATTORNEY

SN 86-283,824. VINCE, LLC, NEW YORK, NY. FILED 5-16-2014.

**VINCE**

THE MARK CONSISTS OF STANDARD CHARACTERS WITHOUT CLAIM TO ANY PARTICULAR FONT, STYLE, SIZE, OR COLOR.

OWNER OF U.S. REG. NOS. 2,929,250, 3,954,985 AND OTHERS.

FOR BRACELETS; BROOCHES; CHARMS; CHARMS FOR COLLAR JEWELRY AND BRACELET; COSTUME JEWELRY; CUFF LINKS; DRESS WATCHES; EARRINGS; JEWELRY; JEWELRY AND IMITATION JEWELRY; JEWELRY, NAMELY, ARM CUFFS; NECKLACES; PINS BEING JEWELRY; POCKET WATCHES; RINGS; SPORTS WATCHES; TIE PINS; WATCH BANDS; WATCH BRACELETS; WATCH CASES; WATCH CHAINS; WATCH FACES; WATCH POUCHES; WATCH STRAPS; WATCHES AND JEWELRY; WATCHES AND STRAPS FOR WATCHES; WRIST WATCHES (U.S. CLS. 2, 27, 28 AND 50).

KEVIN MITTLER, EXAMINING ATTORNEY

SN 86-290,638. SELECT JEWELRY, INC., LONG ISLAND CITY, NY. FILED 5-23-2014.

**AS RARE AS FINDING YOUR ONE TRUE LOVE**

THE MARK CONSISTS OF STANDARD CHARACTERS WITHOUT CLAIM TO ANY PARTICULAR FONT, STYLE, SIZE, OR COLOR.

FOR JEWELRY, NAMELY, WEDDING BANDS, RINGS, BRACELETS, PENDANTS, EARRINGS, NECKLACES, BROOCHES AND JEWELRY PINS (U.S. CLS. 2, 27, 28 AND 50).

JULIE VEPPUMTHARA, EXAMINING ATTORNEY

**CLASS 14—(Continued).**

SN 86-291,141. CARLA MARINA SARDEIRA, COLONIA, NJ. FILED 5-23-2014.

**SARDEIRA**

THE COLOR(S) BLUE IS/ARE CLAIMED AS A FEATURE OF THE MARK.

THE MARK CONSISTS OF THE WORD "SARDEIRA" IN STYLIZED FORM, WHERE THE DOT OF THE "I" APPEARS AS THE LETTER "S" IN A RING OF THREE CIRCLES, WITH THE OUTERMOST HAVING THREE INWARD BUMPS. THE ENTIRETY OF THE MARK APPEARS IN BLUE, AND THE WHITE ONLY IDENTIFIES TRANSPARENT BACKGROUND.

FOR BRACELETS; BROACHES; BROOCHES; CAMEOS; DIAMOND JEWELRY; EARRINGS; JEWELRY; JEWELRY STICKPINS; JEWELRY, NAMELY, STONE PENDANTS; LAPEL PINS; NECKLACES; RINGS; SCARF CLIPS BEING JEWELRY; WOMEN'S JEWELRY (U.S. CLS. 2, 27, 28 AND 50).

CAITLIN WATTS-FITZGERALD, EXAMINING ATTORNEY

SN 86-292,099. ARABOV, ETHAN, HOLLIS, NY. FILED 5-27-2014.

**F O R E V E R**

THE COLOR(S) RED AND BLACK IS/ARE CLAIMED AS A FEATURE OF THE MARK.

THE MARK CONSISTS OF THE LITERAL ELEMENTS "FOREVER EQUAL" WRITTEN IN A STYLIZED FORM IN BLACK COLOR EXCEPT THE FIRST LETTER "E" OF THE WORD "FOREVER" WRITTEN IN THREE RED COLORED HORIZONTAL PARALLEL LINES AND THE WORD "EQUAL" IS PLACED BELOW IT. THE COLOR WHITE IS MERELY BACKGROUND.

FOR PRECIOUS METAL ALLOYS; PRECIOUS METALS AND ALLOYS THEREOF; JEWELRY AND IMITATION JEWELRY, PRECIOUS STONES; HOROLOGICAL AND CHRONOMETRIC INSTRUMENTS AND PARTS THEREOF (U.S. CLS. 2, 27, 28 AND 50).

FIRST USE 4-1-2014; IN COMMERCE 5-22-2014.

DOMINICK J. SALEMI, EXAMINING ATTORNEY

**CLASS 14—(Continued).**

SN 86-318,992. COMMEMORATIVE BRANDS, INC., AUSTIN, TX. FILED 6-24-2014.



THE MARK CONSISTS OF THE STYLIZED LETTERS "A" AND "C".

FOR CLASS RINGS; PERSONALIZED FASHION JEWELRY, NAMELY RINGS, PENDANTS, NECKLACES, CHARMS, BRACELETS AND EARRINGS (U.S. CLS. 2, 27, 28 AND 50).

FIRST USE 3-18-1994; IN COMMERCE 3-18-1994.  
WILLIAM BRECKENFELD, EXAMINING ATTORNEY

**CLASS 15—MUSICAL INSTRUMENTS**

SN 86-071,682. BUDNICK, PATRICK, BLAINE, CA. FILED 9-23-2013.

## Infinity Drumworks

THE MARK CONSISTS OF STANDARD CHARACTERS WITHOUT CLAIM TO ANY PARTICULAR FONT, STYLE, SIZE, OR COLOR.

NO CLAIM IS MADE TO THE EXCLUSIVE RIGHT TO USE "DRUMWORKS", APART FROM THE MARK AS SHOWN.

FOR DRUMS; DRUM KITS COMPRISED OF SNARE DRUM, RACK TOM, FLOOR TOM AND BASS DRUM; SNARE DRUMS; DRUM SHELLS; DRUM HARDWARE, NAMELY, DRUMHEAD FASTENERS; BASS DRUM PEDALS; CYMBAL STANDS; SNARE DRUM STANDS; HI-HAT DRUM STANDS; DRUM STICKS (U.S. CLS. 2, 21 AND 36).

FIRST USE 6-1-2012; IN COMMERCE 6-1-2012.  
RUSS HERMAN, EXAMINING ATTORNEY

SN 86-319,006. COMMEMORATIVE BRANDS, INC., AUSTIN, TX. FILED 6-24-2014.



THE MARK CONSISTS OF THE STYLIZED LETTERS "A" AND "C".

FOR CLASS RINGS; PERSONALIZED FASHION JEWELRY, NAMELY RINGS, PENDANTS, NECKLACES, CHARMS, BRACELETS AND EARRINGS (U.S. CLS. 2, 27, 28 AND 50).

FIRST USE 3-18-1994; IN COMMERCE 3-18-1994.  
WILLIAM BRECKENFELD, EXAMINING ATTORNEY

SN 86-130,387. TECNOPLAST SRL, ROMANO D'EZZELINO (VI), ITALY, FILED 11-27-2013.



THE MARK CONSISTS OF THE WORD "TECHRA", WRITTEN IN FANCIFUL UPPER CASE CHARACTERS, WITHIN A RECTANGULAR FRAME WITH ROUNDED EDGES; EACH LETTER OF THE WORD "TECHRA" IS ACCENTED BY MEANS OF LITTLE SEGMENTS.

FOR DRUMSTICKS; CYMBAL PARTS, NAMELY, QUICK RELEASE CYMBAL QUICK LOCK SYSTEM CONSISTING OF SCREWS, WINGNUTS AND WASHERS THAT ALLOWS FOR FAST AND SECURE LOCKING OF CYMBALS TO A CYMBAL STAND (U.S. CLS. 2, 21 AND 36).

FIRST USE 12-17-2003; IN COMMERCE 12-17-2003.  
DOUGLAS LEE, EXAMINING ATTORNEY



**CLASS 15—(Continued).**

SN 86-147,082. STEWART-MACDONALD MANUFACTURING COMPANY, ATHENS, OH. FILED 12-18-2013.

# WAVERLY

THE MARK CONSISTS OF STANDARD CHARACTERS WITHOUT CLAIM TO ANY PARTICULAR FONT, STYLE, SIZE, OR COLOR.

OWNER OF U.S. REG. NO. 1,124,472.  
SEC. 2(F).

FOR PARTS OF MUSICAL INSTRUMENTS, NAMELY, MUSICAL INSTRUMENT TUNING KEYS, BRIDGE PINS, END PINS, NUTS, MACHINE HEADS, SADDLES, PEGS, GUITAR TAILPIECES, BANJO HEADS, BANJO TAILPIECES, PICKS, STRAP BUTTONS, STRAP LOCKS AND BRIDGES FOR GUITARS, BANJOS, BASS GUITARS, MANDOLINS, DULCIMERS, UKULELES AND VIOLINS (U.S. CLS. 2, 21 AND 36).

FIRST USE 1-1-1922; IN COMMERCE 8-1-1977.  
SUI DUONG, EXAMINING ATTORNEY

SN 86-167,418. PEANUTS WORLDWIDE LLC, NEW YORK, NY. FILED 1-16-2014.



OWNER OF U.S. REG. NOS. 1,256,900, 1,267,166 AND OTHERS.

THE MARK CONSISTS OF TWO PARTIALLY OBSCURED STYLIZED DOG FACES MOSTLY WITHIN A SQUARE WITH THE AMPERSAND SYMBOL BETWEEN THE DOG FACES, THE WORDING "SNOOPY" ALONG THE LEFT SIDE OF THE SQUARE, AND THE WORDING "HIS SISTER BELLE" ALONG THE RIGHT SIDE OF THE SQUARE.

FOR MUSICAL INSTRUMENTS; MUSICAL INSTRUMENT CASES, CARRYING BAGS AND STORAGE BAGS; MUSICAL PERFORMANCE ACCESSORIES, NAMELY, SHEET MUSIC STANDS AND MUSICAL INSTRUMENT STANDS; TUNING FORKS, TUNERS FOR MUSICAL INSTRUMENTS (U.S. CLS. 2, 21 AND 36).  
MIAH ROSENBERG, EXAMINING ATTORNEY

**CLASS 15—(Continued).**

SN 86-203,930. SCOTT RICHARD LENTZ, SAN MARCOS, CA. FILED 2-25-2014.

## Legendary Venues Series

THE MARK CONSISTS OF STANDARD CHARACTERS WITHOUT CLAIM TO ANY PARTICULAR FONT, STYLE, SIZE, OR COLOR.

NO CLAIM IS MADE TO THE EXCLUSIVE RIGHT TO USE "SERIES", APART FROM THE MARK AS SHOWN.

FOR GUITARS (U.S. CLS. 2, 21 AND 36).  
FIRST USE 2-5-2011; IN COMMERCE 2-5-2011.  
DANIEL S. STRINGER, EXAMINING ATTORNEY

SN 86-240,507. SCHOENEMAN, RYAN C, DBA COLBY FEATHERBOTTOM, MOUNT GILEAD, OH. FILED 4-2-2014.

## Colby Featherbottom's Custom Sound Machines

THE MARK CONSISTS OF STANDARD CHARACTERS WITHOUT CLAIM TO ANY PARTICULAR FONT, STYLE, SIZE, OR COLOR.

NO CLAIM IS MADE TO THE EXCLUSIVE RIGHT TO USE "CUSTOM SOUND MACHINES", APART FROM THE MARK AS SHOWN.

THE NAME "COLBY FEATHERBOTTOM" DOES NOT IDENTIFY A LIVING INDIVIDUAL.

FOR ELECTRIC GUITARS CUSTOM BUILT FROM CUSTOMER'S SPECIFICATIONS (U.S. CLS. 2, 21 AND 36).

FIRST USE 9-0-2013; IN COMMERCE 1-0-2014.  
ALEX KEAM, EXAMINING ATTORNEY

SN 86-241,692. LATKER, RICHARD, HOLLIDAYSBURG, PA. FILED 4-3-2014.

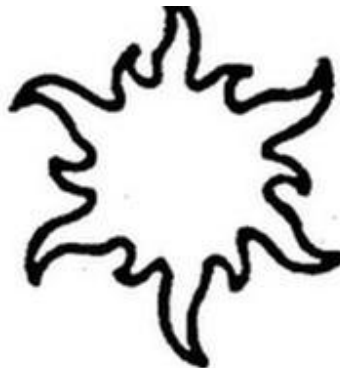

THE MARK CONSISTS OF A SUNBURST DESIGN. FOR STRINGED MUSICAL INSTRUMENTS (U.S. CLS. 2, 21 AND 36).

BARBARA GAYNOR, EXAMINING ATTORNEY

**CLASS 15—(Continued).**

SN 86-242,823. GATOR CASES, INC., TAMPA, FL. FILED 4-4-2014.

**EVOLUTION**

THE MARK CONSISTS OF STANDARD CHARACTERS WITHOUT CLAIM TO ANY PARTICULAR FONT, STYLE, SIZE, OR COLOR.  
FOR CASES FOR PERCUSSION MUSICAL INSTRUMENTS (U.S. CLS. 2, 21 AND 36).  
FIRST USE 10-31-2012; IN COMMERCE 10-31-2012.  
LEIGH LOWRY, EXAMINING ATTORNEY

SN 86-249,596. CODELLA MUSIC, SAN JOSE, CA. FILED 4-11-2014.

**Stormchaser**

THE MARK CONSISTS OF STANDARD CHARACTERS WITHOUT CLAIM TO ANY PARTICULAR FONT, STYLE, SIZE, OR COLOR.  
FOR ELECTRIC GUITARS (U.S. CLS. 2, 21 AND 36).  
FIRST USE 1-1-2014; IN COMMERCE 1-1-2014.  
DAVID COLLIER, EXAMINING ATTORNEY

SN 86-269,805. GIBSON BRANDS, INC., NASHVILLE, TN. FILED 5-2-2014.

**JUMBOPRO**

THE MARK CONSISTS OF STANDARD CHARACTERS WITHOUT CLAIM TO ANY PARTICULAR FONT, STYLE, SIZE, OR COLOR.  
FOR MUSICAL INSTRUMENTS (U.S. CLS. 2, 21 AND 36).  
CAITLIN WATTS-FITZGERALD, EXAMINING ATTORNEY

**CLASS 15—(Continued).**

SN 86-269,878. GIBSON BRANDS, INC., NASHVILLE, TN. FILED 5-2-2014.

**EZ-STRING**

THE MARK CONSISTS OF STANDARD CHARACTERS WITHOUT CLAIM TO ANY PARTICULAR FONT, STYLE, SIZE, OR COLOR.  
FOR GUITAR BRIDGES (U.S. CLS. 2, 21 AND 36).  
CAITLIN WATTS-FITZGERALD, EXAMINING ATTORNEY

SN 86-270,318. GIBSON BRANDS, INC., NASHVILLE, TN. FILED 5-2-2014.

**DESIGNED BY PROFESSIONALS  
TO BE EASY TO PLAY**

THE MARK CONSISTS OF STANDARD CHARACTERS WITHOUT CLAIM TO ANY PARTICULAR FONT, STYLE, SIZE, OR COLOR.  
FOR MUSICAL INSTRUMENTS (U.S. CLS. 2, 21 AND 36).  
CAITLIN WATTS-FITZGERALD, EXAMINING ATTORNEY

SN 86-270,366. GIBSON BRANDS, INC., NASHVILLE, TN. FILED 5-2-2014.

**ONLY AIR GUITAR IS EASIER  
TO PLAY**

THE MARK CONSISTS OF STANDARD CHARACTERS WITHOUT CLAIM TO ANY PARTICULAR FONT, STYLE, SIZE, OR COLOR.  
FOR MUSICAL INSTRUMENTS (U.S. CLS. 2, 21 AND 36).  
CAITLIN WATTS-FITZGERALD, EXAMINING ATTORNEY

**CLASS 16—PAPER GOODS AND PRINTED MATTER**

SN 76-716,077. DUCK COMMANDER, INC., WEST MONROE, LA. FILED 3-26-2014.

**FAITH COMMANDER**

THE MARK CONSISTS OF STANDARD CHARACTERS WITHOUT CLAIM TO ANY PARTICULAR FONT, STYLE, SIZE, OR COLOR.

NO CLAIM IS MADE TO THE EXCLUSIVE RIGHT TO USE "FAITH", APART FROM THE MARK AS SHOWN.

FOR RELIGIOUS BOOKS, STUDY GUIDES, LEADER GUIDES, ALL FEATURING RELIGIOUS AND BIBLICAL ISSUES (U.S. CLS. 2, 5, 22, 23, 29, 37, 38 AND 50).

JESSICA A. POWERS, EXAMINING ATTORNEY

SN 77-254,453. SOUTH FLORIDA TISSUE PAPER (SOFT) COMPANY, MIAMI, FL. FILED 8-14-2007.



NO CLAIM IS MADE TO THE EXCLUSIVE RIGHT TO USE "BATHROOM TISSUE", APART FROM THE MARK AS SHOWN.

THE MARK CONSISTS OF A STYLIZED HORIZONTAL OVAL WITH THE WORDS "ELITE BATHROOM TISSUE" INSIDE THE OVAL.

FOR BATHROOM TISSUE (U.S. CLS. 2, 5, 22, 23, 29, 37, 38 AND 50).

FIRST USE 11-6-2000; IN COMMERCE 11-6-2000.  
ANDREW RHIM, EXAMINING ATTORNEY

SN 77-688,593. KIDS CAN PRESS LTD., TORONTO, ONTARIO, CANADA, FILED 3-11-2009.

**CitizenKid**

THE MARK CONSISTS OF STANDARD CHARACTERS WITHOUT CLAIM TO ANY PARTICULAR FONT, STYLE, SIZE, OR COLOR.

PRIORITY CLAIMED UNDER SEC. 44(D) ON CANADA APPLICATION NO. 1430038, FILED 3-6-2009, REG. NO. TMA881323, DATED 7-7-2014, EXPIRES 7-7-2029.

FOR PRINTED MATERIALS, NAMELY, CHILDREN'S STORY BOOKS, CHILDREN'S COLORING BOOKS, CHILDREN'S WORK BOOKS AND PRINTED BROCHURES IN THE FIELD OF EDUCATION, STICKERS, BOOK MARKS, NOTEPADS, NOTEBOOKS, AND CALENDARS (U.S. CLS. 2, 5, 22, 23, 29, 37, 38 AND 50).

TEJBIR SINGH, EXAMINING ATTORNEY

**CLASS 16—(Continued).**

SN 79-131,707. CONDAT, FRANCE, FILED 4-22-2013.

**CONDAT MAT PERIGORD**

THE MARK CONSISTS OF STANDARD CHARACTERS WITHOUT CLAIM TO ANY PARTICULAR FONT, STYLE, SIZE, OR COLOR.

OWNER OF INTERNATIONAL REGISTRATION 1164342 DATED 4-22-2013, EXPIRES 4-22-2023.

OWNER OF U.S. REG. NOS. 1,394,838, 3,038,620 AND 3,223,166.

THE WORDING "CONDAT MAT PERIGORD" HAS NO MEANING IN A FOREIGN LANGUAGE.

FOR PAPER; PRINTING PAPER; WRITING PAPER; PAPER FOR PUBLISHING; PAPER FOR SCREEN PRINTING; COPYING PAPER; TRACING PAPER; TRACING CLOTH USED AS A PAPER SUBSTITUTE; PRINTED TRACING PATTERNS; CARBON PAPER; LUMINOUS PAPER; PAPIER MACHE; SILVER PAPER; WAXED PAPER; PARCHMENT PAPER; TYPE, PRINTED MATTER, NAMELY, PRINTED ADVERTISING MATERIALS, PRINTED CARDS, PRINTED FORMS, PRINTED PAPER LABELS, PRINTED ART REPRODUCTIONS, PRINTED CALENDARS, PRINTED CHARTS, PRINTED GRAPHS, PRINTED PLANS, PRINTED SEMINAR NOTES; BOOKBINDING MATERIAL; PHOTOGRAPHS; STATIONERY; ADDRESS LABEL PRINTING MACHINES; PRINTING TYPE; POSTERS; BOXES OF PAPER; WRAPPING PAPER; PACKAGING MATERIAL MADE OF STARCHES USED AS A PAPER SUBSTITUTE; PLASTIC FILM FOR WRAPPING; PAPER OR PLASTIC ENVELOPES AND POUCHES FOR PACKAGING; VISCOSE SHEETS FOR WRAPPING USED AS A PAPER SUBSTITUTE; ADHESIVES, NAMELY, ADHESIVES FOR STATIONERY OR HOUSEHOLD USE; PAINTBRUSHES; OFFICE REQUISITES, EXCEPT FURNITURE, NAMELY, ADHESIVE MATERIALS FOR OFFICE USE, ADHESIVE TAPE DISPENSERS, BINDERS, COLLATORS, CORRECTING FLUID FOR TYPE, STAPLERS, GLUE, INK ROLLERS, INKING PADS, TYPEWRITER RIBBONS, DOCUMENT FILES AND FOLDERS, THUMB TACKS, PAPER CLIP HOLDERS, RUBBER BANDS, OFFICE PUNCHES, PAPER KNIVES; INSTRUCTIONAL AND TEACHING MATERIAL, EXCEPT APPARATUS IN THE FIELDS OF ART, GEOGRAPHY, MATHEMATICS, COMPUTING SCIENCE, CHEMISTRY, PHYSICS AND HISTORY; PRINTING BLOCKS; NEWSPAPERS; EDUCATIONAL BOOKS AND PUBLICATIONS IN THE FIELD OF ART, EDUCATION, GEOGRAPHY, MATHEMATICS, COMPUTING SCIENCE, CHEMISTRY, PHYSICS OR HISTORY; PUBLICATIONS, NAMELY, CATALOGS, NEWSPAPERS AND BOOKS IN THE FIELD OF ART, GEOGRAPHY, TRAVEL, HISTORY, SCIENCE, LEISURE, SPORTS, CULTURE AND POLITICS (U.S. CLS. 2, 5, 22, 23, 29, 37, 38 AND 50).

JONATHAN FALK, EXAMINING ATTORNEY

**CLASS 16—(Continued).**

SN 79-142,624. SAPPI EUROPE S.A., BRUSSELS, BELGIUM, FILED 10-24-2013.

# GALERIE

THE MARK CONSISTS OF STANDARD CHARACTERS WITHOUT CLAIM TO ANY PARTICULAR FONT, STYLE, SIZE, OR COLOR.

OWNER OF INTERNATIONAL REGISTRATION 0818672 DATED 9-24-2003, EXPIRES 9-24-2023.

OWNER OF U.S. REG. NO. 3,348,038.

THE ENGLISH TRANSLATION OF "GALERIE" IN THE MARK IS "GALLERY".

FOR UNPRINTED PRINTING PAPER (U.S. CLS. 2, 5, 22, 23, 29, 37, 38 AND 50).

MICHAEL WEBSTER, EXAMINING ATTORNEY

**CLASS 16—(Continued).**

SN 79-145,770. MYLAN GROUP, VIETNAM, FILED 2-11-2014.



PRIORITY DATE OF 11-19-2013 IS CLAIMED. OWNER OF INTERNATIONAL REGISTRATION 1199916 DATED 2-11-2014, EXPIRES 2-11-2024.

NO CLAIM IS MADE TO THE EXCLUSIVE RIGHT TO USE "HIGH BARRIER FILMS FOR HEALTHCARE PRODUCTS", APART FROM THE MARK AS SHOWN.

THE COLOR(S) GREEN AND DARK GREEN IS/ARE CLAIMED AS A FEATURE OF THE MARK.

THE MARK CONSISTS OF THE STYLIZED TEXT "PHARMECOPAK" INCLUDING "PHARM" IN DARK GREEN, "ECOPAK" IN GREEN, OVER THE TEXT "HIGH BARRIER FILMS FOR HEALTHCARE PRODUCTS" IN DARK GREEN AND TWO STYLIZED CURVED SHAPES IN GREEN AND DARK GREEN LOCATED ABOVE THE TEXT "ECOP".

FOR LAMINATED HIGH BARRIER MULTI-LAYER PLASTIC FILMS FOR PACKAGING OF PHARMACEUTICAL PRODUCTS (U.S. CLS. 2, 5, 22, 23, 29, 37, 38 AND 50).

MICHELLE DUBOIS, EXAMINING ATTORNEY

SN 79-143,845. MYLAN GROUP, VIETNAM, FILED 8-15-2013.



PRIORITY DATE OF 7-25-2013 IS CLAIMED. OWNER OF INTERNATIONAL REGISTRATION 1195260 DATED 8-15-2013, EXPIRES 8-15-2023.

NO CLAIM IS MADE TO THE EXCLUSIVE RIGHT TO USE "HIGH BARRIER FILMS", APART FROM THE MARK AS SHOWN.

THE COLOR(S) GREEN AND DARK GREEN IS/ARE CLAIMED AS A FEATURE OF THE MARK.

THE MARK CONSISTS OF THE STYLIZED TEXT "PLECOPAK" INCLUDING "PL" AND "PAK" IN DARK GREEN, "ECO" IN GREEN OVER THE TEXT "HIGH BARRIER FILMS" IN GREEN AND TWO STYLIZED CURVED SHAPES IN GREEN AND DARK GREEN LOCATED ABOVE THE TEXT "ECOP".

FOR HIGH BARRIER PLASTIC FILMS FOR PACKAGING FOOD AND PHARMACEUTICAL PRODUCTS, MADE OF COEXTRUDED POLYPROPYLENE-BASED TIE-LAYERS ETBYRULENE-VINYL ALCOHOL COPOLYMER (PP/TIE/EVOH/TIE/PP) (U.S. CLS. 2, 5, 22, 23, 29, 37, 38 AND 50).

MARGARET POWER, EXAMINING ATTORNEY

SN 79-145,960. NINGBO ZHENHAI CHENGDI STATIONERY CO., LTD., NINGBO CITY ZHEJIANG PROVINCE, CHINA, FILED 2-7-2014.



PRIORITY DATE OF 8-21-2013 IS CLAIMED. OWNER OF INTERNATIONAL REGISTRATION 1200422 DATED 2-7-2014, EXPIRES 2-7-2024.

THE MARK CONSISTS OF THE STYLIZED LETTERS "CD" BEHIND SIX FEMALE CARTOON CHARACTERS DISPLAYED IN VARIOUS POSES.

FOR SCRAPBOOKS; WRITING BOOKS; DRAWING BOOKS; WRITING TABLETS; PAINTINGS; FRAMED OR UNFRAMED PICTURES; BOXES OF CARDBOARD OR PAPER; BOOKBINDING MATERIALS; DOCUMENT FILES; STATIONERY; PENCILS; STICKERS; DRAWING MATERIALS, NAMELY, PENS, PENCILS, CHALK (U.S. CLS. 2, 5, 22, 23, 29, 37, 38 AND 50).

GEOFFREY FOSDICK, EXAMINING ATTORNEY

**CLASS 16—(Continued).**

SN 85-229,063. OILILY WORLD B.V., 1861 CM BERGEN, NETHERLANDS, FILED 1-28-2011.



OWNER OF ERPN CMNTY TM OFC REG. NO. 001052836, DATED 6-14-2000, EXPIRES 1-25-2019.

OWNER OF U.S. REG. NOS. 1,630,912, 1,665,617 AND 3,627,136.

THE MARK CONSISTS OF A DIAMOND DESIGN WITH THE STYLIZED WORD "OILILY" INSIDE.

FOR NOTEBOOKS, COMPOSITION BOOKS, DIARIES, BLANK JOURNALS, ADDRESS BOOKS, AGENDAS, BINDERS, FOLDERS, DAY PLANNERS, ADHESIVE NOTE PADS, WRITING PAPER, POST CARDS, NOTE CARDS, FILLER PAPER, STATIONERY SHEETS, ENVELOPES, ENVELOPE SEALS, NOTEPADS, DESK PADS, POSTERS, PENS, PENCILS, MARKERS, HIGHLIGHTER PENS, PENCIL CASES, BOOK COVERS, BOOKMARKS, ERASERS, PENCIL SHARPENERS, DRAWING RULERS, ADHESIVE TAPES FOR STATIONERY PURPOSES, ADHESIVE TAPE DISPENSERS; STAPLERS, PAPER HOLE PUNCHES, INK STAMPS, GLUE FOR STATIONERY OR HOUSEHOLD USE, GLUE STICKS FOR STATIONERY OR HOUSEHOLD USE, STICKERS, TEMPORARY TATTOOS, DRY ERASE WRITING BOARDS AND WRITING SURFACES, MEMORANDUM BOARDS, PHOTO ALBUMS, PHOTO STANDS, NAMELY, CLIPS TO HOLD PHOTOS, PHOTO STORAGE BOXES, DESK ACCESSORIES, NAMELY, BLOTTERS, PENCIL CUPS, ORGANIZERS; DESK PADS, ORGANIZER FILE FOLDERS, EXPANDABLE FILE FOLDERS, FILE BOXES FOR STORAGE OF BUSINESS AND PERSONAL RECORD, FILE BOXES FOR STORAGE OF MAGAZINES, LAP DESKS (U.S. CLS. 2, 5, 22, 23, 29, 37, 38 AND 50).

TAMARA FRAZIER, EXAMINING ATTORNEY

SN 85-408,469. GOLDEN GATE PAPER COMPANY, INC., CALEXICO, CA. FILED 8-26-2011.

## JAZMIN

THE MARK CONSISTS OF STANDARD CHARACTERS WITHOUT CLAIM TO ANY PARTICULAR FONT, STYLE, SIZE, OR COLOR.

FOR BATHROOM TISSUE; DISPOSABLE NAPKINS; HAND TOWELS OF PAPER; NAPKIN PAPER; NAPKINS OF PAPER FOR REMOVING MAKE-UP; PAPER HANDTOWELS; PAPER NAPKINS; PAPER TOWELS; TABLE NAPKINS OF PAPER; TOILET PAPER; TOILET SEAT COVER PAPER; TOILET TISSUE (U.S. CLS. 2, 5, 22, 23, 29, 37, 38 AND 50).

YAT SYE, LEE, EXAMINING ATTORNEY

**CLASS 16—(Continued).**

SN 85-481,748. PROSPER, INC., PROVO, UT. FILED 11-28-2011.

## PROSPERING

THE MARK CONSISTS OF STANDARD CHARACTERS WITHOUT CLAIM TO ANY PARTICULAR FONT, STYLE, SIZE, OR COLOR.

OWNER OF U.S. REG. NOS. 3,113,045, 3,688,384 AND OTHERS.

FOR PUBLICATIONS, NAMELY, BOOKS, BOOKLETS, MANUALS, WORKBOOKS, INSTRUCTOR MANUALS, NEWSLETTERS, PERIODICALS, PAPER AND TRANSPARENCY DOCUMENTS FOR DISPLAY BY OVER-HEAD PROJECTOR, CHARTS, TABLES AND HANDOUTS, ALL IN THE FIELDS OF BUSINESS AND INVESTING, INCLUDING ECOMMERCE, REALESTATE INVESTING, STOCK MARKET INVESTING, PERSONAL FINANCES, AND SMALL BUSINESS (U.S. CLS. 2, 5, 22, 23, 29, 37, 38 AND 50).

LINDA ESTRADA, EXAMINING ATTORNEY

SN 85-646,667. NEWPAGE CORPORATION, MIAMISBURG, OH. FILED 6-8-2012.

## FUTURA

THE MARK CONSISTS OF STANDARD CHARACTERS WITHOUT CLAIM TO ANY PARTICULAR FONT, STYLE, SIZE, OR COLOR.

OWNER OF U.S. REG. NO. 1,706,723.

THE ENGLISH TRANSLATION OF "FUTURA" IN THE MARK IS "FUTURE".

FOR COMMERCIAL PRINTING PAPERS (U.S. CLS. 2, 5, 22, 23, 29, 37, 38 AND 50).

FIRST USE 9-24-1991; IN COMMERCE 9-24-1991.

MICHAEL TANNER, EXAMINING ATTORNEY

SN 85-683,063. HARRIS PUBLICATIONS, INC., NEW YORK, NY. FILED 7-20-2012.

## DOG NEWS

THE MARK CONSISTS OF STANDARD CHARACTERS WITHOUT CLAIM TO ANY PARTICULAR FONT, STYLE, SIZE, OR COLOR.

NO CLAIM IS MADE TO THE EXCLUSIVE RIGHT TO USE "NEWS", APART FROM THE MARK AS SHOWN. SEC. 2(F).

FOR MAGAZINES IN THE FIELD OF DOGS, DOG SHOWS, DOG COMPETITIONS, DOG BREEDS, AND DOG TRAINING (U.S. CLS. 2, 5, 22, 23, 29, 37, 38 AND 50).

FIRST USE 2-0-1985; IN COMMERCE 2-0-1985.

ANTHONY RINKER, EXAMINING ATTORNEY

**CLASS 16—(Continued).**

SN 85-852,958. SINGAPORE MATH INC., WEST LINN, OR.  
FILED 2-18-2013.

## Essential Math

THE MARK CONSISTS OF STANDARD CHARACTERS WITHOUT CLAIM TO ANY PARTICULAR FONT, STYLE, SIZE, OR COLOR.

NO CLAIM IS MADE TO THE EXCLUSIVE RIGHT TO USE "MATH", APART FROM THE MARK AS SHOWN.  
SEC. 2(F).

FOR EDUCATIONAL PUBLICATIONS, NAMELY, EDUCATIONAL LEARNING CARDS, FLASH CARDS, ACTIVITY CARDS, WORKBOOKS, TEXTBOOKS, ACTIVITY BOOKS, STORY BOOKS, PUZZLE BOOKS, PRINTED PUZZLES, TEACHER GUIDES, MANUALS, POSTERS AND EDUCATIONAL BOOKLETS, ALL BASED ON THE SINGAPORE APPROACH TO EARLY CHILDHOOD EDUCATION IN MATHEMATICS (U.S. CLS. 2, 5, 22, 23, 29, 37, 38 AND 50).

FIRST USE 3-15-2007; IN COMMERCE 3-15-2007.  
LINDA ORNDORFF, EXAMINING ATTORNEY

---

SN 85-866,937. IRVING TISSUE CORPORATION, DIEPPE,  
NEW BRUNSWICK, CANADA, FILED 3-5-2013.



PRIORITY CLAIMED UNDER SEC. 44(D) ON CANADA APPLICATION NO. 1616018, FILED 2-27-2013, REG. NO. TMA878588, DATED 5-23-2014, EXPIRES 5-23-2029.

NO CLAIM IS MADE TO THE EXCLUSIVE RIGHT TO USE "FLUSH", APART FROM THE MARK AS SHOWN.

THE MARK CONSISTS OF A WATER DROP WITH THE WORDING "E-Z FLUSH" INSIDE THE WATER DROP. THE WATER DROP IS MISSING SOME OF THE DROP AT THE BOTTOM TO LOOK LIKE WATER.

FOR BATHROOM TISSUE (U.S. CLS. 2, 5, 22, 23, 29, 37, 38 AND 50).

ZACHARY R. SPARER, EXAMINING ATTORNEY

**CLASS 16—(Continued).**

SN 85-882,574. IRVING TISSUE CORPORATION, DIEPPE,  
NEW BRUNSWICK, CANADA, FILED 3-21-2013.



PRIORITY CLAIMED UNDER SEC. 44(D) ON CANADA APPLICATION NO. 1618232, FILED 3-14-2013, REG. NO. TMA880219, DATED 6-16-2014, EXPIRES 6-16-2029.

OWNER OF U.S. REG. NOS. 1,212,386 AND 4,326,513.  
THE COLOR(S) WHITE, DARK BLUE, AND LIGHT BLUE IS/ARE CLAIMED AS A FEATURE OF THE MARK.

THE MARK CONSISTS OF TWO WHITE KITTENS WITH LIGHT BLUE AND DARK BLUE EYES SURROUNDED ON TOP BY A LIGHT BLUE GLOW ABOVE THE STYLIZED WORDING "ROYALE" IN WHITE. THE KITTENS AND WORDING APPEARS ON A LARGE ROUNDED RECTANGLE IN DARK BLUE WHERE THE PERIMETER COLOR GRADUATES TO LIGHT BLUE IN THE MIDDLE OF THE RECTANGLE AROUND THE LETTER "Y" IN "ROYALE". THERE ARE TWO LIGHT BLUE CURVED BAR SHAPES MADE TO APPEAR BEHIND THE DARK BLUE ROUNDED RECTANGLE, ONE IN THE TOP RIGHT HAND CORNER OF THE RECTANGLE AND ONE IN THE BOTTOM LEFT HAND CORNER.

FOR BATHROOM TISSUE, FACIAL TISSUE, PAPER NAPKINS AND PAPER TOWELS (U.S. CLS. 2, 5, 22, 23, 29, 37, 38 AND 50).

ZACHARY R. SPARER, EXAMINING ATTORNEY

---

SN 85-936,571. MAYO FOUNDATION FOR MEDICAL EDUCATION AND RESEARCH, ROCHESTER, MN. FILED 5-20-2013.

## MAYO CLINIC HEALTHY LIVING

THE MARK CONSISTS OF STANDARD CHARACTERS WITHOUT CLAIM TO ANY PARTICULAR FONT, STYLE, SIZE, OR COLOR.

OWNER OF U.S. REG. NOS. 1,614,853, 2,856,450 AND OTHERS.

NO CLAIM IS MADE TO THE EXCLUSIVE RIGHT TO USE "HEALTHY LIVING", APART FROM THE MARK AS SHOWN.

SEC. 2(F) AS TO "CLINIC".

FOR PRINTED MATERIALS, NAMELY, BOOKS, JOURNALS, MAGAZINES, NEWSLETTERS, PAMPHLETS AND BROCHURES IN THE MEDICAL, HEALTH-CARE AND WELLNESS FIELDS (U.S. CLS. 2, 5, 22, 23, 29, 37, 38 AND 50).

DAVID YONTEF, EXAMINING ATTORNEY

**CLASS 16—(Continued).**

SN 86-035,669. NEW HOPE CHARITABLE FOUNDATION, DEL MAR, CA. FILED 8-12-2013.

**DRAWING OUT GENIUS**

THE MARK CONSISTS OF STANDARD CHARACTERS WITHOUT CLAIM TO ANY PARTICULAR FONT, STYLE, SIZE, OR COLOR.

FOR BLANK JOURNALS; BLANK PAPER NOTEBOOKS; BOOKMARKS; CALENDARS; DIARIES; EDUCATIONAL PUBLICATIONS, NAMELY, ACTIVITY CARDS, BOOKS, WRITTEN ARTICLES, WORKBOOKS, HANDOUTS, TEACHER'S GUIDES, STUDY GUIDES, NEWSLETTERS AND MANUALS IN THE FIELDS OF FICTIONAL STORIES, PARENTING SKILLS, CLASSROOM MANAGEMENT, SETTING CHILDREN UP FOR SUCCESS, IMPROVING LEARNING, CORE SUBJECT REMEDIATION, FACTORS AND SKILLS FOR SUCCESSFUL LEARNING, CHILD, YOUTH, TEEN, AND YOUNG ADULT CULTURE, CAREER EXPLORATION AND OPPORTUNITY, INTEREST EXPLORATION AND OPPORTUNITIES, SELF-AWARENESS, COMMUNITY AWARENESS, LEADERSHIP, TEAM WORK, CLEAR COMMUNICATION, SELF-RESPECT AND RESPECT FOR OTHERS, CONFIDENCE, AND GOAL SETTING AND ACHIEVEMENT; ERASERS; FOLDERS; NOTE CARDS; NOTEBOOK PAPER; NOTEBOOKS; PAPER; PAPER FOLDERS; PEN AND PENCIL CASES; PEN AND PENCIL CASES AND BOXES; PEN OR PENCIL HOLDERS; PENCIL OR PEN BOXES; PENCILS; PENS; POSTERS; STATIONERY WRITING PAPER AND ENVELOPES; WRITING PAPER; WRITING PAPER PADS (U.S. CLS. 2, 5, 22, 23, 29, 37, 38 AND 50).

KATHLEEN M. VANSTON, EXAMINING ATTORNEY

SN 86-043,479. KIRAN INTERNATIONAL LLC, DBA TARANG KIDS, CHANDLER, AZ. FILED 8-21-2013.



NO CLAIM IS MADE TO THE EXCLUSIVE RIGHT TO USE "A MAGAZINE FOR CHILDREN", APART FROM THE MARK AS SHOWN.

THE COLOR(S) BLACK, YELLOW, TEAL, FUCHSIA, GREEN, PURPLE, BROWN, RED, WHITE, ORANGE, BLUE, AND GRAY IS/ARE CLAIMED AS A FEATURE OF THE MARK.

THE WORDING "LEARN WITH FUN" IN YELLOW SMALL LETTERS WITH A BLACK OUTLINE ON THE TOP OF THE MARK ABOVE THE WORD "TARANG", WHICH IS WRITTEN WITH EACH LETTER ON A COLORED POSTER BOARD WITH A BLACK SHADOW. THE LETTER "T" IS IN WHITE ON A TEAL BACKGROUND, THE LETTER "A" IS IN WHITE ON A FUCHSIA BACKGROUND, THE LETTER "R" IS IN WHITE ON A GREEN BACKGROUND, THE LETTER "A" IS IN WHITE ON A PURPLE BACKGROUND, THE LETTER "N" IS IN WHITE ON A FUCHSIA BACKGROUND AND THE LETTER "G" IS IN WHITE ON A BROWN BACKGROUND. ON LETTER "N" IS A PEACOCK DRAWN IN COMIC FORM WITH MULTICOLORED WINGS AND LOOKING AT THE READER. THE PEACOCK ON THE LETTER "N" HAS A BLUE BODY

**CLASS 16—(Continued).**

OUTLINED IN BLACK WITH ORANGE FEET AND NOSE, WHITE EYES OUTLINED IN BLACK, BLACK EYEBALLS, AND RED EARS, WITH WINGS IN GRAY, GREEN, RED, BLUE, YELLOW, FUCHSIA, PURPLE, ORANGE AND TEAL, AND ALL WINGS FEATURING A YELLOW DOT WITH A BLACK OUTLINE. THE WORD "TARANG" IS BORDERED WITH PATCH OF YELLOW COLOR IN ABSTRACT FORM RESEMBLING SPILLED PAINT. "A MAGAZINE FOR CHILDREN" IS WRITTEN BELOW "TARANG" IN CAPITAL BLACK LETTERS.

THE ENGLISH TRANSLATION OF "TARANG" IN THE MARK IS "WAVE".

FOR GENERAL FEATURE MAGAZINE IN THE FIELD OF CHILDREN'S INTEREST SUCH AS STORIES, ESSAYS FOR CHILDREN AGE 6 YRS THRU 12 YRS (U.S. CLS. 2, 5, 22, 23, 29, 37, 38 AND 50).

ALISON POLLACK, EXAMINING ATTORNEY

SN 86-048,867. AMERICAN GIRL, LLC, EL SEGUNDO, CA. FILED 8-27-2013.

**TRULY ME**

THE MARK CONSISTS OF STANDARD CHARACTERS WITHOUT CLAIM TO ANY PARTICULAR FONT, STYLE, SIZE, OR COLOR.

OWNER OF U.S. REG. NO. 3,406,707.

FOR CHILDREN'S BOOKS, BOOKS FEATURING HISTORICAL FICTION, COLORING BOOKS, ADDRESS BOOKS, ACTIVITY BOOKS AND CRAFT BOOKS, DIARIES, BOOKMARKS, STATIONERY, DRAWING PADS, WRITING UTENSILS, GREETING CARDS, PERSONAL ORGANIZERS, PAPER PARTY BAGS, PAPER PARTY DECORATIONS (U.S. CLS. 2, 5, 22, 23, 29, 37, 38 AND 50).

MICHELE SWAIN, EXAMINING ATTORNEY

SN 86-050,597. PRINTINGFORLESS.COM, INC., LIVINGSTON, MT. FILED 8-28-2013.

**SMARTFLEX**

THE MARK CONSISTS OF STANDARD CHARACTERS WITHOUT CLAIM TO ANY PARTICULAR FONT, STYLE, SIZE, OR COLOR.

FOR PLASTIC SUBSTRATE STOCK PRINTING PAPER (U.S. CLS. 2, 5, 22, 23, 29, 37, 38 AND 50).

FIRST USE 8-26-2013; IN COMMERCE 8-26-2013.

EUGENIA MARTIN, EXAMINING ATTORNEY



**CLASS 16—(Continued).**

SN 86-056,540. CQ-ROLL CALL, INC., WASHINGTON, DC. FILED 9-5-2013.

**Roll Call The Source For  
News On Capitol Hill Since  
1955**

THE MARK CONSISTS OF STANDARD CHARACTERS WITHOUT CLAIM TO ANY PARTICULAR FONT, STYLE, SIZE, OR COLOR.

OWNER OF U.S. REG. NOS. 1,790,391, 1,791,611 AND 1,791,614.

NO CLAIM IS MADE TO THE EXCLUSIVE RIGHT TO USE "THE SOURCE FOR NEWS ON CAPITOL HILL SINCE 1955", APART FROM THE MARK AS SHOWN.

FOR NEWSPAPER REPORTING ON THE LEGISLATIVE AND POLITICAL ACTIVITIES OF CONGRESS, MEMBERS OF CONGRESS AND THEIR CAMPAIGNS, CONGRESSIONAL EMPLOYEES, AND OTHER MATTERS OF INTEREST TO PEOPLE WHO WORK OR LIVE ON CAPITOL HILL (U.S. CLS. 2, 5, 22, 23, 29, 37, 38 AND 50).

FIRST USE 11-13-2012; IN COMMERCE 11-13-2012.  
LINDA QUIGLEY, EXAMINING ATTORNEY

SN 86-060,693. HEARTLAND COMMUNICATIONS GROUP, INC., FORT DODGE, IA. FILED 9-10-2013.

**AMERICAN DAIRYMEN**

THE MARK CONSISTS OF STANDARD CHARACTERS WITHOUT CLAIM TO ANY PARTICULAR FONT, STYLE, SIZE, OR COLOR.

SEC. 2(F).

FOR TRADE PUBLICATION, NAMELY, A MAGAZINE DEDICATED TO THE BUSINESS OF COW-CALF PRODUCERS (U.S. CLS. 2, 5, 22, 23, 29, 37, 38 AND 50).

FIRST USE 5-5-2008; IN COMMERCE 5-5-2008.  
SUSAN RICHARDS, EXAMINING ATTORNEY

SN 86-070,127. GREEN PURPOSE, LLC, CHAMPAIGN, IL. FILED 9-20-2013.

**GREEN-O-GRAM**

THE MARK CONSISTS OF STANDARD CHARACTERS WITHOUT CLAIM TO ANY PARTICULAR FONT, STYLE, SIZE, OR COLOR.

FOR GRAPHIC ART PRINTS; POSTERS; PRINTED EDUCATIONAL MATERIALS IN THE FIELD OF RECYCLING AND ENVIRONMENTAL SUSTAINABILITY; PRINTED PAPER LABELS (U.S. CLS. 2, 5, 22, 23, 29, 37, 38 AND 50).

FIRST USE 5-4-2013; IN COMMERCE 5-4-2013.  
MATTHEW GALAN, EXAMINING ATTORNEY

**CLASS 16—(Continued).**

SN 86-072,441. STRATEGIC PARTNERS, INC., CHATSWORTH, CA. FILED 9-23-2013.

**Curo**

THE MARK CONSISTS OF STANDARD CHARACTERS WITHOUT CLAIM TO ANY PARTICULAR FONT, STYLE, SIZE, OR COLOR.

THE ENGLISH TRANSLATION OF "CURO" IN THE MARK IS "TO HEAL".

FOR PENS; POCKET PEN SHIELDS; POCKET SECRETARIES (U.S. CLS. 2, 5, 22, 23, 29, 37, 38 AND 50).

DANNEAN HETZEL, EXAMINING ATTORNEY

SN 86-072,817. CHAPMAN PHARMACEUTICAL CONSULTING, INC., MITCHELLVILLE, MD. FILED 9-24-2013.

**LOIS MAILOU JONES**

THE MARK CONSISTS OF STANDARD CHARACTERS WITHOUT CLAIM TO ANY PARTICULAR FONT, STYLE, SIZE, OR COLOR.

THE NAME(S), PORTRAIT(S), AND/OR SIGNATURE(S) SHOWN IN THE MARK DOES NOT IDENTIFY A PARTICULAR LIVING INDIVIDUAL.

FOR PAINTINGS; PAINTINGS IN MIXED MEDIA; ART PICTURES; ART PRINTS; GRAPHIC ART PRINTS; GRAPHIC ART REPRODUCTIONS; SERIOGRAPHS; NOTE CARDS; AND POSTERS (U.S. CLS. 2, 5, 22, 23, 29, 37, 38 AND 50).

FIRST USE 1-1-2006; IN COMMERCE 8-1-2006.  
DEIRDRE ROBERTSON, EXAMINING ATTORNEY

SN 86-073,431. WINDY HILL SPIRITS, INC., NASHVILLE, TN. FILED 9-24-2013.

**KNOWN BOOTLEGGERS**

THE MARK CONSISTS OF STANDARD CHARACTERS WITHOUT CLAIM TO ANY PARTICULAR FONT, STYLE, SIZE, OR COLOR.

FOR POSTERS (U.S. CLS. 2, 5, 22, 23, 29, 37, 38 AND 50).

SANI KHOURI, EXAMINING ATTORNEY



**CLASS 16—(Continued).**

SN 86-074,746. PR II COCO PALMS LLC, MADISON, NJ. FILED 9-25-2013.

**COCO PALMS**

THE MARK CONSISTS OF STANDARD CHARACTERS WITHOUT CLAIM TO ANY PARTICULAR FONT, STYLE, SIZE, OR COLOR.

FOR GIFT CARDS, NAMELY, PAPER GIFT CARDS AND NON-MAGNETICALLY ENCODED GIFT CARDS; PENS; STATIONERY; PRINTED MATERIALS, NAMELY, PAMPHLETS, BROCHURES, NEWSLETTERS, AND MAGAZINES IN THE FIELD OF HOSPITALITY, ENTERTAINMENT, AND RECREATIONAL SERVICES; NOTE PADS; PAPER NAPKINS; TOILET PAPER; AND PAPER TOWELS (U.S. CLS. 2, 5, 22, 23, 29, 37, 38 AND 50).  
BRENDAN MCCAULEY, EXAMINING ATTORNEY

---

SN 86-083,175. JOSEPH CAMPBELL FOUNDATION, SAN ANSELMO, CA. FILED 10-4-2013.

**HERO'S JOURNEY**

THE MARK CONSISTS OF STANDARD CHARACTERS WITHOUT CLAIM TO ANY PARTICULAR FONT, STYLE, SIZE, OR COLOR.

FOR PRINTED MATTER, NAMELY, BLANK JOURNALS, GREETING CARDS, NOTE CARDS, AND POSTCARDS (U.S. CLS. 2, 5, 22, 23, 29, 37, 38 AND 50).  
RENEE MCCRAY, EXAMINING ATTORNEY

---

SN 86-083,345. K M MOONEY PROD., INC., ELLENTON, FL. FILED 10-4-2013.

**KMARIE**

THE MARK CONSISTS OF STANDARD CHARACTERS WITHOUT CLAIM TO ANY PARTICULAR FONT, STYLE, SIZE, OR COLOR.

THE NAME(S), PORTRAIT(S), AND/OR SIGNATURE(S) SHOWN IN THE MARK IDENTIFIES KELSEY MARIE MOONEY, WHOSE CONSENT(S) TO REGISTER IS MADE OF RECORD.

FOR BOOKS IN THE FIELD OF MUSIC, MOTION PICTURES, MUSICAL PERFORMERS; PHOTOGRAPHS; POSTERS; STICKERS; PRINT MATERIALS, NAMELY, ART PRINTS, COLOR PRINTS, CONCERT EVENT PROGRAMS, CALENDARS, PENS, POST CARDS; GIFT BAGS; PAPER FLAGS; TRADING CARDS (U.S. CLS. 2, 5, 22, 23, 29, 37, 38 AND 50).  
KAMAL PREET, EXAMINING ATTORNEY

**CLASS 16—(Continued).**

SN 86-085,724. EXPRESSTECH INTERNATIONAL, LLC, OREM, UT. FILED 10-8-2013.

**THE 7 NON-NEGOTIABLES OF WINNING**

THE MARK CONSISTS OF STANDARD CHARACTERS WITHOUT CLAIM TO ANY PARTICULAR FONT, STYLE, SIZE, OR COLOR.

FOR PUBLICATIONS, NAMELY, BOOKS, WORKBOOKS, TRAINING MANUALS, FACILITATOR WORKBOOKS AND PRINTED GUIDES, PAPER AND PLASTIC TRANSPARENCIES, PRINTED CHARTS, PRINTED TABLES, DIAGRAMS, HANDOUTS, PRINTED PERIODICALS, AND NEWSLETTERS ALL IN THE FIELDS OF BUILDING INDIVIDUAL AND BUSINESS ORGANIZATIONAL SKILLS, LEADERSHIP, CULTURE, EFFECTIVENESS AND GROWTH, FOCUSED ON THE PRINCIPLES OF RESPECT, BELIEF, TRUST, LOYALTY, COMMITMENT, COURAGE AND GRATITUDE (U.S. CLS. 2, 5, 22, 23, 29, 37, 38 AND 50).

FIRST USE 8-31-2013; IN COMMERCE 8-31-2013.  
COLLEEN DOMBROW, EXAMINING ATTORNEY

---

SN 86-091,954. CARON ORY, FOUNTAIN VALLEY, CA. FILED 10-15-2013.

**Kitchenpreneur**

THE MARK CONSISTS OF STANDARD CHARACTERS WITHOUT CLAIM TO ANY PARTICULAR FONT, STYLE, SIZE, OR COLOR.

FOR A SERIES OF HANDOUTS AND WORKSHEETS IN THE FIELD OF CULINARY ARTS AND BUSINESS (U.S. CLS. 2, 5, 22, 23, 29, 37, 38 AND 50).

FIRST USE 3-2-2013; IN COMMERCE 3-2-2013.  
YAT SYE, LEE, EXAMINING ATTORNEY

**CLASS 16—(Continued).**

SN 86-098,085. AVENINGO, SHAWN E, BEAVERTON, OR.  
FILED 10-22-2013.

## The Poetry Box

THE MARK CONSISTS OF STANDARD CHARACTERS WITHOUT CLAIM TO ANY PARTICULAR FONT, STYLE, SIZE, OR COLOR.

NO CLAIM IS MADE TO THE EXCLUSIVE RIGHT TO USE "POETRY", APART FROM THE MARK AS SHOWN.

FOR ART PRINTS; ART PRINTS COMPRISED OF DIGITAL ILLUSTRATIONS ORIGINATING FROM PHOTOGRAPHS; ART PRINTS ON CANVAS; CARDS BEARING UNIVERSAL GREETINGS; CHRISTMAS CARDS; FRAMED ART PICTURES; FRAMED ART PRINTS; FRAMED GRAPHIC ART REPRODUCTIONS; GIFT BOOKS FEATURING POETRY; GIFT BOXES CONTAINING NOTE CARDS; GREETING CARDS; GREETINGS CARDS AND POSTCARDS; HOLIDAY CARDS; INVITATION CARDS; MOTIVATIONAL CARDS; NOTE CARDS; OCCASION CARDS; PHOTOGRAPHIC PRINTS; PICTURE BOOKS; PICTURE CARDS; PLACE CARDS; POST CARDS; POSTCARDS AND GREETING CARDS; PRINTED ART REPRODUCTIONS; PRINTED CALENDARS; PRINTS; SERIES OF FICTION WORKS, NAMELY, NOVELS AND BOOKS (U.S. CLS. 2, 5, 22, 23, 29, 37, 38 AND 50).

FIRST USE 0-0-2011; IN COMMERCE 0-0-2011.  
SUSAN STIGLITZ, EXAMINING ATTORNEY

SN 86-099,992. SYNCODE, INC., SPRINGBORO, OH. FILED  
10-24-2013.

## SYN-SYN

THE MARK CONSISTS OF STANDARD CHARACTERS WITHOUT CLAIM TO ANY PARTICULAR FONT, STYLE, SIZE, OR COLOR.

FOR PRINTED WORD PUZZLES (U.S. CLS. 2, 5, 22, 23, 29, 37, 38 AND 50).

KATHERINE CONNOLLY, EXAMINING ATTORNEY

**CLASS 16—(Continued).**

SN 86-105,801. SHURTECH BRANDS, LLC, HICKORY, NC.  
FILED 10-30-2013.

## EXPRESS DECOR

THE MARK CONSISTS OF STANDARD CHARACTERS WITHOUT CLAIM TO ANY PARTICULAR FONT, STYLE, SIZE, OR COLOR.

NO CLAIM IS MADE TO THE EXCLUSIVE RIGHT TO USE "DECOR", APART FROM THE MARK AS SHOWN.

FOR ELONGATED STRIP TAPE HAVING A DECORATIVE OUTER FACE WITH A LOW-TACK REUSABLE ADHESIVE BACKING FOR HOME DECORATING USES ON WALLS, FURNITURE AND HOUSEHOLD ITEMS (U.S. CLS. 2, 5, 22, 23, 29, 37, 38 AND 50).

PRISCILLA MILTON, EXAMINING ATTORNEY

SN 86-109,587. REAL EYED LLC, SUFFERN, NY. FILED 11-  
4-2013.

## Real EyeD

THE MARK CONSISTS OF STANDARD CHARACTERS WITHOUT CLAIM TO ANY PARTICULAR FONT, STYLE, SIZE, OR COLOR.

NO CLAIM IS MADE TO THE EXCLUSIVE RIGHT TO USE "REAL", APART FROM THE MARK AS SHOWN.

FOR AN ADHESIVE STICKERS USED FOR ATTACHING TO PRODUCTS AND SCANNING TO DETERMINE WHETHER THE PRODUCT IS AUTHENTIC (U.S. CLS. 2, 5, 22, 23, 29, 37, 38 AND 50).

GINA FINK, EXAMINING ATTORNEY

SN 86-115,906. NATIONAL ASSOCIATION OF CRIMINAL  
DEFENSE LAWYERS, WASHINGTON, DC. FILED 11-11-  
2013.

## NACDL PRESS

THE MARK CONSISTS OF STANDARD CHARACTERS WITHOUT CLAIM TO ANY PARTICULAR FONT, STYLE, SIZE, OR COLOR.

NO CLAIM IS MADE TO THE EXCLUSIVE RIGHT TO USE "PRESS", APART FROM THE MARK AS SHOWN.

FOR BOOKS IN THE FIELD OF CRIMINAL DEFENSE LAW (U.S. CLS. 2, 5, 22, 23, 29, 37, 38 AND 50).

FIRST USE 7-17-2012; IN COMMERCE 7-17-2012.

JULIE VEPPUMTHARA, EXAMINING ATTORNEY

**CLASS 16—(Continued).**

SN 86-134,058. GUANGZHOU NEWLIFE MAGNET ELECTRICITY CO., LTD. GUANGZHOU, CHINA, FILED 12-3-2013.

# CLING-KING

THE MARK CONSISTS OF STANDARD CHARACTERS WITHOUT CLAIM TO ANY PARTICULAR FONT, STYLE, SIZE, OR COLOR.

FOR PRINTED MEDIA ON SUCTION CLING, NAMELY, CUSTOMIZABLE PRINTED GRAPHICS AND SIGNS, AS WELL AS PRINTED ADVERTISING AND PROMOTIONAL PRODUCTS (U.S. CLS. 2, 5, 22, 23, 37, 38 AND 50).

FIRST USE 10-1-2013; IN COMMERCE 10-1-2013.  
REBECCA POVARCHUK, EXAMINING ATTORNEY

**CLASS 16—(Continued).**

SN 86-148,844. KIND DESIGN LLC, BOULDER, CO. FILED 12-19-2013.



THE MARK CONSISTS OF A LIGHT COLORED SNOWFLAKE INSIDE A DARKER RAINDROP WITHIN A DARK RECTANGLE.

FOR STICKERS; DECALS; CALENDARS; PRINTED MATTER, NAMELY, PAPER SIGNS, MANUALS, NEWSLETTERS, INFORMATIONAL CARDS AND BROCHURES IN THE FIELDS OF FASHION, SPORTS AND ECOLOGY; PRINTED EMBLEMS, FORMS AND INVITATIONS (U.S. CLS. 2, 5, 22, 23, 29, 37, 38 AND 50).

IRA J. GOODSAD, EXAMINING ATTORNEY

SN 86-136,646. VESTCOM NEW CENTURY, LLC, LITTLE ROCK, AR. FILED 12-6-2013.

# STACKZ

THE MARK CONSISTS OF STANDARD CHARACTERS WITHOUT CLAIM TO ANY PARTICULAR FONT, STYLE, SIZE, OR COLOR.

FOR PRINTED PAPER LABELS FEATURING PRODUCT INFORMATION FOR RETAILERS, NOT BEING STICKERS; POINT-OF-PURCHASE DISPLAY CARDS MADE OF PRESSURE SENSITIVE MATERIALS FOR RETAILERS, NOT BEING STICKERS (U.S. CLS. 2, 5, 22, 23, 29, 37, 38 AND 50).

FIRST USE 10-31-2013; IN COMMERCE 10-31-2013.  
REBECCA GILBERT, EXAMINING ATTORNEY

SN 86-150,533. BIZ SMART SERVICES LLP, BIRMINGHAM, AL. FILED 12-22-2013.

SN 86-145,963. TOWN OF TIOGA, TIOGA, FL. FILED 12-17-2013.

# Tioga Times

THE MARK CONSISTS OF STANDARD CHARACTERS WITHOUT CLAIM TO ANY PARTICULAR FONT, STYLE, SIZE, OR COLOR.

NO CLAIM IS MADE TO THE EXCLUSIVE RIGHT TO USE "TIOGA", APART FROM THE MARK AS SHOWN.

FOR MAGAZINES FEATURING COMMUNITY NEWS RELATING TO THE HOMEOWNERS' ASSOCIATION FOR TIOGA (U.S. CLS. 2, 5, 22, 23, 29, 37, 38 AND 50).

BERYL GARDNER, EXAMINING ATTORNEY

THE MARK CONSISTS OF THE STYLIZED WORDING "BIZSMARTSERVICES" IN SLIPSTREAM LET FONT. A LINE APPEARS ABOVE AND BELOW THE WORDING.

FOR BUSINESS CARD PAPER; BUSINESS CARDS; OFFICE PAPER STATIONERY; OFFICE STATIONERY; PAPER STATIONERY; PAPER STATIONERY WITH INSPIRATIONAL MESSAGES IMPRINTED THEREON; STATIONERY; STATIONERY WRITING PAPER AND ENVELOPES (U.S. CLS. 2, 5, 22, 23, 29, 37, 38 AND 50).

DAVID HOFFMAN, EXAMINING ATTORNEY

**CLASS 16—(Continued).**

SN 86-150,538. BIZ SMART SERVICES LLP, BIRMINGHAM, AL. FILED 12-22-2013.



THE MARK CONSISTS OF THE STYLIZED WORDING "BIZSMARTVOICE" IN SLIPSTREAM LET FONT. A LINE APPEARS ABOVE AND BELOW THE WORDING.

FOR BUSINESS CARD PAPER; BUSINESS CARDS; BUSINESS FORMS; OFFICE PAPER STATIONERY; OFFICE STATIONERY; PAPER STATIONERY; PAPER STATIONERY WITH INSPIRATIONAL MESSAGES IMPRINTED THEREON; STATIONERY; STATIONERY WRITING PAPER AND ENVELOPES (U.S. CLS. 2, 5, 22, 23, 29, 37, 38 AND 50).

DAVID HOFFMAN, EXAMINING ATTORNEY

**CLASS 16—(Continued).**

SN 86-154,700. QUADRANT DISTRIBUTION LLC, GLENDALE, CA. FILED 12-30-2013.



THE MARK CONSISTS OF STANDARD CHARACTERS WITHOUT CLAIM TO ANY PARTICULAR FONT, STYLE, SIZE, OR COLOR.

NO CLAIM IS MADE TO THE EXCLUSIVE RIGHT TO USE "MEXICO", APART FROM THE MARK AS SHOWN.

THE ENGLISH TRANSLATION OF "COMPA" IN THE MARK IS "BUDDY".

FOR TELEPHONE CALLING CARDS, NAMELY, PREPAID TELEPHONE CALLING CARDS, NOT MAGNETICALLY ENCODED (U.S. CLS. 2, 5, 22, 23, 29, 37, 38 AND 50).

FIRST USE 6-15-2009; IN COMMERCE 6-15-2009.  
ALISON POLLACK, EXAMINING ATTORNEY

SN 86-150,543. BIZ SMART SERVICES LLP, BIRMINGHAM, AL. FILED 12-22-2013.



THE MARK CONSISTS OF THE STYLIZED WORDING "BZSS" IN SLIPSTREAM LET FONT. A LINE APPEARS ABOVE AND BELOW THE WORDING.

FOR BUSINESS CARD PAPER; BUSINESS CARDS; BUSINESS FORMS; ENVELOPES FOR STATIONERY USE; OFFICE PAPER STATIONERY; OFFICE STATIONERY; PAPER STATIONERY; PAPER STATIONERY WITH INSPIRATIONAL MESSAGES IMPRINTED THEREON; STATIONERY; STATIONERY WRITING PAPER AND ENVELOPES (U.S. CLS. 2, 5, 22, 23, 29, 37, 38 AND 50).

DAVID HOFFMAN, EXAMINING ATTORNEY

SN 86-161,230. WORLD WATER BAG CO. LTD., OSAKA-SHI, OSAKA, JAPAN, FILED 1-9-2014.



OWNER OF JAPAN REG. NO. 56680034, DATED 5-9-2014, EXPIRES 5-9-2024.

NO CLAIM IS MADE TO THE EXCLUSIVE RIGHT TO USE "WATER" AND "BAG", APART FROM THE MARK AS SHOWN.

THE MARK CONSISTS OF THE WORDS "WORLD WATER PERFECT BAG" ON TOP OF THE THE INTERLOCKING LETTERS "WWPB".

FOR PLASTIC BAGS, NAMELY, BAGS FOR CARRYING AND PRESERVING LIQUIDS (U.S. CLS. 2, 5, 22, 23, 29, 37, 38 AND 50).

INGA ERVIN, EXAMINING ATTORNEY

**CLASS 16—(Continued).**

SN 86-167,563. PEANUTS WORLDWIDE LLC, NEW YORK, NY. FILED 1-16-2014.



OWNER OF U.S. REG. NOS. 1,256,900, 1,267,166 AND OTHERS.

THE MARK CONSISTS OF TWO PARTIALLY OBSCURED STYLIZED DOG FACES MOSTLY WITHIN A SQUARE WITH THE AMPERSAND SYMBOL BETWEEN THE DOG FACES, THE WORDING "SNOOPY" ALONG THE LEFT SIDE OF THE SQUARE, AND THE WORDING "HIS SISTER BELLE" ALONG THE RIGHT SIDE OF THE SQUARE.

FOR POSTERS, LITHOGRAPHS AND PRINTS; BOOK ENDS, PENCIL CUPS, PENS, PENCILS, ERASERS, DESK BLOTTERS, DRY ERASE BOARD, DRY ERASE MARKERS, MEMO BOARDS, BLANK BANK CHECKS, CHECKBOOK CASES, PRINTED INVITATIONS, TEMPORARY TATTOOS, COMIC STRIPS, COMIC BOOKS, RUBBER STAMPS, CRAYONS, HIGHLIGHTING MARKERS, MARKERS, NOTE BOOKS, NOTE PADS, NOTE CARDS, MEMO PADS, STATIONERY, ADHESIVE NOTE PADS, ADHESIVE TAPE DISPENSERS, ADHESIVE TAPES FOR STATIONERY PURPOSES, RUBBER BANDS, PAPER CLIPS, LOOSE-LEAF PAPER, FILE FOLDERS, PHOTO ALBUMS, DIARIES, ADDRESS BOOKS, GUEST BOOKS, TELEPHONE NUMBER BOOKS, BLANK JOURNALS, SCRAP BOOKS, THREE-RING BINDERS, DECALS, WALL DECALS, STICKERS, WALL STICKERS, BUMPER STICKERS, CALENDARS, IRON-ON HEAT TRANSFERS, PAPER GIFT TAGS, PAPER GIFT BAGS, PAPER SHOPPING BAGS, PAPER LUNCH BAGS, PAPER NAPKINS, PAPER GUEST TOWELS, BANNERS OF PAPER, BOOKMARKS, PATTERNS FOR SEWING, GIFT WRAP PAPER, GREETING CARDS, BOOKS FEATURING CARTOON CHARACTERS, COLORING BOOKS, CONSTRUCTION PAPER, PRINTED PAPER GROWTH CHARTS, PAPER NAME TAGS, GLUE STICKS FOR HOUSEHOLD USE, PAPER NAPKINS, PENCIL BOXES, PENCIL CASES, DRAWING RULERS, PLACE CARDS, WRITING TABLETS, BOOK COVERS, HOLIDAY DECORATIONS MADE OF PAPER, POST-CARDS, LUNCH BAGS OF TEXTILE, FACIAL TISSUE, TOILET PAPER, BIBS OF PAPER, TELEPHONE CALLING CARDS NOT MAGNETICALLY ENCODED; ARTISTS' MATERIALS, NAMELY, STENCILS, PAPER AND PAINT BRUSHES (U.S. CLS. 2, 5, 22, 23, 29, 37, 38 AND 50).

MIAH ROSENBERG, EXAMINING ATTORNEY

**CLASS 16—(Continued).**

SN 86-168,027. WRIGHT II, GARLAND, DBA GT ARTLAND, WARRINGTON, PA. FILED 1-16-2014.



THE COLOR(S) BLACK AND WHITE IS/ARE CLAIMED AS A FEATURE OF THE MARK.

THE MARK CONSISTS OF BLACK LETTERS "GT" OVER "ARTLAND" ON A CURVE WITH WHITE OUTLINING BOTH WORDS ON A WHITE BACKGROUND.

FOR ART PICTURES; ART PRINTS; CHILDREN'S WALL STICKERS AND MURALS; MURALS; POSTERS; SKETCHES (U.S. CLS. 2, 5, 22, 23, 29, 37, 38 AND 50).

BERNICE MIDDLETON, EXAMINING ATTORNEY

SN 86-197,983. PROVISUR TECHNOLOGIES, INC., MOKE-NA, IL. FILED 2-19-2014.

# ACCU NOTCH

THE MARK CONSISTS OF STANDARD CHARACTERS WITHOUT CLAIM TO ANY PARTICULAR FONT, STYLE, SIZE, OR COLOR.

FOR WAXED PAPER (U.S. CLS. 2, 5, 22, 23, 29, 37, 38 AND 50).

EDWARD NELSON, EXAMINING ATTORNEY

SN 86-198,778. ISCHOLAR, INC., EDGEWOOD, NY. FILED 2-20-2014.

# Hashtag

THE MARK CONSISTS OF STANDARD CHARACTERS WITHOUT CLAIM TO ANY PARTICULAR FONT, STYLE, SIZE, OR COLOR.

FOR BLANK PAPER NOTEBOOKS; FITTED FABRIC NOTEBOOK COVERS; NOTEBOOK COVERS; NOTEBOOK COVERS MADE OF POLY; NOTEBOOK DIVIDERS; NOTEBOOK PAPER; NOTEBOOKS; PAPER NOTEBOOKS; REPORTERS' NOTEBOOKS; SCHOOL SUPPLY KITS CONTAINING VARIOUS COMBINATIONS OF SELECTED SCHOOL SUPPLIES, NAMELY, WRITING INSTRUMENTS, PENS, PENCILS, MECHANICAL PENCILS, ERASERS, MARKERS, CRAYONS, HIGHLIGHTER PENS, FOLDERS, NOTEBOOKS, PAPER, PROTRACTORS, PAPER CLIPS, PENCIL SHARPENERS, WRITING GRIPS, GLUE AND BOOK MARKS; SPIRAL-BOUND NOTEBOOKS; STENOGRAPHERS' NOTEBOOKS; WIRE-BOUND NOTEBOOKS (U.S. CLS. 2, 5, 22, 23, 29, 37, 38 AND 50).

FIRST USE 8-10-2012; IN COMMERCE 8-10-2012.

GINA HAYES, EXAMINING ATTORNEY

**CLASS 16—(Continued).**

SN 86-201,955. OMAX CORPORATION, KENT, WA. FILED 2-24-2014.

**MAXIEM ABRASIVE WATERJETS**

THE MARK CONSISTS OF STANDARD CHARACTERS WITHOUT CLAIM TO ANY PARTICULAR FONT, STYLE, SIZE, OR COLOR.

OWNER OF U.S. REG. NOS. 3,826,092, 3,829,226 AND OTHERS.

NO CLAIM IS MADE TO THE EXCLUSIVE RIGHT TO USE "ABRASIVE WATERJETS", APART FROM THE MARK AS SHOWN.

FOR MANUALS IN THE FIELD OF OF INSTRUCTION FOR EXPLAINING THE OPERATION OF A TABLE MACHINE TOOL (U.S. CLS. 2, 5, 22, 23, 29, 37, 38 AND 50).

ALLISON HOLTZ, EXAMINING ATTORNEY

---

SN 86-201,958. OMAX CORPORATION, KENT, WA. FILED 2-24-2014.

**OMAX ABRASIVE WATERJETS**

THE MARK CONSISTS OF STANDARD CHARACTERS WITHOUT CLAIM TO ANY PARTICULAR FONT, STYLE, SIZE, OR COLOR.

OWNER OF U.S. REG. NOS. 1,992,387, 4,471,035 AND OTHERS.

NO CLAIM IS MADE TO THE EXCLUSIVE RIGHT TO USE "ABRASIVE WATERJETS", APART FROM THE MARK AS SHOWN.

FOR MANUALS IN THE FIELD OF OF INSTRUCTION FOR EXPLAINING THE OPERATION OF A TABLE MACHINE TOOL (U.S. CLS. 2, 5, 22, 23, 29, 37, 38 AND 50).

ALLISON HOLTZ, EXAMINING ATTORNEY

---

SN 86-202,402. WOLFE, NATALIE S., MISSION HILLS, KS. FILED 2-24-2014.

**ABC Blessing Book**

THE MARK CONSISTS OF STANDARD CHARACTERS WITHOUT CLAIM TO ANY PARTICULAR FONT, STYLE, SIZE, OR COLOR.

NO CLAIM IS MADE TO THE EXCLUSIVE RIGHT TO USE "BOOK", APART FROM THE MARK AS SHOWN.

FOR PRINTS AND PUBLICATIONS, NAMELY, A SERIES OF BOOKS, STUDY GUIDES, AND REMINDER CARDS DEALING WITH MATTERS OF SPIRITUAL AND BIBLICAL TRUTH (U.S. CLS. 2, 5, 22, 23, 29, 37, 38 AND 50).

JULIE VEPPUMTHARA, EXAMINING ATTORNEY

**CLASS 16—(Continued).**

SN 86-202,663. PAR 17, LLC, NEW YORK, NY. FILED 2-24-2014.

**EFFORTLESS**

THE MARK CONSISTS OF STANDARD CHARACTERS WITHOUT CLAIM TO ANY PARTICULAR FONT, STYLE, SIZE, OR COLOR.

FOR BOOKS, MAGAZINES, LEAFLETS, FOLIOS, JOURNALS, NEWSLETTERS, BOOKLETS, PAMPHLETS AND BROCHURES, ALL OF THE AFORESAID FEATURING INFORMATION IN THE FIELD OF SELF AWARENESS, SELF MASTERY, AND SELF FULFILLMENT; PRINTED EDUCATIONAL, INSTRUCTIONAL, AND TEACHING MATERIALS IN THE FIELD OF SELF AWARENESS, SELF MASTERY, AND SELF FULFILLMENT (U.S. CLS. 2, 5, 22, 23, 29, 37, 38 AND 50).

LOURDES AYALA, EXAMINING ATTORNEY

---

SN 86-202,708. PAR 17, LLC, NEW YORK, NY. FILED 2-24-2014.

**EFFORTLESS LIVING**

THE MARK CONSISTS OF STANDARD CHARACTERS WITHOUT CLAIM TO ANY PARTICULAR FONT, STYLE, SIZE, OR COLOR.

FOR BOOKS, MAGAZINES, LEAFLETS, FOLIOS, JOURNALS, NEWSLETTERS, BOOKLETS, PAMPHLETS AND BROCHURES, ALL OF THE AFORESAID FEATURING INFORMATION IN THE FIELD OF SELF AWARENESS, SELF MASTERY, AND SELF FULFILLMENT; PRINTED EDUCATIONAL, INSTRUCTIONAL, AND TEACHING MATERIALS IN THE FIELD OF SELF AWARENESS, SELF MASTERY, AND SELF FULFILLMENT (U.S. CLS. 2, 5, 22, 23, 29, 37, 38 AND 50).

LOURDES AYALA, EXAMINING ATTORNEY

---

SN 86-215,067. HALLMARK LICENSING, LLC, KANSAS CITY, MO. FILED 3-7-2014.

**SNOWBY**

THE MARK CONSISTS OF STANDARD CHARACTERS WITHOUT CLAIM TO ANY PARTICULAR FONT, STYLE, SIZE, OR COLOR.

FOR GREETING CARDS, PAPER GIFT WRAP, CHILDREN'S BOOKS; CHILDREN'S ACTIVITY BOOKS; ARTS AND CRAFT PAINT KITS; ARTS AND CRAFT CLAY KITS; ACTIVITY CRAFT KITS COMPRISING DRAWING PAPER, MARKER PENS, CRAYONS AND PENCILS; STICKERS; POSTERS; PRINTED SIGNS MADE OF PAPER; AND PRINTED SIGNS MADE OF CARDBOARD (U.S. CLS. 2, 5, 22, 23, 29, 37, 38 AND 50).

KATHLEEN KOLACZ, EXAMINING ATTORNEY

**CLASS 16—(Continued).**

SN 86-215,252. PLANAHEAD, LLC, SANTA MONICA, CA.  
FILED 3-7-2014.

**SEE IT EASIER**

THE MARK CONSISTS OF STANDARD CHARACTERS WITHOUT CLAIM TO ANY PARTICULAR FONT, STYLE, SIZE, OR COLOR.

OWNER OF U.S. REG. NO. 4,074,801.  
FOR PAPER GOODS AND PRINTED MATTER, NAMELY, DAILY PLANNERS, PERSONAL PLANNERS AND DESKTOP PLANNERS; TELEPHONE/ADDRESS BOOKS; APPOINTMENT BOOKS (U.S. CLS. 2, 5, 22, 23, 29, 37, 38 AND 50).

VIVIAN MICZNIK FIRST, EXAMINING ATTORNEY

SN 86-215,748. SUSAN DENCH, DBA MUDDY DOG MEDIA INC, FALMOUTH, ME. FILED 3-10-2014.

**Connectworking**

THE MARK CONSISTS OF STANDARD CHARACTERS WITHOUT CLAIM TO ANY PARTICULAR FONT, STYLE, SIZE, OR COLOR.

FOR A SERIES OF BOOKS, WRITTEN ARTICLES, HANDOUTS AND WORKSHEETS IN THE FIELD OF BUSINESS (U.S. CLS. 2, 5, 22, 23, 29, 37, 38 AND 50).

JOSETTE BEVERLY, EXAMINING ATTORNEY

SN 86-217,271. KOVALIC, JR., ROBERT J., WAUNAKEE, WI.  
FILED 3-11-2014.

**DR. BLINK SUPERHERO SHRINK**

THE MARK CONSISTS OF STANDARD CHARACTERS WITHOUT CLAIM TO ANY PARTICULAR FONT, STYLE, SIZE, OR COLOR.

NO CLAIM IS MADE TO THE EXCLUSIVE RIGHT TO USE "SUPERHERO", APART FROM THE MARK AS SHOWN.

FOR COMIC BOOKS; COMIC STRIPS; COMICS (U.S. CLS. 2, 5, 22, 23, 29, 37, 38 AND 50).

FIRST USE 6-30-2004; IN COMMERCE 6-30-2004.

KHANH LE, EXAMINING ATTORNEY

**CLASS 16—(Continued).**

SN 86-217,630. THE ESTATE OF WHITNEY HOUSTON, ALPHA RETTA, GA. FILED 3-11-2014.

**WHITNEY HOUSTON**

THE MARK CONSISTS OF STANDARD CHARACTERS WITHOUT CLAIM TO ANY PARTICULAR FONT, STYLE, SIZE, OR COLOR.

THE NAME(S), PORTRAIT(S), AND/OR SIGNATURE(S) SHOWN IN THE MARK DOES NOT IDENTIFY A PARTICULAR LIVING INDIVIDUAL.

FOR POSTERS; CONCERT PROGRAMS; CALENDARS; SONG BOOKS (U.S. CLS. 2, 5, 22, 23, 29, 37, 38 AND 50).

FIRST USE 3-0-1994; IN COMMERCE 3-0-1994.  
MICHAEL WIENER, EXAMINING ATTORNEY

SN 86-219,627. ZAPATA-SANTILLANA, EVERARDO, TUSTIN, CA. FILED 3-12-2014.

**EDICIONES COQUITO**

THE MARK CONSISTS OF STANDARD CHARACTERS WITHOUT CLAIM TO ANY PARTICULAR FONT, STYLE, SIZE, OR COLOR.

OWNER OF U.S. REG. NO. 3,426,869.  
NO CLAIM IS MADE TO THE EXCLUSIVE RIGHT TO USE "EDICIONES", APART FROM THE MARK AS SHOWN.

THE ENGLISH TRANSLATION OF "EDICIONES" IN THE MARK IS "EDITIONS".

FOR CHILDREN'S TEXTBOOKS, CHILDREN'S BOOKS, AND CHILDREN'S MAGAZINES (U.S. CLS. 2, 5, 22, 23, 29, 37, 38 AND 50).

FIRST USE 3-3-2006; IN COMMERCE 3-3-2006.

VERNA BETH RIRIE, EXAMINING ATTORNEY

SN 86-227,274. THREE DESIGNING WOMEN, LLC, CARROLLTON, TX. FILED 3-20-2014.

**HAPPY STAMPING!**

THE MARK CONSISTS OF STANDARD CHARACTERS WITHOUT CLAIM TO ANY PARTICULAR FONT, STYLE, SIZE, OR COLOR.

NO CLAIM IS MADE TO THE EXCLUSIVE RIGHT TO USE "STAMPING", APART FROM THE MARK AS SHOWN.

FOR INK STAMPS (U.S. CLS. 2, 5, 22, 23, 29, 37, 38 AND 50).

FIRST USE 1-0-2012; IN COMMERCE 1-0-2012.

ALEXANDER L. POWERS, EXAMINING ATTORNEY

**CLASS 16—(Continued).**

SN 86-227,643. DJ CASSIDY TRADEMARKS LLC, NEW YORK, NY. FILED 3-20-2014.

## DJ CASSIDY

THE MARK CONSISTS OF STANDARD CHARACTERS WITHOUT CLAIM TO ANY PARTICULAR FONT, STYLE, SIZE, OR COLOR.

NO CLAIM IS MADE TO THE EXCLUSIVE RIGHT TO USE "DJ" AS TO THE BOOKS FEATURING CONCERT TOURS; PRINTED CONCERT PROGRAMS; EVENT PROGRAMS AND SOUVENIR EVENT ALBUMS OF CONCERT PERFORMANCES; SERIES OF NON-FICTION BOOKS, MAGAZINES, LEAFLETS, JOURNALS, NEWSLETTERS, BOOKLETS, PAMPHLETS AND BROCHURES, ALL OF THE AFORESAID FEATURING MUSIC, MUSICAL PERFORMANCES AND ARTISTS APART FROM THE MARK AS SHOWN., APART FROM THE MARK AS SHOWN.

THE NAME IN THE MARK IDENTIFIES A LIVING INDIVIDUAL WHOSE CONSENT IS OF RECORD.

FOR POSTERS; CALENDARS; TEMPORARY TATTOOS; STICKERS; DECALS; BUMPER STICKERS; IRON-ON AND PLASTIC TRANSFERS; SHEET MUSIC; TRADING CARDS; POSTCARDS; SCRAPBOOKS; STATIONERY; NOTE PADS; DESK PADS; BOOKMARKS; ADDRESS AND APPOINTMENT BOOKS; DAILY PLANNERS; AUTOGRAPH BOOKS; DESK TOP AND PERSONAL ORGANIZERS; ORGANIZERS FOR STATIONERY USE; STATIONERY-TYPE PORTFOLIOS; PAPER CLIPS; BOOK MARKERS OF PRECIOUS METAL; MONEY CLIPS; HOLDERS FOR DESK ACCESSORIES; LETTER CLIPS; LETTER OPENERS, PEN AND PENCIL CUPS; PENS; PENCILS; EXTENSIONS AND ATTACHMENTS FOR PENCILS; MARKERS; MARKER CADDIES; PEN AND PENCIL SETS; HIGHLIGHTING PENS AND MARKERS; ERASERS; DRAWING RULERS; PENCIL SHARPENERS; BOOKENDS; BOOK COVERS; CHECKBOOK COVERS; COIN AND PHOTOGRAPH ALBUMS; BRAG BOOKS; LEATHER BOOK COVERS; PRINTS; PHOTOGRAPHS; DECORATIVE PAPER CENTERPIECES AND PENCIL-TOP ORNAMENTS; GLOBES; PAPERWEIGHTS; COASTERS MADE OF PAPER; CLIP BOARDS; PAPER EMBLEMS; PRINTED EMBLEMS; PRINTED HOLOGRAMS; BOOKS FEATURING CONCERT TOURS; PRINTED CONCERT PROGRAMS; EVENT PROGRAMS AND SOUVENIR EVENT ALBUMS OF CONCERT PERFORMANCES; SERIES OF NON-FICTION BOOKS, MAGAZINES, LEAFLETS, JOURNALS, NEWSLETTERS, BOOKLETS, PAMPHLETS AND BROCHURES, ALL OF THE AFORESAID FEATURING MUSIC, MUSICAL PERFORMANCES AND ARTISTS (U.S. CLS. 2, 5, 22, 23, 29, 37, 38 AND 50).

REBECCA SMITH, EXAMINING ATTORNEY

**CLASS 16—(Continued).**

SN 86-228,056. CHILDRENS EDUCATIONAL STORIES, LTD., SPRINGFIELD, IL. FILED 3-21-2014.



THE COLOR(S) YELLOW, BLACK, WHITE IS/ARE CLAIMED AS A FEATURE OF THE MARK.

THE MARK CONSISTS OF THE DESIGN OF A SEATED DOG IN PALE YELLOW WITH DARKER YELLOW OUTLINING, BLACK NOSE AND EYES, WEARING A WHITE WIG IN WITH LIGHT GRAY OUTLINING AND A DARK GRAY JUDGE'S ROBE WITH BLACK OUTLINING.

FOR CHILDREN'S BOOKS (U.S. CLS. 2, 5, 22, 23, 29, 37, 38 AND 50).

CHRIS WELLS, EXAMINING ATTORNEY

SN 86-228,162. THOMAS, ANNMARIE, ST. PAUL, MN. FILED 3-21-2014.

## SQUISHY CIRCUITS

THE MARK CONSISTS OF STANDARD CHARACTERS WITHOUT CLAIM TO ANY PARTICULAR FONT, STYLE, SIZE, OR COLOR.

NO CLAIM IS MADE TO THE EXCLUSIVE RIGHT TO USE "CIRCUITS", APART FROM THE MARK AS SHOWN.

FOR EDUCATIONAL PUBLICATIONS, NAMELY, CLASSROOM GUIDES AND TEACHER'S GUIDES FEATURING CURRICULUM CONTENT IN THE FIELD OF ELECTRICAL ENGINEERING EDUCATION (U.S. CLS. 2, 5, 22, 23, 29, 37, 38 AND 50).

FIRST USE 2-28-2011; IN COMMERCE 2-28-2011.

MARYNELLE WILSON, EXAMINING ATTORNEY



**CLASS 16—(Continued).**

SN 86-228,430. TINA M. MARRELLI, VENICE, FL. FILED 3-21-2014.

**DEAR NURSE TINA**

THE MARK CONSISTS OF STANDARD CHARACTERS WITHOUT CLAIM TO ANY PARTICULAR FONT, STYLE, SIZE, OR COLOR.

THE NAME "NURSE TINA" IDENTIFIES A LIVING INDIVIDUAL WHOSE CONSENT IS OF RECORD.

FOR SYNDICATED NEWSPAPER COLUMNS IN THE FIELD OF HEALTHCARE (U.S. CLS. 2, 5, 22, 23, 29, 37, 38 AND 50).

FIRST USE 3-12-2014; IN COMMERCE 3-12-2014.  
MARYNELLE WILSON, EXAMINING ATTORNEY

SN 86-230,317. ENGRAVE IT LLC, NENAN, GA. FILED 3-24-2014.

**The  
TapeThing  
It's Magnetic.**

**www.TheTapeThing.com**

NO CLAIM IS MADE TO THE EXCLUSIVE RIGHT TO USE "MAGNETIC", APART FROM THE MARK AS SHOWN.

"THE MARK CONSISTS OF THE STYLIZED WORDING "THE TAPETHING IT'S MAGNETIC. WWW.THETAPETHING.COM" WHERE "THE" APPEARS IN THE TOP LEFT CORNER WITH "TAPETHING" BELOW IT, FOLLOWED BY "IT'S MAGNETIC." UNDER THE BOTTOM RIGHT OF "THING" AND "WWW.THETAPETHING.COM" CENTERED AT THE BOTTOM.

FOR HOLDERS FOR ADHESIVE TAPES (U.S. CLS. 2, 5, 22, 23, 29, 37, 38 AND 50).

FIRST USE 3-12-2014; IN COMMERCE 3-12-2014.  
LAURA GOLDEN, EXAMINING ATTORNEY

SN 86-231,111. GOOD NEWS PUBLISHERS, WHEATON, IL. FILED 3-25-2014.

**ESV Big Picture Bible**

THE MARK CONSISTS OF STANDARD CHARACTERS WITHOUT CLAIM TO ANY PARTICULAR FONT, STYLE, SIZE, OR COLOR.

OWNER OF U.S. REG. NOS. 3,008,631, 3,746,835 AND OTHERS.

NO CLAIM IS MADE TO THE EXCLUSIVE RIGHT TO USE "BIBLE", APART FROM THE MARK AS SHOWN.

FOR BIBLES; BOOKS IN THE FIELD OF RELIGION; PRINTED MATERIALS, NAMELY, CURRICULA IN THE FIELD OF RELIGION; PRINTED TEACHING MATERIALS IN THE FIELD OF RELIGION (U.S. CLS. 2, 5, 22, 23, 29, 37, 38 AND 50).

WILLIAM P. SHANAHAN, EXAMINING ATTORNEY

**CLASS 16—(Continued).**

SN 86-232,522. YEPPIE PAPER, BEVERLY HILLS, CA. FILED 3-26-2014.

**YEPPIE PAPER**

THE MARK CONSISTS OF STANDARD CHARACTERS WITHOUT CLAIM TO ANY PARTICULAR FONT, STYLE, SIZE, OR COLOR.

NO CLAIM IS MADE TO THE EXCLUSIVE RIGHT TO USE "PAPER", APART FROM THE MARK AS SHOWN.

FOR CARDS BEARING UNIVERSAL GREETINGS; CHRISTMAS CARDS; GREETING CARDS; HOLIDAY CARDS; INVITATION CARDS; STATIONERY (U.S. CLS. 2, 5, 22, 23, 29, 37, 38 AND 50).

FIRST USE 2-26-2014; IN COMMERCE 2-26-2014.  
SCOTT BIBB, EXAMINING ATTORNEY

SN 86-232,560. ROHRBACH, LAURIE MACK, DBA LOBIRD, PALO ALTO, CA. FILED 3-26-2014.

**LOBIRD**

THE MARK CONSISTS OF STANDARD CHARACTERS WITHOUT CLAIM TO ANY PARTICULAR FONT, STYLE, SIZE, OR COLOR.

OWNER OF U.S. REG. NOS. 3,530,760 AND 3,783,396.  
FOR ART PRINTS (U.S. CLS. 2, 5, 22, 23, 29, 37, 38 AND 50).

FIRST USE 3-9-2012; IN COMMERCE 3-9-2012.  
ZHALEH DELANEY, EXAMINING ATTORNEY

**CLASS 16—(Continued).**

SN 86-232,741. GHOST OF JASON MOLINA, LLC, NASHVILLE, TN. FILED 3-26-2014.

**SONGS: OHIA**

THE MARK CONSISTS OF STANDARD CHARACTERS WITHOUT CLAIM TO ANY PARTICULAR FONT, STYLE, SIZE, OR COLOR.

NO CLAIM IS MADE TO THE EXCLUSIVE RIGHT TO USE "SONGS", APART FROM THE MARK AS SHOWN.

FOR PRINTED MATTER, NAMELY, NEWSPAPERS, MAGAZINES AND BOOKS ALL IN THE FIELD OF ENTERTAINMENT AND MUSIC; PRINTED MUSIC BOOKS; MOUNTED AND UNMOUNTED PHOTOGRAPHS; PICTURES, ART PRINTS, PHOTOGRAPHIC PRINTS; POSTERS; GREETING CARDS; ENVELOPES; POSTCARDS; NOTEPADS; ADDRESS PADS; SCRAP BOOKS; FOLDERS; PRINTED TICKETS; CALENDARS; PHOTOGRAPH ALBUMS; DIARIES, BOOKLETS IN THE FIELD OF ENTERTAINMENT AND MUSIC, COMMEMORATIVE STAMP SHEETS; SLEEVES FOR HOLDING AND PROTECTING STAMPS; STAMP ALBUMS; STICKERS; CAR STICKERS; DECALS; CARDBOARD ARTICLES, NAMELY, BOXES, CONTAINERS; STATIONERY, PENS, PENCILS, WRITING INSTRUMENTS, ERASERS, PENCIL SHARPENERS, PENCIL CASES, PAPER, ARTIST, DRAWING AND PAINT BRUSHES; PAPER GIFT BAGS, ENVELOPES, BLACKBOARDS; DISPLAY BOARDS; IRON-ON TRANSFERS; SCRAP BOOKS; ART PRINTS; ART PRINTS ON CANVAS; PENS; BALL PENS; FOUNTAIN PENS; INK PENS; FELT PENS; BOOK COVERS; BOOKMARKS; BUMPER STICKERS; CALLIGRAPHY PAPER; CHALK AND BLACKBOARDS; CHILDREN'S GEL ROLLER PENS; BOOKS IN THE FIELD OF ENTERTAINMENT AND MUSIC; CHRISTMAS CARDS; TRADING CARDS; COMIC BOOKS AND COMIC STRIPS; COOK BOOKS; CUSTOM PAINTINGS; EMBROIDERY DESIGN PATTERNS PRINTED ON PAPER; FLIP BOOKS; FRAMED ART PRINTS; FRAMED PAINTINGS; GIFT BAGS AND WRAPPING PAPER; HIGHLIGHTER PENS AND MARKERS; INK STAMPS; LUNCH BAGS; MEMORY BOOKS; SHEET MUSIC; NAIL STENCILS; STENCILS; NOTEBOOKS; NOTE PAPER; NOTE PADS; PAINTINGS AND CALLIGRAPHIC WORKS; PAPER WEIGHTS; PRINTED EMBLEMS; PRINTED MATTER, NAMELY, VINYL STATIC CLING SHEETS FOR AFFIXATION IN WINDOWS AND WINDSHIELDS; REMOVABLE TATTOO TRANSFERS; SCHOOL SUPPLY KITS CONTAINING VARIOUS COMBINATIONS OF SELECTED SCHOOL SUPPLIES, NAMELY, WRITING INSTRUMENTS, PENS, PENCILS, MECHANICAL PENCILS, ERASERS, MARKERS, CRAYONS, HIGHLIGHTER PENS, FOLDERS, NOTEBOOKS, PAPER, PROTRACTORS, PAPER CLIPS, PENCIL SHARPENERS, WRITING GRIPS, GLUE AND BOOK MARKS (U.S. CLS. 2, 5, 22, 23, 29, 37, 38 AND 50).

FIRST USE 1-30-1996; IN COMMERCE 1-30-1996.

HOWARD SMIGA, EXAMINING ATTORNEY

**CLASS 16—(Continued).**

SN 86-232,789. CARROLL, NORMAJEAN, MYAKKA CITY, FL. FILED 3-26-2014.



THE MARK CONSISTS OF THE WORDS "IMPERFECT WORLD - IMPERFECT CHRISTIAN - ALWAYS CHOSEN" IN A CIRCLE AROUND AN IMAGE OF A CROSS, WITH A PAIR OF ANGEL WINGS ON EITHER SIDE OF THE LOWER PORTION OF THE CROSS, AND A RING SITUATED AT AN ANGLE AROUND THE INTERSECTION OF THE CROSS.

FOR PHOTOGRAPHIC PRINTS; PHOTOGRAPHS; PRINTS; PRINTS FEATURING POEMS (U.S. CLS. 2, 5, 22, 23, 29, 37, 38 AND 50).

AHSEN KHAN, EXAMINING ATTORNEY

SN 86-233,333. CLEMENTE, HENRY, NORWALK, CT. AND CLEMENTE, LASHANI, NORWALK, CT. FILED 3-26-2014.



NO CLAIM IS MADE TO THE EXCLUSIVE RIGHT TO USE "EDUTAINMENT", APART FROM THE MARK AS SHOWN.

THE COLOR(S) GREEN, SILVER, YELLOW, BROWN IS/ ARE CLAIMED AS A FEATURE OF THE MARK.

THE MARK CONSISTS OF THE LETTER "R" BACKWARDS IN GREEN AND "ROOTZ" INSIDE THE TOP PORTION OF THE LETTER "R" AND "REVOLUTION" IN BROWN TO THE RIGHT OF THE "R ROOTZ" VERTICALLY, AND "EDUTAINMENT" UNDERNEATH IN BROWN ALL ON A SILVER AND YELLOW LEAF-VEIN DESIGN BACKGROUND.

FOR MAGAZINES FEATURING POPULAR CULTURE AND LIFESTYLE (U.S. CLS. 2, 5, 22, 23, 29, 37, 38 AND 50).

STEPHANIE ALI, EXAMINING ATTORNEY

**CLASS 16—(Continued).**

SN 86-233,651. FOX, NATHANIEL S., LAS VEGAS, NV.  
FILED 3-27-2014.

**MINI-MADOFF**

THE MARK CONSISTS OF STANDARD CHARACTERS WITHOUT CLAIM TO ANY PARTICULAR FONT, STYLE, SIZE, OR COLOR.

FOR SERIES OF NON-FICTION BOOKS IN THE FIELD OF TRUE CRIME (U.S. CLS. 2, 5, 22, 23, 29, 37, 38 AND 50).

RON FAIRBANKS, EXAMINING ATTORNEY

**CLASS 16—(Continued).**

SN 86-234,041. RX-360 INTERNATIONAL PHARMACEUTICAL SUPPLY CHAIN CONSORTIUM, WASHINGTON, DC. FILED 3-27-2014.

**RX-360**

THE MARK CONSISTS OF STANDARD CHARACTERS WITHOUT CLAIM TO ANY PARTICULAR FONT, STYLE, SIZE, OR COLOR.

FOR PRINTED MATERIALS, NAMELY, WHITE PAPERS, MODEL FORMS, AUDIT GUIDELINES, AND REPORTS IN THE FIELD OF PHARMACEUTICAL SUPPLY CHAIN SECURITY (U.S. CLS. 2, 5, 22, 23, 29, 37, 38 AND 50).

FIRST USE 0-0-2009; IN COMMERCE 0-0-2009.

KELLEY WELLS, EXAMINING ATTORNEY

SN 86-233,891. WEALI MATERIALS CORPORATION, SAN LEANDRO, CA. FILED 3-27-2014.



NO CLAIM IS MADE TO THE EXCLUSIVE RIGHT TO USE "STRETCH WRAP", APART FROM THE MARK AS SHOWN.

THE COLOR(S) BLACK AND GREEN IS/ARE CLAIMED AS A FEATURE OF THE MARK.

THE MARK CONSISTS OF "SPIDER" IN BLACK, "STRETCH" IN GREEN, AND "WRAP" IN BLACK AND A GREEN SPIDER WEB AND A BLACK SPIDER ON THE WEB.

FOR PLASTIC STRETCH FILM FOR USE AS WRAPPING AND PACKAGING MATERIAL FOR WAREHOUSE USE; ADHESIVE PACKING TAPE FOR INDUSTRIAL OR COMMERCIAL USE (U.S. CLS. 2, 5, 22, 23, 29, 37, 38 AND 50).

JOHN SCHUYLER YARD, EXAMINING ATTORNEY

SN 86-234,408. MANHATTAN TO MONTAUK, LLC, EAST QUOGUE, NY. FILED 3-27-2014.



SN 86-233,976. SEVENTH GENERATION, INC., BURLINGTON, VT. FILED 3-27-2014.

**PURELY SOFT**

THE MARK CONSISTS OF STANDARD CHARACTERS WITHOUT CLAIM TO ANY PARTICULAR FONT, STYLE, SIZE, OR COLOR.

NO CLAIM IS MADE TO THE EXCLUSIVE RIGHT TO USE "SOFT", APART FROM THE MARK AS SHOWN.

FOR FACIAL TISSUE; PAPER NAPKINS; PAPER TOWELS; TOILET TISSUE (U.S. CLS. 2, 5, 22, 23, 29, 37, 38 AND 50).

JULIE VEPPUMTHARA, EXAMINING ATTORNEY

THE MARK CONSISTS OF A FISH WITH A CITYSCAPE ALONG SPINE AND A LIGHTHOUSE ON THE TAIL AND "MNHTN2MTK.COM" UNDERNEATH.

FOR STICKERS (U.S. CLS. 2, 5, 22, 23, 29, 37, 38 AND 50).

ELLEN BURNS, EXAMINING ATTORNEY

**CLASS 16—(Continued).**

SN 86-234,454. CHRISTINE COMAFORD ASSOCIATES LLC, MILL VALLEY, CA. FILED 3-27-2014.

**SMARTTRIBES**

THE MARK CONSISTS OF STANDARD CHARACTERS WITHOUT CLAIM TO ANY PARTICULAR FONT, STYLE, SIZE, OR COLOR.

OWNER OF U.S. REG. NO. 4,526,460.

FOR PRINTED MATTER, NAMELY, PAPER SIGNS, BOOKS, MANUALS, CURRICULA, NEWSLETTERS, INFORMATIONAL CARDS AND BROCHURES IN THE FIELD OF STARTING NEW BUSINESSES, BUSINESS ENTREPRENEURSHIP, DEVELOPING AND EXECUTING BUSINESS PLANS, HIRING EMPLOYEES AND ADVISORS, IDENTIFYING AND OBTAINING FINANCIAL BACKING, OVERCOMING OBSTACLES IN GROWING A BUSINESS, DEVELOPING NEW PRODUCTS AND SERVICES AND PUBLIC RELATIONS FOR BUSINESSES (U.S. CLS. 2, 5, 22, 23, 29, 37, 38 AND 50).

FIRST USE 5-30-2013; IN COMMERCE 5-30-2013.

SKYE YOUNG, EXAMINING ATTORNEY

**CLASS 16—(Continued).**

SN 86-236,388. ETHOUGHT.COM LLC, PHOENIX, AZ. FILED 3-29-2014.

**7/52 Bible Study**

THE MARK CONSISTS OF STANDARD CHARACTERS WITHOUT CLAIM TO ANY PARTICULAR FONT, STYLE, SIZE, OR COLOR.

NO CLAIM IS MADE TO THE EXCLUSIVE RIGHT TO USE "BIBLE STUDY", APART FROM THE MARK AS SHOWN.

FOR EDUCATIONAL PUBLICATIONS, NAMELY, EDUCATIONAL LEARNING CARDS, FLASH CARDS, ACTIVITY CARDS, WORKBOOKS, TEXTBOOKS, ACTIVITY BOOKS, STORY BOOKS, PUZZLE BOOKS, PRINTED PUZZLES, TEACHER GUIDES, MANUALS, POSTERS AND EDUCATIONAL BOOKLETS IN THE FIELD OF THE BIBLE (U.S. CLS. 2, 5, 22, 23, 29, 37, 38 AND 50).

JOHN DWYER, EXAMINING ATTORNEY

SN 86-236,455. WU, BRIAN W., EAST GREENWICH, RI. FILED 3-30-2014.

**PRETTY WICKED****CONVERD BOARD**

THE MARK CONSISTS OF STANDARD CHARACTERS WITHOUT CLAIM TO ANY PARTICULAR FONT, STYLE, SIZE, OR COLOR.

NO CLAIM IS MADE TO THE EXCLUSIVE RIGHT TO USE "BOARD", APART FROM THE MARK AS SHOWN.

FOR PAPER BOARDS, NAMELY, RIGID, PAPER BASED PRINT MEDIA WITH MULTI-PLY THICK CONSTRUCTION AND RECYCLED CONTENT FOR STRUCTURAL SIGNAGE APPLICATIONS, HANGING SIGNAGE, INDOOR POINT OF PURCHASE BOARDS, MENU BOARDS, STANDEES, END CAPS, AISLE MARKERS, WINDOW SIGNAGE, TRADE SHOW SIGNAGE, DISPLAYS, TABLE TOPS, DANGLERS, AND CUSTOM PACKAGING IN THE WIDE-FORMAT MARKET (U.S. CLS. 2, 5, 22, 23, 29, 37, 38 AND 50).

JEANIE LEE, EXAMINING ATTORNEY

THE MARK CONSISTS OF STANDARD CHARACTERS WITHOUT CLAIM TO ANY PARTICULAR FONT, STYLE, SIZE, OR COLOR.

FOR AGENDAS; ALMANACS; BOOK COVERS; CALENDAR DESK PADS; CALENDAR REFILLS; CALENDARS; CALENDARS AND DIARIES; COASTERS MADE OF CARDBOARD; COASTERS MADE OF PAPER; COASTERS OF PAPER; DAILY PLANNERS; DESK CALENDARS; DESKTOP PLANNERS; EDUCATIONAL PUBLICATIONS, NAMELY, EDUCATIONAL LEARNING CARDS, FLASH CARDS, ACTIVITY CARDS, ACTIVITY BOOKS, PUZZLE BOOKS, AND PRINTED PUZZLES, IN THE FIELD OF LANGUAGE, VOCABULARY USE, FOREIGN LANGUAGES, SCIENCE, MATHEMATICS, ART, GRAPHIC AND THREE DIMENSIONAL ART, AND HISTORY; POCKET CALENDARS; POSTERS; PRINTED CALENDARS; PRINTED COLLECTOR CARDS MADE PRIMARILY OF PAPER AND ALSO INCLUDING METAL; TEAR-OFF CALENDARS; WALL CALENDARS (U.S. CLS. 2, 5, 22, 23, 29, 37, 38 AND 50).

BRITNEY COGAN, EXAMINING ATTORNEY

**CLASS 16—(Continued).**

SN 86-236,465. STALL, ROXANNE, TUCSON, AZ. FILED 3-30-2014.

# Sound Town

THE MARK CONSISTS OF STANDARD CHARACTERS WITHOUT CLAIM TO ANY PARTICULAR FONT, STYLE, SIZE, OR COLOR.

NO CLAIM IS MADE TO THE EXCLUSIVE RIGHT TO USE "SOUND", APART FROM THE MARK AS SHOWN.

FOR EDUCATIONAL KITS SOLD AS A UNIT IN THE FIELD OF READING CONSISTING PRIMARILY OF INTERACTIVE PRINTED LESSONS, WORKSHEETS, POSTERS, PRINTED PUZZLES, PRINTED TEACHER AND PARENT GUIDES, MANUALS, READERS BEING BOOKS, WORKBOOKS, LEARNING CARDS, FLASHCARDS, BEING IN THE FIELDS OF EDUCATION, AND ALSO INCLUDING DVDS (U.S. CLS. 2, 5, 22, 23, 29, 37, 38 AND 50).

FIRST USE 6-5-1996; IN COMMERCE 9-1-1996.  
ANDREA K. NADELMAN, EXAMINING ATTORNEY

**CLASS 16—(Continued).**

SN 86-237,075. PORTERFIELD, JANE, DEERFIELD BEACH, FL. FILED 3-31-2014.



NO CLAIM IS MADE TO THE EXCLUSIVE RIGHT TO USE "NAME TAGS", APART FROM THE MARK AS SHOWN.

THE COLOR(S) CYAN AND HOT PINK IS/ARE CLAIMED AS A FEATURE OF THE MARK.

THE MARK CONSISTS OF A STYLIZED CAPITAL LETTER "N" WITH THE UPPER PORTION FILLED IN DIAGONALLY WITH THE COLOR CYAN AND THE LOWER PORTION COLORED IN HOT PINK. THE DIAGONAL IS LOWER ON THE LEFT AND HIGHER ON THE RIGHT. THE SAID CAPITAL LETTER "N" IS FOLLOWED BY TWO LINES OF STYLIZED TEXT, WITH THE UPPER TEXT PORTION IN LOWER CASE STYLIZED LETTERS "AUGHTY" COLORED IN CYAN, AND THE LOWER TEXT PORTION IN LOWER CASE STYLIZED LETTERS "AMETAGS" COLORED IN HOT PINK. THE SINGLE CAPITAL LETTER "N" IS USED TO FORM BOTH WORDS, TO-WIT, "NAUGHTY NAMETAGS".

FOR PAPER NAME BADGES (U.S. CLS. 2, 5, 22, 23, 29, 37, 38 AND 50).

FIRST USE 9-5-2001; IN COMMERCE 8-4-2013.  
DAVID MURRAY, EXAMINING ATTORNEY

SN 86-236,855. CENTERPEACES LLC, BURLINGTON, NC. FILED 3-31-2014.



NO CLAIM IS MADE TO THE EXCLUSIVE RIGHT TO USE "LLC" AND "HEALING THROUGH PET LOSS", APART FROM THE MARK AS SHOWN.

THE MARK CONSISTS OF AN OPEN ENDED HEART, TO THE RIGHT OF THE INSIDE OF THE HEART IS A SILHOUETTE OF A DOG, IN THE MIDDLE OF THE HEART IS A CAT SILHOUETTE LOOKING TO THE LEFT WITH ITS BODY OVERLAID AT THE SHOULDER OF THE DOG, THERE IS A BIRD COMPLETING THE HEART AT THE LEFT BASE FACING LEFT AND OVERLAID ON THE CAT AT THE TAIL. THE WORDING "CENTERPEACES LLC" IS UNDER THE DESIGN IN SCRIPT FONT AND THE WORDING "HEALING THROUGH PET LOSS" APPEARS BENEATH THE WORDING "CENTERPEACES LLC".

FOR BOOKS IN THE FIELD OF PET LOSS (U.S. CLS. 2, 5, 22, 23, 29, 37, 38 AND 50).

RONALD MCMORROW, EXAMINING ATTORNEY

SN 86-237,560. CULHANE, WILLIAM, VALENCIA, CA. FILED 3-31-2014.



THE COLOR(S) DARK BLUE, BLACK, AND GRAY IS/ARE CLAIMED AS A FEATURE OF THE MARK.

THE MARK CONSISTS OF "JJTP" IN DARK BLUE LETTERING AND "BECAUSE SOMETHING NEEDS TO BE CLEANED UP." IN BLACK LETTERING. A ROLL OF TOILET PAPER OUTLINED IN BLACK HANGS FROM THE BASE OF EACH "J". A CLASSIC OUTHOUSE OUTLINED IN BLACK IS ON THE RIGHT, WITH GRAY STEAM COMING OUT OF IT. THREE HOUSEFLIES APPEAR IN BLACK NEAR THE LETTERS "JJTP". THE COLOR WHITE REPRESENTS TRANSPARENT AREAS OF THE MARK AND IS NOT CLAIMED AS A FEATURE OF THE MARK.

FOR TOILET PAPER (U.S. CLS. 2, 5, 22, 23, 29, 37, 38 AND 50).

APRIL HESIK, EXAMINING ATTORNEY

**CLASS 16—(Continued).**

SN 86-237,605. KIMBERLY GEIGER STUDIO, SPOKANE, WA. FILED 3-31-2014.

**Save Memories Share HOPE**

THE MARK CONSISTS OF STANDARD CHARACTERS WITHOUT CLAIM TO ANY PARTICULAR FONT, STYLE, SIZE, OR COLOR.

FOR ADHESIVE NOTE PADS; ART PRINTS; ART PRINTS ON CANVAS; BUMPER STICKERS; CALENDARS; CRAFT PAPER; DECORATIVE STICKERS FOR HELMETS; FRAMED GRAPHIC ART REPRODUCTIONS; GRAPHIC ART REPRODUCTIONS; GREETING CARDS; GREETING CARDS HAVING A CHRISTIAN MESSAGE; GREETINGS CARDS AND POSTCARDS; ILLUSTRATED NOTEPADS; ILLUSTRATIONS; MAGNETIC BOARDS; MAGNETIC BUMPER STICKERS; MEMO BLOCKS; MEMO PADS; MOTIVATIONAL CARDS; NAIL STENCILS; NOTE BOOKS; NOTE PADS; PAPER GIFT WRAP; PERSONALIZED WRITING JOURNALS; PRAYER BOOKS; PRINTED CHILDREN'S COLORING PAGES; PRINTED MATTER, NAMELY, VINYL STATIC CLING SHEETS ON WHICH PRAYERS ARE PRINTED FOR AFFIXATION IN WINDOWS AND WINDSHIELDS; PUSH PINS; RUBBER STAMPS (U.S. CLS. 2, 5, 22, 23, 29, 37, 38 AND 50).

FIRST USE 2-6-2014; IN COMMERCE 2-6-2014.  
ALEX KEAM, EXAMINING ATTORNEY

SN 86-238,609. EAKIN, GREGORY, LONGVIEW, TX. FILED 4-1-2014.

**Cap-Tube**

THE MARK CONSISTS OF STANDARD CHARACTERS WITHOUT CLAIM TO ANY PARTICULAR FONT, STYLE, SIZE, OR COLOR.

FOR A CLEAR PLASTIC TUBE USED FOR HOLDING AIR-TITE ENCAPSULATED COINS (U.S. CLS. 2, 5, 22, 23, 29, 37, 38 AND 50).

FIRST USE 9-0-2011; IN COMMERCE 9-3-2012.  
THOMAS MANOR, EXAMINING ATTORNEY

SN 86-240,589. CAVALCADE CREATIVE COMPANY, SALT LAKE CITY, UT. FILED 4-2-2014.

**LEMONBERRY ST.**

THE MARK CONSISTS OF STANDARD CHARACTERS WITHOUT CLAIM TO ANY PARTICULAR FONT, STYLE, SIZE, OR COLOR.

FOR DRY ERASE CANVAS WRITING BOARD; VINYL WALL ART IN THE NATURE OF VINYL WALL DECALS (U.S. CLS. 2, 5, 22, 23, 29, 37, 38 AND 50).

FIRST USE 3-15-2012; IN COMMERCE 3-15-2012.  
CRISTIANA SCHWAB, EXAMINING ATTORNEY

**CLASS 16—(Continued).**

SN 86-240,741. BUSIEK, KURT D, DBA JUKE BOX PRODUCTIONS, CAMAS, WA. FILED 4-3-2014.

**Astro City**

THE MARK CONSISTS OF STANDARD CHARACTERS WITHOUT CLAIM TO ANY PARTICULAR FONT, STYLE, SIZE, OR COLOR.

FOR COMIC BOOKS (U.S. CLS. 2, 5, 22, 23, 29, 37, 38 AND 50).

FIRST USE 7-10-1995; IN COMMERCE 7-10-1995.  
KEVIN CRENNAN, EXAMINING ATTORNEY

SN 86-240,937. FIRST QUALITY TISSUE, LLC, GREAT NECK, NY. FILED 4-3-2014.

**DINNER TABLE READY**

THE MARK CONSISTS OF STANDARD CHARACTERS WITHOUT CLAIM TO ANY PARTICULAR FONT, STYLE, SIZE, OR COLOR.

FOR PAPER TOWELS (U.S. CLS. 2, 5, 22, 23, 29, 37, 38 AND 50).

MEGAN ASKEW, EXAMINING ATTORNEY

SN 86-240,961. ARCH PAPER, LLC, ST. LOUIS, MO. FILED 4-3-2014.

**KONA**

THE MARK CONSISTS OF STANDARD CHARACTERS WITHOUT CLAIM TO ANY PARTICULAR FONT, STYLE, SIZE, OR COLOR.

FOR PAPER (U.S. CLS. 2, 5, 22, 23, 29, 37, 38 AND 50).

FIRST USE 9-10-2010; IN COMMERCE 9-10-2010.  
MICHAEL TANNER, EXAMINING ATTORNEY

**CLASS 16—(Continued).**

SN 86-241,176. HISTORY, LLC, LAKE OSWEGO, OR. FILED 4-3-2014.

HANNAH BERGEN  

---

 HEIRLOOMS

NO CLAIM IS MADE TO THE EXCLUSIVE RIGHT TO USE "HEIRLOOMS", APART FROM THE MARK AS SHOWN.

THE NAME(S), PORTRAIT(S), AND/OR SIGNATURE(S) SHOWN IN THE MARK DOES NOT IDENTIFY A PARTICULAR LIVING INDIVIDUAL.

THE MARK CONSISTS OF A STYLIZED HORIZONTAL LINE BETWEEN THE WORDS "HANNAH BERGEN" ABOVE AND "HEIRLOOMS" BELOW.

FOR MEMORY BOXES, NAMELY, CARDBOARD BOXES CONTAINING CARDBOARD CARDS FOR DISPLAYING AND STORING FAMILY KEEPSAKES AND MEMENTOS (U.S. CLS. 2, 5, 22, 23, 29, 37, 38 AND 50).

TARA BHUPATHI, EXAMINING ATTORNEY

SN 86-241,209. HISTORY, LLC, LAKE OSWEGO, OR. FILED 4-3-2014.

  
 HANNAH BERGEN  

---

 HEIRLOOMS

NO CLAIM IS MADE TO THE EXCLUSIVE RIGHT TO USE "HEIRLOOMS", APART FROM THE MARK AS SHOWN.

THE NAME(S), PORTRAIT(S), AND/OR SIGNATURE(S) SHOWN IN THE MARK DOES NOT IDENTIFY A PARTICULAR LIVING INDIVIDUAL.

THE MARK CONSISTS OF A STYLIZED KEY-AND-TAG LOGO ABOVE A STYLIZED LINE SEPARATING THE WORDS "HANNAH BERGEN" ABOVE AND "HEIRLOOMS" BELOW.

FOR MEMORY BOXES, NAMELY, CARDBOARD BOXES CONTAINING CARDBOARD CARDS FOR DISPLAYING AND STORING FAMILY KEEPSAKES AND MEMENTOS (U.S. CLS. 2, 5, 22, 23, 29, 37, 38 AND 50).

TARA BHUPATHI, EXAMINING ATTORNEY

**CLASS 16—(Continued).**

SN 86-243,510. VISION HARMONY, CHINO HILLS, CA. FILED 4-5-2014.

Plum OutSmart' Em

THE MARK CONSISTS OF STANDARD CHARACTERS WITHOUT CLAIM TO ANY PARTICULAR FONT, STYLE, SIZE, OR COLOR.

FOR EDUCATIONAL PUBLICATIONS, NAMELY, EDUCATIONAL LEARNING CARDS, FLASH CARDS, ACTIVITY CARDS, WORKBOOKS, TEXTBOOKS, ACTIVITY BOOKS, STORY BOOKS, PUZZLE BOOKS, PRINTED PUZZLES, TEACHER GUIDES, MANUALS, POSTERS AND EDUCATIONAL BOOKLETS IN THE FIELD OF SCIENCE, TECHNOLOGY, ENGINEERING, MATHEMATICS, ARTS AND OR LANGUAGE (U.S. CLS. 2, 5, 22, 23, 29, 37, 38 AND 50).

FIRST USE 4-1-2013; IN COMMERCE 4-27-2013.

PATRICIA EVANKO, EXAMINING ATTORNEY

SN 86-243,739. MITCHELL, DRAPER L, NEW YORK, NY. FILED 4-6-2014.

**HYPHEN NATION  
 REPORT**

NO CLAIM IS MADE TO THE EXCLUSIVE RIGHT TO USE "REPORT", APART FROM THE MARK AS SHOWN.

THE MARK CONSISTS OF THE WORDING "HYPHEN NATION" ON LINE ONE IN STYLIZED FONT AND THE WORD "REPORT" ON LINE TWO IN STYLIZED FONT. THE WORD "REPORT" IS POSITIONED UNDERNEATH THE WORD "NATION" IN SUCH A WAY THAT THE LETTER "O" IN THE WORD "NATION" AND LETTER "O" IN THE WORD "REPORT" ARE ALIGNED; THEREFORE CREATING AN OFFSET ALIGNMENT OF THE WORDING "HYPHEN NATION" ON LINE ONE AND THE WORD "REPORT" ON LINE TWO.

FOR MAGAZINE SUPPLEMENTS TO NEWSPAPERS IN THE FIELD OF POLITICS (U.S. CLS. 2, 5, 22, 23, 29, 37, 38 AND 50).

CRISTIANA SCHWAB, EXAMINING ATTORNEY

SN 86-244,186. GOLDSTEIN, IRA, RALEIGH, NC. AND GOLDSTEIN, DAVID, RALEIGH, NC. FILED 4-7-2014.

ACURIT

THE MARK CONSISTS OF STANDARD CHARACTERS WITHOUT CLAIM TO ANY PARTICULAR FONT, STYLE, SIZE, OR COLOR.

FOR ART EQUIPMENT AND ACCESSORIES FOR USE IN THE CREATION OF ART, NAMELY, ROLLING RULERS, DRAWING DEVICES FOR TRANSFERRING PROPORTIONS BETWEEN IMAGES, DRAWING PENS, PENCIL SHARPENERS, CARDBOARD MAILING TUBES, PRESENTATION MOUNTING BOARDS, AND T-SQUARES (U.S. CLS. 2, 5, 22, 23, 29, 37, 38 AND 50).

FIRST USE 4-1-2014; IN COMMERCE 4-1-2014.

AMY KELLY, EXAMINING ATTORNEY

**CLASS 16—(Continued).**

SN 86-244,579. POCKET FULL OF FEELINGS, LLC, LAGUNA NIGUEL, CA. FILED 4-7-2014.

**POCKET FULL OF FEELINGS**

THE MARK CONSISTS OF STANDARD CHARACTERS WITHOUT CLAIM TO ANY PARTICULAR FONT, STYLE, SIZE, OR COLOR.

OWNER OF U.S. REG. NOS. 4,358,449 AND 4,502,287.

FOR PACKAGED KITS COMPRISING PRINTED INSTRUCTIONAL, EDUCATIONAL, AND TEACHING MATERIALS FOR EDUCATIONAL ACTIVITIES IN THE FIELD OF PARENTING AND EMOTIONAL LITERACY; PRINTED EDUCATIONAL MATERIALS IN THE FIELD OF PARENTING AND EMOTIONAL LITERACY (U.S. CLS. 2, 5, 22, 23, 29, 37, 38 AND 50).

FIRST USE 6-0-2013; IN COMMERCE 6-0-2013.

KHANH LE, EXAMINING ATTORNEY

**CLASS 16—(Continued).**

SN 86-245,505. CREATIVE LEGAL SOLUTIONS, LLC, NORTH CANTON, OH. FILED 4-8-2014.



THE MARK CONSISTS OF A SMILING MAN WITH A MUSTACHE, STANDING FACING FORWARD, WEARING A CHEF'S HAT, A CHEF'S JACKET WITH THE NAME "BUDDY" APPEARING ON THE JACKET, AND DARK PANTS, HOLDING A SPOON WITH ONE HAND AND A 3-TIERED CAKED WITH ONE CANDLE ON THE TOP WITH THE OTHER HAND.

FOR PRINTED CHARTS (U.S. CLS. 2, 5, 22, 23, 29, 37, 38 AND 50).

CAROLINE WOOD, EXAMINING ATTORNEY

SN 86-245,070. MCKOY, DENAYE, HIGHTSTOWN, NJ. FILED 4-7-2014.

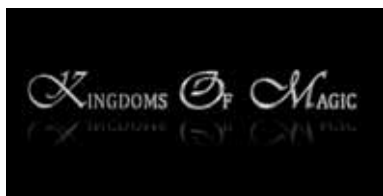

THE COLOR(S) SILVER/CHROME IS/ARE CLAIMED AS A FEATURE OF THE MARK.

THE MARK CONSISTS OF THE STYLIZED WORDING "KINGDOMS OF MAGIC" IN SILVER/CHROME WITH A PARTIAL MIRRORED IMAGE OF THE WORDING IN SILVER/CHROME BENEATH THE WORDING. THE COLOR BLACK IS BACKGROUND AND NOT CLAIMED AS A FEATURE OF THE MARK.

FOR A SERIES OF BOOKS AND WRITTEN ARTICLES IN THE FIELD OF FANTASY; A SERIES OF FICTION WORKS, NAMELY, NOVELS AND BOOKS FEATURING FANTASY KINGDOMS; BOOK COVERS; BOOK MARKERS; BOOK MARKS; BOOK-COVER PAPER; CASES SPECIALLY ADAPTED FOR HOLDING AND CARRYING BOOKS (U.S. CLS. 2, 5, 22, 23, 29, 37, 38 AND 50).

ANDREA K. NADELMAN, EXAMINING ATTORNEY

SN 86-245,648. RAMOS, JORGE SALVADOR, DBA JSALVADOR, POMONA, CA. FILED 4-8-2014.

**SuperEmoFriends**

SN 86-245,078. THE MAGICAL MAILBOX, FRESNO, CA. FILED 4-7-2014.

**PLAY. CREATE. GROW.**

THE MARK CONSISTS OF STANDARD CHARACTERS WITHOUT CLAIM TO ANY PARTICULAR FONT, STYLE, SIZE, OR COLOR.

FOR CRAFT BOOKS, STORY BOOKS, GIFT SETS CONSISTING OF A STORY BOOK AND ARTS AND CRAFTS PAINT KITS (U.S. CLS. 2, 5, 22, 23, 29, 37, 38 AND 50).

PAULA MAHONEY, EXAMINING ATTORNEY

THE MARK CONSISTS OF STANDARD CHARACTERS WITHOUT CLAIM TO ANY PARTICULAR FONT, STYLE, SIZE, OR COLOR.

FOR (BASED ON USE IN COMMERCE) GRAPHIC ART PRINTS; ILLUSTRATIONS(BASED ON INTENT TO USE) GRAPHIC NOVELS (U.S. CLS. 2, 5, 22, 23, 29, 37, 38 AND 50).

FIRST USE 11-23-2009; IN COMMERCE 11-23-2009.

ANDREW RHIM, EXAMINING ATTORNEY



**CLASS 16—(Continued).**

SN 86-246,066. BAYLOR SCOTT & WHITE HOLDINGS, DALLAS, TX. FILED 4-8-2014.

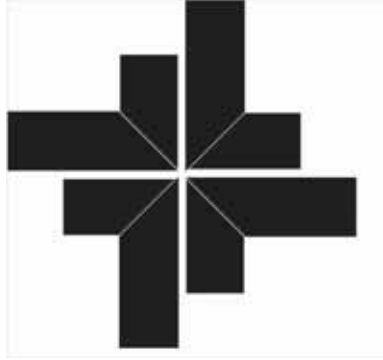

THE MARK CONSISTS OF AN ABSTRACT DIAMOND DESIGN COMPRISED OF FOUR "L" SHAPED POLYGONS. EACH OF THE FOUR "L" SHAPED POLYGONS ARE COMPRISED OF ONE LONG SOLID QUADRILATERAL AND ONE SHORT SOLID QUADRILATERAL.

FOR PRINTED MATERIALS, NAMELY, BOOKS, JOURNALS, MAGAZINES, NEWSLETTERS, PAMPHLETS AND BROCHURES IN THE FIELDS OF MEDICINE, HEALTHCARE, AND WELLNESS (U.S. CLS. 2, 5, 22, 23, 29, 37, 38 AND 50).

SARA KUNKLEMAN, EXAMINING ATTORNEY

SN 86-246,079. BAYLOR SCOTT & WHITE HOLDINGS, DALLAS, TX. FILED 4-8-2014.



THE COLOR(S) DARK BLUE, LIGHT BLUE AND GOLD IS/ARE CLAIMED AS A FEATURE OF THE MARK.

THE MARK CONSISTS OF AN ABSTRACT DIAMOND DESIGN COMPRISED OF FOUR L SHAPED POLYGONS. THE TOP LEFT POLYGON AND THE BOTTOM RIGHT POLYGON ARE EACH COMPRISED OF A LONGER DARK BLUE QUADRILATERAL AND A SHORTER GOLD QUADRILATERAL. THE BOTTOM LEFT POLYGON AND TOP RIGHT POLYGON ARE EACH COMPRISED OF A LONGER DARK BLUE QUADRILATERAL AND A SHORTER LIGHT BLUE QUADRILATERAL.

FOR PRINTED MATERIALS, NAMELY, BOOKS, JOURNALS, MAGAZINES, NEWSLETTERS, PAMPHLETS AND BROCHURES IN THE FIELDS OF MEDICINE, HEALTHCARE, AND WELLNESS (U.S. CLS. 2, 5, 22, 23, 29, 37, 38 AND 50).

SARA KUNKLEMAN, EXAMINING ATTORNEY

**CLASS 16—(Continued).**

SN 86-246,158. KEEP CALM AND FISH ON FISHING CHARTERS LLC, LITHIA, FL. FILED 4-8-2014.

**Fished There Caught That**

THE MARK CONSISTS OF STANDARD CHARACTERS WITHOUT CLAIM TO ANY PARTICULAR FONT, STYLE, SIZE, OR COLOR.

FOR DECALS; STICKERS (U.S. CLS. 2, 5, 22, 23, 29, 37, 38 AND 50).

ERIN FALK, EXAMINING ATTORNEY

SN 86-247,008. MURRAY, WAYNE ARTHUR, MONTREAL, CANADA, FILED 4-9-2014.

**WAM! Comics**

THE MARK CONSISTS OF STANDARD CHARACTERS WITHOUT CLAIM TO ANY PARTICULAR FONT, STYLE, SIZE, OR COLOR.

NO CLAIM IS MADE TO THE EXCLUSIVE RIGHT TO USE "COMICS", APART FROM THE MARK AS SHOWN.

FOR COMIC BOOKS; COMIC MAGAZINES; COMIC STRIPS; COMICS (U.S. CLS. 2, 5, 22, 23, 29, 37, 38 AND 50).

FIRST USE 6-1-2009; IN COMMERCE 6-1-2009.

KATHRYN COWARD, EXAMINING ATTORNEY

SN 86-248,581. THE FOG CUTTER, HAWTHORNE, CA. FILED 4-10-2014.

**Pearinella**

THE MARK CONSISTS OF STANDARD CHARACTERS WITHOUT CLAIM TO ANY PARTICULAR FONT, STYLE, SIZE, OR COLOR.

FOR BOOKS IN THE FIELD OF MYSTERY NOVELS (U.S. CLS. 2, 5, 22, 23, 29, 37, 38 AND 50).

KAELIE KUNG, EXAMINING ATTORNEY

**CLASS 16—(Continued).**

SN 86-248,972. MCCLAFLIN FINANCIAL LLC, ARVADA, CO. FILED 4-10-2014.

## Retirement Adventure Roadmap

THE MARK CONSISTS OF STANDARD CHARACTERS WITHOUT CLAIM TO ANY PARTICULAR FONT, STYLE, SIZE, OR COLOR.

NO CLAIM IS MADE TO THE EXCLUSIVE RIGHT TO USE "RETIREMENT", APART FROM THE MARK AS SHOWN.

FOR PUBLICATIONS, NAMELY, WORKBOOKS AND HAND-OUTS IN THE FIELDS OF SETTING GOALS AND FINANCIAL PLANNING FOR RETIREMENT (U.S. CLS. 2, 5, 22, 23, 29, 37, 38 AND 50).

FIRST USE 9-5-2013; IN COMMERCE 9-5-2013.

WILLIAM BRECKENFELD, EXAMINING ATTORNEY

SN 86-249,131. MASKIT, LLC, ASHLAND, OR. FILED 4-10-2014.

## MaskIT

THE MARK CONSISTS OF STANDARD CHARACTERS WITHOUT CLAIM TO ANY PARTICULAR FONT, STYLE, SIZE, OR COLOR.

FOR PLASTIC BAGS FOR THE STORAGE AND DISPOSAL OF WASTE, INCLUDING SANITARY WASTE SUCH AS FEMININE HYGIENE PRODUCTS (U.S. CLS. 2, 5, 22, 23, 29, 37, 38 AND 50).

BILL DAWE, EXAMINING ATTORNEY

SN 86-249,300. MARBLES, LLC, BONITA SPRINGS, FL. FILED 4-11-2014.

## boxa

THE MARK CONSISTS OF STANDARD CHARACTERS WITHOUT CLAIM TO ANY PARTICULAR FONT, STYLE, SIZE, OR COLOR.

FOR BOXES, CARTONS, STORAGE CONTAINERS, AND PACKAGING CONTAINERS MADE OF PAPER OR CARDBOARD; FILE BOXES FOR STORAGE OF BUSINESS AND PERSONAL RECORD; PHOTO STORAGE BOXES (U.S. CLS. 2, 5, 22, 23, 29, 37, 38 AND 50).

PAUL E. FAHRENKOPF, EXAMINING ATTORNEY

**CLASS 16—(Continued).**

SN 86-249,889. MEDISCA INC., PLATTSBURGH, NY. FILED 4-11-2014.

## TRAIN NOW SHAPE YOUR FUTURE

THE MARK CONSISTS OF STANDARD CHARACTERS WITHOUT CLAIM TO ANY PARTICULAR FONT, STYLE, SIZE, OR COLOR.

FOR PRINTED EDUCATIONAL MATERIALS IN STUDENT PHARMACY FIELD (U.S. CLS. 2, 5, 22, 23, 29, 37, 38 AND 50).

FIRST USE 3-24-2014; IN COMMERCE 3-24-2014.

ELIZABETH HUGHITT, EXAMINING ATTORNEY

SN 86-250,170. MIND TRIP LLC, SUNNY ISLES BEACH, FL. FILED 4-11-2014.

## paperbackpack

THE MARK CONSISTS OF STANDARD CHARACTERS WITHOUT CLAIM TO ANY PARTICULAR FONT, STYLE, SIZE, OR COLOR.

FOR TRAVEL BOOKS (U.S. CLS. 2, 5, 22, 23, 29, 37, 38 AND 50).

JAMES A. RAUEN, EXAMINING ATTORNEY

SN 86-250,631. HAYS, SUSAN R, SCOTTSDALE, AZ. FILED 4-12-2014.

## GARNISHED ANGELS

THE MARK CONSISTS OF STANDARD CHARACTERS WITHOUT CLAIM TO ANY PARTICULAR FONT, STYLE, SIZE, OR COLOR.

FOR A SERIES OF BOOKS, WRITTEN ARTICLES, HANDOUTS AND WORKSHEETS IN THE FIELD OF MANNERS AND DAY TO DAY LIVING.; ART PRINTS; ART PRINTS ON CANVAS; BLANK NOTE CARDS; BLANK OR PARTIALLY PRINTED POSTCARDS; BOOKS IN THE FIELD OF DAY TO DAY LIVING; CALENDARS AND DIARIES; CARDS BEARING UNIVERSAL GREETINGS; CARDS, NAMELY, GREETING AND NOTE CARDS; CHRISTMAS CARDS; DISPOSABLE NAPKINS; EDUCATIONAL PUBLICATIONS, NAMELY, BOOKLETS AND WORKBOOKS IN THE FIELDS OF MANNERS AND COPING WITH DAY TO DAY LIVING; GRAPHIC ART PRINTS; GREETING CARDS; PAPER NAPKINS; PAPER NOTE TABLETS; PAPER STATIONERY; PATTERNS FOR NEEDLEPOINT, CROSS STITCH AND KNITTING; POSTCARDS AND GREETING CARDS; PRINTED EDUCATIONAL MATERIALS IN THE FIELD OF NEEDLE ARTS AND COPING WITH DAY TO DAY LIVING.; PRINTED PATTERNS; PRINTS; STICKERS (U.S. CLS. 2, 5, 22, 23, 29, 37, 38 AND 50).

FIRST USE 2-12-1997; IN COMMERCE 2-12-1997.

GINA HAYES, EXAMINING ATTORNEY

**CLASS 16—(Continued).**

SN 86-251,576. MARVEL CHARACTERS, INC., BURBANK, CA. FILED 4-14-2014.

# AXIS

THE MARK CONSISTS OF STANDARD CHARACTERS WITHOUT CLAIM TO ANY PARTICULAR FONT, STYLE, SIZE, OR COLOR.

FOR COMIC BOOKS; PRINTED PERIODICALS IN THE FIELD OF COMIC BOOK STORIES AND ARTWORK; PRINTED VISUALS IN THE NATURE OF COMIC BOOK STORIES AND ARTWORK (U.S. CLS. 2, 5, 22, 23, 29, 37, 38 AND 50).

MIDGE BUTLER, EXAMINING ATTORNEY

---

SN 86-251,661. DANIEL BONEBRAKE, KEIZER, OR. FILED 4-14-2014.

# ECORR

THE MARK CONSISTS OF STANDARD CHARACTERS WITHOUT CLAIM TO ANY PARTICULAR FONT, STYLE, SIZE, OR COLOR.

OWNER OF U.S. REG. NO. 4,209,910.  
FOR CARDBOARD BOXES; CORRUGATED BOARD; CORRUGATED BOXES; CORRUGATED CONTAINERS (U.S. CLS. 2, 5, 22, 23, 29, 37, 38 AND 50).

FIRST USE 4-1-2011; IN COMMERCE 4-1-2011.

MICHAEL SOUDERS, EXAMINING ATTORNEY

---

SN 86-251,726. SAGE PUBLICATIONS, INC., THOUSAND OAKS, CA. FILED 4-14-2014.

# CORWIN CONNECT

THE MARK CONSISTS OF STANDARD CHARACTERS WITHOUT CLAIM TO ANY PARTICULAR FONT, STYLE, SIZE, OR COLOR.

OWNER OF U.S. REG. NOS. 2,168,847, 3,623,617 AND 3,850,972.

FOR BOOKS AND JOURNALS IN THE FIELDS OF SCHOLARLY, ACADEMIC, PROFESSIONAL, LEARNED, MEDICAL, SCIENTIFIC AND TECHNICAL RESEARCH, TRAINING AND EDUCATION (U.S. CLS. 2, 5, 22, 23, 29, 37, 38 AND 50).

MICHAEL KEATING, EXAMINING ATTORNEY

**CLASS 16—(Continued).**

SN 86-252,330. PINELLAS COUNTY GOVERNMENT (FLORIDA POLITICAL SUBDIVISION OF THE STATE OF FLORIDA PURSUANT TO FL STATUTE, TITLE II, CHAPTER 7; TITLE XI, CHAPTER 125), DBA VISIT ST. PETERSBURG-CLEARWATER A/K/A PINELLAS COUNTY'S CONVENTION AND VISITORS BUREAU, CLEARWATER, FL. FILED 4-15-2014.

# GULF TO BAY

THE MARK CONSISTS OF STANDARD CHARACTERS WITHOUT CLAIM TO ANY PARTICULAR FONT, STYLE, SIZE, OR COLOR.

FOR GENERAL FEATURE MAGAZINE IN THE FIELD OF DESTINATION ENTICEMENT FOR VACATION PLANNING (U.S. CLS. 2, 5, 22, 23, 29, 37, 38 AND 50).

FIRST USE 5-6-2013; IN COMMERCE 5-6-2013.

ALLISON SCHRODY, EXAMINING ATTORNEY

---

SN 86-252,398. MIND TRIP LLC, SUNNY ISLES BEACH, FL. FILED 4-15-2014.

# leave some good behind

THE MARK CONSISTS OF STANDARD CHARACTERS WITHOUT CLAIM TO ANY PARTICULAR FONT, STYLE, SIZE, OR COLOR.

FOR TRAVEL BOOKS (U.S. CLS. 2, 5, 22, 23, 29, 37, 38 AND 50).

JAMES A. RAUEN, EXAMINING ATTORNEY

---

SN 86-259,607. HISTORY, LLC, LAKE OSWEGO, OR. FILED 4-22-2014.



THE MARK CONSISTS OF A STYLIZED KEY-AND-TAG LOGO.

FOR MEMORY BOXES, NAMELY, CARDBOARD BOXES CONTAINING CARDBOARD CARDS FOR DISPLAYING AND STORING FAMILY KEEPSAKES AND MEMENTOS (U.S. CLS. 2, 5, 22, 23, 29, 37, 38 AND 50).

TARA BHUPATHI, EXAMINING ATTORNEY

**CLASS 16—(Continued).**

SN 86-259,972. LEG, INC., DBA WEST ACADEMIC, ST. PAUL, MN. FILED 4-23-2014.

## Bridge to Practice Series

THE MARK CONSISTS OF STANDARD CHARACTERS WITHOUT CLAIM TO ANY PARTICULAR FONT, STYLE, SIZE, OR COLOR.

NO CLAIM IS MADE TO THE EXCLUSIVE RIGHT TO USE "SERIES", APART FROM THE MARK AS SHOWN.

FOR BOOKS IN THE FIELD OF LAW CONTAINING CONCISE DISCUSSION AND PRACTICAL SIMULATIONS ON VARIOUS LEGAL SUBJECTS (U.S. CLS. 2, 5, 22, 23, 29, 37, 38 AND 50).

FIRST USE 3-29-2012; IN COMMERCE 3-29-2012.  
LAURIE KAUFMAN, EXAMINING ATTORNEY

---

SN 86-271,156. DISTRICT 12, LLC, WESTPORT, CT. FILED 5-5-2014.

## MOCKINGJAY

THE MARK CONSISTS OF STANDARD CHARACTERS WITHOUT CLAIM TO ANY PARTICULAR FONT, STYLE, SIZE, OR COLOR.

FOR BOOKENDS; BOOKMARKS; FOLDERS; PENCIL CASES; ART PICTURES; BLANK JOURNALS; CLIPBOARDS; DRY ERASE BOARDS; FRAMED ART PRINTS; IRON-ON TRANSFERS; NOTE PADS WITH OR WITHOUT ADHESIVE; MONEY CLIPS; NOTE CARDS; PAPER LABELS; VINYL DECALS FOR USE AS HOME DECOR; BOOKS IN THE FIELD OF ENTERTAINMENT; CARDBOARD STAND-UP CUTOUTS FEATURING PHOTOGRAPHS OR ARTWORK; GIFT CARDS WITHOUT MAGNETIC ENCODING; INK STAMPS; PHOTOGRAPHS; SHEET MUSIC; TRADING CARDS; WRITING INSTRUMENTS (U.S. CLS. 2, 5, 22, 23, 29, 37, 38 AND 50).

FIRST USE 6-0-2010; IN COMMERCE 6-0-2010.  
DANIELLE JOHNSON, EXAMINING ATTORNEY

---

SN 86-274,187. BOISE WHITE PAPER, L.L.C., BOISE, ID. FILED 5-7-2014.



THE MARK CONSISTS OF A MOUNTAIN RANGE. FOR PAPER (U.S. CLS. 2, 5, 22, 23, 29, 37, 38 AND 50). SANI KHOURI, EXAMINING ATTORNEY

**CLASS 16—(Continued).**

SN 86-289,707. PERK-UP, INC., AKA KARI-OUT, CO., WHITE PLAINS, NY. FILED 5-22-2014.



NO CLAIM IS MADE TO THE EXCLUSIVE RIGHT TO USE "PLEASE RECYCLE THIS BAG", APART FROM THE MARK AS SHOWN.

THE MARK CONSISTS OF THE WORDS "PLEASE RECYCLE THIS BAG." THE "R" HAS AN ELONGATED LINE STARTING FROM THE RIGHT AND UNDERLINING THE REST OF THE WORD "RECYCLE" AND THE WORDS "THIS BAG". THERE ARE 4 LEAVES ON THE ELONGATED LINE.

FOR PAPER SHOPPING BAGS (U.S. CLS. 2, 5, 22, 23, 29, 37, 38 AND 50).

FIRST USE 4-5-2014; IN COMMERCE 4-5-2014.  
EDWARD NELSON, EXAMINING ATTORNEY

---

SN 86-298,087. GOMEZ, TRICIA, DBA DANCE - IN A BOX, REDONDO BEACH, CA. FILED 6-2-2014.

## Hip Hop In a Box

THE MARK CONSISTS OF STANDARD CHARACTERS WITHOUT CLAIM TO ANY PARTICULAR FONT, STYLE, SIZE, OR COLOR.

NO CLAIM IS MADE TO THE EXCLUSIVE RIGHT TO USE "HIP HOP", APART FROM THE MARK AS SHOWN.

FOR EDUCATIONAL KITS SOLD AS A UNIT IN THE FIELD OF DANCE CONSISTING PRIMARILY OF FLASH CARDS, AND ALSO INCLUDING CDS AND DVDS (U.S. CLS. 2, 5, 22, 23, 29, 37, 38 AND 50).

FIRST USE 2-16-2006; IN COMMERCE 2-16-2006.  
BRIAN CALLAGHAN, EXAMINING ATTORNEY

---

SN 86-303,600. SOCIETE BIC, CLICHY, FRANCE, FILED 6-9-2014.

## XTRA-CRAZE

THE MARK CONSISTS OF STANDARD CHARACTERS WITHOUT CLAIM TO ANY PARTICULAR FONT, STYLE, SIZE, OR COLOR.

FOR WRITING INSTRUMENTS, NAMELY PENS, PENCILS AND MECHANICAL PENCILS (U.S. CLS. 2, 5, 22, 23, 29, 37, 38 AND 50).

DOMINIC J. FERRAIUOLO, EXAMINING ATTORNEY

**CLASS 16—(Continued).**

SN 86-304,148. J. PIERCE COLLECTION, LLC, GILBERT, AZ. FILED 6-9-2014.



THE ASSUMED NAME "J. PIERCE" IDENTIFIES THE PSEUDONYM OF JUSTIN PIERCE, A LIVING INDIVIDUAL WHOSE CONSENT IS OF RECORD.

THE MARK CONSISTS OF THE WORDS "J. PIERCE" IN STYLIZED BLACK FONT, WITH AN UPPER CASE "J" FOLLOWED BY A PERIOD, WHICH IS FOLLOWED BY "PIERCE" IN LOWER CASE WITH TWO PERIODS IMMEDIATELY BELOW THE TAIL OF THE "E".

FOR ART PICTURES ON CANVAS; ORIGINAL ART PICTURES ON CANVAS (U.S. CLS. 2, 5, 22, 23, 29, 37, 38 AND 50).

FIRST USE 6-1-2008; IN COMMERCE 6-1-2008.  
ESTHER QUEEN, EXAMINING ATTORNEY

SN 86-314,152. FORE FUN, LLC, CHICAGO, IL. FILED 6-19-2014.

# FORE FUN

THE MARK CONSISTS OF STANDARD CHARACTERS WITHOUT CLAIM TO ANY PARTICULAR FONT, STYLE, SIZE, OR COLOR.

FOR BOOKS IN THE FIELD OF GOLF (U.S. CLS. 2, 5, 22, 23, 29, 37, 38 AND 50).

FIRST USE 6-14-2014; IN COMMERCE 6-14-2014.  
NATALIE KENEALY, EXAMINING ATTORNEY

SN 86-320,993. UNITED STATES POSTAL SERVICE, WASHINGTON, DC. FILED 6-26-2014.

# WINTER FUN

THE MARK CONSISTS OF STANDARD CHARACTERS WITHOUT CLAIM TO ANY PARTICULAR FONT, STYLE, SIZE, OR COLOR.

FOR POSTAGE STAMPS; FIRST DAY COVERS AND DIGITAL CANCELLATIONS POSTMARK COVERS, NAMELY, ENVELOPES POSTMARKED ON THE FIRST DAY OF THE ISSUE OF A POSTAGE STAMP; AMERICAN COMMEMORATIVE POSTAGE STAMP PANELS; AMERICAN COMMEMORATIVE POSTAGE STAMP COLLECTION PAGE (U.S. CLS. 2, 5, 22, 23, 29, 37, 38 AND 50).

JEFFERY COWARD, EXAMINING ATTORNEY

**CLASS 17—RUBBER GOODS**

SN 76-715,099. BROADWAY KLEER-GUARD CORP., MONROE, NJ. FILED 10-2-2013.



OWNER OF U.S. REG. NOS. 2,848,934 AND 3,562,928.  
THE MARK CONSISTS OF THE LETTER "KG" ON A TWO-TONE SHIELD WITH A LINED BORDER.

FOR INSULATION COVERS FOR STORAGE AND TRANSPORTATION OF GOODS, NAMELY, INSULATING BLANKET PADS AND MOVING BLANKETS (U.S. CLS. 1, 5, 12, 13, 35 AND 50).

FIRST USE 4-0-2013; IN COMMERCE 4-0-2013.  
LAURA GOLDEN, EXAMINING ATTORNEY

SN 79-140,648. TAICA CORPORATION, TOKYO 108-0074, JAPAN, FILED 8-2-2013.



OWNER OF INTERNATIONAL REGISTRATION 1187323 DATED 8-2-2013, EXPIRES 8-2-2023.

OWNER OF U.S. REG. NOS. 3,219,781 AND 4,004,494.  
NO CLAIM IS MADE TO THE EXCLUSIVE RIGHT TO USE "GEL" AND "SOFTNESS", APART FROM THE MARK AS SHOWN.

THE MARK CONSISTS OF THE GREEK LETTER ALPHA FOLLOWED BY THE STYLIZED WORD "GEL" IN CAPITAL LETTERS, ON A LINE ABOVE THE STYLIZED WORDING "DISCOVER SOFTNESS".

FOR RUBBER; RUBBER WASHERS; PLASTIC SUBSTANCES, SEMI-PROCESSED FOR FURTHER MANUFACTURE; SEMI-PROCESSED PLASTIC SUBSTANCES FOR FURTHER MANUFACTURE, EXCELLENT IN VIBRATION PROOF, SHOCK ABSORPTION AND THERMAL CONDUCTIVITY AND OTHER PLASTIC SEMI-WORKED PRODUCTS FOR FURTHER MANUFACTURE; ELECTRICAL INSULATING MATERIALS; WATER-PROOF PACKINGS, NAMELY, MOLDABLE COMPOUNDS FOR USE IN WATER ISOLATION; GASKETS FOR GAP SEALING FOR HARD DISCS OR CELLULAR TELEPHONES; SEALING MATERIALS; RUBBER CORDS AND LACES (U.S. CLS. 1, 5, 12, 13, 35 AND 50).

MEREDITH MARESCA, EXAMINING ATTORNEY

**CLASS 17—(Continued).**

SN 79-147,397. SINOCEM LANTIAN CO., LTD., 310051 ZHEJIANG, CHINA, FILED 3-12-2014.

# Fecolar

OWNER OF INTERNATIONAL REGISTRATION 1204260 DATED 3-12-2014, EXPIRES 3-12-2024.

THE MARK CONSISTS OF THE STYLIZED WORDING "FECOLAR".

FOR BIODEGRADABLE PLASTIC FILM FOR AGRICULTURAL USE; PLASTIC FILM FOR PACKING, CUSHIONING, OR STUFFING PURPOSES OTHER THAN FOR WRAPPING; INSULATING MATERIALS; SEMI-WORKED SYNTHETIC PLASTIC AND SYNTHETIC RESINS AS SEMI-FINISHED PRODUCTS IN FORM OF PELLETS, RODS, FOILS, FOAMS, FIBERS, FILMS AND SHEETS; SEMI-PROCESSED PLASTICS IN THE NATURE OF FILTERING MATERIALS FOR USE IN AGRICULTURE; PLASTIC, FOAM AND CORRUGATED PVC FLUTED SUBSTRATES; PLASTIC SHEETING FOR AGRICULTURAL PURPOSES; TINTED, LAMINATED AND REFLECTIVE PLASTIC FILMS FOR USE IN HOME OR AUTO WINDOWS (U.S. CLS. 1, 5, 12, 13, 35 AND 50).

HOWARD B. LEVINE, EXAMINING ATTORNEY

SN 85-934,558. SISKIN ENTERPRISES, INC., SALT LAKE CITY, UT. FILED 5-16-2013.

# SOLARPLATE

THE MARK CONSISTS OF STANDARD CHARACTERS WITHOUT CLAIM TO ANY PARTICULAR FONT, STYLE, SIZE, OR COLOR.

FOR SHEETS OF POLYESTER FILM TO BE APPLIED AS A PROTECTION FOR AUTOMOBILE GLASS; PROTECTIVE POLYESTER FILM FOR USE ON AUTO WINDOWS (U.S. CLS. 1, 5, 12, 13, 35 AND 50).

FIRST USE 2-15-2013; IN COMMERCE 2-15-2013.  
MAYUR VAGHANI, EXAMINING ATTORNEY

SN 86-116,900. LUMICOR, INC., RENTON, WA. FILED 11-12-2013.

# Lumicast

THE MARK CONSISTS OF STANDARD CHARACTERS WITHOUT CLAIM TO ANY PARTICULAR FONT, STYLE, SIZE, OR COLOR.

FOR EXTRUDED PLASTIC IN THE FORM OF SHEETS FOR USE IN MANUFACTURING (U.S. CLS. 1, 5, 12, 13, 35 AND 50).

FIRST USE 11-12-2013; IN COMMERCE 11-12-2013.  
JENNIFER BUTTON, EXAMINING ATTORNEY

**CLASS 17—(Continued).**

SN 86-117,057. LUMICOR, INC., RENTON, WA. FILED 11-12-2013.

# Lumiguard

THE MARK CONSISTS OF STANDARD CHARACTERS WITHOUT CLAIM TO ANY PARTICULAR FONT, STYLE, SIZE, OR COLOR.

FOR EXTRUDED PLASTIC IN THE FORM OF SHEETS FOR USE IN MANUFACTURING (U.S. CLS. 1, 5, 12, 13, 35 AND 50).

FIRST USE 1-1-2003; IN COMMERCE 1-1-2003.  
JENNIFER BUTTON, EXAMINING ATTORNEY

SN 86-161,077. NEPTUNE RESEARCH, INC., DBA NRI, RIVIERA BEACH, FL. FILED 1-9-2014.

# VIPER

THE MARK CONSISTS OF STANDARD CHARACTERS WITHOUT CLAIM TO ANY PARTICULAR FONT, STYLE, SIZE, OR COLOR.

OWNER OF U.S. REG. NO. 4,074,911.  
FOR RESIN IMPREGNATED CARBON FIBER COMPOSITE TAPES, FILMS AND SHEETS FOR THE REPAIR, REINFORCEMENT, AND STRENGTHENING OF PIPES, VESSELS, OR CONVEYANCES AS WELL AS CONCRETE MEMBERS AND WALLS (U.S. CLS. 1, 5, 12, 13, 35 AND 50).

CAITLIN WATTS-FITZGERALD, EXAMINING ATTORNEY

SN 86-190,202. HARRISON BROS., INC., CHAPEL HILL, NC. FILED 2-11-2014.

# GFR TAPE

THE MARK CONSISTS OF STANDARD CHARACTERS WITHOUT CLAIM TO ANY PARTICULAR FONT, STYLE, SIZE, OR COLOR.

NO CLAIM IS MADE TO THE EXCLUSIVE RIGHT TO USE "TAPE", APART FROM THE MARK AS SHOWN.

THE WORD(S) "GFR" HAS NO MEANING IN A FOREIGN LANGUAGE.

FOR GAFFER TAPE, NAMELY, PRESSURE-SENSITIVE ADHESIVE TAPES HAVING A FABRIC SUBSTRATE FOR USE IN THEATER, FILM PRODUCTIONS, TELEVISION PRODUCTIONS, LIVE PERFORMANCES AND STAGE PRODUCTIONS (U.S. CLS. 1, 5, 12, 13, 35 AND 50).

FIRST USE 2-6-2014; IN COMMERCE 2-6-2014.  
HENRY S. ZAK, EXAMINING ATTORNEY

**CLASS 17—(Continued).**

SN 86-196,786. KENTSHARP COMPANY LIMITED, TSUEN WAN, N.T., HONG KONG, FILED 2-18-2014.

# KENTSHARP

THE MARK CONSISTS OF STANDARD CHARACTERS WITHOUT CLAIM TO ANY PARTICULAR FONT, STYLE, SIZE, OR COLOR.

FOR FLEXIBLE PLASTIC PLUMBING PIPES (U.S. CLS. 1, 5, 12, 13, 35 AND 50).

FIRST USE 1-0-2005; IN COMMERCE 1-0-2005.

ROBERT C. CLARK JR., EXAMINING ATTORNEY

---

SN 86-210,300. VEYANCE TECHNOLOGIES, INC, FAIR-LAWN, OH. FILED 3-4-2014.

# VELOCITY

THE MARK CONSISTS OF STANDARD CHARACTERS WITHOUT CLAIM TO ANY PARTICULAR FONT, STYLE, SIZE, OR COLOR.

FOR NON-METALLIC HOSES AND FLEXIBLE PIPES, SPECIFICALLY INDUSTRIAL HOSE FOR USE AS WATER TRANSFER HOSE (U.S. CLS. 1, 5, 12, 13, 35 AND 50).

LAURA GOLDEN, EXAMINING ATTORNEY

---

SN 86-216,369. INVENTEL, LLC, KINNELON, NJ. FILED 3-10-2014.

# GRIPEEZ

THE MARK CONSISTS OF STANDARD CHARACTERS WITHOUT CLAIM TO ANY PARTICULAR FONT, STYLE, SIZE, OR COLOR.

FOR ADHESIVE DOUBLE SIDED MOUNTING TAPE SPECIFICALLY FOR USE IN HANGING PICTURES AND DECORATIVE ITEMS ON WALLS (U.S. CLS. 1, 5, 12, 13, 35 AND 50).

MICHAEL TANNER, EXAMINING ATTORNEY

**CLASS 17—(Continued).**

SN 86-226,331. ECLECTIC PRODUCTS, INC., EUGENE, OR. FILED 3-19-2014.

# FAMOWOOD PROCRETE

THE MARK CONSISTS OF STANDARD CHARACTERS WITHOUT CLAIM TO ANY PARTICULAR FONT, STYLE, SIZE, OR COLOR.

OWNER OF U.S. REG. NO. 1,451,621.

FOR PREPACKAGED CONCRETE PATCH KIT COMPRISED OF A RESIN AND A HARDENER; PREPACKAGED CONCRETE PATCH KIT COMPRISED OF A RESIN, A HARDENER, AND AN AGGREGATE; PREPACKAGED CONCRETE PATCH KIT COMPRISED OF A RESIN, A HARDENER, AN AGGREGATE AND A PRIMER (U.S. CLS. 1, 5, 12, 13, 35 AND 50).

PAUL CROWLEY, EXAMINING ATTORNEY

---

SN 86-236,683. EGW UTILITIES, INC., CARROLLTON, TX. FILED 3-31-2014.

# WHITE RHINO TUFF

THE MARK CONSISTS OF STANDARD CHARACTERS WITHOUT CLAIM TO ANY PARTICULAR FONT, STYLE, SIZE, OR COLOR.

NO CLAIM IS MADE TO THE EXCLUSIVE RIGHT TO USE "TOUGH", APART FROM THE MARK AS SHOWN.

FOR GASKETS MADE OF RUBBER FOR USE IN NATURAL GAS DISTRIBUTION, WATERWORKS, SEWER, PLUMBING, OILFIELD, OR PIPELINE FIELDS; PIPE INSULATION; WASHERS OF RUBBER OR VULCANIZED FIBER; POLYETHYLENE ENCASMENT FOR DUCTILE IRON PIPE (U.S. CLS. 1, 5, 12, 13, 35 AND 50).

FIRST USE 6-30-2011; IN COMMERCE 10-31-2012.

CRISTIANA SCHWAB, EXAMINING ATTORNEY

**CLASS 17—(Continued).**

SN 86-237,762. SPEEDY SUPPLY CO., PARREARRA, QLD, AUSTRALIA, FILED 3-31-2014.



NO CLAIM IS MADE TO THE EXCLUSIVE RIGHT TO USE "EXPANDABLE FLEXIBLE HOSE", APART FROM THE MARK AS SHOWN.

THE COLOR(S) PURPLE, BLACK, WHITE, GRAY, AND GREEN IS/ARE CLAIMED AS A FEATURE OF THE MARK. THE MARK CONSISTS OF CONCENTRIC CIRCLES OUTLINED IN BLACK AND COLORED PURPLE WITH THE WHITE AND GREY WORDING "EXPANDABLE FLEXIBLE" IN THE PERIMETER OF THE CIRCLE; THE INSIDE OF THE CIRCLE IS COLORED WHITE AND THERE IS A MISCELLANEOUS BLACK DESIGN ABOVE A GREEN BANNER THAT INCLUDES THE TERM "HOSE" WHICH IS COLORED WHITE WITH PURPLE LINES; UNDERNEATH THAT TERM APPEAR FIVE STARS COLORED PURPLE.

FOR GARDEN HOSES (U.S. CLS. 1, 5, 12, 13, 35 AND 50).

FIRST USE 3-20-2014; IN COMMERCE 3-20-2014. CHRISTOPHER BUONGIORNO, EXAMINING ATTORNEY

SN 86-246,467. R.M. EXPORTS, JALANDHAR, INDIA, AND RASTOGI, KULVINDER, JALANDHAR, INDIA, AND MALHOTRA, VIKAS, JALANDHAR, INDIA, FILED 4-8-2014.

# ZEPHYR

THE MARK CONSISTS OF STANDARD CHARACTERS WITHOUT CLAIM TO ANY PARTICULAR FONT, STYLE, SIZE, OR COLOR.

FOR RUBBER AND GOODS MADE FROM RUBBER, NAMELY, INDUSTRIAL HOSES MADE OF RUBBER AND PLASTIC FOR USE IN RESIDENTIAL AND COMMERCIAL CONSTRUCTION, AND LANDSCAPING (U.S. CLS. 1, 5, 12, 13, 35 AND 50).

JENNY PARK, EXAMINING ATTORNEY

**CLASS 17—(Continued).**

SN 86-250,531. VOGLER ENTERPRISES, INC., EXCELSIOR SPRINGS, MO. FILED 4-12-2014.

# SOLARFX

THE MARK CONSISTS OF STANDARD CHARACTERS WITHOUT CLAIM TO ANY PARTICULAR FONT, STYLE, SIZE, OR COLOR.

OWNER OF U.S. REG. NO. 4,510,115.

FOR TINTED, LAMINATED AND REFLECTIVE PLASTIC FILMS FOR USE IN HOME OR AUTO WINDOWS (U.S. CLS. 1, 5, 12, 13, 35 AND 50).

FIRST USE 7-31-2013; IN COMMERCE 7-31-2013.

LAUREN BURKE, EXAMINING ATTORNEY

**CLASS 18—LEATHER GOODS**

SN 77-651,996. LUVANIS S.A., LUXEMBOURG, LUXEMBOURG, FILED 1-19-2009.

# PAUL POIRET

THE MARK CONSISTS OF STANDARD CHARACTERS WITHOUT CLAIM TO ANY PARTICULAR FONT, STYLE, SIZE, OR COLOR.

OWNER OF LUXEMBOURG REG. NO. 0954427, DATED 6-16-2014, EXPIRES 4-2-2024.

THE NAME(S), PORTRAIT(S), AND/OR SIGNATURE(S) SHOWN IN THE MARK DOES NOT IDENTIFY A PARTICULAR LIVING INDIVIDUAL.

FOR ALL-PURPOSE CARRYING BAGS IN LEATHER AND IMITATION LEATHER; CARD WALLETS; HANDBAGS; LUGGAGE, NAMELY, TRAVEL BAGS; PURSES; SUITCASES (U.S. CLS. 1, 2, 3, 22 AND 41).

ESTHER A. BORSUK, EXAMINING ATTORNEY

SN 79-140,967. DENISE P. STRANSKY, AUSTRALIA, AND PETER D. STRANSKY, AUSTRALIA, FILED 10-28-2013.

# finbrella

THE MARK CONSISTS OF STANDARD CHARACTERS WITHOUT CLAIM TO ANY PARTICULAR FONT, STYLE, SIZE, OR COLOR.

OWNER OF INTERNATIONAL REGISTRATION 1188117 DATED 10-28-2013, EXPIRES 10-28-2023.

FOR PORTABLE BEACH UMBRELLAS; COVERS FOR UMBRELLAS; FRAMES FOR UMBRELLAS OR PARASOLS; GARDEN UMBRELLAS; PORTABLE UMBRELLAS USED IN COMMERCIAL SETTINGS; PORTABLE SHADE UMBRELLAS; SUNSHADES IN THE NATURE OF UMBRELLAS; UMBRELLA BAGS; UMBRELLAS (U.S. CLS. 1, 2, 3, 22 AND 41).

GENE MACIOL, EXAMINING ATTORNEY



**CLASS 18—(Continued).**

SN 79-142,601. HERM. SPRENGER GMBH & CO. KG, ISELOHN, FED REP GERMANY, FILED 12-12-2013.

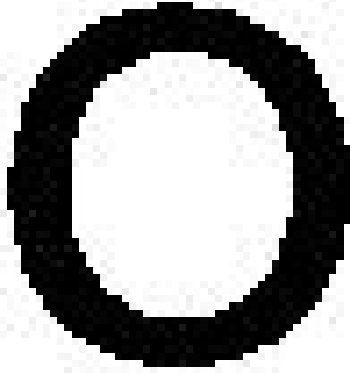

THE MARK CONSISTS OF STANDARD CHARACTERS WITHOUT CLAIM TO ANY PARTICULAR FONT, STYLE, SIZE, OR COLOR.

PRIORITY DATE OF 6-14-2013 IS CLAIMED. OWNER OF INTERNATIONAL REGISTRATION 1192331 DATED 12-12-2013, EXPIRES 12-12-2023. FOR HORSE BITS AND DENTURE PARTS OF IT MADE OF METAL SOLD AS A COMPONENT PART THEREOF (U.S. CLS. 1, 2, 3, 22 AND 41). MEGHAN REINHART, EXAMINING ATTORNEY

SN 85-570,712. WEBSTER FINANCIAL CORPORATION, WATERBURY, CT. FILED 3-15-2012.

# WEBSTER

THE MARK CONSISTS OF STANDARD CHARACTERS WITHOUT CLAIM TO ANY PARTICULAR FONT, STYLE, SIZE, OR COLOR.

FOR TOTE BAGS; UMBRELLAS; GOLF UMBRELLAS; REUSABLE SHOPPER TOTE BAGS (U.S. CLS. 1, 2, 3, 22 AND 41). REBECCA SMITH, EXAMINING ATTORNEY

SN 85-675,151. HAIR DOOZY, LLC, FARMVILLE, NC. FILED 7-12-2012.

# HAIR DOOZY

THE MARK CONSISTS OF STANDARD CHARACTERS WITHOUT CLAIM TO ANY PARTICULAR FONT, STYLE, SIZE, OR COLOR.

NO CLAIM IS MADE TO THE EXCLUSIVE RIGHT TO USE "HAIR", APART FROM THE MARK AS SHOWN. FOR GROOMING ORGANIZERS FOR TRAVEL; ALL-PURPOSE CARRYING BAG FOR GROOMING ORGANIZERS (U.S. CLS. 1, 2, 3, 22 AND 41). DANIEL S. STRINGER, EXAMINING ATTORNEY

**CLASS 18—(Continued).**

SN 85-895,904. SOULCAKE, INC., SAN CLEMENTE, CA. FILED 4-4-2013.

# Indus hiking sticks

THE MARK CONSISTS OF STANDARD CHARACTERS WITHOUT CLAIM TO ANY PARTICULAR FONT, STYLE, SIZE, OR COLOR.

NO CLAIM IS MADE TO THE EXCLUSIVE RIGHT TO USE "HIKING STICKS", APART FROM THE MARK AS SHOWN.

FOR HIKING POLES (U.S. CLS. 1, 2, 3, 22 AND 41). KERI CANTONE, EXAMINING ATTORNEY

SN 86-015,583. DONGGUAN YINGWANG HANDBAG CO.,LTD, DONGGUAN,GUANGDONG, CHINA, FILED 7-20-2013.



# Ma-Te-Ya

THE COLOR(S) BLACK AND OCHRE IS/ARE CLAIMED AS A FEATURE OF THE MARK.

THE MARK CONSISTS OF THE STYLIZED WORDING "MYT" IN OCHRE ABOVE THE WORDING "MA-TE-YA" WHICH IS IN THE COLOR BLACK.

FOR BRIEFCASES; HANDBAGS; POCKET WALLET; PURSES; TRUNKS; VALISES (U.S. CLS. 1, 2, 3, 22 AND 41).

FIRST USE 12-1-2012; IN COMMERCE 12-1-2012. DARRYL SPRUILL, EXAMINING ATTORNEY

SN 86-072,444. STRATEGIC PARTNERS, INC., CHATSWORTH, CA. FILED 9-23-2013.

# Curo

THE MARK CONSISTS OF STANDARD CHARACTERS WITHOUT CLAIM TO ANY PARTICULAR FONT, STYLE, SIZE, OR COLOR.

THE ENGLISH TRANSLATION OF "CURO" IN THE MARK IS "TO HEAL".

FOR TOTE BAGS (U.S. CLS. 1, 2, 3, 22 AND 41). DANNEAN HETZEL, EXAMINING ATTORNEY

**CLASS 18—(Continued).**

SN 86-083,898. JOEL HARRY BROWN, ALTRINCHAM, CHESHIRE, UNITED KINGDOM, FILED 10-7-2013.

## STONE-DRI

THE MARK CONSISTS OF STANDARD CHARACTERS WITHOUT CLAIM TO ANY PARTICULAR FONT, STYLE, SIZE, OR COLOR.

OWNER OF UNITED KINGDOM REG. NO. 2515681, DATED 8-21-2009, EXPIRES 5-15-2019.

OWNER OF U.S. REG. NO. 3,715,461.

FOR LEATHER AND IMITATIONS OF LEATHER; TRUNKS, ATTACHÉ CASES, BRIEFCASES; HANDBAGS, KEY CASES, POCKET WALLETS, PURSES, SUITCASES, VALISES AND UNFITTED VANITY CASES; UMBRELLAS, PARASOLS AND WALKING STICKS (U.S. CLS. 1, 2, 3, 22 AND 41).

STEVEN JACKSON, EXAMINING ATTORNEY

SN 86-111,239. LI, MEI YING, CASTRO VALLEY, CA. FILED 11-6-2013.

## Gemma Li

THE MARK CONSISTS OF STANDARD CHARACTERS WITHOUT CLAIM TO ANY PARTICULAR FONT, STYLE, SIZE, OR COLOR.

THE NAME(S), PORTRAIT(S), AND/OR SIGNATURE(S) SHOWN IN THE MARK IDENTIFIES "MEI YING LI", WHOSE CONSENT(S) TO REGISTER IS MADE OF RECORD.

FOR ALL-PURPOSE CARRYING BAGS; BACK PACKS; BUSINESS CARD CASES; COSMETIC BAGS SOLD EMPTY; KEY CASES; LUGGAGE TAGS; PET CLOTHING; PET TAGS SPECIALLY ADAPTED FOR ATTACHING TO PET LEASHES OR COLLARS; PURSES AND WALLETS; WINE BAGS WITH HANDLES FOR CARRYING OR HOLDING WINE; WINE CARRYING CASES (U.S. CLS. 1, 2, 3, 22 AND 41).

FIRST USE 1-1-1993; IN COMMERCE 11-5-2013.

DORITT L. CARROLL, EXAMINING ATTORNEY

SN 86-142,048. COLIN SULLIVAN-STEVENSON, PORTLAND, ME. FILED 12-12-2013.

## ANCHORPACK

THE MARK CONSISTS OF STANDARD CHARACTERS WITHOUT CLAIM TO ANY PARTICULAR FONT, STYLE, SIZE, OR COLOR.

FOR ALL PURPOSE SPORT BAGS; ALL-PURPOSE ATHLETIC BAGS; ALL-PURPOSE CARRYING BAGS (U.S. CLS. 1, 2, 3, 22 AND 41).

FIRST USE 8-31-2012; IN COMMERCE 8-31-2012.

SUNG IN, EXAMINING ATTORNEY

**CLASS 18—(Continued).**

SN 86-167,579. PEANUTS WORLDWIDE LLC, NEW YORK, NY. FILED 1-16-2014.



OWNER OF U.S. REG. NOS. 1,256,900, 1,267,166 AND OTHERS.

THE MARK CONSISTS OF TWO PARTIALLY OBSCURED STYLIZED DOG FACES MOSTLY WITHIN A SQUARE WITH THE AMPERSAND SYMBOL BETWEEN THE DOG FACES, THE WORDING "SNOOPY" ALONG THE LEFT SIDE OF THE SQUARE, AND THE WORDING "HIS SISTER BELLE" ALONG THE RIGHT SIDE OF THE SQUARE.

FOR BACKPACKS; COSMETIC BAGS SOLD EMPTY; DIAPER BAGS; DUFFEL BAGS; HANDBAGS; LUGGAGE; MESSENGER BAGS; PURSES; SCHOOL BAGS; TOTE BAGS; UMBRELLAS; WAIST PACKS; WALLETS (U.S. CLS. 1, 2, 3, 22 AND 41).

MAIA ROSENBERG, EXAMINING ATTORNEY

SN 86-176,848. CHANG, YING, TAIPEI CITY, TAIWAN, FILED 1-28-2014.



THE NAME "CHANG YING" IDENTIFIES A LIVING INDIVIDUAL WHOSE CONSENT IS OF RECORD.

THE MARK CONSISTS OF THE STYLIZED WORD "CHANGYING" IN A LARGE FONT WITH ALL OF THE LETTERS CONNECTED AND THE WORDS "PURE TWIST" IN SMALLER FONT BENEATH IT. THE STYLIZED LETTERS "C" AND "Y" APPEAR ABOVE THE WORD "CHANGYING" WITH THE "Y" SUPERIMPOSED ON TOP OF THE "C" AND THE STEM OF THE "Y" WRAPPING AROUND THE TOP OF THE "C".

THE WORDING "CHANGYING" HAS NO MEANING IN A FOREIGN LANGUAGE.

FOR PURSES; WALLETS; BACKPACKS; TRUNKS AND SUITCASES; SUITCASES; TOTE BAGS; BRIEFCASES; KEY CASES; COSMETIC BAGS SOLD EMPTY; HANDBAGS; TRAVEL BAGS; STRAPS FOR HANDBAGS; SHOULDER STRAPS; BUSINESS CARD HOLDERS IN THE NATURE OF WALLETS; LEATHER CREDIT CARD WALLETS; CARD WALLETS; PARASOLS; UMBRELLAS; LEATHER STRAPS; ALL-PURPOSE LEATHER STRAPS (U.S. CLS. 1, 2, 3, 22 AND 41).

LINDA QUIGLEY, EXAMINING ATTORNEY

**CLASS 18—(Continued).**

SN 86-190,876. JILL ABBOTT, CORONA, CA. FILED 2-11-2014.



NO CLAIM IS MADE TO THE EXCLUSIVE RIGHT TO USE "PUPPY", APART FROM THE MARK AS SHOWN.

THE MARK CONSISTS OF THE WORD "PUPPY" OVER THE WORDS "PACK AND GO" WHERE THE "P" FROM THE WORD "PUPPY" IS SHARED WITH THE WORD "PACK" AND FURTHER INCLUDES A DOG ON ITS HIND LEGS TOUCHING THE FIRST "P" WITH A FRONT PAW.

FOR PET ACCESSORIES, NAMELY, SPECIALLY DESIGNED CANVAS, VINYL OR LEATHER BAGS THAT ONE CAN ATTACH TO ANIMAL LEASHES FOR HOLDING SMALL ITEMS SUCH AS KEYS, CREDIT CARDS, MONEY OR DISPOSABLE BAGS FOR DISPOSING OF PET WASTE (U.S. CLS. 1, 2, 3, 22 AND 41).

ELISSA GARBER KON, EXAMINING ATTORNEY

**CLASS 18—(Continued).**

SN 86-220,384. GORUCK HOLDINGS, LLC, JACKSONVILLE BEACH, FL. FILED 3-13-2014.



THE MARK CONSISTS OF A FLAG WITH A SOLID IMAGE IN THE UPPER RIGHT CORNER, HORIZONTAL STRIPES IN THE UPPER LEFT CORNER AND HORIZONTAL STRIPES ACROSS THE BOTTOM HALF OF THE FLAG.

FOR BACKPACKS; LUGGAGE; GYM BAGS AND ALL PURPOSE CARRYING BAGS (U.S. CLS. 1, 2, 3, 22 AND 41).

FIRST USE 5-2-2010; IN COMMERCE 5-2-2010.  
SUZANNE BLANE, EXAMINING ATTORNEY

SN 86-223,887. NOUS TECHNOLOGIES LLC, NEWARK, DE. FILED 3-18-2014.

SN 86-211,166. SHENZHEN INNOKIN TECHNOLOGY CO., LIMITED, SHENZHEN, CHINA, FILED 3-5-2014.

**INNOKIN**

THE MARK CONSISTS OF STANDARD CHARACTERS WITHOUT CLAIM TO ANY PARTICULAR FONT, STYLE, SIZE, OR COLOR.

FOR BACKPACKS; BAGS FOR PACKAGING OF LEATHER; BAGS FOR SPORTS; CARD WALLETS; CASES FOR KEYS; HANDBAGS; HAT BOXES OF LEATHER; IMITATION LEATHER; LEATHER BAGS AND WALLETS; LEATHER SHOPPING BAGS; PURSES; PURSES AND WALLETS; TOOL BAGS SOLD EMPTY; WALLETS (U.S. CLS. 1, 2, 3, 22 AND 41).

SUSAN RICHARDS, EXAMINING ATTORNEY



**Colorfulwallets**

NO CLAIM IS MADE TO THE EXCLUSIVE RIGHT TO USE "COLORFUL WALLETS", APART FROM THE MARK AS SHOWN.

THE COLOR(S) BLUE, ORANGE, YELLOW, TURQUOISE AND BLACK IS/ARE CLAIMED AS A FEATURE OF THE MARK.

THE MARK CONSISTS OF FOUR COLORED RECTANGLE BOXES PLACED TOUCHING ONE ANOTHER IN THE FOLLOWING ORDER (FROM LEFT TO RIGHT) BLUE, ORANGE, YELLOW, AND TURQUOISE TO THE LEFT OF THE LITERAL ELEMENT "COLORFULWALLETS" IN BLACK WITH THE LETTER "C" IN UPPER CASE AND REST OF THE LETTERS IN LOWER CASE.

FOR BACKPACKS, BOOK BAGS, SPORTS BAGS, BUM BAGS, WALLETS AND HANDBAGS; CARD WALLETS; HANDBAGS, PURSES AND WALLETS; LEATHER BAGS AND WALLETS; LEATHER BAGS, SUITCASES AND WALLETS; LEATHER CREDIT CARD WALLETS; POCKET WALLETS; WALLETS; WALLETS; WALLETS AND WALLET INSERTS; WALLETS INCLUDING CARD HOLDERS; WALLETS MADE OF LEATHER OR OTHER MATERIALS; WALLETS WITH CARD COMPARTMENTS; WALLETS, NOT OF PRECIOUS METAL (U.S. CLS. 1, 2, 3, 22 AND 41).

KARANENDRA S. CHHINA, EXAMINING ATTORNEY

**CLASS 18—(Continued).**

SN 86-228,954. MELISSA BENTZ, SAN JOSE, CA. FILED 3-21-2014.

## Bentz Luxury

THE MARK CONSISTS OF STANDARD CHARACTERS WITHOUT CLAIM TO ANY PARTICULAR FONT, STYLE, SIZE, OR COLOR.

NO CLAIM IS MADE TO THE EXCLUSIVE RIGHT TO USE "LUXURY", APART FROM THE MARK AS SHOWN.

FOR BACKPACKS, BOOK BAGS, SPORTS BAGS, BUM BAGS, WALLETS AND HANDBAGS; CHANGE PURSES; CLUTCH BAGS; CLUTCH PURSES; CLUTCHES; COIN PURSES; EVENING BAGS; EVENING HANDBAGS; FASHION HANDBAGS; HANDBAGS; HANDBAGS FOR LADIES; HANDBAGS, PURSES AND WALLETS; LEATHER AND IMITATION LEATHER BAGS; LEATHER BAGS AND WALLETS; LEATHER BAGS, SUITCASES AND WALLETS; LEATHER HANDBAGS; LEATHER PURSES; MULTI-PURPOSE PURSES; PURSES; PURSES AND WALLETS; PURSES NOT MADE OF PRECIOUS METAL; PURSES, NOT OF PRECIOUS METAL; SHOULDER BAGS; SMALL CLUTCH PURSES; SMALL PURSES (U.S. CLS. 1, 2, 3, 22 AND 41).

ELIZABETH JACKSON, EXAMINING ATTORNEY

SN 86-234,140. BAB PRODUCTS, LLC, KENT, CT. FILED 3-27-2014.



THE MARK CONSISTS OF STYLIZED LETTERS "BAB" WITH THE FIRST LETTER "B" APPEARING BACKWARDS AND THE MIDDLE HORIZONTAL LINE OF LETTER "A" EXTENDING TO THE BOTTOM PORTION OF THE BACKWARD LETTER "B".

FOR BAGS, NAMELY, HANDBAGS, EVENING BAGS, BEACH BAGS, BOOK BAGS, CARRY-ALL BAGS, ALL-PURPOSE CARRYING BAGS, DUFFEL BAGS, GYM BAGS, TRAVELING BAGS, ATHLETIC BAGS, TOTE BAGS, AND COSMETIC BAGS SOLD EMPTY (U.S. CLS. 1, 2, 3, 22 AND 41).

HEATHER THOMPSON, EXAMINING ATTORNEY

**CLASS 18—(Continued).**

SN 86-234,846. CASANOVA, NANCY, NORTH HOLLYWOOD, CA. FILED 3-28-2014.

## Catsanova Bowties

THE MARK CONSISTS OF STANDARD CHARACTERS WITHOUT CLAIM TO ANY PARTICULAR FONT, STYLE, SIZE, OR COLOR.

NO CLAIM IS MADE TO THE EXCLUSIVE RIGHT TO USE "BOWTIES", APART FROM THE MARK AS SHOWN.

FOR PET COLLAR ACCESSORIES, NAMELY, BOWS AND CHARMS (U.S. CLS. 1, 2, 3, 22 AND 41).

FIRST USE 9-1-2013; IN COMMERCE 9-1-2013.

COLLEEN DOMBROW, EXAMINING ATTORNEY

SN 86-239,667. BAB PRODUCTS, LLC, KENT, CT. FILED 4-2-2014.

## BAB

THE MARK CONSISTS OF STANDARD CHARACTERS WITHOUT CLAIM TO ANY PARTICULAR FONT, STYLE, SIZE, OR COLOR.

FOR BAGS, NAMELY, HANDBAGS, EVENING BAGS, BEACH BAGS, BOOK BAGS, CARRY-ALL BAGS, ALL-PURPOSE CARRYING BAGS, DUFFEL BAGS, GYM BAGS, TRAVELING BAGS, ATHLETIC BAGS, TOTE BAGS, AND COSMETIC BAGS SOLD EMPTY (U.S. CLS. 1, 2, 3, 22 AND 41).

HEATHER THOMPSON, EXAMINING ATTORNEY

SN 86-241,864. THE TRUSTEES OF THE COLONIAL GREENE TRUST, LOS ANGELES, CA. FILED 4-3-2014.

## TWO WOLVES WINE

THE MARK CONSISTS OF STANDARD CHARACTERS WITHOUT CLAIM TO ANY PARTICULAR FONT, STYLE, SIZE, OR COLOR.

NO CLAIM IS MADE TO THE EXCLUSIVE RIGHT TO USE "WINE" FOR "WINE BAGS WITH HANDLES FOR CARRYING WINE; WINE CARRYING CASES", APART FROM THE MARK AS SHOWN.

FOR WINE BAGS WITH HANDLES FOR CARRYING WINE; WINE CARRYING CASES; BOOK, LEATHER SHOPPING, SHOULDER, AND TOTE BAGS; FANNY PACKS AND WAIST PACKS; BACKPACKS; KNAPSACKS; LUGGAGE TAGS; COSMETIC CASES AND BAGS SOLD EMPTY; TOILETRY AND VANITY CASES SOLD EMPTY; KEY CASES; LEATHER KEY CHAINS; WALLETS; UMBRELLAS; PARASOLS (U.S. CLS. 1, 2, 3, 22 AND 41).

CHRISTINA SOBRAL, EXAMINING ATTORNEY

**CLASS 18—(Continued).**

SN 86-244,258. XDESIGN LLC, EASTSOUND, WA. FILED 4-7-2014.

**NYLAR**

THE MARK CONSISTS OF STANDARD CHARACTERS WITHOUT CLAIM TO ANY PARTICULAR FONT, STYLE, SIZE, OR COLOR.

FOR FABRIC SOLD AS AN INTEGRAL COMPONENT OF BACKPACKS, CARRY-ALL BAGS, AND CARRYING CASES (U.S. CLS. 1, 2, 3, 22 AND 41).

MARGARET POWER, EXAMINING ATTORNEY

SN 86-245,406. HEART & SOLE, BLUFFTON, SC. FILED 4-8-2014.

**LuckySoleDesigns**

THE MARK CONSISTS OF STANDARD CHARACTERS WITHOUT CLAIM TO ANY PARTICULAR FONT, STYLE, SIZE, OR COLOR.

FOR DECORATIVE REPURPOSED HORSESHOES (U.S. CLS. 1, 2, 3, 22 AND 41).

FIRST USE 7-1-2013; IN COMMERCE 7-1-2013.  
KEVON CHISOLM, EXAMINING ATTORNEY

SN 86-247,014. PAUL'S PACKS LLC, SIMI VALLEY, CA. FILED 4-9-2014.

**BRINGPACK**

THE MARK CONSISTS OF STANDARD CHARACTERS WITHOUT CLAIM TO ANY PARTICULAR FONT, STYLE, SIZE, OR COLOR.

FOR BACKPACKS (U.S. CLS. 1, 2, 3, 22 AND 41).  
FIRST USE 3-25-2014; IN COMMERCE 3-25-2014.  
TEJBIR SINGH, EXAMINING ATTORNEY

**CLASS 18—(Continued).**

SN 86-248,546. VINCE, LLC, NEW YORK, NY. FILED 4-10-2014.

**VINCE.**

OWNER OF U.S. REG. NOS. 2,929,250, 3,954,985 AND OTHERS.

THE MARK CONSISTS OF THE TERM "VINCE." IN A STYLIZED FONT.

FOR BELT BAGS AND HIP BAGS; BOOK BAGS; CARRY-ALL BAGS; CLUTCH BAGS; CLUTCH PURSES; DIAPER BAGS; DUFFEL BAGS; DUFFLE BAGS; GARMENT BAGS FOR TRAVEL; HOBO BAGS; KEY BAGS; LEATHER BAGS AND WALLETS; LUGGAGE; MESSENGER BAGS; OVERNIGHT BAGS; PURSES; ROLL BAGS; SHOULDER BAGS; SMALL BAGS FOR MEN; TOILETRY BAGS SOLD EMPTY; TOTE BAGS; TRAVEL BAGS; WALLETS; WHEELED BAGS; WRISTLET BAGS (U.S. CLS. 1, 2, 3, 22 AND 41).

KEVIN MITTLER, EXAMINING ATTORNEY

SN 86-248,839. WEIHONG CUI, COMMERCE, CA. FILED 4-10-2014.

**AMPHORA**

THE MARK CONSISTS OF STANDARD CHARACTERS WITHOUT CLAIM TO ANY PARTICULAR FONT, STYLE, SIZE, OR COLOR.

FOR BACKPACKS, BOOK BAGS, SPORTS BAGS, BUM BAGS, WALLETS AND HANDBAGS (U.S. CLS. 1, 2, 3, 22 AND 41).

FIRST USE 3-19-2013; IN COMMERCE 3-19-2013.  
SOPHIA S. KIM, EXAMINING ATTORNEY

**CLASS 18—(Continued).**

SN 86-249,509. VINCE, LLC, NEW YORK, NY. FILED 4-11-2014.

# VINCE

THE MARK CONSISTS OF STANDARD CHARACTERS WITHOUT CLAIM TO ANY PARTICULAR FONT, STYLE, SIZE, OR COLOR.

OWNER OF U.S. REG. NOS. 2,929,250, 3,954,985 AND OTHERS.

FOR BELT BAGS AND HIP BAGS; BOOK BAGS; CARRY-ALL BAGS; CLUTCH BAGS; CLUTCH PURSES; DIAPER BAGS; DUFFEL BAGS; DUFFLE BAGS; GARMENT BAGS FOR TRAVEL; HOBOS BAGS; KEY BAGS; LEATHER BAGS AND WALLETS; LUGGAGE; MESSENGER BAGS; OVERNIGHT BAGS; PURSES; ROLL BAGS; SHOULDER BAGS; SMALL BAGS FOR MEN; TOILETRY BAGS SOLD EMPTY; TOTE BAGS; TRAVEL BAGS; WALLETS; WHEELED BAGS; WRISTLET BAGS (U.S. CLS. 1, 2, 3, 22 AND 41).

KEVIN MITTLER, EXAMINING ATTORNEY

**CLASS 18—(Continued).**

SN 86-250,565. MA YU JIE, XI'AN CITY, SHAANXI, CHINA, FILED 4-12-2014.

# Marlondo Leather

THE MARK CONSISTS OF STANDARD CHARACTERS WITHOUT CLAIM TO ANY PARTICULAR FONT, STYLE, SIZE, OR COLOR.

NO CLAIM IS MADE TO THE EXCLUSIVE RIGHT TO USE "LEATHER", APART FROM THE MARK AS SHOWN.

THE WORDING "MARLONDO" HAS NO MEANING IN A FOREIGN LANGUAGE.

FOR BACKPACKS; BRIEFCASES; CARD WALLETS; HANDBAGS; LUGGAGE TAGS; MESSENGER BAGS; POUCHES OF LEATHER; SATCHELS; SUITCASES; TRAVEL BAGS; WALLETS; WALLETS INCLUDING CARD HOLDERS (U.S. CLS. 1, 2, 3, 22 AND 41).

FIRST USE 4-15-2012; IN COMMERCE 4-15-2012.

ZACHARY R. SPARER, EXAMINING ATTORNEY

SN 86-250,639. MELMAT, INC., HUNTINGTON BEACH, CA. FILED 4-12-2014.

# SPACECASE

THE MARK CONSISTS OF STANDARD CHARACTERS WITHOUT CLAIM TO ANY PARTICULAR FONT, STYLE, SIZE, OR COLOR.

FOR TRUNKS, TRAVELLING BAGS, PLASTIC MOLDED SUITCASES, PADDED TRAVELLING BAGS, HEAVY DUTY FRAME SUITCASES, INJECTION MOLDED FRAME SUITCASES; CUSTOM SIZE SUITCASES, NAMELY BRIEFCASES, SUITCASES (U.S. CLS. 1, 2, 3, 22 AND 41).

FIRST USE 6-1-1986; IN COMMERCE 6-1-1986.

GINA HAYES, EXAMINING ATTORNEY

SN 86-265,511. NORDSTROM, INC., SEATTLE, WA. FILED 4-29-2014.

# WILD PEARL

THE MARK CONSISTS OF STANDARD CHARACTERS WITHOUT CLAIM TO ANY PARTICULAR FONT, STYLE, SIZE, OR COLOR.

NO CLAIM IS MADE TO THE EXCLUSIVE RIGHT TO USE "PEARL" AS TO COIN PURSES, HANDBAGS, KEY CASES, PURSES, AND WALLETS, APART FROM THE MARK AS SHOWN.

FOR BACKPACKS; BRIEFCASES; COIN PURSES; COSMETIC CASES SOLD EMPTY; HANDBAGS; KEY CASES; LUGGAGE; PURSES; TOTE BAGS; TRAVEL BAGS; UMBRELLAS; VANITY CASES SOLD EMPTY; WALLETS (U.S. CLS. 1, 2, 3, 22 AND 41).

SUI DUONG, EXAMINING ATTORNEY

SN 86-249,967. NR MEXICANA DE MODA, S.A. DE C.V., CUAJIMALPA, MEXICO D.F, MEXICO, FILED 4-11-2014.



fiocco  
-México-

NO CLAIM IS MADE TO THE EXCLUSIVE RIGHT TO USE "MEXICO", APART FROM THE MARK AS SHOWN.

THE MARK CONSISTS OF A STYLIZED LINE DRAWING ABOVE THE WORD "FIOCCO" WITH ".MEXICO-" IN SMALLER LETTERS BELOW.

THE ENGLISH TRANSLATION OF "FIOCCO" IN THE MARK IS "BOW".

FOR BACKPACKS; BRIEFCASES; CLUTCH BAGS; HANDBAGS; KEY-CASES; LEATHER BAGS AND WALLETS; LEATHER KEY CHAINS; LUGGAGE; LUGGAGE TAGS; MESSENGER BAGS; PURSES; TOTE BAGS; WALLETS (U.S. CLS. 1, 2, 3, 22 AND 41).

TINA BROWN, EXAMINING ATTORNEY

**CLASS 18—(Continued).**

SN 86-271,681. PANAMA JACK INTERNATIONAL, INC., ORLANDO, FL. FILED 5-5-2014.

**PANAMA JACK OUTFITTERS**

THE MARK CONSISTS OF STANDARD CHARACTERS WITHOUT CLAIM TO ANY PARTICULAR FONT, STYLE, SIZE, OR COLOR.

OWNER OF U.S. REG. NOS. 1,325,935, 1,354,252 AND OTHERS.

NO CLAIM IS MADE TO THE EXCLUSIVE RIGHT TO USE "OUTFITTERS", APART FROM THE MARK AS SHOWN.

THE NAME(S), PORTRAIT(S), AND/OR SIGNATURE(S) SHOWN IN THE MARK DOES NOT IDENTIFY A PARTICULAR LIVING INDIVIDUAL.

FOR BACKPACKS, DUFFEL BAGS, ALL PURPOSE GEAR BAGS, FANNY PACKS, TRAVEL BAGS, TOTE BAGS, BEACH BAGS, WALLETS, HANDBAGS, LUGGAGE TAGS, TRUNKS, LEATHER KEY CHAINS, UMBRELLAS, BEACH UMBRELLAS, ROLL BAGS, ALL-PURPOSE SPORT BAGS, COSMETIC BAGS SOLD EMPTY, LUGGAGE, ATHLETIC BAGS, CLUTCH BAGS, BILLFOLDS, BOOK BAGS, CHANGE PURSES; OVERNIGHT BAGS; POCKETBOOKS; PURSES; SCHOOL BAGS; WALKING STICKS; ATTACHE CASES, BRIEF-CASE-TYPE PORTFOLIOS; BUSINESS CARD CASES; CANES; FOOTLOCKERS AND SUITCASES (U.S. CLS. 1, 2, 3, 22 AND 41).

CAROLINE WOOD, EXAMINING ATTORNEY

SN 86-278,214. MAURICES INCORPORATED, DULUTH, MN. FILED 5-12-2014.



THE MARK CONSISTS OF A STYLIZED FLOWER. FOR HANDBAGS, PURSES, TRAVEL BAGGAGE AND WALLETS (U.S. CLS. 1, 2, 3, 22 AND 41).

WILLIAM P. SHANAHAN, EXAMINING ATTORNEY

**CLASS 18—(Continued).**

SN 86-313,461. PEACE LOVE WORLD, LLC, MIAMI, FL. FILED 6-18-2014.

**I LOVE SUNDAYS**

THE MARK CONSISTS OF STANDARD CHARACTERS WITHOUT CLAIM TO ANY PARTICULAR FONT, STYLE, SIZE, OR COLOR.

FOR BOOK BAGS; LUGGAGE; TOTE BAGS (U.S. CLS. 1, 2, 3, 22 AND 41).

DANIEL CAPSHAW, EXAMINING ATTORNEY

SN 86-316,565. JC WORLD BELL WHOLESALE, HACKENSACK, NJ. FILED 6-21-2014.

**TURTLE NOSE**

THE MARK CONSISTS OF STANDARD CHARACTERS WITHOUT CLAIM TO ANY PARTICULAR FONT, STYLE, SIZE, OR COLOR.

FOR UMBRELLAS (U.S. CLS. 1, 2, 3, 22 AND 41).

JULIE WATSON, EXAMINING ATTORNEY

**CLASS 19—NON-METALLIC BUILDING MATERIALS**

SN 76-716,069. EDGE TECH PARTNERS, LLC, BRENTWOOD, TN. FILED 3-25-2014.

**ARMORLAY**

THE MARK CONSISTS OF STANDARD CHARACTERS WITHOUT CLAIM TO ANY PARTICULAR FONT, STYLE, SIZE, OR COLOR.

FOR A SYNTHETIC ROOFING UNDERLAYMENT (U.S. CLS. 1, 12, 33 AND 50).

CHRISTOPHER BUONGIORNO, EXAMINING ATTORNEY

**CLASS 19—(Continued).**

SN 79-138,152. ITALCEMENTI S.P.A., I-24121 BERGAMO, ITALY, FILED 9-5-2013.

# I.ACTIVE

THE MARK CONSISTS OF STANDARD CHARACTERS WITHOUT CLAIM TO ANY PARTICULAR FONT, STYLE, SIZE, OR COLOR.

PRIORITY DATE OF 5-6-2013 IS CLAIMED.

OWNER OF INTERNATIONAL REGISTRATION 1180914 DATED 9-5-2013, EXPIRES 9-5-2023.

OWNER OF U.S. REG. NOS. 3,359,892 AND 3,879,332.

FOR NON-METALLIC BUILDING MATERIALS, NAMELY, BUILDING CEMENTITIOUS STONES; NON-METALLIC TRANSPORTABLE BUILDINGS; CONCRETE; CEMENT; HYDRAULIC CEMENT; MORTAR; NATURAL OR INDUSTRIAL HYDRAULIC BINDERS, NAMELY, ADHESIVE CEMENT OR MORTAR FOR BUILDING PURPOSES; LIME; ARTIFICIAL STONES (U.S. CLS. 1, 12, 33 AND 50).

ALAIN LAPTER, EXAMINING ATTORNEY

**CLASS 19—(Continued).**

SN 79-138,526. ITALCEMENTI S.P.A., I-24121 BERGAMO, ITALY, FILED 9-5-2013.

# FORTE

THE MARK CONSISTS OF STANDARD CHARACTERS WITHOUT CLAIM TO ANY PARTICULAR FONT, STYLE, SIZE, OR COLOR.

PRIORITY DATE OF 5-31-2013 IS CLAIMED.

OWNER OF INTERNATIONAL REGISTRATION 1181869 DATED 9-5-2013, EXPIRES 9-5-2023.

THE ENGLISH TRANSLATION OF THE FOREIGN WORD(S) IN THE MARK IS: "STRONGHOLD".

FOR CONCRETE; CEMENT; BUILDING STONES; HYDRAULIC CEMENT; MORTAR; NATURAL OR INDUSTRIAL HYDRAULIC BINDERS, NAMELY, ADHESIVE MORTAR FOR BUILDING PURPOSES; NON-AGRICULTURAL SILICEOUS OR CALCAREOUS AGGREGATES; NON-AGRICULTURAL LIME FOR USE IN CONSTRUCTION; REFRACTORY SLABS FOR USE IN CONSTRUCTION (U.S. CLS. 1, 12, 33 AND 50).

ALAIN LAPTER, EXAMINING ATTORNEY

SN 86-027,076. READING ROCK, INCORPORATED, CINCINNATI, OH. FILED 8-2-2013.

SN 79-138,153. ITALCEMENTI S.P.A., I-24121 BERGAMO, ITALY, FILED 9-5-2013.

# GEO

THE MARK CONSISTS OF STANDARD CHARACTERS WITHOUT CLAIM TO ANY PARTICULAR FONT, STYLE, SIZE, OR COLOR.

PRIORITY DATE OF 5-21-2013 IS CLAIMED.

OWNER OF INTERNATIONAL REGISTRATION 1180915 DATED 9-5-2013, EXPIRES 9-5-2023.

FOR NON-METALLIC BUILDING MATERIALS, NAMELY, BUILDING CEMENTITIOUS STONES; NON-METALLIC TRANSPORTABLE BUILDINGS; CONCRETE; CEMENT; HYDRAULIC CEMENT; MORTAR; NATURAL OR INDUSTRIAL HYDRAULIC BINDERS, NAMELY, ADHESIVE CEMENT OR MORTAR FOR BUILDING PURPOSES; LIME; ARTIFICIAL STONES (U.S. CLS. 1, 12, 33 AND 50).

ALAIN LAPTER, EXAMINING ATTORNEY

**THE NEXT GENERATION**

THE MARK CONSISTS OF STANDARD CHARACTERS WITHOUT CLAIM TO ANY PARTICULAR FONT, STYLE, SIZE, OR COLOR.

FOR NON-METAL BUILDING MATERIALS, NAMELY, MACHINE MANUFACTURED BLOCKS OR STONES (U.S. CLS. 1, 12, 33 AND 50).

ANDREA BUTLER, EXAMINING ATTORNEY

SN 86-033,131. SWISSTRAX, INC., INDIO, CA. FILED 8-8-2013.

# VINYLTRAX

THE MARK CONSISTS OF STANDARD CHARACTERS WITHOUT CLAIM TO ANY PARTICULAR FONT, STYLE, SIZE, OR COLOR.

OWNER OF U.S. REG. NOS. 3,127,880, 4,242,637 AND OTHERS.

FOR FLOOR PANELS OF VINYL AND NOT OF METAL; NON-METAL FLOOR PANELS OF VINYL (U.S. CLS. 1, 12, 33 AND 50).

JAMES STEIN, EXAMINING ATTORNEY



**CLASS 19—(Continued).**

SN 86-077,016. GRAIMAN CIA. LTDA., CUENCA, ECUADOR, FILED 9-27-2013.

**PORCELLANIX BY GRAIMAN**

THE MARK CONSISTS OF STANDARD CHARACTERS WITHOUT CLAIM TO ANY PARTICULAR FONT, STYLE, SIZE, OR COLOR.

THE WORDING "PORCELLANIX" AND "GRAIMAN" HAS NO MEANING IN A FOREIGN LANGUAGE.

FOR CERAMIC DRAIN PIPES; CERAMIC FLOOR TILES; CERAMIC ROOFING TILES; CERAMIC SHAPES FOR USE IN REFRACTORY FURNACES; CERAMIC TILES; CERAMIC TILES FOR FLOORING AND FACING; CHIPBOARD; GLASS GRANULES FOR MARKING ROADS; GLASS PANELS FOR BUILDING CONSTRUCTION PURPOSES; MODULAR NON-METAL PIGSTIES; MODULAR NON-METAL POULTRY HOUSES; NON-METAL DUCTS; NON-METAL SELF-ALIGNING DEMOUNTABLE SNAP FASTENERS CONSISTING OF PRESS FASTENERS AND PRESS STUDS FOR USE IN ATTACHING PANELS, HATCHES, FLOORS AND FURNITURE IN BUILDINGS; NON-METAL STORM WINDOWS; STATUETTES OF STONE, CONCRETE OR MARBLE (U.S. CLS. 1, 12, 33 AND 50).

TRACY FLETCHER, EXAMINING ATTORNEY

SN 86-086,163. TAMKO BUILDING PRODUCTS, INC., JOPLIN, MO. FILED 10-8-2013.

**SUPERX**

THE MARK CONSISTS OF STANDARD CHARACTERS WITHOUT CLAIM TO ANY PARTICULAR FONT, STYLE, SIZE, OR COLOR.

FOR ROOFING PRODUCTS, NAMELY, FIBERGLASS REINFORCED ROOFING UNDERLAYMENT (U.S. CLS. 1, 12, 33 AND 50).

BARBARA GAYNOR, EXAMINING ATTORNEY

**CLASS 19—(Continued).**

SN 86-128,432. SWISSTRAX, INC., INDIO, CA. FILED 11-25-2013.



NO CLAIM IS MADE TO THE EXCLUSIVE RIGHT TO USE "WORLD'S FINEST MODULAR FLOORING", APART FROM THE MARK AS SHOWN.

THE COLOR(S) RED, BLACK AND WHITE IS/ARE CLAIMED AS A FEATURE OF THE MARK.

THE MARK CONSISTS OF "SWISSTRAX WORLD'S FINEST MODULAR FLOORING" INSIDE A CURVED-EDGE RECTANGLE OUTLINED IN BLACK WITH THE WORD "SWISS" IN RED, THE BALANCE OF THE WORDING IN BLACK, WHEREIN A BLACK AND WHITE CHECKERED RACING FLAG IS POSITIONED BEHIND THE ABOVE WORDS AND A RED FLAG IS POSITIONED ON THE BEGINNING OF THE CHECKERED RACING FLAG AND A RED FLAG IS POSITIONED AFTER THE LETTER "X" IN THE WORD "SWISSTRAX".

FOR FLOOR PANELS NOT OF METAL; NON-METAL FLOOR PANELS (U.S. CLS. 1, 12, 33 AND 50).

FIRST USE 2-1-2012; IN COMMERCE 2-1-2012.

HEATHER THOMPSON, EXAMINING ATTORNEY

SN 86-140,060. MOBILIER RUSTIQUE INC., QUEBEC, CANADA, FILED 12-10-2013.



OWNER OF CANADA REG. NO. TMA863988, DATED 10-30-2013, EXPIRES 10-30-2028.

OWNER OF U.S. REG. NO. 3,127,281.

NO CLAIM IS MADE TO THE EXCLUSIVE RIGHT TO USE "CEDAR", APART FROM THE MARK AS SHOWN.

THE MARK CONSISTS OF THE PHRASE "CEDAR FIRST" BELOW A GRAPHIC DEPICTION OF A FENCE, AND TWO QUADRILATERALS CONTAINING TWO ROUND CORNERS, ONE INSIDE THE OTHER, WITH THE FENCE DEPICTION INSIDE THE INNER QUADRILATERAL, THE WORD "CEDAR" BETWEEN THE INNER QUADRILATERAL AND THE OUTER QUADRILATERAL, AND A STRAIGHT HORIZONTAL LINE BENEATH THE WORD "FIRST".

FOR COMPONENTS FOR FENCES MADE OF ROUND AND SQUARED CEDAR WOOD, NAMELY, PANELS, POSTS AND STAYS (U.S. CLS. 1, 12, 33 AND 50).

FIRST USE 6-30-2013; IN COMMERCE 6-30-2013.

TRACY CROSS, EXAMINING ATTORNEY

**CLASS 19—(Continued).**

SN 86-154,187. BAKER BOHNERT RUBBER COMPANY, INC., LOUISVILLE, KY. FILED 12-30-2013.

**Baker Energy Group**

THE MARK CONSISTS OF STANDARD CHARACTERS WITHOUT CLAIM TO ANY PARTICULAR FONT, STYLE, SIZE, OR COLOR.

OWNER OF U.S. REG. NO. 3,764,095.

NO CLAIM IS MADE TO THE EXCLUSIVE RIGHT TO USE "ENERGY GROUP", APART FROM THE MARK AS SHOWN.

FOR NON-METAL FLUE DUCT EXPANSION JOINTS (U.S. CLS. 1, 12, 33 AND 50).

FIRST USE 12-4-2013; IN COMMERCE 12-4-2013.

SETH A. RAPPAPORT, EXAMINING ATTORNEY

**CLASS 19—(Continued).**

SN 86-204,483. LONGUST DISTRIBUTING, INC., MESA, AZ. FILED 2-26-2014.

**Legante Italiano**

THE MARK CONSISTS OF STANDARD CHARACTERS WITHOUT CLAIM TO ANY PARTICULAR FONT, STYLE, SIZE, OR COLOR.

OWNER OF U.S. REG. NOS. 3,961,310 AND 3,961,314.

NO CLAIM IS MADE TO THE EXCLUSIVE RIGHT TO USE "ITALIANO", APART FROM THE MARK AS SHOWN.

THE ENGLISH TRANSLATION OF "LEGANTE ITALIANO" IS "BINDER ITALIAN".

FOR CERAMIC FLOOR TILES; CERAMIC TILES; CERAMIC TILES FOR TILE FLOORS AND COVERINGS; CERAMIC WALL TILES; NATURAL STONE AND STONE TILE; NATURAL STONE SLABS AND TILES (U.S. CLS. 1, 12, 33 AND 50).

JORDAN BAKER, EXAMINING ATTORNEY

SN 86-166,079. ROYAL WHITE CEMENT INC, HOUSTON, TX. FILED 1-15-2014.



NO CLAIM IS MADE TO THE EXCLUSIVE RIGHT TO USE "WHITE CEMENT", APART FROM THE MARK AS SHOWN.

THE COLOR(S) BLUE AND WHITE IS/ARE CLAIMED AS A FEATURE OF THE MARK.

THE MARK CONSISTS OF BLUE BOXES WITH THE CAPITAL LETTERS "R" AND "C" IN WHITE WITHIN THE BLUE BOX WITH A WHITE BOX BETWEEN THE BLUE AND WHITE BOXES WITH THE CAPITAL LETTER "W" IN BLUE WITHIN THE WHITE BOX, PLUS THE WORDS IMMEDIATELY BELOW THE BOXES CONTAINING THE INDIVIDUAL BLUE LETTERS, WHICH WORDS ARE "ROYAL WHITE CEMENT", IN CAPITAL LETTERS, WITH THE WORDS EXTENDING FROM THE LEFT EDGE OF THE FIRST BLUE BOX CONTAINING THE CAPITAL LETTER "R" AND EXTENDING HORIZONTALLY TO THE RIGHT WITH THE WORDS ENDING AT THE IMMEDIATE RIGHT VERTICAL EDGE OF THE BLUE BOX CONTAINING THE CAPITAL LETTER "C".

FOR ALMINA CEMENT; CEMENT (U.S. CLS. 1, 12, 33 AND 50).

FIRST USE 10-10-1999; IN COMMERCE 10-10-1999.

TASHIA BUNCH, EXAMINING ATTORNEY

SN 86-215,964. APT ACQUISITION CORP., HARMONY, PA. FILED 3-10-2014.

**LAYKOLD MULTIPLAY**

THE MARK CONSISTS OF STANDARD CHARACTERS WITHOUT CLAIM TO ANY PARTICULAR FONT, STYLE, SIZE, OR COLOR.

OWNER OF U.S. REG. NOS. 631,504, 631,604 AND 2,743,197.

NO CLAIM IS MADE TO THE EXCLUSIVE RIGHT TO USE "MULTIPLAY", APART FROM THE MARK AS SHOWN.

SEC. 2(F) AS TO "LAYKOLD".

FOR ASPHALTIC BASE PROTECTIVE AND DECORATIVE COATINGS FOR APPLICATION TO METAL, MASONRY, ASPHALT, CONCRETE AND CEMENT STRUCTURES AND OTHER SURFACES (U.S. CLS. 1, 12, 33 AND 50).

JOHN DALIER, EXAMINING ATTORNEY

**CLASS 19—(Continued).**

SN 86-216,650. BOSTON CEDAR, INC., MANSFIELD, MA. FILED 3-10-2014.



OWNER OF U.S. REG. NOS. 3,377,642, 3,562,835 AND 3,578,269.

NO CLAIM IS MADE TO THE EXCLUSIVE RIGHT TO USE "WHITE", APART FROM THE MARK AS SHOWN.

THE MARK CONSISTS OF "TIO2" IN A BOX WITH "TITANIUMWHITE" TO THE RIGHT OF THE BOX.

SEC. 2(F). FOR WHITE COATED EXTERIOR WOOD TRIM (U.S. CLS. 1, 12, 33 AND 50).

FIRST USE 9-1-2007. THE MARK WAS FIRST USED ANYWHERE IN A DIFFERENT FORM OTHER THAN THAT SOUGHT TO BE REGISTERED AT LEAST AS EARLY AS 02/28/2006; IN COMMERCE 9-1-2007. THE MARK WAS FIRST USED IN COMMERCE IN A DIFFERENT FORM OTHER THAN THAT SOUGHT TO BE REGISTERED AT LEAST AS EARLY AS 02/28/2006.

SHAILA LEWIS, EXAMINING ATTORNEY

**CLASS 19—(Continued).**

SN 86-234,587. PEXCO LLC, TACOMA, WA. FILED 3-27-2014.



NO CLAIM IS MADE TO THE EXCLUSIVE RIGHT TO USE "POST", APART FROM THE MARK AS SHOWN.

THE MARK CONSISTS OF A LITERAL AND A DESIGN COMPONENT. THE LITERAL COMPONENT CONSISTS OF THE WORD "CITY POST" IN STYLIZED LETTERING. THE DESIGN COMPONENT CONSISTS OF TWO OVER-LAPPING OVAL SHAPES.

FOR NON-METAL TRAFFIC AND BOLLARD CHANNELIZER POSTS (U.S. CLS. 1, 12, 33 AND 50).

FIRST USE 2-0-2013; IN COMMERCE 2-0-2013. PAUL E. FAHRENKOPF, EXAMINING ATTORNEY

SN 86-222,150. INNOVA ECO BUILDING SYSTEM, LLC, MIAMI, FL. FILED 3-14-2014.

# Innova Firewall

THE MARK CONSISTS OF STANDARD CHARACTERS WITHOUT CLAIM TO ANY PARTICULAR FONT, STYLE, SIZE, OR COLOR.

NO CLAIM IS MADE TO THE EXCLUSIVE RIGHT TO USE "FIREWALL", APART FROM THE MARK AS SHOWN.

FOR BUILDING MATERIALS, NAMELY, COMPOSITE PANELS COMPOSED PRIMARILY OF NONMETAL MATERIALS; NON-METAL FIRE-RESISTANT BOARDS AND PANELS FOR CONSTRUCTION; WALL PANELS NOT OF METAL (U.S. CLS. 1, 12, 33 AND 50).

ALYSSA STEEL, EXAMINING ATTORNEY

SN 86-235,061. REGAL HARDWOODS, INC., FARMERS BRANCH, TX. FILED 3-28-2014.

# ON THE 9INE

THE MARK CONSISTS OF STANDARD CHARACTERS WITHOUT CLAIM TO ANY PARTICULAR FONT, STYLE, SIZE, OR COLOR.

FOR BUILDING MATERIALS, NAMELY, HARDWOOD FLOORING AND WALL PANELING NOT OF METAL (U.S. CLS. 1, 12, 33 AND 50).

FIRST USE 7-31-2010; IN COMMERCE 7-31-2010. MATTHEW CUCCIAS, EXAMINING ATTORNEY

SN 86-234,561. PEXCO LLC, TACOMA, WA. FILED 3-27-2014.

# CITY POST

THE MARK CONSISTS OF STANDARD CHARACTERS WITHOUT CLAIM TO ANY PARTICULAR FONT, STYLE, SIZE, OR COLOR.

NO CLAIM IS MADE TO THE EXCLUSIVE RIGHT TO USE "POST", APART FROM THE MARK AS SHOWN.

FOR NON-METAL TRAFFIC AND BOLLARD CHANNELIZER POSTS (U.S. CLS. 1, 12, 33 AND 50).

FIRST USE 2-0-2013; IN COMMERCE 2-0-2013. PAUL E. FAHRENKOPF, EXAMINING ATTORNEY

SN 86-235,096. REGAL HARDWOODS, INC., FARMERS BRANCH, TX. FILED 3-28-2014.

# ON|THE|9INE

THE MARK CONSISTS OF THE WORDS "ON THE 9INE" WITH A SINGLE VERTICAL LINE SEPARATING EACH WORD.

FOR BUILDING MATERIALS, NAMELY, HARDWOOD FLOORING AND WALL PANELING NOT OF METAL (U.S. CLS. 1, 12, 33 AND 50).

FIRST USE 7-31-2010; IN COMMERCE 7-31-2010. MATTHEW CUCCIAS, EXAMINING ATTORNEY

**CLASS 19—(Continued).**

SN 86-236,975. ILLINOIS TOOL WORKS INC., GLENVIEW, IL. FILED 3-31-2014.

# ESCOWELD

THE MARK CONSISTS OF STANDARD CHARACTERS WITHOUT CLAIM TO ANY PARTICULAR FONT, STYLE, SIZE, OR COLOR.

FOR EPOXY GROUT (U.S. CLS. 1, 12, 33 AND 50).  
FIRST USE 7-1-1967; IN COMMERCE 7-1-1967.  
PAUL E. FAHRENKOPF, EXAMINING ATTORNEY

---

SN 86-239,273. ENDEAVOUR MIAMI LLC, MIAMI, FL. FILED 4-1-2014.

# BRITE Flooring

THE MARK CONSISTS OF STANDARD CHARACTERS WITHOUT CLAIM TO ANY PARTICULAR FONT, STYLE, SIZE, OR COLOR.

NO CLAIM IS MADE TO THE EXCLUSIVE RIGHT TO USE "FLOORING", APART FROM THE MARK AS SHOWN.  
FOR HARDWOOD FLOORING; LAMINATE FLOORING; VINYL FLOORING (U.S. CLS. 1, 12, 33 AND 50).  
MATTHEW KLINE, EXAMINING ATTORNEY

---

SN 86-245,256. INDO CUSTOM TEAK FLOORING, LLC, LOS ANGELES, CA. FILED 4-8-2014.

# CINTA

THE MARK CONSISTS OF STANDARD CHARACTERS WITHOUT CLAIM TO ANY PARTICULAR FONT, STYLE, SIZE, OR COLOR.

FOR TILE (U.S. CLS. 1, 12, 33 AND 50).  
HOWARD SMIGA, EXAMINING ATTORNEY

**CLASS 19—(Continued).**

SN 86-245,466. CARTER, RICKY S, PRAIRIEVILLE, LA. FILED 4-8-2014.

# LAMCAR

THE MARK CONSISTS OF STANDARD CHARACTERS WITHOUT CLAIM TO ANY PARTICULAR FONT, STYLE, SIZE, OR COLOR.

FOR PLASTIC SAFETY APPARATUS, NAMELY, SAFETY BARRICADE FENCING USED IN CONSTRUCTION AREAS (U.S. CLS. 1, 12, 33 AND 50).  
FIRST USE 11-13-2001; IN COMMERCE 11-13-2001.  
LEIGH CAROLINE CASE, EXAMINING ATTORNEY

---

SN 86-246,252. LINCO ENTERPRISES, INC., ONTARIO, CA. FILED 4-8-2014.

# Napa Valley Collection

THE MARK CONSISTS OF STANDARD CHARACTERS WITHOUT CLAIM TO ANY PARTICULAR FONT, STYLE, SIZE, OR COLOR.

NO CLAIM IS MADE TO THE EXCLUSIVE RIGHT TO USE "COLLECTION", APART FROM THE MARK AS SHOWN.  
FOR LAMINATE WOOD FLOORING (U.S. CLS. 1, 12, 33 AND 50).  
FIRST USE 12-1-2013; IN COMMERCE 1-21-2014.  
TASNEEM HUSSAIN, EXAMINING ATTORNEY

**CLASS 19—(Continued).**

SN 86-249,219. ANHUI HUIFENG NEW SYNTHETIC MATERIALS CO., LTD., ANHUI PROVINCE, CHINA, FILED 4-11-2014.

# GeoMax

THE MARK CONSISTS OF LETTERS "GEOMAX".  
FOR BUILDING MATERIAL, NAMELY, PLASTIC WEBBING MATERIAL USED TO REINFORCE BITUMINOUS WATERPROOFING SHEETS; BUILDING MATERIALS, NAMELY, PLASTIC PEDESTALS FOR ELEVATING PAVERS; CEMENT SLABS; CONCRETE ROAD PAVEMENT BOARDS; CRASH BARRIERS OF CONCRETE, PLASTIC FOR ROADS; DRAIN PIPES, NOT OF METAL; GLASS GRANULES FOR MARKING ROADS; NON-METALLIC DRAINAGE PIPES; NON-METALLIC REINFORCEMENTS FOR CONCRETE AND WOOD BUILDING CONSTRUCTION, NAMELY, PLATES, RODS AND BARS; PAVING BLOCKS, NOT OF METAL; PLASTIC FLOORBOARDS; PLASTIC ROAD STUDS FOR MARKING OUT ROADS; PLASTIC TILES; POLYMERIC BITUMEN EMULSION FOR WATERPROOFING BUILDINGS; POLYMERIC BITUMEN EMULSIONS FOR ROAD SURFACES; REINFORCING MATERIALS NOT OF METAL FOR BUILDING PURPOSES; ROAD ASPHALT; SLABS, NOT OF METAL, FOR BUILDING; VINYL SIDING; WATERPROOF FABRIC USED IN BUILDING CONSTRUCTION FOR PROTECTION AGAINST FLOODS (U.S. CLS. 1, 12, 33 AND 50).

FIRST USE 6-16-2011; IN COMMERCE 6-16-2011.  
JOHN HWANG, EXAMINING ATTORNEY

SN 86-249,229. CHANGZHOU ALMADEN CO., LTD., CHANGZHOU, JIANGSU, CHINA, FILED 4-11-2014.

# EagleLite

THE MARK CONSISTS OF STYLIZED WORDING "EAGLELITE".

FOR BUILDING GLASS; COLOR COATINGS SOLD AS AN INTEGRAL COMPONENT OF GLASS PANELS FOR BUILDING PURPOSES; FIGURED PLATE GLASS FOR BUILDING; INSULATING GLASS FOR BUILDING; INSULATING GLASS FOR WINDOWS FOR BUILDING PURPOSES; MODIFIED SHEET GLASS; ROOFING, NOT OF METAL, INCORPORATING SOLAR CELLS; SAFETY GLASS FOR BUILDING PURPOSES; WINDOW GLASS; WIRED PLATE GLASS FOR BUILDING (U.S. CLS. 1, 12, 33 AND 50).

FIRST USE 1-8-2013; IN COMMERCE 1-8-2013.  
JOHN HWANG, EXAMINING ATTORNEY

**CLASS 19—(Continued).**

SN 86-249,238. CHANGZHOU ALMADEN CO., LTD., CHANGZHOU, JIANGSU, CHINA, FILED 4-11-2014.

# EagleShield

THE MARK CONSISTS OF STYLIZED WORDING "EAGLESHIELD".

FOR BUILDING GLASS; COLOR COATINGS SOLD AS AN INTEGRAL COMPONENT OF GLASS PANELS FOR BUILDING PURPOSES; FIGURED PLATE GLASS FOR BUILDING; INSULATING GLASS FOR BUILDING; INSULATING GLASS FOR WINDOWS FOR BUILDING PURPOSES; MODIFIED SHEET GLASS; ROOFING, NOT OF METAL, INCORPORATING SOLAR CELLS; SAFETY GLASS FOR BUILDING PURPOSES; WINDOW GLASS; WIRED PLATE GLASS FOR BUILDING (U.S. CLS. 1, 12, 33 AND 50).

FIRST USE 1-8-2013; IN COMMERCE 1-8-2013.  
JOHN HWANG, EXAMINING ATTORNEY

**CLASS 20—FURNITURE AND ARTICLES NOT OTHERWISE CLASSIFIED**

SN 79-133,807. MIRAIAL CO., LTD., JAPAN, FILED 6-12-2013.



PRIORITY DATE OF 5-9-2013 IS CLAIMED.  
OWNER OF INTERNATIONAL REGISTRATION 1169770 DATED 6-12-2013, EXPIRES 6-12-2023.

OWNER OF U.S. REG. NO. 3,667,038.  
THE COLOR(S) SCARLET, DEEP GREEN AND BLACK IS/ARE CLAIMED AS A FEATURE OF THE MARK.

THE MARK IS COMPOSED OF A DEVICE COLORED DEEP GREEN AND THE LETTERS "MIRAIAL" IN BLOCK LETTERS AND COLORED SCARLET; THE DEVICE CONSISTS OF A VERY STYLIZED LETTER "M" IN ROUND SHAPED AND A BOLD TYPE FONT; THE LETTERS CONSIST OF "M" IN CAPITAL LETTER AND "IRAIAL" IN LOWERCASE LETTERS; THE DEVICE AND THE LETTERS INCLUDE SHADOWS COLORED BLACK THEREIN.

THE WORDING "MIRAIAL" HAS NO MEANING IN A FOREIGN LANGUAGE.

FOR CASES, TRAYS, BASKETS AND CONTAINERS MADE OF PLASTICS, FOR SHIPPING, HOUSING, STORING AND TRANSPORTING GOODS FOR INDUSTRIAL PURPOSES (U.S. CLS. 2, 13, 22, 25, 32 AND 50).

JANET LEE, EXAMINING ATTORNEY

**CLASS 20—(Continued).**

SN 79-138,917. RIVATELIER S.R.L., ITALY, FILED 7-30-2013.



PRIORITY DATE OF 7-24-2013 IS CLAIMED.  
OWNER OF INTERNATIONAL REGISTRATION 1182832  
DATED 7-30-2013, EXPIRES 7-30-2023.

THE MARK CONSISTS IN THE WORDING "RIVATELIER" IN LOWER-CASE BOLD FANTASY CHARACTERS; TO THE LEFT OF THE WORDING IS A SQUARE IMPRESSION CONTAINING A STYLIZED REPRESENTATION OF A FLOWER.

FOR DIVANS; SOFABEDS; SOFAS; CUSHIONS; BEDS; FURNITURE; MIRRORS; FURNITURE FRAMES; SEATS; STOOLS; TABLES; OCCASIONAL TABLES; BOOK SHELVES; WRITING DESKS; COMPUTER TABLES; CABINETS; BEDSIDE TABLES; WARDROBES; CUPBOARDS; GLASS CABINETS; WOODEN ORNAMENTS; WOODEN OBJECTS D'ART; TOILETRY TABLES; BEDS WITH CONTAINERS; POUFS (U.S. CLS. 2, 13, 22, 25, 32 AND 50).

KIM MONINGHOFF, EXAMINING ATTORNEY

SN 79-140,862. LE LIT NATIONAL F PEJAUDIER, FRANCE, FILED 8-1-2013.

# LE LIT NATIONAL

THE MARK CONSISTS OF STANDARD CHARACTERS WITHOUT CLAIM TO ANY PARTICULAR FONT, STYLE, SIZE, OR COLOR.

OWNER OF INTERNATIONAL REGISTRATION 1187857  
DATED 8-1-2013, EXPIRES 8-1-2023.

NO CLAIM IS MADE TO THE EXCLUSIVE RIGHT TO USE "LE LIT", APART FROM THE MARK AS SHOWN.

THE ENGLISH TRANSLATION OF "LE LIT" IN THE MARK IS "BED".

FOR BEDDING ARTICLES NAMELY, BEDS, BED BASES, MATTRESSES, HEADBOARDS, FITTED WITH WOOL, FOAM, LINEN, SILK, PLANT FIBERS, SPRINGS OR LATEX (U.S. CLS. 2, 13, 22, 25, 32 AND 50).

THEODORE MCBRIDE, EXAMINING ATTORNEY

SN 79-143,555. BALDUCCI ITALIA PTY LTD, AUSTRALIA, FILED 12-17-2013.

# BALDUCCI ITALIA

THE MARK CONSISTS OF STANDARD CHARACTERS WITHOUT CLAIM TO ANY PARTICULAR FONT, STYLE, SIZE, OR COLOR.

PRIORITY DATE OF 6-25-2013 IS CLAIMED.  
OWNER OF INTERNATIONAL REGISTRATION 1194444  
DATED 12-17-2013, EXPIRES 12-17-2023.

NO CLAIM IS MADE TO THE EXCLUSIVE RIGHT TO USE "ITALIA", APART FROM THE MARK AS SHOWN.

THE ENGLISH TRANSLATION OF "ITALIA" IN THE MARK IS "ITALY".

FOR FURNITURE (U.S. CLS. 2, 13, 22, 25, 32 AND 50).  
TASNEEM HUSSAIN, EXAMINING ATTORNEY

**CLASS 20—(Continued).**

SN 85-425,632. NISSAN JIDOSHA KABUSHIKI KAISHA, TA NISSAN MOTOR CO., LTD., YOKOHAMA-SHI, KANAGAWA, JAPAN, FILED 9-19-2011.

# INFINITI

PRIORITY CLAIMED UNDER SEC. 44(D) ON JAPAN APPLICATION NO. 2011-055225, FILED 8-3-2011, REG. NO. 5505276, DATED 7-6-2012, EXPIRES 7-6-2022.

OWNER OF JAPAN REG. NO. 5528953, DATED 10-19-2012, EXPIRES 10-19-2022.

THE MARK CONSISTS OF STYLIZED WORD "INFINITI". THE WORDING "INFINITI" HAS NO MEANING IN A FOREIGN LANGUAGE.

FOR (BASED ON 44(E)) (BASED ON INTENT TO USE) CABINETS FOR DISPLAYING REPLICAS OF RACING CAR PARTS; CHAIRS; DECORATIVE CUSHIONS, JAPANESE FLOOR CUSHIONS; HAND-HELD FOLDING FANS; NON-METALLIC BOTTLE CAPS; NON-METALLIC BOTTLE STOPPERS; REPLICA MODELS OF VEHICLES MADE OF RESIN, NAMELY, ORNAMENTAL SCULPTURES OF MOTOR VEHICLES MADE OF RESIN; TOOL BOXES NOT OF METAL; PLASTIC STRAPS FOR HOLDING NAME BADGES; (BASED ON INTENT TO USE) NON-METAL KEY HOLDERS; LEATHER KEY RINGS (U.S. CLS. 2, 13, 22, 25, 32 AND 50).

BILL DAWE, EXAMINING ATTORNEY

SN 85-554,711. BEEHIVE STATE, INC., SANDY, UT. FILED 2-28-2012.

# MELLIVO

THE MARK CONSISTS OF STANDARD CHARACTERS WITHOUT CLAIM TO ANY PARTICULAR FONT, STYLE, SIZE, OR COLOR.

THE WORDING "MELLIVO" HAS NO MEANING IN A FOREIGN LANGUAGE.

FOR BEEKEEPING EQUIPMENT, NAMELY, BEEHIVE FRAMES, HIVE BODIES, HIVE FOUNDATIONS, HIVE BOXES, HIVE TOPS, HIVE BOTTOMS, IN-HIVE FEEDERS, HIVE GRIPS, QUEEN EXCLUDERS, COMB FOUNDATIONS, AND FRAME GRIPS (U.S. CLS. 2, 13, 22, 25, 32 AND 50).

TINA L. SNAPP, EXAMINING ATTORNEY

**CLASS 20—(Continued).**

SN 85-891,639. JAVA MUSIC CLUB, INC., SURREY, CANADA, FILED 4-1-2013.

**JAVA MUSIC CLUB**

THE MARK CONSISTS OF STANDARD CHARACTERS WITHOUT CLAIM TO ANY PARTICULAR FONT, STYLE, SIZE, OR COLOR.

NO CLAIM IS MADE TO THE EXCLUSIVE RIGHT TO USE "MUSIC CLUB", APART FROM THE MARK AS SHOWN.

FOR WORKS OF ART OF WOOD, NAMELY, TRADITIONAL ABORIGINAL TALKING STICKS (U.S. CLS. 2, 13, 22, 25, 32 AND 50).

SIMON TENG, EXAMINING ATTORNEY

---

SN 86-042,639. SHAW BUSINESS, LLC, BERNALILLO, NM. FILED 8-20-2013.

**SAFETY IN NUMBERS**

THE MARK CONSISTS OF STANDARD CHARACTERS WITHOUT CLAIM TO ANY PARTICULAR FONT, STYLE, SIZE, OR COLOR.

FOR SCULPTURES OF WOOD (U.S. CLS. 2, 13, 22, 25, 32 AND 50).

FIRST USE 1-1-2009; IN COMMERCE 1-1-2009.

DORITT L. CARROLL, EXAMINING ATTORNEY

---

SN 86-061,054. CHERRY MAN INDUSTRIES, INC., CARSON, CA. FILED 9-10-2013.

**IDESK VINTAGE**

THE MARK CONSISTS OF STANDARD CHARACTERS WITHOUT CLAIM TO ANY PARTICULAR FONT, STYLE, SIZE, OR COLOR.

NO CLAIM IS MADE TO THE EXCLUSIVE RIGHT TO USE "VINTAGE", APART FROM THE MARK AS SHOWN.

FOR OFFICE FURNITURE (U.S. CLS. 2, 13, 22, 25, 32 AND 50).

RAMONA ORTIGA, EXAMINING ATTORNEY

**CLASS 20—(Continued).**

SN 86-070,465. TUBE TECHNOLOGY, LLC, BOCA RATON, FL. FILED 9-20-2013.

**EZ ORGANIZER**

THE MARK CONSISTS OF STANDARD CHARACTERS WITHOUT CLAIM TO ANY PARTICULAR FONT, STYLE, SIZE, OR COLOR.

NO CLAIM IS MADE TO THE EXCLUSIVE RIGHT TO USE "ORGANIZER", APART FROM THE MARK AS SHOWN.

FOR SHELVES (U.S. CLS. 2, 13, 22, 25, 32 AND 50).

B. PARADEWELAI, EXAMINING ATTORNEY

---

SN 86-071,231. SUMMIT ENTERTAINMENT, LLC, SANTA MONICA, CA. FILED 9-22-2013.



THE MARK CONSISTS OF TWO HANDS WITHIN A CIRCLE, CLASPING AT 45 DEGREE ANGLES FROM OPPOSITE ENDS OF THE CIRCLE.

FOR DECORATIVE BOXES OF WOOD OR PLASTIC; NON-METAL KEY HANGERS; MIRRORS; NON-METAL ANIMAL TAGS; NON-METAL KEY CHAINS; NON-METAL NOVELTY LICENSE PLATES; PICTURE FRAMES; PILLOWS; PLASTIC BANNERS OR FLAGS; PLASTIC YARD SIGNS; AND VINYL APPLIQUES FOR ATTACHMENT TO WALLS, WINDOWS, MIRRORS, AND OTHER SOLID SURFACES (U.S. CLS. 2, 13, 22, 25, 32 AND 50).

ZACHARY BELLO, EXAMINING ATTORNEY

**CLASS 20—(Continued).**

SN 86-072,425. STRATEGIC PARTNERS, INC., CHATSWORTH, CA. FILED 9-23-2013.

# Curo

THE MARK CONSISTS OF STANDARD CHARACTERS WITHOUT CLAIM TO ANY PARTICULAR FONT, STYLE, SIZE, OR COLOR.

THE ENGLISH TRANSLATION OF "CURO" IN THE MARK IS "TO HEAL".

FOR CLEAR PLASTIC HOLDERS FOR BADGES; NON-METAL KEY HOLDERS (U.S. CLS. 2, 13, 22, 25, 32 AND 50).

DANNEAN HETZEL, EXAMINING ATTORNEY

SN 86-078,210. RUSSELL CARROLL MFG, INC., RALEIGH, NC. FILED 9-30-2013.



NO CLAIM IS MADE TO THE EXCLUSIVE RIGHT TO USE "HYBRID", APART FROM THE MARK AS SHOWN.

THE COLOR(S) GREEN, WHITE, AND GREY IS/ARE CLAIMED AS A FEATURE OF THE MARK.

THE MARK CONSISTS OF A STYLIZED "H" WHICH IS COMPRISED OF A GREY SQUARE ON THE TOP LEFT SITTING ABOVE A GREEN STYLIZED LOWER CASE "R". THERE IS WHITE SPACE BETWEEN THE SQUARE AND THE TOP OF THE GREEN STYLIZED LETTER "R". THE SERIF OF THE GREEN LETTER "R" INTERCEPTS WITH THE RIGHT PORTION OF THE GREY "H" WITH A THIN WHITE BORDER AROUND THE PORTION OF THE SERIF THAT INTERCEPTS THE "H". THESE ELEMENTS ALL TOGETHER COMPRISE THE STYLIZED LETTER "H" LOGO. THE LOGO SITS IMMEDIATELY ABOVE THE WORD "HYBRID" WHICH IS IN UPPER/LOWER CASE LETTERING. THE LETTERS "HY" ARE IN GREY. THE LETTERS "BRID" ARE IN GREEN. THE DOT IN THE LETTER "I" IS GREY. THE WORD "HYBRID" AND THE LOGO FIT WITHIN THE SAME VERTICAL PLANE ON THE LEFT AND RIGHT.

FOR LIBRARY FURNITURE; OFFICE FURNITURE; SCHOOL FURNITURE (U.S. CLS. 2, 13, 22, 25, 32 AND 50).

B. PARADEWELAI, EXAMINING ATTORNEY

**CLASS 20—(Continued).**

SN 86-102,380. DIAMOND MATTRESS COMPANY, INC., COMPTON, CA. FILED 10-25-2013.

# ACTIVATE

THE MARK CONSISTS OF STANDARD CHARACTERS WITHOUT CLAIM TO ANY PARTICULAR FONT, STYLE, SIZE, OR COLOR.

FOR SLEEP PRODUCTS, NAMELY, MATTRESSES AND MATTRESS FOUNDATIONS (U.S. CLS. 2, 13, 22, 25, 32 AND 50).

HANNO RITTNER, EXAMINING ATTORNEY

SN 86-105,969. KING KOIL LICENSING COMPANY, INC., WILLOWBROOK, IL. FILED 10-30-2013.

# SLEEP CONNOISSEUR BY KING KOIL

THE MARK CONSISTS OF STANDARD CHARACTERS WITHOUT CLAIM TO ANY PARTICULAR FONT, STYLE, SIZE, OR COLOR.

OWNER OF U.S. REG. NOS. 597,377, 2,818,040 AND OTHERS.

NO CLAIM IS MADE TO THE EXCLUSIVE RIGHT TO USE "SLEEP", APART FROM THE MARK AS SHOWN.

FOR BEDS; BOX SPRINGS; MATTRESSES (U.S. CLS. 2, 13, 22, 25, 32 AND 50).

DAVID I, EXAMINING ATTORNEY

SN 86-110,680. DIAMOND MATTRESS COMPANY, INC., COMPTON, CA. FILED 11-5-2013.

# REFUGE

THE MARK CONSISTS OF STANDARD CHARACTERS WITHOUT CLAIM TO ANY PARTICULAR FONT, STYLE, SIZE, OR COLOR.

FOR SLEEP PRODUCTS, NAMELY, MATTRESSES AND MATTRESS FOUNDATIONS (U.S. CLS. 2, 13, 22, 25, 32 AND 50).

HANNO RITTNER, EXAMINING ATTORNEY



**CLASS 20—(Continued).**

SN 86-131,141. SPIN MASTER LTD., TORONTO, ONTARIO, CANADA, FILED 11-27-2013.

**MAKE ROOM FOR FUN**

THE MARK CONSISTS OF STANDARD CHARACTERS WITHOUT CLAIM TO ANY PARTICULAR FONT, STYLE, SIZE, OR COLOR.

OWNER OF CANADA REG. NO. 1254610, DATED 5-29-2007, EXPIRES 5-29-2022.

FOR FURNITURE, NAMELY, HIGH BACK CHAIRS, PULL-OUT SOFAS, ROCKING CHAIRS, CUBE CHAIRS, BEANBAG CHAIRS, RECLINER CHAIRS, FOOTSTOOLS, WALL UNITS, WARDROBE UNITS, NON-METAL CHESTS, CHESTS OF DRAWERS, CUPBOARD UNITS, BED HEAD BOARDS; FURNITURE FOR JUVENILES, NAMELY, PLUSH CHAIRS, PULL-OUT SOFAS, PLUSH ROCKING CHAIRS, CUBE CHAIRS, AND COMBINATION SEATING/SLEEPING FURNITURE; CHILDREN'S FURNITURE, NAMELY, UPHOLSTERED CHAIRS, ROCKING CHAIRS, RECLINER SEATING AND INFLATABLE FURNITURE FOR SITTING; CHAIRS, BEAN BAG CHAIRS, SOFAS, BEAN BAG SOFAS; NON-METAL STORAGE BINS; BEDS; AIR MATTRESSES FOR USE WHEN CAMPING, SLEEPING BAGS, SLEEPING BAGS INCORPORATING INFLATABLE MATTRESSES (U.S. CLS. 2, 13, 22, 25, 32 AND 50).

ESTHER BELENKER, EXAMINING ATTORNEY

SN 86-138,788. CHINGDAR ENTERPRISE CO., LTD., NEW TAIPEI CITY, TAIWAN, FILED 12-9-2013.

**KINGDAR**

THE MARK CONSISTS OF STANDARD CHARACTERS WITHOUT CLAIM TO ANY PARTICULAR FONT, STYLE, SIZE, OR COLOR.

THE WORDING "KINGDAR" HAS NO MEANING IN A FOREIGN LANGUAGE.

FOR MODULAR OFFICE FURNITURE SYSTEM COMPRISING TABLES, DESKS, COMMERCIAL WORKSTATIONS HAVING MULTI-USE WORK SURFACES FOR USE IN A WIDE VARIETY OF FIELDS, SHELVING, STORAGE CABINETS, BOOKCASES, OFFICE CHAIRS, AND MOVABLE OFFICE SPACE PARTITIONING COMPONENTS THEREOF, NAMELY, MOVEABLE WALL PANELS, PARTITIONS AND PRIVACY SCREENS, AND MOVEABLE FULL HEIGHT WALL PARTITIONS (U.S. CLS. 2, 13, 22, 25, 32 AND 50).

FIRST USE 3-22-2004; IN COMMERCE 3-22-2004.  
STEVEN PEREZ, EXAMINING ATTORNEY

**CLASS 20—(Continued).**

SN 86-146,249. CARRASCO BERLANGA, VICTOR MANUEL, VALENCIA, SPAIN, FILED 12-17-2013.

**VICCARBE**

THE MARK CONSISTS OF STANDARD CHARACTERS WITHOUT CLAIM TO ANY PARTICULAR FONT, STYLE, SIZE, OR COLOR.

OWNER OF ERPNCMNTY TM OFC REG. NO. 011702636, DATED 8-28-2013, EXPIRES 8-28-2023.

FOR BATHROOM FURNITURE; BEAUTY SALON FURNITURE, NAMELY, SHAMPOO BOWLS; BEAUTY SALON FURNITURE, NAMELY, SHAMPOO STATIONS; BEAUTY SALON FURNITURE, NAMELY, STYLING STATIONS; BEDROOM FURNITURE; BUFFETS; BUMPER GUARDS FOR FURNITURE; CABINET DOORS FOR FURNITURE CABINETS; CABINETS; CAMPING FURNITURE; CARPET COASTERS FOR PROTECTING FURNITURE LEGS; CAST STONE HOUSEHOLD AND GARDEN FURNITURE; CERAMIC PULLS FOR CABINETS, DRAWERS AND FURNITURE; COMMERCIAL WORKSTATIONS COMPRISING TABLES, TOPS AND CHAIRS; COMPUTER FURNITURE; COMPUTER WORKSTATIONS COMPRISING TABLES, TOPS AND CHAIRS; CUSHIONS; CUSTOM FURNITURE; DINNER WAGONS; DOORS FOR FURNITURE; DRAFTING TABLES; DRAWERS; ENTERTAINMENT CENTERS; FABRIC SOLD AS AN INTEGRAL COMPONENT OF FINISHED FURNITURE; FITTED FABRIC FURNITURE COVERS; FITTED FABRIC SLIPCOVERS FOR FURNITURE; FITTED FURNITURE COVER NOT OF FABRIC; FITTED FURNITURE LEG COVERS FOR FLOOR PROTECTION PURPOSES; FLOWER-STANDS; FREESTANDING PARTITIONS; FURNITURE; FURNITURE CASTERS, NOT OF METAL; FURNITURE CHESTS; FURNITURE FITTINGS, NOT OF METAL; FURNITURE FOR CAMPING; FURNITURE FOR DISPLAYING GOODS; FURNITURE FOR HOUSE, OFFICE AND GARDEN; FURNITURE FOR MOTOR HOMES; FURNITURE FOR USE IN THE HAUNTED ATTRACTION INDUSTRY; FURNITURE FRAMES; FURNITURE HARDWARE, NAMELY, DRAWER SLIDES; FURNITURE MADE FROM STEEL TUBING; FURNITURE MADE FROM WOOD OR SUBSTITUTES FOR WOOD; FURNITURE MADE OF WOOD, VINYL, PLASTIC, METAL, ALUMINIUM, IRON; FURNITURE MOLDINGS; FURNITURE OF METAL; FURNITURE PARTITIONS; FURNITURE PARTS; FURNITURE PARTS, NAMELY, LEGS, TOPS, STRUCTURE FOR TABLES; FURNITURE PRIMARILY OF METAL, NAMELY, MIRRORS, BED FRAMES, DINING TABLES, COFFEE TABLES, END TABLES, DESKS, DISPLAY CASES, SHELVING, DOG GATES, AND BABY GATES; FURNITURE, MIRRORS, PICTURE FRAMES; FURNITURE, NAMELY, DISPLAY UNITS; FURNITURE, NAMELY, DRESSERS; FURNITURE, NAMELY, POUFS; FURNITURE, NAMELY, SALES AND DISPLAY COUNTERS; FURNITURE, NAMELY, SHOWCASES; FURNITURE, NAMELY, SPORTS BAR AND HOSPITALITY UNIT; FURNITURE, NAMELY, WALL UNITS; FURNITURE, NAMELY, WARDROBES; FUTONS; HEAD-RESTS; INDOOR WINDOW BLINDS; INFLATABLE FURNITURE; KIOSKS FOR VENDING PURPOSES COMPRISED OF FURNITURE; KITCHEN FURNITURE, NAMELY, READY TO ASSEMBLE MOBILE KITCHEN ISLANDS; LAMINATED VINYL TO BE AFFIXED TO THE SURFACE OF FURNITURE; LAWN FURNITURE; LIBRARY FURNITURE; LIVING ROOM FURNITURE; METAL FURNITURE; METAL FURNITURE AND FURNITURE FOR CAMPING; MIRRORS; NON-METAL FURNITURE CASTERS; NON-METAL SELF-ALIGNING DEMOUNTABLE SNAP FASTENERS CONSISTING OF PRESS FASTENERS AND PRESS STUDS FOR USE IN ATTACHING PANELS, HATCHES, FLOORS AND FURNITURE IN BOATS, MOTOR VEHICLES, TRAINS AND AIRCRAFT; NYLON ROLLERS FOR FURNITURE PARTS, NAMELY, SLIDING MIRROR DOOR ROLLER, DRAWER ROLLERS AND DOOR ROLLERS; OFFICE FURNITURE; OUT-

**CLASS 20—(Continued).**

DOOR FURNITURE; PATIO FURNITURE; PET FURNITURE; PLASTIC FURNITURE FOR GARDENS; PLASTIC HANDLES FOR DESKS; PLASTIC MOLDS FOR USE IN MANUFACTURING FURNITURE, BED LINERS, TRAILER FLOORING AND DECKS; PLASTIC VINYL SHEETS FOR ATTACHMENT TO FURNITURE TO PREVENT DAMAGE CAUSED BY CAT SCRATCHING; RECLINERS; RESIDENTIAL AND COMMERCIAL FURNITURE; RESIDENTIAL AND COMMERCIAL WROUGHT IRON FURNITURE; SCHOOL FURNITURE; SCREENS; SEATING FURNITURE; SEATS; STONE FURNITURE; STONE PULLS FOR CABINETS, DRAWERS AND FURNITURE; SUPPORT BRACKET NOT MADE OF METAL FOR ATTACHMENT TO FURNITURE TO SUPPORT ITEMS TO BE KEPT IN HANDS' REACH, SUCH AS A PISTOL, REMOTE CONTROL, FLASHLIGHT, CELL PHONE, OR EYEGLASSES; TABLES; TELEVISION STANDS; TOOL BOXES NOT OF METAL; TOOL CHESTS NOT OF METAL; TOWEL CLOSETS; TOY BOXES; UPHOLSTERED FURNITURE; WASHSTANDS (U.S. CLS. 2, 13, 22, 25, 32 AND 50).

ROSELLE HERRERA, EXAMINING ATTORNEY

---

SN 86-149,696. KOHLER CO., KOHLER, WI. FILED 12-20-2013.

**JUTE**

THE MARK CONSISTS OF STANDARD CHARACTERS WITHOUT CLAIM TO ANY PARTICULAR FONT, STYLE, SIZE, OR COLOR.

FOR FURNITURE; MIRRORS; BATHROOM VANITY UNITS; MEDICINE CABINETS; CABINETS; CONSOLE TABLES; CONSOLE TABLE LEGS (U.S. CLS. 2, 13, 22, 25, 32 AND 50).

SCOTT BIBB, EXAMINING ATTORNEY

---

SN 86-149,713. KOHLER CO., KOHLER, WI. FILED 12-20-2013.

**JACQUARD**

THE MARK CONSISTS OF STANDARD CHARACTERS WITHOUT CLAIM TO ANY PARTICULAR FONT, STYLE, SIZE, OR COLOR.

FOR FURNITURE; MIRRORS; BATHROOM VANITY UNITS; MEDICINE CABINETS; CABINETS; CONSOLE TABLES; CONSOLE TABLE LEGS (U.S. CLS. 2, 13, 22, 25, 32 AND 50).

SCOTT BIBB, EXAMINING ATTORNEY

**CLASS 20—(Continued).**

SN 86-167,658. GAMBLE, BRUCE, BETHESDA, MD. FILED 1-16-2014.

**A CLEAR HEAD**

THE MARK CONSISTS OF STANDARD CHARACTERS WITHOUT CLAIM TO ANY PARTICULAR FONT, STYLE, SIZE, OR COLOR.

FOR NOVELTY CONTAINERS AND DECORATIVE SCULPTURES MADE OF GLASS IN THE SHAPE OF A HOLLOW TRANSPARENT HUMAN HEAD (U.S. CLS. 2, 13, 22, 25, 32 AND 50).

ESTHER A. BORSUK, EXAMINING ATTORNEY

---

SN 86-178,122. GREAT BAY PRODUCT, INC., ST. PETERSBURG, FL. FILED 1-29-2014.

**QUICK BIBB**

THE MARK CONSISTS OF STANDARD CHARACTERS WITHOUT CLAIM TO ANY PARTICULAR FONT, STYLE, SIZE, OR COLOR.

NO CLAIM IS MADE TO THE EXCLUSIVE RIGHT TO USE "BIBB", APART FROM THE MARK AS SHOWN.

FOR MOUNTING BRACKET FOR HOSE BIBBS THAT ARE ATTACHED TO A BUILDING USING CPVC FITTINGS, STAINLESS STEEL OR PEX, NAMELY, NON-METAL MOUNTING BRACKETS FOR GENERAL USE (U.S. CLS. 2, 13, 22, 25, 32 AND 50).

FIRST USE 3-1-2002; IN COMMERCE 3-1-2002.  
INGRID C. EULIN, EXAMINING ATTORNEY

---

SN 86-191,683. ROYO WOOD, S.L., VALENCIA, SPAIN, FILED 2-12-2014.

**ROYOBATH**

THE MARK CONSISTS OF STANDARD CHARACTERS WITHOUT CLAIM TO ANY PARTICULAR FONT, STYLE, SIZE, OR COLOR.

THE WORDING "ROYOBATH" HAS NO MEANING IN A FOREIGN LANGUAGE.

FOR BATHROOM FURNITURE; MIRRORS (U.S. CLS. 2, 13, 22, 25, 32 AND 50).

SALLY SHIH, EXAMINING ATTORNEY

**CLASS 20—(Continued).**

SN 86-196,796. KENTSHARP COMPANY LIMITED, TSUEN WAN, N.T., HONG KONG, FILED 2-18-2014.

# KENTSHARP

THE MARK CONSISTS OF STANDARD CHARACTERS WITHOUT CLAIM TO ANY PARTICULAR FONT, STYLE, SIZE, OR COLOR.

FOR VALVES OF PLASTIC BEING OTHER THAN MACHINE PARTS (U.S. CLS. 2, 13, 22, 25, 32 AND 50).

FIRST USE 1-0-2005; IN COMMERCE 1-0-2005.

ROBERT C. CLARK JR., EXAMINING ATTORNEY

---

SN 86-206,903. ANTHONY J. SCHINDLER, CAVE CREEK, AZ. FILED 2-27-2014.



DISCOUNT PATIO.COM  
FURNITURE

NO CLAIM IS MADE TO THE EXCLUSIVE RIGHT TO USE "DISCOUNT" OR "PATIO.COM" OR "FURNITURE", APART FROM THE MARK AS SHOWN.

THE MARK CONSISTS OF THE WORDING "DISCOUNT PATIO.COM FURNITURE" WITH A PATIO UMBRELLA POSITIONED BETWEEN THE WORDS "DISCOUNT" AND "PATIO.COM".

FOR PATIO FURNITURE (U.S. CLS. 2, 13, 22, 25, 32 AND 50).

FIRST USE 9-13-2013; IN COMMERCE 2-1-2014.

EVELYN BRADLEY, EXAMINING ATTORNEY

---

SN 86-214,644. LINET AMERICAS, INC., HUNTERSVILLE, NC. FILED 3-7-2014.

# ERGOZONE

THE MARK CONSISTS OF STANDARD CHARACTERS WITHOUT CLAIM TO ANY PARTICULAR FONT, STYLE, SIZE, OR COLOR.

FOR HOSPITAL BEDS (U.S. CLS. 2, 13, 22, 25, 32 AND 50).

PAUL CROWLEY, EXAMINING ATTORNEY

**CLASS 20—(Continued).**

SN 86-225,707. DESIGNS BY CRICKETZZZ INC., DBA CRICKETZZZ INC., ROSWELL, GA. FILED 3-19-2014.



OWNER OF U.S. REG. NO. 3,224,888.

NO CLAIM IS MADE TO THE EXCLUSIVE RIGHT TO USE "SLUMBER BAGS", APART FROM THE MARK AS SHOWN.

THE COLOR(S) ORANGE, LIGHT PINK, BLACK, WHITE, AND GREEN IS/ARE CLAIMED AS A FEATURE OF THE MARK.

THE MARK CONSISTS OF AN ORANGE STYLIZED CRICKET ON A GREEN LEAF WITH BLACK STYLIZED WORDING "CRICKETZZZ SLUMBER BAGS" ON A WHITE BACKGROUND. THE CRICKET HAS BLACK DOT ANTENNAE, BLACK AND WHITE EYES OUTLINED IN LIGHT PINK, A BLACK MOUTH AND THE CRICKET'S THREE FRONT LEGS ARE IN THE SHAPE OF THE LETTER "Z".

FOR SLUMBER BAGS (U.S. CLS. 2, 13, 22, 25, 32 AND 50).

FIRST USE 12-31-2004; IN COMMERCE 12-31-2004.

KIMBERLY FRYE, EXAMINING ATTORNEY

---

SN 86-227,867. CLOSETPRO, INC., ANDERSON, SC. FILED 3-20-2014.



NO CLAIM IS MADE TO THE EXCLUSIVE RIGHT TO USE "STORAGE CUBBIES .COM", APART FROM THE MARK AS SHOWN.

THE COLOR(S) GREEN, PURPLE, ORANGE, BLUE AND BLACK IS/ARE CLAIMED AS A FEATURE OF THE MARK.

THE MARK CONSISTS OF THREE CUBE DESIGNS IN GREEN, PURPLE AND ORANGE STACKED DIAGONALLY ON TOP OF EACH OTHER, WITH THE WORDING "STORAGE" IN BLUE, "CUBBIES" IN GREEN, AND ".COM" IN BLACK.

FOR CABINETS; FURNITURE; SHELVES FOR STORAGE; SHELVING (U.S. CLS. 2, 13, 22, 25, 32 AND 50).

ALEXANDER L. POWERS, EXAMINING ATTORNEY

**CLASS 20—(Continued).**

SN 86-228,545. INTEX MARKETING LTD., LONG BEACH, CA. FILED 3-21-2014.

**PREMAIRE**

THE MARK CONSISTS OF STANDARD CHARACTERS WITHOUT CLAIM TO ANY PARTICULAR FONT, STYLE, SIZE, OR COLOR.

FOR INFLATABLE AIR BEDS; INFLATABLE AIR MATTRESSES FOR USE WHEN CAMPING; INFLATABLE AIR MATTRESSES FOR INDOOR AND OUTDOOR USE, NOT FOR MEDICAL OR RECREATIONAL USE; INFLATABLE CHAIRS, SOFAS, LOUNGES AND OTHER FURNITURE; INFLATABLE PILLOWS (U.S. CLS. 2, 13, 22, 25, 32 AND 50).

TIMOTHY O. SCHIMPF, EXAMINING ATTORNEY

---

SN 86-231,344. CROWN AWARDS, INC., HAWTHORNE, NY. FILED 3-25-2014.

**TRO-FAVORS**

THE MARK CONSISTS OF STANDARD CHARACTERS WITHOUT CLAIM TO ANY PARTICULAR FONT, STYLE, SIZE, OR COLOR.

FOR PARTY FAVOR KITS COMPRISED PRIMARILY OF NONMETAL TROPHIES, METAL DOG TAGS, STICKERS, RUBBER BRACELETS, TOY FOAM BALLS, AND CARRY ALL BAGS (U.S. CLS. 2, 13, 22, 25, 32 AND 50).

FIRST USE 6-0-2013; IN COMMERCE 6-0-2013.  
JACLYN KIDWELL WALKER, EXAMINING ATTORNEY

---

SN 86-232,270. KELLY, DANIEL, MEDFORD, NJ. FILED 3-26-2014.

**PROGENIC**

THE MARK CONSISTS OF STANDARD CHARACTERS WITHOUT CLAIM TO ANY PARTICULAR FONT, STYLE, SIZE, OR COLOR.

FOR NON-METAL PALLETS; NON-METAL HYGIENIC FLOW THROUGH PALLETS; NON-METAL PALLETS FOR USE IN THE PHARMACEUTICAL, MEDICAL, FOOD, BEVERAGE, AND INDUSTRIAL FIELDS (U.S. CLS. 2, 13, 22, 25, 32 AND 50).

GIANCARLO CASTRO, EXAMINING ATTORNEY

**CLASS 20—(Continued).**

SN 86-233,188. URSUS OUTDOORS CORPORATION, FAYETTE, MO. FILED 3-26-2014.

**Ursus Outdoors**

THE MARK CONSISTS OF STANDARD CHARACTERS WITHOUT CLAIM TO ANY PARTICULAR FONT, STYLE, SIZE, OR COLOR.

NO CLAIM IS MADE TO THE EXCLUSIVE RIGHT TO USE "OUTDOORS", APART FROM THE MARK AS SHOWN.

THE WORDING "URSUS" HAS NO MEANING IN A FOREIGN LANGUAGE.

FOR SLEEPING BAGS (U.S. CLS. 2, 13, 22, 25, 32 AND 50).

CATHERINE TARCU, EXAMINING ATTORNEY

---

SN 86-234,007. TOMMY BAHAMA GROUP, INC., ATLANTA, GA. FILED 3-27-2014.

**Tres Chic**

THE MARK CONSISTS OF STANDARD CHARACTERS WITHOUT CLAIM TO ANY PARTICULAR FONT, STYLE, SIZE, OR COLOR.

THE ENGLISH TRANSLATION OF "TRES" IN THE MARK IS "VERY".

FOR FURNITURE (U.S. CLS. 2, 13, 22, 25, 32 AND 50).

SUZANNE BLANE, EXAMINING ATTORNEY

---

SN 86-234,308. ADVANCED CANNABIS SOLUTIONS, COLORADO SPRINGS, CO. FILED 3-27-2014.

**Yes We CANN**

THE MARK CONSISTS OF STANDARD CHARACTERS WITHOUT CLAIM TO ANY PARTICULAR FONT, STYLE, SIZE, OR COLOR.

FOR PLASTIC MEDICATION CONTAINERS FOR COMMERCIAL USE (U.S. CLS. 2, 13, 22, 25, 32 AND 50).

NICHOLAS ALTREE, EXAMINING ATTORNEY

**CLASS 20—(Continued).**

SN 86-235,044. KROSS KRAFT, LLC, HOLLAND, MI. FILED 3-28-2014.

**THE GROWLER SHOE**

THE MARK CONSISTS OF STANDARD CHARACTERS WITHOUT CLAIM TO ANY PARTICULAR FONT, STYLE, SIZE, OR COLOR.

NO CLAIM IS MADE TO THE EXCLUSIVE RIGHT TO USE "GROWLER", APART FROM THE MARK AS SHOWN. FOR WOODEN CARRIER APPARATUS, NAMELY, A CRATE WITH A CENTER HANDLE SPECIALLY DESIGNED TO CARRY BEER JUGS AND BEER GROWLERS (U.S. CLS. 2, 13, 22, 25, 32 AND 50).

ALISON KEELEY, EXAMINING ATTORNEY

SN 86-236,760. SHAY, DOUGLAS, BUTLER, KY. FILED 3-31-2014.

**Stacky Stables**

THE MARK CONSISTS OF STANDARD CHARACTERS WITHOUT CLAIM TO ANY PARTICULAR FONT, STYLE, SIZE, OR COLOR.

NO CLAIM IS MADE TO THE EXCLUSIVE RIGHT TO USE "STABLES", APART FROM THE MARK AS SHOWN.

FOR MODEL HORSE ACCESSORIES, NAMELY, WOOD CABINETS AND SHELVING FOR DISPLAY PURPOSES (U.S. CLS. 2, 13, 22, 25, 32 AND 50).

JOANNA DUKOVIC, EXAMINING ATTORNEY

SN 86-237,758. FURNITURE TRADITIONS, ORANGE, CA. FILED 3-31-2014.

**STEVEN JAMES COLLECTION**

THE MARK CONSISTS OF STANDARD CHARACTERS WITHOUT CLAIM TO ANY PARTICULAR FONT, STYLE, SIZE, OR COLOR.

NO CLAIM IS MADE TO THE EXCLUSIVE RIGHT TO USE "COLLECTION", APART FROM THE MARK AS SHOWN.

THE NAME(S), PORTRAIT(S), AND/OR SIGNATURE(S) SHOWN IN THE MARK IDENTIFIES A LIVING PERSON, WHOSE CONSENT(S) TO REGISTER IS MADE OF RECORD.

FOR FURNITURE, NAMELY, BOOK CASES, DRESSERS, MIRRORS, CHESTS, ARMOIRES, NIGHTSTANDS, PEDESTALS, BEDS, BED FRAMES, BED HEADBOARDS AND BED FOOTBOARDS (U.S. CLS. 2, 13, 22, 25, 32 AND 50).

DAVID MURRAY, EXAMINING ATTORNEY

**CLASS 20—(Continued).**

SN 86-239,485. KROSS KRAFT, LLC, HOLLAND, MI. FILED 4-2-2014.



THE MARK CONSISTS OF A STYLIZED TWO-DIMENSIONAL REPRESENTATION OF A BEVERAGE CONTAINER HAVING A PAIR OF GRIDDED CIRCLES PROVIDED THEREIN AND A PAIR OF CONCENTRIC CIRCLES POSITIONED ADJACENT TO THE TOP OF THE BEVERAGE CONTAINER.

FOR WOODEN CARRIER APPARATUS, NAMELY, A CRATE WITH A CENTER HANDLE SPECIALLY DESIGNED TO CARRY BEER JUGS AND BEER GROWLERS (U.S. CLS. 2, 13, 22, 25, 32 AND 50).

ALISON KEELEY, EXAMINING ATTORNEY

SN 86-244,451. MICHIGAN TUBE SWAGERS &amp; FABRICATORS, INC., DBA MTS SEATING, TEMPERANCE, MI. FILED 4-7-2014.

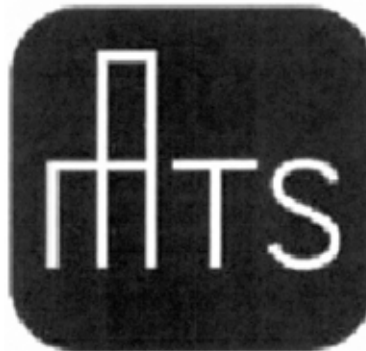

OWNER OF U.S. REG. NOS. 2,442,627 AND 2,703,855. THE MARK CONSISTS OF THE LETTERS "MTS" WHEREIN THE "M" IS STYLIZED TO LOOK LIKE A CHAIR.

FOR CHAIRS (U.S. CLS. 2, 13, 22, 25, 32 AND 50). FIRST USE 4-4-2014; IN COMMERCE 4-4-2014.

HEATHER SAPP, EXAMINING ATTORNEY

**CLASS 20—(Continued).**

SN 86-244,687. TORRES, MARIA, SOUTH AMBOY, NJ.  
FILED 4-7-2014.

## BARK N PARK

THE MARK CONSISTS OF STANDARD CHARACTERS WITHOUT CLAIM TO ANY PARTICULAR FONT, STYLE, SIZE, OR COLOR.  
FOR PET ACCESSORIES, NAMELY, PET BEDS AND PILLOWS (U.S. CLS. 2, 13, 22, 25, 32 AND 50).  
SEAN CROWLEY, EXAMINING ATTORNEY

SN 86-245,707. VIA, INC, SPARKS, NV. FILED 4-8-2014.

## BIRDY

THE MARK CONSISTS OF STANDARD CHARACTERS WITHOUT CLAIM TO ANY PARTICULAR FONT, STYLE, SIZE, OR COLOR.  
FOR FURNITURE (U.S. CLS. 2, 13, 22, 25, 32 AND 50).  
BRENDAN MCCAULEY, EXAMINING ATTORNEY

SN 86-246,627. MAKOFSKE, RUTH, WADING RIVER, NY.  
FILED 4-9-2014.

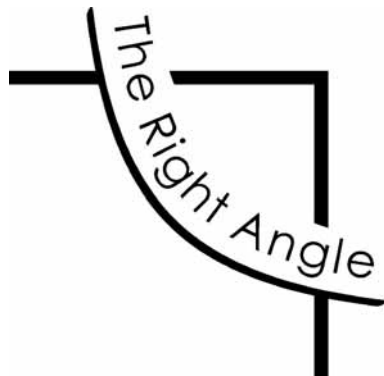

THE MARK CONSISTS OF THE SYMBOL FOR A RIGHT ANGLE WITH THE STYLIZED TEXT "THE RIGHT ANGLE" ON THE CURVED LINE.  
FOR PILLOWS (U.S. CLS. 2, 13, 22, 25, 32 AND 50).  
HAI-LY LAM, EXAMINING ATTORNEY

**CLASS 20—(Continued).**

SN 86-246,845. CROWN AWARDS, INC., HAWTHORNE, NY.  
FILED 4-9-2014.

## GlossDome

THE MARK CONSISTS OF THE WORD "GLOSSDOME" IN STYLIZED LETTERS.  
FOR PROTECTIVE PLASTIC COVERS FOR MEDALS, LAPEL PINS, AND RINGS (U.S. CLS. 2, 13, 22, 25, 32 AND 50).  
FIRST USE 10-31-2013; IN COMMERCE 10-31-2013.  
JACLYN KIDWELL WALKER, EXAMINING ATTORNEY

SN 86-248,541. GRACO CHILDREN'S PRODUCTS INC., ATLANTA, GA. FILED 4-10-2014.

## SOUFFLÉ

THE MARK CONSISTS OF STANDARD CHARACTERS WITHOUT CLAIM TO ANY PARTICULAR FONT, STYLE, SIZE, OR COLOR.  
FOR HIGH CHAIRS FOR INFANTS AND CHILDREN (U.S. CLS. 2, 13, 22, 25, 32 AND 50).  
ELISSA GARBER KON, EXAMINING ATTORNEY

SN 86-249,055. R.A.P. SECURITY, INC., CUDAHY, CA.  
FILED 4-10-2014.

## FLEXI-FOLD

THE MARK CONSISTS OF STANDARD CHARACTERS WITHOUT CLAIM TO ANY PARTICULAR FONT, STYLE, SIZE, OR COLOR.  
FOR PORTABLE COCKTAIL TABLES (U.S. CLS. 2, 13, 22, 25, 32 AND 50).  
JENNIFER BUTTON, EXAMINING ATTORNEY

**CLASS 20—(Continued).**

SN 86-250,661. ETRAVIS INC., HOUSTON, TX. FILED 4-12-2014.

## Woof Kingdom

THE MARK CONSISTS OF STANDARD CHARACTERS WITHOUT CLAIM TO ANY PARTICULAR FONT, STYLE, SIZE, OR COLOR.

FOR BUNK BEDS; CHAIR BEDS; DOG BEDS; DOG KENNELS; DOG TRANSPORT BOXES (U.S. CLS. 2, 13, 22, 25, 32 AND 50).

FIRST USE 12-1-2012; IN COMMERCE 12-1-2012.  
JOHN GARTNER, EXAMINING ATTORNEY

**CLASS 20—(Continued).**

SN 86-302,632. WINDOWCRAFT, INC., GARDEN CITY PARK, NY. FILED 6-6-2014.

## SoloSnap

THE MARK CONSISTS OF STANDARD CHARACTERS WITHOUT CLAIM TO ANY PARTICULAR FONT, STYLE, SIZE, OR COLOR.

FOR WINDOW SHADE SYSTEMS COMPRISED OF WINDOW SHADES, INTERCONNECTING BRACKETS AND FASCIA (U.S. CLS. 2, 13, 22, 25, 32 AND 50).

KAREN K. BUSH, EXAMINING ATTORNEY

SN 86-260,046. COAST TO COAST IMPORTS LLC, MEMPHIS, TN. FILED 4-23-2014.

## TREASURE TROVE accent furniture

THE MARK CONSISTS OF STANDARD CHARACTERS WITHOUT CLAIM TO ANY PARTICULAR FONT, STYLE, SIZE, OR COLOR.

NO CLAIM IS MADE TO THE EXCLUSIVE RIGHT TO USE "ACCENT FURNITURE", APART FROM THE MARK AS SHOWN.

FOR FURNITURE (U.S. CLS. 2, 13, 22, 25, 32 AND 50).  
FIRST USE 3-15-2014; IN COMMERCE 4-1-2014.  
MORGAN WYNNE, EXAMINING ATTORNEY

SN 86-305,335. ERGO-INDUSTRIAL SEATING SYSTEMS INC., MISSISSAUGA, ONTARIO, CANADA, FILED 6-10-2014.

## TCENTRIC HYBRID

THE MARK CONSISTS OF STANDARD CHARACTERS WITHOUT CLAIM TO ANY PARTICULAR FONT, STYLE, SIZE, OR COLOR.

NO CLAIM IS MADE TO THE EXCLUSIVE RIGHT TO USE "HYBRID", APART FROM THE MARK AS SHOWN.

FOR CHAIRS (U.S. CLS. 2, 13, 22, 25, 32 AND 50).  
CAROLINE WOOD, EXAMINING ATTORNEY

SN 86-288,731. GRACO CHILDREN'S PRODUCTS INC., ATLANTA, GA. FILED 5-22-2014.

## SOUS CHEF

THE MARK CONSISTS OF STANDARD CHARACTERS WITHOUT CLAIM TO ANY PARTICULAR FONT, STYLE, SIZE, OR COLOR.

FOR HIGH CHAIRS FOR INFANTS AND CHILDREN, WITH REMOVABLE INFANT ROCKER SEAT (U.S. CLS. 2, 13, 22, 25, 32 AND 50).

ELISSA GARBER KON, EXAMINING ATTORNEY

SN 86-317,187. GRACO CHILDREN'S PRODUCTS INC., ATLANTA, GA. FILED 6-23-2014.

## SLIM SNACKER

THE MARK CONSISTS OF STANDARD CHARACTERS WITHOUT CLAIM TO ANY PARTICULAR FONT, STYLE, SIZE, OR COLOR.

FOR HIGH CHAIRS FOR INFANTS AND CHILDREN (U.S. CLS. 2, 13, 22, 25, 32 AND 50).

ELISSA GARBER KON, EXAMINING ATTORNEY

**CLASS 21—HOUSEWARES AND GLASS**

SN 79-120,055. SPRD.NET AG, VERTRETEN DURCH DEN VORSTAND, 04229 LEIPZIG, FED REP GERMANY, FILED 12-30-2011.

# laFraise

THE MARK CONSISTS OF STANDARD CHARACTERS WITHOUT CLAIM TO ANY PARTICULAR FONT, STYLE, SIZE, OR COLOR.

OWNER OF INTERNATIONAL REGISTRATION 1134749 DATED 12-30-2011, EXPIRES 12-30-2021.

THE ENGLISH TRANSLATION OF "LAFRAISE" IN THE MARK IS "STRAWBERRY".

FOR MUGS (U.S. CLS. 2, 13, 23, 29, 30, 33, 40 AND 50).  
BRENDAN MCCAULEY, EXAMINING ATTORNEY

**CLASS 21—(Continued).**

SN 85-697,990. CORTEX USA, INC., DBA CORTEX INTERNATIONAL, MIAMI GARDENS, FL. FILED 8-8-2012.

**CORTEX PROFESSIONAL**

THE MARK CONSISTS OF STANDARD CHARACTERS WITHOUT CLAIM TO ANY PARTICULAR FONT, STYLE, SIZE, OR COLOR.

NO CLAIM IS MADE TO THE EXCLUSIVE RIGHT TO USE "PROFESSIONAL", APART FROM THE MARK AS SHOWN.

FOR HAIR COMBS; HAIR BRUSHES (U.S. CLS. 2, 13, 23, 29, 30, 33, 40 AND 50).

FIRST USE 1-1-2012; IN COMMERCE 1-1-2012.  
ALICIA COLLINS, EXAMINING ATTORNEY

SN 85-698,021. CORTEX USA, INC., DBA CORTEX INTERNATIONAL, MIAMI GARDENS, FL. FILED 8-8-2012.

**CORTEX INTERNATIONAL**

THE MARK CONSISTS OF STANDARD CHARACTERS WITHOUT CLAIM TO ANY PARTICULAR FONT, STYLE, SIZE, OR COLOR.

NO CLAIM IS MADE TO THE EXCLUSIVE RIGHT TO USE "INTERNATIONAL", APART FROM THE MARK AS SHOWN.

FOR HAIR COMBS; HAIR BRUSHES (U.S. CLS. 2, 13, 23, 29, 30, 33, 40 AND 50).

FIRST USE 9-1-2008; IN COMMERCE 9-1-2008.  
ALICIA COLLINS, EXAMINING ATTORNEY

SN 79-145,199. JINHUA CHNCO CLEANING UTENSILS; CO., LTD., 321000 ZHEJIANG, CHINA, FILED 2-7-2014.



OWNER OF INTERNATIONAL REGISTRATION 1198550 DATED 2-7-2014, EXPIRES 2-7-2024.

THE MARK CONSISTS OF THREE CHINESE CHARACTERS IN STYLIZED FONT ABOVE THE WORDING "CLEANPOEM" IN STYLIZED FONT. THE WORDING "CLEANPOEM" IS UNDERLINED SO THAT THE "P" IN "CLEANPOEM" CONNECTS TO THE UNDERLINE.

THE ENGLISH TRANSLATION OF THE THREE CHINESE CHARACTERS INDIVIDUALLY MEANS "CAN", "PRETTY", AND "SERVANT". THE THREE CHINESE CHARACTERS TOGETHER HAVE NO MEANING AND CANNOT BE TRANSLATED.

THE TRANSLITERATION OF THE NON-LATIN CHARACTERS IN THE MARK IS "KE LI PU".

FOR STEEL WOOL FOR CLEANING; BROOMS; CLOTHS FOR CLEANING; MOPS; SPONGES FOR HOUSEHOLD PURPOSES; GLOVES FOR HOUSEHOLD PURPOSES; PADS FOR CLEANING; COSMETIC UTENSILS, NAMELY, EYEBROW BRUSHES; BRUSHES, NAMELY, SCRUBBING BRUSHES; DUSTBINS (U.S. CLS. 2, 13, 23, 29, 30, 33, 40 AND 50).

CYNTHIA RINALDI, EXAMINING ATTORNEY

SN 86-042,179. CHARLIE WEINBERGER, GARDENA, CA. FILED 8-19-2013.

# OILCAN

THE MARK CONSISTS OF STANDARD CHARACTERS WITHOUT CLAIM TO ANY PARTICULAR FONT, STYLE, SIZE, OR COLOR.

FOR ALL PURPOSE SPOUTLESS PLASTIC PORTABLE HOUSEHOLD CONTAINERS; SPOUTLESS PLASTIC CONTAINERS FOR HOUSEHOLD USE; NONE OF THE FOREGOING INTENDED FOR LUBRICATING OIL, MOTOR OIL OR LANTERN OIL (U.S. CLS. 2, 13, 23, 29, 30, 33, 40 AND 50).

FIRST USE 9-0-2013; IN COMMERCE 9-0-2013.

MARTHA SANTOMARTINO, EXAMINING ATTORNEY



**CLASS 21—(Continued).**

SN 86-047,529. ARMOUR GROUP, INC., HOLLYWOOD, FL. FILED 8-26-2013.

# RhinoGLASS

THE MARK CONSISTS OF STANDARD CHARACTERS WITHOUT CLAIM TO ANY PARTICULAR FONT, STYLE, SIZE, OR COLOR.

OWNER OF U.S. REG. NOS. 3,001,921, 3,067,586 AND 3,889,184.

FOR BALLISTIC GLASS FOR VEHICLE WINDOWS (U.S. CLS. 2, 13, 23, 29, 30, 33, 40 AND 50).

FIRST USE 3-7-2012; IN COMMERCE 3-7-2012.

RAUL CORDOVA, EXAMINING ATTORNEY

SN 86-049,552. NOLA LOVE, LLC, LOCKPORT, LA. FILED 8-27-2013.

# NOLA LOVE

THE MARK CONSISTS OF STANDARD CHARACTERS WITHOUT CLAIM TO ANY PARTICULAR FONT, STYLE, SIZE, OR COLOR.

NO CLAIM IS MADE TO THE EXCLUSIVE RIGHT TO USE "NOLA", APART FROM THE MARK AS SHOWN.

FOR HOUSEWARES, NAMELY, BEER MUGS; BEVERAGEWARE; COFFEE MUGS; COMMEMORATIVE PLATES; CUPS; DRINKING GLASSES; GLASS BEVERAGEWARE; GLASS MUGS; MUGS; PILSNER DRINKING GLASSES; PLASTIC COASTERS; PORCELAIN MUGS; SHOT GLASSES; SOUVENIR PLATES; WINE GLASSES (U.S. CLS. 2, 13, 23, 29, 30, 33, 40 AND 50).

VIVIAN MICZNIK FIRST, EXAMINING ATTORNEY

SN 86-055,305. UNITED COMB & NOVELTY CORPORATION, LEOMINSTER, MA. FILED 9-4-2013.

# United Solutions

THE MARK CONSISTS OF STANDARD CHARACTERS WITHOUT CLAIM TO ANY PARTICULAR FONT, STYLE, SIZE, OR COLOR.

OWNER OF U.S. REG. NOS. 3,314,147, 3,469,634 AND OTHERS.

FOR KITCHEN UTENSILS, NAMELY, DISHPANS; PITCHERS; DRINKING GLASSES, NAMELY, TUMBLERS; BOWLS; PLASTIC STORAGE CONTAINERS FOR DOMESTIC USE; CADDIES, NAMELY, CADDIES FOR HOLDING HEALTH AND BEAUTY AIDS, HOUSEHOLD ITEMS, SHOWER ITEMS, GARDENING ITEMS, CAR ACCESSORIES, TOOLS AND GARAGE ITEMS, ALL FOR HOUSEHOLD AND DOMESTIC USE (U.S. CLS. 2, 13, 23, 29, 30, 33, 40 AND 50).

FIRST USE 6-30-2007; IN COMMERCE 6-30-2007.

CATHERINE TARCU, EXAMINING ATTORNEY

**CLASS 21—(Continued).**

SN 86-072,590. HOGANCAMP, SHANE, COAL TOWNSHIP, PA. FILED 9-24-2013.

# BAIT SWINGER

THE MARK CONSISTS OF STANDARD CHARACTERS WITHOUT CLAIM TO ANY PARTICULAR FONT, STYLE, SIZE, OR COLOR.

NO CLAIM IS MADE TO THE EXCLUSIVE RIGHT TO USE "BAIT", APART FROM THE MARK AS SHOWN.

FOR BUCKETS FOR USE IN FISHING (U.S. CLS. 2, 13, 23, 29, 30, 33, 40 AND 50).

ELI HELLMAN, EXAMINING ATTORNEY

SN 86-086,081. NUWAVE, LLC, LIBERTYVILLE, IL. FILED 10-8-2013.

# NUWAVE PERFECTGREEN COOKWARE

THE MARK CONSISTS OF STANDARD CHARACTERS WITHOUT CLAIM TO ANY PARTICULAR FONT, STYLE, SIZE, OR COLOR.

OWNER OF U.S. REG. NO. 2,826,443.

NO CLAIM IS MADE TO THE EXCLUSIVE RIGHT TO USE "COOKWARE", APART FROM THE MARK AS SHOWN.

FOR COOKING PANS; COOKING POTS AND PANS; COOKWARE FOR USE IN MICROWAVE OVENS; COOKWARE, NAMELY, POTS AND PANS; FRYING PANS; FRYING PANS; METAL PANS; PANS; POT LIDS; STEW-PANS (U.S. CLS. 2, 13, 23, 29, 30, 33, 40 AND 50).

FIRST USE 11-17-2011; IN COMMERCE 11-17-2011.

MARILYN IZZI, EXAMINING ATTORNEY

**CLASS 21—(Continued).**

SN 86-107,548. EKO DEVELOPMENT LIMITED, GUANGZHOU, CHINA, FILED 11-1-2013.



OWNER OF U.S. REG. NO. 4,179,973.  
FOR CLOTHES RACKS, FOR DRYING; COOKING POTS AND PANS; COOKING STEAMERS; GARBAGE CANS; IRONING BOARDS; KITCHEN CONTAINERS; KITCHEN LADLES; LAUNDRY BINS FOR DOMESTIC OR HOUSEHOLD USE; REFUSE BINS; SHOE BRUSHES; TOILET BRUSHES; TOILET PAPER DISPENSERS; TOILET PAPER HOLDERS; TRASH CANS; WASHTUBS; WASTE PAPER BASKETS (U.S. CLS. 2, 13, 23, 29, 30, 33, 40 AND 50).

FIRST USE 7-26-2006; IN COMMERCE 3-10-2009.  
KIM MONINGHOFF, EXAMINING ATTORNEY

SN 86-138,122. TENAFLY IMPORTS, LLC, DBA GUNTER WILHELM CUTLERY, TENAFLY, NJ. FILED 12-9-2013.

**GUNTER WILHELM**

THE MARK CONSISTS OF STANDARD CHARACTERS WITHOUT CLAIM TO ANY PARTICULAR FONT, STYLE, SIZE, OR COLOR.

OWNER OF U.S. REG. NO. 3,512,141.  
THE NAME(S), PORTRAIT(S), AND/OR SIGNATURE(S) SHOWN IN THE MARK IDENTIFIES PAUL L. HELLMAN, A/K/A "GUNTER WILHELM", WHOSE CONSENT(S) TO REGISTER IS MADE OF RECORD.

FOR COOKWARE, NAMELY, POTS AND PANS (U.S. CLS. 2, 13, 23, 29, 30, 33, 40 AND 50).  
FIRST USE 1-1-2013; IN COMMERCE 1-1-2013.  
AMY C. KEAN, EXAMINING ATTORNEY

**CLASS 21—(Continued).**

SN 86-148,240. JULEP BEAUTY, INC., SEATTLE, WA. FILED 12-19-2013.

**PLIÉ WAND**

THE MARK CONSISTS OF STANDARD CHARACTERS WITHOUT CLAIM TO ANY PARTICULAR FONT, STYLE, SIZE, OR COLOR.

NO CLAIM IS MADE TO THE EXCLUSIVE RIGHT TO USE "WAND", APART FROM THE MARK AS SHOWN.

FOR COSMETIC BRUSHES; STYLUS APPLICATOR IN THE NATURE OF APPLICATOR STICKS FOR APPLICATION OF COSMETICS; COSMETIC APPLICATOR SYSTEMS AND KITS CONSISTING OF STYLUS IN THE NATURE OF APPLICATOR STICK, MAGNETIC NAIL POLISH BOTTLE OVERCAP, AND INTERCHANGEABLE NAIL DECORATING TOOLS AND BRUSHES; COSMETIC APPLICATOR SYSTEMS AND KITS CONSISTING OF STYLUS IN THE NATURE OF APPLICATOR STICKS FOR APPLICATION OF COSMETICS AND COSMETIC BRUSHES (U.S. CLS. 2, 13, 23, 29, 30, 33, 40 AND 50).

GINA FINK, EXAMINING ATTORNEY

SN 86-156,539. APOLLO EDUCATION GROUP, INC., PHOENIX, AZ. FILED 1-2-2014.



OWNER OF U.S. REG. NO. 2,089,210.  
NO CLAIM IS MADE TO THE EXCLUSIVE RIGHT TO USE "PHOENIX", APART FROM THE MARK AS SHOWN.

THE MARK CONSISTS OF "UNIVERSITY" ABOVE THE WORDS "OF PHOENIX", IN A CIRCLE WHICH APPEARS A STYLIZED PHOENIX BIRD DESIGN WITH THE BIRD'S LEFT WING FOLDED UPWARD AND FORWARD, ITS HEAD IN PROFILE FACING RIGHT, AND ITS TAIL SUGGESTING FLAMES OR A TORCH WITHIN ANOTHER CIRCLE.

FOR BEVERAGEWARE AND DRINKWARE (U.S. CLS. 2, 13, 23, 29, 30, 33, 40 AND 50).  
FIRST USE 7-11-2013; IN COMMERCE 7-11-2013.  
JOHN HWANG, EXAMINING ATTORNEY

**CLASS 21—(Continued).**

SN 86-192,474. MARKETING IMPACT GROUP PTY. LTD., WYNDHAM VALE, AUSTRALIA, FILED 2-13-2014.

# PrimoChef

THE MARK CONSISTS OF STANDARD CHARACTERS WITHOUT CLAIM TO ANY PARTICULAR FONT, STYLE, SIZE, OR COLOR.

FOR COOKWARE, NAMELY, ACCESSORIES IN THE NATURE OF COOKING GRATERS, STIRRING AND SERVING SPOONS AND FRYING AND SERVING FORKS; HOUSEHOLD UTENSILS, NAMELY, LADLES; COOKING UTENSILS, NAMELY, SEASONING INJECTORS; GRILL ACCESSORIES, NAMELY, GRILL CLEANING SCRAPERS, FOOD CADDIES, GRILL COVERS (U.S. CLS. 2, 13, 23, 29, 30, 33, 40 AND 50).

VERNA BETH RIRIE, EXAMINING ATTORNEY

SN 86-211,313. COLLABORATORIESLLC, VALRICO, FL. FILED 3-5-2014.

# Beau Gâchis

THE MARK CONSISTS OF STANDARD CHARACTERS WITHOUT CLAIM TO ANY PARTICULAR FONT, STYLE, SIZE, OR COLOR.

THE NAME(S), PORTRAIT(S), AND/OR SIGNATURE(S) SHOWN IN THE MARK DOES NOT IDENTIFY A PARTICULAR LIVING INDIVIDUAL.

THE ENGLISH TRANSLATION OF "BEAU GÂCHIS" IN THE MARK IS "BEAUTIFUL MESS".

FOR MAKE UP BRUSH KITS COMPRISED OF A VARIETY OF MAKE-UP BRUSHES CONTAINED WITHIN A CASE OR BAG, SOLD TOGETHER AS A UNIT (U.S. CLS. 2, 13, 23, 29, 30, 33, 40 AND 50).

FIRST USE 1-14-2014; IN COMMERCE 1-24-2014.  
ANNE MADDEN, EXAMINING ATTORNEY

SN 86-211,350. LIBBEY GLASS INC., TOLEDO, OH. FILED 3-5-2014.

# GLASSMASTER

THE MARK CONSISTS OF STANDARD CHARACTERS WITHOUT CLAIM TO ANY PARTICULAR FONT, STYLE, SIZE, OR COLOR.

FOR BEVERAGE GLASSWARE (U.S. CLS. 2, 13, 23, 29, 30, 33, 40 AND 50).

MIAH ROSENBERG, EXAMINING ATTORNEY

**CLASS 21—(Continued).**

SN 86-212,272. LOVING PETS CORPORATION, MONMOUTH JUNCTION, NJ. FILED 3-5-2014.

## MILANO COLLECTION

THE MARK CONSISTS OF STANDARD CHARACTERS WITHOUT CLAIM TO ANY PARTICULAR FONT, STYLE, SIZE, OR COLOR.

NO CLAIM IS MADE TO THE EXCLUSIVE RIGHT TO USE "COLLECTION", APART FROM THE MARK AS SHOWN.

THE ENGLISH TRANSLATION OF THE WORD "MILANO" IN THE MARK IS "MILAN".

FOR PET FEEDING AND DRINKING BOWLS (U.S. CLS. 2, 13, 23, 29, 30, 33, 40 AND 50).

FIRST USE 3-15-2013; IN COMMERCE 3-15-2013.  
ALYSSA STEEL, EXAMINING ATTORNEY

SN 86-212,746. SCHULTZ, WYATT A., DBA LIVING SOUL POTTERY, HOUSTON, TX. FILED 3-6-2014.



THE MARK CONSISTS OF A HAND HOLDING A STYLIZED CERAMIC URN.

FOR WORKS OF ART OF CERAMIC (U.S. CLS. 2, 13, 23, 29, 30, 33, 40 AND 50).

FIRST USE 2-1-2011; IN COMMERCE 2-1-2011.

WENDELL PHILLIPS, EXAMINING ATTORNEY

**CLASS 21—(Continued).**

SN 86-214,198. QUADRA MEDIA, LLC, NEW YORK, NY. FILED 3-7-2014.

# Inked

OWNER OF U.S. REG. NOS. 4,372,365 AND 4,372,392. THE MARK CONSISTS OF THE TERM "INKED" APPEARING IN A STYLIZED MANNER.

FOR HOUSEHOLD UTENSILS, NAMELY, GRATERS, SPATULAS, TURNERS, WHISKS, COLANDERS FOR HOUSEHOLD USE, FLOUR SIFTERS FOR HOUSEHOLD USE, PIE SERVERS, POTATO MASHERS, MELON BALLERS, ICE CREAM SCOOPS, BOTTLE OPENERS, CAKE STANDS, SKIMMERS, VEGETABLE BRUSHES, PASTRY BRUSHES, MIXING BOWLS, TRIVETS, GARLIC PRESSES, CITRUS PRESSES, BRUSHES FOR BASTING MEAT, SIEVES FOR HOUSEHOLD PURPOSES, COOKING STRAINER, COLLAPSIBLE COOKING STEAMERS, FUNNELS WITH STRAINERS, SERVING TONGS, SPOON RESTS, SLOTTED SPOONS, SERVING SPOONS, BASTING SPOONS, MIXING SPOONS, KITCHEN LADLES, SERVING TRAYS NOT MADE OF PRECIOUS METALS, DISH DRYING RACKS, TEA BALLS NOT OF PRECIOUS METAL, CITRUS REAMERS FOR FRUIT JUICE, STOVE TOP BURNER COVERS, CHROME-PLATED PAPER TOWEL HOLDERS; CUTTING BOARDS, CORKSCREWS, ROLLING PINS, COOKIE CUTTERS, CANISTER SETS, SALT AND PEPPER MILLS; DINNERWARE, BEVERAGE GLASSWARE, BAKEWARE; COOKWARE, NAMELY, SKILLETS, PANS, POTS, STEAMERS, NON-ELECTRIC GRIDDLES, ROASTING PANS, FRYING PANS AND WOKS; SOAP AND LOTION DISPENSERS, SOAP DISHES, TUMBLERS, CERAMIC TISSUE BOX COVERS, TOOTH BRUSH HOLDERS, WASTE BASKETS, PITCHERS, AND NAPKIN RINGS NOT MADE OF PRECIOUS METAL (U.S. CLS. 2, 13, 23, 29, 30, 33, 40 AND 50).

DEBORAH LOBO, EXAMINING ATTORNEY

SN 86-216,422. LOVING PETS CORPORATION, CRANBURY, NJ. FILED 3-10-2014.

## SILENT DOUBLE DINER

THE MARK CONSISTS OF STANDARD CHARACTERS WITHOUT CLAIM TO ANY PARTICULAR FONT, STYLE, SIZE, OR COLOR.

NO CLAIM IS MADE TO THE EXCLUSIVE RIGHT TO USE "DOUBLE DINER", APART FROM THE MARK AS SHOWN.

FOR PET FEEDING AND DRINKING BOWLS (U.S. CLS. 2, 13, 23, 29, 30, 33, 40 AND 50).

FIRST USE 6-15-2011; IN COMMERCE 6-15-2011.

ALYSSA STEEL, EXAMINING ATTORNEY

**CLASS 21—(Continued).**

SN 86-216,602. WKI HOLDING COMPANY, INC., ROSEMONT, IL. FILED 3-10-2014.



NO CLAIM IS MADE TO THE EXCLUSIVE RIGHT TO USE "PLATES & BOWLS", "SINCE 1970", "CORNING, NY" AND THE REPRESENTATION OF THE MAP OF THE UNITED STATES OF AMERICA, APART FROM THE MARK AS SHOWN.

THE MARK CONSISTS OF A CIRCLE WITH TRIANGLE SHAPED RIDGES ON THE OUTER EDGE, WITH THE POINTS FACING OUTWARD, WITH THE WORDS "OUR PLATES & BOWLS" IN A CURVE FOLLOWING THE CIRCLE ON THE TOP INSIDE OF THE CIRCLE; UNDERNEATH ARE THE WORDS "ARE MADE WITH PRIDE" IN SCRIPTED FONT WRITTEN STRAIGHT ACROSS, WITH A MAP OF THE UNITED STATES UNDERNEATH THESE WORDS WITH THE WORDS "SINCE 1970" INSIDE THE MAP WITH A BULLET POINT ON EITHER SIDE OF THE WORD "SINCE" AND WITH A STAR SYMBOL TOWARD THE RIGHT INSIDE THE MAP; UNDERNEATH THE MAP ARE THE WORDS "IN CORNING, NY", WITH THE WORD "IN" WRITTEN IN SCRIPTED FONT AND "CORNING, NY" WRITTEN UNDERNEATH IN A CURVE FOLLOWING THE CIRCLE.

FOR GLASS TABLEWARE, NAMELY, PLATES, CUPS, MUGS, SAUCERS, SERVING DISHES AND BOWLS (U.S. CLS. 2, 13, 23, 29, 30, 33, 40 AND 50).

LEE-ANNE BERNS, EXAMINING ATTORNEY

SN 86-217,745. PHILLIPS, LISA M, SPRINGFIELD, VA. AND PHILLIPS, MICHAEL R, SPRINGFIELD, VA. FILED 3-11-2014.

## HEAVEN IN A CUP

THE MARK CONSISTS OF STANDARD CHARACTERS WITHOUT CLAIM TO ANY PARTICULAR FONT, STYLE, SIZE, OR COLOR.

FOR COFFEE CUPS, TEA CUPS AND MUGS; COFFEE MUGS; CUPS AND MUGS; EARTHENWARE MUGS; GLASS MUGS; MUG TREES; MUGS; MUGS, NOT OF PRECIOUS METAL; PORCELAIN MUGS (U.S. CLS. 2, 13, 23, 29, 30, 33, 40 AND 50).

SHAVELL MCPHERSON, EXAMINING ATTORNEY

**CLASS 21—(Continued).**

SN 86-222,500. WOJNO CHRISTOPHER W., HUNTINGTON BEACH, CA. FILED 3-16-2014.

# Handibins

THE MARK CONSISTS OF STANDARD CHARACTERS WITHOUT CLAIM TO ANY PARTICULAR FONT, STYLE, SIZE, OR COLOR.

FOR NON-MODULAR CONTAINERS FOR USE IN TRANSPORTATION AND STORAGE FOR HOUSEHOLD USE; PLASTIC STORAGE CONTAINERS FOR HOUSEHOLD OR DOMESTIC USE; PORTABLE PLASTIC CONTAINERS FOR STORING HOUSEHOLD AND KITCHEN GOODS (U.S. CLS. 2, 13, 23, 29, 30, 33, 40 AND 50).

FIRST USE 3-10-2014; IN COMMERCE 3-10-2014.  
ANDREA BUTLER, EXAMINING ATTORNEY

**CLASS 21—(Continued).**

SN 86-231,396. CROWN AWARDS, INC., HAWTHORNE, NY. FILED 3-25-2014.



OWNER OF U.S. REG. NOS. 2,586,186, 3,535,952 AND OTHERS.

THE MARK CONSISTS OF THE WORDS "CROWN BLACK LABEL" IN STYLIZED LETTERS.

FOR CRYSTAL AWARDS IN THE NATURE OF SCULPTURES OF CRYSTAL (U.S. CLS. 2, 13, 23, 29, 30, 33, 40 AND 50).

FIRST USE 12-0-2013; IN COMMERCE 12-0-2013.  
JACLYN KIDWELL WALKER, EXAMINING ATTORNEY

SN 86-226,265. STRAHAN, MITCHELL, MCKINNEY, TX. FILED 3-19-2014.

# Wine Condom

THE MARK CONSISTS OF STANDARD CHARACTERS WITHOUT CLAIM TO ANY PARTICULAR FONT, STYLE, SIZE, OR COLOR.

NO CLAIM IS MADE TO THE EXCLUSIVE RIGHT TO USE "WINE", APART FROM THE MARK AS SHOWN.

FOR BOTTLE STOPPERS SPECIALLY ADAPTED FOR USE WITH WINE BOTTLES (U.S. CLS. 2, 13, 23, 29, 30, 33, 40 AND 50).

FIRST USE 1-16-2014; IN COMMERCE 1-16-2014.  
ALISON KEELEY, EXAMINING ATTORNEY

SN 86-232,001. CHARLES VIANCIN GROUP, 74650 CHAVANOD, FRANCE, FILED 3-25-2014.

# ORANGE

THE MARK CONSISTS OF STANDARD CHARACTERS WITHOUT CLAIM TO ANY PARTICULAR FONT, STYLE, SIZE, OR COLOR.

FOR REUSABLE SELF-SEALING LIDS FOR HOUSEHOLD USE FEATURING A STACKABLE COMPONENT; REUSABLE SELF-SEALING LIDS FOR BOWLS, CONTAINERS AND THE STORAGE OF FOOD FEATURING A STACKABLE COMPONENT; SEALING LIDS FOR COOKING USE FEATURING A STACKABLE COMPONENT (U.S. CLS. 2, 13, 23, 29, 30, 33, 40 AND 50).

FIRST USE 2-0-2014; IN COMMERCE 2-0-2014.  
JAY FLOWERS, EXAMINING ATTORNEY

SN 86-228,395. CHARLES VIANCIN GROUP, 74650 CHAVANOD, FRANCE, FILED 3-21-2014.

# VORTEX

THE MARK CONSISTS OF STANDARD CHARACTERS WITHOUT CLAIM TO ANY PARTICULAR FONT, STYLE, SIZE, OR COLOR.

FOR COOKWARE, NAMELY, AN ANTI-SPILL SHIELD AND OVER BOIL PROTECTOR FOR USE WITH POTS AND PANS (U.S. CLS. 2, 13, 23, 29, 30, 33, 40 AND 50).

FIRST USE 12-0-2012; IN COMMERCE 12-0-2012.  
JAY FLOWERS, EXAMINING ATTORNEY

SN 86-232,613. GREATER PITTSBURGH COMMUNITY FOOD BANK, DUQUESNE, PA. FILED 3-26-2014.

# GIVING GLOBES

THE MARK CONSISTS OF STANDARD CHARACTERS WITHOUT CLAIM TO ANY PARTICULAR FONT, STYLE, SIZE, OR COLOR.

NO CLAIM IS MADE TO THE EXCLUSIVE RIGHT TO USE "GLOBES", APART FROM THE MARK AS SHOWN.

FOR ORNAMENTAL GLASS SPHERES (U.S. CLS. 2, 13, 23, 29, 30, 33, 40 AND 50).

FIRST USE 12-16-2013; IN COMMERCE 12-16-2013.  
JAMES STEIN, EXAMINING ATTORNEY

**CLASS 21—(Continued).**

SN 86-232,856. CARROLL, NORMAJEAN, MYAKKA CITY, FL. FILED 3-26-2014.

## Perfect Imperfections

THE MARK CONSISTS OF STANDARD CHARACTERS WITHOUT CLAIM TO ANY PARTICULAR FONT, STYLE, SIZE, OR COLOR.

FOR CERAMIC FIGURINES; COFFEE MUGS; SCULPTED FIGURINES OF CHINA; MUGS (U.S. CLS. 2, 13, 23, 29, 30, 33, 40 AND 50).

AHSEN KHAN, EXAMINING ATTORNEY

---

SN 86-233,007. COOPERSMITH, ALLAN, WESTMOUNT, QUEBEC, CANADA, FILED 3-26-2014.

## DenTwist

THE MARK CONSISTS OF STANDARD CHARACTERS WITHOUT CLAIM TO ANY PARTICULAR FONT, STYLE, SIZE, OR COLOR.

FOR DENTAL CARE KIT COMPRISING TOOTHBRUSHES AND FLOSS; DENTAL FLOSS; DENTAL FLOSS PICKS; DENTAL FLOSSERS; DENTAL TAPE (U.S. CLS. 2, 13, 23, 29, 30, 33, 40 AND 50).

LAUREN BURKE, EXAMINING ATTORNEY

---

SN 86-233,604. REBECCA M. BLANTON, CLEMSON, SC. FILED 3-27-2014.

## FUNAIR

THE MARK CONSISTS OF STANDARD CHARACTERS WITHOUT CLAIM TO ANY PARTICULAR FONT, STYLE, SIZE, OR COLOR.

FOR HANDHELD DISPENSERS FOR USING COMPRESSED AIR OR INERT GAS TO DISPENSE A DIRECTED STREAM OF GAS FOR BLOWING OUT CANDLES (U.S. CLS. 2, 13, 23, 29, 30, 33, 40 AND 50).

SEAN CROWLEY, EXAMINING ATTORNEY

**CLASS 21—(Continued).**

SN 86-234,034. KREVARE LLC, MIDDLESEX, NJ. FILED 3-27-2014.

## SOAPTAINER

THE MARK CONSISTS OF STANDARD CHARACTERS WITHOUT CLAIM TO ANY PARTICULAR FONT, STYLE, SIZE, OR COLOR.

FOR AUTOMATIC SOAP DISPENSERS; CONTAINERS FOR HOUSEHOLD OR KITCHEN USE; CONTAINERS FOR HOUSEHOLD USE; DISPENSERS FOR LIQUID SOAP; KITCHEN CONTAINERS; LOTION CONTAINERS SOLD EMPTY FOR DOMESTIC USE; MANUALLY ACTUATED PUMP DISPENSERS FOR ATTACHMENT TO CONTAINERS FOR USE IN DISPENSING LIQUIDS; PLASTIC STORAGE CONTAINERS FOR HOUSEHOLD OR DOMESTIC USE; PORTABLE PLASTIC CONTAINERS FOR STORING HOUSEHOLD AND KITCHEN GOODS; SOAP BOXES; SOAP CONTAINERS; SOAP DISPENSERS; SOAP HOLDERS; SOAP HOLDERS AND BOXES (U.S. CLS. 2, 13, 23, 29, 30, 33, 40 AND 50).

JERI J. FICKES, EXAMINING ATTORNEY

---

SN 86-234,064. KREVARE LLC, MIDDLESEX, NJ. FILED 3-27-2014.

## SNAPDISPENSE

THE MARK CONSISTS OF STANDARD CHARACTERS WITHOUT CLAIM TO ANY PARTICULAR FONT, STYLE, SIZE, OR COLOR.

FOR AUTOMATIC SOAP DISPENSERS; BATHROOM FITTINGS, NAMELY, DISPENSING UNITS FOR HOUSEHOLD PURPOSES FOR DISPENSING HYGIENIC WIPES AND LOTIONS, NOT FOR MEDICAL PURPOSES; CONCESSION DISPENSING EQUIPMENT, NAMELY, CONDIMENT PUMP DISPENSERS; CONCESSION DISPENSING EQUIPMENT, NAMELY, PORTABLE CHILLED BEVERAGE DISPENSERS; DISPENSERS FOR CLEANING AND DISINFECTING SOLUTIONS; DISPENSERS FOR LIQUID SOAP; MANUALLY ACTUATED PUMP DISPENSERS FOR ATTACHMENT TO CONTAINERS FOR USE IN DISPENSING LIQUIDS; PORTABLE BEVERAGE DISPENSERS; SOAP CONTAINERS; SOAP DISPENSERS; SOAP HOLDERS AND BOXES (U.S. CLS. 2, 13, 23, 29, 30, 33, 40 AND 50).

JERI J. FICKES, EXAMINING ATTORNEY

**CLASS 21—(Continued).**

SN 86-234,187. OVER & BACK LLC, HAUPPAUGE, NY. FILED 3-27-2014.

**WHAT A DISH!**

THE MARK CONSISTS OF STANDARD CHARACTERS WITHOUT CLAIM TO ANY PARTICULAR FONT, STYLE, SIZE, OR COLOR.

FOR SERVEWARE FOR SERVING FOOD, DINNERWARE, CUPS, FLOWER POTS, PLANTERS FOR FLOWERS AND PLANTS (U.S. CLS. 2, 13, 23, 29, 30, 33, 40 AND 50).

GRETTA YAO, EXAMINING ATTORNEY

SN 86-235,284. CHARLES VIANCIN GROUP, CHAVANOD, FRANCE, FILED 3-28-2014.

**LIME**

THE MARK CONSISTS OF STANDARD CHARACTERS WITHOUT CLAIM TO ANY PARTICULAR FONT, STYLE, SIZE, OR COLOR.

FOR REUSABLE SELF-SEALING LIDS FOR HOUSEHOLD USE FEATURING A STACKABLE COMPONENT; REUSABLE SELF-SEALING LIDS FOR BOWLS, CONTAINERS AND THE STORAGE OF FOOD FEATURING A STACKABLE COMPONENT; SEALING LIDS FOR COOKING USE FEATURING A STACKABLE COMPONENT (U.S. CLS. 2, 13, 23, 29, 30, 33, 40 AND 50).

FIRST USE 2-0-2014; IN COMMERCE 2-0-2014.

JAY FLOWERS, EXAMINING ATTORNEY

SN 86-235,292. CHARLES VIANCIN GROUP, 74650 CHAVANOD, FRANCE, FILED 3-28-2014.

**LEMON**

THE MARK CONSISTS OF STANDARD CHARACTERS WITHOUT CLAIM TO ANY PARTICULAR FONT, STYLE, SIZE, OR COLOR.

FOR REUSABLE SELF-SEALING LIDS FOR HOUSEHOLD USE FEATURING A STACKABLE COMPONENT; REUSABLE SELF-SEALING LIDS FOR BOWLS, CONTAINERS AND THE STORAGE OF FOOD FEATURING A STACKABLE COMPONENT; SEALING LIDS FOR COOKING USE FEATURING A STACKABLE COMPONENT (U.S. CLS. 2, 13, 23, 29, 30, 33, 40 AND 50).

FIRST USE 2-0-2014; IN COMMERCE 2-0-2014.

JAY FLOWERS, EXAMINING ATTORNEY

**CLASS 21—(Continued).**

SN 86-235,293. ANTI-MICROBIAL MEDICAL PRODUCTS INC., NEW YORK, NY. FILED 3-28-2014.



THE COLOR(S) THE COLORS ORANGE AND WHITE IS/ARE CLAIMED AS A FEATURE OF THE MARK.

THE MARK CONSISTS OF THE LETTERS "A", "M", AND "P", ALL IN WHITE, CENTERED ACROSS THREE ORANGE BADGES IN A HORIZONTAL LINE.

FOR DISPOSABLE LATEX AND NITRILE GLOVES FOR GENERAL USE; DISPOSABLE PLASTIC GLOVES FOR USE IN THE FOOD SERVICE INDUSTRY (U.S. CLS. 2, 13, 23, 29, 30, 33, 40 AND 50).

DAVID GEARHART, EXAMINING ATTORNEY

SN 86-235,877. CLINTON, ANNA DEE GARZA, PLANO, TX. FILED 3-28-2014.

**GRAD SHOT**

THE MARK CONSISTS OF STANDARD CHARACTERS WITHOUT CLAIM TO ANY PARTICULAR FONT, STYLE, SIZE, OR COLOR.

NO CLAIM IS MADE TO THE EXCLUSIVE RIGHT TO USE "SHOT", APART FROM THE MARK AS SHOWN.

FOR SHOT GLASSES (U.S. CLS. 2, 13, 23, 29, 30, 33, 40 AND 50).

ERNEST SHOSHO, EXAMINING ATTORNEY

SN 86-236,837. EMILY MATTESON-WELD, WINDSOR, VT. FILED 3-31-2014.

**SEAMS GREEN**

THE MARK CONSISTS OF STANDARD CHARACTERS WITHOUT CLAIM TO ANY PARTICULAR FONT, STYLE, SIZE, OR COLOR.

NO CLAIM IS MADE TO THE EXCLUSIVE RIGHT TO USE "GREEN", APART FROM THE MARK AS SHOWN.

FOR HOUSEHOLD CONTAINERS FOR FOODS (U.S. CLS. 2, 13, 23, 29, 30, 33, 40 AND 50).

FIRST USE 2-14-2014; IN COMMERCE 2-24-2014.

RONALD MCMORROW, EXAMINING ATTORNEY

**CLASS 21—(Continued).**

SN 86-237,264. LENFEST MEDIA GROUP, LLC, KING OF PRUSSIA, PA. FILED 3-31-2014.



NO CLAIM IS MADE TO THE EXCLUSIVE RIGHT TO USE "NO SPILL", APART FROM THE MARK AS SHOWN. THE COLOR(S) BLUE, DARK BLUE, AND WHITE IS/ARE CLAIMED AS A FEATURE OF THE MARK.

THE MARK CONSISTS OF THE WORDS "NO SPILL" IN STYLIZED BLUE LETTERING WITH A DARK BLUE OUTLINE UNDERNEATH WHICH IS THE WORD "CHILL", IN STYLIZED LETTERING IN BLUE WITH A DARK BLUE OUTLINE. THE WORD "CHILL" HAS THE DESIGN OF SNOW ON TOP OF EACH LETTER AND ON TOP OF THE LOWER PORTION OF THE LETTERS "C", "L" AND "L", IN WHITE WITH A DARK BLUE OUTLINE AND DARK BLUE SHADING. THE WHITE BACKGROUND IS NOT CLAIMED AS FEATURE OF THE MARK.

FOR ICE CUBE MOLDS (U.S. CLS. 2, 13, 23, 29, 30, 33, 40 AND 50).

DANIEL CAPSHAW, EXAMINING ATTORNEY

SN 86-237,738. THE STEINBECK HERITAGE FOUNDATION, OSSINING, NY. FILED 3-31-2014.

OWNER OF U.S. REG. NOS. 2,825,466 AND 2,825,467. THE MARK CONSISTS OF THE WORDING "STEINBECK" WRITTEN IN A STYLIZED FONT RESEMBLING A SIGNATURE.

FOR MUGS (U.S. CLS. 2, 13, 23, 29, 30, 33, 40 AND 50). FIRST USE 8-0-2012; IN COMMERCE 8-0-2012.

GEOFFREY FOSDICK, EXAMINING ATTORNEY

**CLASS 21—(Continued).**

SN 86-240,490. TERENCE, DEE R., DBA IN-N-VATIONS BY DEE, COEUR D'ALENE, ID. FILED 4-2-2014.

## NEVER STOOP

THE MARK CONSISTS OF STANDARD CHARACTERS WITHOUT CLAIM TO ANY PARTICULAR FONT, STYLE, SIZE, OR COLOR.

FOR PET WASTE MANAGEMENT KITS COMPRISING SCOOPS FOR PET WASTE DISPOSAL, PLASTIC BAGS AND LINERS, AND PORTABLE DISPENSERS FOR PLASTIC BAGS AND LINERS SOLD AS A UNIT (U.S. CLS. 2, 13, 23, 29, 30, 33, 40 AND 50).

KATHY DE JONGE, EXAMINING ATTORNEY

SN 86-241,870. THE TRUSTEES OF THE COLONIAL GREENE TRUST, LOS ANGELES, CA. FILED 4-3-2014.

## TWO WOLVES WINE

THE MARK CONSISTS OF STANDARD CHARACTERS WITHOUT CLAIM TO ANY PARTICULAR FONT, STYLE, SIZE, OR COLOR.

NO CLAIM IS MADE TO THE EXCLUSIVE RIGHT TO USE "WINE", APART FROM THE MARK AS SHOWN.

FOR BOTTLE STOPPERS SPECIALLY ADAPTED FOR USE WITH WINE BOTTLES; COOLERS FOR WINE; COOLING BUCKETS FOR WINE; VACUUM BOTTLE STOPPERS SPECIALLY ADAPTED FOR USE WITH WINE BOTTLES; VACUUM PUMPS FOR WINE BOTTLES; WINE AERATORS; WINE BOTTLE CRADLES; WINE BOTTLE VESTS SPECIALLY ADAPTED FOR DECORATING WINE BOTTLES; WINE BUCKETS; WINE COASTERS OF PRECIOUS METAL; WINE COOLING PAILS; WINE DRIP COLLARS SPECIALLY ADAPTED FOR USE AROUND THE TOP OF WINE BOTTLES TO STOP DRIPS; WINE GLASSES; WINE JUGS; WINE OPENERS; WINE POURERS; WINE STRAINERS; WINE TASTERS; BEVERAGEWARE AND STEMWARE; BEVERAGE GLASSWARE AND DRINKING GLASSES; MUGS; CUPS; GOBLETS; DRINKING VESSELS AND HEAT-INSULATED VESSELS; BOTTLE STANDS; COASTERS NOT MADE OF PAPER AND NOT BEING TABLE LINEN; LEATHER COASTERS AND PLASTIC COASTERS; BARWARE, NAMELY, CORK SCREWS, CORK HOLDERS, BOTTLE OPENERS, TUMBLERS, WINE GOBLETS, CARAFES, AND DECANTERS; PORTABLE COOLERS FOR BEVERAGES, NAMELY, WINE; WINE COOLER STANDS, PITCHERS, BUCKETS AND BEVERAGE STIRRERS; PORTABLE COOLERS; PORTABLE BEVERAGE COOLERS AND BEVERAGE DISPENSERS; PORTABLE ICE CHESTS FOR BEVERAGES; THERMAL INSULATED CONTAINERS FOR BEVERAGES; THERMAL INSULATED TOTE BAGS FOR BEVERAGES (U.S. CLS. 2, 13, 23, 29, 30, 33, 40 AND 50).

CHRISTINA SOBRAL, EXAMINING ATTORNEY



**CLASS 21—(Continued).**

SN 86-244,379. COSMICTONIC, LLC, KINGSTON, NH.  
FILED 4-7-2014.

**COSMIC TONIC**

THE MARK CONSISTS OF STANDARD CHARACTERS WITHOUT CLAIM TO ANY PARTICULAR FONT, STYLE, SIZE, OR COLOR.

FOR COASTERS, NOT OF PAPER AND OTHER THAN TABLE LINEN; WATER BOTTLES SOLD EMPTY (U.S. CLS. 2, 13, 23, 29, 30, 33, 40 AND 50).

FIRST USE 2-3-2014; IN COMMERCE 2-3-2014.  
ANNIE NOBLE, EXAMINING ATTORNEY

**CLASS 21—(Continued).**

SN 86-246,981. ROBYN T. GABRIEL, SALEM, OR. FILED 4-9-2014.

**WHOOPSIE DUZIE**

THE MARK CONSISTS OF STANDARD CHARACTERS WITHOUT CLAIM TO ANY PARTICULAR FONT, STYLE, SIZE, OR COLOR.

FOR CERAMIC SCULPTURES, VASES, VESSELS, BOWLS, PLATES AND POTS; CUPS AND MUGS (U.S. CLS. 2, 13, 23, 29, 30, 33, 40 AND 50).

JESSICA A. POWERS, EXAMINING ATTORNEY

SN 86-244,825. CONAIR CORPORATION, STAMFORD, CT.  
FILED 4-7-2014.

**DESIGNZ**

THE MARK CONSISTS OF STANDARD CHARACTERS WITHOUT CLAIM TO ANY PARTICULAR FONT, STYLE, SIZE, OR COLOR.

FOR HAIR BRUSHES; HAIR COMBS (U.S. CLS. 2, 13, 23, 29, 30, 33, 40 AND 50).

KRISTINA MORRIS, EXAMINING ATTORNEY

SN 86-246,985. SFDISPLAY.COM, LLC, SOUTH SAN FRANCISCO, CA. FILED 4-9-2014.

**topPets**

THE MARK CONSISTS OF STANDARD CHARACTERS WITHOUT CLAIM TO ANY PARTICULAR FONT, STYLE, SIZE, OR COLOR.

FOR ANIMAL-ACTIVATED PET FEEDERS THAT INCLUDE DISPENSERS FOR RELEASING PET TOY FEEDER BALLS WITH PET FOOD AND PET TREATS THEREIN; PET FEEDING AND DRINKING BOWLS (U.S. CLS. 2, 13, 23, 29, 30, 33, 40 AND 50).

FIRST USE 3-12-2013; IN COMMERCE 3-12-2013.  
DOUGLAS LEE, EXAMINING ATTORNEY

SN 86-245,209. DEBOER, DAVID, LONG BRANCH, NJ.  
FILED 4-7-2014.

**SNACK ARENA**

THE MARK CONSISTS OF STANDARD CHARACTERS WITHOUT CLAIM TO ANY PARTICULAR FONT, STYLE, SIZE, OR COLOR.

FOR SERVING DISHES; SERVING TRAYS; SERVING-WARE FOR SERVING FOOD (U.S. CLS. 2, 13, 23, 29, 30, 33, 40 AND 50).

CHARLES HISER, EXAMINING ATTORNEY

SN 86-247,405. QUAFFER, LLC, TEMPE, AZ. FILED 4-9-2014.

**QUAFFER**

THE MARK CONSISTS OF STANDARD CHARACTERS WITHOUT CLAIM TO ANY PARTICULAR FONT, STYLE, SIZE, OR COLOR.

FOR BEVERAGE GLASSWARE; DRINKING GLASSES; SHOT GLASSES (U.S. CLS. 2, 13, 23, 29, 30, 33, 40 AND 50).

FIRST USE 9-1-1998; IN COMMERCE 3-1-2000.  
BILL DAWE, EXAMINING ATTORNEY

**CLASS 21—(Continued).**

SN 86-247,619. CANT, LLC, NASHVILLE, TN. FILED 4-9-2014.

**CAN'T AFFORD NOT TO**

THE MARK CONSISTS OF STANDARD CHARACTERS WITHOUT CLAIM TO ANY PARTICULAR FONT, STYLE, SIZE, OR COLOR.

FOR BEER MUGS, COFFEE MUGS, AND BEVERAGE WARE; INSULATORS FOR BEVERAGE CONTAINERS; BOTTLE OPENERS; CORK SCREWS (U.S. CLS. 2, 13, 23, 29, 30, 33, 40 AND 50).

FRANK LATTUCA, EXAMINING ATTORNEY

SN 86-247,782. CHERYL SNYDER, MANCHESTER, NH. FILED 4-9-2014.

**DRINKABLE ARTS**

THE MARK CONSISTS OF STANDARD CHARACTERS WITHOUT CLAIM TO ANY PARTICULAR FONT, STYLE, SIZE, OR COLOR.

FOR DRINKING GLASSES (U.S. CLS. 2, 13, 23, 29, 30, 33, 40 AND 50).

FIRST USE 1-15-2013; IN COMMERCE 1-15-2013.  
PAUL CROWLEY, EXAMINING ATTORNEY

SN 86-248,289. LILLY BRUSH CO., LLC, ENGLEWOOD, CO. FILED 4-10-2014.

**BE FOREVER FURLESS**

THE MARK CONSISTS OF STANDARD CHARACTERS WITHOUT CLAIM TO ANY PARTICULAR FONT, STYLE, SIZE, OR COLOR.

FOR LINT REMOVAL, FABRIC PILL REMOVAL AND PET HAIR REMOVAL BRUSHES (U.S. CLS. 2, 13, 23, 29, 30, 33, 40 AND 50).

CAITLIN WATTS-FITZGERALD, EXAMINING ATTORNEY

**CLASS 21—(Continued).**

SN 86-248,733. MEDIAVISION, INC., FAIRFIELD, NJ. FILED 4-10-2014.

**CLEVER MOP**

THE MARK CONSISTS OF STANDARD CHARACTERS WITHOUT CLAIM TO ANY PARTICULAR FONT, STYLE, SIZE, OR COLOR.

NO CLAIM IS MADE TO THE EXCLUSIVE RIGHT TO USE "MOP", APART FROM THE MARK AS SHOWN.

FOR BUCKETS; MOP WRINGERS; MOPS (U.S. CLS. 2, 13, 23, 29, 30, 33, 40 AND 50).

SETH A. RAPPAPORT, EXAMINING ATTORNEY

SN 86-249,234. CHANGZHOU ALMADEN CO., LTD., CHANGZHOU, JIANGSU, CHINA, FILED 4-11-2014.

**EagleShield**

THE MARK CONSISTS OF STYLIZED WORDING EAGLESHIELD.

FOR ENAMELLED GLASS; FIGURED PLATE GLASS; GLASS FOR VEHICLE WINDOWS; GLASS INCORPORATING FINE ELECTRICAL CONDUCTORS; MOSAICS OF GLASS, NOT FOR BUILDINGS; OPAL GLASS; OPALINE GLASS; SEMI-FINISHED SAFETY GLASS; TEMPERED GLASS; UNWORKED OR SEMI-WORKED GLASS; WIRED PLATE GLASS, NOT FOR BUILDING (U.S. CLS. 2, 13, 23, 29, 30, 33, 40 AND 50).

FIRST USE 1-8-2013; IN COMMERCE 1-8-2013.  
JOHN HWANG, EXAMINING ATTORNEY

SN 86-249,657. GROWOYA PLANT IRRIGATION INC., PORT MOODY, B.C., CANADA, FILED 4-11-2014.

**GROWOYA**

THE MARK CONSISTS OF STANDARD CHARACTERS WITHOUT CLAIM TO ANY PARTICULAR FONT, STYLE, SIZE, OR COLOR.

FOR WATERING POTS (U.S. CLS. 2, 13, 23, 29, 30, 33, 40 AND 50).

FIRST USE 11-13-2013; IN COMMERCE 2-7-2014.  
ZACHARY CROMER, EXAMINING ATTORNEY

**CLASS 21—(Continued).**

SN 86-249,791. INGENIRI, LLC, DBA NUSPIN KIDS, LONG BEACH, CA. FILED 4-11-2014.

# Sip & Spin

THE MARK CONSISTS OF STANDARD CHARACTERS WITHOUT CLAIM TO ANY PARTICULAR FONT, STYLE, SIZE, OR COLOR.

FOR DRINKING STRAWS; TRAINING CUPS FOR BABIES AND CHILDREN (U.S. CLS. 2, 13, 23, 29, 30, 33, 40 AND 50).

LOURDES AYALA, EXAMINING ATTORNEY

SN 86-250,020. CREATIVE MEDICAL DESIGNS, LLC, GLEN BURNIE, MD. FILED 4-11-2014.

# WATERBOY

THE MARK CONSISTS OF STANDARD CHARACTERS WITHOUT CLAIM TO ANY PARTICULAR FONT, STYLE, SIZE, OR COLOR.

FOR PERSONAL FLUID HYDRATION SYSTEMS COMPRISING A FLUID RESERVOIR, A DELIVERY TUBE, A MOUTHPIECE AND A CARRYING PACK; PERSONAL HYDRATION SYSTEMS COMPRISING A BITE VALVE, A FLUID BLADDER SOLD EMPTY, AND DETACHABLE TUBING SOLD AS A UNIT (U.S. CLS. 2, 13, 23, 29, 30, 33, 40 AND 50).

CHRISTINA SÓBRAL, EXAMINING ATTORNEY

SN 86-250,298. DARA GIANTS, LLC, NORTH HOLLYWOOD, CA. FILED 4-11-2014.

# NO GAGGING WHILE BAGGING

THE MARK CONSISTS OF STANDARD CHARACTERS WITHOUT CLAIM TO ANY PARTICULAR FONT, STYLE, SIZE, OR COLOR.

FOR PET WASTE MANAGEMENT KITS COMPRISING SCOOPS AND RAKES FOR PET WASTE DISPOSAL AND BAGS SOLD AS A UNIT (U.S. CLS. 2, 13, 23, 29, 30, 33, 40 AND 50).

WILLIAM JACKSON, EXAMINING ATTORNEY

**CLASS 21—(Continued).**

SN 86-250,836. CHANGZHOU ALMADEN CO., LTD., CHANGZHOU, JIANGSU, CHINA, FILED 4-14-2014.

# EagleLite

THE MARK CONSISTS OF STYLIZED WORDING "EAGLELITE".

FOR ENAMELLED GLASS; FIGURED PLATE GLASS; GLASS FOR VEHICLE WINDOWS; GLASS INCORPORATING FINE ELECTRICAL CONDUCTORS; MOSAICS OF GLASS, NOT FOR BUILDINGS; OPAL GLASS; OPALINE GLASS; SEMI-FINISHED SAFETY GLASS; TEMPERED GLASS; UNWORKED OR SEMI-WORKED GLASS; WIRED PLATE GLASS, NOT FOR BUILDING (U.S. CLS. 2, 13, 23, 29, 30, 33, 40 AND 50).

FIRST USE 1-8-2013; IN COMMERCE 1-8-2013.

JOHN HWANG, EXAMINING ATTORNEY

SN 86-252,834. NAVAJO MANUFACTURING COMPANY, DENVER, CO. FILED 4-15-2014.

# GLOVE CRAFTER

THE MARK CONSISTS OF STANDARD CHARACTERS WITHOUT CLAIM TO ANY PARTICULAR FONT, STYLE, SIZE, OR COLOR.

NO CLAIM IS MADE TO THE EXCLUSIVE RIGHT TO USE "GLOVE", APART FROM THE MARK AS SHOWN.

FOR WORK GLOVES (U.S. CLS. 2, 13, 23, 29, 30, 33, 40 AND 50).

FIRST USE 0-0-2003; IN COMMERCE 0-0-2003.

MAYUR VAGHANI, EXAMINING ATTORNEY

SN 86-261,115. TOTAL MANUFACTURING SOLUTIONS, INC., KNOXVILLE, TN. FILED 4-24-2014.



THE COLOR(S) GREEN AND BLUE IS/ARE CLAIMED AS A FEATURE OF THE MARK.

THE MARK CONSISTS OF A STYLIZED DESIGN CONSISTING OF A SWIRL WITH ALTERNATING GREEN AND BLUE PETALS. THE TERM "GREENSTALK" WITH GREEN IN THE COLOR GREEN AND STALK IN THE COLOR BLUE, AND THE TERMINOLOGY "ENGINEERED TO GROW" BELOW GREENSTALK AND IN GREEN COLOR.

FOR PLANTERS FOR FLOWERS AND PLANTS (U.S. CLS. 2, 13, 23, 29, 30, 33, 40 AND 50).

NICHOLAS COLEMAN, EXAMINING ATTORNEY

**CLASS 21—(Continued).**

SN 86-267,436. DAYSPRING CARDS, INC., SILOAM SPRINGS, AR. FILED 4-30-2014.

## KAREN KINGSBURY POSSIBILITIES WITH DAUGHTER KELSEY

THE MARK CONSISTS OF STANDARD CHARACTERS WITHOUT CLAIM TO ANY PARTICULAR FONT, STYLE, SIZE, OR COLOR.

KAREN RUSSELL AKA "KAREN KINGSBURY" AND KELSEY KUPECKY WHO IS A LIVING INDIVIDUAL WHOSE CONSENT IS OF RECORD.

FOR CERAMIC MUGS (U.S. CLS. 2, 13, 23, 29, 30, 33, 40 AND 50).

MIROSLAV NOVAKOVIC, EXAMINING ATTORNEY

SN 86-278,959. MEDIAVISION, INC., FAIRFIELD, NJ. FILED 5-12-2014.

## CLEVER MICRON MOP

THE MARK CONSISTS OF STANDARD CHARACTERS WITHOUT CLAIM TO ANY PARTICULAR FONT, STYLE, SIZE, OR COLOR.

NO CLAIM IS MADE TO THE EXCLUSIVE RIGHT TO USE "MOP", APART FROM THE MARK AS SHOWN.

FOR BUCKETS; MOP WRINGERS; MOPS (U.S. CLS. 2, 13, 23, 29, 30, 33, 40 AND 50).

SETH A. RAPPAPORT, EXAMINING ATTORNEY

SN 86-293,942. RUBBERMAID INCORPORATED, ATLANTA, GA. FILED 5-28-2014.

## ROUGHNECK

THE MARK CONSISTS OF STANDARD CHARACTERS WITHOUT CLAIM TO ANY PARTICULAR FONT, STYLE, SIZE, OR COLOR.

FOR PORTABLE COOLERS; WATER JUGS SOLD EMPTY (U.S. CLS. 2, 13, 23, 29, 30, 33, 40 AND 50).

THOMAS MANOR, EXAMINING ATTORNEY

**CLASS 21—(Continued).**

SN 86-305,625. MAF, LLC, LAS VEGAS, NV. FILED 6-10-2014.

## MYSHOOTER

THE MARK CONSISTS OF STANDARD CHARACTERS WITHOUT CLAIM TO ANY PARTICULAR FONT, STYLE, SIZE, OR COLOR.

FOR BAR ACCESSORIES, NAMELY, A UTENSIL USED TO APPLY SALT AND LIME TO GLASS BEVERAGEWARE (U.S. CLS. 2, 13, 23, 29, 30, 33, 40 AND 50).

CHRISTOPHER REAMS, EXAMINING ATTORNEY

SN 86-307,344. JAN M. LONG, CARMEL, IN. FILED 6-11-2014.

## GIVE CANCER THE BIRD!

THE MARK CONSISTS OF STANDARD CHARACTERS WITHOUT CLAIM TO ANY PARTICULAR FONT, STYLE, SIZE, OR COLOR.

FOR BIRD BATHS; BIRD FEEDERS; BIRD HOUSES (U.S. CLS. 2, 13, 23, 29, 30, 33, 40 AND 50).

SUE LAWRENCE, EXAMINING ATTORNEY

**CLASS 22—CORDAGE AND FIBERS**

SN 86-072,458. STRATEGIC PARTNERS, INC., CHATSWORTH, CA. FILED 9-23-2013.

## Curo

THE MARK CONSISTS OF STANDARD CHARACTERS WITHOUT CLAIM TO ANY PARTICULAR FONT, STYLE, SIZE, OR COLOR.

THE ENGLISH TRANSLATION OF "CURO" IN THE MARK IS "TO HEAL".

FOR LANYARDS FOR HOLDING BADGES AND KEYS (U.S. CLS. 1, 2, 7, 19, 22, 42 AND 50).

DANNEAN HETZEL, EXAMINING ATTORNEY

**CLASS 22—(Continued).**

SN 86-207,390. INDIAN MOTORCYCLE INTERNATIONAL, LLC, MEDINA, MN. FILED 2-28-2014.



THE MARK CONSISTS OF THE STYLIZED WORDS "INDIAN MOTORCYCLE" LOCATED WITHIN AN INDIAN HEADRESS DESIGN.

FOR TENTS (U.S. CLS. 1, 2, 7, 19, 22, 42 AND 50).  
NAAKWAMA ANKRAH, EXAMINING ATTORNEY

---

SN 86-229,523. SUSTAINABLE TRADING LTD., NEW TERRITORIES, HONG KONG, FILED 3-24-2014.

## CanvasCamp

THE MARK CONSISTS OF STANDARD CHARACTERS WITHOUT CLAIM TO ANY PARTICULAR FONT, STYLE, SIZE, OR COLOR.

PRIORITY CLAIMED UNDER SEC. 44(D) ON ERPNCMNTY TM OFC APPLICATION NO. 12285714, FILED 11-6-2013, REG. NO. 12285714, DATED 4-11-2014, EXPIRES 11-6-2023.

FOR TENTS MADE WHOLLY OR IN SUBSTANTIAL PART OF CANVAS (U.S. CLS. 1, 2, 7, 19, 22, 42 AND 50).  
JOHN SCHUYLER YARD, EXAMINING ATTORNEY

---

SN 86-229,983. WIND DEFENDER, LLC, MIDDLE RIVER, MD. FILED 3-24-2014.

## WIND DEFENDER

THE MARK CONSISTS OF STANDARD CHARACTERS WITHOUT CLAIM TO ANY PARTICULAR FONT, STYLE, SIZE, OR COLOR.

NO CLAIM IS MADE TO THE EXCLUSIVE RIGHT TO USE "WIND", APART FROM THE MARK AS SHOWN.

FOR SHEETING COVER IN THE NATURE OF TARPULINS USED TO SECURE AND COVER FILMS AND LINERS OVER LANDFILLS, CONSTRUCTION SITES AND LARGE LAND AREAS AND MATERIALS STORED THEREON (U.S. CLS. 1, 2, 7, 19, 22, 42 AND 50).  
RON FAIRBANKS, EXAMINING ATTORNEY

**CLASS 22—(Continued).**

SN 86-248,469. BULK LIFT INTERNATIONAL INCORPORATED, CARPENTERSVILLE, IL. FILED 4-10-2014.

## STACK-PAC

THE MARK CONSISTS OF STANDARD CHARACTERS WITHOUT CLAIM TO ANY PARTICULAR FONT, STYLE, SIZE, OR COLOR.

OWNER OF U.S. REG. NOS. 3,106,381 AND 3,355,410.  
FOR SACKS OR BAGS FOR THE TRANSPORTATION OR STORAGE OF MATERIALS IN BULK (U.S. CLS. 1, 2, 7, 19, 22, 42 AND 50).

FIRST USE 6-30-2003; IN COMMERCE 6-30-2003.  
DANIEL S. STRINGER, EXAMINING ATTORNEY

**CLASS 23—YARNS AND THREADS**

SN 86-237,557. KAREN MICHELE DESIGNS, POOLESVILLE, MD. FILED 3-31-2014.

## yarnvelopes

THE MARK CONSISTS OF STANDARD CHARACTERS WITHOUT CLAIM TO ANY PARTICULAR FONT, STYLE, SIZE, OR COLOR.

FOR TEXTILE POUCHES SPECIALLY ADAPTED FOR HOLDING AND PROTECTING YARN WHILE KNITTING (U.S. CL. 43).

KIMBERLY FRYE, EXAMINING ATTORNEY

**CLASS 24—FABRICS**

SN 79-136,596. MIROGLIO TEXTILE S.R.L., I-12051 ALBA (CN), ITALY, FILED 8-1-2013.



PRIORITY DATE OF 7-23-2013 IS CLAIMED.  
OWNER OF INTERNATIONAL REGISTRATION 1176799  
DATED 8-1-2013, EXPIRES 8-1-2023.  
OWNER OF U.S. REG. NO. 2,855,663.

NO CLAIM IS MADE TO THE EXCLUSIVE RIGHT TO USE "TEXTILE", APART FROM THE MARK AS SHOWN.

THE MARK CONSISTS OF THE TERM "ORO" ABOVE THE WORDING "BY MIROGLIO TEXTILE" APPEARING IN STYLIZED FONT.

THE ENGLISH TRANSLATION OF "ORO" IN THE MARK IS "GOLD".

FOR TEXTILES AND TEXTILE GOODS, NAMELY, TEXTILE FABRICS FOR USE IN MANUFACTURING CLOTHING, FOOTWEAR, HEADGEAR, BED LINENS, TABLE LINENS, HOUSEHOLD FURNISHINGS, OFFICE AND INDUSTRIAL FURNISHINGS, FURNITURE AND UPHOLSTERY; NATURAL AND SYNTHETIC TEXTILES AND FABRICS, NAMELY, WOOL, COTTON, LINEN, SILK, POLYESTER AND NYLON FABRICS, KNITTED FABRIC, NON-WOVEN TEXTILE FABRICS, FABRIC FOR FOOTWEAR IN THE NATURE OF BOOTS, SHOES, SLIPPERS, FABRICS FOR TEXTILE USE; VELVET (U.S. CLS. 42 AND 50).

SAIMA MAKHDOOM, EXAMINING ATTORNEY

SN 79-141,301. DORMEUIL FRERES, FRANCE, FILED 9-30-2013.

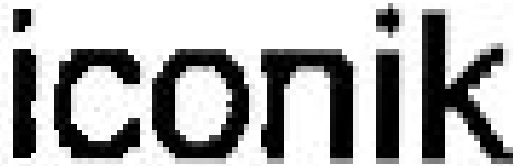

THE MARK CONSISTS OF STANDARD CHARACTERS WITHOUT CLAIM TO ANY PARTICULAR FONT, STYLE, SIZE, OR COLOR.

PRIORITY DATE OF 7-5-2013 IS CLAIMED.  
OWNER OF INTERNATIONAL REGISTRATION 1188967  
DATED 9-30-2013, EXPIRES 9-30-2023.

FOR TEXTILE FABRICS FOR USE IN MAKING CLOTHING, NAMELY, COSTUMES, SUITS, COATS, TROUSERS, DRESSES, JACKETS, SKIRTS, SHIRTS, TIES, SCARVES FOR MEN, WOMEN AND CHILDREN; FABRICS FOR TEXTILE USE (U.S. CLS. 42 AND 50).

MARY CRAWFORD, EXAMINING ATTORNEY

**CLASS 24—(Continued).**

SN 85-546,312. MUCHNICK ENTERPRISES, LLC, DBA BURPLE, NEW HAVEN, CT. FILED 2-17-2012.



THE MARK CONSISTS OF STANDARD CHARACTERS WITHOUT CLAIM TO ANY PARTICULAR FONT, STYLE, SIZE, OR COLOR.

FOR BURP CLOTHS (U.S. CLS. 42 AND 50).  
ELLEN PERKINS, EXAMINING ATTORNEY

SN 85-603,827. BRITANNICA HOME FASHIONS, INC., NEW YORK, NY. FILED 4-20-2012.



THE MARK CONSISTS OF STANDARD CHARACTERS WITHOUT CLAIM TO ANY PARTICULAR FONT, STYLE, SIZE, OR COLOR.

FOR BED SHEETS, COMFORTERS, PILLOW SHAMS, COMFORTER COVERS, DOWN COMFORTERS, QUILTS, BED DUST RUFFLES, FABRIC WINDOW VALANCES, CLOTH WINDOW PANELS, CURTAINS, DRAPERIES AND CLOTH WINDOW SCARVES AND QUILTS (U.S. CLS. 42 AND 50).

SALLY SHIH, EXAMINING ATTORNEY

SN 85-700,355. NORFAB CORPORATION, NORRISTOWN, PA. FILED 8-10-2012.



THE MARK CONSISTS OF STANDARD CHARACTERS WITHOUT CLAIM TO ANY PARTICULAR FONT, STYLE, SIZE, OR COLOR.

FOR FABRICS FOR USE IN MANUFACTURE OF HUMAN PROTECTIVE GARMENTS (U.S. CLS. 42 AND 50).

FIRST USE 12-13-2011; IN COMMERCE 12-13-2011.

ELIZABETH KAJUBI, EXAMINING ATTORNEY

**CLASS 24—(Continued).**

SN 85-822,939. MAD IN ITALY LLC, MIAMI, FL. FILED 1-14-2013.

# MADINITALY

THE MARK CONSISTS OF STANDARD CHARACTERS WITHOUT CLAIM TO ANY PARTICULAR FONT, STYLE, SIZE, OR COLOR.

FOR BABY BEDDING, NAMELY, BUNDLE BAGS, SWADDLING BLANKETS, CRIB BUMPERS, FITTED CRIB SHEETS, CRIB SKIRTS, CRIB BLANKETS, AND DIAPER CHANGING PAD COVERS NOT OF PAPER; BABY BLANKETS; BATH LINEN; BATH SHEETS; BATH TOWELS; BED AND TABLE LINEN; BED AND TABLE LINEN, WALL HANGINGS OF TEXTILE; BED BLANKETS; BED CANOPIES; BED COVERS; BED SPREADS; BEDSPREADS; CHILDREN'S TOWELS; CHILDREN'S BED SHEETS, PILLOW CASES, AND BLANKETS; COMFORTERS; CURTAINS; CURTAINS AND TOWELS; CURTAINS OF TEXTILE OR PLASTIC; DRAPERIES; DUVET COVERS; DUVETS; FABRIC TABLE TOPPERS; FACE TOWELS; FACE TOWELS OF TEXTILES; FUTON QUILTS; HAND TOWELS; HOUSEHOLD LINEN; HOUSEHOLD LINEN, INCLUDING FACE TOWELS; INDIVIDUAL PLACE MATS MADE OF TEXTILE; INTERIOR DECORATION FABRICS; KITCHEN TOWELS; LARGE BATH TOWELS; PILLOW CASES; PILLOW COVERS; PILLOWCASES; PLACE MATS OF TEXTILE MATERIAL; PLACE MATS, NOT OF PAPER; PLASTIC PLACE MATS; QUILT COVERS; QUILTS; SHOWER CURTAINS; TABLE CLOTH OF TEXTILE; TABLE CLOTHS NOT OF PAPER; TABLE LINEN; TABLE MATS NOT OF PAPER; TABLE PADS; TEXTILE PLACE MATS; TOWELS; VINYL PLACE MATS (U.S. CLS. 42 AND 50).  
SARA BENJAMIN, EXAMINING ATTORNEY

**CLASS 24—(Continued).**

SN 86-065,849. FIELD & STREAM LICENSES COMPANY, LLC, WESTPORT, CT. FILED 9-16-2013.

# FIELD & STREAM

THE MARK CONSISTS OF STANDARD CHARACTERS WITHOUT CLAIM TO ANY PARTICULAR FONT, STYLE, SIZE, OR COLOR.

OWNER OF U.S. REG. NOS. 1,360,646, 2,044,018 AND OTHERS.

FOR TOWELS, BEACH TOWELS, BEACH BLANKETS, TABLE NAPKINS OF FABRIC; TABLE CLOTHS NOT OF PAPER (U.S. CLS. 42 AND 50).

KIM SAITO, EXAMINING ATTORNEY

SN 86-087,723. WELSPUN INDIA LIMITED, MUMBAI, INDIA, FILED 10-9-2013.

SN 86-065,833. FIELD & STREAM LICENSES COMPANY, LLC, WESTPORT, CT. FILED 9-16-2013.

# FIELD & STREAM

THE MARK CONSISTS OF STANDARD CHARACTERS WITHOUT CLAIM TO ANY PARTICULAR FONT, STYLE, SIZE, OR COLOR.

OWNER OF U.S. REG. NOS. 1,360,646, 2,044,018 AND OTHERS.

FOR PILLOWCASES; BEDDING, NAMELY, BED CANOPIES, BED BLANKETS, BED LINEN, AND BED COVERS; BED SHEETS (U.S. CLS. 42 AND 50).

FIRST USE 1-1-2013; IN COMMERCE 1-1-2013.

KIM SAITO, EXAMINING ATTORNEY

THE MARK CONSISTS OF STANDARD CHARACTERS WITHOUT CLAIM TO ANY PARTICULAR FONT, STYLE, SIZE, OR COLOR.

NO CLAIM IS MADE TO THE EXCLUSIVE RIGHT TO USE "SOFT", APART FROM THE MARK AS SHOWN.

FOR BED BLANKETS; BED SHEETS; COMFORTERS; DISH CLOTHS; DUVETS; FITTED BED SHEETS; FLAT BED SHEETS; KITCHEN TOWELS; MATTRESS COVERS; MATTRESS PADS; PILLOW CASES; PILLOW SHAMS; SHEET SETS; TOWELS; WASHCLOTHS (U.S. CLS. 42 AND 50).

JEAN IM, EXAMINING ATTORNEY

# SOFT & ALWAYS

**CLASS 24—(Continued).**

SN 86-174,795. DISCOVERY COMMUNICATIONS, LLC,  
SILVER SPRING, MD. FILED 1-24-2014.

**DISCOVERY KIDS**

THE MARK CONSISTS OF STANDARD CHARACTERS WITHOUT CLAIM TO ANY PARTICULAR FONT, STYLE, SIZE, OR COLOR.

OWNER OF U.S. REG. NOS. 3,312,982, 3,643,903 AND OTHERS.

NO CLAIM IS MADE TO THE EXCLUSIVE RIGHT TO USE "KIDS", APART FROM THE MARK AS SHOWN.

FOR BEDSHEETS, COMFORTERS, BEDSPREADS, QUILTS; FABRIC WINDOW COVERINGS, NAMELY, CURTAINS, DRAPERIES, SHEERS, SWAGS, CURTAIN LINERS, AND VALANCES; DUST RUFFLES, BED SKIRTS, BED CANOPIES, COVERLETS, PILLOW CASES, PILLOW SHAMS, TEXTILE WALL HANGINGS, DRY PADS, NAMELY, BED PADS, MATTRESS COVERS, MATTRESS PADS, BED BLANKETS, BEACH TOWELS, BATH TOWELS, HAND TOWELS, WASH CLOTHS, WASH MITTS, BATH GLOVES, BATH LINEN, FITTED TOILET LID COVERS MADE OF FABRIC OR FABRIC SUBSTITUTES, BLANKET THROWS, SHOWER CURTAINS, SHOWER CURTAIN LINERS, DINING TABLE LINENS, VINYL PLACEMATS, DUVET COVERS, FABRIC TABLE TOPPERS, FABRIC TABLECLOTHS, FABRIC TABLE RUNNERS, HOUSEHOLD LINEN, LINEN PLACE MATS, OVEN MITTS, DISH CLOTHS (U.S. CLS. 42 AND 50).

INGRID C. EULIN, EXAMINING ATTORNEY

**CLASS 24—(Continued).**

SN 86-220,264. SECCCO, INC., CARACAS, VENEZUELA,  
FILED 3-13-2014.



THE COLOR(S) WHITE, BLACK, AND BLUE IS/ARE CLAIMED AS A FEATURE OF THE MARK.

THE MARK CONSISTS OF THE WORD "SECCCO" HAVING THE LETTERS "S E C C C" IN WHITE AND THE LETTER "O" IN BLUE WITHIN AN ELLIPTICAL FIGURE WITH A BLACK BACKGROUND.

THE WORDING "SECCCO" HAS NO MEANING IN A FOREIGN LANGUAGE.

FOR TOWELS (U.S. CLS. 42 AND 50).

NAKIA HENRY, EXAMINING ATTORNEY

SN 86-190,325. PAUL MOSTON DESIGNS, LLC, CHADDS  
FORD, PA. FILED 2-11-2014.



THE MARK CONSISTS OF A PERFECT BLACK LINE CIRCLE INCLUDING AN UPPER CASE "A" IN THE MIDDLE WITH CAP LOCKS "ARETÉ" ( HYPHEN OVER THE "É") UNDER THE UPPER CASE "A".

FOR MOISTURE ABSORBENT MICROFIBER TEXTILE FABRICS FOR USE IN THE MANUFACTURE OF ATHLETIC APPAREL, NAMELY, SHIRTS, PANTS, SHORTS, JACKETS, BAGS, TOWELS AND ATHLETIC UNIFORMS (U.S. CLS. 42 AND 50).

FIRST USE 6-2-2013; IN COMMERCE 12-7-2013.

AMY HELLA, EXAMINING ATTORNEY

SN 86-229,112. CHINCOTEAGUE VOLUNTEER FIRE COM-  
PANY, INC., CHINCOTEAGUE ISLAND, VA. FILED 3-22-  
2014.

CHINCOTEAGUE VOL. FIRE CO.

THE MARK CONSISTS OF STANDARD CHARACTERS WITHOUT CLAIM TO ANY PARTICULAR FONT, STYLE, SIZE, OR COLOR.

NO CLAIM IS MADE TO THE EXCLUSIVE RIGHT TO USE "CHINCOTEAGUE" AND "CO.", APART FROM THE MARK AS SHOWN.

FOR BEACH TOWELS (U.S. CLS. 42 AND 50).

KIM MONINGHOFF, EXAMINING ATTORNEY



**CLASS 24—(Continued).**

SN 86-229,113. CHINCOTEAGUE VOLUNTEER FIRE COMPANY, INC., CHINCOTEAGUE ISLAND, VA. FILED 3-22-2014.



NO CLAIM IS MADE TO THE EXCLUSIVE RIGHT TO USE "CHINCOTEAGUE", "CO.", AND "VIRGINIA", APART FROM THE MARK AS SHOWN.

THE COLOR(S) BLUE, RED, YELLOW, BROWN, AND WHITE IS/ARE CLAIMED AS A FEATURE OF THE MARK.

THE MARK CONSISTS OF A BLUE SHIELD WITH A YELLOW BORDER AND HAVING A BROWN AND WHITE PRANCING PONY IMAGE THEREON, WHEREIN THE RED WORDS "CHINCOTEAGUE VOL. FIRE CO." APPEAR ABOVE THE PRANCING PONY AND THE RED WORD "VIRGINIA" APPEARS BELOW THE PONY. THE WHITE AREA OUTSIDE THE SHIELD REPRESENTS A TRANSPARENT AREA NOT CLAIMED AS PART OF THE MARK.

FOR BEACH TOWELS (U.S. CLS. 42 AND 50).  
KIM MONINGHOFF, EXAMINING ATTORNEY

SN 86-231,847. PEKING HANDICRAFT, INC., SOUTH SAN FRANCISCO, CA. FILED 3-25-2014.

**GROMMET GLIDE**

THE MARK CONSISTS OF STANDARD CHARACTERS WITHOUT CLAIM TO ANY PARTICULAR FONT, STYLE, SIZE, OR COLOR.

NO CLAIM IS MADE TO THE EXCLUSIVE RIGHT TO USE "GROMMET", APART FROM THE MARK AS SHOWN. FOR FABRIC WINDOW COVERINGS AND TREATMENTS, NAMELY, CURTAINS, CURTAIN PANELS, DRAPERIES, WINDOW PANELS (U.S. CLS. 42 AND 50).  
BRIAN PINO, EXAMINING ATTORNEY

**CLASS 24—(Continued).**

SN 86-233,284. KEECO, LLC, HAYWARD, CA. FILED 3-26-2014.

**Greyson Collection**

THE MARK CONSISTS OF STANDARD CHARACTERS WITHOUT CLAIM TO ANY PARTICULAR FONT, STYLE, SIZE, OR COLOR.

NO CLAIM IS MADE TO THE EXCLUSIVE RIGHT TO USE "COLLECTION", APART FROM THE MARK AS SHOWN.

FOR BED SKIRTS; COMFORTERS; PILLOW SHAMS; QUILTS (U.S. CLS. 42 AND 50).

STEVEN JACKSON, EXAMINING ATTORNEY

SN 86-235,261. COAR INC., NAPLES, FL. FILED 3-28-2014.

**CELEBRATIONTABLECLOTHS**

THE MARK CONSISTS OF STANDARD CHARACTERS WITHOUT CLAIM TO ANY PARTICULAR FONT, STYLE, SIZE, OR COLOR.

FOR TABLE CLOTHS NOT OF PAPER, NAMELY, PARTY TABLECLOTHS, HAPPY BIRTHDAY TABLECLOTHS, SPORTS TABLECLOTHS, HOLIDAY TABLECLOTHS, SPECIAL OCCASION TABLECLOTHS (U.S. CLS. 42 AND 50).

HANNO RITTNER, EXAMINING ATTORNEY

SN 86-239,655. MILSPORT MEDICAL, LLC, BUFFALO, NY. FILED 4-2-2014.

**AIR O2 TECH**

THE MARK CONSISTS OF STANDARD CHARACTERS WITHOUT CLAIM TO ANY PARTICULAR FONT, STYLE, SIZE, OR COLOR.

NO CLAIM IS MADE TO THE EXCLUSIVE RIGHT TO USE "AIR", APART FROM THE MARK AS SHOWN.

FOR FABRICS FOR THE MANUFACTURE OF MEDICAL HEEL PRESSURE OFFLOADING BOOT PRODUCTS AND MEDICAL LIMB PROTECTIVE AND HEALING PROMOTION DEVICES USED FOR AMPUTATED LIMBS AND/OR DECREASING OR MINIMIZING THE FORMATION OF DECUBITUS ULCERS (U.S. CLS. 42 AND 50).

FIRST USE 3-25-2014; IN COMMERCE 3-25-2014.  
SUSAN STIGLITZ, EXAMINING ATTORNEY

**CLASS 24—(Continued).**

SN 86-246,650. LAUREN HWANG, INC., BROOKLYN, NY. FILED 4-9-2014.

**LAUREN HWANG NEW YORK**

THE MARK CONSISTS OF STANDARD CHARACTERS WITHOUT CLAIM TO ANY PARTICULAR FONT, STYLE, SIZE, OR COLOR.

NO CLAIM IS MADE TO THE EXCLUSIVE RIGHT TO USE "NEW YORK", APART FROM THE MARK AS SHOWN.

THE NAME(S), PORTRAIT(S), AND/OR SIGNATURE(S) SHOWN IN THE MARK IDENTIFIES "LAUREN HWANG", WHOSE CONSENT(S) TO REGISTER IS MADE OF RECORD.

FOR NATURAL FABRICS AND TEXTILES, NAMELY, COTTON, SILK, WOOL AND LINEN FABRICS (U.S. CLS. 42 AND 50).

FIRST USE 0-0-2000; IN COMMERCE 0-0-2000.  
TOBY BULLOFF, EXAMINING ATTORNEY

**CLASS 25—CLOTHING**

SN 76-715,918. SIMKA SOL, LLC, AMESBURY, MA. FILED 2-27-2014.

**SIMKA SOL**

THE MARK CONSISTS OF STANDARD CHARACTERS WITHOUT CLAIM TO ANY PARTICULAR FONT, STYLE, SIZE, OR COLOR.

THE WORDING "SIMKA" HAS NO MEANING IN A FOREIGN LANGUAGE.

THE ENGLISH TRANSLATION OF THE WORD "SOL" IN THE MARK IS "SUN".

FOR CLOTHING, NAMELY, T-SHIRTS, TANK TOPS, SHORTS, PANTS, SKIRTS, DRESSES, UNDERWEAR, JACKETS, SWEATSHIRTS, CARDIGANS, LEGGINGS, VESTS, HOSIERY, ROBES, STOCKINGS, TOPS, SHIRTS, SLEEPWEAR, HEADWEAR, SCARVES, SWIMWEAR, BELTS, AND NECKWEAR (U.S. CLS. 22 AND 39).

FIRST USE 1-27-2014; IN COMMERCE 1-27-2014.  
MICHAEL WIENER, EXAMINING ATTORNEY

**CLASS 25—(Continued).**

SN 76-715,930. HANLEY, PETE, NEW MILFORD, NJ. FILED 3-4-2014.

**DREAM-IT, WILL-IT, LIVE-IT**

THE MARK CONSISTS OF STANDARD CHARACTERS WITHOUT CLAIM TO ANY PARTICULAR FONT, STYLE, SIZE, OR COLOR.

FOR CLOTHING, NAMELY, SHIRTS, PANTS, JACKETS, SWEATERS, CAPS, PULLOVERS AND VESTS (U.S. CLS. 22 AND 39).

FIRST USE 1-2-2001; IN COMMERCE 1-2-2001.  
EVELYN BRADLEY, EXAMINING ATTORNEY

SN 77-890,946. DISNEY ENTERPRISES, INC., BURBANK, CA. FILED 12-10-2009.

**PHINEAS AND FERB**

THE MARK CONSISTS OF STANDARD CHARACTERS WITHOUT CLAIM TO ANY PARTICULAR FONT, STYLE, SIZE, OR COLOR.

OWNER OF U.S. REG. NOS. 3,578,149 AND 3,610,415.

FOR BEACHWEAR; BELTS; BOTTOMS; CHAPS; CLOAKS; CLOTH BIBS; COATS; COSTUMES FOR USE IN ROLE-PLAYING GAMES; BEACH COVER-UPS; DRESSES; EAR MUFFS; FOOTWEAR; GLOVES; HALLOWEEN COSTUMES; HEADWEAR; HOSIERY; INFANTWEAR; JACKETS; LEOTARDS; LINGERIE; LOUNGEWEAR; MITTENS; OVERALLS; PANTS; PONCHOS; RAINWEAR; SCARVES; SHIRTS; SHORTS; SLEEPWEAR; SOCKS; SWEATERS; SWEATSHIRTS; SWIMWEAR; SUITS; TIES; TOPS; UNDERWEAR; WRIST BANDS (U.S. CLS. 22 AND 39).

SUE LAWRENCE, EXAMINING ATTORNEY

SN 79-138,316. ALWAYS CO., LTD, JAPAN, FILED 9-20-2013.



*Mikako Nakamura*

OWNER OF INTERNATIONAL REGISTRATION 1181331 DATED 9-20-2013, EXPIRES 9-20-2023.

THE NAME(S), PORTRAIT(S), AND/OR SIGNATURE(S) SHOWN IN THE MARK IDENTIFIES A PARTICULAR LIVING INDIVIDUAL, WHOSE CONSENT(S) TO REGISTER IS MADE OF RECORD.

THE MARK CONSISTS OF THE STYLIZED WORDING "MIKAKO NAKAMURA" APPEARING BELOW THE DEPICTION OF A CIRCLE CONTAINING CURVED LINES.

FOR GARTERS; FOOTWEAR; CLOTHING, NAMELY, JACKETS; COATS; DRESSES; VESTS; SKIRTS; PANTS; SWEATERS; CARDIGANS; BLOUSES; KNIT SHIRTS; KNITTED CAPS; KNITTED UNDERWEAR; KNITTED GLOVES (U.S. CLS. 22 AND 39).

MICHAEL TANNER, EXAMINING ATTORNEY

**CLASS 25—(Continued).**

SN 79-138,576. CONFEZIONI ELSY S.P.A., CALAMANDRANA, ITALY, FILED 10-2-2013.

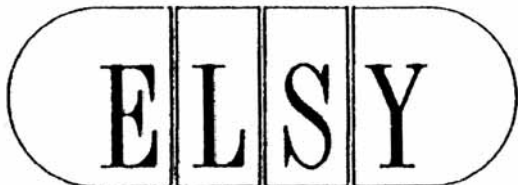

OWNER OF INTERNATIONAL REGISTRATION 0598554 DATED 3-9-1993, EXPIRES 3-9-2023.

THE MARK CONSISTS OF THE STYLIZED WORD "ELSY" AGAINST A SEGMENTED OBLONG BACKGROUND, WITH EACH LETTER OF WORD APPEARING IN A DIFFERENT SEGMENT.

FOR CLOTHING FOR CHILDREN, NAMELY, SHIRTS, PANTS, JACKETS, DRESSES, FOOTWEAR, HEADWEAR, T-SHIRTS, SKIRTS, TIGHTS, OUTERWEAR JACKETS, TOPS, GILETS, SWEATSHIRTS, COATS, GLOVES, SCARVES, BELTS, LEGGINGS, SWEATERS (U.S. CLS. 22 AND 39).

ANDREW LEASER, EXAMINING ATTORNEY

SN 79-139,200. MARK PREECE HOLDINGS PTY LTD, NORTH MANLY NSW 2100, AUSTRALIA, FILED 9-5-2013.



OWNER OF INTERNATIONAL REGISTRATION 0967628 DATED 5-21-2008, EXPIRES 5-21-2018.

NO CLAIM IS MADE TO THE EXCLUSIVE RIGHT TO USE "LONGBOARD CO.", APART FROM THE MARK AS SHOWN.

THE MARK CONSISTS OF "MANLY LONG BOARD CO." INSIDE OF A CIRCLE AND TO THE RIGHT OF A DESIGN OF A MAN ON A LONGBOARD WITH A WAVE IN THE BACKGROUND AND WITH THE LONGBOARD DESIGN EXTENDING BELOW THE TERM "BOARD".

FOR CLOTHING, FOOTWEAR AND HEADGEAR, NAMELY, T-SHIRTS, SHIRTS, SINGLET, JACKETS, JUMPERS, SWEATERS, COATS, RAINCOATS, VESTS, PANTS, TROUSERS, LEG-INS, SHORTS, BOARD SHORTS, DRESSES, SKIRTS, BLOUSES, UNDERCLOTHING, SWIMWEAR, SWIMSUITS, BIKINIS, PYJAMAS, NIGHT GOWNS, SOCKS, WETSUITS, BOOTS, SHOES, SLIPPERS, SANDALS, THONGS, FLIP-FLOPS, BOOTIES, HATS, CAPS, SUN VISORS AND BEANIES (U.S. CLS. 22 AND 39).

ALAIN LAPTEY, EXAMINING ATTORNEY

**CLASS 25—(Continued).**

SN 79-141,300. J.D. WILLIAMS & COMPANY LIMITED, UNITED KINGDOM, FILED 9-26-2013.

# LULU TOUT

THE MARK CONSISTS OF STANDARD CHARACTERS WITHOUT CLAIM TO ANY PARTICULAR FONT, STYLE, SIZE, OR COLOR.

OWNER OF INTERNATIONAL REGISTRATION 1188966 DATED 9-26-2013, EXPIRES 9-26-2023.

THE NAME(S), PORTRAIT(S), AND/OR SIGNATURE(S) SHOWN IN THE MARK DOES NOT IDENTIFY A PARTICULAR LIVING INDIVIDUAL.

FOR CLOTHING, NAMELY, SWIMWEAR, BEACHWEAR INCLUDING KAFTANS AND SARONGS, SHAPING LINGERIE, PANTS, TROUSERS, T-SHIRTS, TOPS, SHORTS, SHORTS SETS, PLAYSUITS, DRESSES, FOOTWEAR, WOMEN'S UNDERWEAR, BRAS, HOSE, LINGERIE, SOCKS, DRESSING GOWNS, PYJAMAS, SLEEPWEAR, LOUNGEWEAR AND DAYWEAR, NAMELY, T-SHIRTS, TOPS, SHORTS, SHORTS SETS, PANTS, TROUSERS, PLAYSUITS, DRESSES (U.S. CLS. 22 AND 39).

HANNO RITTNER, EXAMINING ATTORNEY

SN 79-141,324. HANGZHOU HAN'S TRADE CO., LTD., ZHEJIANG PROVINCE, CHINA, FILED 11-28-2013.



OWNER OF INTERNATIONAL REGISTRATION 1189023 DATED 11-28-2013, EXPIRES 11-28-2023.

OWNER OF U.S. REG. NO. 3,761,426.

THE MARK CONSISTS OF THE STYLIZED WORD "MAXLAND" BENEATH A STYLIZED DEPICTION OF MOUNTAINS.

THE WORDING "MAXLAND" HAS NO MEANING IN A FOREIGN LANGUAGE.

FOR CLOTHING, NAMELY, JACKETS, COATS, SWEATERS, SINGLET, UNDERWEAR, TROUSERS, DUNGAREES, TEE-SHIRTS, SHIRTS, PANTIES, SHORTS, BRIEFS, JEANS, PULLOVERS, JERSEYS, TIGHTS, SUITS, BATHING SUITS (U.S. CLS. 22 AND 39).

MARGERY A. TIERNEY, EXAMINING ATTORNEY

**CLASS 25—(Continued).**

SN 79-142,853. G5 SA, LUXEMBOURG, FILED 12-18-2013.

# BYSKIN

THE MARK CONSISTS OF STANDARD CHARACTERS WITHOUT CLAIM TO ANY PARTICULAR FONT, STYLE, SIZE, OR COLOR.

PRIORITY DATE OF 8-9-2013 IS CLAIMED.

OWNER OF INTERNATIONAL REGISTRATION 1192851 DATED 12-18-2013, EXPIRES 12-18-2023.

FOR CLOTHING, NAMELY, SHIRTS, PANTS, COATS, DRESSES, SKIRTS, FOOTWEAR, HEADGEAR, NAMELY, HATS, CAPS, HEADSCARVES, BANDANNAS; SHIRTS, CLOTHING OF LEATHER OR IMITATION LEATHER, NAMELY, LEATHER HATS, LEATHER PANTS, LEATHER COATS, LEATHER SKIRTS, LEATHER JACKETS; CLOTHING GARMENTS, NAMELY, SHIRTS, PANTS, SKIRTS, SHORTS, JACKETS, BLOUSES; CLOTHING FOR WOMEN, NAMELY, LINGERIE, PANTS, SKIRTS, SHORTS AND DRESSES; CLOTHING, NAMELY, HOODS; CLOTHING, NAMELY, BELTS; CLOTHING, NAMELY, GLOVES; SCARVES; NECKTIES, HOSIERY; SOCKS; BEDROOM SLIPPERS; BEACH, SKI OR SPORTS FOOTWEAR; OVERALLS; SHIRTS; SHORT-SLEEVE SHIRTS; TEE-SHIRTS; CLOTHING, NAMELY, COMBINATIONS; UNDERWEAR, NAMELY, SLIPS; SUITS; TROUSERS; CLOTHING, NAMELY, JACKETS; PULLOVERS; VESTS; SWEATERS; DRESSES; SHIRT YOKES; SHIRT FRONTS; PARTS OF CLOTHING IN THE NATURE OF READY-MADE LININGS, NAMELY, FINISHED TEXTILE LININGS FOR GARMENTS; COATS; CLOTHING, NAMELY, STUFF JACKETS; PELERINES; CLOTHING, NAMELY, GABARDINES; RAINCOATS; POCKETS FOR CLOTHING; POCKET SQUARES; CLOTHING, NAMELY, JERSEYS; KNITWEAR CLOTHING, NAMELY, KNIT SWEATERS, KNIT DRESSES, KNIT CAPS, KNIT SHIRTS, KNIT GLOVES, HATS; BODY LINEN, NAMELY, UNDERWEAR; DRESSING GOWNS; PAJAMAS; ROBES, NAMELY, DRESSING GOWNS; HEADWEAR, NAMELY, CAPS; SASHES FOR WEAR; UNDERWEAR (U.S. CLS. 22 AND 39).

MICHAEL TANNER, EXAMINING ATTORNEY

SN 79-144,206. COLLINA ROBERTO, ITALY, FILED 2-11-2014.

# ROBERTO COLLINA

OWNER OF INTERNATIONAL REGISTRATION 0873910 DATED 8-11-2005, EXPIRES 8-11-2015.

THE NAME(S), PORTRAIT(S), AND/OR SIGNATURE(S) SHOWN IN THE MARK IDENTIFIES "ROBERTO COLLINA", WHOSE CONSENT(S) TO REGISTER IS MADE OF RECORD.

THE MARK CONSISTS OF THE WORDS "ROBERTO COLLINA" WRITTEN IN FANCY CAPITAL PRINTED CHARACTERS.

FOR SUITS AND DRESSES, SHIRTS, BLOUSES, T-SHIRTS, TROUSERS, SKIRTS, UNDERPANTS, PANTIES, SOCKS, STOCKINGS, SWEATERS, JACKETS, HEAVY JACKETS, SHOES, HEADWEAR (U.S. CLS. 22 AND 39).

MICHELLE DUBOIS, EXAMINING ATTORNEY

**CLASS 25—(Continued).**

SN 79-144,442. FUJIAN NANAN SHUNCHANG SHOES INDUSTRY LIMITED, CHINA, FILED 9-9-2013.



OWNER OF INTERNATIONAL REGISTRATION 1196618 DATED 9-9-2013, EXPIRES 9-9-2023.

THE NAME(S), PORTRAIT(S), AND/OR SIGNATURE(S) SHOWN IN THE MARK DOES NOT IDENTIFY A PARTICULAR LIVING INDIVIDUAL.

THE MARK CONSISTS OF TWO CHINESE CHARACTERS ON THE UPPER RIGHT AND BELOW WHICH ARE THE ENGLISH LETTERS "ANG CHUAN", TO THE UPPER LEFT IS A DESIGN LIKE LETTER A.

THE NON-LATIN CHARACTERS IN THE MARK TRANSLITERATE TO "ANG CHUAN" AND THIS HAS NO MEANING IN A FOREIGN LANGUAGE.

FOR SHOES; FOOTWEAR UPPERS; BOOT UPPERS; SOLES FOR FOOTWEAR; HEADWEAR FOR WEAR; HOSIERY; FOOTBALL SHOES; WEDDING GOWNS (U.S. CLS. 22 AND 39).

DAVID HOFFMAN, EXAMINING ATTORNEY

SN 79-145,618. MANIFATTURA CORONA S.R.L., ITALY, FILED 10-31-2013.

# VIRGINIA BLU'

THE MARK CONSISTS OF STANDARD CHARACTERS WITHOUT CLAIM TO ANY PARTICULAR FONT, STYLE, SIZE, OR COLOR.

PRIORITY DATE OF 7-22-2013 IS CLAIMED.

OWNER OF INTERNATIONAL REGISTRATION 1199487 DATED 10-31-2013, EXPIRES 10-31-2023.

"VIRGINIA BLU'" DOES NOT IDENTIFY A LIVING INDIVIDUAL.

FOR JACKETS, BEING CLOTHING; HEAVY JACKETS; HEAVY JACKETS WITH REMOVABLE LINING; LIGHT-WEIGHT JACKETS; STUFF JACKETS; WIND-CHEATERS; OVERCOATS; ANORAKS; COATS; RAINCOATS; DOWN FEATHER JACKETS, BEING CLOTHING; VESTS; WAISTCOATS; WAISTCOATS WITH REMOVABLE LINING; TROUSERS; JEANS; JEGGINGS, NAMELY, PANTS THAT ARE PARTIALLY JEANS AND PARTIALLY LEGGINGS; BERMUDA SHORTS; SHORTS; CAPRI PANTS; CAPRI TROUSERS; CLAM DIGGERS; SHIRTS; BLOUSES; T-SHIRTS; POLO SHIRTS; SHORT-SLEEVE SHIRTS; LONG-SLEEVE SHIRTS; LONG-SLEEVE BLOUSES; SHORT-SLEEVE BLOUSES; TOPS, BEING CLOTHING; SKIRTS (U.S. CLS. 22 AND 39).

ZACHARY CROMER, EXAMINING ATTORNEY

**CLASS 25—(Continued).**

SN 85-563,138. BG USA INC., WAXHAW, NC. FILED 3-7-2012.

**MIX & NY**

THE MARK CONSISTS OF STANDARD CHARACTERS WITHOUT CLAIM TO ANY PARTICULAR FONT, STYLE, SIZE, OR COLOR.

FOR BUTTON DOWN SHIRTS; COLLARED SHIRTS; POLO SHIRTS; SHIRTS (U.S. CLS. 22 AND 39).

FIRST USE 1-25-2012; IN COMMERCE 3-5-2012.  
BARBARA RUTLAND, EXAMINING ATTORNEY

---

SN 85-637,176. FENIX OUTDOOR AB, ÖRNSKÖLDSVIK, SWEDEN, FILED 5-29-2012.

**NUUK**

THE MARK CONSISTS OF STANDARD CHARACTERS WITHOUT CLAIM TO ANY PARTICULAR FONT, STYLE, SIZE, OR COLOR.

PRIORITY CLAIMED UNDER SEC. 44(D) ON ERP N CMNTY TM OFC APPLICATION NO. 010837904, FILED 4-25-2012, REG. NO. 010837904, DATED 4-13-2014, EXPIRES 4-25-2022.

FOR CLOTHING, NAMELY, JACKETS, OVERCOATS, PARKAS, ALL THE FOREGOING EXCLUDING CHILDREN'S CLOTHING AND EXCLUDING T-SHIRTS, SHIRTS, POLO-SHIRTS (U.S. CLS. 22 AND 39).

LAURIE KAUFMAN, EXAMINING ATTORNEY

---

SN 85-644,757. THADDEUS APPAREL GROUP, INC., NEW YORK, NY. FILED 6-6-2012.

**TADD**

THE MARK CONSISTS OF STANDARD CHARACTERS WITHOUT CLAIM TO ANY PARTICULAR FONT, STYLE, SIZE, OR COLOR.

FOR CLOTHING AND ACCESSORIES, NAMELY, SHIRTS, SWEATERS, PANTS, SHORTS, JACKETS, OVERCOATS, SUITS, SPORTS COATS, VESTS, SCARVES, TIES, HATS, GLOVES, SOCKS, UNDERWEAR, BATHING SUITS, FOOTWEAR (U.S. CLS. 22 AND 39).

APRIL HESIK, EXAMINING ATTORNEY

**CLASS 25—(Continued).**

SN 85-667,525. VOCAL, INC., LOS ANGELES, CA. FILED 7-2-2012.

**BE VOCAL**

THE MARK CONSISTS OF STANDARD CHARACTERS WITHOUT CLAIM TO ANY PARTICULAR FONT, STYLE, SIZE, OR COLOR.

FOR DRESSES; JACKETS; PANTS; SHIRTS; SKIRTS; SWEAT PANTS; SWEAT SHIRTS; SWEAT SUITS; T-SHIRTS (U.S. CLS. 22 AND 39).

TARAH HARDY, EXAMINING ATTORNEY

---

SN 85-667,527. VOCAL, INC., LOS ANGELES, CA. FILED 7-2-2012.



NO CLAIM IS MADE TO THE EXCLUSIVE RIGHT TO USE "MADE IN U.S.A.", APART FROM THE MARK AS SHOWN.

THE MARK CONSISTS OF A FLEUR-DI-LIS EMBELLISHED CREST CONTAINING A LARGE LETTER "V" ENTWINED WITH VINES. ABOVE THE "V" IS A BANNER WITH THE WORD "VOCAL" INSIDE. BELOW THE "V" IS THE WORDING "MADE IN U.S.A." INSIDE ANOTHER BANNER.

FOR DRESSES; JACKETS; PANTS; SHIRTS; SKIRTS; SWEAT PANTS; SWEAT SHIRTS; SWEAT SUITS; T-SHIRTS (U.S. CLS. 22 AND 39).

FIRST USE 10-31-2008; IN COMMERCE 10-31-2008.

TARAH HARDY, EXAMINING ATTORNEY

**CLASS 25—(Continued).**

SN 85-690,850. HEADCOVERS UNLIMITED, INC., LEAGUE CITY, TX. FILED 7-31-2012.

**HEADCOVERS UNLIMITED**

THE MARK CONSISTS OF STANDARD CHARACTERS WITHOUT CLAIM TO ANY PARTICULAR FONT, STYLE, SIZE, OR COLOR.

NO CLAIM IS MADE TO THE EXCLUSIVE RIGHT TO USE "HEADCOVERS", APART FROM THE MARK AS SHOWN.

FOR HEADWEAR AND SCARVES, EXCLUDING THOSE INTENDED FOR USE IN GOLF (U.S. CLS. 22 AND 39).

FIRST USE 12-31-2002; IN COMMERCE 12-31-2002.  
SUNG IN, EXAMINING ATTORNEY

SN 85-739,178. BANDI WEAR, LLC, CINCINNATI, OH. FILED 9-26-2012.

**BANDI**

THE MARK CONSISTS OF STANDARD CHARACTERS WITHOUT CLAIM TO ANY PARTICULAR FONT, STYLE, SIZE, OR COLOR.

OWNER OF U.S. REG. NO. 4,180,814.

FOR BEACHWEAR; PANTS; SHIRTS; SKIRTS AND DRESSES; WAISTBANDS; WRIST BANDS (U.S. CLS. 22 AND 39).

ELLEN B. AWRICH, EXAMINING ATTORNEY

SN 85-749,438. CYCLING SPORTS GROUP, INC., BETHEL, CT. FILED 10-9-2012.

OWNER OF U.S. REG. NO. 3,984,418.

THE MARK CONSISTS OF THE STYLIZED LETTERS "CSG", WITH A DOT OVER THE "S" DEPICTING A BICYCLIST.

FOR CLOTHING, NAMELY, JACKETS, VESTS, JERSEYS, SHIRTS, T SHIRTS, TANK TOPS, SHORTS, BIB SHORTS, BIB KNICKERS, SOCKS, BOOTIES, LEGWARMERS, KNEE WARMERS, ARM WARMERS, SHOES, GLOVES, BEANIES, CAPS, HEADBANDS, TIGHTS, RAINWEAR, PANTS AND CHAPS, ALL DESIGNED FOR BICYCLING (U.S. CLS. 22 AND 39).

FIRST USE 4-2-2009; IN COMMERCE 4-2-2009.  
TINA MAI, EXAMINING ATTORNEY

**CLASS 25—(Continued).**

SN 85-779,622. 37.37, INC., LOS ANGELES, CA. FILED 11-14-2012.

**LiAM**

THE MARK CONSISTS OF STANDARD CHARACTERS WITHOUT CLAIM TO ANY PARTICULAR FONT, STYLE, SIZE, OR COLOR.

THE NAME(S), PORTRAIT(S), AND/OR SIGNATURE(S) SHOWN IN THE MARK DOES NOT IDENTIFY A PARTICULAR LIVING INDIVIDUAL.

THE WORDING "LIAM" HAS NO MEANING IN A FOREIGN LANGUAGE.

FOR BELTS; BLOUSES; COATS; COVERALLS; DRESSES; HEADWEAR; JACKETS; JUMPERS; LEGGINGS; LOUNGEWEAR; NECKWEAR; OVERALLS; PANTS; SHIRTS; SHORTS; SKIRTS; SLEEPWEAR; SUSPENDERS; SWEAT SHORTS; SWEATERS; SWEATPANTS; SWEATSHIRTS; SWIM WEAR; T-SHIRTS; TOPS; UNDERWEAR; VESTS; WRISTBANDS (U.S. CLS. 22 AND 39).

WENDY JUN, EXAMINING ATTORNEY

SN 85-812,969. TOUGH CHIK, LLC, MISSION VIEJO, CA. FILED 12-31-2012.

THE MARK CONSISTS OF THE WORDING "TOUGH CHIK" IN STYLIZED FONT APPEARING BELOW A FANCIFUL DESIGN OF A CHICK BEING HATCHED FROM AN EGG.

FOR CYCLING JERSEYS, CYCLING SHORTS, TRIATHLON TOPS, TRIATHLON SHORTS, T-SHIRTS, HATS AND VISORS (U.S. CLS. 22 AND 39).

FIRST USE 7-0-2009; IN COMMERCE 7-0-2009.  
RUSS HERMAN, EXAMINING ATTORNEY

**CLASS 25—(Continued).**

SN 85-831,767. AUXIER, ROBERT E., GLENDALE, AZ.  
FILED 1-24-2013.



THE MARK CONSISTS OF A SHIELD CONTAINING SIX 5-POINT UNSHADED STARS AT THE TOP ON A SHADED BACKGROUND, WITH THE SHADED WORD "CHEETAH" BELOW, WITH A STYLIZED DRAWING OF A CHEETAH BELOW THE WORD "CHEETAH" ON A BACKGROUND CONTAINING 6 SHADED VERTICAL BARS, WITH THE UNSHADED WORDING "BTM" BELOW IN ALL CAPS, WITH THE LETTER "T" LARGER THAN THE LETTERS, "B" AND "M", ON A SHADED BACKGROUND.

FOR CLOTHING, NAMELY, JACKETS, HATS, CAPS, SWEATSHIRTS AND T-SHIRTS (U.S. CLS. 22 AND 39).  
ODESSA BIBBINS, EXAMINING ATTORNEY

SN 85-832,983. KODIAK GROUP HOLDINGS CO., CAMBRIDGE, ONTARIO, CANADA, FILED 1-25-2013.



PRIORITY CLAIMED UNDER SEC. 44(D) ON CANADA APPLICATION NO. 1602715, FILED 11-16-2012, REG. NO. TMA876181, DATED 4-22-2014, EXPIRES 4-22-2029.

THE MARK CONSISTS OF THE WORD "JOB RATED" IN STYLIZED LETTERS WITH A THIN LINE ABOVE "JOB RATED". TO THE LEFT OF THE WORD IS A STYLIZED DEPICTION OF A MAN'S FACE, AND THE MAN IS WEARING A HARD HAT.

FOR BOOTS, SHOES, AND WORKWEAR CLOTHING, NAMELY, SHIRTS, PANTS, OVERALLS, COVERALLS, VESTS, BELTS, SOCKS, UNDERWEAR AND GLOVES (U.S. CLS. 22 AND 39).

DANIEL S. STRINGER, EXAMINING ATTORNEY

**CLASS 25—(Continued).**

SN 85-849,516. KANDE KLOTHING, SPOKANE, WA. FILED 2-14-2013.

**KANDE KLOTHING**

THE MARK CONSISTS OF STANDARD CHARACTERS WITHOUT CLAIM TO ANY PARTICULAR FONT, STYLE, SIZE, OR COLOR.

NO CLAIM IS MADE TO THE EXCLUSIVE RIGHT TO USE "CLOTHING", APART FROM THE MARK AS SHOWN.

FOR CLOTHING, NAMELY, TOPS, BOTTOMS, HEADWEAR, FOOTWEAR, SHIRTS, SWIMWEAR; CHILDREN'S AND INFANT'S APPAREL, NAMELY, JUMPERS, OVERALL SLEEPWEAR, PAJAMAS, ROMPERS AND ONE-PIECE GARMENTS (U.S. CLS. 22 AND 39).

KAREN SEVERSON, EXAMINING ATTORNEY

SN 85-854,499. EAST COAST CYCLE SUPPLY, LLC, FARMINGDALE, NY. FILED 2-20-2013.

**SYNC CYCLES**

THE MARK CONSISTS OF STANDARD CHARACTERS WITHOUT CLAIM TO ANY PARTICULAR FONT, STYLE, SIZE, OR COLOR.

OWNER OF U.S. REG. NO. 4,139,977.

NO CLAIM IS MADE TO THE EXCLUSIVE RIGHT TO USE "CYCLES", APART FROM THE MARK AS SHOWN.

FOR JERSEYS; PINNIES IN THE NATURE OF SCRIMMAGE VESTS FOR USE IN SPORTS; SHIRTS; SHORTS; SOCKS; SPORTS JERSEYS (U.S. CLS. 22 AND 39).

FIRST USE 1-15-2010; IN COMMERCE 1-15-2010.

FRANK LATTUCA, EXAMINING ATTORNEY

SN 85-859,918. JAFRUM INTERNATIONAL INC, CHARLOTTE, NC. FILED 2-26-2013.

**DETOUR**

THE MARK CONSISTS OF STANDARD CHARACTERS WITHOUT CLAIM TO ANY PARTICULAR FONT, STYLE, SIZE, OR COLOR.

FOR CLOTHING, NAMELY, JACKETS, T-SHIRTS, CHAPS, PANTS, AND VESTS (U.S. CLS. 22 AND 39).

FIRST USE 8-12-2010; IN COMMERCE 8-12-2010.

KIMBERLY FRYE, EXAMINING ATTORNEY

**CLASS 25—(Continued).**

SN 85-867,906. SPATEK, INC., SAN JUAN, PUERTO RICO, FILED 3-6-2013.

**STRING TONG**

THE MARK CONSISTS OF THE WORDING "STRING TONG" IN CAPITAL LETTERS AND STYLIZED FONT. FOR BEACH FOOTWEAR; BEACH SHOES; FLIP FLOPS; FOOTWEAR FOR WOMEN; FOOTWEAR, NAMELY, RUBBERS; RUBBER SHOES; SANDALS AND BEACH SHOES; THONGS; WOMEN'S SHOES (U.S. CLS. 22 AND 39).

FIRST USE 2-17-2006; IN COMMERCE 3-21-2008.  
INGRID C. EULIN, EXAMINING ATTORNEY

SN 85-870,665. WATCHMAN, MARIAH, NEW TOWN, ND. FILED 3-8-2013.

**N8TV**

THE MARK CONSISTS OF STANDARD CHARACTERS WITHOUT CLAIM TO ANY PARTICULAR FONT, STYLE, SIZE, OR COLOR.

FOR T-SHIRTS (U.S. CLS. 22 AND 39).  
LAURA GOLDEN, EXAMINING ATTORNEY

SN 85-879,511. DUFFY, TOM, PASS CHRISTIAN, MS. FILED 3-19-2013.

**TONGER**

THE MARK CONSISTS OF STANDARD CHARACTERS WITHOUT CLAIM TO ANY PARTICULAR FONT, STYLE, SIZE, OR COLOR.

FOR CLOTHING, NAMELY, SHIRTS, T-SHIRTS, POLO T-SHIRTS, BUTTON DOWN SHIRTS, LONG AND SHORT SLEEVED SHIRTS, SWEATSHIRTS, LEG WARMERS, ARM WARMERS, BLOUSES, HOODED SWEATSHIRTS, SPAGHETTI STRAP SHIRTS, DRESSES, SKIRTS, BATHING SUITS, JACKETS, JERSEYS, COATS, TANK TOPS, TUBE TOPS, VESTS, PANTS, SWEATPANTS, KHAKIS, SHORTS, UNDERWEAR, JEANS, TROUSERS; BIKINIS, SWIMWEAR; HATS, CAPS, BANDANAS, SCARVES; FOOTWEAR; BELTS, TIES, GLOVES, SOCKS; MONEY BELTS (U.S. CLS. 22 AND 39).

KAREN K. BUSH, EXAMINING ATTORNEY

**CLASS 25—(Continued).**

SN 85-891,691. JAVA MUSIC CLUB, INC., SURREY, CANADA, FILED 4-1-2013.

**JAVA MUSIC CLUB**

THE MARK CONSISTS OF STANDARD CHARACTERS WITHOUT CLAIM TO ANY PARTICULAR FONT, STYLE, SIZE, OR COLOR.

NO CLAIM IS MADE TO THE EXCLUSIVE RIGHT TO USE "MUSIC CLUB", APART FROM THE MARK AS SHOWN.

FOR CLOTHING FOR MEN AND WOMEN, NAMELY, T-SHIRTS, HEAD WEAR, SCARVES, SOCKS, JACKETS, AND SWEATERS (U.S. CLS. 22 AND 39).

SIMON TENG, EXAMINING ATTORNEY

SN 85-903,633. WESTLIFE DISTRIBUTION USA, LLC, LOS ANGELES, CA. FILED 4-14-2013.

**PARKLAN**

THE MARK CONSISTS OF STANDARD CHARACTERS WITHOUT CLAIM TO ANY PARTICULAR FONT, STYLE, SIZE, OR COLOR.

FOR AFTER SKI BOOTS; ATHLETIC APPAREL, NAMELY, SHIRTS, PANTS, JACKETS, FOOTWEAR, HATS AND CAPS, ATHLETIC UNIFORMS; ATHLETIC FOOTWEAR; CAMOUFLAGE JACKETS; CHILDREN'S AND INFANT'S APPAREL, NAMELY, JUMPERS, OVERALL SLEEPWEAR, PAJAMAS, ROMPERS AND ONE-PIECE GARMENTS; DENIM JACKETS; DOWN JACKETS; FOOTWEAR; FOOTWEAR FOR MEN AND WOMEN; GLOVES FOR APPAREL; HEAD WEAR; HEAVY JACKETS; HUNTING JACKETS; JEANS; LEATHER JACKETS; MEN'S AND WOMEN'S JACKETS, COATS, TROUSERS, VESTS; OUTER JACKETS; RAIN JACKETS; RAIN WEAR; RAINPROOF JACKETS; REVERSIBLE JACKETS; SHELL JACKETS; SHOE COVERS FOR USE WHEN WEARING SHOES; SKI AND SNOWBOARD SHOES AND PARTS THEREOF; SKI BOOT CASES; SKI BOOTS; SKI GLOVES; SKI JACKETS; SKI PANTS; SKI SUITS; SKI SUITS FOR COMPETITION; SKI TROUSERS; SPORTS JACKETS; SUEDE JACKETS; SWEAT JACKETS; SWIM WEAR FOR GENTLEMEN AND LADIES; T-SHIRTS; WATERPROOF JACKETS AND PANTS; WET SUITS FOR WATER-SKIING AND SUB-AQUA; WET-SUITS FOR WATER-SKIING; WIND RESISTANT JACKETS; WIND-JACKETS (U.S. CLS. 22 AND 39).

FIRST USE 3-15-2012; IN COMMERCE 3-15-2012.

ALAIN LAPTER, EXAMINING ATTORNEY



**CLASS 25—(Continued).**

SN 85-905,295. VIACOM INTERNATIONAL INC., NEW YORK, NY. FILED 4-16-2013.

**GTL**

THE MARK CONSISTS OF STANDARD CHARACTERS WITHOUT CLAIM TO ANY PARTICULAR FONT, STYLE, SIZE, OR COLOR.

FOR SHIRTS; T-SHIRTS; SWEATSHIRTS; HATS; CAPS; BOXERS; OUTERWEAR, NAMELY, JACKETS, COATS, HOODED SWEATSHIRTS AND SWEATERS (U.S. CLS. 22 AND 39).

FIRST USE 12-31-2009; IN COMMERCE 12-31-2009.  
MARGARET POWER, EXAMINING ATTORNEY

**CLASS 25—(Continued).**

SN 85-915,658. AGELESS OPTIONS INC., COOPER CITY, FL. FILED 4-26-2013.

**SYLA**

THE MARK CONSISTS OF STANDARD CHARACTERS WITHOUT CLAIM TO ANY PARTICULAR FONT, STYLE, SIZE, OR COLOR.

FOR HEADBAND THAT IS WORN AT NIGHT TO REDUCE WRINKLES (U.S. CLS. 22 AND 39).  
INGRID C. EULIN, EXAMINING ATTORNEY

SN 85-908,166. RAE LEAIRE, LLC, ASHLAND, VA. FILED 4-18-2013.

**RAE LEAIRE**

THE MARK CONSISTS OF STANDARD CHARACTERS WITHOUT CLAIM TO ANY PARTICULAR FONT, STYLE, SIZE, OR COLOR.

THE NAME(S), PORTRAIT(S), AND/OR SIGNATURE(S) SHOWN IN THE MARK DOES NOT IDENTIFY A PARTICULAR LIVING INDIVIDUAL.

FOR CLOTHING AND APPAREL, NAMELY, DRESSES, SKIRTS, TOPS, PANTS, T-SHIRTS, VESTS, TIES AND FORMAL WEAR IN THE NATURE OF GOWNS AND SHOES (U.S. CLS. 22 AND 39).

KATHERINE CHANG, EXAMINING ATTORNEY

SN 85-940,335. CHANG, WEILING, ASTORIA, NY. FILED 5-23-2013.

**WEILING CHANG**

SN 85-913,985. ARTICOUTURE INC., CITY OF INDUSTRY, CA. FILED 4-24-2013.

**ARTI COUTURE**

THE MARK CONSISTS OF STANDARD CHARACTERS WITHOUT CLAIM TO ANY PARTICULAR FONT, STYLE, SIZE, OR COLOR.

NO CLAIM IS MADE TO THE EXCLUSIVE RIGHT TO USE "COUTURE", APART FROM THE MARK AS SHOWN. THE WORDING "ARTI" HAS NO MEANING IN A FOREIGN LANGUAGE.

FOR CLOTHING, NAMELY, DRESSES, SWEATERS, COATS, BLAZERS, VESTS, SKIRTS, SWEATSHIRTS, SHORTS, SHIRTS, JEANS, JACKETS, PANTS, LEGGINGS, JUMPSUITS, ROMPERS, ACTIVEWEAR IN THE NATURE OF HOODED SWEATSHIRTS AND SWEATPANTS, PAJAMAS, LOUNGEWEAR, LINGERIE, SWIMWEAR, TANKS (U.S. CLS. 22 AND 39).

FIRST USE 4-30-2011; IN COMMERCE 4-30-2011.  
NELSON SNYDER, EXAMINING ATTORNEY

THE MARK CONSISTS OF STANDARD CHARACTERS WITHOUT CLAIM TO ANY PARTICULAR FONT, STYLE, SIZE, OR COLOR.

THE NAME(S), PORTRAIT(S), AND/OR SIGNATURE(S) SHOWN IN THE MARK IDENTIFIES "WEILING CHANG", WHOSE CONSENT(S) TO REGISTER IS MADE OF RECORD.

FOR CLOTHING FOR WOMEN, NAMELY, SHIRTS, T-SHIRTS, SWEATSHIRTS, LEG WARMERS, ARM WARMERS, BLOUSES, HOODED SWEATSHIRTS, SPAGHETTI STRAP SHIRTS, DRESSES, SKIRTS, BATHING SUITS, JACKETS, COATS, TANK TOPS, TUBE TOPS, PANTS, SWEATPANTS, SHORTS, JEANS, TROUSERS; SWIMWEAR; UNDERGARMENTS; LINGERIE; HEADWEAR; FOOTWEAR; BELTS, TIES, GLOVES, SOCKS (U.S. CLS. 22 AND 39).

WENDY JUN, EXAMINING ATTORNEY

**CLASS 25—(Continued).**

SN 85-944,512. FERNANDEZ, RONALDO, DBA BORN2XL, WHITTIER, CA. AND FERNANDEZ, FRANCES, DBA BORN2XL, WHITTIER, CA. FILED 5-29-2013.



NO CLAIM IS MADE TO THE EXCLUSIVE RIGHT TO USE "JEREMIAH 29:11", APART FROM THE MARK AS SHOWN.

THE COLOR(S) BLACK, WHITE, AND RED IS/ARE CLAIMED AS A FEATURE OF THE MARK.

THE MARK CONSISTS OF A STYLIZED WHITE 2 OUTLINED IN BLACK ABOVE "JEREMIAH 29:11" IN NON-STYLIZED WHITE LETTERS AND NUMBERS, INSIDE A RED RHOMBOID, WITH THE WORD "BORN" IN BLACK STYLIZED LETTERS OVERLAPPING THE RHOMBOID ON THE LEFT SIDE AND "XL" IN BLACK STYLIZED LETTERS OVERLAPPING THE RHOMBOID ON THE RIGHT SIDE.

FOR BASEBALL CAPS AND HATS; TEE SHIRTS (U.S. CLS. 22 AND 39).

FIRST USE 9-2-2006; IN COMMERCE 4-27-2013.  
LUCY ARANT, EXAMINING ATTORNEY

SN 85-947,262. ALPARGATAS S.A., SAO PAULO, SP, BRAZIL, FILED 5-31-2013.

**HAVAIANAS FLAT**

THE MARK CONSISTS OF STANDARD CHARACTERS WITHOUT CLAIM TO ANY PARTICULAR FONT, STYLE, SIZE, OR COLOR.

PRIORITY CLAIMED UNDER SEC. 44(D) ON ERPN CMNTY TM OFC APPLICATION NO. 011750486, FILED 4-18-2013, REG. NO. 011750486, DATED 8-29-2013, EXPIRES 4-18-2023.

OWNER OF U.S. REG. NOS. 4,065,527, 4,326,238 AND OTHERS.

THE ENGLISH TRANSLATION OF "HAVAIANAS" IN THE MARK IS PORTUGUESE FOR "HAWAIIAN".

SEC. 2(F) AS TO "HAVAIANAS".

FOR CLOTHING, NAMELY, SHORTS, JACKETS, BERMUDA SHORTS, KNICKERS, T-SHIRTS, JOGGING SHORTS, DRESSES, SWEAT PANTS, SWEAT SHIRTS, STOCKINGS, CAPS, SOCKS, UNDERPANTS, UNIFORMS, POLO SHIRTS, SOCIAL SHIRTS, SOCIAL PANTS, SPORTS PANTS, BIKINIS, BODY LINEN, BODY SHAPERS, BODY STOCKINGS, BODY SUITS, LONG SKIRTS, SHORT SKIRTS, SUN VISORS, HATS, OVERCOATS, COATS, SUITS, BLAZERS, PARKAS, GLOVES; HEADWEAR; FOOTWEAR, EXCLUDING SHOES WITH HEELS (U.S. CLS. 22 AND 39).

BILL DAWE, EXAMINING ATTORNEY

**CLASS 25—(Continued).**

SN 85-957,178. MARTINIANO LOPEZ CROZET, LOS ANGELES, CA. FILED 6-11-2013.

**Martiniano**

THE MARK CONSISTS OF STANDARD CHARACTERS WITHOUT CLAIM TO ANY PARTICULAR FONT, STYLE, SIZE, OR COLOR.

FOR LEATHER SHOES (U.S. CLS. 22 AND 39).  
FIRST USE 9-30-2012; IN COMMERCE 9-30-2012.  
COLLEEN MULCRONE, EXAMINING ATTORNEY

SN 85-958,398. LAYNE, ADRIAN FRAZIER, DBA CUDDLESTAR, AUSTIN, TX. FILED 6-12-2013.

**Cuddlestar**

THE MARK CONSISTS OF STANDARD CHARACTERS WITHOUT CLAIM TO ANY PARTICULAR FONT, STYLE, SIZE, OR COLOR.

FOR CHILDREN'S AND INFANT'S APPAREL, NAMELY, JUMPERS, OVERALL SLEEPWEAR, PAJAMAS, ROMPERS AND ONE-PIECE GARMENTS (U.S. CLS. 22 AND 39).

FIRST USE 1-1-2010; IN COMMERCE 1-1-2010.  
TEJBIR SINGH, EXAMINING ATTORNEY

SN 85-961,641. PODIUMWEAR CUSTOM SPORTS APPAREL COMPANY, SAINT PAUL, MN. FILED 6-17-2013.

**PODIUMWEAR**

THE MARK CONSISTS OF STANDARD CHARACTERS WITHOUT CLAIM TO ANY PARTICULAR FONT, STYLE, SIZE, OR COLOR.

OWNER OF U.S. REG. NO. 3,954,764.

FOR CLOTHING, NAMELY, SPORTS JERSEYS, SPORTS JACKETS, SPORTS VESTS, SPORTS PANTS, SPORTS SHIRTS, SKI SUITS, SKI BIBS, SKI JACKETS, SKI VESTS, SKI PANTS, SKI WEAR, HATS, HEADBANDS, NECK TUBES, CYCLING JERSEYS, CYCLING SHORTS, CYCLING BIB SHORTS, CYCLING JACKETS, CYCLING VESTS, CYCLING SKINSUITS, ARM WARMERS, KNEE WARMERS, LEG WARMERS, RUNNING SINGLET, RUNNING TOPS, RUNNING TANK TOPS; ATHLETIC APPAREL, NAMELY, ATHLETIC SHIRTS, ATHLETIC TOPS, ATHLETIC SHORTS, ATHLETIC PANTS, ATHLETIC JACKETS, ATHLETIC UNIFORMS (U.S. CLS. 22 AND 39).

FIRST USE 12-1-2004; IN COMMERCE 12-1-2004.  
WENDY JUN, EXAMINING ATTORNEY

**CLASS 25—(Continued).**

SN 85-970,091. THE BAZAAR INTERNATIONAL GROUP, SHERMAN OAKS, CA. FILED 6-26-2013.



THE MARK CONSISTS OF THE STYLIZED TEXT "STONERS GLASS" WITH A DESIGN OF A MARIJUANA LEAF IN THE MIDDLE OF THE TWO WORDS WITH AN UNDERLINE.

FOR T-SHIRTS (U.S. CLS. 22 AND 39).  
FIRST USE 4-20-1999; IN COMMERCE 4-20-1999.  
KATHERINE E. HALMEN, EXAMINING ATTORNEY

SN 85-973,445. HOTTEES COUTURE INC, FORMERLY HOTTEES COUTURE LLC, CASTLE PINES, CO. FILED 6-28-2013.

## Hottees Couture

THE MARK CONSISTS OF STANDARD CHARACTERS WITHOUT CLAIM TO ANY PARTICULAR FONT, STYLE, SIZE, OR COLOR.

NO CLAIM IS MADE TO THE EXCLUSIVE RIGHT TO USE "COUTURE", APART FROM THE MARK AS SHOWN. FOR WOMEN'S APPAREL, NAMELY, JEANS, SHIRTS, DRESSES, BELTS AND SHOES (U.S. CLS. 22 AND 39).

FIRST USE 9-2-2009; IN COMMERCE 11-10-2010.  
JORDAN BAKER, EXAMINING ATTORNEY

SN 86-012,561. CUSTOM WHEEL HOUSE, LLC, RANCHO DOMINGUEZ, CA. FILED 7-17-2013.

## METHOD RACING

THE MARK CONSISTS OF STANDARD CHARACTERS WITHOUT CLAIM TO ANY PARTICULAR FONT, STYLE, SIZE, OR COLOR.

OWNER OF U.S. REG. NOS. 3,880,986, 3,962,454 AND 3,962,455.

NO CLAIM IS MADE TO THE EXCLUSIVE RIGHT TO USE "RACING", APART FROM THE MARK AS SHOWN.

FOR CLOTHING, NAMELY, TOPS, BOTTOMS, SLEEPWEAR, SWIMWEAR, BEACHWEAR, SOCKS, WRISTBANDS, SCARVES, GLOVES, AND UNDERGARMENTS; FOOTWEAR; AND HEADWEAR (U.S. CLS. 22 AND 39).

JONATHAN FALK, EXAMINING ATTORNEY

**CLASS 25—(Continued).**

SN 86-037,199. DART, HUTTON, COLCHESTER, VT. FILED 8-14-2013.

## Graveyard Girls

THE MARK CONSISTS OF STANDARD CHARACTERS WITHOUT CLAIM TO ANY PARTICULAR FONT, STYLE, SIZE, OR COLOR.

FOR BATHING SUITS; T-SHIRTS; TANK TOPS; UNDERWEAR (U.S. CLS. 22 AND 39).

MICHAEL KEATING, EXAMINING ATTORNEY

SN 86-041,873. WOLF, BRANDON, YOUNGSTOWN, OH. FILED 8-19-2013.

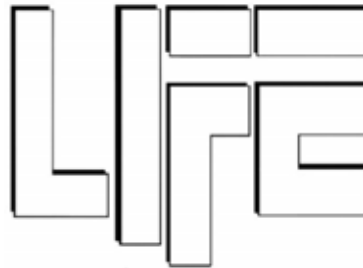

THE MARK CONSISTS OF THE TERM "LIFE" IN STYLIZED LETTERS. TO BE EVEN MORE SPECIFIC, THE "F" AND THE "E" ARE DESIGNED IN A WAY IN WHICH THEY ARE NOT CONTINUOUS BUT RATHER BROKEN UP INTO 2 PARTS. THERE IS A SHADOW TYPE EFFECT BEHIND EACH OF THE LETTERS AND EACH LETTER HAS WHAT CAN BE DESCRIBED AS A BUBBLE EFFECT.

FOR T-SHIRTS, PANTS, SHORTS, LONG-SLEEVE T-SHIRTS, LONG SLEEVE SHIRTS, TANK-TOPS, SWEATSHIRTS, POLO SHIRTS, WRISTBANDS, MITTENS, HATS, SANDALS, SHOES, SINGLETs, SKIRTS, BOOTS, SOCKS, SPORTS SHOES, SPORTS JERSEYS, BATHING SUITS, SWEATERS, UNDERGARMENTS, UNDERWEAR, COATS, EAR MUFFS, GLOVES, HEADBANDS, JACKETS, LEGGINGS (U.S. CLS. 22 AND 39).

FIRST USE 3-23-2013; IN COMMERCE 3-23-2013.

JOHN DWYER, EXAMINING ATTORNEY

**CLASS 25—(Continued).**

SN 86-044,973. PATA, JANA, DBA VON GHOUL, CARSON CITY, NV. FILED 8-22-2013.

# VON GHOUL

THE MARK CONSISTS OF STANDARD CHARACTERS WITHOUT CLAIM TO ANY PARTICULAR FONT, STYLE, SIZE, OR COLOR.

THE NAME(S), PORTRAIT(S), AND/OR SIGNATURE(S) SHOWN IN THE MARK DOES NOT IDENTIFY A PARTICULAR LIVING INDIVIDUAL.

FOR WEARABLE GARMENTS AND CLOTHING, NAMELY, SHIRTS (U.S. CLS. 22 AND 39).

FIRST USE 5-13-2011; IN COMMERCE 5-13-2011.

BERNICE MIDDLETON, EXAMINING ATTORNEY

---

SN 86-046,132. KNIPP, LISA, FREDERICK, CO. FILED 8-23-2013.



THE MARK CONSISTS OF AN ANGULAR SPIRAL DESIGN TOGETHER WITH THE WORDS "PLAY PURE".

FOR ATHLETIC APPAREL, NAMELY, SHIRTS, PANTS, JACKETS, FOOTWEAR, HATS AND CAPS, ATHLETIC UNIFORMS, SWEAT BANDS, GLOVES, VISORS, SWIMSUITS (U.S. CLS. 22 AND 39).

FIRST USE 10-5-2011; IN COMMERCE 10-5-2011.

FONG HSU, EXAMINING ATTORNEY

---

SN 86-047,124. CILANO, JOSHUA, WEST NEW YORK, NJ. FILED 8-24-2013.

# TOOSHIE COUTURE

THE MARK CONSISTS OF STANDARD CHARACTERS WITHOUT CLAIM TO ANY PARTICULAR FONT, STYLE, SIZE, OR COLOR.

NO CLAIM IS MADE TO THE EXCLUSIVE RIGHT TO USE "COUTURE", APART FROM THE MARK AS SHOWN.

FOR CLOTHING, NAMELY, T-SHIRTS, SHIRTS, TOPS, SWEATSHIRTS, SWEATPANTS, BOTTOMS, JEANS, PANTS, JACKETS, SWEATERS, JERSEYS, COATS, SWIMWEAR; UNDERCLOTHING; APRONS; MONEY BELTS; BELTS; BRACES FOR CLOTHING; SUSPENDERS, COLLARS; COMBINATIONS (CLOTHING); CORSETS (UNDERCLOTHING); DRAWERS (CLOTHING); GLOVES; LAYETTES (CLOTHING); MUFFS; POCKETS FOR CLOTHING; UNDERCLOTHING; ANTI-SWEAT UNDERCLOTHING; VEILS; WRISTBANDS; HEADWEAR; FOOTWEAR (U.S. CLS. 22 AND 39).

SKYE YOUNG, EXAMINING ATTORNEY

**CLASS 25—(Continued).**

SN 86-048,145. JESUS SALAS, LOS ANGELES, CA. FILED 8-26-2013.

# GOLDEN BROWN

THE MARK CONSISTS OF STANDARD CHARACTERS WITHOUT CLAIM TO ANY PARTICULAR FONT, STYLE, SIZE, OR COLOR.

FOR CLOTHING, NAMELY, T-SHIRTS, SHORTS, PANTS, SWEATSHIRTS, SWEAT PANTS, BANDANAS, SCARVES, APRONS, JACKETS, TANK TOPS, VESTS, NECKWEAR, SPORTS JERSEYS, SWEATERS, SHIRTS, WIND RESISTANT JACKETS, TRACK PANTS, PONCHOS, AND HOODED SHIRTS; HEADWEAR; FOOTWEAR; BELTS (U.S. CLS. 22 AND 39).

DAWN HAN, EXAMINING ATTORNEY

---

SN 86-049,390. CHRISTIAN MARTINEZ, DBA US-VS-US, SANTA ANA, CA. FILED 8-27-2013.

# VXSUS

THE MARK CONSISTS OF STANDARD CHARACTERS WITHOUT CLAIM TO ANY PARTICULAR FONT, STYLE, SIZE, OR COLOR.

FOR CLOTHING AND SPORTS CLOTHING APPAREL, NAMELY, SHIRTS, T-SHIRTS, SWEATSHIRTS, SWEATPANTS, SWIM WEAR, SHORTS, PANTS, JACKETS, UNDERWEAR AND HATS; CLOTHING, NAMELY, BASE LAYERS; COMPRESSION GARMENTS FOR ATHLETIC OR OTHER NON-MEDICAL USE, NAMELY, COMPRESSION SHORTS, SLEEVES, ARMS, SOCKS, LEGGINGS, JERSEYS; FOOTWEAR; GYM PANTS; GYM SHORTS; GYM SUITS; HEADWEAR; SPORTS BRAS; TOPS; BOTTOMS; WRISTBANDS, HEADBANDS, RAIN SUITS, SKIRTS, ATHLETIC SLEEVES, HOODS, SKULL WRAPS, SKULL CAPS, VESTS, TANK TOPS, BRAS AND GIRDLES (U.S. CLS. 22 AND 39).

ASMAT KHAN, EXAMINING ATTORNEY

**CLASS 25—(Continued).**

SN 86-056,296. RADDISSHME DESIGN HOUSE LIMITED, SHEUNG WAN, HONG KONG, FILED 9-5-2013.



THE MARK CONSISTS OF A POPPY LOGO OVER THE WORD "RADDISSHME" WITH FIVE VERTICAL LINES ABOVE THE END OF THE TAIL IN THE POPPY LOGO.

FOR CLOTHING, NAMELY, SHIRTS, PANTS, SOCKS, JACKETS, SHORTS, COATS, GLOVES, SPORTS JERSEYS, SWEATERS, TEE-SHIRTS, UNDERWEAR, NECKTIES, SCARFS, SUITS, SKIRTS AND DRESSES; FOOTWEAR; HEADWEAR; SHOES; WAIST BELTS (U.S. CLS. 22 AND 39).

CURTIS FRENCH, EXAMINING ATTORNEY

**CLASS 25—(Continued).**

SN 86-060,143. OKABASHI BRANDS, INC., BUFORD, GA. FILED 9-10-2013.

## RED DOG SHOES

THE MARK CONSISTS OF STANDARD CHARACTERS WITHOUT CLAIM TO ANY PARTICULAR FONT, STYLE, SIZE, OR COLOR.

NO CLAIM IS MADE TO THE EXCLUSIVE RIGHT TO USE "SHOES", APART FROM THE MARK AS SHOWN.

FOR FOOTWEAR; SANDALS; SHOES (U.S. CLS. 22 AND 39).

TINA L. SNAPP, EXAMINING ATTORNEY

SN 86-056,454. TANG, WYNNE MICHELLE, KOWLOON, HONG KONG, FILED 9-5-2013.



THE MARK CONSISTS OF TEXT THAT READS "TANI" UNDERNEATH A SQUARE SHAPE WITH TWO CURVED, SYMMETRICAL LINES RUNNING FROM THE SIDES TO THE BOTTOM OF THE SQUARE.

THE ENGLISH TRANSLATION OF "TANI" IN THE MARK IS "VALLEY".

FOR LOUNGEWEAR; SLEEPWEAR; SOCKS; SWIMWEAR; UNDERGARMENTS (U.S. CLS. 22 AND 39).

KAPIL BHANOT, EXAMINING ATTORNEY

SN 86-060,493. FLOP STUDIOS, INC., GREENWOOD VILLAGE, CO. FILED 9-10-2013.

## Pocket Parade

THE MARK CONSISTS OF STANDARD CHARACTERS WITHOUT CLAIM TO ANY PARTICULAR FONT, STYLE, SIZE, OR COLOR.

NO CLAIM IS MADE TO THE EXCLUSIVE RIGHT TO USE "POCKET", APART FROM THE MARK AS SHOWN.

FOR CLOTHING, NAMELY, SHIRTS, T-SHIRTS, PANTS, DRESSES, TOPS, BOTTOMS, AND JACKETS; FOOTWEAR; HEADGEAR, NAMELY, HATS AND CAPS (U.S. CLS. 22 AND 39).

ROBIN MITTLER, EXAMINING ATTORNEY

SN 86-059,955. STARA USA LLC, MOORESTOWN, NJ. FILED 9-10-2013.

## HAVEN

THE MARK CONSISTS OF STANDARD CHARACTERS WITHOUT CLAIM TO ANY PARTICULAR FONT, STYLE, SIZE, OR COLOR.

FOR CLOTHING, NAMELY, MATERNITY BANDS; MATERNITY CLOTHING, NAMELY, SHIRTS, PANTS, SHORTS, SWEATERS, JACKETS, SKIRTS, DRESSES AND SWIMWEAR; MATERNITY LINGERIE; MATERNITY SLEEPWEAR (U.S. CLS. 22 AND 39).

FIRST USE 4-0-2011; IN COMMERCE 4-0-2011.

STEPHANIE ALI, EXAMINING ATTORNEY

SN 86-061,351. TWO GIRLS AND A WINE GUY, LLC, NAPA, CA. FILED 9-11-2013.

## JUST ONE OF THE GIRLS

THE MARK CONSISTS OF STANDARD CHARACTERS WITHOUT CLAIM TO ANY PARTICULAR FONT, STYLE, SIZE, OR COLOR.

FOR APRONS; HATS; SHIRTS (U.S. CLS. 22 AND 39).

JAY FLOWERS, EXAMINING ATTORNEY

**CLASS 25—(Continued).**

SN 86-061,841. MARY O'CONNOR, DBA BLACK IRISH BOXING, ELMIRA, NY. FILED 9-11-2013.



THE MARK CONSISTS OF THE CAPITAL LETTERS "BIB" IMPOSED ON AN OVAL WITH A CONTRASTING RIM. THE FIRST "B" IS BACKWARDS. THERE IS A SHAMROCK WITH PAIR OF BOXING GLOVES HANGING FROM THE STEM SUPERIMPOSED ON THE "I". THE GREY RECTANGULAR BACKGROUND WHICH SURROUNDS THE OVAL DESIGN IS NOT PART OF MARK.

FOR SHIRTS; SHORTS; HATS; SWIM TRUNKS; SWEATSHIRTS; SWEATPANTS; UNDERWEAR; SOCKS; FOOTWEAR; SLEEPWEAR; COATS AND JACKETS; HEADBANDS; ATHLETIC APPAREL, NAMELY, SHIRTS, PANTS, JACKETS, FOOTWEAR, HATS AND CAPS, AND ATHLETIC UNIFORMS; CHILDREN'S AND INFANT'S APPAREL, NAMELY, JUMPERS, OVERALLS, SLEEPWEAR, PAJAMAS, ROMPERS AND ONE-PIECE GARMENTS (U.S. CLS. 22 AND 39).

BILL DAWE, EXAMINING ATTORNEY

SN 86-062,448. DRAKE WORTH DESIGN, LLC, DES MOINES, IA. FILED 9-12-2013.

## Calvalier Boot Warmers

THE MARK CONSISTS OF STANDARD CHARACTERS WITHOUT CLAIM TO ANY PARTICULAR FONT, STYLE, SIZE, OR COLOR.

NO CLAIM IS MADE TO THE EXCLUSIVE RIGHT TO USE "BOOT WARMERS", APART FROM THE MARK AS SHOWN.

FOR LEGGINGS THAT FIT OVER BOOTS, EXCLUDING APPAREL FOR EQUESTRIAN USE (U.S. CLS. 22 AND 39).

FIRST USE 9-1-2013; IN COMMERCE 9-1-2013.  
LINDA LAVACHE, EXAMINING ATTORNEY

**CLASS 25—(Continued).**

SN 86-063,723. JGALT USA SAGL, 6900 LUGANO, SWITZERLAND, FILED 9-13-2013.

## THE ONE IN NY

THE MARK CONSISTS OF STANDARD CHARACTERS WITHOUT CLAIM TO ANY PARTICULAR FONT, STYLE, SIZE, OR COLOR.

NO CLAIM IS MADE TO THE EXCLUSIVE RIGHT TO USE "NY", APART FROM THE MARK AS SHOWN.

FOR CLOTHING, NAMELY, PANTS, SHIRTS, UNDERGARMENTS, SKIRTS AND DRESSES; FOOTWEAR, HEADWEAR; LEATHER AND IMITATION LEATHER BELTS (U.S. CLS. 22 AND 39).

ESTHER BELENKER, EXAMINING ATTORNEY

SN 86-065,573. MARTINEZ, ROGELIO, GOMEZ PALACIO DURANGO, MEXICO, FILED 9-16-2013.

## WEST END

THE MARK CONSISTS OF STANDARD CHARACTERS WITHOUT CLAIM TO ANY PARTICULAR FONT, STYLE, SIZE, OR COLOR.

FOR TOPS, BOTTOMS, JEANS, PANTS, LEGGINGS, JEGGINGS, CAPRI PANTS, CAPRI JEANS, CROP PANTS, CROP JEANS, SKORTS, GAUCHOS, SHORTS, OVERALLS, JUMPSUITS, SKIRTS, JACKETS, SHIRTS, T-SHIRTS, BLOUSES, PULLOVERS, TANK TOPS, CARDIGANS, DRESSES, VESTS, SWEATERS, SWEATSHIRTS, SWEATPANTS, COATS, BELTS, SOCKS, GLOVES, ROBES, NECKTIES, HOSIERY, LINGERIE, SLEEPWEAR, LOUNGEWEAR, SWIMWEAR, FOOTWEAR, NAMELY, SHOES, BOOTS, SANDALS, AND SLIPPERS, AND HEADGEAR, NAMELY, SCARVES, EARMUFFS, HATS, AND CAPS, FOR MEN, WOMEN, AND CHILDREN (U.S. CLS. 22 AND 39).

FIRST USE 5-27-2013; IN COMMERCE 5-27-2013.  
HENRY S. ZAK, EXAMINING ATTORNEY

SN 86-065,819. WE ARE DAT, LLC, NEW ORLEANS, LA. FILED 9-16-2013.

## WD4L

THE MARK CONSISTS OF STANDARD CHARACTERS WITHOUT CLAIM TO ANY PARTICULAR FONT, STYLE, SIZE, OR COLOR.

FOR SHIRTS (U.S. CLS. 22 AND 39).

KEVIN CORWIN, EXAMINING ATTORNEY

**CLASS 25—(Continued).**

SN 86-066,170. FARNHAM, JANNA, CORONA, CA. FILED 9-16-2013.

**The Circle of Villains**

THE MARK CONSISTS OF STANDARD CHARACTERS WITHOUT CLAIM TO ANY PARTICULAR FONT, STYLE, SIZE, OR COLOR.

FOR APPAREL, NAMELY, RAINWEAR, T-SHIRTS, SWEAT SHIRTS, JERSEYS, SHORTS, SWEAT PANTS, JACKETS, HATS, CAPS, SCARVES, GLOVES, HOSIERY, NECKTIES, PAJAMAS, ROBES, NIGHT SHIRTS, NIGHT GOWNS, UNDERWEAR, HEAD BANDS, WRIST BANDS, SWIM SUITS, SKIRTS, SHIRTS, TANK TOPS, PANTS, COATS, SWEATERS, LEOTARDS, LEG WARMERS, STOCKINGS, SOCKS, HOSIERY, TIGHTS, BELTS; FOOTWEAR, NAMELY, SHOES; AND HEADWEAR, NAMELY, HATS AND CAP (U.S. CLS. 22 AND 39).

FIRST USE 7-1-2013; IN COMMERCE 8-20-2013.  
INGA ERVIN, EXAMINING ATTORNEY

**CLASS 25—(Continued).**

SN 86-067,262. NEW LINE PRODUCTIONS, INC., BURBANK, CA. FILED 9-17-2013.



THE COLOR(S) GREEN, YELLOW, TAN, BROWN, BLACK AND WHITE IS/ARE CLAIMED AS A FEATURE OF THE MARK.

THE MARK CONSISTS OF THE STYLIZED GREEN AND YELLOW LETTERS "E" AND "F" OUTLINED IN BLACK, SEPARATED BY A MAN WEARING BLACK SHOES AND BELT, YELLOW LEGGINGS AND A GREEN AND YELLOW JACKET OUTLINED IN BLACK WITH A WHITE COLLAR AND CUFFS, TAN FACE AND BROWN HAIR OUTLINED IN BLACK AND A YELLOW AND BLACK HAT.

FOR HALLOWEEN COSTUMES (U.S. CLS. 22 AND 39).  
FIRST USE 9-1-2005; IN COMMERCE 9-1-2005.  
PAUL MORENO, EXAMINING ATTORNEY

SN 86-069,868. EMPOWERMENT, INC., CHARLOTTE, NC. FILED 9-19-2013.

**empowHERment**

THE MARK CONSISTS OF STANDARD CHARACTERS WITHOUT CLAIM TO ANY PARTICULAR FONT, STYLE, SIZE, OR COLOR.

FOR T-SHIRTS (U.S. CLS. 22 AND 39).  
FIRST USE 6-1-2011; IN COMMERCE 6-1-2011.  
SUZANNE BLANE, EXAMINING ATTORNEY

SN 86-066,182. ARITZIA LP, VANCOUVER, BC, CANADA, FILED 9-16-2013.

**LA NOTTE**

THE MARK CONSISTS OF STANDARD CHARACTERS WITHOUT CLAIM TO ANY PARTICULAR FONT, STYLE, SIZE, OR COLOR.

THE ENGLISH TRANSLATION OF "LA NOTTE" IN THE MARK IS "THE NIGHT".

FOR SHIRTS AND TOPS, T-SHIRTS, SWEATERS, SWEATSHIRTS, JACKETS, BOTTOMS, HEADWEAR, SCARVES (U.S. CLS. 22 AND 39).

FIRST USE 1-0-2013; IN COMMERCE 1-0-2013.  
KELLY TRUSILO, EXAMINING ATTORNEY

SN 86-071,596. LINDSEY NICOLE HAGER, MOUNTVILLE, PA. AND KIMBERLY LINN HAGER, MOUNTVILLE, PA. FILED 9-23-2013.

**faith your fears**

THE MARK CONSISTS OF THE WORDS "FAITH YOUR FEARS" IN A STYLIZED FONT WITH A STYLIZED CROSS POSITIONED WITHIN THE WORD "FAITH" IN THE POSITION OF THE "T".

FOR APPAREL, NAMELY, SHIRTS, HATS, WRISTBANDS AND JACKETS (U.S. CLS. 22 AND 39).  
ESTHER A. BORSUK, EXAMINING ATTORNEY

**CLASS 25—(Continued).**

SN 86-072,637. IMOGA, INC., HARRINGTON PARK, NJ.  
FILED 9-24-2013.

**CREMELLO BY IMOGA**

THE MARK CONSISTS OF STANDARD CHARACTERS WITHOUT CLAIM TO ANY PARTICULAR FONT, STYLE, SIZE, OR COLOR.

OWNER OF U.S. REG. NO. 3,067,813.

NO CLAIM IS MADE TO THE EXCLUSIVE RIGHT TO USE "CREMELLO", APART FROM THE MARK AS SHOWN.

THE ENGLISH TRANSLATION OF "IMOGA" IN THE MARK IS "BY AUNT" OR "FROM AUNT".

FOR CLOTHING, NAMELY, T-SHIRTS, SHIRTS, TOPS, SWEATERS, SWEATSHIRTS, HOODED SWEATSHIRTS; COATS, JERSEYS, JACKETS; BOTTOMS, PANTS, TROUSERS, JEANS, SHORTS, SWEATPANTS, PAJAMAS; DRESSES; SKIRTS; BLOUSES; UNDERWEAR; SWIMWEAR; HEADWEAR; FOOTWEAR (U.S. CLS. 22 AND 39).

DAWN FELDMAN, EXAMINING ATTORNEY

SN 86-073,681. BYSTANDER REVOLUTION, LLC, SEATTLE, WA. FILED 9-24-2013.

**BYSTANDER REVOLUTION**

THE MARK CONSISTS OF STANDARD CHARACTERS WITHOUT CLAIM TO ANY PARTICULAR FONT, STYLE, SIZE, OR COLOR.

FOR CLOTHING, NAMELY, TOPS, BOTTOMS, HEADWEAR, FOOTWEAR, SLEEPWEAR, NECKWEAR, SOCKS, JACKETS AND COATS (U.S. CLS. 22 AND 39).

JENNY PARK, EXAMINING ATTORNEY

SN 86-074,033. JINDAO HE, GUANGZHOU, GUANGDONG, CHINA, FILED 9-25-2013.

**CHAMARIPA**

THE MARK CONSISTS OF STYLIZED LETTERS "CHAMARIPA".

THE WORDING "CHAMARIPA" HAS NO MEANING IN A FOREIGN LANGUAGE.

FOR UNIFORMS; SMOCKS; SUITS; SHIRTS; COATS; SKIRTS; BABY CLOTHING, NAMELY, PANTS; SWIMMING SUITS; WATERPROOF JACKETS AND PANTS; SHOES; BOOTS; SPORTS SHOES; SANDALS; SOLES FOR FOOTWEAR; HEELS FOR FOOTWEAR; INSOLE FOR FOOTWEAR; FOOTBALL SHOES; HATS; HOSIERY; GLOVES BEING CLOTHING; SCARFS; NECKTIES; WAISTBANDS; SASHES FOR WEAR (U.S. CLS. 22 AND 39).

LESLEY LAMOTHE, EXAMINING ATTORNEY

**CLASS 25—(Continued).**

SN 86-074,264. RUGGED SHARK, LLC, HACKENSACK, NJ.  
FILED 9-25-2013.



THE COLOR(S) BLUE AND RED IS/ARE CLAIMED AS A FEATURE OF THE MARK.

THE MARK CONSISTS OF THE WORD "RUGGED" IN BLUE, A SHARK FIN IN RED, AND THE WORD "SHARK" IN BLUE.

FOR CLOTHING, NAMELY, SHORTS, PANTS, RAINWEAR, JACKETS, PANTS, SHORT SLEEVE SHIRTS, LONG SLEEVE SHIRTS, HEADWEAR, BELTS (U.S. CLS. 22 AND 39).

MATTHEW KLINE, EXAMINING ATTORNEY

SN 86-074,279. RUGGED SHARK, LLC, HACKENSACK, NJ.  
FILED 9-25-2013.



THE MARK CONSISTS OF THE WORD "RUGGED SHARK" WITH A SHARK FIN BETWEEN THE TWO WORDS.

FOR CLOTHING, NAMELY, SHORTS, PANTS, RAINWEAR, JACKETS, PANTS, SHORT SLEEVE SHIRTS, LONG SLEEVE SHIRTS, BELTS AND HEADWEAR (U.S. CLS. 22 AND 39).

MATTHEW KLINE, EXAMINING ATTORNEY

SN 86-074,719. ASMA SAAD, DBA SERENITY SCARVES, IRVINE, CA. FILED 9-25-2013.

**SERENITY**

THE MARK CONSISTS OF STANDARD CHARACTERS WITHOUT CLAIM TO ANY PARTICULAR FONT, STYLE, SIZE, OR COLOR.

FOR SCARVES (U.S. CLS. 22 AND 39).

FIRST USE 6-8-2013; IN COMMERCE 6-11-2013.

JOHN WILKE, EXAMINING ATTORNEY



**CLASS 25—(Continued).**

SN 86-074,779. PR II COCO PALMS LLC, MADISON, NJ. FILED 9-25-2013.

**COCO PALMS**

THE MARK CONSISTS OF STANDARD CHARACTERS WITHOUT CLAIM TO ANY PARTICULAR FONT, STYLE, SIZE, OR COLOR.

FOR CLOTHING, NAMELY, T-SHIRTS, TANK TOPS, GOLF SHIRTS, SWEATERS, JACKETS, JOGGING SUITS, SWEAT SHIRTS, SWEAT PANTS, DRESS PANTS, SHORTS, DRESSES, SKIRTS, BLOUSES, SWIM WEAR, BEACH COVER-UPS, HEADWEAR, CAPS, HATS, BANDANAS, FOOTWEAR, SOCKS, ROBES, AND PAJAMAS (U.S. CLS. 22 AND 39).

BRENDAN MCCAULEY, EXAMINING ATTORNEY

SN 86-075,141. DANA-CO LLC, NEW YORK, NY. FILED 9-26-2013.

**SKARLETT BLUE**

THE MARK CONSISTS OF STANDARD CHARACTERS WITHOUT CLAIM TO ANY PARTICULAR FONT, STYLE, SIZE, OR COLOR.

THE NAME(S), PORTRAIT(S), AND/OR SIGNATURE(S) SHOWN IN THE MARK DOES NOT IDENTIFY A PARTICULAR LIVING INDIVIDUAL.

FOR WOMEN'S CLOTHING, NAMELY, BRAS, PANTIES, CAMISOLES, SLIPS, LOUNGEWEAR; SLEEPWEAR, NAMELY, PANTS, TOPS AND SHORTS (U.S. CLS. 22 AND 39).

RUSS HERMAN, EXAMINING ATTORNEY

SN 86-075,241. HODGSON, CLAYTON, MARKHAM, ONTARIO, CANADA, FILED 9-26-2013.

**CoHo**

THE MARK CONSISTS OF STANDARD CHARACTERS WITHOUT CLAIM TO ANY PARTICULAR FONT, STYLE, SIZE, OR COLOR.

PRIORITY CLAIMED UNDER SEC. 44(D) ON CANADA APPLICATION NO. 1644021, FILED 9-18-2013.

FOR BASEBALL HATS, T-SHIRTS, LONG SLEEVE-SHIRTS, HOODIES, TOQUES (U.S. CLS. 22 AND 39).

MEREDITH MARESCA, EXAMINING ATTORNEY

**CLASS 25—(Continued).**

SN 86-076,061. PARSONS, TIMOTHY, NEW YORK, NY. FILED 9-26-2013.

**Every Daze My Birthday**

THE MARK CONSISTS OF STANDARD CHARACTERS WITHOUT CLAIM TO ANY PARTICULAR FONT, STYLE, SIZE, OR COLOR.

FOR CLOTHING, NAMELY, T-SHIRTS, SOCKS, HATS, V-NECK SHIRTS, SWEATSHIRTS, SWEATPANTS FEATURING BIRTHDAY GRAPHICS (U.S. CLS. 22 AND 39).

FIRST USE 6-1-2010; IN COMMERCE 6-1-2010.

GIANCARLO CASTRO, EXAMINING ATTORNEY

SN 86-077,267. MOVABEATS, LLC, TUCSON, AZ. FILED 9-27-2013.



THE MARK CONSISTS OF STYLIZED "MB". FOR BASEBALL CAPS AND HATS; BLOUSES; CAMISOLES; CAPS; HALTER TOPS; HATS; HEAD WEAR; SHIRTS; SHORT-SLEEVED SHIRTS; T-SHIRTS; TANK TOPS; TOPS (U.S. CLS. 22 AND 39).

FIRST USE 1-1-2011; IN COMMERCE 9-12-2013.

TINA MAI, EXAMINING ATTORNEY

SN 86-079,228. COLUMBIA INSURANCE COMPANY, OMAHA, NE. FILED 10-1-2013.



NO CLAIM IS MADE TO THE EXCLUSIVE RIGHT TO USE "ARTISAN CRAFTED", APART FROM THE MARK AS SHOWN.

THE MARK CONSISTS OF THE STYLIZED WORD "MONTANA" ABOVE THE STYLIZED WORDING "ARTISAN CRAFTED". "ARTISAN CRAFTED" IS FLANKED ON EACH SIDE BY A SINGLE FIVE-POINT STAR AND LINE DESIGN. A FLOWER DESIGN IS POSITIONED ABOVE "MONTANA".

FOR FOOTWEAR (U.S. CLS. 22 AND 39).

GRETCHEN ULRICH, EXAMINING ATTORNEY

**CLASS 25—(Continued).**

SN 86-080,199. RIVERSTONE VENTURES, LLC, OVERLAND PARK, KS. FILED 10-1-2013.

**PRIDE UNIVERSE**

THE MARK CONSISTS OF STANDARD CHARACTERS WITHOUT CLAIM TO ANY PARTICULAR FONT, STYLE, SIZE, OR COLOR.

FOR CLOTHING, NAMELY, SHIRTS, SHORT SLEEVE T-SHIRTS, LONG SLEEVE T-SHIRTS, SWEATSHIRTS, HOODED SWEATSHIRTS, ZIPPED HOODED SWEATSHIRTS, SHORT SLEEVE BODYSUITS, LONG SLEEVE BODYSUITS, BLOOMERS, INFANT GOWNS, HATS, BEANIES, BABY CAPS, BASEBALL CAPS, CAPS, SOCKS, GLOVES, SCARVES, EAR MUFFS, ROMPERS, PANTS, SHORTS, SLIPPERS, DRESSES, CLOTH BIBS, APRONS, HALLOWEEN AND MASQUERADE COSTUMES, AND COSTUMES FOR USE IN CHILDREN'S DRESS UP PLAY (U.S. CLS. 22 AND 39).

NATALIE KENEALY, EXAMINING ATTORNEY

SN 86-080,296. DAVIS, ANGEL, NEW ORLEANS, LA. FILED 10-1-2013.

**BAD ASS BROWN CHICK**

THE MARK CONSISTS OF STANDARD CHARACTERS WITHOUT CLAIM TO ANY PARTICULAR FONT, STYLE, SIZE, OR COLOR.

FOR HATS; SWEATSHIRTS; T-SHIRTS (U.S. CLS. 22 AND 39).

FIRST USE 5-22-2013; IN COMMERCE 5-22-2013.

DAWN FELDMAN, EXAMINING ATTORNEY

SN 86-083,167. JOSEPH CAMPBELL FOUNDATION, SAN ANSELMO, CA. FILED 10-4-2013.

**HERO'S JOURNEY**

THE MARK CONSISTS OF STANDARD CHARACTERS WITHOUT CLAIM TO ANY PARTICULAR FONT, STYLE, SIZE, OR COLOR.

FOR CLOTHING, NAMELY, T-SHIRTS, TANK TOPS, POLO SHIRTS, AND SPORTS JERSEYS (U.S. CLS. 22 AND 39).

RENEE MCCRAY, EXAMINING ATTORNEY

**CLASS 25—(Continued).**

SN 86-083,359. K M MOONEY PROD., INC., ELLENTON, FL. FILED 10-4-2013.

**KMARIE**

THE MARK CONSISTS OF STANDARD CHARACTERS WITHOUT CLAIM TO ANY PARTICULAR FONT, STYLE, SIZE, OR COLOR.

THE NAME(S), PORTRAIT(S), AND/OR SIGNATURE(S) SHOWN IN THE MARK IDENTIFIES KELSEY MARIE MOONEY, WHOSE CONSENT(S) TO REGISTER IS MADE OF RECORD.

FOR CLOTHING, NAMELY, SHIRTS, T-SHIRTS, UNDER SHIRTS, NIGHT SHIRTS, RUGBY SHIRTS, POLO SHIRTS, CARDIGANS, JERSEYS, UNIFORMS, SCRUBS NOT FOR MEDICAL PURPOSES, SMOCKS, DRESS SHIRTS, PANTS, TROUSERS, SLACKS, JEANS, CULOTTES, CARGO PANTS, STRETCH PANTS, DENIM JEANS, OVERALLS, COVERALLS, JUMPERS, JUMP SUITS, SHORTS, BOXER SHORTS, TOPS, STRETCH TOPS, TUBE TOPS, CROP TOPS, TANK TOPS, TANKINIS, HALTER TOPS, SWEAT SHIRTS, HOODED SWEAT SHIRTS, SWEAT SHORTS, SWEAT PANTS, WRAPS, WARM-UP SUITS, JOGGING SUITS, TRACK SUITS, PLAY SUITS, BLOUSES, SKIRTS, DRESSES, SWEATERS, VESTS, FLEECE VESTS, PULLOVERS, SNOW SUITS, PARKAS, CAPES, ANORAKS, PONCHOS, CLOAKS, SHRUGS, JACKETS, REVERSIBLE JACKETS, WIND-RESISTANT JACKETS, SHELL JACKETS, SPORTS JACKETS, GOLF AND SKI JACKETS, JEAN JACKETS, COATS, HEAVY COATS, OVER COATS, BLAZERS, SUITS, TURTLENECKS, CLOTH SKI BIBS, SWIMWEAR, BEACHWEAR, TENNIS WEAR, SURF WEAR, SKI WEAR, LAYETTES, INFANT WEAR, INFANTS SLEEPERS, BOOTIES, BABY BIBS NOT OF PAPER, CAPS, SWIM CAPS, BERETS, BEANIES, HATS, VISORS, HEADBANDS, WRIST BANDS, SWEAT BANDS, HEADWEAR, EAR MUFFS, APRONS, SCARVES, BANDANAS, BELTS, SUSPENDERS, NECKWEAR, TIES, NECKERCHIEFS, POCKET SQUARES, ASCOTS, UNDERWEAR, THERMAL UNDERWEAR, LONG UNDERWEAR, BRIEFS, SWIM AND BATHING TRUNKS, BRAS, THONGS, G-STRINGS, SINGLET, SOCKS, LOUNGEWEAR, ROBES, UNDERCLOTHES, PAJAMAS, SLEEPWEAR, NIGHT GOWNS, NIGHTIES, LINGERIE, LEG WARMERS, HOSIERY, PANTYHOSE, BODY STOCKINGS, KNEE HIGHS, LEGGINGS, TIGHTS, GLOVES, MITTENS, RAIN SLICKERS, RAINWEAR, FOOTWEAR, SHOES, SNEAKERS, BOOTS, GALOSHES, SANDALS, FLIP-FLOPS, AND SLIPPERS (U.S. CLS. 22 AND 39).

KAMAL PREET, EXAMINING ATTORNEY

**CLASS 25—(Continued).**

SN 86-083,874. THE EUPORIA GROUP, INCORPORATED, COUNTRY CLUB HILLS, IL. FILED 10-7-2013.



THE MARK CONSISTS OF A DESIGN OF A LAMB. FOR CLOTHING AND RELATED ACCESSORIES FOR INFANTS, TODDLERS AND CHILDREN, NAMELY, DRESSES, SUITS, BLOUSES, SHIRTS, SWEATSHIRTS, SWEATERS, VESTS, PANTS, SHORTS, BODYSUITS, TIES, HATS, AND CAPS (U.S. CLS. 22 AND 39).  
GEORGE LORENZO, EXAMINING ATTORNEY

**CLASS 25—(Continued).**

SN 86-089,736. MEN'S COUTURE, INC., SAN JUAN, PUERTO RICO, FILED 10-11-2013.

LEONARDO  
Fifth Avenue

OWNER OF U.S. REG. NO. 3,651,517.  
THE MARK CONSISTS OF THE WORDS "LEONARDO FIFTH AVENUE" IN SPECIAL TYPE LETTERS.  
FOR MEN'S WEAR, NAMELY, SUITS, SPORT COATS, TOPCOATS, JACKETS, SHIRTS, PANTS, SMOKING JACKETS, DINNER JACKETS, VESTS, BELTS, CUMMERBUNDS WORN WITH SMOKING AND DINNER JACKETS, TIES, SCARVES, GLOVES, SOCKS, SHOES (U.S. CLS. 22 AND 39).  
DORITT L. CARROLL, EXAMINING ATTORNEY

SN 86-085,114. KHAMNEIPUR, ROXANNA BEATRICE, LOS ANGELES, CA. FILED 10-8-2013.

Darner Los Angeles

THE MARK CONSISTS OF STANDARD CHARACTERS WITHOUT CLAIM TO ANY PARTICULAR FONT, STYLE, SIZE, OR COLOR.

NO CLAIM IS MADE TO THE EXCLUSIVE RIGHT TO USE "LOS ANGELES", APART FROM THE MARK AS SHOWN.

FOR CLOTHING, NAMELY, TOPS, BOTTOMS, SHIRTS, PANTS, SHORTS, JACKETS, SWEATERS, SWIMWEAR, SLEEPWEAR, UNDERWEAR, BELTS, SOCKS; HEADWEAR; FOOTWEAR (U.S. CLS. 22 AND 39).

FIRST USE 8-28-2013; IN COMMERCE 9-9-2013.  
DANNEAN HETZEL, EXAMINING ATTORNEY

SN 86-089,768. BRUNO MARS MUSIC, LLC, LOS ANGELES, CA. FILED 10-11-2013.

LA JUNGLA

THE MARK CONSISTS OF STANDARD CHARACTERS WITHOUT CLAIM TO ANY PARTICULAR FONT, STYLE, SIZE, OR COLOR.

THE ENGLISH TRANSLATION OF "LA JUNGLA" IN THE MARK IS "THE JUNGLE".

FOR CLOTHING, NAMELY, SHIRTS, T-SHIRTS, UNDER SHIRTS, NIGHT SHIRTS, RUGBY SHIRTS, POLO SHIRTS, CARDIGANS, JERSEYS, UNIFORMS, SCRUBS NOT FOR MEDICAL PURPOSES, SMOCKS, DRESS SHIRTS, PANTS, TROUSERS, SLACKS, JEANS, CULOTTES, CARGO PANTS, STRETCH PANTS, DENIM JEANS, OVERALLS, COVERALLS, JUMPERS, JUMP SUITS, SHORTS, BOXER SHORTS, TOPS, STRETCH TOPS, TUBE TOPS, CROP TOPS, TANK TOPS, TANKINIS, HALTER TOPS, SWEAT SHIRTS, HOODED SWEAT SHIRTS, SWEAT SHORTS, SWEAT PANTS, WRAPS, WARM-UP SUITS, JOGGING SUITS, TRACK SUITS, PLAY SUITS, BLOUSES, SKIRTS, DRESSES, SWEATERS, VESTS, FLEECE VESTS, PULLOVERS, SNOW SUITS, PARKAS, CAPES, ANORAKS, PONCHOS, CLOAKS, SHRUGS, JACKETS, REVERSIBLE JACKETS, WIND-RESISTANT JACKETS, SHELL JACKETS, SPORTS

**CLASS 25—(Continued).**

JACKETS, GOLF AND SKI JACKETS, JEAN JACKETS, COATS, HEAVY COATS, OVER COATS, BLAZERS, SUITS, TURTLENECKS, CLOTH SKI BIBS, SWIMWEAR, BEACHWEAR, TENNIS WEAR, SURF WEAR, SKI WEAR, LAYETTES, INFANTWEAR, INFANTS SLEEPERS, BOOTIES, BABY BIBS NOT OF PAPER, CAPS, SWIM CAPS, BERETS, BEANIES, HATS, VISORS, HEADBANDS, WRIST BANDS, SWEAT BANDS, HEADWEAR, EAR MUFFS, APRONS, SCARVES, BANDANAS, BELTS, SUSPENDERS, NECKWEAR, TIES, NECKERCHIEFS, POCKET SQUARES, ASCOTS, UNDERWEAR, THERMAL UNDERWEAR, LONG UNDERWEAR, BRIEFS, SWIM AND BATHING TRUNKS, BRAS, THONGS, G-STRINGS, SINGLET, SOCKS, LOUNGEWEAR, ROBES, UNDERCLOTHES, PAJAMAS, SLEEPWEAR, NIGHT GOWNS, NIGHTIES, LINGERIE, LEG WARMERS, HOSIERY, PANTYHOSE, BODY STOCKINGS, KNEE HIGHS, LEGGINGS, TIGHTS, GLOVES, MITTENS, RAIN SLICKERS, RAINWEAR, FOOTWEAR, SHOES, SNEAKERS, BOOTS, GALOSHES, SANDALS, FLIP-FLOPS, AND SLIPPERS (U.S. CLS. 22 AND 39).

VIVIAN MICZNIK FIRST, EXAMINING ATTORNEY

---

SN 86-092,556. GLOBAL TRADEMARKS, INC., STOCKERTOWN, PA. FILED 10-16-2013.

**THE ULTIMATE SWIMSUIT  
EXPERIENCE**

THE MARK CONSISTS OF STANDARD CHARACTERS WITHOUT CLAIM TO ANY PARTICULAR FONT, STYLE, SIZE, OR COLOR.

NO CLAIM IS MADE TO THE EXCLUSIVE RIGHT TO USE "SWIMSUIT", APART FROM THE MARK AS SHOWN. FOR COVERUPS; SWIMWEAR (U.S. CLS. 22 AND 39). TEJBIR SINGH, EXAMINING ATTORNEY

---

SN 86-095,771. HEART DESIGN INC., LEWES, DE. FILED 10-18-2013.

**Power Dress**

THE MARK CONSISTS OF STANDARD CHARACTERS WITHOUT CLAIM TO ANY PARTICULAR FONT, STYLE, SIZE, OR COLOR.

NO CLAIM IS MADE TO THE EXCLUSIVE RIGHT TO USE "DRESS", APART FROM THE MARK AS SHOWN.

FOR WEARING APPAREL, NAMELY, DRESSES, SHIRTS, SKIRTS, PANTS, SUITS, BLAZERS, JEANS, SHORTS, SWEATERS, TOPS, BLOUSES, TANK TOPS, BOLEROS, CARDIGANS, TRACK SUITS, SWEATSHIRTS, SWEATPANTS, VESTS, PARKAS, CAPES, ANORAKS, PONCHOS, JACKETS, COATS, SWIMWEAR, BATHING SUITS, SCARVES, BELTS, UNDERWEAR, BRAS, SPORTS BRAS, HOSIERY, TIGHTS, STOCKINGS, SOCKS, CAMISOLES, SLIPS, LOUNGEWEAR, ROBES, PAJAMAS, SLEEPWEAR, NIGHT GOWNS, LINGERIE, LEOTARDS, UNITARDS, GLOVES, SASHES, SHAWLS, TUNICS, SHRUGS, LEG WARMERS, LEGGINGS, BODY SHAPERS (U.S. CLS. 22 AND 39).

CYNTHIA RINALDI, EXAMINING ATTORNEY

**CLASS 25—(Continued).**

SN 86-095,816. MICHAEL E DODD, SPOKANE, WA. FILED 10-18-2013.

**AD<sup>v</sup>VEN**

THE MARK CONSISTS OF THE WORD "ADVEN" IN STYLIZED FONT WITH A SMALL SILHOUETTE OF A SNOWBOARDER SEPARATING THE LETTERS "D" AND "V".

THE WORDING "ADVEN" HAS NO MEANING IN A FOREIGN LANGUAGE.

FOR ATHLETIC APPAREL, NAMELY, SHIRTS, PANTS, JACKETS, FOOTWEAR, HATS AND CAPS, ATHLETIC UNIFORMS (U.S. CLS. 22 AND 39).

FIRST USE 12-1-2011; IN COMMERCE 12-12-2012.

STEVEN PEREZ, EXAMINING ATTORNEY

---

SN 86-099,175. GOTHAM LICENSING GROUP, LLC, NEW YORK, NY. FILED 10-23-2013.

**POINT BLANC**

THE MARK CONSISTS OF STANDARD CHARACTERS WITHOUT CLAIM TO ANY PARTICULAR FONT, STYLE, SIZE, OR COLOR.

THE ENGLISH TRANSLATION OF "BLANC" IN THE MARK IS "WHITE".

FOR BOTTOMS; COATS; DENIMS; JACKETS; JEANS; TOPS; VESTS (U.S. CLS. 22 AND 39).

MARILYN IZZI, EXAMINING ATTORNEY

**CLASS 25—(Continued).**

SN 86-104,016. QUARLES, SANTOSKAUN C, DBA SANTA-SHA'S STYLES, STAFFORD, VA. FILED 10-29-2013.



NO CLAIM IS MADE TO THE EXCLUSIVE RIGHT TO USE "STYLES", APART FROM THE MARK AS SHOWN.

THE COLOR(S) GREEN, BROWN, RED AND BLACK IS/ARE CLAIMED AS A FEATURE OF THE MARK.

THE MARK CONSISTS OF THE STYLIZED PROFILE OF A WOMAN'S HEAD WITH A CROWN OF LEAVES; THE TOP THIRD OF THE DESIGN IS GREEN WHICH FADES TO THE MIDDLE PORTION IN BROWN WHICH FADES TO THE BOTTOM PORTION IN RED TO THE LEFT OF THE STYLIZED BROWN WORD "SANTASHA'S" WITH THE APOSTROPHE IN GREEN ABOVE THE STYLIZED GREEN WORD "STYLES" ABOVE THE STYLIZED BLACK WORDS "STAY NATURALLY BEAUTIFUL"; WHITE REPRESENTS TRANSPARENCY AND IS NOT PART OF THE MARK

FOR ATHLETIC APPAREL, NAMELY, SHIRTS, PANTS, JACKETS, FOOTWEAR, HATS AND CAPS, ATHLETIC UNIFORMS; T-SHIRTS (U.S. CLS. 22 AND 39).

DAVID TOOLEY, EXAMINING ATTORNEY

SN 86-108,594. TELEMUNDO NETWORK GROUP LLC, HIALEAH, FL. FILED 11-1-2013.

**SUELTA LA SOPA**

THE MARK CONSISTS OF STANDARD CHARACTERS WITHOUT CLAIM TO ANY PARTICULAR FONT, STYLE, SIZE, OR COLOR.

THE ENGLISH TRANSLATION OF "SUELTA LA SOPA" IN THE MARK IS "SPILL THE BEANS".

FOR CLOTHING, NAMELY, T-SHIRTS, SHIRTS, SWEATSHIRTS, TANK TOPS, BLOUSES, JACKETS, SHORTS, PANTS, SKIRTS, DRESSES, LEGGINGS, SOCKS, GLOVES, SCARVES; LOUNGEWEAR; SLEEPWEAR; SWIMWEAR; FOOTWEAR; HEADWEAR (U.S. CLS. 22 AND 39).

JOHN E. MICHOS, EXAMINING ATTORNEY

**CLASS 25—(Continued).**

SN 86-111,555. COLUMBIA INSURANCE COMPANY, OMAHA, NE. FILED 11-6-2013.



NO CLAIM IS MADE TO THE EXCLUSIVE RIGHT TO USE "ARTISAN CRAFTED", APART FROM THE MARK AS SHOWN.

THE MARK CONSISTS OF THE WORD "WILDFLOWER" ABOVE THE WORDS "ARTISAN" AND "CRAFTED", AS WELL AS STAR AND LINE DESIGNS. THE "O" AND THE DOT OVER THE "I" IN "WILDFLOWER" ARE REPLACED WITH A FLOWER DESIGN. A FLOWER DESIGN APPEARS ABOVE THE WORD "WILDFLOWER" AS WELL.

FOR WOMEN'S SHOES, NAMELY CASUAL SHOES, SLIP-ONS, FLATS, FOLDABLE FLATS, LOW-HEELED CASUAL SHOES, HIGH-HEELED CASUAL SHOES, WEDGE SHOES, OXFORD SHOES, DRESS SHOES, PUMPS, LOW-HEELED DRESS SHOES, HIGH-HEELED DRESS SHOES, STILETTOS, PEEP-TOE SHOES, BALLERINAS, CLOGS, MULES, FASHION SHOES, MARY JANES, LEATHER SHOES, LEISURE SHOES, KITTEN-HEELED SHOES, PLATFORM SHOES, RUBBER-SOLED SHOES, LACE-UP SHOES, BEACH SHOES, BOWLING SHOES, BOAT SHOES, CANVAS SHOES, WORK SHOES, SHOES WITH BUCKLE CLOSURES, SUEDE SHOES, SHOES INCORPORATING WOOD, SHOES INCORPORATING FABRIC, SHOES INCORPORATING CORK, SHOES INCORPORATING ELASTIC MATERIAL; SANDALS; WOMEN'S SANDALS, NAMELY, CASUAL SANDALS, SLIP-ONS, WEDGE SANDALS, STILETTOS, FLATS, HIGH-HEELED SANDALS, LOW-HEELED CASUAL SANDALS, LEISURE SANDALS, PLATFORM SANDALS, DRESS SANDALS, LOW-HEELED DRESS SANDALS, HIGH-HEELED DRESS SANDALS, LEATHER SANDALS, ANKLE-STRAP SANDALS, FASHION SANDALS, SANDALS INCORPORATING WOOD, SANDALS INCORPORATING FABRIC, SANDALS INCORPORATING CORK, SANDALS WITH BUCKLE CLOSURES; INSOLES (U.S. CLS. 22 AND 39).

KIMBERLY PERRY, EXAMINING ATTORNEY

SN 86-112,529. HBI BRANDED APPAREL ENTERPRISES, LLC, WINSTON-SALEM, NC. FILED 11-7-2013.

**VENTUREDOWN**

THE MARK CONSISTS OF STANDARD CHARACTERS WITHOUT CLAIM TO ANY PARTICULAR FONT, STYLE, SIZE, OR COLOR.

OWNER OF U.S. REG. NOS. 3,949,191, 4,272,710 AND OTHERS.

FOR FABRIC COMPRISING DOWN SOLD AS AN INTEGRAL COMPONENT OF FINISHED CLOTHING ITEMS, NAMELY, PANTS, JACKETS, VESTS, HATS, CAPS, HEADWEAR, GLOVES (U.S. CLS. 22 AND 39).

ALLISON SCHRODY, EXAMINING ATTORNEY

**CLASS 25—(Continued).**

SN 86-113,233. HIRA LIFESTYLE HOLDINGS LIMITED, HONG KONG, HONG KONG, FILED 11-8-2013.



NO CLAIM IS MADE TO THE EXCLUSIVE RIGHT TO USE "DENIM", APART FROM THE MARK AS SHOWN. THE COLOR(S) RED AND WHITE IS/ARE CLAIMED AS A FEATURE OF THE MARK.

THE MARK CONSISTS OF THE NUMBER "909" AND "DENIM" IN RED AND WHITE COLOUR FONT.

FOR COATS OF DENIM; DENIM COMBINATIONS; DENIM JACKETS; DENIMS (U.S. CLS. 22 AND 39).  
KHANH LE, EXAMINING ATTORNEY

SN 86-118,709. GLOBAL TRADEMARKS, INC., STOCKERTOWN, PA. FILED 11-14-2013.

**ECO FESTIVAL**

THE MARK CONSISTS OF STANDARD CHARACTERS WITHOUT CLAIM TO ANY PARTICULAR FONT, STYLE, SIZE, OR COLOR.

FOR COVERUPS; SWIMWEAR (U.S. CLS. 22 AND 39).  
TEJBIR SINGH, EXAMINING ATTORNEY

SN 86-118,899. EARTH CREATIONS, INC, BESSEMER, AL. FILED 11-14-2013.

**whole earth wear**

THE MARK CONSISTS OF STANDARD CHARACTERS WITHOUT CLAIM TO ANY PARTICULAR FONT, STYLE, SIZE, OR COLOR.

OWNER OF U.S. REG. NOS. 2,241,044 AND 2,257,538.

NO CLAIM IS MADE TO THE EXCLUSIVE RIGHT TO USE "WEAR", APART FROM THE MARK AS SHOWN.

FOR MEN'S, WOMEN'S, AND CHILDREN'S CLOTHING AND ACCESSORIES, NAMELY, T-SHIRTS, SWEATSHIRTS, LONG SLEEVE T-SHIRTS, TANK TOPS, GOLF SHIRTS, FLEECE SWEATSHIRTS, CAPS, BASEBALL CAPS, HATS, SHIRTS, JACKETS, SOCKS, PANTS, SHORTS, SCARVES, OVERALLS, APRONS, AND BANDANAS (U.S. CLS. 22 AND 39).  
MEGHAN REINHART, EXAMINING ATTORNEY

**CLASS 25—(Continued).**

SN 86-119,102. ELIADES, ARISTOTELIS, LAS VEGAS, NV. FILED 11-14-2013.

**GHOST UNIVERSITY**

THE MARK CONSISTS OF STANDARD CHARACTERS WITHOUT CLAIM TO ANY PARTICULAR FONT, STYLE, SIZE, OR COLOR.

FOR CLOTHING, NAMELY, SHIRTS, T-SHIRTS, POLO SHIRTS, LONG-SLEEVED SHIRTS, SHORT-SLEEVED SHIRTS, HATS, HOODED SWEATSHIRTS, SWEATSHIRTS, SWEAT-WRISTBANDS, SWEAT-HEADBANDS, JACKETS, WIND RESISTANT JACKETS, SOCKS, BELTS, TACTICAL BELTS FOR CLOTHING, BEDTIME AND EVENING GOWNS, UNDERWEAR, BOXERS, PAJAMAS, BEANIES, CAPS, HEADWEAR, PONCHOS (U.S. CLS. 22 AND 39).  
KYLE PEETE, EXAMINING ATTORNEY

SN 86-123,225. B.FOREVER, PARIS, FRANCE, FILED 11-19-2013.



OWNER OF ERPN CMNTY TM OFC REG. NO. 891167, DATED 12-30-2005, EXPIRES 12-30-2015.

OWNER OF U.S. REG. NOS. 2,053,915 AND 2,094,567.

NO CLAIM IS MADE TO THE EXCLUSIVE RIGHT TO USE "HOMME PARIS", APART FROM THE MARK AS SHOWN.

THE MARK CONSISTS OF THE WORDS "b.HOMME PARIS". THE LETTER "b" IS IN LOWERCASE SCRIPT AND FOLLOWED BY A PERIOD. THE WORD "HOMME" IS VERTICAL AND IN UPPER CASE TEXT. THE WORD "PARIS" IS VERTICAL AND IN UPPER CASE TEXT.

THE ENGLISH TRANSLATION OF "HOMME" IN THE MARK IS "MAN".

FOR (BASED ON INTENT TO USE) COATS; HATS; JACKETS; PANTS; SCARVES; SHIRTS; SHORTS; SUITS; SWEATERS; SWEATSHIRTS; VESTS(BASED ON 44(E)) COATS; HATS; JACKETS; PANTS; SCARVES; SHIRTS; SHORTS; SUITS; SWEATERS; SWEATSHIRTS; VESTS (U.S. CLS. 22 AND 39).  
LINDA MICKLEBURGH, EXAMINING ATTORNEY

**CLASS 25—(Continued).**

SN 86-123,530. HONDA MOTOR CO., LTD., TOKYO, JAPAN, FILED 11-19-2013.

# RIDE RED

THE MARK CONSISTS OF STANDARD CHARACTERS WITHOUT CLAIM TO ANY PARTICULAR FONT, STYLE, SIZE, OR COLOR.

FOR CLOTHING, NAMELY, CAPS, HATS, T-SHIRTS, SHIRTS, PANTS, JACKETS, VESTS, AND GLOVES, EXCLUDING CLOTHING MARKETED FOR USE IN WINTER SPORTS (U.S. CLS. 22 AND 39).

APRIL REEVES, EXAMINING ATTORNEY

**CLASS 25—(Continued).**

SN 86-124,650. TRACY ARAKELIAN, LOUDONVILLE, NY, AND MICHAEL J. SLOCUM, LOUDONVILLE, NY, FILED 11-20-2013.

# SPRAY 360°

THE MARK CONSISTS OF THE WORD "SPRAY" FOLLOWED BY THE NUMERAL "360" AND THE DEGREE SYMBOL.

FOR HEADWEAR, HATS, PANTS, SWEATPANTS, EXERCISE PANTS, TROUSERS, SHORTS, BATHING SUITS, SHIRTS, SWEATERS, SWEATSHIRTS, UNDERSHIRTS, SHORT SLEEVE T-SHIRTS, LONG SLEEVE T-SHIRTS, BOXER SHORTS, LEGGINGS, SUITS, VESTS, BLAZERS, NECKWEAR, TIES, BOW TIES, SKIRTS, BLOUSES, TANK TOPS, SCARVES, HOSIERY, SHOES, SANDALS, RUBBERS, BOOTS, FLIP FLOPS, SLIPPERS, JACKETS, FLEECE PULLOVERS, FLEECE BOTTOMS, ANORAKS, COATS, RAINWEAR, FOUL WEATHER GEAR, PARKAS AND BATHROBES; SMOCKS; CLOTH BIBS; WET SUITS; DRY SUITS; VISORS; GLOVES (U.S. CLS. 22 AND 39).

CHRISTOPHER LAW, EXAMINING ATTORNEY

SN 86-124,315. HWANG, IN-SEON, BUSAN, REPUBLIC OF KOREA, FILED 11-20-2013.



NO CLAIM IS MADE TO THE EXCLUSIVE RIGHT TO USE "USA SHOWROOM", APART FROM THE MARK AS SHOWN.

THE COLOR(S) BLACK, WHITE, PINK, BLUE, RED, AQUA, ORANGE, PURPLE, YELLOW AND LIGHT GREEN IS/ARE CLAIMED AS A FEATURE OF THE MARK.

THE MARK CONSISTS OF THE WORDING "USA" IN WHITE AND "SHOWROOM" IN PINK GRADIENT WITH COLORED DOTS ADJACENT TO "SHOWROOM" WITH THE TOP ROW OF DOTS FROM LEFT TO RIGHT IN THE COLORS BLUE, PINK, RED, AQUA AND YELLOW, THE MIDDLE ROW OF DOTS IN THE COLORS RED, PURPLE, LIGHT GREEN, ORANGE AND AQUA, AND THE BOTTOM ROW OF DOTS IN THE COLORS PINK, PINK, BLUE, AQUA, AND ORANGE, ALL ON A BLACK RECTANGULAR BACKGROUND.

FOR JACKETS; CARDIGANS; T-SHIRTS; DRESSES; AND COATS (U.S. CLS. 22 AND 39).

MICHELE SWAIN, EXAMINING ATTORNEY

SN 86-124,660. TRACY ARAKELIAN, LOUDONVILLE, NY, AND MICHAEL J. SLOCUM, LOUDONVILLE, NY, FILED 11-20-2013.

# SLOCUM 360°

THE MARK CONSISTS OF THE WORD "SLOCUM" FOLLOWED BY THE NUMERAL "360" AND THE DEGREE SYMBOL.

FOR HEADWEAR, HATS, PANTS, SWEATPANTS, EXERCISE PANTS, TROUSERS, SHORTS, BATHING SUITS, SHIRTS, SWEATERS, SWEATSHIRTS, UNDERSHIRTS, SHORT SLEEVE T-SHIRTS, LONG SLEEVE T-SHIRTS, BOXER SHORTS, LEGGINGS, SUITS, VESTS, BLAZERS, NECKWEAR, TIES, BOW TIES, SKIRTS, BLOUSES, TANK TOPS, SCARVES, HOSIERY, SHOES, SANDALS, RUBBERS, BOOTS, FLIP FLOPS, SLIPPERS, JACKETS, FLEECE PULLOVERS, FLEECE BOTTOMS, ANORAKS, COATS, RAINWEAR, FOUL WEATHER GEAR, PARKAS AND BATHROBES; SMOCKS; CLOTH BIBS; WET SUITS; DRY SUITS; VISORS; GLOVES (U.S. CLS. 22 AND 39).

CHRISTOPHER LAW, EXAMINING ATTORNEY

**CLASS 25—(Continued).**

SN 86-126,830. PAYTON, JONNELL, NEW YORK, NY. FILED 11-22-2013.

**D.A.Y. O.N.E.**

DREAMS ASPIRE YOUTHS OVERCOMING NEGATIVE ENERGY



THE MARK CONSISTS OF THE WORDS "DAY ONE" WHERE EACH LETTER IS FOLLOWED BY A PERIOD AND THE WORDS "DREAMS ASPIRE YOUTHS OVERCOMING NEGATIVE ENERGY" UNDERNEATH THE "DAY ONE" LETTERS AND A STYLIZED "D" AND NUMBER "1" APPEARING UNDERNEATH THE LETTERS AND WORDS.

FOR CAPS: CREW NECK SWEATERS; HEADWEAR; HOODED PULLOVERS; HOODED SWEATSHIRTS; JACKETS; SHORT-SLEEVED OR LONG-SLEEVED T-SHIRTS; SKULLIES; SWEATERS; T-SHIRTS; V-NECK SWEATERS (U.S. CLS. 22 AND 39).

FIRST USE 6-0-2006; IN COMMERCE 6-0-2006.

EMILY CHUO, EXAMINING ATTORNEY

SN 86-128,462. LARA. DOUGLAS M, DBA DUGGINK STUDIO, LOS ANGELES, CA. FILED 11-25-2013.

**Be Fly Stay Fly**

THE MARK CONSISTS OF STANDARD CHARACTERS WITHOUT CLAIM TO ANY PARTICULAR FONT, STYLE, SIZE, OR COLOR.

FOR CLOTHING, NAMELY TOPS, T-SHIRTS, TANK TOPS, SWEATSHIRTS, HOODED SWEATSHIRTS, POLO SHIRTS, BOTTOMS, PANTS, SWEATPANTS, SHORTS, HEADWEAR, HATS, CAPS, BEANIES (U.S. CLS. 22 AND 39).

FIRST USE 6-1-2013; IN COMMERCE 6-1-2013.

SUSAN LESLIE DUBOIS, EXAMINING ATTORNEY

SN 86-132,668. NICKERSON, WILLIAM J., CLEVELAND, GA. FILED 12-2-2013.

**R U POZITIVITY?**

THE MARK CONSISTS OF STANDARD CHARACTERS WITHOUT CLAIM TO ANY PARTICULAR FONT, STYLE, SIZE, OR COLOR.

FOR SHIRTS (U.S. CLS. 22 AND 39).

COLLEEN DOMBROW, EXAMINING ATTORNEY

**CLASS 25—(Continued).**

SN 86-135,173. DIESEL S.P.A., BREGANZE (VI), ITALY, FILED 12-4-2013.

**JOGGJEANS**

THE MARK CONSISTS OF STANDARD CHARACTERS WITHOUT CLAIM TO ANY PARTICULAR FONT, STYLE, SIZE, OR COLOR.

FOR CLOTHING AND LEATHER CLOTHING, NAMELY, COATS, MANTLES, RAINCOATS, DRESSES, SUITS, SKIRTS, JACKETS, TROUSERS, JEANS, WAISTCOATS, SHIRTS, T-SHIRTS, BLOUSES, JERSEY, SWEATERS, PULLOVERS, BLAZERS, CARDIGANS, UNDERWEAR, CORSETS, BRASSIERES, NIGHTGOWNS, NIGHTWEAR, BOXER SHORTS, BODY SUITS, WOMAN'S SUITS, SHORTS, SUN SUITS, SPORT JACKETS, WIND-RESISTANT JACKETS, ANORAKS FOR EXERCISES, ANORAKS NOT FOR EXERCISES, SWEAT SUITS, TIES, NECKTIES, SCARVES, SHAWLS, CAPS, HAT, HEADWEAR, SASHES, BELTS (U.S. CLS. 22 AND 39).

FIRST USE 8-1-2011; IN COMMERCE 8-1-2011.

KIMBERLY PARKS, EXAMINING ATTORNEY

SN 86-135,666. MCDONALD, VERA P, DBA PEACE BY THE SHORE, SARASOTA, FL. FILED 12-5-2013.



THE MARK CONSISTS OF THE STYLIZED TEXT "PEACE" ABOVE THE STYLIZED TEXT "BY THE SHORE" ON THE BOTTOM RIGHT, AND A PEACE DESIGN ON THE BOTTOM LEFT OF THE STYLIZED TEXT "PEACE". TO THE LEFT OF "BY THE SHORE" IS A PEACE SIGN.

FOR BLOUSES; COATS; DENIM JACKETS; DENIMS; DRESSES; GLOVES AS CLOTHING; HATS; HOISERY; JACKETS; JUMPSUITS; LEGGINGS; LINGERIE; PANTS; ROMPERS; SCARVES; SHIRTS; SHORTS; SHRUGS; SKIRTS; SLEEPWEAR; SOCKS; SWEATERS; SWIMWEAR; T-SHIRTS; VESTS; YOGA PANTS; YOGA SHIRTS (U.S. CLS. 22 AND 39).

CAROLINE WOOD, EXAMINING ATTORNEY



**CLASS 25—(Continued).**

SN 86-136,498. P WILLIE STYLE, LLC, ST. LOUIS, MO. FILED 12-5-2013.



THE NAME(S), PORTRAIT(S), AND/OR SIGNATURE(S) SHOWN IN THE MARK IDENTIFIES PATRICK WILLIS, WHOSE CONSENT(S) TO REGISTER IS MADE OF RECORD.

THE MARK CONTAINS AN IMAGE OF PATRICK WILLIS INCORPORATED INTO A CAPITAL LETTER "P", WITH HIS ARMS EXTENDED OUTWARD AND THE WORD "I'M" ON HIS RIGHT BICEP AND THE WORD "ME" ON HIS LEFT BICEP AND THE NUMBER "52" ON HIS CHEST.

FOR ATHLETIC APPAREL, NAMELY, SHIRTS, PANTS, JACKETS, FOOTWEAR, HATS AND CAPS, ATHLETIC UNIFORMS (U.S. CLS. 22 AND 39).

FIRST USE 9-8-2013; IN COMMERCE 9-8-2013.  
LESLEY LAMOTHE, EXAMINING ATTORNEY

SN 86-143,681. LOLA GETTS ACTIVE, LLC, SCOTTSDALE, AZ. FILED 12-13-2013.

**LOLA GETTS ACTIVE**

THE MARK CONSISTS OF STANDARD CHARACTERS WITHOUT CLAIM TO ANY PARTICULAR FONT, STYLE, SIZE, OR COLOR.

NO CLAIM IS MADE TO THE EXCLUSIVE RIGHT TO USE "ACTIVE", APART FROM THE MARK AS SHOWN.

"LOLA GETTS" DOES NOT IDENTIFY A LIVING INDIVIDUAL.

FOR CLOTHING, NAMELY, SHIRTS, T-SHIRTS, CARDIGANS, JERSEYS, PANTS, JUMPERS, JUMP SUITS, SHORTS, TOPS, CROP TOPS, TANK TOPS, HALTER TOPS, SWEAT SHIRTS, SWEAT SHORTS, SWEAT PANTS, WRAPS, WARM-UP SUITS, JOGGING SUITS, TRACK SUITS, SKIRTS, DRESSES, VESTS, FLEECE VESTS, PULLOVERS, SNOW SUITS, PARKAS, CAPES, PONCHOS, JACKETS, REVERSIBLE JACKETS, COATS, SWIMWEAR, BEACHWEAR, TENNIS WEAR, SURF WEAR, SKI WEAR, CAPS, BEANIES, HATS, VISORS, HEADBANDS, WRIST BANDS, SWEAT BANDS, SCARVES, BANDANAS, NECKWEAR, UNDERWEAR, BRAS, SPORTS BRAS, SOCKS, LOUNGEWEAR, UNDERCLOTHES, SARONGS, LEG WARMERS, LEGGINGS, TIGHTS, AND BODY SUITS; FOOTWEAR; HEADWEAR (U.S. CLS. 22 AND 39).

REBECCA POVARCHUK, EXAMINING ATTORNEY

**CLASS 25—(Continued).**

SN 86-145,220. TEGOL, INC., LOS ANGELES, CA. FILED 12-16-2013.

**REBEL ADVANCE MOTORCYCLE GEAR**

THE MARK CONSISTS OF STANDARD CHARACTERS WITHOUT CLAIM TO ANY PARTICULAR FONT, STYLE, SIZE, OR COLOR.

OWNER OF U.S. REG. NO. 4,028,949.

NO CLAIM IS MADE TO THE EXCLUSIVE RIGHT TO USE "ADVANCE MOTORCYCLE GEAR", APART FROM THE MARK AS SHOWN.

FOR LEATHER JACKETS; MOTORCYCLE JACKETS (U.S. CLS. 22 AND 39).

FIRST USE 8-0-2009; IN COMMERCE 8-0-2009.

MARY CRAWFORD, EXAMINING ATTORNEY

SN 86-147,734. RAYMOND D. TROTMAN, QUEENS, NY. FILED 12-18-2013.

**HNGR PNS 2 HALPH PHILL**

THE MARK CONSISTS OF STANDARD CHARACTERS WITHOUT CLAIM TO ANY PARTICULAR FONT, STYLE, SIZE, OR COLOR.

FOR ATHLETIC APPAREL, NAMELY, SHIRTS, PANTS, JACKETS, FOOTWEAR, HATS AND CAPS, ATHLETIC UNIFORMS; ATHLETIC PANTS; ATHLETIC SHIRTS; CAMOUFLAGE PANTS; CAPRI PANTS; CARGO PANTS; DENIMS; GYM PANTS; HOODED SWEAT SHIRTS; HOODED SWEATSHIRTS; HOODED SWEATSHIRTS FOR ADULTS; JACKETS; JERSEYS; JOGGING PANTS; KNIT SHIRTS; LEATHER PANTS; LOUNGE PANTS; PANTS; SHIRTS; SHIRTS AND SHORT-SLEEVED SHIRTS; SHORT-SLEEVED OR LONG-SLEEVED T-SHIRTS; SLEEP PANTS; SPORTS PANTS; STRETCH PANTS; SWEAT PANTS; T-SHIRTS; TOPS; TRACK PANTS; WATERPROOF JACKETS AND PANTS; WOMEN'S CLOTHING, NAMELY, SHIRTS, DRESSES, SKIRTS, BLOUSES (U.S. CLS. 22 AND 39).

FIRST USE 12-9-2013; IN COMMERCE 12-9-2013.

LINDA MICKLEBURGH, EXAMINING ATTORNEY

**CLASS 25—(Continued).**

SN 86-148,504. GUTTER, CEDRIC, FORT WORTH, TX. FILED 12-19-2013.



THE MARK CONSISTS OF THE STYLIZED TERM "KOPZ". THE TOP OF THE LETTER "K" GOES THROUGH THE CENTER OF THE "O".

FOR ATHLETIC APPAREL, NAMELY, SHIRTS, PANTS, JACKETS, FOOTWEAR, HATS AND CAPS, ATHLETIC UNIFORMS; CAPS; COMPRESSION GARMENTS FOR ATHLETIC OR OTHER NON-MEDICAL USE, NAMELY, SHIRTS AND SHORTS; FOOTWEAR; GLOVES; HATS; HEADBANDS; JACKETS; KNITTED CAPS; SHIRTS; SHORT-SLEEVED OR LONG-SLEEVED T-SHIRTS; SOCKS; SWEAT PANTS; SWEAT SHIRTS; T-SHIRTS; UNDERGARMENTS; UNDERWEAR; WRISTBANDS (U.S. CLS. 22 AND 39).

FIRST USE 10-12-2013; IN COMMERCE 10-12-2013.  
LINDA M. KING, EXAMINING ATTORNEY

SN 86-148,861. KIND DESIGN LLC, BOULDER, CO. FILED 12-19-2013.



THE MARK CONSISTS OF A LIGHT COLORED SNOWFLAKE INSIDE A DARKER RAINDROP WITHIN A DARK RECTANGLE.

FOR CLOTHING, NAMELY, T-SHIRTS, SWEAT SHIRTS, HOODED PULLOVERS, PANTS, TOPS, SHORTS, BOARD SHORTS, SKI GLOVES, SKI SOCKS, SKI TROUSERS, SKI BIBS, SKI SUITS, SKI JACKETS, SKI BOOTS AND THERMAL BASE LAYERS; HEADWEAR, NAMELY, BASEBALL CAPS, BEANIES, WINTER HATS; FOOTWEAR (U.S. CLS. 22 AND 39).

IRA J. GOODSAD, EXAMINING ATTORNEY

**CLASS 25—(Continued).**

SN 86-150,132. EDDIE BAUER LICENSING SERVICES LLC, BELLEVUE, WA. FILED 12-20-2013.

# FREEVENT

THE MARK CONSISTS OF STANDARD CHARACTERS WITHOUT CLAIM TO ANY PARTICULAR FONT, STYLE, SIZE, OR COLOR.

FOR CLOTHING, NAMELY, SHIRTS, FLANNEL SHIRTS, HOODED SWEATSHIRTS, MOCK TURTLENECK SHIRTS, ZIPPERED SWEATSHIRTS, ZIPPERED HOODED SWEATSHIRTS, CREWNECK SHIRTS, PULLOVERS, HOODED PULLOVERS, PANTS, TURTLENECK SHIRTS, JOGGING PANTS, SWEATERS, SWEATSHIRTS, T-SHIRTS, THERMAL UNDERWEAR, PANTS, TROUSERS, SLEEPWEAR AND SOCKS; OUTERWEAR, NAMELY, FOOTWEAR, HEADWEAR, FLEECE JACKETS, HOODED JACKETS, JACKETS, COATS, HATS, SCARVES, WIND RESISTANT JACKETS, ANORAKS, PARKAS, VESTS, MITTENS AND GLOVES; CLOTHING, NAMELY, SHIRTS, FLANNEL SHIRTS, HOODED SWEATSHIRTS, MOCK TURTLENECK SHIRTS, ZIPPERED SWEATSHIRTS, ZIPPERED HOODED SWEATSHIRTS, CREWNECK SHIRTS, PULLOVERS, HOODED PULLOVERS, PANTS, TURTLENECK SHIRTS, JOGGING PANTS, SWEATERS, SWEATSHIRTS, T-SHIRTS, THERMAL UNDERWEAR, PANTS, TROUSERS, SLEEPWEAR AND SOCKS, ALL WITH A FABRIC TREATMENT FOR VENTILATION; OUTERWEAR, NAMELY, FOOTWEAR, HEADWEAR, FLEECE JACKETS, HOODED JACKETS, JACKETS, COATS, HATS, SCARVES, WIND RESISTANT JACKETS, ANORAKS, PARKAS, VESTS, MITTENS AND GLOVES, ALL WITH A FABRIC TREATMENT FOR VENTILATION; CLOTHING, NAMELY, SHIRTS, FLANNEL SHIRTS, HOODED SWEATSHIRTS, MOCK TURTLENECK SHIRTS, ZIPPERED SWEATSHIRTS, ZIPPERED HOODED SWEATSHIRTS, CREWNECK SHIRTS, PULLOVERS, HOODED PULLOVERS, PANTS, TURTLENECK SHIRTS, JOGGING PANTS, SWEATERS, SWEATSHIRTS, T-SHIRTS, THERMAL UNDERWEAR, PANTS, TROUSERS, SLEEPWEAR AND SOCKS, ALL WITH A VENTILATION FEATURE; OUTERWEAR, NAMELY, FOOTWEAR, HEADWEAR, FLEECE JACKETS, HOODED JACKETS, JACKETS, COATS, HATS, SCARVES, WIND RESISTANT JACKETS, ANORAKS, PARKAS, VESTS, MITTENS AND GLOVES, ALL WITH A VENTILATION FEATURE; FEATURE SOLD AS AN INTEGRAL COMPONENT OF THE AFOREMENTIONED CLOTHING AND OUTERWEAR GOODS, NAMELY, A FABRIC WITH A VENTILATION FEATURE (U.S. CLS. 22 AND 39).

HANNO RITTNER, EXAMINING ATTORNEY

**CLASS 25—(Continued).**

SN 86-152,884. SATOR SPORTS, INC., TORRANCE, CA.  
FILED 12-26-2013.



OWNER OF U.S. REG. NO. 4,450,503.  
THE MARK CONSISTS OF A STYLIZED BAT ANIMAL  
ABOVE THE WORDING "AGORA".  
THE ENGLISH TRANSLATION OF "AGORA" IN THE  
MARK IS THE PORTUGUESE WORD "NOW".  
FOR PINNIES IN THE NATURE OF SCRIMMAGE  
VESTS FOR USE IN SOCCER (U.S. CLS. 22 AND 39).  
FIRST USE 3-1-2001; IN COMMERCE 3-1-2001.  
NORA BUCHANAN WILL, EXAMINING ATTORNEY

SN 86-155,742. MIUSOL, LIMITED LIABILITY COMPANY,  
FALLS CHURCH, VA. FILED 1-1-2014.

# MIUSOL

THE MARK CONSISTS OF STYLIZED LETTERS "MIU-  
SOL".  
FOR BODY LINEN; DOWN JACKETS; HATS; KNIT  
DRESSES; MEN'S AND WOMEN'S JACKETS, COATS,  
TROUSERS, VESTS; SHIRTS; SHOES; SKIRTS; TROU-  
SERS; WEDDING GOWNS (U.S. CLS. 22 AND 39).  
FIRST USE 10-20-2013; IN COMMERCE 10-20-2013.  
LESLEY LAMOTHE, EXAMINING ATTORNEY

SN 86-160,526. TEAM FILM, LLC, INDIANAPOLIS, IN.  
FILED 1-8-2014.

# live your film

THE MARK CONSISTS OF STANDARD CHARACTERS  
WITHOUT CLAIM TO ANY PARTICULAR FONT, STYLE,  
SIZE, OR COLOR.  
FOR ATHLETIC APPAREL, NAMELY, SHIRTS,  
PANTS, JACKETS, FOOTWEAR, HATS AND CAPS,  
ATHLETIC UNIFORMS (U.S. CLS. 22 AND 39).  
FIRST USE 10-7-2013; IN COMMERCE 10-7-2013.  
PAUL E. FAHRENKOPF, EXAMINING ATTORNEY

**CLASS 25—(Continued).**

SN 86-162,124. THOMPOSON, RICARDO A., MIAMI, FL.  
FILED 1-10-2014.



THE MARK CONSISTS OF THE WORDING "ISR IN-  
SPIRATION". ABOVE THE WORDING THERE IS AN OVAL  
IMAGE WITH A DESIGN THAT CONTAINS A DRAWING  
OF A HUMAN FIGURE. THE FIGURE IS WEARING A  
BASEBALL HAT AND A NARROW NECK TIE WITH THEIR  
LEFT ARM RAISED UP IN THE AIR AND THE RIGHT  
ARM AIMED DOWNWARDS. THE RIGHT UPWARDS  
PART OF THE FIGURE HAS A BRUSH HANDLE WITH A  
TUFT. THE TIP OF THE BRISTLES ARE DRIPPING WITH  
FOUR PAINT DROPS. THE BACKGROUND IS FILLED  
WITH HORIZONTAL AND VERTICAL ARROWS AND  
CURVED BANDS. THERE ARE ALSO CIRCLES AND  
SMALL DOTS WITHIN THE BACKGROUND OF THE OVAL  
DESIGN.

FOR A-SHIRTS; APPAREL FOR DANCERS, NAMELY,  
TEE SHIRTS, SWEATSHIRTS, PANTS, LEGGINGS,  
SHORTS AND JACKETS; ATHLETIC APPAREL,  
NAMELY, SHIRTS, PANTS, JACKETS, FOOTWEAR,  
HATS AND CAPS, ATHLETIC UNIFORMS; BABIES'  
PANTS; BELTS; BOW TIES; BUSINESS WEAR, NAMELY,  
SUITS, JACKETS, TROUSERS, BLAZERS, BLOUSES,  
SHIRTS, SKIRTS, DRESSES AND FOOTWEAR; BUTTON  
DOWN SHIRTS; CLOTHING FOR ATHLETIC USE,  
NAMELY, PADDED PANTS; CLOTHING FOR ATH-  
LETIC USE, NAMELY, PADDED SHIRTS; CLOTHING  
SHIELDS, NAMELY, PADS APPLIED TO THE UNDER-  
ARMS OF SHIRTS, BLOUSES AND SWEATERS; CLOTH-  
ING, NAMELY, ATHLETIC SLEEVES; FASHION HATS;  
TIES (U.S. CLS. 22 AND 39).

FIRST USE 1-4-2014; IN COMMERCE 1-4-2014.  
SETH A. RAPPAPORT, EXAMINING ATTORNEY

SN 86-163,221. NIXON, DANIEL L., DBA I.C.E. LAND,  
NASHVILLE, TN. FILED 1-11-2014.



THE COLOR(S) BROWN RED AND GREEN IS/ARE  
CLAIMED AS A FEATURE OF THE MARK.

THE MARK CONSISTS OF THE STYLIZED WORDING  
"I.C.E. LAND" APPEARING IN BROWN WITH A RED ROSE  
WITH A GREEN STEM AND LEAVES BETWEEN THE  
TERMS. THE WHITE BACKGROUND IS NOT A FEATURE  
OF THE MARK.

FOR LONG-SLEEVED SHIRTS; SHORT-SLEEVED OR  
LONG-SLEEVED T-SHIRTS (U.S. CLS. 22 AND 39).  
DONALD JOHNSON, EXAMINING ATTORNEY

**CLASS 25—(Continued).**

SN 86-165,912. MARTINEZ, LUIS, EDINBURG, TX. FILED 1-15-2014.

**DOGO BRAND**

THE MARK CONSISTS OF STANDARD CHARACTERS WITHOUT CLAIM TO ANY PARTICULAR FONT, STYLE, SIZE, OR COLOR.

NO CLAIM IS MADE TO THE EXCLUSIVE RIGHT TO USE "BRAND", APART FROM THE MARK AS SHOWN.

THE ENGLISH TRANSLATION OF "DOGO" IN THE MARK IS "BULL MASTIFF".

FOR CLOTHING, NAMELY, T-SHIRTS, SHIRTS, TOPS, SWEATERS, SWEATSHIRTS, HOODED SWEATSHIRTS; COATS, JERSEYS, JACKETS, BOTTOMS, PANTS, TROUSERS, JEANS, SHORTS, SWEATPANTS, PAJAMAS, DRESSES, SKIRTS, BLOUSES, UNDERWEAR, SWIMWEAR, HEADWEAR, FOOTWEAR, SLEEPWEAR, PANTIES, BOXERS, JACKETS, HATS, VESTS, LEGGINGS; MARTIAL ARTS UNIFORMS, NAMELY, GIS; MIXED MARTIAL ARTS SUITS; FIGHT SHORTS FOR MIXED MARTIAL ARTS OR GRAPPLING (U.S. CLS. 22 AND 39).  
MARY ROSSMAN, EXAMINING ATTORNEY

**CLASS 25—(Continued).**

SN 86-166,935. MEDINA, WILLIAM, DBA FR3AK, RIVERVIEW, FL. FILED 1-16-2014.

**FR3AK**

THE MARK CONSISTS OF STANDARD CHARACTERS WITHOUT CLAIM TO ANY PARTICULAR FONT, STYLE, SIZE, OR COLOR.

FOR APPAREL FOR DANCERS, NAMELY, TEE SHIRTS, SWEATSHIRTS, PANTS, LEGGINGS, SHORTS AND JACKETS; ATHLETIC APPAREL, NAMELY, SHIRTS, PANTS, JACKETS, FOOTWEAR, HATS AND CAPS, ATHLETIC UNIFORMS; BASEBALL CAPS AND HATS; HOODED SWEATSHIRTS; SHORT-SLEEVED OR LONG-SLEEVED T-SHIRTS; SWEATSHIRTS; SWEATSHIRTS FOR ADULTS AND CHILDREN; T-SHIRTS; T-SHIRTS FOR ADULTS AND CHILDREN (U.S. CLS. 22 AND 39).

EMILY CHUO, EXAMINING ATTORNEY

SN 86-167,639. PEANUTS WORLDWIDE LLC, NEW YORK, NY. FILED 1-16-2014.

SN 86-166,724. TIM LAKE, DBA OCEANSIDE CARVERS, GROVER BEACH, CA. FILED 1-15-2014.



NO CLAIM IS MADE TO THE EXCLUSIVE RIGHT TO USE "GROVER BEACH, CA", APART FROM THE MARK AS SHOWN.

THE MARK CONSISTS OF THE LETTERS "OSC" IN A CIRCLE AND THE STYLIZED WORDING "OCEANSIDE CARVERS GROVER BEACH, CA".

FOR T-SHIRTS (U.S. CLS. 22 AND 39).  
FIRST USE 12-20-2013; IN COMMERCE 12-20-2013.  
KIM MONINGHOFF, EXAMINING ATTORNEY



OWNER OF U.S. REG. NOS. 1,256,900, 1,267,166 AND OTHERS.

THE MARK CONSISTS OF TWO PARTIALLY OBSCURED STYLIZED DOG FACES MOSTLY WITHIN A SQUARE WITH THE AMPERSAND SYMBOL BETWEEN THE DOG FACES, THE WORDING "SNOOPY" ALONG THE LEFT SIDE OF THE SQUARE, AND THE WORDING "HIS SISTER BELLE" ALONG THE RIGHT SIDE OF THE SQUARE.

FOR CLOTHING, NAMELY, SLEEPWEAR, UNDERWEAR, SHIRTS, PANTS, JEANS, JUMPERS, OVERALLS, ROMPERS, SKIRTS, DRESSES, SHORTS, TOPS, BLOUSES, LEGGINGS, TIGHTS, SOCKS, SWEAT SHIRTS, SWEAT SHIRTS WITH HOODS, COATS, RAINCOATS, JACKETS, VESTS, MITTENS, SCARVES, GLOVES, BELTS, NECK TIES, SWEATERS, SWIMWEAR, BIBS NOT OF PAPER, LOUNGE WEAR, INFANT WEAR, LAYETTES, MASQUERADE COSTUMES; HEADWEAR; FOOTWEAR (U.S. CLS. 22 AND 39).

MAIA ROSENBERG, EXAMINING ATTORNEY

**CLASS 25—(Continued).**

SN 86-168,947. EARTH CREATIONS, INC., BESSEMER, AL. FILED 1-17-2014.



OWNER OF U.S. REG. NOS. 2,241,044 AND 2,257,538.  
NO CLAIM IS MADE TO THE EXCLUSIVE RIGHT TO USE "WEAR", APART FROM THE MARK AS SHOWN.

THE MARK CONSISTS OF THE WORDS "WHOLE EARTH WEAR" SURROUNDED BY A RECTANGULAR BOX WITH A STYLIZED HALF-MOON SHAPE CONTAINING A WAVE DESIGN APPEARING ON TOP OF THE RECTANGULAR BOX ABOVE WHERE THE WORD "EARTH" APPEARS IN THE BOX.

FOR T-SHIRTS FOR ADULTS, CHILDREN, WOMEN, MEN; MEN'S, WOMEN'S, AND CHILDREN'S CLOTHING AND ACCESSORIES, NAMELY, T-SHIRTS, SWEATSHIRTS, LONG SLEEVE T-SHIRTS, TANK TOPS, GOLF SHIRTS, FLEECE SWEATSHIRTS, CAPS, BASEBALL CAPS, HATS, SHIRTS, JACKETS, SOCKS, PANTS, SHORTS, SCARVES, OVERALLS, APRONS, AND BANDANAS (U.S. CLS. 22 AND 39).

FIRST USE 6-6-2013; IN COMMERCE 11-20-2013.  
MEGHAN REINHART, EXAMINING ATTORNEY

**CLASS 25—(Continued).**

SN 86-175,578. P.I.N.K.E.D! LLC, ELKRIDGE, MD. FILED 1-27-2014.

P.I.N.K.E.D! COUTURE

THE MARK CONSISTS OF STANDARD CHARACTERS WITHOUT CLAIM TO ANY PARTICULAR FONT, STYLE, SIZE, OR COLOR.

NO CLAIM IS MADE TO THE EXCLUSIVE RIGHT TO USE "COUTURE", APART FROM THE MARK AS SHOWN.

FOR CLOTHING, NAMELY, TOPS, BOTTOMS, DRESSES, GOWNS, SLEEPWEAR, SWIMWEAR, BRIDAL GOWNS, BRIDESMAIDS DRESSES; FOOTWEAR, NAMELY, CUSTOM SHOES, SHOES, CUSTOM SHOES WITH PERSONALIZED SOLES, DYEABLE SHOES (U.S. CLS. 22 AND 39).

FIRST USE 7-11-2012; IN COMMERCE 7-11-2012.  
DAVID TAYLOR, EXAMINING ATTORNEY

SN 86-169,417. MEGHAN KELLEY, CAMARILLO, CA. FILED 1-18-2014.

Crazy Irish Girls

THE MARK CONSISTS OF STANDARD CHARACTERS WITHOUT CLAIM TO ANY PARTICULAR FONT, STYLE, SIZE, OR COLOR.

NO CLAIM IS MADE TO THE EXCLUSIVE RIGHT TO USE "GIRLS", APART FROM THE MARK AS SHOWN.

FOR HATS; HOODED SWEATSHIRTS; JACKETS; PANTS; SHORT-SLEEVED OR LONG-SLEEVED T-SHIRTS; SHORTS; SOCKS; SWEATERS; SWEATSHIRTS; T-SHIRTS; TANK TOPS (U.S. CLS. 22 AND 39).

FIRST USE 3-17-2006; IN COMMERCE 1-3-2013.  
ELIZABETH HUGHITT, EXAMINING ATTORNEY

SN 86-178,155. BROCK, MARTIN EDWARD, PALESTINE, IL. FILED 1-29-2014.

RDR INTERNATIONAL

THE MARK CONSISTS OF STANDARD CHARACTERS WITHOUT CLAIM TO ANY PARTICULAR FONT, STYLE, SIZE, OR COLOR.

NO CLAIM IS MADE TO THE EXCLUSIVE RIGHT TO USE "INTERNATIONAL", APART FROM THE MARK AS SHOWN.

FOR HATS (U.S. CLS. 22 AND 39).  
TIMOTHY FINNEGAN, EXAMINING ATTORNEY

**CLASS 25—(Continued).**

SN 86-178,332. THE REALLY WILD CLOTHING COMPANY LIMITED, BERKSHIRE, UNITED KINGDOM, FILED 1-29-2014.



PRIORITY CLAIMED UNDER SEC. 44(D) ON UNITED KINGDOM APPLICATION NO. UK0000301652, FILED 8-2-2013.

NO CLAIM IS MADE TO THE EXCLUSIVE RIGHT TO USE "COLLECTION LONDON", APART FROM THE MARK AS SHOWN.

THE MARK CONSISTS OF THE STYLIZED LETTERS "RW" ABOVE THE WORD "COLLECTION" AND THE WORD "LONDON" UNDERNEATH THE WORD "COLLECTION".

FOR CLOTHING, NAMELY, LINGERIE, T-SHIRTS, SWEATSHIRTS; FOUL WEATHER GEAR, WATER-PROOF JACKETS AND PANTS, WIND RESISTANT JACKETS, WIND SHIRTS AND RAINWEAR; FOOTWEAR; AND HEADGEAR, NAMELY, CAPS AND BASEBALL HATS (U.S. CLS. 22 AND 39).

REBECCA SMITH, EXAMINING ATTORNEY

**CLASS 25—(Continued).**

SN 86-178,552. MARGARET O'LEARY, INC., SAN FRANCISCO, CA. FILED 1-29-2014.



OWNER OF U.S. REG. NO. 1,969,952.

THE MARK CONSISTS OF THE LETTERS "MOL" IN STYLIZED FORM INSIDE A CIRCLE. THE LETTERS "M" AND "L" OVERLAP THE LETTER "O" INSIDE THE CIRCLE.

FOR CLOTHING, NAMELY, SWEATERS, SHIRTS, T-SHIRTS, JACKETS, HATS, SCARVES, SHAWLS, PANTS, BLOUSES, SOCKS, GLOVES, SHOES, BOOTS, BELTS, LEGWARMERS, STOCKINGS, LEGGINGS, TIGHTS, LINGERIE, AND SPORTSWEAR, NAMELY, SPORTS SHIRTS, SPORTS PANTS, SPORTS BRAS, SWEAT SUITS AND JOGGING SUITS (U.S. CLS. 22 AND 39).

WON TEAK OH, EXAMINING ATTORNEY

SN 86-178,550. MARGARET O'LEARY, INC., SAN FRANCISCO, CA. FILED 1-29-2014.



SN 86-185,495. KOVAL, OLESYA, LAS VEGAS, NV. FILED 2-5-2014.

**Aubergine**

OWNER OF U.S. REG. NO. 1,969,952.  
THE NAME(S), PORTRAIT(S), AND/OR SIGNATURE(S) SHOWN IN THE MARK DOES NOT IDENTIFY A PARTICULAR LIVING INDIVIDUAL.

THE MARK CONSISTS OF THE WORDS "LIAM O'LEARY" IN A STYLIZED FORM.

FOR MEN'S CLOTHING, NAMELY, SWEATERS; MEN'S CLOTHING, NAMELY, SHIRTS, PULL OVERS, JACKETS, SCARVES, SWEAT PANTS, SWEAT SHIRTS, T-SHIRTS, VESTS, BELTS, SOCKS, HATS AND GLOVES (U.S. CLS. 22 AND 39).

FIRST USE 7-15-2013; IN COMMERCE 7-15-2013.

WON TEAK OH, EXAMINING ATTORNEY

THE MARK CONSISTS OF STANDARD CHARACTERS WITHOUT CLAIM TO ANY PARTICULAR FONT, STYLE, SIZE, OR COLOR.

FOR CLOTHING, NAMELY, SHIRTS, PANTS, DRESSES, GOWNS, SHORTS, SKIRTS, JACKETS, COATS, VESTS, SWEATERS, SUITS, UNDERWEAR, BELTS, AND FOOTWEAR (U.S. CLS. 22 AND 39).

TIMOTHY FINNEGAN, EXAMINING ATTORNEY

**CLASS 25—(Continued).**

SN 86-185,673. MARRERO, GUILLERMO, SAN DIEGO, CA. AND JUAREZ, CAROLINA, SAN DIEGO, CA. FILED 2-5-2014.

## Humble Warrior

THE MARK CONSISTS OF STANDARD CHARACTERS WITHOUT CLAIM TO ANY PARTICULAR FONT, STYLE, SIZE, OR COLOR.

FOR ATHLETIC APPAREL, NAMELY, SHIRTS, PANTS, JACKETS, FOOTWEAR, HATS AND CAPS, ATHLETIC UNIFORMS; BANDANAS; BELTS FOR CLOTHING; BOARD SHORTS; BOTTOMS; COMPRESSION GARMENTS FOR ATHLETIC OR OTHER NON-MEDICAL USE, NAMELY, COMPRESSION SOCKS, STOCKINGS, LEGGINGS, JERSEYS, VESTS, TROUSERS FOR YOGA, RUNNING, CROSS-FIT; GLOVES AS CLOTHING; HEAD WRAPS; HEADBANDS FOR CLOTHING; HEADWEAR; HOODED SWEATSHIRTS; HOODS; JACKETS; JERSEYS; JUMPERS; LEGGINGS; MUSCLE TOPS; PANTS; SANDALS; SCARVES; SHIRTS; SHORT SETS; SHORTS; SOCKS; SPORTS PANTS; SUN VISORS; SWEATSHIRTS; T-SHIRTS; TANK TOPS; TIGHTS; TOPS; UNDERWEAR; VESTS; VISORS; WRISTBANDS (U.S. CLS. 22 AND 39).

ALICE BENMAMAN, EXAMINING ATTORNEY

SN 86-186,904. SENIZERGUES, PIERRE ANDRE, NEWPORT BEACH, CA. FILED 2-6-2014.

## THERMOTHANE

THE MARK CONSISTS OF STANDARD CHARACTERS WITHOUT CLAIM TO ANY PARTICULAR FONT, STYLE, SIZE, OR COLOR.

FOR OUTSOLES SOLD AS A COMPONENT OF NON-ORTHOPEDIC FOOTWEAR (U.S. CLS. 22 AND 39).

KATHERINE CHANG, EXAMINING ATTORNEY

**CLASS 25—(Continued).**

SN 86-191,126. ONOVAKPURI, OGHENERUNO, AKA LUNAR JONES, ROSEVILLE, CA. FILED 2-11-2014.



NO CLAIM IS MADE TO THE EXCLUSIVE RIGHT TO USE "GIRLS", APART FROM THE MARK AS SHOWN.

THE MARK CONSISTS OF THE NUMBER "101" OVER THE WORDING "FINE GIRLS" WITH SILHOUETTES OF SITTING WOMEN ON EACH END OF THE "1'S" AND WITH THE FIRST NUMERAL "1" FACING BACKWARD; A HORIZONTAL LINE SEPARATES "101" AND SILHOUETTES AND THE WORDING "FINE GIRLS".

FOR A-SHIRTS: APPAREL FOR DANCERS, NAMELY, TEE SHIRTS, SWEATSHIRTS, PANTS, LEGGINGS, SHORTS AND JACKETS; ATHLETIC APPAREL, NAMELY, SHIRTS, PANTS, JACKETS, FOOTWEAR, HATS AND CAPS, ATHLETIC UNIFORMS; ATHLETIC SHIRTS; BELTS; BODY SHIRTS; BUTTON DOWN SHIRTS; DRAWERS; LADIES' UNDERWEAR; THONG UNDERWEAR; UNDERWEAR; UNDERWEAR, NAMELY, BOY SHORTS; WOMEN'S UNDERWEAR (U.S. CLS. 22 AND 39).

RICHARD WHITE, EXAMINING ATTORNEY

SN 86-191,210. BEATING THE BULLY LLC, FOREST HEIGHTS, MD. FILED 2-12-2014.

## I am beating the bully We are beating the bully So let's beat the bully

THE MARK CONSISTS OF STANDARD CHARACTERS WITHOUT CLAIM TO ANY PARTICULAR FONT, STYLE, SIZE, OR COLOR.

FOR ADULT NOVELTY GAG CLOTHING ITEM, NAMELY, SOCKS; ATHLETIC TOPS AND BOTTOMS FOR TEAM AND INDIVIDUAL SWEAT AND WARM UP SUITS; BABIES' PANTS; BABY LAYETTES FOR CLOTHING; BELTS; BELTS FOR CLOTHING; BELTS MADE OUT OF CLOTH; BIBS NOT OF CLOTH OR PAPER; BOTTOMS; CHILDREN'S AND INFANTS' CLOTH BIBS; CHILDREN'S CLOTH EATING BIBS; CLOTH BIBS; CLOTH BIBS FOR ADULT DINERS; CLOTH BIBS FOR USE BY SENIOR CITIZENS OR PHYSICALLY- OR MENTALLY-CHALLENGED PERSONS; CLOTHING EXTENSION USED TO EXTEND THE NORMAL SIZE RANGE OF CLOTHING ITEMS TO ACCOMMODATE PREGNANCY SIZE CHANGES; CLOTHING FOR ATHLETIC USE, NAMELY, PADDED ELBOW COMPRESSION SLEEVES BEING PART OF AN ATHLETIC GARMENT; CLOTHING FOR ATHLETIC USE, NAMELY, PADDED PANTS; CLOTHING FOR ATHLETIC USE, NAMELY, PADDED SHIRTS; CLOTHING FOR ATHLETIC USE, NAMELY, PADDED SHORTS; CLOTHING FOR BABIES, TODDLERS AND CHILDREN, TREATED WITH FIRE AND HEAT RETARDANTS, NAMELY, PAJAMAS, JACKETS, SHIRTS, PANTS, JUMPERS; CLOTHING FOR WEAR IN JUDO PRACTICES; CLOTHING FOR WEAR IN WRESTLING GAMES; CLOTHING ITEMS, NAMELY, ADHESIVE POCKETS THAT MAY BE AFFIXED DIRECTLY TO THE BODY AS A DECORATIVE PIECE OF CLOTHING WITH UTILITY; CLOTHING ITEMS, NAMELY, ADHESIVE POCKETS THAT MAY BE AFFIXED DIRECTLY TO THE INSIDE OF CLOTHING FOR STORAGE AND SAFEKEEPING OF PERSONAL ITEMS; CLOTHING ITEMS, NAMELY, BLINDFOLDS WORN OVER THE

**CLASS 25—(Continued).**

EYES; CLOTHING ITEMS, NAMELY, GAGS WORN OVER THE MOUTH; CLOTHING SHIELDS, NAMELY, PADS APPLIED TO THE UNDERARMS OF SHIRTS, BLOUSES AND SWEATERS; CLOTHING STRAPS FOR SHOES; CLOTHING, NAMELY, ARM WARMERS; CLOTHING, NAMELY, ATHLETIC SLEEVES; CLOTHING, NAMELY, BASE LAYERS; CLOTHING, NAMELY, COWLS AND SMOKE RING SCARVES; CLOTHING, NAMELY, CROPS; CLOTHING, NAMELY, FOLK COSTUMES; CLOTHING, NAMELY, HAND-WARMERS; CLOTHING, NAMELY, KHAKIS; CLOTHING, NAMELY, KNEE WARMERS; CLOTHING, NAMELY, MATERNITY BANDS; CLOTHING, NAMELY, NECK TUBES; CLOTHING, NAMELY, THOBES; CLOTHING, NAMELY, WRAP-AROUNDS; COMBINATIONS; CORSETS; DRAWERS; DUSTERS; EYESHADES; FIGURE SKATING CLOTHING, NAMELY, UNIFORMS AND COSTUMES; FOULARDS; GLOVES AS CLOTHING; HEAD WRAPS; HEADBANDS FOR CLOTHING; HOODS; INFANT AND TODDLER ONE PIECE CLOTHING; JACKETS; JERSEYS; LEATHER BELTS; MANTLES; MATERNITY CLOTHING, NAMELY, DRESSES AND SHIRTS; MUFFLERS; NON-DISPOSABLE CLOTH TRAINING PANTS; PAPER HATS FOR USE AS CLOTHING ITEMS; PARTS OF CLOTHING, NAMELY, GUSSETS FOR TIGHTS, GUSSETS FOR STOCKINGS, GUSSETS FOR BATHING SUITS, GUSSETS FOR UNDERWEAR, GUSSETS FOR LEOTARDS AND GUSSETS FOR FOOTLETS; PARTS OF CLOTHING, NAMELY, UNDERARM GUSSETS; PERSPIRATION ABSORBENT UNDERWEAR CLOTHING; POCKET SQUARES; POCKETS FOR CLOTHING; SHIRTS; SHORT SETS; SHOULDER WRAPS; SHOULDER WRAPS FOR CLOTHING; SUN PROTECTIVE CLOTHING, NAMELY, VISORS AND BALL CAPS; SWADDLING CLOTHES; TIES; TOPS; TRAVEL CLOTHING CONTAINED IN A PACKAGE COMPRISING REVERSIBLE JACKETS, PANTS, SKIRTS, TOPS AND A BELT OR SCARF; TRIATHLON CLOTHING, NAMELY, TRIATHLON TIGHTS, TRIATHLON SHORTS, TRIATHLON SINGLET, TRIATHLON SHIRTS, TRIATHLON SUITS; UNDERARM CLOTHING SHIELDS; WEARABLE GARMENTS AND CLOTHING, NAMELY, SHIRTS; WOMEN'S CLOTHING, NAMELY, SHIRTS, DRESSES, SKIRTS, BLOUSES; WRAPS; WRIST BANDS; WRISTBANDS (U.S. CLS. 22 AND 39).

FIRST USE 11-1-2013; IN COMMERCE 11-1-2013.  
KELLY BOULTON, EXAMINING ATTORNEY

**CLASS 25—(Continued).**

SN 86-192,815. CANCER SUPPORT COMMUNITY OF GREATER ANN ARBOR, DBA THE BRIDES PROJECT, ANN ARBOR, MI. FILED 2-13-2014.



NO CLAIM IS MADE TO THE EXCLUSIVE RIGHT TO USE "BRIDES", APART FROM THE MARK AS SHOWN.

THE MARK CONSISTS OF A STYLIZED DESIGN OF A DRESS COMPOSED OF THE STACKED WORDING "THE BRIDES PROJECT" WITH THE DESIGNS OF A SCALLOPED EDGE AND SHOULDER STRAPS ABOVE THE WORD "THE", THE DESIGN OF A WAISTBAND BETWEEN THE WORDS "THE" AND "BRIDES".

FOR DRESSES; EVENING DRESSES; WEDDING DRESSES; WOMEN'S CEREMONIAL DRESSES (U.S. CLS. 22 AND 39).

FIRST USE 5-26-2011; IN COMMERCE 5-26-2011.

INGRID C. EULIN, EXAMINING ATTORNEY

SN 86-196,026. SLADE, KEVIN, LLOYDMINSTER, ALBERTA, CANADA, FILED 2-18-2014.

**REBELS SINS**

THE MARK CONSISTS OF STANDARD CHARACTERS WITHOUT CLAIM TO ANY PARTICULAR FONT, STYLE, SIZE, OR COLOR.

FOR CLOTHING OF PREMIUM QUALITY, NAMELY, LONG SLEEVE SHIRTS, SHORT SLEEVE SHIRTS, POLOS, PANTS, DENIM PANTS, DRESSES, JACKETS, LEATHER JACKETS, SCARVES, TOPS, NAMELY, BLOUSES, TUNICS, WOMEN'S AND MEN'S CLOTHING, NAMELY, T-SHIRTS, TOPS, SHIRTS, WOVEN SHIRTS, DRESS SHIRTS, LONG-SLEEVE SHIRTS, SHORT-SLEEVE SHIRTS, POLO SHIRTS, DENIM PANTS, SLACKS, TROUSERS, PANTS, LEATHER PANTS, DRESSES, JACKETS, LEATHER JACKETS, COATS, LEATHER COATS, BLAZERS AND SCARVES (U.S. CLS. 22 AND 39).

SHANNON TWOHIG, EXAMINING ATTORNEY



**CLASS 25—(Continued).**

SN 86-196,508. KHURRAM MALIK, LAHORE, PAKISTAN, AND KHAWAR MALIK, LAHORE, PAKISTAN, FILED 2-18-2014.

**RESURGENCE GEAR**

THE MARK CONSISTS OF STANDARD CHARACTERS WITHOUT CLAIM TO ANY PARTICULAR FONT, STYLE, SIZE, OR COLOR.

NO CLAIM IS MADE TO THE EXCLUSIVE RIGHT TO USE "GEAR", APART FROM THE MARK AS SHOWN.

FOR JEANS, CARGO TROUSERS, CARGO PANTS, JACKETS, T-SHIRTS, SHORTS, DENIM PANTS (U.S. CLS. 22 AND 39).

FIRST USE 3-31-2013; IN COMMERCE 3-31-2013.  
BARBARA A. GOLD, EXAMINING ATTORNEY

---

SN 86-196,994. CABELA'S INCORPORATED, SIDNEY, NE. FILED 2-18-2014.

**4MOST DRY**

THE MARK CONSISTS OF STANDARD CHARACTERS WITHOUT CLAIM TO ANY PARTICULAR FONT, STYLE, SIZE, OR COLOR.

NO CLAIM IS MADE TO THE EXCLUSIVE RIGHT TO USE "DRY", APART FROM THE MARK AS SHOWN.

FOR RAINWEAR, JACKETS, PARKAS, SHIRTS, PULL-OVERS, SWEATSHIRTS, PANTS, SHORTS, SKIRTS, GLOVES, MITTENS, HATS, CAPS, HIKING BOOTS, HUNTING BOOTS, WINTER PAC BOOTS, ATHLETIC SHOES, BOAT AND WATER SHOES, SANDALS, HUNTING WADERS, FISHING WADERS (U.S. CLS. 22 AND 39).

SANI KHOURI, EXAMINING ATTORNEY

---

SN 86-197,050. CABELA'S INCORPORATED, SIDNEY, NE. FILED 2-18-2014.

**4MOST THERMAL**

THE MARK CONSISTS OF STANDARD CHARACTERS WITHOUT CLAIM TO ANY PARTICULAR FONT, STYLE, SIZE, OR COLOR.

NO CLAIM IS MADE TO THE EXCLUSIVE RIGHT TO USE "THERMAL", APART FROM THE MARK AS SHOWN.

FOR RAINWEAR, JACKETS, PARKAS, PANTS, SHIRTS, PULLOVERS, SWEATSHIRTS, SHORTS, SKIRTS, GLOVES, MITTENS, HATS, CAPS, HIKING BOOTS, HUNTING BOOTS, WINTER PAC BOOTS, ATHLETIC SHOES, BOAT AND WATER SHOES, SANDALS, SOCKS, HUNTING WADERS, FISHING WADERS (U.S. CLS. 22 AND 39).

SANI KHOURI, EXAMINING ATTORNEY

**CLASS 25—(Continued).**

SN 86-197,066. CABELA'S INCORPORATED, SIDNEY, NE. FILED 2-18-2014.

**4MOST WICK**

THE MARK CONSISTS OF STANDARD CHARACTERS WITHOUT CLAIM TO ANY PARTICULAR FONT, STYLE, SIZE, OR COLOR.

NO CLAIM IS MADE TO THE EXCLUSIVE RIGHT TO USE "WICK", APART FROM THE MARK AS SHOWN.

FOR SHIRTS, PULLOVERS, SWEATSHIRTS, PANTS, SHORTS, SKIRTS, JACKETS, PARKAS, GLOVES, MITTENS, HATS, CAPS, SOCKS, HIKING BOOTS, HUNTING BOOTS, WINTER PAC BOOTS, ATHLETIC SHOES, BOAT AND WATER SHOES, SANDALS, HUNTING WADERS, FISHING WADERS (U.S. CLS. 22 AND 39).

SANI KHOURI, EXAMINING ATTORNEY

---

SN 86-198,394. SCHOEN BY YU, ALTADENA, CA. FILED 2-19-2014.

**Schoen by Yu**

THE MARK CONSISTS OF STANDARD CHARACTERS WITHOUT CLAIM TO ANY PARTICULAR FONT, STYLE, SIZE, OR COLOR.

THE ENGLISH TRANSLATION OF "SCHOEN" IN THE MARK IS "BEAUTIFUL".

FOR BOTTOMS; DENIMS; KNIT BOTTOMS; WOVEN BOTTOMS (U.S. CLS. 22 AND 39).

TIMOTHY FINNEGAN, EXAMINING ATTORNEY

**CLASS 25—(Continued).**

SN 86-198,810. RINAT BRODACH LIMITED LIABILITY COMPANY, NEW YORK, NY. FILED 2-20-2014.



THE MARK CONSISTS OF THE "R" IS A CUSTOM DESIGN AND REVERSED AND THE "B" CUSTOM DESIGN AND UPSIDE DOWN REVERSED.

FOR CLOTHING, NAMELY, TOPS, SHIRTS, SWEATERS, JACKETS, COATS, PONCHOS, CAPES, PANTS, SHORTS, SKIRTS, DRESSES, TIGHTS, HATS, SOCKS, GLOVES, SCARVES, LINGERIE, UNDERWEAR, SHOES (U.S. CLS. 22 AND 39).

FIRST USE 11-1-2013; IN COMMERCE 11-1-2013.  
HOWARD SMIGA, EXAMINING ATTORNEY

**CLASS 25—(Continued).**

SN 86-198,975. JAVIER VALENTIN, WEST HARRISON, NY. FILED 2-20-2014.



THE MARK CONSISTS OF A SHIELD OUTLINE CONTAINING THE LETTERS "M O S".

FOR A-SHIRTS; ANTI-SWEAT UNDERWEAR; APPAREL FOR DANCERS, NAMELY, TEE SHIRTS, SWEATSHIRTS, PANTS, LEGGINGS, SHORTS AND JACKETS; ATHLETIC APPAREL, NAMELY, SHIRTS, PANTS, JACKETS, FOOTWEAR, HATS AND CAPS, ATHLETIC UNIFORMS; ATHLETIC PANTS; ATHLETIC SHIRTS; BABIES' PANTS; BODY SHIRTS; BRIEFS; BUSINESS WEAR, NAMELY, SUITS, JACKETS, TROUSERS, BLAZERS, BLOUSES, SHIRTS, SKIRTS, DRESSES AND FOOTWEAR; BUTTON DOWN SHIRTS; BUTTON-FRONT ALOHA SHIRTS; CAMOUFLAGE PANTS; CAMOUFLAGE SHIRTS; CAPRI PANTS; CARGO PANTS; CLOTHING FOR ATHLETIC USE, NAMELY, PADDED PANTS; CLOTHING FOR BABIES, TODDLERS AND CHILDREN, TREATED WITH FIRE AND HEAT RETARDANTS, NAMELY, PAJAMAS, JACKETS, SHIRTS, PANTS, JUMPERS; CROP PANTS; DENIMS; DRESS PANTS; FLOOD PANTS; KNITTED UNDERWEAR; LADIES' UNDERWEAR; LONG UNDERWEAR; MEN'S UNDERWEAR; PERSPIRATION ABSORBENT UNDERWEAR CLOTHING; THERMAL UNDERWEAR; THONG UNDERWEAR; UNDERWEAR; UNDERWEAR, NAMELY, BOY SHORTS; WOMEN'S UNDERWEAR; WOVEN OR KNITTED UNDERWEAR (U.S. CLS. 22 AND 39).

TINA MAI, EXAMINING ATTORNEY

SN 86-200,762. GOLDEN BRAND INC., LOS ANGELES, CA. FILED 2-21-2014.

**TESORO MODA**

THE MARK CONSISTS OF STANDARD CHARACTERS WITHOUT CLAIM TO ANY PARTICULAR FONT, STYLE, SIZE, OR COLOR.

NO CLAIM IS MADE TO THE EXCLUSIVE RIGHT TO USE "MODA", APART FROM THE MARK AS SHOWN.

THE ENGLISH TRANSLATION OF THE WORD "TESORO MODA" IN THE MARK IS "TREASURES IN FASHION".

FOR BLOUSES; BOMBER JACKETS; COATS FOR MEN AND WOMEN; DRESSES; DUSTERS; JACKETS; JEGGINGS, NAMELY, PANTS THAT ARE PARTIALLY JEANS AND PARTIALLY LEGGINGS; KNIT JACKETS; KNIT TOPS; LEATHER COATS; LEATHER JACKETS; LEGGINGS; PANTS; SHORTS; SKIRTS; SKIRTS AND DRESSES; T-SHIRTS; TANK TOPS; TUNICS; WOMEN'S TOPS, NAMELY, CAMIS (U.S. CLS. 22 AND 39).

JACQUELINE ABRAMS, EXAMINING ATTORNEY

**CLASS 25—(Continued).**

SN 86-201,190. COLON, NICHOLAS JASON, BRIDGEPORT, CT. FILED 2-22-2014.



NO CLAIM IS MADE TO THE EXCLUSIVE RIGHT TO USE "CLOTHING", APART FROM THE MARK AS SHOWN. THE MARK CONSISTS OF THE WORDING "N.J.C. NOT JUST CLOTHING" IN STYLIZED FONT. THE LETTERING "N.J.C." APPEARS OVER THE WORDING "NOT JUST CLOTHING". A BOLD LINE APPEARS ABOVE AND BELOW THE WORDING "N.J.C.", AS WELL AS BELOW THE WORDING "NOT JUST CLOTHING". ABOVE THE WORDING APPEARS A STYLIZED DESIGN REPRESENTING CHATTERING TEETH. THE TEETH ALSO CONTAIN EYES AND A TONGUE.

FOR SHIRTS; HATS; CLOTHING, NAMELY, JACKETS AND SWEATERS; APPAREL FOR CHILDREN AND ADULTS, NAMELY, JACKETS AND SWEATERS (U.S. CLS. 22 AND 39).  
CATHERINE TARCU, EXAMINING ATTORNEY

SN 86-201,681. O'DONNELL, EILEEN M., NORRIDGE, IL. FILED 2-24-2014.

**Grace Community Center Gym**

THE MARK CONSISTS OF STANDARD CHARACTERS WITHOUT CLAIM TO ANY PARTICULAR FONT, STYLE, SIZE, OR COLOR.

NO CLAIM IS MADE TO THE EXCLUSIVE RIGHT TO USE "GYM", APART FROM THE MARK AS SHOWN.

FOR MENS, LADIES, AND CHILDRENS CLOTHING, NAMELY, JACKETS, JEANS, JOGGING SUITS, JUMPSUITS, KNIT SHIRTS, LEATHER COATS, LEGGINGS, MINISKIRTS, BELTS, OVERALLS, PANTS, RAINCOATS, RAINWEAR, SWEATPANTS, SWEATSHIRTS, BATHING SUITS, BATHING TRUNKS, T-SHIRTS, TANK TOPS, SOCKS (U.S. CLS. 22 AND 39).

FIRST USE 2-20-2014; IN COMMERCE 2-20-2014.  
JOHN KELLY, EXAMINING ATTORNEY

**CLASS 25—(Continued).**

SN 86-202,537. COLD SUMMER, KENNESAW, REP OF GEORGIA, FILED 2-24-2014.



NO CLAIM IS MADE TO THE EXCLUSIVE RIGHT TO USE "SUMMER" AND "MMXIII", APART FROM THE MARK AS SHOWN.

THE MARK CONSISTS OF A SHADED RECTANGLE CONTAINING THE WORD "COLD" WITH VERTICAL LINES SEPARATING EACH LETTER, ABOVE A RECTANGLE WITH THE WORD "SUMMER" WITH VERTICAL LINES SEPARATING EACH LETTER AND A HORIZONTAL LINE ACROSS THE MIDDLE OF EACH LETTER IN THE WORD, ABOVE A SHADED RECTANGLE WITH A SMALL DOT FOLLOWED BY THE WORDING "MMXIII" FOLLOWED BY A SMALL DOT.

FOR HATS; JACKETS; PANTS; T-SHIRTS (U.S. CLS. 22 AND 39).  
SHAVELL MCPHERSON, EXAMINING ATTORNEY

SN 86-203,252. O'DONNELL, EILEEN M., NORRIDGE, IL. FILED 2-25-2014.

**Long Pond Inn Training Camp**

THE MARK CONSISTS OF STANDARD CHARACTERS WITHOUT CLAIM TO ANY PARTICULAR FONT, STYLE, SIZE, OR COLOR.

FOR MENS, LADIES, AND CHILDRENS CLOTHING, NAMELY, JACKETS, JEANS, JOGGING SUITS, JUMPSUITS, KNIT SHIRTS, LEATHER COATS, LEGGINGS, MINISKIRTS, BELTS, OVERALLS, PANTS, RAINCOATS, RAINWEAR, SWEATPANTS, SWEATSHIRTS, BATHING SUITS, BATHING TRUNKS, T-SHIRTS, TANK TOPS, SOCKS (U.S. CLS. 22 AND 39).

FIRST USE 2-24-2014; IN COMMERCE 2-24-2014.  
JOHN KELLY, EXAMINING ATTORNEY

**CLASS 25—(Continued).**

SN 86-204,099. RICHARDSON, RAYMOND KEVIN, AKA RIBZ, CORONADO, CA. FILED 2-25-2014.



THE MARK CONSISTS OF A HALF SECTION OF STYLIZED RIBS.

FOR ATHLETIC APPAREL, NAMELY, SHIRTS, PANTS, JACKETS, FOOTWEAR, HATS AND CAPS, ATHLETIC UNIFORMS (U.S. CLS. 22 AND 39).

FIRST USE 1-1-1999; IN COMMERCE 1-1-2007. KELLY BOULTON, EXAMINING ATTORNEY

**CLASS 25—(Continued).**

SN 86-206,082. ALETHOS CLOTHING COMPANY, SAN ANTONIO, TX. FILED 2-27-2014.

ALETHOS CLOTHING COMPANY

THE MARK CONSISTS OF STANDARD CHARACTERS WITHOUT CLAIM TO ANY PARTICULAR FONT, STYLE, SIZE, OR COLOR.

NO CLAIM IS MADE TO THE EXCLUSIVE RIGHT TO USE "CLOTHING COMPANY", APART FROM THE MARK AS SHOWN.

THE WORDING "ALETHOS" HAS NO MEANING IN A FOREIGN LANGUAGE.

FOR CLOTHING, NAMELY, T-SHIRTS, SHIRTS, TOPS, SWEATERS, SWEATSHIRTS, HOODED SWEATSHIRTS; COATS, JERSEYS, JACKETS; BOTTOMS, PANTS, TROUSERS, JEANS, SHORTS, SWEATPANTS, PAJAMAS; DRESSES; SKIRTS; BLOUSES; UNDERWEAR; SWIMWEAR; HEADWEAR; FOOTWEAR; BELTS, TIES, GLOVES, SOCKS (U.S. CLS. 22 AND 39).

MICHAEL TANNER, EXAMINING ATTORNEY

SN 86-205,307. HANEEFAH M. LLC, DUNELLEN, NJ. FILED 2-26-2014.

Haneefah M.

THE MARK CONSISTS OF STANDARD CHARACTERS WITHOUT CLAIM TO ANY PARTICULAR FONT, STYLE, SIZE, OR COLOR.

THE NAME(S), PORTRAIT(S), AND/OR SIGNATURE(S) SHOWN IN THE MARK IDENTIFIES A LIVING INDIVIDUAL, WHOSE CONSENT(S) TO REGISTER IS MADE OF RECORD.

FOR BOTTOMS; DRESSES FOR WOMEN; FOOTWEAR FOR WOMEN; SCARFS; SHIRTS FOR WOMEN; SWEATERS FOR WOMEN; TOPS FOR WOMEN; WOMEN'S CLOTHING, NAMELY, SHIRTS, DRESSES, SKIRTS, BLOUSES; WOMEN'S SHOES (U.S. CLS. 22 AND 39).

FIRST USE 7-1-2008; IN COMMERCE 7-1-2008. DARRYL SPRUILL, EXAMINING ATTORNEY

SN 86-207,053. RED DOG BRANDS LLC, WEST NEW YORK, NJ. FILED 2-28-2014.

RH RUFF HEWN HERITAGE

THE MARK CONSISTS OF STANDARD CHARACTERS WITHOUT CLAIM TO ANY PARTICULAR FONT, STYLE, SIZE, OR COLOR.

OWNER OF U.S. REG. NOS. 1,266,411, 1,410,610 AND 2,983,545.

FOR CLOTHING, NAMELY, SHIRTS, PANTS, SHORTS, JACKETS, HATS, BELTS, SUSPENDERS, BLAZERS, COATS, SCARVES, SWEATERS, TIES, SOCKS, SHOES, KNIT TOPS, AND WOMEN'S AND GIRLS' SKIRTS, DRESSES, BLOUSES AND KERCHIEFS; FOOTWEAR; HEADGEAR, NAMELY, HATS, CAPS, HEADWEAR (U.S. CLS. 22 AND 39).

JEAN IM, EXAMINING ATTORNEY

**CLASS 25—(Continued).**

SN 86-208,130. SAKS & COMPANY, NEW YORK, NY. FILED 2-28-2014.

MADISON SUPPLY

THE MARK CONSISTS OF STANDARD CHARACTERS WITHOUT CLAIM TO ANY PARTICULAR FONT, STYLE, SIZE, OR COLOR.

NO CLAIM IS MADE TO THE EXCLUSIVE RIGHT TO USE "SUPPLY", APART FROM THE MARK AS SHOWN.

FOR CLOTHING, NAMELY, SHIRTS, T-SHIRTS, TURTLENECKS, TROUSERS, PANTS, JEANS, CARDIGANS, SWEATERS, VESTS, SUITS, BLAZERS, JACKETS, COATS, SWEATPANTS, SWEATSHIRTS, JERSEYS, JOGGING SUITS, JUMPSUITS, BATHROBES, PAJAMAS, LOUNGEWEAR, UNDERWEAR, SOCKS, SWIMSUITS, SCARVES, GLOVES, BELTS, COLLARS, TIES, CUMMERBUNDS; HEADWEAR; FOOTWEAR (U.S. CLS. 22 AND 39).

JAMES LOVELACE, EXAMINING ATTORNEY

**CLASS 25—(Continued).**

SN 86-211,192. ORTIZ, GERENA ERNESTO, AKA XTONE, APPLE VALLEY, CA. FILED 3-5-2014.



THE COLOR(S) BLACK AND WHITE IS/ARE CLAIMED AS A FEATURE OF THE MARK.

THE MARK CONSISTS OF THE TERM "DRONIKA" IN STYLIZED LETTERING SHOWN IN THE COLOR WHITE. THE WORDING IS SUPERIMPOSED OVER A BLACK SKULL DESIGN WITH CURVED WHITE LINES WITH BLACK VERTICAL LINES COMING OUT OF THE TOP AND BOTTOM OF THE SKULL.

FOR T-SHIRTS (U.S. CLS. 22 AND 39).

PAM WILLIS, EXAMINING ATTORNEY

SN 86-211,414. STUMP, DEREK, YAKIMA, WA. FILED 3-5-2014.

SN 86-210,413. BLOOMSBURG UNIVERSITY OF PENNSYLVANIA OF THE STATE SYSTEM OF HIGHER EDUCATION, BLOOMSBURG, PA. FILED 3-4-2014.

**BU**  
HUSKIES

THE MARK CONSISTS OF STYLIZED LETTERS "B" AND "U" WITH THE LITERAL ELEMENT "HUSKIES" UNDERNEATH IN A SLANTED STYLIZED FORMAT.

FOR CLOTHING PRIMARILY WORN BY STUDENTS, NAMELY, T-SHIRTS, SWEATSHIRTS, BASEBALL HATS AND JACKETS (U.S. CLS. 22 AND 39).

FIRST USE 1-1-2002; IN COMMERCE 1-1-2002.

PARKER HOWARD, EXAMINING ATTORNEY



THE COLOR(S) BLACK, WHITE AND GREEN IS/ARE CLAIMED AS A FEATURE OF THE MARK.

THE MARK CONSISTS OF TWO CONCENTRIC CIRCLES, WITH THE INNERMOST CIRCLE DEPICTED IN BLACK, OUTLINED IN WHITE AND CONTAINING THE INTERTWINED WHITE LETTERS "DC" WITHIN. THE OUTER CIRCLE IS DEPICTED IN GREEN WITH A WHITE AND GREEN BORDER. INSIDE THE GREEN CIRCLE ARE SEVERAL DESIGNS. AT THE TOP OF THE CIRCLE PROCEEDING CLOCKWISE IS A RHINOCEROS DEPICTED IN WHITE, TO THE RIGHT IS A DEPICTION OF ALASKA IN WHITE, FOLLOWED BY A WHITE PINEAPPLE, WHITE WEDGE OF CHEESE, WHITE SQUIRREL, WHITE CROWN, A BLACK AND WHITE SPIDER AND A WHITE FIREARM.

FOR HATS; JACKETS; SWEATERS; T-SHIRTS (U.S. CLS. 22 AND 39).

EMILY CARLSEN, EXAMINING ATTORNEY

**CLASS 25—(Continued).**

SN 86-211,595. RANDALL, EDWIN, NEW YORK, NY. FILED 3-5-2014.

## Little Humans by Jacob Randall

THE MARK CONSISTS OF STANDARD CHARACTERS WITHOUT CLAIM TO ANY PARTICULAR FONT, STYLE, SIZE, OR COLOR.

THE NAME(S), PORTRAIT(S), AND/OR SIGNATURE(S) SHOWN IN THE MARK IDENTIFIES A LIVING INDIVIDUAL, WHOSE CONSENT(S) TO REGISTER IS MADE OF RECORD.

FOR ATHLETIC PANTS; ATHLETIC SHIRTS; ATHLETIC SHOES; ATHLETIC TOPS AND BOTTOMS FOR BABIES TODDLERS CHILDREN; BABIES' PANTS; BABY LAYETTES FOR CLOTHING; BELTS; BELTS FOR CLOTHING; BELTS MADE OUT OF CLOTH; BIBS NOT OF CLOTH OR PAPER; BODY SHIRTS; BOTTOMS; BOTTOMS FOR BABIES TODDLERS CHILDREN; BUTTON DOWN SHIRTS; CANVAS SHOES; CAPRI PANTS; CAPS; CARGO PANTS; CHILDREN'S AND INFANTS' CLOTH BIBS; CHILDREN'S CLOTH EATING BIBS; CHILDREN'S HEADWEAR; CLOTH BIBS; CLOTHING FOR BABIES, TODDLERS AND CHILDREN, TREATED WITH FIRE AND HEAT RETARDANTS, NAMELY, PAJAMAS, JACKETS, SHIRTS, PANTS, JUMPERS; COLARED SHIRTS; COMBINATIONS; DENIMS; DRAWERS; DRESS PANTS; DRESS SHIRTS; GRAPHIC T-SHIRTS; GYM PANTS; HEAD WRAPS; HOODED SWEAT SHIRTS; HOODS; INFANT AND TODDLER ONE PIECE CLOTHING; INFANTS' SHOES AND BOOTS; JACKETS; JERSEYS; JOGGING PANTS; KNIT SHIRTS; LEATHER BELTS; LEATHER PANTS; LEATHER SHIRTS; LEATHER SHOES; LONG-SLEEVED SHIRTS; NIGHT SHIRTS; NON-DISPOSABLE CLOTH TRAINING PANTS; OPEN-NECKED SHIRTS; OVER SHIRTS; PANTS; SHIRTS; SHIRTS AND SHORT-SLEEVED SHIRTS; SHIRTS FOR INFANTS, BABIES, TODDLERS AND CHILDREN; SHORT SETS; SHORT-SLEEVED OR LONG-SLEEVED T-SHIRTS; SHORT-SLEEVED SHIRTS; SKI PANTS; SKULLIES; SLEEP PANTS; SLEEP SHIRTS; SLEEVES WORN SEPARATE AND APART FROM BLOUSES, SHIRTS AND OTHER TOPS; SNAP CROTCH SHIRTS FOR INFANTS AND TODDLERS; SPORT SHIRTS; SPORTS PANTS; SPORTS SHIRTS; SPORTS SHIRTS WITH SHORT SLEEVES; SWADDLING CLOTHES; SWEAT BANDS; SWEAT JACKETS; SWEAT PANTS; SWEAT SHIRTS; SWEAT SHORTS; SWEAT SUITS; T-SHIRTS; T-SHIRTS FOR CHILDREN BABIES TODDLERS; TEE SHIRTS (U.S. CLS. 22 AND 39).

FIRST USE 11-11-2012; IN COMMERCE 11-11-2012.  
MARY CRAWFORD, EXAMINING ATTORNEY

**CLASS 25—(Continued).**

SN 86-214,857. SUTOR USA INC., CORAL GABLES, FL. FILED 3-7-2014.

## Di Bianco SPQR

THE MARK CONSISTS OF STANDARD CHARACTERS WITHOUT CLAIM TO ANY PARTICULAR FONT, STYLE, SIZE, OR COLOR.

OWNER OF U.S. REG. NO. 4,215,594.

NO CLAIM IS MADE TO THE EXCLUSIVE RIGHT TO USE "DI BIANCO", APART FROM THE MARK AS SHOWN. THE ENGLISH TRANSLATION OF "DI BIANCO" IN THE MARK IS "WHITE".

FOR DRESS SHOES; CASUAL SHOES (U.S. CLS. 22 AND 39).

FIRST USE 2-1-2014; IN COMMERCE 2-1-2014.

TASNEEM HUSSAIN, EXAMINING ATTORNEY

SN 86-215,313. MASTERS, EZRA M, MIAMI, FL. FILED 3-7-2014.



THE MARK CONSISTS OF A GRAPHIC OF A FRONT FACING HOVERING FACE OF A WOOLY MAMMOTH. TWO FULLY FORMED EXTENDED TUSK POSITIONED EQUALLY BOTH LEFT AND RIGHT OF CENTER WITH TRUNK EXTENDED IN THE CENTER DOWNWARD. THE WORD "MAMMOTH" IS WRITTEN BENEATH THE ILLUSTRATION.

FOR ANTI-SWEAT UNDERWEAR; BRIEFS; MEN'S UNDERWEAR; PERSPIRATION ABSORBENT UNDERWEAR CLOTHING; THERMAL UNDERWEAR; THONG UNDERWEAR (U.S. CLS. 22 AND 39).

ALYSSA STEEL, EXAMINING ATTORNEY

**CLASS 25—(Continued).**

SN 86-215,482. BROWN, HIRAM B. AKA HB, HUGGBER, RICHMOND, VA. FILED 3-8-2014.



NO CLAIM IS MADE TO THE EXCLUSIVE RIGHT TO USE "PRODUCTIONS", APART FROM THE MARK AS SHOWN.

THE MARK CONSISTS OF A STYLIZED PORTRAIT DESIGN OF A WHITE BEAR OUTLINED IN BLACK WITH BLUE EYES AND A RED TONGUE. IN THE LOWER RIGHT CORNER OF THE DESIGN IS THE WORDING "HUGGBER PRODUCTIONS". THE TERM "HUGGBER" IS SHOWN IN BLUE. THE TERM "PRODUCTIONS" IS SHOWN IN WHITE.

FOR GRAPHIC T-SHIRTS; SHORT-SLEEVED OR LONG-SLEEVED T-SHIRTS; T-SHIRTS (U.S. CLS. 22 AND 39).

RUSS HERMAN, EXAMINING ATTORNEY

SN 86-216,039. FIT MOM DIET, LLC, CHANDLER, AZ. FILED 3-10-2014.

**LOVE your STRENGTH**

THE MARK CONSISTS OF STANDARD CHARACTERS WITHOUT CLAIM TO ANY PARTICULAR FONT, STYLE, SIZE, OR COLOR.

FOR ATHLETIC APPAREL, NAMELY, SHIRTS, PANTS, JACKETS, FOOTWEAR, HATS AND CAPS, ATHLETIC UNIFORMS; ATHLETIC SHIRTS; ATHLETIC TOPS AND BOTTOMS FOR RUNNING, YOGA AND WORKING OUT; BASEBALL CAPS AND HATS; CROP TOPS; FASHION HATS; GRAPHIC T-SHIRTS; HEADBANDS; HEADBANDS AGAINST SWEATING; HEADBANDS FOR CLOTHING; HOODED SWEATSHIRTS; JACKETS; JERSEYS; MUSCLE TOPS; SHORT-SLEEVED OR LONG-SLEEVED T-SHIRTS; SPORTS BRA; SPORTS SHIRTS; SPORTS SHIRTS WITH SHORT SLEEVES; SWEATSHIRTS; T-SHIRTS; T-SHIRTS FOR WOMEN; TANK TOPS; TOPS; WEARABLE GARMENTS AND CLOTHING, NAMELY, SHIRTS; WOMEN'S CLOTHING, NAMELY, SHIRTS, DRESSES, SKIRTS, BLOUSES; WRISTBANDS (U.S. CLS. 22 AND 39).

FIRST USE 12-1-2012; IN COMMERCE 12-1-2012.

JESSICA FATHY, EXAMINING ATTORNEY

**CLASS 25—(Continued).**

SN 86-216,388. INVENTEL, LLC, KINNELON, NJ. FILED 3-10-2014.

**HOLLYWOOD JEANZ**

THE MARK CONSISTS OF STANDARD CHARACTERS WITHOUT CLAIM TO ANY PARTICULAR FONT, STYLE, SIZE, OR COLOR.

NO CLAIM IS MADE TO THE EXCLUSIVE RIGHT TO USE "JEANS", APART FROM THE MARK AS SHOWN.

FOR JEANS (U.S. CLS. 22 AND 39).

MICHAEL TANNER, EXAMINING ATTORNEY

SN 86-216,509. CJD LLC, CADILLAC, MI. FILED 3-10-2014.



THE MARK CONSISTS OF A HIGHLY STYLIZED LETTER "C" AND "J" THAT APPEAR TOGETHER AS A LOWER CASE LETTER "D".

FOR HATS; SHIRTS (U.S. CLS. 22 AND 39).

CARYN GLASSER, EXAMINING ATTORNEY

SN 86-216,866. SCHALLER, JUSTIN GARY, SAN CLEMENTE, CA. AND DI GENNARO, CHRISTOPHER, SAN CLEMENTE, CA. FILED 3-10-2014.

**TWO BAGS FULL**

THE MARK CONSISTS OF STANDARD CHARACTERS WITHOUT CLAIM TO ANY PARTICULAR FONT, STYLE, SIZE, OR COLOR.

FOR MEN'S CLOTHING, NAMELY, SHIRTS, PANTS, SHORTS, JACKETS, SWEATSHIRTS, UNDERGARMENTS, SOCKS, SHOES, SNEAKERS, SANDALS, BEANIES, HATS, CAPS, BELTS (U.S. CLS. 22 AND 39).

ALYSSA STEEL, EXAMINING ATTORNEY

**CLASS 25—(Continued).**

SN 86-217,390. BLUE CAST DENIM CO., INC., NEW YORK, NY. FILED 3-11-2014.

## THE TRAVELING JEAN BY HYDRAULIC

THE MARK CONSISTS OF STANDARD CHARACTERS WITHOUT CLAIM TO ANY PARTICULAR FONT, STYLE, SIZE, OR COLOR.

NO CLAIM IS MADE TO THE EXCLUSIVE RIGHT TO USE "JEAN", APART FROM THE MARK AS SHOWN.

FOR JEANS, PANTS, SKIRTS, SHORTS, KNIT TOPS, JACKETS, JUMPERS AND DRESSES (U.S. CLS. 22 AND 39).

SHAILA LEWIS, EXAMINING ATTORNEY

---

SN 86-217,413. BLUE CAST DENIM CO., INC., NEW YORK, NY. FILED 3-11-2014.

## THE JOURNEY JEAN BY HYDRAULIC

THE MARK CONSISTS OF STANDARD CHARACTERS WITHOUT CLAIM TO ANY PARTICULAR FONT, STYLE, SIZE, OR COLOR.

NO CLAIM IS MADE TO THE EXCLUSIVE RIGHT TO USE "JEAN", APART FROM THE MARK AS SHOWN.

FOR JEANS, PANTS, SKIRTS, SHORTS, KNIT TOPS, JACKETS, JUMPERS AND DRESSES (U.S. CLS. 22 AND 39).

SHAILA LEWIS, EXAMINING ATTORNEY

---

SN 86-217,620. THE ESTATE OF WHITNEY HOUSTON, ALPHA RETTA, GA. FILED 3-11-2014.

## WHITNEY HOUSTON

THE MARK CONSISTS OF STANDARD CHARACTERS WITHOUT CLAIM TO ANY PARTICULAR FONT, STYLE, SIZE, OR COLOR.

THE NAME(S), PORTRAIT(S), AND/OR SIGNATURE(S) SHOWN IN THE MARK DOES NOT IDENTIFY A PARTICULAR LIVING INDIVIDUAL.

FOR T-SHIRTS; SHIRTS; SWEATSHIRTS; HOODED SWEATSHIRTS; HATS; HEADWEAR (U.S. CLS. 22 AND 39).

FIRST USE 8-1-1987; IN COMMERCE 8-1-1987.

MICHAEL WIENER, EXAMINING ATTORNEY

**CLASS 25—(Continued).**

SN 86-217,670. COMPONENTS BY JOHN MCCOY, INC, NEW YORK, NY. FILED 3-11-2014.

## PORTO BESPOKE

THE MARK CONSISTS OF STANDARD CHARACTERS WITHOUT CLAIM TO ANY PARTICULAR FONT, STYLE, SIZE, OR COLOR.

NO CLAIM IS MADE TO THE EXCLUSIVE RIGHT TO USE "BESPOKE", APART FROM THE MARK AS SHOWN.

THE ENGLISH TRANSLATION OF "PORTO" IN THE MARK IS "PORT".

FOR MEN'S CLOTHING, NAMELY, SHIRTS, PANTS, JACKETS, COATS, SUITS, SWEATERS AND SHORTS (U.S. CLS. 22 AND 39).

PRISCILLA MILTON, EXAMINING ATTORNEY

---

SN 86-217,692. COMPONENTS BY JOHN MCCOY, INC, NEW YORK, NY. FILED 3-11-2014.

## PORTO

THE MARK CONSISTS OF STANDARD CHARACTERS WITHOUT CLAIM TO ANY PARTICULAR FONT, STYLE, SIZE, OR COLOR.

THE ENGLISH TRANSLATION OF "PORTO" IN THE MARK IS "PORT".

FOR MEN'S CLOTHING, NAMELY, SHIRTS, PANTS, JACKETS, COATS, SUITS, SWEATERS AND SHORTS (U.S. CLS. 22 AND 39).

PRISCILLA MILTON, EXAMINING ATTORNEY



**CLASS 25—(Continued).**

SN 86-217,774. CAMBUCI S.A., PINHEIROS SAO PAULO, BRAZIL, FILED 3-11-2014.



OWNER OF U.S. REG. NO. 2,590,945.  
THE MARK CONSISTS OF TWO WAVY LINES WITH THE WORD "PENALTY" UNDERNEATH.

FOR SPORTS AND GYMNASTICS CLOTHES AND ACCESSORIES, NAMELY, SHORTS, SHIRTS, JACKETS, COATS, SWEATSUITS, SWIMSUITS, T-SHIRTS, SINGLET, UNIFORMS, VESTS, WAISTCOATS, JERSEYS, CAPS, GLOVES, LEOTARDS, UNITARDS, AND TIGHTS; CLOTHING MADE FROM KNITTED FABRICS, NAMELY, SHORTS, SHIRTS, JACKETS, SWEATSUITS, SWIMSUITS, T-SHIRTS, SINGLET, GLOVES, CAPS, SOCKS, SWEAT-ABSORBENT SOCKS, COATS, HOSIERY, UNIFORMS, VESTS, WAISTCOATS, JERSEYS; CLOTHING FOR GYMNASTICS, NAMELY, LEOTARDS, UNITARDS, SHORTS, SINGLET, AND TIGHTS; ATHLETIC SHOES, SHOES FOR SPORTS PRACTICE, SOCCER SHOES, GYMNASTIC SHOES, BOOTS, FOOTWEAR; CLEATS FOR ATTACHMENT TO SPORTS SHOES, SOCCER CLEATS; SOLES FOR FOOTWEAR (U.S. CLS. 22 AND 39).

MATTHEW GALAN, EXAMINING ATTORNEY

**CLASS 25—(Continued).**

SN 86-219,038. WILLIAM SAFFORD, SAN DIEGO, CA. FILED 3-12-2014.



SN 86-218,839. DE LA TORRE, JUAN, CERES, CA. FILED 3-12-2014.

**BRICK X BRICK**

THE MARK CONSISTS OF STANDARD CHARACTERS WITHOUT CLAIM TO ANY PARTICULAR FONT, STYLE, SIZE, OR COLOR.

FOR CLOTHING, NAMELY, SHIRTS, HATS, JACKETS, FOOTWEAR, HEADWEAR; ANKLE BOOTS; ATHLETIC FOOTWEAR; BANDANAS; BATHING SUITS; BATHROBES; BEACH FOOTWEAR; BEACHWEAR; BELTS; BERETS; BODY SHAPERS; BOOTS; BOXER SHORTS; CAMISOLES; CAPS; COATS; CORSETS; CREEPERS; DRESSES; EARMUFFS; FISHING WADERS; FLIP FLOPS; FOOTWEAR; GLOVES; HALTER TOPS; HATS; HEADBANDS; HEADWEAR; HOODS; JACKETS; JEANS; KNEE HIGHS; KNEE-HIGH STOCKINGS; LEATHER HEADWEAR; LINGERIE; LOAFERS; LOUNGE PANTS; LOUNGEWEAR; NECKTIES; NEGLIGEEES; NIGHTCAPS; NIGHTDRESSES; NIGHTGOWNS; NIGHTSHIRTS; NIGHTWEAR; PANTS; PAJAMAS; POLO SHIRTS; ROBES; SANDALS; SCARVES; SHIRTS; SHOES; SHORTS; SKIRTS; SLEEP MASKS; SLEEP PANTS; SLEEP SHIRTS; SLEEPING GARMENTS; SLEEPWEAR; SLIPPERS; SLIPS; SOCKS; STOCKINGS; SUN VISORS; SUSPENDERS; SWEAT BANDS; SWEAT PANTS; SWEAT SHIRTS; SWEAT SUITS; SWIMWEAR; T-SHIRTS; TANK TOPS; TEDDIES; UNDERGARMENTS; UNDERWEAR; VISORS; WRAPS; WRISTBANDS (U.S. CLS. 22 AND 39).

DOUGLAS LEE, EXAMINING ATTORNEY

THE MARK CONSISTS OF A STYLIZED FLAG WITH FIVE STRIPES AND A RECTANGLE IN THE UPPER LEFT CORNER WITHIN A CIRCLE.

FOR ATHLETIC APPAREL, NAMELY, SHIRTS, PANTS, JACKETS, FOOTWEAR, HATS AND CAPS, ATHLETIC UNIFORMS; ATHLETIC SHIRTS; ATHLETIC SHORTS; HATS; HOODED SWEAT SHIRTS; JACKETS; LONG-SLEEVED SHIRTS; SHIRTS; SHIRTS AND SHORT-SLEEVED SHIRTS; SHORT-SLEEVED OR LONG-SLEEVED T-SHIRTS; SHORT-SLEEVED SHIRTS; SHORTS; SPORT SHIRTS; SPORTS CAPS AND HATS; SWEAT SHIRTS; T-SHIRTS; TEE SHIRTS; TOPS (U.S. CLS. 22 AND 39).

FIRST USE 9-1-2013; IN COMMERCE 2-15-2014.  
GIANCARLO CASTRO, EXAMINING ATTORNEY

**CLASS 25—(Continued).**

SN 86-219,724. 3E THREADS, INC., DBA CALI AUTHENTIC, GARDENA, CA. FILED 3-13-2014.



NO CLAIM IS MADE TO THE EXCLUSIVE RIGHT TO USE "CA", APART FROM THE MARK AS SHOWN.

THE MARK CONSISTS OF THE LETTER "A" AND "C". THE LETTER "A" IS CREATED USING THE SHAPE OF CALIFORNIA ON THE RIGHT SIDE AND A SERIF FONT DESIGN ON THE LEFT WHICH CONNECT TO FORM AN "A". THE "A" IS THEN WRAPPED AROUND A BLOCK SERIF STYLE FONT LETTER "C". BOTH LETTERS ARE THEN WRAPPED AROUND AN OUTLINED ROUNDED SQUARE.

FOR DENIMS; GRAPHIC T-SHIRTS; HATS; HEADGEAR, NAMELY, HATS, BEANIES; HOODED SWEAT SHIRTS; HOODS; JACKETS; JERSEYS; JOGGING PANTS; LONG-SLEEVED SHIRTS; PANTS; SHIRTS; SHIRTS AND SHORT-SLEEVED SHIRTS; SHIRTS FOR WOMEN, MEN, AND KIDS; SHORT-SLEEVED OR LONG-SLEEVED T-SHIRTS; SHORT-SLEEVED SHIRTS; SWEAT PANTS; T-SHIRTS; T-SHIRTS FOR WOMEN, MEN, AND KIDS; TEE SHIRTS; TOPS; TOPS FOR WOMEN, MEN, AND KIDS; WEARABLE GARMENTS AND CLOTHING, NAMELY, SHIRTS; WOMEN'S CLOTHING, NAMELY, SHIRTS, DRESSES, SKIRTS, BLOUSES (U.S. CLS. 22 AND 39).

FIRST USE 8-0-2013; IN COMMERCE 9-0-2013.

DOMINICK J. SALEMI, EXAMINING ATTORNEY

SN 86-220,754. TWISTED AXIS INCORPORATION, NEW LENOX, IL. FILED 3-13-2014.

## Twisted Axis Incorporated

THE MARK CONSISTS OF STANDARD CHARACTERS WITHOUT CLAIM TO ANY PARTICULAR FONT, STYLE, SIZE, OR COLOR.

NO CLAIM IS MADE TO THE EXCLUSIVE RIGHT TO USE "INCORPORATED", APART FROM THE MARK AS SHOWN.

FOR BANDANAS; JACKETS; SHIRTS; SHOES; T-SHIRTS (U.S. CLS. 22 AND 39).

PAM WILLIS, EXAMINING ATTORNEY

**CLASS 25—(Continued).**

SN 86-221,368. SHIMON WRIGHT, DETROIT, MI. FILED 3-14-2014.

# john Doe



THE GOODHEARTED BRAND

OWNER OF U.S. REG. NO. 4,520,418.

NO CLAIM IS MADE TO THE EXCLUSIVE RIGHT TO USE "BRAND", APART FROM THE MARK AS SHOWN.

THE NAME(S), PORTRAIT(S), AND/OR SIGNATURE(S) SHOWN IN THE MARK DOES NOT IDENTIFY A PARTICULAR LIVING INDIVIDUAL.

AT THE TOP, THE MARK CONSISTS OF THE WORDS "JOHN DOE" IN STYLIZED LETTERING. JUST BELOW AND CENTERED IS AN OLD VINTAGE SEWING MACHINE WITH 1 WING FACING FORWARD AND 1 WING FACING BACKWARDS AND JUST BENEATH THE SEWING MACHINE, ENTERED AT THE BOTTOM ARE THE WORDS "THE GOODHEARTED BRAND".

FOR BELTS; BOTTOMS; CAPES; CLOTHING, NAMELY, KHAKIS; COATS; DENIM JACKETS; DENIMS; FOOTWEAR; GLOVES; HEADWEAR; JACKETS; JEANS; JUMPSUITS; RAINWEAR; SCARVES; SHIRTS; SHORTS; SWEAT JACKETS; SWEAT PANTS; SWEAT SHIRTS; SWEATERS; T-SHIRTS; TOPS; TROUSERS; UNDERGARMENTS; VESTS (U.S. CLS. 22 AND 39).

GINA FINK, EXAMINING ATTORNEY

SN 86-222,139. SHIMON WRIGHT, DETROIT, MI. FILED 3-14-2014.



THE NAME(S), PORTRAIT(S), AND/OR SIGNATURE(S) SHOWN IN THE MARK DOES NOT IDENTIFY A PARTICULAR LIVING INDIVIDUAL.

THE MARK CONSISTS OF TWO STYLIZED LETTERS, LOWER CASE "J" AND UPPERCASE "D" FUSED TOGETHER TO FORM A STYLIZED INITIALS-LIKE MARK OF "JD".

FOR BOTTOMS; CLOTHING, NAMELY, KHAKIS; DENIMS; JEANS; PANTS; T-SHIRTS; TOPS (U.S. CLS. 22 AND 39).

FIRST USE 4-1-2013; IN COMMERCE 7-1-2013.

GINA FINK, EXAMINING ATTORNEY

**CLASS 25—(Continued).**

SN 86-222,566. THE SOFT SKIN COMPANY, LLC, HIGHLANDS RANCH, CO. FILED 3-16-2014.

# STRETCH SOFTLY

THE MARK CONSISTS OF STANDARD CHARACTERS WITHOUT CLAIM TO ANY PARTICULAR FONT, STYLE, SIZE, OR COLOR.

NO CLAIM IS MADE TO THE EXCLUSIVE RIGHT TO USE "STRETCH", APART FROM THE MARK AS SHOWN.

FOR MATERNITY CLOTHING, NAMELY, SHIRT AND SHORTS.; MATERNITY LINGERIE; MATERNITY SLEEPWEAR (U.S. CLS. 22 AND 39).

DOMINIC J. FERRAIUOLO, EXAMINING ATTORNEY

SN 86-223,338. MIRELES, ALMEIDA, BROOKLYN, NY. FILED 3-17-2014.

ALMEIDA



MIRELES

THE NAME(S), PORTRAIT(S), AND/OR SIGNATURE(S) SHOWN IN THE MARK DOES NOT IDENTIFY A PARTICULAR LIVING INDIVIDUAL.

THE MARK CONSISTS OF "ALMEIDA MIRELES" TYPE SEPARATED BY STYLIZED SQUARE IMAGE WITH ROUNDED EDGES IN THE MIDDLE OF THE WORDS.

THE WORDING "ALMEIDA MIRELES" HAS NO MEANING IN A FOREIGN LANGUAGE.

FOR CLOTHING, NAMELY, TOPS, PANTS (U.S. CLS. 22 AND 39).

MICHAEL KEATING, EXAMINING ATTORNEY

**CLASS 25—(Continued).**

SN 86-224,001. STAR ASSET INTERNATIONAL LIMITED, THE VALLEY, ANGUILLA, FILED 3-18-2014.

# Norman Norell

THE MARK CONSISTS OF STANDARD CHARACTERS WITHOUT CLAIM TO ANY PARTICULAR FONT, STYLE, SIZE, OR COLOR.

THE NAME(S), PORTRAIT(S), AND/OR SIGNATURE(S) SHOWN IN THE MARK DOES NOT IDENTIFY A PARTICULAR LIVING INDIVIDUAL.

FOR BELTS, BABIES PANTS, BATH ROBES, DRESSES, DRESSING GOWNS, CLOTHING MADE OF IMITATIONS OF LEATHER AND LEATHER, NAMELY, COATS, BEACH SHOES, CAPS, CAMISOLES, FURS, NAMELY, JACKETS, COATS, HEADBANDS, HEADGEAR FOR WEAR, NAMELY, HATS, CAPS, JACKETS, JERSEYS, JUMPERS, KNITWEAR, NAMELY, PANTS, SHIRTS, LACE BOOTS, LAYETTES, LEGGINGS, PAJAMAS, SCARVES, SHIRTS, SHAWLS, SHOES, SKIRTS, BOOTS, SLIPPERS, SPORT SHOES, STOCKINGS, SUITS, BATHING SUITS, CORSETS, UNDERWEAR, SPORT SHOES, HATS, UNDERPANTS, UNDERCLOTHING, WAISTCOATS, BEACH SHOES, BOOTS, BOOTS FOR SPORTS, SKI BOOTS, RIDING BOOTS, TRAINERS IN THE NATURE OF SHOES, FOOTBALL BOOTS, FOOTBALL SHOES, GYMNASTIC SHOES, HALF-BOOTS, SANDALS, SPORTS SHOES, SOCKS, FOOTWEAR (U.S. CLS. 22 AND 39).

FIRST USE 1-1-2014; IN COMMERCE 1-1-2014.

WILLIAM ROSSMAN, EXAMINING ATTORNEY

SN 86-224,013. STAR ASSET INTERNATIONAL LIMITED, THE VALLEY, ANGUILLA, FILED 3-18-2014.

# Pauline Trigère

THE MARK CONSISTS OF STANDARD CHARACTERS WITHOUT CLAIM TO ANY PARTICULAR FONT, STYLE, SIZE, OR COLOR.

THE NAME(S), PORTRAIT(S), AND/OR SIGNATURE(S) SHOWN IN THE MARK DOES NOT IDENTIFY A PARTICULAR LIVING INDIVIDUAL.

FOR BELTS, BABIES PANTS, BATH ROBES, DRESSES, DRESSING GOWNS, CLOTHING MADE OF IMITATIONS OF LEATHER AND LEATHER, NAMELY, COATS, BEACH SHOES, CAPS, CAMISOLES, FURS, NAMELY, JACKETS, COATS, HEADBANDS, HEADGEAR FOR WEAR, NAMELY, HATS, CAPS, JACKETS, JERSEYS, JUMPERS, KNITWEAR, NAMELY, PANTS, SHIRTS, LACE BOOTS, LAYETTES, LEGGINGS, PAJAMAS, SCARVES, SHIRTS, SHAWLS, SHOES, SKIRTS, BOOTS, SLIPPERS, SPORT SHOES, STOCKINGS, SUITS, BATHING SUITS, CORSETS, UNDERWEAR, SPORT SHOES, HATS, UNDERPANTS, UNDERCLOTHING, WAISTCOATS, BEACH SHOES, BOOTS, BOOTS FOR SPORTS, SKI BOOTS, RIDING BOOTS, TRAINERS IN THE NATURE OF SHOES, FOOTBALL BOOTS, FOOTBALL SHOES, GYMNASTIC SHOES, HALF-BOOTS, SANDALS, SPORTS SHOES, SOCKS, FOOTWEAR (U.S. CLS. 22 AND 39).

FIRST USE 1-1-2014; IN COMMERCE 1-1-2014.

WILLIAM ROSSMAN, EXAMINING ATTORNEY

**CLASS 25—(Continued).**

SN 86-224,155. ETHOS PRODUCTIONS LLC, NEW YORK, NY. FILED 3-18-2014.



THE MARK CONSISTS OF THE LETTERS "EN" AND A SWIRL WITH TWO DOTS ON EITHER SIDE. FOR CLOTHING, NAMELY, SHIRTS, T-SHIRTS AND SWEATSHIRTS (U.S. CLS. 22 AND 39).  
TIMOTHY FINNEGAN, EXAMINING ATTORNEY

**CLASS 25—(Continued).**

SN 86-225,392. HUMAN PERFORMANCE ENGINEERING LIMITED, LONDON W4 4EG, UNITED KINGDOM, FILED 3-19-2014.



THE MARK CONSISTS OF STANDARD CHARACTERS WITHOUT CLAIM TO ANY PARTICULAR FONT, STYLE, SIZE, OR COLOR.  
OWNER OF ERPN CMNTY TM OFC REG. NO. 010361566, DATED 3-2-2012, EXPIRES 10-21-2021.  
FOR CLOTHING, NAMELY, SHIRTS, T-SHIRTS, SPORTS SHIRTS, TOPS, VESTS, TANK TOPS, POLO SHIRTS, BLOUSES, SWEATERS, PULLOVERS, JACKETS, HOODED SWEATSHIRTS, COATS, TROUSERS, PANTS, SPORTS PANTS, SHORTS, WARM UP SUITS, TRACK SUITS, SKIRTS, SWIMWEAR, TENNIS WEAR, SOCKS, TIGHTS, LEGGINGS, UNDERWEAR, GLOVES, LEATHER BELTS; FOOTWEAR; HEADWEAR (U.S. CLS. 22 AND 39).  
ELISSA GARBER KON, EXAMINING ATTORNEY

SN 86-224,277. WHITNER, MARCUS, CONGERVILLE, IL. FILED 3-18-2014.



THE MARK CONSISTS OF A SOLID CROWN ABOVE THE LITERAL ELEMENT "BMSCR" ABOVE TWO PARALLEL SOLID LINES ABOVE THE LITERAL ELEMENT "BLESSED MAN SUCCESS CERTIFIED ROYALTY".  
FOR CLOTHING, NAMELY, T-SHIRTS, HATS, HOODED SWEATSHIRTS, SWEATER, JACKETS, SWEAT PANTS, AND TANK TOPS (U.S. CLS. 22 AND 39).  
RUSS HERMAN, EXAMINING ATTORNEY

SN 86-225,685. CLARISSE, INC., NARBERTH, PA. FILED 3-19-2014.



THE MARK CONSISTS OF STANDARD CHARACTERS WITHOUT CLAIM TO ANY PARTICULAR FONT, STYLE, SIZE, OR COLOR.  
OWNER OF U.S. REG. NOS. 3,346,348, 4,122,137 AND OTHERS.  
NO CLAIM IS MADE TO THE EXCLUSIVE RIGHT TO USE "ATELIER", APART FROM THE MARK AS SHOWN.  
FOR WOMEN'S CLOTHING, NAMELY, FORMAL WOMEN'S WEAR, NAMELY, EVENING GOWNS, COCKTAIL DRESSES, BRIDAL GOWNS AND DRESSES, WEDDING GOWNS, BRIDE'S MAIDS DRESSES, MOTHER OF THE BRIDE DRESSES, PROM GOWNS AND PROM DRESSES, PAGEANT DRESSES, SPECIAL OCCASION DRESSES, FOOTWEAR (U.S. CLS. 22 AND 39).  
ALISON KEELEY, EXAMINING ATTORNEY

**CLASS 25—(Continued).**

SN 86-225,982. SWEENEY, DENNIS, WESTAMPTON, NJ, AND SCHIEDA, JOHN, MONROE TWP., NJ. FILED 3-19-2014.



THE COLOR(S) WHITE, BLUE, RED, BLACK, GRAY IS/ ARE CLAIMED AS A FEATURE OF THE MARK.

THE MARK CONSISTS OF A STYLIZED LETTER "A" OVERLAPPING A STYLIZED LETTER "L", BOTH LETTERS IN WHITE OUTLINED IN BLUE AND RED, THE LETTERS LOCATED ON A BLACK BACKGROUND HAVING A PLURALITY OF GRAY FIVE POINTED STARS.

FOR CLOTHING, NAMELY, T-SHIRTS, TANK TOPS, SPORT SHIRTS, KNIT SHIRTS, POLO SHIRTS, FLEECE TOPS, WALKING SHORTS, SWIMWEAR, BATHING SUITS, ATHLETIC SHORTS, PANTS, SWEATSHIRTS, SWEATPANTS, OUTERWEAR JACKETS, COATS, SHOES, HATS, BEANIES, SOCKS, SHIRTS, SWEATERS, DRESSES, BLOUSES, BEACH COVER-UPS, FOOTWEAR, SANDALS, HEADBANDS, SWEATBANDS, WRISTBANDS, VISORS, BANDANAS, AND WETSUITS (U.S. CLS. 22 AND 39).

WANDA KAY PRICE, EXAMINING ATTORNEY

**CLASS 25—(Continued).**

SN 86-226,244. DAVIDYAN CUSTOM FOOTWEAR INC., VANCOUVER, WA. FILED 3-19-2014.



NO CLAIM IS MADE TO THE EXCLUSIVE RIGHT TO USE "HANDMADE IN USA" AND "EST. 1955", APART FROM THE MARK AS SHOWN.

THE MARK CONSISTS OF AN OUTLINE OF A MOUNTAIN, TWO OVERLAPPING CAPITALIZED STYLIZED LETTER "D" BELOW THE OUTLINE OF THE MOUNTAIN, THE STYLIZED WORD "DAVIDYAN" BELOW THE OVERLAPPING CAPITALIZED STYLIZED LETTER "D" AND THE STYLIZED WORDS "HANDMADE IN USA" AND "EST. 1955" BELOW THE WORD "DAVIDYAN".

FOR FOOTWEAR (U.S. CLS. 22 AND 39).

FIRST USE 1-24-2014; IN COMMERCE 1-24-2014.

JOHN SCHUYLER YARD, EXAMINING ATTORNEY

SN 86-226,058. JEREMY RICHTER, LIBERTYVILLE, IL. FILED 3-19-2014.

STADIUM OF MIND

THE MARK CONSISTS OF STANDARD CHARACTERS WITHOUT CLAIM TO ANY PARTICULAR FONT, STYLE, SIZE, OR COLOR.

FOR HATS, T-SHIRTS (U.S. CLS. 22 AND 39).

DAVID ELTON, EXAMINING ATTORNEY

SN 86-227,434. JJ APPAREL CROCKER, INC., DBA NAKED ZEBRA, LOS ANGELES, CA. FILED 3-20-2014.

NORAH

THE MARK CONSISTS OF STANDARD CHARACTERS WITHOUT CLAIM TO ANY PARTICULAR FONT, STYLE, SIZE, OR COLOR.

FOR WOMEN'S CLOTHING, NAMELY, SHIRTS, DRESSES, SKIRTS, BLOUSES (U.S. CLS. 22 AND 39).

FIRST USE 3-20-2014; IN COMMERCE 3-20-2014.

JENNIFER MARTIN, EXAMINING ATTORNEY

**CLASS 25—(Continued).**

SN 86-227,904. BETSY C HEAFITZ, MONTECITO, CA. AND ANNABELLE A BROWNELL, SANTA BARBARA, CA. FILED 3-21-2014.



OWNER OF U.S. REG. NO. 4,523,390.  
 THE MARK CONSISTS OF THE WORDS "DOUBLE SCOOP" WITH STYLIZED FONT, AND THE DOUBLE "O"'S FORMING AN ICON REPRESENTING A WOMAN'S BREASTS/CLEAVAGE.  
 FOR LINGERIE ACCESSORIES, NAMELY, REMOVABLE SILICONE BREAST ENHANCER PADS USED IN A BRA; SHAPEWEAR, NAMELY, BRA INSERTS (U.S. CLS. 22 AND 39).  
 FIRST USE 6-20-2013; IN COMMERCE 12-1-2013.  
 THOMAS MANOR, EXAMINING ATTORNEY

SN 86-228,061. HAZAN & RABANI LLC, CONCORD, MA. FILED 3-21-2014.

CHEF ISLAND

THE MARK CONSISTS OF STANDARD CHARACTERS WITHOUT CLAIM TO ANY PARTICULAR FONT, STYLE, SIZE, OR COLOR.  
 FOR CLOTHING IN THE NATURE OF CULINARY GARMENTS, NAMELY, PANTS, SHIRTS, COATS, APRONS AND HATS (U.S. CLS. 22 AND 39).  
 FIRST USE 8-1-2013; IN COMMERCE 8-1-2013.  
 THOMAS MANOR, EXAMINING ATTORNEY

**CLASS 25—(Continued).**

SN 86-228,215. LIMITED STORES, LLC, NEW ALBANY, OH. FILED 3-21-2014.



OWNER OF U.S. REG. NOS. 1,020,794, 4,108,367 AND OTHERS.  
 THE COLOR(S) BLACK, WHITE AND GRAY IS/ARE CLAIMED AS A FEATURE OF THE MARK.  
 THE MARK CONSISTS THE WORDING "THE LIMITED" IN WHITE, STYLIZED FONT, CENTERED WITHIN A RECTANGLE WITH THE LEFT AND LOWER THIRD SHOWN IN BLACK, AND THE REMAINDER SHOWN IN GRAY.  
 FOR BELTS, BOTTOMS, BRAS, COATS, DRESSES, FOOTWEAR, HEADWEAR, HOSIERY, JACKETS, LINGERIE, LOUNGEWEAR, SCARVES, BODY SHAPERS, FOUNDATION GARMENTS, TIGHTS, SLEEPWEAR, TOPS, UNDERWEAR, SWIMWEAR, GLOVES AND SOCKS (U.S. CLS. 22 AND 39).  
 ESTHER BELENKER, EXAMINING ATTORNEY

SN 86-228,600. SPENCER MARK K, DBA MARK SPENCER, MORENO VALLEY, CA. FILED 3-21-2014.



NO CLAIM IS MADE TO THE EXCLUSIVE RIGHT TO USE "THREADS", APART FROM THE MARK AS SHOWN.  
 THE MARKS CONSISTS OF THE STYLIZED TERM "IE" WITH THE WORD "THREADS" APPEARING UNDERNEATH IT. THE "I" AND THE "E" OVERLAP SUCH THAT THE "E" APPEARS BEHIND THE LETTER "I".  
 FOR CLOTHING, NAMELY, T-SHIRTS, HATS, SHIRTS, AND PANTS (U.S. CLS. 22 AND 39).  
 BRIN ANDERSON, EXAMINING ATTORNEY

**CLASS 25—(Continued).**

SN 86-228,853. GARCIA, JOSEPH, SYLMAR, CA. FILED 3-21-2014.



THE MARK CONSISTS OF A DIAMOND WITH A CROWN ON TOP, AND THE LETTERS "RYR" APPEARING BELOW WITH THE SECOND LETTER "R" SHOWN BACKWARDS.

FOR CLOTHING, NAMELY, SHIRTS, T-SHIRTS, POLO SHIRTS, BUTTON DOWN SHIRTS, SWEATERS, SWEATSHIRTS, HOODED SWEATSHIRTS, JACKETS, COATS, JEANS, PANTS, BABY TEE SHIRTS, TOPS, DRESSES, BLOUSES, SKIRTS, THERMAL SHIRTS, SHORTS, SOCKS, ROBES, SCARVES, BEANIES, HATS, AND CAPS (U.S. CLS. 22 AND 39).

TIMOTHY O. SCHIMPF, EXAMINING ATTORNEY

**CLASS 25—(Continued).**

SN 86-229,299. DIANA ZAPATERIA, INC., PARAMOUNT, CA. FILED 3-23-2014.



THE COLOR(S) RED, GRAY, AND WHITE IS/ARE CLAIMED AS A FEATURE OF THE MARK.

THE MARK CONSISTS OF A GRAY BULL IN THE CENTER OF AN OVAL ELEMENT OUTLINED IN RED, ON A WHITE BACKGROUND, FOLLOWED BY A RED RIBBON UNDER THE OVAL ELEMENT AND THE WORDS "EL TORO MORO" IN WHITE COLORING INSIDE THE RED RIBBON.

THE ENGLISH TRANSLATION OF "EL TORO" IN THE MARK IS "THE BULL". THE WORDING "MORO" HAS NO MEANING IN A FOREIGN LANGUAGE.

FOR BELTS; BELTS MADE OF LEATHER; BOMBER JACKETS; BUTTON DOWN SHIRTS; CAPS; DENIM JACKETS; DOWN JACKETS; FOOTWEAR; FOOTWEAR FOR MEN AND WOMEN; FOOTWEAR, NAMELY, WORK BOOTS; HEADWEAR; JACKETS; LEATHER JACKETS; LONG-SLEEVED SHIRTS; MEN'S AND WOMEN'S JACKETS, COATS, TROUSERS, VESTS; SHIRTS (U.S. CLS. 22 AND 39).

ERIC SABLE, EXAMINING ATTORNEY

SN 86-229,184. GOMEZ, STEVIN, R, FREMONT, CA. FILED 3-22-2014.



**PEARL**  
*Clothing*

NO CLAIM IS MADE TO THE EXCLUSIVE RIGHT TO USE "CLOTHING", APART FROM THE MARK AS SHOWN. THE MARK CONSISTS OF THE STYLIZED WORDING "PEARL CLOTHING" COMBINED WITH A STYLIZED CLAM WITH A PEARL ON ITS TONGUE.

FOR CREW NECK SWEATERS; DENIMS; FASHION HATS; GRAPHIC T-SHIRTS (U.S. CLS. 22 AND 39).

KIM MONINGHOFF, EXAMINING ATTORNEY

SN 86-229,794. REED, CHRISTOPHER M., GRENADA, MS. FILED 3-24-2014.



NO CLAIM IS MADE TO THE EXCLUSIVE RIGHT TO USE "SPORTING GOODS", APART FROM THE MARK AS SHOWN.

THE MARK CONSISTS OF THE STACKED WORDING, "OUTLAW" OVER "SPORTING GOODS" WITH THE DESIGN OF A DEER SKULL OVER AND DIVIDING THE WORD, "OUTLAW"; THE DESIGN OF AN ARROW SEPARATES THE STACKED WORDING.

FOR ATHLETIC SHIRTS; BASEBALL CAPS AND HATS; BUTTON DOWN SHIRTS; CAMOUFLAGE SHIRTS; COLLARED SHIRTS; DRESS SHIRTS; GOLF PANTS, SHIRTS AND SKIRTS; GOLF SHIRTS; GRAPHIC T-SHIRTS; HOODED SWEAT SHIRTS; HUNTING JACKETS; HUNTING PANTS; HUNTING SHIRTS; HUNTING VESTS; SHIRTS; SPORT SHIRTS; SPORTS CAPS AND HATS; SPORTS SHIRTS; T-SHIRTS; TOBOGGAN HATS; WOMEN'S HATS AND HOODS (U.S. CLS. 22 AND 39).

FIRST USE 3-6-2012; IN COMMERCE 5-6-2012.

GILBERT SWIFT, EXAMINING ATTORNEY

**CLASS 25—(Continued).**

SN 86-230,843. SSOB INC., SEATTLE, WA. FILED 3-25-2014.

**SSOB Inc.**

THE MARK CONSISTS OF STANDARD CHARACTERS WITHOUT CLAIM TO ANY PARTICULAR FONT, STYLE, SIZE, OR COLOR.

NO CLAIM IS MADE TO THE EXCLUSIVE RIGHT TO USE "INC.", APART FROM THE MARK AS SHOWN. FOR CLOTHING, NAMELY, T-SHIRTS, HATS, WRISTBANDS (U.S. CLS. 22 AND 39).

DOMINICK J. SALEMI, EXAMINING ATTORNEY

---

SN 86-231,252. JOSE PABLO HERNANDEZ GONZALEZ, PRSMA. DEL RINCON, GTO, MEXICO, FILED 3-25-2014.

**DUTY GEAR**

THE MARK CONSISTS OF STANDARD CHARACTERS WITHOUT CLAIM TO ANY PARTICULAR FONT, STYLE, SIZE, OR COLOR.

NO CLAIM IS MADE TO THE EXCLUSIVE RIGHT TO USE "GEAR", APART FROM THE MARK AS SHOWN. FOR BOOTS; SHOES (U.S. CLS. 22 AND 39).

FIRST USE 2-15-2014; IN COMMERCE 2-15-2014. CASSONDRAN ANDERSON, EXAMINING ATTORNEY

---

SN 86-231,700. LEVEL ONE APPAREL, ROSEVILLE, CA. FILED 3-25-2014.

**LVL1 Apparel**

THE MARK CONSISTS OF STANDARD CHARACTERS WITHOUT CLAIM TO ANY PARTICULAR FONT, STYLE, SIZE, OR COLOR.

NO CLAIM IS MADE TO THE EXCLUSIVE RIGHT TO USE "APPAREL", APART FROM THE MARK AS SHOWN.

FOR A-SHIRTS; ATHLETIC APPAREL, NAMELY, SHIRTS, PANTS, JACKETS, FOOTWEAR, HATS AND CAPS, ATHLETIC UNIFORMS; ATHLETIC SHORTS; ATHLETIC UNIFORMS; CHILDREN'S AND INFANT'S APPAREL, NAMELY, JUMPERS, OVERALL SLEEPWEAR, PAJAMAS, RÖMPERS AND ONE-PIECE GARMENTS; CLOTHING FOR ATHLETIC USE, NAMELY, PADDED ELBOW COMPRESSION SLEEVES BEING PART OF AN ATHLETIC GARMENT; CLOTHING FOR ATHLETIC USE, NAMELY, PADDED PANTS; CLOTHING FOR ATHLETIC USE, NAMELY, PADDED SHIRTS; CLOTHING FOR ATHLETIC USE, NAMELY, PADDED SHORTS; GLOVES FOR APPAREL; GRAPHIC T-SHIRTS; HEADBANDS FOR CLOTHING; HOODED SWEAT SHIRTS; JACKETS; JERSEYS; POLO SHIRTS; SPORTS SHIRTS; SPORTS SHIRTS WITH SHORT SLEEVES; SWEAT SHIRTS; T-SHIRTS (U.S. CLS. 22 AND 39).

FIRST USE 1-1-2013; IN COMMERCE 1-1-2013. MARYNELLE WILSON, EXAMINING ATTORNEY

**CLASS 25—(Continued).**

SN 86-232,040. ROD PATRICK INC., WEATHERFORD, TX. FILED 3-25-2014.

**LUXE CROCODILE**

THE MARK CONSISTS OF STANDARD CHARACTERS WITHOUT CLAIM TO ANY PARTICULAR FONT, STYLE, SIZE, OR COLOR.

NO CLAIM IS MADE TO THE EXCLUSIVE RIGHT TO USE "CROCODILE", APART FROM THE MARK AS SHOWN. FOR CROCODILE LEATHER FOOTWEAR (U.S. CLS. 22 AND 39).

KIM MONINGHOFF, EXAMINING ATTORNEY

---

SN 86-232,043. ELIOT PROJECT, LLC, BEVERLY HILLS, CA. FILED 3-25-2014.

**ELIOT PROJECT**

THE MARK CONSISTS OF STANDARD CHARACTERS WITHOUT CLAIM TO ANY PARTICULAR FONT, STYLE, SIZE, OR COLOR.

FOR HOODED SWEATSHIRTS; SCARVES; SHIRTS; SOCKS; SWEATERS; SWEATSHIRTS (U.S. CLS. 22 AND 39).

FIRST USE 12-17-2013; IN COMMERCE 12-17-2013. AMY KERTGATE, EXAMINING ATTORNEY

---

SN 86-232,317. DETROIT GUITAR LLC, BIRMINGHAM, MI. FILED 3-26-2014.



NO CLAIM IS MADE TO THE EXCLUSIVE RIGHT TO USE "DETROIT", APART FROM THE MARK AS SHOWN.

THE COLOR(S) BLACK, WHITE, AND GREY IS/ARE CLAIMED AS A FEATURE OF THE MARK.

THE MARK CONSISTS OF STYLIZED WORD "DETROIT" IN WHITE LETTERS WITH A GREY LIGHTENING BOLT INSIDE THE "O". SMALLER LETTERS SPELL "GUITAR" IN GREY ON LOWER LINE ON A BLACK BACKGROUND.

FOR T-SHIRTS (U.S. CLS. 22 AND 39). FIRST USE 3-3-2011; IN COMMERCE 3-3-2011.

WARREN L. OLANDRIA, EXAMINING ATTORNEY



**CLASS 25—(Continued).**

SN 86-232,387. OSBORN COMMERCIAL CO., LTD., MARKHAM, ONTARIO, CANADA, FILED 3-26-2014.

# Bonnafacio

THE MARK CONSISTS OF STANDARD CHARACTERS WITHOUT CLAIM TO ANY PARTICULAR FONT, STYLE, SIZE, OR COLOR.

THE WORDING "BONNAFACIO" HAS NO MEANING IN A FOREIGN LANGUAGE.

FOR APRONS; BANDANAS; BATHROBES; BELTS; BIKINIS; BLOUSES; BOXER SHORTS; BRAS; CAMISOLES; CAPRI PANTS; CAPS; CARDIGANS; CARGO PANTS; COATS; DRESSES; FOOTWEAR; GLOVES; GOLF SHIRTS; HATS; HEADBANDS; HOODED PULLOVERS; JACKETS; JEANS; LEGGINGS; NIGHT SHIRTS; NIGHTGOWNS; OVERALLS; PAJAMAS; PANTS; POLO SHIRTS; PONCHOS; PULLOVERS; RAIN COATS; SCARVES; SHORTS; SKIRTS; SOCKS; SUITS; SWEATERS; SWEATPANTS; SWEATSHIRTS; SWIM WEAR; T-SHIRTS; TANK TOPS; TIES; TIGHTS; TROUSERS; TURTLE NECK SHIRTS; TURTLENECK SWEATERS; UNDERWEAR; UNIFORMS; VESTS (U.S. CLS. 22 AND 39).

FIRST USE 3-20-2014; IN COMMERCE 3-20-2014.

MATTHEW MCDOWELL, EXAMINING ATTORNEY

SN 86-232,661. TAWFIK, SONDRRA, LOS ALTOS HILLS, CA. FILED 3-26-2014.



THE NAME(S), PORTRAIT(S), AND/OR SIGNATURE(S) SHOWN IN THE MARK DOES NOT IDENTIFY A PARTICULAR LIVING INDIVIDUAL.

THE COLOR(S) BLACK, WHITE AND BLUE IS/ARE CLAIMED AS A FEATURE OF THE MARK.

THE MARK CONSISTS OF THE STYLIZED BLACK WORDING "SONDRRELLA" ABOVE THE DESIGN OF AN EYE. THE OUTLINE OF THE EYE IS BLACK. THE CENTER PORTION OF THE EYE APPEARS IN WHITE. THE COLOR BLUE APPEARS IN THE PUPIL OF THE EYE WHICH IS OUTLINED IN BLACK AND HAS A FOUR-POINT WHITE STAR DESIGN THEREIN. THE WHITE AREA BEHIND THE MARK REPRESENTS BACKGROUND OR TRANSPARENCY AND IS NOT A PART OF THE MARK.

FOR DRESSES; JACKETS; PANTS; SHIRTS; SHOES (U.S. CLS. 22 AND 39).

FIRST USE 1-1-2012; IN COMMERCE 1-1-2012.

JOANNA FIORELLI, EXAMINING ATTORNEY

**CLASS 25—(Continued).**

SN 86-232,700. ACEZ GOLF APPAREL, SAINT PETERSBURG, FL. FILED 3-26-2014.



THE MARK CONSISTS OF "ACEZ" IN CAPITAL STYLIZED LETTERS ON A BANNER.

FOR HATS; SHIRTS (U.S. CLS. 22 AND 39).

FIRST USE 9-1-2009; IN COMMERCE 9-1-2009.

JEFFERY COWARD, EXAMINING ATTORNEY

SN 86-232,917. LALO, LLC, SAN DIEGO, CA. FILED 3-26-2014.

## THE ONLY EASY DAY WAS YESTERDAY

THE MARK CONSISTS OF STANDARD CHARACTERS WITHOUT CLAIM TO ANY PARTICULAR FONT, STYLE, SIZE, OR COLOR.

OWNER OF U.S. REG. NO. 4,540,664.

FOR (BASED ON USE IN COMMERCE) FOOTWEAR, SHOES, MILITARY BOOTS, HUNTING BOOTS, OUTDOOR FOOTWEAR; (BASED ON INTENT TO USE) BOOTS, FISHING BOOTS, CLIMBING BOOTS, RAFTING FOOTWEAR (U.S. CLS. 22 AND 39).

FIRST USE 2-14-2014; IN COMMERCE 2-14-2014.

JEFFERY COWARD, EXAMINING ATTORNEY

SN 86-232,942. GHOST OF JASON MOLINA, LLC, NASHVILLE, TN. FILED 3-26-2014.

## SONGS: OHIA

THE MARK CONSISTS OF STANDARD CHARACTERS WITHOUT CLAIM TO ANY PARTICULAR FONT, STYLE, SIZE, OR COLOR.

NO CLAIM IS MADE TO THE EXCLUSIVE RIGHT TO USE "SONGS", APART FROM THE MARK AS SHOWN.

FOR ARTICLES OF CLOTHING, NAMELY, JACKETS, COATS, PANTS, SKIRTS, DRESSES, SHORTS, BLOUSES, SHIRTS, TANK TOPS, SWEATBANDS, PULLOVERS, SWEATERS, SWEATSHIRTS; FOOTWEAR; HEADWEAR, SCARVES; BOXER SHORTS; SOCKS; T-SHIRTS, HATS AND CAPS, JACKETS, PAJAMAS, SLIPPERS, WRISTBANDS, HEADBANDS, TIES; ARTICLES OF CLOTHING FOR BABIES AND TODDLERS, NAMELY, CLOTH BIBS, ROMPER SUITS, ONE-PIECE GARMENTS; BELTS; HEADWEAR; BATHING SUITS; BATH ROBES; NECKWEAR; COVERALLS; DANCE COSTUMES; DENIM PANTS AND JACKETS; EARMUFFS; GLOVES; NECKERCHIEFS; POCKET SQUARES; PONCHOS; SCARVES; SHAWLS (U.S. CLS. 22 AND 39).

HOWARD SMIGA, EXAMINING ATTORNEY

**CLASS 25—(Continued).**

SN 86-233,115. FREEBALLERS B.V., DEN HAAG, NETHERLANDS, FILED 3-26-2014.

# FRE:DEM

THE MARK CONSISTS OF STANDARD CHARACTERS WITHOUT CLAIM TO ANY PARTICULAR FONT, STYLE, SIZE, OR COLOR.

FOR BLOUSES; CAPS; HATS; JEANS; PANTS; SHIRTS; SHORTS (U.S. CLS. 22 AND 39).

DAVID BROOKSHIRE, EXAMINING ATTORNEY

---

SN 86-233,374. VIE ACTIVE, INC., CLOVELLY, AUSTRALIA, FILED 3-26-2014.

# VIE ACTIVE

THE MARK CONSISTS OF STANDARD CHARACTERS WITHOUT CLAIM TO ANY PARTICULAR FONT, STYLE, SIZE, OR COLOR.

NO CLAIM IS MADE TO THE EXCLUSIVE RIGHT TO USE "ACTIVE", APART FROM THE MARK AS SHOWN.

FOR ATHLETIC TOPS AND BOTTOMS FOR EXERCISE, RUNNING, YOGA AND PILATES; JACKETS; LEGGINGS; SHIRTS; SHORTS; SPORTS BRAS; T-SHIRTS; TANK TOPS; TIGHTS (U.S. CLS. 22 AND 39).

FIRST USE 4-15-2013; IN COMMERCE 4-15-2013.

JOHN SCHUYLER YARD, EXAMINING ATTORNEY

---

SN 86-234,210. EADS, DARREN, CENTERVILLE, OH. AND EADS, KATIE, CENTERVILLE, OH. FILED 3-27-2014.

# COAST TO COAST LAX

THE MARK CONSISTS OF STANDARD CHARACTERS WITHOUT CLAIM TO ANY PARTICULAR FONT, STYLE, SIZE, OR COLOR.

NO CLAIM IS MADE TO THE EXCLUSIVE RIGHT TO USE "LAX", APART FROM THE MARK AS SHOWN.

FOR SWEATSHIRTS; T-SHIRTS (U.S. CLS. 22 AND 39).

DEZMONA MIZELLE, EXAMINING ATTORNEY

**CLASS 25—(Continued).**

SN 86-234,386. MANHATTAN TO MONTAUK, LLC, EAST QUOGUE, NY. FILED 3-27-2014.



THE MARK CONSISTS OF A FISH WITH A CITYSCAPE ALONG SPINE AND A LIGHTHOUSE ON THE TAIL AND "MNHTN2MTK.COM" UNDERNEATH.

FOR HATS; SWEATSHIRTS; T-SHIRTS (U.S. CLS. 22 AND 39).

ELLEN BURNS, EXAMINING ATTORNEY

---

SN 86-234,659. BABY COME INC, JACKSON HEIGHTS, NY. FILED 3-27-2014.



NO CLAIM IS MADE TO THE EXCLUSIVE RIGHT TO USE "BABY", APART FROM THE MARK AS SHOWN.

THE MARK CONSISTS OF STYLIZED LETTERS "OOPSI BABY" IN TWO LINES, WHERE THE FIRST "O" RESEMBLES A BABY FACE, THE SECOND "O" HAS A STAR IN THE MIDDLE AND CURVED LINES ABOVE AND BELOW, THE "S" HAS A CURVED LINE ABOVE, THE DOT OF THE "I" IS A STAR, AND THERE ARE THREE MORE STARS ON THE RIGHT OF LETTER "I"; THE LETTERS "BABY" IS ON A BOWL-SHAPE BACKGROUND WITH A CURVED LINE BELOW THE BOWL SHAPE ON THE RIGHT, AND THERE IS A STAR IN THE MIDDLE OF THE SECOND LETTER "B" IN "BABY."

FOR BABIES' PANTS; BABY BIBS NOT OF PAPER; BABY BUNTING; BABY LAYETTES FOR CLOTHING; CHILDREN'S AND INFANT'S APPAREL, NAMELY, JUMPERS, OVERALL SLEEPWEAR, PAJAMAS, ROMPERS AND ONE-PIECE GARMENTS; CLOTHING FOR BABIES, TODDLERS AND CHILDREN, TREATED WITH FIRE AND HEAT RETARDANTS, NAMELY, PAJAMAS, JACKETS, SHIRTS, PANTS, JUMPERS; PONCHOS; RAIN COATS; SWIM TRUNKS (U.S. CLS. 22 AND 39).

FIRST USE 3-1-2013; IN COMMERCE 3-1-2013.

CHARLOTTE CORWIN, EXAMINING ATTORNEY

**CLASS 25—(Continued).**

SN 86-234,861. FLAWLESS THREADS, LLC, EAGLE, ID. FILED 3-28-2014.

## Flawless Threads

THE MARK CONSISTS OF STANDARD CHARACTERS WITHOUT CLAIM TO ANY PARTICULAR FONT, STYLE, SIZE, OR COLOR.

NO CLAIM IS MADE TO THE EXCLUSIVE RIGHT TO USE "THREADS", APART FROM THE MARK AS SHOWN.

FOR BASEBALL CAPS AND HATS; GRAPHIC T-SHIRTS; HATS; HOODED SWEAT SHIRTS; LONG-SLEEVED SHIRTS; SHIRTS; SHIRTS AND SHORT-SLEEVED SHIRTS; SHORT-SLEEVED OR LONG-SLEEVED T-SHIRTS; SHORT-SLEEVED SHIRTS; SWEAT SHIRTS; T-SHIRTS; TEE SHIRTS; WEARABLE GARMENTS AND CLOTHING, NAMELY, SHIRTS (U.S. CLS. 22 AND 39).

FIRST USE 1-1-2010; IN COMMERCE 1-1-2010.  
DANNEAN HETZEL, EXAMINING ATTORNEY

---

SN 86-234,927. SIMON, DEWAN, EL MIRAGE, AZ. FILED 3-28-2014.



THE MARK CONSISTS OF A STYLIZED LETTER "S" WITHIN A FIGURE EIGHT KNOT DESIGN.

FOR BLOUSES; COATS; DRESS SHIRTS; DRESSES; HATS; HEADWEAR; PANTS; SHOES; SHORTS; SLACKS; SNEAKERS; SOCKS; SUITS; SWEAT SUITS; T-SHIRTS; UNDERWEAR (U.S. CLS. 22 AND 39).

FIRST USE 6-1-1996; IN COMMERCE 1-1-2000.  
LAUREN BURKE, EXAMINING ATTORNEY

**CLASS 25—(Continued).**

SN 86-234,997. HOHAN, MARIA-LUCIA, BUCHAREST, ROMANIA, FILED 3-28-2014.

## .marialuciahohan.

THE NAME "MARIALUCIAHOHAN" IDENTIFIES A LIVING INDIVIDUAL WHOSE CONSENT IS OF RECORD.

THE MARK CONSISTS OF THE WORDING "MARIALUCIAHOHAN" IN A SPECIAL TYPEFACE COMPOSED OF DOTS WITH A LARGE DOT AT THE BEGINNING AND END OF THE MARK.

FOR CLOTHING, NAMELY, DRESSES, TROUSERS, PANTS, LEGGINGS, CORSELETS, VEILS, BLOUSES, SHIRTS, SKIRTS, PETTICOATS, JACKETS, CUMMERBUNDS, GLOVES, MITTENS, TEE-SHIRTS, WAISTCOATS, TOPCOATS, PAJAMAS, SLEEP MASKS, HATS, CAPS, FLAT CAPS, TOP HATS, EAR MUFFS, PELERINES, PINAFORES, PULLOVERS, JERSEYS, SCARVES, HEAD SCARVES; BEACH CLOTHES, NAMELY, BATHING SUITS, SWIMSUITS, BATHING TRUNKS, BATHING DRAWERS; UNDERWEAR, NAMELY, UNDERPANTS, PANTIES, UNDERSHIRTS, GARTERS, SUSPENDERS; FOOTWEAR, NAMELY, SHOES, HEELS, SANDALS, BOOTS, SLIPPERS (U.S. CLS. 22 AND 39).  
DANNEAN HETZEL, EXAMINING ATTORNEY

---

SN 86-235,057. GLOBAL TRADEMARKS, INC., STOCKERTOWN, PA. FILED 3-28-2014.

## ANGELA CHASE

THE MARK CONSISTS OF STANDARD CHARACTERS WITHOUT CLAIM TO ANY PARTICULAR FONT, STYLE, SIZE, OR COLOR.

THE NAME(S), PORTRAIT(S), AND/OR SIGNATURE(S) SHOWN IN THE MARK DOES NOT IDENTIFY A PARTICULAR LIVING INDIVIDUAL.

FOR BOTTOMS; JEANS; SHAPEWEAR, NAMELY, GIRDLES; SWIMWEAR; TEE SHIRTS; TOPS (U.S. CLS. 22 AND 39).

LAUREN BURKE, EXAMINING ATTORNEY

**CLASS 25—(Continued).**

SN 86-235,219. DIRTY SHOES, INC., SAN ANTONIO, TX. FILED 3-28-2014.

## DIRTY SHOES

THE MARK CONSISTS OF STANDARD CHARACTERS WITHOUT CLAIM TO ANY PARTICULAR FONT, STYLE, SIZE, OR COLOR.

NO CLAIM IS MADE TO THE EXCLUSIVE RIGHT TO USE "SHOES", APART FROM THE MARK AS SHOWN.

FOR FOOTWEAR (U.S. CLS. 22 AND 39).  
CASSONDRRA ANDERSON, EXAMINING ATTORNEY

**CLASS 25—(Continued).**

SN 86-235,359. KOHARIK, PATRICIA, BEREA, OH. FILED 3-28-2014.



SN 86-235,243. SONG, JACK, STUDIO CITY, CA. FILED 3-28-2014.

## enti glamour

THE MARK CONSISTS OF STANDARD CHARACTERS WITHOUT CLAIM TO ANY PARTICULAR FONT, STYLE, SIZE, OR COLOR.

THE ENGLISH TRANSLATION OF THE WORDING "ENTI GLAMOUR" IN THE MARK IS "GLAMOROUS BODIES"

FOR BELTS; BLOUSES; COATS; DRESSES; HATS; HOODED SWEAT SHIRTS; JACKETS; JEANS; PAJAMAS; PANTS; SCARVES; SHIRTS; SHOES; SHORTS; SKIRTS; SLACKS; SWEAT PANTS; SWEAT SHIRTS; SWEATERS; SWIMWEAR; T-SHIRTS; TOPS; VESTS (U.S. CLS. 22 AND 39).

FIRST USE 11-24-2013; IN COMMERCE 11-24-2013.  
ERIC SABLE, EXAMINING ATTORNEY

THE LINING AND STIPPLING ARE FEATURES OF THE MARK AND DO NOT INDICATE COLOR.

THE MARK CONSISTS OF THE WORDING "EWE GOT SOCKS" ABOVE A SHEEP WEARING SOCKS AND HOLDING KNITTING NEEDLES IN ITS MOUTH.

FOR SOCKS (U.S. CLS. 22 AND 39).  
FIRST USE 10-0-2013; IN COMMERCE 10-0-2013.  
AMY HELLA, EXAMINING ATTORNEY

SN 86-235,289. WOO-HOOS LLC, ALLENTOWN, PA. FILED 3-28-2014.



THE MARK CONSISTS OF THE WORDING "WOOHOOS" WITH THE FIRST LETTER "O" DEPICTED AS AN INCOMPLETE CIRCLE, AND THE SECOND "O" COMPRISED OF A SOLID CIRCLE WITH A FIVE POINT STAR INSIDE, BOTH OF WHICH ARE ABOVE A CURVED LINE, ALL TOGETHER COMPRISING A WINKING SMILING FACE.

FOR HATS; SWEAT SHIRTS; T-SHIRTS (U.S. CLS. 22 AND 39).  
EMILY CARLSEN, EXAMINING ATTORNEY

SN 86-235,738. FUKUSHIMA, JASON, SAN MATEO, CA. FILED 3-28-2014.

## caliber workwear

THE MARK CONSISTS OF STANDARD CHARACTERS WITHOUT CLAIM TO ANY PARTICULAR FONT, STYLE, SIZE, OR COLOR.

NO CLAIM IS MADE TO THE EXCLUSIVE RIGHT TO USE "WORKWEAR", APART FROM THE MARK AS SHOWN.

FOR CLOTHING, NAMELY, SHIRTS, HATS, SWEATSHIRTS, AND JACKETS (U.S. CLS. 22 AND 39).  
SUZANNE BLANE, EXAMINING ATTORNEY

**CLASS 25—(Continued).**

SN 86-236,055. IMOST LLC, SAN ANTONIO, TX. FILED 3-28-2014.



THE MARK CONSISTS OF A DESIGN OF A PERSON JUMPING TO THE LEFT OF THE WORDING "IMOST". THE DESIGN AND THE WORDING APPEAR INSIDE A CIRCLE DESIGN.

FOR HATS; SWEATSHIRTS; T-SHIRTS (U.S. CLS. 22 AND 39).

SETH A. RAPPAPORT, EXAMINING ATTORNEY

**CLASS 25—(Continued).**

SN 86-236,551. SCHILLING, JENNIFER R., DBA C'EST LA VIE, OAK BLUFFS, MA. AND SCHILLING, ROGER J., DBA C'EST LA VIE, OAK BLUFFS, MA. FILED 3-30-2014.



NO CLAIM IS MADE TO THE EXCLUSIVE RIGHT TO USE "MARTHA'S VINEYARD" AND THE DESIGN OF THE MAP OF THE ISLAND OF MARTHA'S VINEYARD, APART FROM THE MARK AS SHOWN.

THE MARK CONSISTS OF THE WORDING "LOVE" IN CAPITAL LETTERS, MINUS THE "O". INSTEAD, THE SPACE IS FILLED WITH THE GEOGRAPHICAL SHAPE OF THE ISLAND OF MARTHA'S VINEYARD. THE ISLAND IS ANGLED -25 DEGREES TO FIT THE SPACE. BELOW THIS, "MARTHA'S VINEYARD" IS IN CAPITALS, CENTERED, AND 25% SMALLER THAN ABOVE.

FOR BASEBALL CAPS AND HATS; BUCKET CAPS; GRAPHIC T-SHIRTS; HOODED SWEATSHIRTS; SHORT-SLEEVED OR LONG-SLEEVED T-SHIRTS (U.S. CLS. 22 AND 39).

PARKER HOWARD, EXAMINING ATTORNEY

SN 86-236,398. HYATT, LORIAN, DISCOVERY BAY, CA. FILED 3-29-2014.

I Don't Sweat - I Sparkle

THE MARK CONSISTS OF STANDARD CHARACTERS WITHOUT CLAIM TO ANY PARTICULAR FONT, STYLE, SIZE, OR COLOR.

FOR APPAREL FOR DANCERS, NAMELY, TEE SHIRTS, SWEATSHIRTS, PANTS, LEGGINGS, SHORTS AND JACKETS; ATHLETIC APPAREL, NAMELY, SHIRTS, PANTS, JACKETS, FOOTWEAR, HATS AND CAPS, ATHLETIC UNIFORMS; ATHLETIC SHIRTS; BASEBALL CAPS AND HATS; CLOTHING FOR BABIES, TODDLERS AND CHILDREN, TREATED WITH FIRE AND HEAT RETARDANTS, NAMELY, PAJAMAS, JACKETS, SHIRTS, PANTS, JUMPERS; HIKING JACKETS (U.S. CLS. 22 AND 39).

DOMINICK J. SALEMI, EXAMINING ATTORNEY

SN 86-236,589. SMITH, ZAIR M., RIVERSIDE, CA. FILED 3-31-2014.



THE MARK CONSISTS OF THE WORDING "CONSCIOUS CREATIONS 06" IN A STYLIZED FONT AND A RECTANGULAR CARRIER WITH TWO CIRCLES. THE "0" IS COMPOSED OF SECTIONS AND THE "6" IS COMPOSED OF A DISTORTED "C" AND COLON AND A DISTORTED INVERSED LOWERCASE "C". BOTH OF THESE ELEMENTS OF THE LOGO ARE COMBINED TOGETHER TO FORM AN "8". THE WORD "CONSCIOUS" IS TYPED ABOVE THE IMAGE AND "CREATIONS" IS BELOW THE "06" INVERTED IN A MIRROR OF ITSELF.

FOR ATHLETIC APPAREL, NAMELY, SHIRTS, PANTS, JACKETS, FOOTWEAR, HATS AND CAPS, ATHLETIC UNIFORMS (U.S. CLS. 22 AND 39).

RENEE MCCRAY, EXAMINING ATTORNEY

**CLASS 25—(Continued).**

SN 86-237,350. GO DEEP LLC, EAST TAUNTON, MA. FILED 3-31-2014.



THE MARK CONSISTS OF THE WORDING "FIRST." ABOVE THE WORDING "GO" IN STYLIZED FONT. THE IMAGE OF A SILHOUETTE OF A MAN IN A THROWING POSE IS SITUATED BETWEEN THE AFOREMENTIONED WORDING "GO" AND THE WORDING "DEEP" IN THE SAME STYLIZED FONT. BELOW IS THE WORDING "STOP SWEAT".

FOR CLOTHING, NAMELY, UNDERWEAR, T-SHIRTS, ATHLETIC SHIRTS, AND ATHLETIC TIGHTS (U.S. CLS. 22 AND 39).

CYNTHIA RINALDI, EXAMINING ATTORNEY

SN 86-237,509. A.F. GILMORE COMPANY, LOS ANGELES, CA. FILED 3-31-2014.

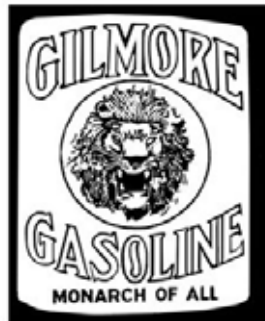

OWNER OF U.S. REG. NO. 3,499,598.  
NO CLAIM IS MADE TO THE EXCLUSIVE RIGHT TO USE "GASOLINE", APART FROM THE MARK AS SHOWN.  
THE MARK CONSISTS OF A ROARING LION'S HEAD WITHIN A CIRCLE; ABOVE THE CIRCLE IS THE WORD "GILMORE", BELOW THE CIRCLE ARE THE WORDS "GASOLINE MONARCH OF ALL"; THE ENTIRE DESIGN IS WITHIN A RECTANGLE.

FOR CLOTHING, NAMELY, T-SHIRTS (U.S. CLS. 22 AND 39).

FIRST USE 0-0-2010; IN COMMERCE 0-0-2010.

LINDA MICKLEBURGH, EXAMINING ATTORNEY

**CLASS 25—(Continued).**

SN 86-237,612. NATURAL HAIR MAG, LLC, ATLANTA, GA. FILED 3-31-2014.

**TEAM NATURALS**

THE MARK CONSISTS OF STANDARD CHARACTERS WITHOUT CLAIM TO ANY PARTICULAR FONT, STYLE, SIZE, OR COLOR.

NO CLAIM IS MADE TO THE EXCLUSIVE RIGHT TO USE "NATURALS", APART FROM THE MARK AS SHOWN.  
FOR BOTTOMS; CAPS; COATS; FOOTWEAR; HEADWEAR; HOODED SWEATSHIRTS; JACKETS; PANTS; SHIRTS; SOCKS; SWEAT PANTS; TANK-TOPS; TOPS; UNDERWEAR (U.S. CLS. 22 AND 39).

FIRST USE 3-6-2014; IN COMMERCE 3-6-2014.

B. PARADEWELAI, EXAMINING ATTORNEY

SN 86-237,616. NATURAL HAIR MAG, LLC, ATLANTA, GA. FILED 3-31-2014.

**BROOKLYN NATURALS**

THE MARK CONSISTS OF STANDARD CHARACTERS WITHOUT CLAIM TO ANY PARTICULAR FONT, STYLE, SIZE, OR COLOR.

NO CLAIM IS MADE TO THE EXCLUSIVE RIGHT TO USE "NATURALS", APART FROM THE MARK AS SHOWN.  
FOR BOTTOMS; CAPS; COATS; FOOTWEAR; HEADWEAR; HOODED SWEATSHIRTS; JACKETS; PANTS; SHIRTS; SOCKS; SWEAT PANTS; TANK-TOPS; TOPS; UNDERWEAR (U.S. CLS. 22 AND 39).

FIRST USE 3-6-2014; IN COMMERCE 3-6-2014.

B. PARADEWELAI, EXAMINING ATTORNEY

SN 86-237,715. GLOBAL APPAREL ALLIANCE LLC, CHARLOTTE, NC. FILED 3-31-2014.

**Cooper & Stewart**

THE MARK CONSISTS OF STANDARD CHARACTERS WITHOUT CLAIM TO ANY PARTICULAR FONT, STYLE, SIZE, OR COLOR.

OWNER OF U.S. REG. NO. 4,458,259.  
FOR SHOES, NAMELY, WORK SHOES, SPORTS SHOES, BEACH SHOES, LEATHER SHOES, CANVAS SHOES, AND BOAT SHOES; SANDALS; AND BOOTS, NAMELY, WINTER BOOTS, WORK BOOTS, LEATHER BOOTS, AND HIKING BOOTS (U.S. CLS. 22 AND 39).

FIRST USE 2-1-2014; IN COMMERCE 2-1-2014.

BRIDGETT SMITH, EXAMINING ATTORNEY

**CLASS 25—(Continued).**

SN 86-237,862. GACHECHE, ALEX, MCLEAN, VA. FILED 3-31-2014.

# Maisha ni poa

THE MARK CONSISTS OF STANDARD CHARACTERS WITHOUT CLAIM TO ANY PARTICULAR FONT, STYLE, SIZE, OR COLOR.

THE ENGLISH TRANSLATION OF "MAISHA NI POA" IN THE MARK IS "LIFE IS COOL".

FOR BOTTOMS; HATS; SHIRTS; TOPS (U.S. CLS. 22 AND 39).

KATHERINE CHANG, EXAMINING ATTORNEY

**CLASS 25—(Continued).**

SN 86-238,008. ROLLINS, VANESSA A, DBA ROLLINS ENTERPRISE GROUP, POMPANO BEACH, FL. FILED 3-31-2014.



THE MARK CONSISTS OF THE STYLIZED WORDING "RUDE NESS" AND TWO STYLIZED FEMALE HEAD DESIGNS.

FOR SHIRTS FOR WOMEN AND CHILDREN (U.S. CLS. 22 AND 39).

FIRST USE 9-12-2013; IN COMMERCE 12-22-2013.

BRIAN PINO, EXAMINING ATTORNEY

SN 86-237,930. DZINESQUARE, INC., DBA 2 CRAVE, LA MIRADA, CA. FILED 3-31-2014.



THE COLOR(S) RED AND BLACK IS/ARE CLAIMED AS A FEATURE OF THE MARK.

THE MARK CONSISTS OF THE DESIGN OF TWO "H" CHARACTERS IN BLACK SUPERIMPOSED ON RED FIGURES SUGGESTIVE OF A DIAGONAL LINE.

FOR ATHLETIC PANTS; ATHLETIC SHIRTS; BASEBALL CAPS; BASEBALL CAPS AND HATS; BELTS; BELTS FOR CLOTHING; BELTS MADE FROM IMITATION LEATHER; BELTS MADE OF LEATHER; BELTS MADE OUT OF CLOTH; BELTS OF TEXTILE; BUTTON DOWN SHIRTS; CAP VISORS; CAPS; CAPS WITH VISORS; CREW NECK SWEATERS; DENIM JACKETS; DOWN JACKETS; FABRIC BELTS; GOLF CAPS; GRAPHIC T-SHIRTS; GYM PANTS; HATS; HEADGEAR, NAMELY, HATS AND CAPS; HEAVY JACKETS; HOODED SWEAT SHIRTS; JACKETS; JACKETS AND SOCKS; JOGGING PANTS; KNIT SHIRTS; KNITTED CAPS; LEATHER BELTS; LONG JACKETS; LONG-SLEEVED SHIRTS; LOUNGE PANTS; MEN'S AND WOMEN'S JACKETS, COATS, TROUSERS, VESTS; MOCK TURTLE-NECK SWEATERS; OPEN-NECKED SHIRTS; OUTER JACKETS; POLO SHIRTS; REVERSIBLE JACKETS; SHIRTS; SHIRTS AND SHORT-SLEEVED SHIRTS; SHIRTS FOR ADULTS; SHORT-SLEEVED OR LONG-SLEEVED T-SHIRTS; SHORT-SLEEVED SHIRTS; SPORTS CAPS AND HATS; SPORTS JACKETS; SPORTS PANTS; SPORTS SHIRTS; SWEAT JACKETS; SWEAT PANTS; SWEAT SHIRTS; SWEATERS; SWEATERS FOR ADULTS; T-SHIRTS; T-SHIRTS FOR ADULTS; TEE SHIRTS; TOPS; TOPS FOR ADULTS; TRACK PANTS; TURTLE NECK SHIRTS; TURTLENECK SWEATERS; V-NECK SWEATERS; WEARABLE GARMENTS AND CLOTHING, NAMELY, SHIRTS; WOMEN'S CLOTHING, NAMELY, SHIRTS, DRESSES, SKIRTS, BLOUSES; WOMEN'S HATS AND HOODS (U.S. CLS. 22 AND 39).

KRISTIN DAHLING, EXAMINING ATTORNEY

SN 86-238,066. BRANNON LEHANE, HOOVER, AL. FILED 4-1-2014.

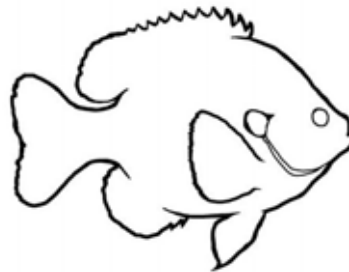

THE MARK CONSISTS OF THE STYLIZED DESIGN OF A PROFILE OF A BLUEGILL BRIM FISH.

FOR T-SHIRTS (U.S. CLS. 22 AND 39).

FIRST USE 4-25-2014; IN COMMERCE 4-25-2014.

DANIEL S. STRINGER, EXAMINING ATTORNEY

**CLASS 25—(Continued).**

SN 86-238,363. AIME LEON DORE INC., NEW YORK, NY.  
FILED 4-1-2014.

**AIMÉ LEON DORE**

THE NAME "AIME LEON DORE" SHOWN IN THE MARK DOES NOT IDENTIFY A LIVING INDIVIDUAL.

THE MARK CONSISTS OF THE STYLIZED WORDS "AIME LEON DORE".

THE ENGLISH TRANSLATION OF "AIMÉ" IN THE MARK IS "LOVED".

FOR CLOTHING, NAMELY, SHIRTS, T-SHIRTS, LONG-SLEEVED SHIRTS, POLO SHIRTS, RUGBY SHIRTS, JERSEYS, DRESS SHIRTS, JEANS, HOODED SWEAT SHIRTS, WARM-UP SUITS, SNOW SUITS, PARKAS, CARDIGANS, PANTS, DENIM JACKETS, CARGO PANTS, SHORTS, BOXER SHORTS, TOPS, TANK TOPS, SWEAT SHIRTS, SWEAT JACKETS, SWEAT SHORTS, SWEAT PANTS, SWEATERS, VESTS, FLEECE VESTS, PULLOVERS, JACKETS, COATS, BLAZERS, SUITS, TURTLENECKS, REVERSIBLE JACKETS, SHELL JACKETS, SPORTS JACKETS, HEAVY COATS, OVER COATS, TOP COATS, SWIMWEAR, BEACHWEAR, VISORS, HEADBANDS, EAR MUFFS, THERMAL UNDERWEAR, LONG UNDERWEAR, UNDERCLOTHES, CAPS, HATS, HEADWEAR, SCARVES, BANDANAS, BELTS, NECKWEAR, TIES, ROBES, GLOVES, BOOTS, RAINWEAR, FOOTWEAR, SHOES, SNEAKERS (U.S. CLS. 22 AND 39).  
FIRST USE 1-31-2014; IN COMMERCE 1-31-2014.

RENEE MCCRAY, EXAMINING ATTORNEY

SN 86-238,991. GLOBAL APPAREL ALLIANCE LLC, CHARLOTTE, NC. FILED 4-1-2014.

**Cooper & Stewart**

THE MARK CONSISTS OF STANDARD CHARACTERS WITHOUT CLAIM TO ANY PARTICULAR FONT, STYLE, SIZE, OR COLOR.

OWNER OF U.S. REG. NO. 4,458,259.  
FOR MEN'S TIES, BOW TIES, AND SCARVES (U.S. CLS. 22 AND 39).

FIRST USE 2-1-2014; IN COMMERCE 2-1-2014.  
BRIDGETT SMITH, EXAMINING ATTORNEY

**CLASS 25—(Continued).**

SN 86-239,392. MAIKAU CORPORATION, SAN CLEMENTE, CA. FILED 4-1-2014.

**KOA**

OWNER OF U.S. REG. NO. 3,721,366.

THE MARK CONSISTS OF STYLIZED LETTERS "K", "O" AND "A".

THE ENGLISH TRANSLATION OF THE MARK IS "WARRIOR", "FEARLESS" AND "BRAVE".

FOR FLIP FLOPS; FOOTWEAR; FOOTWEAR FOR MEN; FOOTWEAR FOR MEN AND WOMEN; FOOTWEAR FOR WOMEN; FOOTWEAR, NAMELY, RUBBERS; JAPANESE STYLE SANDALS (ZORI); SANDALS; SANDALS AND BEACH SHOES; SOLES FOR JAPANESE STYLE SANDALS; THONG FOOTWEAR; ZORI (U.S. CLS. 22 AND 39).

FIRST USE 12-15-2008; IN COMMERCE 3-25-2014.

REBECCA SMITH, EXAMINING ATTORNEY

SN 86-239,838. V4 CLOTHING LTD, EASTCHESTER, NY.  
FILED 4-2-2014.



THE MARK CONSISTS OF A DOWNWARD POINTED ARROW WITH A VERTICAL BAR LINE EXTENDING FROM THE MIDDLE OF THE ARROW UPWARD, WHICH HAS A HORIZONTAL BAR LINE INTERSECTING THE VERTICAL BAR LINE EXTENDING TO THE LEFT AND CONNECTED TO THE RIGHT STEM OF THE ARROW.

FOR BASEBALL CAPS AND HATS; BEANIES; GLOVES; LONG-SLEEVED SHIRTS; SOCKS; SWEATERS; SWEATPANTS; T-SHIRTS; TANK TOPS (U.S. CLS. 22 AND 39).

SAMUEL E. SHARPER JR., EXAMINING ATTORNEY



**CLASS 25—(Continued).**

SN 86-239,881. THE BURTON CORPORATION, BURLINGTON, VT. FILED 4-2-2014.

# FACE LAYER

THE MARK CONSISTS OF STANDARD CHARACTERS WITHOUT CLAIM TO ANY PARTICULAR FONT, STYLE, SIZE, OR COLOR.

NO CLAIM IS MADE TO THE EXCLUSIVE RIGHT TO USE FACE, APART FROM THE MARK AS SHOWN.

FOR CLOTHING, NAMELY, HEADWEAR, FACE MASKS, HATS, BEANIES, HOODS, SCARVES, BANDANAS, HEADBANDS, BALACLAVAS, AND NECK GAITERS (U.S. CLS. 22 AND 39).

DORITT L. CARROLL, EXAMINING ATTORNEY

---

SN 86-240,192. CAPITAL NINE INC., ROCHESTER, MN. FILED 4-2-2014.

# RUN USA

THE MARK CONSISTS OF STANDARD CHARACTERS WITHOUT CLAIM TO ANY PARTICULAR FONT, STYLE, SIZE, OR COLOR.

NO CLAIM IS MADE TO THE EXCLUSIVE RIGHT TO USE "USA", APART FROM THE MARK AS SHOWN.

FOR ATHLETIC APPAREL, NAMELY, SHIRTS, PANTS, JACKETS, FOOTWEAR, HATS AND CAPS, ATHLETIC UNIFORMS; BODY SHIRTS; CLOTHING FOR BABIES, TODDLERS AND CHILDREN, TREATED WITH FIRE AND HEAT RETARDANTS, NAMELY, PAJAMAS, JACKETS, SHIRTS, PANTS, JUMPERS; HOODED SWEAT SHIRTS; LONG-SLEEVED SHIRTS; MOISTURE-WICKING SPORTS SHIRTS; SHIRTS AND SHORT-SLEEVED SHIRTS; SHORT-SLEEVED OR LONG-SLEEVED T-SHIRTS; SHORT-SLEEVED SHIRTS; SPORTS SHIRTS; SPORTS SHIRTS WITH SHORT SLEEVES; SWEAT SHIRTS; T-SHIRTS; TEE SHIRTS; TRIATHLON CLOTHING, NAMELY, TRIATHLON TIGHTS, TRIATHLON SHORTS, TRIATHLON SINGLETTS, TRIATHLON SHIRTS, TRIATHLON SUITS; WEARABLE GARMENTS AND CLOTHING, NAMELY, SHIRTS; WIND SHIRTS; YOGA SHIRTS (U.S. CLS. 22 AND 39).

HAI-LY LAM, EXAMINING ATTORNEY

**CLASS 25—(Continued).**

SN 86-240,247. KING'S FLAIR MARKETING LIMITED, TORTOLA, BR.VIRGIN ISLANDS, FILED 4-2-2014.



THE MARK CONSISTS OF LITERAL ELEMENT "ALEYBO" AND A SPECIAL DESIGN OF THE LETTER "A" ON THE LEFT SIDE OF THE LITERAL ELEMENT "ALEYBO".

THE WORDING "ALEYBO" HAS NO MEANING IN A FOREIGN LANGUAGE.

FOR BABY LAYETTES FOR CLOTHING; BELTS FOR CLOTHING; BIBS NOT OF PAPER; BOTTOMS; CAPS; FOOTWEAR; GIRDLES; GLOVES AS CLOTHING; HATS; HOODS; HOSIERY; INFANT WEAR; JACKETS; JERSEYS; LEG-WARMERS; LEOTARDS; MASQUERADE COSTUMES; NECKTIES; NECKWEAR; NON-SLIP SOLES FOR FOOTWEAR; SCARFS; SCARVES; SHAWLS AND STOLE; SHOWER CAPS; SKI GLOVES; SOCKS AND STOCKINGS; SWIM WEAR; TOPS; TURBANS; UNDERWEAR; WATERPROOF FOOTWEAR; WATERPROOF JACKETS AND PANTS (U.S. CLS. 22 AND 39).

FIRST USE 10-20-2013; IN COMMERCE 3-5-2014.

ELIZABETH JACKSON, EXAMINING ATTORNEY

---

SN 86-240,433. REDSTONE CAPITAL CORPORATION, GREENWICH, CT. FILED 4-2-2014.

# Polar Designs

THE MARK CONSISTS OF STANDARD CHARACTERS WITHOUT CLAIM TO ANY PARTICULAR FONT, STYLE, SIZE, OR COLOR.

NO CLAIM IS MADE TO THE EXCLUSIVE RIGHT TO USE "DESIGNS", APART FROM THE MARK AS SHOWN.

FOR ATHLETIC PANTS (U.S. CLS. 22 AND 39).

FIRST USE 2-11-2013; IN COMMERCE 3-4-2014.

RONALD DELGIZZI, EXAMINING ATTORNEY

**CLASS 25—(Continued).**

SN 86-240,443. ASJ INSPIRATIONS, MASON, OH. FILED 4-2-2014.



THE MARK CONSISTS OF A SILHOUETTE OF A MAN WITH RAISED ARMS, DISPLAYED WITHIN A DIAMOND SHAPED DESIGN.

FOR HATS; HEADBANDS; POLO SHIRTS; T-SHIRTS (U.S. CLS. 22 AND 39).

EVELYN BRADLEY, EXAMINING ATTORNEY

**CLASS 25—(Continued).**

SN 86-240,592. JENNIFER YOUNG, LOS ANGELES, CA. FILED 4-2-2014.

## Sweet Forever

THE MARK CONSISTS OF STANDARD CHARACTERS WITHOUT CLAIM TO ANY PARTICULAR FONT, STYLE, SIZE, OR COLOR.

FOR FLIP FLOPS; PEDICURE SANDALS; SANDAL-CLOGS; SANDALS; SANDALS AND BEACH SHOES; SHOES (U.S. CLS. 22 AND 39).

FIRST USE 1-10-2010; IN COMMERCE 1-15-2010.

REBECCA GILBERT, EXAMINING ATTORNEY

SN 86-240,539. WALLAROO HAT COMPANY, LLC, BOULDER, CO. FILED 4-2-2014.



OWNER OF U.S. REG. NO. 3,487,867.

NO CLAIM IS MADE TO THE EXCLUSIVE RIGHT TO USE "HAT COMPANY", APART FROM THE MARK AS SHOWN.

THE MARK CONSISTS OF A STYLIZED KANGAROO INSIDE OF AN OVAL CIRCLE WITH THE WORD WALLAROO IN CAPITALS AROUND THE TOP OF THE OVAL AND THE WORDS HAT COMPANY AROUND THE BOTTOM OF THE OVAL WITH A WAVY LINE IN BETWEEN THE WORDS WALLAROO AND HAT, AND BETWEEN THE WORDS WALLAROO AND COMPANY, ALL OF WHICH IS ENCLOSED IN A LARGER OVAL CIRCLE.

FOR MEN'S AND WOMEN'S APPAREL, NAMELY, HATS (U.S. CLS. 22 AND 39).

ALEX KEAM, EXAMINING ATTORNEY

SN 86-241,728. CAPITAL NINE INC., ROCHESTER, MN. FILED 4-3-2014.

## RUN FLORIDA

THE MARK CONSISTS OF STANDARD CHARACTERS WITHOUT CLAIM TO ANY PARTICULAR FONT, STYLE, SIZE, OR COLOR.

NO CLAIM IS MADE TO THE EXCLUSIVE RIGHT TO USE "FLORIDA", APART FROM THE MARK AS SHOWN.

FOR ATHLETIC APPAREL, NAMELY, SHIRTS, PANTS, JACKETS, FOOTWEAR, HATS AND CAPS, ATHLETIC UNIFORMS; BODY SHIRTS; CLOTHING FOR BABIES, TODDLERS AND CHILDREN, TREATED WITH FIRE AND HEAT RETARDANTS, NAMELY, PAJAMAS, JACKETS, SHIRTS, PANTS, JUMPERS; HOODED SWEAT SHIRTS; LONG-SLEEVED SHIRTS; MOISTURE-WICKING SPORTS SHIRTS; SHIRTS AND SHORT-SLEEVED SHIRTS; SHORT-SLEEVED OR LONG-SLEEVED T-SHIRTS; SHORT-SLEEVED SHIRTS; SPORTS SHIRTS; SPORTS SHIRTS WITH SHORT SLEEVES; SWEAT SHIRTS; T-SHIRTS; TEE SHIRTS; TRIATHLON CLOTHING, NAMELY, TRIATHLON TIGHTS, TRIATHLON SHORTS, TRIATHLON SINGLETTS, TRIATHLON SHIRTS, TRIATHLON SUITS; WEARABLE GARMENTS AND CLOTHING, NAMELY, SHIRTS; WIND SHIRTS; YOGA SHIRTS (U.S. CLS. 22 AND 39).

HAI-LY LAM, EXAMINING ATTORNEY

**CLASS 25—(Continued).**

SN 86-241,729. T.D.C. USA, INC., FAIRFIELD, NJ. FILED 4-3-2014.

# LYONSCOTT

THE MARK CONSISTS OF STANDARD CHARACTERS WITHOUT CLAIM TO ANY PARTICULAR FONT, STYLE, SIZE, OR COLOR.

THE NAME "LYON SCOTT" DOES NOT IDENTIFY A LIVING INDIVIDUAL.

FOR JACKETS; JEANS; PAJAMAS; PANTS; SHIRTS; SOCKS (U.S. CLS. 22 AND 39).

ALISON KEELEY, EXAMINING ATTORNEY

SN 86-241,736. CAPITAL NINE INC., ROCHESTER, MN. FILED 4-3-2014.

# RUN OKLAHOMA

THE MARK CONSISTS OF STANDARD CHARACTERS WITHOUT CLAIM TO ANY PARTICULAR FONT, STYLE, SIZE, OR COLOR.

NO CLAIM IS MADE TO THE EXCLUSIVE RIGHT TO USE "OKLAHOMA", APART FROM THE MARK AS SHOWN.

FOR ATHLETIC APPAREL, NAMELY, SHIRTS, PANTS, JACKETS, FOOTWEAR, HATS AND CAPS, ATHLETIC UNIFORMS; BODY SHIRTS; CLOTHING FOR BABIES, TODDLERS AND CHILDREN, TREATED WITH FIRE AND HEAT RETARDANTS, NAMELY, PAJAMAS, JACKETS, SHIRTS, PANTS, JUMPERS; HOODED SWEAT SHIRTS; LONG-SLEEVED SHIRTS; MOISTURE-WICKING SPORTS SHIRTS; SHIRTS AND SHORT-SLEEVED SHIRTS; SHORT-SLEEVED OR LONG-SLEEVED T-SHIRTS; SHORT-SLEEVED SHIRTS; SPORTS SHIRTS; SPORTS SHIRTS WITH SHORT SLEEVES; SWEAT SHIRTS; T-SHIRTS; TEE SHIRTS; TRIATHLON CLOTHING, NAMELY, TRIATHLON TIGHTS, TRIATHLON SHORTS, TRIATHLON SING-LETS, TRIATHLON SHIRTS, TRIATHLON SUITS; WEARABLE GARMENTS AND CLOTHING, NAMELY, SHIRTS; WIND SHIRTS; YOGA SHIRTS (U.S. CLS. 22 AND 39).

HAI-LY LAM, EXAMINING ATTORNEY

**CLASS 25—(Continued).**

SN 86-241,746. CAPITAL NINE INC., ROCHESTER, MN. FILED 4-3-2014.

# RUN MONTANA

THE MARK CONSISTS OF STANDARD CHARACTERS WITHOUT CLAIM TO ANY PARTICULAR FONT, STYLE, SIZE, OR COLOR.

NO CLAIM IS MADE TO THE EXCLUSIVE RIGHT TO USE "MONTANA", APART FROM THE MARK AS SHOWN.

FOR ATHLETIC APPAREL, NAMELY, SHIRTS, PANTS, JACKETS, FOOTWEAR, HATS AND CAPS, ATHLETIC UNIFORMS; BODY SHIRTS; CLOTHING FOR BABIES, TODDLERS AND CHILDREN, TREATED WITH FIRE AND HEAT RETARDANTS, NAMELY, PAJAMAS, JACKETS, SHIRTS, PANTS, JUMPERS; HOODED SWEAT SHIRTS; LONG-SLEEVED SHIRTS; MOISTURE-WICKING SPORTS SHIRTS; SHIRTS AND SHORT-SLEEVED SHIRTS; SHORT-SLEEVED OR LONG-SLEEVED T-SHIRTS; SHORT-SLEEVED SHIRTS; SPORTS SHIRTS; SPORTS SHIRTS WITH SHORT SLEEVES; SWEAT SHIRTS; T-SHIRTS; TEE SHIRTS; TRIATHLON CLOTHING, NAMELY, TRIATHLON TIGHTS, TRIATHLON SHORTS, TRIATHLON SING-LETS, TRIATHLON SHIRTS, TRIATHLON SUITS; WEARABLE GARMENTS AND CLOTHING, NAMELY, SHIRTS; WIND SHIRTS; YOGA SHIRTS (U.S. CLS. 22 AND 39).

HAI-LY LAM, EXAMINING ATTORNEY

SN 86-241,751. CAPITAL NINE INC., ROCHESTER, MN. FILED 4-3-2014.

# RUN VIRGINIA

THE MARK CONSISTS OF STANDARD CHARACTERS WITHOUT CLAIM TO ANY PARTICULAR FONT, STYLE, SIZE, OR COLOR.

NO CLAIM IS MADE TO THE EXCLUSIVE RIGHT TO USE "VIRGINIA", APART FROM THE MARK AS SHOWN.

FOR ATHLETIC APPAREL, NAMELY, SHIRTS, PANTS, JACKETS, FOOTWEAR, HATS AND CAPS, ATHLETIC UNIFORMS; BODY SHIRTS; CLOTHING FOR BABIES, TODDLERS AND CHILDREN, TREATED WITH FIRE AND HEAT RETARDANTS, NAMELY, PAJAMAS, JACKETS, SHIRTS, PANTS, JUMPERS; HOODED SWEAT SHIRTS; LONG-SLEEVED SHIRTS; MOISTURE-WICKING SPORTS SHIRTS; SHIRTS AND SHORT-SLEEVED SHIRTS; SHORT-SLEEVED OR LONG-SLEEVED T-SHIRTS; SHORT-SLEEVED SHIRTS; SPORTS SHIRTS; SPORTS SHIRTS WITH SHORT SLEEVES; SWEAT SHIRTS; T-SHIRTS; TEE SHIRTS; TRIATHLON CLOTHING, NAMELY, TRIATHLON TIGHTS, TRIATHLON SHORTS, TRIATHLON SING-LETS, TRIATHLON SHIRTS, TRIATHLON SUITS; WEARABLE GARMENTS AND CLOTHING, NAMELY, SHIRTS; WIND SHIRTS; YOGA SHIRTS (U.S. CLS. 22 AND 39).

HAI-LY LAM, EXAMINING ATTORNEY

**CLASS 25—(Continued).**

SN 86-241,766. CAPITAL NINE INC., ROCHESTER, MN.  
FILED 4-3-2014.

**RUN MISSOURI**

THE MARK CONSISTS OF STANDARD CHARACTERS WITHOUT CLAIM TO ANY PARTICULAR FONT, STYLE, SIZE, OR COLOR.

NO CLAIM IS MADE TO THE EXCLUSIVE RIGHT TO USE "MISSOURI", APART FROM THE MARK AS SHOWN.

FOR ATHLETIC APPAREL, NAMELY, SHIRTS, PANTS, JACKETS, FOOTWEAR, HATS AND CAPS, ATHLETIC UNIFORMS; BODY SHIRTS; CLOTHING FOR BABIES, TODDLERS AND CHILDREN, TREATED WITH FIRE AND HEAT RETARDANTS, NAMELY, PAJAMAS, JACKETS, SHIRTS, PANTS, JUMPERS; HOODED SWEAT SHIRTS; LONG-SLEEVED SHIRTS; MOISTURE-WICKING SPORTS SHIRTS; SHIRTS AND SHORT-SLEEVED SHIRTS; SHORT-SLEEVED OR LONG-SLEEVED T-SHIRTS; SHORT-SLEEVED SHIRTS; SPORTS SHIRTS; SPORTS SHIRTS WITH SHORT SLEEVES; SWEAT SHIRTS; T-SHIRTS; TEE SHIRTS; TRIATHLON CLOTHING, NAMELY, TRIATHLON TIGHTS, TRIATHLON SHORTS, TRIATHLON SING-LETS, TRIATHLON SHIRTS, TRIATHLON SUITS; WEARABLE GARMENTS AND CLOTHING, NAMELY, SHIRTS; WIND SHIRTS; YOGA SHIRTS (U.S. CLS. 22 AND 39).

HAI-LY LAM, EXAMINING ATTORNEY

**CLASS 25—(Continued).**

SN 86-241,779. CAPITAL NINE INC., ROCHESTER, MN.  
FILED 4-3-2014.

**RUN PENNSYLVANIA**

THE MARK CONSISTS OF STANDARD CHARACTERS WITHOUT CLAIM TO ANY PARTICULAR FONT, STYLE, SIZE, OR COLOR.

NO CLAIM IS MADE TO THE EXCLUSIVE RIGHT TO USE "PENNSYLVANIA", APART FROM THE MARK AS SHOWN.

FOR ATHLETIC APPAREL, NAMELY, SHIRTS, PANTS, JACKETS, FOOTWEAR, HATS AND CAPS, ATHLETIC UNIFORMS; BODY SHIRTS; CLOTHING FOR BABIES, TODDLERS AND CHILDREN, TREATED WITH FIRE AND HEAT RETARDANTS, NAMELY, PAJAMAS, JACKETS, SHIRTS, PANTS, JUMPERS; HOODED SWEAT SHIRTS; LONG-SLEEVED SHIRTS; MOISTURE-WICKING SPORTS SHIRTS; SHIRTS AND SHORT-SLEEVED SHIRTS; SHORT-SLEEVED OR LONG-SLEEVED T-SHIRTS; SHORT-SLEEVED SHIRTS; SPORTS SHIRTS; SPORTS SHIRTS WITH SHORT SLEEVES; SWEAT SHIRTS; T-SHIRTS; TEE SHIRTS; TRIATHLON CLOTHING, NAMELY, TRIATHLON TIGHTS, TRIATHLON SHORTS, TRIATHLON SING-LETS, TRIATHLON SHIRTS, TRIATHLON SUITS; WEARABLE GARMENTS AND CLOTHING, NAMELY, SHIRTS; WIND SHIRTS; YOGA SHIRTS (U.S. CLS. 22 AND 39).

HAI-LY LAM, EXAMINING ATTORNEY

SN 86-241,775. CAPITAL NINE INC., ROCHESTER, MN.  
FILED 4-3-2014.

**RUN MASSACHUSETTS**

THE MARK CONSISTS OF STANDARD CHARACTERS WITHOUT CLAIM TO ANY PARTICULAR FONT, STYLE, SIZE, OR COLOR.

NO CLAIM IS MADE TO THE EXCLUSIVE RIGHT TO USE "MASSACHUSETTS", APART FROM THE MARK AS SHOWN.

FOR ATHLETIC APPAREL, NAMELY, SHIRTS, PANTS, JACKETS, FOOTWEAR, HATS AND CAPS, ATHLETIC UNIFORMS; BODY SHIRTS; CLOTHING FOR BABIES, TODDLERS AND CHILDREN, TREATED WITH FIRE AND HEAT RETARDANTS, NAMELY, PAJAMAS, JACKETS, SHIRTS, PANTS, JUMPERS; HOODED SWEAT SHIRTS; LONG-SLEEVED SHIRTS; MOISTURE-WICKING SPORTS SHIRTS; SHIRTS AND SHORT-SLEEVED SHIRTS; SHORT-SLEEVED OR LONG-SLEEVED T-SHIRTS; SHORT-SLEEVED SHIRTS; SPORTS SHIRTS; SPORTS SHIRTS WITH SHORT SLEEVES; SWEAT SHIRTS; T-SHIRTS; TEE SHIRTS; TRIATHLON CLOTHING, NAMELY, TRIATHLON TIGHTS, TRIATHLON SHORTS, TRIATHLON SING-LETS, TRIATHLON SHIRTS, TRIATHLON SUITS; WEARABLE GARMENTS AND CLOTHING, NAMELY, SHIRTS; WIND SHIRTS; YOGA SHIRTS (U.S. CLS. 22 AND 39).

HAI-LY LAM, EXAMINING ATTORNEY

SN 86-241,789. CAPITAL NINE INC., ROCHESTER, MN.  
FILED 4-3-2014.

**RUN NEW JERSEY**

THE MARK CONSISTS OF STANDARD CHARACTERS WITHOUT CLAIM TO ANY PARTICULAR FONT, STYLE, SIZE, OR COLOR.

NO CLAIM IS MADE TO THE EXCLUSIVE RIGHT TO USE "NEW JERSEY", APART FROM THE MARK AS SHOWN.

FOR ATHLETIC APPAREL, NAMELY, SHIRTS, PANTS, JACKETS, FOOTWEAR, HATS AND CAPS, ATHLETIC UNIFORMS; BODY SHIRTS; CLOTHING FOR BABIES, TODDLERS AND CHILDREN, TREATED WITH FIRE AND HEAT RETARDANTS, NAMELY, PAJAMAS, JACKETS, SHIRTS, PANTS, JUMPERS; HOODED SWEAT SHIRTS; LONG-SLEEVED SHIRTS; MOISTURE-WICKING SPORTS SHIRTS; SHIRTS AND SHORT-SLEEVED SHIRTS; SHORT-SLEEVED OR LONG-SLEEVED T-SHIRTS; SHORT-SLEEVED SHIRTS; SPORTS SHIRTS; SPORTS SHIRTS WITH SHORT SLEEVES; SWEAT SHIRTS; T-SHIRTS; TEE SHIRTS; TRIATHLON CLOTHING, NAMELY, TRIATHLON TIGHTS, TRIATHLON SHORTS, TRIATHLON SING-LETS, TRIATHLON SHIRTS, TRIATHLON SUITS; WEARABLE GARMENTS AND CLOTHING, NAMELY, SHIRTS; WIND SHIRTS; YOGA SHIRTS (U.S. CLS. 22 AND 39).

HAI-LY LAM, EXAMINING ATTORNEY

**CLASS 25—(Continued).**

SN 86-241,797. CAPITAL NINE INC., ROCHESTER, MN.  
FILED 4-3-2014.

**RUN KANSAS**

THE MARK CONSISTS OF STANDARD CHARACTERS WITHOUT CLAIM TO ANY PARTICULAR FONT, STYLE, SIZE, OR COLOR.

NO CLAIM IS MADE TO THE EXCLUSIVE RIGHT TO USE "KANSAS", APART FROM THE MARK AS SHOWN.

FOR ATHLETIC APPAREL, NAMELY, SHIRTS, PANTS, JACKETS, FOOTWEAR, HATS AND CAPS, ATHLETIC UNIFORMS; BODY SHIRTS; CLOTHING FOR BABIES, TODDLERS AND CHILDREN, TREATED WITH FIRE AND HEAT RETARDANTS, NAMELY, PAJAMAS, JACKETS, SHIRTS, PANTS, JUMPERS; HOODED SWEAT SHIRTS; LONG-SLEEVED SHIRTS; MOISTURE-WICKING SPORTS SHIRTS; SHIRTS AND SHORT-SLEEVED SHIRTS; SHORT-SLEEVED OR LONG-SLEEVED T-SHIRTS; SHORT-SLEEVED SHIRTS; SPORTS SHIRTS; SPORTS SHIRTS WITH SHORT SLEEVES; SWEAT SHIRTS; T-SHIRTS; TEE SHIRTS; TRIATHLON CLOTHING, NAMELY, TRIATHLON TIGHTS, TRIATHLON SHORTS, TRIATHLON SINGLET, TRIATHLON SHIRTS, TRIATHLON SUITS; WEARABLE GARMENTS AND CLOTHING, NAMELY, SHIRTS; WIND SHIRTS; YOGA SHIRTS (U.S. CLS. 22 AND 39).

HAI-LY LAM, EXAMINING ATTORNEY

**CLASS 25—(Continued).**

SN 86-242,358. NU ORIGIN APPAREL LLC, LAS VEGAS, NV.  
FILED 4-4-2014.



THE MARK CONSISTS OF A CIRCLE CONTAINING THE STYLIZED LETTERS "NU".

FOR SHIRTS; T-SHIRTS; PANTS; UNDERWEAR; LINGERIE; HATS; SCARVES; JACKETS; SWEATERS; BELTS; SHOES; SOCKS; GLOVES (U.S. CLS. 22 AND 39).  
HENRY S. ZAK, EXAMINING ATTORNEY

SN 86-241,887. THE TRUSTEES OF THE COLONIAL GREENE TRUST, LOS ANGELES, CA. FILED 4-3-2014.

**TWO WOLVES WINE**

THE MARK CONSISTS OF STANDARD CHARACTERS WITHOUT CLAIM TO ANY PARTICULAR FONT, STYLE, SIZE, OR COLOR.

FOR CLOTHING, NAMELY, SHIRTS, LONG-SLEEVED SHIRTS, T-SHIRTS, NIGHT SHIRTS, POLO SHIRTS, PANTS, JEANS, SHORTS, BOXER SHORTS, TOPS, STRETCH TOPS, CROP TOPS, TANK TOPS, TANKINIS, SWEAT SHIRTS, HOODED SWEAT SHIRTS, SWEAT JACKETS, SWEAT SHORTS, SWEAT PANTS, WARM-UP SUITS, TRACK SUITS, FLEECE VESTS, PULLOVERS, JACKETS, LAYETTES, INFANTWEAR, INFANTS SLEEPERS, BOOTIES, CAPS, HATS, VISORS, HEADBANDS, WRIST BANDS, SWEAT BANDS, HEADWEAR, EAR MUFFS, APRONS, SCARVES, BANDANAS, NECKWEAR, SOCKS, LOUNGEWEAR, ROBES, PAJAMAS, SLEEPWEAR, HOSIERY, GLOVES, MITTENS, RAINWEAR, FOOTWEAR, SNEAKERS, SHOES, SANDALS, FLIP-FLOPS, AND SLIPPERS (U.S. CLS. 22 AND 39).

CHRISTINA SOBRAL, EXAMINING ATTORNEY

SN 86-242,813. CLASS ACT SPORTS, LLC, LONG BEACH, NY. FILED 4-4-2014.

**Brack Attack**

THE MARK CONSISTS OF STANDARD CHARACTERS WITHOUT CLAIM TO ANY PARTICULAR FONT, STYLE, SIZE, OR COLOR.

FOR CLOTHING, NAMELY, T-SHIRTS, BUTTON DOWN SHIRTS, SWEATSHIRTS, UNDERSHIRTS, LONG SLEEVE SHIRTS, WRISTBANDS, HEADBANDS, PANTS, SWEATPANTS, SHORTS, SOCKS, GLOVES, JACKETS, BELTS, UNDERGARMENTS, NIGHT SHIRTS, SWIM WEAR, PAJAMAS AND BANDANAS; HEADWEAR, NAMELY, HATS; FOOTWEAR, NAMELY, CASUAL SHOES IN THE NATURE OF LEISURE SHOES AND SANDALS, SNEAKERS, AND FLIP FLOPS (U.S. CLS. 22 AND 39).

JERI J. FICKES, EXAMINING ATTORNEY

**CLASS 25—(Continued).**

SN 86-243,100. GO DEEP, LLC, EAST TAUNTON, MA. FILED 4-4-2014.



THE MARK CONSISTS OF A SILHOUETTE OF A MAN IN AN ACTION POSE. THERE ARE MARKINGS ON HIS WAIST AND LEGS OUTLINING UNDERWEAR. ONE ARM IS EXTENDED AND THE OTHER ARM IS BENT IN A THROWING POSITION WITH THE PALM OF HIS HAND EMPTY.

FOR CLOTHING, NAMELY, UNDERWEAR, T-SHIRTS, ATHLETIC SHIRTS, AND ATHLETIC TIGHTS (U.S. CLS. 22 AND 39).

CYNTHIA RINALDI, EXAMINING ATTORNEY

SN 86-243,139. WILD WEST GUNS LLC, ANCHORAGE, AK. FILED 4-4-2014.

## Wild West Alaska Gear

THE MARK CONSISTS OF STANDARD CHARACTERS WITHOUT CLAIM TO ANY PARTICULAR FONT, STYLE, SIZE, OR COLOR.

NO CLAIM IS MADE TO THE EXCLUSIVE RIGHT TO USE "ALASKA GEAR", APART FROM THE MARK AS SHOWN.

FOR BANDANAS; BEANIES; BELTS; BLOUSES; BOOTS; CAPS; FOOTWEAR; GLOVES; HATS; HEADBANDS; HOODED SWEATSHIRTS; JACKETS; JEANS; JERSEYS; JOGGING SUITS; JUMPSUITS; PANTS; SANDALS; SCARFS; SHIRTS; SHOES; SHORTS; SKIRTS; SLEEPWEAR; SUSPENDERS; SWEATERS; SWEATPANTS; SWEATSHIRTS; SWEATSUITS; SWIMSUITS; SWIMWEAR; T-SHIRTS; TANK-TOPS; TIES; TOPS; UNDERWEAR; VESTS; VISORS; WRAPS (U.S. CLS. 22 AND 39).

ALLISON HOLTZ, EXAMINING ATTORNEY

SN 86-243,222. DAVIS, STEPHEN, NOBLESVILLE, IN. FILED 4-4-2014.

## I'M NOT YOU I'M ME

THE MARK CONSISTS OF STANDARD CHARACTERS WITHOUT CLAIM TO ANY PARTICULAR FONT, STYLE, SIZE, OR COLOR.

FOR T-SHIRTS (U.S. CLS. 22 AND 39).

JAMES A. RAUEN, EXAMINING ATTORNEY

**CLASS 25—(Continued).**

SN 86-243,441. VIP FASHION, INC., LOS ANGELES, CA. FILED 4-4-2014.



NO CLAIM IS MADE TO THE EXCLUSIVE RIGHT TO USE "AMERICAN" AND "CASUAL WEAR", APART FROM THE MARK AS SHOWN.

THE MARK CONSISTS OF AN EAGLE WITH ITS WINGS SPREAD ABOVE THE WORDS "AMERICAN BREED" WITH THE WORDS "CASUAL WEAR" UNDERNEATH IT.

FOR CLOTHING, NAMELY, MEN'S AND WOMEN'S SWEATERS, SHIRTS, SWEATSHIRTS, PANTS, SHORTS, JACKETS, COATS, VESTS, HATS, SCARVES, GLOVES, BELTS, TIES, UNDERWEAR, SOCKS, SHOES, SNEAKERS, BOOTS, SLEEPWEAR, ROBES, SUITS (U.S. CLS. 22 AND 39).

FIRST USE 11-12-2013; IN COMMERCE 11-12-2013.

MICHAEL ENGEL, EXAMINING ATTORNEY

SN 86-243,971. ELANGOVAN, KANNAN, SOUTH PADRE ISLAND, TX. FILED 4-7-2014.



THE MARK CONSISTS OF LITERAL ELEMENTS "NISU" WRITTEN IN STYLIZED FORM WHEREIN ON THE LEFT SIDE OF LITERAL ELEMENTS A STYLIZED IMAGE IS PLACED WHICH DEPICTS THE LETTERS "N" AND "U".

FOR CLOTHING NAMELY T-SHIRTS, POLO T-SHIRTS, SHIRTS, TOPS, SWEATERS, SWEATSHIRTS, HOODED SWEATSHIRTS; COATS, JERSEYS, JACKETS; BOTTOMS, PANTS, TROUSERS, JEANS, SHORTS, SWEATPANTS, PAJAMAS; DRESSES; SKIRTS; BLOUSES; UNDERWEAR; SWIMWEAR; HEADWEAR; FOOTWEAR; BELTS, TIES, GLOVES, SOCKS; LEGGINGS; CAPRIS; CAMISOLES; LINGERIE; BOXERS; KNITTED TOPS (U.S. CLS. 22 AND 39).

MAH ROSENBERG, EXAMINING ATTORNEY

**CLASS 25—(Continued).**

SN 86-244,148. BONEDRY, LLC, TUCSON, AZ. FILED 4-7-2014.

WE'VE GOT YOU COVERED.

THE MARK CONSISTS OF STANDARD CHARACTERS WITHOUT CLAIM TO ANY PARTICULAR FONT, STYLE, SIZE, OR COLOR.

FOR ATHLETIC APPAREL, NAMELY, SHIRTS, PANTS, JACKETS, FOOTWEAR, HATS AND CAPS, ATHLETIC UNIFORMS (U.S. CLS. 22 AND 39).

FIRST USE 10-15-2013; IN COMMERCE 10-15-2013.  
NICOLE A NGUYEN, EXAMINING ATTORNEY

**CLASS 25—(Continued).**

SN 86-244,480. LEE, BONGJUN, PALISADES PARK, NJ. AND KWON, TAE JIN, PALISADES PARK, NJ. FILED 4-7-2014.

KOODOO

THE MARK CONSISTS OF STANDARD CHARACTERS WITHOUT CLAIM TO ANY PARTICULAR FONT, STYLE, SIZE, OR COLOR.

FOR BOTTOMS; HATS; PANTS; SHIRTS; SHOES; SWIMWEAR; TOPS; UNDERWEAR (U.S. CLS. 22 AND 39).

TASHIA BUNCH, EXAMINING ATTORNEY

SN 86-244,206. SOTO, OSCAR, BROOKLYN, NY. FILED 4-7-2014.

D.A.D.S. R.O.C.K. / SOTO  
SomeOneTrulyOriginal

THE MARK CONSISTS OF STANDARD CHARACTERS WITHOUT CLAIM TO ANY PARTICULAR FONT, STYLE, SIZE, OR COLOR.

FOR HATS; PANTS; SHIRTS; T-SHIRTS (U.S. CLS. 22 AND 39).

LINDA M. KING, EXAMINING ATTORNEY

SN 86-244,496. DYNAMIC BRANDS, LLC, RICHMOND, VA. FILED 4-7-2014.

PIVOTAL

THE MARK CONSISTS OF STANDARD CHARACTERS WITHOUT CLAIM TO ANY PARTICULAR FONT, STYLE, SIZE, OR COLOR.

FOR CLOTHING, SPORTS CLOTHING, AND APPAREL, NAMELY, PANTS, SHORTS, SHIRTS, T-SHIRTS, SHOES, PULLOVERS, SWEAT SHIRTS, SWEAT PANTS, SKIRTS, SWEATERS, JACKETS, COATS, SOCKS, HEADWEAR, GLOVES, BELTS, COATS, AND VESTS (U.S. CLS. 22 AND 39).

BRIAN NEVILLE, EXAMINING ATTORNEY

SN 86-244,417. COSMICTONIC, LLC, KINGSTON, NH. FILED 4-7-2014.

COSMIC TONIC

THE MARK CONSISTS OF STANDARD CHARACTERS WITHOUT CLAIM TO ANY PARTICULAR FONT, STYLE, SIZE, OR COLOR.

FOR SHORT-SLEEVED OR LONG-SLEEVED T-SHIRTS (U.S. CLS. 22 AND 39).

FIRST USE 1-28-2014; IN COMMERCE 1-28-2014.  
ANNIE NOBLE, EXAMINING ATTORNEY

SN 86-244,770. DONNA SALYERS' FABULOUS-FURS, INC., COVINGTON, KY. FILED 4-7-2014.

FAUXY

THE MARK CONSISTS OF STANDARD CHARACTERS WITHOUT CLAIM TO ANY PARTICULAR FONT, STYLE, SIZE, OR COLOR.

FOR CLOTHING, NAMELY, COATS, JACKETS, HATS, HEADBANDS, ANORAKS, PARKAS, WRAPS, VESTS, HEADWEAR (U.S. CLS. 22 AND 39).

EMILY CARLSEN, EXAMINING ATTORNEY

**CLASS 25—(Continued).**

SN 86-245,007. ITSME JEAN, INC., DBA ITZME, LOS ANGELES, CA. FILED 4-7-2014.

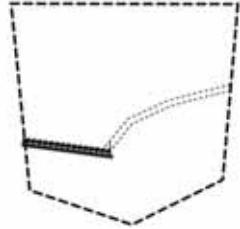

THE MARK CONSISTS OF A POCKET DESIGN. THE SHAPE OF THE POCKET AND BROKEN LINES FORMING THE POCKET ARE NOT PART OF THE MARK. THE MARK CONSISTS OF TWO SINGLE-STITCHED LINES STARTING HALFWAY DOWN THE RIGHT SIDE OF THE POCKET, MOVING DOWNWARD, AND ENDING OFF-CENTERED AT THE HALFWAY POINT OF THE POCKET. THE TWO SINGLE-STITCHED LINES INTERSECT WITH A ZIGZAG STITCH THAT MOVES ACROSS THE POCKET TO THE LEFT SIDE AT AN UPWARD ANGLE. UNDERNEATH THE ZIGZAG STITCH LINE IS A SOLID SINGLE STITCH LINE AT THE SAME UPWARD ANGLE.

FOR CLOTHING, NAMELY, DENIMS, JEANS, AND PANTS (U.S. CLS. 22 AND 39).  
CURTIS FRENCH, EXAMINING ATTORNEY

SN 86-245,295. GRAND CENTRAL TRADING LLC, NEW YORK, NY. FILED 4-8-2014.

**CONTEMPORARY EDGE**

THE MARK CONSISTS OF STANDARD CHARACTERS WITHOUT CLAIM TO ANY PARTICULAR FONT, STYLE, SIZE, OR COLOR.

FOR CLOTHING, NAMELY, TOPS, BOTTOMS, JACKETS, JERSEYS, UNDERWEAR (U.S. CLS. 22 AND 39).  
DOMINICK J. SALEMI, EXAMINING ATTORNEY

SN 86-245,302. LEACH, PATRICK, TANNERSVILLE, NY. FILED 4-8-2014.

**DIGEST YOURSELF**

THE MARK CONSISTS OF STANDARD CHARACTERS WITHOUT CLAIM TO ANY PARTICULAR FONT, STYLE, SIZE, OR COLOR.

FOR CLOTHING NAMELY, T-SHIRTS, HATS, TOPS, BOTTOMS, HEADWEAR (U.S. CLS. 22 AND 39).  
DOMINICK J. SALEMI, EXAMINING ATTORNEY

**CLASS 25—(Continued).**

SN 86-245,331. NEW PLAYERS CLUB LLC, WOODLAND PARK, NJ. FILED 4-8-2014.

**Chop'n Knights Nation**

THE MARK CONSISTS OF STANDARD CHARACTERS WITHOUT CLAIM TO ANY PARTICULAR FONT, STYLE, SIZE, OR COLOR.

OWNER OF U.S. REG. NOS. 4,137,966 AND 4,271,437.  
FOR CLOTHING, NAMELY, SHIRTS (U.S. CLS. 22 AND 39).

FIRST USE 1-2-2010; IN COMMERCE 6-2-2010.

RONALD MCMORROW, EXAMINING ATTORNEY

SN 86-245,332. HALSTEAD, JAKE, KANSAS CITY, MO. FILED 4-8-2014.

**A Fight For Rights 2**

THE MARK CONSISTS OF STANDARD CHARACTERS WITHOUT CLAIM TO ANY PARTICULAR FONT, STYLE, SIZE, OR COLOR.

FOR HATS; T-SHIRTS (U.S. CLS. 22 AND 39).

RONALD MCMORROW, EXAMINING ATTORNEY

SN 86-245,337. HOWERY GROUP LLC, LILLIAN, AL. FILED 4-8-2014.

**FULLY FUNCTIONAL WEAR**

THE MARK CONSISTS OF STANDARD CHARACTERS WITHOUT CLAIM TO ANY PARTICULAR FONT, STYLE, SIZE, OR COLOR.

NO CLAIM IS MADE TO THE EXCLUSIVE RIGHT TO USE "WEAR", APART FROM THE MARK AS SHOWN.

FOR SHIRTS; JACKETS; TROUSERS; PANTS; BELTS; FOOTWEAR (U.S. CLS. 22 AND 39).

RONALD MCMORROW, EXAMINING ATTORNEY



**CLASS 25—(Continued).**

SN 86-245,403. TAIRONG KNITTING & TEXTILE GROUP CO., LTD., ZHUJI, ZHEJIANG, CHINA, FILED 4-8-2014.

**TWELVE LUCKY ZODIAC**

THE MARK CONSISTS OF STANDARD CHARACTERS WITHOUT CLAIM TO ANY PARTICULAR FONT, STYLE, SIZE, OR COLOR.

FOR SHIRTS; PANTS; SWEATSHIRTS; SWEATPANTS; UNDERWEAR; PANTIES; BRAS; SOCKS; JACKETS (U.S. CLS. 22 AND 39).

FONG HSU, EXAMINING ATTORNEY

---

SN 86-245,482. PEACE LOVE WORLD, LLC, MIAMI, FL. FILED 4-8-2014.

**I AM LOVELY**

THE MARK CONSISTS OF STANDARD CHARACTERS WITHOUT CLAIM TO ANY PARTICULAR FONT, STYLE, SIZE, OR COLOR.

FOR HOODED SWEAT SHIRTS; HOODED SWEATSHIRTS; LONG-SLEEVED SHIRTS; SHIRTS; SHIRTS AND SHORT-SLEEVED SHIRTS; SHORT-SLEEVED OR LONG-SLEEVED T-SHIRTS; SHORT-SLEEVED SHIRTS; T-SHIRTS; TANK TOPS; TANK-TOPS; TEE SHIRTS (U.S. CLS. 22 AND 39).

FIRST USE 9-24-2013; IN COMMERCE 9-24-2013.  
CASSONDRANDERSON, EXAMINING ATTORNEY

---

SN 86-245,486. THE BOLIVAR GROUP, INC., LONG ISLAND CITY, NY. FILED 4-8-2014.

**MILAGUA**

THE MARK CONSISTS OF STANDARD CHARACTERS WITHOUT CLAIM TO ANY PARTICULAR FONT, STYLE, SIZE, OR COLOR.

THE WORDING "MILAGUA" HAS NO MEANING IN A FOREIGN LANGUAGE.

FOR BATHING SUITS; BEACH COVER-UPS; SWIMSUITS (U.S. CLS. 22 AND 39).

FONG HSU, EXAMINING ATTORNEY

**CLASS 25—(Continued).**

SN 86-245,517. PEACE LOVE WORLD, LLC, MIAMI, FL. FILED 4-8-2014.

**HAPPY IS THE NEW BLACK**

THE MARK CONSISTS OF STANDARD CHARACTERS WITHOUT CLAIM TO ANY PARTICULAR FONT, STYLE, SIZE, OR COLOR.

FOR LONG-SLEEVED SHIRTS; SHIRTS; SHIRTS AND SHORT-SLEEVED SHIRTS; SHORT-SLEEVED OR LONG-SLEEVED T-SHIRTS; SHORT-SLEEVED SHIRTS; SWEAT SHIRTS; SWEATERS; SWEATSHIRTS; T-SHIRTS; TEE SHIRTS (U.S. CLS. 22 AND 39).

FIRST USE 4-10-2012; IN COMMERCE 4-10-2012.  
CASSONDRANDERSON, EXAMINING ATTORNEY

---

SN 86-245,528. CLARK, VIVIAN V., DALLAS, TX. AND SCOTT, SHARON A., DALLAS, TX. FILED 4-8-2014.

**I'M JUST SIMPLY ME...**

THE MARK CONSISTS OF STANDARD CHARACTERS WITHOUT CLAIM TO ANY PARTICULAR FONT, STYLE, SIZE, OR COLOR.

FOR HATS; SHIRTS (U.S. CLS. 22 AND 39).

FIRST USE 4-4-2014; IN COMMERCE 4-4-2014.  
GEORGE LORENZO, EXAMINING ATTORNEY

---

SN 86-245,622. LULU'S FASHION LOUNGE, INC., CHICO, CA. FILED 4-8-2014.

**LULU'S**

THE MARK CONSISTS OF STANDARD CHARACTERS WITHOUT CLAIM TO ANY PARTICULAR FONT, STYLE, SIZE, OR COLOR.

OWNER OF U.S. REG. NO. 3,743,619.

FOR CLOTHING, NAMELY DRESSES, TOPS, SWEATERS, VESTS, JACKETS, SKIRTS, PANTS, JEANS, SHORTS, LEGGINGS, TIGHTS, SOCKS, OVERALLS, SWIMWEAR, ROMPERS, JUMPSUITS, LINGERIE, AND BODYSUITS; HEADWEAR, NAMELY, HATS; FOOTWEAR, NAMELY, SHOES, BOOTS, FLIP FLOPS, AND SANDALS (U.S. CLS. 22 AND 39).

FIRST USE 8-31-1996; IN COMMERCE 8-31-1996.  
LOKSYE G LEE RISO, EXAMINING ATTORNEY

**CLASS 25—(Continued).**

SN 86-245,630. LULU'S FASHION LOUNGE, INC., CHICO, CA. FILED 4-8-2014.



OWNER OF U.S. REG. NO. 3,743,619.

THE MARK CONSISTS OF THE WORD "LULU'S" IN A STYLIZED FONT WITH THE APOSTROPHE BETWEEN THE LETTERS "U" AND "S" APPEARING AS A STAR.

FOR CLOTHING, NAMELY DRESSES, TOPS, SWEATERS, VESTS, JACKETS, SKIRTS, PANTS, JEANS, SHORTS, LEGGINGS, TIGHTS, SOCKS, OVERALLS, SWIMWEAR, ROMPERS, JUMPSUITS, LINGERIE, AND BODYSUITS; HEADWEAR, NAMELY, HATS; FOOTWEAR, NAMELY, SHOES, BOOTS, FLIP FLOPS, AND SANDALS (U.S. CLS. 22 AND 39).

FIRST USE 8-31-1996; IN COMMERCE 8-31-1996.  
LOKSYE G LEE RISO, EXAMINING ATTORNEY

SN 86-245,641. ACI INTERNATIONAL, LOS ANGELES, CA. FILED 4-8-2014.

## SPEEDKNIT

THE MARK CONSISTS OF STANDARD CHARACTERS WITHOUT CLAIM TO ANY PARTICULAR FONT, STYLE, SIZE, OR COLOR.

FOR FOOTWEAR (U.S. CLS. 22 AND 39).  
DAVID TAYLOR, EXAMINING ATTORNEY

SN 86-245,656. LAURENCE MADSEN, NEW YORK, NY. FILED 4-8-2014.

## Elegance at Work

THE MARK CONSISTS OF STANDARD CHARACTERS WITHOUT CLAIM TO ANY PARTICULAR FONT, STYLE, SIZE, OR COLOR.

FOR ATHLETIC AND CASUAL APPAREL, NAMELY, SHIRTS, PANTS, JACKETS; FOOTWEAR, HATS AND CAPS, ATHLETIC UNIFORMS; ATHLETIC TOPS AND BOTTOMS FOR YOGA (U.S. CLS. 22 AND 39).

KEVIN CRENNAN, EXAMINING ATTORNEY

**CLASS 25—(Continued).**

SN 86-245,663. RIVERSTONE VENTURES, LLC, OVERLAND PARK, KS. FILED 4-8-2014.

## BUG BEEP

THE MARK CONSISTS OF STANDARD CHARACTERS WITHOUT CLAIM TO ANY PARTICULAR FONT, STYLE, SIZE, OR COLOR.

FOR CLOTHING FOR BABIES, TODDLERS AND CHILDREN, NAMELY, SHIRTS, SHORT SLEEVE T-SHIRTS, LONG SLEEVE T-SHIRTS, SWEATSHIRTS, HOODED SWEATSHIRTS, ZIPPED HOODED SWEATSHIRTS, SHORT SLEEVE BODYSUITS, LONG SLEEVE BODYSUITS, BLOOMERS, INFANT GOWNS, HATS, BEANIES, BABY CAPS, BASEBALL CAPS, CAPS, SOCKS, GLOVES, SCARVES, EAR MUFFS, ROMPERS, PANTS, SHORTS, SLIPPERS, DRESSES, CLOTH BIBS, APRONS, HALLOWEEN AND MASQUERADE COSTUMES, AND COSTUMES FOR USE IN CHILDREN'S DRESS UP PLAY (U.S. CLS. 22 AND 39).

FIRST USE 3-13-2014; IN COMMERCE 3-13-2014.  
CATHERINE TARCU, EXAMINING ATTORNEY

SN 86-245,746. PEACE LOVE WORLD, LLC, MIAMI, FL. FILED 4-8-2014.

## SWEAT LOVE

THE MARK CONSISTS OF STANDARD CHARACTERS WITHOUT CLAIM TO ANY PARTICULAR FONT, STYLE, SIZE, OR COLOR.

FOR SHIRTS; SHIRTS AND SHORT-SLEEVED SHIRTS; SHORT-SLEEVED SHIRTS; T-SHIRTS; TANK TOPS; TANK-TOPS; TEE SHIRTS (U.S. CLS. 22 AND 39).

FIRST USE 7-31-2013; IN COMMERCE 7-31-2013.  
CASSONDRA ANDERSON, EXAMINING ATTORNEY

SN 86-245,770. PEACE LOVE WORLD, LLC, MIAMI, FL. FILED 4-8-2014.

## I LOVE SATURDAYS

THE MARK CONSISTS OF STANDARD CHARACTERS WITHOUT CLAIM TO ANY PARTICULAR FONT, STYLE, SIZE, OR COLOR.

FOR HOODED SWEAT SHIRTS; HOODED SWEATSHIRTS; SHIRTS; SHIRTS AND SHORT-SLEEVED SHIRTS; SHORT-SLEEVED SHIRTS; T-SHIRTS; TANK TOPS; TANK-TOPS; TEE SHIRTS (U.S. CLS. 22 AND 39).

CASSONDRA ANDERSON, EXAMINING ATTORNEY

**CLASS 25—(Continued).**

SN 86-245,779. PEACE LOVE WORLD, LLC, MIAMI, FL.  
FILED 4-8-2014.

**I LOVE FRIDAYS**

THE MARK CONSISTS OF STANDARD CHARACTERS WITHOUT CLAIM TO ANY PARTICULAR FONT, STYLE, SIZE, OR COLOR.

FOR HOODED SWEAT SHIRTS; HOODED SWEATSHIRTS; SHIRTS; SHIRTS AND SHORT-SLEEVED SHIRTS; SHORT-SLEEVED SHIRTS; T-SHIRTS; TANK TOPS; TANK-TOPS; TEE SHIRTS (U.S. CLS. 22 AND 39).  
CASSONDRRA ANDERSON, EXAMINING ATTORNEY

SN 86-245,822. GEM MOTORSPORTS, LLC, MARENGO, OH.  
FILED 4-8-2014.

**Drag Racing is my passion,  
firesuits are my fashion**

THE MARK CONSISTS OF STANDARD CHARACTERS WITHOUT CLAIM TO ANY PARTICULAR FONT, STYLE, SIZE, OR COLOR.

FOR HATS; HEADBANDS; HOODED SWEATSHIRTS; JACKETS; SHORTS; SWEATPANTS; T-SHIRTS; TANK TOPS (U.S. CLS. 22 AND 39).  
KELLY BOULTON, EXAMINING ATTORNEY

SN 86-245,847. GEM MOTORSPORTS, LLC, MARENGO, OH.  
FILED 4-8-2014.

**Jr. Drag Racing is my  
passion, firesuits are my  
fashion**

THE MARK CONSISTS OF STANDARD CHARACTERS WITHOUT CLAIM TO ANY PARTICULAR FONT, STYLE, SIZE, OR COLOR.

FOR HATS; HEADBANDS; HOODED SWEATSHIRTS; JACKETS; SHORTS; SWEATPANTS; T-SHIRTS; TANK TOPS (U.S. CLS. 22 AND 39).  
KELLY BOULTON, EXAMINING ATTORNEY

**CLASS 25—(Continued).**

SN 86-246,024. BOWERY APPAREL LLC, MIAMI, FL. FILED  
4-8-2014.

**ESSEX DRY GOODS**

THE MARK CONSISTS OF STANDARD CHARACTERS WITHOUT CLAIM TO ANY PARTICULAR FONT, STYLE, SIZE, OR COLOR.

NO CLAIM IS MADE TO THE EXCLUSIVE RIGHT TO USE "DRY GOODS", APART FROM THE MARK AS SHOWN.

FOR T-SHIRTS (U.S. CLS. 22 AND 39).

FIRST USE 2-27-2014; IN COMMERCE 2-27-2014.  
CAROLYN CATALDO, EXAMINING ATTORNEY

SN 86-246,034. BAYLOR SCOTT & WHITE HOLDINGS,  
DALLAS, TX. FILED 4-8-2014.



THE MARK CONSISTS OF AN ABSTRACT DIAMOND DESIGN COMPRISED OF FOUR "L" SHAPED POLYGONS. EACH OF THE FOUR "L" SHAPED POLYGONS ARE COMPRISED OF ONE LONG SOLID QUADRILATERAL AND ONE SHORT SOLID QUADRILATERAL.

FOR CLOTHING, NAMELY, LAB COATS, SOCKS, JACKETS, PANTS, SHIRTS, T-SHIRTS, VESTS, SWEATSHIRTS, AND HATS (U.S. CLS. 22 AND 39).

SARA KUNKLEMAN, EXAMINING ATTORNEY

SN 86-246,094. IMAGINEHOUSE LLC, DOVER, DE. FILED 4-  
8-2014.

**WONDERBUND**

THE MARK CONSISTS OF STANDARD CHARACTERS WITHOUT CLAIM TO ANY PARTICULAR FONT, STYLE, SIZE, OR COLOR.

FOR CUMMERBUNDS (U.S. CLS. 22 AND 39).  
FIRST USE 10-14-2013; IN COMMERCE 4-8-2014.  
BRITTNEY COGAN, EXAMINING ATTORNEY

**CLASS 25—(Continued).**

SN 86-246,362. LAWRENCE FINE, HASTINGS-ON-HUDSON, NY. FILED 4-8-2014.

**MURDERING LAWYERS**

THE MARK CONSISTS OF STANDARD CHARACTERS WITHOUT CLAIM TO ANY PARTICULAR FONT, STYLE, SIZE, OR COLOR.

FOR HATS; SHIRTS (U.S. CLS. 22 AND 39).  
ALYSSA STEEL, EXAMINING ATTORNEY

SN 86-246,469. K AND K PROMOTIONS, INC., LAS VEGAS, NV. FILED 4-8-2014.

**Evel Spirit**

THE MARK CONSISTS OF STANDARD CHARACTERS WITHOUT CLAIM TO ANY PARTICULAR FONT, STYLE, SIZE, OR COLOR.

OWNER OF U.S. REG. NOS. 2,450,740 AND 3,897,224.

THE NAME(S), PORTRAIT(S), AND/OR SIGNATURE(S) SHOWN IN THE MARK DOES NOT IDENTIFY A PARTICULAR LIVING INDIVIDUAL.

FOR BEANIES; BELTS; BLOUSES; CAPS; FOOTWEAR; GLOVES; HATS; HEADBANDS; HOODED SWEATSHIRTS; JACKETS; JEANS; JERSEYS; JOGGING SUITS; JUMPSUITS; PANTS; SANDALS; SHIRTS; SHOES; SHORTS; SKIRTS; SLEEPWEAR; SUSPENDERS; SWEATERS; SWEATPANTS; SWEATSHIRTS; SWEATSUITS; SWIMSUITS; SWIMWEAR; T-SHIRTS; TANK-TOPS; TIES; TOPS; UNDERWEAR; VESTS; VISORS (U.S. CLS. 22 AND 39).

SUNG IN, EXAMINING ATTORNEY

**CLASS 25—(Continued).**

SN 86-246,554. HONGKONG LALA INTERNATIONAL CO., LIMITED, 33 MONG KOK RD., KL, HONG KONG, FILED 4-9-2014.

**Lalawow**

THE MARK CONSISTS OF STANDARD CHARACTERS WITHOUT CLAIM TO ANY PARTICULAR FONT, STYLE, SIZE, OR COLOR.

THE WORDING "LALAWOW" HAS NO MEANING IN A FOREIGN LANGUAGE.

FOR BLOUSES; BODY LINEN; CLOTHING FOR ATHLETIC USE, NAMELY, PADDED PANTS; COATS; DRESS PANTS; DRESS STRAPS; DRESS SUITS; DRESSES; DRESSES MADE FROM SKINS; FINISHED TEXTILE LININGS FOR GARMENTS; FUR COATS; JACKETS; JACKETS AND SOCKS; KNIT JACKETS; LEATHER COATS; LEATHER JACKETS; SKIRTS; SKIRTS AND DRESSES; SWEATERS; TURTLENECK SWEATERS; UNDERWEAR; WEARABLE GARMENTS AND CLOTHING, NAMELY, SHIRTS; WOMEN'S UNDERWEAR (U.S. CLS. 22 AND 39).

FIRST USE 12-12-2013; IN COMMERCE 12-18-2013.

DAVID ALESKOW, EXAMINING ATTORNEY

SN 86-246,609. WISE, DARRIN, COLVILLE, WA. FILED 4-9-2014.

**WAY-OUT WEAR**

THE MARK CONSISTS OF STANDARD CHARACTERS WITHOUT CLAIM TO ANY PARTICULAR FONT, STYLE, SIZE, OR COLOR.

NO CLAIM IS MADE TO THE EXCLUSIVE RIGHT TO USE "WEAR", APART FROM THE MARK AS SHOWN.

FOR CLOTHING, NAMELY, TOPS, BOTTOMS, BEACHWEAR, SWIMWEAR, HATS, SHOES, JACKETS, FOOTWEAR, HEADWEAR, SWEATSHIRTS, T-SHIRTS (U.S. CLS. 22 AND 39).

CYNTHIA RINALDI, EXAMINING ATTORNEY

SN 86-246,628. SPANX, INC., ATLANTA, GA. FILED 4-9-2014.

**... YOU'LL LOOK RED HOT!**

THE MARK CONSISTS OF STANDARD CHARACTERS WITHOUT CLAIM TO ANY PARTICULAR FONT, STYLE, SIZE, OR COLOR.

FOR CLOTHING, NAMELY, BODY SHAPERS, BODY-SUITS, BRAS, HOSIERY, TIGHTS, CAMISOLES, SLIPS AND UNDERWEAR (U.S. CLS. 22 AND 39).

FIRST USE 6-28-2012; IN COMMERCE 6-28-2012.

DAVID MURRAY, EXAMINING ATTORNEY

**CLASS 25—(Continued).**

SN 86-246,635. SPANX, INC., ATLANTA, GA. FILED 4-9-2014.

**LOVE YOUR ASSETS**

THE MARK CONSISTS OF STANDARD CHARACTERS WITHOUT CLAIM TO ANY PARTICULAR FONT, STYLE, SIZE, OR COLOR.

FOR CLOTHING, NAMELY, UNDERWEAR, CAMI-SOLES, HOSIERY, BODY SHAPERS, BRAS, AND SWIMWEAR (U.S. CLS. 22 AND 39).

FIRST USE 7-21-2005; IN COMMERCE 7-21-2005.  
DAVID MURRAY, EXAMINING ATTORNEY

**CLASS 25—(Continued).**

SN 86-246,828. COHEN, SAUL, NEW YORK, NY. FILED 4-9-2014.

**NECESSARY CLOTHING**

THE MARK CONSISTS OF STANDARD CHARACTERS WITHOUT CLAIM TO ANY PARTICULAR FONT, STYLE, SIZE, OR COLOR.

NO CLAIM IS MADE TO THE EXCLUSIVE RIGHT TO USE "CLOTHING", APART FROM THE MARK AS SHOWN. FOR CLOTHING, NAMELY, TOPS, BOTTOMS, FOOTWEAR (U.S. CLS. 22 AND 39).

FIRST USE 1-1-1995; IN COMMERCE 1-1-1995.  
GINA HAYES, EXAMINING ATTORNEY

SN 86-246,636. SPANX, INC., ATLANTA, GA. FILED 4-9-2014.

**WE PUT THE SKINNY IN THE JEANS**

THE MARK CONSISTS OF STANDARD CHARACTERS WITHOUT CLAIM TO ANY PARTICULAR FONT, STYLE, SIZE, OR COLOR.

FOR CLOTHING, NAMELY PANTS (U.S. CLS. 22 AND 39).

DAVID MURRAY, EXAMINING ATTORNEY

SN 86-246,937. COLOR ME NAKED LLC, CATLETT, VA. FILED 4-9-2014.

**Color Me Naked**

THE MARK CONSISTS OF STANDARD CHARACTERS WITHOUT CLAIM TO ANY PARTICULAR FONT, STYLE, SIZE, OR COLOR.

FOR HATS; SWEATSHIRTS; T-SHIRTS (U.S. CLS. 22 AND 39).

JULIE WATSON, EXAMINING ATTORNEY

SN 86-246,638. SPANX, INC., ATLANTA, GA. FILED 4-9-2014.

**WE PUT THE SLIM IN SWIM**

THE MARK CONSISTS OF STANDARD CHARACTERS WITHOUT CLAIM TO ANY PARTICULAR FONT, STYLE, SIZE, OR COLOR.

FOR CLOTHING, NAMELY SWIMWEAR (U.S. CLS. 22 AND 39).

DAVID MURRAY, EXAMINING ATTORNEY

SN 86-247,331. PEACE LOVE WORLD, LLC, MIAMI, FL. FILED 4-9-2014.

**I AM MUSIC**

THE MARK CONSISTS OF STANDARD CHARACTERS WITHOUT CLAIM TO ANY PARTICULAR FONT, STYLE, SIZE, OR COLOR.

FOR HOODED SWEAT SHIRTS; HOODED SWEATSHIRTS; SHIRTS; SHIRTS AND SHORT-SLEEVED SHIRTS; SHORT-SLEEVED SHIRTS; T-SHIRTS; TEE SHIRTS (U.S. CLS. 22 AND 39).

FIRST USE 12-1-2009; IN COMMERCE 12-1-2009.  
DANIEL CAPSHAW, EXAMINING ATTORNEY

**CLASS 25—(Continued).**

SN 86-247,341. PUTMAN, MAX, COLORADO SPRINGS, CO. FILED 4-9-2014.

ALTITUDE...IT'S AN ATTITUDE

THE MARK CONSISTS OF STANDARD CHARACTERS WITHOUT CLAIM TO ANY PARTICULAR FONT, STYLE, SIZE, OR COLOR.

FOR CLOTHING, NAMELY, T-SHIRTS, SHIRTS, TOPS, SWEATSHIRTS; COATS, JACKETS; BOTTOMS, PANTS, TROUSERS, JEANS, SHORTS; HEADWEAR, NAMELY, HATS (U.S. CLS. 22 AND 39).

ZACHARY BELLO, EXAMINING ATTORNEY

---

SN 86-247,345. NEWTON, JAMES CHADWICK, ENGLEWOOD, FL. AND CONNORS, ANTOINE BRICE, SPARTANBURG, SC. FILED 4-9-2014.

SnoBall Ice Therapy

THE MARK CONSISTS OF STANDARD CHARACTERS WITHOUT CLAIM TO ANY PARTICULAR FONT, STYLE, SIZE, OR COLOR.

FOR ATHLETIC APPAREL, NAMELY, SHIRTS, PANTS, JACKETS, FOOTWEAR, HATS AND CAPS, ATHLETIC UNIFORMS; ATHLETIC PANTS; ATHLETIC SHIRTS; BASEBALL CAPS AND HATS; BUTTON DOWN SHIRTS; COLLARED SHIRTS; DRESS SHIRTS; GOLF SHIRTS; GRAPHIC T-SHIRTS; GYM PANTS; HATS; HOODED SWEAT SHIRTS; HOODED SWEATSHIRTS; KNIT SHIRTS; LONG-SLEEVED SHIRTS; MOISTURE-WICKING SPORTS PANTS; MOISTURE-WICKING SPORTS SHIRTS; POLO KNIT TOPS; POLO SHIRTS; SHIRTS AND SHORT-SLEEVED SHIRTS; SHORT-SLEEVED OR LONG-SLEEVED T-SHIRTS; SPORT SHIRTS; SPORTS CAPS AND HATS; SPORTS SHIRTS; STOCKING HATS; SWEATSHIRTS; T-SHIRTS (U.S. CLS. 22 AND 39).

ZACHARY BELLO, EXAMINING ATTORNEY

---

SN 86-247,374. JANTZI, STACY, FORT CAMPBELL, KY. FILED 4-9-2014.

Ausomeism: Autism Redefined

THE MARK CONSISTS OF STANDARD CHARACTERS WITHOUT CLAIM TO ANY PARTICULAR FONT, STYLE, SIZE, OR COLOR.

FOR CLOTHING, NAMELY, HATS, T-SHIRTS, AND SWEATSHIRTS (U.S. CLS. 22 AND 39).

CRISTIANA SCHWAB, EXAMINING ATTORNEY

**CLASS 25—(Continued).**

SN 86-247,435. HU-NU ACTIVEWEAR LIMITED, WEST SHEUNG WAN, HONG KONG, FILED 4-9-2014.

HU.NU

THE MARK CONSISTS OF STANDARD CHARACTERS WITHOUT CLAIM TO ANY PARTICULAR FONT, STYLE, SIZE, OR COLOR.

OWNER OF U.S. REG. NO. 4,162,210.

THE WORDING "HU.NU" HAS NO MEANING IN A FOREIGN LANGUAGE.

FOR ATHLETIC PANTS; ATHLETIC SHORTS; ATHLETIC TIGHTS; BELTS FOR CLOTHING; CAPRI PANTS; CLOTHING, NAMELY, WRAP-AROUNDS; DRESSES; FLIP FLOPS; GLOVES; JACKETS; JOGGING PANTS; LEG WARMERS; LEGGINGS; PANTS; RAINWEAR; SCARVES; SHIRTS; SHOES; SKIRTS; SOCKS; SPORTS BRAS; SPORTS CAPS AND HATS; SPORTS PANTS; SUN VISORS; T-SHIRTS; TOPS; WEARABLE GARMENTS AND CLOTHING, NAMELY, SHIRTS; WOMEN'S CLOTHING, NAMELY, SHIRTS, DRESSES, SKIRTS, BLOUSES; WRAPS (U.S. CLS. 22 AND 39).

FIRST USE 6-0-2012; IN COMMERCE 7-0-2012.

JENNIFER BUTTON, EXAMINING ATTORNEY

---

SN 86-247,521. MEREDITH-WEBB PRINTING COMPANY, INC., BURLINGTON, NC. FILED 4-9-2014.

HeadBanners

THE MARK CONSISTS OF STANDARD CHARACTERS WITHOUT CLAIM TO ANY PARTICULAR FONT, STYLE, SIZE, OR COLOR.

FOR HEADWEAR (U.S. CLS. 22 AND 39).

COLLEEN MULCRONE, EXAMINING ATTORNEY

**CLASS 25—(Continued).**

SN 86-247,538. LIFE'S TOO SHORT..., LLC, HUNTSVILLE, AL. FILED 4-9-2014.



THE COLOR(S) BLACK AND IVORY IS/ARE CLAIMED AS A FEATURE OF THE MARK.

THE MARK CONSISTS OF A TORN CORNER PIECE OF RULED, HOLE-PUNCHED IVORY LOOSE-LEAF PAPER WITH THE WORDS "LIFE'S TOO SHORT..." WRITTEN IN BLACK WITHIN THE FIRST FOUR BLACK LINES OF THE PAPER, FOLLOWED BY "1)" AND "2)" WRITTEN IN BLACK ON THE SIXTH AND SEVENTH BLACK LINES, RESPECTIVELY.

FOR BASEBALL CAPS; GRAPHIC T-SHIRTS (U.S. CLS. 22 AND 39).

FIRST USE 4-2-2014; IN COMMERCE 4-2-2014.  
KEVIN DINALLO, EXAMINING ATTORNEY

SN 86-247,555. LIFE'S TOO SHORT..., LLC, HUNTSVILLE, AL. FILED 4-9-2014.

## Life's too short...

THE MARK CONSISTS OF STANDARD CHARACTERS WITHOUT CLAIM TO ANY PARTICULAR FONT, STYLE, SIZE, OR COLOR.

FOR BASEBALL CAPS; GRAPHIC T-SHIRTS (U.S. CLS. 22 AND 39).

FIRST USE 4-2-2014; IN COMMERCE 4-2-2014.  
KEVIN DINALLO, EXAMINING ATTORNEY

SN 86-247,560. RAMIREZ, ANGELIQUE, BROOKLYN, NY. FILED 4-9-2014.

## WOOLIFE!

THE MARK CONSISTS OF STANDARD CHARACTERS WITHOUT CLAIM TO ANY PARTICULAR FONT, STYLE, SIZE, OR COLOR.

FOR CLOTHING, NAMELY, SHIRTS, HATS, PANTS, JACKETS, SOCKS, AND SWEATS (U.S. CLS. 22 AND 39).  
DAVID COLLIER, EXAMINING ATTORNEY

**CLASS 25—(Continued).**

SN 86-247,603. UNION OF ANGELS, DELAPHANE, VA. FILED 4-9-2014.

## UNION OF ANGELS

THE MARK CONSISTS OF STANDARD CHARACTERS WITHOUT CLAIM TO ANY PARTICULAR FONT, STYLE, SIZE, OR COLOR.

FOR BELTS; BELTS FOR CLOTHING; BELTS MADE FROM IMITATION LEATHER; BELTS MADE OF LEATHER; BELTS MADE OUT OF CLOTH; BELTS OF TEXTILE; BLOUSES; COATS; DRESSES; GLOVES; JACKETS; LEATHER BELTS; PANTS; SCARVES; SHIRTS; SHORTS; SKIRTS; SOCKS; STOCKINGS; SWEATERS (U.S. CLS. 22 AND 39).

FIRST USE 12-16-2010; IN COMMERCE 12-16-2010.  
DAVID COLLIER, EXAMINING ATTORNEY

SN 86-247,631. JAMAA GREEN & PEACE, INC, FRAMINGHAM, MA. FILED 4-9-2014.

## Promote Humanity

THE MARK CONSISTS OF STANDARD CHARACTERS WITHOUT CLAIM TO ANY PARTICULAR FONT, STYLE, SIZE, OR COLOR.

FOR HATS; JEANS; SHIRTS; SHOES; T-SHIRTS (U.S. CLS. 22 AND 39).

FIRST USE 10-0-2013; IN COMMERCE 10-0-2013.  
JANICE L. MCMORROW, EXAMINING ATTORNEY

SN 86-247,777. NORTHEAST LAND MANAGEMENT, LLC, CARLISLE, PA. FILED 4-9-2014.

## Fish This

THE MARK CONSISTS OF STANDARD CHARACTERS WITHOUT CLAIM TO ANY PARTICULAR FONT, STYLE, SIZE, OR COLOR.

NO CLAIM IS MADE TO THE EXCLUSIVE RIGHT TO USE "FISH", APART FROM THE MARK AS SHOWN.  
FOR FISHING SHIRTS (U.S. CLS. 22 AND 39).  
FRANK LATTUCA, EXAMINING ATTORNEY

**CLASS 25—(Continued).**

SN 86-247,883. BUJI, INC., MIAMI, FL. FILED 4-10-2014.

**CANDY RUSH**

THE MARK CONSISTS OF STANDARD CHARACTERS WITHOUT CLAIM TO ANY PARTICULAR FONT, STYLE, SIZE, OR COLOR.

FOR G-STRINGS; PANTIES (U.S. CLS. 22 AND 39).  
BRENDAN MCCAULEY, EXAMINING ATTORNEY

---

SN 86-247,907. BUTU GROUP INC., BEVERLY HILLS, CA.  
FILED 4-10-2014.

**BEHAVE ROYALLY**

THE MARK CONSISTS OF STANDARD CHARACTERS WITHOUT CLAIM TO ANY PARTICULAR FONT, STYLE, SIZE, OR COLOR.

FOR FOOTWEAR; HATS; JACKETS; PANTS; SHIRTS;  
SOCKS (U.S. CLS. 22 AND 39).  
SIDDHARTH JAGANNATHAN, EXAMINING ATTORNEY

---

SN 86-248,106. BAEZ, CHRISTOPHER MANUEL, NEW YORK, NY. FILED 4-10-2014.

**GUERRILLA WEARFARE**

THE MARK CONSISTS OF STANDARD CHARACTERS WITHOUT CLAIM TO ANY PARTICULAR FONT, STYLE, SIZE, OR COLOR.

FOR BELTS; BLAZERS; BLOUSES; COATS; DRESSES;  
FOOTWEAR; GLOVES; HEADWEAR; JACKETS; JEANS;  
JERSEYS; LINGERIE; PAJAMAS; PANTS; SCARVES;  
SHIRTS; SHORTS; SKIRTS; SOCKS; SUITS; SWEATERS;  
SWEATSHIRTS; SWIMWEAR; T-SHIRTS; TIES; UNDERGARMENTS;  
VESTS; WETSUITS (U.S. CLS. 22 AND 39).  
JENNY PARK, EXAMINING ATTORNEY

**CLASS 25—(Continued).**

SN 86-248,501. PERFECT AS U ARE, LP, SINKING SPRING, PA. FILED 4-10-2014.



THE MARK CONSISTS OF THE WORD "PERFECT" IN CURSIVE WRITING WITH A CAPITAL "P" WITH A BUTTERFLY SHAPE LOCATED AT THE TOP OF THE CAPITAL "P" WITH ONE WING BEING THE CIRCLE IN THE CAPITAL "P" AND THE OTHER WING AND ANTENNAE NEXT TO IT WITH THE WORDS "AS U ARE" IN CURSIVE WRITING IMMEDIATELY UNDER THE LETTERS "ECT" IN THE WORD "PERFECT".

FOR CLOTHING, NAMELY, WOMEN'S SHIRTS, SHORTS AND SOCKS (U.S. CLS. 22 AND 39).  
FIRST USE 8-9-2013; IN COMMERCE 10-26-2013.  
CHRIS WELLS, EXAMINING ATTORNEY

---

SN 86-248,609. NICE SWING 59, LLC, ELIZABETH, IN.  
FILED 4-10-2014.



THE MARK CONSISTS OF A STYLIZED OUTLINE OF A GOLFER IN MID-SWING AT IMPACT POSITION.

FOR GOLF CAPS; GOLF CLEATS; GOLF PANTS, SHIRTS AND SKIRTS; GOLF SHIRTS; GOLF SHOES; GOLF SHORTS; GOLF SPIKES; GOLF TROUSERS (U.S. CLS. 22 AND 39).

ALICE BENMAMAN, EXAMINING ATTORNEY



**CLASS 25—(Continued).**

SN 86-248,611. COFFEA, LLC, GREAT NECK, NY. FILED 4-10-2014.

**DID YOU KNOW?**

THE MARK CONSISTS OF STANDARD CHARACTERS WITHOUT CLAIM TO ANY PARTICULAR FONT, STYLE, SIZE, OR COLOR.

OWNER OF U.S. REG. NO. 4,310,750.

FOR CHILDREN'S AND INFANT'S APPAREL, NAMELY, JUMPERS, OVERALL SLEEPWEAR, PAJAMAS, ROMPERS AND ONE-PIECE GARMENTS; HATS; JACKETS; PANTS; SHORTS; SWEATPANTS; SWEATSHIRTS (U.S. CLS. 22 AND 39).

ALICE BENMAMAN, EXAMINING ATTORNEY

**CLASS 25—(Continued).**

SN 86-248,976. FOOTE, MICHAEL B, ALBUQUERQUE, NM. FILED 4-10-2014.

**RAKECITY**

THE MARK CONSISTS OF STANDARD CHARACTERS WITHOUT CLAIM TO ANY PARTICULAR FONT, STYLE, SIZE, OR COLOR.

FOR ATHLETIC SHORTS; BASEBALL CAPS AND HATS; SPORT COATS; SPORT SHIRTS; SPORT STOCKINGS; SPORTS CAPS AND HATS; SPORTS JACKETS; SPORTS OVER UNIFORMS; SPORTS PANTS; SPORTS SHIRTS; SPORTS SHIRTS WITH SHORT SLEEVES (U.S. CLS. 22 AND 39).

WILLIAM BRECKENFELD, EXAMINING ATTORNEY

SN 86-248,821. BERTHIAUME, ASHLEY, NEW YORK, NY. FILED 4-10-2014.

**Go Follow Rabbits**

THE MARK CONSISTS OF STANDARD CHARACTERS WITHOUT CLAIM TO ANY PARTICULAR FONT, STYLE, SIZE, OR COLOR.

FOR WOMEN'S APPAREL, NAMELY, SKIRTS, DRESSES, ARM WARMERS, SWIMSUITS, TOPS, BOXERS, AND SHORTS (U.S. CLS. 22 AND 39).

FIRST USE 11-1-2012; IN COMMERCE 11-1-2012.

ZHALEH DELANEY, EXAMINING ATTORNEY

SN 86-249,085. HARD RIDE INC., ALEXANDER, ND. FILED 4-10-2014.

**Hard Ride Clothing**

THE MARK CONSISTS OF STANDARD CHARACTERS WITHOUT CLAIM TO ANY PARTICULAR FONT, STYLE, SIZE, OR COLOR.

OWNER OF U.S. REG. NO. 4,567,211.

NO CLAIM IS MADE TO THE EXCLUSIVE RIGHT TO USE "CLOTHING", APART FROM THE MARK AS SHOWN. FOR BEANIES; HATS; JACKETS; SWEATSHIRTS; T-SHIRTS (U.S. CLS. 22 AND 39).

FIRST USE 11-15-2013; IN COMMERCE 11-15-2013.

RON FAIRBANKS, EXAMINING ATTORNEY

SN 86-248,914. LIZUM LIFE, YONKERS, NY. FILED 4-10-2014.

**Lizum Life**

THE MARK CONSISTS OF STANDARD CHARACTERS WITHOUT CLAIM TO ANY PARTICULAR FONT, STYLE, SIZE, OR COLOR.

FOR TOPS, BOTTOMS, T-SHIRTS, JACKETS, HATS, PANTS, SOCKS, HOODS (U.S. CLS. 22 AND 39).

JEFFREY LOOK, EXAMINING ATTORNEY

SN 86-249,162. NORTHEAST LAND MANAGEMENT, LLC, CARLISLE, PA. FILED 4-10-2014.

**Hunt This**

THE MARK CONSISTS OF STANDARD CHARACTERS WITHOUT CLAIM TO ANY PARTICULAR FONT, STYLE, SIZE, OR COLOR.

NO CLAIM IS MADE TO THE EXCLUSIVE RIGHT TO USE "HUNT", APART FROM THE MARK AS SHOWN.

FOR HUNTING SHIRTS (U.S. CLS. 22 AND 39).

FRANK LATTUCA, EXAMINING ATTORNEY

**CLASS 25—(Continued).**

SN 86-249,255. EVERYTHING GLITTERS, SCOTTSDALE, AZ. FILED 4-11-2014.

**EVERYTHING GLITTERS**

THE MARK CONSISTS OF STANDARD CHARACTERS WITHOUT CLAIM TO ANY PARTICULAR FONT, STYLE, SIZE, OR COLOR.

FOR CLOTHING, NAMELY, TOPS, BOTTOMS; HATS; SHOES (U.S. CLS. 22 AND 39).  
DAVID TAYLOR, EXAMINING ATTORNEY

SN 86-249,280. MULLINS, VALENCIA, NORTH MIAMI, FL. FILED 4-11-2014.

**#HOEBHAVENA**

THE MARK CONSISTS OF STANDARD CHARACTERS WITHOUT CLAIM TO ANY PARTICULAR FONT, STYLE, SIZE, OR COLOR.

FOR CLOTHING, NAMELY, T-SHIRTS, SHIRTS, TOPS, SWEATERS, SWEATSHIRTS, HOODED SWEATSHIRTS, COATS, JERSEYS, JACKETS, BOTTOMS, PANTS, TROUSERS, JEANS, SHORTS, SWEATPANTS, PAJAMAS, DRESSES, SKIRTS, BLOUSES; UNDERWEAR; BELTS; TIES; GLOVES; SOCKS; HEADWEAR; FOOTWEAR (U.S. CLS. 22 AND 39).  
JAMES LOVELACE, EXAMINING ATTORNEY

SN 86-249,354. ALTERNATE LATITUDE, LLC, ST. THOMAS, US VIRGIN ISLANDS, FILED 4-11-2014.



THE COLOR(S) BLUE, WHITE AND TURQUOISE IS/ARE CLAIMED AS A FEATURE OF THE MARK.

THE MARK CONSISTS OF THE STYLIZED WORDS FIND YOUR ALTERNATE LATITUDE IN BLUE. THE STYLIZED WORDS ALTERNATE AND LATITUDE ARE SEPARATED BY THE ARTISTIC RENDERING OF A COMPASS STAR IN WHITE AND BLUE WHICH APPEARS ON TOP OF A TURQUOISE CIRCLE WITH A WHITE INTERIOR. THE ARTISTIC RENDERING OF A WAVE IN TURQUOISE APPEARS AS THE UNDERLINE TO ALTERNATE LATITUDE.

FOR CLOTHING, NAMELY, T-SHIRTS, LONG SLEEVE SHIRTS, SHIRTS, PULLOVERS, SWEATSHIRTS; HATS (U.S. CLS. 22 AND 39).

FIRST USE 3-0-2014; IN COMMERCE 3-0-2014.  
JOHN WILKE, EXAMINING ATTORNEY

**CLASS 25—(Continued).**

SN 86-249,629. RIGHTSIDE SHIRTS, INC., JAMAICA PLAIN, MA. FILED 4-11-2014.

**rightside**

THE MARK CONSISTS OF STANDARD CHARACTERS WITHOUT CLAIM TO ANY PARTICULAR FONT, STYLE, SIZE, OR COLOR.

FOR GRAPHIC T-SHIRTS; SHIRTS; SHIRTS AND SHORT-SLEEVED SHIRTS; SHORT-SLEEVED OR LONG-SLEEVED T-SHIRTS; T-SHIRTS; TEE SHIRTS; WEARABLE GARMENTS AND CLOTHING, NAMELY, SHIRTS (U.S. CLS. 22 AND 39).

FIRST USE 4-27-2012; IN COMMERCE 12-17-2012.  
HENRY S. ZAK, EXAMINING ATTORNEY

SN 86-249,730. HARRIS, ARONUL, GREENSBORO, NC. AND DENNIS, EVERICK, GREENSBORO, NC. FILED 4-11-2014.

**Talk Nice To Us**

THE MARK CONSISTS OF STANDARD CHARACTERS WITHOUT CLAIM TO ANY PARTICULAR FONT, STYLE, SIZE, OR COLOR.

FOR HATS; SHIRTS; SWEATSUITS (U.S. CLS. 22 AND 39).  
TEJBIR SINGH, EXAMINING ATTORNEY

SN 86-249,873. MARTIN, KAREN, NEW YORK, NY. AND NILES, ALLISON, NEW YORK, NY. FILED 4-11-2014.

**DEANS**

THE MARK CONSISTS OF STANDARD CHARACTERS WITHOUT CLAIM TO ANY PARTICULAR FONT, STYLE, SIZE, OR COLOR.

FOR CAPES; COATS; DRESSES; GLOVES AS CLOTHING; HEADWEAR; JACKETS; MITTENS; PANTS; PONCHOS; SCARVES; SHAWLS; SKIRTS; SWEATERS; TOPS (U.S. CLS. 22 AND 39).

HOWARD SMIGA, EXAMINING ATTORNEY

**CLASS 25—(Continued).**

SN 86-249,908. WHITTAKER, JEFFREY FRANCIS, CHESAPEAKE, VA. FILED 4-11-2014.

**Generation Changers**

THE MARK CONSISTS OF STANDARD CHARACTERS WITHOUT CLAIM TO ANY PARTICULAR FONT, STYLE, SIZE, OR COLOR.

FOR BOTTOMS; HATS; HEADBANDS; HOODS; JACKETS; SCARVES; SWEATSHIRTS; T-SHIRTS; TOPS; WRISTBANDS (U.S. CLS. 22 AND 39).  
EVELYN BRADLEY, EXAMINING ATTORNEY

SN 86-250,045. KANG 4 INC., COOPER CITY, FL. FILED 4-11-2014.

**Game Over I Win**

THE MARK CONSISTS OF STANDARD CHARACTERS WITHOUT CLAIM TO ANY PARTICULAR FONT, STYLE, SIZE, OR COLOR.

FOR SHIRTS; T-SHIRTS; TOPS; WEARABLE GARMENTS AND CLOTHING, NAMELY, SHIRTS (U.S. CLS. 22 AND 39).

JANICE L. MCMORROW, EXAMINING ATTORNEY

SN 86-250,126. DIVA MUSIC & GEAR, TRAVERSE CITY, MI. FILED 4-11-2014.

**Diva with Buck Feva**

THE MARK CONSISTS OF STANDARD CHARACTERS WITHOUT CLAIM TO ANY PARTICULAR FONT, STYLE, SIZE, OR COLOR.

FOR CLOTHING, NAMELY, HATS, SHIRTS, PANTS, SOCKS, COATS (U.S. CLS. 22 AND 39).

TARAH HARDY, EXAMINING ATTORNEY

**CLASS 25—(Continued).**

SN 86-250,237. VAN NORDEN, ALLEN, CAMBRIDGE, MD. FILED 4-11-2014.

**ANATOMY PROJECTS**

THE MARK CONSISTS OF STANDARD CHARACTERS WITHOUT CLAIM TO ANY PARTICULAR FONT, STYLE, SIZE, OR COLOR.

FOR HATS; JACKETS; JEANS; RUGBY SHIRTS; SOCKS; SWEATPANTS; T-SHIRTS (U.S. CLS. 22 AND 39).  
SAMUEL E. SHARPER JR., EXAMINING ATTORNEY

SN 86-250,272. JOSH STORMENT, WICHITA, KS. FILED 4-11-2014.



THE MARK CONSISTS OF THE WORD "GORILLA" WHEREIN THE FIRST TWO LETTERS ARE SUGGESTED BY A GORILLA IMAGE, AND THE WORD "NILLA" OVERLYING THE "RILLA" PORTION OF SAID "GORILLA" WORD.

FOR ATHLETIC SHORTS; BASEBALL CAPS; BASEBALL CAPS AND HATS; GRAPHIC T-SHIRTS; GYM SHORTS; HOODED PULLOVERS; HOODED SWEAT SHIRTS; HOODED SWEATSHIRTS; KNITTED CAPS; LEG WARMERS; LEG-WARMERS; LEGGINGS; SHORT-SLEEVED OR LONG-SLEEVED T-SHIRTS; STOCKING CAPS; SWEAT PANTS; SWEATPANTS; T-SHIRTS; TANK TOPS; TANK-TOPS; TEE SHIRTS (U.S. CLS. 22 AND 39).  
KAPIL BHANOT, EXAMINING ATTORNEY

SN 86-250,407. REESE, SKEET, AUBURN, CA. FILED 4-11-2014.



THE MARK CONSISTS OF THE STYLIZED LETTERS "S" AND "R" JOINED AT THE TOP OF THE TWO LETTERS WITH A CONNECTING LINE OVER WHICH IS AN ARCHED AND SHAPED CRESCENT ENDING AT THE BOTTOM OF THE ARCH WITH A HOOK ON THE UPPER SIDE OF THE CRESCENT.

FOR CLOTHING, NAMELY T-SHIRTS, SWEATSHIRTS, BASEBALL CAPS, HATS, HEADBANDS, GLOVES, JACKETS, SWEATERS, SOCKS, AND PANTS (U.S. CLS. 22 AND 39).

FIRST USE 2-22-2014; IN COMMERCE 2-22-2014.  
LEE-ANNE BERNS, EXAMINING ATTORNEY

**CLASS 25—(Continued).**

SN 86-250,416. RICHARD YUN, LOS ANGELES, CA. FILED 4-11-2014.

**THRUST**

THE MARK CONSISTS OF STANDARD CHARACTERS WITHOUT CLAIM TO ANY PARTICULAR FONT, STYLE, SIZE, OR COLOR.

FOR ADULT NOVELTY GAG CLOTHING ITEM, NAMELY, SOCKS; ANKLE SOCKS; ATHLETIC SHORTS; ATHLETIC TIGHTS; BASEBALL CAPS; BASEBALL CAPS AND HATS; BATHING COSTUMES; BATHING SUITS; BATHING SUITS FOR MEN; BATHING TRUNKS; BEACH FOOTWEAR; BELTS; BELTS FOR CLOTHING; BELTS MADE FROM IMITATION LEATHER; BELTS MADE OF LEATHER; BELTS MADE OUT OF CLOTH; BELTS OF TEXTILE; BERMUDA SHORTS; BOARD SHORTS; BOXER SHORTS; BRIEFS; BUTTON DOWN SHIRTS; CAPS; CAPS WITH VISORS; COLLARED SHIRTS; DRESSING GOWNS AND BATH ROBES; FOOTWEAR; FOOTWEAR FOR MEN; FOOTWEAR FOR MEN AND WOMEN; GRAPHIC T-SHIRTS; HEADGEAR, NAMELY, HEADBANDS, CAPS AND VISORS; LEATHER BELTS; LONG SLEEVE PULLOVERS; MEN'S DRESS SOCKS; MEN'S SOCKS; MEN'S UNDERWEAR; PANTS; POLO SHIRTS; PULLOVERS; ROBES; SANDALS; SANDALS AND BEACH SHOES; SHIRTS; SHIRTS AND SHORT-SLEEVED SHIRTS; SHIRTS FOR MEN AND BOYS; SHORT TROUSERS; SHORT-SLEEVED OR LONG-SLEEVED T-SHIRTS; SHORT-SLEEVED SHIRTS; SHORTS; SHORTS FOR MEN AND BOYS; SLIPPERS; SPORT SHIRTS; SPORTS CAPS AND HATS; SPORTS SHIRTS; SPORTS SHIRTS WITH SHORT SLEEVES; SUN VISORS; SWIM TRUNKS; SWIMMING TRUNKS; T-SHIRTS; T-SHIRTS FOR MEN AND BOYS; TEE SHIRTS; TIGHTS; TRUNKS; UNDERPANTS; UNDERWEAR; VISORS; WAIST BELTS; WEARABLE GARMENTS AND CLOTHING, NAMELY, SHIRTS (U.S. CLS. 22 AND 39).

JENNY PARK, EXAMINING ATTORNEY

SN 86-250,536. AIRBOAT APPAREL, INC, FORT LAUDERDALE, FL. FILED 4-12-2014.

**LADIES OF THE MARSH**

THE MARK CONSISTS OF STANDARD CHARACTERS WITHOUT CLAIM TO ANY PARTICULAR FONT, STYLE, SIZE, OR COLOR.

FOR CLOTHING, NAMELY, SHIRTS, T-SHIRTS, LONG AND SHORT SLEEVED T-SHIRTS, POLO T-SHIRTS, BUTTON DOWN SHIRTS, LONG AND SHORT SLEEVED SHIRTS, SWEATSHIRTS, HOODED SWEATSHIRTS, LEG WARMERS, ARM WARMERS, BLOUSES, SPAGHETTI STRAP SHIRTS, DRESSES, SKIRTS, JACKETS, JERSEYS, COATS, TANK TOPS, TUBE TOPS, PANTS, SWEATPANTS, JEANS, TROUSERS, SHORTS, BATHING SUITS, BIKINIS, SWIMWEAR; UNDERWEAR; BELTS; TIES; GLOVES; SOCKS; HEADWEAR; FOOTWEAR (U.S. CLS. 22 AND 39).

FIRST USE 5-30-2012; IN COMMERCE 5-30-2012.  
COLLEEN DOMBROW, EXAMINING ATTORNEY

**CLASS 25—(Continued).**

SN 86-250,539. HU, YULONG, SHANGHAI, CHINA, FILED 4-12-2014.

**KREUZZZ**

THE MARK CONSISTS OF STANDARD CHARACTERS WITHOUT CLAIM TO ANY PARTICULAR FONT, STYLE, SIZE, OR COLOR.

THE NAME(S), PORTRAIT(S), AND/OR SIGNATURE(S) SHOWN IN THE MARK DOES NOT IDENTIFY A PARTICULAR LIVING INDIVIDUAL.

FOR FASHION HATS; FUR HATS; HAT BANDS; HAT LINERS; MITTENS; SCARFS; TRAVEL CLOTHING CONTAINED IN A PACKAGE COMPRISING REVERSIBLE JACKETS, PANTS, SKIRTS, TOPS AND A BELT OR SCARF (U.S. CLS. 22 AND 39).

FIRST USE 0-0-2001; IN COMMERCE 0-0-2001.

ANNE E. GUSTASON, EXAMINING ATTORNEY

SN 86-250,603. GOHEN, GREGG ALAN, DBA CELEBRATE THE QUIRK, WARRINGTON, PA. FILED 4-12-2014.

**Celebrate The Quirk**

THE MARK CONSISTS OF STANDARD CHARACTERS WITHOUT CLAIM TO ANY PARTICULAR FONT, STYLE, SIZE, OR COLOR.

FOR BASEBALL CAPS AND HATS; GRAPHIC T-SHIRTS; SWEATSHIRTS (U.S. CLS. 22 AND 39).

DANIEL S. STRINGER, EXAMINING ATTORNEY

SN 86-250,726. COURTEAU, LOUIS, LONGUEUIL, CANADA, FILED 4-13-2014.

**STARPIECE**

THE MARK CONSISTS OF STANDARD CHARACTERS WITHOUT CLAIM TO ANY PARTICULAR FONT, STYLE, SIZE, OR COLOR.

FOR HOODED SWEATSHIRTS; SPORTS JERSEYS; SWEATSHIRTS; T-SHIRTS (U.S. CLS. 22 AND 39).

KATHERINE CHANG, EXAMINING ATTORNEY

**CLASS 25—(Continued).**

SN 86-250,854. AIRBOAT APPAREL, INC, FORT LAUDERDALE, FL. FILED 4-14-2014.

**AIRBOATS GONE WILD**

THE MARK CONSISTS OF STANDARD CHARACTERS WITHOUT CLAIM TO ANY PARTICULAR FONT, STYLE, SIZE, OR COLOR.

FOR CLOTHING, NAMELY, SHIRTS, T-SHIRTS, LONG AND SHORT SLEEVED T-SHIRTS, POLO T-SHIRTS, BUTTON DOWN SHIRTS, LONG AND SHORT SLEEVED SHIRTS, SWEATSHIRTS, HOODED SWEATSHIRTS, LEG WARMERS, ARM WARMERS, BLOUSES, SPAGHETTI STRAP SHIRTS, DRESSES, SKIRTS, JACKETS, JERSEYS, COATS, TANK TOPS, TUBE TOPS, PANTS, SWEATPANTS, JEANS, TROUSERS, SHORTS, BATHING SUITS, BIKINIS, SWIMWEAR; UNDERWEAR; BELTS; TIES; GLOVES; SOCKS; HEADWEAR; FOOTWEAR (U.S. CLS. 22 AND 39).

COLLEEN DOMBROW, EXAMINING ATTORNEY

SN 86-251,727. JACOBS JEWELS ETC., RATHDRUM, ID. FILED 4-14-2014.

**Totally Outrageously  
Fouled Up !!!! TOFU**

THE MARK CONSISTS OF STANDARD CHARACTERS WITHOUT CLAIM TO ANY PARTICULAR FONT, STYLE, SIZE, OR COLOR.

FOR HATS; JACKETS; SWEATSHIRTS; T-SHIRTS (U.S. CLS. 22 AND 39).

EMILY CHUO, EXAMINING ATTORNEY

SN 86-251,853. FOAMLICIOUS LLC, LAKE STEVENS, WA. FILED 4-14-2014.

**Foamlicious**

THE MARK CONSISTS OF STANDARD CHARACTERS WITHOUT CLAIM TO ANY PARTICULAR FONT, STYLE, SIZE, OR COLOR.

FOR CLOTHING, NAMELY, TOPS, BOTTOMS, SHIRTS, T-SHIRTS, SWEATSHIRTS, HOODED SWEATSHIRTS, PANTS, SWEATPANTS, HEADWEAR, HATS (U.S. CLS. 22 AND 39).

FIRST USE 3-23-2013; IN COMMERCE 3-23-2013.

SIMON TENG, EXAMINING ATTORNEY

**CLASS 25—(Continued).**

SN 86-251,886. MORGADO, JEFFERSON, MIAMI, FL. FILED 4-14-2014.

**Y5**

THE MARK CONSISTS OF STANDARD CHARACTERS WITHOUT CLAIM TO ANY PARTICULAR FONT, STYLE, SIZE, OR COLOR.

FOR HATS; PANTS; SHOES; SHORTS; T-SHIRTS; TOPS (U.S. CLS. 22 AND 39).

SIMON TENG, EXAMINING ATTORNEY

SN 86-251,918. CURTIS, JATEM, TAYLOR, TX. FILED 4-14-2014.

**Loyalty Builds Empires**

THE MARK CONSISTS OF STANDARD CHARACTERS WITHOUT CLAIM TO ANY PARTICULAR FONT, STYLE, SIZE, OR COLOR.

FOR BANDANAS; CAPS; HOODED SWEATSHIRTS; JACKETS; PANTS; SCARVES; SOCKS; SWEATSHIRTS; T-SHIRTS; UNDERWEAR (U.S. CLS. 22 AND 39).

FIRST USE 2-19-1986; IN COMMERCE 2-27-2014.

INGRID C. EULIN, EXAMINING ATTORNEY

SN 86-251,954. GAULT, ANN MARIE, GARY, IN. FILED 4-14-2014.

**MODÈLE LA PHYSIQUE**

THE MARK CONSISTS OF STANDARD CHARACTERS WITHOUT CLAIM TO ANY PARTICULAR FONT, STYLE, SIZE, OR COLOR.

THE ENGLISH TRANSLATION OF "MODÈLE LA PHYSIQUE" IN THE MARK IS "MODEL LADY PHYSIQUE".

FOR CLOTHING, NAMELY HATS, BEANIES, HEADBANDS, SHIRTS, CROP TOPS, SWEATSHIRTS, PULL-OVERS, JACKETS, SWEATPANTS, LEGGINGS, JEANS, JUMPSUITS, JOGGING SUITS, TRACK SUITS, SPORT BRAS, WRISTBANDS, SWEATBANDS, AND SOCKS (U.S. CLS. 22 AND 39).

KATHERINE CONNOLLY, EXAMINING ATTORNEY

**CLASS 25—(Continued).**

SN 86-253,695. COLORADO TRADING & CLOTHING COMPANY, DBA ACTIVE FASHION GROUP, GREENWOOD VILLAGE, CO. FILED 4-16-2014.



OWNER OF U.S. REG. NO. 2,777,071.  
 NO CLAIM IS MADE TO THE EXCLUSIVE RIGHT TO USE "CLOTHING", APART FROM THE MARK AS SHOWN. THE MARK CONSISTS OF A SWIRL SHAPE DESIGN MADE UP OF THREE CURVED LINES THAT MEET IN THE CENTER ABOVE THE WORDS "COLORADO CLOTHING". SEC. 2(F) AS TO "COLORADO CLOTHING".  
 FOR CLOTHING, NAMELY, OUTERWEAR IN THE NATURE OF COATS AND JACKETS; FLEECE IN THE NATURE OF TOPS; VESTS, SHIRTS, LOUNGEWEAR, DRESSES, TOPS, TANK TOPS, SKIRTS, SHORTS, PANTS, LEGGINGS, HEADWEAR AND HEADBANDS, SWEATERS AND SWEATSHIRTS (U.S. CLS. 22 AND 39).  
 FIRST USE 1-0-2009; IN COMMERCE 1-0-2009.  
 KERI CANTONE, EXAMINING ATTORNEY

SN 86-253,725. COLORADO TRADING & CLOTHING COMPANY, DBA ACTIVE FASHION GROUP, GREENWOOD VILLAGE, CO. FILED 4-16-2014.

TRANQUILITY BY COLORADO  
 CLOTHING

THE MARK CONSISTS OF STANDARD CHARACTERS WITHOUT CLAIM TO ANY PARTICULAR FONT, STYLE, SIZE, OR COLOR.  
 NO CLAIM IS MADE TO THE EXCLUSIVE RIGHT TO USE "CLOTHING", APART FROM THE MARK AS SHOWN. SEC. 2(F) AS TO "COLORADO CLOTHING".  
 FOR CLOTHING, NAMELY, OUTERWEAR IN THE NATURE OF COATS AND JACKETS; FLEECE IN THE NATURE OF TOPS; VESTS, SHIRTS, LOUNGEWEAR, DRESSES, TOPS, TANK TOPS, SKIRTS, SHORTS, PANTS, LEGGINGS, HEADWEAR AND HEADBANDS, SWEATERS AND SWEATSHIRTS (U.S. CLS. 22 AND 39).  
 KERI CANTONE, EXAMINING ATTORNEY

**CLASS 25—(Continued).**

SN 86-259,746. AIRBOAT APPAREL, INC., FORT LAUDERDALE, FL. FILED 4-23-2014.

AIRBOATS N HOES

THE MARK CONSISTS OF STANDARD CHARACTERS WITHOUT CLAIM TO ANY PARTICULAR FONT, STYLE, SIZE, OR COLOR.  
 FOR CLOTHING, NAMELY, SHIRTS, PANTS, SHORTS, JACKETS, HATS, AND TANK TOPS (U.S. CLS. 22 AND 39).  
 COLLEEN DOMBROW, EXAMINING ATTORNEY

SN 86-260,638. MOMENTUM LICENSING, INC., LOS ANGELES, CA. FILED 4-23-2014.

ROYAL TESTIMONY

THE MARK CONSISTS OF STANDARD CHARACTERS WITHOUT CLAIM TO ANY PARTICULAR FONT, STYLE, SIZE, OR COLOR.  
 FOR MEN'S AND BOY'S CLOTHING, NAMELY, SHIRTS, T-SHIRTS, PULLOVERS, SWEATERS, HOODIES, VESTS, PANTS, SHORTS, JACKETS, SWIMWEAR, SHOES, SANDALS, AND SOCKS; MEN'S AND BOY'S ACTIVEWEAR, NAMELY, SHIRTS, SHORTS, TANK TOPS, HOODIES, JACKETS, VESTS, PANTS, AND JOGGING OUTFITS; MEN'S AND BOY'S ACCESSORIES, NAMELY, BELTS, HATS, AND SCARVES (U.S. CLS. 22 AND 39).  
 FIRST USE 1-1-2012; IN COMMERCE 1-1-2012.  
 SIMON TENG, EXAMINING ATTORNEY

**CLASS 25—(Continued).**

SN 86-261,605. REBUILDING WARRIORS, NORCO, CA. FILED 4-24-2014.

**CLASS 25—(Continued).**

SN 86-274,178. CHEYENNE RIESTER, TRUCKEE, CA. FILED 5-7-2014.



THE MARK CONSISTS OF A DOGS PAW PRINT, ONE LARGE PAD WITH FOUR SMALLER PADS. AT THE TOP AT A 180 DEGREE CURVE AROUND THE PAW ARE THE WORDS SAVING WARRIORS. UNDER THE PAW PRINT CURVING UP FROM LEFT TO RIGHT ARE THE WORDS "ONE DOG AT A TIME".

FOR CLOTHING, NAMELY, SHIRTS, HATS, SWEAT-SHIRTS AND JACKETS (U.S. CLS. 22 AND 39).  
LESLEY LAMOTHE, EXAMINING ATTORNEY

## Cannabis 4 Cancer

THE MARK CONSISTS OF STANDARD CHARACTERS WITHOUT CLAIM TO ANY PARTICULAR FONT, STYLE, SIZE, OR COLOR.

FOR EYESHADES; HATS; HEAD WRAPS; HEAD-BANDS; JACKETS; JERSEYS; PAPER HATS FOR USE AS CLOTHING ITEMS; POCKET SQUARES; POCKETS FOR CLOTHING; SANDALS AND BEACH SHOES; SHOES; SHORT SETS; TIES; TOPS; WEARABLE GARMENTS AND CLOTHING, NAMELY, SHIRTS; WOMEN'S CLOTHING, NAMELY, SHIRTS, DRESSES, SKIRTS, BLOUSES; WRAPS; WRIST BANDS; WRISTBANDS (U.S. CLS. 22 AND 39).

JEFFREY LOOK, EXAMINING ATTORNEY

SN 86-274,139. CHEYENNE RIESTER, TRUCKEE, CA. FILED 5-7-2014.

SN 86-274,581. PEACE LOVE WORLD, LLC, MIAMI, FL. FILED 5-7-2014.

## Cannabis for Cancer

## I AM HOPE

THE MARK CONSISTS OF STANDARD CHARACTERS WITHOUT CLAIM TO ANY PARTICULAR FONT, STYLE, SIZE, OR COLOR.

FOR EYESHADES; HATS; HEAD WRAPS; HEAD-BANDS FOR CLOTHING; JERSEYS; PAPER HATS FOR USE AS CLOTHING ITEMS; POCKET SQUARES; POCKETS FOR CLOTHING; SANDALS AND BEACH SHOES; SHOES; SHORT SETS; TIES; TOPS; WEARABLE GARMENTS AND CLOTHING, NAMELY, SHIRTS; WOMEN'S CLOTHING, NAMELY, SHIRTS, DRESSES, SKIRTS, BLOUSES; WRAPS; WRIST BANDS; WRISTBANDS (U.S. CLS. 22 AND 39).

JEFFREY LOOK, EXAMINING ATTORNEY

THE MARK CONSISTS OF STANDARD CHARACTERS WITHOUT CLAIM TO ANY PARTICULAR FONT, STYLE, SIZE, OR COLOR.

FOR BASEBALL CAPS; BASEBALL CAPS AND HATS; CAPS; HATS; HOODED SWEAT SHIRTS; HOODED SWEATSHIRTS; SHIRTS; SHIRTS AND SHORT-SLEEVED SHIRTS; SHORT-SLEEVED SHIRTS; T-SHIRTS; TEE SHIRTS (U.S. CLS. 22 AND 39).

FIRST USE 10-6-2010; IN COMMERCE 10-6-2010.  
DANIEL CAPSHAW, EXAMINING ATTORNEY

**CLASS 25—(Continued).**

SN 86-274,867. KIDZ CONCEPTS, LLC, NEW YORK, NY. FILED 5-7-2014.

**XTREME COTTON**

THE MARK CONSISTS OF STANDARD CHARACTERS WITHOUT CLAIM TO ANY PARTICULAR FONT, STYLE, SIZE, OR COLOR.

NO CLAIM IS MADE TO THE EXCLUSIVE RIGHT TO USE "COTTON", APART FROM THE MARK AS SHOWN.

FOR ANKLE SOCKS; ATHLETIC APPAREL, NAMELY, SHIRTS, PANTS, JACKETS, FOOTWEAR, HATS AND CAPS, ATHLETIC UNIFORMS; ATHLETIC FOOTWEAR; ATHLETIC SHIRTS; ATHLETIC SHOES; ATHLETIC SHORTS; ATHLETIC TIGHTS; BABY BOTTOMS; BABY TOPS; BLAZERS; BOARD SHORTS; BOAT SHOES; BOOTIES; BOOTS; BOTTOMS; BUTTON DOWN SHIRTS; CANVAS SHOES; CHILDREN'S AND INFANT'S APPAREL, NAMELY, JUMPERS, OVERALL SLEEPWEAR, PAJAMAS, ROMPERS AND ONE-PIECE GARMENTS; CHILDREN'S HEADWEAR; CREEPERS; DECK-SHOES; DENIM JACKETS; DOWN JACKETS; DRESS SHIRTS; DRESSES; FLEECE BOTTOMS; FLEECE SHORTS; FLEECE TOPS; FOOTWEAR; GYM PANTS; GYM SHORTS; HATS FOR INFANTS, BABIES, TODDLERS AND CHILDREN; HOODED SWEATSHIRTS; HOSIERY; INFANT SLEEPERS; INFANT WEAR; INFANTS' SHOES AND BOOTS; JACKETS; JUMPER DRESSES; JUMPERS; KNEE-HIGH STOCKINGS; KNIT BOTTOMS; KNIT SHIRTS; KNIT TOPS; LAYETTES; LEGGINGS; LEISURE SHOES; LEOTARDS AND TIGHTS FOR WOMEN, MEN AND CHILDREN OF NYLON, COTTON OR OTHER TEXTILE FIBERS; LOUNGE PANTS; NON-SLIP SOCKS; ONE PIECE GARMENT FOR INFANTS AND TODDLERS; OUTER JACKETS; PANTIES, SHORTS AND BRIEFS; PANTS; POLO SHIRTS; RAIN BOOTS; SANDALS; SANDALS AND BEACH SHOES; SHIRTS; SHIRTS FOR INFANTS, BABIES, TODDLERS AND CHILDREN; SHOES; SHORTS; SKIRTS; SLIPPER SOCKS; SLIPPERS; SNEAKERS; SPORT STOCKINGS; SPORTS BRAS; SPORTS JACKETS; SPORTS PANTS; SPORTS SHIRTS; SWEAT BANDS; SWEAT SHIRTS; SWEAT SUITS; SWIMWEAR; TENNIS SHOES; THERMAL SOCKS; THERMAL UNDERWEAR; TIGHTS; TOPS; WIND-JACKETS; WINTER BOOTS; WOMEN'S ATHLETIC TOPS WITH BUILT-IN BRAS; WOOLLEN SOCKS; YOGA PANTS; YOGA SHIRTS; ALL THE AFORESAID MADE IN WHOLE OR SIGNIFICANT PART OF COTTON (U.S. CLS. 22 AND 39).

JASON TURNER, EXAMINING ATTORNEY

**CLASS 25—(Continued).**

SN 86-274,896. KIDZ CONCEPTS, LLC, NEW YORK, NY. FILED 5-7-2014.

**XCOTTON**

THE MARK CONSISTS OF STANDARD CHARACTERS WITHOUT CLAIM TO ANY PARTICULAR FONT, STYLE, SIZE, OR COLOR.

FOR ANKLE SOCKS; ATHLETIC APPAREL, NAMELY, SHIRTS, PANTS, JACKETS, FOOTWEAR, HATS AND CAPS, ATHLETIC UNIFORMS; ATHLETIC FOOTWEAR; ATHLETIC SHIRTS; ATHLETIC SHOES; ATHLETIC SHORTS; ATHLETIC TIGHTS; BABY BOTTOMS; BABY TOPS; BLAZERS; BOARD SHORTS; BOAT SHOES; BOOTIES; BOOTS; BOTTOMS; BUTTON DOWN SHIRTS; CANVAS SHOES; CHILDREN'S AND INFANT'S APPAREL, NAMELY, JUMPERS, OVERALL SLEEPWEAR, PAJAMAS, ROMPERS AND ONE-PIECE GARMENTS; CHILDREN'S HEADWEAR; CREEPERS; DECK-SHOES; DENIM JACKETS; DOWN JACKETS; DRESS SHIRTS; DRESSES; FLEECE BOTTOMS; FLEECE SHORTS; FLEECE TOPS; FOOTWEAR; GYM PANTS; GYM SHORTS; HATS FOR INFANTS, BABIES, TODDLERS AND CHILDREN; HOODED SWEATSHIRTS; HOSIERY; INFANT SLEEPERS; INFANT WEAR; INFANTS' SHOES AND BOOTS; JACKETS; JUMPER DRESSES; JUMPERS; KNEE-HIGH STOCKINGS; KNIT BOTTOMS; KNIT SHIRTS; KNIT TOPS; LAYETTES; LEGGINGS; LEISURE SHOES; LEOTARDS AND TIGHTS FOR WOMEN, MEN AND CHILDREN OF NYLON, COTTON OR OTHER TEXTILE FIBERS; LOUNGE PANTS; NON-SLIP SOCKS; ONE PIECE GARMENT FOR INFANTS AND TODDLERS; OUTER JACKETS; PANTIES, SHORTS AND BRIEFS; PANTS; POLO SHIRTS; RAIN BOOTS; SANDALS; SANDALS AND BEACH SHOES; SHIRTS; SHIRTS FOR INFANTS, BABIES, TODDLERS AND CHILDREN; SHOES; SHORTS; SKIRTS; SLIPPER SOCKS; SLIPPERS; SNEAKERS; SPORT STOCKINGS; SPORTS BRAS; SPORTS JACKETS; SPORTS PANTS; SPORTS SHIRTS; SPORTS SHOES; STOCKINGS; SWEAT BANDS; SWEAT JACKETS; SWEAT PANTS; SWEAT SHIRTS; SWEAT SHORTS; SWEAT SUITS; SWIMWEAR; TENNIS SHOES; THERMAL SOCKS; THERMAL UNDERWEAR; TIGHTS; TOPS; WIND-JACKETS; WINTER BOOTS; WOMEN'S ATHLETIC TOPS WITH BUILT-IN BRAS; WOOLLEN SOCKS; YOGA PANTS; YOGA SHIRTS; ALL THE AFORESAID MADE IN WHOLE OR SIGNIFICANT PART OF COTTON (U.S. CLS. 22 AND 39).

JASON TURNER, EXAMINING ATTORNEY

SN 86-275,330. PORTICO IP HOLDING, LLC, NORTH-BROOK, IL. FILED 5-8-2014.

**PORTICO**

THE MARK CONSISTS OF STANDARD CHARACTERS WITHOUT CLAIM TO ANY PARTICULAR FONT, STYLE, SIZE, OR COLOR.

OWNER OF U.S. REG. NOS. 2,641,451, 3,963,241 AND 3,963,242.

FOR CAMISOLES; CHEMISES; TANKS; T-SHIRTS; TUNICS; LEGGINGS; PAJAMAS; ROBES; LONG-SLEEVED T-SHIRTS; WRAPS; SWEATERS; CARDIGANS; JACKETS; PANTS; SHORTS; JUMPSUITS; SKIRTS; DRESSES; SLIPPERS (U.S. CLS. 22 AND 39).

ALEX KEAM, EXAMINING ATTORNEY



**CLASS 25—(Continued).**

SN 86-276,017. PEACE LOVE WORLD, LLC, MIAMI, FL.  
FILED 5-8-2014.



THE MARK CONSISTS OF A SKULL COMPOSED OF HAPPY FACES, HEARTS, AND PEACE SYMBOLS, UNDER WHICH A PAIR OF CROSSBONES ARE LOCATED.

FOR HOODED SWEAT SHIRTS; HOODED SWEATSHIRTS; LONG-SLEEVED SHIRTS; PANTS; SHIRTS; SHIRTS AND SHORT-SLEEVED SHIRTS; SHORT-SLEEVED OR LONG-SLEEVED T-SHIRTS; SHORT-SLEEVED SHIRTS; SWEAT PANTS; SWEATERS; SWEATPANTS; SWEATSHIRTS; T-SHIRTS; TEE SHIRTS (U.S. CLS. 22 AND 39).

FIRST USE 7-18-2013; IN COMMERCE 7-18-2013.  
DANIEL CAPSHAW, EXAMINING ATTORNEY

**CLASS 25—(Continued).**

SN 86-282,644. CAVE SPRINGS, INC., WILMINGTON, DE.  
FILED 5-15-2014.

LUXE ESSENTIALS BY A PEA  
IN THE POD

THE MARK CONSISTS OF STANDARD CHARACTERS WITHOUT CLAIM TO ANY PARTICULAR FONT, STYLE, SIZE, OR COLOR.

OWNER OF U.S. REG. NOS. 1,427,963, 4,183,420 AND OTHERS.

FOR MATERNITY CLOTHING, NAMELY, JEANS, PANTS, SHIRTS, TOPS, BLOUSES, T-SHIRTS, TANK TOPS, CAMISOLES, SWEATERS, DRESSES, BLAZERS, SHORTS, SKIRTS, JACKETS, COATS, VESTS, LOUNGEWEAR, JUMPERS, SWEAT PANTS, YOGA PANTS, SWEAT JACKETS, SLEEPWEAR, ROBES, BRAS, UNDERWEAR, SHAPEWEAR, NAMELY, PANTIES, SHORTS, CAMISOLES, AND TANK TOPS, SWIMWEAR, SWIM AND BEACH COVER-UPS, LEGGINGS, HOSIERY, TIGHTS, MATERNITY GARMENTS, NAMELY, ELASTIC FABRIC BAND TO BE WORN DURING AND AFTER PREGNANCY TO RETAIN UNFASTENED PRE-PREGNANCY PANTS AND SKIRTS OR OVERSIZED MATERNITY CLOTHING; NURSING APPAREL, NAMELY, TOPS, SHIRTS, T-SHIRTS, TANK TOPS, BLOUSES, CAMISOLES, DRESSES, BRAS, SHAPEWEAR, NAMELY, CAMISOLES AND TANK TOPS, AND SLEEPWEAR (U.S. CLS. 22 AND 39).

JEFFERY COWARD, EXAMINING ATTORNEY

SN 86-278,209. MAURICES INCORPORATED, DULUTH, MN. FILED 5-12-2014.



THE MARK CONSISTS OF A STYLIZED FLOWER.  
FOR CLOTHING, NAMELY, HEADBANDS, SCARVES, PANTS, JACKETS, BRAS, SWEATSHIRTS, T-SHIRTS, TANK TOPS, HATS, SOCKS, FOOTWEAR (U.S. CLS. 22 AND 39).

WILLIAM P. SHANAHAN, EXAMINING ATTORNEY

SN 86-286,287. GLOBAL TRADEMARKS, INC., STOCKERTOWN, PA. FILED 5-20-2014.

S.P.A. SPORT PERFORMANCE  
ACTIVE

THE MARK CONSISTS OF STANDARD CHARACTERS WITHOUT CLAIM TO ANY PARTICULAR FONT, STYLE, SIZE, OR COLOR.

NO CLAIM IS MADE TO THE EXCLUSIVE RIGHT TO USE "SPORT" AND "PERFORMANCE ACTIVE", APART FROM THE MARK AS SHOWN.

FOR LEGGINGS; LEOTARDS; SWIMWEAR; T-SHIRTS; TIGHTS (U.S. CLS. 22 AND 39).

LAUREN BURKE, EXAMINING ATTORNEY

**CLASS 25—(Continued).**

SN 86-290,164. LEEWARD INTERNATIONAL INC., TEANECK, NJ. FILED 5-23-2014.



NO CLAIM IS MADE TO THE EXCLUSIVE RIGHT TO USE "DURABLE DRY GOODS", APART FROM THE MARK AS SHOWN.

THE MARK CONSISTS OF THE TERM "FELDTON" INSIDE OF A DIAMOND SHAPED IMAGE WITH THE TERM "DURABLE" AND "DRY GOODS" PRINTED ON THE TOP INNER BORDER OF THE DIAMOND AND SEPARATED BY TWO INTERLOCKING DIAMOND SHAPES AND THE TERMS "RECTITUDE" AND "INTEGRITY" PRINTED ON THE BOTTOM INNER BORDER OF THE DIAMOND AND SEPARATED BY TWO INTERLOCKING DIAMOND SHAPES.

FOR HEADGEAR, NAMELY, HATS AND CAPS; HEAD SCARVES; SCARVES; SHOULDER SCARVES; SILK SCARVES; DRESS SHIRTS; GOLF SHIRTS; KNIT SHIRTS; T-SHIRTS, NIGHT SHIRTS; POLO SHIRTS; SHIRTS; SHIRTS FOR SUITS; SLEEP SHIRTS; CAPRI PANTS; CARGO PANTS; DENIM PANTS; PANTS; SWEAT PANTS; SKIRT SUITS; SKIRTS; SKIRTS AND DRESSES; DRESS SUITS; DRESSES; DRESSING GOWNS; SWIMSUITS; HATS; SOCKS; UNDERWEAR; WOMEN'S UNDERWEAR; BERMUDA SHORTS; GYM SHORTS; SHORTS; SWEAT SHORTS; SANDALS; JACKETS; LEATHER JACKETS; GLOVES; LINGERIE; BLOUSES, PAJAMA; SKI BOOT BAGS, SHOES, BELTS, VEST; SNOW SUITS; SWEATERS, JOGGING SUITS (U.S. CLS. 22 AND 39).

TASNEEM HUSSAIN, EXAMINING ATTORNEY

SN 86-294,512. GLITTER STARZ INC., MCCOOK, IL. FILED 5-29-2014.

**GLITTER STARZ**

THE MARK CONSISTS OF STANDARD CHARACTERS WITHOUT CLAIM TO ANY PARTICULAR FONT, STYLE, SIZE, OR COLOR.

FOR CUSTOM CHEER AND DANCE ACTIVE WEAR, NAMELY, WARM UP OUTFITS, WARM UP SUITS, TEE SHIRTS, SWEATSHIRTS, PANTS, LEGGINGS, SHORTS, JACKETS, BERETS, DRESSES, FASHION HATS, FOOTWEAR, BRAS, BRASSIERES, BELTS, SOCKS, TANK TOPS, BODY SUITS, BODY SHAPERS, SKIRTS, ATHLETIC PANTS, STRETCH PANTS, ATHLETIC TIGHTS, POLO SHIRTS, LEOTARDS AND SPORTS BRAS (U.S. CLS. 22 AND 39).

FIRST USE 0-0-2007; IN COMMERCE 0-0-2007.  
WILLIAM JACKSON, EXAMINING ATTORNEY

**CLASS 25—(Continued).**

SN 86-294,541. GLITTER STARZ INC., MCCOOK, IL. FILED 5-29-2014.

**RHINESTONE LEADERS OF THE WORLD**

THE MARK CONSISTS OF STANDARD CHARACTERS WITHOUT CLAIM TO ANY PARTICULAR FONT, STYLE, SIZE, OR COLOR.

NO CLAIM IS MADE TO THE EXCLUSIVE RIGHT TO USE "RHINESTONE", APART FROM THE MARK AS SHOWN.

FOR CUSTOM CHEER AND DANCE ACTIVE WEAR, NAMELY, WARM UP OUTFITS, WARM UP SUITS, TEE SHIRTS, SWEATSHIRTS, PANTS, LEGGINGS, SHORTS, JACKETS, BERETS, DRESSES, FASHION HATS, FOOTWEAR, BRAS, BRASSIERES, BELTS, SOCKS, TANK TOPS, BODY SUITS, BODY SHAPERS, SKIRTS, ATHLETIC PANTS, STRETCH PANTS, ATHLETIC TIGHTS, POLO SHIRTS, LEOTARDS AND SPORTS BRAS (U.S. CLS. 22 AND 39).

FIRST USE 0-0-2012; IN COMMERCE 0-0-2012.  
WILLIAM JACKSON, EXAMINING ATTORNEY

SN 86-295,992. LAGREE, SEBASTIEN, SANTA MONICA, CA. FILED 5-30-2014.



OWNER OF U.S. REG. NOS. 4,291,320 AND 4,297,498.  
NO CLAIM IS MADE TO THE EXCLUSIVE RIGHT TO USE "FITNESS", APART FROM THE MARK AS SHOWN.

THE COLOR(S) BLACK, GREY, SILVER AND RED IS/ ARE CLAIMED AS A FEATURE OF THE MARK.

THE MARK CONSISTS OF A SHIELD OUTLINED IN SILVER WITH MAN, COLORED IN SILVER, GREY, AND BLACK, AIMING A SILVER BOW AND ARROW UPWARD, WITHIN THE OUTLINE OF THE SHIELD. A SILVER AND GREY WAVE APPEARS BEHIND THE FIGURE OF THE MAN, WHERE THE EDGE AND CURVATURE OF THE WAVE IS INCORPORATED AS THE BOW. THE SPACES WITHIN THE SHIELD BEHIND THE MAN, BOW, OR THE WAVE APPEAR IN BLACK. "LAGREE FITNESS" APPEARS TO THE RIGHT OF THE SHIELD, WITH "LAGREE" IN GREY OUTLINED IN BLACK APPEARING ABOVE "FITNESS" IN RED; THE COLOR WHITE IN THE BACKGROUND IS NOT CLAIMED AS A FEATURE OF THE MARK.

FOR FOOTWEAR AND APPAREL, NAMELY, SHIRTS, PANTS, JACKETS, HATS, CAPS, BELTS, JEANS, SOCKS, GLOVES, SCARVES, NECKTIES, ATHLETIC UNIFORMS, VESTS, UNDERWEAR, SHORTS, T-SHIRTS, DRESSES, SKIRTS, TIGHTS, BRAS, TOPS, SWEATERS, SWEAT SHIRTS, HOODED SHIRTS, AND HOODED SWEAT SHIRTS; GIFT PACKAGES SOLD AS A UNIT CONSISTING PRIMARILY OF A SHIRT AND ALSO INCLUDING A WATER BOTTLE, TOTE BAG, AND TOWEL; PERFORMANCE APPAREL, NAMELY, GYM SUITS AND SHOES (U.S. CLS. 22 AND 39).

FIRST USE 2-6-2010; IN COMMERCE 2-10-2010.  
TIFFANY CHIANG, EXAMINING ATTORNEY

**CLASS 25—(Continued).**

SN 86-296,396. LOKAI HOLDINGS LLC, NEW YORK, NY. FILED 5-30-2014.

# LOKAI

THE MARK CONSISTS OF STANDARD CHARACTERS WITHOUT CLAIM TO ANY PARTICULAR FONT, STYLE, SIZE, OR COLOR.

OWNER OF U.S. REG. NO. 4,429,129.  
FOR ATHLETIC APPAREL, NAMELY, SHIRTS, PANTS, JACKETS, FOOTWEAR, HATS AND CAPS, ATHLETIC UNIFORMS (U.S. CLS. 22 AND 39).  
JUSTIN SEVERSON, EXAMINING ATTORNEY

---

SN 86-296,403. LOKAI HOLDINGS LLC, NEW YORK, NY. FILED 5-30-2014.



OWNER OF U.S. REG. NO. 4,429,129.  
THE MARK CONSISTS OF THE WORD "LOKAI" WITH AN OPEN DOT ABOVE THE LETTER "I" AND A SOLID DOT BELOW THE LETTER "I".

FOR ATHLETIC APPAREL, NAMELY, SHIRTS, PANTS, JACKETS, FOOTWEAR, HATS AND CAPS, ATHLETIC UNIFORMS (U.S. CLS. 22 AND 39).  
JUSTIN SEVERSON, EXAMINING ATTORNEY

---

SN 86-296,409. LOKAI HOLDINGS LLC, NEW YORK, NY. FILED 5-30-2014.



OWNER OF U.S. REG. NO. 4,429,129.  
THE MARK CONSISTS OF TWO CONCENTRIC STYLIZED WATER DROPLETS CONTAINING TWO CIRCLES.

FOR ATHLETIC APPAREL, NAMELY, SHIRTS, PANTS, JACKETS, FOOTWEAR, HATS AND CAPS, ATHLETIC UNIFORMS (U.S. CLS. 22 AND 39).  
JUSTIN SEVERSON, EXAMINING ATTORNEY

**CLASS 25—(Continued).**

SN 86-299,447. QS WHOLESALE, INC., HUNTINGTON BEACH, CA. FILED 6-3-2014.

# AMPLA FORCEPOWER

THE MARK CONSISTS OF STANDARD CHARACTERS WITHOUT CLAIM TO ANY PARTICULAR FONT, STYLE, SIZE, OR COLOR.

FOR FOOTWEAR (U.S. CLS. 22 AND 39).  
MICHAEL WIENER, EXAMINING ATTORNEY

---

SN 86-301,638. ROBERT ROSENHECK, LOS ANGELES, CA. FILED 6-5-2014.

# LORD JONES

THE MARK CONSISTS OF STANDARD CHARACTERS WITHOUT CLAIM TO ANY PARTICULAR FONT, STYLE, SIZE, OR COLOR.

THE NAME(S), PORTRAIT(S), AND/OR SIGNATURE(S) SHOWN IN THE MARK DOES NOT IDENTIFY A PARTICULAR LIVING INDIVIDUAL.

FOR BATHING SUITS; DUNGAREES; HATS; JEANS; PANTS; SHIRTS; SWEAT PANTS; SWEAT SHIRTS; T-SHIRTS; UNDERWEAR (U.S. CLS. 22 AND 39).  
SAMUEL PAQUIN, EXAMINING ATTORNEY

---

SN 86-303,413. MCCOY, STEPHEN L, BOWLING GREEN, KY. FILED 6-8-2014.

# SCORING MACHINE

THE MARK CONSISTS OF STANDARD CHARACTERS WITHOUT CLAIM TO ANY PARTICULAR FONT, STYLE, SIZE, OR COLOR.

FOR CLOTHING AND APPAREL, NAMELY, T-SHIRTS, SHIRTS, SWEATSHIRTS, TANK TOPS, SHORTS, PANTS, HATS, CAPS (U.S. CLS. 22 AND 39).  
HAI-LY LAM, EXAMINING ATTORNEY

**CLASS 25—(Continued).**

SN 86-303,417. MCCOY, STEPHEN L, BOWLING GREEN, KY. FILED 6-8-2014.

**RUNNING MACHINE**

THE MARK CONSISTS OF STANDARD CHARACTERS WITHOUT CLAIM TO ANY PARTICULAR FONT, STYLE, SIZE, OR COLOR.

FOR CLOTHING AND APPAREL, NAMELY, T-SHIRTS, SHIRTS, SWEATSHIRTS, SPORTS BRAS, VISORS, TANK TOPS, SHORTS, PANTS, HATS, CAPS (U.S. CLS. 22 AND 39).

HAI-LY LAM, EXAMINING ATTORNEY

SN 86-307,194. GAMELI CRUZ RICARDEZ, NORTH LAS VEGAS, NV. FILED 6-11-2014.

**WATERBLADE**

THE MARK CONSISTS OF STANDARD CHARACTERS WITHOUT CLAIM TO ANY PARTICULAR FONT, STYLE, SIZE, OR COLOR.

FOR SWIM SUITS; T-SHIRTS (U.S. CLS. 22 AND 39).

KATHERINE CHANG, EXAMINING ATTORNEY

SN 86-308,419. JOE'S TEAM SPORTS LLC, LAGUNA HILLS, CA. FILED 6-12-2014.



NO CLAIM IS MADE TO THE EXCLUSIVE RIGHT TO USE "SURF CO.", APART FROM THE MARK AS SHOWN.

THE MARK CONSISTS OF A PICTURE OF A PALM TREE, THEN THE WORDS "KOLOA SURF CO." WITH A LINE UNDER PALM TREE PICTURE AND WORDS.

THE WORDING "KOLOA" HAS NO MEANING IN A FOREIGN LANGUAGE.

FOR CLOTHING, NAMELY, T-SHIRTS AND HATS (U.S. CLS. 22 AND 39).

FIRST USE 1-1-2014; IN COMMERCE 1-1-2014.

AHSEN KHAN, EXAMINING ATTORNEY

**CLASS 25—(Continued).**

SN 86-310,390. GAULT, ANN MARIE, GARY, IN. FILED 6-16-2014.

**APPRÉCIATION DE L'ART**

THE MARK CONSISTS OF STANDARD CHARACTERS WITHOUT CLAIM TO ANY PARTICULAR FONT, STYLE, SIZE, OR COLOR.

THE ENGLISH TRANSLATION OF "APPRÉCIATION DE L'ART" IN THE MARK IS "ART APPRECIATION".

FOR BOTTOMS; DRESSES; HATS; JACKETS; LEGGINGS; PANTS; PONCHOS; SCARVES; SHORTS; T-SHIRTS; TOPS (U.S. CLS. 22 AND 39).

KATHERINE CONNOLLY, EXAMINING ATTORNEY

SN 86-310,977. K AND K PROMOTIONS, INC., LAS VEGAS, NV. FILED 6-16-2014.

**7 Inch Daredevil**

THE MARK CONSISTS OF STANDARD CHARACTERS WITHOUT CLAIM TO ANY PARTICULAR FONT, STYLE, SIZE, OR COLOR.

FOR BEANIES; BELTS; BLOUSES; CAPS; FOOTWEAR; GLOVES; HALLOWEEN COSTUMES AND MASKS SOLD IN CONNECTION THEREWITH; HATS; HOODED SWEATSHIRTS; JACKETS; JEANS; JERSEYS; JOGGING SUITS; JUMPSUITS; PANTS; SANDALS; SHIRTS; SHOES; SHORTS; SKIRTS; SLEEPWEAR; SUSPENDERS; SWEATERS; SWEATPANTS; SWEATSHIRTS; SWEATSUITS; SWIMSUITS; SWIMWEAR; T-SHIRTS; TANK-TOPS; TIES; TOPS; UNDERWEAR; VESTS; VISORS; WRISTBANDS (U.S. CLS. 22 AND 39).

SUNG IN, EXAMINING ATTORNEY

SN 86-975,045. BCS PROPERTIES, LLC, IRVING, TX. FILED 8-14-2013.

**NEW YEARS SIX BOWLS**

THE MARK CONSISTS OF STANDARD CHARACTERS WITHOUT CLAIM TO ANY PARTICULAR FONT, STYLE, SIZE, OR COLOR.

FOR MEN'S, WOMEN'S, AND CHILDREN'S CLOTHING, NAMELY, T-SHIRTS, SWEAT SHIRTS, SWEAT PANTS, CAPS, HATS, PULLOVERS, JERSEYS, JACKETS, VISORS, SHORTS, SOCKS, SWEATBANDS, SCARVES, AND SWEATERS (U.S. CLS. 22 AND 39).

GRETTA YAO, EXAMINING ATTORNEY

**CLASS 26—FANCY GOODS**

SN 79-140,572. SERAM, FRANCE, FILED 9-11-2013.



PRIORITY DATE OF 3-13-2013 IS CLAIMED.  
OWNER OF INTERNATIONAL REGISTRATION 1187117  
DATED 9-11-2013, EXPIRES 9-11-2023.

NO CLAIM IS MADE TO THE EXCLUSIVE RIGHT TO  
USE "MERCERIE" OR "DIY AND FASHION", APART  
FROM THE MARK AS SHOWN.

THE COLOR(S) BLUE, WHITE AND RED IS/ARE  
CLAIMED AS A FEATURE OF THE MARK.

THE MARK CONSISTS OF A BLUE CIRCLE DESIGN  
WITH THE WORDING "LA MERCERIE CHIC" IN WHITE,  
IN THE CENTER OF THE CIRCLE WITH THE WORDING  
"DIY AND FASHION", ALSO IN WHITE, UNDERNEATH,  
IN A SEMI-CIRCULAR DESIGN. WHITE DOTTED LINES  
EXTEND FROM THE BOTH ENDS OF THE "DIY AND  
FASHION" WORDING WITH RED HEARTS AT EACH END  
OF THE DOTS. A WHITE LINE DESIGN IS LOCATED  
AROUND THE INNER EDGE OF THE CIRCLE AND  
FORMS A STYLIZED TRIANGULAR SHAPE AT THE TOP.

THE ENGLISH TRANSLATION OF "MERCERIE" IN THE  
MARK IS "HABERDASHERY".

FOR LACE AND EMBROIDERY; SNAP BUTTONS,  
SEWING BUTTONS, THREADING BUTTONS; CRO-  
CHET HOOKS HABERDASHERY, CROCHET HOOKS  
FOR EMBROIDERING, CROCHET HOOKS FOR SHOES;  
EYELETS FOR CLOTHING, EYELETS FOR FOOTWEAR;  
PINS OTHER THAN JEWELRY, PIN CUSHIONS; SEW-  
ING NEEDLES, BINDING NEEDLES, DARNING NEE-  
DLES, KNITTING NEEDLES, SHOEMAKERS' NEEDLES,  
SADDLERS' NEEDLES, BOXES FOR NEEDLES, NEE-  
DLE CASES; HABERDASHERY EXCEPT THREADS  
AND YARNS, NAMELY, BIRDS' FEATHERS CLOTHING  
ACCESSORIES, SPANGLES FOR CLOTHING, BEADS  
OTHER THAN FOR MAKING JEWELRY, HEAT ADHE-  
SIVE PATCHES FOR THE DECORATION AND REPAIR  
OF TEXTILE ARTICLES, HAIR CLIPS, FEATHERS  
CLOTHING ACCESSORIES, TOP-KNOTS POMPOMS;  
LACE TRIMMINGS; FASTENERS AND CLASPS FOR  
CLOTHING; ORNAMENTS FOR THE HAIR; ARTIFI-  
CIAL FLOWERS (U.S. CLS. 37, 39, 40, 42 AND 50).

CURTIS FRENCH, EXAMINING ATTORNEY

**CLASS 26—(Continued).**

SN 79-141,287. MIYUKI CO., LTD., JAPAN, FILED 11-11-2013.



OWNER OF INTERNATIONAL REGISTRATION 1188932  
DATED 11-11-2013, EXPIRES 11-11-2023.

THE COLOR(S) BLACK, GRAY AND PINK IS/ARE  
CLAIMED AS A FEATURE OF THE MARK.

THE MARK CONSISTS OF THE WORDING "MIYUKI" IN  
STYLIZED BLACK LETTERING; A STYLIZED CAPITAL M  
IN GRAY WITH A PINK DOT ABOVE THE CENTER  
PORTION WITH A PINK WEDGE SUPERIMPOSED ON  
THE BODY OF THE DESIGN.

THE WORDING "MIYUKI" HAS NO MEANING IN A  
FOREIGN LANGUAGE.

FOR BEADS FOR HANDICRAFT WORK (U.S. CLS. 37,  
39, 40, 42 AND 50).

NATALIE POLZER, EXAMINING ATTORNEY

SN 86-063,977. AMERICAN GIRL, LLC, EL SEGUNDO, CA.  
FILED 9-13-2013.

**TRULY ME**

THE MARK CONSISTS OF STANDARD CHARACTERS  
WITHOUT CLAIM TO ANY PARTICULAR FONT, STYLE,  
SIZE, OR COLOR.

OWNER OF U.S. REG. NO. 3,406,707.

FOR HAIR ACCESSORIES, NAMELY, HAIR BOWS  
AND RIBBONS, BARRETTES, SCRUNCHIES, CLAMPS,  
CLIPS, BANDS, ELASTICS (U.S. CLS. 37, 39, 40, 42 AND  
50).

MICHELE SWAIN, EXAMINING ATTORNEY

SN 86-074,341. COMMANDO, LLC, SOUTH BURLINGTON,  
VT. FILED 9-25-2013.

**PICK-UP STICKS**

THE MARK CONSISTS OF STANDARD CHARACTERS  
WITHOUT CLAIM TO ANY PARTICULAR FONT, STYLE,  
SIZE, OR COLOR.

FOR CLOTHING TAPE FOR TEMPORARILY HEM-  
MING PANTS TO ADJUST INSEAM LENGTH; BODY  
TAPE, NAMELY, BREAST LIFTING TAPE (U.S. CLS. 37,  
39, 40, 42 AND 50).

LOURDES AYALA, EXAMINING ATTORNEY

**CLASS 26—(Continued).**

SN 86-103,873. JELLY TIES, LLC, AUSTIN, TX. FILED 10-29-2013.



NO CLAIM IS MADE TO THE EXCLUSIVE RIGHT TO USE "JELLY TIES" AND "CUSTOM HAIR TIES", APART FROM THE MARK AS SHOWN.

THE COLOR(S) HOT PINK AND BLACK IS/ARE CLAIMED AS A FEATURE OF THE MARK.

THE MARK CONSISTS OF THE WORDING "JELLY TIES" IN CURSIVE. THE LOOP IN THE "J" IS HOT PINK AND THE REMAINING LETTERS ARE BLACK. A DESIGN OF A BLACK SCISSORS IS DEPICTED BELOW AND AS IF DISSECTING THROUGH THE PINK LOOP. THE WORDING "CUSTOM HAIR TIES" IS WRITTEN TO THE RIGHT OF THE WORD "JELLY" AND UNDER THE WORD "TIES" AND APPEARS ALL IN CAPITAL LETTERS AND IN THE COLOR BLACK. THE MARK APPEARS ON A TRANSPARENT BACKGROUND AND NO OTHER COLORS ARE CLAIMED AS A FEATURE OF THE MARK.

FOR HAIR ACCESSORIES, NAMELY, HAIR TIES (U.S. CLS. 37, 39, 40, 42 AND 50).

LEE-ANNE BERNS, EXAMINING ATTORNEY

**CLASS 26—(Continued).**

SN 86-139,206. OMNI INTERNATIONAL TRADING CORP., MIAMI, FL. FILED 12-10-2013.

**MY LIKE**

THE MARK CONSISTS OF STANDARD CHARACTERS WITHOUT CLAIM TO ANY PARTICULAR FONT, STYLE, SIZE, OR COLOR.

FOR HAIR PRODUCTS, NAMELY, WIGS, HAIR PIECES, ADD-IN AND ADD-ON HAIR ACCESSORIES CONSTRUCTED PRIMARILY OF SYNTHETIC AND/OR HUMAN HAIR, LACE WIGS, HAIR WEFT EXTENSIONS AND BRAIDS, HAIR EXTENSIONS (U.S. CLS. 37, 39, 40, 42 AND 50).

FIRST USE 8-30-2012; IN COMMERCE 8-30-2012.

AMY KERTGATE, EXAMINING ATTORNEY

SN 86-139,221. OMNI INTERNATIONAL TRADING CORP., MIAMI, FL. FILED 12-10-2013.

**ORIGEN**

SN 86-128,780. EVE HAIR, INC., LAKEWOOD, CA. FILED 11-25-2013.

**Venezian**

THE MARK CONSISTS OF STANDARD CHARACTERS WITHOUT CLAIM TO ANY PARTICULAR FONT, STYLE, SIZE, OR COLOR.

FOR HAIR EXTENSIONS; HAIR PIECES; HAIR PIECES AND WIGS; HAIR WEAVES; WIGS, HAIR-PIECES, AND ADD-IN AND ADD-ON HAIR ACCESSORIES CONSTRUCTED PRIMARILY OF SYNTHETIC AND/OR HUMAN HAIR (U.S. CLS. 37, 39, 40, 42 AND 50).

LESLIE RICHARDS, EXAMINING ATTORNEY

THE MARK CONSISTS OF STANDARD CHARACTERS WITHOUT CLAIM TO ANY PARTICULAR FONT, STYLE, SIZE, OR COLOR.

FOR HAIR PRODUCTS, NAMELY, WIGS, HAIR PIECES, ADD-IN AND ADD-ON HAIR ACCESSORIES CONSTRUCTED PRIMARILY OF SYNTHETIC AND/OR HUMAN HAIR, LACE WIGS, HAIR WEFT EXTENSIONS AND BRAIDS, HAIR EXTENSIONS (U.S. CLS. 37, 39, 40, 42 AND 50).

FIRST USE 4-30-2013; IN COMMERCE 4-30-2013.

AMY KERTGATE, EXAMINING ATTORNEY

**CLASS 26—(Continued).**

SN 86-167,649. PEANUTS WORLDWIDE LLC, NEW YORK, NY. FILED 1-16-2014.



OWNER OF U.S. REG. NOS. 1,256,900, 1,267,166 AND OTHERS.

THE MARK CONSISTS OF TWO PARTIALLY OBSCURED STYLIZED DOG FACES MOSTLY WITHIN A SQUARE WITH THE AMPERSAND SYMBOL BETWEEN THE DOG FACES. THE WORDING "SNOOPY" ALONG THE LEFT SIDE OF THE SQUARE, AND THE WORDING "HIS SISTER BELLE" ALONG THE RIGHT SIDE OF THE SQUARE.

FOR LACE AND EMBROIDERY, RIBBONS AND BRAID; BUTTONS, HOOKS AND EYES, SEWING PINS AND NEEDLES; ARTIFICIAL FLOWERS; SHOE STRINGS; HAIR RIBBONS, HAIR ORNAMENTS, BARRETTES, PONY TAIL AND HAIR CLIPS, HAIR PINS; ORNAMENTAL NOVELTY BUTTONS, BADGES AND PINS; SHOE LACE FASTENERS; SHOE BUCKLES; HAIR BANDS; HAIR ORNAMENTS; FABRIC APPLIQUES; EMBROIDERED PATCHES FOR CLOTHING (U.S. CLS. 37, 39, 40, 42 AND 50).

MIAH ROSENBERG, EXAMINING ATTORNEY

SN 86-220,986. GUANGZHOU GOOATION TRADING LIMITED, HAIZHU, GUANGZHOU, CHINA, FILED 3-14-2014.

# SUREWELLS

THE MARK CONSISTS OF STANDARD CHARACTERS WITHOUT CLAIM TO ANY PARTICULAR FONT, STYLE, SIZE, OR COLOR.

FOR BRAIDS; FALSE BEARDS; FALSE HAIR; HAIR BANDS; HAIR EXTENSIONS; HAIR GRIPS; HAIR NETS; HAIR SLIDES; LACE; RIBBONS AND BRAIDS; TOUPEES; TOUPEES; WIGS; WIGS, HAIRPIECES, AND ADD-IN AND ADD-ON HAIR ACCESSORIES CONSTRUCTED PRIMARILY OF SYNTHETIC AND/OR HUMAN HAIR (U.S. CLS. 37, 39, 40, 42 AND 50).

FIRST USE 5-18-2012; IN COMMERCE 5-18-2012.

GINA FINK, EXAMINING ATTORNEY

**CLASS 26—(Continued).**

SN 86-221,359. BOATENG, SCOTT, SOUTHFIELD, MI. FILED 3-14-2014.

# PREVA

THE COLOR(S) BLACK AND RED IS/ARE CLAIMED AS A FEATURE OF THE MARK.

THE MARK CONSISTS OF THE WORD "PREVA" WITH A RED LETTER "V" AND BLACK LETTERS "PRE" AND "A". THE WHITE BACKGROUND IS USED TO SHOW PLACEMENT AND IS NOT CLAIMED AS A FEATURE OF THE MARK.

THE WORDING "PREVA" HAS NO MEANING IN A FOREIGN LANGUAGE.

FOR HAIR EXTENSIONS (U.S. CLS. 37, 39, 40, 42 AND 50).

FIRST USE 3-1-2014; IN COMMERCE 3-1-2014.

EVIN L. KOZAK, EXAMINING ATTORNEY

SN 86-232,199. NACHISON, MALKA, LAKEWOOD, NJ. FILED 3-26-2014.

# ANMOUR

THE MARK CONSISTS OF THE LITERAL ELEMENT "ANMOUR" WITH TWO HEARTS IN PLACE OF THE "O"; A HEART INSIDE THE CENTER OF THE "R".

FOR HAIR ACCESSORIES, NAMELY, HAIR TIES, HAIR SCRUNCHIES, HEAD RIBBONS, HAIRBANDS, HAIR CLIPS, HAIR BOWS (U.S. CLS. 37, 39, 40, 42 AND 50).

ELLEN BURNS, EXAMINING ATTORNEY

SN 86-242,388. KISSLETOE, LLC, PARK CITY, UT. FILED 4-4-2014.

# KISSLETOE

THE MARK CONSISTS OF STANDARD CHARACTERS WITHOUT CLAIM TO ANY PARTICULAR FONT, STYLE, SIZE, OR COLOR.

FOR EMBROIDERED PATCHES FOR USE AS GOOD LUCK CHARMS (U.S. CLS. 37, 39, 40, 42 AND 50).

FIRST USE 3-28-2014; IN COMMERCE 3-29-2014.

THEODORE MCBRIDE, EXAMINING ATTORNEY



**CLASS 26—(Continued).**

SN 86-247,825. BAD TO THE BOWS, GREENSBORO, NC.  
FILED 4-9-2014.

**SUMMIT**

THE MARK CONSISTS OF STANDARD CHARACTERS  
WITHOUT CLAIM TO ANY PARTICULAR FONT, STYLE,  
SIZE, OR COLOR.

FOR HAIR BOWS (U.S. CLS. 37, 39, 40, 42 AND 50).  
FIRST USE 4-5-2014; IN COMMERCE 4-5-2014.  
PAUL CROWLEY, EXAMINING ATTORNEY

SN 86-249,176. BAD TO THE BOWS, GREENSBORO, NC.  
FILED 4-11-2014.

**WORLDS**

THE MARK CONSISTS OF STANDARD CHARACTERS  
WITHOUT CLAIM TO ANY PARTICULAR FONT, STYLE,  
SIZE, OR COLOR.

FOR HAIR BOWS (U.S. CLS. 37, 39, 40, 42 AND 50).  
FIRST USE 2-24-2013; IN COMMERCE 2-24-2013.  
PAUL CROWLEY, EXAMINING ATTORNEY

SN 86-249,970. CONAIR CORPORATION, STAMFORD, CT.  
FILED 4-11-2014.

**Everyday & Active**

THE MARK CONSISTS OF STANDARD CHARACTERS  
WITHOUT CLAIM TO ANY PARTICULAR FONT, STYLE,  
SIZE, OR COLOR.

OWNER OF U.S. REG. NO. 3,900,634.  
FOR HAIR ACCESSORIES, NAMELY, TWISTERS;  
HAIR BANDS; HAIR ELASTICS; HAIR ORNAMENTS  
IN THE NATURE OF HAIR WRAPS; HAIR SCRUN-  
CHIES; PONYTAIL HOLDERS (U.S. CLS. 37, 39, 40, 42  
AND 50).

FIRST USE 1-27-2014; IN COMMERCE 1-27-2014.  
KRISTINA MORRIS, EXAMINING ATTORNEY

**CLASS 26—(Continued).**

SN 86-261,789. THOSE CHARACTERS FROM CLEVELAND,  
INC., CLEVELAND, OH. FILED 4-24-2014.

**CARE BEARS**

THE MARK CONSISTS OF STANDARD CHARACTERS  
WITHOUT CLAIM TO ANY PARTICULAR FONT, STYLE,  
SIZE, OR COLOR.

OWNER OF U.S. REG. NOS. 1,270,509, 3,767,824 AND  
OTHERS.

NO CLAIM IS MADE TO THE EXCLUSIVE RIGHT TO  
USE "BEARS", APART FROM THE MARK AS SHOWN.

FOR BARRETTES; HAIR ACCESSORIES, NAMELY,  
CLAW CLIPS; HAIR BOWS; PONYTAIL HOLDERS AND  
HAIR RIBBONS (U.S. CLS. 37, 39, 40, 42 AND 50).

LESLIE RICHARDS, EXAMINING ATTORNEY

**CLASS 27—FLOOR COVERINGS**

SN 79-145,156. REBEL WALLS AB, SWEDEN, FILED 12-30-  
2013.

**Rebel Walls**

THE MARK CONSISTS OF STANDARD CHARACTERS  
WITHOUT CLAIM TO ANY PARTICULAR FONT, STYLE,  
SIZE, OR COLOR.

PRIORITY DATE OF 9-17-2013 IS CLAIMED.  
OWNER OF INTERNATIONAL REGISTRATION 1198430  
DATED 12-30-2013, EXPIRES 12-30-2023.

NO CLAIM IS MADE TO THE EXCLUSIVE RIGHT TO  
USE "WALLS", APART FROM THE MARK AS SHOWN.

FOR WALLPAPERS (U.S. CLS. 19, 20, 37, 42 AND 50).  
SAIMA MAKHDOOM, EXAMINING ATTORNEY

SN 86-025,459. STUSSY, INC., IRVINE, CA. FILED 7-31-2013.

**STUSSY**

THE MARK CONSISTS OF STANDARD CHARACTERS  
WITHOUT CLAIM TO ANY PARTICULAR FONT, STYLE,  
SIZE, OR COLOR.

OWNER OF U.S. REG. NOS. 3,112,126, 4,410,371 AND  
OTHERS.

SEC. 2(F).  
FOR DOOR MATS; DOOR MATS OF TEXTILE; RUGS  
(U.S. CLS. 19, 20, 37, 42 AND 50).

FIRST USE 6-29-2013; IN COMMERCE 6-29-2013.  
WANDA KAY PRICE, EXAMINING ATTORNEY



**CLASS 27—(Continued).**

SN 86-087,726. WELSPUN INDIA LIMITED, MUMBAI, INDIA, FILED 10-9-2013.

**SOFT & ALWAYS**

THE MARK CONSISTS OF STANDARD CHARACTERS WITHOUT CLAIM TO ANY PARTICULAR FONT, STYLE, SIZE, OR COLOR.

NO CLAIM IS MADE TO THE EXCLUSIVE RIGHT TO USE "SOFT", APART FROM THE MARK AS SHOWN.

FOR AREA RUGS; BATH MATS; RUGS (U.S. CLS. 19, 20, 37, 42 AND 50).

JEAN IM, EXAMINING ATTORNEY

SN 86-167,668. PEANUTS WORLDWIDE LLC, NEW YORK, NY. FILED 1-16-2014.



OWNER OF U.S. REG. NOS. 1,256,900, 1,267,166 AND OTHERS.

THE MARK CONSISTS OF TWO PARTIALLY OBSCURED STYLIZED DOG FACES MOSTLY WITHIN A SQUARE WITH THE AMPERSAND SYMBOL BETWEEN THE DOG FACES, THE WORDING "SNOOPY" ALONG THE LEFT SIDE OF THE SQUARE, AND THE WORDING "HIS SISTER BELLE" ALONG THE RIGHT SIDE OF THE SQUARE.

FOR BATH MATS; CARPETS; FLOOR MATS; NON-TEXTILE WALL HANGINGS; RUGS; WALL PAPER; WALLCOVERINGS (U.S. CLS. 19, 20, 37, 42 AND 50).

MIAH ROSENBERG, EXAMINING ATTORNEY

SN 86-245,429. HOME CONCEPT, INC., WATERTOWN, WI. FILED 4-8-2014.

**HOMECONCEPT**

THE MARK CONSISTS OF STANDARD CHARACTERS WITHOUT CLAIM TO ANY PARTICULAR FONT, STYLE, SIZE, OR COLOR.

OWNER OF U.S. REG. NOS. 1,960,980 AND 3,429,425.

FOR ANTI-FATIGUE FLOOR MATS (U.S. CLS. 19, 20, 37, 42 AND 50).

DEBORAH LOBO, EXAMINING ATTORNEY

**CLASS 27—(Continued).**

SN 86-247,819. HUIDONG WEIKANG RUBBER AND PLASTIC PRODUCTS CO.,LTD., GUANGDONG PROVINCE, CHINA, FILED 4-9-2014.



THE MARK CONSISTS OF STYLIZED WORD "ROCOCO" AND THERE ARE THREE CHINESE CHARACTERS UNDER WORD "ROCOCO".

THE ENGLISH TRANSLATION OF "LUO KE KE" IN THE MARK IS "ROCOCO".

THE NON-LATIN CHARACTERS IN THE MARK TRANSLITERATE TO "LUO KE KE" AND THIS MEANS "ROCOCO" IN ENGLISH.

FOR ARTIFICIAL TURF; BATH MATS; CARPET UNDERLAY; DOOR MATS; FLOOR COVERINGS; GYMNASIUM EXERCISE MATS; GYMNASIUM MATS; LINOLEUM; MATS OF WOVEN ROPE FOR CREATING SKI SLOPE SURFACES; NON-SLIP MATS FOR BATHS; VEHICLE CARPETS; VINYL FLOOR COVERINGS (U.S. CLS. 19, 20, 37, 42 AND 50).

JENNIFER MARTIN, EXAMINING ATTORNEY

**CLASS 28—TOYS AND SPORTING GOODS**

SN 79-127,977. MARKETING 360° S.R.L., 60019 SENIGALLIA (AN), SAN MARINO, FILED 1-31-2013.



OWNER OF INTERNATIONAL REGISTRATION 1154746 DATED 1-31-2013, EXPIRES 1-31-2023.

THE NAME(S), PORTRAIT(S), AND/OR SIGNATURE(S) SHOWN IN THE MARK DOES NOT IDENTIFY A PARTICULAR LIVING INDIVIDUAL.

THE MARK CONSISTS OF THE STYLIZED WORDING "TOM" WRITTEN IN A HANDWRITING STYLE WITH THE WORDING "CARUSO" APPEARING IN SMALL LETTERING UNDER THE LETTER "M".

FOR GOODS AND APPLIANCES FOR GYMNASICS AND SPORTS, IN PARTICULAR FOR BEACH TENNIS, SURFING, SKATEBOARDING, SNOWBOARDING, KITE SURFING AND WINDSURFING, NAMELY, HAND GRIPS FOR SPORTS EQUIPMENT, TENNIS BALLS, WEIGHTS FOR TENNIS RACKETS, SURFBOARDS, TENNIS RACKETS, SKATEBOARDS, GYMNASIUM EQUIPMENT, BAGS SPECIALLY ADAPTED FOR SPORTS EQUIPMENT; FISHING TACKLE (U.S. CLS. 22, 23, 38 AND 50).

HOWARD B. LEVINE, EXAMINING ATTORNEY

**CLASS 28—(Continued).**

SN 79-135,356. SIEPER LÜDENSCHIED GMBH & CO. KG, 58511 LÜDENSCHIED, FED REP GERMANY, FILED 7-16-2013.

# SIKUWORLD

THE MARK CONSISTS OF STANDARD CHARACTERS WITHOUT CLAIM TO ANY PARTICULAR FONT, STYLE, SIZE, OR COLOR.

PRIORITY DATE OF 1-25-2013 IS CLAIMED.

OWNER OF INTERNATIONAL REGISTRATION 1173546 DATED 7-16-2013, EXPIRES 7-16-2023.

FOR BOARD GAMES, TOY CARDS, NAMELY, PLAYING CARDS, TOY MODEL CARS, DIE-CAST MODELS, NAMELY, DIE-CAST TOY MODELS (U.S. CLS. 22, 23, 38 AND 50).

DOUGLAS LEE, EXAMINING ATTORNEY

SN 79-137,072. SIEPER LÜDENSCHIED GMBH & CO. KG, 58511 LÜDENSCHIED, FED REP GERMANY, FILED 7-24-2013.

# SIKURacing

THE MARK CONSISTS OF STANDARD CHARACTERS WITHOUT CLAIM TO ANY PARTICULAR FONT, STYLE, SIZE, OR COLOR.

PRIORITY DATE OF 5-24-2013 IS CLAIMED.

OWNER OF INTERNATIONAL REGISTRATION 1177939 DATED 7-24-2013, EXPIRES 7-24-2023.

FOR BOARD GAMES, TOY CARDS, NAMELY, PLAYING CARDS, TOY MODEL CARS, DIE-CAST MODELS, NAMELY, DIE-CAST TOY MODELS (U.S. CLS. 22, 23, 38 AND 50).

DOUGLAS LEE, EXAMINING ATTORNEY

SN 79-141,370. UNIVERSAL ENTERTAINMENT CORPORATION, TOKYO, JAPAN, FILED 11-12-2013.

# CYBER SEVEN

PRIORITY DATE OF 11-1-2013 IS CLAIMED.

OWNER OF INTERNATIONAL REGISTRATION 1189209 DATED 11-12-2013, EXPIRES 11-12-2023.

NO CLAIM IS MADE TO THE EXCLUSIVE RIGHT TO USE "CYBER", APART FROM THE MARK AS SHOWN.

FOR GAMING MACHINES; GAMING MACHINES WITH MULTI-TERMINALS; HOME VIDEO GAME MACHINES; MAGNETIC CARD OPERATED ARCADE VIDEO GAME MACHINES; ARCADE VIDEO GAME MACHINES WITH MULTI-TERMINALS; ARCADE VIDEO GAME MACHINES; SLOT MACHINES; COIN-OPERATED ARCADE VIDEO GAME MACHINES; HAND-HELD GAMES WITH LIQUID CRYSTAL DISPLAYS (U.S. CLS. 22, 23, 38 AND 50).

COLLEEN MULCRONE, EXAMINING ATTORNEY

**CLASS 28—(Continued).**

SN 79-147,603. ZHEJIANG RAYTHEON TECHNOLOGY CO., LTD., CHINA, FILED 2-27-2014.

# MBB

OWNER OF INTERNATIONAL REGISTRATION 1204834 DATED 2-27-2014, EXPIRES 2-27-2024.

THE MARK CONSISTS OF THE STYLIZED LETTERS "MBB".

FOR CONJURING APPARATUS, NAMELY, MAGIC TRICKS; TOY SCOOTERS; BODY-TRAINING APPARATUS; HANG GLIDERS; CHEST EXPANDERS; BODY-TRAINING TONER EXERCISE APPARATUS; MACHINES FOR PHYSICAL EXERCISES, NAMELY, ROWING MACHINES; APPLIANCES FOR GYMNASTICS; SKATEBOARDS; SPRING BOARDS BEING SPORTS ARTICLES (U.S. CLS. 22, 23, 38 AND 50).

BERNICE MIDDLETON, EXAMINING ATTORNEY

SN 79-148,645. UNIVERSAL ENTERTAINMENT CORPORATION, JAPAN, FILED 4-9-2014.

# SAMURAI DRAGON

PRIORITY DATE OF 3-28-2014 IS CLAIMED.

OWNER OF INTERNATIONAL REGISTRATION 1207500 DATED 4-9-2014, EXPIRES 4-9-2024.

FOR GAMING MACHINES; GAMING MACHINES WITH MULTI-TERMINALS; HOME VIDEO GAME MACHINES; MAGNETIC CARD OPERATED ARCADE VIDEO GAME MACHINES; ARCADE VIDEO GAME MACHINES WITH MULTI-TERMINALS; ARCADE VIDEO GAME MACHINES; SLOT MACHINES; COIN-OPERATED ARCADE VIDEO GAME MACHINES; HAND-HELD GAMES WITH LIQUID CRYSTAL DISPLAYS (U.S. CLS. 22, 23, 38 AND 50).

LINDA MICKLEBURGH, EXAMINING ATTORNEY

SN 85-278,009. HOUR OF THE JACKAL GAMES, LLC, UNIVERSITY PLACE, WA, FILED 3-27-2011.

# Z DAY SURVIVOR

THE MARK CONSISTS OF STANDARD CHARACTERS WITHOUT CLAIM TO ANY PARTICULAR FONT, STYLE, SIZE, OR COLOR.

FOR BOARD GAMES (U.S. CLS. 22, 23, 38 AND 50).

FIRST USE 5-11-2010; IN COMMERCE 1-1-2011.

INGRID C. EULIN, EXAMINING ATTORNEY

**CLASS 28—(Continued).**

SN 85-845,932. WARIFU, LLC, SAN FRANCISCO, CA. FILED 2-11-2013.

**WARIFU**

THE MARK CONSISTS OF STANDARD CHARACTERS WITHOUT CLAIM TO ANY PARTICULAR FONT, STYLE, SIZE, OR COLOR.

THE ENGLISH TRANSLATION OF "WARIFU" IN THE MARK IS "TALLIES".

FOR BOARD GAME (U.S. CLS. 22, 23, 38 AND 50).  
MICHAEL P EISNACH, EXAMINING ATTORNEY

SN 85-890,494. THE MAYA GROUP, INC., TORRANCE, CA. FILED 3-29-2013.

**MAYA GROUP**

THE MARK CONSISTS OF STANDARD CHARACTERS WITHOUT CLAIM TO ANY PARTICULAR FONT, STYLE, SIZE, OR COLOR.

NO CLAIM IS MADE TO THE EXCLUSIVE RIGHT TO USE "GROUP", APART FROM THE MARK AS SHOWN.

FOR TOYS AND SPORTING GOODS, NAMELY, TOY VEHICLES, REMOTE CONTROL TOY VEHICLES, TOY GUNS, TOY WEAPONS, SOFT-PROJECTILE TOY LAUNCHERS, TOY JEWELRY MAKING KITS, TOY HAIR-PLAY KITS, TOY WATER GLOBES, TOY LAUNCHERS DESIGNED TO LAUNCH TOY AMMUNITION MADE FROM A SUPER ABSORBENT POLYMER, TOY JEWELRY MAKING KITS INCORPORATING SUPER ABSORBENT POLYMERS, TOY AMMUNITION MADE OF SUPER ABSORBENT POLYMERS, AND TOYS INCORPORATING SUPER ABSORBENT POLYMER SPHERES IN THE NATURE OF PLAY SETS FOR ACTION FIGURES, TOY WEAPONS, AND TOY GUNS (U.S. CLS. 22, 23, 38 AND 50).

FIRST USE 2-1-1992; IN COMMERCE 2-1-1992.  
ALICIA COLLINS, EXAMINING ATTORNEY

SN 85-922,744. MUELLER SPORTS MEDICINE, INC., PRAIRIE DU SAC, WI. FILED 5-3-2013.

**MATRIX**

THE MARK CONSISTS OF STANDARD CHARACTERS WITHOUT CLAIM TO ANY PARTICULAR FONT, STYLE, SIZE, OR COLOR.

FOR MOUTH GUARDS FOR ATHLETIC USE (U.S. CLS. 22, 23, 38 AND 50).

FIRST USE 6-20-2013; IN COMMERCE 6-20-2013.  
GRETTA YAO, EXAMINING ATTORNEY

**CLASS 28—(Continued).**

SN 85-922,761. MUELLER SPORTS MEDICINE, INC., PRAIRIE DU SAC, WI. FILED 5-3-2013.

**MUELLER MATRIX**

THE MARK CONSISTS OF STANDARD CHARACTERS WITHOUT CLAIM TO ANY PARTICULAR FONT, STYLE, SIZE, OR COLOR.

OWNER OF U.S. REG. NOS. 1,485,883, 3,698,099 AND OTHERS.

FOR MOUTH GUARDS FOR ATHLETIC USE (U.S. CLS. 22, 23, 38 AND 50).

FIRST USE 6-20-2013; IN COMMERCE 6-20-2013.  
GRETTA YAO, EXAMINING ATTORNEY

SN 85-969,174. GODOGGO, INC., GIG HARBOR, WA. FILED 6-25-2013.

**Fetch Machine**

THE MARK CONSISTS OF STANDARD CHARACTERS WITHOUT CLAIM TO ANY PARTICULAR FONT, STYLE, SIZE, OR COLOR.

NO CLAIM IS MADE TO THE EXCLUSIVE RIGHT TO USE "MACHINE", APART FROM THE MARK AS SHOWN. SEC. 2(F).

FOR PET TOY IN THE NATURE OF A MECHANICAL BALL LAUNCHER FOR PROPELLING OBJECTS TO BE CAUGHT AND RETRIEVED BY DOGS (U.S. CLS. 22, 23, 38 AND 50).

FIRST USE 9-1-1999; IN COMMERCE 3-1-2000.  
VIVIAN MICZNIK FIRST, EXAMINING ATTORNEY

SN 86-005,544. LRMD HOLDINGS PTY LTD., ACT, AUSTRALIA, FILED 7-9-2013.

**CADDYRACK**

THE MARK CONSISTS OF STANDARD CHARACTERS WITHOUT CLAIM TO ANY PARTICULAR FONT, STYLE, SIZE, OR COLOR.

PRIORITY CLAIMED UNDER SEC. 44(D) ON CANADA APPLICATION NO. 1613470, FILED 2-6-2013, REG. NO. 1497850, DATED 6-22-2012, EXPIRES 6-22-2022.

FOR (BASED ON 44(E)) COVERS FOR GOLF CLUB HEADS; GOLF APPARATUS, NAMELY, GOLF CLUB ORGANIZERS; GOLF CLUB BAGS; (BASED ON 44(D) PRIORITY APPLICATION) GOLF BAGS AND PARTS AND ACCESSORIES THEREFOR, NAMELY, GOLF CLUB ORGANIZERS (U.S. CLS. 22, 23, 38 AND 50).

ADA HAN, EXAMINING ATTORNEY

**CLASS 28—(Continued).**

SN 86-009,477. CURSHELLAS, LISA, GENEVA, IL. FILED 7-12-2013.



THE COLOR(S) RED, BROWN, BLACK, AND WHITE IS/ARE CLAIMED AS A FEATURE OF THE MARK.

THE MARK CONSISTS OF THE FOLLOWING: THE WORDING "MISSION UNBOXABLE THINK OUTSIDE THE BOX" AND DESIGN OF A SPY PEEKING OUT OF A BOX WHEREIN THE TERM "MISSION" IS IN THE COLOR RED AND THE LETTER "O" IS REPRESENTED BY THE DESIGN OF A SPY IN BLACK WITH WHITE EYES PEEKING OUT OF A BROWN BOX, THE TERM "UNBOXABLE" IS IN THE COLOR BROWN AND THE WORDING "THINK OUTSIDE THE BOX" APPEARS IN THE COLOR BLACK.

FOR HOBBY CRAFT IN THE NATURE OF A TOY SPY SET COMPRISING PRINTED MISSIONS, DISGUISES, MESSAGE DECODERS, WRITING INSTRUMENTS AND CRAYONS, NOTEBOOKS, TOY FINGERPRINT LIFTING EQUIPMENT, SECRET AGENT BADGES, MAGNIFYING GLASSES, BRIEFCASES, BINOCULARS, BALLOON CAR RACERS, BOUNCY BALLS, FLYING DISKS, TOY WORM, TOY BRACELETS AND HANDCUFFS, GAME BOARDS, INVENTOR KIT THAT INCLUDES FINGER LIGHT, PAPERCLIPS, WOODEN CRAFT STICKS, PIPE CLEANERS, FOAM PAPER, AND RUBBER BANDS, ALL SOLD AS A UNIT (U.S. CLS. 22, 23, 38 AND 50).

FIRST USE 6-21-2013; IN COMMERCE 6-21-2013.  
KAREN BRACEY, EXAMINING ATTORNEY

SN 86-010,231. PLAYMATES TOYS, INC., EL SEGUNDO, CA. FILED 7-15-2013.

# NANO

THE MARK CONSISTS OF STANDARD CHARACTERS WITHOUT CLAIM TO ANY PARTICULAR FONT, STYLE, SIZE, OR COLOR.

FOR DOLLS AND RELATED DOLL ACCESSORIES (U.S. CLS. 22, 23, 38 AND 50).

TASHIA BUNCH, EXAMINING ATTORNEY

**CLASS 28—(Continued).**

SN 86-018,351. SHWARTZMAN, IAN, SAN BERNARDINO, CA. FILED 7-24-2013.



NO CLAIM IS MADE TO THE EXCLUSIVE RIGHT TO USE "STROKE", APART FROM THE MARK AS SHOWN.

THE COLOR(S) YELLOW, RED AND BLACK IS/ARE CLAIMED AS A FEATURE OF THE MARK.

THE MARK CONSISTS OF THREE HORIZONTAL TRIANGLES. TWO ARE IN RED AND ONE IS IN YELLOW, AND ALL TRIANGLES ARE OUTLINED IN BLACK. THE TRIANGLES COME TO A POINT. NEXT TO THE POINT ARE THE STYLIZED TERMS "BULLET STROKE" IN BLACK FONT.

FOR SPORTS TRAINING DEVICES IN THE NATURE OF HOLLOW, WEIGHTED METAL TUBES FOR BASEBALL AND TENNIS FOR LEARNING, PRACTICING, AND IMPROVING FOCUS, TEMPO, SWING PLANE, IMPACT POSITION, AND BALL STRIKING ACCURACY; SPORTS TRAINING DEVICES IN THE NATURE OF HOLLOW, WEIGHTED METAL TUBES FOR MARTIAL ARTS FOR LEARNING, PRACTICING, AND IMPROVING HAND STRIKES, TORSO STRENGTHENING MOVES, FOCUS, AND IMPACT POSITION (U.S. CLS. 22, 23, 38 AND 50).

FIRST USE 4-15-2011; IN COMMERCE 4-15-2011.  
MARYNELLE WILSON, EXAMINING ATTORNEY

SN 86-029,794. MARVEL CHARACTERS, INC., BURBANK, CA. FILED 8-6-2013.

# STARK INDUSTRIES

THE MARK CONSISTS OF STANDARD CHARACTERS WITHOUT CLAIM TO ANY PARTICULAR FONT, STYLE, SIZE, OR COLOR.

OWNER OF U.S. REG. NOS. 4,032,090 AND 4,127,017.

FOR ACTION SKILL GAMES; ACTION FIGURES AND ACCESSORIES THEREFOR; ARCADE GAMES; BOARD GAMES; CARD GAMES; CHILDREN'S MULTIPLE ACTIVITY TOYS; BADMINTON SETS; BALLOONS; BASKETBALLS; BATH TOYS; BASEBALL BATS; BASEBALLS; BEACH BALLS; BEAN BAGS; BEAN BAG DOLLS; BOBBLEHEAD DOLLS; BOWLING BALLS; BUBBLE MAKING WANDS AND SOLUTION SETS; CHESS SETS; CHILDREN'S PLAY COSMETICS; CHRISTMAS STOCKINGS; CHRISTMAS TREE ORNAMENTS AND DECORATIONS; COIN-OPERATED VIDEO GAMES; COLLECTABLE TOY FIGURES; CRIB MOBILES; CRIB TOYS; DISC TOSS TOYS; DOLLS; DOLL CLOTHING; DOLL ACCESSORIES; DOLL PLAYSETS; ELBOW PADS FOR ATHLETIC USE; ELECTRIC ACTION TOYS; EQUIPMENT SOLD AS A UNIT FOR PLAYING CARD GAMES; FISHING TACKLE; FLYING DISCS; FOOTBALLS; GOLF BALLS; GOLF GLOVES; GOLF BALL

**CLASS 28—(Continued).**

MARKERS; HAND-HELD UNITS FOR PLAYING ELECTRONIC GAMES OTHER THAN THOSE ADAPTED FOR USE WITH OR WITHOUT AN EXTERNAL DISPLAY SCREEN OR MONITOR; HOCKEY PUCKS; HOCKEY STICKS; INFANT TOYS; INFLATABLE TOYS; JIGSAW PUZZLES; JUMP ROPES; KITES; KNEE GUARDS FOR ATHLETIC USE; MAGIC TRICKS; MARBLES; MANIPULATIVE GAMES; MECHANICAL TOYS; MUSIC BOX TOYS; MUSICAL TOYS; PARLOR GAMES; PARTY FAVORS IN THE NATURE OF SMALL TOYS; PAPER PARTY HATS; PARTY GAMES; PINBALL GAMES; PLAYING CARDS; PLUSH TOYS; PUPPETS; ROLLER SKATES; RUBBER BALLS; SKATEBOARDS; SNOW BOARDS; SNOW GLOBES; SOCCER BALLS; SPINNING TOPS; SQUEEZE TOYS; STUFFED TOYS; SWIM BOARDS FOR RECREATIONAL USE; TABLE TENNIS BALLS; TABLE TENNIS PADDLES AND RACKETS; TABLE TENNIS TABLES; TALKING TOYS; TARGET GAMES; TEDDY BEARS; TENNIS BALLS; TENNIS RACKETS; TOY ACTION FIGURES AND ACCESSORIES THEREFOR; TOY BUCKET AND SHOVEL SETS; TOY BUILDING BLOCKS; TOY MOBILES; TOY VEHICLES; TOY SCOOTERS; TOY CARS; TOY MODEL HOBBY-CRAFT KITS; TOY FIGURES; TOY BANKS; TOY TRUCKS; TOY WATCHES; TOY WEAPONS; VIDEO GAME MACHINES FOR USE WITH TELEVISIONS; VOLLEY BALLS; WATER SQUIRTING TOYS; WIND-UP TOYS; YO-YOS (U.S. CLS. 22, 23, 38 AND 50).  
LOURDES AYALA, EXAMINING ATTORNEY

SN 86-043,249. KRAUSKO, LLC, RACINE, WI. FILED 8-20-2013.

# COLT

THE MARK CONSISTS OF STANDARD CHARACTERS WITHOUT CLAIM TO ANY PARTICULAR FONT, STYLE, SIZE, OR COLOR.

FOR SPORTING EQUIPMENT FOR BOXING AND MARTIAL ARTS, NAMELY, PADS FOR USE IN MARTIAL ARTS AND BOXING IN THE NATURE OF MARTIAL ARTS TRAINING DUMMIES, MARTIAL ARTS GRAPPLING DUMMIES, MARTIAL ARTS GRAPPLING SIMULATORS, MARTIAL ARTS HEAVY BAGS AND MARTIAL ARTS TRAINING BAGS AND TARGET PADS (U.S. CLS. 22, 23, 38 AND 50).  
JENNIFER RICHARDSON, EXAMINING ATTORNEY

SN 86-049,059. HOSTETLER, JOHN, SOMERS, CT. FILED 8-27-2013.

# GYM RAT

THE MARK CONSISTS OF STANDARD CHARACTERS WITHOUT CLAIM TO ANY PARTICULAR FONT, STYLE, SIZE, OR COLOR.

FOR SPORTS TRAINING APPARATUS, NAMELY, A SPORTS BALL SUPPORT DEVICE USEFUL IN TRAINING, SHOOTING, THROWING AND OTHER SPORTS TECHNIQUES (U.S. CLS. 22, 23, 38 AND 50).  
BRIAN CALLAGHAN, EXAMINING ATTORNEY

**CLASS 28—(Continued).**

SN 86-056,034. THE WILD GYM LLC, ERIE, CO. FILED 9-4-2013.

# MONKII

THE MARK CONSISTS OF STANDARD CHARACTERS WITHOUT CLAIM TO ANY PARTICULAR FONT, STYLE, SIZE, OR COLOR.

FOR MANUALLY-OPERATED EXERCISE EQUIPMENT (U.S. CLS. 22, 23, 38 AND 50).

FIRST USE 6-1-2013; IN COMMERCE 6-1-2013.  
LEE-ANNE BERNIS, EXAMINING ATTORNEY

SN 86-057,503. TW INTERNATIONAL INC., S. EL MONTE, CA. FILED 9-6-2013.

# DIMIAN

THE MARK CONSISTS OF STANDARD CHARACTERS WITHOUT CLAIM TO ANY PARTICULAR FONT, STYLE, SIZE, OR COLOR.

FOR TOY STROLLERS; TOY BEDS; TOY CRIBS; TOY WALKERS; TOY HIGH CHAIRS; TOY DOLLS; STUFFED ANIMALS; TOY ANIMALS; CHILDREN'S MULTIPLE ACTIVITY TOYS; TOY UTENSILS; TOY SHOPPING CARTS; TOY PLAY FOOD BOXES; TOY PET HOUSES; TOY FURNITURE; TOY IRONS; TOY CLOTHING, NAMELY, CLOTHING FOR DOLLS; TOY IRONING BOARDS; TOY BIB FOR DOLLS; TOY NURSERY BEDS; TOY TRAVEL BEDS; TOY TRANSPORT BAGS, NAMELY, CARRYING BAGS SPECIALLY ADAPTED FOR TOY VEHICLES (U.S. CLS. 22, 23, 38 AND 50).  
JAY FLOWERS, EXAMINING ATTORNEY

SN 86-057,683. LOU FRENCH, HOLIDAY HILLS, IL. FILED 9-6-2013.

## Pro Safety Skid Stabilizer

THE MARK CONSISTS OF STANDARD CHARACTERS WITHOUT CLAIM TO ANY PARTICULAR FONT, STYLE, SIZE, OR COLOR.

NO CLAIM IS MADE TO THE EXCLUSIVE RIGHT TO USE "SAFETY SKID STABILIZER", APART FROM THE MARK AS SHOWN.

FOR REMOTE CONTROL TOY GLIDER, AIRPLANE AND SAILPLANE EQUIPMENT, NAMELY, SKID STABILIZERS (U.S. CLS. 22, 23, 38 AND 50).

FIRST USE 9-5-2013; IN COMMERCE 9-5-2013.  
KATHRYN COWARD, EXAMINING ATTORNEY

**CLASS 28—(Continued).**

SN 86-059,084. MATTEL, INC., EL SEGUNDO, CA. FILED 9-9-2013.

**TURBO HEAT**

THE MARK CONSISTS OF STANDARD CHARACTERS WITHOUT CLAIM TO ANY PARTICULAR FONT, STYLE, SIZE, OR COLOR.

OWNER OF U.S. REG. NOS. 3,335,244, 3,474,764 AND OTHERS.

FOR TOY ACTION FIGURES AND ACCESSORIES THEREFOR (U.S. CLS. 22, 23, 38 AND 50).

BRIDGETT SMITH, EXAMINING ATTORNEY

---

SN 86-059,875. NAGY, ISTVAN, BOXBOROUGH, MA. FILED 9-9-2013.

**KAAWA - KAAWA**

THE MARK CONSISTS OF STANDARD CHARACTERS WITHOUT CLAIM TO ANY PARTICULAR FONT, STYLE, SIZE, OR COLOR.

FOR WAKEBOARDS (U.S. CLS. 22, 23, 38 AND 50).

KAREN BRACEY, EXAMINING ATTORNEY

---

SN 86-063,948. GUIDECRAFT, INC., WINTHROP, MN. FILED 9-13-2013.

**BETTER BUILDERS**

THE MARK CONSISTS OF STANDARD CHARACTERS WITHOUT CLAIM TO ANY PARTICULAR FONT, STYLE, SIZE, OR COLOR.

FOR CONSTRUCTION TOYS INCORPORATING MAGNETS; TOY BUILDING BLOCKS; TOY BUILDING BLOCKS CAPABLE OF INTERCONNECTION (U.S. CLS. 22, 23, 38 AND 50).

DANIEL S. STRINGER, EXAMINING ATTORNEY

**CLASS 28—(Continued).**

SN 86-067,664. KING SHOW GAMES, INC., MINNETONKA, MN. FILED 9-18-2013.

**BLAZING 21**

THE MARK CONSISTS OF STANDARD CHARACTERS WITHOUT CLAIM TO ANY PARTICULAR FONT, STYLE, SIZE, OR COLOR.

NO CLAIM IS MADE TO THE EXCLUSIVE RIGHT TO USE "21", APART FROM THE MARK AS SHOWN.

FOR ELECTRONIC GAMING MACHINES, NAMELY, DEVICES WHICH ACCEPT A WAGER; GAMING EQUIPMENT, NAMELY, SLOT MACHINES WITH OR WITHOUT VIDEO OUTPUT; GAMING MACHINES FEATURING A DEVICE THAT ACCEPTS WAGERS; GAMING MACHINES INCLUDING SLOT MACHINES OR VIDEO LOTTERY TERMINALS; GAMING MACHINES THAT GENERATE OR DISPLAY WAGER OUTCOMES; GAMING MACHINES, NAMELY SLOT MACHINES AND VIDEO LOTTERY TERMINALS; GAMING MACHINES, NAMELY, DEVICES WHICH ACCEPT A WAGER; GAMING MACHINES, NAMELY, ELECTRONIC SLOT AND BINGO MACHINES (U.S. CLS. 22, 23, 38 AND 50).

EUGENIA MARTIN, EXAMINING ATTORNEY

---

SN 86-067,684. KING SHOW GAMES, INC., MINNETONKA, MN. FILED 9-18-2013.

**BLAZING ROULETTE**

THE MARK CONSISTS OF STANDARD CHARACTERS WITHOUT CLAIM TO ANY PARTICULAR FONT, STYLE, SIZE, OR COLOR.

NO CLAIM IS MADE TO THE EXCLUSIVE RIGHT TO USE "ROULETTE", APART FROM THE MARK AS SHOWN.

FOR ELECTRONIC GAMING MACHINES, NAMELY, DEVICES WHICH ACCEPT A WAGER; GAMING DEVICES, NAMELY, GAMING MACHINES, SLOT MACHINES, BINGO MACHINES, WITH OR WITHOUT VIDEO OUTPUT; GAMING EQUIPMENT, NAMELY, SLOT MACHINES WITH OR WITHOUT VIDEO OUTPUT; GAMING MACHINES; GAMING MACHINES FEATURING A DEVICE THAT ACCEPTS WAGERS; GAMING MACHINES INCLUDING SLOT MACHINES OR VIDEO LOTTERY TERMINALS; GAMING MACHINES THAT GENERATE OR DISPLAY WAGER OUTCOMES; GAMING MACHINES, NAMELY SLOT MACHINES AND VIDEO LOTTERY TERMINALS; GAMING MACHINES, NAMELY, DEVICES WHICH ACCEPT A WAGER; GAMING MACHINES, NAMELY, ELECTRONIC SLOT AND BINGO MACHINES (U.S. CLS. 22, 23, 38 AND 50).

EUGENIA MARTIN, EXAMINING ATTORNEY

**CLASS 28—(Continued).**

SN 86-067,699. KING SHOW GAMES, INC., MINNETONKA, MN. FILED 9-18-2013.

**BLAZING BINGO**

THE MARK CONSISTS OF STANDARD CHARACTERS WITHOUT CLAIM TO ANY PARTICULAR FONT, STYLE, SIZE, OR COLOR.

NO CLAIM IS MADE TO THE EXCLUSIVE RIGHT TO USE "BINGO", APART FROM THE MARK AS SHOWN.

FOR ELECTRONIC GAMING MACHINES, NAMELY, DEVICES WHICH ACCEPT A WAGER; GAMING DEVICES, NAMELY, GAMING MACHINES, SLOT MACHINES, BINGO MACHINES, WITH OR WITHOUT VIDEO OUTPUT; GAMING EQUIPMENT, NAMELY, SLOT MACHINES WITH OR WITHOUT VIDEO OUTPUT; GAMING MACHINES FEATURING A DEVICE THAT ACCEPTS WAGERS; GAMING MACHINES INCLUDING SLOT MACHINES OR VIDEO LOTTERY TERMINALS; GAMING MACHINES THAT GENERATE OR DISPLAY WAGER OUTCOMES; GAMING MACHINES, NAMELY SLOT MACHINES AND VIDEO LOTTERY TERMINALS; GAMING MACHINES, NAMELY, DEVICES WHICH ACCEPT A WAGER; GAMING MACHINES, NAMELY, ELECTRONIC SLOT AND BINGO MACHINES (U.S. CLS. 22, 23, 38 AND 50).

EUGENIA MARTIN, EXAMINING ATTORNEY

**CLASS 28—(Continued).**

SN 86-081,111. HOBBYKINS, WAUKESHA, WI. FILED 10-2-2013.

**Venom Blowguns**

THE MARK CONSISTS OF STANDARD CHARACTERS WITHOUT CLAIM TO ANY PARTICULAR FONT, STYLE, SIZE, OR COLOR.

NO CLAIM IS MADE TO THE EXCLUSIVE RIGHT TO USE "BLOWGUNS", APART FROM THE MARK AS SHOWN.

FOR BLOWGUNS FOR RECREATIONAL SHOOTING OR HUNTING; SPORTS EQUIPMENT, NAMELY, PNEUMATIC DEVICE FOR PROPELLING PROJECTILES (U.S. CLS. 22, 23, 38 AND 50).

FIRST USE 3-1-2012; IN COMMERCE 3-1-2012.

KIMBERLY PERRY, EXAMINING ATTORNEY

SN 86-081,816. BLUE BOX TOY FACTORY LIMITED, KOWLOON, HONG KONG, FILED 10-3-2013.

**CRYSTAL PANDA**

THE MARK CONSISTS OF STANDARD CHARACTERS WITHOUT CLAIM TO ANY PARTICULAR FONT, STYLE, SIZE, OR COLOR.

PRIORITY CLAIMED UNDER SEC. 44(D) ON HONG KONG APPLICATION NO. 302577240, FILED 4-12-2013, REG. NO. 302577240, DATED 4-12-2013, EXPIRES 4-12-2023.

FOR TOY ACTION FIGURES; COLLECTABLE TOY FIGURES; TOY DOLLS; ACTION FIGURE DOLLS; ACCESSORIES FOR DOLLS; CLOTHING ACCESSORIES FOR DOLLS; PORTABLE GAMES WITH LIQUID CRYSTAL DISPLAYS; TOY HOUSES; TOY TENTS; TOY FURNITURE; TOY GARAGES; TOY JEWELRY; TOY TEA SETS; TOY COSMETICS; STUFFED TOY FIGURINES; AUTOMATIC AND COIN OPERATED AMUSEMENT MACHINES; TOY PUSHCHAIRS; TOY PLAY SETS, NAMELY, PLAY SETS FOR DOLLS; PLAY SETS FOR ACTION FIGURES, PLAY SETS FOR VEHICLES; ROLE PLAYING TOYS IN THE NATURE OF PLAY SETS FOR CHILDREN TO IMITATE REAL LIFE OCCUPATIONS; PARTS AND FITTINGS FOR THE AFORESAID GOODS (U.S. CLS. 22, 23, 38 AND 50).

ROGER T. MCDORMAN, EXAMINING ATTORNEY

SN 86-070,617. MATTEL, INC., EL SEGUNDO, CA. FILED 9-20-2013.

**FIGHT THE INVASION. SAVE EARTH.**

THE MARK CONSISTS OF STANDARD CHARACTERS WITHOUT CLAIM TO ANY PARTICULAR FONT, STYLE, SIZE, OR COLOR.

FOR TOY ACTION FIGURES AND ACCESSORIES THEREFOR, TOY ACTION FIGURE PLAYSETS AND ACCESSORIES THEREFOR, TOY VEHICLES AND ACCESSORIES THEREFOR, TOY VEHICLE PLAYSETS AND ACCESSORIES THEREFOR (U.S. CLS. 22, 23, 38 AND 50).

DANNEAN HETZEL, EXAMINING ATTORNEY

**CLASS 28—(Continued).**

SN 86-082,444. ARQEX OUTDOOR FITNESS SYSTEMS, LLC, RYE BROOK, NY. FILED 10-3-2013.



NO CLAIM IS MADE TO THE EXCLUSIVE RIGHT TO USE "OUTDOOR FITNESS", APART FROM THE MARK AS SHOWN.

THE COLOR(S) BLUE, BLACK AND WHITE IS/ARE CLAIMED AS A FEATURE OF THE MARK.

THE MARK CONSISTS OF A STYLIZED BLUE OVAL IN WHICH THE LOWER CURVES RISE UP TO FORM THE LETTER "X" IN THE CENTER OF THE OVAL. BELOW WHICH APPEARS THE WORD "ARQEX" WITH THE LETTERS IN BLACK WITH WHITE HIGHLIGHTING, AND THE "Q" IN BLUE. BELOW THAT IS THE WORDING "OUTDOOR FITNESS" IN PLAIN ALL-CAPS BLACK LETTERING. THE BACKGROUND OF THE MARK IS WHITE, AND IS NOT CLAIMED AS A FEATURE OF THE MARK.

FOR EXERCISE MACHINES (U.S. CLS. 22, 23, 38 AND 50).

KERI CANTONE, EXAMINING ATTORNEY

**CLASS 28—(Continued).**

SN 86-083,484. IMPERIAL TOY, LLC, NORTH HILLS, CA. FILED 10-4-2013.

**GOOGLY TOWN**

THE MARK CONSISTS OF STANDARD CHARACTERS WITHOUT CLAIM TO ANY PARTICULAR FONT, STYLE, SIZE, OR COLOR.

OWNER OF U.S. REG. NO. 3,265,527.

FOR GAMES AND PLAYTHINGS, NAMELY, INFLATABLE ELASTOMERIC TOYS IN THE SHAPE OF ANIMALS, INSECTS, FIGURINES, AND CREATURES, AND OTHER RECOGNIZABLE OBJECT SHAPES WHEN NOT IN A STRESSED OR STRETCHED STATE; ELASTOMERIC TOY JEWELRY, ELASTOMERIC HOLIDAY ORNAMENTS; AND ELASTOMERIC BALLS FOR PLAY (U.S. CLS. 22, 23, 38 AND 50).

MICHAEL TANNER, EXAMINING ATTORNEY

SN 86-083,404. SKYROCKET TOYS, LLC, VENICE, CA. FILED 10-4-2013.

**PRANK STAR**

THE MARK CONSISTS OF STANDARD CHARACTERS WITHOUT CLAIM TO ANY PARTICULAR FONT, STYLE, SIZE, OR COLOR.

NO CLAIM IS MADE TO THE EXCLUSIVE RIGHT TO USE "PRANK", APART FROM THE MARK AS SHOWN.

FOR ELECTRONIC ACTION TOYS; ELECTRONIC NOVELTY TOYS, NAMELY, TOYS THAT ELECTRONICALLY RECORD, PLAY BACK, AND DISTORT OR MANIPULATE VOICES AND SOUNDS; NOVELTY TOY ITEMS IN THE NATURE OF FAKE POO, SOUND/NOISE MAKERS FOR USE AS PRANKS AND GAGS; TALKING ELECTRONIC PRESS-DOWN TOY; TOY AND NOVELTY FACE MASKS; TOY NOISEMAKERS; WATER SQUIRTING TOYS (U.S. CLS. 22, 23, 38 AND 50).

FIRST USE 9-0-2013; IN COMMERCE 9-0-2013.

TASHIA BUNCH, EXAMINING ATTORNEY

SN 86-085,129. HELIGEAR ENGINEERING (HK) COMPANY LIMITED, NEW TERRITORIES, HONG KONG, FILED 10-8-2013.

**AIRY ROTOR**

THE MARK CONSISTS OF STANDARD CHARACTERS WITHOUT CLAIM TO ANY PARTICULAR FONT, STYLE, SIZE, OR COLOR.

THE WORDING "AIRY ROTOR" HAS NO MEANING IN A FOREIGN LANGUAGE.

FOR ARTIFICIAL FISHING BAIT; BITE INDICATORS; BITE SENSORS; FISHING CREELS; FISHING HOOKS; FISHING REELS; FISHING TACKLE; FLOATS FOR FISHING; GUT FOR FISHING; LANDING NETS FOR ANGLERS; LINES FOR FISHING; LURES FOR HUNTING OR FISHING; REELS FOR FISHING; RODS FOR FISHING; SCENT LURES FOR HUNTING OR FISHING (U.S. CLS. 22, 23, 38 AND 50).

KELLY BOULTON, EXAMINING ATTORNEY



**CLASS 28—(Continued).**

SN 86-090,581. ARISTOCRAT TECHNOLOGIES AUSTRALIA PTY LTD., NORTH RYDE, NSW, AUSTRALIA, FILED 10-14-2013.

**PRETTY BIRD**

THE MARK CONSISTS OF STANDARD CHARACTERS WITHOUT CLAIM TO ANY PARTICULAR FONT, STYLE, SIZE, OR COLOR.

PRIORITY CLAIMED UNDER SEC. 44(D) ON AUSTRALIA APPLICATION NO. 1583442, FILED 10-1-2013, REG. NO. 1583442, DATED 5-5-2014, EXPIRES 10-1-2023.

OWNER OF U.S. REG. NOS. 2,668,306 AND 3,059,297. FOR ELECTRONIC GAMING MACHINES, NAMELY, DEVICES WHICH ACCEPT A WAGER (U.S. CLS. 22, 23, 38 AND 50).

JEAN IM, EXAMINING ATTORNEY

---

SN 86-091,542. ARISTOCRAT TECHNOLOGIES AUSTRALIA PTY LTD., NORTH RYDE, NSW, AUSTRALIA, FILED 10-15-2013.

**IDOL RICHES**

THE MARK CONSISTS OF STANDARD CHARACTERS WITHOUT CLAIM TO ANY PARTICULAR FONT, STYLE, SIZE, OR COLOR.

OWNER OF AUSTRALIA REG. NO. 1585500, DATED 10-11-2013, EXPIRES 10-11-2023.

OWNER OF U.S. REG. NOS. 3,528,188, 3,836,909 AND OTHERS.

FOR ELECTRONIC GAMING MACHINES, NAMELY, DEVICES WHICH ACCEPT A WAGER (U.S. CLS. 22, 23, 38 AND 50).

JEAN IM, EXAMINING ATTORNEY

---

SN 86-094,354. JAY FRANCO & SONS, INC., NEW YORK, NY. FILED 10-17-2013.

**TWISTY**

THE MARK CONSISTS OF STANDARD CHARACTERS WITHOUT CLAIM TO ANY PARTICULAR FONT, STYLE, SIZE, OR COLOR.

OWNER OF U.S. REG. NO. 3,731,727. FOR STUFFED TOY ANIMAL WITH ELECTRIC LIGHT ATTACHED TO THE TAIL (U.S. CLS. 22, 23, 38 AND 50).

DOMINICK J. SALEMI, EXAMINING ATTORNEY

**CLASS 28—(Continued).**

SN 86-097,376. SKYROCKET TOYS, LLC, VENICE, CA. FILED 10-21-2013.

**NANO WARS**

THE MARK CONSISTS OF STANDARD CHARACTERS WITHOUT CLAIM TO ANY PARTICULAR FONT, STYLE, SIZE, OR COLOR.

FOR REMOTE CONTROL TOYS, NAMELY, NAMELY, CARS, TRUCKS, TANKS AND OTHER VEHICLES IN THE NATURE OF ACTION AND ADVENTURE, MILITARY, FUTURISTIC AND COMBAT STYLE VEHICLES (U.S. CLS. 22, 23, 38 AND 50).

TASHIA BUNCH, EXAMINING ATTORNEY

---

SN 86-105,495. ARISTOCRAT TECHNOLOGIES AUSTRALIA PTY LTD., NORTH RYDE, NSW, AUSTRALIA, FILED 10-30-2013.

**GOLD POWER REELS**

THE MARK CONSISTS OF STANDARD CHARACTERS WITHOUT CLAIM TO ANY PARTICULAR FONT, STYLE, SIZE, OR COLOR.

PRIORITY CLAIMED UNDER SEC. 44(D) ON AUSTRALIA APPLICATION NO. 1587913, FILED 10-25-2013, REG. NO. 1587913, DATED 10-25-2013, EXPIRES 10-25-2023.

NO CLAIM IS MADE TO THE EXCLUSIVE RIGHT TO USE "REELS", APART FROM THE MARK AS SHOWN.

FOR ELECTRONIC GAMING MACHINES, NAMELY, DEVICES WHICH ACCEPT A WAGER (U.S. CLS. 22, 23, 38 AND 50).

JEAN IM, EXAMINING ATTORNEY

**CLASS 28—(Continued).**

SN 86-107,582. GOLAD, ADAR, HATTEM, NETHERLANDS, FILED 11-1-2013.



THE COLOR(S) RED, YELLOW, WHITE, BLACK, AND GRAY ARE CLAIMED AS A FEATURE OF THE MARK IS/ ARE CLAIMED AS A FEATURE OF THE MARK.

THE MARK CONSISTS OF A RED SQUARE SURROUNDED BY A GRAY BORDER, SHOWING THE WORDING "GOLIATH" IN WHITE OUTLINED WITH BLACK SHADOW; A YELLOW DICE OUTLINED IN BLACK SHOWING FIVE BLACK DOTS IS ABOVE THE WORDING AS THE DOT ON THE LETTER "I" OF THE WORD "GOLIATH".

FOR ACTION SKILL GAMES; ACTION TARGET GAMES; ACTION-TYPE TARGET GAMES; ARROWS; BOARD GAMES; BUILDING GAMES; CARD GAMES; COLLECTABLE TOY FIGURES; CROSSBOWS; EDUCATIONAL CARD GAMES; GAME CARDS; MUSICAL TOYS; PARLOUR GAMES; PARTY GAMES; PLAYING CARDS AND CARD GAMES; PLUSH TOYS; PUZZLE GAMES; RING GAMES; TARGET GAMES; TOY BOWS AND ARROWS; TRIVIA GAME PLAYED WITH CARDS AND GAME COMPONENTS (U.S. CLS. 22, 23, 38 AND 50).

FIRST USE 11-5-2005; IN COMMERCE 2-1-2006.  
ALEX KEAM, EXAMINING ATTORNEY

SN 86-110,634. MORAIS, ALLEN WALTER JOSEPH, SHARQ, KUWAIT, FILED 11-5-2013.

**QIRIVER**

THE MARK CONSISTS OF STANDARD CHARACTERS WITHOUT CLAIM TO ANY PARTICULAR FONT, STYLE, SIZE, OR COLOR.

FOR YOGA MATS; YOGA BLOCKS; BAGS SPECIALLY ADAPTED TO CARRY YOGA EQUIPMENT, NAMELY, YOGA MAT BAGS; YOGA STRAPS; YOGA BOLSTERS; MEDITATION PILLOWS AND CUSHIONS (U.S. CLS. 22, 23, 38 AND 50).

MEREDITH MARESCA, EXAMINING ATTORNEY

**CLASS 28—(Continued).**

SN 86-117,863. RICH CHINA INDUSTRIES HOLDINGS LIMITED, CENTRAL HONG KONG, HONG KONG, FILED 11-13-2013.



OWNER OF HONG KONG REG. NO. 2000B10235, DATED 10-23-1999, EXPIRES 10-23-2016.

THE MARK CONSISTS OF A SQUARE WITH A BORDER ALONG THE INSIDE EDGE, WITH THE WORDING "RCI" INSIDE.

FOR TOYS, NAMELY, PLUSH TOYS, STUFFED TOYS, BOARD GAMES, DOLLS, AND PLASTIC TOYS, NAMELY, MECHANICAL ACTION TOYS, TOY AIRPLANES, TOY ARROWS, TOY BANKS, BATH TOYS, BENDABLE TOYS, TOY BUILDING BLOCKS, TOY CONSTRUCTION BLOCKS, TOY BOXES, CAT TOYS, DOG TOYS, DRAWING TOYS, MECHANICAL ACTIONS TOYS, MECHANICAL TOYS, MUSIC BOX TOYS, TOY NOISEMAKERS, PET TOYS, SQUEEZE TOYS, AND TOY FIGURES (U.S. CLS. 22, 23, 38 AND 50).

ALLISON HOLTZ, EXAMINING ATTORNEY

SN 86-118,471. THOMPSON, DENNIS EDWARD, SEVEN VALLEYS, PA. FILED 11-14-2013.

**PAATS**

THE MARK CONSISTS OF STANDARD CHARACTERS WITHOUT CLAIM TO ANY PARTICULAR FONT, STYLE, SIZE, OR COLOR.

FOR AUTOMATED ACTION TARGET GAMES FEATURING SERVO-CONTROLLED FIREARM TARGETS AND A COMPUTER CONTROLLED COMMAND CENTER, ALL SOLD AS A UNIT (U.S. CLS. 22, 23, 38 AND 50).

RUSS HERMAN, EXAMINING ATTORNEY

**CLASS 28—(Continued).**

SN 86-119,845. OLD WORLD LIMITED LLC, DBA MEDICAL MONKEYS, SHAKOPEE, MN. FILED 11-15-2013.



NO CLAIM IS MADE TO THE EXCLUSIVE RIGHT TO USE "MONKEYS", APART FROM THE MARK AS SHOWN. THE COLOR(S) BLACK, WHITE, RED, CHARCOAL, GRAY IS/ARE CLAIMED AS A FEATURE OF THE MARK. THE MARK CONSISTS OF "THE MEDICAL MONKEYS" LOGO IS ROUND, WITH THE WORD "MEDICAL" ON THE TOP, AND "MONKEYS" ON THE BOTTOM. THE OUTER BAND IS BLACK, THE LETTERING IS RED. A CARICATURE OF A SMILING MONKEY IN THE MIDDLE, WITH A CHARCOAL FACE, GRAY ACCENTS, FUR IN WHITE AND BLACK; TWO CHARCOAL AND GRAY HANDS GRIPPING BOTTOM EDGE OF LOGO. MONKEY SHOWN WITH RED TONGUE, TWO BLACK NOSTRILS, AND WIDE WHITE EYES WITH BLACK CENTERS; GRAY EYEBROWS.

SEC. 2(F).

FOR PLUSH TOYS; STUFFED AND PLUSH TOYS (U.S. CLS. 22, 23, 38 AND 50).

FIRST USE 2-12-2012. THE MARK WAS FIRST USED ANYWHERE IN A DIFFERENT FORM OTHER THAN THAT SOUGHT TO BE REGISTERED AT LEAST AS EARLY AS 02/12/2012 ; IN COMMERCE 2-12-2012. THE MARK WAS FIRST USED IN COMMERCE IN A DIFFERENT FORM OTHER THAN THAT SOUGHT TO BE REGISTERED AT LEAST AS EARLY AS 02/12/2012.

DOMINIC J. FERRAIUOLO, EXAMINING ATTORNEY

SN 86-123,504. HONDA MOTOR CO., LTD., TOKYO, JAPAN, FILED 11-19-2013.

## RIDE RED

THE MARK CONSISTS OF STANDARD CHARACTERS WITHOUT CLAIM TO ANY PARTICULAR FONT, STYLE, SIZE, OR COLOR.

FOR TOYS, NAMELY, MINIATURE REPLICAS OF MOTORCYCLES, ALL-TERRAIN VEHICLES, SIDE-BY-SIDE VEHICLES, MOTORSCOOTERS, AND PERSONAL WATERCRAFT (U.S. CLS. 22, 23, 38 AND 50).

APRIL REEVES, EXAMINING ATTORNEY

**CLASS 28—(Continued).**

SN 86-134,072. NOWSTALGIC TOYS, INC., CANAL WINCHESTER, OH. FILED 12-3-2013.

## SONIC FLASHERS

THE MARK CONSISTS OF STANDARD CHARACTERS WITHOUT CLAIM TO ANY PARTICULAR FONT, STYLE, SIZE, OR COLOR.

NO CLAIM IS MADE TO THE EXCLUSIVE RIGHT TO USE "FLASHERS", APART FROM THE MARK AS SHOWN. FOR MINIATURE TOY VEHICLES (U.S. CLS. 22, 23, 38 AND 50).

KATHERINE CONNOLLY, EXAMINING ATTORNEY

SN 86-136,736. IMPERIAL TOY, LLC, NORTH HILLS, CA. FILED 12-6-2013.

## FUZZBIES

THE MARK CONSISTS OF STANDARD CHARACTERS WITHOUT CLAIM TO ANY PARTICULAR FONT, STYLE, SIZE, OR COLOR.

FOR TOYS, GAMES AND PLAYTHINGS, NAMELY, PLUSH TOYS, PLUSH STUFFED TOYS, PLUSH DOLLS, PLUSH COVERED BALLS (U.S. CLS. 22, 23, 38 AND 50).

MICHAEL TANNER, EXAMINING ATTORNEY

SN 86-156,533. APOLLO EDUCATION GROUP, INC., PHOENIX, AZ. FILED 1-2-2014.



University of Phoenix

OWNER OF U.S. REG. NO. 3,988,757.

NO CLAIM IS MADE TO THE EXCLUSIVE RIGHT TO USE "PHOENIX", APART FROM THE MARK AS SHOWN.

THE MARK CONSISTS OF "UNIVERSITY OF PHOENIX, ABOVE" WHICH APPEARS A STYLIZED PHOENIX BIRD DESIGN WITH THE BIRD'S LEFT WING FOLDED UPWARD AND FORWARD, ITS HEAD IN PROFILE FACING RIGHT, AND ITS TAIL SUGGESTING FLAMES OR A TORCH.

FOR TOYS, NAMELY, FLYING DISCS (U.S. CLS. 22, 23, 38 AND 50).

FIRST USE 1-23-2012; IN COMMERCE 1-23-2012.

JOHN HWANG, EXAMINING ATTORNEY

**CLASS 28—(Continued).**

SN 86-165,487. GREAT TRANGO HOLDINGS, INC., LOUISVILLE, CO. FILED 1-14-2014.

## Rock Prodigy

THE MARK CONSISTS OF STANDARD CHARACTERS WITHOUT CLAIM TO ANY PARTICULAR FONT, STYLE, SIZE, OR COLOR.

NO CLAIM IS MADE TO THE EXCLUSIVE RIGHT TO USE "ROCK", APART FROM THE MARK AS SHOWN.

FOR STRENGTH AND FITNESS TRAINING PRODUCTS AND ACCESSORIES, NAMELY, BODY TRAINING APPARATUS AND FINGER BOARDS; PULLEYS AND RUBBER STRETCHING CORDS USED TO TRAIN AND STRENGTHEN THE UPPER BODY, BACK, CHEST, ARMS, HANDS, FINGERS AND GRIP FOR INCREASING CONTACT STRENGTH, ABDOMINAL AND CORE STRENGTH AND ENDURANCE (U.S. CLS. 22, 23, 38 AND 50).

FIRST USE 3-6-2013; IN COMMERCE 7-31-2013.  
SAIMA MAKHDOOM, EXAMINING ATTORNEY

SN 86-167,638. JOSEY SKATELAND INC, LEWISVILLE, TX. FILED 1-16-2014.

## EPIC SKATES

THE MARK CONSISTS OF STANDARD CHARACTERS WITHOUT CLAIM TO ANY PARTICULAR FONT, STYLE, SIZE, OR COLOR.

NO CLAIM IS MADE TO THE EXCLUSIVE RIGHT TO USE "SKATES", APART FROM THE MARK AS SHOWN.

FOR ROLLER-SKATES (U.S. CLS. 22, 23, 38 AND 50).  
FIRST USE 7-5-2012; IN COMMERCE 7-5-2012.  
LINDA E. BLOHM, EXAMINING ATTORNEY

SN 86-183,508. SCHÖNFELD, ANDREAS, KARLSRUHE, FED REP GERMANY, FILED 2-4-2014.



OWNER OF ERPN CMNTY TM OFC REG. NO. 010235083, DATED 12-22-2011, EXPIRES 12-22-2021.

NO CLAIM IS MADE TO THE EXCLUSIVE RIGHT TO USE "MINITRAINS", APART FROM THE MARK AS SHOWN.

THE COLOR(S) YELLOW AND BLACK IS/ARE CLAIMED AS A FEATURE OF THE MARK.

THE MARK CONSISTS OF THE TERM "MINITRAINS" IN YELLOW ON A BLACK BACKGROUND, WITH THE LETTERS "M" AND "S" ON THE ENDS LARGER THAN OTHER LETTERS, AND A LINE EMANATING FROM THE BOTTOM RIGHT OF THE LETTER "M" AND EXTENDING TO THE RIGHT UNTIL THE END OF THE LETTER "N".

FOR MODEL TRAINS AND MODEL RAILROADS (U.S. CLS. 22, 23, 38 AND 50).

LINDA E. BLOHM, EXAMINING ATTORNEY

**CLASS 28—(Continued).**

SN 86-189,264. LANDSCAPE STRUCTURES, INC., DELANO, MN. FILED 2-10-2014.

## HELIX NET

THE MARK CONSISTS OF STANDARD CHARACTERS WITHOUT CLAIM TO ANY PARTICULAR FONT, STYLE, SIZE, OR COLOR.

OWNER OF U.S. REG. NO. 3,428,884.  
SEC. 2(F).

FOR PLAYGROUND EQUIPMENT, NAMELY, CLIMBING UNITS (U.S. CLS. 22, 23, 38 AND 50).

FIRST USE 12-7-2006; IN COMMERCE 12-7-2006.  
DOUGLAS LEE, EXAMINING ATTORNEY

SN 86-189,290. LANDSCAPE STRUCTURES, INC., DELANO, MN. FILED 2-10-2014.

## CRESCENT CLIMBER

THE MARK CONSISTS OF STANDARD CHARACTERS WITHOUT CLAIM TO ANY PARTICULAR FONT, STYLE, SIZE, OR COLOR.

OWNER OF U.S. REG. NO. 3,383,481.

NO CLAIM IS MADE TO THE EXCLUSIVE RIGHT TO USE "CLIMBER", APART FROM THE MARK AS SHOWN.

SEC. 2(F).  
FOR PLAYGROUND EQUIPMENT, NAMELY, CLIMBING UNITS (U.S. CLS. 22, 23, 38 AND 50).

FIRST USE 12-7-2006; IN COMMERCE 12-7-2006.  
DOUGLAS LEE, EXAMINING ATTORNEY

SN 86-189,307. LANDSCAPE STRUCTURES, INC., DELANO, MN. FILED 2-10-2014.

## GYRO TWISTER

THE MARK CONSISTS OF STANDARD CHARACTERS WITHOUT CLAIM TO ANY PARTICULAR FONT, STYLE, SIZE, OR COLOR.

OWNER OF U.S. REG. NO. 3,387,061.  
SEC. 2(F).

FOR PLAYGROUND EQUIPMENT, NAMELY, STRUCTURES TO BE CLIMBED UPON; PLAYGROUND EQUIPMENT, NAMELY, ROTATABLY MOUNTED CLIMBING STRUCTURES UPON WHICH A USER ROTATES AROUND AN AXIS (U.S. CLS. 22, 23, 38 AND 50).

FIRST USE 12-7-2006; IN COMMERCE 12-7-2006.  
DOUGLAS LEE, EXAMINING ATTORNEY

**CLASS 28—(Continued).**

SN 86-199,183. NYMAN, ALLYSON, AMESBURY, MA. FILED 2-20-2014.

# Slombie

THE MARK CONSISTS OF STANDARD CHARACTERS WITHOUT CLAIM TO ANY PARTICULAR FONT, STYLE, SIZE, OR COLOR.

FOR STUFFED DOLLS AND ANIMALS (U.S. CLS. 22, 23, 38 AND 50).

FIRST USE 1-1-2013; IN COMMERCE 1-1-2013.  
DAYNA BROWNE, EXAMINING ATTORNEY

**CLASS 28—(Continued).**

SN 86-211,714. DREAM SHOOTERS TRADING CARDS AND VIDEO GAMES, NORFOLK, VA. FILED 3-5-2014.



TRADING CARDS AND VIDEO GAMES

NO CLAIM IS MADE TO THE EXCLUSIVE RIGHT TO USE "TRADING CARDS AND VIDEO GAMES", APART FROM THE MARK AS SHOWN.

THE COLOR(S) BLUE, BLACK, BROWN, YELLOW, PINK, WHITE, GRAY, RED, ORANGE IS/ARE CLAIMED AS A FEATURE OF THE MARK.

THE MARK CONSISTS OF "DREAM SHOOTERS" AT THE TOP IN WHITE LETTERS, ENCLOSED INSIDE BLUE BOXES. "TRADING CARDS AND VIDEO GAMES" IS WRITTEN AT THE BOTTOM IN PINK. SANDWICHED IN THE MIDDLE IS THE IMAGE OF A BROWN HAND HOLDING A GRAY AND BLACK GUN. THERE IS YELLOW, ORANGE, AND RED FIRING COMING OUT OF THE GUN, AND ON THE OTHER END OF THE GUN IS A YELLOW SHOOTING STAR WITH BLACK EYES.

FOR CARD GAMES; COMPUTER GAME CONSOLES FOR USE WITH AN EXTERNAL DISPLAY SCREEN OR MONITOR; COMPUTER GAME JOYSTICKS; ELECTRONIC GAMES OTHER THAN THOSE ADAPTED FOR USE WITH TELEVISION RECEIVERS ONLY; FACE PLATES FOR VIDEO GAME CONSOLES FOR USE WITH EXTERNAL MONITORS; GAME CARDS; GAME CONTROLLERS FOR COMPUTER GAMES; GAMES ADAPTED FOR USE WITH TELEVISION RECEIVERS; GAMING HEADSETS ADAPTED FOR USE IN PLAYING VIDEO GAMES; HAND HELD UNITS FOR PLAYING ELECTRONIC GAMES; HOME VIDEO GAME MACHINES; JOYSTICKS FOR VIDEO GAMES; PROTECTIVE CARRYING CASES SPECIALLY ADAPTED FOR HANDHELD VIDEO GAMES; PROTECTIVE CARRYING CASES SPECIALLY ADAPTED FOR VIDEO GAME CONSOLES FOR USE WITH AN EXTERNAL DISPLAY SCREEN OR MONITOR; TABLETOP GAMES; TABLETOP HOBBY BATTLE GAMES IN THE NATURE OF BATTLE, WAR AND SKIRMISH GAMES, AND FANTASY GAMES, AND PLAYING EQUIPMENT SOLD AS A UNIT THEREWITH; TRADING CARD GAMES; VIDEO GAME CONSOLES FOR USE WITH AN EXTERNAL DISPLAY SCREEN OR MONITOR; VIDEO GAME INTERACTIVE HAND HELD REMOTE CONTROLS FOR PLAYING ELECTRONIC GAMES (U.S. CLS. 22, 23, 38 AND 50).

MARTHA SANTOMARTINO, EXAMINING ATTORNEY

SN 86-209,818. BLACK LAB PRODUCTS, LLC, LOS ANGELES, CA. FILED 3-3-2014.

# Friend Chips

THE MARK CONSISTS OF STANDARD CHARACTERS WITHOUT CLAIM TO ANY PARTICULAR FONT, STYLE, SIZE, OR COLOR.

NO CLAIM IS MADE TO THE EXCLUSIVE RIGHT TO USE "CHIPS", APART FROM THE MARK AS SHOWN.

FOR COLLECTABLE TOYS, NAMELY, PLASTIC CHIPS THAT KIDS CAN COLLECT AND TRADE WITH THEIR FRIENDS (U.S. CLS. 22, 23, 38 AND 50).

KIMBERLY PARKS, EXAMINING ATTORNEY

**CLASS 28—(Continued).**

SN 86-211,715. BANANAGRAMS, INC., PROVIDENCE, RI. FILED 3-5-2014.



OWNER OF U.S. REG. NOS. 3,055,926, 4,271,356 AND OTHERS.

THE MARK CONSISTS OF THE BANANAGRAMS LOGO WHICH CONSISTS OF THE WORD "BANANAGRAMS" IN AN OVAL, WITH A MONKEY AND LARGE JUNGLE LEAVES ABOVE THE BANANAGRAMS LOGO AND THE WORDS "WILD TILES" BELOW IT.

FOR COMBINATION ANAGRAM AND CROSSWORD PUZZLE WORD GAME PLAYABLE ON ANY FLAT SURFACE (U.S. CLS. 22, 23, 38 AND 50).

TAMARA FRAZIER, EXAMINING ATTORNEY

**CLASS 28—(Continued).**

SN 86-215,431. GENETIPETZ, LLC, CHARLOTTE, NC. FILED 3-8-2014.

# Hawx

THE MARK CONSISTS OF STANDARD CHARACTERS WITHOUT CLAIM TO ANY PARTICULAR FONT, STYLE, SIZE, OR COLOR.

FOR PLUSH TOY FOR USE BY CHILDREN IN THE NATURE OF AN ANIMAL THAT IS PART FOX, PART HAWK (U.S. CLS. 22, 23, 38 AND 50).

FIRST USE 10-15-2013; IN COMMERCE 2-15-2014.

MICHELLE DUBOIS, EXAMINING ATTORNEY

SN 86-215,123. HALLMARK LICENSING, LLC, KANSAS CITY, MO. FILED 3-7-2014.

# SNOWBY

THE MARK CONSISTS OF STANDARD CHARACTERS WITHOUT CLAIM TO ANY PARTICULAR FONT, STYLE, SIZE, OR COLOR.

FOR PLUSH TOYS; CHRISTMAS TREE ORNAMENTS; INTERACTIVE AND RECORDABLE PARTY GAMES; INDOOR TABLE-TOP GAMES; POINT AND SHOOT TARGET GAMES; PARTY FAVORS IN THE NATURE OF SMALL TOYS; PUZZLES; PINBALL-TYPE GAMES; ACTIVITY GAME EQUIPMENT SOLD AS A UNIT COMPRISING BEAN BAGS, DISCS, RINGS, FOAM BALLS OR SPORTS BALLS FOR PLAYING TOSS GAMES; DOLLS; ACTION FIGURES; IMAGINARY PLAY SETS FOR ACTION FIGURES; TOY PIGGY BANKS; ACTIVITY GAME EQUIPMENT SOLD AS A SET COMPRISING MOLDS FOR CREATING SNOW CHARACTERS, BLOCKS FOR CREATING IMAGINARY SCENES, ALL FOR OUTDOOR SNOW PLAY; TOY VEHICLES; REMOTE-CONTROL TOY VEHICLES; TOY BUILDING BLOCKS; CARD GAMES; PUPPETS; SLEDS; SNOW BOARDS; SNOW SAUCERS; TOY INFLATABLE YARD DECORATIONS; CHRISTMAS STOCKINGS (U.S. CLS. 22, 23, 38 AND 50).

KATHLEEN KOLACZ, EXAMINING ATTORNEY

SN 86-216,289. HALLMARK LICENSING, LLC, KANSAS CITY, MO. FILED 3-10-2014.

# JAZ

THE MARK CONSISTS OF STANDARD CHARACTERS WITHOUT CLAIM TO ANY PARTICULAR FONT, STYLE, SIZE, OR COLOR.

FOR PLUSH TOYS; CHRISTMAS TREE ORNAMENTS; INTERACTIVE AND RECORDABLE PARTY GAMES; INDOOR TABLE-TOP GAMES; POINT AND SHOOT TARGET GAMES; PARTY FAVORS IN THE NATURE OF SMALL TOYS; PUZZLES; PINBALL-TYPE GAMES; ACTIVITY GAME EQUIPMENT SOLD AS A UNIT COMPRISING BEAN BAGS, DISCS, RINGS, FOAM BALLS OR SPORTS BALLS FOR PLAYING TOSS GAMES; DOLLS; ACTION FIGURES; IMAGINARY PLAY SETS FOR ACTION FIGURES; TOY PIGGY BANKS; ACTIVITY GAME EQUIPMENT SOLD AS A SET COMPRISING MOLDS FOR CREATING SNOW CHARACTERS, BLOCKS FOR CREATING IMAGINARY SCENES, ALL FOR OUTDOOR SNOW PLAY; TOY VEHICLES; REMOTE-CONTROL TOY VEHICLES; TOY BUILDING BLOCKS; CARD GAMES; PUPPETS; SLEDS; SNOW BOARDS; SNOW SAUCERS; TOY INFLATABLE YARD DECORATIONS; CHRISTMAS STOCKINGS (U.S. CLS. 22, 23, 38 AND 50).

CAROLINE WOOD, EXAMINING ATTORNEY

**CLASS 28—(Continued).**

SN 86-216,726. HALLMARK LICENSING, LLC, KANSAS CITY, MO. FILED 3-10-2014.

CHARLIE THE YETI

THE MARK CONSISTS OF STANDARD CHARACTERS WITHOUT CLAIM TO ANY PARTICULAR FONT, STYLE, SIZE, OR COLOR.

FOR PLUSH TOYS; CHRISTMAS TREE ORNAMENTS; INTERACTIVE AND RECORDABLE PARTY GAMES; INDOOR TABLE-TOP GAMES; POINT AND SHOOT TARGET GAMES; PARTY FAVORS IN THE NATURE OF SMALL TOYS; PUZZLES; PINBALL-TYPE GAMES; ACTIVITY GAME EQUIPMENT SOLD AS A UNIT COMPRISING BEAN BAGS, DISCS, RINGS, FOAM BALLS OR SPORTS BALLS FOR PLAYING TOSS GAMES; DOLLS; ACTION FIGURES; IMAGINARY PLAY SETS FOR ACTION FIGURES; TOY PIGGY BANKS; ACTIVITY GAME EQUIPMENT SOLD AS A SET COMPRISING MOLDS FOR CREATING SNOW CHARACTERS, BLOCKS FOR CREATING IMAGINARY SCENES, ALL FOR OUTDOOR SNOW PLAY; TOY VEHICLES; REMOTE-CONTROL TOY VEHICLES; TOY BUILDING BLOCKS; CARD GAMES; PUPPETS; SLEDS; SNOW BOARDS; SNOW SAUCERS; TOY INFLATABLE YARD DECORATIONS; CHRISTMAS STOCKINGS (U.S. CLS. 22, 23, 38 AND 50).

THEODORE MCBRIDE, EXAMINING ATTORNEY

**CLASS 28—(Continued).**

SN 86-217,748. CAMBUCI S.A., PINHEIROS SAO PAULO, BRAZIL, FILED 3-11-2014.



OWNER OF U.S. REG. NO. 2,590,945.

THE MARK CONSISTS OF TWO WAVY LINES WITH THE WORD "PENALTY" UNDERNEATH.

FOR BALLS FOR SOCCER, BALLS FOR INDOOR SOCCER, BALLS FOR BEACH SOCCER, BALLS FOR BASKETBALL, BALLS FOR HANDBALL, BALLS FOR VOLLEYBALL, BALLS FOR BEACH VOLLEYBALL, BALLS FOR WATER POLO; BALLS FOR BEACH HANDBALL, BALLS FOR FOOTVOLLEY; BODY PROTECTORS FOR THIGHS, ELBOW, SHINS, KNEES AND WRISTS FOR USE IN SOCCER, INDOOR SOCCER, BEACH SOCCER, BASKETBALL, HANDBALL, VOLLEYBALL, BEACH VOLLEYBALL, BEACH HANDBALL AND FOOTVOLLEY; SOCCER GLOVES; HANDBALL GLOVES; GOALKEEPERS' GLOVES; WEIGHTLIFTING GLOVES; WORK-OUT GLOVES (U.S. CLS. 22, 23, 38 AND 50).

MATTHEW GALAN, EXAMINING ATTORNEY

SN 86-217,200. JHPIEGO CORPORATION, BALTIMORE, MD. FILED 3-11-2014.

Task Master  
Mining for Data

THE MARK CONSISTS OF THE WORDS "TASK MASTER MINING FOR DATA" IN STYLIZED LETTERING WITH THE WORDS "MINING FOR DATA" APPEARING BELOW "TASK MASTER" AND A HORIZONTAL LINE WITH A CIRCLE ON EACH END OF THE LINE ON BOTH SIDES OF THE WORDS "MINING FOR DATA".

FOR A CARD GAME FOR COLLECTING AND ANALYZING INFORMATION FROM HEALTH PROFESSIONALS FOR USE IN IMPROVING HEALTH SYSTEMS, SOLD AS A UNIT WITH INSTRUCTIONS (U.S. CLS. 22, 23, 38 AND 50).

KATHERINE CHANG, EXAMINING ATTORNEY

SN 86-221,409. CAROL AND MICHAEL TOBEY, DBA THE WRAPPER SLAPPER, LLC, BEND, OR. FILED 3-14-2014.

Yoga Mat Wrap

THE MARK CONSISTS OF STANDARD CHARACTERS WITHOUT CLAIM TO ANY PARTICULAR FONT, STYLE, SIZE, OR COLOR.

NO CLAIM IS MADE TO THE EXCLUSIVE RIGHT TO USE "YOGA MAT", APART FROM THE MARK AS SHOWN.

FOR FITNESS EQUIPMENT, NAMELY, STRAPS USED FOR YOGA AND OTHER FITNESS ACTIVITIES AND FOR CARRYING A YOGA MAT (U.S. CLS. 22, 23, 38 AND 50).

FIRST USE 1-1-2014; IN COMMERCE 1-1-2014.

JEFF DEFORD, EXAMINING ATTORNEY



**CLASS 28—(Continued).**

SN 86-224,221. GROUNDSWELL SUPPLY LLC, CARLSBAD, CA. FILED 3-18-2014.

## Groundswell Supply

THE MARK CONSISTS OF STANDARD CHARACTERS WITHOUT CLAIM TO ANY PARTICULAR FONT, STYLE, SIZE, OR COLOR.

NO CLAIM IS MADE TO THE EXCLUSIVE RIGHT TO USE "SUPPLY", APART FROM THE MARK AS SHOWN.

FOR SKATEBOARDS; SKATEBOARD DECKS; SKATEBOARD GRIP TAPES; SKATEBOARD PADDLE BOARDS; SKATEBOARD PADDLES; SKATEBOARD RAILS; SKATEBOARD RISER PADS; SKATEBOARD TRUCKS; SKATEBOARD WAX; SKATEBOARD WHEELS; SURF BOARDS; SURF FINNS; SURF PADDLES; SURF SKIS; PADDLE BOARDS (U.S. CLS. 22, 23, 38 AND 50).

HOWARD B. LEVINE, EXAMINING ATTORNEY

SN 86-225,427. DEBBIE OSGOOD, ST. SIMONS ISLAND, GA. FILED 3-19-2014.

## YOGAKNEES

THE MARK CONSISTS OF STANDARD CHARACTERS WITHOUT CLAIM TO ANY PARTICULAR FONT, STYLE, SIZE, OR COLOR.

OWNER OF U.S. REG. NO. 4,292,598.

FOR PROTECTIVE KNEE PADS FOR ATHLETIC AND EXERCISE USE; AND KNEE PADS FOR USE IN EXERCISE AND ATHLETIC ACTIVITIES (U.S. CLS. 22, 23, 38 AND 50).

INGRID C. EULIN, EXAMINING ATTORNEY

SN 86-225,590. DARRYL HEALE, TOMS RIVER, NJ. FILED 3-19-2014.



THE MARK CONSISTS OF THREE CONCENTRIC CIRCLES, THE OUTER AND INNERMOST CONCENTRIC CIRCLES BEING SHADED, AND THE OUTER CONCENTRIC CIRCLE HAVING A DECORATIVE, SCALLOPED EDGE. TWO PIECES OF GARLAND EXTEND OUTWARDLY, LEFT AND RIGHT, FROM A CENTER POINT BENEATH THE OUTER CIRCLE. THE MIDDLE, UNSHADED CONCENTRIC CIRCLE IS FULLY DISSECTED

**CLASS 28—(Continued).**

BY A HORIZONTAL LINE AND CONTAINS THE WORDS, "VENERATIO". WITHIN THE ARCHING TOP PORTION OF THE MIDDLE CIRCLE, "OTIS". WITHIN THE DISSECTING LINE EXTENDING ACROSS THE MIDDLE CIRCLE, AND "VESTRI", WITHIN THE ARCHING BOTTOM PORTION OF THE MIDDLE CIRCLE. THE WORD "OTIS" INCLUDES TWO FLOATING ENDPOINTS ON EITHER SIDE OF THE WORD. THE HORIZONTAL LINE DISSECTING THE MIDDLE CIRCLE ALSO DISSECTS THE INNERMOST, SHADED CIRCLE INTO TWO SEMI CIRCLES. WITHIN THE INNERMOST, SHADED CIRCLE IS THE OUTLINE OF A CREST, ALSO DISSECTED BY THE HORIZONTAL LINE. THE CREST INCLUDES A STANDING SILHOUETTE OF A GOAT WITH TWO PIECES OF GARLAND EXTENDING OUTWARDLY FROM AROUND THE GOAT'S FEET, THEREIN. BOTH THE GOAT AND THE GARLAND ARE POSITIONED ON TOP OF THE DISSECTING HORIZONTAL LINE OF THE MIDDLE. UNSHADED CONCENTRIC CIRCLE WHICH READS, "OTIS".

THE ENGLISH TRANSLATION OF THE WORDS "VENERATIO VESTRI" IN THE MARK IS "HONOR YOURS".

FOR TOY ANIMALS; TOY ANIMALS AND ACCESSORIES THEREFOR; NOVELTY TOY ITEMS IN THE NATURE OF INTERACTIVE TOTEMS AND TOYS, NAMELY, TOTEM ANIMALS AND TOY ANIMALS; INTERACTIVE ELECTRONIC TOY FIGURINES FEATURING TECHNOLOGY WHICH CAN BE USED INDEPENDENTLY, AND WHICH CAN BE INTERFACED TO SEPARATE COMPUTER HARDWARE TO ENABLE USERS TO UPLOAD, STORE, SHARE, ARCHIVE, AND RECORD PERSONAL STORIES, PICTURES, JOURNALS, VIDEOS, AUDIO, AND DIGITAL MEDIA IN GENERAL, TO INCREASE PERSONAL HAPPINESS IN TERMS OF PERSONAL AND FAMILIAL RELATIONSHIPS AND TRADITIONS, PERSONAL DEVELOPMENT, PERSONAL GROWTH AND MOTIVATION, AND SELF-FULFILLMENT; ELECTRONIC LEARNING TOYS (U.S. CLS. 22, 23, 38 AND 50).

JOANNA FIORELLI, EXAMINING ATTORNEY

SN 86-226,502. SUPER FISHING TACKLE CO., LTD., FUJIAN PROVINCE, CHINA, FILED 3-20-2014.



THE MARK CONSISTS OF A DESIGN ON THE LEFT COMPRISING A FIVE POINTED STAR INSIDE A SQUARE WITH ROUND CORNER, AND THE STYLIZED WORD "SFT" ON THE RIGHT, ALL INSIDE A RECTANGULAR DESIGN.

THE WORDING "SFT" HAS NO MEANING IN A FOREIGN LANGUAGE.

FOR ARTIFICIAL FISHING BAIT; ARTIFICIAL FISHING LURES; FISH ATTRACTANTS; FISHING HOOKS; FISHING LINES; FISHING REELS; FISHING RODS; FISHING TACKLE; LURES FOR HUNTING OR FISHING; SCENT LURES FOR HUNTING OR FISHING (U.S. CLS. 22, 23, 38 AND 50).

ALICE BENMAMAN, EXAMINING ATTORNEY



**CLASS 28—(Continued).**

SN 86-228,592. TWENTIETH CENTURY FOX FILM CORPORATION, LOS ANGELES, CA. FILED 3-21-2014.

# THE SIMPSONS

THE MARK CONSISTS OF STANDARD CHARACTERS WITHOUT CLAIM TO ANY PARTICULAR FONT, STYLE, SIZE, OR COLOR.

OWNER OF U.S. REG. NOS. 1,771,608, 3,280,365 AND OTHERS.  
SEC. 2(F).

FOR SLOT MACHINES; COIN-OPERATED AMUSEMENT MACHINES; COIN-OPERATED VIDEO GAMES; ARCADE GAME MACHINES; ARCADE GAMES; ARCADE-TYPE ELECTRONIC VIDEO GAMES; CHRISTMAS TREE ORNAMENTS; DOLLS AND DOLL CLOTHING; TOY FIGURES; BATHTUB TOYS; RUBBER CHARACTER TOYS; BENDABLE TOYS; WIND-UP TOYS; TOY BUILDING BLOCKS; JIGSAW AND MANIPULATIVE PUZZLES; TOY ACTION FIGURES AND ACCESSORIES THEREFOR; ACTION FIGURE PLAY ENVIRONMENTS; PARTY GAMES; PARLOR GAMES; ROLE PLAYING GAMES; ACTION SKILL GAMES; CARD GAMES; PLAYING CARDS; FLYING DISCS; TOY JEWELRY; TOY WATCHES; DART BOARDS; TOY VEHICLES AND ACCESSORIES THEREFOR; SIT-IN AND RIDE-ON TOY VEHICLES; INDOOR PLAY TENTS; HAND HELD PUPPETS; TOY BANKS; WATER SQUIRTING TOYS; TOY PISTOLS; PINBALL AND ARCADE GAME MACHINES; BALLS FOR GAMES; BALLS FOR SPORTS; TENNIS RACKETS; SKATEBOARDS; BALLOONS; HOBBY CRAFT KITS COMPRISED OF TOY FIGURE PLASTIC MOLDS, FASTENERS FOR ATTACHING TOY FIGURE MOLDS, AND DECORATIVE ACCESSORIES FOR MOLDED TOY FIGURES; FLOTATION DEVICES FOR RECREATIONAL USE, NAMELY, INFLATABLE BALLS AND WATER WINGS SWIM AIDS FOR RECREATIONAL USE (U.S. CLS. 22, 23, 38 AND 50).  
KRISTINA MORRIS, EXAMINING ATTORNEY

SN 86-229,566. GREEN, MARK, ORLANDO, FL. AND GREEN, JAMES, ORLANDO, FL. FILED 3-24-2014.

# Heavy G Systems

THE MARK CONSISTS OF STANDARD CHARACTERS WITHOUT CLAIM TO ANY PARTICULAR FONT, STYLE, SIZE, OR COLOR.

NO CLAIM IS MADE TO THE EXCLUSIVE RIGHT TO USE "SYSTEMS", APART FROM THE MARK AS SHOWN.  
FOR MANUALLY-OPERATED EXERCISE EQUIPMENT (U.S. CLS. 22, 23, 38 AND 50).  
CARYN GLASSER, EXAMINING ATTORNEY

**CLASS 28—(Continued).**

SN 86-230,141. ON DEMAND DIRECT RESPONSE III, LLC, SHERMAN OAKS, CA. FILED 3-24-2014.

# CLOUD PETS

THE MARK CONSISTS OF STANDARD CHARACTERS WITHOUT CLAIM TO ANY PARTICULAR FONT, STYLE, SIZE, OR COLOR.

NO CLAIM IS MADE TO THE EXCLUSIVE RIGHT TO USE "CLOUD", APART FROM THE MARK AS SHOWN.

FOR STUFFED AND PLUSH DOLLS AND TOYS; STUFFED AND PLUSH TOY ANIMALS; ELECTRONIC NOVELTY TOYS, NAMELY, TOYS THAT ELECTRONICALLY RECORD, PLAY BACK, AND DISTORT OR MANIPULATE VOICES AND SOUNDS; ELECTRONIC STUFFED AND PLUSH DOLLS, ANIMALS AND TOYS (U.S. CLS. 22, 23, 38 AND 50).

LOKSYE G LEE RISO, EXAMINING ATTORNEY

SN 86-230,149. ON DEMAND DIRECT RESPONSE III, LLC, SHERMAN OAKS, CA. FILED 3-24-2014.

# CLOUD PET

THE MARK CONSISTS OF STANDARD CHARACTERS WITHOUT CLAIM TO ANY PARTICULAR FONT, STYLE, SIZE, OR COLOR.

NO CLAIM IS MADE TO THE EXCLUSIVE RIGHT TO USE "CLOUD", APART FROM THE MARK AS SHOWN.

FOR STUFFED AND PLUSH DOLLS AND TOYS; STUFFED AND PLUSH TOY ANIMALS; ELECTRONIC NOVELTY TOYS, NAMELY, TOYS THAT ELECTRONICALLY RECORD, PLAY BACK, AND DISTORT OR MANIPULATE VOICES AND SOUNDS; ELECTRONIC STUFFED AND PLUSH DOLLS, ANIMALS AND TOYS (U.S. CLS. 22, 23, 38 AND 50).

LOKSYE G LEE RISO, EXAMINING ATTORNEY

**CLASS 28—(Continued).**

SN 86-234,853. ETRAVIS INC., HOUSTON, TX. FILED 3-28-2014.

## Kids Authority

THE MARK CONSISTS OF STANDARD CHARACTERS WITHOUT CLAIM TO ANY PARTICULAR FONT, STYLE, SIZE, OR COLOR.

NO CLAIM IS MADE TO THE EXCLUSIVE RIGHT TO USE "KIDS", APART FROM THE MARK AS SHOWN.

FOR CHILDREN'S MULTIPLE ACTIVITY TOYS; COLLECTABLE TOY FIGURES; CONSTRUCTION TOYS; DOLLS AND DOLL ACCESSORIES, NAMELY, CLOTHING FOR DOLLS, DOLL ROOMS, DOLL BEDS, DOLL HOUSES, TOY FABRICS AND LINENS FOR DOLLS AND STROLLERS FOR DOLLS; ELECTRIC EDUCATIONAL TOY USED TO DEMONSTRATE ALTERNATIVE ENERGY SOURCES; ELECTRONIC ACTION TOYS; ELECTRONIC LEARNING TOYS; ELECTRONIC NOVELTY TOYS, NAMELY, TOYS THAT ELECTRONICALLY RECORD, PLAY BACK, AND DISTORT OR MANIPULATE VOICES AND SOUNDS; ELECTRONIC TOY BUILDING BLOCKS THAT LIGHT UP AS A NIGHT LIGHT; ELECTRONIC TOY VEHICLES; FLYING TOYS USING ELECTROSTATIC LEVITATION; GIFT BASKETS CONTAINING PLUSH TOYS; HAND-POWERED NON-MECHANICAL FLYING TOY; INFANT TOYS; MECHANICAL TOYS; MODEL TOY VEHICLES; MUSIC BOX TOYS; MUSICAL TOYS; PLUSH TOYS; PUSH TOYS; RADIO CONTROLLED TOY VEHICLES; REMOTE CONTROL TOYS, NAMELY, WATERCRAFTS, VEHICLES, PLANES AND HELICOPTERS; RIDE-ON TOYS; RIDE-ON TOYS AND ACCESSORIES THEREFOR; RIDEABLE TOY VEHICLES; RIDEABLE TOYS AND ACCESSORIES THEREFOR; SKETCHING TOYS; TOY AIRPLANES; TOY AND NOVELTY FACE MASKS; TOY ANIMALS; TOY ARMOR; TOY BEANBAGS; TOY BOATS; TOY BOWS AND ARROWS; TOY BOXES; TOY BROOCHES; TOY BUILDING BLOCKS; TOY BUILDING BLOCKS CAPABLE OF INTERCONNECTION; TOY BUILDING STRUCTURES AND TOY VEHICLE TRACKS; TOY BUILDINGS AND ACCESSORIES THEREFOR; TOY BUTTERFLY NETS; TOY CANDY DISPENSERS; TOY CAP PISTOLS; TOY CARS; TOY CHRISTMAS TREES; TOY CLOCKS AND WATCHES; TOY CONSTRUCTION BLOCKS; TOY CONSTRUCTION SETS; TOY FIGURES; TOY FIGURES IN THE FORM OF A POTATO; TOY FILM CARTRIDGES AND VIEWERS; TOY FIREWORKS; TOY FOAM NOVELTY ITEMS, NAMELY, FOAM FINGERS AND HANDS; TOY FURNITURE; TOY GLIDERS; TOY GLOCKENSPIELS; TOY GUNS; TOY HARMONICAS; TOY HOLSTERS; TOY HOOP SETS; TOY HOUSES; TOY JEWELRY; TOY MICROSCOPES; TOY MODELING DOUGH (U.S. CLS. 22, 23, 38 AND 50).

JOHN GARTNER, EXAMINING ATTORNEY

**CLASS 28—(Continued).**

SN 86-237,522. SILVER CREEK INNOVATIONS, LLC, ASHTABULA, OH. FILED 3-31-2014.

## GearDock

THE MARK CONSISTS OF STANDARD CHARACTERS WITHOUT CLAIM TO ANY PARTICULAR FONT, STYLE, SIZE, OR COLOR.

FOR HOLDER SPECIALLY ADAPTED FOR CARRYING SPORTING GOODS, NAMELY, FISHING RODS AND HAND-HELD FISHING NETS (U.S. CLS. 22, 23, 38 AND 50).

FIRST USE 6-19-2013; IN COMMERCE 6-19-2013.  
KIM MONINGHOFF, EXAMINING ATTORNEY

SN 86-237,826. XAVIER A. HONABLUE, DBA WRINGBELL LABS, STATEN ISLAND, NY. FILED 3-31-2014.

## Wringbells

THE MARK CONSISTS OF STANDARD CHARACTERS WITHOUT CLAIM TO ANY PARTICULAR FONT, STYLE, SIZE, OR COLOR.

FOR BARBELLS (U.S. CLS. 22, 23, 38 AND 50).  
JOHN WILKE, EXAMINING ATTORNEY

SN 86-238,423. HEMINGWAY, LTD., NEW YORK, NY. FILED 4-1-2014.

## HEMINGWAY

THE MARK CONSISTS OF STANDARD CHARACTERS WITHOUT CLAIM TO ANY PARTICULAR FONT, STYLE, SIZE, OR COLOR.

OWNER OF U.S. REG. NOS. 1,384,390, 1,765,090 AND OTHERS.

THE NAME(S), PORTRAIT(S), AND/OR SIGNATURE(S) SHOWN IN THE MARK DOES NOT IDENTIFY A PARTICULAR LIVING INDIVIDUAL.

SEC. 2(F).

FOR FISHING RODS, FISHING REELS, FISHING TACKLES, FISHING HOOKS, FISHING FLIES, HAND-HELD FISHING NETS, FISHING LINES, FISHING FLOATS, FISHING LURES, ARTIFICIAL FISHING BAIT, FISHING BUOYS, FISHING GAFFS, WINGING MATERIAL FOR FISHING FLIES AND JIGS, FISHING SPINNERS, FISHING LURE ROD CASES, FISHING FLY BOXES, FISHING LURE BOXES, FISHING TACKLE BOXES, FISHING POLE HOLDERS INCLUDING THOSE WORN ON THE BODY (U.S. CLS. 22, 23, 38 AND 50).

DOUGLAS LEE, EXAMINING ATTORNEY

**CLASS 28—(Continued).**

SN 86-238,699. SHIELD BOARDS, EDGEWATER, MD. FILED 4-1-2014.

## Wheel Shields

THE MARK CONSISTS OF STANDARD CHARACTERS WITHOUT CLAIM TO ANY PARTICULAR FONT, STYLE, SIZE, OR COLOR.

NO CLAIM IS MADE TO THE EXCLUSIVE RIGHT TO USE "WHEEL", APART FROM THE MARK AS SHOWN.

FOR PROTECTIVE COVERINGS FOR SKATEBOARD AND LONGBOARD WHEELS (U.S. CLS. 22, 23, 38 AND 50).

FIRST USE 7-18-2012; IN COMMERCE 7-18-2012.  
BILL DAWE, EXAMINING ATTORNEY

---

SN 86-239,792. MAGIC BOX INT. TOYS, S.L.U., SANT CUGAT DEL VALLES, SPAIN, FILED 4-2-2014.

## ZOMLINGS

THE MARK CONSISTS OF STANDARD CHARACTERS WITHOUT CLAIM TO ANY PARTICULAR FONT, STYLE, SIZE, OR COLOR.

OWNER OF ERPN CMNTY TM OFC REG. NO. 11807765, DATED 9-19-2013, EXPIRES 5-13-2023.

FOR GAMES AND PLAYTHINGS, NAMELY, TOY FIGURES; GYMNAS TIC AND SPORTING ARTICLES, NAMELY, BALANCE BEAMS, GYMNAS TIC APPARATUS, GYMNAS TIC HORIZONTAL BARS, GYMNAS TIC PARALLEL BARS, GYMNAS TIC TRAINING STOOLS, SPRING BOARDS, GOLF BALL DISPENSERS, HANDLE GRIPS FOR SPORTING EQUIPMENT, ATHLETIC WRIST AND JOINT SUPPORTS; DECORATIONS FOR CHRISTMAS TREES (U.S. CLS. 22, 23, 38 AND 50).

MEREDITH MARESCA, EXAMINING ATTORNEY

---

SN 86-241,461. DEFEO, CARMINE AMADEO, FREDONIA, AZ. FILED 4-3-2014.

## THE CHOKE

THE MARK CONSISTS OF STANDARD CHARACTERS WITHOUT CLAIM TO ANY PARTICULAR FONT, STYLE, SIZE, OR COLOR.

FOR OUTDOOR ACTIVITY GAME EQUIPMENT SOLD AS A UNIT COMPRISING OF A GRIP PLACED AROUND THE SHAFT A BASEBALL BAT FOR PLAYING GAMES (U.S. CLS. 22, 23, 38 AND 50).

FIRST USE 10-1-2013; IN COMMERCE 10-1-2013.  
MARTHA FROMM, EXAMINING ATTORNEY

**CLASS 28—(Continued).**

SN 86-241,605. LENFEST MEDIA GROUP, LLC, KING OF PRUSSIA, PA. FILED 4-3-2014.



THE COLOR(S) BLUE, LIGHT BLUE, WHITE, DARK BLUE, DARK GREEN, LIGHT GREEN, AND GREEN IS/ ARE CLAIMED AS A FEATURE OF THE MARK.

THE MARK CONSISTS OF THE WORDS "WOBBLE WAG" IN STYLIZED LETTERING SHADING FROM TOP TO BOTTOM IN DARKER TO LIGHTER SHADES OF BLUE, OUTLINED IN WHITE AND DARK BLUE UNDERNEATH WHICH IS THE WORD "GIGGLE" IN STYLIZED LETTERING SHADING FROM TOP TO BOTTOM IN DARKER TO LIGHTER SHADES OF GREEN OUTLINED IN WHITE AND DARK BLUE. TO THE RIGHT OF THE WORD "GIGGLE" THERE IS A CIRCLE THAT CONTAINS A DESIGN OF AN ANIMAL PAW IN BLUE BEHIND WHICH ARE SWIRLS IN DARK GREEN AND LIGHT GREEN AND SEVERAL SMALL OVALS OF BLUE AND GREEN. THIS CIRCLE IS OUTLINED IN WHITE AND DARK BLUE. THE WHITE BACKGROUND IS NOT CLAIMED AS FEATURE OF THE MARK.

FOR PET TOYS (U.S. CLS. 22, 23, 38 AND 50).  
DANIEL CAPSHAW, EXAMINING ATTORNEY

---

SN 86-241,839. MATTEL, INC., EL SEGUNDO, CA. FILED 4-3-2014.

## CLAWDIA WOLF

THE MARK CONSISTS OF STANDARD CHARACTERS WITHOUT CLAIM TO ANY PARTICULAR FONT, STYLE, SIZE, OR COLOR.

OWNER OF U.S. REG. NO. 3,803,817.  
THE NAME "CLAWDIA WOLF" DOES NOT IDENTIFY A LIVING INDIVIDUAL.

FOR DOLLS, DOLL CLOTHING AND DOLL ACCESSORIES (U.S. CLS. 22, 23, 38 AND 50).

LESLEY LAMOTHE, EXAMINING ATTORNEY

**CLASS 28—(Continued).**

SN 86-242,107. ALLIED PLUSH, INC., ARCADIA, CA. FILED 4-3-2014.

**Bear with Me**

THE MARK CONSISTS OF STANDARD CHARACTERS WITHOUT CLAIM TO ANY PARTICULAR FONT, STYLE, SIZE, OR COLOR.

FOR NOVELTY TOY ITEMS IN THE NATURE OF ARTICLES OF CLOTHING FOR TOYS AND MINIATURE HANDHELD TOY TOOLS FOR ATTACHMENT ON PLUSH TOYS; STUFFED AND PLUSH TOYS; STUFFED TOY ANIMALS; STUFFED TOY BEARS; STUFFED TOYS; TOY ANIMALS AND ACCESSORIES THEREFOR; ARTICLES OF CLOTHING FOR TOYS (U.S. CLS. 22, 23, 38 AND 50).

EVELYN BRADLEY, EXAMINING ATTORNEY

SN 86-243,880. SHFL ENTERTAINMENT (AUSTRALASIA) PTY LIMITED, MILPERRA, AUSTRALIA, FILED 4-6-2014.



NO CLAIM IS MADE TO THE EXCLUSIVE RIGHT TO USE "HIGH STAKES", APART FROM THE MARK AS SHOWN.

THE MARK CONSISTS OF "HIGH STAKES" AND HORSE AND JOCKEY DESIGN.

FOR SLOT MACHINES; GAMBLING MACHINES; ELECTRONIC GAMING MACHINES; REPLACEMENT PARTS FOR ALL OF THE FOREGOING (U.S. CLS. 22, 23, 38 AND 50).

REBECCA GILBERT, EXAMINING ATTORNEY

SN 86-244,683. ANDREW BRECKMAN, MADISON, NJ. FILED 4-7-2014.

**LATE FOR SCHOOL**

THE MARK CONSISTS OF STANDARD CHARACTERS WITHOUT CLAIM TO ANY PARTICULAR FONT, STYLE, SIZE, OR COLOR.

FOR BOARD GAMES (U.S. CLS. 22, 23, 38 AND 50).

CHARLES HISER, EXAMINING ATTORNEY

**CLASS 28—(Continued).**

SN 86-244,718. WORLDWISE, INC., SAN RAFAEL, CA. FILED 4-7-2014.

**LOCOLASER**

THE MARK CONSISTS OF STANDARD CHARACTERS WITHOUT CLAIM TO ANY PARTICULAR FONT, STYLE, SIZE, OR COLOR.

OWNER OF U.S. REG. NOS. 3,552,094 AND 3,985,170.

FOR PET TOYS (U.S. CLS. 22, 23, 38 AND 50).

MARIA-VICTORIA SUAREZ, EXAMINING ATTORNEY

SN 86-245,490. WILDGAME INNOVATIONS, LLC, BROUSSARD, LA. FILED 4-8-2014.

**ERASE**

THE MARK CONSISTS OF STANDARD CHARACTERS WITHOUT CLAIM TO ANY PARTICULAR FONT, STYLE, SIZE, OR COLOR.

FOR SCENT ELIMINATION SPRAY FOR USE DURING HUNTING AND OUTDOOR RECREATION (U.S. CLS. 22, 23, 38 AND 50).

FONG HSU, EXAMINING ATTORNEY

SN 86-245,659. DAVID EVANS, YAHUI EVANS, ALEX TSAI, YU-LING TSAI, LOS ANGELES, CA. FILED 4-8-2014.

**Savage X Lacrosse**

THE MARK CONSISTS OF STANDARD CHARACTERS WITHOUT CLAIM TO ANY PARTICULAR FONT, STYLE, SIZE, OR COLOR.

NO CLAIM IS MADE TO THE EXCLUSIVE RIGHT TO USE "LACROSSE", APART FROM THE MARK AS SHOWN.

FOR LACROSSE BALL BAGS; LACROSSE BALLS; LACROSSE GLOVES; LACROSSE STICK BAGS; LACROSSE STICK HANDLES; LACROSSE STICK HEADS; LACROSSE STICK STRINGS; LACROSSE STICKS (U.S. CLS. 22, 23, 38 AND 50).

KRISTIN DAHLING, EXAMINING ATTORNEY

**CLASS 28—(Continued).**

SN 86-245,669. NATIONAL HOT ROD ASSOCIATION, GLEN-DORA, CA. FILED 4-8-2014.

**SAFETY SAFARI**

THE MARK CONSISTS OF STANDARD CHARACTERS WITHOUT CLAIM TO ANY PARTICULAR FONT, STYLE, SIZE, OR COLOR.

OWNER OF U.S. REG. NO. 1,669,845.  
FOR TOY MODEL CARS (U.S. CLS. 22, 23, 38 AND 50).  
FIRST USE 10-1-2011; IN COMMERCE 10-1-2011.  
LOKSYE G LEE RISO, EXAMINING ATTORNEY

---

SN 86-245,717. INCREDIBLE TECHNOLOGIES, INC., VERNON HILLS, IL. FILED 4-8-2014.

**SCATTER WAYS**

THE MARK CONSISTS OF STANDARD CHARACTERS WITHOUT CLAIM TO ANY PARTICULAR FONT, STYLE, SIZE, OR COLOR.

FOR GAMING EQUIPMENT, NAMELY, SLOT MACHINES WITH OR WITHOUT VIDEO OUTPUT (U.S. CLS. 22, 23, 38 AND 50).

JACLYN KIDWELL WALKER, EXAMINING ATTORNEY

---

SN 86-245,860. BARNES & NOBLE BOOKSELLERS, INC., NEW YORK, NY. FILED 4-8-2014.

**ESPARI**

THE MARK CONSISTS OF STANDARD CHARACTERS WITHOUT CLAIM TO ANY PARTICULAR FONT, STYLE, SIZE, OR COLOR.

THE WORDING "ESPARI" HAS NO MEANING IN A FOREIGN LANGUAGE.

FOR TOYS AND GAMES, NAMELY, DOLLS, DOLL CLOTHING, DOLL COSTUMES, DOLL ACCESSORIES, DOLL SHOES, DOLL HAIR ACCESSORIES, DOLL PLAYSETS, DOLL HOUSES, DOLL HOUSE FURNISHINGS AND DOLL CASES; TOY ACTION FIGURES AND ACCESSORIES THEREFOR (U.S. CLS. 22, 23, 38 AND 50).

VERNA BETH RIRIE, EXAMINING ATTORNEY

**CLASS 28—(Continued).**

SN 86-246,187. GUARDIAN PROTECTION SOLUTIONS, LLC, NORTH ROYALTON, OH. FILED 4-8-2014.



THE MARK CONSISTS OF THE CAPITAL "B" IS ON THE LEFT AND THE CAPITAL LETTER "O" IS SITTING ON TOP OF THE CAPITAL LETTER "T" WITH THE LAST LETTER CAPITAL "C" ALL TOGETHER. THEY ARE GROUPED TOGETHER WITH THE B AND THE C AS THE END LETTERS.

FOR STUFFED TOY ANIMALS (U.S. CLS. 22, 23, 38 AND 50).

FIRST USE 11-29-2013; IN COMMERCE 11-29-2013.  
TASHIA BUNCH, EXAMINING ATTORNEY

---

SN 86-246,481. JOHNSON, MARC, STUDIO CITY, CA. FILED 4-8-2014.

**THE WORKS**

THE MARK CONSISTS OF STANDARD CHARACTERS WITHOUT CLAIM TO ANY PARTICULAR FONT, STYLE, SIZE, OR COLOR.

FOR ACCESSORIES FOR SKATEBOARDS, NAMELY, GRIP TAPE, BEARINGS, NUTS AND BOLTS, SKATEBOARD RAILS, AND SKATEBOARD WAX; SKATEBOARD DECKS; SKATEBOARD BAGS (U.S. CLS. 22, 23, 38 AND 50).

TINA L. SNAPP, EXAMINING ATTORNEY

**CLASS 28—(Continued).**

SN 86-246,614. SUN, YU TAO, DANCHENG COUNTY, HE-NAN., CHINA, FILED 4-9-2014.



THE MARK CONSISTS OF THE WORDING "PROSEA" AND A STYLISED "P" DEVICE WITH WAVES.

THE WORDING "PROSEA" HAS NO MEANING IN A FOREIGN LANGUAGE.

FOR BAGS ESPECIALLY DESIGNED FOR SURF-BOARDS; BILLIARD CUES; BODY SURF HAND PLANES; BOWS FOR ARCHERY; CHRISTMAS TREE STANDS; GOLF CLUBS; HANG GLIDERS; INFANT TOYS; KITES; LEASHES USED IN CONJUNCTION WITH SURFING; NON-SLIP RESIN SPRAYS FOR USE BY ATHLETES; PERSONAL EXERCISE MATS; PET TOYS; PROTECTIVE PADDING FOR PLAYING FOOTBALL, BASKETBALL, SKI AND SURFING; RODS FOR FISHING; SKI BAGS; SURF BOARDS; SURF PADDLES; SURF SKIS; SURFBOARD FINS; SURFBOARD TRACTION PADS; SURFBOARD WAX (U.S. CLS. 22, 23, 38 AND 50).

FIRST USE 3-20-2013; IN COMMERCE 8-20-2013.  
LIEF MARTIN, EXAMINING ATTORNEY

SN 86-246,737. NEW BREED OUTDOORS, LLC, FULTON-DALE, AL. FILED 4-9-2014.

**SEDUCTION**

THE MARK CONSISTS OF STANDARD CHARACTERS WITHOUT CLAIM TO ANY PARTICULAR FONT, STYLE, SIZE, OR COLOR.

FOR ARCHERY BOWS (U.S. CLS. 22, 23, 38 AND 50).  
BARBARA BROWN, EXAMINING ATTORNEY

SN 86-246,742. IGT, RENO, NV. FILED 4-9-2014.

**MERLIN**

THE MARK CONSISTS OF STANDARD CHARACTERS WITHOUT CLAIM TO ANY PARTICULAR FONT, STYLE, SIZE, OR COLOR.

OWNER OF U.S. REG. NO. 3,458,487.  
FOR GAMING MACHINES, NAMELY, DEVICES WHICH ACCEPT A WAGER (U.S. CLS. 22, 23, 38 AND 50).

LEIGH CAROLINE CASE, EXAMINING ATTORNEY

**CLASS 28—(Continued).**

SN 86-246,743. IGT, RENO, NV. FILED 4-9-2014.

**IT'S RAINING CASH**

THE MARK CONSISTS OF STANDARD CHARACTERS WITHOUT CLAIM TO ANY PARTICULAR FONT, STYLE, SIZE, OR COLOR.

OWNER OF U.S. REG. NO. 3,349,606.

FOR GAMING MACHINES, NAMELY, DEVICES WHICH ACCEPT A WAGER (U.S. CLS. 22, 23, 38 AND 50).

LEIGH CAROLINE CASE, EXAMINING ATTORNEY

SN 86-246,750. THOSE CHARACTERS FROM CLEVELAND, INC., CLEVELAND, OH. FILED 4-9-2014.

**HERSELF THE ELF**

THE MARK CONSISTS OF STANDARD CHARACTERS WITHOUT CLAIM TO ANY PARTICULAR FONT, STYLE, SIZE, OR COLOR.

FOR PLUSH TOYS; TOY ACTION FIGURES AND ACCESSORIES THEREFOR; TOY FIGURES (U.S. CLS. 22, 23, 38 AND 50).

LESLIE RICHARDS, EXAMINING ATTORNEY

SN 86-246,763. TAYLOR MADE GOLF COMPANY, INC., CARLSBAD, CA. FILED 4-9-2014.

**OWN THE SECOND SHOT**

THE MARK CONSISTS OF STANDARD CHARACTERS WITHOUT CLAIM TO ANY PARTICULAR FONT, STYLE, SIZE, OR COLOR.

FOR GOLF CLUBS (U.S. CLS. 22, 23, 38 AND 50).

FIRST USE 1-21-2014; IN COMMERCE 1-21-2014.

DOMINICK J. SALEMI, EXAMINING ATTORNEY

**CLASS 28—(Continued).**

SN 86-246,766. THOSE CHARACTERS FROM CLEVELAND, INC., CLEVELAND, OH. FILED 4-9-2014.

# SOUR GRAPES

THE MARK CONSISTS OF STANDARD CHARACTERS WITHOUT CLAIM TO ANY PARTICULAR FONT, STYLE, SIZE, OR COLOR.  
FOR PLUSH TOYS; TOY ACTION FIGURES AND ACCESSORIES THEREFOR; TOY FIGURES (U.S. CLS. 22, 23, 38 AND 50).  
LESLIE RICHARDS, EXAMINING ATTORNEY

---

SN 86-246,772. THOSE CHARACTERS FROM CLEVELAND, INC., CLEVELAND, OH. FILED 4-9-2014.

# APPLE DUMPLIN

THE MARK CONSISTS OF STANDARD CHARACTERS WITHOUT CLAIM TO ANY PARTICULAR FONT, STYLE, SIZE, OR COLOR.  
FOR PLUSH TOYS; TOY ACTION FIGURES AND ACCESSORIES THEREFOR; TOY FIGURES (U.S. CLS. 22, 23, 38 AND 50).  
LESLIE RICHARDS, EXAMINING ATTORNEY

---

SN 86-246,776. THOSE CHARACTERS FROM CLEVELAND, INC., CLEVELAND, OH. FILED 4-9-2014.

# SWEET GRAPES

THE MARK CONSISTS OF STANDARD CHARACTERS WITHOUT CLAIM TO ANY PARTICULAR FONT, STYLE, SIZE, OR COLOR.  
FOR PLUSH TOYS; TOY ACTION FIGURES AND ACCESSORIES THEREFOR; TOY FIGURES (U.S. CLS. 22, 23, 38 AND 50).  
LESLIE RICHARDS, EXAMINING ATTORNEY

**CLASS 28—(Continued).**

SN 86-246,806. NEW BREED OUTDOORS, LLC, FULTON-DALE, AL. FILED 4-9-2014.

# GENETIX

THE MARK CONSISTS OF STANDARD CHARACTERS WITHOUT CLAIM TO ANY PARTICULAR FONT, STYLE, SIZE, OR COLOR.  
FOR ARCHERY BOWS (U.S. CLS. 22, 23, 38 AND 50).  
BARBARA BROWN, EXAMINING ATTORNEY

---

SN 86-246,812. MATTEL, INC., EL SEGUNDO, CA. FILED 4-9-2014.

# ORIGINAL 16

THE MARK CONSISTS OF STANDARD CHARACTERS WITHOUT CLAIM TO ANY PARTICULAR FONT, STYLE, SIZE, OR COLOR.  
FOR TOY VEHICLES AND ACCESSORIES THEREFOR (U.S. CLS. 22, 23, 38 AND 50).  
JAMES GRIFFIN, EXAMINING ATTORNEY

---

SN 86-246,814. MATTEL, INC., EL SEGUNDO, CA. FILED 4-9-2014.

# GEEK SHRIEK

THE MARK CONSISTS OF STANDARD CHARACTERS WITHOUT CLAIM TO ANY PARTICULAR FONT, STYLE, SIZE, OR COLOR.  
FOR DOLLS, DOLL CLOTHING AND DOLL ACCESSORIES (U.S. CLS. 22, 23, 38 AND 50).  
JAMES GRIFFIN, EXAMINING ATTORNEY

**CLASS 28—(Continued).**

SN 86-246,816. MATTEL, INC., EL SEGUNDO, CA. FILED 4-9-2014.

# MARISOL COXI

THE MARK CONSISTS OF STANDARD CHARACTERS WITHOUT CLAIM TO ANY PARTICULAR FONT, STYLE, SIZE, OR COLOR.

THE NAME(S), PORTRAIT(S), AND/OR SIGNATURE(S) SHOWN IN THE MARK DOES NOT IDENTIFY A PARTICULAR LIVING INDIVIDUAL.

FOR DOLLS, DOLL CLOTHING AND DOLL ACCESSORIES (U.S. CLS. 22, 23, 38 AND 50).  
JAMES GRIFFIN, EXAMINING ATTORNEY



SN 86-246,830. NEW BREED OUTDOORS, LLC, FULTON-DALE, AL. FILED 4-9-2014.

# LYCAN

THE MARK CONSISTS OF STANDARD CHARACTERS WITHOUT CLAIM TO ANY PARTICULAR FONT, STYLE, SIZE, OR COLOR.

FOR ARCHERY BOWS (U.S. CLS. 22, 23, 38 AND 50).  
BARBARA BROWN, EXAMINING ATTORNEY



SN 86-246,842. NEW BREED OUTDOORS, LLC, FULTON-DALE, AL. FILED 4-9-2014.

# CYBORG

THE MARK CONSISTS OF STANDARD CHARACTERS WITHOUT CLAIM TO ANY PARTICULAR FONT, STYLE, SIZE, OR COLOR.

FOR ARCHERY BOWS (U.S. CLS. 22, 23, 38 AND 50).  
BARBARA BROWN, EXAMINING ATTORNEY

**CLASS 28—(Continued).**

SN 86-246,890. MATTEL, INC., EL SEGUNDO, CA. FILED 4-9-2014.

# RIVER

THE MARK CONSISTS OF STANDARD CHARACTERS WITHOUT CLAIM TO ANY PARTICULAR FONT, STYLE, SIZE, OR COLOR.

FOR DOLLS, DOLL CLOTHING AND DOLL ACCESSORIES (U.S. CLS. 22, 23, 38 AND 50).  
JAMES GRIFFIN, EXAMINING ATTORNEY



SN 86-246,892. MATTEL, INC., EL SEGUNDO, CA. FILED 4-9-2014.

# HUDSON

THE MARK CONSISTS OF STANDARD CHARACTERS WITHOUT CLAIM TO ANY PARTICULAR FONT, STYLE, SIZE, OR COLOR.

FOR DOLLS, DOLL CLOTHING AND DOLL ACCESSORIES (U.S. CLS. 22, 23, 38 AND 50).  
JAMES GRIFFIN, EXAMINING ATTORNEY



SN 86-246,930. NEW BREED OUTDOORS, LLC, FULTON-DALE, AL. FILED 4-9-2014.

# HORIZON

THE MARK CONSISTS OF STANDARD CHARACTERS WITHOUT CLAIM TO ANY PARTICULAR FONT, STYLE, SIZE, OR COLOR.

FOR ARCHERY BOWS (U.S. CLS. 22, 23, 38 AND 50).  
BARBARA BROWN, EXAMINING ATTORNEY



**CLASS 28—(Continued).**

SN 86-246,950. KABUSHIKI KAISHA SQUARE ENIX (ALSO TRADING AS SQUARE ENIX CO., LTD.), TOKYO, JAPAN, FILED 4-9-2014.

# CHOCOBO

THE MARK CONSISTS OF STANDARD CHARACTERS WITHOUT CLAIM TO ANY PARTICULAR FONT, STYLE, SIZE, OR COLOR.

OWNER OF JAPAN REG. NO. 4529084, DATED 12-14-2001, EXPIRES 12-14-2021.

OWNER OF U.S. REG. NOS. 2,523,458, 3,971,759 AND OTHERS.

FOR DOLLS; TOY FIGURES; PLUSH TOYS; STUFFED TOYS; INFLATABLE TOYS; TOY SCALE MODELS; TOY VEHICLES; TOY GUNS; TOY SWORDS; PLAYING CARDS; CARD GAMES; BOARD GAMES; JIGSAW PUZZLES; HAND HELD UNITS FOR PLAYING VIDEO GAMES OTHER THAN THOSE ADAPTED FOR USE WITH AN EXTERNAL DISPLAY SCREEN OR MONITOR; VIDEO GAME CONTROLLERS (U.S. CLS. 22, 23, 38 AND 50).

ERIC SABLE, EXAMINING ATTORNEY

**CLASS 28—(Continued).**

SN 86-247,267. ABATRON, INC., KENOSHA, WI. FILED 4-9-2014.

# WHALEBACK

THE MARK CONSISTS OF STANDARD CHARACTERS WITHOUT CLAIM TO ANY PARTICULAR FONT, STYLE, SIZE, OR COLOR.

FOR PADDLE BOARDS; PADDLE SURFBOARDS; STAND-UP PADDLE BOARDS; STAND-UP SURF PADDLES (U.S. CLS. 22, 23, 38 AND 50).

SIMON TENG, EXAMINING ATTORNEY

SN 86-247,697. G. LOOMIS, INC., WOODLAND, WA. FILED 4-9-2014.

# GUARANTEED LOVE

SN 86-246,957. NEW BREED OUTDOORS, LLC, FULTONDALE, AL. FILED 4-9-2014.

# SPAWN

THE MARK CONSISTS OF STANDARD CHARACTERS WITHOUT CLAIM TO ANY PARTICULAR FONT, STYLE, SIZE, OR COLOR.

FOR ARCHERY BOWS (U.S. CLS. 22, 23, 38 AND 50).  
BARBARA BROWN, EXAMINING ATTORNEY

THE MARK CONSISTS OF STANDARD CHARACTERS WITHOUT CLAIM TO ANY PARTICULAR FONT, STYLE, SIZE, OR COLOR.

FOR FISHING POLES; FISHING REELS; FISHING RODS; FISHING TACKLE (U.S. CLS. 22, 23, 38 AND 50).  
BRIAN PINO, EXAMINING ATTORNEY

SN 86-247,199. TESFAYE, KIROS, COLUMBIA HEIGHTS, MN. FILED 4-9-2014.



The logo for T-GLOVE features the text "T-GLOVE" in a bold, sans-serif font. The "T" is significantly larger and positioned to the left of "GLOVE". The text is white and set against a dark, rectangular background.

THE MARK CONSISTS OF A GOLF TEE, A HYPHEN FOLLOWING THE GOLF TEE AND THE WORD "GLOVE" FOLLOWING THE HYPHEN.

FOR GLOVES FOR GOLF (U.S. CLS. 22, 23, 38 AND 50).

FIRST USE 8-31-2011; IN COMMERCE 8-31-2011.  
JENNIFER MARTIN, EXAMINING ATTORNEY

SN 86-247,727. GAMELI CRUZ RICARDEZ, NORTH LAS VEGAS, NV. FILED 4-9-2014.

# WATERBLADE

THE MARK CONSISTS OF STANDARD CHARACTERS WITHOUT CLAIM TO ANY PARTICULAR FONT, STYLE, SIZE, OR COLOR.

FOR BOARDS USED IN THE PRACTICE OF WATER SPORTS; LEASHES USED IN CONJUNCTION WITH SURFING (U.S. CLS. 22, 23, 38 AND 50).

KATHERINE CHANG, EXAMINING ATTORNEY

**CLASS 28—(Continued).**

SN 86-247,918. SENNOTT, HOLLY, FRANKLIN, MA. FILED 4-10-2014.

## Kooky Critters

THE MARK CONSISTS OF STANDARD CHARACTERS WITHOUT CLAIM TO ANY PARTICULAR FONT, STYLE, SIZE, OR COLOR.

FOR STUFFED DOLLS AND ANIMALS (U.S. CLS. 22, 23, 38 AND 50).

FIRST USE 2-5-2010; IN COMMERCE 2-5-2010.  
HEATHER SAPP, EXAMINING ATTORNEY

---

SN 86-248,270. AGS LLC, LAS VEGAS, NV. FILED 4-10-2014.

## GETTING BIZZY

THE MARK CONSISTS OF STANDARD CHARACTERS WITHOUT CLAIM TO ANY PARTICULAR FONT, STYLE, SIZE, OR COLOR.

FOR GAMING EQUIPMENT, NAMELY, SLOT MACHINES WITH OR WITHOUT VIDEO OUTPUT; GAMING MACHINES FOR GAMBLING; GAMING MACHINES INCLUDING SLOT MACHINES OR VIDEO LOTTERY TERMINALS; GAMING MACHINES, NAMELY SLOT MACHINES AND VIDEO LOTTERY TERMINALS; GAMING MACHINES, NAMELY, DEVICES WHICH ACCEPT A WAGER; MACHINES FOR PLAYING GAMES OF CHANCE; SLOT MACHINES (U.S. CLS. 22, 23, 38 AND 50).

CAITLIN WATTS-FITZGERALD, EXAMINING ATTORNEY

---

SN 86-248,274. AGS LLC, LAS VEGAS, NV. FILED 4-10-2014.

## KISS CORRAL

THE MARK CONSISTS OF STANDARD CHARACTERS WITHOUT CLAIM TO ANY PARTICULAR FONT, STYLE, SIZE, OR COLOR.

FOR GAMING EQUIPMENT, NAMELY, SLOT MACHINES WITH OR WITHOUT VIDEO OUTPUT; GAMING MACHINES FOR GAMBLING; GAMING MACHINES INCLUDING SLOT MACHINES OR VIDEO LOTTERY TERMINALS; GAMING MACHINES, NAMELY SLOT MACHINES AND VIDEO LOTTERY TERMINALS; GAMING MACHINES, NAMELY, DEVICES WHICH ACCEPT A WAGER; MACHINES FOR PLAYING GAMES OF CHANCE; SLOT MACHINES (U.S. CLS. 22, 23, 38 AND 50).

CAITLIN WATTS-FITZGERALD, EXAMINING ATTORNEY

**CLASS 28—(Continued).**

SN 86-248,277. AGS LLC, LAS VEGAS, NV. FILED 4-10-2014.

## TONGUE TIED

THE MARK CONSISTS OF STANDARD CHARACTERS WITHOUT CLAIM TO ANY PARTICULAR FONT, STYLE, SIZE, OR COLOR.

FOR GAMING EQUIPMENT, NAMELY, SLOT MACHINES WITH OR WITHOUT VIDEO OUTPUT; GAMING MACHINES FOR GAMBLING; GAMING MACHINES INCLUDING SLOT MACHINES OR VIDEO LOTTERY TERMINALS; GAMING MACHINES, NAMELY SLOT MACHINES AND VIDEO LOTTERY TERMINALS; GAMING MACHINES, NAMELY, DEVICES WHICH ACCEPT A WAGER; MACHINES FOR PLAYING GAMES OF CHANCE; SLOT MACHINES (U.S. CLS. 22, 23, 38 AND 50).

CAITLIN WATTS-FITZGERALD, EXAMINING ATTORNEY

---

SN 86-248,279. AGS LLC, LAS VEGAS, NV. FILED 4-10-2014.

## KISS CONNECT

THE MARK CONSISTS OF STANDARD CHARACTERS WITHOUT CLAIM TO ANY PARTICULAR FONT, STYLE, SIZE, OR COLOR.

FOR GAMING EQUIPMENT, NAMELY, SLOT MACHINES WITH OR WITHOUT VIDEO OUTPUT; GAMING MACHINES FOR GAMBLING; GAMING MACHINES INCLUDING SLOT MACHINES OR VIDEO LOTTERY TERMINALS; GAMING MACHINES, NAMELY SLOT MACHINES AND VIDEO LOTTERY TERMINALS; GAMING MACHINES, NAMELY, DEVICES WHICH ACCEPT A WAGER; MACHINES FOR PLAYING GAMES OF CHANCE; SLOT MACHINES (U.S. CLS. 22, 23, 38 AND 50).

CAITLIN WATTS-FITZGERALD, EXAMINING ATTORNEY

---

SN 86-248,339. HARDISTY, HANS, POUGHKEEPSIE, NY. FILED 4-10-2014.

## Chicken Fingers

THE MARK CONSISTS OF STANDARD CHARACTERS WITHOUT CLAIM TO ANY PARTICULAR FONT, STYLE, SIZE, OR COLOR.

FOR INFANT, BABY, AND YOUNG CHILDREN TOYS, NAMELY, NON-EDIBLE TOYS THAT RESEMBLE CHICKENS USED BY INFANTS, BABIES, OR YOUNG CHILDREN WHEN THEY ARE MOUTHING OR TEE-THING (U.S. CLS. 22, 23, 38 AND 50).

TOBY BULLOFF, EXAMINING ATTORNEY

**CLASS 28—(Continued).**

SN 86-248,776. DUNLOP SPORTS COMPANY LIMITED, KOBE, JAPAN, FILED 4-10-2014.

# WEDGECRAFT

THE MARK CONSISTS OF STANDARD CHARACTERS WITHOUT CLAIM TO ANY PARTICULAR FONT, STYLE, SIZE, OR COLOR.  
FOR GOLF CLUBS (U.S. CLS. 22, 23, 38 AND 50).  
EDWARD NELSON, EXAMINING ATTORNEY

---

SN 86-248,781. MARBLES HOLDINGS, INC., CHICAGO, IL. FILED 4-10-2014.

# IdiomAddict

THE MARK CONSISTS OF STANDARD CHARACTERS WITHOUT CLAIM TO ANY PARTICULAR FONT, STYLE, SIZE, OR COLOR.  
FOR PARLOUR GAMES (U.S. CLS. 22, 23, 38 AND 50).  
FIRST USE 8-12-2013; IN COMMERCE 8-12-2013.  
MIAH ROSENBERG, EXAMINING ATTORNEY

---

SN 86-248,790. MARBLES HOLDINGS, INC., CHICAGO, IL. FILED 4-10-2014.

# Tic Tac Two

THE MARK CONSISTS OF STANDARD CHARACTERS WITHOUT CLAIM TO ANY PARTICULAR FONT, STYLE, SIZE, OR COLOR.  
FOR PARLOUR GAMES (U.S. CLS. 22, 23, 38 AND 50).  
FIRST USE 9-21-2011; IN COMMERCE 9-21-2011.  
MIAH ROSENBERG, EXAMINING ATTORNEY

**CLASS 28—(Continued).**

SN 86-248,888. WORDTOV LLC, DBA WORDTOV, MIAMI BEACH, FL. FILED 4-10-2014.

# WORDTOV

THE MARK CONSISTS OF STANDARD CHARACTERS WITHOUT CLAIM TO ANY PARTICULAR FONT, STYLE, SIZE, OR COLOR.  
FOR BOARD GAMES; ELECTRONIC INTERACTIVE BOARD GAMES FOR USE WITH EXTERNAL MONITOR; EQUIPMENT SOLD AS A UNIT FOR PLAYING BOARD GAMES; GAME TABLES; GAMING TABLES; MEMORY GAMES; PORTABLE GAMES WITH LIQUID CRYSTAL DISPLAYS; POSITIONABLE PRINTED TOY FIGURES FOR USE IN GAMES; POSITIONABLE THREE DIMENSIONAL TOYS FOR USE IN GAMES; PRINTED POSITIONABLE TOYS FOR USE IN CHILDREN'S BOARD GAMES (U.S. CLS. 22, 23, 38 AND 50).  
JOHN DALIER, EXAMINING ATTORNEY

---

SN 86-248,918. LANG, KENNETH, MCHENRY, IL. FILED 4-10-2014.

# SwingalignGolf.com

THE MARK CONSISTS OF STANDARD CHARACTERS WITHOUT CLAIM TO ANY PARTICULAR FONT, STYLE, SIZE, OR COLOR.  
FOR GOLF CLUB SWING AID. NAMELY, A BASE BOARD USED TO CREATE FEEDBACK FOR SWING ADJUSTMENTS (U.S. CLS. 22, 23, 38 AND 50).  
EMILY CHUO, EXAMINING ATTORNEY

---

SN 86-248,935. DQC INTERNATIONAL, CORP., TAMPA, FL. FILED 4-10-2014.

# AMBITION

THE MARK CONSISTS OF STANDARD CHARACTERS WITHOUT CLAIM TO ANY PARTICULAR FONT, STYLE, SIZE, OR COLOR.  
FOR FISHING REELS; FISHING RODS (U.S. CLS. 22, 23, 38 AND 50).  
FIRST USE 7-10-2012; IN COMMERCE 9-1-2012.  
RAMONA ORTIGA, EXAMINING ATTORNEY

**CLASS 28—(Continued).**

SN 86-249,058. DQC INTERNATIONAL, CORP., TAMPA, FL.  
FILED 4-10-2014.

# ENVY

THE MARK CONSISTS OF STANDARD CHARACTERS  
WITHOUT CLAIM TO ANY PARTICULAR FONT, STYLE,  
SIZE, OR COLOR.

FOR FISHING RODS (U.S. CLS. 22, 23, 38 AND 50).  
FIRST USE 6-6-2012; IN COMMERCE 8-10-2012.  
RAMONA ORTIGA, EXAMINING ATTORNEY

---

SN 86-249,681. KALAMA, KAHANA, SAN DIEGO, CA. AND  
WICKENS, BILLY, SAN DIEGO, CA. FILED 4-11-2014.

# SHOOTS

THE MARK CONSISTS OF STANDARD CHARACTERS  
WITHOUT CLAIM TO ANY PARTICULAR FONT, STYLE,  
SIZE, OR COLOR.

FOR SPORTING GOODS, NAMELY, SURFBOARDS  
AND STAND UP PADDLE BOARDS, BODY BOARDS,  
PARTS AND ACCESSORIES FOR ANY OF THE AFORE-  
GOING GOODS, INCLUDING FINS AND FIN BOXES,  
DECK GRIPS AND TRACTION PADS FOR BOARDS,  
BAGS AND COVERS FOR SPORTING GOODS,  
NAMELY, BOARD BAGS AND COVERS, PADDLE  
BAGS, WAX COMBS, LEG ROPES AND LEASHES FOR  
ANY OF THE AFOREGOING SPORTING GOODS (U.S.  
CLS. 22, 23, 38 AND 50).

FIRST USE 5-7-2011; IN COMMERCE 5-7-2011.  
SCOTT BIBB, EXAMINING ATTORNEY

---

SN 86-250,253. DUCK CREEK DECOY WORKS LLC, DEN-  
VER, CO. FILED 4-11-2014.

# FLASHBACK

THE MARK CONSISTS OF STANDARD CHARACTERS  
WITHOUT CLAIM TO ANY PARTICULAR FONT, STYLE,  
SIZE, OR COLOR.

FOR WATERFOWL HUNTING DECOYS (U.S. CLS. 22,  
23, 38 AND 50).  
DOUGLAS LEE, EXAMINING ATTORNEY

**CLASS 28—(Continued).**

SN 86-250,270. MAJOR CRAFT CO., LTD., OSAKA-SHI,  
OSAKA, JAPAN, FILED 4-11-2014.

# NANOACE

THE MARK CONSISTS OF STANDARD CHARACTERS  
WITHOUT CLAIM TO ANY PARTICULAR FONT, STYLE,  
SIZE, OR COLOR.

FOR FISHING TACKLE (U.S. CLS. 22, 23, 38 AND 50).  
KAPIL BHANOT, EXAMINING ATTORNEY

---

SN 86-251,759. KOPPERS FISHING AND TACKLE CORP.,  
NIAGARA ON THE LAKE, CANADA, FILED 4-14-2014.

# MATCH THE HATCH

THE MARK CONSISTS OF STANDARD CHARACTERS  
WITHOUT CLAIM TO ANY PARTICULAR FONT, STYLE,  
SIZE, OR COLOR.

FOR ARTIFICIAL FISHING LURES (U.S. CLS. 22, 23,  
38 AND 50).

ANDREA K. NADELMAN, EXAMINING ATTORNEY

---

SN 86-251,834. DQC INTERNATIONAL, CORP., TAMPA, FL.  
FILED 4-14-2014.

# Widow Maker

THE MARK CONSISTS OF STANDARD CHARACTERS  
WITHOUT CLAIM TO ANY PARTICULAR FONT, STYLE,  
SIZE, OR COLOR.

FOR FISHING RODS (U.S. CLS. 22, 23, 38 AND 50).  
FIRST USE 6-1-2013; IN COMMERCE 1-1-2014.  
RAMONA ORTIGA, EXAMINING ATTORNEY

**CLASS 28—(Continued).**

SN 86-252,029. STUCKEY, BRYAN W, EULESS, TX. FILED 4-14-2014.

# Mortarball

THE MARK CONSISTS OF STANDARD CHARACTERS WITHOUT CLAIM TO ANY PARTICULAR FONT, STYLE, SIZE, OR COLOR.

FOR ACTION SKILL GAMES; EQUIPMENT SOLD AS A UNIT FOR PLAYING ACTION TYPE TARGET GAMES; HAND-HELD, NON-ELECTRONIC SKILL GAMES; OUTDOOR ACTIVITY GAME EQUIPMENT SOLD AS A UNIT COMPRISING BALL LAUNCHERS AND BALL LAUNCHER ACCESSORIES FOR PLAYING GAMES (U.S. CLS. 22, 23, 38 AND 50).

TEJBIR SINGH, EXAMINING ATTORNEY

**CLASS 28—(Continued).**

SN 86-256,152. IGT, RENO, NV. FILED 4-18-2014.

# GONG XI FA CAI

THE MARK CONSISTS OF STANDARD CHARACTERS WITHOUT CLAIM TO ANY PARTICULAR FONT, STYLE, SIZE, OR COLOR.

THE ENGLISH TRANSLATION OF GONG XI FA CAI IN THE MARK IS WISHING YOU BECOME RICH.

FOR GAMING MACHINES, NAMELY, DEVICES WHICH ACCEPT A WAGER (U.S. CLS. 22, 23, 38 AND 50).

LEIGH CAROLINE CASE, EXAMINING ATTORNEY

SN 86-253,378. REQUISITE SOLUTIONS INCORPORATED, CHICAGO, IL. FILED 4-16-2014.



THE MARK CONSISTS OF THE WORD "BOUNCE" WITH THE "O" IN THE MARK FORMED BY A BOUNCING BALL.

FOR GAME EQUIPMENT, NAMELY, BALLS AND PLAY STRUCTURES CONTAINING OPENINGS FOR PLAYING INDOOR AND OUTDOOR GAMES (U.S. CLS. 22, 23, 38 AND 50).

BARBARA A. GOLD, EXAMINING ATTORNEY

SN 86-257,814. DQC INTERNATIONAL, CORP., TAMPA, FL. FILED 4-21-2014.

# HellBent

THE MARK CONSISTS OF STANDARD CHARACTERS WITHOUT CLAIM TO ANY PARTICULAR FONT, STYLE, SIZE, OR COLOR.

FOR FISHING RODS (U.S. CLS. 22, 23, 38 AND 50).

FIRST USE 6-1-2013; IN COMMERCE 7-16-2013.

RAMONA ORTIGA, EXAMINING ATTORNEY

SN 86-256,149. IGT, RENO, NV. FILED 4-18-2014.



THE MARK CONSISTS OF AN ANGLED CHECK MARK WITH A POINTED END SUPERIMPOSED ON AN IMAGE OF A SHIELD.

FOR GAMING MACHINES, NAMELY, DEVICES WHICH ACCEPT A WAGER (U.S. CLS. 22, 23, 38 AND 50).

LEIGH CAROLINE CASE, EXAMINING ATTORNEY

SN 86-259,821. DQC INTERNATIONAL, CORP., TAMPA, FL. FILED 4-23-2014.

# MUSE

THE MARK CONSISTS OF STANDARD CHARACTERS WITHOUT CLAIM TO ANY PARTICULAR FONT, STYLE, SIZE, OR COLOR.

FOR FISHING POLES; FISHING RODS; RODS FOR FISHING (U.S. CLS. 22, 23, 38 AND 50).

RAMONA ORTIGA, EXAMINING ATTORNEY

**CLASS 28—(Continued).**

SN 86-267,888. WILDGAME INNOVATIONS, LLC, BROUSSARD, LA. FILED 4-30-2014.

**CLASS 28—(Continued).**

SN 86-272,620. GRACO CHILDREN'S PRODUCTS INC., OAK BROOK, IL. FILED 5-6-2014.

## TRU-TOUCH

THE MARK CONSISTS OF STANDARD CHARACTERS WITHOUT CLAIM TO ANY PARTICULAR FONT, STYLE, SIZE, OR COLOR.

FOR HUNTING GAME CALLS (U.S. CLS. 22, 23, 38 AND 50).

FONG HSU, EXAMINING ATTORNEY

## SIMPLE SWAY

THE MARK CONSISTS OF STANDARD CHARACTERS WITHOUT CLAIM TO ANY PARTICULAR FONT, STYLE, SIZE, OR COLOR.

FOR BABY SWINGS (U.S. CLS. 22, 23, 38 AND 50).

ELISSA GARBER KON, EXAMINING ATTORNEY

SN 86-268,988. DQC INTERNATIONAL, CORP., TAMPA, FL. FILED 5-1-2014.

## The Snitch

THE MARK CONSISTS OF STANDARD CHARACTERS WITHOUT CLAIM TO ANY PARTICULAR FONT, STYLE, SIZE, OR COLOR.

FOR FISHING RODS (U.S. CLS. 22, 23, 38 AND 50). FIRST USE 1-15-2014; IN COMMERCE 1-15-2014.

RAMONA ORTIGA, EXAMINING ATTORNEY

SN 86-281,046. JAKKS PACIFIC, INC., MALIBU, CA. FILED 5-14-2014.

SN 86-269,101. DQC INTERNATIONAL, CORP., TAMPA, FL. FILED 5-1-2014.

## FIRST FOOT FORWARD

## Frosty

THE MARK CONSISTS OF STANDARD CHARACTERS WITHOUT CLAIM TO ANY PARTICULAR FONT, STYLE, SIZE, OR COLOR.

FOR FISHING REELS; FISHING RODS; REELS FOR FISHING; RODS FOR FISHING (U.S. CLS. 22, 23, 38 AND 50).

FIRST USE 4-1-2013; IN COMMERCE 9-10-2013.

RAMONA ORTIGA, EXAMINING ATTORNEY

THE MARK CONSISTS OF STANDARD CHARACTERS WITHOUT CLAIM TO ANY PARTICULAR FONT, STYLE, SIZE, OR COLOR.

FOR RIDE-ON TOYS (U.S. CLS. 22, 23, 38 AND 50).

TARA BHUPATHI, EXAMINING ATTORNEY

**CLASS 28—(Continued).**

SN 86-281,354. MAIKAU CORPORATION, SAN CLEMENTE, CA. FILED 5-14-2014.



OWNER OF U.S. REG. NO. 3,721,366.  
THE MARK CONSISTS OF STYLIZED LETTERS "K", "O" AND "A".

THE ENGLISH TRANSLATION OF THE MARK IS "WARRIOR", "FEARLESS" AND "BRAVE".

FOR BAGS ESPECIALLY DESIGNED FOR SURFBOARDS; BAGS FOR SKATEBOARDS; BALL BEARINGS FOR SKATEBOARDS; BINDINGS FOR SNOWBOARDS; DECK GRIPS FOR SPORTS EQUIPMENT BOARDS, NAMELY, TRACTION PADS; HARNESES SPECIALLY ADAPTED FOR CARRYING SNOWBOARDS, SKIS AND SKATEBOARDS; LEASHES FOR SURFBOARDS; PADDLE SURFBOARDS; PADDLES FOR USE WITH SURFBOARDS; PROTECTIVE PADDING FOR SKATEBOARDING; PROTECTIVE PADDING FOR SNOWBOARDING; SKATEBOARD DECKS; SKATEBOARD GRIP TAPES; SKATEBOARD RAILS; SKATEBOARD RISER PADS; SKATEBOARD TRUCKS; SKATEBOARD WAX; SKATEBOARD WHEELS; SKATEBOARDING GLOVES; SKATEBOARDS; SNOWBOARD BINDINGS; SNOWBOARD DECKS; SNOWBOARD WAX; SNOWBOARDS; SPORTS EQUIPMENT, NAMELY, ROTATING INTERFACES SPECIALLY ADAPTED FOR ATTACHING SNOWBOARDS TO BINDINGS; SURFBOARD CARRIER WORN ON THE BODY; SURFBOARD FINS; SURFBOARD HOLDER WORN ON THE BODY; SURFBOARD LEASHES; SURFBOARD STORAGE RACK; SURFBOARD TRACTION PADS; SURFBOARD WAX; SURFBOARDS; TRACTION PADS FOR SPORTS EQUIPMENT BOARDS, NAMELY, TRACTION PADS; TRACTION PADS FOR SURFBOARDS; WAKEBOARDS; WAX FOR SPORTS EQUIPMENT, NAMELY, TRACTION WAX; WAXING BRUSHES FOR SKIING AND SNOWBOARDING (U.S. CLS. 22, 23, 38 AND 50).

FIRST USE 3-25-2014; IN COMMERCE 3-25-2014.  
REBECCA SMITH, EXAMINING ATTORNEY

SN 86-283,015. SLAB JIGGIES, MIRA LOMA, CA. FILED 5-16-2014.

## REEL IN RESULTS

THE MARK CONSISTS OF STANDARD CHARACTERS WITHOUT CLAIM TO ANY PARTICULAR FONT, STYLE, SIZE, OR COLOR.

FOR FISHING TACKLE; LURES FOR HUNTING OR FISHING (U.S. CLS. 22, 23, 38 AND 50).

CHRISTINA SOBRAL, EXAMINING ATTORNEY

**CLASS 28—(Continued).**

SN 86-285,416. WORDTOV LLC, DBA WORDTOV, MIAMI BEACH, FL. FILED 5-19-2014.

SPREAD YOUR COLOR ALL OVER

THE MARK CONSISTS OF STANDARD CHARACTERS WITHOUT CLAIM TO ANY PARTICULAR FONT, STYLE, SIZE, OR COLOR.

FOR BOARD GAMES; ELECTRONIC INTERACTIVE BOARD GAMES FOR USE WITH EXTERNAL MONITOR; EQUIPMENT SOLD AS A UNIT FOR PLAYING BOARD GAMES; GAME TABLES; GAMING TABLES; MEMORY GAMES; PORTABLE GAMES WITH LIQUID CRYSTAL DISPLAYS; POSITIONABLE PRINTED TOY FIGURES FOR USE IN GAMES; POSITIONABLE THREE DIMENSIONAL TOYS FOR USE IN GAMES; PRINTED POSITIONABLE TOYS FOR USE IN CHILDREN'S BOARD GAMES (U.S. CLS. 22, 23, 38 AND 50).

JOHN DALIER, EXAMINING ATTORNEY

SN 86-292,624. RUBIE'S COSTUME CO., INC., RICHMOND HILL, NY. FILED 5-27-2014.

## CHARACTEREYES

THE MARK CONSISTS OF STANDARD CHARACTERS WITHOUT CLAIM TO ANY PARTICULAR FONT, STYLE, SIZE, OR COLOR.

FOR DISGUISE MASKS; FACE MASKS, PARTIAL AND FULL FACE MASKS; COSTUME MASKS; TOY AND NOVELTY FACE MASKS (U.S. CLS. 22, 23, 38 AND 50).

LOKSYE G LEE RISO, EXAMINING ATTORNEY

SN 86-294,569. DUNLOP SPORTS COMPANY LIMITED, KOBE, JAPAN, FILED 5-29-2014.

## TOUR EXTREME

THE MARK CONSISTS OF STANDARD CHARACTERS WITHOUT CLAIM TO ANY PARTICULAR FONT, STYLE, SIZE, OR COLOR.

FOR GOLF CLUBS (U.S. CLS. 22, 23, 38 AND 50).

EDWARD NELSON, EXAMINING ATTORNEY

**CLASS 28—(Continued).**

SN 86-299,385. DUNLOP SPORTS COMPANY LIMITED, KOBE, JAPAN, FILED 6-3-2014.

# TOUR RACK

THE MARK CONSISTS OF STANDARD CHARACTERS WITHOUT CLAIM TO ANY PARTICULAR FONT, STYLE, SIZE, OR COLOR.  
FOR GOLF CLUBS (U.S. CLS. 22, 23, 38 AND 50).  
EDWARD NELSON, EXAMINING ATTORNEY

SN 86-311,755. TAYLOR MADE GOLF COMPANY, INC., CARLSBAD, CA. FILED 6-17-2014.

# AEROBURNER

THE MARK CONSISTS OF STANDARD CHARACTERS WITHOUT CLAIM TO ANY PARTICULAR FONT, STYLE, SIZE, OR COLOR.  
OWNER OF U.S. REG. NOS. 1,411,498, 3,673,923 AND 3,680,379.  
FOR GOLF CLUBS (U.S. CLS. 22, 23, 38 AND 50).  
DOMINICK J. SALEMI, EXAMINING ATTORNEY

SN 86-315,425. VTECH ELECTRONICS NORTH AMERICA, LLC, ARLINGTON HEIGHTS, IL. FILED 6-20-2014.

# MAGICPOINT

THE MARK CONSISTS OF STANDARD CHARACTERS WITHOUT CLAIM TO ANY PARTICULAR FONT, STYLE, SIZE, OR COLOR.  
FOR BATTERY OPERATED ACTION TOYS; CHILDREN'S MULTIPLE ACTIVITY TOYS; ELECTRONIC ACTION TOYS; ELECTRONIC LEARNING TOYS; FANTASY CHARACTER TOYS; MECHANICAL ACTION TOYS; PLASTIC CHARACTER TOYS (U.S. CLS. 22, 23, 38 AND 50).  
RONALD MCMORROW, EXAMINING ATTORNEY

**CLASS 29—MEATS AND PROCESSED FOODS**

SN 79-118,113. LIDL STIFTUNG & CO. KG, FED REP GERMANY, FILED 7-19-2012.



PRIORITY DATE OF 1-31-2012 IS CLAIMED.  
OWNER OF INTERNATIONAL REGISTRATION 1129736 DATED 7-19-2012, EXPIRES 7-19-2022.

THE COLOR(S) BLACK, WHITE AND GOLD IS/ARE CLAIMED AS A FEATURE OF THE MARK.

THE MARK CONSISTS OF A RECTANGLE WITH CURVED SIDES, THE BORDER OF WHICH APPEARS IN GOLD, WITH THE WORDING "FRESCA FETTA" IN WHITE APPEARING UPON A BLACK BACKGROUND.

THE ENGLISH TRANSLATION OF "FRESCA FETTA" IN THE MARK IS "FRESH SLICE".

FOR SAUSAGE; SAUSAGE PRODUCTS, NAMELY, LIVER SAUSAGE, POULTRY SAUSAGE, LYONER-TYPE SAUSAGE, NAMELY, GARLIC BOLOGNA SAUSAGE, SMOKED SAUSAGE SPREAD, FRANKFURTERS, BAVARIAN MEATLOAF BEING SAUSAGE PRODUCT MADE FROM COMBINATIONS OF HAM, PORK, VEAL, AND LIVER; SMOKED SAUSAGE, SAUSAGE PRESERVES, BLACK PUDDING, SALAD MADE OF SAUSAGE, AND READY-TO-SERVE PREPARED MEALS CONSISTING PRIMARILY OF SAUSAGE AND SAUSAGE PRODUCTS; MEAT; MEAT PRODUCTS, NAMELY, COLD CUTS OF ROAST BEEF, COLD CUTS OF ROAST PORK, COLD CUTS OF ROAST CHICKEN, COLD CUTS OF ROAST TURKEY, HAM, TURKEY BREAST, BACON, BREAKFAST MEAT, MEAT PRESERVES, MEAT JELLIES, MEAT SALAD, CHICKEN, PORK AND BEEF PATTIES, MEATBALLS, MEAT SPREADS, AND READY-TO-SERVE PREPARED MEALS CONSISTING PRIMARILY OF MEAT AND MEAT PRODUCTS (U.S. CL. 46).

MARC LEIPZIG, EXAMINING ATTORNEY

SN 79-138,120. QUESOS NAVALMORAL, S.A., SPAIN, FILED 8-21-2013.



OWNER OF INTERNATIONAL REGISTRATION 1180825 DATED 8-21-2013, EXPIRES 8-21-2023.

NO CLAIM IS MADE TO THE EXCLUSIVE RIGHT TO USE THE PICTORIAL REPRESENTATION OF THE MAP OF CASTILLA-LA MANCHA, APART FROM THE MARK AS SHOWN.

THE COLOR(S) YELLOW, DARK PURPLE, PURPLE, WHITE AND BLACK IS/ARE CLAIMED AS A FEATURE OF THE MARK.

THE MARK CONSISTS OF THE STYLIZED WORDING



**CLASS 29—(Continued).**

"FIONE" IN THE COLOR YELLOW ACROSS A DARK PURPLE BANNER WITH A YELLOW BORDER ON THE TOP AND BOTTOM OF THE BANNER. THE BANNER IS SUPERIMPOSED OVER THE LEFT SIDE OF A WHITE CIRCLE WITH A WHITE EXTERIOR BORDER, FOLLOWED BY A BLACK INTERIOR BORDER, FOLLOWED BY A THIN WHITE INTERIOR BORDER, FOLLOWED BY A THIN PURPLE INTERIOR BORDER, WITH THE INTERIOR OF THE CIRCLE DESIGN IN THE COLOR WHITE. AT THE TOP OF THE WHITE CIRCLE IS A SMALL BLACK CIRCLE THAT CONTAINS A DEPICTION OF THE MAP OF THE REGION OF CASTILLA-LA MANCHA, WITH THE MAP BEING BLACK WITH A YELLOW OUTLINE AND HAVING A WHITE STYLIZED LETTER "N" WITHIN THE MAP.

THE WORDING "FIONE" HAS NO MEANING IN A FOREIGN LANGUAGE.

FOR CHEESE; DAIRY PRODUCTS EXCLUDING ICE CREAM, ICE MILK AND FROZEN YOGURT (U.S. CL. 46).

KRISTIN CARLSON, EXAMINING ATTORNEY

**CLASS 29—(Continued).**

SN 79-141,523. JIANNING XIAN HUAXIN FOOD CO.,LTD, CHINA, FILED 12-2-2013.



OWNER OF INTERNATIONAL REGISTRATION 1189592 DATED 12-2-2013, EXPIRES 12-2-2023.

THE MARK CONSISTS OF A DESIGN OF TWO BEEHIVES BETWEEN TWO CHINESE CHARACTERS.

THE ENGLISH TRANSLATION OF THE FOREIGN WORD(S) IN THE MARK IS: THE FIRST CHINESE CHARACTER TRANSLITERATED AS "FEI" MEANS "FLY", THE SECOND ONE TRANSLITERATED AS "JIE" MEANS "SWIFT".

THE TRANSLITERATION OF THE NON-LATIN CHARACTERS IN THE MARK IS "FEIJIE".

FOR DRIED EDIBLE BAMBOO SHOOTS; PROCESSED LOTUS SEEDS; DRIED EDIBLE FUNGUS; SALTED VEGETABLES; DRIED VEGETABLES; CANNED BAMBOO SHOOTS; CANDIED FRUIT (U.S. CL. 46).

BERNICE MIDDLETON, EXAMINING ATTORNEY

SN 79-138,278. LACTEAS GARCIA-BAQUERO, S.A., SPAIN, FILED 8-19-2013.



OWNER OF INTERNATIONAL REGISTRATION 1181245 DATED 8-19-2013, EXPIRES 8-19-2023.

THE NAME(S), PORTRAIT(S), AND/OR SIGNATURE(S) SHOWN IN THE MARK IDENTIFIES MIGUEL ANGEL "GARCIA BAQUERO", WHOSE CONSENT(S) TO REGISTER IS MADE OF RECORD.

THE COLOR(S) RED, GOLD, YELLOW, BLACK, WHITE AND GRAY IS/ARE CLAIMED AS A FEATURE OF THE MARK.

THE MARK CONSISTS OF THE WORDS "GARCIA BAQUERO" IN WHITE, OUTLINED IN BLACK WITHIN A RED BANNER OUTLINED IN GOLD. ABOVE THE BANNER, IS A BLACK AND GRAY WINDMILL DESIGN, BEHIND WHICH IS A YELLOW SUN OUTLINED IN GOLD.

FOR CHEESES (U.S. CL. 46).

FLORENTINA BLANDU, EXAMINING ATTORNEY

SN 85-659,775. ROCKY MOUNTAIN HONEY SMOKED FISH COMPANY, LLC, DBA HONEY SMOKED FISH CO., AURORA, CO. FILED 6-23-2012.



NO CLAIM IS MADE TO THE EXCLUSIVE RIGHT TO USE "SMOKED SALMON", APART FROM THE MARK AS SHOWN.

THE MARK CONSISTS OF THE WORDS "HONEY SMOKED SALMON" ON THE SIDE OF A FISH WHICH IS SUPERIMPOSED ON A BODY OF WATER WITH A MOUNTAIN RANGE LANDSCAPE IN THE BACKGROUND.

SEC. 2(F) AS TO "HONEY SMOKED SALMON".

FOR PRESERVED FISH (U.S. CL. 46).

FIRST USE 7-0-1997; IN COMMERCE 7-0-1997.

WILLIAM P. SHANAHAN, EXAMINING ATTORNEY

SN 79-139,265. ARLA FOODS AMBA, VIBY J, DENMARK, FILED 10-4-2013.

# HAVGUS

THE MARK CONSISTS OF STANDARD CHARACTERS WITHOUT CLAIM TO ANY PARTICULAR FONT, STYLE, SIZE, OR COLOR.

OWNER OF INTERNATIONAL REGISTRATION 1183684 DATED 10-4-2013, EXPIRES 10-4-2023.

THE ENGLISH TRANSLATION OF THE WORD "HAVGUS" IN THE MARK IS "SEA FOG".

FOR CHEESE (U.S. CL. 46).

EVELYN BRADLEY, EXAMINING ATTORNEY

**CLASS 29—(Continued).**

SN 85-758,841. GRAY & COMPANY, PORTLAND, OR. FILED 10-19-2012.

**CLASS 29—(Continued).**

SN 86-043,632. DAIRYFOOD USA, INC., BLUE MOUNDS, WI. FILED 8-21-2013.

**FARM TO MARKET**

THE MARK CONSISTS OF STANDARD CHARACTERS WITHOUT CLAIM TO ANY PARTICULAR FONT, STYLE, SIZE, OR COLOR.

FOR MARASCHINO CHERRIES (U.S. CL. 46).  
FIRST USE 2-12-2013; IN COMMERCE 2-12-2013.  
JENNIFER BUTTON, EXAMINING ATTORNEY

**QUESO DE CASA**

THE MARK CONSISTS OF STANDARD CHARACTERS WITHOUT CLAIM TO ANY PARTICULAR FONT, STYLE, SIZE, OR COLOR.

NO CLAIM IS MADE TO THE EXCLUSIVE RIGHT TO USE "QUESO", APART FROM THE MARK AS SHOWN. THE ENGLISH TRANSLATION OF "QUESO DE CASA" IN THE MARK IS "HOUSE OF CHEESE".  
FOR CHEESE (U.S. CL. 46).

BRENDAN MCCAULEY, EXAMINING ATTORNEY

SN 85-763,416. PERL'S BROS, TORONTO, ONTARIO, CANADA, FILED 10-25-2012.

**BUN POPPERS**

THE MARK CONSISTS OF STANDARD CHARACTERS WITHOUT CLAIM TO ANY PARTICULAR FONT, STYLE, SIZE, OR COLOR.

PRIORITY CLAIMED UNDER SEC. 44(D) ON CANADA APPLICATION NO. 1575205, FILED 4-26-2012.

FOR WIENERS, FRANKFURTERS, HOT DOGS AND SAUSAGES (U.S. CL. 46).

FIRST USE 4-28-2014; IN COMMERCE 4-28-2014.  
KAELIE KUNG, EXAMINING ATTORNEY

SN 86-043,890. CRAB COUNTRY GOURMET, LLC, SALISBURY, MD. FILED 8-21-2013.

SN 86-039,268. WOJCIEHOWSKI, CHARLES, DBA CAPT'N CHUCKY'S CRAB CAKE CO., LLC, NEWTOWN SQUARE, PA. FILED 8-15-2013.

**CRAB COUNTRY GOURMET**

"CAPT'N CHUCKY" IDENTIFIES THE NICKNAME OF CHARLES WOJCIEHOWSKI, A LIVING INDIVIDUAL WHOSE CONSENT IS OF RECORD.

THE COLOR(S) RED AND YELLOW AND BLACK IS/ARE CLAIMED AS A FEATURE OF THE MARK.

THE MARK CONSISTS OF A RED CRAB WITH WHITE SAILOR HAT AND A BLACK AND YELLOW VISOR. THE WORDS "CAPT'N CHUCKY'S" AND "CRAB CAKE CO" APPEAR IN RED TEXT NEXT TO THE CRAB AND "CRAB WITH AN ATTITUDE" APPEARS IN BLACK TEXT NEXT TO THE CRAB. THE BACKGROUND FOR THE ENTIRE DESIGN IS WHITE.

FOR CRAB CAKES (U.S. CL. 46).  
FIRST USE 10-14-2001; IN COMMERCE 10-14-2001.  
DORITT L. CARROLL, EXAMINING ATTORNEY

THE MARK CONSISTS OF STANDARD CHARACTERS WITHOUT CLAIM TO ANY PARTICULAR FONT, STYLE, SIZE, OR COLOR.

NO CLAIM IS MADE TO THE EXCLUSIVE RIGHT TO USE "CRAB" AND "GOURMET", APART FROM THE MARK AS SHOWN.

FOR PREPARED ENTREES CONSISTING PRIMARILY OF SEAFOOD (U.S. CL. 46).  
HEATHER BIDDULPH, EXAMINING ATTORNEY

**CLASS 29—(Continued).**

SN 86-047,620. FAGE LUXEMBOURG S.Á R.L, LUXEMBOURG, LUXEMBOURG, FILED 8-26-2013.



OWNER OF U.S. REG. NOS. 2,860,116, 3,289,607 AND OTHERS.

NO CLAIM IS MADE TO THE EXCLUSIVE RIGHT TO USE "#1 YOGURT IN GREECE", APART FROM THE MARK AS SHOWN.

THE COLOR(S) DARK BLUE AND LIGHT BLUE IS/ARE CLAIMED AS A FEATURE OF THE MARK.

THE MARK CONSISTS OF THE FOLLOWING: A LIGHT BLUE INCOMPLETE OVAL IN THE DESIGN OF A BRUSH STROKE SURROUNDING THE DARK BLUE UPWARDLY SLANTING WORDS "FAGE #1 YOGURT IN GREECE". THE COLOR WHITE REPRESENTS THE BACKGROUND AND IS NOT A PART OF THE MARK.

THE ENGLISH TRANSLATION OF THE WORD "FAGE" IN THE MARK IS "EAT".

FOR DAIRY PRODUCTS, NAMELY, YOGURT (U.S. CL. 46).

FIRST USE 8-19-2013; IN COMMERCE 8-19-2013.  
LANA PHAM, EXAMINING ATTORNEY

SN 86-063,956. MESEONZNIK, ALEXANDER, VALLEY VILLAGES, CA. FILED 9-13-2013.

7ja

THE MARK CONSISTS OF STANDARD CHARACTERS WITHOUT CLAIM TO ANY PARTICULAR FONT, STYLE, SIZE, OR COLOR.

THE ENGLISH TRANSLATION OF "JA" IN THE MARK IS "YES".

FOR CANNED FRUITS AND VEGETABLES; FRUIT AND VEGETABLE SALADS; FRUIT CONSERVES; FRUIT PRESERVES; FRUIT SALADS AND VEGETABLE SALADS; FRUITS IN PRESERVED FORM; MARINATED FRUITS AND VEGETABLES; PICKLED VEGETABLES; PRESERVED FRUIT AND VEGETABLES; PRESERVED FRUITS; PRESERVED FRUITS AND VEGETABLES; PRESERVED VEGETABLES; PRESERVED VEGETABLES (IN OIL); PROCESSED VEGETABLES; PROCESSED VEGETABLES AND FRUITS; PROCESSED VEGETABLES, NAMELY, COOKED CUCUMBER, DAIKON, MUSHROOMS, BELLFLOWER ROOT, SPINACH, SOYBEAN SPROUTS AND BRACKEN FERN STEMS USED IN BIBIMBAP DISHES; VEGETABLE PASTE; VEGETABLE PUREE; VEGETABLES IN VINEGAR (U.S. CL. 46).

FIRST USE 9-1-2012; IN COMMERCE 9-1-2012.  
NATALIE KENEALY, EXAMINING ATTORNEY

**CLASS 29—(Continued).**

SN 86-070,682. WAYMOUTH FARMS, INC., NEW HOPE, MN. FILED 9-20-2013.

Brainy Munchies

THE MARK CONSISTS OF STANDARD CHARACTERS WITHOUT CLAIM TO ANY PARTICULAR FONT, STYLE, SIZE, OR COLOR.

NO CLAIM IS MADE TO THE EXCLUSIVE RIGHT TO USE "MUNCHIES", APART FROM THE MARK AS SHOWN. FOR SNACK MIXES CONSISTING PRIMARILY OF NUTS AND DRIED FRUIT (U.S. CL. 46).

KERI CANTONE, EXAMINING ATTORNEY

SN 86-072,767. LM RESTAURANTS, INC., RALEIGH, NC. FILED 9-24-2013.

FRICKLES

THE MARK CONSISTS OF STANDARD CHARACTERS WITHOUT CLAIM TO ANY PARTICULAR FONT, STYLE, SIZE, OR COLOR.

FOR MENU ITEMS, NAMELY, FRIED PICKLES (U.S. CL. 46).

DAVID MURRAY, EXAMINING ATTORNEY

SN 86-095,348. RAHMOUN MIZRAHI, BROOKLYN, NY. FILED 10-18-2013.

Black Diamond Caviar

THE MARK CONSISTS OF STANDARD CHARACTERS WITHOUT CLAIM TO ANY PARTICULAR FONT, STYLE, SIZE, OR COLOR.

NO CLAIM IS MADE TO THE EXCLUSIVE RIGHT TO USE "BLACK" AND "CAVIAR", APART FROM THE MARK AS SHOWN.

FOR CAVIAR, NAMELY, FISH EGGS INCLUDING BOWFIN EGGS, HACKLEBACK EGGS AND PADDLE-FISH EGGS (U.S. CL. 46).

FIRST USE 8-1-2012; IN COMMERCE 3-1-2013.

KATHLEEN M. VANSTON, EXAMINING ATTORNEY

**CLASS 29—(Continued).**

SN 86-104,366. LONG, JOANNE M, BLOOMSBURG, PA. FILED 10-29-2013.

**INNER RELIEF**

THE MARK CONSISTS OF STANDARD CHARACTERS WITHOUT CLAIM TO ANY PARTICULAR FONT, STYLE, SIZE, OR COLOR.

FOR EDIBLE OIL (U.S. CL. 46).  
FIRST USE 1-2-2001; IN COMMERCE 1-2-2001.  
GINA HAYES, EXAMINING ATTORNEY

SN 86-110,984. TRUSTEES OF THE JAMIR & RACQUEL FAMILY TRUST, PARADISE VALLEY, AZ. FILED 11-5-2013.

**CRAVE THE CRUNCH**

THE MARK CONSISTS OF STANDARD CHARACTERS WITHOUT CLAIM TO ANY PARTICULAR FONT, STYLE, SIZE, OR COLOR.

FOR POTATO CHIPS (U.S. CL. 46).  
FIRST USE 4-16-2010; IN COMMERCE 4-16-2010.  
KELLEY WELLS, EXAMINING ATTORNEY

SN 86-125,495. UNILEVER N.V., ROTTERDAM, NETHERLANDS, FILED 11-21-2013.

**BERTOLLI ESSENZIALE**

THE MARK CONSISTS OF STANDARD CHARACTERS WITHOUT CLAIM TO ANY PARTICULAR FONT, STYLE, SIZE, OR COLOR.

OWNER OF U.S. REG. NOS. 3,699,084, 4,130,299 AND OTHERS.

THE NAME(S), PORTRAIT(S), AND/OR SIGNATURE(S) SHOWN IN THE MARK DOES NOT IDENTIFY A PARTICULAR LIVING INDIVIDUAL.

THE ENGLISH TRANSLATION OF "ESSENZIALE" IN THE MARK IS "ESSENTIAL".

FOR EDIBLE OILS AND FATS (U.S. CL. 46).  
DAVID ALESKOW, EXAMINING ATTORNEY

**CLASS 29—(Continued).**

SN 86-126,157. CLASSIC COOKING LLC, JAMAICA, NY. FILED 11-21-2013.

**hUMMBurgers**

THE MARK CONSISTS OF STANDARD CHARACTERS WITHOUT CLAIM TO ANY PARTICULAR FONT, STYLE, SIZE, OR COLOR.

FOR VEGGIE FOOD PRODUCTS, NAMELY, VEGETABLE BASED MEAT SUBSTITUTES, TEXTURED VEGETABLE PROTEIN FOR USE AS A MEAT SUBSTITUTE (U.S. CL. 46).

TASHIA BUNCH, EXAMINING ATTORNEY

SN 86-139,432. 13TH AVE FISH MARKET INC., DBA FREUND'S FISH, BROOKLYN, NY. FILED 12-10-2013.

**FREUND'S FAMOUS**

THE MARK CONSISTS OF STANDARD CHARACTERS WITHOUT CLAIM TO ANY PARTICULAR FONT, STYLE, SIZE, OR COLOR.

NO CLAIM IS MADE TO THE EXCLUSIVE RIGHT TO USE "FAMOUS", APART FROM THE MARK AS SHOWN.

FOR GEFILTE FISH, FRESH FISH, NOT LIVE, FROZEN FISH, CANNED TUNA FISH, AND BREADED FISH FILLETS (U.S. CL. 46).

FIRST USE 10-1-2013; IN COMMERCE 10-1-2013.  
DAVID ELTON, EXAMINING ATTORNEY

SN 86-139,577. 13TH AVE FISH MARKET INC., DBA FREUND'S FISH, BROOKLYN, NY. FILED 12-10-2013.



NO CLAIM IS MADE TO THE EXCLUSIVE RIGHT TO USE "FAMOUS", APART FROM THE MARK AS SHOWN.

THE COLOR(S) WHITE, YELLOW, GRAY, BLUE AND BLACK IS/ARE CLAIMED AS A FEATURE OF THE MARK.

THE MARK CONSISTS OF THE WORDING "FREUND'S FAMOUS" IN WHITE AND YELLOW ABOVE WHICH IS A GRAPHIC OF A FISH IN GRAY, BLUE, BLACK AND WHITE, ALL IN A BLUE CURVED RECTANGLE WITH ROUNDED CORNERS.

FOR GEFILTE FISH, FRESH FISH, NOT LIVE, FROZEN FISH, CANNED TUNA FISH, AND BREADED FISH FILLETS (U.S. CL. 46).

FIRST USE 10-1-2013; IN COMMERCE 10-1-2013.  
DAVID ELTON, EXAMINING ATTORNEY

**CLASS 29—(Continued).**

SN 86-159,217. FAREWAY STORES, INC., BOONE, IA. FILED 1-7-2014.

**FAREWAY MEAT MARKET**

THE MARK CONSISTS OF STANDARD CHARACTERS WITHOUT CLAIM TO ANY PARTICULAR FONT, STYLE, SIZE, OR COLOR.

OWNER OF U.S. REG. NOS. 3,162,689, 3,593,782 AND 3,629,379.

NO CLAIM IS MADE TO THE EXCLUSIVE RIGHT TO USE "MEAT MARKET", APART FROM THE MARK AS SHOWN.

FOR MEAT (U.S. CL. 46).

LESLIE RICHARDS, EXAMINING ATTORNEY

**CLASS 29—(Continued).**

SN 86-166,241. SAVORY HARVEST, DENVER, CO. FILED 1-15-2014.

**Savory Harvest**

THE MARK CONSISTS OF STANDARD CHARACTERS WITHOUT CLAIM TO ANY PARTICULAR FONT, STYLE, SIZE, OR COLOR.

NO CLAIM IS MADE TO THE EXCLUSIVE RIGHT TO USE "SAVORY", APART FROM THE MARK AS SHOWN.

FOR NUT-BASED SNACK BARS; NUT-BASED SNACK FOODS; VEGETABLE-BASED SNACK FOODS (U.S. CL. 46).

MARK SPARACINO, EXAMINING ATTORNEY

SN 86-159,322. FAREWAY STORES, INC., BOONE, IA. FILED 1-7-2014.

**FAREWAY**

THE MARK CONSISTS OF STANDARD CHARACTERS WITHOUT CLAIM TO ANY PARTICULAR FONT, STYLE, SIZE, OR COLOR.

OWNER OF U.S. REG. NOS. 3,162,689, 6,162,689 AND OTHERS.

FOR MEAT (U.S. CL. 46).

FIRST USE 11-4-2013; IN COMMERCE 11-4-2013.

LESLIE RICHARDS, EXAMINING ATTORNEY

SN 86-182,966. ALPACA MEAT USA LLC, MANITOWOC, WI. FILED 2-3-2014.

**ALPACA FANTASTICKS**

THE MARK CONSISTS OF STANDARD CHARACTERS WITHOUT CLAIM TO ANY PARTICULAR FONT, STYLE, SIZE, OR COLOR.

NO CLAIM IS MADE TO THE EXCLUSIVE RIGHT TO USE "ALPACA", APART FROM THE MARK AS SHOWN.

FOR JERKY AND DRIED MEAT (U.S. CL. 46).

LINDA ORNDORFF, EXAMINING ATTORNEY

SN 86-163,717. ORTO FOODS LLC, CONGERS, NY. FILED 1-13-2014.

**JICA CHIPS**

THE MARK CONSISTS OF STANDARD CHARACTERS WITHOUT CLAIM TO ANY PARTICULAR FONT, STYLE, SIZE, OR COLOR.

NO CLAIM IS MADE TO THE EXCLUSIVE RIGHT TO USE "CHIPS", APART FROM THE MARK AS SHOWN.

THE WORD(S) "JICA" HAS NO MEANING IN A FOREIGN LANGUAGE.

FOR VEGETABLE-BASED SNACK FOODS (U.S. CL. 46).

MARK T. MULLEN, EXAMINING ATTORNEY

SN 86-183,057. UNIFIED GROCERS, INC., COMMERCE, CA. FILED 2-3-2014.

**SPRING FRESH**

THE MARK CONSISTS OF STANDARD CHARACTERS WITHOUT CLAIM TO ANY PARTICULAR FONT, STYLE, SIZE, OR COLOR.

NO CLAIM IS MADE TO THE EXCLUSIVE RIGHT TO USE "FRESH", APART FROM THE MARK AS SHOWN.

FOR DAIRY PRODUCTS, NAMELY, MILK (U.S. CL. 46).

MARY CRAWFORD, EXAMINING ATTORNEY

**CLASS 29—(Continued).**

SN 86-185,498. BUNGE LIMITED (A BERMUDA CORPORATION), WHITE PLAINS, NY. FILED 2-5-2014.



OWNER OF U.S. REG. NOS. 2,036,787, 4,524,954 AND OTHERS.  
 THE MARK CONSISTS OF THE WORD "BUNGE" WITH A STYLIZED GLOBE EXTENDING OUT OF THE "U".  
 FOR EDIBLE OILS; EDIBLE FATS; SHORTENINGS; MARGARINES (U.S. CL. 46).  
 FIRST USE 5-0-2004; IN COMMERCE 5-0-2004.  
 TIMOTHY FINNEGAN, EXAMINING ATTORNEY

SN 86-191,777. WHITMIRE, STEVEN F, BRASSTOWN, NC. FILED 2-12-2014.

**Brasstown Beef**

THE MARK CONSISTS OF STANDARD CHARACTERS WITHOUT CLAIM TO ANY PARTICULAR FONT, STYLE, SIZE, OR COLOR.  
 NO CLAIM IS MADE TO THE EXCLUSIVE RIGHT TO USE "BEEF", APART FROM THE MARK AS SHOWN.  
 FOR BEEF (U.S. CL. 46).  
 FIRST USE 6-1-2009; IN COMMERCE 6-1-2009.  
 GEOFFREY FOSDICK, EXAMINING ATTORNEY

SN 86-192,951. PESCA INDUSTRIAL MAROS, S.A. DE C.V., MAZATLAN, MEXICO, FILED 2-13-2014.



NO CLAIM IS MADE TO THE EXCLUSIVE RIGHT TO USE "SINALOA", APART FROM THE MARK AS SHOWN.  
 THE MARK CONSISTS OF THE WORDING "SINALOA" WITH THE WORDING "BLUE" IMMEDIATELY BELOW WITHIN A RECTANGLE AND "PIM" TO THE RIGHT WITHIN A CIRCLE.  
 THE WORDING "SINALOA" HAS NO MEANING IN A FOREIGN LANGUAGE.  
 FOR SEAFOOD, NOT LIVE; SHRIMP, NOT LIVE (U.S. CL. 46).  
 FIRST USE 8-19-1999; IN COMMERCE 8-19-1999.  
 SUE LAWRENCE, EXAMINING ATTORNEY

**CLASS 29—(Continued).**

SN 86-195,726. SARRIS, GEORGE, BIRMINGHAM, AL. FILED 2-17-2014.



NO CLAIM IS MADE TO THE EXCLUSIVE RIGHT TO USE "EXTRA VIRGIN OLIVE OIL", "FIRST COLD PRESSED", "ACIDITY 0-0.8%", "PRODUCT OF GREECE" AND "NET 0.5LT / 16.9 FL. OZ.", APART FROM THE MARK AS SHOWN.

THE NAME(S), PORTRAIT(S), AND/OR SIGNATURE(S) SHOWN IN THE MARK IDENTIFIES GEORGE SARRIS, WHOSE CONSENT(S) TO REGISTER IS MADE OF RECORD.

THE COLOR(S) GREEN, YELLOW, BLACK, WHITE, BROWN, AND RED IS/ARE CLAIMED AS A FEATURE OF THE MARK.

THE MARK CONSISTS OF A YELLOW VERTICAL RECTANGULAR BACKGROUND. WITHIN THE YELLOW RECTANGLE AT THE TOP APPEAR FIVE GREEN STARS ALIGNED HORIZONTALLY. BELOW THE FIVE STARS IS THE WORDING "GEORGE SARRIS" IN THE COLOR BLACK AND ALL IN CAPS. BELOW THE WORDING "GEORGE SARRIS" APPEARS AN INNER VERTICAL RECTANGLE SHOWING AN OLIVE TREE IN THE COLORS BROWN, WHITE AND GREEN AND SURROUNDED BY GREEN AND YELLOW GRASS. AT THE TOP OF THIS INNER VERTICAL RECTANGLE APPEARS THE WORDING "EXTRA VIRGIN" IN THE COLOR BLACK AND ALL IN CAPS, WHICH IS SURROUNDED BY A HORIZONTAL WHITE RECTANGLE OUTLINED BY YELLOW LINES ABOVE AND BELOW THE HORIZONTAL WHITE RECTANGLE. BELOW THE WORDING "EXTRA VIRGIN" APPEARS THE WORDING "OLIVE OIL" IN THE COLOR WHITE AND ALL IN CAPS. BELOW THE WORDING "OLIVE OIL" APPEARS THE WORDING "FIRST COLD PRESSED, ACIDITY 0-0.8%" IN THE COLOR YELLOW AND ALL IN CAPS. IN THE MIDDLE PORTION OF THE MARK APPEARS THE WORDING "EVERY GREAT RECIPE STARTS WITH MY EXTRA VIRGIN OLIVE OIL" IN THE COLOR WHITE AND APPEARING IN QUOTATION MARKS. BELOW THIS WORDING APPEARS THE SIGNATURE "GEORGE SARRIS" IN THE COLOR WHITE. TO THE LEFT OF THIS SIGNATURE APPEARS A PHOTOGRAPH OF GEORGE SARRIS IN THE COLORS BROWN AND WHITE WITH A RED DESIGN ON THE BREAST POCKET AREA OF THE CHEF'S JACKET. AT THE VERY BOTTOM OF THE MARK AND OUTSIDE THE INNER VERTICAL RECTANGLE APPEARS THE WORDING "PRODUCT OF GREECE NET 0.5 LT / 16.9 FL. OZ." IN THE COLOR BLACK.

FOR OLIVE OIL (U.S. CL. 46).  
 FIRST USE 1-1-2012; IN COMMERCE 1-1-2012.  
 ANDREW RHIM, EXAMINING ATTORNEY



**CLASS 29—(Continued).**

SN 86-212,161. TASTY KARMA LLC, PALO ALTO, CA. FILED 3-5-2014.

# Tasty Karma

THE MARK CONSISTS OF STANDARD CHARACTERS WITHOUT CLAIM TO ANY PARTICULAR FONT, STYLE, SIZE, OR COLOR.

NO CLAIM IS MADE TO THE EXCLUSIVE RIGHT TO USE "TASTY", APART FROM THE MARK AS SHOWN.

FOR CHICKPEA CHIPS, SNACK DIPS, CHICKPEA-BASED SNACK FOODS IN THE NATURE OF CHICKPEA TRUFFLES (U.S. CL. 46).

FIRST USE 5-2-2013; IN COMMERCE 5-2-2013.  
FRED CARL, EXAMINING ATTORNEY

**CLASS 29—(Continued).**

SN 86-215,648. UNITED DAIRYMEN OF ARIZONA, TEMPE, AZ. FILED 3-9-2014.



SN 86-213,152. THE KEVIN D. CROFTON BUSINESS TRUST, TAMPA, FL. FILED 3-6-2014.

# UNCLE JOHN'S PRIDE

THE MARK CONSISTS OF STANDARD CHARACTERS WITHOUT CLAIM TO ANY PARTICULAR FONT, STYLE, SIZE, OR COLOR.

OWNER OF U.S. REG. NO. 3,365,049.

FOR SAUSAGE AND FRESH AND SMOKED MEATS (U.S. CL. 46).

FIRST USE 6-1-1975; IN COMMERCE 1-1-1976.  
JAY FLOWERS, EXAMINING ATTORNEY

NO CLAIM IS MADE TO THE EXCLUSIVE RIGHT TO USE "SINCE 1960" OR "ARIZONA", APART FROM THE MARK AS SHOWN.

THE COLOR(S) WHITE, BLUE, GOLD, RED, BLACK, IS/ARE CLAIMED AS A FEATURE OF THE MARK.

THE MARK CONSISTS OF LOWER-CASE WHITE TEXT "SINCE 1960" APPEARS CENTERED ACROSS THE TOP EDGE OF A DARK BLUE CIRCLE WITH "SEAL OF ARIZONA" IN GOLD UPPER-CASE TEXT IMMEDIATELY BELOW IT. NEAR THE BOTTOM OF THIS DARK BLUE CIRCLE CENTERED IN WHITE TEXT IS "UNITED DAIRYMEN OF ARIZONA". POSITIONED IN THE CENTER OF THE CIRCLE AND PROTRUDING OUTWARD LEFT-TO-RIGHT IS MULTICOLORED RECTANGLE WITH ALTERNATING GOLD AND RED RAYS PROJECTING UPWARD FROM THE CENTER OF A BLACK SILHOUETTED HORIZON SHOWING A CACTUS ON THE LEFT AND A DAIRY COW ON THE RIGHT.

FOR DAIRY PRODUCTS EXCLUDING ICE CREAM, ICE MILK AND FROZEN YOGURT (U.S. CL. 46).  
ANNE MADDEN, EXAMINING ATTORNEY

SN 86-214,232. REYES, JOSE, MARIETTA, GA. FILED 3-7-2014.



NO CLAIM IS MADE TO THE EXCLUSIVE RIGHT TO USE "POLLO", APART FROM THE MARK AS SHOWN.

THE MARK CONSISTS OF THE STYLIZED WORDS "CHEF POLLO" INSIDE A CHEF'S HAT.

THE ENGLISH TRANSLATION OF "POLLO" IN THE MARK IS "CHICKEN".

FOR BOUILLON (U.S. CL. 46).

FIRST USE 1-1-2013; IN COMMERCE 1-1-2013.  
GILBERT SWIFT, EXAMINING ATTORNEY

SN 86-218,877. RARE ANTIBODY ANTIGEN SUPPLY, INC., AGOURA HILLS, CA. FILED 3-12-2014.

# OHHIKYMY

THE MARK CONSISTS OF STANDARD CHARACTERS WITHOUT CLAIM TO ANY PARTICULAR FONT, STYLE, SIZE, OR COLOR.

THE WORDING "OHHIKYMY" HAS NO MEANING IN A FOREIGN LANGUAGE.

FOR EDIBLE BIRD'S NESTS (U.S. CL. 46).  
JOHN HWANG, EXAMINING ATTORNEY

**CLASS 29—(Continued).**

SN 86-225,113. ALL THINGS PALEO, LLC, SAN FRANCISCO, CA. FILED 3-18-2014.



NO CLAIM IS MADE TO THE EXCLUSIVE RIGHT TO USE "BAR" AND "PALEO", APART FROM THE MARK AS SHOWN.

THE MARK CONSISTS OF A STYLIZED WHOLLY MAMMOTH IMAGE IS AT THE TOP WITH THE WORDS "MAMMOTH BAR" UNDERNEATH THE IMAGE, AND AT THE BOTTOM OF THE MARK IS THE SLOGAN "PALEO FOR THE MODERN WORLD".

FOR ORGANIC NUT AND SEED-BASED SNACK BARS (U.S. CL. 46).

FIRST USE 11-30-2013; IN COMMERCE 11-30-2013.  
JAY FLOWERS, EXAMINING ATTORNEY

SN 86-226,066. HATCH CHILE FACTORY, LLC, HATCH, NM. FILED 3-19-2014.

## Holiday Blend

THE MARK CONSISTS OF STANDARD CHARACTERS WITHOUT CLAIM TO ANY PARTICULAR FONT, STYLE, SIZE, OR COLOR.

NO CLAIM IS MADE TO THE EXCLUSIVE RIGHT TO USE "BLEND", APART FROM THE MARK AS SHOWN.

FOR FROZEN VEGETABLES (U.S. CL. 46).  
JERI J. FICKES, EXAMINING ATTORNEY

SN 86-226,127. HATCH CHILE FACTORY, LLC, HATCH, NM. FILED 3-19-2014.

## Late Harvest Blend

THE MARK CONSISTS OF STANDARD CHARACTERS WITHOUT CLAIM TO ANY PARTICULAR FONT, STYLE, SIZE, OR COLOR.

NO CLAIM IS MADE TO THE EXCLUSIVE RIGHT TO USE "BLEND", APART FROM THE MARK AS SHOWN.

FOR FROZEN VEGETABLES (U.S. CL. 46).  
JERI J. FICKES, EXAMINING ATTORNEY

**CLASS 29—(Continued).**

SN 86-228,877. MANN, STEPHANIE, JACKSONVILLE, FL. FILED 3-21-2014.

## DANIELLE'S SEAFOOD DIP

THE MARK CONSISTS OF STANDARD CHARACTERS WITHOUT CLAIM TO ANY PARTICULAR FONT, STYLE, SIZE, OR COLOR.

NO CLAIM IS MADE TO THE EXCLUSIVE RIGHT TO USE "SEAFOOD DIP", APART FROM THE MARK AS SHOWN.

FOR DIPS (U.S. CL. 46).

FIRST USE 6-29-2013; IN COMMERCE 6-29-2013.  
INGA ERVIN, EXAMINING ATTORNEY

SN 86-229,366. RARE ANTIBODY ANTIGEN SUPPLY, INC., AGOURA HILLS, CA. FILED 3-23-2014.

## KHMYCARE HEALTHY BABIES

THE MARK CONSISTS OF STANDARD CHARACTERS WITHOUT CLAIM TO ANY PARTICULAR FONT, STYLE, SIZE, OR COLOR.

NO CLAIM IS MADE TO THE EXCLUSIVE RIGHT TO USE "HEALTHY BABIES", APART FROM THE MARK AS SHOWN.

FOR DRIED MILK POWDER; MILK POWDER; MILK POWDER FOR NUTRITIONAL PURPOSES (U.S. CL. 46).

JOHN HWANG, EXAMINING ATTORNEY

SN 86-229,368. RARE ANTIBODY ANTIGEN SUPPLY, INC., AGOURA HILLS, CA. FILED 3-23-2014.

## KHMYCARE HEALTHY CHILDREN AND ADULTS

THE MARK CONSISTS OF STANDARD CHARACTERS WITHOUT CLAIM TO ANY PARTICULAR FONT, STYLE, SIZE, OR COLOR.

NO CLAIM IS MADE TO THE EXCLUSIVE RIGHT TO USE "HEALTHY CHILDREN AND ADULTS", APART FROM THE MARK AS SHOWN.

FOR DRIED MILK POWDER; MILK POWDER; MILK POWDER FOR NUTRITIONAL PURPOSES (U.S. CL. 46).  
JOHN HWANG, EXAMINING ATTORNEY



**CLASS 29—(Continued).**

SN 86-229,497. RANDAZZO, FRANK C, MIAMI SHORES, FL.  
FILED 3-24-2014.

# Aye Yuca

THE MARK CONSISTS OF STANDARD CHARACTERS WITHOUT CLAIM TO ANY PARTICULAR FONT, STYLE, SIZE, OR COLOR.

NO CLAIM IS MADE TO THE EXCLUSIVE RIGHT TO USE "YUCA", APART FROM THE MARK AS SHOWN.

FOR YUCCA CHIPS (U.S. CL. 46).  
TRACY FLETCHER, EXAMINING ATTORNEY

**CLASS 29—(Continued).**

SN 86-233,420. JUAN PABLO GUZMAN, CHARLOTTE, NC.  
FILED 3-26-2014.



NO CLAIM IS MADE TO THE EXCLUSIVE RIGHT TO USE "ARTISAN" AND "TROPIC", APART FROM THE MARK AS SHOWN.

THE COLOR(S) OLIVE GREEN, LIGHT OLIVE GREEN, WHITE, AND BLACK IS/ARE CLAIMED AS A FEATURE OF THE MARK.

THE MARK CONSISTS OF A PALM TREE WITH A WHITE TRUNK AND SIX OLIVE GREEN BRANCHES, WITH AN OLIVE GREEN SEMI-CIRCLE BORDER ABOVE THE PALM TREE ON A WHITE BACKGROUND, A LIGHT OLIVE GREEN MOUNTAIN LANDSCAPE WITH ITS BASE IN THE SHAPE OF A SEMI-CIRCLE ON EACH SIDE OF THE TRUNK OF THE PALM TREE, WITH THE WORD "ARTISAN" BELOW THE MOUNTAIN LANDSCAPE IN OLIVE GREEN IN ALL CAPS, AND THE WORD, "TROPIC" IN BLACK, BELOW "ARTISAN".

FOR (BASED ON USE IN COMMERCE) PLANTAIN CHIPS; (BASED ON INTENT TO USE) DEHYDRATED FRUIT SNACKS; DRIED FRUITS; FRUIT CHIPS; FRUIT-BASED SNACK FOOD; PROCESSED SWEET POTATOES; YUCCA CHIPS (U.S. CL. 46).

FIRST USE 3-5-2014; IN COMMERCE 3-5-2014.  
ODESSA BIBBINS, EXAMINING ATTORNEY

SN 86-231,185. PREPARADOS ALIMENTICIOS, S.A., E-08908,  
SPAIN, FILED 3-25-2014.



OWNER OF U.S. REG. NOS. 2,468,051 AND 2,807,239.  
NO CLAIM IS MADE TO THE EXCLUSIVE RIGHT TO USE "AVEC VITAMINE A", APART FROM THE MARK AS SHOWN.

THE COLOR(S) RED, YELLOW, BLUE AND WHITE IS/ARE CLAIMED AS A FEATURE OF THE MARK.

THE MARK CONSISTS OF A RECTANGLE DIVIDED INTO FOUR QUADRANTS WITH THE HORIZONTAL DIVIDE A STRAIGHT LINE AND THE VERTICAL DIVIDER A WAVY LINE. THE TOP LEFT AND BOTTOM RIGHT QUADRANTS HAVE A RED BACKGROUND OVER WHICH APPEARS THE WORD "JUMBO" IN YELLOW BENEATH A YELLOW CROWN. THE TOP RIGHT AND BOTTOM LEFT QUADRANTS HAVE A YELLOW BACKGROUND OVER WHICH APPEARS A WHITE CAPSULE SHAPE ON WHICH APPEARS THE WORDING "AVEC VITAMINE A" IN A STYLIZED BLUE FONT WITH THE "V" IN THE SHAPE OF A CHECK MARK AND FINAL A APPEARING LARGER THAN THE OTHER LETTERS. IN THE CENTER OF THE MARK APPEARS A WHITE CIRCLE FEATURING A BLUE OUTLINE OF A PERSON WITH RAISED ARMS OVER A BLUE CIRCLE.

THE ENGLISH TRANSLATION OF "AVEC VITAMINE A" IN THE MARK IS WITH "VITAMIN A".

FOR SOUPS AND BROTHS; PREPARATIONS FOR MAKING SOUPS AND BROTHS; BOUILLON PREPARATIONS (U.S. CL. 46).

FIRST USE 1-1-2012; IN COMMERCE 1-1-2012.  
LYNDSEY KUYKENDALL, EXAMINING ATTORNEY

SN 86-235,709. SIMPLY NATIVE, LLC, RIVER FALLS, WI.  
FILED 3-28-2014.

# SIMPLY NATIVE

THE MARK CONSISTS OF STANDARD CHARACTERS WITHOUT CLAIM TO ANY PARTICULAR FONT, STYLE, SIZE, OR COLOR.

FOR HOT GRAIN BREAKFAST CEREALS, WILD RICE READY-TO-EAT CEREALS, CEREAL DERIVED ENERGY BARS, AND CRACKERS (U.S. CL. 46).

WILLIAM P. SHANAHAN, EXAMINING ATTORNEY

**CLASS 29—(Continued).**

SN 86-235,962. TUMAC LUMBER CO., INC., DBA TUMAC  
COMMODITIES, INC., PORTLAND, OR. FILED 3-28-2014.

# TUFRESH

THE MARK CONSISTS OF STANDARD CHARACTERS  
WITHOUT CLAIM TO ANY PARTICULAR FONT, STYLE,  
SIZE, OR COLOR.

OWNER OF U.S. REG. NO. 4,551,511.  
FOR COOKING OIL (U.S. CL. 46).  
FIRST USE 3-6-2014; IN COMMERCE 3-6-2014.  
WILLIAM P. SHANAHAN, EXAMINING ATTORNEY

---

SN 86-242,553. OS ENTERPRISE, LLC, SAN FRANCISCO,  
CA. FILED 4-4-2014.

# LOONG KONG CHICKEN

THE MARK CONSISTS OF STANDARD CHARACTERS  
WITHOUT CLAIM TO ANY PARTICULAR FONT, STYLE,  
SIZE, OR COLOR.

NO CLAIM IS MADE TO THE EXCLUSIVE RIGHT TO  
USE "CHICKEN", APART FROM THE MARK AS SHOWN.  
THE WORDING "LOONG KONG" HAS NO MEANING IN  
A FOREIGN LANGUAGE.

FOR MARINATED CHICKENS AND MEATS; PRO-  
CESSED MEAT, NAMELY, COOKED CHICKENS (U.S.  
CL. 46).

FIRST USE 11-1-2002; IN COMMERCE 11-1-2002.  
SIMON TENG, EXAMINING ATTORNEY

---

SN 86-243,386. DEL MONTE INTERNATIONAL GMBH,  
MONTE CARLO, MONACO, FILED 4-4-2014.

# Fruit Express

THE MARK CONSISTS OF STANDARD CHARACTERS  
WITHOUT CLAIM TO ANY PARTICULAR FONT, STYLE,  
SIZE, OR COLOR.

NO CLAIM IS MADE TO THE EXCLUSIVE RIGHT TO  
USE "FRUIT", APART FROM THE MARK AS SHOWN.

FOR CUT FRUITS; FRUIT AND VEGETABLE SAL-  
ADS; FRUIT PRESERVES; FRUIT PUREES; FRUIT  
SALADS; FRUIT-BASED SNACK FOOD; FRUITS IN  
PRESERVED FORM; PRESERVED FRUITS; PRE-  
SERVED, DRIED AND COOKED FRUIT AND VEGETA-  
BLES; PROCESSED FRUITS; PROCESSED VEGETABLES  
AND FRUITS; SLICED FRUITS (U.S. CL. 46).

JOHN SCHUYLER YARD, EXAMINING ATTORNEY

**CLASS 29—(Continued).**

SN 86-244,107. FRANK BRUNCKHORST CO., L.L.C.,  
BROOKLYN, NY. FILED 4-7-2014.

# BUTCHER CRAFT

THE MARK CONSISTS OF STANDARD CHARACTERS  
WITHOUT CLAIM TO ANY PARTICULAR FONT, STYLE,  
SIZE, OR COLOR.

FOR PROCESSED MEAT (U.S. CL. 46).  
SHANNON TWOHIG, EXAMINING ATTORNEY

---

SN 86-244,317. M.ROBZEN, INC., KINGSTON, PA. FILED 4-7-  
2014.

# SteakTacular

THE MARK CONSISTS OF STANDARD CHARACTERS  
WITHOUT CLAIM TO ANY PARTICULAR FONT, STYLE,  
SIZE, OR COLOR.

FOR PACKAGED MEATS (U.S. CL. 46).  
SANJEEV VOHRA, EXAMINING ATTORNEY

---

SN 86-245,356. VARIETY FRANKS LLC, WINSTON-SALEM,  
NC. FILED 4-8-2014.

# Wagon Wheels

THE MARK CONSISTS OF STANDARD CHARACTERS  
WITHOUT CLAIM TO ANY PARTICULAR FONT, STYLE,  
SIZE, OR COLOR.

FOR FRANKFURTERS (U.S. CL. 46).  
DOMINIC J. FERRAIUOLO, EXAMINING ATTORNEY

**CLASS 29—(Continued).**

SN 86-246,553. NEAL, TRACY, STONE MOUNTAIN, GA. FILED 4-9-2014.

**VIVID FRUIT**

THE MARK CONSISTS OF STANDARD CHARACTERS WITHOUT CLAIM TO ANY PARTICULAR FONT, STYLE, SIZE, OR COLOR.

NO CLAIM IS MADE TO THE EXCLUSIVE RIGHT TO USE "FRUIT", APART FROM THE MARK AS SHOWN.

FOR CANNED FRUITS; CANNED VEGETABLES; PROTEIN MILK (U.S. CL. 46).  
ESTHER QUEEN, EXAMINING ATTORNEY

**CLASS 29—(Continued).**

SN 86-248,445. NOAH W. KREIDER & SONS, LLP, MANHEIM, PA. FILED 4-10-2014.

**NOAH'S PRIDE**

THE MARK CONSISTS OF STANDARD CHARACTERS WITHOUT CLAIM TO ANY PARTICULAR FONT, STYLE, SIZE, OR COLOR.

FOR CAGE FREE EGGS (U.S. CL. 46).  
CHRIS WELLS, EXAMINING ATTORNEY

SN 86-248,127. STRATAKOS, DIAMANDO P, DBA STRATAKOS FAMILY PRODUCTS, LLC, ITHACA, NY. FILED 4-10-2014.

**GOLIVE**  
SPARTAN

THE COLOR(S) YELLOW AND GREEN IS/ARE CLAIMED AS A FEATURE OF THE MARK.

THE MARK CONSISTS OF ALL CAPITAL LETTERS FOR GOLIVE, THE G AND LIVE BEING YELLOW IN COLOR, THE O BEING GREEN IN COLOR. THE WORD SPARTAN IS BELOW GOLIVE. THE S IS CAPITALIZED. THE ENTIRE WORD IS IN THE SAME GREEN COLOR AS THE O IN GOLIVE. SPARTAN IS ALIGNED WITH THE BOTTOM RIGHT SIDE OF GOLIVE AND IS HALF THE SIZE OF GOLIVE.

FOR (BASED ON USE IN COMMERCE) EDIBLE OIL; OLIVE OIL; OLIVE OIL; OLIVE OILS(BASED ON INTENT TO USE) OLIVE PASTES; PROCESSED OLIVES (U.S. CL. 46).

FIRST USE 10-29-2013; IN COMMERCE 3-24-2014.  
JOANNA DUKOVIC, EXAMINING ATTORNEY

SN 86-248,494. NOAH W. KREIDER & SONS, LLP, MANHEIM, PA. FILED 4-10-2014.

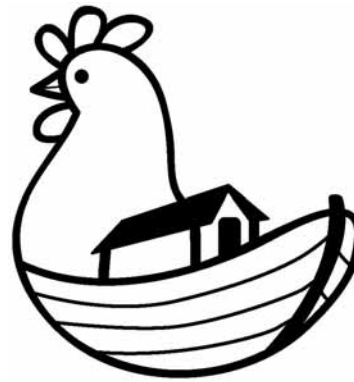

THE MARK CONSISTS OF A REPRESENTATION OF A CHICKEN ARK.

FOR CAGE FREE EGGS (U.S. CL. 46).  
CHRIS WELLS, EXAMINING ATTORNEY

SN 86-248,256. DARIGOLD, INC., SEATTLE, WA. FILED 4-10-2014.

**RE:**

THE MARK CONSISTS OF STANDARD CHARACTERS WITHOUT CLAIM TO ANY PARTICULAR FONT, STYLE, SIZE, OR COLOR.

FOR MILK-BASED ENERGY DRINKS; MILK-BASED BEVERAGES; MILK-BASED BEVERAGES WITH CHOCOLATE; BEVERAGES CONSISTING PRINCIPALLY OF MILK; CHOCOLATE MILK; DAIRY PRODUCTS EXCLUDING ICE CREAM, ICE MILK AND FROZEN YOGURT; DAIRY-BASED BEVERAGES (U.S. CL. 46).

KAELIE KUNG, EXAMINING ATTORNEY

SN 86-248,569. DARIGOLD, INC., SEATTLE, WA. FILED 4-10-2014.

**RE:BUILD**

THE MARK CONSISTS OF STANDARD CHARACTERS WITHOUT CLAIM TO ANY PARTICULAR FONT, STYLE, SIZE, OR COLOR.

FOR MILK-BASED ENERGY DRINKS; MILK-BASED BEVERAGES; MILK-BASED BEVERAGES WITH CHOCOLATE; BEVERAGES CONSISTING PRINCIPALLY OF MILK; CHOCOLATE MILK; DAIRY PRODUCTS EXCLUDING ICE CREAM, ICE MILK AND FROZEN YOGURT; DAIRY-BASED BEVERAGES (U.S. CL. 46).

KAELIE KUNG, EXAMINING ATTORNEY

**CLASS 29—(Continued).**

SN 86-248,576. DARIGOLD, INC., SEATTLE, WA. FILED 4-10-2014.

**RE:SHAPE**

THE MARK CONSISTS OF STANDARD CHARACTERS WITHOUT CLAIM TO ANY PARTICULAR FONT, STYLE, SIZE, OR COLOR.

FOR MILK-BASED ENERGY DRINKS; MILK-BASED BEVERAGES; MILK-BASED BEVERAGES WITH CHOCOLATE; BEVERAGES CONSISTING PRINCIPALLY OF MILK; CHOCOLATE MILK; DAIRY PRODUCTS EXCLUDING ICE CREAM, ICE MILK AND FROZEN YOGURT; DAIRY-BASED BEVERAGES (U.S. CL. 46).

KAELIE KUNG, EXAMINING ATTORNEY

SN 86-249,314. ABB PARTNERS, LLC, PALM BEACH, FL. FILED 4-11-2014.

**Beast Man**

THE MARK CONSISTS OF STANDARD CHARACTERS WITHOUT CLAIM TO ANY PARTICULAR FONT, STYLE, SIZE, OR COLOR.

FOR JERKY (U.S. CL. 46).

CHRISTINA SOBRAL, EXAMINING ATTORNEY

SN 86-250,056. THEALL, JAMES D, LOS ANGELES, CA. FILED 4-11-2014.

**Cheese from Trees**

THE MARK CONSISTS OF STANDARD CHARACTERS WITHOUT CLAIM TO ANY PARTICULAR FONT, STYLE, SIZE, OR COLOR.

FOR NUT CHEESE, NAMELY, CHEESE-TYPE PRODUCT MADE FROM NUTS (U.S. CL. 46).

SUSAN STIGLITZ, EXAMINING ATTORNEY

**CLASS 29—(Continued).**

SN 86-250,433. A GOOD CHURN, LLC, DBA BANNER BUTTER, DECATUR, GA. FILED 4-11-2014.

**Banner Butter**

THE MARK CONSISTS OF STANDARD CHARACTERS WITHOUT CLAIM TO ANY PARTICULAR FONT, STYLE, SIZE, OR COLOR.

NO CLAIM IS MADE TO THE EXCLUSIVE RIGHT TO USE "BUTTER", APART FROM THE MARK AS SHOWN, FOR BUTTER, NAMELY SMALL-BATCH CULTURED BUTTER (U.S. CL. 46).

CHRISTOPHER REAMS, EXAMINING ATTORNEY

SN 86-250,650. UTAH CHIPS COMPANY, DBA SNACKCO OF AMERICA, CLEARFIELD, UT. FILED 4-12-2014.

**Jebediahs Gold**

THE MARK CONSISTS OF STANDARD CHARACTERS WITHOUT CLAIM TO ANY PARTICULAR FONT, STYLE, SIZE, OR COLOR.

FOR POTATO-BASED SNACK FOODS (U.S. CL. 46).

JENNIFER MARTIN, EXAMINING ATTORNEY

SN 86-255,424. CIBAO MEAT PRODUCTS INC., BRONX, NY. FILED 4-17-2014.

**INCARNA**

THE MARK CONSISTS OF STANDARD CHARACTERS WITHOUT CLAIM TO ANY PARTICULAR FONT, STYLE, SIZE, OR COLOR.

THE ENGLISH TRANSLATION OF THE WORD INCARNA IN THE MARK IS "TO INCARNATE".

FOR PROCESSED MEATS, NAMELY, SAUSAGE (U.S. CL. 46).

MICHAEL SOUDERS, EXAMINING ATTORNEY

**CLASS 29—(Continued).**

SN 86-261,759. FRANK BRUNCKHORST CO., L.L.C.,  
BROOKLYN, NY. FILED 4-24-2014.

# AROASTICA

THE MARK CONSISTS OF STANDARD CHARACTERS  
WITHOUT CLAIM TO ANY PARTICULAR FONT, STYLE,  
SIZE, OR COLOR.

FOR PROCESSED MEAT (U.S. CL. 46).  
SHANNON TWOHIG, EXAMINING ATTORNEY

SN 86-268,122. SHURFINE FOODS, INC., TIGARD, OR.  
FILED 4-30-2014.

# SHUR SAVING

THE MARK CONSISTS OF STANDARD CHARACTERS  
WITHOUT CLAIM TO ANY PARTICULAR FONT, STYLE,  
SIZE, OR COLOR.

OWNER OF U.S. REG. NOS. 1,237,527, 1,711,996 AND  
OTHERS.

FOR CANNED TOMATOES; SAUERKRAUT; CANNED  
TUNA; CHILI WITH BEANS; CHILI CON CARNE;  
LUNCHEON LOAF; CANNED CHICKEN; INSTANT  
POTATOES; PROCESSED POTATOES; IMITATION BA-  
CON BITS; PROCESSED NUTS; ROASTED NUTS;  
SHELLED NUTS; SOUPS; CANNED SOUPS; BROTH;  
CANNED BEANS; CANNED PORK AND BEANS; DRIED  
BEANS; WHIPPED TOPPING; FROZEN VEGETABLES;  
PROCESSED CHEESE; SAUSAGES; LUNCHEON MEATS;  
LEMON JUICE FOR COOKING PURPOSES (U.S. CL. 46).  
FIRST USE 5-0-2013; IN COMMERCE 5-0-2013.

MICHAEL P EISNACH, EXAMINING ATTORNEY

SN 86-283,571. HEB GROCERY COMPANY, LP, SAN ANTO-  
NIO, TX. FILED 5-16-2014.



OWNER OF U.S. REG. NOS. 3,194,958, 3,930,507 AND  
OTHERS.

THE COLOR(S) RED AND WHITE IS/ARE CLAIMED AS  
A FEATURE OF THE MARK.

THE MARK CONSISTS OF THE LETTERS "H-E-B" IN  
WHITE LETTERS WITHIN A RED AND WHITE OVAL  
DESIGN.

FOR FROZEN ENTREES CONSISTING PRIMARILY  
OF MEAT, FISH, POULTRY OR VEGETABLES (U.S. CL.  
46).

LEE-ANNE BERNS, EXAMINING ATTORNEY

**CLASS 29—(Continued).**

SN 86-314,257. FRANK BRUNCKHORST CO., L.L.C.,  
BROOKLYN, NY. FILED 6-19-2014.

# LONZAPEPE

THE MARK CONSISTS OF STANDARD CHARACTERS  
WITHOUT CLAIM TO ANY PARTICULAR FONT, STYLE,  
SIZE, OR COLOR.

THE ENGLISH TRANSLATION OF "LONZAPEPE" IN  
THE MARK IS "LOIN PEPPER".

FOR PROCESSED MEAT (U.S. CL. 46).  
SHANNON TWOHIG, EXAMINING ATTORNEY

SN 86-314,292. FRANK BRUNCKHORST CO., L.L.C.,  
BROOKLYN, NY. FILED 6-19-2014.

# PERFECT PIZZA STARTS WITH PERFECT CHEESE

THE MARK CONSISTS OF STANDARD CHARACTERS  
WITHOUT CLAIM TO ANY PARTICULAR FONT, STYLE,  
SIZE, OR COLOR.

FOR CHEESE (U.S. CL. 46).  
SHANNON TWOHIG, EXAMINING ATTORNEY

SN 86-315,799. RARE ANTIBODY ANTIGEN SUPPLY, INC.,  
AGOURA HILLS, CA. FILED 6-20-2014.

# RAAS NUTRITIONALS HEALTHY BABIES

THE MARK CONSISTS OF STANDARD CHARACTERS  
WITHOUT CLAIM TO ANY PARTICULAR FONT, STYLE,  
SIZE, OR COLOR.

NO CLAIM IS MADE TO THE EXCLUSIVE RIGHT TO  
USE "NUTRITIONALS HEALTHY BABIES", APART FROM  
THE MARK AS SHOWN.

FOR DRIED MILK POWDER; MILK POWDER; MILK  
POWDER FOR NUTRITIONAL PURPOSES (U.S. CL. 46).  
JOHN HWANG, EXAMINING ATTORNEY

**CLASS 29—(Continued).**

SN 86-315,801. RARE ANTIBODY ANTIGEN SUPPLY, INC.,  
AGOURA HILLS, CA. FILED 6-20-2014.

RAAS NUTRITIONALS HEALTHY  
CHILDREN AND ADULTS

THE MARK CONSISTS OF STANDARD CHARACTERS  
WITHOUT CLAIM TO ANY PARTICULAR FONT, STYLE,  
SIZE, OR COLOR.

NO CLAIM IS MADE TO THE EXCLUSIVE RIGHT TO  
USE "NUTRITIONALS HEALTHY CHILDREN AND  
ADULTS", APART FROM THE MARK AS SHOWN.

FOR DRIED MILK POWDER; MILK POWDER; MILK  
POWDER FOR NUTRITIONAL PURPOSES (U.S. CL. 46).  
JOHN HWANG, EXAMINING ATTORNEY

---

SN 86-326,653. GRUPPO CAPPELLI, INC., DBA VILLA  
CAPPELLI, KENEDY, TX. FILED 7-2-2014.

THE ONE WITH THE PUGLIA  
PINCH

THE MARK CONSISTS OF STANDARD CHARACTERS  
WITHOUT CLAIM TO ANY PARTICULAR FONT, STYLE,  
SIZE, OR COLOR.

FOR OLIVE OIL; OLIVE OIL; OLIVE OILS (U.S. CL.  
46).

FIRST USE 12-31-2005; IN COMMERCE 12-31-2005.  
DARRYL SPRUILL, EXAMINING ATTORNEY

**CLASS 30—STAPLE FOODS**

SN 76-716,078. SI ROBERTSON, WEST MONROE, LA. FILED  
3-26-2014.

**UNCLE SI'S SWEET TEA**

THE MARK CONSISTS OF STANDARD CHARACTERS  
WITHOUT CLAIM TO ANY PARTICULAR FONT, STYLE,  
SIZE, OR COLOR.

NO CLAIM IS MADE TO THE EXCLUSIVE RIGHT TO  
USE "SWEET TEA", APART FROM THE MARK AS SHOWN.  
THE NAME "UNCLE SI" IDENTIFIES A LIVING INDIVI-  
DUAL WHOSE CONSENT IS OF RECORD.

FOR TEA AND ICED TEA (U.S. CL. 46).  
RAMONA ORTIGA, EXAMINING ATTORNEY

**CLASS 30—(Continued).**

SN 76-716,080. SI ROBERTSON, WEST MONROE, LA. FILED  
3-26-2014.

**UNCLE SI'S**

THE MARK CONSISTS OF STANDARD CHARACTERS  
WITHOUT CLAIM TO ANY PARTICULAR FONT, STYLE,  
SIZE, OR COLOR.

THE NAME "UNCLE SI" IDENTIFIES A LIVING INDIVI-  
DUAL WHOSE CONSENT IS OF RECORD.

FOR TEA AND ICED TEA (U.S. CL. 46).  
RAMONA ORTIGA, EXAMINING ATTORNEY

---

SN 76-716,083. SI ROBERTSON, WEST MONROE, LA. FILED  
3-26-2014.

**UNCLE SI'S ICED TEA**

THE MARK CONSISTS OF STANDARD CHARACTERS  
WITHOUT CLAIM TO ANY PARTICULAR FONT, STYLE,  
SIZE, OR COLOR.

NO CLAIM IS MADE TO THE EXCLUSIVE RIGHT TO  
USE "ICED TEA", APART FROM THE MARK AS SHOWN.  
THE NAME "UNCLE SI" IDENTIFIES A LIVING INDIVI-  
DUAL WHOSE CONSENT IS OF RECORD.

FOR TEA AND ICED TEA (U.S. CL. 46).  
RAMONA ORTIGA, EXAMINING ATTORNEY

**CLASS 30—(Continued).**

SN 79-138,217. BARILLA G. E. R. FRATELLI - SOCIETÀ PER AZIONI, I-43100 PARMA, ITALY, FILED 9-26-2013.



PRIORITY DATE OF 9-16-2013 IS CLAIMED.  
OWNER OF INTERNATIONAL REGISTRATION 1181113  
DATED 9-26-2013, EXPIRES 9-26-2023.

OWNER OF U.S. REG. NOS. 1,499,817 AND 4,105,415.  
THE COLOR(S) BLUE, YELLOW AND WHITE IS/ARE CLAIMED AS A FEATURE OF THE MARK.  
THE MARK CONSISTS OF THE FOLLOWING: THE WHITE WORD "PAVESINI" WITH BLUE USED TO THE RIGHT OF THE LETTERS TO INDICATE DEPTH ON A YELLOW QUADRILATERAL WITH CURVED SIDES OVERLAPPING A BLUE OVAL.

FOR COFFEE, TEA, COCOA, SUGAR, RICE, TAPIOCA, SAGO, ARTIFICIAL COFFEE; FLOUR AND PREPARATIONS MADE FROM CEREALS, NAMELY, BREAKFAST CEREALS, BREAD, BREAD SUBSTITUTES AND OTHER BREAD PRODUCTS, NAMELY, BREADSTICKS, RUSKS, CRACKERS, BREAD ROLLS; SNACKS MADE FROM CEREALS, NAMELY, CEREAL BASED SNACK FOOD; BISCUITS, PASTRY AND CONFECTIONERY MADE OF SUGAR; CHOCOLATE AND CHOCOLATE-BASED PRODUCTS OR PRODUCTS CONTAINING CHOCOLATE, NAMELY, CHOCOLATE BARS; BAKERY PRODUCTS; SNACKS AND SWEET SNACKS, NAMELY, GRAIN-BASED SNACK FOOD AND SWEET GRAIN-BASED SNACK FOOD; PREPARATIONS FOR MAKING CAKES, NAMELY, MIXES FOR MAKING CAKES; PIZZAS AND PREPARATIONS FOR PIZZAS, NAMELY, PIZZA CRUST MIXES; ICE CREAM; HONEY, TREACLE; YEAST, BAKING POWDER; SALT, MUSTARD; VINEGAR, SAUCES (CONDIMENTS); SPICES; ICE (U.S. CL. 46).

REBECCA GILBERT, EXAMINING ATTORNEY

**CLASS 30—(Continued).**

SN 79-140,584. VALFLEURI PATES ALIMENTAIRES, SA, FRANCE, FILED 10-14-2013.



OWNER OF INTERNATIONAL REGISTRATION 1187140  
DATED 10-14-2013, EXPIRES 10-14-2023.

THE COLOR(S) BEIGE, ORANGE, BLUE, PURPLE, RED, WHITE, BROWN, YELLOW, GREEN, BLACK AND GRAY IS/ARE CLAIMED AS A FEATURE OF THE MARK.

THE MARK CONSISTS OF A WOMAN IN PROFILE WITH HER FACE FORWARD USING A BROWN ROLLING PIN. THE WOMAN HAS BROWN HAIR, WITH A BLACK HAIR BOW, BEIGE SKIN, A WHITE DRESS WITH A WHITE APRON. THE TOP PART OF THE DRESS IS GREEN WITH A RED FLORAL PATTERN. THE DRESS HAS A PURPLE BELT AND A RED SKIRT. BELOW THE RED SKIRT APPEARS A BLUE AND WHITE STRIPE SKIRT. IN FRONT OF THE WOMAN APPEARS A NEST OF SEVEN BEIGE EGGS WITH ONE HALF OPEN, ALL ON TOP OF BEIGE WHEAT HEADS ON A BROWN TABLE, WITH THREE GREEN LEAVES ON THE RIGHT SIDE. TO THE RIGHT OF THE WOMAN APPEARS A GRAY POT WITH AN ORANGE TOP. HANGING ON THE WALL IN FRONT OF THE WOMAN APPEAR TWO GRAY POTS AND ONE ORANGE POT ON A BROWN WALL. ABOVE THE WOMAN APPEARS THE WHITE LETTERING "VALFLEURI" OUTLINED IN RED.

THE ENGLISH TRANSLATION OF "VALFLEURI" IN THE MARK IS "FLOWERED VALLEY".

FOR PASTA OF ALL TYPES AND IN ALL FORMS (U.S. CL. 46).

CAROLINE WOOD, EXAMINING ATTORNEY

SN 79-139,858. VALFLEURI PATES ALIMENTAIRES (SOCIÉTÉ ANONYME), WITTENHEIM, FRANCE, FILED 10-14-2013.

# MOULIN FLEURI

THE MARK CONSISTS OF STANDARD CHARACTERS WITHOUT CLAIM TO ANY PARTICULAR FONT, STYLE, SIZE, OR COLOR.

OWNER OF INTERNATIONAL REGISTRATION 1185177  
DATED 10-14-2013, EXPIRES 10-14-2023.

THE ENGLISH TRANSLATION OF "MOULIN FLEURI" IN THE MARK IS "FLOWERY MILL".

FOR PASTA OF ALL TYPES AND IN ALL FORMS (U.S. CL. 46).

CAROLINE WOOD, EXAMINING ATTORNEY

SN 79-142,597. HAUSBRANDT TRIESTE 1892 S.P.A., ITALY, FILED 11-15-2013.

# MATE NITE

THE MARK CONSISTS OF STANDARD CHARACTERS WITHOUT CLAIM TO ANY PARTICULAR FONT, STYLE, SIZE, OR COLOR.

PRIORITY DATE OF 11-7-2013 IS CLAIMED.

OWNER OF INTERNATIONAL REGISTRATION 1192321  
DATED 11-15-2013, EXPIRES 11-15-2023.

NO CLAIM IS MADE TO THE EXCLUSIVE RIGHT TO USE "MATE", APART FROM THE MARK AS SHOWN.

FOR HERBAL BEVERAGES NOT FOR MEDICINAL USE, NAMELY, HERBAL TEAS; HERBAL PREPARATIONS FOR MAKING BEVERAGES, NOT FOR MEDICINAL USE, NAMELY, HERBAL FLAVORINGS FOR MAKING BEVERAGES; HERBAL TEAS AND INFUSIONS, NOT FOR MEDICINAL USE; HERBAL AROMATIC PREPARATIONS FOR MAKING NON-MEDICINAL HERBAL TEAS AND INFUSIONS; ALL THE FOREGOING CONTAINING MATE LEAVES (U.S. CL. 46).

LIEF MARTIN, EXAMINING ATTORNEY



**CLASS 30—(Continued).**

SN 79-142,836. METTE MUNK A/S, DK-5000 ODENSE C, DENMARK, FILED 11-27-2013.

# METTE MUNK

THE MARK CONSISTS OF STANDARD CHARACTERS WITHOUT CLAIM TO ANY PARTICULAR FONT, STYLE, SIZE, OR COLOR.

OWNER OF INTERNATIONAL REGISTRATION 1192807 DATED 11-27-2013, EXPIRES 11-27-2023.

OWNER OF U.S. REG. NO. 778,572.

THE NAME(S), PORTRAIT(S), AND/OR SIGNATURE(S) SHOWN IN THE MARK DOES NOT IDENTIFY A PARTICULAR LIVING INDIVIDUAL.

FOR CEREALS, NAMELY, CEREAL BARS, PROCESSED CEREALS AND CEREAL-BASED SNACK FOODS; BREAD, PASTRY AND CONFECTIONERY MADE OF SUGAR; ICES; DANISH PASTRIES, PIES AND TARTS WITH FILLING OF FRUIT AND BERRIES; SAVOURY PIES, INCLUDING VEGETABLE PIES AND PIES WITH FILLING OF MEAT, FISH, POULTRY OR GAME (U.S. CL. 46).

NELSON SNYDER, EXAMINING ATTORNEY

SN 85-005,879. JONES, TRACY L. DBA THE HUMANI-TEA COMPANY, SAINT PETERSBURG, FL. FILED 4-4-2010.

# HumaniTEA

THE MARK CONSISTS OF STANDARD CHARACTERS WITHOUT CLAIM TO ANY PARTICULAR FONT, STYLE, SIZE, OR COLOR.

FOR BLACK TEA; CHAI TEA; GREEN TEA; HERB TEA; HERBAL TEA; INSTANT TEA; OOLONG TEA; TEA; TEA BAGS (U.S. CL. 46).

ANDREW LEASER, EXAMINING ATTORNEY

SN 85-550,328. NAMASTE WATER LLC, LAS VEGAS, NV. FILED 2-22-2012.

# namastetea

THE MARK CONSISTS OF STANDARD CHARACTERS WITHOUT CLAIM TO ANY PARTICULAR FONT, STYLE, SIZE, OR COLOR.

FOR BEVERAGES MADE OF TEA; BLACK TEA; CHAI TEA; FRUIT TEAS; GINSENG TEA; GREEN TEA; HERB TEA; ICED TEA; ALL THE FOREGOING EXCLUDING TEA BAGS, TEA LEAVES, DRIED BOTANICALS, POWDERED TEAS, TEA POUCHES OR ANY DRIED TEA PRODUCTS (U.S. CL. 46).

WARREN L. OLANDRIA, EXAMINING ATTORNEY

**CLASS 30—(Continued).**

SN 85-551,050. ORGANIC MILLING ACQUISITION, LLC, SAN DIMAS, CA. FILED 2-23-2012.



NO CLAIM IS MADE TO THE EXCLUSIVE RIGHT TO USE "BREAKFAST", APART FROM THE MARK AS SHOWN.

THE COLOR(S) BLUE, LIGHT BLUE, WHITE, RED, BLACK AND TAN IS/ARE CLAIMED AS A FEATURE OF THE MARK.

THE MARK CONSISTS OF THE WORDS "BREAKFAST CHOICE" IN WHITE ON A BLUE BACKGROUND BANNER. UNDER THE WORDING IS A BOWL OF CEREAL WHICH IS BLUE WITH TAN CEREAL AND BLACK OUTLINES. NEXT TO THE BOWL OF CEREAL ARE A WHITE SPOON AND A RED STRAWBERRY.

FOR BREAKFAST CEREALS (U.S. CL. 46).

FIRST USE 3-0-2010; IN COMMERCE 3-0-2010.

DAWN FELDMAN, EXAMINING ATTORNEY

SN 85-640,564. INTERNATIONAL FOODSTUFFS CO, SHARJAH, UNITED ARAB EMIR., FILED 6-1-2012.



NO CLAIM IS MADE TO THE EXCLUSIVE RIGHT TO USE THE DESIGN OF CHOCOLATE CANDY BARS, APART FROM THE MARK AS SHOWN.

THE MARK CONSISTS OF THE WORD "ADORE" IN STYLIZED FONT ABOVE SWIRLING LIQUID CHOCOLATE CONTAINING TWO RECTANGULAR CHOCOLATE BARS BEARING THE WORD "ADORE" IN STYLIZED FONT AND WHITE LIQUID DEPICTING MILK SPLASHES.

FOR READY-TO-EAT CHOCOLATES (U.S. CL. 46).

EVIN L. KOZAK, EXAMINING ATTORNEY



**CLASS 30—(Continued).**

SN 85-706,515. COMAKER LLC, INCLINE VILLAGE, NV.  
FILED 8-17-2012.

**Muscle Munch**

THE MARK CONSISTS OF STANDARD CHARACTERS WITHOUT CLAIM TO ANY PARTICULAR FONT, STYLE, SIZE, OR COLOR.

FOR PREPARED FOOD KITS CONSISTING PRIMARILY OF DEHYDRATED PASTAS, PROCESSED GRAINS, SAUCES OR SEASONINGS, AND ALSO INCLUDING MEAT, POULTRY, SEAFOOD AND/OR VEGETABLES, READY FOR RECONSTITUTING (U.S. CL. 46).  
NELSON SNYDER, EXAMINING ATTORNEY

SN 85-810,134. LYTE BEVERAGES LP, TORONTO, ONTARIO, CANADA, FILED 12-24-2012.



OWNER OF CANADA REG. NO. TMA878871, DATED 5-28-2014, EXPIRES 5-28-2029.

NO CLAIM IS MADE TO THE EXCLUSIVE RIGHT TO USE "ICE", APART FROM THE MARK AS SHOWN.

THE MARK CONSISTS OF THE WORD "ICE" IN LOWER CASE LETTERS, TO THE LEFT OF A CIRCLE FEATURING A MITSUDOMOE TRIPPLICATE SWIRL DESIGN, AND TO THE RIGHT THE WORD "LYTE" IN LOWER CASE LETTERS.

FOR FROZEN CONFECTIONS (U.S. CL. 46).  
MARK SPARACINO, EXAMINING ATTORNEY

SN 85-834,665. NEXTJEN MEDIA LLC, NOKOMIS, FL.  
FILED 1-29-2013.

**MOVIE-POP**

THE MARK CONSISTS OF STANDARD CHARACTERS WITHOUT CLAIM TO ANY PARTICULAR FONT, STYLE, SIZE, OR COLOR.

FOR UNPOPPED POPCORN AND MICROWAVE POPCORN (U.S. CL. 46).

FIRST USE 2-10-2009; IN COMMERCE 2-10-2009.  
LEIGH CAROLINE CASE, EXAMINING ATTORNEY

**CLASS 30—(Continued).**

SN 85-913,062. BARRY CALLEBAUT AG, 8005 ZURICH, SWITZERLAND, FILED 4-24-2013.

**COCOABRAN**

THE MARK CONSISTS OF STANDARD CHARACTERS WITHOUT CLAIM TO ANY PARTICULAR FONT, STYLE, SIZE, OR COLOR.

OWNER OF U.S. REG. NO. 4,337,383.  
FOR COCOA SHELLS IN POWDERED FORM; COCOA AND COCOA-BASED GOODS CONTAINING COCOA SHELLS IN POWDERED FORM, NAMELY, COCOA POWDER; COMPOUND CHOCOLATE, NAMELY, COMPOUND CHOCOLATE COATING FOR USE IN THE MANUFACTURE OF CAKES AND FROZEN CONFECTIONS (U.S. CL. 46).

SCOTT BIBB, EXAMINING ATTORNEY

SN 85-921,641. TOUFAYAN BAKERY, INC., RIDGEFIELD, NJ. FILED 5-2-2013.

**TOUFAYAN BAKERIES  
PitaPocketz**

THE MARK CONSISTS OF STANDARD CHARACTERS WITHOUT CLAIM TO ANY PARTICULAR FONT, STYLE, SIZE, OR COLOR.

OWNER OF U.S. REG. NOS. 1,800,957, 4,272,221 AND OTHERS.

NO CLAIM IS MADE TO THE EXCLUSIVE RIGHT TO USE "BAKERIES PITA POCKETS", APART FROM THE MARK AS SHOWN.

FOR CRISP BREAD; FLOUR-BASED CHIPS; MULTI-GRAIN-BASED SNACK FOODS; PITA CHIPS; WHEAT-BASED SNACK FOODS (U.S. CL. 46).

ADA HAN, EXAMINING ATTORNEY

SN 85-921,664. TOUFAYAN BAKERY, INC., RIDGEFIELD, NJ. FILED 5-2-2013.

**TOUFAYAN BAKERIES PITA  
POCKETZ**

THE MARK CONSISTS OF STANDARD CHARACTERS WITHOUT CLAIM TO ANY PARTICULAR FONT, STYLE, SIZE, OR COLOR.

OWNER OF U.S. REG. NOS. 1,800,957, 4,272,221 AND OTHERS.

NO CLAIM IS MADE TO THE EXCLUSIVE RIGHT TO USE "BAKERIES PITA POCKETS", APART FROM THE MARK AS SHOWN.

FOR CRISP BREAD; FLOUR-BASED CHIPS; MULTI-GRAIN-BASED SNACK FOODS; PITA CHIPS; WHEAT-BASED SNACK FOODS (U.S. CL. 46).

ADA HAN, EXAMINING ATTORNEY

**CLASS 30—(Continued).**

SN 85-944,123. SWEET SHOP CANDIES, INC., MOUNT PLEASANT, TX. FILED 5-28-2013.

**SWEET SHOP USA**

THE MARK CONSISTS OF STANDARD CHARACTERS WITHOUT CLAIM TO ANY PARTICULAR FONT, STYLE, SIZE, OR COLOR.

OWNER OF U.S. REG. NOS. 1,173,486 AND 1,682,456. SEC. 2(F).

FOR CHOCOLATES; CANDIES; CANDY COATED POPCORN; AND CHOCOLATE AND CARAMEL COVERED APPLES (U.S. CL. 46).

FIRST USE 4-30-1990; IN COMMERCE 6-30-1990. JOHN DALIER, EXAMINING ATTORNEY

**CLASS 30—(Continued).**

SN 86-014,832. POST FOODS, LLC, PARSIPPANY, NJ. FILED 7-19-2013.

**SIMPLE INGREDIENTS. SIMPLY MADE.**

THE MARK CONSISTS OF STANDARD CHARACTERS WITHOUT CLAIM TO ANY PARTICULAR FONT, STYLE, SIZE, OR COLOR.

FOR BREAKFAST CEREALS; CRACKERS (U.S. CL. 46).

FIRST USE 2-28-2011; IN COMMERCE 2-28-2011. JORDAN BAKER, EXAMINING ATTORNEY

SN 86-009,800. MICHAEL SHEENA, SOUTHFIELD, MI. FILED 7-14-2013.



NO CLAIM IS MADE TO THE EXCLUSIVE RIGHT TO USE "BAKER'S", "SUGAR PREMIUM GRANULATED PURE CANE" AND "NET WT 4 LB (1.81 KG)", APART FROM THE MARK AS SHOWN.

THE COLOR(S) BLUE, ORANGE, WHITE AND PINK IS/ARE CLAIMED AS A FEATURE OF THE MARK.

THE MARK CONSISTS OF AN ORANGE OUTER RECTANGULAR CARRIER HOLDING AN ORANGE AND BLUE RECTANGULAR CENTER PORTION WITH A PICTURE OF A PINK BAKER WEARING A WHITE BAKER'S HAT APPEARING IN WHITE AND BLUE ON AN ORANGE BACKGROUND. THE WORDS "BAKER'S CHOICE" APPEAR IN WHITE WITH BLUE OUTLINE BELOW THE PICTURE OF THE BAKER INSIDE AN ORANGE OVAL CENTER. THE WORD "SUGAR" APPEARS IN WHITE WITH BLUE OUTLINE LOCATED BELOW THE PICTURE OF THE BAKER AND WORDS "PREMIUM GRANULATED" APPEAR IN BLUE WITH A BLUE DOT BETWEEN THE WORDS. THE TERM "PURE CANE" APPEARS IN WHITE. THE TERM "NET WT 4 LB (1.81KG)" APPEARS IN BLUE ON A MOUND OF WHITE SUGAR WITH WHITE LINES AT THE BOTTOM OF THE MARK.

FOR BAKERY DESSERTS; BAKERY GOODS; BAKERY GOODS AND DESSERT ITEMS, NAMELY, CHEESECAKES FOR RETAIL AND WHOLESALE DISTRIBUTION AND CONSUMPTION ON OR OFF THE PREMISES; BROWN SUGAR; CRYSTAL SUGAR; CRYSTAL SUGAR PIECES; CUBE SUGAR; NATURAL BROWN SUGAR; PALM SUGAR; POWDERED SUGAR; SUGAR AND SUGAR SUBSTITUTES (U.S. CL. 46). SAIMA MAKHDOOM, EXAMINING ATTORNEY

SN 86-025,465. STUSSY, INC., IRVINE, CA. FILED 7-31-2013.

**STUSSY**

THE MARK CONSISTS OF STANDARD CHARACTERS WITHOUT CLAIM TO ANY PARTICULAR FONT, STYLE, SIZE, OR COLOR.

OWNER OF U.S. REG. NOS. 3,112,126, 4,410,371 AND OTHERS.

SEC. 2(F).

FOR CANDY; CHEWING GUM; COFFEE; COFFEE BEANS; ROASTED COFFEE BEANS (U.S. CL. 46).

FIRST USE 4-24-2012; IN COMMERCE 4-24-2012. WANDA KAY PRICE, EXAMINING ATTORNEY

**CLASS 30—(Continued).**

SN 86-037,515. EASTERN GROCERS INC, SCHAUMBURG, IL. FILED 8-14-2013.

# GRUHINI

THE MARK CONSISTS OF STANDARD CHARACTERS WITHOUT CLAIM TO ANY PARTICULAR FONT, STYLE, SIZE, OR COLOR.

THE ENGLISH TRANSLATION OF "GRUHINI" IN THE MARK IS "HOUSEWIFE".

FOR COFFEE, TEA, COCOA, SUGAR, RICE, TAPIOCA, SAGO, ARTIFICIAL COFFEE; FLOUR AND PREPARATIONS MADE FROM CEREALS, NAMELY, HIGH PROTEIN CEREAL BARS; BREAD, PASTRY AND CONFECTIONERY, ICES; HONEY, TREACLE, YEAST, BAKING-POWDER; SALT, MUSTARD; VINEGAR, SPICE BLENDS; SPICE RUBS; SPICES; ICE; CANDY; CHOCOLATES; CURRY POWDER, WAFERS, COOKIES, BISCUITS, FLOUR; CEREAL BASED SNACK FOODS, RICE BASED SNACK FOODS, PROCESSED GRAINS, PROCESSED WHEAT, DESSERTS, NAMELY, BAKERY DESSERTS AND DAIRY BASED DESSERTS, NAMELY, CHILLED OR WARM CAKE OR DUMPLING HAVING A MILK BASED FILLING, SAUCES, CHUTNEY, BAKERY GOODS, FROZEN AND PREPARED MEALS CONSISTING PRIMARILY OF PASTA AND RICE; GROCERIES, NAMELY, MAYONNAISE AND PRETZELS; RAW NUTS; ROASTED AND GROUND SESAME SEEDS; PROCESSED GRAINS, PROCESSED WHEAT, SEASONINGS; ARTIFICIAL RICE, INDIAN CEREAL BASED SNACK FOODS, DAILY BASED INDIAN DESSERTS IN THE NATURE OF PUDDINGS, DAIRY BASED INDIAN BAKERY GOODS, DAIRY BASED INDIAN BISCUITS, DAIRY BASED INDIAN COOKIES (U.S. CL. 46).

FIRST USE 7-1-2012; IN COMMERCE 7-1-2012.

JASON BLAIR, EXAMINING ATTORNEY

**CLASS 30—(Continued).**

SN 86-045,529. SUNNY - HKV INVESTMENTS, LLC, BURLEN, WA. FILED 8-22-2013.



THE COLOR(S) BLUE, GREEN, WHITE, YELLOW AND RED IS/ARE CLAIMED AS A FEATURE OF THE MARK.

THE MARK CONSISTS OF THREE WHITE GOATS IN A GREEN FIELD UNDER A BLUE SKY, ENCIRCLED ON BOTH SIDES BY YELLOW LEAVES HAVING WISPS OF GREEN GRASS ON THEIR OUTER BORDERS. BELOW THE GOATS IS A GREEN AND YELLOW BANNER WITH RED CAMBODIAN CHARACTERS AND THE WORDS "WHITE GOATS" IN RED.

THE ENGLISH TRANSLATION OF THE CAMBODIAN CHARACTERS IN THE MARK IS "WHITE GOATS".

THE NON-LATIN CHARACTERS IN THE MARK TRANSLITERATE TO "SANH-NHA-POER-SOR-PHO-PHER" AND THIS MEANS "WHITE GOATS" IN ENGLISH.

FOR RICE (U.S. CL. 46).

FIRST USE 12-31-2012; IN COMMERCE 12-31-2012.

APRIL REEVES, EXAMINING ATTORNEY

SN 86-048,947. L.A. BURDICK CHOCOLATES, INC., WALPOLE, NH. FILED 8-27-2013.



THE COLOR(S) WHITE AND BROWN IS/ARE CLAIMED AS A FEATURE OF THE MARK.

THE MARK CONSISTS OF A THREE-DIMENSIONAL CONFIGURATION OF A CHOCOLATE CONFECTION COMPRISING A GHOST WITH A WHITE FLOWING SHEET-LIKE GARMENT AND TWO BROWN EYES.

SEC. 2(F).

FOR CHOCOLATE AND CHOCOLATES, CHOCOLATE CANDIES; CHOCOLATE CONFECTIONS, NAMELY, HAND-MADE CHOCOLATE BASED CONFECTIONS (U.S. CL. 46).

FIRST USE 9-30-2002; IN COMMERCE 9-30-2002.

JILLIAN CANTOR, EXAMINING ATTORNEY

**CLASS 30—(Continued).**

SN 86-057,392. SCHMIDT, JOHN, BLOOMFIELD HILLS, MI.  
FILED 9-6-2013.

**BAHAMA BLEND**

THE MARK CONSISTS OF STANDARD CHARACTERS WITHOUT CLAIM TO ANY PARTICULAR FONT, STYLE, SIZE, OR COLOR.

NO CLAIM IS MADE TO THE EXCLUSIVE RIGHT TO USE "BLEND", APART FROM THE MARK AS SHOWN.

FOR BREAD AND PASTRY; FRESH BAKED AND FROZEN BREAD, ROLLS AND CAKES (U.S. CL. 46).

JEFFREY LOOK, EXAMINING ATTORNEY

SN 86-058,051. QUICK RESTAURANTS, EN ABRÉGÉ  
QUICK, SOCIÉTÉ ANONYME, BRUSSELS, BELGIUM,  
FILED 9-6-2013.

**SUPREME GIANT**

THE MARK CONSISTS OF STANDARD CHARACTERS WITHOUT CLAIM TO ANY PARTICULAR FONT, STYLE, SIZE, OR COLOR.

PRIORITY CLAIMED UNDER SEC. 44(D) ON BENELUX APPLICATION NO. 1272481, FILED 7-26-2013, REG. NO. 0941706, DATED 7-29-2013, EXPIRES 7-26-2023.

FOR EDIBLE SANDWICHES, MEAT SANDWICHES, PORK SANDWICHES, FISH SANDWICHES, CHICKEN SANDWICHES (U.S. CL. 46).

MARCIE MILONE, EXAMINING ATTORNEY

SN 86-059,486. LAOMANUTSAK, RATHCHAPON, DBA  
WEALTH CREATION, ARLETA, CA. FILED 9-9-2013.



NO CLAIM IS MADE TO THE EXCLUSIVE RIGHT TO USE THE NON-LATIN CHARACTERS THAT TRANSLITERATE TO "TEA" AND "GENMAI FLAVOR", APART FROM THE MARK AS SHOWN.

THE COLOR(S) WHITE, YELLOW, BROWN, BLACK, GREEN, DARK GREEN, AND ORANGE IS/ARE CLAIMED AS A FEATURE OF THE MARK.

THE MARK CONSISTS OF THE WORD "KINCHA" IN

**CLASS 30—(Continued).**

WHITE OUTLINED BY BROWN, WITH LEAVES IN LIGHT GREEN AROUND DARK GREEN GROWING OUT THE TOP OF THE "I". BELOW ARE THAI CHARACTERS IN BROWN AND BLACK. AT THE BOTTOM IS A BROWN TEA POT WITH A BLACK SMILING FACE ON IT AND A WHITE KNOB ON TOP. IT IS POURING WHITE LIQUID INTO A BROWN CUP WITH BLACK LINES ON THE SIDE, WITH TWO GREEN LEAVES ON THE LIP. A SMALL WHITE STEAM IN THE SHAPE OF A HEART APPEARS ABOVE THE WATER, ALONG WITH A BROWN CIRCLE WITH ORANGE, GREEN, DARK GREEN AND BROWN CHARACTERS WITHIN IT, WHICH TRANSLATE TO GOLDEN TEA IN KATAKANA SYMBOLS OF THE JAPANESE LANGUAGE. THESE CHARACTERS PHONETICALLY SOUND LIKE "KINCHA" WHEN READ IN THE JAPANESE LANGUAGE. ON THE RIGHT HAND SIDE IS A BROWN-BORDERED GREEN AREA WITH WHITE KANJI SYMBOLS OF THE JAPANESE LANGUAGE. THESE CHARACTERS ALSO PHONETICALLY SOUND LIKE "KINCHA" WHEN READ IN THE JAPANESE LANGUAGE. ALL THIS APPEARS ON A YELLOW BACKGROUND WITH A BROWN BORDER, OUTSIDE WHICH THE BACKGROUND IS ORANGE.

THE ENGLISH TRANSLATION OF "KINCHA" IN THE MARK IS "GOLDEN TEA".

THE NON-LATIN CHARACTERS IN THE MARK TRANSLITERATE TO "KINCHA", CHA KIAW, ROD KAO YEE PUN AND THIS MEANS "GOLDEN TEA", "GOLDEN TEA", AND "GENMAI FLAVOR" IN ENGLISH.

FOR GREEN TEA (U.S. CL. 46).

FIRST USE 8-27-2013; IN COMMERCE 8-27-2013.

CAITLIN WATTS-FITZGERALD, EXAMINING ATTORNEY

SN 86-060,733. DIAZ BANDERA, SAID ANTONIO, CARTAGENA, COLOMBIA, FILED 9-10-2013.



THE MARK CONSISTS OF A THE WORD "AJIBASCO" IN STYLIZED LETTERS SURROUNDED BY AN ABSTRACT DESIGN FORMED BY A THIN LINE.

FOR HOT PEPPER SAUCE (U.S. CL. 46).

PAM WILLIS, EXAMINING ATTORNEY

**CLASS 30—(Continued).**

SN 86-064,002. ROYCE' CONFECT CO., LTD., SAPPORO-SHI, HOKKAIDO, JAPAN, FILED 9-13-2013.

ROYCE' HONOLULU

THE MARK CONSISTS OF STANDARD CHARACTERS WITHOUT CLAIM TO ANY PARTICULAR FONT, STYLE, SIZE, OR COLOR.

OWNER OF U.S. REG. NOS. 2,976,406 AND 3,462,609.

NO CLAIM IS MADE TO THE EXCLUSIVE RIGHT TO USE "HONOLULU", APART FROM THE MARK AS SHOWN.

FOR COFFEE, TEA, COCOA, RICE, TAPIOCA, ARTIFICIAL COFFEE, BREAD, PASTRY, CONFECTIONERY MADE OF SUGAR, ICES (U.S. CL. 46).

AMY C. KEAN, EXAMINING ATTORNEY

SN 86-064,179. PROMOTION IN MOTION, INC., ALLENDALE, NJ. FILED 9-13-2013.

BEST LICK ON A STICK

THE MARK CONSISTS OF STANDARD CHARACTERS WITHOUT CLAIM TO ANY PARTICULAR FONT, STYLE, SIZE, OR COLOR.

NO CLAIM IS MADE TO THE EXCLUSIVE RIGHT TO USE "ON A STICK", APART FROM THE MARK AS SHOWN.

FOR CANDY, NAMELY, LOLLIPOPS, CHOCOLATE ON A STICK, CONFECTIONARY MADE OF SUGAR ON A STICK, STICK SHAPED CONFECTIONARY MADE OF SUGAR AND STICK SHAPED CHOCOLATE (U.S. CL. 46).

CARYN GLASSER, EXAMINING ATTORNEY

SN 86-066,223. SONG, ROBERT M., EAST LANSING, MI. FILED 9-16-2013.

mahalo

THE MARK CONSISTS OF STANDARD CHARACTERS WITHOUT CLAIM TO ANY PARTICULAR FONT, STYLE, SIZE, OR COLOR.

THE ENGLISH TRANSLATION OF "MAHALO" IN THE MARK IS "THANK YOU".

FOR SUSHI (U.S. CL. 46).

FIRST USE 4-16-2009; IN COMMERCE 4-26-2009.

GRETCHEN ULRICH, EXAMINING ATTORNEY

**CLASS 30—(Continued).**

SN 86-066,331. SONG, ROBERT M., EAST LANSING, MI. FILED 9-17-2013.

papa crema

THE MARK CONSISTS OF STANDARD CHARACTERS WITHOUT CLAIM TO ANY PARTICULAR FONT, STYLE, SIZE, OR COLOR.

NO CLAIM IS MADE TO THE EXCLUSIVE RIGHT TO USE "CREMA", APART FROM THE MARK AS SHOWN.

THE ENGLISH TRANSLATION OF "CREMA" IN THE MARK IS "CREAM".

FOR SUSHI (U.S. CL. 46).

FIRST USE 4-16-2009; IN COMMERCE 4-16-2009.

GRETCHEN ULRICH, EXAMINING ATTORNEY

SN 86-077,787. SCHUELLER, MICHAEL S., DBA MISHI'S STRUDEL, SAN PEDRO, CA. AND SCHUELLER, ANIKO M., DBA MISHI'S STRUDEL, SAN PEDRO, CA. FILED 9-29-2013.



NO CLAIM IS MADE TO THE EXCLUSIVE RIGHT TO USE "STRUDEL BAKERY AND CAFE" AND "HOMEMADE HUNGARIAN", APART FROM THE MARK AS SHOWN.

THE COLOR(S) WHITE, GREEN, BLACK, RED, TAN, BLUE, YELLOW AND PINK IS/ARE CLAIMED AS A FEATURE OF THE MARK.

THE MARK CONSISTS OF A MISCELLANEOUS POLYGON SHAPE WITH A WHITE BACKGROUND THROUGHOUT THE POLYGON SHAPE AND OUTLINED IN GREEN, BLACK, RED AND TAN. INSIDE THE POLYGON SHAPE AND NEAR THE TOP APPEARS THE LANGUAGE "MISHI'S STRUDEL" IN RED AND OUTLINED IN BLACK AND WHITE. BELOW THIS IS A WHITE BANNER OUTLINED IN GREEN AND RED WITH THREE RED DOTS FOLLOWED BY THE LANGUAGE "BAKERY AND CAFE" IN GREEN AND OUTLINED IN TAN FOLLOWED BY THREE RED DOTS, ALL APPEARING ON THE BANNER. BENEATH THE BANNER IS AN INCOMPLETE TAN CIRCLE WITH A WHITE BACKGROUND AND WITH BLUE, YELLOW, GREEN, RED AND PINK FLOWERS WITH THE RED LANGUAGE "HOMEMADE HUNGARIAN" BENEATH THE FLOWERS, ALL WITHIN THE CIRCLE.

FOR BAKERY DESSERTS; BAKERY GOODS; BAKERY GOODS, NAMELY, STRUDEL FOR RETAIL AND WHOLESALE DISTRIBUTION AND CONSUMPTION ON OR OFF THE PREMISES; BAKERY PRODUCTS; BAKERY PRODUCTS, NAMELY, SWEET BAKERY GOODS (U.S. CL. 46).

FIRST USE 12-7-2007; IN COMMERCE 12-7-2007.

Laurie Mayes, Examining Attorney

**CLASS 30—(Continued).**

SN 86-082,477. CHIPOLLINI, LLC, BALTIMORE, MD. FILED 10-3-2013.

buckwheat creations

THE MARK CONSISTS OF STANDARD CHARACTERS WITHOUT CLAIM TO ANY PARTICULAR FONT, STYLE, SIZE, OR COLOR.

NO CLAIM IS MADE TO THE EXCLUSIVE RIGHT TO USE "BUCKWHEAT", APART FROM THE MARK AS SHOWN.

FOR DESSERT PUDDINGS; PUDDINGS; PUDDINGS FOR USE AS DESSERTS; ALL OF THE FOREGOING CONTAINING IN SIGNIFICANT PART BUCKWHEAT (U.S. CL. 46).

FIRST USE 8-1-2013; IN COMMERCE 8-1-2013.  
SIDDHARTH JAGANNATHAN, EXAMINING ATTORNEY

**CLASS 30—(Continued).**

SN 86-084,755. BAMBANG SAWIRAN, JAKARTA, INDONESIA, FILED 10-7-2013.



NO CLAIM IS MADE TO THE EXCLUSIVE RIGHT TO USE "BRAND", APART FROM THE MARK AS SHOWN.

THE MARK CONSISTS OF THE TERM "ROTARY" APPEARING TO THE RIGHT OF A RECTANGULAR SHAPE WHICH FEATURES THEREIN A DESIGN WITH AN OUTER BORDER WITH THE SHAPE OF A HEXAGON WITH TWO HALF CIRCLES, ONE APPEARING ABOVE THE OTHER, DEPICTED WITHIN THE HEXAGON SHAPE AND WITH AN IMAGE IN THE SHAPE OF THE LETTER "N" APPEARING WITHIN THE TWO HALF CIRCLES AND THE TERM "BRAND" APPEARING BENEATH THE RECTANGULAR SHAPE.

FOR CRACKERS; FISH CRACKERS; ONION CRACKERS; STICK BAR CRACKERS (U.S. CL. 46).  
NAAKWAMA ANKRAH, EXAMINING ATTORNEY

SN 86-083,007. UNCLE MILLIS LLC, PERRY, MI. FILED 10-4-2013.

The Killer Cook

THE MARK CONSISTS OF STANDARD CHARACTERS WITHOUT CLAIM TO ANY PARTICULAR FONT, STYLE, SIZE, OR COLOR.

FOR HOT SAUCE (U.S. CL. 46).  
FIRST USE 9-21-2013; IN COMMERCE 9-21-2013.  
JAY FLOWERS, EXAMINING ATTORNEY

SN 86-085,487. FOOD DIRECTIONS INC., SCARBOROUGH, ONTARIO, CANADA, FILED 10-8-2013.



PRIORITY CLAIMED UNDER SEC. 44(D) ON CANADA APPLICATION NO. 1622504, FILED 4-9-2013, REG. NO. TMA867352, DATED 12-16-2013, EXPIRES 12-16-2028.

NO CLAIM IS MADE TO THE EXCLUSIVE RIGHT TO USE "PASTA", APART FROM THE MARK AS SHOWN.

THE MARK CONSISTS OF THE STYLIZED WORDS "PASTA JOY READY" WITH A HORIZONTAL LINE UNDER THE WORD "READY".

FOR RICE PASTA (U.S. CL. 46).  
FIRST USE 5-0-2004; IN COMMERCE 5-0-2004.  
CHRISTOPHER LAW, EXAMINING ATTORNEY



**CLASS 30—(Continued).**

SN 86-088,218. TURNER DAIRY FARMS, INC., PITTSBURGH, PA. FILED 10-10-2013.



NO CLAIM IS MADE TO THE EXCLUSIVE RIGHT TO USE "TEA 150", APART FROM THE MARK AS SHOWN. THE MARK CONSISTS OF THE STYLIZED WORD "TEA" AND STYLIZED NUMBER "150" TO THE LEFT OF A STYLIZED LIGHT BULB WITH STYLIZED LIGHT RAYS. FOR ICED TEA; TEA-BASED ICED BEVERAGES (U.S. CL. 46).

FIRST USE 8-31-2008; IN COMMERCE 8-31-2008.  
BRITTANY ESTELL, EXAMINING ATTORNEY

SN 86-090,679. WM. WRIGLEY JR. COMPANY, CHICAGO, IL. FILED 10-14-2013.

**LIFE SAVERS GUMMIES TANGY  
COLLISIONS**

THE MARK CONSISTS OF STANDARD CHARACTERS WITHOUT CLAIM TO ANY PARTICULAR FONT, STYLE, SIZE, OR COLOR.

OWNER OF U.S. REG. NOS. 3,462,916, 4,214,036 AND 4,321,642.

NO CLAIM IS MADE TO THE EXCLUSIVE RIGHT TO USE "GUMMIES TANGY", APART FROM THE MARK AS SHOWN.

FOR CANDY (U.S. CL. 46).  
KAREN BRACEY, EXAMINING ATTORNEY

SN 86-093,029. PERFORMANCE FOOD GROUP, INC., RICHMOND, VA. FILED 10-16-2013.

**PIANCONE GRANO D'ORO**

THE MARK CONSISTS OF STANDARD CHARACTERS WITHOUT CLAIM TO ANY PARTICULAR FONT, STYLE, SIZE, OR COLOR.

OWNER OF U.S. REG. NOS. 1,203,751, 3,178,644 AND 3,205,568.

NO CLAIM IS MADE TO THE EXCLUSIVE RIGHT TO USE "GRANO D'ORO", APART FROM THE MARK AS SHOWN.

THE ENGLISH TRANSLATION OF "GRANO D'ORO" IN THE MARK IS "GOLDEN WHEAT".

FOR PASTA (U.S. CL. 46).  
JENNIFER RICHARDSON, EXAMINING ATTORNEY

**CLASS 30—(Continued).**

SN 86-094,325. THE TIEN CHU (HONG KONG) COMPANY LIMITED, TSING YI, NT, HONG KONG, FILED 10-17-2013.



THE COLOR(S) RED AND WHITE IS/ARE CLAIMED AS A FEATURE OF THE MARK.

THE MARK CONSISTS OF THE FOLLOWING: TWO PARALLEL HORIZONTAL WHITE STRIPES TRAVERSING A RED CIRCLE WITH TWO ADDITIONAL VERTICAL WHITE STRIPES EXTENDING FROM THE BOTTOM OF THE PERIMETER OF THE CIRCLE AND CONVERGING TO FORM AN ACUTE ANGLE. THE VERTEX OF THE ANGLE TOUCHING THE UPPERMOST HORIZONTAL STRIPE.

THE NON-LATIN CHARACTERS IN THE MARK TRANSLITERATE TO "TIEN" AND THIS MEANS "SKY" IN ENGLISH.

FOR PROCESSED GRAINS, NAMELY, DUMPLINGS, FLOUR, READY TO EAT CEREAL DERIVED FOOD BARS, GRANOLA BASED SNACK MIXES IN THE NATURE OF CRYSTALLIZED POWDERS IN PREPARATION OF TEA BASED BEVERAGES, GRAIN BASED BEVERAGES, HERBAL FOOD BEVERAGES NOT BEING VEGETABLE BASED; FOOD FLAVORING, NAMELY, MONOSODIUM GLUTAMATE, ALMOND PASTE, BARBECUE SAUCES, GARLIC POWDERS, CRYSTALLIZED GINGER, NUTMEG AND SAGE (U.S. CL. 46).

LUCY ARANT, EXAMINING ATTORNEY

SN 86-095,538. MAYAGUEZ S.A., CALI-VALLE, COLOMBIA, FILED 10-18-2013.

**EVOLVING ENERGY**

THE MARK CONSISTS OF STANDARD CHARACTERS WITHOUT CLAIM TO ANY PARTICULAR FONT, STYLE, SIZE, OR COLOR.

PRIORITY CLAIMED UNDER SEC. 44(D) ON COLOMBIA APPLICATION NO. 13119784, FILED 5-15-2013, REG. NO. 437428, DATED 11-24-2011, EXPIRES 11-24-2021.

FOR CAKES; CANDIES; CHOCOLATE; COCOA; COFFEE; CONFECTIONERY MADE OF SUGAR; COOKIES; COOKING SALT; CRACKERS; HONEY; ICE-CREAM; NATURAL SWEETENER; PASTRIES; RICE; SUGAR; SWEETMEATS (U.S. CL. 46).

DOUGLAS LEE, EXAMINING ATTORNEY

**CLASS 30—(Continued).**

SN 86-098,467. CEREALES Y PASTAS, S.A. DE C.V., CELAYA GUANAJUATO, MEXICO, FILED 10-22-2013.



PRIORITY CLAIMED UNDER SEC. 44(D) ON MEXICO APPLICATION NO. 1423433, FILED 10-17-2013, REG. NO. 1430016, DATED 1-27-2014, EXPIRES 11-17-2023.

OWNER OF U.S. REG. NOS. 3,666,019 AND 4,363,507.

NO CLAIM IS MADE TO THE EXCLUSIVE RIGHT TO USE "FOODS", "BRAN" AND THE PICTORIAL REPRESENTATION OF A SPOON OF CEREAL, APART FROM THE MARK AS SHOWN.

THE COLOR(S) RED, WHITE, BLUE, ORANGE, BLACK, YELLOW, GOLD, BROWN, LIGHT BROWN, DARK BROWN, SILVER IS/ARE CLAIMED AS A FEATURE OF THE MARK.

THE MARK CONSISTS OF DESIGN FEATURES OF THE FRONT OF A CEREAL BOX PACKAGE. THE DOTTED OUTLINE OF THE PACKAGING IS INTENDED TO SHOW THE POSITION OF THE MARK AND IS NOT PART OF THE MARK. A BANNER DESIGN WHICH HAS THE WORDS "GOLDEN FOODS" IN WHITE LETTERS ON A RED BACKGROUND APPEARS IN THE UPPER LEFT CORNER. TWO WAVY LINES IN BLUE AND YELLOW APPEAR AT THE BOTTOM OF THE BANNER DESIGN. AN ORANGE CURVED BORDER APPEARS ON THE UPPER PORTION OF THE CEREAL PACKAGE. SEVERAL GOLD AND BROWN STALKS OF WHEAT APPEAR SUPERIMPOSED ON THE BORDER IN THE UPPER RIGHT PORTION OF THE PACKAGE. BELOW THE BANNER, THE WORD "SPECIAL" APPEARS IN ORANGE AND IS LOCATED ABOVE WORD "BRAN" WHICH APPEARS IN BLACK, ALL APPEARING ON A WHITE BACKGROUND. AN ORANGE LINE CURVES AROUND THE RIGHT SIDE OF THE WORDING "SPECIAL BRAN". A SILVER SPOON WITH BROWN CEREALS APPEARS BELOW THE CURVED LINE ON A WHEAT FIELD BACKGROUND. THE WHEAT STALKS APPEAR IN YELLOW, GOLD, LIGHT BROWN AND BROWN COLORS. THE COLORS YELLOW AND GOLD APPEAR ON THE BACKGROUND OF THE SPOON AND THE COLORS LIGHT BROWN AND BROWN APPEAR ON THE FOREGROUND OF THE SPOON. THE COLORS DARK BROWN AND BLACK APPEAR AS SHADOWING OF THE WHEAT FIELD. A CURVED ORANGE DESIGN APPEARS IN THE LOWER RIGHT CORNER.

FOR BREAKFAST CEREALS; CEREAL BARS; CEREAL BASED SNACK FOOD; HIGH-PROTEIN CEREAL BARS; PROCESSED CEREAL-BASED FOOD TO BE USED AS A BREAKFAST FOOD, SNACK FOOD OR INGREDIENT FOR MAKING OTHER FOODS; READY-TO-EAT CEREALS (U.S. CL. 46).

TRACY FLETCHER, EXAMINING ATTORNEY

**CLASS 30—(Continued).**

SN 86-099,102. NOA SPECIALITY PRODUCTS INC., RIVER-HEAD, NY. FILED 10-23-2013.

# NOA

THE MARK CONSISTS OF STANDARD CHARACTERS WITHOUT CLAIM TO ANY PARTICULAR FONT, STYLE, SIZE, OR COLOR.

FOR GRAIN-BASED FOOD BARS ALSO CONTAINING ROLLED OATS, ALMOND BUTTER, AGAVE, NUTS, DRIED FRUITS, MILLED FLAX SEEDS, SALT AND NATURAL FLAVORS (U.S. CL. 46).

FIRST USE 10-7-2013; IN COMMERCE 10-7-2013.  
ZACHARY CROMER, EXAMINING ATTORNEY

SN 86-105,118. VINTAGE TEAS CEYLON PRIVATE LIMITED, DBA TEA EXPORTER, MULLERIYAWA NORTH., SRI LANKA, FILED 10-30-2013.



OWNER OF AUSTRALIA REG. NO. 1512087, DATED 9-3-2012, EXPIRES 9-3-2022.

NO CLAIM IS MADE TO THE EXCLUSIVE RIGHT TO USE "TEA", APART FROM THE MARK AS SHOWN.

THE MARK CONSISTS OF A SKETCH OF A SUN WITH SHADOW INSIDE A BLACK SQUARE WITH TEXT "MORNINGAFTER TEA" ABOVE THE SQUARE INSIDE A CIRCLE.

FOR TEA BAGS (U.S. CL. 46).

FIRST USE 4-5-2009; IN COMMERCE 9-1-2010.

CAROLYN CATALDO, EXAMINING ATTORNEY



**CLASS 30—(Continued).**

SN 86-107,660. S.J. MCCULLAGH, INC., BUFFALO, NY.  
FILED 11-1-2013.



OWNER OF U.S. REG. NO. 3,663,101.  
NO CLAIM IS MADE TO THE EXCLUSIVE RIGHT TO USE "TEA", APART FROM THE MARK AS SHOWN.  
THE MARK CONSISTS OF "ECOVERDE" IN STYLIZED LETTERING PLACED OVER A STYLIZED REPRESENTATION OF TEA LEAVES AND "TEA" IN STYLIZED LETTERING PLACED BELOW "ECOVERDE".  
FOR TEA (U.S. CL. 46).  
B. PARADEWELAI, EXAMINING ATTORNEY

SN 86-115,074. BAKER, DIONNE LASLO, VICTORIA, BC,  
CANADA, FILED 11-11-2013.

**DEEBEE'S SPECIALTEA FOODS**

THE MARK CONSISTS OF STANDARD CHARACTERS WITHOUT CLAIM TO ANY PARTICULAR FONT, STYLE, SIZE, OR COLOR.  
NO CLAIM IS MADE TO THE EXCLUSIVE RIGHT TO USE "SPECIAL TEA FOODS", APART FROM THE MARK AS SHOWN.  
FOR FROZEN CONFECTIONERY; ICE CREAM; WATER ICE; TEA (U.S. CL. 46).  
KELLY TRUSILO, EXAMINING ATTORNEY

SN 86-124,248. BAKER, DIONNE LASLO, VICTORIA, BC,  
CANADA, FILED 11-20-2013.



NO CLAIM IS MADE TO THE EXCLUSIVE RIGHT TO USE "TEA" AND THE DEPICTION OF A TEA BAG, APART FROM THE MARK AS SHOWN.  
THE MARK CONSISTS OF A CIRCLE CONTAINING AN IMAGE OF A TEA BAG WITH A TAG CONTAINING THE WORD "TEA", WHICH IS SURROUNDED BY AN OUTER CIRCLE CONTAINING THE PHRASE "TEA IS A RICH SOURCE OF HAPPINESS".  
FOR FROZEN CONFECTIONERY; ICE CREAM; WATER ICE; TEA (U.S. CL. 46).  
KELLY TRUSILO, EXAMINING ATTORNEY

**CLASS 30—(Continued).**

SN 86-126,089. CUSH'S HOMEGROWN, OLD LYME, CT.  
FILED 11-21-2013.

**Cush's Homegrown**

THE MARK CONSISTS OF STANDARD CHARACTERS WITHOUT CLAIM TO ANY PARTICULAR FONT, STYLE, SIZE, OR COLOR.  
NO CLAIM IS MADE TO THE EXCLUSIVE RIGHT TO USE "HOMEGROWN", APART FROM THE MARK AS SHOWN.  
THE NAME "CUSH" IDENTIFIES CHRISTOPHER CUSHING, A LIVING INDIVIDUAL WHOSE CONSENT IS OF RECORD.  
FOR RELISH; SALSA (U.S. CL. 46).  
FIRST USE 9-15-1994; IN COMMERCE 12-7-2009.  
AMY ALFIERI, EXAMINING ATTORNEY

SN 86-126,161. CLASSIC COOKING LLC, JAMAICA, NY.  
FILED 11-21-2013.

**Patitas**

THE MARK CONSISTS OF STANDARD CHARACTERS WITHOUT CLAIM TO ANY PARTICULAR FONT, STYLE, SIZE, OR COLOR.  
THE ENGLISH TRANSLATION OF "PATITAS" IN THE MARK IS "LITTLE FEET".  
FOR FROZEN DOUGH WITH A FILLING OF MEAT, MEAT SUBSTITUTE, CHEESE, VEGETABLES, SAUCE, INDIVIDUALLY AND WITH COMBINATIONS OF THE FOREGOING FILLINGS (U.S. CL. 46).  
TASHIA BUNCH, EXAMINING ATTORNEY

SN 86-127,808. BABA'S COOKING SCHOOL LLC, WASHINGTON, DC. FILED 11-24-2013.

**BABA'S COOKING SCHOOL**

THE MARK CONSISTS OF STANDARD CHARACTERS WITHOUT CLAIM TO ANY PARTICULAR FONT, STYLE, SIZE, OR COLOR.  
NO CLAIM IS MADE TO THE EXCLUSIVE RIGHT TO USE "COOKING SCHOOL", APART FROM THE MARK AS SHOWN.  
THE ENGLISH TRANSLATION OF "BABA'S" IN THE MARK IS "DAD".  
FOR CHILI SAUCE; DUMPLINGS (U.S. CL. 46).  
FIRST USE 12-1-2012; IN COMMERCE 12-1-2012.  
HOWARD SMIGA, EXAMINING ATTORNEY

**CLASS 30—(Continued).**

SN 86-127,811. BABA'S COOKING SCHOOL LLC, WASHINGTON, DC. FILED 11-24-2013.



NO CLAIM IS MADE TO THE EXCLUSIVE RIGHT TO USE "COOKING SCHOOL", APART FROM THE MARK AS SHOWN.

THE MARK CONSISTS OF THE WORDS "BABA'S COOKING SCHOOL" AND DESIGN. THE DESIGN CONSISTS OF A CIRCLE WITH TWO DIAGONAL LINES INTERSECTING THE CIRCLE, WITH THE LINES AT THE TOP THICKER THAN THOSE AT THE BOTTOM; THE LINES TAPER. ON THE RIGHT AND LEFT SIDE OF THE CIRCLE THERE ARE TWO PARALLEL HORIZONTAL LINES, EACH SIDE FEATURING THE NUMBER, "8". INSIDE THE CIRCLE ARE CHINESE CHARACTERS AND NONE OF THE LINES APPEAR INSIDE OF THE CIRCLE. ABOVE THE CIRCLE IS THE WORD, "BABA'S" AND BELOW THE CIRCLE ARE THE WORDS, "COOKING SCHOOL".

THE ENGLISH TRANSLATION OF "BABA'S" IN THE MARK IS "DAD".

THE NON-LATIN CHARACTERS IN THE MARK TRANSLITERATE TO "BABA'S" AND THIS MEANS "DAD" IN ENGLISH.

FOR CHILI SAUCE; DUMPLINGS (U.S. CL. 46).

FIRST USE 12-1-2012; IN COMMERCE 12-1-2012.

HOWARD SMIGA, EXAMINING ATTORNEY

SN 86-130,646. EDIBLE ARRANGEMENTS, LLC, WALLINGFORD, CT. FILED 11-27-2013.

**JOYOUS BOUQUET**

THE MARK CONSISTS OF STANDARD CHARACTERS WITHOUT CLAIM TO ANY PARTICULAR FONT, STYLE, SIZE, OR COLOR.

OWNER OF U.S. REG. NOS. 3,429,717, 4,332,099 AND OTHERS.

SEC. 2(F) AS TO "BOUQUET".

FOR FRESH FRUIT CUT INTO SHAPES AND AT LEAST PARTIALLY COATED WITH AN EDIBLE TOPPING, NAMELY, CHOCOLATE, COCONUT, CINNAMON AND NUT BASED TOPPING AND ARRANGED IN CONTAINERS AS FLORAL DESIGNS; FRESH FRUIT CUT INTO SHAPES AND AT LEAST PARTIALLY COATED WITH AN EDIBLE TOPPING, NAMELY, CHOCOLATE, COCONUT, CINNAMON AND NUT BASED TOPPING AND ARRANGED IN CONTAINERS AS FLORAL DESIGNS (U.S. CL. 46).

FIRST USE 11-1-2012; IN COMMERCE 11-1-2012.

GIANCARLO CASTRO, EXAMINING ATTORNEY

**CLASS 30—(Continued).**

SN 86-138,558. EDIBLE ARRANGEMENT, LLC, WALLINGFORD, CT. FILED 12-9-2013.

**HOLIDAY STAR BOUQUET**

THE MARK CONSISTS OF STANDARD CHARACTERS WITHOUT CLAIM TO ANY PARTICULAR FONT, STYLE, SIZE, OR COLOR.

OWNER OF U.S. REG. NOS. 3,429,717, 3,615,353 AND OTHERS.

SEC. 2(F) AS TO "BOUQUET".

FOR FRESH FRUIT CUT INTO SHAPES AND AT LEAST PARTIALLY COATED WITH AN EDIBLE TOPPING, NAMELY, CHOCOLATE, COCONUT, CINNAMON AND NUT BASED TOPPING AND ARRANGED IN CONTAINERS AS FLORAL DESIGNS; FRESH FRUIT CUT INTO SHAPES AND AT LEAST PARTIALLY COATED WITH AN EDIBLE TOPPING, NAMELY, CHOCOLATE, COCONUT, CINNAMON AND NUT BASED TOPPING AND ARRANGED IN CONTAINERS AS FLORAL DESIGNS (U.S. CL. 46).

GIANCARLO CASTRO, EXAMINING ATTORNEY

SN 86-139,349. CEREALES Y PASTAS, S.A. DE C.V., CELAYA GUANAJUATO, MEXICO, FILED 12-10-2013.



PRIORITY CLAIMED UNDER SEC. 44(D) ON MEXICO APPLICATION NO. 1436805, FILED 11-29-2013, REG. NO. 1449421, DATED 4-25-2014, EXPIRES 11-29-2023.

OWNER OF U.S. REG. NOS. 3,666,019 AND 4,363,507.

NO CLAIM IS MADE TO THE EXCLUSIVE RIGHT TO USE "FOODS", "CRUNCHY" AND THE PICTORIAL REPRESENTATION OF A BOWL OF CEREAL, APART FROM THE MARK AS SHOWN.

THE COLOR(S) GOLD, TAN, YELLOW, BLUE, DARK BROWN, LIGHT BROWN, BLACK, RED, WHITE, DARK RED, WHITE, GRAY AND TURQUOISE IS/ARE CLAIMED AS A FEATURE OF THE MARK.

THE MARK CONSISTS OF THE DESIGN FEATURES OF THE FRONT OF A CEREAL BOX PACKAGE. THE DOTTED OUTLINE OF THE PACKAGING IS INTENDED TO SHOW THE POSITION OF THE MARK AND IS NOT PART OF THE MARK. A BANNER DESIGN WHICH HAS THE WORDS "GOLDEN FOODS" IN WHITE LETTERS ON A RED BACKGROUND APPEARS IN THE UPPER LEFT CORNER. TWO WAVY LINES IN BLUE AND YELLOW APPEAR AT THE BOTTOM OF THE BANNER DESIGN. BELOW THE BANNER, THE WORD "CRUNCHY" IN WHITE IS LOCATED ABOVE THE WORD "KING" IN GOLD. THE WORDS "CRUNCHY" AND "KING" ARE PARTIALLY

**CLASS 30—(Continued).**

OUTLINED IN BLUE AND PARTIALLY APPEAR ON A BLUE BACKGROUND. ON THE RIGHT SIDE OF THE PACKAGE THERE IS A FANCIFUL CHARACTER OF A KING IN A STANDING POSITION WITH FOLDED ARMS. THERE IS A BOWL OF CEREAL IN SPLASHING MILK ON THE LEFT SIDE OF THE PACKAGE. ABOVE THE BOWL OF CEREAL THERE IS A GRAY CASTLE. THE COLOR DARK BROWN APPEARS ON THE KING'S UPPER PORTION OF HIS HAIR, EYEBROWS, BUTTON OF THE CAPE, SUIT, BELT AND SLEEVE CUFFS, THE COLOR LIGHT BROWN APPEARS ON THE LOWER PORTION OF THE KING'S SUIT AND ON THE BOWL. THE COLOR TAN APPEARS ON THE KING'S FACE AND HANDS. THE COLOR GOLD APPEARS ON THE KING'S CROWN. THE COLOR YELLOW APPEARS ON KING'S TORSO, THE BELT BUCKLE AND THE BOWL. THE COLOR BLUE APPEARS ON THE KING'S EYES, CAPE AND THE TOP OF THE CASTLE. THE COLOR WHITE APPEARS ON THE KING'S EYES, TEETH AND THE MILK. THE COLOR BLACK APPEARS ON THE KING'S SLEEVES, PANTS, EYES AND AS SHADING OF THE KING'S SILHOUETTE. THE COLOR TURQUOISE IS ON THE DESIGN OF CEREAL BOWL. THE COLOR DARK RED IS ON THE PACKAGING BACKGROUND.

FOR BREAKFAST CEREALS; CEREAL BARS; CEREAL BASED SNACK FOOD; HIGH-PROTEIN CEREAL BARS; PROCESSED CEREAL-BASED FOOD TO BE USED AS A BREAKFAST FOOD, SNACK FOOD OR INGREDIENT FOR MAKING OTHER FOODS; READY-TO-EAT CEREALS (U.S. CL. 46).

TRACY FLETCHER, EXAMINING ATTORNEY

SN 86-139,379. CEREALES Y PASTAS, S.A. DE C.V., CELAYA GUANAJUATO, MEXICO, FILED 12-10-2013.



PRIORITY CLAIMED UNDER SEC. 44(D) ON MEXICO APPLICATION NO. 1436807, FILED 11-29-2013, REG. NO. 1449423, DATED 4-25-2014, EXPIRES 11-29-2023.

OWNER OF U.S. REG. NOS. 3,666,019, 4,363,507 AND 4,457,448.

NO CLAIM IS MADE TO THE EXCLUSIVE RIGHT TO USE "FOODS", "APPLE BITS" THE DESIGN OF AN APPLE AND THE PICTORIAL REPRESENTATION OF A BOWL OF CEREAL, APART FROM THE MARK AS SHOWN.

THE COLOR(S) RED, BLUE, BLACK, ORANGE, YELLOW, BROWN, LIGHT GREEN, DARK GREEN AND WHITE IS/ARE CLAIMED AS A FEATURE OF THE MARK.

THE MARK CONSISTS OF THE DESIGN FEATURES OF THE FRONT OF A CEREAL BOX PACKAGE. THE DOTTED OUTLINE OF THE PACKAGING IS INTENDED TO SHOW THE POSITION OF THE MARK AND IS NOT PART OF THE MARK. A BANNER DESIGN WHICH HAS THE WORDS "GOLDEN FOODS" IN WHITE LETTERS ON A RED BACKGROUND APPEARS IN THE UPPER LEFT CORNER. TWO WAVY LINES IN BLUE AND YELLOW APPEAR AT THE BOTTOM OF THE BANNER DESIGN. BELOW THE BANNER, THE WORD "APPLE" APPEARS ABOVE THE WORD "BITS." THE COLOR BLACK APPEARS ON THE WORD "APPLE." IN THE OUTLINE OF THE WORD "BITS" AND AS A SHADING ON THE APPLE STEMS. THE COLOR WHITE APPEARS IN THE OUTLINE OF THE WORDS "APPLE" AND "BITS." A RED APPLE WITH A BROWN

**CLASS 30—(Continued).**

STEM AND A DARK GREEN LEAF APPEARS BEHIND AND ABOVE THE LETTERS "L" AND "E" IN THE WORD "APPLE" AND "BITS." THE COLOR DARK GREEN APPEARS ON APPLE LEAVES. THERE IS ANOTHER APPLE WITH A BROWN STEM AND A DARK GREEN LEAF BELOW THE LETTER "P" IN THE WORD "APPLE" SURROUNDED BY SPLASHING MILK IN WHITE. BELOW THE SPLASHING MILK AND ABOVE THE WORD "BITS" APPEAR TWO CINNAMON STICKS IN BROWN THAT ARE BEHIND THE WORD "BITS." THERE IS A RED BOWL OF CEREAL BELOW THE WORD "BITS." THE COLORS GREEN AND ORANGE APPEAR IN CEREAL. IN THE PACKAGING BACKGROUND, APPEAR PIECES OF CEREAL IN ORANGE AND GREEN COLOR. THE COLOR LIGHT GREEN APPEARS AS A PACKAGING BACKGROUND.

FOR BREAKFAST CEREALS; CEREAL BARS; CEREAL BASED SNACK FOOD; HIGH-PROTEIN CEREAL BARS; PROCESSED CEREAL-BASED FOOD TO BE USED AS A BREAKFAST FOOD, SNACK FOOD OR INGREDIENT FOR MAKING OTHER FOODS; READY-TO-EAT CEREALS (U.S. CL. 46).

TRACY FLETCHER, EXAMINING ATTORNEY

SN 86-139,553. MARK-NYS, INC., SANTA MONICA, CA. FILED 12-10-2013.



THE MARK CONSISTS OF THREE BOTTLES PLAYING INSTRUMENTS.

FOR ICED TEA (U.S. CL. 46).

BRIAN PINO, EXAMINING ATTORNEY

SN 86-144,501. LAWRENCE FOODS, INC., ELK GROVE VILLAGE, IL. FILED 12-16-2013.

**DIAMOND GLAZE**

THE MARK CONSISTS OF STANDARD CHARACTERS WITHOUT CLAIM TO ANY PARTICULAR FONT, STYLE, SIZE, OR COLOR.

NO CLAIM IS MADE TO THE EXCLUSIVE RIGHT TO USE "GLAZE", APART FROM THE MARK AS SHOWN.

FOR ICING AND GLAZES FOR CAKES, PIES, DONUTS, AND BAKERY GOODS (U.S. CL. 46).

FIRST USE 12-12-2013; IN COMMERCE 12-12-2013.

JOHN HWANG, EXAMINING ATTORNEY

**CLASS 30—(Continued).**

SN 86-148,574. MURRAY, TONI, KENMORE, WA. FILED 12-19-2013.



THE MARK CONSISTS OF THREE PEOPLE, TWO WOMEN AND A BOY, IN SILHOUETTE, ABOVE THE STYLIZED WORDING "BADERS".  
FOR COOKIES (U.S. CL. 46).  
KIM MONINGHOFF, EXAMINING ATTORNEY

**CLASS 30—(Continued).**

SN 86-152,634. CONOPCO, INC., ENGLEWOOD CLIFFS, NJ. FILED 12-26-2013.



OWNER OF U.S. REG. NOS. 514,280, 3,232,270 AND OTHERS.  
THE COLOR(S) BLUE AND WHITE IS/ARE CLAIMED AS A FEATURE OF THE MARK.  
THE MARK CONSISTS OF THE WORD "HELLMAN'S" ON TOP OF THE QUOTED WORDS "BRING OUT THE BEST", ALL IN STYLIZED LETTERING IN THE COLOR WHITE ON A DARK BLUE BACKGROUND WITH A LIGHT BLUE RIBBON AT THE BOTTOM AND A WHITE LINE ON TOP.  
FOR MAYONNAISE AND SALAD DRESSINGS (U.S. CL. 46).  
JOHN DALIER, EXAMINING ATTORNEY

---

SN 86-150,800. KSF ACQUISITION CORPORATION, WEST PALM BEACH, FL. FILED 12-23-2013.

**SLIMBOX**

THE MARK CONSISTS OF STANDARD CHARACTERS WITHOUT CLAIM TO ANY PARTICULAR FONT, STYLE, SIZE, OR COLOR.  
FOR CHOCOLATE-BASED MEAL REPLACEMENT BARS; GRANOLA-BASED SNACK BARS; CEREAL BARS; CEREAL BASED ENERGY BARS; HIGH-PROTEIN CEREAL BARS; READY-TO-EAT CEREAL DERIVED FOOD BARS (U.S. CL. 46).  
JOHN DALIER, EXAMINING ATTORNEY

---

SN 86-176,807. OROS TEA, LLC, SANTA MONICA, CA. FILED 1-27-2014.

**KLIO**

THE MARK CONSISTS OF STANDARD CHARACTERS WITHOUT CLAIM TO ANY PARTICULAR FONT, STYLE, SIZE, OR COLOR.  
FOR TEA; CHEWING GUM (U.S. CL. 46).  
INGA ERVIN, EXAMINING ATTORNEY

**CLASS 30—(Continued).**

SN 86-182,033. BOSWORTH, LEE S., CARLSBAD, CA. FILED 2-2-2014.



NO CLAIM IS MADE TO THE EXCLUSIVE RIGHT TO USE "BORREGO SPRINGS, CALIFORNIA" AND "FUDGE CO.", APART FROM THE MARK AS SHOWN.

THE COLOR(S) WHITE, BROWN AND YELLOW IS/ARE CLAIMED AS A FEATURE OF THE MARK.

THE MARK CONSISTS OF A STYLIZED BIGHORN SHEEP HEAD IN BROWN, YELLOW AND WHITE, WITH A CIRCULAR BROWN, YELLOW, AND WHITE BANNER OVER THE SHEEP WITH THE WORDS "BORREGO SPRINGS, CALIFORNIA" IN WHITE AND YELLOW, IN YELLOW OUTLINED IN BROWN, AND THE WORDS "BIGHORN" AND "FUDGE CO." IN BROWN ON A YELLOW AND BROWN BANNER UNDER THE SHEEP.

FOR FUDGE (U.S. CL. 46).  
FIRST USE 7-1-2013; IN COMMERCE 7-1-2013.  
HEATHER SAPP, EXAMINING ATTORNEY

SN 86-183,238. EARTH HONEY CHOCOLATE INC., SAN FRANCISCO, CA. FILED 2-3-2014.

**EARTH HONEY CHOCOLATE**

THE MARK CONSISTS OF STANDARD CHARACTERS WITHOUT CLAIM TO ANY PARTICULAR FONT, STYLE, SIZE, OR COLOR.

NO CLAIM IS MADE TO THE EXCLUSIVE RIGHT TO USE "CHOCOLATE", APART FROM THE MARK AS SHOWN.

FOR CHOCOLATE; CHOCOLATE BARS; CHOCOLATE CANDIES; CHOCOLATE CHIPS; COCOA NIBS; CHOCOLATE-COVERED NUTS; CHOCOLATE-COVERED COFFEE BEANS; CHOCOLATE-COVERED FRUIT; CHOCOLATE POWDER; CHOCOLATE SYRUP, CHOCOLATE TOPPING; SPREAD CONTAINING CHOCOLATE; HOT CHOCOLATE; CHOCOLATE TRUFFLES; CHOCOLATE-BASED FILLINGS FOR CAKES AND PIES; CHOCOLATE-BASED READY-TO-EAT FOOD BARS (U.S. CL. 46).

KEVON CHISOLM, EXAMINING ATTORNEY

**CLASS 30—(Continued).**

SN 86-183,239. EARTH HONEY CHOCOLATE INC., SAN FRANCISCO, CA. FILED 2-3-2014.



NO CLAIM IS MADE TO THE EXCLUSIVE RIGHT TO USE "HONEY CHOCOLATE", APART FROM THE MARK AS SHOWN.

THE COLOR(S) BROWN IS/ARE CLAIMED AS A FEATURE OF THE MARK.

THE MARK CONSISTS OF THE WORDING "LUSTY RAW GOODNESS EARTH HONEY CHOCOLATE" AND THE DESIGN ELEMENTS OF A PLAQUE, SCROLL, AND LIGHT RAYS.

FOR CHOCOLATE; CHOCOLATE BARS; CHOCOLATE CANDIES; CHOCOLATE CHIPS; COCOA NIBS; CHOCOLATE-COVERED NUTS; CHOCOLATE-COVERED COFFEE BEANS; CHOCOLATE-COVERED FRUIT; CHOCOLATE POWDER; CHOCOLATE SYRUP, CHOCOLATE TOPPING; SPREAD CONTAINING CHOCOLATE; HOT CHOCOLATE; CHOCOLATE TRUFFLES; CHOCOLATE-BASED FILLINGS FOR CAKES AND PIES; CHOCOLATE-BASED READY-TO-EAT FOOD BARS (U.S. CL. 46).

KEVON CHISOLM, EXAMINING ATTORNEY

SN 86-183,242. EARTH HONEY CHOCOLATE INC., SAN FRANCISCO, CA. FILED 2-3-2014.

**WANT NEED KISS YOUR LIPS I  
LINGERING INTOXICATING  
CHOCOLATE LUSTY RAW  
GOODNESS DESIRE NOW  
INSATIABLE & QUIXOTIC  
SAUCY RAVAGE MELTING  
KISSES PASSION**

THE MARK CONSISTS OF STANDARD CHARACTERS WITHOUT CLAIM TO ANY PARTICULAR FONT, STYLE, SIZE, OR COLOR.

NO CLAIM IS MADE TO THE EXCLUSIVE RIGHT TO USE "CHOCOLATE" AND "RAW", APART FROM THE MARK AS SHOWN.

FOR CHOCOLATE; CHOCOLATE BARS; CHOCOLATE CANDIES; CHOCOLATE CHIPS; COCOA NIBS; CHOCOLATE-COVERED NUTS; CHOCOLATE-COVERED COFFEE BEANS; CHOCOLATE-COVERED FRUIT; CHOCOLATE POWDER; CHOCOLATE SYRUP, CHOCOLATE TOPPING; SPREAD CONTAINING CHOCOLATE; HOT CHOCOLATE; CHOCOLATE TRUFFLES; CHOCOLATE-BASED FILLINGS FOR CAKES AND PIES; CHOCOLATE-BASED READY-TO-EAT FOOD BARS (U.S. CL. 46).

KEVON CHISOLM, EXAMINING ATTORNEY



**CLASS 30—(Continued).**

SN 86-186,760. THAI, CORTNEY C., DBA ONO GIANT COMPANY, HONOLULU, HI. FILED 2-6-2014.

# Ono Giant

THE MARK CONSISTS OF STANDARD CHARACTERS WITHOUT CLAIM TO ANY PARTICULAR FONT, STYLE, SIZE, OR COLOR.

OWNER OF U.S. REG. NO. 4,295,493.

NO CLAIM IS MADE TO THE EXCLUSIVE RIGHT TO USE "ONO", APART FROM THE MARK AS SHOWN.

THE ENGLISH TRANSLATION OF "ONO" IN THE MARK IS "DELICIOUS".

FOR FOOD SEASONINGS (U.S. CL. 46).

FIRST USE 6-18-2012; IN COMMERCE 7-1-2012.

PAUL CROWLEY, EXAMINING ATTORNEY

SN 86-187,423. BRUCE LEE ENTERPRISES, LLC, LOS ANGELES, CA. FILED 2-7-2014.



OWNER OF U.S. REG. NOS. 3,224,921, 4,320,242 AND OTHERS.

THE NAME(S), PORTRAIT(S), AND/OR SIGNATURE(S) SHOWN IN THE MARK DOES NOT IDENTIFY A PARTICULAR LIVING INDIVIDUAL.

THE MARK CONSISTS OF THE SIGNATURE OF "BRUCE LEE", IN CURSIVE TYPE.

FOR ARTIFICIAL COFFEE AND TEA; BEVERAGES MADE OF TEA; BEVERAGES WITH A TEA BASE; COFFEE AND TEA; ICED TEA; TEA; TEA FOR INFUSIONS; TEA-BASED BEVERAGES; TEA-BASED BEVERAGES WITH FRUIT FLAVORING; TEA-BASED ICED BEVERAGES (U.S. CL. 46).

FIRST USE 2-1-2014; IN COMMERCE 2-1-2014.

COLLEEN MULCRONE, EXAMINING ATTORNEY

SN 86-190,295. HERBAL BLISS, LLC, SUMMERVILLE, SC. FILED 2-11-2014.

## HERBAL BLISS ALL NATURAL TEA

THE MARK CONSISTS OF STANDARD CHARACTERS WITHOUT CLAIM TO ANY PARTICULAR FONT, STYLE, SIZE, OR COLOR.

NO CLAIM IS MADE TO THE EXCLUSIVE RIGHT TO USE "HERBAL" AND "ALL NATURAL TEA", APART FROM THE MARK AS SHOWN.

FOR ALL NATURAL, HERBAL TEA-BASED BEVERAGES (U.S. CL. 46).

ALLISON HOLTZ, EXAMINING ATTORNEY

**CLASS 30—(Continued).**

SN 86-193,719. MINI MELTS, INC., NORWICH, CT. FILED 2-14-2014.

# MINI MELTS BIG

THE MARK CONSISTS OF STANDARD CHARACTERS WITHOUT CLAIM TO ANY PARTICULAR FONT, STYLE, SIZE, OR COLOR.

OWNER OF U.S. REG. NO. 4,154,231.

NO CLAIM IS MADE TO THE EXCLUSIVE RIGHT TO USE "MINI", APART FROM THE MARK AS SHOWN.

FOR ICE CREAM (U.S. CL. 46).

BRENDAN REGAN, EXAMINING ATTORNEY

SN 86-194,532. METCO, S.A. DE C.V., MÉXICO, D.F., MEXICO, FILED 2-14-2014.



OWNER OF U.S. REG. NOS. 3,438,079, 3,872,681 AND 3,879,064.

NO CLAIM IS MADE TO THE EXCLUSIVE RIGHT TO USE THE DESIGN OF SUGAR AND "AZÚCAR" AND "STEVIA", APART FROM THE MARK AS SHOWN.

THE COLOR(S) BLUE, GREEN, WHITE, MEDIUM BROWN, LIGHT BROWN, AND PALE YELLOW IS/ARE CLAIMED AS A FEATURE OF THE MARK.

THE MARK CONSISTS OF THE WORDS "AZÚCAR METCO BC" IN STYLIZED LETTERS. THE WORD "AZÚCAR" APPEARS IN BLUE LETTERS, WITH THE ACCENT MARK OVER THE LETTER "U" REPRESENTED BY A STYLIZED GREEN LEAF. THE WORD "METCO" IS PRINTED VERTICALLY IN SMALL GREEN LETTERS BENEATH THE ARC IN THE LETTER "R" IN "AZÚCAR". THE LETTERS "B," "C" APPEAR IN LARGE GREEN LETTERS NEXT TO THE WORD "METCO". THE PHRASE "AZÚCAR Y STEVIA" APPEAR IN SMALLER GREEN LETTERS BENEATH "AZÚCAR METCO BC", JUSTIFIED TO THE RIGHT. THE LITERAL ELEMENTS OF THE MARK ARE SUPERIMPOSED ON A ROUGHLY RECTANGULAR BACKGROUND. THIS BACKGROUND CONTAINS A BLUE ZONE AT THE TOP, THE BOTTOM EDGE OF WHICH

**CLASS 30—(Continued).**

FORMS AN "S" CURVE; A GREEN AND WHITE ZONE IN THE MIDDLE; AND A WOODEN TABLETOP AT THE BOTTOM. THE TABLETOP IS MEDIUM BROWN AND LIGHT BROWN IN COLOR AND HOLDS A SMALL WHITE RECTANGLE OF PAPER, WITH ONE CORNER TURNED UP, A WHITE BOWL FILLED WITH WHITE GRANULATED SWEETENER AND CONTAINING A MEDIUM BROWN WOODEN SPOON, THREE GREEN SUGAR CANE STALKS WITH PALE YELLOW TIPS, AND A SPRIG OF GREEN LEAVES.

THE ENGLISH TRANSLATION OF "AZÚCAR" IN THE MARK IS "SUGAR".

FOR NATURAL SWEETENER; SUGAR SUBSTITUTES (U.S. CL. 46).

JOHN DWYER, EXAMINING ATTORNEY

---

SN 86-195,473. AMARANTH BIO COMPANY, LLC, DBA AMARANTH BIO COMPANY, SAN DIEGO, CA. FILED 2-17-2014.



NO CLAIM IS MADE TO THE EXCLUSIVE RIGHT TO USE "AMARANTH BIO COMPANY", APART FROM THE MARK AS SHOWN.

THE COLOR(S) VIOLET AND GREEN IS/ARE CLAIMED AS A FEATURE OF THE MARK.

THE MARK CONSISTS OF A STYLIZED VIOLET AMARANTH FLOWER WITH THREE GREEN LEAVES LOCATED INSIDE GREEN CIRCUMFERENCE ON THE LEFT SIDE AND THE WORDING "AMARANTH BIO COMPANY" WITH CAPITALIZED LETTERS ON THE RIGHT SIDE. THE WORDING "AMARANTH" IS IN VIOLET AND THE WORDING "BIO COMPANY" IN GREEN IS LOCATED BELOW "AMARANTH" BETWEEN TWO GREEN HORIZONTAL LINES.

FOR FLOUR FOR FOOD; PROCESSED BRAN; PROCESSED GRAINS, NAMELY, AMARANTH; PROTEIN REDUCED AND GLUTEN FREE FLOUR AND BREAD (U.S. CL. 46).

JAMES STEIN, EXAMINING ATTORNEY

---

SN 86-198,965. THE RUFFLED CUP, LLC, AMARILLO, TX. FILED 2-20-2014.

TheRuffledCup

THE MARK CONSISTS OF STANDARD CHARACTERS WITHOUT CLAIM TO ANY PARTICULAR FONT, STYLE, SIZE, OR COLOR.

FOR BAKERY GOODS AND DESSERT ITEMS, NAMELY, CUPCAKES AND CHEESECAKES (U.S. CL. 46).

FIRST USE 11-0-2010; IN COMMERCE 2-4-2011.

GINA HAYES, EXAMINING ATTORNEY

**CLASS 30—(Continued).**

SN 86-203,167. POWERICE, INC., STEAMBOAT SPRINGS, CO. FILED 2-25-2014.



THE MARK CONSISTS OF THE LETTERS "PI" IN A CIRCLE. THE LETTER "I" IS DESIGNED AS AN ICICLE.

FOR FLAVORED ICE CONTAINING ELECTROLYTES AND ADDED NUTRIENTS AND SUPPLEMENTS TO ENHANCE HYDRATION (U.S. CL. 46).

ASMAT KHAN, EXAMINING ATTORNEY

---

SN 86-204,075. HARRY AND DAVID, LLC, MEDFORD, OR. FILED 2-25-2014.

MOOSE CRUNCH

THE MARK CONSISTS OF STANDARD CHARACTERS WITHOUT CLAIM TO ANY PARTICULAR FONT, STYLE, SIZE, OR COLOR.

OWNER OF U.S. REG. NOS. 2,000,672, 3,305,759 AND OTHERS.

NO CLAIM IS MADE TO THE EXCLUSIVE RIGHT TO USE "CRUNCH", APART FROM THE MARK AS SHOWN.

FOR CHOCOLATE CONFECTIONS; CHOCOLATE COVERED NUTS (U.S. CL. 46).

ALEXANDER L. POWERS, EXAMINING ATTORNEY

**CLASS 30—(Continued).**

SN 86-204,273. NEZAT'S CAJUN FOODS LLC, PORT BARRE, LA. FILED 2-26-2014.



NO CLAIM IS MADE TO THE EXCLUSIVE RIGHT TO USE "CAJUN" AND THE MAP REPRESENTATION OF THE STATE OF LOUISIANA, APART FROM THE MARK AS SHOWN.

THE MARK CONSISTS OF THE STYLIZED TERMS "CAJUN BAIT" ON AN OUTLINE OF THE STATE OF LOUISIANA WITH TWO PEPPERS AND A FISHING BOBBER.

FOR FOOD SEASONINGS; FLAVORINGS AND SEASONINGS; DRY SPICE RUB FOR MEATS AND FISH (U.S. CL. 46).

HOWARD B. LEVINE, EXAMINING ATTORNEY

SN 86-204,372. LEWIS BROTHERS BAKERIES INCORPORATED, DBA LEWIS BAKERIES, INC., EVANSVILLE, IN. FILED 2-26-2014.

**AVOIDING CARBS BUT LOVE BREAD?**

THE MARK CONSISTS OF STANDARD CHARACTERS WITHOUT CLAIM TO ANY PARTICULAR FONT, STYLE, SIZE, OR COLOR.

OWNER OF U.S. REG. NOS. 4,347,807 AND 4,351,222. FOR BAKERY PRODUCTS, NAMELY, BREAD (U.S. CL. 46).

FIRST USE 5-8-2014; IN COMMERCE 5-8-2014. DOUGLAS LEE, EXAMINING ATTORNEY

SN 86-205,299. JILL SEGAL, ST. LOUIS, MO. FILED 2-26-2014.

**JILLY'S CUPCAKE BAR**

THE MARK CONSISTS OF STANDARD CHARACTERS WITHOUT CLAIM TO ANY PARTICULAR FONT, STYLE, SIZE, OR COLOR.

OWNER OF U.S. REG. NO. 3,463,412.

NO CLAIM IS MADE TO THE EXCLUSIVE RIGHT TO USE "CUPCAKE BAR", APART FROM THE MARK AS SHOWN.

FOR FROZEN CONFECTIONS; FROZEN CONFECTIONS, NAMELY, ICE CREAM, ICE CREAM PIES, ICE CREAM SANDWICHES, ICE CREAM CAKES, SUNDAES AND MALTS; BAKERY PRODUCTS, NAMELY, CUPCAKES (U.S. CL. 46).

FIRST USE 5-0-2007; IN COMMERCE 5-0-2007. LAURA KOVALSKY, EXAMINING ATTORNEY

**CLASS 30—(Continued).**

SN 86-206,297. SEBAG, PHILIPPE, MONTREAL, QUEBEC, CANADA, FILED 2-27-2014.

**ANDARRA SAUCE**

THE MARK CONSISTS OF STANDARD CHARACTERS WITHOUT CLAIM TO ANY PARTICULAR FONT, STYLE, SIZE, OR COLOR.

NO CLAIM IS MADE TO THE EXCLUSIVE RIGHT TO USE "SAUCE", APART FROM THE MARK AS SHOWN. FOR SAUCES (U.S. CL. 46).

GISELLE AGOSTO, EXAMINING ATTORNEY

SN 86-214,824. 'CHUPS, LLC, WASHINGTON, DC. FILED 3-7-2014.

**'CHUPS**

THE MARK CONSISTS OF AN APOSTROPHE FOLLOWED BY THE WORD "CHUPS".

FOR DIPPING SAUCES; FOOD CONDIMENTS, NAMELY, SAUCES (U.S. CL. 46).

FIRST USE 1-0-2013; IN COMMERCE 1-0-2013. DOUGLAS LEE, EXAMINING ATTORNEY

SN 86-215,129. HALLMARK LICENSING, LLC, KANSAS CITY, MO. FILED 3-7-2014.

**SNOWBY**

THE MARK CONSISTS OF STANDARD CHARACTERS WITHOUT CLAIM TO ANY PARTICULAR FONT, STYLE, SIZE, OR COLOR.

FOR COOKIES; MOLDED CHOCOLATE CANDY; GIFT PACKAGES SOLD AS A UNIT CONSISTING OF COOKIES, CANDY, COCOA AND UTENSILS THEREFOR (U.S. CL. 46).

KATHLEEN KOLACZ, EXAMINING ATTORNEY



**CLASS 30—(Continued).**

SN 86-216,297. HALLMARK LICENSING, LLC, KANSAS CITY, MO. FILED 3-10-2014.

# JAZ

THE MARK CONSISTS OF STANDARD CHARACTERS WITHOUT CLAIM TO ANY PARTICULAR FONT, STYLE, SIZE, OR COLOR.

FOR COOKIES; MOLDED CHOCOLATE CANDY; GIFT PACKAGES SOLD AS A UNIT CONSISTING PRIMARILY OF COOKIES, CANDY, COCOA AND UTENSILS THEREFOR (U.S. CL. 46).

CAROLINE WOOD, EXAMINING ATTORNEY

SN 86-216,731. HALLMARK LICENSING, LLC, KANSAS CITY, MO. FILED 3-10-2014.

# CHARLIE THE YETI

THE MARK CONSISTS OF STANDARD CHARACTERS WITHOUT CLAIM TO ANY PARTICULAR FONT, STYLE, SIZE, OR COLOR.

FOR COOKIES; MOLDED CHOCOLATE CANDY; GIFT PACKAGES SOLD AS A UNIT CONSISTING PRIMARILY OF COOKIES, CANDY, AND COCOA AND ALSO INCLUDING UTENSILS THEREFOR (U.S. CL. 46).

THEODORE MCBRIDE, EXAMINING ATTORNEY

SN 86-218,537. HERSHEY CREAMERY COMPANY, HARRISBURG, PA. FILED 3-12-2014.



NO CLAIM IS MADE TO THE EXCLUSIVE RIGHT TO USE "TWISTED" AND "SOFT PRETZELS", APART FROM THE MARK AS SHOWN.

THE COLOR(S) ORANGE, BLACK, YELLOW AND BROWN IS/ARE CLAIMED AS A FEATURE OF THE MARK.

THE MARK CONSISTS OF THE WORD "TWISTED" IN ORANGE WITH A BLACK BORDER ABOVE THE WORD "TOM'S" IN BROWN WITH A YELLOW AND BLACK BORDER WITH THE "O" IN THE SHAPE OF AN UPSIDE DOWN SOFT PRETZEL ABOVE THE WORDS "SOFT PRETZELS" IN ORANGE WITH A BLACK BORDER.

FOR SOFT PRETZELS (U.S. CL. 46).

TRACY WHITTAKER-BROWN, EXAMINING ATTORNEY

**CLASS 30—(Continued).**

SN 86-221,877. FUN SWEETS, LLC, WEST PALM BEACH, FL. FILED 3-14-2014.



THE COLOR(S) LIGHT BLUE, DARK BLUE, PINK AND WHITE IS/ARE CLAIMED AS A FEATURE OF THE MARK.

THE MARK CONSISTS OF A STYLIZED PINK FLAMINGO IN CARTOON CARICATURE FORM WITH A DARK BLUE TAIL, BEAK, EYES AND EYEBROWS. THE FLAMINGO IS HOLDING A LIGHT BLUE AND PINK STYLIZED COTTON CANDY WITH A WHITE HANDLE. THE ENTIRE IMAGE IS OUTLINED IN DARK BLUE.

FOR CONFECTIONERY PRODUCTS, NAMELY, COTTON CANDY (U.S. CL. 46).

FIRST USE 5-16-2013; IN COMMERCE 5-16-2013.

CRISTIANA SCHWAB, EXAMINING ATTORNEY

SN 86-224,817. REAL TOBACCO OF AMERICA CORP., MIAMI, FL. FILED 3-18-2014.

# GARGOLLA

THE MARK CONSISTS OF STANDARD CHARACTERS WITHOUT CLAIM TO ANY PARTICULAR FONT, STYLE, SIZE, OR COLOR.

THE ENGLISH TRANSLATION OF THE WORD "GARGOLLA" IN THE MARK IS "GARGOYLE".

FOR ELECTRONIC CIGARETTE LIQUID (E-LIQUID) COMPRISED OF FLAVORINGS IN LIQUID FORM USED TO REFILL ELECTRONIC CIGARETTE CARTRIDGES; PROPYLENE GLYCOL-BASED AND GLYCERIN-BASED CHEMICAL FLAVORINGS IN LIQUID FORM USED TO REFILL CARTRIDGES AND CARTOMIZERS IN ELECTRONIC SMOKING DEVICES AND ALSO TO SUPPLY VAPOR (U.S. CL. 46).

MATTHEW EINSTEIN, EXAMINING ATTORNEY

**CLASS 30—(Continued).**

SN 86-226,095. YORKSHIRE FOOD SALES CORP., NEW HYDE PARK, NY. FILED 3-19-2014.

**SIDESHOW SNACKS**

THE MARK CONSISTS OF STANDARD CHARACTERS WITHOUT CLAIM TO ANY PARTICULAR FONT, STYLE, SIZE, OR COLOR.

OWNER OF U.S. REG. NO. 2,578,341.  
NO CLAIM IS MADE TO THE EXCLUSIVE RIGHT TO USE "SNACKS", APART FROM THE MARK AS SHOWN.  
FOR POPCORN; KETTLE CORN; FLAVOR-COATED POPPED POPCORN (U.S. CL. 46).  
JANET LEE, EXAMINING ATTORNEY

---

SN 86-226,152. NOT FOR SALE FUND, SAN FRANCISCO, CA. FILED 3-19-2014.



**NOT FOR SALE**

THE MARK CONSISTS OF A DOLLAR SIGN WITHIN A CIRCLE, WITH THE WORDS "NOT FOR SALE" APPEARING UNDERNEATH.

FOR TEA; TEA-BASED BEVERAGES; COFFEE; COFFEE BEANS; COFFEE BASED BEVERAGES; HIGH-PROTEIN CEREAL BARS; GRANOLA-BASED SNACK BARS (U.S. CL. 46).  
ELIZABETH CHANG, EXAMINING ATTORNEY

**CLASS 30—(Continued).**

SN 86-226,266. ROSE, HAROLD, LAS VEGAS, NV. FILED 3-19-2014.



NO CLAIM IS MADE TO THE EXCLUSIVE RIGHT TO USE "CINNAMON ROLLS", APART FROM THE MARK AS SHOWN.

THE MARK CONSISTS OF A DESIGN OF A MAN IN A CHEF'S HAT HOLDING A PASTRY, ALL WITHIN A SHADED CIRCLE. THE STYLIZED WORDING "HOMIES" IS POSITIONED ABOVE THE DESIGN AND THE WORDING "CINNAMON ROLLS" APPEARS BELOW THE DESIGN. A DESIGN OF A STYLIZED FISH APPEARS BETWEEN THE WORDS "CINNAMON" AND "ROLLS".

FOR BAKERY GOODS (U.S. CL. 46).  
FIRST USE 7-26-2001; IN COMMERCE 7-26-2001.  
JOANNA FIORELLI, EXAMINING ATTORNEY

---

SN 86-227,754. BUEHLER, MORGAN, HERMOSA BEACH, CA. FILED 3-20-2014.

**Skinny Seeds**

THE MARK CONSISTS OF STANDARD CHARACTERS WITHOUT CLAIM TO ANY PARTICULAR FONT, STYLE, SIZE, OR COLOR.

NO CLAIM IS MADE TO THE EXCLUSIVE RIGHT TO USE "SEEDS", APART FROM THE MARK AS SHOWN.

FOR BREAKFAST CEREALS; CEREAL-BASED SNACK FOODS; MILLED FLAX SEEDS; PROCESSED CEREAL-BASED FOOD TO BE USED AS A BREAKFAST FOOD, SNACK FOOD OR INGREDIENT FOR MAKING OTHER FOODS; READY-TO-EAT CEREALS (U.S. CL. 46).  
JONATHAN FALK, EXAMINING ATTORNEY

**CLASS 30—(Continued).**

SN 86-228,031. PIEDMONT CANDY CO., LEXINGTON, NC.  
FILED 3-21-2014.



OWNER OF U.S. REG. NO. 3,323,301.

NO CLAIM IS MADE TO THE EXCLUSIVE RIGHT TO USE "SOUTHERN" AND "SINCE 1890", APART FROM THE MARK AS SHOWN.

THE MARK CONSISTS OF A DRAWING OF A CARDINAL BISECTED BY THE TOP OF A CLOUD-LIKE SHAPE CONTAINING THE STYLIZED PHRASE "RED BIRD" IN THE MIDDLE THEREOF DISPLACED ABOVE THE PHRASE "SOUTHERN REFRESH-MINTS" AND AN OVAL CONTAINING THE PHRASE "SINCE 1890".

FOR CANDY (U.S. CL. 46).

FIRST USE 3-17-2014; IN COMMERCE 3-17-2014.

DAVID MURRAY, EXAMINING ATTORNEY

SN 86-228,046. PIEDMONT CANDY CO., LEXINGTON, NC.  
FILED 3-21-2014.



OWNER OF U.S. REG. NO. 3,323,301.

NO CLAIM IS MADE TO THE EXCLUSIVE RIGHT TO USE "SINCE 1890" AND "SOUTHERN", APART FROM THE MARK AS SHOWN.

THE MARK CONSISTS OF A DRAWING OF A CARDINAL ABOVE THE STYLIZED PHRASE "RED BIRD," WHICH HAS THE STYLIZED PHRASE "SINCE 1890" DISPLACED ABOVE THE LETTERS "IRD" AND THE STYLIZED PHRASE "SOUTHERN REFRESH-MINTS" DISPLACED BELOW IT.

FOR CANDY (U.S. CL. 46).

FIRST USE 3-17-2014; IN COMMERCE 3-17-2014.

DAVID MURRAY, EXAMINING ATTORNEY

**CLASS 30—(Continued).**

SN 86-229,954. ANGIE'S ARTISAN TREATS, LLC, NORTH  
MANKATO, MN. FILED 3-24-2014.



OWNER OF U.S. REG. NOS. 3,103,415, 3,960,563 AND 4,303,647.

THE MARK CONSISTS OF THE STYLIZED WORD "ANGIE'S" ABOVE STYLIZED "A" ON A CIRCULAR BACKGROUND SURROUNDED BY SECOND CIRCULAR LINE.

FOR READY TO EAT, POPCORN-BASED SNACK BARS AND CLUSTER SNACK BARS (U.S. CL. 46).

CHRISTINA SOBRAL, EXAMINING ATTORNEY

SN 86-230,554. FOXY'S PASH IP, LLC, VENTURA, CA.  
FILED 3-24-2014.

**FOXY'S PREMIUM FROZEN  
YOGURT**

THE MARK CONSISTS OF STANDARD CHARACTERS WITHOUT CLAIM TO ANY PARTICULAR FONT, STYLE, SIZE, OR COLOR.

NO CLAIM IS MADE TO THE EXCLUSIVE RIGHT TO USE "PREMIUM FROZEN YOGURT", APART FROM THE MARK AS SHOWN.

THE NAME(S), PORTRAIT(S), AND/OR SIGNATURE(S) SHOWN IN THE MARK DOES NOT IDENTIFY A PARTICULAR LIVING INDIVIDUAL.

FOR FROZEN YOGURT (U.S. CL. 46).

FIRST USE 9-12-2012; IN COMMERCE 9-12-2012.

LINDA MICKLEBURGH, EXAMINING ATTORNEY

**CLASS 30—(Continued).**

SN 86-230,681. FOUR CEDARS, LLC, LEXINGTON, CA. FILED 3-24-2014.

KENTUCKY CHILI BLUEGRASS  
SPICE BLEND

THE MARK CONSISTS OF STANDARD CHARACTERS WITHOUT CLAIM TO ANY PARTICULAR FONT, STYLE, SIZE, OR COLOR.

NO CLAIM IS MADE TO THE EXCLUSIVE RIGHT TO USE "KENTUCKY CHILI" AND "SPICE BLEND", APART FROM THE MARK AS SHOWN.

FOR SPICE BLENDS; SPICES; FOOD FLAVORINGS; FOOD SEASONINGS; CHILI SEASONING (U.S. CL. 46).  
FIRST USE 11-27-2010; IN COMMERCE 11-27-2010.  
BARBARA RUTLAND, EXAMINING ATTORNEY

---

SN 86-231,373. PODWORKS CORP., KIRKLAND, WA. FILED 3-25-2014.

BEDTIME BROWNIE

THE MARK CONSISTS OF STANDARD CHARACTERS WITHOUT CLAIM TO ANY PARTICULAR FONT, STYLE, SIZE, OR COLOR.

NO CLAIM IS MADE TO THE EXCLUSIVE RIGHT TO USE "BROWNIE", APART FROM THE MARK AS SHOWN.

FOR BAKED GOODS, NAMELY, BROWNIES, PUFFED RICE CEREAL BARS, BANANA BREAD, COOKIES, AND CUPCAKES (U.S. CL. 46).

FIRST USE 6-1-2013; IN COMMERCE 6-1-2013.  
DAWN FELDMAN, EXAMINING ATTORNEY

**CLASS 30—(Continued).**

SN 86-231,727. JOE FROYO LLC, LAKEWOOD, WA. FILED 3-25-2014.



NO CLAIM IS MADE TO THE EXCLUSIVE RIGHT TO USE "FROYO", APART FROM THE MARK AS SHOWN.

THE NAME "JOE FROYO" DOES NOT IDENTIFY A LIVING INDIVIDUAL.

THE MARK CONSISTS OF A SHIELD ON WHICH THE WORDING "JOE FROYO" IS WRITTEN.

FOR BEVERAGES CONTAINING FROZEN YOGURT, NAMELY, COFFEE-BASED AND COFFEE EXTRACT-BASED BEVERAGES CONTAINING FROZEN YOGURT; FROZEN YOGURT; FROZEN YOGURT AND ICE CREAM; SHAVED ICE CONFECTIONS; ICE CREAM; ICE CREAM SUBSTITUTE; ICE CREAM SANDWICHES; ICE MILK; ICE CREAM CAKES; FROZEN CONFECTIONS; FROZEN CUSTARDS; FROZEN DESSERT CONSISTING OF FRUIT AND CREAM OR CREAM SUBSTITUTE (U.S. CL. 46).

BARBARA BROWN, EXAMINING ATTORNEY

---

SN 86-232,711. LOLO'S INC., PHOENIX, AZ. FILED 3-26-2014.



OWNER OF U.S. REG. NO. 4,555,667.  
THE MARK CONSISTS OF STYLIZED LETTERS RESEMBLING WOODEN BOARDS SPELLING "LO-LO'S".

FOR WAFFLE MIX (U.S. CL. 46).  
FIRST USE 9-30-2012; IN COMMERCE 9-30-2012.  
KAREN BRACEY, EXAMINING ATTORNEY

**CLASS 30—(Continued).**

SN 86-233,638. THE HILLSHIRE BRANDS COMPANY,  
CHICAGO, IL. FILED 3-27-2014.

**APPLE ORCHARD**

THE MARK CONSISTS OF STANDARD CHARACTERS  
WITHOUT CLAIM TO ANY PARTICULAR FONT, STYLE,  
SIZE, OR COLOR.

OWNER OF U.S. REG. NO. 2,827,836.  
FOR BAKERY GOODS (U.S. CL. 46).  
FIRST USE 8-24-2000; IN COMMERCE 8-24-2000.  
SUZANNE BLANE, EXAMINING ATTORNEY

SN 86-234,714. NERO COMMERCE UG (HAFTUNGSBES-  
CHRÄNK), BERLIN, FED REP GERMANY, FILED 3-27-  
2014.

**GOURMESSO**

THE MARK CONSISTS OF STANDARD CHARACTERS  
WITHOUT CLAIM TO ANY PARTICULAR FONT, STYLE,  
SIZE, OR COLOR.

FOR COFFEE; GROUND COFFEE BEANS; COFFEE;  
GROUND COFFEE; FLAVORED COFFEE; ROASTED  
COFFEE BEANS; DECAFFEINATED COFFEE; COFFEE  
CONCENTRATES; COFFEE PODS; COFFEE CAPSULES  
CONTAINING COFFEE FOR BREWING; COFFEE FLA-  
VORINGS; CHOCOLATE COFFEE; COFFEE BEANS (U.S.  
CL. 46).

FIRST USE 2-12-2013; IN COMMERCE 2-10-2014.  
AMY C. KEAN, EXAMINING ATTORNEY

SN 86-234,985. PAUL & JIMMY'S RISTORANTE, INC., NEW  
YORK, NY. FILED 3-28-2014.

**Paul & Jimmy's Ristorante**

THE MARK CONSISTS OF STANDARD CHARACTERS  
WITHOUT CLAIM TO ANY PARTICULAR FONT, STYLE,  
SIZE, OR COLOR.

NO CLAIM IS MADE TO THE EXCLUSIVE RIGHT TO  
USE "RISTORANTE", APART FROM THE MARK AS  
SHOWN.

THE ENGLISH TRANSLATION OF "RISTORANTE" IN  
THE MARK IS "RESTAURANT".

FOR COOKING SAUCES; PASTA SAUCE; READY-  
MADE SAUCES; SPAGHETTI SAUCE; TOMATO SAUCE  
(U.S. CL. 46).

FIRST USE 2-17-2014; IN COMMERCE 2-17-2014.  
KAREN BRACEY, EXAMINING ATTORNEY

**CLASS 30—(Continued).**

SN 86-235,838. OC FLAVORS, INC., DBA OC FLAVORS, INC.,  
ONTARIO, CA. FILED 3-28-2014.

**OC Flavors, Inc.**

THE MARK CONSISTS OF STANDARD CHARACTERS  
WITHOUT CLAIM TO ANY PARTICULAR FONT, STYLE,  
SIZE, OR COLOR.

NO CLAIM IS MADE TO THE EXCLUSIVE RIGHT TO  
USE "FLAVORS, INC.", APART FROM THE MARK AS  
SHOWN.

FOR FLAVOR ENHANCERS USED IN FOOD AND  
BEVERAGE PRODUCTS (U.S. CL. 46).

FIRST USE 2-27-2007; IN COMMERCE 3-14-2007.  
MORGAN WYNNE, EXAMINING ATTORNEY

SN 86-236,698. ESTADELLA, ANTONIO, SOUTHAMPTON,  
NY. FILED 3-31-2014.

**SAU SEA**

THE MARK CONSISTS OF STANDARD CHARACTERS  
WITHOUT CLAIM TO ANY PARTICULAR FONT, STYLE,  
SIZE, OR COLOR.

OWNER OF U.S. REG. NO. 1,270,912.  
FOR SAUCES; PREPARED HORSERADISH (U.S. CL.  
46).

FIRST USE 1-1-1987; IN COMMERCE 1-1-1987.  
KAELIE KUNG, EXAMINING ATTORNEY

SN 86-237,155. FAMOUS SAMOSAS, EDISON, NJ. FILED 3-  
31-2014.



NO CLAIM IS MADE TO THE EXCLUSIVE RIGHT TO  
USE "FAMOUS ROLLS", APART FROM THE MARK AS  
SHOWN.

THE COLOR(S) RED AND YELLOW IS/ARE CLAIMED  
AS A FEATURE OF THE MARK.

"THE MARK CONSISTS OF THE STYLIZED TEXT  
"FAMOUS ROLLS" IN RED WITH A TRIANGLE WITH  
THE LETTERS "F" IN RED AND "S" IN YELLOW INTER-  
TWINED TOGETHER ABOVE THE TEXT. THE BLACK  
AND WHITE IN THE MARK REPRESENT BACKGROUND  
OR OUTLINING AREAS AND ARE NOT A PART OF THE  
MARK.

FOR FROZEN SPRING ROLLS (U.S. CL. 46).  
REBECCA GILBERT, EXAMINING ATTORNEY

**CLASS 30—(Continued).**

SN 86-237,197. DRC HOLDINGS, INC., DBA SHIRLEY'S GOURMET POPCORN COMPANY, BLUFFTON, OH, OH. FILED 3-31-2014.

## Shirley's Gourmet Popcorn Company

THE MARK CONSISTS OF STANDARD CHARACTERS WITHOUT CLAIM TO ANY PARTICULAR FONT, STYLE, SIZE, OR COLOR.

OWNER OF U.S. REG. NO. 3,837,267.

NO CLAIM IS MADE TO THE EXCLUSIVE RIGHT TO USE "GOURMET POPCORN COMPANY", APART FROM THE MARK AS SHOWN.

THE NAME "SHIRLEY" DOES NOT IDENTIFY A LIVING INDIVIDUAL.

FOR CANDY COATED POPCORN; CARAMEL POPCORN; GLAZED POPCORN; POPCORN; POPPED POPCORN; PROCESSED POPCORN; PROCESSED UNPOPPED POPCORN (U.S. CL. 46).

FIRST USE 7-15-2009; IN COMMERCE 7-15-2009.

REBECCA GILBERT, EXAMINING ATTORNEY

---

SN 86-237,811. TWISTED PINE COFFEE ROASTERS, GREEN BAY, WI. FILED 3-31-2014.

## Twist Up Some Brew!

THE MARK CONSISTS OF STANDARD CHARACTERS WITHOUT CLAIM TO ANY PARTICULAR FONT, STYLE, SIZE, OR COLOR.

FOR WHOLE BEAN COFFEE, GROUND COFFEE, COFFEE SOLD IN SINGLE SERVE CUP CONTAINERS (U.S. CL. 46).

FIRST USE 6-11-2013; IN COMMERCE 9-1-2013.

CRISTIANA SCHWAB, EXAMINING ATTORNEY

---

SN 86-238,282. JEROME BENSIMON, NEW YORK, NY. FILED 4-1-2014.

## Jacqueline & Jerome

THE MARK CONSISTS OF STANDARD CHARACTERS WITHOUT CLAIM TO ANY PARTICULAR FONT, STYLE, SIZE, OR COLOR.

FOR PREPARED SALAD DRESSINGS TO BE USED AS SALAD DRESSINGS OR AS DIPS; SAUCES; MARIANES AND SALSA (U.S. CL. 46).

FIRST USE 12-23-2013; IN COMMERCE 3-24-2014.

DEIRDRE ROBERTSON, EXAMINING ATTORNEY

**CLASS 30—(Continued).**

SN 86-238,469. BALON INTERNATIONAL CORP., CHICAGO, IL. FILED 4-1-2014.



NO CLAIM IS MADE TO THE EXCLUSIVE RIGHT TO USE HABANA, APART FROM THE MARK AS SHOWN.

THE MARK CONSISTS OF A STYLIZED WOMAN DRINKING A CUP OF COFFEE IN FRONT OF A WAVING FLAG INSIDE A RECTANGULAR BORDER THAT INCLUDES PALM TREES, AND FLOWERS. THE TEXT "HABANA" IS WRITTEN ON A BANNER ACROSS THE FRONT.

THE ENGLISH TRANSLATION OF "HABANA" IN THE MARK IS "HAVANA".

FOR COFFEE BEANS (U.S. CL. 46).

FIRST USE 12-19-2013; IN COMMERCE 12-19-2013.

JOHN HWANG, EXAMINING ATTORNEY

---

SN 86-238,728. THOSE LITTLE DONUTS INC., CALGARY, ALBERTA, CANADA, FILED 4-1-2014.

## THOSE LITTLE DONUTS

THE MARK CONSISTS OF STANDARD CHARACTERS WITHOUT CLAIM TO ANY PARTICULAR FONT, STYLE, SIZE, OR COLOR.

OWNER OF U.S. REG. NOS. 1,792,803, 1,937,705 AND 2,024,952.

NO CLAIM IS MADE TO THE EXCLUSIVE RIGHT TO USE "LITTLE DONUTS", APART FROM THE MARK AS SHOWN.

FOR DONUTS (U.S. CL. 46).

FIRST USE 6-1-1986; IN COMMERCE 8-1-1988.

JORDAN BAKER, EXAMINING ATTORNEY

**CLASS 30—(Continued).**

SN 86-239,665. RARE ANTIBODY ANTIGEN SUPPLY, INC.,  
AGOURA HILLS, CA. FILED 4-2-2014.

**TENNOKAFE**

THE MARK CONSISTS OF STANDARD CHARACTERS  
WITHOUT CLAIM TO ANY PARTICULAR FONT, STYLE,  
SIZE, OR COLOR.

THE WORDING "TENNOKAFE" HAS NO MEANING IN  
A FOREIGN LANGUAGE.  
FOR COFFEE; COFFEE-BASED BEVERAGES (U.S. CL.  
46).

JOHN HWANG, EXAMINING ATTORNEY

**CLASS 30—(Continued).**

SN 86-243,459. DOUGHNUT ENVY, LLC, LAS VEGAS, NV.  
FILED 4-4-2014.

**YEAST INFECTION**

THE MARK CONSISTS OF STANDARD CHARACTERS  
WITHOUT CLAIM TO ANY PARTICULAR FONT, STYLE,  
SIZE, OR COLOR.

FOR BAKERY GOODS; CAKES; DOUGHNUT HOLES;  
DOUGHNUTS; PASTRIES (U.S. CL. 46).

SUE LAWRENCE, EXAMINING ATTORNEY

SN 86-243,468. DOUGHNUT ENVY, LLC, LAS VEGAS, NV.  
FILED 4-4-2014.

SN 86-243,404. DOUGHNUT ENVY, LLC, LAS VEGAS, NV.  
FILED 4-4-2014.

**LITTLE BLUE PILL**

THE MARK CONSISTS OF STANDARD CHARACTERS  
WITHOUT CLAIM TO ANY PARTICULAR FONT, STYLE,  
SIZE, OR COLOR.

FOR BAKERY GOODS; CAKES; DOUGHNUT HOLES;  
DOUGHNUTS; PASTRIES (U.S. CL. 46).

APRIL REEVES, EXAMINING ATTORNEY

THE MARK CONSISTS OF STANDARD CHARACTERS  
WITHOUT CLAIM TO ANY PARTICULAR FONT, STYLE,  
SIZE, OR COLOR.

FOR BAKERY GOODS; CAKES; DOUGHNUT HOLES;  
DOUGHNUTS; PASTRIES (U.S. CL. 46).

SUE LAWRENCE, EXAMINING ATTORNEY

SN 86-243,846. LOZANO, CARLOS, MIAMI SHORES, FL.  
FILED 4-6-2014.

SN 86-243,426. DOUGHNUT ENVY, LLC, LAS VEGAS, NV.  
FILED 4-4-2014.

**BRAZILLION**

THE MARK CONSISTS OF STANDARD CHARACTERS  
WITHOUT CLAIM TO ANY PARTICULAR FONT, STYLE,  
SIZE, OR COLOR.

FOR BAKERY GOODS; CAKES; DOUGHNUT HOLES;  
DOUGHNUTS; PASTRIES (U.S. CL. 46).

APRIL REEVES, EXAMINING ATTORNEY



OWNER OF U.S. REG. NOS. 3,531,876, 3,886,138 AND  
OTHERS.

THE MARK CONSISTS OF THE STYLIZED WORDS "LOS  
PERROS" WITH THE FIRST LETTER "R" OF "PERROS"  
BEING REVERSED AND APPEARING BACKWARDS. THE  
ENTIRETY OF THE MARK APPEARS ON A SHADED  
BACKGROUND.

THE ENGLISH TRANSLATION OF "LOS PERROS" IN  
THE MARK IS "THE DOGS".

FOR SALSA (U.S. CL. 46).

FIRST USE 4-6-2014; IN COMMERCE 4-6-2014.

LAURA GOLDEN, EXAMINING ATTORNEY

**CLASS 30—(Continued).**

SN 86-244,261. WOW MANAGEMENT LLC, EAST HAMP-  
TON, NY. FILED 4-7-2014.

TOAST & ROAST

THE MARK CONSISTS OF STANDARD CHARACTERS  
WITHOUT CLAIM TO ANY PARTICULAR FONT, STYLE,  
SIZE, OR COLOR.

FOR BAGELS (U.S. CL. 46).  
MARGARET POWER, EXAMINING ATTORNEY

SN 86-244,355. DANIEL LOHMAN, LITTLETON, CO. FILED  
4-7-2014.

NOBEE

THE MARK CONSISTS OF STANDARD CHARACTERS  
WITHOUT CLAIM TO ANY PARTICULAR FONT, STYLE,  
SIZE, OR COLOR.

FOR SUGAR AND SUGAR SUBSTITUTES; NATURAL  
SWEETENER (U.S. CL. 46).  
WON TEAK OH, EXAMINING ATTORNEY

**CLASS 30—(Continued).**

SN 86-244,745. COMESTIBLES MASTER CO., LTD., TAI-  
CHUNG CITY, TAIWAN, FILED 4-7-2014.

一顆

THE MARK CONSISTS OF CHINESE CHARACTERS.

THE NON-LATIN CHARACTERS IN THE MARK TRANS-  
LITERATE TO "YI" AND "KE" AND THIS MEANS "ONE;  
ALONE" AND "A PIECE; A DROP" IN ENGLISH.

FOR BEVERAGES MADE OF COFFEE; BEVERAGES  
MADE OF TEA; BISCUITS; BREAD; BUNS; CAKES;  
CANDY; CHOCOLATE; CHOCOLATE FOOD BEV-  
ERAGES NOT BEING DAIRY-BASED OR VEGETABLE  
BASED; COCOA; COCOA BEVERAGES WITH MILK;  
COFFEE; COFFEE-BASED BEVERAGE CONTAINING  
MILK; COOKIES; CUSTARD; EDIBLE DECORATIONS  
FOR CAKES; EDIBLE FRUIT ICES; FARINACEOUS  
FOOD PASTES FOR HUMAN CONSUMPTION; HONEY;  
ICE CREAM; ICED TEA; MEAT PIES; MILK CHOCO-  
LATE; NOODLES; PANCAKES; PASTRIES; PASTRIES,  
NAMELY, PASTIES; PIES; PIZZA; POPCORN; PRE-  
PARED COCOA AND COCOA-BASED BEVERAGES;  
PREPARED COFFEE AND COFFEE-BASED BEV-  
ERAGES; PROCESSED OATS; RUSKS; SANDWICHES;  
SHERBET; SORBETS; SPAGHETTI; SUSHI; SWEET-  
MEATS; TEA-BASED BEVERAGES; TORTILLAS (U.S.  
CL. 46).

STEVEN JACKSON, EXAMINING ATTORNEY

SN 86-245,432. DARNALL, VALERIE, MYRTLE BEACH, SC.  
FILED 4-8-2014.

confectionate people

THE MARK CONSISTS OF STANDARD CHARACTERS  
WITHOUT CLAIM TO ANY PARTICULAR FONT, STYLE,  
SIZE, OR COLOR.

FOR BREAD; CAKES; COOKIES; PIES; SCONES (U.S.  
CL. 46).  
WILLIAM JACKSON, EXAMINING ATTORNEY



**CLASS 30—(Continued).**

SN 86-245,706. REVELRY BRANDS, LLC, BOULDER, CO.  
FILED 4-8-2014.

**LITTLE SECRETS**

THE MARK CONSISTS OF STANDARD CHARACTERS  
WITHOUT CLAIM TO ANY PARTICULAR FONT, STYLE,  
SIZE, OR COLOR.  
FOR CANDY AND CHOCOLATE (U.S. CL. 46).  
CYNTHIA RINALDI, EXAMINING ATTORNEY

SN 86-245,839. MOLINOS DE EL SALVADOR, SOCIEDAD  
ANONIMA DE CAPITAL VARIABLE, SAN SALVADOR,  
EL SALVADOR, FILED 4-8-2014.

**WAFERRICH**

THE MARK CONSISTS OF STANDARD CHARACTERS  
WITHOUT CLAIM TO ANY PARTICULAR FONT, STYLE,  
SIZE, OR COLOR.  
OWNER OF U.S. REG. NO. 3,516,839.  
FOR COOKIES (U.S. CL. 46).  
FIRST USE 9-26-2006; IN COMMERCE 9-26-2006.  
MICHAEL WEBSTER, EXAMINING ATTORNEY

SN 86-245,937. IF YOU DARE FOODS, L.L.C., LINCOLN, NE.  
FILED 4-8-2014.

**Embers**

THE MARK CONSISTS OF STANDARD CHARACTERS  
WITHOUT CLAIM TO ANY PARTICULAR FONT, STYLE,  
SIZE, OR COLOR.  
FOR FOOD CONDIMENT CONSISTING PRIMARILY  
OF KETCHUP AND SALSA (U.S. CL. 46).  
TASHIA BUNCH, EXAMINING ATTORNEY

**CLASS 30—(Continued).**

SN 86-245,988. DUFRESNE, EDOUARD W., JR., NEW YORK,  
NY. FILED 4-8-2014.

**BYGGYPYGGY**

THE MARK CONSISTS OF STANDARD CHARACTERS  
WITHOUT CLAIM TO ANY PARTICULAR FONT, STYLE,  
SIZE, OR COLOR.  
FOR SANDWICHES (U.S. CL. 46).  
CAROLYN CATALDO, EXAMINING ATTORNEY

SN 86-246,004. DIAS ENTERPRISES, INC., SAN JUAN  
BAUTISTA, CA. FILED 4-8-2014.



NO CLAIM IS MADE TO THE EXCLUSIVE RIGHT TO  
USE "GILROY", APART FROM THE MARK AS SHOWN.  
THE MARK CONSISTS OF A CIRCLE WITH THE  
WORDING "GILROY HOT STUFF" AROUND UPPER  
EDGE AND THE WORDING "GARLIC AND HABANERO  
BRINGS OUT THE DEVIL IN ME" AROUND BOTTOM  
EDGE. IN THE CENTER OF THE CIRCLE APPEARS A  
DESIGN DEPICTING A GARLIC BULB WITH A SMILING  
DEVIL FACE AND HORNS. THE ENTIRE MARK APPEARS  
ON A SQUARE BACKGROUND.

FOR SPICE BLENDS; SPICES (U.S. CL. 46).  
NAAKWAMA ANKRAH, EXAMINING ATTORNEY

SN 86-246,019. DUFRESNE, EDOUARD W., JR., NEW YORK,  
NY. FILED 4-8-2014.

**BYGGYBEEF**

THE MARK CONSISTS OF STANDARD CHARACTERS  
WITHOUT CLAIM TO ANY PARTICULAR FONT, STYLE,  
SIZE, OR COLOR.  
FOR SANDWICHES (U.S. CL. 46).  
CAROLYN CATALDO, EXAMINING ATTORNEY

**CLASS 30—(Continued).**

SN 86-246,506. HOUSE OF BRANDS LLC, AVENTURA, FL.  
FILED 4-8-2014.

# BRONCO

THE MARK CONSISTS OF STANDARD CHARACTERS WITHOUT CLAIM TO ANY PARTICULAR FONT, STYLE, SIZE, OR COLOR.

FOR ELECTRONIC CIGARETTE LIQUID (E-LIQUID) COMPRISED OF FLAVORINGS IN LIQUID FORM USED TO REFILL ELECTRONIC CIGARETTE CARTRIDGES (U.S. CL. 46).

SUNG IN, EXAMINING ATTORNEY

SN 86-246,510. MELANIE WHOLESALE, INC., AKA MELANIE WHOLESALE, BROOKLYN, NY. FILED 4-8-2014.

# MARHUMAR

THE MARK CONSISTS OF STANDARD CHARACTERS WITHOUT CLAIM TO ANY PARTICULAR FONT, STYLE, SIZE, OR COLOR.

FOR ARTIFICIAL COFFEE AND TEA; BARLEY TEA; BLACK TEA; CHAI TEA; CITRON TEA; FLAVOURINGS OF TEA; FRUIT TEAS; GINGER TEA; GINSENG TEA; GREEN TEA; HERB TEA; HERBAL TEA; TEA; TEA BAGS; TEA EXTRACTS; TEA SUBSTITUTES (U.S. CL. 46).

SUNG IN, EXAMINING ATTORNEY

SN 86-246,875. AS GREEN AS IT GETS Y COPROPIEDAD, SACATEPEQUEZ, GUATEMALA, FILED 4-9-2014.

# DE LA GENTE

THE MARK CONSISTS OF STANDARD CHARACTERS WITHOUT CLAIM TO ANY PARTICULAR FONT, STYLE, SIZE, OR COLOR.

THE ENGLISH TRANSLATION OF "DE LA GENTE" IN THE MARK IS "FROM THE PEOPLE".

FOR COFFEE (U.S. CL. 46).

FIRST USE 4-2-2014; IN COMMERCE 4-8-2014.

ELLEN B. AWRICH, EXAMINING ATTORNEY

**CLASS 30—(Continued).**

SN 86-246,911. HAJJAWI, OMAR, MISSION VIEJO, CA.  
FILED 4-9-2014.

# MEDUSA

THE MARK CONSISTS OF STANDARD CHARACTERS WITHOUT CLAIM TO ANY PARTICULAR FONT, STYLE, SIZE, OR COLOR.

FOR ELECTRONIC CIGARETTE LIQUID (E-LIQUID) COMPRISED OF FLAVORINGS IN LIQUID FORM USED TO REFILL ELECTRONIC CIGARETTE CARTRIDGES; CHEMICAL FLAVORINGS IN LIQUID FORM USED TO REFILL ELECTRONIC CIGARETTE CARTRIDGES; CARTRIDGES SOLD FILLED WITH CHEMICAL FLAVORINGS IN LIQUID FORM FOR ELECTRONIC CIGARETTES (U.S. CL. 46).

ELIZABETH CHANG, EXAMINING ATTORNEY

SN 86-247,094. MARK L. BOSSEY, CENTERPORT, NY.  
FILED 4-9-2014.

# LOYAL LEMON

THE MARK CONSISTS OF STANDARD CHARACTERS WITHOUT CLAIM TO ANY PARTICULAR FONT, STYLE, SIZE, OR COLOR.

NO CLAIM IS MADE TO THE EXCLUSIVE RIGHT TO USE "LEMON", APART FROM THE MARK AS SHOWN.

FOR TEA-BASED BEVERAGES, TEA, NON-MEDICINAL HERBAL TEAS (U.S. CL. 46).

FIRST USE 3-18-2014; IN COMMERCE 3-18-2014.

GIANCARLO CASTRO, EXAMINING ATTORNEY

SN 86-247,106. MEDERER GMBH, 90763 FUERTH, FED REP GERMANY, FILED 4-9-2014.

# WACKY QUACKY

THE MARK CONSISTS OF STANDARD CHARACTERS WITHOUT CLAIM TO ANY PARTICULAR FONT, STYLE, SIZE, OR COLOR.

FOR NON-MEDICATED CANDY CONTAINING AT LEAST ONE OF FRUIT GUM, FOAM SUGAR, JELLY, OR LICORICE (U.S. CL. 46).

EVELYN BRADLEY, EXAMINING ATTORNEY

**CLASS 30—(Continued).**

SN 86-247,126. MARK L. BOSSEY, CENTERPORT, NY. FILED 4-9-2014.

**PATRIOTIC PEACH**

THE MARK CONSISTS OF STANDARD CHARACTERS WITHOUT CLAIM TO ANY PARTICULAR FONT, STYLE, SIZE, OR COLOR.

NO CLAIM IS MADE TO THE EXCLUSIVE RIGHT TO USE "PEACH", APART FROM THE MARK AS SHOWN.

FOR TEA-BASED BEVERAGES, TEA, NON-MEDICINAL HERBAL TEAS (U.S. CL. 46).

GIANCARLO CASTRO, EXAMINING ATTORNEY

**CLASS 30—(Continued).**

SN 86-247,413. LA SIEMBRA CO-OPERATIVE, INC., AKA COOPÉRATIVE LA SIEMBRA INC., OTTAWA, ONTARIO, CANADA, FILED 4-9-2014.

**CAMINO**

THE MARK CONSISTS OF STANDARD CHARACTERS WITHOUT CLAIM TO ANY PARTICULAR FONT, STYLE, SIZE, OR COLOR.

THE ENGLISH TRANSLATION OF "CAMINO" IN THE MARK IS "PATH".

FOR CHOCOLATES AND CHOCOLATE BASED READY TO EAT CANDIES AND SNACKS (U.S. CL. 46).

ERNEST SHOSHO, EXAMINING ATTORNEY

SN 86-247,159. MARK L. BOSSEY, CENTERPORT, NY. FILED 4-9-2014.

**REBEL RASPBERRY**

THE MARK CONSISTS OF STANDARD CHARACTERS WITHOUT CLAIM TO ANY PARTICULAR FONT, STYLE, SIZE, OR COLOR.

NO CLAIM IS MADE TO THE EXCLUSIVE RIGHT TO USE "RASPBERRY", APART FROM THE MARK AS SHOWN.

FOR TEA-BASED BEVERAGES, TEA, NON-MEDICINAL HERBAL TEAS (U.S. CL. 46).

GIANCARLO CASTRO, EXAMINING ATTORNEY

SN 86-248,229. LEWIS BROTHERS BAKERIES, INCORPORATED, DBA LEWIS BAKERIES, INC., EVANSVILLE, IN. FILED 4-10-2014.

**MILLBROOK**

THE MARK CONSISTS OF STANDARD CHARACTERS WITHOUT CLAIM TO ANY PARTICULAR FONT, STYLE, SIZE, OR COLOR.

OWNER OF U.S. REG. NO. 1,273,784. FOR STUFFING MIXES CONTAINING BREAD, CAKE, COOKIES, CORN PATTIES, DONUTS AND FRUIT CAKE (U.S. CL. 46).

LOKSYE G LEE RISO, EXAMINING ATTORNEY

SN 86-247,171. NEXXCUP COFFEE COMPANY, LLC, RICHMOND, BC, CANADA, FILED 4-9-2014.

**NEXXCUP**

THE MARK CONSISTS OF STANDARD CHARACTERS WITHOUT CLAIM TO ANY PARTICULAR FONT, STYLE, SIZE, OR COLOR.

FOR COFFEE (U.S. CL. 46).

JOHN WILKE, EXAMINING ATTORNEY

SN 86-248,554. HAHT SAHS, LLC, SOUTH ORANGE, NJ. FILED 4-10-2014.

**YEAH, YOU CAN PUT IT ON THAT!**

THE MARK CONSISTS OF STANDARD CHARACTERS WITHOUT CLAIM TO ANY PARTICULAR FONT, STYLE, SIZE, OR COLOR.

FOR SAUCES (U.S. CL. 46).

FIRST USE 3-1-2014; IN COMMERCE 3-1-2014.

TEJBIR SINGH, EXAMINING ATTORNEY

**CLASS 30—(Continued).**

SN 86-248,805. CASEY'S SAUCES INC., RIDGECREST, CA. FILED 4-10-2014.



OWNER OF U.S. REG. NO. 4,500,915.  
NO CLAIM IS MADE TO THE EXCLUSIVE RIGHT TO USE "HOT BBQ SAUCE", APART FROM THE MARK AS SHOWN.

THE MARK CONSISTS OF THE STYLIZED WORDS "CASEY'S HOME RUN THE HEATER HOT BBQ SAUCE" WITH A BASEBALL DIAMOND AT THE TOP OF THE MARK WITH A BASEBALL PLAYER SWINGING A BAT IN THE MIDDLE OF THE DIAMOND. UNDERNEATH THE DESIGN IS THE WORDING "CASEY'S HOME RUN HOT BBQ SAUCE". TO THE RIGHT OF THE WORDING IS A FLAMING BASEBALL, WITH THE WORDING "THE HEATER" IN A BANNER IN THE MIDDLE OF THE MARK.

FOR BBQ SAUCE (U.S. CL. 46).  
SCOTT BIBB, EXAMINING ATTORNEY

SN 86-249,429. CASEY'S SAUCES INC., RIDGECREST, CA. FILED 4-11-2014.



OWNER OF U.S. REG. NO. 4,500,915.  
NO CLAIM IS MADE TO THE EXCLUSIVE RIGHT TO USE "ORIGINAL BBQ SAUCE", APART FROM THE MARK AS SHOWN.

THE MARK CONSISTS OF THE STYLIZED WORDS "CASEY'S HOME RUN ORIGINAL BBQ SAUCE" WITH A BASEBALL DIAMOND AT THE TOP OF THE MARK WITH A BASEBALL PLAYER SWINGING A BAT IN THE MIDDLE OF THE DIAMOND. THE WORDING "CASEY'S HOME RUN ORIGINAL BBQ SAUCE" IS BELOW WITH THE WORD "ORIGINAL" IN A BANNER.

FOR BBQ SAUCE (U.S. CL. 46).  
SCOTT BIBB, EXAMINING ATTORNEY

**CLASS 30—(Continued).**

SN 86-249,861. BRANDSTORM, INC., VAN NUYS, CA. FILED 4-11-2014.

**ICE**

THE MARK CONSISTS OF STANDARD CHARACTERS WITHOUT CLAIM TO ANY PARTICULAR FONT, STYLE, SIZE, OR COLOR.

FOR EDIBLE SALT; EDIBLE SPICES; FLAVORED SALT; FLAVOURINGS AND SEASONINGS; SALT; SPICE BLENDS; SPICES (U.S. CL. 46).

INGRID C. EULIN, EXAMINING ATTORNEY

SN 86-251,723. GROUNDS AND HOUNDS LLC, SOUTH BEND, IN. FILED 4-14-2014.

**Every cup saves a pup**

THE MARK CONSISTS OF STANDARD CHARACTERS WITHOUT CLAIM TO ANY PARTICULAR FONT, STYLE, SIZE, OR COLOR.

FOR COFFEE (U.S. CL. 46).  
MIDGE BUTLER, EXAMINING ATTORNEY

SN 86-252,169. W. B. LAW & SON, INC., NEWARK, NJ. FILED 4-15-2014.



NO CLAIM IS MADE TO THE EXCLUSIVE RIGHT TO USE "ARTISAN COFFEE", APART FROM THE MARK AS SHOWN.

THE MARK CONSISTS OF AN IMAGE OF A BARN WITH A ROAD LEADING TO IT. A TREE IS PLACED NEXT TO THE LEFT OF BARN. BUSHES ARE PLACED ON THE LEFT AND RIGHT OF THE BARN. AN IMAGE OF A MOUNTAIN IS PLACED BEHIND THE BARN, TREES, AND BUSHES. THIS IMAGE IS PLACED IN AN OVAL. ABOVE THE IMAGE ARE THE LITERAL ELEMENTS "SHADOWBROOK", STYLIZED. BELOW THE IMAGE ARE THE LITERAL ELEMENTS "ARTISAN COFFEE", STYLIZED. THE IMAGE AND LITERAL ELEMENTS ARE ENCLOSED IN A SECOND OVAL.

FOR COFFEE; COFFEE AND TEA; COFFEE BEANS; WHOLE BEAN SPECIALTY COFFEES; COFFEE-BASED BEVERAGES; ROASTED COFFEE BEANS (U.S. CL. 46).  
FIRST USE 1-2-2014; IN COMMERCE 1-2-2014.  
TEJBIR SINGH, EXAMINING ATTORNEY

**CLASS 30—(Continued).**

SN 86-253,341. W. B. LAW & SON, INC., NEWARK, NJ.  
FILED 4-16-2014.

**SHADOWBROOK ARTISAN COFFEE**

THE MARK CONSISTS OF STANDARD CHARACTERS WITHOUT CLAIM TO ANY PARTICULAR FONT, STYLE, SIZE, OR COLOR.

NO CLAIM IS MADE TO THE EXCLUSIVE RIGHT TO USE "ARTISAN COFFEE", APART FROM THE MARK AS SHOWN.

FOR COFFEE; COFFEE AND TEA; COFFEE BEANS; WHOLE BEAN SPECIALTY COFFEES; COFFEE-BASED BEVERAGES; ROASTED COFFEE BEANS (U.S. CL. 46).

FIRST USE 1-2-2014; IN COMMERCE 1-2-2014.  
TEJBIR SINGH, EXAMINING ATTORNEY

SN 86-268,129. SHURFINE FOODS, INC., TIGARD, OR.  
FILED 4-30-2014.

**SHUR SAVING**

THE MARK CONSISTS OF STANDARD CHARACTERS WITHOUT CLAIM TO ANY PARTICULAR FONT, STYLE, SIZE, OR COLOR.

OWNER OF U.S. REG. NOS. 1,237,527, 1,711,996 AND OTHERS.

FOR CAKE MIXES; BROWNIE MIXES; MUFFIN MIXES; PANCAKE MIXES; FROSTINGS; TABLE SYRUP; PROCESSED OATS; OATMEAL; KETCHUP; PASTA SAUCE; HOT SAUCE; TOMATO SAUCE; MARSHMALLOWS; RELISH; CANNED PASTA WITH SAUCE; DRY SEASONING MIXES FOR FAJITAS, TACOS, GRAVY, SPAGHETTI, CHILI, AND GROUND MEAT SANDWICHES; FOOD SEASONINGS; SEASONING MIXES; GRAVY MIXES; SALT; PEPPER; HOMINY; POPCORN; FROZEN BURRITOS; FROZEN PIZZA; FROZEN WAFFLES; SHERBET; FROZEN CONFECTIONS, NAMELY, FREEZER POPS (U.S. CL. 46).

FIRST USE 4-0-2013; IN COMMERCE 4-0-2013.  
MICHAEL P EISNACH, EXAMINING ATTORNEY

SN 86-269,335. ROBERT ROSENHECK, LOS ANGELES, CA.  
FILED 5-1-2014.

**FOR YOUR ROYAL HIGHNESS**

THE MARK CONSISTS OF STANDARD CHARACTERS WITHOUT CLAIM TO ANY PARTICULAR FONT, STYLE, SIZE, OR COLOR.

FOR BAKERY GOODS, NAMELY, CAKES AND COOKIES; CANDY; CHOCOLATE; CHOCOLATE CANDIES (U.S. CL. 46).

SAMUEL PAQUIN, EXAMINING ATTORNEY

**CLASS 30—(Continued).**

SN 86-286,649. TYSON FOODS, INC., SPRINGDALE, AR.  
FILED 5-20-2014.



OWNER OF U.S. REG. NO. 4,096,812.

THE MARK CONSISTS OF A LOGO IN THE SHAPE OF A STYLIZED SHIELD WITH A BANNER APPEARING ACROSS AND CONTAINED WITHIN THE SHIELD. THE WORD "POWER" IS IN THE BANNER AND THE WORD "TYSON" APPEARS ABOVE THE BANNER AND THE WORD "UPZ" APPEARS BELOW THE BANNER. NEAR THE TOP OF THE SHIELD AND CENTERED ABOVE THE WORD "TYSON" IS A STAR. NEAR THE BOTTOM OF THE SHIELD AND CENTERED BELOW THE WORD "UPZ" IS A STAR. CONCENTRIC CIRCLES EMANATE FROM THE LEFT AND RIGHT SIDES OF THE SHIELD AND FOUR LIGHTNING BOLTS SURROUND THE SHIELD.

FOR SANDWICHES, NAMELY, CHICKEN, BEEF, PORK, EGG, EGG WHITES AND/OR CHEESE COMBINED WITH A BUN, BREAD, MUFFULETTA, CIABATTA, FLATBREAD, CROISSANT OR TORTILLA; BREAKFAST SANDWICHES, NAMELY, CHICKEN, BEEF, PORK, EGG, EGG WHITES AND/OR CHEESE COMBINED WITH BISCUITS, WAFFLES, PANCAKES, FLATBREAD, TORTILLAS, ENGLISH MUFFINS OR BAGELS (U.S. CL. 46).

ALYSSA STEEL, EXAMINING ATTORNEY

SN 86-288,756. KANY CORPORATION, WELLESEY, MA.  
FILED 5-22-2014.

**Premco**

THE MARK CONSISTS OF STANDARD CHARACTERS WITHOUT CLAIM TO ANY PARTICULAR FONT, STYLE, SIZE, OR COLOR.

THE WORDING "PREMCO" HAS NO MEANING IN A FOREIGN LANGUAGE.

FOR COCOA; COCOA POWDER (U.S. CL. 46).  
TIFFANY CHIANG, EXAMINING ATTORNEY

**CLASS 30—(Continued).**

SN 86-289,288. HERR HOLDINGS, INC., WILMINGTON, DE. FILED 5-22-2014.



THE MARK CONSISTS OF THE STYLIZED WORDING "PRETZLERS", WITH TWO BALLS APPEARING BEHIND AND LARGELY ABOVE THE WORDING. ONE OF THE BALLS INCLUDES AN OVOID FIGURE CONTAINING SCATTERED SHORT HORIZONTAL LINES AND APPEARS IN FRONT OF AND PARTIALLY OBSCURES THE OTHER BALL.

FOR CANDY COATED PRETZEL BALLS (U.S. CL. 46). CHRISTOPHER REAMS, EXAMINING ATTORNEY

**CLASS 31—NATURAL AGRICULTURAL PRODUCTS**

SN 76-714,599. FARM SOURCES INTERNATIONAL HOLDINGS, LLC, SCOTTSDALE, AZ. FILED 7-24-2013.



NO CLAIM IS MADE TO THE EXCLUSIVE RIGHT TO USE "FARM SOURCES INTERNATIONAL", APART FROM THE MARK AS SHOWN.

THE COLOR(S) BLACK, YELLOW, GREEN, AND WHITE IS/ARE CLAIMED AS A FEATURE OF THE MARK.

THE MARK CONSISTS OF A GREEN CREST WITH A YELLOW BORDER AND OUTLINED IN GREEN. THE LETTERS "FSI" APPEAR IN WHITE ON THE CREST. THE CREST SITS IN THE MIDDLE OF TWO YELLOW, CONNECTING OLIVE BRANCHES. THE WORDS "FARM SOURCES INTERNATIONAL" APPEAR IN BLACK IMMEDIATELY BELOW THE OLIVE BRANCHES.

FOR HAY; ANIMAL FEED FORAGE PRODUCTS, NAMELY, ALFALFA, TIMOTHY AND BERMUDA HAY, OATS, BARLEY, CORN AND WHEAT (U.S. CLS. 1 AND 46).

FIRST USE 3-15-2011; IN COMMERCE 3-15-2011. JOANNA DUKOVIC, EXAMINING ATTORNEY

SN 76-714,600. FSI CUBE AND PELLET, LLC, SCOTTSDALE, AZ. FILED 7-24-2013.



NO CLAIM IS MADE TO THE EXCLUSIVE RIGHT TO USE "CUBE AND PELLET", APART FROM THE MARK AS SHOWN.

THE COLOR(S) GREEN, WHITE, YELLOW, AND BLACK IS/ARE CLAIMED AS A FEATURE OF THE MARK.

THE MARK CONSISTS OF A GREEN CREST WITH A YELLOW BORDER AND OUTLINED IN GREEN. THE LETTERS "FSI" APPEAR IN WHITE ON THE CREST. THE CREST SITS IN THE MIDDLE OF TWO YELLOW, CONNECTING OLIVE BRANCHES. THE WORDS "FSI CUBE AND PELLET" APPEAR IN BLACK IMMEDIATELY BELOW THE OLIVE BRANCHES.

FOR HAY; ANIMAL FEED FORAGE PRODUCTS, NAMELY, ALFALFA CUBES, ALFALFA BLEND CUBES, AND TIMOTHY HAY CUBES (U.S. CLS. 1 AND 46).

FIRST USE 10-1-2012; IN COMMERCE 10-1-2012. JOANNA DUKOVIC, EXAMINING ATTORNEY

SN 86-310,091. EASTLAND FOOD CORPORATION, JESSUP, MD. FILED 6-15-2014.

**CHILI KING**

THE MARK CONSISTS OF STANDARD CHARACTERS WITHOUT CLAIM TO ANY PARTICULAR FONT, STYLE, SIZE, OR COLOR.

NO CLAIM IS MADE TO THE EXCLUSIVE RIGHT TO USE "CHILI", APART FROM THE MARK AS SHOWN.

FOR CHILI PASTE FOR USE AS A SEASONING; CHILI SAUCE; SRIRACHA HOT CHILI SAUCE (U.S. CL. 46).

SUNG IN, EXAMINING ATTORNEY

**CLASS 31—(Continued).**

SN 79-142,376. BEEKENKAMP PLANTS B.V., MAASDIJK, NETHERLANDS, FILED 12-19-2013.

# BEAUVILIA

THE MARK CONSISTS OF STANDARD CHARACTERS WITHOUT CLAIM TO ANY PARTICULAR FONT, STYLE, SIZE, OR COLOR.

PRIORITY DATE OF 7-30-2013 IS CLAIMED.  
OWNER OF INTERNATIONAL REGISTRATION 1191717 DATED 12-19-2013, EXPIRES 12-19-2023.  
THE WORDING "BEAUVILIA" HAS NO MEANING IN A FOREIGN LANGUAGE.  
FOR NATURAL PLANTS AND FLOWERS, NAMELY, BEGONIAS; BEGONIA SEEDS (U.S. CLS. 1 AND 46).  
TRICIA SONNEBORN, EXAMINING ATTORNEY

---

SN 85-875,239. CHROMATIN, INC., CHICAGO, IL. FILED 3-13-2013.

# RESTORE

THE MARK CONSISTS OF STANDARD CHARACTERS WITHOUT CLAIM TO ANY PARTICULAR FONT, STYLE, SIZE, OR COLOR.

FOR SORGHUM SEED (U.S. CLS. 1 AND 46).  
BARBARA GAYNOR, EXAMINING ATTORNEY

---

SN 85-897,937. SOW OFFSHORE SARL, BEIRUT, LEBANON, FILED 4-8-2013.

# KARM

THE MARK CONSISTS OF STANDARD CHARACTERS WITHOUT CLAIM TO ANY PARTICULAR FONT, STYLE, SIZE, OR COLOR.

THE ENGLISH TRANSLATION OF THE WORD "KARM" IN THE MARK IS "FATE".

FOR VEGETABLE SEEDS FOR PLANTING; FRUIT SEEDS FOR PLANTING; FLOWER SEEDS FOR PLANTING; HERB SEEDS FOR PLANTING; AGRICULTURE SEEDS FOR PLANTING; CROP SEEDS FOR PLANTING, INCLUDING CORN, PEAS AND BEANS (U.S. CLS. 1 AND 46).

GIANCARLO CASTRO, EXAMINING ATTORNEY

**CLASS 31—(Continued).**

SN 86-018,625. CENTRAL AMERICAN PRODUCE, INC., POMPANNO BEACH, FL. FILED 7-24-2013.

# MAYAN VALLEY

THE MARK CONSISTS OF STANDARD CHARACTERS WITHOUT CLAIM TO ANY PARTICULAR FONT, STYLE, SIZE, OR COLOR.

OWNER OF U.S. REG. NO. 2,109,255.  
FOR (BASED ON USE IN COMMERCE) MANGOES; (BASED ON INTENT TO USE) MELONS, CANTALOUPE, HONEYDEWS, WATERMELONS, PAPAYAS, BLUEBERRIES, EGGPLANT, ONIONS, PEPPERS, CUCUMBERS, AVOCADOS, ASPARAGUS, LIMES, GREEN BEANS, SNOW PEAS, SUGAR SNAPS, PINEAPPLES; ALL BEING FRESH (U.S. CLS. 1 AND 46).  
FIRST USE 4-1-2006; IN COMMERCE 4-1-2006.  
BERNICE MIDDLETON, EXAMINING ATTORNEY

---

SN 86-033,337. AGROPECUARIA LA NORTEÑITA, S. DE R.L. DE C.V., CUAUHTEMOC, MEXICO, FILED 8-9-2013.



OWNER OF MEXICO REG. NO. 1040080, DATED 10-19-2007, EXPIRES 10-19-2017.

THE COLOR(S) YELLOW, RED, GREEN AND BLUE IS/ARE CLAIMED AS A FEATURE OF THE MARK.

THE MARK CONSISTS OF A SMILEY APPLE IN THE COLORS RED AND GREEN. THE TERM "CHAVALINAS" APPEARING IN THE COLORS YELLOW, RED, GREEN AND BLUE ON TOP OF TWO STYLIZED LINES IN THE COLORS RED AND GREEN.

THE WORDING "CHAVALINAS" HAS NO MEANING IN A FOREIGN LANGUAGE.

FOR FRESH FRUIT (U.S. CLS. 1 AND 46).  
CARYN GLASSER, EXAMINING ATTORNEY

---

SN 86-043,056. HILL'S PET NUTRITION, INC., TOPEKA, KS. FILED 8-20-2013.

# ACTIVE

THE MARK CONSISTS OF STANDARD CHARACTERS WITHOUT CLAIM TO ANY PARTICULAR FONT, STYLE, SIZE, OR COLOR.

FOR PET FOOD (U.S. CLS. 1 AND 46).  
DEZMONA MIZELLE, EXAMINING ATTORNEY

**CLASS 31—(Continued).**

SN 86-055,725. APPLE AND PEAR AUSTRALIA LIMITED, NORTH MELBOURNE, VIC, AUSTRALIA, FILED 9-4-2013.

# KANDI PINK

THE MARK CONSISTS OF STANDARD CHARACTERS WITHOUT CLAIM TO ANY PARTICULAR FONT, STYLE, SIZE, OR COLOR.

FOR AGRICULTURAL AND HORTICULTURAL PRODUCTS, NAMELY, FRESH FRUIT INCLUDING APPLES, LIVE PLANTS AND TREES INCLUDING APPLE TREES (U.S. CLS. 1 AND 46).

TINA L. SNAPP, EXAMINING ATTORNEY

---

SN 86-067,996. UNIPET INTERNATIONAL LIMITED, SITTINGBOURNE, KENT, UNITED KINGDOM, FILED 9-18-2013.

# HERBA-DENT

THE MARK CONSISTS OF STANDARD CHARACTERS WITHOUT CLAIM TO ANY PARTICULAR FONT, STYLE, SIZE, OR COLOR.

OWNER OF ERPN CMNTY TM OFC REG. NO. 004594404, DATED 1-10-2007, EXPIRES 8-17-2015.

FOR LIVE ANIMALS; FRESH FRUITS AND VEGETABLES FOR BIRDS AND ANIMALS; UNPROCESSED EDIBLE SEEDS FOR BIRDS AND ANIMALS; NATURAL LIVE PLANTS AND LIVE FLOWERS; FOODSTUFFS FOR ANIMALS; MALT FOR BREWING AND DISTILLING; AND DOG AND PET TREATS (U.S. CLS. 1 AND 46).

JEANIE LEE, EXAMINING ATTORNEY

---

SN 86-072,603. MITCHELL, RONALD, BERKELE, CA. FILED 9-24-2013.



NO CLAIM IS MADE TO THE EXCLUSIVE RIGHT TO USE "LOCAL GREENS", APART FROM THE MARK AS SHOWN.

THE COLOR(S) GREEN IS/ARE CLAIMED AS A FEATURE OF THE MARK.

THE MARK CONSISTS OF THE STYLIZED GREEN WORDING "LOCAL GREENS" WITH A GREEN SEMICIRCULAR MARK WITH A GREEN LEAF ON TOP CIRCLING THE "G".

FOR FRESH LETTUCE; RAW BEAN SPROUTS (U.S. CLS. 1 AND 46).

FIRST USE 4-20-2013; IN COMMERCE 5-15-2013.

KRISTINA MORRIS, EXAMINING ATTORNEY

**CLASS 31—(Continued).**

SN 86-072,711. BACKYARD FARMS LLC, MADISON, ME. FILED 9-24-2013.

# BACKYARD BEAUTIES

THE MARK CONSISTS OF STANDARD CHARACTERS WITHOUT CLAIM TO ANY PARTICULAR FONT, STYLE, SIZE, OR COLOR.

OWNER OF U.S. REG. NO. 3,377,608.

FOR FRESH TOMATOES (U.S. CLS. 1 AND 46).

JUHI KAVEESHVAR, EXAMINING ATTORNEY

---

SN 86-084,778. HIDDEN STAR ORCHARDS, OAKLAND, CA. FILED 10-7-2013.

# Hidden Star Orchards

THE MARK CONSISTS OF STANDARD CHARACTERS WITHOUT CLAIM TO ANY PARTICULAR FONT, STYLE, SIZE, OR COLOR.

NO CLAIM IS MADE TO THE EXCLUSIVE RIGHT TO USE "ORCHARDS", APART FROM THE MARK AS SHOWN.

FOR FRESH FRUITS (U.S. CLS. 1 AND 46).

FIRST USE 7-1-2001; IN COMMERCE 7-1-2001.

RONALD MCMORROW, EXAMINING ATTORNEY

---

SN 86-085,021. SOFIA PRODUCE, LLC, NOGALES, AZ. FILED 10-7-2013.

# TRUSWEET

THE MARK CONSISTS OF STANDARD CHARACTERS WITHOUT CLAIM TO ANY PARTICULAR FONT, STYLE, SIZE, OR COLOR.

FOR FRESH FRUIT AND VEGETABLES (U.S. CLS. 1 AND 46).

FIRST USE 9-22-2013; IN COMMERCE 9-22-2013.

TOBY BULLOFF, EXAMINING ATTORNEY



**CLASS 31—(Continued).**

SN 86-085,039. SIMPLE LIVING FARM, RALEIGH, NC. FILED 10-7-2013.

## Simple Living Farm

THE MARK CONSISTS OF STANDARD CHARACTERS WITHOUT CLAIM TO ANY PARTICULAR FONT, STYLE, SIZE, OR COLOR.

NO CLAIM IS MADE TO THE EXCLUSIVE RIGHT TO USE "FARM", APART FROM THE MARK AS SHOWN.

FOR FRESH FRUIT AND VEGETABLES (U.S. CLS. 1 AND 46).

FIRST USE 10-1-2013; IN COMMERCE 10-1-2013.  
WILLIAM VERHOSEK, EXAMINING ATTORNEY

SN 86-116,519. LANGHORNE HOUSE, DANVILLE, VA. FILED 11-12-2013.

## Lady Astor Rose

THE MARK CONSISTS OF STANDARD CHARACTERS WITHOUT CLAIM TO ANY PARTICULAR FONT, STYLE, SIZE, OR COLOR.

NO CLAIM IS MADE TO THE EXCLUSIVE RIGHT TO USE "ROSE", APART FROM THE MARK AS SHOWN.

THE NAME "LADY ASTOR ROSE" DOES NOT IDENTIFY A LIVING INDIVIDUAL.

FOR ROSES (U.S. CLS. 1 AND 46).  
FIRST USE 11-9-2010; IN COMMERCE 11-9-2010.  
LINDA ORNDORFF, EXAMINING ATTORNEY

SN 86-162,429. VAN GRONINGEN & SONS, INC., MANTECA, CA. FILED 1-10-2014.



NO CLAIM IS MADE TO THE EXCLUSIVE RIGHT TO USE "YOSEMITE FRESH", "WATERMELONS", "SONS, INC." AND "MANTECA, CA 95336", APART FROM THE MARK AS SHOWN.

THE MARK CONSISTS OF TWO MOUNTAINS THAT INCLUDE STIPPLING, A SKY BACKGROUND, A STREAM RUNNING BETWEEN THEM, AND PINE TREES WITH

**CLASS 31—(Continued).**

STIPPLING IN THE FOREGROUND; THE SCENE IS SURROUNDED BY A ROPE WITH LINING AND HAS TWO WATERMELON SLICES ON THE LEFT SIDE; THE WORDS "YOSEMITE" AND "FRESH" APPEAR ACROSS THE TOP; THE WORD "YOSEMITE" HAS A SHADOW OF HORIZONTAL LINES; BELOW THIS SCENE IS A BANNER CONTAINING THE WORD "WATERMELONS" AND TWO DOTS ON EITHER SIDE OF THE WORD; BELOW THE BANNER IN SMALLER FONT IS THE WORDING "VAN GRONINGEN & SONS, INC. MANTECA, CA 95336".

FOR FRESH FRUIT, NAMELY, WATERMELONS (U.S. CLS. 1 AND 46).

FIRST USE 3-1-1998; IN COMMERCE 3-1-1998.  
MICHELLE DUBOIS, EXAMINING ATTORNEY

SN 86-163,358. LEXUNDER INC, BROOKLYN, NY. FILED 1-12-2014.



NO CLAIM IS MADE TO THE EXCLUSIVE RIGHT TO USE "FOOD", APART FROM THE MARK AS SHOWN.

THE COLOR(S) BROWN, GREEN, BLUE, WHITE, AND GRAY IS/ARE CLAIMED AS A FEATURE OF THE MARK.

THE MARK CONSISTS OF THE WORDS "FOOD TO LIVE" IN BROWN, A GREEN LEAF WITH A WHITE VEIN OVER THE LETTER "I", AND A BLUE AND GRAY UNDERLINING.

FOR FRESH NUTS SOLD ONLY VIA THE INTERNET (U.S. CLS. 1 AND 46).

FIRST USE 0-0-2013; IN COMMERCE 0-0-2013.  
DAVID C. REIHNER, EXAMINING ATTORNEY

SN 86-173,317. THREE DOG BAKERY, LLC, KANSAS CITY, MO. FILED 1-23-2014.

## PUP-KIN SPICED LATTÉ

THE MARK CONSISTS OF STANDARD CHARACTERS WITHOUT CLAIM TO ANY PARTICULAR FONT, STYLE, SIZE, OR COLOR.

NO CLAIM IS MADE TO THE EXCLUSIVE RIGHT TO USE "SPICED LATTÉ", APART FROM THE MARK AS SHOWN.

FOR EDIBLE PET TREATS (U.S. CLS. 1 AND 46).  
FIRST USE 8-0-2012; IN COMMERCE 8-0-2012.  
SETH A. RAPPAPORT, EXAMINING ATTORNEY

**CLASS 31—(Continued).**

SN 86-173,421. THREE DOG BAKERY, LLC, KANSAS CITY, MO. FILED 1-23-2014.

**BEG NOG LATTE**

THE MARK CONSISTS OF STANDARD CHARACTERS WITHOUT CLAIM TO ANY PARTICULAR FONT, STYLE, SIZE, OR COLOR.

NO CLAIM IS MADE TO THE EXCLUSIVE RIGHT TO USE "NOG LATTE", APART FROM THE MARK AS SHOWN.

FOR EDIBLE PET TREATS (U.S. CLS. 1 AND 46).  
FIRST USE 10-0-2012; IN COMMERCE 10-0-2012.  
SETH A. RAPPAPORT, EXAMINING ATTORNEY

SN 86-176,911. BERNARD, DAVID, BROADWAY, NC. AND LEWIS, TONYA, BROADWAY, NC. FILED 1-28-2014.

**OFF-BROADWAY PRODUCTIONS**

THE MARK CONSISTS OF STANDARD CHARACTERS WITHOUT CLAIM TO ANY PARTICULAR FONT, STYLE, SIZE, OR COLOR.

FOR AGRICULTURAL PRODUCTS, NAMELY, ORGANIC FRESH FRUITS AND FRESH VEGETABLES, AND FRESH HERBS (U.S. CLS. 1 AND 46).

JONATHAN FALK, EXAMINING ATTORNEY

SN 86-183,986. AWE SUM ORGANICS, SANTA CRUZ, CA. FILED 2-4-2014.

**FRUIT FOR YOUR SOUL**

THE MARK CONSISTS OF STANDARD CHARACTERS WITHOUT CLAIM TO ANY PARTICULAR FONT, STYLE, SIZE, OR COLOR.

FOR FRESH FRUITS AND FRESH VEGETABLES ORGANICALLY GROWN (U.S. CLS. 1 AND 46).

LINDA QUIGLEY, EXAMINING ATTORNEY

**CLASS 31—(Continued).**

SN 86-187,522. ESPECIALISTAS EN PAPAYAS, S.A. DE C.V., ZAPOPAN, JALISCO, MEXICO, FILED 2-7-2014.

**PASSION RED**

THE MARK CONSISTS OF STANDARD CHARACTERS WITHOUT CLAIM TO ANY PARTICULAR FONT, STYLE, SIZE, OR COLOR.

NO CLAIM IS MADE TO THE EXCLUSIVE RIGHT TO USE "RED", APART FROM THE MARK AS SHOWN.

FOR AGRICULTURAL SEEDS; FRESH FRUIT AND VEGETABLES (U.S. CLS. 1 AND 46).

CHRISTOPHER REAMS, EXAMINING ATTORNEY

SN 86-190,903. HOOD RIVER ORGANIC UPICK FARMS LLC, HOOD RIVER, OR. FILED 2-11-2014.

**Gorge Organic U-Pick**

THE MARK CONSISTS OF STANDARD CHARACTERS WITHOUT CLAIM TO ANY PARTICULAR FONT, STYLE, SIZE, OR COLOR.

NO CLAIM IS MADE TO THE EXCLUSIVE RIGHT TO USE "ORGANIC YOU PICK", APART FROM THE MARK AS SHOWN.

FOR FLOWERS, NAMELY, ORGANIC FLOWERS; ORGANIC FRESH FRUIT; ORGANIC FRESH VEGETABLES (U.S. CLS. 1 AND 46).

ASMAT KHAN, EXAMINING ATTORNEY

SN 86-215,157. PABLO BORQUEZ ALMADA, SONORA 83680, MEXICO, FILED 3-7-2014.

**CAMPOS BORQUEZ**

OWNER OF U.S. REG. NO. 4,375,569.

THE MARK CONSISTS OF THE FANCIFUL DESIGN OF A SUN OVER A FANCIFUL DESIGN OF FIELDS AND MOUNTAINS ALL WITHIN A CIRCLE, UNDER WHICH APPEAR THE WORDS "CAMPOS BORQUEZ".

THE ENGLISH TRANSLATION OF "CAMPOS" IN THE MARK IS "FIELDS".

FOR FRESH FRUIT AND VEGETABLES (U.S. CLS. 1 AND 46).

FIRST USE 7-1-2012; IN COMMERCE 7-1-2012.

BRIN ANDERSON, EXAMINING ATTORNEY

**CLASS 31—(Continued).**

SN 86-228,597. GARDEN INNOVATIONS, LLC, CLEVELAND, GA. FILED 3-21-2014.

**FLOWEROLOGY**

THE MARK CONSISTS OF STANDARD CHARACTERS WITHOUT CLAIM TO ANY PARTICULAR FONT, STYLE, SIZE, OR COLOR.

FOR MULCH AND SEEDS FOR AGRICULTURAL PURPOSES, NAMELY, MATS COMPOSED OF WOOD FIBER MULCH CONTAINING SEEDS FOR FLOWERS AND GROUND COVER (U.S. CLS. 1 AND 46).

KYLE PEETE, EXAMINING ATTORNEY

SN 86-229,969. RAW PAWS, INDIANAPOLIS, IN. FILED 3-24-2014.

**Raw Paws**

THE MARK CONSISTS OF STANDARD CHARACTERS WITHOUT CLAIM TO ANY PARTICULAR FONT, STYLE, SIZE, OR COLOR.

NO CLAIM IS MADE TO THE EXCLUSIVE RIGHT TO USE "RAW", APART FROM THE MARK AS SHOWN.

FOR EDIBLE FOOD FOR ANIMALS FOR CHEWING; FOOD FOR ANIMALS; PET FOOD (U.S. CLS. 1 AND 46).

FIRST USE 1-1-2008; IN COMMERCE 1-1-2008.  
DAVID MURRAY, EXAMINING ATTORNEY

SN 86-229,993. CARDINAL LABS, INC., BALDWIN HILLS, CA. FILED 3-24-2014.



OWNER OF U.S. REG. NOS. 3,416,555 AND 3,416,556.  
NO CLAIM IS MADE TO THE EXCLUSIVE RIGHT TO USE "PET BOTANICS", APART FROM THE MARK AS SHOWN.

THE COLOR(S) GREEN, BROWN, WHITE AND GRAY IS/ARE CLAIMED AS A FEATURE OF THE MARK.

THE MARK CONSISTS OF A CURVED SHAPE WITH A TRIM DESIGN ON THE UPPER AND LOWER EDGES. SUPERIMPOSED ON THIS IS A SQUARE DESIGN WITH A TRIM DESIGN ON THE UPPER AND LOWER EDGES. IN THE MIDDLE OF THE CURVED SHAPE IS THE WORDING "PET BOTANICS". IN THE MIDDLE OF THE SQUARE

**CLASS 31—(Continued).**

SHAPE IS THE DESIGN OF A DOG'S HEAD WITH A LEAF DESIGN BELOW THE HEAD. THERE IS A SHADOW EFFECT AROUND THE EDGES OF THE CURVED DESIGN AND THE TOP OF THE SQUARE DESIGN. THE BACKGROUNDS OF THE CURVED SHAPE AND OF THE SQUARE DESIGN ARE IN GREEN, AS IS THE LEAF DESIGN. THE TRIMS OF THE CURVED AND SQUARE SHAPES, AND THE DOG'S HEAD, ARE IN BROWN. THE WORDING "PET BOTANICS" IS IN WHITE. THE SHADOW EFFECT IS IN GRAY.

FOR DOG FOOD; EDIBLE FOOD FOR ANIMALS FOR CHEWING; EDIBLE ORGANIC PET TREATS FOR DOGS AND CATS (U.S. CLS. 1 AND 46).

FIRST USE 1-1-2013; IN COMMERCE 1-1-2013.  
NANCY CLARKE, EXAMINING ATTORNEY

SN 86-234,617. NATURAL BALANCE PET FOODS, INC., BURBANK, CA. FILED 3-27-2014.

**JUMPIN' STIX**

THE MARK CONSISTS OF STANDARD CHARACTERS WITHOUT CLAIM TO ANY PARTICULAR FONT, STYLE, SIZE, OR COLOR.

NO CLAIM IS MADE TO THE EXCLUSIVE RIGHT TO USE "STICKS", APART FROM THE MARK AS SHOWN.

FOR DOG TREATS AND CAT TREATS (U.S. CLS. 1 AND 46).

KELLY BOULTON, EXAMINING ATTORNEY

SN 86-235,141. RUSH DIRECT, INC., WOOD DALE, IL. FILED 3-28-2014.

**Fruit-N-Licious**

THE MARK CONSISTS OF STANDARD CHARACTERS WITHOUT CLAIM TO ANY PARTICULAR FONT, STYLE, SIZE, OR COLOR.

OWNER OF U.S. REG. NO. 4,521,841.

FOR DOG TREATS (U.S. CLS. 1 AND 46).

PARKER HOWARD, EXAMINING ATTORNEY

**CLASS 31—(Continued).**

SN 86-236,548. CEF LICENSING, AUSTIN, TX. FILED 3-30-2014.

## Bark n' Purr

THE MARK CONSISTS OF STANDARD CHARACTERS WITHOUT CLAIM TO ANY PARTICULAR FONT, STYLE, SIZE, OR COLOR.

OWNER OF U.S. REG. NOS. 3,668,162 AND 4,443,054.  
FOR PET FOOD; PET TREATS (U.S. CLS. 1 AND 46).  
ELLEN PERKINS, EXAMINING ATTORNEY

**CLASS 31—(Continued).**

SN 86-245,680. PROFILE PRODUCTS LLC, BUFFALO GROVE, IL. FILED 4-8-2014.

## GEOPERM

THE MARK CONSISTS OF STANDARD CHARACTERS WITHOUT CLAIM TO ANY PARTICULAR FONT, STYLE, SIZE, OR COLOR.

FOR MULCHES, HYDRAULIC MULCHES, WOOD FIBER MULCHES (U.S. CLS. 1 AND 46).  
FIRST USE 5-7-2003; IN COMMERCE 5-7-2003.  
AHSEN KHAN, EXAMINING ATTORNEY

SN 86-242,044. PLANT SOURCE INC., SAN MARCOS, CA. FILED 4-3-2014.

## Successful Gardener

THE MARK CONSISTS OF STANDARD CHARACTERS WITHOUT CLAIM TO ANY PARTICULAR FONT, STYLE, SIZE, OR COLOR.

NO CLAIM IS MADE TO THE EXCLUSIVE RIGHT TO USE "GARDENER", APART FROM THE MARK AS SHOWN.

FOR LIVE PLANTS; LIVING PLANTS (U.S. CLS. 1 AND 46).  
JAMES STEIN, EXAMINING ATTORNEY

SN 86-245,699. PROFILE PRODUCTS LLC, BUFFALO GROVE, IL. FILED 4-8-2014.

## GEOMATRIX

THE MARK CONSISTS OF STANDARD CHARACTERS WITHOUT CLAIM TO ANY PARTICULAR FONT, STYLE, SIZE, OR COLOR.

FOR MULCHES, HYDRAULIC MULCHES, WOOD FIBER MULCHES (U.S. CLS. 1 AND 46).  
FIRST USE 4-27-2009; IN COMMERCE 4-27-2009.  
AHSEN KHAN, EXAMINING ATTORNEY

SN 86-245,052. HUNTER D YORI, STOCKTON, CA. FILED 4-7-2014.

## GARLICQUE

THE MARK CONSISTS OF STANDARD CHARACTERS WITHOUT CLAIM TO ANY PARTICULAR FONT, STYLE, SIZE, OR COLOR.

FOR GARLIC BRIQUETS (U.S. CLS. 1 AND 46).  
THEODORE MCBRIDE, EXAMINING ATTORNEY

SN 86-246,409. AEQUOR, INC., OCEANSIDE, CA. FILED 4-8-2014.

## AEQUOR

THE MARK CONSISTS OF STANDARD CHARACTERS WITHOUT CLAIM TO ANY PARTICULAR FONT, STYLE, SIZE, OR COLOR.

FOR AGRICULTURAL, HORTICULTURAL AND FORESTRY PRODUCTS AND GRAINS, NAMELY, FRESH FRUITS AND VEGETABLES; PLANT SEEDS, NATURAL PLANTS AND FLOWERS; FOODSTUFFS FOR ANIMALS (U.S. CLS. 1 AND 46).  
DOUGLAS LEE, EXAMINING ATTORNEY

**CLASS 31—(Continued).**

SN 86-246,988. BURLO PET SERVICES, INC, CEDARBURG, WI. FILED 4-9-2014.

# REALITY

THE MARK CONSISTS OF STANDARD CHARACTERS WITHOUT CLAIM TO ANY PARTICULAR FONT, STYLE, SIZE, OR COLOR.  
FOR FOODSTUFFS FOR ANIMALS (U.S. CLS. 1 AND 46).  
DOUGLAS LEE, EXAMINING ATTORNEY

---

SN 86-247,543. CALIFORNIA VINEYARDS, VISALIA, CA. FILED 4-9-2014.

# CALIFORNIA VINEYARDS

THE MARK CONSISTS OF STANDARD CHARACTERS WITHOUT CLAIM TO ANY PARTICULAR FONT, STYLE, SIZE, OR COLOR.  
NO CLAIM IS MADE TO THE EXCLUSIVE RIGHT TO USE "VINEYARDS", APART FROM THE MARK AS SHOWN.  
SEC. 2(F).  
FOR FRESH GRAPES (U.S. CLS. 1 AND 46).  
FIRST USE 12-31-2006; IN COMMERCE 12-31-2006.  
COLLEEN MULCRONE, EXAMINING ATTORNEY

---

SN 86-248,121. SO BRIGHT, LLC, KIEL, WI. FILED 4-10-2014.

# SO BRIGHT

THE MARK CONSISTS OF STANDARD CHARACTERS WITHOUT CLAIM TO ANY PARTICULAR FONT, STYLE, SIZE, OR COLOR.  
FOR PET FOOD, NAMELY, BENEFICIAL PET TREATS (U.S. CLS. 1 AND 46).  
FIRST USE 5-21-2008; IN COMMERCE 5-21-2008.  
DAVID MURRAY, EXAMINING ATTORNEY

**CLASS 31—(Continued).**

SN 86-248,493. UNIVERSITY OF GUELPH, GUELPH, ON, CANADA, FILED 4-10-2014.

# ASPARABEST

THE MARK CONSISTS OF STANDARD CHARACTERS WITHOUT CLAIM TO ANY PARTICULAR FONT, STYLE, SIZE, OR COLOR.  
FOR AGRICULTURAL SEEDS; LIVE PLANTS; LIVING PLANTS; PLANT SEEDS; SEEDS FOR FRUIT AND VEGETABLES; VEGETABLE SEEDS FOR PLANTING (U.S. CLS. 1 AND 46).  
CHRIS WELLS, EXAMINING ATTORNEY

---

SN 86-250,377. K & L FOODS, SHARON, WI. FILED 4-11-2014.

# TreatSimple

THE MARK CONSISTS OF STANDARD CHARACTERS WITHOUT CLAIM TO ANY PARTICULAR FONT, STYLE, SIZE, OR COLOR.  
FOR DOG BISCUITS; DOG TREATS; PET TREATS (U.S. CLS. 1 AND 46).  
FIRST USE 3-1-2014; IN COMMERCE 3-1-2014.  
WILLIAM VERHOSEK, EXAMINING ATTORNEY

---

SN 86-254,671. MERRICK PET CARE, INC., AMARILLO, TX. FILED 4-17-2014.

# FOREVER HOME HOLIDAY RECIPE

THE MARK CONSISTS OF STANDARD CHARACTERS WITHOUT CLAIM TO ANY PARTICULAR FONT, STYLE, SIZE, OR COLOR.  
NO CLAIM IS MADE TO THE EXCLUSIVE RIGHT TO USE "RECIPE", APART FROM THE MARK AS SHOWN.  
FOR PET FOOD; PET TREATS (U.S. CLS. 1 AND 46).  
MAH ROSENBERG, EXAMINING ATTORNEY

**CLASS 31—(Continued).**

SN 86-254,704. MERRICK PET CARE, INC., AMARILLO, TX.  
FILED 4-17-2014.

**FESTIVE HOLIDAY STEW**

THE MARK CONSISTS OF STANDARD CHARACTERS WITHOUT CLAIM TO ANY PARTICULAR FONT, STYLE, SIZE, OR COLOR.

OWNER OF U.S. REG. NO. 3,322,525.  
NO CLAIM IS MADE TO THE EXCLUSIVE RIGHT TO USE "STEW", APART FROM THE MARK AS SHOWN.  
FOR PET FOOD; PET TREATS (U.S. CLS. 1 AND 46).  
MIAH ROSENBERG, EXAMINING ATTORNEY

SN 86-255,779. LOVING PETS CORPORATION, CRANBURY, NJ. FILED 4-18-2014.

**TOTALLY GRAINLESS**

THE MARK CONSISTS OF STANDARD CHARACTERS WITHOUT CLAIM TO ANY PARTICULAR FONT, STYLE, SIZE, OR COLOR.

NO CLAIM IS MADE TO THE EXCLUSIVE RIGHT TO USE "GRAINLESS", APART FROM THE MARK AS SHOWN.  
FOR PET TREATS (U.S. CLS. 1 AND 46).  
ALYSSA STEEL, EXAMINING ATTORNEY

SN 86-281,106. AMERICAN NUTRITION, OGDEN, UT.  
FILED 5-14-2014.

**AMERICAN PET NUTRITION**

THE MARK CONSISTS OF STANDARD CHARACTERS WITHOUT CLAIM TO ANY PARTICULAR FONT, STYLE, SIZE, OR COLOR.

NO CLAIM IS MADE TO THE EXCLUSIVE RIGHT TO USE "PET NUTRITION", APART FROM THE MARK AS SHOWN.  
SEC. 2(F) AS TO "AMERICAN".  
FOR CAT FOOD; DOG BISCUITS; DOG FOOD; PET FOOD; PET TREATS (U.S. CLS. 1 AND 46).  
TAMARA HUDSON, EXAMINING ATTORNEY

**CLASS 32—LIGHT BEVERAGES**

SN 76-322,946. CC1 LIMITED PARTNERSHIP, CATANO, PUERTO RICO, FILED 10-9-2001.

**MALTA CORONA**

SUBJECT TO CONCURRENT USE PROCEEDING WITH MALTA CORONA, L.L.C., OWNER OF U.S. REGISTRATION NO. 661,749 AND APPLICATION SERIAL NO. 76/041,672. APPLICANT CLAIMS EXCLUSIVE RIGHT TO USE THE MARK IN THE AREA COMPRISING THE COMMONWEALTH OF PUERTO RICO AND THE U.S. VIRGIN ISLANDS.

OWNER OF U.S. REG. NO. 3,134,580.  
NO CLAIM IS MADE TO THE EXCLUSIVE RIGHT TO USE "MALTA", APART FROM THE MARK AS SHOWN.  
THE ENGLISH TRANSLATION OF THE SPANISH WORD "MALTA CORONA" IS "MALT CROWN".  
FOR NON-ALCOHOLIC MALT BEVERAGES MADE FROM MALT, HOPS AND CEREALS (U.S. CLS. 45, 46 AND 48).

FIRST USE 10-20-1960; IN COMMERCE 10-20-1960.  
GEOFFREY FOSDICK, EXAMINING ATTORNEY

SN 76-716,095. TENNESSEE HIGH GRAVITY, LLC, NASHVILLE, TN. FILED 3-27-2014.

**TRIPEL STAR**

THE MARK CONSISTS OF STANDARD CHARACTERS WITHOUT CLAIM TO ANY PARTICULAR FONT, STYLE, SIZE, OR COLOR.

NO CLAIM IS MADE TO THE EXCLUSIVE RIGHT TO USE "TRIPEL", APART FROM THE MARK AS SHOWN.  
FOR BEERS (U.S. CLS. 45, 46 AND 48).  
MATTHEW MCDOWELL, EXAMINING ATTORNEY

SN 79-143,891. WIEZE BEER BELGIUM NV, BELGIUM, FILED 1-29-2014.

**WIEZE PILS**

THE MARK CONSISTS OF STANDARD CHARACTERS WITHOUT CLAIM TO ANY PARTICULAR FONT, STYLE, SIZE, OR COLOR.

OWNER OF INTERNATIONAL REGISTRATION 1076662 DATED 3-11-2011, EXPIRES 3-11-2021.  
NO CLAIM IS MADE TO THE EXCLUSIVE RIGHT TO USE "PILS", APART FROM THE MARK AS SHOWN.  
FOR BEERS (U.S. CLS. 45, 46 AND 48).  
TASNEEM HUSSAIN, EXAMINING ATTORNEY

**CLASS 32—(Continued).**

SN 79-146,519. ANHEUSER-BUSCH INBEV S.A., B-1000 BRUXELLES, BELGIUM, FILED 1-30-2014.



PRIORITY DATE OF 7-30-2013 IS CLAIMED.  
OWNER OF INTERNATIONAL REGISTRATION 1201873  
DATED 1-30-2014, EXPIRES 1-30-2024.

THE COLOR(S) WHITE, BLACK, GOLD AND SALMON IS/ARE CLAIMED AS A FEATURE OF THE MARK.

THE MARK CONSISTS OF A WHITE AND CREAM SKULL WITH GOLD OUTLINING INSIDE A WHITE SQUARE WITH GOLD OUTLINE. THE SKULL IS DECORATED IN A CARIBBEAN FOLK ART STYLE WITH SCROLLING AND LINING IN WHITE, GOLD AND SALMON, A STYLIZED MUSTACHE IN GOLD, AND STYLIZED EYEBROWS WITH A DIAMOND IN BETWEEN APPEARING IN BLACK.

FOR BEERS, FLAVORED BEERS (U.S. CLS. 45, 46 AND 48).

JOANNA DUKOVIC, EXAMINING ATTORNEY

SN 85-561,805. EXHALE PREMIUM BEVERAGES, INC., MIAMI, FL. FILED 3-6-2012.

**PEACHY KEEN**

THE MARK CONSISTS OF STANDARD CHARACTERS WITHOUT CLAIM TO ANY PARTICULAR FONT, STYLE, SIZE, OR COLOR.

FOR BEER; BEERS; ENERGY DRINKS; FRUIT JUICES AND FRUIT DRINKS; FRUIT-FLAVORED BEVERAGES; MINERAL AND AERATED WATERS; NON-ALCOHOLIC BEVERAGES CONTAINING FRUIT JUICES; NON-ALCOHOLIC BEVERAGES WITH TEA FLAVOR; NON-ALCOHOLIC DRINKS, NAMELY, ENERGY SHOTS; SYRUPS FOR MAKING BEVERAGES (U.S. CLS. 45, 46 AND 48).

JENNIFER BUTTON, EXAMINING ATTORNEY

**CLASS 32—(Continued).**

SN 85-954,533. MELORO, MICHAEL, WILKES-BARRE, PA. FILED 6-8-2013.



THE MARK CONSISTS OF THE WORD "WARNING" WITH A CIRCLE AROUND THE LETTER "A".  
FOR ENERGY DRINKS (U.S. CLS. 45, 46 AND 48).  
SHANNON TWOHIG, EXAMINING ATTORNEY

SN 86-039,604. UNION RESTAURANT GROUP, LLC, VENTURA, CA. FILED 8-15-2013.

**SHANGHAI BEER GARDEN**

THE MARK CONSISTS OF STANDARD CHARACTERS WITHOUT CLAIM TO ANY PARTICULAR FONT, STYLE, SIZE, OR COLOR.

NO CLAIM IS MADE TO THE EXCLUSIVE RIGHT TO USE "BEER GARDEN", APART FROM THE MARK AS SHOWN.

FOR BEER (U.S. CLS. 45, 46 AND 48).  
BRIAN NEVILLE, EXAMINING ATTORNEY

SN 86-043,474. FROST, A GELATO SHOPPE, L.L.C., TUCSON, AZ. FILED 8-21-2013.

**Sorbettini**

THE MARK CONSISTS OF STANDARD CHARACTERS WITHOUT CLAIM TO ANY PARTICULAR FONT, STYLE, SIZE, OR COLOR.

FOR SORBETS IN THE NATURE OF BEVERAGES (U.S. CLS. 45, 46 AND 48).  
FIRST USE 3-15-2008; IN COMMERCE 3-15-2008.  
HEATHER BIDDULPH, EXAMINING ATTORNEY

**CLASS 32—(Continued).**

SN 86-049,631. MILES, TOM DR., DBA REAL ENERGY, MALVERN, PA. FILED 8-27-2013.



NO CLAIM IS MADE TO THE EXCLUSIVE RIGHT TO USE "ENERGY", APART FROM THE MARK AS SHOWN.

THE COLOR(S) RED, WHITE, SILVER AND GREY IS/ ARE CLAIMED AS A FEATURE OF THE MARK.

THE MARK CONSISTS OF THE MARK CONSISTS OF A RED "R" WITH RED SHADING INCORPORATING A WHITE FIGURE OF A RUNNER WITH FOUR RED AND SILVER MOTION LINES TO THE LEFT OF THE "R" AND TO THE RIGHT OF THE "R" APPEARS A SILVER "E" WITH GREY SHADING. BELOW THE "RE" ARE THE WORDS "REAL" IN RED AND "ENERGY" IN SILVER, AND BELOW THAT ARE THE WORDS IN SILVER - "REAL FOOD...FOR REALLY BUSY PEOPLE!"

FOR FRUIT AND VEGETABLE BASED BEVERAGES, NAMELY, FRUIT AND VEGETABLE JUICE DRINKS; NON-ALCOHOLIC SOY, ALMOND, RICE, HEMP OR COCONUT BASED BEVERAGES NOT USED AS A MILK SUBSTITUTE; SPORTS BEVERAGES; ENERGY BEVERAGES; BEVERAGES IN AERATED FORM, NAMELY, AERATED WATER, SPARKLING WATER, NATURAL SODAS, FLAVORED WITH ADDITIVES IN THE NATURE OF POWDERED SEAWEED, VITAMINS, MINERALS, LEMON, CHIA, FRUIT JUICE, AND STEVIA; BEVERAGES IN NON-AERATED FORM, NAMELY, BOTTLED WATER, SPRING WATER, MINERAL WATER, COCONUT WATER; FLAVORED NON-AERATED BEVERAGES OR WATERS WITH ADDITIVES IN THE NATURE OF SEAWEED POWDER, VITAMINS, MINERALS, LEMON, CHIA, FRUIT JUICE, AND STEVIA, NAMELY, BOTTLED WATER, SPRING WATER, MINERAL WATER, COCONUT WATER; POWDERED FORMULAS FOR MAKING BEVERAGES, NAMELY, SPORTS BEVERAGES, ISOTONIC DRINKS, FRUIT AND VEGETABLE BASED BEVERAGES; FRUIT, ALMOND, SOY OR COCONUT MILK NOT USED AS A MILK SUBSTITUTE CONCENTRATES AND PUREES USED AS INGREDIENTS FOR BEVERAGES; VEGETABLE AND FRUIT CONCENTRATES AND PUREES USED AS INGREDIENTS FOR FRUIT AND VEGETABLE BEVERAGES; FRUIT-FLAVORED BEVERAGES; NON-ALCOHOLIC BEVERAGES WITH TEA FLAVOR; NON-ALCOHOLIC BEVERAGES, NAMELY, NON-ALCOHOLIC COCKTAILS; NON-ALCOHOLIC FRUIT EXTRACTS USED IN THE PREPARATION OF BEVERAGES; COCONUT WATER WITH FLAVOR EXTRACTS; FRUIT AND VEGETABLE DRINKS CONTAINING ADDITIVES IN THE NATURE OF CHIA, APPLE CIDER VINEGAR, KOMBUCHA, LEMON, STEVIA, HERBS AND SPICES; FERMENTED NON-ALCOHOLIC BEVERAGES, NAMELY, KOMBUCHA TEA FLAVORED DRINKS (U.S. CLS. 45, 46 AND 48).

NATALIE KENEALY, EXAMINING ATTORNEY

**CLASS 32—(Continued).**

SN 86-057,625. PALMIA CORPORATION, SAN FRANCISCO, CA. FILED 9-6-2013.



NO CLAIM IS MADE TO THE EXCLUSIVE RIGHT TO USE "INSPIRED BY SPAIN BREWED IN THE USA LAGER CON LIMON", APART FROM THE MARK AS SHOWN.

"PALMIA" DOES NOT IDENTIFY A LIVING INDIVIDUAL.

THE MARK CONSISTS OF THE WORDING "INSPIRED BY SPAIN" "BREWED IN THE USA" IN STYLIZED FONT, DIRECTLY BELOW THE WORDING IS A TRIANGULAR DESIGN. WITHIN THE TRIANGULAR DESIGN IS THE WORDING "PALMIA LAGER CON LIMON" IN STYLIZED FONT. DIRECTLY BELOW THE WORDING IS A DESIGN OF A LEMON. DIRECTLY BELOW THAT IS A DESIGN THAT DEPICTS A SPLASH OF WATER.

THE WORDING "PALMIA" HAS NO MEANING IN A FOREIGN LANGUAGE.

FOR BEER (U.S. CLS. 45, 46 AND 48).

FIRST USE 5-21-2013; IN COMMERCE 8-16-2013.

MARGERY A. TIERNEY, EXAMINING ATTORNEY

SN 86-061,375. DUCLAW BREWERY, LLC, BALTIMORE, MD. FILED 9-11-2013.

CRAFT BE CHERISHED. RULES BE DAMNED

THE MARK CONSISTS OF STANDARD CHARACTERS WITHOUT CLAIM TO ANY PARTICULAR FONT, STYLE, SIZE, OR COLOR.

OWNER OF U.S. REG. NO. 4,219,009.

FOR BEER (U.S. CLS. 45, 46 AND 48).

FIRST USE 10-31-2011; IN COMMERCE 10-31-2011.

TINA BROWN, EXAMINING ATTORNEY



**CLASS 32—(Continued).**

SN 86-061,798. POP WATER, INC., NEW YORK, NY. FILED 9-11-2013.

**TEAM POP WATER**

THE MARK CONSISTS OF STANDARD CHARACTERS WITHOUT CLAIM TO ANY PARTICULAR FONT, STYLE, SIZE, OR COLOR.

OWNER OF U.S. REG. NOS. 4,162,094 AND 4,445,218. NO CLAIM IS MADE TO THE EXCLUSIVE RIGHT TO USE "WATER", APART FROM THE MARK AS SHOWN.

FOR WATER BEVERAGES, NAMELY, BOTTLED WATER, MINERAL WATER, DRINKING WATER, SPRING WATER, CARBONATED WATERS, SELTZER WATER, FLAVORED BOTTLED WATER, AND FLAVORED WATERS; SOFT DRINKS; SOFT DRINKS FLAVORED WITH TEA; COFFEE-FLAVORED SOFT DRINKS; FRUIT-FLAVORED SOFT DRINKS (U.S. CLS. 45, 46 AND 48).

GRETTA YAO, EXAMINING ATTORNEY

**CLASS 32—(Continued).**

SN 86-070,219. ANHEUSER-BUSCH LLC, ST. LOUIS, MO. FILED 9-20-2013.

**BUD LIGHT LIME RITAS**

THE MARK CONSISTS OF STANDARD CHARACTERS WITHOUT CLAIM TO ANY PARTICULAR FONT, STYLE, SIZE, OR COLOR.

OWNER OF U.S. REG. NOS. 3,770,049, 4,384,714 AND OTHERS.

NO CLAIM IS MADE TO THE EXCLUSIVE RIGHT TO USE "LIGHT" & "LIME", APART FROM THE MARK AS SHOWN.

FOR FLAVORED BEERS (U.S. CLS. 45, 46 AND 48). NAKIA HENRY, EXAMINING ATTORNEY

SN 86-071,635. UPDATE FOODS LTD., TEL AVIV, ISRAEL, FILED 9-23-2013.

**UPDATE**

THE MARK CONSISTS OF STANDARD CHARACTERS WITHOUT CLAIM TO ANY PARTICULAR FONT, STYLE, SIZE, OR COLOR.

FOR FRUIT-BASED BEVERAGES, NAMELY, HOT AND COLD BEVERAGES MADE FROM DATE KERNELS, PITS AND OR SEEDS (U.S. CLS. 45, 46 AND 48). VIVIAN MICZNIK FIRST, EXAMINING ATTORNEY

SN 86-071,658. UPDATE FOODS LTD., TEL AVIV, ISRAEL, FILED 9-23-2013.

**APP CAP**

THE MARK CONSISTS OF STANDARD CHARACTERS WITHOUT CLAIM TO ANY PARTICULAR FONT, STYLE, SIZE, OR COLOR.

FOR BEERS; MINERAL AND AERATED WATERS; NON-ALCOHOLIC BEVERAGES, NAMELY, NON-ALCOHOLIC CARBONATED DRINKS, FRUIT DRINKS, FRUIT-FLAVORED DRINKS, ENERGY DRINKS, NON-ALCOHOLIC MEAL REPLACEMENT DRINKS NOT FOR USE FOR MEDICAL OR WEIGHT LOSS PURPOSES; SPORT DRINKS AND SOFT DRINKS, FRUIT BEVERAGES AND FRUIT JUICES; SYRUPS FOR PREPARATION OF SOFT DRINKS; ELECTROLYTE REPLACEMENT BEVERAGES FOR GENERAL NON-MEDICAL AND SPORTS PURPOSES (U.S. CLS. 45, 46 AND 48).

JEFFREY LOOK, EXAMINING ATTORNEY



THE STIPPLING IS FOR SHADING PURPOSES ONLY. THE MARK CONSISTS OF THE WORDING "UPDATE" AND THREE DATE PALM TREE IN A SCALLOPED OVAL FOR FRUIT-BASED BEVERAGES, NAMELY, HOT AND COLD BEVERAGES MADE FROM DATE KERNELS, PITS AND/OR SEEDS (U.S. CLS. 45, 46 AND 48). VIVIAN MICZNIK FIRST, EXAMINING ATTORNEY

**CLASS 32—(Continued).**

SN 86-072,340. AMOREPACIFIC CORPORATION, SEOUL, REPUBLIC OF KOREA, FILED 9-23-2013.

# LANEIGE

THE MARK CONSISTS OF STANDARD CHARACTERS WITHOUT CLAIM TO ANY PARTICULAR FONT, STYLE, SIZE, OR COLOR.

OWNER OF REPUBLIC OF KOREA REG. NO. 40-1016305, DATED 1-7-2014, EXPIRES 1-7-2024.

OWNER OF U.S. REG. NOS. 2,110,811, 3,773,872 AND OTHERS.

FOR FRUIT-FLAVORED BEVERAGES; FRUIT JUICES; MINERAL WATER; BEER; WATER; WATER FOR BEVERAGE; SPRING WATER FOR BEVERAGES; SYRUPS FOR BEVERAGES; VEGETABLE JUICE BEVERAGES; GRAPE MUST; FRUIT-FLAVORED MIXED BEVERAGES; FRUIT DRINKS CONTAINING GREEN TEA EXTRACT; FRUIT BEVERAGES CONTAINING GREEN TEA EXTRACT; FRUIT-FLAVORED BEVERAGES CONTAINING COLLAGEN; FRUIT JUICES CONTAINING COLLAGEN; VEGETABLE JUICE BEVERAGES CONTAINING COLLAGEN; AERATED WATER; FRUIT DRINK CONTAINING RED GINSENG EXTRACT (U.S. CLS. 45, 46 AND 48).

REGINA DRUMMOND, EXAMINING ATTORNEY

**CLASS 32—(Continued).**

SN 86-077,354. FLYING BIKE COOPERATIVE BREWERY, SEATTLE, WA. FILED 9-27-2013.



NO CLAIM IS MADE TO THE EXCLUSIVE RIGHT TO USE "COOPERATIVE BREWERY", APART FROM THE MARK AS SHOWN.

THE MARK CONSISTS OF A DRAWING OF A HOT-AIR BALLOON FROM WHICH IS SUSPENDED A PERSON ASTRIDE AN OLD-FASHIONED BICYCLE. SET AGAINST AN OVAL BACKGROUND OF CLOUDS, FLYING BIRDS, MOUNTAINS, AND THE LANDSCAPE OF SEATTLE. THE WORDS "FLYING BIKE" APPEAR IN RECTANGULAR BOX ABOVE THE WORDS "COOPERATIVE BREWERY", SET IN A BANNER STYLE BOX, BOTH BEING SET AGAINST THE DESIGN OF THE HOT-AIR BALLOON.

FOR BEER, ALE, LAGER, STOUT AND PORTER (U.S. CLS. 45, 46 AND 48).

SETH A. RAPPAPORT, EXAMINING ATTORNEY

SN 86-073,038. MOCKTAIL BEVERAGES, INC., WENHAM, MA. FILED 9-24-2013.

# SEVILLA RED

THE MARK CONSISTS OF STANDARD CHARACTERS WITHOUT CLAIM TO ANY PARTICULAR FONT, STYLE, SIZE, OR COLOR.

NO CLAIM IS MADE TO THE EXCLUSIVE RIGHT TO USE "RED", APART FROM THE MARK AS SHOWN.

FOR NON-ALCOHOLIC COCKTAILS (U.S. CLS. 45, 46 AND 48).

JAMES LOVELACE, EXAMINING ATTORNEY

SN 86-077,880. PISCO PORTON, LLC, HOUSTON, TX. FILED 9-30-2013.

# PISCO PORTON

THE MARK CONSISTS OF STANDARD CHARACTERS WITHOUT CLAIM TO ANY PARTICULAR FONT, STYLE, SIZE, OR COLOR.

OWNER OF U.S. REG. NOS. 4,016,736 AND 4,068,503.

NO CLAIM IS MADE TO THE EXCLUSIVE RIGHT TO USE "PISCO", APART FROM THE MARK AS SHOWN.

THE ENGLISH TRANSLATION OF "PORTON" IN THE MARK IS "GATE".

FOR NON-ALCOHOLIC COCKTAIL BASES; NON-ALCOHOLIC COCKTAIL MIXES; NON-ALCOHOLIC COCKTAILS (U.S. CLS. 45, 46 AND 48).

LURIE KAUFMAN, EXAMINING ATTORNEY

**CLASS 32—(Continued).**

SN 86-079,529. ORPHEUS BREWING COMPANY, LLC, ATLANTA, GA. FILED 10-1-2013.

**ORPHEUS BREWING**

THE MARK CONSISTS OF STANDARD CHARACTERS WITHOUT CLAIM TO ANY PARTICULAR FONT, STYLE, SIZE, OR COLOR.

OWNER OF U.S. REG. NO. 2,213,094.  
NO CLAIM IS MADE TO THE EXCLUSIVE RIGHT TO USE "BREWING", APART FROM THE MARK AS SHOWN.  
FOR BEER (U.S. CLS. 45, 46 AND 48).  
BARBARA BROWN, EXAMINING ATTORNEY

SN 86-096,873. CALIFORNIA MILK PROCESSOR BOARD, SAN CLEMENTE, CA. FILED 10-21-2013.

**got milk?**

OWNER OF U.S. REG. NOS. 1,903,870, 2,689,741 AND 3,730,703.

NO CLAIM IS MADE TO THE EXCLUSIVE RIGHT TO USE "MILK", APART FROM THE MARK AS SHOWN.

THE MARK CONSISTS OF THE WORDING "GOT MILK?" IN LOWER CASE LETTERS IN PHENIX AMERICAN FONT. FOR POWDERS FOR FLAVORING DAIRY-BASED BEVERAGES; POWDERS FOR FLAVORING BEVERAGES (U.S. CLS. 45, 46 AND 48).  
BRIAN NEVILLE, EXAMINING ATTORNEY

SN 86-097,781. DIAGEO NORTH AMERICA, INC., NORWALK, CT. FILED 10-22-2013.



THE MARK CONSISTS OF THE LITERAL ELEMENT "TRAGOS FRESCOS" IN STYLIZED LETTERING; TO THE RIGHT OF THE LITERAL ELEMENT IS THE DESIGN OF THE OUTLINE OF A PARTIALLY VISIBLE JAR; ON THE LOWER LEFT HAND CORNER AND ON THE UPPER RIGHT HAND CORNER IS AN ABSTRACT STAMP DESIGN.

THE ENGLISH TRANSLATION OF "TRAGOS FRESCOS" IN THE MARK IS "FRESH SIPS".

FOR BREWED MALT-BASED ALCOHOLIC BEVERAGE IN THE NATURE OF A BEER (U.S. CLS. 45, 46 AND 48).

DAVID TAYLOR, EXAMINING ATTORNEY

**CLASS 32—(Continued).**

SN 86-112,921. CONSHOHOCKEN BREWING COMPANY, LLC, CONSHOHOCKEN, PA. FILED 11-7-2013.



**CONSHOHOCKEN**  
★ BREWING COMPANY ★

NO CLAIM IS MADE TO THE EXCLUSIVE RIGHT TO USE "CONSHOHOCKEN BREWING COMPANY", APART FROM THE MARK AS SHOWN.

THE MARK CONSISTS OF THE SILHOUETTE OF A MAN WEARING A BOWLER HAT, HOLDING A GLASS AND RIDING AN ANTIQUE BICYCLE, CENTERED ABOVE THE WORDS CONSHOHOCKEN BREWING COMPANY, WITH A FIVE-POINT STAR ON EITHER SIDE OF "BREWING COMPANY".

FOR BEER (U.S. CLS. 45, 46 AND 48).  
IRA J. GOODSaid, EXAMINING ATTORNEY

SN 86-113,040. NIAGARA BOTTLING, LLC, ONTARIO, CA. FILED 11-7-2013.

**CRYSTAL MIST**

THE MARK CONSISTS OF STANDARD CHARACTERS WITHOUT CLAIM TO ANY PARTICULAR FONT, STYLE, SIZE, OR COLOR.

OWNER OF U.S. REG. NO. 3,975,661.  
FOR BOTTLED WATER; WATER BEVERAGES (U.S. CLS. 45, 46 AND 48).

WILLIAM P. SHANAHAN, EXAMINING ATTORNEY

SN 86-115,656. CATAWBA VALLEY BREWING COMPANY, HICKORY, NC. FILED 11-11-2013.

**King Winterbolt Winter Ale**

THE MARK CONSISTS OF STANDARD CHARACTERS WITHOUT CLAIM TO ANY PARTICULAR FONT, STYLE, SIZE, OR COLOR.

NO CLAIM IS MADE TO THE EXCLUSIVE RIGHT TO USE "WINTER ALE", APART FROM THE MARK AS SHOWN.

FOR BEER (U.S. CLS. 45, 46 AND 48).  
LINDA ESTRADA, EXAMINING ATTORNEY

**CLASS 32—(Continued).**

SN 86-150,980. COMPANHIA DE BEBIDAS DAS AMERICAS - AMBEV, 04530-000 SAO PAULO SP, BRAZIL, FILED 12-23-2013.



THE COLOR(S) RED IS/ARE CLAIMED AS A FEATURE OF THE MARK.

THE MARK CONSISTS OF A RED ARROW FORMING AN INCOMPLETE CIRCLE GOING IN A CLOCKWISE DIRECTION.

FOR BEERS (U.S. CLS. 45, 46 AND 48).

KELLY TRUSILO, EXAMINING ATTORNEY

---

SN 86-163,547. SANJEEV VOHRA, NEW DELHI, INDIA, FILED 1-13-2014.

## Bow River

THE MARK CONSISTS OF STANDARD CHARACTERS WITHOUT CLAIM TO ANY PARTICULAR FONT, STYLE, SIZE, OR COLOR.

FOR BEERS (U.S. CLS. 45, 46 AND 48).

GEOFFREY FOSDICK, EXAMINING ATTORNEY

---

SN 86-175,054. MCDONALD-MILEY, CONNIE, CHESTER, VA. AND MILEY, KEITH, CHESTER, VA. FILED 1-24-2014.

## WATER JUICE! A KIDS DRINK OF CHOICE!

THE MARK CONSISTS OF STANDARD CHARACTERS WITHOUT CLAIM TO ANY PARTICULAR FONT, STYLE, SIZE, OR COLOR.

NO CLAIM IS MADE TO THE EXCLUSIVE RIGHT TO USE "WATER JUICE", APART FROM THE MARK AS SHOWN.

FOR FLAVORED ENHANCED WATER (U.S. CLS. 45, 46 AND 48).

CAITLIN WATTS-FITZGERALD, EXAMINING ATTORNEY

**CLASS 32—(Continued).**

SN 86-178,598. SURE PROFIT TRADING (ASIA) COMPANY LIMITED, NEW TERRITORIES, HONG KONG, FILED 1-29-2014.



NO CLAIM IS MADE TO THE EXCLUSIVE RIGHT TO USE "ENERGY", APART FROM THE MARK AS SHOWN.

THE MARK CONSISTS OF A DESIGN THE WORDING "ENERGY WATT" IN STYLIZED FONT ABOVE FIVE CHINESE CHARACTERS INSIDE AN OVAL ABOVE A CURVED LINE.

THE NON-LATIN CHARACTERS IN THE MARK TRANSLITERATE TO "PUI", "LIK", "TAK" AND "TIN GUIDE" AND THIS MEANS "COPIOUS, ABUNDANT", "STRENGTH, FORCE", "SPECIAL" AND "ELECTROLYSIS" IN ENGLISH.

FOR BEERS; FRUIT BEVERAGES; FRUIT JUICES; MINERAL AND AERATED WATERS; NON-ALCOHOLIC BEVERAGES, NAMELY, CARBONATED BEVERAGES; SOFT DRINKS; SPORTS DRINKS (U.S. CLS. 45, 46 AND 48).

KAELIE KUNG, EXAMINING ATTORNEY

---

SN 86-179,599. SALISBURY COVE ASSOCIATES, INC., DBA ATLANTIC BREWING COMPANY, BAR HARBOR, ME. FILED 1-30-2014.

## NEW GUY IPA

THE MARK CONSISTS OF STANDARD CHARACTERS WITHOUT CLAIM TO ANY PARTICULAR FONT, STYLE, SIZE, OR COLOR.

NO CLAIM IS MADE TO THE EXCLUSIVE RIGHT TO USE "IPA", APART FROM THE MARK AS SHOWN.

FOR BEER (U.S. CLS. 45, 46 AND 48).

FIRST USE 2-24-2012; IN COMMERCE 2-24-2012.

LINDA ORNDORFF, EXAMINING ATTORNEY

**CLASS 32—(Continued).**

SN 86-179,679. SALISBURY COVE ASSOCIATES, INC., DBA ATLANTIC BREWING COMPANY, BAR HARBOR, ME. FILED 1-30-2014.

**COAL PORTER**

THE MARK CONSISTS OF STANDARD CHARACTERS WITHOUT CLAIM TO ANY PARTICULAR FONT, STYLE, SIZE, OR COLOR.

NO CLAIM IS MADE TO THE EXCLUSIVE RIGHT TO USE "PORTER", APART FROM THE MARK AS SHOWN. FOR BEER (U.S. CLS. 45, 46 AND 48). FIRST USE 2-17-1999; IN COMMERCE 2-17-1999. LINDA ORNDORFF, EXAMINING ATTORNEY

**CLASS 32—(Continued).**

SN 86-210,906. SLO PUB LLC, SAN LUIS OBISPO, CA. FILED 3-4-2014.

**Reggae Red**

THE MARK CONSISTS OF STANDARD CHARACTERS WITHOUT CLAIM TO ANY PARTICULAR FONT, STYLE, SIZE, OR COLOR.

NO CLAIM IS MADE TO THE EXCLUSIVE RIGHT TO USE "RED", APART FROM THE MARK AS SHOWN. FOR BEER (U.S. CLS. 45, 46 AND 48). FIRST USE 7-1-2010; IN COMMERCE 7-1-2010. MATTHEW KLINE, EXAMINING ATTORNEY

SN 86-190,308. HERBAL BLISS, LLC, SUMMERVILLE, SC. FILED 2-11-2014.

**BLISS NATURAL ENERGY DRINK**

THE MARK CONSISTS OF STANDARD CHARACTERS WITHOUT CLAIM TO ANY PARTICULAR FONT, STYLE, SIZE, OR COLOR.

NO CLAIM IS MADE TO THE EXCLUSIVE RIGHT TO USE "NATURAL ENERGY DRINK", APART FROM THE MARK AS SHOWN. FOR ENERGY DRINKS OF NATURAL INGREDIENTS (U.S. CLS. 45, 46 AND 48). ALLISON HOLTZ, EXAMINING ATTORNEY

SN 86-214,268. KENSINGTON BREWING, L.L.C., KENSINGTON, MD. FILED 3-7-2014.

**SMALL AXE**

THE MARK CONSISTS OF STANDARD CHARACTERS WITHOUT CLAIM TO ANY PARTICULAR FONT, STYLE, SIZE, OR COLOR.

FOR BEER (U.S. CLS. 45, 46 AND 48). DAVID MURRAY, EXAMINING ATTORNEY

SN 86-204,991. BOOTSTRAP BREWING COMPANY LLC, DBA BOOTSTRAP BREWING, NIWOT, CO. FILED 2-26-2014.

**Wreak Havoc**

THE MARK CONSISTS OF STANDARD CHARACTERS WITHOUT CLAIM TO ANY PARTICULAR FONT, STYLE, SIZE, OR COLOR.

FOR BEER, ALE, LAGER, STOUT AND PORTER (U.S. CLS. 45, 46 AND 48). FIRST USE 12-1-2013; IN COMMERCE 12-1-2013. MICHAEL KEATING, EXAMINING ATTORNEY

SN 86-217,676. URBAN CHESTNUT BREWING COMPANY, INC., ST. LOUIS, MO. FILED 3-11-2014.

**REVOLUTION SERIES**

THE MARK CONSISTS OF STANDARD CHARACTERS WITHOUT CLAIM TO ANY PARTICULAR FONT, STYLE, SIZE, OR COLOR.

NO CLAIM IS MADE TO THE EXCLUSIVE RIGHT TO USE "SERIES", APART FROM THE MARK AS SHOWN. FOR BEER (U.S. CLS. 45, 46 AND 48). FIRST USE 1-26-2011; IN COMMERCE 1-26-2011. PRISCILLA MILTON, EXAMINING ATTORNEY

**CLASS 32—(Continued).**

SN 86-221,583. AUSTIN, DANA, ALPENA, MI. FILED 3-14-2014.

**AUSTIN BROTHERS' BEER  
COMPANY**

THE MARK CONSISTS OF STANDARD CHARACTERS WITHOUT CLAIM TO ANY PARTICULAR FONT, STYLE, SIZE, OR COLOR.

NO CLAIM IS MADE TO THE EXCLUSIVE RIGHT TO USE "BROTHERS' BEER COMPANY", APART FROM THE MARK AS SHOWN.

FOR BEER (U.S. CLS. 45, 46 AND 48).  
MARK SPARACINO, EXAMINING ATTORNEY

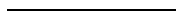

SN 86-222,749. WONCIK, JOHN, GRANADA HILLS, CA. FILED 3-17-2014.

**"UNADULTERATED"  
(adjective:) Simple, Straight,  
Supreme QUALITY: Purely,  
Powerfully, POTENT!**

THE MARK CONSISTS OF STANDARD CHARACTERS WITHOUT CLAIM TO ANY PARTICULAR FONT, STYLE, SIZE, OR COLOR.

NO CLAIM IS MADE TO THE EXCLUSIVE RIGHT TO USE "UNADULTERATED" AND "SUPREME QUALITY", APART FROM THE MARK AS SHOWN.

FOR NON-ALCOHOLIC FRUIT JUICE BEVERAGES (U.S. CLS. 45, 46 AND 48).  
FIRST USE 1-22-2012; IN COMMERCE 1-22-2012.  
STEVEN PEREZ, EXAMINING ATTORNEY



SN 86-224,044. SMITH, TYLER, SANTA ROSA, CA. FILED 3-18-2014.

**Cooperage Brewing Company**

THE MARK CONSISTS OF STANDARD CHARACTERS WITHOUT CLAIM TO ANY PARTICULAR FONT, STYLE, SIZE, OR COLOR.

NO CLAIM IS MADE TO THE EXCLUSIVE RIGHT TO USE "BREWING COMPANY", APART FROM THE MARK AS SHOWN.

FOR BEER (U.S. CLS. 45, 46 AND 48).  
TRACY WHITTAKER-BROWN, EXAMINING ATTORNEY

**CLASS 32—(Continued).**

SN 86-227,254. FOOD PACKAGING GROUP, INC., HAVERHILL, MA. FILED 3-20-2014.



THE MARK CONSISTS OF THE STYLIZED WORDING "JUICED" FOLLOWED BY A STYLIZED IMAGE OF A PERSON CONSISTING OF TWO CURVED UPWARD ARROWS REPRESENTING ARMS AND LEGS, ONE CURVING TO THE RIGHT, THE OTHER CURVING TO THE LEFT, AND AN OVAL REPRESENTING A HEAD, FOLLOWED BY THE STYLIZED WORD "UP".

FOR APPLE JUICE BEVERAGES; COCONUT JUICE; FRUIT BEVERAGES; FRUIT CONCENTRATES AND PUREES USED AS INGREDIENTS OF BEVERAGES; FRUIT DRINKS; FRUIT DRINKS AND FRUIT JUICES; FRUIT DRINKS AND JUICES; FRUIT JUICE; FRUIT JUICES; FRUIT JUICES AND FRUIT DRINKS; FRUIT JUICES, NAMELY, CANTALOUPE, HONEYDEW, WATERMELON, PINEAPPLE, GRAPE, ORANGE, GRAPEFRUIT, LEMON, LIME, APPLE, PEAR, STRAWBERRY, RASPBERRY, BLUEBERRY, BLACKBERRY, PEACH, PLUM, KIWI, MANGO, PAPAYA, BANANA, AND NECTARINE JUICE; FRUIT-BASED BEVERAGES; FRUIT-FLAVORED BEVERAGES; FRUIT-FLAVOURED BEVERAGES; GRAPE JUICE; GRAPE JUICE BEVERAGES; NON-ALCOHOLIC BEVERAGES CONTAINING FRUIT JUICES; NON-ALCOHOLIC FRUIT EXTRACTS USED IN THE PREPARATION OF BEVERAGES; NON-ALCOHOLIC FRUIT JUICE BEVERAGES; ORANGE JUICE; ORANGE JUICE BEVERAGES; PINEAPPLE JUICE BEVERAGES; PREPARED ENTREES CONSISTING OF FRUIT DRINKS AND FRUIT JUICES, FRUIT-BASED BEVERAGES, NON-ALCOHOLIC BEVERAGES CONTAINING FRUIT JUICES, NON-ALCOHOLIC FRUIT EXTRACTS USED IN THE PREPARATION OF BEVERAGES, NON-ALCOHOLIC FRUIT JUICE BEVERAGES, VEGETABLE-FRUIT JUICES AND SMOOTHIES; SMOOTHIES; VEGETABLE JUICE; VEGETABLE JUICES; VEGETABLE-FRUIT JUICES (U.S. CLS. 45, 46 AND 48).  
FIRST USE 12-20-2013; IN COMMERCE 12-20-2013.  
BRENDAN MCCAULEY, EXAMINING ATTORNEY

**CLASS 32—(Continued).**

SN 86-227,444. SOZO GLOBAL, INC., AUSTIN, TX. FILED 3-20-2014.



OWNER OF U.S. REG. NO. 3,820,973.  
THE MARK CONSISTS OF AN ABSTRACT FIGURE OF A MAN WITH THREE ROUND OBJECTS NEAR THE CENTER.

FOR FRUIT-BASED BEVERAGES; CONCENTRATES AND POWDERS USED IN THE PREPARATION OF ENERGY DRINKS AND FRUIT-BASED BEVERAGES; ENERGY DRINKS (U.S. CLS. 45, 46 AND 48).  
FIRST USE 2-1-2014; IN COMMERCE 2-1-2014.  
BRIAN CALLAGHAN, EXAMINING ATTORNEY

SN 86-227,775. SIERRA NEVADA BREWING CO., CHICO, CA. FILED 3-20-2014.

## Tater Ridge

THE MARK CONSISTS OF STANDARD CHARACTERS WITHOUT CLAIM TO ANY PARTICULAR FONT, STYLE, SIZE, OR COLOR.  
NO CLAIM IS MADE TO THE EXCLUSIVE RIGHT TO USE "TATER", APART FROM THE MARK AS SHOWN.  
FOR BEER (U.S. CLS. 45, 46 AND 48).  
AMY HELLA, EXAMINING ATTORNEY

SN 86-227,817. SIERRA NEVADA BREWING CO., CHICO, CA. FILED 3-20-2014.

## Yonder Bock

THE MARK CONSISTS OF STANDARD CHARACTERS WITHOUT CLAIM TO ANY PARTICULAR FONT, STYLE, SIZE, OR COLOR.  
NO CLAIM IS MADE TO THE EXCLUSIVE RIGHT TO USE "BOCK", APART FROM THE MARK AS SHOWN.  
FOR BEER (U.S. CLS. 45, 46 AND 48).  
AMY HELLA, EXAMINING ATTORNEY

**CLASS 32—(Continued).**

SN 86-228,460. COAST BREWING COMPANY, LLC, MT. PLEASANT, SC. FILED 3-21-2014.

## Coast Brewing Company

THE MARK CONSISTS OF STANDARD CHARACTERS WITHOUT CLAIM TO ANY PARTICULAR FONT, STYLE, SIZE, OR COLOR.

NO CLAIM IS MADE TO THE EXCLUSIVE RIGHT TO USE "BREWING COMPANY", APART FROM THE MARK AS SHOWN.

FOR BEER (U.S. CLS. 45, 46 AND 48).  
FIRST USE 2-1-2007; IN COMMERCE 2-1-2007.  
INGA ERVIN, EXAMINING ATTORNEY

SN 86-228,779. MOCKTAILS BEVERAGES, INC., WENHAM, MA. FILED 3-21-2014.

## DRINK ALTERNATIVES WITH STYLE

THE MARK CONSISTS OF STANDARD CHARACTERS WITHOUT CLAIM TO ANY PARTICULAR FONT, STYLE, SIZE, OR COLOR.

NO CLAIM IS MADE TO THE EXCLUSIVE RIGHT TO USE "DRINK ALTERNATIVES", APART FROM THE MARK AS SHOWN.

FOR NON-ALCOHOLIC COCKTAILS (U.S. CLS. 45, 46 AND 48).  
JILLIAN CANTOR, EXAMINING ATTORNEY

SN 86-229,361. RARE ANTIBODY ANTIGEN SUPPLY, INC., AGOURA HILLS, CA. FILED 3-23-2014.

## KUNAMIN

THE MARK CONSISTS OF STANDARD CHARACTERS WITHOUT CLAIM TO ANY PARTICULAR FONT, STYLE, SIZE, OR COLOR.

THE WORDING "KUNAMIN" HAS NO MEANING IN A FOREIGN LANGUAGE.

FOR CONCENTRATES FOR MAKING FRUIT DRINKS; GRAPE JUICE; GRAPE JUICE BEVERAGES (U.S. CLS. 45, 46 AND 48).

JOHN HWANG, EXAMINING ATTORNEY

**CLASS 32—(Continued).**

SN 86-229,850. BAUHAUS BREW LABS, LLC, DBA BAUHAUS BREW LABS, MINNEAPOLIS, MN. FILED 3-24-2014.



OWNER OF U.S. REG. NO. 4,548,562.  
NO CLAIM IS MADE TO THE EXCLUSIVE RIGHT TO USE "BREW", APART FROM THE MARK AS SHOWN.  
THE MARK CONSISTS OF THE WORD "BAUHAUS" IN STYLIZED, UPPER CASE LETTERS; THE LETTERS "A" AND "U" IN THE WORD "BAUHAUS" APPEAR IN A STACKED CONFIGURATION. THE WORDING "BREW LABS" APPEARS IN A SMALLER FONT SIZE AND IN UPPER CASE LETTERS UNDER THE WORD "BAUHAUS".  
FOR BEER (U.S. CLS. 45, 46 AND 48).  
FIRST USE 11-12-2013; IN COMMERCE 2-14-2014.  
CHARLOTTE CORWIN, EXAMINING ATTORNEY

---

SN 86-230,902. NEW JERSEY BEVERAGE DISTRIBUTORS, LLC, EDISON, NJ. FILED 3-25-2014.

**DRINK YOUR DOSE**

THE MARK CONSISTS OF STANDARD CHARACTERS WITHOUT CLAIM TO ANY PARTICULAR FONT, STYLE, SIZE, OR COLOR.  
FOR NON-ALCOHOLIC DRINKS CONTAINING VITAMINS, NAMELY, ENERGY DRINKS (U.S. CLS. 45, 46 AND 48).  
CURTIS FRENCH, EXAMINING ATTORNEY

**CLASS 32—(Continued).**

SN 86-231,173. SUJA LIFE, LLC, DBA SUJA JUICE, SAN DIEGO, CA. FILED 3-25-2014.

**Green Delight**

THE MARK CONSISTS OF STANDARD CHARACTERS WITHOUT CLAIM TO ANY PARTICULAR FONT, STYLE, SIZE, OR COLOR.

NO CLAIM IS MADE TO THE EXCLUSIVE RIGHT TO USE "GREEN", APART FROM THE MARK AS SHOWN.

FOR BEAUTY BEVERAGES, NAMELY, FRUIT JUICES AND ENERGY DRINKS CONTAINING NUTRITIONAL SUPPLEMENTS; FRUIT BEVERAGES; FRUIT DRINKS; FRUIT DRINKS AND FRUIT JUICES; FRUIT DRINKS AND JUICES; FRUIT JUICE; FRUIT JUICES; FRUIT JUICES AND FRUIT DRINKS; HERBAL JUICES; MIXED FRUIT JUICE; NON-ALCOHOLIC BEVERAGES CONTAINING FRUIT JUICES; NON-ALCOHOLIC FRUIT JUICE BEVERAGES; SMOOTHIES; VEGETABLE DRINKS; VEGETABLE JUICE; VEGETABLE JUICES; VEGETABLE-FRUIT JUICES (U.S. CLS. 45, 46 AND 48).

FIRST USE 1-15-2014; IN COMMERCE 1-27-2014.  
BRIAN NEVILLE, EXAMINING ATTORNEY

---

SN 86-232,035. CHIGE PRODUCTS, LLC, SAVANNAH, GA. FILED 3-25-2014.

**Chige Soda Co.**

THE MARK CONSISTS OF STANDARD CHARACTERS WITHOUT CLAIM TO ANY PARTICULAR FONT, STYLE, SIZE, OR COLOR.

NO CLAIM IS MADE TO THE EXCLUSIVE RIGHT TO USE "SODA CO.", APART FROM THE MARK AS SHOWN.

FOR POP; SOFT DRINKS; SOFT DRINKS, NAMELY, SODAS; SOFT DRINKS, NAMELY, VITAMIN ENHANCED AND LOW CALORIE SOFT-DRINKS (U.S. CLS. 45, 46 AND 48).

EMILY CARLSEN, EXAMINING ATTORNEY

---

SN 86-232,202. NEW JERSEY BEVERAGE DISTRIBUTORS, LLC, EDISON, NJ. FILED 3-26-2014.

**VITA DOSE**

THE MARK CONSISTS OF STANDARD CHARACTERS WITHOUT CLAIM TO ANY PARTICULAR FONT, STYLE, SIZE, OR COLOR.

NO CLAIM IS MADE TO THE EXCLUSIVE RIGHT TO USE "DOSE", APART FROM THE MARK AS SHOWN.

FOR NON-ALCOHOLIC BEVERAGES CONTAINING VITAMINS, NAMELY, ENERGY DRINKS (U.S. CLS. 45, 46 AND 48).

CURTIS FRENCH, EXAMINING ATTORNEY



**CLASS 32—(Continued).**

SN 86-235,148. DIAGEO NORTH AMERICA, INC., NORWALK, CT. FILED 3-28-2014.

**THUMP KEG**

THE MARK CONSISTS OF STANDARD CHARACTERS WITHOUT CLAIM TO ANY PARTICULAR FONT, STYLE, SIZE, OR COLOR.

NO CLAIM IS MADE TO THE EXCLUSIVE RIGHT TO USE "KEG", APART FROM THE MARK AS SHOWN.

FOR BEER; BREWED MALT-BASED ALCOHOLIC BEVERAGE IN THE NATURE OF A BEER (U.S. CLS. 45, 46 AND 48).

ELLEN BURNS, EXAMINING ATTORNEY

SN 86-236,298. MIRONETS, ALEKSANDER, LYNNWOOD, WA. FILED 3-29-2014.

**KVASCO**

THE MARK CONSISTS OF STANDARD CHARACTERS WITHOUT CLAIM TO ANY PARTICULAR FONT, STYLE, SIZE, OR COLOR.

THE WORDING "KVASCO" HAS NO MEANING IN A FOREIGN LANGUAGE.

FOR BEAUTY BEVERAGES, NAMELY, FRUIT JUICES AND ENERGY DRINKS CONTAINING NUTRITIONAL SUPPLEMENTS; CONCENTRATES, SYRUPS OR POWDERS FOR MAKING SOFT DRINKS OR TEA-FLAVORED BEVERAGES; FRUIT BEVERAGES; FRUIT-FLAVORED BEVERAGES; KVASS; NON-ALCOHOLIC BEVERAGES, NAMELY, CARBONATED BEVERAGES; NON-ALCOHOLIC BEER FLAVORED BEVERAGES; NON-ALCOHOLIC HONEY-BASED BEVERAGES; SHERBET BEVERAGES; SMOOTHIES; SYRUPS FOR BEVERAGES; VEGETABLE JUICES (U.S. CLS. 45, 46 AND 48).

KAPIL BHANOT, EXAMINING ATTORNEY

SN 86-236,814. THE BROOKLYN BREWERY CORPORATION, BROOKLYN, NY. FILED 3-31-2014.

**BROOKLYN THORBRIDGE  
SERPENT ALE**

THE MARK CONSISTS OF STANDARD CHARACTERS WITHOUT CLAIM TO ANY PARTICULAR FONT, STYLE, SIZE, OR COLOR.

OWNER OF U.S. REG. NOS. 3,186,501, 3,513,023 AND OTHERS.

NO CLAIM IS MADE TO THE EXCLUSIVE RIGHT TO USE "BROOKLYN" OR "ALE", APART FROM THE MARK AS SHOWN.

FOR BEER (U.S. CLS. 45, 46 AND 48).

JESSICA A. POWERS, EXAMINING ATTORNEY

**CLASS 32—(Continued).**

SN 86-238,667. SHELTON, WILLIAM T, ANDOVER, NH. FILED 4-1-2014.

**Big Brother Beer**

THE MARK CONSISTS OF STANDARD CHARACTERS WITHOUT CLAIM TO ANY PARTICULAR FONT, STYLE, SIZE, OR COLOR.

NO CLAIM IS MADE TO THE EXCLUSIVE RIGHT TO USE "BEER", APART FROM THE MARK AS SHOWN.

FOR BEER (U.S. CLS. 45, 46 AND 48).

SHAVELL MCPHERSON, EXAMINING ATTORNEY

SN 86-238,867. LOVE BIRCH, INC, CAMARILLO, CA. FILED 4-1-2014.

**LOVE BIRCH**

THE MARK CONSISTS OF STANDARD CHARACTERS WITHOUT CLAIM TO ANY PARTICULAR FONT, STYLE, SIZE, OR COLOR.

OWNER OF U.S. REG. NO. 4,530,946.

NO CLAIM IS MADE TO THE EXCLUSIVE RIGHT TO USE "BIRCH", APART FROM THE MARK AS SHOWN.

FOR NON-ALCOHOLIC, NON-CARBONATED, FRUIT-FLAVORED BEVERAGES CONTAINING BIRCH (U.S. CLS. 45, 46 AND 48).

FIRST USE 2-24-2014; IN COMMERCE 2-24-2014.

TINA BROWN, EXAMINING ATTORNEY

SN 86-239,376. DRINK DEEP, LLC, LOUISBURG, KS. FILED 4-1-2014.

**Sip-licity**

THE MARK CONSISTS OF STANDARD CHARACTERS WITHOUT CLAIM TO ANY PARTICULAR FONT, STYLE, SIZE, OR COLOR.

FOR NON-ALCOHOLIC SPARKLING FRUIT JUICE BEVERAGES (U.S. CLS. 45, 46 AND 48).

JEAN IM, EXAMINING ATTORNEY

**CLASS 32—(Continued).**

SN 86-241,482. PEPSICO, INC., PURCHASE, NY. FILED 4-3-2014.

REAL. BIG. SUMMER.

THE MARK CONSISTS OF STANDARD CHARACTERS WITHOUT CLAIM TO ANY PARTICULAR FONT, STYLE, SIZE, OR COLOR.  
FOR SOFT DRINKS (U.S. CLS. 45, 46 AND 48).  
JENNIFER RICHARDSON, EXAMINING ATTORNEY

SN 86-242,436. WHITE LION BREWING COMPANY, SPRINGFIELD, MA. FILED 4-4-2014.

Insane Mane

THE MARK CONSISTS OF STANDARD CHARACTERS WITHOUT CLAIM TO ANY PARTICULAR FONT, STYLE, SIZE, OR COLOR.  
FOR BEERS (U.S. CLS. 45, 46 AND 48).  
TASHIA BUNCH, EXAMINING ATTORNEY

SN 86-243,078. DAVID M. OLSEN, LLC, DBA CRAFT ARTISAN ALES, PACIFIC GROVE, CA. FILED 4-4-2014.

RICKETTS LAB IPA

THE MARK CONSISTS OF STANDARD CHARACTERS WITHOUT CLAIM TO ANY PARTICULAR FONT, STYLE, SIZE, OR COLOR.

NO CLAIM IS MADE TO THE EXCLUSIVE RIGHT TO USE "IPA", APART FROM THE MARK AS SHOWN.  
FOR BEER, ALE AND LAGER (U.S. CLS. 45, 46 AND 48).

FIRST USE 3-1-2014; IN COMMERCE 4-1-2014.  
BARBARA GAYNOR, EXAMINING ATTORNEY

**CLASS 32—(Continued).**

SN 86-243,660. NATURALLY PLUS DIRECT MARKETING PTE. LTD., SINGAPORE, SINGAPORE, FILED 4-5-2014.

IZUMIO

THE MARK CONSISTS OF STANDARD CHARACTERS WITHOUT CLAIM TO ANY PARTICULAR FONT, STYLE, SIZE, OR COLOR.

THE WORDING "IZUMIO" IS A COINED WORD AND HAS NO MEANING IN A FOREIGN LANGUAGE.

FOR MINERAL AND AERATED WATERS (U.S. CLS. 45, 46 AND 48).

TARA BHUPATHI, EXAMINING ATTORNEY

SN 86-244,816. COMESTIBLES MASTER CO., LTD., TAI-CHUNG CITY, TAIWAN, FILED 4-7-2014.

一顆

THE MARK CONSISTS OF CHINESE CHARACTERS. THE NON-LATIN CHARACTERS IN THE MARK TRANSLITERATE TO "YI" AND "KE" AND THIS MEANS "ONE; ALONE" AND "A PIECE; A DROP" IN ENGLISH.

FOR AERATED WATER; BEER; DRINKING WATERS; FRUIT JUICES; FRUIT NECTARS; FRUIT-BASED SOFT DRINKS FLAVORED WITH TEA; GRAPE MUST; LEMONADES; MINERAL WATERS; MUST; NON-ALCOHOLIC BEVERAGES CONTAINING FRUIT JUICES; NON-ALCOHOLIC BEVERAGES WITH TEA FLAVOR; NON-ALCOHOLIC COCKTAIL MIXES; NON-ALCOHOLIC FRUIT EXTRACTS USED IN THE PREPARATION OF BEVERAGES; NON-ALCOHOLIC FRUIT JUICE BEVERAGES; NONALCOHOLIC APERITIFS; SELTZER WATER; SODA WATER; SOFT DRINKS FLAVORED WITH TEA; TOMATO JUICE BEVERAGES; VEGETABLE JUICES; WHEY BEVERAGES (U.S. CLS. 45, 46 AND 48).  
STEVEN JACKSON, EXAMINING ATTORNEY

**CLASS 32—(Continued).**

SN 86-246,688. OCEAN SPRAY CRANBERRIES, INC., LAKEVILLE-MIDDLEBORO, MA. FILED 4-9-2014.

**PACT**

THE MARK CONSISTS OF STANDARD CHARACTERS WITHOUT CLAIM TO ANY PARTICULAR FONT, STYLE, SIZE, OR COLOR.

FOR CRANBERRY EXTRACT SOLD AS AN INTEGRAL INGREDIENT IN A WATER BEVERAGE; CRANBERRY EXTRACT SOLD AS AN INTEGRAL INGREDIENT IN A FRUIT BEVERAGE; CRANBERRY EXTRACT SOLD AS AN INTEGRAL INGREDIENT IN A FRUIT DRINK AND JUICE; CRANBERRY EXTRACT SOLD AS AN INTEGRAL INGREDIENT IN A NON-ALCOHOLIC CARBONATED BEVERAGE (U.S. CLS. 45, 46 AND 48).

REBECCA GILBERT, EXAMINING ATTORNEY

SN 86-246,714. PEPSICO, INC., PURCHASE, NY. FILED 4-9-2014.

**A CREATIVE TAKE ON WATER**

THE MARK CONSISTS OF STANDARD CHARACTERS WITHOUT CLAIM TO ANY PARTICULAR FONT, STYLE, SIZE, OR COLOR.

NO CLAIM IS MADE TO THE EXCLUSIVE RIGHT TO USE "WATER", APART FROM THE MARK AS SHOWN.

FOR FLAVORED WATERS (U.S. CLS. 45, 46 AND 48).  
JENNIFER RICHARDSON, EXAMINING ATTORNEY

SN 86-246,866. RIO PERLA PROPERTIES, L. P., SAN ANTONIO, TX. FILED 4-9-2014.

**EMMA**

THE MARK CONSISTS OF STANDARD CHARACTERS WITHOUT CLAIM TO ANY PARTICULAR FONT, STYLE, SIZE, OR COLOR.

FOR BEER (U.S. CLS. 45, 46 AND 48).  
THOMAS MANOR, EXAMINING ATTORNEY

**CLASS 32—(Continued).**

SN 86-247,250. SMART STUFF INTERNATIONAL, INC., MANHASSET, NY. FILED 4-9-2014.

**SMART ELIXERS**

THE MARK CONSISTS OF STANDARD CHARACTERS WITHOUT CLAIM TO ANY PARTICULAR FONT, STYLE, SIZE, OR COLOR.

FOR FRUIT JUICES AND FRUIT BLENDED SMOOTHIES (U.S. CLS. 45, 46 AND 48).

BRIAN NEVILLE, EXAMINING ATTORNEY

SN 86-247,970. STOKELY-VAN CAMP, INC., CHICAGO, IL. FILED 4-10-2014.



OWNER OF U.S. REG. NOS. 848,245, 2,856,121 AND OTHERS.

THE COLOR(S) YELLOW, ORANGE, GREEN RED AND BLACK IS/ARE CLAIMED AS A FEATURE OF THE MARK.

THE MARK CONSISTS OF THE WORD "GATORADE" IN GREEN WITHIN A RECTANGULAR IMAGE WITH THE OUTSIDE BORDER BEING THE COLOR BLACK AND THE INSIDE BORDER BEING THE COLOR RED. A LIGHTNING BOLT DESIGN IN THE COLOR ORANGE AND OUTLINED IN YELLOW, WITH SOME SHADING OF BLACK ON THE RIGHT SIDE, IS PLACED TO LOOK LIKE IT IS GOING THROUGH THE RECTANGULAR IMAGE AND BEHIND THE WORD "GATORADE".

FOR NON-ALCOHOLIC, NON-CARBONATED FRUIT FLAVORED BEVERAGES (U.S. CLS. 45, 46 AND 48).  
ZACHARY BELLO, EXAMINING ATTORNEY

SN 86-248,489. ROCLAND ESTATES PTY LTD, NURIOTPA, AUSTRALIA, FILED 4-10-2014.

**ROYAL DONK**

THE MARK CONSISTS OF STANDARD CHARACTERS WITHOUT CLAIM TO ANY PARTICULAR FONT, STYLE, SIZE, OR COLOR.

FOR BEER (U.S. CLS. 45, 46 AND 48).  
KEVIN MITTLER, EXAMINING ATTORNEY

**CLASS 32—(Continued).**

SN 86-248,547. ROCLAND ESTATES PTY LTD, NURIOOTPA, AUSTRALIA, FILED 4-10-2014.

## STUBBORN JACK

THE MARK CONSISTS OF STANDARD CHARACTERS WITHOUT CLAIM TO ANY PARTICULAR FONT, STYLE, SIZE, OR COLOR.

FOR BEER (U.S. CLS. 45, 46 AND 48).  
KEVIN MITTLER, EXAMINING ATTORNEY

---

SN 86-249,904. ALLINONE VEGETABLES, LLC, NEW YORK, NY. FILED 4-11-2014.

## Drink Your Salad

THE MARK CONSISTS OF STANDARD CHARACTERS WITHOUT CLAIM TO ANY PARTICULAR FONT, STYLE, SIZE, OR COLOR.

FOR VEGETABLE JUICE (U.S. CLS. 45, 46 AND 48).  
IRA J. GOODSAD, EXAMINING ATTORNEY

---

SN 86-250,031. BLUEJACKET LLC, ALEXANDRIA, VA. FILED 4-11-2014.

## Lost Weekend

THE MARK CONSISTS OF STANDARD CHARACTERS WITHOUT CLAIM TO ANY PARTICULAR FONT, STYLE, SIZE, OR COLOR.

FOR BEER (U.S. CLS. 45, 46 AND 48).  
FIRST USE 10-23-2013; IN COMMERCE 10-23-2013.  
JOHN E. MICHOS, EXAMINING ATTORNEY

**CLASS 32—(Continued).**

SN 86-250,168. REMEDE LLC, IRVINE, CA. FILED 4-11-2014.

## Roselle

THE MARK CONSISTS OF STANDARD CHARACTERS WITHOUT CLAIM TO ANY PARTICULAR FONT, STYLE, SIZE, OR COLOR.

FOR BEAUTY BEVERAGES, NAMELY, FRUIT JUICES AND ENERGY DRINKS CONTAINING NUTRITIONAL SUPPLEMENTS; ENERGY DRINKS ENHANCED WITH VITAMINS AND MINERALS; FRUIT FLAVORED DRINKS; FRUIT-BASED SOFT DRINKS FLAVORED WITH TEA; NON-ALCOHOLIC DRINKS, NAMELY, ENERGY SHOTS; SOFT DRINKS FLAVORED WITH TEA; SPORTS DRINKS ENHANCED WITH VITAMINS AND MINERALS; SPORTS DRINKS, NAMELY, PERFORMANCE DRINKS; SPORTS DRINKS, NAMELY, RECOVERY DRINKS (U.S. CLS. 45, 46 AND 48).  
JAMES A. RAUEN, EXAMINING ATTORNEY

---

SN 86-250,477. CROWDED CASTLE BREWING COMPANY, EXTON, PA. FILED 4-11-2014.

## Crowded Castle Brewing Company

THE MARK CONSISTS OF STANDARD CHARACTERS WITHOUT CLAIM TO ANY PARTICULAR FONT, STYLE, SIZE, OR COLOR.

NO CLAIM IS MADE TO THE EXCLUSIVE RIGHT TO USE "BREWING COMPANY", APART FROM THE MARK AS SHOWN.  
FOR BEER (U.S. CLS. 45, 46 AND 48).  
GEORGE LORENZO, EXAMINING ATTORNEY

---

SN 86-250,485. CARLON HOLDINGS, INDIANAPOLIS, IN. FILED 4-11-2014.

## BollyGood

THE MARK CONSISTS OF STANDARD CHARACTERS WITHOUT CLAIM TO ANY PARTICULAR FONT, STYLE, SIZE, OR COLOR.

FOR FRUIT-FLAVORED BEVERAGES (U.S. CLS. 45, 46 AND 48).  
DAVID MURRAY, EXAMINING ATTORNEY

**CLASS 32—(Continued).**

SN 86-250,649. CARLON HOLDINGS, INDIANAPOLIS, IN.  
FILED 4-12-2014.

# Mumbai

THE MARK CONSISTS OF STANDARD CHARACTERS  
WITHOUT CLAIM TO ANY PARTICULAR FONT, STYLE,  
SIZE, OR COLOR.  
FOR FRUIT-FLAVORED BEVERAGES (U.S. CLS. 45,  
46 AND 48).  
DAVID MURRAY, EXAMINING ATTORNEY

**CLASS 32—(Continued).**

SN 86-251,042. BLUEJACKET LLC, ALEXANDRIA, VA.  
FILED 4-14-2014.

# Mexican Radio

THE MARK CONSISTS OF STANDARD CHARACTERS  
WITHOUT CLAIM TO ANY PARTICULAR FONT, STYLE,  
SIZE, OR COLOR.  
FOR BEER (U.S. CLS. 45, 46 AND 48).  
FIRST USE 10-23-2013; IN COMMERCE 10-23-2013.  
JOHN E. MICHOS, EXAMINING ATTORNEY

---

SN 86-250,768. CARLON HOLDINGS, INDIANAPOLIS, IN.  
FILED 4-13-2014.

# Spiceade

THE MARK CONSISTS OF STANDARD CHARACTERS  
WITHOUT CLAIM TO ANY PARTICULAR FONT, STYLE,  
SIZE, OR COLOR.  
FOR NON-ALCOHOLIC BEVERAGES CONTAINING  
FRUIT JUICES (U.S. CLS. 45, 46 AND 48).  
DAVID MURRAY, EXAMINING ATTORNEY

---

SN 86-251,114. BLUEJACKET LLC, ALEXANDRIA, VA.  
FILED 4-14-2014.

# Cut & Dry

THE MARK CONSISTS OF STANDARD CHARACTERS  
WITHOUT CLAIM TO ANY PARTICULAR FONT, STYLE,  
SIZE, OR COLOR.  
FOR BEER (U.S. CLS. 45, 46 AND 48).  
FIRST USE 10-23-2013; IN COMMERCE 10-23-2013.  
JOHN E. MICHOS, EXAMINING ATTORNEY

---

SN 86-250,960. BLUEJACKET LLC, ALEXANDRIA, VA.  
FILED 4-14-2014.

# Forbidden Planet

THE MARK CONSISTS OF STANDARD CHARACTERS  
WITHOUT CLAIM TO ANY PARTICULAR FONT, STYLE,  
SIZE, OR COLOR.  
FOR BEER (U.S. CLS. 45, 46 AND 48).  
FIRST USE 10-23-2013; IN COMMERCE 10-23-2013.  
JOHN E. MICHOS, EXAMINING ATTORNEY

---

SN 86-253,709. NEW ORLEANS LAGER AND ALE BREW-  
ING COMPANY, LLC, NEW ORLEANS, LA. FILED 4-16-  
2014.

# 7th Street

THE MARK CONSISTS OF STANDARD CHARACTERS  
WITHOUT CLAIM TO ANY PARTICULAR FONT, STYLE,  
SIZE, OR COLOR.  
FOR BEER (U.S. CLS. 45, 46 AND 48).  
FIRST USE 7-6-2010; IN COMMERCE 7-6-2010.  
LESLEY LAMOTHE, EXAMINING ATTORNEY

**CLASS 32—(Continued).**

SN 86-253,736. NEW ORLEANS LAGER AND ALE BREWING COMPANY, LLC, NEW ORLEANS, LA. FILED 4-16-2014.

# Flambeau

THE MARK CONSISTS OF STANDARD CHARACTERS WITHOUT CLAIM TO ANY PARTICULAR FONT, STYLE, SIZE, OR COLOR.

THE ENGLISH TRANSLATION OF "FLAMBEAU" IN THE MARK IS "BEAUTIFUL FLAME".

FOR BEER (U.S. CLS. 45, 46 AND 48).

FIRST USE 2-23-2011; IN COMMERCE 2-23-2011.

LESLEY LAMOTHE, EXAMINING ATTORNEY

SN 86-254,737. OCEAN SPRAY CRANBERRIES, INC., LAKEVILLE-MIDDLEBORO, MA. FILED 4-17-2014.



THE MARK CONSISTS OF A STYLIZED CROSS-SECTION OF A CRANBERRY, SURROUNDED BY A CIRCLE OF DOTS, SURROUNDED BY A CIRCLE, SURROUNDED BY A CIRCLE OF DASHES.

FOR CRANBERRY EXTRACT SOLD AS AN INTEGRAL INGREDIENT IN A WATER BEVERAGE; CRANBERRY EXTRACT SOLD AS AN INTEGRAL INGREDIENT IN A FRUIT BEVERAGE; CRANBERRY EXTRACT SOLD AS AN INTEGRAL INGREDIENT IN A FRUIT DRINK AND JUICE; CRANBERRY EXTRACT SOLD AS AN INTEGRAL INGREDIENT IN A NON-ALCOHOLIC CARBONATED BEVERAGE (U.S. CLS. 45, 46 AND 48).

REBECCA GILBERT, EXAMINING ATTORNEY

**CLASS 32—(Continued).**

SN 86-259,129. PEPSICO, INC., PURCHASE, NY. FILED 4-22-2014.



OWNER OF U.S. REG. NOS. 820,362, 3,674,349 AND OTHERS.

THE MARK CONSISTS OF THE WORDS "MTN DEW" IN STYLIZED FORM AND THE WORDS "SOLAR FLARE" OUTLINED BY A PENTAGON SHAPE.

FOR CONCENTRATES, SYRUPS OR POWDERS USED IN THE PREPARATION OF SOFT DRINKS; SOFT DRINKS (U.S. CLS. 45, 46 AND 48).

JENNIFER RICHARDSON, EXAMINING ATTORNEY

SN 86-259,143. PEPSICO, INC., PURCHASE, NY. FILED 4-22-2014.

# BAJA BLAST

THE MARK CONSISTS OF STANDARD CHARACTERS WITHOUT CLAIM TO ANY PARTICULAR FONT, STYLE, SIZE, OR COLOR.

OWNER OF U.S. REG. NO. 2,950,372.

FOR CONCENTRATES, SYRUPS OR POWDERS USED IN THE PREPARATION OF SOFT DRINKS; SOFT DRINKS (U.S. CLS. 45, 46 AND 48).

FIRST USE 7-30-2004; IN COMMERCE 7-30-2004.

JENNIFER RICHARDSON, EXAMINING ATTORNEY

SN 86-259,375. PREMIER HOMECARE OPTIONS, LLC, WALDORF, MD. FILED 4-22-2014.

# FBOOZE

THE MARK CONSISTS OF STANDARD CHARACTERS WITHOUT CLAIM TO ANY PARTICULAR FONT, STYLE, SIZE, OR COLOR.

FOR BEER (U.S. CLS. 45, 46 AND 48).

DAVID BROOKSHIRE, EXAMINING ATTORNEY

**CLASS 32—(Continued).**

SN 86-263,962. EASTLAND FOOD CORPORATION, JESSUP, MD. FILED 4-27-2014.

# AMIGO

THE MARK CONSISTS OF STANDARD CHARACTERS WITHOUT CLAIM TO ANY PARTICULAR FONT, STYLE, SIZE, OR COLOR.

THE ENGLISH TRANSLATION OF "AMIGO" IN THE MARK IS "FRIEND".

FOR ALOE JUICE BEVERAGES; FRUIT JUICES AND FRUIT DRINKS; FRUIT-BASED BEVERAGES (U.S. CLS. 45, 46 AND 48).

SUNG IN, EXAMINING ATTORNEY

**CLASS 32—(Continued).**

SN 86-267,698. RARE ANTIBODY ANTIGEN SUPPLY, INC., AGOURA HILLS, CA. FILED 4-30-2014.

# KunaKINminP

THE MARK CONSISTS OF STANDARD CHARACTERS WITHOUT CLAIM TO ANY PARTICULAR FONT, STYLE, SIZE, OR COLOR.

THE WORDING "KUNAKINMINP" HAS NO MEANING IN A FOREIGN LANGUAGE.

FOR CONCENTRATES FOR MAKING FRUIT JUICES; GRAPE JUICE; GRAPE JUICE BEVERAGES; SOY-BASED BEVERAGES NOT BEING MILK SUBSTITUTES (U.S. CLS. 45, 46 AND 48).

JOHN HWANG, EXAMINING ATTORNEY

SN 86-266,589. VICTORY BREWING COMPANY, DOWNTOWN, PA. FILED 4-29-2014.

# WILD MONKEY

THE MARK CONSISTS OF STANDARD CHARACTERS WITHOUT CLAIM TO ANY PARTICULAR FONT, STYLE, SIZE, OR COLOR.

OWNER OF U.S. REG. NO. 2,571,440.

FOR ALE; BEER (U.S. CLS. 45, 46 AND 48).

DOMINIC J. FERRAIUOLO, EXAMINING ATTORNEY

SN 86-267,703. RARE ANTIBODY ANTIGEN SUPPLY, INC., AGOURA HILLS, CA. FILED 4-30-2014.

# KunaKINminD

THE MARK CONSISTS OF STANDARD CHARACTERS WITHOUT CLAIM TO ANY PARTICULAR FONT, STYLE, SIZE, OR COLOR.

THE WORDING "KUNAKINMIND" HAS NO MEANING IN A FOREIGN LANGUAGE.

FOR CONCENTRATES FOR MAKING FRUIT JUICES; GRAPE JUICE; GRAPE JUICE BEVERAGES; SOY-BASED BEVERAGES NOT BEING MILK SUBSTITUTES (U.S. CLS. 45, 46 AND 48).

JOHN HWANG, EXAMINING ATTORNEY

SN 86-267,692. RARE ANTIBODY ANTIGEN SUPPLY, INC., AGOURA HILLS, CA. FILED 4-30-2014.

# KUNAKINMIN

THE MARK CONSISTS OF STANDARD CHARACTERS WITHOUT CLAIM TO ANY PARTICULAR FONT, STYLE, SIZE, OR COLOR.

THE WORDING "KUNAKINMIN" HAS NO MEANING IN A FOREIGN LANGUAGE.

FOR CONCENTRATES FOR MAKING FRUIT JUICES; GRAPE JUICE; GRAPE JUICE BEVERAGES; SOY-BASED BEVERAGES NOT BEING MILK SUBSTITUTES (U.S. CLS. 45, 46 AND 48).

JOHN HWANG, EXAMINING ATTORNEY

SN 86-268,976. PEPSICO, INC., PURCHASE, NY. FILED 5-1-2014.

# PEPSI MAX CHERRY BLAST

THE MARK CONSISTS OF STANDARD CHARACTERS WITHOUT CLAIM TO ANY PARTICULAR FONT, STYLE, SIZE, OR COLOR.

OWNER OF U.S. REG. NOS. 3,607,615, 3,911,249 AND OTHERS.

NO CLAIM IS MADE TO THE EXCLUSIVE RIGHT TO USE "CHERRY", APART FROM THE MARK AS SHOWN.

FOR CONCENTRATES, SYRUPS OR POWDERS USED IN THE PREPARATION OF SOFT DRINKS; SOFT DRINKS (U.S. CLS. 45, 46 AND 48).

JENNIFER RICHARDSON, EXAMINING ATTORNEY

**CLASS 32—(Continued).**

SN 86-277,059. SOUTHERN PINES BREWING COMPANY, LLC, SOUTHERN PINES, NC. FILED 5-9-2014.

**Rooted in the Community**

THE MARK CONSISTS OF STANDARD CHARACTERS WITHOUT CLAIM TO ANY PARTICULAR FONT, STYLE, SIZE, OR COLOR.

FOR BEER: BEER, ALE, LAGER, STOUT, PORTER, SHANDY (U.S. CLS. 45, 46 AND 48).

ELLEN B. AWRICH, EXAMINING ATTORNEY

---

SN 86-288,295. NIAGARA BOTTLING, LLC, ONTARIO, CA. FILED 5-21-2014.

**ALOHA BLAST**

THE MARK CONSISTS OF STANDARD CHARACTERS WITHOUT CLAIM TO ANY PARTICULAR FONT, STYLE, SIZE, OR COLOR.

FOR FRUIT PUNCH; FRUIT JUICE; FRUIT BEVERAGES; FRUIT-FLAVORED BEVERAGES; NON-ALCOHOLIC FRUIT-FLAVORED BEVERAGES (U.S. CLS. 45, 46 AND 48).

JIM RINGLE, EXAMINING ATTORNEY

---

SN 86-296,313. SUNNY SKY PRODUCTS LLC, HOUSTON, TX. FILED 5-30-2014.

**ICE DOG**

THE MARK CONSISTS OF STANDARD CHARACTERS WITHOUT CLAIM TO ANY PARTICULAR FONT, STYLE, SIZE, OR COLOR.

NO CLAIM IS MADE TO THE EXCLUSIVE RIGHT TO USE "ICE", APART FROM THE MARK AS SHOWN.

FOR FRUIT DRINKS AND JUICES (U.S. CLS. 45, 46 AND 48).

FIRST USE 9-30-2013; IN COMMERCE 10-31-2013.

BRITTNEY COGAN, EXAMINING ATTORNEY

**CLASS 32—(Continued).**

SN 86-296,336. SUNNY SKY PRODUCTS LLC, HOUSTON, TX. FILED 5-30-2014.



NO CLAIM IS MADE TO THE EXCLUSIVE RIGHT TO USE "ICE", APART FROM THE MARK AS SHOWN.

THE MARK CONSISTS OF A STYLIZED FORM OF THE LITERAL ELEMENT "ICE DOG" WITH THE WORD "ICE" ABOVE "DOG" AND THE STYLIZED HEAD OF A HUSKY TYPE DOG IN SUNGLASSES AND A SCARF ABOVE THE WORD "ICE" AND IN FRONT OF A TOP PORTION OF A SPHERE.

FOR FRUIT DRINKS AND JUICES (U.S. CLS. 45, 46 AND 48).

FIRST USE 9-30-2013; IN COMMERCE 10-31-2013.

BRITTNEY COGAN, EXAMINING ATTORNEY

---

SN 86-298,267. DIAGEO IRELAND, DUBLIN 8, IRELAND, FILED 6-2-2014.

**WINTER SPIRIT**

THE MARK CONSISTS OF STANDARD CHARACTERS WITHOUT CLAIM TO ANY PARTICULAR FONT, STYLE, SIZE, OR COLOR.

NO CLAIM IS MADE TO THE EXCLUSIVE RIGHT TO USE "WINTER", APART FROM THE MARK AS SHOWN.

FOR BEER (U.S. CLS. 45, 46 AND 48).

MEREDITH MARESCA, EXAMINING ATTORNEY

---

SN 86-327,705. SEA DOG BRANDS, LLC, SOUTH PORTLAND, ME. FILED 7-3-2014.

**SEA DOG**

THE MARK CONSISTS OF STANDARD CHARACTERS WITHOUT CLAIM TO ANY PARTICULAR FONT, STYLE, SIZE, OR COLOR.

OWNER OF U.S. REG. NOS. 2,810,284, 4,206,889 AND OTHERS.

FOR BEER (U.S. CLS. 45, 46 AND 48).

FIRST USE 12-31-1993; IN COMMERCE 12-31-1993.

ANNIE NOBLE, EXAMINING ATTORNEY



**CLASS 33—WINES AND SPIRITS**

SN 76-716,099. STROTZ, CHARLES R., PIEDMONT, CA. AND STROTZ, LORNA W., PIEDMONT, CA. FILED 3-27-2014.

# PICKBERRY

THE MARK CONSISTS OF STANDARD CHARACTERS WITHOUT CLAIM TO ANY PARTICULAR FONT, STYLE, SIZE, OR COLOR.

OWNER OF U.S. REG. NO. 2,871,329.  
FOR WINE (U.S. CLS. 47 AND 49).  
FIRST USE 9-1-2009; IN COMMERCE 9-1-2009.  
BRIN ANDERSON, EXAMINING ATTORNEY

SN 79-135,539. SANDRO BOTTEGA, COLLE UMBERTO (TREVISO), ITALY, FILED 7-29-2013.



PRIORITY DATE OF 1-30-2013 IS CLAIMED.  
OWNER OF INTERNATIONAL REGISTRATION 1174009 DATED 7-29-2013, EXPIRES 7-29-2023.

THE COLOR(S) LIGHT YELLOW, GOLD, DARK GOLD IS/ARE CLAIMED AS A FEATURE OF THE MARK.

THE MARK CONSISTS OF A THREE-DIMENSIONAL DESIGN OF A BOTTLE IN GOLD WITH A DARK GOLD FOIL COVERED CAP; A LIGHT YELLOW BAND AROUND THE NECK OF THE BOTTLE APPEARS BELOW THE FOIL CAP; THE LETTER "B" IN GOLD APPEARS ON THE BOTTLE BELOW WHICH IS A FLAME DESIGN IN LIGHT YELLOW. THE DOTTED LINES INDICATE THE PLACEMENT OF THE MARK AND ARE NOT PART OF THE MARK AS SHOWN. THE SHAPE OF THE BOTTLE IS NOT CLAIMED AS A FEATURE OF THE MARK.

FOR ALCOHOLIC BEVERAGES EXCEPT BEERS; BRANDY; PEPPERMINT LIQUEURS; RICE ALCOHOL; SPIRITS BEVERAGES; BITTERS; ANISE LIQUEUR; ANISETTE LIQUEUR; APERITIFS; ARAK ARRACK; ALCOHOLIC BEVERAGES, EXCEPT BEER; ALCOHOLIC BEVERAGES CONTAINING FRUIT; PRE-MIXED ALCOHOLIC BEVERAGES, OTHER THAN BEER-BASED; DISTILLED BEVERAGES; COCKTAILS; CURACAO; DIGESTERS LIQUEURS AND SPIRITS; ALCOHOLIC ESSENCES; ALCOHOLIC EXTRACTS; FRUIT EXTRACTS, ALCOHOLIC; GIN; HYDROMEL MEAD; KIRSCH; LIQUEURS; NIRA SUGARCANE-BASED ALCOHOLIC BEVERAGE; RUM; SAKE; CIDER; PERRY; PIQUETTE; WINE; VODKA; WHISKY (U.S. CLS. 47 AND 49).

DEBORAH LOBO, EXAMINING ATTORNEY

**CLASS 33—(Continued).**

SN 79-136,755. MIGRAINEPOLICE AS, NORWAY, FILED 8-8-2013.



PRIORITY DATE OF 8-7-2013 IS CLAIMED.  
OWNER OF INTERNATIONAL REGISTRATION 1177200 DATED 8-8-2013, EXPIRES 8-8-2023.

THE COLOR(S) RED AND WHITE IS/ARE CLAIMED AS A FEATURE OF THE MARK.

THE MARK CONSIST OF A DESIGN OF A CIRCULAR WAX SEAL IN THE COLOR RED AND REFLECTIONS AT THE TOP AND BOTTOM OF THE SEAL IN THE COLOR WHITE. WITHIN THE SEAL, AT THE TOP, IS A DESIGN OF A BOTTLE AND WINE GLASS IN THE COLOR WHITE. BELOW THE WINE AND BOTTLE DESIGN IS THE WORDING "MIGRAINE" CENTERED OVER THE WORDING "POLICE", BOTH IN LARGE LETTERS AND CENTERED OVER THE WORDING "MIGRAINEPOLICE.COM" IN SMALL LETTERS. ALL OF THE WORDING APPEARS IN THE COLOR WHITE. ALL OTHER INSTANCES OF THE COLOR WHITE IN THE MARK REPRESENTS BACKGROUND, OUTLINING, SHADING AND/OR TRANSPARENT AREAS AND IS NOT CLAIMED AS A FEATURE OF THE MARK.

FOR ALCOHOLIC BEVERAGES EXCEPT BEERS; WINE (U.S. CLS. 47 AND 49).

JEANIE LEE, EXAMINING ATTORNEY

**CLASS 33—(Continued).**

SN 79-138,518. CANTINE SETTESOLI S.C.A., ITALY, FILED 9-6-2013.



PRIORITY DATE OF 8-6-2013 IS CLAIMED.  
OWNER OF INTERNATIONAL REGISTRATION 1181849  
DATED 9-6-2013, EXPIRES 9-6-2023.

THE COLOR(S) RED, ORANGE, YELLOW, GREEN AND DARK GREEN IS/ARE CLAIMED AS A FEATURE OF THE MARK.

THE MARK CONSISTS OF A STYLIZED IMAGE OF A SUN WITH A GREEN AND DARK GREEN CENTER WITH RED, ORANGE AND YELLOW RAYS AND SMALL RED, ORANGE, AND YELLOW CIRCLES.

FOR WINES (U.S. CLS. 47 AND 49).  
CIMMERIAN COLEMAN, EXAMINING ATTORNEY

SN 79-139,639. SAS CHATEAU D'AGEL, FRANCE, FILED 10-14-2013.

**CHATEAU D'AGEL**

PRIORITY DATE OF 8-12-2013 IS CLAIMED.  
OWNER OF INTERNATIONAL REGISTRATION 1184618  
DATED 10-14-2013, EXPIRES 10-14-2023.

NO CLAIM IS MADE TO THE EXCLUSIVE RIGHT TO USE "CHATEAU", APART FROM THE MARK AS SHOWN.

FOR ALCOHOLIC BEVERAGES EXCEPT BEERS; HARD CIDERS; DIGESTERS, NAMELY, LIQUEURS AND SPIRITS; WINES; SPIRITS (U.S. CLS. 47 AND 49).  
KIM MONINGHOFF, EXAMINING ATTORNEY

SN 79-139,661. LOGETTE XAVIER, F-84300 CAVAILLON, FRANCE, FILED 8-29-2013.



PRIORITY DATE OF 3-15-2013 IS CLAIMED.  
OWNER OF INTERNATIONAL REGISTRATION 1184688  
DATED 8-29-2013, EXPIRES 8-29-2023.

NO CLAIM IS MADE TO THE EXCLUSIVE RIGHT TO USE "1903" AND "2006", APART FROM THE MARK AS SHOWN.

THE NAME(S), PORTRAIT(S), AND/OR SIGNATURE(S) SHOWN IN THE MARK DOES NOT IDENTIFY A PARTICULAR LIVING INDIVIDUAL.

THE MARK CONSISTS OF A RECTANGULAR SHAPED

**CLASS 33—(Continued).**

BORDER WITH DEEPEMED CURVE CORNERS. INSIDE THE BOTTOM PORTION OF THE BORDER ARE THE LARGE UNDERLINED WORDS "EMMA M. LOUISE". THE TOP INSIDE PORTION OF THE BORDER FEATURES THE WORD "MAISON" FEATURING A THREE-POINTED FORK-LIKE DESIGN ON EACH SIDE. BELOW THIS IS A STYLIZED ANGEL-LIKE FIGURE FEATURING FLOWERS, LEAVES, AND VINES EXTENDING OUTWARD IN A CURVED MANNER. TO THE LEFT IS THE YEAR "1903" WITH ONE DOT ON THE LEFT AND RIGHT SIDE. BELOW THAT IS AN ARTISTIC FRAME FEATURING A PICTURE OF A STYLIZED STAFF. TO THE RIGHT OF THE ANGEL IS THE YEAR "2006" WITH ONE DOT ON THE LEFT AND RIGHT SIDE. BELOW THAT IS AN OVAL BORDER FEATURING A STYLIZED PORTRAIT OF A FEMALE LOOKING TOWARDS THE LEFT.

THE ENGLISH TRANSLATION OF "MAISON" IN THE MARK IS "HOUSE".

FOR WINES; WINES PROTECTED BY AN APPELLATION OF ORIGIN; ALCOHOLIC BEVERAGES, EXCEPT BEER; SPIRITS; ALCOHOLIC FRUIT EXTRACTS; LIQUEUR CONTAINING ANISEED; ALCOHOLIC BEVERAGES, NAMELY, APERITIFS; DISTILLED SPIRITS; HARD CIDERS; ALCOHOLIC COCKTAIL MIXES; ALCOHOLIC BEVERAGES AND LIQUEURS, NAMELY, DIGESTIFS; MEAD; HYDROMEL; PERRY; RUM (U.S. CLS. 47 AND 49).  
SIMON TENG, EXAMINING ATTORNEY

SN 79-139,664. ERIK MEYBLUM, FRANCE, FILED 9-26-2013.



PRIORITY DATE OF 4-25-2013 IS CLAIMED.  
OWNER OF INTERNATIONAL REGISTRATION 1184692  
DATED 9-26-2013, EXPIRES 9-26-2023.

NO CLAIM IS MADE TO THE EXCLUSIVE RIGHT TO USE "& FILS", APART FROM THE MARK AS SHOWN.

THE MARK CONSISTS OF THE WORDING "MEYBLUM & FILS" AND THE DESIGN OF A THREE TOWERED CASTLE ON A HILLSIDE.

THE ENGLISH TRANSLATION OF "FILS" IN THE MARK IS "SON".

FOR ALCOHOLIC BEVERAGES EXCEPT BEERS; HARD CIDERS; DIGESTERS IN THE NATURE OF LIQUEURS AND SPIRITS; WINES; SPIRITS (U.S. CLS. 47 AND 49).  
SEAN CROWLEY, EXAMINING ATTORNEY

**CLASS 33—(Continued).**

SN 79-139,985. SAS CHATEAU D'AGEL, FRANCE, FILED 10-14-2013.



OWNER OF INTERNATIONAL REGISTRATION 1185520 DATED 10-14-2013, EXPIRES 10-14-2023.

THE COLOR(S) BLACK IS/ARE CLAIMED AS A FEATURE OF THE MARK.

THE MARK CONSISTS OF A SKETCH OF A CASTLE IN BLACK. THE COLOR WHITE IN THE DRAWING REPRESENTS TRANSPARENT AREAS AND A TRANSPARENT BACKGROUND THAT ARE NOT CLAIMED AS PART OF THE MARK.

FOR ALCOHOLIC BEVERAGES EXCEPT BEERS; HARD CIDERS; DIGESTERS, NAMELY, LIQUEURS AND SPIRITS; WINES; SPIRITS; ALCOHOLIC EXTRACTS AND ESSENCES (U.S. CLS. 47 AND 49).

KIM MONINGHOFF, EXAMINING ATTORNEY

SN 79-140,537. BAROKES PTY LTD, TULLAMARINE, AUSTRALIA, FILED 11-18-2013.

## LOVERS WINE

THE MARK CONSISTS OF STANDARD CHARACTERS WITHOUT CLAIM TO ANY PARTICULAR FONT, STYLE, SIZE, OR COLOR.

OWNER OF INTERNATIONAL REGISTRATION 1187001 DATED 11-18-2013, EXPIRES 11-18-2023.

OWNER OF U.S. REG. NO. 3,639,882.

NO CLAIM IS MADE TO THE EXCLUSIVE RIGHT TO USE "WINE", APART FROM THE MARK AS SHOWN.

FOR WINES, BOTH STILL AND SPARKLING; ALCOHOLIC BEVERAGES MADE FROM FRUIT (U.S. CLS. 47 AND 49).

MARY CRAWFORD, EXAMINING ATTORNEY

SN 79-141,056. MASTRI VIGNAI DISTRIBUZIONE S.R.L., PIACENZA (PIACENZA), ITALY, FILED 10-22-2013.

## COLTO VITATO

THE MARK CONSISTS OF STANDARD CHARACTERS WITHOUT CLAIM TO ANY PARTICULAR FONT, STYLE, SIZE, OR COLOR.

PRIORITY DATE OF 10-16-2013 IS CLAIMED.

OWNER OF INTERNATIONAL REGISTRATION 1188384 DATED 10-22-2013, EXPIRES 10-22-2023.

NO CLAIM IS MADE TO THE EXCLUSIVE RIGHT TO USE "VITATO", APART FROM THE MARK AS SHOWN.

THE ENGLISH TRANSLATION OF "COLTO VITATO" IN THE MARK IS "READ VINEYARD".

FOR WINES (U.S. CLS. 47 AND 49).

GEOFFREY FOSDICK, EXAMINING ATTORNEY

**CLASS 33—(Continued).**

SN 79-142,096. TONGYU COUNTY JIHECUN WINE BREWING CO., LTD., BAICHENG CITY JILIN PROVINCE, CHINA, FILED 10-16-2013.



OWNER OF INTERNATIONAL REGISTRATION 1191052 DATED 10-16-2013, EXPIRES 10-16-2023.

THE MARK CONSISTS OF THE STYLIZED LETTERS "JH" SURROUNDED BY A FANCIFUL DESIGN OF A CRANE, ABOVE WHICH APPEAR THE CHINESE CHARACTERS THAT TRANSLITERATE TO "JI" "HE" AND "CUN".

THE CHINESE CHARACTERS IN THE MARK TRANSLITERATE TO "JI", "HE", "CUN", AND THESE MEAN "LUCKY", "CRANE", AND "VILLAGE", RESPECTIVELY, IN ENGLISH. THE COMBINATION OF THE THREE CHARACTERS HAS NO MEANING IN THE FOREIGN LANGUAGE.

FOR LIQUEURS; SPIRITS (U.S. CLS. 47 AND 49).

ANDREW LEASER, EXAMINING ATTORNEY

SN 79-142,526. CANTINA DEL CIABOT DI FIA ROCCO, ITALY, FILED 11-14-2013.

## NAVIANTE

THE MARK CONSISTS OF STANDARD CHARACTERS WITHOUT CLAIM TO ANY PARTICULAR FONT, STYLE, SIZE, OR COLOR.

PRIORITY DATE OF 10-2-2013 IS CLAIMED.

OWNER OF INTERNATIONAL REGISTRATION 1192131 DATED 11-14-2013, EXPIRES 11-14-2023.

FOR ALCOHOLIC BEVERAGES EXCEPT BEERS (U.S. CLS. 47 AND 49).

CARYN GLASSER, EXAMINING ATTORNEY

SN 79-142,731. BODEGAS PEDRO MARTÍNEZ ALESANCO, S.L., BADARAN (LA RIOJA), SPAIN, FILED 10-18-2013.

## PEDRO MARTINEZ ALESANCO

THE MARK CONSISTS OF STANDARD CHARACTERS WITHOUT CLAIM TO ANY PARTICULAR FONT, STYLE, SIZE, OR COLOR.

OWNER OF INTERNATIONAL REGISTRATION 1192548 DATED 10-18-2013, EXPIRES 10-18-2023.

THE NAME(S), PORTRAIT(S), AND/OR SIGNATURE(S) SHOWN IN THE MARK IDENTIFIES "PEDRO MARTINEZ ALESANCO", WHOSE CONSENT(S) TO REGISTER IS MADE OF RECORD.

FOR ALCOHOLIC BEVERAGES EXCLUDING BEERS (U.S. CLS. 47 AND 49).

CHRISTOPHER REAMS, EXAMINING ATTORNEY

**CLASS 33—(Continued).**

SN 79-144,528. SCHMITT SÖHNE GMBH WEINKELLEREI, LONGUICH, FED REP GERMANY, FILED 2-7-2014.



OWNER OF INTERNATIONAL REGISTRATION 0608254 DATED 9-3-1993, EXPIRES 9-3-2023.  
OWNER OF U.S. REG. NO. 1,273,036.  
THE COLOR(S) RED, BLACK AND YELLOW IS/ARE CLAIMED AS A FEATURE OF THE MARK.  
THE MARK CONSIST OF A RED OVAL CONTAINING A YELLOW SUN WITH A FACE THAT IS OUTLINED IN BLACK.  
FOR WINES, SEMI-SPARKLING WINES, SPARKLING WINES, SPIRITS (U.S. CLS. 47 AND 49).  
SHANNON TWOHIG, EXAMINING ATTORNEY

SN 79-144,907. CARLINDEPAOLO S.N.C.; DI PONTE GIAN-CARLO E C., ITALY, FILED 2-20-2014.

**CARLINdePAOLO**



OWNER OF INTERNATIONAL REGISTRATION 1136403 DATED 9-3-2012, EXPIRES 9-3-2022.  
THE NAME(S), PORTRAIT(S), AND/OR SIGNATURE(S) SHOWN IN THE MARK DOES NOT IDENTIFY A PARTICULAR LIVING INDIVIDUAL.  
THE MARK CONSISTS OF THE STYLIZED WORDING "CARLINDEPAOLO" OVER THE DESIGN OF A MAN WALKING.  
FOR WINES; SWEET WINES; GRAPPA BRANDY (U.S. CLS. 47 AND 49).  
DOMINIC J. FERRAIUOLO, EXAMINING ATTORNEY

**CLASS 33—(Continued).**

SN 79-145,723. MARC DUMONT, SWITZERLAND, FILED 2-21-2014.



PRIORITY DATE OF 1-15-2014 IS CLAIMED.  
OWNER OF INTERNATIONAL REGISTRATION 1199780 DATED 2-21-2014, EXPIRES 2-21-2024.  
NO CLAIM IS MADE TO THE EXCLUSIVE RIGHT TO USE "CHATEAU", APART FROM THE MARK AS SHOWN.  
THE MARK CONSISTS OF THE TERM "CHATEAU DE MESSEY" WITH THE DESIGN OF A LONG BUILDING WITH A TOWER AND FIELD IN FRONT.  
FOR AOC WINES WITH THE PROTECTED APPELLATION OF ORIGIN FROM FRANCE (U.S. CLS. 47 AND 49).  
CAROLINE WOOD, EXAMINING ATTORNEY

SN 79-146,188. BACARDI & COMPANY LIMITED, FL-9490 VADUZ, LIECHTENSTEIN, FILED 2-19-2014.

**CARTA NEGRA**

THE MARK CONSISTS OF STANDARD CHARACTERS WITHOUT CLAIM TO ANY PARTICULAR FONT, STYLE, SIZE, OR COLOR.  
PRIORITY DATE OF 9-26-2013 IS CLAIMED.  
OWNER OF INTERNATIONAL REGISTRATION 1201024 DATED 2-19-2014, EXPIRES 2-19-2024.  
NO CLAIM IS MADE TO THE EXCLUSIVE RIGHT TO USE "NEGRA", APART FROM THE MARK AS SHOWN.  
THE ENGLISH TRANSLATION OF "CARTA NEGRA" IN THE MARK IS "BLACK CARD".  
FOR RUM, RUM-BASED BEVERAGES, FLAVOURED RUMS, COCKTAILS FLAVOURED WITH RUM (U.S. CLS. 47 AND 49).  
SIMON TENG, EXAMINING ATTORNEY

SN 85-405,983. BLACK SQUIREL ENTERPRISES, INC., BOSTON, MA. FILED 8-24-2011.

**INFUSION DIABOLIQUE**

THE MARK CONSISTS OF STANDARD CHARACTERS WITHOUT CLAIM TO ANY PARTICULAR FONT, STYLE, SIZE, OR COLOR.  
OWNER OF U.S. REG. NOS. 3,581,857 AND 3,720,156.  
NO CLAIM IS MADE TO THE EXCLUSIVE RIGHT TO USE "INFUSION", APART FROM THE MARK AS SHOWN.  
THE ENGLISH TRANSLATION OF "DIABOLIQUE" IN THE MARK IS "DIABOLICAL".  
FOR ALCOHOLIC BEVERAGES, NAMELY, BOURBON AND RUM (BASED ON USE IN COMMERCE); ALCOHOLIC BEVERAGES, NAMELY, TEQUILA (U.S. CLS. 47 AND 49).  
FIRST USE 11-1-2005; IN COMMERCE 1-11-2006.  
JEFF DEFORD, EXAMINING ATTORNEY

**CLASS 33—(Continued).**

SN 85-471,744. VISION WINE & SPIRITS, LLC, SECAUCUS, NJ. FILED 11-14-2011.

TXT CELLARS ROFL!!!

THE MARK CONSISTS OF STANDARD CHARACTERS WITHOUT CLAIM TO ANY PARTICULAR FONT, STYLE, SIZE, OR COLOR.

OWNER OF U.S. REG. NOS. 4,031,389 AND 4,031,399. NO CLAIM IS MADE TO THE EXCLUSIVE RIGHT TO USE "CELLARS", APART FROM THE MARK AS SHOWN. FOR WINES (U.S. CLS. 47 AND 49). ANGELA M. MICHELI, EXAMINING ATTORNEY

SN 85-471,843. VISION WINE & SPIRITS, LLC, SECAUCUS, NJ. FILED 11-14-2011.

ROFL!!

THE MARK CONSISTS OF STANDARD CHARACTERS WITHOUT CLAIM TO ANY PARTICULAR FONT, STYLE, SIZE, OR COLOR.

FOR WINES (U.S. CLS. 47 AND 49). ANGELA M. MICHELI, EXAMINING ATTORNEY

**CLASS 33—(Continued).**

SN 85-554,820. TAKARA HOLDINGS INC., KYOTO, JAPAN, FILED 2-28-2012.

澗  
MIO

PRIORITY CLAIMED UNDER SEC. 44(D) ON ERPN CMNTY TM OFC APPLICATION NO. 10233047, FILED 9-1-2011.

THE MARK CONSISTS OF JAPANESE CHARACTER THAT TRANSLITERATES TO "MIO", ABOVE THE WORDING "MIO".

THE ENGLISH TRANSLATION OF "MIO" IN THE MARK IS A "WATER ROUTE, A WATERWAY".

THE NON-LATIN CHARACTERS IN THE MARK TRANSLITERATE TO "MIO" AND THIS MEANS A "WATER ROUTE, A WATERWAY" IN ENGLISH.

FOR SAKE; WINES; JAPANESE WHITE LIQUOR (SHOCHU); SPIRITS; LIQUEURS; PREPARED ALCOHOLIC COCKTAIL; JAPANESE SHOCHU-BASED MIXED LIQUOR (MIRIN) (U.S. CLS. 47 AND 49). GIANCARLO CASTRO, EXAMINING ATTORNEY

SN 85-669,215. BODEGAS SAN HUBERTO S.A., 1054 BUENOS AIRES, ARGENTINA, FILED 7-5-2012.

SAN HUBERTO

THE MARK CONSISTS OF STANDARD CHARACTERS WITHOUT CLAIM TO ANY PARTICULAR FONT, STYLE, SIZE, OR COLOR.

THE NAME(S), PORTRAIT(S), AND/OR SIGNATURE(S) SHOWN IN THE MARK DOES NOT IDENTIFY A PARTICULAR LIVING INDIVIDUAL.

THE ENGLISH TRANSLATION OF "SAN" IN THE MARK IS "SAINT".

FOR WINES (U.S. CLS. 47 AND 49). FIRST USE 1-31-1999; IN COMMERCE 11-30-2003. EUGENIA MARTIN, EXAMINING ATTORNEY

**CLASS 33—(Continued).**

SN 85-686,519. SCHMIDT, PAUL, W., MINNEAPOLIS, MN.  
FILED 7-25-2012.

**SPA VODKA**

THE MARK CONSISTS OF STANDARD CHARACTERS WITHOUT CLAIM TO ANY PARTICULAR FONT, STYLE, SIZE, OR COLOR.

NO CLAIM IS MADE TO THE EXCLUSIVE RIGHT TO USE "VODKA", APART FROM THE MARK AS SHOWN.

FOR ALCOHOLIC BEVERAGES, NAMELY, VODKA (U.S. CLS. 47 AND 49).

SHAVELL MCPHERSON, EXAMINING ATTORNEY

SN 85-797,286. JF STROTHMAN DISTILLERY, INC., GRAND JUNCTION, CO. FILED 12-7-2012.

**BITCHIN' BOURBON**

THE MARK CONSISTS OF STANDARD CHARACTERS WITHOUT CLAIM TO ANY PARTICULAR FONT, STYLE, SIZE, OR COLOR.

NO CLAIM IS MADE TO THE EXCLUSIVE RIGHT TO USE "BOURBON", APART FROM THE MARK AS SHOWN.

FOR DISTILLED SPIRITS, BOURBON (U.S. CLS. 47 AND 49).

FONG HSU, EXAMINING ATTORNEY

SN 85-800,453. MEIER'S WINE CELLARS, INC., CINCINNATI, OH. FILED 12-12-2012.

**KENTUCKY PETE'S**

THE MARK CONSISTS OF STANDARD CHARACTERS WITHOUT CLAIM TO ANY PARTICULAR FONT, STYLE, SIZE, OR COLOR.

NO CLAIM IS MADE TO THE EXCLUSIVE RIGHT TO USE "KENTUCKY", APART FROM THE MARK AS SHOWN.

FOR HARD CIDER (U.S. CLS. 47 AND 49).

CHARLES L. JENKINS, EXAMINING ATTORNEY

**CLASS 33—(Continued).**

SN 85-856,866. ALLIED ROYAL WINES, INC., NEW YORK, NY. FILED 2-21-2013.

**Terra Incognita**

THE MARK CONSISTS OF STANDARD CHARACTERS WITHOUT CLAIM TO ANY PARTICULAR FONT, STYLE, SIZE, OR COLOR.

THE ENGLISH TRANSLATION OF "TERRA INCOGNITA" IN THE MARK IS "UNKNOWN LAND".

FOR WINE (U.S. CLS. 47 AND 49).

MARC LEIPZIG, EXAMINING ATTORNEY

SN 85-887,609. MAST-JAEGERMEISTER SE, 38296 WOLFENBUETTEL, FED REP GERMANY, FILED 3-27-2013.



OWNER OF U.S. REG. NOS. 857,604, 3,183,955 AND OTHERS.

NO CLAIM IS MADE TO THE EXCLUSIVE RIGHT TO USE "PRODUCED AND BOTTLED BY", "SE", "SEIT 1878", "WOLFENBÜTTEL GERMANY" AND "IMPORTED HERBAL LIQUEUR", APART FROM THE MARK AS SHOWN.

THE COLOR(S) BRIGHT GREEN, GREEN, DARK GREEN, HUNTER GREEN, ORANGE, GOLD, LIGHT BROWN, BROWN, DARK BROWN, BLACK, AND WHITE IS/ARE CLAIMED AS A FEATURE OF THE MARK.

THE MARK CONSISTS OF THE DESIGN OF A BOTTLE LABEL WHICH IS RECTANGULAR IN SHAPE, THE SIDES AND BOTTOM EDGES OF WHICH ARE STRAIGHT, THE CORNERS ARE SLIGHTLY ROUNDED, AND THE UPPER EDGE IS ARCHED. THE OUTER EDGE OF THE LABEL IS A GOLD OUTLINE NEXT TO WHICH IS AN INNER NARROW BAND OF WHITE, NEXT TO WHICH IS A BAND OF GRADIENT SHADES OF GREEN WITH BRIGHT GREEN BEING THE DOMINANT COLOR AND THE MIDDLE SECTION OF THE RIGHT AND LEFT SIDES OF THE BAND BEING DARK GREEN. SUPERIMPOSED ON THE GREEN BAND, IN GOLD STYLIZED LETTERS, IS THE LITERAL ELEMENT "DAS IST DES JÄGERS EHRENSCHILD, DASS ER BESCHÜTZT UND HEGT SEIN WILD, WEIDMÄNNISCH JAGT, WIE SICH'S GEHÖRT DEN SCHÖPFER IM GESCHÖEPFE EHRT" RUNNING UPWARDS FROM THE BOTTOM LEFT CORNER, AROUND THE TOP AND DOWN TO THE LOWER RIGHT SIDE CORNER OF THE RECTANGULAR BAND. SUPERIMPOSED ON THE BOTTOM PORTION OF THE GREEN BAND, ON BOTH THE RIGHT AND LEFT SIDE, IS A GOLD HORIZONTAL LINE, WHICH STARTS NEAR THE OUTER EDGE OF THE GREEN BAND, WITH A GOLD DOT NEXT TO THE INNER END OF EITHER LINE. BETWEEN THE LINE AND DOT DESIGNS IS THE WORDING "IMPORTED HERBAL LIQUEUR" IN STYLIZED GOLD LETTERS. BOTH THE INNER AND OUTER EDGES OF THE GREEN BAND ARE OUTLINED IN GOLD. A WHITE BAND IS NEXT TO THE GOLD

**CLASS 33—(Continued).**

OUTLINING THE INNER EDGE OF THE GREEN BAND AND THE INNER EDGE OF THE WHITE BAND IS DEFINED BY A THIN GOLD LINE. THE REMAINDER OF THE INSIDE OF THE DESIGN OF THE LABEL IS WHITE. IN THE MIDDLE OF THE LABEL, CROSSING FROM LEFT TO RIGHT, IS AN ORANGE BANNER WITH GOLD BANDS OUTLINED IN BLACK DEFINING THE UPPER AND LOWER EDGES OF THE BANNER. IN THE MIDDLE OF THE BANNER IS THE LITERAL ELEMENT "JÄGERMEISTER" IN BLACK STYLIZED LETTERS WITH GOLD SHADOWING. ABOVE THE CENTER OF THE BANNER, RESTING SLIGHTLY ON THE BODY OF THE BANNER AND REACHING TO THE GOLD LINE DEFINING THE INNER EDGE OF THE WHITE BAND, IS A CIRCULAR DESIGN ELEMENT WITH AN OUTER GOLD BAND. AT THE BOTTOM OF THE CIRCULAR GOLD BAND ARE GOLD OAK LEAVES REACHING TO THE LEFT AND GOLD FIR LEAVES REACHING TO THE RIGHT. A GREEN BAND WITH A GOLD LINE INSIDE THE RIGHT AND LEFT EDGES OF THE BAND COVERS THE BOTTOMS OF OAK AND FIR LEAVES. INSIDE THE CIRCLE, DIRECTLY ABOVE THE GREEN BAND COVERING THE BOTTOM OF THE LEAVES, IS A DARK BROWN STAG WITH WHITE THAT HIGHLIGHTS THE PARTICULAR CHARACTERISTICS OF THE STAG. CENTERED BETWEEN THE ANTLERS OF THE STAG IS A WHITE LATIN CROSS WHICH IS SURROUNDED BY GOLD RAYS WHICH FORM A SOLID FRAMEWORK AROUND THE CROSS AND THEN RADIATE OUT NEARLY TO THE INNER EDGE OF THE GOLD RING DEFINING THE CIRCLE SHAPE. THE BACKGROUND INSIDE THE CIRCLE PROGRESSES FROM LIGHT BROWN TO BROWN TO DARK BROWN. A THIN WHITE LINE IS BETWEEN THE GOLD OUTER BAND OF THE CIRCLE AND THE INSIDE BROWN BACKGROUND. BELOW THE ORANGE BANNER, IN UPPER CASE BLACK LETTERS IS THE WORDING "PRODUCED AND" ABOVE "BOTTLED BY" WHICH IS ALSO IN ALL UPPER CASE BLACK LETTERS. DIRECTLY BELOW "PRODUCED AND BOTTLED BY" IS THE WORD "MAST-" IN STYLIZED HUNTER GREEN LETTERS, UNDER WHICH IS THE WORDING "JÄGERMEISTER SE", ALSO IN STYLIZED HUNTER GREEN FONT. BELOW "JÄGERMEISTER SE" IS THE WORD "WOLFENBÜTTEL" IN UPPER CASE BLACK LETTERS WHICH IS ABOVE THE WORD "GERMANY" ALSO IN UPPER CASE BLACK LETTERS. "JÄGERMEISTER SE" AND "WOLFENBÜTTEL" ARE SUPERIMPOSED OVER AN OUTLINE DESIGN OF GOLD OAK AND FIR LEAVES. CENTERED NEAR THE BOTTOM OF THE LABEL, WITHIN THE WHITE BACKGROUND, IS AN ORANGE LENGTHWISE RECTANGLE WITH STYLIZED LEFT AND RIGHT SIDES WHICH IS OUTLINED IN GOLD AND UPON WHICH IS SUPERIMPOSED THE LITERAL ELEMENT "SEIT 1872" IN GOLD LETTERS AND NUMBERS. OTHER THAN AS DESCRIBED, THE COLOR WHITE IS NOT PART OF THE MARK BUT REPRESENTS A TRANSPARENT BACKGROUND.

THE ENGLISH TRANSLATION OF THE WORD "JÄGERMEISTER" IN THE MARK IS "MASTER OF THE HUNT", THE TRANSLATION OF THE WORD "SEIT" IN THE MARK IS "SINCE", AND THE TRANSLATION OF THE WORDING AROUND THE BORDER OF THE LABEL "DAS IST DES JÄGERS EHRENSCHILD, DASS ER BESCHÜTZT UND HEGT SEIN WILD, WEIDMÄNNISCH JAGT, WIE SICH'S GEHÖRT DEN SCHÖPFER IM GESCHOEPFE EHRT" IN THE MARK IS "IT IS A POINT OF HONOR TO A GAMEKEEPER TO PROTECT AND GUARD HIS GAME, TO HUNT SPORTSMANLIKE AND ACCORDING TO THE RULES, AND TO HONOR THE CREATOR BY HONORING THE GAME".

FOR LIQUEURS, IN PARTICULAR HERBAL LIQUEURS; SPIRITS (U.S. CLS. 47 AND 49).  
FIRST USE 8-14-2013; IN COMMERCE 8-14-2013.  
KATHLEEN KOLACZ, EXAMINING ATTORNEY

**CLASS 33—(Continued).**

SN 85-918,043. LITWACK, BENJAMIN S, EXETER, CA.  
FILED 4-29-2013.

# ZINZANITY

THE MARK CONSISTS OF STANDARD CHARACTERS WITHOUT CLAIM TO ANY PARTICULAR FONT, STYLE, SIZE, OR COLOR.

FOR WINE (U.S. CLS. 47 AND 49).  
JONATHAN FALK, EXAMINING ATTORNEY

SN 85-954,716. GONSALEZ, FRANCISCO F., CASTAIC, CA.  
FILED 6-9-2013.

# CUADRA

THE MARK CONSISTS OF STANDARD CHARACTERS WITHOUT CLAIM TO ANY PARTICULAR FONT, STYLE, SIZE, OR COLOR.

THE ENGLISH TRANSLATION OF "CUADRA" IN THE MARK IS "STABLE" OR "A STREET BLOCK".

FOR TEQUILA; VODKA (U.S. CLS. 47 AND 49).  
FIRST USE 3-17-2011; IN COMMERCE 3-17-2011.  
MICHAEL ENGEL, EXAMINING ATTORNEY

SN 85-964,497. ANKH WINES, LLC, NAPA, CA. FILED 6-19-2013.

# EL NIL

THE MARK CONSISTS OF STANDARD CHARACTERS WITHOUT CLAIM TO ANY PARTICULAR FONT, STYLE, SIZE, OR COLOR.

THE ENGLISH TRANSLATION OF "EL" IN THE MARK IS "THE".

FOR ALCOHOLIC BEVERAGES EXCEPT BEERS (U.S. CLS. 47 AND 49).  
JACQUELINE ABRAMS, EXAMINING ATTORNEY



**CLASS 33—(Continued).**

SN 86-040,871. BOATHOUSE BEVERAGE LLC, WESTPORT, CT. FILED 8-17-2013.



NO CLAIM IS MADE TO THE EXCLUSIVE RIGHT TO USE "SPIKED SELTZER", APART FROM THE MARK AS SHOWN.

THE MARK CONSISTS OF A CIRCLE WITH BUBBLES AND A MERMAID HOLDING A TRIDENT WITH A SLICE OF LIME AT THE TOP OF THE TRIDENT. THE WORDS "SPIKED SELTZER" APPEAR AT THE TOP OF THE CIRCLE.

FOR FLAVORED BREWED ALCOHOLIC BEVERAGES IN THE NATURE OF BEER (U.S. CLS. 47 AND 49).

FIRST USE 5-14-2013; IN COMMERCE 5-14-2013.  
ESTHER A. BORSUK, EXAMINING ATTORNEY

**CLASS 33—(Continued).**

SN 86-046,971. CEJ, LLC, DBA WILDWOOD SPIRITS CO. AND WILDWOOD SPIRITS COMPANY, BELLEVUE, WA. FILED 8-23-2013.

WILDWOOD SPIRITS COMPANY

THE MARK CONSISTS OF STANDARD CHARACTERS WITHOUT CLAIM TO ANY PARTICULAR FONT, STYLE, SIZE, OR COLOR.

NO CLAIM IS MADE TO THE EXCLUSIVE RIGHT TO USE "SPIRITS COMPANY", APART FROM THE MARK AS SHOWN.

FOR BRANDY; DISTILLED SPIRITS; LIQUOR; SCOTCH; SPIRITS; WHISKEY (U.S. CLS. 47 AND 49).

TINA MAI, EXAMINING ATTORNEY

SN 86-045,437. PHINNEY, DAVID S., RUTHERFORD, CA. FILED 8-22-2013.



SN 86-056,295. BUZZBALLZ, LLC, CARROLLTON, TX. FILED 9-5-2013.

BLUE BALL CHILLER

OWNER OF U.S. REG. NO. 3,507,483.

THE MARK CONSISTS OF A MERCURY HEAD DIME. WITHIN THE DIME, THERE IS A PROFILE OF THE WINGED HEAD OF THE FEMALE ROMAN GOD MERCURY. THE HEAD PARTIALLY OVERLAPS THE WORD "LIBERTY" AND TO THE BOTTOM LEFT OF THE HEAD IS THE WORDING "IN GOD WE TRUST" AND BELOW THE HEAD IS THE NUMBER "1942". THE BACKGROUND BEHIND THE DIME IS NOT CLAIMED AS A FEATURE OF THE MARK.

FOR WINE (U.S. CLS. 47 AND 49).  
FIRST USE 3-16-2004; IN COMMERCE 3-16-2004.  
SARA BENJAMIN, EXAMINING ATTORNEY

THE MARK CONSISTS OF STANDARD CHARACTERS WITHOUT CLAIM TO ANY PARTICULAR FONT, STYLE, SIZE, OR COLOR.

NO CLAIM IS MADE TO THE EXCLUSIVE RIGHT TO USE "BLUE BALL", APART FROM THE MARK AS SHOWN. FOR ALCOHOLIC BEVERAGES EXCEPT BEERS (U.S. CLS. 47 AND 49).

FIRST USE 6-15-2013; IN COMMERCE 8-20-2013.  
ALICE BENMAMAN, EXAMINING ATTORNEY



**CLASS 33—(Continued).**

SN 86-061,417. LOTTE CHILSUNG BEVERAGE CO., LTD., SEOUL, REPUBLIC OF KOREA, FILED 9-11-2013.



PRIORITY CLAIMED UNDER SEC. 44(D) ON UNITED KINGDOM APPLICATION NO. 3020914, FILED 9-5-2013.

OWNER OF U.S. REG. NO. 3,442,826.

THE COLOR(S) BLACK, GREEN, LIGHT GREEN, YELLOW AND BEIGE IS/ARE CLAIMED AS A FEATURE OF THE MARK.

THE MARK CONSISTS OF KOREAN LETTERS IN BLACK ON THE UPPER LEFT, AN ILLUSTRATED FLYING BIRD IN BLACK WITH A YELLOW BEAK APPEARS ON THE UPPER RIGHT. BELOW IS THE WORDING "CHUM CHURUM" IN BLACK CAPITAL LETTERS. THE TERM "CHUM" APPEARS ABOVE THE TERM "CHURUM" AND BELOW THE TERM "CHURUM" IS A HORIZONTAL LINE THAT TRANSITIONS FROM GREEN TO LIGHT GREEN AND TO YELLOW. ALL APPEAR ON A BEIGE BACKGROUND.

THE ENGLISH TRANSLATION OF "CHUM CHURUM" IN THE MARK IS "LIKE THE FIRST TIME" OR "FOR THE FIRST TIME".

THE NON-LATIN CHARACTERS IN THE MARK TRANSLITERATE TO "CHUM CHURUM" AND THIS MEANS "LIKE THE FIRST TIME" OR "FOR THE FIRST TIME" IN ENGLISH.

FOR KOREAN DISTILLED LIQUORS (SOJU); DISTILLED SPIRITS OF RICE; VODKA; LIQUEURS; SPIRITS; ALCOHOLIC BEVERAGES EXCEPT BEER; DISTILLED BEVERAGES, NAMELY, DISTILLED SPIRITS; COCKTAILS, NAMELY, ALCOHOLIC COCKTAIL MIXES; GIN; RUM; SAKE; WINE (U.S. CLS. 47 AND 49).  
MARLENE BELL, EXAMINING ATTORNEY

SN 86-063,164. DS LAND, LLC, ENGLEWOOD, CO. FILED 9-12-2013.

**1876 COLORADO CENTENNIAL**

THE MARK CONSISTS OF STANDARD CHARACTERS WITHOUT CLAIM TO ANY PARTICULAR FONT, STYLE, SIZE, OR COLOR.

NO CLAIM IS MADE TO THE EXCLUSIVE RIGHT TO USE "COLORADO", APART FROM THE MARK AS SHOWN.

FOR BOURBON; DISTILLED SPIRITS; GIN; RUM; VODKA; WHISKEY (U.S. CLS. 47 AND 49).

RUDY R. SINGLETON, EXAMINING ATTORNEY

**CLASS 33—(Continued).**

SN 86-067,224. WÖLFFER ESTATE VINEYARD & STABLES, SAGAPONACK, NY. FILED 9-17-2013.

**WÖLFFER ESTATE**

THE MARK CONSISTS OF STANDARD CHARACTERS WITHOUT CLAIM TO ANY PARTICULAR FONT, STYLE, SIZE, OR COLOR.

NO CLAIM IS MADE TO THE EXCLUSIVE RIGHT TO USE "ESTATE", APART FROM THE MARK AS SHOWN. SEC. 2(F).

FOR WINES (U.S. CLS. 47 AND 49).

FIRST USE 0-0-1996; IN COMMERCE 0-0-1996.

ANDREA K. NADELMAN, EXAMINING ATTORNEY

SN 86-069,812. WHEATLEY, TERRY, HUGHSON, CA. FILED 9-19-2013.

**QUEEN OF THE WEST**

THE MARK CONSISTS OF STANDARD CHARACTERS WITHOUT CLAIM TO ANY PARTICULAR FONT, STYLE, SIZE, OR COLOR.

FOR ALCOHOLIC BEVERAGES EXCEPT BEERS (U.S. CLS. 47 AND 49).

ELLEN PERKINS, EXAMINING ATTORNEY

SN 86-069,823. WHEATLEY, TERRY, HUGHSON, CA. FILED 9-19-2013.

**GODDESS OF THE VALLEY**

THE MARK CONSISTS OF STANDARD CHARACTERS WITHOUT CLAIM TO ANY PARTICULAR FONT, STYLE, SIZE, OR COLOR.

FOR ALCOHOLIC BEVERAGES EXCEPT BEERS (U.S. CLS. 47 AND 49).

ELLEN PERKINS, EXAMINING ATTORNEY

**CLASS 33—(Continued).**

SN 86-069,848. WHEATLEY, TERRY, HUGHSON, CA. FILED 9-19-2013.

LIGHT OF THE MOON

THE MARK CONSISTS OF STANDARD CHARACTERS WITHOUT CLAIM TO ANY PARTICULAR FONT, STYLE, SIZE, OR COLOR.

FOR ALCOHOLIC BEVERAGES EXCEPT BEERS (U.S. CLS. 47 AND 49).  
ELLEN PERKINS, EXAMINING ATTORNEY

SN 86-071,574. LES GRANDS CHAIS DE FRANCE, PETERSBACH, FRANCE, FILED 9-23-2013.

PHILIPPE DUBLANC

THE MARK CONSISTS OF STANDARD CHARACTERS WITHOUT CLAIM TO ANY PARTICULAR FONT, STYLE, SIZE, OR COLOR.

PRIORITY CLAIMED UNDER SEC. 44(D) ON FRANCE APPLICATION NO. 13/4033948, FILED 9-20-2013, REG. NO. 134033948, DATED 1-10-2014, EXPIRES 9-20-2023.

"PHILIPPE DUBLANC" DOES NOT IDENTIFY A LIVING INDIVIDUAL.

FOR ALCOHOLIC BEVERAGES EXCEPT BEER; HARD CIDER; DIGESTERS, NAMELY, LIQUEURS AND SPIRITS; WINE; SPARKLING WINES; SPIRITS; ALCOHOLIC EXTRACTS OR ESSENCES (U.S. CLS. 47 AND 49).  
KIMBERLY PERRY, EXAMINING ATTORNEY

SN 86-072,428. GHOST HORSE VINEYARDS, LLC, NAPA, CA. FILED 9-23-2013.

THE TODD

THE MARK CONSISTS OF STANDARD CHARACTERS WITHOUT CLAIM TO ANY PARTICULAR FONT, STYLE, SIZE, OR COLOR.

FOR ALCOHOLIC BEVERAGES EXCEPT BEERS (U.S. CLS. 47 AND 49).  
JORDAN BAKER, EXAMINING ATTORNEY

**CLASS 33—(Continued).**

SN 86-086,816. PINE RIDGE WINERY, LLC, NAPA, CA. FILED 10-9-2013.

CB+V

THE MARK CONSISTS OF STANDARD CHARACTERS WITHOUT CLAIM TO ANY PARTICULAR FONT, STYLE, SIZE, OR COLOR.

FOR WINE (U.S. CLS. 47 AND 49).  
KERI CANTONE, EXAMINING ATTORNEY

SN 86-088,712. TERRE DA VINO S.P.A., BAROLO, CUNEO, ITALY, FILED 10-10-2013.



THE MARK CONSISTS OF A COAT OF ARMS DESIGN AT THE VERY TOP WITH A DESIGN OF A RURAL LANDSCAPE INCLUDING A CASTLE AND A FIELD ENCOMPASSED BY AN ORNAMENTAL BORDER CONSISTING OF FOLIAGE WITH A LION'S HEAD AT THE TOP MIDDLE OF THE BORDER, ALL NEAR THE BOTTOM AND THE STYLIZED WORDING "BARRERI & ROVATI" DIRECTLY BELOW. THE RECTANGLE CARRIER REPRESENTS PLACEMENT OF THE MARK AND IS NOT PART OF THE MARK. THE COLORS BLACK AND GRAY REPRESENT BACKGROUND, OUTLINING, SHADING AND/OR TRANSPARENT AREAS AND ARE NOT PART OF THE MARK.

FOR WINES (U.S. CLS. 47 AND 49).  
FIRST USE 10-1-2013; IN COMMERCE 10-1-2013.  
DEBORAH MEINERS, EXAMINING ATTORNEY

**CLASS 33—(Continued).**

SN 86-089,659. HOTELES Y VIÑEDOS DEL VALLE DE GUADALUPE S.A. DE C.V., COZUMEL, MEXICO, FILED 10-11-2013.

# GALILEO

THE MARK CONSISTS OF STANDARD CHARACTERS WITHOUT CLAIM TO ANY PARTICULAR FONT, STYLE, SIZE, OR COLOR.

FOR RED WINE; ROSE WINE; WINE; WINES (U.S. CLS. 47 AND 49).

KELLY BOULTON, EXAMINING ATTORNEY

SN 86-092,864. VYTAUTAS MAKSTUTIS, WEYMOUTH, MA, FILED 10-16-2013.



NO CLAIM IS MADE TO THE EXCLUSIVE RIGHT TO USE "MARGARITA", APART FROM THE MARK AS SHOWN.

THE MARK CONSISTS OF A GENERALLY SQUARE CELTIC CROSS DESIGN APPEARING ABOVE THE WORDS "RUSTIC SPIRITS" IN STYLIZED BLOCK LETTERS, ALL APPEARING OVER THE WORD "MARGARITA" IN STYLIZED SCRIPT. THE SQUARE DESIGN ITSELF CONSISTS OF A STYLIZED CROSS PATTEE WITH A PATTERN OF STYLIZED FLEURS-DE-LIS PROJECTING AT FORTY-FIVE DEGREE ANGLES BETWEEN THE ENDS OF THE CROSS ARMS TO COMPRISE A CIRCLE AROUND THE CENTER OF THE CROSS.

FOR ALCOHOLIC BEVERAGES, NAMELY, MARGARITAS (U.S. CLS. 47 AND 49).

KERI CANTONE, EXAMINING ATTORNEY

SN 86-095,672. BEVELAND, S.A., BEGUDÀ, GIRONA, SPAIN, FILED 10-18-2013.

# GLEN SILVERS

THE MARK CONSISTS OF STANDARD CHARACTERS WITHOUT CLAIM TO ANY PARTICULAR FONT, STYLE, SIZE, OR COLOR.

OWNER OF ERPN CMNTY TM OFC REG. NO. 4687729, DATED 10-6-2006, EXPIRES 10-28-2015.

THE NAME(S), PORTRAIT(S), AND/OR SIGNATURE(S) SHOWN IN THE MARK DOES NOT IDENTIFY A PARTICULAR LIVING INDIVIDUAL.

FOR ALCOHOLIC BEVERAGES EXCEPT BEERS (U.S. CLS. 47 AND 49).

KRISTIN DAHLING, EXAMINING ATTORNEY

**CLASS 33—(Continued).**

SN 86-097,261. JUN CO., LTD., TOKYO, JAPAN, FILED 10-21-2013.

# CHATEAU JUN

THE MARK CONSISTS OF STANDARD CHARACTERS WITHOUT CLAIM TO ANY PARTICULAR FONT, STYLE, SIZE, OR COLOR.

PRIORITY CLAIMED UNDER SEC. 44(D) ON JAPAN APPLICATION NO. 2013-054542, FILED 7-12-2013, REG. NO. 5643000, DATED 1-17-2014, EXPIRES 1-17-2024.

NO CLAIM IS MADE TO THE EXCLUSIVE RIGHT TO USE "CHATEAU", APART FROM THE MARK AS SHOWN. FOR WINE, BRANDY, ALCOHOLIC BEVERAGES, NAMELY, WINE-BASED PREMIXED ALCOHOLIC BEVERAGES AND BRANDY-BASED PREMIXED ALCOHOLIC BEVERAGES (U.S. CLS. 47 AND 49).

LEE-ANNE BERNS, EXAMINING ATTORNEY

SN 86-114,594. GRAND BOHEMIAN WINE, LLC, NAPA, CA, FILED 11-9-2013.



THE MARK CONSISTS OF A STYLIZED LETTER "K".

FOR WINE (U.S. CLS. 47 AND 49). FIRST USE 4-1-2013; IN COMMERCE 4-1-2013.

JEFF DEFORD, EXAMINING ATTORNEY

SN 86-120,494. COOPERATIVA VITIVINICOLA AROUSANA, S.C.G., MEANO (PONTEVEDRA), SPAIN, FILED 11-15-2013.



PRIORITY CLAIMED UNDER SEC. 44(D) ON ERPN CMNTY TM OFC APPLICATION NO. 12094331, FILED 8-28-2013, REG. NO. 012094331, DATED 1-8-2014, EXPIRES 8-28-2023.

OWNER OF U.S. REG. NO. 4,137,659. THE MARK CONSISTS OF A RECTANGLE DESIGN FEATURING EVENLY-SPACED REPETITIVE CIRCLES AND RECTANGULAR SHAPE WITHIN.

FOR ALCOHOLIC BEVERAGES, NAMELY, WINES, SPARKLING WINES AND LIQUEURS (U.S. CLS. 47 AND 49).

JACQUELINE ABRAMS, EXAMINING ATTORNEY

**CLASS 33—(Continued).**

SN 86-120,597. ASPIRA CORPORATION, DBA ASPIRA BRANDS, SANTA BARBARA, CA. FILED 11-15-2013.



THE COLOR(S) RED, BLACK, AND YELLOW IS/ARE CLAIMED AS A FEATURE OF THE MARK.  
 THE MARK CONSISTS OF A BLACK, VERTICAL RECTANGLE WITH A BLACK DRAGON THAT HAS YELLOW EYES POSITIONED DOWN THE LENGTH OF THE RECTANGLE. THE DRAGON IS SURROUNDED BY AN ABSTRACT DESIGN IN RED. THE WORDING "ELEMENTUM" IS IN RED AND APPEARS AT THE BOTTOM OF THE RECTANGLE UNDER THE DRAGON.  
 FOR WINE (U.S. CLS. 47 AND 49).  
 FIRST USE 11-6-2013; IN COMMERCE 11-12-2013.  
 AISHA CLARKE, EXAMINING ATTORNEY

SN 86-133,718. SPIRITS OF THE USA LLC, DBA SPIRITSUSA, CUMMING, GA. FILED 12-3-2013.

**Legends Whisky**

THE MARK CONSISTS OF STANDARD CHARACTERS WITHOUT CLAIM TO ANY PARTICULAR FONT, STYLE, SIZE, OR COLOR.  
 NO CLAIM IS MADE TO THE EXCLUSIVE RIGHT TO USE "WHISKY", APART FROM THE MARK AS SHOWN.  
 FOR LIQUOR (U.S. CLS. 47 AND 49).  
 B. PARADEWELAI, EXAMINING ATTORNEY

SN 86-133,878. RIVER CITY SPIRITS, LLC, AUSTIN, TX. FILED 12-3-2013.



THE MARK CONSISTS OF STANDARD CHARACTERS WITHOUT CLAIM TO ANY PARTICULAR FONT, STYLE, SIZE, OR COLOR.  
 FOR TEQUILA; TEQUILA INFUSED WITH VITAMINS (U.S. CLS. 47 AND 49).  
 KAMAL PREET, EXAMINING ATTORNEY

**CLASS 33—(Continued).**

SN 86-137,495. COEUR D'ALENE CELLARS, LLC, COEUR D'ALENE, ID. FILED 12-6-2013.

Hole	1	2	3	4	5	6	7	8	9	Total
Yards	499	377	114	256	120	155	389	399	540	2849
Par	5	4	3	4	3	3	4	4	5	35
Annika	⊙	⊙	⊙	⊙	⊙	⊙	⊙	⊙	⊙	⊙

THE MARK CONSISTS OF A GOLF SCORECARD DESIGN WITH THE WORDING "HOLE" AND NUMBERS "1" THROUGH "9", FOLLOWED BY THE WORD "TOTAL"; "YARDS" WITH NUMBERS "499", "377", "114", "256", "120", "155", "389", "399", "540", AND "2849"; AND "PAR" WITH NUMBERS "5", "4", "3", "4", "3", "3", "4", "4", "5", AND "35"; AND THE NAME "ANNIKA" WITH THE NUMBERS "4", "3", "3", "3", "3", "3", "3", "4", AND "29", WITH CIRCLES AROUND THE FIRST, SECOND, FOURTH, SEVENTH, EIGHTH, AND NINTH NUMBERS IN THE ROW.  
 FOR ALCOHOLIC BEVERAGES EXCEPT BEERS; WINE (U.S. CLS. 47 AND 49).  
 FIRST USE 4-22-2013; IN COMMERCE 4-22-2013.  
 JOHN E. MICHOS, EXAMINING ATTORNEY

SN 86-137,507. COEUR D'ALENE CELLARS, LLC, COEUR D'ALENE, ID. FILED 12-6-2013.

Hole	10	11	12	13	14	15	16	17	18	Total
Yards	406	506	180	293	147	462	401	236	434	3065
Par	4	5	3	4	3	5	4	4	4	36
Annika	⊙	⊙	⊙	⊙	⊙	⊙	⊙	⊙	⊙	⊙

THE MARK CONSISTS OF A GOLF SCORECARD DESIGN WITH THE WORDING HOLE AND NUMBERS "10" THROUGH "18", FOLLOWED BY THE WORD "TOTAL"; "YARDS" WITH NUMBERS "406", "506", "180", "293", "147", "462", "401", "236", "434", AND "3065"; "PAR" WITH NUMBERS "4", "5", "3", "4", "3", "5", "4", "4", "4", AND "36"; AND THE NAME "ANNIKA" WITH THE NUMBERS "3", "4", "3", "3", "3", "5", "3", "3", "3", AND "30", WITH CIRCLES AROUND THE FIRST, SECOND, FOURTH, SEVENTH, EIGHTH, AND NINTH NUMBERS IN THE ROW.  
 FOR ALCOHOLIC BEVERAGES EXCEPT BEERS; WINE (U.S. CLS. 47 AND 49).  
 FIRST USE 4-22-2013; IN COMMERCE 4-22-2013.  
 JOHN E. MICHOS, EXAMINING ATTORNEY

SN 86-145,839. SOCIETA' AGRICOLA LA RAIA S.S., NOVI LIGURE (AL), ITALY, FILED 12-17-2013.

**TENUTA DEL MELOGRANO**

THE MARK CONSISTS OF STANDARD CHARACTERS WITHOUT CLAIM TO ANY PARTICULAR FONT, STYLE, SIZE, OR COLOR.  
 NO CLAIM IS MADE TO THE EXCLUSIVE RIGHT TO USE "TENUTA", APART FROM THE MARK AS SHOWN.  
 THE ENGLISH TRANSLATION OF "TENUTA DEL MELOGRANO" IN THE MARK IS "ESTATE OF THE POMEGRANATE TREE".  
 FOR ALCOHOLIC BEVERAGES EXCEPT BEERS; LIQUEURS; SPARKLING WINES; WINES (U.S. CLS. 47 AND 49).  
 BRIAN PINO, EXAMINING ATTORNEY

**CLASS 33—(Continued).**

SN 86-187,230. CHATEAU LAROSE TRINTAUDON, SAINT LAURENT DU MEDOC, FRANCE, FILED 2-7-2014.



NO CLAIM IS MADE TO THE EXCLUSIVE RIGHT TO USE "SUSTAINABLE VINEYARD", APART FROM THE MARK AS SHOWN.

THE MARK CONSISTS OF A CIRCLE DESIGN ELEMENT CONTAINING A PICTORIAL DEPICTION OF A HOUSE AND PLANTING ROWS. TO THE RIGHT OF THE CIRCLE ELEMENT IS THE WORDING "SUSTAINABLE VINEYARD."

FOR ALCOHOLIC BEVERAGES, EXCEPT BEERS; WINES; SPIRITS (U.S. CLS. 47 AND 49).  
JEFF DEFORD, EXAMINING ATTORNEY

SN 86-191,281. STE. MICHELLE WINE ESTATES LTD., WOODINVILLE, WA. FILED 2-12-2014.



OWNER OF U.S. REG. NOS. 1,439,435, 4,001,382 AND OTHERS.

NO CLAIM IS MADE TO THE EXCLUSIVE RIGHT TO USE "ESTATES", APART FROM THE MARK AS SHOWN.

THE MARK CONSISTS OF A LARGE, STYLIZED "C" CENTERED IN A THREE-SIDED SHIELD WITH AN EXTERNAL BORDER AROUND THE SHIELD WITH THE BOTTOM OF THE "C" PIERCING THROUGH A LEAF WITH THE STYLIZED WORDS "COLUMBIA CREST GRAND ESTATES" INTERSECTING THE LETTER "C".

FOR ALCOHOLIC BEVERAGES, EXCEPT BEERS (U.S. CLS. 47 AND 49).

FIRST USE 3-29-2013; IN COMMERCE 3-29-2013.  
CAROLINE WOOD, EXAMINING ATTORNEY

**CLASS 33—(Continued).**

SN 86-203,165. GEORGETOWN TRADING CO., LLC, WASHINGTON, DC. FILED 2-25-2014.

# 1776

THE MARK CONSISTS OF STANDARD CHARACTERS WITHOUT CLAIM TO ANY PARTICULAR FONT, STYLE, SIZE, OR COLOR.

OWNER OF U.S. REG. NOS. 4,132,977 AND 4,528,599. FOR ALCOHOLIC BEVERAGES EXCEPT BEERS (U.S. CLS. 47 AND 49).

FIRST USE 2-11-2012; IN COMMERCE 2-11-2012.  
DAVID I, EXAMINING ATTORNEY

SN 86-208,895. PIRATE DOG BRAND LLC, SALEM, MA. FILED 3-3-2014.

## Exceptional rum for spirited folks with stories to share.

THE MARK CONSISTS OF STANDARD CHARACTERS WITHOUT CLAIM TO ANY PARTICULAR FONT, STYLE, SIZE, OR COLOR.

NO CLAIM IS MADE TO THE EXCLUSIVE RIGHT TO USE "RUM", APART FROM THE MARK AS SHOWN.

FOR ALCOHOLIC BEVERAGES, NAMELY, RUM (U.S. CLS. 47 AND 49).

FIRST USE 9-24-2013; IN COMMERCE 2-28-2014.  
ALLISON HOLTZ, EXAMINING ATTORNEY

SN 86-209,570. SUTTER HOME WINERY, INC., ST. HELENA, CA. FILED 3-3-2014.

## MENAGE A TROIS BLACK

THE MARK CONSISTS OF STANDARD CHARACTERS WITHOUT CLAIM TO ANY PARTICULAR FONT, STYLE, SIZE, OR COLOR.

OWNER OF U.S. REG. NOS. 3,147,087 AND 3,974,306. NO CLAIM IS MADE TO THE EXCLUSIVE RIGHT TO USE "BLACK", APART FROM THE MARK AS SHOWN.

THE ENGLISH TRANSLATION OF "MENAGE A TROIS" IN THE MARK IS "FAMILY OF THREE".

FOR WINE (U.S. CLS. 47 AND 49).  
STEVEN JACKSON, EXAMINING ATTORNEY

**CLASS 33—(Continued).**

SN 86-209,580. SUTTER HOME WINERY, INC., ST. HELENA, CA. FILED 3-3-2014.

**MENAGE A TROIS BLACK SERIES**

THE MARK CONSISTS OF STANDARD CHARACTERS WITHOUT CLAIM TO ANY PARTICULAR FONT, STYLE, SIZE, OR COLOR.

OWNER OF U.S. REG. NOS. 3,147,087 AND 3,974,306.

NO CLAIM IS MADE TO THE EXCLUSIVE RIGHT TO USE "BLACK SERIES", APART FROM THE MARK AS SHOWN.

THE ENGLISH TRANSLATION OF "MENAGE A TROIS" IN THE MARK IS "FAMILY OF THREE".

FOR WINE (U.S. CLS. 47 AND 49).

STEVEN JACKSON, EXAMINING ATTORNEY

SN 86-215,082. WARDEN, TODD, KEENE, NH. FILED 3-7-2014.

**Westslope Spirits**

THE MARK CONSISTS OF STANDARD CHARACTERS WITHOUT CLAIM TO ANY PARTICULAR FONT, STYLE, SIZE, OR COLOR.

NO CLAIM IS MADE TO THE EXCLUSIVE RIGHT TO USE "SPIRITS", APART FROM THE MARK AS SHOWN.

FOR DISTILLED SPIRITS; GIN; VODKA; WHISKEY (U.S. CLS. 47 AND 49).

DANNEAN HETZEL, EXAMINING ATTORNEY

SN 86-216,874. SOUTHERN COMFORT PROPERTIES, INC., SAN RAFAEL, CA. FILED 3-10-2014.



OWNER OF U.S. REG. NOS. 317,529, 3,986,790 AND OTHERS.

THE MARK CONSISTS OF THE WORDS "SOUTHERN

**CLASS 33—(Continued).**

COMFORT" ARRANGED IN A DOWNWARD-TURNING ARCH. BELOW THE WORDING ARE THE LETTERS "S" AND "C" WITH AN EIGHT-POINTED STAR COMPRISED OF TWO HEXAGONAL SHAPES WITH CONCAVE ENDS BETWEEN THE TWO LETTERS. THE WORD "ONE" APPEARS INSIDE THE STAR AND EIGHT SHORT STRAIGHT LINES REPRESENTING LIGHT BEAMS MOVE AWAY FROM THE STAR DESIGN IN ALL DIRECTIONS. BELOW THE STAR DESIGN IS THE WORDING "CATEGORY OF ONE" ARRANGED IN AN UPWARD-TURNING ARCH.

FOR ALCOHOLIC BEVERAGES EXCEPT BEERS (U.S. CLS. 47 AND 49).

ALISON KEELEY, EXAMINING ATTORNEY

SN 86-216,886. SOUTHERN COMFORT PROPERTIES, INC., SAN RAFAEL, CA. FILED 3-10-2014.



OWNER OF U.S. REG. NOS. 1,522,030, 3,986,790 AND OTHERS.

THE NAME SHOWN IN THE MARK DOES NOT IDENTIFY A PARTICULAR LIVING INDIVIDUAL.

THE MARK CONSISTS OF THE WORDS "M.W. HERON'S" ABOVE THE WORDING "SOUTHERN COMFORT". THE WORDING "SOUTHERN COMFORT" APPEARS LARGE, CENTRALLY, AND OUTLINED, GIVING THE LETTERS A THREE-DIMENSIONAL EFFECT. THE WORDING "SOUTHERN" IS ABOVE AND SLIGHTLY SMALLER THAN THE WORD "COMFORT". BELOW THIS WORDING APPEARS THE WORDING "CATEGORY OF ONE" IN A SMALLER FONT. BELOW "CATEGORY OF ONE" IS AN 8-POINTED STAR, WITH THE LETTERS "S" AND "C" TO THE LEFT AND RIGHT OF THE STAR, RESPECTIVELY, AND THE WORD "ONE" APPEARING INSIDE THE STAR. EIGHT SHORT STRAIGHT LINES REPRESENTING LIGHT BEAMS MOVE AWAY FROM THE STAR DESIGN IN ALL DIRECTIONS. ALL OF THESE ELEMENTS ARE SURROUNDED BY A BORDER COMPOSED OF TWO LINES THAT IS ROUNDED ON THE TOP, STRAIGHT ON THE SIDES, AND DIPS DOWN ON THE BOTTOM TO ACCOMMODATE THE STAR DESIGN.

FOR ALCOHOLIC BEVERAGES EXCEPT BEERS (U.S. CLS. 47 AND 49).

ALISON KEELEY, EXAMINING ATTORNEY

**CLASS 33—(Continued).**

SN 86-218,898. RARE ANTIBODY ANTIGEN SUPPLY, INC., AGOURA HILLS, CA. FILED 3-12-2014.

# KAMIBUDO

THE MARK CONSISTS OF STANDARD CHARACTERS WITHOUT CLAIM TO ANY PARTICULAR FONT, STYLE, SIZE, OR COLOR.

THE WORDING "KAMIBUDO" HAS NO MEANING IN A FOREIGN LANGUAGE.

FOR WINE (U.S. CLS. 47 AND 49).

JOHN HWANG, EXAMINING ATTORNEY

SN 86-218,902. RARE ANTIBODY ANTIGEN SUPPLY, INC., AGOURA HILLS, CA. FILED 3-12-2014.

# TENNO BUDO

THE MARK CONSISTS OF STANDARD CHARACTERS WITHOUT CLAIM TO ANY PARTICULAR FONT, STYLE, SIZE, OR COLOR.

THE ENGLISH TRANSLATION OF "TENNO BUDO" IS "HEAVENLY SOVEREIGN MARTIAL WAY".

FOR WINE (U.S. CLS. 47 AND 49).

JOHN HWANG, EXAMINING ATTORNEY

SN 86-220,584. BEVHAUS, INC., SAN FRANCISCO, CA. FILED 3-13-2014.

**BROOKS DRY CIDER**  
BORN IN CALIFORNIA



NO CLAIM IS MADE TO THE EXCLUSIVE RIGHT TO USE "DRY CIDER" AND "CALIFORNIA", APART FROM THE MARK AS SHOWN.

THE MARK CONSISTS OF A BEAR RIDING A BICYCLE WITH THE WORDING "BROOKS DRY CIDER BORN IN CALIFORNIA" WRITTEN ABOVE IT.

FOR ALCOHOLIC BEVERAGES EXCEPT BEERS; HARD CIDER (U.S. CLS. 47 AND 49).

GEOFFREY FOSDICK, EXAMINING ATTORNEY

**CLASS 33—(Continued).**

SN 86-220,589. BEVHAUS, INC., SAN FRANCISCO, CA. FILED 3-13-2014.

**BROOKS DRY CIDER**  
BORN IN CALIFORNIA



NO CLAIM IS MADE TO THE EXCLUSIVE RIGHT TO USE "DRY CIDER" AND "CALIFORNIA", APART FROM THE MARK AS SHOWN.

THE MARK CONSISTS OF A BEAR DRIVING A CAR WITH THE WORDING "BROOKS DRY CIDER BORN IN CALIFORNIA" WRITTEN ABOVE IT.

FOR ALCOHOLIC BEVERAGES EXCEPT BEERS; HARD CIDER (U.S. CLS. 47 AND 49).

GEOFFREY FOSDICK, EXAMINING ATTORNEY

SN 86-220,595. BEVHAUS, INC., SAN FRANCISCO, CA. FILED 3-13-2014.



**BROOKS DRY CIDER**  
BORN IN CALIFORNIA

NO CLAIM IS MADE TO THE EXCLUSIVE RIGHT TO USE "DRY CIDER" AND "CALIFORNIA", APART FROM THE MARK AS SHOWN.

THE MARK CONSISTS OF THE HEAD OF A BEAR WITH THE WORDING "BROOKS DRY CIDER" WRITTEN UNDERNEATH AND THE WORDING "BORN IN CALIFORNIA" WRITTEN UNDERNEATH THAT.

FOR ALCOHOLIC BEVERAGES EXCEPT BEERS; HARD CIDER (U.S. CLS. 47 AND 49).

GEOFFREY FOSDICK, EXAMINING ATTORNEY

**CLASS 33—(Continued).**

SN 86-222,297. RARE ANTIBODY ANTIGEN SUPPLY, INC., AGOURA HILLS, CA. FILED 3-15-2014.

**OHHI BUDO**

THE MARK CONSISTS OF STANDARD CHARACTERS WITHOUT CLAIM TO ANY PARTICULAR FONT, STYLE, SIZE, OR COLOR.

THE WORDING "OHHI" HAS NO MEANING IN A FOREIGN LANGUAGE. THE ENGLISH TRANSLATION OF "BUDO" IS "MARTIAL WAY".

FOR WINE (U.S. CLS. 47 AND 49).  
JOHN HWANG, EXAMINING ATTORNEY

SN 86-225,932. BROWN-FORMAN CORPORATION, LOUISVILLE, KY. FILED 3-19-2014.

**MADE OF MEXICO**

THE MARK CONSISTS OF STANDARD CHARACTERS WITHOUT CLAIM TO ANY PARTICULAR FONT, STYLE, SIZE, OR COLOR.

FOR DISTILLED SPIRITS ORIGINATING IN MEXICO (U.S. CLS. 47 AND 49).

PAUL E. FAHRENKOPF, EXAMINING ATTORNEY

SN 86-226,334. THE AMENDED MARK D. GAMBLE 1996 LIVING TRUST, SAN FRANCISCO, CA. FILED 3-19-2014.

**OAKVILLE FARMHOUSE**

THE MARK CONSISTS OF STANDARD CHARACTERS WITHOUT CLAIM TO ANY PARTICULAR FONT, STYLE, SIZE, OR COLOR.

NO CLAIM IS MADE TO THE EXCLUSIVE RIGHT TO USE "OAKVILLE", APART FROM THE MARK AS SHOWN.

FOR WINES DERIVED FROM GRAPES GROWN IN THE OAKVILLE AMERICAN VITICULTURAL AREA, LABELED AND ADVERTISED IN COMPLIANCE WITH UNITED STATES LAWS FOR THE OAKVILLE AMERICAN VITICULTURAL AREA APPELLATION OF ORIGIN (U.S. CLS. 47 AND 49).

DAVID MURRAY, EXAMINING ATTORNEY

**CLASS 33—(Continued).**

SN 86-226,339. CASA ARMANDO GUILLERMO PRIETO, S.A. DE C.V., JIUTEPEC, MORELOS, MEXICO, FILED 3-19-2014.



OWNER OF MEXICO REG. NO. 1445012, DATED 3-31-2014, EXPIRES 10-9-2023.

OWNER OF U.S. REG. NO. 3,325,608.

NO CLAIM IS MADE TO THE EXCLUSIVE RIGHT TO USE "ARTESANAL", "OAXACA" AND "MEZCAL", APART FROM THE MARK AS SHOWN.

THE COLOR(S) MAGENTA, ORANGE, GREEN AND WHITE IS/ARE CLAIMED AS A FEATURE OF THE MARK.

THE MARK CONSISTS OF A RECTANGULAR, MAGENTA BOX BORDERED BY ORANGE AND GREEN LINES. AT THE BOTTOM OF THE MAGENTA BOX ARE TWO PARALLEL, HORIZONTAL ORANGE DASHES, IN BETWEEN WHICH IS A SPIRAL, GREEN LOGO WITH RAYS EMANATING FROM ITS CENTER. IN THE MIDDLE OF THE MAGENTA BOX ARE TWO, CRISS-CROSSED, OVERLAPPING ORANGE BOXES. THE TOP ORANGE BOX IS OUTLINED IN WHITE AND CONTAINS A PARALLEL INTERIOR BORDER IN MAGENTA AND WHITE. WITHIN THE BORDER ARE WHITE DASHES RUNNING PERPENDICULARLY, WITH OCCASIONAL SHADES OF GREEN. AT THE TOP OF THE BORDER IS A PENTAGON INSIDE OF WHICH IS A SMALLER, GREEN PENTAGON AND AN IMAGE OF AN ANIMAL HEAD IN MAGENTA OUTLINE WITH MAGENTA DASHES TO ITS SIDE. INSIDE OF THE TOP ORANGE BOX ARE THE WORDS "MEZCAL EL RECUERDO DE OAXACA. MEZCAL" IS IN MAGENTA LETTERS WITH HORIZONTAL GREEN DASHES ON EACH SIDE, AND "EL RECUERDO DE OAXACA" IS IN WHITE. THE WORD "RECUERDO" IS OUTLINED IN BOTH GREEN AND MAGENTA COLORS. THE BOTTOM ORANGE BOX HAS AN INTERIOR MAGENTA BORDER. AT THE TOP ARE THE WORDS "TRADICIÓN ARTESANAL" IN WHITE FONT, SHADOWED IN MAGENTA. AT THE BOTTOM ARE THE WORDS "HERENCIA Y TRADICIÓN DESDE EL SIGLO XVI" IN WHITE LETTERS.

THE ENGLISH TRANSLATION OF "TRADICIÓN ARTESANAL MEZCAL EL RECUERDO DE OAXACA HERENCIA Y TRADICIÓN DESDE EL SIGLO XVI" IN THE MARK IS "ARTISINAL TRADITION, MEZCAL, THE MEMORY OF OAXACA, HERITAGE AND TRADITION SINCE THE 16TH CENTURY".

FOR MEZCAL (U.S. CLS. 47 AND 49).

FRANK LATTUCA, EXAMINING ATTORNEY



**CLASS 33—(Continued).**

SN 86-227,989. DIAGEO NORTH AMERICA, INC., NORWALK, CT. FILED 3-21-2014.



OWNER OF U.S. REG. NO. 2,074,482.  
 NO CLAIM IS MADE TO THE EXCLUSIVE RIGHT TO USE "FLAVOR", APART FROM THE MARK AS SHOWN.  
 THE MARK CONSISTS OF A CROWN DESIGN OVER THE WORDS "OLD WORLD FLAVOR" WHICH ARE ARCHED OVER A CREST CONTAINING BERRIES AND SURROUNDED BY VINES AND LEAVES ON THE SIDES, ALL OF WHICH APPEAR ABOVE THE WORDS "BLACK HAUS" IN STYLIZED LETTERING AND SIT INSIDE AN OUTLINED BACKGROUND THAT ROUNDS TO A POINT ON TOP.  
 THE ENGLISH TRANSLATION OF "HAUS" IN THE MARK IS "HOUSE".  
 FOR ALCOHOLIC BEVERAGES EXCEPT BEERS (U.S. CLS. 47 AND 49).  
 ELLEN BURNS, EXAMINING ATTORNEY

SN 86-228,071. AMAZON RANCH WINERY, NAPA, CA. FILED 3-21-2014.

**SK8R Wines**

THE MARK CONSISTS OF STANDARD CHARACTERS WITHOUT CLAIM TO ANY PARTICULAR FONT, STYLE, SIZE, OR COLOR.  
 NO CLAIM IS MADE TO THE EXCLUSIVE RIGHT TO USE "WINES", APART FROM THE MARK AS SHOWN.  
 FOR WINE (U.S. CLS. 47 AND 49).  
 KELLY BOULTON, EXAMINING ATTORNEY

**CLASS 33—(Continued).**

SN 86-229,123. CRIPPS, KAISA, GERALDINE HOLLOWAY, FAIRHAVEN, MA. FILED 3-22-2014.

**MASS CRANSHINE**

THE MARK CONSISTS OF STANDARD CHARACTERS WITHOUT CLAIM TO ANY PARTICULAR FONT, STYLE, SIZE, OR COLOR.  
 NO CLAIM IS MADE TO THE EXCLUSIVE RIGHT TO USE "MASS", APART FROM THE MARK AS SHOWN.  
 FOR ALCOHOLIC BEVERAGES CONTAINING FRUIT; SPIRITS (U.S. CLS. 47 AND 49).  
 ELLEN B. AWRICH, EXAMINING ATTORNEY

SN 86-229,334. ANYELA'S VINEYARDS, LLC, AUBURN, NY. FILED 3-23-2014.

**ANYELA'S VINEYARDS SENZA**

THE MARK CONSISTS OF STANDARD CHARACTERS WITHOUT CLAIM TO ANY PARTICULAR FONT, STYLE, SIZE, OR COLOR.  
 OWNER OF U.S. REG. NO. 3,572,965.  
 NO CLAIM IS MADE TO THE EXCLUSIVE RIGHT TO USE "VINEYARDS", APART FROM THE MARK AS SHOWN.  
 THE ENGLISH TRANSLATION OF "SENZA" IS "WITHOUT".  
 FOR WINE (U.S. CLS. 47 AND 49).  
 BRIAN PINO, EXAMINING ATTORNEY

SN 86-231,652. J. P. WISER DISTILLERY LIMITED, TORONTO, ONTARIO, CANADA, FILED 3-25-2014.

**MAKE THE WISER CALL**

THE MARK CONSISTS OF STANDARD CHARACTERS WITHOUT CLAIM TO ANY PARTICULAR FONT, STYLE, SIZE, OR COLOR.  
 OWNER OF U.S. REG. NOS. 997,669, 3,368,013 AND OTHERS.  
 FOR ALCOHOLIC BEVERAGES EXCEPT BEERS (U.S. CLS. 47 AND 49).  
 JUSTINE D. PARKER, EXAMINING ATTORNEY

**CLASS 33—(Continued).**

SN 86-231,870. YEALANDS ESTATE WINES LIMITED, MARLBOROUGH, NEW ZEALAND, FILED 3-25-2014.

**PETER YEALANDS**

THE MARK CONSISTS OF STANDARD CHARACTERS WITHOUT CLAIM TO ANY PARTICULAR FONT, STYLE, SIZE, OR COLOR.

OWNER OF U.S. REG. NO. 3,549,467.  
THE NAME(S), PORTRAIT(S), AND/OR SIGNATURE(S) SHOWN IN THE MARK IDENTIFIES "PETER YEALANDS", WHOSE CONSENT(S) TO REGISTER IS MADE OF RECORD.

FOR WINE (U.S. CLS. 47 AND 49).  
KAMAL PREET, EXAMINING ATTORNEY

**CLASS 33—(Continued).**

SN 86-232,737. LIVERAS LIMITED, BARNET, HERTFORDSHIRE, UNITED KINGDOM, FILED 3-26-2014.

**PROTOX**

THE MARK CONSISTS OF STANDARD CHARACTERS WITHOUT CLAIM TO ANY PARTICULAR FONT, STYLE, SIZE, OR COLOR.

OWNER OF UNITED KINGDOM REG. NO. UK0000301831, DATED 12-20-2013, EXPIRES 8-15-2023.

FOR ALCOHOLIC BEVERAGES ENHANCED WITH PROTEIN AND VITAMINS, EXCEPT BEERS; ALCOHOLIC BEVERAGES FORTIFIED WITH PROTEIN, VITAMINS AND MINERALS, EXCEPT BEERS (U.S. CLS. 47 AND 49).

DAVID HOFFMAN, EXAMINING ATTORNEY

SN 86-232,145. AUSTIN PRODUCT LAB LLC, AUSTIN, TX, FILED 3-26-2014.

**MARTINE HONEYSUCKLE LIQUEUR**

THE MARK CONSISTS OF STANDARD CHARACTERS WITHOUT CLAIM TO ANY PARTICULAR FONT, STYLE, SIZE, OR COLOR.

NO CLAIM IS MADE TO THE EXCLUSIVE RIGHT TO USE "HONEYSUCKLE LIQUEUR", APART FROM THE MARK AS SHOWN.

FOR ALCOHOLIC CORDIALS; SPIRITS AND LIQUEURS (U.S. CLS. 47 AND 49).

MARY ROSSMAN, EXAMINING ATTORNEY

SN 86-233,054. LAS JOYAS DEL AGAVE LLC, ALAMEDA, CA. FILED 3-26-2014.

**HENRI VALLET**

THE MARK CONSISTS OF STANDARD CHARACTERS WITHOUT CLAIM TO ANY PARTICULAR FONT, STYLE, SIZE, OR COLOR.

THE NAME(S), PORTRAIT(S), AND/OR SIGNATURE(S) SHOWN IN THE MARK DOES NOT IDENTIFY A PARTICULAR LIVING INDIVIDUAL.

FOR ALCOHOLIC BEVERAGES EXCEPT BEERS; ALCOHOLIC CORDIALS; LIQUEUR (U.S. CLS. 47 AND 49).

FIRST USE 3-26-2014; IN COMMERCE 3-26-2014.  
JULIE GUTTADAURO, EXAMINING ATTORNEY

SN 86-232,576. SOUTHERN COMFORT PROPERTIES, INC., SAN RAFAEL, CA. FILED 3-26-2014.

**MAKE MINE COMFORTABLE**

THE MARK CONSISTS OF STANDARD CHARACTERS WITHOUT CLAIM TO ANY PARTICULAR FONT, STYLE, SIZE, OR COLOR.

OWNER OF U.S. REG. NOS. 1,048,272 AND 4,404,561.  
FOR ALCOHOLIC BEVERAGES EXCEPT BEERS (U.S. CLS. 47 AND 49).

ALISON KEELEY, EXAMINING ATTORNEY

SN 86-233,073. LAS JOYAS DEL AGAVE LLC, ALAMEDA, CA. FILED 3-26-2014.

**ROYAL VALLET**

THE MARK CONSISTS OF STANDARD CHARACTERS WITHOUT CLAIM TO ANY PARTICULAR FONT, STYLE, SIZE, OR COLOR.

FOR ALCOHOLIC BEVERAGES EXCEPT BEERS; ALCOHOLIC CORDIALS; LIQUEUR (U.S. CLS. 47 AND 49).

JULIE GUTTADAURO, EXAMINING ATTORNEY

**CLASS 33—(Continued).**

SN 86-233,974. SEYFERTH, JOHN S., CHICAGO, IL. FILED 3-27-2014.

## Big Boy Punch

THE MARK CONSISTS OF STANDARD CHARACTERS WITHOUT CLAIM TO ANY PARTICULAR FONT, STYLE, SIZE, OR COLOR.

NO CLAIM IS MADE TO THE EXCLUSIVE RIGHT TO USE "PUNCH", APART FROM THE MARK AS SHOWN.

FOR ALCOHOLIC PUNCH (U.S. CLS. 47 AND 49).  
ROBIN CHOSID, EXAMINING ATTORNEY

---

SN 86-234,161. THE INDIANA WHISKEY COMPANY, SOUTH BEND, IN. FILED 3-27-2014.

## Silver Sweet Corn Whiskey

THE MARK CONSISTS OF STANDARD CHARACTERS WITHOUT CLAIM TO ANY PARTICULAR FONT, STYLE, SIZE, OR COLOR.

NO CLAIM IS MADE TO THE EXCLUSIVE RIGHT TO USE "SWEET CORN WHISKEY", APART FROM THE MARK AS SHOWN.

FOR WHISKEY (U.S. CLS. 47 AND 49).  
FIRST USE 9-1-2013; IN COMMERCE 9-1-2013.  
SUSAN RICHARDS, EXAMINING ATTORNEY

---

SN 86-235,105. DIAGEO CHATEAU & ESTATE WINES COMPANY, NAPA, CA. FILED 3-28-2014.

## TRUVÉE

THE MARK CONSISTS OF STANDARD CHARACTERS WITHOUT CLAIM TO ANY PARTICULAR FONT, STYLE, SIZE, OR COLOR.

THE WORDING "TRUVÉE" HAS NO MEANING IN A FOREIGN LANGUAGE.

FOR ALCOHOLIC BEVERAGES EXCEPT BEERS (U.S. CLS. 47 AND 49).

TIMOTHY O. SCHIMPF, EXAMINING ATTORNEY

**CLASS 33—(Continued).**

SN 86-235,561. DESTILERIAS CAMPENY, S.A., EL MASNOU (BARCELONA), SPAIN, FILED 3-28-2014.



THE COLOR(S) BLACK, ORANGE, AND WHITE IS/ARE CLAIMED AS A FEATURE OF THE MARK.

THE MARK CONSISTS OF A THREE-DIMENSIONAL CONFIGURATION OF A BLACK BOTTLE DESIGN. ACROSS THE FRONT OF THE BODY OF THE BOTTLE DESIGN IS A DIAGONAL DESIGN ELEMENT FEATURING A WHITE AND ORANGE CRYSTAL ENCRUSTATION. IN THE CENTER OF THE DIAGONAL ELEMENT IS A LARGER BLACK RECTANGULAR CARRIER DESIGN ELEMENT WITH THE WORDING "AXELVÄR" IN ORANGE LETTERS. BELOW THE LARGER RECTANGULAR CARRIER DESIGN ELEMENT IS A SMALLER BLACK RECTANGULAR CARRIER DESIGN ELEMENT. ACROSS THE NECK OF THE BOTTLE DESIGN IS A DIAGONAL DESIGN ELEMENT FEATURING A WHITE AND ORANGE CRYSTAL ENCRUSTATION. THE DOTTED OUTLINE OF THE BOTTLE IS NOT PART OF THE MARK BUT IS MERELY INTENDED TO SHOW THE POSITION OF THE MARK.

THE WORDING "AXELVÄR" HAS NO MEANING IN A FOREIGN LANGUAGE.

FOR VODKA (U.S. CLS. 47 AND 49).  
AMY ALFIERI, EXAMINING ATTORNEY

---

SN 86-235,701. ROOTS SPIRITS LTD LTD, 106 72 ATHENS, GREECE, FILED 3-28-2014.

## ROOTS

### THE FINEST SWEET LIQUOR FOR THE SOUL

THE MARK CONSISTS OF STANDARD CHARACTERS WITHOUT CLAIM TO ANY PARTICULAR FONT, STYLE, SIZE, OR COLOR.

FOR ALCOHOLIC BEVERAGES EXCEPT BEER, NAMELY, RAKOMELO, MASTIHA, TENTURA, HERB SPIRIT, AND RAKI; LIQUOR SEASONED WITH MASTIC; LIQUOR HAVING CLOVES, CINNAMON, NUTMEG AND CITRUS FRUITS; BRANDY; VODKA; ALCOHOLIC BEVERAGES EXCEPT BEER HAVING NATURAL EXTRACTS; ALCOHOLIC BEVERAGES EXCEPT BEER HAVING HONEY; WINE; FLAVORED VODKA; ALCOHOLIC SPIRITS; ALCOHOLIC BEVERAGES EXCEPT BEER; DISTILLED SPIRITS; LIQUEURS; ALCOHOLIC BEVERAGES EXCEPT BEER, NAMELY, DIGESTER; GIN; SPIRITS, NAMELY, GRAPE POMACE DISTILLATE WITH HONEY AND CLOVE BUDS (U.S. CLS. 47 AND 49).

AHSEN KHAN, EXAMINING ATTORNEY

**CLASS 33—(Continued).**

SN 86-236,352. WALLACE, JOE, WOODLAND HILLS, CA.  
FILED 3-29-2014.

**Tiger Monkey INC**

THE MARK CONSISTS OF STANDARD CHARACTERS  
WITHOUT CLAIM TO ANY PARTICULAR FONT, STYLE,  
SIZE, OR COLOR.

NO CLAIM IS MADE TO THE EXCLUSIVE RIGHT TO  
USE "INC", APART FROM THE MARK AS SHOWN.

FOR LIQUOR IN ICE CREAM FORM; LIQUOR IN  
WHIPPED CREAM FORM (U.S. CLS. 47 AND 49).  
DOMINICK J. SALEMI, EXAMINING ATTORNEY

**CLASS 33—(Continued).**

SN 86-239,331. CABERNET CORPORATION, NOVATO, CA.  
FILED 4-1-2014.

**EYZAGUIRRE**

THE MARK CONSISTS OF STANDARD CHARACTERS  
WITHOUT CLAIM TO ANY PARTICULAR FONT, STYLE,  
SIZE, OR COLOR.

SEC. 2(F).

FOR GRAPE WINE (U.S. CLS. 47 AND 49).

FIRST USE 1-1-1997; IN COMMERCE 1-1-1997.

CHRISTINA SOBRAL, EXAMINING ATTORNEY

SN 86-239,150. THE IRISH DAIRY BOARD CO-OPERATIVE  
LIMITED, DUBLIN 2, IRELAND, FILED 4-1-2014.

**KERRYGOLD**

THE MARK CONSISTS OF STANDARD CHARACTERS  
WITHOUT CLAIM TO ANY PARTICULAR FONT, STYLE,  
SIZE, OR COLOR.

OWNER OF U.S. REG. NOS. 883,443, 4,543,887 AND  
OTHERS.

FOR ALCOHOL BEVERAGES, NAMELY, CREAM  
LIQUOR (U.S. CLS. 47 AND 49).

ANDREA K. NADELMAN, EXAMINING ATTORNEY

SN 86-239,668. RARE ANTIBODY ANTIGEN SUPPLY, INC.,  
AGOURA HILLS, CA. FILED 4-2-2014.

**OHHIBUDO**

THE MARK CONSISTS OF STANDARD CHARACTERS  
WITHOUT CLAIM TO ANY PARTICULAR FONT, STYLE,  
SIZE, OR COLOR.

THE WORDING "OHHIBUDO" HAS NO MEANING IN A  
FOREIGN LANGUAGE.

FOR WINE (U.S. CLS. 47 AND 49).

JOHN HWANG, EXAMINING ATTORNEY

SN 86-239,293. CABERNET CORPORATION, NOVATO, CA.  
FILED 4-1-2014.

**ANTUCO**

THE MARK CONSISTS OF STANDARD CHARACTERS  
WITHOUT CLAIM TO ANY PARTICULAR FONT, STYLE,  
SIZE, OR COLOR.

THE ENGLISH TRANSLATION OF "ANTUCO" IN THE  
MARK IS "THE INDIAN'S WATER".

FOR GRAPE WINE (U.S. CLS. 47 AND 49).

CHRISTINA SOBRAL, EXAMINING ATTORNEY

SN 86-239,684. RARE ANTIBODY ANTIGEN SUPPLY, INC.,  
AGOURA HILLS, CA. FILED 4-2-2014.

**OHJOBUDO**

THE MARK CONSISTS OF STANDARD CHARACTERS  
WITHOUT CLAIM TO ANY PARTICULAR FONT, STYLE,  
SIZE, OR COLOR.

THE WORDING "OHJOBUDO" HAS NO MEANING IN A  
FOREIGN LANGUAGE.

FOR WINE (U.S. CLS. 47 AND 49).

JOHN HWANG, EXAMINING ATTORNEY

**CLASS 33—(Continued).**

SN 86-239,699. RARE ANTIBODY ANTIGEN SUPPLY, INC.,  
AGOURA HILLS, CA. FILED 4-2-2014.

**HIDENKABUDO**

THE MARK CONSISTS OF STANDARD CHARACTERS  
WITHOUT CLAIM TO ANY PARTICULAR FONT, STYLE,  
SIZE, OR COLOR.

THE WORDING "HIDENKABUDO" HAS NO MEANING  
IN A FOREIGN LANGUAGE.

FOR WINE (U.S. CLS. 47 AND 49).

JOHN HWANG, EXAMINING ATTORNEY

---

SN 86-241,739. BROWN-FORMAN CORPORATION, LOUIS-  
VILLE, KY. FILED 4-3-2014.

**HECHO DE MEXICO**

THE MARK CONSISTS OF STANDARD CHARACTERS  
WITHOUT CLAIM TO ANY PARTICULAR FONT, STYLE,  
SIZE, OR COLOR.

THE ENGLISH TRANSLATION OF "HECHO DE MEX-  
ICO" IN THE MARK IS "MADE OF MEXICO".

FOR DISTILLED SPIRITS ORIGINATING IN MEXICO  
(U.S. CLS. 47 AND 49).

PAUL E. FAHRENKOPF, EXAMINING ATTORNEY

---

SN 86-241,896. THE TRUSTEES OF THE COLONIAL  
GREENE TRUST, LOS ANGELES, CA. FILED 4-3-2014.

**TWO WOLVES WINE**

THE MARK CONSISTS OF STANDARD CHARACTERS  
WITHOUT CLAIM TO ANY PARTICULAR FONT, STYLE,  
SIZE, OR COLOR.

NO CLAIM IS MADE TO THE EXCLUSIVE RIGHT TO  
USE "WINE", APART FROM THE MARK AS SHOWN.

FOR WINES; APERITIF WINES; COOKING WINE;  
DESSERT WINES; FORTIFIED WINES; FRUIT WINE;  
GRAPE WINE; HONEY WINE; NATURAL SPARKLING  
WINES; PORT WINES; RED WINES; ROSE WINE;  
SPARKLING FRUIT WINE; SPARKLING GRAPE WINE;  
SPARKLING WINES; STILL WINES; STRAWBERRY  
WINE; SWEET WINES; TABLE WINES; WHITE WINE;  
WINE-BASED DRINKS (U.S. CLS. 47 AND 49).

CHRISTINA SOBRAL, EXAMINING ATTORNEY

**CLASS 33—(Continued).**

SN 86-242,971. FETZER VINEYARDS, HOPLAND, CA.  
FILED 4-4-2014.

**SPLITWATER**

THE MARK CONSISTS OF STANDARD CHARACTERS  
WITHOUT CLAIM TO ANY PARTICULAR FONT, STYLE,  
SIZE, OR COLOR.

FOR WINE (U.S. CLS. 47 AND 49).

DAVID GEARHART, EXAMINING ATTORNEY

---

SN 86-244,091. DANIEL GUILLERMO REBOLLEDO FER-  
NANDEZ, SANTA MARTHA ACATITLA, MEXICO,  
FILED 4-7-2014.

**TEQUIPONCH**

THE MARK CONSISTS OF STANDARD CHARACTERS  
WITHOUT CLAIM TO ANY PARTICULAR FONT, STYLE,  
SIZE, OR COLOR.

FOR ALCOHOLIC COCKTAIL MIXES; PREPARED  
ALCOHOLIC COCKTAIL (U.S. CLS. 47 AND 49).

MARK SPARACINO, EXAMINING ATTORNEY

---

SN 86-244,349. BENEDUCE VINEYARDS LLC, PITTSTOWN,  
NJ. FILED 4-7-2014.

**CENTERFOLD**

THE MARK CONSISTS OF STANDARD CHARACTERS  
WITHOUT CLAIM TO ANY PARTICULAR FONT, STYLE,  
SIZE, OR COLOR.

FOR WINE (U.S. CLS. 47 AND 49).

FIRST USE 7-28-2012; IN COMMERCE 7-28-2012.

TEJBIR SINGH, EXAMINING ATTORNEY

**CLASS 33—(Continued).**

SN 86-244,356. BENEDEUCE VINEYARDS LLC, PITTS TOWN, NJ. FILED 4-7-2014.

**THREE WINDOWS**

THE MARK CONSISTS OF STANDARD CHARACTERS WITHOUT CLAIM TO ANY PARTICULAR FONT, STYLE, SIZE, OR COLOR.

FOR WINE (U.S. CLS. 47 AND 49).  
FIRST USE 7-28-2012; IN COMMERCE 7-28-2012.  
TEJBIR SINGH, EXAMINING ATTORNEY

---

SN 86-245,057. THORNTON WINERY, TEMECULA, CA. FILED 4-7-2014.

**TOOT SWEET BUBBLES**

THE MARK CONSISTS OF STANDARD CHARACTERS WITHOUT CLAIM TO ANY PARTICULAR FONT, STYLE, SIZE, OR COLOR.

FOR WINE (U.S. CLS. 47 AND 49).  
THEODORE MCBRIDE, EXAMINING ATTORNEY

---

SN 86-246,447. BEAR CREEK WINERY, LLC, HOMER, AK. FILED 4-8-2014.

**GLACIER BEAR**

THE MARK CONSISTS OF STANDARD CHARACTERS WITHOUT CLAIM TO ANY PARTICULAR FONT, STYLE, SIZE, OR COLOR.

FOR ALCOHOLIC BEVERAGES EXCEPT BEERS (U.S. CLS. 47 AND 49).  
VIVIAN MICZNIK FIRST, EXAMINING ATTORNEY

**CLASS 33—(Continued).**

SN 86-246,491. JADELAND, INC., PASADENA, CA. FILED 4-8-2014.



THE COLOR(S) RED, GOLD, IS/ARE CLAIMED AS A FEATURE OF THE MARK.

THE MARK CONSISTS OF MISTS AND CLOUDS (IN CURLY SHAPES) ABOVE AND BENEATH THE NAME OF THE BRAND, "FUME DE JADE". THE MISTS AND CLOUDS ARE IN THE COLOR OF GOLD, AND THE CHARACTERS "FUMÉ DE JADE" ARE IN THE COLOR OF RED, SHADOWED BY THE COLOR OF GOLD.

THE ENGLISH TRANSLATION OF "FUMÉ DE JADE" IN THE MARK IS "SMOKE OF THE JADE".

FOR ACANTHOPANAX WINE (OGAPIJU); APERITIF WINES; APERITIFS WITH A WINE BASE; BLACK RASPBERRY WINE (BOKBUNJAJU); COOKING WINE; DESSERT WINES; FORTIFIED WINES; FRUIT WINE; GRAPE WINE; HONEY WINE; KITS FOR MAKING WINE; KOREAN TRADITIONAL RICE WINE (MAK-GEOLI); NATURAL SPARKLING WINES; PORT WINES; PREPARED WINE COCKTAILS; RED WINE; RED WINES; ROSE WINE; SPARKLING FRUIT WINE; SPARKLING GRAPE WINE; SPARKLING WINES; STILL WINES; STRAWBERRY WINE; SWEET WINES; TABLE WINES; TONIC SWEET GRAPE WINE CONTAINING EXTRACTS FROM GINSENG AND CONCHONA BARK (NINJIN-KINATETSU WINE); WHITE WINE; WINE; WINE COOLERS; WINE PUNCH; WINE PUNCHES; WINE-BASED BEVERAGE, NAMELY, PIQUETTE; WINE-BASED DRINKS; WINES; WINES AND FORTIFIED WINES; WINES AND LIQUEURS; WINES AND SPARKLING WINES; WINES DERIVED FROM GRAPES GROWN IN WASHINGTON, LABELED AND ADVERTISED IN COMPLIANCE WITH WASHINGTON AND U.S. FEDERAL LAWS FOR WINES (U.S. CLS. 47 AND 49).

TINA L. SNAPP, EXAMINING ATTORNEY

---

SN 86-247,130. OAKLEY SPIRITS COMPANY, LLC, CINCINNATI, OH. FILED 4-9-2014.

**Comber**

THE MARK CONSISTS OF STANDARD CHARACTERS WITHOUT CLAIM TO ANY PARTICULAR FONT, STYLE, SIZE, OR COLOR.

FOR WHISKEY (U.S. CLS. 47 AND 49).  
AHSEN KHAN, EXAMINING ATTORNEY

**CLASS 33—(Continued).**

SN 86-247,135. OAKLEY SPIRITS COMPANY, LLC, CINCINNATI, OH. FILED 4-9-2014.

**Old Comber**

THE MARK CONSISTS OF STANDARD CHARACTERS WITHOUT CLAIM TO ANY PARTICULAR FONT, STYLE, SIZE, OR COLOR.  
FOR WHISKEY (U.S. CLS. 47 AND 49).  
AHSEN KHAN, EXAMINING ATTORNEY

SN 86-247,447. TURN KEY WINE BRANDS LLC, SANTA BARBARA, CA. FILED 4-9-2014.

**JEBEDIAH DRINKWELL'S**

THE MARK CONSISTS OF STANDARD CHARACTERS WITHOUT CLAIM TO ANY PARTICULAR FONT, STYLE, SIZE, OR COLOR.  
THE NAME "JEBEDIAH DRINKWELL" DOES NOT IDENTIFY A LIVING INDIVIDUAL.  
FOR WINES (U.S. CLS. 47 AND 49).  
CHRISTOPHER LAW, EXAMINING ATTORNEY

SN 86-247,605. JC CELLARS, INC., OAKLAND, CA. FILED 4-9-2014.

**MISC. STUFF**

THE MARK CONSISTS OF STANDARD CHARACTERS WITHOUT CLAIM TO ANY PARTICULAR FONT, STYLE, SIZE, OR COLOR.  
FOR WINE (U.S. CLS. 47 AND 49).  
FIRST USE 0-0-2010; IN COMMERCE 0-0-2010.  
ROGER T. MCDORMAN, EXAMINING ATTORNEY

**CLASS 33—(Continued).**

SN 86-247,676. LAETITIA VINEYARD AND WINERY, INC., ARROYO GRANDE, CA. FILED 4-9-2014.

**AVILA**

THE MARK CONSISTS OF STANDARD CHARACTERS WITHOUT CLAIM TO ANY PARTICULAR FONT, STYLE, SIZE, OR COLOR.  
FOR WINE (U.S. CLS. 47 AND 49).  
KRISTIN CARLSON, EXAMINING ATTORNEY

SN 86-247,926. BLACKMAR, MATT, NAPERVILLE, IL. FILED 4-10-2014.



THE MARK CONSISTS OF A DESIGN OF A DOG WITH A TOP HAT AND BOW TIE.  
FOR WINES (U.S. CLS. 47 AND 49).  
FIRST USE 4-18-2013; IN COMMERCE 4-18-2013.  
GEORGE LORENZO, EXAMINING ATTORNEY

SN 86-248,026. MS ELECTRONICS LLC, OVERLAND PARK, KS. FILED 4-10-2014.

**CATWALK**

THE MARK CONSISTS OF STANDARD CHARACTERS WITHOUT CLAIM TO ANY PARTICULAR FONT, STYLE, SIZE, OR COLOR.  
FOR WINES (U.S. CLS. 47 AND 49).  
LINDA E. BLOHM, EXAMINING ATTORNEY

**CLASS 33—(Continued).**

SN 86-249,593. THE OTHER GUYS, INC., SONOMA, CA.  
FILED 4-11-2014.

## SEXTILIS

THE MARK CONSISTS OF STANDARD CHARACTERS  
WITHOUT CLAIM TO ANY PARTICULAR FONT, STYLE,  
SIZE, OR COLOR.

FOR ALCOHOLIC BEVERAGES EXCEPT BEERS (U.S.  
CLS. 47 AND 49).

DAVID COLLIER, EXAMINING ATTORNEY

**CLASS 33—(Continued).**

SN 86-251,822. PRP WINE INTERNATIONAL, NAPERVILLE,  
IL. FILED 4-14-2014.

## Travicello

THE MARK CONSISTS OF STANDARD CHARACTERS  
WITHOUT CLAIM TO ANY PARTICULAR FONT, STYLE,  
SIZE, OR COLOR.

OWNER OF U.S. REG. NO. 3,301,362.

FOR WINE (U.S. CLS. 47 AND 49).

FIRST USE 6-1-1989; IN COMMERCE 6-1-1989.

SUSAN LESLIE DUBOIS, EXAMINING ATTORNEY

SN 86-250,583. VIGNERON LLC, HUNTINGTON BEACH,  
CA. FILED 4-12-2014.

## Comandon Cognac Coronation

THE MARK CONSISTS OF STANDARD CHARACTERS  
WITHOUT CLAIM TO ANY PARTICULAR FONT, STYLE,  
SIZE, OR COLOR.

OWNER OF U.S. REG. NO. 3,524,912.

NO CLAIM IS MADE TO THE EXCLUSIVE RIGHT TO  
USE "COGNAC", APART FROM THE MARK AS SHOWN.

FOR GRAPE BRANDY DISTILLED IN THE COGNAC  
REGION OF FRANCE IN COMPLIANCE WITH THE  
LAWS AND REGULATIONS OF THE FRENCH GOV-  
ERNMENT (U.S. CLS. 47 AND 49).

FIRST USE 10-1-2013; IN COMMERCE 10-1-2013.

JOHN WILKE, EXAMINING ATTORNEY

SN 86-251,823. C&C IP (NO.2) SARL, LUXEMBOURG,  
LUXEMBOURG, FILED 4-14-2014.

## CIDERBRATION

THE MARK CONSISTS OF STANDARD CHARACTERS  
WITHOUT CLAIM TO ANY PARTICULAR FONT, STYLE,  
SIZE, OR COLOR.

FOR HARD CIDER (U.S. CLS. 47 AND 49).

LINDA MICKLEBURGH, EXAMINING ATTORNEY

SN 86-251,802. C&C IP (NO.2) SARL, LUXEMBOURG,  
LUXEMBOURG, FILED 4-14-2014.

## OUT ON A LIMB

THE MARK CONSISTS OF STANDARD CHARACTERS  
WITHOUT CLAIM TO ANY PARTICULAR FONT, STYLE,  
SIZE, OR COLOR.

FOR HARD CIDER (U.S. CLS. 47 AND 49).

LINDA MICKLEBURGH, EXAMINING ATTORNEY

SN 86-253,048. WILSON, KIRSTEN, IRVINE, CA. FILED 4-15-  
2014.

## InChic Cocktails

THE MARK CONSISTS OF STANDARD CHARACTERS  
WITHOUT CLAIM TO ANY PARTICULAR FONT, STYLE,  
SIZE, OR COLOR.

OWNER OF U.S. REG. NOS. 4,187,842, 4,187,844 AND  
OTHERS.

NO CLAIM IS MADE TO THE EXCLUSIVE RIGHT TO  
USE "COCKTAILS", APART FROM THE MARK AS  
SHOWN.

FOR BEVERAGES, NAMELY, PREPARED ALCO-  
HOLIC COCKTAILS AND LIQUORS (U.S. CLS. 47 AND  
49).

FIRST USE 1-9-2014; IN COMMERCE 1-9-2014.

LAURA GOLDEN, EXAMINING ATTORNEY



**CLASS 33—(Continued).**

SN 86-256,047. CALINI GROUP LLC, OVERLAND PARK, KS. FILED 4-18-2014.

# CLASSIC CARS

THE MARK CONSISTS OF STANDARD CHARACTERS WITHOUT CLAIM TO ANY PARTICULAR FONT, STYLE, SIZE, OR COLOR.  
FOR WINE (U.S. CLS. 47 AND 49).  
ESTHER QUEEN, EXAMINING ATTORNEY

---

SN 86-256,053. CALINI GROUP LLC, OVERLAND PARK, KS. FILED 4-18-2014.

# CAPTAIN WINGS

THE MARK CONSISTS OF STANDARD CHARACTERS WITHOUT CLAIM TO ANY PARTICULAR FONT, STYLE, SIZE, OR COLOR.  
FOR WINE (U.S. CLS. 47 AND 49).  
ESTHER QUEEN, EXAMINING ATTORNEY

---

SN 86-267,709. RARE ANTIBODY ANTIGEN SUPPLY, INC., AGOURA HILLS, CA. FILED 4-30-2014.

# TENNO

THE MARK CONSISTS OF STANDARD CHARACTERS WITHOUT CLAIM TO ANY PARTICULAR FONT, STYLE, SIZE, OR COLOR.  
THE ENGLISH TRANSLATION OF "TENNO" IS "HEAVENLY SOVEREIGN" OR "HEAVENLY EMPEROR".  
FOR LIQUOR; TEQUILA (U.S. CLS. 47 AND 49).  
JOHN HWANG, EXAMINING ATTORNEY

**CLASS 33—(Continued).**

SN 86-267,726. RARE ANTIBODY ANTIGEN SUPPLY, INC., AGOURA HILLS, CA. FILED 4-30-2014.

# OHHI

THE MARK CONSISTS OF STANDARD CHARACTERS WITHOUT CLAIM TO ANY PARTICULAR FONT, STYLE, SIZE, OR COLOR.  
THE WORDING "OHHI" HAS NO MEANING IN A FOREIGN LANGUAGE.  
FOR ALCOHOLIC COCKTAIL MIXES, NAMELY, MARGARITA MIXES; LIQUOR AND LIQUEUR BEVERAGES, NAMELY, MARGARITAS; TEQUILA (U.S. CLS. 47 AND 49).  
JOHN HWANG, EXAMINING ATTORNEY

---

SN 86-271,907. C&C IP (NO.2) SARL, LUXEMBOURG, LUXEMBOURG, FILED 5-5-2014.

# HOPSATION

THE MARK CONSISTS OF STANDARD CHARACTERS WITHOUT CLAIM TO ANY PARTICULAR FONT, STYLE, SIZE, OR COLOR.  
FOR HARD CIDER (U.S. CLS. 47 AND 49).  
LINDA MICKLEBURGH, EXAMINING ATTORNEY

---

SN 86-283,396. C&C IP (NO.2) SARL, LUXEMBOURG, LUXEMBOURG, FILED 5-16-2014.

# GUMPTION

THE MARK CONSISTS OF STANDARD CHARACTERS WITHOUT CLAIM TO ANY PARTICULAR FONT, STYLE, SIZE, OR COLOR.  
FOR HARD CIDER (U.S. CLS. 47 AND 49).  
LINDA MICKLEBURGH, EXAMINING ATTORNEY

**CLASS 33—(Continued).**

SN 86-283,517. E. & J. GALLO WINERY, MODESTO, CA.  
FILED 5-16-2014.

**OJO DE LOS ALTOS**

THE MARK CONSISTS OF STANDARD CHARACTERS WITHOUT CLAIM TO ANY PARTICULAR FONT, STYLE, SIZE, OR COLOR.

THE ENGLISH TRANSLATION OF "OJO DE LOS ALTOS" IN THE MARK IS "EYE OF THE SENIOR".

FOR ALCOHOLIC BEVERAGES EXCEPT BEERS (U.S. CLS. 47 AND 49).

TEJBIR SINGH, EXAMINING ATTORNEY

SN 86-289,758. SAN ANTONIO WINERY, INC., LOS ANGELES, CA. FILED 5-22-2014.

**CAMPIONE**

THE MARK CONSISTS OF STANDARD CHARACTERS WITHOUT CLAIM TO ANY PARTICULAR FONT, STYLE, SIZE, OR COLOR.

THE ENGLISH TRANSLATION OF THE WORD "CAMPIONE" IN THE MARK IS "CHAMPION".

FOR WINES (U.S. CLS. 47 AND 49).

ZACHARY R. SPARER, EXAMINING ATTORNEY

SN 86-294,284. DIAGEO CHATEAU & ESTATE WINES COMPANY, NAPA, CA. FILED 5-28-2014.



THE MARK CONSISTS OF A BIRD WITH A SCROLLING FEATHER TAIL CURVED AROUND A STYLIZED LETTER "R".

FOR ALCOHOLIC BEVERAGES EXCEPT BEERS (U.S. CLS. 47 AND 49).

TIMOTHY O. SCHIMPF, EXAMINING ATTORNEY

**CLASS 33—(Continued).**

SN 86-300,628. VIGNERON LLC, HUNTINGTON BEACH, CA. FILED 6-4-2014.

**DOVECOTE**

THE MARK CONSISTS OF STANDARD CHARACTERS WITHOUT CLAIM TO ANY PARTICULAR FONT, STYLE, SIZE, OR COLOR.

FOR DISTILLED SPIRITS (U.S. CLS. 47 AND 49).

JOHN WILKE, EXAMINING ATTORNEY

SN 86-301,586. DAVIS FAMILY ESTATES, LLC, DBA DAVIS ESTATE, HUNTINGTON BEACH, CA. FILED 6-5-2014.



OWNER OF U.S. REG. NO. 4,444,322.

THE COLOR(S) BEIGE, BLACK, AND WHITE IS/ARE CLAIMED AS A FEATURE OF THE MARK.

THE MARK CONSISTS OF A BEIGE WINDMILL ON A WHITE BACKGROUND, WITH THE WORDS "WINDMILL VALLEY" APPEARING IN BLACK UNDERNEATH.

FOR WINE (U.S. CLS. 47 AND 49).

FIRST USE 12-7-2012; IN COMMERCE 12-7-2012.

JASON BLAIR, EXAMINING ATTORNEY

SN 86-328,334. CALINI GROUP LLC, OVERLAND PARK, KS. FILED 7-3-2014.

**PHILEAS FOGG**

THE MARK CONSISTS OF STANDARD CHARACTERS WITHOUT CLAIM TO ANY PARTICULAR FONT, STYLE, SIZE, OR COLOR.

FOR WINE (U.S. CLS. 47 AND 49).

ESTHER QUEEN, EXAMINING ATTORNEY

**CLASS 34—SMOKERS' ARTICLES**

SN 76-715,153. P.T. DJARUM, KUDUS, INDONESIA, FILED 10-11-2013.

**DJARUM GRANDE**

THE MARK CONSISTS OF STANDARD CHARACTERS WITHOUT CLAIM TO ANY PARTICULAR FONT, STYLE, SIZE, OR COLOR.

OWNER OF U.S. REG. NOS. 1,398,760, 4,310,928 AND OTHERS.

NO CLAIM IS MADE TO THE EXCLUSIVE RIGHT TO USE "GRANDE", APART FROM THE MARK AS SHOWN.

THE ENGLISH TRANSLATION OF "DJARUM" IN THE MARK IS "NEEDLE" AND THE ENGLISH TRANSLATION OF "GRANDE" IN THE MARK IS "LARGE".

FOR TOBACCO AND TOBACCO PRODUCTS, NAMELY, CIGARS (U.S. CLS. 2, 8, 9 AND 17).

FIRST USE 12-0-2011; IN COMMERCE 12-0-2011.

KATHERINE E. HALMEN, EXAMINING ATTORNEY

**CLASS 34—(Continued).**

SN 86-040,936. STARBUZZ TOBACCO, INC., STANTON, CA. FILED 8-18-2013.

**MARGARITA FREEZE**

THE MARK CONSISTS OF STANDARD CHARACTERS WITHOUT CLAIM TO ANY PARTICULAR FONT, STYLE, SIZE, OR COLOR.

OWNER OF U.S. REG. NO. 4,287,967.

NO CLAIM IS MADE TO THE EXCLUSIVE RIGHT TO USE "MARGARITA", APART FROM THE MARK AS SHOWN.

FOR PIPE TOBACCO; MOLASSES TOBACCO; TOBACCO; SMOKING TOBACCO; FLAVORED TOBACCO (U.S. CLS. 2, 8, 9 AND 17).

FIRST USE 6-18-2013; IN COMMERCE 6-18-2013.

MICHAEL WEBSTER, EXAMINING ATTORNEY

SN 79-146,793. TITANIUM DISTRIBUTION, HUNINGUE, FRANCE, FILED 3-11-2014.

**Glænway**

PRIORITY DATE OF 1-20-2014 IS CLAIMED.

OWNER OF INTERNATIONAL REGISTRATION 1202628 DATED 3-11-2014, EXPIRES 3-11-2024.

THE MARK CONSISTS OF THE STYLIZED WORDING "GLEENWAY" WITH THE FIRST LETTER "E" APPEARING UPSIDE DOWN.

FOR TOBACCO; SMOKERS' ARTICLES, NAMELY, CIGARETTE HOLDERS, CIGARETTE CASES, CIGARETTE FILTERS; MATCHES; CIGARS; CIGARETTES; CIGARETTE PAPER; PIPES, NAMELY, SMOKING PIPES; LIGHTERS FOR SMOKERS; ASHTRAYS FOR SMOKERS; ELECTRONIC CIGARETTES (U.S. CLS. 2, 8, 9 AND 17).

ALLISON SCHRODY, EXAMINING ATTORNEY

SN 86-069,963. BELLO, PEDRO, MIAMI, FL. FILED 9-20-2013.

**BELLA VAPOR**

THE MARK CONSISTS OF STANDARD CHARACTERS WITHOUT CLAIM TO ANY PARTICULAR FONT, STYLE, SIZE, OR COLOR.

NO CLAIM IS MADE TO THE EXCLUSIVE RIGHT TO USE "VAPOR", APART FROM THE MARK AS SHOWN.

THE ENGLISH TRANSLATION OF THE WORD "BELLA" IN THE MARK IS "BEAUTIFUL".

FOR ELECTRONIC CIGARETTES; ELECTRONIC HOOKAHS (U.S. CLS. 2, 8, 9 AND 17).

LAURA FIONDA, EXAMINING ATTORNEY

SN 85-776,295. TMS INTERNATIONAL CORP., TARZANA, CA. FILED 11-9-2012.

**YOLO**

THE MARK CONSISTS OF STANDARD CHARACTERS WITHOUT CLAIM TO ANY PARTICULAR FONT, STYLE, SIZE, OR COLOR.

THE WORDING "YOLO" HAS NO MEANING IN A FOREIGN LANGUAGE.

FOR ELECTRONIC CIGARETTES; ELECTRONIC HOOKAHS; ELECTRONIC SMOKING PIPES (U.S. CLS. 2, 8, 9 AND 17).

JASON TURNER, EXAMINING ATTORNEY

SN 86-071,895. PHILIP MORRIS USA INC., RICHMOND, VA. FILED 9-23-2013.

**BRISTOL**

THE MARK CONSISTS OF STANDARD CHARACTERS WITHOUT CLAIM TO ANY PARTICULAR FONT, STYLE, SIZE, OR COLOR.

OWNER OF U.S. REG. NOS. 1,177,549 AND 1,654,064.

FOR TOBACCO PRODUCTS, NAMELY, CIGARETTES (U.S. CLS. 2, 8, 9 AND 17).

ELIZABETH CHANG, EXAMINING ATTORNEY

**CLASS 34—(Continued).**

SN 86-075,465. SMOKE SAFELY, LLC, HENDERSON, NV.  
FILED 9-26-2013.

# JOESTICK

THE MARK CONSISTS OF STANDARD CHARACTERS WITHOUT CLAIM TO ANY PARTICULAR FONT, STYLE, SIZE, OR COLOR.

FOR ELECTRONIC CIGARETTES; REFILL CARTRIDGES FOR ELECTRONIC CIGARETTES, SOLD EMPTY; ELECTRONIC CIGARETTE STARTER KITS COMPRISING PRIMARILY ELECTRONIC CIGARETTES AND ALSO INCLUDING CIGARETTE REFILL LIQUIDS, A RECHARGEABLE BATTERY, A USB BATTERY CHARGER, AND AN ATOMIZER, SOLD TOGETHER AS A UNIT (U.S. CLS. 2, 8, 9 AND 17).

FIRST USE 2-0-2013; IN COMMERCE 2-0-2013.  
KEVIN DINALLO, EXAMINING ATTORNEY

---

SN 86-126,464. HAWAIIAN ROYAL TRADING LTD, BEAVERTON, OR. FILED 11-22-2013.

# Volcano

THE MARK CONSISTS OF STANDARD CHARACTERS WITHOUT CLAIM TO ANY PARTICULAR FONT, STYLE, SIZE, OR COLOR.

FOR CIGARS (U.S. CLS. 2, 8, 9 AND 17).  
FIRST USE 1-1-1997; IN COMMERCE 1-1-1997.  
CHRISTINA SOBRAL, EXAMINING ATTORNEY

---

SN 86-181,218. ROBINSON, JAMES, PITTSBURGH, PA.  
FILED 1-31-2014.

# ISLAND JIM

THE MARK CONSISTS OF STANDARD CHARACTERS WITHOUT CLAIM TO ANY PARTICULAR FONT, STYLE, SIZE, OR COLOR.

THE NAME(S), PORTRAIT(S), AND/OR SIGNATURE(S) SHOWN IN THE MARK IDENTIFIES JIM ROBINSON, WHOSE CONSENT(S) TO REGISTER IS MADE OF RECORD.

FOR CIGARS (U.S. CLS. 2, 8, 9 AND 17).  
KAPIL BHANOT, EXAMINING ATTORNEY

**CLASS 34—(Continued).**

SN 86-190,537. BG MEYER'S, INC., LOS ANGELES, CA.  
FILED 2-11-2014.



NO CLAIM IS MADE TO THE EXCLUSIVE RIGHT TO USE "CO.", APART FROM THE MARK AS SHOWN.

THE NAME(S), PORTRAIT(S), AND/OR SIGNATURE(S) SHOWN IN THE MARK DOES NOT IDENTIFY A PARTICULAR LIVING INDIVIDUAL.

THE MARK CONSISTS OF THE WORDING "THE BMG B.G. MEYER CO." ONSIDE THREE CONCENTRIC DIAMONDS.

FOR TOBACCO (U.S. CLS. 2, 8, 9 AND 17).  
MATTHEW EINSTEIN, EXAMINING ATTORNEY

---

SN 86-210,572. SHENZHEN KANGER TECHNOLOGY CO., LTD, SHENSHEN, GUANGDONG, CHINA, FILED 3-4-2014.



OWNER OF U.S. REG. NO. 4,494,123.

THE MARK CONSISTS OF A CIRCLE DIVIDED IN HALF WITH THE LEFT HALF FILLED WITH HORIZONTAL LINES AND THE RIGHT HALF COVERED WITH SOLID BACKGROUND AND A LETTER "K" RUNNING THROUGH IT.

FOR ELECTRONIC CIGARETTES; ELECTRONIC CIGARETTE REFILL CARTRIDGES SOLD EMPTY; TOBACCO; CIGARS; CIGARETTES; CIGARILLOS; TOBACCO PIPES; CIGARETTE CASES; CIGARETTE FILTER TIPS; LIGHTERS FOR SMOKERS; FILTER TIPS OF YELLOW AMBER FOR CIGAR AND CIGARETTE HOLDERS (U.S. CLS. 2, 8, 9 AND 17).

ELIZABETH JACKSON, EXAMINING ATTORNEY

**CLASS 34—(Continued).**

SN 86-220,043. TABACALERA FALTO, INC., MAYAGUEZ, PUERTO RICO, FILED 3-13-2014.

**MI VIEJO #8 #9**

THE MARK CONSISTS OF STANDARD CHARACTERS WITHOUT CLAIM TO ANY PARTICULAR FONT, STYLE, SIZE, OR COLOR.

THE ENGLISH TRANSLATION OF "MI VIEJO" IN THE MARK IS "MY OLD MAN".

FOR CIGARS (U.S. CLS. 2, 8, 9 AND 17).

FIRST USE 5-31-2009; IN COMMERCE 5-31-2009.

REBECCA SMITH, EXAMINING ATTORNEY

**CLASS 34—(Continued).**

SN 86-226,756. LA HOJA CIGAR COMPANY, LLC, FORT LEE, NJ. FILED 3-20-2014.

**HOJA DE GOMEZ**

THE MARK CONSISTS OF STANDARD CHARACTERS WITHOUT CLAIM TO ANY PARTICULAR FONT, STYLE, SIZE, OR COLOR.

THE ENGLISH TRANSLATION OF "HOJA" IN THE MARK IS "SHEET" OR "LEAF".

FOR ASHTRAYS FOR SMOKERS; CIGAR BOXES; CIGAR LIGHTERS; CIGARS; HUMIDORS; LIGHTERS FOR SMOKERS (U.S. CLS. 2, 8, 9 AND 17).

BRIN ANDERSON, EXAMINING ATTORNEY

SN 86-220,532. TABACALERA FALTO, INC., MAYAGUEZ, PUERTO RICO, FILED 3-13-2014.

**DOS BANDERAS**

THE MARK CONSISTS OF STANDARD CHARACTERS WITHOUT CLAIM TO ANY PARTICULAR FONT, STYLE, SIZE, OR COLOR.

THE ENGLISH TRANSLATION OF "DOS BANDERAS" IN THE MARK IS "TWO FLAGS".

FOR CIGARS (U.S. CLS. 2, 8, 9 AND 17).

FIRST USE 3-13-2014; IN COMMERCE 3-13-2014.

REBECCA SMITH, EXAMINING ATTORNEY

SN 86-227,060. SOCIAL SMOKE, INC., ARLINGTON, TX. FILED 3-20-2014.

**PISTACHIO BREEZE**

THE MARK CONSISTS OF STANDARD CHARACTERS WITHOUT CLAIM TO ANY PARTICULAR FONT, STYLE, SIZE, OR COLOR.

NO CLAIM IS MADE TO THE EXCLUSIVE RIGHT TO USE "PISTACHIO", APART FROM THE MARK AS SHOWN. FOR TOBACCO (U.S. CLS. 2, 8, 9 AND 17).

KRISTINA MORRIS, EXAMINING ATTORNEY

SN 86-221,674. LOEBLICH, KURT, MCHENRY, IL. FILED 3-14-2014.



NO CLAIM IS MADE TO THE EXCLUSIVE RIGHT TO USE "INC.", APART FROM THE MARK AS SHOWN.

THE MARK CONSISTS OF THE STYLIZED WORDING "CLOUD CHASERS INC." AGAINST A CIRCULAR DESIGN WITH BROKEN LINES.

FOR ELECTRONIC CIGARETTES (U.S. CLS. 2, 8, 9 AND 17).

TIMOTHY FINNEGAN, EXAMINING ATTORNEY

SN 86-230,213. SCIENTIFIC INC, SANTA ROSA, CA. FILED 3-24-2014.



THE MARK CONSISTS OF THE WORDING "DABOLOGY" IN LOWERCASE HIGHLY-STYLIZED FONT WITH LINE UNDER THE LETTERS "DABOLOG". THE UNDERLINE HAS A CIRCLE ON EACH END. THE LOWERCASE LETTERS "D" AND "B" EACH HAVE A CIRCLE AT THE TOP OF THE VERTICAL LINE IN THE LETTER. THE LOWERCASE LETTER "A" HAS A CIRCLE AT THE BOTTOM OF THE VERTICAL LINE IN THE LETTER. THE LOWERCASE LETTER "Y" HAS TWO CIRCLES LOCATED AT THE TOP OF EACH PART OF THE "U" SHAPE THAT MAKES UP THE TOP PORTION OF THE LETTER.

FOR TOBACCO WATER PIPES (U.S. CLS. 2, 8, 9 AND 17).

FIRST USE 12-1-2013; IN COMMERCE 12-1-2013.

MICHAEL TANNER, EXAMINING ATTORNEY

**CLASS 34—(Continued).**

SN 86-230,510. PERFORMANCE PLUS MARKETING, INC., POMPANO BEACH, FL. FILED 3-24-2014.



NO CLAIM IS MADE TO THE EXCLUSIVE RIGHT TO USE "SUPREME ELECTRONIC-CIG", APART FROM THE MARK AS SHOWN.

THE MARK CONSISTS OF THE WORD "SUPREME" IN LOWER-CASE SCRIPT, THE TERM "ELECTRONIC-CIG" IN SMALL CAPITAL LETTERS BELOW THE WORD "SUPREME", AND A FIVE POINT CROWN AND CURLED VINES WITH LEAVES ABOVE THE WORD "SUPREME".

FOR ELECTRONIC CIGARETTES (U.S. CLS. 2, 8, 9 AND 17).

FIRST USE 1-7-2011; IN COMMERCE 1-7-2011.  
BRIN ANDERSON, EXAMINING ATTORNEY

**CLASS 34—(Continued).**

SN 86-231,860. NADDOUR, JOHN, TUSTIN, CA. AND UTAMA, DANIEL DARMANTA, PONTIANAK 78111, INDONESIA, FILED 3-25-2014.

**TITANIUM COCONUT COAL**

THE MARK CONSISTS OF STANDARD CHARACTERS WITHOUT CLAIM TO ANY PARTICULAR FONT, STYLE, SIZE, OR COLOR.

NO CLAIM IS MADE TO THE EXCLUSIVE RIGHT TO USE "COCONUT COAL", APART FROM THE MARK AS SHOWN.

FOR SMOKERS' ARTICLES, NAMELY, HOOKAH CHARCOAL (U.S. CLS. 2, 8, 9 AND 17).

PAUL CROWLEY, EXAMINING ATTORNEY

SN 86-233,563. CORMIER, HOWARD, DALLAS, NC. FILED 3-27-2014.



THE COLOR(S) BLACK, RED, WHITE, GREEN AND BROWN IS/ARE CLAIMED AS A FEATURE OF THE MARK.

THE MARK CONSISTS OF THE LITERAL ELEMENTS "VAPONATOR" WRITTEN IN STYLIZED FORM IN THE COLOR BLACK, THE COLOR RED APPEARS WITHIN THE FIRST LETTER "O" WHICH IS OUTLINED IN BLACK AND CONTAINS A PLUS SIGN IN THE COLOR WHITE AND A CADUCEUS IN THE COLOR BROWN WITH A GREEN STYLIZED SHADOW IMAGE IS PLACED ON THE LETTER "O".

FOR ELECTRONIC SMOKING PIPES; SMOKING PIPES; ELECTRONIC CIGARETTES; SMOKELESS CIGARETTE VAPORIZER PIPE (U.S. CLS. 2, 8, 9 AND 17).

EDWARD NELSON, EXAMINING ATTORNEY

SN 86-230,517. PERFORMANCE PLUS MARKETING, INC., POMPANO BEACH, FL. FILED 3-24-2014.



NO CLAIM IS MADE TO THE EXCLUSIVE RIGHT TO USE "SUPREME E-CIG", APART FROM THE MARK AS SHOWN.

THE MARK CONSISTS OF THE WORD "SUPREME" IN LOWER-CASE SCRIPT, A SLASH SYMBOL BELOW THE WORD "SUPREME", THE TERM "E-CIG" IN CAPITAL LETTERS WITHIN A RECTANGULAR BORDER AND BELOW THE SLASH SYMBOL, ALL OF THE FOREGOING WRITTEN IN VERTICAL TEXT, AND A FIVE POINT CROWN ABOVE THE WORD "SUPREME".

FOR ELECTRONIC CIGARETTES (U.S. CLS. 2, 8, 9 AND 17).

FIRST USE 1-7-2011; IN COMMERCE 1-7-2011.  
BRIN ANDERSON, EXAMINING ATTORNEY

SN 86-234,354. CORPORACION CIGAR EXPORT, SRL, SANTIAGO, DOMINICAN REP, FILED 3-27-2014.



THE MARK CONSISTS OF THE WORD "SAGA" IN A BOLD STYLIZED FONT IN CAPITAL FORM.

FOR TOBACCO PRODUCTS, NAMELY, CIGARS (U.S. CLS. 2, 8, 9 AND 17).

JULIE GUTTADAURO, EXAMINING ATTORNEY

**CLASS 34—(Continued).**

SN 86-234,439. ROSSWIL, LLC, MEMPHIS, TN. FILED 3-27-2014.

**KENTUCKY KING**

THE MARK CONSISTS OF STANDARD CHARACTERS WITHOUT CLAIM TO ANY PARTICULAR FONT, STYLE, SIZE, OR COLOR.

NO CLAIM IS MADE TO THE EXCLUSIVE RIGHT TO USE "KENTUCKY", APART FROM THE MARK AS SHOWN.

FOR CHEWING TOBACCO (U.S. CLS. 2, 8, 9 AND 17).  
FIRST USE 1-1-1975; IN COMMERCE 1-1-1975.  
KELLY BOULTON, EXAMINING ATTORNEY

**CLASS 34—(Continued).**

SN 86-241,652. VAPORWAVE, LLC, GREER, SC. FILED 4-3-2014.

**Wave**

THE MARK CONSISTS OF STANDARD CHARACTERS WITHOUT CLAIM TO ANY PARTICULAR FONT, STYLE, SIZE, OR COLOR.

FOR ELECTRIC VAPORIZERS FOR VAPORIZATION AND INHALATION OF HERBAL MATTER AND CONCENTRATES DERIVED FROM HERBAL MATTER (U.S. CLS. 2, 8, 9 AND 17).

FONG HSU, EXAMINING ATTORNEY

SN 86-237,304. STARBUZZ TOBACCO, INC., GARDEN GROVE, CA. FILED 3-31-2014.

**The ultimate hookah  
experience.**

THE MARK CONSISTS OF STANDARD CHARACTERS WITHOUT CLAIM TO ANY PARTICULAR FONT, STYLE, SIZE, OR COLOR.

NO CLAIM IS MADE TO THE EXCLUSIVE RIGHT TO USE "ULTIMATE HOOKAH", APART FROM THE MARK AS SHOWN.

FOR HOOKAHS; SMOKING PIPES; TOBACCO WATER PIPES (U.S. CLS. 2, 8, 9 AND 17).  
CAROLINE WOOD, EXAMINING ATTORNEY

SN 86-241,832. HTT TRADEMARKS, LLC, MIDLOTHIAN, VA. FILED 4-3-2014.

**HTC  
CIGARS**

NO CLAIM IS MADE TO THE EXCLUSIVE RIGHT TO USE "CIGARS", APART FROM THE MARK AS SHOWN.

THE MARK CONSISTS OF THE STYLIZED LETTERS "HTC" APPEARING OVER THE STYLIZED WORD "CIGARS".

FOR CIGARS (U.S. CLS. 2, 8, 9 AND 17).  
JAMES STEIN, EXAMINING ATTORNEY

SN 86-241,023. LORILLARD LICENSING COMPANY, LLC, GREENSBORO, NC. FILED 4-3-2014.

**NEWPORT SMOOTH GOLD  
NON-MENTHOL**

THE MARK CONSISTS OF STANDARD CHARACTERS WITHOUT CLAIM TO ANY PARTICULAR FONT, STYLE, SIZE, OR COLOR.

OWNER OF U.S. REG. NOS. 4,048,144, 4,077,768 AND OTHERS.

NO CLAIM IS MADE TO THE EXCLUSIVE RIGHT TO USE "SMOOTH" AND "NON-MENTHOL", APART FROM THE MARK AS SHOWN.

FOR CIGARETTES (U.S. CLS. 2, 8, 9 AND 17).  
CHRISTINA SOBRAL, EXAMINING ATTORNEY

SN 86-242,082. HARRIS, JASON, R, AKA JEROME BAKER DESIGNS, HAIKU, HI. FILED 4-3-2014.

**JBD**

THE MARK CONSISTS OF THE LETTERS "J" "B" "D" IN BLACK OUTLINE WITH ARROWHEADS.

FOR TOBACCO PIPES; TOBACCO TINS; TOBACCO WATER PIPES (U.S. CLS. 2, 8, 9 AND 17).

FIRST USE 1-1-1995; IN COMMERCE 1-1-1995.  
MIDGE BUTLER, EXAMINING ATTORNEY

**CLASS 34—(Continued).**

SN 86-242,758. TIGER EYES TOBACCO, STERLING HEIGHTS, MI. FILED 4-4-2014.

# X CLASS

THE MARK CONSISTS OF STANDARD CHARACTERS WITHOUT CLAIM TO ANY PARTICULAR FONT, STYLE, SIZE, OR COLOR.

FOR ELECTRONIC CIGARETTES (U.S. CLS. 2, 8, 9 AND 17).

KRISTINA MORRIS, EXAMINING ATTORNEY

SN 86-242,901. TIGER EYES TOBACCO, STERLING HEIGHTS, MI. FILED 4-4-2014.

# ALCO

THE MARK CONSISTS OF STANDARD CHARACTERS WITHOUT CLAIM TO ANY PARTICULAR FONT, STYLE, SIZE, OR COLOR.

FOR ELECTRONIC CIGARETTES; ELECTRONIC HOOKAHS; HOOKAH TOBACCO (U.S. CLS. 2, 8, 9 AND 17).

KRISTINA MORRIS, EXAMINING ATTORNEY

SN 86-246,915. MAGNUM INTERNATIONAL INC, CARROLLTON, TX. FILED 4-9-2014.

# EVERLAST

THE MARK CONSISTS OF STANDARD CHARACTERS WITHOUT CLAIM TO ANY PARTICULAR FONT, STYLE, SIZE, OR COLOR.

FOR ELECTRONIC HOOKAHS; HOOKAH PARTS, NAMELY, HOSES, BOWLS, MOUTHPIECES, BASES; HOOKAH TOBACCO; HOOKAHS (U.S. CLS. 2, 8, 9 AND 17).

FIRST USE 2-7-2013; IN COMMERCE 4-22-2013.

WILLIAM BRECKENFELD, EXAMINING ATTORNEY

**CLASS 34—(Continued).**

SN 86-248,539. OUTLAW CIGAR, KANSAS CITY, MO. FILED 4-10-2014.

# Nightmare

THE MARK CONSISTS OF STANDARD CHARACTERS WITHOUT CLAIM TO ANY PARTICULAR FONT, STYLE, SIZE, OR COLOR.

FOR CIGARS (U.S. CLS. 2, 8, 9 AND 17).

FIRST USE 3-10-2014; IN COMMERCE 3-10-2014.

JOHN WILKE, EXAMINING ATTORNEY

SN 86-248,551. YIN, HSUEH CHENG, GARDENA, CA. FILED 4-10-2014.

# asmodus

THE MARK CONSISTS OF STANDARD CHARACTERS WITHOUT CLAIM TO ANY PARTICULAR FONT, STYLE, SIZE, OR COLOR.

FOR ELECTRONIC CIGARETTES; ELECTRONIC CIGARETTE ATOMIZERS; ELECTRONIC CIGARETTE ATOMIZERS SOLD EMPTY; ELECTRONIC CIGARETTE FILTERS; CIGARETTES CONTAINING TOBACCO SUBSTITUTES NOT FOR MEDICAL PURPOSES; ELECTRONIC CIGARETTE FOR CONSUMING HERBAL APPETITE SUPPRESSANTS, CAFFEINE, NUTRITIONAL AND DIETARY SUPPLEMENTS AND VITAMINS; NICOTINE-FREE ELECTRONIC CIGARETTES; ELECTRONIC CIGARETTE KITS, EACH CONSISTING OF ELECTRONIC CIGARETTE CARTRIDGES SOLD EMPTY, A BATTERY, A BATTERY CHARGER THAT CAN BE PLUGGED INTO A WALL, AND AN ATOMIZER; CARRYING CASES SPECIFICALLY DESIGNED TO CARRY ELECTRONIC CIGARETTES; SMOKER'S ARTICLES, NAMELY, HANDHELD ELECTRONIC VAPORIZERS FOR PERSONAL INHALATION OF DRY HERBS AND OILS (U.S. CLS. 2, 8, 9 AND 17).

ALISON POLLACK, EXAMINING ATTORNEY

SN 86-255,301. TINY TONY USA, LLC, VAN NUYS, CA. FILED 4-17-2014.

# NUVAPEFUN

THE MARK CONSISTS OF STANDARD CHARACTERS WITHOUT CLAIM TO ANY PARTICULAR FONT, STYLE, SIZE, OR COLOR.

FOR ELECTRONIC CIGARETTES (U.S. CLS. 2, 8, 9 AND 17).

JEFFREY LOOK, EXAMINING ATTORNEY



**CLASS 34—(Continued).**

SN 86-258,980. MISSOURI MEERSCHAUM COMPANY, WASHINGTON, MO. FILED 4-22-2014.

**MISSOURI MEERSCHAUM**

THE MARK CONSISTS OF STANDARD CHARACTERS WITHOUT CLAIM TO ANY PARTICULAR FONT, STYLE, SIZE, OR COLOR.  
OWNER OF U.S. REG. NO. 887,723.  
SEC. 2(F).  
FOR CIGARS; SMOKING PIPES, NAMELY, CORN COB PIPES AND HARDWOOD SMOKING PIPES; SMOKING TOBACCO (U.S. CLS. 2, 8, 9 AND 17).  
MICHAEL P EISNACH, EXAMINING ATTORNEY

**CLASS 34—(Continued).**

SN 86-294,858. LORILLARD LICENSING COMPANY, LLC, GREENSBORO, NC. FILED 5-29-2014.

**NEWPORT NON-MENTHOL SMOOTH GOLD**

THE MARK CONSISTS OF STANDARD CHARACTERS WITHOUT CLAIM TO ANY PARTICULAR FONT, STYLE, SIZE, OR COLOR.  
OWNER OF U.S. REG. NOS. 1,108,876, 4,077,768 AND OTHERS.  
NO CLAIM IS MADE TO THE EXCLUSIVE RIGHT TO USE "NON-MENTHOL SMOOTH", APART FROM THE MARK AS SHOWN.  
FOR CIGARETTES (U.S. CLS. 2, 8, 9 AND 17).  
CHRISTINA SOBRAL, EXAMINING ATTORNEY

SN 86-272,450. ALNIMRI, SAMER GHASSAN, BAKERSFIELD, CA. FILED 5-6-2014.

**GET LEI'D**

THE MARK CONSISTS OF STANDARD CHARACTERS WITHOUT CLAIM TO ANY PARTICULAR FONT, STYLE, SIZE, OR COLOR.  
FOR HOOKAH TOBACCO; MOLASSES TOBACCO; PIPE TOBACCO (U.S. CLS. 2, 8, 9 AND 17).  
FIRST USE 5-1-2014; IN COMMERCE 5-1-2014.  
ROBIN CHOSID, EXAMINING ATTORNEY

SN 86-299,681. CIGARS INTERNATIONAL, INC., BETHLEHEM, PA. FILED 6-4-2014.

**RED EYE**

THE MARK CONSISTS OF STANDARD CHARACTERS WITHOUT CLAIM TO ANY PARTICULAR FONT, STYLE, SIZE, OR COLOR.  
OWNER OF U.S. REG. NO. 3,918,046.  
FOR PIPE TOBACCO (U.S. CLS. 2, 8, 9 AND 17).  
TEJBIR SINGH, EXAMINING ATTORNEY

SN 86-273,697. ELHALWANI, WAEL SALIM, GARDEN GROVE, CA. FILED 5-6-2014.

**The Ultimate Vaping Experience.**

THE MARK CONSISTS OF STANDARD CHARACTERS WITHOUT CLAIM TO ANY PARTICULAR FONT, STYLE, SIZE, OR COLOR.  
FOR SMOKELESS CIGARETTE VAPORIZER PIPE (U.S. CLS. 2, 8, 9 AND 17).  
FIRST USE 5-6-2014; IN COMMERCE 5-6-2014.  
ROBERT STRUCK, EXAMINING ATTORNEY

SN 86-299,683. CIGARS INTERNATIONAL, INC., BETHLEHEM, PA. FILED 6-4-2014.

**SPECTRE**

THE MARK CONSISTS OF STANDARD CHARACTERS WITHOUT CLAIM TO ANY PARTICULAR FONT, STYLE, SIZE, OR COLOR.  
OWNER OF U.S. REG. NO. 4,526,410.  
FOR PIPE TOBACCO (U.S. CLS. 2, 8, 9 AND 17).  
TEJBIR SINGH, EXAMINING ATTORNEY

CLASS 35—(Continued).

CLASS 35—(Continued).

SN 77-629,302. VICTOIRE, PARIS, FRANCE, FILED 12-9-2008.

SERVICE MARKS

CLASS 35—ADVERTISING AND BUSINESS

SN 76-714,294. STRATTON, DOUGLAS S., GLENDORA, CA. FILED 5-31-2013.

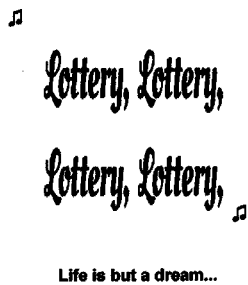

VICTOIRE

THE MARK CONSISTS OF STANDARD CHARACTERS WITHOUT CLAIM TO ANY PARTICULAR FONT, STYLE, SIZE, OR COLOR.

OWNER OF FRANCE REG. NO. 1300304, DATED 8-2-1985, EXPIRES 2-24-2015.

OWNER OF U.S. REG. NOS. 1,447,589, 1,512,757 AND 3,484,878.

THE ENGLISH TRANSLATION OF "VICTOIRE" IN THE MARK IS "VICTORY".

FOR RETAIL STORE SERVICES FEATURING MEN'S AND WOMEN'S CLOTHING (U.S. CLS. 100, 101 AND 102).

ZHALEH DELANEY, EXAMINING ATTORNEY

NO CLAIM IS MADE TO THE EXCLUSIVE RIGHT TO USE "LOTTERY", APART FROM THE MARK AS SHOWN.

THE MARK CONSISTS OF THE WORDING "LOTTERY, LOTTERY, LOTTERY, LOTTERY, LIFE IS BUT A DREAM..." WITH MUSICAL NOTES APPEARING ON THE RIGHT SIDE AND UPPER-LEFT CORNER, OF THE MARK.

FOR ADVERTISING AND PROMOTION OF LOTTERIES (U.S. CLS. 100, 101 AND 102).

LIEF MARTIN, EXAMINING ATTORNEY

SN 79-125,094. HUIZHOU SUN MOON METLA & WOODEN PRODUCT CO., LTD, HUIZHOU CITY GUANGDONG, CHINA, FILED 12-18-2012.



SN 76-716,011. TENNESSEE DEPARTMENT OF TOURIST DEVELOPMENT, NASHVILLE, TN. FILED 3-18-2014.

Made in Tennessee

THE MARK CONSISTS OF STANDARD CHARACTERS WITHOUT CLAIM TO ANY PARTICULAR FONT, STYLE, SIZE, OR COLOR.

OWNER OF U.S. REG. NOS. 3,021,992, 4,148,177 AND OTHERS.

NO CLAIM IS MADE TO THE EXCLUSIVE RIGHT TO USE "TENNESSEE", APART FROM THE MARK AS SHOWN.

FOR PROMOTING RECREATION AND TOURISM IN THE STATE OF TENNESSEE; MARKETING SERVICES IN THE FIELD OF TRAVEL TO THE STATE OF TENNESSEE (U.S. CLS. 100, 101 AND 102).

FIRST USE 11-26-2013; IN COMMERCE 11-26-2013.

STEVEN PEREZ, EXAMINING ATTORNEY

PRIORITY DATE OF 7-9-2012 IS CLAIMED.

OWNER OF INTERNATIONAL REGISTRATION 1147386 DATED 12-18-2012, EXPIRES 12-18-2022.

NO CLAIM IS MADE TO THE EXCLUSIVE RIGHT TO USE "GRILL", APART FROM THE MARK AS SHOWN.

THE MARK CONSISTS OF THE UNDERLINED WORDING "APEX" APPEARING ON TOP OF THE UNDERLINED WORDING "GRILL" IN WHICH THE LETTER "I" IS REPRESENTED BY A FLAME DESIGN.

FOR BILL-POSTING; ADVERTISING; PRODUCTION OF TELEVISION COMMERCIALS; PRODUCTION OF ADVERTISING FILMS; COMMERCIAL AND INDUSTRIAL MANAGEMENT ASSISTANCE; ADVERTISING BY MAIL ORDER; BUSINESS RESEARCH; IMPORT-EXPORT AGENCIES; LAYOUT SERVICES FOR ADVERTISING PURPOSES; PERSONNEL MANAGEMENT CONSULTANCY (U.S. CLS. 100, 101 AND 102).

HAI-LY LAM, EXAMINING ATTORNEY

**CLASS 35—(Continued).**

SN 79-136,019. FRAISA HOLDING AG; BEI FRAISA SA, BELLACH, SWITZERLAND, FILED 8-15-2013.

# TOOLCARE

THE MARK CONSISTS OF STANDARD CHARACTERS WITHOUT CLAIM TO ANY PARTICULAR FONT, STYLE, SIZE, OR COLOR.

PRIORITY DATE OF 3-15-2013 IS CLAIMED.

OWNER OF INTERNATIONAL REGISTRATION 1175239 DATED 8-15-2013, EXPIRES 8-15-2023.

FOR ELECTRONIC INVENTORY MANAGEMENT SERVICES; PROMOTIONAL MARKETING SERVICES; COMPILATION OF BUSINESS STATISTICS AND COMMERCIAL INFORMATION (U.S. CLS. 100, 101 AND 102). SIDDHARTH JAGANNATHAN, EXAMINING ATTORNEY

**CLASS 35—(Continued).**

SN 79-142,962. IMBULL B.V., AMSTERDAM, NETHERLANDS, FILED 1-7-2014.

# Flipit

OWNER OF INTERNATIONAL REGISTRATION 1193152 DATED 1-7-2014, EXPIRES 1-7-2024.

FOR ADMINISTRATIVE SERVICES FOR LOYALTY PROGRAMS BASED DISCOUNTS IN WHICH RETAIL OFFERS, DEALS, COUPONS, VOUCHERS, PROMOTIONAL CODES, PROMOTIONAL CONTESTS, REBATES, PRICE COMPARISON INFORMATION, PRODUCT REVIEWS, LINKS TO RETAIL WEBSITES OF OTHERS AND SHOPPING-RELATED INFORMATION ARE SHARED AND PROMOTED ONLINE (U.S. CLS. 100, 101 AND 102).

TASNEEM HUSSAIN, EXAMINING ATTORNEY

SN 79-142,481. TAMARANG, S.A., BARCELONA, SPAIN, FILED 11-29-2013.

# TAMARANG

THE MARK CONSISTS OF STANDARD CHARACTERS WITHOUT CLAIM TO ANY PARTICULAR FONT, STYLE, SIZE, OR COLOR.

OWNER OF INTERNATIONAL REGISTRATION 1191967 DATED 11-29-2013, EXPIRES 11-29-2023.

THE WORDING "TAMARANG" IS NOT A TERM OF ART WITHIN APPLICANT'S INDUSTRY NOR DOES IT HAVE ANY SIGNIFICANCE AS APPLIED TO THE SERVICES OF THE APPLICATION.

FOR ADVERTISING SERVICES; BUSINESS MANAGEMENT; BUSINESS ADMINISTRATION AND OFFICE WORK; BUSINESS ADMINISTRATION ASSISTANCE, NAMELY, BUSINESS ASSISTANCE SERVICES FOR OPERATIONAL OR BUSINESS MANAGEMENT OF INDUSTRIAL OR COMMERCIAL COMPANIES; ORGANIZATION OF FAIRS AND EXHIBITIONS FOR COMMERCIAL OR ADVERTISING PURPOSES; IMPORT EXPORT AGENCIES IN THE FIELD OF PHARMACEUTICALS, MEDICATED, DIETETIC MEDICINAL, CHEMICAL, VETERINARY AND SANITARY PRODUCTS FOR MEDICAL USE AND RAW MATERIAL FOR MANUFACTURING SUCH GOODS; RETAIL AND WHOLESALE STORES SERVICES AND ONLINE RETAIL AND WHOLESALE STORE SERVICES IN THE FIELD OF PHARMACEUTICALS, MEDICATED, DIETETIC MEDICINAL, CHEMICAL, VETERINARY AND SANITARY PRODUCTS FOR MEDICAL USE AND RAW MATERIAL FOR MANUFACTURING SUCH GOODS; DISTRIBUTION OF SAMPLES FOR PUBLICITY PURPOSES; DEMONSTRATION OF GOODS; MARKET RESEARCH STUDIES; DATABASE MANAGEMENT; BUSINESS MANAGEMENT CONSULTANCY, ADVISORY AND INFORMATION SERVICES AND ONLINE BUSINESS MANAGEMENT; ONLINE BUSINESS MANAGEMENT CONSULTANCY, ADVISORY AND INFORMATION SERVICES (U.S. CLS. 100, 101 AND 102).

LUCY ARANT, EXAMINING ATTORNEY

SN 79-147,503. DOTTIKON ES HOLDING AG, SWITZERLAND, FILED 4-9-2014.

# Dottikonerli

THE MARK CONSISTS OF STANDARD CHARACTERS WITHOUT CLAIM TO ANY PARTICULAR FONT, STYLE, SIZE, OR COLOR.

OWNER OF INTERNATIONAL REGISTRATION 1204526 DATED 4-9-2014, EXPIRES 4-9-2024.

FOR ADVERTISING; BUSINESS MANAGEMENT (U.S. CLS. 100, 101 AND 102).

LINDA LAVACHE, EXAMINING ATTORNEY

SN 79-148,853. LEE KYUNG ROK, REPUBLIC OF KOREA, FILED 12-9-2013.

# CLIV

OWNER OF INTERNATIONAL REGISTRATION 1208006 DATED 12-9-2013, EXPIRES 12-9-2023.

FOR RETAIL STORE SERVICES FEATURING COSMETICS; WHOLESALE STORE SERVICES FEATURING COSMETICS (U.S. CLS. 100, 101 AND 102).

JORDAN BAKER, EXAMINING ATTORNEY

**CLASS 35—(Continued).**

SN 85-152,621. SUPERVALUE, INC., CBP-1A, PASAY CITY, PHILIPPINES, FILED 10-14-2010.



PRIORITY CLAIMED UNDER SEC. 44(D) ON PHILIPPINES APPLICATION NO. 04-2010-0039, FILED 4-14-2010, REG. NO. 42010003930, DATED 12-31-2010, EXPIRES 12-31-2020.

NO CLAIM IS MADE TO THE EXCLUSIVE RIGHT TO USE "SUPERMARKET", APART FROM THE MARK AS SHOWN.

THE COLOR(S) DARK BLUE, LIGHT BLUE AND WHITE IS/ARE CLAIMED AS A FEATURE OF THE MARK.

THE MARK CONSISTS OF THE LETTERS "SM" OUTLINED IN DARK BLUE WITHIN A WHITE CIRCLE OUTLINED IN DARK BLUE, ABOVE THE WORD "SUPERMARKET" IN LIGHT BLUE.

FOR RETAIL GROCERY STORE SERVICES (U.S. CLS. 100, 101 AND 102).

EVELYN BRADLEY, EXAMINING ATTORNEY

**CLASS 35—(Continued).**

SN 85-277,372. SURF NEWS NETWORK LLC, DBA SNN SURF NEWS NETWORK, HONOLULU, HI. FILED 3-25-2011.



NO CLAIM IS MADE TO THE EXCLUSIVE RIGHT TO USE "SURF NEWS NETWORK", APART FROM THE MARK AS SHOWN.

THE COLOR(S) PALE BLUE, DARK BLUE, BLACK, WHITE, LIGHT BLUE AND MIDNIGHT BLUE IS/ARE CLAIMED AS A FEATURE OF THE MARK.

THE MARK CONSISTS OF A DESIGN ELEMENT CONSISTING OF A BARREL OF A WAVE WITH THE TOP IN PALE BLUE AND THE BACK OF THE WAVE IN DARK BLUE, AND THE BARREL IN PALE BLUE, ALL OUTLINED IN BLACK WITH WHITE SHADING APPEARING IN THE EXTERIOR AND THE INTERIOR PORTIONS OF THE WAVE DESIGN, DEPICTED TO THE RIGHT OF THE DESIGN IS THE LETTERING "SNN" ABOVE THE WORDING "SURF NEWS NETWORK," THE SHADING OF WHICH GOES FROM LIGHT BLUE TO MIDNIGHT BLUE.

FOR ADVERTISING AND PUBLICITY SERVICES, NAMELY, PROMOTING THE GOODS, SERVICES, BRAND IDENTITY AND COMMERCIAL INFORMATION AND NEWS OF THIRD PARTIES THROUGH PRINT, AUDIO, VIDEO, DIGITAL AND ON-LINE MEDIUM (U.S. CLS. 100, 101 AND 102).

FIRST USE 1-1-1980; IN COMMERCE 1-1-2000.

KATHERINE STOIDES, EXAMINING ATTORNEY

SN 85-540,923. PERIWINKLE, LLC, ARLINGTON, VA. FILED 2-13-2012.



THE COLOR(S) WHITE, LAVENDER BLUE, AND BLACK IS/ARE CLAIMED AS A FEATURE OF THE MARK.

THE MARK CONSISTS OF THE LITERAL TEXT "PERIWINKLE" HORIZONTALLY DISPLAYED IN LOWER CASE TYPE WITH AN IMAGE OF A FLOWER CONTAINING SIX (6) LAVENDER BLUE PETALS, OUTLINED IN BLACK, POSITIONED BOTH TO THE LEFT AND RIGHT OF THE TEXT. A LAVENDER BLUE OVAL IS CENTERED ON THE TEXT AND FLOWER IMAGES AND ENCIRCLED THE SAME. ALL OF THE FOREGOING IS ENCIRCLED BY A BOLD BLACK OVAL THAT IS SLIGHTLY LARGER THAN THE LAVENDER BLUE OVAL. ALL OF THE FOREGOING IS OVERLAID ON A WHITE BACKGROUND.

FOR ON-LINE RETAIL GIFT SHOPS; ON-LINE RETAIL STORE SERVICES FEATURING CLOTHING, FASHION, AND ACCESSORIES; RETAIL APPAREL STORES; RETAIL CLOTHING BOUTIQUES; RETAIL DEPARTMENT STORE SERVICES; RETAIL GIFT SHOPS; RETAIL JEWELRY STORES (U.S. CLS. 100, 101 AND 102).

FIRST USE 10-1-2005; IN COMMERCE 10-1-2005.

GILBERT SWIFT, EXAMINING ATTORNEY

SN 85-163,659. NORTHWEST TIRE FACTORY LLC, PORTLAND, OR. FILED 10-28-2010.



REGISTRATION LIMITED TO THE AREA COMPRISING THE ENTIRE UNITED STATES WITH THE EXCEPTION OF THE STATE OF MICHIGAN PURSUANT TO CONCURRENT USE PROCEEDING NO. 94002361. CONCURRENT REGISTRATION WITH REGISTRATION NO. 4215746.

OWNER OF U.S. REG. NO. 2,314,658.

NO CLAIM IS MADE TO THE EXCLUSIVE RIGHT TO USE "TIRE", APART FROM THE MARK AS SHOWN.

THE COLOR(S) BLUE, WHITE AND RED IS/ARE CLAIMED AS A FEATURE OF THE MARK.

THE MARK CONSISTS OF A DESIGN OF A PORTION OF A BLUE TIRE WITH WHITE TREAD TO THE LEFT OF THE WORDS "TIRE" IN RED LETTERS AND "FACTORY" IN BLUE LETTERS.

FOR RETAIL TIRE STORE SERVICES, NAMELY, AUTOMOTIVE AND TRUCK TIRES, WHEELS, BRAKES, SHOCKS, STRUTS, BATTERIES, AND RELATED AUTOMOBILE ACCESSORIES (U.S. CLS. 100, 101 AND 102).

FIRST USE 8-30-2004; IN COMMERCE 12-31-2004.

JOHN GARTNER, EXAMINING ATTORNEY

**CLASS 35—(Continued).**

SN 85-557,453. FIRST PERSON, INC., INDIANAPOLIS, IN.  
FILED 3-1-2012.

**TALK TO YOUR DOC!**

THE MARK CONSISTS OF STANDARD CHARACTERS WITHOUT CLAIM TO ANY PARTICULAR FONT, STYLE, SIZE, OR COLOR.

FOR PROVIDING ASSISTANCE, FITNESS EVALUATION AND CONSULTATION TO EMPLOYER CLIENTS TO HELP THEIR EMPLOYEES MAKE HEALTH, WELLNESS AND NUTRITIONAL CHANGES IN THEIR DAILY LIVING TO INCREASE PRODUCTIVITY AND LOWER HEALTH CARE COSTS (U.S. CLS. 100, 101 AND 102).

FIRST USE 9-8-2010; IN COMMERCE 9-8-2010.  
SCOTT BIBB, EXAMINING ATTORNEY

SN 85-610,797. SCANSION, INC., SAN FRANCISCO, CA.  
FILED 4-27-2012.

**WAVELINE**

THE MARK CONSISTS OF STANDARD CHARACTERS WITHOUT CLAIM TO ANY PARTICULAR FONT, STYLE, SIZE, OR COLOR.

FOR ADVERTISING AND MARKETING CONSULTANCY; ANALYSIS OF MARKET RESEARCH DATA AND STATISTICS; BRANDING SERVICES, NAMELY, CONSULTING, DEVELOPMENT, MANAGEMENT AND MARKETING OF BRANDS FOR BUSINESSES; BUSINESS CONSULTING IN THE CONSUMER PRODUCTS INDUSTRY; BUSINESS MONITORING AND CONSULTING SERVICES, NAMELY, TRACKING WEB SITES AND APPLICATIONS OF OTHERS TO PROVIDE STRATEGY, INSIGHT, MARKETING, SALES, OPERATION, PRODUCT DESIGN, PARTICULARLY SPECIALIZING IN THE USE OF ANALYTIC AND STATISTIC MODELS FOR THE UNDERSTANDING AND PREDICTING OF CONSUMERS, BUSINESSES, AND MARKET TRENDS AND ACTIONS; CONSULTANCY SERVICES REGARDING BUSINESS STRATEGIES; PROVIDING INFORMATION IN THE FIELDS OF BUSINESS INNOVATION PROCESS, BUSINESS MANAGEMENT AND BUSINESS OPPORTUNITIES (U.S. CLS. 100, 101 AND 102).

FIRST USE 12-27-2010; IN COMMERCE 8-15-2011.  
BARBARA RUTLAND, EXAMINING ATTORNEY

**CLASS 35—(Continued).**

SN 85-632,755. THE CANDY COMPANY, INC., NORCROSS, GA. FILED 5-23-2012.

**U-SERV MARKET**

THE MARK CONSISTS OF STANDARD CHARACTERS WITHOUT CLAIM TO ANY PARTICULAR FONT, STYLE, SIZE, OR COLOR.

NO CLAIM IS MADE TO THE EXCLUSIVE RIGHT TO USE "MARKET", APART FROM THE MARK AS SHOWN.

FOR RETAIL CONVENIENCE STORES; RETAIL STORE SERVICES FEATURING A WIDE VARIETY OF CONSUMER GOODS OF OTHERS; RETAIL STORE SERVICES FEATURING THE FOOD AND BEVERAGES OF OTHERS; RETAIL FOOD AND BEVERAGE STORES FEATURING THE FOOD AND BEVERAGES OF OTHERS (U.S. CLS. 100, 101 AND 102).

FIRST USE 1-15-2009; IN COMMERCE 1-15-2009.  
CAROLYN CATALDO, EXAMINING ATTORNEY

SN 85-676,950. KAPPA KAPPA GAMMA FRATERNITY, COLUMBUS, OH. FILED 7-13-2012.

Kappa Kappa Gamma  
*aspire to be*

OWNER OF U.S. REG. NOS. 1,128,082, 1,748,381 AND OTHERS.

THE MARK CONSISTS OF THE STYLIZED PHRASE "KAPPA KAPPA GAMMA" TO THE LEFT OF A FLEUR-DE-LIS DESIGN AND SET ABOVE THE STYLIZED PHRASE "ASPIRE TO BE".

FOR ASSOCIATION SERVICES, NAMELY, ORGANIZING CHAPTERS OF A FRATERNITY AND PROMOTING AND FOSTERING GOOD WILL, FRIENDSHIP AND SOCIAL AND ACADEMIC ACHIEVEMENT AMONG AND BY MEMBERS AND PROSPECTIVE MEMBERS OF APPLICANT ORGANIZATION (U.S. CLS. 100, 101 AND 102).

FIRST USE 6-21-2012; IN COMMERCE 6-21-2012.  
YAT SYE, LEE, EXAMINING ATTORNEY

SN 85-676,969. KAPPA KAPPA GAMMA FRATERNITY, COLUMBUS, OH. FILED 7-13-2012.

**ASPIRE TO BE**

THE MARK CONSISTS OF STANDARD CHARACTERS WITHOUT CLAIM TO ANY PARTICULAR FONT, STYLE, SIZE, OR COLOR.

FOR ASSOCIATION SERVICES, NAMELY, ORGANIZING CHAPTERS OF A FRATERNITY AND PROMOTING AND FOSTERING GOOD WILL, FRIENDSHIP AND SOCIAL AND ACADEMIC ACHIEVEMENT AMONG AND BY MEMBERS AND PROSPECTIVE MEMBERS OF APPLICANT ORGANIZATION (U.S. CLS. 100, 101 AND 102).

FIRST USE 6-21-2012; IN COMMERCE 6-21-2012.  
YAT SYE, LEE, EXAMINING ATTORNEY

**CLASS 35—(Continued).**

SN 85-694,350. GENESIMEDIA LLC., NEW YORK, NY.  
FILED 8-3-2012.

## Genesis Media

THE MARK CONSISTS OF STANDARD CHARACTERS WITHOUT CLAIM TO ANY PARTICULAR FONT, STYLE, SIZE, OR COLOR.

NO CLAIM IS MADE TO THE EXCLUSIVE RIGHT TO USE "MEDIA", APART FROM THE MARK AS SHOWN.

FOR ADVERTISEMENT FOR OTHERS ON THE INTERNET; ON-LINE ADVERTISING SERVICES FOR OTHERS (U.S. CLS. 100, 101 AND 102).

FIRST USE 9-9-2011; IN COMMERCE 10-1-2011.  
INGRID C. EULIN, EXAMINING ATTORNEY

SN 85-732,459. EVOLUTION FRESH, INC., SAN BERNARDINO, CA. FILED 9-19-2012.



The logo for Evolution Fresh features the word "evolution" in a lowercase, cursive script font, with the word "FRESH" in a smaller, uppercase, sans-serif font positioned directly below it.

PRIORITY CLAIMED UNDER SEC. 44(D) ON AUSTRALIA APPLICATION NO. 1486830, FILED 4-20-2012, REG. NO. 1486830, DATED 1-15-2014, EXPIRES 4-20-2022.

OWNER OF U.S. REG. NOS. 3,774,723 AND 3,774,724.

NO CLAIM IS MADE TO THE EXCLUSIVE RIGHT TO USE "FRESH" FOR RETAIL STORE SERVICES IN THE FIELD OF COFFEE, TEA, NON-ALCOHOLIC BEVERAGES INCLUDING FRUIT JUICE, VEGETABLE JUICE, WATER, PACKAGED AND PREPARED FOODS, NUTRITIONAL SUPPLEMENTS AND DIETARY SUPPLEMENTS, WHOLESALE DISTRIBUTORSHIPS, WHOLESALE STORES AND WHOLESALE ORDERING SERVICES ALL IN THE FIELD OF NON-ALCOHOLIC BEVERAGES INCLUDING FRUIT JUICE, VEGETABLE JUICE, WATER, PACKAGED AND PREPARED FOODS, NUTRITIONAL SUPPLEMENTS AND DIETARY SUPPLEMENTS IN CLASS 35, APART FROM THE MARK AS SHOWN.

THE MARK CONSISTS OF THE WORDS "EVOLUTION FRESH" IN A STYLIZED FORMAT.

FOR (BASED ON USE IN COMMERCE) BUSINESS ADMINISTRATION; BUSINESS MANAGEMENT; (BASED ON 44(E)) (BASED ON USE IN COMMERCE) RETAIL STORE SERVICES IN THE FIELD OF COFFEE, TEA, NON-ALCOHOLIC BEVERAGES INCLUDING FRUIT JUICE, VEGETABLE JUICE, WATER, PACKAGED AND PREPARED FOODS, NUTRITIONAL SUPPLEMENTS AND DIETARY SUPPLEMENTS, WHOLESALE DISTRIBUTORSHIPS, WHOLESALE STORES AND WHOLESALE ORDERING SERVICES ALL IN THE FIELD OF NON-ALCOHOLIC BEVERAGES INCLUDING FRUIT JUICE, VEGETABLE JUICE, WATER, PACKAGED AND PREPARED FOODS, NUTRITIONAL SUPPLEMENTS AND DIETARY SUPPLEMENTS (U.S. CLS. 100, 101 AND 102).

FIRST USE 3-19-2012; IN COMMERCE 3-19-2012.  
DOUGLAS LEE, EXAMINING ATTORNEY

**CLASS 35—(Continued).**

SN 85-741,162. COMMUNITECH CORPORATION, KITCHENER, ONTARIO, CANADA, FILED 9-28-2012.



PRIORITY CLAIMED UNDER SEC. 44(D) ON CANADA APPLICATION NO. 1,571,339, FILED 3-30-2012.

NO CLAIM IS MADE TO THE EXCLUSIVE RIGHT TO USE "CANADIAN DIGITAL MEDIA NETWORK", APART FROM THE MARK AS SHOWN.

THE MARK CONSISTS OF A NUMBER OF SMALL HOURGLASS-SHAPED FIGURES ARRANGED IN THE SHAPE OF A MAPLE LEAF SITUATED BESIDE THE WORDS "CANADIAN DIGITAL MEDIA NETWORK".

FOR CONDUCTING, THROUGH MEMBER DIGITAL MEDIA HUBS, BUSINESS RESEARCH AND COMMERCIALIZATION ACTIVITIES, NAMELY, PROVIDING START-UP SUPPORT FOR BUSINESSES OF OTHERS, NAMELY, ACCELERATING THE STARTUP AND GROWTH OF TECHNOLOGY ORIENTED COMPANIES; ARRANGING AND CONDUCTING SPECIAL EVENTS FOR BUSINESS PURPOSES WITH THE GOAL OF ACCELERATING THE PACE OF COMMERCIALIZATION OF DIGITAL MEDIA TECHNOLOGIES FOR JOB AND WEALTH CREATION (U.S. CLS. 100, 101 AND 102).  
SCOTT BIBB, EXAMINING ATTORNEY

SN 85-749,499. CYCLING SPORTS GROUP, INC., BETHEL, CT. FILED 10-9-2012.



The logo for Cycling Sports Group (CSG) features the letters "CSG" in a bold, stylized, sans-serif font. The letter "S" is significantly larger and more prominent than the "C" and "G", and it has a small dot above it.

OWNER OF U.S. REG. NO. 3,984,418.

THE MARK CONSISTS OF THE STYLIZED LETTERS "CSG", WITH A DOT OVER THE "S" DEPICTING A BICYCLIST.

FOR ONLINE DISTRIBUTORSHIP SERVICES IN THE FIELD OF BICYCLES AND BICYCLE-RELATED CLOTHING AND ACCESSORIES; CONSUMER AND COMMERCIAL INFORMATION SERVICES IN THE FIELD OF BICYCLES AND BICYCLE-RELATED CLOTHING AND ACCESSORIES (U.S. CLS. 100, 101 AND 102).

FIRST USE 4-2-2009; IN COMMERCE 4-2-2009.  
TINA MAI, EXAMINING ATTORNEY

**CLASS 35—(Continued).**

SN 85-823,811. TAP SYSTEMS INCORPORATED, DBA ETHNIC TECHNOLOGIES, RIDGEWOOD, NJ. FILED 1-15-2013.

## Ethnic Technologies

THE MARK CONSISTS OF STANDARD CHARACTERS WITHOUT CLAIM TO ANY PARTICULAR FONT, STYLE, SIZE, OR COLOR.

OWNER OF U.S. REG. NO. 4,461,251.

NO CLAIM IS MADE TO THE EXCLUSIVE RIGHT TO USE "TECHNOLOGIES", APART FROM THE MARK AS SHOWN.

SEC. 2(F).

FOR PROVIDING MARKETING SERVICES FOR MULTICULTURAL MARKETERS FEATURING BUSINESS INFORMATION IN THE NATURE OF MARKETING DATA (U.S. CLS. 100, 101 AND 102).

FIRST USE 12-28-2000; IN COMMERCE 12-28-2000.

SIMON TENG, EXAMINING ATTORNEY

---

SN 85-827,211. CASTRO PETERSEN, INC., LONG BEACH, CA. FILED 1-18-2013.

## CREATIVE PRODUCTIONS

THE MARK CONSISTS OF STANDARD CHARACTERS WITHOUT CLAIM TO ANY PARTICULAR FONT, STYLE, SIZE, OR COLOR.

SEC. 2(F).

FOR ADVERTISING AND MARKETING CONSULTANCY; ADVERTISING AND PROMOTIONAL SERVICES (U.S. CLS. 100, 101 AND 102).

FIRST USE 9-1-1992; IN COMMERCE 9-1-1992.

GRETTA YAO, EXAMINING ATTORNEY

**CLASS 35—(Continued).**

SN 85-834,619. DECOR CRAFT, INC., DBA DCI, PROVIDENCE, RI. FILED 1-28-2013.

## DECOR CRAFT INC

THE MARK CONSISTS OF STANDARD CHARACTERS WITHOUT CLAIM TO ANY PARTICULAR FONT, STYLE, SIZE, OR COLOR.

NO CLAIM IS MADE TO THE EXCLUSIVE RIGHT TO USE "INC", APART FROM THE MARK AS SHOWN.

SEC. 2(F).

FOR ONLINE STORE SERVICES AND MAIL AND TELEPHONE ORDER CATALOG SERVICES FEATURING GADGETS, NAMELY, PLUG OUTS, CUP HOLDERS, FLASH LIGHTS, FLASH DRIVES, COMPUTER MICE, USB HUBS, UNIVERSAL TRAVEL ADAPTERS, UNIVERSAL USB CHARGERS, USB PHONE CHARGERS, MOBILE DEVICE STANDS, ACOUSTIC AMPLIFIERS, MOBILE DEVICE STANDS AND CORD WRAPPERS, CABLE ORGANIZERS, USB POWER STRIPS, MICROPHONE SPEAKERS, SPEAKERS, PENS, EARBUDS, EARBUDS AND CORD WRAPPER SETS, HEADPHONES, HEADPHONE SPLITTERS, MOBILE TELEPHONE COVERS, ACCESSORIES, NAMELY, BAGS AND POUCHES, PORTABLE FANS, LIP BALM AND DECORATIVE LIP BALM TOPS, PORTABLE STEREO SYSTEMS, PURSES AND PENCIL CASES, LIP GLOSS, MANICURE SETS, WALLETS, RINGS, KEY CHAINS, KEY CHAINS AND COMPACT MIRROR SETS, BACK-SCRATCHERS, FLY SWATTERS, PERSONAL MIRRORS, EXTENDABLE FLASHLIGHTS AND MAGNETS, TRAVEL TOOLS, HEAD MASSAGERS, THERMOMETERS, CORD WRAPPER DISPLAYS, SHOE HORNS, TWEEZERS, NAIL FILES, ICE CUBE FORMS, FOOD STORAGE CONTAINERS AND BOXES, INSULATIVE DRINK/BOTTLE SLEEVES, TOYS AND NOVELTY ITEMS NAMELY, SQUIRT GUNS, LED FLYING TOYS, BALLS, BUBBLE BLOWERS, MAGIC FROG TO PRINCE, LED HEARTS, FIRST AID KITS, SEWING KITS, PUG BANKS, CANDLES, LED BUBBLE BLOWING GUNS, STATIONERY, NAMELY, SCISSORS, STRAIGHT EDGE LASER-GUIDED SCISSORS, ADHESIVE TAPE DISPENSERS, PEN DISPLAYS, PEN POTS, STICKERS, MAGNETS, RE-POSITIONAL NOTES, PADS AND PAPER, TAPE MEASURES, PAPER CLIPS, ADHESIVE NOTE-PADS, ERASERS, PAPER IN ASSORTED SHAPE, COLORS, SIZES AND SETS, STATIONERY ORGANIZERS, STATIONERY SETS, CALCULATORS, PUSH PINS, CHALKS, CHALKBOARD SQUARES, STAPLES, PENCIL SHARPENERS, KITCHEN, CULINARY AND COOKING GOODS, NAMELY, CUPS, CUP LIDS, CUP SLEEVES, TEA INFUSERS, NAPKIN NOTES, FOOD FLAGS, PLACE CARDS, PARTY PICKS, COOK AND SERVE WARE, NAMELY, DISHES, NAPKINS, CUTTING BOARDS, SUSHI MOLDS, SALT AND PEPPER SHAKERS, CLIPS AND BAG CLIPS, UTENSILS, MEASURING CUPS, MEASURING SPOONS, PIZZA CUTTERS, CONTAINERS IN A FORM OF A CUP, PLASTIC WATER BOTTLES, GLASS WATER BOTTLES, DRINK MARKERS, BOTTLE OPENERS, SERVING TRAYS, KNIVES, CHEESE KNIVES, STEAK KNIVES, GRATERS, MIXING BOWLS, CHOPSTICKS AND SOUP SPOON IN ONE, CHOPSTICK HOLDERS, CHOPSTICKS, SALAD SERVERS, RUBBER GLOVES, DRAIN STOPPERS, COOKING UTENSIL SETS, BRUSHES FOR COOKING, NAMELY, BASTING BRUSHES, CAKE MOLDS, CAKE PANS, COLLAPSIBLE LUNCH BOXES, WINE GLASSES, BEER GLASSES, SHOT GLASSES, COCKTAIL SHAKERS, BOTTLE STOPPERS, BOTTLE NOTES, MEAT TENDERIZERS, BBQ TOOLS, BBQ BRANDING IRONS, OVEN MITTS, ICE TRAYS, TRAYS, WHISKS, SPATULAS, CUPCAKE HOLDERS, TONGS, SPOONS, SILICONE LUNCH BOXES, MARTINI FLASKS, HOUSEWARES, NAMELY, PILLOWS, HANGER HOOKS, CLOCKS, ALARM CLOCKS, HERB PLANTER SETS, SHOWER CURTAINS, SHOWER CAPS, MAGNETIC VASES, NOVELTY AND DECORATIVE INFLATABLE ANIMAL

**CLASS 35—(Continued).**

SCULPTURES, TRAVEL ALL-PURPOSE CARRYING BAGS, ALL-PURPOSE CARRYING BAGS, HOLIDAY WARES, NAMELY, ANIMAL SHAPED NUTCRACKERS, HOLIDAY GLOVES, POLYESTER STOCKINGS, POCKETS FOR CHRISTMAS COOKIES, CHRISTMAS ORNAMENTS, INFLATABLE WREATHS, LED MENORAHS, GLOW STICKS, ARTIFICIAL AND DECORATIVE CHRISTMAS TREES, REUSABLE HOLIDAY BAGS AND POUCHES, WINTER WARMERS, SYNTHETIC DECORATIVE SNOW, MAGIC GROWING TREES, MAGIC JUMBO TREES, AND MAGIC GROWING PLANTS (U.S. CLS. 100, 101 AND 102).

FIRST USE 11-2-1990; IN COMMERCE 11-2-1990.  
ALEXANDER L. POWERS, EXAMINING ATTORNEY

SN 85-834,643. DECOR CRAFT, INC., DBA DCI, PROVIDENCE, RI. FILED 1-28-2013.



THE COLOR(S) RED AND WHITE IS/ARE CLAIMED AS A FEATURE OF THE MARK.

THE MARK CONSISTS OF THE MARK "DCI" IN STYLIZED FORM WITH ROUNDED OUTLINE. THE OUTLINE IS IN RED WHILE THE WORD "DCI" IS IN WHITE.

FOR ONLINE STORE SERVICES AND MAIL AND TELEPHONE ORDER CATALOG SERVICES FEATURING GADGETS, NAMELY, PLUG OUTS, CUP HOLDERS, FLASH LIGHTS, FLASH DRIVES, COMPUTER MICE, USB HUBS, UNIVERSAL TRAVEL ADAPTERS, UNIVERSAL USB CHARGERS, USB PHONE CHARGERS, MOBILE DEVICE STANDS, ACOUSTIC AMPLIFIERS, MOBILE DEVICE STANDS AND CORD WRAPPERS, CABLE ORGANIZERS, USB POWER STRIPS, MICROPHONE SPEAKERS, SPEAKERS, PENS, EARBUDS, EARBUDS AND CORD WRAPPER SETS, HEADPHONES, HEADPHONE SPLITTERS, MOBILE TELEPHONE COVERS, ACCESSORIES, NAMELY, BAGS AND POUCHES, PORTABLE FANS, LIP BALM AND DECORATIVE LIP BALM TOPS, PORTABLE STEREO SYSTEMS, PURSES AND PENCIL CASES, LIP GLOSS, MANICURE SETS, WALLETS, RINGS, KEY CHAINS, KEY CHAINS AND COMPACT MIRROR SETS, BACKSCRATCHERS, FLY SWATTERS, PERSONAL MIRRORS, EXTENDABLE FLASHLIGHTS AND MAGNETS, TRAVEL TOOLS, HEAD MASSAGERS, THERMOMETERS, CORD WRAPPER DISPLAYS, SHOE HORNS, TWEEZERS, NAIL FILES, ICE CUBE FORMS, FOOD STORAGE CONTAINERS AND BOXES, INSULATIVE DRINK/BOTTLE SLEEVES, TOYS AND NOVELTY ITEMS NAMELY, SQUIRT GUNS, LED FLYING TOYS, BALLS, BUBBLE BLOWERS, MAGIC FROG TO PRINCE, LED HEARTS, FIRST AID KITS, SEWING KITS, PUG BANKS, CANDLES, LED BUBBLE BLOWING GUNS, STATIONERY, NAMELY, SCISSORS, STRAIGHT EDGE LASER-GUIDED SCISSORS, ADHESIVE TAPE DISPENSERS, PEN DISPLAYS, PEN POTS, STICKERS, MAGNETS, RE-POSITIONAL NOTES, PADS AND PAPER, TAPE MEASURES, PAPER CLIPS, ADHESIVE NOTE-PADS, ERASERS, PAPER IN ASSORTED SHAPE, COLORS, SIZES AND SETS, STATIONERY ORGANIZERS, STATIONERY SETS, CALCULATORS, PUSH PINS, CHALKS, CHALKBOARD SQUARES, STAPLES, PENCIL SHARPENERS, KITCHEN, CULINARY AND COOKING GOODS, NAMELY, CUPS, CUP LIDS, CUP SLEEVES, TEA INFUSERS, NAPKIN NOTES, FOOD FLAGS, PLACE CARDS, PARTY PICKS, COOK AND SERVE WARE, NAMELY, DISHES, NAPKINS, CUTTING BOARDS, SUSHI MOLDS, SALT AND PEPPER SHA-

**CLASS 35—(Continued).**

KERS, CLIPS AND BAG CLIPS, UTENSILS, MEASURING CUPS, MEASURING SPOONS, PIZZA CUTTERS, CONTAINERS IN A FORM OF A CUP, PLASTIC WATER BOTTLES, GLASS WATER BOTTLES, DRINK MARKERS, BOTTLE OPENERS, SERVING TRAYS, KNIVES, CHEESE KNIVES, STEAK KNIVES, GRATERS, MIXING BOWLS, CHOPSTICKS AND SOUP SPOON IN ONE, CHOPSTICK HOLDERS, CHOPSTICKS, SALAD SERVERS, RUBBER GLOVES, DRAIN STOPPERS, COOKING UTENSIL SETS, BRUSHES FOR COOKING, NAMELY, BASTING BRUSHES, CAKE MOLDS, CAKE PANS, COLLAPSIBLE LUNCH BOXES, WINE GLASSES, BEER GLASSES, SHOT GLASSES, COCKTAIL SHAKERS, BOTTLE STOPPERS, BOTTLE NOTES, MEAT TENDERIZERS, BBQ TOOLS, BBQ BRANDING IRONS, OVEN MITTS, ICE TRAYS, TRAYS, WHISKS, SPATULAS, CUPCAKE HOLDERS, TONGS, SPOONS, SILICONE LUNCH BOXES, MARTINI FLASKS, HOUSEWARES, NAMELY, PILLOWS, HANGER HOOKS, CLOCKS, ALARM CLOCKS, HERB PLANTER SETS, SHOWER CURTAINS, SHOWER CAPS, MAGNETIC VASES, NOVELTY AND DECORATIVE INFLATABLE ANIMAL SCULPTURES, TRAVEL ALL-PURPOSE CARRYING BAGS, ALL-PURPOSE CARRYING BAGS, HOLIDAY WARES, NAMELY, ANIMAL SHAPED NUTCRACKERS, HOLIDAY GLOVES, POLYESTER STOCKINGS, POCKETS FOR CHRISTMAS COOKIES, CHRISTMAS ORNAMENTS, INFLATABLE WREATHS, LED MENORAHS, GLOW STICKS, ARTIFICIAL AND DECORATIVE CHRISTMAS TREES, REUSABLE HOLIDAY BAGS AND POUCHES, WINTER WARMERS, SYNTHETIC DECORATIVE SNOW, MAGIC GROWING TREES, MAGIC JUMBO TREES, AND MAGIC GROWING PLANTS (U.S. CLS. 100, 101 AND 102).

FIRST USE 11-2-1990; IN COMMERCE 11-2-1990.  
ALEXANDER L. POWERS, EXAMINING ATTORNEY

SN 85-839,169. MISTRESS TRENDS AND RESEARCH COMPANY, LLC, SANTA MONICA, CA. FILED 2-1-2013.

**TAROT**

THE MARK CONSISTS OF STANDARD CHARACTERS WITHOUT CLAIM TO ANY PARTICULAR FONT, STYLE, SIZE, OR COLOR.

FOR CREATIVE SERVICES, NAMELY, ADVERTISING AND MARKETING, BRANDING SERVICES IN THE NATURE OF CONSULTING, DEVELOPMENT, MANAGEMENT AND MARKETING OF BRANDS FOR BUSINESSES AND/OR INDIVIDUALS AND CREATING TRADEMARKS FOR OTHERS (U.S. CLS. 100, 101 AND 102).

CHRISTINA SOBRAL, EXAMINING ATTORNEY



**CLASS 35—(Continued).**

SN 85-863,220. JERSEY DEVIL SURF LLC, LINWOOD, NJ. FILED 2-28-2013.

**JERSEY DEVIL SURF**

THE MARK CONSISTS OF STANDARD CHARACTERS WITHOUT CLAIM TO ANY PARTICULAR FONT, STYLE, SIZE, OR COLOR.

NO CLAIM IS MADE TO THE EXCLUSIVE RIGHT TO USE "SURF", APART FROM THE MARK AS SHOWN.

FOR ON-LINE RETAIL STORE SERVICES FEATURING MEN AND WOMEN'S CLOTHING AND ACCESSORIES, WATCHES, WALLETS, PURSES, CARRY BAGS, CAN COOLERS, DRINKING GLASSES, BACK PACKS, BOOK BAGS, STICKERS, SUNGLASSES, RASH GUARDS, SWIMSUITS, AND SPORTS EQUIPMENT, NAMELY, SURF BOARDS, BODY BOARDS, SURF BOARD BAGS, SKIM BOARDS, SKATEBOARDS, WET SUITS, SURFBOARD LEASHES, FINS, WAX, GRIP PADS, AND BODY BOARD LEASHES; RETAIL STORE SERVICES FEATURING MEN AND WOMEN'S CLOTHING AND ACCESSORIES, WATCHES, WALLETS, PURSES, CARRY BAGS, CAN COOLERS, DRINKING GLASSES, BACK PACKS, BOOK BAGS, STICKERS, SUNGLASSES, RASH GUARDS, SWIMSUITS, AND SPORTS EQUIPMENT, NAMELY, SURF BOARDS, BODY BOARDS, SURF BOARD BAGS, SKIM BOARDS, SKATEBOARDS, WET SUITS, SURFBOARD LEASHES, FINS, WAX, GRIP PADS, AND BODY BOARD LEASHES (U.S. CLS. 100, 101 AND 102).

BARBARA RUTLAND, EXAMINING ATTORNEY

SN 85-875,037. PROJECT HEALTHY LIVING, INC., NEW YORK, NY. FILED 3-13-2013.

**ALOHA**

THE MARK CONSISTS OF STANDARD CHARACTERS WITHOUT CLAIM TO ANY PARTICULAR FONT, STYLE, SIZE, OR COLOR.

FOR ONLINE RETAIL STORES FEATURING ACTIVE GEAR AND APPAREL, FOOD, DRINKS, BEVERAGES, NUTRITIONAL SUPPLEMENTS, AROMATHERAPY PRODUCTS, AND WELL-BEING, LIFESTYLE, BATH, BEAUTY, PERSONAL CARE, AND SELF-ACTUALIZATION PRODUCTS IN THE FIELD OF HEALTH, NUTRITION, BEAUTY, SPIRITUALITY AND HEALTHY LIFESTYLES; PROVIDING A WEBSITE FEATURING CONSUMER INFORMATION AND PUBLICATIONS IN THE FIELD OF HEALTH, NUTRITION, BEAUTY, SPIRITUALITY AND HEALTHY LIFESTYLES; PROMOTING THE GOODS AND SERVICES OF OTHERS BY PROVIDING A WEBSITE FEATURING COUPONS, REBATES, PRICE-COMPARISON INFORMATION, PRODUCT REVIEWS, LINKS TO THE RETAIL WEBSITES OF OTHERS, AND DISCOUNT INFORMATION IN THE FIELD OF HEALTH, NUTRITION, BEAUTY, SPIRITUALITY AND HEALTHY LIFESTYLES (U.S. CLS. 100, 101 AND 102).

JULIE VEPPUMTHARA, EXAMINING ATTORNEY

**CLASS 35—(Continued).**

SN 85-876,899. JACK MILLER BUYING POWER, INC., HOUSTON, TX. FILED 3-15-2013.

**BuyingPower**

THE MARK CONSISTS OF THE LITERAL COMPONENT "BUYINGPOWER" WHERE THE LETTER "O" RESEMBLES THE SYMBOL FOR THE POWER-ON SWITCH ON A COMPUTER.

FOR ADMINISTRATION OF A PROGRAM FOR ENABLING PARTICIPANTS TO OBTAIN DISCOUNTS ON GOODS AND RECEIVE IMPROVED SERVICES; ADMINISTRATION OF A PROGRAM FOR ENABLING PARTICIPANTS TO OBTAIN DISCOUNTS ON THE COST OF SERVICES OR RECEIVE IMPROVED SERVICES (U.S. CLS. 100, 101 AND 102).

FIRST USE 11-1-2012. THE MARK WAS FIRST USED ANYWHERE IN A DIFFERENT FORM OTHER THAN THAT SOUGHT TO BE REGISTERED AT LEAST AS EARLY AS 07/02/1999; IN COMMERCE 11-1-2012. THE MARK WAS FIRST USED IN COMMERCE IN A DIFFERENT FORM OTHER THAN THAT SOUGHT TO BE REGISTERED AT LEAST AS EARLY AS 07/02/1999.

NICHOLAS COLEMAN, EXAMINING ATTORNEY

SN 85-881,068. KIDS SKATE FREE, LLC, DBA KIDSSKATE-FREE.COM, OSPREY, FL. FILED 3-20-2013.

**Kids Skate Free**

THE MARK CONSISTS OF STANDARD CHARACTERS WITHOUT CLAIM TO ANY PARTICULAR FONT, STYLE, SIZE, OR COLOR.

FOR PROMOTIONAL SERVICES, NAMELY, PROMOTING THE GOODS OF OTHERS BY MEANS OF PROVIDING ONLINE COUPONS FOR FREE SKATING PASSES (U.S. CLS. 100, 101 AND 102).

JACQUELINE ABRAMS, EXAMINING ATTORNEY

SN 85-882,131. POSHVOICE, LLC, CASTLE ROCK, CO. FILED S.R. 3-21-2013; AM. P.R. 7-7-2014.

**Poshvoice**

THE MARK CONSISTS OF STANDARD CHARACTERS WITHOUT CLAIM TO ANY PARTICULAR FONT, STYLE, SIZE, OR COLOR.

FOR RETAIL STORE SERVICES FEATURING CLOTHING, SHOES, JEWELRY, ACCESSORIES, DECORATIVE ITEMS AND FASHION (U.S. CLS. 100, 101 AND 102).

MARIA-VICTORIA SUAREZ, EXAMINING ATTORNEY

**CLASS 35—(Continued).**

SN 85-905,988. ENTRAVISION COMMUNICATIONS CORPORATION, SANTA MONICA, CA. FILED 4-16-2013.

**ENTRAVISION SOLUTIONS**

THE MARK CONSISTS OF STANDARD CHARACTERS WITHOUT CLAIM TO ANY PARTICULAR FONT, STYLE, SIZE, OR COLOR.

OWNER OF U.S. REG. NOS. 2,566,989 AND 4,361,510.

NO CLAIM IS MADE TO THE EXCLUSIVE RIGHT TO USE "SOLUTIONS", APART FROM THE MARK AS SHOWN.

FOR PROVIDING MEDIA MARKETING SERVICES IN THE FIELDS OF RADIO, TELEVISION, SOCIAL MEDIA, INTERNET WEB SITES, MOBILE COMMUNICATIONS, AND PORTABLE AND WIRELESS COMMUNICATIONS DEVICES AND PROVIDING MARKETING REPRESENTATION AND CONSULTING SERVICES IN CONNECTION THEREWITH (U.S. CLS. 100, 101 AND 102).

FIRST USE 1-31-2013; IN COMMERCE 1-31-2013.

DEBORAH LOBO, EXAMINING ATTORNEY

---

SN 85-906,668. CJ ADVERTISING, LLC, NASHVILLE, TN. FILED 4-17-2013.

**CJ ADVERTISING**

THE MARK CONSISTS OF STANDARD CHARACTERS WITHOUT CLAIM TO ANY PARTICULAR FONT, STYLE, SIZE, OR COLOR.

NO CLAIM IS MADE TO THE EXCLUSIVE RIGHT TO USE "ADVERTISING", APART FROM THE MARK AS SHOWN.

FOR ADVERTISING AGENCY SERVICES DIRECTED TO LAW FIRMS (U.S. CLS. 100, 101 AND 102).

FIRST USE 2-27-1995; IN COMMERCE 2-27-1995.

JULIE WATSON, EXAMINING ATTORNEY

---

SN 85-911,718. GO FLORIDA PROPERTIES LLC, WILMINGTON, DE. FILED 4-23-2013.

**Feast Card**

THE MARK CONSISTS OF STANDARD CHARACTERS WITHOUT CLAIM TO ANY PARTICULAR FONT, STYLE, SIZE, OR COLOR.

NO CLAIM IS MADE TO THE EXCLUSIVE RIGHT TO USE "CARD", APART FROM THE MARK AS SHOWN.

FOR PROMOTING THE GOODS AND SERVICES OF OTHERS THROUGH THE DISTRIBUTION OF DISCOUNT CARDS (U.S. CLS. 100, 101 AND 102).

TARAH HARDY, EXAMINING ATTORNEY

**CLASS 35—(Continued).**

SN 85-916,551. ZIONIST POLICY AND ADVOCACY COALITION, INC., ALEXANDRIA, VA. FILED 4-26-2013.

**ZPAC**

THE MARK CONSISTS OF STANDARD CHARACTERS WITHOUT CLAIM TO ANY PARTICULAR FONT, STYLE, SIZE, OR COLOR.

FOR PUBLIC POLICY ADVOCACY TO PROMOTE AWARENESS OF THE NEED FOR STRONG POLITICAL, MILITARY AND CULTURAL TIES BETWEEN THE UNITED STATES AND ISRAEL, AND THE PROTECTION OF THE STATE OF ISRAEL AND THE JEWISH PEOPLE; CHARITABLE SERVICES, NAMELY, THE PROMOTION OF CROSS-CULTURAL UNDERSTANDING AND THE ADMINISTRATION OF CULTURAL AND EDUCATIONAL EXCHANGES PROGRAMS BETWEEN THE UNITED STATES AND ISRAEL; PROVIDING INFORMATION ABOUT AND PROMOTION OF NON-PARTISAN RESEARCH AND ANALYSIS ON U.S. FOREIGN AND DOMESTIC POLICY CONCERNING ISRAEL AND THE MIDDLE EAST (U.S. CLS. 100, 101 AND 102).

JULIE WATSON, EXAMINING ATTORNEY

---

SN 85-921,824. TOOSH CASUALS, INC., NEW YORK, NY. FILED 5-2-2013.

**TOOSH**

THE MARK CONSISTS OF STANDARD CHARACTERS WITHOUT CLAIM TO ANY PARTICULAR FONT, STYLE, SIZE, OR COLOR.

THE ENGLISH TRANSLATION OF "TOOSH" IN THE MARK IS "MARKER".

FOR RETAIL APPAREL STORES; RETAIL STORE SERVICES FEATURING APPAREL, HANDBAGS, PURSES AND APPAREL ACCESSORIES (U.S. CLS. 100, 101 AND 102).

FIRST USE 4-21-1994; IN COMMERCE 4-21-1994.

LESLEY LAMOTHE, EXAMINING ATTORNEY

**CLASS 35—(Continued).**

SN 85-934,332. 3ETHOS, INC., MYSTIC, CT. FILED 5-16-2013.

**LeaderMetrics**

THE MARK CONSISTS OF STANDARD CHARACTERS WITHOUT CLAIM TO ANY PARTICULAR FONT, STYLE, SIZE, OR COLOR.

FOR BUSINESS CONSULTING SERVICES IN THE FIELD OF BUSINESS LEADERSHIP DEVELOPMENT USING A FRAMEWORK TO EXAMINE AND ANALYZE THE EFFECTIVENESS OF A CRITICAL DECISION-MAKER WHO IS SERVING IN A LEADERSHIP ROLE AND TO SUBSTANTIATE MULTIPLE PROFESSIONAL AND REGULATORY STANDARDS OF CARE, NAMELY, FIDUCIARY STANDARDS OF CARE FOR AN INVESTMENT ADVISOR, TRUSTEE, OR INVESTMENT COMMITTEE MEMBER, GOVERNANCE STANDARDS OF CARE FOR A BUSINESS BOARD OF DIRECTORS, PROJECT MANAGEMENT STANDARDS OF CARE FOR STAFF AND GLOBAL WEALTH MANAGEMENT STANDARDS OF CARE FOR A WEALTH HOLDER OR FAMILY OFFICE VIA THE BUSINESS LEADERSHIP DEVELOPMENT CONSULTING SERVICES (U.S. CLS. 100, 101 AND 102).

FIRST USE 3-12-2013; IN COMMERCE 3-12-2013.  
SHANNON TWOHIG, EXAMINING ATTORNEY

**CLASS 35—(Continued).**

SN 85-945,770. SIGNATURE TAX LLC, SHERMAN OAKS, CA. FILED 5-29-2013.

**SIGNATURE TAX**

THE MARK CONSISTS OF STANDARD CHARACTERS WITHOUT CLAIM TO ANY PARTICULAR FONT, STYLE, SIZE, OR COLOR.

NO CLAIM IS MADE TO THE EXCLUSIVE RIGHT TO USE "TAX", APART FROM THE MARK AS SHOWN.

FOR AUDIT SUPPORT SERVICES, NAMELY, REVIEW AND ANALYSIS OF A COMPANY'S SALES, AS WELL AS THE PREPARATION, ORGANIZATION AND PRESENTATION OF THE DOCUMENTS AND DATA REQUESTED BY A GOVERNMENT BODY, AND ADVICE ON GOVERNMENT AUDIT PROCESSES, POLICIES AND STRATEGY (U.S. CLS. 100, 101 AND 102).

FIRST USE 5-17-2013; IN COMMERCE 5-17-2013.

DOMINIC J. FERRAIUOLO, EXAMINING ATTORNEY

SN 85-941,667. INDUSTRIES FOR THE BLIND, INC., WEST ALLIS, WI. FILED 5-24-2013.



NO CLAIM IS MADE TO THE EXCLUSIVE RIGHT TO USE "WOUNDED WARRIOR SUPPLY PROGRAM", APART FROM THE MARK AS SHOWN.

THE MARK CONSISTS OF A FLAG WITH ONE STAR AND THREE STRIPES ABOVE THE WORDS "WOUNDED WARRIOR SUPPLY PROGRAM".

FOR EMPLOYMENT HIRING, RECRUITING, PLACEMENT, STAFFING AND CAREER NETWORKING SERVICES; RETAIL STORE SERVICES FEATURING OFFICE SUPPLIES AND OFFICE EQUIPMENT, HOUSEHOLD AND KITCHEN EQUIPMENT AND TOOLS, MEDICAL AND HEALTHCARE ITEMS, PERSONAL CARE, FACILITY SUPPLIES, FOOD SERVICE EQUIPMENT AND SUPPLIES, FOOD SERVICE CHEMICALS, HOUSEKEEPING CHEMICALS, SAFETY EQUIPMENT, LAUNDRY EQUIPMENT AND SUPPLIES, BREAK ROOM SUPPLIES, BEDDING, FURNITURE, TOOLS, AND MAINTENANCE, REPAIR AND OPERATIONS (MRO) EQUIPMENT INCLUDING LUBRICATIONS, HARDWARE, AND PAINTS (U.S. CLS. 100, 101 AND 102).

FIRST USE 5-21-2012; IN COMMERCE 5-21-2012.  
MARTHA FROMM, EXAMINING ATTORNEY

SN 85-948,186. MATRIX PROVIDERS INC, MONUMENT, CO. FILED 5-31-2013.

**Still In Service**

THE MARK CONSISTS OF STANDARD CHARACTERS WITHOUT CLAIM TO ANY PARTICULAR FONT, STYLE, SIZE, OR COLOR.

FOR EMPLOYMENT AGENCY SERVICES, NAMELY, FILLING THE TEMPORARY AND PERMANENT STAFFING NEEDS OF BUSINESSES; EMPLOYMENT HIRING, RECRUITING, PLACEMENT, STAFFING AND CAREER NETWORKING SERVICES; EMPLOYMENT RECRUITING AND STAFFING SERVICES PROVIDED VIA TEXT MESSAGING; EMPLOYMENT STAFFING CONSULTATION SERVICES; EMPLOYMENT STAFFING IN THE FIELD OF MEDICAL PERSONNEL; PROFESSIONAL STAFFING AND RECRUITING SERVICES; STRATEGIC SOURCING, NAMELY, STAFFING IN THE FIELD OF ENGINEERING (U.S. CLS. 100, 101 AND 102).

FIRST USE 8-3-2012; IN COMMERCE 8-3-2012.

PAUL MORENO, EXAMINING ATTORNEY

**CLASS 35—(Continued).**

SN 85-956,575. TOWERS PERRIN CAPITAL CORPORATION, WILMINGTON, DE. FILED 6-11-2013.

## Ideas Exchange

THE MARK CONSISTS OF STANDARD CHARACTERS WITHOUT CLAIM TO ANY PARTICULAR FONT, STYLE, SIZE, OR COLOR.

FOR ORGANIZING AND CONDUCTING BUSINESS CONFERENCES FOR INVESTMENT INDUSTRY PROFESSIONALS IN THE FIELDS OF INVESTING AND RISK MANAGEMENT (U.S. CLS. 100, 101 AND 102).

TRACY FLETCHER, EXAMINING ATTORNEY

---

SN 85-957,628. NOMI NETWORK, INC., NEW YORK, NY. FILED 6-12-2013.

## SEW INTO HER SUCCESS

THE MARK CONSISTS OF STANDARD CHARACTERS WITHOUT CLAIM TO ANY PARTICULAR FONT, STYLE, SIZE, OR COLOR.

FOR CHARITABLE SERVICES, NAMELY, PROMOTING PUBLIC AWARENESS ABOUT SEX SLAVERY AND HUMAN TRAFFICKING THROUGH EDUCATION, EVENTS AND MEDIA PROGRAMS; ON-LINE RETAIL STORE SERVICES FEATURING CLOTHING ITEMS, BAGS, ORNAMENTS, JEWELRY AND CLOTHING ACCESSORIES MADE BY SURVIVORS OF SEX SLAVERY AND HUMAN TRAFFICKING; CREATING JOB OPPORTUNITIES TO ENCOURAGE EMPOWERMENT AMONG SURVIVORS OF SEX SLAVERY AND HUMAN TRAFFICKING, NAMELY, PROVIDING NETWORKING AND PLACEMENT OPPORTUNITIES FOR INDIVIDUALS SEEKING EMPLOYMENT (U.S. CLS. 100, 101 AND 102).

FIRST USE 12-30-2012; IN COMMERCE 12-30-2012.  
CHARLES L. JENKINS, EXAMINING ATTORNEY

---

SN 85-957,890. TVB, INC., PROSPER, TX. FILED 6-12-2013.

## THE VAPOR BAR

THE MARK CONSISTS OF STANDARD CHARACTERS WITHOUT CLAIM TO ANY PARTICULAR FONT, STYLE, SIZE, OR COLOR.

NO CLAIM IS MADE TO THE EXCLUSIVE RIGHT TO USE "VAPOR", APART FROM THE MARK AS SHOWN.

FOR RETAIL STORE SERVICES FEATURING ELECTRONIC CIGARETTES, KITS, AND ACCESSORIES; ON-LINE RETAIL STORE SERVICES FEATURING ELECTRONIC CIGARETTES, KITS, AND ACCESSORIES (U.S. CLS. 100, 101 AND 102).

FIRST USE 12-0-2011; IN COMMERCE 12-0-2011.  
STEVEN JACKSON, EXAMINING ATTORNEY

**CLASS 35—(Continued).**

SN 85-960,306. PROPERTYVALU DATA STREAM LLC, DBA GOMOBILE SOLUTIONS, NEWPORT BEACH, CA. FILED 6-14-2013.

## GOMOBILE SOLUTIONS

THE MARK CONSISTS OF STANDARD CHARACTERS WITHOUT CLAIM TO ANY PARTICULAR FONT, STYLE, SIZE, OR COLOR.

NO CLAIM IS MADE TO THE EXCLUSIVE RIGHT TO USE "SOLUTIONS", APART FROM THE MARK AS SHOWN.

FOR ADVERTISING AND MARKETING SERVICES PROVIDED BY MEANS OF INDIRECT METHODS OF MARKETING COMMUNICATIONS, NAMELY, SOCIAL MEDIA, SEARCH ENGINE MARKETING, INQUIRY MARKETING, INTERNET MARKETING, MOBILE MARKETING, BLOGGING AND OTHER FORMS OF PASSIVE, SHARABLE OR VIRAL COMMUNICATIONS CHANNELS; BUSINESS MONITORING AND CONSULTING SERVICES, NAMELY, PROVIDING STRATEGY, INSIGHT, MARKETING GUIDANCE, AND TRAINING FOR ANALYZING, UNDERSTANDING AND PREDICTING CONSUMER BEHAVIOR AND MOTIVATIONS, AND MARKET TRENDS (U.S. CLS. 100, 101 AND 102).

FIRST USE 6-0-2011; IN COMMERCE 6-0-2011.  
ROSELLE HERRERA, EXAMINING ATTORNEY

---

SN 85-965,761. NUTRAMARKS, INC., PARK CITY, UT. FILED 6-20-2013.



NO CLAIM IS MADE TO THE EXCLUSIVE RIGHT TO USE "VITAMINS", APART FROM THE MARK AS SHOWN. THE COLOR(S) YELLOW, GREEN AND ORANGE IS/ARE CLAIMED AS A FEATURE OF THE MARK.

THE MARK CONSISTS OF THE WORDS "FRESH VITAMINS" IN YELLOW LETTERS OUTLINED IN GREEN WITH A DESIGN OF AN ORANGE CIRCLE/SUN BEHIND THE WORDS.

SEC. 2(F) AS TO "FRESH VITAMINS".

FOR RETAIL STORE SERVICES FEATURING A WIDE VARIETY OF HEALTH PRODUCTS, NUTRITIONAL SUPPLEMENTS, AND COSMETIC AND HEALTH AND BEAUTY PRODUCTS (U.S. CLS. 100, 101 AND 102).

FIRST USE 6-1-2007; IN COMMERCE 6-1-2007.  
JOHN GARTNER, EXAMINING ATTORNEY

**CLASS 35—(Continued).**

SN 85-982,245. CONTINENTAL RECOVERY SERVICES, DBA CRF SOLUTIONS, SIMI VALLEY, CA. FILED 1-30-2013.

# LIENVIEW

THE MARK CONSISTS OF STANDARD CHARACTERS WITHOUT CLAIM TO ANY PARTICULAR FONT, STYLE, SIZE, OR COLOR.

SEC. 2(F).

FOR DATA MANAGEMENT SERVICES FOR USE IN DEBT COLLECTION, NAMELY, ELECTRONIC DATA COLLECTION AND ON-LINE CLAIMS MANAGEMENT (U.S. CLS. 100, 101 AND 102).

EVIN L. KOZAK, EXAMINING ATTORNEY

**CLASS 35—(Continued).**

SN 86-007,852. FORT WORTH MEDTECH CENTER, INC., DBA TECH FORT WORTH, FORT WORTH, TX. FILED 7-11-2013.



NO CLAIM IS MADE TO THE EXCLUSIVE RIGHT TO USE "COWTOWN ANGELS", APART FROM THE MARK AS SHOWN.

THE MARK CONSISTS OF THE STYLIZED WORDS "COWTOWN ANGELS" UNDERNEATH AN ABSTRACT STYLIZED STEER HEAD IN WHICH THE CROSSBAR OF THE "T" IN "COWTOWN" IS COMPRISED OF THE HORNS FOR BUSINESS SERVICES, NAMELY, MATCHING POTENTIAL INVESTORS WITH ENTREPRENEURS NEEDING FUNDING (U.S. CLS. 100, 101 AND 102).

FIRST USE 8-13-2012; IN COMMERCE 8-13-2012.

CAITLIN WATTS-FITZGERALD, EXAMINING ATTORNEY

SN 86-009,548. STARPOINT STRATEGIES, INC., GRANITE BAY, CA. FILED 7-13-2013.

## NAVIGATING A CONSTELLATION OF STRATEGIES

SN 86-002,821. GET HEALTHY NATION, LLC, DBA GET HEALTHY MICHIGAN, OKEMOS, MI. FILED 7-4-2013.



NO CLAIM IS MADE TO THE EXCLUSIVE RIGHT TO USE "MICHIGAN", APART FROM THE MARK AS SHOWN.

THE COLOR(S) WHITE, GREEN, AND COCOA-BLACK IS/ARE CLAIMED AS A FEATURE OF THE MARK.

THE MARK CONSISTS OF WHITE-BORDERED GREEN EXCLAMATION POINT WITH WHITE-BORDERED GREEN HEART AS THE POINT; NEXT TO THE EXCLAMATION MARK, TELEGRAFICO-FONT IN COCOA-BLACK CAPITALIZED THE WORDS "GET" AND BELOW IT, "HEALTHY"; BELOW IT, AMERICAN-TYPEWRITER-BOLD-FONT IN WHITE LOWER CASE THE WORD "MICHIGAN". ALL INSIDE COCOA-BLACK BORDERED, GREEN CONVERSATION MARK.

FOR PROVIDING MARKETING SERVICES FOR WELLNESS INDUSTRY (U.S. CLS. 100, 101 AND 102).

FIRST USE 8-1-2012; IN COMMERCE 1-1-2013.

FLORENTINA BLANDU, EXAMINING ATTORNEY

THE MARK CONSISTS OF STANDARD CHARACTERS WITHOUT CLAIM TO ANY PARTICULAR FONT, STYLE, SIZE, OR COLOR.

FOR ACCOUNTING CONSULTATION; ACQUISITION AND MERGER CONSULTATION; BUSINESS CONSULTANCY; BUSINESS CONSULTING, MANAGEMENT, PLANNING AND SUPERVISION; BUSINESS DEVELOPMENT CONSULTING SERVICES; BUSINESS MANAGEMENT AND ENTERPRISE ORGANIZATION CONSULTANCY; BUSINESS MANAGEMENT CONSULTANCY AND ADVISORY SERVICES; BUSINESS MANAGEMENT CONSULTANCY AS WELL AS DEVELOPMENT OF PROCESSES FOR THE ANALYSIS AND THE IMPLEMENTATION OF STRATEGY PLANS AND MANAGEMENT PROJECTS; BUSINESS MANAGEMENT CONSULTANCY SERVICES; BUSINESS MANAGEMENT CONSULTATION; BUSINESS MANAGEMENT CONSULTING AND ADVISORY SERVICES; BUSINESS MANAGEMENT CONSULTING IN THE FIELD OF TEAM DEVELOPMENT; BUSINESS MANAGEMENT CONSULTING WITH RELATION TO STRATEGY, MARKETING, PRODUCTION, PERSONNEL AND RETAIL SALE MATTERS; BUSINESS MERGER CONSULTATION; BUSINESS ORGANISATION AND MANAGEMENT CONSULTING SERVICES; BUSINESS ORGANISATION CONSULTING; BUSINESS ORGANIZATION AND MANAGEMENT CONSULTANCY INCLUDING PERSONNEL MANAGEMENT; BUSINESS ORGANIZATION AND MANAGEMENT CONSULTING; BUSINESS ORGANIZATION AND OPERATION CONSULTANCY; BUSINESS ORGANIZATION CONSULTING; BUSINESS RISK MANAGEMENT CONSULTATION; BUSINESS SUPPORT SERVICES, NAMELY, BUSINESS CONSULTING TO FREELANCERS, START-UPS, EXISTING BUSINESSES AND NON-PROFIT ORGANIZATIONS; CONSULTANCY AND ADVISORY SERVICES IN THE FIELD OF BUSINESS STRATEGY; CONSULTANCY SERVICES REGARDING BUSINESS STRATEGIES; CONSULTATION IN THE FIELD OF BUSINESS ACQUISITIONS; CONSULTING SERVICES IN BUSINESS LEADERSHIP DEVELOPMENT

**CLASS 35—(Continued).**

AND BUSINESS MANAGEMENT; CONSULTING SERVICES IN BUSINESS ORGANIZATION AND MANAGEMENT; CONSULTING SERVICES IN THE AREA OF SUSTAINABLE BUSINESS SOLUTIONS; CONSULTING SERVICES IN THE FIELD OF HUMAN RESOURCES DEVELOPMENT, NAMELY, FOR THE PROMOTION OF EMPLOYEE RETENTION, CAREER GROWTH, AND INCREASED PRODUCTIVITY FOR EMPLOYEES AND EMPLOYERS; CONSULTING SERVICES IN THE FIELD OF HUMAN RESOURCES DEVELOPMENT, NAMELY, UTILIZING TECHNOLOGY FOR THE PROMOTION OF EMPLOYEE RETENTION, CAREER GROWTH AND INCREASED PRODUCTIVITY FOR EMPLOYEES AND EMPLOYERS; CONSULTING SERVICES IN THE FIELD OF MANAGING INTELLECTUAL PROPERTIES; CONSULTING SERVICES IN THE FIELDS OF BUSINESS MANAGEMENT, HUMAN RESOURCES, AND BUSINESS ORGANIZATIONAL DESIGN; HUMAN RESOURCES CONSULTANCY; HUMAN RESOURCES CONSULTATION; INCOME TAX CONSULTATION; INTERNATIONAL BUSINESS CONSULTING SERVICES RELATING TO THE LEGAL, ACCOUNTING, RISK MANAGEMENT, AFFILIATIONS MANAGEMENT, FINANCIAL, HUMAN RESOURCE, REAL ESTATE, MERGERS AND ACQUISITIONS, AND ADMINISTRATIVE FUNCTIONS OF GLOBAL COMPANIES; MANAGEMENT CONSULTING AND ADVISORY SERVICES IN THE AREAS OF CORPORATE GROWTH STRATEGY, INNOVATION AND GROWTH PROCESSES, ORGANIZATIONAL TRANSFORMATION, AND TALENT MANAGEMENT AND DEVELOPMENT STRATEGIES; TAX AND TAXATION PLANNING, ADVICE, INFORMATION AND CONSULTANCY SERVICES; TAX CONSULTATION (U.S. CLS. 100, 101 AND 102).

FIRST USE 6-4-2001; IN COMMERCE 6-4-2001.  
BRIN ANDERSON, EXAMINING ATTORNEY

**CLASS 35—(Continued).**

HEIGHT WITH A RED BORDER LINE AND A RED GRADIENT BACKGROUND. THE RECTANGLE CONSISTS OF THE STATE OF TEXAS IN A BLUE GRADIENT, OUTLINED IN WHITE, AND A WHITE STAR LOCATED IN THE BLUE SECTION OF THE RIGHT SIDE OF THE STATE OF TEXAS DESIGN, APPEARING ON A BACKGROUND WITH A RED GRADIENT. BEHIND THE STATE OF TEXAS DESIGN, ON THE RED GRADIENT BACKGROUND, APPEARS THREE COLUMNS AND FOUR ROWS OF RED STARS.

FOR ORGANIZING, ARRANGING, PROMOTING, ADVERTISING AND CONDUCTING TRADE EXHIBITIONS, BUSINESS CONVENTIONS, TRADESHOWS AND BUSINESS CONFERENCES ALL FOR BUSINESS PURPOSES FEATURING BOOTHS AND DISPLAYS, NAMELY, PROVIDING READY TO USE OR CUSTOMIZED SPACES FOR SALE OR LEASE FOR DISPLAYING THE PRODUCTS OF OTHERS IN THE FIELDS OF GIFTS, APPAREL, HOME FURNISHINGS, ELECTRONICS AND LIGHTING, AND RELATED MERCHANDISE; ORGANIZATION EXHIBITIONS FOR MANUFACTURERS FOR COMMERCIAL AND ADVERTISING PURPOSES IN THE FIELDS OF GIFTS, APPAREL, HOME FURNISHINGS, ELECTRONICS AND LIGHTING, AND RELATED MERCHANDISE; IMPORT-EXPORT AGENCIES IN THE FIELD OF GIFTS, APPAREL, HOME FURNISHINGS, ELECTRONICS AND LIGHTING, AND RELATED MERCHANDISE; MARKETING SERVICES, NAMELY, MARKETING TRADE SHOWROOMS AND RELATED SHOWROOM FACILITIES FOR MANUFACTURERS IN THE FIELDS OF GIFTS, APPAREL, HOME FURNISHING, ELECTRONICS AND LIGHTING, AND RELATED MERCHANDISE (U.S. CLS. 100, 101 AND 102).

FIRST USE 7-2-2010; IN COMMERCE 11-4-2010.  
BILL DAWE, EXAMINING ATTORNEY

SN 86-013,201. CCW, LLC, DBA HOUSTON TRADE CENTER, SUGAR LAND, TX. FILED 7-17-2013.

SN 86-019,152. VLADIMIR GENDELMAN, WEST BLOOMFIELD, MI. FILED 7-24-2013.



# Printwand

NO CLAIM IS MADE TO THE EXCLUSIVE RIGHT TO USE "HOUSTON TRADE CENTER" AND THE PICTORIAL REPRESENTATION OF THE STATE OF TEXAS, APART FROM THE MARK AS SHOWN.

THE COLOR(S) RED, WHITE, AND BLUE IS/ARE CLAIMED AS A FEATURE OF THE MARK.

THE MARK CONSISTS OF TWO RECTANGLES WITH RED BORDER LINES LOCATED SIDE BY SIDE OF EACH OTHER. THE RECTANGLE ON THE RIGHT SIDE CONSISTS OF STYLIZED LETTERS "HTC" IN LARGE WHITE FONT WITH A SHADOW ADJACENT TO EACH LETTER, APPEARING ON A BLUE GRADIENT BACKGROUND. BENEATH IS THE WORDING "HOUSTON TRADE CENTER" IN SMALLER WHITE STYLIZED FONT, APPEARING ON A RED BACKGROUND. TO THE LEFT OF THIS RECTANGLE IS SMALLER RECTANGLE OF THE SAME

THE MARK CONSISTS OF STANDARD CHARACTERS WITHOUT CLAIM TO ANY PARTICULAR FONT, STYLE, SIZE, OR COLOR.

FOR WHOLESALE AND RETAIL STORE SERVICES FEATURING CUSTOMIZABLE PROMOTIONAL, ADVERTISING, AND MARKETING PRODUCTS, ITEMS, AND GIFTS FOR OTHERS (U.S. CLS. 100, 101 AND 102).

FIRST USE 7-20-2011; IN COMMERCE 7-20-2011.  
GRETCHEN ULRICH, EXAMINING ATTORNEY

**CLASS 35—(Continued).**

SN 86-030,691. JKG ASSOCIATES, INC., SANTA MONICA, CA. FILED 8-6-2013.

**CEREAL PRIZE**

THE MARK CONSISTS OF STANDARD CHARACTERS WITHOUT CLAIM TO ANY PARTICULAR FONT, STYLE, SIZE, OR COLOR.

NO CLAIM IS MADE TO THE EXCLUSIVE RIGHT TO USE "PRIZE", APART FROM THE MARK AS SHOWN.

FOR RETAIL STORE SERVICES FEATURING A WIDE VARIETY OF CONSUMER GOODS; PROVIDING CONSUMER PRODUCT INFORMATION VIA THE INTERNET OR OTHER COMMUNICATIONS NETWORKS; COMPUTERIZED ON-LINE ORDERING SERVICES FEATURING A WIDE VARIETY OF CONSUMER GOODS (U.S. CLS. 100, 101 AND 102).

TIMOTHY FINNEGAN, EXAMINING ATTORNEY

**CLASS 35—(Continued).**

SN 86-036,637. PLAID SKY, INC., OMAHA, NE. FILED 8-13-2013.

**Kenz Laurenz**

THE MARK CONSISTS OF STANDARD CHARACTERS WITHOUT CLAIM TO ANY PARTICULAR FONT, STYLE, SIZE, OR COLOR.

THE NAME(S), PORTRAIT(S), AND/OR SIGNATURE(S) SHOWN IN THE MARK IDENTIFIES MCKENZIE LAUREN BECK-KOSIBA, WHOSE CONSENT(S) TO REGISTER IS MADE OF RECORD.

FOR ON-LINE RETAIL GIFT SHOPS (U.S. CLS. 100, 101 AND 102).

FIRST USE 10-2-2012; IN COMMERCE 10-2-2012.

LUCY ARANT, EXAMINING ATTORNEY

SN 86-032,180. THE NATIONAL COMMUNICATION ASSOCIATION, WASHINGTON, DC. FILED 8-8-2013.



NO CLAIM IS MADE TO THE EXCLUSIVE RIGHT TO USE "ASSOCIATION", APART FROM THE MARK AS SHOWN.

THE COLOR(S) BROWN, BEIGE AND WHITE IS/ARE CLAIMED AS A FEATURE OF THE MARK.

THE MARK CONSISTS OF TWO INTERSECTING CIRCLE ELEMENTS IN WHICH THE CIRCLE ON THE LEFT IN THE COLOR BROWN INTERSECTS WITH THE CIRCLE ELEMENT ON THE RIGHT IN THE COLOR BEIGE AT A WHITE FIELD IN THE MIDDLE. TO THE RIGHT OF THESE GRAPHIC ELEMENTS IS THE LITERAL ELEMENT "NATIONAL COMMUNICATION ASSOCIATION" IN STACKED CONFIGURATION IN THE COLOR BROWN.

SEC. 2(F) AS TO "NATIONAL COMMUNICATION ASSOCIATION".

FOR ASSOCIATION SERVICES, NAMELY, PROMOTING THE INTERESTS OF SCHOLARS, TEACHERS AND PRACTITIONERS IN THE FIELD OF COMMUNICATION; PROMOTING THE PUBLIC AWARENESS OF WIDESPREAD APPRECIATION OF THE IMPORTANCE OF COMMUNICATION IN PUBLIC AND PRIVATE LIFE, THE APPLICATION OF COMPETENT COMMUNICATION TO IMPROVE THE QUALITY OF HUMAN LIFE AND RELATIONSHIPS, AND THE USE OF KNOWLEDGE ABOUT COMMUNICATION TO SOLVE HUMAN PROBLEMS (U.S. CLS. 100, 101 AND 102).

FIRST USE 3-1-2013; IN COMMERCE 3-1-2013.

TRACY CROSS, EXAMINING ATTORNEY

SN 86-040,918. ATTACK!MARKETING, LLC, SAN FRANCISCO, CA. FILED 8-17-2013.



OWNER OF U.S. REG. NOS. 4,410,720 AND 4,410,721.

THE MARK CONSISTS OF THE DESIGN OF A SUMO WRESTLER VIEWED FROM THE SIDE WITH THE LITERAL ELEMENT "ATTACK!" SET FORTH IN-LINE AND TO THE RIGHT OF THE SUMO WRESTLER.

FOR ADVERTISING AND PROMOTION SERVICES AND RELATED CONSULTING; ADVERTISING, MARKETING AND PROMOTION SERVICES; PUBLIC RELATIONS, NAMELY, ARRANGING AND CONDUCTING MARKETING PROMOTIONAL EVENTS FOR OTHERS; MARKET RESEARCH AND ANALYSIS SERVICES; EVENT STAFFING SERVICES; DEVELOPMENT AND IMPLEMENTATION OF DIGITAL MARKETING STRATEGIES, NAMELY, ONLINE PRESENCE DEVELOPMENT, SOCIAL MEDIA MARKETING, AND MOBILE MARKETING INTEGRATION; DEVELOPMENT OF RETAIL MARKETING SOLUTIONS IN THE NATURE OF IN-STORE EVENTS AND POPUP SHOPS, ASSISTED SALES AND INCENTIVIZED PROGRAMS (U.S. CLS. 100, 101 AND 102).

FIRST USE 0-0-2001; IN COMMERCE 0-0-2001.

VIVIAN MICZNIK FIRST, EXAMINING ATTORNEY



**CLASS 35—(Continued).**

SN 86-043,910. CRAB COUNTRY GOURMET, LLC, SALISBURY, MD. FILED 8-21-2013.

**CRAB COUNTRY GOURMET**

THE MARK CONSISTS OF STANDARD CHARACTERS WITHOUT CLAIM TO ANY PARTICULAR FONT, STYLE, SIZE, OR COLOR.

NO CLAIM IS MADE TO THE EXCLUSIVE RIGHT TO USE "CRAB" AND "GOURMET", APART FROM THE MARK AS SHOWN.

FOR ON-LINE RETAIL STORE SERVICES FEATURING PREPARED FOODS (U.S. CLS. 100, 101 AND 102).

HEATHER BIDDULPH, EXAMINING ATTORNEY

SN 86-045,126. KIVUTO SOLUTIONS INC., OTTAWA, ONTARIO, CANADA, FILED 8-22-2013.

**OnTheHub**

THE MARK CONSISTS OF STANDARD CHARACTERS WITHOUT CLAIM TO ANY PARTICULAR FONT, STYLE, SIZE, OR COLOR.

OWNER OF CANADA REG. NO. TMA794971, DATED 4-6-2011, EXPIRES 4-6-2026.

FOR ONLINE RETAIL STORE SERVICES FEATURING ACADEMIC DISCOUNT SOFTWARE DIRECTED TO MEMBERS OF THE ACADEMIC COMMUNITY; PROVIDING AN INTERNET WEBSITE PORTAL FEATURING LINKS TO ACADEMIC DISCOUNT SOFTWARE PRODUCTS OF OTHERS FOR RETAIL PURPOSES; PROMOTING THE GOODS AND SERVICES OF OTHERS BY PROVIDING A WEBSITE FEATURING INFORMATION ABOUT ACADEMIC DISCOUNT SOFTWARE PRODUCTS OF OTHERS AND LINKS TO THIRD-PARTY, SCHOOL BRANDED ONLINE RETAIL STORES FEATURING ACADEMIC DISCOUNT SOFTWARE (U.S. CLS. 100, 101 AND 102).

FIRST USE 8-1-2005; IN COMMERCE 8-1-2005.

NICHOLAS ALTREE, EXAMINING ATTORNEY

SN 86-047,452. PETERS, KRISTINE, PORT ADELAIDE, AUSTRALIA, AND JUDD, JOHN, PORT ADELAIDE, AUSTRALIA, FILED 8-26-2013.

**PLANZLY**

THE MARK CONSISTS OF STANDARD CHARACTERS WITHOUT CLAIM TO ANY PARTICULAR FONT, STYLE, SIZE, OR COLOR.

FOR ONLINE BUSINESS PLANNING AND BUSINESS ADVISORY SUPPORT; ADVISORY SERVICES RELATING TO BUSINESS MANAGEMENT AND BUSINESS OPERATIONS (U.S. CLS. 100, 101 AND 102).

LESLIE RICHARDS, EXAMINING ATTORNEY

**CLASS 35—(Continued).**

SN 86-049,784. FIRM ADVICE, INC., WASHINGTON, DC. FILED 8-28-2013.



THE MARK CONSISTS OF THE WORDING "FIRM ADVICE" BELOW A SILHOUETTE OF A GROUP OF PEOPLE.

FOR PERSONNEL PLACEMENT AND RECRUITMENT, PERSONNEL MANAGEMENT AND PERSONNEL MANAGEMENT CONSULTATION (U.S. CLS. 100, 101 AND 102).

FIRST USE 7-31-2013, THE MARK WAS FIRST USED ANYWHERE IN A DIFFERENT FORM OTHER THAN THAT SOUGHT TO BE REGISTERED AT LEAST AS EARLY AS 03/27/2000; IN COMMERCE 7-31-2013, THE MARK WAS FIRST USED IN COMMERCE IN A DIFFERENT FORM OTHER THAN THAT SOUGHT TO BE REGISTERED AT LEAST AS EARLY AS 03/27/2000.

JUSTINE D. PARKER, EXAMINING ATTORNEY

SN 86-049,950. MHAMMEDI ALAOU, HICHAM, BOSTON, MA. AND RACHID, GHASSAN, BOSTON, MA. FILED 8-28-2013.



NO CLAIM IS MADE TO THE EXCLUSIVE RIGHT TO USE "MOROCCO", APART FROM THE MARK AS SHOWN.

THE MARK CONSISTS OF THE STYLIZED WORDING "EXPERIENCE MOROCCO" TO THE RIGHT OF THE LETTER "M" WITH THE SHAPE OF A MINARET SILHOUETTED IN THE BOTTOM PORTION OF THE LETTER, FOR PROMOTING RECREATION AND TOURISM IN MOROCCO (U.S. CLS. 100, 101 AND 102).

FIRST USE 6-28-2013; IN COMMERCE 6-28-2013.

KATHERINE CHANG, EXAMINING ATTORNEY



**CLASS 35—(Continued).**

SN 86-050,712. SELECT COMFORT CORPORATION, PLYMOUTH, MN. FILED 8-28-2013.

**KNOW BETTER SLEEP**

THE MARK CONSISTS OF STANDARD CHARACTERS WITHOUT CLAIM TO ANY PARTICULAR FONT, STYLE, SIZE, OR COLOR.

FOR RETAIL STORE SERVICES, ON-LINE RETAIL STORE SERVICES AND TELEPHONE SHOP AT HOME SERVICES, ALL FEATURING BEDS, MATTRESSES, MATTRESS TOPPERS, PILLOWS, BED FRAMES, ADJUSTABLE BASES FOR BEDS, MODULAR BASES FOR BEDS, HEADBOARDS, AND BEDDING, NAMELY, MATTRESS PADS, BED SHEETS, PILLOW CASES, BLANKETS, COMFORTERS, BEDSPREADS, COMFORTER COVERS, BED COVERS, PILLOW PROTECTORS, AND MATTRESS PROTECTORS (U.S. CLS. 100, 101 AND 102).

BRIAN CALLAGHAN, EXAMINING ATTORNEY

SN 86-052,746. RELIC VINTAGE, LLC, SCOTTSDALE, AZ. FILED 8-30-2013.



NO CLAIM IS MADE TO THE EXCLUSIVE RIGHT TO USE "VINTAGE", APART FROM THE MARK AS SHOWN.

THE COLOR(S) BLACK, GRAY, BROWN, AND BLUE IS/ARE CLAIMED AS A FEATURE OF THE MARK.

THE MARK CONSISTS OF A CIRCLE WITH A CROSS IN THE CENTER COMPRISING THE COLORS BROWN AND BLACK. THE FOUR QUADRANTS BETWEEN THE CIRCLE AND THE CROSS CONTAIN ALTERNATING PICTURES OF A SKULL AND CROSSED ARROWS IN GRAY WITH A LIGHT BROWN BACKGROUND. THE WORDS "RELIC VINTAGE" ARE CENTERED IN THE MIDDLE OF THE CIRCLE AND CROSS AND ARE WRITTEN IN BLUE STYLIZED FONT. THE COLOR BLACK IN THE BACKGROUND OF THE MARK MERELY INDICATES A TRANSPARENT COLOR.

FOR RETAIL STORE SERVICES FEATURING CLOTHING, JEWELRY, BOOTS, PURSES, AND ACCESSORIES THEREFOR (U.S. CLS. 100, 101 AND 102).

FIRST USE 1-15-2013; IN COMMERCE 6-30-2013.  
JENNIFER BUTTON, EXAMINING ATTORNEY

**CLASS 35—(Continued).**

SN 86-053,196. OUTERWALL INC., BELLEVUE, WA. FILED 8-30-2013.

**CREATING A BETTER EVERYDAY**

THE MARK CONSISTS OF STANDARD CHARACTERS WITHOUT CLAIM TO ANY PARTICULAR FONT, STYLE, SIZE, OR COLOR.

FOR ADVERTISING AND PROMOTION SERVICES; PROMOTING THE GOODS AND SERVICES OF OTHERS, NAMELY, PROVIDING COUPONS, REBATES, VOUCHERS, CERTIFICATES, DISCOUNTS, GIFT CARDS, STORED VALUE CARDS, AND SPECIAL OFFERS FOR THE GOODS AND SERVICES OF OTHERS; VENDING MACHINE SERVICES; RETAIL STORE SERVICES IN THE FIELD OF BUYING AND SELLING GIFT CARDS AND STORED VALUE CARDS; RETAIL STORE SERVICES IN THE FIELD OF BUYING GIFT CARDS AND ISSUING VOUCHERS FOR CASH; RETAIL STORE SERVICES FEATURING ELECTRONIC TERMINAL VENDING OF TELEPHONY, SPECIFICALLY PREPAID WIRELESS; VENDING SERVICES VIA AN ELECTRONIC TERMINAL IN THE FIELD OF TELEPHONY, SPECIFICALLY, PREPAID WIRELESS CARDS; RETAIL STORE SERVICES, NAMELY, A SECTION WITHIN A RETAIL ESTABLISHMENT PROMOTING THE GOODS OR SERVICES OF OTHERS; ISSUING GIFT CARDS, CERTIFICATES, VOUCHERS, AND PURCHASE INCENTIVES WHICH MAY BE REDEEMED FOR GOODS OR SERVICES; PROVIDING CONSUMER PRODUCT ORDERING SERVICES (U.S. CLS. 100, 101 AND 102).

HEATHER THOMPSON, EXAMINING ATTORNEY

SN 86-055,969. LIFEVANTAGE CORPORATION, SANDY, UT. FILED 9-4-2013.

**MASTER TRACK PROGRAM**

THE MARK CONSISTS OF STANDARD CHARACTERS WITHOUT CLAIM TO ANY PARTICULAR FONT, STYLE, SIZE, OR COLOR.

NO CLAIM IS MADE TO THE EXCLUSIVE RIGHT TO USE "PROGRAM", APART FROM THE MARK AS SHOWN.

FOR BUSINESS CONSULTING SERVICES IN THE FIELD OF OPERATION OF DISTRIBUTORSHIPS, PERSON TO PERSON, WHOLESALE AND RETAIL SELLING SERVICES FOR NUTRITIONAL AND DIETARY SUPPLEMENTS, COSMETICS, BEVERAGES, AND JUICES; PRODUCT MERCHANDISING SERVICES IN THE FIELD OF NUTRITIONAL AND DIETARY SUPPLEMENTS, BEVERAGES, AND JUICES (U.S. CLS. 100, 101 AND 102).

SUSAN STIGLITZ, EXAMINING ATTORNEY

**CLASS 35—(Continued).**

SN 86-056,060. GREAT AMERICAN DEALS IP, LP, BEVERLY HILLS, CA. FILED 9-4-2013.

**GREAT AMERICAN DEALS**

THE MARK CONSISTS OF STANDARD CHARACTERS WITHOUT CLAIM TO ANY PARTICULAR FONT, STYLE, SIZE, OR COLOR.

NO CLAIM IS MADE TO THE EXCLUSIVE RIGHT TO USE "DEALS", APART FROM THE MARK AS SHOWN.

FOR ADVERTISING AND PROMOTIONAL SERVICES; ONLINE ADVERTISING AND PROMOTIONAL SERVICES; PROMOTING THE GOODS AND SERVICES OF OTHERS BY PROVIDING A WEBSITE FEATURING COUPONS, REBATES, PRICE-COMPARISON INFORMATION, PRODUCT REVIEWS, LINKS TO THE RETAIL WEBSITES OF OTHERS, AND DISCOUNT INFORMATION; PROMOTING THE GOODS AND SERVICES OF OTHERS VIA A GLOBAL COMPUTER NETWORK; PROMOTING THE GOODS OF OTHERS, NAMELY, PROVIDING COUPONS, REBATES AND VOUCHERS FOR THE GOODS OF OTHERS; PROMOTING THE GOODS OF OTHERS, NAMELY, PROVIDING INFORMATION REGARDING DISCOUNTS, COUPONS, REBATES, VOUCHERS AND SPECIAL OFFERS FOR THE GOODS OF OTHERS; PUBLICITY AND SALES PROMOTION SERVICES; SALES PROMOTION SERVICES; SALES PROMOTION SERVICES FOR THIRD PARTIES (U.S. CLS. 100, 101 AND 102).

JENNIFER RICHARDSON, EXAMINING ATTORNEY

**CLASS 35—(Continued).**

SN 86-057,080. COUNTY OF LOS ANGELES, ALHAMBRA, CA. FILED 9-5-2013.



NO CLAIM IS MADE TO THE EXCLUSIVE RIGHT TO USE "LA", "REDUCE REUSE RECYCLE" AND "RESIDENTIAL RECYCLING PROGRAM", APART FROM THE MARK AS SHOWN.

THE MARK CONSISTS OF THE IMAGE OF A GLOBE WITH CONTINENTS, CIRCLED BY THE WORDS "RESIDENTIAL RECYCLING PROGRAM", CIRCLING THOSE WORDS ARE FOUR ARROWS, WITH THE WORDS "REDUCE", "REUSE", "RECYCLE" AND "RETHINK" INSIDE EACH ARROW. CURVED ALONG THE TOP OF THE ENTIRE IMAGE ARE THE WORDS "RETHINK LA".

FOR PROMOTING PUBLIC AWARENESS OF THE NEED FOR RECYCLING, WASTE REDUCTION, AND POLLUTION PREVENTION (U.S. CLS. 100, 101 AND 102).

FIRST USE 9-8-2010; IN COMMERCE 9-8-2010.  
JERI J. FICKES, EXAMINING ATTORNEY

SN 86-056,727. SEGMINT INC., AKRON, OH. FILED 9-5-2013.

**SHARE OF MIND**

THE MARK CONSISTS OF STANDARD CHARACTERS WITHOUT CLAIM TO ANY PARTICULAR FONT, STYLE, SIZE, OR COLOR.

FOR BEHAVIORAL ADVERTISING SERVICES, NAMELY, PROVIDING BUYER PROFILES WITH PROVEN PURCHASING PATTERNS REGARDING SPECIFIC PRODUCTS AND SERVICES; AND MARKETING RESEARCH AND CONSUMER RESEARCH, NAMELY, SERVICES TO DETERMINE THE AUDIENCE FOR AN ADVERTISEMENT AND OTHER ADVERTISING MEDIA CONTENT (U.S. CLS. 100, 101 AND 102).

CAITLIN WATTS-FITZGERALD, EXAMINING ATTORNEY

SN 86-059,197. AILERON, TIPP CITY, OH. FILED 9-9-2013.



NO CLAIM IS MADE TO THE EXCLUSIVE RIGHT TO USE "PROFESSIONAL MANAGEMENT", "OPERATION", "LEADERSHIP", "STRATEGY", "CULTURE", "PERFORMANCE MANAGEMENT", "BUSINESS STRUCTURE" AND "PEOPLE DEVELOPMENT", APART FROM THE MARK AS SHOWN.

THE MARK CONSISTS OF THE LITERAL ELEMENT "PROFESSIONAL MANAGEMENT DIRECTION LEADERSHIP STRATEGY OPERATION BUSINESS STRUCTURE PEOPLE DEVELOPMENT CONTROL CULTURE PERFOR-

**CLASS 35—(Continued).**

MANCE MANAGEMENT". THE DESIGN IS COMPRISED OF A CIRCLE ABOVE A SECOND CIRCLE WHICH IS ABOVE A THIRD CIRCLE. THE CENTER OF THE CIRCLE CONTAINS "PROFESSIONAL MANAGEMENT". THE SECOND CIRCLE, WHICH IS BROKEN INTO THIRDS, CONSISTS OF "DIRECTION OPERATION" AND "CONTROL". THE THIRD CIRCLE, WHICH IS BROKEN INTO THIRDS, CONSISTS OF "LEADERSHIP STRATEGY BUSINESS STRUCTURE PEOPLE DEVELOPMENT CULTURE" AND "PERFORMANCE MANAGEMENT".

FOR CONSULTING SERVICES IN THE FIELDS OF BUSINESS MANAGEMENT, PROFESSIONAL MANAGEMENT, MANAGEMENT STYLES, BUSINESS PERFORMANCE MANAGEMENT SYSTEMS, BUSINESS STRATEGY AND OPERATION, LEADERSHIP DEVELOPMENT, STRATEGY FOR BUSINESSES, CORPORATE CULTURE AND BUSINESS STRUCTURE (U.S. CLS. 100, 101 AND 102).

FIRST USE 5-6-2013; IN COMMERCE 5-6-2013.

REGINA DRUMMOND, EXAMINING ATTORNEY

---

SN 86-059,367. NORTH AMERICAN INSULATION MANUFACTURERS ASSOCIATION, ALEXANDRIA, VA. FILED S.R. 9-9-2013; AM. P.R. 6-11-2014.

ENGINEERED TO OUTPERFORM

THE MARK CONSISTS OF STANDARD CHARACTERS WITHOUT CLAIM TO ANY PARTICULAR FONT, STYLE, SIZE, OR COLOR.

FOR ASSOCIATION SERVICES, NAMELY, PROMOTING ENERGY EFFICIENCY IN THE SELECTION AND IMPLEMENTATION OF FIBER GLASS AND MINERAL WOOL INSULATION (U.S. CLS. 100, 101 AND 102).

FIRST USE 7-0-2013; IN COMMERCE 7-0-2013.

JOSETTE BEVERLY, EXAMINING ATTORNEY

---

SN 86-059,921. TELLEM, SUSAN, MALIBU, CA. AND THOMPSON, MARSHALL, MALIBU, CA. FILED 9-10-2013.

WORLD TURTLE DAY

THE MARK CONSISTS OF STANDARD CHARACTERS WITHOUT CLAIM TO ANY PARTICULAR FONT, STYLE, SIZE, OR COLOR.

NO CLAIM IS MADE TO THE EXCLUSIVE RIGHT TO USE "TURTLE DAY", APART FROM THE MARK AS SHOWN.

SEC. 2(F).

FOR PROMOTING PUBLIC AWARENESS OF THE NEED FOR CONSERVATION OF TURTLES AND TORTOISES; PROMOTING PUBLIC AWARENESS OF CONSERVATION OF TURTLES AND TORTOISES THROUGH A NATIONAL ANNUAL DAY EVENT (U.S. CLS. 100, 101 AND 102).

FIRST USE 4-1-2000; IN COMMERCE 4-1-2000.

LEIGH CAROLINE CASE, EXAMINING ATTORNEY

**CLASS 35—(Continued).**

SN 86-060,243. CHICAGO TOY & GAME GROUP, INC., LINCOLNWOOD, IL. FILED 9-10-2013.

CHICAGO TOY & GAME FAIR

THE MARK CONSISTS OF STANDARD CHARACTERS WITHOUT CLAIM TO ANY PARTICULAR FONT, STYLE, SIZE, OR COLOR.

OWNER OF U.S. REG. NO. 2,880,519.

NO CLAIM IS MADE TO THE EXCLUSIVE RIGHT TO USE "TOY & GAME FAIR", APART FROM THE MARK AS SHOWN.

SEC. 2(F).

FOR ARRANGING AND CONDUCTING TRADE INDUSTRY, CONSUMER AND MEDIA TRADE SHOW EXHIBITIONS IN THE FIELD OF TOYS, GAMES AND PLAY (U.S. CLS. 100, 101 AND 102).

FIRST USE 11-30-2001; IN COMMERCE 11-30-2001.

CAROL SPILS, EXAMINING ATTORNEY

---

SN 86-060,302. MUSLIM PUBLIC AFFAIRS COUNCIL, LOS ANGELES, CA. FILED 9-10-2013.

MPAC

THE MARK CONSISTS OF STANDARD CHARACTERS WITHOUT CLAIM TO ANY PARTICULAR FONT, STYLE, SIZE, OR COLOR.

FOR PUBLIC ADVOCACY TO PROMOTE BETTER UNDERSTANDING OF ISLAM AND MUSLIMS THROUGH EDUCATION, OUTREACH AND RESEARCH (U.S. CLS. 100, 101 AND 102).

FIRST USE 12-0-1988; IN COMMERCE 12-0-1988.

RONALD MCMORROW, EXAMINING ATTORNEY

---

SN 86-060,309. MUSLIM PUBLIC AFFAIRS COUNCIL, LOS ANGELES, CA. FILED 9-10-2013.

Muslim Public Affairs  
Council

THE MARK CONSISTS OF STANDARD CHARACTERS WITHOUT CLAIM TO ANY PARTICULAR FONT, STYLE, SIZE, OR COLOR.

NO CLAIM IS MADE TO THE EXCLUSIVE RIGHT TO USE "PUBLIC AFFAIRS COUNCIL", APART FROM THE MARK AS SHOWN.

SEC. 2(F).

FOR PUBLIC ADVOCACY TO PROMOTE BETTER UNDERSTANDING OF ISLAM AND MUSLIMS THROUGH EDUCATION, OUTREACH AND RESEARCH (U.S. CLS. 100, 101 AND 102).

FIRST USE 12-0-1988; IN COMMERCE 12-0-1988.

RONALD MCMORROW, EXAMINING ATTORNEY

**CLASS 35—(Continued).**

SN 86-061,731. AMERICA-MIDEAST EDUCATIONAL AND TRAINING SERVICES, INC., WASHINGTON, DC. FILED 9-11-2013.

SKILLS FOR SUCCESS

THE MARK CONSISTS OF STANDARD CHARACTERS WITHOUT CLAIM TO ANY PARTICULAR FONT, STYLE, SIZE, OR COLOR.

FOR CAREER PLANNING SERVICES; RESUME PREPARATION AND RESUME WRITING; PROVIDING EMPLOYMENT INFORMATION; EMPLOYMENT COUNSELING IN THE FIELDS OF CAREER DEVELOPMENT, JOB SEARCH SKILLS, ENGLISH LANGUAGE PROFICIENCY, INTERVIEWING SKILLS, NETWORKING, JOB ATTAINMENT AND PROFESSIONAL DEVELOPMENT; PROVIDING CAREER INFORMATION; CAREER NETWORKING SERVICES; PROVIDING INFORMATION OVER A GLOBAL COMPUTER NETWORK RELATING TO CAREER DEVELOPMENT, BASIC BUSINESS SKILLS, BUSINESS NETWORKING, JOB SEARCH SKILLS, INTERVIEWING SKILLS, CAREER STRATEGY, WORKPLACE RELATIONS, RESUME DEVELOPMENT, JOB ATTAINMENT, HUMAN RESOURCE MANAGEMENT, AND PROFESSIONAL DEVELOPMENT IN THE FIELD OF BUSINESS; PROMOTING THE PROGRAMS OF OTHERS DESIGNED TO PROMOTE AND DEVELOP GLOBAL COMMUNICATION, REGIONAL ECONOMIC DEVELOPMENT, AND EDUCATION AND WORKFORCE SKILLS TO GRADUATES AND PROFESSIONALS IN THE MIDDLE EAST AND NORTH AFRICA BY MEANS OF ARRANGING FINANCIAL AND CORPORATE SPONSORSHIP OF SUCH PROGRAMS (U.S. CLS. 100, 101 AND 102).

JENNIFER BUTTON, EXAMINING ATTORNEY

**CLASS 35—(Continued).**

SN 86-061,880. PRO PARTS DISTRIBUTION COOPERATIVE, FT. WRIGHT, KY. FILED 9-11-2013.



NO CLAIM IS MADE TO THE EXCLUSIVE RIGHT TO USE "PRO PARTS", APART FROM THE MARK AS SHOWN. THE MARK CONSISTS OF A LARGE STYLIZED LETTER "P" WITHIN A RECTANGULAR SHADED BOX ALSO CONTAINING THE WORDING "PRO" ABOVE THE WORDING "PARTS" BOTH IN SMALLER FONT.

FOR MARKETING SERVICES FOR THE HEAVY DUTY, MEDIUM DUTY, AND LIGHT DUTY TRUCK PARTS OF OTHERS; BUYING GROUP SERVICES, NAMELY, BUYING CLUB SERVICES IN THE FIELD OF HEAVY DUTY, MEDIUM DUTY, AND LIGHT DUTY TRUCK PARTS REPRESENTING WHOLESALE DISTRIBUTORS AND PARTS DEALERS (U.S. CLS. 100, 101 AND 102).

FIRST USE 2-0-2013; IN COMMERCE 2-0-2013.  
DANNEAN HETZEL, EXAMINING ATTORNEY

SN 86-063,073. CURRENTC, LLC, SOUTHFIELD, MI. FILED 9-12-2013.



THE MARK CONSISTS OF THE STYLIZED WORDING "CURRENTC" WITH THE TERM "CURRENTC" APPEARING BELOW A CONCENTRIC CIRCLE. THE LETTER "C" APPEARS INSIDE THE CIRCLE, WITH THE PORTION OF THE CONCENTRIC CIRCLE OPPOSITE SHADED.

FOR PROVIDING AN ON-LINE AND MOBILE DIRECTORY OF INFORMATION REGARDING MERCHANTS WHO ACCEPT CONTACTLESS MOBILE PAYMENTS (U.S. CLS. 100, 101 AND 102).

JERI J. FICKES, EXAMINING ATTORNEY

**CLASS 35—(Continued).**

SN 86-063,691. LYLE SELTZER, ATLANTA, GA. FILED 9-13-2013.

**All-Pro Athletic Apparel**

THE MARK CONSISTS OF STANDARD CHARACTERS WITHOUT CLAIM TO ANY PARTICULAR FONT, STYLE, SIZE, OR COLOR.

NO CLAIM IS MADE TO THE EXCLUSIVE RIGHT TO USE "ATHLETIC APPAREL", APART FROM THE MARK AS SHOWN.

FOR MAIL ORDER CATALOG SERVICES FEATURING CLOTHING AND ACCESSORIES (U.S. CLS. 100, 101 AND 102).

FLORENTINA BLANDU, EXAMINING ATTORNEY

---

SN 86-064,265. SUMMIT PARTNERS LP, BOSTON, MA. FILED 9-13-2013.



OWNER OF U.S. REG. NOS. 3,312,767, 4,242,749 AND OTHERS.

NO CLAIM IS MADE TO THE EXCLUSIVE RIGHT TO USE "PARTNERS" AND "GROUP", APART FROM THE MARK AS SHOWN.

THE MARK CONSISTS OF A MOUNTAIN DESIGN WITHIN A RECTANGLE WITH THE LEFT SLOPE OF THE MOUNTAIN EXTENDING OUT OF THE LOWER LEFT SIDE OF THE RECTANGLE. THE MOUNTAIN DESIGN AND THE WORDS "SUMMIT PARTNERS" ARE STACKED ON THE WORDS "PEAK PERFORMANCE GROUP".

FOR BUSINESS CONSULTATION SERVICES FOR MANAGEMENT TEAMS IN THE FIELDS OF SALES, MANUFACTURING AND SUPPLY CHAIN PROCESS, MARKETING, FINANCE, STRATEGY, TALENT ACQUISITION AND MANAGEMENT; PROVIDING BUSINESS SUPPORT STAFF SERVICES FOR MANAGEMENT TEAMS IN THE FIELDS OF SALES, MANUFACTURING AND SUPPLY CHAIN PROCESS, MARKETING, FINANCE, STRATEGY, TALENT ACQUISITION AND MANAGEMENT; PROVIDING BUSINESS ORGANIZATION ADVICE FOR MANAGEMENT TEAMS IN THE FIELDS OF SALES, MANUFACTURING AND SUPPLY CHAIN PROCESS, MARKETING, FINANCE, STRATEGY, TALENT ACQUISITION AND MANAGEMENT (U.S. CLS. 100, 101 AND 102).

SUI DUONG, EXAMINING ATTORNEY

**CLASS 35—(Continued).**

SN 86-065,532. GYRO LLC, NEW YORK, NY. FILED 9-16-2013.

**GYRO:**

THE MARK CONSISTS OF STANDARD CHARACTERS WITHOUT CLAIM TO ANY PARTICULAR FONT, STYLE, SIZE, OR COLOR.

OWNER OF U.S. REG. NO. 2,435,360.

FOR ADVERTISING AND MARKETING SERVICES; SOCIAL MEDIA, MOBILE AND OTHER FORMS OF DIGITAL ADVERTISING; CONTENT MARKETING; ARRANGING AND CONDUCTING MARKETING PROMOTIONAL EVENTS FOR OTHERS; EVENT PLANNING AND MANAGEMENT FOR MARKETING, BRANDING, PROMOTING OR ADVERTISING THE GOODS AND SERVICES OF OTHERS; PROVIDING MARKETING AND PROMOTION OF SPECIAL EVENTS; BRANDING SERVICES, NAMELY, CONSULTING, DEVELOPMENT, MANAGEMENT AND MARKETING OF BRANDS FOR BUSINESSES AND/OR INDIVIDUALS; EVENT PLANNING AND MANAGEMENT FOR MARKETING, BRANDING, PROMOTING OR ADVERTISING THE GOODS AND SERVICES OF OTHERS; MARKETING AND BRANDING SERVICES, NAMELY, PROVIDING CUSTOMIZED COMMUNICATION PROGRAMS TO OBTAIN CONSUMER INSIGHTS AND DEVELOP BRANDING STRATEGIES; DEVELOPMENT OF MARKETING STRATEGIES, CONCEPTS AND TACTICS, NAMELY, AUDIENCE DEVELOPMENT, BRAND AWARENESS, CUSTOMER RELATIONS, ONLINE COMMUNITY BUILDING AND DIGITAL WORD OF MOUTH COMMUNICATIONS (U.S. CLS. 100, 101 AND 102).

FIRST USE 5-0-2011; IN COMMERCE 5-0-2011.

HENRY S. ZAK, EXAMINING ATTORNEY

---

SN 86-065,841. LEAN ENTERPRISE INSTITUTE, INC., CAMBRIDGE, MA. FILED 9-16-2013.



THE MARK CONSISTS OF A STICK FIGURE WEARING A CAP ON ITS HEAD AND HAS A ROUND FACE WITH EYES, NOSE, AND A MOUTH, AND IS STANDING ON AN OVAL SHADOW.

FOR BUSINESS RESEARCH IN THE FIELD OF BUSINESS MANAGEMENT PRACTICES AND ORGANIZATION OF BUSINESS CONFERENCES CONCERNING MANAGEMENT PRACTICES (U.S. CLS. 100, 101 AND 102).

ANTHONY RINKER, EXAMINING ATTORNEY

**CLASS 35—(Continued).**

SN 86-065,930. JENNIFER RESTREPO, MIAMI, FL. FILED 9-16-2013.

# REGEMIT

THE MARK CONSISTS OF STANDARD CHARACTERS WITHOUT CLAIM TO ANY PARTICULAR FONT, STYLE, SIZE, OR COLOR.

FOR OPERATING ON-LINE MARKET PLACES FOR SELLERS AND BUYERS OF DIAMONDS AND JEWELS OF CERTIFIED QUALITY; ON-LINE EXCHANGE SERVICES, NAMELY, BARTERING OF DIAMONDS AND JEWELS OF CERTIFIED QUALITY (U.S. CLS. 100, 101 AND 102).

JANET LEE, EXAMINING ATTORNEY

---

SN 86-067,817. VAMAC, INCORPORATED, RICHMOND, VA. FILED 9-19-2013.



NO CLAIM IS MADE TO THE EXCLUSIVE RIGHT TO USE "INC.", APART FROM THE MARK AS SHOWN.

THE MARK CONSISTS OF THE WORD "THE" PRECEDED BY OPEN QUOTATIONS ABOVE THE WORD "VAMAC" WITH THE WORD "INC." IN THE OPEN PART OF THE LETTER "C" AND SEVERAL HORIZONTAL LINES EXTENDING OUT TO THE RIGHT OF THE WORD "VAMAC" AND THE WORD "DIFFERENCE" WITH CLOSING QUOTATIONS UNDERNEATH.

FOR RETAIL AND WHOLESALE STORE SERVICES, ONLINE RETAIL AND WHOLESALE STORE SERVICES, ALL FEATURING BATHROOM AND KITCHEN FAUCETS, LAVATORIES, SINKS; COOLERS, NAMELY, WATER COOLERS; TOILETS, BIDETS, TOILET SEATS, TUBS, SHOWERS, WHIRLPOOLS, SHOWER DOORS, BATHROOM AND KITCHEN FURNITURE, BATHROOM AND KITCHEN ACCESSORIES, PLUMBING PARTS, PLUMBING ACCESSORIES, WATER HEATER PARTS AND ACCESSORIES, PIPE AND PIPE FITTINGS, TUBULAR PRODUCTS, HYDRANTS AND TRAPS; HEATING PRODUCTS, NAMELY, WATERHEATERS, HEAT EXCHANGERS, BOILERS, HEATERS, AND PUMPS; VALVES, DRAINS AND DISPOSALS, SEALANTS AND GLUES, TOOLS FOR USE IN PLUMBING AND HEATING, DRINKING AND EYEWASH STATIONS, WELL PUMPS AND TANKS, WELL CASINGS, SCREENS, PIPES AND FITTINGS, WELL PUMPS, WIRES AND CABLES, WELL PARTS AND ACCESSORIES, AND WATER TREATMENT PRODUCTS, NAMELY, WATER SOFTENERS, WATER CONDITIONERS, WATER TREATMENT FILTERS AND ACCESSORIES; SEPTIC AND IRRIGATION PRODUCTS, NAMELY, SEPTIC TANKS, SYSTEMS AND DRIP IRRIGATION PRODUCTS, ALTERNATIVE SEPTIC TREATMENT UNITS, SEPTIC PUMPS AND BASINS, CONTROL PANELS, FILTERS, FLOATS, FABRIC AND ALARMS, SEPTIC PARTS AND ACCESSORIES (U.S. CLS. 100, 101 AND 102).

FIRST USE 12-31-1998; IN COMMERCE 12-31-1998.  
ESTHER BELENKER, EXAMINING ATTORNEY

**CLASS 35—(Continued).**

SN 86-073,888. PARTSSOURCE, INC., AURORA, OH. FILED 9-25-2013.

# MYSERVICES

THE MARK CONSISTS OF STANDARD CHARACTERS WITHOUT CLAIM TO ANY PARTICULAR FONT, STYLE, SIZE, OR COLOR.

FOR CUSTOMIZED REPORTING AND ANALYTICS, NAMELY, PREPARING CUSTOMIZED BUSINESS REPORTS, AND CUSTOMIZED BUSINESS DATA ANALYSIS; ORDER FULFILLMENT SERVICES; PROCUREMENT SERVICES, NAMELY, PURCHASING MEDICAL REPLACEMENT PARTS FOR OTHERS (U.S. CLS. 100, 101 AND 102).

ANTHONY RINKER, EXAMINING ATTORNEY

---

SN 86-073,916. BRATTLE SQUARE FLORIST, CAMBRIDGE, MA. FILED 9-25-2013.

# Brattle Square Florist

THE MARK CONSISTS OF STANDARD CHARACTERS WITHOUT CLAIM TO ANY PARTICULAR FONT, STYLE, SIZE, OR COLOR.

NO CLAIM IS MADE TO THE EXCLUSIVE RIGHT TO USE "FLORIST", APART FROM THE MARK AS SHOWN.

SEC. 2(F).  
FOR RETAIL FLORIST SHOPS (U.S. CLS. 100, 101 AND 102).

FIRST USE 1-1-1973; IN COMMERCE 1-1-1973.  
COLLEEN DOMBROW, EXAMINING ATTORNEY

**CLASS 35—(Continued).**

SN 86-074,228. MCKAY ENTERPRISES, BIRCH RUN, MI. FILED 9-25-2013.



NO CLAIM IS MADE TO THE EXCLUSIVE RIGHT TO USE "BRIDAL", "TUXEDOS" AND "PROM", APART FROM THE MARK AS SHOWN.

THE MARK CONSISTS OF THE STYLIZED WORDS "PERFECT FIT" ABOVE AN ELONGATED BAR WITH ROUNDED EDGES WITH THE WORDS "BRIDAL TUXEDOS PROM" INSIDE THE BAR WITH A CIRCLE BULLET SEPARATING EACH WORD.

FOR RETAIL STORE SERVICES FEATURING FORMAL WEAR, BRIDAL GOWNS, PROM GOWNS, BRIDAL PARTY GOWNS, FLOWER GIRL DRESSES, QUINCEANERA GOWNS, HOMECOMING DRESSES, DRESSES FOR TODDLERS, CHILDREN AND TWEENS, BRIDAL AND PROM JEWELRY, ACCESSORIES, SHOES, TIARAS, VEILS, EARRINGS, TUXEDOS (U.S. CLS. 100, 101 AND 102).

FIRST USE 6-16-2009; IN COMMERCE 6-16-2009.  
JENNIFER MARTIN, EXAMINING ATTORNEY

SN 86-074,482. WILSON, DAN, BEVERLY HILLS, CA. FILED 9-25-2013.

## SOCIAL MEDIA TOP TEAM THE NEXT LEVEL SYSTEM

THE MARK CONSISTS OF STANDARD CHARACTERS WITHOUT CLAIM TO ANY PARTICULAR FONT, STYLE, SIZE, OR COLOR.

NO CLAIM IS MADE TO THE EXCLUSIVE RIGHT TO USE "SOCIAL MEDIA" AND "SYSTEM", APART FROM THE MARK AS SHOWN.

FOR BUSINESS CONSULTING SERVICES, NAMELY, PROVIDING ASSISTANCE IN DEVELOPMENT OF BUSINESS STRATEGIES AND CREATIVE IDEATION (U.S. CLS. 100, 101 AND 102).

JOHN HWANG, EXAMINING ATTORNEY

SN 86-075,407. GOODPEOPLE GLOBAL, INC., SAN FRANCISCO, CA. FILED 9-26-2013.

## GOBIGDOGGOOD

THE MARK CONSISTS OF STANDARD CHARACTERS WITHOUT CLAIM TO ANY PARTICULAR FONT, STYLE, SIZE, OR COLOR.

FOR ONLINE RETAIL STORE SERVICES FEATURING CLOTHING, SPORTING GOODS, BOARD SPORTS EQUIPMENT AND ACCESSORIES (U.S. CLS. 100, 101 AND 102).

MICHAEL WEBSTER, EXAMINING ATTORNEY

**CLASS 35—(Continued).**

SN 86-075,931. WBC GROUP, LLC, HUDSON, OH. FILED 9-26-2013.

## ELIVATE

THE MARK CONSISTS OF STANDARD CHARACTERS WITHOUT CLAIM TO ANY PARTICULAR FONT, STYLE, SIZE, OR COLOR.

FOR RETAIL STORE SERVICES FEATURING THE GOODS OF OTHERS, NAMELY, EXERCISE AND FITNESS EQUIPMENT AND PRODUCTS, SPORTING GOODS, CLOTHING AND APPAREL, ATHLETIC CLOTHING, REHABILITATIVE EQUIPMENT AND SUPPLIES FOR PHYSICAL REHABILITATION AFTER PLAYING SPORTS, EXERCISING OR INJURY, AND PHYSICAL- AND MASSAGE-THERAPY PRODUCTS; RETAIL STORE SERVICES FEATURING EXERCISE AND FITNESS EQUIPMENT AND PRODUCTS, SPORTING GOODS, CLOTHING AND APPAREL, ATHLETIC CLOTHING, REHABILITATIVE EQUIPMENT AND SUPPLIES FOR PHYSICAL REHABILITATION AFTER PLAYING SPORTS, EXERCISING OR INJURY, AND PHYSICAL- AND MASSAGE-THERAPY PRODUCTS; WHOLESALE STORE AND WHOLESALE DISTRIBUTORSHIP SERVICES FEATURING EXERCISE AND FITNESS EQUIPMENT AND PRODUCTS, SPORTING GOODS, CLOTHING AND APPAREL, ATHLETIC CLOTHING, REHABILITATIVE EQUIPMENT AND SUPPLIES FOR PHYSICAL REHABILITATION AFTER PLAYING SPORTS, EXERCISING OR INJURY, AND PHYSICAL- AND MASSAGE-THERAPY PRODUCTS; MAIL ORDER AND ONLINE RETAIL STORE SERVICES FEATURING EXERCISE AND FITNESS EQUIPMENT AND PRODUCTS, SPORTING GOODS, CLOTHING AND APPAREL, ATHLETIC CLOTHING, REHABILITATIVE EQUIPMENT AND SUPPLIES FOR PHYSICAL REHABILITATION AFTER PLAYING SPORTS, EXERCISING OR INJURY, AND PHYSICAL- AND MASSAGE-THERAPY PRODUCTS (U.S. CLS. 100, 101 AND 102).

KIM MONINGHOFF, EXAMINING ATTORNEY

SN 86-077,149. FIVE STAR FRAGRANCE COMPANY, INC., BELLPORT, NY. FILED 9-27-2013.

## FIVE STAR FRAGRANCE COMPANY

THE MARK CONSISTS OF STANDARD CHARACTERS WITHOUT CLAIM TO ANY PARTICULAR FONT, STYLE, SIZE, OR COLOR.

NO CLAIM IS MADE TO THE EXCLUSIVE RIGHT TO USE "FRAGRANCE COMPANY", APART FROM THE MARK AS SHOWN.

FOR DISTRIBUTORSHIP SERVICES IN THE FIELD OF FRAGRANCE, COSMETICS, BODY AND BEAUTY CARE; WHOLESALE DISTRIBUTORSHIP SERVICES FEATURING FRAGRANCE, COSMETICS, BODY AND BEAUTY CARE PRODUCTS (U.S. CLS. 100, 101 AND 102).

FIRST USE 11-26-1997; IN COMMERCE 11-26-1997.  
LYNDESEY KUYKENDALL, EXAMINING ATTORNEY

**CLASS 35—(Continued).**

SN 86-080,275. VPG ENTERPRISES, INC., DBA CASA FOODS, MIDDLETON, MA. FILED 10-1-2013.



NO CLAIM IS MADE TO THE EXCLUSIVE RIGHT TO USE "FOODS", APART FROM THE MARK AS SHOWN.

THE MARK CONSISTS OF THE STYLIZED LETTERS "CF" FOLLOWED BY THE WORDING "CASA FOODS", ALL INSIDE A RECTANGLE HAVING ROUNDED CORNERS.

THE ENGLISH TRANSLATION OF THE WORD "CASA" IN THE MARK IS "HOUSE".

FOR DISTRIBUTORSHIP SERVICES IN THE FIELD OF FOOD (U.S. CLS. 100, 101 AND 102).

FIRST USE 9-20-2013; IN COMMERCE 9-20-2013.

MICHAEL WIENER, EXAMINING ATTORNEY

**CLASS 35—(Continued).**

SN 86-080,600. C&H CLUBS USA, INC., LAKE FOREST, CA. FILED 10-2-2013.

**RARE BEER CLUB**

THE MARK CONSISTS OF STANDARD CHARACTERS WITHOUT CLAIM TO ANY PARTICULAR FONT, STYLE, SIZE, OR COLOR.

NO CLAIM IS MADE TO THE EXCLUSIVE RIGHT TO USE "BEER", APART FROM THE MARK AS SHOWN.

SEC. 2(F).

FOR ON-LINE AND TELEPHONE ORDERING SERVICES IN THE FIELD OF BEER; ON-LINE ORDERING SERVICES FEATURING PERIODIC BEER SHIPMENTS TO MEMBERS; PROMOTIONAL SERVICES, NAMELY, PROMOTING THE GOODS OF OTHERS BY PROVIDING AN ONLINE GIFT SERVICE FEATURING BEER SHIPPED ON A PERIODIC BASIS TO MEMBERS (U.S. CLS. 100, 101 AND 102).

FIRST USE 7-10-2004; IN COMMERCE 7-10-2004.

DAVID MURRAY, EXAMINING ATTORNEY

SN 86-080,555. C&H CLUBS USA, INC., LAKE FOREST, CA. FILED 10-2-2013.

**MONTHLYCLUBS.COM**

THE MARK CONSISTS OF STANDARD CHARACTERS WITHOUT CLAIM TO ANY PARTICULAR FONT, STYLE, SIZE, OR COLOR.

SEC. 2(F).

FOR ON-LINE AND TELEPHONE ORDERING SERVICES IN THE FIELDS OF WINE, BEER, CIGARS, FLOWERS, FOOD AND/OR BEVERAGES; ON-LINE ORDERING SERVICES FEATURING PERIODIC WINE, BEER, CIGARS, FLOWERS, FOOD AND/OR BEVERAGES SHIPMENTS TO CLUB MEMBERS; PROMOTIONAL SERVICES, NAMELY, PROMOTING THE GOODS OF OTHERS BY PROVIDING AN ONLINE GIFT SERVICE FEATURING WINE, BEER, CIGARS, FLOWERS, FOOD AND/OR BEVERAGES SHIPPED ON A PERIODIC BASIS TO MEMBERS (U.S. CLS. 100, 101 AND 102).

FIRST USE 7-22-2002; IN COMMERCE 7-22-2002.

DAVID MURRAY, EXAMINING ATTORNEY

SN 86-081,010. TITAN OUTDOOR LLC, NEW YORK, NY. FILED 10-2-2013.



OWNER OF U.S. REG. NOS. 2,769,675 AND 3,331,056. THE COLOR(S) GRAY AND BLUE IS/ARE CLAIMED AS A FEATURE OF THE MARK.

THE MARK CONSISTS OF THE WORD "TITAN" IN BLUE AND UNDERNEATH THE WORD "TITAN" IS THE WORDING "TITAN360.COM" IN GRAY.

FOR ADVERTISING SERVICES, NAMELY, PROMOTING THE SERVICES AND PRODUCTS OF OTHERS THROUGH THE PREPARING, PLANNING, PRODUCTION, POSTING AND DISTRIBUTION OF OUTDOOR, OUT OF HOME AND TRANSIT ADVERTISING (U.S. CLS. 100, 101 AND 102).

FIRST USE 8-27-2009; IN COMMERCE 8-31-2009.

IRA J. GOODSaid, EXAMINING ATTORNEY



**CLASS 35—(Continued).**

SN 86-081,759. KOZY SHACK ENTERPRISES, LLC, ARDEN HILLS, MN. FILED 10-3-2013.



OWNER OF U.S. REG. NOS. 1,225,221, 4,043,683 AND OTHERS.

NO CLAIM IS MADE TO THE EXCLUSIVE RIGHT TO USE "PUDDING" AND "CLUB", APART FROM THE MARK AS SHOWN.

THE MARK CONSISTS OF A CIRCLE WHICH INCLUDES A CIRCULAR LINE WITHIN THE CIRCLE AN IMAGE OF A BOY AND GIRL HOLDING A SPOON IN THE AIR ABOVE A BOWL DEPICTING PUDDING. ABOVE THE IMAGE IS THE WORD "PUDDING" AND BELOW THE IMAGE ARE THE WORDS "ENTHUSIAST CLUB". BELOW THE WORDS "ENTHUSIAST CLUB" IS A BANNER WITH THE WORDS "KOZY SHACK". BELOW THE CIRCLE IS A BANNER WITH THE PHRASE "SE PUDDINGUS EADIT".

FOR ADVERTISING SERVICES, NAMELY, PROMOTING AND MARKETING GOODS AND SERVICES IN THE FIELD OF FOOD VIA PRINT AND SOCIAL MEDIA (U.S. CLS. 100, 101 AND 102).

JORDAN BAKER, EXAMINING ATTORNEY

SN 86-083,375. K M MOONEY PROD., INC., ELLENTON, FL. FILED 10-4-2013.

**KMARIE**

THE MARK CONSISTS OF STANDARD CHARACTERS WITHOUT CLAIM TO ANY PARTICULAR FONT, STYLE, SIZE, OR COLOR.

THE NAME(S), PORTRAIT(S), AND/OR SIGNATURE(S) SHOWN IN THE MARK IDENTIFIES KELSEY MARIE MOONEY, WHOSE CONSENT(S) TO REGISTER IS MADE OF RECORD.

FOR PRODUCT MERCHANDISING; ONLINE RETAIL STORE SERVICES FEATURING MUSIC, MUSICAL RECORDINGS, MOTION PICTURES, CLOTHING AND ACCESSORIES, NOVELTY ITEMS; PROVIDING AN INTERNET WEBSITE PORTAL FEATURING LINKS RELATING MERCHANDISE OF A FEMALE ENTERTAINER FOR RETAIL PURPOSES; ENTERTAINMENT MARKETING SERVICES, NAMELY, MARKETING, PROMOTION AND ADVERTISING FOR RECORDING AND PERFORMING ARTISTS (U.S. CLS. 100, 101 AND 102).

KAMAL PREET, EXAMINING ATTORNEY

**CLASS 35—(Continued).**

SN 86-083,696. GROWING GREEK, LLC, GLEN CARBON, IL. FILED 10-5-2013.

**Growing Greek**

THE MARK CONSISTS OF STANDARD CHARACTERS WITHOUT CLAIM TO ANY PARTICULAR FONT, STYLE, SIZE, OR COLOR.

FOR ONLINE RETAIL STORE AND MAIL-ORDER STORE FEATURING HOME AND GARDENING ACCESSORIES AND GIFTS (U.S. CLS. 100, 101 AND 102).

JEAN IM, EXAMINING ATTORNEY

SN 86-085,233. WEBSTER FINANCIAL CORPORATION, WATERBURY, CT. FILED 10-8-2013.

**WEBSTER BANK LIVING UP TO YOU**

THE MARK CONSISTS OF STANDARD CHARACTERS WITHOUT CLAIM TO ANY PARTICULAR FONT, STYLE, SIZE, OR COLOR.

OWNER OF U.S. REG. NOS. 3,012,979, 3,334,640 AND OTHERS.

NO CLAIM IS MADE TO THE EXCLUSIVE RIGHT TO USE "BANK", APART FROM THE MARK AS SHOWN.

FOR TAX PLANNING, REPORTING AND CONSULTATION SERVICES; TRUST, ESTATE AND INVESTMENT CUSTODY, ADMINISTRATION, RECORD KEEPING AND REPORTING SERVICES, NAMELY, PREPARING TAX LETTERS, STATEMENTS, SUMMARIES AND REPORTS, AND SHAREHOLDER RECORD KEEPING SERVICES; CORPORATE FINANCIAL ACTION REPORTING AND MANAGEMENT, TRACKING AND REPORTING FINANCIAL ACCOUNT, ASSET AND FINANCIAL TRANSACTION INFORMATION, PREPARING FINANCIAL ACCOUNT STATEMENTS AND SUMMARIES FOR BUSINESSES; PROVIDING INFORMATION IN THE FIELD OF TAXES VIA VARIOUS MEANS, WHICH MAY INCLUDE BUT ARE NOT LIMITED TO, THE INTERNET, GLOBAL NETWORKS, TELEPHONE, AND FACSIMILE (U.S. CLS. 100, 101 AND 102).

FIRST USE 4-7-2014, THE MARK WAS FIRST USED ANYWHERE IN A DIFFERENT FORM OTHER THAN THAT SOUGHT TO BE REGISTERED AT LEAST AS EARLY AS 11/01/1995.; IN COMMERCE 4-7-2014, THE MARK WAS FIRST USED IN COMMERCE IN A DIFFERENT FORM OTHER THAN THAT SOUGHT TO BE REGISTERED AT LEAST AS EARLY AS 11/01/1995..

AMY HELLA, EXAMINING ATTORNEY

**CLASS 35—(Continued).**

SN 86-086,483. VINCENT, DEBORAH, DBA CHOKOLÁ, TAOS, NM. AND ETXANIZ, JAVIER A., DBA CHOKOLA, TAOS, NM. FILED 10-9-2013.

# casachokolá

THE MARK CONSISTS OF STANDARD CHARACTERS WITHOUT CLAIM TO ANY PARTICULAR FONT, STYLE, SIZE, OR COLOR.

THE ENGLISH TRANSLATION OF "CASA" IN THE MARK IS "HOUSE". THE WORDING "CHOKOLA" HAS NO MEANING IN A FOREIGN LANGUAGE.

FOR RETAIL STORE SERVICES FEATURING CHOCOLATE CANDIES, CHOCOLATE CANDY BARS, AND CHOCOLATE TRUFFLES ACCESSIBLE ON-LINE AND BY TELEPHONE, FACSIMILE AND MAIL ORDER (U.S. CLS. 100, 101 AND 102).

FIRST USE 9-1-2013; IN COMMERCE 9-1-2013.  
KEVON CHISOLM, EXAMINING ATTORNEY

**CLASS 35—(Continued).**

SN 86-087,030. ADYAPPER, INC., DBA SELECT ONE, CHICAGO, IL. FILED 10-9-2013.

# vLayer

THE MARK CONSISTS OF STANDARD CHARACTERS WITHOUT CLAIM TO ANY PARTICULAR FONT, STYLE, SIZE, OR COLOR.

FOR DATA COLLECTION AND ANALYSIS FOR BUSINESS PURPOSES, ADVERTISING ANALYTICS AND BUSINESS MANAGEMENT CONSULTING SERVICES, NAMELY, MONITORING, TRACKING, VALIDATING, REPORTING, OPTIMIZING, AND INCREASING REVENUE DERIVED FROM THE USE OF DIGITAL MEDIA, CONTENT, AND DIGITAL ADVERTISEMENTS, BUSINESS MONITORING SERVICES IN THE NATURE OF TRACKING DIGITAL MEDIA, CONTENT, AND DIGITAL ADVERTISEMENTS OF OTHERS TO PROVIDE DETAILS ABOUT USER TRAFFIC IN RELATION TO AD VIEWABILITY, ALL TO ENSURE ACCOUNTABILITY AND IMPROVE ADVERTISING EFFECTIVENESS (U.S. CLS. 100, 101 AND 102).

FIRST USE 0-0-2012; IN COMMERCE 0-0-2012.  
JULIE WATSON, EXAMINING ATTORNEY

---

SN 86-086,991. ADYAPPER, INC., CHICAGO, IL. FILED 10-9-2013.

# vCTR

THE MARK CONSISTS OF STANDARD CHARACTERS WITHOUT CLAIM TO ANY PARTICULAR FONT, STYLE, SIZE, OR COLOR.

FOR DATA COLLECTION AND ANALYSIS FOR BUSINESS PURPOSES, ADVERTISING ANALYTICS AND BUSINESS MANAGEMENT CONSULTING SERVICES, NAMELY, MONITORING, TRACKING, VALIDATING, REPORTING, OPTIMIZING, AND INCREASING REVENUE DERIVED FROM THE USE OF DIGITAL MEDIA, CONTENT, AND DIGITAL ADVERTISEMENTS, BUSINESS MONITORING SERVICES IN THE NATURE OF TRACKING DIGITAL MEDIA, CONTENT, AND DIGITAL ADVERTISEMENTS OF OTHERS TO PROVIDE DETAILS ABOUT USER TRAFFIC IN RELATION TO AD VIEWABILITY, ALL TO ENSURE ACCOUNTABILITY AND IMPROVE ADVERTISING EFFECTIVENESS (U.S. CLS. 100, 101 AND 102).

FIRST USE 0-0-2012; IN COMMERCE 0-0-2012.  
JULIE WATSON, EXAMINING ATTORNEY

---

SN 86-087,058. ADYAPPER, INC., DBA SELECT ONE, CHICAGO, IL. FILED 10-9-2013.

# vReach

THE MARK CONSISTS OF STANDARD CHARACTERS WITHOUT CLAIM TO ANY PARTICULAR FONT, STYLE, SIZE, OR COLOR.

FOR DATA COLLECTION AND ANALYSIS FOR BUSINESS PURPOSES, ADVERTISING ANALYTICS AND BUSINESS MANAGEMENT CONSULTING SERVICES, NAMELY, MONITORING, TRACKING, VALIDATING, REPORTING, OPTIMIZING, AND INCREASING REVENUE DERIVED FROM THE USE OF DIGITAL MEDIA, CONTENT, AND DIGITAL ADVERTISEMENTS, BUSINESS MONITORING SERVICES IN THE NATURE OF TRACKING DIGITAL MEDIA, CONTENT, AND DIGITAL ADVERTISEMENTS OF OTHERS TO PROVIDE DETAILS ABOUT USER TRAFFIC IN RELATION TO AD VIEWABILITY, ALL TO ENSURE ACCOUNTABILITY AND IMPROVE ADVERTISING EFFECTIVENESS (U.S. CLS. 100, 101 AND 102).

FIRST USE 0-0-2012; IN COMMERCE 0-0-2012.  
JULIE WATSON, EXAMINING ATTORNEY

**CLASS 35—(Continued).**

SN 86-087,091. ADYAPPER, INC., CHICAGO, IL. FILED 10-9-2013.

## vConversion

THE MARK CONSISTS OF STANDARD CHARACTERS WITHOUT CLAIM TO ANY PARTICULAR FONT, STYLE, SIZE, OR COLOR.

FOR DATA COLLECTION AND ANALYSIS FOR BUSINESS PURPOSES, ADVERTISING ANALYTICS AND BUSINESS MANAGEMENT CONSULTING SERVICES, NAMELY, MONITORING, TRACKING, VALIDATING, REPORTING, OPTIMIZING, AND INCREASING REVENUE DERIVED FROM THE USE OF DIGITAL MEDIA, CONTENT, AND DIGITAL ADVERTISEMENTS, BUSINESS MONITORING SERVICES IN THE NATURE OF TRACKING DIGITAL MEDIA, CONTENT, AND DIGITAL ADVERTISEMENTS OF OTHERS TO PROVIDE DETAILS ABOUT USER TRAFFIC IN RELATION TO AD VIEWABILITY, ALL TO ENSURE ACCOUNTABILITY AND IMPROVE ADVERTISING EFFECTIVENESS (U.S. CLS. 100, 101 AND 102).

FIRST USE 0-0-2012; IN COMMERCE 0-0-2012.

JULIE WATSON, EXAMINING ATTORNEY

SN 86-090,095. MILLIONS TWO ONE, CASSELBERRY, FL. FILED 10-12-2013.

## MILLIONS TWO ONE

THE MARK CONSISTS OF STANDARD CHARACTERS WITHOUT CLAIM TO ANY PARTICULAR FONT, STYLE, SIZE, OR COLOR.

FOR ON-LINE BUSINESS DIRECTORIES FEATURING MINORITY OWNED BUSINESSES; PROVIDING ON-LINE WEB DIRECTORY SERVICES FEATURING HYPERLINKS TO THE WEBSITES OF OTHERS (U.S. CLS. 100, 101 AND 102).

KATHERINE CHANG, EXAMINING ATTORNEY

**CLASS 35—(Continued).**

SN 86-091,568. ER MARKS, INC., WILMINGTON, DE. FILED 10-15-2013.

## ON AIR. ONLINE. ON Q.

THE MARK CONSISTS OF STANDARD CHARACTERS WITHOUT CLAIM TO ANY PARTICULAR FONT, STYLE, SIZE, OR COLOR.

OWNER OF U.S. REG. NO. 1,914,291.

NO CLAIM IS MADE TO THE EXCLUSIVE RIGHT TO USE "ON AIR. ONLINE.", APART FROM THE MARK AS SHOWN.

FOR PROVIDING HOME SHOPPING SERVICES IN THE FIELD OF GENERAL MERCHANDISE BY MEANS OF MOBILE PHONE, PORTABLE HAND-HELD DIGITAL DEVICES, INTERNET AND BY MEANS OF TELEVISION (U.S. CLS. 100, 101 AND 102).

FIRST USE 9-23-2007; IN COMMERCE 9-23-2007.

MICHELE SWAIN, EXAMINING ATTORNEY

SN 86-091,973. ELITE RESEARCH, LLC, DBA ELITE DEFENSE, CHELSEA, MI. FILED 10-15-2013.

## OFFICIAL SPONSOR OF THE GOOD GUYS

THE MARK CONSISTS OF STANDARD CHARACTERS WITHOUT CLAIM TO ANY PARTICULAR FONT, STYLE, SIZE, OR COLOR.

FOR INDEPENDENT SALES REPRESENTATIVES IN THE FIELD OF DEFENSE ARTICLES, SMALL ARMS, OPTICAL AND HOLOGRAPHIC SIGHTS, AND MILITARY-RELATED ITEMS; WHOLESALE DISTRIBUTORSHIPS FEATURING DEFENSE ARTICLES, SMALL ARMS, OPTICAL AND HOLOGRAPHIC SIGHTS, AND MILITARY-RELATED ITEMS; ADVERTISING SERVICES, NAMELY, PROMOTING THE SALE OF DEFENSE ARTICLES OF OTHERS (U.S. CLS. 100, 101 AND 102).

FIRST USE 1-15-2011; IN COMMERCE 1-15-2011.

ELIZABETH JACKSON, EXAMINING ATTORNEY

SN 86-093,710. CALISE PARTNERS, INC., DALLAS, TX. FILED 10-17-2013.

## WORK THAT WORKS

THE MARK CONSISTS OF STANDARD CHARACTERS WITHOUT CLAIM TO ANY PARTICULAR FONT, STYLE, SIZE, OR COLOR.

FOR ADVERTISING, MARKETING AND PROMOTIONAL SERVICES; PUBLIC RELATIONS (U.S. CLS. 100, 101 AND 102).

FIRST USE 10-2-2013; IN COMMERCE 10-2-2013.

CYNTHIA RINALDI, EXAMINING ATTORNEY

**CLASS 35—(Continued).**

SN 86-096,114. MCMANUS, EUGENE, ANAHEIM, CA. FILED 10-19-2013.

**Incumbout**

THE MARK CONSISTS OF STANDARD CHARACTERS WITHOUT CLAIM TO ANY PARTICULAR FONT, STYLE, SIZE, OR COLOR.

FOR PROVIDING A WEBSITE FEATURING INFORMATION ABOUT POLITICAL ISSUES; PROVIDING AN INTERNET WEBSITE FEATURING NEWS AND INFORMATION IN THE FIELD OF NATIONAL AND INTERNATIONAL POLITICS; PROVIDING AN ON-LINE SEARCHABLE DATABASE FEATURING INFORMATION ON POLITICAL CAMPAIGNS; PROVIDING INFORMATION ABOUT POLITICAL ELECTIONS; PROVIDING INFORMATION REGARDING POLITICAL ISSUES, KNOWING HOW TO VOTE AND KNOWING HOW TO REGISTER TO VOTE (U.S. CLS. 100, 101 AND 102).

BRITTANY ESTELL, EXAMINING ATTORNEY

---

SN 86-096,124. LEVEL 7 CREATIVE STUDIO, LLC, DBA LEVEL 7 DIGITAL, RIDLEY PARK, PA. FILED 10-19-2013.

**iSmart**

THE MARK CONSISTS OF STANDARD CHARACTERS WITHOUT CLAIM TO ANY PARTICULAR FONT, STYLE, SIZE, OR COLOR.

FOR ADVERTISING AND MARKETING SERVICES PROVIDED BY MEANS OF INDIRECT METHODS OF MARKETING COMMUNICATIONS, NAMELY, SOCIAL MEDIA, SEARCH ENGINE MARKETING, INQUIRY MARKETING, INTERNET MARKETING, MOBILE MARKETING, BLOGGING AND OTHER FORMS OF PASSIVE, SHARABLE OR VIRAL COMMUNICATIONS CHANNELS (U.S. CLS. 100, 101 AND 102).

FIRST USE 8-1-2013; IN COMMERCE 9-5-2013.  
TARAH HARDY, EXAMINING ATTORNEY

**CLASS 35—(Continued).**

SN 86-096,796. EQUALITY FLORIDA INSTITUTE, INC., ST PETERSBURG, FL. AND EQUALITY FLORIDA, INC., ST. PETERSBURG, FL. FILED 10-21-2013.



OWNER OF U.S. REG. NO. 4,466,366.  
THE COLOR(S) GREEN, BLACK AND WHITE IS/ARE CLAIMED AS A FEATURE OF THE MARK.

THE MARK CONSISTS OF A HEART DESIGN IN WHITE ON GREEN CIRCLE FIELD WITH A GREEN EQUAL SIGN IN THE CENTER OF THE HEART. THE WORDS "I'M ENGAGED" ARE IN WHITE ON THE GREEN FIELD, ALL IN A BLACK AND WHITE RIMMED CIRCLE.

FOR ASSOCIATION SERVICES, NAMELY, PROMOTING THE INTERESTS OF LESBIAN, GAY, BISEXUAL, AND TRANSGENDER INDIVIDUALS; LOBBYING SERVICES, NAMELY, PROMOTING THE INTERESTS OF LESBIAN, GAY, BISEXUAL, AND TRANSGENDER INDIVIDUALS IN THE FIELDS OF LEGISLATION AND REGULATION; PROMOTING PUBLIC AWARENESS OF THE NEED FOR FULL EQUALITY OF RIGHTS FOR LESBIAN, GAY, BISEXUAL, AND TRANSGENDER INDIVIDUALS; PUBLIC ADVOCACY TO PROMOTE AWARENESS OF DISCRIMINATION BASED ON SEXUAL ORIENTATION AND GENDER IDENTITY (U.S. CLS. 100, 101 AND 102).

FIRST USE 6-20-2013; IN COMMERCE 6-20-2013.  
LESLIE RICHARDS, EXAMINING ATTORNEY

---

SN 86-097,140. THE CITY OF TROUTDALE, TROUTDALE, OR. FILED 10-21-2013.

**GATEWAY TO THE GORGE**

THE MARK CONSISTS OF STANDARD CHARACTERS WITHOUT CLAIM TO ANY PARTICULAR FONT, STYLE, SIZE, OR COLOR.

NO CLAIM IS MADE TO THE EXCLUSIVE RIGHT TO USE "THE GORGE", APART FROM THE MARK AS SHOWN.

FOR CHAMBER OF COMMERCE SERVICES, NAMELY, PROMOTING BUSINESS AND TOURISM IN THE CITY OF TROUTDALE, OREGON AND THE COLUMBIA RIVER GORGE AREA (U.S. CLS. 100, 101 AND 102).

FIRST USE 10-2-2007; IN COMMERCE 10-2-2007.  
GIANCARLO CASTRO, EXAMINING ATTORNEY

**CLASS 35—(Continued).**

SN 86-099,621. COSMIC CART, INC., CHARLOTTE, NC. FILED 10-23-2013.

# Cosmic Cart

THE MARK CONSISTS OF STANDARD CHARACTERS WITHOUT CLAIM TO ANY PARTICULAR FONT, STYLE, SIZE, OR COLOR.

FOR ON-LINE RETAIL STORE SERVICES FEATURING A VARIETY OF CONSUMER GOODS OF MULTIPLE OTHER VENDERS (U.S. CLS. 100, 101 AND 102).

FIRST USE 12-15-2011; IN COMMERCE 10-1-2013.  
ALICIA COLLINS, EXAMINING ATTORNEY

SN 86-100,289. ADORAMA, INC., NEW YORK, NY. FILED 10-24-2013.



OWNER OF U.S. REG. NOS. 3,296,024, 3,622,793 AND 3,622,802.

THE MARK CONSISTS OF THE WORD "ADORAMA" IN A STYLIZED FONT WITH DIAGONAL LINES IN THE LETTER "O".

FOR RETAIL STORE SERVICES, MAIL ORDER SERVICES AND ON-LINE RETAIL STORE SERVICES FEATURING PHOTOGRAPHIC, AUDIO, VIDEO, OPTICAL, COMPUTER AND ASTRONOMY EQUIPMENT, NAMELY, CAMERAS, LENSES, CAMERA AND LENS FILTERS, EXPOSURE METERS, BINOCULARS, SPOTTING SCOPES, NIGHT VISION SCOPES, MICROSCOPES, TELESCOPES, PHOTO ALBUMS, CASES AND BAGS FOR PHOTOGRAPHIC, AUDIO AND VIDEO EQUIPMENT, CAMERA FILM, TRIPODS, CAMERA MOUNTING EQUIPMENT, BACKGROUND MOUNTING FOR PHOTOGRAPHY EQUIPMENT, BACKGROUND SUPPORT FOR PHOTOGRAPHY EQUIPMENT, BACKGROUND MATERIAL FOR PHOTOGRAPHY EQUIPMENT, TELEPROMPTERS, VOICE RECORDERS, PROJECTOR ACCESSORIES, LED LIGHTING, FLUORESCENT LIGHTING, AND STROBE LIGHTING FOR PHOTOGRAPHY, LIGHTING SUPPORT EQUIPMENT FOR PHOTOGRAPHY AND VIDEO, LIGHTING EQUIPMENT FOR PHOTOGRAPHY AND VIDEO, RECHARGEABLE BATTERIES, BATTERY PACKS, DVDS, CDS, DESKTOP COMPUTERS, COMPUTER MONITORS, OPERATING SYSTEM AND UTILITY SOFTWARE, SERVERS AND ROUTERS, DESKTOP COMPUTER UPGRADES, NOTEBOOK COMPUTERS, NOTEBOOK COMPUTER ACCESSORIES, NAMELY, BAGS, SLEEVES, SURGE PROTECTORS, REPLACEMENT BATTERIES AND SOLAR POWERED PANELS FOR NOTEBOOK COMPUTERS, NOTEBOOK COMPUTER UPGRADES, CABLES AND HUBS FOR COMPUTERS, KEYBOARDS, MICE, CONTROLLERS, EXTERNAL HARD DRIVES, MONITOR ACCESSORIES, NAMELY, SLEEVES, BAGS, SURGE PROTECTORS, HOODS, ANTI-GLARE SCREEN PANELS FOR MONITORS, CLEANING ACCESSORIES FOR DESKTOP AND NOTEBOOK COMPUTERS, MONITORS AND PRINTERS, NAMELY, MICROFIBER CLOTHES, CLEANING FLUIDS AND ANTISTATIC BRUSHES, AUDIO EQUIPMENT, NAMELY, MP3 AND MP4 PLAYERS, SPEAKERS, CASES, HOLDERS AND CONNECTORS, WIRELESS MICROPHONES AND CABLES THEREFOR, COLOR CALIBRATION SYSTEMS CONSISTING OF COLOR READERS AND TUNING DEVICES, GRAPHIC TABLETS FOR WRITING AND DRAWING TEXT OR PICTURES AND TRANSMITTING THEM TO A COMPUTER MONITOR, WIRELESS TRANSMITTERS AND RECEIVERS, WEB CAMS AND

**CLASS 35—(Continued).**

CABLES THEREFOR, SCAN CONVERTERS, REMOVABLE STORAGE UNITS, MOUNTING EQUIPMENT, NAMELY, MOUNTING BRACKETS, TABLES AND PLATFORMS FOR SCANNING UNITS AND PROJECTORS, MONITORS AND TELEVISIONS, COMPUTER SECURITY EQUIPMENT, NAMELY, CAMERAS, DVD RECEIVERS AND IMAGE SPLITTERS FOR IMPLEMENTING THE DISPLAY OF THE READOUTS OF MULTIPLE SECURITY CAMERAS ON A SINGLE MONITOR OR DVD PLAYER, CD/DVD CREATORS AND ACCESSORIES, NAMELY, STORAGE HOLDERS, DVD DISC CORRECTORS FOR ELIMINATING BUMPS AND WAVES ON A CD OR DVD DISC, CREATIVE SOFTWARE PRINTERS AND CABLES THEREFOR, INKJET PRINTERS, INKJET PRINTER PAPER AND OTHER INKJET RECEIVER MEDIA, NAMELY, VELVET AND CANVAS, INKJET CABLES AND CLEANERS, INKJET INKS, DYE SUBLIMATION PRINTERS, DYE SUBLIMATION PRINTER ACCESSORIES, NAMELY, PAPER AND SPECIAL SUBLIMATION PRINTER RECEIVER MEDIA, CABLES, DYE SUBLIMATION INKS AND DYE SUBLIMATION PROFILE SOFTWARE, AND PRINTER DRIVERS, ANTI-SPYWARE SOFTWARE, SPYWARE EQUIPMENT, FORENSIC, LAW ENFORCEMENT, MILITARY AND SHOOTING SUPPLIES, SECURITY SCANNERS AND METAL DETECTORS, AUTOMOTIVE ACCESSORIES, BOAT ACCESSORIES AND MOTORCYCLE ACCESSORIES (U.S. CLS. 100, 101 AND 102).

FIRST USE 7-1-1987; IN COMMERCE 7-1-1987.  
HEATHER BIDDULPH, EXAMINING ATTORNEY

SN 86-104,225. CHRISTOPHER'S KITCHEN, LLC, PALM BEACH GARDENS, FL. FILED 10-29-2013.

## CK TO GO AND JUICE MARKET

THE MARK CONSISTS OF STANDARD CHARACTERS WITHOUT CLAIM TO ANY PARTICULAR FONT, STYLE, SIZE, OR COLOR.

NO CLAIM IS MADE TO THE EXCLUSIVE RIGHT TO USE "TO GO AND JUICE MARKET", APART FROM THE MARK AS SHOWN.

FOR RETAIL STORE SERVICES AND ONLINE RETAIL STORE SERVICES BOTH FEATURING PACKAGED ORGANIC FOOD PRODUCTS AND ORGANIC JUICE BEVERAGES (U.S. CLS. 100, 101 AND 102).

FIRST USE 6-1-2013; IN COMMERCE 6-1-2013.  
BERYL GARDNER, EXAMINING ATTORNEY

**CLASS 35—(Continued).**

SN 86-105,740. W.W. GRAINGER, INC., LAKE FOREST, IL. FILED 10-30-2013.

**GRAINGER WORKBENCH**

THE MARK CONSISTS OF STANDARD CHARACTERS WITHOUT CLAIM TO ANY PARTICULAR FONT, STYLE, SIZE, OR COLOR.

OWNER OF U.S. REG. NOS. 1,559,199, 2,128,519 AND OTHERS.

FOR PROVISION OF INFORMATION AND ADVICE TO CONSUMERS REGARDING FEATURES, ADVANTAGES, BENEFITS, AND USES OF MAINTENANCE, REPAIR AND OPERATIONS (MRO) PRODUCTS; PROVIDING A WEBSITE FEATURING NON-DOWNLOADABLE INSTRUCTIONAL VIDEOS RELATING TO FEATURES, ADVANTAGES, BENEFITS, AND USES OF MAINTENANCE, REPAIR AND OPERATIONS (MRO) PRODUCTS (U.S. CLS. 100, 101 AND 102).

FIRST USE 9-13-2013; IN COMMERCE 9-13-2013.  
ODESSA BIBBINS, EXAMINING ATTORNEY

**CLASS 35—(Continued).**

SN 86-109,928. NORDSTROM, INC., SEATTLE, WA. FILED 11-4-2013.



NO CLAIM IS MADE TO THE EXCLUSIVE RIGHT TO USE "SALE", APART FROM THE MARK AS SHOWN.

THE COLOR(S) BLACK, YELLOW, GREEN, ORANGE AND PURPLE IS/ARE CLAIMED AS A FEATURE OF THE MARK.

THE MARK CONSISTS OF THE LETTERS "S", "A", "L" AND "E" IN BLACK, EACH ON AN OVERLAPPING CIRCLE COLORED YELLOW, GREEN, ORANGE AND PURPLE.

FOR RETAIL STORE SERVICES, ONLINE RETAIL STORE SERVICES, CATALOG AND TELEPHONE ORDERING SERVICES FEATURING MEN'S, WOMEN'S AND CHILDREN'S APPAREL, FOOTWEAR, FASHION ACCESSORIES, FRAGRANCES, COSMETICS, PERSONAL CARE PRODUCTS, EYEWEAR, BEDDING AND BEDS, SPECIALTY GOOD ITEMS (U.S. CLS. 100, 101 AND 102).

FIRST USE 7-19-1996; IN COMMERCE 7-19-1996.  
HEATHER BIDDULPH, EXAMINING ATTORNEY

SN 86-110,737. LTN INC., BRIDGETOWN, BARBADOS, FILED 11-5-2013.

**JEWELRYTHIS**

THE MARK CONSISTS OF STANDARD CHARACTERS WITHOUT CLAIM TO ANY PARTICULAR FONT, STYLE, SIZE, OR COLOR.

FOR ON-LINE RETAIL STORE SERVICES FEATURING JEWELRY DESIGNS AND JEWELRY ITEMS (U.S. CLS. 100, 101 AND 102).

FIRST USE 11-1-2013; IN COMMERCE 11-1-2013.  
TIMOTHY O. SCHIMPF, EXAMINING ATTORNEY

SN 86-108,171. THE HADDAD APPAREL GROUP, LTD., BAYONNE, NJ. FILED 11-1-2013.

**ROOKIE VILLA**

THE MARK CONSISTS OF STANDARD CHARACTERS WITHOUT CLAIM TO ANY PARTICULAR FONT, STYLE, SIZE, OR COLOR.

FOR RETAIL STORES, ONLINE ORDERING SERVICES, ONLINE RETAIL STORES, ELECTRONIC RETAIL STORE SERVICES VIA COMPUTER, AND RETAIL STORE SERVICES, AVAILABLE THROUGH COMPUTER COMMUNICATIONS AND INTERACTIVE TELEVISION, ALL FEATURING BAGS AND ACCESSORIES THEREFOR, CLOTHING AND ACCESSORIES THEREFOR, HEADWEAR AND FOOTWEAR (U.S. CLS. 100, 101 AND 102).

BRENDAN REGAN, EXAMINING ATTORNEY

SN 86-111,548. WHATS IN YOUR AREA, LLC, UTICA, MI. FILED 11-6-2013.



THE MARK CONSISTS OF WORD "WIYA" LIGHT BULB WITH PLANT SEEDLING INSIDE "A" UNDERNEATH WORDS "WHATSIYOURAREA.COM" CAPITAL LETTERS IN BON VENO FONT, SMALL LETTERS IN CALBRI FONT. FOR ADVERTISING AND MARKETING (U.S. CLS. 100, 101 AND 102).

FIRST USE 1-1-2009; IN COMMERCE 1-1-2009.  
DOMINIC J. FERRAIUOLO, EXAMINING ATTORNEY

**CLASS 35—(Continued).**

SN 86-112,133. BBVA COMPASS BANCSHARES, INC., BIRMINGHAM, AL. FILED 11-6-2013.



OWNER OF U.S. REG. NOS. 4,479,027, 4,479,028 AND 4,479,029.

NO CLAIM IS MADE TO THE EXCLUSIVE RIGHT TO USE "WORKPLACE DIVERSITY & INCLUSION", APART FROM THE MARK AS SHOWN.

THE COLOR(S) MAGENTA, DARK BLUE, ORANGE, LIGHT GREEN, LIGHT BLUE, YELLOW AND WHITE IS/ARE CLAIMED AS A FEATURE OF THE MARK.

THE MARK CONSISTS OF A GENERALLY SIX SIDED ABSTRACT REPRESENTATION OF A STAR-LIKE DESIGN, EACH OF THE 6 POINTS OF THE STAR MADE UP OF AN ABSTRACT REPRESENTATION OF A HUMAN-LIKE FIGURE, EACH RESPECTIVELY IN THE COLORS OF MAGENTA, DARK BLUE, ORANGE, LIGHT GREEN, LIGHT BLUE AND YELLOW, AND EACH OF WHICH ARE ON A WHITE BACKGROUND, AND INTERTWINED, MAKING UP THE OVERALL STAR-LIKE DESIGN WHICH IS ABOVE THE WORDS "BLENDING THE BEST WORKPLACE DIVERSITY & INCLUSION" WHERE THE WORD "BLENDING" IS IN A DARK BLUE COLOR AND IS ABOVE THE WORD "THE BEST" WHICH IS IN A LIGHT BLUE COLOR AND WHERE THE WORDS "WORKPLACE DIVERSITY & INCLUSION" ARE DIRECTLY BELOW "THE BEST" AND ARE IN AN ORANGE COLOR.

FOR HUMAN RESOURCE SERVICES IN THE FIELDS OF BANKING AND FINANCE, NAMELY, PROVIDING DIVERSITY EMPLOYEE RECRUITING; CHARITABLE SERVICES, NAMELY, PROMOTING AWARENESS OF MINORITY OWNED BUSINESSES TO THE COMMUNITY (U.S. CLS. 100, 101 AND 102).

FIRST USE 7-12-2013; IN COMMERCE 9-10-2013.  
ELIZABETH CHANG, EXAMINING ATTORNEY

SN 86-114,324. MACARON HOLDING LLC, SARASOTA, FL. FILED 11-8-2013.



NO CLAIM IS MADE TO THE EXCLUSIVE RIGHT TO USE "CO." AND "MACARON AND FRENCH PASTRIES", APART FROM THE MARK AS SHOWN.

THE COLOR(S) GRAY, PURPLE, WHITE, YELLOW, PINK, GREEN, ORANGE, BLUE, RED, AND BROWN IS/ARE CLAIMED AS A FEATURE OF THE MARK.

THE MARK CONSISTS OF TWO CONCENTRIC CIRCLES, WITH THE OUTER CIRCLE IN GRAY AND THE INNER CIRCLE IN PURPLE, WITHIN WHICH APPEARS THE

**CLASS 35—(Continued).**

WHITE STYLIZED WORDING "JANETTE & CO. MACARON AND FRENCH PASTRIES", AND A FANCIFUL DESIGN OF THE EIFFEL TOWER. THE EIFFEL TOWER IS CENTERED IN THE CIRCLES AND CONSISTS OF MACARONS. THE TOP TO THE MIDDLE OF THE EIFFEL TOWER CONSISTS OF A YELLOW MACARON, A PINK MACARON, A YELLOW MACARON, A GREEN MACARON, AN ORANGE MACARON, A PURPLE MACARON, AND A PINK MACARON. THE CENTER OF THE EIFFEL TOWER CONSISTS OF A GREEN MACARON WITH AN ORANGE MACARON ON EACH SIDE, TWO BLUE MACARONS, TWO GRAY MACARONS, AND THREE RED MACARONS. THE BOTTOM LEFT OF THE EIFFEL TOWER CONSISTS OF AN ORANGE MACARON, A GREEN MACARON, A YELLOW MACARON, AND A BROWN MACARON. THE BOTTOM RIGHT OF THE EIFFEL TOWER CONSISTS OF A PINK MACARON, AN ORANGE MACARON, A YELLOW MACARON, AND A BROWN MACARON. THE BOTTOM CENTER OF THE EIFFEL TOWER CONSISTS OF A YELLOW MACARON WITH A PINK MACARON ON EACH SIDE. THE WORDING "JANETTE & CO." IS IN AN ARC SHAPE ABOVE THE EIFFEL TOWER DESIGN AND "MACARON AND FRENCH PASTRIES" IS ARC'D UNDERNEATH THE EIFFEL TOWER DESIGN. THE LIGHT GRAY IN THE BACKGROUND REPRESENTS BACKGROUND AREA ONLY AND IS NOT PART OF THE MARK.

FOR PASTRY SHOPS (U.S. CLS. 100, 101 AND 102).  
FIRST USE 10-29-2013; IN COMMERCE 10-29-2013.  
MEREDITH MARESCA, EXAMINING ATTORNEY

SN 86-114,647. SWIRLZ USA LLC, DBA BERRY FIELD FROZEN YOGURT, WINTER SPRINGS, FL. FILED 11-9-2013.



NO CLAIM IS MADE TO THE EXCLUSIVE RIGHT TO USE "FROZEN YOGURT", APART FROM THE MARK AS SHOWN.

THE COLOR(S) RED, PURPLE, PINK, GREEN, BLACK, WHITE, AND GREY IS/ARE CLAIMED AS A FEATURE OF THE MARK.

THE MARK CONSISTS OF THE WORDS "BERRY FIELD FROZEN YOGURT". THE STRAWBERRY IS IN RED, BLUE BERRY IN PURPLE, RASPBERRY IN PINK AND A WAVY HILL WITH GREEN COLOR BELOW THEM. THE TERM "BERRY FIELD" IS IN BLACK AND THE WORDING "FROZEN YOGURT" IN GREY. WHITE IS USED FOR THE BACKGROUND COLOR.

FOR SELF-SERVE FROZEN YOGURT SHOP SERVICES (U.S. CLS. 100, 101 AND 102).  
FIRST USE 7-1-2012; IN COMMERCE 7-1-2012.  
CURTIS FRENCH, EXAMINING ATTORNEY



**CLASS 35—(Continued).**

SN 86-115,308. DAVID KNOTT, CARLSBAD, CA. FILED 11-11-2013.

**UNITED ASSET RECOVERY**

THE MARK CONSISTS OF STANDARD CHARACTERS WITHOUT CLAIM TO ANY PARTICULAR FONT, STYLE, SIZE, OR COLOR.

NO CLAIM IS MADE TO THE EXCLUSIVE RIGHT TO USE "ASSET RECOVERY", APART FROM THE MARK AS SHOWN.

FOR BUSINESS SERVICES, NAMELY, ASSET RECOVERY SERVICES TO IDENTIFY, LOCATE AND REUNITE LOST OWNERS OR HEIRS WITH THEIR UNCLAIMED ASSETS (U.S. CLS. 100, 101 AND 102).

FIRST USE 10-13-2005; IN COMMERCE 10-13-2005.  
KIMBERLY PERRY, EXAMINING ATTORNEY

---

SN 86-117,918. THE PET OUTPOST, MILWAUKEE, WI. FILED 11-13-2013.



NO CLAIM IS MADE TO THE EXCLUSIVE RIGHT TO USE "PET", APART FROM THE MARK AS SHOWN.

THE COLOR(S) PLUM, LIGHT GREEN AND WHITE IS/ARE CLAIMED AS A FEATURE OF THE MARK.

THE MARK CONSISTS OF A PLUM SQUARE CONTAINING THE STYLIZED WORDS "THE PET OUTPOST". THE WORDS "THE" AND "OUTPOST" APPEAR IN WHITE WITH THE SECOND "O" IN THE WORD "OUTPOST" COMPRISED OF A FILLED WHITE CIRCLE UNDER FOUR VERTICALLY ORIENTED OVALS ALIGNED SO THAT THE CIRCLE AND OVALS SUGGEST A PAW PRINT, THE WORD "PET" APPEARS IN LIGHT GREEN.

FOR PROMOTING THE GOODS AND SERVICES OF OTHERS BY PROVIDING A WEBSITE FEATURING THE LOGOS OF BRANDS OFFERED AT A RETAIL STORE; PROVIDING A WEBSITE FEATURING INFORMATION FOR CONSUMERS IN THE FIELD OF PET FOOD, PET TREATS AND PET TOYS FOR PARTICULAR PET BREEDS; RETAIL SHOPS FEATURING PET FOOD, PET TREATS, PET SUPPLIES (U.S. CLS. 100, 101 AND 102).

FIRST USE 11-15-2011; IN COMMERCE 12-10-2011.  
CHRISTINA SOBRAL, EXAMINING ATTORNEY

**CLASS 35—(Continued).**

SN 86-120,820. DUCKETT, G. KATHRYN, FERNANDINA BEACH, FL. AND DUCKETT IV, R. THOMAS, FERNANDINA BEACH, FL. FILED 11-16-2013.

**CRÈME BRANDS**

NO CLAIM IS MADE TO THE EXCLUSIVE RIGHT TO USE "BRANDS", APART FROM THE MARK AS SHOWN.

THE MARK CONSISTS OF THE STYLIZED WORDS "CRÈME BRANDS" WRITTEN IN THE CHRONICLE TYPEFACE AND MODIFIED SO "C" "R" AND "E" ARE VISUALLY CONNECTED AS WELL AS "M" "E" AND "B" "R" "A" "N" "D".

FOR BRAND IMAGERY CONSULTING SERVICES; BRANDING SERVICES, NAMELY, CONSULTING, DEVELOPMENT, MANAGEMENT AND MARKETING OF BRANDS FOR BUSINESSES AND/OR INDIVIDUALS (U.S. CLS. 100, 101 AND 102).

FIRST USE 10-21-2013; IN COMMERCE 10-21-2013.  
JEFFREY LOOK, EXAMINING ATTORNEY

---

SN 86-121,316. CERTIFIED AUTOMOTIVE PARTS ASSOCIATION, WASHINGTON, DC. FILED 11-18-2013.



OWNER OF U.S. REG. NOS. 1,565,199, 1,779,330 AND 1,804,975.

NO CLAIM IS MADE TO THE EXCLUSIVE RIGHT TO USE "CERTIFIED AUTO PARTS", APART FROM THE MARK AS SHOWN.

THE MARK CONSISTS OF A RECTANGULAR CARRIER ENCOMPASSING THE WORD "CERTIFIED" OVER THE WORDS "AUTO PARTS". ALL TO THE RIGHT OF A SECOND RECTANGULAR CARRIER ENCOMPASSING THE STYLIZED LETTERS "CAPA".

FOR ASSOCIATION SERVICES, NAMELY, PROMOTING THE COMMON BUSINESS INTERESTS OF ASSOCIATION MEMBERS FROM THE AUTOMOBILE INSURANCE, PARTS DISTRIBUTION, AND REPAIR INDUSTRIES, AND CONSUMERS CONCERNED WITH THE QUALITY OF AFTERMARKET AUTOMOTIVE PARTS (U.S. CLS. 100, 101 AND 102).

FIRST USE 5-0-2011; IN COMMERCE 5-0-2011.  
BRIAN CALLAGHAN, EXAMINING ATTORNEY



**CLASS 35—(Continued).**

SN 86-123,083. BALTIKO SPIRITS LLC, HOUSTON, TX. FILED 11-19-2013.



NO CLAIM IS MADE TO THE EXCLUSIVE RIGHT TO USE "USA", APART FROM THE MARK AS SHOWN. THE MARK CONSISTS OF TWO HALF CIRCULAR DESIGNS, AND THE WORDING "CANACINTRA" APPEARS TO THE SIDE OF THE DESIGN AND ABOVE THE WORDING "USA".

FOR ASSOCIATION SERVICES, NAMELY, PROMOTING THE INTERESTS OF INDUSTRIALIST, BUSINESS OWNERS, ENTREPRENEURS, AND INVESTORS (U.S. CLS. 100, 101 AND 102).

FIRST USE 11-9-2013; IN COMMERCE 11-9-2013.  
DARRYL SPRULL, EXAMINING ATTORNEY

---

SN 86-123,560. COLLINS, MARK A. DBA MCX ENTERPRISES, YORBA LINDA, CA. FILED 11-19-2013.

# TrepMetrics

THE MARK CONSISTS OF STANDARD CHARACTERS WITHOUT CLAIM TO ANY PARTICULAR FONT, STYLE, SIZE, OR COLOR.

FOR BUSINESS MANAGEMENT CONSULTING AND ADVISORY SERVICES (U.S. CLS. 100, 101 AND 102).

FIRST USE 11-18-2013; IN COMMERCE 11-18-2013.  
SEAN CROWLEY, EXAMINING ATTORNEY

---

SN 86-128,040. THE SEIBELS BRUCE GROUP, INC., DBA SEIBELS, COLUMBIA, SC. FILED 11-25-2013.

# RPX

THE MARK CONSISTS OF STANDARD CHARACTERS WITHOUT CLAIM TO ANY PARTICULAR FONT, STYLE, SIZE, OR COLOR.

FOR BUSINESS ASSISTANCE, ADVISORY AND CONSULTING SERVICES IN THE FIELD OF IMPLEMENTING REINSPECTION PROGRAMS IN THE PROPERTY AND CASUALTY INSURANCE UNDERWRITING, CLAIM ADMINISTRATION, CLAIM ADJUSTING AND CLAIM PROCESSING FIELD (U.S. CLS. 100, 101 AND 102).

REBECCA GILBERT, EXAMINING ATTORNEY

**CLASS 35—(Continued).**

SN 86-128,147. KRISTINA LEMON, ST PAUL, MN. FILED 11-25-2013.

# Art Mob

THE MARK CONSISTS OF STANDARD CHARACTERS WITHOUT CLAIM TO ANY PARTICULAR FONT, STYLE, SIZE, OR COLOR.

NO CLAIM IS MADE TO THE EXCLUSIVE RIGHT TO USE "ART", APART FROM THE MARK AS SHOWN.

FOR ART GALLERIES (U.S. CLS. 100, 101 AND 102).

FIRST USE 10-1-2013; IN COMMERCE 11-8-2013.  
MORGAN WYNNE, EXAMINING ATTORNEY

---

SN 86-130,517. TUCSON COIN & AUTOGRAPH, L.L.C., TUCSON, AZ. FILED 11-27-2013.

# TUCSON COIN

THE MARK CONSISTS OF STANDARD CHARACTERS WITHOUT CLAIM TO ANY PARTICULAR FONT, STYLE, SIZE, OR COLOR.

NO CLAIM IS MADE TO THE EXCLUSIVE RIGHT TO USE "COIN", APART FROM THE MARK AS SHOWN.

SEC. 2(F).

FOR RETAIL AND WHOLESALE DEALERSHIP SERVICES IN THE FIELD OF COINS, CURRENCY, PRECIOUS METALS AND COLLECTABLES (U.S. CLS. 100, 101 AND 102).

FIRST USE 5-25-1994; IN COMMERCE 5-25-1994.  
GISELLE AGOSTO, EXAMINING ATTORNEY

**CLASS 35—(Continued).**

SN 86-132,093. FORBIS LOGISTICS, INC., DBA FORBIS LOGISTICS, MIAMI, FL. FILED 11-30-2013.



NO CLAIM IS MADE TO THE EXCLUSIVE RIGHT TO USE "LOGISTICS", APART FROM THE MARK AS SHOWN. THE COLOR(S) GREEN, TEAL, BLUE AND WHITE IS/ ARE CLAIMED AS A FEATURE OF THE MARK.

THE MARK CONSISTS OF THE WORDING "FORBIS LOGISTICS". THE LETTER "F" OF THE TERM "FORBIS" IS IN GREEN, THE LETTER "O" IS IN WHITE WITH A GREEN CENTER AND THE LETTERS "RBIS" ARE IN WHITE ABOVE THE TERM "LOGISTICS" IN TEAL. THE LETTERS "ORBIS" AND THE TERM "LOGISTICS" ARE ENCLOSED IN A BLUE CIRCLE. A GREEN LINE IS BELOW THE BLUE CIRCLE.

THE WORDING "FORBIS" HAS NO MEANING IN A FOREIGN LANGUAGE.

FOR TRANSPORTATION LOGISTICS SERVICES, NAMELY, ARRANGING THE TRANSPORTATION OF GOODS FOR OTHERS (U.S. CLS. 100, 101 AND 102).

FIRST USE 7-1-2013; IN COMMERCE 7-1-2013.

SALLY SHIH, EXAMINING ATTORNEY

---

SN 86-133,366. PALJEN, LLC, DORAL, FL. FILED 12-3-2013.



NO CLAIM IS MADE TO THE EXCLUSIVE RIGHT TO USE "VAPOR", APART FROM THE MARK AS SHOWN.

THE MARK CONSISTS OF THE WORDING "VAPOR WIDGETS" WITH EACH TERM SEPARATED BY A DESIGN OF THREE GEARS.

FOR RETAIL STORE SERVICES FEATURING ELECTRONIC CIGARETTES (U.S. CLS. 100, 101 AND 102).

ANN E. SAPPENFIELD, EXAMINING ATTORNEY

**CLASS 35—(Continued).**

SN 86-133,598. EARTHBOUND TRADING CO, GRAPEVINE, TX. FILED 12-3-2013.

**EARTHBONE TRADING CO**

THE MARK CONSISTS OF STANDARD CHARACTERS WITHOUT CLAIM TO ANY PARTICULAR FONT, STYLE, SIZE, OR COLOR.

NO CLAIM IS MADE TO THE EXCLUSIVE RIGHT TO USE "TRADING CO", APART FROM THE MARK AS SHOWN.

FOR RETAIL STORE SERVICES, FEATURING DOG APPAREL AND ACCESSORIES (U.S. CLS. 100, 101 AND 102).

KAELIE KUNG, EXAMINING ATTORNEY

---

SN 86-135,874. TRACFONE WIRELESS, INC., MIAMI, FL. FILED 12-5-2013.

**COMPLETE WIRELESS**

THE MARK CONSISTS OF STANDARD CHARACTERS WITHOUT CLAIM TO ANY PARTICULAR FONT, STYLE, SIZE, OR COLOR.

OWNER OF U.S. REG. NO. 2,247,585.

NO CLAIM IS MADE TO THE EXCLUSIVE RIGHT TO USE "WIRELESS", APART FROM THE MARK AS SHOWN.

FOR DISTRIBUTORSHIP SERVICES IN THE FIELD OF CELLULAR TELEPHONES, PREPAID AIR TIME CELLULAR TELEPHONE AND PREPAID AIR TIME DEBIT CARDS AND SOFTWARE FOR CONTROLLING AND MONITORING PREPAID AIR TIME CELLULAR SERVICE; ON-LINE RETAIL STORE SERVICES FEATURING CELLULAR TELEPHONES, PREPAID WIRELESS AIR TIME CARDS, CELLULAR TELEPHONE ACCESSORIES AND WIRELESS SERVICES (U.S. CLS. 100, 101 AND 102).

TARAH HARDY, EXAMINING ATTORNEY

---

SN 86-136,023. BEST PLUMBING SPECIALTIES, INC., MYERSVILLE, MD. FILED 12-5-2013.



NO CLAIM IS MADE TO THE EXCLUSIVE RIGHT TO USE "BEST PLUMBING SPECIALTIES" AND "EST. 1962", APART FROM THE MARK AS SHOWN.

THE MARK CONSISTS OF THE WORD "BEST" SHOWN IN THICK CAPITAL LETTERS ABOVE AN INVERTED TRIANGLE. OUTSIDE THE INVERTED TRIANGLE AND

**CLASS 35—(Continued).**

TO THE BOTTOM LEFT OF THE INVERTED TRIANGLE IS THE WORD "EST." IN CAPITAL LETTERS. OUTSIDE THE INVERTED TRIANGLE AND TO THE BOTTOM RIGHT OF THE TRIANGLE IS THE YEAR "1962". INSIDE THE INVERTED TRIANGLE AND AT THE TOP OF THE INVERTED TRIANGLE IS THE WORDS "PLUMBING SPECIALTIES" IN CAPITAL LETTERS. SUPERIMPOSED OVER THE INVERTED TRIANGLE AND BELOW THE WORDS "PLUMBING SPECIALTIES" IS AN EAGLE WITH WINGS SPREAD.

FOR WHOLESALE ORDERING SERVICES IN THE FIELD OF PARTS FOR THE OVERHAUL AND MAINTENANCE OF PLUMBING FITTINGS AND FIXTURES (U.S. CLS. 100, 101 AND 102).

FIRST USE 0-0-2012; IN COMMERCE 0-0-2012.

KATHERINE E. HALMEN, EXAMINING ATTORNEY

---

SN 86-136,284. SABIDURIA INFINITA S.A., PANAMA, PANAMA, FILED 12-5-2013.

### DISCOVER YOUR TRAVEL PERSONALITY

THE MARK CONSISTS OF STANDARD CHARACTERS WITHOUT CLAIM TO ANY PARTICULAR FONT, STYLE, SIZE, OR COLOR.

NO CLAIM IS MADE TO THE EXCLUSIVE RIGHT TO USE "TRAVEL", APART FROM THE MARK AS SHOWN.

FOR PROVIDING INCENTIVE AWARD PROGRAMS THROUGH ISSUANCE AND PROCESSING OF LOYALTY POINTS FOR PURCHASE OF A COMPANY'S GOODS AND SERVICES (U.S. CLS. 100, 101 AND 102).

FIRST USE 10-23-2013; IN COMMERCE 10-23-2013.

SUZANNE BLANE, EXAMINING ATTORNEY

---

SN 86-136,293. SABIDURIA INFINITA S.A., PANAMA, PANAMA, FILED 12-5-2013.

### NAMU TRAVEL GROUP

THE MARK CONSISTS OF STANDARD CHARACTERS WITHOUT CLAIM TO ANY PARTICULAR FONT, STYLE, SIZE, OR COLOR.

NO CLAIM IS MADE TO THE EXCLUSIVE RIGHT TO USE "TRAVEL GROUP", APART FROM THE MARK AS SHOWN.

THE ENGLISH TRANSLATION OF "NAMU" IN THE MARK IS "JAGUAR".

FOR PROVIDING INCENTIVE AWARD PROGRAMS THROUGH ISSUANCE AND PROCESSING OF LOYALTY POINTS FOR PURCHASE OF A COMPANY'S GOODS AND SERVICES (U.S. CLS. 100, 101 AND 102).

FIRST USE 8-1-2013; IN COMMERCE 8-1-2013.

SUZANNE BLANE, EXAMINING ATTORNEY

**CLASS 35—(Continued).**

SN 86-137,003. SHAMUS MCCLURE, LINCOLN, CA. AND MELISSA MCCLURE, LINCOLN, CA. FILED 12-6-2013.

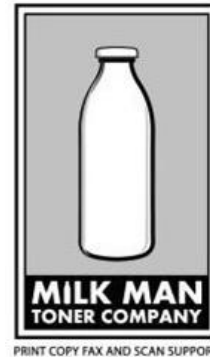

NO CLAIM IS MADE TO THE EXCLUSIVE RIGHT TO USE "TONER COMPANY" AND "PRINT COPY FAX AND SCAN SUPPORT", APART FROM THE MARK AS SHOWN.

THE MARK CONSISTS OF AN OUTLINED RECTANGLE ENCLOSED WITHIN WHICH IS AN IMAGE OF A GLASS MILK BOTTLE WITH THE WORDS "MILK MAN" DIRECTLY UNDER THE BOTTLE IMAGE. THE "I" IN THE WORD "MILK" CONSISTS OF A MILK BOTTLE. THE WORDS "TONER COMPANY" ARE DIRECTLY BELOW THE WORDS "MILK MAN". THE WORDS "PRINT COPY FAX AND SCAN SUPPORT" ARE LOCATED OUTSIDE OF THE RECTANGLE UNDER THE WORDS "TONER COMPANY".

FOR MARKETING OF PRINTER TONER PRODUCTS FOR OTHERS; RETAIL STORE SERVICES FEATURING PRINTER TONER PRODUCTS; MAIL ORDER SERVICES FEATURING PRINTER TONER PRODUCTS; ON-LINE RETAIL STORE SERVICES FEATURING PRINTER TONER PRODUCTS; LEASING AND RENTING OF PRINTERS, AND ALL-IN-ONE PRINTER, COPY, FAX AND SCANNER MACHINES (U.S. CLS. 100, 101 AND 102).

ANTHONY RINKER, EXAMINING ATTORNEY

---

SN 86-141,197. BOWERY LIGHTING, FARMINGDALE, NY. FILED 12-11-2013.

### Bowery Lighting

THE MARK CONSISTS OF STANDARD CHARACTERS WITHOUT CLAIM TO ANY PARTICULAR FONT, STYLE, SIZE, OR COLOR.

NO CLAIM IS MADE TO THE EXCLUSIVE RIGHT TO USE "LIGHTING", APART FROM THE MARK AS SHOWN.

FOR ON-LINE WHOLESALE AND RETAIL STORE SERVICES FEATURING LIGHTING FIXTURES, CHANDELIERS, LAMPS, FURNITURE, AND WALL DECOR; WHOLESALE AND RETAIL STORE SERVICES FEATURING LIGHTING FIXTURES, CHANDELIERS, LAMPS, AND FURNITURE (U.S. CLS. 100, 101 AND 102).

FIRST USE 1-12-2008; IN COMMERCE 1-12-2008.

MICHAEL KEATING, EXAMINING ATTORNEY

**CLASS 35—(Continued).**

SN 86-145,205. BANKI, NAADER, LOS ANGELES, CA. FILED 12-16-2013.

**Zeitlos Entertainment**

THE MARK CONSISTS OF STANDARD CHARACTERS WITHOUT CLAIM TO ANY PARTICULAR FONT, STYLE, SIZE, OR COLOR.

NO CLAIM IS MADE TO THE EXCLUSIVE RIGHT TO USE "ENTERTAINMENT", APART FROM THE MARK AS SHOWN.

THE ENGLISH TRANSLATION OF "ZEITLOS" IN THE MARK IS "TIMELESS".

FOR BUSINESS CONSULTING, BUSINESS MANAGEMENT AND PROVIDING INFORMATION IN THE MUSIC BUSINESS FIELD; TALENT MANAGEMENT SERVICES FOR MUSICIANS (U.S. CLS. 100, 101 AND 102).

FIRST USE 10-17-2013; IN COMMERCE 10-17-2013.  
LOURDES AYALA, EXAMINING ATTORNEY

---

SN 86-145,277. TRP RESEARCH LTD., SOMERSET, UNITED KINGDOM, FILED 12-16-2013.

**TRP**

THE MARK CONSISTS OF STANDARD CHARACTERS WITHOUT CLAIM TO ANY PARTICULAR FONT, STYLE, SIZE, OR COLOR.

FOR ADVERTISING CONSULTING SERVICES IN THE FIELDS OF ADVERTISING AND MARKETING STRATEGY, MARKETING, AND DESIGNING PRODUCTS TO MAXIMIZE CONSUMER INTEREST, ALL BASED ON THE USE OF ANALYTIC AND STATISTIC MODELS TO PREDICT THE BEHAVIOR OF CONSUMERS AND BUSINESS AND TO TRACK MARKET TRENDS (U.S. CLS. 100, 101 AND 102).

FIRST USE 6-1-1999; IN COMMERCE 6-1-1999.  
KIMBERLY FRYE, EXAMINING ATTORNEY

**CLASS 35—(Continued).**

SN 86-146,238. NEW TOWN RECORDS, DBA WORSHIPPROVIDER, TUSTIN, CA. FILED 12-17-2013.

**WorshipProvider**

THE MARK CONSISTS OF STANDARD CHARACTERS WITHOUT CLAIM TO ANY PARTICULAR FONT, STYLE, SIZE, OR COLOR.

FOR RETAIL STORE SERVICES FEATURING BOOKS, PRINTED INSTRUCTIONAL MATERIALS, PRINTED TEACHING MATERIALS, NEWSLETTERS, CATALOGS, GREETING CARDS, AUDIO TAPES, COMPACT DISCS, INTERACTIVE SOFTWARE, MULTI-MEDIA SOFTWARE, FLOPPY DISCS, DISKETTES, ELECTRONIC BOOKS, AUDIO BOOKS, RECORDED BOOKS, CD-ROMS, DVD'S, MUSIC DOWNLOADS, VIDEO DOWNLOADS, AUDIO DOWNLOADS; COMPUTER SOFTWARE DOWNLOADS FEATURING A WIDE RANGE OF RELIGIOUS AND EDUCATIONAL TOPICS, SHEET MUSIC, SHEET MUSIC DOWNLOADS CHURCH SUPPLIES, MUSICAL INSTRUMENTS, PAINTINGS, PRINTS, GIFT ITEMS ACCESSIBLE ON-LINE AND BY TELEPHONE, FACSIMILE AND MAIL ORDER; AND DISTRIBUTORSHIP SERVICES, NAMELY, WHOLESALE DISTRIBUTORSHIPS FEATURING BOOKS, PRINTED INSTRUCTIONAL MATERIALS, PRINTED TEACHING MATERIALS, NEWSLETTERS, CATALOGS, GREETING CARDS, MAPS, ATLASES, GLOBES, POSTCARDS, NOTE PADS, BOOK COVERS, BOOK ENDS, COMPACT DISCS, INTERACTIVE SOFTWARE, MULTI-MEDIA SOFTWARE, ELECTRONIC BOOKS, AUDIO BOOKS, RECORDED BOOKS, CD-ROMS, DVD'S, VIDEO DOWNLOADS, AUDIO DOWNLOADS, COMPUTER SOFTWARE DOWNLOADS FEATURING A WIDE RANGE OF RELIGIOUS AND EDUCATIONAL TOPICS, SHEET MUSIC, SHEET MUSIC DOWNLOADS, CHURCH SUPPLIES, AND MUSICAL INSTRUMENTS (U.S. CLS. 100, 101 AND 102).

FIRST USE 1-2-2009; IN COMMERCE 1-2-2009.  
KIMBERLY PERRY, EXAMINING ATTORNEY

---

SN 86-149,152. SGI, INC., CINCINNATI, OH. FILED 12-20-2013.

**SHEAKLEY THE HUMAN RESOURCES PEOPLE**

THE MARK CONSISTS OF STANDARD CHARACTERS WITHOUT CLAIM TO ANY PARTICULAR FONT, STYLE, SIZE, OR COLOR.

OWNER OF U.S. REG. NO. 3,588,711.

NO CLAIM IS MADE TO THE EXCLUSIVE RIGHT TO USE "THE HUMAN RESOURCES PEOPLE", APART FROM THE MARK AS SHOWN.

FOR OUTSOURCING IN THE FIELD OF HUMAN RESOURCES, PAYROLL, WORKERS' COMPENSATION, UNEMPLOYMENT SERVICES, INSURANCE, RETIREMENT PLANS, AND HEALTHCARE; EMPLOYEE ADMINISTRATION SERVICES IN THE FIELDS OF HUMAN RESOURCE MANAGEMENT, WORKERS' COMPENSATION, UNEMPLOYMENT, SAFETY/RISK MANAGEMENT, EMPLOYEE BENEFITS AND PAYROLL ADMINISTRATION (U.S. CLS. 100, 101 AND 102).

FIRST USE 12-3-2013; IN COMMERCE 12-16-2013.  
TRACY CROSS, EXAMINING ATTORNEY

**CLASS 35—(Continued).**

SN 86-152,052. GRABSTER INC., LOS ANGELES, CA. FILED 12-24-2013.

# Grabster

THE MARK CONSISTS OF STANDARD CHARACTERS WITHOUT CLAIM TO ANY PARTICULAR FONT, STYLE, SIZE, OR COLOR.

FOR PROVIDING AUCTION AND ONLINE TRADING SERVICES IN WHICH SELLERS POST PRODUCTS AND SERVICES TO BE AUCTIONED AND BIDDING IS DONE VIA THE INTERNET AND MOBILE APPLICATIONS; ON-LINE RETAIL STORE SERVICES FEATURING A WIDE VARIETY OF CONSUMER GOODS AND SERVICES OF OTHERS (U.S. CLS. 100, 101 AND 102).

GISELLE AGOSTO, EXAMINING ATTORNEY

SN 86-154,552. TIRE SUPPLY SERVICE CENTERS, LLC, BUTTE, MT. FILED 12-30-2013.



NO CLAIM IS MADE TO THE EXCLUSIVE RIGHT TO USE "TIRE SUPPLY" AND "SERVICE CENTERS", APART FROM THE MARK AS SHOWN.

THE COLOR(S) RED, BLUE, WHITE, BLACK AND GRAY IS/ARE CLAIMED AS A FEATURE OF THE MARK.

THE MARK CONSISTS OF "TIRE SUPPLY" IN RED LETTERS WITH A THIN WHITE OUTLINE AND A THIN BLUE OUTLINE AROUND THE LETTERING. THE WORDS "SERVICE CENTERS" APPEAR IN WHITE LETTERS INSIDE A BLUE CIRCULAR OUTLINE OF THE LETTERS. THERE ARE THREE INTERLOCKING CIRCLES WHICH ARE GRAY IN COLOR, WITH THE COLOR BEING THE LIGHTEST AT THE LEFT SIDE OF THE CIRCLES, AND PROGRESSIVELY GETTING DARKER TOWARDS THE RIGHT EDGE OF THE CIRCLES. THERE ARE TWO TIRE TREAD MARKS ABOVE AND BELOW THE WORDS "SERVICE CENTERS". THE TIRE TREAD MARKS ARE WHITE, GRAY AND BLACK IN COLOR WITH THE LIGHTEST AT THE LEFT SIDE OF THE TIRE TREAD MARKS AND GETTING PROGRESSIVELY DARKER TOWARDS THE RIGHT EDGE OF THE TIRE TREAD MARKS.

FOR RETAIL TIRE STORES (U.S. CLS. 100, 101 AND 102).

SHAILA LEWIS, EXAMINING ATTORNEY

**CLASS 35—(Continued).**

SN 86-159,416. SUTTON, JOHN F., DBA GASKET GOONS, QUAKERTOWN, PA. FILED 1-7-2014.



THE COLOR(S) BLACK, WHITE, RED, DARK RED, PINK, GOLD, BLUE AND GREY IS/ARE CLAIMED AS A FEATURE OF THE MARK.

THE MARK CONSISTS OF THE WORDS "GASKET GOONS" IN DARK RED APPEARING ABOVE THE CENTRAL IMAGE, AND THE WORDS "PARTS UNKNOWN" APPEAR AT THE BOTTOM ALSO IN DARK RED, WITH A DARK RED STAR TO EITHER SIDE. THE IMAGE CONSISTS OF THE PINK HEAD OF A MAN WHO IS WINKING, WITH A BLUE, BLACK AND WHITE OPEN EYE, HAS A BLACK GOATEE AND A GREY TOOTH, AND IS WEARING A BLACK AND WHITE CHECKERED SKULLCAP UNDER A RED AND DARK RED CROWN. BEHIND THE MAN'S HEAD APPEARS A BLUE AND GREY WRENCH, OVERLAPPED WITH A GOLD GASKET ON WHICH THERE APPEARS A RED DIAMOND ON THE LEFT AND A BLACK SPADE ON THE RIGHT, TO MAKE A SORT OF "CROSS-BONES" STYLE X. THE WHITE APPEARING BEHIND THE GASKET HOLES, DIAMOND AND SPADE INDICATE TRANSPARENT BACKGROUND AREAS, AND ARE NOT A FEATURE OF THE MARK. TO THE RIGHT OF THE CENTRAL IMAGE IS A DARK RED DIAMOND WITH A GOLD OUTLINE AND TWO GOLD CS ON IT.

FOR CLUB SERVICES, NAMELY, PROMOTING THE INTERESTS OF CAR ENTHUSIASTS (U.S. CLS. 100, 101 AND 102).

FIRST USE 1-14-1980; IN COMMERCE 1-14-1980.

CAITLIN WATTS-FITZGERALD, EXAMINING ATTORNEY

SN 86-159,820. DONKOR, JOYCE, B, ALEXANDRIA, VA. FILED S.R. 1-8-2014; AM. P.R. 6-30-2014.

## AFWDC African Fashion Week DC

THE MARK CONSISTS OF STANDARD CHARACTERS WITHOUT CLAIM TO ANY PARTICULAR FONT, STYLE, SIZE, OR COLOR.

NO CLAIM IS MADE TO THE EXCLUSIVE RIGHT TO USE "AFRICAN FASHION WEEK DC", APART FROM THE MARK AS SHOWN.

FOR FASHION SHOW EXHIBITIONS FOR COMMERCIAL PURPOSES; ORGANIZATION OF FASHION SHOWS FOR COMMERCIAL PURPOSES (U.S. CLS. 100, 101 AND 102).

FIRST USE 4-1-2013; IN COMMERCE 6-10-2013.

JENNIFER MARTIN, EXAMINING ATTORNEY

**CLASS 35—(Continued).**

SN 86-162,347. NCPA SERVICES, INC., DBA NATIONAL COOPERATIVE PURCHASING ALLIANCE, HOUSTON, TX. FILED 1-10-2014.



NO CLAIM IS MADE TO THE EXCLUSIVE RIGHT TO USE "NATIONAL COOPERATIVE PURCHASING ALLIANCE", APART FROM THE MARK AS SHOWN.

THE MARK CONSISTS OF THE LETTERS "NCPA" WITH A GREATER THAN SYMBOL THROUGH THE LETTERS "C" AND "P". UNDERNEATH THE LETTERS "NCPA" ARE THE WORDS "NATIONAL COOPERATIVE PURCHASING ALLIANCE".

FOR PURCHASING AND PROCUREMENT SERVICES, NAMELY, PROCURING OF CONTRACTS FOR OTHERS FOR THE PURCHASE OF GOODS AND LABOR CONTRACTING SERVICES (U.S. CLS. 100, 101 AND 102).

FIRST USE 9-1-2011; IN COMMERCE 9-1-2011.  
DAVID MURRAY, EXAMINING ATTORNEY

SN 86-162,648. THE MENTAL HEALTH ASSOCIATION OF ROCHESTER/MONROE COUNTY, INCORPORATED, ROCHESTER, NY. FILED 1-10-2014.

**WHERE'S YOUR WELLNESS?**

THE MARK CONSISTS OF STANDARD CHARACTERS WITHOUT CLAIM TO ANY PARTICULAR FONT, STYLE, SIZE, OR COLOR.

FOR PROMOTING PUBLIC AWARENESS IN THE FIELD OF MENTAL AND PHYSICAL WELLNESS (U.S. CLS. 100, 101 AND 102).

SAMUEL E. SHARPER JR., EXAMINING ATTORNEY

**CLASS 35—(Continued).**

SN 86-165,452. PREMIER HOMECARE OPTIONS, LLC, WALDORF, MD. FILED 1-14-2014.

**H2OZEOLITE**

THE MARK CONSISTS OF STANDARD CHARACTERS WITHOUT CLAIM TO ANY PARTICULAR FONT, STYLE, SIZE, OR COLOR.

FOR (BASED ON USE IN COMMERCE) PROMOTING THE GOODS AND SERVICES OF OTHERS BY PROVIDING HYPERLINKS TO THE WEBSITES OF OTHERS (BASED ON INTENT TO USE) ON-LINE RETAIL STORE SERVICES FEATURING A WIDE VARIETY OF CONSUMER GOODS (U.S. CLS. 100, 101 AND 102).

FIRST USE 1-10-2014; IN COMMERCE 1-10-2014.  
INGRID C. EULIN, EXAMINING ATTORNEY

SN 86-165,683. PATA MICRONESIA CHAPTER, TUMON, GUAM, FILED S.R. 1-15-2014; AM. P.R. 5-21-2014.



NO CLAIM IS MADE TO THE EXCLUSIVE RIGHT TO USE "MICRONESIA", APART FROM THE MARK AS SHOWN.

THE COLOR(S) BROWN, LIGHT GREEN, AQUA, GREY IS/ARE CLAIMED AS A FEATURE OF THE MARK.

THE MARK CONSISTS OF ON THE LEFT - A BROWN CIRCLE ENCOMPASSING TWO LIGHT GREEN PALM TREE LEAFS ON THE TOP AND A AQUA RIP CURL THAT CURLS TO THE LEFT. TO THE RIGHT OF THE BROWN CIRCLE ARE TWO ROWS OF GREY TEXT. TOP ROW OF TEXT READS "MICRONESIA" IN ALL CAPS. BOTTOM ROW OF TEXT READS "EXPERIENCE THE WARMTH" IN SCRIPT FONT.

FOR CHAMBER OF COMMERCE SERVICES, NAMELY, PROMOTING BUSINESS AND TOURISM IN THE MICRONESIA AREA; CONVENTION AND VISITORS BUREAU SERVICES, NAMELY, PROMOTING BUSINESS AND TOURISM IN THE MICRONESIA AREA; CONVENTION AND VISITORS BUREAU SERVICES, NAMELY, PROMOTING BUSINESS, TOURISM AND THE HOLDING OF CONVENTIONS IN THE MICRONESIA AREA; CONVENTION AND VISITORS BUREAU SERVICES, NAMELY, PROMOTING CONVENTIONS AND TOURISM IN THE MICRONESIA AREA; CONVENTION AND VISITORS BUREAU SERVICES, NAMELY, PROMOTING TOURISM, BUSINESS AND CONVENTIONS IN AND AROUND THE MICRONESIA AREA; PROMOTING RECREATION AND TOURISM IN MICRONESIA; PROMOTING TOURISM IN MICRONESIA AREA; PUBLIC RELATIONS, ADVERTISING AND MARKETING SERVICES FOR THE TOURISM AND CONVENTION INDUSTRY, NAMELY, ORGANIZING AND HOSTING SITE INSPECTIONS AND FAMILIARIZATION TOURS FOR WHOLESALERS, TOUR OPERATORS, TRAVEL AGENTS, MEETING AND INCENTIVE TRAVEL PLANNERS AND TRAVEL MEDIA (U.S. CLS. 100, 101 AND 102).

FIRST USE 0-0-1989; IN COMMERCE 0-0-1989.  
LESLIE RICHARDS, EXAMINING ATTORNEY

**CLASS 35—(Continued).**

SN 86-167,131. MAZZELLA LIFTING TECHNOLOGIES, INC., CLEVELAND, OH. FILED 1-16-2014.

**HOIST PARTS PRO**

THE MARK CONSISTS OF STANDARD CHARACTERS WITHOUT CLAIM TO ANY PARTICULAR FONT, STYLE, SIZE, OR COLOR.

NO CLAIM IS MADE TO THE EXCLUSIVE RIGHT TO USE "HOIST PARTS", APART FROM THE MARK AS SHOWN.

FOR ONLINE ORDERING SERVICES FEATURING SPARE AND REPLACEMENT PARTS FOR CRANES AND WIRE ROPE; PROVIDING A WEBSITE FOR ONLINE ORDERING OF SPARE AND REPLACEMENT PARTS FOR CRANES AND WIRE ROPE (U.S. CLS. 100, 101 AND 102).

MARK SPARACINO, EXAMINING ATTORNEY

**CLASS 35—(Continued).**

SN 86-170,840. BIG CITY MOMS, INC., GARDEN CITY, NEW YORK, NY. FILED 1-21-2014.

**The Biggest Baby Shower  
Ever**

THE MARK CONSISTS OF STANDARD CHARACTERS WITHOUT CLAIM TO ANY PARTICULAR FONT, STYLE, SIZE, OR COLOR.

NO CLAIM IS MADE TO THE EXCLUSIVE RIGHT TO USE "BABY SHOWER", APART FROM THE MARK AS SHOWN.

FOR EVENT PLANNING AND MANAGEMENT FOR MARKETING, BRANDING, PROMOTING OR ADVERTISING THE GOODS AND SERVICES OF OTHERS; PROMOTING, ADVERTISING AND MARKETING OF THE BRANDS, PRODUCTS, SERVICES AND ONLINE WEBSITES OF INDIVIDUALS, BUSINESSES AND NON-PROFIT ORGANIZATIONS (U.S. CLS. 100, 101 AND 102).

FIRST USE 4-5-2004; IN COMMERCE 4-5-2004.  
RAUL CORDOVA, EXAMINING ATTORNEY

SN 86-170,817. BIG CITY MOMS, INC., GARDEN CITY, NY. FILED 1-21-2014.

**Big City Moms**

THE MARK CONSISTS OF STANDARD CHARACTERS WITHOUT CLAIM TO ANY PARTICULAR FONT, STYLE, SIZE, OR COLOR.

NO CLAIM IS MADE TO THE EXCLUSIVE RIGHT TO USE "MOMS", APART FROM THE MARK AS SHOWN.

FOR EVENT PLANNING AND MANAGEMENT FOR MARKETING, BRANDING, PROMOTING OR ADVERTISING THE GOODS AND SERVICES OF OTHERS; PROMOTING, ADVERTISING AND MARKETING OF THE BRANDS, PRODUCTS, SERVICES AND ONLINE WEBSITES OF INDIVIDUALS, BUSINESSES AND NON-PROFIT ORGANIZATIONS (U.S. CLS. 100, 101 AND 102).

FIRST USE 4-5-2004; IN COMMERCE 4-5-2004.  
RAUL CORDOVA, EXAMINING ATTORNEY

SN 86-172,946. STRAUSS, RANDY S., DBA STRAUSSGROUP, BUFFALO, NY. FILED 1-23-2014.

**We Read People, Not Resumes**

THE MARK CONSISTS OF STANDARD CHARACTERS WITHOUT CLAIM TO ANY PARTICULAR FONT, STYLE, SIZE, OR COLOR.

FOR EMPLOYMENT RECRUITING, STAFFING AND HIRING CONSULTATION SERVICES; EMPLOYMENT COUNSELING AND RECRUITING, NAMELY, EXECUTIVE SEARCH CONSULTANT SERVICES; BUSINESS CONSULTING SERVICES, NAMELY, ONBOARDING CONSULTING TO PROMOTE NEW EMPLOYEE PRODUCTIVITY, CAREER PLANNING AND EXISTING EMPLOYEE RETENTION; PROVIDING EMPLOYMENT COUNSELING INFORMATION ON HOW TO SUCCESSFULLY TRANSITION JOBS (U.S. CLS. 100, 101 AND 102).

FIRST USE 8-9-2012; IN COMMERCE 1-10-2014.  
TRICIA SONNEBORN, EXAMINING ATTORNEY

**CLASS 35—(Continued).**

SN 86-174,995. GUARDVEST, LLC, DALLAS, TX. FILED 1-24-2014.

**THE ADVISOR REPORT CARD**

THE MARK CONSISTS OF STANDARD CHARACTERS WITHOUT CLAIM TO ANY PARTICULAR FONT, STYLE, SIZE, OR COLOR.

NO CLAIM IS MADE TO THE EXCLUSIVE RIGHT TO USE "ADVISOR", APART FROM THE MARK AS SHOWN.

FOR FINANCIAL DATA ANALYSIS, NAMELY, COMPILING AND ANALYZING STATISTICS, FINANCIAL DATA AND OTHER SOURCES OF INFORMATION FOR PREPARATION OF CONSUMER REPORTS (U.S. CLS. 100, 101 AND 102).

SUSAN STIGLITZ, EXAMINING ATTORNEY

**CLASS 35—(Continued).**

SN 86-176,114. BUTTERMILK SKY OF TN LLC, KNOXVILLE, TN. FILED 1-27-2014.



NO CLAIM IS MADE TO THE EXCLUSIVE RIGHT TO USE "KNOXVILLE, TENNESSEE" AND "BUTTERMILK" AND "PIE SHOP", APART FROM THE MARK AS SHOWN. FOR ONLINE RETAIL BAKERY SHOPS; RETAIL BAKERY SHOPS (U.S. CLS. 100, 101 AND 102).

FIRST USE 11-0-2013, THE MARK WAS FIRST USED ANYWHERE IN A DIFFERENT FORM OTHER THAN THAT SOUGHT TO BE REGISTERED AT LEAST AS EARLY AS 03/00/2011; IN COMMERCE 11-0-2013, THE MARK WAS FIRST USED IN COMMERCE IN A DIFFERENT FORM OTHER THAN THAT SOUGHT TO BE REGISTERED AT LEAST AS EARLY AS 03/00/2011.

MARY CRAWFORD, EXAMINING ATTORNEY

SN 86-177,345. AMERICAN SOCIETY OF CLINICAL ONCOLOGY, INC., ALEXANDRIA, VA. FILED 1-28-2014.

SN 86-175,010. GUARDVEST, LLC, DALLAS, TX. FILED 1-24-2014.

**THE FREE LOOK PORTFOLIO**

THE MARK CONSISTS OF STANDARD CHARACTERS WITHOUT CLAIM TO ANY PARTICULAR FONT, STYLE, SIZE, OR COLOR.

NO CLAIM IS MADE TO THE EXCLUSIVE RIGHT TO USE "PORTFOLIO", APART FROM THE MARK AS SHOWN.

FOR FINANCIAL DATA ANALYSIS, NAMELY, COMPILING AND ANALYZING STATISTICS, FINANCIAL DATA AND OTHER SOURCES OF INFORMATION FOR PREPARATION OF CONSUMER REPORTS (U.S. CLS. 100, 101 AND 102).

SUSAN STIGLITZ, EXAMINING ATTORNEY



NO CLAIM IS MADE TO THE EXCLUSIVE RIGHT TO USE "FEDERALLY FUNDED RESEARCH", APART FROM THE MARK AS SHOWN.

THE MARK CONSISTS OF A CIRCLE CONTAINING THE IMAGE OF A "DNA" STRAND DOUBLE HELIX IN THE FOREGROUND AND A COLUMNED BUILDING IN THE BACKGROUND. THE CIRCLE IS BORDERED ABOVE BY A CURVED LINE AND BORDERED BELOW BY THE WORDS "FEDERALLY FUNDED RESEARCH".

FOR PUBLIC ADVOCACY TO PROMOTE AWARENESS OF THE EFFECTS AND BENEFITS OF FEDERAL FUNDING FOR SCIENTIFIC RESEARCH (U.S. CLS. 100, 101 AND 102).

FIRST USE 5-30-2013; IN COMMERCE 5-30-2013. CHRIS WELLS, EXAMINING ATTORNEY



**CLASS 35—(Continued).**

SN 86-178,352. GIFT ANTHONY, HAMBURG, FED REP GERMANY, FILED 1-29-2014.

# UrbanNerd

THE MARK CONSISTS OF STANDARD CHARACTERS WITHOUT CLAIM TO ANY PARTICULAR FONT, STYLE, SIZE, OR COLOR.

FOR ON-LINE RETAIL STORE SERVICES FEATURING PET SUPPLIES, MOBILE PHONES, SMARTPHONES, TABLETS, LAPTOPS, ADDITIONAL PARTS AND ACCESSORIES FOR MOBILE PHONES, CLOTHING, SHOES AND FASHION ACCESSORIES; ON-LINE WHOLESALE STORE SERVICES FEATURING PET SUPPLIES, MOBILE PHONES, SMARTPHONES, TABLETS, LAPTOPS, ADDITIONAL PARTS AND ACCESSORIES FOR MOBILE PHONES, CLOTHING, SHOES AND FASHION ACCESSORIES; RETAIL STORE SERVICES FEATURING PET SUPPLIES, MOBILE PHONES, SMARTPHONES, TABLETS, LAPTOPS, ADDITIONAL PARTS AND ACCESSORIES FOR MOBILE PHONES, CLOTHING, SHOES AND FASHION ACCESSORIES; WHOLESAL STORE SERVICES FEATURING PET SUPPLIES, MOBILE PHONES, SMARTPHONES, TABLETS, LAPTOPS, ADDITIONAL PARTS AND ACCESSORIES FOR MOBILE PHONES, CLOTHING, SHOES AND FASHION ACCESSORIES (U.S. CLS. 100, 101 AND 102).

ELIZABETH HUGHITT, EXAMINING ATTORNEY

---

SN 86-178,554. MARGARET O'LEARY, INC., SAN FRANCISCO, CA. FILED 1-29-2014.



OWNER OF U.S. REG. NO. 1,969,952.  
THE NAME(S), PORTRAIT(S), AND/OR SIGNATURE(S) SHOWN IN THE MARK IDENTIFIES "MARGARET O'LEARY", WHOSE CONSENT(S) TO REGISTER IS MADE OF RECORD.

THE MARK CONSISTS OF THE STYLIZED WORDS "MARGARET O'LEARY" INSIDE A CIRCLE.

FOR RETAIL STORE SERVICES, FEATURING, CLOTHING, GLOVES, SCARVES, HATS, SKIRTS, TUNICS, SWEATERS, COATS, LINGERIE, SHOES, BOOTS, PERFUME, BODY PRODUCTS, JEWELRY, HANDBAGS AND ACCESSORIES (U.S. CLS. 100, 101 AND 102).

FIRST USE 0-0-2000; IN COMMERCE 0-0-2000.

WON TEAK OH, EXAMINING ATTORNEY

**CLASS 35—(Continued).**

SN 86-178,555. REED ELSEVIER PROPERTIES INC., WILMINGTON, DE. FILED 1-29-2014.

# LEXISNEXIS

THE MARK CONSISTS OF STANDARD CHARACTERS WITHOUT CLAIM TO ANY PARTICULAR FONT, STYLE, SIZE, OR COLOR.

OWNER OF U.S. REG. NOS. 2,370,256, 4,497,457 AND OTHERS.

FOR PROVIDING A DATABASE OF BUSINESS INFORMATION REGARDING MEDICAL PROVIDERS FOR USE IN ADMINISTERING AND PROCESSING OF EMPLOYER AND EMPLOYEE INSURANCE AND BENEFITS, FOR USE IN ADMINISTERING AND PROCESSING INSURANCE CARRIER SERVICES, FOR USE IN ADMINISTERING AND PROCESSING INVOICES AND PAYMENTS TO AND FROM BENEFIT PROVIDERS AND INSURANCE COMPANIES, AND FOR ADMINISTERING AND PROCESSING EMPLOYER AND EMPLOYEE INSURANCE AND BENEFITS FOR USE BY EMPLOYERS, THIRD PARTY ADMINISTRATORS, AND MEDICAL AND DENTAL SERVICE PROVIDERS (U.S. CLS. 100, 101 AND 102).

FIRST USE 9-11-2013; IN COMMERCE 9-11-2013.

MICHELLE DUBOIS, EXAMINING ATTORNEY

---

SN 86-179,474. DOK, LLC, DBA FLO GRILLS, AUSTIN, TX. FILED 1-30-2014.

# FLO Grills

THE MARK CONSISTS OF STANDARD CHARACTERS WITHOUT CLAIM TO ANY PARTICULAR FONT, STYLE, SIZE, OR COLOR.

NO CLAIM IS MADE TO THE EXCLUSIVE RIGHT TO USE "GRILLS", APART FROM THE MARK AS SHOWN.

FOR FRANCHISE SERVICES, NAMELY, OFFERING BUSINESS MANAGEMENT ASSISTANCE IN THE ESTABLISHMENT AND OPERATION OF RETAIL STORES SPECIALIZING IN OUTDOOR LIVING, NAMELY, KITCHENS (U.S. CLS. 100, 101 AND 102).

FIRST USE 6-6-2007; IN COMMERCE 1-29-2014.

KATHLEEN M. VANSTON, EXAMINING ATTORNEY

**CLASS 35—(Continued).**

SN 86-182,108. RICK SNYDER BUSINESS COACHING LLC, ASHLAND, OR. FILED 2-2-2014.

# Three Hats

THE MARK CONSISTS OF STANDARD CHARACTERS WITHOUT CLAIM TO ANY PARTICULAR FONT, STYLE, SIZE, OR COLOR.

FOR ASSISTANCE, ADVISORY SERVICES AND CONSULTANCY WITH REGARD TO BUSINESS PLANNING, BUSINESS ANALYSIS, BUSINESS MANAGEMENT, AND BUSINESS ORGANIZATION (U.S. CLS. 100, 101 AND 102).

LESLEY LAMOTHE, EXAMINING ATTORNEY

---

SN 86-184,508. THREEEVEN, INC, DBA PEACE LOVE SWAP, VIRGINIA BEACH, VA. FILED 2-4-2014.



NO CLAIM IS MADE TO THE EXCLUSIVE RIGHT TO USE "SWAP", APART FROM THE MARK AS SHOWN.

THE MARK CONSISTS OF THE WORDS "PEACE", "LOVE", AND "SWAP" AND THE DESIGN OF A STYLIZED HEART FORMED BY TWO ARROWS. INSIDE OF THE HEART SHAPE IS A PEACE SYMBOL.

FOR ARRANGING AND CONDUCTING SWAP MEETS IN THE FIELD OF BABY, KID, AND MATERNITY ITEMS (U.S. CLS. 100, 101 AND 102).

FIRST USE 8-28-2013; IN COMMERCE 8-28-2013.  
KATHRYN COWARD, EXAMINING ATTORNEY

**CLASS 35—(Continued).**

SN 86-184,963. STYLISH SOPHISTICATE MEDIA LLC, BROOKLYN, NY. FILED 2-5-2014.



NO CLAIM IS MADE TO THE EXCLUSIVE RIGHT TO USE "STYLISH", APART FROM THE MARK AS SHOWN.

THE MARK CONSISTS OF A SUITCASE WITH A STYLIZED "SS" AND "STYLISH SOPHISTICATE" WRITTEN ON THE SUITCASE.

FOR PROMOTING AND MARKETING THE GOODS AND SERVICES OF OTHERS BY DISTRIBUTING ADVERTISING MATERIAL THAT SHOWCASES STYLISH FEMALES ACROSS INDUSTRIES ONLINE AND OVER MOBILE APPLICATIONS; PROMOTING THE GOODS AND SERVICES OF OTHERS BY PROVIDING A WEBSITE FEATURING ADVERTISING AND PROMOTIONAL MATERIAL IN THE NATURE OF FASHION AND BEAUTY COLLAGES, EDITORIALS, INTERVIEWS, AND OTHER PHOTOSHOOTS AND VIDEOSHOOTS; PROVIDING CONSUMER INFORMATION SERVICES AND MAKING REFERRALS IN THE FIELD OF ENTERTAINMENT SERVICES FOR PRODUCTS, SERVICES, EVENTS, ACTIVITIES, FACILITIES AND LOCATIONS; PROVISION OF SPACE ON WEBSITES FOR ADVERTISING GOODS AND SERVICES (U.S. CLS. 100, 101 AND 102).

FIRST USE 1-29-2014; IN COMMERCE 2-1-2014.  
RENEE MCCRAY, EXAMINING ATTORNEY

---

SN 86-190,445. COUNTY OF PLACER, AUBURN, CA. FILED 2-11-2014.



NO CLAIM IS MADE TO THE EXCLUSIVE RIGHT TO USE "PLACER", APART FROM THE MARK AS SHOWN.

THE MARK CONSISTS OF A GREEN LINE REPRESENTING THE OUTLINE OF A MOUNTAIN AND A BLUE LINE REPRESENTING A RIVER. IN BETWEEN THE MOUNTAIN AND THE RIVER IS THE WORD "PLACER" IN BLACK. THE ENTIRE MARK IS ON A WHITE BACKGROUND AND NOT PART OF THE MARK.

FOR CHAMBER OF COMMERCE SERVICES, NAMELY, PROMOTING BUSINESS AND TOURISM IN THE PLACER COUNTY AREA (U.S. CLS. 100, 101 AND 102).

BRITTANY ESTELL, EXAMINING ATTORNEY

**CLASS 35—(Continued).**

SN 86-190,694. MARKETPLACE EVENTS LLC, SOLON, OH.  
FILED 2-11-2014.

**RALEIGH SPRING HOME SHOW**

THE MARK CONSISTS OF STANDARD CHARACTERS WITHOUT CLAIM TO ANY PARTICULAR FONT, STYLE, SIZE, OR COLOR.

NO CLAIM IS MADE TO THE EXCLUSIVE RIGHT TO USE "HOME SHOW", APART FROM THE MARK AS SHOWN.

SEC. 2(F).

FOR ARRANGING AND CONDUCTING COMMERCIAL EXHIBITIONS AND TRADE SHOWS IN THE FIELDS OF HOME DESIGN, HOME DECORATING, FURNITURE, HOME APPLIANCES, GARDEN DECORATING AND LANDSCAPING (U.S. CLS. 100, 101 AND 102).

FIRST USE 0-0-2008; IN COMMERCE 0-0-2008.

LINDA MICKLEBURGH, EXAMINING ATTORNEY

SN 86-190,725. MARKETPLACE EVENTS LLC, SOLON, OH.  
FILED 2-11-2014.

**RALEIGH FALL HOME SHOW**

THE MARK CONSISTS OF STANDARD CHARACTERS WITHOUT CLAIM TO ANY PARTICULAR FONT, STYLE, SIZE, OR COLOR.

NO CLAIM IS MADE TO THE EXCLUSIVE RIGHT TO USE "HOME SHOW", APART FROM THE MARK AS SHOWN.

SEC. 2(F).

FOR ARRANGING AND CONDUCTING COMMERCIAL EXHIBITIONS AND TRADE SHOWS IN THE FIELDS OF HOME DESIGN, HOME DECORATING, FURNITURE, HOME APPLIANCES, GARDEN DECORATING AND LANDSCAPING (U.S. CLS. 100, 101 AND 102).

FIRST USE 0-0-2008; IN COMMERCE 0-0-2008.

LINDA MICKLEBURGH, EXAMINING ATTORNEY

SN 86-190,970. SCHMALFELDT JOY NICOLE, LA JOLLA, CA. FILED 2-11-2014.

**Pixel Girl**

THE MARK CONSISTS OF STANDARD CHARACTERS WITHOUT CLAIM TO ANY PARTICULAR FONT, STYLE, SIZE, OR COLOR.

FOR WHOLESALE ORDERING AND ONLINE ORDERING SERVICES FEATURING T-SHIRTS, SKATEBOARDS, SNOWBOARDS, STICKERS, HATS, AND OTHER APPAREL (U.S. CLS. 100, 101 AND 102).

FIRST USE 1-1-1994; IN COMMERCE 1-2-1996.

PAM WILLIS, EXAMINING ATTORNEY

**CLASS 35—(Continued).**

SN 86-192,501. CADENCE KIDWELL, DBA FUZZY GOAT, TALLAHASSEE, FL. FILED 2-13-2014.

**Fuzzy Goat**

THE MARK CONSISTS OF STANDARD CHARACTERS WITHOUT CLAIM TO ANY PARTICULAR FONT, STYLE, SIZE, OR COLOR.

FOR RETAIL STORES FEATURING KNITTING AND CROCHET SUPPLIES (U.S. CLS. 100, 101 AND 102).

FIRST USE 3-30-2013; IN COMMERCE 11-19-2013.

GRETTA YAO, EXAMINING ATTORNEY

SN 86-193,906. WHOZAGOOD, INC., SE CALGARY, CANADA, FILED 2-14-2014.

**The Best Ratings Money  
Can't Buy**

THE MARK CONSISTS OF STANDARD CHARACTERS WITHOUT CLAIM TO ANY PARTICULAR FONT, STYLE, SIZE, OR COLOR.

FOR BUSINESS RESEARCH AND SURVEYS; CONDUCTING ON-LINE BUSINESS MANAGEMENT RESEARCH SURVEYS; PROVIDING A SEARCHABLE WEBSITE FEATURING THE GOODS AND SERVICES OF OTHERS; PROVIDING A WEBSITE FEATURING THE RATINGS, REVIEWS AND RECOMMENDATIONS ON PRODUCTS AND SERVICES FOR COMMERCIAL PURPOSES POSTED BY USERS (U.S. CLS. 100, 101 AND 102).

KATHERINE CHANG, EXAMINING ATTORNEY

SN 86-194,541. URTH ORGANIC, GRASS VALLEY, CA. FILED 2-14-2014.

**URTH**

THE MARK CONSISTS OF STANDARD CHARACTERS WITHOUT CLAIM TO ANY PARTICULAR FONT, STYLE, SIZE, OR COLOR.

FOR BUSINESS CONSULTING IN THE FIELDS OF AGRICULTURE, LIVESTOCK, WATER REMEDIATION, SOIL REMEDIATION AND CONVERSATION, AQUACULTURE, SUSTAINABILITY AND HOME, GARDEN AND FLORAL (U.S. CLS. 100, 101 AND 102).

FIRST USE 3-23-2011; IN COMMERCE 3-23-2011.

ANNE E. GUSTASON, EXAMINING ATTORNEY

**CLASS 35—(Continued).**

SN 86-194,550. URTH ORGANIC, GRASS VALLEY, CA. FILED 2-14-2014.

**URTH AGRICULTURE**

THE MARK CONSISTS OF STANDARD CHARACTERS WITHOUT CLAIM TO ANY PARTICULAR FONT, STYLE, SIZE, OR COLOR.

NO CLAIM IS MADE TO THE EXCLUSIVE RIGHT TO USE "AGRICULTURE", APART FROM THE MARK AS SHOWN.

FOR BUSINESS CONSULTING IN THE FIELDS OF AGRICULTURE, LIVESTOCK, WATER REMEDIATION, SOIL REMEDIATION AND CONVERSATION, AQUACULTURE, SUSTAINABILITY AND HOME, GARDEN AND FLORAL (U.S. CLS. 100, 101 AND 102).

FIRST USE 3-23-2011; IN COMMERCE 3-23-2011.  
ANNE E. GUSTASON, EXAMINING ATTORNEY

---

SN 86-197,292. CAPITAL MOTORSPORTS WAREHOUSE INC., ADAMS, MA. FILED 2-19-2014.



NO CLAIM IS MADE TO THE EXCLUSIVE RIGHT TO USE "MOTORSPORTS WAREHOUSE INC.", APART FROM THE MARK AS SHOWN.

THE COLOR(S) YELLOW, BLACK AND WHITE IS/ARE CLAIMED AS A FEATURE OF THE MARK.

THE MARK CONSISTS OF THE WORDING "CAPITAL" IN BLACK WITH A YELLOW AND RED OUTLINE ON A BLACK AND WHITE CHECKERED BACKGROUND WITH YELLOW BELOW AND "MOTORSPORTS WAREHOUSE INC." IN WHITE ON A BLACK BACKGROUND.

FOR ON-LINE RETAIL STORE SERVICES FEATURING RACE CAR PARTS, ACCESSORIES AND SAFETY EQUIPMENT (U.S. CLS. 100, 101 AND 102).

FIRST USE 1-1-1999; IN COMMERCE 1-1-1999.  
CAROLINE WOOD, EXAMINING ATTORNEY

---

SN 86-199,368. COGNISIGHT, LLC, ROCHESTER, NY. AND GREATER ROCHESTER INDEPENDENT PRACTICE ASSOCIATION INC., ROCHESTER, NY. FILED 2-20-2014.

**COGNISIGHTDX**

THE MARK CONSISTS OF STANDARD CHARACTERS WITHOUT CLAIM TO ANY PARTICULAR FONT, STYLE, SIZE, OR COLOR.

OWNER OF U.S. REG. NO. 3,388,571.  
FOR BUSINESS AND MANAGEMENT CONSULTING FOR HEALTHCARE PROVIDERS AND RELATED BUSINESSES (U.S. CLS. 100, 101 AND 102).

FIRST USE 1-1-2008; IN COMMERCE 1-1-2008.  
KATHERINE E. HALMEN, EXAMINING ATTORNEY

**CLASS 35—(Continued).**

SN 86-199,411. COGNISIGHT, LLC, ROCHESTER, NY. AND GREATER ROCHESTER INDEPENDENT PRACTICE ASSOCIATION, INC., ROCHESTER, NY. FILED 2-20-2014.

**PACE Assist**

THE MARK CONSISTS OF STANDARD CHARACTERS WITHOUT CLAIM TO ANY PARTICULAR FONT, STYLE, SIZE, OR COLOR.

NO CLAIM IS MADE TO THE EXCLUSIVE RIGHT TO USE "ASSIST", APART FROM THE MARK AS SHOWN.

FOR BUSINESS AND MANAGEMENT CONSULTING FOR HEALTHCARE PROVIDERS AND RELATED BUSINESSES (U.S. CLS. 100, 101 AND 102).

KATHERINE E. HALMEN, EXAMINING ATTORNEY

---

SN 86-199,450. PARLANT TECHNOLOGY, INC., DBA PAR-ENTLINK, PROVO, UT. FILED 2-20-2014.

**APPTIVATE**

THE MARK CONSISTS OF STANDARD CHARACTERS WITHOUT CLAIM TO ANY PARTICULAR FONT, STYLE, SIZE, OR COLOR.

FOR CONDUCTING BUSINESS AND MARKET RESEARCH SURVEYS (U.S. CLS. 100, 101 AND 102).

FLORENTINA BLANDU, EXAMINING ATTORNEY

**CLASS 35—(Continued).**

SN 86-199,805. POLLINATE MEDIA GROUP LLC, COSTA MESA, CA. FILED 2-21-2014.

**WEAVE MADE MEDIA**

THE MARK CONSISTS OF STANDARD CHARACTERS WITHOUT CLAIM TO ANY PARTICULAR FONT, STYLE, SIZE, OR COLOR.

NO CLAIM IS MADE TO THE EXCLUSIVE RIGHT TO USE "MEDIA", APART FROM THE MARK AS SHOWN.

FOR ADVERTISING AGENCIES; ADVERTISING, MARKETING AND PROMOTION SERVICES; ADVERTISING AND PUBLICITY SERVICES, NAMELY, PROMOTING THE GOODS, SERVICES, BRAND IDENTITY AND COMMERCIAL INFORMATION AND NEWS OF THIRD PARTIES THROUGH PRINT, AUDIO, VIDEO, DIGITAL AND ON-LINE MEDIUM; BRANDING SERVICES, NAMELY, CONSULTING, DEVELOPMENT, MANAGEMENT AND MARKETING OF BRANDS FOR BUSINESSES AND/OR INDIVIDUALS; PROVIDING A WEB SITE FEATURING THE RATINGS, REVIEWS AND RECOMMENDATIONS ON PRODUCTS AND SERVICES FOR COMMERCIAL PURPOSES POSTED BY USERS; ADVERTISING AND MARKETING SERVICES PROVIDED BY MEANS OF INDIRECT METHODS OF MARKETING COMMUNICATIONS, NAMELY, SOCIAL MEDIA, SEARCH ENGINE MARKETING, INQUIRY MARKETING, INTERNET MARKETING, MOBILE MARKETING, BLOGGING AND OTHER FORMS OF PASSIVE, SHARABLE OR VIRAL COMMUNICATIONS CHANNELS (U.S. CLS. 100, 101 AND 102).

FIRST USE 10-1-2013; IN COMMERCE 10-1-2013.  
LINDA MICKLEBURGH, EXAMINING ATTORNEY

SN 86-200,320. INNJOY TRAVEL, LLC, SANIBEL, FL. FILED 2-21-2014.

**INNJOY** travel  
what are you INN to?

NO CLAIM IS MADE TO THE EXCLUSIVE RIGHT TO USE "TRAVEL", APART FROM THE MARK AS SHOWN.

THE MARK CONSISTS OF THE WORDING "INNJOY" IN ALL CAPITAL LETTERS NEXT TO THE WORDING "TRAVEL" IN LOWER CASE LETTERS. BELOW THE WORDING "TRAVEL" IS THE WORDING "WHAT ARE YOU INN TO?" WITH THE WORDING "INN" IN ALL CAPITAL LETTERS AND THE WORDING "WHAT ARE YOU" AND "TO?" IN LOWER CASE LETTERS. BOTH THE WORDING "TRAVEL" AND "WHAT ARE YOU INN TO?" APPEAR TO THE RIGHT OF THE WORDING "INNJOY" AND SLOPE UPWARDS FROM LEFT TO RIGHT.

FOR PROMOTING THE GOODS AND SERVICES OF OTHERS BY PROVIDING A WEBSITE FEATURING LINKS TO LODGING PROVIDER WEBSITES OF OTHERS ALL IN THE FIELD OF LODGING (U.S. CLS. 100, 101 AND 102).

FIRST USE 8-2-2013; IN COMMERCE 8-2-2013.  
CRISTIANA SCHWAB, EXAMINING ATTORNEY

**CLASS 35—(Continued).**

SN 86-202,198. SMI MOLD TESTING & REMEDIATION, INC., REMSENBURG, NY. FILED 2-24-2014.



**DISASTER  
RECOVERY  
SERVICES**

NO CLAIM IS MADE TO THE EXCLUSIVE RIGHT TO USE "DISASTER RECOVERY SERVICES", APART FROM THE MARK AS SHOWN.

THE STIPPLING IS FOR SHADING PURPOSES ONLY.

THE MARK CONSISTS OF A DESIGN OF A BALL SHAPE/COLOR WHEEL GOING AROUND WITH AN OPEN CENTER WITH THE STYLIZED TEXT "DISASTER RECOVERY SERVICES" TO THE RIGHT, SEPARATED BY A VERTICAL LINE.

FOR DISASTER RECOVERY SERVICES, NAMELY, BUSINESS PLANNING AND BUSINESS CONTINUITY CONSULTING (U.S. CLS. 100, 101 AND 102).

SUSAN STIGLITZ, EXAMINING ATTORNEY

SN 86-203,044. KNOWLEDGEWORKS FOUNDATION, CINCINNATI, OH. FILED 2-25-2014.

**KNOWLEDGEWORKS**

THE MARK CONSISTS OF STANDARD CHARACTERS WITHOUT CLAIM TO ANY PARTICULAR FONT, STYLE, SIZE, OR COLOR.

OWNER OF U.S. REG. NOS. 2,825,512 AND 4,154,611.

FOR ADVOCACY SERVICES, NAMELY, PROMOTING PUBLIC AWARENESS OF THE NEED FOR COLLEGE AND CAREER PREPARATION FOR STUDENTS, PARTICULARLY FOR THOSE STUDENTS WHO HAVE BEEN HISTORICALLY UNDERREPRESENTED IN HIGHER EDUCATION ATTENDANCE AND ATTAINMENT; AND PROMOTING PUBLIC AWARENESS IN THE FIELDS OF SCHOOL FUNDING, PLANNING AND DESIGN (U.S. CLS. 100, 101 AND 102).

FIRST USE 5-1-2010; IN COMMERCE 5-1-2010.  
CURTIS FRENCH, EXAMINING ATTORNEY

SN 86-204,494. JOD GLOBAL PHILANTHROPIES LLC, FORT LAUDERDALE, FL. FILED 2-26-2014.

**The difference in making a  
difference.**

THE MARK CONSISTS OF STANDARD CHARACTERS WITHOUT CLAIM TO ANY PARTICULAR FONT, STYLE, SIZE, OR COLOR.

FOR BUSINESS SERVICES, NAMELY, DEVELOPING FUNDRAISING CAMPAIGNS FOR OTHERS (U.S. CLS. 100, 101 AND 102).

FIRST USE 1-1-2003; IN COMMERCE 1-1-2003.  
SALLY SHIH, EXAMINING ATTORNEY

**CLASS 35—(Continued).**

SN 86-205,509. NUDY PATOOTY INC., NEW YORK, NY. FILED 2-26-2014.



THE NAME "MICHELLE SHEMILT" IDENTIFIES A LIVING INDIVIDUAL WHOSE CONSENT IS OF RECORD. THE MARK CONSISTS OF AN IMAGE OF A WOMAN, FEATURING HER HEAD AND TORSO, INSIDE A CIRCLE, AND ABOVE THE STYLIZED WORDING "NUDYPATOOTY BY MICHELLE SHEMILT", WITH THE WORDING "BY MICHELLE SHEMILT" APPEARING IN SMALLER FONT BENEATH THE WORD "PATOOTY".

FOR ON-LINE RETAIL STORE SERVICES FEATURING UNDERGARMENTS, SLEEPWEAR, AND LOUNGEWEAR FOR WOMEN; RETAIL CLOTHING BOUTIQUES; RETAIL CLOTHING STORES (U.S. CLS. 100, 101 AND 102).

FIRST USE 3-25-2013; IN COMMERCE 3-25-2013. NICHOLAS ALTREE, EXAMINING ATTORNEY

SN 86-205,857. BIRTH CHOICE PREGNANCY CENTERS, INC., ALISO VIEJO, CA. FILED 2-27-2014.

**OBRIA**

THE MARK CONSISTS OF STANDARD CHARACTERS WITHOUT CLAIM TO ANY PARTICULAR FONT, STYLE, SIZE, OR COLOR.

THE ENGLISH TRANSLATION OF "OBRIA" IN THE MARK IS "OPENED".

FOR BUSINESS CONSULTATION SERVICES, NAMELY, PROVIDING BUSINESS INFORMATION AND ADVICE TO MEDICAL CLINICS REGARDING MARKETING, DONOR DEVELOPMENT, AND BUSINESS PRACTICES; ADVERTISING, MARKETING AND PROMOTION SERVICES IN THE FIELD OF HEALTH CARE FOR WOMEN; BUSINESS CONSULTATION SERVICES TO ASSIST NON-PROFIT ORGANIZATIONS IN PLANNING, MANAGING, AND CONDUCTING FUNDRAISING ACTIVITIES (U.S. CLS. 100, 101 AND 102).

COLLEEN DOMBROW, EXAMINING ATTORNEY

**CLASS 35—(Continued).**

SN 86-207,205. NORDQUIST, PATTI, RED BLUFF, CA. FILED 2-28-2014.

**Homey Comforts**

THE MARK CONSISTS OF STANDARD CHARACTERS WITHOUT CLAIM TO ANY PARTICULAR FONT, STYLE, SIZE, OR COLOR.

FOR ON-LINE RETAIL STORE SERVICES FEATURING COTTON PAPER TOWELS, PURSES, TOTE BAGS, LOG TOTE BAGS, APRONS, BIBS AND FEMININE HYGIENE PRODUCTS (U.S. CLS. 100, 101 AND 102).

JOHN E. MICHOS, EXAMINING ATTORNEY

SN 86-208,780. ECOARK, INC., ROGERS, AR. FILED 3-3-2014.



THE COLOR(S) BLUE, GREEN, LIGHT SILVER, WHITE AND GRAY IS/ARE CLAIMED AS A FEATURE OF THE MARK.

THE MARK CONSISTS OF THE WORD "ECOARK" IN BLUE WITH A BLUE ARROW AND A GREEN ARROW ENCIRCLING THE "O" IN THE WORD. THE WORDING APPEARS IN A LIGHT SILVER AND GRAY OBLONG DESIGN. THE MARK CONTAINS A LARGE STYLIZED INFINITY SYMBOL TRACED BY A BLUE ARROW AND A GREEN ARROW IN THE BACKGROUND. THE ARROW DESIGNS CONTAIN GRAY SHADOWS OF VARYING WIDTH. THE INTERIOR OF THE INFINITY SYMBOL AND SHADOWS IS WHITE.

FOR BUSINESS CONSULTING SERVICES IN THE FIELD OF INTEGRATED SUPPLY CHAIN MANAGEMENT (U.S. CLS. 100, 101 AND 102).

FIRST USE 1-15-2014; IN COMMERCE 1-15-2014.

DANIEL CAPSHAW, EXAMINING ATTORNEY

**CLASS 35—(Continued).**

SN 86-211,131. LEYVA, ALFONSO SOTO, TLALNEPANTLA, MEXICO, FILED 3-4-2014.



OWNER OF U.S. REG. NO. 3,819,517.

NO CLAIM IS MADE TO THE EXCLUSIVE RIGHT TO USE "THE BAND", APART FROM THE MARK AS SHOWN.

THE COLOR(S) YELLOW, RED, ORANGE, GREEN, PURPLE, BLUE, TEAL, PINK, WHITE AND BLACK IS/ARE CLAIMED AS A FEATURE OF THE MARK.

THE MARK CONSISTS OF THE WORDING "GEEHAA" IN YELLOW, RED, ORANGE, GREEN, PURPLE, BLUE, TEAL AND WHITE WITH TWO MUSICAL NOTES ATTACHED THE TWO "A"'S, AND THE WORDING "THE BAND" IN BLACK, WITH THE IMAGE OF A THE LETTER "G" IN WHITE ON A PINK CIRCULAR CARRIER.

FOR ON-LINE RETAIL STORE SERVICES FEATURING CLOTHING, SHOES, TOYS, BAGS, CUPS, GLASSES, MUGS, PRODUCED PHONOGRAMS AND VIDEOS, BLANK ELECTRONIC STORAGE MEDIA, CANDIES, COSMETICS, BACKPACKS AND BOOKS; RETAIL STORE SERVICES FEATURING CLOTHING, SHOES, TOYS, BAGS, CUPS, GLASSES, MUGS, PRODUCED PHONOGRAMS AND VIDEOS, BLANK ELECTRONIC STORAGE MEDIA, CANDIES, COSMETICS, BACKPACKS AND BOOKS (U.S. CLS. 100, 101 AND 102).

ERIN FALK, EXAMINING ATTORNEY

**CLASS 35—(Continued).**

SN 86-211,442. PM INVESTIGATIONS, INC., ATLANTA, GA. FILED 3-5-2014.

## COMPUTER FORENSIC SURVEILLANCE

THE MARK CONSISTS OF STANDARD CHARACTERS WITHOUT CLAIM TO ANY PARTICULAR FONT, STYLE, SIZE, OR COLOR.

OWNER OF U.S. REG. NO. 3,396,784.

NO CLAIM IS MADE TO THE EXCLUSIVE RIGHT TO USE "SURVEILLANCE", APART FROM THE MARK AS SHOWN.

SEC. 2(F).

FOR BUSINESS INVESTIGATION SERVICES, NAMELY, ELECTRONIC INVESTIGATIONS CONDUCTED ON PEOPLE, PLACES, OR THINGS WHICH RESULTED DIRECTLY FROM THE DISCOVERY OF PIECES OF DIGITAL EVIDENCE BEING OBTAINED BY USING COMMON TECHNIQUES AND METHODS PERFORMED IN THE USUAL CONDUCT OF EXAMINATIONS (U.S. CLS. 100, 101 AND 102).

FIRST USE 2-7-2006; IN COMMERCE 2-7-2006.

KATHERINE CHANG, EXAMINING ATTORNEY

SN 86-211,509. PRINCESS & THE P DIAPER CAKERY, INC., VALLEY STREAM, NY. FILED 3-5-2014.



## SUPERSHIELDZ

SN 86-211,207. PHILATRONIC INC, PHILADELPHIA, PA. FILED 3-5-2014.

THE MARK CONSISTS OF STANDARD CHARACTERS WITHOUT CLAIM TO ANY PARTICULAR FONT, STYLE, SIZE, OR COLOR.

FOR RETAIL AND ONLINE RETAIL STORE SERVICES FEATURING PERIPHERALS AND ACCESSORIES FOR COMPUTERS AND MOBILE ELECTRONIC CELLULAR DEVICES, AND ELECTRICAL AND ELECTRONIC EQUIPMENT FOR COMPUTERS, WIRELESS TRANSMISSION AND COMPUTER NETWORKING PRODUCTS, POWER CHARGING AND POWER MANAGEMENT DEVICES (U.S. CLS. 100, 101 AND 102).

FIRST USE 5-21-2013; IN COMMERCE 2-24-2014.

SHAILA LEWIS, EXAMINING ATTORNEY

NO CLAIM IS MADE TO THE EXCLUSIVE RIGHT TO USE "DIAPER CAKERY", APART FROM THE MARK AS SHOWN.

THE MARK CONSISTS OF A CLOTH DIAPER WITH DIAPER PINS BELOW A MULTI-TIERED CROWN, WITH THE WORDING "PRINCESS & THE P DIAPER CAKERY" BELOW. THE WORDING "PRINCESS & THE P" IS IN STYLIZED FORM.

FOR ONLINE RETAIL STORE SERVICES FEATURING DIAPER CAKES, WASHCLOTH ARRANGEMENTS, BABY SHOWER FAVORS, BABY PRODUCTS AND GIFTS, NAMELY SHOES, CLOTHING, PACIFIERS, DIAPER PINS AND HAIR ACCESSORIES (U.S. CLS. 100, 101 AND 102).

FIRST USE 5-15-2012; IN COMMERCE 5-15-2012.

TAMARA FRAZIER, EXAMINING ATTORNEY

**CLASS 35—(Continued).**

SN 86-211,538. VESSENES, KATHERINE, CHANHASSEN, MN. FILED 3-5-2014.

# No-Sell Sale

THE MARK CONSISTS OF STANDARD CHARACTERS WITHOUT CLAIM TO ANY PARTICULAR FONT, STYLE, SIZE, OR COLOR.

NO CLAIM IS MADE TO THE EXCLUSIVE RIGHT TO USE "SALE", APART FROM THE MARK AS SHOWN.

FOR CONSULTING IN SALES TECHNIQUES AND SALES PROGRAMMES (U.S. CLS. 100, 101 AND 102).

FIRST USE 1-1-2005; IN COMMERCE 1-1-2005.  
ANDREW LEASER, EXAMINING ATTORNEY

**CLASS 35—(Continued).**

BLUE-COLORED CORE. THE OTHER LETTERS HAVE A BLACK CORE. EACH LETTER IS SURROUNDED BY WHITE BORDERING/EDGING ON ALL SIDES. THE WHITE BORDERING/EDGING OF EACH LETTER MERGES WITH THE WHITE BORDERING/EDGING OF THE NEIGHBORING LETTER. THE MARK FURTHER COMPRISES GRAY SHADING ON ALL SIDES OF THE WHITE BORDERING/EDGING. BACKGROUND COLOR (SHOWN IN WHITE) IS NOT CLAIMED AS A FEATURE OF THE MARK.

FOR ADVERTISING AND COMMERCIAL INFORMATION SERVICES, VIA THE INTERNET; ADVERTISING AND MARKETING SERVICES, NAMELY, PROMOTING THE GOODS AND SERVICES OF OTHERS; ADVERTISING AND PUBLICITY SERVICES; ADVERTISING SERVICES; ADVERTISING SERVICES, NAMELY, PROMOTING THE BRANDS, GOODS AND SERVICES OF OTHERS; ADVERTISING, MARKETING, AND PROMOTING THE GOODS AND SERVICES OF OTHERS VIA PRESENTING VIRTUAL REPRESENTATIONS OF PRODUCTS AND/OR SERVICES IN IMMERSIVE VIRTUAL ENVIRONMENT (U.S. CLS. 100, 101 AND 102).

FIRST USE 12-1-2011; IN COMMERCE 12-1-2012.  
C. DIONNE CLYBURN, EXAMINING ATTORNEY

SN 86-211,752. TRENT HARVEY, KNOXVILLE, TN. FILED 3-5-2014.



NO CLAIM IS MADE TO THE EXCLUSIVE RIGHT TO USE "SERVICE", APART FROM THE MARK AS SHOWN.

THE COLOR(S) ORANGE AND GREY IS/ARE CLAIMED AS A FEATURE OF THE MARK.

THE MARK CONSISTS OF A DRAWING OF A HANDSHAKE IN ORANGE AND GREY, WITH THE WORD "SERVICE" APPEARING IN ORANGE AND THE WORD "CONNECTION" APPEARING IN GREY.

FOR BUSINESS MANAGEMENT; PROVIDING ONLINE REFERRALS IN THE FIELDS OF BUILDING MAINTENANCE AND REPAIR, INSTALLATION AND ASSEMBLY OF HOME FURNISHINGS, LAWN MAINTENANCE, COMMERCIAL BUILDING MAINTENANCE, ELECTRONIC INSTALLATION AND REPAIR, AND PERSONAL FITNESS (U.S. CLS. 100, 101 AND 102).

FIRST USE 12-0-2013; IN COMMERCE 12-0-2013.  
ALYSSA STEEL, EXAMINING ATTORNEY

SN 86-213,206. NATIONAL CHAMBER LITIGATION CENTER, INC., NEW YORK, NY. FILED 3-6-2014.

## U.S. CHAMBER LITIGATION CENTER

SN 86-212,482. ROOMS INC, SAN FRANCISCO, CA. FILED 3-6-2014.



THE COLOR(S) BLUE, BLACK, WHITE, GRAY IS/ARE CLAIMED AS A FEATURE OF THE MARK.

THE MARK CONSISTS OF THE LITERAL ELEMENT "MYWEBROOM". THE FIRST LETTER OF THE WORD IS NOT CAPITALIZED. ONLY THE LETTERS "W" AND "R" ARE CAPITALIZED. THE FIRST TWO LETTERS HAVE A

THE MARK CONSISTS OF STANDARD CHARACTERS WITHOUT CLAIM TO ANY PARTICULAR FONT, STYLE, SIZE, OR COLOR.

OWNER OF U.S. REG. NOS. 1,430,627, 3,320,642 AND OTHERS.

NO CLAIM IS MADE TO THE EXCLUSIVE RIGHT TO USE "LITIGATION CENTER", APART FROM THE MARK AS SHOWN.

SEC. 2(F) AS TO "U.S. CHAMBER".

FOR ADVOCACY FOR THE FAIR TREATMENT OF BUSINESS IN THE COURTS AND BEFORE REGULATORY AGENCIES (U.S. CLS. 100, 101 AND 102).

CATHERINE TARCU, EXAMINING ATTORNEY



**CLASS 35—(Continued).**

SN 86-214,281. WORKCITE TECHNOLOGIES, LLC, FAYETTEVILLE, AR. FILED 3-7-2014.



THE MARK CONSISTS OF THE TERM "WORKCITE" WITH THE LETTER "I" SUBSTITUTED WITH A WRENCH. FOR PROVIDING ELECTRONIC TRACKING OF EMPLOYEES, PERSONNEL, AND CONTRACTORS TO OTHERS FOR BUSINESS ADMINISTRATION PURPOSES; PROVIDING TRACKING SERVICES AND INFORMATION CONCERNING TRACKING OF ASSETS IN TRANSIT, NAMELY, EMPLOYEES AND CONTRACTORS FOR BUSINESS PURPOSES; PROVIDING COMPUTERIZED TRACKING OF PERSONNEL TO OTHERS FOR BUSINESS ADMINISTRATION PURPOSES; PROVIDING AN EMPLOYER WITH CANDIDATES OR POTENTIAL EMPLOYEES TO FILL TEMPORARY, CONTRACT AND PERMANENT POSITIONS (U.S. CLS. 100, 101 AND 102).

FIRST USE 3-6-2014; IN COMMERCE 3-6-2014.  
HAI-LY LAM, EXAMINING ATTORNEY

**CLASS 35—(Continued).**

SN 86-214,523. EVGLEVSKIY SERGEY, MOSCOW, RUSSIAN FED., FILED 3-7-2014.



SN 86-214,336. JOHNNY SWIRLS CORP, JUPITER, FL. FILED 3-7-2014.

## JOHNNY SWIRLS

THE MARK CONSISTS OF STANDARD CHARACTERS WITHOUT CLAIM TO ANY PARTICULAR FONT, STYLE, SIZE, OR COLOR.

FOR RETAIL STORE SERVICES FEATURING FROZEN YOGURT AND ICE CREAM (U.S. CLS. 100, 101 AND 102).

DANNEAN HETZEL, EXAMINING ATTORNEY

SN 86-214,422. FORMULAB NATURALLY, DBA KEVGO BRANDS, ALBUQUERQUE, NM. FILED 3-7-2014.

## CHILE HUNGRY

THE MARK CONSISTS OF STANDARD CHARACTERS WITHOUT CLAIM TO ANY PARTICULAR FONT, STYLE, SIZE, OR COLOR.

NO CLAIM IS MADE TO THE EXCLUSIVE RIGHT TO USE "CHILE", APART FROM THE MARK AS SHOWN.

FOR ON-LINE ORDERING SERVICES FEATURING GROCERY ITEMS (U.S. CLS. 100, 101 AND 102).

FIRST USE 1-1-2014; IN COMMERCE 2-1-2014.  
CYNTHIA RINALDI, EXAMINING ATTORNEY

THE MARK CONSISTS OF THE WORDING "POINT ART" IN STYLIZED LETTERS IN WHICH THE WORD "ART" IS POSITIONED IN THE CENTER OF THE SHADED CIRCLE.

FOR DISTRIBUTORSHIP SERVICES IN THE FIELD OF TOBACCO PRODUCTS, NAMELY, HOOKAHS, HOOKAH CHARCOAL, TOBACCO, FLAVORED TOBACCO, HERBS FOR SMOKING, HOOKAH ACCESSORIES, NAMELY, HOOKAH STEMS, HOOKAH HOSES, HOOKAH BASES, HOOKAH BOWLS, HOOKAH MOUTHPIECES; IMPORT-EXPORT AGENCIES IN THE FIELD OF TOBACCO PRODUCTS AND SMOKING ACCESSORIES; ONLINE RETAIL SERVICES THROUGH DIRECT SOLICITATION BY DISTRIBUTORS DIRECTED TO END-USERS FEATURING TOBACCO PRODUCTS, NAMELY, HOOKAHS, HOOKAH CHARCOAL, TOBACCO, FLAVORED TOBACCO, HERBS FOR SMOKING, HOOKAH ACCESSORIES, NAMELY, HOOKAH STEMS, HOOKAH HOSES, HOOKAH BASES, HOOKAH BOWLS, HOOKAH MOUTHPIECES; OPERATING AN ON-LINE SHOPPING SITE IN THE FIELD OF TOBACCO PRODUCTS, NAMELY, HOOKAHS, HOOKAH CHARCOAL, TOBACCO, FLAVORED TOBACCO, HERBS FOR SMOKING, HOOKAH ACCESSORIES, NAMELY, HOOKAH STEMS, HOOKAH HOSES, HOOKAH BASES, HOOKAH BOWLS, HOOKAH MOUTHPIECES; RETAIL SERVICES THROUGH DIRECT SOLICITATION BY DISTRIBUTORS DIRECTED TO END-USERS FEATURING TOBACCO PRODUCTS, NAMELY, HOOKAHS, HOOKAH CHARCOAL, TOBACCO, FLAVORED TOBACCO, HERBS FOR SMOKING, HOOKAH ACCESSORIES, NAMELY, HOOKAH STEMS, HOOKAH HOSES, HOOKAH BASES, HOOKAH BOWLS, HOOKAH MOUTHPIECES; SMOKE SHOPS (U.S. CLS. 100, 101 AND 102).

EMILY CHUO, EXAMINING ATTORNEY

**CLASS 35—(Continued).**

SN 86-215,659. BUCHANAN, SONYA J, ELLENWOOD, GA. FILED 3-9-2014.



THE COLOR(S) BLUE AND RED IS/ARE CLAIMED AS A FEATURE OF THE MARK.

THE MARK CONSISTS OF CAPITAL LETTERS "CP" IN THE COLOR BLUE WITH MONOTYPE CORSIVA FONT. A SOLID RED LINE UNDERNEATH INITIALS "CP." THE COLOR BLUE "COMFORTING" IN TIMES NEW ROMAN FONT ON 2ND LINE. THE COLOR BLUE "PROMISES" IN TIMES NEW ROMAN FONT ON 3RD LINE. THEN UNDERNEATH "PROMISES" IN TWO SOLID RED LINES.

FOR PROMOTING THE GOODS AND SERVICES OF OTHERS BY MEANS OF AN INCENTIVE REWARD PROGRAM FEATURING GIFT REDEMPTION (U.S. CLS. 100, 101 AND 102).

VIVIAN MICZNIK FIRST, EXAMINING ATTORNEY

SN 86-215,709. THE COUTURE CLUB, LLC, UNION, NJ. FILED 3-10-2014.



OWNER OF U.S. REG. NO. 4,243,312.

NO CLAIM IS MADE TO THE EXCLUSIVE RIGHT TO USE "COUTURE CLUB", APART FROM THE MARK AS SHOWN.

THE MARK CONSISTS OF TWO OLD FASHIONED KEYS INTERLOCKED PERPENDICULAR, WITH THE ENTRY POINTS OF THE KEYS POINTING DOWN, AND THE WORD "THE" UNDERNEATH THE KEYS, FOLLOWED BY THE WORDS "COUTURE CLUB" UNDERNEATH "THE", FOLLOWED BY "ACCESS TO LUXURY" UNDERNEATH.

FOR ADMINISTRATION OF A CONSUMER MEMBERSHIP PROGRAM FOR ENABLING PARTICIPANTS TO RECEIVE PRODUCT SAMPLES AND DISCOUNTS IN THE FIELD OF CLOTHING (U.S. CLS. 100, 101 AND 102).

FIRST USE 12-15-2013; IN COMMERCE 1-5-2014.

JESSICA FATHY, EXAMINING ATTORNEY

**CLASS 35—(Continued).**

SN 86-215,751. SUSAN DENCH, DBA MUDDY DOG MEDIA INC., FALMOUTH, ME. FILED 3-10-2014.

## The Connectworker

THE MARK CONSISTS OF STANDARD CHARACTERS WITHOUT CLAIM TO ANY PARTICULAR FONT, STYLE, SIZE, OR COLOR.

FOR BRANDING SERVICES, NAMELY, CONSULTING, DEVELOPMENT, MANAGEMENT AND MARKETING OF BRANDS FOR BUSINESSES AND/OR INDIVIDUALS; BUSINESS CONSULTANCY (U.S. CLS. 100, 101 AND 102).

JOSETTE BEVERLY, EXAMINING ATTORNEY

SN 86-216,301. FREE TO BREATHE, INC., MADISON, WI. FILED 3-10-2014.



OWNER OF U.S. REG. NOS. 3,429,584 AND 3,621,371.

NO CLAIM IS MADE TO THE EXCLUSIVE RIGHT TO USE "A PARTNERSHIP FOR LUNG CANCER SURVIVAL", APART FROM THE MARK AS SHOWN.

THE MARK CONSISTS OF THE WORDS "FREE TO BREATHE" STACKED OVER "A PARTNERSHIP FOR LUNG CANCER SURVIVAL", NEXT TO A STYLIZED PAIR OF LUNGS.

FOR PROMOTING PUBLIC AWARENESS OF LUNG CANCER, ITS DIAGNOSIS, ITS TREATMENT, AND SEX DIFFERENCES BETWEEN LUNG CANCER IN MALES AND FEMALES; PROMOTING PUBLIC AWARENESS OF THE NEED FOR LUNG CANCER RESEARCH AND RESEARCH FUNDING (U.S. CLS. 100, 101 AND 102).

FIRST USE 2-0-2014; IN COMMERCE 2-0-2014.

STEVEN PEREZ, EXAMINING ATTORNEY

SN 86-216,756. ALADIN COMMUNICATIONS INC., SEOUL, REPUBLIC OF KOREA, FILED 3-10-2014.



NO CLAIM IS MADE TO THE EXCLUSIVE RIGHT TO USE "BOOK", APART FROM THE MARK AS SHOWN.

THE MARK CONSISTS OF WORDS "BOOK MONSTER" WHERE WORD "MONSTER" INCLUDES STYLIZED DESIGN ON LETTER "O".

FOR AUCTIONEERING SERVICES; RETAIL AND WHOLESALE STORE SERVICES FEATURING A WIDE VARIETY OF CONSUMER GOODS; PROVIDING CONSUMER PRODUCT INFORMATION VIA THE INTERNET OR OTHER COMMUNICATIONS NETWORKS; COMPUTERIZED ONLINE ORDERING SERVICES FEATURING A WIDE VARIETY OF CONSUMER GOODS (U.S. CLS. 100, 101 AND 102).

THEODORE MCBRIDE, EXAMINING ATTORNEY

**CLASS 35—(Continued).**

SN 86-217,242. OPAL TECHNOLOGIES, INCORPORATED, DBA OPALSTAFF, MILLERSVILLE, MD. FILED 3-11-2014.



THE COLOR(S) BLACK AND GREEN IS/ARE CLAIMED AS A FEATURE OF THE MARK.

THE MARK CONSISTS OF THE FOLLOWING: THE WORD "OPALSTAFF" IN BLACK FOLLOWED BY A SIMPLE FIGURE OF A PERSON IN GREEN RAISING HIS HANDS WHILE BENT AT THE KNEES.

FOR EMPLOYMENT HIRING, RECRUITING, PLACEMENT, STAFFING AND CAREER NETWORKING SERVICES; EMPLOYMENT RECRUITING CONSULTATION; EXECUTIVE RECRUITING SERVICES; PERSONNEL PLACEMENT AND RECRUITMENT; PERSONNEL RECRUITMENT SERVICES AND EMPLOYMENT AGENCIES; PROFESSIONAL STAFFING AND RECRUITING SERVICES (U.S. CLS. 100, 101 AND 102).

FIRST USE 4-1-2002; IN COMMERCE 4-1-2002.  
ANNE MADDEN, EXAMINING ATTORNEY

**CLASS 35—(Continued).**

SN 86-218,535. LIBERTY NATIONAL LIFE INSURANCE COMPANY, MCKINNEY, TX. FILED 3-12-2014.

LIBERTY NATIONAL DISCOUNT  
CARD

THE MARK CONSISTS OF STANDARD CHARACTERS WITHOUT CLAIM TO ANY PARTICULAR FONT, STYLE, SIZE, OR COLOR.

OWNER OF U.S. REG. NO. 2,407,770.

NO CLAIM IS MADE TO THE EXCLUSIVE RIGHT TO USE "DISCOUNT CARD", APART FROM THE MARK AS SHOWN.

SEC. 2(F) 2(F) AS TO "NATIONAL".

FOR PROVIDING DISCOUNTS AT PARTICIPATING ESTABLISHMENTS OF OTHERS IN THE FIELDS OF VISION, CHIROPRACTIC, PHARMACY, HEARING AND DENTAL THROUGH THE PRESENTATION OF A MEMBERSHIP CARD; MAIL ORDER SERVICES FEATURING PHARMACEUTICALS (U.S. CLS. 100, 101 AND 102).

JOHN WILKE, EXAMINING ATTORNEY

SN 86-219,068. ACTIVELIGHT, INC., NAPLES, FL. FILED 3-12-2014.

activelight

THE MARK CONSISTS OF STANDARD CHARACTERS WITHOUT CLAIM TO ANY PARTICULAR FONT, STYLE, SIZE, OR COLOR.

FOR ADVERTISING AND MARKETING; ADVERTISING AND MARKETING SERVICES, NAMELY, PROMOTING THE GOODS AND SERVICES OF OTHERS; ADVERTISING SERVICES, NAMELY, PROMOTING AND MARKETING THE GOODS AND SERVICES OF OTHERS THROUGH ALL PUBLIC COMMUNICATION MEANS; ADVERTISING, MARKETING AND PROMOTING THE GOODS AND SERVICES OF OTHERS USING KIOSKS; ADVERTISING, MARKETING AND PROMOTION SERVICES, NAMELY, PROMOTING THE GOODS AND SERVICES OF OTHERS BY PROVIDING CUSTOMIZED EXHIBITS; ADVERTISING, MARKETING, AND PROMOTING THE GOODS AND SERVICES OF OTHERS VIA DIGITAL SIGNAGE, KIOSKS, ELECTRONIC SCREENS, TELEVISION; MARKETING CONSULTING; PROMOTING AND MARKETING THE GOODS AND SERVICES OF OTHERS BY TELEVISION, DIGITAL SIGNAGE, MULTIMEDIA; PROVIDING MARKETING AND PROMOTION OF SPECIAL EVENTS (U.S. CLS. 100, 101 AND 102).

FIRST USE 2-11-2014; IN COMMERCE 2-11-2014.  
ANTHONY RINKER, EXAMINING ATTORNEY

SN 86-218,526. EDWARD M EDWARDS, PRATTVILLE, AL. FILED 3-12-2014.

Right Now Sales & Leasing

THE MARK CONSISTS OF STANDARD CHARACTERS WITHOUT CLAIM TO ANY PARTICULAR FONT, STYLE, SIZE, OR COLOR.

NO CLAIM IS MADE TO THE EXCLUSIVE RIGHT TO USE "SALES & LEASING", APART FROM THE MARK AS SHOWN.

FOR RETAIL STORE SERVICES IN THE FIELD OF FURNITURE, APPLIANCES, COMPUTERS AND ELECTRONICS THAT CAN BE PURCHASED UNDER A RENT-TO-OWN CONTRACT (U.S. CLS. 100, 101 AND 102).

PAUL CROWLEY, EXAMINING ATTORNEY

**CLASS 35—(Continued).**

SN 86-219,962. MEDAFFORD GLOBAL INC, FLORHAM PARK, NJ. FILED 3-13-2014.



MEDAFFORDGLOBAL

NO CLAIM IS MADE TO THE EXCLUSIVE RIGHT TO USE MEDICAL CROSS DESIGN, APART FROM THE MARK AS SHOWN.

THE MARK CONSISTS OF AN IMAGE OF AN EARTH GLOBE BEHIND THE STYLIZED LETTERS "MG" AND THE IMAGE OF A MEDICAL CROSS, WITH AN ARROW SWOOPING AROUND THE GLOBE, AND THE WORDS "MEDAFFORDGLOBAL". A SHADOW IS FEATURED BELOW THE GLOBE DESIGN AND A VERTICAL LINE SEPARATES THE WORDING "MG" AND THE WORDING "MEDAFFORDGLOBAL".

FOR ADVERTISING SERVICES, NAMELY, PROMOTING AND MARKETING THE GOODS AND SERVICES OF OTHERS IN THE FIELD OF MEDICAL TOURISM VIA PRINT AND ELECTRONIC MEDIA (U.S. CLS. 100, 101 AND 102).

FIRST USE 7-1-2011; IN COMMERCE 7-1-2011.

JULIE VEPPUMTHARA, EXAMINING ATTORNEY

SN 86-220,664. DAY RAMPHAL, HAPEVILLE, GA. AND THOMAS SCHOMAKER, HAPEVILLE, GA. FILED 3-13-2014.

# Psycho Sisters

THE MARK CONSISTS OF STANDARD CHARACTERS WITHOUT CLAIM TO ANY PARTICULAR FONT, STYLE, SIZE, OR COLOR.

FOR ON-LINE CONSIGNMENT SERVICES WHEREBY GOODS ARE RECEIVED ON CONSIGNMENT FOR AUCTION ON AN ONLINE AUCTION SITE; ON-LINE CONSIGNMENT SERVICES WHEREBY GOODS ARE RECEIVED ON CONSIGNMENT IN ON-LINE RETAIL STORES FEATURING CLOTHING; ON-LINE RETAIL CONSIGNMENT STORES FEATURING CLOTHING; RETAIL CONSIGNMENT STORES FEATURING CLOTHING; RETAIL CONSIGNMENT STORES IN THE FIELD OF CLOTHING (U.S. CLS. 100, 101 AND 102).

FIRST USE 1-20-2014; IN COMMERCE 1-20-2014.

KATHERINE CONNOLLY, EXAMINING ATTORNEY

**CLASS 35—(Continued).**

SN 86-220,837. TRACTOR SUPPLY CO. OF TEXAS, LP, BRENTWOOD, TN. FILED 3-13-2014.

# P.A.W.

THE MARK CONSISTS OF STANDARD CHARACTERS WITHOUT CLAIM TO ANY PARTICULAR FONT, STYLE, SIZE, OR COLOR.

FOR PROMOTING PUBLIC AWARENESS OF THE NEED FOR ANIMAL ADOPTION, ANIMAL RESCUE, RESPONSIBLE PET OWNERSHIP, AND THE PROPER CARE, TREATMENT, AND TRAINING OF PETS; PROVIDING CONSUMER INFORMATION IN THE FIELD OF PETS, NAMELY, PET-RELATED PRODUCTS, PET TREATS, PET TOYS, AND PET ADOPTION (U.S. CLS. 100, 101 AND 102).

FIRST USE 5-0-2011; IN COMMERCE 5-0-2011.

DANIEL S. STRINGER, EXAMINING ATTORNEY

SN 86-220,845. TRACTOR SUPPLY CO. OF TEXAS, LP, BRENTWOOD, TN. FILED 3-13-2014.



OWNER OF U.S. REG. NOS. 884,786, 3,014,654 AND OTHERS.

NO CLAIM IS MADE TO THE EXCLUSIVE RIGHT TO USE "PET APPRECIATION WEEK", APART FROM THE MARK AS SHOWN.

THE MARK CONSISTS OF THE IMAGE OF A PAW PRINT WITH A BANNER DISPLAYING THE WORDS "PET APPRECIATION WEEK" SUPERIMPOSED OVER THE UPPER PORTION OF THE PAW DESIGN AND THE LETTERS "P.A.W." APPEARING IN THE CENTER OF THE PAW DESIGN WITH A PAW PRINT APPEARING WITHIN THE LETTER "A". THE BOTTOM OF THE PAW DESIGN IS COMPOSED OF A DOG COLLAR IMAGE WITH THE LETTERS "TSC" APPEARING ON A DOG TAG HANGING FROM THE DOG COLLAR.

FOR PROMOTING PUBLIC AWARENESS OF THE NEED FOR ANIMAL ADOPTION, ANIMAL RESCUE, RESPONSIBLE PET OWNERSHIP, AND THE PROPER CARE, TREATMENT, AND TRAINING OF PETS; PROVIDING CONSUMER INFORMATION IN THE FIELD OF PETS, NAMELY, PET-RELATED PRODUCTS, PET TREATS, PET TOYS, AND PET ADOPTION (U.S. CLS. 100, 101 AND 102).

FIRST USE 6-0-2013; IN COMMERCE 6-0-2013.

DANIEL S. STRINGER, EXAMINING ATTORNEY

**CLASS 35—(Continued).**

SN 86-220,951. EAGLES CLUB ORGANIZATION CORPORATION, MIAMI, FL. FILED 3-14-2014.



NO CLAIM IS MADE TO THE EXCLUSIVE RIGHT TO USE "CLUB", APART FROM THE MARK AS SHOWN.

THE MARK CONSISTS OF A DOUBLE HEADED EAGLE WITHIN A CROSS. THERE IS A CROWN ON TOP OF THE DOUBLE HEADED EAGLE AND A CIRCLE BETWEEN THE EAGLE AND THE CROSS. THE EAGLE IS HOLDING A BALL IN EACH CLAW. THERE IS A RIBBON BELOW THE CROSS WITH THE WORDS "EAGLES CLUB" IN THE CENTER OF IT. BELOW THE RIBBON ARE THE WORDS "P2P SMILE TECHNOLOGY".

FOR OPERATING ON-LINE MARKETPLACES FOR SELLERS AND BUYERS OF GOODS AND/OR SERVICES; PROVIDING A WEBSITE FEATURING AN ON-LINE MARKETPLACE FOR EXCHANGING GOODS AND SERVICES WITH OTHER USERS (U.S. CLS. 100, 101 AND 102).

KIMBERLY FRYE, EXAMINING ATTORNEY

**CLASS 35—(Continued).**

SN 86-221,045. INSPIREHUB, INC., DALLAS, TX. FILED 3-14-2014.

inspirehub

THE MARK CONSISTS OF THE STYLIZED WORDING "INSPIREHUB" WHEREIN THE LETTER "U" APPEARS AS THE DEPICTION OF STYLIZED PERSON WITH OUT-STRETCHED ARMS.

FOR BUSINESS CONSULTING SERVICES FOR CHARITABLE ORGANIZATIONS, NAMELY, ASSISTING OTHERS IN THE ESTABLISHMENT OF CHARITABLE ORGANIZATIONS, PROMOTION AND MARKETING SERVICES AND RELATED MARKETING CONSULTING FOR CHARITABLE ORGANIZATIONS, PROMOTIONAL SERVICES IN THE FIELD OF PLANNED-GIVING FOR NON-PROFIT AND CHARITABLE ORGANIZATIONS, ASSISTING CHARITABLE ORGANIZATIONS WITH BUSINESS MANAGEMENT AND PLANNING, BUSINESS MANAGEMENT CONSULTING, STRATEGIC PLANNING AND BUSINESS ADVISORY SERVICES PROVIDED TO NON-PROFIT CHARITABLE ORGANIZATIONS; BUSINESS SERVICES, NAMELY, PROVIDING ACCOUNTING SERVICES TO CHARITABLE FUNDRAISING ORGANIZATIONS (U.S. CLS. 100, 101 AND 102).

FIRST USE 7-15-2013; IN COMMERCE 7-15-2013.

MICHAEL TANNER, EXAMINING ATTORNEY

SN 86-221,052. SEMPITERNA, LLC, MONROE, LA. FILED 3-14-2014.

The Original Bayou Bobby

THE MARK CONSISTS OF STANDARD CHARACTERS WITHOUT CLAIM TO ANY PARTICULAR FONT, STYLE, SIZE, OR COLOR.

THE NAME(S), PORTRAIT(S), AND/OR SIGNATURE(S) SHOWN IN THE MARK DOES NOT IDENTIFY A PARTICULAR LIVING INDIVIDUAL.

FOR ADVERTISING AGENCY SPECIALIZING IN THE DESIGN AND EXECUTION OF WORD OF MOUTH, VIRAL, BUZZ AND EXPERIENTIAL MARKETING PROGRAMS; ADVERTISING AND MARKETING; ADVERTISING AND MARKETING CONSULTANCY; ADVERTISING AND MARKETING SERVICES PROVIDED BY MEANS OF INDIRECT METHODS OF MARKETING COMMUNICATIONS, NAMELY, SOCIAL MEDIA, SEARCH ENGINE MARKETING, INQUIRY MARKETING, INTERNET MARKETING, MOBILE MARKETING, BLOGGING AND OTHER FORMS OF PASSIVE, SHARABLE OR VIRAL COMMUNICATIONS CHANNELS; ADVERTISING AND MARKETING SERVICES, NAMELY, PROMOTING THE GOODS AND SERVICES OF OTHERS; ADVERTISING SERVICES, NAMELY, PROMOTING AND MARKETING THE GOODS AND SERVICES OF OTHERS IN THE FIELD OF BUSINESS VIA PRINT AND ELECTRONIC MEDIA; ADVERTISING SERVICES, NAMELY, PROMOTING AND MARKETING THE GOODS AND SERVICES OF OTHERS THROUGH ALL PUBLIC COMMUNICATION MEANS; ADVERTISING, MARKETING AND PROMOTION SERVICES (U.S. CLS. 100, 101 AND 102).

PATRICIA EVANKO, EXAMINING ATTORNEY

SN 86-220,961. LH TECHNOLOGIES, LLC, DBA QWERKE, SANDY, UT. FILED 3-14-2014.

Qwerke

THE MARK CONSISTS OF STANDARD CHARACTERS WITHOUT CLAIM TO ANY PARTICULAR FONT, STYLE, SIZE, OR COLOR.

FOR CAREER PLACEMENT CONSULTING SERVICES; CAREER PLANNING SERVICES; EMPLOYMENT HIRING, RECRUITING, PLACEMENT, STAFFING AND CAREER NETWORKING SERVICES; EMPLOYMENT RECRUITING CONSULTATION (U.S. CLS. 100, 101 AND 102).

KAELIE KUNG, EXAMINING ATTORNEY

**CLASS 35—(Continued).**

SN 86-221,103. VAPEDAY, LLC, SANTA MONICA, CA. FILED 3-14-2014.



NO CLAIM IS MADE TO THE EXCLUSIVE RIGHT TO USE "PREMIUM E-CIGS", APART FROM THE MARK AS SHOWN.

THE MARK CONSISTS OF "VAPEDAY" AND A CIRCULAR ICON TO THE TOP RIGHT AND "PREMIUM E-CIGS & MORE" BELOW ALL STYLIZED FONT.

FOR ON-LINE RETAIL STORE SERVICES FEATURING ELECTRONIC CIGARETTES, E-LIQUID AND ACCESSORIES (U.S. CLS. 100, 101 AND 102).

FIRST USE 1-1-2014; IN COMMERCE 1-1-2014.

GILBERT SWIFT, EXAMINING ATTORNEY

**CLASS 35—(Continued).**

SN 86-222,042. THERESE MANCINI AND ANGELA WHEELER, MARLTON, NJ. FILED 3-14-2014.

## Gimme Delights

THE MARK CONSISTS OF STANDARD CHARACTERS WITHOUT CLAIM TO ANY PARTICULAR FONT, STYLE, SIZE, OR COLOR.

FOR MOBILE STREET VENDOR SERVICES FEATURING ICE CREAM AND BAKED GOODS ALLOWING PARTICIPANTS TO CREATE CUSTOM SUNDAES AND CUPCAKES (U.S. CLS. 100, 101 AND 102).

TASHIA BUNCH, EXAMINING ATTORNEY

SN 86-221,891. ONE INC., SALINA, KS. FILED 3-14-2014.

The logo for ONE CITY features the word "ONE" in a large, bold, serif font. Below "ONE" is the word "CITY" in a smaller, bold, serif font.

THE MARK CONSISTS OF THE STYLIZED WORDING "ONE CITY".

FOR BUSINESS SERVICES, NAMELY, PROVIDING AN ONLINE NETWORK FOR CONTRACTORS TO RECEIVE BIDDING OPPORTUNITIES BY MEANS OF AN ONLINE MARKETPLACE FOR THE PURPOSE OF DEVELOPING BUSINESS FOR SUSTAINABLE RELATED BUILDING PRODUCTS; BUSINESS SERVICES, NAMELY, PROVIDING AN ONLINE NETWORK FOR CONTRACTORS TO RECEIVE BIDDING OPPORTUNITIES BY MEANS OF AN ONLINE MARKETPLACE FOR THE PURPOSE OF DEVELOPING BUSINESS IN THE REAL ESTATE, HEALTHCARE, TRAVEL, LEISURE, COMMUNICATIONS, ENERGY, ENVIRONMENTAL, AND TECHNOLOGY INDUSTRY; BUSINESS SERVICES, NAMELY, PROVIDING AN ONLINE NETWORK FOR CONTRACTORS TO RECEIVE BIDDING OPPORTUNITIES FROM SENIORS AND VETERANS BY MEANS OF AN ONLINE MARKETPLACE (U.S. CLS. 100, 101 AND 102).

B. PARADEWELAI, EXAMINING ATTORNEY

SN 86-222,366. TOWN OF WARRENTON, WARRENTON, NC. FILED 3-15-2014.

## HISTORY WORTH REPEATING

THE MARK CONSISTS OF STANDARD CHARACTERS WITHOUT CLAIM TO ANY PARTICULAR FONT, STYLE, SIZE, OR COLOR.

FOR CONVENTION AND VISITORS BUREAU SERVICES, NAMELY, PROMOTING TOURISM, BUSINESS, RECREATION AND THE HOLDING OF CONVENTIONS IN THE NORTH CAROLINA TOWNS OF EDENTON, HALIFAX, HILLSBOROUGH, MURFREESBORO, AND WARRENTON (U.S. CLS. 100, 101 AND 102).

JEAN IM, EXAMINING ATTORNEY

**CLASS 35—(Continued).**

SN 86-222,650. SYNOPTOS INC., DBA SYNOPTOS, RESTON, VA. FILED 3-17-2014.



NO CLAIM IS MADE TO THE EXCLUSIVE RIGHT TO USE "INTELLIGENCE", APART FROM THE MARK AS SHOWN.

THE COLOR(S) RED, ORANGE, GOLD, GREEN, TURQUOISE, BLUE, AND DARK GREY IS/ARE CLAIMED AS A FEATURE OF THE MARK.

THE MARK CONSISTS OF A FIBONACCI CONCENTRIC CIRCLES DESIGN COMPRISING A SPIRAL IN THE COLORS, FROM INTERIOR TO EXTERIOR, RED, ORANGE, GOLD, GREEN, TURQUOISE, AND BLUE. TO THE RIGHT OF THE SPIRAL IS THE WORD "SYNOPTOS" IN DARK GREY, BENEATH WHICH IS THE WORDING "FOCUSED INTELLIGENCE" IN TURQUOISE. THE WHITE IS NOT PART OF THE MARK AND REPRESENTS BACKGROUND AREA.

FOR ON-LINE BUSINESS RESEARCH SERVICE THAT ALLOWS THE USER TO ANALYZE OPINION TRENDS CONTAINED IN DOCUMENTS ON THE INTERNET; ONLINE MEDIA MONITORING SERVICES USING COMPUTER SOFTWARE TO AUTOMATICALLY MONITOR INTERNET WEBSITES AND ONLINE PUBLICATIONS FOR CUSTOMER-SPECIFIED TOPICS AND TO CAPTURE RELEVANT CONTENT ON THOSE TOPICS, AND PROVIDING DOCUMENTATION AND ANALYSIS OF THAT ONLINE CONTENT TO OTHERS FOR BUSINESS PURPOSES (U.S. CLS. 100, 101 AND 102).

FIRST USE 1-27-2014; IN COMMERCE 1-27-2014.  
ELLEN B. AWRICH, EXAMINING ATTORNEY

SN 86-222,845. GRANDVIEW ANALYTICS LLC, CHICAGO, IL. FILED 3-17-2014.



NO CLAIM IS MADE TO THE EXCLUSIVE RIGHT TO USE "ANALYTICS", APART FROM THE MARK AS SHOWN.

THE COLOR(S) BLUE AND GREY IS/ARE CLAIMED AS A FEATURE OF THE MARK.

THE MARK CONSISTS OF THE NAME "GRANDVIEW ANALYTICS" THERE ARE 2 INTERSECTING ARROWS THAT REPRESENT AN X/Y AXIS. THE ARROWS AND THE WORD "ANALYTICS" ARE IN 2 DIFFERENT SHADES OF GREY. THE WORD "GRANDVIEW" IS BLUE.

FOR BUSINESS CONSULTING SERVICES RELATING TO THE INTEGRATION OF THE AREAS OF BUSINESS PROCESS TECHNOLOGY, ORGANIZATIONAL LEARNING, CHANGE MANAGEMENT, AND OPERATIONAL SUSTAINABILITY (U.S. CLS. 100, 101 AND 102).

FIRST USE 3-1-2014; IN COMMERCE 3-1-2014.  
CURTIS FRENCH, EXAMINING ATTORNEY

**CLASS 35—(Continued).**

SN 86-222,877. MOSING AUTOSPORT LLC, AUSTIN, TX. FILED 3-17-2014.

**DRIVE YOURSELF HAPPY**

THE MARK CONSISTS OF STANDARD CHARACTERS WITHOUT CLAIM TO ANY PARTICULAR FONT, STYLE, SIZE, OR COLOR.

FOR AUTOMOBILE DEALERSHIP SERVICES FEATURING EXOTIC, PERFORMANCE, AND VINTAGE AUTOMOBILES (U.S. CLS. 100, 101 AND 102).

FIRST USE 6-15-2012; IN COMMERCE 7-15-2012.  
CURTIS FRENCH, EXAMINING ATTORNEY

SN 86-223,050. TYLER CHRISTOPHERSON AND ASSOCIATES, INC, EDINA, MN. FILED 3-17-2014.

**Ty Buys**

THE MARK CONSISTS OF STANDARD CHARACTERS WITHOUT CLAIM TO ANY PARTICULAR FONT, STYLE, SIZE, OR COLOR.

NO CLAIM IS MADE TO THE EXCLUSIVE RIGHT TO USE "BUYS", APART FROM THE MARK AS SHOWN.

FOR AUTOMOBILE PROCUREMENT SERVICES FOR CONSUMERS FEATURING INITIAL AUTOMOBILE PURCHASING CONSULTATION, VEHICLE SEARCH AND SELECTION SERVICES, AND VEHICLE TEST DRIVING SERVICES; PROVIDING CONSUMER PRODUCT INFORMATION ABOUT AUTOMOBILES FOR THE PURPOSE OF SELECTING AUTOMOBILES TO MEET THE PARTICULAR CONSUMER'S SPECIFICATIONS; NEGOTIATING AND CONCLUSION OF AUTOMOBILE PURCHASE TRANSACTIONS FOR THIRD PARTIES (U.S. CLS. 100, 101 AND 102).

FIRST USE 1-1-2011; IN COMMERCE 5-1-2011.  
JEFFERY COWARD, EXAMINING ATTORNEY

SN 86-223,659. SMALL CHANGE COMPANY LLC, AUSTIN, TX. FILED 3-17-2014.

**LUFLI**

THE MARK CONSISTS OF STANDARD CHARACTERS WITHOUT CLAIM TO ANY PARTICULAR FONT, STYLE, SIZE, OR COLOR.

FOR ON-LINE RETAIL STORE SERVICES FEATURING BAGS, HANDBAGS, WALLETS, AND JEWELRY (U.S. CLS. 100, 101 AND 102).

FIRST USE 11-21-2013; IN COMMERCE 11-21-2013.  
ZACHARY R. SPARER, EXAMINING ATTORNEY

**CLASS 35—(Continued).**

SN 86-224,335. THE MACALAN GROUP, INC., COLORADO SPRINGS, CO. FILED 3-18-2014.

The Macalan Group, Inc.

THE MARK CONSISTS OF STANDARD CHARACTERS WITHOUT CLAIM TO ANY PARTICULAR FONT, STYLE, SIZE, OR COLOR.

NO CLAIM IS MADE TO THE EXCLUSIVE RIGHT TO USE "GROUP, INC.", APART FROM THE MARK AS SHOWN.

FOR BUSINESS ADVISORY SERVICES, CONSULTANCY AND INFORMATION; BUSINESS SERVICES, NAMELY, COMBINED STRATEGIC GOODS OR SERVICES SOURCING AND COOPERATIVE PURCHASING FOR OTHERS; BUSINESS SERVICES, NAMELY, PROCURING QUALIFIED AND CREDENTIALLED THIRD-PARTY EXPERTS, PROFESSIONALS AND OTHER QUALIFIED PERSONNEL, AND DOCUMENTATION AND INFORMATION ALL ON BEHALF OF OTHERS; BUSINESS STRATEGIC PLANNING SERVICES; BUSINESS STRATEGY DEVELOPMENT SERVICES (U.S. CLS. 100, 101 AND 102).

FIRST USE 1-1-2013; IN COMMERCE 1-1-2013.  
STEVEN PEREZ, EXAMINING ATTORNEY

**CLASS 35—(Continued).**

SN 86-225,009. MCCLURE INTERACTIVE, LLC, TULSA, OK. FILED 3-18-2014.



NO CLAIM IS MADE TO THE EXCLUSIVE RIGHT TO USE "CHEAPEST VITAMINS.COM", APART FROM THE MARK AS SHOWN.

THE COLOR(S) TURQUOISE, GREEN, WHITE, AND BLACK IS/ARE CLAIMED AS A FEATURE OF THE MARK.

THE MARK CONSISTS OF A WHITE PILL BOTTLE LAYING ON ITS SIDE WITH TURQUOISE AND WHITE PILLS AND GREEN AND WHITE PILLS SPILLING FROM THE BOTTLE. TO THE RIGHT OF THE BOTTLE IS THE STYLIZED WORDING "CHEAPEST" IN TURQUOISE AND "VITAMINS.COM" IN BLACK.

FOR ON-LINE RETAIL STORE SERVICES FEATURING A WIDE VARIETY OF CONSUMER GOODS OF OTHERS (U.S. CLS. 100, 101 AND 102).

FIRST USE 11-30-2011; IN COMMERCE 11-30-2011.  
DAVID ALESKOW, EXAMINING ATTORNEY

SN 86-225,136. BJ'S WHOLESALE CLUB, INC., WESTBOROUGH, MA. FILED 3-18-2014.

**BJ'S EASY RENEWAL**

Grey Haven Media

SN 86-224,954. MARSALA, WAYNE, LIVERMORE, CA. FILED 3-18-2014.

THE MARK CONSISTS OF STANDARD CHARACTERS WITHOUT CLAIM TO ANY PARTICULAR FONT, STYLE, SIZE, OR COLOR.

OWNER OF U.S. REG. NOS. 1,707,164, 4,368,729 AND OTHERS.

NO CLAIM IS MADE TO THE EXCLUSIVE RIGHT TO USE "RENEWAL", APART FROM THE MARK AS SHOWN.

FOR BUSINESS SERVICES, NAMELY, ADMINISTRATION OF MEMBERSHIP RENEWALS FOR WAREHOUSE SHOPPING CLUB MEMBERS (U.S. CLS. 100, 101 AND 102).

ZACHARY R. SPARER, EXAMINING ATTORNEY

THE MARK CONSISTS OF STANDARD CHARACTERS WITHOUT CLAIM TO ANY PARTICULAR FONT, STYLE, SIZE, OR COLOR.

NO CLAIM IS MADE TO THE EXCLUSIVE RIGHT TO USE "MEDIA", APART FROM THE MARK AS SHOWN.

FOR MANAGEMENT OF PERFORMING AND RECORDING ARTISTS (U.S. CLS. 100, 101 AND 102).

DANNEAN HETZEL, EXAMINING ATTORNEY



**CLASS 35—(Continued).**

SN 86-225,340. WEDDINGWIRE, INC., CHEVY CHASE, MD.  
FILED 3-19-2014.



OWNER OF U.S. REG. NOS. 3,316,183 AND 3,536,449.  
THE MARK CONSISTS OF A STYLIZED DESIGN OF A  
FLOWER BOUQUET.

FOR OPERATING ON-LINE MARKETPLACES FOR  
SELLERS AND BUYERS OF GOODS AND/OR SERVICES  
(U.S. CLS. 100, 101 AND 102).

FIRST USE 1-31-2006; IN COMMERCE 1-31-2006.  
JASON MALASHEVICH, EXAMINING ATTORNEY

SN 86-225,378. THE ATTILIO GROUP, LLC, RACINE, WI.  
FILED 3-19-2014.

**TAG**

THE MARK CONSISTS OF STANDARD CHARACTERS  
WITHOUT CLAIM TO ANY PARTICULAR FONT, STYLE,  
SIZE, OR COLOR.

OWNER OF U.S. REG. NOS. 3,596,156 AND 3,596,157.  
FOR ACCOUNTING ADVISORY SERVICES; BOOK-  
KEEPING; ADMINISTRATION, BILLING AND RECON-  
CILIATION OF ACCOUNTS ON BEHALF OF OTHERS;  
PROVIDING OFFICE SUPPORT STAFF SERVICES; PAY-  
ROLL ADMINISTRATION AND MANAGEMENT SER-  
VICES; ESTIMATING OF CONTRACTING WORK;  
BUSINESS ADMINISTRATION SERVICES, NAMELY,  
ADMINISTRATIVE PROCESSING OF PURCHASE OR-  
DERS AND DISBURSEMENTS (U.S. CLS. 100, 101 AND  
102).

FIRST USE 8-0-2008; IN COMMERCE 8-0-2008.  
SETH A. RAPPAPORT, EXAMINING ATTORNEY

SN 86-225,570. DOT COM INTERNET SPORTS, LLC, DBA  
WARCHANT.COM, TALLAHASSEE, FL. FILED 3-19-2014.

THE COLOR(S) GOLD, BLACK, WHITE, RED, GRAY,  
ORANGE, AND YELLOW IS/ARE CLAIMED AS A FEAT-  
URE OF THE MARK.

THE MARK CONSISTS OF THE STYLIZED TEXT

**CLASS 35—(Continued).**

"WARCHANT.COM" WHERE THE INITIAL CAPITAL "W"  
IS OUTLINED IN GOLD AND CONTAINS A DESIGN OF  
AN INDIAN FACE WITH BLACK HAIR AND WHITE AND  
GOLD FACIAL PAINT WEARING A WHITE OUTFIT WITH  
A GOLD COLLAR AND A RED AND BLACK HEADRESS  
WITH GOLD TRIM AND GRAY, GOLD, AND RED  
FEATHERS, THE DESIGN HAVING AN ORANGE AND  
YELLOW FLAME BACKGROUND; THE REMAINING  
LOWER-CASE LETTERS AND DOT SYMBOL ARE IN  
GOLD AND OUTLINED IN RED.

FOR ADVERTISING AND PUBLICITY SERVICES,  
NAMELY, PROMOTING THE GOODS, SERVICES,  
BRAND IDENTITY AND COMMERCIAL INFORMA-  
TION AND NEWS OF THIRD PARTIES THROUGH ON-  
LINE MEDIUM; MAIL ORDER CATALOG SERVICES  
FEATURING SPORTS LOGO CLOTHING (U.S. CLS. 100,  
101 AND 102).

FIRST USE 3-1-1999; IN COMMERCE 3-15-1999.  
KEVIN MITTLER, EXAMINING ATTORNEY

SN 86-225,646. MOMBACHO CIGARS, S.A., GRANADA,  
NICARAGUA, FILED 3-19-2014.

**TIERRA VOLCAN**

THE MARK CONSISTS OF STANDARD CHARACTERS  
WITHOUT CLAIM TO ANY PARTICULAR FONT, STYLE,  
SIZE, OR COLOR.

THE ENGLISH TRANSLATION OF "TIERRA VOLCAN"  
IN THE MARK IS "LAND VOLCANO".

FOR ON-LINE RETAIL STORE SERVICES FEATUR-  
ING MATCHES, CIGAR CUTTERS, ASHTRAYS, BEV-  
ERAGE COASTERS, SHIRTS, BASEBALL CAPS,  
TOQUES AND HATS; WHOLESALE ORDERING SER-  
VICES IN THE FIELD OF CIGARS, MATCHES, CIGAR  
CUTTERS, ASHTRAYS, BEVERAGE COASTERS,  
SHIRTS, BASEBALL CAPS, TOQUES AND HATS (U.S.  
CLS. 100, 101 AND 102).

ANNE E. GUSTASON, EXAMINING ATTORNEY

**CLASS 35—(Continued).**

SN 86-225,648. GREY GLOBAL GROUP INC., NEW YORK, NY. FILED 3-19-2014.

**GREY FAMOUSLY EFFECTIVE  
SINCE 1917**

THE MARK CONSISTS OF STANDARD CHARACTERS WITHOUT CLAIM TO ANY PARTICULAR FONT, STYLE, SIZE, OR COLOR.

OWNER OF U.S. REG. NOS. 1,913,691, 4,099,342 AND OTHERS.

NO CLAIM IS MADE TO THE EXCLUSIVE RIGHT TO USE "SINCE 1917", APART FROM THE MARK AS SHOWN.

FOR ADVERTISING AGENCY SERVICES; MARKETING SERVICES; MARKETING COMMUNICATION SERVICES; MARKET RESEARCH SERVICES; PUBLIC RELATIONS SERVICES; DIRECT MAIL ADVERTISING SERVICES; DIRECT MARKETING SERVICES; BUSINESS MARKETING SERVICES; DEVELOPMENT OF MARKETING STRATEGIES AND CONCEPTS FOR OTHERS; CREATING CORPORATE AND BRAND IDENTITIES FOR OTHERS; BRAND STRATEGY CONSULTATION SERVICES IN THE FIELD OF BRAND CREATION AND DEVELOPMENT; BUSINESS RESEARCH SERVICES, NAMELY, PROVIDING ANALYSIS OF DATA IN THE FIELD OF BRAND STRATEGY; SALES PROMOTION SERVICES, NAMELY, PROMOTING THE GOODS AND SERVICES OF OTHERS, ARRANGING AND CONDUCTING PROMOTIONAL MARKETING EVENTS FOR OTHERS; MEDIA PLANNING, NAMELY, MEDIA PLANNING, NAMELY, ADVISING CLIENTS ON TIMES, VENUES, AND MEDIA IN WHICH TO ADVERTISE THEIR PRODUCTS AND SERVICES BASED ON MEDIA ANALYSIS OF THE MARKET FOR THAT MEDIA AND SECURING OF ADVERTISING MEDIA SPACE AND AIRTIME FOR OTHERS; CONDUCTING MARKET AND MEDIA RESEARCH SERVICES FOR OTHERS FOR MARKETING AND ADVERTISING PURPOSES; INTERNET ADVERTISING SERVICES (U.S. CLS. 100, 101 AND 102).

FIRST USE 3-7-2014; IN COMMERCE 3-7-2014.

ANNE E. GUSTASON, EXAMINING ATTORNEY

SN 86-225,749. ENVISION PHARMACEUTICAL HOLDINGS LLC, TWINSBURG, OH. FILED 3-19-2014.



NO CLAIM IS MADE TO THE EXCLUSIVE RIGHT TO USE "PHARMACEUTICAL SERVICES", APART FROM THE MARK AS SHOWN.

THE MARK CONSISTS OF A CIRCLE WITH TWO PROGRESSIVELY LARGER CRESCENT SHAPES UNDERNEATH; THE WORD "ORCHARD" APPEARS TO THE RIGHT SIDE OF THE DESIGN WITH THE WORDS "PHARMACEUTICAL SERVICES" UNDERNEATH.

FOR MAIL ORDER PHARMACY SERVICES (U.S. CLS. 100, 101 AND 102).

FIRST USE 4-1-2013; IN COMMERCE 4-1-2013.

GRETTA YAO, EXAMINING ATTORNEY

**CLASS 35—(Continued).**

SN 86-225,928. CTR MARKETING, LLC, CHARLESTON, MO. FILED 3-19-2014.

## Extreme Man Cave

THE MARK CONSISTS OF STANDARD CHARACTERS WITHOUT CLAIM TO ANY PARTICULAR FONT, STYLE, SIZE, OR COLOR.

FOR AD SERVING, NAMELY, PLACING ADVERTISEMENTS ON WEBSITES FOR OTHERS USING SPECIALIZED COMPUTER SOFTWARE; ADVERTISING AND DIRECTORY SERVICES, NAMELY, PROMOTING THE SERVICES OF OTHERS BY PROVIDING A WEB PAGE FEATURING LINKS TO THE WEBSITES OF OTHERS; ADVERTISING SERVICES, NAMELY, PROVIDING A WEBSITE FOR THE PROMOTION OF THE BOOKS OF OTHERS IN THE FIELD OF LAW, INCLUDING NEWS AND REVIEWS REGARDING SAME; CHARITABLE SERVICES, NAMELY, PROVIDING A FREE ONLINE RESOURCE IN THE NATURE OF A WEBSITE FOR CONNECTING PEOPLE WHO HAVE SERVICE NEEDS WITH PEOPLE WHO ARE WILLING TO PROVIDE VOLUNTEER SERVICES; MAGAZINE ADVERTISING; MAGAZINE SUBSCRIPTION AND FULFILLMENT SERVICES RELATING TO MAGAZINES OF INTEREST TO MEN; MAIL ORDER SERVICES FEATURING MAGAZINES OF INTEREST TO MEN; MARKETING SERVICES IN THE NATURE OF PROVIDING HYPERLINKS TO WEBSITES OF OTHERS, AND BY DISTRIBUTING COUPONS AND REBATES; MARKETING THE GOODS AND SERVICES OF OTHERS BY PROVIDING HYPERLINKS TO WEBSITES OF OTHERS, AND BY DISTRIBUTING COUPONS AND REBATES; ON-LINE PROMOTION OF COMPUTER NETWORKS AND WEBSITES; ON-LINE RETAIL STORE SERVICES FEATURING DOWNLOADABLE MAGAZINES AND BOOKS OF INTEREST TO MEN; ONLINE MEDIA MONITORING SERVICES USING COMPUTER SOFTWARE TO AUTOMATICALLY MONITOR INTERNET WEBSITES AND ONLINE PUBLICATIONS FOR CUSTOMER-SPECIFIED TOPICS AND TO CAPTURE RELEVANT CONTENT ON THOSE TOPICS, AND PROVIDING DOCUMENTATION AND ANALYSIS OF THAT ONLINE CONTENT TO OTHERS FOR BUSINESS PURPOSES; PROMOTING AND MARKETING THE GOODS AND SERVICES OF OTHERS BY PROVIDING HYPERLINKS TO WEBSITES OF OTHERS, AND BY DISTRIBUTING COUPONS AND REBATES; PROMOTING THE GOODS AND SERVICES OF OTHERS BY PREPARING AND PLACING ADVERTISEMENTS IN AN ELECTRONIC MAGAZINE ACCESSED THROUGH A GLOBAL COMPUTER NETWORK; PROMOTING THE GOODS AND SERVICES OF OTHERS BY PROVIDING A WEBSITE FEATURING COUPONS, REBATES, PRICE-COMPARISON INFORMATION, PRODUCT REVIEWS, LINKS TO THE RETAIL WEBSITES OF OTHERS, AND DISCOUNT INFORMATION; PROMOTING THE GOODS AND SERVICES OF OTHERS BY PROVIDING A WEBSITE FEATURING DISCOUNT VOUCHERS, REBATES, AND PROVIDING HYPERLINKS TO WEBSITES OF OTHERS; PROMOTING THE GOODS AND SERVICES OF OTHERS BY PROVIDING AN INTERACTIVE WEBSITE WHERE USERS CAN INCREASE THE CURRENT VALUE OF AN ONLINE DISCOUNT BEING OFFERED BY PURCHASING THE GOODS AND SERVICES ASSOCIATED WITH THAT DISCOUNT IN THE FORM OF AN ONLINE COUPON, VOUCHER OR GIFT CARD; PROMOTING THE GOODS AND SERVICES OF OTHERS BY PROVIDING HYPERLINKS TO WEBSITES OF OTHERS, AND BY DISTRIBUTING COUPONS AND REBATES; PROMOTING, ADVERTISING AND MARKETING OF THE BRANDS, PRODUCTS, SERVICES AND ONLINE WEBSITES OF INDIVIDUALS, BUSINESSES AND NON-PROFIT ORGANIZATIONS; PROMOTION, ADVERTISING AND MARKETING OF ON-LINE WEBSITES; PROMOTIONAL SERVICES, NAMELY, PROVIDING A WEBSITE FEATURING THE ONLINE PORTFOLIO OF ARTISTS TO SHOWCASE THEIR TALENT; PROVIDING A JOB-READINESS AND CAREER-DEVELOPMENT WEBSITE FEATURING INFORMATION FOR COLLEGI-

**CLASS 35—(Continued).**

ATE ATHLETES THAT HAVE GRADUATED OR WHO ARE GRADUATING; PROVIDING A SEARCHABLE ONLINE ADVERTISING WEBSITE AND GUIDE FEATURING THE GOODS AND SERVICES OF OTHER VENDORS VIA THE INTERNET; PROVIDING A SEARCHABLE WEBSITE FEATURING THE GOODS AND SERVICES OF OTHER VENDORS; PROVIDING A WEBSITE FEATURING A SEARCHABLE DATABASE OF INVESTORS FOR USE BY INVENTORS; PROVIDING A WEBSITE FEATURING COMPANY PROFILES ENTREPRENEURS CAN USE TO ATTRACT VENTURE CAPITAL; PROVIDING A WEBSITE FEATURING INFORMATION ABOUT POLITICAL ISSUES; PROVIDING A WEBSITE FEATURING INFORMATION FOR CONSUMERS IN THE FIELD OF PET FOOD, PET TREATS AND PET TOYS FOR PARTICULAR PET BREEDS; PROVIDING A WEBSITE FEATURING PRODUCTS AND SERVICES RATINGS OF OTHERS IN THE FIELD OF HOME CONTRACT SERVICES RECOMMENDED BY CONSUMERS; PROVIDING A WEBSITE FEATURING PUBLIC POLICY INFORMATION IN THE FIELD OF TAX REFORM AND TAX POLICY; PROVIDING A WEBSITE FEATURING THE RATINGS, REVIEWS AND RECOMMENDATIONS POSTED BY CONSUMERS ON RESTAURANTS, FOOD AND WINE FOR COMMERCIAL PURPOSES; PROVIDING A WEBSITE FOR CONNECTING SELLERS WITH BUYERS; PROVIDING A WEBSITE FOR DENTAL PRACTICE MANAGEMENT AND ADMINISTRATIVE SUPPORT SERVICES TO INDIVIDUAL DENTISTS OR GROUP PRACTICES; PROVIDING A WEBSITE FOR MANAGING, CONDUCTING AND ORGANIZING ONLINE AUCTIONS THAT ARE DESIGNED TO RAISE MONEY FOR SELECTED CHARITIES; PROVIDING A WEBSITE FOR USERS WITH SPECIFIC INFORMED RECOMMENDATIONS OF SPECIFIC CONSUMER PRODUCTS AND SERVICES VALIDATED BY THE USERS' INPUTTED PREFERENCES AND SOCIAL NETWORK; PROVIDING A WEBSITE THROUGH WHICH ANIMAL RESCUE PROVIDERS AND AIRLINE OWNERS AND PILOTS CAN CONNECT TO EACH OTHER TO ARRANGE AND DISCUSS THE RESCUE AND DELIVERY OF ANIMALS; PROVIDING A WEBSITE THROUGH WHICH PROPERTY LESSORS CAN REVIEW PROSPECTIVE TENANTS' APPLICATION INFORMATION; PROVIDING ADVERTISING SPACE IN PERIODICALS, NEWSPAPERS AND MAGAZINES; PROVIDING ADVERTISING, MARKETING AND PROMOTIONAL SERVICES, NAMELY, DEVELOPMENT OF ADVERTISING CAMPAIGNS PROVIDED THROUGH CABLE TELEVISION BROADCAST, WEB CASTS, RADIO BROADCASTS, NEWSPAPERS, MAGAZINES, ONLINE BANNERS, OUTDOOR BILLBOARDS, WILD POSTINGS, BUS AND SUBWAY ADS; PROVIDING AN INTERACTIVE WEBSITE FOR USERS TO REVIEW AND RATE INTERNET CONTENT, PEOPLE, COMPANIES, PRODUCTS AND/OR SERVICES IN EXCHANGE FOR POINTS EARNED FOR PROMOTIONAL ITEMS CONSISTING OF COUPONS, REBATES, DISCOUNTS OR SPECIAL OFFERINGS ON GOODS AND/OR SERVICES PROVIDED BY WEBSITE SPONSORS; PROVIDING AN INTERNET WEBSITE FEATURING NEWS AND INFORMATION IN THE FIELD OF NATIONAL AND INTERNATIONAL POLITICS; PROVIDING AN INTERNET WEBSITE FEATURING NEWS AND INFORMATION IN THE FIELD OF NATURAL RESOURCE MANAGEMENT RELATING TO THE ENVIRONMENT AND PUBLIC LANDS; PROVIDING AN INTERNET WEBSITE PORTAL FEATURING PROMOTION AND ADVERTISING FOR HOME SERVICE PROVIDERS AND PRODUCT MANUFACTURERS; PROVIDING BUSINESS INFORMATION VIA A WEBSITE; PROVIDING ON-LINE WEB DIRECTORY SERVICES FEATURING HYPERLINKS TO THE WEBSITES OF OTHERS; PROVISION OF SPACE ON WEBSITES FOR ADVERTISING GOODS AND SERVICES; THE FOREGOING ALL EXCLUDING THE CONSTRUCTION, ARCHITECTURAL AND HOME DECORATING FIELDS (U.S. CLS. 100, 101 AND 102).

ZHALEH DELANEY, EXAMINING ATTORNEY

**CLASS 35—(Continued).**

SN 86-226,119. SIMPLESVERX, INC., CHANDLER, AZ. FILED 3-19-2014.

# Simple\$aveRx

THE MARK CONSISTS OF STANDARD CHARACTERS WITHOUT CLAIM TO ANY PARTICULAR FONT, STYLE, SIZE, OR COLOR.

FOR PROVIDING INFORMATION IN THE NATURE OF PRESCRIPTION DRUG COSTS AND COST COMPARISONS VIA COMPUTER NETWORKS AND WIRELESS NETWORKS (U.S. CLS. 100, 101 AND 102).

DOUGLAS LEE, EXAMINING ATTORNEY

SN 86-226,130. SIMPLESVERX, INC., CHANDLER, AZ. FILED 3-19-2014.

# It's Good Business

THE MARK CONSISTS OF STANDARD CHARACTERS WITHOUT CLAIM TO ANY PARTICULAR FONT, STYLE, SIZE, OR COLOR.

FOR PROVIDING INFORMATION IN THE NATURE OF PRESCRIPTION DRUG COSTS AND COST COMPARISONS VIA COMPUTER NETWORKS AND WIRELESS NETWORKS (U.S. CLS. 100, 101 AND 102).

DOUGLAS LEE, EXAMINING ATTORNEY

SN 86-226,156. NOT FOR SALE FUND, SAN FRANCISCO, CA. FILED 3-19-2014.



OWNER OF U.S. REG. NO. 4,552,635.

THE MARK CONSISTS OF A DOLLAR SIGN WITHIN A CIRCLE.

FOR CONDUCTING A PUBLIC AWARENESS CAMPAIGN TO PROMOTE, PROTECT, AND ADVANCE HUMAN RIGHTS (U.S. CLS. 100, 101 AND 102).

FIRST USE 2-5-2013; IN COMMERCE 2-5-2013.

ELIZABETH CHANG, EXAMINING ATTORNEY

**CLASS 35—(Continued).**

SN 86-226,506. COURTNEY ZAWISA, VIRGINIA BEACH, VA. FILED 3-20-2014.



NO CLAIM IS MADE TO THE EXCLUSIVE RIGHT TO USE "CLUB", APART FROM THE MARK AS SHOWN.

THE MARK CONSISTS OF A CIRCLE DESIGN WITH THE WORDING "S THE FUTURE BILLIONAIRE'S CLUB S WITH A LITTLE LUCK & LOTS OF HEART- WE CAN DO ANYTHING!" SURROUNDING A FOUR-LEAF CLOVER WITH CENTERED STYLIZED LETTERS "F" AND "B".

FOR GENERAL BUSINESS NETWORKING REFERRAL SERVICES, NAMELY, PROMOTING THE GOODS AND SERVICES OF OTHERS BY PASSING BUSINESS LEADS AND REFERRALS AMONG GROUP MEMBERS (U.S. CLS. 100, 101 AND 102).

FIRST USE 3-17-2011; IN COMMERCE 3-17-2011.  
LINDA ORNDORFF, EXAMINING ATTORNEY

SN 86-226,642. RONALD ROBERTS, EAGLEVILLE, PA. FILED 3-20-2014.

## TEAM IQ

THE MARK CONSISTS OF STANDARD CHARACTERS WITHOUT CLAIM TO ANY PARTICULAR FONT, STYLE, SIZE, OR COLOR.

NO CLAIM IS MADE TO THE EXCLUSIVE RIGHT TO USE "TEAM", APART FROM THE MARK AS SHOWN.

FOR BUSINESS MANAGEMENT AND CONSULTATION IN THE FIELD OF TEAM BUILDING; BUSINESS MANAGEMENT CONSULTING IN THE FIELD OF TEAM DEVELOPMENT; INTERNATIONAL BUSINESS CONSULTING SERVICES RELATING TO TEAM BUILDING; THE FOREGOING EXCLUDING SERVICES IN THE FIELDS OF CONSTRUCTION AND ENERGY EFFICIENCY (U.S. CLS. 100, 101 AND 102).

ZHALEH DELANEY, EXAMINING ATTORNEY

**CLASS 35—(Continued).**

SN 86-226,874. FRONT DOOR FARMS, SALINAS, CA. FILED 3-20-2014.

## FRONT DOOR FARMS

THE MARK CONSISTS OF STANDARD CHARACTERS WITHOUT CLAIM TO ANY PARTICULAR FONT, STYLE, SIZE, OR COLOR.

NO CLAIM IS MADE TO THE EXCLUSIVE RIGHT TO USE "FARMS", APART FROM THE MARK AS SHOWN.

FOR ON-LINE RETAIL STORE SERVICES FEATURING FARM FRESH FOOD PRODUCTS; RETAIL AND ON-LINE GROCERY STORE SERVICES FEATURING HOME DELIVERY SERVICE OF FARM FRESH FOODS; BUSINESS MANAGEMENT AND BUSINESS ADMINISTRATION SERVICES FEATURING THE PRODUCTION, SALE, AND DELIVERY OF FARM FRESH FOOD PRODUCTS (U.S. CLS. 100, 101 AND 102).

FIRST USE 11-12-2013; IN COMMERCE 11-12-2013.  
ALEXANDER L. POWERS, EXAMINING ATTORNEY

SN 86-226,879. COACH MY IDEA, NEW YORK, NY. FILED 3-20-2014.

## COACH MY IDEA

THE MARK CONSISTS OF STANDARD CHARACTERS WITHOUT CLAIM TO ANY PARTICULAR FONT, STYLE, SIZE, OR COLOR.

FOR ONLINE BUSINESS NETWORKING SERVICE TO CONNECT ENTREPRENEURS AND SUBJECT MATTER EXPERTS IN THE FIELD OF BUSINESS CONSULTING (U.S. CLS. 100, 101 AND 102).

PAUL CROWLEY, EXAMINING ATTORNEY

SN 86-226,967. HOGGE, BRUCE, HOUSTON, TX. FILED 3-20-2014.

## Aggregate for Advantage

THE MARK CONSISTS OF STANDARD CHARACTERS WITHOUT CLAIM TO ANY PARTICULAR FONT, STYLE, SIZE, OR COLOR.

FOR BUSINESS CONSULTING, NAMELY, SUPPLY CHAIN MANAGEMENT SERVICES, BUSINESS STRATEGIC PLANNING SERVICES IN THE FIELD OF SUPPLY CHAIN MANAGEMENT AND LOGISTICS (U.S. CLS. 100, 101 AND 102).

MICHAEL TANNER, EXAMINING ATTORNEY

**CLASS 35—(Continued).**

SN 86-227,188. FINE WINE HOSTING, LLC, LAKESIDE, CA.  
FILED 3-20-2014.



NO CLAIM IS MADE TO THE EXCLUSIVE RIGHT TO USE "RAMONA VALLEY VINEYARD ASSOCIATION", APART FROM THE MARK AS SHOWN.

THE MARK CONSISTS OF THE WORDING "RAMONA VALLEY VINEYARD ASSOCIATION" IN STYLIZED FONT. A LINE THAT IS CURLED AROUND THE CHARACTER "V" WITHIN THE WORDING "VINEYARD" UNDERLINES THE CHARACTERS "ONA ALL" WITHIN THE WORDING "RAMONA VALLEY" AND CONNECTS TO THE CHARACTER "D". DIRECTLY BELOW THE WORDING "VINEYARD" IS A LINE THAT UNDERLINES THE CHARACTERS "INEYAR". DIRECTLY TO THE RIGHT OF THE WORDING IS A DESIGN THAT DEPICTS ONE BUNCH OF GRAPES WITH LEAVES AT THE TOP OF THE BUNCH.

FOR ADMINISTERING A WINE CLUB BY MEANS OF SELECTING WINES BASED ON CONSUMER EXPECTATIONS AND ARRANGING PERIODIC SHIPMENT TO CLUB MEMBERS; ASSOCIATION SERVICES, NAMELY, PROMOTING THE INTERESTS OF WINES AND WINERIES; CLUB SERVICES, NAMELY, PROMOTING THE INTERESTS OF WINES AND WINERIES (U.S. CLS. 100, 101 AND 102).

FIRST USE 5-1-2009; IN COMMERCE 5-1-2009.  
ZACHARY CROMER, EXAMINING ATTORNEY

SN 86-227,516. TEXAS DEPARTMENT OF MOTOR VEHICLES, AUSTIN, TX. FILED 3-20-2014.



Auto Burglary & Theft Prevention Authority

NO CLAIM IS MADE TO THE EXCLUSIVE RIGHT TO USE "NEVER UNLOCKED. NOTHING IN VIEW. AUTO BURGLARY & THEFT PREVENTION AUTHORITY", APART FROM THE MARK AS SHOWN.

THE COLOR(S) BLACK, WHITE AND ORANGE IS/ARE CLAIMED AS A FEATURE OF THE MARK.

THE MARK CONSISTS OF A BLACK SWOOPING LINE THAT FORMS THE TOP OUTLINE OF A CAR IN PROFILE.

**CLASS 35—(Continued).**

A SECOND BLACK LINE FORMS MOST OF THE DRIVER'S SIDE WINDOW. UNDERNEATH THESE LINES IN ORANGE CAPITAL LETTERS IS THE PHRASE "PROTECT IT. IT'S YOURS.". IN A BLACK PARALLELOGRAM UNDER THIS PHRASE IN WHITE CAPITAL LETTERS IS THE PHRASE "NEVER UNLOCKED. NOTHING IN VIEW.". AT THE VERY BOTTOM FOLLOWING A SLIGHTLY LARGER SPACE IN BLACK FONT WITH THE FIRST LETTER OF EACH WORD CAPITALIZED IS "AUTO BURGLARY & THEFT PREVENTION AUTHORITY".

FOR PROMOTING PUBLIC AWARENESS OF AUTOMOBILE BURGLARY AND THEFT PREVENTION PROCEDURES AS PART OF A STATEWIDE EFFORT TO PREVENT, DETER, AND REDUCE AUTOMOBILE BURGLARY AND THEFT (U.S. CLS. 100, 101 AND 102).

FIRST USE 6-0-2013; IN COMMERCE 9-0-2013.  
APRIL HESIK, EXAMINING ATTORNEY

SN 86-227,553. ABC ATHLETIC RECRUITING, LLC, CORAL GABLES, FL. FILED 3-20-2014.



NO CLAIM IS MADE TO THE EXCLUSIVE RIGHT TO USE "ATHLETIC RECRUITING", APART FROM THE MARK AS SHOWN.

THE COLOR(S) YELLOW, WHITE, BLUE IS/ARE CLAIMED AS A FEATURE OF THE MARK.

THE MARK CONSISTS OF A BLUE BACKGROUND WITH LIGHT BLUE APPEARING HAS RAYS OF LIGHT AND DARK BLUE IN THE REMAINING BACKGROUND. THE COLOR YELLOW APPEARS IN THE STARS AND THE OUTER BORDER OF THE SHIELD AND BANNER. THE COLOR WHITE APPEARS IN THE INNER BORDER OF THE SHIELD AND BANNER, THE OUTER BORDER OF THE STARS, AND IN THE WORDING "ABC ATHLETIC RECRUITING".

FOR SPORTS RECRUITING SERVICES FOR HIGH SCHOOL ATHLETES; TALENT RECRUITING SERVICES IN THE FIELD OF SPORTS (U.S. CLS. 100, 101 AND 102).

FIRST USE 1-1-2014; IN COMMERCE 1-1-2014.  
DANNEAN HETZEL, EXAMINING ATTORNEY

**CLASS 35—(Continued).**

SN 86-227,620. CHAMBER OF COMMERCE OF THE UNITED STATES OF AMERICA, WASHINGTON, DC. FILED 3-20-2014.

## WORKFORCE FREEDOM INITIATIVE

THE MARK CONSISTS OF STANDARD CHARACTERS WITHOUT CLAIM TO ANY PARTICULAR FONT, STYLE, SIZE, OR COLOR.

NO CLAIM IS MADE TO THE EXCLUSIVE RIGHT TO USE "WORKFORCE" AND "INITIATIVE", APART FROM THE MARK AS SHOWN.

FOR PROMOTING THE INTERESTS OF EMPLOYERS (U.S. CLS. 100, 101 AND 102).

FIRST USE 7-21-2008; IN COMMERCE 7-21-2008.  
SUZANNE BLANE, EXAMINING ATTORNEY

SN 86-227,638. CONNECT ANYTHING, LLC, ST. THOMAS, US VIRGIN ISLANDS, FILED 3-20-2014.

## We Choose the Best So You Can Enjoy the Best

THE MARK CONSISTS OF STANDARD CHARACTERS WITHOUT CLAIM TO ANY PARTICULAR FONT, STYLE, SIZE, OR COLOR.

FOR PROVIDING A WEB SITE WHICH FEATURES ADVERTISEMENTS TO ENCOURAGE BOOKING AND PURCHASING OF THE GOODS AND SERVICES OF OTHERS ON A GLOBAL COMPUTER NETWORK IN THE EVENT AND HOSPITALITY INDUSTRY; PROMOTING THE GOODS AND SERVICES OF OTHERS IN THE EVENT AND HOSPITALITY INDUSTRY BY PROVIDING A WEBSITE FEATURING EVENT POSTINGS, WRITTEN PROFILES, VIP SPECIALS, OPERATING HOURS, INFORMATIONAL CONTENT TO ENCOURAGE BOOKING AND PURCHASING GOODS AND SERVICES OF OTHERS (U.S. CLS. 100, 101 AND 102).

NATALIE KENEALY, EXAMINING ATTORNEY

SN 86-227,911. MAGNUM VINO LLC, DBA MAGNUM VINO, YOUNTVILLE, CA. FILED 3-21-2014.

## Magnum Vino

THE MARK CONSISTS OF STANDARD CHARACTERS WITHOUT CLAIM TO ANY PARTICULAR FONT, STYLE, SIZE, OR COLOR.

NO CLAIM IS MADE TO THE EXCLUSIVE RIGHT TO USE "VINO", APART FROM THE MARK AS SHOWN.

FOR ADVERTISING, MARKETING AND PROMOTION SERVICES IN THE FIELD OF WINE (U.S. CLS. 100, 101 AND 102).

FIRST USE 4-24-2013; IN COMMERCE 4-24-2013.  
THOMAS MANOR, EXAMINING ATTORNEY

**CLASS 35—(Continued).**

SN 86-228,414. MCKINLEY CROWN, LLC, MASON, OH. FILED 3-21-2014.



THE COLOR(S) PURPLE AND YELLOW IS/ARE CLAIMED AS A FEATURE OF THE MARK.

THE MARK CONSISTS OF THE WORD "MCKINLEY" WITH A CROWN OVER THE TOP AND THE TEXT "UNCOVERING JEWELS TO YOUR SUCCESS..." ON THE BOTTOM. THE LETTERS AND CROWN ARE PURPLE AND BOTH HAVE A YELLOW SHADOW AROUND THEM.

FOR BUSINESS CONSULTING AND INFORMATION SERVICES; BUSINESS MANAGEMENT (U.S. CLS. 100, 101 AND 102).

LAURIE KAUFMAN, EXAMINING ATTORNEY

SN 86-228,463. MANAGED CARE OF NORTH AMERICA, INC., FORT LAUDERDALE, FL. FILED 3-21-2014.

## STARR

THE MARK CONSISTS OF STANDARD CHARACTERS WITHOUT CLAIM TO ANY PARTICULAR FONT, STYLE, SIZE, OR COLOR.

FOR ADMINISTRATION OF IN-NETWORK DENTAL PROVIDER INCENTIVE PROGRAM (U.S. CLS. 100, 101 AND 102).

FIRST USE 8-1-2013; IN COMMERCE 12-1-2013.  
MAYUR VAGHANI, EXAMINING ATTORNEY

SN 86-228,504. HEELSTONE PROPRIETARY, LLC, ALBUQUERQUE, NM. FILED 3-21-2014.



NO CLAIM IS MADE TO THE EXCLUSIVE RIGHT TO USE "IP PARTNERS", APART FROM THE MARK AS SHOWN.

THE MARK CONSISTS OF AN SERIES OF FIVE-POINTED STARS ARRANGED IN AN ARC EXTENDING

**CLASS 35—(Continued).**

OVER A LARGER FIVE-POINTED STAR AND THE WORDS "PLATINUM STAR" POSITIONED ABOVE THE LARGER FIVE-POINTED STAR AND BELOW THE APEX OF THE ARC, THE LETTER "I" POSITIONED TO THE LEFT OF THE LARGER FIVE-POINTED STAR AND TO THE RIGHT OF THE LEFT PORTION OF THE ARC, THE LETTER "P" POSITIONED TO THE RIGHT OF THE LARGER FIVE-POINTED STAR AND TO THE LEFT OF THE RIGHT PORTION OF THE ARC, AND THE WORD "PARTNERS" BELOW THE LARGER FIVE-POINTED STAR.

FOR BUSINESS CONSULTING IN THE FIELD OF ENVIRONMENTAL MANAGEMENT, NAMELY, ADVISING BUSINESSES AND INDIVIDUALS ON ISSUES OF ENVIRONMENTAL IMPACT, CONSERVATION, PRESERVATION AND PROTECTION, AND ECONOMIC ANALYSIS FOR BUSINESS PURPOSES (U.S. CLS. 100, 101 AND 102).

RICHARD WHITE, EXAMINING ATTORNEY

---

SN 86-228,601. CORE RECRUITMENT, LLC, KATY, TX. FILED 3-21-2014.



THE MARK CONSISTS OF A FANCIFUL REPRESENTATION OF A LEAF.

FOR PROFESSIONAL STAFFING AND RECRUITING SERVICES (U.S. CLS. 100, 101 AND 102).

FIRST USE 8-0-2012; IN COMMERCE 8-0-2012.

APRIL REEVES, EXAMINING ATTORNEY

---

SN 86-228,635. CORE RECRUITMENT, LLC, KATY, TX. FILED 3-21-2014.

ONWARD, UPWARD RECRUITMENT  
SOLUTIONS

THE MARK CONSISTS OF STANDARD CHARACTERS WITHOUT CLAIM TO ANY PARTICULAR FONT, STYLE, SIZE, OR COLOR.

NO CLAIM IS MADE TO THE EXCLUSIVE RIGHT TO USE "RECRUITMENT SOLUTIONS", APART FROM THE MARK AS SHOWN.

FOR PROFESSIONAL STAFFING AND RECRUITING SERVICES (U.S. CLS. 100, 101 AND 102).

FIRST USE 1-0-2014; IN COMMERCE 1-0-2014.

APRIL REEVES, EXAMINING ATTORNEY

**CLASS 35—(Continued).**

SN 86-229,110. CHINCOTEAGUE VOLUNTEER FIRE COMPANY, INC., CHINCOTEAGUE ISLAND, VA. FILED 3-22-2014.

CHINCOTEAGUE VOLUNTEER  
FIRE COMPANY

THE MARK CONSISTS OF STANDARD CHARACTERS WITHOUT CLAIM TO ANY PARTICULAR FONT, STYLE, SIZE, OR COLOR.

NO CLAIM IS MADE TO THE EXCLUSIVE RIGHT TO USE "CHINCOTEAGUE" AND "COMPANY", APART FROM THE MARK AS SHOWN.

FOR ON-LINE RETAIL STORE SERVICES FEATURING CLOTHING, BOOKS, DVDS, KEY CHAINS, LANYARDS, COLLECTIBLE COINS, DRINKWARE, AND PATCHES (U.S. CLS. 100, 101 AND 102).

FIRST USE 10-1-2013; IN COMMERCE 10-1-2013.

KIM MONINGHOFF, EXAMINING ATTORNEY

---

SN 86-229,359. CAMPUS SPORTS NET LLC, SUNRISE, FL. FILED 3-23-2014.

CAMPUS SPORTS NET

THE MARK CONSISTS OF STANDARD CHARACTERS WITHOUT CLAIM TO ANY PARTICULAR FONT, STYLE, SIZE, OR COLOR.

NO CLAIM IS MADE TO THE EXCLUSIVE RIGHT TO USE "SPORTS NET", APART FROM THE MARK AS SHOWN.

FOR ON-LINE RETAIL STORE SERVICES FEATURING SPORTS MEMORABILIA AND APPAREL (U.S. CLS. 100, 101 AND 102).

AMY C. KEAN, EXAMINING ATTORNEY

---

SN 86-229,363. CAMPUS SPORTS NET LLC, SUNRISE, FL. FILED 3-23-2014.

CAMPUS SPORTS

THE MARK CONSISTS OF STANDARD CHARACTERS WITHOUT CLAIM TO ANY PARTICULAR FONT, STYLE, SIZE, OR COLOR.

NO CLAIM IS MADE TO THE EXCLUSIVE RIGHT TO USE "SPORTS", APART FROM THE MARK AS SHOWN.

FOR ON-LINE RETAIL STORE SERVICES FEATURING SPORTS MEMORABILIA AND APPAREL (U.S. CLS. 100, 101 AND 102).

AMY C. KEAN, EXAMINING ATTORNEY



**CLASS 35—(Continued).**

SN 86-230,007. FREDRIKSEN, VANESSA, BAKERSFIELD, CA. FILED 3-24-2014.



NO CLAIM IS MADE TO THE EXCLUSIVE RIGHT TO USE "FIGHT SHOP" AND THE PICTORIAL REPRESENTATION OF THE STATE OF CALIFORNIA, APART FROM THE MARK AS SHOWN.

THE MARK CONSISTS OF THE STYLIZED TEXT "LEFTCOAST" AT THE TOP OF THE MARK IN BOLD OUTLINED LETTERS. UNDER THE WORDING "LEFTCOAST" IS A KNOTTED TIE WITH THE "KNOT" FEATURING A PICTORIAL REPRESENTATION OF THE STATE OF CALIFORNIA, AND THE WORD "FIGHT" ON THE LEFT OF THE TIE, AND THE WORD "SHOP" ON THE RIGHT OF THE TIE.

FOR RETAIL STORE SERVICES FEATURING CLOTHING, STICKERS, PATCHES, FIGHT GEAR, RECOVERY GEAR (U.S. CLS. 100, 101 AND 102).

DAVID MURRAY, EXAMINING ATTORNEY

SN 86-230,817. COASTAL CAROLINA FURNITURE, MYRTLE BEACH, SC. FILED 3-25-2014.

THE GRAND STRAND LEADER IN  
FINE FURNITURE BRANDS  
SELECTION AND SERVICE  
YOU DESERVE THE BEST

THE MARK CONSISTS OF STANDARD CHARACTERS WITHOUT CLAIM TO ANY PARTICULAR FONT, STYLE, SIZE, OR COLOR.

NO CLAIM IS MADE TO THE EXCLUSIVE RIGHT TO USE "THE GRAND STRAND LEADER IN FINE FURNITURE BRANDS SELECTION AND SERVICE", APART FROM THE MARK AS SHOWN.

FOR RETAIL FURNITURE STORE SERVICES (U.S. CLS. 100, 101 AND 102).

KRISTIN DAHLING, EXAMINING ATTORNEY

**CLASS 35—(Continued).**

SN 86-231,026. INDUSTRIAL PACKAGING CORPORATION, ATLANTA, GA. FILED 3-25-2014.

**YOUR SOLUTIONS PEOPLE**

THE MARK CONSISTS OF STANDARD CHARACTERS WITHOUT CLAIM TO ANY PARTICULAR FONT, STYLE, SIZE, OR COLOR.

FOR DISTRIBUTORSHIP SERVICES IN THE FIELDS OF INDUSTRIAL ABRASIVES AND ADHESIVES, PACKAGING MATERIALS AND EQUIPMENT, PROTECTIVE SAFETY DEVICES, NAMELY, PROTECTIVE EYEWEAR, EAR WEAR AND GLOVES, PROTECTIVE CLOTHING AND RESPIRATORY DEVICES, AND SANITATION AND JANITORIAL MATERIALS (U.S. CLS. 100, 101 AND 102).

REBECCA SMITH, EXAMINING ATTORNEY

SN 86-231,211. INDUSTRIAL PACKAGING CORPORATION, ATLANTA, GA. FILED 3-25-2014.



THE MARK CONSISTS OF THE LETTERS "IPC" POSITIONED ADJACENT A PERSPECTIVE VIEW OF A BOX HAVING A STYLIZED HAND ON THE BOX.

FOR DISTRIBUTORSHIP SERVICES IN THE FIELDS OF INDUSTRIAL ABRASIVES AND ADHESIVES, PACKAGING MATERIALS AND EQUIPMENT, PROTECTIVE SAFETY DEVICES, NAMELY, PROTECTIVE EYEWEAR, EAR WEAR AND GLOVES, PROTECTIVE CLOTHING AND RESPIRATORY DEVICES, AND SANITATION AND JANITORIAL MATERIALS (U.S. CLS. 100, 101 AND 102).

REBECCA SMITH, EXAMINING ATTORNEY

SN 86-231,351. DECIDE SPORTS MARKETING, LLC, MASON, OH. FILED 3-25-2014.

**DECIDE SPORTS**

THE MARK CONSISTS OF STANDARD CHARACTERS WITHOUT CLAIM TO ANY PARTICULAR FONT, STYLE, SIZE, OR COLOR.

NO CLAIM IS MADE TO THE EXCLUSIVE RIGHT TO USE "SPORTS", APART FROM THE MARK AS SHOWN.

FOR SPORTS RECRUITING SERVICES FOR HIGH SCHOOL ATHLETES (U.S. CLS. 100, 101 AND 102).

TOBY BULLOFF, EXAMINING ATTORNEY



**CLASS 35—(Continued).**

SN 86-231,547. LEACH, JOHN, SAINT LOUIS, MO. FILED 3-25-2014.

**Easy Home Connections**

THE MARK CONSISTS OF STANDARD CHARACTERS WITHOUT CLAIM TO ANY PARTICULAR FONT, STYLE, SIZE, OR COLOR.

NO CLAIM IS MADE TO THE EXCLUSIVE RIGHT TO USE "HOME CONNECTIONS", APART FROM THE MARK AS SHOWN.

FOR PROVIDING INFORMATION AND CONSULTATION ON THE AVAILABILITY OF PHONE, INTERNET, TELEVISION, SECURITY, AND HOME INSURANCE SERVICES FOR OTHERS BASED ON LOCATION; ARRANGING FOR THE PROVISION OF PUBLIC UTILITIES, PHONE, INTERNET, TELEVISION, SECURITY, AND HOME INSURANCE SERVICES FOR OTHERS; ARRANGING FOR THE TRANSFER OF PUBLIC UTILITIES, PHONE, INTERNET, TELEVISION, SECURITY, AND HOME INSURANCE SERVICES FOR OTHERS (U.S. CLS. 100, 101 AND 102).

FIRST USE 11-0-2007; IN COMMERCE 1-0-2009.  
JEFF DEFORD, EXAMINING ATTORNEY

---

SN 86-231,704. CALIFORNIA MILK PRODUCERS ADVISORY BOARD, AN INSTRUMENTALITY OF THE STATE OF CALIFORNIA, DEPARTMENT OF FOOD AND AGRICULTURE, SOUTH SAN FRANCISCO, CA. FILED 3-25-2014.

**CALIFARMIA**

THE MARK CONSISTS OF STANDARD CHARACTERS WITHOUT CLAIM TO ANY PARTICULAR FONT, STYLE, SIZE, OR COLOR.

FOR PROMOTION AND MARKETING SERVICES, NAMELY, PROMOTING THE INTERESTS OF MILK PRODUCERS THROUGH COMMERCIAL ADVERTISEMENTS PROMOTING MILK AND MILK PRODUCTS IN THE FORM OF TELEVISION, RADIO, PRINT AND ELECTRONIC MEDIA, MARKETING PROGRAMS INVOLVING DISTRIBUTION OF PROMOTIONAL MATERIALS; CONSULTING SERVICES CONCERNING PROMOTION AND MARKETING SERVICES FOR MILK PRODUCERS; DISTRIBUTION AND DISSEMINATION OF ADVERTISING MATERIAL IN THE NATURE OF PRINTED MATERIAL; ADVERTISING AND MARKETING SERVICES FOR MILK PRODUCERS PROVIDED BY MEANS OF INDIRECT METHODS OF MARKETING COMMUNICATIONS, NAMELY, SOCIAL MEDIA, SEARCH ENGINE MARKETING, INQUIRY MARKETING, INTERNET MARKETING, MOBILE MARKETING, BLOGGING AND OTHER FORMS OF PASSIVE, SHARABLE OR VIRAL COMMUNICATIONS CHANNELS (U.S. CLS. 100, 101 AND 102).

DAVID ALESKOW, EXAMINING ATTORNEY

**CLASS 35—(Continued).**

SN 86-231,878. FOUR QUADRANT, TIBURON, CA. FILED 3-25-2014.



NO CLAIM IS MADE TO THE EXCLUSIVE RIGHT TO USE "RECRUIT" AND "HS ATHLETES", APART FROM THE MARK AS SHOWN.

THE MARK CONSISTS OF A DESIGN OF A CIRCULAR PROCESS ARROW THAT IS COMPRISED OF 6 SEGMENTS. THE STYLIZED TEXT "RECRUIT" IS TO THE RIGHT OF THE DESIGN AND PLACED SO THAT THE "REC" PORTION IS INSIDE OF THE CIRCULAR PROCESS DESIGN. TO THE RIGHT OF "RECRUIT" IS A SPACE AND A DIVIDING LINE. TO THE RIGHT OF THE DIVIDING LINE IS THE STYLIZED TEXT "HS" AND "ATHLETES" STACKED ON TOP OF EACH OTHER. IN BETWEEN THE TEXT IS A HORIZONTAL DIVIDING LINE.

FOR PROMOTIONAL SERVICES, NAMELY, PROVIDING A WEBSITE FEATURING THE ONLINE PORTFOLIO OF ATHLETES TO SHOWCASE THEIR TALENT (U.S. CLS. 100, 101 AND 102).

FIRST USE 2-1-2014; IN COMMERCE 2-1-2014.  
BRIAN CALLAGHAN, EXAMINING ATTORNEY

---

SN 86-231,948. TEKCAPITAL PLC, NORTH MIAMI, FL. FILED 3-25-2014.

**TEKCAPITAL**

THE MARK CONSISTS OF STANDARD CHARACTERS WITHOUT CLAIM TO ANY PARTICULAR FONT, STYLE, SIZE, OR COLOR.

FOR CONSULTING SERVICES IN THE FIELD OF MANAGING INTELLECTUAL PROPERTIES; BUSINESS RESEARCH AND BUSINESS REPORTING REGARDING THIRD PARTY INTELLECTUAL PROPERTIES, NAMELY, PROVIDING BUSINESS RESEARCH AND BUSINESS INFORMATION ABOUT INTELLECTUAL PROPERTY RIGHTS AVAILABLE FOR POSSIBLE ACQUISITION (U.S. CLS. 100, 101 AND 102).

FIRST USE 6-27-2012; IN COMMERCE 6-27-2012.  
ELLEN B. AWRICH, EXAMINING ATTORNEY

**CLASS 35—(Continued).**

SN 86-232,188. NATIONAL RENAL ADMINISTRATORS ASSOCIATION, PHILADELPHIA, PA. FILED 3-26-2014.



OWNER OF U.S. REG. NOS. 3,974,352 AND 3,974,358.  
THE MARK CONSISTS OF INTERTWINED RECTANGLE DESIGN AND THE LETTERS "NRAA".

FOR ASSOCIATION SERVICES, NAMELY, PROMOTING THE INTERESTS OF REGIONAL AND COMMUNITY BASED DIALYSIS PROVIDERS (U.S. CLS. 100, 101 AND 102).

FIRST USE 9-25-2013; IN COMMERCE 9-25-2013.  
DONALD JOHNSON, EXAMINING ATTORNEY

**CLASS 35—(Continued).**

SN 86-232,335. PICK 6 KICKS LLC, ATHENS, GA. FILED 3-26-2014.



NO CLAIM IS MADE TO THE EXCLUSIVE RIGHT TO USE "KICKS", APART FROM THE MARK AS SHOWN.

THE MARK CONSISTS OF THE LETTER "P" WITH THE NUMBER "6" OVERLAPPING IT AND TO THE LEFT OF THE WORDS "PICK SIX KICKS".

FOR RETAIL CLOTHING STORES (U.S. CLS. 100, 101 AND 102).

FIRST USE 9-13-2013; IN COMMERCE 12-23-2013.  
BARBARA BROWN, EXAMINING ATTORNEY

SN 86-232,261. OMAHA STEAKS INTERNATIONAL, INC., OMAHA, NE. FILED 3-26-2014.

**STEAKLOVER REWARDS**

THE MARK CONSISTS OF STANDARD CHARACTERS WITHOUT CLAIM TO ANY PARTICULAR FONT, STYLE, SIZE, OR COLOR.

OWNER OF U.S. REG. NO. 2,086,604.

NO CLAIM IS MADE TO THE EXCLUSIVE RIGHT TO USE "REWARDS", APART FROM THE MARK AS SHOWN.

FOR CUSTOMER LOYALTY SERVICES AND CUSTOMER CLUB SERVICES, FOR COMMERCIAL, PROMOTIONAL AND/OR ADVERTISING PURPOSES; ADMINISTRATION OF AN INCENTIVE AWARD PROGRAM ENABLING PARTICIPANTS TO OBTAIN DISCOUNTS AND COMPLIMENTARY AWARDS ON GOODS AND SERVICES THROUGH MEMBERSHIP (U.S. CLS. 100, 101 AND 102).

HOWARD B. LEVINE, EXAMINING ATTORNEY

SN 86-232,468. LOLO'S INC., PHOENIX, AZ. FILED 3-26-2014.



OWNER OF U.S. REG. NO. 4,555,667.

NO CLAIM IS MADE TO THE EXCLUSIVE RIGHT TO USE "CHICKEN & WAFFLES", APART FROM THE MARK AS SHOWN.

THE MARK CONSISTS OF STYLIZED "LO-LO'S" ABOVE THE STYLIZED WORDS "CHICKEN & WAFFLES".

FOR RESTAURANT FRANCHISING, NAMELY, OFFERING BUSINESS MANAGEMENT ASSISTANCE IN THE ESTABLISHMENT AND/OR OPERATION OF RESTAURANTS (U.S. CLS. 100, 101 AND 102).

KAREN BRACEY, EXAMINING ATTORNEY

**CLASS 35—(Continued).**

SN 86-232,598. MARICONDA MARKETING SOLUTIONS, LLC, EAST NORTHPORT, NY. FILED 3-26-2014.

MARKETING  
NOW

NO CLAIM IS MADE TO THE EXCLUSIVE RIGHT TO USE "MARKETING", APART FROM THE MARK AS SHOWN.

THE MARK CONSISTS OF THE WORDS "MARKETING NOW" WHERE THE "O" OF "NOW" APPEARS AS TWO CONCENTRIC CIRCLES WITH SPOKES DIVIDING THE CIRCLES INTO EIGHT SECTIONS.

FOR ADVERTISING AND MARKETING; ADVERTISING SERVICES, NAMELY, CREATING CORPORATE AND BRAND IDENTITY FOR OTHERS; BUSINESS MARKETING CONSULTING SERVICES; CREATIVE MARKETING DESIGN SERVICES; DIRECT MARKETING SERVICES; PUBLIC RELATIONS (U.S. CLS. 100, 101 AND 102).

FIRST USE 12-17-2013; IN COMMERCE 12-17-2013.  
ANDREA K. NADELMAN, EXAMINING ATTORNEY

SN 86-232,703. LC EXCLUSIVITIES, INC., MANCHESTER, NJ. FILED 3-26-2014.



NO CLAIM IS MADE TO THE EXCLUSIVE RIGHT TO USE "LATINO CUISINE" AND "FOOD PRODUCTS AND BEVERAGE TRADE SHOW" AND THE REPRESENTATIONS OF THE MAPS OF MEXICO, CENTRAL AMERICA, CUBA, JAMAICA, HAITI, THE DOMINICAN REPUBLIC, PUERTO RICO AND SOUTH AMERICA, APART FROM THE MARK AS SHOWN.

THE COLOR(S) BLACK, RED, YELLOW, WHITE, GREEN, DARK BLUE AND LIGHT BLUE IS/ARE CLAIMED AS A FEATURE OF THE MARK.

THE MARK CONSISTS OF THE WORDING "THE WORLD OF THE LATINO CUISINE FOOD PRODUCTS AND BEVERAGE TRADE SHOW" WITH THE TERM "THE" IN BLACK OVER THE TERM "WORLD" IN YELLOW AND THE WORDING "OF THE" IN BLACK. THE DESIGN OF A CHEF'S HAT APPEARS IN RED AND OUTLINED IN BLACK OVER THE LETTER "O" IN THE TERM "WORLD". UNDERNEATH THE WORDING "WORLD OF THE" APPEARS THE WORDING "LATINO" OVER "CUISINE" IN RED AND OUTLINED IN BLACK. THE BLACK WORDING "FOOD PRODUCTS AND BEVERAGE TRADE SHOW" APPEARS UNDERNEATH THE TERM "CUISINE" SEPA-

**CLASS 35—(Continued).**

RATED BY A YELLOW LINE. THE MAPS OF MEXICO, CENTRAL AMERICA, CUBA, JAMAICA, HAITI, THE DOMINICAN REPUBLIC, PUERTO RICO AND SOUTH AMERICA APPEAR TO THE RIGHT OF THE WORDING. THE MAPS ARE ALL OUTLINED IN BLACK AND CONTAIN COLORED STRIPES IN THE FOLLOWING COLORS FROM TOP TO BOTTOM: WHITE, RED, GREEN, DARK BLUE, YELLOW, DARK BLUE, YELLOW, DARK BLUE, RED, YELLOW, GREEN, WHITE, RED, LIGHT BLUE, YELLOW AND WHITE.

FOR PROMOTING AND CONDUCTING TRADE SHOWS IN THE FIELD OF FOOD AND BEVERAGE PRODUCTS AND SERVICES (U.S. CLS. 100, 101 AND 102).

FIRST USE 2-15-2014; IN COMMERCE 2-15-2014.  
JEFFERY COWARD, EXAMINING ATTORNEY

SN 86-232,710. CARROT CREATIVE, LLC, BROOKLYN, NY. FILED 3-26-2014.

Carrot

THE MARK CONSISTS OF STANDARD CHARACTERS WITHOUT CLAIM TO ANY PARTICULAR FONT, STYLE, SIZE, OR COLOR.

OWNER OF U.S. REG. NOS. 4,295,877, 4,429,071 AND 4,454,893.

FOR MARKETING, ADVERTISING AND BRANDING CONSULTANCY; ADVERTISING AND PROMOTION SERVICES, NAMELY, CONSULTING, DEVELOPMENT, AND MARKETING OF BRANDS FOR BUSINESSES; BRAND CONCEPT AND BRAND DEVELOPMENT SERVICES FOR CORPORATE CLIENTS; SOCIAL MEDIA STRATEGY AND MARKETING CONSULTANCY FOCUSING ON HELPING CLIENTS CREATE AND EXTEND THEIR PRODUCT AND BRAND STRATEGIES BY BUILDING VIRALLY ENGAGING MARKETING SOLUTIONS; CONSULTING SERVICES REGARDING USAGE OF SOCIAL MEDIA TOOLS AND SOCIAL MEDIA OUTLETS IN THE FIELD OF MARKETING; CONSULTING SERVICES REGARDING SOCIAL MEDIA STRATEGY, PROMOTION CREATION AND IMPLEMENTATION IN THE FIELD OF MARKETING (U.S. CLS. 100, 101 AND 102).

FIRST USE 6-6-2005; IN COMMERCE 6-6-2005.  
PAM WILLIS, EXAMINING ATTORNEY

SN 86-232,753. MANGUAL, REYNALDO, JERSEY CITY, NJ. FILED 3-26-2014.

Voicetastic

THE MARK CONSISTS OF STANDARD CHARACTERS WITHOUT CLAIM TO ANY PARTICULAR FONT, STYLE, SIZE, OR COLOR.

FOR PROVIDING VOICE OVERS FOR COMMERCIALS (U.S. CLS. 100, 101 AND 102).

FIRST USE 9-26-2011; IN COMMERCE 9-26-2011.  
CHARLOTTE CORWIN, EXAMINING ATTORNEY

**CLASS 35—(Continued).**

SN 86-233,416. NE3RD LLC, WEST PALM BEACH, FL. FILED 3-26-2014.

# ne<sup>3</sup>rd

THE MARK CONSISTS OF THE TERM, "NERD", WITH THE LOWERCASE LETTERS "NE", FOLLOWED BY A CUBED NUMBER "3", AS IN TO THE THIRD POWER, WHICH IS THEN FOLLOWED BY THE LOWERCASE LETTERS "RD".

FOR BUSINESS CONSULTING IN THE FIELD OF ENVIRONMENTAL MANAGEMENT, NAMELY, ADVISING BUSINESSES AND INDIVIDUALS ON ISSUES OF ENVIRONMENTAL IMPACT, CONSERVATION, PRESERVATION AND PROTECTION, AND ECONOMIC ANALYSIS FOR BUSINESS PURPOSES; BUSINESS CONSULTING SERVICES FOR THE ELECTRIC ENERGY INDUSTRY; BUSINESS DATA ANALYSIS; MANAGING THE EXPLORATION, PRODUCTION AND OPERATIONS OF NATURAL GAS AND OIL PROPERTIES FOR OTHERS (U.S. CLS. 100, 101 AND 102).

FIRST USE 2-21-2014; IN COMMERCE 3-13-2014.  
ODESSA BIBBINS, EXAMINING ATTORNEY

---

SN 86-233,798. TINY JEWEL BOX, INC., WASHINGTON, DC. FILED 3-27-2014.

## TINY JEWEL BOX

THE MARK CONSISTS OF STANDARD CHARACTERS WITHOUT CLAIM TO ANY PARTICULAR FONT, STYLE, SIZE, OR COLOR.

NO CLAIM IS MADE TO THE EXCLUSIVE RIGHT TO USE "JEWEL BOX", APART FROM THE MARK AS SHOWN.

FOR RETAIL STORE SERVICES FEATURING JEWELRY, WATCHES, CLOCKS, PRECIOUS AND SEMI-PRECIOUS STONES, CUFFLINKS, MONEY CLIPS, BUSINESS CARD HOLDERS, PICTURE FRAMES, FIGURINES, JEWELRY BOXES, CRYSTAL GLASSES, BOWLS, VASES, JARS, CANDLESTICKS AND BOXES, EARTHENWARE PLATES, BOWLS AND BOXES, DECOUPAGE BOXES, LETTER HOLDERS, PENCIL CUPS AND BOOK-ENDS, PEN AND PENCIL HOLDERS, PAPERWEIGHTS, LETTER OPENERS, AND WRITING BLOTTERS (U.S. CLS. 100, 101 AND 102).

FIRST USE 0-0-1944; IN COMMERCE 0-0-1944.  
TRACY FLETCHER, EXAMINING ATTORNEY

**CLASS 35—(Continued).**

SN 86-233,959. TPM, INC., INDIANAPOLIS, IN. FILED 3-27-2014.



OWNER OF U.S. REG. NOS. 4,241,058, 4,402,640 AND OTHERS.

NO CLAIM IS MADE TO THE EXCLUSIVE RIGHT TO USE "PRODUCE" AND "PICKS", APART FROM THE MARK AS SHOWN.

THE MARK CONSISTS OF TWO CIRCLES, ONE INSIDE THE OTHER TO CREATE A RING OR BORDER IMAGE, WITH THE WORDS "PRODUCE MOM" APPEARING IN THE TOP PORTION BETWEEN THE TWO CIRCLES AND THE WORD "PICKS" SIMILARLY APPEARING INSIDE THE TWO CIRCLES IN THE BOTTOM PORTION, AND THE LIKENESS OF A SMILING FACE WITH HAIR AND A FIST WITH THE THUMB UP IN THE CENTER OF THE CIRCLES, THE FIST AND THUMB CROSSING THE TWO CIRCLES TO APPEAR THREE DIMENSIONAL.

FOR PROMOTING THE GOODS AND SERVICES OF OTHERS THROUGH THE DISTRIBUTION OF ON-LINE AND PRINTED MATERIALS AND INFORMATION, PROMOTIONAL EXHIBITS, AND ALL MEANS OF COMMUNICATION TO THE GENERAL PUBLIC; ADVERTISING, MARKETING AND PROMOTIONAL SERVICES FOR FRUITS AND VEGETABLES OF OTHERS, NAMELY, PRODUCE DISTRIBUTORS, VENDORS, GROCERY STORES AND RESTAURANTS (U.S. CLS. 100, 101 AND 102).

FIRST USE 3-3-2014; IN COMMERCE 3-3-2014.  
JENNIFER MARTIN, EXAMINING ATTORNEY

---

SN 86-234,061. RX-360 INTERNATIONAL PHARMACEUTICAL SUPPLY CHAIN CONSORTIUM, WASHINGTON, DC. FILED 3-27-2014.

# RX-360

THE MARK CONSISTS OF STANDARD CHARACTERS WITHOUT CLAIM TO ANY PARTICULAR FONT, STYLE, SIZE, OR COLOR.

FOR ASSOCIATION SERVICES, NAMELY, ORGANIZING A CONSORTIUM IN THE FIELD OF PHARMACEUTICAL SUPPLY CHAIN SECURITY AND PROMOTING THE INTERESTS OF MEMBERS THEREOF; PROMOTING THE INTERESTS OF BIOTECHNOLOGY, PHARMACEUTICAL AND GENERIC DRUG MANUFACTURERS, SUPPLIERS, WHOLESALERS AND DISTRIBUTORS IN THE FIELD OF PHARMACEUTICAL SUPPLY CHAIN SECURITY (U.S. CLS. 100, 101 AND 102).

FIRST USE 0-0-2009; IN COMMERCE 0-0-2009.  
KELLEY WELLS, EXAMINING ATTORNEY

**CLASS 35—(Continued).**

SN 86-234,295. HOPWOOD, DEREK, DENHAM SPRINGS, LA. FILED 3-27-2014.

## Bucket of Wishes

THE MARK CONSISTS OF STANDARD CHARACTERS WITHOUT CLAIM TO ANY PARTICULAR FONT, STYLE, SIZE, OR COLOR.

FOR CHARITABLE SERVICES, NAMELY, COORDINATION OF VOLUNTEERS TO HELP CHILDREN WITH ILLNESSES (U.S. CLS. 100, 101 AND 102).

LAURA FIONDA, EXAMINING ATTORNEY

**CLASS 35—(Continued).**

SN 86-234,616. 9G ENTERPRISES, INC., DBA SURVEYVITALS, SPRINGTOWN, TX. FILED 3-27-2014.



THE COLOR(S) BLUE AND BLACK IS/ARE CLAIMED AS A FEATURE OF THE MARK.

THE MARK CONSISTS OF A BLUE CLOUD WITH THE LETTERS "SIMPL" EMBEDDED WITH A BLACK ARROW POINTING UP, REPRESENTING AN ABBREVIATION FOR SURVEY IMPLEMENTATION LOGIC UPLOAD.

FOR CONDUCTING BUSINESS SURVEYS; CONDUCTING EMPLOYEE SURVEYS FOR OTHERS FOR PURPOSES OF IMPROVING EMPLOYEE PERFORMANCE AND MORALE (U.S. CLS. 100, 101 AND 102).

FIRST USE 2-17-2013; IN COMMERCE 2-17-2013.  
ANNE MADDEN, EXAMINING ATTORNEY

SN 86-234,325. THE KAVI GROUP, LORTON, VA. FILED 3-27-2014.

## THE KAVI GROUP

THE MARK CONSISTS OF STANDARD CHARACTERS WITHOUT CLAIM TO ANY PARTICULAR FONT, STYLE, SIZE, OR COLOR.

NO CLAIM IS MADE TO THE EXCLUSIVE RIGHT TO USE "GROUP", APART FROM THE MARK AS SHOWN.

FOR BUSINESS MANAGEMENT CONSULTING (U.S. CLS. 100, 101 AND 102).

FIRST USE 3-27-2014; IN COMMERCE 3-27-2014.  
STEPHANIE ALI, EXAMINING ATTORNEY

SN 86-234,632. KONARQUI CORPORATION, DORAL, FL. FILED 3-27-2014.



SN 86-234,425. PENNSYLVANIA INSURANCE FRAUD PREVENTION AUTHORITY, MECHANICSBURG, PA. FILED 3-27-2014.

## DON'T BE A BUT

THE MARK CONSISTS OF STANDARD CHARACTERS WITHOUT CLAIM TO ANY PARTICULAR FONT, STYLE, SIZE, OR COLOR.

FOR PROMOTING PUBLIC AWARENESS OF THE NEED FOR EDUCATION ABOUT INSURANCE FRAUD AND THE NEED TO DISCOURAGE, REDUCE, AND PREVENT INSURANCE FRAUD (U.S. CLS. 100, 101 AND 102).

KEVIN CORWIN, EXAMINING ATTORNEY

NO CLAIM IS MADE TO THE EXCLUSIVE RIGHT TO USE "LUGGAGE", APART FROM THE MARK AS SHOWN.

THE MARK CONSISTS OF THE WORD "LUGGAGE" ABOVE THE WORD "MORE". TO THE RIGHT OF THE WORDING IS A LARGE AMPERSAND. A BANNER DESIGN COMPRISING A RECTANGLE WITH ROUNDED CORNERS APPEARS BEHIND "LUGGAGE" AND THE UPPER PORTION OF THE AMPERSAND. THERE IS SLIGHT SHADOWING BELOW THE WORDING AND DESIGNS.

FOR RETAIL STORE SERVICES FEATURING LUGGAGE, TRAVEL ACCESSORIES, AND TRAVEL SECURITY ITEMS (U.S. CLS. 100, 101 AND 102).

FIRST USE 8-20-2004; IN COMMERCE 8-20-2004.  
MAUREEN DALL, EXAMINING ATTORNEY

**CLASS 35—(Continued).**

SN 86-234,638. 9G ENTERPRISES, INC., DBA SURVEYVITALS, SPRINGTOWN, TX. FILED 3-27-2014.



THE COLOR(S) SHADES OF PURPLE IS/ARE CLAIMED AS A FEATURE OF THE MARK.

THE MARK CONSISTS OF A PURPLE BRAIN SHAPE WITH THE WORD "SMART" ON IT, AN ACRONYM FOR SURVEY MONITORING AND RESPONSE TAILORING.

FOR CONDUCTING BUSINESS SURVEYS; CONDUCTING EMPLOYEE SURVEYS FOR OTHERS FOR PURPOSES OF IMPROVING EMPLOYEE PERFORMANCE AND MORALE; CONDUCTING QUALITY ASSURANCE SURVEYS IN HOSPITALS TO DETERMINE SERVICE QUALITY (U.S. CLS. 100, 101 AND 102).

FIRST USE 2-17-2013; IN COMMERCE 2-17-2013.  
ANNE MADDEN, EXAMINING ATTORNEY

**CLASS 35—(Continued).**

SN 86-234,848. YU, MEIYU, ANN ARBOR, MI. FILED 3-28-2014.

Qvette

THE MARK CONSISTS OF STANDARD CHARACTERS WITHOUT CLAIM TO ANY PARTICULAR FONT, STYLE, SIZE, OR COLOR.

THE WORDING "QVETTE" HAS NO MEANING IN A FOREIGN LANGUAGE.

FOR ON-LINE RETAIL STORE SERVICES FEATURING MORTAR AND PESTLES AND CRUCIBLES (U.S. CLS. 100, 101 AND 102).

KEVIN CRENNAN, EXAMINING ATTORNEY

SN 86-234,670. USED WELL, LLC, SAN FRANCISCO, CA. FILED 3-27-2014.

USED WELL

THE MARK CONSISTS OF STANDARD CHARACTERS WITHOUT CLAIM TO ANY PARTICULAR FONT, STYLE, SIZE, OR COLOR.

FOR ONLINE RETAIL STORE, CATALOG ORDERING SERVICES, AND RETAIL STORE DISTRIBUTION SERVICES FEATURING COOKING UTENSILS, KITCHEN UTENSILS, HOUSEHOLD UTENSILS, COOKINGWARE, KITCHENWARE, AND HOUSEWARES OF OTHERS; PROVIDING CONSUMER PRODUCT INFORMATION AND PRODUCT REVIEWS OF COOKING UTENSILS, KITCHEN UTENSILS, HOUSEHOLD UTENSILS, COOKINGWARE, KITCHENWARE, AND HOUSEWARES OF OTHERS (U.S. CLS. 100, 101 AND 102).

AHSEN KHAN, EXAMINING ATTORNEY

SN 86-235,023. BLUECROSS BLUESHIELD OF TENNESSEE, INC., CHATTANOOGA, TN. FILED 3-28-2014.

CUSTOM 360

THE MARK CONSISTS OF STANDARD CHARACTERS WITHOUT CLAIM TO ANY PARTICULAR FONT, STYLE, SIZE, OR COLOR.

NO CLAIM IS MADE TO THE EXCLUSIVE RIGHT TO USE "CUSTOM", APART FROM THE MARK AS SHOWN.

FOR BUSINESS ADMINISTRATION SERVICES FOR HEALTH CARE PLANS, EMPLOYERS AND BUSINESSES, NAMELY, BUSINESS ADMINISTRATION OF DISEASE PREVENTION, WELLNESS AND HEALTH PROMOTION PROGRAMS CONSISTING OF HEALTH RISK APPRAISALS, HIGH RISK MANAGEMENT AND HEALTH RISK MANAGEMENT ACCOUNTABILITY (U.S. CLS. 100, 101 AND 102).

DAVID GEARHART, EXAMINING ATTORNEY



**CLASS 35—(Continued).**

SN 86-235,161. LABELIUM USA, LLC, NEW YORK, NY.  
FILED 3-28-2014.

**LABELIUM**

THE MARK CONSISTS OF STANDARD CHARACTERS WITHOUT CLAIM TO ANY PARTICULAR FONT, STYLE, SIZE, OR COLOR.

THE WORDING "LABELIUM" HAS NO MEANING IN A FOREIGN LANGUAGE.

FOR ADVERTISING AND MARKETING SERVICES FOR OTHERS VIA AN ON-LINE COMMUNICATIONS NETWORK ON THE INTERNET, NAMELY, PROVIDING ADVERTISING AND COMMERCIAL INFORMATION SERVICES, VIA THE INTERNET; BUSINESS MARKETING CONSULTING SERVICES, NAMELY, MEDIA PLANNING AND PLACEMENT SERVICES FOR OTHERS IN CONNECTION WITH ONLINE ADVERTISING, AND ANALYZING SEARCH ENGINE AND KEYWORD PLACEMENTS FOR OTHERS FOR SEARCH ENGINE OPTIMIZATION; PROVIDING ADVERTISING, MARKETING AND PROMOTIONAL SERVICES, NAMELY, DEVELOPMENT OF ADVERTISING CAMPAIGNS; DEVELOPMENT, OPERATION AND ADMINISTRATION OF DIGITAL ADVERTISING SYSTEMS FOR OTHERS, NAMELY, PROVIDING ADVERTISING SPACE BY ELECTRONIC MEANS AND GLOBAL COMPUTER INFORMATION NETWORKS; TRACKING THE PERFORMANCE OF AN ONLINE BANNER FOR OTHERS (U.S. CLS. 100, 101 AND 102).

FIRST USE 1-1-2006; IN COMMERCE 1-1-2006.

ERIC SABLE, EXAMINING ATTORNEY

**CLASS 35—(Continued).**

SN 86-235,361. KLOUDSCRIPT, INC., OAK BROOK, IL.  
FILED 3-28-2014.



SN 86-235,302. KLOUDSCRIPT, INC., OAK BROOK, IL.  
FILED 3-28-2014.

**SPECIALTY CARE REDEFINED**

THE MARK CONSISTS OF STANDARD CHARACTERS WITHOUT CLAIM TO ANY PARTICULAR FONT, STYLE, SIZE, OR COLOR.

NO CLAIM IS MADE TO THE EXCLUSIVE RIGHT TO USE "SPECIALTY CARE", APART FROM THE MARK AS SHOWN.

FOR BUSINESS MANAGEMENT AND CONSULTATION SERVICES IN THE FIELD OF SPECIALTY PHARMACY; BUSINESS MANAGEMENT, ADVISORY AND CONSULTATION SERVICES FOR PHARMACIES REGARDING PROVISION OF SPECIALTY PHARMACEUTICALS TO PATIENTS WITH SERIOUS MEDICAL CONDITIONS; ARRANGING OF MANAGED CARE CONTRACTUAL SERVICES IN THE FIELDS OF SPECIALTY PHARMACY; ADMINISTERING PHARMACY REIMBURSEMENT SUPPORT PROGRAMS AND SERVICES; SPECIALIZED RETAIL PHARMACY SERVICES TO ENABLE "SPECIALTY CARE AT RETAIL PROGRAMS" FOR PATIENTS USING SPECIALTY MEDICATIONS; SPECIALIZED RETAIL, MAIL ORDER AND WHOLESALE PHARMACY SERVICES ENABLING PATIENTS TO ACCESS CO-PAY ASSISTANCE AND OTHER FUNDING SOURCES TO PAY FOR SPECIALTY MEDICATIONS (U.S. CLS. 100, 101 AND 102).

ESTHER A. BORSUK, EXAMINING ATTORNEY

THE COLOR(S) BURGUNDY AND GREY IS/ARE CLAIMED AS A FEATURE OF THE MARK.

THE MARK CONSISTS OF A DESIGN ELEMENT CONSISTING OF A GROTESQUE SHADOW OF A MAN WITH SPREAD-OUT ARMS AND LEGS, ALL IN BURGUNDY COLOR, WITH A CLOUD-SHAPED SHADOW ON THE FOREGROUND IN GRAY COLOR.

FOR BUSINESS MANAGEMENT AND CONSULTATION SERVICES IN THE FIELD OF SPECIALTY PHARMACY; BUSINESS MANAGEMENT, ADVISORY AND CONSULTATION SERVICES FOR PHARMACIES REGARDING PROVISION OF SPECIALTY PHARMACEUTICALS TO PATIENTS WITH SERIOUS MEDICAL CONDITIONS; ARRANGING OF MANAGED CARE CONTRACTUAL SERVICES IN THE FIELDS OF SPECIALTY PHARMACY; ADMINISTERING PHARMACY REIMBURSEMENT SUPPORT PROGRAMS AND SERVICES; SPECIALIZED RETAIL PHARMACY SERVICES TO ENABLE "SPECIALTY CARE AT RETAIL PROGRAMS" FOR PATIENTS USING SPECIALTY MEDICATIONS; SPECIALIZED RETAIL, MAIL ORDER AND WHOLESALE PHARMACY SERVICES ENABLING PATIENTS TO ACCESS CO-PAY ASSISTANCE AND OTHER FUNDING SOURCES TO PAY FOR SPECIALTY MEDICATIONS (U.S. CLS. 100, 101 AND 102).

ESTHER A. BORSUK, EXAMINING ATTORNEY

**CLASS 35—(Continued).**

SN 86-235,577. EAT WELL DISTRIBUTION, LLC, COLUMBUS, OH. FILED 3-28-2014.

**CLASS 35—(Continued).**

SN 86-235,605. FARMSPUN, LLC, MORRISTOWN, NJ. FILED 3-28-2014.

EAT WELL DISTRIBUTION



THE MARK CONSISTS OF STANDARD CHARACTERS WITHOUT CLAIM TO ANY PARTICULAR FONT, STYLE, SIZE, OR COLOR.

NO CLAIM IS MADE TO THE EXCLUSIVE RIGHT TO USE "DISTRIBUTION", APART FROM THE MARK AS SHOWN.

FOR WHOLESALE FOOD DISTRIBUTORSHIP SERVICES; WHOLESALE SERVICES BY DIRECT SOLICITATION BY SALES AGENTS IN THE FIELD OF FOOD; WHOLESALE FOOD MARKETING SERVICES FOR OTHERS; ON-LINE WHOLESALE STORE SERVICES FEATURING FOOD; WHOLESALE STORE SERVICES FEATURING FOOD; WHOLESALE SERVICES THROUGH DIRECT SOLICITATION BY SALES PERSONS DIRECTED TO END-USERS FEATURING FOOD; WHOLESALE SERVICES THROUGH DIRECT SOLICITATION BY DISTRIBUTORS DIRECTED TO END-USERS FEATURING FOOD (U.S. CLS. 100, 101 AND 102).

FIRST USE 10-12-2011; IN COMMERCE 10-12-2011.

TARAH HARDY, EXAMINING ATTORNEY

THE COLOR(S) LIGHT BLUE, BLUE, OLIVE GREEN, GREY, BLACK, WHITE, PEACH AND PINK IS/ARE CLAIMED AS A FEATURE OF THE MARK.

THE MARK CONSISTS OF A BLACK CIRCLE DISPLAYING A MULTICOLORED PLOWED FIELD IN THE LOWER HALF IN THE COLORS, FROM LEFT TO RIGHT, OLIVE GREEN, GREY, PEACH, PINK, BLUE, OLIVE GREEN, GREY, PEACH, PINK. ABOVE THE FIELD IS A LIGHT BLUE SKY IN THE TOP HALF WHICH IS INTERSECTED WITH A WHITE BANNER WITH BLACK BORDER DISPLAYING THE WORD "FARMSPUN" IN BLACK FONT CAPITAL LETTERS.

FOR ONLINE RETAIL STORE SERVICES IN THE FIELD OF KNITTING, WEAVING, SPINNING AND CROCHETING YARNS, FLEECE, ROVING, BATTING AND OTHER TEXTILES AND HOOKS, NEEDLES AND RELATED ACCESSORIES; MAIL ORDER AND ELECTRONIC CATALOG SERVICES FEATURING KNITTING, WEAVING, SPINNING AND CROCHETING YARNS, FLEECE, ROVING, BATTING AND OTHER TEXTILES AND HOOKS, NEEDLES AND RELATED ACCESSORIES; ONLINE RETAIL CONSIGNMENT SERVICES IN THE FIELD OF KNITTING, WEAVING, SPINNING AND CROCHETING YARNS, FLEECE, ROVING, BATTING AND OTHER TEXTILES AND HOOKS, NEEDLES AND RELATED ACCESSORIES (U.S. CLS. 100, 101 AND 102).

FIRST USE 3-0-2014; IN COMMERCE 3-0-2014.

MORGAN WYNNE, EXAMINING ATTORNEY



**CLASS 35—(Continued).**

SN 86-235,619. SCIOTO ENERGY, LLC, COLUMBUS, OH. FILED 3-28-2014.

Scioto Energy

THE MARK CONSISTS OF STANDARD CHARACTERS WITHOUT CLAIM TO ANY PARTICULAR FONT, STYLE, SIZE, OR COLOR.

NO CLAIM IS MADE TO THE EXCLUSIVE RIGHT TO USE "ENERGY", APART FROM THE MARK AS SHOWN.

FOR ENERGY MANAGEMENT SERVICES, NAMELY, PROVIDING A SERVICE THAT ALLOWS CUSTOMERS TO PURCHASE ENERGY FROM VARIOUS ENERGY PROVIDERS; ENERGY MANAGEMENT SERVICES, NAMELY, PROVIDING A SERVICE THAT ALLOWS CUSTOMERS TO PURCHASE ENERGY, NAMELY, ELECTRICITY, NATURAL GAS AND RENEWABLE ENERGY, AT A FIXED PRICE; ENERGY PRICE COMPARISON SERVICES; ENERGY USAGE MANAGEMENT; ENERGY USAGE MANAGEMENT INFORMATION SERVICES (U.S. CLS. 100, 101 AND 102).

FIRST USE 12-22-2008; IN COMMERCE 12-22-2008. TRACY FLETCHER, EXAMINING ATTORNEY

**CLASS 35—(Continued).**

SN 86-235,683. XLT CLOTHING LLC, HUNTSVILLE, AL. FILED 3-28-2014.



NO CLAIM IS MADE TO THE EXCLUSIVE RIGHT TO USE "CLOTHING", APART FROM THE MARK AS SHOWN.

THE COLOR(S) BLACK, BURGUNDY, AND GRAY IS/ARE CLAIMED AS A FEATURE OF THE MARK.

THE MARK CONSISTS OF THE STYLIZED WORDING "XLT CLOTHING". A VERTICAL LINE APPEARS BETWEEN THE WORDING "XLT" AND "CLOTHING". THE WORDING "XLT" APPEARS IN THE COLORS BLACK, BURGUNDY AND GRAY. THE LINE DESIGN APPEARS IN THE COLOR BLACK. THE WORDING "CLOTHING" APPEARS IN THE COLOR GRAY.

FOR RETAIL APPAREL STORES (U.S. CLS. 100, 101 AND 102).

CIMMERIAN COLEMAN, EXAMINING ATTORNEY

SN 86-235,719. SCIOTO ENERGY, LLC, COLUMBUS, OH. FILED 3-28-2014.

SN 86-235,659. LORENA SHIFF, GOLDEN BEACH, FL. FILED 3-28-2014.



THE COLOR(S) PERIWINKLE IS/ARE CLAIMED AS A FEATURE OF THE MARK.

THE MARK CONSISTS OF A PERIWINKLE SILHOUETTE OF A WOMAN'S HEAD WITH FLOWING HAIR.

FOR ON-LINE CONSIGNMENT RETAIL STORE FEATURING NEW AND VINTAGE LUXURY GOODS, NAMELY, BUSINESS ITEMS, PERSONAL ITEMS, FIXTURES, HOUSEHOLD ITEMS, FURNITURE, CLOTHING, ACCESSORIES, ANTIQUES, COLLECTIBLES, AND SPORTING GOODS (U.S. CLS. 100, 101 AND 102).

FIRST USE 3-28-2014; IN COMMERCE 3-28-2014. BRENDAN MCCAULEY, EXAMINING ATTORNEY



NO CLAIM IS MADE TO THE EXCLUSIVE RIGHT TO USE "ENERGY", APART FROM THE MARK AS SHOWN.

THE COLOR(S) BLUE, BROWN, YELLOW, AND ORANGE IS/ARE CLAIMED AS A FEATURE OF THE MARK.

THE MARK CONSISTS OF THE BLUE WORDING "SCIOTO" AND THE BROWN WORDING "ENERGY" BELOW A DIAMOND PATTERN OF YELLOW AND ORANGE CIRCLES THAT APPEAR TO MOVE IN A WAVE-LIKE MANNER

FOR ENERGY MANAGEMENT SERVICES, NAMELY, PROVIDING A SERVICE THAT ALLOWS CUSTOMERS TO PURCHASE ENERGY FROM VARIOUS ENERGY PROVIDERS; ENERGY MANAGEMENT SERVICES, NAMELY, PROVIDING A SERVICE THAT ALLOWS CUSTOMERS TO PURCHASE ENERGY, NAMELY, ELECTRICITY, NATURAL GAS AND RENEWABLE ENERGY, AT A FIXED PRICE; ENERGY PRICE COMPARISON SERVICES; ENERGY USAGE MANAGEMENT; ENERGY USAGE MANAGEMENT INFORMATION SERVICES (U.S. CLS. 100, 101 AND 102).

FIRST USE 12-22-2008; IN COMMERCE 12-22-2008. TRACY FLETCHER, EXAMINING ATTORNEY

**CLASS 35—(Continued).**

SN 86-235,836. YE OLDE DOPE SHOPPE CORPORATION, SHORELINE, WA. FILED 3-28-2014.

## Ye Olde Dope Shoppe

THE MARK CONSISTS OF STANDARD CHARACTERS WITHOUT CLAIM TO ANY PARTICULAR FONT, STYLE, SIZE, OR COLOR.

NO CLAIM IS MADE TO THE EXCLUSIVE RIGHT TO USE "DOPE SHOPPE", APART FROM THE MARK AS SHOWN.

FOR RETAIL STORE SERVICES FEATURING MARIJUANA AND RELATED CONSUMER GOODS (U.S. CLS. 100, 101 AND 102).

JULIE VEPPUMTHARA, EXAMINING ATTORNEY

**CLASS 35—(Continued).**

SN 86-236,032. FILE RIGHT LLC, MIDDLETOWN, DE. FILED 3-28-2014.

## INMIGRACION EN TUS MANOS

THE MARK CONSISTS OF STANDARD CHARACTERS WITHOUT CLAIM TO ANY PARTICULAR FONT, STYLE, SIZE, OR COLOR.

NO CLAIM IS MADE TO THE EXCLUSIVE RIGHT TO USE "INMIGRACION", APART FROM THE MARK AS SHOWN.

THE ENGLISH TRANSLATION OF "INMIGRACION EN TUS MANOS" IN THE MARK IS "IMMIGRATION IN YOUR HANDS".

FOR PROVIDING AN ON-LINE COMMERCIAL INFORMATION DIRECTORY ON THE INTERNET; REFERRALS IN THE FIELD OF IMMIGRATION-RELATED LEGAL CONSULTANTS; MATCHING CONSUMERS WITH PROFESSIONALS IN THE FIELD OF IMMIGRATION LAW (U.S. CLS. 100, 101 AND 102).

BARBARA BROWN, EXAMINING ATTORNEY

SN 86-235,971. CALIFORNIA CUT FLOWER COMMISSION, SANTA BARBARA, CA. FILED 3-28-2014.



NO CLAIM IS MADE TO THE EXCLUSIVE RIGHT TO USE "AMERICAN GROWN", APART FROM THE MARK AS SHOWN.

THE COLOR(S) RED, WHITE, AND BLUE IS/ARE CLAIMED AS A FEATURE OF THE MARK.

THE MARK CONSISTS OF A DESIGN WITH A HEART SHAPE AND FLOWER ELEMENTS. WITHIN THE HEART ARE ELEMENTS OF THE AMERICAN FLAG. THE UPPER LEFT PART CONSISTS OF WHITE STARS AGAINST A BLUE BACKGROUND AND THE REST OF THE HEART CONSISTS OF RED AND WHITE STRIPES. FIVE BLUE PETAL SHAPES APPEAR ABOVE THE LEFT SIDE OF THE HEART AND TWO STYLIZED LEAVES APPEAR BELOW THE HEART. THE HEART IS OUTLINED IN WHITE. TO THE RIGHT OF THE DESIGN IS THE WORDING "AMERICAN GROWN TAKE PRIDE IN YOUR FLOWERS." WITH "AMERICAN" IN BLUE, "GROWN" IN RED, AND "TAKE PRIDE IN YOUR FLOWERS." IN BLUE.

FOR ASSOCIATION SERVICES, NAMELY, PROMOTING THE INTERESTS OF FLOWER FARMERS IN THE UNITED STATES (U.S. CLS. 100, 101 AND 102).

FIRST USE 2-27-2014; IN COMMERCE 2-27-2014.

REBECCA POVARCHUK, EXAMINING ATTORNEY

SN 86-236,120. WEALTH OCEAN INC., IRVINE, CA. FILED 3-28-2014.



THE MARK CONSISTS OF A MARK SIMILAR TO A LOWER CASE LETTER "D" WHERE THE TOP OF THE LETTER "D" IS SHAPED LIKE AN OCEAN WAVE AND THE "D" IS NOT CLOSED AND THE WORDS "WEALTH OCEAN" IS ON THE RIGHT OF THE MARK AND THE "O" IN "OCEAN" IS SHAPED SIMILAR TO THE MARK.

FOR IMPORT-EXPORT AGENCIES IN THE FIELD OF CHEMICAL RAW MATERIALS, NAMELY, TITANIUM DIOXIDE, UV STABILIZERS, HINDERED AMINE LIGHT STABILIZERS (HALS), PHOTOINITIATORS, PHENOLIC RESINS, THERMOPLASTIC ELASTOMERS (TPE), RUBBER ADDITIVES, RUBBERS AND PLASTICS RAW MATERIAL, NAMELY, CHLORINATED RUBBER, NITRILE RUBBER, POLYVINYL CHLORIDE (PVC), POLYCHLOROPRENE RUBBER, POLYCHLOROPRENE LATEX, ETHYLENE PROPYLENE DIENE MONOMER, POLYPHENYLENE ETHER, POLYPHENYLENE OXIDE, POLYOXYMETHYLENE, CHEMICALS AND UNPROCESSED PLASTICS, POLYMERS, ELASTOMERS, POLYMERS AND POLYMERIC ADDITIVES FOR USE IN THE MANUFACTURE OF PHARMACEUTICAL MATERIALS, RUBBER AND PLASTICS IN UNPROCESSED FORM, IN POWDER, LIQUID OR PASTE FORM, UNPROCESSED SYNTHETIC RESINS, RUBBERS AND PLASTIC ADDITIVES, CHLORINATED RUBBER, ISOBUTYLENE-ISOPRENE RUBBER, LATEX RUBBER FOR USE IN MANUFACTURING, FINE AND SPECIALTY CHEMICALS (U.S. CLS. 100, 101 AND 102).

FIRST USE 1-1-2010; IN COMMERCE 1-1-2010.

MARK SPARACINO, EXAMINING ATTORNEY

**CLASS 35—(Continued).**

SN 86-236,249. MILLER, VERNON, LOS ANGELES, CA. AND DYER, KEVIN, LOS ANGELES, CA. FILED 3-29-2014.

**YOU CALL WE DELIVER**

THE MARK CONSISTS OF STANDARD CHARACTERS WITHOUT CLAIM TO ANY PARTICULAR FONT, STYLE, SIZE, OR COLOR.

NO CLAIM IS MADE TO THE EXCLUSIVE RIGHT TO USE "WE DELIVER", APART FROM THE MARK AS SHOWN.

FOR RETAIL CLOTHING STORES; ON-LINE RETAIL CLOTHING STORE SERVICES (U.S. CLS. 100, 101 AND 102).

ALISON KEELEY, EXAMINING ATTORNEY

**CLASS 35—(Continued).**

SN 86-236,417. THE ENCIMA GROUP, INC., NEWARK, DE. FILED 3-29-2014.

**THE ENCIMA GROUP**

THE MARK CONSISTS OF STANDARD CHARACTERS WITHOUT CLAIM TO ANY PARTICULAR FONT, STYLE, SIZE, OR COLOR.

NO CLAIM IS MADE TO THE EXCLUSIVE RIGHT TO USE "GROUP", APART FROM THE MARK AS SHOWN.

THE ENGLISH TRANSLATION OF "ENCIMA" IN THE MARK IS "ABOVE".

FOR PROVIDING BUSINESS ADVISORY SERVICES, NAMELY, PROVIDING ADVICE IN THE FIELDS OF MARKETING, SALES METHODS, SALES MANAGEMENT, SALES IMPROVEMENT AND BUSINESS OPERATIONS; BUSINESS ANALYSIS SERVICES (U.S. CLS. 100, 101 AND 102).

KATHERINE CHANG, EXAMINING ATTORNEY

SN 86-236,279. LSP PARTNERS LLC, BAYSIDE, WI. FILED 3-29-2014.

**XL12 Index**

THE MARK CONSISTS OF STANDARD CHARACTERS WITHOUT CLAIM TO ANY PARTICULAR FONT, STYLE, SIZE, OR COLOR.

NO CLAIM IS MADE TO THE EXCLUSIVE RIGHT TO USE "INDEX", APART FROM THE MARK AS SHOWN.

FOR PROVIDING AND UPDATING A FINANCIAL INDEX OF SECURITIES VALUES AND CLASSIFICATION, ANALYSIS, AND REPORTING THEREOF (U.S. CLS. 100, 101 AND 102).

DANIEL S. STRINGER, EXAMINING ATTORNEY

SN 86-236,418. THE ENCIMA GROUP, INC., NEWARK, DE. FILED 3-29-2014.

**ENCIMA**

THE MARK CONSISTS OF STANDARD CHARACTERS WITHOUT CLAIM TO ANY PARTICULAR FONT, STYLE, SIZE, OR COLOR.

THE ENGLISH TRANSLATION OF "ENCIMA" IN THE MARK IS "ABOVE".

FOR PROVIDING BUSINESS ADVISORY SERVICES, NAMELY, PROVIDING ADVICE IN THE FIELDS OF MARKETING, SALES METHODS, SALES MANAGEMENT, SALES IMPROVEMENT AND BUSINESS OPERATIONS; BUSINESS ANALYSIS SERVICE (U.S. CLS. 100, 101 AND 102).

FIRST USE 1-1-2014; IN COMMERCE 1-1-2014.  
KATHERINE CHANG, EXAMINING ATTORNEY

SN 86-236,416. THE ENCIMA GROUP, INC., NEWARK, DE. FILED 3-29-2014.

**TEG**

THE MARK CONSISTS OF STANDARD CHARACTERS WITHOUT CLAIM TO ANY PARTICULAR FONT, STYLE, SIZE, OR COLOR.

FOR PROVIDING BUSINESS ADVISORY SERVICES, NAMELY, PROVIDING ADVICE IN THE FIELDS OF MARKETING, SALES METHODS, SALES MANAGEMENT, SALES IMPROVEMENT AND BUSINESS OPERATIONS; BUSINESS ANALYSIS SERVICES (U.S. CLS. 100, 101 AND 102).

KATHERINE CHANG, EXAMINING ATTORNEY

SN 86-236,493. PRINT GENIUS, LLC, ARLINGTON, TX. FILED 3-30-2014.

**Print Genius**

THE MARK CONSISTS OF STANDARD CHARACTERS WITHOUT CLAIM TO ANY PARTICULAR FONT, STYLE, SIZE, OR COLOR.

NO CLAIM IS MADE TO THE EXCLUSIVE RIGHT TO USE "PRINT", APART FROM THE MARK AS SHOWN.

FOR BUSINESS ADVISORY SERVICES IN THE FIELD OF PRINT PRODUCTION (U.S. CLS. 100, 101 AND 102).

FIRST USE 4-5-2011; IN COMMERCE 4-5-2011.  
MARK SPARACINO, EXAMINING ATTORNEY

**CLASS 35—(Continued).**

SN 86-236,640. GATE PETROLEUM COMPANY, DBA GATE, JACKSONVILLE, FL. FILED 3-31-2014.



OWNER OF U.S. REG. NOS. 1,456,042, 3,539,478 AND OTHERS.

NO CLAIM IS MADE TO THE EXCLUSIVE RIGHT TO USE "PREMIUM QUALITY INGREDIENTS", "FRESH", AND "TO GO", APART FROM THE MARK AS SHOWN.

THE MARK CONSISTS OF A SEAL CONTAINING THE PHRASE "PREMIUM QUALITY INGREDIENTS" APPEARING IN THE UPPER PORTION, THE PHRASE "TO GO" APPEARING IN THE BOTTOM PORTION, A RIBBON RUNNING ACROSS THE SEAL WITH THE PHRASE "ALWAYS FRESH" WITH AN IMAGE APPEARING IN THE UPPER CENTER OF THE SEAL APPEARING AS A FOUR SIDED ENCLOSURE HAVING ROUNDED EDGES CONTAINING THE WORD "GATE" AND A RENDITION OF A GATE, AND STALKS OF WHEAT EXTENDING OUTWARD FROM EACH SIDE OF THE BOTTOM OF THE ENCLOSURE.

FOR RETAIL CONVENIENCE STORES; RETAIL GROCERY STORES; RETAIL STORE SERVICES FEATURING CONVENIENCE STORE ITEMS AND GASOLINE; RETAIL GROCERY STORES FEATURING PREPACKAGED FOOD PRODUCTS SOLD AT THE STORES (U.S. CLS. 100, 101 AND 102).

FIRST USE 4-0-2014; IN COMMERCE 4-0-2014.  
SARA BENJAMIN, EXAMINING ATTORNEY

**CLASS 35—(Continued).**

FIRST BAR IS RED, THE NEXT IS WHITE, THE LAST BAR IS BLUE, AND ALL THE BARS HAVE A BLUE BOARDER. THE STYLIZED ROD IS WHITE WITH A BLUE BOARDER AND THERE IS A BLUE COIL AROUND THE ROD. THE WORDING "RECORD GRABBER" APPEARS IN BLUE AND IN A STYLIZED FONT TO THE RIGHT OF THE ROD OF ASCLEPIUS WITH THREE HORIZONTAL BARS BELOW THE WORDING. THE FIRST BAR IS RED, THE NEXT BAR IS WHITE, THE FINAL BAR IS BLUE, AND ALL THE BARS HAVE A BLUE BOARDER.

FOR RECORDS MANAGEMENT SERVICES, NAMELY, PROVIDING RETRIEVAL, ACQUISITION, SECURE MANAGEMENT AND ORGANIZATION OF MEDICAL RECORDS TO FACILITATE PATIENT-AUTHORIZED HIPAA-COMPLIANT SHARING OF THE PATIENT'S MEDICAL RECORDS WITH MEDICAL PROVIDERS, MEDICAL INSTITUTIONS, LEGAL PROFESSIONALS, INSURANCE COMPANIES, EMPLOYERS, THIRD PARTY ADMINISTRATORS, MANAGED CARE ORGANIZATIONS, AND ANY ENTITY AUTHORIZED BY THE PATIENT (U.S. CLS. 100, 101 AND 102).

FIRST USE 1-12-2014; IN COMMERCE 3-25-2014.  
MICHAEL P EISNACH, EXAMINING ATTORNEY

SN 86-236,690. PATRON TECHNOLOGY, LLC, NEW YORK, NY. FILED 3-31-2014.

## PATRONMAIL

THE MARK CONSISTS OF STANDARD CHARACTERS WITHOUT CLAIM TO ANY PARTICULAR FONT, STYLE, SIZE, OR COLOR.

OWNER OF U.S. REG. NO. 2,733,116.

FOR ADVERTISING, PROMOTION AND MARKETING SERVICES IN THE NATURE OF E-MAIL BLAST CAMPAIGNS FOR OTHERS (U.S. CLS. 100, 101 AND 102).

FIRST USE 10-24-2001; IN COMMERCE 10-30-2001.  
KAELIE KUNG, EXAMINING ATTORNEY

SN 86-236,647. RECORD GRABBER LLC, MCCORDSVILLE, IN. FILED 3-31-2014.



NO CLAIM IS MADE TO THE EXCLUSIVE RIGHT TO USE "RECORD", APART FROM THE MARK AS SHOWN.

THE COLOR(S) RED, WHITE, BLUE IS/ARE CLAIMED AS A FEATURE OF THE MARK.

THE MARK CONSISTS OF A WHITE HAND WITH A BLUE BORDER HOLDING A STYLIZED ROD OF ASCLEPIUS WITH THREE BARS AT THE TOP OF THE ROD OF ASCLEPIUS. THE ROD INTERSECTS THE BARS SUCH THAT THE BARS APPEAR AS WINGS ON THE ROD. THE

SN 86-236,776. WILSON, DR. MARK, PALM DESERT, CA. FILED 3-31-2014.

## Los Angeles Conquistadores

THE MARK CONSISTS OF STANDARD CHARACTERS WITHOUT CLAIM TO ANY PARTICULAR FONT, STYLE, SIZE, OR COLOR.

NO CLAIM IS MADE TO THE EXCLUSIVE RIGHT TO USE "LOS ANGELES", APART FROM THE MARK AS SHOWN.

FOR ON-LINE RETAIL STORE SERVICES FEATURING A WIDE VARIETY OF CONSUMER GOODS OF OTHERS (U.S. CLS. 100, 101 AND 102).

DAVID MURRAY, EXAMINING ATTORNEY

**CLASS 35—(Continued).**

SN 86-236,914. ORGAN ALLIANCE, INC., WHITE PLAINS, NY. FILED 3-31-2014.

**THE 53RD REGISTRY**

THE MARK CONSISTS OF STANDARD CHARACTERS WITHOUT CLAIM TO ANY PARTICULAR FONT, STYLE, SIZE, OR COLOR.

NO CLAIM IS MADE TO THE EXCLUSIVE RIGHT TO USE "REGISTRY", APART FROM THE MARK AS SHOWN. FOR PROVIDING A WEBSITE FEATURING A REGISTRY OF ORGAN DONORS (U.S. CLS. 100, 101 AND 102).

AMY HELLA, EXAMINING ATTORNEY

SN 86-237,030. EDDI, INC., CHINO, CA. FILED 3-31-2014.

**BOX OF STUFF**

THE MARK CONSISTS OF STANDARD CHARACTERS WITHOUT CLAIM TO ANY PARTICULAR FONT, STYLE, SIZE, OR COLOR.

FOR OPERATING AN ON-LINE MARKETPLACE FOR SELLERS OF GOODS AND/OR SERVICES; PROVIDING A WEBSITE FEATURING AN ONLINE MARKETPLACE FOR EXCHANGING GOODS AND SERVICES WITH OTHER USERS; OPERATING AN ONLINE MOBILE MARKETPLACE FOR SELLERS OF GOODS AND/OR SERVICES; PROVIDING A WEBSITE FEATURING AN ONLINE MOBILE MARKETPLACE FOR EXCHANGING GOODS AND SERVICES WITH OTHER USERS; ONLINE RETAIL STORE SERVICES IN THE FIELDS OF ELECTRONICS, CELLULAR PHONES, CELLULAR PHONE ACCESSORIES, CAMERAS, GAMING, APPAREL, TILE, LUMBER, STONES, PAVERS, BARKS, MULCHES, PIPES, PIPE FITTINGS, POWER TOOLS, FAUCETS, LIGHTING, HOME DÉCOR, LOCKS, DEADBOLTS, CABINETS, CABINET HARDWARE, CONSTRUCTION MATERIALS, AUTOMOTIVE PARTS, SPORTING GOODS, HOME APPLIANCES, POOL SUPPLIES, POOL EQUIPMENT, GARDEN EQUIPMENT, SECURITY AND SURVEILLANCE EQUIPMENT; PROMOTING THE GOODS AND SERVICES OF OTHERS BY PROVIDING A WEB SITE FEATURING PRODUCT INFORMATION AND REVIEWS, INFORMATION ABOUT PRACTICES AND TRENDS, HOW-TO ARTICLES AND VIDEOS, DISCOUNTS AND COUPONS, AND LINKS TO THE WEB SITES OF OTHERS, ALL IN THE FIELDS OF ELECTRONICS, CELLULAR PHONES, CELLULAR PHONE ACCESSORIES, CAMERAS, GAM-

**CLASS 35—(Continued).**

ING, APPAREL, TILE, LUMBER, STONES, PAVERS, BARKS, MULCHES, PIPES, PIPE FITTINGS, SHELVING, POWER TOOLS, FAUCETS, LIGHTING, HOME DÉCOR, LOCKS, DEADBOLTS, CABINETS, CABINET HARDWARE, CONSTRUCTION MATERIALS, AUTOMOTIVE PARTS, SPORTING GOODS, HOME APPLIANCES, POOL SUPPLIES, POOL EQUIPMENT, GARDEN EQUIPMENT, SECURITY AND SURVEILLANCE EQUIPMENT; CONSUMER MEMBERSHIP AND SUBSCRIPTION PROGRAM SERVICES IN THE NATURE OF PROVIDING DISCOUNTS TO MEMBERS IN THE FIELDS OF ELECTRONICS, CELLULAR PHONES, CELLULAR PHONE ACCESSORIES, CAMERAS, GAMING, APPAREL, TILE, LUMBER, STONES, PAVERS, BARKS, MULCHES, PIPES, PIPE FITTINGS, SHELVING, POWER TOOLS, FAUCETS, LIGHTING, HOME DÉCOR, LOCKS, DEADBOLTS, CABINETS, CABINET HARDWARE, CONSTRUCTION MATERIALS, AUTOMOTIVE PARTS, SPORTING GOODS, HOME APPLIANCES, POOL SUPPLIES, POOL EQUIPMENT, GARDEN EQUIPMENT, SECURITY AND SURVEILLANCE EQUIPMENT (U.S. CLS. 100, 101 AND 102).

KEVIN MITTLER, EXAMINING ATTORNEY

SN 86-237,087. CRT MEDICAL SYSTEMS, INC., NOVI, MI. FILED 3-31-2014.



OWNER OF U.S. REG. NO. 4,553,077.

NO CLAIM IS MADE TO THE EXCLUSIVE RIGHT TO USE "FISCAL CARE", APART FROM THE MARK AS SHOWN.

THE COLOR(S) GREEN AND BLUE IS/ARE CLAIMED AS A FEATURE OF THE MARK.

THE MARK CONSISTS OF THE WORDS "FISCAL CARE" AND A ZIG-ZAG LINE DEPICTING AN ANIMATED HEART MONITOR EKG LINE, WITH THE WORD "FISCAL" AND THE LEFT HALF OF THE LINE APPEARING IN GREEN AND THE WORD "CARE" AND THE RIGHT HALF OF THE LINE APPEARING IN BLUE.

FOR HEALTHCARE PRACTICE MANAGEMENT AND ADMINISTRATIVE SUPPORT SERVICES; MEDICAL BILLING SUPPORT SERVICES (U.S. CLS. 100, 101 AND 102).

FIRST USE 11-6-2013; IN COMMERCE 11-6-2013.

ANDREA K. NADELMAN, EXAMINING ATTORNEY

**CLASS 35—(Continued).**

SN 86-237,106. GREEN DOT ENTERPRISES, INC., SANTA MONICA, CA. FILED 3-31-2014.



THE COLOR(S) GREEN, BLACK, ORANGE, AND WHITE IS/ARE CLAIMED AS A FEATURE OF THE MARK.

THE MARK CONSISTS OF A GREEN CIRCLE OUTLINED IN BLACK WEARING BLACK SUN GLASSES, WHICH ARE OUTLINED IN WHITE AND OVERLAID WITH WHITE, GREEN AND ORANGE SPOTS, WITH WHITE ARMS AND LEGS OUTLINED IN BLACK EXTENDING FROM THE EXTERIOR BORDER OF THE GREEN CIRCLE. THE CONTOURS OF THE ARMS AND LEGS ARE BLURRED GREEN AND WHITE TO INDICATE SPEED AND/OR MOTION. THE BLACK BACKGROUND IS USED TO SHOW PLACEMENT, AND IS NOT CLAIMED AS A FEATURE OF THE MARK.

FOR BUSINESS CONSULTING SERVICES IN THE AGRICULTURAL FIELD; BUSINESS CONSULTING SERVICES RELATING TO PRODUCT DISTRIBUTION, OPERATIONS MANAGEMENT SERVICES, LOGISTICS, REVERSE LOGISTICS, SUPPLY CHAIN, AND PRODUCTION SYSTEMS AND DISTRIBUTION SOLUTIONS; BUSINESS CONSULTING SERVICES, NAMELY, PROVIDING ASSISTANCE IN DEVELOPMENT OF BUSINESS STRATEGIES AND CREATIVE IDEATION (U.S. CLS. 100, 101 AND 102).

EVIN L. KOZAK, EXAMINING ATTORNEY

SN 86-237,209. TAMPA BAY ARENA, L.P., TAMPA, FL. FILED 3-31-2014.



NO CLAIM IS MADE TO THE EXCLUSIVE RIGHT TO USE "TAMPA BAY SPORTS", APART FROM THE MARK AS SHOWN.

THE COLOR(S) DARK BLUE, SKY BLUE AND WHITE IS/ARE CLAIMED AS A FEATURE OF THE MARK.

THE MARK CONSISTS OF THE WORDS AND LETTERS "TB TAMPA BAY SPORTS". "T" AND "B" ARE INSIDE A HORIZONTAL OVAL WITH "T" IN WHITE AGAINST A DARK BLUE BACKGROUND AND "B" IN WHITE AGAINST A SKY BLUE BACKGROUND, TO THE LEFT OF "TAMPA BAY SPORTS", WITH "TAMPA BAY" IN DARK BLUE AND "SPORTS" IN SKY BLUE.

FOR RETAIL APPAREL STORES; SPECIALTY MERCHANDISING SERVICES, NAMELY, PROMOTING THE GOODS AND SERVICES OF OTHERS THROUGH THE DISTRIBUTION OF CUSTOMIZED ADVERTISING MATERIALS, NAMELY, CLOTHING, KEY CHAINS, MUGS AND OTHER LOGO BEARING PROMOTIONAL ITEMS PROMOTING A PARTICULAR PROFESSIONAL HOCKEY TEAM (U.S. CLS. 100, 101 AND 102).

FIRST USE 3-16-2012; IN COMMERCE 3-16-2012.  
ELISSA GARBER KON, EXAMINING ATTORNEY

**CLASS 35—(Continued).**

SN 86-237,369. RAJPARTH ACHIEVERS, LLC, BOCA RATON, FL. FILED 3-31-2014.

# BALANCIT

THE MARK CONSISTS OF STANDARD CHARACTERS WITHOUT CLAIM TO ANY PARTICULAR FONT, STYLE, SIZE, OR COLOR.

FOR ORGANIZATIONAL SERVICES FOR BUSINESS PURPOSES, NAMELY, CONSULTING REGARDING DEVELOPMENT OF OPTIMAL TIME MANAGEMENT TO ACHIEVE BUSINESS, PERSONAL AND FAMILY GOALS; PROVIDING INFORMATION IN THE FIELD OF TIME MANAGEMENT FOR BUSINESS PURPOSES (U.S. CLS. 100, 101 AND 102).

FIRST USE 2-3-2014; IN COMMERCE 2-3-2014.  
SHARON MEIER, EXAMINING ATTORNEY

SN 86-237,446. UNDERCITY ENTERPRISES LLC, WHITTIER, CA. FILED 3-31-2014.

# Undercity

THE MARK CONSISTS OF STANDARD CHARACTERS WITHOUT CLAIM TO ANY PARTICULAR FONT, STYLE, SIZE, OR COLOR.

FOR ON-LINE RETAIL STORE SERVICES FEATURING COMIC BOOKS, GRAPHIC NOVELS, GAMING-RELATED COLLECTIBLES, GAMING CARDS AND ACCESSORIES, BOARD GAMES, AND TOYS; RETAIL STORE SERVICES FEATURING COMIC BOOKS, GRAPHIC NOVELS, GAMING-RELATED COLLECTIBLES, GAMING CARDS AND ACCESSORIES, BOARD GAMES, AND TOYS (U.S. CLS. 100, 101 AND 102).

FIRST USE 4-1-2010; IN COMMERCE 4-1-2010.  
DEBORAH MEINERS, EXAMINING ATTORNEY

SN 86-237,639. PETIT VOUR, HOUSTON, TX. FILED 3-31-2014.

# Be Bold Be Kind

THE MARK CONSISTS OF STANDARD CHARACTERS WITHOUT CLAIM TO ANY PARTICULAR FONT, STYLE, SIZE, OR COLOR.

FOR ON-LINE RETAIL STORE SERVICES FEATURING VEGAN BEAUTY PRODUCTS AND COSMETIC ACCESSORIES (U.S. CLS. 100, 101 AND 102).

FIRST USE 8-11-2012; IN COMMERCE 8-11-2012.  
LINDA POWELL, EXAMINING ATTORNEY



**CLASS 35—(Continued).**

SN 86-237,646. MARRIAH MEDIA, LLC, RINGOES, NJ.  
FILED 3-31-2014.

## The Santa Gallery Mall

THE MARK CONSISTS OF STANDARD CHARACTERS WITHOUT CLAIM TO ANY PARTICULAR FONT, STYLE, SIZE, OR COLOR.

NO CLAIM IS MADE TO THE EXCLUSIVE RIGHT TO USE "GALLERY MALL", APART FROM THE MARK AS SHOWN.

FOR OPERATING ON-LINE MARKETPLACES FOR SELLERS AND BUYERS OF GOODS AND/OR SERVICES (U.S. CLS. 100, 101 AND 102).

FIRST USE 9-20-2013; IN COMMERCE 10-7-2013.  
SHAUNIA CARLYLE, EXAMINING ATTORNEY

**CLASS 35—(Continued).**

SN 86-237,964. QUINTANILLA, HECTOR, CONROE, TX.  
FILED 3-31-2014.

## RED BARN OUTLET

THE MARK CONSISTS OF STANDARD CHARACTERS WITHOUT CLAIM TO ANY PARTICULAR FONT, STYLE, SIZE, OR COLOR.

NO CLAIM IS MADE TO THE EXCLUSIVE RIGHT TO USE "OUTLET", APART FROM THE MARK AS SHOWN.

FOR ON-LINE RETAIL STORE SERVICES FEATURING A WIDE VARIETY OF CONSUMER GOODS OF OTHERS; RETAIL STORE SERVICES FEATURING A WIDE VARIETY OF CONSUMER GOODS OF OTHERS (U.S. CLS. 100, 101 AND 102).

JACLYN KIDWELL WALKER, EXAMINING ATTORNEY

SN 86-237,950. HORSE LINGO, LLC, PLAINFIELD, IL.  
FILED 3-31-2014.



NO CLAIM IS MADE TO THE EXCLUSIVE RIGHT TO USE "HORSE", APART FROM THE MARK AS SHOWN.

THE MARK CONSISTS OF A STYLIZED HORSE HEAD WITH THE PHRASE "HORSE LINGO" LOCATED WHERE THE BODY OF THE HORSE WOULD BE.

FOR ADVERTISING AGENCY SERVICES, INCLUDING PROMOTING THE GOODS AND SERVICES OF OTHERS THROUGH SOCIAL MEDIA, ONLINE, AND MOBILE APPLICATION ADVERTISEMENTS; PROMOTING, ADVERTISING, AND MARKETING THE WEBSITES AND SOCIAL MEDIA SITES OF OTHERS; BUSINESS CONSULTING SERVICES IN THE FIELDS OF MARKETING AND ADVERTISING; PROVIDING MARKETING AND ADVERTISING SERVICES, NAMELY, THE DEVELOPMENT AND MANAGEMENT OF SOCIAL MEDIA CAMPAIGNS, ONLINE BANNERS, AND CONTENT POSTS FOR HORSES, BARNs, BREEDING PROGRAMS, EQUINE BUSINESSES, AND EQUINE-RELATED ENDEAVORS (U.S. CLS. 100, 101 AND 102).

FIRST USE 10-29-2012; IN COMMERCE 11-5-2012.  
SETH DENNIS, EXAMINING ATTORNEY

SN 86-238,142. BIKEWISH LLC, LAWRENCE, KS. FILED 4-1-2014.

## Bikewish

THE MARK CONSISTS OF STANDARD CHARACTERS WITHOUT CLAIM TO ANY PARTICULAR FONT, STYLE, SIZE, OR COLOR.

FOR PROVIDING A SERVICE OF INTRODUCING AND CONNECTING BUYERS OF MOTORCYCLES AND SCOOTERS WITH SELLERS OF MOTORCYCLES AND SCOOTERS; PROVIDING MOTORCYCLE AND SCOOTER PURCHASE ADVISORY AND CONSULTING SERVICE; GATHERING AND PROVIDING STATISTICAL ANALYSIS OF MOTORCYCLE AND SCOOTER PRICE DATA; PROVIDING STATISTICAL ANALYSIS OF PRICING BASED ON ACTUAL PURCHASE DATA; MARKETING AND ADVERTISING SERVICE PROVIDED FOR SELLERS OF NEW AND USED MOTORCYCLES AND SCOOTERS (U.S. CLS. 100, 101 AND 102).

FIRST USE 3-21-2014; IN COMMERCE 3-21-2014.  
CHRISTINA SOBRAL, EXAMINING ATTORNEY

**CLASS 35—(Continued).**

SN 86-238,274. GEXA ENERGY, LP, HOUSTON, TX. FILED 4-1-2014.

# GEXA

THE MARK CONSISTS OF STANDARD CHARACTERS WITHOUT CLAIM TO ANY PARTICULAR FONT, STYLE, SIZE, OR COLOR.

OWNER OF U.S. REG. NOS. 2,928,862, 3,943,739 AND 3,943,741.

FOR BUSINESS CONSULTING IN THE FIELD OF ENERGY AND WATER CONSERVATION PROGRAM DEVELOPMENT AND COORDINATION; DETAILED ENERGY USE ANALYSIS; ENERGY USE MANAGEMENT, NAMELY, ENERGY SAVINGS MONITORING AND VERIFICATION AND CONSERVATION MANAGEMENT, ALL FOR INDEPENDENT POWER PRODUCERS, GOVERNMENTS, PUBLIC HOUSING AUTHORITIES, RESIDENTIAL HOUSING DEVELOPMENTS, COMMERCIAL BUSINESSES, INSTITUTIONS AND MUNICIPAL ENERGY CONSUMERS AND NOT FOR RESIDENTIAL CONSUMERS; FACILITIES MANAGEMENT OF TECHNICAL OPERATION SERVICES FOR ON-SITE ENERGY GENERATION AND POWER PLANT OPERATION (U.S. CLS. 100, 101 AND 102).

MARTHA SANTOMARTINO, EXAMINING ATTORNEY

---

SN 86-238,511. ER MARKS, INC., WILMINGTON, DE. FILED 4-1-2014.

# Q IN

THE MARK CONSISTS OF STANDARD CHARACTERS WITHOUT CLAIM TO ANY PARTICULAR FONT, STYLE, SIZE, OR COLOR.

OWNER OF U.S. REG. NOS. 1,914,291, 3,508,372 AND OTHERS.

FOR PROVIDING HOME SHOPPING SERVICES IN THE FIELD OF GENERAL MERCHANDISE BY MEANS OF MOBILE PHONE, PORTABLE HAND-HELD DIGITAL DEVICES, INTERNET AND BY MEANS OF TELEVISION (U.S. CLS. 100, 101 AND 102).

FIRST USE 8-17-2013; IN COMMERCE 8-17-2013.

JOANNA FIORELLI, EXAMINING ATTORNEY

**CLASS 35—(Continued).**

SN 86-238,599. BEST NEW PRODUCT AWARDS INC., TORONTO, ONTARIO, CANADA, FILED 4-1-2014.



NO CLAIM IS MADE TO THE EXCLUSIVE RIGHT TO USE "MOST TRUSTED" AND "BY AMERICAN SHOPPERS", APART FROM THE MARK AS SHOWN.

THE MARK CONSISTS OF A SHADED RECTANGULAR BOX THAT CONTAINS AN INSET UNSHADED SQUARE WITH THE WORDS "MOST TRUSTED" IN BLOCK LETTERS IN THE UPPER PORTION OF THE SQUARE; A SHADED TOP-HALF OF AN OVAL DESIGN IS CENTRED IN THE LOWER PORTION OF THE UNSHADED SQUARE; THE SHADED HALF OVAL DESIGN CONTAINS A FIVE-POINTED HALF-STAR DESIGN IN THE CENTRE. THE WORDS "BRANDSPARK" APPEAR IN STYLIZED FONT AT THE TOP OF THE SHADED RECTANGLE, AND THE WORDS "BY AMERICAN SHOPPERS" APPEAR AT THE BOTTOM OF THE SHADED RECTANGLE.

FOR ORGANIZING AND OPERATING A CONSUMER VOTED AWARDS PROGRAM WHERE BRANDS ARE EVALUATED IN THE CATEGORIES OF FOOD AND BEVERAGE, HEALTH AND BEAUTY AND HOUSEHOLD PRODUCTS AND IDENTIFIED BY CONSUMERS AS BRANDS THAT THEY PREFER TO PURCHASE BASED ON PAST EXPERIENCE, LONGEVITY OF USE, BRAND LOYALTY, PRODUCT SATISFACTION, PRODUCT QUALITY, AND PRODUCT EFFECTIVENESS; MARKET RESEARCH SERVICES (U.S. CLS. 100, 101 AND 102).

RONALD DELGIZZI, EXAMINING ATTORNEY

---

SN 86-239,096. KITCHEN TRADER, INC., FAIRFIELD, NJ. FILED 4-1-2014.

# RECYCLING LUXURY

THE MARK CONSISTS OF STANDARD CHARACTERS WITHOUT CLAIM TO ANY PARTICULAR FONT, STYLE, SIZE, OR COLOR.

OWNER OF U.S. REG. NOS. 3,614,772 AND 3,704,124.

FOR DEALERSHIPS FEATURING PRE-OWNED, LUXURY, OVERSTOCK AND DISCONTINUED LUXURY KITCHEN COMPONENTS, NAMELY, CABINETS, COUNTERTOPS, APPLIANCES, SINKS, LIGHTING FIXTURES, PLUMBING FIXTURES, FURNITURE AND DECORATIVE ITEMS (U.S. CLS. 100, 101 AND 102).

FIRST USE 4-1-2014; IN COMMERCE 4-1-2014.

ALLISON HOLTZ, EXAMINING ATTORNEY



**CLASS 35—(Continued).**

SN 86-239,167. SUCCESS PARTNERS HOLDING CO., LAKE DALLAS, TX. FILED 4-1-2014.

**SUCCESS PARTNERS**

THE MARK CONSISTS OF STANDARD CHARACTERS WITHOUT CLAIM TO ANY PARTICULAR FONT, STYLE, SIZE, OR COLOR.

NO CLAIM IS MADE TO THE EXCLUSIVE RIGHT TO USE "PARTNERS", APART FROM THE MARK AS SHOWN.

FOR ORDER FULFILLMENT SERVICES FOR OTHERS, NAMELY, SOURCING AND DISTRIBUTION OF BOOKS, MAGAZINES, PAMPHLETS, PHOTOGRAPHS, MANUALS, CARDS, BROCHURES, TRAINING MATERIALS, KITS, DECALS, FLYERS, PLAQUES, CERTIFICATES, PINS, PENS, JEWELRY, CLOTHING, FLASHLIGHTS, CUPS, GLASSES, BEVERAGE INSULATORS, KEY CHAINS AND HATS IN THE FIELDS OF ENTREPRENEURSHIP AND PERSONAL DEVELOPMENT; ADVERTISING AND MARKETING SERVICES, NAMELY, CREATION OF STYLE GUIDES, LOGOS, WEBSITES, MARKETING BROCHURES AND RECRUITING BROCHURES IN THE FIELDS OF ENTREPRENEURSHIP AND PERSONAL DEVELOPMENT (U.S. CLS. 100, 101 AND 102).

JOHN WILKE, EXAMINING ATTORNEY

SN 86-240,140. ER MARKS, INC., WILMINGTON, DE. FILED 4-2-2014.

**STYLE ON Q**

THE MARK CONSISTS OF STANDARD CHARACTERS WITHOUT CLAIM TO ANY PARTICULAR FONT, STYLE, SIZE, OR COLOR.

OWNER OF U.S. REG. NOS. 1,914,291, 4,497,066 AND OTHERS.

NO CLAIM IS MADE TO THE EXCLUSIVE RIGHT TO USE "STYLE", APART FROM THE MARK AS SHOWN.

FOR PROVIDING HOME SHOPPING SERVICES IN THE FIELD OF GENERAL MERCHANDISE BY MEANS OF MOBILE PHONE, PORTABLE HAND-HELD DIGITAL DEVICES, INTERNET AND BY MEANS OF TELEVISION (U.S. CLS. 100, 101 AND 102).

FIRST USE 8-0-2013; IN COMMERCE 8-0-2013.

JOANNA FIORELLI, EXAMINING ATTORNEY

**CLASS 35—(Continued).**

SN 86-240,206. BLESSED LOTUS LLC, CHARLOTTE, NC. FILED 4-2-2014.

**Blessed Lotus**

THE MARK CONSISTS OF STANDARD CHARACTERS WITHOUT CLAIM TO ANY PARTICULAR FONT, STYLE, SIZE, OR COLOR.

FOR WHOLESALE AND RETAIL STORE SERVICES FEATURING WOMEN'S APPAREL (U.S. CLS. 100, 101 AND 102).

FIRST USE 7-12-2012; IN COMMERCE 7-12-2012.

BERNICE MIDDLETON, EXAMINING ATTORNEY

SN 86-240,233. SHAREBITE, LLC, NEW YORK, NY. FILED 4-2-2014.

**SHAREBITE**

THE MARK CONSISTS OF STANDARD CHARACTERS WITHOUT CLAIM TO ANY PARTICULAR FONT, STYLE, SIZE, OR COLOR.

FOR BUSINESS SERVICES, NAMELY, PROVIDING COMPUTER DATABASES REGARDING THE PURCHASE AND SALE OF A WIDE VARIETY OF PRODUCTS AND SERVICES OF OTHERS; MARKET RESEARCH AND BUSINESS ANALYSES; MARKETING SERVICES IN THE FIELD OF RESTAURANTS, CATERING, FOOD STORES, AND CHARITIES; ON-LINE ORDERING SERVICES FEATURING A WIDE VARIETY OF PERSONAL FOOD, DRINK, AND RETAIL CONSUMER PRODUCTS; PROMOTIONAL SERVICES, NAMELY, PROMOTING THE CHARITIES OF OTHERS; PROVIDING CONSUMER PRODUCT INFORMATION RELATING TO FOOD AND DRINK PRODUCTS; PROVISION OF ADVERTISING SPACE BY ELECTRONIC MEANS AND GLOBAL INFORMATION NETWORKS (U.S. CLS. 100, 101 AND 102).

PARKER HOWARD, EXAMINING ATTORNEY

**CLASS 35—(Continued).**

SN 86-240,481. REELIO, INC., NEW YORK, NY. FILED 4-2-2014.



THE COLOR(S) GRAY AND RED IS/ARE CLAIMED AS A FEATURE OF THE MARK.

THE MARK CONSISTS OF A RED DOUBLE ARROW CHEVRON SHAPE POINTING RIGHT TO THE WORD "REELIO" IN GRAY HANDWRITING SCRIPT LETTERING. THE WHITE SHOWN IN THE MARK IS BACKGROUND ONLY AND NOT CLAIMED AS A FEATURE OF THE MARK.

FOR ADVERTISING AND MARKETING SERVICES PROVIDED BY MEANS OF INDIRECT METHODS OF MARKETING COMMUNICATIONS, NAMELY, SOCIAL MEDIA, SEARCH ENGINE MARKETING, INQUIRY MARKETING, INTERNET MARKETING, MOBILE MARKETING, BLOGGING AND OTHER FORMS OF PASSIVE, SHARABLE OR VIRAL COMMUNICATIONS CHANNELS; BUSINESS RESEARCH SERVICES IN THE FIELD OF DIGITAL MEDIA AND INTERNET ADVERTISING; ONLINE MEDIA MONITORING SERVICES USING COMPUTER SOFTWARE TO AUTOMATICALLY MONITOR INTERNET WEBSITES AND ONLINE PUBLICATIONS FOR CUSTOMER-SPECIFIED TOPICS AND TO CAPTURE RELEVANT CONTENT ON THOSE TOPICS, AND PROVIDING DOCUMENTATION AND ANALYSIS OF THAT ONLINE CONTENT TO OTHERS FOR BUSINESS PURPOSES; PROMOTING AND MARKETING THE GOODS AND SERVICES OF OTHERS BY DISTRIBUTING ADVERTISING MATERIAL, COUPONS AND DISCOUNT OFFERS VIA TEXT MESSAGES; PROVIDING BUSINESS INFORMATION IN THE FIELD OF SOCIAL MEDIA (U.S. CLS. 100, 101 AND 102).

FIRST USE 3-3-2014; IN COMMERCE 3-3-2014.  
JAMES GRIFFIN, EXAMINING ATTORNEY

SN 86-240,665. CONSERVACO, LLC, DBA REPUTATION SENTINEL, FORT LAUDERDALE, FL. FILED 4-2-2014.

## Reputation Sentinel

THE MARK CONSISTS OF STANDARD CHARACTERS WITHOUT CLAIM TO ANY PARTICULAR FONT, STYLE, SIZE, OR COLOR.

NO CLAIM IS MADE TO THE EXCLUSIVE RIGHT TO USE "REPUTATION", APART FROM THE MARK AS SHOWN.

FOR BUSINESS REPUTATION MANAGEMENT AND IMPROVEMENT SERVICES (U.S. CLS. 100, 101 AND 102).  
FIRST USE 2-12-2014; IN COMMERCE 3-1-2014.

KATHLEEN M. VANSTON, EXAMINING ATTORNEY

**CLASS 35—(Continued).**

SN 86-240,697. DOMA EXPORT COMPANY INCORPORATED, LINDEN, NJ. FILED 4-2-2014.



NO CLAIM IS MADE TO THE EXCLUSIVE RIGHT TO USE "EXPORT CO INC.", APART FROM THE MARK AS SHOWN.

THE COLOR(S) RED, WHITE, BLUE, AND BLACK IS/ARE CLAIMED AS A FEATURE OF THE MARK.

THE MARK CONSISTS OF THE WORD "DOMA", WHICH IS SPLIT TO INCORPORATE THE WORDS "EXPORT CO INC." WITHIN IT. THE TOP HALF OF THE "D" AND "O" IN "DOMA" IS IN WHITE COLOR WITH BLUE OUTLINE AND THE BOTTOM HALF IN IN RED COLOR. THE TOP HALF OF THE "M" IN "DOMA" IS IN BLUE COLOR WITH WHITE STARS, AND THE BOTTOM HALF OF M AND THE ENTIRE LETTER "A" IN "DOMA" ARE IN RED AND WHITE STRIPES. THE WORDING "EXPORT CO INC." IS IN BLACK COLOR.

THE WORDING "DOMA" HAS NO MEANING IN A FOREIGN LANGUAGE.

FOR EXPORT AND IMPORT AGENCIES (U.S. CLS. 100, 101 AND 102).

FIRST USE 6-1-1986; IN COMMERCE 6-1-1986.  
LAURA KOVALSKY, EXAMINING ATTORNEY

SN 86-240,838. HINDERER AUTOMOTIVE, LLC, DUBLIN, OH. FILED 4-3-2014.

## TOY BARN

THE MARK CONSISTS OF STANDARD CHARACTERS WITHOUT CLAIM TO ANY PARTICULAR FONT, STYLE, SIZE, OR COLOR.

FOR AUTOMOBILE DEALERSHIPS (U.S. CLS. 100, 101 AND 102).

FIRST USE 3-5-1999; IN COMMERCE 3-5-1999.  
DAVID TOOLEY, EXAMINING ATTORNEY

**CLASS 35—(Continued).**

SN 86-240,920. FANTASTIC SAMS FRANCHISE CORPORATION, BEVERLY, MA. FILED 4-3-2014.

**A BEAUTIFUL INVESTMENT**

THE MARK CONSISTS OF STANDARD CHARACTERS WITHOUT CLAIM TO ANY PARTICULAR FONT, STYLE, SIZE, OR COLOR.

NO CLAIM IS MADE TO THE EXCLUSIVE RIGHT TO USE "INVESTMENT", APART FROM THE MARK AS SHOWN.

FOR FRANCHISING, NAMELY, OFFERING BUSINESS MANAGEMENT ASSISTANCE IN THE ESTABLISHMENT AND/OR OPERATION OF HAIRDRESSING AND BEAUTY SALONS (U.S. CLS. 100, 101 AND 102).

DAVID MURRAY, EXAMINING ATTORNEY

SN 86-241,145. BUNABU INC., LOS ANGELES, CA. FILED 4-3-2014.



THE COLOR(S) GREEN, PINK, ORANGE, BLUE, AND GRAY IS/ARE CLAIMED AS A FEATURE OF THE MARK.

THE MARK CONSISTS OF A GREEN ARROW POINTING DOWN, MOVING CLOCKWISE TO A PINK ARROW POINTING LEFT, MOVING CLOCKWISE TO AN ORANGE ARROW POINTING UP, MOVING CLOCKWISE TO A BLUE ARROW POINTING RIGHT, ABOVE THE WORDING "HAPPY TO SERVE" IN GRAY.

FOR ADVERTISING AND MARKETING; DESIGN OF INTERNET ADVERTISING; ELECTRONIC COMMERCE SERVICES, NAMELY, PROVIDING INFORMATION ABOUT PRODUCTS VIA TELECOMMUNICATION NETWORKS FOR ADVERTISING AND SALES PURPOSES (U.S. CLS. 100, 101 AND 102).

FIRST USE 9-0-2013; IN COMMERCE 9-0-2013.  
MICHAEL ENGEL, EXAMINING ATTORNEY

SN 86-241,236. PARTNERSHIP FOR A DRUG-FREE AMERICA, INC., NEW YORK, NY. FILED 4-3-2014.

**PARTNERSHIP FOR DRUG-FREE KIDS**

THE MARK CONSISTS OF STANDARD CHARACTERS WITHOUT CLAIM TO ANY PARTICULAR FONT, STYLE, SIZE, OR COLOR.

FOR PROMOTING PUBLIC AWARENESS OF THE DANGERS TO CHILDREN AND SOCIETY OF DRUG ABUSE AND PROVISION OF INFORMATION TO ASSIST FAMILIES IN PROMOTING AWARENESS FOR THEIR CHILDREN OF THE DANGERS OF DRUG ABUSE (U.S. CLS. 100, 101 AND 102).

LINDA MICKLEBURGH, EXAMINING ATTORNEY

**CLASS 35—(Continued).**

SN 86-241,247. PARTNERSHIP FOR A DRUG-FREE AMERICA, INC., NEW YORK, NY. FILED 4-3-2014.

**WHERE FAMILIES FIND ANSWERS**

THE MARK CONSISTS OF STANDARD CHARACTERS WITHOUT CLAIM TO ANY PARTICULAR FONT, STYLE, SIZE, OR COLOR.

FOR PROMOTING PUBLIC AWARENESS OF THE DANGERS TO CHILDREN AND SOCIETY OF DRUG ABUSE AND PROVISION OF INFORMATION TO ASSIST FAMILIES IN PROMOTING AWARENESS FOR THEIR CHILDREN OF THE DANGERS OF DRUG ABUSE (U.S. CLS. 100, 101 AND 102).

LINDA MICKLEBURGH, EXAMINING ATTORNEY

SN 86-241,602. DISALVATORE, JR., JOHN A., POTOMAC, MD. FILED 4-3-2014.

**Mercedes Transcription**

THE MARK CONSISTS OF STANDARD CHARACTERS WITHOUT CLAIM TO ANY PARTICULAR FONT, STYLE, SIZE, OR COLOR.

NO CLAIM IS MADE TO THE EXCLUSIVE RIGHT TO USE "TRANSCRIPTION", APART FROM THE MARK AS SHOWN.

FOR MEDICAL TRANSCRIPTION SERVICES (U.S. CLS. 100, 101 AND 102).

LEIGH CAROLINE CASE, EXAMINING ATTORNEY

SN 86-241,917. THE TRUSTEES OF THE COLONIAL GREENE TRUST, LOS ANGELES, CA. FILED 4-3-2014.

**TWO WOLVES WINE**

THE MARK CONSISTS OF STANDARD CHARACTERS WITHOUT CLAIM TO ANY PARTICULAR FONT, STYLE, SIZE, OR COLOR.

NO CLAIM IS MADE TO THE EXCLUSIVE RIGHT TO USE "WINE", APART FROM THE MARK AS SHOWN.

FOR ONLINE RETAIL STORE SERVICES FEATURING WINES AND WINE ACCESSORIES (U.S. CLS. 100, 101 AND 102).

CHRISTINA SOBRAL, EXAMINING ATTORNEY

**CLASS 35—(Continued).**

SN 86-242,136. MISTRESS VENTURES CORPORATION, SANTA MONICA, CA. FILED 4-3-2014.

**MOMENTS PLANNING**

THE MARK CONSISTS OF STANDARD CHARACTERS WITHOUT CLAIM TO ANY PARTICULAR FONT, STYLE, SIZE, OR COLOR.

NO CLAIM IS MADE TO THE EXCLUSIVE RIGHT TO USE "PLANNING", APART FROM THE MARK AS SHOWN. FOR ADVERTISING AND MARKETING; ADVERTISING AND MARKETING CONSULTANCY; ADVERTISING, MARKETING AND PROMOTION SERVICES; BUSINESS CONSULTING SERVICES, NAMELY, PROVIDING ASSISTANCE IN DEVELOPMENT OF BUSINESS STRATEGIES AND CREATIVE IDEATION; CONSULTATION SERVICES, NAMELY, CREATIVE AND STRATEGIC CONSULTATION REGARDING DEVELOPMENT AND PRODUCTION OF MARKETING CAMPAIGNS FOR OTHERS; CREATIVE MARKETING DESIGN SERVICES (U.S. CLS. 100, 101 AND 102).

CAITLIN WATTS-FITZGERALD, EXAMINING ATTORNEY

**CLASS 35—(Continued).**

SN 86-243,016. BSN SPORTS, INC., FARMERS BRANCH, TX. FILED 4-4-2014.



THE MARK CONSISTS OF THE WORDS "MY TEAM SHOP" WITHIN AN IRREGULARLY SHAPED RECTANGULAR BORDER, WITH THE INDIVIDUAL LETTERS SHADED.

FOR ONLINE RETAIL STORE SERVICES FEATURING CLOTHING, UNIFORMS AND FOOTWEAR, SPORTING AND ATHLETIC GOODS, EQUIPMENT AND SUPPLIES; ADMINISTRATION OF DEDICATED CUSTOMIZED ONLINE RETAIL SERVICE TO THE ORDER AND SPECIFICATION OF OTHERS TO FACILITATE AND EFFECT THE SALE OF A PRE-DESIGNATED INVENTORY OF CLOTHING, UNIFORMS, FOOTWEAR, AND SPORTING AND ATHLETIC GOODS, EQUIPMENT AND SUPPLIES (U.S. CLS. 100, 101 AND 102).

FIRST USE 8-0-2008; IN COMMERCE 8-0-2008.  
THOMAS MANOR, EXAMINING ATTORNEY

SN 86-242,882. GENERAL NUTRITION INVESTMENT COMPANY, WILMINGTON, DE. FILED 4-4-2014.

**GO FROM "LAME" TO "IN THE GAME"**

THE MARK CONSISTS OF STANDARD CHARACTERS WITHOUT CLAIM TO ANY PARTICULAR FONT, STYLE, SIZE, OR COLOR.

FOR RETAIL STORE SERVICES AND ONLINE RETAIL STORE SERVICES FEATURING HEALTH FOODS, DIETARY SUPPLEMENTS, NUTRITIONAL SUPPLEMENTS, HERBS, VITAMINS, SPORTS NUTRITION PRODUCTS, FITNESS PRODUCTS AND APPAREL, COSMETICS, BODY CARE, DIAGNOSTIC EXERCISE OR AROMATHERAPY PRODUCTS (U.S. CLS. 100, 101 AND 102).

PAUL E. FAHRENKOPF, EXAMINING ATTORNEY

SN 86-243,879. BRANCHED CHAIN INC., BROOKLYN, NY. FILED 4-6-2014.



THE MARK CONSISTS OF A SIX-SIDED SHIELD WITH THE WORDS "BRANCHED CHAIN" INSIDE, IN WHICH THE FIRST WORD "BRANCHED" IS PROTRUDING THE LEFT AND RIGHT SIDES OF THE SHIELD, AND THE SECOND WORD "CHAIN" IS ENCLOSED IN THE SHIELD UNDER THE FIRST WORD.

FOR BUSINESS CONSULTING, MANAGEMENT, PLANNING AND SUPERVISION; BUSINESS MANAGEMENT OF SPORTS PEOPLE (U.S. CLS. 100, 101 AND 102).  
BRIAN PINO, EXAMINING ATTORNEY

**CLASS 35—(Continued).**

SN 86-244,041. FORBES CONSULTING GROUP, LLC, LEXINGTON, MA. FILED 4-7-2014.

**CLASS 35—(Continued).**

SN 86-244,475. PROJECT AWESOME, L.L.C., DBA WERKLY, NEW ORLEANS, LA. FILED 4-7-2014.

**EXPERIENTIAL DISCOVERY**

THE MARK CONSISTS OF STANDARD CHARACTERS WITHOUT CLAIM TO ANY PARTICULAR FONT, STYLE, SIZE, OR COLOR.

FOR CONDUCTING CONSUMER AND PRODUCT ASSESSMENTS AND SURVEYS; CONDUCTING ASSESSMENTS AND SURVEYS OF CONSUMER BEHAVIOR TOWARD AND REACTIONS TO PRODUCTS AND SERVICES TO ASSESS CONSUMER EMOTIONAL RESPONSE (U.S. CLS. 100, 101 AND 102).

FIRST USE 3-31-2014; IN COMMERCE 3-31-2014.  
TAMARA HUDSON, EXAMINING ATTORNEY

**WERKLY**

THE MARK CONSISTS OF STANDARD CHARACTERS WITHOUT CLAIM TO ANY PARTICULAR FONT, STYLE, SIZE, OR COLOR.

FOR BUSINESS SERVICES, NAMELY, PROVIDING AN ONLINE NETWORK FOR CONTRACTORS TO RECEIVE LEADS AND BIDDING OPPORTUNITIES BY MEANS OF AN ONLINE MARKETPLACE FOR THE PURPOSE OF DEVELOPING BUSINESS; ON-LINE BUSINESS DIRECTORIES FEATURING LOCAL CONTRACTORS FOR HIRE; PROVIDING A SEARCHABLE ONLINE ADVERTISING WEBSITE AND GUIDE FEATURING THE GOODS AND SERVICES OF OTHER VENDORS VIA THE INTERNET; PROVIDING AN ON-LINE SEARCHABLE DATABASE FEATURING CLASSIFIED AD LISTINGS AND EMPLOYMENT OPPORTUNITIES; PROVIDING AN ON-LINE SEARCHABLE DATABASE FEATURING EMPLOYMENT OPPORTUNITIES AND CONTENT ABOUT EMPLOYMENT; PROVIDING ON-LINE TRADE DIRECTORY SERVICES (U.S. CLS. 100, 101 AND 102).

FIRST USE 10-1-2013; IN COMMERCE 10-1-2013.  
JENNIFER WILLISTON, EXAMINING ATTORNEY

SN 86-244,163. A AND M LLC, NEW YORK, NY. FILED 4-7-2014.

**ORB HEADPHONES**

THE MARK CONSISTS OF STANDARD CHARACTERS WITHOUT CLAIM TO ANY PARTICULAR FONT, STYLE, SIZE, OR COLOR.

NO CLAIM IS MADE TO THE EXCLUSIVE RIGHT TO USE "HEADPHONES", APART FROM THE MARK AS SHOWN.

FOR ONLINE RETAIL STORE SERVICES FEATURING HEADPHONES AND EARPHONES (U.S. CLS. 100, 101 AND 102).

FIRST USE 2-0-2013; IN COMMERCE 3-0-2013.  
CHRISTINA SOBRAL, EXAMINING ATTORNEY

SN 86-244,599. MOUTH FOODS, INC., BROOKLYN, NY. FILED 4-7-2014.

**MOUTH**

THE MARK CONSISTS OF STANDARD CHARACTERS WITHOUT CLAIM TO ANY PARTICULAR FONT, STYLE, SIZE, OR COLOR.

FOR ON-LINE RETAIL STORE SERVICES FEATURING A WIDE VARIETY OF CONSUMER GOODS OF OTHERS; RETAIL STORE SERVICES FEATURING FOODS, BEVERAGES, COOKBOOKS, HOUSEWARES, AND GIFT PACKAGES CONTAINING FOODS, BEVERAGES AND/OR HOUSEWARES AND COOKBOOKS; SUBSCRIPTIONS TO GIFT PACKAGES CONTAINING FOODS AND BEVERAGES (U.S. CLS. 100, 101 AND 102).

FIRST USE 5-20-2013; IN COMMERCE 5-20-2013.  
LEIGH LOWRY, EXAMINING ATTORNEY

**CLASS 35—(Continued).**

SN 86-244,604. ENGAGE HOSPITALITY, LLC, SAN FRANCISCO, CA. FILED 4-7-2014.

WE DO EVERYTHING BUT DREAM  
FOR YOU

THE MARK CONSISTS OF STANDARD CHARACTERS WITHOUT CLAIM TO ANY PARTICULAR FONT, STYLE, SIZE, OR COLOR.

FOR BUSINESS MANAGEMENT OF HOTELS FOR OTHERS; HOTEL MANAGEMENT FOR OTHERS; MANAGEMENT OF HOTEL INCENTIVE PROGRAMS OF OTHERS; MANAGING AND OPERATING RESORT HOTELS AND BUSINESS CONFERENCE CENTERS OF OTHERS; MARKETING SERVICES FOR THE HOTELS OF OTHERS (U.S. CLS. 100, 101 AND 102).

FIRST USE 11-4-2010; IN COMMERCE 12-1-2010.  
PETER BODRI, EXAMINING ATTORNEY

**CLASS 35—(Continued).**

SN 86-245,126. MJK PARTNERS LLC, BELMONT, MA. FILED 4-7-2014.

INSPIRED BY INNOVATION

THE MARK CONSISTS OF STANDARD CHARACTERS WITHOUT CLAIM TO ANY PARTICULAR FONT, STYLE, SIZE, OR COLOR.

FOR BUSINESS CONSULTING SERVICES IN THE FIELD OF MERGERS AND ACQUISITIONS, STRATEGIC PLANNING, TECHNOLOGY STRATEGY, INTELLECTUAL PROPERTY STRATEGY, TECHNOLOGY TRANSFER, INTELLECTUAL PROPERTY TRANSFER, TECHNOLOGY TRANSACTIONS, AND INTELLECTUAL PROPERTY TRANSACTIONS; BUSINESS DEVELOPMENT SERVICES (U.S. CLS. 100, 101 AND 102).

FIRST USE 4-27-2014; IN COMMERCE 4-27-2014.  
KATHLEEN KOLACZ, EXAMINING ATTORNEY

SN 86-244,800. SMITH & JONES ADVERTISING, INC., STURBRIDGE, MA. FILED 4-7-2014.

IDEA AGENCY

THE MARK CONSISTS OF STANDARD CHARACTERS WITHOUT CLAIM TO ANY PARTICULAR FONT, STYLE, SIZE, OR COLOR.

NO CLAIM IS MADE TO THE EXCLUSIVE RIGHT TO USE "AGENCY", APART FROM THE MARK AS SHOWN.

FOR ADVERTISING SERVICES; BRANDING SERVICES, NAMELY, CONSULTING, DEVELOPMENT, MANAGEMENT AND MARKETING OF BRANDS FOR BUSINESSES AND/OR INDIVIDUALS (U.S. CLS. 100, 101 AND 102).

FIRST USE 8-31-2010; IN COMMERCE 12-8-2010.  
ADA HAN, EXAMINING ATTORNEY

SN 86-245,218. RYSE MEDICAL SOLUTIONS, LLC, BELLEVUE, WA. FILED 4-7-2014.

RYSE

THE MARK CONSISTS OF STANDARD CHARACTERS WITHOUT CLAIM TO ANY PARTICULAR FONT, STYLE, SIZE, OR COLOR.

FOR ADVERTISING, MARKETING AND PROMOTION SERVICES FOR HEALTHCARE PROVIDERS; SALES PROMOTION SERVICES FOR HEALTHCARE PROVIDERS (U.S. CLS. 100, 101 AND 102).

HEATHER SAPP, EXAMINING ATTORNEY

SN 86-245,053. SWAMPUM LLC, WILMETTE, IL. FILED 4-7-2014.

SWAMPUM

THE MARK CONSISTS OF STANDARD CHARACTERS WITHOUT CLAIM TO ANY PARTICULAR FONT, STYLE, SIZE, OR COLOR.

FOR ONLINE SERVICES IN WHICH USERS POST OFFERS TO EXCHANGE ITEMS WITH OTHER USERS (U.S. CLS. 100, 101 AND 102).

THEODORE MCBRIDE, EXAMINING ATTORNEY

SN 86-245,219. RYSE MEDICAL SOLUTIONS, LLC, BELLEVUE, WA. FILED 4-7-2014.



THE MARK CONSISTS OF STANDARD LETTERS "R", "S" AND "E" AS WELL AS A STYLIZED LETTER "Y".

FOR ADVERTISING, MARKETING AND PROMOTION SERVICES FOR HEALTHCARE PROVIDERS; SALES PROMOTION SERVICES FOR HEALTHCARE PROVIDERS (U.S. CLS. 100, 101 AND 102).

HEATHER SAPP, EXAMINING ATTORNEY

**CLASS 35—(Continued).**

SN 86-245,235. ROSETTA MARKETING GROUP, LLC, HAMILTON, NJ. FILED 4-7-2014.

**UNLOCK AND ACTIVATE**

THE MARK CONSISTS OF STANDARD CHARACTERS WITHOUT CLAIM TO ANY PARTICULAR FONT, STYLE, SIZE, OR COLOR.

FOR ADVERTISING AND MARKETING CONSULTING SERVICES; BUSINESS MANAGEMENT AND CONSULTATION IN THE FIELDS OF PROVIDING DATA, ANALYTICAL TECHNIQUES, MARKETING, E-COMMERCE, INFORMATION TECHNOLOGY, WEB SITE DESIGN AND DEVELOPMENT, APPLICATION AND BUSINESS SYSTEMS INTEGRATION, DIGITAL BUSINESS DEVELOPMENT, AND CUSTOMER RELATIONSHIP MANAGEMENT (U.S. CLS. 100, 101 AND 102).

MEREDITH MARESCA, EXAMINING ATTORNEY

SN 86-245,307. BOOTLEDGER, INC., CAMBRIDGE, MA. FILED 4-8-2014.

**BOOTLEDGER**

THE MARK CONSISTS OF STANDARD CHARACTERS WITHOUT CLAIM TO ANY PARTICULAR FONT, STYLE, SIZE, OR COLOR.

FOR PROVIDING A WEBSITE FEATURING AN ONLINE BUSINESS TO BUSINESS MARKETPLACE FOR THE ALCOHOLIC BEVERAGE DISTRIBUTION INDUSTRY (U.S. CLS. 100, 101 AND 102).

DOMINICK J. SALEMI, EXAMINING ATTORNEY

SN 86-245,373. HINDERER AUTOMOTIVE, LLC, DUBLIN, OH. FILED 4-8-2014.



THE MARK CONSISTS OF THE STYLIZED WORDS "TOY" AND "BARN" WITH A STYLIZED CAR ABOVE THE "N" IN THE WORD "BARN".

FOR AUTOMOBILE DEALERSHIPS (U.S. CLS. 100, 101 AND 102).

FIRST USE 3-5-1999; IN COMMERCE 3-5-1999.  
DAVID TOOLEY, EXAMINING ATTORNEY

**CLASS 35—(Continued).**

SN 86-245,489. TRIDENT-PSI, INC., 8 MENOMONEE FALLS, WI. FILED 4-8-2014.

**SEARCHING THE GLOBE FOR EXCELLENCE**

THE MARK CONSISTS OF STANDARD CHARACTERS WITHOUT CLAIM TO ANY PARTICULAR FONT, STYLE, SIZE, OR COLOR.

FOR EMPLOYMENT AGENCY SERVICES, NAMELY, FILLING THE TEMPORARY AND PERMANENT STAFFING NEEDS OF BUSINESSES (U.S. CLS. 100, 101 AND 102).

FIRST USE 6-25-2009; IN COMMERCE 6-25-2009.

FONG HSU, EXAMINING ATTORNEY

SN 86-245,692. PELLURU SURAJ, FRISCO, TX. FILED 4-8-2014.

**Shreya**

THE MARK CONSISTS OF STANDARD CHARACTERS WITHOUT CLAIM TO ANY PARTICULAR FONT, STYLE, SIZE, OR COLOR.

FOR ACCOUNT AUDITING; ACCOUNTANCY SERVICES; ACCOUNTING CONSULTATION; ACCOUNTING FOR THIRD PARTIES; ACCOUNTING SERVICES; ACCOUNTS RECEIVABLE SERVICES; ADMINISTRATION, BILLING AND RECONCILIATION OF ACCOUNTS ON BEHALF OF OTHERS; ADMINISTRATIVE ACCOUNTING; COMPUTERIZED ACCOUNTING SERVICES; CONSULTING AND INFORMATION CONCERNING ACCOUNTING; CONSULTING SERVICES, NAMELY, EXPERT ANALYSIS AND MANAGEMENT CONSULTING IN ECONOMICS AND ACCOUNTING; COST ACCOUNTING (U.S. CLS. 100, 101 AND 102).

CAROLINE WOOD, EXAMINING ATTORNEY

SN 86-245,811. FIRST CAPITOL CONSULTING, INC., LOS ANGELES, CA. FILED 4-8-2014.

**Assisting Government Serve the People**

THE MARK CONSISTS OF STANDARD CHARACTERS WITHOUT CLAIM TO ANY PARTICULAR FONT, STYLE, SIZE, OR COLOR.

FOR TAX CONSULTING SERVICES (U.S. CLS. 100, 101 AND 102).

FIRST USE 10-4-2013; IN COMMERCE 10-4-2013.  
NICOLE A NGUYEN, EXAMINING ATTORNEY

**CLASS 35—(Continued).**

SN 86-245,844. MORRIS, WENDELL, SANTA MONICA, CA. FILED 4-8-2014.

# BE PLAY

THE MARK CONSISTS OF STANDARD CHARACTERS WITHOUT CLAIM TO ANY PARTICULAR FONT, STYLE, SIZE, OR COLOR.

FOR ON-LINE RETAIL STORE SERVICES FEATURING SPORTS AND EXERCISE CLOTHING AND EQUIPMENT INCLUDING TOWELS, YOGA MATS, YOGA BAGS, TRAVEL BAGS, STAND UP PADDLE BOARDS, YOGA SHORTS, UNDERWEAR, T-SHIRTS; RETAIL STORE SERVICES FEATURING SPORTS AND EXERCISE CLOTHING AND EQUIPMENT INCLUDING TOWELS, YOGA MATS, YOGA BAGS, TRAVEL BAGS, STAND UP PADDLE BOARDS, YOGA SHORTS, UNDERWEAR, T-SHIRTS (U.S. CLS. 100, 101 AND 102).

LINDA LAVACHE, EXAMINING ATTORNEY

---

SN 86-246,263. SERRNO, ANTONIO, ARLINGTON, TX. FILED 4-8-2014.

# 1844DOCSNOW.COM

THE MARK CONSISTS OF STANDARD CHARACTERS WITHOUT CLAIM TO ANY PARTICULAR FONT, STYLE, SIZE, OR COLOR.

FOR ADVERTISING AND MARKETING (U.S. CLS. 100, 101 AND 102).

EMILY CARLSEN, EXAMINING ATTORNEY

**CLASS 35—(Continued).**

SN 86-246,356. OZIAS OILFIELD SOLUTIONS, THE WOODLANDS, TX. FILED 4-8-2014.

# eEnergyCommerce

THE MARK CONSISTS OF STANDARD CHARACTERS WITHOUT CLAIM TO ANY PARTICULAR FONT, STYLE, SIZE, OR COLOR.

FOR COMPUTERIZED ON-LINE RETAIL STORE SERVICES IN THE FIELD OF OILFIELD, OIL EXTRACTION, AND GAS EXTRACTION EQUIPMENT AND SERVICES; MARKETING THE GOODS AND SERVICES OF OTHERS BY MEANS OF A WEBSITE FEATURING OILFIELD, OIL EXTRACTION, AND GAS EXTRACTION EQUIPMENT AND SERVICES; ON-LINE RETAIL STORE SERVICES FEATURING OILFIELD, OIL EXTRACTION, AND GAS EXTRACTION EQUIPMENT AND SERVICES; OPERATING ON-LINE MARKETPLACES FEATURING OILFIELD, OIL EXTRACTION, AND GAS EXTRACTION EQUIPMENT AND SERVICES; OPERATING ON-LINE MARKETPLACES FOR SELLERS AND BUYERS OF GOODS AND/OR SERVICES; PROMOTING AND MARKETING THE GOODS AND SERVICES OF OTHERS BY MEANS OF A WEBSITE FEATURING OILFIELD, OIL EXTRACTION, AND GAS EXTRACTION EQUIPMENT AND SERVICES; PROMOTING THE GOODS AND SERVICES OF OTHERS BY PROVIDING A WEBSITE FEATURING OILFIELD, OIL EXTRACTION, AND GAS EXTRACTION EQUIPMENT AND SERVICES; PROVIDING A SEARCHABLE ONLINE ADVERTISING WEBSITE AND INFORMATIONAL GUIDE FEATURING THE GOODS AND SERVICES OF OTHER VENDORS VIA THE INTERNET IN THE FIELD OF OILFIELD, OIL EXTRACTION, AND GAS EXTRACTION EQUIPMENT AND SERVICES; PROVIDING A SEARCHABLE WEBSITE FEATURING THE GOODS AND SERVICES OF OTHER VENDORS; PROVIDING A WEBSITE FEATURING A LIST OF ITEMS AND SERVICES AVAILABLE FOR RENT BY OTHERS; PROVIDING A WEBSITE FEATURING AN ONLINE MARKETPLACE FOR EXCHANGING GOODS AND SERVICES WITH OTHER USERS; PROVIDING A WEBSITE FOR CONNECTING SELLERS WITH BUYERS (U.S. CLS. 100, 101 AND 102).

DOUGLAS LEE, EXAMINING ATTORNEY

---

SN 86-246,634. NO PERFECT PEOPLE INC., CORAL SPRINGS, FL. FILED 4-9-2014.

# FEED THE CITY

THE MARK CONSISTS OF STANDARD CHARACTERS WITHOUT CLAIM TO ANY PARTICULAR FONT, STYLE, SIZE, OR COLOR.

FOR CHARITABLE SERVICES IN THE NATURE OF COORDINATION OF THE PROCUREMENT AND DISTRIBUTION OF FOOD DONATIONS FROM THE GENERAL PUBLIC TO NEEDY PERSONS (U.S. CLS. 100, 101 AND 102).

FIRST USE 10-1-2012; IN COMMERCE 10-1-2012.

TIMOTHY O. SCHIMPF, EXAMINING ATTORNEY



**CLASS 35—(Continued).**

SN 86-246,781. PRIMA BEAUTY, OKLAHOMA CITY, OK. FILED 4-9-2014.

**Prima Beauty**

THE MARK CONSISTS OF STANDARD CHARACTERS WITHOUT CLAIM TO ANY PARTICULAR FONT, STYLE, SIZE, OR COLOR.

NO CLAIM IS MADE TO THE EXCLUSIVE RIGHT TO USE "BEAUTY", APART FROM THE MARK AS SHOWN.

FOR COMPUTERIZED ON-LINE RETAIL STORE SERVICES IN THE FIELD OF BEAUTY SUPPLIES AND COSMETICS (U.S. CLS. 100, 101 AND 102).

FIRST USE 3-10-2014; IN COMMERCE 3-10-2014.  
LINDA LAVACHE, EXAMINING ATTORNEY



SN 86-246,893. EXPONENTIAL INTERACTIVE, INC., EMERYVILLE, CA. FILED 4-9-2014.

**AERO**

THE MARK CONSISTS OF STANDARD CHARACTERS WITHOUT CLAIM TO ANY PARTICULAR FONT, STYLE, SIZE, OR COLOR.

FOR ADVERTISING AND MARKETING SERVICES, NAMELY, PROMOTING THE GOODS AND SERVICES OF OTHERS; ADVERTISING AND MARKETING CONSULTANCY SERVICES AND MEDIA PLACEMENT ADVICE; DISSEMINATION OF ADVERTISING FOR OTHERS VIA THE INTERNET AND OTHER ELECTRONIC COMMUNICATIONS NETWORKS; ADVERTISING CAMPAIGN MANAGEMENT SERVICES FOR OTHERS; IMPROVING THE EFFECTIVENESS OF ONLINE ADVERTISING CAMPAIGNS BY CLASSIFYING CONSUMERS BASED ON THEIR BROWSING HABITS, AND SERVING DISPLAY, VIDEO AND MOBILE ADVERTISEMENTS TO THE SCREENS OF THE CONSUMERS MOST LIKELY TO PURCHASE THE ADVERTISED GOODS AND SERVICES; PREDICTION OF LIKELY CONSUMER RESPONSE TO ADVERTISING CAMPAIGNS, ANALYSIS OF ACTUAL ADVERTISING RESPONSE, AND PROVIDING SCORING AND DATA RESULTS TO ADVERTISERS ON THE EFFECTIVENESS OF THEIR ADVERTISING CAMPAIGNS (U.S. CLS. 100, 101 AND 102).

FIRST USE 4-7-2014; IN COMMERCE 4-7-2014.  
JAMES GRIFFIN, EXAMINING ATTORNEY

**CLASS 35—(Continued).**

SN 86-246,968. WORKING SIMPLY, INC., CHARLOTTE, NC. FILED 4-9-2014.

**CARSON TATE**

THE MARK CONSISTS OF STANDARD CHARACTERS WITHOUT CLAIM TO ANY PARTICULAR FONT, STYLE, SIZE, OR COLOR.

THE NAME "CARSON TATE" IDENTIFIES A LIVING INDIVIDUAL WHOSE CONSENT IS OF RECORD.

FOR BUSINESS AND MANAGEMENT CONSULTING SERVICES IN THE FIELD OF CORPORATE AGILITY, EMPLOYEE ENGAGEMENT, PRODUCTIVITY AND EFFECTIVENESS, AND LEADERSHIP DEVELOPMENT (U.S. CLS. 100, 101 AND 102).

KATHRYN COWARD, EXAMINING ATTORNEY



SN 86-246,976. WORKING SIMPLY, INC., CHARLOTTE, NC. FILED 4-9-2014.

**WORK SIMPLY LIVE FULLY**

THE MARK CONSISTS OF STANDARD CHARACTERS WITHOUT CLAIM TO ANY PARTICULAR FONT, STYLE, SIZE, OR COLOR.

FOR BUSINESS AND MANAGEMENT CONSULTING SERVICES IN THE FIELD OF CORPORATE AGILITY, EMPLOYEE ENGAGEMENT, PRODUCTIVITY AND EFFECTIVENESS, AND LEADERSHIP DEVELOPMENT (U.S. CLS. 100, 101 AND 102).

KATHRYN COWARD, EXAMINING ATTORNEY

**CLASS 35—(Continued).**

SN 86-246,983. WORKING SIMPLY, INC., CHARLOTTE, NC. FILED 4-9-2014.



THE NAME "CARSON TATE" IDENTIFIES A LIVING INDIVIDUAL WHOSE CONSENT IS OF RECORD.

THE MARK CONSISTS OF THREE LINES OF TEXT SUPERIMPOSED ON TOP OF A LINE-DRAWN CIRCLE; THE FIRST LINE OF WORDING IS "CARSON TATE" WRITTEN IN CAPITAL, BLOCK LETTERS, THE SECOND LINE OF WORDING, WHICH APPEARS DIRECTLY BELOW THE FIRST, IS "WORK SIMPLY" WRITTEN IN LOWER-CASE BLOCK LETTERS, AND THE THIRD LINE OF WORDING, WHICH APPEARS DIRECTLY BELOW THE SECOND, IS "LIVE FULLY" WRITTEN IN SCRIPT LETTERING.

FOR BUSINESS AND MANAGEMENT CONSULTING SERVICES IN THE FIELD OF CORPORATE AGILITY, EMPLOYEE ENGAGEMENT, PRODUCTIVITY AND EFFECTIVENESS, AND LEADERSHIP DEVELOPMENT (U.S. CLS. 100, 101 AND 102).

KATHRYN COWARD, EXAMINING ATTORNEY

SN 86-246,996. KOPROWSKY, ASHLEY, BROOKLYN, NY. FILED 4-9-2014.

**ASHLEY KEEPER**

THE MARK CONSISTS OF STANDARD CHARACTERS WITHOUT CLAIM TO ANY PARTICULAR FONT, STYLE, SIZE, OR COLOR.

THE NAME(S), PORTRAIT(S), AND/OR SIGNATURE(S) SHOWN IN THE MARK DOES NOT IDENTIFY A PARTICULAR LIVING INDIVIDUAL.

FOR COMPUTERIZED ON-LINE RETAIL STORE SERVICES IN THE FIELD OF JEWELRY, CLOTHING, FASHION ACCESSORIES (U.S. CLS. 100, 101 AND 102).

FIRST USE 11-1-2013; IN COMMERCE 2-1-2014.  
DOUGLAS LEE, EXAMINING ATTORNEY

**CLASS 35—(Continued).**

SN 86-247,039. NEW LIFE VISION,LLC, CAPE CORAL, FL. FILED 4-9-2014.

**GOD MADE MILLIONAIRE**

THE MARK CONSISTS OF STANDARD CHARACTERS WITHOUT CLAIM TO ANY PARTICULAR FONT, STYLE, SIZE, OR COLOR.

FOR ONLINE RETAIL STORE SERVICES FEATURING BOOKS, SHIRTS, HATS, SCREEN SAVERS, CALENDARS, COFFEE CUPS, MUGS (U.S. CLS. 100, 101 AND 102).

LIEF MARTIN, EXAMINING ATTORNEY

SN 86-247,044. YRIGOLLEN, ADRIAN, CYPRESS, CA. FILED 4-9-2014.



THE MARK CONSISTS OF THE PHRASE "MY WORLD..." STYLIZED AND WITH EACH DOT FROM THE ELLIPSIS DRAWN OUT AS THE CHARACTER SYMBOLS OF A HEART, A PEACE SIGN SLIGHTLY SQUARE SHAPED AND A HAPPY FACE WITH A TUFT OF HAIR ON TOP OF IT.

FOR ON-LINE RETAIL STORE SERVICES FEATURING CLOTHING NAMELY T-SHIRTS, HATS, SWEATERS, TANK TOPS, SCARVES, GLOVES, PANTS, SHORTS, AND SOCKS; RETAIL STORE SERVICES FEATURING CLOTHING NAMELY T-SHIRTS, HATS, SWEATERS, TANK TOPS, SCARVES, GLOVES, PANTS, SHORTS, AND SOCKS (U.S. CLS. 100, 101 AND 102).

KATHRYN COWARD, EXAMINING ATTORNEY

**CLASS 35—(Continued).**

SN 86-247,351. TKT & ASSOCIATES, INC., LOUISVILLE, KY.  
FILED 4-9-2014.

**TKT KONNECT**

THE MARK CONSISTS OF STANDARD CHARACTERS WITHOUT CLAIM TO ANY PARTICULAR FONT, STYLE, SIZE, OR COLOR.

OWNER OF U.S. REG. NOS. 4,157,417, 4,189,488 AND 4,718,358.

FOR BUSINESS CONSULTATION SERVICES; BUSINESS CONSULTING SERVICES IN THE FIELD OF SUPPLIER DIVERSITY, TALENT ACQUISITION, WORKFORCE MANAGEMENT PROCESSES, PERFORMANCE ANALYTICS, INFORMATION TECHNOLOGY SUPPORT, AND QUALITY CONTROL; BUSINESS CONSULTING SERVICES RELATING TO THE INTEGRATION OF THE AREAS OF BUSINESS PROCESS TECHNOLOGY, ORGANIZATIONAL LEARNING, CHANGE MANAGEMENT, AND OPERATIONAL SUSTAINABILITY; BUSINESS CONSULTING SERVICES, NAMELY, PROVIDING ASSISTANCE IN DEVELOPMENT OF BUSINESS STRATEGIES AND CREATIVE IDEATION (U.S. CLS. 100, 101 AND 102).

FIRST USE 4-9-2013; IN COMMERCE 4-18-2013.

JOHN WILKE, EXAMINING ATTORNEY

---

SN 86-247,446. MARTIN, CHRISTOPHER, SEWICKLEY, PA.  
FILED 4-9-2014.

**STORYSEND**

THE MARK CONSISTS OF STANDARD CHARACTERS WITHOUT CLAIM TO ANY PARTICULAR FONT, STYLE, SIZE, OR COLOR.

FOR MARKETING SERVICES, NAMELY, PROMOTING OR ADVERTISING THE GOODS AND SERVICES OF OTHERS (U.S. CLS. 100, 101 AND 102).

FIRST USE 3-18-2014; IN COMMERCE 3-18-2014.

JENNIFER RICHARDSON, EXAMINING ATTORNEY

---

SN 86-247,455. MICHAEL PAPAIE, ENCINO, CA. FILED 4-9-2014.

**NAAK**

THE MARK CONSISTS OF STANDARD CHARACTERS WITHOUT CLAIM TO ANY PARTICULAR FONT, STYLE, SIZE, OR COLOR.

FOR BUSINESS CONSULTATION IN THE FIELD OF THE MUSIC INDUSTRY SPECIALIZING IN A 360 APPROACH TO MARKETING AND PROMOTION STRATEGIES FOR ENTERTAINERS WITH RADIO STATIONS THAT INCLUDE ON-AIR, ONLINE AND ON-STAGE INTEGRATION (U.S. CLS. 100, 101 AND 102).

ZACHARY CROMER, EXAMINING ATTORNEY

**CLASS 35—(Continued).**

SN 86-247,465. LOCUMLINK, LLC, SPRINGFIELD, MO.  
FILED 4-9-2014.

**LOCUMLINK**

THE MARK CONSISTS OF STANDARD CHARACTERS WITHOUT CLAIM TO ANY PARTICULAR FONT, STYLE, SIZE, OR COLOR.

FOR BUSINESS MANAGEMENT IN THE FIELD OF THE PROCUREMENT OF TEMPORARY PHYSICIAN AND MID-LEVEL HEALTHCARE PROVIDERS FOR OTHERS; EMPLOYMENT AGENCY SERVICES; TEMPORARY EMPLOYMENT AGENCIES (U.S. CLS. 100, 101 AND 102).

FIRST USE 1-16-2014; IN COMMERCE 1-16-2014.

LEIGH CAROLINE CASE, EXAMINING ATTORNEY

---

SN 86-247,477. TWOFOUR INSIGHT GROUP, LLC, MCMURRAY, PA. FILED 4-9-2014.

**TWOFOUR INSIGHT GROUP**

THE MARK CONSISTS OF STANDARD CHARACTERS WITHOUT CLAIM TO ANY PARTICULAR FONT, STYLE, SIZE, OR COLOR.

NO CLAIM IS MADE TO THE EXCLUSIVE RIGHT TO USE "GROUP", APART FROM THE MARK AS SHOWN.

FOR BUSINESS CONSULTING, ADVISORY AND INFORMATION SERVICES IN THE FIELDS OF LIFE SCIENCE, PHARMACEUTICS, AND BIOTECHNOLOGY; GOVERNMENT RELATIONS CONSULTANCY SERVICES; PROVIDING BUSINESS INTELLIGENCE SERVICES; BUSINESS STRATEGY DEVELOPMENT SERVICES; MARKET ANALYSIS AND RESEARCH SERVICES; BUSINESS INFORMATION SERVICES IN THE NATURE OF PROVIDING INFORMATION ON BUSINESS OPPORTUNITIES (U.S. CLS. 100, 101 AND 102).

FIRST USE 4-4-2014; IN COMMERCE 4-4-2014.

THEODORE MCBRIDE, EXAMINING ATTORNEY

**CLASS 35—(Continued).**

SN 86-247,485. TWOFOUR INSIGHT GROUP, LLC, MCMURRAY, PA. FILED 4-9-2014.



NO CLAIM IS MADE TO THE EXCLUSIVE RIGHT TO USE "GROUP", APART FROM THE MARK AS SHOWN.

THE MARK CONSISTS OF A STYLIZED "24" ABOVE THE WORDING "TWOFOUR INSIGHT GROUP".

FOR BUSINESS CONSULTING, ADVISORY AND INFORMATION SERVICES IN THE FIELDS OF LIFE SCIENCE, PHARMACEUTICS, AND BIOTECHNOLOGY; GOVERNMENT RELATIONS CONSULTANCY SERVICES; PROVIDING BUSINESS INTELLIGENCE SERVICES; BUSINESS STRATEGY DEVELOPMENT SERVICES; MARKET ANALYSIS AND RESEARCH SERVICES; BUSINESS INFORMATION SERVICES IN THE NATURE OF PROVIDING INFORMATION ON BUSINESS OPPORTUNITIES (U.S. CLS. 100, 101 AND 102).

FIRST USE 4-4-2014; IN COMMERCE 4-4-2014.

THEODORE MCBRIDE, EXAMINING ATTORNEY

SN 86-247,563. MILLER, JULE, FAIRBANKS, AK. FILED 4-9-2014.

SEE THE WORLD BEAUTIFUL

THE MARK CONSISTS OF STANDARD CHARACTERS WITHOUT CLAIM TO ANY PARTICULAR FONT, STYLE, SIZE, OR COLOR.

FOR ON-LINE RETAIL STORE SERVICES FEATURING EYEGLASSES, SUNGLASSES; RETAIL STORE SERVICES FEATURING EYEGLASSES, SUNGLASSES (U.S. CLS. 100, 101 AND 102).

SETH A. RAPPAPORT, EXAMINING ATTORNEY

**CLASS 35—(Continued).**

SN 86-247,723. OZIAS OILFIELD SOLUTIONS, THE WOODLANDS, TX. FILED 4-9-2014.

Ozias

THE MARK CONSISTS OF STANDARD CHARACTERS WITHOUT CLAIM TO ANY PARTICULAR FONT, STYLE, SIZE, OR COLOR.

FOR COMPUTERIZED ON-LINE RETAIL STORE SERVICES IN THE FIELD OF OILFIELD, OIL EXTRACTION, AND GAS EXTRACTION EQUIPMENT AND SERVICES; MARKETING THE GOODS AND SERVICES OF OTHERS BY MEANS OF A WEBSITE FEATURING OILFIELD, OIL EXTRACTION, AND GAS EXTRACTION EQUIPMENT AND SERVICES; ON-LINE RETAIL STORE SERVICES FEATURING OILFIELD, OIL EXTRACTION, AND GAS EXTRACTION EQUIPMENT AND SERVICES; OPERATING ON-LINE MARKETPLACES FEATURING OILFIELD, OIL EXTRACTION, AND GAS EXTRACTION EQUIPMENT AND SERVICES; OPERATING ON-LINE MARKETPLACES FOR SELLERS AND BUYERS OF GOODS AND/OR SERVICES; PROMOTING AND MARKETING THE GOODS AND SERVICES OF OTHERS BY MEANS OF A WEBSITE FEATURING OILFIELD, OIL EXTRACTION, AND GAS EXTRACTION EQUIPMENT AND SERVICES; PROMOTING THE GOODS AND SERVICES OF OTHERS BY PROVIDING A WEBSITE FEATURING OILFIELD, OIL EXTRACTION, AND GAS EXTRACTION EQUIPMENT AND SERVICES; PROVIDING A SEARCHABLE ONLINE ADVERTISING WEBSITE AND INFORMATIONAL GUIDE FEATURING THE GOODS AND SERVICES OF OTHER VENDORS VIA THE INTERNET IN THE FIELD OF OILFIELD, OIL EXTRACTION, AND GAS EXTRACTION EQUIPMENT AND SERVICES; PROVIDING A SEARCHABLE WEBSITE FEATURING THE GOODS AND SERVICES OF OTHER VENDORS; PROVIDING A WEBSITE FEATURING A LIST OF ITEMS AND SERVICES AVAILABLE FOR RENT BY OTHERS; PROVIDING A WEBSITE FEATURING AN ONLINE MARKETPLACE FOR EXCHANGING GOODS AND SERVICES WITH OTHER USERS; PROVIDING A WEBSITE FOR CONNECTING SELLERS WITH BUYERS (U.S. CLS. 100, 101 AND 102).

DOUGLAS LEE, EXAMINING ATTORNEY

SN 86-247,817. SMACK MEDIA LLC, SOLANA BEACH, CA. FILED 4-9-2014.

PUBLIC RELATION(SHIP)S

THE MARK CONSISTS OF STANDARD CHARACTERS WITHOUT CLAIM TO ANY PARTICULAR FONT, STYLE, SIZE, OR COLOR.

FOR PUBLIC RELATIONS; BUSINESS DEVELOPMENT CONSULTING SERVICES; CONCEPT AND BRAND DEVELOPMENT IN THE FIELD OF PRODUCT MARKETING, SOCIAL MEDIA AND SERVICE PROMOTIONS (U.S. CLS. 100, 101 AND 102).

HAI-LY LAM, EXAMINING ATTORNEY

**CLASS 35—(Continued).**

SN 86-247,903. ORGANIC VOICES ACTION FUND, MANCHESTER, NH. FILED 4-10-2014.

**JUST LABEL IT!**

THE MARK CONSISTS OF STANDARD CHARACTERS WITHOUT CLAIM TO ANY PARTICULAR FONT, STYLE, SIZE, OR COLOR.

FOR PUBLIC ADVOCACY TO PROMOTE AWARENESS OF THE NEED FOR MANDATORY LABELING OF GENETICALLY ENGINEERED FOODS (U.S. CLS. 100, 101 AND 102).

FIRST USE 10-0-2011; IN COMMERCE 10-0-2011.  
TEJBIR SINGH, EXAMINING ATTORNEY

SN 86-247,954. KINGSISLE ENTERTAINMENT, INC., PLANO, TX. FILED 4-10-2014.

**RISE & DESTROY**

THE MARK CONSISTS OF STANDARD CHARACTERS WITHOUT CLAIM TO ANY PARTICULAR FONT, STYLE, SIZE, OR COLOR.

FOR PROVIDING CONSUMER PRODUCT INFORMATION, ONLINE SUPPORT, AND A KNOWLEDGE BASE IN THE FIELD OF ELECTRONIC GAMES (U.S. CLS. 100, 101 AND 102).

HEATHER SAPP, EXAMINING ATTORNEY

SN 86-248,044. SMITH, STEPHEN PAUL, NEW ORLEANS, LA. FILED 4-10-2014.

**Aqua Theory**

THE MARK CONSISTS OF STANDARD CHARACTERS WITHOUT CLAIM TO ANY PARTICULAR FONT, STYLE, SIZE, OR COLOR.

FOR ON-LINE RETAIL STORE SERVICES FEATURING SWIMWEAR AND CLOTHING FOR WOMEN AND MEN, SUNGLASSES, BEACHTOWELS, BANDANAS, BEACH BAGS, HATS, BACKPACKS, T-SHIRTS, BEACH UMBRELLAS, FOOTWEAR, SUNCARE LOTIONS, SKINCARE PRODUCTS, SPF LOTIONS, LIP BALM, BRONZERS, SELF TANNING LOTIONS, AND ALOE PRODUCTS (U.S. CLS. 100, 101 AND 102).

EMILY CHUO, EXAMINING ATTORNEY

**CLASS 35—(Continued).**

SN 86-248,129. URWITNESS, INC., ESCONDIDO, CA. FILED 4-10-2014.

**URWITNESS**

THE MARK CONSISTS OF STANDARD CHARACTERS WITHOUT CLAIM TO ANY PARTICULAR FONT, STYLE, SIZE, OR COLOR.

FOR ADVERTISING ON THE INTERNET FOR OTHERS; PROVIDING A SEARCHABLE ON-LINE ADVERTISING WEBSITE AND GUIDE FEATURING THE GOODS AND SERVICES OF OTHER VENDORS VIA THE INTERNET (U.S. CLS. 100, 101 AND 102).

JOANNA DUKOVIC, EXAMINING ATTORNEY

SN 86-248,500. SITTING ON A GOLD MINE, INC., PENN VALLEY, PA. FILED 4-10-2014.

**SITTING ON A GOLD MINE**

THE MARK CONSISTS OF STANDARD CHARACTERS WITHOUT CLAIM TO ANY PARTICULAR FONT, STYLE, SIZE, OR COLOR.

OWNER OF U.S. REG. NO. 2,157,853.  
FOR ADVERTISING AGENCIES, NAMELY, PROMOTING THE GOODS AND SERVICES OF OTHERS (U.S. CLS. 100, 101 AND 102).

FIRST USE 1-10-1995; IN COMMERCE 1-10-1995.  
CHRIS WELLS, EXAMINING ATTORNEY

SN 86-248,540. KAMA SUTRA CLOSET, INC., VENTURA, CA. FILED 4-10-2014.

**TRYSTOLOGY**

THE MARK CONSISTS OF STANDARD CHARACTERS WITHOUT CLAIM TO ANY PARTICULAR FONT, STYLE, SIZE, OR COLOR.

FOR ON-LINE RETAIL STORE SERVICES FEATURING ADULT SENSUAL PLAY PRODUCTS, NAMELY LINGERIE, LOUNGEWEAR, SLEEPWEAR, CLOTHING, VIBRATORS, MASSAGERS, SEXUAL AIDS, LUBRICANTS, MASSAGE OILS, STIMULATING BALMS, BOOKS, GAMES, MASSAGE OIL CANDLES, SENSUAL PLAY DEVICES, AND SEXUAL AIDS.; RETAIL STORE SERVICES FEATURING LINGERIE, LOUNGEWEAR, SLEEPWEAR, CLOTHING, VIBRATORS, MASSAGERS, SEXUAL AIDS, LUBRICANTS, MASSAGE OILS, STIMULATING BALMS, BOOKS, GAMES, MASSAGE OIL CANDLES, SENSUAL PLAY DEVICES, AND SEXUAL AIDS (U.S. CLS. 100, 101 AND 102).

FIRST USE 4-6-2014; IN COMMERCE 4-6-2014.  
TARAH HARDY, EXAMINING ATTORNEY

**CLASS 35—(Continued).**

SN 86-248,723. WEST VIRGINIA OIL AND NATURAL GAS ASSOCIATION, INC., CHARLESTON, WV. FILED 4-10-2014.

EnergizeWV

THE MARK CONSISTS OF STANDARD CHARACTERS WITHOUT CLAIM TO ANY PARTICULAR FONT, STYLE, SIZE, OR COLOR.

FOR PUBLIC ADVOCACY TO PROMOTE AWARENESS OF THE OIL AND GAS INDUSTRY (U.S. CLS. 100, 101 AND 102).

FIRST USE 8-17-2006; IN COMMERCE 1-1-2007.

JASON BLAIR, EXAMINING ATTORNEY

SN 86-248,813. CARSAVVY, INC., DBA BEEPI, LOS ALTOS, CA. FILED 4-10-2014.



THE MARK CONSISTS OF A CIRCLE WITH A STYLIZED CAR INSIDE.

FOR OPERATING ON-LINE MARKETPLACES FOR SELLERS AND BUYERS OF GOODS AND/OR SERVICES; PROVIDING A WEBSITE FEATURING AN ON-LINE MARKETPLACE FOR EXCHANGING GOODS AND SERVICES WITH OTHER USERS (U.S. CLS. 100, 101 AND 102).

FIRST USE 8-1-2013; IN COMMERCE 8-1-2013.

TINA MAI, EXAMINING ATTORNEY

**CLASS 35—(Continued).**

SN 86-248,898. TORI RICHARD, LTD., HONOLULU, HI. FILED 4-10-2014.



THE MARK CONSISTS OF THE STYLIZED LETTERS "TR" SUPERIMPOSED ON EACH OTHER, INSIDE A RECTANGLE WITH OUTWARDLY CURVED SIDES.

FOR RETAIL STORE SERVICES FEATURING CLOTHING; ON-LINE RETAIL STORES FEATURING CLOTHING (U.S. CLS. 100, 101 AND 102).

FIRST USE 10-1-2013; IN COMMERCE 10-1-2013.

RONALD MCMORROW, EXAMINING ATTORNEY

SN 86-248,936. HUGH M. METHENY, NEW MARKET, MD. FILED 4-10-2014.

LOOKS EXPENSIVE BUT IT ISN'T

THE MARK CONSISTS OF STANDARD CHARACTERS WITHOUT CLAIM TO ANY PARTICULAR FONT, STYLE, SIZE, OR COLOR.

FOR ADVERTISING AND MARKETING; ADVERTISING AND MARKETING SERVICES, NAMELY, PROMOTING THE GOODS AND SERVICES OF OTHERS; ADVERTISING SERVICES; ADVERTISING SERVICES, NAMELY, PROMOTING AND MARKETING THE GOODS AND SERVICES OF OTHERS THROUGH ALL PUBLIC COMMUNICATION MEANS; ADVERTISING SERVICES, NAMELY, PROMOTING CAR DEALERSHIPS OF OTHERS (U.S. CLS. 100, 101 AND 102).

FIRST USE 5-25-2010; IN COMMERCE 5-25-2010.

COLLEEN MULCRONE, EXAMINING ATTORNEY

**CLASS 35—(Continued).**

SN 86-248,958. HUGH M. METHENY, NEW MARKET, MD.  
FILED 4-10-2014.

**JUDGE MY DEAL**

THE MARK CONSISTS OF STANDARD CHARACTERS WITHOUT CLAIM TO ANY PARTICULAR FONT, STYLE, SIZE, OR COLOR.

FOR ADVERTISING AND MARKETING; ADVERTISING AND MARKETING SERVICES, NAMELY, PROMOTING THE GOODS AND SERVICES OF OTHERS; ADVERTISING SERVICES; ADVERTISING SERVICES, NAMELY, PROMOTING AND MARKETING THE GOODS AND SERVICES OF OTHERS THROUGH ALL PUBLIC COMMUNICATION MEANS; ADVERTISING SERVICES, NAMELY, PROMOTING CAR DEALERSHIPS OF OTHERS (U.S. CLS. 100, 101 AND 102).

FIRST USE 5-25-2010; IN COMMERCE 5-25-2010.  
COLLEEN MULCRONE, EXAMINING ATTORNEY

**CLASS 35—(Continued).**

SN 86-249,270. BRIDGES OF UNDERSTANDING FOUNDATION, NEW YORK, NY. FILED 4-11-2014.

**Let's Stand Together**

THE MARK CONSISTS OF STANDARD CHARACTERS WITHOUT CLAIM TO ANY PARTICULAR FONT, STYLE, SIZE, OR COLOR.

FOR PROMOTING PUBLIC INTEREST AND AWARENESS OF THE NEED TO IMPROVE AND BUILD RELATIONSHIPS BETWEEN ARAB COUNTRIES AND THE UNITED STATES; ORGANIZING AND DEVELOPING CHARITABLE PROJECTS THAT AIM TO BUILD RELATIONSHIPS BETWEEN ARAB COUNTRIES AND THE UNITED STATES (U.S. CLS. 100, 101 AND 102).

FIRST USE 7-1-2013; IN COMMERCE 7-1-2013.  
JASON BLAIR, EXAMINING ATTORNEY

SN 86-249,020. SAPIRE, COLIN, PACIFIC PALISADES, CA.  
FILED 4-10-2014.

**NOPE**

THE MARK CONSISTS OF STANDARD CHARACTERS WITHOUT CLAIM TO ANY PARTICULAR FONT, STYLE, SIZE, OR COLOR.

FOR PROVIDE AN INTERACTIVE WEBSITE FOR USERS TO REVIEW AND RATE INTERNET CONTENT, PEOPLE, COMPANIES, PRODUCTS, AND/OR SERVICES FOR PURPOSES OF CRITIQUING THE SAME (U.S. CLS. 100, 101 AND 102).

GINA HAYES, EXAMINING ATTORNEY

SN 86-249,283. NATICK MEDIA LLC, NATICK, MA. FILED 4-11-2014.

**affordable insurance for  
all**

THE MARK CONSISTS OF STANDARD CHARACTERS WITHOUT CLAIM TO ANY PARTICULAR FONT, STYLE, SIZE, OR COLOR.

FOR GENERAL BUSINESS NETWORKING REFERRAL SERVICES, NAMELY, PROMOTING THE GOODS AND SERVICES OF OTHERS BY PASSING BUSINESS LEADS AND REFERRALS AMONG GROUP MEMBERS (U.S. CLS. 100, 101 AND 102).

FIRST USE 10-1-2013; IN COMMERCE 10-1-2013.  
JAMES LOVELACE, EXAMINING ATTORNEY

SN 86-249,246. SOTOMAYOR, JOSE, MIAMI BEACH, FL.  
FILED 4-11-2014.

**BOGOSONLINE.COM**

THE MARK CONSISTS OF STANDARD CHARACTERS WITHOUT CLAIM TO ANY PARTICULAR FONT, STYLE, SIZE, OR COLOR.

FOR PROMOTING THE GOODS OF OTHERS, NAMELY, PROVIDING INFORMATION REGARDING DISCOUNTS, COUPONS, REBATES, VOUCHERS AND SPECIAL OFFERS FOR THE GOODS OF OTHERS; PROVIDING A WEB SITE AT WHICH USERS CAN OFFER GOODS FOR SALE AND BUY GOODS OFFERED BY OTHERS (U.S. CLS. 100, 101 AND 102).

MICHAEL WIENER, EXAMINING ATTORNEY

SN 86-249,578. RACK N GILL OUTDOORS LLC, MORROW, OH. FILED 4-11-2014.

**RACK N GILL**

THE MARK CONSISTS OF STANDARD CHARACTERS WITHOUT CLAIM TO ANY PARTICULAR FONT, STYLE, SIZE, OR COLOR.

FOR ON-LINE RETAIL STORE SERVICES FEATURING HUNTING PRODUCTS AND FISHING PRODUCTS (U.S. CLS. 100, 101 AND 102).

EDWARD FENNESSY, EXAMINING ATTORNEY

**CLASS 35—(Continued).**

SN 86-249,643. NEW LEAF COMMUNITY MARKETS, INC., SANTA CRUZ, CA. FILED 4-11-2014.



THE COLOR(S) WHITE, GREEN, AND RED IS/ARE CLAIMED AS A FEATURE OF THE MARK.

THE MARK CONSISTS OF A STYLIZED DRAWING OF A LEAF WITH THE BOTTOM HALF IN SOLID GREEN, AND UPPER HALF IN GREEN AND WHITE SEGMENTS; THE LEAF IS IN CENTER OF A WHITE DIAMOND BORDERED IN ALL SIDES BY SOLID NARROW GREEN LINE; OVERLAPPING A SQUARE IN RED.

FOR RETAIL GROCERY STORES (U.S. CLS. 100, 101 AND 102).

FIRST USE 5-0-1990; IN COMMERCE 5-0-1990. ODESSA BIBBINS, EXAMINING ATTORNEY

**CLASS 35—(Continued).**

SN 86-249,780. HI 5 LOW PRICES L.L.C., LOCKPORT, LA. FILED 4-11-2014.



THE COLOR(S) GREEN, WHITE AND BLACK IS/ARE CLAIMED AS A FEATURE OF THE MARK.

THE MARK CONSISTS OF A CIRCLE OUTLINED IN BLACK, FILLED IN WITH GREEN WITH A WHITE HAND IN THE CENTER OUTLINED IN BLACK CONTAINING THE LETTERS "HI-" IN BLACK AND THE NUMBERS "1" AND "5" IN GREEN WITH THE "1" SLIGHTLY BEHIND THE "5".

FOR RETAIL STORES SERVICES IN THE FIELD OF GENERAL MERCHANDISE SELLING AT FIVE DOLLARS AND LOWER (U.S. CLS. 100, 101 AND 102).

FIRST USE 8-1-2013; IN COMMERCE 8-1-2013. RONALD DELGIZZI, EXAMINING ATTORNEY

SN 86-249,789. HI 5 LOW PRICES L.L.C., LOCKPORT, LA. FILED 4-11-2014.



THE COLOR(S) BLACK, GRAY, YELLOW, WHITE, ORANGE, BLUE, PINK AND GREEN IS/ARE CLAIMED AS A FEATURE OF THE MARK.

THE MARK CONSISTS OF FIVE CIRCLES EACH INSIDE A BLACK BOX OUTLINED IN GRAY, THE FIRST CIRCLE IN YELLOW WITH A WHITE HAND OUTLINED IN BLACK WITH A THUMB POINTING UP WITH A NUMBER "1" IN THE TOP AND LOWER PORTIONS OF THE CIRCLE, THE SECOND CIRCLE IN ORANGE WITH A WHITE HAND OUTLINED IN BLACK HOLDING UP TWO FINGERS WITH A NUMBER "2" IN THE TOP AND LOWER PORTIONS OF THE CIRCLE, THE THIRD CIRCLE IN BLUE WITH A WHITE HAND OUTLINED IN BLACK WITH THREE FINGERS HELD UP AND THE THUMB AND FOREFINGER TOUCHING UP WITH A NUMBER "3" IN THE TOP AND LOWER PORTIONS OF THE CIRCLE, THE FOURTH CIRCLE IN PINK WITH A WHITE FIST OUTLINED IN BLACK WITH A NUMBER "4" IN THE TOP AND LOWER PORTIONS OF THE CIRCLE, AND THE FIFTH CIRCLE IN GREEN WITH A WHITE HAND OPENED OUTLINED IN BLACK WITH A NUMBER "5" IN THE TOP AND LOWER PORTIONS OF THE CIRCLE.

FOR RETAIL STORES SERVICES IN THE FIELD OF GENERAL MERCHANDISE SELLING AT FIVE DOLLARS AND LOWER (U.S. CLS. 100, 101 AND 102).

FIRST USE 8-1-2013; IN COMMERCE 8-1-2013. RONALD DELGIZZI, EXAMINING ATTORNEY

SN 86-249,771. HI 5 LOW PRICES L.L.C., LOCKPORT, LA. FILED 4-11-2014.

hi1-5

THE MARK CONSISTS OF STANDARD CHARACTERS WITHOUT CLAIM TO ANY PARTICULAR FONT, STYLE, SIZE, OR COLOR.

FOR RETAIL STORES SERVICES IN THE FIELD OF GENERAL MERCHANDISE SELLING AT FIVE DOLLARS AND LOWER (U.S. CLS. 100, 101 AND 102).

FIRST USE 8-1-2013; IN COMMERCE 8-1-2013. RONALD DELGIZZI, EXAMINING ATTORNEY



**CLASS 35—(Continued).**

SN 86-249,982. MISS PAIGE, LTD, DBA JOBGIRAFFE, CHICAGO, IL. FILED 4-11-2014.

A DIFFERENT KIND OF ANIMAL  
IN RECRUITING AND STAFFING

THE MARK CONSISTS OF STANDARD CHARACTERS WITHOUT CLAIM TO ANY PARTICULAR FONT, STYLE, SIZE, OR COLOR.

FOR TEMPORARY AND PERMANENT PERSONNEL STAFFING SERVICES (U.S. CLS. 100, 101 AND 102).  
BRITTNEY COGAN, EXAMINING ATTORNEY

SN 86-249,986. LOCALITEZ, LLC, DBA LOCALPALZ, SEATTLE, WA. FILED 4-11-2014.

LOCALPALZ

THE MARK CONSISTS OF STANDARD CHARACTERS WITHOUT CLAIM TO ANY PARTICULAR FONT, STYLE, SIZE, OR COLOR.

FOR PROVIDING TRAVEL MANAGEMENT SERVICES; ADVERTISING SERVICES, NAMELY, PROMOTING AND MARKETING THE GOODS AND SERVICES OF OTHERS IN THE FIELDS OF TRAVEL, EXCURSIONS, SIGHTSEEING TOURS, CULTURAL EVENTS, SOCIAL EVENTS, AND ENTERTAINMENT EVENTS; PROCUREMENT, NAMELY, PURCHASING TICKETS TO ENTERTAINMENT EVENTS FOR OTHERS; ON-LINE PRICE MONITORING AND ADJUSTING FOR CUSTOMERS OF TRAVEL RELATED PURCHASES; OPERATING ON-LINE MARKETPLACES FOR SELLERS OF GOODS AND/OR SERVICES; ONLINE BUSINESS AND PROFESSIONAL NETWORKING SERVICES; ISSUING GIFT CERTIFICATES WHICH MAY THEN BE REDEEMED FOR GOODS OR SERVICES; PROMOTING THE GOODS OF OTHERS, NAMELY, PROVIDING COUPONS, REBATES AND VOUCHERS FOR THE GOODS OF OTHERS; REDEEMING THE VOUCHERS OF OTHERS FOR PAYMENT OF GOODS OR SERVICES (U.S. CLS. 100, 101 AND 102).

ELISSA GARBER KON, EXAMINING ATTORNEY

SN 86-250,037. VAPERSTATE, LLC., PORT RICHEY, FL. FILED 4-11-2014.

VaperState

THE MARK CONSISTS OF STANDARD CHARACTERS WITHOUT CLAIM TO ANY PARTICULAR FONT, STYLE, SIZE, OR COLOR.

FOR RETAIL STORE SERVICES FEATURING E-CIGARETTES, E-CIGARETTE ACCESSORIES, AND E-CIGARETTE COMPONENTS (U.S. CLS. 100, 101 AND 102).  
JOHN E. MICHOS, EXAMINING ATTORNEY

**CLASS 35—(Continued).**

SN 86-250,175. 5326 INDUSTRIES, WHITEFISH, MT. FILED 4-11-2014.

Long Live The Brotherhood

THE MARK CONSISTS OF STANDARD CHARACTERS WITHOUT CLAIM TO ANY PARTICULAR FONT, STYLE, SIZE, OR COLOR.

FOR ON-LINE RETAIL STORE SERVICES FEATURING SPECIAL FORCES TACTICAL GEAR, CLOTHING, AND SPECIAL FORCES-RELATED MEMORABILIA AND GOODS (U.S. CLS. 100, 101 AND 102).  
JAMES A. RAUEN, EXAMINING ATTORNEY

SN 86-250,239. RECUPERO, MICHELE, MIDDLE ISLAND, NY. FILED 4-11-2014.

The Q Angels

THE MARK CONSISTS OF STANDARD CHARACTERS WITHOUT CLAIM TO ANY PARTICULAR FONT, STYLE, SIZE, OR COLOR.

FOR ASSOCIATION SERVICES, NAMELY, PROMOTING THE INTERESTS OF BUSINESS OWNERS ON A MISSION TO MAKE A DIFFERENCE IN THE LIVES OF OTHERS (U.S. CLS. 100, 101 AND 102).

FIRST USE 9-10-2011; IN COMMERCE 9-15-2011.

SUSAN STIGLITZ, EXAMINING ATTORNEY

SN 86-250,382. AUDACITY, INC., CARLSBAD, CA. FILED 4-11-2014.

BRANDSUPREMACY

THE MARK CONSISTS OF STANDARD CHARACTERS WITHOUT CLAIM TO ANY PARTICULAR FONT, STYLE, SIZE, OR COLOR.

FOR ADVERTISING AND BUSINESS MANAGEMENT CONSULTANCY; ADVERTISING AND MARKETING CONSULTANCY; ADVERTISING SERVICES; ADVERTISING, MARKETING AND PROMOTION SERVICES; BUSINESS CONSULTATION SERVICES; MARKETING SERVICES (U.S. CLS. 100, 101 AND 102).

FIRST USE 9-1-2012; IN COMMERCE 9-1-2012.

TOBY BULLOFF, EXAMINING ATTORNEY

**CLASS 35—(Continued).**

SN 86-250,426. DAVIS, DONNA DIGHTMON, CASTRO VALLEY, CA. FILED 4-11-2014.

# KÉKICAKE

THE MARK CONSISTS OF STANDARD CHARACTERS WITHOUT CLAIM TO ANY PARTICULAR FONT, STYLE, SIZE, OR COLOR.

FOR ONLINE RETAIL STORE SERVICES FEATURING CAKES, CAKE COMPONENTS, AND DO-IT-YOURSELF CAKE KITS; RETAIL STORE SERVICES FEATURING CAKES, CAKE COMPONENTS, AND DO-IT-YOURSELF CAKE KITS (U.S. CLS. 100, 101 AND 102).  
JOHN DALIER, EXAMINING ATTORNEY

SN 86-250,633. REPENSEK, JOSHUA M, MIAMI, FL. FILED 4-12-2014.

# Drone Wars

THE MARK CONSISTS OF STANDARD CHARACTERS WITHOUT CLAIM TO ANY PARTICULAR FONT, STYLE, SIZE, OR COLOR.

FOR COORDINATION OF RECREATIONAL SPORTING OPPORTUNITIES FOR INDIVIDUALS WHO WISH TO PARTICIPATE IN TEAM LEAGUE SPORTS (U.S. CLS. 100, 101 AND 102).  
CHRISTINA SOBRAL, EXAMINING ATTORNEY

SN 86-250,963. CARSAVVY, INC., DBA BEEPI, LOS ALTOS, CA. FILED 4-14-2014.

# FROM 0 TO HAPPY

THE MARK CONSISTS OF STANDARD CHARACTERS WITHOUT CLAIM TO ANY PARTICULAR FONT, STYLE, SIZE, OR COLOR.

FOR OPERATING ON-LINE MARKETPLACES FOR SELLERS AND BUYERS OF GOODS AND/OR SERVICES; PROVIDING A WEBSITE FEATURING AN ON-LINE MARKETPLACE FOR EXCHANGING GOODS AND SERVICES WITH OTHER USERS (U.S. CLS. 100, 101 AND 102).  
TINA MAI, EXAMINING ATTORNEY

**CLASS 35—(Continued).**

SN 86-251,383. CARSAVVY, INC., DBA BEEPI, LOS ALTOS, CA. FILED 4-14-2014.

# MORE THAN A LOT BETTER

THE MARK CONSISTS OF STANDARD CHARACTERS WITHOUT CLAIM TO ANY PARTICULAR FONT, STYLE, SIZE, OR COLOR.

FOR OPERATING ON-LINE MARKETPLACES FOR SELLERS AND BUYERS OF GOODS AND/OR SERVICES; PROVIDING A WEBSITE FEATURING AN ON-LINE MARKETPLACE FOR EXCHANGING GOODS AND SERVICES WITH OTHER USERS (U.S. CLS. 100, 101 AND 102).

FIRST USE 8-1-2013; IN COMMERCE 8-1-2013.  
TINA MAI, EXAMINING ATTORNEY

SN 86-251,780. LORIN V. WALKER, IDAHO FALLS, ID. FILED 4-14-2014.

# Portion Control Fresh

THE MARK CONSISTS OF STANDARD CHARACTERS WITHOUT CLAIM TO ANY PARTICULAR FONT, STYLE, SIZE, OR COLOR.

FOR BRANDING SERVICES, NAMELY, CONSULTING, DEVELOPMENT, MANAGEMENT AND MARKETING OF BRANDS FOR BUSINESSES AND/OR INDIVIDUALS (U.S. CLS. 100, 101 AND 102).

APRIL ROACH, EXAMINING ATTORNEY

SN 86-251,798. PINELLAS COUNTY GOVERNMENT (FLORIDA POLITICAL SUBDIVISION OF THE STATE OF FLORIDA PURSUANT TO FL STATUTE, TITLE II, CHAPTER 7; TITLE XI, CHAPTER 125), DBA VISIT ST. PETERSBURG-CLEARWATER A/K/A PINELLAS COUNTY'S CONVENTION AND VISITORS BUREAU, CLEARWATER, FL. FILED 4-14-2014.

# MANAPHIN

THE MARK CONSISTS OF STANDARD CHARACTERS WITHOUT CLAIM TO ANY PARTICULAR FONT, STYLE, SIZE, OR COLOR.

FOR CHAMBER OF COMMERCE SERVICES, NAMELY, PROMOTING BUSINESS AND TOURISM IN THE ST. PETERSBURG-CLEARWATER, FLORIDA AREA (U.S. CLS. 100, 101 AND 102).

FIRST USE 4-4-2014; IN COMMERCE 4-4-2014.  
ALLISON SCHRODY, EXAMINING ATTORNEY

**CLASS 35—(Continued).**

SN 86-252,024. TIME WARNER CABLE ENTERPRISES LLC,  
NEW YORK, NY. FILED 4-14-2014.

# KERNEL

THE MARK CONSISTS OF STANDARD CHARACTERS WITHOUT CLAIM TO ANY PARTICULAR FONT, STYLE, SIZE, OR COLOR.

FOR CREATION AND PRODUCTION OF ADVERTISING FOR OTHERS; PREPARING AND PLACING ADVERTISING FOR OTHERS ACROSS MULTIPLE PLATFORMS INCLUSIVE OF ON-AIR, ONLINE AND ON DEMAND; DISSEMINATION OF ADVERTISING VIA AN ON-LINE COMMUNICATIONS NETWORK, BROADCAST COMMUNICATION NETWORK AND VIA ON-DEMAND PLATFORMS (U.S. CLS. 100, 101 AND 102).  
JENNY PARK, EXAMINING ATTORNEY

SN 86-252,314. BIRCHBOX, INC., NEW YORK, NY. FILED 4-15-2014.

# OPEN FOR BEAUTIFUL

THE MARK CONSISTS OF STANDARD CHARACTERS WITHOUT CLAIM TO ANY PARTICULAR FONT, STYLE, SIZE, OR COLOR.

FOR RETAIL STORE SERVICES AND ONLINE RETAIL STORE SERVICES FEATURING COSMETIC, BEAUTY, PERFUMERY, MAKE-UP, TOILETRY, LIFESTYLE, SKIN, HAIR AND PERSONAL CARE PRODUCTS AND ACCESSORIES, BATH AND BODY PRODUCTS AND ACCESSORIES, FOOD, COFFEE, TEA, ALCOHOLIC AND NON-ALCOHOLIC BEVERAGES, APPAREL, BAGS, HOUSEWARES, GARDEN TOOLS, CUTLERY, HOME ACCESSORIES, TABLEWARE, CLOCKS, WATCHES, ELECTRONIC DOCKING STATIONS, JEWELRY, CANDLES, HOME AND PARTY DECORATIONS, PICTURE AND PHOTO FRAMES AND STATIONERY; PROMOTING THE GOODS AND SERVICES OF OTHERS BY PROVIDING A WEB SITE FEATURING CONSUMER PRODUCT INFORMATION AND REVIEWS AND RELATED PRODUCT INFORMATION ABOUT PRACTICES AND TRENDS, ALL IN THE FIELDS OF COSMETICS, BEAUTY, PERFUMERY, MAKE-UP, TOILETRY, LIFESTYLE, SKIN, HAIR AND PERSONAL CARE PRODUCTS AND ACCESSORIES, BATH AND BODY PRODUCTS AND ACCESSORIES, FOOD, COFFEE, TEA, ALCOHOLIC AND NON-ALCOHOLIC BEVERAGES, APPAREL, BAGS, HOUSEWARES, GARDEN TOOLS, CUTLERY, HOME ACCESSORIES, TABLEWARE, CLOCKS, WATCHES, ELECTRONIC DOCKING STATIONS, JEWELRY, CANDLES, HOME AND PARTY DECORATIONS, PICTURE AND PHOTO FRAMES AND STATIONERY; PROMOTING THE GOODS AND SERVICES OF OTHERS BY PROVIDING A WEB SITE FEATURING DISCOUNT INFORMATION, COUPONS, AND LINKS TO THE RETAIL WEB SITES OF OTHERS, ALL IN THE FIELDS OF COSMETIC, BEAUTY, PERFUMERY, MAKE-UP, TOILETRY, LIFESTYLE, SKIN, HAIR AND PERSONAL CARE PRODUCTS AND ACCESSORIES, BATH AND BODY PRODUCTS AND ACCESSORIES, FOOD, COFFEE, TEA, ALCOHOLIC AND NON-ALCOHOLIC BEVERAGES, APPAREL, BAGS, HOUSEWARES, GARDEN TOOLS, CUTLERY, HOME ACCESSORIES, TABLEWARE, CLOCKS, WATCHES, ELECTRONIC DOCKING STATIONS, JEWELRY, CANDLES, HOME AND PARTY

**CLASS 35—(Continued).**

DECORATIONS, PICTURE AND PHOTO FRAMES AND STATIONERY; ADMINISTRATION OF A CONSUMER MEMBERSHIP PROGRAM FOR ENABLING PARTICIPANTS TO RECEIVE PRODUCTS, PRODUCT SAMPLES, DISCOUNTS, PRINTED MATERIAL, INFORMATION, AND LOYALTY POINTS FOR ON-LINE PURCHASE OF GOODS AND SERVICES, ALL IN THE FIELD OF COSMETIC, BEAUTY, PERFUMERY, MAKE-UP, TOILETRY, LIFESTYLE, SKIN, HAIR AND PERSONAL CARE PRODUCTS AND ACCESSORIES, BATH AND BODY PRODUCTS AND ACCESSORIES, FOOD, COFFEE, TEA, ALCOHOLIC AND NON-ALCOHOLIC BEVERAGES, APPAREL, BAGS, HOUSEWARES, GARDEN TOOLS, CUTLERY, HOME ACCESSORIES, TABLEWARE, CLOCKS, WATCHES, ELECTRONIC DOCKING STATIONS, JEWELRY, CANDLES, HOME AND PARTY DECORATIONS, PICTURE AND PHOTO FRAMES AND STATIONERY; MARKETING SERVICES, NAMELY, CONSUMER RESEARCH IN THE NATURE OF COLLECTING, ANALYZING, AND PROCESSING CONSUMER PREFERENCE AND PRODUCT USAGE INFORMATION IN THE FIELD OF BEAUTY, PERSONAL CARE AND LIFESTYLE PRODUCTS; MARKETING SERVICES, NAMELY, PROVIDING CONSUMER RESEARCH INFORMATION ABOUT CONSUMER PREFERENCE AND PRODUCT USAGE TO PROVIDERS OF BEAUTY, PERSONAL CARE AND LIFESTYLE PRODUCTS (U.S. CLS. 100, 101 AND 102).

GEORGE LORENZO, EXAMINING ATTORNEY

SN 86-252,455. LOVE BEYOND WALLS, COLLEGE PARK, GA. FILED 4-15-2014.



THE MARK CONSISTS OF A BOXED HEART TO THE LEFT OF THE STYLIZED TEXT "LOVE BEYOND WALLS". FOR PROMOTING PUBLIC AWARENESS OF SOCIAL INJUSTICES (U.S. CLS. 100, 101 AND 102).

FIRST USE 10-7-2013; IN COMMERCE 10-7-2013.  
LINDA MICKLEBURGH, EXAMINING ATTORNEY

SN 86-253,155. YAPTA, INC., SEATTLE, WA. FILED 4-15-2014.

# ROOMIQ

THE MARK CONSISTS OF STANDARD CHARACTERS WITHOUT CLAIM TO ANY PARTICULAR FONT, STYLE, SIZE, OR COLOR.

FOR PROVIDING COMMERCIAL INFORMATION IN THE FIELD OF TRAVEL AND TRANSPORTATION; TRAVEL MANAGEMENT SERVICES, NAMELY, PROVIDING A SERVICE THAT ALLOWS CUSTOMERS TO MONITOR TRAVEL COSTS DYNAMICALLY AND RECEIVE ANALYTICAL REPORTS AND NOTIFICATIONS ON CHANGES IN TRAVEL COSTS (U.S. CLS. 100, 101 AND 102).

JASON MALASHEVICH, EXAMINING ATTORNEY

**CLASS 35—(Continued).**

SN 86-254,438. CHARITY POP INC., BEDFORD, NY. FILED 4-16-2014.

# CHARITYPOP

THE MARK CONSISTS OF STANDARD CHARACTERS WITHOUT CLAIM TO ANY PARTICULAR FONT, STYLE, SIZE, OR COLOR.

FOR ON-LINE AUCTION SERVICES FEATURING AN AUCTION PLATFORM WHERE CONSUMERS BID ON ONCE IN A LIFETIME EXPERIENCES (U.S. CLS. 100, 101 AND 102).

EVIN L. KOZAK, EXAMINING ATTORNEY

---

SN 86-255,465. WEST PAK AVOCADO, INC., MURRIETA, CA. FILED 4-17-2014.

# AVOCADOMORE

THE MARK CONSISTS OF STANDARD CHARACTERS WITHOUT CLAIM TO ANY PARTICULAR FONT, STYLE, SIZE, OR COLOR.

FOR BUSINESS MANAGEMENT CONSULTING WITH RELATION TO STRATEGY, MARKETING, SALES, OPERATION, PRODUCT DESIGN PARTICULARLY SPECIALIZING IN THE USE OF ANALYTIC AND STATISTIC MODELS FOR THE UNDERSTANDING AND PREDICTING OF CONSUMERS, BUSINESSES, AND MARKET TRENDS AND ACTIONS; PROVIDING AN ON-LINE COMPUTER WEB SITE THAT PROVIDES COMMERCIAL FINANCIAL TRANSACTION DATA, ACCOUNT MANAGEMENT, FINANCIAL REPORTING, ACCOUNTING FEATURES AND RELATED REFERENCE INFORMATION; PROVIDING ONLINE BUSINESS MANAGEMENT SERVICES INCLUDING ACCOUNTING, MARKETING, BUSINESS PROJECT MANAGEMENT, AND BUSINESS DEVELOPMENT (U.S. CLS. 100, 101 AND 102).

FIRST USE 4-25-2013; IN COMMERCE 4-25-2013.  
SOPHIA S. KIM, EXAMINING ATTORNEY

**CLASS 35—(Continued).**

SN 86-271,264. LIQUID AGENCY, INC., SAN JOSE, CA. FILED 5-5-2014.

# SVT

THE MARK CONSISTS OF STANDARD CHARACTERS WITHOUT CLAIM TO ANY PARTICULAR FONT, STYLE, SIZE, OR COLOR.

FOR BUSINESS AND MARKETING CONSULTING SERVICES; BUSINESS CONSULTATION, NAMELY, BRANDING STRATEGIES CONSULTATION; MARKETING AND CUSTOMER ANALYSIS; BUSINESS AND MARKETING RESEARCH SERVICES, NAMELY, CONDUCTING MARKET, CONSUMER TREND ANALYSIS AND AUDIENCE RESEARCH FOR BUSINESS PURPOSES IN THE APPAREL, CONSUMER ELECTRONICS, ENERGY, FINANCIAL, FOOD AND BEVERAGE, NOT-FOR-PROFIT, RETAIL, TECHNOLOGY AND COMMUNICATIONS INDUSTRIES; MARKETING SERVICES, NAMELY, CONSUMER MARKETING RESEARCH; BRAND NAME DEVELOPMENT AND CORPORATE IDENTITY SERVICES, NAMELY, CREATING, EVALUATING, AND MANAGING BRAND NAMES, TRADEMARKS, SERVICE MARKS AND BUSINESS NAMES FOR OTHERS; DEVELOPMENT AND IMPLEMENTATION OF MARKETING STRATEGIES FOR OTHERS, NAMELY, BUSINESS CONSULTING SERVICES IN THE FIELDS OF ADVERTISING, MARKETING, CORPORATE IDENTITY DEVELOPMENT, PRODUCT BRANDING, PRODUCT PROMOTION AND LAUNCHING OF NEW BRANDS AND PRODUCTS (U.S. CLS. 100, 101 AND 102).

AMY C. KEAN, EXAMINING ATTORNEY

---

SN 86-272,486. BLACK HILLS VAPORS LLC., RAPID CITY, SD. FILED 5-6-2014.

# GO VAPE YOURSELF

THE MARK CONSISTS OF STANDARD CHARACTERS WITHOUT CLAIM TO ANY PARTICULAR FONT, STYLE, SIZE, OR COLOR.

NO CLAIM IS MADE TO THE EXCLUSIVE RIGHT TO USE "VAPE", APART FROM THE MARK AS SHOWN.

FOR RETAIL STORE AND ONLINE RETAIL STORE FEATURING ELECTRONIC CIGARETTES AND ELECTRONIC CIGARETTE ACCESSORIES (U.S. CLS. 100, 101 AND 102).

FIRST USE 1-19-2014; IN COMMERCE 2-15-2014.  
WON TEAK OH, EXAMINING ATTORNEY

**CLASS 35—(Continued).**

SN 86-274,183. TANNER GUN SHOW, INC., DENVER, CO. FILED 5-7-2014.



OWNER OF U.S. REG. NO. 3,449,074.  
NO CLAIM IS MADE TO THE EXCLUSIVE RIGHT TO USE "GUN SHOW", APART FROM THE MARK AS SHOWN. THE COLOR(S) FLORESCENT PINK AND BLACK IS/ARE CLAIMED AS A FEATURE OF THE MARK.  
THE MARK CONSISTS OF A FLORESCENT PINK RECTANGLE WITH THE WORDS "TANNER GUN SHOW" IN BLACK CAPITAL LETTERS ALONG THE TOP OF THE RECTANGLE.  
FOR PROMOTING AND CONDUCTING TRADE SHOWS IN THE FIELD OF GUNS, KNIVES, HUNTING AND OUTDOOR EQUIPMENT (U.S. CLS. 100, 101 AND 102).  
FIRST USE 4-12-2014; IN COMMERCE 4-12-2014.  
LINDA LAVACHE, EXAMINING ATTORNEY

**CLASS 35—(Continued).**

SN 86-283,632. ZULILY, INC., SEATTLE, WA. FILED 5-16-2014.



OWNER OF U.S. REG. NOS. 3,868,643, 4,349,566 AND 4,357,191.  
THE MARK CONSISTS OF THE STYLIZED WORD "ZULILY"; A HALF CIRCLE COMPRISED OF FLOWER PETALS SURROUNDS THE LETTERS "ZU".  
FOR ON-LINE RETAIL STORE SERVICES FEATURING A WIDE VARIETY OF CONSUMER GOODS OF OTHERS (U.S. CLS. 100, 101 AND 102).  
FIRST USE 5-2-2014; IN COMMERCE 5-2-2014.  
CHRISTINA SOBRAL, EXAMINING ATTORNEY

SN 86-275,851. FASTENAL IP COMPANY, WINONA, MN. FILED 5-8-2014.

**RSS**

THE MARK CONSISTS OF STANDARD CHARACTERS WITHOUT CLAIM TO ANY PARTICULAR FONT, STYLE, SIZE, OR COLOR.  
FOR ONLINE WHOLESALE AND RETAIL OUTLET STORE SERVICES FEATURING FASTENERS, ELECTRICAL TOOLS AND WIRING, GLOVES, PROTECTIVE EYEWEAR, FIRST AID PRODUCTS, BUILDING CONSTRUCTION TOOLS AND EQUIPMENT USED FOR PLUMBING PURPOSES, JANITORIAL EQUIPMENT AND SUPPLIES USED FOR INDUSTRIAL, INSTITUTIONAL AND COMMERCIAL PURPOSES (U.S. CLS. 100, 101 AND 102).  
MARK T. MULLEN, EXAMINING ATTORNEY

SN 86-286,867. TY LOKE, LLC, LOS ANGELES, CA. FILED 5-20-2014.

**FLAWSOME**

THE MARK CONSISTS OF STANDARD CHARACTERS WITHOUT CLAIM TO ANY PARTICULAR FONT, STYLE, SIZE, OR COLOR.  
FOR EVENT PLANNING AND MANAGEMENT FOR MARKETING, BRANDING, PROMOTING OR ADVERTISING THE GOODS AND SERVICES OF OTHERS; SPECIAL EVENT PLANNING FOR BUSINESS PURPOSES; SPECIAL EVENT PLANNING FOR COMMERCIAL, PROMOTIONAL OR ADVERTISING PURPOSES (U.S. CLS. 100, 101 AND 102).  
IRA J. GOODSaid, EXAMINING ATTORNEY

**CLASS 35—(Continued).**

SN 86-287,468. TPM, INC., INDIANAPOLIS, IN. FILED 5-21-2014.

**THE PRODUCE MOM**

THE MARK CONSISTS OF STANDARD CHARACTERS WITHOUT CLAIM TO ANY PARTICULAR FONT, STYLE, SIZE, OR COLOR.

OWNER OF U.S. REG. NOS. 4,241,058, 4,386,931 AND OTHERS.

NO CLAIM IS MADE TO THE EXCLUSIVE RIGHT TO USE "PRODUCE", APART FROM THE MARK AS SHOWN.

FOR PROMOTING THE GOODS AND SERVICES OF OTHERS THROUGH THE DISTRIBUTION OF ON-LINE AND PRINTED MATERIALS AND INFORMATION, PROMOTIONAL EXHIBITS, AND ALL MEANS OF COMMUNICATION TO THE GENERAL PUBLIC; ADVERTISING, MARKETING AND PROMOTIONAL SERVICES FOR FRUITS AND VEGETABLES OF OTHERS, NAMELY, PRODUCE DISTRIBUTORS, VENDORS, GROCERY STORES AND RESTAURANTS (U.S. CLS. 100, 101 AND 102).

FIRST USE 3-14-2012; IN COMMERCE 3-14-2012.  
JENNIFER MARTIN, EXAMINING ATTORNEY

SN 86-290,466. QUICKSTART BRANDS, INC., LAS VEGAS, NV. FILED 5-23-2014.

**Premium Media 360**

THE MARK CONSISTS OF STANDARD CHARACTERS WITHOUT CLAIM TO ANY PARTICULAR FONT, STYLE, SIZE, OR COLOR.

NO CLAIM IS MADE TO THE EXCLUSIVE RIGHT TO USE "PREMIUM MEDIA", APART FROM THE MARK AS SHOWN.

FOR AD SERVING, NAMELY, PLACING ADVERTISEMENTS ON WEBSITES FOR OTHERS USING SPECIALIZED COMPUTER SOFTWARE; ADVERTISEMENT AND PUBLICITY SERVICES BY TELEVISION, RADIO, MAIL; ADVERTISEMENT FOR OTHERS ON THE INTERNET; ADVERTISING AGENCIES; ADVERTISING AND BUSINESS SERVICES, NAMELY, SECURING AIRTIME ON ALL FORMS OF MEDIA COMMUNICATIONS STATIONS, SYSTEMS, NETWORKS, AND SERVICES FOR THE PURPOSE OF PROMOTING THE GOODS AND SERVICES OF OTHERS; AGENCIES FOR ADVERTISING TIME AND SPACE; ANALYSIS OF ADVERTISING RESPONSE; ANALYSIS OF MARKET RESEARCH DATA AND STATISTICS; BUSINESS RESEARCH SERVICES, NAMELY, PROVIDING ANALYSIS OF RETAIL DATA ON SPECIFIC BUSINESS LOCATIONS; COMPILING AND ANALYZING STATISTICS, DATA AND OTHER SOURCES OF INFORMATION FOR BUSINESS PURPOSES; DATA PROCESSING SERVICES (U.S. CLS. 100, 101 AND 102).

FIRST USE 5-1-2014; IN COMMERCE 5-1-2014.  
SANI KHOURI, EXAMINING ATTORNEY

**CLASS 35—(Continued).**

SN 86-291,946. CALIENTE RESORTS, LLC., DBA CALIENTE RESORT AND SPA, LAND O LAKES, FL. FILED 5-27-2014.

**Skinny Dip Sundae**

THE MARK CONSISTS OF STANDARD CHARACTERS WITHOUT CLAIM TO ANY PARTICULAR FONT, STYLE, SIZE, OR COLOR.

NO CLAIM IS MADE TO THE EXCLUSIVE RIGHT TO USE "SKINNY DIP", APART FROM THE MARK AS SHOWN.

FOR ARRANGING AND CONDUCTING SPECIAL EVENTS FOR COMMERCIAL, PROMOTIONAL OR ADVERTISING PURPOSES (U.S. CLS. 100, 101 AND 102).

FIRST USE 5-1-2010; IN COMMERCE 5-1-2010.  
TEJBIR SINGH, EXAMINING ATTORNEY

SN 86-294,247. DEG: THE DIGITAL ENTERTAINMENT GROUP, LOS ANGELES, CA. FILED 5-28-2014.

**DEG**

THE MARK CONSISTS OF STANDARD CHARACTERS WITHOUT CLAIM TO ANY PARTICULAR FONT, STYLE, SIZE, OR COLOR.

SEC. 2(F).

FOR ASSOCIATION SERVICES, NAMELY, PROMOTING THE INTERESTS OF MEMBER CONSUMER ELECTRONICS MANUFACTURERS, MOTION PICTURE STUDIOS, MUSIC COMPANIES, INFORMATION TECHNOLOGY COMPANIES, AND OF THE HOME ENTERTAINMENT INDUSTRY GENERALLY (U.S. CLS. 100, 101 AND 102).

FIRST USE 12-8-2003; IN COMMERCE 12-8-2003.  
DANIEL CAPSHAW, EXAMINING ATTORNEY

SN 86-294,498. TIME WARNER CABLE ENTERPRISES LLC, NEW YORK, NY. FILED 5-29-2014.



THE MARK CONSISTS OF THE STYLIZED WORD "KERNEL" WITH A DESIGN THAT RESEMBLES AN EAR OF CORN AND A LIGHTBULB.

FOR CREATION AND PRODUCTION OF ADVERTISING FOR OTHERS; PREPARING AND PLACING ADVERTISING FOR OTHERS ACROSS MULTIPLE PLATFORMS INCLUSIVE OF ON-AIR, ONLINE AND ON DEMAND; DISSEMINATION OF ADVERTISING VIA AN ON-LINE COMMUNICATIONS NETWORK, BROADCAST COMMUNICATION NETWORK AND VIA ON-DEMAND PLATFORMS (U.S. CLS. 100, 101 AND 102).

JENNY PARK, EXAMINING ATTORNEY

**CLASS 35—(Continued).**

SN 86-295,966. WPP PROPERTIES, NEW YORK, NY. FILED 5-30-2014.

# PINNAKLE

THE MARK CONSISTS OF STANDARD CHARACTERS WITHOUT CLAIM TO ANY PARTICULAR FONT, STYLE, SIZE, OR COLOR.

FOR BUSINESS MARKETING CONSULTING SERVICES RELATING TO BRAND MARKETING, BRAND DEVELOPMENT AND BRAND POTENTIAL IN THE FIELDS OF HEALTHCARE AND PHARMACEUTICALS; MARKET RESEARCH, MARKET ANALYSIS AND DATA ANALYTICS RELATING TO BRAND MARKETING, BRAND DEVELOPMENT AND BRAND POTENTIAL IN THE FIELDS OF HEALTHCARE AND PHARMACEUTICALS (U.S. CLS. 100, 101 AND 102).

CHRISTOPHER REAMS, EXAMINING ATTORNEY

SN 86-296,734. BIRCHBOX, INC., NEW YORK, NY. FILED 5-30-2014.

# OPEN FOR HANDSOME

THE MARK CONSISTS OF STANDARD CHARACTERS WITHOUT CLAIM TO ANY PARTICULAR FONT, STYLE, SIZE, OR COLOR.

FOR RETAIL STORE SERVICES AND ONLINE RETAIL STORE SERVICES FEATURING COSMETIC, BEAUTY, PERFUMERY, MAKE-UP, TOILETRY, LIFESTYLE, SKIN, HAIR AND PERSONAL CARE PRODUCTS AND ACCESSORIES, BATH AND BODY PRODUCTS AND ACCESSORIES, FOOD, COFFEE, TEA, ALCOHOLIC AND NON-ALCOHOLIC BEVERAGES, APPAREL, BAGS, HOUSEWARES, GARDEN TOOLS, CUTLERY, HOME ACCESSORIES, TABLEWARE, CLOCKS, WATCHES, ELECTRONIC DOCKING STATIONS, JEWELRY, CANDLES, HOME AND PARTY DECORATIONS, PICTURE AND PHOTO FRAMES AND STATIONERY; PROMOTING THE GOODS AND SERVICES OF OTHERS BY PROVIDING A WEB SITE FEATURING CONSUMER PRODUCT INFORMATION AND REVIEWS AND RELATED PRODUCT INFORMATION ABOUT PRACTICES AND TRENDS, ALL IN THE FIELDS OF COSMETICS, BEAUTY, PERFUMERY, MAKE-UP, TOILETRY, LIFESTYLE, SKIN, HAIR AND PERSONAL CARE PRODUCTS AND ACCESSORIES, BATH AND BODY PRODUCTS AND ACCESSORIES, FOOD, COFFEE, TEA, ALCOHOLIC AND NON-ALCOHOLIC BEVERAGES, APPAREL, BAGS, HOUSEWARES, GARDEN TOOLS, CUTLERY, HOME ACCESSORIES, TABLEWARE, CLOCKS, WATCHES, ELECTRONIC DOCKING STATIONS, JEWELRY, CANDLES, HOME AND PARTY DECORATIONS, PICTURE AND PHOTO FRAMES AND STATIONERY; PROMOTING THE GOODS AND SERVICES OF OTHERS BY PROVIDING A WEB SITE FEATURING DISCOUNT INFORMATION, COUPONS, AND LINKS TO THE RETAIL WEB SITES OF OTHERS, ALL IN THE FIELDS OF COSMETIC, BEAUTY, PERFUMERY, MAKE-UP, TOILETRY, LIFESTYLE, SKIN, HAIR AND PERSONAL CARE PRODUCTS AND ACCESSORIES, BATH AND BODY PRODUCTS AND ACCESSORIES, FOOD, COFFEE, TEA, ALCOHOLIC AND NON-ALCOHOLIC BEVERAGES, APPAREL, BAGS, HOUSEWARES, GARDEN TOOLS, CUTLERY, HOME ACCESSORIES, TABLEWARE, CLOCKS, WATCHES, ELECTRONIC DOCKING

**CLASS 35—(Continued).**

STATIONS, JEWELRY, CANDLES, HOME AND PARTY DECORATIONS, PICTURE AND PHOTO FRAMES AND STATIONERY. ADMINISTRATION OF A CONSUMER MEMBERSHIP PROGRAM FOR ENABLING PARTICIPANTS TO RECEIVE PRODUCTS, PRODUCT SAMPLES, DISCOUNTS, PRINTED MATERIAL, INFORMATION, AND LOYALTY POINTS FOR ON-LINE PURCHASE OF GOODS AND SERVICES, ALL IN THE FIELD OF COSMETIC, BEAUTY, PERFUMERY, MAKE-UP, TOILETRY, LIFESTYLE, SKIN, HAIR AND PERSONAL CARE PRODUCTS AND ACCESSORIES, BATH AND BODY PRODUCTS AND ACCESSORIES, FOOD, COFFEE, TEA, ALCOHOLIC AND NON-ALCOHOLIC BEVERAGES, APPAREL, BAGS, HOUSEWARES, GARDEN TOOLS, CUTLERY, HOME ACCESSORIES, TABLEWARE, CLOCKS, WATCHES, ELECTRONIC DOCKING STATIONS, JEWELRY, CANDLES, HOME AND PARTY DECORATIONS, PICTURE AND PHOTO FRAMES AND STATIONERY; MARKETING SERVICES, NAMELY CONSUMER RESEARCH IN THE NATURE OF COLLECTING, ANALYZING, AND PROCESSING CONSUMER PREFERENCE AND PRODUCT USAGE INFORMATION IN THE FIELD OF BEAUTY, PERSONAL CARE AND LIFESTYLE PRODUCTS; MARKETING SERVICES, NAMELY, PROVIDING CONSUMER RESEARCH INFORMATION ABOUT CONSUMER PREFERENCE AND PRODUCT USAGE TO PROVIDERS OF BEAUTY, PERSONAL CARE AND LIFESTYLE PRODUCTS (U.S. CLS. 100, 101 AND 102).

GEORGE LORENZO, EXAMINING ATTORNEY

SN 86-298,712. LOKAI HOLDINGS LLC, NEW YORK, NY. FILED 6-3-2014.

# LOKAI LENS

THE MARK CONSISTS OF STANDARD CHARACTERS WITHOUT CLAIM TO ANY PARTICULAR FONT, STYLE, SIZE, OR COLOR.

OWNER OF U.S. REG. NO. 4,429,129.

FOR RETAIL STORE SERVICES FEATURING JEWELRY (U.S. CLS. 100, 101 AND 102).

JUSTIN SEVERSON, EXAMINING ATTORNEY

SN 86-298,717. LOKAI HOLDINGS LLC, NEW YORK, NY. FILED 6-3-2014.

# LOKAI

THE MARK CONSISTS OF STANDARD CHARACTERS WITHOUT CLAIM TO ANY PARTICULAR FONT, STYLE, SIZE, OR COLOR.

OWNER OF U.S. REG. NO. 4,429,129.

FOR RETAIL STORE SERVICES FEATURING JEWELRY (U.S. CLS. 100, 101 AND 102).

FIRST USE 6-4-2013; IN COMMERCE 6-4-2013.

JUSTIN SEVERSON, EXAMINING ATTORNEY

**CLASS 35—(Continued).**

SN 86-301,129. PROFESSIONAL BULL RIDERS, INC., PUEBLO, CO. FILED 6-5-2014.

**BRAND YOUR HIDE**

THE MARK CONSISTS OF STANDARD CHARACTERS WITHOUT CLAIM TO ANY PARTICULAR FONT, STYLE, SIZE, OR COLOR.

FOR RETAIL STORE SERVICES FEATURING CLOTHING, ACCESSORIES AND GIFTS (U.S. CLS. 100, 101 AND 102).

BRITTANY ESTELL, EXAMINING ATTORNEY

---

SN 86-306,189. GENERAL NUTRITION INVESTMENT COMPANY, WILMINGTON, DE. FILED 6-11-2014.

**BRING OUT YOUR INNER BEAUTY**

THE MARK CONSISTS OF STANDARD CHARACTERS WITHOUT CLAIM TO ANY PARTICULAR FONT, STYLE, SIZE, OR COLOR.

FOR RETAIL STORE SERVICES FEATURING HEALTH FOODS, DIETARY SUPPLEMENTS, NUTRITIONAL SUPPLEMENTS, HERBS, VITAMINS, SPORTS NUTRITION PRODUCTS, FITNESS PRODUCTS, AND DIAGNOSTIC EXERCISE AND AROMATHERAPY PRODUCTS (U.S. CLS. 100, 101 AND 102).

PAUL E. FAHRENKOPF, EXAMINING ATTORNEY

---

SN 86-308,041. PEPSICO, INC., PURCHASE, NY. FILED 6-12-2014.

**KOLA HOUSE**

THE MARK CONSISTS OF STANDARD CHARACTERS WITHOUT CLAIM TO ANY PARTICULAR FONT, STYLE, SIZE, OR COLOR.

NO CLAIM IS MADE TO THE EXCLUSIVE RIGHT TO USE "KOLA", APART FROM THE MARK AS SHOWN.

FOR PROVIDING MARKETING AND PROMOTION OF SPECIAL EVENTS (U.S. CLS. 100, 101 AND 102).

JENNIFER RICHARDSON, EXAMINING ATTORNEY

**CLASS 35—(Continued).**

SN 86-310,321. TECHCRUNCH, INC., SAN FRANCISCO, CA. FILED 6-16-2014.

**TC INCLUDE**

THE MARK CONSISTS OF STANDARD CHARACTERS WITHOUT CLAIM TO ANY PARTICULAR FONT, STYLE, SIZE, OR COLOR.

FOR BUSINESS ADVISORY AND SUPPORT SERVICES, NAMELY, BUSINESS CONSULTING TO SOCIAL ENTERPRISES AND EXISTING FOR-PROFIT AND NON-PROFIT BUSINESSES WORKING TO FOSTER DIVERSITY AND INCLUSION IN THE TECHNOLOGY INDUSTRY (U.S. CLS. 100, 101 AND 102).

FIRST USE 6-3-2014; IN COMMERCE 6-3-2014.

CHRISTINA SOBRAL, EXAMINING ATTORNEY

---

SN 86-310,362. TECHCRUNCH, INC., SAN FRANCISCO, CA. FILED 6-16-2014.



THE COLOR(S) GREEN AND BLACK IS/ARE CLAIMED AS A FEATURE OF THE MARK.

THE MARK CONSISTS OF THE LETTER TC IN GREEN ABOVE AND TO THE LETTERS INCLUDE IN BLACK.

FOR BUSINESS ADVISORY AND SUPPORT SERVICES, NAMELY, BUSINESS CONSULTING TO SOCIAL ENTERPRISES AND EXISTING FOR-PROFIT AND NON-PROFIT BUSINESSES WORKING TO FOSTER DIVERSITY AND INCLUSION IN THE TECHNOLOGY INDUSTRY (U.S. CLS. 100, 101 AND 102).

FIRST USE 6-3-2014; IN COMMERCE 6-3-2014.

CHRISTINA SOBRAL, EXAMINING ATTORNEY

---

SN 86-317,017. GENERAL NUTRITION INVESTMENT COMPANY, WILMINGTON, DE. FILED 6-23-2014.

**HAPPY WELLNESS**

THE MARK CONSISTS OF STANDARD CHARACTERS WITHOUT CLAIM TO ANY PARTICULAR FONT, STYLE, SIZE, OR COLOR.

FOR RETAIL STORE SERVICES FEATURING HEALTH FOODS, DIETARY SUPPLEMENTS, NUTRITIONAL SUPPLEMENTS, HERBS, VITAMINS, SPORTS NUTRITION PRODUCTS, FITNESS PRODUCTS, DIAGNOSTIC EXERCISE AND AROMATHERAPY PRODUCTS PROVIDED VIA WIRELESS COMMUNICATIONS (U.S. CLS. 100, 101 AND 102).

PAUL E. FAHRENKOPF, EXAMINING ATTORNEY



**CLASS 35—(Continued).**

SN 86-323,741. UNITED STATES STRATEGY GROUP SUPPORT SERVICES, LLC, TALLAHASSEE, FL. FILED 6-29-2014.

SOUTHERN STRATEGY GROUP

THE MARK CONSISTS OF STANDARD CHARACTERS WITHOUT CLAIM TO ANY PARTICULAR FONT, STYLE, SIZE, OR COLOR.

OWNER OF U.S. REG. NOS. 2,778,005 AND 4,229,137.

NO CLAIM IS MADE TO THE EXCLUSIVE RIGHT TO USE "STRATEGY GROUP", APART FROM THE MARK AS SHOWN.

SEC. 2(F).

FOR PUBLIC RELATIONS CONSULTING SERVICES AND BUSINESS CONSULTING SERVICES IN THE FIELDS OF BUSINESS STRATEGIES, CORPORATE POSITIONING, LEGISLATIVE AFFAIRS, PUBLIC AFFAIRS, COMMUNITY AFFAIRS, MEDIA RELATIONS, AND GOVERNMENT RELATIONS SERVICES FOR OTHERS, NAMELY, PROVIDING LOBBYING SERVICES (U.S. CLS. 100, 101 AND 102).

FIRST USE 6-21-1999; IN COMMERCE 6-21-1999.  
SANJEEV VOHRA, EXAMINING ATTORNEY

SN 86-326,874. DEPANNEUR, INC., SAN FRANCISCO, CA. FILED 7-2-2014.

YUMBIN

THE MARK CONSISTS OF STANDARD CHARACTERS WITHOUT CLAIM TO ANY PARTICULAR FONT, STYLE, SIZE, OR COLOR.

FOR FOOD KIOSK SERVICES; VENDING IN THE FIELD OF FOOD AND DRINK (U.S. CLS. 100, 101 AND 102).

FIRST USE 1-27-2014; IN COMMERCE 1-27-2014.  
SKYE YOUNG, EXAMINING ATTORNEY

**CLASS 36—INSURANCE AND FINANCIAL**

SN 77-620,185. G-FORCE TRADING, LLC, CENTENNIAL, CO. FILED 11-22-2008.

G-FORCE

THE MARK CONSISTS OF STANDARD CHARACTERS WITHOUT CLAIM TO ANY PARTICULAR FONT, STYLE, SIZE, OR COLOR.

FOR AGENCIES FOR BROKERAGE OF SECURITIES TRADING IN OVERSEAS SECURITIES MARKETS AND OF TRANSACTIONS ON COMMISSION OF OVERSEAS MARKET SECURITIES FUTURES; AGENCIES FOR COMMODITY FUTURES TRADING; AGENCIES OR BROKERAGE FOR TRADING OF SECURITIES, SECURITIES INDEX FUTURES, SECURITIES OPTIONS, AND OVERSEAS MARKET SECURITIES FUTURES; BROKERAGE HOUSES IN THE FIELD OF STOCKS, COMMODITIES, AND FUTURES; COMMODITY BROKERAGE; COMMODITY INVESTMENT ADVICE; COMMODITY QUOTATIONS; COMMODITY TRADING FOR OTHERS; FINANCIAL AND INVESTMENT SERVICES, NAMELY, MANAGEMENT AND BROKERAGE IN THE FIELDS OF STOCKS, BONDS, OPTIONS, COMMODITIES, FUTURES AND OTHER SECURITIES, AND THE INVESTMENT OF FUNDS OF OTHERS; FINANCIAL SERVICES, NAMELY, PROVIDING FOR THE EXCHANGE OF FOREIGN CURRENCY, COMMODITIES, FINANCIAL DERIVATIVES, INTEREST RATE PRODUCTS, AND EQUITIES VIA THE INTERNET AND INTRANET SYSTEMS; FINANCIAL SERVICES, NAMELY, PROVIDING INFORMATION IN THE FIELDS OF FOREIGN CURRENCY, COMMODITIES, FINANCIAL DERIVATIVES, INTEREST RATE PRODUCTS, AND EQUITIES VIA THE INTERNET AND INTRANET SYSTEMS; INVESTMENT ADVISORY SERVICES; INVESTMENT BROKERAGE; INVESTMENT CONSULTATION; INVESTMENT MANAGEMENT; INVESTMENT OF FUNDS FOR OTHERS; PROVIDING A WEB SITE THAT FEATURES INFORMATION ON THE OPTIONS MARKETS; PROVIDING INFORMATION ON TRADING OPTIONS AND ON PROFITING FROM THE TIME DELAY OF OPTIONS; SECURITIES TRADING AND INVESTING SERVICES FOR OTHERS VIA THE INTERNET (U.S. CLS. 100, 101 AND 102).

FIRST USE 10-14-2007; IN COMMERCE 3-0-2008.  
KATHERINE STOIDES, EXAMINING ATTORNEY

SN 79-139,907. GIVEMATCHER PTY LTD, CROWS NEST NSW 2065, AUSTRALIA, FILED 10-29-2013.

GIVEMATCHER

THE MARK CONSISTS OF STANDARD CHARACTERS WITHOUT CLAIM TO ANY PARTICULAR FONT, STYLE, SIZE, OR COLOR.

PRIORITY DATE OF 9-6-2013 IS CLAIMED.

OWNER OF INTERNATIONAL REGISTRATION 1185275 DATED 10-29-2013, EXPIRES 10-29-2023.

FOR CHARITABLE SERVICES, NAMELY, FINANCIAL SERVICES FOR CHARITABLE FUNDRAISING; CHARITABLE FUNDRAISING (U.S. CLS. 100, 101 AND 102).

LESLEY LAMOTHE, EXAMINING ATTORNEY

**CLASS 36—(Continued).**

SN 79-140,859. IFM INVESTORS PTY LTD, MELBOURNE VIC 3000, AUSTRALIA, FILED 10-17-2013.



PRIORITY DATE OF 10-17-2013 IS CLAIMED.  
OWNER OF INTERNATIONAL REGISTRATION 1187842 DATED 10-17-2013, EXPIRES 10-17-2023.  
OWNER OF U.S. REG. NOS. 3,692,728, 3,699,088 AND 3,699,089.

NO CLAIM IS MADE TO THE EXCLUSIVE RIGHT TO USE "INVESTORS", APART FROM THE MARK AS SHOWN.

THE MARK CONSISTS OF THE LETTERS "IFM" AND THE WORD "INVESTORS" UNDERNEATH THE LETTER "M" IN "IFM".

FOR FINANCIAL SERVICES, NAMELY, MANAGEMENT OF SUPERANNUATION INVESTMENT FUNDS, FUNDS INVESTMENT, INVESTMENT ADVICE, AND INVESTMENT MANAGEMENT (U.S. CLS. 100, 101 AND 102).

STEPHANIE ALI, EXAMINING ATTORNEY

**CLASS 36—(Continued).**

SN 85-247,927. HOPE FOR THE WARRIORS, JACKSONVILLE, NC. FILED 2-22-2011.

Team Hope for the Warriors

THE MARK CONSISTS OF STANDARD CHARACTERS WITHOUT CLAIM TO ANY PARTICULAR FONT, STYLE, SIZE, OR COLOR.

OWNER OF U.S. REG. NO. 3,425,225.

FOR CHARITABLE FUNDRAISING SERVICES BY MEANS OF ORGANIZING AND ENCOURAGING PARTICIPATION IN ATHLETIC EVENTS TO OBTAIN DONATIONS USED TO SUPPORT THE TRAVEL TO AND PARTICIPATION IN SUCH EVENTS BY VETERANS OF THE ARMED FORCES, EXCLUDING CHARITABLE SERVICES RELATING TO CANCER (U.S. CLS. 100, 101 AND 102).

FIRST USE 9-1-2007; IN COMMERCE 9-1-2007.

WON TEAK OH, EXAMINING ATTORNEY

SN 85-330,534. ESPREEVA, INC, IRVINE, CA. FILED 5-26-2011.

YOUR PHONE IS YOUR WALLET

SN 79-147,103. SANPOWER GROUP, CHINA, FILED 3-26-2014.



OWNER OF INTERNATIONAL REGISTRATION 1203408 DATED 3-26-2014, EXPIRES 3-26-2024.

FOR LIFE INSURANCE UNDERWRITING; FINANCING SERVICES; ART APPRAISAL; REAL ESTATE AGENCIES; REAL ESTATE MANAGEMENT; REAL ESTATE BROKERAGE; FINANCIAL GUARANTEES; CHARITABLE FUND RAISING; FIDUCIARY REPRESENTATIVES; PAWNBROKERAGE (U.S. CLS. 100, 101 AND 102).

JULIE VEPPUMTHARA, EXAMINING ATTORNEY

THE MARK CONSISTS OF STANDARD CHARACTERS WITHOUT CLAIM TO ANY PARTICULAR FONT, STYLE, SIZE, OR COLOR.

FOR LOYALTY PROGRAM PAYMENT PROCESSING SERVICES; PAYMENT PROCESSING SERVICES, NAMELY, CREDIT CARD AND DEBIT CARD TRANSACTION PROCESSING SERVICES; PROVIDING MULTIPLE PAYMENT OPTIONS BY MEANS OF CUSTOMER-OPERATED ELECTRONIC TERMINALS AVAILABLE ON-SITE IN RETAIL STORES; REDEEMING THE VOUCHERS OF OTHERS FOR PAYMENT OF GOODS OR SERVICES (U.S. CLS. 100, 101 AND 102).

KEVIN CORWIN, EXAMINING ATTORNEY

**CLASS 36—(Continued).**

SN 85-570,586. INFINITY INSURANCE COMPANY, BIRMINGHAM, AL. FILED 3-15-2012.



OWNER OF U.S. REG. NOS. 1,819,181, 3,455,432 AND OTHERS.

NO CLAIM IS MADE TO THE EXCLUSIVE RIGHT TO USE "AUTO INSURANCE", APART FROM THE MARK AS SHOWN.

THE MARK CONSISTS OF THE WORD "INFINITY" WITH A LINE BELOW IT AND THE WORDS "AUTO INSURANCE" BELOW THE LINE AND A PICTURE OF A ROAD WITH A WHITE STRIPE TO THE LEFT OF THE WORD "INFINITY".

FOR INSURANCE SERVICES, NAMELY, WRITING PROPERTY AND CASUALTY INSURANCE (U.S. CLS. 100, 101 AND 102).

FIRST USE 3-1-2012; IN COMMERCE 3-1-2012.  
GINA FINK, EXAMINING ATTORNEY

**CLASS 36—(Continued).**

SN 85-620,906. KAISER FEDERAL FINANCIAL GROUP, INC., CORVINA, CA. FILED 5-9-2012.



NO CLAIM IS MADE TO THE EXCLUSIVE RIGHT TO USE "BANK", APART FROM THE MARK AS SHOWN.

THE MARK CONSISTS OF A FOUR LEAF CLOVER DESIGN SHAPE BETWEEN THE WORDS "SIMPLICITY BANK", WITH THE WORDS "BANK SIMPLY" UNDER THE CLOVER DESIGN.

FOR BANKING AND FINANCIAL SERVICES, NAMELY, ASSUMING FINANCIAL RISK OF OTHERS BY ENTERING INTO OPTIONS AND SWAPS, CREDIT AND FINANCIAL CONSULTATION, ELECTRONIC FINANCIAL SERVICES FOR THE PURCHASE OF SAVINGS BONDS, FINANCIAL ANALYSIS AND CONSULTATION, FINANCIAL CLEARING HOUSES, FINANCIAL CONSULTATION, FINANCIAL DUE DILIGENCE, FINANCIAL EVALUATION FOR INSURANCE PURPOSES, FINANCIAL EXCHANGE, FINANCIAL FORECASTING, FINANCIAL GUARANTEE AND SURETY, FINANCIAL INFORMATION IN THE NATURE OF RATES OF EXCHANGE, FINANCIAL INFORMATION PROVIDED BY ELECTRONIC MEANS, FINANCIAL INFORMATION PROCESSING, FINANCIAL LOAN CONSULTATION, FINANCIAL MANAGEMENT, FINANCIAL RESEARCH, FINANCIAL RISK MANAGEMENT, FINANCIAL SERVICES, NAMELY, MONEY LENDING, PROVIDING ON-LINE STORED VALUE ACCOUNTS IN AN ELECTRONIC ENVIRONMENT, FINANCIAL TRUST OPERATIONS, FINANCIAL VALUATION OF PERSONAL PROPERTY AND REAL ESTATE; AND PROVIDING ON-LINE FINANCIAL CALCULATORS (U.S. CLS. 100, 101 AND 102).

ELLEN BURNS, EXAMINING ATTORNEY

SN 85-600,332. WEISS ENTERPRISES, INC., WABASH, IN. FILED 4-17-2012.

## WeCare Card

THE MARK CONSISTS OF STANDARD CHARACTERS WITHOUT CLAIM TO ANY PARTICULAR FONT, STYLE, SIZE, OR COLOR.

NO CLAIM IS MADE TO THE EXCLUSIVE RIGHT TO USE "CARD", APART FROM THE MARK AS SHOWN.

FOR DEBIT CARD SERVICES, NAMELY, PROVIDING A SERVICE WHEREBY MULTIPLE DONORS CAN DONATE MONEY INTO A SINGLE DEBIT CARD ACCOUNT FOR USE BY THE RECIPIENT (U.S. CLS. 100, 101 AND 102).

FIRST USE 7-23-2012; IN COMMERCE 7-23-2012.  
LYNDSEY KUYKENDALL, EXAMINING ATTORNEY

SN 85-646,050. HERO ASSOCIATES, LLC, PAOLI, PA. FILED 6-7-2012.

## HERO ENERGY SHOT

THE MARK CONSISTS OF STANDARD CHARACTERS WITHOUT CLAIM TO ANY PARTICULAR FONT, STYLE, SIZE, OR COLOR.

NO CLAIM IS MADE TO THE EXCLUSIVE RIGHT TO USE "ENERGY SHOT", APART FROM THE MARK AS SHOWN.

FOR CHARITABLE FUNDRAISING SERVICES, NAMELY, ELEEMOSYNARY SERVICES IN THE FIELD OF COLLECTION, BY MEANS OF SELLING ENERGY SHOTS, MANAGEMENT, AND DISBURSEMENTS OF MONEY IN CONNECTION WITH PROGRAMS AND FACILITIES FOR THE WELFARE OF POLICE, FIREFIGHTERS, EMTS AND ARMED FORCES; CHARITABLE FUNDRAISING SERVICES BY MEANS OF SELLING ENERGY SHOTS TO RAISE FUNDS FOR POLICE, FIREFIGHTERS, EMTS AND ARMED FORCES (U.S. CLS. 100, 101 AND 102).

FIRST USE 5-0-2010; IN COMMERCE 5-0-2010.  
JEFFERY COWARD, EXAMINING ATTORNEY

**CLASS 36—(Continued).**

SN 85-646,085. HERO ASSOCIATES, LLC, PAOLI, PA. FILED 6-7-2012.



NO CLAIM IS MADE TO THE EXCLUSIVE RIGHT TO USE "ENERGY SHOT", APART FROM THE MARK AS SHOWN.

THE COLOR(S) RED, WHITE AND BLUE IS/ARE CLAIMED AS A FEATURE OF THE MARK.

THE MARK CONSISTS OF A WHITE STAR OUTLINED IN BLUE WITH A BLUE, RED AND WHITE TAIL ABOVE THE WORD "HERO" IN WHITE ABOVE THE WORD "ENERGY" IN WHITE WITH A RED CROSS TO THE RIGHT FOLLOWED BY THE WORD "SHOT" IN WHITE. THE WORDING AND CROSS DESIGN ARE ALL CONTAINED WITHIN BLUE OUTLINING.

FOR CHARITABLE FUNDRAISING SERVICES, NAMELY, ELEEMOSYNARY SERVICES IN THE FIELD OF COLLECTION, BY MEANS OF SELLING ENERGY SHOTS, MANAGEMENT, AND DISBURSEMENTS OF MONEY IN CONNECTION WITH PROGRAMS AND FACILITIES FOR THE WELFARE OF POLICE, FIREFIGHTERS, EMTS AND ARMED FORCES; CHARITABLE FUNDRAISING SERVICES BY MEANS OF SELLING ENERGY SHOTS TO RAISE FUNDS FOR POLICE, FIREFIGHTERS, EMTS AND ARMED FORCES (U.S. CLS. 100, 101 AND 102).

FIRST USE 5-0-2010; IN COMMERCE 5-0-2010.  
JEFFERY COWARD, EXAMINING ATTORNEY

SN 85-674,390. JOSHUA DAVID MELLBERG, LLC, TUCSON, AZ. FILED 7-11-2012.

**SENIOR ANNUITY ALERT**

THE MARK CONSISTS OF STANDARD CHARACTERS WITHOUT CLAIM TO ANY PARTICULAR FONT, STYLE, SIZE, OR COLOR.

NO CLAIM IS MADE TO THE EXCLUSIVE RIGHT TO USE "SENIOR ANNUITY", APART FROM THE MARK AS SHOWN.

FOR INTERNET WEBSITE FEATURING INFORMATION ABOUT ANNUITIES (U.S. CLS. 100, 101 AND 102).  
FIRST USE 1-1-2010; IN COMMERCE 1-1-2010.

VIVIAN MICZNIK FIRST, EXAMINING ATTORNEY

**CLASS 36—(Continued).**

SN 85-680,837. BOFI FEDERAL BANK, SAN DIEGO, CA. FILED 7-18-2012.

**CASH IN A FLASH**

THE MARK CONSISTS OF STANDARD CHARACTERS WITHOUT CLAIM TO ANY PARTICULAR FONT, STYLE, SIZE, OR COLOR.

FOR FINANCING SERVICES, NAMELY, CASH FLOW SERVICES WHEREBY CASH IS PROVIDED TO CONSUMERS IN EXCHANGE FOR OWNERSHIP OF OR A SECURITY INTEREST IN LOTTERY PRIZE, STRUCTURED SETTLEMENT, AND DEFERRED PAYMENT OBLIGATIONS; CONSUMER LENDING SERVICES, NAMELY, PROVIDING LOANS WHEREBY LOTTERY PRIZE, STRUCTURED SETTLEMENT, AND DEFERRED PAYMENTS ARE USED AS LOAN COLLATERAL (U.S. CLS. 100, 101 AND 102).

MICHELLE DUBOIS, EXAMINING ATTORNEY

SN 85-748,307. PAYWARD, INC., SACRAMENTO, CA. FILED 10-8-2012.

**KRAKEN**

THE MARK CONSISTS OF STANDARD CHARACTERS WITHOUT CLAIM TO ANY PARTICULAR FONT, STYLE, SIZE, OR COLOR.

FOR AN ONLINE COMMODITY, CURRENCY AND SECURITIES EXCHANGE AND BROKERAGE (U.S. CLS. 100, 101 AND 102).

JOHN DWYER, EXAMINING ATTORNEY

**CLASS 36—(Continued).**

SN 85-792,798, PRESTAMOS PRENDARIOS DEPOFIN, S.A. DE C.V., MEXICO, D.F., MEXICO, FILED 12-3-2012.



OWNER OF U.S. REG. NOS. 2,899,009 AND 3,221,605.  
NO CLAIM IS MADE TO THE EXCLUSIVE RIGHT TO USE "TU CASA DE EMPENO", APART FROM THE MARK AS SHOWN.

THE MARK CONSISTS OF THE WORDS "PRENDA MEX" IN STYLIZED LETTERING WITH A DOLLAR SIGN SUPERIMPOSED ON THE LETTERING, AND UNDERNEATH THE WORDS "TU CASA DE EMPENO" IN STYLIZED LETTERING ENCLOSED IN A RECTANGULAR BACKGROUND.

THE ENGLISH TRANSLATION OF "PRENDA" IN THE MARK IS "SECURITY", "PLEDGE", "GUARANTY", OR "TOKEN" AND THE ENGLISH TRANSLATION OF "TU CASA DE EMPENO" IS "YOUR HOUSE OF PAWN".

FOR PAWN BROKERAGE SERVICES; PAWN SHOP SERVICES; FINANCIAL SERVICES, NAMELY, VEHICLE TITLE LOAN SERVICES, CASH ADVANCE SERVICES, CHECK CASHING SERVICES, MONEY TRANSFER SERVICES, AND CURRENCY EXCHANGE SERVICES (U.S. CLS. 100, 101 AND 102).

FIRST USE 10-28-1996; IN COMMERCE 7-12-2010.  
NORA BUCHANAN WILL, EXAMINING ATTORNEY

**CLASS 36—(Continued).**

SN 85-815,619, CRIF CORPORATION, ATLANTA, GA. FILED 1-4-2013.



SN 85-815,581, CRIF CORPORATION, ATLANTA, GA. FILED 1-4-2013.



OWNER OF U.S. REG. NO. 4,077,592.  
THE COLOR(S) BLUE, ORANGE, AND WHITE IS/ARE CLAIMED AS A FEATURE OF THE MARK.

THE MARK CONSISTS OF THE WORDING "CRIF ACTION", WITH THE WORD "CRIF" IN BLUE, THE LETTERS "ACT" IN ORANGE, THE LETTERS "ION" IN BLUE, NEXT TO A BLUE CIRCULAR DESIGN CONTAINING WHITE ARROWS.

FOR FINANCIAL SERVICES, NAMELY, FINANCIAL SERVICES RENDERED IN CONNECTION WITH THE ISSUANCE, RECEIPT AND TRANSFER OF LINES OF CREDIT, NAMELY, CREDIT PROCESSING SERVICES, LOAN DEFAULT MITIGATION SERVICES, STRATEGIC FINANCIAL ADVISORY SERVICES, FINANCIAL ADVISORY AND CONSULTANCY SERVICES RELATING TO MICRO CREDITS AND MICRO FINANCE, FINANCIAL ADVISORY AND CONSULTANCY SERVICES; FINANCIAL AFFAIRS AND MONETARY AFFAIRS, NAMELY, FINANCIAL INFORMATION, MANAGEMENT AND ANALYSIS SERVICES, FINANCIAL CREDIT SCORING SERVICES, FINANCIAL EVALUATION, TRACKING, ANALYSIS, FORECASTING, CONSULTANCY, ADVISORY AND RESEARCH SERVICES RELATING TO SECURITIES AND OTHER FINANCIAL INSTRUMENTS (U.S. CLS. 100, 101 AND 102).

FIRST USE 1-9-2011; IN COMMERCE 1-9-2011.  
WANDA KAY PRICE, EXAMINING ATTORNEY

OWNER OF U.S. REG. NO. 4,077,592.  
NO CLAIM IS MADE TO THE EXCLUSIVE RIGHT TO USE "SYNERGY", APART FROM THE MARK AS SHOWN.  
THE COLOR(S) BLUE AND ORANGE IS/ARE CLAIMED AS A FEATURE OF THE MARK.

THE MARK CONSISTS OF THE WORDING "CRIF SYNERGY" WITH "CRIF" IN BLUE, "SYNERGY" IN ORANGE, AND AN ORANGE CIRCLE SURROUNDED BY BLUE SWIRLS.

FOR FINANCIAL SERVICES, NAMELY, FINANCIAL SERVICES RENDERED IN CONNECTION WITH THE ISSUANCE, RECEIPT AND TRANSFER OF LINES OF CREDIT, NAMELY, CREDIT PROCESSING SERVICES, LOAN DEFAULT MITIGATION SERVICES, STRATEGIC FINANCIAL ADVISORY SERVICES, FINANCIAL ADVISORY AND CONSULTANCY SERVICES RELATING TO MICRO CREDITS AND MICRO FINANCE, FINANCIAL ADVISORY AND CONSULTANCY SERVICES; FINANCIAL AFFAIRS AND MONETARY AFFAIRS, NAMELY, FINANCIAL INFORMATION, MANAGEMENT AND ANALYSIS SERVICES, FINANCIAL CREDIT SCORING SERVICES, FINANCIAL EVALUATION, TRACKING, ANALYSIS, FORECASTING, CONSULTANCY, ADVISORY AND RESEARCH SERVICES RELATING TO SECURITIES AND OTHER FINANCIAL INSTRUMENTS (U.S. CLS. 100, 101 AND 102).

FIRST USE 1-9-2011; IN COMMERCE 1-9-2011.  
WANDA KAY PRICE, EXAMINING ATTORNEY

**CLASS 36—(Continued).**

SN 85-843,598. WIRTH FINANCIAL & INSURANCE SERVICES, IRVINE, CA. FILED 2-7-2013.



THE MARK CONSISTS OF AN ARCHER SUPERIMPOSED OVER THE LETTERS "WFIS".

FOR FINANCIAL PLANNING; FINANCIAL SERVICES, NAMELY, FINANCIAL ADVICE AND CONSULTANCY, AND FINANCIAL ASSET MANAGEMENT, NAMELY, ASSET PROTECTION PLANNING; INSURANCE PLANNING CONSULTATION IN THE NATURE OF PLANS FOR INSURANCE PURCHASES AND ADMINISTRATION, NAMELY, LIFE INSURANCE PLANNING, DISABILITY INSURANCE PLANNING, LONG TERM CARE INSURANCE PLANNING, CRITICAL ILLNESS INSURANCE PLANNING; INSURANCE BROKERAGE, AND INSURANCE SERVICES, NAMELY, INSURANCE AGENCY AND INSURANCE CLAIMS PROCESSING; INVESTMENT PLANNING IN THE NATURE OF INVESTMENT CONSULTATION; INVESTMENT SERVICES, NAMELY, INITIATION OF INVESTMENT OF FUNDS FOR OTHERS AND INVESTMENT MANAGEMENT IN THE FIELD OF SAVINGS FUNDS, RETIREMENT FUNDS, COLLEGE SAVINGS PROGRAMS, FIXED ANNUITIES, AND VARIABLE ANNUITIES; INVESTMENT ADVISORY SERVICES; AND EMPLOYEE BENEFIT SERVICES, NAMELY, INITIATION AND ADMINISTRATION OF EMPLOYEE BENEFIT PLANS CONCERNING INSURANCE AND FINANCE, RETIREMENT PLANS, PROFIT SHARING PLANS, PENSION PLANS, AND STOCK OPTION PLANS (U.S. CLS. 100, 101 AND 102).

COLLEEN MULCRONE, EXAMINING ATTORNEY

**CLASS 36—(Continued).**

SN 85-843,702. WIRTH FINANCIAL & INSURANCE SERVICES, IRVINE, CA. FILED 2-7-2013.

# WFIS

THE MARK CONSISTS OF STANDARD CHARACTERS WITHOUT CLAIM TO ANY PARTICULAR FONT, STYLE, SIZE, OR COLOR.

FOR FINANCIAL PLANNING; FINANCIAL SERVICES, NAMELY, FINANCIAL ADVICE AND CONSULTANCY, AND FINANCIAL ASSET MANAGEMENT, NAMELY, ASSET PROTECTION PLANNING; INSURANCE PLANNING CONSULTATION IN THE NATURE OF PLANS FOR INSURANCE PURCHASES AND ADMINISTRATION, NAMELY, LIFE INSURANCE PLANNING, DISABILITY INSURANCE PLANNING, LONG TERM CARE INSURANCE PLANNING, CRITICAL ILLNESS INSURANCE PLANNING; INSURANCE BROKERAGE, AND INSURANCE SERVICES, NAMELY, INSURANCE AGENCY AND INSURANCE CLAIMS PROCESSING; INVESTMENT PLANNING IN THE NATURE OF INVESTMENT CONSULTATION; INVESTMENT SERVICES, NAMELY, INITIATION OF INVESTMENT OF FUNDS FOR OTHERS AND INVESTMENT MANAGEMENT IN THE FIELD OF SAVINGS FUNDS, RETIREMENT FUNDS, COLLEGE SAVINGS PROGRAMS, FIXED ANNUITIES, AND VARIABLE ANNUITIES; INVESTMENT ADVISORY SERVICES; AND EMPLOYEE BENEFIT SERVICES, NAMELY, INITIATION AND ADMINISTRATION OF EMPLOYEE BENEFIT PLANS CONCERNING INSURANCE AND FINANCE, RETIREMENT PLANS, PROFIT SHARING PLANS, PENSION PLANS, AND STOCK OPTION PLANS (U.S. CLS. 100, 101 AND 102).

COLLEEN MULCRONE, EXAMINING ATTORNEY

SN 85-931,861. GEORGIA LOAN COMPANY, LEESBURG, GA. FILED 5-14-2013.

# NEWLEAF

THE MARK CONSISTS OF STANDARD CHARACTERS WITHOUT CLAIM TO ANY PARTICULAR FONT, STYLE, SIZE, OR COLOR.

FOR CONSUMER LENDING SERVICES (U.S. CLS. 100, 101 AND 102).

FIRST USE 2-1-2010; IN COMMERCE 2-1-2010.

JESSICA FATHY, EXAMINING ATTORNEY

**CLASS 36—(Continued).**

SN 85-934,324. FMR LLC, BOSTON, MA. FILED 5-16-2013.



OWNER OF U.S. REG. NO. 1,463,861.

THE MARK CONSISTS OF THE LETTER "N" WITHIN A CIRCLE, WITH A PARTIAL SUN COMING OUT OF THE TOP OF THE "N".

FOR PROVIDING INFORMATION ABOUT INVESTMENTS, MUTUAL FUNDS, SECURITIES AND FINANCIAL ACCOUNTS BY MEANS OF THE INTERNET; PROVIDING FINANCIAL INFORMATION IN THE FIELD OF RETIREMENT PLANNING; MUTUAL FUND INVESTMENT SERVICES; RETIREMENT FUND INVESTMENT SERVICES; EMPLOYEE FINANCIAL, HEALTH INSURANCE AND INSURANCE BENEFIT AND FINANCIAL RETIREMENT PLAN ADMINISTRATION SERVICES; INVESTMENT MANAGEMENT SERVICES; SECURITIES BROKERAGE SERVICES (U.S. CLS. 100, 101 AND 102).

FIRST USE 4-24-2013; IN COMMERCE 4-24-2013.  
KIM MONINGHOFF, EXAMINING ATTORNEY**CLASS 36—(Continued).**

SN 85-941,338. BEKEN, LLC, PORTLAND, OR. FILED 5-23-2013.

**BEKEN**

SN 85-935,585. MASSACHUSETTS FINANCIAL SERVICES COMPANY, BOSTON, MA. FILED 5-17-2013.

**1924 CAPITAL**

THE MARK CONSISTS OF STANDARD CHARACTERS WITHOUT CLAIM TO ANY PARTICULAR FONT, STYLE, SIZE, OR COLOR.

NO CLAIM IS MADE TO THE EXCLUSIVE RIGHT TO USE "CAPITAL", APART FROM THE MARK AS SHOWN.

FOR HEDGE FUND INVESTMENT SERVICES; ADMINISTRATION AND DISTRIBUTION OF HEDGE FUNDS; INVESTMENT MANAGEMENT SERVICES; INVESTMENT ADVISORY SERVICES (U.S. CLS. 100, 101 AND 102).

LINDA ORNDORFF, EXAMINING ATTORNEY

THE MARK CONSISTS OF STANDARD CHARACTERS WITHOUT CLAIM TO ANY PARTICULAR FONT, STYLE, SIZE, OR COLOR.

FOR FINANCIAL TRANSACTION AND PAYMENT PROCESSING SERVICES, NAMELY, CREDIT CARD, DEBIT CARD, RELOADABLE PREPAID CARD, GIFT CARD, HEALTH SAVINGS ACCOUNT CARD, AND PAYROLL CARD TRANSACTION PROCESSING SERVICES; CREDIT, DEBIT, AND PREPAID CARD MANAGEMENT SERVICES, NAMELY, ISSUANCE, ACTIVATION, AND RE-ISSUANCE SERVICES FOR CREDIT CARDS, DEBIT CARDS, AND PREPAID CARDS; AUTOMATED TELLER MACHINE SERVICES, NAMELY, TERMINAL MANAGEMENT IN THE NATURE OF FINANCIAL TRANSACTION AND PAYMENT PROCESSING SERVICES; MERCHANT SERVICES, NAMELY, PAYMENT TRANSACTION PROCESSING; PROVIDING AN INTERNET WEBSITE PORTAL IN THE FIELD OF FINANCIAL TRANSACTION AND PAYMENT PROCESSING SERVICES FOR IMPLEMENTATION AND OPERATION OF DEBIT CARD, CREDIT CARD, AUTOMATED TELLER MACHINE, AND PREPAID CARD PROGRAMS; FRAUD REIMBURSEMENT SERVICES IN THE FIELD OF CREDIT AND DEBIT CARD PURCHASES (U.S. CLS. 100, 101 AND 102).

STEPHANIE ALI, EXAMINING ATTORNEY

**CLASS 36—(Continued).**

SN 85-963,027. VANTIV, LLC, CINCINNATI, OH. FILED 6-18-2013.



NO CLAIM IS MADE TO THE EXCLUSIVE RIGHT TO USE "COO", APART FROM THE MARK AS SHOWN.

THE MARK CONSISTS OF THE LETTERS "C" "O" AND "O" TO THE LEFT OF THREE EQUALLY SIZED CIRCLES, THE FIRST CIRCLE FEATURING THREE SMALLER CIRCLES CONNECTED BY TWO LINES, THE SECOND CIRCLE FEATURING SIX LINES SET IN THE SHAPE OF A STAR, AND THE THIRD CIRCLE FEATURING AN ARROW POINTING VERTICALLY, ALL ABOVE THE WORDS "EXCEEDING...BY DESIGN".

FOR FINANCIAL SERVICES, NAMELY, CREDIT CARD TRANSACTION PROCESSING SERVICES, PAYMENT PROCESSING SERVICES IN THE NATURE OF CREDIT CARD AND DEBIT CARD TRANSACTION PROCESSING SERVICES, ELECTRONIC PAYMENT SERVICES INVOLVING ELECTRONIC PROCESSING AND SUBSEQUENT TRANSMISSION OF BILL PAYMENT DATA, PAYMENT PROCESSING SERVICES IN THE FIELD OF TAX AND INSURANCE PAYMENTS, OPERATIONS OF DEBIT CARD SERVICES AND DEBIT CARD TRANSACTION PROCESSING SERVICES, BANK CARD SERVICES, NAMELY, DEBIT CARD SERVICES AND CREDIT AND CASH CARD SERVICES, BANK CARD TRANSACTION PROCESSING SERVICES, NAMELY, PAYMENT PROCESSING SERVICES IN THE NATURE OF CREDIT CARD AND DEBIT CARD TRANSACTION PROCESSING SERVICES, STORED VALUE CARD SERVICES AND STORED VALUE CARD TRANSACTION PROCESSING SERVICES, GIFT CARD TRANSACTION PROCESSING SERVICES, LOYALTY CARD TRANSACTION PROCESSING SERVICES IN THE NATURE OF PROCESSING ELECTRONIC PAYMENTS MADE THROUGH PREPAID CARDS AND DEBIT CARD TRANSACTION PROCESSING SERVICES, ELECTRONIC FUNDS TRANSFER AND BANK ACCOUNT SETTLEMENT SERVICES VIA A GLOBAL COMPUTER NETWORK, NAMELY, ON-LINE BANKING SERVICES (U.S. CLS. 100, 101 AND 102).

KATHERINE CONNOLLY, EXAMINING ATTORNEY

**CLASS 36—(Continued).**

SN 86-005,288. TRUSTEES OF THE UNIVERSITY OF PENNSYLVANIA, PHILADELPHIA, PA. FILED 7-9-2013.

**PENN COMPACT 2020**

THE MARK CONSISTS OF STANDARD CHARACTERS WITHOUT CLAIM TO ANY PARTICULAR FONT, STYLE, SIZE, OR COLOR.

OWNER OF U.S. REG. NOS. 1,771,509, 1,773,257 AND OTHERS.

SEC. 2(F) AS TO "PENN".

FOR CHARITABLE FUNDRAISING SERVICES BY MEANS OF ORGANIZING AND CONDUCTING SPECIAL EVENTS; CHARITABLE FUNDRAISING SERVICES FOR PROMOTING RESEARCH, EDUCATION AND OTHER ACTIVITIES RELATING TO THE GOALS AND ASPIRATIONS OF AN INSTITUTION OF HIGHER EDUCATION; CHARITABLE SERVICES, NAMELY, FUNDRAISING SERVICES BY MEANS OF ORGANIZING SPECIAL EVENTS FOR THE PURPOSE OF PROMOTING RESEARCH, EDUCATION AND OTHER ACTIVITIES RELATING TO THE GOALS AND ASPIRATIONS OF AN INSTITUTION OF HIGHER EDUCATION (U.S. CLS. 100, 101 AND 102).

FIRST USE 8-27-2013; IN COMMERCE 8-27-2013.

PATRICIA EVANKO, EXAMINING ATTORNEY

SN 86-009,635. BLACK PORTFOLIO GROUP, INC, CLEARWATER, FL. FILED 7-13-2013.



THE COLOR(S) RED, GREEN, BLUE, YELLOW, BLACK AND WHITE IS/ARE CLAIMED AS A FEATURE OF THE MARK.

THE MARK CONSISTS OF A BLACK DIAMOND AT THE CENTER OF THE DESIGN CONTAINING THE LETTERS "BPG" IN WHITE WITH A WHITE CROWN ON TOP OF THE "BPG". RADIATING FROM THE BLACK DIAMOND IS A NORTH POINTING RED ARROW, AN EAST POINTING GREEN ARROW, A SOUTH POINTING BLUE ARROW, AND A WEST POINTING YELLOW ARROW.

FOR CREDIT AND FINANCIAL CONSULTATION; FINANCIAL ADVICE; FINANCIAL ADVICE AND CONSULTANCY SERVICES; FINANCIAL ADVISORY AND CONSULTANCY SERVICES; FINANCIAL CONSULTANCY AND INSURANCE CONSULTANCY (U.S. CLS. 100, 101 AND 102).

FIRST USE 7-2-2013; IN COMMERCE 7-2-2013.

BRIN ANDERSON, EXAMINING ATTORNEY



**CLASS 36—(Continued).**

SN 86-043,328. OPENGATE CAPITAL LLC, LOS ANGELES, CA. FILED 8-20-2013.

**OPENGATE CAPITAL**

THE MARK CONSISTS OF STANDARD CHARACTERS WITHOUT CLAIM TO ANY PARTICULAR FONT, STYLE, SIZE, OR COLOR.

NO CLAIM IS MADE TO THE EXCLUSIVE RIGHT TO USE "CAPITAL", APART FROM THE MARK AS SHOWN.

FOR FINANCIAL SERVICES, NAMELY, FINANCIAL INVESTMENT IN THE FIELD OF MANAGEMENT BUYOUT INVESTMENTS, CORPORATE BUYOUT INVESTMENTS, AND LEVERAGED BUYOUT INVESTMENTS; FINANCIAL SERVICES, NAMELY, FINANCIAL CONSULTING AND ADVISING IN THE FIELD OF MERGERS AND ACQUISITIONS, NAMELY, MANAGEMENT BUYOUTS, CORPORATE BUYOUTS AND LEVERAGED BUYOUTS; FUNDS INVESTMENT SERVICES; PRIVATE EQUITY FUND INVESTMENT, MANAGEMENT AND CONSULTATION RENDERED IN CONNECTION THEREWITH; AND FINANCIAL MANAGEMENT SERVICES RENDERED IN CONNECTION WITH ALL OF THE FOREGOING SERVICES; FINANCIAL CONSULTING SERVICES; FINANCIAL INVESTMENT BROKERAGE SERVICES; PRIVATE EQUITY FUND INVESTMENT MANAGEMENT SERVICES; AND PRIVATE EQUITY FUND INVESTMENT CONSULTING SERVICES (U.S. CLS. 100, 101 AND 102).

KATHLEEN M. VANSTON, EXAMINING ATTORNEY

**CLASS 36—(Continued).**

SN 86-045,256. SCHMIDT, NATHAN, MOORESVILLE, NC. FILED 8-22-2013.

**MYRESERVE**

THE MARK CONSISTS OF STANDARD CHARACTERS WITHOUT CLAIM TO ANY PARTICULAR FONT, STYLE, SIZE, OR COLOR.

FOR INSURANCE BROKERAGE IN THE FIELDS OF LIFE AND HEALTH INSURANCE, NAMELY, PROVIDING PLANS FOR WITHDRAWING FUNDS FROM DIVIDEND PAYING LIFE INSURANCE POLICIES (U.S. CLS. 100, 101 AND 102).

FIRST USE 8-14-2013; IN COMMERCE 8-14-2013.

COLLEEN MULCRONE, EXAMINING ATTORNEY

SN 86-054,100. THE LION FOUNDATION, CAMP HILL, PA. FILED 9-3-2013.

SN 86-043,343. THE ILLUMINATORS EDUCATIONAL FOUNDATION, HEMET, CA. FILED 8-20-2013.



NO CLAIM IS MADE TO THE EXCLUSIVE RIGHT TO USE "EDUCATIONAL FOUNDATION", APART FROM THE MARK AS SHOWN.

THE COLOR(S) YELLOW, ORANGE, AND BLACK IS/ ARE CLAIMED AS A FEATURE OF THE MARK.

THE MARK CONSISTS OF A YELLOW AND ORANGE FLAME DESIGN NEXT TO THE WORD "ILLUMINATORS" IN BLACK AND THE WORDS "EDUCATIONAL FOUNDATION" IN ORANGE AND IN SMALLER FONT LOCATED UNDER THE WORD "ILLUMINATORS".

FOR CHARITABLE FOUNDATION SERVICES, NAMELY, PROVIDING FUNDRAISING ACTIVITIES, FUNDING, SCHOLARSHIPS AND/OR FINANCIAL ASSISTANCE FOR HIGH SCHOOL AND COLLEGE STUDENTS (U.S. CLS. 100, 101 AND 102).

FIRST USE 6-0-2007; IN COMMERCE 6-0-2007.

FLORENTINA BLANDU, EXAMINING ATTORNEY



NO CLAIM IS MADE TO THE EXCLUSIVE RIGHT TO USE "FOUNDATION", "ESTABLISHED 2003", OR "CAMP HILL, PENNSYLVANIA", APART FROM THE MARK AS SHOWN.

THE MARK CONSISTS OF TWO CONCENTRIC CIRCLES. THE SILHOUETTE OF A LION OVER THE PHRASE "ESTABLISHED 2003" APPEARS WITHIN THE INNER CIRCLE. THE PHRASE "THE LION FOUNDATION CAMP HILL, PENNSYLVANIA" APPEARS BETWEEN THE CONCENTRIC CIRCLES.

FOR CHARITABLE FUNDRAISING IN CONNECTION WITH THE CAMP HILL, PENNSYLVANIA BOROUGH, COMMUNITY AND SCHOOL DISTRICT (U.S. CLS. 100, 101 AND 102).

FIRST USE 3-17-2009; IN COMMERCE 3-17-2009.

NICHOLAS COLEMAN, EXAMINING ATTORNEY

**CLASS 36—(Continued).**

SN 86-054,226. MILLER MC, INC., DBA LARRY H. MILLER MANAGEMENT CORPORATION, SANDY, UT. FILED 9-3-2013.

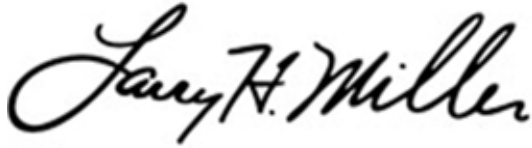

OWNER OF U.S. REG. NOS. 3,465,572 AND 3,914,868.  
THE NAME "LARRY H. MILLER" DOES NOT IDENTIFY A LIVING INDIVIDUAL.  
THE MARK CONSISTS OF THE NAME "LARRY H. MILLER" IN CURSIVE WRITING.

FOR FINANCING LOANS FOR CONSUMER AUTOMOBILE PURCHASES; REAL ESTATE SERVICES, NAMELY, RENTAL, BROKERAGE, LEASING AND MANAGEMENT OF COMMERCIAL PROPERTY, OFFICES AND OFFICE SPACE; INSURANCE SERVICES, NAMELY, UNDERWRITING EXTENDED WARRANTY CONTRACTS IN THE FIELD OF AUTOMOBILES (U.S. CLS. 100, 101 AND 102).

FIRST USE 10-0-2008; IN COMMERCE 10-0-2008.  
LESLIE RICHARDS, EXAMINING ATTORNEY

---

SN 86-056,736. OUR LADY OF THE LAKE FOUNDATION, BATON ROUGE, LA. FILED 9-5-2013.

## TIPTOE GOAL

THE MARK CONSISTS OF STANDARD CHARACTERS WITHOUT CLAIM TO ANY PARTICULAR FONT, STYLE, SIZE, OR COLOR.

FOR CHARITABLE FUNDRAISING TO SUPPORT CAPITAL CAMPAIGNS TO BUILD A FREE-STANDING CHILDREN'S HOSPITAL (U.S. CLS. 100, 101 AND 102).

FIRST USE 8-16-2013; IN COMMERCE 8-16-2013.  
COLLEEN DOMBROW, EXAMINING ATTORNEY

---

SN 86-057,447. GLUSKIN SHEFF + ASSOCIATES INC., TORONTO, ONTARIO, CANADA, FILED 9-6-2013.

## GLUSKIN SHEFF

THE MARK CONSISTS OF STANDARD CHARACTERS WITHOUT CLAIM TO ANY PARTICULAR FONT, STYLE, SIZE, OR COLOR.

OWNER OF CANADA REG. NO. TMA763,289, DATED 4-6-2010, EXPIRES 4-6-2025.

FOR INVESTMENT FUND AND MUTUAL FUND MANAGEMENT, ADMINISTRATION AND DISTRIBUTION; INVESTMENT COUNSELLING, INVESTMENT PLANNING AND PORTFOLIO MANAGEMENT SERVICES (U.S. CLS. 100, 101 AND 102).

FIRST USE 12-0-1988; IN COMMERCE 12-0-1988.  
MELISSA VALLILLO, EXAMINING ATTORNEY

**CLASS 36—(Continued).**

SN 86-057,449. GLUSKIN SHEFF + ASSOCIATES INC., TORONTO, ONTARIO, CANADA, FILED 9-6-2013.



OWNER OF CANADA REG. NO. TMA763,082, DATED 3-31-2010, EXPIRES 3-31-2025.

THE MARK CONSISTS OF THE WORDING "GLUSKIN", A LINE, AND THE WORDING "SHEFF", ALL WITHIN A SHADED SQUARE.

FOR INVESTMENT FUND AND MUTUAL FUND MANAGEMENT, ADMINISTRATION AND DISTRIBUTION; INVESTMENT COUNSELING, INVESTMENT PLANNING AND PORTFOLIO MANAGEMENT SERVICES (U.S. CLS. 100, 101 AND 102).

FIRST USE 2-0-2008; IN COMMERCE 2-0-2008.  
MELISSA VALLILLO, EXAMINING ATTORNEY

---

SN 86-058,577. CHIAVARAS, RACHEL A, SEATTLE, WA. FILED 9-7-2013.

## Calvin's Kids

THE MARK CONSISTS OF STANDARD CHARACTERS WITHOUT CLAIM TO ANY PARTICULAR FONT, STYLE, SIZE, OR COLOR.

NO CLAIM IS MADE TO THE EXCLUSIVE RIGHT TO USE "KIDS", APART FROM THE MARK AS SHOWN.

THE LIKENESS (OR, "PORTRAIT") IN THE MARK DOES NOT IDENTIFY A LIVING INDIVIDUAL.

FOR CHARITABLE FUNDRAISING; CHARITABLE FUNDRAISING SERVICES; CHARITABLE SERVICES, NAMELY, PROVIDING FINANCIAL ASSISTANCE TO MEET THE PHYSICAL, PSYCHOLOGICAL, SOCIAL AND OTHER SPECIAL NEEDS OF CHILDREN (U.S. CLS. 100, 101 AND 102).

FIRST USE 5-1-2013; IN COMMERCE 5-1-2013.  
CAITLIN WATTS-FITZGERALD, EXAMINING ATTORNEY

**CLASS 36—(Continued).**

SN 86-061,935. BERENSON & COMPANY, INC., NEW YORK, NY. FILED 9-11-2013.

BERENSON HOLDINGS LLC

THE MARK CONSISTS OF STANDARD CHARACTERS WITHOUT CLAIM TO ANY PARTICULAR FONT, STYLE, SIZE, OR COLOR.

OWNER OF U.S. REG. NO. 2,924,546.

NO CLAIM IS MADE TO THE EXCLUSIVE RIGHT TO USE "HOLDINGS LLC", APART FROM THE MARK AS SHOWN.

SEC. 2(F).

FOR FINANCIAL ADVISORY AND CONSULTANCY SERVICES; INVESTMENT BANKING SERVICES (U.S. CLS. 100, 101 AND 102).

FIRST USE 10-26-2012; IN COMMERCE 10-26-2012.

ELLEN BURNS, EXAMINING ATTORNEY

**CLASS 36—(Continued).**

SN 86-065,062. FROSCO, DONNA, CHAPPAQUA, NY. FILED 9-15-2013.

Charity Hub

THE MARK CONSISTS OF STANDARD CHARACTERS WITHOUT CLAIM TO ANY PARTICULAR FONT, STYLE, SIZE, OR COLOR.

NO CLAIM IS MADE TO THE EXCLUSIVE RIGHT TO USE "CHARITY", APART FROM THE MARK AS SHOWN.

FOR CHARITABLE FUNDRAISING SERVICES BY MEANS OF A WEBSITE WHERE DONORS SEARCH FOR AND MAKE MONETARY DONATIONS ONLINE TO THEIR FAVORITE CHARITY (U.S. CLS. 100, 101 AND 102).

BERYL GARDNER, EXAMINING ATTORNEY

SN 86-063,162. NATIONAL FINANCIAL SERVICES GROUP INC, RED BANK, NJ. FILED 9-12-2013.

PUTTING THE WORLD IN THE  
PALM OF YOUR HAND

THE MARK CONSISTS OF STANDARD CHARACTERS WITHOUT CLAIM TO ANY PARTICULAR FONT, STYLE, SIZE, OR COLOR.

FOR FINANCIAL SERVICES, NAMELY, ASSUMING FINANCIAL RISK OF OTHERS BY ENTERING INTO OPTIONS AND SWAPS, FINANCIAL ANALYSIS AND CONSULTATION, FINANCIAL FORECASTING, FINANCIAL INFORMATION PROVIDED BY ELECTRONIC MEANS, FINANCIAL INVESTMENT IN THE FIELD OF REAL ESTATE, SECURITIES, MORTGAGES, REITS (REAL ESTATE INVESTMENT TRUSTS), CORPORATE AND MUNICIPAL BONDS AND INSURANCE, FINANCIAL MANAGEMENT, FINANCIAL PLANNING, FINANCIAL PORTFOLIO MANAGEMENT, FINANCIAL RESEARCH, FINANCIAL SERVICES IN THE NATURE OF AN INVESTMENT SECURITY, FINANCIAL SERVICES, NAMELY, INVESTMENT FUND TRANSFER AND TRANSACTION SERVICES, FINANCIAL VALUATION OF PERSONAL PROPERTY AND REAL ESTATE (U.S. CLS. 100, 101 AND 102).

FIRST USE 3-1-2003; IN COMMERCE 3-1-2003.

RUDY R. SINGLETON, EXAMINING ATTORNEY

SN 86-066,092. COMERCIALIZADORA ARTURO CALLE S.A.S., BOGOTA D.C., COLOMBIA, FILED 9-16-2013.

ARTURO CALLE

THE NAME(S), PORTRAIT(S), AND/OR SIGNATURE(S) SHOWN IN THE MARK IDENTIFIES "ARTURO CALLE", WHOSE CONSENT(S) TO REGISTER IS MADE OF RECORD.

THE MARK CONSISTS OF THE PHRASE "ARTURO CALLE" WITH THE LETTERS "A C" IN THE BACKGROUND.

FOR ISSUING STORED VALUE CARDS; PROVIDING STORED VALUE CARD SERVICES (U.S. CLS. 100, 101 AND 102).

PATRICIA EVANKO, EXAMINING ATTORNEY

**CLASS 36—(Continued).**

SN 86-071,128. FUNDINGTON, LLC, FARMINGTON HILLS, MI. FILED 9-21-2013.

## FUNDINGTON

THE MARK CONSISTS OF STANDARD CHARACTERS WITHOUT CLAIM TO ANY PARTICULAR FONT, STYLE, SIZE, OR COLOR.

FOR ON-LINE BUSINESS FUNDRAISING SERVICES; FINANCIAL SERVICES, NAMELY, BUSINESS FUNDRAISING PROVIDED OVER A COMPUTER NETWORK SUCH AS THE INTERNET; VENTURE CAPITAL FUNDING SERVICES FOR SMALL BUSINESS STARTUPS AND NEW BUSINESSES THROUGH CROWDFUNDING, NAMELY, PROVIDING BUSINESS FUNDING BY A LARGE GROUP OF PEOPLE OVER THE INTERNET OR OTHER ONLINE MEANS; CONSULTING SERVICES IN REGARD TO UTILIZING CROWDFUNDING, NAMELY, PROVIDING BUSINESS FUNDING BY A LARGE GROUP OF PEOPLE OVER THE INTERNET OR OTHER ONLINE MEANS IN ORDER TO RAISE SMALL BUSINESS STARTUP AND NEW BUSINESS CAPITAL (U.S. CLS. 100, 101 AND 102).

FIRST USE 5-13-2012; IN COMMERCE 5-13-2012.  
JAMES A. RAUEN, EXAMINING ATTORNEY

**CLASS 36—(Continued).**

SN 86-073,887. SIACHOQUE, DAVID, MIAMI, FL. FILED 9-25-2013.

## TUPROYECTO

THE MARK CONSISTS OF STANDARD CHARACTERS WITHOUT CLAIM TO ANY PARTICULAR FONT, STYLE, SIZE, OR COLOR.

THE ENGLISH TRANSLATION OF "TUPROYECTO" IN THE MARK IS "YOUR PROJECT".

FOR FINANCING SERVICES; VENTURE CAPITAL FINANCING; CROWD FINANCING SERVICES, NAMELY, PROVIDING CROWD FUNDING FOR OTHER (U.S. CLS. 100, 101 AND 102).

FIRST USE 1-1-2013; IN COMMERCE 1-1-2013.  
KAREN BRACEY, EXAMINING ATTORNEY

SN 86-074,314. VETERINARY PET INSURANCE COMPANY, BREA, CA. FILED 9-25-2013.



NO CLAIM IS MADE TO THE EXCLUSIVE RIGHT TO USE "PET WELLNESS BASICS", "CARE", AND "PREVENTIVE COVERAGE PLAN", APART FROM THE MARK AS SHOWN.

THE MARK CONSISTS OF A SYRINGE APPEARS TO THE LEFT OF THE VERTICALLY STACKED PHRASES "PET WELLNESS BASICS" "EVERYDAY CARE" AND "PREVENTIVE COVERAGE PLAN".

FOR INSURANCE SERVICES, NAMELY, UNDERWRITING AND BROKERAGE IN THE FIELD OF PET INSURANCE (U.S. CLS. 100, 101 AND 102).

FIRST USE 8-1-2013; IN COMMERCE 8-1-2013.  
SARA BENJAMIN, EXAMINING ATTORNEY

SN 86-073,135. THE BOSTON FOUNDATION FOR SIGHT, INC., NEEDHAM, MA. FILED 9-24-2013.



THE MARK CONSISTS OF SHORT AND LONG RAYS FORMING AN EYEBURST.

FOR ADMINISTRATION OF MONETARY CHARITABLE CONTRIBUTIONS AND DISTRIBUTION OF MONETARY CHARITABLE CONTRIBUTIONS TO IMPROVE THE QUALITY OF LIFE FOR PATIENTS AND FAMILIES WITH COMPLEX CORNEAL DISEASE (U.S. CLS. 100, 101 AND 102).

FIRST USE 5-0-2002; IN COMMERCE 5-0-2002.  
DANNEAN HETZEL, EXAMINING ATTORNEY

SN 86-078,275. TOWN OF TIOGA, NEWBERRY, FL. FILED 9-30-2013.

## Your Tioga Specialist

THE MARK CONSISTS OF STANDARD CHARACTERS WITHOUT CLAIM TO ANY PARTICULAR FONT, STYLE, SIZE, OR COLOR.

NO CLAIM IS MADE TO THE EXCLUSIVE RIGHT TO USE "TIOGA SPECIALIST", APART FROM THE MARK AS SHOWN.

FOR REAL ESTATE BROKERAGE (U.S. CLS. 100, 101 AND 102).

BERYL GARDNER, EXAMINING ATTORNEY

**CLASS 36—(Continued).**

SN 86-078,430. GLOBAL AEROSPACE, INC., PARSIPPANY, NJ. FILED 9-30-2013.

GLOBAL AEROSPACE

THE MARK CONSISTS OF STANDARD CHARACTERS WITHOUT CLAIM TO ANY PARTICULAR FONT, STYLE, SIZE, OR COLOR.

NO CLAIM IS MADE TO THE EXCLUSIVE RIGHT TO USE "AEROSPACE", APART FROM THE MARK AS SHOWN.

SEC. 2(F).

FOR INSURANCE UNDERWRITING IN THE FIELD OF PROPERTY AND CASUALTY INSURANCE FOR AIRPLANES AND SPACE VEHICLES (U.S. CLS. 100, 101 AND 102).

FIRST USE 7-0-2001; IN COMMERCE 7-0-2001.  
KIMBERLY PERRY, EXAMINING ATTORNEY

**CLASS 36—(Continued).**

SN 86-085,482. TOWN OF AQUINNAH, AQUINNAH, MA. FILED 10-8-2013.



NO CLAIM IS MADE TO THE EXCLUSIVE RIGHT TO USE "GAY HEAD LIGHTHOUSE" AND "MARTHA'S VINEYARD", APART FROM THE MARK AS SHOWN.

THE MARK CONSISTS OF A LIGHTHOUSE WITHIN A CIRCLE DESIGN. A DESIGN OF TWO STREAKS OF LIGHT DIRECTED LEFT AND RIGHT EMIT FROM THE TOP OF THE LIGHTHOUSE. TO THE RIGHT OF THE CIRCLE DESIGN IS THE STYLIZED WORDING "GAY HEAD" ABOVE THE WORDING "LIGHTHOUSE" ABOVE "MARTHA'S VINEYARD" FOLLOWED BY A DOT AND THE WORDING "KEEP ON SHINING".

FOR CHARITABLE FUNDRAISING SERVICES (U.S. CLS. 100, 101 AND 102).

FIRST USE 6-19-2013; IN COMMERCE 6-19-2013.  
ZACHARY R. SPARER, EXAMINING ATTORNEY

SN 86-085,148. SHARMA, SURAJ, HAUPPAUGE, NY. FILED 10-8-2013.

SKS CAPITAL

THE MARK CONSISTS OF STANDARD CHARACTERS WITHOUT CLAIM TO ANY PARTICULAR FONT, STYLE, SIZE, OR COLOR.

NO CLAIM IS MADE TO THE EXCLUSIVE RIGHT TO USE "CAPITAL", APART FROM THE MARK AS SHOWN.

FOR FINANCIAL AND INVESTMENT SERVICES, NAMELY, MANAGEMENT AND BROKERAGE IN THE FIELDS OF STOCKS, BONDS, OPTIONS, COMMODITIES, FUTURES AND OTHER SECURITIES, AND THE INVESTMENT OF FUNDS OF OTHERS (U.S. CLS. 100, 101 AND 102).

FIRST USE 8-1-2013; IN COMMERCE 8-1-2013.  
ROBERT C. CLARK JR., EXAMINING ATTORNEY

SN 86-087,180. TECHNOLOGY ENTREPRENEUR CENTER, INC., DBA T-REX, ST. LOUIS, MO. FILED 10-9-2013.

T-REX

THE MARK CONSISTS OF STANDARD CHARACTERS WITHOUT CLAIM TO ANY PARTICULAR FONT, STYLE, SIZE, OR COLOR.

FOR INCUBATION SERVICES, NAMELY, RENTAL OF OFFICE SPACE TO FREELANCERS, START-UPS, EXISTING BUSINESSES, AND NON-PROFITS (U.S. CLS. 100, 101 AND 102).

FIRST USE 8-0-2011; IN COMMERCE 8-0-2011.  
JANICE KIM, EXAMINING ATTORNEY

**CLASS 36—(Continued).**

SN 86-087,240. TECHNOLOGY ENTREPRENEUR CENTER, INC., DBA T-REX, ST. LOUIS, MO. FILED 10-9-2013.



THE MARK CONSISTS OF THE PROFILE OF A DINOSAUR HEAD IN A GEOMETRIC STYLE.

FOR INCUBATION SERVICES, NAMELY, RENTAL OF OFFICE SPACE TO FREELANCERS, START-UPS, EXISTING BUSINESSES, AND NON-PROFITS (U.S. CLS. 100, 101 AND 102).

FIRST USE 9-8-2013; IN COMMERCE 9-8-2013.  
JANICE KIM, EXAMINING ATTORNEY

SN 86-088,728. INTERACTIVE DONOR CORP, NEW YORK, NY. FILED 10-10-2013.

## IGNITING THE 21ST CENTURY PHILANTHROPIST

THE MARK CONSISTS OF STANDARD CHARACTERS WITHOUT CLAIM TO ANY PARTICULAR FONT, STYLE, SIZE, OR COLOR.

NO CLAIM IS MADE TO THE EXCLUSIVE RIGHT TO USE "21ST CENTURY PHILANTHROPIST", APART FROM THE MARK AS SHOWN.

FOR CHARITABLE FUNDRAISING SERVICES, BY MEANS OF PROVIDING INDIVIDUALS WITH THE INFORMATION AND OPPORTUNITY TO MAKE MONETARY DONATIONS TO THEIR FAVORITE CHARITY (U.S. CLS. 100, 101 AND 102).

FIRST USE 4-1-2013; IN COMMERCE 4-1-2013.  
PRISCILLA MILTON, EXAMINING ATTORNEY

**CLASS 36—(Continued).**

SN 86-088,821. STRATEGIC INVESTMENT MANAGEMENT, LLC, ARLINGTON, VA. FILED 10-10-2013.



OWNER OF U.S. REG. NOS. 2,613,952 AND 3,688,299.  
NO CLAIM IS MADE TO THE EXCLUSIVE RIGHT TO USE "INVESTMENT GROUP", APART FROM THE MARK AS SHOWN.

THE MARK CONSISTS OF THE WORDS "STRATEGIC INVESTMENT GROUP" TO THE RIGHT OF A STYLIZED ALPHA SYMBOL.

SEC. 2(F) AS TO "STRATEGIC INVESTMENT GROUP", FOR FINANCIAL PORTFOLIO MANAGEMENT AND INVESTMENT ADVISORY SERVICES (U.S. CLS. 100, 101 AND 102).

ALICIA COLLINS, EXAMINING ATTORNEY

SN 86-091,526. RUST, CHRISTOPHER, PORTOLA VALLEY, CA. FILED 10-15-2013.

## Clear Venture Partners

THE MARK CONSISTS OF STANDARD CHARACTERS WITHOUT CLAIM TO ANY PARTICULAR FONT, STYLE, SIZE, OR COLOR.

NO CLAIM IS MADE TO THE EXCLUSIVE RIGHT TO USE "VENTURE PARTNERS", APART FROM THE MARK AS SHOWN.

FOR VENTURE CAPITAL FINANCING (U.S. CLS. 100, 101 AND 102).

ELLEN B. AWRICH, EXAMINING ATTORNEY

SN 86-091,991. LEGG MASON & CO., LLC, BALTIMORE, MD. FILED 10-15-2013.

## YOUR LEGG MASON

THE MARK CONSISTS OF STANDARD CHARACTERS WITHOUT CLAIM TO ANY PARTICULAR FONT, STYLE, SIZE, OR COLOR.

OWNER OF U.S. REG. NOS. 1,799,634, 4,107,178 AND OTHERS.

FOR FINANCIAL SERVICES, NAMELY, ASSET, INVESTMENT AND PORTFOLIO MANAGEMENT SERVICES (U.S. CLS. 100, 101 AND 102).

STEVEN PEREZ, EXAMINING ATTORNEY

**CLASS 36—(Continued).**

SN 86-092,042. LEGG MASON & CO., LLC, BALTIMORE, MD. FILED 10-15-2013.

**CLASS 36—(Continued).**

SN 86-098,507. COLLABHEALTH PLAN SERVICES, INC., ENGLEWOOD, CO. FILED 10-22-2013.

# YOURLEGGMASON

THE MARK CONSISTS OF STANDARD CHARACTERS WITHOUT CLAIM TO ANY PARTICULAR FONT, STYLE, SIZE, OR COLOR.

OWNER OF U.S. REG. NOS. 1,799,634, 4,107,178 AND OTHERS.

FOR FINANCIAL SERVICES, NAMELY, ASSET, INVESTMENT AND PORTFOLIO MANAGEMENT SERVICES (U.S. CLS. 100, 101 AND 102).

STEVEN PEREZ, EXAMINING ATTORNEY



SN 86-098,470. COLLABHEALTH PLAN SERVICES, INC., ENGLEWOOD, CO. FILED 10-22-2013.



NO CLAIM IS MADE TO THE EXCLUSIVE RIGHT TO USE "HEALTH", APART FROM THE MARK AS SHOWN.

THE MARK CONSISTS OF A WATERWAY APPEARING BETWEEN TWO PEAKS, WITH THE WORDS "CLEAR", "RIVER" AND "HEALTH" APPEARING BELOW.

FOR INSURANCE SERVICES, NAMELY, INSURANCE ADMINISTRATION AND UNDERWRITING INSURANCE PLANS IN THE FIELDS OF HEALTH AND LIFE INSURANCE; INSURANCE ADMINISTRATION IN THE FIELD OF PREPAID HEALTH CARE PLANS; ADMINISTRATION OF EMPLOYEE BENEFIT PLANS CONCERNING HEALTH CARE INSURANCE; INSURANCE UNDERWRITING IN THE FIELD OF HEALTH CARE INSURANCE; INSURANCE UNDERWRITING IN THE FIELD OF HEALTH CARE; ADMINISTRATION OF PREFERRED PROVIDER PLANS IN THE FIELD OF MEDICAL CARE; MEDICAL INSURANCE UNDERWRITING; INSURANCE ADMINISTRATION IN THE FIELD OF LIABILITY INSURANCE, NAMELY, INSURANCE CLAIMS ADMINISTRATION (U.S. CLS. 100, 101 AND 102).

JOHN DWYER, EXAMINING ATTORNEY

NO CLAIM IS MADE TO THE EXCLUSIVE RIGHT TO USE "HEALTH", APART FROM THE MARK AS SHOWN.

THE MARK CONSISTS OF A CIRCLE WITH A SUN AND A FIELD APPEARING THEREIN, WITH THE WORDS "HEARTLAND", "TRUST" AND "HEALTH" APPEARING BELOW.

FOR INSURANCE SERVICES, NAMELY, INSURANCE ADMINISTRATION AND UNDERWRITING INSURANCE PLANS IN THE FIELDS OF HEALTH AND LIFE INSURANCE; INSURANCE ADMINISTRATION IN THE FIELD OF PREPAID HEALTH CARE PLANS; ADMINISTRATION OF EMPLOYEE BENEFIT PLANS CONCERNING HEALTH CARE INSURANCE; INSURANCE UNDERWRITING IN THE FIELD OF HEALTH CARE INSURANCE; INSURANCE UNDERWRITING IN THE FIELD OF HEALTH CARE; ADMINISTRATION OF PREFERRED PROVIDER PLANS IN THE FIELD OF MEDICAL CARE; MEDICAL INSURANCE UNDERWRITING; INSURANCE ADMINISTRATION IN THE FIELD OF LIABILITY INSURANCE, NAMELY, INSURANCE CLAIMS ADMINISTRATION (U.S. CLS. 100, 101 AND 102).

JOHN DWYER, EXAMINING ATTORNEY

**CLASS 36—(Continued).**

SN 86-098,529. COLLABHEALTH PLAN SERVICES, INC., ENGLEWOOD, CO. FILED 10-22-2013.



NO CLAIM IS MADE TO THE EXCLUSIVE RIGHT TO USE "HEALTH", APART FROM THE MARK AS SHOWN.

THE MARK CONSISTS OF A FENCE AND ROLLING HILLS, WITH THE WORDS "STABLE", "VIEW" AND "HEALTH" APPEARING BELOW.

FOR INSURANCE SERVICES, NAMELY, INSURANCE ADMINISTRATION AND UNDERWRITING INSURANCE PLANS IN THE FIELDS OF HEALTH AND LIFE INSURANCE; INSURANCE ADMINISTRATION IN THE FIELD OF PREPAID HEALTH CARE PLANS; ADMINISTRATION OF EMPLOYEE BENEFIT PLANS CONCERNING HEALTH CARE INSURANCE; INSURANCE UNDERWRITING IN THE FIELD OF HEALTH CARE INSURANCE; INSURANCE UNDERWRITING IN THE FIELD OF HEALTH CARE; ADMINISTRATION OF PREFERRED PROVIDER PLANS IN THE FIELD OF MEDICAL CARE; MEDICAL INSURANCE UNDERWRITING; INSURANCE ADMINISTRATION IN THE FIELD OF LIABILITY INSURANCE, NAMELY, INSURANCE CLAIMS ADMINISTRATION (U.S. CLS. 100, 101 AND 102).

JOHN DWYER, EXAMINING ATTORNEY

**CLASS 36—(Continued).**

SN 86-099,515. GARNETT HOLDINGS, LLC, HOLLYWOOD, FL. FILED 10-23-2013.



NO CLAIM IS MADE TO THE EXCLUSIVE RIGHT TO USE "CHARITY", APART FROM THE MARK AS SHOWN.

THE MARK CONSISTS OF A DESIGN OF A FIGURE SITTING IN A STYLIZED WHEEL CHAIR DEPICTED AS MOVING FORWARD WITH THREE CURVED BANDS APPEARING BEHIND THE WHEEL CHAIR. THE WORDING "SCOOTING FOR CHARITY" APPEARS UNDERNEATH THE FIGURE AND WHEEL CHAIR DESIGN.

FOR CHARITABLE FUNDRAISING; CHARITABLE FUNDRAISING SERVICES BY MEANS OF ORGANIZING AND CONDUCTING SPECIAL EVENTS; CHARITABLE FUNDRAISING SERVICES BY MEANS OF CONDUCTING LIVE EVENTS AND SPECIAL PROGRAMS; CHARITABLE SERVICES, NAMELY, FUNDRAISING SERVICES BY MEANS OF ORGANIZING SPECIAL EVENTS FOR TRAVEL INDUSTRY PROFESSIONALS (U.S. CLS. 100, 101 AND 102).

FIRST USE 9-20-2013; IN COMMERCE 9-20-2013.

HAI-LY LAM, EXAMINING ATTORNEY

SN 86-100,873. COLLABHEALTH PLAN SERVICES, INC., WEST ENGLEWOOD, CO. FILED 10-24-2013.

**CLEARRIVER HEALTH**

THE MARK CONSISTS OF STANDARD CHARACTERS WITHOUT CLAIM TO ANY PARTICULAR FONT, STYLE, SIZE, OR COLOR.

NO CLAIM IS MADE TO THE EXCLUSIVE RIGHT TO USE "HEALTH", APART FROM THE MARK AS SHOWN.

FOR INSURANCE SERVICES, NAMELY, INSURANCE ADMINISTRATION AND UNDERWRITING INSURANCE PLANS IN THE FIELDS OF HEALTH AND LIFE INSURANCE; INSURANCE ADMINISTRATION IN THE FIELD OF PREPAID HEALTH CARE PLANS; ADMINISTRATION OF EMPLOYEE BENEFIT PLANS CONCERNING HEALTH CARE INSURANCE; INSURANCE UNDERWRITING IN THE FIELD OF HEALTH CARE INSURANCE; INSURANCE UNDERWRITING IN THE FIELD OF HEALTH CARE; ADMINISTRATION OF PREFERRED PROVIDER PLANS IN THE FIELD OF MEDICAL CARE; MEDICAL INSURANCE UNDERWRITING; INSURANCE ADMINISTRATION IN THE FIELD OF LIABILITY INSURANCE, NAMELY, INSURANCE CLAIMS ADMINISTRATION (U.S. CLS. 100, 101 AND 102).

JOHN DWYER, EXAMINING ATTORNEY



**CLASS 36—(Continued).**

SN 86-100,885. COLLABHEALTH PLAN SERVICES, INC., ENGLEWOOD, CO. FILED 10-24-2013.

**HEARTLANDTRUST HEALTH**

THE MARK CONSISTS OF STANDARD CHARACTERS WITHOUT CLAIM TO ANY PARTICULAR FONT, STYLE, SIZE, OR COLOR.

NO CLAIM IS MADE TO THE EXCLUSIVE RIGHT TO USE "HEALTH", APART FROM THE MARK AS SHOWN.

FOR INSURANCE SERVICES, NAMELY, INSURANCE ADMINISTRATION AND UNDERWRITING INSURANCE PLANS IN THE FIELDS OF HEALTH AND LIFE INSURANCE; INSURANCE ADMINISTRATION IN THE FIELD OF PREPAID HEALTH CARE PLANS; ADMINISTRATION OF EMPLOYEE BENEFIT PLANS CONCERNING HEALTH CARE INSURANCE; INSURANCE UNDERWRITING IN THE FIELD OF HEALTH CARE INSURANCE; INSURANCE UNDERWRITING IN THE FIELD OF HEALTH CARE; ADMINISTRATION OF PREFERRED PROVIDER PLANS IN THE FIELD OF MEDICAL CARE; MEDICAL INSURANCE UNDERWRITING; INSURANCE ADMINISTRATION IN THE FIELD OF LIABILITY INSURANCE, NAMELY, INSURANCE CLAIMS ADMINISTRATION (U.S. CLS. 100, 101 AND 102).

JOHN DWYER, EXAMINING ATTORNEY

SN 86-100,897. COLLABHEALTH PLAN SERVICES, INC., ENGLEWOOD, CO. FILED 10-24-2013.

**STABLEVIEW HEALTH**

THE MARK CONSISTS OF STANDARD CHARACTERS WITHOUT CLAIM TO ANY PARTICULAR FONT, STYLE, SIZE, OR COLOR.

NO CLAIM IS MADE TO THE EXCLUSIVE RIGHT TO USE "HEALTH", APART FROM THE MARK AS SHOWN.

FOR INSURANCE SERVICES, NAMELY, INSURANCE ADMINISTRATION AND UNDERWRITING INSURANCE PLANS IN THE FIELDS OF HEALTH AND LIFE INSURANCE; INSURANCE ADMINISTRATION IN THE FIELD OF PREPAID HEALTH CARE PLANS; ADMINISTRATION OF EMPLOYEE BENEFIT PLANS CONCERNING HEALTH CARE INSURANCE; INSURANCE UNDERWRITING IN THE FIELD OF HEALTH CARE INSURANCE; INSURANCE UNDERWRITING IN THE FIELD OF HEALTH CARE; ADMINISTRATION OF PREFERRED PROVIDER PLANS IN THE FIELD OF MEDICAL CARE; MEDICAL INSURANCE UNDERWRITING; INSURANCE ADMINISTRATION IN THE FIELD OF LIABILITY INSURANCE, NAMELY, INSURANCE CLAIMS ADMINISTRATION (U.S. CLS. 100, 101 AND 102).

JOHN DWYER, EXAMINING ATTORNEY

**CLASS 36—(Continued).**

SN 86-105,146. THE TRUSTEES OF THE DANIEL MELLINKOFF TRUST DATED JUNE 9, 1995, PASADENA, CA. FILED 10-30-2013.

**Indiana Colony**

THE MARK CONSISTS OF STANDARD CHARACTERS WITHOUT CLAIM TO ANY PARTICULAR FONT, STYLE, SIZE, OR COLOR.

FOR RENTAL OF SPACE IN MARKETPLACES FOR SELLERS OF GOODS AND/OR SERVICES; SHOPPING CENTER SERVICES, NAMELY, RENTAL OF SHOPPING CENTER SPACE (U.S. CLS. 100, 101 AND 102).

JIM RINGLE, EXAMINING ATTORNEY

SN 86-111,572. SANCHEZ, PILAR, ROSLINDALE, MA. FILED 11-6-2013.



NO CLAIM IS MADE TO THE EXCLUSIVE RIGHT TO USE "MC BOSTON MA", APART FROM THE MARK AS SHOWN.

THE COLOR(S) ELECTRIC BLUE, BLACK, GREY, TAN, SILVER AND BROWN IS/ARE CLAIMED AS A FEATURE OF THE MARK.

THE MARK CONSISTS OF AN IMAGE OF AN ARTISTIC MOTORCYCLE BALANCING ON ITS BACK WHEEL. THE BODY OF THE MOTORCYCLE IS ELECTRIC BLUE IN COLOR WITH LARGE, SILVER HANDLEBARS THAT ARE BEING HELD BY A FEMALE RIDER WITH LONG, FLOWING BROWN HAIR, TAN AND BLACK SHADED FEATURES AND TAN SKIN. THE FEMALE IS DRESSED IN A BLACK JUMPSUIT AND HAS A SMALL, BLUE CROWN ON THE TOP OF HER HEAD. THE FEMALE IS HOLDING A LONG, LIGHT GREY CHAIN THAT LOOPS AROUND THE MOTORCYCLE, ENDING AT THE FRONT WHEEL. THE WHEEL IS PRIMARILY BLACK IN COLOR WITH LIGHT GREY INTERIOR AND A THIN, LIGHT GREY OUTLINE. BEHIND THE MOTORCYCLE IS A CLUSTER OF DARK AND LIGHT GREY ROCKS THAT APPEAR TO BE FAR OFF IN THE DISTANCE. THE ROCKS ARE OUTLINED WITH SEVERAL THIN GREY LINES WITH SLIGHT BROWN SHADING UNDER THE ROCKS THAT LEAD INTO THE WORDS "BOSTON MA" DIRECTLY UNDERNEATH. THE WORD "BOSTON" IS ELECTRIC BLUE IN COLOR WITH STYLIZED THIN FONT AND SLIGHT GRAY SHADING. UNDERNEATH ARE THE LETTERS "MA",

**CLASS 36—(Continued).**

WHICH APPEARS IN THE SAME STYLIZED THIN, ELECTRIC BLUE FONT WITH GRAY SHADING. AT THE VERY TOP OF THE MARK IS THE PHRASE "FEARLESS QUEENS", WHICH APPEARS IN STYLIZED THIN, ELECTRIC BLUE FONT WITH GRAY SHADING THROUGHOUT THE PHRASE. DIRECTLY UNDER THE PHRASE "FEARLESS QUEENS" ARE THE LETTERS "MC", WHICH APPEAR IN THE SAME STYLIZED THIN, ELECTRIC BLUE FONT WITH GRAY SHADING, ALL OF THE ABOVE OVER A CLEAR BACKGROUND.

FOR CHARITABLE FUNDRAISING SERVICES BY MEANS OF ENTERTAINMENT EVENTS (U.S. CLS. 100, 101 AND 102).

DOMINIC J. FERRAIUOLO, EXAMINING ATTORNEY

---

SN 86-114,412. GENERATION GIVE, MISSION VIEJO, CA. FILED 11-8-2013.

**CHARITY CHAMPIONSHIP SUNDAY**

THE MARK CONSISTS OF STANDARD CHARACTERS WITHOUT CLAIM TO ANY PARTICULAR FONT, STYLE, SIZE, OR COLOR.

NO CLAIM IS MADE TO THE EXCLUSIVE RIGHT TO USE "CHARITY" OR "SUNDAY", APART FROM THE MARK AS SHOWN.

FOR ACCEPTING AND ADMINISTERING MONETARY CHARITABLE CONTRIBUTIONS; ADMINISTERING MONETARY CHARITABLE CONTRIBUTIONS FOR THE BENEFIT OF SCHOOLS AND NON-PROFIT ORGANIZATIONS; CHARITABLE FUNDRAISING; CHARITABLE FUNDRAISING SERVICES; CHARITABLE FUNDRAISING SERVICES BY MEANS OF ORGANIZING AND CONDUCTING SPECIAL EVENTS (U.S. CLS. 100, 101 AND 102).

MARY CRAWFORD, EXAMINING ATTORNEY

---

SN 86-117,193. RTP CAPITAL ADVISORS, LLC, CARY, NC. FILED 11-12-2013.



NO CLAIM IS MADE TO THE EXCLUSIVE RIGHT TO USE "NNNAUTO", APART FROM THE MARK AS SHOWN. THE COLOR(S) RED AND BLACK IS/ARE CLAIMED AS A FEATURE OF THE MARK.

THE MARK CONSISTS OF THE LITERAL ELEMENTS "NNNAUTO" IN BLACK, AND IN RED, A GEAR IN THE MIDDLE OF LINES INCREASING IN LENGTH FROM BOTTOM TO TOP.

FOR REAL ESTATE BROKERAGE SERVICES FOR AUTOMOTIVE CORPORATIONS AND FRANCHISES, NAMELY, LAND ACQUISITION SERVICES AND DISPOSITIONS OF COMMERCIAL REAL ESTATE, COMMERCIAL REAL ESTATE BROKERAGE, LEASING OF COMMERCIAL REAL ESTATE ALL RELATING TO FULL SERVICE AUTOMOTIVE REPAIR LOCATIONS, GAS STATIONS AND CONVENIENCE STORE LOCATIONS (U.S. CLS. 100, 101 AND 102).

HOWARD SMIGA, EXAMINING ATTORNEY

**CLASS 36—(Continued).**

SN 86-119,424. THE TRUSTEES OF THE DANIEL MELLINKOFF TRUST DATED JUNE 9, 1995, PASADENA, CA. FILED 11-14-2013.

**Indiana Colony Market**

THE MARK CONSISTS OF STANDARD CHARACTERS WITHOUT CLAIM TO ANY PARTICULAR FONT, STYLE, SIZE, OR COLOR.

NO CLAIM IS MADE TO THE EXCLUSIVE RIGHT TO USE "MARKET", APART FROM THE MARK AS SHOWN.

FOR RENTAL OF SPACE IN MARKETPLACES FOR SELLERS OF GOODS AND/OR SERVICES; SHOPPING CENTER SERVICES, NAMELY, RENTAL OF SHOPPING CENTER SPACE (U.S. CLS. 100, 101 AND 102).

JIM RINGLE, EXAMINING ATTORNEY

---

SN 86-120,515. COLLABHEALTH PLAN SERVICES, INC., ENGLEWOOD, CO. FILED 11-15-2013.

**RIVERLINK HEALTH**

THE MARK CONSISTS OF STANDARD CHARACTERS WITHOUT CLAIM TO ANY PARTICULAR FONT, STYLE, SIZE, OR COLOR.

NO CLAIM IS MADE TO THE EXCLUSIVE RIGHT TO USE "HEALTH", APART FROM THE MARK AS SHOWN.

FOR INSURANCE SERVICES, NAMELY, INSURANCE ADMINISTRATION AND UNDERWRITING INSURANCE PLANS IN THE FIELDS OF HEALTH AND LIFE INSURANCE; INSURANCE ADMINISTRATION IN THE FIELD OF PREPAID HEALTH CARE PLANS; ADMINISTRATION OF EMPLOYEE BENEFIT PLANS CONCERNING HEALTH CARE INSURANCE; INSURANCE UNDERWRITING IN THE FIELD OF HEALTH CARE INSURANCE; INSURANCE UNDERWRITING IN THE FIELD OF HEALTH CARE; ADMINISTRATION OF PREFERRED PROVIDER PLANS IN THE FIELD OF MEDICAL CARE; MEDICAL INSURANCE UNDERWRITING; INSURANCE ADMINISTRATION IN THE FIELD OF LIABILITY INSURANCE, NAMELY, INSURANCE CLAIMS ADMINISTRATION (U.S. CLS. 100, 101 AND 102).

JOHN DWYER, EXAMINING ATTORNEY

**CLASS 36—(Continued).**

SN 86-120,529. COLLABHEALTH PLAN SERVICES, INC., ENGLEWOOD, CO. FILED 11-15-2013.



NO CLAIM IS MADE TO THE EXCLUSIVE RIGHT TO USE "HEALTH", APART FROM THE MARK AS SHOWN.

THE MARK CONSISTS OF A WATERWAY APPEARING UNDER A BRIDGE, WITH THE WORDS "RIVER", "LINK" AND "HEALTH" APPEARING BELOW.

FOR INSURANCE SERVICES, NAMELY, INSURANCE ADMINISTRATION AND UNDERWRITING INSURANCE PLANS IN THE FIELDS OF HEALTH AND LIFE INSURANCE; INSURANCE ADMINISTRATION IN THE FIELD OF PREPAID HEALTH CARE PLANS; ADMINISTRATION OF EMPLOYEE BENEFIT PLANS CONCERNING HEALTH CARE INSURANCE; INSURANCE UNDERWRITING IN THE FIELD OF HEALTH CARE INSURANCE; INSURANCE UNDERWRITING IN THE FIELD OF HEALTH CARE; ADMINISTRATION OF PREFERRED PROVIDER PLANS IN THE FIELD OF MEDICAL CARE; MEDICAL INSURANCE UNDERWRITING; INSURANCE ADMINISTRATION IN THE FIELD OF LIABILITY INSURANCE, NAMELY, INSURANCE CLAIMS ADMINISTRATION (U.S. CLS. 100, 101 AND 102).

JOHN DWYER, EXAMINING ATTORNEY

**CLASS 36—(Continued).**

SN 86-122,674. VISION REAL ESTATE, L.L.C., DENVER, CO. FILED 11-19-2013.



NO CLAIM IS MADE TO THE EXCLUSIVE RIGHT TO USE "REAL ESTATE", APART FROM THE MARK AS SHOWN.

THE COLOR(S) GREEN AND WHITE IS/ARE CLAIMED AS A FEATURE OF THE MARK.

THE MARK CONSISTS OF THE WORD "VISION" IN THE COLOR GREEN AND THE WORDS "REAL ESTATE" IN WHITE BELOW THE WORD "VISION," WITH A GREEN OUTLINE OF A HOUSE INCLUDING A SLANTED ROOF AND A CHIMNEY ABOVE THE WORD "VISION". THE COLOR BLACK IN THE DRAWING IS FOR BACKGROUND PURPOSES ONLY AND IS NOT CLAIMED AS A FEATURE OF THE MARK.

FOR COMMERCIAL AND RESIDENTIAL REAL ESTATE AGENCY SERVICES (U.S. CLS. 100, 101 AND 102).

FIRST USE 1-1-2007; IN COMMERCE 1-1-2007.  
PRISCILLA MILTON, EXAMINING ATTORNEY

SN 86-122,661. VISION REAL ESTATE, L.L.C., DENVER, CO. FILED 11-19-2013.

**VISION REAL ESTATE**

THE MARK CONSISTS OF STANDARD CHARACTERS WITHOUT CLAIM TO ANY PARTICULAR FONT, STYLE, SIZE, OR COLOR.

NO CLAIM IS MADE TO THE EXCLUSIVE RIGHT TO USE "REAL ESTATE", APART FROM THE MARK AS SHOWN.

FOR COMMERCIAL AND RESIDENTIAL REAL ESTATE AGENCY SERVICES (U.S. CLS. 100, 101 AND 102).

FIRST USE 1-2-2007; IN COMMERCE 1-2-2007.  
PRISCILLA MILTON, EXAMINING ATTORNEY

SN 86-122,905. FMR LLC, BOSTON, MA. FILED 11-19-2013.

**FIDELITY YIELD INVESTIGATOR**

THE MARK CONSISTS OF STANDARD CHARACTERS WITHOUT CLAIM TO ANY PARTICULAR FONT, STYLE, SIZE, OR COLOR.

OWNER OF U.S. REG. NOS. 1,543,851, 3,092,354 AND OTHERS.

NO CLAIM IS MADE TO THE EXCLUSIVE RIGHT TO USE "YIELD", APART FROM THE MARK AS SHOWN.

FOR PROVIDING AN ON-LINE FINANCIAL CALCULATOR (U.S. CLS. 100, 101 AND 102).

ANGELA DUONG, EXAMINING ATTORNEY

**CLASS 36—(Continued).**

SN 86-128,349. BRINKMERE CAPITAL PARTNERS, LLC, JACKSONVILLE, FL. FILED 11-25-2013.

# BRINKMERE

THE MARK CONSISTS OF STANDARD CHARACTERS WITHOUT CLAIM TO ANY PARTICULAR FONT, STYLE, SIZE, OR COLOR.

FOR FINANCIAL SERVICES RELATED TO CORPORATE ACQUISITIONS, EXPANSIONS, RESTRUCTURINGS AND BUYOUTS; PRIVATE EQUITY FUND INVESTMENT SERVICES AND ASSET AND INVESTMENT ACQUISITION SERVICES PERTAINING TO PRIVATE EQUITY FUNDS; INVESTMENT ADVISORY SERVICES; FINANCIAL AND INVESTMENT SERVICES, NAMELY, ASSET ACQUISITION, CONSULTATION, DEVELOPMENT AND MANAGEMENT SERVICES; FINANCIAL SERVICES, NAMELY, PURCHASE OF SECURITIES AND OTHER FINANCIAL INSTRUMENTS; INVESTMENT BANKING SERVICES (U.S. CLS. 100, 101 AND 102).

FIRST USE 11-15-2012; IN COMMERCE 11-15-2012.  
LIEF MARTIN, EXAMINING ATTORNEY

**CLASS 36—(Continued).**

SN 86-137,597. FRANKLIN RESOURCES, INC., DBA FRANKLIN TEMPLETON INVESTMENTS, SAN MATEO, CA. FILED 12-6-2013.

## INCOME FOR WHAT'S NEXT

THE MARK CONSISTS OF STANDARD CHARACTERS WITHOUT CLAIM TO ANY PARTICULAR FONT, STYLE, SIZE, OR COLOR.

FOR ADVICE RELATING TO INVESTMENTS; ESTABLISHING MUTUAL FUNDS FOR OTHERS; FINANCIAL ADVISORY AND CONSULTANCY SERVICES; FINANCIAL ANALYSIS AND CONSULTATION; FINANCIAL INFORMATION AND ADVISORY SERVICES; FINANCIAL SERVICES, NAMELY, INVESTMENT ADVICE, INVESTMENT MANAGEMENT, INVESTMENT CONSULTATION AND INVESTMENT OF FUNDS FOR OTHERS, INCLUDING PRIVATE AND PUBLIC EQUITY AND DEBT INVESTMENT SERVICES; FINANCIAL SERVICES, NAMELY, INVESTMENT FUND TRANSFER AND TRANSACTION SERVICES; FUNDS INVESTMENT; INVESTMENT ADVISORY SERVICES; INVESTMENT CONSULTATION; INVESTMENT MANAGEMENT; INVESTMENT OF FUNDS FOR OTHERS; MUTUAL FUND DISTRIBUTION; MUTUAL FUND INVESTMENT; MUTUAL FUNDS AND CAPITAL INVESTMENT; TRANSFER AGENCY SERVICES RENDERED TO ISSUERS OF INVESTMENT SECURITIES (U.S. CLS. 100, 101 AND 102).

FIRST USE 10-0-2013; IN COMMERCE 10-0-2013.  
JOANNA FIORELLI, EXAMINING ATTORNEY

SN 86-142,893. COLLABHEALTH PLAN SERVICES, INC., ENGLEWOOD, CO. FILED 12-13-2013.



# PIMSA

THE MARK CONSISTS OF STANDARD CHARACTERS WITHOUT CLAIM TO ANY PARTICULAR FONT, STYLE, SIZE, OR COLOR.

FOR MEDICARE SET ASIDE PRODUCTION SERVICES, NAMELY, INSURANCE SERVICES RELATED TO THE MEDICARE SET ASIDE PROGRAM, NAMELY, CLAIMS ADMINISTRATION AND CONSULTING SERVICES RENDERED TO INDIVIDUALS WHO HAVE SUFFERED PERSONAL INJURY AND PARTICIPATE IN THE MEDICARE SET ASIDE PROGRAM (U.S. CLS. 100, 101 AND 102).

DAVID MURRAY, EXAMINING ATTORNEY

NO CLAIM IS MADE TO THE EXCLUSIVE RIGHT TO USE "HEALTH", APART FROM THE MARK AS SHOWN.

THE MARK CONSISTS OF A CIRCLE WITH A SUN AND A FIELD APPEARING THEREIN, WITH THE WORDS "HEARTLAND", "PLAINS" AND "HEALTH" APPEARING BELOW.

FOR INSURANCE SERVICES, NAMELY, INSURANCE ADMINISTRATION AND UNDERWRITING INSURANCE PLANS IN THE FIELDS OF HEALTH AND LIFE INSURANCE; INSURANCE ADMINISTRATION IN THE FIELD OF PREPAID HEALTH CARE PLANS; ADMINISTRATION OF EMPLOYEE BENEFIT PLANS CONCERNING HEALTH CARE INSURANCE; INSURANCE UNDERWRITING IN THE FIELD OF HEALTH CARE INSURANCE; INSURANCE UNDERWRITING IN THE FIELD OF HEALTH CARE; ADMINISTRATION OF PREFERRED PROVIDER PLANS IN THE FIELD OF MEDICAL CARE; MEDICAL INSURANCE UNDERWRITING; INSURANCE ADMINISTRATION IN THE FIELD OF LIABILITY INSURANCE, NAMELY, INSURANCE CLAIMS ADMINISTRATION (U.S. CLS. 100, 101 AND 102).

JOHN DWYER, EXAMINING ATTORNEY

SN 86-128,992. KENT A. TAKEMOTO, TAMPA, FL. FILED 11-25-2013.

**CLASS 36—(Continued).**

SN 86-142,896. COLLABHEALTH PLAN SERVICES, INC., ENGLEWOOD, CO. FILED 12-13-2013.

**HEARTLANDPLAINS HEALTH**

THE MARK CONSISTS OF STANDARD CHARACTERS WITHOUT CLAIM TO ANY PARTICULAR FONT, STYLE, SIZE, OR COLOR.

NO CLAIM IS MADE TO THE EXCLUSIVE RIGHT TO USE "HEALTH", APART FROM THE MARK AS SHOWN.

FOR INSURANCE SERVICES, NAMELY, INSURANCE ADMINISTRATION AND UNDERWRITING INSURANCE PLANS IN THE FIELDS OF HEALTH AND LIFE INSURANCE; INSURANCE ADMINISTRATION IN THE FIELD OF PREPAID HEALTH CARE PLANS; ADMINISTRATION OF EMPLOYEE BENEFIT PLANS CONCERNING HEALTH CARE INSURANCE; INSURANCE UNDERWRITING IN THE FIELD OF HEALTH CARE INSURANCE; INSURANCE UNDERWRITING IN THE FIELD OF HEALTH CARE; ADMINISTRATION OF PREFERRED PROVIDER PLANS IN THE FIELD OF MEDICAL CARE; MEDICAL INSURANCE UNDERWRITING; INSURANCE ADMINISTRATION IN THE FIELD OF LIABILITY INSURANCE, NAMELY, INSURANCE CLAIMS ADMINISTRATION (U.S. CLS. 100, 101 AND 102).

JOHN DWYER, EXAMINING ATTORNEY

SN 86-147,703. CROOK, MICHAEL, PLANT CITY, FL. FILED 12-18-2013.

**VERIBOOK**

THE MARK CONSISTS OF STANDARD CHARACTERS WITHOUT CLAIM TO ANY PARTICULAR FONT, STYLE, SIZE, OR COLOR.

FOR CREDIT CARD TRANSACTION PROCESSING SERVICES, NAMELY, CREDIT CARD VERIFICATION (U.S. CLS. 100, 101 AND 102).

FIRST USE 6-1-2012; IN COMMERCE 6-1-2012.  
BRIN ANDERSON, EXAMINING ATTORNEY

SN 86-153,572. SAN DIEGO COUNTY CREDIT UNION, SAN DIEGO, CA. FILED 12-27-2013.

**BANK MEGA**

THE MARK CONSISTS OF STANDARD CHARACTERS WITHOUT CLAIM TO ANY PARTICULAR FONT, STYLE, SIZE, OR COLOR.

NO CLAIM IS MADE TO THE EXCLUSIVE RIGHT TO USE "BANK", APART FROM THE MARK AS SHOWN.

FOR CREDIT UNION SERVICES (U.S. CLS. 100, 101 AND 102).

FIRST USE 12-6-2013; IN COMMERCE 12-6-2013.  
WANDA KAY PRICE, EXAMINING ATTORNEY

**CLASS 36—(Continued).**

SN 86-153,984. VMS TECHNOLOGY GROUP, LLC, DBA HIZZOME, FALLS CHURCH, VA. FILED 12-30-2013.

**Hizzome**

THE MARK CONSISTS OF STANDARD CHARACTERS WITHOUT CLAIM TO ANY PARTICULAR FONT, STYLE, SIZE, OR COLOR.

FOR PROVIDING A DATABASE OF INFORMATION ABOUT RESIDENTIAL REAL ESTATE LISTINGS IN DIFFERENT NEIGHBORHOODS AND COMMUNITIES; PROVIDING A DATABASE OF RESIDENTIAL REAL ESTATE LISTINGS WITHIN NEIGHBORHOODS AND COMMUNITIES SPECIFICALLY IDENTIFIED BY USERS; PROVIDING INFORMATION IN THE FIELD OF REAL ESTATE VIA THE INTERNET; PROVIDING REAL ESTATE LISTINGS AND REAL ESTATE INFORMATION VIA THE INTERNET; REAL ESTATE LISTING SERVICES FOR HOUSING RENTALS AND APARTMENT RENTALS; REAL ESTATE MANAGEMENT OF APARTMENT, CONDOMINIUM, TOWNHOME AND HOUSING COMMUNITIES; REAL ESTATE MANAGEMENT SERVICES; REAL ESTATE SERVICE, NAMELY, RENTAL PROPERTY MANAGEMENT; REAL ESTATE SERVICES, NAMELY, CONDOMINIUM MANAGEMENT SERVICES; REAL ESTATE SERVICES, NAMELY, PROPERTY MANAGEMENT SERVICES FOR CONDOMINIUM ASSOCIATIONS, HOMEOWNER ASSOCIATIONS AND APARTMENT BUILDINGS (U.S. CLS. 100, 101 AND 102).  
FIRST USE 10-1-2013; IN COMMERCE 10-15-2013.  
JACLYN KIDWELL WALKER, EXAMINING ATTORNEY

SN 86-154,533. LANDMARK APARTMENT TRUST OF AMERICA HOLDINGS, L.P., RICHMOND, VA. FILED 12-30-2013.

**LANDMARK APARTMENT TRUST**

THE MARK CONSISTS OF STANDARD CHARACTERS WITHOUT CLAIM TO ANY PARTICULAR FONT, STYLE, SIZE, OR COLOR.

NO CLAIM IS MADE TO THE EXCLUSIVE RIGHT TO USE "APARTMENT TRUST", APART FROM THE MARK AS SHOWN.

FOR LEASING OF APARTMENTS; MANAGEMENT OF APARTMENTS; REAL ESTATE MANAGEMENT OF APARTMENT BUILDINGS; REAL ESTATE MANAGEMENT SERVICES; RENTAL OF APARTMENTS; RENTAL OF APARTMENTS IN AN APARTMENT COMMUNITY; RENTING OF APARTMENTS; MANAGEMENT, LEASING, AND RENTAL OF MULTIFAMILY PROPERTIES (U.S. CLS. 100, 101 AND 102).

FIRST USE 8-0-2012; IN COMMERCE 8-0-2012.  
REBECCA POVARCHUK, EXAMINING ATTORNEY

**CLASS 36—(Continued).**

SN 86-154,536. LANDMARK APARTMENT TRUST OF AMERICA HOLDINGS, L.P., RICHMOND, VA. FILED 12-30-2013.

# LAT

THE MARK CONSISTS OF STANDARD CHARACTERS WITHOUT CLAIM TO ANY PARTICULAR FONT, STYLE, SIZE, OR COLOR.

FOR LEASING OF APARTMENTS; MANAGEMENT OF APARTMENTS; REAL ESTATE MANAGEMENT OF APARTMENT BUILDINGS; REAL ESTATE MANAGEMENT SERVICES; RENTAL OF APARTMENTS; RENTAL OF APARTMENTS IN AN APARTMENT COMMUNITY; RENTING OF APARTMENTS; MANAGEMENT, LEASING, AND RENTAL OF MULTIFAMILY PROPERTIES (U.S. CLS. 100, 101 AND 102).

FIRST USE 8-0-2012; IN COMMERCE 8-0-2012.  
REBECCA POVARCHUK, EXAMINING ATTORNEY

SN 86-163,647. ASTORIA FEDERAL SAVINGS AND LOAN ASSOCIATION, LAKE SUCCESS, NY. FILED 1-13-2014.

# ASTORIA BANK

THE MARK CONSISTS OF STANDARD CHARACTERS WITHOUT CLAIM TO ANY PARTICULAR FONT, STYLE, SIZE, OR COLOR.

OWNER OF U.S. REG. NOS. 2,385,476, 2,406,323 AND 2,406,324.

NO CLAIM IS MADE TO THE EXCLUSIVE RIGHT TO USE "BANK", APART FROM THE MARK AS SHOWN.

FOR BANKING SERVICES; FINANCIAL SERVICES, NAMELY, MORTGAGE LENDING, PROVIDING CONSUMER LOANS, PROVIDING LINES OF CREDIT, PROVIDING REVOLVING CREDIT, PROVIDING SMALL BUSINESS LOANS, ADMINISTRATION OF SAVINGS ACCOUNTS, ADMINISTRATION OF CHECKING ACCOUNTS, ADMINISTRATION OF MONEY MARKET ACCOUNTS, ISSUING CERTIFICATES OF DEPOSIT, ISSUING ATM DEBIT CARDS AND ATM BANKING SERVICES, DEBIT AND CREDIT CARD SERVICES, TRUST MANAGEMENT ACCOUNTS, PROVIDING FOREIGN CURRENCY EXCHANGE, SAFE DEPOSIT BOX SERVICES, ISSUING OF TRAVELERS CHECKS, WIRE MONEY TRANSFERS, MUTUAL FUND INVESTMENT AND BROKERAGE, ADMINISTRATION OF FIXED ANNUITIES, ADMINISTRATION OF VARIABLE ANNUITIES, ADMINISTRATION OF COLLEGE SAVINGS ACCOUNTS, CASH MANAGEMENT SERVICES, PAYROLL TAX DEBITING SERVICES, LOCK BOX SAFE DEPOSIT SERVICES, FINANCIAL ADMINISTRATION OF RETIREMENT PLANS, MERCHANT CREDIT CARD SERVICES, ISSUING LETTERS OF CREDIT, ONLINE BANKING WITH BILL PAYMENT SERVICES, ADMINISTRATION OF LANDLORD OPERATING SAVINGS ACCOUNTS; INSURANCE SERVICES AND PRODUCTS, NAMELY, INSURANCE BROKERAGE IN THE FIELD OF TERM LIFE, WHOLE LIFE, UNIVERSAL LIFE, VARIABLE LIFE, LONG TERM CARE, DISABILITY INCOME, MORTGAGE TERM, HOME OWNER AND RENTER, AND PERSONAL UMBRELLA INSURANCE (U.S. CLS. 100, 101 AND 102).

COLLEEN MULCRONE, EXAMINING ATTORNEY

**CLASS 36—(Continued).**

SN 86-164,025. FIRSTVIEW, LLC, ATLANTA, GA. FILED 1-13-2014.

# WHY BE A RESELLER

THE MARK CONSISTS OF STANDARD CHARACTERS WITHOUT CLAIM TO ANY PARTICULAR FONT, STYLE, SIZE, OR COLOR.

FOR FINANCIAL SERVICES, NAMELY, MANAGEMENT AND PROCESSING OF PREPAID CREDIT CARD PROGRAMS (U.S. CLS. 100, 101 AND 102).

ROBERT STRUCK, EXAMINING ATTORNEY

SN 86-166,286. TRANSATLANTIC HOLDINGS, INC., NEW YORK, NY. FILED 1-15-2014.

# CALPE INSURANCE COMPANY

THE MARK CONSISTS OF STANDARD CHARACTERS WITHOUT CLAIM TO ANY PARTICULAR FONT, STYLE, SIZE, OR COLOR.

NO CLAIM IS MADE TO THE EXCLUSIVE RIGHT TO USE "INSURANCE COMPANY", APART FROM THE MARK AS SHOWN.

THE WORDING "CALPE" HAS NO MEANING IN A FOREIGN LANGUAGE.

FOR INSURANCE SERVICES, NAMELY, REINSURANCE UNDERWRITING AND REINSURANCE ADMINISTRATION SERVICES (U.S. CLS. 100, 101 AND 102).

JAMES A. RAUEN, EXAMINING ATTORNEY

SN 86-181,354. BOB MILLS FURNITURE CO., LLC, OKLAHOMA CITY, OK. FILED 1-31-2014.

# SMARTBUY

THE MARK CONSISTS OF STANDARD CHARACTERS WITHOUT CLAIM TO ANY PARTICULAR FONT, STYLE, SIZE, OR COLOR.

FOR EXTENDED WARRANTY SERVICES, NAMELY, SERVICE CONTRACTS (U.S. CLS. 100, 101 AND 102).

FIRST USE 6-1-2008; IN COMMERCE 6-1-2008.

RENEE MCCRAY, EXAMINING ATTORNEY

**CLASS 36—(Continued).**

SN 86-185,952. HOUSEBLICK LLC, LAKEWOOD, NJ. FILED 2-6-2014.

HOUSE BLICK.COM

THE MARK CONSISTS OF STANDARD CHARACTERS WITHOUT CLAIM TO ANY PARTICULAR FONT, STYLE, SIZE, OR COLOR.

NO CLAIM IS MADE TO THE EXCLUSIVE RIGHT TO USE "HOUSE", APART FROM THE MARK AS SHOWN.

FOR PROVIDING REAL ESTATE LISTINGS VIA THE INTERNET (U.S. CLS. 100, 101 AND 102).

FIRST USE 2-6-2014; IN COMMERCE 2-6-2014.  
INGRID C. EULIN, EXAMINING ATTORNEY

SN 86-186,106. PINK PARTY BREAST CANCER FOUNDATION INC., KAUKAUNA, WI. FILED 2-6-2014.



NO CLAIM IS MADE TO THE EXCLUSIVE RIGHT TO USE "BREAST CANCER FOUNDATION, INC.", APART FROM THE MARK AS SHOWN.

THE COLOR(S) PINK, DARK PINK, BLACK AND WHITE IS/ARE CLAIMED AS A FEATURE OF THE MARK.

THE MARK CONSISTS OF A PINK AWARENESS RIBBON WITH THE WORDS "PINK PARTY" SUPERIMPOSED OVER THE LEFT EDGE OF THE RIBBON AND THE LETTER P IN BOTH WORDS IS WHITE OUTLINED IN PINK IN LARGER TYPE THAN THE OTHER LETTERS THAT ARE DARK PINK AND A PINK SILHOUETTE OUTLINE OF A SIDEWAYS HUMAN FACE IN WHITE WITH BLACK EYELASHES TO THE RIGHT OF THE RIBBON, ALL ABOVE THE WORDS "BREAST CANCER FOUNDATION, INC." WHERE THE FIRST LETTER IN EACH WORD IS PINK OUTLINED IN WHITE AND THE OTHER LETTERS ARE DARK PINK.

FOR CHARITABLE FOUNDATION SERVICES, NAMELY, PROVIDING FUNDRAISING ACTIVITIES TO SUPPORT MEDICAL RESEARCH AND PROCEDURES FOR THOSE IN NEED (U.S. CLS. 100, 101 AND 102).

FIRST USE 6-0-2011; IN COMMERCE 6-0-2011.  
DOUGLAS LEE, EXAMINING ATTORNEY

**CLASS 36—(Continued).**

SN 86-186,223. SILVERLEAF REALTY CORPORATION, DBA SILVERLEAF REALTY GROUP, HOLLYWOOD, FL. FILED 2-6-2014.



NO CLAIM IS MADE TO THE EXCLUSIVE RIGHT TO USE "REALTY GROUP", APART FROM THE MARK AS SHOWN.

THE COLOR(S) BLUE, SILVER AND WHITE IS/ARE CLAIMED AS A FEATURE OF THE MARK.

THE MARK CONSISTS OF A PICTURE OF A LEAF (THE COLOR OF THE LEAF IS SILVER AND DARK SILVER), BENEATH THE PICTURE OF THE LEAF IS THE WORD "SILVERLEAF" (THE LETTERS "SILVER" ARE IN BLUE AND THE LETTERS "LEAF" ARE IN SILVER), BENEATH THE WORD "SILVERLEAF" ARE THE WORDS "REALTY GROUP" (THE LETTERS OF WHICH ARE ALL IN DARK SILVER), THE BACKGROUND IS WHITE.

FOR REAL ESTATE AGENCY AND BROKERAGE SERVICES FOR RESIDENTIAL COMMUNITIES, NAMELY, HOUSES AND APARTMENTS, AND COMMERCIAL PROPERTIES, NAMELY, INDUSTRIAL BUILDINGS, OFFICE AND RETAIL SPACE, BUT SPECIFICALLY EXCLUDING THE FOLLOWING: (I) REAL ESTATE MANAGEMENT AND REAL ESTATE AGENCY AND BROKERAGE SERVICES FEATURING TIME-SHARE RESORTS, CONDO RESORTS AND RESORT LOTS; (II) REAL ESTATE MANAGEMENT SERVICES, NAMELY, THE OPERATION OF A PLANNED COMMUNITY; (III) REAL ESTATE DEVELOPMENT SERVICES, NAMELY, THE DEVELOPMENT OF MASTER PLANNED COMMUNITIES, PLANNING AND DEVELOPMENT OF RESIDENTIAL COMMUNITIES, NAMELY, HOUSES, APARTMENTS AND PLANNING AND DEVELOPMENT OF COMMERCIAL PROPERTIES, NAMELY, INDUSTRIAL BUILDINGS, OFFICE AND RETAIL SPACE; AND (IV) LAND DEVELOPMENT SERVICES, NAMELY, CONSTRUCTION OF A PLANNED COMMUNITY DEVELOPMENT OF MIXED USE, GATED AND UNGATED RESIDENTIAL, OFFICE, RETAIL, AND INDUSTRIAL PROPERTIES (U.S. CLS. 100, 101 AND 102).

TINA MAL, EXAMINING ATTORNEY

SN 86-187,512. JACKSON NATIONAL LIFE INSURANCE COMPANY, LANSING, MI. FILED 2-7-2014.

Elite Access Brokerage  
Edition

THE MARK CONSISTS OF STANDARD CHARACTERS WITHOUT CLAIM TO ANY PARTICULAR FONT, STYLE, SIZE, OR COLOR.

OWNER OF U.S. REG. NOS. 4,223,090, 4,360,162 AND 4,360,163.

NO CLAIM IS MADE TO THE EXCLUSIVE RIGHT TO USE "BROKERAGE EDITION", APART FROM THE MARK AS SHOWN.

FOR FINANCIAL SERVICES, NAMELY, ANNUITY UNDERWRITING SERVICES (U.S. CLS. 100, 101 AND 102).

HEATHER BIDDULPH, EXAMINING ATTORNEY

**CLASS 36—(Continued).**

SN 86-196,864. ESMITH REALTY PARTNERS, L.L.C., DALLAS, TX. FILED 2-18-2014.



NO CLAIM IS MADE TO THE EXCLUSIVE RIGHT TO USE "REALTY PARTNERS", APART FROM THE MARK AS SHOWN.

THE NAME(S), PORTRAIT(S), AND/OR SIGNATURE(S) SHOWN IN THE MARK IDENTIFIES EMMITT JAMES SMITH, III, WHOSE CONSENT(S) TO REGISTER IS MADE OF RECORD.

THE MARK CONSISTS OF THE LETTER "E" AND THE LETTER "S" ARE HIDDEN IN SYMBOLS THAT LOOK LIKE BUILDINGS ABOVE THE STYLIZED TEXT "E SMITH REALTY PARTNERS".

FOR REAL ESTATE CONSULTATION; REAL ESTATE AGENCIES; REAL ESTATE FINANCIAL ADVISORY SERVICES, NAMELY, ADVISING ON FINANCING OF REAL ESTATE DEVELOPMENT PROJECTS; REAL ESTATE BROKERAGE (U.S. CLS. 100, 101 AND 102).

FIRST USE 8-15-2013; IN COMMERCE 8-15-2013.  
ZACHARY CROMER, EXAMINING ATTORNEY

SN 86-198,151. NEUBERGER BERMAN GROUP LLC, NEW YORK, NY. FILED 2-19-2014.

### SERIOUS INVESTING FOR 75 YEARS

THE MARK CONSISTS OF STANDARD CHARACTERS WITHOUT CLAIM TO ANY PARTICULAR FONT, STYLE, SIZE, OR COLOR.

OWNER OF U.S. REG. NO. 4,088,034.

NO CLAIM IS MADE TO THE EXCLUSIVE RIGHT TO USE "INVESTING FOR 75 YEARS", APART FROM THE MARK AS SHOWN.

FOR FINANCIAL SERVICES, NAMELY, INVESTMENT ADVISORY, INVESTMENT MANAGEMENT, ASSET MANAGEMENT, PORTFOLIO MANAGEMENT, INVESTMENT BROKERAGE, SECURITIES BROKERAGE, INVESTMENT CONSULTATION, WEALTH MANAGEMENT, AND FINANCIAL PLANNING SERVICES; FINANCIAL AND INVESTMENT SERVICES, NAMELY, INVESTMENT ADVISORY AND INVESTMENT MANAGEMENT AND BROKERAGE OF SECURITIES, HEDGE FUNDS, PRIVATE EQUITY FUNDS, WRAP FEE PROGRAMS, SEPARATE ACCOUNTS, VARIABLE ANNUITY PROGRAMS, STOCKS, BONDS, COMMODITIES, DERIVATIVES AND DEBT INVESTMENT, AND LIMITED PARTNERSHIPS; FINANCIAL SERVICES, NAMELY, FINANCIAL RESEARCH, FINANCIAL ANALYSIS, CONSULTATION, RECORD KEEPING AND INFORMATION SERVICES, TRANSFER AGENT

**CLASS 36—(Continued).**

SERVICES, CUSTODIAN SERVICES, MANAGEMENT AND INVESTMENT OF FUNDS AND ASSETS OF OTHERS, CAPITAL INVESTMENT SERVICES, AND FINANCIAL TRANSACTION SERVICES; FINANCIAL SERVICES, NAMELY, MUTUAL FUND ADVISORY AND INVESTMENT MANAGEMENT SERVICES, MUTUAL FUND DISTRIBUTION SERVICES, MUTUAL FUND UNDERWRITING AND ADMINISTRATION SERVICES, AND VARIABLE ANNUITIES INVESTMENT SERVICES; CLEARANCE SERVICES, NAMELY, CLEARING AND SETTLING FINANCIAL TRANSACTIONS ON BEHALF OF OTHERS; MAINTAINING ASSETS AND SECURITIES FOR OTHERS, AND CONFIRMING AND TRACKING FINANCIAL TRANSACTIONS FOR OTHERS; INSURANCE INVESTMENT SERVICES; TRUST AND ESTATE PLANNING AND MANAGEMENT SERVICES; RETIREMENT PLANNING SERVICES; REAL ESTATE INVESTMENT TRUST ADVISORY AND MANAGEMENT SERVICES; PROVIDING A WEB SITE FEATURING FINANCIAL INFORMATION AND FINANCIAL ADVICE (U.S. CLS. 100, 101 AND 102).

FIRST USE 1-1-2014; IN COMMERCE 1-1-2014.  
AMY C. KEAN, EXAMINING ATTORNEY

SN 86-200,670. WELLS FARGO & COMPANY, MINNEAPOLIS, MN. FILED 2-21-2014.

### WATS FX PROFESSIONAL

THE MARK CONSISTS OF STANDARD CHARACTERS WITHOUT CLAIM TO ANY PARTICULAR FONT, STYLE, SIZE, OR COLOR.

OWNER OF U.S. REG. NO. 3,151,896.

NO CLAIM IS MADE TO THE EXCLUSIVE RIGHT TO USE "FX PROFESSIONAL", APART FROM THE MARK AS SHOWN.

FOR FINANCIAL SERVICES, NAMELY, PROVIDING FINANCIAL INFORMATION, TRADE EXECUTION AND REPORTING SERVICES IN THE FIELD OF FOREIGN EXCHANGE, ALL VIA A GLOBAL COMMUNICATION NETWORK (U.S. CLS. 100, 101 AND 102).

BRIAN PINO, EXAMINING ATTORNEY

SN 86-205,015. EQUITY PARTNERS INSURANCE SERVICES, INC., SLIDELL, LA. FILED 2-26-2014.

### WHERE OTHERS GIVE PROMISES, WE GIVE SERVICES

THE MARK CONSISTS OF STANDARD CHARACTERS WITHOUT CLAIM TO ANY PARTICULAR FONT, STYLE, SIZE, OR COLOR.

FOR INSURANCE SERVICES, NAMELY, GENERAL AGENCY, WHOLESALE BROKERAGE AND RETAIL AGENCY SERVICES FOR INSURANCE LINES OF ACCIDENT, AVIATION, CASUALTY, COMMERCIAL GENERAL LIABILITY, ENERGY, ENVIRONMENTAL, FLOOD, MARINE, PROFESSIONAL LIABILITY, PROPERTY, TRANSPORTATION, SPORTS AND ENTERTAINMENT AND UMBRELLAS THEREFOR (U.S. CLS. 100, 101 AND 102).

FIRST USE 1-1-2012; IN COMMERCE 1-1-2012.  
HANNO RITTNER, EXAMINING ATTORNEY



**CLASS 36—(Continued).**

SN 86-205,265. NOVARUS CAPITAL GROUP, INC., FORMERLY NEW WEST CAPITAL CORPORATION, DENVER, CO. FILED 2-26-2014.



THE COLOR(S) BLUE AND GREEN IS/ARE CLAIMED AS A FEATURE OF THE MARK.

THE MARK CONSISTS OF THE WORD "NOVARUS" WRITTEN IN STYLIZED FONT. THE WORDING APPEARS IN BLUE WITH GREEN IN THE BOTTOM HALF OF THE "V" AND IN THE TOP HALF OF THE "A". THE MARK APPEARS ON A TRANSPARENT BACKGROUND AND NO OTHER COLOR IS CLAIMED AS A FEATURE OF THE MARK.

THE WORDING "NOVARUS" HAS NO MEANING IN A FOREIGN LANGUAGE.

FOR EQUITY CAPITAL INVESTMENT; MONEY LENDING SERVICES, NAMELY, PROVIDING DEVELOPMENT CAPITAL, PRIVATE EQUITY AND INVESTMENT FUNDING (U.S. CLS. 100, 101 AND 102).

FIRST USE 1-8-2014; IN COMMERCE 1-8-2014.

CATHERINE TARCU, EXAMINING ATTORNEY

---

SN 86-205,290. U-PIC INSURANCE SERVICES, INC., AGOURA HILLS, CA. FILED 2-26-2014.

## INSURE HAPPINESS

THE MARK CONSISTS OF STANDARD CHARACTERS WITHOUT CLAIM TO ANY PARTICULAR FONT, STYLE, SIZE, OR COLOR.

FOR INSURANCE SERVICES, NAMELY, UNDERWRITING, ISSUANCE AND ADMINISTRATION OF PARCEL INSURANCE POLICIES (U.S. CLS. 100, 101 AND 102).

FIRST USE 2-26-2014; IN COMMERCE 2-26-2014.

SIDDHARTH JAGANNATHAN, EXAMINING ATTORNEY

---

SN 86-209,625. ERIKA RODRIGUES GOMES SAMPAIO, NEW YORK, NY. FILED 3-3-2014.

## TEN15NYC

THE MARK CONSISTS OF STANDARD CHARACTERS WITHOUT CLAIM TO ANY PARTICULAR FONT, STYLE, SIZE, OR COLOR.

FOR RENTING OF APARTMENTS (U.S. CLS. 100, 101 AND 102).

FIRST USE 3-1-2012; IN COMMERCE 3-1-2012.

ROBIN CHOSID, EXAMINING ATTORNEY

**CLASS 36—(Continued).**

SN 86-210,617. TUCKER BOYNTON FINANCIAL GROUP, INC., AKA TUCKER BOYNTON COMPANY, INC., CHARLOTTE, NC. FILED 3-4-2014.

## Balancing your life, wealth, and legacy

THE MARK CONSISTS OF STANDARD CHARACTERS WITHOUT CLAIM TO ANY PARTICULAR FONT, STYLE, SIZE, OR COLOR.

FOR ADVISORY SERVICES IN THE FIELD OF EMPLOYEE BENEFITS FOR GROUP HEALTHCARE AND BUSINESS INSURANCE OFFERED TO EMPLOYEES IN ADDITION TO STANDARD BENEFITS SUCH AS MEDICAL, DENTAL, LIFE INSURANCE INCLUDING SHORT TERM DISABILITY, LONG TERM DISABILITY, CANCER INSURANCE, ACCIDENTAL DEATH AND DISMEMBERMENT; ESTATE PLANNING; FINANCIAL ADVISORY AND CONSULTANCY SERVICES, NAMELY, THE CREATION OF PERSONALIZED STRATEGIES TO ACHIEVE FINANCIAL INDEPENDENCE; FINANCIAL INVESTMENT IN THE FIELD OF FINANCIAL AND INVESTMENT PLANNING FOR INDIVIDUALS, NAMELY, ESTATE PLANNING, COLLEGE FUNDING, RETIREMENT PLANNING, MUTUAL FUNDS, VARIABLE ANNUITIES, AND ASSET ALLOCATION; FINANCIAL PLANNING, NAMELY, EXECUTIVE BENEFIT PLANS, KEY PERSON INSURANCE, AND BUY-SELL FUNDING; FINANCIAL TRUST PLANNING; INSURANCE CONSULTING IN THE FIELD OF LIFE, HEALTH, DISABILITY, LONG-TERM CARE, VARIABLE UNIVERSAL LIFE, ANNUITIES AND MEDICARE SUPPLEMENTS FOR INDIVIDUALS; INSURANCE SERVICES, NAMELY, INSURANCE ELIGIBILITY REVIEW AND VERIFICATION AND CONSULTATION IN THE EMPLOYEE BENEFITS INDUSTRY; PROVIDING INFORMATION IN THE FIELD OF EMPLOYEE FINANCIAL BENEFIT PLANS (U.S. CLS. 100, 101 AND 102).

FIRST USE 7-25-2012; IN COMMERCE 8-1-2012.

ALISON POLLACK, EXAMINING ATTORNEY

---

SN 86-213,766. GRAND MUTUAL INSURANCE, INC., WOODLAND HILLS, CA. FILED 3-6-2014.



## GRAND MUTUAL

NO CLAIM IS MADE TO THE EXCLUSIVE RIGHT TO USE "MUTUAL", APART FROM THE MARK AS SHOWN.

THE MARK CONSISTS OF THE WORDS "GRAND MUTUAL" IN UPPER CASE, UNDERLINED, TO THE RIGHT OF A DESIGN OF A PILLARED BUILDING.

FOR INSURANCE AGENCY SERVICES FOR INDIVIDUALS, FAMILIES AND BUSINESSES IN THE FIELDS OF PERSONAL, COMMERCIAL, LIFE AND HEALTH INSURANCE SERVICES (U.S. CLS. 100, 101 AND 102).

FIRST USE 4-1-2012; IN COMMERCE 4-1-2012.

LINDA POWELL, EXAMINING ATTORNEY

**CLASS 36—(Continued).**

SN 86-214,210. GRAND MUTUAL INSURANCE, INC., WOODLAND HILLS, CA. FILED 3-7-2014.

**GRAND MUTUAL**

THE MARK CONSISTS OF STANDARD CHARACTERS WITHOUT CLAIM TO ANY PARTICULAR FONT, STYLE, SIZE, OR COLOR.

NO CLAIM IS MADE TO THE EXCLUSIVE RIGHT TO USE "MUTUAL", APART FROM THE MARK AS SHOWN.

FOR INSURANCE AGENCY SERVICES FOR INDIVIDUALS, FAMILIES AND BUSINESSES IN THE FIELDS OF PERSONAL, COMMERCIAL, LIFE AND HEALTH INSURANCE SERVICES (U.S. CLS. 100, 101 AND 102).

FIRST USE 4-1-2012; IN COMMERCE 4-1-2012.  
LINDA POWELL, EXAMINING ATTORNEY

**CLASS 36—(Continued).**

SN 86-216,575. COMMUNITYONE BANK, NATIONAL ASSOCIATION, ASHEBORO, NC. FILED 3-10-2014.

**CommunityOne  
Auto Finance**

OWNER OF U.S. REG. NOS. 4,450,037 AND 4,526,524.  
NO CLAIM IS MADE TO THE EXCLUSIVE RIGHT TO USE "AUTO FINANCE", APART FROM THE MARK AS SHOWN.

THE MARK CONSISTS OF THE STYLIZED WORDING "COMMUNITYONE" SET ABOVE THE STYLIZED WORDING "AUTO FINANCE".

FOR FINANCIAL SERVICES, NAMELY, AUTO LOANS AND AUTO FINANCING SERVICES (U.S. CLS. 100, 101 AND 102).

FIRST USE 5-1-2014; IN COMMERCE 5-1-2014.  
MATTHEW GALAN, EXAMINING ATTORNEY

SN 86-215,117. TONY CARIBALTES, LLC, JACKSONVILLE, FL. FILED 3-7-2014.

**LET'S GET YOU HOME**

THE MARK CONSISTS OF STANDARD CHARACTERS WITHOUT CLAIM TO ANY PARTICULAR FONT, STYLE, SIZE, OR COLOR.

FOR COMMERCIAL AND RESIDENTIAL REAL ESTATE AGENCY SERVICES (U.S. CLS. 100, 101 AND 102).

FIRST USE 5-1-2013; IN COMMERCE 5-1-2013.  
BERYL GARDNER, EXAMINING ATTORNEY

SN 86-216,621. WEALTH2K, INC., BOSTON, MA. FILED 3-10-2014.

**HYBRID TIME-SEGMENTATION**

THE MARK CONSISTS OF STANDARD CHARACTERS WITHOUT CLAIM TO ANY PARTICULAR FONT, STYLE, SIZE, OR COLOR.

NO CLAIM IS MADE TO THE EXCLUSIVE RIGHT TO USE "TIME-SEGMENTATION", APART FROM THE MARK AS SHOWN.

FOR RETIREMENT INCOME PLANNING SERVICES (U.S. CLS. 100, 101 AND 102).

HEATHER SAPP, EXAMINING ATTORNEY

SN 86-216,427. IEX GROUP, INC., NEW YORK, NY. FILED 3-10-2014.

**IEX**

THE MARK CONSISTS OF STANDARD CHARACTERS WITHOUT CLAIM TO ANY PARTICULAR FONT, STYLE, SIZE, OR COLOR.

OWNER OF U.S. REG. NO. 4,478,973.

FOR FINANCIAL ADMINISTRATION OF STOCK EXCHANGE TRADING OF SHARES AND OTHER FINANCIAL SECURITIES IN FINANCIAL MARKETS; FINANCIAL SECURITIES EXCHANGE SERVICES; SECURITIES TRADE EXECUTION SERVICES (U.S. CLS. 100, 101 AND 102).

FIRST USE 10-25-2013; IN COMMERCE 10-25-2013.  
KATHLEEN KOLACZ, EXAMINING ATTORNEY

SN 86-218,631. FIRSTBANK OF NEBRASKA, WAHOO, NE. FILED 3-12-2014.



NO CLAIM IS MADE TO THE EXCLUSIVE RIGHT TO USE "FIRSTBANK OF NEBRASKA", APART FROM THE MARK AS SHOWN.

THE COLOR(S) RED, BLACK, WHITE IS/ARE CLAIMED AS A FEATURE OF THE MARK.

THE MARK CONSISTS OF A RED NUMBER "1" CONNECTED TO THREE DIAGONAL BLACK STRIPES FROM TOP LEFT TO BOTTOM RIGHT. THE TOP LEFT PORTION OF THE BLACK STRIPES SEPARATES THE RED NUMBER

**CLASS 36—(Continued).**

"1" FROM A WHITE EAGLE DESIGN. THE WHITE EAGLE DESIGN IS IMPRINTED ON A RED LETTER "B". IMMEDIATELY TO THE RIGHT OF THE RED "B" ARE THE WORDS "FIRSTBANK" IN BLACK ABOVE THE WORDING "OF NEBRASKA" IN BLACK. THIS ALL APPEARS ABOVE A RED HORIZONTAL LINE. BELOW THE RED HORIZONTAL LINE IS THE PHRASE, IN BLACK, "SERVING OUR COMMUNITIES...INVESTING IN YOU." BELOW THE PHRASE "SERVING OUR COMMUNITIES...INVESTING IN YOU" IS ANOTHER HORIZONTAL RED LINE.

FOR BANKING AND FINANCING SERVICES (U.S. CLS. 100, 101 AND 102).

FIRST USE 12-19-2013; IN COMMERCE 12-19-2013.  
SHAILA LEWIS, EXAMINING ATTORNEY

**CLASS 36—(Continued).**

SN 86-219,435. FINISH STRONG MINISTRIES, INC., COLORADO SPRINGS, CO. FILED 3-12-2014.



SN 86-219,149. CPA WEALTH MANAGEMENT SERVICES, P.A., SATELLITE BEACH, FL. FILED 3-12-2014.



NO CLAIM IS MADE TO THE EXCLUSIVE RIGHT TO USE "FINANCIAL", APART FROM THE MARK AS SHOWN.

THE MARK CONSISTS OF A WAVE DESIGN IN THE FORM OF A SERIES OF ARCS, WITH TWO DOTS APPEARING ABOVE THE FIRST ARC, ONE DOT APPEARING ABOVE THE SECOND ARC AND THE WORDS "THE FINANCIAL FOUNDATION EXPERIENCE" APPEARING TO THE RIGHT OF THE SERIES OF ARCS.

FOR CONSULTING SERVICES, NAMELY, CONSULTING, COUNSELING, ADVISING, PLANNING, AND FINANCIAL MANAGEMENT SERVICES FOR INDIVIDUALS IN THE FIELDS OF WEALTH PLANNING, WEALTH MANAGEMENT, MONEY MANAGEMENT, AND PERSONAL FINANCE; ESTATE PLANNING; DESIGN, ADMINISTRATION AND ADVISORY SERVICES FOR EMPLOYER-SPONSORED RETIREMENT PLANS (U.S. CLS. 100, 101 AND 102).

FIRST USE 8-6-2013; IN COMMERCE 8-6-2013.  
AMY KELLY, EXAMINING ATTORNEY

THE MARK CONSISTS OF A SILHOUETTE OF A WOMAN STANDING NEXT TO THE WORDS "FINISH STRONG" WHICH ARE RENDERED IN CURSIVE HANDWRITING.

FOR CHARITABLE FOUNDATION SERVICES, NAMELY, PROVIDING FINANCIAL SUPPORT TO ENLISTED MILITARY MEMBERS WISHING TO BECOME OFFICERS, TO CHARITIES ALL OVER THE GLOBE PROVIDING FOOD AND EDUCATION TO THOSE LESS FORTUNATE, AND TO CHARITIES THAT ENGAGE IN DEVOTIONS, PRODUCE ALBUMS, AND PLAN PUBLIC SPEAKING ENGAGEMENTS IN ORDER TO INSPIRE PEOPLE TO WORK HARD AND BELIEVE IN THEMSELVES, LEAD MORE VIRTUOUS LIVES, AND BECOME INVOLVED IN MINISTRY WORK (U.S. CLS. 100, 101 AND 102).

FIRST USE 11-1-2013; IN COMMERCE 11-1-2013.  
JASON MALASHEVICH, EXAMINING ATTORNEY

SN 86-219,409. WOOLLEY, BRETT H, GILBERT, AZ. FILED 3-12-2014.

## The Living CMA

THE MARK CONSISTS OF STANDARD CHARACTERS WITHOUT CLAIM TO ANY PARTICULAR FONT, STYLE, SIZE, OR COLOR.

NO CLAIM IS MADE TO THE EXCLUSIVE RIGHT TO USE "CMA", APART FROM THE MARK AS SHOWN.

FOR REAL ESTATE VALUATION SERVICES (U.S. CLS. 100, 101 AND 102).

FIRST USE 12-14-2010; IN COMMERCE 12-14-2010.  
MATTHEW GALAN, EXAMINING ATTORNEY

SN 86-220,152. NEXT GENERATION ENTREPRENEURS, VENICE, FL. FILED 3-13-2014.

## Next G En

THE MARK CONSISTS OF STANDARD CHARACTERS WITHOUT CLAIM TO ANY PARTICULAR FONT, STYLE, SIZE, OR COLOR.

FOR CHARITABLE FOUNDATION SERVICES, NAMELY, PROVIDING FINANCIAL ASSISTANCE FOR PROGRAMS AND SERVICES CONCERNING MENTORSHIP AND GUIDANCE FOR ASPIRING YOUNG ENTREPRENEURS (U.S. CLS. 100, 101 AND 102).

MIROSLAV NOVAKOVIC, EXAMINING ATTORNEY

**CLASS 36—(Continued).**

SN 86-220,230. PATTEN AND PATTEN, INC., CHATTANOOGA, TN. FILED 3-13-2014.



NO CLAIM IS MADE TO THE EXCLUSIVE RIGHT TO USE "INC.", APART FROM THE MARK AS SHOWN.

THE MARK CONSISTS OF AN UPRIGHT RECTANGLE, OVERLAID WITH A CIRCLE, FORMING A STYLIZED "P" TO THE LEFT OF THE WORDS "PATTEN AND PATTEN, INC."

FOR ADVICE RELATING TO INVESTMENTS; FINANCIAL AND INVESTMENT SERVICES, NAMELY, MANAGEMENT AND BROKERAGE IN THE FIELDS OF STOCKS, BONDS, OPTIONS, COMMODITIES, FUTURES AND OTHER SECURITIES, AND THE INVESTMENT OF FUNDS OF OTHERS; FINANCIAL SERVICES, NAMELY, COORDINATION, WITHIN A SINGLE ACCOUNT, OF AN INVESTMENT PORTFOLIO'S MAINTENANCE, TRADING, REBALANCING, AND TAX MANAGEMENT NEEDS; FINANCIAL SERVICES, NAMELY, INVESTMENT ADVICE, INVESTMENT MANAGEMENT, INVESTMENT CONSULTATION AND INVESTMENT OF FUNDS FOR OTHERS, INCLUDING PRIVATE AND PUBLIC EQUITY AND DEBT INVESTMENT SERVICES; INVESTMENT ADVISORY SERVICES; INVESTMENT CONSULTATION; INVESTMENT MANAGEMENT; PROVIDING INFORMATION AND ADVICE IN THE FIELD OF FINANCE, FINANCIAL INVESTMENTS, FINANCIAL VALUATIONS, AND THE FINANCIAL ASPECTS OF RETIREMENT (U.S. CLS. 100, 101 AND 102).

FIRST USE 4-14-1976; IN COMMERCE 4-14-1976.  
FONG HSU, EXAMINING ATTORNEY

SN 86-220,287. THE CBORD GROUP, INC., ITHACA, NY. FILED 3-13-2014.



OWNER OF U.S. REG. NOS. 3,438,358 AND 3,438,359.  
THE MARK CONSISTS OF THE STYLIZED WORD "UGRYD".

FOR DEBIT CARD SERVICES; ELECTRONIC COMMERCE PAYMENT SERVICES, NAMELY, ESTABLISHING FUNDED ACCOUNTS USED TO PURCHASE GOODS AND SERVICES ON THE INTERNET; ELECTRONIC FUNDS TRANSFER (U.S. CLS. 100, 101 AND 102).

FIRST USE 4-30-2009. THE MARK WAS FIRST USED ANYWHERE IN A DIFFERENT FORM OTHER THAN THAT SOUGHT TO BE REGISTERED AT LEAST AS EARLY AS 06/26/2007; IN COMMERCE 4-30-2009, THE MARK WAS FIRST USED IN COMMERCE IN A DIFFERENT FORM OTHER THAN THAT SOUGHT TO BE REGISTERED AT LEAST AS EARLY AS 06/26/2007.

LYNDSEY KUYKENDALL, EXAMINING ATTORNEY

**CLASS 36—(Continued).**

SN 86-220,667. STORE CAPITAL ADVISORS, LLC, SCOTTSDALE, AZ. FILED 3-13-2014.



OWNER OF U.S. REG. NOS. 4,199,616, 4,285,986 AND OTHERS.

THE COLOR(S) DARK BLUE IS/ARE CLAIMED AS A FEATURE OF THE MARK.

THE MARK CONSISTS OF THE WORD "STORE" WITH EACH CHARACTER SEPARATED BY A VERTICAL LINE OF THE SAME CHARACTER HEIGHT ALL IN THE COLOR DARK BLUE.

FOR FINANCIAL SERVICES, NAMELY, REAL ESTATE ASSET MANAGEMENT, REAL ESTATE INVESTMENT, AND MORTGAGE LENDING (U.S. CLS. 100, 101 AND 102).

FIRST USE 5-18-2011; IN COMMERCE 6-9-2011.  
ROBERT STRUCK, EXAMINING ATTORNEY

SN 86-220,971. STREET HOLDINGS GROUP, INC., SILVER SPRING, MD. FILED 3-14-2014.



OWNER OF U.S. REG. NOS. 3,840,876, 3,900,059 AND OTHERS.

NO CLAIM IS MADE TO THE EXCLUSIVE RIGHT TO USE "HOLDINGS", APART FROM THE MARK AS SHOWN.  
THE COLOR(S) WHITE AND GREEN IS/ARE CLAIMED AS A FEATURE OF THE MARK.

THE MARK CONSISTS OF THE WORD "STREET HOLDINGS" IN WHITE, A GREEN RECTANGULAR BACK GROUND, AND A WHITE RECTANGULAR LINE WITH IN THE GREEN BACK GROUND.

FOR PRIVATE REAL ESTATE INVESTMENTS (U.S. CLS. 100, 101 AND 102).

FIRST USE 5-7-2004. THE MARK WAS FIRST USED ANYWHERE IN A DIFFERENT FORM OTHER THAN THAT SOUGHT TO BE REGISTERED AT LEAST AS EARLY AS 05/07/2004; IN COMMERCE 5-7-2004, THE MARK WAS FIRST USED IN COMMERCE IN A DIFFERENT FORM OTHER THAN THAT SOUGHT TO BE REGISTERED AT LEAST AS EARLY AS 05/07/2004.

KAELIE KUNG, EXAMINING ATTORNEY

**CLASS 36—(Continued).**

SN 86-221,533. JL ALPHA LLC, SAN FRANCISCO, CA. FILED 3-14-2014.

**NEXT WORLD CAPITAL**

THE MARK CONSISTS OF STANDARD CHARACTERS WITHOUT CLAIM TO ANY PARTICULAR FONT, STYLE, SIZE, OR COLOR.

OWNER OF U.S. REG. NO. 3,667,486.

NO CLAIM IS MADE TO THE EXCLUSIVE RIGHT TO USE "CAPITAL", APART FROM THE MARK AS SHOWN.

FOR FINANCIAL INVESTMENT AND FINANCIAL MANAGEMENT SERVICES IN THE AREA OF INFORMATION TECHNOLOGY, SOFTWARE TECHNOLOGY, INTERNET TECHNOLOGY, AND MOBILE TECHNOLOGY (U.S. CLS. 100, 101 AND 102).

NAKIA HENRY, EXAMINING ATTORNEY

**CLASS 36—(Continued).**

SN 86-223,279. DEMONT ASSOCIATES, INC., PORTLAND, ME. FILED 3-17-2014.

**CULTURE OF PHILANTHROPY  
EVALUATION (COPE)**

THE MARK CONSISTS OF STANDARD CHARACTERS WITHOUT CLAIM TO ANY PARTICULAR FONT, STYLE, SIZE, OR COLOR.

NO CLAIM IS MADE TO THE EXCLUSIVE RIGHT TO USE "PHILANTHROPY EVALUATION", APART FROM THE MARK AS SHOWN.

FOR PHILANTHROPY CONSULTATION RELATING TO CHARITABLE FUNDRAISING (U.S. CLS. 100, 101 AND 102).

FIRST USE 7-1-2010; IN COMMERCE 11-19-2010.

TIMOTHY FINNEGAN, EXAMINING ATTORNEY

SN 86-221,586. ACADEMY PARTNERS LTD. LIABILITY COMPANY, DENVER, CO. FILED 3-14-2014.



SN 86-224,156. ETHOS PRODUCTIONS LLC, NEW YORK, NY. FILED 3-18-2014.

NO CLAIM IS MADE TO THE EXCLUSIVE RIGHT TO USE "PROPERTY TRUST", APART FROM THE MARK AS SHOWN.

THE MARK CONSISTS OF THE WORDS "NAVIGATE PROPERTY TRUST" AND GRAPHICAL ELEMENTS. THE WORD "NAVIGATE" APPEARS IN A LARGER FONT THAN "PROPERTY TRUST". THE LETTERS "NAV" ARE SOLID, WHILE THE LETTERS "IGATE" ARE PRESENTED IN OUTLINE FORM. A SOLID HORIZONTAL GRAPHIC ELEMENT UNDERSCORES AND SEPARATES THE WORD "NAVIGATE" AND "PROPERTY TRUST". "PROPERTY TRUST" IS IN A SMALLER FONT, SUCH THAT ITS BEGINNING AND TERMINUS ARE ALIGNED WITH, AND FULLY CONTAINED WITHIN THE SAME LATERAL BOUNDARIES AS "NAVIGATE". TO THE LEFT OF, AND CENTERED ON THESE ELEMENTS, IS A GRAPHICAL SEGMENTED CIRCLE FORMED BY ALTERNATING SHORT AND LONG LINES RADIATING OUTWARD IN A SUNBURST DESIGN. ENCLOSED WITHIN THE SEGMENTED CIRCLE IS A GRAPHICAL CHEVRON POINTING UPWARD, WHICH CASTS A GRAPHICAL SHADOW.

FOR LEASING OF REAL ESTATE; REAL ESTATE ACQUISITION SERVICES; REAL ESTATE INVESTMENT SERVICES; REAL ESTATE INVESTMENT TRUST ADVISORY SERVICES; REAL ESTATE INVESTMENT TRUST MANAGEMENT SERVICES; REAL ESTATE INVESTMENT TRUST SERVICES; REAL ESTATE MANAGEMENT SERVICES (U.S. CLS. 100, 101 AND 102).

MARK SPARACINO, EXAMINING ATTORNEY



THE MARK CONSISTS OF THE LETTERS EN AND A SWIRL WITH TWO DOTS ON EITHER SIDE.

FOR CHARITABLE FUNDRAISING SERVICES BY MEANS OF MUSICAL CONCERTS; CHARITABLE FUNDRAISING SERVICES BY MEANS OF ENTERTAINMENT EVENTS (U.S. CLS. 100, 101 AND 102).

TIMOTHY FINNEGAN, EXAMINING ATTORNEY

**CLASS 36—(Continued).**

SN 86-224,752. UMPQUA BANK, EUGENE, OR. FILED 3-18-2014.

UMPQUA PURCHASE ADVANTAGE

THE MARK CONSISTS OF STANDARD CHARACTERS WITHOUT CLAIM TO ANY PARTICULAR FONT, STYLE, SIZE, OR COLOR.

OWNER OF U.S. REG. NOS. 3,829,744, 4,208,150 AND OTHERS.

NO CLAIM IS MADE TO THE EXCLUSIVE RIGHT TO USE "UMPQUA" AND "PURCHASE", APART FROM THE MARK AS SHOWN.

FOR PERSONAL AND COMMERCIAL BANKING SERVICES, NAMELY, CONSUMER AND COMMERCIAL LENDING SERVICES, MORTGAGE LENDING, MORTGAGE LOAN ORIGINATION SERVICES, MORTGAGE BANKING, FINANCIAL CONSULTATION, MORTGAGE SERVICING, NAMELY, MORTGAGE LOAN PAYMENT PROCESSING SERVICES, FINANCIAL ADMINISTRATION OF MORTGAGE ESCROW ACCOUNTS, MORTGAGE LOAN FORECLOSURE SERVICES AND DEBT COLLECTION FOR MORTGAGE LOANS, AND PROVIDING FINANCIAL INFORMATION IN THE FIELDS OF REAL ESTATE LOANS AND MORTGAGE SERVICES (U.S. CLS. 100, 101 AND 102).

KYLE PEETE, EXAMINING ATTORNEY

---

SN 86-224,781. ROCKSTREET PARTNERS, LLC, DALLAS, TX. FILED 3-18-2014.

Rockstreet Partners

THE MARK CONSISTS OF STANDARD CHARACTERS WITHOUT CLAIM TO ANY PARTICULAR FONT, STYLE, SIZE, OR COLOR.

NO CLAIM IS MADE TO THE EXCLUSIVE RIGHT TO USE "PARTNERS", APART FROM THE MARK AS SHOWN.

FOR FINANCIAL SERVICES, NAMELY, FINANCIAL MANAGEMENT AND FINANCIAL ASSET MANAGEMENT IN THE FIELD OF REAL ESTATE; REAL ESTATE MANAGEMENT, FINANCIAL INVESTMENT ANALYSIS AND ADVICE, INVESTMENT MANAGEMENT, INVESTMENT CONSULTATION AND INVESTMENT OF FUNDS FOR OTHERS, NAMELY, INVESTING THE FUNDS OF JOINT VENTURES AND PRIVATE EQUITY FUNDS IN THE FIELD OF REAL ESTATE, AND INVESTING THE FUNDS OF OTHERS INTO JOINT VENTURES AND PRIVATE EQUITY FUNDS IN THE FIELD OF REAL ESTATE (U.S. CLS. 100, 101 AND 102).

FIRST USE 6-15-2013; IN COMMERCE 6-15-2013.  
ELIZABETH CHANG, EXAMINING ATTORNEY

**CLASS 36—(Continued).**

SN 86-224,869. PORTFOLIO RECOVERY ASSOCIATES, INC., NORFOLK, VA. FILED 3-18-2014.



OWNER OF U.S. REG. NOS. 4,142,598, 4,375,192 AND OTHERS.

NO CLAIM IS MADE TO THE EXCLUSIVE RIGHT TO USE "GROUP", APART FROM THE MARK AS SHOWN.

THE COLOR(S) BLUE, GRAY, GREEN, AND YELLOW IS/ARE CLAIMED AS A FEATURE OF THE MARK.

THE MARK CONSISTS OF "PRA" IN ALL DARK BLUE CAPITAL LETTERS ABOVE THE WORD "GROUP". THE WORD "GROUP", WHICH IS IN GRAY, HAS A CAPITAL "G" AND THE REST IS WRITTEN IN LOWERCASE. TO THE RIGHT OF "PRA GROUP" ARE 3 OVERLAPPING SQUARES. A LIGHT BLUE SQUARE IS ATTACHED ABOVE A YELLOW SQUARE. ON TOP OF THE BLUE AND YELLOW SQUARES, A GREEN SQUARE IS CENTERED TO THE RIGHT.

FOR DEBT RECOVERY, DEBT COLLECTION, PURCHASING DEBT, DEBT ADMINISTRATION, DEBT PAYMENT PROCESSING, AND DEBT ACCOUNT MANAGEMENT SERVICES FOR FINANCIAL INSTITUTIONS, LENDERS, CREDITORS, GOVERNMENT CLIENTS AND OTHER THIRD PARTIES (U.S. CLS. 100, 101 AND 102).

FIRST USE 3-6-2014; IN COMMERCE 3-6-2014.  
ANDREA CORNWELL, EXAMINING ATTORNEY

---

SN 86-225,250. JOHNSON, DAVID, CORONA, CA. FILED 3-19-2014.

Lycancoin

THE MARK CONSISTS OF STANDARD CHARACTERS WITHOUT CLAIM TO ANY PARTICULAR FONT, STYLE, SIZE, OR COLOR.

FOR FINANCIAL SERVICES, NAMELY, PROVIDING A VIRTUAL CURRENCY FOR USE BY MEMBERS OF AN ON-LINE COMMUNITY VIA A GLOBAL COMPUTER NETWORK (U.S. CLS. 100, 101 AND 102).

FIRST USE 2-8-2014; IN COMMERCE 2-8-2014.  
KYLE PEETE, EXAMINING ATTORNEY



**CLASS 36—(Continued).**

SN 86-225,403. ANICCA CAPITAL LP, NEW YORK, NY. FILED 3-19-2014.

**ANICCA CAPITAL**

THE MARK CONSISTS OF STANDARD CHARACTERS WITHOUT CLAIM TO ANY PARTICULAR FONT, STYLE, SIZE, OR COLOR.

NO CLAIM IS MADE TO THE EXCLUSIVE RIGHT TO USE "CAPITAL", APART FROM THE MARK AS SHOWN.

FOR FINANCIAL SERVICES, NAMELY, INVESTMENT MANAGEMENT SERVICES, INVESTMENT ADVISORY SERVICES AND ASSET MANAGEMENT SERVICES (U.S. CLS. 100, 101 AND 102).

SETH A. RAPPAPORT, EXAMINING ATTORNEY

**CLASS 36—(Continued).**

SN 86-225,745. HAYWARD APPRAISERS, HAYWARD, CA. FILED 3-19-2014.

**Hayward Appraisers**

THE MARK CONSISTS OF STANDARD CHARACTERS WITHOUT CLAIM TO ANY PARTICULAR FONT, STYLE, SIZE, OR COLOR.

NO CLAIM IS MADE TO THE EXCLUSIVE RIGHT TO USE "APPRAISERS", APART FROM THE MARK AS SHOWN.

SEC. 2(F).

FOR HOME APPRAISAL SERVICES (U.S. CLS. 100, 101 AND 102).

FIRST USE 6-1-1987; IN COMMERCE 7-1-2005.

ANNIE NOBLE, EXAMINING ATTORNEY

SN 86-225,832. CAPITAL ONE FINANCIAL CORPORATION, RICHMOND, VA. FILED 3-19-2014.

**LIVING MONEY**

THE MARK CONSISTS OF STANDARD CHARACTERS WITHOUT CLAIM TO ANY PARTICULAR FONT, STYLE, SIZE, OR COLOR.

NO CLAIM IS MADE TO THE EXCLUSIVE RIGHT TO USE "MONEY", APART FROM THE MARK AS SHOWN.

FOR PROVIDING PERSONAL FINANCIAL MANAGEMENT SERVICES, NAMELY MANAGEMENT OF CHECKING AND OTHER DEPOSIT ACCOUNTS DELIVERED THROUGH A GLOBAL COMPUTER NETWORK (U.S. CLS. 100, 101 AND 102).

JAY FLOWERS, EXAMINING ATTORNEY

SN 86-225,724. LION CASH, LLC, CLIFTON, NJ. FILED 3-19-2014.



NO CLAIM IS MADE TO THE EXCLUSIVE RIGHT TO USE "CASH" AND "\$100", APART FROM THE MARK AS SHOWN.

THE COLOR(S) GREEN, WHITE, BLACK IS/ARE CLAIMED AS A FEATURE OF THE MARK.

THE MARK CONSISTS OF THE SIDE VIEW OF A LION'S HEAD TO THE LEFT OF THE WORDING "LION CASH." IN THE LION'S MOUTH IS A STACK OF MONEY WITH THE WORDING "\$100" VISIBLE ON IT. THE LION'S MANE, THE WORD "LION," AND THE STACK OF MONEY ARE GREEN. THE WORD "CASH" AND ALL OUTLINING ARE BLACK. THE LION'S FACE, THE LINES ON THE MONEY, AND WORDING "\$100" ON THE MONEY ARE WHITE.

FOR CASH ADVANCE SERVICES FOR SMALL BUSINESSES AND MERCHANTS (U.S. CLS. 100, 101 AND 102).

JASON BLAIR, EXAMINING ATTORNEY

SN 86-225,949. ABBEY'S HOPE CHARITABLE FOUNDATION, EDINA, MN. FILED 3-19-2014.



THE COLOR(S) PINK AND MAUVE IS/ARE CLAIMED AS A FEATURE OF THE MARK.

THE MARK CONSISTS OF THE WORDING "ABBEY'S HOPE" IN THE COLOR MAUVE. THE WORDING "ABBEY'S" IS IN LOWER CASE LETTERING WITH A STYLIZED

**CLASS 36—(Continued).**

DRAGONFLY IMAGE IN THE COLORS PINK AND MAUVE, IN THE FORM OF A SERIES OF MAUVE VERTICAL SOLID CIRCLES RISING OUT OF THE SPACE BETWEEN THE "Y" AND THE "S" IN PLACE OF AN APOSTROPHE, AND STYLIZED WINGS IN THE COLOR PINK WHICH ARE ABOVE THE "E" TO THE LEFT AND THE SPACE BETWEEN THE WORDS "ABBEYS" AND "HOPE" TO THE RIGHT. THE WORD "HOPE" APPEARS IN CAPITAL LETTERING TO THE RIGHT-HAND SIDE OF THE LOGO DESIGN.

FOR CHARITABLE FOUNDATION SERVICES, NAMELY, PROVIDING FUNDRAISING ACTIVITIES TO SUPPORT POOL SAFETY EDUCATION TO CHILDREN, ADULTS AND POOL OPERATORS (U.S. CLS. 100, 101 AND 102).

FIRST USE 11-4-2008; IN COMMERCE 11-4-2008.  
WANDA KAY PRICE, EXAMINING ATTORNEY

**CLASS 36—(Continued).**

SN 86-226,982. BARROW STREET ADVISORS, LLC, STAMFORD, CT. FILED 3-20-2014.



NO CLAIM IS MADE TO THE EXCLUSIVE RIGHT TO USE "FUNDS", APART FROM THE MARK AS SHOWN.

THE MARK CONSISTS OF THE STYLIZED LETTERS "B" AND "F" OVERLAPPING NEXT TO THE TERMS "BARROW" AND "FUNDS".

FOR ADVICE RELATING TO INVESTMENTS; CAPITAL INVESTMENT CONSULTING; CAPITAL INVESTMENT SERVICES; MUTUAL FUND ADVISORY SERVICES; MUTUAL FUND ANALYSIS SERVICES; MUTUAL FUND INVESTMENT; MUTUAL FUNDS AND CAPITAL INVESTMENT (U.S. CLS. 100, 101 AND 102).

FIRST USE 8-30-2013; IN COMMERCE 8-30-2013.  
STEVEN JACKSON, EXAMINING ATTORNEY

SN 86-226,205. MEDPRO BILLING, INC., TAMARAC, FL. FILED 3-19-2014.



THE MARK CONSISTS OF TWO ADJACENT CRESCENTS ARCHING OVER AND BENEATH THE WORD "MEDPRO", STARTING FROM THE LETTER "M" AND ENDING AT THE LETTER "R".

FOR MEDICAL DEBT COLLECTIONS (U.S. CLS. 100, 101 AND 102).

FIRST USE 3-31-2011; IN COMMERCE 3-31-2011.  
MATTHEW MCDOWELL, EXAMINING ATTORNEY

SN 86-227,999. THE CREDIT PROS INTERNATIONAL CORPORATION, NEWARK, NJ. FILED 3-21-2014.



NO CLAIM IS MADE TO THE EXCLUSIVE RIGHT TO USE "CREDITREPAIR" AND "CREDIT PROS", APART FROM THE MARK AS SHOWN.

THE COLOR(S) WHITE, BLACK, LIGHT BLUE AND DARK BLUE IS/ARE CLAIMED AS A FEATURE OF THE MARK.

THE MARK CONSIST OF A RECTANGLE LINED IN BLACK WITH A WHITE BACKGROUND, CONTAINING A SMALLER RECTANGLE WITH A DARK BLUE AND LIGHT BLUE BACKGROUND, CONTAINING THE WHITE STYLIZED LETTERS "TCP", WHEREIN THE LETTERS "C" AND "P" ARE CONNECTED AT THE BOTTOM WITH A VERTICAL BLACK LINE TO THE RIGHT, FOLLOWED BY THE WORDING, "TCP CREDITREPAIR", WITH "TCP" AND "CREDIT" IN THE COLOR BLUE, AND "REPAIR" IN THE COLOR BLACK, WITH THE SMALLER WORDING, "THE CREDIT PROS" IN BLACK, IN ALL CAPS PRINTED BELOW.

FOR FINANCIAL SERVICES, NAMELY, CREDIT REPAIR AND RESTORATION (U.S. CLS. 100, 101 AND 102).  
ODESSA BIBBINS, EXAMINING ATTORNEY

SN 86-226,654. ATW INVESTMENTS INC., SAN ANTONIO, TX. FILED 3-20-2014.



NO CLAIM IS MADE TO THE EXCLUSIVE RIGHT TO USE "INVESTMENTS", APART FROM THE MARK AS SHOWN.

THE MARK CONSISTS OF THE WORDS "ATW" IN LARGE LETTERING WITH "INVESTMENTS" IN SMALLER LETTERING BENEATH. THE "A" IS A STYLIZED TRIANGULAR SHAPE WITH A GLOBE INSCRIBED WITHIN IT.

FOR REAL ESTATE INVESTMENT SERVICES; REAL ESTATE INVESTMENT SERVICES IN THE NATURE OF PURCHASING AND SELLING OF REAL ESTATE FOR OTHERS (U.S. CLS. 100, 101 AND 102).

FIRST USE 1-0-2004; IN COMMERCE 1-0-2005.  
RONALD MCMORROW, EXAMINING ATTORNEY



**CLASS 36—(Continued).**

SN 86-228,149. MAINE SAVINGS FEDERAL CREDIT UNION, HAMPDEN, ME. FILED 3-21-2014.



NO CLAIM IS MADE TO THE EXCLUSIVE RIGHT TO USE "MAINE SAVINGS FEDERAL CREDIT UNION", APART FROM THE MARK AS SHOWN.

THE MARK CONSISTS OF A COMPASS APPEARING IN A SQUARE SHAPE FOLLOWED BY THE WORD "MAINE" IN STYLIZED FONT STACKED ABOVE THE WORD "SAVINGS" IN STYLIZED FONT STACKED ABOVE THE PHRASE "FEDERAL CREDIT UNION" IN STYLIZED FONT.

FOR CREDIT UNION SERVICES (U.S. CLS. 100, 101 AND 102).

FIRST USE 9-24-2001; IN COMMERCE 9-24-2001.  
ALLISON HOLTZ, EXAMINING ATTORNEY

**CLASS 36—(Continued).**

SN 86-229,998. JL ALPHA LLC, SAN FRANCISCO, CA. FILED 3-24-2014.

**NEXT WORLD BRANDS**

THE MARK CONSISTS OF STANDARD CHARACTERS WITHOUT CLAIM TO ANY PARTICULAR FONT, STYLE, SIZE, OR COLOR.

OWNER OF U.S. REG. NO. 3,667,486.

NO CLAIM IS MADE TO THE EXCLUSIVE RIGHT TO USE "BRANDS", APART FROM THE MARK AS SHOWN.

FOR FINANCIAL INVESTMENT AND FINANCIAL MANAGEMENT SERVICES, NAMELY, FORMING LONG-TERM INVESTMENT POOLS WITH HIGH NET-WORTH ENTITIES FOR INVESTMENT FUNDING IN THE AREAS OF NEW MEDIA PRODUCTS AND SERVICES, CONSUMER PRODUCTS AND SERVICES, INTERNET TECHNOLOGY PRODUCTS AND SERVICES, E-COMMERCE PRODUCTS AND SERVICES, AND RETAIL PRODUCTS AND SERVICES (U.S. CLS. 100, 101 AND 102).

NAKIA HENRY, EXAMINING ATTORNEY

SN 86-229,870. BLAIR HALL ADVISORS, LLC, NEW YORK, NY. FILED 3-24-2014.

**BLAIR HALL ADVISORS**

THE MARK CONSISTS OF STANDARD CHARACTERS WITHOUT CLAIM TO ANY PARTICULAR FONT, STYLE, SIZE, OR COLOR.

NO CLAIM IS MADE TO THE EXCLUSIVE RIGHT TO USE "ADVISORS", APART FROM THE MARK AS SHOWN.

FOR FINANCIAL SERVICES, NAMELY, INVESTMENT ADVICE, INVESTMENT MANAGEMENT, INVESTMENT CONSULTATION AND INVESTMENT OF FUNDS FOR OTHERS, INCLUDING PRIVATE AND PUBLIC EQUITY AND DEBT INVESTMENT SERVICES (U.S. CLS. 100, 101 AND 102).

FIRST USE 2-4-2014; IN COMMERCE 2-4-2014.  
JENNIFER DIXON, EXAMINING ATTORNEY

SN 86-230,336. RD LEGAL FUNDING, LLC, CRESSKILL, NJ. FILED 3-24-2014.



OWNER OF U.S. REG. NOS. 2,309,098 AND 4,493,935.

THE COLOR(S) GREEN AND DARK GRAY IS/ARE CLAIMED AS A FEATURE OF THE MARK.

THE MARK CONSISTS OF THE LETTER "R" SUPERIMPOSED AGAINST A GREEN SQUARE BACKGROUND NEXT TO THE LETTER "D" SUPERIMPOSED AGAINST A DARK GRAY SQUARE BACKGROUND; THE COLOR WHITE IS NOT PART OF THE MARK AND REPRESENTS TRANSPARENT AREAS.

FOR FINANCIAL AND INVESTMENT SERVICES, NAMELY, MONEY LENDING AND PURCHASING ACCOUNT RECEIVABLES DIRECTED TOWARD LAWYERS (U.S. CLS. 100, 101 AND 102).

DEIRDRE ROBERTSON, EXAMINING ATTORNEY

**CLASS 36—(Continued).**

SN 86-230,503. BROWN, PHILLIP, RIVERDALE, MD. FILED 3-24-2014.

## Washington United LLC

THE MARK CONSISTS OF STANDARD CHARACTERS WITHOUT CLAIM TO ANY PARTICULAR FONT, STYLE, SIZE, OR COLOR.

NO CLAIM IS MADE TO THE EXCLUSIVE RIGHT TO USE "WASHINGTON" AND "LLC", APART FROM THE MARK AS SHOWN.

FOR BROKERAGE IN THE FIELD OF INSURANCE; CONSULTING AND INFORMATION CONCERNING INSURANCE; DESIGN AND DEVELOPMENT OF INSURANCE POLICIES FOR OTHERS; FINANCIAL ADVICE AND CONSULTANCY SERVICES (U.S. CLS. 100, 101 AND 102).

FIRST USE 3-15-2013; IN COMMERCE 3-15-2013.  
MELISSA VALLILLO, EXAMINING ATTORNEY

---

SN 86-230,814. GENERAL MOTORS LLC, DETROIT, MI. FILED 3-25-2014.

## BUYPOWER BUSINESS CARD

THE MARK CONSISTS OF STANDARD CHARACTERS WITHOUT CLAIM TO ANY PARTICULAR FONT, STYLE, SIZE, OR COLOR.

NO CLAIM IS MADE TO THE EXCLUSIVE RIGHT TO USE "BUSINESS CARD", APART FROM THE MARK AS SHOWN.

FOR CREDIT CARD SERVICES (U.S. CLS. 100, 101 AND 102).

LYNDSEY KUYKENDALL, EXAMINING ATTORNEY

---

SN 86-230,818. GENERAL MOTORS LLC, DETROIT, MI. FILED 3-25-2014.

## BUYPOWER BUSINESS

THE MARK CONSISTS OF STANDARD CHARACTERS WITHOUT CLAIM TO ANY PARTICULAR FONT, STYLE, SIZE, OR COLOR.

NO CLAIM IS MADE TO THE EXCLUSIVE RIGHT TO USE "BUSINESS", APART FROM THE MARK AS SHOWN.

FOR CREDIT CARD SERVICES (U.S. CLS. 100, 101 AND 102).

LYNDSEY KUYKENDALL, EXAMINING ATTORNEY

**CLASS 36—(Continued).**

SN 86-231,136. VERI, HIGHLANDS RANCH, CO. FILED 3-25-2014.

## VERI

THE MARK CONSISTS OF STANDARD CHARACTERS WITHOUT CLAIM TO ANY PARTICULAR FONT, STYLE, SIZE, OR COLOR.

THE ENGLISH TRANSLATION OF "VERI" IN THE MARK IS "REAL" OR "TRUE".

FOR COMMERCIAL AND RESIDENTIAL REAL ESTATE AGENCY SERVICES; PROVIDING INFORMATION IN THE FIELD OF REAL ESTATE VIA THE INTERNET; REAL ESTATE AGENCIES; REAL ESTATE BROKERAGE; REAL ESTATE CONSULTATION; REAL ESTATE LISTING; RESIDENTIAL REAL ESTATE AGENCY SERVICES (U.S. CLS. 100, 101 AND 102).

FIRST USE 1-1-2014; IN COMMERCE 1-1-2014.  
ROSELLE HERRERA, EXAMINING ATTORNEY

---

SN 86-232,165. SPOLINI, MELISA, CLOVIS, CA. FILED 3-26-2014.

## EDINHART Realty & Design Corp.

THE MARK CONSISTS OF STANDARD CHARACTERS WITHOUT CLAIM TO ANY PARTICULAR FONT, STYLE, SIZE, OR COLOR.

NO CLAIM IS MADE TO THE EXCLUSIVE RIGHT TO USE "REALTY & DESIGN CORP.", APART FROM THE MARK AS SHOWN.

FOR REAL ESTATE BROKERAGE (U.S. CLS. 100, 101 AND 102).

SUSAN RICHARDS, EXAMINING ATTORNEY

**CLASS 36—(Continued).**

SN 86-233,087. GREGORY ENTERPRISES, INC., ADA, OK.  
FILED 3-26-2014.



OWNER OF U.S. REG. NO. 4,179,771.  
NO CLAIM IS MADE TO THE EXCLUSIVE RIGHT TO USE "EASY PAY", APART FROM THE MARK AS SHOWN. THE COLOR(S) RED, WHITE, AND BLACK IS/ARE CLAIMED AS A FEATURE OF THE MARK.  
THE MARK CONSISTS OF THE LETTERS "EZ" IN WHITE LETTERING IN A RED BOX PRECEDING AND ADJACENT TO THE WORD "PAY" IN BLACK LETTERING, ALL ON A FIELD OF WHITE.

FOR FACILITATING AND ARRANGING FOR THE FINANCING OF FOUNDATION, LEVELING, SUPPORTING AND REPAIR SERVICES AND SEAWALL, LAKEWALL, AND RETAINING WALL STABILIZATION AND REPAIR SERVICES (U.S. CLS. 100, 101 AND 102).

FIRST USE 7-1-2009; IN COMMERCE 7-1-2009.  
SUSAN LESLIE DUBOIS, EXAMINING ATTORNEY

---

SN 86-233,906. HINES GLOBAL REIT II, INC., HOUSTON, TX. FILED 3-27-2014.

Hines Global REIT II  
INVESTING WORLDWIDE FOR  
GROWTH AND INCOME

THE MARK CONSISTS OF STANDARD CHARACTERS WITHOUT CLAIM TO ANY PARTICULAR FONT, STYLE, SIZE, OR COLOR.

OWNER OF U.S. REG. NOS. 2,409,958, 2,619,735 AND OTHERS.

NO CLAIM IS MADE TO THE EXCLUSIVE RIGHT TO USE "GLOBAL REIT II INVESTING WORLDWIDE FOR GROWTH AND INCOME", APART FROM THE MARK AS SHOWN.

FOR FINANCIAL INVESTMENT IN THE FIELD OF REAL ESTATE OWNERSHIP AND INTERESTS IN REAL ESTATE; REAL ESTATE INVESTMENT SERVICES (U.S. CLS. 100, 101 AND 102).

SHARON MEIER, EXAMINING ATTORNEY

**CLASS 36—(Continued).**

SN 86-234,222. MASRAF AL RAYAN, DOHA, QATAR, FILED 3-27-2014.



**Al Rayan**

OWNER OF QATAR REG. NO. 73648, DATED 6-26-2013, EXPIRES 3-19-2022.

OWNER OF U.S. REG. NO. 3,482,949.

THE NAME "AL RAYAN" DOES NOT IDENTIFY A LIVING INDIVIDUAL.

THE MARK CONSISTS OF A SQUARE WITH ROUNDED CORNERS INSIDE OF WHICH APPEARS FIVE PARALLEL ARCS OF INCREASING SIZE FROM TOP TO BOTTOM AND BELOW WHICH APPEARS THE WORDING "AL RAYAN".

THE WORDING "AL RAYAN" HAS NO MEANING IN A FOREIGN LANGUAGE.

FOR BANKING SERVICES, NAMELY, MOBILE BANKING SERVICES PROVIDED VIA MOBILE TELECOMMUNICATION DEVICES (U.S. CLS. 100, 101 AND 102).

CHARLOTTE CORWIN, EXAMINING ATTORNEY

---

SN 86-234,257. TRUSTEES OF THE ANNE RAY CHARITABLE TRUST, CRYSTAL BAY, MN. FILED 3-27-2014.

**Anne Ray Foundation**

THE MARK CONSISTS OF STANDARD CHARACTERS WITHOUT CLAIM TO ANY PARTICULAR FONT, STYLE, SIZE, OR COLOR.

OWNER OF U.S. REG. NO. 3,892,941.

NO CLAIM IS MADE TO THE EXCLUSIVE RIGHT TO USE "FOUNDATION", APART FROM THE MARK AS SHOWN.

THE NAME SHOWN IN THE MARK DOES NOT IDENTIFY A PARTICULAR LIVING INDIVIDUAL.

FOR CHARITABLE SERVICES, NAMELY, PROVIDING GRANTS TO CHARITABLE ORGANIZATIONS (U.S. CLS. 100, 101 AND 102).

ESTHER BELENKER, EXAMINING ATTORNEY

**CLASS 36—(Continued).**

SN 86-234,269. FLOORPLAN XPRESS LLC-OK, OKLAHOMA CITY, OK. FILED 3-27-2014.



OWNER OF U.S. REG. NOS. 3,404,444, 3,408,184 AND 3,503,611.

NO CLAIM IS MADE TO THE EXCLUSIVE RIGHT TO USE "FLOORPLAN", APART FROM THE MARK AS SHOWN.

THE MARK CONSISTS OF THE LETTERS, "FX", NEXT TO THE WORDS, "FLOORPLAN XPRESS", UNDER STYLIZED LINES.

FOR FINANCIAL SERVICES IN THE FIELD OF MONEY LENDING FOR AUTOMOBILE DEALERSHIPS (U.S. CLS. 100, 101 AND 102).

AMEEN IMAM, EXAMINING ATTORNEY

**CLASS 36—(Continued).**

SN 86-234,344. VANTIUM CAPITAL, INC., FRISCO, TX. FILED 3-27-2014.

**ClearSpring Mortgage, LLC**

THE MARK CONSISTS OF STANDARD CHARACTERS WITHOUT CLAIM TO ANY PARTICULAR FONT, STYLE, SIZE, OR COLOR.

NO CLAIM IS MADE TO THE EXCLUSIVE RIGHT TO USE "MORTGAGE, LLC", APART FROM THE MARK AS SHOWN.

FOR MORTGAGE BANKING SERVICES, NAMELY, LENDING (U.S. CLS. 100, 101 AND 102).

ZACHARY CROMER, EXAMINING ATTORNEY

SN 86-234,332. VANTIUM CAPITAL, INC., FRISCO, TX. FILED 3-27-2014.

**ClearSpring Financial, LLC**

THE MARK CONSISTS OF STANDARD CHARACTERS WITHOUT CLAIM TO ANY PARTICULAR FONT, STYLE, SIZE, OR COLOR.

NO CLAIM IS MADE TO THE EXCLUSIVE RIGHT TO USE "FINANCIAL, LLC", APART FROM THE MARK AS SHOWN.

FOR MORTGAGE BANKING SERVICES, NAMELY, LENDING (U.S. CLS. 100, 101 AND 102).

ZACHARY CROMER, EXAMINING ATTORNEY

SN 86-234,355. VANTIUM CAPITAL, INC., FRISCO, TX. FILED 3-27-2014.

**ClearSpring Servicing, Inc.**

THE MARK CONSISTS OF STANDARD CHARACTERS WITHOUT CLAIM TO ANY PARTICULAR FONT, STYLE, SIZE, OR COLOR.

NO CLAIM IS MADE TO THE EXCLUSIVE RIGHT TO USE "SERVICING, INC.", APART FROM THE MARK AS SHOWN.

FOR MORTGAGE BANKING SERVICES, NAMELY, LENDING (U.S. CLS. 100, 101 AND 102).

ZACHARY CROMER, EXAMINING ATTORNEY

SN 86-234,338. VANTIUM CAPITAL, INC., FRISCO, TX. FILED 3-27-2014.

**ClearSpring Loan Services, Inc.**

THE MARK CONSISTS OF STANDARD CHARACTERS WITHOUT CLAIM TO ANY PARTICULAR FONT, STYLE, SIZE, OR COLOR.

NO CLAIM IS MADE TO THE EXCLUSIVE RIGHT TO USE "LOAN SERVICES, INC.", APART FROM THE MARK AS SHOWN.

FOR MORTGAGE BANKING SERVICES, NAMELY, LENDING (U.S. CLS. 100, 101 AND 102).

ZACHARY CROMER, EXAMINING ATTORNEY

SN 86-234,363. VANTIUM CAPITAL, INC., FRISCO, TX. FILED 3-27-2014.

**ClearSpring Home Loans, LLC**

THE MARK CONSISTS OF STANDARD CHARACTERS WITHOUT CLAIM TO ANY PARTICULAR FONT, STYLE, SIZE, OR COLOR.

NO CLAIM IS MADE TO THE EXCLUSIVE RIGHT TO USE "HOME LOANS, LLC", APART FROM THE MARK AS SHOWN.

FOR MORTGAGE BANKING SERVICES, NAMELY, LENDING (U.S. CLS. 100, 101 AND 102).

ZACHARY CROMER, EXAMINING ATTORNEY

**CLASS 36—(Continued).**

SN 86-234,622. DEL NORTE CREDIT UNION, DBA DEL NORTE INVESTMENT SERVICES, LOS ALAMOS, NM. FILED 3-27-2014.



OWNER OF U.S. REG. NOS. 2,923,944 AND 3,928,610.  
NO CLAIM IS MADE TO THE EXCLUSIVE RIGHT TO USE "INVESTMENT SERVICES", APART FROM THE MARK AS SHOWN.

THE MARK CONSISTS OF THE WORDS "DEL NORTE INVESTMENT SERVICES" EXCEPT THAT THE LETTER "O" IS REPLACED BY A SNOW FLAKE DESIGN.

THE ENGLISH TRANSLATION OF THE WORD "DEL NORTE" IN THE MARK IS "NORTHERN".

FOR FINANCIAL ADVICE; FINANCIAL ADVICE AND CONSULTANCY SERVICES; FINANCIAL INVESTMENT BROKERAGE SERVICES; FINANCIAL PLANNING AND INVESTMENT ADVISORY SERVICES; FINANCIAL SERVICES, NAMELY, INVESTMENT ADVICE, INVESTMENT MANAGEMENT, INVESTMENT CONSULTATION AND INVESTMENT OF FUNDS FOR OTHERS, INCLUDING PRIVATE AND PUBLIC EQUITY AND DEBT INVESTMENT SERVICES; INVESTMENT ADVICE (U.S. CLS. 100, 101 AND 102).

ALEXANDER L. POWERS, EXAMINING ATTORNEY

---

SN 86-234,959. BOSTON TRUST & INVESTMENT MANAGEMENT COMPANY, BOSTON, MA. FILED 3-28-2014.

BOSTON TRUST & INVESTMENT  
MANAGEMENT COMPANY

THE MARK CONSISTS OF STANDARD CHARACTERS WITHOUT CLAIM TO ANY PARTICULAR FONT, STYLE, SIZE, OR COLOR.

OWNER OF U.S. REG. NO. 3,875,637.

NO CLAIM IS MADE TO THE EXCLUSIVE RIGHT TO USE "TRUST & INVESTMENT MANAGEMENT COMPANY", APART FROM THE MARK AS SHOWN.  
SEC. 2(F).

FOR FINANCIAL SERVICES, NAMELY, TRUST COMPANY SERVICES, ASSET MANAGEMENT SERVICES, INVESTMENT ADVISORY AND INVESTMENT MANAGEMENT SERVICES (U.S. CLS. 100, 101 AND 102).

FIRST USE 12-31-2003; IN COMMERCE 12-31-2003.

BRENDAN MCCAULEY, EXAMINING ATTORNEY

**CLASS 36—(Continued).**

SN 86-234,971. BOSTON TRUST & INVESTMENT MANAGEMENT COMPANY, BOSTON, MA. FILED 3-28-2014.

WALDEN ASSET MANAGEMENT

THE MARK CONSISTS OF STANDARD CHARACTERS WITHOUT CLAIM TO ANY PARTICULAR FONT, STYLE, SIZE, OR COLOR.

NO CLAIM IS MADE TO THE EXCLUSIVE RIGHT TO USE "ASSET MANAGEMENT", APART FROM THE MARK AS SHOWN.

FOR FINANCIAL SERVICES, NAMELY, ASSET MANAGEMENT SERVICES, INVESTMENT ADVISORY AND INVESTMENT MANAGEMENT SERVICES (U.S. CLS. 100, 101 AND 102).

FIRST USE 1-1-1998; IN COMMERCE 1-1-1998.

BRENDAN MCCAULEY, EXAMINING ATTORNEY

---

SN 86-235,125. NEW MUSEUM OF CONTEMPORARY ART, NEW YORK, NY. FILED 3-28-2014.

NEW INC

THE MARK CONSISTS OF STANDARD CHARACTERS WITHOUT CLAIM TO ANY PARTICULAR FONT, STYLE, SIZE, OR COLOR.

NO CLAIM IS MADE TO THE EXCLUSIVE RIGHT TO USE "INC", APART FROM THE MARK AS SHOWN.

FOR PROVIDING FUNDING AND GRANTS FOR ARTISTS AND DESIGNERS (U.S. CLS. 100, 101 AND 102).

JASON MALASHEVICH, EXAMINING ATTORNEY

---

SN 86-235,162. COVE FEDERAL CREDIT UNION, EDGEWOOD, KY. FILED 3-28-2014.

COVE FEDERAL CREDIT UNION

THE MARK CONSISTS OF STANDARD CHARACTERS WITHOUT CLAIM TO ANY PARTICULAR FONT, STYLE, SIZE, OR COLOR.

NO CLAIM IS MADE TO THE EXCLUSIVE RIGHT TO USE "FEDERAL CREDIT UNION", APART FROM THE MARK AS SHOWN.

FOR CREDIT UNION SERVICES (U.S. CLS. 100, 101 AND 102).

MARC LEIPZIG, EXAMINING ATTORNEY

**CLASS 36—(Continued).**

SN 86-235,309. DENTALPLANS.COM, INC., PLANTATION, FL. FILED 3-28-2014.



NO CLAIM IS MADE TO THE EXCLUSIVE RIGHT TO USE "DENTALPLANS.COM", APART FROM THE MARK AS SHOWN.

THE MARK CONSISTS OF THE PHRASE "DENTALPLANS.COM". THERE ARE TWO DOTS NEXT TO THE LETTER "D".

FOR ADMINISTRATION OF PREFERRED PROVIDER PLANS IN THE FIELD OF DENTAL CARE; BROKERAGE SERVICES, NAMELY, ACTING AS AN AGENT IN ARRANGING SALES FOR THIRD PARTIES OF MEMBERSHIP CLUB SERVICES THAT PROVIDE DISCOUNTS FOR THE SERVICES OF OTHERS (U.S. CLS. 100, 101 AND 102).

KIMBERLY PERRY, EXAMINING ATTORNEY

---

SN 86-235,486. SUNRIVER CAPITAL PARTNERS LLC, STAMFORD, CT. FILED 3-28-2014.

**SUNRIVER CAPITAL PARTNERS**

THE MARK CONSISTS OF STANDARD CHARACTERS WITHOUT CLAIM TO ANY PARTICULAR FONT, STYLE, SIZE, OR COLOR.

NO CLAIM IS MADE TO THE EXCLUSIVE RIGHT TO USE "CAPITAL PARTNERS", APART FROM THE MARK AS SHOWN.

FOR FINANCIAL SERVICES, NAMELY, HEDGE FUND INVESTMENT SERVICES (U.S. CLS. 100, 101 AND 102).

ZHALEH DELANEY, EXAMINING ATTORNEY

---

SN 86-235,489. SUNRIVER CAPITAL MANAGEMENT LLC, STAMFORD, CT. FILED 3-28-2014.

**SUNRIVER CAPITAL MANAGEMENT**

THE MARK CONSISTS OF STANDARD CHARACTERS WITHOUT CLAIM TO ANY PARTICULAR FONT, STYLE, SIZE, OR COLOR.

NO CLAIM IS MADE TO THE EXCLUSIVE RIGHT TO USE "CAPITAL MANAGEMENT", APART FROM THE MARK AS SHOWN.

FOR FINANCIAL SERVICES, NAMELY, MANAGEMENT OF A HEDGE FUND (U.S. CLS. 100, 101 AND 102).

ZHALEH DELANEY, EXAMINING ATTORNEY

**CLASS 36—(Continued).**

SN 86-235,575. EASYFINANCIAL SERVICES INC., MISSISSAUGA, ONTARIO, CANADA, FILED 3-28-2014.



OWNER OF CANADA REG. NO. TMA714,599, DATED 5-16-2008, EXPIRES 5-16-2023.

OWNER OF U.S. REG. NO. 3,585,166.

NO CLAIM IS MADE TO THE EXCLUSIVE RIGHT TO USE "SERVICES", APART FROM THE MARK AS SHOWN.

THE MARK CONSISTS OF "EASYFINANCIAL SERVICES" WITH THE IMAGE OF A HOUSE SURROUNDING THE LETTER "E" IN "EASYFINANCIAL" AND THE WORDING "SERVICES" IN SMALLER FONT APPEARING TO THE RIGHT AND UNDER "EASYFINANCIAL".

FOR LOAN CONSOLIDATION SERVICES, PROVIDING SHORT-TERM LOANS, PRE-PAID CREDIT CARD SERVICES, DEBIT CARD SERVICES AND CHECK CASHING SERVICES (U.S. CLS. 100, 101 AND 102).

KEVIN CRENNAN, EXAMINING ATTORNEY

---

SN 86-235,635. CENTEROAK PARTNERS, LLC, DALLAS, TX. FILED 3-28-2014.

**CENTEROAK PARTNERS**

THE MARK CONSISTS OF STANDARD CHARACTERS WITHOUT CLAIM TO ANY PARTICULAR FONT, STYLE, SIZE, OR COLOR.

NO CLAIM IS MADE TO THE EXCLUSIVE RIGHT TO USE "PARTNERS", APART FROM THE MARK AS SHOWN.

FOR EQUITY CAPITAL INVESTMENT; FINANCIAL PORTFOLIO MANAGEMENT; INVESTMENT SERVICES, NAMELY, ASSET ACQUISITION, CONSULTATION, DEVELOPMENT AND MANAGEMENT SERVICES; PRIVATE EQUITY FUND INVESTMENT SERVICES (U.S. CLS. 100, 101 AND 102).

BRIN ANDERSON, EXAMINING ATTORNEY

---

SN 86-235,758. SULLIVANCURTISMONROE INSURANCE SERVICES, LLC, IRVINE, CA. FILED 3-28-2014.

**SCM**

THE MARK CONSISTS OF STANDARD CHARACTERS WITHOUT CLAIM TO ANY PARTICULAR FONT, STYLE, SIZE, OR COLOR.

OWNER OF U.S. REG. NO. 3,704,924.

FOR INSURANCE BROKERAGE (U.S. CLS. 100, 101 AND 102).

FIRST USE 1-25-2001; IN COMMERCE 1-25-2001.

MICHELE SWAIN, EXAMINING ATTORNEY

**CLASS 36—(Continued).**

SN 86-235,850. WYNNEFIELD CAPITAL, INC., NEW YORK CITY, NY. FILED 3-28-2014.

**Wynnefield Capital**

THE MARK CONSISTS OF STANDARD CHARACTERS WITHOUT CLAIM TO ANY PARTICULAR FONT, STYLE, SIZE, OR COLOR.

NO CLAIM IS MADE TO THE EXCLUSIVE RIGHT TO USE "CAPITAL", APART FROM THE MARK AS SHOWN.

FOR FINANCIAL SERVICES, NAMELY, INVESTMENT ADVICE, INVESTMENT MANAGEMENT, INVESTMENT CONSULTATION AND INVESTMENT OF FUNDS FOR OTHERS, INCLUDING PRIVATE AND PUBLIC EQUITY AND DEBT INVESTMENT SERVICES (U.S. CLS. 100, 101 AND 102).

FIRST USE 11-1-1992; IN COMMERCE 11-1-1992.  
TRACY FLETCHER, EXAMINING ATTORNEY

**CLASS 36—(Continued).**

SN 86-237,518. HARMONY FINANCIAL STRATEGIES, TO-PANGA, CA. FILED 3-31-2014.

**Financial Advisors for  
LGBT individuals, same-sex  
couples & modern families**

THE MARK CONSISTS OF STANDARD CHARACTERS WITHOUT CLAIM TO ANY PARTICULAR FONT, STYLE, SIZE, OR COLOR.

NO CLAIM IS MADE TO THE EXCLUSIVE RIGHT TO USE "FINANCIAL ADVISORS FOR LGBT INDIVIDUALS, SAME-SEX COUPLES" OR "FAMILIES", APART FROM THE MARK AS SHOWN.

FOR FINANCIAL SERVICES, NAMELY, WEALTH MANAGEMENT SERVICES (U.S. CLS. 100, 101 AND 102).  
DORITT L. CARROLL, EXAMINING ATTORNEY

SN 86-237,923. CDF FIREFIGHTERS, SACRAMENTO, CA. FILED 3-31-2014.

**NO ONE LEFT BEHIND**

THE MARK CONSISTS OF STANDARD CHARACTERS WITHOUT CLAIM TO ANY PARTICULAR FONT, STYLE, SIZE, OR COLOR.

FOR CHARITABLE FUNDRAISING SERVICES, BY MEANS OF RAISING FUNDS FOR THE BENEFIT OF THE CALIFORNIA FIREFIGHTERS' CANCER SUPPORT NETWORK (U.S. CLS. 100, 101 AND 102).  
SEAN CROWLEY, EXAMINING ATTORNEY

SN 86-236,456. HICKEY, VIRGINIA D., MIAMI, FL. FILED 3-30-2014.

**Wings of Purple Hope**



THE COLOR(S) PURPLE IS/ARE CLAIMED AS A FEATURE OF THE MARK.

THE MARK CONSISTS OF A PURPLE RIBBON INCORPORATED WITHIN PURPLE WINGS WITH THE WORDING "WINGS OF PURPLE HOPE" IN THE COLOR PURPLE ABOVE THE MARK. THE COLOR WHITE REPRESENTS THE BACKGROUND ONLY.

FOR CHARITABLE FUNDRAISING (U.S. CLS. 100, 101 AND 102).  
FIRST USE 6-1-2012; IN COMMERCE 6-1-2012.  
FRANK LATTUCA, EXAMINING ATTORNEY

SN 86-238,512. FRANKLIN SQUARE HOLDINGS, L.P., PHILADELPHIA, PA. FILED 4-1-2014.



THE MARK CONSISTS OF FOUR DIFFERENTLY SHADED SQUARES IN THE SHAPE OF A DIAMOND.

FOR INVESTMENT OF FUNDS FOR OTHERS; MANAGEMENT OF INVESTMENT OF FUNDS FOR OTHERS; INVESTMENT MANAGEMENT SERVICES (U.S. CLS. 100, 101 AND 102).

RONALD DELGIZZI, EXAMINING ATTORNEY

**CLASS 36—(Continued).**

SN 86-238,996. NEWSPRONET, INC., MIAMI, FL. FILED 4-1-2014.

**ECOMPRAUSA**

THE MARK CONSISTS OF STANDARD CHARACTERS WITHOUT CLAIM TO ANY PARTICULAR FONT, STYLE, SIZE, OR COLOR.

THE ENGLISH TRANSLATION OF "COMPRA" IN THE MARK IS "BUY".

FOR CREDIT AND DEBIT CARD SERVICES; ELECTRONIC COMMERCE PAYMENT SERVICES, NAMELY, ESTABLISHING FUNDED ACCOUNTS USED TO PURCHASE GOODS AND SERVICES ON THE INTERNET (U.S. CLS. 100, 101 AND 102).

APRIL HESIK, EXAMINING ATTORNEY

**CLASS 36—(Continued).**

SN 86-240,703. DEANNA RIVETTI, DBA SUPER WOMAN OF REAL ESTATE, INC., VALENCIA, CA. FILED 4-2-2014.

**Super Woman of Real Estate**

THE MARK CONSISTS OF STANDARD CHARACTERS WITHOUT CLAIM TO ANY PARTICULAR FONT, STYLE, SIZE, OR COLOR.

NO CLAIM IS MADE TO THE EXCLUSIVE RIGHT TO USE "REAL ESTATE", APART FROM THE MARK AS SHOWN.

FOR REAL ESTATE PROCUREMENT FOR OTHERS (U.S. CLS. 100, 101 AND 102).

FIRST USE 8-2-2011; IN COMMERCE 8-2-2011.  
LAURA KOVALSKY, EXAMINING ATTORNEY

SN 86-239,211. GROMBACHER, GEORGE, SCOTTSDALE, AZ. FILED 4-1-2014.

The SEED Process  
Savings, Expenses, Earnings and Dreams  
Planting, Cultivating and Growing your family's Future

THE MARK CONSISTS OF STANDARD CHARACTERS WITHOUT CLAIM TO ANY PARTICULAR FONT, STYLE, SIZE, OR COLOR.

NO CLAIM IS MADE TO THE EXCLUSIVE RIGHT TO USE "PROCESS", APART FROM THE MARK AS SHOWN.

FOR FINANCIAL PLANNING (U.S. CLS. 100, 101 AND 102).

FIRST USE 1-1-2014; IN COMMERCE 1-1-2014.  
SIMON TENG, EXAMINING ATTORNEY

SN 86-241,974. HABERKORN, TIMOTHY, CHICAGO, IL. FILED 4-3-2014.

**Commodity Brain**

THE MARK CONSISTS OF STANDARD CHARACTERS WITHOUT CLAIM TO ANY PARTICULAR FONT, STYLE, SIZE, OR COLOR.

NO CLAIM IS MADE TO THE EXCLUSIVE RIGHT TO USE "COMMODITY", APART FROM THE MARK AS SHOWN.

FOR INFORMATION, ADVISORY, CONSULTANCY AND RESEARCH SERVICES RELATING TO FINANCE AND INVESTMENTS (U.S. CLS. 100, 101 AND 102).

FIRST USE 7-1-2012; IN COMMERCE 12-1-2012.  
MIDGE BUTLER, EXAMINING ATTORNEY

SN 86-240,410. RIPPLED PURPOSE INC., CHARLOTTE, NC. FILED 4-2-2014.

**Rippled Purpose**

THE MARK CONSISTS OF STANDARD CHARACTERS WITHOUT CLAIM TO ANY PARTICULAR FONT, STYLE, SIZE, OR COLOR.

FOR CHARITABLE FUNDRAISING SERVICES, BY MEANS OF RAISING FUNDS TO PROVIDE FOOD, MEDICAL AND DENTAL CARE, COLLEGE AID AND VOCATIONAL EDUCATION AND TRAINING TO NEEDY PERSONS (U.S. CLS. 100, 101 AND 102).

FIRST USE 7-12-2012; IN COMMERCE 7-12-2012.  
DEBORAH LOBO, EXAMINING ATTORNEY

SN 86-242,717. CWS APARTMENT HOMES, LLC, AUSTIN, TX. FILED 4-4-2014.

**M5250**

THE MARK CONSISTS OF STANDARD CHARACTERS WITHOUT CLAIM TO ANY PARTICULAR FONT, STYLE, SIZE, OR COLOR.

FOR MANAGEMENT AND LEASING OF APARTMENTS (U.S. CLS. 100, 101 AND 102).

ALAIN LAPTER, EXAMINING ATTORNEY



**CLASS 36—(Continued).**

SN 86-242,914. PACIFIC ALTERNATIVE ASSET MANAGEMENT COMPANY, LLC, IRVINE, CA. FILED 4-4-2014.

**completeAlpha**

THE MARK CONSISTS OF STANDARD CHARACTERS WITHOUT CLAIM TO ANY PARTICULAR FONT, STYLE, SIZE, OR COLOR.

FOR FINANCIAL SERVICES, NAMELY, INVESTMENT ADVICE, INVESTMENT MANAGEMENT, AND INVESTMENT OF FUNDS FOR OTHERS; FINANCIAL SERVICES, NAMELY, OPERATION OF INVESTMENT FUNDS (U.S. CLS. 100, 101 AND 102).

KRISTINA MORRIS, EXAMINING ATTORNEY

---

SN 86-244,612. ROMAN BOSS, MUNICH, FED REP GERMANY, FILED 4-7-2014.

**CRYPTONATOR**

THE MARK CONSISTS OF STANDARD CHARACTERS WITHOUT CLAIM TO ANY PARTICULAR FONT, STYLE, SIZE, OR COLOR.

FOR FINANCIAL SERVICES, NAMELY, PROVIDING INFORMATION IN THE FIELDS OF FOREIGN CURRENCY, COMMODITIES, FINANCIAL DERIVATIVES, INTEREST RATE PRODUCTS, AND EQUITIES VIA THE INTERNET AND INTRANET SYSTEMS (U.S. CLS. 100, 101 AND 102).

FIRST USE 2-14-2014; IN COMMERCE 2-14-2014.

LEIGH LOWRY, EXAMINING ATTORNEY

---

SN 86-245,364. NSDB PTY LTD, SYDNEY NSW, AUSTRALIA, FILED 4-8-2014.

**B!**

THE MARK CONSISTS OF STANDARD CHARACTERS WITHOUT CLAIM TO ANY PARTICULAR FONT, STYLE, SIZE, OR COLOR.

FOR FINANCIAL SERVICES RENDERED BY A GLOBAL COMPUTER NETWORK, NAMELY, FINANCIAL ANALYSIS AND CONSULTATION, FINANCIAL CLEARINGHOUSE SERVICES, ONLINE BILL PAYMENT SERVICES, FINANCIAL PORTFOLIO MANAGEMENT SERVICES, AND FINANCIAL PLANNING SERVICES (U.S. CLS. 100, 101 AND 102).

FIRST USE 3-1-2005; IN COMMERCE 3-1-2005.

DOMINIC J. FERRAIUOLO, EXAMINING ATTORNEY

**CLASS 36—(Continued).**

SN 86-245,374. NSDB PTY LTD, SYDNEY NSW, AUSTRALIA, FILED 4-8-2014.

**BANGK!**

THE MARK CONSISTS OF STANDARD CHARACTERS WITHOUT CLAIM TO ANY PARTICULAR FONT, STYLE, SIZE, OR COLOR.

FOR FINANCIAL SERVICES RENDERED BY A GLOBAL COMPUTER NETWORK, NAMELY, FINANCIAL ANALYSIS AND CONSULTATION, FINANCIAL CLEARINGHOUSE SERVICES, ONLINE BILL PAYMENT SERVICES, FINANCIAL PORTFOLIO MANAGEMENT SERVICES, AND FINANCIAL PLANNING SERVICES (U.S. CLS. 100, 101 AND 102).

FIRST USE 3-1-2005; IN COMMERCE 3-1-2005.

DOMINIC J. FERRAIUOLO, EXAMINING ATTORNEY

---

SN 86-245,461. LEE, SIPE, AND ASSOCIATES, INC., ROCKVILLE, MD. FILED 4-8-2014.



OWNER OF U.S. REG. NO. 3,833,009.

THE COLOR(S) RED, WHITE, AND BLUE IS/ARE CLAIMED AS A FEATURE OF THE MARK.

THE MARK CONSISTS OF THE TEXT SERVING THOSE WHO SERVE IN WHITE TEXT ON A BLUE BACKGROUND, A WHITE FIVE POINTED STAR IN THE FOREGROUND, TWO WHITE AND ONE RED PARALLEL WAVY LINES, AND A RED BANNER WITH A ROUNDED BOTTOM EDGE. THE WHITE SECTION AT THE BOTTOM OF THE DRAWING IS NOT CLAIMED AS A FEATURE OF THE MARK.

FOR FINANCIAL PLANNING AND INVESTMENT ADVISORY SERVICES (U.S. CLS. 100, 101 AND 102).

FIRST USE 1-2-2014; IN COMMERCE 1-2-2014.

CURTIS FRENCH, EXAMINING ATTORNEY

**CLASS 36—(Continued).**

SN 86-245,530. HOMESTEAD FUNDS, INC., ARLINGTON, VA. FILED 4-8-2014.



THE MARK CONSISTS OF FOUR SETS OF TWO TRAPEZOIDS, IN WHICH EACH SET IS JOINED IN A CHEVRON SHAPE AT THE LONG BASE, WITH FOUR CONVEX POINTS OF THE JOINED TRAPEZOIDS ALMOST MEETING IN THE CENTER OF THE DESIGN, FORMING A SPACE BETWEEN THE FOUR JOINED TRAPEZOIDS THAT APPEARS TO BE TWO INTERSECTING LINES ON THE HORIZONTAL AND VERTICAL AXES, AND FOUR DIAMONDS APPEAR AT THE OUTER EDGE OF THE DESIGN, IN EACH OF THE FOUR SPACES BETWEEN THE JOINED TRAPEZOIDS.

FOR MUTUAL FUNDS INVESTMENT SERVICES (U.S. CLS. 100, 101 AND 102).  
LINDA POWELL, EXAMINING ATTORNEY

**CLASS 36—(Continued).**

SN 86-245,891. NEXTRADE HOLDINGS, INC., CLEARWATER, FL. FILED 4-8-2014.

**NEXTRADE**

THE MARK CONSISTS OF STANDARD CHARACTERS WITHOUT CLAIM TO ANY PARTICULAR FONT, STYLE, SIZE, OR COLOR.

OWNER OF U.S. REG. NO. 2,511,406.  
FOR ON-LINE TRADING OF FINANCIAL INSTRUMENTS, SHARES, OPTIONS AND OTHER DERIVATIVE PRODUCTS; AND FINANCIAL CONSULTING (U.S. CLS. 100, 101 AND 102).  
TOBY BULLOFF, EXAMINING ATTORNEY

SN 86-246,239. THE LEADERS GROUP, INC., LITTLETON, CO. FILED 4-8-2014.



**TRIAGEMD**

SN 86-245,767. PROFESSIONAL FINANCIAL ADVISORS, INC., RADNOR, PA. FILED 4-8-2014.

THE MARK CONSISTS OF STANDARD CHARACTERS WITHOUT CLAIM TO ANY PARTICULAR FONT, STYLE, SIZE, OR COLOR.

FOR FINANCIAL SERVICES, NAMELY, FINANCIAL CONSULTING SERVICES AND FINANCIAL ASSET PROTECTION AND FINANCIAL ASSET MANAGEMENT (U.S. CLS. 100, 101 AND 102).  
KIM MONINGHOFF, EXAMINING ATTORNEY

OWNER OF U.S. REG. NOS. 2,796,810 AND 2,796,811.  
NO CLAIM IS MADE TO THE EXCLUSIVE RIGHT TO USE "GROUP", APART FROM THE MARK AS SHOWN.

THE MARK CONSISTS OF A DESIGN OF AN EAGLE WITH EACH OF THE FOLLOWING WORDS ON A SEPARATE LINE BELOW THE EAGLE "THE LEADERS GROUP".  
FOR INSURANCE BROKERAGE AND INVESTMENT BROKERAGE IN THE FIELDS OF MUTUAL FUNDS, VARIABLE LIFE INSURANCE AND VARIABLE ANNUITIES (U.S. CLS. 100, 101 AND 102).  
FIRST USE 2-12-2013; IN COMMERCE 2-12-2013.  
BARNEY CHARLON, EXAMINING ATTORNEY

**CLASS 36—(Continued).**

SN 86-246,530. CALCON MUTUAL MORTGAGE LLC, DBA ONETRUST HOME LOANS, SAN DIEGO, CA. FILED 4-9-2014.



THE MARK CONSISTS OF AN ARM CIRCLING THE PERIMETER OF THE IMAGE OF A HOUSE IN A HALF MOON SHAPE RESEMBLING THE LETTER "C" WITH A HAND CUPPING THE HOUSE WHICH INCLUDES A ROOF AND WINDOW WITH WINDOW PANE SEPARATING THE WINDOW INTO 4 SECTIONS. THE TOP 2 SECTIONS OF THE WINDOW ARE RECTANGULAR IN SHAPE WITH CURVED TOPS AND THE BOTTOM TWO ARE SQUARE.

FOR MORTGAGE BANKING (U.S. CLS. 100, 101 AND 102).

FIRST USE 4-1-2013; IN COMMERCE 4-1-2013.  
LINDA MICKLEBURGH, EXAMINING ATTORNEY

SN 86-247,054. EDWARDS LIFESCIENCES CORPORATION, IRVINE, CA. FILED 4-9-2014.

EVERY HEARTBEAT MATTERS

THE MARK CONSISTS OF STANDARD CHARACTERS WITHOUT CLAIM TO ANY PARTICULAR FONT, STYLE, SIZE, OR COLOR.

FOR CHARITABLE FOUNDATION SERVICES, NAMELY, PROVIDING PROJECT GRANTS FOR PROGRAMS AND SERVICES OF OTHERS THAT IMPACT AWARENESS, PREVENTION AND TREATMENT OF HEART DISEASE (U.S. CLS. 100, 101 AND 102).

ANDREA BUTLER, EXAMINING ATTORNEY

**CLASS 36—(Continued).**

SN 86-247,246. TEAYS RIVER INVESTMENTS, LLC, ZIONS-VILLE, IN. FILED 4-9-2014.

TEAYS RIVER

THE MARK CONSISTS OF STANDARD CHARACTERS WITHOUT CLAIM TO ANY PARTICULAR FONT, STYLE, SIZE, OR COLOR.

FOR FINANCIAL AND INVESTMENT SERVICES, NAMELY, ASSET AND INVESTMENT ACQUISITION, CONSULTATION, ADVISORY AND DEVELOPMENT; FINANCIAL INVESTMENT IN THE FIELD OF AGRICULTURE; INVESTMENT MANAGEMENT; INVESTMENT SERVICES, NAMELY, ASSET ACQUISITION, CONSULTATION, DEVELOPMENT AND MANAGEMENT SERVICES (U.S. CLS. 100, 101 AND 102).

FIRST USE 11-0-2007; IN COMMERCE 11-0-2007.  
BRIAN NEVILLE, EXAMINING ATTORNEY

SN 86-247,479. MELVIN CAPITAL LLC, NEW YORK, NY. FILED 4-9-2014.

MELVIN

THE MARK CONSISTS OF STANDARD CHARACTERS WITHOUT CLAIM TO ANY PARTICULAR FONT, STYLE, SIZE, OR COLOR.

FOR HEDGE FUND INVESTMENT SERVICES (U.S. CLS. 100, 101 AND 102).

THEODORE MCBRIDE, EXAMINING ATTORNEY

SN 86-247,814. FUSION FAMILY WEALTH, LLC, COLD SPRING HARBOR, NY. FILED 4-9-2014.

PsyFi

THE MARK CONSISTS OF STANDARD CHARACTERS WITHOUT CLAIM TO ANY PARTICULAR FONT, STYLE, SIZE, OR COLOR.

FOR FINANCIAL PLANNING AND INVESTMENT ADVISORY SERVICES; FINANCIAL SERVICES, NAMELY, WEALTH MANAGEMENT SERVICES (U.S. CLS. 100, 101 AND 102).

FIRST USE 1-15-2014; IN COMMERCE 1-15-2014.  
PAUL CROWLEY, EXAMINING ATTORNEY

**CLASS 36—(Continued).**

SN 86-247,824. SHIPLEY, COURTENAY, ALEXANDRIA, VA. FILED 4-9-2014.

**RETIREMENT PLANOLGY**

THE MARK CONSISTS OF STANDARD CHARACTERS WITHOUT CLAIM TO ANY PARTICULAR FONT, STYLE, SIZE, OR COLOR.

NO CLAIM IS MADE TO THE EXCLUSIVE RIGHT TO USE "RETIREMENT", APART FROM THE MARK AS SHOWN.

FOR FINANCIAL RETIREMENT PLAN CONSULTING SERVICES; INVESTMENT ADVISORY SERVICES (U.S. CLS. 100, 101 AND 102).

FIRST USE 3-19-2014; IN COMMERCE 3-19-2014.  
LINDA E. BLOHM, EXAMINING ATTORNEY

---

SN 86-248,057. ARK ROYAL INSURANCE COMPANY, ST. PETERSBURG, FL. FILED 4-10-2014.

**We've got tomorrow covered**

THE MARK CONSISTS OF STANDARD CHARACTERS WITHOUT CLAIM TO ANY PARTICULAR FONT, STYLE, SIZE, OR COLOR.

FOR INSURANCE SERVICES, NAMELY, WRITING PROPERTY AND CASUALTY INSURANCE (U.S. CLS. 100, 101 AND 102).

FIRST USE 2-28-2014; IN COMMERCE 2-28-2014.  
CYNTHIA RINALDI, EXAMINING ATTORNEY

---

SN 86-248,075. SNAP CAPITAL, LLC, CHARLESTON, SC. FILED 4-10-2014.

**SNAPCAP**

THE MARK CONSISTS OF STANDARD CHARACTERS WITHOUT CLAIM TO ANY PARTICULAR FONT, STYLE, SIZE, OR COLOR.

FOR FINANCIAL SERVICES, NAMELY, MONEY LENDING; PROVIDING TEMPORARY LOANS (U.S. CLS. 100, 101 AND 102).

FIRST USE 12-0-2012; IN COMMERCE 12-0-2012.  
WILLIAM ROSSMAN, EXAMINING ATTORNEY

**CLASS 36—(Continued).**

SN 86-248,079. SCOTTSDALE INSURANCE COMPANY, SCOTTSDALE, AZ. FILED 4-10-2014.

**FREEDOM SPECIALTY  
INSURANCE COMPANY**

THE MARK CONSISTS OF STANDARD CHARACTERS WITHOUT CLAIM TO ANY PARTICULAR FONT, STYLE, SIZE, OR COLOR.

OWNER OF U.S. REG. NO. 3,677,253.

NO CLAIM IS MADE TO THE EXCLUSIVE RIGHT TO USE "SPECIALTY INSURANCE COMPANY", APART FROM THE MARK AS SHOWN.

FOR INSURANCE SERVICES, NAMELY, UNDERWRITING DIRECTORS, OFFICERS, PROFESSIONAL LIABILITY AND SPECIALTY INSURANCE (U.S. CLS. 100, 101 AND 102).

FIRST USE 3-31-2008; IN COMMERCE 3-31-2008.  
ELLEN B. AWRICH, EXAMINING ATTORNEY

---

SN 86-248,092. MARK W. PEARSON, SAVAGE, MN. FILED 4-10-2014.

**RESEARCH WITH CLARITY**

THE MARK CONSISTS OF STANDARD CHARACTERS WITHOUT CLAIM TO ANY PARTICULAR FONT, STYLE, SIZE, OR COLOR.

OWNER OF U.S. REG. NOS. 4,184,339 AND 4,306,618.

FOR ESTATE PLANNING; FINANCIAL ADVICE AND CONSULTANCY SERVICES; FINANCIAL INVESTMENT BROKERAGE; FINANCIAL PLANNING AND INVESTMENT ADVISORY SERVICES; FINANCIAL PLANNING CONSULTATION; FINANCIAL PORTFOLIO ANALYSIS SERVICES; FINANCIAL PORTFOLIO MANAGEMENT; FINANCIAL RESEARCH AND EQUITY RESEARCH BROKERAGE SERVICES; FINANCIAL RESEARCH AND INFORMATION SERVICES (U.S. CLS. 100, 101 AND 102).

ALICE BENMAMAN, EXAMINING ATTORNEY

---

SN 86-248,152. WEXFORD CAPITAL LP, GREENWICH, CT. FILED 4-10-2014.

**WEXFORD**

THE MARK CONSISTS OF STANDARD CHARACTERS WITHOUT CLAIM TO ANY PARTICULAR FONT, STYLE, SIZE, OR COLOR.

OWNER OF U.S. REG. NO. 3,448,093.

FOR FINANCIAL SERVICES, NAMELY, PROVIDING INVESTMENT ADVICE RELATING TO BANKRUPTCY/DISTRESSED ENTITIES, ENERGY/NATURAL RESOURCES, REAL ESTATE, TECHNOLOGY, TELECOMMUNICATIONS, AND TRANSPORTATION (U.S. CLS. 100, 101 AND 102).

KAREN BRACEY, EXAMINING ATTORNEY

**CLASS 36—(Continued).**

SN 86-248,179. LIGHTHOUSE REALTY ADVISORS LLC,  
ENGLEWOOD CLIFFS, NJ. FILED 4-10-2014.

# COSO

THE MARK CONSISTS OF STANDARD CHARACTERS  
WITHOUT CLAIM TO ANY PARTICULAR FONT, STYLE,  
SIZE, OR COLOR.

FOR REAL ESTATE SERVICES, NAMELY, LEASING  
AND RENTAL OF RESIDENTIAL AND COMMERCIAL  
PROPERTY (U.S. CLS. 100, 101 AND 102).

FIRST USE 12-4-2013; IN COMMERCE 12-4-2013.  
ZACHARY CROMER, EXAMINING ATTORNEY

---

SN 86-248,382. GOLD N CONNECTION, LLC, POMPANO  
BEACH, FL. FILED 4-10-2014.

# GCPAWN.COM

THE MARK CONSISTS OF STANDARD CHARACTERS  
WITHOUT CLAIM TO ANY PARTICULAR FONT, STYLE,  
SIZE, OR COLOR.

FOR PAWN BROKERAGE; PAWN SHOPS (U.S. CLS.  
100, 101 AND 102).

JAY FLOWERS, EXAMINING ATTORNEY

---

SN 86-248,571. 360 BLUE, LLC, SANTA ROSA BEACH, FL.  
FILED 4-10-2014.

# 360 BLUE

THE MARK CONSISTS OF STANDARD CHARACTERS  
WITHOUT CLAIM TO ANY PARTICULAR FONT, STYLE,  
SIZE, OR COLOR.

FOR REAL ESTATE SERVICES, NAMELY, RENTAL  
OF VACATION HOMES; REAL ESTATE SERVICES,  
NAMELY, VACATION HOME RENTAL MANAGEMENT  
SERVICES (U.S. CLS. 100, 101 AND 102).

FIRST USE 10-2-2008; IN COMMERCE 10-2-2008.  
KAELIE KUNG, EXAMINING ATTORNEY

**CLASS 36—(Continued).**

SN 86-248,601. FIRST MERCHANTS CORPORATION, MUN-  
CIE, IN. FILED 4-10-2014.

# THE STRENGTH OF BIG, THE SERVICE OF SMALL

THE MARK CONSISTS OF STANDARD CHARACTERS  
WITHOUT CLAIM TO ANY PARTICULAR FONT, STYLE,  
SIZE, OR COLOR.

FOR BANKING, FINANCING AND TRUST SERVICES,  
NAMELY, INVESTMENT AND TRUST COMPANY SER-  
VICES; INSURANCE SERVICES, NAMELY, INSURANCE  
BROKERAGE SERVICES IN THE FIELDS OF COMMER-  
CIAL LINES, INCLUDING GENERAL BUSINESS LIABI-  
LITY (GBL) AND EMPLOYEE BENEFITS, AND  
PERSONAL LINES, INCLUDING LIFE, PROPERTY  
AND CASUALTY (U.S. CLS. 100, 101 AND 102).

FIRST USE 2-28-2008; IN COMMERCE 2-28-2008.  
MATTHEW EINSTEIN, EXAMINING ATTORNEY

---

SN 86-248,662. AMALGAMATED BANK, NEW YORK, NY.  
FILED 4-10-2014.

# BANK WITH PURPOSE

THE MARK CONSISTS OF STANDARD CHARACTERS  
WITHOUT CLAIM TO ANY PARTICULAR FONT, STYLE,  
SIZE, OR COLOR.

FOR BANKING SERVICES (U.S. CLS. 100, 101 AND  
102).

KAPIL BHANOT, EXAMINING ATTORNEY

---

SN 86-248,686. EQUINOX FINANCIAL GROUP, LLC, DEN-  
VER, CO. FILED 4-10-2014.

# Equinox

THE MARK CONSISTS OF STANDARD CHARACTERS  
WITHOUT CLAIM TO ANY PARTICULAR FONT, STYLE,  
SIZE, OR COLOR.

FOR INVESTMENT AND FINANCIAL SERVICES,  
NAMELY, INVESTMENT BROKERAGE, INVESTMENT  
MANAGEMENT, ASSET MANAGEMENT, INVESTMENT  
ADVICE, INVESTMENT CONSULTATION, BROKER-  
DEALER SERVICES, FINANCIAL RESEARCH IN THE  
FIELDS OF MUTUAL FUNDS, COMMODITY POOLS  
AND MANAGED FUTURE FUNDS (U.S. CLS. 100, 101  
AND 102).

FIRST USE 7-1-2004; IN COMMERCE 7-1-2004.  
RONALD MCMORROW, EXAMINING ATTORNEY

**CLASS 36—(Continued).**

SN 86-248,789. SHIELD SERVICES, INC., OCALA, FL. FILED 4-10-2014.

**DIANA ROSE MACE**

THE MARK CONSISTS OF STANDARD CHARACTERS WITHOUT CLAIM TO ANY PARTICULAR FONT, STYLE, SIZE, OR COLOR.

THE NAME(S), PORTRAIT(S), AND/OR SIGNATURE(S) SHOWN IN THE MARK IDENTIFIES "DIANA ROSE MACE", WHOSE CONSENT(S) TO REGISTER IS MADE OF RECORD.

FOR INSURANCE UNDERWRITING SERVICES FOR ALL TYPES OF INSURANCE; SURETY SERVICES (U.S. CLS. 100, 101 AND 102).

FIRST USE 5-24-1969; IN COMMERCE 5-24-1969.  
ESTHER A. BORSUK, EXAMINING ATTORNEY

---

SN 86-248,819. GANART TECHNOLOGIES, INC., CARROLLTON, TX. FILED 4-10-2014.

**BECAUSE SOMETIMES YOU JUST  
NEED \$20**

THE MARK CONSISTS OF STANDARD CHARACTERS WITHOUT CLAIM TO ANY PARTICULAR FONT, STYLE, SIZE, OR COLOR.

FOR BUSINESS SERVICES, NAMELY, ELECTRONIC TRANSFER OF FINANCIAL INSTRUMENTS, NAMELY, MONEY ORDERS AND WIRE TRANSFERS OF FUNDS; ELECTRONIC FUNDS TRANSFER, NAMELY, ELECTRONIC PROCESSING AND PAYMENT OF BILLS AND INVOICES AND ELECTRONIC TRANSFER OF MONEY, CONSULTATION SERVICES FOR ALL OF THE FOREGOING PROVIDED VIA A GLOBAL COMPUTER NETWORK, ELECTRONIC FUNDS TRANSFER (U.S. CLS. 100, 101 AND 102).

FIRST USE 2-13-2014; IN COMMERCE 2-13-2014.  
RON FAIRBANKS, EXAMINING ATTORNEY

---

SN 86-249,755. BLUE CROSS AND BLUE SHIELD OF MASSACHUSETTS, INC., BOSTON, MA. FILED 4-11-2014.

**PATHWAY TO SAVINGS**

THE MARK CONSISTS OF STANDARD CHARACTERS WITHOUT CLAIM TO ANY PARTICULAR FONT, STYLE, SIZE, OR COLOR.

FOR HEALTH INSURANCE UNDERWRITING; INSURANCE INFORMATION; PROVIDING INFORMATION ABOUT HEALTHCARE INSURANCE PLANS (U.S. CLS. 100, 101 AND 102).

FIRST USE 2-21-2013; IN COMMERCE 2-21-2013.  
ELIZABETH JACKSON, EXAMINING ATTORNEY

**CLASS 36—(Continued).**

SN 86-249,778. SECURITY BENEFIT CORPORATION, TOPEKA, KS. FILED 4-11-2014.



TO AND THROUGH RETIREMENT

OWNER OF U.S. REG. NOS. 3,357,188, 3,525,888 AND OTHERS.

THE MARK CONSISTS OF A DESIGN ELEMENT, WHICH IS INTENDED TO REPRESENT THE LETTER "S", PLUS THE WORD "SECURITY" IMMEDIATELY ABOVE THE WORD "BENEFIT", BOTH WORDS TO THE RIGHT OF THE "S" DESIGN, AND INCLUDING THE PHRASE "TO AND THROUGH RETIREMENT" IMMEDIATELY UNDERNEATH ALL.

FOR ADMINISTRATION OF QUALIFIED AND NON-QUALIFIED GROUP RETIREMENT AND SAVINGS PLANS, ISSUANCE AND ADMINISTRATION OF ANNUITIES, ISSUANCE AND ADMINISTRATION OF INDIVIDUAL RETIREMENT ACCOUNTS, ALL IN THE FIELDS OF INSURANCE AND FINANCE (U.S. CLS. 100, 101 AND 102).

DANIEL S. STRINGER, EXAMINING ATTORNEY

---

SN 86-249,794. LORBER, DAVID, BOCA RATON, FL. FILED 4-11-2014.

**Stay In The Game**

THE MARK CONSISTS OF STANDARD CHARACTERS WITHOUT CLAIM TO ANY PARTICULAR FONT, STYLE, SIZE, OR COLOR.

FOR FINANCIAL ASSET MANAGEMENT; FINANCIAL SERVICES, NAMELY, WEALTH MANAGEMENT SERVICES (U.S. CLS. 100, 101 AND 102).

KIM MONINGHOFF, EXAMINING ATTORNEY

---

SN 86-249,944. HABITAT FOR HUMANITY OF OMAHA, INC., OMAHA, NE. FILED 4-11-2014.

**BREW HAHA**

THE MARK CONSISTS OF STANDARD CHARACTERS WITHOUT CLAIM TO ANY PARTICULAR FONT, STYLE, SIZE, OR COLOR.

FOR CHARITABLE FUNDRAISING SERVICES, NAMELY, ORGANIZING AND CONDUCTING FOOD AND BEER TASTING FUNDRAISING EVENTS (U.S. CLS. 100, 101 AND 102).

FIRST USE 9-30-2006; IN COMMERCE 9-30-2006.  
MARILYN IZZI, EXAMINING ATTORNEY

**CLASS 36—(Continued).**

SN 86-250,459. PRIVATE BANCSHARES, INC., ATLANTA, GA. FILED 4-11-2014.

**PRIVATEPLUS**

THE MARK CONSISTS OF STANDARD CHARACTERS WITHOUT CLAIM TO ANY PARTICULAR FONT, STYLE, SIZE, OR COLOR.

FOR MORTGAGE BANKING SERVICES (U.S. CLS. 100, 101 AND 102).

FIRST USE 4-4-2014; IN COMMERCE 4-4-2014.  
MEGHAN REINHART, EXAMINING ATTORNEY

---

SN 86-251,632. BRAVO FINANCIAL LLC, MINNEAPOLIS, MN. FILED 4-14-2014.

**PAWNWORKS**

THE MARK CONSISTS OF STANDARD CHARACTERS WITHOUT CLAIM TO ANY PARTICULAR FONT, STYLE, SIZE, OR COLOR.

FOR PAWN SHOP SERVICES (U.S. CLS. 100, 101 AND 102).

LAURIE KAUFMAN, EXAMINING ATTORNEY

---

SN 86-254,436. CHARITY POP INC., BEDFORD, NY. FILED 4-16-2014.

**CHARITYPOP**

THE MARK CONSISTS OF STANDARD CHARACTERS WITHOUT CLAIM TO ANY PARTICULAR FONT, STYLE, SIZE, OR COLOR.

FOR CHARITABLE FUNDRAISING SERVICES; CHARITABLE FUNDRAISING SERVICES BY MEANS OF CONNECTING AND ENGAGING CONSUMERS, BRANDS AND CULTURAL ICONS IN CONNECTION WITH PHILANTHROPIC EXPERIENCES (U.S. CLS. 100, 101 AND 102).

EVIN L. KOZAK, EXAMINING ATTORNEY

**CLASS 36—(Continued).**

SN 86-255,439. SNAP CAPITAL, LLC, CHARLESTON, SC. FILED 4-17-2014.

**VANISHING INTEREST RATE**

THE MARK CONSISTS OF STANDARD CHARACTERS WITHOUT CLAIM TO ANY PARTICULAR FONT, STYLE, SIZE, OR COLOR.

NO CLAIM IS MADE TO THE EXCLUSIVE RIGHT TO USE "INTEREST RATE", APART FROM THE MARK AS SHOWN.

FOR FINANCIAL SERVICES, NAMELY, MONEY LENDING; PROVIDING TEMPORARY LOANS (U.S. CLS. 100, 101 AND 102).

WILLIAM ROSSMAN, EXAMINING ATTORNEY

---

SN 86-257,815. CALCON MUTUAL MORTGAGE LLC, SAN DIEGO, CA. FILED 4-21-2014.

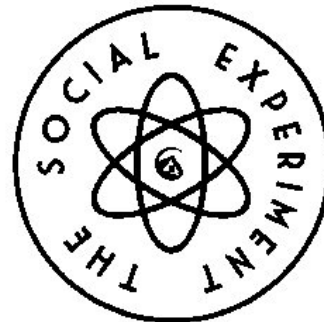

THE MARK CONSISTS OF A CIRCULAR BORDER. WITHIN THAT BORDER ARE THE WORDS "THE SOCIAL EXPERIMENT" WRITTEN IN A CIRCULAR FORMAT TO FOLLOW THE OUTLINE OF THE CIRCULAR BORDER. IN THE CENTER OF THE LOGO IS AN ATOMIC LIKE STRUCTURE OF INTERCONNECTED RINGS. IN THE MIDDLE OF THIS RING CLUSTER, AT THE VERY CENTER OF THE LOGO, IS OUR COMPANY LOGO WHICH CONSISTS OF AN ARM CIRCLING THE PERIMETER OF A HOUSE IN A HALF MOON SHAPE RESEMBLING THE LETTER "C" WITH A HAND CUPPING THE HOUSE WHICH INCLUDES A ROOF AND WINDOW WITH WINDOW PANE SEPARATING THE WINDOW INTO 4 SECTIONS. THE TOP 2 SECTIONS OF THE WINDOW ARE RECTANGULAR IN SHAPE WITH CURVED TOPS AND THE BOTTOM TWO ARE SQUARE.

FOR MORTGAGE BANKING (U.S. CLS. 100, 101 AND 102).

LINDA MICKLEBURGH, EXAMINING ATTORNEY

**CLASS 36—(Continued).**

SN 86-258,230. FAS HOLDINGS, INC., SAN DIEGO, CA. FILED 4-21-2014.

CATCHLIGHT CAPITAL

THE MARK CONSISTS OF STANDARD CHARACTERS WITHOUT CLAIM TO ANY PARTICULAR FONT, STYLE, SIZE, OR COLOR.

NO CLAIM IS MADE TO THE EXCLUSIVE RIGHT TO USE "CAPITAL", APART FROM THE MARK AS SHOWN.

FOR FULL-SERVICE FINANCIAL ADVISORY AND CONSULTANCY SERVICES AND ASSET AND INVESTMENT MANAGEMENT AND BROKERAGE SERVICES PROVIDED TO PROFESSIONAL INDEPENDENT FINANCIAL ADVISORS AND BROKER/DEALERS AND TO THE INVESTING PUBLIC (U.S. CLS. 100, 101 AND 102).

ROBIN CHOSID, EXAMINING ATTORNEY

---

SN 86-261,996. STORE CAPITAL ADVISORS, LLC, SCOTTSDALE, AZ. FILED 4-24-2014.



OWNER OF U.S. REG. NO. 4,537,829.  
NO CLAIM IS MADE TO THE EXCLUSIVE RIGHT TO USE "FUNDING SOLUTIONS", APART FROM THE MARK AS SHOWN.

THE MARK CONSISTS OF THE WORDS "MASTER FUNDING SOLUTIONS" AND THREE COLUMNAR POLYGONS. THE THREE COLUMNAR POLYGONS ARE LOCATED TO THE LEFT OF THE WORDS "MASTER FUNDING SOLUTIONS". THE WORDS "MASTER FUNDING" ARE IN INITIAL CAPS AND ARE LOCATED ABOVE THE WORD "SOLUTIONS".

FOR FINANCIAL SERVICES, NAMELY, REAL ESTATE ASSET MANAGEMENT, REAL ESTATE INVESTMENT, AND MORTGAGE LENDING (U.S. CLS. 100, 101 AND 102).

ROBERT STRUCK, EXAMINING ATTORNEY

**CLASS 36—(Continued).**

SN 86-262,888. PORTFOLIO RECOVERY ASSOCIATES, INC., NORFOLK, VA. FILED 4-25-2014.

PRA Group

THE MARK CONSISTS OF STANDARD CHARACTERS WITHOUT CLAIM TO ANY PARTICULAR FONT, STYLE, SIZE, OR COLOR.

OWNER OF U.S. REG. NOS. 4,142,598, 4,375,192 AND OTHERS.

NO CLAIM IS MADE TO THE EXCLUSIVE RIGHT TO USE "GROUP", APART FROM THE MARK AS SHOWN.

FOR DEBT RECOVERY, DEBT COLLECTION, PURCHASING DEBT, DEBT ADMINISTRATION, DEBT PAYMENT PROCESSING, AND DEBT ACCOUNT MANAGEMENT SERVICES FOR FINANCIAL INSTITUTIONS, LENDERS, CREDITORS, GOVERNMENT CLIENTS AND OTHER THIRD PARTIES (U.S. CLS. 100, 101 AND 102).

FIRST USE 3-6-2014; IN COMMERCE 3-6-2014.

ANDREA CORNWELL, EXAMINING ATTORNEY

---

SN 86-274,648. JOSEPH A. HARDY & ASSOCIATES, EIGHTY FOUR, PA. FILED 5-7-2014.

84 LUMBER

THE MARK CONSISTS OF STANDARD CHARACTERS WITHOUT CLAIM TO ANY PARTICULAR FONT, STYLE, SIZE, OR COLOR.

OWNER OF U.S. REG. NOS. 1,705,441, 1,705,671 AND OTHERS.

NO CLAIM IS MADE TO THE EXCLUSIVE RIGHT TO USE "LUMBER", APART FROM THE MARK AS SHOWN.

SEC. 2(F).  
FOR FINANCING SERVICES (U.S. CLS. 100, 101 AND 102).

FIRST USE 0-0-1956; IN COMMERCE 0-0-1956.

DAVID COLLIER, EXAMINING ATTORNEY



**CLASS 36—(Continued).**

SN 86-281,171. PORTFOLIO RECOVERY ASSOCIATES, INC., NORFOLK, VA. FILED 5-14-2014.

PRA

THE MARK CONSISTS OF STANDARD CHARACTERS WITHOUT CLAIM TO ANY PARTICULAR FONT, STYLE, SIZE, OR COLOR.

OWNER OF U.S. REG. NOS. 4,142,598, 4,224,558 AND OTHERS.

FOR DEBT RECOVERY, DEBT COLLECTION, PURCHASING DEBT, DEBT ADMINISTRATION, DEBT PAYMENT PROCESSING, AND DEBT ACCOUNT MANAGEMENT SERVICES FOR FINANCIAL INSTITUTIONS, LENDERS, CREDITORS, GOVERNMENT CLIENTS AND OTHER THIRD PARTIES (U.S. CLS. 100, 101 AND 102).

FIRST USE 12-15-2003; IN COMMERCE 12-15-2003.  
ANDREA CORNWELL, EXAMINING ATTORNEY

**CLASS 36—(Continued).**

SN 86-297,575. STATE FARM MUTUAL AUTOMOBILE INSURANCE COMPANY, BLOOMINGTON, IL. FILED 6-2-2014.

State Farm  
NEIGHBORHOOD SESSIONS

OWNER OF U.S. REG. NOS. 1,979,585, 4,407,111 AND OTHERS.

NO CLAIM IS MADE TO THE EXCLUSIVE RIGHT TO USE "SESSIONS", APART FROM THE MARK AS SHOWN.

THE MARK CONSISTS OF THE WORDS "STATE FARM NEIGHBORHOOD SESSIONS" WHERE "STATE FARM" IS CENTERED ABOVE "NEIGHBORHOOD" AND "SESSIONS" IS CENTERED BELOW "NEIGHBORHOOD". THREE OVALS TOUCHING FORMING AN OVERALL TRIANGULAR SHAPE WHERE ONE OVAL APPEARS CENTERED ABOVE THE OTHER TWO OVALS APPEARS DIRECTLY UNDER THE WORDING "STATE FARM". MUSICAL NOTES REPRESENT THE "O'S IN THE "HOOD" PORTION OF THE WORD "NEIGHBORHOOD".

FOR CHARITABLE FUNDRAISING SERVICES BY MEANS OF MUSICAL CONCERTS (U.S. CLS. 100, 101 AND 102).

FIRST USE 5-14-2014; IN COMMERCE 5-14-2014.  
SANJEEV VOHRA, EXAMINING ATTORNEY

SN 86-286,076. GOLD N CONNECTION, LLC, POMPANO BEACH, FL. FILED 5-20-2014.

GCPAWN.COM

THE COLOR(S) RED AND BLACK IS/ARE CLAIMED AS A FEATURE OF THE MARK.

THE MARK CONSISTS OF THE LETTERING GCPAWN.COM WITH AN IMAGE OF THREE BALLS CONNECTED THROUGH A CURVED LINE AND A VERTICAL LINE INSIDE THE LETTER O, THE LETTERS G, C AND O ARE IN RED AND THE IMAGE INSIDE THE LETTER O AND THE REMAINING LETTERS AND DOT ARE IN BLACK.

FOR PAWN BROKERAGE; PAWN SHOPS (U.S. CLS. 100, 101 AND 102).

JAY FLOWERS, EXAMINING ATTORNEY

SN 86-300,964. BAYLOR SCOTT & WHITE HOLDINGS, DALLAS, TX. FILED 6-5-2014.

VITAL TRADITIONS

THE MARK CONSISTS OF STANDARD CHARACTERS WITHOUT CLAIM TO ANY PARTICULAR FONT, STYLE, SIZE, OR COLOR.

FOR PROVIDING HEALTH INSURANCE SERVICES, NAMELY, UNDERWRITING, ISSUANCE, ADMINISTRATION AND BROKERAGE OF MEDICAL, HEALTH, DENTAL AND PHARMACY INSURANCE BENEFITS; HEALTH CARE BENEFIT CLAIMS ADMINISTRATION; HEALTH CARE BENEFIT CLAIMS PROCESSING; PROVIDING HEALTH CARE BENEFIT CLAIM INFORMATION (U.S. CLS. 100, 101 AND 102).

FIRST USE 10-1-2013; IN COMMERCE 10-1-2013.  
SARA KUNKLEMAN, EXAMINING ATTORNEY

**CLASS 36—(Continued).**

SN 86-318,626. SECURIAN FINANCIAL GROUP, INC., ST. PAUL, MN. FILED 6-24-2014.

**YOU MATTER. PLAN  
ACCORDINGLY.**

THE MARK CONSISTS OF STANDARD CHARACTERS WITHOUT CLAIM TO ANY PARTICULAR FONT, STYLE, SIZE, OR COLOR.

FOR UNDERWRITING AND BROKERAGE OF CRITICAL ILLNESS INSURANCE (U.S. CLS. 100, 101 AND 102).

JUHI KAVEESHVAR, EXAMINING ATTORNEY

SN 86-325,240. HABITAT FOR HUMANITY OF OMAHA, INC., OMAHA, NE. FILED 7-1-2014.

**RAISE THE ROOF**

THE MARK CONSISTS OF STANDARD CHARACTERS WITHOUT CLAIM TO ANY PARTICULAR FONT, STYLE, SIZE, OR COLOR.

FOR CHARITABLE FUNDRAISING SERVICES BY MEANS OF ORGANIZING AND CONDUCTING SPECIAL EVENTS (U.S. CLS. 100, 101 AND 102).

FIRST USE 10-30-2009; IN COMMERCE 10-30-2009.

MARILYN IZZI, EXAMINING ATTORNEY

**CLASS 37—CONSTRUCTION AND REPAIR**

SN 76-716,107. SWIFTSHIPS, L.L.C., VIENNA, VA. FILED 3-31-2014.

**SWIFTSHIPS**

THE MARK CONSISTS OF STANDARD CHARACTERS WITHOUT CLAIM TO ANY PARTICULAR FONT, STYLE, SIZE, OR COLOR.

OWNER OF U.S. REG. NO. 3,223,638.  
FOR CUSTOM MANUFACTURE AND REPAIR OF MARINE VESSELS (U.S. CLS. 100, 103 AND 106).

FIRST USE 12-31-1969; IN COMMERCE 12-31-1969.

JASON MALASHEVICH, EXAMINING ATTORNEY

**CLASS 37—(Continued).**

SN 85-786,587. ADAIR PLUMBING, LLC, MESA, AZ. FILED 11-25-2012.

**Adair Plumbing**

THE MARK CONSISTS OF STANDARD CHARACTERS WITHOUT CLAIM TO ANY PARTICULAR FONT, STYLE, SIZE, OR COLOR.

NO CLAIM IS MADE TO THE EXCLUSIVE RIGHT TO USE "PLUMBING", APART FROM THE MARK AS SHOWN. SEC. 2(F).

FOR PLUMBING SERVICES (U.S. CLS. 100, 103 AND 106).

FIRST USE 11-4-1999; IN COMMERCE 11-4-1999.

LINDA M. KING, EXAMINING ATTORNEY

SN 85-835,361. POWELL ENTERPRISES OF CENTRAL FLORIDA, INC., ORLANDO, FL. FILED 1-29-2013.

**Covenant Cleaning**

NO CLAIM IS MADE TO THE EXCLUSIVE RIGHT TO USE "CLEANING", APART FROM THE MARK AS SHOWN.

THE MARK CONSISTS OF THE WORDS "COVENANT CLEANING" WITH A LATIN CROSS SUBSTITUTED FOR THE "T" IN THE WORD "COVENANT".

FOR CLEANING OF COMMERCIAL PREMISES AND RESIDENTIAL HOUSES (U.S. CLS. 100, 103 AND 106).

FIRST USE 8-21-2003; IN COMMERCE 8-21-2003.

MARY CRAWFORD, EXAMINING ATTORNEY

SN 85-843,316. NINE ENERGY CANADA INC., CALGARY, CANADA, FILED 2-7-2013.

**ENVIROLINE**

THE MARK CONSISTS OF STANDARD CHARACTERS WITHOUT CLAIM TO ANY PARTICULAR FONT, STYLE, SIZE, OR COLOR.

PRIORITY CLAIMED UNDER SEC. 44(D) ON CANADA APPLICATION NO. 1605203, FILED 12-5-2012, REG. NO. TMA878705, DATED 5-26-2014, EXPIRES 5-26-2029.

FOR WIRELINING FOR OIL AND GAS WELLS (U.S. CLS. 100, 103 AND 106).

HOWARD SMIGA, EXAMINING ATTORNEY

**CLASS 37—(Continued).**

SN 85-845,303. ASSET PERFORMANCE TECHNOLOGIES, INC., DBA APT, INC., CORRALES, NM. FILED 2-8-2013.



THE MARK CONSISTS OF THE OUTLINE OF A SPHERE WITH TWO INTERSECTING LINES ON THE SURFACE, FOLLOWED BY THE LETTERS "A","P","T".

FOR PROVIDING AN ONLINE COMPUTER DATABASE IN THE FIELD OF PREVENTIVE MAINTENANCE FOR INDUSTRIAL EQUIPMENT; PROVIDING AN ONLINE SEARCHABLE DATABASE FEATURING RECOMMENDATIONS TO OPTIMIZE MAINTENANCE PLANS FOR INDUSTRIAL EQUIPMENT (U.S. CLS. 100, 103 AND 106).

FRANK LATTUCA, EXAMINING ATTORNEY

SN 86-005,195. CHORE MASTERS, LLC, AUSTIN, TX. FILED 7-9-2013.



NO CLAIM IS MADE TO THE EXCLUSIVE RIGHT TO USE "SINGLE SOURCE" AND "PROPERTY MAINTENANCE", APART FROM THE MARK AS SHOWN.

THE COLOR(S) BLACK, GRAY, WHITE, AND PINK IS/ARE CLAIMED AS A FEATURE OF THE MARK.

THE MARK CONSISTS OF THREE LINES OF TEXT. LINE ONE CONSISTS OF THE WORDS "SINGLE SOURCE" IN ALL CAPITAL PINK LETTERING CENTERED ON THE MARK AND IN A HALF CIRCLE. THE SECOND LINE OF TEXT CONSISTS OF THE WORDS "CHORE 1 MASTERS", THE WORD "CHORE" IS IN ALL BLACK CAPITAL LETTERS, THE "1" IS PINK AND THREE TIMES LARGER THAN THE REST OF THE LETTERS IN THIS LINE, THE WORD "MASTERS" IS IN BLACK. BELOW THE WORD "CHORE" AND "MASTERS" APPEARS A GRAY UNDERLINE. THE THIRD LINE OF TEXT CONSISTS OF THE WORDS "PROPERTY MAINTENANCE CONCIERGE" IN ALL CAPITAL PINK LETTERS. THE ENTIRE MARK IS SET AGAINST A WHITE BACKGROUND.

FOR BUILDING MAINTENANCE AND REPAIR (U.S. CLS. 100, 103 AND 106).

FIRST USE 3-6-2013; IN COMMERCE 4-1-2013.  
DEBORAH LOBO, EXAMINING ATTORNEY

**CLASS 37—(Continued).**

SN 86-044,498. ICRACKED INC., DBA ICRACKED, REDWOOD CITY, CA. FILED 8-21-2013.

local repair & buyback.  
worldwide.

THE MARK CONSISTS OF STANDARD CHARACTERS WITHOUT CLAIM TO ANY PARTICULAR FONT, STYLE, SIZE, OR COLOR.

OWNER OF U.S. REG. NO. 4,457,787.

FOR COMPUTER HARDWARE INSTALLATION AND REPAIR, INCLUDING MOBILE PERFORMANCE OF SUCH SERVICES ON CUSTOMER PREMISES; INSTALLATION AND REPAIR OF COMPUTER HARDWARE; INSTALLATION, MAINTENANCE AND REPAIR OF CELL PHONE RELATED HARDWARE; INSTALLATION, MAINTENANCE AND REPAIR OF COMPUTER HARDWARE; MAINTENANCE AND REPAIR OF TELECOMMUNICATIONS NETWORKING HARDWARE, APPARATUS, AND INSTRUMENTS; REFURBISHING OF CELL PHONES, COMPUTERS, AND MOBILE DEVICES; TECHNICAL SUPPORT SERVICES, NAMELY, TECHNICAL ADVICE RELATED TO THE REPAIR OF CELL PHONE HARDWARE AND MOBILE DEVICES; TECHNICAL SUPPORT SERVICES, NAMELY, TROUBLESHOOTING IN THE NATURE OF THE REPAIR OF COMPUTER HARDWARE (U.S. CLS. 100, 103 AND 106).

FIRST USE 7-16-2013; IN COMMERCE 7-16-2013.

MARY ROSSMAN, EXAMINING ATTORNEY

SN 86-064,434. MERITAGE HOMES CORPORATION, SCOTTSDALE, AZ. FILED 9-13-2013.

PHILLIPS BUILDERS

THE MARK CONSISTS OF STANDARD CHARACTERS WITHOUT CLAIM TO ANY PARTICULAR FONT, STYLE, SIZE, OR COLOR.

NO CLAIM IS MADE TO THE EXCLUSIVE RIGHT TO USE "BUILDERS", APART FROM THE MARK AS SHOWN. SEC. 2(F).

FOR HOMEBUILDING SERVICES (U.S. CLS. 100, 103 AND 106).

FIRST USE 7-6-2006; IN COMMERCE 7-6-2006.  
JORDAN BAKER, EXAMINING ATTORNEY

**CLASS 37—(Continued).**

SN 86-064,482. THE HOWARD HUGHES COMPANY, LLC, DALLAS, TX. FILED 9-13-2013.



OWNER OF U.S. REG. NOS. 1,528,732, 1,623,566 AND 2,060,346.

THE MARK CONSISTS OF A STYLIZED MOUNTAIN DESIGN.

FOR REAL ESTATE DEVELOPMENT SERVICES (U.S. CLS. 100, 103 AND 106).

FIRST USE 3-8-1988; IN COMMERCE 3-8-1988.

JENNY PARK, EXAMINING ATTORNEY

---

SN 86-071,038. SS TRUCK & PERFORMANCE CENTER, INC., SHREVEPORT, LA. FILED 9-20-2013.



THE MARK CONSISTS OF THE STYLIZED TEXT "OUTLAW" WITH ENLARGED "O" AND A REVOLVER TO THE SIDE OF THE "O" WITH BULLET FLYING AWAY FROM REVOLVER.

FOR INSTALLATION OF LIFT KITS ON TRUCKS, AFTERMARKET WHEELS, AND TIRES (U.S. CLS. 100, 103 AND 106).

JACQUELINE ABRAMS, EXAMINING ATTORNEY

---

SN 86-077,853. BUG I'D, INC., SAUSALITO, CA. FILED 9-30-2013.



# BugID

THE MARK CONSISTS OF THE LITERAL ELEMENTS "BUG ID" WRITTEN IN STYLIZED FORM WHEREIN THERE IS AN IMAGE OF BUG/BEE WEARING HEADPHONES INSIDE THE CIRCLE AND BELOW THAT THE WORDS "BUG ID" ARE WRITTEN.

FOR INSTALLATION AND MAINTENANCE OF DIGITAL SIGNAGE AND AUDIO VISUAL PRODUCTS SOLD THEREWITH; INSTALLATION OF COMPUTER SYSTEMS; INSTALLATION OF CUSTOM AUDIO AND VIDEO SYSTEMS (U.S. CLS. 100, 103 AND 106).

FIRST USE 7-10-2008; IN COMMERCE 7-10-2008.

TEJBIR SINGH, EXAMINING ATTORNEY

**CLASS 37—(Continued).**

SN 86-078,151. SKYSHIELD CONSTRUCTION, LLC, LUBBOCK, TX. FILED 9-30-2013.

**SKYSHIELD CONSTRUCTION**

THE MARK CONSISTS OF STANDARD CHARACTERS WITHOUT CLAIM TO ANY PARTICULAR FONT, STYLE, SIZE, OR COLOR.

NO CLAIM IS MADE TO THE EXCLUSIVE RIGHT TO USE "CONSTRUCTION", APART FROM THE MARK AS SHOWN.

FOR ROOFING CONSTRUCTION AND INSTALLATION SERVICES FOR RESIDENTIAL AND COMMERCIAL PROPERTIES (U.S. CLS. 100, 103 AND 106).

FIRST USE 12-1-2012; IN COMMERCE 12-1-2012.

BILL DAWE, EXAMINING ATTORNEY

---

SN 86-078,871. TECHNICAL SERVICES & LOGISTICS, INC., ANAHEIM, CA. FILED 9-30-2013.



THE MARK CONSISTS OF A WORLD GLOBE HALF COVERED BY LINES OF LONGITUDE AND LATITUDE, THE OTHER HALF IS COVERED BY ABSTRACT LINES, TWO RINGS ORBIT THE GLOBE.

FOR MAINTENANCE AND REPAIR OF PRINTERS, SCANNERS, SCANNER SCALES, POINT OF SALES SYSTEMS, AND CASH REGISTERS (U.S. CLS. 100, 103 AND 106).

FIRST USE 4-0-2008; IN COMMERCE 4-0-2008.

KAPIL BHANOT, EXAMINING ATTORNEY

**CLASS 37—(Continued).**

SN 86-111,631. MIDWEST LOG HOME CONSTRUCTION, LLC, CHALMERS, IN. FILED 11-6-2013.

**American Rustic Builders**

THE MARK CONSISTS OF STANDARD CHARACTERS WITHOUT CLAIM TO ANY PARTICULAR FONT, STYLE, SIZE, OR COLOR.

NO CLAIM IS MADE TO THE EXCLUSIVE RIGHT TO USE "BUILDERS", APART FROM THE MARK AS SHOWN. SEC. 2(F).

FOR CONSTRUCTION PLANNING; CONSTRUCTION, MAINTENANCE AND RENOVATION OF PROPERTY; CONSULTING IN THE FIELD OF BUILDING CONSTRUCTION; CUSTOM CONSTRUCTION AND BUILDING RENOVATION; CUSTOM CONSTRUCTION OF HOMES; HOUSING SERVICES, NAMELY, REPAIR, IMPROVEMENT, AND CONSTRUCTION OF RESIDENTIAL REAL PROPERTY (U.S. CLS. 100, 103 AND 106).

FIRST USE 6-5-2009; IN COMMERCE 6-5-2009.  
ESTHER A. BORSUK, EXAMINING ATTORNEY

SN 86-115,773. BISHOP, GILMAN GOLDEN, SAN DIEGO, CA. FILED 11-11-2013.

**BISHOP & COMPANY**

THE MARK CONSISTS OF STANDARD CHARACTERS WITHOUT CLAIM TO ANY PARTICULAR FONT, STYLE, SIZE, OR COLOR.

NO CLAIM IS MADE TO THE EXCLUSIVE RIGHT TO USE "& COMPANY", APART FROM THE MARK AS SHOWN.

FOR REAL ESTATE DEVELOPMENT AND CONSTRUCTION OF COMMERCIAL, RESIDENTIAL AND HOTEL PROPERTY (U.S. CLS. 100, 103 AND 106).

FIRST USE 11-8-2013; IN COMMERCE 11-8-2013.  
HOWARD B. LEVINE, EXAMINING ATTORNEY

**CLASS 37—(Continued).**

SN 86-135,974. R & C ROOFING INC, FIFE, WA. FILED 12-5-2013.



NO CLAIM IS MADE TO THE EXCLUSIVE RIGHT TO USE "SEALED" AND "WWW.SEALEDROOF.COM", APART FROM THE MARK AS SHOWN.

THE COLOR(S) NAVY BLUE, BLUE, GREY, YELLOW, GREEN, SILVER, BLACK, AND WHITE IS/ARE CLAIMED AS A FEATURE OF THE MARK.

THE MARK CONSISTS OF A DESIGN OF A GREY AND BLACK SEAL WEARING A YELLOW AND BLACK HARD HAT. THE SEAL HAS A BLACK AND WHITE NOSE, BLACK EYES, AND BLACK WHISKERS. THE SEAL IS ON TOP OF WATER THAT IS BLUE AND WHITE. THE SEAL IS HOLDING A TOOL THAT IS GREEN, BLACK, AND SILVER. THIS DESIGN ELEMENT APPEARS INSIDE A GRAY AND NAVY BLUE CIRCLE WITH THE WORDING "WWW.SEALEDROOF.COM" WRITTEN FOUR TIMES IN WHITE WITH WHITE SHADED CIRCLES SEPARATING THE WORDING. A NAVY BLUE LINE CUTS ACROSS THE CIRCLE AND THE DESIGN. THE WORDING "SEAL'D" APPEARS IN WHITE ON THIS NAVY BLUE LINE.

FOR ROOFING SERVICES, NAMELY, PROVIDING BUILDING ENVELOPE MAINTENANCE AND REPAIR (U.S. CLS. 100, 103 AND 106).

SETH A. RAPPAPORT, EXAMINING ATTORNEY

SN 86-140,041. SILVER FOX FIRE PROTECTION, LLC, BROOMFIELD, CO. FILED 12-10-2013.



THE MARK CONSISTS OF A PROFILE VIEW OF A FOX'S HEAD.

FOR FIRE EXTINGUISHER RECHARGING SERVICES (U.S. CLS. 100, 103 AND 106).

FIRST USE 4-25-2012; IN COMMERCE 4-24-2013.  
JOANNA DUKOVIC, EXAMINING ATTORNEY

**CLASS 37—(Continued).**

SN 86-143,303. CRITTER CONTROL INC, TRAVERSE CITY, MI. FILED 12-13-2013.

## ECO-WISE PEST MANAGEMENT

THE MARK CONSISTS OF STANDARD CHARACTERS WITHOUT CLAIM TO ANY PARTICULAR FONT, STYLE, SIZE, OR COLOR.

NO CLAIM IS MADE TO THE EXCLUSIVE RIGHT TO USE "PEST MANAGEMENT", APART FROM THE MARK AS SHOWN.

FOR PEST CONTROL (U.S. CLS. 100, 103 AND 106).  
FIRST USE 2-0-2008; IN COMMERCE 2-0-2008.  
COLLEEN MULCRONE, EXAMINING ATTORNEY

SN 86-188,213. TARANTINO & COMPANY, LLC, WAUKESHA, WI. FILED 2-7-2014.

TARANTINO & COMPANY

NO CLAIM IS MADE TO THE EXCLUSIVE RIGHT TO USE "& COMPANY", APART FROM THE MARK AS SHOWN.

THE MARK CONSISTS OF THE WORDING "TARANTINO" ABOVE, AND TO THE LEFT OF AN AMPERSAND SYMBOL, APPEARING IN A DISTINCTIVE FONT, AND THE WORDING "COMPANY" BENEATH AND TO THE RIGHT OF THE AMPERSAND.

SEC. 2(F).  
FOR REAL ESTATE DEVELOPMENT (U.S. CLS. 100, 103 AND 106).  
FIRST USE 2-2-1992; IN COMMERCE 2-2-1992.  
MARY CRAWFORD, EXAMINING ATTORNEY

SN 86-189,716. DENTALFIX RX, LLC, DAVIE, FL. FILED 2-10-2014.

The *faster* Fix

OWNER OF U.S. REG. NOS. 3,897,037 AND 3,901,446.  
THE COLOR(S) BLUE AND BLACK IS/ARE CLAIMED AS A FEATURE OF THE MARK.

THE MARK CONSISTS OF THE WORDS "THE FASTER FIX" WITH THE WORD "FASTER" IN BLUE CURSIVE AND UNDERLINED, AND THE WORDS "THE" AND "FIX" IN BLACK TYPE.

FOR MAINTENANCE AND REPAIR OF DENTAL EQUIPMENT AND HAND PIECES (U.S. CLS. 100, 103 AND 106).

FIRST USE 3-1-2013; IN COMMERCE 3-1-2013.  
BRITTANY ESTELL, EXAMINING ATTORNEY

**CLASS 37—(Continued).**

SN 86-191,356. CARIBBEAN PROMOTION GROUP INCORPORATED, SAN JUAN, PUERTO RICO, FILED 2-12-2014.



NO CLAIM IS MADE TO THE EXCLUSIVE RIGHT TO USE "ADVANCED SECURITY TECH", APART FROM THE MARK AS SHOWN.

THE COLOR(S) LIGHT GREEN, MEDIUM GREEN, DARK GREEN, RED, BLACK AND WHITE IS/ARE CLAIMED AS A FEATURE OF THE MARK.

THE MARK CONSISTS OF THE FOLLOWING: WORD "VIVESEGURO" IN STYLIZED LETTERS IN WHICH "VIVE" IS IN RED COLOR AND "SEGURO" IS IN MEDIUM GREEN COLOR, THE WORDS "ADVANCED SECURITY TECH" IN STYLIZED LETTERS IN BLACK COLOR, A DRAWING OF A HOUSE IN DARK GREEN WITH THE ROOF ON MEDIUM GREEN AND LIGHT GREEN, THE REPRESENTATION OF A HUMAN PERSON CENTERED IN THE HOUSE IN RED COLOR BUT SEPARATED FROM THE HOUSE BY A WHITE COLOR LINE, AND A KEYHOLE IN THE CENTER OF THE HUMAN PERSON IN DARK GREEN COLOR.

THE ENGLISH TRANSLATION OF "VIVESEGURO" IN THE MARK IS "LIVE SAFE".

FOR INSTALLATION AND MAINTENANCE OF BURGLAR AND/OR FIRE ALARMS (U.S. CLS. 100, 103 AND 106).

ANNE E. GUSTASON, EXAMINING ATTORNEY

SN 86-192,740. ZIEGLER, WILLIAM EVANS, DBA GREAT FOUNDATIONS, MARIETTA, GA. FILED 2-13-2014.



NO CLAIM IS MADE TO THE EXCLUSIVE RIGHT TO USE "FOUNDATIONS" AND "REAL ESTATE SOLUTIONS", APART FROM THE MARK AS SHOWN.

THE COLOR(S) GREEN AND BLUE IS/ARE CLAIMED AS A FEATURE OF THE MARK.

THE MARK CONSISTS OF A GREEN TREE WITH A LARGE CANOPY AND ROOT SYSTEM WITH A BLUE PERSON SITTING UNDERNEATH THE TREE. UNDERNEATH THE DESIGN IS THE LITERAL ELEMENT "GREAT FOUNDATIONS" IN BLUE AND "REAL ESTATE SOLUTIONS" IN BLUE. THE TWO PHRASES ARE SEPARATED BY A GREEN LINE.

FOR HOUSING SERVICES, NAMELY, DEVELOPMENT OF REAL PROPERTY, NAMELY, REPAIR, IMPROVEMENT, AND NEW CONSTRUCTION; HOUSING SERVICES, NAMELY, REPAIR, IMPROVEMENT, AND CONSTRUCTION OF RESIDENTIAL REAL PROPERTY; PROVIDING INFORMATION AND COMMENTARY IN THE FIELD OF REAL ESTATE DEVELOPMENT; REAL ESTATE DEVELOPMENT; REAL ESTATE DEVELOPMENT AND CONSTRUCTION OF COMMERCIAL, RESIDENTIAL AND HOTEL PROPERTY; REAL ESTATE SITE SELECTION (U.S. CLS. 100, 103 AND 106).

FIRST USE 1-2-2014; IN COMMERCE 1-2-2014.  
ESTHER A. BORSUK, EXAMINING ATTORNEY



**CLASS 37—(Continued).**

SN 86-194,528. LEID'S INC, DBA BOBBY PAGE'S DRY CLEANERS, CARSON CITY, NV. FILED 2-14-2014.



THE COLOR(S) ROYAL BLUE, LIME GREEN IS/ARE CLAIMED AS A FEATURE OF THE MARK.

THE MARK CONSISTS OF THE WORDS "DI AQUAJET" THAT ARE IN ROYAL BLUE WITH A LIME GREEN OUTLINE. "DI AQUAJET" IS UNDERLINED WITH THE "Q" AND "J" CONNECTED TO THE LINE WITH A SPACE IN BETWEEN THE "I" AND "A" FOR SEPARATION.

FOR CLEANING OF TEXTILES AND CLOTHING UTILIZING A SPECIALIZED CLEANING PROCESS TO DEODORIZE AND CLEAN TEXTILES THAT CANNOT BE PROCESSED BY TRADITIONAL WET OR DRY WASHING EQUIPMENT (U.S. CLS. 100, 103 AND 106).

FIRST USE 12-1-2013; IN COMMERCE 1-3-2014.  
JENNIFER MARTIN, EXAMINING ATTORNEY

---

SN 86-202,017. FOTI, JAMES, PHOENIX, AZ. FILED 2-24-2014.

## The Pool Police

THE MARK CONSISTS OF STANDARD CHARACTERS WITHOUT CLAIM TO ANY PARTICULAR FONT, STYLE, SIZE, OR COLOR.

NO CLAIM IS MADE TO THE EXCLUSIVE RIGHT TO USE "POOL", APART FROM THE MARK AS SHOWN.

FOR REMODELING OF POOLS; REPAIR OF POOLS (U.S. CLS. 100, 103 AND 106).

FRED CARL, EXAMINING ATTORNEY

---

SN 86-207,266. GREAT ROCK MANAGEMENT LLC, PORTLAND, CT. FILED 2-28-2014.

## HUBBY-DO

THE MARK CONSISTS OF STANDARD CHARACTERS WITHOUT CLAIM TO ANY PARTICULAR FONT, STYLE, SIZE, OR COLOR.

FOR BUILDING CONSTRUCTION, REMODELING AND REPAIR; GENERAL CONSTRUCTION CONTRACTING; HANDYMAN SERVICE, NAMELY, BUILDING REPAIR AND MAINTENANCE; RESIDENTIAL AND COMMERCIAL BUILDING CONSTRUCTION (U.S. CLS. 100, 103 AND 106).

FIRST USE 6-28-2013; IN COMMERCE 6-28-2013.  
ESTHER A. BORSUK, EXAMINING ATTORNEY

**CLASS 37—(Continued).**

SN 86-209,058. MATTISON MARTINOLI, INC, MONROE, WA. FILED 3-3-2014.

## Mattison Martinoli, Inc

THE MARK CONSISTS OF STANDARD CHARACTERS WITHOUT CLAIM TO ANY PARTICULAR FONT, STYLE, SIZE, OR COLOR.

NO CLAIM IS MADE TO THE EXCLUSIVE RIGHT TO USE "INC.", APART FROM THE MARK AS SHOWN.

FOR BUILDING CONSTRUCTION SERVICES; BUILDING CONSTRUCTION, REMODELING AND REPAIR; CONSTRUCTION AND RENOVATION OF BUILDINGS; CONSTRUCTION OF BUILDINGS; CUSTOM CONSTRUCTION AND BUILDING RENOVATION; CUSTOM CONSTRUCTION OF HOMES; GENERAL CONSTRUCTION CONTRACTING (U.S. CLS. 100, 103 AND 106).

FIRST USE 1-1-1995; IN COMMERCE 1-1-1995.  
CAROLINE WOOD, EXAMINING ATTORNEY

---

SN 86-210,741. CONTRACTORS TERMITE AND PEST CONTROL INC, PHOENIX, AZ. FILED 3-4-2014.



THE MARK CONSISTS OF A MOUSE IN SUIT WITH GUN HOLDING A SPIDER WITH CROSSHAIRS IN THE BACKGROUND.

FOR PEST CONTROL (U.S. CLS. 100, 103 AND 106).  
FIRST USE 10-2-1995; IN COMMERCE 10-2-1995.  
ROBERT STRUCK, EXAMINING ATTORNEY

**CLASS 37—(Continued).**

SN 86-211,412. NEYER CONSTRUCTION, LLC, CINCINNATI, OH. FILED 3-5-2014.

**NEYER CONSTRUCTION**

THE MARK CONSISTS OF STANDARD CHARACTERS WITHOUT CLAIM TO ANY PARTICULAR FONT, STYLE, SIZE, OR COLOR.

OWNER OF U.S. REG. NOS. 3,384,582 AND 3,534,838.

NO CLAIM IS MADE TO THE EXCLUSIVE RIGHT TO USE "CONSTRUCTION", APART FROM THE MARK AS SHOWN.

SEC. 2(F).

FOR BUILDING CONSTRUCTION SERVICES (U.S. CLS. 100, 103 AND 106).

FIRST USE 11-12-2013; IN COMMERCE 11-12-2013.

RUSS HERMAN, EXAMINING ATTORNEY

---

SN 86-211,970. MAGIC GARAGE CLEANERS, LLC, SPARTA, NJ. FILED 3-5-2014.

**MAGIC GARAGE CLEANERS**

THE MARK CONSISTS OF STANDARD CHARACTERS WITHOUT CLAIM TO ANY PARTICULAR FONT, STYLE, SIZE, OR COLOR.

NO CLAIM IS MADE TO THE EXCLUSIVE RIGHT TO USE "GARAGE CLEANERS", APART FROM THE MARK AS SHOWN.

FOR CLEANING OF GARAGES (U.S. CLS. 100, 103 AND 106).

FIRST USE 9-1-2013; IN COMMERCE 9-1-2013.

PAUL CROWLEY, EXAMINING ATTORNEY

---

SN 86-212,137. CONTRACTORS TERMITE AND PEST CONTROL INC, PHOENIX, AZ. FILED 3-5-2014.

**Contractors Termite & Pest Control, Inc.**

THE MARK CONSISTS OF STANDARD CHARACTERS WITHOUT CLAIM TO ANY PARTICULAR FONT, STYLE, SIZE, OR COLOR.

NO CLAIM IS MADE TO THE EXCLUSIVE RIGHT TO USE "TERMITE & PEST CONTROL, INC.", APART FROM THE MARK AS SHOWN.

FOR PEST CONTROL (U.S. CLS. 100, 103 AND 106).

FIRST USE 10-2-1995; IN COMMERCE 10-2-1995.

ROBERT STRUCK, EXAMINING ATTORNEY

**CLASS 37—(Continued).**

SN 86-212,171. MAGIC GARAGE CLEANERS, LLC, SPARTA, NJ. FILED 3-5-2014.



NO CLAIM IS MADE TO THE EXCLUSIVE RIGHT TO USE "GARAGE CLEANERS", APART FROM THE MARK AS SHOWN.

THE COLOR(S) ORANGE, BLACK, GRAY, AND, WHITE IS/ARE CLAIMED AS A FEATURE OF THE MARK.

THE MARK CONSISTS OF THE WORD "MAGIC" IN STYLIZED LETTERING WITH A DESIGN OF A TOP HAT REPRESENTING THE LETTER "I" WITH A BAND AROUND THE HAT AND SEVEN STARS ABOVE THE HAT AND WITH THE WORDS "GARAGE CLEANERS" APPEARING BELOW THE LETTERS "MAG" IN "MAGIC". THE COLOR ORANGE APPEARS IN THE LETTERS "MAG" AND "C" IN "MAGIC" AND IN THREE OF THE STARS; THE COLOR BLACK APPEARS IN THE HAT, IN THREE OF THE STARS AND IN THE WORDS "GARAGE CLEANERS"; THE COLOR GRAY APPEARS IN THE HAT BAND AND THE COLOR WHITE APPEARS IN ONE OF THE STARS.

FOR CLEANING OF GARAGES (U.S. CLS. 100, 103 AND 106).

FIRST USE 9-1-2013; IN COMMERCE 9-1-2013.

PAUL CROWLEY, EXAMINING ATTORNEY

---

SN 86-212,236. TITAN INDUSTRIAL METAL, INC., FONTANA, CA. FILED 3-5-2014.



NO CLAIM IS MADE TO THE EXCLUSIVE RIGHT TO USE "INDUSTRIAL METAL CORPORATION", APART FROM THE MARK AS SHOWN.

THE COLOR(S) SILVER, DARK BLUE, LIGHT BLUE, WHITE, AND BLACK IS/ARE CLAIMED AS A FEATURE OF THE MARK.

THE MARK CONSISTS OF THE WORD "TIMCORP" WHICH IS IN FOUR COLORS IN DESCENDING ORDER STARTING AT THE TOP WITH DARK BLUE, LIGHT BLUE, WHITE, LIGHT BLUE, WHITE, AND BLACK; THERE IS A PERIOD AFTER "TIMCORP" WHICH IS IN FOUR COLORS IN DESCENDING ORDER STARTING AT THE TOP WITH DARK BLUE, LIGHT BLUE, WHITE, LIGHT BLUE, WHITE, AND BLACK; DIRECTLY BELOW "TIMCORP" IS THE WORDS "TITAN INDUSTRIAL METAL CORPORATION", THAT IS IN ALL CAPS AND BLACK IN COLOR; THE LITERAL ELEMENTS ARE ON TOP OF A RECTANGLE THAT RESEMBLES A METAL PLATE AND IS SILVER; EACH CORNER OF THE RECTANGLE HAS A SHADED CIRCLE SHAPE TO GIVE THE APPEARANCE THAT THE RECTANGLE IS A METAL PLATE BOLTED ONTO WHATEVER SERVICE THE MARK IS DISPLAYED; "TIMCORP" AND THE RECTANGLE HAVE SHADING TO GIVE IT A THREE DIMENSION APPEAL.

FOR COLLECTION OF METAL FOR RECYCLING (U.S. CLS. 100, 103 AND 106).

FIRST USE 1-1-2010; IN COMMERCE 1-1-2010.

ALAIN LAPTER, EXAMINING ATTORNEY



**CLASS 37—(Continued).**

SN 86-214,547. AVARTAR PROPERTIES, INC., SCOTTS-DALE, AZ. FILED 3-7-2014.



NO CLAIM IS MADE TO THE EXCLUSIVE RIGHT TO USE "HOMES", APART FROM THE MARK AS SHOWN.

THE COLOR(S) BLUE AND WHITE IS/ARE CLAIMED AS A FEATURE OF THE MARK.

THE MARK CONSISTS OF A BLUE SQUARE BOX WITH 3 LINES OF LETTERING WITH ONE WORD PER LINE READING "ROYAL OAK HOMES" CENTERED IN THE BOX IN WHITE. THE TERMINAL OF THE "R" IS EXTENDED DOWN IN A SWOOPING FASHION TO FORM THE BAR OF THE LETTER "A" AND THE UPPER ARM OF THE LETTER "K" IN THE WORD "OAK". A WHITE OAK LEAF RESTS TO THE RIGHT OF THE LETTER "K".

FOR RESIDENTIAL BUILDING CONSTRUCTION (U.S. CLS. 100, 103 AND 106).

FIRST USE 10-28-2010; IN COMMERCE 10-28-2010.  
EMILY CHUO, EXAMINING ATTORNEY

**CLASS 37—(Continued).**

SN 86-222,240. STITH, IRIS, MCALLEN, TX. FILED 3-15-2014.

**GADGET RESCUE**

THE MARK CONSISTS OF STANDARD CHARACTERS WITHOUT CLAIM TO ANY PARTICULAR FONT, STYLE, SIZE, OR COLOR.

NO CLAIM IS MADE TO THE EXCLUSIVE RIGHT TO USE "GADGET", APART FROM THE MARK AS SHOWN.

FOR REPAIR AND MAINTENANCE OF SMART PHONES, MP3 PLAYERS, COMPUTERS, AND GAME CONSOLES (U.S. CLS. 100, 103 AND 106).

ERIC SABLE, EXAMINING ATTORNEY

SN 86-227,826. RENEW CREW CALIFORNIA LLC, RIVERSIDE, CA. FILED 3-20-2014.



NO CLAIM IS MADE TO THE EXCLUSIVE RIGHT TO USE "CREW" AND "CALIFORNIA" OR THE PICTORIAL REPRESENTATION OF THE UNITED STATES, APART FROM THE MARK AS SHOWN.

THE COLOR(S) BLUE, GREEN, GREY AND BLACK IS/ARE CLAIMED AS A FEATURE OF THE MARK.

THE MARK CONSISTS OF THE WORDING "RENEW CREW" COLORED IN BLUE AND HAVING THE WORDING "CALIFORNIA", COLORED IN BLACK, POSITIONED BELOW IT AND TOWARD ITS RIGHT END; THREE GREEN ARROWS ARE ARRANGED IN A CIRCULAR SHAPE, WHICH IS TILTED TOWARD THE RIGHT, SUCH THAT THE CIRCULAR SHAPE PASSES BETWEEN THE TERM "RENEW" AND THE TERM "CREW", AND ENCIRCLES AN OUTLINE OF THE UNITED STATES COLORED IN GREY AND POSITIONED BELOW THE TERM "RENEW". THE COLOR WHITE REPRESENTS TRANSPARENT BACKGROUND AND IS NOT CLAIMED AS A FEATURE OF THE MARK.

FOR RECYCLING SERVICES, NAMELY, COLLECTION OF USED CLOTHING AND SHOES FOR LATER DISTRIBUTION (U.S. CLS. 100, 103 AND 106).

FIRST USE 7-0-2013; IN COMMERCE 7-0-2013.  
DANIEL S. STRINGER, EXAMINING ATTORNEY

SN 86-219,550. NERRAD HOLDINGS, LLC, AIKEN, SC. FILED 3-12-2014.



NO CLAIM IS MADE TO THE EXCLUSIVE RIGHT TO USE "FACILITY SOLUTIONS", APART FROM THE MARK AS SHOWN.

THE COLOR(S) BLUE AND ORANGE IS/ARE CLAIMED AS A FEATURE OF THE MARK.

THE MARK CONSISTS OF THE STYLIZED WORDING "NERRAD FACILITY SOLUTIONS" IN BLUE, ONE BLUE CURVED ARROW ABOVE THE WORD SOLUTIONS AND ONE ORANGE CURVED ARROW IMMEDIATELY ABOVE THE BLUE ARROW.

FOR CLEANING OF COMMERCIAL PREMISES (U.S. CLS. 100, 103 AND 106).

ALISON POLLACK, EXAMINING ATTORNEY

**CLASS 37—(Continued).**

SN 86-228,021. LIFTPRO GARAGE DOOR SERVICE, INC., LARGO, FL. FILED 3-21-2014.



THE MARK CONSISTS OF THE STYLIZED WORDING "LIFTPRO" APPEARING TO THE RIGHT OF THE DEPICTION OF A STYLIZED GARAGE.

FOR RESIDENTIAL AND COMMERCIAL GARAGE DOOR REPAIR AND INSTALLATION (U.S. CLS. 100, 103 AND 106).

FIRST USE 12-18-2013; IN COMMERCE 2-1-2014.  
MICHAEL TANNER, EXAMINING ATTORNEY

SN 86-230,152. EHAB HOMES INC., ANTIOCH, CA. FILED 3-24-2014.



NO CLAIM IS MADE TO THE EXCLUSIVE RIGHT TO USE "SMART", "PROPERTIES" AND "ETHICAL ENVIRONMENTAL ECONOMICAL", APART FROM THE MARK AS SHOWN.

THE MARK CONSISTS OF A STYLIZED HOUSE ROOF AND SIDING WITH A WINDOW, TWO LEAVES COMING FORTH OUT OF THE CHIMNEY AND A 3 DIMENSIONAL ARROW CURVING FROM UNDER THE PEAK OF THE ROOF TOWARD THE TOP OF THE HOUSE POINT TO A STYLIZED LOWER CASE "E3". THE LEAVES HAVE DEW DROPS ON THEM. THE "E" HAS HORIZONTAL LINES EXTENDING LEFT AND RIGHT ABOVE AND BELOW THE LETTER TO THE LEFT OF THE STYLIZED TEXT "E3 SMART E3HAB PROPERTIES ETHICAL . ENVIRONMENTAL . ECONOMICAL".

FOR REAL ESTATE REHABILITATION SERVICES, NAMELY, RENOVATION OF HOMES TO MAKE THEM MORE ENERGY EFFICIENT (U.S. CLS. 100, 103 AND 106).

FIRST USE 2-1-2013; IN COMMERCE 2-1-2013.  
APRIL HESIK, EXAMINING ATTORNEY

**CLASS 37—(Continued).**

SN 86-230,646. YJ LINK, DALSEONG-GUN, DAEGU, REPUBLIC OF KOREA, FILED 3-24-2014.



OWNER OF REPUBLIC OF KOREA REG. NO. 45-0040820, DATED 7-6-2012, EXPIRES 7-26-2022.

NO CLAIM IS MADE TO THE EXCLUSIVE RIGHT TO USE "LINK", APART FROM THE MARK AS SHOWN. THE MARK CONSISTS OF THE WORDS "YJ LINK" WITH AN "I" HAVING A WAVE DESIGN.

FOR OFFICE MACHINES AND EQUIPMENT INSTALLATION, MAINTENANCE AND REPAIR; REBUILDING MACHINES THAT HAVE BEEN WORN OR PARTIALLY DESTROYED (U.S. CLS. 100, 103 AND 106).

DAVID HOFFMAN, EXAMINING ATTORNEY

SN 86-231,194. GARAGE DOOR MEDICS, INC., SAN DIEGO, CA. FILED 3-25-2014.

**GARAGE DOOR MEDICS**

THE MARK CONSISTS OF STANDARD CHARACTERS WITHOUT CLAIM TO ANY PARTICULAR FONT, STYLE, SIZE, OR COLOR.

NO CLAIM IS MADE TO THE EXCLUSIVE RIGHT TO USE "GARAGE DOOR", APART FROM THE MARK AS SHOWN.

FOR CONSTRUCTION, REPAIR, AND INSTALLATION OF DOORS, GARAGE DOORS AND RELATED ACCESSORIES; CONSULTATION RELATING TO CONSTRUCTION, REPAIR, AND INSTALLATION OF DOORS, GARAGE DOORS, AND RELATED ACCESSORIES (U.S. CLS. 100, 103 AND 106).

FIRST USE 9-1-2009; IN COMMERCE 9-1-2009.  
SETH DENNIS, EXAMINING ATTORNEY

SN 86-233,145. SOLSTYS ENVIRONMENTAL, LLC, REXBURG, ID. FILED 3-26-2014.

**SOLSTYS ENVIRONMENTAL**

THE MARK CONSISTS OF STANDARD CHARACTERS WITHOUT CLAIM TO ANY PARTICULAR FONT, STYLE, SIZE, OR COLOR.

NO CLAIM IS MADE TO THE EXCLUSIVE RIGHT TO USE "ENVIRONMENTAL", APART FROM THE MARK AS SHOWN.

FOR PEST CONTROL; PEST CONTROL AND EXTERMINATION OTHER THAN FOR AGRICULTURAL PURPOSES (U.S. CLS. 100, 103 AND 106).

FIRST USE 2-0-2013; IN COMMERCE 4-0-2013.  
KIM SAITO, EXAMINING ATTORNEY

**CLASS 37—(Continued).**

SN 86-233,683. GATOR AIR CONDITIONING INC., BRADENTON, FL. FILED 3-27-2014.

**Stress Free Service Call**

THE MARK CONSISTS OF STANDARD CHARACTERS WITHOUT CLAIM TO ANY PARTICULAR FONT, STYLE, SIZE, OR COLOR.

NO CLAIM IS MADE TO THE EXCLUSIVE RIGHT TO USE "SERVICE CALL", APART FROM THE MARK AS SHOWN.

FOR REPAIR OF RESIDENTIAL AND COMMERCIAL AIR CONDITIONING UNITS (U.S. CLS. 100, 103 AND 106).

FIRST USE 12-15-2013; IN COMMERCE 12-15-2013.  
DARRYL SPRUILL, EXAMINING ATTORNEY

---

SN 86-233,746. TRINITY PLUMBING LLC, DALLAS, GA. FILED 3-27-2014.

**Trinity Plumbing LLC**

THE MARK CONSISTS OF STANDARD CHARACTERS WITHOUT CLAIM TO ANY PARTICULAR FONT, STYLE, SIZE, OR COLOR.

NO CLAIM IS MADE TO THE EXCLUSIVE RIGHT TO USE "PLUMBING LLC", APART FROM THE MARK AS SHOWN.

FOR PLUMBING SERVICES (U.S. CLS. 100, 103 AND 106).

FIRST USE 5-1-2010; IN COMMERCE 5-1-2010.  
JERI J. FICKES, EXAMINING ATTORNEY

---

SN 86-233,860. CLEARDEFENSE PEST CONTROL OF RALEIGH, LLC, AKA CLEARDEFENSE PEST CONTROL, DURHAM, NC. FILED 3-27-2014.



NO CLAIM IS MADE TO THE EXCLUSIVE RIGHT TO USE "PEST CONTROL", APART FROM THE MARK AS SHOWN.

THE MARK CONSISTS OF THE WORDING "CLEARDEFENSE PEST CONTROL" WITH A SHIELD THAT IS IN THE BACKGROUND; THE COLORS BLACK, WHITE AND A GRAY REPRESENT BACKGROUND, OUTLINING, SHADING AND TRANSPARENT AREAS AND ARE NOT PART OF THE MARK.

FOR PEST CONTROL; PEST CONTROL AND EXTERMINATION OTHER THAN FOR AGRICULTURAL PURPOSES; TERMITE AND PEST CONTROL (U.S. CLS. 100, 103 AND 106).

FIRST USE 2-1-2013; IN COMMERCE 4-15-2013.  
ALEXANDER L. POWERS, EXAMINING ATTORNEY

**CLASS 37—(Continued).**

SN 86-235,395. SRW ENTERPRISES, INC., BELLEVUE, WA. FILED 3-28-2014.

**BENCHMARK MOTORING**

THE MARK CONSISTS OF STANDARD CHARACTERS WITHOUT CLAIM TO ANY PARTICULAR FONT, STYLE, SIZE, OR COLOR.

NO CLAIM IS MADE TO THE EXCLUSIVE RIGHT TO USE "MOTORING", APART FROM THE MARK AS SHOWN.

FOR AUTOMOBILE CUSTOMIZATION SERVICES; CUSTOM INSTALLATION OF AUTOMOBILE INTERIORS; INSTALLATION, MAINTENANCE AND REPAIR OF MOBILE ELECTRONICS IN AUTOMOBILES; PROVIDING INFORMATION RELATED TO THE INSTALLATION, MAINTENANCE AND REPAIR OF MOBILE ELECTRONICS IN AUTOMOBILES (U.S. CLS. 100, 103 AND 106).

FIRST USE 10-31-2004; IN COMMERCE 12-31-2005.  
LINDA E. BLOHM, EXAMINING ATTORNEY

---

SN 86-235,520. UNITED SUBCONTRACTORS, INC., ST. PAUL, MN. FILED 3-28-2014.



NO CLAIM IS MADE TO THE EXCLUSIVE RIGHT TO USE "BUILDING SOLUTIONS", APART FROM THE MARK AS SHOWN.

THE MARK CONSISTS OF THE LETTERS "U", "S" AND "I" ABOVE THE TERM "BUILDING SOLUTIONS".

FOR BUILDING CONSTRUCTION INFORMATION; BUILDING CONSTRUCTION SERVICES; BUILDING INSPECTION; BUILDING MAINTENANCE AND REPAIR; BUILDING SEALING AND CAULKING SERVICES; CONSTRUCTION AND INSTALLATION OF MASONRY WALLS AND STRUCTURES; CONSTRUCTION MANAGEMENT; CONSTRUCTION OF AIRPORTS; CONSTRUCTION OF AQUATICS FACILITIES; CONSTRUCTION OF FACILITIES, STRUCTURES, LIVING QUARTERS, AND UTILITY BUILDINGS, PRODUCTION MODULES AND SUBSEA MODULES IN THE OIL AND GAS INDUSTRY; CONSTRUCTION OF MEDICAL ESTABLISHMENTS; CONSTRUCTION SERVICES, NAMELY, PLANNING, LAYING OUT AND CONSTRUCTION OF RESIDENTIAL AND COMMERCIAL COMMUNITIES; CONSULTATION SERVICES IN THE FIELD OF CONSTRUCTION OF ENVIRONMENTALLY-CONSCIOUS BUILDINGS; CONSULTING IN THE FIELD OF BUILDING CONSTRUCTION; CONSULTING SERVICES FOR REPAIR AND RESTORATION OF HISTORIC BUILDINGS AND STRUCTURES; CONSULTING SERVICES IN THE FIELD OF WINDSTORM DAMAGE PROTECTION OF STRUCTURES, IN PARTICULAR BUILDINGS, USING WIND FLOW CONTROL DEVICES, SHIELDS, AND DEFLECTORS; CUSTOM CONSTRUCTION AND BUILDING RENOVATION; CUSTOM CONSTRUCTION OF HOMES; GENERAL BUILDING CONTRACTOR SERVICES; INSTALLATION OF BUILDING INSULATION; RESIDENTIAL AND COMMERCIAL BUILDING CONSTRUCTION (U.S. CLS. 100, 103 AND 106).

TARAH HARDY, EXAMINING ATTORNEY

**CLASS 37—(Continued).**

SN 86-235,696. WONDERFUL WINDOWS & SIDING, LP, KATY, TX. FILED 3-28-2014.

WONDERFUL WINDOWS & SIDING

THE MARK CONSISTS OF STANDARD CHARACTERS WITHOUT CLAIM TO ANY PARTICULAR FONT, STYLE, SIZE, OR COLOR.

NO CLAIM IS MADE TO THE EXCLUSIVE RIGHT TO USE "WINDOWS & SIDING", APART FROM THE MARK AS SHOWN.

FOR BUILDING CONSTRUCTION, REMODELING AND REPAIR; INSTALLATION, MAINTENANCE AND REPAIR OF COMMERCIAL AND RESIDENTIAL WINDOWS, SIDING AND DOORS; PROVIDING INFORMATION RELATED TO THE INSTALLATION, MAINTENANCE AND REPAIR OF COMMERCIAL AND RESIDENTIAL WINDOWS, SIDING AND DOORS (U.S. CLS. 100, 103 AND 106).

FIRST USE 0-0-2004; IN COMMERCE 0-0-2004.  
CHARLOTTE CORWIN, EXAMINING ATTORNEY

SN 86-235,716. WONDERFUL WINDOWS & SIDING, LP, KATY, TX. FILED 3-28-2014.



NO CLAIM IS MADE TO THE EXCLUSIVE RIGHT TO USE "WINDOWS & SIDING", APART FROM THE MARK AS SHOWN.

THE MARK CONSISTS OF RECTANGULAR DESIGN CONTAINING THE TERM "WONDERFUL" IN STYLIZED FONT ABOVE A RECTANGULAR BOX WHICH IS BISECTED BY THE LETTER "F" IN THE TERM "WONDERFUL", AND CONTAINS THE TERMS "WINDOWS & SIDING" IN STYLIZED FONT.

FOR BUILDING CONSTRUCTION, REMODELING AND REPAIR; INSTALLATION, MAINTENANCE AND REPAIR OF COMMERCIAL AND RESIDENTIAL WINDOWS, SIDING AND DOORS; PROVIDING INFORMATION RELATED TO THE INSTALLATION, MAINTENANCE AND REPAIR OF COMMERCIAL AND RESIDENTIAL WINDOWS, SIDING AND DOORS (U.S. CLS. 100, 103 AND 106).

FIRST USE 0-0-2004; IN COMMERCE 0-0-2004.  
CHARLOTTE CORWIN, EXAMINING ATTORNEY

**CLASS 37—(Continued).**

SN 86-235,913. GARAGE DOOR MEDICS, INC., SAN DIEGO, CA. FILED 3-28-2014.



NO CLAIM IS MADE TO THE EXCLUSIVE RIGHT TO USE "GARAGE DOOR", APART FROM THE MARK AS SHOWN.

THE COLOR(S) BLACK, WHITE, RED, AND GRAY IS/ARE CLAIMED AS A FEATURE OF THE MARK.

THE MARK CONSISTS OF THE WORDS "GARAGE DOOR" IN BLACK WITH THE WORD "MEDICS" DIRECTLY UNDERNEATH IN WHITE LETTERING WITH A GRAY BACKGROUND. BELOW THE WORD "MEDICS" IS A RED LINE. TO THE RIGHT OF THE WORDS "GARAGE DOOR MEDICS" IS A STAR OF LIFE DESIGN IN WHITE ENCLOSED BY A RED CIRCLE. OUTLINING THE WORDING "GARAGE DOOR MEDICS" AND STAR OF LIFE DESIGN IS A BLACK LINE.

FOR CONSTRUCTION, REPAIR, AND INSTALLATION OF DOORS, GARAGE DOORS AND RELATED ACCESSORIES; CONSULTATION RELATING TO CONSTRUCTION, REPAIR, AND INSTALLATION OF DOORS, GARAGE DOORS, AND RELATED ACCESSORIES (U.S. CLS. 100, 103 AND 106).

FIRST USE 9-1-2009; IN COMMERCE 9-1-2009.  
SETH DENNIS, EXAMINING ATTORNEY

SN 86-235,935. KARABERIS, WILLIAM, ROSEDALE, MD. FILED 3-28-2014.

platinum emergency services

THE MARK CONSISTS OF STANDARD CHARACTERS WITHOUT CLAIM TO ANY PARTICULAR FONT, STYLE, SIZE, OR COLOR.

NO CLAIM IS MADE TO THE EXCLUSIVE RIGHT TO USE "EMERGENCY SERVICES", APART FROM THE MARK AS SHOWN.

FOR PROPERTY RESTORATION SERVICES FOR DAMAGED COMMERCIAL AND RESIDENTIAL REAL PROPERTY, NAMELY, EMERGENCY WINTERIZATION OF DAMAGED REAL PROPERTY; REPAIRS OF REAL PROPERTY, BOARD UP, ROOF COVERING AND SECURING OF OPENINGS IN REAL PROPERTY CAUSED BY DISASTERS SUCH AS FIRES, FLOODS, VEHICULAR ACCIDENTS, WINDS, STORMS, UNAUTHORIZED FENCING (U.S. CLS. 100, 103 AND 106).

EMILY CHUO, EXAMINING ATTORNEY

**CLASS 37—(Continued).**

SN 86-236,274. PULIDO, GEORGE, TURLOCK, CA. FILED 3-29-2014.

**TACTICAL TREASURES**

THE MARK CONSISTS OF STANDARD CHARACTERS WITHOUT CLAIM TO ANY PARTICULAR FONT, STYLE, SIZE, OR COLOR.

NO CLAIM IS MADE TO THE EXCLUSIVE RIGHT TO USE "TACTICAL", APART FROM THE MARK AS SHOWN, FOR REPAIR OR MAINTENANCE OF FIREARMS (U.S. CLS. 100, 103 AND 106).

DANIEL S. STRINGER, EXAMINING ATTORNEY

SN 86-236,523. AUTOWASH, LLLP, DENVER, CO. FILED S.R. 3-30-2014; AM. P.R. 7-7-2014.



NO CLAIM IS MADE TO THE EXCLUSIVE RIGHT TO USE "AUTOWASH", APART FROM THE MARK AS SHOWN.

THE COLOR(S) ROYAL BLUE, NAVY BLUE, ORANGE, WHITE, AND BLACK IS/ARE CLAIMED AS A FEATURE OF THE MARK.

THE MARK CONSISTS OF THE TERM "AUTOWASH" WITH ROYAL BLUE ON THE TOP HALF OF EACH LETTER AND NAVY BLUE ON THE BOTTOM HALF OF EACH LETTER WITH A WHITE LINE RUNNING THROUGH THE LETTERS. THE WHITE LINE THAT SEPARATES THE TWO SHADES OF BLUE CREATES THE APPEARANCE OF A WAVE THROUGH THE LETTERS. ALL LETTERS ARE OUTLINED IN WHITE AND A THIN LINE OF BLACK. AN ORANGE ARC OR SWOOSH EXTENDS FROM ABOVE THE "A," AND THEN DOWN BEHIND THE "H," ENDING SLIGHTLY BELOW THE WORDING.

FOR AUTOMOBILE CLEANING AND CAR WASHING (U.S. CLS. 100, 103 AND 106).

FIRST USE 9-13-2012; IN COMMERCE 3-15-2013.

COLLEEN MULCRONE, EXAMINING ATTORNEY

**CLASS 37—(Continued).**

SN 86-236,786. TRUSTWORTHY SERVICES, LLC, TOWN AND COUNTRY, MO. FILED 3-31-2014.

**Trusty Maid Service**

THE MARK CONSISTS OF STANDARD CHARACTERS WITHOUT CLAIM TO ANY PARTICULAR FONT, STYLE, SIZE, OR COLOR.

NO CLAIM IS MADE TO THE EXCLUSIVE RIGHT TO USE "MAID SERVICE", APART FROM THE MARK AS SHOWN.

FOR MAID SERVICES (U.S. CLS. 100, 103 AND 106).

FIRST USE 8-15-2003; IN COMMERCE 8-15-2003.

JAMES GRIFFIN, EXAMINING ATTORNEY

SN 86-237,242. GOT DIRTY BLINDS? LLC, HOUSTON, TX. FILED 3-31-2014.

**Got Dirty Blinds?**

THE MARK CONSISTS OF STANDARD CHARACTERS WITHOUT CLAIM TO ANY PARTICULAR FONT, STYLE, SIZE, OR COLOR.

NO CLAIM IS MADE TO THE EXCLUSIVE RIGHT TO USE "DIRTY BLINDS", APART FROM THE MARK AS SHOWN.

FOR CLEANING SERVICES FOR BLINDS, CURTAINS, AND WINDOW TREATMENTS (U.S. CLS. 100, 103 AND 106).

FIRST USE 2-6-2014; IN COMMERCE 3-5-2014.

APRIL HESIK, EXAMINING ATTORNEY

SN 86-237,730. YOUNG, JAMES W., DBA EAR CANDY, BURLINGTON, NC. FILED 3-31-2014.

**Ear Candy**

THE MARK CONSISTS OF STANDARD CHARACTERS WITHOUT CLAIM TO ANY PARTICULAR FONT, STYLE, SIZE, OR COLOR.

OWNER OF U.S. REG. NO. 3,355,435.

FOR INSTALLATION OF HOME THEATRES AND RELATED STRUCTURED WIRING (U.S. CLS. 100, 103 AND 106).

FIRST USE 10-2-1989; IN COMMERCE 9-18-1991.

JASON MALASHEVICH, EXAMINING ATTORNEY

**CLASS 37—(Continued).**

SN 86-238,295. GEXA ENERGY, LP, HOUSTON, TX. FILED 4-1-2014.

# GEXA

THE MARK CONSISTS OF STANDARD CHARACTERS WITHOUT CLAIM TO ANY PARTICULAR FONT, STYLE, SIZE, OR COLOR.

OWNER OF U.S. REG. NOS. 2,928,862, 3,943,739 AND 3,943,741.

FOR CONSTRUCTION OF RENEWABLE ENERGY SYSTEMS, INCLUDING SOLAR PHOTOVOLTAIC, WIND, BIOMASS, GEOTHERMAL, LANDFILL GAS, AND DIGESTER GAS SYSTEMS; CONSTRUCTION SERVICES, NAMELY, PLANNING AND MANAGEMENT OF HVAC SYSTEM IMPROVEMENTS, WATER CONSERVATION RETROFITS, WATER EFFICIENCY PROJECTS, WASTE WATER MANAGEMENT FACILITIES AND PLANTS; CONSTRUCTION AND INSTALLATION OF ENERGY CONSERVATION PLANTS, EQUIPMENT AND FIXTURES TO REDUCE ENERGY CONSUMPTION AND IMPROVE EFFICIENCY; CONSULTING SERVICES IN THE FIELD OF CONSTRUCTION OF ENVIRONMENTALLY CONSCIOUS BUILDINGS (U.S. CLS. 100, 103 AND 106).

MARTHA SANTOMARTINO, EXAMINING ATTORNEY

SN 86-239,089. SQUEEGEE BROTHERS, PLEASANTON, CA. FILED 4-1-2014.

# Squeegee Brothers

THE MARK CONSISTS OF STANDARD CHARACTERS WITHOUT CLAIM TO ANY PARTICULAR FONT, STYLE, SIZE, OR COLOR.

NO CLAIM IS MADE TO THE EXCLUSIVE RIGHT TO USE "SQUEEGEE", APART FROM THE MARK AS SHOWN.

FOR CLEANING OF WINDOWS, WINDOW SCREENS, MIRRORS, AND SKYLIGHTS (U.S. CLS. 100, 103 AND 106).

FIRST USE 2-3-2006; IN COMMERCE 2-3-2006.

KATHLEEN M. VANSTON, EXAMINING ATTORNEY

SN 86-240,416. FASTPASS CARWASH, LLC, PLYMOUTH, MI. FILED 4-2-2014.

# FastPass CarWash

THE MARK CONSISTS OF STANDARD CHARACTERS WITHOUT CLAIM TO ANY PARTICULAR FONT, STYLE, SIZE, OR COLOR.

NO CLAIM IS MADE TO THE EXCLUSIVE RIGHT TO USE "CARWASH", APART FROM THE MARK AS SHOWN.

FOR CAR CLEANING; CAR WASHING; VEHICLE WASHING (U.S. CLS. 100, 103 AND 106).

DEBORAH LOBO, EXAMINING ATTORNEY

**CLASS 37—(Continued).**

SN 86-240,518. PELTECH, LLC, SHERIDAN, WY. FILED 4-2-2014.



NO CLAIM IS MADE TO THE EXCLUSIVE RIGHT TO USE "PROTECTOR PELLET", APART FROM THE MARK AS SHOWN.

THE MARK CONSISTS OF A CIRCLE WITH A FIELD AND PLANT LEAVES IN IT TO THE RIGHT THE WORDS "PROTECTOR PELLET".

FOR AGRICULTURAL SERVICES, NAMELY, PLACING A PROTECTIVE COATING ON SEEDS FOR OTHERS (U.S. CLS. 100, 103 AND 106).

ALEX KEAM, EXAMINING ATTORNEY

SN 86-241,127. WILLIAM N. ADKINS, CORNELIUS, NC. AND MARK R. ADKINS, CORNELIUS, NC. FILED 4-3-2014.

# CABIMINIUM

THE MARK CONSISTS OF STANDARD CHARACTERS WITHOUT CLAIM TO ANY PARTICULAR FONT, STYLE, SIZE, OR COLOR.

FOR REAL ESTATE DEVELOPMENT (U.S. CLS. 100, 103 AND 106).

ESTHER QUEEN, EXAMINING ATTORNEY

SN 86-242,053. NO MAS CONSTRUCTION LLC, DENVER, CO. FILED 4-3-2014.

# No Mas Construction

THE MARK CONSISTS OF STANDARD CHARACTERS WITHOUT CLAIM TO ANY PARTICULAR FONT, STYLE, SIZE, OR COLOR.

NO CLAIM IS MADE TO THE EXCLUSIVE RIGHT TO USE "CONSTRUCTION", APART FROM THE MARK AS SHOWN.

THE ENGLISH TRANSLATION OF "NO MAS" IS "NO MORE".

FOR BUILDING CONSTRUCTION; BUILDING CONSTRUCTION AND REPAIR; BUILDING CONSTRUCTION SERVICES; BUILDING CONSTRUCTION SUPERVISION; BUILDING CONSTRUCTION, REMODELING AND REPAIR; CONSTRUCTING PORCHES; CONSTRUCTING SUNROOMS; CONSTRUCTION AND INSTALLATION OF MASONRY WALLS AND STRUCTURES; CONSTRUCTION AND RENOVATION OF BUILDINGS; CONSTRUCTION AND REPAIR OF BUILDINGS; CONSTRUCTION AND REPAIR OF MOVIE AND THEATRICAL SETS AND SCENERY; CONSTRUCTION CONSULTANCY (U.S. CLS. 100, 103 AND 106).

TIMOTHY O. SCHIMPF, EXAMINING ATTORNEY

**CLASS 37—(Continued).**

SN 86-243,298. SCHUELKE PLUMBING, INC., VAN NUYS, CA. FILED 4-4-2014.

IF YOU SEE A CRACK, WE WILL  
GIVE YOUR MONEY BACK

THE MARK CONSISTS OF STANDARD CHARACTERS WITHOUT CLAIM TO ANY PARTICULAR FONT, STYLE, SIZE, OR COLOR.

FOR PLUMBING; PLUMBING CONTRACTOR SERVICES; PLUMBING SERVICES (U.S. CLS. 100, 103 AND 106).

FIRST USE 5-1-2010; IN COMMERCE 5-24-2013.  
COLLEEN MULCRONE, EXAMINING ATTORNEY

SN 86-244,924. ANAGO CLEANING SYSTEMS, POMPANO BEACH, FL. FILED 4-7-2014.

We Clean America's  
Businesses

THE MARK CONSISTS OF STANDARD CHARACTERS WITHOUT CLAIM TO ANY PARTICULAR FONT, STYLE, SIZE, OR COLOR.

FOR CLEANING OF COMMERCIAL PREMISES (U.S. CLS. 100, 103 AND 106).

FIRST USE 7-1-1995; IN COMMERCE 7-1-1995.  
TRICIA SONNEBORN, EXAMINING ATTORNEY

SN 86-247,660. BUILD BY OWNER, LLC, DICKINSON, TX. FILED 4-9-2014.

BUILD BY OWNER

THE MARK CONSISTS OF STANDARD CHARACTERS WITHOUT CLAIM TO ANY PARTICULAR FONT, STYLE, SIZE, OR COLOR.

OWNER OF U.S. REG. NOS. 3,589,368 AND 3,625,636. SEC. 2(F).  
FOR CONSULTING IN THE FIELD OF BUILDING CONSTRUCTION (U.S. CLS. 100, 103 AND 106).  
FIRST USE 0-0-2006; IN COMMERCE 0-0-2006.  
EMILY CHUO, EXAMINING ATTORNEY

**CLASS 37—(Continued).**

SN 86-248,477. FRANKS, RICHARD, FORTSON, GA. FILED 4-10-2014.



OWNER OF U.S. REG. NO. 1,953,255.  
NO CLAIM IS MADE TO THE EXCLUSIVE RIGHT TO USE "AUTO PAINTING & COLLISION", APART FROM THE MARK AS SHOWN.

THE MARK CONSISTS OF A DRAWING OF A PEACH TO THE LEFT OF THE CURSIVE WORD "PEACH" ABOVE THE WORDS "AUTO PAINTING" ABOVE THE WORDS "& COLLISION" AND ALL THE LETTERS ARE OUTLINED.

FOR AUTOMOTIVE COLLISION REPAIR SERVICES; AUTOMOTIVE MAINTENANCE AND REPAIR; AUTOMOTIVE REFINISHING (U.S. CLS. 100, 103 AND 106).

FIRST USE 6-1-1991; IN COMMERCE 6-1-1991.  
JOHN DALIER, EXAMINING ATTORNEY

SN 86-248,688. IMAGE FIRST HEALTHCARE LAUNDRY SPECIALISTS, INC., KING OF PRUSSIA, PA. FILED 4-10-2014.

IMAGEFIRST

THE MARK CONSISTS OF STANDARD CHARACTERS WITHOUT CLAIM TO ANY PARTICULAR FONT, STYLE, SIZE, OR COLOR.

OWNER OF U.S. REG. NOS. 2,808,203, 4,098,553 AND OTHERS.

FOR MEDICAL WASTE DISPOSAL (U.S. CLS. 100, 103 AND 106).

FIRST USE 10-0-2012; IN COMMERCE 10-0-2012.  
TEJBIR SINGH, EXAMINING ATTORNEY

SN 86-248,798. MAGIC BUBBLES, JUPITER, FL. FILED 4-10-2014.

Magic Bubbles

THE MARK CONSISTS OF STANDARD CHARACTERS WITHOUT CLAIM TO ANY PARTICULAR FONT, STYLE, SIZE, OR COLOR.

FOR AUTOMOBILE DETAILING; PRESSURE WASHING SERVICES (U.S. CLS. 100, 103 AND 106).

FIRST USE 7-1-2007; IN COMMERCE 7-1-2007.  
ESTHER A. BORSUK, EXAMINING ATTORNEY

**CLASS 37—(Continued).**

SN 86-248,923. HOLUBECK, JESSE R, FAIRFIELD, IA. FILED 4-10-2014.

**2 GEEKS AND A COMPUTER**

THE MARK CONSISTS OF STANDARD CHARACTERS WITHOUT CLAIM TO ANY PARTICULAR FONT, STYLE, SIZE, OR COLOR.

FOR COMPUTER HARDWARE INSTALLATION AND REPAIR, INCLUDING MOBILE PERFORMANCE OF SUCH SERVICES ON CUSTOMER PREMISES (U.S. CLS. 100, 103 AND 106).

FIRST USE 12-30-2008; IN COMMERCE 12-30-2008.  
EMILY CHUO, EXAMINING ATTORNEY

---

SN 86-249,023. ENSCO INTERNATIONAL INCORPORATED, HOUSTON, TX. FILED 4-10-2014.

**Canti-Leverage Advantage**

THE MARK CONSISTS OF STANDARD CHARACTERS WITHOUT CLAIM TO ANY PARTICULAR FONT, STYLE, SIZE, OR COLOR.

FOR CONTRACT DRILLING OF OIL AND GAS WELLS (U.S. CLS. 100, 103 AND 106).

BRIDGETT SMITH, EXAMINING ATTORNEY

---

SN 86-273,087. EVEREADY BATTERY COMPANY, INC., ST. LOUIS, MO. FILED 5-6-2014.

**ENERGIZER**

THE MARK CONSISTS OF STANDARD CHARACTERS WITHOUT CLAIM TO ANY PARTICULAR FONT, STYLE, SIZE, OR COLOR.

OWNER OF U.S. REG. NOS. 1,502,902, 4,158,144 AND OTHERS.

FOR BATTERY CHARGING SERVICES; RENTAL OF PERSONAL ELECTRONIC DEVICE CHARGING EQUIPMENT (U.S. CLS. 100, 103 AND 106).

ESTHER QUEEN, EXAMINING ATTORNEY

**CLASS 37—(Continued).**

SN 86-286,219. RA HOLDINGS, LLC, DBA AKAMAI ENERGY, HONOLULU, HI. FILED 5-20-2014.

**AKAMAI ENERGY**

THE MARK CONSISTS OF STANDARD CHARACTERS WITHOUT CLAIM TO ANY PARTICULAR FONT, STYLE, SIZE, OR COLOR.

NO CLAIM IS MADE TO THE EXCLUSIVE RIGHT TO USE "ENERGY", APART FROM THE MARK AS SHOWN.

THE ENGLISH TRANSLATION OF THE WORD "AKAMAI" IN THE MARK IS "CLEVER, EXPERT, INTELLIGENT, SMART".

FOR INSTALLATION AND MAINTENANCE OF PHOTOVOLTAIC INSTALLATIONS; INSTALLATION AND MAINTENANCE OF LIGHTING AND ELECTRICAL SYSTEMS; ELECTRICAL REPAIRS, MAINTENANCE, AND INSTALLATION OF ELECTRICAL WIRING, OUTLETS, LIGHT FIXTURES, AND ELECTRICAL PANELS; TECHNICAL CONSULTATION IN THE FIELD OF INSTALLATION OF LIGHTING APPARATUS, LIGHTING INSTRUMENTS AND LIGHTING SYSTEMS; BUILDING CONSTRUCTION, REMODELING AND REPAIR (U.S. CLS. 100, 103 AND 106).

FIRST USE 1-1-2012; IN COMMERCE 2-1-2012.  
ALLISON HOLTZ, EXAMINING ATTORNEY

---

SN 86-309,514. IVAN STEPHAN COLLINS, UPPER MARLBORO, MD. FILED 6-13-2014.

**INNOFACE SYSTEMS**

THE MARK CONSISTS OF STANDARD CHARACTERS WITHOUT CLAIM TO ANY PARTICULAR FONT, STYLE, SIZE, OR COLOR.

NO CLAIM IS MADE TO THE EXCLUSIVE RIGHT TO USE "SYSTEMS", APART FROM THE MARK AS SHOWN.

FOR INSTALLATION OF HIGH-END AUDIO VISUAL SYSTEMS AND CONSULTATION REGARDING THE INSTALLATION OF HIGH-END AUDIO VISUAL SYSTEMS (U.S. CLS. 100, 103 AND 106).

FIRST USE 4-0-2005; IN COMMERCE 8-4-2005.  
DAVID MURRAY, EXAMINING ATTORNEY

---

SN 86-325,481. HABITAT FOR HUMANITY OF OMAHA, INC., OMAHA, NE. FILED 7-1-2014.

**FRAMING FRENZY**

THE MARK CONSISTS OF STANDARD CHARACTERS WITHOUT CLAIM TO ANY PARTICULAR FONT, STYLE, SIZE, OR COLOR.

FOR CHARITABLE SERVICES, NAMELY, CONSTRUCTING HOMES FOR LOW INCOME FAMILIES (U.S. CLS. 100, 103 AND 106).

MARILYN IZZI, EXAMINING ATTORNEY



**CLASS 38—COMMUNICATION**

SN 77-580,490, THE MOTHERHOOD, INC., PITTSBURGH, PA. FILED 9-27-2008.

**THE MOTHERHOOD**

THE MARK CONSISTS OF STANDARD CHARACTERS WITHOUT CLAIM TO ANY PARTICULAR FONT, STYLE, SIZE, OR COLOR.

SEC. 2(F).

FOR PROVIDING ONLINE ELECTRONIC BULLETIN BOARDS FOR TRANSMISSION OF MESSAGES AMONG COMPUTER USERS CONCERNING PARENTAL TRAINING, THE EDUCATION OR ENTERTAINMENT OF CHILDREN, THE HEALTH OF CHILDREN AND INTRAFAMILY RELATIONSHIPS (U.S. CLS. 100, 101 AND 104).

AHSEN KHAN, EXAMINING ATTORNEY

**CLASS 38—(Continued).**

SN 79-145,198, HORSE LIFESTYLE NETWORK LTD.,; VERENIGD KONINKRIJK NAAR BRITS RECHT, NETHERLANDS, FILED 1-19-2014.



OWNER OF INTERNATIONAL REGISTRATION 1198545 DATED 1-19-2014, EXPIRES 1-19-2024.

NO CLAIM IS MADE TO THE EXCLUSIVE RIGHT TO USE "HORSE", APART FROM THE MARK AS SHOWN.

THE MARK CONSISTS OF A HORSE GALLOPING TO THE LEFT SIDE ABOVE THE WORDS "HORSE LIFESTYLE".

FOR BROADCASTING OF TELEVISION PROGRAMS (U.S. CLS. 100, 101 AND 104).

CHRIS WELLS, EXAMINING ATTORNEY

SN 85-800,884, VORTEXX ENTERTAINMENT VENTURES LLC, LOS ANGELES, CA. FILED 12-12-2012.

**SO ACTION-WHACKED**

THE MARK CONSISTS OF STANDARD CHARACTERS WITHOUT CLAIM TO ANY PARTICULAR FONT, STYLE, SIZE, OR COLOR.

FOR TELEVISION BROADCASTING SERVICES; BROADCASTING PRE-RECORDED VIDEOS FEATURING MOTION PICTURES, MUSIC, TELEVISION PROGRAMS, SPORTS, NEWS, AND OTHER ENTERTAINMENT RELATED PROGRAMS VIA TELEVISION, CABLE TELEVISION, SATELLITE TELEVISION, DIGITAL TELEVISION, TELEVISION ON DEMAND, VIDEO ON DEMAND, AND OTHER COMMUNICATION NETWORKS; BROADCASTING SERVICES, NAMELY, THE ELECTRONIC TRANSMISSION AND STREAMING OF DIGITAL AUDIO, VIDEO, GRAPHICS, TEXT AND DATA VIA THE INTERNET, BROADBAND SYSTEMS, TELEPHONES, AND PORTABLE AND WIRELESS COMMUNICATION DEVICES; PROVIDING ON-LINE CHAT ROOMS FOR TRANSMISSION OF MESSAGES AMONG COMPUTER USERS CONCERNING THE TOPICS OF TELEVISION AND ON-LINE ENTERTAINMENT; PROVIDING ON-LINE ELECTRONIC BULLETIN BOARDS FOR TRANSMISSION OF MESSAGES AMONG COMPUTER USERS CONCERNING THE TOPICS OF TELEVISION AND ON-LINE ENTERTAINMENT; PROVIDING WIRELESS ELECTRONIC TRANSMISSION OF UPLOADING AND DOWNLOADING RING TONES, VOICE, MUSIC, MP3 FILES, GRAPHICS, GAMES, VIDEO IMAGES, TELEVISION PROGRAMS, INFORMATION, AND NEWS VIA A GLOBAL COMPUTER NETWORK TO A WIRELESS COMMUNICATION DEVICE (U.S. CLS. 100, 101 AND 104).

FIRST USE 8-25-2012; IN COMMERCE 8-25-2012.

FRED CARL, EXAMINING ATTORNEY

SN 79-057,768, BRAINJUICER LIMITED, UNITED KINGDOM, FILED 7-18-2008.

**MindReader**

THE MARK CONSISTS OF STANDARD CHARACTERS WITHOUT CLAIM TO ANY PARTICULAR FONT, STYLE, SIZE, OR COLOR.

OWNER OF INTERNATIONAL REGISTRATION 0974389 DATED 7-18-2008, EXPIRES 7-18-2018.

FOR TELECOMMUNICATION, NAMELY, TRANSMITTING COMPUTER PROGRAMS VIA GLOBAL COMPUTER NETWORKS; TRANSMITTING APPLICATION SOFTWARE; PROVISION OF TELECOMMUNICATION CONNECTIONS TO A GLOBAL COMPUTER NETWORK, PROVIDING ACCESS TO DATABASES, AND PROPRIETARY SOFTWARE, PROVIDING MULTIPLE USER ACCESS TO PROPRIETARY COLLECTIONS OF INFORMATION BY MEANS OF GLOBAL COMPUTER INFORMATION NETWORKS, TRANSMISSIONS OF APPLICATION SOFTWARE; ADVISORY AND CONSULTANCY SERVICES RELATING TO THE AFORESAID SERVICES (U.S. CLS. 100, 101 AND 104).

CARYN GLASSER, EXAMINING ATTORNEY

**CLASS 38—(Continued).**

SN 86-045,326. ECLINICALWORKS, LLC, WESTBOROUGH, MA. FILED 8-22-2013.

**HEALOW OPEN ACCESS**

THE MARK CONSISTS OF STANDARD CHARACTERS WITHOUT CLAIM TO ANY PARTICULAR FONT, STYLE, SIZE, OR COLOR.

NO CLAIM IS MADE TO THE EXCLUSIVE RIGHT TO USE "OPEN ACCESS", APART FROM THE MARK AS SHOWN.

FOR PROVIDING ACCESS TO WEBSITE(S) THAT ALLOW COMMUNICATIONS BETWEEN PATIENTS AND THEIR HEALTH CARE PROVIDERS (U.S. CLS. 100, 101 AND 104).

CYNTHIA TRIPI, EXAMINING ATTORNEY

SN 86-062,945. THREE LIONS ENTERTAINMENT, LLC, NEW YORK, NY. FILED 9-12-2013.

**SPORTS ROCK**

THE MARK CONSISTS OF STANDARD CHARACTERS WITHOUT CLAIM TO ANY PARTICULAR FONT, STYLE, SIZE, OR COLOR.

NO CLAIM IS MADE TO THE EXCLUSIVE RIGHT TO USE "SPORTS", APART FROM THE MARK AS SHOWN.

FOR STREAMING OF AUDIO, VISUAL AND AUDIO-VISUAL MATERIAL VIA A GLOBAL COMPUTER NETWORK; VIDEO-ON-DEMAND TRANSMISSION SERVICES VIA THE INTERNET (U.S. CLS. 100, 101 AND 104).

MEREDITH MARESCA, EXAMINING ATTORNEY

SN 86-076,349. THE NAME LLC, NEW YORK, NY. FILED 9-27-2013.

**40/40 CLUB**

THE MARK CONSISTS OF STANDARD CHARACTERS WITHOUT CLAIM TO ANY PARTICULAR FONT, STYLE, SIZE, OR COLOR.

OWNER OF U.S. REG. NOS. 3,157,149, 4,342,116 AND OTHERS.

FOR ELECTRONIC TRANSMISSION AND STREAMING OF DIGITAL MEDIA CONTENT, NAMELY, VIDEO CLIPS, SOUND CLIPS, TEXT AND MULTIMEDIA FILES ALL IN THE FIELD OF SPORTS, ENTERTAINMENT AND CULTURE (U.S. CLS. 100, 101 AND 104).

FIRST USE 6-18-2003; IN COMMERCE 6-18-2003.  
JORDAN BAKER, EXAMINING ATTORNEY

**CLASS 38—(Continued).**

SN 86-076,398. THE NAME LLC, NEW YORK, NY. FILED 9-27-2013.



OWNER OF U.S. REG. NOS. 3,157,149, 4,342,116 AND OTHERS.

THE MARK CONSISTS OF THE STYLIZED TERM "40/40" INSIDE A DIAMOND-SHAPED BACKGROUND OVER THE WORD "CLUB", WHICH SITS UNDER AN OUTLINED STRAIGHT LINE AND SITS ABOVE A SHORTER SOLID STRAIGHT LINE.

FOR ELECTRONIC TRANSMISSION AND STREAMING OF DIGITAL MEDIA CONTENT, NAMELY, VIDEO CLIPS, SOUND CLIPS, TEXT AND MULTIMEDIA FILES ALL IN THE FIELDS OF SPORTS, ENTERTAINMENT, AND CULTURE (U.S. CLS. 100, 101 AND 104).

FIRST USE 6-18-2003; IN COMMERCE 6-18-2003.  
JORDAN BAKER, EXAMINING ATTORNEY

SN 86-085,838. CURATE ENTERTAINMENT, INC., NEW YORK, NY. FILED 10-8-2013.

**CURATE ENTERTAINMENT**

THE MARK CONSISTS OF STANDARD CHARACTERS WITHOUT CLAIM TO ANY PARTICULAR FONT, STYLE, SIZE, OR COLOR.

NO CLAIM IS MADE TO THE EXCLUSIVE RIGHT TO USE "ENTERTAINMENT", APART FROM THE MARK AS SHOWN.

FOR TELEVISION, CABLE TELEVISION, CABLE RADIO, SATELLITE, RADIO, WIRELESS AND INTERNET BROADCASTING SERVICES (U.S. CLS. 100, 101 AND 104).

JORDAN BAKER, EXAMINING ATTORNEY

SN 86-109,175. KROMA, LLC, SAN CLEMENTE, CA. FILED 11-4-2013.

**KROMA**

THE MARK CONSISTS OF STANDARD CHARACTERS WITHOUT CLAIM TO ANY PARTICULAR FONT, STYLE, SIZE, OR COLOR.

FOR COMPUTER SERVICES, NAMELY, PROVIDING ONLINE FACILITIES, IN THE NATURE OF PROVIDING TELECOMMUNICATIONS CONNECTIONS TO A RELATIONAL DATABASE FOR REAL TIME INTERACTION BETWEEN EMPLOYERS AND POTENTIAL EMPLOYEES BASED ON CERTAIN PARAMETERS (U.S. CLS. 100, 101 AND 104).

APRIL ROACH, EXAMINING ATTORNEY

**CLASS 38—(Continued).**

SN 86-129,081. ACTIVESERVE INC., MIAMI, FL. FILED 11-26-2013.

activedialer

THE MARK CONSISTS OF STANDARD CHARACTERS WITHOUT CLAIM TO ANY PARTICULAR FONT, STYLE, SIZE, OR COLOR.

OWNER OF U.S. REG. NOS. 4,070,603 AND 4,439,238.  
FOR PBX DIALING SERVICES; PROVIDING MULTIPLE USER DIAL-UP AND DEDICATED ACCESS TO THE INTERNET (U.S. CLS. 100, 101 AND 104).  
LIEF MARTIN, EXAMINING ATTORNEY

---

SN 86-135,872. TRACFONE WIRELESS, INC., MIAMI, FL. FILED 12-5-2013.

COMPLETE WIRELESS

THE MARK CONSISTS OF STANDARD CHARACTERS WITHOUT CLAIM TO ANY PARTICULAR FONT, STYLE, SIZE, OR COLOR.

OWNER OF U.S. REG. NO. 2,247,585.  
NO CLAIM IS MADE TO THE EXCLUSIVE RIGHT TO USE "WIRELESS", APART FROM THE MARK AS SHOWN.  
FOR TELECOMMUNICATION SERVICES, NAMELY, TRANSMISSION OF VOICE, DATA, GRAPHICS, IMAGES, AUDIO AND VIDEO BY MEANS OF TELECOMMUNICATIONS NETWORKS, WIRELESS COMMUNICATION NETWORKS, AND THE INTERNET; TELECOMMUNICATION SERVICES, NAMELY, WIRELESS TELEPHONE SERVICES; TELEPHONE COMMUNICATION SERVICES (U.S. CLS. 100, 101 AND 104).  
TARAH HARDY, EXAMINING ATTORNEY

**CLASS 38—(Continued).**

SN 86-145,407. KHURSHID, ALAM, SARASOTA, FL. FILED 12-17-2013.



NO CLAIM IS MADE TO THE EXCLUSIVE RIGHT TO USE "NEWS", APART FROM THE MARK AS SHOWN.  
THE MARK CONSISTS OF A STYLIZED WORDING "ARY NEWS" WITH TWO RECTANGLES.

FOR BROADCASTING OF RADIO PROGRAMMES; BROADCASTING OF TELEVISION PROGRAMMES; BROADCASTING PROGRAMS VIA A GLOBAL COMPUTER NETWORK; BROADCASTING SERVICES AND PROVISION OF TELECOMMUNICATION ACCESS TO FILMS AND TELEVISION PROGRAMMES PROVIDED VIA A VIDEO-ON-DEMAND SERVICE; CABLE TELEVISION BROADCASTING; INTERNET BROADCASTING SERVICES; INTERNET RADIO BROADCASTING SERVICES; RADIO BROADCASTING CONSULTATION; RADIO BROADCASTING INFORMATION; SATELLITE TELEVISION BROADCASTING; SATELLITE TRANSMISSION SERVICES, TELEVISION AND RADIO BROADCASTING SERVICES; SUBSCRIPTION TELEVISION BROADCASTING (U.S. CLS. 100, 101 AND 104).

B. PARADEWELAI, EXAMINING ATTORNEY

---

SN 86-172,066. TEKSCAPE IT, LLC, NEW YORK, NY. FILED 1-22-2014.



THE MARK CONSISTS OF AN IMAGE OF THE TIP OF AN ARROW WITH THE WORD "TEKSCAPE" TO THE RIGHT OF THE IMAGE.

FOR HOSTED VOICE PHONE SERVICES (U.S. CLS. 100, 101 AND 104).  
FIRST USE 7-1-2010; IN COMMERCE 7-1-2010.  
LINDA LAVACHE, EXAMINING ATTORNEY

**CLASS 38—(Continued).**

SN 86-173,836. BROWN BROTHERS HARRIMAN & CO.,  
NEW YORK, NY. FILED 1-23-2014.

**INFOMEDIARY**

THE MARK CONSISTS OF STANDARD CHARACTERS WITHOUT CLAIM TO ANY PARTICULAR FONT, STYLE, SIZE, OR COLOR.

OWNER OF U.S. REG. NO. 2,713,892.

FOR SIGNAL TRANSMISSION OF ELECTRONIC COMMERCE INVOLVING FINANCIAL INSTRUMENTS VIA TELECOMMUNICATION SYSTEMS AND DATA COMMUNICATION SYSTEMS; TELECOMMUNICATIONS GATEWAY SERVICES IN THE FINANCIAL SERVICES AND BANKING FIELDS, NAMELY, RECEIVING BANKING, STOCK MARKET, CURRENCY EXCHANGE, CORPORATE ACTIONS, AND TRADE INSTRUCTIONS DATA IN ELECTRONIC FORMATS AND TRANSMISSION OF THE DATA OVER WORLD-WIDE BANKING AND PROPRIETARY COMPUTER NETWORKS; AND TRANSMISSION OF FINANCIAL DATABASE INFORMATION VIA TELECOMMUNICATIONS NETWORKS (U.S. CLS. 100, 101 AND 104).

FIRST USE 3-22-2002; IN COMMERCE 1-1-2003.

DAVID C. REIHNER, EXAMINING ATTORNEY

---

SN 86-182,865. AUTOMOTIVE NETWORKS CORPORATION,  
DBA WHEELSTV, ACTON, MA. FILED 2-3-2014.

**WheelsTV**

THE MARK CONSISTS OF STANDARD CHARACTERS WITHOUT CLAIM TO ANY PARTICULAR FONT, STYLE, SIZE, OR COLOR.

FOR FOR: SATELLITE, CABLE, VIDEO ON DEMAND, INTERNET, MOBILE AND BROADBAND TRANSMISSION OF IMAGES, SOUNDS AND DATA OF WHEELED VEHICLES (U.S. CLS. 100, 101 AND 104).

FIRST USE 1-1-1993; IN COMMERCE 8-1-1995.

CAROLYN CATALDO, EXAMINING ATTORNEY

---

SN 86-189,023. NANT HOLDINGS IP, LLC, CULVER CITY,  
CA. FILED 2-10-2014.

**GENOMICS WORLD**

THE MARK CONSISTS OF STANDARD CHARACTERS WITHOUT CLAIM TO ANY PARTICULAR FONT, STYLE, SIZE, OR COLOR.

NO CLAIM IS MADE TO THE EXCLUSIVE RIGHT TO USE "GENOMICS", APART FROM THE MARK AS SHOWN.

FOR PROVIDING ACCESS TO ON-LINE COMPUTER DATABASES CONTAINING INFORMATION BASED ON THE RESULTS OF SEQUENCING OF THE HUMAN GENOME (U.S. CLS. 100, 101 AND 104).

MARTHA FROMM, EXAMINING ATTORNEY

**CLASS 38—(Continued).**

SN 86-201,915. ARBORRY HILL ROAD COMPANY, LLC,  
SAN ANTONIO, TX. FILED 2-24-2014.

**SERVICE ACADEMY FORUMS**

THE MARK CONSISTS OF STANDARD CHARACTERS WITHOUT CLAIM TO ANY PARTICULAR FONT, STYLE, SIZE, OR COLOR.

OWNER OF U.S. REG. NO. 3,581,963.

NO CLAIM IS MADE TO THE EXCLUSIVE RIGHT TO USE "FORUMS", APART FROM THE MARK AS SHOWN. SEC. 2(F).

FOR PROVIDING INTERNET CHATROOMS; PROVIDING ELECTRONIC BULLETIN BOARDS FOR THE TRANSMISSION AND EXCHANGE OF MESSAGES AND PICTURES BETWEEN AND FOR NETWORKING AMONG USERS IN THE FIELD OF TOPICS OF GENERAL INTEREST TO PEOPLE WHO ATTEND, WHO HAVE ATTENDED OR WHO ARE INTERESTED IN ATTENDING THE UNITED STATES SERVICE ACADEMIES; NETCASTING SERVICES IN THE NATURE OF PROVIDING ON-LINE FORUMS FOR TRANSMISSION OF MESSAGES AMONG COMPUTER USERS IN THE FIELD OF TOPICS OF GENERAL INTEREST TO PEOPLE WHO ATTEND, WHO HAVE ATTENDED OR WHO ARE INTERESTED IN ATTENDING THE UNITED STATES SERVICE ACADEMIES (U.S. CLS. 100, 101 AND 104).

FIRST USE 6-8-2006; IN COMMERCE 6-8-2006.

BERYL GARDNER, EXAMINING ATTORNEY

---

SN 86-209,823. CELLCO PARTNERSHIP, DBA VERIZON  
WIRELESS, BASKING RIDGE, NJ. FILED 3-3-2014.

**ALL DATA**

THE MARK CONSISTS OF STANDARD CHARACTERS WITHOUT CLAIM TO ANY PARTICULAR FONT, STYLE, SIZE, OR COLOR.

NO CLAIM IS MADE TO THE EXCLUSIVE RIGHT TO USE "DATA", APART FROM THE MARK AS SHOWN.

FOR WIRELESS COMMUNICATION SERVICES, NAMELY, WIRELESS MOBILE TELEPHONE CALLING PLANS AND DATA AND MESSAGING SERVICE PLANS (U.S. CLS. 100, 101 AND 104).

CARYN GLASSER, EXAMINING ATTORNEY

**CLASS 38—(Continued).**

SN 86-220,367. INTELSAT INVESTMENTS S.A., L-1246 LUXEMBOURG, LUXEMBOURG, FILED 3-13-2014.



OWNER OF U.S. REG. NOS. 2,563,571, 4,339,900 AND OTHERS.

THE MARK CONSISTS OF THE STYLIZED WORD "INTELSAT" ABOVE THE STYLIZED WORDS "ENVISION. CONNECT. TRANSFORM." TO THE LEFT OF THE WORDING IS A DESIGN FEATURING TWO TRIANGULAR SHAPES ON THE LEFT SIDE OF THE DESIGN AND A FOUR-SIDED GEOMETRIC SHAPE ON THE RIGHT SIDE OF THE DESIGN.

FOR SATELLITE COMMUNICATION SERVICES (U.S. CLS. 100, 101 AND 104).

SIDDHARTH JAGANNATHAN, EXAMINING ATTORNEY

SN 86-226,063. SPARKNET COMMUNICATIONS LP, VANCOUVER, BC, CANADA, FILED 3-19-2014.

# QUICKHITZ

THE MARK CONSISTS OF STANDARD CHARACTERS WITHOUT CLAIM TO ANY PARTICULAR FONT, STYLE, SIZE, OR COLOR.

FOR RADIO BROADCASTING OF MUSIC; STREAMING AUDIO AND VIDEO FEATURING MUSIC VIA THE INTERNET (U.S. CLS. 100, 101 AND 104).

ROBIN CHOSID, EXAMINING ATTORNEY

SN 86-226,080. SPARKNET COMMUNICATIONS LP, VANCOUVER, BC, CANADA, FILED 3-19-2014.

# TWICE THE MUSIC

THE MARK CONSISTS OF STANDARD CHARACTERS WITHOUT CLAIM TO ANY PARTICULAR FONT, STYLE, SIZE, OR COLOR.

FOR RADIO BROADCASTING OF MUSIC; STREAMING AUDIO AND VIDEO FEATURING MUSIC VIA THE INTERNET (U.S. CLS. 100, 101 AND 104).

ROBIN CHOSID, EXAMINING ATTORNEY

**CLASS 38—(Continued).**

SN 86-227,465. SPARKNET COMMUNICATIONS LP, VANCOUVER, BC, CANADA, FILED 3-20-2014.

# TWICE THE MUSIC, HALF THE TIME

THE MARK CONSISTS OF STANDARD CHARACTERS WITHOUT CLAIM TO ANY PARTICULAR FONT, STYLE, SIZE, OR COLOR.

FOR RADIO BROADCASTING OF MUSIC; STREAMING AUDIO AND VIDEO FEATURING MUSIC VIA THE INTERNET (U.S. CLS. 100, 101 AND 104).

ROBIN CHOSID, EXAMINING ATTORNEY

SN 86-228,249. DATINGNUMBER.COM, LLC, JOHNSON CITY, TN. FILED 3-21-2014.

# datingnumber

THE MARK CONSISTS OF STANDARD CHARACTERS WITHOUT CLAIM TO ANY PARTICULAR FONT, STYLE, SIZE, OR COLOR.

FOR DIGITAL NETWORK TELECOMMUNICATIONS SERVICES; TELECOMMUNICATION SERVICES, NAMELY, PROVIDING ADVANCED CALLING FEATURES; TELECOMMUNICATION SERVICES, NAMELY, WIRELESS TELEPHONE SERVICES; WIRELESS TELEPHONE TELECOMMUNICATIONS SERVICES, NAMELY, WIRELESS MOBILE TELEPHONE CALLING PLANS (U.S. CLS. 100, 101 AND 104).

TAMARA HUDSON, EXAMINING ATTORNEY

SN 86-233,776. KEVIN JOHNSON, BROOMFIELD, CO. FILED 3-27-2014.

# MY RV FRIENDS

THE MARK CONSISTS OF STANDARD CHARACTERS WITHOUT CLAIM TO ANY PARTICULAR FONT, STYLE, SIZE, OR COLOR.

FOR COMPUTER SERVICES, NAMELY, PROVIDING MULTIPLE USER ACCESS TO COMPUTER NETWORKS FOR THE TRANSFER AND DISSEMINATION OF INFORMATION RELATING TO THE RECREATIONAL INDUSTRY VIA AN ON-LINE, ELECTRONIC COMMUNICATIONS NETWORK (U.S. CLS. 100, 101 AND 104).

AISHA CLARKE, EXAMINING ATTORNEY

**CLASS 38—(Continued).**

SN 86-235,285. ELECTRIC TEA GARDEN, LLC, SEATTLE, WA. FILED 3-28-2014.

**ELECTRIC TEA GARDEN**

THE MARK CONSISTS OF STANDARD CHARACTERS WITHOUT CLAIM TO ANY PARTICULAR FONT, STYLE, SIZE, OR COLOR.

FOR INTERNET RADIO SERVICES, NAMELY, TRANSMISSION OF AUDIO MATERIAL VIA THE INTERNET (U.S. CLS. 100, 101 AND 104).

KEVIN MITTLER, EXAMINING ATTORNEY

SN 86-237,565. OTELCO INC., ONEONTA, AL. FILED 3-31-2014.

**OTELCO LIGHTWAVE**

THE MARK CONSISTS OF STANDARD CHARACTERS WITHOUT CLAIM TO ANY PARTICULAR FONT, STYLE, SIZE, OR COLOR.

OWNER OF U.S. REG. NO. 3,615,841.

NO CLAIM IS MADE TO THE EXCLUSIVE RIGHT TO USE "LIGHTWAVE", APART FROM THE MARK AS SHOWN.

FOR TELECOMMUNICATIONS SERVICES, NAMELY, LOCAL AND LONG DISTANCE TRANSMISSION OF VOICE, DATA, SOUND AND VISUAL IMAGES BY MEANS OF FIBER OPTIC NETWORKS; BROADBAND SERVICES, NAMELY, BROADBAND COMMUNICATION SERVICES; CABLE TELEVISION TRANSMISSION SERVICES; PROVIDING INTERNET ACCESS VIA FIBER OPTIC NETWORKS (U.S. CLS. 100, 101 AND 104).

JOHN HWANG, EXAMINING ATTORNEY

SN 86-239,700. DELCOM TELECOMMUNICATIONS, LLC, POMPANO BEACH, FL. FILED 4-2-2014.

**Fastlight**

THE MARK CONSISTS OF STANDARD CHARACTERS WITHOUT CLAIM TO ANY PARTICULAR FONT, STYLE, SIZE, OR COLOR.

FOR TELECOMMUNICATIONS SERVICES, NAMELY, TELEVISION TRANSMISSION SERVICES, PROVIDING INTERNET ACCESS, TELEPHONE COMMUNICATION SERVICES, AND TRANSMISSION OF VOICE, VIDEO, AND DATA VIA TELECOMMUNICATIONS NETWORKS (U.S. CLS. 100, 101 AND 104).

ALEX KEAM, EXAMINING ATTORNEY

**CLASS 38—(Continued).**

SN 86-239,715. DELCOM TELECOMMUNICATIONS, LLC, POMPANO BEACH, FL. FILED 4-2-2014.

**Techcierge**

THE MARK CONSISTS OF STANDARD CHARACTERS WITHOUT CLAIM TO ANY PARTICULAR FONT, STYLE, SIZE, OR COLOR.

FOR TELECOMMUNICATIONS SERVICES, NAMELY, TELEVISION TRANSMISSION SERVICES, PROVIDING INTERNET ACCESS, TELEPHONE COMMUNICATION SERVICES, AND TRANSMISSION OF VOICE, VIDEO, AND DATA VIA TELECOMMUNICATIONS NETWORKS (U.S. CLS. 100, 101 AND 104).

ALEX KEAM, EXAMINING ATTORNEY

SN 86-240,211. TREALCO LLC, CHICAGO, IL. FILED 4-2-2014.

**TREALCO. COMMUNICATIONS**

THE MARK CONSISTS OF STANDARD CHARACTERS WITHOUT CLAIM TO ANY PARTICULAR FONT, STYLE, SIZE, OR COLOR.

NO CLAIM IS MADE TO THE EXCLUSIVE RIGHT TO USE "COMMUNICATIONS", APART FROM THE MARK AS SHOWN.

FOR INTERNET RADIO SERVICES, NAMELY, TRANSMISSION OF AUDIO MATERIAL VIA THE INTERNET (U.S. CLS. 100, 101 AND 104).

LINDA M. KING, EXAMINING ATTORNEY

SN 86-240,309. SPARKNET COMMUNICATIONS LP, VANCOUVER, BC, CANADA, FILED 4-2-2014.

**JOE FM**

THE MARK CONSISTS OF STANDARD CHARACTERS WITHOUT CLAIM TO ANY PARTICULAR FONT, STYLE, SIZE, OR COLOR.

NO CLAIM IS MADE TO THE EXCLUSIVE RIGHT TO USE "FM", APART FROM THE MARK AS SHOWN.

FOR RADIO BROADCASTING SERVICES; INTERNET BROADCASTING SERVICES; AUDIO STREAMING OVER THE INTERNET (U.S. CLS. 100, 101 AND 104).

ROBIN CHOSID, EXAMINING ATTORNEY

**CLASS 38—(Continued).**

SN 86-240,369. DELCOM TELECOMMUNICATIONS, LLC, POMPANO BEACH, FL. FILED 4-2-2014.

**CLASS 38—(Continued).**

SN 86-240,409. DELCOM TELECOMMUNICATIONS, LLC, POMPANO BEACH, FL. FILED 4-2-2014.

FastLite

xstreme

THE MARK CONSISTS OF STANDARD CHARACTERS WITHOUT CLAIM TO ANY PARTICULAR FONT, STYLE, SIZE, OR COLOR.

FOR TELECOMMUNICATIONS SERVICES, NAMELY, TELEVISION TRANSMISSION SERVICES, PROVIDING INTERNET ACCESS, TELEPHONE COMMUNICATION SERVICES, AND TRANSMISSION OF VOICE, VIDEO, AND DATA VIA TELECOMMUNICATIONS NETWORKS (U.S. CLS. 100, 101 AND 104).

ALEX KEAM, EXAMINING ATTORNEY

THE MARK CONSISTS OF STANDARD CHARACTERS WITHOUT CLAIM TO ANY PARTICULAR FONT, STYLE, SIZE, OR COLOR.

FOR TELECOMMUNICATIONS SERVICES, NAMELY, TELEVISION TRANSMISSION SERVICES, PROVIDING INTERNET ACCESS, TELEPHONE COMMUNICATION SERVICES, AND TRANSMISSION OF VOICE, VIDEO, AND DATA VIA TELECOMMUNICATIONS NETWORKS (U.S. CLS. 100, 101 AND 104).

ALEX KEAM, EXAMINING ATTORNEY

SN 86-240,389. DELCOM TELECOMMUNICATIONS, LLC, POMPANO BEACH, FL. FILED 4-2-2014.

SN 86-240,426. DELCOM TELECOMMUNICATIONS, LLC, POMPANO BEACH, FL. FILED 4-2-2014.

FastLite

xstreme

THE COLOR(S) BLACK AND ORANGE IS/ARE CLAIMED AS A FEATURE OF THE MARK.

THE MARK CONSISTS OF THE WORD "FASTLITE", THE WORDING "FAST" IN FAT BLACK LETTERS AND THE WORD "LITE" IN SKINNY ORANGE LETTERS.

FOR TELECOMMUNICATIONS SERVICES, NAMELY, TELEVISION TRANSMISSION SERVICES, PROVIDING INTERNET ACCESS, TELEPHONE COMMUNICATION SERVICES, AND TRANSMISSION OF VOICE, VIDEO, AND DATA VIA TELECOMMUNICATIONS NETWORKS (U.S. CLS. 100, 101 AND 104).

ALEX KEAM, EXAMINING ATTORNEY

THE COLOR(S) ORANGE AND BLACK IS/ARE CLAIMED AS A FEATURE OF THE MARK.

THE MARK CONSISTS OF THE WORDING "XSTREME", THE LETTER "X" IN ORANGE AND THE LETTERS "STREME" IN BLACK.

FOR TELECOMMUNICATIONS SERVICES, NAMELY, TELEVISION TRANSMISSION SERVICES, PROVIDING INTERNET ACCESS, TELEPHONE COMMUNICATION SERVICES, AND TRANSMISSION OF VOICE, VIDEO, AND DATA VIA TELECOMMUNICATIONS NETWORKS (U.S. CLS. 100, 101 AND 104).

ALEX KEAM, EXAMINING ATTORNEY

**CLASS 38—(Continued).**

SN 86-240,484. DELCOM TELECOMMUNICATIONS, LLC, POMPANO BEACH, FL. FILED 4-2-2014.



THE COLOR(S) ORANGE, WHITE, AND LIGHT BLUE IS/ ARE CLAIMED AS A FEATURE OF THE MARK.

THE MARK CONSISTS OF A PICTURE OF THE SUN, THE MIDDLE OF WHICH IS WHITE, WITH SMALL AND LARGE CONES PROTRUDING FROM THE OUTSIDE OF THE SUN, THE MIDDLE OF SUCH CONES ARE A SHADE OF ORANGE AND THE END OF SUCH CONES ARE A DARKER SHADE OF ORANGE, WITH A LIGHT BLUE CIRCLE SURROUNDING THE SUN.

FOR TELECOMMUNICATIONS SERVICES, NAMELY, TELEVISION TRANSMISSION SERVICES, PROVIDING INTERNET ACCESS, TELEPHONE COMMUNICATION SERVICES, AND TRANSMISSION OF VOICE, VIDEO, AND DATA VIA TELECOMMUNICATIONS NETWORKS (U.S. CLS. 100, 101 AND 104).

ALEX KEAM, EXAMINING ATTORNEY

SN 86-242,104. BE HEARD, LLC, GREENVILLE, SC. FILED 4-3-2014.

# VOICE

THE MARK CONSISTS OF STANDARD CHARACTERS WITHOUT CLAIM TO ANY PARTICULAR FONT, STYLE, SIZE, OR COLOR.

FOR ELECTRONIC MESSAGE SENDING; MESSAGE SENDING AND RECEIVING SERVICES; ON-LINE SERVICES, NAMELY, MESSAGE SENDING (U.S. CLS. 100, 101 AND 104).

BRIAN PINO, EXAMINING ATTORNEY

**CLASS 38—(Continued).**

SN 86-244,892. DATACARE CORPORATION, SAN JOSE, CA. FILED 4-7-2014.

# CASEBOOK

THE MARK CONSISTS OF STANDARD CHARACTERS WITHOUT CLAIM TO ANY PARTICULAR FONT, STYLE, SIZE, OR COLOR.

FOR COMMUNICATION SERVICES, NAMELY, ELECTRONIC TRANSMISSION OF DATA AND DOCUMENTS AMONG USERS OF COMPUTERS; PROVISION OF ACCESS TO DATA OR DOCUMENTS STORED ELECTRONICALLY IN CENTRAL FILES FOR REMOTE CONSULTATION (U.S. CLS. 100, 101 AND 104).

FIRST USE 6-18-2014; IN COMMERCE 6-18-2014.

MORGAN WYNNE, EXAMINING ATTORNEY

SN 86-247,863. SHENZHEN DANALE TECHNOLOGY CO., LTD, SHENZHEN CITY, CHINA, FILED 4-10-2014.

# Danale

THE MARK CONSISTS OF THE STYLIZED WORD "DANALE".

THE WORDING "DANALE" HAS NO MEANING IN A FOREIGN LANGUAGE.

FOR CELLULAR TELEPHONE COMMUNICATION; COMPUTER-AIDED TRANSMISSION OF MESSAGES AND IMAGES; ELECTRONIC MAIL; FACSIMILE TRANSMISSION; ON-LINE SERVICES, NAMELY, MESSAGE SENDING; PROVIDING ACCESS TO DATABASES; PROVIDING TELECOMMUNICATIONS CONNECTIONS TO A GLOBAL COMPUTER NETWORK; TELEVISION BROADCASTING; TRANSMISSION OF DIGITAL FILES; VOICE MAIL SERVICES (U.S. CLS. 100, 101 AND 104).

DAWN FELDMAN, EXAMINING ATTORNEY

SN 86-250,113. INVIDZ, LLC, DUNEDIN, FL. FILED 4-11-2014.

# InVidz

THE MARK CONSISTS OF STANDARD CHARACTERS WITHOUT CLAIM TO ANY PARTICULAR FONT, STYLE, SIZE, OR COLOR.

FOR VIDEO BROADCASTING SERVICES OVER THE INTERNET OR OTHER COMMUNICATIONS NETWORK FEATURING THE UPLOADED, POSTED AND TAGGED VIDEOS OF OTHERS; VIDEO BROADCASTING SERVICES OVER THE INTERNET OR OTHER COMMUNICATIONS NETWORK, NAMELY, ELECTRONICALLY TRANSMITTING VIDEO CLIPS (U.S. CLS. 100, 101 AND 104).

TEJBIR SINGH, EXAMINING ATTORNEY



**CLASS 38—(Continued).**

SN 86-259,453. TIME WARNER CABLE ENTERPRISES LLC, NEW YORK, NY. FILED 4-22-2014.

GREAT MOMENTS LIVE  
FOREVER. GREAT MOMENTS  
LIVE HERE.

THE MARK CONSISTS OF STANDARD CHARACTERS WITHOUT CLAIM TO ANY PARTICULAR FONT, STYLE, SIZE, OR COLOR.

FOR VIDEO-ON-DEMAND CABLE TELEVISION TRANSMISSION, AND BROADCASTING SERVICES; CABLE TELEVISION TRANSMISSION SERVICES; NAMELY TRANSMISSION OF DIGITAL VIDEO RECORDINGS; BROADBAND COMMUNICATIONS SERVICES, NAMELY ANALOG AND DIGITAL CABLE TELEVISION TRANSMISSION SERVICES, TRANSMISSION OF INTERACTIVE TELEVISION PROGRAMS AND TRANSMISSION OF HIGH-DEFINITION TELEVISION PROGRAMS (U.S. CLS. 100, 101 AND 104).  
JENNY PARK, EXAMINING ATTORNEY

SN 86-274,157. T-MOBILE USA, INC., BELLEVUE, WA. FILED 5-7-2014.

\$40, PUNTO.

THE MARK CONSISTS OF STANDARD CHARACTERS WITHOUT CLAIM TO ANY PARTICULAR FONT, STYLE, SIZE, OR COLOR.

OWNER OF U.S. REG. NO. 4,530,987.

NO CLAIM IS MADE TO THE EXCLUSIVE RIGHT TO USE "\$40", APART FROM THE MARK AS SHOWN.

THE ENGLISH TRANSLATION OF "PUNTO" IN THE MARK IS "PERIOD".

FOR CELLULAR TELECOMMUNICATIONS SERVICES, NAMELY, TRANSMISSION OF VOICE, AUDIO, DATA, TEXT, IMAGES, VIDEO, MUSIC AND INFORMATION VIA CELLULAR TELECOMMUNICATIONS NETWORKS AND THE INTERNET; CELLULAR TELECOMMUNICATIONS SERVICES, NAMELY, TWO-WAY REAL-TIME TRANSMISSION OF VOICE, AUDIO, VIDEO AND DATA BETWEEN WIRELESS TELECOMMUNICATIONS DEVICES; WIRELESS TELEPHONE TELECOMMUNICATIONS SERVICES, NAMELY, PROVIDING WIRELESS CALLING PLANS; TEXT MESSAGING AND MULTIMEDIA ELECTRONIC MESSAGING SERVICES; PROVIDING MULTIPLE-USER ACCESS TO A GLOBAL COMPUTER NETWORK; PROVIDING TECHNICAL SUPPORT REGARDING THE USAGE OF CELLULAR TELECOMMUNICATIONS EQUIPMENT; WIRELESS ROAMING SERVICES, NAMELY, PROVIDING ACCESS TO A CELLULAR TELECOMMUNICATION NETWORK; ELECTRONIC MAIL SERVICES; TELEPHONE COMMUNICATION SERVICES, NAMELY, RINGBACK TONE SERVICES (U.S. CLS. 100, 101 AND 104).

FIRST USE 7-25-2013; IN COMMERCE 7-25-2013.

JOHN SCHUYLER YARD, EXAMINING ATTORNEY

**CLASS 39—TRANSPORTATION AND STORAGE**

SN 76-713,408. TERVITA CORPORATION, CALGARY, AB, CANADA, FILED 2-7-2013.

MINIMIZING IMPACT, MAXIMIZING RETURNS

THE MARK CONSISTS OF STANDARD CHARACTERS WITHOUT CLAIM TO ANY PARTICULAR FONT, STYLE, SIZE, OR COLOR.

FOR CRUDE OIL TERMINAL SERVICES, NAMELY, TRANSPORTATION, DISTRIBUTION AND SHIPPING OF CRUDE OIL; CRUDE OIL STORAGE SERVICES; FRAC SAND TERMINAL SERVICES, NAMELY, TRANSPORTATION, DISTRIBUTION AND SHIPPING OF FRAC SAND; TRANSPORTATION SERVICES, NAMELY, TRANSPORTING OF GOODS BY TRUCK AND RAIL INCLUDING THE LOADING AND UNLOADING OF GOODS; HAULING SERVICES BY WAY OF TRUCK AND RAIL; EMERGENCY, SPILL, AND HAZARDOUS SUBSTANCE RESPONSE AND SITE MANAGEMENT SERVICES, NAMELY, HAZARDOUS WASTE TRANSPORTATION SERVICES; TRUCK HAULING OF OIL-FIELD AND INDUSTRIAL FLUIDS AND WASTE; WASTE TRANSPORTATION AND TRACKING SERVICES, NAMELY, TRANSPORT OF WASTE BY TRUCK AND RAIL; LOGISTICS SERVICES FOR TRANSPORTATION, HAULING AND DISPOSAL OF OILFIELD AND INDUSTRIAL WASTE NAMELY, SERVICES IN THE NATURE OF STORAGE, TRANSPORTATION AND DELIVERY OF NON-HAZARDOUS OILFIELD AND INDUSTRIAL WASTE FOR OTHERS BY RAIL OR TRUCK; DELIVERY AND PICK UP SERVICES FOR SCRAP METAL COLLECTION CONTAINERS (U.S. CLS. 100 AND 105).

SAMUEL PAQUIN, EXAMINING ATTORNEY

SN 79-129,165. DEMCHENKO DMYTRO OLEKSANDROVYCH, KYIV 03191, UKRAINE, FILED 2-5-2013.



OWNER OF INTERNATIONAL REGISTRATION 1157848 DATED 2-5-2013, EXPIRES 2-5-2023.

FOR AMBULANCE TRANSPORT; CHAUFFEUR SERVICES; DELIVERY OF NEWSPAPERS; FLOWER DELIVERY; GUARDED TRANSPORT OF VALUABLES; TRUCK HAULING; MESSAGE DELIVERY; RESCUE SERVICES; STREETCAR TRANSPORT; TRANSPORTATION RESERVATION SERVICES; TAXI TRANSPORT; TRANSPORT OF TRAVELERS (U.S. CLS. 100 AND 105).

MELISSA VALLILLO, EXAMINING ATTORNEY

**CLASS 39—(Continued).**

SN 85-430,637. SERVIENTREGA S.A., BOGOTÁ, COLOMBIA, FILED 9-23-2011.

**SERVIENTREGA**

THE MARK CONSISTS OF STANDARD CHARACTERS WITHOUT CLAIM TO ANY PARTICULAR FONT, STYLE, SIZE, OR COLOR.

OWNER OF COLOMBIA REG. NO. 491115, DATED 5-27-2014, EXPIRES 5-27-2024.

OWNER OF U.S. REG. NOS. 2,295,127 AND 2,913,596.

THE WORDING "SERVIENTREGA" HAS NO MEANING IN A FOREIGN LANGUAGE.

FOR AIR TRANSPORT; DELIVERY OF GOODS; MERCHANDISE PACKAGING FOR OTHERS; ORGANIZATION OF TRIPS; PACKAGING ARTICLES FOR TRANSPORTATION; STORAGE OF GOODS; TRANSPORT AND DELIVERY OF GOODS; TRANSPORTATION AND DELIVERY SERVICES BY AIR, ROAD, RAIL AND SEA; TRANSPORTATION AND DELIVERY SERVICES, NAMELY, SAME DAY SHIPMENT SERVICES; TRANSPORTATION OF GOODS; TRAVEL AGENCY SERVICES, NAMELY, MAKING RESERVATIONS AND BOOKINGS FOR TRANSPORTATION (U.S. CLS. 100 AND 105).

RAUL CORDOVA, EXAMINING ATTORNEY

SN 85-926,550. THE FRUIT GUYS, LLC, SOUTH SAN FRANCISCO, CA. FILED 5-8-2013.

**SmileSnack**

THE MARK CONSISTS OF STANDARD CHARACTERS WITHOUT CLAIM TO ANY PARTICULAR FONT, STYLE, SIZE, OR COLOR.

FOR DELIVERY SERVICES OF FRESH PRODUCE AND RELATED FOOD ITEMS, INCLUDING BUT NOT LIMITED TO FRUITS, VEGETABLES, DAIRY PRODUCTS, PACKAGED MEALS, AND OTHER PREPARED FOODS TO RESIDENCES, OFFICES, DORMITORIES, SCHOOLS, AND BUSINESS LOCATIONS BY TRUCK, MAIL AND OVERNIGHT COURIER (U.S. CLS. 100 AND 105).

FIRST USE 4-24-2011; IN COMMERCE 1-1-2013.

DAVID MURRAY, EXAMINING ATTORNEY

**CLASS 39—(Continued).**

SN 86-043,867. CRAB COUNTRY GOURMET, LLC, SALISBURY, MD. FILED 8-21-2013.

**CRAB COUNTRY GOURMET**

THE MARK CONSISTS OF STANDARD CHARACTERS WITHOUT CLAIM TO ANY PARTICULAR FONT, STYLE, SIZE, OR COLOR.

NO CLAIM IS MADE TO THE EXCLUSIVE RIGHT TO USE "CRAB" AND "GOURMET", APART FROM THE MARK AS SHOWN.

FOR PACKAGING ARTICLES FOR TRANSPORTATION; PACKAGING ARTICLES TO THE ORDER AND SPECIFICATION OF OTHERS (U.S. CLS. 100 AND 105).

HEATHER BIDDULPH, EXAMINING ATTORNEY

SN 86-044,090. LOS ANGELES COUNTY WATERWORKS DISTRICT NO. 21, ALHAMBRA, CA. AND LOS ANGELES COUNTY WATERWORKS DISTRICT NO. 29, ALHAMBRA, CA. AND LOS ANGELES COUNTY WATERWORKS DISTRICT NO. 36, ALHAMBRA, CA. AND LOS ANGELES COUNTY WATERWORKS DISTRICT NO. 37, ALHAMBRA, CA. AND LOS ANGELES COUNTY WATERWORKS DISTRICT NO. 40, ALHAMBRA, CA. FILED 8-21-2013.



NO CLAIM IS MADE TO THE EXCLUSIVE RIGHT TO USE "LOS ANGELES COUNTY WATERWORKS DISTRICTS", APART FROM THE MARK AS SHOWN.

THE MARK CONSISTS OF THE LETTERS "LACWD" ABOVE A GRAPHIC IMAGE OF WATER CURRENTS AND THE WORDS "LOS ANGELES COUNTY WATERWORKS DISTRICTS" AT THE BOTTOM OF THE MARK.

FOR PUBLIC UTILITY SERVICES IN THE NATURE OF WATER SUPPLY AND DISTRIBUTION (U.S. CLS. 100 AND 105).

FIRST USE 1-31-2012; IN COMMERCE 1-31-2012.

ANDREA BUTLER, EXAMINING ATTORNEY

SN 86-064,377. GREEN TEAM CAB CORP., NEW ROCHELLE, NY. FILED 9-13-2013.



THE COLOR(S) DARK GREEN, GREEN AND BLUE ARE CLAIMED AS A FEATURE OF THE MARK IS/ARE CLAIMED AS A FEATURE OF THE MARK.

THE MARK CONSISTS OF THE WORDING "GREENTEAM" APPEARING BELOW A STYLIZED GLOBE WITH

**CLASS 39—(Continued).**

GREEN OUTLINE AND DARK GREEN MAP. THE WORDING "GREEN" IS GREEN AND THE WORDING "TEAM" IS BLUE WITH BLUE LEAF APPEARING TO THE RIGHT OF THE WORDING "TEAM" AND BELOW THE GLOBE. BENEATH THE WORDING "GREENTeam" IS A LEAF DESIGN WITH GREEN AND DARK GREEN OUTLINES WITH DARK CIRCLE DESIGNS RESEMBLING TIRES BEING PART OF THE LEAF. THE COLOR WHITE APPEARING IN THE MARK MERELY REPRESENTS THE BACKGROUND AND IS NOT A FEATURE OF THE MARK.

FOR LIMOUSINE SERVICES PROVIDED BY ENVIRONMENTALLY FRIENDLY VEHICLES; TAXI TRANSPORT PROVIDED BY ENVIRONMENTALLY FRIENDLY VEHICLES (U.S. CLS. 100 AND 105).

FIRST USE 5-0-2010; IN COMMERCE 5-0-2010.  
JENNY PARK, EXAMINING ATTORNEY

SN 86-066,774. DREW ESTATE HOLDING COMPANY LLC, MIAMI, FL. FILED 9-17-2013.

**CIGAR SAFARI**

THE MARK CONSISTS OF STANDARD CHARACTERS WITHOUT CLAIM TO ANY PARTICULAR FONT, STYLE, SIZE, OR COLOR.

SEC. 2(F).

FOR ARRANGING AND COORDINATING TRAVEL ARRANGEMENTS FOR INDIVIDUALS AND GROUPS, NAMELY, DESTINATION STAYS; ARRANGING AND CONDUCTING TRAVEL TOURS; COORDINATING TRAVEL ARRANGEMENTS FOR INDIVIDUALS AND FOR GROUPS; ORGANIZATION OF TRAVEL TRIPS (U.S. CLS. 100 AND 105).

FIRST USE 7-31-2008; IN COMMERCE 7-31-2008.  
LAURIE MAYES, EXAMINING ATTORNEY

SN 86-068,417. NORDIC COLD STORAGE HOLDINGS, LLC, ATLANTA, GA. FILED 9-18-2013.

**NORDIC**

THE MARK CONSISTS OF STANDARD CHARACTERS WITHOUT CLAIM TO ANY PARTICULAR FONT, STYLE, SIZE, OR COLOR.

FOR COLD STORAGE AND TRANSPORTATION SERVICES, NAMELY, DRAYAGE SERVICES VIA REFRIGERATED TRUCKS, REFRIGERATED WAREHOUSE STORAGE OF FROZEN FOODS AND ARRANGEMENT OF TRUCKING AND SHIPMENT OF FROZEN FOODS; LOGISTICS MANAGEMENT IN THE FIELD OF REFRIGERATED TRANSPORTATION MANAGEMENT, NAMELY, TRUCKING, SHIPPING AND ARRANGEMENT OF TRANSPORTATION OF GOODS BY RAIL VIA REFRIGERATED RAILROAD FLEET; WAREHOUSING SERVICES, NAMELY, DISTRIBUTION OF REFRIGERATED GOODS AND GOODS THAT REQUIRE REFRIGERATION; FREIGHT ROUTING, NAMELY, REFRIGERATED TRUCKING VEHICLE ROUTING BY COMPUTER ON DATA NETWORKS (U.S. CLS. 100 AND 105).

FIRST USE 12-31-1985; IN COMMERCE 12-31-1985.  
AMY C. KEAN, EXAMINING ATTORNEY

**CLASS 39—(Continued).**

SN 86-076,357. THE NAME LLC, NEW YORK, NY. FILED 9-27-2013.

**40/40 CLUB**

THE MARK CONSISTS OF STANDARD CHARACTERS WITHOUT CLAIM TO ANY PARTICULAR FONT, STYLE, SIZE, OR COLOR.

OWNER OF U.S. REG. NOS. 3,157,149, 4,342,116 AND OTHERS.

FOR WEB, DIGITAL, VIDEO AND MEDIA CONTENT ARCHIVING SERVICES (U.S. CLS. 100 AND 105).

FIRST USE 6-18-2003; IN COMMERCE 6-18-2003.  
JORDAN BAKER, EXAMINING ATTORNEY

SN 86-076,405. THE NAME LLC, NEW YORK, NY. FILED 9-27-2013.



OWNER OF U.S. REG. NOS. 3,157,149, 4,342,116 AND OTHERS.

THE MARK CONSISTS OF THE STYLIZED TERM "40/40" INSIDE A DIAMOND-SHAPED BACKGROUND OVER THE WORD "CLUB", WHICH SITS UNDER AN OUTLINED STRAIGHT LINE AND SITS ABOVE A SHORTER SOLID STRAIGHT LINE.

FOR WEB, DIGITAL, VIDEO, AND MEDIA CONTENT ARCHIVING SERVICES (U.S. CLS. 100 AND 105).

FIRST USE 6-18-2003; IN COMMERCE 6-18-2003.  
JORDAN BAKER, EXAMINING ATTORNEY

**CLASS 39—(Continued).**

SN 86-105,448. HOSTED HUNTS, INC., WARROAD, MN. FILED 10-30-2013.



NO CLAIM IS MADE TO THE EXCLUSIVE RIGHT TO USE "HUNTS, INC.", APART FROM THE MARK AS SHOWN.

THE MARK CONSISTS OF THE WORDS "HOSTED HUNTS, INC. HH" WITHIN A COMPASS.

FOR ORGANIZATION OF TRAVEL; PERSONAL TRAVEL TOUR GUIDE SERVICES; PROVIDING A WEBSITE FEATURING INFORMATION ON TRAVEL; TRAVEL AGENCY SERVICES, NAMELY, BOOKING AND MAKING RESERVATIONS FOR TRANSPORTATION; EXCURSION ARRANGEMENTS FOR HUNTERS; TRAVEL TOUR GUIDE SERVICES (U.S. CLS. 100 AND 105).

FIRST USE 0-0-2009; IN COMMERCE 0-0-2009.  
ZACHARY BELLO, EXAMINING ATTORNEY

SN 86-131,541. UNLEASHED, LLC, WAYLAND, MA. FILED 11-27-2013.



NO CLAIM IS MADE TO THE EXCLUSIVE RIGHT TO USE "TAXI FARE FINDER", APART FROM THE MARK AS SHOWN.

THE COLOR(S) YELLOW, BLACK, AND WHITE IS/ARE CLAIMED AS A FEATURE OF THE MARK.

THE MARK CONSISTS OF THE WORD "TAXI" IN BLACK, CAPITAL LETTERS WITH THE WORDS "FARE FINDER" IMMEDIATELY BELOW IN BLACK, CAPITAL LETTERS IN A SMALLER FONT SUCH THAT THE WORDS APPEAR JUSTIFIED IN ALIGNMENT. ABOVE THE

**CLASS 39—(Continued).**

WORDS IS A DESIGN ELEMENT CONSISTING OF TEN (10) SQUARES AS DESCRIBED HEREIN. THE TITTLE OVER THE "I" IN "TAXI" IS A SQUARE, YELLOW IN COLOR, WHICH FADES TO WHITE AT THE VERY TOP IMITATING A LIGHT GLARE. FROM THAT YELLOW SQUARE THERE IS AN ARRAY OF YELLOW AND BLACK SQUARES RISING UP AND TO THE LEFT IN THE PATTERN WHICH IMITATES SMOKE RISING. EACH OF THESE YELLOW AND BLACK SQUARES HAS THE SAME WHITE AT THE TOP AS DESCRIBED FOR THE TITTLE.

FOR PROVIDING TRAVEL INFORMATION TO TRAVELERS REGARDING FARES, TIMETABLES AND PUBLIC TRANSPORT (U.S. CLS. 100 AND 105).

FIRST USE 2-22-2012; IN COMMERCE 2-27-2012.  
CHARLOTTE CORWIN, EXAMINING ATTORNEY

SN 86-132,534. SENERGY PETROLEUM, LLC, SCOTTSDALE, AZ. FILED 12-2-2013.



THE COLOR(S) RED AND ORANGE IS/ARE CLAIMED AS A FEATURE OF THE MARK.

THE MARK CONSISTS OF AN IMAGE IN THE SHAPE OF THE LETTER "S" THE TOP CURVE OF THE "S" IS A THICK RED LINE WITH A CLEF ON THE UPPER RIGHT HAND SIDE AND THE BOTTOM CURVE OF THE "S" IS A THICK ORANGE LINE WITH A CLEF ON THE LOWER LEFT HAND SIDE. THE RED AND ORANGE CURVE LINES DO NOT TOUCH IN THE "S" FORMATION.

FOR DISTRIBUTION AND TRANSPORTATION OF GASOLINE, DIESEL FUELS AND LUBRICATING OILS AND GREASES (U.S. CLS. 100 AND 105).

MARC LEIPZIG, EXAMINING ATTORNEY

SN 86-136,281. SABIDURIA INFINITA S.A., PANAMA, PANAMA, FILED 12-5-2013.

**DISCOVER YOUR TRAVEL PERSONALITY**

THE MARK CONSISTS OF STANDARD CHARACTERS WITHOUT CLAIM TO ANY PARTICULAR FONT, STYLE, SIZE, OR COLOR.

NO CLAIM IS MADE TO THE EXCLUSIVE RIGHT TO USE "TRAVEL", APART FROM THE MARK AS SHOWN.

FOR ARRANGING TRAVEL TOURS; BOOKING OF TRAVEL TICKETS ; COORDINATING TRAVEL ARRANGEMENTS FOR INDIVIDUALS AND FOR GROUPS; PROVIDING A WEBSITE FEATURING INFORMATION ON TRAVEL (U.S. CLS. 100 AND 105).

FIRST USE 10-23-2013; IN COMMERCE 10-23-2013.  
SUZANNE BLANE, EXAMINING ATTORNEY

**CLASS 39—(Continued).**

SN 86-136,286. SABIDURIA INFINITA S.A., PANAMA, PANAMA, FILED 12-5-2013.

**NAMU TRAVEL GROUP**

THE MARK CONSISTS OF STANDARD CHARACTERS WITHOUT CLAIM TO ANY PARTICULAR FONT, STYLE, SIZE, OR COLOR.

NO CLAIM IS MADE TO THE EXCLUSIVE RIGHT TO USE "TRAVEL GROUP", APART FROM THE MARK AS SHOWN.

THE ENGLISH TRANSLATION OF "NAMU" IN THE MARK IS "JAGUAR".

FOR ARRANGING TRAVEL TOURS; BOOKING OF TRAVEL TICKETS ; COORDINATING TRAVEL ARRANGEMENTS FOR INDIVIDUALS AND FOR GROUPS; PROVIDING A WEBSITE FEATURING INFORMATION ON TRAVEL (U.S. CLS. 100 AND 105).

FIRST USE 8-1-2013; IN COMMERCE 8-1-2013.  
SUZANNE BLANE, EXAMINING ATTORNEY

SN 86-147,222. ITS TECHNOLOGIES & LOGISTICS, LLC, TINLEY PARK, IL. FILED 12-18-2013.

**IN-TERMINAL SERVICES**

THE MARK CONSISTS OF STANDARD CHARACTERS WITHOUT CLAIM TO ANY PARTICULAR FONT, STYLE, SIZE, OR COLOR.

NO CLAIM IS MADE TO THE EXCLUSIVE RIGHT TO USE "SERVICES", APART FROM THE MARK AS SHOWN. SEC. 2(F).

FOR FREIGHT LOADING SERVICES; FREIGHT TRANSPORTATION CONSULTATION IN THE FIELD OF FREIGHT TRANSPORTATION BY RAIL AND RAIL INTERMODAL TERMINAL SERVICES (U.S. CLS. 100 AND 105).

FIRST USE 3-0-1985; IN COMMERCE 3-0-1985.  
DAVID MURRAY, EXAMINING ATTORNEY

SN 86-151,642. HENRY M CAMPBELL, DBA H M CAMPBELL TRANSPORT CORPORATION, STATEN ISLAND, NY. FILED 12-23-2013.

**H M Campbell Transport Corporation**

THE MARK CONSISTS OF STANDARD CHARACTERS WITHOUT CLAIM TO ANY PARTICULAR FONT, STYLE, SIZE, OR COLOR.

NO CLAIM IS MADE TO THE EXCLUSIVE RIGHT TO USE "TRANSPORT CORPORATION", APART FROM THE MARK AS SHOWN.

THE NAME "H M CAMPBELL" IDENTIFIES A LIVING INDIVIDUAL WHOSE CONSENT IS OF RECORD.

FOR TRUCK TRANSPORT (U.S. CLS. 100 AND 105).  
MORGAN WYNNE, EXAMINING ATTORNEY

**CLASS 39—(Continued).**

SN 86-165,746. PRESTO LOGISTICS, INC., CALABASAS, CA. FILED 1-15-2014.

**Presto Logistics**

THE MARK CONSISTS OF STANDARD CHARACTERS WITHOUT CLAIM TO ANY PARTICULAR FONT, STYLE, SIZE, OR COLOR.

NO CLAIM IS MADE TO THE EXCLUSIVE RIGHT TO USE "LOGISTICS", APART FROM THE MARK AS SHOWN. FOR FREIGHT FORWARDING SERVICES; MOVING COMPANY SERVICES (U.S. CLS. 100 AND 105).

FIRST USE 8-1-2007; IN COMMERCE 12-1-2007.  
SETH A. RAPPAPORT, EXAMINING ATTORNEY

SN 86-169,144. WCITIES INTERNATIONAL, INC., SAN FRANCISCO, CA. FILED 1-17-2014.

**hotelseeker**

THE MARK CONSISTS OF STANDARD CHARACTERS WITHOUT CLAIM TO ANY PARTICULAR FONT, STYLE, SIZE, OR COLOR.

FOR PROVIDING A WEB SITE FEATURING TRAVEL INFORMATION AND COMMENTARY; PROVIDING A WEBSITE FEATURING INFORMATION ON TRAVEL; PROVIDING AN ON-LINE COMPUTER DATABASE IN THE FIELD OF TRAVEL INFORMATION SERVICES; TRAVEL GUIDE AND TRAVEL INFORMATION SERVICES; TRAVEL GUIDE SERVICES (U.S. CLS. 100 AND 105).

FIRST USE 11-1-2013; IN COMMERCE 1-1-2014.  
JOHN DALIER, EXAMINING ATTORNEY

SN 86-171,911. KEYSTONE AUTOMOTIVE INDUSTRIES, INC., NASHVILLE, TN. FILED 1-22-2014.

**KEY COLOR**

THE MARK CONSISTS OF STANDARD CHARACTERS WITHOUT CLAIM TO ANY PARTICULAR FONT, STYLE, SIZE, OR COLOR.

NO CLAIM IS MADE TO THE EXCLUSIVE RIGHT TO USE "COLOR", APART FROM THE MARK AS SHOWN.

FOR DISTRIBUTION SERVICES, NAMELY, DELIVERY OF AUTOMOTIVE PAINTS AND AUTOMOTIVE, COMMERCIAL AND INDUSTRIAL FINISHES (U.S. CLS. 100 AND 105).

MARY ROSSMAN, EXAMINING ATTORNEY

**CLASS 39—(Continued).**

SN 86-174,788. SHESTELL, INC., MAMARONECK, NY.  
FILED 1-24-2014.

**SHE CAB**

THE MARK CONSISTS OF STANDARD CHARACTERS WITHOUT CLAIM TO ANY PARTICULAR FONT, STYLE, SIZE, OR COLOR.

NO CLAIM IS MADE TO THE EXCLUSIVE RIGHT TO USE "CAB", APART FROM THE MARK AS SHOWN.

FOR PASSENGER TRANSPORT, TRANSPORT OF PERSONS, TRANSPORTATION RESERVATION SERVICES, LIMOUSINE AND LIVERY SERVICES, TAXI SERVICES (U.S. CLS. 100 AND 105).

GRETTA YAO, EXAMINING ATTORNEY

**CLASS 39—(Continued).**

SN 86-189,584. WRAPCO, LLC, SAN ANTONIO, TX. FILED 2-10-2014.

**Ikon Wraps**

THE MARK CONSISTS OF STANDARD CHARACTERS WITHOUT CLAIM TO ANY PARTICULAR FONT, STYLE, SIZE, OR COLOR.

NO CLAIM IS MADE TO THE EXCLUSIVE RIGHT TO USE "WRAPS", APART FROM THE MARK AS SHOWN.

FOR DISTRIBUTION SERVICES, NAMELY, DELIVERY OF SELF-ADHESIVES, VINYL SELF-ADHESIVES AND TOOLS FOR INSTALLING SELF-ADHESIVES (U.S. CLS. 100 AND 105).

FIRST USE 5-1-2013; IN COMMERCE 5-1-2013.

BRIAN NEVILLE, EXAMINING ATTORNEY

SN 86-183,114. GHC SERVICES, INC., CENTENNIAL, CO.  
FILED 2-3-2014.

**Asset Equal**

THE MARK CONSISTS OF STANDARD CHARACTERS WITHOUT CLAIM TO ANY PARTICULAR FONT, STYLE, SIZE, OR COLOR.

NO CLAIM IS MADE TO THE EXCLUSIVE RIGHT TO USE "ASSET", APART FROM THE MARK AS SHOWN.

FOR FREIGHT TRANSPORTATION BROKERAGE (U.S. CLS. 100 AND 105).

FIRST USE 2-1-2013; IN COMMERCE 2-1-2013.

JESSICA A. POWERS, EXAMINING ATTORNEY

SN 86-192,662. TRINITY MEDICAL PHARMACY, LLC, NEW PORT RICHEY, FL. FILED 2-13-2014.

**MEDS TO BEDS**

THE MARK CONSISTS OF STANDARD CHARACTERS WITHOUT CLAIM TO ANY PARTICULAR FONT, STYLE, SIZE, OR COLOR.

NO CLAIM IS MADE TO THE EXCLUSIVE RIGHT TO USE "MEDS", APART FROM THE MARK AS SHOWN.

FOR MEDICATION DELIVERY SERVICES (U.S. CLS. 100 AND 105).

FIRST USE 7-0-2012; IN COMMERCE 7-0-2012.

ASMAT KHAN, EXAMINING ATTORNEY

SN 86-185,337. A&E MOVING & STORAGE INC., BROOKLYN, NY. FILED 2-5-2014.

**A&E MOVING & STORAGE**

THE MARK CONSISTS OF STANDARD CHARACTERS WITHOUT CLAIM TO ANY PARTICULAR FONT, STYLE, SIZE, OR COLOR.

NO CLAIM IS MADE TO THE EXCLUSIVE RIGHT TO USE "MOVING & STORAGE", APART FROM THE MARK AS SHOWN.

FOR PROVIDING SELF-STORAGE FACILITIES FOR OTHERS; RENTAL OF MOVING TRUCKS; MOVING COMPANY SERVICES (U.S. CLS. 100 AND 105).

SETH DENNIS, EXAMINING ATTORNEY

SN 86-216,779. NCL CORPORATION LTD., MIAMI, FL.  
FILED 3-10-2014.

**THE WATERFRONT**

THE MARK CONSISTS OF STANDARD CHARACTERS WITHOUT CLAIM TO ANY PARTICULAR FONT, STYLE, SIZE, OR COLOR.

FOR CRUISE SHIP SERVICES; CRUISE SHIP SERVICES IN THE NATURE OF PROVIDING A DESIGNATED AREA OF A CRUISE SHIP SET UP LIKE A BOARDWALK FEATURING RESTAURANTS, BARS, CAFES, AND LIVE ENTERTAINMENT (U.S. CLS. 100 AND 105).

FIRST USE 4-28-2013; IN COMMERCE 4-28-2013.

MAH ROSENBERG, EXAMINING ATTORNEY

**CLASS 39—(Continued).**

SN 86-216,824. NCL CORPORATION LTD., MIAMI, FL.  
FILED 3-10-2014.

## 678 OCEAN PLACE

THE MARK CONSISTS OF STANDARD CHARACTERS WITHOUT CLAIM TO ANY PARTICULAR FONT, STYLE, SIZE, OR COLOR.

FOR CRUISE SHIP SERVICES; CRUISE SHIP SERVICES IN THE NATURE OF PROVIDING A DESIGNATED AREA OF A CRUISE SHIP OFFERING RESTAURANTS, BARS, CASINOS, CAFES, AND DANCE CLUB SERVICES (U.S. CLS. 100 AND 105).

FIRST USE 4-28-2013; IN COMMERCE 4-28-2013.  
MIAH ROSENBERG, EXAMINING ATTORNEY

**CLASS 39—(Continued).**

SN 86-225,731. DUPERIER'S AUTHENTIC JOURNEYS, LLC,  
BETHESDA, MD. FILED 3-19-2014.

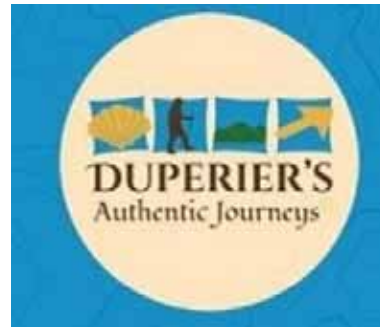

SN 86-223,358. S & H HAULING, ALBUQUERQUE, NM.  
FILED 3-17-2014.



NO CLAIM IS MADE TO THE EXCLUSIVE RIGHT TO USE "HAULING", "NM, USA", AND "EST 2011", APART FROM THE MARK AS SHOWN.

THE MARK CONSISTS OF A CIRCULAR SHAPED LOGO THAT LOOKS LIKE A CATTLE BRAND. IT SAYS "S & H HAULING" IN THE CENTER OF THE LOGO WITH THE "S & H" ON TOP OF THE "HAULING". THE LOGO HAS 5 STARS AROUND THE LETTERING BUT INSIDE THE CIRCULAR BRAND- 3 ON TOP, 2 ON THE BOTTOM. LOGO SAYS "EST 2011" ON THE BOTTOM PORTION OF THE LOGO, BELOW ALL THE STARS AND LETTERING. THERE IS A BADGE THAT SAYS "NM, USA" IN BETWEEN THE 2 STARS ON THE BOTTOM. THE LOGO HAS A RUGGED LOOK THROUGHOUT THE SCHEME.

FOR JUNK, TRASH AND DEBRIS REMOVAL (U.S. CLS. 100 AND 105).

MARTHA FROMM, EXAMINING ATTORNEY

NO CLAIM IS MADE TO THE EXCLUSIVE RIGHT TO USE "JOURNEYS", APART FROM THE MARK AS SHOWN. THE COLOR(S) BLACK, BLUE, BROWN, GREEN, WHITE AND YELLOW IS/ARE CLAIMED AS A FEATURE OF THE MARK.

THE MARK CONSISTS OF A WHITE CIRCLE SURROUNDED BY BLUE BACKGROUND, WITH THE BLACK WORDS "DUPERIER'S AUTHENTIC JOURNEYS" AND FOUR BLUE SQUARES WITHIN THE CIRCLE, WITH THOSE THREE WORDS LOCATED BELOW THE BLUE SQUARES, AND WITH THE BLUE SQUARES ARRANGED FROM LEFT TO RIGHT ACROSS THE MIDDLE OF THE CIRCLE, WITH THE LEFT-MOST BLUE SQUARE HAVING SUPERIMPOSED ON IT THE IMAGE OF A YELLOW SEASHELL, THE SECOND-FROM-THE-LEFT BLUE SQUARE HAVING SUPERIMPOSED ON IT A BROWN SILHOUETTE OF A HIKER WEARING A HAT AND HOLDING A WALKING STICK, THE THIRD-FROM-THE-LEFT BLUE SQUARE HAVING SUPERIMPOSED ON IT THE IMAGE OF GREEN MOUNTAINS, AND THE RIGHT-MOST BLUE SQUARE HAVING SUPERIMPOSED ON IT THE IMAGE OF A YELLOW ARROW POINTING DIAGONALLY UP TO THE RIGHT.

FOR ARRANGING, CONDUCTING, LEADING AND COORDINATING TRAVEL EXCURSIONS AND TRAVEL TOURS IN SPAIN FOR INDIVIDUALS AND GROUPS FOR SIGHTSEEING; PROVIDING TRAVEL TOUR GUIDE SERVICES; TRAVEL AGENCY SERVICES, NAMELY, MAKING RESERVATIONS AND BOOKINGS FOR TRANSPORTATION; COORDINATING TRAVEL ARRANGEMENTS FOR OTHERS; ESCORTING AND LEADING INDIVIDUALS AND GROUPS ON TRAVEL EXCURSIONS, TOURS AND HIKES IN SPAIN (U.S. CLS. 100 AND 105).

FIRST USE 10-1-2013; IN COMMERCE 10-1-2013.

JORDAN BAKER, EXAMINING ATTORNEY



**CLASS 39—(Continued).**

SN 86-228,364. BOTT ENTERPRISES, INC., DBA BARCO RENT A TRUCK, SALT LAKE CITY, UT. FILED 3-21-2014.



NO CLAIM IS MADE TO THE EXCLUSIVE RIGHT TO USE "RENT-A-TRUCK", APART FROM THE MARK AS SHOWN.

THE MARK CONSISTS OF A POLYGONAL SHAPE WITH INTERNAL LINES AND THE TRADEMARK "BARCO" AND THE TERM "RENT-A-TRUCK" INSIDE OF THE SHAPE.

FOR RENTAL OF MOTOR VEHICLES; RENTAL OF TRUCKS; RENTAL OF VEHICLES (U.S. CLS. 100 AND 105).

FIRST USE 3-16-2004; IN COMMERCE 3-16-2004.  
LEIGH LOWRY, EXAMINING ATTORNEY

**CLASS 39—(Continued).**

SN 86-231,693. KRAKEN WORLDWIDE LLC, BERRYVILLE, VA. FILED 3-25-2014.



NO CLAIM IS MADE TO THE EXCLUSIVE RIGHT TO USE "WORLDWIDE", APART FROM THE MARK AS SHOWN.

THE MARK CONSISTS OF THE PHRASE "KRAKEN WORLDWIDE" IN A STYLIZED FONT IN TWO HORIZONTAL LINES IN THE MIDDLE SECTION OF A CREATURE RESEMBLING AN OCTOPUS.

FOR ARRANGING, ORGANIZING, AND CONDUCTING HUNTING AND FISHING TRIPS (U.S. CLS. 100 AND 105).

CAITLIN WATTS-FITZGERALD, EXAMINING ATTORNEY

SN 86-231,620. KRAKEN WORLDWIDE LLC, BERRYVILLE, VA. FILED 3-25-2014.

KRAKEN WORLDWIDE

THE MARK CONSISTS OF STANDARD CHARACTERS WITHOUT CLAIM TO ANY PARTICULAR FONT, STYLE, SIZE, OR COLOR.

NO CLAIM IS MADE TO THE EXCLUSIVE RIGHT TO USE "WORLDWIDE", APART FROM THE MARK AS SHOWN.

FOR ARRANGING, ORGANIZING, AND CONDUCTING HUNTING AND FISHING TRIPS (U.S. CLS. 100 AND 105).

CAITLIN WATTS-FITZGERALD, EXAMINING ATTORNEY

SN 86-231,869. RUBBISH POD, LLC, AUSTIN, TX. FILED 3-25-2014.

RUBBISH POD

THE MARK CONSISTS OF STANDARD CHARACTERS WITHOUT CLAIM TO ANY PARTICULAR FONT, STYLE, SIZE, OR COLOR.

NO CLAIM IS MADE TO THE EXCLUSIVE RIGHT TO USE "RUBBISH", APART FROM THE MARK AS SHOWN.

FOR GARBAGE COLLECTION, NAMELY, COLLECTION AND REMOVAL OF WASTE MATERIALS AND DEBRIS FROM COMMERCIAL, INDUSTRIAL, AND CONSTRUCTION LOCATIONS; TRANSPORTATION OF WASTE MATERIALS AND DEBRIS FOR DISPOSAL; TRASH SERVICES, NAMELY, RENTAL OF DUMPSTERS AND WASTE CONTAINERS (U.S. CLS. 100 AND 105).

FIRST USE 1-1-2014; IN COMMERCE 1-1-2014.  
PAUL CROWLEY, EXAMINING ATTORNEY



**CLASS 39—(Continued).**

SN 86-239,178. SUCCESS PARTNERS HOLDING CO., LAKE DALLAS, TX. FILED 4-1-2014.

**SUCCESS PARTNERS**

THE MARK CONSISTS OF STANDARD CHARACTERS WITHOUT CLAIM TO ANY PARTICULAR FONT, STYLE, SIZE, OR COLOR.

NO CLAIM IS MADE TO THE EXCLUSIVE RIGHT TO USE "PARTNERS", APART FROM THE MARK AS SHOWN. FOR PACKAGING VIDEO AND AUDIO MEDIA, MANUALS AND KITS TO THE ORDER AND SPECIFICATIONS OF OTHERS (U.S. CLS. 100 AND 105).

JOHN WILKE, EXAMINING ATTORNEY

**CLASS 39—(Continued).**

SN 86-239,428. NIGHT SCHOOL, OAKLAND, CA. FILED 4-2-2014.

**Make tonight a school night**

THE MARK CONSISTS OF STANDARD CHARACTERS WITHOUT CLAIM TO ANY PARTICULAR FONT, STYLE, SIZE, OR COLOR.

FOR BUS TRANSPORT; MAKING TRANSPORTATION BOOKINGS AND RESERVATIONS FOR OTHERS BY MEANS OF A WEBSITE; ON-LINE TRANSPORTATION RESERVATION AND TRAVEL TICKET RESERVATION SERVICES; PROVIDING A WEBSITE FEATURING INFORMATION IN THE FIELD OF BUS TRANSPORTATION; PROVIDING AN ON-LINE COMPUTER DATABASE IN THE FIELD OF BUS TRANSPORTATION; PROVIDING TRAVEL INFORMATION TO TRAVELERS REGARDING FARES, TIMETABLES AND PUBLIC TRANSPORT; TRANSPORT OF PASSENGERS; TRANSPORT RESERVATION; TRANSPORTATION SERVICES, NAMELY, PROVIDING SHUTTLE SERVICES BY BUS (U.S. CLS. 100 AND 105).

CHARLES HISER, EXAMINING ATTORNEY

SN 86-240,788. JIANGSU XINNING LOGISTICS CO., LTD., JIANGSU PROVINCE,, CHINA, FILED 4-3-2014.

新宁

**Night School**

SN 86-239,412. NIGHT SCHOOL, OAKLAND, CA. FILED 4-2-2014.

THE MARK CONSISTS OF STANDARD CHARACTERS WITHOUT CLAIM TO ANY PARTICULAR FONT, STYLE, SIZE, OR COLOR.

FOR BUS TRANSPORT; MAKING RESERVATIONS AND BOOKINGS FOR TRANSPORTATION; MAKING TRANSPORTATION BOOKINGS AND RESERVATIONS FOR OTHERS BY MEANS OF A WEBSITE; ON-LINE TRANSPORTATION RESERVATION AND TRAVEL TICKET RESERVATION SERVICES; PROVIDING A WEBSITE FEATURING INFORMATION IN THE FIELD OF BUS TRANSPORTATION; PROVIDING AN ON-LINE COMPUTER DATABASE IN THE FIELD OF BUS TRANSPORTATION; PROVIDING TRAVEL INFORMATION TO TRAVELERS REGARDING FARES, TIMETABLES AND PUBLIC TRANSPORT; TRANSPORT OF PASSENGERS; TRANSPORT RESERVATION; TRANSPORTATION SERVICES, NAMELY, PROVIDING SHUTTLE SERVICES BY BUS (U.S. CLS. 100 AND 105).

CHARLES HISER, EXAMINING ATTORNEY

THE MARK CONSISTS OF TWO STYLIZED CHINESE CHARACTERS REPRESENTING THE WORDS "XIN NING" IN THE PINYIN CHINESE ROMANIZATION SYSTEM.

THE NON-LATIN CHARACTERS IN THE MARK TRANSLITERATE TO "XINNING" AND THIS HAS NO MEANING IN A FOREIGN LANGUAGE.

FOR CARGO HANDLING; CARGO UNLOADING; COURIER SERVICES; DELIVERY OF GOODS; DELIVERY OF MESSAGES; FREIGHT TRANSPORTATION BROKERAGE; FREIGHTING SERVICES; HARBOR CRANE UNLOADING; IMPORT AND EXPORT CARGO HANDLING SERVICES; RENTAL OF LOADING-UNLOADING MACHINES AND APPARATUS; RENTAL OF WAREHOUSES; SHIP UNLOADING; STORAGE AND DELIVERY OF GOODS; STORAGE OF GOODS; SUPPLY CHAIN LOGISTICS AND REVERSE LOGISTICS SERVICES, NAMELY, STORAGE, TRANSPORTATION AND DELIVERY OF DOCUMENTS, PACKAGES, RAW MATERIALS, AND OTHER FREIGHT FOR OTHERS BY AIR, RAIL, SHIP OR TRUCK; TRANSPORT AND DELIVERY OF GOODS; TRANSPORT AND STORAGE OF GOODS; TRANSPORT BY LAND; TRANSPORT OF GOODS; TRANSPORTATION AND STORAGE OF GOODS (U.S. CLS. 100 AND 105).

FIRST USE 9-24-2004; IN COMMERCE 3-14-2008.

RAMONA ORTIGA, EXAMINING ATTORNEY

**CLASS 39—(Continued).**

SN 86-246,051. IRON HORSE TRUCKING, LLC, HOUSTON, TX. FILED 4-8-2014.

**IRON HORSE TRUCKING**

THE MARK CONSISTS OF STANDARD CHARACTERS WITHOUT CLAIM TO ANY PARTICULAR FONT, STYLE, SIZE, OR COLOR.

NO CLAIM IS MADE TO THE EXCLUSIVE RIGHT TO USE "TRUCKING", APART FROM THE MARK AS SHOWN.

FOR TRUCKING SERVICES, NAMELY, HAULING OF OILFIELD EQUIPMENT, OILFIELD TOOLS, PIPES, AND CONTAINERS (U.S. CLS. 100 AND 105).

FIRST USE 2-28-2011; IN COMMERCE 2-28-2011.  
ERIN FALK, EXAMINING ATTORNEY

---

SN 86-246,167. IRON HORSE TRUCKING, LLC, HOUSTON, TX. FILED 4-8-2014.

**IRON HORSE LOGISTICS**

THE MARK CONSISTS OF STANDARD CHARACTERS WITHOUT CLAIM TO ANY PARTICULAR FONT, STYLE, SIZE, OR COLOR.

NO CLAIM IS MADE TO THE EXCLUSIVE RIGHT TO USE "LOGISTICS", APART FROM THE MARK AS SHOWN.

FOR TRUCKING SERVICES, NAMELY, HAULING OF OILFIELD EQUIPMENT, OILFIELD TOOLS, PIPES, AND CONTAINERS (U.S. CLS. 100 AND 105).

ERIN FALK, EXAMINING ATTORNEY

---

SN 86-246,987. FARAH, ABDIRAHMAN, SACRAMENTO, CA. FILED 4-9-2014.

**ROYAL RENTAL CAR**

THE MARK CONSISTS OF STANDARD CHARACTERS WITHOUT CLAIM TO ANY PARTICULAR FONT, STYLE, SIZE, OR COLOR.

NO CLAIM IS MADE TO THE EXCLUSIVE RIGHT TO USE "RENTAL CAR", APART FROM THE MARK AS SHOWN.

FOR CAR RENTAL (U.S. CLS. 100 AND 105).  
DOUGLAS LEE, EXAMINING ATTORNEY

**CLASS 39—(Continued).**

SN 86-248,142. PROFIT LEASING, LLC, ST. LOUIS, MO. FILED 4-10-2014.

**MAKING DRIVERS MONEY**

THE MARK CONSISTS OF STANDARD CHARACTERS WITHOUT CLAIM TO ANY PARTICULAR FONT, STYLE, SIZE, OR COLOR.

FOR LEASING OF TRUCKS (U.S. CLS. 100 AND 105).  
FIRST USE 3-0-2014; IN COMMERCE 3-0-2014.  
HEATHER SAPP, EXAMINING ATTORNEY

---

SN 86-248,642. AIR TAHITI NUI CORPORATION, PAPEETE, FRENCH POLYNESIA, FILED 4-10-2014.



OWNER OF U.S. REG. NO. 2,818,935.  
NO CLAIM IS MADE TO THE EXCLUSIVE RIGHT TO USE "CLASS", APART FROM THE MARK AS SHOWN.

THE MARK CONSISTS OF THE WORD "MOANA" IN BOLD AND THE OUTLINE OF A TAHITIAN TIARE FLOWER IN THE UPPER RIGHT SIDE AND A SWISH LINE UNDERNEATH THE "OANA" PORTION OF THE WORD AND THE WORD "CLASS" UNDERNEATH THE SWISH LINE.

THE ENGLISH TRANSLATION OF "MOANA" IN THE MARK IS "OCEAN".

FOR AIR TRANSPORTATION SERVICES, NAMELY, THE CARRIAGE OF PASSENGERS AND CARGO BY AIR; TRAVEL AGENCY SERVICES, NAMELY MAKING RESERVATIONS AND BOOKINGS FOR AIR TRANSPORTATION; AND AIR TRANSPORTATION SERVICE FEATURING A FREQUENT FLYER PROGRAM (U.S. CLS. 100 AND 105).

FIRST USE 6-30-2013; IN COMMERCE 6-30-2013.  
LINDA E. BLOHM, EXAMINING ATTORNEY

**CLASS 39—(Continued).**

SN 86-249,122. BAKIR, FARID, SAN DIEGO, CA. AND ALAMI, KARIM, SAN DIEGO, CA. FILED 4-10-2014.

parximity

THE MARK CONSISTS OF STANDARD CHARACTERS WITHOUT CLAIM TO ANY PARTICULAR FONT, STYLE, SIZE, OR COLOR.

FOR CAR PARKING; CAR RENTAL, GARAGE AND PARKING SPACE RENTAL; PARKING GARAGES SERVICES; PARKING LOT SERVICES; PARKING SPACE RENTAL; PARKING SPACE RESERVATION SERVICE; PROVIDING A WEBSITE FEATURING INFORMATION ON AIRPORT PARKING; PROVIDING REAL-TIME INFORMATION CONCERNING VEHICLE PARKING SPACE AVAILABILITY; RENTAL OF CAR PARKING SPACES; RENTAL OF PARKING SPACES; RENTAL OF VEHICLE PARKING SPACES; VEHICLE PARKING; VEHICLE PARKING SERVICES RELATING TO THE AVAILABILITY OF ON-STREET AND OFF-STREET PARKING SPACES (U.S. CLS. 100 AND 105).

JUDITH HELFMAN, EXAMINING ATTORNEY

---

SN 86-249,405. DROPOFF, INC., AUSTIN, TX. FILED 4-11-2014.

DROPOFF

THE MARK CONSISTS OF STANDARD CHARACTERS WITHOUT CLAIM TO ANY PARTICULAR FONT, STYLE, SIZE, OR COLOR.

FOR COURIER SERVICES (U.S. CLS. 100 AND 105).  
DAVID MURRAY, EXAMINING ATTORNEY

---

SN 86-249,413. DROPOFF, INC., AUSTIN, TX. FILED 4-11-2014.



THE MARK CONSISTS OF THE WORD "DROPOFF" IN STYLIZED LOWERCASE LETTERING; THE LOOP OF THE LETTER "D" ENDS IN AN ARROW FORMED BY A CIRCLE THAT CURVES COUNTERCLOCKWISE AND ULTIMATELY POINTS TO THE RIGHT. THE LETTER "D" IS ITSELF CONTAINED WITHIN A LARGER CIRCLE, WHICH IS BROKEN AT THE TOP BY THE HIGHEST POINT OF THE LETTER "D" AND AT THE BOTTOM RIGHT BY THE LETTER "R".

FOR COURIER SERVICES (U.S. CLS. 100 AND 105).  
DAVID MURRAY, EXAMINING ATTORNEY

**CLASS 39—(Continued).**

SN 86-249,425. DROPOFF, INC., AUSTIN, TX. FILED 4-11-2014.



THE MARK CONSISTS OF THE LETTER "D" IN LOWERCASE; THE LOOP OF THE LETTER "D" ENDS IN AN ARROW FORMED BY A CIRCLE THAT CURVES COUNTERCLOCKWISE AND ULTIMATELY POINTS TO THE RIGHT. THE LETTER "D" IS CONTAINED WITHIN A LARGER CIRCLE, WHICH IS BROKEN AT THE TOP BY THE HIGHEST POINT OF THE LETTER "D".

FOR COURIER SERVICES (U.S. CLS. 100 AND 105).  
DAVID MURRAY, EXAMINING ATTORNEY

---

SN 86-249,871. CENTRAL OHIO TRANSIT AUTHORITY, COLUMBUS, OH. FILED 4-11-2014.



NO CLAIM IS MADE TO THE EXCLUSIVE RIGHT TO USE "CBUS", APART FROM THE MARK AS SHOWN.

THE MARK CONSISTS OF "CBUS " WITH A FIVE POINTED STAR CENTERED ABOVE THE LETTER "U".

FOR BUS TRANSPORT; MASS TRANSIT SERVICES FOR THE GENERAL PUBLIC; TRANSPORT OF PERSONS (U.S. CLS. 100 AND 105).

FIRST USE 2-26-2014; IN COMMERCE 4-8-2014.  
INGRID C. EULIN, EXAMINING ATTORNEY

**CLASS 40—MATERIAL TREATMENT**

SN 85-818,589. CAPITAL POWER CORPORATION, EDMONTON, ALBERTA, CANADA, FILED 1-9-2013.



OWNER OF CANADA REG. NO. TMA862608, DATED 10-15-2013, EXPIRES 10-15-2028.

OWNER OF U.S. REG. NOS. 4,169,638 AND 4,184,676. NO CLAIM IS MADE TO THE EXCLUSIVE RIGHT TO USE "POWER", APART FROM THE MARK AS SHOWN.

THE MARK CONSISTS OF THE WORDS "CAPITAL POWER" STYLIZED AND AN ELLIPTICAL DESIGN ON THE RIGHT SIDE OF THE MARK.

FOR ELECTRICAL POWER GENERATION (U.S. CLS. 100, 103 AND 106).

JULIE WATSON, EXAMINING ATTORNEY

---

SN 85-860,700. NUVERRA ENVIRONMENTAL SOLUTIONS, INC., CORAOPOLIS, PA. FILED 2-26-2013.

WE PUT OUR ENERGY BEHIND  
SUSTAINABILITY

THE MARK CONSISTS OF STANDARD CHARACTERS WITHOUT CLAIM TO ANY PARTICULAR FONT, STYLE, SIZE, OR COLOR.

FOR ENVIRONMENTAL SERVICES, NAMELY, WASTE WATER TREATMENT SERVICES, MOTOR OIL AND OIL FILTER RECYCLING SERVICES, SOLVENT RECYCLING SERVICES, ANTIFREEZE RECYCLING SERVICES AND INDUSTRIAL WASTE MANAGEMENT SERVICES (U.S. CLS. 100, 103 AND 106).

LESLEY LAMOTHE, EXAMINING ATTORNEY

---

SN 85-966,824. REGENERON PHARMACEUTICALS, INC., TARRYTOWN, NY. FILED 6-21-2013.

FASTR

THE MARK CONSISTS OF STANDARD CHARACTERS WITHOUT CLAIM TO ANY PARTICULAR FONT, STYLE, SIZE, OR COLOR.

FOR PRODUCTION OF CELL LINES FOR USE IN THE MANUFACTURE OF BIOPHARMACEUTICALS (U.S. CLS. 100, 103 AND 106).

EUGENIA MARTIN, EXAMINING ATTORNEY

**CLASS 40—(Continued).**

SN 86-046,211. WARRIOR DIAMOND, INC., CONSHOHOCKEN, PA. FILED 8-23-2013.

WDI

THE MARK CONSISTS OF STANDARD CHARACTERS WITHOUT CLAIM TO ANY PARTICULAR FONT, STYLE, SIZE, OR COLOR.

FOR CUSTOM MANUFACTURING TO THE ORDER AND SPECIFICATION OF OTHERS OF DIAMOND POWER BLADES FOR BOTH COMMERCIAL AND NON-COMMERCIAL USE (U.S. CLS. 100, 103 AND 106).

MARK SPARACINO, EXAMINING ATTORNEY

---

SN 86-046,972. CEJ, LLC, DBA WILDWOOD SPIRITS CO. AND WILDWOOD SPIRITS COMPANY, BELLEVUE, WA. FILED 8-23-2013.

WILDWOOD SPIRITS COMPANY

THE MARK CONSISTS OF STANDARD CHARACTERS WITHOUT CLAIM TO ANY PARTICULAR FONT, STYLE, SIZE, OR COLOR.

NO CLAIM IS MADE TO THE EXCLUSIVE RIGHT TO USE "SPIRITS COMPANY", APART FROM THE MARK AS SHOWN.

FOR ALCOHOL DISTILLERY SERVICES; SPIRITS DISTILLERY SERVICES; WHISKY DISTILLERY SERVICES (U.S. CLS. 100, 103 AND 106).

TINA MAI, EXAMINING ATTORNEY

**CLASS 40—(Continued).**

SN 86-048,079. DEL MONACO SPECIALTY FOODS, INC., MORGAN HILL, CA. FILED 8-26-2013.



NO CLAIM IS MADE TO THE EXCLUSIVE RIGHT TO USE "SPECIALTY FOODS", APART FROM THE MARK AS SHOWN.

THE MARK CONSISTS OF THE WORD "DEL" ABOVE THE LETTER "M" IN THE WORD "MONACO" BELOW WHICH IS THE ITALIZED WORD "SPECIALTY" NEXT TO THE WORD "FOODS".

SEC. 2(F).

FOR CUSTOM MANUFACTURE OF FOOD PRODUCTS; FOOD PROCESSING; MANUFACTURE OF GENERAL PRODUCT LINES IN THE FIELD OF FOOD TO THE ORDER AND SPECIFICATION OF OTHERS; MANUFACTURE OF FOOD PRODUCTS TO ORDER AND/OR SPECIFICATION OF OTHERS (U.S. CLS. 100, 103 AND 106).

FIRST USE 12-31-1977; IN COMMERCE 5-4-1998.  
CHRISTINA SOBRAL, EXAMINING ATTORNEY

---

SN 86-070,678. MCKAY ENTERPRISES, LLC, MENDOTA HEIGHTS, MN. FILED 9-20-2013.



NO CLAIM IS MADE TO THE EXCLUSIVE RIGHT TO USE "ENTERPRISES", APART FROM THE MARK AS SHOWN.

THE COLOR(S) BLUE AND ORANGE IS/ARE CLAIMED AS A FEATURE OF THE MARK.

THE MARK CONSISTS OF A STYLIZED LETTER "M" WITH A LINE THROUGH THE CENTER OF THE "M" ABOVE THE STYLIZED WORDS "MCKAY ENTERPRISES". THE STYLIZED "M" AND THE WORDING "MCKAY ENTERPRISES" ARE IN BLUE, AND THE LINE THROUGH THE "M" IS IN ORANGE.

FOR CUSTOM MANUFACTURE OF FIREARMS AND FIREARM COMPONENTS FOR OTHERS (U.S. CLS. 100, 103 AND 106).

FIRST USE 6-5-2005; IN COMMERCE 6-5-2005.  
NANCY CLARKE, EXAMINING ATTORNEY

**CLASS 40—(Continued).**

SN 86-071,651. CPS PRINTING, DBA ZUZA, CARLSBAD, CA. FILED 9-23-2013.

# ZUZA

THE MARK CONSISTS OF STANDARD CHARACTERS WITHOUT CLAIM TO ANY PARTICULAR FONT, STYLE, SIZE, OR COLOR.

FOR COMMERCIAL PRINTING SERVICES AND BINDERY SERVICES FOR OTHERS, NAMELY, PRINTING OF BROCHURES, CATALOGS, BUSINESS STATIONERY, COLLATING, STAPLING, PERFORATING, CUTTING AND BINDING OF PRINTED MATERIALS; CUSTOM MAIL PRINTING SERVICES TO THE ORDER AND SPECIFICATION OF OTHERS (U.S. CLS. 100, 103 AND 106).

FIRST USE 9-0-2011; IN COMMERCE 9-0-2011.  
DOMINIC J. FERRAIUOLO, EXAMINING ATTORNEY

---

SN 86-082,024. AQUEI TECHNOLOGIES LLC, GLEN ALLEN, VA. FILED 10-3-2013.

# Aquei

THE MARK CONSISTS OF STANDARD CHARACTERS WITHOUT CLAIM TO ANY PARTICULAR FONT, STYLE, SIZE, OR COLOR.

THE WORDING "AQUEI" HAS NO MEANING IN A FOREIGN LANGUAGE.

FOR SUSTAINABLE ON-SITE WATER RECYCLING AND WASTEWATER TREATMENT SERVICES (U.S. CLS. 100, 103 AND 106).

EDWARD NELSON, EXAMINING ATTORNEY

---

SN 86-126,558. VICTORY AWNING, INC., FORT WORTH, TX. FILED 11-22-2013.

# VICTORY AWNING

THE MARK CONSISTS OF STANDARD CHARACTERS WITHOUT CLAIM TO ANY PARTICULAR FONT, STYLE, SIZE, OR COLOR.

NO CLAIM IS MADE TO THE EXCLUSIVE RIGHT TO USE "AWNING", APART FROM THE MARK AS SHOWN.

FOR CUSTOM MANUFACTURE OF AWNINGS, CANOPIES, PATIO COVERS, SHADE STRUCTURES, CABANAS, SOUND WALLS, OIL BOOMS, AND HAZARDOUS MATERIAL CONTAINMENT BERMS; CUSTOM MANUFACTURE OF HAIL COVERS FOR AUTOMOBILES AND OF COVERS FOR AVIATION FUEL LINES (U.S. CLS. 100, 103 AND 106).

FIRST USE 3-0-2004; IN COMMERCE 1-0-2007.  
KEVIN CORWIN, EXAMINING ATTORNEY

**CLASS 40—(Continued).**

SN 86-143,426. DPT LABORATORIES, LTD., SAN ANTONIO, TX. FILED 12-13-2013.

**CONFAB A DPT COMPANY**

THE MARK CONSISTS OF STANDARD CHARACTERS WITHOUT CLAIM TO ANY PARTICULAR FONT, STYLE, SIZE, OR COLOR.

OWNER OF U.S. REG. NOS. 2,465,651, 2,465,652 AND 3,133,102.

NO CLAIM IS MADE TO THE EXCLUSIVE RIGHT TO USE "COMPANY", APART FROM THE MARK AS SHOWN.

FOR CUSTOM MANUFACTURING OF SOLID DOSAGE, SEMI-SOLID AND LIQUID DOSAGE DRUG PRODUCTS IN THE FIELD OF ETHICAL PHARMACEUTICALS AND OVER THE COUNTER DRUGS (U.S. CLS. 100, 103 AND 106).

FIRST USE 10-15-2013; IN COMMERCE 10-15-2013.

SCOTT BIBB, EXAMINING ATTORNEY

SN 86-208,459. MINICHIELLO BROS., INC., EVERETT, MA. FILED 3-1-2014.



NO CLAIM IS MADE TO THE EXCLUSIVE RIGHT TO USE "BROS. INC." AND "THE UNIVERSAL RECYCLING SYMBOL", APART FROM THE MARK AS SHOWN.

THE MARK CONSISTS OF THE WORDS "SCRAP IT" "TURN YOUR METAL INTO MONEY" MINICHIELLO BROS. INC.". THERE IS A STAR BETWEEN "SCRAP" AND "IT". A DEPICTION OF EARTH WITHIN A PARTIAL RECYCLING SYMBOL APPEARS TO THE LEFT OF "SCRAP".

FOR RECYCLING OF METALS; METAL RECLAMATION SERVICES; PROCESSING OF SCRAP METALS (U.S. CLS. 100, 103 AND 106).

FIRST USE 12-0-2005; IN COMMERCE 12-0-2005.

DAVID TAYLOR, EXAMINING ATTORNEY

SN 86-222,596. BULLOCK, JAMAAL, DBA 123CUSTOMTEE, CRANSTON, RI. FILED 3-16-2014.

**123customtee**

THE MARK CONSISTS OF STANDARD CHARACTERS WITHOUT CLAIM TO ANY PARTICULAR FONT, STYLE, SIZE, OR COLOR.

FOR IMPRINTING OF DECORATIVE DESIGNS ON T-SHIRTS (U.S. CLS. 100, 103 AND 106).

JORDAN BAKER, EXAMINING ATTORNEY

**CLASS 40—(Continued).**

SN 86-235,129. WATERJETS UNLIMITED INC., RONKONKOMA, NY. FILED 3-28-2014.

**Waterjets Unlimited**

THE MARK CONSISTS OF STANDARD CHARACTERS WITHOUT CLAIM TO ANY PARTICULAR FONT, STYLE, SIZE, OR COLOR.

NO CLAIM IS MADE TO THE EXCLUSIVE RIGHT TO USE "WATERJETS", APART FROM THE MARK AS SHOWN.

FOR WATERJET CUTTING SERVICES, NAMELY, CUTTING OF GLASS, PLASTIC, STONE, METAL, AND FLOORING (U.S. CLS. 100, 103 AND 106).

FIRST USE 9-3-2002; IN COMMERCE 9-3-2002.

CHRISTINA RIEPEL, EXAMINING ATTORNEY

SN 86-236,856. FTL CAPITAL, LLC, CLAYTON, MO. FILED 3-31-2014.

**RISE SOLAR**

THE MARK CONSISTS OF STANDARD CHARACTERS WITHOUT CLAIM TO ANY PARTICULAR FONT, STYLE, SIZE, OR COLOR.

NO CLAIM IS MADE TO THE EXCLUSIVE RIGHT TO USE "SOLAR", APART FROM THE MARK AS SHOWN.

FOR LEASING SERVICES, NAMELY, LEASING OF ENERGY GENERATING EQUIPMENT AND RENEWABLE ENERGY EQUIPMENT (U.S. CLS. 100, 103 AND 106).

RONALD MCMORROW, EXAMINING ATTORNEY

SN 86-237,873. FLORABELLA INTERNATIONAL, LLC, LAYTON, UT. FILED 3-31-2014.

**SPEAKING ROSES**

THE MARK CONSISTS OF STANDARD CHARACTERS WITHOUT CLAIM TO ANY PARTICULAR FONT, STYLE, SIZE, OR COLOR.

NO CLAIM IS MADE TO THE EXCLUSIVE RIGHT TO USE "ROSES", APART FROM THE MARK AS SHOWN.

FOR CUSTOM IMPRINTING OF CUT FLOWERS WITH MESSAGES, COMPANY LOGOS AND DECORATIVE DESIGNS (U.S. CLS. 100, 103 AND 106).

FIRST USE 1-0-2002; IN COMMERCE 1-0-2002.

RONALD DELGIZZI, EXAMINING ATTORNEY

**CLASS 40—(Continued).**

SN 86-239,117. ROWAN'S GLOBAL, VALLEY STREAM, NY. FILED 4-1-2014.



The logo for Rowan's Global features the word "Rowan's" in a bold, sans-serif font with a stylized graphic above the 'n' that resembles a signal or a wave. Below "Rowan's" is the word "GLOBAL" in a larger, all-caps, sans-serif font.

NO CLAIM IS MADE TO THE EXCLUSIVE RIGHT TO USE "GLOBAL", APART FROM THE MARK AS SHOWN.

THE NAME "ROWAN" IDENTIFIES A LIVING INDIVIDUAL WHOSE CONSENT IS OF RECORD.

THE MARK CONSISTS OF THE WORDING "ROWAN'S GLOBAL" WITH THE APOSTROPHE AND LETTERS "S" AND "A" IN STYLIZED FORM. THE APOSTROPHE IS STYLIZED IN THE FORM OF THREE CURVED LINES APPEARING OUT OF THE TOP OF THE LETTER "S".

FOR CUSTOM MANUFACTURE OF COMPUTERS FOR OTHERS (U.S. CLS. 100, 103 AND 106).

FIRST USE 1-1-2004; IN COMMERCE 1-1-2004.

CRISTIANA SCHWAB, EXAMINING ATTORNEY

SN 86-244,866. PORATH BUSINESS SERVICES, CLEVELAND, OH. FILED 4-7-2014.

## WE PUT THE INK INTO THINKING OUTSIDE THE BOX

THE MARK CONSISTS OF STANDARD CHARACTERS WITHOUT CLAIM TO ANY PARTICULAR FONT, STYLE, SIZE, OR COLOR.

FOR PRINTING SERVICES; CUSTOM IMPRINTING OF DECORATIVE DESIGNS, COMPANY NAMES AND LOGOS ON THE GOODS OF OTHERS, NAMELY, ON PROMOTIONAL MERCHANDISE, APPAREL AND CORPORATE GIFTS (U.S. CLS. 100, 103 AND 106).

FIRST USE 3-14-2014; IN COMMERCE 3-17-2014.

ELISSA GARBER KON, EXAMINING ATTORNEY

SN 86-247,150. ECOSPHERE TECHNOLOGIES, INC., STUART, FL. FILED 4-9-2014.



The logo for CaviSonix features the word "CaviSonix" in a serif font. The 'i' in "Cavi" has a dot, and the 'S' in "Sonix" is stylized with a horizontal line through it.

THE MARK CONSISTS OF STANDARD CHARACTERS WITHOUT CLAIM TO ANY PARTICULAR FONT, STYLE, SIZE, OR COLOR.

FOR WATER TREATMENT SERVICES, NAMELY, A WATER TREATMENT PROCESS TO DECONTAMINATE WATER (U.S. CLS. 100, 103 AND 106).

SIMON TENG, EXAMINING ATTORNEY

**CLASS 40—(Continued).**

SN 86-251,833. ALL ACCESS MANUFACTURING LLC, LAS VEGAS, NV. FILED 4-14-2014.

ALL ACCESS MANUFACTURING

THE MARK CONSISTS OF STANDARD CHARACTERS WITHOUT CLAIM TO ANY PARTICULAR FONT, STYLE, SIZE, OR COLOR.

NO CLAIM IS MADE TO THE EXCLUSIVE RIGHT TO USE "MANUFACTURING", APART FROM THE MARK AS SHOWN.

FOR CUSTOM MANUFACTURE OF WALL AND FLOORING MATERIALS (U.S. CLS. 100, 103 AND 106).

FIRST USE 7-30-2013; IN COMMERCE 7-30-2013.

INGRID C. EULIN, EXAMINING ATTORNEY

SN 86-251,919. ALL ACCESS MANUFACTURING LLC, LAS VEGAS, NV. FILED 4-14-2014.



The logo for ARTEGO features the word "ARTEGO" in a bold, serif font.

THE MARK CONSISTS OF STANDARD CHARACTERS WITHOUT CLAIM TO ANY PARTICULAR FONT, STYLE, SIZE, OR COLOR.

FOR TREATMENT OF MATERIALS, NAMELY, GLASS, CONCRETE, WOOD, FIBERGLASS, METAL, PLASTIC AND OTHER SUBSTRATES FOR INTERIOR AND EXTERIOR COMMERCIAL AND/OR RESIDENTIAL APPLICATIONS (U.S. CLS. 100, 103 AND 106).

INGRID C. EULIN, EXAMINING ATTORNEY

**CLASS 41—EDUCATION AND ENTERTAINMENT**

SN 76-714,747. CRAAN, COLEITE, BURBANK, CA. FILED 8-13-2013.

STANDING TALL COMEDY KIDS  
& TEENS SINCE 1995

THE MARK CONSISTS OF STANDARD CHARACTERS WITHOUT CLAIM TO ANY PARTICULAR FONT, STYLE, SIZE, OR COLOR.

NO CLAIM IS MADE TO THE EXCLUSIVE RIGHT TO USE "COMEDY", "KIDS & TEENS" AND "SINCE 1995", APART FROM THE MARK AS SHOWN.

FOR ENTERTAINMENT SERVICES IN THE NATURE OF COMEDY SHOWS FOR KIDS AND TEENS TO HAVE AN OUTLET TO EXPRESS THEMSELVES AND THEIR POINTS OF VIEW IN AN UPLIFTING AND COMEDIC WAY (U.S. CLS. 100, 101 AND 107).

FIRST USE 7-28-1999; IN COMMERCE 7-28-1999.

KATINA MISTER, EXAMINING ATTORNEY

**CLASS 41—(Continued).**

SN 76-716,154. MICHAEL EPSTEIN SPORTS PRODUCTIONS INC, AGOURA HILLS, CA. FILED 4-8-2014.



NO CLAIM IS MADE TO THE EXCLUSIVE RIGHT TO USE RUN, APART FROM THE MARK AS SHOWN.

THE COLORS BLACK AND YELLOW ARE CLAIMED AS A FEATURE OF THE MARK.

THE MARK CONSISTS OF THE WORDS THE CHARDONNAY RUN IN A STYLIZED BLACK FONT TO THE LEFT OF THE REPRESENTATION OF A WINE GLASS OUTLINED IN BLACK CONTAINING A YELLOW LIQUID.

FOR ARRANGING AND CONDUCTING ATHLETIC COMPETITIONS (U.S. CLS. 100, 101 AND 107).

FIRST USE 3-5-2014; IN COMMERCE 3-5-2014.

MIDGE BUTLER, EXAMINING ATTORNEY

**CLASS 41—(Continued).**

SN 79-125,573. TELEVISION VERSIONING & TRANSLATION; (TVT) LIMITED, HAMPSHIRE, UNITED KINGDOM, FILED 11-19-2012.

THE MARK CONSISTS OF STANDARD CHARACTERS WITHOUT CLAIM TO ANY PARTICULAR FONT, STYLE, SIZE, OR COLOR.

PRIORITY DATE OF 5-28-2012 IS CLAIMED.

OWNER OF INTERNATIONAL REGISTRATION 1148616 DATED 11-19-2012, EXPIRES 11-19-2022.

FOR EDUCATION, NAMELY, PROVIDING CLASSES, SEMINARS, WORKSHOPS, TUTORING, AND MENTORING IN THE FIELDS OF MUSIC, VIDEOS, FILM, TELEVISION AND TRANSLATION; PROVIDING OF TRAINING IN THE FIELDS OF MUSIC, VIDEOS, FILM, TELEVISION AND TRANSLATION; ENTERTAINMENT, NAMELY, EDITING, PRODUCTION, AND TRANSLATION OF MUSIC, VIDEO, FILM AND TELEVISION RECORDINGS; ORGANIZING COMMUNITY SPORTING AND CULTURAL ACTIVITIES; AUDIO, FILM, VIDEO AND TELEVISION RECORDING SERVICES; PREPARATION OF ENTERTAINMENT PROGRAMMES FOR BROADCASTING, NAMELY, TRANSCODING, EDITING OF SOUND AND IMAGES, DUBBING, RESTORATION OF SOUND AND IMAGES, AND SUBTITLING; PROVIDING NON-DOWNLOADABLE ELECTRONIC PUBLICATIONS, NAMELY BOOKS, MAGAZINES, NEWSPAPERS, MANUALS IN THE FIELDS OF MUSIC, VIDEOS, FILM, TELEVISION AND TRANSLATION; PRODUCTION OF TELEVISION, FILM AND RADIO BROADCASTS AND RECORDINGS; PUBLICATION OF TEXTS OTHER THAN PUBLICITY TEXTS; PRODUCTION OF AUDIO, SOUND AND MUSICAL RECORDINGS; VIDEO, AUDIO AND MULTIMEDIA PUBLISHING SERVICES; PRODUCTION, DISTRIBUTION, RENTAL, AND SYNDICATION OF TELEVISION AND RADIO PROGRAMMES; RECORDING, FILM, VIDEO AND TELEVISION STUDIO SERVICES; EDITING OF TELEVISION AND RADIO PROGRAMMES; POST-PRODUCTION EDITING SERVICES IN THE FIELD OF MUSIC, VIDEOS AND FILM; TRANSLATION SERVICES; CONSULTANCY, ADVISORY AND INFORMATION SERVICES RELATING TO THE FOREGOING (U.S. CLS. 100, 101 AND 107).

TOBY BULLOFF, EXAMINING ATTORNEY

SN 77-688,586. KIDS CAN PRESS LTD., TORONTO, ONTARIO, CANADA, FILED 3-11-2009.

THE MARK CONSISTS OF STANDARD CHARACTERS WITHOUT CLAIM TO ANY PARTICULAR FONT, STYLE, SIZE, OR COLOR.

OWNER OF CANADA REG. NO. TMA881323, DATED 7-7-2014, EXPIRES 7-7-2029.

FOR ENTERTAINMENT SERVICES, NAMELY, THE PRESENTATION OF AWARDS FOR MERITORIOUS YOUTH ACHIEVEMENTS (U.S. CLS. 100, 101 AND 107).

TEJBIR SINGH, EXAMINING ATTORNEY



**CLASS 41—(Continued).**

SN 79-135,864. STEVE PILLEMER, AUSTRALIA, FILED 5-20-2013.

# YOUR SHOT

THE MARK CONSISTS OF STANDARD CHARACTERS WITHOUT CLAIM TO ANY PARTICULAR FONT, STYLE, SIZE, OR COLOR.

PRIORITY DATE OF 5-15-2013 IS CLAIMED.

OWNER OF INTERNATIONAL REGISTRATION 1174881 DATED 5-20-2013, EXPIRES 5-20-2023.

FOR ORGANIZATION OF DISC JOCKEY COMPETITIONS; ORGANIZATION OF MUSIC FESTIVALS; PRODUCTION OF TELEVISION PROGRAMS; ORGANIZING, PRODUCING, PRESENTING AND CONDUCTING OF MUSIC PERFORMANCES AND EVENTS, NAMELY, ENTERTAINMENT SERVICES IN THE NATURE OF LIVE MUSICAL PERFORMANCES; MUSICAL ENTERTAINMENT SERVICES, NAMELY, LIVE PERFORMANCES BY MUSICAL BANDS; NIGHT CLUB SERVICES; ORGANIZATION AND CONDUCTING OF DANCE, MUSIC AND ART FESTIVALS; PRODUCTION AND PRESENTATION OF RADIO AND TELEVISION PROGRAMS, FILMS AND SHOWS; PRODUCTION OF VIDEO TAPES AND VIDEO DISCS; RADIO ENTERTAINMENT PRODUCTION; TELEVISION ENTERTAINMENT PRODUCTION (U.S. CLS. 100, 101 AND 107).

ROBERT STRUCK, EXAMINING ATTORNEY

**CLASS 41—(Continued).**

SN 79-139,887. NICOLE CAVEGN, NICADANCE<sup>(r)</sup>, CH-8006 ZÜRICH, SWITZERLAND, FILED 10-27-2013.

# nicadance

THE MARK CONSISTS OF STANDARD CHARACTERS WITHOUT CLAIM TO ANY PARTICULAR FONT, STYLE, SIZE, OR COLOR.

OWNER OF INTERNATIONAL REGISTRATION 1185223 DATED 10-27-2013, EXPIRES 10-27-2023.

THE NAME(S), PORTRAIT(S), AND/OR SIGNATURE(S) SHOWN IN THE MARK DOES NOT IDENTIFY A PARTICULAR LIVING INDIVIDUAL.

FOR EDUCATION SERVICES, NAMELY, PROVIDING CLASSES IN THE FIELD OF AEROBIC, DANCE AND FITNESS EXERCISE; TRAINING IN THE FIELD OF DANCE AND FITNESS; ENTERTAINMENT, NAMELY, IN THE NATURE OF COMPETITIONS IN THE FIELD OF DANCE AND FITNESS; ORGANIZING COMMUNITY SPORTING AND CULTURAL EVENTS (U.S. CLS. 100, 101 AND 107).

LEE-ANNE BERNIS, EXAMINING ATTORNEY

SN 79-138,451. YOUNG POTENTIAL DEVELOPMENT, S.L., SPAIN, FILED 8-13-2013.



OWNER OF INTERNATIONAL REGISTRATION 1181692 DATED 8-13-2013, EXPIRES 8-13-2023.

NO CLAIM IS MADE TO THE EXCLUSIVE RIGHT TO USE "DEVELOPMENT", APART FROM THE MARK AS SHOWN.

FOR EDUCATION SERVICES, NAMELY, PROVIDING LIVE AND ON-LINE EDUCATIONAL ACTIVITY CONSISTING OF CLASSES, SEMINARS AND WORKSHOPS IN THE FIELD OF EMOTIONAL AND SOFT SKILLS DEVELOPMENT, CREATIVITY, COMMUNICATION, LEADERSHIP AND ENERGY IN THE NATURE OF MIND AND BALANCE; TRAINING SERVICES IN THE FIELD OF EMOTIONAL AND SOFT SKILLS DEVELOPMENT, CREATIVITY, COMMUNICATION, LEADERSHIP AND ENERGY IN THE NATURE OF MIND AND BALANCE (U.S. CLS. 100, 101 AND 107).

KAELIE KUNG, EXAMINING ATTORNEY

SN 79-146,146. PLARIUM GLOBAL LTD., ISRAEL, FILED 2-23-2014.



PRIORITY DATE OF 2-6-2014 IS CLAIMED.

OWNER OF INTERNATIONAL REGISTRATION 1200918 DATED 2-23-2014, EXPIRES 2-23-2024.

THE COLOR(S) SILVER, BRONZE, RED AND DARK GRAY IS/ARE CLAIMED AS A FEATURE OF THE MARK.

THE MARK CONSISTS OF THE WORDING "SPARTA WAR OF EMPIRES" IN SILVER SUPERIMPOSED OVER A BRONZE SHIELD WITH A RED CHEVRON DESIGN THEREON, ALL APPEARING ON A DARK GRAY RECTANGULAR BACKGROUND.

FOR ENTERTAINMENT SERVICES, NAMELY, PROVIDING ON-LINE COMPUTER GAMES (U.S. CLS. 100, 101 AND 107).

DAVID ELTON, EXAMINING ATTORNEY

**CLASS 41—(Continued).**

SN 85-481,719. PROSPER, INC., PROVO, UT. FILED 11-28-2011.

**PROSPERING**

THE MARK CONSISTS OF STANDARD CHARACTERS WITHOUT CLAIM TO ANY PARTICULAR FONT, STYLE, SIZE, OR COLOR.

OWNER OF U.S. REG. NOS. 3,113,045, 3,688,384 AND OTHERS.

FOR EDUCATIONAL SERVICES, NAMELY, TRAINING, WORKSHOPS, SEMINARS, AND PERSONAL COACHING, ALL IN THE FIELDS OF BUSINESS AND INVESTING, INCLUDING ECOMMERCE, REAL ESTATE INVESTING, STOCK MARKET INVESTING, PERSONAL FINANCE AND SMALL BUSINESS; PROVIDING ONLINE BOOKS, WORKBOOKS, MANUALS, PERIODICALS AND NEWSLETTERS IN THE FIELDS OF BUSINESS AND INVESTING, PROVIDING A WEBSITE FEATURING NON-DOWNLOADABLE BOOKS, WORKBOOKS, MANUALS, PERIODICALS AND NEWSLETTERS FEATURING INFORMATION IN THE FIELDS OF BUSINESS AND INVESTING, INCLUDING ECOMMERCE, REAL ESTATE INVESTING, STOCK MARKET INVESTING, PERSONAL FINANCE AND SMALL BUSINESS; NON-DOWNLOADABLE ONLINE ELECTRONIC BOOKS, WORKBOOKS, MANUALS, PERIODICALS AND NEWSLETTERS DELIVERED BY E-MAIL IN THE FIELDS OF BUSINESS AND INVESTING, INCLUDING ECOMMERCE, REAL ESTATE INVESTING, STOCK MARKET INVESTING, PERSONAL FINANCE AND SMALL BUSINESS (U.S. CLS. 100, 101 AND 107).

LINDA ESTRADA, EXAMINING ATTORNEY

SN 85-651,551. EASLEY, TAKKIA, THOMPSON STATION, TN. FILED 6-14-2012.

**BELLA BLEU EVENTS**

THE MARK CONSISTS OF STANDARD CHARACTERS WITHOUT CLAIM TO ANY PARTICULAR FONT, STYLE, SIZE, OR COLOR.

NO CLAIM IS MADE TO THE EXCLUSIVE RIGHT TO USE "EVENTS", APART FROM THE MARK AS SHOWN.

THE ENGLISH TRANSLATION OF "BELLA BLEU" IN THE MARK IS "BEAUTY BLUE".

FOR SPECIAL EVENT PLANNING FOR SOCIAL ENTERTAINMENT PURPOSES (U.S. CLS. 100, 101 AND 107).

FIRST USE 5-1-2011; IN COMMERCE 5-1-2011.

DANIEL CAPSHAW, EXAMINING ATTORNEY

**CLASS 41—(Continued).**

SN 85-710,617. PALAESTRA PRODUCTIONS, LLC, DALLAS, TX. FILED 8-22-2012.



NO CLAIM IS MADE TO THE EXCLUSIVE RIGHT TO USE "PRODUCTIONS", APART FROM THE MARK AS SHOWN.

THE MARK CONSISTS OF TWO HUMAN FIGURES IN A MARTIAL ARTS FIGHTING POSITION WITH A RECTANGULAR BACKGROUND BORDER, ALL ABOVE THE WORDS "PALAESTRA PRODUCTIONS".

FOR ENTERTAINMENT SERVICES, NAMELY, MOTION PICTURE PRODUCTION SERVICES (U.S. CLS. 100, 101 AND 107).

KELLEY WELLS, EXAMINING ATTORNEY

SN 85-710,620. PALAESTRA PRODUCTIONS, LLC, DALLAS, TX. FILED 8-22-2012.

**PALAESTRA PRODUCTIONS**

THE MARK CONSISTS OF STANDARD CHARACTERS WITHOUT CLAIM TO ANY PARTICULAR FONT, STYLE, SIZE, OR COLOR.

NO CLAIM IS MADE TO THE EXCLUSIVE RIGHT TO USE "PRODUCTIONS", APART FROM THE MARK AS SHOWN.

FOR ENTERTAINMENT SERVICES, NAMELY, MOTION PICTURE PRODUCTION SERVICES (U.S. CLS. 100, 101 AND 107).

KELLEY WELLS, EXAMINING ATTORNEY

**CLASS 41—(Continued).**

SN 85-812,835. FRIENDS OF MAYANOT INSTITUTE INC,  
NEW YORK, NY. FILED 12-31-2012.

# Mayanot

THE MARK CONSISTS OF STANDARD CHARACTERS WITHOUT CLAIM TO ANY PARTICULAR FONT, STYLE, SIZE, OR COLOR.

THE ENGLISH TRANSLATION OF "MAYANOT" IN THE MARK IS "WELLSPRINGS".

FOR EDUCATION SERVICES, NAMELY, PROVIDING LIVE AND ON-LINE TOURS AND COURSES IN THE FIELD OF ISRAEL AND JUDAISM (U.S. CLS. 100, 101 AND 107).

FIRST USE 1-1-1990; IN COMMERCE 1-1-1990.  
ESTHER A. BORSUK, EXAMINING ATTORNEY

---

SN 85-860,798. SHOW CREATORS INC., LAS VEGAS, NV.  
FILED 2-26-2013.

# Showbot

THE MARK CONSISTS OF STANDARD CHARACTERS WITHOUT CLAIM TO ANY PARTICULAR FONT, STYLE, SIZE, OR COLOR.

FOR ENTERTAINMENT IN THE NATURE OF VISUAL AND AUDIO PERFORMANCES BY AN ACTOR (U.S. CLS. 100, 101 AND 107).

FIRST USE 11-0-2002; IN COMMERCE 11-0-2002.  
WENDY JUN, EXAMINING ATTORNEY

---

SN 85-864,467. DON REIMER, PINEY FLATS, TN. FILED 3-1-2013.

## REACTIVE OPERATOR PISTOL (ROP)

THE MARK CONSISTS OF STANDARD CHARACTERS WITHOUT CLAIM TO ANY PARTICULAR FONT, STYLE, SIZE, OR COLOR.

NO CLAIM IS MADE TO THE EXCLUSIVE RIGHT TO USE "REACTIVE OPERATOR PISTOL", APART FROM THE MARK AS SHOWN.

FOR TRAINING SERVICES, NAMELY, PROVIDING LAW ENFORCEMENT, SECURITY PROFESSIONALS AND MILITARY PERSONNEL WITH REACTIONARY TRAINING IN USE OF PISTOL (U.S. CLS. 100, 101 AND 107).

FIRST USE 3-1-2013; IN COMMERCE 3-1-2013.  
EUGENIA MARTIN, EXAMINING ATTORNEY

**CLASS 41—(Continued).**

SN 85-887,867. OLIVA, VICTORIA, FOREST HILLS, NY.  
FILED 3-27-2013.

# V FUSION

THE MARK CONSISTS OF STANDARD CHARACTERS WITHOUT CLAIM TO ANY PARTICULAR FONT, STYLE, SIZE, OR COLOR.

FOR CONDUCTING FITNESS CLASSES; PHYSICAL FITNESS CONDITIONING CLASSES; PHYSICAL FITNESS INSTRUCTION; PHYSICAL FITNESS STUDIO SERVICES, NAMELY, PROVIDING EXERCISE CLASSES, BODY SCULPTING CLASSES, AND GROUP FITNESS CLASSES; PHYSICAL FITNESS TRAINING OF INDIVIDUALS AND GROUPS (U.S. CLS. 100, 101 AND 107).

FIRST USE 9-1-2012; IN COMMERCE 9-1-2012.  
TEJBIR SINGH, EXAMINING ATTORNEY

---

SN 85-891,231. LEADING ATTITUDES, INC., FREDERICK, MD. FILED 3-31-2013.

## AWAKEN YOUR HEROINE!

THE MARK CONSISTS OF STANDARD CHARACTERS WITHOUT CLAIM TO ANY PARTICULAR FONT, STYLE, SIZE, OR COLOR.

FOR (BASED ON USE IN COMMERCE) PERSONAL LIFE COACHING, EDUCATIONAL, TRAINING, SERVICES, NAMELY, PROVIDING IN-PERSON, TELEPHONE, AND ON-LINE CLASSES, SEMINARS, WORKSHOPS, CONFERENCES, AND TRAINING PROGRAMS IN THE FIELDS OF MOTIVATION, PERSONAL, PROFESSIONAL, AND CAREER DEVELOPMENT, SPIRITUALITY, WOMEN'S EMPOWERMENT AND TRANSFORMATION, INTERPERSONAL COMMUNICATION, PERSONAL LEADERSHIP SKILLS, AND PERSONAL WELLNESS, AND ONLINE AND WRITTEN COURSE MATERIALS PROVIDED IN CONNECTION THEREWITH, NAMELY, JOURNALS, WRITTEN COURSE TRANSCRIPTS, AND WORKBOOKS; PROVIDING ONLINE NEWSLETTERS AND ARTICLES VIA E-MAIL AND VIA A WEBSITE IN THE FIELDS OF MOTIVATION, PERSONAL, PROFESSIONAL, AND CAREER DEVELOPMENT, SPIRITUALITY, WOMEN'S EMPOWERMENT AND TRANSFORMATION, INTERPERSONAL COMMUNICATION, PERSONAL LEADERSHIP SKILLS, AND PERSONAL WELLNESS; (BASED ON INTENT TO USE) PROVIDING A WEB SITE THAT FEATURES NON-DOWNLOADABLE AUDIO AND VIDEO RECORDINGS IN THE FIELDS OF MOTIVATION, PERSONAL, PROFESSIONAL, AND CAREER DEVELOPMENT, SPIRITUALITY, WOMEN'S EMPOWERMENT AND TRANSFORMATION, INTERPERSONAL COMMUNICATION, PERSONAL LEADERSHIP SKILLS, AND PERSONAL WELLNESS (U.S. CLS. 100, 101 AND 107).

FIRST USE 2-1-2013; IN COMMERCE 2-1-2013.  
PAUL MORENO, EXAMINING ATTORNEY

**CLASS 41—(Continued).**

SN 85-892,922. ALSUP, CRAIG, REPUBLIC, MO. AND ALSUP, JENNIFER, REPUBLIC, MO. FILED 4-2-2013.

**CENTURION**

THE MARK CONSISTS OF STANDARD CHARACTERS WITHOUT CLAIM TO ANY PARTICULAR FONT, STYLE, SIZE, OR COLOR.

FOR INTERACTIVE ONLINE WEB JOURNALS FEATURING SHARED STORIES ABOUT COSTUMES, WARDROBE MALFUNCTIONS, INJURIES, LEVELS OF EXHAUSTION AND/OR CHALLENGE AS WELL AS FUN IN CONNECTION WITH PARTICIPATION IN AN OBSTACLE RACE, RUN AND WALK EVENT; ORGANIZING, ARRANGING, AND CONDUCTING GROUP OBSTACLE RACE, RUN AND WALK EVENTS; PROVIDING A WEB SITE THAT FEATURES INFORMAL INSTRUCTION ON HOW TO PREPARE FOR AN OBSTACLE RACE, RUN AND WALK EVENT ON A SHORT SCHEDULE AND FOR THE LESS THAN YEAR-ROUND DEDICATED ENDURANCE-TRAINING ATHLETE (U.S. CLS. 100, 101 AND 107).

SUSAN LESLIE DUBOIS, EXAMINING ATTORNEY

SN 85-902,296. MCGRAW-HILL SCHOOL EDUCATION HOLDINGS LLC, NEW YORK, NY. FILED 4-12-2013.

**WORKFORCE ACCESS**

THE MARK CONSISTS OF STANDARD CHARACTERS WITHOUT CLAIM TO ANY PARTICULAR FONT, STYLE, SIZE, OR COLOR.

PRIORITY CLAIMED UNDER SEC. 44(D) ON CANADA APPLICATION NO. 1621968, FILED 4-10-2013.

NO CLAIM IS MADE TO THE EXCLUSIVE RIGHT TO USE "WORKFORCE", APART FROM THE MARK AS SHOWN.

FOR EDUCATION SERVICES, NAMELY, PROVIDING A WEBSITE FEATURING ONLINE COURSES OF INSTRUCTION IN THE FIELDS OF BASIC ACADEMIC SKILLS AND INTRODUCTORY INDUSTRY SPECIFIC SKILLS AND DISTRIBUTION OF COURSE MATERIALS IN CONNECTION THEREWITH; EDUCATIONAL SERVICES, NAMELY, NON-DOWNLOADABLE EDUCATIONAL PUBLICATIONS IN THE NATURE OF PRINTED ASSESSMENTS, PRINTED REPORTS, TEACHER RESOURCE MATERIALS IN THE NATURE OF LESSON OUTLINES, PLANNING GUIDES AND GRAPHIC ORGANIZERS IN THE FIELDS OF BASIC ACADEMIC SKILLS AND INTRODUCTORY INDUSTRY SPECIFIC SKILLS FOR ADULT LEARNERS (U.S. CLS. 100, 101 AND 107).

SUSAN RICHARDS, EXAMINING ATTORNEY

**CLASS 41—(Continued).**

SN 85-919,897. KARA, PATRICIA, DBA KARA ENTERTAINMENT, INC., LOS ANGELES, CA. FILED 5-1-2013.

**DISH WITH TRISH**

THE MARK CONSISTS OF STANDARD CHARACTERS WITHOUT CLAIM TO ANY PARTICULAR FONT, STYLE, SIZE, OR COLOR.

THE NAME(S), PORTRAIT(S), AND/OR SIGNATURE(S) SHOWN IN THE MARK IDENTIFIES PATRICIA KARA, WHOSE CONSENT(S) TO REGISTER IS MADE OF RECORD.

FOR ENTERTAINMENT SERVICES, NAMELY, THE PRODUCTION AND DISTRIBUTION OF A CONTINUING VARIETY SHOW RELATED TO RECREATION AND LIFESTYLE BROADCAST OVER THE INTERNET (U.S. CLS. 100, 101 AND 107).

SHAILA LEWIS, EXAMINING ATTORNEY

SN 85-922,320. TELEvisa, S.A. DE C.V., SANTA FE, MEXICO, FILED 5-3-2013.

**VERANO DE AMOR**

THE MARK CONSISTS OF STANDARD CHARACTERS WITHOUT CLAIM TO ANY PARTICULAR FONT, STYLE, SIZE, OR COLOR.

THE ENGLISH TRANSLATION OF "VERANO DE AMOR" IN THE MARK IS "SUMMER OF LOVE".

FOR ENTERTAINMENT SERVICES IN THE NATURE OF AN ONGOING DRAMATIC TELEVISION PROGRAM (U.S. CLS. 100, 101 AND 107).

MARK SHINER, EXAMINING ATTORNEY

SN 85-925,541. SIOUX FALLS SPORTS, LLC, SIOUX FALLS, SD. FILED 5-7-2013.

**SIOUX FALLS CANARIES**

THE MARK CONSISTS OF STANDARD CHARACTERS WITHOUT CLAIM TO ANY PARTICULAR FONT, STYLE, SIZE, OR COLOR.

NO CLAIM IS MADE TO THE EXCLUSIVE RIGHT TO USE "SIOUX FALLS", APART FROM THE MARK AS SHOWN.

FOR ENTERTAINMENT IN THE NATURE OF BASEBALL GAMES (U.S. CLS. 100, 101 AND 107).

FIRST USE 12-31-1993; IN COMMERCE 12-31-1993.

KELLEY WELLS, EXAMINING ATTORNEY

**CLASS 41—(Continued).**

SN 85-929,763. KIDZABLAZE MINISTRIES INTERNATIONAL, CONCORD, NC. FILED 5-13-2013.

**TWEEN YOU AND ME**

THE MARK CONSISTS OF STANDARD CHARACTERS WITHOUT CLAIM TO ANY PARTICULAR FONT, STYLE, SIZE, OR COLOR.

FOR ENTERTAINMENT, NAMELY, A CONTINUING CHRISTIAN CHILDREN'S SHOW BROADCAST OVER TELEVISION (U.S. CLS. 100, 101 AND 107).

FIRST USE 3-1-2013; IN COMMERCE 3-1-2013.  
BRIAN CALLAGHAN, EXAMINING ATTORNEY

---

SN 85-944,574. IN THE BUILDING, BROOKLYN, NY. FILED 5-29-2013.

**IN THE BUILDING**

THE MARK CONSISTS OF STANDARD CHARACTERS WITHOUT CLAIM TO ANY PARTICULAR FONT, STYLE, SIZE, OR COLOR.

FOR CONDUCTING ENTERTAINMENT EXHIBITIONS IN THE NATURE OF LIVE MUSIC EVENTS AND EXHIBITIONS FEATURING PRESENTATIONS OF PRE-RECORDED MUSIC, FASHION, FILM AND TELEVISION EVENTS, PROVIDING ENTERTAINMENT SERVICES IN THE NATURE OF PRESENTING LIVE MUSICAL PERFORMANCES; ENTERTAINMENT SERVICES, NAMELY, PRODUCTION AND POST-PRODUCTION SERVICES IN THE FIELDS OF MUSIC, AUDIO RECORDINGS, MOTION PICTURE, RADIO PROGRAMS, INTERNET ENTERTAINMENT PROGRAMS, AND TELEVISION PROGRAMS, AND IN THE FIELDS OF MUSIC, AUDIO RECORDINGS, MOTION PICTURE, RADIO PROGRAMS, INTERNET ENTERTAINMENT PROGRAMS, AND TELEVISION PROGRAMS ABOUT THE ARTS, EDUCATION, BEAUTY, FASHION, MODELING, CULTURE, POLITICS, LIFESTYLES AND SPORTS; PHOTOGRAPHY SERVICES; PROVIDING A WEB SITE FEATURING NON-DOWNLOADABLE MUSICAL PERFORMANCES, MUSICAL VIDEOS, RELATED FILM CLIPS, PHOTOGRAPHS, AND OTHER MULTIMEDIA MATERIALS FEATURING MUSIC, MUSIC ARTISTS, FILMS AND TELEVISION PROGRAMS; ENTERTAINMENT SERVICES, NAMELY, PROVIDING NON-DOWNLOADABLE PRERECORDED MUSIC, INFORMATION IN THE FIELD OF ENTERTAINMENT AND MUSIC, AND COMMENTARY AND NON-DOWNLOADABLE ARTICLES IN THE FIELD OF ENTERTAINMENT AND MUSIC; PROVIDING A WEBSITE FEATURING NON-DOWNLOADABLE ARTICLES IN THE FIELD OF MUSIC, MUSIC ARTISTS, FASHION, FILM AND TELEVISION, VIA A GLOBAL COMPUTER NETWORK; PROVIDING A WEB SITE THAT FEATURES INFORMATION IN THE FIELD OF ENTERTAINMENT (U.S. CLS. 100, 101 AND 107).

FIRST USE 3-13-2011; IN COMMERCE 1-23-2012.  
JEAN IM, EXAMINING ATTORNEY

**CLASS 41—(Continued).**

SN 85-966,327. TRAVEL DAILY NEWS, INC., WASHINGTON, DC. FILED 6-21-2013.

**THE PERFECT MURDER**

THE MARK CONSISTS OF STANDARD CHARACTERS WITHOUT CLAIM TO ANY PARTICULAR FONT, STYLE, SIZE, OR COLOR.

NO CLAIM IS MADE TO THE EXCLUSIVE RIGHT TO USE "MURDER", APART FROM THE MARK AS SHOWN.

FOR ENTERTAINMENT AND EDUCATIONAL SERVICES IN THE NATURE OF TELEVISION AND MULTIMEDIA PROGRAM SERIES FEATURING SUBJECTS OF GENERAL HUMAN INTEREST DISTRIBUTED VIA VARIOUS PLATFORMS ACROSS MULTIPLE FORMS OF TRANSMISSION MEDIA; PROVIDING ENTERTAINMENT INFORMATION TO OTHERS VIA A GLOBAL COMPUTER NETWORK (U.S. CLS. 100, 101 AND 107).

ELLEN PERKINS, EXAMINING ATTORNEY

---

SN 85-971,116. AMERICA PRESS, INC., NEW YORK, NY. FILED 6-26-2013.

**America Media**

THE MARK CONSISTS OF STANDARD CHARACTERS WITHOUT CLAIM TO ANY PARTICULAR FONT, STYLE, SIZE, OR COLOR.

OWNER OF U.S. REG. NO. 3,204,983.

NO CLAIM IS MADE TO THE EXCLUSIVE RIGHT TO USE "MEDIA", APART FROM THE MARK AS SHOWN.

SEC. 2(F).

FOR PUBLICATION OF ARTICLES, LECTURES, MAGAZINES AND BOOKS IN BOTH PRINTED AND ELECTRONIC FORMATS CONCERNING THE CATHOLIC RELIGION AND MATTERS OF INTEREST TO SCHOLARS AND FOLLOWERS OF THE CATHOLIC RELIGION (U.S. CLS. 100, 101 AND 107).

MATTHEW EINSTEIN, EXAMINING ATTORNEY

**CLASS 41—(Continued).**

SN 86-002,096. BURKE, THERESA KARMINSKI, KING OF PRUSSIA, PA. FILED 7-3-2013.



THE MARK CONSISTS OF AN IMAGE OF A DOVE WITH OUTSTRETCHED WINGS FLYING ACROSS THE UPPER RIGHT CORNER OF A SQUARE CONTAINING A CROSS. FOR EDUCATIONAL SERVICES, NAMELY, CONDUCTING CLASSES, SEMINARS, CONFERENCES, WORKSHOPS, RETREATS, CAMPS AND FIELD TRIPS IN THE FIELD OF HEALING, PSYCHOLOGICAL AND EMOTIONAL WELL-BEING OF THOSE EFFECTED BY ABORTION AND DISTRIBUTION OF TRAINING MATERIAL IN CONNECTION THEREWITH (U.S. CLS. 100, 101 AND 107).  
FIRST USE 1-31-2006; IN COMMERCE 1-31-2006.  
SUSAN STIGLITZ, EXAMINING ATTORNEY

SN 86-007,195. CONNELL, KATHLEEN, WASHINGTON, DC. FILED 7-11-2013.

**CONNECT**

THE MARK CONSISTS OF STANDARD CHARACTERS WITHOUT CLAIM TO ANY PARTICULAR FONT, STYLE, SIZE, OR COLOR. FOR EDUCATIONAL SERVICES, NAMELY, PROVIDING COURSES OF INSTRUCTION AT THE HIGH SCHOOL, COMMUNITY COLLEGE, TECHNICAL COLLEGE, AND COLLEGE LEVEL (U.S. CLS. 100, 101 AND 107).  
FIRST USE 6-24-2014; IN COMMERCE 6-24-2014.  
ANTHONY RINKER, EXAMINING ATTORNEY

**CLASS 41—(Continued).**

SN 86-020,578. PATTILLO, ANN LOUISE, HUNTSVILLE, AL. FILED 7-26-2013.



NO CLAIM IS MADE TO THE EXCLUSIVE RIGHT TO USE "ORFF MUSIC FOR CHILDREN", APART FROM THE MARK AS SHOWN. THE MARK CONSISTS OF THE LITERAL ELEMENTS "ORFF MUSIC FOR CHILDREN" WRITTEN IN STYLIZED FORM WHEREIN IMAGE LIKE OF THREE DANCING HUMANS ARE PLACED BETWEEN THE WORDING "ORFF" WHICH IS PLACED AT THE TOP AND WORDING "MUSIC FOR CHILDREN" WRITTEN AT THE BOTTOM. FOR EDUCATIONAL SERVICES, NAMELY, CONDUCTING CLASSES IN MUSIC FOR CHILDREN (U.S. CLS. 100, 101 AND 107).  
FIRST USE 1-11-1985; IN COMMERCE 1-11-1985.  
ALICIA COLLINS, EXAMINING ATTORNEY

SN 86-022,939. MARCHER LORD PRESS, COLORADO SPRINGS, CO. FILED 7-29-2013.



NO CLAIM IS MADE TO THE EXCLUSIVE RIGHT TO USE "PRESS", APART FROM THE MARK AS SHOWN. THE MARK CONSISTS OF THE STYLIZED WORDING "MARCHER LORD PRESS" AND A STYLIZED SILHOUETTE OF A MAN HOLDING A LONG POLE WITH A PENNANT. THE MAN IS STANDING ON A THREE TIERED PLATFORM ABOVE THE STYLIZED WORDING "MARCHER" OVER THE STYLIZED WORDING "LORD" OVER THE STYLIZED WORDING "PRESS". FOR BOOK PUBLISHING; PUBLISHING OF BOOKS, E-BOOKS, AUDIO BOOKS, MUSIC AND ILLUSTRATIONS (U.S. CLS. 100, 101 AND 107).  
FIRST USE 10-1-2008; IN COMMERCE 10-1-2008.  
DOMINIC J. FERRAIUOLO, EXAMINING ATTORNEY

**CLASS 41—(Continued).**

SN 86-023,053. MILLER, TIMOTHY, ALLENTOWN, PA.  
FILED 7-30-2013.

# STSK

THE MARK CONSISTS OF STANDARD CHARACTERS WITHOUT CLAIM TO ANY PARTICULAR FONT, STYLE, SIZE, OR COLOR.

FOR PROVIDING EDUCATION THROUGH CLASSES IN THE FIELD OF FIREARMS AND SELF-DEFENSE AND SAFETY (U.S. CLS. 100, 101 AND 107).

FIRST USE 1-22-2013; IN COMMERCE 2-5-2013.  
BRIDGETT SMITH, EXAMINING ATTORNEY

SN 86-040,510. NEW HOPE CHARITABLE FOUNDATION,  
DEL MAR, CA. FILED 8-16-2013.

## DRAWING OUT GENIUS

THE MARK CONSISTS OF STANDARD CHARACTERS WITHOUT CLAIM TO ANY PARTICULAR FONT, STYLE, SIZE, OR COLOR.

FOR EDUCATIONAL AND ENTERTAINMENT SERVICES, NAMELY, A CONTINUING PROGRAM ABOUT FICTIONAL STORIES, PARENTING SKILLS, CLASSROOM MANAGEMENT, SETTING CHILDREN UP FOR SUCCESS, IMPROVING LEARNING, CORE SUBJECT REMEDIATION, FACTORS AND SKILLS FOR SUCCESSFUL LEARNING, CHILD, YOUTH, TEEN, AND YOUNG ADULT LEARNING AND CULTURE, CAREER EXPLORATION AND OPPORTUNITY, INTEREST EXPLORATION AND OPPORTUNITIES, SELF-AWARENESS, COMMUNITY AWARENESS, LEADERSHIP, TEAM WORK, CLEAR COMMUNICATION, SELF-RESPECT AND RESPECT FOR OTHERS, CONFIDENCE, AND GOAL SETTING AND ACHIEVEMENT ACCESSIBLE BY MEANS OF RADIO, MOVIE, TELEVISION, SATELLITE, AUDIO, VIDEO, WEB-BASED APPLICATIONS, MOBILE PHONE APPLICATIONS, AND COMPUTER NETWORKS; EDUCATIONAL AND ENTERTAINMENT SERVICES, NAMELY, PROVIDING MOTIVATIONAL AND EDUCATIONAL SPEAKERS; EDUCATIONAL SERVICES, NAMELY, CONDUCTING COACHING SESSIONS, SEMINARS, LECTURES, WORKSHOPS, CLASSES, CONFERENCES, TELESEMINARS, TELECLASSES, TUTORING, MENTORING, PANEL DISCUSSIONS AND KEY NOTE SPEECHES IN THE FIELDS OF FICTIONAL STORIES, PARENTING SKILLS, CLASSROOM MANAGEMENT, SETTING CHILDREN UP FOR SUCCESS, IMPROVING LEARNING, CORE SUBJECT REMEDIATION, FACTORS AND SKILLS FOR SUCCESSFUL LEARNING, CHILD, YOUTH, TEEN, AND YOUNG ADULT LEARNING AND CULTURE, CAREER EXPLORATION AND OPPORTUNITY, INTEREST EXPLORATION AND OPPORTUNITIES, SELF-AWARENESS, COMMUNITY AWARENESS, LEADERSHIP, TEAM WORK, CLEAR COMMUNICATION, SELF-RESPECT AND RESPECT FOR OTHERS, CONFIDENCE, AND GOAL SETTING AND ACHIEVEMENT AND DISTRIBUTION OF TRAINING MATERIALS IN CONNECTION THEREWITH; ENTERTAINMENT SERVICES, NAMELY, PROVIDING ONLINE VIDEO GAMES; ENTERTAINMENT SERVICES, NAMELY, PROVIDING PODCASTS IN THE FIELD OF FICTIONAL STORIES, PARENTING SKILLS, CLASSROOM MANAGEMENT, SETTING CHILDREN UP FOR SUCCESS, IMPROVING LEARNING, CORE SUBJECT REMEDIATION, FACTORS

**CLASS 41—(Continued).**

AND SKILLS FOR SUCCESSFUL LEARNING, CHILD, YOUTH, TEEN, AND YOUNG ADULT LEARNING AND CULTURE, CAREER EXPLORATION AND OPPORTUNITY, INTEREST EXPLORATION AND OPPORTUNITIES, SELF-AWARENESS, COMMUNITY AWARENESS, LEADERSHIP, TEAM WORK, CLEAR COMMUNICATION, SELF-RESPECT AND RESPECT FOR OTHERS, CONFIDENCE, AND GOAL SETTING AND ACHIEVEMENT; FILM AND VIDEO PRODUCTION; FILM AND VIDEO PRODUCTION CONSULTING SERVICES; FILM EDITING; MOTION PICTURE FILM PRODUCTION; ORGANIZING EXHIBITIONS FOR ENTERTAINMENT AND EDUCATIONAL PURPOSES IN THE FIELDS OF FICTIONAL STORIES, PARENTING SKILLS, CLASSROOM MANAGEMENT, SETTING CHILDREN UP FOR SUCCESS, IMPROVING LEARNING, CORE SUBJECT REMEDIATION, FACTORS AND SKILLS FOR SUCCESSFUL LEARNING, CHILD, YOUTH, TEEN, AND YOUNG ADULT LEARNING AND CULTURE, CAREER EXPLORATION AND OPPORTUNITY, INTEREST EXPLORATION AND OPPORTUNITIES, SELF-AWARENESS, COMMUNITY AWARENESS, LEADERSHIP, TEAM WORK, CLEAR COMMUNICATION, SELF-RESPECT AND RESPECT FOR OTHERS, CONFIDENCE, AND GOAL SETTING AND ACHIEVEMENT; PROVIDING A WEBSITE FEATURING BLOGS AND NON-DOWNLOADABLE PUBLICATIONS IN THE NATURE OF BOOKS, MAGAZINES, ARTICLES, NEWSLETTERS, PERSONAL JOURNAL ENTRIES, AND/OR BROCHURES IN THE FIELD(S) OF FICTIONAL STORIES, PARENTING SKILLS, CLASSROOM MANAGEMENT, SETTING CHILDREN UP FOR SUCCESS, IMPROVING LEARNING, CORE SUBJECT REMEDIATION, FACTORS AND SKILLS FOR SUCCESSFUL LEARNING, CHILD, YOUTH, TEEN, AND YOUNG ADULT LEARNING AND CULTURE, CAREER EXPLORATION AND OPPORTUNITY, INTEREST EXPLORATION AND OPPORTUNITIES, SELF-AWARENESS, COMMUNITY AWARENESS, LEADERSHIP, TEAM WORK, CLEAR COMMUNICATION, SELF-RESPECT AND RESPECT FOR OTHERS, CONFIDENCE, AND GOAL SETTING AND ACHIEVEMENT; PROVIDING A WEBSITE FEATURING INFORMATION IN THE FIELDS OF EDUCATION AND ENTERTAINMENT FOR CHILDREN; PROVIDING INFORMATION IN THE FIELD OF CHILDREN'S EDUCATION; PROVIDING INFORMATION RELATING TO EDUCATION SERVICES FOR CHILDREN; PROVIDING INFORMATION RELATING TO EDUCATIONAL AND ENTERTAINMENT ACTIVITIES AND EVENTS FOR CHILDREN; PROVIDING INFORMATION RELATING TO EDUCATIONAL SERVICES; PROVIDING ON-LINE NEWSLETTERS IN THE FIELD OF FICTIONAL STORIES, PARENTING SKILLS, CLASSROOM MANAGEMENT, SETTING CHILDREN UP FOR SUCCESS, IMPROVING LEARNING, CORE SUBJECT REMEDIATION, FACTORS AND SKILLS FOR SUCCESSFUL LEARNING, CHILD, YOUTH, TEEN, AND YOUNG ADULT LEARNING AND CULTURE, CAREER EXPLORATION AND OPPORTUNITY, INTEREST EXPLORATION AND OPPORTUNITIES, SELF-AWARENESS, COMMUNITY AWARENESS, LEADERSHIP, TEAM WORK, CLEAR COMMUNICATION, SELF-RESPECT AND RESPECT FOR OTHERS, CONFIDENCE, AND GOAL SETTING AND ACHIEVEMENT; PROVIDING ON-LINE TRAINING COACHING SESSIONS, SEMINARS, LECTURES, WORKSHOPS, CLASSES, CONFERENCES, TUTORING, MENTORING, AND PANEL DISCUSSIONS IN THE FIELD OF FICTIONAL STORIES, PARENTING SKILLS, CLASSROOM MANAGEMENT, SETTING CHILDREN UP FOR SUCCESS, IMPROVING LEARNING, CORE SUBJECT REMEDIATION, FACTORS AND SKILLS FOR SUCCESSFUL LEARNING, CHILD, YOUTH, TEEN, AND YOUNG ADULT LEARNING AND CULTURE, CAREER EXPLORATION AND OPPORTUNITY, INTEREST EXPLORATION AND OPPORTUNITIES, SELF-AWARENESS, COMMUNITY AWARENESS, LEADERSHIP, TEAM WORK, CLEAR COMMUNICATION, SELF-RESPECT AND RESPECT FOR OTHERS, CONFIDENCE, AND GOAL SETTING AND ACHIEVEMENT; VIDEO EDITING (U.S. CLS. 100, 101 AND 107).

KATHLEEN M. VANSTON, EXAMINING ATTORNEY

**CLASS 41—(Continued).**

SN 86-041,004. JONES, CHARLES PAUL, DBA B J PRODUCTIONS, STUDIO CITY, CA. FILED 8-18-2013.



NO CLAIM IS MADE TO THE EXCLUSIVE RIGHT TO USE "THE CAMERA FORUM", APART FROM THE MARK AS SHOWN.

THE COLOR(S) YELLOW, ORANGE, ORANGE-YELLOW, BLACK, WHITE AND GRAY IS/ARE CLAIMED AS A FEATURE OF THE MARK.

THE MARK CONSISTS OF A GRAPHICAL REPRESENTATION OF A MIRRORLESS TYPE CAMERA BODY IN THE COLOR GRAY AND OUTLINED IN BLACK WITH WHITE SHADING AROUND THE LENS, WITH A FURTHER GRAPHICAL REPRESENTATION OF A RIGHT HAND FACING BLACK SILHOUETTE OF A PHOTOGRAPHER TAKING A PHOTO ON AN ORANGE BACKGROUND NEXT TO THE WORDING "THE CAMERA FORUM" IN THE COLOR GRAY AND OUTLINED IN BLACK, ALL SET ON A RECTANGULAR BACKGROUND OF A COLOR GRADIENT OF THE COLOR YELLOW ON LEFT EDGE TO ORANGE-YELLOW TO ORANGE ON THE RIGHT EDGE.

FOR ENTERTAINMENT SERVICES, NAMELY, PROVIDING A WEB SITE FEATURING PHOTOGRAPHIC, AUDIO, VIDEO AND PROSE PRESENTATIONS FEATURING PHOTOGRAPHY (U.S. CLS. 100, 101 AND 107). FIRST USE 10-4-2012; IN COMMERCE 10-4-2012.

MICHELE SWAIN, EXAMINING ATTORNEY

SN 86-045,293. THRIVE EDUTAINMENT, LLC, TULSA, OK. FILED 8-22-2013.

## Thrive Edutainment

THE MARK CONSISTS OF STANDARD CHARACTERS WITHOUT CLAIM TO ANY PARTICULAR FONT, STYLE, SIZE, OR COLOR.

NO CLAIM IS MADE TO THE EXCLUSIVE RIGHT TO USE "EDUTAINMENT", APART FROM THE MARK AS SHOWN.

FOR DEVELOPING EDUCATIONAL MANUALS FOR OTHERS IN THE FIELD OF CLASSES, SEMINARS, WORKSHOPS; DEVELOPMENT AND DISSEMINATION OF PRINTED EDUCATIONAL MATERIALS OF OTHERS IN THE FIELD OF ENTREPRENEURSHIP; EDUCATION SERVICES, NAMELY, PROVIDING LIVE AND ON-LINE CLASSES, SEMINARS, WORKSHOPS IN THE FIELD OF ENTREPRENEURSHIP; EDUCATION SERVICES, NAMELY, PROVIDING CLASSES, SEMINARS, WORKSHOPS IN THE FIELD OF ENTREPRENEURSHIP; EDUCATIONAL AND ENTERTAINMENT SERVICES, NAMELY, A CONTINUING PROGRAM ABOUT ENTREPRENEURSHIP ACCESSIBLE BY MEANS OF WEB-BASED APPLICATIONS, MOBILE PHONE APPLICATIONS AND COMPUTER NETWORKS; EDUCATIONAL AND ENTERTAINMENT SERVICES, NAMELY, PROVIDING MOTIVATIONAL AND EDUCATIONAL SPEAKERS; EDUCATIONAL AND ENTERTAINMENT SERVICES, NAMELY, PROVIDING MOTIVATIONAL SPEAKING SERVICES IN THE FIELD OF ENTREPRENEURSHIP; EDUCATIONAL SERVICES, NAMELY, CONDUCTING PROGRAMS IN THE FIELD OF ENTREPRENEURSHIP (U.S. CLS. 100, 101 AND 107).

JORDAN BAKER, EXAMINING ATTORNEY

**CLASS 41—(Continued).**

SN 86-046,273. LAREDO HOSPITALITY VENTURES, LLC, CHICAGO, IL. FILED 8-23-2013.



THE MARK CONSISTS OF THE WORDS "STELLA'S PLACE" IN A STYLIZED FONT. AN EIGHT-POINT STAR APPEARS ABOVE THE APOSTROPHE IN THE WORD "STELLA'S". THE WORD "STELLA'S" APPEARS ABOVE THE WORD "PLACE".

FOR PROVIDING FACILITIES FOR VIDEO AND ON-LINE GAMING (U.S. CLS. 100, 101 AND 107).

BRENDAN REGAN, EXAMINING ATTORNEY

SN 86-047,204. CLARK, THERESE A, DBA LIVE & BREATHE BEAUTY, SCOTTSDALE, AZ. FILED 8-24-2013.

## live & breathe beauty

THE MARK CONSISTS OF STANDARD CHARACTERS WITHOUT CLAIM TO ANY PARTICULAR FONT, STYLE, SIZE, OR COLOR.

FOR PROVIDING A WEBSITE FEATURING BLOGS AND NON-DOWNLOADABLE PUBLICATIONS IN THE NATURE OF ARTICLES AND NEWSLETTERS IN THE FIELD(S) OF HEALTH, WELLNESS, FITNESS, LIFESTYLE, BEAUTY, NUTRITION, AND PHILANTHROPY (U.S. CLS. 100, 101 AND 107).

VIVIAN MICZNIK FIRST, EXAMINING ATTORNEY

SN 86-048,638. DICK, STEPHEN M., LATHAM, NY. FILED 8-27-2013.



THE MARK CONSISTS OF THE WORD "NITE MOVES" IN A STYLIZED FONT. THE LETTER "O" IN THE WORDS "MOVES" IS PRESENTED IN A CRESCENT MOON SHAPE IMAGE.

FOR NIGHT CLUBS (U.S. CLS. 100, 101 AND 107).

FIRST USE 8-0-1997; IN COMMERCE 8-0-1997.  
ELIZABETH CHANG, EXAMINING ATTORNEY



**CLASS 41—(Continued).**

SN 86-048,860. MOTOR VEHICLE CRIMINAL INTERDICTION ASSOCIATION, PHOENIX, AZ. FILED 8-27-2013.



NO CLAIM IS MADE TO THE EXCLUSIVE RIGHT TO USE "MOTOR VEHICLE CRIMINAL INTERDICTION ASSOCIATION", APART FROM THE MARK AS SHOWN.

THE COLOR(S) RED, WHITE, BLUE, AND BLACK IS/ARE CLAIMED AS A FEATURE OF THE MARK.

THE MARK CONSISTS OF A SHIELD HAVING A RED TOP AND A BLUE BODY, WITH A WHITE LINE BETWEEN THE TOP RED AND THE BLUE BODY. THE SHIELD IS OUTLINED IN WHITE. THE WHITE IS OUTLINED IN BLACK. THE RED TOP PART HAS THE LETTERS "D. I. A. P." IN WHITE WITH A SHADOW. THE BLUE BODY HAS THE WORDS "MOTOR VEHICLE CRIMINAL INTERDICTION ASSOCIATION" IN WHITE LETTERS WITH A SHADOW.

FOR EDUCATION SERVICES, NAMELY, PROVIDING CAREER RE-TRAINING COURSES, SEMINARS, AND CONFERENCES IN THE FIELDS OF LAW ENFORCEMENT (U.S. CLS. 100, 101 AND 107).

GINA HAYES, EXAMINING ATTORNEY

SN 86-053,206. OUTERWALL INC., BELLEVUE, WA. FILED 8-30-2013.

CREATING A BETTER EVERYDAY

THE MARK CONSISTS OF STANDARD CHARACTERS WITHOUT CLAIM TO ANY PARTICULAR FONT, STYLE, SIZE, OR COLOR.

FOR ENTERTAINMENT INFORMATION; ENTERTAINMENT SERVICES, NAMELY, PROVIDING NON-DOWNLOADABLE MOVIES AND TELEVISION SHOWS, VIA A VIDEO-ON-DEMAND SERVICE; PROVIDING INFORMATION REGARDING MOVIES AND TELEVISION SHOWS; RENTAL OF DVDS, MOTION PICTURES, ENTERTAINMENT, MEDIA AND DIGITAL CONTENT; PROVIDING TICKET ORDERING SERVICES, RESERVATION SERVICES, AND SECURE DELIVERY SERVICES FOR ENTERTAINMENT, SPORTING AND CULTURAL EVENTS; BOOKING OF SEATS FOR SHOWS AND SPORTS EVENTS; ENTERTAINMENT TICKET AGENCY SERVICES; ON-LINE ENTERTAINMENT TICKET AGENCY SERVICES AND SECURE DELIVERY SERVICES (U.S. CLS. 100, 101 AND 107).

HEATHER THOMPSON, EXAMINING ATTORNEY

**CLASS 41—(Continued).**

SN 86-053,712. ATWATER, MARCELLA, DURHAM, NC. FILED 9-2-2013.

NO CLAIM IS MADE TO THE EXCLUSIVE RIGHT TO USE "METHOD", APART FROM THE MARK AS SHOWN.

THE MARK CONSISTS OF THE WORD "COMFORT" WITH SOLID AREAS INSIDE BOTH "O" LETTERS AND THE WORD "THE" WITHIN THE SOLID AREA OF THE FIRST "O" WITH THE WORD "METHOD" BENEATH.

FOR EDUCATIONAL SERVICES, NAMELY, CONDUCTING CLASSES, SEMINARS, AND WORKSHOPS IN THE FIELD OF INTERPERSONAL RELATIONSHIPS (U.S. CLS. 100, 101 AND 107).

FIRST USE 12-1-2012; IN COMMERCE 12-1-2012.

CAROL SPILLS, EXAMINING ATTORNEY

SN 86-054,354. READ SMART, LLC, TULSA, OK. FILED 9-3-2013.

READ SMART

THE MARK CONSISTS OF STANDARD CHARACTERS WITHOUT CLAIM TO ANY PARTICULAR FONT, STYLE, SIZE, OR COLOR.

NO CLAIM IS MADE TO THE EXCLUSIVE RIGHT TO USE "READ", APART FROM THE MARK AS SHOWN.

FOR EDUCATIONAL SERVICES, NAMELY, INDIVIDUALIZED ASSESSMENT OF READING ABILITY, CONSULTATION REGARDING AND PREPARATION OF PERSONALIZED PLANS FOR READING DEVELOPMENT AND TEACHING READING, SPELLING AND WRITING (U.S. CLS. 100, 101 AND 107).

FIRST USE 8-27-2013; IN COMMERCE 8-27-2013.

JENNIFER MARTIN, EXAMINING ATTORNEY

**CLASS 41—(Continued).**

SN 86-054,516. DESIGNING SPACES, LLC, POMPANO BEACH, FL. FILED 9-3-2013.

## Designing Spaces

THE MARK CONSISTS OF STANDARD CHARACTERS WITHOUT CLAIM TO ANY PARTICULAR FONT, STYLE, SIZE, OR COLOR.

SEC. 2(F).

FOR EDUCATIONAL AND ENTERTAINMENT SERVICES, NAMELY, A CONTINUING PROGRAM ABOUT HOME IMPROVEMENT, REPAIR, REMODELING, DESIGN, ARCHITECTURE AND REAL ESTATE ACCESSIBLE BY MEANS OF CABLE AND BROADCAST TELEVISION, RADIO, SATELLITE, INTERNET, WEB BASED APPLICATIONS, MOBILE PHONE APPLICATIONS, AND COMPUTER NETWORKS; ENTERTAINMENT SERVICES, NAMELY, PRODUCTION AND DISTRIBUTION OF ONGOING TELEVISION PROGRAMS IN THE FIELD OF HOME IMPROVEMENT, REPAIR, REMODELING, DESIGN, ARCHITECTURE AND REAL ESTATE (U.S. CLS. 100, 101 AND 107).

FIRST USE 5-0-2005; IN COMMERCE 5-0-2005.

KATINA MISTER, EXAMINING ATTORNEY

---

SN 86-055,816. THE MORGRIDGE FAMILY FOUNDATION, DENVER, CO. FILED 9-4-2013.

## STEMOSPHERE

THE MARK CONSISTS OF STANDARD CHARACTERS WITHOUT CLAIM TO ANY PARTICULAR FONT, STYLE, SIZE, OR COLOR.

FOR EDUCATIONAL SERVICES, NAMELY, PROVIDING SEMINARS, TRAINING, AND WORKSHOPS TO EDUCATORS RELATED TO EDUCATIONAL PRACTICES; ORGANIZING EXHIBITIONS FOR EDUCATIONAL PURPOSES; CONDUCTING EDUCATIONAL EXHIBITIONS IN THE NATURE OF INTERACTIVE EXHIBITS, COMPETITIONS AND NETWORKING SEMINARS IN THE FIELDS OF SCIENCE, TECHNOLOGY, ENGINEERING, AND MATHEMATICS (U.S. CLS. 100, 101 AND 107).

FIRST USE 5-4-2013; IN COMMERCE 5-4-2013.

JUSTINE D. PARKER, EXAMINING ATTORNEY

**CLASS 41—(Continued).**

SN 86-056,680. GLACIERWORKS, INC., MARBLEHEAD, MA. FILED 9-5-2013.

## CLIMATE + CHANGE

THE MARK CONSISTS OF STANDARD CHARACTERS WITHOUT CLAIM TO ANY PARTICULAR FONT, STYLE, SIZE, OR COLOR.

NO CLAIM IS MADE TO THE EXCLUSIVE RIGHT TO USE "CLIMATE", APART FROM THE MARK AS SHOWN.

FOR PROVIDING AN INTERACTIVE WEBSITE FEATURING CURRENT EVENTS AND ENTERTAINMENT NEWS AND INFORMATION IN THE FIELDS OF ART, SCIENCE, HISTORY, CULTURE, NATURE, ADVENTURE, EXPLORATION, WEATHER AND GEOGRAPHY; PROVIDING A WEBSITE FEATURING BLOGS AND NON-DOWNLOADABLE ARTICLES AND EDUCATIONAL PUBLICATIONS, NAMELY, BOOKS, NEWSLETTERS, MAGAZINES, BROCHURES AND PHOTOGRAPHS, WEBCASTS, AUDIO PODCASTS, GAMES AND COMPETITIONS IN THE FIELDS OF ART, SCIENCE, HISTORY, CULTURE, NATURE, ADVENTURE, EXPLORATION, WEATHER AND GEOGRAPHY; EDUCATIONAL SERVICES, NAMELY, PROVIDING AN ONLINE SUMMIT IN THE FIELDS OF ART, SCIENCE, HISTORY, CULTURE, NATURE, ADVENTURE, EXPLORATION, WEATHER AND GEOGRAPHY; EDUCATIONAL SERVICES, NAMELY, CONDUCTING SEMINARS, LECTURES, EXHIBITIONS AND DISPLAYS IN THE FIELDS OF ART, SCIENCE, HISTORY, CULTURE, NATURE, ADVENTURE, EXPLORATION, WEATHER AND GEOGRAPHY; PROVIDING ONLINE GAMES; DOCUMENTARY FILM AND VIDEO PRODUCTION (U.S. CLS. 100, 101 AND 107).

ALLISON SCHRODY, EXAMINING ATTORNEY

---

SN 86-057,111. PLOGER, MARIANNE, BRENTWOOD, TN. FILED 9-5-2013.

## Ploger Method

THE MARK CONSISTS OF STANDARD CHARACTERS WITHOUT CLAIM TO ANY PARTICULAR FONT, STYLE, SIZE, OR COLOR.

NO CLAIM IS MADE TO THE EXCLUSIVE RIGHT TO USE "METHOD", APART FROM THE MARK AS SHOWN.

SEC. 2(F).

FOR EDUCATIONAL SERVICES, NAMELY, DEVELOPING CURRICULUM AND COURSEWORK FOR INSTRUCTION IN THE FIELD OF MUSIC THEORY FOR OTHERS (U.S. CLS. 100, 101 AND 107).

FIRST USE 1-16-2003; IN COMMERCE 1-16-2003.

PAUL CROWLEY, EXAMINING ATTORNEY

**CLASS 41—(Continued).**

SN 86-057,117. INTERNATIONAL TRAINING SERVICES, INC., DBA WELL CONTROL SCHOOL, HOUSTON, TX. FILED 9-5-2013.

COMMITTED TO  
QUALITY...DELIVERING VALUE!

THE MARK CONSISTS OF STANDARD CHARACTERS WITHOUT CLAIM TO ANY PARTICULAR FONT, STYLE, SIZE, OR COLOR.

FOR EDUCATIONAL SERVICES, NAMELY, PROVIDING WEB-BASED, ON-LINE COMPUTER-BASED, AND CLASSROOM TRAINING OF OILFIELD SERVICES PERSONNEL FOR CERTIFICATION IN THE FIELD OF WELL CONTROL; EDUCATIONAL SERVICES, NAMELY, CONDUCTING CLASSES, SEMINARS, AND TRAINING COURSES FOR CERTIFICATION OF OILFIELD SERVICES PERSONNEL IN THE FIELD OF WELL CONTROL AND CONTINUING EDUCATION COURSES FOR OILFIELD SERVICES PERSONNEL IN THE FIELD OF WELL CONTROL (U.S. CLS. 100, 101 AND 107).

FIRST USE 4-14-2010; IN COMMERCE 4-14-2010.  
PAUL CROWLEY, EXAMINING ATTORNEY

---

SN 86-059,619. BODHIMINDS, INC., CUPERTINO, CA. FILED 9-9-2013.

SuccessSage

THE MARK CONSISTS OF STANDARD CHARACTERS WITHOUT CLAIM TO ANY PARTICULAR FONT, STYLE, SIZE, OR COLOR.

FOR EDUCATIONAL SERVICES, NAMELY, PROVIDING PERSONAL AND GROUP COACHING, MOTIVATIONAL SPEAKING, AND SEMINARS IN THE FIELD OF PERSONAL DEVELOPMENT (U.S. CLS. 100, 101 AND 107).

FIRST USE 1-15-2013; IN COMMERCE 1-15-2013.  
ELLEN B. AWRICH, EXAMINING ATTORNEY

---

SN 86-060,976. AOL INC., DULLES, VA. FILED 9-10-2013.

THE WANAMAKER PLACE AWARD

THE MARK CONSISTS OF STANDARD CHARACTERS WITHOUT CLAIM TO ANY PARTICULAR FONT, STYLE, SIZE, OR COLOR.

NO CLAIM IS MADE TO THE EXCLUSIVE RIGHT TO USE "AWARD", APART FROM THE MARK AS SHOWN.

FOR PROVIDING RECOGNITION BY WAY OF AWARDS TO DEMONSTRATE EXCELLENCE IN THE FIELD OF ADVERTISING (U.S. CLS. 100, 101 AND 107).

LINDA LAVACHE, EXAMINING ATTORNEY

**CLASS 41—(Continued).**

SN 86-061,485. TELEVISA FOUNDATION, INC., MIAMI, FL. FILED 9-11-2013.

GOLAZO EDUCATIVO

THE MARK CONSISTS OF STANDARD CHARACTERS WITHOUT CLAIM TO ANY PARTICULAR FONT, STYLE, SIZE, OR COLOR.

NO CLAIM IS MADE TO THE EXCLUSIVE RIGHT TO USE "EDUCATIVO", APART FROM THE MARK AS SHOWN.

THE ENGLISH TRANSLATION OF "GOLAZO EDUCATIVO" IN THE MARK IS "EDUCATIONAL SUPER GOAL".

FOR ENTERTAINMENT, NAMELY, CONTINUING SPORTS SHOWS BROADCAST OVER THE INTERNET AND TELEVISION (U.S. CLS. 100, 101 AND 107).

JOHN DWYER, EXAMINING ATTORNEY

---

SN 86-061,890. DAVE BURGESS CONSULTING, INC., SAN DIEGO, CA. FILED 9-11-2013.

Teach Like a PIRATE

THE MARK CONSISTS OF STANDARD CHARACTERS WITHOUT CLAIM TO ANY PARTICULAR FONT, STYLE, SIZE, OR COLOR.

FOR EDUCATION SERVICES, NAMELY, PROVIDING WORKSHOPS AND TRAINING IN THE FIELD OF PROFESSIONAL DEVELOPMENT FOR EDUCATORS (U.S. CLS. 100, 101 AND 107).

FIRST USE 8-10-2005; IN COMMERCE 11-10-2009.  
ROBIN MITTLER, EXAMINING ATTORNEY

**CLASS 41—(Continued).**

SN 86-062,985. STELLA HOLDINGS LLC, CHARLOTTE, NC. FILED 9-12-2013.



OWNER OF U.S. REG. NOS. 1,233,073 AND 1,500,816.  
 NO CLAIM IS MADE TO THE EXCLUSIVE RIGHT TO USE "COMEDY", APART FROM THE MARK AS SHOWN.  
 THE MARK CONSISTS OF THE WORDS "THE COMEDY ZONE" IN STYLIZED LETTERS WITH SMALL DESIGNS SCATTERED AROUND THE WORDS.  
 FOR ENTERTAINMENT SERVICES, NAMELY, PROVIDING LIVE SHOWS INVOLVING COMEDIANS (U.S. CLS. 100, 101 AND 107).  
 FIRST USE 6-5-1985; IN COMMERCE 6-8-1985.  
 PAUL E. FAHRENKOPF, EXAMINING ATTORNEY

SN 86-064,794. KIZZANG, INC., LAS VEGAS, NV. FILED 9-14-2013.

**MAGNANIMOUS MILLIONS**

THE MARK CONSISTS OF STANDARD CHARACTERS WITHOUT CLAIM TO ANY PARTICULAR FONT, STYLE, SIZE, OR COLOR.  
 NO CLAIM IS MADE TO THE EXCLUSIVE RIGHT TO USE "MILLIONS", APART FROM THE MARK AS SHOWN.  
 FOR ENTERTAINMENT SERVICES, NAMELY, CONDUCTING CONTESTS; ENTERTAINMENT SERVICES, NAMELY, PROVIDING AN ON-LINE COMPUTER GAME; ENTERTAINMENT SERVICES, NAMELY, PROVIDING GAMES OF CHANCE VIA THE INTERNET; ENTERTAINMENT SERVICES, NAMELY, PROVIDING ON-LINE COMPUTER GAMES; ENTERTAINMENT SERVICES, NAMELY, PROVIDING ONLINE ELECTRONIC GAMES (U.S. CLS. 100, 101 AND 107).  
 INGA ERVIN, EXAMINING ATTORNEY

**CLASS 41—(Continued).**

SN 86-065,093. KIZZANG, INC., LAS VEGAS, NV. FILED 9-15-2013.

**PENGUIN RICHES**

THE MARK CONSISTS OF STANDARD CHARACTERS WITHOUT CLAIM TO ANY PARTICULAR FONT, STYLE, SIZE, OR COLOR.

NO CLAIM IS MADE TO THE EXCLUSIVE RIGHT TO USE "PENGUIN", APART FROM THE MARK AS SHOWN.  
 FOR ENTERTAINMENT SERVICES, NAMELY, CONDUCTING CONTESTS; ENTERTAINMENT SERVICES, NAMELY, PROVIDING AN ON-LINE COMPUTER GAME; ENTERTAINMENT SERVICES, NAMELY, PROVIDING GAMES OF CHANCE VIA THE INTERNET; ENTERTAINMENT SERVICES, NAMELY, PROVIDING ON-LINE COMPUTER GAMES; ENTERTAINMENT SERVICES, NAMELY, PROVIDING ONLINE ELECTRONIC GAMES (U.S. CLS. 100, 101 AND 107).  
 INGA ERVIN, EXAMINING ATTORNEY

SN 86-065,893. MITTMAN ENTERTAINMENT, LLC, ALLENTOWN, PA. FILED 9-16-2013.

**Fun! DJ. Lighting.  
Photobooth.**

THE MARK CONSISTS OF STANDARD CHARACTERS WITHOUT CLAIM TO ANY PARTICULAR FONT, STYLE, SIZE, OR COLOR.  
 NO CLAIM IS MADE TO THE EXCLUSIVE RIGHT TO USE "DJ. LIGHTING. PHOTOBOOTH.", APART FROM THE MARK AS SHOWN.  
 FOR DISC JOCKEY SERVICES; ENTERTAINMENT, NAMELY, LIGHTING PRODUCTION; RENTAL OF PORTABLE PHOTOGRAPHY AND/OR VIDEOGRAPHY BOOTHS FOR TAKING OF PICTURES AND VIDEOS (U.S. CLS. 100, 101 AND 107).  
 FIRST USE 8-13-2013; IN COMMERCE 8-13-2013.  
 MAUREEN DALL, EXAMINING ATTORNEY

**CLASS 41—(Continued).**

SN 86-066,366. MEDINA, HECTOR, ORANGE, CA. FILED 9-17-2013.



NO CLAIM IS MADE TO THE EXCLUSIVE RIGHT TO USE "MAKEUP ACADEMY", APART FROM THE MARK AS SHOWN.

THE COLOR(S) BLACK, WHITE, ORANGE, YELLOW, RUST AND RED IS/ARE CLAIMED AS A FEATURE OF THE MARK.

THE MARK CONSISTS OF THE LITERAL ELEMENTS "OCPRO MAKEUP ACADEMY" WRITTEN IN STYLIZED FORM IN THE CENTER OF A BLACK SQUARE WITH A WHITE LINE IN THE CENTER. THE WORD "MAKEUP ACADEMY" IN WHITE COLOR ARE WRITTEN BELOW THE UNDERLINED WORDS "OCPRO" WHEREIN THE LETTER "O" IS WRITTEN IN YELLOW COLOR, LETTER "C" IS WRITTEN IN ORANGE COLOR, THE LETTER "P" IS WRITTEN IN RUST COLOR AND THE LETTERS "RO" IS WRITTEN IN RED COLOR.

FOR EDUCATIONAL SERVICES IN THE NATURE OF BEAUTY SCHOOLS; EDUCATIONAL SERVICES IN THE NATURE OF COSMETICS AND MAKEUP SCHOOLS; EDUCATIONAL SERVICES, NAMELY, PROVIDING LECTURES, SEMINARS, CONFERENCES, COURSES, WORKSHOPS AND MENTORING IN THE FIELDS OF COSMETICS AND MAKEUP (U.S. CLS. 100, 101 AND 107).

DAVID MURRAY, EXAMINING ATTORNEY

SN 86-066,987. CURET, HILDA, ROSEDALE, MD. FILED 9-17-2013.

# TITE CURET

THE MARK CONSISTS OF STANDARD CHARACTERS WITHOUT CLAIM TO ANY PARTICULAR FONT, STYLE, SIZE, OR COLOR.

THE NAME(S), PORTRAIT(S), AND/OR SIGNATURE(S) SHOWN IN THE MARK DOES NOT IDENTIFY A PARTICULAR LIVING INDIVIDUAL.

FOR ENTERTAINMENT SERVICES, NAMELY, PROVIDING A WEBSITE FEATURING ENTERTAINMENT INFORMATION ON A RECORDING ARTIST, BIOGRAPHY, NON-DOWNLOADABLE AUDIO AND AUDIOVISUAL RECORDINGS FEATURING MUSIC AND MUSICAL-BASED ENTERTAINMENT, PHOTOGRAPHS, AND OTHER ENTERTAINMENT INFORMATION; ON-LINE JOURNALS, NAMELY, BLOGS FEATURING INFORMATION ON A RECORDING ARTIST; FAN CLUBS (U.S. CLS. 100, 101 AND 107).

GINA FINK, EXAMINING ATTORNEY

**CLASS 41—(Continued).**

SN 86-067,540. BLADES, PAULINE ELIZABETH, HALIFAX, CANADA, FILED 9-18-2013.

# MILLION DOLLAR MIND

THE MARK CONSISTS OF STANDARD CHARACTERS WITHOUT CLAIM TO ANY PARTICULAR FONT, STYLE, SIZE, OR COLOR.

FOR EDUCATION SERVICES, NAMELY, PROVIDING LIVE AND ON-LINE CLASSES, SEMINARS, AND WORKSHOPS IN THE FIELDS OF HOLISTIC HEALTH, PSYCHOLOGY, SPIRITUALITY, HEALTH, AND WELLNESS; MEDICAL TRAINING AND TEACHING (U.S. CLS. 100, 101 AND 107).

JEAN IM, EXAMINING ATTORNEY

SN 86-068,403. GREENBERG, N.F., PACIFIC PALISADES, CA. FILED 9-18-2013.

# NIKKIFINKE.COM

THE MARK CONSISTS OF STANDARD CHARACTERS WITHOUT CLAIM TO ANY PARTICULAR FONT, STYLE, SIZE, OR COLOR.

THE NAME(S), PORTRAIT(S), AND/OR SIGNATURE(S) SHOWN IN THE MARK IDENTIFIES "NIKKI FINKE", WHOSE CONSENT(S) TO REGISTER IS MADE OF RECORD.

FOR PROVIDING A WEB SITE FEATURING ON-LINE ARTICLES AND BLOGS FOR NEWS, ANALYSIS, AND COMMENTARY ABOUT THE HOLLYWOOD FILM AND TV COMMUNITY (U.S. CLS. 100, 101 AND 107).

ALLISON SCHRODY, EXAMINING ATTORNEY

SN 86-068,421. GREENBERG, N.F., PACIFIC PALISADES, CA. FILED 9-18-2013.

# NIKKIFINKE

THE MARK CONSISTS OF STANDARD CHARACTERS WITHOUT CLAIM TO ANY PARTICULAR FONT, STYLE, SIZE, OR COLOR.

THE NAME(S), PORTRAIT(S), AND/OR SIGNATURE(S) SHOWN IN THE MARK IDENTIFIES "NIKKI FINKE", WHOSE CONSENT(S) TO REGISTER IS MADE OF RECORD.

FOR PROVIDING A WEB SITE FEATURING ON-LINE ARTICLES AND BLOGS FOR NEWS, ANALYSIS, AND COMMENTARY ABOUT THE HOLLYWOOD FILM AND TV COMMUNITY (U.S. CLS. 100, 101 AND 107).

ALLISON SCHRODY, EXAMINING ATTORNEY

**CLASS 41—(Continued).**

SN 86-068,436. GREENBERG, N.F., PACIFIC PALISADES, CA. FILED 9-18-2013.

NikkiFinkeHollywood.com

THE MARK CONSISTS OF STANDARD CHARACTERS WITHOUT CLAIM TO ANY PARTICULAR FONT, STYLE, SIZE, OR COLOR.

THE NAME(S), PORTRAIT(S), AND/OR SIGNATURE(S) SHOWN IN THE MARK IDENTIFIES "NIKKI FINKE", WHOSE CONSENT(S) TO REGISTER IS MADE OF RECORD.

FOR PROVIDING A WEB SITE FEATURING ON-LINE ARTICLES AND BLOGS FOR NEWS, ANALYSIS, AND COMMENTARY ABOUT THE HOLLYWOOD FILM AND TV COMMUNITY (U.S. CLS. 100, 101 AND 107).  
ALLISON SCHRODY, EXAMINING ATTORNEY

---

SN 86-068,448. GREENBERG, N.F., PACIFIC PALISADES, CA. FILED 9-18-2013.

NikkiFinkesHollywood

THE MARK CONSISTS OF STANDARD CHARACTERS WITHOUT CLAIM TO ANY PARTICULAR FONT, STYLE, SIZE, OR COLOR.

THE NAME(S), PORTRAIT(S), AND/OR SIGNATURE(S) SHOWN IN THE MARK IDENTIFIES "NIKKI FINKE", WHOSE CONSENT(S) TO REGISTER IS MADE OF RECORD.

FOR PROVIDING A WEB SITE FEATURING ON-LINE ARTICLES AND BLOGS FOR NEWS, ANALYSIS, AND COMMENTARY ABOUT THE HOLLYWOOD FILM AND TV COMMUNITY (U.S. CLS. 100, 101 AND 107).  
ALLISON SCHRODY, EXAMINING ATTORNEY

---

SN 86-069,979. OBIE-BARRETT, CHRISTY, EUGENE, OR. FILED 9-20-2013.

HERO FOR A DAY

THE MARK CONSISTS OF STANDARD CHARACTERS WITHOUT CLAIM TO ANY PARTICULAR FONT, STYLE, SIZE, OR COLOR.

FOR EDUCATIONAL AND ENTERTAINMENT SERVICES, NAMELY, PROVIDING A VOLUNTEER PROGRAM FEATURING RECREATIONAL ACTIVITIES, LITERACY TRAINING, ART EVENTS, SPORTING EVENTS AND MEETING WITH LOCAL ATHLETES, POLICE, FIREMAN, MILITARY PERSONNEL, FOR CHILDREN IN FOSTER CARE (U.S. CLS. 100, 101 AND 107).

LINDA POWELL, EXAMINING ATTORNEY

**CLASS 41—(Continued).**

SN 86-070,255. JILL BERKE, MONTCLAIR, NJ. FILED 9-20-2013.

SEXTYSOMETHING

THE MARK CONSISTS OF STANDARD CHARACTERS WITHOUT CLAIM TO ANY PARTICULAR FONT, STYLE, SIZE, OR COLOR.

FOR ON-LINE ELECTRONIC NEWSLETTERS DELIVERED BY E-MAIL IN THE FIELD OF SUPPORT SERVICES FOR MATURE ADULTS IN THE NATURE OF EMOTIONAL SUPPORT INFORMATION, ADVICE AND COUNSELING FOR MATURE ADULTS ON VARIED TOPICS IN THE NATURE OF LOVE, ROMANCE AND INTERPERSONAL RELATIONSHIPS; ON-LINE JOURNALS, NAMELY, BLOGS FEATURING SUPPORT SERVICES FOR MATURE ADULTS IN THE NATURE OF EMOTIONAL SUPPORT INFORMATION, ADVICE AND COUNSELING FOR MATURE ADULTS ON VARIED TOPICS IN THE NATURE OF LOVE, ROMANCE AND INTERPERSONAL RELATIONSHIPS; ON-LINE PUBLICATION OF NEWSLETTERS; PROVIDING A WEBSITE FEATURING BLOGS AND NON-DOWNLOADABLE PUBLICATIONS IN THE NATURE OF ARTICLES AND NEWSLETTERS IN THE FIELD OF SUPPORT SERVICES FOR MATURE ADULTS IN THE NATURE OF EMOTIONAL SUPPORT INFORMATION, ADVICE AND COUNSELING FOR MATURE ADULTS ON VARIED TOPICS IN THE NATURE OF LOVE, ROMANCE AND INTERPERSONAL RELATIONSHIPS (U.S. CLS. 100, 101 AND 107).

ELLEN PERKINS, EXAMINING ATTORNEY

---

SN 86-070,537. MATTEL, INC., EL SEGUNDO, CA. FILED 9-20-2013.

FIGHT THE INVASION. SAVE EARTH.

THE MARK CONSISTS OF STANDARD CHARACTERS WITHOUT CLAIM TO ANY PARTICULAR FONT, STYLE, SIZE, OR COLOR.

FOR ENTERTAINMENT SERVICES, NAMELY, PROVIDING ONLINE COMPUTER GAMES (U.S. CLS. 100, 101 AND 107).

DANNEAN HETZEL, EXAMINING ATTORNEY

**CLASS 41—(Continued).**

SN 86-070,928. MID-SOUTH FAIR, INC., MEMPHIS, TN. FILED 9-20-2013.

**MID-SOUTH FAIR**

THE MARK CONSISTS OF STANDARD CHARACTERS WITHOUT CLAIM TO ANY PARTICULAR FONT, STYLE, SIZE, OR COLOR.

NO CLAIM IS MADE TO THE EXCLUSIVE RIGHT TO USE "FAIR", APART FROM THE MARK AS SHOWN.

FOR ENTERTAINMENT SERVICES, NAMELY, CONDUCTING FAIRS; EDUCATIONAL SERVICES, NAMELY, CONDUCTING PROGRAMS IN THE FIELD OF AGRICULTURE (U.S. CLS. 100, 101 AND 107).

FIRST USE 3-0-1929; IN COMMERCE 12-0-1936.  
KERI CANTONE, EXAMINING ATTORNEY

---

SN 86-072,277. CULINARY ENTERTAINMENT, INC., GUAYNABO, PUERTO RICO, FILED 9-23-2013.

**PETIT CHEF**

THE MARK CONSISTS OF STANDARD CHARACTERS WITHOUT CLAIM TO ANY PARTICULAR FONT, STYLE, SIZE, OR COLOR.

OWNER OF U.S. REG. NO. 3,944,490.

NO CLAIM IS MADE TO THE EXCLUSIVE RIGHT TO USE "CHEF", APART FROM THE MARK AS SHOWN.

THE ENGLISH TRANSLATION OF "PETIT" IN THE MARK IS "LITTLE".

FOR ENTERTAINMENT SERVICES IN THE NATURE OF A CHILDREN'S TELEVISION SHOW ON COOKING (U.S. CLS. 100, 101 AND 107).

MIAH ROSENBERG, EXAMINING ATTORNEY

---

SN 86-072,599. KIZZANG, INC., LAS VEGAS, NV. FILED 9-24-2013.

**MONEY BOOTH**

THE MARK CONSISTS OF STANDARD CHARACTERS WITHOUT CLAIM TO ANY PARTICULAR FONT, STYLE, SIZE, OR COLOR.

NO CLAIM IS MADE TO THE EXCLUSIVE RIGHT TO USE "MONEY", APART FROM THE MARK AS SHOWN.

FOR ENTERTAINMENT SERVICES, NAMELY, CONDUCTING CONTESTS; ENTERTAINMENT SERVICES, NAMELY, PROVIDING AN ON-LINE COMPUTER GAME; ENTERTAINMENT SERVICES, NAMELY, PROVIDING GAMES OF CHANCE VIA THE INTERNET; ENTERTAINMENT SERVICES, NAMELY, PROVIDING ON-LINE COMPUTER GAMES; ENTERTAINMENT SERVICES, NAMELY, PROVIDING ONLINE ELECTRONIC GAMES (U.S. CLS. 100, 101 AND 107).

INGA ERVIN, EXAMINING ATTORNEY

**CLASS 41—(Continued).**

SN 86-073,019. THE BREAKTHROUGH COLLABORATIVE, INC., SAN FRANCISCO, CA. FILED 9-24-2013.

**BREAKTHROUGH STUDENTS  
TEACHING STUDENTS**

THE MARK CONSISTS OF STANDARD CHARACTERS WITHOUT CLAIM TO ANY PARTICULAR FONT, STYLE, SIZE, OR COLOR.

OWNER OF U.S. REG. NO. 4,260,967.

SEC. 2(F) AS TO "STUDENTS TEACHING STUDENTS".

FOR ORGANIZING PROGRAMS FOR THE INSTRUCTION, MENTORING AND TUTORING OF MIDDLE SCHOOL STUDENTS BY HIGH SCHOOL AND COLLEGE STUDENTS IN THE AREAS OF ACADEMIC, ORGANIZATIONAL, AND SOCIAL SKILLS (U.S. CLS. 100, 101 AND 107).

FIRST USE 4-1-2002; IN COMMERCE 4-1-2002.

JULIE WATSON, EXAMINING ATTORNEY

---

SN 86-073,831. TELEMUNDO NETWORK GROUP LLC, HIALEAH, FL. FILED 9-24-2013.

**WELCOME TO LOS VARGAS**

THE MARK CONSISTS OF STANDARD CHARACTERS WITHOUT CLAIM TO ANY PARTICULAR FONT, STYLE, SIZE, OR COLOR.

THE ENGLISH TRANSLATION OF "LOS" IN THE MARK IS "THE".

FOR ENTERTAINMENT SERVICES IN THE NATURE OF A TELEVISION SERIES FEATURING SUBJECTS OF GENERAL HUMAN INTEREST; PROVIDING A WEBSITE FEATURING INFORMATION RELATED TO ENTERTAINMENT VIA GLOBAL COMPUTER AND WIRELESS COMMUNICATION NETWORKS; ENTERTAINMENT SERVICES IN THE NATURE OF IMAGES AND VIDEOS FEATURING SUBJECTS OF GENERAL HUMAN INTEREST TRANSMITTED VIA GLOBAL COMPUTER AND WIRELESS COMMUNICATION NETWORKS (U.S. CLS. 100, 101 AND 107).

JOHN E. MICHOS, EXAMINING ATTORNEY

**CLASS 41—(Continued).**

SN 86-074,458. WORLDWIDE GREEKS, LLC, DBA GREEK BOSTON, ARLINGTON, MA. FILED 9-25-2013.

## Worldwide Greeks

THE MARK CONSISTS OF STANDARD CHARACTERS WITHOUT CLAIM TO ANY PARTICULAR FONT, STYLE, SIZE, OR COLOR.

NO CLAIM IS MADE TO THE EXCLUSIVE RIGHT TO USE "GREEKS", APART FROM THE MARK AS SHOWN. SEC. 2(F).

FOR PROVIDING A WEBSITE FEATURING INFORMATION ABOUT GREEK CULTURE, NAMELY, HISTORICAL EDUCATIONAL INFORMATION, MUSIC INFORMATION, AND INFORMATION ON EDUCATIONAL AND RECREATIONAL GREEK EVENTS (U.S. CLS. 100, 101 AND 107).

FIRST USE 1-1-1998; IN COMMERCE 1-1-1998.

VIVIAN MICZNIK FIRST, EXAMINING ATTORNEY

---

SN 86-074,594. HAPPINESS GLUE, LLC, LOS ANGELES, CA. FILED 9-25-2013.

## JULIUS

THE MARK CONSISTS OF STANDARD CHARACTERS WITHOUT CLAIM TO ANY PARTICULAR FONT, STYLE, SIZE, OR COLOR.

FOR ENTERTAINMENT SERVICES, NAMELY, COMEDY, AND VENTRILOQUIST PERFORMANCES (U.S. CLS. 100, 101 AND 107).

DOMINIC FATHY, EXAMINING ATTORNEY

---

SN 86-075,346. ESTHER NETWORK INTERNATIONAL, INC., WEST PALM BEACH, FL. FILED 9-26-2013.

## Prayer. You're the app for that.

THE MARK CONSISTS OF STANDARD CHARACTERS WITHOUT CLAIM TO ANY PARTICULAR FONT, STYLE, SIZE, OR COLOR.

NO CLAIM IS MADE TO THE EXCLUSIVE RIGHT TO USE "PRAYER", APART FROM THE MARK AS SHOWN.

FOR CHARITABLE SERVICES, NAMELY, PROVIDING PRAYER WORKSHOPS, CONFERENCES AND SEMINARS IN THE FIELD OF GLOBAL INTERCESSION (U.S. CLS. 100, 101 AND 107).

MARK SPARACINO, EXAMINING ATTORNEY

**CLASS 41—(Continued).**

SN 86-075,372. TMXWORKOUT.COM INC., MIAMI, FL. FILED 9-26-2013.

## TONY MAX THE MOST XTREME WORKOUT

THE MARK CONSISTS OF STANDARD CHARACTERS WITHOUT CLAIM TO ANY PARTICULAR FONT, STYLE, SIZE, OR COLOR.

NO CLAIM IS MADE TO THE EXCLUSIVE RIGHT TO USE "WORKOUT", APART FROM THE MARK AS SHOWN. THE NAME(S), PORTRAIT(S), AND/OR SIGNATURE(S) SHOWN IN THE MARK IDENTIFIES "TONY MAX" IDENTIFIES THE NICKNAME OF ANTHONY ALICEA, WHOSE CONSENT(S) TO REGISTER IS MADE OF RECORD.

FOR PROVIDING A WEBSITE FEATURING NON-DOWNLOADABLE VIDEOS AND INFORMATION IN THE FIELD OF PHYSICAL FITNESS (U.S. CLS. 100, 101 AND 107).

JOANNA DUKOVIC, EXAMINING ATTORNEY

---

SN 86-076,367. THE NAME LLC, NEW YORK, NY. FILED 9-27-2013.

## 40/40 CLUB

THE MARK CONSISTS OF STANDARD CHARACTERS WITHOUT CLAIM TO ANY PARTICULAR FONT, STYLE, SIZE, OR COLOR.

OWNER OF U.S. REG. NOS. 3,157,149, 4,342,116 AND OTHERS.

FOR ENTERTAINMENT, SPORTING, AND CULTURAL ACTIVITIES, NAMELY, SPORTS GAMES, COMPETITIONS, AND EXHIBITIONS RENDERED THROUGH BROADCAST MEDIA INCLUDING TELEVISION AND VIA A COMPUTER NETWORK OR A COMMERCIAL ON-LINE SERVICE; INFORMATION SERVICES, NAMELY, PROVIDING INFORMATION IN THE FIELDS OF SPORTS, ENTERTAINMENT, CULTURAL ACTIVITIES AND RELATED TOPICS AND PROVIDING FOR INFORMATIONAL MESSAGES RELATING THERETO; DIGITAL VIDEO, AUDIO AND MULTIMEDIA PUBLISHING SERVICES FEATURING ONLINE COMMENTARY, ARTICLES, IMAGES AND PHOTOS ABOUT SPORTS, ENTERTAINMENT AND CULTURE; PROVIDING ON-LINE ENVIRONMENTS WHERE USERS CAN FIND AND EXCHANGE COMMENTARY, ARTICLES, IMAGES, AND PHOTOS ABOUT SPORTS, ENTERTAINMENT, AND CULTURE AND WHERE USERS CAN INTERACT FOR ENTERTAINMENT, SPORTS, AND CULTURAL PURPOSES AND TO EXPRESS OPINIONS ABOUT SPORTS, ENTERTAINMENT, AND CULTURE (U.S. CLS. 100, 101 AND 107).

FIRST USE 6-18-2003; IN COMMERCE 6-18-2003.

JORDAN BAKER, EXAMINING ATTORNEY



**CLASS 41—(Continued).**

SN 86-076,416. THE NAME LLC, NEW YORK, NY. FILED 9-27-2013.



OWNER OF U.S. REG. NOS. 3,157,149, 4,342,116 AND OTHERS.

THE MARK CONSISTS OF THE STYLIZED TERM "40/40" INSIDE A DIAMOND-SHAPED BACKGROUND OVER THE WORD "CLUB", WHICH SITS UNDER AN OUTLINED STRAIGHT LINE AND SITS ABOVE A SHORTER SOLID STRAIGHT LINE; THE COLORS BLACK AND WHITE REPRESENT BACKGROUND, OUTLINING, SHADING AND/OR TRANSPARENT AREAS AND ARE NOT PART OF THE MARK.

FOR ENTERTAINMENT, SPORTING, AND CULTURAL ACTIVITIES, NAMELY, SPORTS GAMES, COMPETITIONS, AND EXHIBITIONS RENDERED THROUGH BROADCAST MEDIA INCLUDING TELEVISION AND VIA A COMPUTER NETWORK OR A COMMERCIAL ON-LINE SERVICE; INFORMATION SERVICES, NAMELY, PROVIDING INFORMATION IN THE FIELDS OF SPORTS, ENTERTAINMENT, CULTURAL ACTIVITIES AND RELATED TOPICS AND PROVIDING FOR INFORMATIONAL MESSAGES RELATING THERETO; DIGITAL VIDEO, AUDIO AND MULTIMEDIA PUBLISHING SERVICES FEATURING ONLINE COMMENTARY, ARTICLES, IMAGES AND PHOTOS ABOUT SPORTS, ENTERTAINMENT AND CULTURE; PROVIDING ENVIRONMENTS WHERE USERS CAN FIND AND EXCHANGE COMMENTARY, ARTICLES, IMAGES, AND PHOTOS ABOUT SPORTS, ENTERTAINMENT, AND CULTURE AND WHERE USERS CAN INTERACT FOR ENTERTAINMENT, SPORTS, AND CULTURAL PURPOSES AND TO EXPRESS OPINIONS ABOUT SPORTS, ENTERTAINMENT, AND CULTURE (U.S. CLS. 100, 101 AND 107).

FIRST USE 6-18-2003; IN COMMERCE 6-18-2003.  
JORDAN BAKER, EXAMINING ATTORNEY

SN 86-076,757. E B FITNESS CLUB LLC, CLEVELAND, OH. FILED 9-27-2013.

## E B FITNESS

THE MARK CONSISTS OF STANDARD CHARACTERS WITHOUT CLAIM TO ANY PARTICULAR FONT, STYLE, SIZE, OR COLOR.

NO CLAIM IS MADE TO THE EXCLUSIVE RIGHT TO USE "FITNESS", APART FROM THE MARK AS SHOWN.

FOR PERSONAL FITNESS INSTRUCTION AND TRAINING SERVICES, NAMELY, PROVIDING EXERCISE AND WELLNESS CLASSES, FITNESS, WEIGHT LOSS, AND SPORTS INSTRUCTION SERVICES (U.S. CLS. 100, 101 AND 107).

ZACHARY BELLO, EXAMINING ATTORNEY

**CLASS 41—(Continued).**

SN 86-078,890. WARD ROBINSON, EAST BRUNSWICK, NJ. AND SHERIKE MORRIS, HYDE PARK, MA. FILED 9-30-2013.



NO CLAIM IS MADE TO THE EXCLUSIVE RIGHT TO USE "SNEAKER BATTLE", APART FROM THE MARK AS SHOWN.

THE MARK CONSISTS OF THE LITERAL ELEMENTS "FRSHR THAN YOUR AVRGE SNEAKER BATTLE", A FIGURATIVE DEPICTION OF A TURNTABLE AND A PAIR OF SNEAKERS. THE TERMS "SNEAKR BATTLE" ARE HOUSED IN A BANNER.

FOR ORGANIZING AND CONDUCTING EVENTS, NAMELY, FASHION SHOWS FOR ENTERTAINMENT PURPOSES; ORGANIZING AND CONDUCTING EVENTS, NAMELY, COMPETITIONS IN THE FIELD OF FASHION, ATHLETIC FOOTWEAR AND APPAREL FOR ENTERTAINMENT PURPOSES (U.S. CLS. 100, 101 AND 107).

FIRST USE 9-0-2011; IN COMMERCE 9-0-2011.  
LINDA ESTRADA, EXAMINING ATTORNEY

SN 86-080,566. PERSONAL HEALTH STRATEGIES, INC., ORLANDO, FL. FILED 10-2-2013.

## HOW TO HAVE A HUNDRED HEALTHY BIRTHDAYS

THE MARK CONSISTS OF STANDARD CHARACTERS WITHOUT CLAIM TO ANY PARTICULAR FONT, STYLE, SIZE, OR COLOR.

FOR CONDUCTING WORKSHOPS AND SEMINARS IN THE FIELD OF NUTRITION (U.S. CLS. 100, 101 AND 107).

FIRST USE 3-13-2013; IN COMMERCE 3-13-2013.  
BRIN ANDERSON, EXAMINING ATTORNEY

**CLASS 41—(Continued).**

SN 86-081,263. NEXTGEN CLIMATE ACTION, SAN FRANCISCO, CA. FILED 10-2-2013.

# OUR LAND

THE MARK CONSISTS OF STANDARD CHARACTERS WITHOUT CLAIM TO ANY PARTICULAR FONT, STYLE, SIZE, OR COLOR.

FOR EDUCATIONAL SERVICES, NAMELY, PROVIDING ONLINE NON-DOWNLOADABLE MATERIALS, NAMELY, LETTERS, NEWSLETTERS, PREVIOUSLY DISTRIBUTED EMAIL LETTERS, WEBSITE ARTICLES AND POSTINGS, NAMELY, PHOTOS AND VIDEOS, ALL IN THE FIELD OF ENVIRONMENTAL ISSUES; EDUCATIONAL SERVICES, NAMELY, ON-JOURNALS, NAMELY, BLOGS IN THE FIELD OF ENVIRONMENTAL ISSUES (U.S. CLS. 100, 101 AND 107).

BILL DAWE, EXAMINING ATTORNEY

SN 86-083,388. K M MOONEY PROD., INC., ELLENTON, FL. FILED 10-4-2013.

# KMARIE

THE MARK CONSISTS OF STANDARD CHARACTERS WITHOUT CLAIM TO ANY PARTICULAR FONT, STYLE, SIZE, OR COLOR.

THE NAME(S), PORTRAIT(S), AND/OR SIGNATURE(S) SHOWN IN THE MARK IDENTIFIES KELSEY MARIE MOONEY, WHOSE CONSENT(S) TO REGISTER IS MADE OF RECORD.

FOR ENTERTAINMENT SERVICES, NAMELY, PROVIDING A WEBSITE FEATURING INFORMATION AND LINKS RELATING TO THE ARTIST AND ACTIVITIES OF A FEMALE ENTERTAINER, ENTERTAINMENT SERVICES, NAMELY, INFORMATION IN THE FIELD OF MUSIC, ENTERTAINMENT, TELEVISION SHOW PRODUCTION, FILM AND FILMMAKING, GAMES AND ENTERTAINMENT-RELATED INFORMATION ABOUT THE ARTS; ENTERTAINMENT SERVICES, NAMELY, PROVIDING A WEB SITE FEATURING NON-DOWNLOADABLE MUSICAL PERFORMANCES, MUSICAL VIDEOS, RELATED FILM CLIPS, PHOTOGRAPHS, AND OTHER MULTIMEDIA MATERIALS FEATURING SUBJECTS OF GENERAL HUMAN INTEREST; ENTERTAINMENT SERVICES, NAMELY, PROVIDING NON-DOWNLOADABLE PRERECORDED MUSIC ALL ON-LINE VIA A GLOBAL COMPUTER NETWORK, ENTERTAINMENT SERVICES, NAMELY, PROVIDING ONLINE VIDEO GAMES, DANCE EVENTS BY A RECORDING ARTIST, MULTIMEDIA PRODUCTION SERVICES; ENTERTAINMENT SERVICES IN THE NATURE OF LIVE MUSICAL PERFORMANCES BY A FEMALE ENTERTAINER, PRODUCTION OF MOTION PICTURE FILMS, FAN CLUBS; ENTERTAINMENT SERVICES, NAMELY, PROVIDING NON-DOWNLOADABLE PRERECORDED MUSIC, ALL ONLINE VIA A GLOBAL COMPUTER NETWORK; ENTERTAINMENT, NAMELY, PERSONAL APPEARANCES BY A MUSICIAN, MUSICAL GROUP OR MUSICAL BAND (U.S. CLS. 100, 101 AND 107).

KAMAL PREET, EXAMINING ATTORNEY

**CLASS 41—(Continued).**

SN 86-083,603. SHUTTS, ANTHONY LEE, DBA ISO-AQUATICS, WAVERLY, OH. AND SHUTTS, JULI LOY, DBA ISO-AQUATICS, WAVERLY, OH. FILED 10-5-2013.

# ISO-AQUATICS

THE MARK CONSISTS OF STANDARD CHARACTERS WITHOUT CLAIM TO ANY PARTICULAR FONT, STYLE, SIZE, OR COLOR.

FOR PERSONAL FITNESS TRAINING SERVICES AND CONSULTANCY (U.S. CLS. 100, 101 AND 107).

SETH A. RAPPAPORT, EXAMINING ATTORNEY

SN 86-083,708. OYE INTERACTIVE GAMES LIMITED, WANCHAI, HONG KONG, FILED 10-6-2013.



THE MARK CONSISTS OF A CASINO CHIP WITH A SPADE IN THE MIDDLE AND THE LETTER "Y" AND "E". THE ENGLISH TRANSLATION OF "OYE" IN THE MARK IS "OH YEAH".

FOR AMUSEMENT PARKS; ENTERTAINMENT, EDUCATIONAL AND SPORTS SERVICES, NAMELY, ORGANIZING EDUCATIONAL, ENTERTAINMENT AND SPORTS COMPETITIONS; ENTERTAINMENT SERVICES, NAMELY, PROVIDING ON-LINE COMPUTER GAMES; ON-LINE ENTERTAINMENT TICKET AGENCY SERVICES; ONLINE ELECTRONIC PUBLISHING OF BOOKS AND PERIODICALS; PRODUCTION OF RADIO AND TELEVISION PROGRAMS; PUBLICATION OF BOOKS (U.S. CLS. 100, 101 AND 107).

FIRST USE 2-1-2012; IN COMMERCE 2-1-2012.  
LESLEY LAMOTHE, EXAMINING ATTORNEY

SN 86-085,001. GERBER, DANIELLE, SANTA MONICA, CA. FILED 10-7-2013.



THE MARK CONSISTS OF PROFILE PICTURE OF A DOG WITH EAR BLOWING IN THE WIND.

SEC. 2(F).  
FOR ON-LINE JOURNALS, NAMELY, BLOGS FEATURING REVIEWS OF AND RECOMMENDATIONS OF MUSIC (U.S. CLS. 100, 101 AND 107).  
FIRST USE 12-23-2007; IN COMMERCE 12-23-2007.  
GEOFFREY FOSDICK, EXAMINING ATTORNEY

**CLASS 41—(Continued).**

SN 86-085,788. EXPRESSTECH INTERNATIONAL, LLC, OREM, UT. FILED 10-8-2013.

**CLASS 41—(Continued).**

SN 86-087,808. RUDOLPH, LON, BROWN DEER, WI. FILED 10-10-2013.

**THE 7 NON-NEGOTIABLES OF WINNING**

THE MARK CONSISTS OF STANDARD CHARACTERS WITHOUT CLAIM TO ANY PARTICULAR FONT, STYLE, SIZE, OR COLOR.

FOR PROVIDING WEBSITES, INTERACTIVE ONLINE WEB JOURNALS AND BLOGS FEATURING NON-DOWNLOADABLE ELECTRONIC PUBLICATIONS IN THE NATURE OF ARTICLES IN THE FIELD OF ACHIEVING SUCCESS IN PERSONAL LIFE AND IN BUSINESS; PROVIDING INTERACTIVE ONLINE WEB JOURNALS AND BLOGS FEATURING EDUCATIONAL INFORMATION IN THE FIELD OF ACHIEVING SUCCESS IN PERSONAL LIFE AND IN BUSINESS; PROVIDING WEBSITES, INTERACTIVE ONLINE WEB JOURNALS AND BLOGS FEATURING EDUCATIONAL TRAINING IN THE FIELD OF ACHIEVING SUCCESS IN PERSONAL LIFE AND IN BUSINESS; PROVIDING EDUCATIONAL SERVICES, NAMELY WORKSHOPS, SEMINARS, CONFERENCES, CLASSES, AND SYMPOSIUMS IN THE FIELD OF ACHIEVING SUCCESS IN PERSONAL LIFE AND IN BUSINESS; PROVIDING NON-DOWNLOADABLE ONLINE ELECTRONIC NEWSLETTERS DELIVERED BY E-MAIL IN THE FIELD OF ACHIEVING SUCCESS IN PERSONAL LIFE AND IN BUSINESS (U.S. CLS. 100, 101 AND 107).

FIRST USE 8-31-2013; IN COMMERCE 8-31-2013. COLLEEN DOMBROW, EXAMINING ATTORNEY

**OMG-TMT Oh my God translate my text**

THE MARK CONSISTS OF STANDARD CHARACTERS WITHOUT CLAIM TO ANY PARTICULAR FONT, STYLE, SIZE, OR COLOR.

FOR ENTERTAINMENT SERVICES, NAMELY, THE PRODUCTION AND DISTRIBUTION OF ONGOING TELEVISION PROGRAMS IN THE FIELD OF GAME SHOWS OVER TELEVISION, SATELLITE, AUDIO AND VIDEO MEDIA (U.S. CLS. 100, 101 AND 107).

DANIEL S. STRINGER, EXAMINING ATTORNEY

SN 86-086,801. BENTLEY UNIVERSITY, WALTHAM, MA. FILED 10-9-2013.

SN 86-087,984. BUSTI, STEVE, AUSTIN, TX. FILED 10-10-2013.

**CORPORATE IMMERSION**

THE MARK CONSISTS OF STANDARD CHARACTERS WITHOUT CLAIM TO ANY PARTICULAR FONT, STYLE, SIZE, OR COLOR.

NO CLAIM IS MADE TO THE EXCLUSIVE RIGHT TO USE "IMMERSION", APART FROM THE MARK AS SHOWN.

FOR EDUCATIONAL SERVICES, NAMELY, PROVIDING COURSES OF INSTRUCTION AT THE UNDERGRADUATE, GRADUATE, EXECUTIVE EDUCATION, HIGH SCHOOL, AND CONTINUING EDUCATION LEVELS ALL IN THE FIELD OF BUSINESS MANAGEMENT, MARKETING, CUSTOMER RELATIONS AND PRODUCT DEVELOPMENT; ORGANIZING AND CONDUCTING LECTURES, SEMINARS, EDUCATIONAL CONFERENCES, WORKSHOPS, AND EDUCATIONAL EXHIBITIONS IN THE FIELDS OF BUSINESS MANAGEMENT, MARKETING, CUSTOMER RELATIONS AND PRODUCT DEVELOPMENT (U.S. CLS. 100, 101 AND 107).

FIRST USE 10-8-2013; IN COMMERCE 10-8-2013. ELLEN PERKINS, EXAMINING ATTORNEY

**Busti's**

THE MARK CONSISTS OF STANDARD CHARACTERS WITHOUT CLAIM TO ANY PARTICULAR FONT, STYLE, SIZE, OR COLOR.

FOR AMUSEMENT CENTERS; AMUSEMENT PARK AND THEME PARK SERVICES; ENTERTAINMENT SERVICES IN THE NATURE OF AN AMUSEMENT PARK ATTRACTION; NAMELY, A THEMED AREA; PROVIDING AMUSEMENT FACILITIES (U.S. CLS. 100, 101 AND 107).

MATTHEW GALAN, EXAMINING ATTORNEY

**CLASS 41—(Continued).**

SN 86-089,778. BRUNO MARS MUSIC, LLC, LOS ANGELES, CA. FILED 10-11-2013.

# LA JUNGLA

THE MARK CONSISTS OF STANDARD CHARACTERS WITHOUT CLAIM TO ANY PARTICULAR FONT, STYLE, SIZE, OR COLOR.

THE ENGLISH TRANSLATION OF "LA JUNGLA" IN THE MARK IS "THE JUNGLE".

FOR ENTERTAINMENT IN THE NATURE OF LIVE MUSICAL PERFORMANCES; ENTERTAINMENT IN THE NATURE OF LIVE PERFORMANCES BY A MUSICAL ARTIST; ENTERTAINMENT, NAMELY, LIVE MUSIC CONCERTS; LIVE PERFORMANCES FEATURING PRERECORDED VOCAL AND INSTRUMENTAL PERFORMANCES VIEWED ON A BIG SCREEN; RECORD PRODUCTION; MUSIC PRODUCTION; AUDIO RECORDING AND PRODUCTION; VIDEOTAPE PRODUCTION; MOTION PICTURE SONG PRODUCTION; PRODUCTION OF VIDEO DISCS FOR OTHERS; RECORDING STUDIOS; ENTERTAINMENT SERVICES, NAMELY, PRODUCTION AND DISTRIBUTION OF MUSICAL AUDIO AND VIDEO PROGRAMS; PRODUCTION AND DISTRIBUTION OF MUSICAL AUDIO AND VIDEO RECORDINGS FOR BROADCAST; MUSIC COMPOSITION AND TRANSCRIPTION FOR OTHERS; SONG WRITING SERVICES FOR NON-ADVERTISING PURPOSES; MUSIC PUBLISHING SERVICES; ENTERTAINMENT, NAMELY, PERSONAL APPEARANCES BY A MUSICIAN OR ENTERTAINER; ENTERTAINMENT SERVICES NAMELY LIVE, TELEVISED AND MOVIE APPEARANCES BY A PROFESSIONAL ENTERTAINER; ENTERTAINMENT SERVICES, NAMELY, PROVIDING A WEB SITE FEATURING MUSICAL PERFORMANCES, MUSICAL VIDEOS, RELATED FILM CLIPS, AND PHOTOGRAPHS; ENTERTAINMENT SERVICES, NAMELY, PROVIDING NON-DOWNLOADABLE PRERECORDED MUSIC, INFORMATION IN THE FIELD OF MUSIC, COMMENTARY AND ARTICLES ABOUT MUSIC, ALL ONLINE VIA A GLOBAL COMPUTER NETWORK; ENTERTAINMENT IN THE NATURE OF LIVE TRAVELING TOURS BY A PROFESSIONAL ENTERTAINER FEATURING MUSIC; ENTERTAINMENT SERVICES, NAMELY, PRESENTING NON-DOWNLOADABLE RINGTONES, PRE-RECORDED MUSIC, VIDEO AND GRAPHICS TO MOBILE COMMUNICATIONS DEVICES VIA A GLOBAL COMPUTER NETWORK AND WIRELESS NETWORKS (U.S. CLS. 100, 101 AND 107).

VIVIAN MICZNIK FIRST, EXAMINING ATTORNEY

**CLASS 41—(Continued).**

SN 86-093,911. MAUSNER, DESIREE CASTELLANO, OVIEDO, FL. FILED 10-17-2013.

# TALIAJOY18

THE MARK CONSISTS OF STANDARD CHARACTERS WITHOUT CLAIM TO ANY PARTICULAR FONT, STYLE, SIZE, OR COLOR.

THE NAME SHOWN IN THE MARK DOES NOT IDENTIFY A PARTICULAR LIVING INDIVIDUAL.

FOR ENTERTAINMENT SERVICES, NAMELY, PROVIDING ENTERTAINMENT INFORMATION VIA BLOGS, TEXT MESSAGING, INSTANT MESSAGING, VOICE MESSAGING, SOCIAL MEDIA AND SOCIAL NETWORKING CHANNELS; PROVIDING A WEBSITE FEATURING NON-DOWNLOADABLE IMAGES, VIDEOS, MUSIC AND NEWS ARTICLES, IN THE FIELD OF CANCER, CANCER RECOVERY AND SURVIVAL; INTERACTIVE ONLINE WEB JOURNALS FEATURING USER-DEFINED CONTENT IN THE FIELD OF CANCER, CANCER RECOVERY AND SURVIVAL (U.S. CLS. 100, 101 AND 107).

FIRST USE 7-11-2011; IN COMMERCE 7-11-2011.  
ANDREW LEASER, EXAMINING ATTORNEY

---

SN 86-096,885. KINDRED READERS, LLC, SANTA FE, NM. FILED 10-21-2013.

# Kindred Readers

THE MARK CONSISTS OF STANDARD CHARACTERS WITHOUT CLAIM TO ANY PARTICULAR FONT, STYLE, SIZE, OR COLOR.

NO CLAIM IS MADE TO THE EXCLUSIVE RIGHT TO USE "READERS", APART FROM THE MARK AS SHOWN.

FOR ENTERTAINMENT SERVICES, NAMELY, PROVIDING A WEB SITE WHERE USERS CAN POST AND OBTAIN INFORMATION, RATINGS, REVIEWS AND RECOMMENDATIONS ON LITERATURE (U.S. CLS. 100, 101 AND 107).

DAVID TAYLOR, EXAMINING ATTORNEY

**CLASS 41—(Continued).**

SN 86-097,934. VANESSA BELL CALLOWAY, LOS ANGELES, CA. FILED 10-22-2013.

**That's So Very Vanessa**

THE MARK CONSISTS OF STANDARD CHARACTERS WITHOUT CLAIM TO ANY PARTICULAR FONT, STYLE, SIZE, OR COLOR.

THE NAME(S), PORTRAIT(S), AND/OR SIGNATURE(S) SHOWN IN THE MARK IDENTIFIES VANESSA BELL CALLOWAY, WHOSE CONSENT(S) TO REGISTER IS MADE OF RECORD.

FOR ENTERTAINMENT, NAMELY, A CONTINUING RADIO TALK SHOW BROADCAST OVER THE INTERNET (U.S. CLS. 100, 101 AND 107).

FIRST USE 7-1-2013; IN COMMERCE 8-1-2013.

ANGELA M. MICHELI, EXAMINING ATTORNEY

**CLASS 41—(Continued).**

SN 86-104,323. MARTIN, VICTORIA F., BANNOCKBURN, IL. FILED 10-29-2013.

**THROW LIKE A GIRL**

THE MARK CONSISTS OF STANDARD CHARACTERS WITHOUT CLAIM TO ANY PARTICULAR FONT, STYLE, SIZE, OR COLOR.

FOR SPORT CAMP SERVICES; SPORT CAMPS (U.S. CLS. 100, 101 AND 107).

KATHERINE STOIDES, EXAMINING ATTORNEY

SN 86-106,240. ROCK HILL COME-SEE-ME FESTIVAL, INC., ROCK HILL, SC. FILED 10-30-2013.

SN 86-098,157. SHAWN AVENINGO, BEAVERTON, OR. FILED 10-22-2013.

**Verse On The Vine**

THE MARK CONSISTS OF STANDARD CHARACTERS WITHOUT CLAIM TO ANY PARTICULAR FONT, STYLE, SIZE, OR COLOR.

FOR ARRANGING AND CONDUCTING SPECIAL EVENTS FOR SOCIAL ENTERTAINMENT PURPOSES; ARRANGING, ORGANIZING, CONDUCTING, AND HOSTING SOCIAL ENTERTAINMENT EVENTS; CONDUCTING ENTERTAINMENT EXHIBITIONS IN THE NATURE OF POETRY, ART AND/OR WINE; MASTER OF CEREMONY SERVICES FOR PARTIES AND SPECIAL EVENTS; ORGANIZATION OF CULTURAL SHOWS; ORGANIZATION OF EVENTS FOR CULTURAL PURPOSES; ORGANIZING AND HOSTING OF EVENTS FOR CULTURAL PURPOSES; ORGANIZING COMMUNITY FESTIVALS FEATURING A VARIETY OF ACTIVITIES, NAMELY, SPORTING EVENTS, ART EXHIBITIONS, FLEA MARKETS, ETHNIC DANCES AND THE LIKE; ORGANIZING CULTURAL AND ARTS EVENTS; PROVIDING AN INTERNET WEBSITE PORTAL IN THE FIELD OF ENTERTAINMENT, CULTURAL AND SPORTING EVENTS; SPECIAL EVENT PLANNING FOR SOCIAL ENTERTAINMENT PURPOSES (U.S. CLS. 100, 101 AND 107).

FIRST USE 1-0-2012; IN COMMERCE 1-0-2012.

LOURDES AYALA, EXAMINING ATTORNEY



OWNER OF U.S. REG. NOS. 4,161,239, 4,161,243 AND OTHERS.

NO CLAIM IS MADE TO THE EXCLUSIVE RIGHT TO USE "50TH" AND "ROCK HILL, SOUTH CAROLINA", APART FROM THE MARK AS SHOWN.

THE NAME(S), PORTRAIT(S), AND/OR SIGNATURE(S) SHOWN IN THE MARK DOES NOT IDENTIFY A PARTICULAR LIVING INDIVIDUAL.

THE MARK CONSISTS OF AN IMAGE OF A CARTOON FROG BESIDE THE WORDS "COME - SEE - ME!" AND ABOVE THE WORDS "ROCK HILL, SOUTH CAROLINA". "50TH" APPEARS BESIDE "COME - SEE - ME!", AND A CARTOON OWL APPEARS ABOVE THE CARTOON FROG.

FOR ORGANIZING COMMUNITY FESTIVALS FEATURING PRIMARILY MUSIC, SPORTING EVENTS, ART EXHIBITIONS, MARKET AND ALSO PROVIDING THEATRIC PERFORMANCES, ANIMAL EXHIBITS, ETHNIC DANCE, PARADE (U.S. CLS. 100, 101 AND 107).

FIRST USE 10-30-2013; IN COMMERCE 10-30-2013.

KATHRYN COWARD, EXAMINING ATTORNEY

**CLASS 41—(Continued).**

SN 86-106,460. HOME BOX OFFICE, INC., NEW YORK, NY. FILED 10-31-2013.

YOU KNOW WHEN IT'S HBO

THE MARK CONSISTS OF STANDARD CHARACTERS WITHOUT CLAIM TO ANY PARTICULAR FONT, STYLE, SIZE, OR COLOR.

OWNER OF U.S. REG. NOS. 1,020,101, 3,958,013 AND OTHERS.

FOR ENTERTAINMENT SERVICES, NAMELY, PRODUCTION AND DISTRIBUTION OF MOTION PICTURES, COMEDY AND DRAMATIC TELEVISION SERIES, DOCUMENTARIES AND SPORTING EVENTS RENDERED THROUGH THE MEDIA OF TELEVISION, CABLE, SATELLITE, WIRELESS COMMUNICATION DEVICES AND VIA THE INTERNET; PROVIDING INFORMATION IN THE FIELD OF ENTERTAINMENT RENDERED VIA TELEVISION, CABLE, SATELLITE, WIRELESS COMMUNICATION DEVICES AND THE INTERNET; PREMIUM OR PAY TELEVISION PROGRAMMING SERVICES; PRODUCTION AND DISTRIBUTION OF PREMIUM OR PAY TELEVISION PROGRAMS (U.S. CLS. 100, 101 AND 107).

ALAIN LAPTER, EXAMINING ATTORNEY

**CLASS 41—(Continued).**

SN 86-108,595. TELEMUNDO NETWORK GROUP LLC, HIALEAH, FL. FILED 11-1-2013.

SUELTA LA SOPA

THE MARK CONSISTS OF STANDARD CHARACTERS WITHOUT CLAIM TO ANY PARTICULAR FONT, STYLE, SIZE, OR COLOR.

THE ENGLISH TRANSLATION OF "SUELTA LA SOPA" IN THE MARK IS "SPILL THE BEANS".

FOR ENTERTAINMENT SERVICES IN THE NATURE OF A TELEVISION SERIES FEATURING COMMENTARY, INTERVIEWS AND INFORMATION IN THE FIELD OF ENTERTAINMENT; ENTERTAINMENT SERVICES IN THE NATURE OF IMAGES AND VIDEOS IN THE FIELD OF ENTERTAINMENT PROVIDED VIA GLOBAL COMPUTER AND WIRELESS COMMUNICATION NETWORKS; PROVIDING A WEBSITE FEATURING INFORMATION RELATED TO ENTERTAINMENT PROGRAMMING FEATURING SUBJECTS OF GENERAL HUMAN INTEREST (U.S. CLS. 100, 101 AND 107).

JOHN E. MICHOS, EXAMINING ATTORNEY

SN 86-108,590. KINDRED COMPANIONS LLC, FRENCH-TOWN, NJ. FILED 11-1-2013.



NO CLAIM IS MADE TO THE EXCLUSIVE RIGHT TO USE "LLC" AND "DOG TRAINING, BEHAVIORAL COUNSELING, PET SITTING", APART FROM THE MARK AS SHOWN.

THE MARK CONSISTS OF THE OUTLINED PROFILE OF A DOG. TO THE RIGHT IS THE WORDING "KINDRED COMPANIONS LLC" ABOVE THE SMALLER WORDING "DOG TRAINING, BEHAVIORAL COUNSELING, PET SITTING".

FOR ANIMAL TRAINING; DOG TRAINING; PET OBEDIENCE TRAINING SERVICES; PET TRAINING SERVICES; TRAINING ANIMALS FOR OTHERS (U.S. CLS. 100, 101 AND 107).

FIRST USE 3-6-2008; IN COMMERCE 3-6-2008.

TARAH HARDY, EXAMINING ATTORNEY

SN 86-108,716. UNLOCKING POTENTIAL, LLC, FAIRFAX, VA. FILED 11-2-2013.

Perceptive Parents

THE MARK CONSISTS OF STANDARD CHARACTERS WITHOUT CLAIM TO ANY PARTICULAR FONT, STYLE, SIZE, OR COLOR.

NO CLAIM IS MADE TO THE EXCLUSIVE RIGHT TO USE "PARENTS", APART FROM THE MARK AS SHOWN.

FOR EDUCATION SERVICES, NAMELY, PROVIDING MENTORING, TUTORING, CLASSES, SEMINARS AND WORKSHOPS IN THE FIELD OF CHILDHOOD DEVELOPMENT AND PARENTING SKILLS (U.S. CLS. 100, 101 AND 107).

MATTHEW KLINE, EXAMINING ATTORNEY

**CLASS 41—(Continued).**

SN 86-109,449. ADORAMA, INC., NEW YORK, NY. FILED 11-4-2013.



OWNER OF U.S. REG. NOS. 3,296,024, 3,622,793 AND 3,622,802.

THE MARK CONSISTS OF THE WORD "ADORAMA" IN A STYLIZED FONT WITH DIAGONAL LINES IN THE LETTER "O".

FOR EDUCATIONAL SERVICES, NAMELY, PROVIDING A WEBSITE FEATURING INSTRUCTIONAL INFORMATION AND EDUCATIONAL RESOURCES IN THE NATURE OF NON-DOWNLOADABLE INSTRUCTIONAL VIDEO CLIPS AND ARTICLES ON TOPICS RELATED TO PHOTOGRAPHY, VIDEOGRAPHY, AUDIO, DIGITAL IMAGING EQUIPMENT, SERVICES AND PRODUCTION, HOME ENTERTAINMENT ELECTRONICS EQUIPMENT, CONSUMER ELECTRONICS EQUIPMENT, AND COMPUTER EQUIPMENT; PROVIDING A WEBSITE FEATURING ON-LINE NEWSLETTERS IN THE FIELDS OF PHOTOGRAPHY, VIDEOGRAPHY, AUDIO, DIGITAL IMAGING EQUIPMENT, SERVICES AND PRODUCTION, HOME ENTERTAINMENT ELECTRONICS EQUIPMENT, CONSUMER ELECTRONICS EQUIPMENT, AND COMPUTER EQUIPMENT; EDUCATIONAL SERVICES, NAMELY, PROVIDING WORKSHOPS, SEMINARS, AND LECTURES TO OTHERS IN THE FIELDS OF PHOTOGRAPHY, VIDEOGRAPHY, AUDIO, AND DIGITAL IMAGING EQUIPMENT, SERVICES AND PRODUCTION; PROVIDING ONLINE NEWSLETTERS ON TOPICS RELATED TO PHOTOGRAPHY, VIDEOGRAPHY, AUDIO, AND DIGITAL IMAGING EQUIPMENT, SERVICES AND PRODUCTION VIA E-MAIL (U.S. CLS. 100, 101 AND 107).

FIRST USE 0-0-2004; IN COMMERCE 0-0-2004.

HEATHER BIDDULPH, EXAMINING ATTORNEY

SN 86-110,944. STEALTH ELECTRONIC CIGS LLC, FRISCO, TX. FILED 11-5-2013.



THE MARK CONSISTS OF STANDARD CHARACTERS WITHOUT CLAIM TO ANY PARTICULAR FONT, STYLE, SIZE, OR COLOR.

FOR SMOKING LOUNGE SERVICES (U.S. CLS. 100, 101 AND 107).

CHRISTOPHER REAMS, EXAMINING ATTORNEY

**CLASS 41—(Continued).**

SN 86-111,097. THE JIM HENSON COMPANY, INC., LOS ANGELES, CA. FILED 11-5-2013.



THE MARK CONSISTS OF STANDARD CHARACTERS WITHOUT CLAIM TO ANY PARTICULAR FONT, STYLE, SIZE, OR COLOR.

OWNER OF U.S. REG. NOS. 1,432,302, 1,814,144 AND 4,248,383.

NO CLAIM IS MADE TO THE EXCLUSIVE RIGHT TO USE "CHALLENGE", APART FROM THE MARK AS SHOWN.

THE NAME "JIM HENSON" DOES NOT IDENTIFY A LIVING INDIVIDUAL.

SEC. 2(F) AS TO "CREATURE SHOP".

FOR ENTERTAINMENT SERVICES IN THE NATURE OF AN ONGOING REALITY-BASED TELEVISION PROGRAM (U.S. CLS. 100, 101 AND 107).

FIRST USE 3-0-2014; IN COMMERCE 3-0-2014.

JAMES LOVELACE, EXAMINING ATTORNEY

SN 86-114,406. EDUCATION MANAGEMENT LLC, PITTSBURGH, PA. FILED 11-8-2013.



THE MARK CONSISTS OF STANDARD CHARACTERS WITHOUT CLAIM TO ANY PARTICULAR FONT, STYLE, SIZE, OR COLOR.

OWNER OF U.S. REG. NOS. 1,601,475, 4,500,280 AND OTHERS.

NO CLAIM IS MADE TO THE EXCLUSIVE RIGHT TO USE "ART INSTITUTE", APART FROM THE MARK AS SHOWN.

SEC. 2(F).

FOR EDUCATION SERVICES, NAMELY, PROVIDING COURSES OF INSTRUCTION AT THE POST-SECONDARY LEVEL, AND DISTRIBUTION OF COURSE MATERIAL IN CONNECTION THEREWITH (U.S. CLS. 100, 101 AND 107).

SKYE YOUNG, EXAMINING ATTORNEY

SN 86-114,468. ASHI HOLDING COMPANY, EUGENE, OR. FILED 11-8-2013.



THE MARK CONSISTS OF STANDARD CHARACTERS WITHOUT CLAIM TO ANY PARTICULAR FONT, STYLE, SIZE, OR COLOR.

FOR FIRST AID TRAINING SERVICES (U.S. CLS. 100, 101 AND 107).

HEATHER THOMPSON, EXAMINING ATTORNEY

**CLASS 41—(Continued).**

SN 86-114,472. ASHI HOLDING COMPANY, EUGENE, OR.  
FILED 11-8-2013.

**LOOP TROOPER**

THE MARK CONSISTS OF STANDARD CHARACTERS  
WITHOUT CLAIM TO ANY PARTICULAR FONT, STYLE,  
SIZE, OR COLOR.

FOR FIRST AID TRAINING SERVICES (U.S. CLS. 100,  
101 AND 107).

HEATHER THOMPSON, EXAMINING ATTORNEY

SN 86-114,474. ASHI HOLDING COMPANY, EUGENE, OR.  
FILED 11-8-2013.

**ELOOP**

THE MARK CONSISTS OF STANDARD CHARACTERS  
WITHOUT CLAIM TO ANY PARTICULAR FONT, STYLE,  
SIZE, OR COLOR.

FOR FIRST AID TRAINING SERVICES (U.S. CLS. 100,  
101 AND 107).

HEATHER THOMPSON, EXAMINING ATTORNEY

SN 86-114,475. ASHI HOLDING COMPANY, EUGENE, OR.  
FILED 11-8-2013.

**ILOOP**

THE MARK CONSISTS OF STANDARD CHARACTERS  
WITHOUT CLAIM TO ANY PARTICULAR FONT, STYLE,  
SIZE, OR COLOR.

FOR FIRST AID TRAINING SERVICES (U.S. CLS. 100,  
101 AND 107).

HEATHER THOMPSON, EXAMINING ATTORNEY

**CLASS 41—(Continued).**

SN 86-115,606. THE FEATURE PRESENTATION MUSIC  
GROUP, INC., NEW YORK, NY. FILED 11-11-2013.



NO CLAIM IS MADE TO THE EXCLUSIVE RIGHT TO  
USE "THE FEATURE PRESENTATION MUSIC GROUP",  
APART FROM THE MARK AS SHOWN.

THE COLOR(S) BLACK, YELLOW AND BLUE IS/ARE  
CLAIMED AS A FEATURE OF THE MARK.

THE MARK CONSISTS OF "THE FEATURE PRESENTA-  
TION MUSIC GROUP" IN BLACK LETTERS WITH TWO  
EXPANDING BEAMS GOING ACROSS THE WORDS IN  
YELLOW AND IN BLUE.

FOR MUSICAL SOUND RECORDINGS; AUDIO-VI-  
SUAL RECORDINGS, NAMELY, COMPACT DISCS,  
TAPE CASSETTES, AUDIO CASSETTES, AUDIO TAPES,  
AUDIO DISCS, RECORDS, CD-ROMS, VIDEO TAPES,  
VIDEO CASSETTES, VIDEO DISCS, DVDS, DATS, AND  
LASER DISCS, ALL FEATURING MUSIC; DISC JOCK-  
EYING AND SUBJECT MATTERS GENERALLY RE-  
LATED TO THE ENTERTAINMENT INDUSTRY,  
NAMELY, MUSIC, MOVIES, TELEVISION, GAMING,  
MUSIC VIDEOS, ATHLETICS, BIOGRAPHIES, DRAMA  
AND COMEDIES; VIDEO RECORDINGS FEATURING  
MUSIC; ELECTRONIC PUBLICATIONS IN THE NATURE  
OF BOOKS, BOOKLETS, MAGAZINES, JOURNALS,  
MANUALS, BROCHURES, LEAFLETS, PAMPHLETS  
AND NEWSLETTERS, ALL IN THE FIELDS OF MUSIC,  
DISC JOCKEYING AND SUBJECT MATTERS GENER-  
ALLY RELATED TO THE ENTERTAINMENT INDUS-  
TRY, NAMELY, MUSIC, MOVIES, TELEVISION,  
GAMING, MUSIC VIDEOS, ATHLETICS, BIOGRAPHIES,  
DRAMA AND COMEDIES; ELECTRONIC PUBLICA-  
TIONS, NAMELY, BOOKS, BOOKLETS, MAGAZINES,  
JOURNALS, MANUALS, BROCHURES, LEAFLETS,  
PAMPHLETS AND NEWSLETTERS, ALL IN THE  
FIELDS OF MUSIC, DISC JOCKEYING AND SUBJECT  
MATTERS GENERALLY RELATED TO THE ENTER-  
TAINMENT INDUSTRY, NAMELY, MUSIC, MOVIES,  
TELEVISION, GAMING, MUSIC VIDEOS, ATHLETICS,  
BIOGRAPHIES, DRAMA AND COMEDIES, ALL RE-  
CORDED ON CD-ROMS, DISKETTES, FLOPPY DISKS,  
VIDEO CASSETTES, AND MAGNETIC TAPES; MAG-  
NETS; DECORATIVE MAGNETS; REFRIGERATOR  
MAGNETS; NOVELTY MAGNETS; MOUSE PADS; COM-  
PACT DISC CASES; FITTED CASES FOR STORAGE  
AND TRANSPORTATION, NAMELY, CASES FOR COM-  
PACT DISCS, AUDIO CASSETTES, VIDEO CASSETTES,  
CD-ROMS, HOME VIDEO GAMES, HOME VIDEO GAME  
ACCESSORIES, COMPUTERS, COMPUTER ACCES-  
SORIES, CAMERAS, CAMCORDERS AND PORTABLE  
PHONES; COMPUTER CARRYING CASES; WRIST  
RESTS AND SUPPORTS FOR COMPUTER MOUSE  
USERS; WRIST RESTS FOR COMPUTER PRODUCTS;  
COMPUTER KEYBOARD WRIST PADS; COMPUTER  
GAME CARTRIDGES, CASSETTES, TAPES, DISCS, JOY-  
STICKS, PROGRAMS AND SOFTWARE; ELECTRONIC  
GAME PROGRAMS; VIDEO GAME CARTRIDGES, TAPE  
CASSETTES, DISCS, JOYSTICKS, PROGRAMS AND  
SOFTWARE; ELECTRONIC GAME PROGRAMS; ELEC-  
TRONIC GOODS, PLAYERS AND RECORDERS,  
NAMELY, AUDIO CASSETTE RECORDERS, AUDIO  
TAPE RECORDERS, COMPACT DISC RECORDERS,  
DIGITAL VIDEO RECORDERS, VIDEO TAPE RECOR-  
DERS, PHONOGRAPH PLAYERS, MP3 PLAYERS, DIGI-  
TAL AUDIO PLAYERS, DIGITAL VIDEO PLAYERS,  
PORTABLE MEDIA PLAYERS, AUDIO TAPE PLAYERS  
AND COMPACT DISC PLAYERS (U.S. CLS. 100, 101 AND  
107).

FIRST USE 4-15-2013; IN COMMERCE 5-7-2013.

BRIDGETT SMITH, EXAMINING ATTORNEY



**CLASS 41—(Continued).**

SN 86-115,971. RUNWAY MAGAZINE INC., WEST HOLLYWOOD, CA. FILED 11-12-2013.



OWNER OF U.S. REG. NOS. 3,586,631 AND 4,093,206.  
THE MARK CONSISTS OF CAPITAL LETTER "R", CENTERED INSIDE A SQUARE BOX WITH ROUNDED CORNERS.

FOR PROVIDING ONLINE GENERAL FEATURE MAGAZINE IN THE FIELD OF FASHION, BEAUTY, LIFESTYLE, ENTERTAINMENT (U.S. CLS. 100, 101 AND 107).

FIRST USE 1-1-1996; IN COMMERCE 1-1-1997.

NAAKWAMA ANKRAH, EXAMINING ATTORNEY

**CLASS 41—(Continued).**

SN 86-116,079. NATIONAL ASSOCIATION OF CRIMINAL DEFENSE LAWYERS, WASHINGTON, DC. FILED 11-12-2013.



NO CLAIM IS MADE TO THE EXCLUSIVE RIGHT TO USE "CLE INSTITUTE" AND THE SCALES OF JUSTICE, APART FROM THE MARK AS SHOWN.

THE MARK CONSISTS OF SCALES INSIDE A CIRCLE WITH "NACDL'S CLE INSTITUTE" AROUND THE OUTSIDE OF THE CIRCLE.

FOR EDUCATION SERVICES, NAMELY, CONDUCTING CONVENTIONS, CLASSES, CONFERENCES, SEMINARS, WORKSHOPS, AND CONTINUING EDUCATION IN THE FIELD OF LEGAL EDUCATION, NAMELY, CRIMINAL DEFENSE LAW (U.S. CLS. 100, 101 AND 107).

FIRST USE 11-10-2010; IN COMMERCE 11-20-2010.

JULIE VEPPUMTHARA, EXAMINING ATTORNEY

SN 86-116,075. NATIONAL ASSOCIATION OF CRIMINAL DEFENSE LAWYERS, WASHINGTON, DC. FILED 11-12-2013.

NACDL'S CLE INSTITUTE

THE MARK CONSISTS OF STANDARD CHARACTERS WITHOUT CLAIM TO ANY PARTICULAR FONT, STYLE, SIZE, OR COLOR.

NO CLAIM IS MADE TO THE EXCLUSIVE RIGHT TO USE "CLE INSTITUTE", APART FROM THE MARK AS SHOWN.

FOR EDUCATION SERVICES, NAMELY, CONDUCTING CONVENTIONS, CLASSES, CONFERENCES, SEMINARS, WORKSHOPS, AND CONTINUING EDUCATION IN THE FIELD OF LEGAL EDUCATION, NAMELY, CRIMINAL DEFENSE LAW (U.S. CLS. 100, 101 AND 107).

FIRST USE 11-10-2010; IN COMMERCE 11-20-2010.

JULIE VEPPUMTHARA, EXAMINING ATTORNEY

SN 86-116,689. ADVNC LACROSSE, INC., SAN FRANCISCO, CA. FILED 11-12-2013.



THE MARK CONSISTS OF A STYLIZED LETTER "A" IN THE FORM OF AN INVERTED TRIANGLE IN THE CENTER OF WHICH IS A SMALL CIRCLE.

FOR ATHLETIC TRAINING SERVICES IN THE FIELD OF LACROSSE; COACHING IN THE FIELD OF SPORTS; SPORTS AND EDUCATION RELATED ENTERTAINMENT AND COMMUNITY SERVICES RELATING TO THE SPORT OF LACROSSE, NAMELY, PROVIDING CLINICS, LESSONS, WORKSHOPS, SEMINARS, CAMPS, TRAINING, COMPETITIONS, GAMES, EXHIBITIONS, TOURNAMENTS, PROGRAMS, AND EVENTS, ALL IN THE FIELD OF LACROSSE (U.S. CLS. 100, 101 AND 107).

FIRST USE 8-0-2012; IN COMMERCE 8-0-2012.

VERNA BETH RIRIE, EXAMINING ATTORNEY

**CLASS 41—(Continued).**

SN 86-117,031. HARRIS, BRANDON JAREAL, AKA B.J. HARRIS, KALAMAZOO, MI. FILED 11-12-2013.



THE MARK CONSISTS OF THE WORDING "HI-V HIGH FIVE" IN WHITE LETTERS INSIDE OF A SOLID BLACK FIVE FINGER HAND. THE WORDING "HELP IGNITE VALIDITY AND FIGHT THE STIGMA OF HIV" IS IN BLACK LETTERING AND SURROUNDS THE BLACK HAND.

FOR EDUCATION SERVICES, NAMELY, PROVIDING LIVE AND ON-LINE WORKSHOPS IN THE FIELD OF HIV/AIDS (U.S. CLS. 100, 101 AND 107).

FIRST USE 10-30-2013; IN COMMERCE 11-12-2013.  
ELIZABETH KAJUBI, EXAMINING ATTORNEY

**CLASS 41—(Continued).**

SN 86-118,717. ORAMETRIX, INC., RICHARDSON, TX. FILED 11-14-2013.

SUREU

THE MARK CONSISTS OF STANDARD CHARACTERS WITHOUT CLAIM TO ANY PARTICULAR FONT, STYLE, SIZE, OR COLOR.

OWNER OF U.S. REG. NO. 2,724,644.

FOR EDUCATIONAL SERVICES, NAMELY, CONDUCTING ONLINE COURSES IN THE FIELD OF ORTHODONTICS AND DENTISTRY AND PRINCIPLE MATERIALS DISTRIBUTED THEREWITH (U.S. CLS. 100, 101 AND 107).

MICHELLE DUBOIS, EXAMINING ATTORNEY

SN 86-117,033. SITECOMPLI, LLC, NEW YORK, NY. FILED 11-12-2013.

INFAC T

THE MARK CONSISTS OF STANDARD CHARACTERS WITHOUT CLAIM TO ANY PARTICULAR FONT, STYLE, SIZE, OR COLOR.

FOR PROVIDING ONLINE REPORTS REGARDING GOVERNMENT AND MUNICIPAL DATA USED IN THE REAL ESTATE, BANKING AND INSURANCE INDUSTRIES (U.S. CLS. 100, 101 AND 107).

HAI-LY LAM, EXAMINING ATTORNEY

SN 86-118,727. ORAMETRIX, INC., RICHARDSON, TX. FILED 11-14-2013.

sureU

OWNER OF U.S. REG. NO. 2,724,644.

THE MARK CONSISTS OF THE LETTERS "SURE" IN STYLIZED FORM TO THE LEFT OF THE LETTER "U" IN STYLIZED FORM WITHIN A HALF-OVAL CARRIER.

FOR EDUCATIONAL SERVICES, NAMELY, CONDUCTING ONLINE COURSES IN THE FIELD OF ORTHODONTICS AND DENTISTRY AND PRINCIPLE MATERIALS DISTRIBUTED THEREWITH (U.S. CLS. 100, 101 AND 107).

MICHELLE DUBOIS, EXAMINING ATTORNEY

**CLASS 41—(Continued).**

SN 86-118,730. ORAMETRIX, INC., RICHARDSON, TX.  
FILED 11-14-2013.



OWNER OF U.S. REG. NO. 2,724,644.  
THE MARK CONSISTS OF THE LETTERS "SURE" IN  
STYLIZED FORM ABOVE THE LETTER "U" IN STYLIZED  
FORM WITHIN A HALF-OVAL CARRIER.

FOR EDUCATIONAL SERVICES, NAMELY, CON-  
DUCTING ONLINE COURSES IN THE FIELD OF  
ORTHODONTICS AND DENTISTRY AND PRINCIPLE  
MATERIALS DISTRIBUTED THEREWITH (U.S. CLS.  
100, 101 AND 107).

MICHELLE DUBOIS, EXAMINING ATTORNEY

SN 86-119,655. VASQUEZ, CARLOS ALBERTO, LOS AN-  
GELES, CA. FILED 11-15-2013.



NO CLAIM IS MADE TO THE EXCLUSIVE RIGHT TO  
USE "BANDA", APART FROM THE MARK AS SHOWN.  
THE COLOR(S) RED AND BLACK IS/ARE CLAIMED AS  
A FEATURE OF THE MARK.

THE MARK CONSISTS OF THE WORDING "BANDA LA"  
IN THE COLOR BLACK CENTERED ABOVE THE WORD-  
ING "FANTASTICA" IN STYLIZED RED FONT OUTLINED  
IN BLACK. BEHIND THE WORDING "FANTASTICA"  
APPEARS BLACK ABSTRACT DESIGN ELEMENTS.

THE ENGLISH TRANSLATION OF "BANDA LA FAN-  
TASTICA" IN THE MARK IS "THE FANTASTIC BAND".

FOR ENTERTAINMENT SERVICES, NAMELY, LIVE  
PERFORMANCES BY A MUSICAL GROUP (U.S. CLS.  
100, 101 AND 107).

DAVID I, EXAMINING ATTORNEY

**CLASS 41—(Continued).**

SN 86-119,736. MCGLAUGHLIN, RICK, GAITHERSBURG,  
MD. FILED 11-15-2013.

## Washington Buckskins

THE MARK CONSISTS OF STANDARD CHARACTERS  
WITHOUT CLAIM TO ANY PARTICULAR FONT, STYLE,  
SIZE, OR COLOR.

NO CLAIM IS MADE TO THE EXCLUSIVE RIGHT TO  
USE "WASHINGTON", APART FROM THE MARK AS  
SHOWN.

FOR ENTERTAINMENT SERVICES, NAMELY, PRE-  
SENTATIONS OF FOOTBALL CONTEST (U.S. CLS. 100,  
101 AND 107).

SUSAN LESLIE DUBOIS, EXAMINING ATTORNEY

SN 86-121,466. GM&O RAILS-TO-TRAILS RECREATIONAL  
DISTRICT OF NORTH MISSISSIPPI, PONTOTOC, MS.  
FILED 11-18-2013.

## TANGLEFOOT TRAIL

THE MARK CONSISTS OF STANDARD CHARACTERS  
WITHOUT CLAIM TO ANY PARTICULAR FONT, STYLE,  
SIZE, OR COLOR.

NO CLAIM IS MADE TO THE EXCLUSIVE RIGHT TO  
USE "TRAIL", APART FROM THE MARK AS SHOWN.

FOR RECREATIONAL PARK SERVICES (U.S. CLS.  
100, 101 AND 107).

FIRST USE 10-20-2013; IN COMMERCE 10-20-2013.

DARRYL SPRUILL, EXAMINING ATTORNEY

SN 86-121,476. GM&O RAILS-TO-TRAILS RECREATIONAL  
DISTRICT OF NORTH MISSISSIPPI, PONTOTOC, MS.  
FILED 11-18-2013.



NO CLAIM IS MADE TO THE EXCLUSIVE RIGHT TO  
USE "TRAIL", APART FROM THE MARK AS SHOWN.

THE MARK CONSISTS OF A STYLIZED MAP OF THE  
STATE OF MISSISSIPPI IN WHICH APPEARS A STYLIZED  
WALKER IN THE TOP LEFT, A STYLIZED BIKER IN THE  
TOP RIGHT, AND A STYLIZED RUNNER IN THE BOTTOM  
LEFT. A STYLIZED RAILROAD TRACK RUNS THROUGH  
THE MIDDLE IN A CURVED PATTERN. TO THE RIGHT  
APPEARS THE WORDS "TANGLEFOOT TRAIL", WITH AN  
IMAGE OF SMOKE COMING FROM THE LAST "T" IN  
"TANGLEFOOT".

FOR RECREATIONAL PARK SERVICES (U.S. CLS.  
100, 101 AND 107).

FIRST USE 10-20-2013; IN COMMERCE 10-20-2013.

DARRYL SPRUILL, EXAMINING ATTORNEY

**CLASS 41—(Continued).**

SN 86-124,523. PLAN C PRODUCTIONS, LLC, JERSEY CITY, NJ. FILED 11-20-2013.

**THE STRAWBERRY TRAFFIC JAM**

THE MARK CONSISTS OF STANDARD CHARACTERS WITHOUT CLAIM TO ANY PARTICULAR FONT, STYLE, SIZE, OR COLOR.

FOR ENTERTAINMENT SERVICES FOR CHILDREN, NAMELY, PROVIDING LIVE PERFORMANCES BY A MUSICAL GROUP; EDUCATIONAL SERVICES, NAMELY, WORKSHOPS FOR CHILDREN IN THE FIELDS OF WRITING, POETRY, AND SONGWRITING (U.S. CLS. 100, 101 AND 107).

FIRST USE 9-0-2001; IN COMMERCE 9-0-2001.  
JORDAN BAKER, EXAMINING ATTORNEY

---

SN 86-126,014. SMITH, STEPHEN L., COPPELL, TX. FILED 11-21-2013.

**CAMPAIGNSHORTCUTS**

THE MARK CONSISTS OF STANDARD CHARACTERS WITHOUT CLAIM TO ANY PARTICULAR FONT, STYLE, SIZE, OR COLOR.

FOR EDUCATIONAL SERVICES, NAMELY, CONDUCTING CLASSES, SEMINARS, PROGRAMS, CONFERENCES AND WORKSHOPS IN THE FIELDS OF BUSINESS AND ORGANIZATIONAL DEVELOPMENT AND MANAGEMENT AND DISTRIBUTION OF TRAINING MATERIALS IN CONNECTION THEREWITH (U.S. CLS. 100, 101 AND 107).

FIRST USE 6-1-2011; IN COMMERCE 6-1-2011.  
LAURIE KAUFMAN, EXAMINING ATTORNEY

---

SN 86-138,320. ETHICS OF CARING, LOS ANGELES, CA. FILED 12-9-2013.

**ETHICS OF CARING**

THE MARK CONSISTS OF STANDARD CHARACTERS WITHOUT CLAIM TO ANY PARTICULAR FONT, STYLE, SIZE, OR COLOR.

NO CLAIM IS MADE TO THE EXCLUSIVE RIGHT TO USE "ETHICS", APART FROM THE MARK AS SHOWN.

FOR EDUCATIONAL SERVICES, NAMELY, CONDUCTING CLASSES, SEMINARS, AND CONFERENCES IN THE FIELD OF ETHICS AND DISTRIBUTION OF EDUCATIONAL MATERIALS IN CONNECTION THEREWITH (U.S. CLS. 100, 101 AND 107).

FIRST USE 3-17-1994; IN COMMERCE 3-17-1994.  
CIMMERIAN COLEMAN, EXAMINING ATTORNEY

**CLASS 41—(Continued).**

SN 86-139,230. LIBERTY UNIVERSITY, LYNCHBURG, VA. FILED 12-10-2013.



OWNER OF U.S. REG. NO. 3,603,562.

THE MARK CONSISTS OF A SOLITARY EAGLE HEAD. FOR EDUCATING AT UNIVERSITY OR COLLEGES; EDUCATION SERVICES IN THE NATURE OF COURSES AT THE UNIVERSITY LEVEL (U.S. CLS. 100, 101 AND 107).

FIRST USE 12-1-2007, THE MARK WAS FIRST USED ANYWHERE IN A DIFFERENT FORM OTHER THAN THAT SOUGHT TO BE REGISTERED AT LEAST AS EARLY AS 12/01/2007; IN COMMERCE 2-1-2008, THE MARK WAS FIRST USED IN COMMERCE IN A DIFFERENT FORM OTHER THAN THAT SOUGHT TO BE REGISTERED AT LEAST AS EARLY AS 02/01/2008.

ALLISON SCHRODY, EXAMINING ATTORNEY

---

SN 86-143,761. BROWN, MARCUS, YORBA LINDA, CA. FILED 12-14-2013.



THE MARK CONSISTS OF THE WORDING "NO KURFEW CREATIVES NEVER SLEEP!" IN STYLIZED UPPER-CASE LETTERING WRITTEN ON TWO LINES UNDERNEATH A OUTLINE OF AN OWL'S HEAD WEARING A BOW TIE RIGHT UNDER THE BEAK.

FOR PHOTOGRAPHY; ENTERTAINMENT SERVICES, NAMELY, PROVIDING A WEBSITE FEATURING ENTERTAINMENT INFORMATION (U.S. CLS. 100, 101 AND 107).

FIRST USE 1-1-2010; IN COMMERCE 3-1-2013.  
REBECCA POVARCHUK, EXAMINING ATTORNEY

**CLASS 41—(Continued).**

SN 86-146,177. TWEAK YOUR SPACE PRODUCTIONS, INC., TAMPA, FL. FILED 12-17-2013.

**TWEAK YOUR SPACE**

THE MARK CONSISTS OF STANDARD CHARACTERS WITHOUT CLAIM TO ANY PARTICULAR FONT, STYLE, SIZE, OR COLOR.

FOR ENTERTAINMENT IN THE NATURE OF ONGOING TELEVISION PROGRAMS IN THE FIELD OF INTERIOR DECORATING (U.S. CLS. 100, 101 AND 107).  
APRIL ROACH, EXAMINING ATTORNEY

SN 86-146,181. TWEAK YOUR SPACE PRODUCTIONS, INC., TAMPA, FL. FILED 12-17-2013.



THE MARK CONSISTS OF THE STYLIZED WORDING "TWEAK YOUR SPACE" TO THE RIGHT OF A LAMP HAVING A TILTED LAMPSHADE WITH LIGHT SHINING FROM THE BOTTOM OF THE LAMPSHADE ONTO THE WORDS.

FOR ENTERTAINMENT IN THE NATURE OF ONGOING TELEVISION PROGRAMS IN THE FIELD OF INTERIOR DECORATING (U.S. CLS. 100, 101 AND 107).  
APRIL ROACH, EXAMINING ATTORNEY

SN 86-146,869. HARPO, INC., CHICAGO, IL. FILED 12-18-2013.

**OPRAH PRESENTS BELIEF**

THE MARK CONSISTS OF STANDARD CHARACTERS WITHOUT CLAIM TO ANY PARTICULAR FONT, STYLE, SIZE, OR COLOR.

OWNER OF U.S. REG. NOS. 3,727,871, 4,321,765 AND OTHERS.

THE NAME "OPRAH" IDENTIFIES A LIVING INDIVIDUAL WHOSE CONSENT IS OF RECORD.

FOR EDUCATIONAL AND ENTERTAINMENT SERVICES, NAMELY, PROGRAMS ABOUT SPIRITUALITY, RELIGION AND FAITH ACCESSIBLE BY MEANS OF TELEVISION, SATELLITE, AUDIO, VIDEO, WEB-BASED APPLICATIONS, MOBILE PHONE APPLICATIONS, COMPUTER NETWORKS AND OTHER WIRELESS COMMUNICATIONS NETWORKS (U.S. CLS. 100, 101 AND 107).

YAT SYE, LEE, EXAMINING ATTORNEY

**CLASS 41—(Continued).**

SN 86-147,499. SECRETS OF CRITICAL CARE, HUNTINGTON BEACH, CA. FILED 12-18-2013.

**Secrets of Critical Care**

THE MARK CONSISTS OF STANDARD CHARACTERS WITHOUT CLAIM TO ANY PARTICULAR FONT, STYLE, SIZE, OR COLOR.

NO CLAIM IS MADE TO THE EXCLUSIVE RIGHT TO USE "CRITICAL CARE", APART FROM THE MARK AS SHOWN.

FOR EDUCATION AND CONSULTING SERVICES IN THE FIELD OF MEDICAL EDUCATION (U.S. CLS. 100, 101 AND 107).

FIRST USE 4-19-2012; IN COMMERCE 4-19-2012.  
INGA ERVIN, EXAMINING ATTORNEY

SN 86-147,806. ACTION GAMING INC., LAS VEGAS, NV. FILED 12-19-2013.

**ANY PLAY CASINO**

THE MARK CONSISTS OF STANDARD CHARACTERS WITHOUT CLAIM TO ANY PARTICULAR FONT, STYLE, SIZE, OR COLOR.

NO CLAIM IS MADE TO THE EXCLUSIVE RIGHT TO USE "CASINO", APART FROM THE MARK AS SHOWN.

FOR PROVIDING ON-LINE COMPUTER GAMES (U.S. CLS. 100, 101 AND 107).

FIRST USE 12-17-2013; IN COMMERCE 12-17-2013.  
AISHA CLARKE, EXAMINING ATTORNEY

SN 86-155,431. BEST, STEPHANIE K, OVIEDO, FL. FILED 12-31-2013.



THE MARK CONSISTS OF THE WORDING "PRO SWINGS.COM", A STYLIZED DESIGN FEATURING A FEMALE SWINGING A BAT, POSITIONED BETWEEN THE WORD "PRO" AND "SWINGS.COM".

FOR SOFTBALL CAMPS (U.S. CLS. 100, 101 AND 107).  
FIRST USE 8-21-2013; IN COMMERCE 10-13-2013.  
JAY FLOWERS, EXAMINING ATTORNEY

**CLASS 41—(Continued).**

SN 86-159,470. PEOPLEVEST LLC, BERWYN, PA. FILED 1-7-2014.

# PEOPLEVEST

THE MARK CONSISTS OF STANDARD CHARACTERS WITHOUT CLAIM TO ANY PARTICULAR FONT, STYLE, SIZE, OR COLOR.

FOR BUSINESS TRAINING IN THE FIELDS OF LEADERSHIP AND OF BUSINESS SKILLS DEVELOPMENT (U.S. CLS. 100, 101 AND 107).

FIRST USE 7-31-2013; IN COMMERCE 7-31-2013.

THEODORE MCBRIDE, EXAMINING ATTORNEY

**CLASS 41—(Continued).**

SN 86-160,846. HEALTH CONNECTIONS YOGA LLC, RUTHERFORD, NJ. FILED 1-8-2014.



THE COLOR(S) BLUE, GREEN, ROSE, PINK, AND BLACK IS/ARE CLAIMED AS A FEATURE OF THE MARK.

THE MARK CONSISTS OF A BLUE LOTUS FLOWER WITH GREEN LEAVES SURROUNDING A PINK AND ROSE HEART AND STETHOSCOPE, INSIDE OF WHICH IS A BLACK SILHOUETTE OF A WOMAN IN A YOGA POSE; EACH ELEMENT OF THE MARK IS OUTLINED IN BLACK.

FOR PROVIDING CONTINUING NURSING EDUCATION COURSES; PROVIDING INFORMATION IN THE FIELD OF NURSING EDUCATION VIA THE INTERNET; YOGA INSTRUCTION (U.S. CLS. 100, 101 AND 107).

PAUL E. FAHRENKOPF, EXAMINING ATTORNEY

SN 86-160,285. NEW YORK PUBLIC RADIO, NEW YORK, NY. FILED 1-8-2014.

# TLDR

THE MARK CONSISTS OF STANDARD CHARACTERS WITHOUT CLAIM TO ANY PARTICULAR FONT, STYLE, SIZE, OR COLOR.

FOR PROVIDING AN INTERNET WEBSITE FEATURING NEWS ABOUT CURRENT EVENTS RELATING TO THE INTERNET AND ONLINE CULTURE; ENTERTAINMENT SERVICES, NAMELY, PROVIDING PODCASTS IN THE FIELD OF CURRENT EVENTS RELATING TO THE INTERNET AND ONLINE CULTURE (U.S. CLS. 100, 101 AND 107).

FIRST USE 9-3-2013; IN COMMERCE 9-3-2013.

BARBARA GAYNOR, EXAMINING ATTORNEY

SN 86-165,568. ENGLILITY CORPORATION, CHANTILLY, VA. FILED 1-14-2014.

# D3IA

THE MARK CONSISTS OF STANDARD CHARACTERS WITHOUT CLAIM TO ANY PARTICULAR FONT, STYLE, SIZE, OR COLOR.

FOR PROVIDING TRAINING, EDUCATION, AND INTEGRATED LEARNING SERVICES, NAMELY, THE DESIGN, DEVELOPMENT, AND PRESENTATION OF CLASSES, SEMINARS, WORKSHOPS, EXERCISES, MENTORSHIPS, AND TRAIN THE TRAINER SERVICES IN THE FIELDS OF TRANSPORTATION, INTERNATIONAL SERVICES, SECURITY, ACQUISITION, PROCUREMENT, MILITARY SERVICES, LEADERSHIP, AND GOVERNMENT SERVICES (U.S. CLS. 100, 101 AND 107).

FIRST USE 9-12-2013; IN COMMERCE 11-26-2013.

JOHN HWANG, EXAMINING ATTORNEY

**CLASS 41—(Continued).**

SN 86-166,032. SADOWITZ, SAMUEL, LOS ANGELES, CA.  
FILED 1-15-2014.

**SAMMY SERIOUS**

THE MARK CONSISTS OF STANDARD CHARACTERS WITHOUT CLAIM TO ANY PARTICULAR FONT, STYLE, SIZE, OR COLOR.

THE NAME "SAMMY SERIOUS" IDENTIFIES A LIVING INDIVIDUAL WHOSE CONSENT IS OF RECORD.

FOR LIVE PERFORMANCES BY A MUSICAL GROUP; ENTERTAINMENT SERVICES IN THE NATURE OF LIVE MUSICAL PERFORMANCES (U.S. CLS. 100, 101 AND 107).

FIRST USE 1-1-1982; IN COMMERCE 5-3-1982.

DEBORAH MEINERS, EXAMINING ATTORNEY

**CLASS 41—(Continued).**

SN 86-167,754. SAINT VINCENT COLLEGE, LATROBE, PA.  
FILED 1-16-2014.

**SAINT VINCENT COLLEGE**

THE MARK CONSISTS OF STANDARD CHARACTERS WITHOUT CLAIM TO ANY PARTICULAR FONT, STYLE, SIZE, OR COLOR.

OWNER OF U.S. REG. NO. 3,889,775.

NO CLAIM IS MADE TO THE EXCLUSIVE RIGHT TO USE "COLLEGE", APART FROM THE MARK AS SHOWN.

FOR EDUCATIONAL AND ENTERTAINMENT SERVICES, NAMELY, CONDUCTING EDUCATIONAL COURSES, SEMINARS, TRAINING PROGRAMS AND CONFERENCES AT THE POST-SECONDARY, UNDERGRADUATE AND GRADUATE LEVEL AND ARRANGING AND CONDUCTING COLLEGIATE ATHLETIC COMPETITIONS AND CULTURAL EVENTS (U.S. CLS. 100, 101 AND 107).

FIRST USE 0-0-1846; IN COMMERCE 0-0-1846.

ELISSA GARBER KON, EXAMINING ATTORNEY

SN 86-167,187. INTERNATIONAL HEALTH SERVICES,  
SOUTHEASTERN, PA. FILED 1-16-2014.

**IHS GLOBAL**

THE MARK CONSISTS OF STANDARD CHARACTERS WITHOUT CLAIM TO ANY PARTICULAR FONT, STYLE, SIZE, OR COLOR.

NO CLAIM IS MADE TO THE EXCLUSIVE RIGHT TO USE "GLOBAL", APART FROM THE MARK AS SHOWN.

FOR EDUCATION SERVICES, NAMELY, ARRANGING AND ORGANIZING CONFERENCES, SEMINARS, WORKSHOPS, FORUMS, TRAINING LECTURES, COURSES, SYMPOSIA, AND COMMUNITY EVENTS, ALL IN THE FIELDS OF CHRISTIANITY, RELIGION, MINISTRY, EVANGELISM, COUNSELING, ETHICS, CHURCH, BUSINESS, EDUCATION, AND THE INTEGRATION OF FAITH WITH THE MEDICAL AND HEALTH CARE PROFESSIONS, CHURCH, BUSINESS, AND EDUCATION; PROVIDING ONLINE NEWSLETTERS IN THE FIELDS OF CHRISTIANITY, RELIGION, MINISTRY, EVANGELISTIC MINISTERIAL SERVICES, COUNSELING, ETHICS, CHURCH, BUSINESS, EDUCATION, AND THE INTEGRATION OF FAITH WITH THE MEDICAL AND HEALTH CARE PROFESSIONS, CHURCH, BUSINESS, AND EDUCATION (U.S. CLS. 100, 101 AND 107).

KAREN K. BUSH, EXAMINING ATTORNEY

SN 86-168,620. RAIKAR, AJAY, DINANATH, LAKEVILLE,  
MN. FILED 1-17-2014.



THE MARK CONSISTS OF TWO QUARTER CIRCLES FACING OUTWARDS WITH A HORIZONTAL CONNECTING LINE AND TWO VERTICAL LINES DOWN THE MIDDLE. TWO SMALL SOLID CIRCLES APPEAR IN THE MIDDLE AREA OF THE HORIZONTAL LINE. THE WORDING "ARDU TIME" APPEARS HORIZONTALLY JUST ABOVE THE TWO SMALL SOLID CIRCLES.

FOR EDUCATIONAL SERVICES, NAMELY, DEVELOPING A PROGRESSIVE LEARNING PHYSICAL COMPUTING CURRICULUM FOR OTHERS IN THE FIELD OF TEACHING COMPUTER PROGRAMMING (U.S. CLS. 100, 101 AND 107).

BRIAN CALLAGHAN, EXAMINING ATTORNEY

**CLASS 41—(Continued).**

SN 86-170,881. DOUGLAS OLSEN, NAPLES, FL. FILED 1-21-2014.

**KITTY CLAUS**

THE MARK CONSISTS OF STANDARD CHARACTERS WITHOUT CLAIM TO ANY PARTICULAR FONT, STYLE, SIZE, OR COLOR.

THE NAME(S), PORTRAIT(S), AND/OR SIGNATURE(S) SHOWN IN THE MARK IDENTIFIES DOUGLAS OLSEN, WHOSE CONSENT(S) TO REGISTER IS MADE OF RECORD.

FOR ENTERTAINMENT IN THE NATURE OF VISUAL AND AUDIO PERFORMANCES, NAMELY, COMEDY, DRAMA, MUSICAL PERFORMANCES, TELEVISION PERFORMANCES, RADIO PERFORMANCES, LIVE PERFORMANCES, VARIETY PERFORMANCES, AND STAGE PERFORMANCES BY AN ACTOR (U.S. CLS. 100, 101 AND 107).

FIRST USE 6-30-2011; IN COMMERCE 6-30-2011.  
SALLY SHIH, EXAMINING ATTORNEY

**CLASS 41—(Continued).**

SN 86-173,599. THIS OLD HOUSE VENTURES, INC., NEW YORK, NY. FILED 1-23-2014.

**THIS OLD HOUSE**

THE MARK CONSISTS OF STANDARD CHARACTERS WITHOUT CLAIM TO ANY PARTICULAR FONT, STYLE, SIZE, OR COLOR.

OWNER OF U.S. REG. NOS. 2,326,190, 4,227,312 AND OTHERS.

NO CLAIM IS MADE TO THE EXCLUSIVE RIGHT TO USE "HOUSE". APART FROM THE MARK AS SHOWN.

FOR ENTERTAINMENT SERVICES, NAMELY, PROVIDING ON-LINE COMPUTER GAMES; ENTERTAINMENT SERVICES, NAMELY, PROVIDING VIRTUAL ENVIRONMENTS IN WHICH USERS CAN INTERACT FOR RECREATIONAL, LEISURE OR ENTERTAINMENT PURPOSES; PROVIDING INFORMATION ON-LINE RELATING TO COMPUTER GAMES AND COMPUTER ENHANCEMENTS FOR GAMES (U.S. CLS. 100, 101 AND 107).

DAVID I, EXAMINING ATTORNEY

SN 86-175,510. EPLING, GERALD A., LAS VEGAS, NV. FILED 1-27-2014.

**BIOEXPERIENCE**

SN 86-173,411. MAIJ ENTERTAINMENT LLC, WALTON, NY. FILED 1-23-2014.

**WE=LV<sup>2</sup>**

THE MARK CONSISTS OF THE CHARACTERS "WE=LV" WITH A SUPERScript "2" NEXT TO THE "V" TO DENOTE THE SQUARED SYMBOL.

FOR ENTERTAINMENT SERVICES, NAMELY, PROVIDING A WEBSITE FEATURING BLOGS AND VIDEOS IN THE FIELD OF LOVE AND RELATIONSHIPS (U.S. CLS. 100, 101 AND 107).

ALLISON HOLTZ, EXAMINING ATTORNEY

THE MARK CONSISTS OF STANDARD CHARACTERS WITHOUT CLAIM TO ANY PARTICULAR FONT, STYLE, SIZE, OR COLOR.

FOR EDUCATION AND ENTERTAINMENT SERVICES, NAMELY, PROVIDING AND CONDUCTING CLASSES, SEMINARS, TELESEMINARS, TELECLASSES AND WORKSHOPS IN THE FIELDS OF LEARNING, MEMORY, COGNITION, NEUROSCIENCE, MIND, CONSCIOUSNESS, PSYCHOLOGY, HEALTH, WELLNESS, SELF-AWARENESS AND DISTRIBUTING EDUCATIONAL MATERIALS INCLUDING PRINTED PRESENTATIONS, DIGITAL PRESENTATIONS AND COMPUTER PROGRAMS IN CONNECTION THEREWITH (U.S. CLS. 100, 101 AND 107).

FIRST USE 2-20-2006; IN COMMERCE 2-20-2007.  
BARNEY CHARLON, EXAMINING ATTORNEY



**CLASS 41—(Continued).**

SN 86-180,333. HUIYING JIA, FOREST HILLS, NY. FILED 1-30-2014.

# AGS48

THE MARK CONSISTS OF STANDARD CHARACTERS WITHOUT CLAIM TO ANY PARTICULAR FONT, STYLE, SIZE, OR COLOR.

FOR ENTERTAINMENT SERVICES IN THE NATURE OF LIVE VISUAL AND AUDIO PERFORMANCES, NAMELY, MUSICAL BAND, ROCK GROUP, GYMNASIAC, DANCE, AND BALLET PERFORMANCES (U.S. CLS. 100, 101 AND 107).

DORITT L. CARROLL, EXAMINING ATTORNEY

SN 86-181,462. EDUCATIONAL ADVANTAGE, LLC, SAN DIMAS, CA. FILED 1-31-2014.



OWNER OF U.S. REG. NO. 3,375,014.  
NO CLAIM IS MADE TO THE EXCLUSIVE RIGHT TO USE "TUTORING", APART FROM THE MARK AS SHOWN.  
THE COLOR(S) BLUE IS/ARE CLAIMED AS A FEATURE OF THE MARK.

THE MARK CONSISTS OF THE WORDS "XAMAZE TUTORING" IN BLUE FOLLOWED BY A SILHOUETTE OF A STUDENT WEARING A GRADUATION CAP AND A CAPE IN BLUE. ANY WHITE SEEN IN THE MARK IS FOR BACKGROUND PURPOSES AND IS NOT PART OF THE MARK.

FOR EDUCATION SERVICES, NAMELY, PROVIDING TUTORING IN THE FIELD OF LANGUAGE ARTS, SCIENCE, MATH, FOREIGN LANGUAGES, AND TEST PREPARATION (U.S. CLS. 100, 101 AND 107).

FIRST USE 8-31-2011. THE MARK WAS FIRST USED ANYWHERE IN A DIFFERENT FORM OTHER THAN THAT SOUGHT TO BE REGISTERED AT LEAST AS EARLY AS 01/19/2007; IN COMMERCE 8-31-2011. THE MARK WAS FIRST USED IN COMMERCE IN A DIFFERENT FORM OTHER THAN THAT SOUGHT TO BE REGISTERED AT LEAST AS EARLY AS 01/19/2007 .

DEZMONA MIZELLE, EXAMINING ATTORNEY

**CLASS 41—(Continued).**

SN 86-182,496. TRIFECTA CONSULTING, LLC, FORT WALTON BEACH, FL. FILED 2-3-2014.

## CRABISLAND.COM

THE MARK CONSISTS OF STANDARD CHARACTERS WITHOUT CLAIM TO ANY PARTICULAR FONT, STYLE, SIZE, OR COLOR.

SEC. 2(F).

FOR PROVIDING A WEBSITE FEATURING INFORMATION ABOUT RECREATIONAL ACTIVITIES, NAMELY, OUTDOOR WATER ACTIVITIES AT CRAB ISLAND (U.S. CLS. 100, 101 AND 107).

FIRST USE 4-19-2002; IN COMMERCE 4-19-2002.

MELISSA VALLILLO, EXAMINING ATTORNEY

SN 86-183,576. TYNDA HOLDINGS LLC, DBA VICTORY CASINO CRUISES, CAPE CANAVERAL, FL. FILED 2-4-2014.

## VICTORY CASINO, IT'S THE RIGHT PLAY

THE MARK CONSISTS OF STANDARD CHARACTERS WITHOUT CLAIM TO ANY PARTICULAR FONT, STYLE, SIZE, OR COLOR.

NO CLAIM IS MADE TO THE EXCLUSIVE RIGHT TO USE "CASINO", APART FROM THE MARK AS SHOWN.

FOR GAMING SERVICES IN THE NATURE OF CASINO GAMING (U.S. CLS. 100, 101 AND 107).

NELSON SNYDER, EXAMINING ATTORNEY

SN 86-184,555. TORRES-RODRIGUEZ, JAVIER, DBA JAVIER TORRES, DOWNEY, CA. FILED 2-4-2014.

## JAVIER TORRES

THE MARK CONSISTS OF STANDARD CHARACTERS WITHOUT CLAIM TO ANY PARTICULAR FONT, STYLE, SIZE, OR COLOR.

OWNER OF U.S. REG. NOS. 3,570,972 AND 3,884,605.

THE NAME(S), PORTRAIT(S), AND/OR SIGNATURE(S) SHOWN IN THE MARK IDENTIFIES JAVIER TORRES-RODRIGUEZ, WHOSE CONSENT(S) TO REGISTER IS MADE OF RECORD.

FOR ENTERTAINMENT SERVICES IN THE NATURE OF LIVE MUSICAL PERFORMANCES; ENTERTAINMENT SERVICES IN THE NATURE OF LIVE VISUAL AND AUDIO PERFORMANCES BY A MUSICAL ARTIST OR BAND; ENTERTAINMENT, NAMELY, LIVE MUSIC CONCERTS (U.S. CLS. 100, 101 AND 107).

FIRST USE 7-7-1994; IN COMMERCE 7-7-1994.

SETH A. RAPPAPORT, EXAMINING ATTORNEY

**CLASS 41—(Continued).**

SN 86-186,215. POWDR ENTERPRISES LLC, PARK CITY, UT. FILED 2-6-2014.

**WORLD OF ADVENTURE**

THE MARK CONSISTS OF STANDARD CHARACTERS WITHOUT CLAIM TO ANY PARTICULAR FONT, STYLE, SIZE, OR COLOR.

OWNER OF U.S. REG. NO. 3,123,613.

NO CLAIM IS MADE TO THE EXCLUSIVE RIGHT TO USE "ADVENTURE", APART FROM THE MARK AS SHOWN.

FOR ENTERTAINMENT IN THE NATURE OF AUDIO-VISUAL MEDIA IN THE FIELD OF ADVENTURE AND ACTION SPORTS EVENTS AND ATHLETE PROFILES (U.S. CLS. 100, 101 AND 107).

JOHN DALIER, EXAMINING ATTORNEY

---

SN 86-186,993. CLIPPED IN LLC, PHOENIX, AZ. FILED 2-6-2014.

**Clipped In**

THE MARK CONSISTS OF STANDARD CHARACTERS WITHOUT CLAIM TO ANY PARTICULAR FONT, STYLE, SIZE, OR COLOR.

FOR PROVIDING A WEBSITE FEATURING SPORTING EVENT INFORMATION AND NEWS RELATING TO CYCLING AND TRIATHLON (U.S. CLS. 100, 101 AND 107).

JIM RINGLE, EXAMINING ATTORNEY

---

SN 86-187,199. CRISTINA TEIXEIRA, STATEN ISLAND, NY. AND MANI ALIKHANI, STATEN ISLAND, NY. FILED 2-7-2014.

**CTOR Consortium for  
Translational Orthodontic  
Research**

THE MARK CONSISTS OF STANDARD CHARACTERS WITHOUT CLAIM TO ANY PARTICULAR FONT, STYLE, SIZE, OR COLOR.

NO CLAIM IS MADE TO THE EXCLUSIVE RIGHT TO USE "CONSORTIUM FOR TRANSLATIONAL ORTHODONTIC RESEARCH", APART FROM THE MARK AS SHOWN.

FOR EDUCATIONAL SERVICES, NAMELY, PROVIDING SEMINARS, CONFERENCES AND CONTINUING EDUCATION COURSES, OPEN-ACCESS PUBLISHING SERVICES IN THE NATURE OF THE PUBLICATION OF ELECTRONIC ARTICLES AND RESEARCH PAPERS, AND PROVIDING ONLINE NEWSLETTERS, WITH ALL OF THE FOREGOING IN THE FIELD OF ORTHODONTICS (U.S. CLS. 100, 101 AND 107).

FIRST USE 9-1-2009; IN COMMERCE 9-1-2009.

ELIZABETH HUGHITT, EXAMINING ATTORNEY

**CLASS 41—(Continued).**

SN 86-187,588. SCG POWER RANGERS LLC, LOS ANGELES, CA. FILED 2-7-2014.

**POWER RANGERS DINO CHARGE**

THE MARK CONSISTS OF STANDARD CHARACTERS WITHOUT CLAIM TO ANY PARTICULAR FONT, STYLE, SIZE, OR COLOR.

OWNER OF U.S. REG. NOS. 1,891,642, 4,526,157 AND OTHERS.

NO CLAIM IS MADE TO THE EXCLUSIVE RIGHT TO USE "DINO", APART FROM THE MARK AS SHOWN.

FOR ENTERTAINMENT SERVICES IN THE NATURE OF A LIVE-ACTION TELEVISION SERIES; ENTERTAINMENT SERVICES, NAMELY, PRODUCTION OF LIVE THEATRICAL EVENTS FOR CHILDREN; ENTERTAINMENT SERVICES, NAMELY, PROVIDING ON-LINE COMPUTER GAMES OFFERED OVER A WORLDWIDE COMMUNICATION NETWORK AND A WEBSITE FEATURING INFORMATION RELATING TO TELEVISION SHOW PROGRAMS AND FAMILY ENTERTAINMENT VIA A GLOBAL COMMUNICATIONS NETWORK; ENTERTAINMENT SERVICES OFFERED ON-LINE OVER A WORLDWIDE COMMUNICATION NETWORK, NAMELY, PROVIDING INTERACTIVE CHILDREN'S STORIES; PROVIDING A WEB SITE FEATURING VIDEO CLIPS, AND OTHER MULTIMEDIA MATERIALS, ALL RELATING TO TELEVISION SHOW PROGRAMS AND FAMILY ENTERTAINMENT VIA A GLOBAL COMMUNICATIONS NETWORK; AND ENTERTAINMENT INFORMATION IN THE NATURE OF INFORMATION ABOUT LIVE ACTION ENTERTAINMENT FOR CHILDREN (U.S. CLS. 100, 101 AND 107).

KHANH LE, EXAMINING ATTORNEY

---

SN 86-188,979. THE KORU CENTER FOR MINDFULNESS, LLC, DURHAM, NC. FILED 2-10-2014.

**KORU MINDFULNESS**

THE MARK CONSISTS OF STANDARD CHARACTERS WITHOUT CLAIM TO ANY PARTICULAR FONT, STYLE, SIZE, OR COLOR.

NO CLAIM IS MADE TO THE EXCLUSIVE RIGHT TO USE "MINDFULNESS", APART FROM THE MARK AS SHOWN.

THE ENGLISH TRANSLATION OF THE WORD "KORU" IN THE MARK IS "LOOP".

FOR EDUCATIONAL SERVICES, NAMELY, CONDUCTING CLASSES, SEMINARS, CONFERENCES, WORKSHOPS, TELESEMINARS, TELECONFERENCES, AND ONLINE WORKSHOPS ALL IN THE FIELD OF MINDFULNESS AND DISTRIBUTION OF COURSE MATERIAL IN CONNECTION THEREWITH (U.S. CLS. 100, 101 AND 107).

FIRST USE 9-30-2011; IN COMMERCE 9-30-2011.

MARGERY A. TIERNEY, EXAMINING ATTORNEY

**CLASS 41—(Continued).**

SN 86-189,583. HONDA MOTOR CO., LTD., MINATO-KU, TOKYO, JAPAN, FILED 2-10-2014.

**HONDA HERITAGE CENTER**

THE MARK CONSISTS OF STANDARD CHARACTERS WITHOUT CLAIM TO ANY PARTICULAR FONT, STYLE, SIZE, OR COLOR.

OWNER OF U.S. REG. NOS. 2,954,443, 4,317,732 AND OTHERS.

NO CLAIM IS MADE TO THE EXCLUSIVE RIGHT TO USE "HERITAGE CENTER", APART FROM THE MARK AS SHOWN.

FOR MUSEUM SERVICES FEATURING AUTOMOBILES AND AUTOMOTIVE HISTORY; EDUCATIONAL SERVICES, NAMELY, CONDUCTING EXHIBITIONS, PROGRAMS, SEMINARS, DEMONSTRATIONS, COURSES, AND WORKSHOPS IN THE FIELD OF AUTOMOBILES, AUTOMOTIVE HISTORY, TECHNOLOGY, AND MANUFACTURING; PROVIDING INFORMATION IN THE FIELD OF MUSEUMS VIA ELECTRONIC GLOBAL COMMUNICATION NETWORKS (U.S. CLS. 100, 101 AND 107).

ALLISON HOLTZ, EXAMINING ATTORNEY

**CLASS 41—(Continued).**

SN 86-190,416. BERNAL, MARTHA, MEMPHIS, TN. FILED 2-11-2014.

**WET NOSE UNIVERSITY**

THE MARK CONSISTS OF STANDARD CHARACTERS WITHOUT CLAIM TO ANY PARTICULAR FONT, STYLE, SIZE, OR COLOR.

NO CLAIM IS MADE TO THE EXCLUSIVE RIGHT TO USE "UNIVERSITY", APART FROM THE MARK AS SHOWN.

FOR ANIMAL TRAINING; TRAINING SERVICE DOGS FOR INDIVIDUALS SUFFERING FROM POST TRAUMATIC STRESS DISORDER; DOG TRAINING (U.S. CLS. 100, 101 AND 107).

FIRST USE 7-1-2013; IN COMMERCE 1-1-2014.

TINA L. SNAPP, EXAMINING ATTORNEY

SN 86-189,737. EAGLE SYSTEMS INTERNATIONAL, INC., OREM, UT. FILED 2-10-2014.

**WHAT MATTERS MOST**

THE MARK CONSISTS OF STANDARD CHARACTERS WITHOUT CLAIM TO ANY PARTICULAR FONT, STYLE, SIZE, OR COLOR.

FOR EDUCATIONAL SERVICES, NAMELY, CONDUCTING CLASSES, SEMINARS OR WORKSHOPS IN THE FIELD OF LEADERSHIP, MANAGEMENT, AND PERSONAL DEVELOPMENT AND DISTRIBUTION OF EDUCATIONAL MATERIALS IN CONNECTION THEREWITH (U.S. CLS. 100, 101 AND 107).

FIRST USE 1-31-2010; IN COMMERCE 1-31-2010.

JORDAN BAKER, EXAMINING ATTORNEY

SN 86-190,468. BERNAL, MARTHA, MEMPHIS, TN. FILED 2-11-2014.



SN 86-189,773. ROSENBLATT, WILLIAM, MERRICK, NY. FILED 2-10-2014.

**NEVELE**

THE MARK CONSISTS OF STANDARD CHARACTERS WITHOUT CLAIM TO ANY PARTICULAR FONT, STYLE, SIZE, OR COLOR.

FOR ARRANGING AND CONDUCTING NIGHTCLUB ENTERTAINMENT EVENTS; ENTERTAINMENT SERVICES, NAMELY, CASINO GAMING; NIGHT CLUBS (U.S. CLS. 100, 101 AND 107).

ROBERT C. CLARK JR., EXAMINING ATTORNEY

NO CLAIM IS MADE TO THE EXCLUSIVE RIGHT TO USE "UNIVERSITY", APART FROM THE MARK AS SHOWN.

THE COLOR(S) RED, BLACK, WHITE, BLUE, AND GREY IS/ARE CLAIMED AS A FEATURE OF THE MARK.

THE MARK CONSISTS OF THE WORDS "WET NOSE" DEPICTED IN RED, AND OUTLINED IN WHITE AND BLACK, ON A BLACK BACKGROUND, UNDER WHICH IS THE WORD "UNIVERSITY" DEPICTED IN WHITE AND OUTLINED IN BLACK ON A RED COLORED BANNER. BELOW THIS WORDING IS THE DISPLAY OF A STYLIZED DOG'S HEAD DEPICTED IN WHITE, BLACK, RED, AND BLUE. ALL OF THE PRIOR ELEMENTS LISTED ARE DISPLAYED IN FRONT OF AN ILLUSTRATED SHIELD IN THE COLOR RED AND OUTLINED IN WHITE AND BLACK.

FOR ANIMAL TRAINING; TRAINING SERVICE DOGS FOR INDIVIDUALS SUFFERING FROM POST TRAUMATIC STRESS DISORDER; DOG TRAINING (U.S. CLS. 100, 101 AND 107).

FIRST USE 7-1-2013; IN COMMERCE 1-1-2014.

TINA L. SNAPP, EXAMINING ATTORNEY

**CLASS 41—(Continued).**

SN 86-190,496. TRIBURY KARATE & FITNESS LLC, SOUTH-BURY, CT. FILED 2-11-2014.



NO CLAIM IS MADE TO THE EXCLUSIVE RIGHT TO USE "KID FITNESS", APART FROM THE MARK AS SHOWN.

THE COLOR(S) RED, YELLOW, BLUE, GREEN, ORANGE, PURPLE, GRAY, PINK, BLACK, WHITE AND BEIGE IS/ARE CLAIMED AS A FEATURE OF THE MARK.

THE MARK CONSISTS OF A STYLIZED, THREE-DIMENSIONAL VERSION OF THE WORDS "KID FITNESS" IN TWO ROWS. IN THE FIRST/TOP ROW, THE FIRST LETTER "K" IS RED; THE SECOND LETTER "I" IS YELLOW; AND THE THIRD LETTER "D" IS BLUE. IN THE SECOND/BOTTOM ROW, THE FIRST LETTER "F" IS BLUE; THE SECOND LETTER "I" IS GREEN; THE THIRD LETTER "T" IS YELLOW; THE FOURTH LETTER "N" IS ORANGE; THE FIFTH LETTER "E" IS RED; THE SIXTH LETTER "S" IS PURPLE; AND THE SEVENTH LETTER "S" IS BLUE. THE THREE-DIMENSIONAL SHADOW OF EACH LETTER IS GRAY. ON THE LEFT SIDE OF THE WORDS "KID FITNESS" IS A BOY WITH ORANGE HAIR DOING A ONE-HANDED HAND STAND, WEARING A RED SHIRT AND BLUE PANTS, THE BOY ALSO HAS WHITE TEETH, GRAY SHOES, WITH A BEIGE SKIN COLOR. THE BOY IS OUTLINED IN BLACK. TO THE RIGHT OF THE LETTER "D" IN "KID", AND ON TOP OF THE SECOND "S" IN "FITNESS", IS A GIRL WITH PURPLE PANTS, A PINK SHIRT, AND YELLOW HAIR, KNEELING A SOCCER BALL THAT IS BLACK AND WHITE. THE GIRL ALSO HAS WHITE EYES AND WHITE TEETH, GRAY SHOES, WITH A BEIGE SKIN COLOR. THE GIRL IS OUTLINED IN BLACK. LAST, AN ORANGE JUMP ROPE WITH BLACK HANDLES LIES IN THE FOREFRONT OF THE IMAGE BELOW THE WORD "FITNESS".

FOR PHYSICAL FITNESS INSTRUCTION; PHYSICAL FITNESS TRAINING SERVICES; PROVIDING A WEBSITE FEATURING INFORMATION ON EXERCISE AND FITNESS; PROVIDING ADVICE AND INFORMATION IN THE FIELD OF EDUCATIONAL AND ENTERTAINMENT ACTIVITIES AND EVENTS FOR CHILDREN (U.S. CLS. 100, 101 AND 107).

FIRST USE 2-1-2014; IN COMMERCE 2-1-2014.  
BRITTANY ESTELL, EXAMINING ATTORNEY

**CLASS 41—(Continued).**

SN 86-190,885. BIG APPLE TUTORING LLC, NEW YORK, NY. FILED 2-11-2014.



NO CLAIM IS MADE TO THE EXCLUSIVE RIGHT TO USE "TUTORING LLC", APART FROM THE MARK AS SHOWN.

THE MARK CONSISTS OF THE DESIGN OF AN APPLE DEPICTED OVER A STYLIZED DESIGN OF AN OPEN BOOK WITH THE WORDING "BIG APPLE TUTORING LLC" APPEARING TO THE RIGHT OF THE APPLE AND OPEN BOOK DESIGNS.

SEC. 2(F) AS TO "BIG APPLE TUTORING LLC".  
FOR CONDUCTING AFTER SCHOOL MATH, ENGLISH, SCIENCE, FOREIGN LANGUAGES AND STANDARDIZED TEST PREPARATION IN GRADES K-12 AND COLLEGE LEVEL TUTORING PROGRAMS; EDUCATION SERVICES, NAMELY, PROVIDING TUTORING IN THE FIELDS OF MATH, ENGLISH, SCIENCE, FOREIGN LANGUAGES, HISTORY, SOCIAL SCIENCES AND STANDARDIZED TEST PREPARATION FOR GRADES K-12 AND COLLEGE LEVEL (U.S. CLS. 100, 101 AND 107).

FIRST USE 11-0-2001; IN COMMERCE 11-0-2001.  
SUSAN RICHARDS, EXAMINING ATTORNEY

SN 86-190,899. TEXAS LANTANA, LLC, ADDISON, TX. FILED 2-11-2014.



THE MARK CONSISTS OF A STYLIZED "9" WITHIN WHICH ARE TWO INTERSECTING LINES, AND, EXTENDING TO THE LEFT AND THE RIGHT OF THE STYLIZED "9" ARE HORIZONTAL LINES WITHIN WHICH ARE THREE VERTICAL LINES. ALL AFOREMENTIONED LINES REPRESENT A TARGET ALIGNMENT GUIDE.

FOR PERSONAL TRAINING SERVICES, NAMELY, STRENGTH AND CONDITIONING TRAINING; MILITARY TRAINING SERVICES; PROVIDING A TRAINING FACILITY IN THE FIELD OF MILITARY TRAINING; PROVIDING AND ARRANGING FOR TRAINING COURSES IN THE FIELD OF MILITARY TRAINING (U.S. CLS. 100, 101 AND 107).

FIRST USE 4-1-2013; IN COMMERCE 4-1-2013.  
COLLEEN MULCRONE, EXAMINING ATTORNEY

**CLASS 41—(Continued).**

SN 86-190,918. TEXAS LANTANA, LLC, ADDISON, TX.  
FILED 2-11-2014.

**JUST ADD WARRIOR**

THE MARK CONSISTS OF STANDARD CHARACTERS WITHOUT CLAIM TO ANY PARTICULAR FONT, STYLE, SIZE, OR COLOR.

FOR PERSONAL TRAINING SERVICES, NAMELY, STRENGTH AND CONDITIONING TRAINING; MILITARY TRAINING SERVICES; PROVIDING A TRAINING FACILITY IN THE FIELD OF MILITARY TRAINING; PROVIDING AND ARRANGING FOR TRAINING COURSES IN THE FIELD OF MILITARY TRAINING (U.S. CLS. 100, 101 AND 107).

COLLEEN MULCRONE, EXAMINING ATTORNEY

**CLASS 41—(Continued).**

SN 86-192,990. ADVANCE MAGAZINE PUBLISHERS, INC.,  
NEW YORK, NY. FILED 2-13-2014.

**TEENVOGUE BACK-TO-SCHOOL  
SATURDAY**

THE MARK CONSISTS OF STANDARD CHARACTERS WITHOUT CLAIM TO ANY PARTICULAR FONT, STYLE, SIZE, OR COLOR.

OWNER OF U.S. REG. NOS. 2,568,246, 3,436,616 AND OTHERS.

NO CLAIM IS MADE TO THE EXCLUSIVE RIGHT TO USE "BACK-TO-SCHOOL" OR "SATURDAY", APART FROM THE MARK AS SHOWN.

FOR COORDINATING EVENTS IN THE NATURE OF BACK TO SCHOOL EVENTS IN SHOPPING CENTERS AND RETAIL STORES FEATURING PRIZES, GAMES, MUSIC, AND FASHION SHOWS; ORGANIZATION OF FASHION SHOWS FOR ENTERTAINMENT PURPOSES; ENTERTAINMENT IN THE NATURE OF FASHION SHOWS (U.S. CLS. 100, 101 AND 107).

FIRST USE 8-11-2012; IN COMMERCE 8-11-2012.

MICHAEL WIENER, EXAMINING ATTORNEY

SN 86-193,555. BROADWAY INMOTION, INC., NEW YORK,  
NY. FILED 2-13-2014.



NO CLAIM IS MADE TO THE EXCLUSIVE RIGHT TO USE "BROADWAY", APART FROM THE MARK AS SHOWN.

THE COLOR(S) GOLD, BLACK, BLUE, WHITE, PURPLE, PINK, RED, BROWN AND BEIGE IS/ARE CLAIMED AS A FEATURE OF THE MARK.

THE MARK CONSISTS OF THE WORDS "BROADWAY INMOTION" IN GOLD ON A BLACK BACKGROUND; ABOVE AND BELOW THE WORDING IS A BLUE LINE; BETWEEN AND BEHIND THE WORDING IS PHOTOS OF MEN AND WOMEN ENTERTAINING WITH WHITE LIGHTS WITH BLUE EDGING BEING SHOWN ONTO THEM; FROM LEFT TO RIGHT IS A BEIGE WOMAN WITH BROWN HAIR SINGING INTO A WHITE MICROPHONE; A BEIGE WOMAN IN RED LEOTARD HOLDING A WHITE HAT; A BEIGE MAN ON HIS KNEES IN BLUE PANTS AND PINK SHIRT WITH BLUE AND PURPLE BACKGROUND; A BROWN WOMAN IN A WHITE DRESS WITH BLUE BACKGROUND.

FOR ENTERTAINMENT AND EDUCATIONAL SERVICES, NAMELY, THE PRESENTATION OF WORKSHOPS IN THE FIELD OF THEATRE; ENTERTAINMENT SERVICES, NAMELY, PRODUCTION OF LIVE VISUAL AND AUDIO PERFORMANCES BY ACTORS, DANCERS AND MUSICAL BANDS; AND ENTERTAINMENT SERVICES, NAMELY, PRODUCTION OF LIVE MUSICAL PERFORMANCES AND SHOWS (U.S. CLS. 100, 101 AND 107).

FIRST USE 10-1-2013; IN COMMERCE 10-1-2013.

LINDA MICKLEBURGH, EXAMINING ATTORNEY

SN 86-192,799. FIGHT FOR LIFE FOUNDATION, INC.,  
INDIANAPOLIS, IN. FILED 2-13-2014.



THE MARK CONSISTS OF THE TEXT "BUILDING DREAMS" IN AN ARC ABOVE AN OUTLINED CIRCLE WHICH IS COMPRISED OF THE OUTLINE OF THREE CHILDREN PLAYING IN A FIELD OF GRASS WITH SUN RAYS EMITTING FROM THE FIELD PLACED ON A STARRY SKY. THE MIDDLE CHILD HOLDS A GLOBE OF THE WORLD OVER HIS HEAD.

FOR PROVIDING AFTER SCHOOL EDUCATIONAL PROGRAMS FOR CHILDREN IN GRADES K - 12 (U.S. CLS. 100, 101 AND 107).

FIRST USE 4-25-2013; IN COMMERCE 4-25-2013.

RONALD AIKENS, EXAMINING ATTORNEY

**CLASS 41—(Continued).**

SN 86-195,417. BRADLEY PRESENTS, INC., NORTHAMPTON, MA. FILED 2-17-2014.

**Mediterranean Living**

THE MARK CONSISTS OF STANDARD CHARACTERS WITHOUT CLAIM TO ANY PARTICULAR FONT, STYLE, SIZE, OR COLOR.

NO CLAIM IS MADE TO THE EXCLUSIVE RIGHT TO USE "MEDITERRANEAN", APART FROM THE MARK AS SHOWN.

FOR BOOK PUBLISHING; COOKING INSTRUCTION; PROVIDING A WEBSITE FEATURING NON-DOWNLOADABLE VIDEOS IN THE FIELD OF COOKING; PROVIDING ON-LINE VIDEOS FEATURING COOKING INSTRUCTION, NOT DOWNLOADABLE (U.S. CLS. 100, 101 AND 107).

FIRST USE 4-29-2013; IN COMMERCE 4-29-2013.  
PAM WILLIS, EXAMINING ATTORNEY

---

SN 86-198,620. SHANGHAI ICE INFORMATION TECHNOLOGY CO., LTD., SHANGHAI, CHINA, FILED 2-20-2014.

**STEEL OCEAN**

THE MARK CONSISTS OF STANDARD CHARACTERS WITHOUT CLAIM TO ANY PARTICULAR FONT, STYLE, SIZE, OR COLOR.

FOR PROVIDING ONLINE COMPUTER GAMES (U.S. CLS. 100, 101 AND 107).

DAVID ELTON, EXAMINING ATTORNEY

---

SN 86-200,588. SHOP Y2K, INC., NEW YORK, NY. FILED 2-21-2014.

**Frienemies**

THE MARK CONSISTS OF STANDARD CHARACTERS WITHOUT CLAIM TO ANY PARTICULAR FONT, STYLE, SIZE, OR COLOR.

FOR ARRANGING, ORGANIZING, CONDUCTING, AND HOSTING OF A SOCIAL ENTERTAINMENT EVENT (U.S. CLS. 100, 101 AND 107).

ALAIN LAPTER, EXAMINING ATTORNEY

**CLASS 41—(Continued).**

SN 86-200,862. WESTERN NEWS & INFO, INC., YUMA, AZ. FILED 2-21-2014.

**WESTERN NEWS&INFO, INC.**

THE MARK CONSISTS OF STANDARD CHARACTERS WITHOUT CLAIM TO ANY PARTICULAR FONT, STYLE, SIZE, OR COLOR.

OWNER OF U.S. REG. NO. 3,574,265.

NO CLAIM IS MADE TO THE EXCLUSIVE RIGHT TO USE "NEWS & INFO, INC.", APART FROM THE MARK AS SHOWN.

SEC. 2(F).

FOR PUBLICATION OF ELECTRONIC NEWSPAPERS ACCESSIBLE VIA A GLOBAL COMPUTER NETWORK, PORTABLE AND WIRELESS COMMUNICATIONS DEVICES, AND VARIOUS PLATFORMS ACROSS MULTIPLE FORMS OF MEDIA; PUBLICATION OF NEWSPAPERS AND OTHER PRINTED MATERIALS (U.S. CLS. 100, 101 AND 107).

FIRST USE 3-18-2008; IN COMMERCE 3-18-2008.  
ALICIA COLLINS, EXAMINING ATTORNEY

---

SN 86-200,984. SAN FRANCISCO MUSEUM OF MODERN ART, SAN FRANCISCO, CA. FILED 2-21-2014.

**FOG DESIGN + ART**

THE MARK CONSISTS OF STANDARD CHARACTERS WITHOUT CLAIM TO ANY PARTICULAR FONT, STYLE, SIZE, OR COLOR.

NO CLAIM IS MADE TO THE EXCLUSIVE RIGHT TO USE "DESIGN + ART", APART FROM THE MARK AS SHOWN.

FOR ART EXHIBITIONS; ORGANIZING COMMUNITY FESTIVALS PRIMARILY FEATURING ART EXHIBITIONS, EDUCATIONAL LECTURES AND WORKSHOPS IN THE FIELD OF ART AND LIVE PERFORMANCES BY MUSICAL, VISUAL AND PERFORMANCE ARTISTS, ALSO FEATURING FOOD AND BEVERAGE TASTING (U.S. CLS. 100, 101 AND 107).

FIRST USE 1-17-2014; IN COMMERCE 1-17-2014.  
RAMONA ORTIGA, EXAMINING ATTORNEY



**CLASS 41—(Continued).**

SN 86-203,017. PURR DESIGN, LLC, NASHVILLE, TN. FILED 2-25-2014.

## Love & Olive Oil

THE MARK CONSISTS OF STANDARD CHARACTERS WITHOUT CLAIM TO ANY PARTICULAR FONT, STYLE, SIZE, OR COLOR.

NO CLAIM IS MADE TO THE EXCLUSIVE RIGHT TO USE "OLIVE OIL", APART FROM THE MARK AS SHOWN.

FOR ON-LINE JOURNALS, NAMELY, BLOGS FEATURING RECIPES, COOKING TIPS, PHOTOGRAPHY, AND RELATED COOKING INFORMATION (U.S. CLS. 100, 101 AND 107).

FIRST USE 2-16-2007; IN COMMERCE 2-16-2007.  
LOURDES AYALA, EXAMINING ATTORNEY

**CLASS 41—(Continued).**

SN 86-204,505. SIMPLY WED LLC, EDMONDS, WA. FILED 2-26-2014.

## Simply Wed

THE MARK CONSISTS OF STANDARD CHARACTERS WITHOUT CLAIM TO ANY PARTICULAR FONT, STYLE, SIZE, OR COLOR.

NO CLAIM IS MADE TO THE EXCLUSIVE RIGHT TO USE "WED", APART FROM THE MARK AS SHOWN.

FOR WEDDING RECEPTION COORDINATION AND WEDDING RECEPTION COORDINATION CONSULTATION SERVICES, NAMELY, WEDDING RECEPTION PLANNING, COORDINATION OF WEDDING RECEPTION DESIGN, AND COORDINATION OF WEDDING RECEPTION FLORAL DESIGN; SPECIAL EVENT CONSULTATION FOR SOCIAL ENTERTAINMENT PURPOSES; PARTY AND WEDDING RECEPTION PLANNING CONSULTATION SERVICES (U.S. CLS. 100, 101 AND 107).

FIRST USE 8-0-2002; IN COMMERCE 8-0-2002.  
KIMBERLY PARKS, EXAMINING ATTORNEY

SN 86-204,257. SARA NYANTI, MONROVIA, LIBERIA, FILED 2-26-2014.



THE COLOR(S) BLACK, BROWN, GOLDEN YELLOW, GOLDEN BROWN, PURPLE IS/ARE CLAIMED AS A FEATURE OF THE MARK.

THE MARK CONSISTS OF THE CHARACTER "E" AND THE WORDING "TEACHIT" CONNECTED BY A HYPHEN, IN A STYLIZED FONT OF GOLDEN YELLOW, GOLDEN BROWN AND BROWN IN A MIXTURE OF COLORS, WHEREIN THE LETTER "T" RESEMBLES A HOLY CROSS, WITH A PURPLE DRAPE OVER THE CROSS BAR. THE LETTERING IS SHADED IN BLACK. THE BLACK BACKGROUND ON THE DRAWING PAGE REPRESENTS A TRANSPARENT AREA AND IS NOT A PART OF THE MARK.

FOR PROVIDING ON-LINE RELIGIOUS INSTRUCTION PROMOTING CHRISTIAN AND FAMILY VALUES; RELIGIOUS INSTRUCTION SERVICES (U.S. CLS. 100, 101 AND 107).

FIRST USE 4-13-2013; IN COMMERCE 4-13-2013.  
GINA FINK, EXAMINING ATTORNEY

SN 86-204,858. B. CHRISTINE PARK, MIRAMAR, FL. FILED 2-26-2014.



OWNER OF U.S. REG. NO. 4,555,111.

THE COLOR(S) GREEN, BROWN, BLUE, DARK BLUE AND BLACK IS/ARE CLAIMED AS A FEATURE OF THE MARK.

THE MARK CONSISTS OF FOUR CONNECTED PUZZLE PIECES IN A DIAMOND SHAPE PRESENTED IN THE COLORS GREEN, BROWN, BLUE AND DARK BLUE TO THE LEFT OF THE LITERAL ELEMENT "STRATEGIC LIFE ARCHITECH" WHICH APPEARS IN BLACK.

FOR LIFE COACHING SERVICES IN THE FIELD OF PERSONAL DEVELOPMENT AND IMPROVEMENT AND HEALTH AND WELLNESS (U.S. CLS. 100, 101 AND 107).

FIRST USE 1-1-2013; IN COMMERCE 1-1-2013.  
JOHN GARTNER, EXAMINING ATTORNEY

**CLASS 41—(Continued).**

SN 86-205,399. TITAN HOCKEY VENTURES, LLC, LOS ANGELES, CA. FILED 2-26-2014.



NO CLAIM IS MADE TO THE EXCLUSIVE RIGHT TO USE "CALIFORNIA" AND "HOCKEY", APART FROM THE MARK AS SHOWN.

THE MARK CONSISTS OF A SEAL DESIGN WITH THE WORDS "CALIFORNIA" AND "TITANS" APPEARING AT THE TOP OF THE CIRCLE AND THE WORD "HOCKEY" AT THE BOTTOM; THE CENTER OF THE SEAL HOLDS A SWORD SHAPE WITH THE LETTER "C" AND "T" LAID OVER EACH OTHER.

FOR ORGANIZATION OF SPORTS EVENTS, NAMELY, ICE HOCKEY PROGRAMS, ICE HOCKEY INSTRUCTION, COACHING AND TOURNAMENTS FOR YOUTHS; ORGANIZATION OF YOUTH ICE HOCKEY PROGRAM AND TEAMS; PROVIDING A WEBSITE FEATURING INFORMATION RELATING TO THE SPORT OF COMPETITIVE ICE HOCKEY (U.S. CLS. 100, 101 AND 107).

FIRST USE 0-0-2011; IN COMMERCE 0-0-2011.  
JOHN DWYER, EXAMINING ATTORNEY

**CLASS 41—(Continued).**

SN 86-205,863. INMAN, LARRY C., WILLIAMSBURG, MI. FILED 2-27-2014.



NO CLAIM IS MADE TO THE EXCLUSIVE RIGHT TO USE "THE EXHIBIT", APART FROM THE MARK AS SHOWN.

THE COLOR(S) DARK GREY, LIGHT GREY, RED, BLUE AND WHITE IS/ARE CLAIMED AS A FEATURE OF THE MARK.

THE MARK CONSISTS OF THE UPPER CASE LETTERS "REMEMBER AMELIA" IN DARK GREY ON TOP OF AND ARCING AROUND A GLOBE OF THE WORLD DISPLAYING THE NORTH AND SOUTH AMERICAN CONTINENTS IN DARK GREY ON A LIGHT GREY BACKGROUND DEPICTING OCEANS. A RED PROP PLANE, WITH ITS WING TIPS TOUCHING BOTH CONTINENTS, FLIES ABOVE THE GLOBE FROM SOUTHEAST TO NORTHWEST WITH A BLUE STREAM EMANATING FROM THE TAIL AND STRETCHING AROUND THE GLOBE TO THE SOUTHEAST. THE UPPER CASE WORDS "THE EXHIBIT" ARE DISPLAYED BELOW AND ARC AROUND THE GLOBE IN DARK GREY. THE ENTIRE IMAGE IS ON A WHITE BACKGROUND.

FOR CONDUCTING EDUCATIONAL EXHIBITIONS IN THE NATURE OF THE LIFE, TIMES, MOTIVATIONS, DISAPPEARANCE AND SEARCH FOR AMELIA EARHART; EDUCATIONAL SERVICES, NAMELY, PROVIDING DISPLAYS AND EXHIBITS IN THE FIELD OF THE LIFE, TIMES, MOTIVATIONS, DISAPPEARANCE AND SEARCH FOR AMELIA EARHART (U.S. CLS. 100, 101 AND 107).

FIRST USE 1-8-2014; IN COMMERCE 1-8-2014.  
INGRID C. EULIN, EXAMINING ATTORNEY

SN 86-205,755. MARCUS PROMOTIONS, INC., NEW BERLIN, WI. FILED 2-27-2014.

**FOOTLIGHTS.COM**

THE MARK CONSISTS OF STANDARD CHARACTERS WITHOUT CLAIM TO ANY PARTICULAR FONT, STYLE, SIZE, OR COLOR.

FOR PROVIDING ONLINE INFORMATION FEATURING THEATER, SPECIAL EVENTS FOR SOCIAL ENTERTAINMENT PURPOSES, AND THE PERFORMING ARTS (U.S. CLS. 100, 101 AND 107).

FIRST USE 8-15-2012; IN COMMERCE 8-15-2012.  
BRENDAN REGAN, EXAMINING ATTORNEY



**CLASS 41—(Continued).**

SN 86-206,259. SUPERHANDLES, INC., DAYTON, OR. FILED 2-27-2014.



OWNER OF U.S. REG. NO. 3,054,266.  
THE MARK CONSISTS OF THE WORD "SUPERHANDLES" BELOW A SILHOUETTE OF A BASKETBALL PLAYER IN MOTION HOLDING A BASKETBALL IN EACH HAND.

SEC. 2(F) AS TO "SUPERHANDLES".  
FOR INSTRUCTION IN THE FIELD OF BASKETBALL (U.S. CLS. 100, 101 AND 107).

FIRST USE 12-1-2011, THE MARK WAS FIRST USED ANYWHERE IN A DIFFERENT FORM OTHER THAN THAT SOUGHT TO BE REGISTERED AT LEAST AS EARLY AS 09/14/2004.; IN COMMERCE 4-1-2013, THE MARK WAS FIRST USED IN COMMERCE IN A DIFFERENT FORM OTHER THAN THAT SOUGHT TO BE REGISTERED AT LEAST AS EARLY AS 09/14/2004..

KRISTIN CARLSON, EXAMINING ATTORNEY

SN 86-206,305. MARINI-QUESADA, VICTOR, MAYAGUEZ, PUERTO RICO, FILED 2-27-2014.



THE COLOR(S) BLACK AND YELLOW IS/ARE CLAIMED AS A FEATURE OF THE MARK.

THE MARK CONSISTS OF AN IMAGE OF A ROOSTER SILHOUETTE IN BLACK COLOR, AT THE CENTER OF WHICH ARE THE WORDS "MISA" IN STYLIZED LETTERS AND IN YELLOW COLOR, BENEATH SAID WORD IS THE LETTER "E" IN STYLIZED FONT AND IN YELLOW COLOR, BENEATH SAID LETTER IS THE WORD "GALLO" IN STYLIZED LETTERS AND IN YELLOW COLOR.

THE ENGLISH TRANSLATION OF "MISA E GALLO" IN THE MARK IS "ROOSTER MASS".

FOR ENTERTAINMENT, NAMELY, LIVE PERFORMANCES BY A MUSICAL BAND (U.S. CLS. 100, 101 AND 107).

FIRST USE 11-26-2013; IN COMMERCE 11-26-2013.  
GISELLE AGOSTO, EXAMINING ATTORNEY

**CLASS 41—(Continued).**

SN 86-208,597. TENNESSEE KINGS, LLC, NASHVILLE, TN. FILED 3-2-2014.

**TENNESSEE KINGS**

THE MARK CONSISTS OF STANDARD CHARACTERS WITHOUT CLAIM TO ANY PARTICULAR FONT, STYLE, SIZE, OR COLOR.

NO CLAIM IS MADE TO THE EXCLUSIVE RIGHT TO USE "TENNESSEE", APART FROM THE MARK AS SHOWN.

FOR ENTERTAINMENT SERVICES IN THE NATURE OF RECORDING, PRODUCTION AND POST-PRODUCTION SERVICES IN THE FIELD OF MUSIC; MUSIC PUBLISHING SERVICES (U.S. CLS. 100, 101 AND 107).

JUSTIN SEVERSON, EXAMINING ATTORNEY

SN 86-208,750. THE WALLEYE GUYS, LINCOLN, NE. FILED 3-2-2014.



NO CLAIM IS MADE TO THE EXCLUSIVE RIGHT TO USE "WALLEYE", APART FROM THE MARK AS SHOWN.

THE MARK CONSISTS OF THE STYLIZED LITERAL ELEMENT "THE WALLEYE GUYS" ARCHED OVER THE PICTURE OF FISH BONES, AND ABOVE THE WORDING "WWW.THEWALLEYEGUYS.COM"; THE COLOR BLACK REPRESENTS BACKGROUND AND IS NOT CLAIMED AS A FEATURE OF THE MARK.

FOR FISHING GUIDE SERVICES; PROVIDING A WEBSITE FEATURING INFORMATION ABOUT HUNTING AND FISHING; PROVIDING INFORMATION IN THE FIELD OF HUNTING AND FISHING VIA THE INTERNET; PROVIDING INFORMATION ON FISHING TOURNAMENTS; PROVIDING INFORMATION ON RECREATIONAL FISHING; PROVIDING INFORMATION ON RECREATIONAL FISHING HOTSPOTS; PROVIDING INFORMATION ON RECREATIONAL FISHING, NAMELY, WHERE TO FIND CERTAIN KINDS OF FISH FOR FISHING PURPOSES (U.S. CLS. 100, 101 AND 107).

FIRST USE 12-15-2011; IN COMMERCE 2-1-2014.  
NICHOLAS COLEMAN, EXAMINING ATTORNEY

**CLASS 41—(Continued).**

SN 86-211,579. BRAWL CALL LLC, TAMPA, FL. FILED 3-5-2014.

## United Fight Alliance

THE MARK CONSISTS OF STANDARD CHARACTERS WITHOUT CLAIM TO ANY PARTICULAR FONT, STYLE, SIZE, OR COLOR.

NO CLAIM IS MADE TO THE EXCLUSIVE RIGHT TO USE "FIGHT ALLIANCE", APART FROM THE MARK AS SHOWN.

FOR ENTERTAINMENT SERVICES, NAMELY, PRODUCTION AND DISTRIBUTION OF TELEVISION PROGRAMMING IN THE FIELD OF FIGHTING, CONTACT SPORTS, MARTIAL ARTS AND FIGHTING SPORTS FOR OTHERS; DISTRIBUTION OF TELEVISION PROGRAMS FOR OTHERS IN THE FIELD OF FIGHTING, CONTACT SPORTS, MARTIAL ARTS AND FIGHTING SPORTS FOR VIEWING VIA TELEVISION, INTERNET, VOD, PAY PER VIEW AND DVD (U.S. CLS. 100, 101 AND 107).

FIRST USE 11-21-2011; IN COMMERCE 12-10-2011.  
MATTHEW KLINE, EXAMINING ATTORNEY

SN 86-211,787. CENTER FOR TECHNOLOGY, ENTERPRISE AND DEVELOPMENT, DELRAY BEACH, FL. FILED 3-5-2014.

## BUSINESS WOMEN ROCK

THE MARK CONSISTS OF STANDARD CHARACTERS WITHOUT CLAIM TO ANY PARTICULAR FONT, STYLE, SIZE, OR COLOR.

NO CLAIM IS MADE TO THE EXCLUSIVE RIGHT TO USE "BUSINESS WOMEN", APART FROM THE MARK AS SHOWN.

FOR ARRANGING AND CONDUCTING BUSINESS SEMINARS IN THE FIELD OF BUSINESS DEVELOPMENT, LEADERSHIP, ENTREPRENEURSHIP, AND BUSINESS MANAGEMENT; CONDUCTING WORKSHOPS AND SEMINARS IN BUSINESS DEVELOPMENT, LEADERSHIP, ENTREPRENEURSHIP, AND BUSINESS MANAGEMENT; EDUCATION SERVICES, NAMELY, PROVIDING MENTORING, TUTORING, CLASSES, SEMINARS AND WORKSHOPS IN THE FIELD OF BUSINESS DEVELOPMENT, LEADERSHIP, ENTREPRENEURSHIP, AND BUSINESS MANAGEMENT; EDUCATIONAL SERVICES, NAMELY, CONDUCTING CLASSES, SEMINARS, CONFERENCES, WORKSHOPS, RETREATS, CAMPS AND FIELD TRIPS IN THE FIELD OF BUSINESS DEVELOPMENT, LEADERSHIP, ENTREPRENEURSHIP, AND BUSINESS MANAGEMENT AND DISTRIBUTION OF TRAINING MATERIAL IN CONNECTION THEREWITH; ORGANIZATION OF SEMINARS; PROVIDING CLASSES, WORKSHOPS, SEMINARS AND CAMPS IN THE FIELDS OF FITNESS, EXERCISE, BOXING, KICK BOXING AND MIXED MARTIAL ARTS; RUNNING SEMINARS IN THE FIELD OF ONCOLOGY; WORKSHOPS AND SEMINARS IN THE FIELD OF BUSINESS DEVELOPMENT, LEADERSHIP, ENTREPRENEURSHIP, AND BUSINESS MANAGEMENT (U.S. CLS. 100, 101 AND 107).

FIRST USE 8-9-2012; IN COMMERCE 8-9-2012.  
MICHAEL TANNER, EXAMINING ATTORNEY

**CLASS 41—(Continued).**

SN 86-212,662. CRAZY BEAUTIFUL INC., COOKEVILLE, TN. FILED 3-6-2014.

## Crazy Beautiful Inc. Changing the face of fitness

THE MARK CONSISTS OF STANDARD CHARACTERS WITHOUT CLAIM TO ANY PARTICULAR FONT, STYLE, SIZE, OR COLOR.

NO CLAIM IS MADE TO THE EXCLUSIVE RIGHT TO USE "INC.", APART FROM THE MARK AS SHOWN.

FOR LIFE COACHING SERVICES IN THE FIELD OF WELLNESS; PHYSICAL FITNESS INSTRUCTION (U.S. CLS. 100, 101 AND 107).

FIRST USE 5-1-2012; IN COMMERCE 5-1-2012.  
KELLY BOULTON, EXAMINING ATTORNEY

SN 86-213,906. SYNAPSII, LLC, NEW HOPE, PA. FILED 3-6-2014.

## VERA

THE MARK CONSISTS OF STANDARD CHARACTERS WITHOUT CLAIM TO ANY PARTICULAR FONT, STYLE, SIZE, OR COLOR.

THE NAME(S), PORTRAIT(S), AND/OR SIGNATURE(S) SHOWN IN THE MARK DOES NOT IDENTIFY A PARTICULAR LIVING INDIVIDUAL.

FOR EDUCATIONAL SERVICES, NAMELY, CONDUCTING ONLINE CLASSES IN THE FIELD OF HEALTHCARE AND MEDICINE (U.S. CLS. 100, 101 AND 107).

FIRST USE 2-0-2012; IN COMMERCE 2-0-2012.  
MARGERY A. TIERNEY, EXAMINING ATTORNEY

SN 86-214,624. DYNASTIK INC., RANCHO PALOS VERDES, CA. FILED 3-7-2014.

## BLACKMOUF

THE MARK CONSISTS OF STANDARD CHARACTERS WITHOUT CLAIM TO ANY PARTICULAR FONT, STYLE, SIZE, OR COLOR.

FOR PRODUCTION, EDITING AND DIRECTING OF FILMS (U.S. CLS. 100, 101 AND 107).

FIRST USE 6-1-2011; IN COMMERCE 6-1-2011.  
PAUL CROWLEY, EXAMINING ATTORNEY

**CLASS 41—(Continued).**

SN 86-214,643. DYNASTIK INC., RANCHO PALOS VERDES, CA. FILED 3-7-2014.



THE MARK CONSISTS OF A STYLIZED DESIGN OF A HUMAN FACE WITH A BASEBALL CAP IN A BACKWARDS POSITION ON TOP OF THE HEAD AND OBSCURING THE EYES OF THE FACE.

FOR PRODUCTION, EDITING AND DIRECTING OF FILMS (U.S. CLS. 100, 101 AND 107).

FIRST USE 6-1-2011; IN COMMERCE 6-1-2011.

PAUL CROWLEY, EXAMINING ATTORNEY

---

SN 86-214,860. BRITO, JACQUELINE, ORLANDO, FL. FILED 3-7-2014.

**RECYCLE REGRETS**

THE MARK CONSISTS OF STANDARD CHARACTERS WITHOUT CLAIM TO ANY PARTICULAR FONT, STYLE, SIZE, OR COLOR.

FOR ON-LINE JOURNALS, NAMELY, BLOGS FEATURING SELF-IMPROVEMENT INFORMATION; EDUCATION SERVICES, NAMELY, PROVIDING WORKSHOPS, SEMINARS AND LECTURES IN THE FIELD OF LIFE CAREER, AND BUSINESS CONSULTING (U.S. CLS. 100, 101 AND 107).

LINDA ORNDORFF, EXAMINING ATTORNEY

---

SN 86-215,125. LAFFS COMEDY, LLC, DBA LAFFS INC., TOLEDO, OH. FILED 3-7-2014.

**LAFFS INC.**

THE MARK CONSISTS OF STANDARD CHARACTERS WITHOUT CLAIM TO ANY PARTICULAR FONT, STYLE, SIZE, OR COLOR.

NO CLAIM IS MADE TO THE EXCLUSIVE RIGHT TO USE "INC.", APART FROM THE MARK AS SHOWN.

FOR COMEDY CLUB SERVICES (U.S. CLS. 100, 101 AND 107).

FIRST USE 3-7-2014; IN COMMERCE 3-7-2014.

BERYL GARDNER, EXAMINING ATTORNEY

**CLASS 41—(Continued).**

SN 86-215,608. GRIEF CARE FELLOWSHIP, INC., HUDSON, FL. FILED 3-9-2014.



NO CLAIM IS MADE TO THE EXCLUSIVE RIGHT TO USE "GRIEF CARE FELLOWSHIP", APART FROM THE MARK AS SHOWN.

THE COLOR(S) RED AND BLACK IS/ARE CLAIMED AS A FEATURE OF THE MARK.

THE MARK CONSISTS OF TWO HANDS WITH THE RIGHT HAND OVER LAPPING THE LEFT WITH ITS THUMB THESE TWO HANDS CREATE A SHAPE OF HEART IN RED. THE LITERAL ELEMENTS BELOW THE SYMBOL OF TWO HANDS READ "GRIEF CARE FELLOWSHIP", APPEARING IN THE COLOR BLACK.

FOR EDUCATIONAL SERVICES, NAMELY, DEVELOPING CURRICULUM FOR OTHERS IN THE FIELD OF GRIEF COUNSELING (U.S. CLS. 100, 101 AND 107).

FIRST USE 1-15-2014; IN COMMERCE 1-31-2014.

RONALD AIKENS, EXAMINING ATTORNEY

---

SN 86-215,883. AMY TRIPPLE PHOTOGRAPHY AND DESIGN INCORPORATED, DOWNERS GROVE, IL. FILED 3-10-2014.

**SWEET SHOTS**

THE MARK CONSISTS OF STANDARD CHARACTERS WITHOUT CLAIM TO ANY PARTICULAR FONT, STYLE, SIZE, OR COLOR.

NO CLAIM IS MADE TO THE EXCLUSIVE RIGHT TO USE "SHOTS", APART FROM THE MARK AS SHOWN.

FOR EDUCATIONAL SERVICES, NAMELY, PROVIDING SEMINARS AND CLASSES IN THE FIELD OF PHOTOGRAPHY; PHOTOGRAPHY SERVICES (U.S. CLS. 100, 101 AND 107).

FIRST USE 6-16-2010; IN COMMERCE 6-16-2010.

JOSETTE BEVERLY, EXAMINING ATTORNEY

**CLASS 41—(Continued).**

SN 86-216,342. PMI 5 MEDIA LLC, SANTA MONICA, CA. FILED 3-10-2014.



NO CLAIM IS MADE TO THE EXCLUSIVE RIGHT TO USE "DAILY", APART FROM THE MARK AS SHOWN.

THE MARK CONSISTS OF THE WORDS "HER DAILY". THE WORD "HER" IS PRESENTED IN A STYLIZED CURSIVE FONT. IN BETWEEN THE WORDS "HER" AND "DAILY" IS A SMALL SHADED CIRCLE. THE WORD "DAILY" IS PRESENTED IN A NON-CURSIVE FONT.

FOR PROVIDING A WEBSITE FEATURING ENTERTAINMENT INFORMATION; PROVIDING ENTERTAINMENT INFORMATION VIA A WEBSITE (U.S. CLS. 100, 101 AND 107).

FIRST USE 3-0-2009; IN COMMERCE 3-0-2009.  
CRISTIANA SCHWAB, EXAMINING ATTORNEY

**CLASS 41—(Continued).**

SN 86-218,658. ADVANCE MAGAZINE PUBLISHERS, INC., NEW YORK, NY. FILED 3-12-2014.



OWNER OF U.S. REG. NOS. 340,115, 2,340,335 AND OTHERS.

THE MARK CONSISTS OF A STYLIZED FORMAT OF THE WORD "BRIDES".

SEC. 2(F).

FOR ENTERTAINMENT SERVICES, NAMELY, A CONTINUING PROGRAM ABOUT WEDDINGS, WEDDING STYLES AND LIFESTYLES ACCESSIBLE BY COMPUTER NETWORKS, CABLE TV AND NETWORK TV; ENTERTAINMENT SERVICES, NAMELY, PROVIDING A WEBSITE FEATURING NON-DOWNLOADABLE VIDEOS ABOUT WEDDINGS, WEDDING STYLES AND LIFESTYLES (U.S. CLS. 100, 101 AND 107).

FIRST USE 12-31-2012; IN COMMERCE 12-31-2012.  
NANCY CLARKE, EXAMINING ATTORNEY

SN 86-217,888. CAPEMOMENTS, INC., BOSTON, MA. FILED 3-11-2014.

**EXPRESSIVE DIGITAL IMAGERY**

THE MARK CONSISTS OF STANDARD CHARACTERS WITHOUT CLAIM TO ANY PARTICULAR FONT, STYLE, SIZE, OR COLOR.

NO CLAIM IS MADE TO THE EXCLUSIVE RIGHT TO USE "DIGITAL IMAGERY", APART FROM THE MARK AS SHOWN.

FOR CHARITABLE SERVICES, NAMELY, PROVIDING INSTRUCTION AND TRAINING TO THE PUBLIC IN THE FIELD OF PHOTOGRAPHY; PROVIDING INSTRUCTION AND TRAINING TO THE PUBLIC IN THE FIELD OF PHOTOGRAPHY FOR THERAPEUTIC PURPOSES; CONDUCTING EDUCATIONAL WORKSHOPS IN THE FIELD OF PHOTOGRAPHY AND DISTRIBUTION OF PRINTED COURSE MATERIALS IN CONNECTION THEREWITH; DEVELOPMENT, PUBLICATION, AND DISSEMINATION OF PRINTED EDUCATIONAL MATERIALS OF OTHERS IN THE FIELD OF PHOTOGRAPHY (U.S. CLS. 100, 101 AND 107).

FIRST USE 1-0-2014; IN COMMERCE 1-0-2014.  
STEVEN PEREZ, EXAMINING ATTORNEY

SN 86-218,743. GAYOT, MAYALUCA, DBA ONE STOP PHOTO AND PRINT, TAMARAC, FL. FILED 3-12-2014.



NO CLAIM IS MADE TO THE EXCLUSIVE RIGHT TO USE "PHOTO AND PRINT", APART FROM THE MARK AS SHOWN.

THE MARK CONSISTS OF THE WORDS "ONE STOP" IN LARGE FONT, AND THE WORDS "PHOTO AND PRINT" IN SMALLER FONT AND ALL CAPITAL LETTERS ON THE LINE BELOW. A SERIES OF SORT OF FLYING RECTANGLES EXPAND AND COME OFF OF THE "O" IN ONE.

FOR PHOTOGRAPHY SERVICES (U.S. CLS. 100, 101 AND 107).

FIRST USE 1-1-2014; IN COMMERCE 2-6-2014.  
MARK SPARACINO, EXAMINING ATTORNEY

**CLASS 41—(Continued).**

SN 86-218,752. FLORIDA GANG INVESTIGATORS ASSOCIATION, INC., ST. JOHNS, FL. FILED 3-12-2014.



NO CLAIM IS MADE TO THE EXCLUSIVE RIGHT TO USE "FLORIDA GANG INVESTIGATORS ASSOCIATION", "GANGS" AND "EST. 1993" AND THE REPRESENTATION OF THE STATE OF FLORIDA, APART FROM THE MARK AS SHOWN.

THE COLOR(S) RED, WHITE AND BLACK IS/ARE CLAIMED AS A FEATURE OF THE MARK.

THE MARK CONSISTS OF THE FOLLOWING: A THE WORDS "FLORIDA GANG INVESTIGATORS ASSOCIATION" AND "EST. 1993" IN WHITE BOLD LETTERING WHICH IS SUPERIMPOSED OVER A BLACK OUTLINE OF A CIRCLE WITH A RED BORDER WITH TWO WHITE STARS BETWEEN "EST. 1993". THE WORDING IS CIRCULING THE INSIDE OF THE RED CIRCLE. IN THE INSIDE OF THE RED CIRCLE APPEARS A WHITE CREST OUTLINED IN BLACK WITH THE OUTLINE OF THE STATE OF FLORIDA INSIDE THE CREST IN BLACK. ALSO INSIDE THE CREST IS THE WORD "GANGS" IN BLACK FONT CIRCLED BY A RED CIRCLE WITH A DIAGONAL RED LINE THROUGH THE CIRCLE AND THE WORD "GANGS".

FOR DEVELOPMENT AND DISSEMINATION OF PRINTED EDUCATIONAL MATERIALS OF OTHERS IN THE FIELD OF GANG INVESTIGATIONS AND DEVELOPMENT; EDUCATIONAL SERVICES, NAMELY, PROVIDING CLASSES, CONFERENCES, SEMINARS, WORKSHOPS AND CERTIFICATIONS IN THE FIELDS OF GANG INVESTIGATION AND INTELLIGENCE (U.S. CLS. 100, 101 AND 107).

FIRST USE 1-1-2003; IN COMMERCE 1-1-2003.  
ALICE BENMAMAN, EXAMINING ATTORNEY

**CLASS 41—(Continued).**

SN 86-219,017. PROJECT LIFE MASTERY INC., AKA STEFAN PYLARINOS, VANCOUVER, BC, CANADA, FILED 3-12-2014.



THE MARK CONSISTS OF THE WORDING "PROJECT LIFE MASTERY" AND AN IMAGE OF A MAN ON TOP OF A MOUNTAINTOP, A CURVED LINE APPEARING AT THE BOTTOM OF THE MOUNTAIN DESIGN AND A SUN HAVING LINES REPRESENTING THE SUN RAYS IN THE BACKGROUND. A VERTICAL LINE SEPARATES THE WORDING "PROJECT LIFE MASTERY" AND THE DESIGN ELEMENT.

FOR LIFE COACHING SERVICES IN THE FIELD OF PERSONAL IMPROVEMENT AND INTERNET MARKETING ADVICE; ON-LINE JOURNALS, NAMELY, BLOGS FEATURING PERSONAL IMPROVEMENT AND INTERNET MARKETING ADVICE (U.S. CLS. 100, 101 AND 107).

FIRST USE 1-1-2012; IN COMMERCE 1-1-2012.  
JENNY PARK, EXAMINING ATTORNEY

SN 86-219,458. WICK, ABBEY, FARGO, ND. FILED 3-12-2014.

## SHARE Farm

THE MARK CONSISTS OF STANDARD CHARACTERS WITHOUT CLAIM TO ANY PARTICULAR FONT, STYLE, SIZE, OR COLOR.

NO CLAIM IS MADE TO THE EXCLUSIVE RIGHT TO USE "FARM", APART FROM THE MARK AS SHOWN.

FOR FARMER EDUCATION IN THE NATURE OF EDUCATION SERVICES, NAMELY, PROVIDING CLASSES, SEMINARS, WORKSHOPS IN THE FIELDS OF SOIL HEALTH MANAGEMENT PRACTICES; EDUCATION SERVICES FOR FARMERS, NAMELY, PROVIDING CLASSES, SEMINARS, WORKSHOPS IN THE FIELDS OF IN THE FIELDS OF SOIL HEALTH MANAGEMENT PRACTICES; EDUCATION SERVICES, NAMELY, PROVIDING LIVE AND ON-LINE CLASSES, SEMINARS, WORKSHOPS IN THE FIELD OF FARMING, NAMELY, SOIL HEALTH MANAGEMENT PRACTICES EDUCATION SERVICES, NAMELY, PROVIDING MENTORING, TUTORING, CLASSES, SEMINARS AND WORKSHOPS TO FARMERS IN THE FIELD OF SOIL HEALTH; MANAGEMENT PRACTICES EDUCATION SERVICES, NAMELY, A YEAR-LONG FARMING PREPARATION PROGRAM FOR EMERGING FARMERS IN THE FIELDS OF SOIL HEALTH MANAGEMENT PRACTICES (U.S. CLS. 100, 101 AND 107).

RONALD DELGIZZI, EXAMINING ATTORNEY

**CLASS 41—(Continued).**

SN 86-221,232. ICEARIZONA HOCKEY CO. LP, GLENDALE, AZ. FILED 3-14-2014.



NO CLAIM IS MADE TO THE EXCLUSIVE RIGHT TO USE "AZ" OR THE OUTLINE OF THE STATE OF ARIZONA, APART FROM THE MARK AS SHOWN.

THE MARK CONSISTS OF THE LETTERS "AZ" UNDER A STRIPED PATTERN EMBEDDED WITHIN AN OUTLINE OF THE STATE OF ARIZONA.

FOR ENTERTAINMENT SERVICES, NAMELY, PROFESSIONAL ICE HOCKEY EXHIBITIONS (U.S. CLS. 100, 101 AND 107).

JULIE VEPPUMTHARA, EXAMINING ATTORNEY

SN 86-221,314. GYPSET GODDESS LLC, PHOENIX, AZ. FILED 3-14-2014.

**GYPSET GODDESS**

THE MARK CONSISTS OF STANDARD CHARACTERS WITHOUT CLAIM TO ANY PARTICULAR FONT, STYLE, SIZE, OR COLOR.

FOR EDUCATION, NAMELY, PROVIDING A WEBSITE FEATURING INFORMATION IN THE FIELD OF YOGA EXERCISE AND FITNESS; EDUCATION, NAMELY, PROVIDING ON-LINE NON-DOWNLOADABLE VIDEO FILES FEATURING YOGA, FITNESS AND HEALTH INSTRUCTION AND COMMENTARY; ON-LINE JOURNALS, NAMELY, BLOGS FEATURING YOGA, FITNESS AND HEALTH INSTRUCTION AND COMMENTARY; YOGA, FITNESS AND HEALTH INSTRUCTION; EDUCATION, NAMELY, LIVE PERFORMANCES IN THE NATURE OF YOGA, FITNESS AND HEALTH INSTRUCTION (U.S. CLS. 100, 101 AND 107).

EVIN L. KOZAK, EXAMINING ATTORNEY

**CLASS 41—(Continued).**

SN 86-221,339. SUZUKI LEARNING CENTER OF BUCKHEAD, INC., ATLANTA, GA. FILED 3-14-2014.

**Montessori Teacher  
Education Institute at the  
Suzuki School**

THE MARK CONSISTS OF STANDARD CHARACTERS WITHOUT CLAIM TO ANY PARTICULAR FONT, STYLE, SIZE, OR COLOR.

OWNER OF U.S. REG. NOS. 3,305,567 AND 3,377,939.

NO CLAIM IS MADE TO THE EXCLUSIVE RIGHT TO USE "MONTESSORI TEACHER EDUCATION INSTITUTE", APART FROM THE MARK AS SHOWN.

SEC. 2(F).

FOR EDUCATIONAL SERVICES, NAMELY, PROVIDING TRAINING OF TEACHERS FOR CERTIFICATION IN THE FIELD OF MONTESSORI PRESCHOOL EDUCATION (U.S. CLS. 100, 101 AND 107).

FIRST USE 2-1-2013; IN COMMERCE 2-1-2013.

AHSEN KHAN, EXAMINING ATTORNEY

SN 86-221,650. LADIES OF GLAM EVENT PLANNING, BROOKLYN, NY. FILED 3-14-2014.

**LADIES OF GLAM EVENT  
PLANNERS**

THE MARK CONSISTS OF STANDARD CHARACTERS WITHOUT CLAIM TO ANY PARTICULAR FONT, STYLE, SIZE, OR COLOR.

NO CLAIM IS MADE TO THE EXCLUSIVE RIGHT TO USE "EVENT PLANNERS", APART FROM THE MARK AS SHOWN.

FOR ADMISSION TICKET RESERVATION AND BOOKING SERVICES FOR NIGHT CLUBS AND NIGHT CLUB EVENTS; ARRANGING AND CONDUCTING NIGHTCLUB ENTERTAINMENT EVENTS; ARRANGING, ORGANIZING, CONDUCTING, AND HOSTING SOCIAL ENTERTAINMENT EVENTS; CONSULTATION IN THE FIELD OF SPECIAL EVENT PLANNING FOR SOCIAL ENTERTAINMENT PURPOSES; DANCE EVENTS; HOSTING A BACK TO SCHOOL EVENT IN A SHOPPING CENTER FEATURING PRIZES, GAMES, MUSIC, AND A FASHION SHOW; HOSTING SOCIAL ENTERTAINMENT EVENTS, NAMELY, WEDDINGS, BIRTHDAY PARTIES, BABY SHOWERS, BRIDAL SHOWERS, AND ENGAGEMENT PARTIES FOR OTHERS; MASTER OF CEREMONY SERVICES FOR PARTIES AND SPECIAL EVENTS; ORGANIZATION OF DANCING EVENTS; PARTY AND WEDDING RECEPTION PLANNING AND COORDINATION SERVICES; PARTY AND WEDDING RECEPTION PLANNING CONSULTATION SERVICES; PARTY AND WEDDING RECEPTION PLANNING, COORDINATION AND CONSULTATION SERVICES; PARTY PLANNING; PARTY PLANNING CONSULTATION; SOCIAL CLUB SERVICES, NAMELY, ARRANGING, ORGANIZING, AND HOSTING SOCIAL EVENTS, GET-TOGETHERS, AND PARTIES FOR CLUB MEMBERS; SPECIAL EVENT PLANNING FOR SOCIAL ENTERTAINMENT PURPOSES; WEDDING RECEPTION PLANNING AND COORDINATION CONSULTATION SERVICES; WEDDING RECEPTION PLANNING AND COORDINATION SERVICES (U.S. CLS. 100, 101 AND 107).

FIRST USE 8-14-2013; IN COMMERCE 11-1-2013.

NATALIE POLZER, EXAMINING ATTORNEY

**CLASS 41—(Continued).**

SN 86-222,218. ZEPEDA, DAVID R., JURUPA VALLEY, CA. AND AYON, JOSE, JURUPA VALLEY, CA. AND AYON, GERARDO, JURUPA VALLEY, CA. AND GONZALEZ, ERIC, JURUPA VALLEY, CA. AND SANCHEZ, EUGENIO, JURUPA VALLEY, CA. AND HEREDIA, MANUEL, JURUPA VALLEY, CA. FILED 3-14-2014.

**Banda Viento de Oro**

THE MARK CONSISTS OF STANDARD CHARACTERS WITHOUT CLAIM TO ANY PARTICULAR FONT, STYLE, SIZE, OR COLOR.

NO CLAIM IS MADE TO THE EXCLUSIVE RIGHT TO USE "BANDA", APART FROM THE MARK AS SHOWN.

THE ENGLISH TRANSLATION OF "BANDA VIENTO DE ORO" IN THE MARK IS "WIND OF GOLD BAND".

FOR ENTERTAINMENT SERVICES IN THE NATURE OF LIVE MUSICAL PERFORMANCES (U.S. CLS. 100, 101 AND 107).

FIRST USE 1-1-1998; IN COMMERCE 1-1-1998.  
DAVID HOFFMAN, EXAMINING ATTORNEY

SN 86-222,385. MORRIS, SAMUEL W, WEST HOLLYWOOD, CA. FILED 3-15-2014.

**Zen Warrior Training**

THE MARK CONSISTS OF STANDARD CHARACTERS WITHOUT CLAIM TO ANY PARTICULAR FONT, STYLE, SIZE, OR COLOR.

NO CLAIM IS MADE TO THE EXCLUSIVE RIGHT TO USE "TRAINING", APART FROM THE MARK AS SHOWN.

FOR BUSINESS EDUCATION AND TRAINING SERVICES, NAMELY, DEVELOPING CUSTOMIZED IN-COMPANY LEADERSHIP AND EXECUTIVE DEVELOPMENT PROGRAMS, PROVIDING EXECUTIVE COACHING SERVICES, AND PROVIDING PUBLIC AND IN-COMPANY KEYNOTE PRESENTATIONS TO BUSINESS LEADERS; BUSINESS EDUCATION AND TRAINING SERVICES, NAMELY, DEVELOPING CUSTOMIZED LEADERSHIP AND EXECUTIVE DEVELOPMENT PROGRAMS, PROVIDING EXECUTIVE COACHING SERVICES, AND PROVIDING BUSINESS EDUCATION PROGRAMS TO EMPLOYEES AND EXECUTIVES; BUSINESS TRAINING IN THE FIELD OF PERSONAL AND ORGANIZATIONAL DEVELOPMENT.; COACHING IN THE FIELD OF SPORTS; EDUCATIONAL SERVICES, NAMELY, PROFESSIONAL COACHING OF TEACHERS IN THE FIELD OF PERSONAL AND ORGANIZATIONAL DEVELOPMENT PROVIDED ON A REAL-TIME BASIS DURING CLASSROOM INSTRUCTION; LIFE COACHING SERVICES IN THE FIELD OF PERSONAL DEVELOPMENT.; PEER TO PEER COACHING SERVICES IN THE FIELD OF PERSONAL DEVELOPMENT.; PERSONAL COACHING SERVICES IN THE FIELD OF PERSONAL DEVELOPMENT.; PROFESSIONAL COACHING SERVICES IN THE FIELD OF PERSONAL AND ORGANIZATIONAL DEVELOPMENT.; PROVIDING GROUP COACHING AND IN-PERSON LEARNING FORUMS IN THE FIELD OF LEADERSHIP DEVELOPMENT; PROVIDING GROUP COACHING IN THE FIELD OF PERSONAL AND ORGANIZATIONAL DEVELOPMENT (U.S. CLS. 100, 101 AND 107).

FIRST USE 11-15-2013; IN COMMERCE 12-8-2013.  
KATHERINE CONNOLLY, EXAMINING ATTORNEY

**CLASS 41—(Continued).**

SN 86-222,782. WEISS, ELLIOT, DBA EVENTZ PHOTO BOOTH, BOCA RATON, FL. FILED 3-17-2014.



NO CLAIM IS MADE TO THE EXCLUSIVE RIGHT TO USE "PHOTO BOOTH", APART FROM THE MARK AS SHOWN.

THE MARK CONSISTS OF THE STYLIZED STACKED WORDING "EVENTZ" AND "PHOTO BOOTH" ANGLED UPWARD TO THE RIGHT OVER A LARGE CIRCLE. BELOW THE "O" IN THE TERM "PHOTO" IS A FIVE-POINTED STAR. BELOW THE "HOTO" PORTION OF "PHOTO" IS A RECTANGLE WITH ROUNDED EDGES FORMING THE BACKGROUND OF A STYLIZED CAMERA LENS. BELOW THE CAMERA LENS IS AN ARCHED BANNER WITH THE WORDS "FUN CAPTURED!" WITHIN THE BANNER.

FOR RENTAL OF PORTABLE PHOTOGRAPHY AND/OR VIDEOGRAPHY BOOTHS FOR TAKING OF PICTURES AND VIDEOS (U.S. CLS. 100, 101 AND 107).

FIRST USE 12-1-2012; IN COMMERCE 12-1-2012.  
PAULA MAHONEY, EXAMINING ATTORNEY

SN 86-223,757. BRIDGES READING AND WRITING INSTITUTE, INC., IRVINE, CA. FILED 3-17-2014.

**BRIDGES READING & WRITING INSTITUTE**

THE MARK CONSISTS OF STANDARD CHARACTERS WITHOUT CLAIM TO ANY PARTICULAR FONT, STYLE, SIZE, OR COLOR.

NO CLAIM IS MADE TO THE EXCLUSIVE RIGHT TO USE "READING & WRITING INSTITUTE", APART FROM THE MARK AS SHOWN.

FOR KINDERGARTEN THROUGH EIGHTH GRADE EDUCATION SERVICES, NAMELY, PROVIDING TUTORING, WORKSHOPS AND CLASSES IN THE FIELDS OF READING, WRITING AND LANGUAGE ARTS PROVIDED AS A SUMMER PROGRAM AND AN AFTER-SCHOOL PROGRAM (U.S. CLS. 100, 101 AND 107).

FIRST USE 3-0-2005; IN COMMERCE 3-0-2005.  
DEBORAH MEINERS, EXAMINING ATTORNEY



**CLASS 41—(Continued).**

SN 86-223,776. BRIDGES READING AND WRITING INSTITUTE, INC., IRVINE, CA. FILED 3-17-2014.

**PROJECT INK**

THE MARK CONSISTS OF STANDARD CHARACTERS WITHOUT CLAIM TO ANY PARTICULAR FONT, STYLE, SIZE, OR COLOR.

NO CLAIM IS MADE TO THE EXCLUSIVE RIGHT TO USE "PROJECT", APART FROM THE MARK AS SHOWN.

FOR EDUCATION SERVICES, NAMELY, PROVIDING TUTORING, WORKSHOPS, CLASSES AND SUMMER CAMPS IN THE FIELDS OF READING, WRITING AND LANGUAGE ARTS (U.S. CLS. 100, 101 AND 107).

FIRST USE 6-0-2009; IN COMMERCE 6-0-2009.

DEBORAH MEINERS, EXAMINING ATTORNEY

**CLASS 41—(Continued).**

SN 86-224,510. COUP ENTERTAINMENT LLC, NEW YORK, NY. FILED 3-18-2014.

**REAL SMART DOCTORS**

THE MARK CONSISTS OF STANDARD CHARACTERS WITHOUT CLAIM TO ANY PARTICULAR FONT, STYLE, SIZE, OR COLOR.

FOR ENTERTAINMENT, NAMELY, A CONTINUING DOCUMENTARY REALITY-STYLE SHOW BROADCAST OVER TELEVISION AND INTERNET (U.S. CLS. 100, 101 AND 107).

FIRST USE 5-0-2011; IN COMMERCE 5-0-2011.

KERI CANTONE, EXAMINING ATTORNEY

SN 86-223,786. DESIR, ROBY, HARRIMAN, NY. FILED 3-17-2014.



THE COLOR(S) RED, WHITE, AND BLACK IS/ARE CLAIMED AS A FEATURE OF THE MARK.

THE MARK CONSISTS OF THE INSIDE OF A RECTANGLE FILLED IN WITH A RED BACKGROUND THAT FADES TO BLACK AT THE BOTTOM WITH THE WORD "BOUJE" CENTERED IN WHITE CAPITAL SCRIPTED LETTERS TILTED TO THE RIGHT WITH A WHITE ACCENT OVER THE LETTER "E"; THE LETTER "O" IS A SMILEY FACE THAT IS OUTLINED IN BLACK AND FILLED IN WITH WHITE AND HAS A BLACK SMILE AND BLACK OVAL LAYING ON ITS SIDE WHICH FORMS A GOATEE AND TWO BLACK DIAMONDS ON TOP OF THE CENTER PART OF THE "O" THAT OVERLAP TO LOOK LIKE HAIR; UNDER THE WORD "BOUJE" THERE IS A PARTIAL REFLECTION VISIBLE OF THE WORD "BOUJE".

THE ENGLISH TRANSLATION OF "BOUJE" IN THE MARK IS "TO MOVE" OR "TO BUDGE".

FOR EDUCATION AND ENTERTAINMENT SERVICES, NAMELY, PROVIDING CLASSES AND INSTRUCTION IN THE FIELD OF DANCE, FITNESS AND EXERCISE (U.S. CLS. 100, 101 AND 107).

FIRST USE 3-15-2014; IN COMMERCE 3-15-2014.

CATHERINE TARCU, EXAMINING ATTORNEY

SN 86-224,936. IMMEDIA, LLC, SCOTTSDALE, AZ. FILED 3-18-2014.

connected  
CLASSROOM

NO CLAIM IS MADE TO THE EXCLUSIVE RIGHT TO USE "CLASSROOM", APART FROM THE MARK AS SHOWN.

THE COLOR(S) BLACK AND BLUE IS/ARE CLAIMED AS A FEATURE OF THE MARK.

THE MARK CONSISTS OF THE TOP WORD "CONNECTED" IN BLACK, AND THE BOTTOM WORD "CLASSROOM" IN BLUE.

FOR TRAINING SERVICES IN THE FIELDS OF EDUCATION AND MOBILE APPLICATION TECHNOLOGY (U.S. CLS. 100, 101 AND 107).

FIRST USE 11-0-2012; IN COMMERCE 4-0-2013.

JAY FLOWERS, EXAMINING ATTORNEY



**CLASS 41—(Continued).**

SN 86-225,061. IMMEDIA, LLC, SCOTTSDALE, AZ. FILED 3-18-2014.



THE COLOR(S) BLACK, WHITE, BLUE, GREEN, YELLOW AND PURPLE IS/ARE CLAIMED AS A FEATURE OF THE MARK.

THE MARK CONSISTS OF AN ICON THAT INCLUDES DIFFERENT SIZE AND COLOR SQUARES IN BLUE, GREEN, YELLOW AND PURPLE REPRESENTING BUILDING BLOCKS INSIDE A BLACK AND WHITE RECTANGLE WITH AN OPEN PART ON THE TOP AND A WHOTE DOT ON THE RIGHT.

FOR TRAINING SERVICES IN THE FIELDS OF EDUCATION AND MOBILE APPLICATION TECHNOLOGY (U.S. CLS. 100, 101 AND 107).

FIRST USE 11-0-2012; IN COMMERCE 4-0-2013.  
JAY FLOWERS, EXAMINING ATTORNEY

SN 86-225,091. IMMEDIA, LLC, SCOTTSDALE, AZ. FILED 3-18-2014.

NO CLAIM IS MADE TO THE EXCLUSIVE RIGHT TO USE "EDU", APART FROM THE MARK AS SHOWN.

THE COLOR(S) BLUE, GREEN AND WHITE IS/ARE CLAIMED AS A FEATURE OF THE MARK.

THE MARK CONSISTS OF THE WORD "IMMEDIA" IN WHITE OUTLINED IN BLUE, AND THE WORD "EDU" IN WHITE OUTLINED IN GREEN.

FOR TRAINING SERVICES IN THE FIELDS OF EDUCATION AND MOBILE APPLICATION TECHNOLOGY (U.S. CLS. 100, 101 AND 107).

FIRST USE 11-0-2012; IN COMMERCE 4-0-2013.  
JAY FLOWERS, EXAMINING ATTORNEY

**CLASS 41—(Continued).**

SN 86-226,145. LIRIA PARTNERS, NEW YORK, NY. FILED 3-19-2014.

## Liria Partners

THE MARK CONSISTS OF STANDARD CHARACTERS WITHOUT CLAIM TO ANY PARTICULAR FONT, STYLE, SIZE, OR COLOR.

NO CLAIM IS MADE TO THE EXCLUSIVE RIGHT TO USE "PARTNERS", APART FROM THE MARK AS SHOWN. FOR BUSINESS FORMATION AND MANAGEMENT WORKSHOPS (U.S. CLS. 100, 101 AND 107).

FIRST USE 8-30-2012; IN COMMERCE 2-1-2013.  
DOUGLAS LEE, EXAMINING ATTORNEY

SN 86-226,148. PERSONAL TRAINING DESTINATION, LLC, OCEANSIDE, NY. FILED 3-19-2014.



THE MARK CONSISTS OF TWO BOOMERANG SHAPED DESIGNS OVERLAPPING WITH A SHADOW EFFECT AND THE WORDS "PERSONAL TRAINING DESTINATION CONNECTING BODY AND MIND" BELOW THE DESIGN.

FOR PERSONAL FITNESS TRAINING SERVICES AND CONSULTANCY (U.S. CLS. 100, 101 AND 107).

FIRST USE 5-30-2013; IN COMMERCE 10-1-2013.  
DOUGLAS LEE, EXAMINING ATTORNEY

SN 86-226,606. INVENT NOW, INC., NORTH CANTON, OH. FILED 3-20-2014.



THE MARK CONSISTS OF THE SHAPE OF A LIGHT BULB MADE UP OF THE FOLLOWING ITEMS: A COMPASS, A FLY SWATTER, A PLURALITY OF SCREWDRIVERS, A LENGTH OF ROPE, A PLURALITY OF SPRINGS,

**CLASS 41—(Continued).**

TACKS, A PLURALITY OF CIRCUIT BOARDS, PINS, GEARS, PLIERS, A GLOBE, A MAGNET, THE LETTERS T E A AND M, ELECTRICAL CAPS, A FLOWER, A COMPASS, NUTS AND BOLTS, A HAMMER, A HORN, A SWITCH, A BUTTON, TAPE MEASURE, PAPER CLIPS, SAFETY GOGGLES, LIGHT SWITCH, PLUS AND MINUS SYMBOLS, ROLL OF TAPE, BATTERIES, A ROLL OF CORD, A BALL OF BANDS, A WATER VALVE, A WRENCH, A PENCIL, A MAGNIFYING GLASS, A MOTOR, A WHISTLE, SCISSORS, CHIPS, A WHEEL, PROTRACTOR, AND A VALVE.

FOR EDUCATIONAL SERVICES, NAMELY, CONDUCTING CLASSES AND WORKSHOPS IN THE FIELD OF CREATIVITY AND INVENTION DURING DAY CAMPS FOR CHILDREN AGES 6 TO 13 (U.S. CLS. 100, 101 AND 107).

FIRST USE 9-8-2013; IN COMMERCE 9-8-2013.  
KEVIN MITTLER, EXAMINING ATTORNEY

**CLASS 41—(Continued).**

SN 86-227,548. SLOAN HEALTH GLOBAL, LLC, DBA RECHARGE PILATES & BARRE, CHAPEL HILL, NC. FILED 3-20-2014.

## Recharge

THE MARK CONSISTS OF STANDARD CHARACTERS WITHOUT CLAIM TO ANY PARTICULAR FONT, STYLE, SIZE, OR COLOR.

FOR EXERCISE INSTRUCTION AND CLASSES, SPECIFICALLY GROUP FITNESS CLASSES, PILATES INSTRUCTION, BARRE EXERCISE CLASSES, YOGA CLASSES, YOGA WITH WEIGHTS, YOGA AND BARRE AND YOGA FOR CHILDREN; PROVIDING A WEBSITE FEATURING INFORMATION ON EXERCISE AND FITNESS (U.S. CLS. 100, 101 AND 107).

FIRST USE 6-22-2013; IN COMMERCE 6-22-2013.  
DAVID MURRAY, EXAMINING ATTORNEY

SN 86-226,797. JOHNSON, DEVONDERICK, GAINESVILLE, FL. FILED 3-20-2014.

## Black Galaxy Entertainment

THE MARK CONSISTS OF STANDARD CHARACTERS WITHOUT CLAIM TO ANY PARTICULAR FONT, STYLE, SIZE, OR COLOR.

NO CLAIM IS MADE TO THE EXCLUSIVE RIGHT TO USE "ENTERTAINMENT", APART FROM THE MARK AS SHOWN.

FOR MEDIA PRODUCTION SERVICES, NAMELY, VIDEO AND FILM PRODUCTION; PHOTOGRAPHY SERVICES; PRODUCTION OF SOUND AND MUSIC VIDEO RECORDINGS; RECORD PRODUCTION (U.S. CLS. 100, 101 AND 107).

GISELLE AGOSTO, EXAMINING ATTORNEY

SN 86-227,809. EAGLECLAW FOOTBALL CLUB, INC., DBA EAGLECLAW FOOTBALL ACADEMY, SEATTLE, WA. FILED 3-20-2014.

## Eagleclaw Football Club

SN 86-227,035. STIHLLE BROADCAST NETWORK RECORDS, HAMPTON, VA. FILED 3-20-2014.

## Stihlle Broadcast Network Records

THE MARK CONSISTS OF STANDARD CHARACTERS WITHOUT CLAIM TO ANY PARTICULAR FONT, STYLE, SIZE, OR COLOR.

NO CLAIM IS MADE TO THE EXCLUSIVE RIGHT TO USE "BROADCAST NETWORK RECORDS", APART FROM THE MARK AS SHOWN.

FOR DISC JOCKEY SERVICES; DISC JOCKEYS FOR PARTIES AND SPECIAL EVENTS; ENTERTAINMENT SERVICES IN THE NATURE OF LIVE MUSICAL PERFORMANCES; MUSIC PRODUCTION SERVICES; MUSIC VIDEO PRODUCTION; PRESENTATION OF MUSICAL PERFORMANCE; VIDEO PRODUCTION SERVICES (U.S. CLS. 100, 101 AND 107).

KAREN K. BUSH, EXAMINING ATTORNEY

THE MARK CONSISTS OF STANDARD CHARACTERS WITHOUT CLAIM TO ANY PARTICULAR FONT, STYLE, SIZE, OR COLOR.

NO CLAIM IS MADE TO THE EXCLUSIVE RIGHT TO USE "FOOTBALL CLUB", APART FROM THE MARK AS SHOWN.

FOR ATHLETIC AND SPORT SERVICES, NAMELY, SOCCER COACHING, SOCCER CAMPS, SOCCER SCHOOLS, SOCCER WORKSHOPS, CONDUCTING AND ORGANIZING SOCCER MATCHES AND TOURNAMENTS FEATURING SPECIALLY SELECTED TEAMS; CONDUCTING COURSES OF INSTRUCTION, WORKSHOPS AND CAMPS FEATURING COACHING AND INSTRUCTION IN SOCCER (U.S. CLS. 100, 101 AND 107).

FIRST USE 10-1-2010; IN COMMERCE 10-1-2010.  
ZACHARY R. SPARER, EXAMINING ATTORNEY

**CLASS 41—(Continued).**

SN 86-227,869. BROADBASE, INC., WEST SACRAMENTO, CA. FILED 3-20-2014.

# BOLF CUP

THE MARK CONSISTS OF STANDARD CHARACTERS WITHOUT CLAIM TO ANY PARTICULAR FONT, STYLE, SIZE, OR COLOR.

NO CLAIM IS MADE TO THE EXCLUSIVE RIGHT TO USE "CUP", APART FROM THE MARK AS SHOWN.

FOR ORGANIZATION, PLANNING, AND OPERATION OF SPORTING EVENTS, NAMELY, TOURNAMENTS AND COMPETITIONS FOR A SPORT THAT COMBINES ELEMENTS OF BASEBALL AND GOLF ON A BASEBALL FIELD; EDUCATION AND TRAINING SERVICES, NAMELY, INSTRUCTION FOR A SPORT THAT COMBINES ELEMENTS OF BASEBALL AND GOLF ON A BASEBALL FIELD; PROVIDING A WEBSITE FOR INFORMATION ON A SPORT THAT COMBINES ELEMENTS OF BASEBALL AND GOLF ON A BASEBALL FIELD (U.S. CLS. 100, 101 AND 107).

PAUL CROWLEY, EXAMINING ATTORNEY

SN 86-228,429. LASHELL OOTEN, VICTORVILLE, CA. FILED 3-21-2014.

## 23 DIAMOND PRODUCTION

THE MARK CONSISTS OF STANDARD CHARACTERS WITHOUT CLAIM TO ANY PARTICULAR FONT, STYLE, SIZE, OR COLOR.

NO CLAIM IS MADE TO THE EXCLUSIVE RIGHT TO USE "PRODUCTION", APART FROM THE MARK AS SHOWN.

FOR ENTERTAINMENT AND RECORD LABEL SERVICES, NAMELY, MUSIC AND SONG WRITING SERVICES FOR NON-ADVERTISING PURPOSES, RECORDING, PRODUCTION AND POST-PRODUCTION SERVICES IN THE FIELD OF MUSIC; PRODUCTION OF MUSICAL SOUND RECORDINGS; MUSIC PUBLISHING SERVICES; MUSIC VIDEO PRODUCTION; RECORDING STUDIO SERVICES; EDUCATION SERVICES IN THE NATURE OF ARTIST DEVELOPMENT, NAMELY, MENTORING IN THE FIELD OF SONGWRITING, COMPOSING, VOCAL DEVELOPMENT, AND MUSIC PRODUCTION FOR MUSICAL ARTISTS; ARRANGING AND CONDUCTING OF CONCERTS; ORGANIZING ENTERTAINMENT EVENTS FEATURING LIVE MUSICAL PERFORMANCES; PROVIDING A WEBSITE FOR ENTERTAINMENT PURPOSES FEATURING PHOTOS, VIDEOS, STREAMING MUSIC, AND INFORMATION ABOUT PERFORMING ARTISTS AND MUSICAL GROUPS (U.S. CLS. 100, 101 AND 107).

ELIZABETH JACKSON, EXAMINING ATTORNEY

**CLASS 41—(Continued).**

SN 86-228,473. ADAM CHRISTIAN LA REAU, BOSTON, MA. FILED 3-21-2014.



THE COLOR(S) BLACK, WHITE, GRAY AND RED IS/ ARE CLAIMED AS A FEATURE OF THE MARK.

THE MARK CONSISTS OF A BLACK CIRCLE WITH A STYLIZED MOUNTAIN IN GRAY INSIDE THE CIRCLE AND WITH THE STYLIZED IMAGE OF TWO CHILDREN HOLDING HANDS WITH A SOLDIER, ALL SHOWN IN WHITE, IN FRONT OF THE MOUNTAIN WITH A RED TRIANGULAR BOX SHAPE BELOW THE STYLIZED PEOPLE WITH THE WORDS "ONE SUMMIT" IN WHITE INSIDE THE RED BOX AND WITH A WHITE LINE ABOVE AND BELOW THE RED BOX.

FOR CHARITABLE SERVICES IN THE NATURE OF CAMPS AND SOCIAL ENTERTAINMENT RETREATS, ACTIVITIES AND EVENTS FOR CHILDREN WITH CANCER AND FOR SIBLINGS OF CHILDREN WITH CANCER; CHARITABLE SERVICES IN THE NATURE OF EDUCATIONAL RETREATS, ACTIVITIES AND EVENTS FOR CHILDREN WITH CANCER AND FOR FAMILIES OF CHILDREN WITH CANCER TO EDUCATE THEM IN THE AREAS OF SELF-CONFIDENCE, COURAGE AND SKILLS TO OVERCOME PHYSICAL CHALLENGES AND CHALLENGES OF DEALING WITH CANCER (U.S. CLS. 100, 101 AND 107).

FIRST USE 1-10-2014; IN COMMERCE 1-10-2014.  
KELLEY WELLS, EXAMINING ATTORNEY

SN 86-228,673. MALLERY VENTURES, FOLSOM, CA. FILED 3-21-2014.

## Anima Expanding Wellness

THE MARK CONSISTS OF STANDARD CHARACTERS WITHOUT CLAIM TO ANY PARTICULAR FONT, STYLE, SIZE, OR COLOR.

NO CLAIM IS MADE TO THE EXCLUSIVE RIGHT TO USE "WELLNESS", APART FROM THE MARK AS SHOWN.

FOR PROFESSIONAL COACHING SERVICES IN THE FIELD OF HEALTH AND WELLNESS (U.S. CLS. 100, 101 AND 107).

RON FAIRBANKS, EXAMINING ATTORNEY

**CLASS 41—(Continued).**

SN 86-228,720. HOMETOWN TICKETS, LLC, FOND DU LAC, WI. FILED 3-21-2014.

HOMETOWN TICKETS

THE MARK CONSISTS OF STANDARD CHARACTERS WITHOUT CLAIM TO ANY PARTICULAR FONT, STYLE, SIZE, OR COLOR.

NO CLAIM IS MADE TO THE EXCLUSIVE RIGHT TO USE "TICKETS", APART FROM THE MARK AS SHOWN.

FOR ENTERTAINMENT TICKET AGENCY SERVICES (U.S. CLS. 100, 101 AND 107).

FIRST USE 10-1-2013; IN COMMERCE 3-8-2014.

MARYNELLE WILSON, EXAMINING ATTORNEY

**CLASS 41—(Continued).**

SN 86-229,129. IGO.LLC, MONUMENT, CO. FILED 3-22-2014.

**iGoCycling**

THE MARK CONSISTS OF THE STYLIZED WORDING "IGOCYCLING" WITH A STYLIZED BICYCLE AND RIDER IN THE "CYCLING" WORDING.

FOR PROVIDING A WEBSITE FEATURING CENTRALIZED LOCATIONS OF ALL CYCLING EVENTS AROUND THE COUNTRY; PROVIDING A WEB SITE FEATURING THE RATINGS, REVIEWS AND RECOMMENDATIONS OF USERS ON CYCLING EVENTS AND ACTIVITIES (U.S. CLS. 100, 101 AND 107).

BRIAN PINO, EXAMINING ATTORNEY

SN 86-228,725. SOCCER WITHOUT BORDERS, WEST CHESTER, PA. FILED 3-21-2014.



NO CLAIM IS MADE TO THE EXCLUSIVE RIGHT TO USE "SOCCER", APART FROM THE MARK AS SHOWN.

THE COLOR(S) DARK YELLOW, SKY BLUE, DARK BLUE, GREEN, WHITE, AND BLACK IS/ARE CLAIMED AS A FEATURE OF THE MARK.

THE MARK CONSISTS OF A STYLIZED WHITE DOVE WITH SKY BLUE OUTLINING ON A SKY BLUE CIRCLE, THE DOVE HAVING A BLACK EYE AND HOLDING IN ITS BEAK A BLACK BRANCH WITH GREEN LEAVES. IN THE CENTER OF THE DOVE IS A STYLIZED GREEN AND WHITE SOCCER BALL ENCIRCLED BY DARK BLUE ARCS AND A DARK BLUE SHADED SEMI-CIRCLE. TWO DARK YELLOW ARCS ARE AT THE TOP OF THE IMAGE, AND THE WORDING "SOCCER WITHOUT BORDERS" APPEARS AT THE BOTTOM OF THE IMAGE IN BLACK. THE ENTIRE IMAGE IS PLACED ON A TRANSPARENT BACKGROUND.

FOR CHARITABLE SERVICES, NAMELY, PROVIDING EDUCATIONAL AND TRAINING SERVICES IN THE FIELD OF SOCCER INSTRUCTION THROUGH CLASSES, WORKSHOPS AND CAMPS FOR CHILDREN (U.S. CLS. 100, 101 AND 107).

FIRST USE 7-1-2007; IN COMMERCE 7-1-2007.

JOANNA FIORELLI, EXAMINING ATTORNEY

SN 86-229,314. SALTZBERG, EDWARD, FALLS CHURCH, VA. FILED 3-23-2014.



NO CLAIM IS MADE TO THE EXCLUSIVE RIGHT TO USE "SECURITY & SUSTAINABILITY FORUM", APART FROM THE MARK AS SHOWN.

THE MARK CONSISTS OF TWO LEAVES WITH FIVE WATER DROPS ON AND AROUND THE LEAVES. THE TOP LEAF HAS A KEY HOLE WITH A KEY IN IT. THE WORDING "SECURITY & SUSTAINABILITY FORUM" APPEARS TO THE RIGHT OF THE LEAVES WRITTEN IN STYLIZED LETTERING WITH A SHADOW OF THE SAME PHRASE UNDERNEATH IT. THE WORDING "CONVENING GLOBAL EXPERTS TO GUIDE DECISION MAKING" IS LOCATED UNDERNEATH THE PHRASE "SECURITY & SUSTAINABILITY FORUM".

FOR EDUCATION SERVICES, NAMELY, PROVIDING NON-DOWNLOADABLE WEBINARS IN THE FIELD OF CLIMATE SECURITY, CLIMATE CHANGE, ENVIRONMENT, FOOD AND WATER SECURITY, PUBLIC HEALTH, ECONOMY, INFRASTRUCTURE, AND GOVERNANCE TO FIND BETTER SOLUTIONS IN MEETING GLOBAL CHALLENGES; EDUCATION SERVICES, NAMELY, PROVIDING PANEL DISCUSSIONS, SEMINARS, LECTURES, AND WORKSHOPS IN THE FIELDS OF CLIMATE SECURITY, CLIMATE CHANGE, ENVIRONMENT, FOOD AND WATER SECURITY, PUBLIC HEALTH, ECONOMY, INFRASTRUCTURE, AND GOVERNANCE TO FIND BETTER SOLUTIONS IN MEETING GLOBAL CHALLENGES; ENTERTAINMENT AND EDUCATIONAL SERVICES, NAMELY, THE PRESENTATION OF SEMINARS, LECTURES, WORKSHOPS AND PANEL DISCUSSIONS; AND ONGOING TELEVISION AND RADIO TALK SHOWS ALL IN THE FIELD OF PUBLIC INTEREST CONCERNING CLIMATE SECURITY, CLIMATE CHANGE, ENVIRONMENT, FOOD AND WATER SECURITY, PUBLIC HEALTH, ECONOMY, INFRASTRUCTURE, AND GOVERNANCE TO FIND BETTER SOLUTIONS IN MEETING GLOBAL CHALLENGES (U.S. CLS. 100, 101 AND 107).

FIRST USE 12-31-2009; IN COMMERCE 12-31-2009.

CASSONDRANDERSON, EXAMINING ATTORNEY

**CLASS 41—(Continued).**

SN 86-229,350. GRAVITATIONAL SOLUTIONS, INC., DBA EVENTVIBE, SAN DIEGO, CA. FILED 3-23-2014.

# Eventvibe

THE MARK CONSISTS OF STANDARD CHARACTERS WITHOUT CLAIM TO ANY PARTICULAR FONT, STYLE, SIZE, OR COLOR.

FOR ORGANIZING AND PROVIDING ENTERTAINMENT IN THE NATURE OF LIVE CONCERTS, DISC JOCKEY CONCERTS, MUSICAL AND ARTISTIC PERFORMANCES, NIGHTCLUBS, AND DANCE PARTIES (U.S. CLS. 100, 101 AND 107).

FIRST USE 1-1-2000; IN COMMERCE 1-1-2000.

HOWARD B. LEVINE, EXAMINING ATTORNEY

**CLASS 41—(Continued).**

SN 86-229,369. CAMPUS SPORTS NET LLC, SUNRISE, FL. FILED 3-23-2014.

# CAMPUS SPORTS NET

THE MARK CONSISTS OF STANDARD CHARACTERS WITHOUT CLAIM TO ANY PARTICULAR FONT, STYLE, SIZE, OR COLOR.

NO CLAIM IS MADE TO THE EXCLUSIVE RIGHT TO USE "SPORTS NET", APART FROM THE MARK AS SHOWN.

FOR PROVIDING INFORMATION, NEWS AND COMMENTARY IN THE FIELD OF ENTERTAINMENT (U.S. CLS. 100, 101 AND 107).

FIRST USE 8-13-2013; IN COMMERCE 8-13-2013.

AMY C. KEAN, EXAMINING ATTORNEY

SN 86-229,351. GRAVITATIONAL SOLUTIONS, INC., DBA EVENTVIBE, SAN DIEGO, CA. FILED 3-23-2014.



THE MARK CONSISTS OF A STYLIZED RENDERING OF THE TEXT "EVENTVIBE".

FOR ORGANIZING AND PROVIDING ENTERTAINMENT IN THE NATURE OF LIVE CONCERTS, DISC JOCKEY CONCERTS, MUSICAL AND ARTISTIC PERFORMANCES, NIGHTCLUBS, AND DANCE PARTIES (U.S. CLS. 100, 101 AND 107).

FIRST USE 1-1-2000; IN COMMERCE 1-1-2000.

HOWARD B. LEVINE, EXAMINING ATTORNEY

SN 86-229,779. PRO ARTS MANAGEMENT & CONSULTING LLC, ASTORIA, NY. FILED 3-24-2014.

# The Metropolitan Players

THE MARK CONSISTS OF STANDARD CHARACTERS WITHOUT CLAIM TO ANY PARTICULAR FONT, STYLE, SIZE, OR COLOR.

NO CLAIM IS MADE TO THE EXCLUSIVE RIGHT TO USE "PLAYERS", APART FROM THE MARK AS SHOWN.

FOR ENTERTAINMENT SERVICES IN THE NATURE OF LIVE MUSICAL PERFORMANCES; SPECIAL EVENT PLANNING FOR SOCIAL ENTERTAINMENT PURPOSES (U.S. CLS. 100, 101 AND 107).

FIRST USE 6-15-2013; IN COMMERCE 6-15-2013.

SUSAN RICHARDS, EXAMINING ATTORNEY

SN 86-229,367. CAMPUS SPORTS NET LLC, SUNRISE, FL. FILED 3-23-2014.

# CAMPUS SPORTS

THE MARK CONSISTS OF STANDARD CHARACTERS WITHOUT CLAIM TO ANY PARTICULAR FONT, STYLE, SIZE, OR COLOR.

NO CLAIM IS MADE TO THE EXCLUSIVE RIGHT TO USE "SPORTS", APART FROM THE MARK AS SHOWN.

FOR PROVIDING INFORMATION, NEWS AND COMMENTARY IN THE FIELD OF ENTERTAINMENT (U.S. CLS. 100, 101 AND 107).

FIRST USE 3-20-2014; IN COMMERCE 3-20-2014.

AMY C. KEAN, EXAMINING ATTORNEY

SN 86-229,852. IGO.LLC, MONUMENT, CO. FILED 3-24-2014.

# iGoCycling

THE MARK CONSISTS OF STANDARD CHARACTERS WITHOUT CLAIM TO ANY PARTICULAR FONT, STYLE, SIZE, OR COLOR.

FOR PROVIDING A WEBSITE FEATURING CENTRALIZED LOCATIONS OF ALL CYCLING EVENTS AROUND THE COUNTRY; PROVIDING A WEB SITE FEATURING THE RATINGS, REVIEWS AND RECOMMENDATIONS OF USERS ON CYCLING EVENTS AND ACTIVITIES (U.S. CLS. 100, 101 AND 107).

BRIAN PINO, EXAMINING ATTORNEY

**CLASS 41—(Continued).**

SN 86-229,897. GAP INTERNATIONAL, INC., DBA GAP INTERNATIONAL, SPRINGFIELD, PA. FILED 3-24-2014.

### Leveraging Genius Online

THE MARK CONSISTS OF STANDARD CHARACTERS WITHOUT CLAIM TO ANY PARTICULAR FONT, STYLE, SIZE, OR COLOR.

NO CLAIM IS MADE TO THE EXCLUSIVE RIGHT TO USE "ONLINE", APART FROM THE MARK AS SHOWN.

FOR PROVIDING EDUCATION COURSES IN THE FIELD OF BUSINESS CONSULTING AS IT PERTAINS TO CREATING AND INNOVATING NEW THINKING AND RESULTS OFFERED THROUGH ONLINE, NON-DOWNLOADABLE VIDEOS AND INSTRUCTOR ASSISTANCE (U.S. CLS. 100, 101 AND 107).

FIRST USE 2-1-2013; IN COMMERCE 2-1-2013.  
BRIAN NEVILLE, EXAMINING ATTORNEY

**CLASS 41—(Continued).**

SN 86-229,985. BISHOP KENNY HIGH SCHOOL, JACKSONVILLE, FL. FILED 3-24-2014.



NO CLAIM IS MADE TO THE EXCLUSIVE RIGHT TO USE "HIGH SCHOOL", APART FROM THE MARK AS SHOWN.

THE NAME "BISHOP KENNY" DOES NOT IDENTIFY A LIVING INDIVIDUAL.

THE MARK CONSISTS OF THE INITIALS "B", "K", "H" AND "S" WITH THE "B" AND "K" ABOVE THE "H" AND "S" TO THE LEFT OF THE PHRASE "BISHOP KENNY HIGH SCHOOL".

FOR EDUCATIONAL SERVICES, NAMELY, PROVIDING COURSES OF INSTRUCTION IN A PAROCHIAL HIGH SCHOOL ENCOMPASSING GRADES 9-12 (U.S. CLS. 100, 101 AND 107).

FIRST USE 1-1-1987; IN COMMERCE 1-1-1987.  
RON FAIRBANKS, EXAMINING ATTORNEY

SN 86-230,552. OLIVARES, RODOLFO, COPPELL, TX. FILED 3-24-2014.

### Memories in a Box

THE MARK CONSISTS OF STANDARD CHARACTERS WITHOUT CLAIM TO ANY PARTICULAR FONT, STYLE, SIZE, OR COLOR.

FOR RENTAL OF PORTABLE DIGITAL PHOTOGRAPHY BOOTHS FOR TAKING OF PICTURES (U.S. CLS. 100, 101 AND 107).

FIRST USE 1-3-2013; IN COMMERCE 1-3-2013.  
SETH DENNIS, EXAMINING ATTORNEY

SN 86-229,967. CAROLINA BREWMASTERS, INC., CHARLOTTE, NC. FILED 3-24-2014.

### CHARLOTTE OKTOBERFEST

THE MARK CONSISTS OF STANDARD CHARACTERS WITHOUT CLAIM TO ANY PARTICULAR FONT, STYLE, SIZE, OR COLOR.

NO CLAIM IS MADE TO THE EXCLUSIVE RIGHT TO USE "OKTOBERFEST", APART FROM THE MARK AS SHOWN.

SEC. 2(F).

FOR CONDUCTING ENTERTAINMENT EXHIBITIONS IN THE NATURE OF CULTURAL FESTIVALS FEATURING FOOD, BEVERAGES, LIVE MUSICAL PERFORMANCES, AND ENTERTAINMENT (U.S. CLS. 100, 101 AND 107).

FIRST USE 9-20-1999; IN COMMERCE 10-16-1999.  
ROSELLE HERRERA, EXAMINING ATTORNEY

SN 86-230,559. SMARTY PAWS CANINE COACHING OF LAS VEGAS, LLC, DBA SMARTY PAWS CANINE COACHING, LAS VEGAS, NV. FILED 3-24-2014.

### Smarty Paws Canine Coaching

THE MARK CONSISTS OF STANDARD CHARACTERS WITHOUT CLAIM TO ANY PARTICULAR FONT, STYLE, SIZE, OR COLOR.

NO CLAIM IS MADE TO THE EXCLUSIVE RIGHT TO USE "CANINE COACHING", APART FROM THE MARK AS SHOWN.

FOR DOG TRAINING (U.S. CLS. 100, 101 AND 107).  
FIRST USE 3-15-2002; IN COMMERCE 3-15-2002.  
RONALD AIKENS, EXAMINING ATTORNEY

**CLASS 41—(Continued).**

SN 86-230,810. SUAREZ, REBECCA, KISSIMMEE, FL. AND RODRIGUEZ, ABIGAIL, KISSIMMEE, FL. AND NIEVES, EUNICE, KISSIMMEE, FL. AND SUAREZ, LIDIA ESTER, KISSIMMEE, FL. FILED 3-25-2014.

**R.E.A.L. MINISTRIES**

THE MARK CONSISTS OF STANDARD CHARACTERS WITHOUT CLAIM TO ANY PARTICULAR FONT, STYLE, SIZE, OR COLOR.

NO CLAIM IS MADE TO THE EXCLUSIVE RIGHT TO USE "MINISTRIES", APART FROM THE MARK AS SHOWN.

FOR ENTERTAINMENT RENDERED BY A MUSICAL GROUP, NAMELY, ENTERTAINMENT IN THE NATURE OF LIVE VISUAL AND AUDIO PERFORMANCES BY A MUSICAL GROUP; LIVE PERFORMANCES BY A MUSICAL GROUP; PROVIDING AN INTERNET WEBSITE PORTAL IN THE FIELD OF MUSIC; ENTERTAINMENT SERVICES, NAMELY, LIVE, TELEVISED AND MOVIE APPEARANCES BY A MUSICAL GROUP; ENTERTAINMENT SERVICES, NAMELY, PERSONAL APPEARANCES BY A MUSICAL GROUP (U.S. CLS. 100, 101 AND 107).

ROBIN CHOSID, EXAMINING ATTORNEY

SN 86-230,870. ALI A. PABARJA, NAPERVILLE, IL. FILED 3-25-2014.

**ELITE TUTORING PLACE**

THE MARK CONSISTS OF STANDARD CHARACTERS WITHOUT CLAIM TO ANY PARTICULAR FONT, STYLE, SIZE, OR COLOR.

NO CLAIM IS MADE TO THE EXCLUSIVE RIGHT TO USE "TUTORING PLACE", APART FROM THE MARK AS SHOWN.

FOR EDUCATION SERVICES, NAMELY, PROVIDING TUTORING IN THE FIELD OF SUBJECTS AT THE ELEMENTARY, JUNIOR HIGH OR MIDDLE SCHOOL LEVEL, HIGH SCHOOL, AND/OR COLLEGE LEVEL (U.S. CLS. 100, 101 AND 107).

DOMINICK J. SALEMI, EXAMINING ATTORNEY

**CLASS 41—(Continued).**

SN 86-230,915. BOARD OF REGENTS OF THE UNIVERSITY OF WISCONSIN SYSTEM, MADISON, WI. FILED 3-25-2014.

**First Wave**

THE MARK CONSISTS OF STANDARD CHARACTERS WITHOUT CLAIM TO ANY PARTICULAR FONT, STYLE, SIZE, OR COLOR.

OWNER OF U.S. REG. NO. 3,378,318.

FOR EDUCATIONAL SERVICES, NAMELY, PROVIDING OUTREACH PROGRAMS, SCHOLARLY SEMINARS, AND BIENNIAL FESTIVALS FOR VISUAL AND PERFORMING ARTS TIED TO A LEARNING COMMUNITY WITH EMPHASIS ON HIP HOP ARTS, CULTURE AND PEDAGOGY (U.S. CLS. 100, 101 AND 107).

FIRST USE 6-30-2007; IN COMMERCE 6-30-2007.

GRETTA YAO, EXAMINING ATTORNEY

SN 86-230,929. WARD THOMAS IP LTD., LONDON, UNITED KINGDOM, FILED 3-25-2014.

**WARD THOMAS**

THE MARK CONSISTS OF STANDARD CHARACTERS WITHOUT CLAIM TO ANY PARTICULAR FONT, STYLE, SIZE, OR COLOR.

THE NAME "WARD THOMAS" DOES NOT IDENTIFY A LIVING INDIVIDUAL.

FOR ENTERTAINMENT SERVICES, NAMELY, LIVE MUSIC PERFORMANCES AND PROVIDING PUBLIC APPEARANCES BY A PERFORMING ARTIST, NAMELY, MUSICIANS AND MUSICAL RECORDING ARTISTS; ENTERTAINMENT, NAMELY, LIVE PERFORMANCES BY A MUSICAL BAND; PROVIDING A WEBSITE FEATURING NON-DOWNLOADABLE AUDIO-VISUAL CONTENT, NAMELY, MUSIC PERFORMANCES AND MUSIC VIDEOS; PROVIDING A WEBSITE FEATURING ENTERTAINMENT INFORMATION ON A PERFORMING ARTIST, INCLUDING TOURING, APPEARANCES, NEWS, BIOGRAPHY, PHOTOGRAPHS, AND OTHER ENTERTAINMENT INFORMATION (U.S. CLS. 100, 101 AND 107).

FIRST USE 11-0-2013; IN COMMERCE 11-0-2013.

ALISON KEELEY, EXAMINING ATTORNEY

**CLASS 41—(Continued).**

SN 86-231,259. BROWN, ZALIKA SITI, WASHINGTON, DC. FILED 3-25-2014.

**Brown Girls Cook**

THE MARK CONSISTS OF STANDARD CHARACTERS WITHOUT CLAIM TO ANY PARTICULAR FONT, STYLE, SIZE, OR COLOR.

NO CLAIM IS MADE TO THE EXCLUSIVE RIGHT TO USE "COOK", APART FROM THE MARK AS SHOWN.

FOR COOKING INSTRUCTION; EDUCATIONAL SERVICES, NAMELY, PROVIDING ONLINE INSTRUCTION IN THE FIELD OF FOOD AND COOKING VIA AN ONLINE WEBSITE; ENTERTAINMENT SERVICES, NAMELY, PROVIDING ON-LINE REVIEWS OF RECIPES AND COOKING TIPS; ON-LINE JOURNALS, NAMELY, BLOGS FEATURING COOKING SUGGESTIONS, TIPS, IDEAS, RECIPES, ALONG WITH VIDEOS AND PHOTOGRAPHS OF DISHES AND INGREDIENTS (U.S. CLS. 100, 101 AND 107).

SHANNON TWOHIG, EXAMINING ATTORNEY

---

SN 86-231,300. SYLVIE SHERMAN, ST. LOUIS, MO. FILED 3-25-2014.

**THE MMBYE REPORT**

THE MARK CONSISTS OF STANDARD CHARACTERS WITHOUT CLAIM TO ANY PARTICULAR FONT, STYLE, SIZE, OR COLOR.

NO CLAIM IS MADE TO THE EXCLUSIVE RIGHT TO USE "REPORT", APART FROM THE MARK AS SHOWN.

FOR PROVIDING A BLOG REGARDING CURRENT EVENTS, SOCIAL MEDIA, CULTURAL TRENDS AND ENTERTAINMENT (U.S. CLS. 100, 101 AND 107).

FIRST USE 3-15-2014; IN COMMERCE 3-15-2014.

ZACHARY CROMER, EXAMINING ATTORNEY

---

SN 86-231,759. MIDWEST LAX BASH LACROSSE LLC, WASHINGTON, MI. FILED 3-25-2014.

**Lax Bash**

THE MARK CONSISTS OF STANDARD CHARACTERS WITHOUT CLAIM TO ANY PARTICULAR FONT, STYLE, SIZE, OR COLOR.

NO CLAIM IS MADE TO THE EXCLUSIVE RIGHT TO USE "LAX", APART FROM THE MARK AS SHOWN.

FOR ORGANIZING, CONDUCTING AND OPERATING AMATEUR LACROSSE TOURNAMENTS (U.S. CLS. 100, 101 AND 107).

FIRST USE 3-1-2011; IN COMMERCE 3-1-2011.

MARIA-VICTORIA SUAREZ, EXAMINING ATTORNEY

**CLASS 41—(Continued).**

SN 86-232,475. SALT SOLUTIONS, INC., URBAN DALE, IA. FILED 3-26-2014.

**EARNED LEVEL**

THE MARK CONSISTS OF STANDARD CHARACTERS WITHOUT CLAIM TO ANY PARTICULAR FONT, STYLE, SIZE, OR COLOR.

NO CLAIM IS MADE TO THE EXCLUSIVE RIGHT TO USE "LEVEL", APART FROM THE MARK AS SHOWN.

FOR ONLINE EDUCATIONAL SERVICES, NAMELY, PROVIDING ONLINE CLASSES AND COURSES TO ASSIST STUDENTS IN PREPARING FOR ACTUARIAL EXAMS (U.S. CLS. 100, 101 AND 107).

FIRST USE 12-1-2013; IN COMMERCE 12-1-2013.

KIMBERLY PARKS, EXAMINING ATTORNEY

---

SN 86-232,684. THE SHOWALTER GROUP, INC., DBA THE SHOWALTER GROUP, INC., CINCINNATI, OH. FILED 3-26-2014.

**Grassroots Influence Pulse**

THE MARK CONSISTS OF STANDARD CHARACTERS WITHOUT CLAIM TO ANY PARTICULAR FONT, STYLE, SIZE, OR COLOR.

NO CLAIM IS MADE TO THE EXCLUSIVE RIGHT TO USE "GRASSROOTS INFLUENCE", APART FROM THE MARK AS SHOWN.

FOR EDUCATIONAL SERVICES, NAMELY, CONDUCTING EDUCATIONAL CONFERENCES THAT FACILITATE NETWORKING OPPORTUNITIES IN THE FIELD OF GRASSROOTS, POLITICAL ACTION COMMITTEE, AND LOBBYING DISCIPLINES (U.S. CLS. 100, 101 AND 107).

FIRST USE 8-30-2013; IN COMMERCE 10-10-2013.

BARNEY CHARLON, EXAMINING ATTORNEY



**CLASS 41—(Continued).**

SN 86-232,786. GHOST OF JASON MOLINA, LLC, NASHVILLE, TN. FILED 3-26-2014.

# SONGS: OHIA

THE MARK CONSISTS OF STANDARD CHARACTERS WITHOUT CLAIM TO ANY PARTICULAR FONT, STYLE, SIZE, OR COLOR.

NO CLAIM IS MADE TO THE EXCLUSIVE RIGHT TO USE "SONGS", APART FROM THE MARK AS SHOWN.

FOR ENTERTAINMENT SERVICES, NAMELY, ARRANGING AND CONDUCTING LIVE PERFORMANCES, PERSONAL APPEARANCES AS WELL AS LIVE TELEVISION AND RADIO PERFORMANCES BY MUSICAL ARTISTS; ENTERTAINMENT, NAMELY, PRODUCTION OF LIVE THEATRICAL SHOWS, LIVE MUSICAL SHOWS, CONCERTS, MULTIMEDIA ENTERTAINMENT EVENTS, VIDEOS, MULTIMEDIA VIDEOS, MOTION PICTURE FILMS, INTERACTIVE MULTIMEDIA ENTERTAINMENT AND RADIO AND TELEVISION PROGRAMS; APPEARANCES BY A CELEBRITY; FAN CLUB SERVICES; AUDIO AND VIDEO RECORDING SERVICES; PRODUCTION OF VIDEO AND AUDIO RECORDINGS ON CASSETTES, DVDS, COMPACT DISCS, RECORDS AND IN DIGITAL FORMAT, FEATURING MUSIC; PROVIDING NON-DOWNLOADABLE ELECTRONIC PUBLICATIONS, NAMELY, BLOGS AND ONLINE MAGAZINES FEATURING INFORMATION ABOUT MUSIC, FILM, TELEVISION, ANIMATION, COMICS AND POPULAR CULTURE; ENTERTAINMENT SERVICES, NAMELY, PROVIDING THE ONLINE PLAYBACK OF NON-DOWNLOADABLE PRERECORDED MUSIC AND VIDEOS FEATURING MUSIC ONLINE VIA A GLOBAL COMPUTER NETWORK; PROVIDING A WEBSITE FEATURING INFORMATION ON MUSICAL ARTISTS, NAMELY, PERFORMANCES, RECORDS, APPEARANCES AND BIOGRAPHICAL INFORMATION ONLINE VIA A GLOBAL COMPUTER NETWORK; MUSIC PUBLISHING SERVICES; CONDUCTING ONLINE SWEEPSTAKES AND CONTESTS; PROVIDING ONLINE INFORMATION ABOUT MUSIC, CELEBRITY, FILM, TELEVISION, ANIMATION, COMICS AND POPULAR CULTURE (U.S. CLS. 100, 101 AND 107).

FIRST USE 1-1-1995; IN COMMERCE 1-1-1995.  
HOWARD SMIGA, EXAMINING ATTORNEY

SN 86-232,929. WATCHUNG HILLS SOCCER ASSOCIATION, INC., MARTINSVILLE, NJ. FILED 3-26-2014.

# NJ ELITE

THE MARK CONSISTS OF STANDARD CHARACTERS WITHOUT CLAIM TO ANY PARTICULAR FONT, STYLE, SIZE, OR COLOR.

NO CLAIM IS MADE TO THE EXCLUSIVE RIGHT TO USE "NJ", APART FROM THE MARK AS SHOWN.

FOR ENTERTAINMENT IN THE NATURE OF SOCCER GAMES; ORGANIZATION OF SOCCER GAMES; ORGANIZING AND CONDUCTING ATHLETIC COMPETITIONS AND GAMES IN THE FIELD OF SOCCER; ORGANIZING SPORTING EVENTS, NAMELY, SOCCER COMPETITION; ORGANIZING, CONDUCTING AND OPERATING SOCCER TOURNAMENTS; SOCCER CAMPS; SOCCER INSTRUCTION (U.S. CLS. 100, 101 AND 107).

FIRST USE 9-0-2007; IN COMMERCE 9-0-2007.  
ERNEST SHOSHO, EXAMINING ATTORNEY

**CLASS 41—(Continued).**

SN 86-233,043. GHOST OF JASON MOLINA, LLC, NASHVILLE, TN. FILED 3-26-2014.

# MAGNOLIA ELECTRIC CO.

THE MARK CONSISTS OF STANDARD CHARACTERS WITHOUT CLAIM TO ANY PARTICULAR FONT, STYLE, SIZE, OR COLOR.

NO CLAIM IS MADE TO THE EXCLUSIVE RIGHT TO USE "CO.", APART FROM THE MARK AS SHOWN.

FOR ENTERTAINMENT SERVICES, NAMELY, ARRANGING AND CONDUCTING LIVE PERFORMANCES, PERSONAL APPEARANCES AS WELL AS LIVE TELEVISION AND RADIO PERFORMANCES BY MUSICAL ARTISTS; ENTERTAINMENT, NAMELY, PRODUCTION OF LIVE THEATRICAL SHOWS, LIVE MUSICAL SHOWS, CONCERTS, MULTIMEDIA ENTERTAINMENT EVENTS, VIDEOS, MULTIMEDIA VIDEOS, MOTION PICTURE FILMS, INTERACTIVE MULTIMEDIA ENTERTAINMENT AND RADIO AND TELEVISION PROGRAMS; APPEARANCES BY A CELEBRITY; FAN CLUB SERVICES; AUDIO AND VIDEO RECORDING SERVICES; PRODUCTION OF VIDEO AND AUDIO RECORDINGS ON CASSETTES, DVDS, COMPACT DISCS, RECORDS AND IN DIGITAL FORMAT, FEATURING MUSIC; PROVIDING NON-DOWNLOADABLE ELECTRONIC PUBLICATIONS, NAMELY, BLOGS AND ONLINE MAGAZINES FEATURING INFORMATION ABOUT MUSIC, FILM, TELEVISION, ANIMATION, COMICS AND POPULAR CULTURE; ENTERTAINMENT SERVICES, NAMELY, PROVIDING THE ONLINE PLAYBACK OF NON-DOWNLOADABLE PRERECORDED MUSIC AND VIDEOS FEATURING MUSIC ONLINE VIA A GLOBAL COMPUTER NETWORK; PROVIDING A WEBSITE FEATURING INFORMATION ON MUSICAL ARTISTS, NAMELY, PERFORMANCES, RECORDS, APPEARANCES AND BIOGRAPHICAL INFORMATION ONLINE VIA A GLOBAL COMPUTER NETWORK; MUSIC PUBLISHING SERVICES; CONDUCTING ONLINE SWEEPSTAKES AND CONTESTS; PROVIDING ONLINE INFORMATION ABOUT MUSIC, CELEBRITY, FILM, TELEVISION, ANIMATION, COMICS AND POPULAR CULTURE (U.S. CLS. 100, 101 AND 107).

FIRST USE 11-3-2003; IN COMMERCE 11-3-2003.  
HOWARD SMIGA, EXAMINING ATTORNEY

**CLASS 41—(Continued).**

SN 86-233,121. FIGURE SKATING IN HARLEM, INC., NEW YORK, NY. FILED 3-26-2014.



NO CLAIM IS MADE TO THE EXCLUSIVE RIGHT TO USE "FIGURE SKATING IN THE BRONX", APART FROM THE MARK AS SHOWN.

THE MARK CONSISTS OF A SILHOUETTE OF A FIGURE SKATER TO THE LEFT OF THE WORDS "FIGURE SKATING IN THE BRONX".

FOR EDUCATIONAL SERVICES, NAMELY, COURSES OF INSTRUCTION IN THE FIELDS OF SKATING, DANCE AND YOGA; PROVIDING CLASSES IN THE FIELD OF LIFE SKILLS; EDUCATIONAL SERVICES, NAMELY, PROVIDING ACADEMIC TUTORING IN THE FIELDS OF LANGUAGE, ARTS AND MATH; CONDUCTING AFTER SCHOOL ACADEMIC TUTORING PROGRAMS; MENTORING IN THE FIELD OF SOCIAL AND ACADEMIC DEVELOPMENT; ACADEMIC ENRICHMENT CLASSES IN THE FIELDS OF WRITING, HISTORY, NUTRITION AND CIVICS (U.S. CLS. 100, 101 AND 107).

JANET LEE, EXAMINING ATTORNEY

---

SN 86-233,193. ELECTRONIC ARTS INC., REDWOOD CITY, CA. FILED 3-26-2014.

# EA SPORTS

THE MARK CONSISTS OF STANDARD CHARACTERS WITHOUT CLAIM TO ANY PARTICULAR FONT, STYLE, SIZE, OR COLOR.

OWNER OF U.S. REG. NOS. 3,244,216, 4,206,221 AND OTHERS.

SEC. 2(F) AS TO "SPORTS".

FOR ENTERTAINMENT SERVICES, NAMELY, PROVIDING AN ON-LINE COMPUTER GAME; PROVISION OF INFORMATION RELATING TO ELECTRONIC COMPUTER GAMES PROVIDED VIA THE INTERNET (U.S. CLS. 100, 101 AND 107).

FIRST USE 11-24-2004; IN COMMERCE 11-24-2004.

ADA HAN, EXAMINING ATTORNEY

**CLASS 41—(Continued).**

SN 86-233,289. PEARL, JAMES, LOS ANGELES, CA. FILED 3-26-2014.

## Somebody Else's Business

THE MARK CONSISTS OF STANDARD CHARACTERS WITHOUT CLAIM TO ANY PARTICULAR FONT, STYLE, SIZE, OR COLOR.

FOR ENTERTAINMENT SERVICES, NAMELY, FILM AND VIDEO PRODUCTION; PRODUCTION OF MOVIES AND COMMERCIALS; AND ENTERTAINMENT IN THE NATURE OF LIVE THEATRICAL PERFORMANCES; PRODUCTION OF PLAYS AND SKITS (U.S. CLS. 100, 101 AND 107).

STEVEN JACKSON, EXAMINING ATTORNEY

---

SN 86-233,493. SMITH, BETTY J., BUCKLEY, WA. FILED 3-27-2014.

## dnaCellTalk

THE MARK CONSISTS OF STANDARD CHARACTERS WITHOUT CLAIM TO ANY PARTICULAR FONT, STYLE, SIZE, OR COLOR.

FOR PROVIDING EDUCATION COURSES IN THE FIELD OF HUMAN ENGINEERING AND RESEARCH TRANSITIONAL TECHNOLOGIES OFFERED THROUGH ONLINE, NON-DOWNLOADABLE VIDEOS AND INSTRUCTOR ASSISTANCE (U.S. CLS. 100, 101 AND 107).

FIRST USE 3-17-1987; IN COMMERCE 3-17-2014.

MARIA-VICTORIA SUAREZ, EXAMINING ATTORNEY

---

SN 86-233,518. NEURU, MARY-JOY, VISTA, CA. FILED 3-27-2014.

## DIVINE QUANTUM REIKI

THE MARK CONSISTS OF STANDARD CHARACTERS WITHOUT CLAIM TO ANY PARTICULAR FONT, STYLE, SIZE, OR COLOR.

NO CLAIM IS MADE TO THE EXCLUSIVE RIGHT TO USE "QUANTUM REIKI", APART FROM THE MARK AS SHOWN.

FOR EDUCATION SERVICES, NAMELY, PROVIDING CLASSES AND INSTRUCTION IN THE FIELD OF ENERGY HEALING (U.S. CLS. 100, 101 AND 107).

FIRST USE 3-24-2014; IN COMMERCE 3-24-2014.

TIFFANY CHIANG, EXAMINING ATTORNEY

**CLASS 41—(Continued).**

SN 86-233,852. JESSE JAMES FITNESS, LLC., , FLOWER MOUND, TX. FILED 3-27-2014.



NO CLAIM IS MADE TO THE EXCLUSIVE RIGHT TO USE "FIT", APART FROM THE MARK AS SHOWN.

THE NAME(S), PORTRAIT(S), AND/OR SIGNATURE(S) SHOWN IN THE MARK IDENTIFIES JESSE JAMES LEVYA, WHOSE CONSENT(S) TO REGISTER IS MADE OF RECORD.

THE COLOR(S) BLACK, PURPLE, DARK PURPLE AND DARK GRAY IS/ARE CLAIMED AS A FEATURE OF THE MARK.

THE MARK CONSISTS OF THE PHRASE "JESSE FIT JAMES" IN STYLIZED, PURPLE TEXT WITH "FIT" IN A DARKER SHADE OF PURPLE. "FIT" IS INSIDE A BLACK CIRCLE WITH PURPLE GRADIENT FILL WITH "JESSE" AND "JAMES" ON EITHER SIDE OF THE CIRCLE. ALONG THE TOP AND THE BOTTOM OF THE TRADEMARK ARE GEAR-LIKE, STYLIZED MARKINGS IN DARK GRAY.

FOR HEALTH CLUB SERVICES, NAMELY, PROVIDING INSTRUCTION AND EQUIPMENT IN THE FIELD OF PHYSICAL EXERCISE; PERSONAL FITNESS TRAINING SERVICES AND CONSULTANCY; PROVIDING ASSISTANCE, PERSONAL TRAINING AND PHYSICAL FITNESS CONSULTATION TO INDIVIDUALS TO HELP THEM MAKE PHYSICAL FITNESS, STRENGTH, CONDITIONING, AND EXERCISE IMPROVEMENT IN THEIR DAILY LIVING (U.S. CLS. 100, 101 AND 107).  
FIRST USE 5-1-2010; IN COMMERCE 5-1-2010.  
SCOTT BIBB, EXAMINING ATTORNEY

**CLASS 41—(Continued).**

SN 86-234,059. GOOD SHEPHERD MOTORSPORTS LLC, BEVERLY HILLS, CA. FILED 3-27-2014.



THE MARK CONSISTS OF A STYLIZED "A" WITHIN A CIRCLE.

FOR ENTERTAINMENT SERVICES, NAMELY, PARTICIPATION IN AUTOMOBILE AND MOTORSPORTS RACE EVENTS AND COMPETITIONS; ENTERTAINMENT IN THE NATURE OF AUTOMOBILE AND MOTORSPORTS RACING, SPORTS CAR RACING, AND EXHIBITIONS; PROVIDING ONLINE INFORMATION IN THE FIELD OF AUTOMOBILE AND MOTORSPORTS RACE EVENTS AND COMPETITIONS VIA THE INTERNET; PRODUCTION OF VIDEOS AND FILMS IN THE FIELD OF MOTORSPORTS; ENTERTAINMENT SERVICES, NAMELY, PERSONAL APPEARANCES BY A SPORTS CELEBRITY; CONDUCTING EDUCATIONAL PROGRAMS FOR CHILDREN IN THE FIELDS OF SELF-ESTEEM, POSITIVE THINKING, WORK HABITS, AND AUTOMOBILE AND MOTORSPORTS RACING CONDUCTED BY A SPORTS CELEBRITY (U.S. CLS. 100, 101 AND 107).  
MORGAN WYNNE, EXAMINING ATTORNEY

SN 86-234,110. GOOD SHEPHERD MOTORSPORTS LLC, BEVERLY HILLS, CA. FILED 3-27-2014.

THERE IS A HERO IN EVERYONE

THE MARK CONSISTS OF STANDARD CHARACTERS WITHOUT CLAIM TO ANY PARTICULAR FONT, STYLE, SIZE, OR COLOR.

FOR ENTERTAINMENT SERVICES, NAMELY, PARTICIPATION IN AUTOMOBILE AND MOTORSPORTS RACE EVENTS AND COMPETITIONS; ENTERTAINMENT IN THE NATURE OF AUTOMOBILE AND MOTORSPORTS RACING, SPORTS CAR RACING, AND EXHIBITIONS; PROVIDING ONLINE INFORMATION IN THE FIELD OF AUTOMOBILE AND MOTORSPORTS RACE EVENTS AND COMPETITIONS VIA THE INTERNET; PRODUCTION OF VIDEOS AND FILMS IN THE FIELD OF MOTORSPORTS; ENTERTAINMENT SERVICES, NAMELY, PERSONAL APPEARANCES BY A SPORTS CELEBRITY; CONDUCTING EDUCATIONAL PROGRAMS FOR CHILDREN IN THE FIELDS OF SELF-ESTEEM, POSITIVE THINKING, WORK HABITS, AND AUTOMOBILE AND MOTORSPORTS RACING CONDUCTED BY A SPORTS CELEBRITY (U.S. CLS. 100, 101 AND 107).  
MORGAN WYNNE, EXAMINING ATTORNEY

SN 86-234,019. RX-360 INTERNATIONAL PHARMACEUTICAL SUPPLY CHAIN CONSORTIUM, WASHINGTON, DC. FILED 3-27-2014.

RX-360

THE MARK CONSISTS OF STANDARD CHARACTERS WITHOUT CLAIM TO ANY PARTICULAR FONT, STYLE, SIZE, OR COLOR.

FOR EDUCATIONAL SERVICES, NAMELY, PROVIDING SEMINARS, SYMPOSIA, AND WORKSHOPS IN THE FIELD OF PHARMACEUTICAL SUPPLY CHAIN SECURITY; PROVIDING NON-DOWNLOADABLE WEBINARS IN THE FIELD OF PHARMACEUTICAL SUPPLY CHAIN SECURITY (U.S. CLS. 100, 101 AND 107).  
FIRST USE 0-0-2009; IN COMMERCE 0-0-2009.  
KELLEY WELLS, EXAMINING ATTORNEY

**CLASS 41—(Continued).**

SN 86-234,185. GOOD SHEPHERD MOTORSPORTS LLC, BEVERLY HILLS, CA. FILED 3-27-2014.

# ACER

THE MARK CONSISTS OF STANDARD CHARACTERS WITHOUT CLAIM TO ANY PARTICULAR FONT, STYLE, SIZE, OR COLOR.

FOR ENTERTAINMENT SERVICES, NAMELY, PARTICIPATION IN AUTOMOBILE AND MOTORSPORTS RACE EVENTS AND COMPETITIONS; ENTERTAINMENT IN THE NATURE OF AUTOMOBILE AND MOTORSPORTS RACING, SPORTS CAR RACING, AND EXHIBITIONS; PROVIDING ONLINE INFORMATION IN THE FIELD OF AUTOMOBILE AND MOTORSPORTS RACE EVENTS AND COMPETITIONS VIA THE INTERNET; PRODUCTION OF VIDEOS AND FILMS IN THE FIELD OF MOTORSPORTS; ENTERTAINMENT SERVICES, NAMELY, PERSONAL APPEARANCES BY A SPORTS CELEBRITY; CONDUCTING EDUCATIONAL PROGRAMS FOR CHILDREN IN THE FIELDS OF SELF-ESTEEM, POSITIVE THINKING, WORK HABITS, AND AUTOMOBILE AND MOTORSPORTS RACING CONDUCTED BY A SPORTS CELEBRITY (U.S. CLS. 100, 101 AND 107).

MORGAN WYNNE, EXAMINING ATTORNEY

SN 86-234,320. MANHATTAN TO MONTAUK, LLC, EAST QUOGUE, NY. FILED 3-27-2014.



THE MARK CONSISTS OF A FISH WITH A CITYSCAPE ALONG SPINE AND A LIGHTHOUSE ON THE TAIL AND "MNHTN2MTK.COM" UNDERNEATH.

FOR PROVIDING A WEBSITE FEATURING NON-DOWNLOADABLE ARTICLES IN THE FIELD OF FISHING (U.S. CLS. 100, 101 AND 107).

ELLEN BURNS, EXAMINING ATTORNEY

**CLASS 41—(Continued).**

SN 86-234,447. PRETTY LITTLE BASH LLC, FOWLER, MI. FILED 3-27-2014.

# Pretty Little Bash

THE MARK CONSISTS OF STANDARD CHARACTERS WITHOUT CLAIM TO ANY PARTICULAR FONT, STYLE, SIZE, OR COLOR.

FOR PARTY AND WEDDING RECEPTION PLANNING, COORDINATION AND CONSULTATION SERVICES (U.S. CLS. 100, 101 AND 107).

FIRST USE 2-25-2014; IN COMMERCE 2-25-2014.  
SKYE YOUNG, EXAMINING ATTORNEY

SN 86-234,759. KATNIK4, LLC, DBA TEAMRIDE, SACRAMENTO, CA. FILED 3-27-2014.



THE MARK CONSISTS OF A STYLIZED CIRCULAR FLOWER WITHIN A SINGLE LINE CIRCLE. TO THE RIGHT OF THE FLOWER IS THE WORDING "TEAMRIDE".

FOR PHYSICAL FITNESS STUDIO SERVICES, NAMELY, PROVIDING GROUP EXERCISE INSTRUCTION, EQUIPMENT, AND FACILITIES (U.S. CLS. 100, 101 AND 107).

FIRST USE 1-3-2012; IN COMMERCE 1-3-2012.  
TARAH HARDY, EXAMINING ATTORNEY

SN 86-234,901. MOUKHTAROV, DJARBAIL, JAMAICA, NY. FILED 3-28-2014.

# FIGHTEROBICS

THE MARK CONSISTS OF STANDARD CHARACTERS WITHOUT CLAIM TO ANY PARTICULAR FONT, STYLE, SIZE, OR COLOR.

FOR CONDUCTING FITNESS CLASSES (U.S. CLS. 100, 101 AND 107).

MAYUR VAGHANI, EXAMINING ATTORNEY

**CLASS 41—(Continued).**

SN 86-235,031. NEW MUSEUM OF CONTEMPORARY ART, NEW YORK, NY. FILED 3-28-2014.

**NEW INC**

THE MARK CONSISTS OF STANDARD CHARACTERS WITHOUT CLAIM TO ANY PARTICULAR FONT, STYLE, SIZE, OR COLOR.

NO CLAIM IS MADE TO THE EXCLUSIVE RIGHT TO USE "INC", APART FROM THE MARK AS SHOWN.

FOR PROVIDING FACILITIES FOR ARTISTS' AND DESIGNERS' STUDIOS AND EXHIBITS (U.S. CLS. 100, 101 AND 107).

JASON MALASHEVICH, EXAMINING ATTORNEY

**CLASS 41—(Continued).**

SN 86-235,163. ROCHE, JAMES, VALENCIA, CA. FILED 3-28-2014.

**FREEDOM BASED LIFESTYLE**

THE MARK CONSISTS OF STANDARD CHARACTERS WITHOUT CLAIM TO ANY PARTICULAR FONT, STYLE, SIZE, OR COLOR.

FOR EDUCATION SERVICES, NAMELY, ONE-ON-ONE MENTORING IN THE FIELD OF BUSINESS MARKETING; EDUCATION SERVICES, NAMELY, PROVIDING TELESEMINARS, WORKSHOPS AND CLASSES IN THE FIELD OF BUSINESS MARKETING; EDUCATION SERVICES FOR ENTREPRENEURS, NAMELY, PROVIDING WORKSHOPS AND SEMINARS IN THE FIELDS OF BUSINESS AND MARKETING; EDUCATIONAL SERVICES, NAMELY, PROVIDING ONLINE TUTORIALS IN THE FIELD OF BUSINESS AND MARKETING; PROFESSIONAL COACHING SERVICES IN THE FIELD OF BUSINESS AND MARKETING; PROVIDING ON-LINE NEWSLETTERS IN THE FIELD OF BUSINESS AND MARKETING; AND ON-LINE JOURNALS, NAMELY, BLOGS IN THE FIELD OF BUSINESS AND MARKETING (U.S. CLS. 100, 101 AND 107).

FIRST USE 7-0-2013; IN COMMERCE 12-1-2013.

MARC LEIPZIG, EXAMINING ATTORNEY

SN 86-235,155. GARDEN TRIBE LLC, SAN RAFAEL, CA. FILED 3-28-2014.

**Garden Tribe**

THE MARK CONSISTS OF STANDARD CHARACTERS WITHOUT CLAIM TO ANY PARTICULAR FONT, STYLE, SIZE, OR COLOR.

NO CLAIM IS MADE TO THE EXCLUSIVE RIGHT TO USE "GARDEN", APART FROM THE MARK AS SHOWN.

FOR EDUCATIONAL SERVICES, NAMELY, PROVIDING ON-LINE CLASSES, SEMINARS, AND WORKSHOPS IN THE FIELD OF GARDENING AND HORTICULTURE (U.S. CLS. 100, 101 AND 107).

FIRST USE 9-1-2013; IN COMMERCE 9-1-2013.

B. PARADEWELAI, EXAMINING ATTORNEY

SN 86-235,202. NEW MUSEUM OF CONTEMPORARY ART, NEW YORK, NY. FILED 3-28-2014.

**NEW INC**

THE MARK CONSISTS OF STANDARD CHARACTERS WITHOUT CLAIM TO ANY PARTICULAR FONT, STYLE, SIZE, OR COLOR.

OWNER OF U.S. REG. NO. 2,370,045.

NO CLAIM IS MADE TO THE EXCLUSIVE RIGHT TO USE "INC", APART FROM THE MARK AS SHOWN.

FOR MUSEUM SERVICES (U.S. CLS. 100, 101 AND 107).

JASON MALASHEVICH, EXAMINING ATTORNEY

**CLASS 41—(Continued).**

SN 86-235,698. SCHAEFER, DENNIS, PARKLAND, FL. AND MCNALLY, MARK, MONTVALE, NJ. FILED 3-28-2014.

**THE ORIGINAL PIG BAND**

THE MARK CONSISTS OF STANDARD CHARACTERS WITHOUT CLAIM TO ANY PARTICULAR FONT, STYLE, SIZE, OR COLOR.

NO CLAIM IS MADE TO THE EXCLUSIVE RIGHT TO USE "ORIGINAL" AND "BAND", APART FROM THE MARK AS SHOWN.

FOR ENTERTAINMENT SERVICES IN THE NATURE OF RECORDING, PRODUCTION AND POST-PRODUCTION SERVICES IN THE FIELD OF MUSIC; ENTERTAINMENT, NAMELY, LIVE MUSIC CONCERTS (U.S. CLS. 100, 101 AND 107).

JASON MALASHEVICH, EXAMINING ATTORNEY

SN 86-236,006. HENDERSON, BRENDA, SAN ANTONIO, TX. FILED 3-28-2014.

**sacred womb book**

THE MARK CONSISTS OF STANDARD CHARACTERS WITHOUT CLAIM TO ANY PARTICULAR FONT, STYLE, SIZE, OR COLOR.

NO CLAIM IS MADE TO THE EXCLUSIVE RIGHT TO USE "BOOK", APART FROM THE MARK AS SHOWN.

FOR TEACHING SPIRITUAL ART CLASS (U.S. CLS. 100, 101 AND 107).

CHRISTOPHER LAW, EXAMINING ATTORNEY

SN 86-236,153. BEVERAGE TESTING INSTITUTE, INC., CHICAGO, IL. FILED 3-28-2014.

**DRINKIPEDIA**

THE MARK CONSISTS OF STANDARD CHARACTERS WITHOUT CLAIM TO ANY PARTICULAR FONT, STYLE, SIZE, OR COLOR.

FOR PROVIDING A WEBSITE FEATURING AN ONLINE DIGITAL REFERENCE, NAMELY, ENCYCLOPEDIAS PROVIDING INFORMATION, REFERENCE IMAGES, AND COMMENTARY IN THE FIELD OF FOOD AND BEVERAGES (U.S. CLS. 100, 101 AND 107).

MATTHEW KLINE, EXAMINING ATTORNEY

**CLASS 41—(Continued).**

SN 86-236,156. BEVERAGE TESTING INSTITUTE, INC., CHICAGO, IL. FILED 3-28-2014.

**DR. PALATE**

THE MARK CONSISTS OF STANDARD CHARACTERS WITHOUT CLAIM TO ANY PARTICULAR FONT, STYLE, SIZE, OR COLOR.

FOR WEB BASED EDUCATIONAL AND ENTERTAINMENT SERVICES, NAMELY, ON-GOING WEB BASED PROGRAMS FEATURING A FICTIONAL CHARACTER THAT PROVIDES INFORMATION, ADVICE, ORIGINAL IMAGES, PURCHASING RECOMMENDATIONS, ANALYSIS, AND COMMENTARY IN FIELD OF FOOD AND BEVERAGES (U.S. CLS. 100, 101 AND 107).

MATTHEW KLINE, EXAMINING ATTORNEY

SN 86-236,215. NOBLE PURSUIT, INC., LONG BEACH, CA. FILED 3-29-2014.

**California Girl Series**

THE MARK CONSISTS OF STANDARD CHARACTERS WITHOUT CLAIM TO ANY PARTICULAR FONT, STYLE, SIZE, OR COLOR.

NO CLAIM IS MADE TO THE EXCLUSIVE RIGHT TO USE "SERIES", APART FROM THE MARK AS SHOWN.

FOR ORGANIZING, ARRANGING, AND CONDUCTING CYCLING, RUNNING, AND TRIATHALON EVENTS (U.S. CLS. 100, 101 AND 107).

NATALIE KENEALY, EXAMINING ATTORNEY

SN 86-236,301. HARRIS, MOLLY R, WILLIAMS, AZ. FILED 3-29-2014.

**Spirit Trekk**

THE MARK CONSISTS OF STANDARD CHARACTERS WITHOUT CLAIM TO ANY PARTICULAR FONT, STYLE, SIZE, OR COLOR.

NO CLAIM IS MADE TO THE EXCLUSIVE RIGHT TO USE "SPIRIT", APART FROM THE MARK AS SHOWN.

FOR ENTERTAINMENT SERVICES, NAMELY, AN ONGOING SERIES FEATURING SCIENCE AND SPIRIT PROVIDED THROUGH INTERNET AND TELEVISION (U.S. CLS. 100, 101 AND 107).

FIRST USE 3-1-2012; IN COMMERCE 4-10-2013.

DANIEL S. STRINGER, EXAMINING ATTORNEY

**CLASS 41—(Continued).**

SN 86-236,345. OBSCENE SOUNDS LLC, MIAMI, FL. FILED 3-29-2014.



OWNER OF U.S. REG. NO. 3,900,191.  
THE MARK CONSISTS OF A MALE FACE WITH GLASSES, SMIRKING AND WEARING A BOW TIE. THE HAIR ON THE MALE FACE IS STYLED WITH FIVE ("5") JAGGED SPIKES. BELOW, THERE IS THE STYLIZED TEXT "OBSCENE" ON ONE LINE.

FOR DISC JOCKEYS FOR PARTIES AND SPECIAL EVENTS (U.S. CLS. 100, 101 AND 107).  
BRIAN PINO, EXAMINING ATTORNEY

SN 86-236,439. FOUNDATION FOR THE ART RENEWAL CENTER, INC., PORT READING, NJ. FILED 3-30-2014.

**The Da Vinci Initiative**

THE MARK CONSISTS OF STANDARD CHARACTERS WITHOUT CLAIM TO ANY PARTICULAR FONT, STYLE, SIZE, OR COLOR.

NO CLAIM IS MADE TO THE EXCLUSIVE RIGHT TO USE "INITIATIVE", APART FROM THE MARK AS SHOWN.  
FOR EDUCATIONAL SERVICES, NAMELY, COURSES, SEMINARS AND WORKSHOPS FOR TRAINING TEACHERS AND EDUCATORS IN THE FIELD OF ART, AND THE DISTRIBUTION OF TRAINING MATERIALS IN CONNECTION THEREWITH; EDUCATIONAL SERVICES, NAMELY, DEVELOPING CURRICULUM FOR TEACHERS AND EDUCATORS (U.S. CLS. 100, 101 AND 107).

REBECCA SMITH, EXAMINING ATTORNEY

SN 86-236,477. IMORTALIKA LLC, MIAMI BEACH, FL. FILED 3-30-2014.

**IMORTALIKA**

THE MARK CONSISTS OF STANDARD CHARACTERS WITHOUT CLAIM TO ANY PARTICULAR FONT, STYLE, SIZE, OR COLOR.

THE WORDING "IMORTALIKA" HAS NO MEANING IN A FOREIGN LANGUAGE.  
FOR PHOTOGRAPHY SERVICES; PORTRAIT PHOTOGRAPHY (U.S. CLS. 100, 101 AND 107).

FIRST USE 5-13-2013; IN COMMERCE 5-13-2013.  
TIMOTHY O. SCHIMPF, EXAMINING ATTORNEY

**CLASS 41—(Continued).**

SN 86-236,478. MONKEYS IN SPACE, LLC, MIAMI, FL. FILED 3-30-2014.

**LET'S PLANT A SEED**

THE MARK CONSISTS OF STANDARD CHARACTERS WITHOUT CLAIM TO ANY PARTICULAR FONT, STYLE, SIZE, OR COLOR.

FOR EDUCATIONAL SERVICES, NAMELY, CONDUCTING CLASSES, SEMINARS, CONFERENCES, AND WORKSHOPS IN THE FIELD OF PERSONAL AND PROFESSIONAL DEVELOPMENT (U.S. CLS. 100, 101 AND 107).

MIAH ROSENBERG, EXAMINING ATTORNEY

SN 86-236,484. DENISE LINN, PASO ROBLES, CA. FILED 3-30-2014.

**Elemental Space Clearing**

THE MARK CONSISTS OF STANDARD CHARACTERS WITHOUT CLAIM TO ANY PARTICULAR FONT, STYLE, SIZE, OR COLOR.

NO CLAIM IS MADE TO THE EXCLUSIVE RIGHT TO USE "SPACE CLEARING", APART FROM THE MARK AS SHOWN.

FOR ARRANGING AND CONDUCTING BUSINESS SEMINARS IN THE FIELD OF SPACE CLEARING (U.S. CLS. 100, 101 AND 107).

KEVIN MITTLER, EXAMINING ATTORNEY

SN 86-236,561. R. WAVE PARTNERS LLC, KIHEI, HI. FILED 3-30-2014.

**Workin' Hawaii**

THE MARK CONSISTS OF STANDARD CHARACTERS WITHOUT CLAIM TO ANY PARTICULAR FONT, STYLE, SIZE, OR COLOR.

NO CLAIM IS MADE TO THE EXCLUSIVE RIGHT TO USE "HAWAII", APART FROM THE MARK AS SHOWN.

FOR EDUCATIONAL AND ENTERTAINMENT SERVICES, NAMELY, A CONTINUING PROGRAM ABOUT JOBS IN HAWAII ACCESSIBLE BY RADIO, TELEVISION, SATELLITE, AUDIO, VIDEO AND COMPUTER NETWORKS (U.S. CLS. 100, 101 AND 107).

BRIN ANDERSON, EXAMINING ATTORNEY

**CLASS 41—(Continued).**

SN 86-236,826. UNIVERSITY FOR LEADERS, ELGIN, IL. FILED 3-31-2014.

## Universidad para Líderes

THE MARK CONSISTS OF STANDARD CHARACTERS WITHOUT CLAIM TO ANY PARTICULAR FONT, STYLE, SIZE, OR COLOR.

NO CLAIM IS MADE TO THE EXCLUSIVE RIGHT TO USE "UNIVERSIDAD", APART FROM THE MARK AS SHOWN.

THE ENGLISH TRANSLATION OF "UNIVERSIDAD PARA LÍDERES" IN THE MARK IS "UNIVERSITY FOR LEADERS".

FOR EDUCATION SERVICES IN THE NATURE OF COURSES AT THE UNIVERSITY LEVEL (U.S. CLS. 100, 101 AND 107).

FIRST USE 1-25-2007; IN COMMERCE 1-25-2007.  
RENEE MCCRAY, EXAMINING ATTORNEY

---

SN 86-237,148. JAMIE GOTTSCHALL, COOPERSBURG, PA. FILED 3-31-2014.

## INDOMITABLESTYLE

THE MARK CONSISTS OF STANDARD CHARACTERS WITHOUT CLAIM TO ANY PARTICULAR FONT, STYLE, SIZE, OR COLOR.

FOR PROVIDING A WEBSITE FEATURING BLOGS AND NON-DOWNLOADABLE PUBLICATIONS IN THE NATURE OF ARTICLES, BLOG POSTS, AND VIDEO BLOGS IN THE FIELD(S) OF HEALTH, WELLNESS, FITNESS, STYLE, FASHION, FOOD, HOME, DECORATING, HOLIDAYS, WEDDINGS, CHILDREN, AND LIFESTYLE (U.S. CLS. 100, 101 AND 107).

FIRST USE 3-5-2014; IN COMMERCE 3-5-2014.  
ADA HAN, EXAMINING ATTORNEY

---

SN 86-237,330. B.U.A MUSIC GROUP, NEW ORLEANS, LA. FILED 3-31-2014.

## B.U.A Music Group

THE MARK CONSISTS OF STANDARD CHARACTERS WITHOUT CLAIM TO ANY PARTICULAR FONT, STYLE, SIZE, OR COLOR.

NO CLAIM IS MADE TO THE EXCLUSIVE RIGHT TO USE "MUSIC GROUP", APART FROM THE MARK AS SHOWN.

FOR ENTERTAINMENT SERVICES IN THE NATURE OF PRESENTING LIVE MUSICAL PERFORMANCES; ENTERTAINMENT SERVICES IN THE NATURE OF RECORDING, PRODUCTION AND POST-PRODUCTION SERVICES IN THE FIELD OF MUSIC (U.S. CLS. 100, 101 AND 107).

KAREN K. BUSH, EXAMINING ATTORNEY

**CLASS 41—(Continued).**

SN 86-237,385. FORD, SCOTT, HUMBLE, TX. FILED 3-31-2014.

## Mr. Ford's Class

THE MARK CONSISTS OF STANDARD CHARACTERS WITHOUT CLAIM TO ANY PARTICULAR FONT, STYLE, SIZE, OR COLOR.

NO CLAIM IS MADE TO THE EXCLUSIVE RIGHT TO USE "CLASS", APART FROM THE MARK AS SHOWN.

THE NAME "MR. FORD" IDENTIFIES A LIVING INDIVIDUAL WHOSE CONSENT IS OF RECORD.

FOR EDUCATION SERVICES, NAMELY, PROVIDING ON-LINE TUTORIALS IN THE FIELD OF LIFE SCIENCE AND TECHNOLOGY (U.S. CLS. 100, 101 AND 107).

FIRST USE 10-28-2007; IN COMMERCE 11-1-2007.  
KATHERINE CHANG, EXAMINING ATTORNEY

---

SN 86-237,457. VOCAMOTIVE, INC., HINSDALE, IL. FILED 3-31-2014.



OWNER OF U.S. REG. NOS. 3,282,123 AND 3,381,091.  
THE MARK CONSISTS OF THE WORD "VOCAMOTIVE" FOLLOWED BY A GEOMETRIC FIGURE REPRESENTING A PERSON.

THE WORDING "VOCAMOTIVE" HAS NO MEANING IN A FOREIGN LANGUAGE.

FOR VOCATIONAL EDUCATION IN THE FIELD OF VOCATIONAL REHABILITATION CONSULTING (U.S. CLS. 100, 101 AND 107).

FIRST USE 3-1-2012; IN COMMERCE 3-1-2012.  
BRIAN PINO, EXAMINING ATTORNEY



**CLASS 41—(Continued).**

SN 86-237,559. CARR, BRADLEY, CULVER CITY, CA. FILED 3-31-2014.



THE STIPPLING IS FOR SHADING PURPOSES ONLY. THE MARK CONSISTS OF THE WORD "EVE" IS LOWER CASE "E" UPPER CASE "V" LOWER CASE "E". THE WORD "OF" TO THE RIGHT OF THAT, LOWER CASE, SLIGHTLY LOWER. THE WORD "THUNDER" APPEARS WITH THE "T" SPELLED WITH A LARGE CRUCIFIX OR CROSS. THE REMAINING LETTERS OF THE WORD "THUNDER" ARE SMALLER THAN THE T/CROSS AND ARE UPPER CASE. THE T/CROSS HAS A BLOOD FLOW FROM NEAR THE TOP OF THE LETTER TO ITS BASE.

FOR ENTERTAINMENT SERVICES, NAMELY, THE PRODUCTION AND DISTRIBUTION OF MOTION PICTURES; PROVIDING NEWS AND INFORMATION IN THE FIELD OF ENTERTAINMENT RELATING TO MOTION PICTURE FILMS (U.S. CLS. 100, 101 AND 107). DANIEL CAPSHAW, EXAMINING ATTORNEY

SN 86-237,563. PAGE, COREY, OAKLAND, CA. FILED 3-31-2014.

# Verbal Sax

THE MARK CONSISTS OF STANDARD CHARACTERS WITHOUT CLAIM TO ANY PARTICULAR FONT, STYLE, SIZE, OR COLOR.

NO CLAIM IS MADE TO THE EXCLUSIVE RIGHT TO USE "SAX", APART FROM THE MARK AS SHOWN.

FOR ENTERTAINMENT SERVICES IN THE NATURE OF LIVE POETRY AND MUSIC PERFORMANCES (U.S. CLS. 100, 101 AND 107).

FIRST USE 11-23-2013; IN COMMERCE 11-23-2013. JOHN HWANG, EXAMINING ATTORNEY

**CLASS 41—(Continued).**

SN 86-237,610. HUGHES HUBBARD & REED LLP, NEW YORK, NY. FILED 3-31-2014.

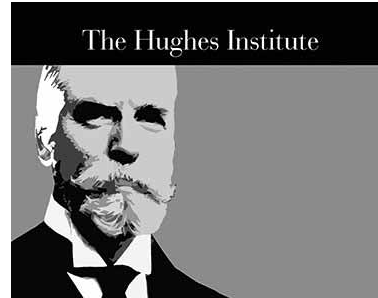

OWNER OF U.S. REG. NOS. 2,137,912, 2,710,710 AND 3,376,049.

NO CLAIM IS MADE TO THE EXCLUSIVE RIGHT TO USE "INSTITUTE", APART FROM THE MARK AS SHOWN. THE LIKENESS (OR, "PORTRAIT") IN THE MARK DOES NOT IDENTIFY A LIVING INDIVIDUAL.

THE MARK CONSISTS OF THE WORDS "THE HUGHES INSTITUTE" WITH AN IMAGE OF CHARLES EVAN HUGHES PICTURED BELOW THE WORDS.

FOR TRAINING SERVICES IN THE FIELD OF LAW (U.S. CLS. 100, 101 AND 107).

FIRST USE 10-7-2013; IN COMMERCE 11-22-2013.

VIVIAN MICZNIK FIRST, EXAMINING ATTORNEY

SN 86-237,673. GORDON, LAMAR F, MORGANFIELD, KY. FILED 3-31-2014.



NO CLAIM IS MADE TO THE EXCLUSIVE RIGHT TO USE "RECORDS", APART FROM THE MARK AS SHOWN. THE COLOR(S) RED, WHITE, GRAY AND BLACK IS/ARE CLAIMED AS A FEATURE OF THE MARK.

THE MARK CONSISTS OF THE WORDING "NUTURFF" IN RED AND "RECORDS" IN BLACK, WITH THE LETTER "N" IN WHITE ON A GRAY CIRCULAR CARRIER LOCATED IN THE BACKGROUND.

FOR AUDIO RECORDING AND PRODUCTION; ENTERTAINMENT IN THE NATURE OF PROVIDING A WEB SITE FEATURING NON-DOWNLOADABLE MUSICAL RECORDINGS, MUSICAL PERFORMANCES, MUSICAL VIDEOS, RELATED FILM CLIPS, PHOTOGRAPHS, AND OTHER MULTIMEDIA MATERIALS FEATURING MUSIC; ENTERTAINMENT SERVICES IN THE NATURE OF RECORDING, PRODUCTION AND POST-PRODUCTION SERVICES IN THE FIELD OF MUSIC; MUSIC PRODUCTION SERVICES; MUSIC PUBLISHING SERVICES; PROVIDING A WEBSITE FEATURING INFORMATION IN THE FIELD OF MUSIC AND ENTERTAINMENT; RECORD MASTER PRODUCTION; RECORD MASTERING; RECORD PRODUCTION; RECORDING STUDIO SERVICES (U.S. CLS. 100, 101 AND 107).

ANDREA K. NADELMAN, EXAMINING ATTORNEY

**CLASS 41—(Continued).**

SN 86-237,948. BOSS BARBELL, DBA BOSS BARBELL CLUB, INC., MOUNTAIN VIEW, CA. FILED S.R. 3-31-2014; AM. P.R. 7-2-2014.

# Boss Barbell

THE MARK CONSISTS OF STANDARD CHARACTERS WITHOUT CLAIM TO ANY PARTICULAR FONT, STYLE, SIZE, OR COLOR.

FOR TRAINING SERVICES IN THE FIELD OF PHYSICAL FITNESS AND WEIGHT TRAINING; COACHING IN THE FIELD OF PHYSICAL FITNESS AND WEIGHT TRAINING VIA THE INTERNET; COACHING IN THE FIELD OF PHYSICAL FITNESS AND WEIGHT TRAINING; PROVIDING FACILITIES, NAMELY, A GYM FOR PHYSICAL FITNESS TRAINING AND WEIGHT TRAINING; EDUCATION SERVICES, NAMELY, PROVIDING SEMINARS IN THE FIELD OF PHYSICAL FITNESS AND WEIGHT TRAINING (U.S. CLS. 100, 101 AND 107).

FIRST USE 9-1-2009; IN COMMERCE 10-1-2012.  
CYNTHIA RINALDI, EXAMINING ATTORNEY

SN 86-238,182. HEALTHY MATURE LIVING FOUNDATION, LOS GATOS, CA. FILED 4-1-2014.

## ABL CONVERSATION STARTER

THE MARK CONSISTS OF STANDARD CHARACTERS WITHOUT CLAIM TO ANY PARTICULAR FONT, STYLE, SIZE, OR COLOR.

NO CLAIM IS MADE TO THE EXCLUSIVE RIGHT TO USE "ABL", APART FROM THE MARK AS SHOWN.

FOR PROVIDING ONLINE PUBLICATIONS IN THE NATURE OF MAGAZINES, NEWSLETTERS, BROCHURES AND ARTICLES IN THE FIELDS OF INCONTINENCE, ACCIDENTAL BOWEL LEAKAGE AND SOLUTIONS THEREFOR; EDUCATIONAL SERVICES, NAMELY, CONDUCTING PROGRAMS IN THE FIELDS OF INCONTINENCE, ACCIDENTAL BOWEL LEAKAGE AND SOLUTIONS THEREFOR; ARRANGING AND CONDUCTING CLASSES, SEMINARS AND WORKSHOPS IN THE FIELDS OF INCONTINENCE, ACCIDENTAL BOWEL LEAKAGE AND SOLUTIONS THEREFOR, AND DISTRIBUTION OF COURSE MATERIALS IN CONNECTION THEREWITH (U.S. CLS. 100, 101 AND 107).

KATHERINE CHANG, EXAMINING ATTORNEY

**CLASS 41—(Continued).**

SN 86-238,346. THOMPSON, ALEXANDER, BROOKLYN, NY. FILED 4-1-2014.

## PONYBOY MAGAZINE

THE MARK CONSISTS OF STANDARD CHARACTERS WITHOUT CLAIM TO ANY PARTICULAR FONT, STYLE, SIZE, OR COLOR.

NO CLAIM IS MADE TO THE EXCLUSIVE RIGHT TO USE "MAGAZINE", APART FROM THE MARK AS SHOWN. FOR PROVIDING ON-LINE NON-DOWNLOADABLE MAGAZINES IN THE FIELDS OF VINTAGE POPULAR CULTURE, VINTAGE INSPIRED POPULAR CULTURE, VINTAGE FASHION, LIFESTYLE AND MUSIC, AND VINTAGE INSPIRED FASHION, LIFESTYLE, MUSIC AND PEOPLE (U.S. CLS. 100, 101 AND 107).

FIRST USE 12-15-2013; IN COMMERCE 12-15-2013.  
LINDA E. BLOHM, EXAMINING ATTORNEY

SN 86-238,961. FRONTRUNNER MEDIA PRODUCTIONS INC., INDIANAPOLIS, IN. FILED 4-1-2014.

## Fronrunner Media Productions

THE MARK CONSISTS OF STANDARD CHARACTERS WITHOUT CLAIM TO ANY PARTICULAR FONT, STYLE, SIZE, OR COLOR.

NO CLAIM IS MADE TO THE EXCLUSIVE RIGHT TO USE "MEDIA PRODUCTIONS", APART FROM THE MARK AS SHOWN.

FOR MEDIA PRODUCTION SERVICES, NAMELY, VIDEO AND FILM PRODUCTION (U.S. CLS. 100, 101 AND 107).

FIRST USE 3-14-2014; IN COMMERCE 3-14-2014.  
CAITLIN WATTS-FITZGERALD, EXAMINING ATTORNEY

SN 86-239,158. SKECHERS U.S.A., INC. II, MANHATTAN BEACH, CA. FILED 4-1-2014.

## TWINKLE TOES

THE MARK CONSISTS OF STANDARD CHARACTERS WITHOUT CLAIM TO ANY PARTICULAR FONT, STYLE, SIZE, OR COLOR.

OWNER OF U.S. REG. NO. 4,426,779. FOR ENTERTAINMENT, NAMELY, A CONTINUING ANIMATED ENTERTAINMENT SHOW BROADCAST OVER TELEVISION (U.S. CLS. 100, 101 AND 107).

SUE LAWRENCE, EXAMINING ATTORNEY

**CLASS 41—(Continued).**

SN 86-239,175. SUCCESS PARTNERS HOLDING CO., LAKE DALLAS, TX. FILED 4-1-2014.

**SUCCESS PARTNERS**

THE MARK CONSISTS OF STANDARD CHARACTERS WITHOUT CLAIM TO ANY PARTICULAR FONT, STYLE, SIZE, OR COLOR.

NO CLAIM IS MADE TO THE EXCLUSIVE RIGHT TO USE "PARTNERS", APART FROM THE MARK AS SHOWN.

FOR ELECTRONIC PUBLISHING SERVICES, NAMELY, PRODUCTION AND PUBLICATION OF TEXT, GRAPHIC, MOTION PICTURE AND VIDEO WORKS IN PRINTED AND ELECTRONIC FORM IN THE FIELDS OF ENTREPRENEURSHIP AND PERSONAL DEVELOPMENT; MUSIC COMPOSITION SERVICES FOR OTHERS, NAMELY, COMPOSITION OF MUSIC TO BE USED IN FILMS AND VIDEOS IN THE FIELDS OF ENTREPRENEURSHIP AND PERSONAL DEVELOPMENT; MOVIE AND VIDEO PRODUCTION AND DIRECTION SERVICES FOR OTHERS, NAMELY, CREATING MOVIES AND VIDEO IMAGES, SCRIPTING, STORYBOARDING, CASTING, LOCATION SCOUTING, MANAGEMENT, PRODUCTION, DIRECTION AND EDITING IN THE FIELDS OF ENTREPRENEURSHIP AND PERSONAL DEVELOPMENT; PHOTOGRAPHY SERVICES, NAMELY, PHOTOGRAPHIC COMPOSITION, TAKING OF PHOTOGRAPHS, AND DIGITAL IMAGING SERVICES FOR OTHERS IN THE FIELDS OF ENTREPRENEURSHIP AND PERSONAL DEVELOPMENT; CUSTOM WRITING SERVICES, NAMELY, WRITING BOOKS, MAGAZINES, MOTION PICTURE AND VIDEO SCRIPTS AND AUDIO SCRIPTS FOR OTHERS IN THE FIELDS OF ENTREPRENEURSHIP AND PERSONAL DEVELOPMENT (U.S. CLS. 100, 101 AND 107).

JOHN WILKE, EXAMINING ATTORNEY

SN 86-239,255. WORD SPRUCE LLC, DELTONA, FL. FILED 4-1-2014.

**Word Spruce**

THE MARK CONSISTS OF STANDARD CHARACTERS WITHOUT CLAIM TO ANY PARTICULAR FONT, STYLE, SIZE, OR COLOR.

NO CLAIM IS MADE TO THE EXCLUSIVE RIGHT TO USE "WORD", APART FROM THE MARK AS SHOWN.

FOR CUSTOM WRITING SERVICES FOR NON-ADVERTISING PURPOSES (U.S. CLS. 100, 101 AND 107).

KAREN K. BUSH, EXAMINING ATTORNEY

**CLASS 41—(Continued).**

SN 86-239,728. CLUESEARCHPUZZLES LLC, COLORADO SPRINGS, CO. FILED 4-2-2014.

**ClueSearchPuzzles.com**

THE MARK CONSISTS OF STANDARD CHARACTERS WITHOUT CLAIM TO ANY PARTICULAR FONT, STYLE, SIZE, OR COLOR.

FOR ENTERTAINMENT SERVICES, NAMELY, PROVIDING A WEBSITE FEATURING GAMES AND PUZZLES (U.S. CLS. 100, 101 AND 107).

FIRST USE 4-1-2003; IN COMMERCE 4-1-2003.

JASON BLAIR, EXAMINING ATTORNEY

SN 86-240,027. 5 O'CLOCK, LLC, BURBANK, CA. FILED 4-2-2014.



THE COLOR(S) BLACK, BROWN, ORANGE, YELLOW, AND WHITE IS/ARE CLAIMED AS A FEATURE OF THE MARK.

THE MARK CONSISTS OF THE LETTERS "WWD" IN ORANGE FONT WITH A WHITE OUTLINE ABOVE THE WORDS "WHAT WENT DOWN" IN ORANGE FONT WITH WHITE OUTLINE. THE WORDING APPEARS ABOVE THE DESIGN OF A WHITE FADED RECTANGLE. THE TOP LINE OF THE RECTANGLE INCLUDES TWO PARTS WHERE THERE IS A BREAK IN THE LINE INTO THREE SMALL WHITE RECTANGULAR SEGMENTS. THE SIDE LINES OF THE RECTANGLE ARE BROKEN AT THE CENTER INTO TWO RECTANGULAR SEGMENTS AND A THIN WHITE CIRCLE WITH A SMALLER FILLED-IN WHITE CIRCLE IN THE CENTER. THERE ARE FOUR WHITE ANGLED LINES INSIDE THE CORNERS OF THE RECTANGLE. THE ENTIRE MARK APPEARS ON A BACKGROUND WHICH LOOKS LIKE RUSTY METAL AND IS IN THE COLORS BROWN, ORANGE, AND BLACK. BEHIND THE WORDING ARE BLACK SHADOWS TO GIVE THE APPEARANCE THAT THE WORDING IS FLOATING. IN THE TOP LEFT CORNER OF THE LETTERS "WWD" IS A WHITE, YELLOW, AND ORANGE SPARK. THERE ARE TWO FADED LIGHT YELLOW AND LIGHT ORANGE HORIZONTAL LINES EMANATING FROM THE SPARK ACROSS THE RIGHT SIDE OF THE MARK. THERE ARE SMALL WHITE DOTS RANDOMLY DISPERSED ON THE RUSTY METAL BACKGROUND.

FOR ENTERTAINMENT IN THE NATURE OF ONGOING TELEVISION PROGRAMS IN THE FIELD OF SPORTS AND ENTERTAINMENT BLOOPERS.; ENTERTAINMENT SERVICES IN THE NATURE OF CREATION, DEVELOPMENT, AND PRODUCTION OF TELEVISION PROGRAMMING (U.S. CLS. 100, 101 AND 107).

JUHI KAVEESHVAR, EXAMINING ATTORNEY

**CLASS 41—(Continued).**

SN 86-241,025. HAMA, ALICE, HARBOR CITY, CA. FILED 4-3-2014.

# WINEderland

THE MARK CONSISTS OF STANDARD CHARACTERS WITHOUT CLAIM TO ANY PARTICULAR FONT, STYLE, SIZE, OR COLOR.

FOR PROVIDING ON-LINE NEWSLETTERS IN THE FIELD OF WINE AND FOOD (U.S. CLS. 100, 101 AND 107).

LAURA GOLDEN, EXAMINING ATTORNEY

SN 86-241,164. KAT ROWBEESHOW, LLC, GREENSBORO, NC. FILED 4-3-2014.

# KAT THE LION

THE MARK CONSISTS OF STANDARD CHARACTERS WITHOUT CLAIM TO ANY PARTICULAR FONT, STYLE, SIZE, OR COLOR.

FOR ENTERTAINMENT SERVICES, NAMELY, LIVE MUSICAL AND VOCAL PERFORMANCES BY A RECORDING ARTIST, MUSICAL ARTIST, MUSICAL BAND OR MUSICAL GROUP; ENTERTAINMENT SERVICES IN THE NATURE OF VISUAL AND AUDIO PERFORMANCES BY A RECORDING ARTIST, MUSICAL ARTIST, MUSICAL BAND OR MUSICAL GROUP; ENTERTAINMENT SERVICES, NAMELY, LIVE MUSIC CONCERTS; ENTERTAINMENT SERVICES, NAMELY, PERSONAL APPEARANCES BY A RECORDING AND MUSICAL ARTIST; PRODUCTION OF SOUND RECORDINGS IN THE NATURE OF MUSICAL AND VOCAL RECORDINGS; ENTERTAINMENT SERVICES, NAMELY, PROVIDING A WEBSITE FEATURING INFORMATION ABOUT MUSICAL PERFORMANCES AND OTHER ENTERTAINMENT INFORMATION RELATING TO A RECORDING ARTIST, MUSICAL ARTIST, MUSICAL BAND OR MUSICAL GROUP (U.S. CLS. 100, 101 AND 107).

BRITTANY ESTELL, EXAMINING ATTORNEY

**CLASS 41—(Continued).**

SN 86-241,225. OLIVE CREST TREATMENT CENTERS, INC., DBA OLIVE CREST, SANTA ANA, CA. FILED 4-3-2014.

# OLIVE CREST ACADEMY

THE MARK CONSISTS OF STANDARD CHARACTERS WITHOUT CLAIM TO ANY PARTICULAR FONT, STYLE, SIZE, OR COLOR.

OWNER OF U.S. REG. NOS. 2,857,256 AND 2,876,110. NO CLAIM IS MADE TO THE EXCLUSIVE RIGHT TO USE "ACADEMY", APART FROM THE MARK AS SHOWN.

FOR EDUCATIONAL SERVICES, NAMELY, CONDUCTING A PRIVATE SCHOOL PROVIDING COURSES OF INSTRUCTION FOR CHILDREN AND ADOLESCENTS AT THE PRIMARY AND SECONDARY LEVEL (U.S. CLS. 100, 101 AND 107).

FIRST USE 7-31-2010; IN COMMERCE 7-31-2010.

ZACHARY BELLO, EXAMINING ATTORNEY

SN 86-241,454. ZERO-GRAVITY CORPORATION, ARLINGTON, VA. FILED 4-3-2014.

# ZERO G

THE MARK CONSISTS OF STANDARD CHARACTERS WITHOUT CLAIM TO ANY PARTICULAR FONT, STYLE, SIZE, OR COLOR.

OWNER OF U.S. REG. NOS. 2,149,884, 2,177,500 AND 3,104,908.

SEC. 2(F).

FOR EDUCATION AND ENTERTAINMENT SERVICES, NAMELY, PROVIDING SIMULATED SPACE FLIGHT CONDITIONS AND INSTRUCTIONAL CLASSES RELATING TO SPACE EXPLORATION AND TRAVEL (U.S. CLS. 100, 101 AND 107).

FIRST USE 9-25-1997; IN COMMERCE 9-25-1997.

MARTHA FROMM, EXAMINING ATTORNEY

SN 86-241,513. POLO NOW, LLC, WELLINGTON, FL. FILED 4-3-2014.

# CHUKKERTV

THE MARK CONSISTS OF STANDARD CHARACTERS WITHOUT CLAIM TO ANY PARTICULAR FONT, STYLE, SIZE, OR COLOR.

FOR ENTERTAINMENT SERVICES, NAMELY, PROVIDING ONGOING TELEVISION PROGRAMS IN THE FIELD OF POLO VIA A GLOBAL COMPUTER NETWORK; ENTERTAINMENT SERVICES, NAMELY, PROVIDING WEBCASTS IN THE FIELD OF POLO (U.S. CLS. 100, 101 AND 107).

AMY KERTGATE, EXAMINING ATTORNEY

**CLASS 41—(Continued).**

SN 86-242,066. NICHOLS, JANAY KEESHANA, DBA A HUNGRY NOMAD, ATLANTA, GA. FILED 4-3-2014.

## A Hungry Nomad

THE MARK CONSISTS OF STANDARD CHARACTERS WITHOUT CLAIM TO ANY PARTICULAR FONT, STYLE, SIZE, OR COLOR.

FOR PROVIDING A WEBSITE FEATURING BLOGS AND NON-DOWNLOADABLE PUBLICATIONS IN THE NATURE OF ARTICLES AND REVIEWS IN THE FIELD OF COOKING INSTRUCTION; EDUCATIONAL SERVICES, NAMELY, PROVIDING ONLINE INSTRUCTION IN THE FIELD(S) OF FOOD AND COOKING VIA ONLINE WEBSITE; ENTERTAINMENT SERVICES, NAMELY, PROVIDING ON-LINE REVIEWS OF RECIPES AND COOKING TIPS; ON-LINE JOURNALS, NAMELY, BLOGS FEATURING COOKING SUGGESTIONS, TIPS, IDEAS, RECIPES, ALONG WITH VIDEOS AND PHOTOGRAPHS OF DISHES AND INGREDIENTS (U.S. CLS. 100, 101 AND 107).

FIRST USE 2-0-2014; IN COMMERCE 2-0-2014.  
DANIEL CAPSHAW, EXAMINING ATTORNEY

---

SN 86-242,778. WE TV LLC, NEW YORK, NY. FILED 4-4-2014.

## MATCH MADE IN HEAVEN

THE MARK CONSISTS OF STANDARD CHARACTERS WITHOUT CLAIM TO ANY PARTICULAR FONT, STYLE, SIZE, OR COLOR.

FOR ENTERTAINMENT SERVICES IN THE NATURE OF AN ON-GOING REALITY BASED TELEVISION PROGRAM (U.S. CLS. 100, 101 AND 107).

JUDITH HELFMAN, EXAMINING ATTORNEY

---

SN 86-242,812. AMORY, ROBERT, GLOUCESTER, MA. FILED 4-4-2014.

## THE LIGHT OF OTHERS

THE MARK CONSISTS OF STANDARD CHARACTERS WITHOUT CLAIM TO ANY PARTICULAR FONT, STYLE, SIZE, OR COLOR.

OWNER OF U.S. REG. NO. 3,592,235.

FOR ENTERTAINMENT SERVICES, NAMELY, PROVIDING A WEBSITE FEATURING PHOTOGRAPHS (U.S. CLS. 100, 101 AND 107).

FIRST USE 7-9-2007; IN COMMERCE 7-9-2007.  
JERI J. FICKES, EXAMINING ATTORNEY

**CLASS 41—(Continued).**

SN 86-243,617. CELAYA, JESUS MANUEL FIERRO, NEW YORK, NY. FILED 4-5-2014.

## COCKFIGHT

THE MARK CONSISTS OF STANDARD CHARACTERS WITHOUT CLAIM TO ANY PARTICULAR FONT, STYLE, SIZE, OR COLOR.

FOR HOSTING SOCIAL ENTERTAINMENT EVENTS, NAMELY, DANCE PARTIES, FOR OTHERS (U.S. CLS. 100, 101 AND 107).

FIRST USE 5-4-2011; IN COMMERCE 5-4-2011.  
KATINA MISTER, EXAMINING ATTORNEY

---

SN 86-243,714. WORLDWIDE CYBER ENTERPRISES, INC., CHICAGO, IL. FILED 4-6-2014.

## POLE POSITION

THE MARK CONSISTS OF STANDARD CHARACTERS WITHOUT CLAIM TO ANY PARTICULAR FONT, STYLE, SIZE, OR COLOR.

FOR ENTERTAINMENT SERVICES IN THE NATURE OF CONTINUING PROGRAM SERIES, FEATURING LIVE ACTION, COMEDY AND DRAMA PROVIDED THROUGH CABLE TELEVISION, BROADCAST TELEVISION, INTERNET, VIDEO-ON-DEMAND, AND THROUGH OTHER DISTRIBUTION PLATFORMS; PROVIDING ONLINE INFORMATION IN THE FIELD OF ENTERTAINMENT CONCERNING TELEVISION PROGRAMS (U.S. CLS. 100, 101 AND 107).

HEATHER SAPP, EXAMINING ATTORNEY

**CLASS 41—(Continued).**

SN 86-243,736. SPARTAN GROUP TACTICAL TRAINING LLC, AKA SPARTAN GROUP, RANDOLPH, NJ. FILED 4-6-2014.



NO CLAIM IS MADE TO THE EXCLUSIVE RIGHT TO USE "GROUP", APART FROM THE MARK AS SHOWN.

THE COLOR(S) BLUE, NAVY, WHITE IS/ARE CLAIMED AS A FEATURE OF THE MARK.

THE MARK CONSISTS OF A NAVY BACKGROUND CONTAINING A WHITE SWORD AND TWO CROSSED WHITE ARROWS BENEATH A BLUE AND WHITE ROUND SHIELD CONTAINING A WHITE HELMET OUTLINED IN NAVY. BENEATH THE DESIGN IS THE STYLIZED WORDING "SPARTAN GROUP" IN WHITE.

FOR EDUCATION SERVICES, NAMELY, PROVIDING LIVE AND ON-LINE WORKSHOPS, CLASSES, TRAINING, SEMINARS IN THE FIELD OF WEAPONS, SELF-DEFENSE, FIREARMS, COMBAT, MILITARY TACTICS, SECURITY, AND SAFETY FOR SELF AND OTHERS, TERRORISM AWARENESS, TRAVEL SAFETY, HOME INVASION DEFENSE, AND KIDNAPPING PREVENTION AND RESPONSE; EDUCATION SERVICES, NAMELY, PROVIDING MENTORING, TUTORING, CLASSES, SEMINARS AND WORKSHOPS IN THE FIELD OF WEAPONS, SELF-DEFENSE, FIREARMS, COMBAT, MILITARY TACTICS, SECURITY, AND SAFETY FOR SELF AND OTHERS, TERRORISM AWARENESS, TRAVEL SAFETY, HOME INVASION DEFENSE, AND KIDNAPPING PREVENTION AND RESPONSE; EDUCATIONAL SERVICES, NAMELY, CONDUCTING WORKSHOPS, CLASSES, TRAINING, SEMINARS IN THE FIELDS OF WEAPONS, SELF-DEFENSE, FIREARMS, COMBAT, MILITARY TACTICS, SECURITY, AND SAFETY FOR SELF AND OTHERS, TERRORISM AWARENESS, TRAVEL SAFETY, HOME INVASION DEFENSE, AND KIDNAPPING PREVENTION AND RESPONSE AND DISTRIBUTION OF TRAINING MATERIALS IN CONNECTION THEREWITH (U.S. CLS. 100, 101 AND 107).

FIRST USE 3-31-2014; IN COMMERCE 3-31-2014.

HEATHER SAPP, EXAMINING ATTORNEY

**CLASS 41—(Continued).**

SN 86-243,893. CLASS ACT SPORTS, LLC, LONG BEACH, NY. FILED 4-6-2014.

## Don't Let One Team Bust Your Bracket

THE MARK CONSISTS OF STANDARD CHARACTERS WITHOUT CLAIM TO ANY PARTICULAR FONT, STYLE, SIZE, OR COLOR.

FOR ENTERTAINMENT SERVICES, NAMELY, PROVIDING SPORTS AND FANTASY SPORTS INFORMATION, ONLINE, NON-DOWNLOADABLE COMPUTER GAMES AND CONTESTS VIA THE INTERNET AND OTHER COMMUNICATIONS NETWORKS IN THE FIELDS OF SPORTS AND FANTASY SPORTS GAMES AND CONTESTS; PROVIDING ONLINE NON-DOWNLOADABLE GAME AND CONTEST SOFTWARE; PROVIDING ONLINE NON-DOWNLOADABLE SOFTWARE FOR PLAYING FANTASY SPORTS GAMES AND CONTESTS (U.S. CLS. 100, 101 AND 107).

FIRST USE 1-22-2014; IN COMMERCE 3-7-2014.

JERI J. FICKES, EXAMINING ATTORNEY

SN 86-244,586. AUDIOMACHINE, BEVERLY HILLS, CA. FILED 4-7-2014.



OWNER OF U.S. REG. NOS. 3,963,320, 4,540,058 AND 4,540,059.

THE MARK CONSISTS OF TWO MACHINE-LIKE GEARS WITH SPEAKERS POSITIONED ABOVE THE WORD "AUDIOMACHINE", WITH A PLUG STRETCHING FROM THE LARGER, UPPERMOST GEAR/SPEAKER TO THE "I" IN AUDIO, SERVING AS THE DOT OF SUCH LETTER. ALTHOUGH IT IS ONE WORD, "AUDIO" IS BOLDED FONT AND "MACHINE" IS REGULAR FONT. BELOW ALL OF IT IS THE PHRASE "WHERE EPIC MUSIC LIVES".

FOR COMPOSITION OF MUSIC FOR OTHERS; ENTERTAINMENT SERVICES BY A MUSICAL ARTIST AND PRODUCER, NAMELY, MUSICAL COMPOSITION FOR OTHERS AND PRODUCTION OF MUSICAL SOUND RECORDINGS; ENTERTAINMENT SERVICES IN THE NATURE OF DEVELOPMENT, CREATION, PRODUCTION AND POST-PRODUCTION SERVICES OF MULTIMEDIA ENTERTAINMENT CONTENT; ENTERTAINMENT SERVICES IN THE NATURE OF RECORDING, PRODUCTION AND POST-PRODUCTION SERVICES IN THE FIELD OF MUSIC; ENTERTAINMENT SERVICES, NAMELY, PROVIDING NON-DOWNLOADABLE PLAYBACK OF MUSIC VIA GLOBAL COMMUNICATIONS NETWORKS; MULTIMEDIA ENTERTAINMENT SERVICES IN THE NATURE OF RECORDING, PRODUCTION AND POST-PRODUCTION SERVICES IN THE FIELDS OF MUSIC, VIDEO, AND FILMS; MUSIC COMPOSITION AND TRANSCRIPTION FOR OTHERS; MUSIC PRODUCTION SERVICES; MUSIC PUBLISHING SERVICES; MUSIC SELECTION SERVICES FOR USE IN TELEVISION, FILM, RADIO AND VIDEO GAMES; PROVIDING AN INTERNET WEBSITE PORTAL IN THE FIELD OF MUSIC (U.S. CLS. 100, 101 AND 107).

SKYE YOUNG, EXAMINING ATTORNEY

**CLASS 41—(Continued).**

SN 86-244,779. BENELLI, CHARLTON, TULSA, OH. FILED 4-7-2014.

## Sissyknuckles

THE MARK CONSISTS OF STANDARD CHARACTERS WITHOUT CLAIM TO ANY PARTICULAR FONT, STYLE, SIZE, OR COLOR.

FOR ON-LINE JOURNALS, NAMELY, BLOGS FEATURING SINGLE PARENTING (U.S. CLS. 100, 101 AND 107).

SANJEEV VOHRA, EXAMINING ATTORNEY

SN 86-244,836. COVE, MICHELLE, BROOKLINE, MA. FILED 4-7-2014.

## MEDIAGIRLS

THE MARK CONSISTS OF STANDARD CHARACTERS WITHOUT CLAIM TO ANY PARTICULAR FONT, STYLE, SIZE, OR COLOR.

FOR EDUCATIONAL SERVICES, NAMELY, DEVELOPING, ARRANGING, AND CONDUCTING AFTER SCHOOL EDUCATION PROGRAMS FOR MIDDLE SCHOOL GIRLS IN THE FIELDS OF DECONSTRUCTING GENDER MEDIA MESSAGES AND TEACHING SKILLS FOR CREATING MEDIA CONTENT (U.S. CLS. 100, 101 AND 107).

SEAN CROWLEY, EXAMINING ATTORNEY

SN 86-245,274. DEV JUMPSTART LLC, DBA MAKERSQUARE, AUSTIN, TX. FILED 4-8-2014.

## MAKERSQUARE

THE MARK CONSISTS OF STANDARD CHARACTERS WITHOUT CLAIM TO ANY PARTICULAR FONT, STYLE, SIZE, OR COLOR.

FOR COMPUTER EDUCATION TRAINING SERVICES; CONTINUING EDUCATION SERVICES, NAMELY, PROVIDING LIVE AND ON-LINE CONTINUING PROFESSIONAL EDUCATION SEMINARS IN THE FIELD OF COMPUTER PROGRAMMING, WEB TECHNOLOGY AND ENGINEERING.; DEVELOPMENT AND DISSEMINATION OF PRINTED EDUCATIONAL MATERIALS OF OTHERS IN THE FIELD OF COMPUTER PROGRAMMING, WEB TECHNOLOGY AND ENGINEERING.; EDUCATION IN THE FIELDS OF COMPUTER PROGRAMMING, WEB TECHNOLOGY AND ENGINEERING RENDERED THROUGH CORRESPONDENCE COURSES; EDUCATION SERVICES, NAMELY, MENTORING IN THE FIELD OF COMPUTER PROGRAMMING, WEB TECHNOLOGY AND ENGINEERING.; EDUCATION SERVICES, NAMELY, PROVIDING CAREER RE-TRAINING CLASSES, TUTORING AND WORKSHOPS IN THE FIELDS OF COMPUTER PRO-

**CLASS 41—(Continued).**

GRAMMING, WEB TECHNOLOGY AND ENGINEERING.; EDUCATION SERVICES, NAMELY, PROVIDING LIVE AND ON-LINE CLASSES, TUTORING AND WORKSHOPS IN THE FIELD OF COMPUTER PROGRAMMING, WEB TECHNOLOGY AND ENGINEERING.; EDUCATION SERVICES, NAMELY, PROVIDING MENTORING, TUTORING, CLASSES, SEMINARS AND WORKSHOPS IN THE FIELD OF COMPUTER PROGRAMMING, WEB TECHNOLOGY AND ENGINEERING.; EDUCATION SERVICES, NAMELY, PROVIDING CLASSES, TUTORING AND WORKSHOPS IN THE FIELDS OF COMPUTER PROGRAMMING, WEB TECHNOLOGY AND ENGINEERING.; EDUCATIONAL SERVICES, NAMELY, CONDUCTING CLASSES, SEMINARS, CONFERENCES, WORKSHOPS, RETREATS, CAMPS AND FIELD TRIPS IN THE FIELD OF COMPUTER PROGRAMMING, WEB TECHNOLOGY AND ENGINEERING AND DISTRIBUTION OF TRAINING MATERIAL IN CONNECTION THEREWITH; EDUCATIONAL SERVICES, NAMELY, CONDUCTING INFORMAL PROGRAMS IN THE FIELDS OF COMPUTER PROGRAMMING, WEB TECHNOLOGY AND ENGINEERING., USING ON-LINE ACTIVITIES AND INTERACTIVE EXHIBITS, AND PRINTABLE MATERIALS DISTRIBUTED THEREWITH; EDUCATIONAL SERVICES, NAMELY, CONDUCTING CLASSES, TUTORING AND WORKSHOPS IN THE FIELD OF COMPUTER PROGRAMMING, WEB TECHNOLOGY AND ENGINEERING.; EDUCATIONAL SERVICES, NAMELY, PROVIDING INTERNSHIPS AND APPRENTICESHIPS IN THE FIELD OF COMPUTER PROGRAMMING, WEB TECHNOLOGY AND ENGINEERING (U.S. CLS. 100, 101 AND 107).

FIRST USE 3-12-2013; IN COMMERCE 3-12-2013.  
LOKSYE G LEE RISO, EXAMINING ATTORNEY

SN 86-245,468. IGT, RENO, NV. FILED 4-8-2014.

## CRYSTAL BLOSSOMS

THE MARK CONSISTS OF STANDARD CHARACTERS WITHOUT CLAIM TO ANY PARTICULAR FONT, STYLE, SIZE, OR COLOR.

OWNER OF U.S. REG. NOS. 3,728,833, 3,994,391 AND OTHERS.

FOR ENTERTAINMENT SERVICES, NAMELY, PROVIDING ON-LINE COMPUTER GAMES (U.S. CLS. 100, 101 AND 107).

LEIGH CAROLINE CASE, EXAMINING ATTORNEY

SN 86-245,631. DAVID HEIL & ASSOCIATES, INC., PORTLAND, OR. FILED 4-8-2014.

## INNOVATE FOR LIFE

THE MARK CONSISTS OF STANDARD CHARACTERS WITHOUT CLAIM TO ANY PARTICULAR FONT, STYLE, SIZE, OR COLOR.

FOR EDUCATION SERVICES, NAMELY, PROVIDING STATE, REGIONAL, NATIONAL AND/OR INTERNATIONAL EDUCATION COMPETITIONS FOR STUDENTS IN GRADES K-12 IN THE FIELDS OF SCIENCE, TECHNOLOGY, ENGINEERING AND MATHEMATICS (U.S. CLS. 100, 101 AND 107).

MIDGE BUTLER, EXAMINING ATTORNEY

**CLASS 41—(Continued).**

SN 86-245,681. COLEMAN, JOSEPH, POTOMAC, MD. AND LEONARD, GLENN, GLENNDALE, MD. AND BLUNT, JOSEPH, TEMPLE HILLS, MD. FILED 4-8-2014.

LEONARD, COLEMAN & BLUNT

THE MARK CONSISTS OF STANDARD CHARACTERS WITHOUT CLAIM TO ANY PARTICULAR FONT, STYLE, SIZE, OR COLOR.

FOR ENTERTAINMENT RENDERED BY A MUSICAL GROUP, NAMELY, ENTERTAINMENT IN THE NATURE OF LIVE VISUAL AND AUDIO PERFORMANCES BY A MUSICAL GROUP; LIVE PERFORMANCES BY A MUSICAL GROUP; PROVIDING AN INTERNET WEBSITE PORTAL IN THE FIELD OF MUSIC; ENTERTAINMENT SERVICES, NAMELY, LIVE, TELEVISED AND MOVIE APPEARANCES BY A MUSICAL GROUP; ENTERTAINMENT SERVICES, NAMELY, PERSONAL APPEARANCES BY A MUSICAL GROUP (U.S. CLS. 100, 101 AND 107).

FIRST USE 9-24-2010; IN COMMERCE 9-24-2010.  
CAROLINE WOOD, EXAMINING ATTORNEY

SN 86-245,776. WE CARE HOME HEALTH SERVICES, LLC, AUBURN, NH. FILED 4-8-2014.

CAREGIVER KEYS

THE MARK CONSISTS OF STANDARD CHARACTERS WITHOUT CLAIM TO ANY PARTICULAR FONT, STYLE, SIZE, OR COLOR.

NO CLAIM IS MADE TO THE EXCLUSIVE RIGHT TO USE "CAREGIVER", APART FROM THE MARK AS SHOWN.

FOR EDUCATIONAL SERVICES, NAMELY, CONDUCTING GROUP CLASSES, SEMINARS, CONFERENCES, AND WORKSHOPS FOR CAREGIVERS AND FAMILIES IN THE FIELD OF ELDER CARE AND DEMENTIA CARE AND DISTRIBUTION OF TRAINING MATERIALS IN CONNECTION THEREWITH; PROVIDING GROUP COACHING FOR CAREGIVERS AND FAMILIES IN THE FIELD OF ELDER CARE AND DEMENTIA CARE; EDUCATIONAL SERVICES, NAMELY, PROVIDING NON-DOWNLOADABLE WEBINARS FOR CAREGIVERS AND FAMILIES IN THE FIELD OF ELDER CARE AND DEMENTIA CARE (U.S. CLS. 100, 101 AND 107).

HOWARD SMIGA, EXAMINING ATTORNEY

**CLASS 41—(Continued).**

SN 86-245,867. MIND RIDE LLC, DBA MIND RIDE, PURCELLVILLE, VA. FILED 4-8-2014.

Mind Ride

THE MARK CONSISTS OF STANDARD CHARACTERS WITHOUT CLAIM TO ANY PARTICULAR FONT, STYLE, SIZE, OR COLOR.

FOR ENTERTAINMENT SERVICES IN THE NATURE OF LIVE AUDIO PERFORMANCES BY PLAYING MUSIC; ENTERTAINMENT SERVICES IN THE NATURE OF LIVE VISUAL AND AUDIO PERFORMANCES BY PLAYING MUSIC, DANCING, ACTING.; ENTERTAINMENT SERVICES IN THE NATURE OF LIVE VISUAL AND AUDIO PERFORMANCES, NAMELY, MUSICAL BAND, ROCK GROUP, GYMNASIAC, DANCE, AND BALLET PERFORMANCES; ENTERTAINMENT SERVICES IN THE NATURE OF LIVE VOCAL PERFORMANCES BY SINGING, PLAYING MUSIC, SOLO AND IN A GROUP.; ENTERTAINMENT, NAMELY, LIVE PERFORMANCES BY A MUSICAL BAND; ENTERTAINMENT, NAMELY, LIVE PERFORMANCES BY MUSICAL BANDS; PROVIDING A WEBSITE FOR ENTERTAINMENT PURPOSES FEATURING BAND PROMOTION, VIDEO, MUSIC SALES, ABOUT ROCK BAND (U.S. CLS. 100, 101 AND 107).

VERNA BETH RIRIE, EXAMINING ATTORNEY

SN 86-246,035. DAKOTA VIDEO & POST PRODUCTIONS, L.L.C., SIOUX FALLS, SD. FILED 4-8-2014.



THE MARK CONSISTS OF A SILHOUETTE OF A STYLIZED BUFFALO.

FOR VIDEO PRODUCTION SERVICES (U.S. CLS. 100, 101 AND 107).

FIRST USE 0-0-2013; IN COMMERCE 0-0-2013.  
ALYSSA STEEL, EXAMINING ATTORNEY



**CLASS 41—(Continued).**

SN 86-246,041. CEO OF YOUR LIFE, INC., BROSSARD, QUEBEC, CANADA, FILED 4-8-2014.

**CEO OF YOUR LIFE**

THE MARK CONSISTS OF STANDARD CHARACTERS WITHOUT CLAIM TO ANY PARTICULAR FONT, STYLE, SIZE, OR COLOR.

NO CLAIM IS MADE TO THE EXCLUSIVE RIGHT TO USE "CEO, LIFE", APART FROM THE MARK AS SHOWN.

FOR BUSINESS TRAINING IN THE FIELD OF LEADERSHIP DEVELOPMENT, EXECUTIVE COACHING AND CAREER COACHING; LIFE COACHING SERVICES IN THE FIELD OF PERSONAL HAPPINESS (U.S. CLS. 100, 101 AND 107).

FRANK LATTUCA, EXAMINING ATTORNEY

**CLASS 41—(Continued).**

SN 86-246,289. WINDFALL ENTERTAINMENT, LLC, WE-SOCSVILLE, PA. FILED 4-8-2014.

**Go Windfall!**

THE MARK CONSISTS OF STANDARD CHARACTERS WITHOUT CLAIM TO ANY PARTICULAR FONT, STYLE, SIZE, OR COLOR.

FOR PROVIDING A WEB-BASED SYSTEM AND ON-LINE PORTAL TO PARTICIPATE IN ON-LINE GAMES (U.S. CLS. 100, 101 AND 107).

FIRST USE 4-7-2014; IN COMMERCE 4-7-2014.

JAMES A. RAUEN, EXAMINING ATTORNEY

SN 86-246,217. KOVARS, INC., CARMICHAEL, CA. FILED 4-8-2014.

**MAAB MARTIAL ARTISTS AGAINST BULLYING**

THE MARK CONSISTS OF STANDARD CHARACTERS WITHOUT CLAIM TO ANY PARTICULAR FONT, STYLE, SIZE, OR COLOR.

NO CLAIM IS MADE TO THE EXCLUSIVE RIGHT TO USE "MARTIAL ARTISTS AGAINST BULLYING", APART FROM THE MARK AS SHOWN.

FOR EDUCATIONAL SERVICES, NAMELY, CONDUCTING PROGRAMS IN THE FIELD OF MARTIAL ARTS TO PROMOTE ANTI-BULLYING AWARENESS (U.S. CLS. 100, 101 AND 107).

FIRST USE 2-26-2014; IN COMMERCE 2-26-2014.

TIMOTHY O. SCHIMPF, EXAMINING ATTORNEY

SN 86-246,446. BAKER & DABOLL, LLC, CINCINNATI, OH. FILED 4-8-2014.

**DAUGHTERS IN CHARGE**

THE MARK CONSISTS OF STANDARD CHARACTERS WITHOUT CLAIM TO ANY PARTICULAR FONT, STYLE, SIZE, OR COLOR.

FOR (BASED ON USE IN COMMERCE) EDUCATIONAL SERVICES, NAMELY, PROVIDING ONLINE INSTRUCTION IN THE FIELD OF FAMILY BUSINESS ISSUES VIA AN ONLINE WEBSITE; ON-LINE JOURNALS, NAMELY, BLOGS FEATURING FAMILY BUSINESS ISSUES, INCLUDING LEADERSHIP DEVELOPMENT, MANAGEMENT SKILLS, CAREER DEVELOPMENT, FINANCES AND FAMILY RELATIONSHIPS; PROVIDING ONLINE NEWSLETTERS IN THE FIELD OF FAMILY BUSINESS ISSUES, INCLUDING LEADERSHIP DEVELOPMENT, MANAGEMENT SKILLS, CAREER DEVELOPMENT, FINANCES AND FAMILY RELATIONSHIPS VIA E-MAIL(BASED ON INTENT TO USE) BUSINESS TRAINING IN THE FIELD OF LEADERSHIP DEVELOPMENT, MANAGEMENT SKILLS, CAREER DEVELOPMENT AND FAMILY BUSINESS ISSUES; EDUCATION SERVICES, NAMELY, PROVIDING LIVE AND ON-LINE SEMINARS, WORKSHOPS AND PANEL DISCUSSIONS IN THE FIELD OF FAMILY BUSINESS ISSUES; EDUCATIONAL SERVICES, NAMELY, PROVIDING A CONTINUING PRERECORDED AUDIO PROGRAM IN THE FIELD OF FAMILY BUSINESS ISSUES, INCLUDING LEADERSHIP DEVELOPMENT, MANAGEMENT SKILLS, CAREER DEVELOPMENT, FINANCES AND FAMILY RELATIONSHIPS ACCESSIBLE OVER THE INTERNET; EDUCATIONAL SERVICES, NAMELY, PROVIDING EDUCATIONAL SPEAKERS IN THE FIELD OF FAMILY BUSINESS ISSUES, INCLUDING LEADERSHIP DEVELOPMENT, MANAGEMENT SKILLS, CAREER DEVELOPMENT, FINANCES AND FAMILY RELATIONSHIPS (U.S. CLS. 100, 101 AND 107).

FIRST USE 11-0-2013; IN COMMERCE 11-0-2013.

SUNG IN, EXAMINING ATTORNEY

SN 86-246,248. KOVARS, INC., CARMICHAEL, CA. FILED 4-8-2014.

**DONE WITH BULLYING**

THE MARK CONSISTS OF STANDARD CHARACTERS WITHOUT CLAIM TO ANY PARTICULAR FONT, STYLE, SIZE, OR COLOR.

FOR EDUCATIONAL SERVICES, NAMELY, CONDUCTING PROGRAMS IN THE FIELD OF MARTIAL ARTS TO PROMOTE ANTI-BULLYING AWARENESS (U.S. CLS. 100, 101 AND 107).

FIRST USE 2-26-2014; IN COMMERCE 2-26-2014.

TIMOTHY O. SCHIMPF, EXAMINING ATTORNEY

**CLASS 41—(Continued).**

SN 86-246,470. JACOBSON, HILLARY, BEVERLY HILLS, CA. FILED 4-8-2014.

**IN SEARCH OF THE NEXT MEAL**

THE MARK CONSISTS OF STANDARD CHARACTERS WITHOUT CLAIM TO ANY PARTICULAR FONT, STYLE, SIZE, OR COLOR.

FOR ON-LINE JOURNALS, NAMELY, BLOGS FEATURING INTERESTING, HEALTHY AND DELICIOUS FOOD CHOICES (U.S. CLS. 100, 101 AND 107).

FIRST USE 11-30-2012; IN COMMERCE 11-30-2012.  
SUNG IN, EXAMINING ATTORNEY

---

SN 86-246,702. HOPE LUTHERAN CHURCH, ROCHESTER, NY. FILED 4-9-2014.



NO CLAIM IS MADE TO THE EXCLUSIVE RIGHT TO USE "VACATION BIBLE SCHOOL", APART FROM THE MARK AS SHOWN.

THE MARK CONSISTS OF THE STYLIZED WORDS "VACATION BIBLE SCHOOL". A GRADIENT DISK OF THE SUN WITH THE WORDS VACATION BIBLE SCHOOL CENTERED OVER THE TOP. THE LETTER "T" IN VACATION IS MUCH LARGER TO LOOK LIKE A CROSS.

FOR EDUCATIONAL SERVICES, NAMELY, PROVIDING EDUCATIONAL, RELIGIOUS, AND RECREATIONAL ACTIVITIES IN THE NATURE OF AFTER-SCHOOL AND SUMMER YOUTH PROGRAMS (U.S. CLS. 100, 101 AND 107).

FIRST USE 5-1-2004; IN COMMERCE 5-1-2004.  
ANGELA M. MICHELI, EXAMINING ATTORNEY

---

SN 86-246,745. THOSE CHARACTERS FROM CLEVELAND, INC., CLEVELAND, OH. FILED 4-9-2014.

**HERSELF THE ELF**

THE MARK CONSISTS OF STANDARD CHARACTERS WITHOUT CLAIM TO ANY PARTICULAR FONT, STYLE, SIZE, OR COLOR.

FOR ENTERTAINMENT SERVICES IN THE NATURE OF ONGOING TELEVISION PROGRAMS IN THE FIELD OF CHILDREN'S ENTERTAINMENT (U.S. CLS. 100, 101 AND 107).

LESLIE RICHARDS, EXAMINING ATTORNEY

**CLASS 41—(Continued).**

SN 86-246,748. IGT, RENO, NV. FILED 4-9-2014.

**WILD ADVENTURE**

THE MARK CONSISTS OF STANDARD CHARACTERS WITHOUT CLAIM TO ANY PARTICULAR FONT, STYLE, SIZE, OR COLOR.

OWNER OF U.S. REG. NO. 3,735,067.

FOR ENTERTAINMENT SERVICES, NAMELY, PROVIDING ON-LINE COMPUTER GAMES (U.S. CLS. 100, 101 AND 107).

LEIGH CAROLINE CASE, EXAMINING ATTORNEY

---

SN 86-246,754. POLICE ATHLETIC LEAGUE, INC., NEW YORK, NY. FILED 4-9-2014.

**PAL PLAYSTREETS**

THE MARK CONSISTS OF STANDARD CHARACTERS WITHOUT CLAIM TO ANY PARTICULAR FONT, STYLE, SIZE, OR COLOR.

OWNER OF U.S. REG. NOS. 1,818,724 AND 2,824,832.

FOR CHARITABLE AND ORGANIZATION SERVICES, NAMELY, ORGANIZING CULTURAL AND ARTS EVENTS, PROVIDING SAFE YEAR-ROUND LOCATIONS TO PROMOTE HEALTH, SOCIAL, EDUCATIONAL, VOCATIONAL AND CHARACTER DEVELOPMENT OF CHILDREN; EDUCATIONAL AND ENTERTAINMENT SERVICES, NAMELY, PROVIDING WEEKLY PREVENTION AND LIFE SKILLS PROGRAMS FEATURING RECREATIONAL ACTIVITIES, RELATIONSHIP TRAINING, ART AND CULTURE EVENTS, SPORTING EVENTS FOR CHILDREN; PHYSICAL EDUCATION SERVICES; ORGANIZING COMMUNITY SPORTING AND CULTURAL EVENTS TO PROMOTE PUBLIC AND ENVIRONMENTAL AWARENESS; ORGANIZING ANNUAL DAY CELEBRATIONS AND EVENTS; DEVELOP AND PROMOTE PROGRAMS THAT IDENTIFY PRECINCT AWARENESS, SOCIAL AND COMMUNITY AWARENESS (U.S. CLS. 100, 101 AND 107).

FIRST USE 7-8-2013; IN COMMERCE 7-8-2013.

DOMINICK J. SALEMI, EXAMINING ATTORNEY

**CLASS 41—(Continued).**

SN 86-246,760. HAUGLAND, KATIE, HOUSTON, TX. FILED 4-9-2014.

# Star Style

THE MARK CONSISTS OF STANDARD CHARACTERS WITHOUT CLAIM TO ANY PARTICULAR FONT, STYLE, SIZE, OR COLOR.

FOR PROVIDING A WEBSITE FOR ENTERTAINMENT PURPOSES FEATURING PHOTOGRAPHIC AND PROSE PRESENTATIONS ABOUT THE FASHION, STYLE, AND PRODUCTS USED BY CELEBRITIES (U.S. CLS. 100, 101 AND 107).

DOMINICK J. SALEMI, EXAMINING ATTORNEY

**CLASS 41—(Continued).**

SN 86-247,109. ROBERTS, SHANELL, STERLING, VA. FILED 4-9-2014.



THE COLOR(S) PINK AND BLACK IS/ARE CLAIMED AS A FEATURE OF THE MARK.

THE MARK CONSISTS OF THE STYLIZED WORDS "VALID REMARKS" IN BLACK, WRITTEN ON TOP OF A PINK LIPS DESIGN. THE WHITE BACKGROUND IS NOT CLAIMED AS A FEATURE OF THE MARK.

FOR ENTERTAINMENT, NAMELY, LIVE MUSIC CONCERTS; PROVIDING A WEBSITE FEATURING INFORMATION IN THE FIELD OF MUSIC AND ENTERTAINMENT; SONG WRITING SERVICES FOR NON-ADVERTISING PURPOSES (U.S. CLS. 100, 101 AND 107).

DANIEL CAPSHAW, EXAMINING ATTORNEY

SN 86-246,829. QUALITY INTERACTIONS, INC., CAMBRIDGE, MA. FILED 4-9-2014.



OWNER OF U.S. REG. NOS. 4,128,408 AND 4,149,201.  
THE COLOR(S) WHITE, GRAY, AND BLUE IS/ARE CLAIMED AS A FEATURE OF THE MARK.

THE MARK CONSISTS OF A CIRCLE THAT ENDS WITH AN ARROW IN THE BOTTOM RIGHT PORTION OF THE CIRCLE. THE CIRCLE CONSISTS OF RIBBONS OF COLOR IN MOSTLY VARIOUS SHADES OF BLUE, WITH A LITTLE GRAY AND WHITE.

FOR EDUCATION SERVICES, NAMELY, PROVIDING A TRAINING PROGRAM ON CULTURAL COMPETENCY AND CROSS-CULTURAL CARE IN THE FIELD OF HEALTHCARE, VIA GLOBAL COMPUTER NETWORKS AND LIVE PRESENTATIONS AND DISTRIBUTING EDUCATIONAL RESOURCE MATERIALS IN CONNECTION THEREWITH (U.S. CLS. 100, 101 AND 107).

FIRST USE 11-30-2013; IN COMMERCE 11-30-2013.  
JANICE L. MCMORROW, EXAMINING ATTORNEY

SN 86-247,235. APOGEE MEDIA LLC, NEW YORK, NY. FILED 4-9-2014.

# You Don't Know Squat

THE MARK CONSISTS OF STANDARD CHARACTERS WITHOUT CLAIM TO ANY PARTICULAR FONT, STYLE, SIZE, OR COLOR.

FOR EDUCATIONAL SERVICES, NAMELY, PROVIDING CLASSES AND INSTRUCTION IN THE FIELDS OF EXERCISE AND FITNESS (U.S. CLS. 100, 101 AND 107).

TIMOTHY FINNEGAN, EXAMINING ATTORNEY

SN 86-247,274. APOGEE MEDIA LLC, NEW YORK, NY. FILED 4-9-2014.

# Buns with Attitude

THE MARK CONSISTS OF STANDARD CHARACTERS WITHOUT CLAIM TO ANY PARTICULAR FONT, STYLE, SIZE, OR COLOR.

FOR EDUCATIONAL SERVICES, NAMELY, PROVIDING CLASSES AND INSTRUCTION IN THE FIELDS OF EXERCISE AND FITNESS (U.S. CLS. 100, 101 AND 107).

TIMOTHY FINNEGAN, EXAMINING ATTORNEY

**CLASS 41—(Continued).**

SN 86-247,312. ROCK 'N RYDE LLC., BASKING RIDGE, NJ. FILED 4-9-2014.

## Rock 'N Ryde

THE MARK CONSISTS OF STANDARD CHARACTERS WITHOUT CLAIM TO ANY PARTICULAR FONT, STYLE, SIZE, OR COLOR.

FOR PROVIDING PHYSICAL FITNESS AND EXERCISE SERVICE, NAMELY, INDOOR CYCLING; PROVIDING FACILITIES FOR INDOOR CYCLING TRAINING (U.S. CLS. 100, 101 AND 107).

FIRST USE 11-1-2013; IN COMMERCE 12-9-2013.  
JENNIFER BUTTON, EXAMINING ATTORNEY

**CLASS 41—(Continued).**

SN 86-247,569. QUALITY INTERACTIONS, INC., CAMBRIDGE, MA. FILED 4-9-2014.

## THE KEY TO HIGH-VALUE HEALTHCARE

THE MARK CONSISTS OF STANDARD CHARACTERS WITHOUT CLAIM TO ANY PARTICULAR FONT, STYLE, SIZE, OR COLOR.

FOR EDUCATION SERVICES, NAMELY, PROVIDING A TRAINING PROGRAM ON CULTURAL COMPETENCY AND CROSS-CULTURAL CARE IN THE FIELD OF HEALTHCARE, VIA GLOBAL COMPUTER NETWORKS AND LIVE PRESENTATIONS AND DISTRIBUTING EDUCATIONAL RESOURCE MATERIALS IN CONNECTION THEREWITH (U.S. CLS. 100, 101 AND 107).

FIRST USE 11-30-2013; IN COMMERCE 11-30-2013.  
JANICE L. MCMORROW, EXAMINING ATTORNEY

SN 86-247,358. STAGE NINE DESIGN, LLC, WEST SACRAMENTO, CA. FILED 4-9-2014.

## POPnology

THE MARK CONSISTS OF STANDARD CHARACTERS WITHOUT CLAIM TO ANY PARTICULAR FONT, STYLE, SIZE, OR COLOR.

FOR CONDUCTING EDUCATIONAL EXHIBITIONS IN THE FIELD OF TECHNOLOGY, ENTERTAINMENT AND POPULAR CULTURE (U.S. CLS. 100, 101 AND 107).  
DANIELLE JOHNSON, EXAMINING ATTORNEY

SN 86-247,595. CALLAHAN, GLENN, VISALIA, CA. FILED 4-9-2014.

## THE RIFLESON

THE MARK CONSISTS OF STANDARD CHARACTERS WITHOUT CLAIM TO ANY PARTICULAR FONT, STYLE, SIZE, OR COLOR.

FOR ENTERTAINMENT MEDIA PRODUCTION SERVICES FOR MOTION PICTURES, TELEVISION AND INTERNET (U.S. CLS. 100, 101 AND 107).

FIRST USE 12-12-2012; IN COMMERCE 12-12-2012.  
MEGHAN REINHART, EXAMINING ATTORNEY

SN 86-247,423. NORMAN G. SUBER, CHARLOTTE, NC. FILED 4-9-2014.

## NoWu NOBODY OUTWORKS US

THE MARK CONSISTS OF STANDARD CHARACTERS WITHOUT CLAIM TO ANY PARTICULAR FONT, STYLE, SIZE, OR COLOR.

THE WORDING "NOWU" HAS NO MEANING IN A FOREIGN LANGUAGE.

FOR ATHLETIC TRAINING SERVICES; COACHING IN THE FIELD OF SPORTS (U.S. CLS. 100, 101 AND 107).

FIRST USE 6-18-2012; IN COMMERCE 7-5-2013.  
SIDDHARTH JAGANNATHAN, EXAMINING ATTORNEY

SN 86-247,620. OSTENFELD, LORI A., WARREN, NJ. FILED 4-9-2014.

## Inner Perfectionista

THE MARK CONSISTS OF STANDARD CHARACTERS WITHOUT CLAIM TO ANY PARTICULAR FONT, STYLE, SIZE, OR COLOR.

FOR EDUCATION SERVICES, NAMELY, DEVELOPING, ARRANGING AND PROVIDING LIVE, ON-LINE AND TELEPHONIC PRESENTATIONS, WORKSHOPS, CLASSES, SEMINARS, RETREATS, CONFERENCES, PRERECORDED AUDIO PROGRAMS, WEBINARS, GROUP COACHING, INDIVIDUAL COACHING IN THE FIELD OF PERSONAL GROWTH AND AWARENESS AND DISTRIBUTION OF EDUCATIONAL MATERIALS IN CONNECTION THEREWITH (U.S. CLS. 100, 101 AND 107).

FIRST USE 9-1-2012; IN COMMERCE 10-7-2013.  
ZACHARY CROMER, EXAMINING ATTORNEY

**CLASS 41—(Continued).**

SN 86-247,812. FIREARTH, FORMERLY FIREARTH: PERSONAL TRAINING & MARTIAL ARTS, MANCHESTER, CT. FILED 4-9-2014.



THE COLOR(S) ORANGE, BLUE AND DARK BLUE IS/ ARE CLAIMED AS A FEATURE OF THE MARK.

THE MARK CONSISTS OF A DARK BLUE WAVY LINE REPRESENTING A STYLIZED MOUNTAIN RANGE, AN ORANGE LINE IN THE SHAPE OF A THREE QUARTER CIRCLE REPRESENTING THE RISING SUN INTERCEPTED BY THE DARK BLUE STYLIZED MOUNTAIN RANGE AND THE STYLIZED WORDING "FIREARTH" IN ALL CAPITAL LETTERS IN BLUE APPEARING BENEATH ALL THE FOREGOING. THE COLOR WHITE REPRESENTS TRANSPARENT BACKGROUND AND IS NOT CLAIMED AS A FEATURE OF THE MARK.

FOR CONSULTING SERVICES IN THE FIELDS OF FITNESS AND EXERCISE; COUNSELING SERVICES IN THE FIELD OF PHYSICAL FITNESS; PERSONAL FITNESS TRAINING SERVICES AND CONSULTANCY; PERSONAL FITNESS TRAINING SERVICES FEATURING AEROBIC AND ANAEROBIC ACTIVITIES COMBINED WITH RESISTANCE AND FLEXIBILITY TRAINING; PHYSICAL FITNESS CONDITIONING CLASSES; PHYSICAL FITNESS CONSULTATION; PHYSICAL FITNESS INSTRUCTION; PHYSICAL FITNESS TRAINING SERVICES; PROVIDING A WEBSITE FEATURING INFORMATION ON EXERCISE AND FITNESS; PROVIDING AN INTERACTIVE WEBSITE FEATURING INFORMATION AND LINKS RELATING TO FITNESS; PROVIDING AN ON-LINE COMPUTER DATABASE FEATURING INFORMATION REGARDING EXERCISE AND FITNESS; PROVIDING ASSISTANCE, PERSONAL TRAINING AND PHYSICAL FITNESS CONSULTATION TO INDIVIDUALS TO HELP THEM MAKE PHYSICAL FITNESS, STRENGTH, CONDITIONING, AND EXERCISE IMPROVEMENT IN THEIR DAILY LIVING (U.S. CLS. 100, 101 AND 107).

FIRST USE 10-1-2013; IN COMMERCE 10-1-2013.  
DANIEL S. STRINGER, EXAMINING ATTORNEY

SN 86-247,826. CHERYL SNYDER, MANCHESTER, NH. FILED 4-9-2014.

**DRINKABLE ARTS**

THE MARK CONSISTS OF STANDARD CHARACTERS WITHOUT CLAIM TO ANY PARTICULAR FONT, STYLE, SIZE, OR COLOR.

FOR INSTRUCTION IN THE FIELD OF ART (U.S. CLS. 100, 101 AND 107).

FIRST USE 8-1-2013; IN COMMERCE 8-1-2013.  
PAUL CROWLEY, EXAMINING ATTORNEY

**CLASS 41—(Continued).**

SN 86-247,946. NORTHFIELD MOUNT HERMON SCHOOL, MOUNT HERMON, MA. FILED 4-10-2014.

**EDUCATION FOR THE HEAD,  
HEART, AND HAND**

THE MARK CONSISTS OF STANDARD CHARACTERS WITHOUT CLAIM TO ANY PARTICULAR FONT, STYLE, SIZE, OR COLOR.

FOR BOARDING SCHOOLS; EDUCATING AT SENIOR HIGH SCHOOLS (U.S. CLS. 100, 101 AND 107).  
FIRST USE 7-31-2009; IN COMMERCE 7-31-2009.  
JOHN WILKE, EXAMINING ATTORNEY

SN 86-247,957. KINGSISLE ENTERTAINMENT, INC., PLANO, TX. FILED 4-10-2014.

**RISE & DESTROY**

THE MARK CONSISTS OF STANDARD CHARACTERS WITHOUT CLAIM TO ANY PARTICULAR FONT, STYLE, SIZE, OR COLOR.

FOR ENTERTAINMENT SERVICES, NAMELY, PROVIDING ON-LINE INTERACTIVE GAMES; PROVIDING ONLINE NON-DOWNLOADABLE GAME SOFTWARE (U.S. CLS. 100, 101 AND 107).

HEATHER SAPP, EXAMINING ATTORNEY

SN 86-248,037. THEHUFFINGTONPOST.COM, INC., DULLES, VA. FILED 4-10-2014.

**MIDDLEBROW**

THE MARK CONSISTS OF STANDARD CHARACTERS WITHOUT CLAIM TO ANY PARTICULAR FONT, STYLE, SIZE, OR COLOR.

FOR PROVIDING ONLINE NEWSLETTERS IN THE FIELDS OF ENTERTAINMENT, CELEBRITIES, POP CULTURE, MOVIES, TELEVISION, AND MUSIC VIA E-MAIL; PROVIDING INFORMATION, NEWS, AND COMMENTARY IN THE FIELDS OF ENTERTAINMENT, CELEBRITIES, POP CULTURE, MOVIES, TELEVISION, AND MUSIC; ONLINE JOURNALS, NAMELY, BLOGS IN THE FIELDS OF ENTERTAINMENT, CELEBRITIES, POP CULTURE, MOVIES, TELEVISION, AND MUSIC (U.S. CLS. 100, 101 AND 107).

FIRST USE 2-12-2014; IN COMMERCE 2-12-2014.  
CHRISTOPHER REAMS, EXAMINING ATTORNEY

**CLASS 41—(Continued).**

SN 86-248,242. CUCALORUS FILM FOUNDATION, AKA CUCALORUS FILM FESTIVAL, WILMINGTON, NC. FILED 4-10-2014.



THE MARK CONSISTS OF A SQUARE WITH ROUGH EDGES, FEATURING THE TERM "CUCALORUS" IN STYLIZED FORM AND ALL CAPS, DEPICTED IN A MANNER REMINISCENT OF ROUGH CUT-OUTS FROM THE SQUARE AND IN THREE ROWS WITH "CUC" ON TOP, "ALO" IN THE MIDDLE, AND "RUS" ON THE BOTTOM.

FOR ENTERTAINMENT SERVICES, NAMELY, PLANNING, MANAGING, AND CONDUCTING FILM FESTIVALS; ENTERTAINMENT AND EDUCATIONAL SERVICES, NAMELY, CONDUCTING CONFERENCES, SEMINARS, RESIDENCY PROGRAMS AND WORKSHOPS IN THE FIELD OF FILMMAKING; ENTERTAINMENT SERVICES, NAMELY, ARRANGING AND CONDUCTING PARTIES, GET-TOGETHERS AND SOCIAL EVENTS (U.S. CLS. 100, 101 AND 107).

FIRST USE 1-1-2001; IN COMMERCE 3-21-2001.  
LOKSYE G LEE RISO, EXAMINING ATTORNEY

SN 86-248,434. CHASIN' CRAZY, LLC, NASHVILLE, TN. FILED 4-10-2014.

**CHASIN' CRAZY**

THE MARK CONSISTS OF STANDARD CHARACTERS WITHOUT CLAIM TO ANY PARTICULAR FONT, STYLE, SIZE, OR COLOR.

FOR ENTERTAINMENT, NAMELY, LIVE PERFORMANCES BY A MUSICAL BAND (U.S. CLS. 100, 101 AND 107).

FIRST USE 5-0-2013; IN COMMERCE 5-0-2013.  
GINA FINK, EXAMINING ATTORNEY

**CLASS 41—(Continued).**

SN 86-248,461. HECHMATI LAURENT, LOS ANGELES, CA. FILED 4-10-2014.

**a winner every minute!**

THE MARK CONSISTS OF STANDARD CHARACTERS WITHOUT CLAIM TO ANY PARTICULAR FONT, STYLE, SIZE, OR COLOR.

FOR SWEEPSTAKE SERVICES (U.S. CLS. 100, 101 AND 107).

MARILYN IZZI, EXAMINING ATTORNEY

SN 86-248,471. SIMPLY EVENTS, INC., LARGO, FL. FILED 4-10-2014.

**NURSES NIGHT OUT**

THE MARK CONSISTS OF STANDARD CHARACTERS WITHOUT CLAIM TO ANY PARTICULAR FONT, STYLE, SIZE, OR COLOR.

FOR ARRANGING AND CONDUCTING SPECIAL EVENTS FOR SOCIAL ENTERTAINMENT PURPOSES (U.S. CLS. 100, 101 AND 107).

DANIEL S. STRINGER, EXAMINING ATTORNEY

SN 86-248,657. METROPOLITAN LIFE INSURANCE COMPANY, NEW YORK, NY. FILED 4-10-2014.

**METLIFE IGNITION**

THE MARK CONSISTS OF STANDARD CHARACTERS WITHOUT CLAIM TO ANY PARTICULAR FONT, STYLE, SIZE, OR COLOR.

OWNER OF U.S. REG. NOS. 1,541,862, 4,338,523 AND OTHERS.

FOR ARRANGING AND CONDUCTING CONFERENCES, SEMINARS, PRESENTATIONS, TRAINING COURSES, WORKSHOPS, SEMINARS, LECTURES, AND PROGRAMS IN THE FIELD OF GROUP IDEATION, BRAINSTORMING, CREATIVITY, AND INNOVATION LEADERSHIP TRAINING WITHIN THE FINANCIAL SERVICES, INSURANCE AND INFORMATION TECHNOLOGY INDUSTRIES (U.S. CLS. 100, 101 AND 107).

LEIGH CAROLINE CASE, EXAMINING ATTORNEY

**CLASS 41—(Continued).**

SN 86-248,737. WILD BASIN FITNESS AT STEINER RANCH, LLC, AUSTIN, TX. FILED 4-10-2014.

# Wild Child

THE MARK CONSISTS OF STANDARD CHARACTERS WITHOUT CLAIM TO ANY PARTICULAR FONT, STYLE, SIZE, OR COLOR.

FOR PHYSICAL FITNESS TRAINING (U.S. CLS. 100, 101 AND 107).

FIRST USE 5-1-2012; IN COMMERCE 5-1-2012.

SETH A. RAPPAPORT, EXAMINING ATTORNEY

**CLASS 41—(Continued).**

SN 86-248,931. UGLY DUCKLING LIMITED, LYMM, CHE-SHIRE, UNITED KINGDOM, FILED 4-10-2014.

# THE WAREHOUSE PROJECT

THE MARK CONSISTS OF STANDARD CHARACTERS WITHOUT CLAIM TO ANY PARTICULAR FONT, STYLE, SIZE, OR COLOR.

FOR ENTERTAINMENT, NAMELY, ARRANGING AND PROMOTING LIVE AND RECORDED MUSICAL PERFORMANCES; PROVIDING ON-LINE ENTERTAINMENT INFORMATION, NAMELY, INFORMATION ABOUT LIVE AND RECORDED MUSICAL PERFORMANCES (U.S. CLS. 100, 101 AND 107).

DAVID MURRAY, EXAMINING ATTORNEY

SN 86-248,856. GULLIVERS GATE LLC, BROOKLYN, NY. FILED 4-10-2014.

# GULLIVER'S GATE

THE MARK CONSISTS OF STANDARD CHARACTERS WITHOUT CLAIM TO ANY PARTICULAR FONT, STYLE, SIZE, OR COLOR.

FOR ARRANGING, ORGANIZING AND CONDUCTING EXHIBITIONS OF MODEL AND MINIATURE TRAINS (U.S. CLS. 100, 101 AND 107).

STEPHANIE ALI, EXAMINING ATTORNEY

SN 86-248,945. ADVENTURECORPS, OAK PARK, CA. FILED 4-10-2014.

# AdventureCORPS

THE MARK CONSISTS OF STANDARD CHARACTERS WITHOUT CLAIM TO ANY PARTICULAR FONT, STYLE, SIZE, OR COLOR.

OWNER OF U.S. REG. NO. 4,240,870.

FOR ENTERTAINMENT SERVICES, NAMELY, AN ONGOING SERIES FEATURING ATHLETIC ENDURANCE EVENTS PROVIDED THROUGH TELEVISION, WEBCASTS, AND INTERNET, AND THE PROVISION OF CONTINUING PROGRAMS, SEGMENTS, AND MOVIES FEATURING NEWS AND COMMENTARY DELIVERED BY TELEVISION, VIDEO, AND THE INTERNET (U.S. CLS. 100, 101 AND 107).

FIRST USE 7-30-2000; IN COMMERCE 7-30-2000.

AHSEN KHAN, EXAMINING ATTORNEY

SN 86-248,893. SKYBRIDGE CAPITAL II, LLC, DBA SKYBRIDGE CAPITAL, NEW YORK, NY. FILED 4-10-2014.

# FIND YOUR FORTUNE WITHOUT LOSING YOUR SOUL

THE MARK CONSISTS OF STANDARD CHARACTERS WITHOUT CLAIM TO ANY PARTICULAR FONT, STYLE, SIZE, OR COLOR.

FOR ENTERTAINMENT SERVICES IN THE NATURE OF AN ONGOING TELEVISION PROGRAM FEATURING FINANCIAL TOPICS; ENTERTAINMENT SERVICES IN THE NATURE OF A CONTINUING SHOW BROADCAST OVER THE INTERNET FEATURING FINANCIAL TOPICS (U.S. CLS. 100, 101 AND 107).

RONALD MCMORROW, EXAMINING ATTORNEY

SN 86-249,140. UNLIMITED RICHES, LLC, MISSOURI CITY, TX. FILED 4-10-2014.

# *Daddy's Little Bride*

THE COLOR(S) BLACK, MAUVE, WHITE IS/ARE CLAIMED AS A FEATURE OF THE MARK.

THE MARK CONSISTS OF A WHITE BACKGROUND WITH THE STYLIZED TEXT "DADDY'S" IN BLACK, FOLLOWED BY THE STYLIZED TEXT "LITTLE" IN MAUVE, FOLLOWED BY STYLIZED TEXT "BRIDE" IN BLACK.

FOR PROVIDING CLASSES, SEMINARS, WORKSHOPS AND TRAINING FOR INDIVIDUALS IN THE FIELD OF DANCES FOR WEDDING CEREMONIES, CELEBRATIONS AND HOLIDAY EVENTS (U.S. CLS. 100, 101 AND 107).

FIRST USE 5-10-2013; IN COMMERCE 9-12-2013.

BRENDAN MCCAULEY, EXAMINING ATTORNEY

**CLASS 41—(Continued).**

SN 86-249,151. GOGI'S ADVENTURES LLC, DORAL, FL. FILED 4-10-2014.

**GOGI'S ADVENTURES**

THE MARK CONSISTS OF STANDARD CHARACTERS WITHOUT CLAIM TO ANY PARTICULAR FONT, STYLE, SIZE, OR COLOR.

FOR AMUSEMENT PARK AND THEME PARK SERVICES (U.S. CLS. 100, 101 AND 107).

DAVID TAYLOR, EXAMINING ATTORNEY

SN 86-249,304. MORE MILES MORE SMILES, LLC, BRENTWOOD, MO. FILED 4-11-2014.



THE MARK CONSISTS OF A DESIGN OF A FOOTPRINT, WITH THE WORDS "MORE MILES" COMPRISING THE TOP PART OF THE DESIGN OF THE FOOT PRINT AND THE WORDS "MORE SMILES" COMPRISING THE BOTTOM PART OF THE DESIGN OF THE FOOTPRINT AND A SMILING FACE APPEARING IN THE "O'S".

FOR ORGANIZING, ARRANGING, AND CONDUCTING RUNNING AND WALKING EVENTS (U.S. CLS. 100, 101 AND 107).

FIRST USE 4-8-2014; IN COMMERCE 4-8-2014.  
KAREN K. BUSH, EXAMINING ATTORNEY

**CLASS 41—(Continued).**

SN 86-249,599. BODY BY O, INC., TEMECULA, CA. FILED 4-11-2014.

**Body By O**

THE MARK CONSISTS OF STANDARD CHARACTERS WITHOUT CLAIM TO ANY PARTICULAR FONT, STYLE, SIZE, OR COLOR.

FOR PERSONAL FITNESS TRAINING SERVICES AND CONSULTANCY; PERSONAL TRAINING PROVIDED IN CONNECTION WITH WEIGHT LOSS AND EXERCISE PROGRAMS; PERSONAL TRAINING SERVICES, NAMELY, STRENGTH AND CONDITIONING TRAINING; PERSONAL TRAINING SERVICES, NAMELY, STRENGTH AND CONDITIONING TRAINING AND SPEED TRAINING; PHYSICAL FITNESS TRAINING SERVICES; PROVIDING ASSISTANCE, PERSONAL TRAINING AND PHYSICAL FITNESS CONSULTATION TO INDIVIDUALS TO HELP THEM MAKE PHYSICAL FITNESS, STRENGTH, CONDITIONING, AND EXERCISE IMPROVEMENT IN THEIR DAILY LIVING (U.S. CLS. 100, 101 AND 107).

FIRST USE 1-1-2002; IN COMMERCE 1-1-2002.  
REBECCA SMITH, EXAMINING ATTORNEY

SN 86-249,604. KOHEN, ROBERT, NEW YORK, NY. FILED 4-11-2014.

**Ivy Impact**

THE MARK CONSISTS OF STANDARD CHARACTERS WITHOUT CLAIM TO ANY PARTICULAR FONT, STYLE, SIZE, OR COLOR.

FOR CONDUCTING AFTER SCHOOL ACADEMIC AND STANDARDIZED TEST PREPARATION TUTORING PROGRAMS; EDUCATION SERVICES, NAMELY, PROVIDING MENTORING, TUTORING, CLASSES, SEMINARS AND WORKSHOPS IN THE FIELD OF STANDARDIZED TEST PREPARATION AND ACADEMIC SUBJECTS (U.S. CLS. 100, 101 AND 107).

HENRY S. ZAK, EXAMINING ATTORNEY

SN 86-249,694. THE BURN BRIGHT, LLC, TAUNTON, MA. FILED 4-11-2014.

**THE BURN BRIGHT**

THE MARK CONSISTS OF STANDARD CHARACTERS WITHOUT CLAIM TO ANY PARTICULAR FONT, STYLE, SIZE, OR COLOR.

FOR ENTERTAINMENT SERVICES, NAMELY, LIVE PERFORMANCES BY A MUSICAL BAND (U.S. CLS. 100, 101 AND 107).

EDWARD NELSON, EXAMINING ATTORNEY



**CLASS 41—(Continued).**

SN 86-249,715. VIRALITY ENTERPRISES LLC, HENDERSON, NV. FILED 4-11-2014.

## Twinosophy

THE MARK CONSISTS OF STANDARD CHARACTERS WITHOUT CLAIM TO ANY PARTICULAR FONT, STYLE, SIZE, OR COLOR.

FOR ON-LINE JOURNALS, NAMELY, BLOGS FEATURING COMMENTARY AND INFORMATION IN THE FIELDS OF TRAVEL, FOOD, WINE, HEALTH, BEAUTY, FITNESS, SPORTS, ENTERTAINMENT AND MUSIC (U.S. CLS. 100, 101 AND 107).

FIRST USE 2-13-2014; IN COMMERCE 3-9-2014.  
SETH DENNIS, EXAMINING ATTORNEY

**CLASS 41—(Continued).**

SN 86-249,879. ROYAL FLUSH EVENTS, INC., LEWES, DE. FILED 4-11-2014.

## CIGAR DOLLS

THE MARK CONSISTS OF STANDARD CHARACTERS WITHOUT CLAIM TO ANY PARTICULAR FONT, STYLE, SIZE, OR COLOR.

NO CLAIM IS MADE TO THE EXCLUSIVE RIGHT TO USE "CIGAR", APART FROM THE MARK AS SHOWN.

FOR ARRANGING AND CONDUCTING SPECIAL EVENTS FOR SOCIAL ENTERTAINMENT PURPOSES; CIGAR LOUNGE SERVICES; CONDUCTING ENTERTAINMENT EXHIBITIONS IN THE NATURE OF LIVE CIGAR ROLLING PERFORMANCES OR DEMONSTRATIONS HELD AT SPECIAL EVENTS; ENTERTAINMENT IN THE NATURE OF LIVE CIGAR ROLLING PERFORMANCES OR DEMONSTRATIONS HELD AT SPECIAL EVENTS (U.S. CLS. 100, 101 AND 107).

FIRST USE 3-15-2010; IN COMMERCE 7-21-2010.  
BRITTNEY COGAN, EXAMINING ATTORNEY

SN 86-249,882. SARANT LLC, DOVER, DE. FILED 4-11-2014.

## TOLDU

THE MARK CONSISTS OF STANDARD CHARACTERS WITHOUT CLAIM TO ANY PARTICULAR FONT, STYLE, SIZE, OR COLOR.

FOR ENTERTAINMENT SERVICES, NAMELY, PROVIDING TEMPORARY USE OF NON-DOWNLOADABLE INTERACTIVE GAMES DURING LIVE TELEVISION OR INTERNET BROADCASTS FOR USE ON WIRELESS DEVICES AND COMPUTERS (U.S. CLS. 100, 101 AND 107).

REBECCA SMITH, EXAMINING ATTORNEY

SN 86-250,050. MOUNTRIGI MANAGEMENT GROUP, LTD., ZUG, SWITZERLAND, FILED 4-11-2014.

## JOHN LAUTNER

THE MARK CONSISTS OF STANDARD CHARACTERS WITHOUT CLAIM TO ANY PARTICULAR FONT, STYLE, SIZE, OR COLOR.

THE NAME(S), PORTRAIT(S), AND/OR SIGNATURE(S) SHOWN IN THE MARK DOES NOT IDENTIFY A PARTICULAR LIVING INDIVIDUAL.

FOR EDUCATIONAL SERVICES, NAMELY, CONDUCTING GUIDED TOURS OF ARCHITECTURAL SITES; EDUCATIONAL SERVICES, NAMELY, LECTURES, SEMINARS, AND WORKSHOPS IN THE FIELD OF ARCHITECTURAL DESIGN HISTORY, SPECIFICALLY WITH REGARD TO JOHN LAUTNER DESIGNS (U.S. CLS. 100, 101 AND 107).

FIRST USE 2-2-1996; IN COMMERCE 10-29-2000.  
TOBY BULLOFF, EXAMINING ATTORNEY

## LA DUEÑA

THE MARK CONSISTS OF STANDARD CHARACTERS WITHOUT CLAIM TO ANY PARTICULAR FONT, STYLE, SIZE, OR COLOR.

OWNER OF U.S. REG. NO. 4,049,435.

THE ENGLISH TRANSLATION OF "LA DUEÑA" IN THE MARK IS "THE LANDLADY".

FOR ENTERTAINMENT SERVICES IN THE NATURE OF A CONTINUING DRAMATIC SHOW BROADCAST OVER THE INTERNET AND AN ONGOING DRAMATIC TELEVISION PROGRAM (U.S. CLS. 100, 101 AND 107).

TEJBIR SINGH, EXAMINING ATTORNEY

**CLASS 41—(Continued).**

SN 86-250,098. MAC K9 LLC, OKLAHOMA CITY, OK. FILED 4-11-2014.

# MAC K9 LLC

THE MARK CONSISTS OF STANDARD CHARACTERS WITHOUT CLAIM TO ANY PARTICULAR FONT, STYLE, SIZE, OR COLOR.

NO CLAIM IS MADE TO THE EXCLUSIVE RIGHT TO USE "K9 LLC", APART FROM THE MARK AS SHOWN. FOR DOG TRAINING (U.S. CLS. 100, 101 AND 107).  
GINA HAYES, EXAMINING ATTORNEY

---

SN 86-250,112. ULTIMATE PEAK TRANSFORMATION LLC, SOQUEL, CA. FILED 4-11-2014.

# From Lead To Gold

THE MARK CONSISTS OF STANDARD CHARACTERS WITHOUT CLAIM TO ANY PARTICULAR FONT, STYLE, SIZE, OR COLOR.

FOR EDUCATION SERVICES, NAMELY, PROVIDING TUTORING IN THE FIELDS OF LEADERSHIP TRAINING AND BUSINESS DEVELOPMENT (U.S. CLS. 100, 101 AND 107).

CHRISTINA SOBRAL, EXAMINING ATTORNEY

---

SN 86-250,225. LOZOYA, RICK, BONNERS FERRY, ID. FILED 4-11-2014.

# children of warriors

THE MARK CONSISTS OF STANDARD CHARACTERS WITHOUT CLAIM TO ANY PARTICULAR FONT, STYLE, SIZE, OR COLOR.

FOR CONSULTATION IN THE FIELD OF SPECIAL EVENT PLANNING FOR SOCIAL ENTERTAINMENT PURPOSES; DAY CAMP SERVICES; PROVIDING FACILITIES FOR RECREATION ACTIVITIES; PROVIDING RECREATION FACILITIES; SPECIAL EVENT PLANNING FOR SOCIAL ENTERTAINMENT PURPOSES (U.S. CLS. 100, 101 AND 107).

JENNIFER BUTTON, EXAMINING ATTORNEY

**CLASS 41—(Continued).**

SN 86-250,281. FS ORLANDO GOLF, LLC, ORLANDO, FL. FILED 4-11-2014.

# TRANQUILO

THE MARK CONSISTS OF STANDARD CHARACTERS WITHOUT CLAIM TO ANY PARTICULAR FONT, STYLE, SIZE, OR COLOR.

THE ENGLISH TRANSLATION OF "TRANQUILO" IN THE MARK IS "CALM, PEACEFUL, QUIET, TRANQUIL". FOR GOLF CLUB SERVICES; GOLF COURSES (U.S. CLS. 100, 101 AND 107).

MARY CRAWFORD, EXAMINING ATTORNEY

---

SN 86-250,430. GLIMPSE LABS, INC., OAKLAND GARDENS, NY. FILED 4-11-2014.

# LADYBOSS

THE MARK CONSISTS OF STANDARD CHARACTERS WITHOUT CLAIM TO ANY PARTICULAR FONT, STYLE, SIZE, OR COLOR.

FOR EDUCATIONAL AND ENTERTAINMENT SERVICES, NAMELY, A CONTINUING PROGRAM ABOUT BUSINESS ACCESSIBLE BY RADIO, TELEVISION, SATELLITE, AUDIO, VIDEO AND COMPUTER NETWORKS; ENTERTAINMENT SERVICES IN THE NATURE OF AN ONGOING REALITY BASED TELEVISION PROGRAM; ENTERTAINMENT SERVICES IN THE NATURE OF CREATION, DEVELOPMENT, AND PRODUCTION OF TELEVISION PROGRAMMING; ENTERTAINMENT SERVICES IN THE NATURE OF DEVELOPMENT, CREATION, PRODUCTION AND POST-PRODUCTION SERVICES OF MULTIMEDIA ENTERTAINMENT CONTENT; ENTERTAINMENT SERVICES, NAMELY, MULTIMEDIA PRODUCTION SERVICES; ENTERTAINMENT SERVICES, NAMELY, PRODUCTION AND DISTRIBUTION OF ONGOING TELEVISION PROGRAMS IN THE FIELD OF BUSINESS; ENTERTAINMENT SERVICES, NAMELY, PROVIDING ONGOING TELEVISION PROGRAMS IN THE FIELD OF BUSINESS VIA A GLOBAL COMPUTER NETWORK; ENTERTAINMENT SERVICES, NAMELY, PROVIDING ONGOING WEBSERIES FEATURING THE FIELD OF BUSINESS VIA A GLOBAL COMPUTER NETWORK; MULTIMEDIA ENTERTAINMENT SERVICES IN THE NATURE OF DEVELOPMENT, PRODUCTION AND POST-PRODUCTION SERVICES IN THE FIELDS OF VIDEO AND FILMS (U.S. CLS. 100, 101 AND 107).

TEJBIR SINGH, EXAMINING ATTORNEY

**CLASS 41—(Continued).**

SN 86-250,479. WAVE GARDEN HAWAII LLC, AUSTIN, TX. FILED 4-11-2014.

**Think Green Dream Blue**

THE MARK CONSISTS OF STANDARD CHARACTERS WITHOUT CLAIM TO ANY PARTICULAR FONT, STYLE, SIZE, OR COLOR.

FOR AMUSEMENT PARKS; MUSEUMS; PROVIDING EDUCATIONAL SERVICES, NAMELY, PROVIDING CLASSES IN AGRICULTURE, PROVIDING CLASSES IN AQUACULTURE, PROVIDING CLASSES IN ENVIRONMENTAL SUSTAINABILITY, PROVIDING CLASSES IN SURFBOARD DESIGN AND SHAPING; PROVIDING FACILITIES FOR RECREATIONAL ACTIVITIES, NAMELY, SURFBOARD DESIGN AND SHAPING; RENTAL OF SURF BOARDS; PROVIDING PHYSICAL FITNESS AND EXERCISE SERVICES, NAMELY, SURF LESSONS, WATER SAFETY TRAINING, YOGA CLASSES AND PHYSICAL FITNESS INSTRUCTION; PROVIDING FACILITIES FOR RECREATIONAL ACTIVITIES, NAMELY, BEACH VOLLEYBALL TRAINING; PROVIDING FACILITIES FOR RECREATIONAL ACTIVITIES, NAMELY, ROCK CLIMBING; PROVIDING FACILITIES FOR RECREATIONAL ACTIVITIES, NAMELY, FLYING DISC SPORTS; PROVIDING ZIP LINE RIDES FOR RECREATIONAL PURPOSES; PROVIDING FACILITIES FOR RECREATIONAL ACTIVITIES, NAMELY, SLACKLINE TRAINING; PROVIDING ROPES CHALLENGE COURSES; PROVIDING FACILITIES FOR RECREATIONAL ACTIVITIES, NAMELY, SKATEBOARDING; PROVIDING FACILITIES FOR RECREATIONAL ACTIVITIES, NAMELY, TETHERED HOT AIR BALLOONING; PROVIDING FACILITIES FOR RECREATIONAL ACTIVITIES, NAMELY, TRAINING RUNNERS; AND PROVIDING FITNESS AND EXERCISE FACILITIES (U.S. CLS. 100, 101 AND 107).

ALLISON HOLTZ, EXAMINING ATTORNEY

SN 86-251,417. FOX LATIN AMERICAN CHANNEL LLC, LOS ANGELES, CA. FILED 4-14-2014.

**EL ANTITOUR**

THE MARK CONSISTS OF STANDARD CHARACTERS WITHOUT CLAIM TO ANY PARTICULAR FONT, STYLE, SIZE, OR COLOR.

THE ENGLISH TRANSLATION OF "EL ANTITOUR" IN THE MARK IS "THE ANTI-TOUR".

FOR ENTERTAINMENT SERVICES IN THE NATURE OF A TELEVISION SERIES FEATURING TRAVEL, FOOD, CULTURE AND LIFESTYLE; PROVIDING ONLINE INFORMATION IN THE FIELD OF TELEVISION SHOWS AND VIDEO ENTERTAINMENT FEATURING TRAVEL, FOOD, CULTURE AND LIFESTYLE VIA THE INTERNET; ENTERTAINMENT SERVICES IN THE NATURE OF NON-DOWNLOADABLE VIDEOS AND IMAGES FEATURING TELEVISION SHOWS ABOUT TRAVEL, FOOD, CULTURE AND LIFESTYLE TRANSMITTED VIA THE INTERNET AND WIRELESS COMMUNICATION NETWORKS; ON-LINE JOURNALS, NAMELY, BLOGS FEATURING PERSONAL OPINIONS IN THE FIELDS OF GENERAL INTEREST, TRAVEL, FOOD, CULTURE AND LIFESTYLE (U.S. CLS. 100, 101 AND 107).

KAPIL BHANOT, EXAMINING ATTORNEY

**CLASS 41—(Continued).**

SN 86-251,447. THE MOODY BIBLE INSTITUTE OF CHICAGO, CHICAGO, IL. FILED 4-14-2014.

**PASTOR'S ONLY**

THE MARK CONSISTS OF STANDARD CHARACTERS WITHOUT CLAIM TO ANY PARTICULAR FONT, STYLE, SIZE, OR COLOR.

NO CLAIM IS MADE TO THE EXCLUSIVE RIGHT TO USE "PASTOR'S", APART FROM THE MARK AS SHOWN.

FOR EDUCATIONAL AND ENTERTAINMENT SERVICES, NAMELY: A CONTINUING PROGRAM ABOUT ISSUES FACING CHURCH PASTORS AND CHRISTIAN MINISTRY LEADERS ACCESSIBLE BY MEANS OF RADIO, AND INTERNET; PROVIDING PODCASTS AND VIDEO PODCASTS ABOUT ISSUES FACING CHURCH PASTORS AND CHRISTIAN MINISTRY LEADERS (U.S. CLS. 100, 101 AND 107).

SIDDHARTH JAGANNATHAN, EXAMINING ATTORNEY

SN 86-251,628. KATIE O LLC, SEATTLE, WA. FILED 4-14-2014.

**KATIE O**

THE MARK CONSISTS OF STANDARD CHARACTERS WITHOUT CLAIM TO ANY PARTICULAR FONT, STYLE, SIZE, OR COLOR.

FOR EDUCATION SERVICES, NAMELY, PROVIDING ONLINE COURSES, CLASSES, AND SEMINARS IN THE FIELD OF CAREER DEVELOPMENT AND LIFE COACHING (U.S. CLS. 100, 101 AND 107).

EDWARD FENNESSY, EXAMINING ATTORNEY

**CLASS 41—(Continued).**

SN 86-251,733. SAGE PUBLICATIONS, INC., THOUSAND OAKS, CA. FILED 4-14-2014.

**CORWIN CONNECT**

THE MARK CONSISTS OF STANDARD CHARACTERS WITHOUT CLAIM TO ANY PARTICULAR FONT, STYLE, SIZE, OR COLOR.

OWNER OF U.S. REG. NOS. 2,168,847, 3,850,973 AND OTHERS.

FOR PUBLISHING SERVICES, NAMELY, PUBLISHING OF BOOKS, JOURNALS, AND MAGAZINES; PROVIDING ON-LINE PUBLICATIONS IN THE NATURE OF BOOKS AND JOURNALS IN THE FIELDS OF SCHOLARLY, ACADEMIC, PROFESSIONAL, LEARNED, MEDICAL, SCIENTIFIC, AND TECHNICAL RESEARCH INCLUDING TRAINING AND EDUCATIONAL INFORMATION RELATED TO THESE AREAS; PROVIDING INFORMATION IN THE FIELDS OF EDUCATIONAL RESEARCH AND TRAINING IN THE FIELDS OF LIFE SCIENCE, BIOMEDICAL SCIENCES, CLINICAL MEDICINE, PSYCHOLOGY, PSYCHIATRY, NURSING, FOOD SCIENCE, PHYSICS, MATHEMATICS, COMPUTING, MATERIAL SCIENCE, ENGINEERING, CHEMISTRY, ENVIRONMENTAL SCIENCE VIA GLOBAL COMPUTER NETWORKS; PROVIDING A WEBSITE FEATURING BLOGS AND NON-DOWNLOADABLE PUBLICATIONS IN THE NATURE OF BOOKS AND JOURNALS IN THE FIELDS OF SCHOLARLY, ACADEMIC, PROFESSIONAL, LEARNED, MEDICAL, SCIENTIFIC, AND TECHNICAL RESEARCH (U.S. CLS. 100, 101 AND 107).  
MICHAEL KEATING, EXAMINING ATTORNEY

SN 86-255,433. IGT, RENO, NV. FILED 4-17-2014.

**MEDIEVAL MONEY**

THE MARK CONSISTS OF STANDARD CHARACTERS WITHOUT CLAIM TO ANY PARTICULAR FONT, STYLE, SIZE, OR COLOR.

OWNER OF U.S. REG. NOS. 2,955,621, 3,931,477 AND OTHERS.

NO CLAIM IS MADE TO THE EXCLUSIVE RIGHT TO USE "MONEY", APART FROM THE MARK AS SHOWN.

FOR ENTERTAINMENT SERVICES, NAMELY, PROVIDING ON-LINE COMPUTER GAMES (U.S. CLS. 100, 101 AND 107).

LEIGH CAROLINE CASE, EXAMINING ATTORNEY

**CLASS 41—(Continued).**

SN 86-255,896. PARSONS, JENNIFER LYNN, HOOKSTOWN, PA. FILED 4-18-2014.

**No One Told Me! Seminar**

THE MARK CONSISTS OF STANDARD CHARACTERS WITHOUT CLAIM TO ANY PARTICULAR FONT, STYLE, SIZE, OR COLOR.

NO CLAIM IS MADE TO THE EXCLUSIVE RIGHT TO USE "SEMINAR", APART FROM THE MARK AS SHOWN, FOR VOCATIONAL GUIDANCE (U.S. CLS. 100, 101 AND 107).

FIRST USE 3-1-2014; IN COMMERCE 4-1-2014.

MAUREEN DALL, EXAMINING ATTORNEY

SN 86-256,146. IGT, RENO, NV. FILED 4-18-2014.



THE MARK CONSISTS OF AN ANGLED CHECK MARK WITH A POINTED END SUPERIMPOSED ON AN IMAGE OF A SHIELD.

FOR ENTERTAINMENT SERVICES, NAMELY, PROVIDING ON-LINE COMPUTER GAMES (U.S. CLS. 100, 101 AND 107).

LEIGH CAROLINE CASE, EXAMINING ATTORNEY

SN 86-256,281. RAGAN, THOMAS O., SHEBOYGAN, WI. FILED 4-18-2014.

**RAGANOMIX**

THE MARK CONSISTS OF THE STYLIZED WORD "RAGANOMIX" WHEREIN EACH LETTER "A" IS SUPERIMPOSED ON A CIRCLE AND FEATURES A DIAGONAL LINE ACROSS THE LETTER AS TO APPEAR LIKE AN ANARCHY SYMBOL.

FOR ENTERTAINMENT SERVICES IN THE NATURE OF LIVE MUSICAL PERFORMANCES AND COMEDY SHOWS (U.S. CLS. 100, 101 AND 107).

ELIZABETH JACKSON, EXAMINING ATTORNEY

**CLASS 41—(Continued).**

SN 86-259,461. TIME WARNER CABLE ENTERPRISES LLC,  
NEW YORK, NY. FILED 4-22-2014.

GREAT MOMENTS LIVE  
FOREVER. GREAT MOMENTS  
LIVE HERE.

THE MARK CONSISTS OF STANDARD CHARACTERS  
WITHOUT CLAIM TO ANY PARTICULAR FONT, STYLE,  
SIZE, OR COLOR.

FOR TELEVISION ON DEMAND IN THE NATURE OF  
THE PROVISION OF NON-DOWNLOADABLE TELEVI-  
SION PROGRAMS VIA VIDEO-ON-DEMAND SERVICES;  
PRODUCTION OF TELEVISION PROGRAMS, TELEVI-  
SION PROGRAMMING SERVICES; ENTERTAINMENT  
SERVICES IN THE NATURE OF A CONTINUOUS  
RUNNING CABLE TELEVISION PROGRAM SPECIALIZ-  
ING IN SPORTS; PROVIDING AN INTERNET WEBSITE  
FEATURING NEWS, CURRENT EVENTS AND INFOR-  
MATION ON SPORTS (U.S. CLS. 100, 101 AND 107).

JENNY PARK, EXAMINING ATTORNEY

SN 86-261,096. WUHRMAN, KRISTIN, MEDINA, WA. FILED  
4-24-2014.

BEVEGAN

THE MARK CONSISTS OF STANDARD CHARACTERS  
WITHOUT CLAIM TO ANY PARTICULAR FONT, STYLE,  
SIZE, OR COLOR.

FOR EDUCATIONAL SERVICES, NAMELY, CON-  
DUCTING TRAINING AND TEACHING IN THE FIELD  
OF VEGAN LIFESTYLES, HEALTH AND NUTRITION  
AND DISTRIBUTION OF TRAINING MATERIAL IN  
CONNECTION THEREWITH (U.S. CLS. 100, 101 AND  
107).

FIRST USE 4-11-2014; IN COMMERCE 4-11-2014.  
BRIAN PINO, EXAMINING ATTORNEY

SN 86-264,254. PADGETT, JORDAN, ST. ALBANS, NY.  
FILED 4-28-2014.

WHERE YOUR DIGITAL GAMING  
BEGINS

THE MARK CONSISTS OF STANDARD CHARACTERS  
WITHOUT CLAIM TO ANY PARTICULAR FONT, STYLE,  
SIZE, OR COLOR.

FOR ENTERTAINMENT SERVICES, NAMELY, PRO-  
VIDING ONLINE VIDEO GAMES; ENTERTAINMENT  
SERVICES, NAMELY, PROVIDING TEMPORARY USE  
OF NON-DOWNLOADABLE VIDEO GAMES (U.S. CLS.  
100, 101 AND 107).

JILLIAN CANTOR, EXAMINING ATTORNEY

**CLASS 41—(Continued).**

SN 86-265,755. NORTH CAROLINA STATE UNIVERSITY,  
RALEIGH, NC. FILED 4-29-2014.

DESIGNLIFE

THE MARK CONSISTS OF STANDARD CHARACTERS  
WITHOUT CLAIM TO ANY PARTICULAR FONT, STYLE,  
SIZE, OR COLOR.

FOR EDUCATION SERVICES IN THE NATURE OF  
COURSES AT THE COLLEGE AND POST-GRADUATE  
LEVEL; EDUCATIONAL AND CULTURAL EXHIBITION  
SERVICES FEATURING THE PRESENTATION OF  
WORKS OF VISUAL ART AND LITERATURE, AND  
INFORMATION ABOUT THE FOREGOING, TO THE  
PUBLIC FOR EDUCATIONAL AND CULTURAL PUR-  
POSES; NON-DOWNLOADABLE ON-LINE DIGITAL  
PUBLICATIONS IN THE NATURE OF MAGAZINES IN  
THE FIELD OF ART AND DESIGN; PROVIDING ON-  
LINE JOURNALS, NAMELY, BLOGS IN THE FIELD OF  
ART AND DESIGN (U.S. CLS. 100, 101 AND 107).

FIRST USE 5-1-2012; IN COMMERCE 5-1-2012.  
MARTHA FROMM, EXAMINING ATTORNEY

SN 86-268,139. HEALTH EDUCATION SERVICES LLC, AKA  
HES LLC, FARMINGTON, CT. FILED 4-30-2014.

Children of the Golden  
Light

THE MARK CONSISTS OF STANDARD CHARACTERS  
WITHOUT CLAIM TO ANY PARTICULAR FONT, STYLE,  
SIZE, OR COLOR.

FOR EDUCATIONAL SERVICES, NAMELY, CON-  
DUCTING CLASSES, LESSONS, COURSES, SEMINARS,  
PROGRAMS, TRAININGS, LEARNING EXPERIENCES,  
STORYTELLING, CHILDREN'S PLAY ACTIVITIES,  
CONFERENCES, WORKSHOPS, NON-DOWNLOAD-  
ABLE WEBINARS AND ONLINE, NON-DOWNLOAD-  
ABLE ELECTRONIC MEDIA AUDIO-VIDEO  
PRESENTATIONS IN THE FIELD OF MULTICULTURAL  
AWARENESS, PLAYFUL PASTIMES, FITNESS,  
HEALTH, EXERCISE, MOVEMENT ACTIVITIES, ART,  
MUSIC, DANCE, CRAFTS, GAMES, WELLNESS, MIND-  
BODY EXERCISE, LEARNING A HEALTHY LIFE-  
STYLE, AND LEADERSHIP AND PUBLISHING AND  
DISTRIBUTING EDUCATIONAL MATERIALS IN CON-  
NECTION THEREWITH (U.S. CLS. 100, 101 AND 107).

FIRST USE 7-15-2010; IN COMMERCE 7-15-2010.  
CHRISTOPHER REAMS, EXAMINING ATTORNEY

**CLASS 41—(Continued).**

SN 86-269,758. MARTHA STEWART LIVING OMNIMEDIA, INC., NEW YORK, NY. FILED 5-2-2014.

## Martha Stewart's Cooking School

THE MARK CONSISTS OF STANDARD CHARACTERS WITHOUT CLAIM TO ANY PARTICULAR FONT, STYLE, SIZE, OR COLOR.

OWNER OF U.S. REG. NOS. 1,947,885, 3,592,212 AND OTHERS.

NO CLAIM IS MADE TO THE EXCLUSIVE RIGHT TO USE "COOKING SCHOOL", APART FROM THE MARK AS SHOWN.

THE NAME(S), PORTRAIT(S), AND/OR SIGNATURE(S) SHOWN IN THE MARK IDENTIFIES "MARTHA STEWART", WHOSE CONSENT(S) TO REGISTER IS MADE OF RECORD.

FOR ENTERTAINMENT IN THE NATURE OF ONGOING TELEVISION PROGRAMS IN THE FIELD OF FOOD AND COOKING; ENTERTAINMENT SERVICES, NAMELY, THE PROVISION OF CONTINUING PROGRAMS AND SHOWS FEATURING FOOD AND COOKING DELIVERED BY TELEVISION, RADIO, SATELLITE AND THE INTERNET (U.S. CLS. 100, 101 AND 107).

FIRST USE 4-19-2012; IN COMMERCE 10-6-2012.

THEODORE MCBRIDE, EXAMINING ATTORNEY

---

SN 86-270,457. FOX LATIN AMERICAN CHANNEL LLC, LOS ANGELES, CA. FILED 5-2-2014.

## LIMOMASTERS

THE MARK CONSISTS OF STANDARD CHARACTERS WITHOUT CLAIM TO ANY PARTICULAR FONT, STYLE, SIZE, OR COLOR.

FOR ENTERTAINMENT SERVICES IN THE NATURE OF A DOCUMENTARY AND REALITY TELEVISION SERIES; PROVIDING ON-LINE INFORMATION IN THE FIELD OF DOCUMENTARY AND REALITY TELEVISION SHOWS VIA A GLOBAL COMMUNICATIONS NETWORK; ENTERTAINMENT SERVICES IN THE NATURE OF NON-DOWNLOADABLE VIDEOS AND IMAGES FEATURING DOCUMENTARY AND REALITY TELEVISION SHOWS TRANSMITTED VIA THE INTERNET AND WIRELESS COMMUNICATION NETWORKS; ON-LINE JOURNALS, NAMELY, BLOGS FEATURING PERSONAL OPINIONS IN THE FIELD OF GENERAL INTEREST AND DOCUMENTARY AND REALITY TELEVISION SHOWS (U.S. CLS. 100, 101 AND 107).

KAPIL BHANOT, EXAMINING ATTORNEY

**CLASS 41—(Continued).**

SN 86-270,664. LIVE NATION WORLDWIDE, INC., BEVERLY HILLS, CA. FILED 5-2-2014.

## BORDERTOWN

THE MARK CONSISTS OF STANDARD CHARACTERS WITHOUT CLAIM TO ANY PARTICULAR FONT, STYLE, SIZE, OR COLOR.

FOR ENTERTAINMENT SERVICES IN THE NATURE OF A LIVE MUSIC FESTIVAL (U.S. CLS. 100, 101 AND 107).

LAURA KOVALSKY, EXAMINING ATTORNEY

---

SN 86-274,656. JOSEPH A. HARDY & ASSOCIATES, EIGHTY FOUR, PA. FILED 5-7-2014.

## 84 LUMBER

THE MARK CONSISTS OF STANDARD CHARACTERS WITHOUT CLAIM TO ANY PARTICULAR FONT, STYLE, SIZE, OR COLOR.

NO CLAIM IS MADE TO THE EXCLUSIVE RIGHT TO USE "LUMBER", APART FROM THE MARK AS SHOWN.

FOR PROVIDING A WEBSITE FEATURING NON-DOWNLOADABLE PUBLICATIONS IN THE NATURE OF BUILDING IN THE FIELD OF CONSTRUCTION; PROVIDING A WEBSITE FEATURING NON-DOWNLOADABLE VIDEOS IN THE FIELD OF CONSTRUCTION (U.S. CLS. 100, 101 AND 107).

DAVID COLLIER, EXAMINING ATTORNEY

---

SN 86-276,941. INVENT NOW, INC., NORTH CANTON, OH. FILED 5-9-2014.



NO CLAIM IS MADE TO THE EXCLUSIVE RIGHT TO USE "INVENTION", APART FROM THE MARK AS SHOWN.

THE MARK CONSISTS OF A STYLIZED LETTER THAT IS THE COMBINATION OF AN "I" AND A "P" PARTIALLY SURROUNDED BY A CIRCLE WITH A PLURALITY OF LINES EXTENDING RADIALLY OUTWARD FROM THE EXTERIOR OF THE CIRCLE WITH THE OPEN END OF THE CIRCLE AT THE BOTTOM OF THE "P" WITH THE WORDS "INVENTION PROJECT" TO THE RIGHT OF THE "P" IN A CIRCLE.

FOR EDUCATIONAL SERVICES, NAMELY, CONDUCTING CLASSES AND WORKSHOPS IN THE FIELD OF CREATIVITY AND INVENTION DURING DAY CAMPS FOR CHILDREN (U.S. CLS. 100, 101 AND 107).

FIRST USE 4-20-2014; IN COMMERCE 4-20-2014.

KEVIN MITTLER, EXAMINING ATTORNEY

**CLASS 41—(Continued).**

SN 86-279,758. STATE UNIVERSITY OF NEW YORK BY AND ON BEHALF OF STONY BROOK UNIVERSITY, STONY BROOK, NY. FILED 5-13-2014.

**OPEN THE FREEZER**

THE MARK CONSISTS OF STANDARD CHARACTERS WITHOUT CLAIM TO ANY PARTICULAR FONT, STYLE, SIZE, OR COLOR.

FOR EDUCATION SERVICES IN THE NATURE OF COURSES AT THE UNIVERSITY LEVEL AND DISTRIBUTION OF EDUCATIONAL MATERIAL IN CONNECTION THEREWITH; EDUCATING AT UNIVERSITIES OR COLLEGES; PROVIDING A WEBSITE THAT FEATURES INFORMATION ABOUT HIGHER EDUCATION SERVICES, NAMELY, JOURNALISM, JOURNALISM EDUCATION, JOURNALISM TEACHING METHODS AND JOURNALISM WORKSHOPS; PROVIDING INFORMATION ABOUT EDUCATION; CONDUCTING EDUCATIONAL WORKSHOPS IN THE FIELD OF JOURNALISM AND JOURNALISM TEACHING METHODS; EDUCATION SERVICES IN THE NATURE OF JOURNALISM COURSES AT THE UNIVERSITY AND UNIVERSITY GRADUATE LEVEL, AND DISTRIBUTION OF EDUCATIONAL MATERIALS IN CONNECTION THEREWITH (U.S. CLS. 100, 101 AND 107).

FIRST USE 5-13-2013; IN COMMERCE 5-13-2013.  
THOMAS MANOR, EXAMINING ATTORNEY

**CLASS 41—(Continued).**

SN 86-298,734. FITBOOM LLC, CHEYENNE, WY. FILED 6-3-2014.

**STRONG. HEALTHY. HAPPY**

THE MARK CONSISTS OF STANDARD CHARACTERS WITHOUT CLAIM TO ANY PARTICULAR FONT, STYLE, SIZE, OR COLOR.

FOR PHYSICAL FITNESS CONSULTATION; PHYSICAL FITNESS INSTRUCTION; PHYSICAL FITNESS TRAINING SERVICES; PROVIDING A WEB SITE FEATURING INFORMATION ON EXERCISE AND FITNESS; PROVIDING AN INTERACTIVE WEBSITE FEATURING INFORMATION AND LINKS RELATING TO FITNESS; PROVIDING INFORMATION ON PHYSICAL EXERCISE; PROVIDING CLASSES, WORKSHOPS, AND SEMINARS IN THE FIELDS OF NUTRITION, WELLNESS, AND HEALTH (U.S. CLS. 100, 101 AND 107).

HANNO RITTNER, EXAMINING ATTORNEY

SN 86-304,720. WILSON (III), ROBERT E., ST. LOUIS, MO. FILED 6-9-2014.

SN 86-294,400. MIAMI TRI EVENTS LLC, MIAMI, FL. AND WILBER ANDERSON, MIAMI, FL. FILED 5-29-2014.

**SAINT JOAN OF ARC F. C.**

NO CLAIM IS MADE TO THE EXCLUSIVE RIGHT TO USE "ST AUGUSTINE HALF MARATHON 13.1 MI 10K 5K KIDS' RACE", APART FROM THE MARK AS SHOWN.

THE COLOR(S) BLACK, YELLOW, ORANGE, GRAY AND WHITE IS/ARE CLAIMED AS A FEATURE OF THE MARK.

THE MARK CONSISTS OF THE DESIGN OF A MAN'S HEAD WEARING A CONQUISTADOR HELMET AND THE WORDING "ST AUGUSTINE HALF MARATHON 13.1 MI / 10K / 5K / KIDS' RACE". THE DESIGN OF THE MAN'S HEAD IS BLACK, "ST AUGUSTINE" IS YELLOW, "HALF MARATHON" IS ORANGE, AND "13.1 MI/10K/5K/KIDS' RACE" IS WHITE IN A GRAY BOX.

FOR ENTERTAINMENT IN THE NATURE OF TRACK AND FIELD COMPETITIONS; ENTERTAINMENT IN THE NATURE OF RUNNING RACES; ENTERTAINMENT SERVICES, NAMELY, ARRANGING AND CONDUCTING OF COMPETITIONS FOR ATHLETES (U.S. CLS. 100, 101 AND 107).

FIRST USE 3-1-2011; IN COMMERCE 3-1-2011.  
KIM SAITO, EXAMINING ATTORNEY

THE MARK CONSISTS OF STANDARD CHARACTERS WITHOUT CLAIM TO ANY PARTICULAR FONT, STYLE, SIZE, OR COLOR.

NO CLAIM IS MADE TO THE EXCLUSIVE RIGHT TO USE "F.C.", APART FROM THE MARK AS SHOWN.

FOR ENTERTAINMENT SERVICES, NAMELY, SOCCER EXHIBITIONS RENDERED LIVE IN A STADIUM; ENTERTAINMENT SERVICES, NAMELY, PROVIDING A SERIES OF LIVE TELEVISION PROGRAMS, RADIO PROGRAMS AND WEBCASTS IN THE FIELD OF SOCCER COMPETITIONS; PROVISION OF ENTERTAINMENT IN THE NATURE OF NON-DOWNLOADABLE PRE-RECORDED FILM CLIPS FROM SOCCER GAMES, PRESENTED VIA MOBILE COMMUNICATION DEVICES; PROVISION OF INFORMATION IN THE FIELD OF SOCCER COMPETITIONS VIA THE INTERNET AND MOBILE DEVICES (U.S. CLS. 100, 101 AND 107).

SHARON MEIER, EXAMINING ATTORNEY

**CLASS 41—(Continued).**

SN 86-306,142. JUDELLE, TARA, TALLAHASSEE, FL. FILED 6-11-2014.

## The Embodied Science of Yoga

THE MARK CONSISTS OF STANDARD CHARACTERS WITHOUT CLAIM TO ANY PARTICULAR FONT, STYLE, SIZE, OR COLOR.

FOR CONTINUING EDUCATION SERVICES, NAMELY, PROVIDING LIVE AND ON-LINE CONTINUING PROFESSIONAL EDUCATION SEMINARS IN THE FIELD OF YOGA; EDUCATION IN THE FIELDS OF YOGA RENDERED THROUGH CORRESPONDENCE COURSES; EDUCATION SERVICES, NAMELY, MENTORING IN THE FIELD OF YOGA; EDUCATION SERVICES, NAMELY, ONE-ON-ONE MENTORING IN THE FIELD OF YOGA; EDUCATION SERVICES, NAMELY, ONE-ON-ONE MENTORING IN THE FIELDS OF YOGA; EDUCATION SERVICES, NAMELY, PROVIDING PANEL DISCUSSIONS IN THE FIELD OF YOGA; EDUCATIONAL SERVICES, NAMELY, CONDUCTING CLASSES, SEMINARS, CONFERENCES, WORKSHOPS, RETREATS, CAMPS AND FIELD TRIPS IN THE FIELD OF YOGA AND DISTRIBUTION OF TRAINING MATERIAL IN CONNECTION THEREWITH; INTERACTIVE ON-LINE TRAINING SERVICES IN THE FIELD OF YOGA; PHYSICAL FITNESS STUDIO SERVICES, NAMELY, PROVIDING EXERCISE CLASSES, BODY SCULPTING CLASSES, AND GROUP FITNESS CLASSES; PROVIDING PHYSICAL FITNESS AND EXERCISE SERVICE, NAMELY, INDOOR CYCLING AND YOGA INSTRUCTION; TRAINING SERVICES IN THE FIELD OF YOGA; YOGA INSTRUCTION (U.S. CLS. 100, 101 AND 107).

TOBY BULLOFF, EXAMINING ATTORNEY

**CLASS 41—(Continued).**

SN 86-309,935. WILSON (III), ROBERT E., ST. LOUIS, MO. FILED 6-14-2014.

## SONS AND DAUGHTERS OF GANDHI F. C.

THE MARK CONSISTS OF STANDARD CHARACTERS WITHOUT CLAIM TO ANY PARTICULAR FONT, STYLE, SIZE, OR COLOR.

NO CLAIM IS MADE TO THE EXCLUSIVE RIGHT TO USE "F.C.", APART FROM THE MARK AS SHOWN.

FOR ENTERTAINMENT SERVICES, NAMELY, SOCCER EXHIBITIONS RENDERED LIVE IN A STADIUM; ENTERTAINMENT SERVICES, NAMELY, PROVIDING A SERIES OF LIVE TELEVISION PROGRAMS, RADIO PROGRAMS AND WEBCASTS IN THE FIELD OF SOCCER COMPETITIONS; PROVISION OF ENTERTAINMENT IN THE NATURE OF NON-DOWNLOADABLE PRE-RECORDED FILM CLIPS FROM SOCCER GAMES, PRESENTED VIA MOBILE COMMUNICATION DEVICES; PROVISION OF INFORMATION IN THE FIELD OF SOCCER COMPETITIONS VIA THE INTERNET AND MOBILE DEVICES (U.S. CLS. 100, 101 AND 107).

SHARON MEIER, EXAMINING ATTORNEY

SN 86-306,764. MAYWEATHER PROMOTIONS, LLC, LAS VEGAS, NV. FILED 6-11-2014.

## TMG THE MONEY GIRLS

THE MARK CONSISTS OF STANDARD CHARACTERS WITHOUT CLAIM TO ANY PARTICULAR FONT, STYLE, SIZE, OR COLOR.

FOR ENTERTAINMENT SERVICES, NAMELY, ARRANGING AND CONDUCTING SPORTING EVENTS, MUSICAL CONCERTS AND ENTERTAINMENT SHOWS; PRODUCTION OF TELEVISION PROGRAMS FEATURING SPORTING EVENTS, MUSICAL CONCERTS AND ENTERTAINMENT SHOWS; ATHLETIC TRAINING SERVICES; PROVIDING FACILITIES FOR SPORTS TRAINING (U.S. CLS. 100, 101 AND 107).

DAVID GEARHART, EXAMINING ATTORNEY

SN 86-313,591. HIGH POINT UNIVERSITY, HIGH POINT, NC. FILED 6-18-2014.

## PREPARING HEALTHCARE PROFESSIONALS FOR THE WORLD AS IT IS GOING TO BE

THE MARK CONSISTS OF STANDARD CHARACTERS WITHOUT CLAIM TO ANY PARTICULAR FONT, STYLE, SIZE, OR COLOR.

FOR EDUCATING AT UNIVERSITY OR COLLEGES (U.S. CLS. 100, 101 AND 107).

JENNIFER RICHARDSON, EXAMINING ATTORNEY



**CLASS 41—(Continued).**

SN 86-318,584. THE UNIVERSITY OF AKRON, AKRON, OH.  
FILED 6-24-2014.

**CLASS 42—SCIENTIFIC AND COMPUTER SERVICES**

SN 76-716,024. TIGER SIX, LLC, WEST PALM BEACH, FL.  
FILED 3-18-2014.



THE MARK CONSISTS OF STYLIZED OVERLAPPING OF THE LETTERS "E", "J", AND "T".

FOR ENTERTAINMENT SERVICES IN THE NATURE OF ORGANIZING, PROMOTING AND PRESENTING CONCERTS, THEATER PRODUCTIONS AND OTHER CULTURAL PERFORMANCES (U.S. CLS. 100, 101 AND 107).

FIRST USE 7-24-1984; IN COMMERCE 7-24-1984.  
JUSTIN SEVERSON, EXAMINING ATTORNEY



NO CLAIM IS MADE TO THE EXCLUSIVE RIGHT TO USE "POWERED BY", APART FROM THE MARK AS SHOWN.

THE MARK CONSISTS OF A COMBINATION OF GEOMETRIC FIGURES REPRESENTING A PERSON DISPLAYED IN A SQUARE WITH CURVED SIDES, TO THE RIGHT OF WHICH IS THE WORDING "MOTION" AND "POWERED BY TIGERSIX". THERE IS PROGRESSIVELY LIGHTER SHADING FROM TOP TO BOTTOM IN THE WORD "MOTION".

FOR SOFTWARE AS A SERVICE (SAAS) SERVICES, NAMELY, HOSTING SOFTWARE FOR USE BY OTHERS FOR USE IN DATABASE MANAGEMENT, NAMELY, DANCE STUDIO MANAGEMENT (U.S. CLS. 100 AND 101).

FIRST USE 1-1-2013; IN COMMERCE 1-1-2013.  
REBECCA POVARCHUK, EXAMINING ATTORNEY

SN 86-325,406. NORTHERN BELLE, LLC, HARTFORD, CT.  
FILED 7-1-2014.

**NORTHERN BELLE**

THE MARK CONSISTS OF STANDARD CHARACTERS WITHOUT CLAIM TO ANY PARTICULAR FONT, STYLE, SIZE, OR COLOR.

FOR ORGANIZING, ARRANGING, AND CONDUCTING SOCIAL ENTERTAINMENT EVENTS (U.S. CLS. 100, 101 AND 107).

FIRST USE 8-31-2011; IN COMMERCE 10-31-2012.  
SKYE YOUNG, EXAMINING ATTORNEY

SN 77-500,061. APPLICATIONS TECHNOLOGY (APPTek), LLC, MCLEAN, VA. FILED 6-16-2008.

**VIDEOSCRIBE**

THE MARK CONSISTS OF STANDARD CHARACTERS WITHOUT CLAIM TO ANY PARTICULAR FONT, STYLE, SIZE, OR COLOR.

OWNER OF U.S. REG. NO. 3,710,102.  
FOR COMPUTER SERVICES, NAMELY, PROVIDING SEARCH ENGINES FOR OBTAINING VIDEO AND AUDIO CONTENT OVER A COMPUTER NETWORK (U.S. CLS. 100 AND 101).

FIRST USE 4-30-2008; IN COMMERCE 4-30-2008.  
MICHELLE DUBOIS, EXAMINING ATTORNEY

**CLASS 42—(Continued).**

SN 79-122,982. YUMEMI INC., JAPAN, FILED 10-18-2012.

**Sprocket**

PRIORITY DATE OF 9-18-2012 IS CLAIMED.  
OWNER OF INTERNATIONAL REGISTRATION 1142382  
DATED 10-18-2012, EXPIRES 10-18-2022.

THE COLOR(S) BLACK, WHITE, PINK, YELLOW, LIGHT  
BLUE, AND GREEN IS/ARE CLAIMED AS A FEATURE OF  
THE MARK.

THE MARK CONSISTS OF THE WORD "SPROCKET" IN  
BLACK, TO THE RIGHT OF A BLACK GEAR WITH A  
PARTIAL CIRCLE FORMED BY A WHITE CURVED  
ARROW IN THE CENTER OF THE GEAR. GREEN,  
YELLOW, LIGHT BLUE, AND PINK DOTS APPEAR IN  
THE CENTER OF THE CIRCLE.

FOR PROVIDING USE OF WEB-BASED APPLICA-  
TIONS VIA THE INTERNET FOR ANALYZING AC-  
TIONS OF WEBSITE-USERS; PROVIDING USE OF  
WEB-BASED APPLICATIONS VIA THE INTERNET FOR  
ANALYZING ADVERTISING EFFECTIVENESS OF  
WEBSITE; CONSULTANCY AND PROVIDING INFOR-  
MATION RELATING TO CONSTRUCTION AND MAIN-  
TENANCE OF WEBSITE; PROVIDING INFORMATION  
RELATING TO ANALYSIS OF COMPUTER SYSTEMS  
FOR WEBSITE (U.S. CLS. 100 AND 101).

LIEF MARTIN, EXAMINING ATTORNEY

**CLASS 42—(Continued).**

SN 79-144,016. PANAYA LTD., ISRAEL, FILED 1-5-2014.



THE MARK CONSISTS OF STANDARD CHARACTERS  
WITHOUT CLAIM TO ANY PARTICULAR FONT, STYLE,  
SIZE, OR COLOR.

PRIORITY DATE OF 7-15-2013 IS CLAIMED.

OWNER OF INTERNATIONAL REGISTRATION 1195650  
DATED 1-5-2014, EXPIRES 1-5-2024.

OWNER OF U.S. REG. NO. 4,247,953.

FOR SOFTWARE AS A SERVICE FEATURING SOFT-  
WARE FOR UPGRADING, TESTING, UPDATING, DE-  
PLOYING, CONSOLIDATING, INTEGRATING,  
MAINTAINING, MONITORING, ANALYZING, DIAG-  
NOSING, CONFIGURING, AND SYNCHRONIZING OF  
COMPUTER PROGRAMS AND SOFTWARE APPLICA-  
TIONS AND COMPONENTS FOR USE IN BUSINESS  
MANAGEMENT, BUSINESS ENTERPRISE RESOURCE  
PLANNING, FINANCIAL PLANNING AND REPORT-  
ING, SALES ORDER PROCESSING, HUMAN CAPITAL  
MANAGEMENT, SUPPLY CHAIN MANAGEMENT,  
WAREHOUSE MANAGEMENT, PRODUCT LIFECYCLE  
MANAGEMENT, AND CUSTOMER RELATIONSHIP  
MANAGEMENT (U.S. CLS. 100 AND 101).

DAYNA BROWNE, EXAMINING ATTORNEY

SN 79-140,707. CONTOVISTA AG, CH-8952 SCHLIEREN,  
SWITZERLAND, FILED 11-25-2013.



THE MARK CONSISTS OF STANDARD CHARACTERS  
WITHOUT CLAIM TO ANY PARTICULAR FONT, STYLE,  
SIZE, OR COLOR.

PRIORITY DATE OF 6-14-2013 IS CLAIMED.

OWNER OF INTERNATIONAL REGISTRATION 1187438  
DATED 11-25-2013, EXPIRES 11-25-2023.

THE ENGLISH TRANSLATION OF THE WORDS "CON-  
TO" AND "VISTA" IN THE MARK IS "ACCOUNT" AND  
"VIEW".

FOR PROVIDING A WEBSITE FEATURING THE  
TEMPORARY USE OF ONLINE NONDOWNLOADABLE  
SOFTWARE WHICH ALLOWS USERS TO TRACK AND  
ANALYSE PERSONAL FINANCIAL DATA, PROVIDING  
SOFTWARE ALLOWING END-USERS AND FINANCIAL  
INSTITUTIONS TO VISUALIZE AND ANALYSE FINAN-  
CIAL DATA; DESIGN AND DEVELOPMENT OF COM-  
PUTERS AND SOFTWARE (U.S. CLS. 100 AND 101).

REBECCA POVARCHUK, EXAMINING ATTORNEY

SN 85-690,185. VISIONAIRE LIGHTING, LLC, RANCHO  
DOMINGUEZ, CA. FILED 7-30-2012.



THE MARK CONSISTS OF STANDARD CHARACTERS  
WITHOUT CLAIM TO ANY PARTICULAR FONT, STYLE,  
SIZE, OR COLOR.

NO CLAIM IS MADE TO THE EXCLUSIVE RIGHT TO  
USE "LIGHTING", APART FROM THE MARK AS SHOWN.  
THE ENGLISH TRANSLATION OF "VISIONAIRE" IN  
THE MARK IS "VISIONARY".

FOR LIGHTING DESIGN AND TECHNOLOGY SPECI-  
FICATION SERVICES PERTAINING TO PERMANENT  
OR TEMPORARY AREA, ROADWAY ARCHITECTUR-  
AL, ORNAMENTAL, WALL AND CEILING, BOLLARDS,  
COMMERCIAL AND/OR RESIDENTIAL APPLICATIONS  
(U.S. CLS. 100 AND 101).

FIRST USE 6-15-2000; IN COMMERCE 6-15-2000.

BARBARA BROWN, EXAMINING ATTORNEY

**CLASS 42—(Continued).**

SN 85-690,194. VISIONAIRE LIGHTING, LLC, RANCHO DOMINGUEZ, CA. FILED 7-30-2012.



NO CLAIM IS MADE TO THE EXCLUSIVE RIGHT TO USE "LIGHTING", APART FROM THE MARK AS SHOWN. THE MARK CONSISTS OF A LARGE "V" WITH A TRIANGLE DESIGN WITHIN THE LETTER PRECEDING THE WORDS.

THE ENGLISH TRANSLATION OF "VISIONAIRE" IN THE MARK IS "VISIONARY".

FOR LIGHTING DESIGN AND TECHNOLOGY SPECIFICATION SERVICES PERTAINING TO PERMANENT OR TEMPORARY AREA, ROADWAY ARCHITECTURAL, ORNAMENTAL, WALL AND CEILING, BOLLARDS, COMMERCIAL AND/OR RESIDENTIAL APPLICATIONS (U.S. CLS. 100 AND 101).

FIRST USE 6-15-2000; IN COMMERCE 6-15-2000.  
BARBARA BROWN, EXAMINING ATTORNEY

**CLASS 42—(Continued).**

SN 85-858,265. SKYHIGH NETWORKS, INC., CUPERTINO, CA. FILED 2-23-2013.

# SKYHIGH

SN 85-714,818. PATTERSON VETERINARY SUPPLY, INC., ST. PAUL, MN. FILED 8-28-2012.

# ESHELF

THE MARK CONSISTS OF STANDARD CHARACTERS WITHOUT CLAIM TO ANY PARTICULAR FONT, STYLE, SIZE, OR COLOR.

FOR PROVIDING TEMPORARY USE VIA THE INTERNET OF ONLINE NON-DOWNLOADABLE INVENTORY CONTROL SOFTWARE FOR VETERINARY PROFESSIONALS (U.S. CLS. 100 AND 101).

INGRID C. EULIN, EXAMINING ATTORNEY

THE MARK CONSISTS OF STANDARD CHARACTERS WITHOUT CLAIM TO ANY PARTICULAR FONT, STYLE, SIZE, OR COLOR.

FOR COMPUTER SERVICES, NAMELY, SOFTWARE AS A SERVICE (SAAS) COMPUTER NETWORK SERVICES FEATURING SOFTWARE, NAMELY, COMPUTER SOFTWARE FOR PROVIDING SECURITY FOR CLOUD COMPUTING SERVICES, WITH FUNCTIONS CONSISTING OF DATA SECURITY, INFORMATION PROTECTION, DATA LOSS PREVENTION, DATA AUTHENTICATION, MANAGEMENT OF SECURITY POLICIES, NETWORK MANAGEMENT, NETWORK MONITORING, MONITORING CLOUD SERVICES USAGE, CONTROLLING EMPLOYEE ACCESS, CONTROLLING USER ACCESS, MONITORING AND AUDITING CLOUD SERVICES, GOVERNANCE AND AUDITING OF PUBLIC AND PRIVATE IT CLOUD SERVICES, AND MONITORING THE SECURITY OF REMOTE COMPUTERS AND MOBILE ELECTRONIC DEVICES; SAAS SERVICES FEATURING COMPUTER ENCRYPTION SOFTWARE TO ENABLE SECURE TRANSMISSION OF DIGITAL INFORMATION AND DATA; SAAS SERVICES FEATURING COMPUTER SOFTWARE TO INTEGRATE MANAGED SECURITY SERVICES, WITH EXISTING COMMUNICATIONS NETWORKS, SOFTWARE AND SERVICES; SAAS SERVICES FEATURING COMPUTER SOFTWARE FOR DATA COMMUNICATIONS APPLICATIONS, AND FOR THE ENCRYPTION AND AUTHENTICATION OF DIGITAL INFORMATION AND DATA; SAAS SERVICES FEATURING COMPUTER SOFTWARE FOR AUTHENTICATION AND IDENTITY MANAGEMENT INFORMATION SECURITY (U.S. CLS. 100 AND 101).

MIAH ROSENBERG, EXAMINING ATTORNEY

SN 85-837,006. CONTINENTAL RECOVERY SERVICES, DBA CRF SOLUTIONS, SIMI VALLEY, CA. FILED 1-30-2013.

# LIENVIEW

THE MARK CONSISTS OF STANDARD CHARACTERS WITHOUT CLAIM TO ANY PARTICULAR FONT, STYLE, SIZE, OR COLOR.

SEC. 2(F).

FOR COMPUTER SERVICES, NAMELY, PROVIDING AN INTERACTIVE WEB SITE FEATURING TECHNOLOGY THAT ALLOWS USERS TO TRACK MECHANICS LIEN TRANSACTIONS (U.S. CLS. 100 AND 101).

FIRST USE 4-1-2003; IN COMMERCE 4-1-2003.

EVIN L. KOZAK, EXAMINING ATTORNEY

**CLASS 42—(Continued).**

SN 85-858,269. SKYHIGH NETWORKS, INC., CUPERTINO, CA. FILED 2-23-2013.

**SKYHIGH NETWORKS**

THE MARK CONSISTS OF STANDARD CHARACTERS WITHOUT CLAIM TO ANY PARTICULAR FONT, STYLE, SIZE, OR COLOR.

NO CLAIM IS MADE TO THE EXCLUSIVE RIGHT TO USE "NETWORKS", APART FROM THE MARK AS SHOWN.

FOR COMPUTER SERVICES, NAMELY, SOFTWARE AS A SERVICE (SAAS) COMPUTER NETWORK SERVICES FEATURING SOFTWARE, NAMELY, COMPUTER SOFTWARE FOR PROVIDING SECURITY FOR CLOUD COMPUTING SERVICES, WITH FUNCTIONS CONSISTING OF DATA SECURITY, INFORMATION PROTECTION, DATA LOSS PREVENTION, DATA AUTHENTICATION, MANAGEMENT OF SECURITY POLICIES, NETWORK MANAGEMENT, NETWORK MONITORING, MONITORING CLOUD SERVICES USAGE, CONTROLLING EMPLOYEE ACCESS, CONTROLLING USER ACCESS, MONITORING AND AUDITING CLOUD SERVICES, GOVERNANCE AND AUDITING OF PUBLIC AND PRIVATE IT CLOUD SERVICES, AND MONITORING THE SECURITY OF REMOTE COMPUTERS AND MOBILE ELECTRONIC DEVICES; SAAS SERVICES FEATURING COMPUTER ENCRYPTION SOFTWARE TO ENABLE SECURE TRANSMISSION OF DIGITAL INFORMATION AND DATA; SAAS SERVICES FEATURING COMPUTER SOFTWARE TO INTEGRATE MANAGED SECURITY SERVICES, WITH EXISTING COMMUNICATIONS NETWORKS, SOFTWARE AND SERVICES; SAAS SERVICES FEATURING COMPUTER SOFTWARE FOR DATA COMMUNICATIONS APPLICATIONS, AND FOR THE ENCRYPTION AND AUTHENTICATION OF DIGITAL INFORMATION AND DATA; SAAS SERVICES FEATURING COMPUTER SOFTWARE FOR AUTHENTICATION AND IDENTITY MANAGEMENT INFORMATION SECURITY (U.S. CLS. 100 AND 101).

MIAH ROSENBERG, EXAMINING ATTORNEY

SN 85-864,959. TAPSHOP, LLC, CALABASAS, CA. FILED 3-1-2013.

**TAPSHOP**

THE MARK CONSISTS OF STANDARD CHARACTERS WITHOUT CLAIM TO ANY PARTICULAR FONT, STYLE, SIZE, OR COLOR.

FOR COMPUTER SERVICES, NAMELY, INTEGRATION OF COMPUTER SOFTWARE INTO MULTIPLE SYSTEMS AND NETWORKS; COMPUTER SERVICES, NAMELY, REMOTE AND ON-SITE MANAGEMENT OF SOFTWARE AND SOFTWARE APPLICATIONS OF OTHERS; COMPUTER SOFTWARE DEVELOPMENT; COMPUTER SOFTWARE DEVELOPMENT IN THE FIELD OF MOBILE APPLICATIONS; COMPUTER SOFTWARE DEVELOPMENT; DESIGN, DEVELOPMENT AND INSTALLATION OF COMPUTER SOFTWARE; PROGRAMMING OF COMPUTER SOFTWARE FOR OTHERS (U.S. CLS. 100 AND 101).

FIRST USE 9-24-2012; IN COMMERCE 10-9-2012.  
ELLEN BURNS, EXAMINING ATTORNEY

**CLASS 42—(Continued).**

SN 85-865,835. PHOTO MARKETING ASSOCIATION INTERNATIONAL, JACKSON, MI. FILED S.R. 3-4-2013; AM. P.R. 6-30-2014.

**BIG PHOTO SHOW**

THE MARK CONSISTS OF STANDARD CHARACTERS WITHOUT CLAIM TO ANY PARTICULAR FONT, STYLE, SIZE, OR COLOR.

NO CLAIM IS MADE TO THE EXCLUSIVE RIGHT TO USE "PHOTO", APART FROM THE MARK AS SHOWN.

FOR PROVIDING A WEBSITE FEATURING TECHNOLOGY THAT ENABLES USERS TO PRESENT PRODUCTS, SERVICES AND PROPOSALS TO OTHERS FOR COMMENT, AND GATHER FEEDBACK FROM THOSE OTHERS ABOUT THOSE PRODUCTS, SERVICES AND PROPOSALS (U.S. CLS. 100 AND 101).

CHRISTOPHER BUONGIORNO, EXAMINING ATTORNEY

SN 85-869,298. PHARMACYCLICS, INC., SUNNYVALE, CA. FILED 3-7-2013.

**RESONATE**

THE MARK CONSISTS OF STANDARD CHARACTERS WITHOUT CLAIM TO ANY PARTICULAR FONT, STYLE, SIZE, OR COLOR.

FOR MEDICAL AND SCIENTIFIC RESEARCH, NAMELY, CONDUCTING CLINICAL TRIALS FOR PHARMACEUTICAL PREPARATIONS AND PROVIDING INFORMATION ON THE EFFICACY OF A PHARMACEUTICAL PREPARATION FOR THE TREATMENT OF B-CELL MALIGNANCIES (U.S. CLS. 100 AND 101).

ALAIN LAPTER, EXAMINING ATTORNEY

**CLASS 42—(Continued).**

SN 85-885,849. VESCO OIL CORPORATION, SOUTHFIELD, MI. FILED 3-25-2013.



OWNER OF U.S. REG. NOS. 2,372,535 AND 3,488,008.  
NO CLAIM IS MADE TO THE EXCLUSIVE RIGHT TO USE "FOR A CLEANER ENVIRONMENT" AND "OIL", APART FROM THE MARK AS SHOWN.

THE MARK CONSISTS OF A CIRCLE IN WHICH EXISTS AN UPSIDE DOWN TRIANGLE WITH AN OIL DROP IN THE MIDDLE OF THE TRIANGLE AND SOLID SHADING ABOVE THE TRIANGLE. BETWEEN THE BORDER OF THE TRIANGLE AND THE BORDER OF THE CIRCLE ARE ALTERNATING SOLID LINES. THE PHRASE "FOR A CLEANER ENVIRONMENT" IS PLACED ABOVE THE CIRCLE IN A SEMI-CIRCLE AND THE WORDS "VESCO OIL" ARE IN A STRAIGHT HORIZONTAL LINE BELOW THE CIRCLE.

FOR SCIENTIFIC AND TECHNOLOGICAL SERVICES, NAMELY, SCIENTIFIC RESEARCH, ANALYSIS AND TESTING IN THE FIELD OF AUTOMOTIVE AND INDUSTRIAL LUBRICANTS AND THE IMPACT THEREOF ON THE ENVIRONMENT; CONSULTANCY SERVICES RELATING TO ENVIRONMENTAL MATTERS, NAMELY, TECHNICAL AND BUSINESS CONSULTING SERVICES IN THE FIELD OF ENVIRONMENTAL ASSESSMENT, COMPLIANCE AND PLANNING; TESTING, ANALYSIS, AND EVALUATION, SERVICES IN CONNECTION WITH LUBRICANTS; TESTING, ANALYSIS, AND EVALUATION SERVICES, IN CONNECTION WITH INDUSTRIAL, COMMERCIAL AND MARINE LUBRICANTS; CONSUMER PRODUCT SAFETY TESTING CONSULTATION; DESIGN AND TESTING FOR NEW PRODUCT DEVELOPMENT; PRODUCT SAFETY TESTING; DESIGN, DEVELOPMENT AND CONSULTING SERVICES RELATED THERETO IN THE FIELD OF AUTOMOTIVE AND INDUSTRIAL LUBRICANT DISTRIBUTION AND STORAGE; INDUSTRIAL DESIGN SERVICES (U.S. CLS. 100 AND 101).

FIRST USE 0-0-1982; IN COMMERCE 0-0-1982.  
PATRICIA EVANKO, EXAMINING ATTORNEY

**CLASS 42—(Continued).**

SN 85-899,082. J.L. SOUSER & ASSOCIATES, INC., DBA JLS AUTOMATION, YORK, PA. FILED 4-9-2013.

**DESIGN FOR AGILITY**

THE MARK CONSISTS OF STANDARD CHARACTERS WITHOUT CLAIM TO ANY PARTICULAR FONT, STYLE, SIZE, OR COLOR.

FOR DESIGN FOR OTHERS OF PACKAGING AND WRAPPING MATERIALS, NAMELY, SHRINK WRAP MACHINES, BOXES AND MACHINES FOR MASS PACKAGING FOR CONSUMER GOODS (U.S. CLS. 100 AND 101).

FIRST USE 10-30-2008; IN COMMERCE 10-30-2008.  
GIANCARLO CASTRO, EXAMINING ATTORNEY

SN 85-921,643. OLIVIER, LAURENCE R, ALPHARETTA, GA. FILED 5-2-2013.



THE MARK CONSISTS OF A FLAME-LIKE SHAPE WITH A CAPITAL "Q" VISIBLE IN THE NEGATIVE SPACE AT THE CENTER OF THE IMAGE.

FOR PROVIDING A WEBSITE FEATURING TECHNOLOGY THAT ENABLES USERS TO VISUALIZE AND ANALYZE INFORMATION RECEIVED FROM DEVICES FOR MEASURING, CALCULATING, DISPLAYING AND/OR UPLOADING TO THE INTERNET INFORMATION PERTAINING TO AN INDIVIDUAL'S ENERGY UPTAKE, ENERGY EXPENDITURE, ENERGY BALANCE, BODY COMPOSITION, AND/OR GENERAL METABOLIC CONDITION, AND TO UTILIZE THIS INFORMATION TO UPDATE THE USER'S STATUS OR PROFILE ON SOCIAL NETWORKS OR GAMING ENVIRONMENTS FOR ENTERTAINMENT PURPOSES (U.S. CLS. 100 AND 101).

WILLIAM BRECKENFELD, EXAMINING ATTORNEY

**CLASS 42—(Continued).**

SN 85-931,152. LACNY, SHERILYNNE, AKA PUSH IT, SAN DIEGO, CA. FILED 5-14-2013.

# PUSH IT

THE MARK CONSISTS OF STANDARD CHARACTERS WITHOUT CLAIM TO ANY PARTICULAR FONT, STYLE, SIZE, OR COLOR.

FOR PROVIDING TEMPORARY USE OF ON-LINE NON-DOWNLOADABLE SOFTWARE FOR USE IN CUSTOMER RELATIONSHIP MANAGEMENT (CRM) (U.S. CLS. 100 AND 101).

FIRST USE 6-1-2010; IN COMMERCE 6-10-2010.

ROBERT C. CLARK JR., EXAMINING ATTORNEY

---

SN 85-963,032. VANTIV, LLC, CINCINNATI, OH. FILED 6-18-2013.



NO CLAIM IS MADE TO THE EXCLUSIVE RIGHT TO USE "COO", APART FROM THE MARK AS SHOWN.

THE MARK CONSISTS OF THE LETTERS "C" "O" AND "O" TO THE LEFT OF THREE EQUALLY SIZED CIRCLES, THE FIRST CIRCLE FEATURING THREE SMALLER CIRCLES CONNECTED BY TWO LINES, THE SECOND CIRCLE FEATURING SIX LINES SET IN THE SHAPE OF A STAR, AND THE THIRD CIRCLE FEATURING AN ARROW POINTING VERTICALLY, ALL ABOVE THE WORDS "EXCEEDING...BY DESIGN".

FOR INFORMATION TECHNOLOGY SERVICES, NAMELY, DESIGNING AND MAINTAINING COMPUTER PROGRAMS FOR OTHERS IN THE AREA OF PAYMENT PROCESSING SERVICES THAT FACILITATE ELECTRONIC PROCESSING, TRANSMISSION, TRANSFER AND BANK ACCOUNT SETTLEMENT OF CREDIT CARD, DEBIT CARD, BANK CARD, STORED VALUE CARD, LOYALTY CARD, GIFT CARD, ELECTRONIC BENEFITS, CHECK, MOBILE, ONLINE, ELECTRONIC FUNDS, AND BILL PAYMENT AND TRANSACTION DATA VIA A GLOBAL COMPUTER NETWORK, DATA ENCRYPTION AND DATA SECURITY SERVICES, NAMELY, PROVIDING SECURITY AND ANONYMITY FOR ELECTRONICALLY TRANSMITTED CREDIT CARD, DEBIT CARD, BANK CARD, STORED VALUE CARD, LOYALTY CARD, GIFT CARD, ELECTRONIC BENEFITS, CHECK, MOBILE, ONLINE, ELECTRONIC FUNDS, AND BILL PAYMENT DATA AND TRANSACTIONS VIA A GLOBAL COMPUTER NETWORK, PROVIDING USE OF ON-LINE, NON-DOWNLOADABLE SOFTWARE FOR USE BY ENTITIES, NAMELY, FINANCIAL INSTITUTIONS, MERCHANTS, VALUE-ADDED RESELLERS, SOFTWARE DEALERS AND OTHER PAYMENT PROCESSORS, IN ORDER TO PROCESS CREDIT CARD, DEBIT CARD, BANK CARD, STORED VALUE CARD, LOYALTY CARD, GIFT CARD, ELECTRONIC BENEFITS, CHECK, MOBILE, ONLINE, ELECTRONIC FUNDS, AND BILL PAYMENT TRANSACTIONS VIA A GLOBAL COMPUTER NETWORK, PROVIDING TEMPORARY USE OF ON-LINE NON-DOWNLOADABLE SOFTWARE FOR USE IN ANALYZING CREDIT AND DEBIT CARD EXPENDITURES AND GENERATING REPORTS RELATING THERETO (U.S. CLS. 100 AND 101).

KATHERINE CONNOLLY, EXAMINING ATTORNEY

**CLASS 42—(Continued).**

SN 86-007,117. WHIPCODE, INC., HENDERSON, NV. FILED 7-10-2013.

# Yabuka AdPlant

THE MARK CONSISTS OF STANDARD CHARACTERS WITHOUT CLAIM TO ANY PARTICULAR FONT, STYLE, SIZE, OR COLOR.

THE WORDING "YABUKA" HAS NO MEANING IN A FOREIGN LANGUAGE.

FOR PROVIDING ONLINE NON-DOWNLOADABLE SOFTWARE FOR POSTING ADVERTISEMENTS AND DISPLAYING ADVERTISEMENTS FOR USE IN THE FIELD OF DIGITAL MEDIA ADVERTISING (U.S. CLS. 100 AND 101).

TINA BROWN, EXAMINING ATTORNEY

---

SN 86-037,123. THE UNIVERSITY OF UTAH, SALT LAKE CITY, UT. FILED 8-14-2013.

# WHAT'S POSSIBLE

THE MARK CONSISTS OF STANDARD CHARACTERS WITHOUT CLAIM TO ANY PARTICULAR FONT, STYLE, SIZE, OR COLOR.

FOR RESEARCH IN THE FIELDS OF CANCER, CANCER DIAGNOSIS, CANCER PREVENTION AND CANCER TREATMENT; PROVIDING MEDICAL RESEARCH INFORMATION AND CONSULTATION IN THE FIELDS OF CANCER RESEARCH AND CANCER TESTING; ON-LINE MEDICAL RESEARCH INFORMATION SERVICES IN THE FIELDS OF CANCER, CANCER RESEARCH AND CANCER TESTING; AND ON-LINE SEARCH ENGINE FACILITY SERVICES IN THE FIELDS OF CANCER, CANCER AWARENESS, CANCER RESEARCH, CANCER TESTING, CANCER DIAGNOSIS, CANCER PREVENTION, AND CANCER TREATMENT (U.S. CLS. 100 AND 101).

ALISON POLLACK, EXAMINING ATTORNEY

**CLASS 42—(Continued).**

SN 86-045,212. C T CORPORATION SYSTEM, NEW YORK, NY. FILED 8-22-2013.

# ILIENMVP

THE MARK CONSISTS OF STANDARD CHARACTERS WITHOUT CLAIM TO ANY PARTICULAR FONT, STYLE, SIZE, OR COLOR.

OWNER OF U.S. REG. NO. 3,659,581.

FOR PROVIDING ON-LINE, NON-DOWNLOADABLE, INTERNET-BASED SOFTWARE IN THE FIELD OF VEHICLE REGISTRATION, TITLE, AND LIEN TRANSACTIONS; APPLICATION SERVICE PROVIDER (ASP) FEATURING SOFTWARE FOR FILING AND TRACKING A VEHICLE REGISTRATION, TITLE OR LIEN; APPLICATION SERVICE PROVIDER (ASP) FEATURING SOFTWARE FOR ESTIMATING COSTS ASSOCIATED WITH FILING VEHICLE REGISTRATION, TITLE OR LIEN REQUESTS; PROVIDING ON-LINE, NON-DOWNLOADABLE, INTERNET-BASED SOFTWARE THAT FEATURES DOCUMENTATION AND INFORMATION RELATED TO VEHICLE REGISTRATION, TITLE OR LIEN FILINGS; PROVIDING ON-LINE, NON-DOWNLOADABLE, INTERNET-BASED SOFTWARE THAT GIVES VEHICLE LIEN CUSTOMERS THE ABILITY TO UPLOAD, VIEW, COPY, PRINT, DOWNLOAD, SHARE AND MANAGE ACCESS TO DOCUMENTS AND INFORMATION (U.S. CLS. 100 AND 101).

ARETHA SOMERVILLE, EXAMINING ATTORNEY

**CLASS 42—(Continued).**

SN 86-052,855. SOFTWARE ENGINEERING PROFESSIONALS, INC., CARMEL, IN. FILED 8-30-2013.

# FRONTEGA

THE MARK CONSISTS OF STANDARD CHARACTERS WITHOUT CLAIM TO ANY PARTICULAR FONT, STYLE, SIZE, OR COLOR.

OWNER OF U.S. REG. NO. 3,711,209.

FOR IT CONSULTING SERVICES; COMPUTER SERVICES, NAMELY, COMPUTER CONSULTATION IN THE FIELD OF INVESTMENT MANAGEMENT AND ACQUISITIONS IN INFORMATION TECHNOLOGY, HIGH TECH AND SOFTWARE-ENABLED SERVICES (U.S. CLS. 100 AND 101).

ALICIA COLLINS, EXAMINING ATTORNEY

SN 86-055,783. BIOCLEAN TECHNOLOGIES LLC, LAGUNA NIGEL, CA. FILED 9-4-2013.



# TalentCircles

THE MARK CONSISTS OF STANDARD CHARACTERS WITHOUT CLAIM TO ANY PARTICULAR FONT, STYLE, SIZE, OR COLOR.

FOR PROVIDING A WEB SITE FEATURING TECHNOLOGY THAT ENABLES RECRUITERS AND HIRING MANAGERS TO MANAGE THE ENTIRE CANDIDATE ATTRACTION AND SELECTION PROCESS, NAMELY, TECHNOLOGY THAT FACILITATES THE ADMINISTRATION OF BACK GROUND CHECKS OVER A GLOBAL COMPUTER NETWORK, THE ADMINISTRATION OF ONLINE ASSESSMENTS AND SKILLS TESTS, AND TECHNOLOGY THAT ALLOWS FOR THE COMPI- LATION OF JOB CANDIDATE DATA THROUGHOUT THE HIRING PROCESS (U.S. CLS. 100 AND 101).

FIRST USE 7-12-2011; IN COMMERCE 7-12-2011.  
MATTHEW GALAN, EXAMINING ATTORNEY

NO CLAIM IS MADE TO THE EXCLUSIVE RIGHT TO USE "BIOCLEAN TECHNOLOGIES", APART FROM THE MARK AS SHOWN.

THE COLOR(S) BLUE AND GREEN IS/ARE CLAIMED AS A FEATURE OF THE MARK.

THE MARK CONSISTS OF A HALF ATOM SHOWING THE TOP HALF HAVING FOUR GREEN ELECTRON PATHS WITH THREE BLUE ELECTRONS ON THREE OF THE FOUR ELECTRON PATHS, HAVING THE WORDS DIRECTLY TO THE RIGHT OF THE HALF ATOM "BIO-CLEAN" IN BLUE OVER THE WORD "TECHNOLOGIES" IN GREEN. THE COLOR WHITE REPRESENTS BACK- GROUND, OUTLINING, SHADING, AND/OR TRANSPAR- ENT AREAS AND IS NOT PART OF THE MARK.

FOR CHEMICAL ANALYSIS; CHEMICAL ENGINEER- ING; CHEMICAL LABORATORIES; CHEMICAL RE- SEARCH; CHEMICAL, BIOCHEMICAL, BIOLOGICAL AND BACTERIOLOGICAL RESEARCH AND ANALYSIS; CUSTOM DESIGN AND DEVELOPMENT OF CHEMI- CAL REAGENTS AND BIOCHEMICAL ASSAYS; DEVEL- OPMENT AND TEST OF CHEMICAL PRODUCTION METHODS (U.S. CLS. 100 AND 101).

FIRST USE 6-2-2013; IN COMMERCE 6-2-2013.  
BARNEY CHARLON, EXAMINING ATTORNEY

**CLASS 42—(Continued).**

SN 86-057,407. MEDICAL INFORMATICS CORP, RICHMOND, VA. FILED 9-6-2013.

## SAVING LIVES BIT BY BIT

THE MARK CONSISTS OF STANDARD CHARACTERS WITHOUT CLAIM TO ANY PARTICULAR FONT, STYLE, SIZE, OR COLOR.

FOR ON-LINE NON-DOWNLOADABLE COMPUTER SOFTWARE FOR USE IN DATA COLLECTION, ANALYSIS, AND REVIEW OF DATA COLLECTED FROM MEDICAL MONITORING DEVICES; DESIGN AND DEVELOPMENT OF COMPUTER SOFTWARE; COMPUTER SOFTWARE DEVELOPMENT, COMPUTER PROGRAMMING AND MAINTENANCE OF COMPUTER SOFTWARE FOR THE MEDICAL FIELD (U.S. CLS. 100 AND 101).

FIRST USE 9-10-2010; IN COMMERCE 9-10-2010.  
CAROLINE WOOD, EXAMINING ATTORNEY

**CLASS 42—(Continued).**

SN 86-058,817. TOSHIBA AMERICA INFORMATION SYSTEMS, INC., IRVINE, CA. FILED 9-9-2013.



PRIORITY CLAIMED UNDER SEC. 44(D) ON JAPAN APPLICATION NO. 2013-018920, FILED 3-15-2013.

NO CLAIM IS MADE TO THE EXCLUSIVE RIGHT TO USE "STORAGE", APART FROM THE MARK AS SHOWN.

THE MARK CONSISTS OF THE WORD "STORAGE" ABOVE THE WORD "PLACE" TO THE RIGHT OF AN ARROW DESIGN IN WHICH TWO ARROWS ARE SUPERIMPOSED OVER A STYLIZED CLOUD WITHIN A RECTANGULAR SHAPE. TWO CORNERS OF THE RECTANGLE ARE ROUNDED.

FOR PROVIDING TEMPORARY USE OF NON-DOWNLOADABLE COMPUTER PROGRAM THAT ENABLES THE STORING AND ARCHIVAL OF MULTIMEDIA DATA, NAMELY, IMAGES, PICTURES, VIDEO MOVIES, AND DOCUMENTS, AND ENABLES ACCESS TO THOSE STORED, ARCHIVED MULTIMEDIA DATA BEFORE MENTIONED IN CLOUD COMPUTING NETWORK; PROVIDING TEMPORARY USE OF ON-LINE NON-DOWNLOADABLE CLOUD COMPUTING SOFTWARE FOR USE IN ELECTRONIC STORAGE OF DATA (U.S. CLS. 100 AND 101).

FIRST USE 7-12-2013; IN COMMERCE 7-12-2013.  
DAVID ALESKOW, EXAMINING ATTORNEY

SN 86-058,220. THOUGHTWORKS, INC., CHICAGO, IL. FILED 9-6-2013.

## THOUGHTWORKS

THE MARK CONSISTS OF STANDARD CHARACTERS WITHOUT CLAIM TO ANY PARTICULAR FONT, STYLE, SIZE, OR COLOR.

OWNER OF U.S. REG. NOS. 1,866,548 AND 2,361,539.  
FOR COMPUTER SOFTWARE DEVELOPMENT; TECHNOLOGICAL CONSULTING IN THE FIELD OF COMPUTER HARDWARE SYSTEMS AND COMPUTER SOFTWARE CONSULTATION (U.S. CLS. 100 AND 101).

FIRST USE 6-1-1993; IN COMMERCE 6-1-1993.  
TARAH HARDY, EXAMINING ATTORNEY

SN 86-059,484. CONTECH HOLDINGS, LLC, WINTER PARK, FL. FILED 9-9-2013.

## Reactive Segmenting

THE MARK CONSISTS OF STANDARD CHARACTERS WITHOUT CLAIM TO ANY PARTICULAR FONT, STYLE, SIZE, OR COLOR.

OWNER OF U.S. REG. NOS. 4,175,001 AND 4,175,002.  
NO CLAIM IS MADE TO THE EXCLUSIVE RIGHT TO USE "SEGMENTING", APART FROM THE MARK AS SHOWN.

FOR APPLICATION SERVICE PROVIDER SERVICES, NAMELY, PROVIDING A WEBSITE FEATURING TEMPORARY USE OF NON-DOWNLOADABLE SOFTWARE ALLOWING WEBSITE PUBLISHERS TO DIVIDE USERS INTO MARKETABLE GROUPS BASED ON BID DATA FROM ADVERTISERS (U.S. CLS. 100 AND 101).

DAVID ELTON, EXAMINING ATTORNEY



**CLASS 42—(Continued).**

SN 86-062,470. ARTISTECARD, INC., CHICAGO, IL. FILED 9-12-2013.

**ARTIST ECARD**

THE MARK CONSISTS OF STANDARD CHARACTERS WITHOUT CLAIM TO ANY PARTICULAR FONT, STYLE, SIZE, OR COLOR.

NO CLAIM IS MADE TO THE EXCLUSIVE RIGHT TO USE "ARTIST", APART FROM THE MARK AS SHOWN.

FOR APPLICATION SERVICE PROVIDER (ASP) FEATURING SOFTWARE TO ENABLE OTHERS TO CREATE AND DESIGN WEBPAGES FOR THE TRANSMISSION, VIEWING, UPLOADING, DOWNLOADING, POSTING, SHOWING, DISPLAYING, BLOGGING, SHARING OR OTHERWISE PROVIDING OF ELECTRONIC MEDIA AND INFORMATION OVER THE INTERNET OR OTHER COMMUNICATIONS NETWORK; COMPUTER SERVICES, NAMELY, HOSTING AND MAINTAINING AN ONLINE WEBSITE FOR OTHERS TO FACILITATE THE TRANSMISSION, VIEWING, UPLOADING, DOWNLOADING, POSTING, SHOWING, DISPLAYING, BLOGGING, SHARING OR OTHERWISE PROVIDING OF ELECTRONIC MEDIA AND INFORMATION OVER THE INTERNET OR OTHER COMMUNICATIONS NETWORK; COMPUTER SOFTWARE DEVELOPMENT IN THE FIELD OF MOBILE APPLICATIONS; PLATFORM AS A SERVICE (PAAS) FEATURING COMPUTER SOFTWARE PLATFORMS THAT ALLOW USERS TO DEVELOP CUSTOMIZED WEBSITES, ELECTRONIC PRESS KITS, AND MOBILE COMPUTER SOFTWARE APPLICATIONS; NONE OF THE FOREGOING FOR USE IN CONNECTION WITH ELECTRONIC GREETING CARDS (U.S. CLS. 100 AND 101).

FIRST USE 3-25-2009; IN COMMERCE 3-25-2009.  
LINDA LAVACHE, EXAMINING ATTORNEY

**CLASS 42—(Continued).**

SN 86-062,494. ARTISTECARD, INC., CHICAGO, IL. FILED 9-12-2013.



NO CLAIM IS MADE TO THE EXCLUSIVE RIGHT TO USE "ARTIST", APART FROM THE MARK AS SHOWN.

THE MARK CONSISTS OF THE WORD "ARTIST" IN STYLIZED LETTERS WITH A STAR ABOVE THE LETTER "I" AND THE LETTERS "E C A R D" DIRECTLY BELOW.

FOR APPLICATION SERVICE PROVIDER (ASP) FEATURING SOFTWARE TO ENABLE OTHERS TO CREATE AND DESIGN WEBPAGES FOR THE TRANSMISSION, VIEWING, UPLOADING, DOWNLOADING, POSTING, SHOWING, DISPLAYING, BLOGGING, SHARING OR OTHERWISE PROVIDING OF ELECTRONIC MEDIA AND INFORMATION OVER THE INTERNET OR OTHER COMMUNICATIONS NETWORK; COMPUTER SERVICES, NAMELY, HOSTING AND MAINTAINING AN ONLINE WEBSITE FOR OTHERS TO FACILITATE THE TRANSMISSION, VIEWING, UPLOADING, DOWNLOADING, POSTING, SHOWING, DISPLAYING, BLOGGING, SHARING OR OTHERWISE PROVIDING OF ELECTRONIC MEDIA AND INFORMATION OVER THE INTERNET OR OTHER COMMUNICATIONS NETWORK; COMPUTER SOFTWARE DEVELOPMENT IN THE FIELD OF MOBILE APPLICATIONS; PLATFORM AS A SERVICE (PAAS) FEATURING COMPUTER SOFTWARE PLATFORMS THAT ALLOW USERS TO DEVELOP CUSTOMIZED WEBSITES, ELECTRONIC PRESS KITS, AND MOBILE COMPUTER SOFTWARE APPLICATIONS; NONE OF THE FOREGOING FOR USE IN CONNECTION WITH ELECTRONIC GREETING CARDS (U.S. CLS. 100 AND 101).

FIRST USE 3-25-2009; IN COMMERCE 3-25-2009.  
LINDA LAVACHE, EXAMINING ATTORNEY

SN 86-063,818. MELINTA THERAPEUTICS, INC., NEW HAVEN, CT. FILED 9-13-2013.

**MELINTA THERAPEUTICS**

THE MARK CONSISTS OF STANDARD CHARACTERS WITHOUT CLAIM TO ANY PARTICULAR FONT, STYLE, SIZE, OR COLOR.

NO CLAIM IS MADE TO THE EXCLUSIVE RIGHT TO USE "THERAPEUTICS", APART FROM THE MARK AS SHOWN.

FOR DRUG DISCOVERY SERVICES; RESEARCH AND DEVELOPMENT OF ANTIBIOTICS (U.S. CLS. 100 AND 101).

GRETTA YAO, EXAMINING ATTORNEY

**CLASS 42—(Continued).**

SN 86-064,207. COAGULO INC, LOS ANGELES, CA. FILED 9-13-2013.

# Coagulo

THE MARK CONSISTS OF STANDARD CHARACTERS WITHOUT CLAIM TO ANY PARTICULAR FONT, STYLE, SIZE, OR COLOR.

THE ENGLISH TRANSLATION OF "COAGULO" IN THE MARK IS "CLOT".

FOR APPLICATION SERVICE PROVIDER, NAMELY, HOSTING, MANAGING, DEVELOPING, AND MAINTAINING APPLICATIONS AND SOFTWARE IN THE FIELDS OF PERSONAL HEALTH AND WELLNESS AND HEALTH AWARENESS (U.S. CLS. 100 AND 101).

FIRST USE 8-19-2013; IN COMMERCE 8-19-2013.  
KEVIN CORWIN, EXAMINING ATTORNEY

---

SN 86-064,291. PROPTESTER, INC., CYPRESS, TX. FILED 9-13-2013.

PERFORMANCE CRITICAL DATA  
WHEREVER YOU NEED IT

THE MARK CONSISTS OF STANDARD CHARACTERS WITHOUT CLAIM TO ANY PARTICULAR FONT, STYLE, SIZE, OR COLOR.

NO CLAIM IS MADE TO THE EXCLUSIVE RIGHT TO USE "DATA", APART FROM THE MARK AS SHOWN.

FOR QUALITY CONTROL SERVICES FOR OILFIELD APPLICATIONS (U.S. CLS. 100 AND 101).

KHANH LE, EXAMINING ATTORNEY

---

SN 86-064,632. PIXPLUS, LLC, SANTA MONICA, CA. FILED 9-13-2013.

YOUR STORY. YOUR WAY.

THE MARK CONSISTS OF STANDARD CHARACTERS WITHOUT CLAIM TO ANY PARTICULAR FONT, STYLE, SIZE, OR COLOR.

FOR CREATING AN ON-LINE COMMUNITY FOR INDIVIDUALS TO CAPTURE PHOTOS, IMAGES, VIDEOS AND OTHER MULTIMEDIA MATERIALS, TO SHARE AND COLLABORATE ON THEM AS A COMMUNITY, AND CREATE STORIES BASED ON THEM THAT CAN BE DIGITALLY PUBLISHED OR PRINTED (U.S. CLS. 100 AND 101).

ELLEN PERKINS, EXAMINING ATTORNEY

**CLASS 42—(Continued).**

SN 86-065,470. DIGITAL GLOBAL SYSTEMS, INC., BELTSVILLE, MD. FILED 9-16-2013.

NO CLAIM IS MADE TO THE EXCLUSIVE RIGHT TO USE "DIGITAL GLOBAL SYSTEMS", APART FROM THE MARK AS SHOWN.

THE COLOR(S) BLACK, GREEN, LIGHT GREEN, MAROON AND FUSCHIA IS/ARE CLAIMED AS A FEATURE OF THE MARK.

THE MARK CONSISTS OF THE TERMS "DIGITAL GLOBAL SYSTEMS" WITH THE TERM "DIGITAL" IN BLACK, EXCEPT FOR THE LETTER I IN MAROON, APPEARING ABOVE THE TERMS "GLOBAL SYSTEMS" IN MAROON AND WITH A GREEN SPHERE WITH LIGHT GREEN SHADING BETWEEN THE TERMS "GLOBAL AND "SYSTEMS" AND WITH A FUSCHIA WAVY LINE ACROSS THE SPHERE.

FOR DESIGN AND DEVELOPMENT OF ELECTRONIC EQUIPMENT, COMPUTER HARDWARE AND SOFTWARE IN THE FIELD OF WIRELESS ELECTRONIC COMMUNICATIONS FOR RADIO FREQUENCY SPECTRUM ANALYSIS, RADIO FREQUENCY SPECTRUM MANAGEMENT, AND RADIO FREQUENCY SIGNAL OPTIMIZATION (U.S. CLS. 100 AND 101).

FIRST USE 5-31-2012; IN COMMERCE 5-31-2012.  
ALEXANDER L. POWERS, EXAMINING ATTORNEY

---

SN 86-068,576. SCHMITT, SARAH, DBA S2, HENDERSON, NV. FILED 9-18-2013.

# cycle solAir

THE MARK CONSISTS OF STANDARD CHARACTERS WITHOUT CLAIM TO ANY PARTICULAR FONT, STYLE, SIZE, OR COLOR.

NO CLAIM IS MADE TO THE EXCLUSIVE RIGHT TO USE "CYCLE", APART FROM THE MARK AS SHOWN.

FOR SOLAR-CHARGED BICYCLE AIR INFLATION STATION (U.S. CLS. 100 AND 101).

SUZANNE BLANE, EXAMINING ATTORNEY

**CLASS 42—(Continued).**

SN 86-070,789. J. E. DUNN CONSTRUCTION COMPANY, KANSAS CITY, MO. FILED 9-20-2013.

**ASE**

THE MARK CONSISTS OF STANDARD CHARACTERS WITHOUT CLAIM TO ANY PARTICULAR FONT, STYLE, SIZE, OR COLOR.

FOR PROVIDING NON-DOWNLOADABLE PROPRIETARY SOFTWARE THAT ALLOWS USERS TO OBTAIN REAL TIME PROJECTED COST ESTIMATES AND EVALUATIONS FOR USE IN CONSTRUCTION PROJECT MANAGEMENT AND CONSTRUCTION DESIGN INCORPORATING SPREADSHEET GRAPHIC TECHNOLOGY (U.S. CLS. 100 AND 101).

FIRST USE 12-0-2005; IN COMMERCE 12-0-2005.  
KATHLEEN KOLACZ, EXAMINING ATTORNEY

**CLASS 42—(Continued).**

SN 86-074,673. D4D TECHNOLOGIES, LLC, RICHARDSON, TX. FILED 9-25-2013.



OWNER OF U.S. REG. NOS. 3,399,669, 4,448,052 AND OTHERS.

NO CLAIM IS MADE TO THE EXCLUSIVE RIGHT TO USE "TECHNOLOGIES", APART FROM THE MARK AS SHOWN.

THE MARK CONSISTS OF THE STYLIZED LETTERING "E4D," WITH THE "4" BEING CREATED BY CONTRAST BETWEEN THE "E" AND "D." TO THE RIGHT OF THE "E4D" LETTERING PREVIOUSLY DESCRIBED THERE IS A VERTICAL BAR. TO THE LEFT OF THE VERTICAL BAR ARE THE WORDS "E4D TECHNOLOGIES".

FOR DESIGN AND DEVELOPMENT OF DENTAL APPARATUS AND INSTRUMENTS, DENTAL TOOLS, IMAGING SYSTEMS, SOFTWARE, AND MILLING MACHINES FOR MANUFACTURING DENTAL PROSTHETICS (U.S. CLS. 100 AND 101).

TINA L. SNAPP, EXAMINING ATTORNEY

SN 86-076,375. THE NAME LLC, NEW YORK, NY. FILED 9-27-2013.

**40/40 CLUB**

THE MARK CONSISTS OF STANDARD CHARACTERS WITHOUT CLAIM TO ANY PARTICULAR FONT, STYLE, SIZE, OR COLOR.

OWNER OF U.S. REG. NOS. 3,157,149, 4,342,116 AND OTHERS.

FOR HOSTING AN ONLINE COMMUNITY WEBSITE FEATURING DATA, INFORMATION AND UPDATES ON TOPICS OF INTEREST TO USERS OF AN ON-LINE COMMUNITY, NAMELY, SPORTS, ENTERTAINMENT, AND CULTURE INFORMATION; COMPUTER SERVICES, NAMELY, CREATING AN ONLINE VIRTUAL ENVIRONMENT FEATURING TECHNOLOGY THAT AGGREGATES AND INTEGRATES INFORMATION, IMAGES AND CONTENT FROM SOCIAL NETWORKS AND PUBLICLY AVAILABLE SOURCES AND ENABLES USERS TO INTERACT WITH INFORMATION AND CONTENT OF GREATEST INTEREST TO THEM; COMPUTER SERVICES, NAMELY, PROVIDING A VIRTUAL ENVIRONMENT FEATURING ON-LINE, NON-DOWNLOADABLE SOFTWARE THAT ENABLES USERS OF COMPUTERS AND MOBILE DEVICES TO ACCESS, AGGREGATE AND INTERACT WITH CONTENT, INFORMATION AND IMAGES FROM SOCIAL MEDIA WEBSITES AND PUBLICLY AVAILABLE SOURCES; COMPUTER SERVICES, NAMELY, CREATING AN ON-LINE VIRTUAL ENVIRONMENT ENABLING USERS TO AGGREGATE ONLINE COMMUNITY INFORMATION AND BY WHICH USERS CAN SEARCH AND ACCESS INTERNET AND SOCIAL CONTENT (U.S. CLS. 100 AND 101).

FIRST USE 2-11-2011; IN COMMERCE 2-11-2011.  
JORDAN BAKER, EXAMINING ATTORNEY

SN 86-073,277. ENSR MEDICAL, INC., LAS VEGAS, NV. FILED 9-24-2013.

**POW<sub>r</sub>**

THE MARK CONSISTS OF STANDARD CHARACTERS WITHOUT CLAIM TO ANY PARTICULAR FONT, STYLE, SIZE, OR COLOR.

FOR PROVIDING TEMPORARY USE OF A WEB-BASED SOFTWARE APPLICATION THAT ENABLES HEALTH PROFESSIONALS TO INPUT AND ACCURATELY TRACK CLINICAL PATIENT OUTCOMES ACHIEVED BY USING BIOFEEDBACK NEURO-MODULATION DEVICES IN THE FIELD OF HEALTH CARE INFORMATION SERVICES, MEDICAL APPARATUS AND INSTRUMENTS, MEDICAL SERVICES AND HEALTHCARE MANAGEMENT (U.S. CLS. 100 AND 101).

KATHERINE CHANG, EXAMINING ATTORNEY

**CLASS 42—(Continued).**

SN 86-076,431. THE NAME LLC, NEW YORK, NY. FILED 9-27-2013.



OWNER OF U.S. REG. NOS. 3,157,149, 4,342,116 AND OTHERS.

THE MARK CONSISTS OF THE STYLIZED TERM "40/40" INSIDE A DIAMOND-SHAPED BACKGROUND OVER THE WORD "CLUB", WHICH SITS UNDER AN OUTLINED STRAIGHT LINE AND SITS ABOVE A SHORTER SOLID STRAIGHT LINE; THE COLORS BLACK AND WHITE REPRESENT BACKGROUND, OUTLINING, SHADING AND/OR TRANSPARENT AREAS AND ARE NOT PART OF THE MARK. COLOR IS NOT CLAIMED AS A FEATURE OF THE MARK.

FOR HOSTING AN ONLINE COMMUNITY WEBSITE FEATURING DATA, INFORMATION AND UPDATES ON TOPICS OF INTEREST TO USERS OF AN ON-LINE COMMUNITY, NAMELY, SPORTS, ENTERTAINMENT, AND CULTURE INFORMATION; COMPUTER SERVICES, NAMELY, CREATING AN ONLINE VIRTUAL ENVIRONMENT FEATURING TECHNOLOGY THAT AGGREGATES AND INTEGRATES INFORMATION, IMAGES AND CONTENT FROM SOCIAL NETWORKS AND PUBLICLY AVAILABLE SOURCES AND ENABLES USERS TO INTERACT WITH INFORMATION AND CONTENT OF GREATEST INTEREST TO THEM; COMPUTER SERVICES, NAMELY, PROVIDING A VIRTUAL ENVIRONMENT FEATURING ON-LINE, NON-DOWNLOADABLE SOFTWARE THAT ENABLES USERS OF COMPUTERS AND MOBILE DEVICES TO ACCESS, AGGREGATE AND INTERACT WITH CONTENT, INFORMATION AND IMAGES FROM SOCIAL MEDIA WEBSITES AND PUBLICLY AVAILABLE SOURCES; COMPUTER SERVICES, NAMELY, CREATING AN ON-LINE VIRTUAL ENVIRONMENT ENABLING USERS TO AGGREGATE ONLINE COMMUNITY INFORMATION AND BY WHICH USERS CAN SEARCH AND ACCESS INTERNET AND SOCIAL CONTENT (U.S. CLS. 100 AND 101).

FIRST USE 2-11-2011; IN COMMERCE 2-11-2011.  
JORDAN BAKER, EXAMINING ATTORNEY

SN 86-078,237. COMPLIANCE ACQUISITION CORP., WOBURN, MA. FILED 9-30-2013.



NO CLAIM IS MADE TO THE EXCLUSIVE RIGHT TO USE "SOLUTIONS", APART FROM THE MARK AS SHOWN.

THE MARK CONSISTS OF THE WORDS "ADJUVANT SOLUTIONS" AND A STYLIZED DESIGN OF TWO SETS OF FIVE ADJACENT AND CURVED LINES WHICH CURVE TOWARDS ONE ANOTHER.

FOR CLINICAL AND TOXICOLOGY TESTING LABORATORY, NAMELY, A LABORATORY THAT TESTS BODILY FLUIDS FOR THE PRESENCE OR ABSENCE OF DRUGS (U.S. CLS. 100 AND 101).

KHANH LE, EXAMINING ATTORNEY

**CLASS 42—(Continued).**

SN 86-080,336. CLOSERV, LLC, ATLANTA, GA. FILED 10-2-2013.

# CLOSERV

THE MARK CONSISTS OF STANDARD CHARACTERS WITHOUT CLAIM TO ANY PARTICULAR FONT, STYLE, SIZE, OR COLOR.

FOR PROVIDING A WEBSITE FEATURING NON-DOWNLOADABLE SOFTWARE FOR USE AS A WORKFLOW MANAGER AND A SALES TRACKING TOOL BY PROFESSIONALS IN THE MORTGAGE INDUSTRY (U.S. CLS. 100 AND 101).

FIRST USE 4-0-2007; IN COMMERCE 4-0-2007.  
TINA BROWN, EXAMINING ATTORNEY

SN 86-080,485. OQINTERNATIONAL, LLC, PEORIA, IL. FILED 10-2-2013.

## Organizing for Quality Improvement

THE MARK CONSISTS OF STANDARD CHARACTERS WITHOUT CLAIM TO ANY PARTICULAR FONT, STYLE, SIZE, OR COLOR.

NO CLAIM IS MADE TO THE EXCLUSIVE RIGHT TO USE "QUALITY IMPROVEMENT", APART FROM THE MARK AS SHOWN.

FOR QUALITY MANAGEMENT CONSULTING SERVICES, NAMELY, QUALITY EVALUATION AND ANALYSIS, QUALITY ASSURANCE, AND QUALITY CONTROL, IN THE FIELDS OF AEROSPACE AND DEFENSE, COMMUNICATIONS, ELECTRONICS, MEDICAL, INDUSTRIAL, AND AUTOMOTIVE MANUFACTURING; CALIBRATION OF GENERAL PURPOSE TEST EQUIPMENT AND GAGING EQUIPMENT (U.S. CLS. 100 AND 101).

FIRST USE 4-1-2013; IN COMMERCE 4-1-2013.  
ESTHER A. BORSUK, EXAMINING ATTORNEY

**CLASS 42—(Continued).**

SN 86-083,042. GOOGLE INC., MOUNTAIN VIEW, CA.  
FILED 10-4-2013.

**AUTO-TUNE**

THE MARK CONSISTS OF STANDARD CHARACTERS WITHOUT CLAIM TO ANY PARTICULAR FONT, STYLE, SIZE, OR COLOR.

PRIORITY CLAIMED UNDER SEC. 44(D) ON JAMAICA APPLICATION NO. 62313, FILED 4-4-2013.

FOR COMPUTER SERVICES, NAMELY, PROVIDING A WEBSITE FEATURING TECHNOLOGY FOR USE WITH ENERGY DELIVERY CONTROL SYSTEMS AND ENVIRONMENTAL CONTROL SYSTEMS THAT FACILITATE INCREASED ENERGY EFFICIENCY; PLATFORM AS A SERVICE (PAAS) FEATURING COMPUTER SOFTWARE PLATFORMS THAT FACILITATE ENERGY EFFICIENCY IN ENERGY DELIVERY CONTROL SYSTEMS AND ENVIRONMENTAL CONTROL SYSTEMS; SOFTWARE AS A SERVICE (SAAS) SERVICES FEATURING COMPUTER SOFTWARE FOR USE WITH ENERGY DELIVERY CONTROL SYSTEMS AND ENVIRONMENTAL CONTROL SYSTEMS THAT FACILITATE INCREASED ENERGY EFFICIENCY (U.S. CLS. 100 AND 101).

ALLISON SCHRODY, EXAMINING ATTORNEY

---

SN 86-083,055. GOOGLE INC., MOUNTAIN VIEW, CA.  
FILED 10-4-2013.

**WEAVE**

THE MARK CONSISTS OF STANDARD CHARACTERS WITHOUT CLAIM TO ANY PARTICULAR FONT, STYLE, SIZE, OR COLOR.

PRIORITY CLAIMED UNDER SEC. 44(D) ON JAMAICA APPLICATION NO. 62311, FILED 4-4-2013.

FOR COMPUTER SERVICES, NAMELY, PROVIDING A WEBSITE FEATURING TECHNOLOGY FOR USE WITH DEVICES FOR ENVIRONMENTAL MONITORING AND CONTROL; COMPUTER SERVICES, NAMELY, PROVIDING A WEBSITE FEATURING TECHNOLOGY THAT ALLOWS USERS TO REMOTELY INTERACT WITH ENVIRONMENTAL MONITORING AND CONTROL DEVICES; PLATFORM AS A SERVICE (PAAS) FEATURING COMPUTER SOFTWARE PLATFORMS FOR USE WITH ENVIRONMENTAL MONITORING AND CONTROL DEVICES THAT ALLOWS THE SHARING AND TRANSMISSION OF DATA AND INFORMATION BETWEEN DEVICES FOR THE PURPOSES OF FACILITATING ENVIRONMENTAL MONITORING AND CONTROL; SOFTWARE AS A SERVICE (SAAS) SERVICES FEATURING COMPUTER SOFTWARE FOR USE WITH ENVIRONMENTAL MONITORING AND CONTROL DEVICES THAT ALLOWS THE SHARING AND TRANSMISSION OF DATA AND INFORMATION BETWEEN DEVICES FOR THE PURPOSES OF FACILITATING ENVIRONMENTAL MONITORING AND CONTROL (U.S. CLS. 100 AND 101).

ALLISON SCHRODY, EXAMINING ATTORNEY

**CLASS 42—(Continued).**

SN 86-089,039. SOFTECH USA, DBA GEMFIND, NEWPORT BEACH, CA. FILED 10-11-2013.

**pendant builder**

THE MARK CONSISTS OF STANDARD CHARACTERS WITHOUT CLAIM TO ANY PARTICULAR FONT, STYLE, SIZE, OR COLOR.

OWNER OF U.S. REG. NO. 3,586,375.

NO CLAIM IS MADE TO THE EXCLUSIVE RIGHT TO USE "PENDANT", APART FROM THE MARK AS SHOWN.

FOR CUSTOM DESIGN OF PENDANTS BASED UPON PERSONAL SELECTIONS MADE BY THE CUSTOMER VIA A WEBSITE (U.S. CLS. 100 AND 101).

FIRST USE 9-8-2011; IN COMMERCE 9-8-2011.

FLORENTINA BLANDU, EXAMINING ATTORNEY

---

SN 86-089,040. SOFTECH USA, DBA GEMFIND, NEWPORT BEACH, CA. FILED 10-11-2013.

**stud builder**

THE MARK CONSISTS OF STANDARD CHARACTERS WITHOUT CLAIM TO ANY PARTICULAR FONT, STYLE, SIZE, OR COLOR.

OWNER OF U.S. REG. NO. 3,586,375.

NO CLAIM IS MADE TO THE EXCLUSIVE RIGHT TO USE "STUD", APART FROM THE MARK AS SHOWN.

FOR CUSTOM DESIGN OF STUDS BASED UPON PERSONAL SELECTIONS MADE BY THE CUSTOMER VIA A WEBSITE (U.S. CLS. 100 AND 101).

FIRST USE 9-8-2011; IN COMMERCE 9-8-2011.

FLORENTINA BLANDU, EXAMINING ATTORNEY

**CLASS 42—(Continued).**

SN 86-089,727. VACATION CLOUD, INC., HENNIKER, NH. FILED 10-11-2013.

## Vacation Cloud

THE MARK CONSISTS OF STANDARD CHARACTERS WITHOUT CLAIM TO ANY PARTICULAR FONT, STYLE, SIZE, OR COLOR.

NO CLAIM IS MADE TO THE EXCLUSIVE RIGHT TO USE "CLOUD", APART FROM THE MARK AS SHOWN.

FOR PROVIDING TEMPORARY USE OF WEB-BASED COMPUTER SOFTWARE APPLICATION FOR TRACKING CUSTOMER ORDERS AND INQUIRIES, TRACKING INVENTORY, AND GENERATING REPORTS IN THE FIELD OF LEASING AND RENTAL SERVICES; PROVIDING TEMPORARY USE OF A WEB-BASED SOFTWARE APPLICATION FEATURING INFORMATION IN THE FIELD OF LEASING AND RENTAL SERVICES OF LODGING, SHORT TERM VEHICLE RENTALS, TRANSPORTATION, AND ACTIVITIES RENTALS; PROVIDING TEMPORARY USE OF A WEB-BASED SOFTWARE APPLICATION THAT COMPILES AND TRACKS CUSTOMER PURCHASES FOR LEASING AND RENTAL SERVICE COMPANIES; PROVIDING TEMPORARY USE OF A WEB-BASED COMPUTER SOFTWARE APPLICATION FOR DISPLAYING AND PROVIDING REAL ESTATE INFORMATION BY MEANS OF LINKING THE WEB SITE TO OTHER WEB SITES (U.S. CLS. 100 AND 101).

FIRST USE 12-29-2011; IN COMMERCE 8-1-2013.  
ELLEN PERKINS, EXAMINING ATTORNEY

**CLASS 42—(Continued).**

SN 86-097,545. NI, YAWEI, COLLEGE STATION, TX. FILED 10-22-2013.

## There is no expert on unknown

THE MARK CONSISTS OF STANDARD CHARACTERS WITHOUT CLAIM TO ANY PARTICULAR FONT, STYLE, SIZE, OR COLOR.

FOR SCIENTIFIC RESEARCH AND DEVELOPMENT; BIOTECHNOLOGY RESEARCH; CONSULTING SERVICES IN THE FIELDS OF BIOTECHNOLOGY, PHARMACEUTICAL RESEARCH AND DEVELOPMENT; RESEARCH AND DEVELOPMENT OF NEW PRODUCTS; SCIENTIFIC AND TECHNOLOGICAL SERVICES, NAMELY, PROVIDING RESEARCH AND DEVELOPMENT AND TESTING IN THE FIELDS OF BIOTECHNOLOGY AND PHARMACEUTICALS (U.S. CLS. 100 AND 101).

RONALD AIKENS, EXAMINING ATTORNEY

SN 86-098,110. DZINE STEPS, LLC, EAGLE, ID. FILED 10-22-2013.



SN 86-090,282. SYMMETRY ELEVATING SOLUTIONS, CLOVIS, CA. FILED 10-13-2013.

## SpeCreator

THE MARK CONSISTS OF STANDARD CHARACTERS WITHOUT CLAIM TO ANY PARTICULAR FONT, STYLE, SIZE, OR COLOR.

FOR DESIGNING COMPUTER SOFTWARE (U.S. CLS. 100 AND 101).

FIRST USE 3-1-2009; IN COMMERCE 3-1-2009.  
AHSEN KHAN, EXAMINING ATTORNEY

NO CLAIM IS MADE TO THE EXCLUSIVE RIGHT TO USE "DESIGN", APART FROM THE MARK AS SHOWN.

THE MARK CONSISTS OF A STYLIZED "D" PLACED LEFT OF THE WORDS "DZINE STEPS". THE STYLIZED "D" HAS A THREE DIMENSIONAL STAIRCASE ON THE STRAIGHT EDGE OF THE "D" MADE UP OF FIVE POLYGONS. A SOLID TRIANGLE FORMS AT THE BOTTOM MOST STEP. THE WORD "DZINE" IS BOLDFACED COMPARED TO THE WORD "STEPS".

FOR PROVIDING A WEBSITE THAT FEATURES TEMPORARY USE OF NON-DOWNLOADABLE CLOUD BASED SOFTWARE ALLOWING WEBSITE USERS TO CREATE AND CUSTOMIZE A DESIGN SPACE FOR INTERIOR OR EXTERIOR PLANS AND LIFESTYLE GOODS; PROVIDING A WEBSITE THAT FEATURES TEMPORARY USE OF NON-DOWNLOADABLE SOFTWARE ALLOWING WEBSITE USERS TO UPLOAD, DESIGN, POST/COMMENT, SHARE, DISPLAY AND/OR BROWSE ONLINE PHOTOS OF A DESIGN; PROVIDING ONLINE CLOUD BASED DATABASES AND ONLINE SEARCHABLE DATABASES IN THE FIELD OF INTERIOR AND EXTERIOR DESIGN (U.S. CLS. 100 AND 101).

EMILY CARLSEN, EXAMINING ATTORNEY

**CLASS 42—(Continued).**

SN 86-112,548. 1STPAYGATEWAY, LLC, FORT WORTH, TX. FILED 11-7-2013.

# 1stView

THE MARK CONSISTS OF STANDARD CHARACTERS WITHOUT CLAIM TO ANY PARTICULAR FONT, STYLE, SIZE, OR COLOR.

OWNER OF U.S. REG. NOS. 3,203,268, 4,452,518 AND 4,452,519.

FOR APPLICATION SERVICE PROVIDER SERVICES, NAMELY, PROVIDING TEMPORARY USE OF ONLINE NON-DOWNLOADABLE SOFTWARE FOR VALUE ADDED PAYMENT CARD TRANSACTION PROCESSING, RISK MANAGEMENT SERVICES, AND MERCHANT REPORTING, ALL IN THE FIELD OF ELECTRONIC PAYMENT PROCESSING (U.S. CLS. 100 AND 101).

ZACHARY CROMER, EXAMINING ATTORNEY

**CLASS 42—(Continued).**

SN 86-120,928. COASTAL HOME FURNISHINGS, INC., DBA PLATNER & CO., MALIBU, CA. FILED 11-17-2013.

# Peggy Platner Collection

THE MARK CONSISTS OF STANDARD CHARACTERS WITHOUT CLAIM TO ANY PARTICULAR FONT, STYLE, SIZE, OR COLOR.

NO CLAIM IS MADE TO THE EXCLUSIVE RIGHT TO USE "COLLECTION", APART FROM THE MARK AS SHOWN.

THE NAME(S), PORTRAIT(S), AND/OR SIGNATURE(S) SHOWN IN THE MARK IDENTIFIES "PEGGY PLATNER", WHOSE CONSENT(S) TO REGISTER IS MADE OF RECORD.

FOR INTERIOR DESIGN SERVICES, NAMELY, SELECTION OF FABRICS AND FURNISHINGS (U.S. CLS. 100 AND 101).

FIRST USE 4-1-2013; IN COMMERCE 4-1-2013.

MARC LEIPZIG, EXAMINING ATTORNEY

SN 86-120,239. ACP/GREENE + ASSOCIATES, TA PLANNING NEXT, COLUMBUS, OH. FILED 11-15-2013.

The logo features the word "planning" in a lowercase, sans-serif font. Below it, the word "NEXT" is written in a large, bold, red, distressed-style font. Underneath "NEXT" is the tagline "moving communities forward." in a smaller, lowercase, sans-serif font.

NO CLAIM IS MADE TO THE EXCLUSIVE RIGHT TO USE "PLANNING", APART FROM THE MARK AS SHOWN. THE COLOR(S) RED IS/ARE CLAIMED AS A FEATURE OF THE MARK.

THE MARK CONSISTS OF "PLANNING" WRITTEN IN LOWER CASE APPEARING ABOVE THE WORD "NEXT" WRITTEN IN UPPER CASE APPEARING ABOVE THE WORDING "MOVING COMMUNITIES FORWARD." IN LOWER CASE. ALL TEXT APPEARS IN THE IN COLOR RED.

FOR URBAN PLANNING (U.S. CLS. 100 AND 101). DAVID I, EXAMINING ATTORNEY

SN 86-123,620. ESCHER GROUP (IRL) LIMITED, DUBLIN, IRELAND, FILED 11-19-2013.

# POSTPORT

THE MARK CONSISTS OF STANDARD CHARACTERS WITHOUT CLAIM TO ANY PARTICULAR FONT, STYLE, SIZE, OR COLOR.

FOR PROVIDING ON-LINE NON-DOWNLOADABLE COMPUTER SOFTWARE FEATURING A TRACKING AND TRACING SYSTEM THAT PROVIDES THE USER WITH INFORMATION RELATING TO THE DELIVERY STATUS AND DESCRIPTION OF THE CONTENTS OF PACKAGES, CATALOGS AND/OR OTHER MAIL PIECES SENT TO OR BY THE USER THROUGH CATALOG COMPANIES, DELIVERY SERVICES AND/OR THE POSTAL SERVICE, AND ALLOWS THE USER TO VIEW A DIGITAL IMAGE OF THE MAIL PIECES AND TAKE ACTIONS AND INITIATE ELECTRONIC BILL PAYMENTS IN CONNECTION WITH THE MAIL PIECES (U.S. CLS. 100 AND 101).

EMILY CHUO, EXAMINING ATTORNEY

**CLASS 42—(Continued).**

SN 86-147,838. 4EDENTAL.COM, STAFFORD, VA. FILED 12-19-2013.

# 4EDENTAL

THE MARK CONSISTS OF STANDARD CHARACTERS WITHOUT CLAIM TO ANY PARTICULAR FONT, STYLE, SIZE, OR COLOR.

FOR TECHNICAL SUPPORT SERVICES, NAMELY, PROVIDING ONLINE SOFTWARE SUPPORT INFORMATION IN THE FIELD OF DENTAL HEALTH; TECHNICAL SUPPORT SERVICES, NAMELY, TROUBLESHOOTING OF COMPUTER SOFTWARE PROBLEMS FOR DENTISTS; SOFTWARE AS A SERVICE (SAAS) SERVICES FEATURING SOFTWARE FOR USE IN DATABASE MANAGEMENT, FOR USE AS A SPREADSHEET, FOR WORD PROCESSING, AND FOR SERVICE DESK MANAGEMENT (U.S. CLS. 100 AND 101).

WANDA KAY PRICE, EXAMINING ATTORNEY

---

SN 86-148,187. RICHARD D. WARREN, RANCHO SANTA MARGARITA, CA. FILED 12-19-2013.



OWNER OF U.S. REG. NO. 4,402,876.  
THE MARK CONSISTS OF THE LETTER "D" WITH A CROSS DESIGN INSIDE THE LETTER.

FOR PROVIDING A WEBSITE FEATURING ON-LINE NON-DOWNLOADABLE SOFTWARE THAT ENABLES USERS TO ACCESS A DATABASE AND INFORMATION RELATING TO FAITH, FOOD, FITNESS, FRIENDS, FOCUS, NUTRITION, WEIGHT MANAGEMENT AND ACHIEVING PERSONAL GOALS; PROVIDING A WEBSITE FEATURING ON-LINE NON-DOWNLOADABLE SOFTWARE THAT ENABLES USERS TO DEVELOP AND MONITOR GOALS AND INFORMATION RELATING TO FAITH, FOOD, FITNESS, FRIENDS, FOCUS, NUTRITION, WEIGHT MANAGEMENT AND ACHIEVING PERSONAL GOALS; PROVIDING A WEBSITE FEATURING ON-LINE NON-DOWNLOADABLE SOFTWARE THAT ENABLES USERS TO ORGANIZE AND SCHEDULE SMALL GROUP MEETINGS (U.S. CLS. 100 AND 101).

B. PARADEWELAI, EXAMINING ATTORNEY

**CLASS 42—(Continued).**

SN 86-163,501. MICRO SYSTEMS MANAGEMENT COMPANY, INC., WESTLAKE, OH. FILED 1-13-2014.



THE COLOR(S) MAROON, GOLD AND WHITE IS/ARE CLAIMED AS A FEATURE OF THE MARK.

THE MARK CONSISTS OF THE OVERALL SHAPE OF THE MARK IS A TRIANGLE. THERE IS A GOLD CROSS IN THE CENTER OF THE MARK, AND EACH OF THE CORNERS IS A MAROON COLOR. THE CORNERS THEMSELVES ARE COMPRISED OF MAROON TRIANGLES WITH A CURVE ON THE INSIDE ELEMENT THAT ALLOWS FOR A CIRCLE OF WHITE TO BE IN THE CENTER OF THE MARK. THE GOLD CROSS IS IN THE CENTER OF THE WHITE CIRCLE.

FOR COMPUTER CONSULTATION (U.S. CLS. 100 AND 101).

FIRST USE 9-1-1987; IN COMMERCE 9-1-1987.  
GEORGE LORENZO, EXAMINING ATTORNEY

---

SN 86-164,207. CONCORDE, INC., PHILADELPHIA, PA. FILED 1-13-2014.

# DQ-IT

THE MARK CONSISTS OF STANDARD CHARACTERS WITHOUT CLAIM TO ANY PARTICULAR FONT, STYLE, SIZE, OR COLOR.

FOR PROVIDING TEMPORARY USE OF ON-LINE NON-DOWNLOADABLE SOFTWARE FOR USE IN DATABASE MANAGEMENT AND USE IN ELECTRONIC STORAGE OF DATA IN THE FIELD OF DRIVER QUALIFICATIONS; TEMPORARY ELECTRONIC STORAGE OF INFORMATION AND DATA (U.S. CLS. 100 AND 101).

FIRST USE 10-27-2009; IN COMMERCE 10-27-2009.  
ALISON POLLACK, EXAMINING ATTORNEY



**CLASS 42—(Continued).**

SN 86-167,411. ETECHCAMPUS, L.L.C., LEXINGTON, KY.  
FILED 1-16-2014.

# CONVERGE

THE MARK CONSISTS OF STANDARD CHARACTERS WITHOUT CLAIM TO ANY PARTICULAR FONT, STYLE, SIZE, OR COLOR.

FOR PROVIDING TEMPORARY USE OF NON-DOWNLOADABLE SOFTWARE TO SCHOOLS AND COLLEGES FOR CONDUCTING AND MANAGING ONLINE COURSES (U.S. CLS. 100 AND 101).

MICHELLE DUBOIS, EXAMINING ATTORNEY

**CLASS 42—(Continued).**

SN 86-174,150. FACTS, INC, MIAMI, FL. FILED 1-24-2014.



THE COLOR(S) RED, BLACK, WHITE, GREY IS/ARE CLAIMED AS A FEATURE OF THE MARK.

THE MARK CONSISTS OF A STYLIZED LITERAL ELEMENT AND A DESIGN ELEMENT WHEREBY THE WORD "VIRAL" IS IN A RED STYLIZED FONT, NEXT TO A CALL OUT IN BLACK CONTAINING A WHITE BOX AND WHITE HORIZONTAL LINES, FOLLOWED BY THE WORD "TRAP" IN A GREY STYLIZED FONT, ALL ON A GREY BACKGROUND.

FOR ONLINE NETWORK SERVICE AND SUPPORTING APPLICATION SERVICES, NAMELY, PROVIDING A WEB SITE FEATURING TECHNOLOGY THAT ENABLE USERS TO POST, UPLOAD, DOWNLOAD, STREAM, DISPLAY, BLOG OR SHARE ELECTRONIC MEDIA OR INFORMATION IN VARIOUS LANGUAGES AND FORMATS, INCLUDING TEXT, IMAGE, VIDEO, AUDIO AND GRAPHICS AND SUPPORT SOCIAL NETWORKING FUNCTIONALITIES (U.S. CLS. 100 AND 101).

GRETTA YAO, EXAMINING ATTORNEY

SN 86-171,379. LAYLA GRAYCE, INC., PASADENA, CA.  
FILED 1-21-2014.

# LAYLA GRAYCE

THE MARK CONSISTS OF STANDARD CHARACTERS WITHOUT CLAIM TO ANY PARTICULAR FONT, STYLE, SIZE, OR COLOR.

OWNER OF U.S. REG. NO. 4,149,563.

THE NAME(S), PORTRAIT(S), AND/OR SIGNATURE(S) SHOWN IN THE MARK DOES NOT IDENTIFY A PARTICULAR LIVING INDIVIDUAL.

FOR DESIGN OF INTERIOR DECOR; DESIGN OF TEXTILES; FURNITURE DESIGN SERVICES; INTERIOR DECORATION CONSULTATION; INTERIOR DESIGN SERVICES; INTERIOR DESIGN SERVICES INCLUDING SPACE PLANNING, FURNITURE SELECTION, MATERIAL AND SURFACE SELECTION (U.S. CLS. 100 AND 101).

ANNE FARRELL, EXAMINING ATTORNEY

SN 86-178,095. HEALTHISM SYSTEMS INC., DBA INPUTHEALTH SYSTEMS, VANCOUVER, BC, CANADA,  
FILED 1-29-2014.

# InputHealth

THE MARK CONSISTS OF STANDARD CHARACTERS WITHOUT CLAIM TO ANY PARTICULAR FONT, STYLE, SIZE, OR COLOR.

FOR CLOUD COMPUTING FEATURING SOFTWARE FOR USE IN PROVIDING MEDICAL HISTORY INFORMATION, CONSENTING TO MEDICAL CONSULTATIONS, ACCESSING DYNAMIC RISK ASSESSMENTS, ACCESSING EDUCATIONAL AND PROMOTIONAL MATERIALS, RESPONDING TO PATIENT SATISFACTION SURVEYS, AND UPDATING PATIENT MEDICAL REPORTS IN THE MEDICAL FIELD FOR USE ON MOBILE ELECTRONIC DEVICES, SMARTPHONES, TABLET COMPUTERS, LAPTOP, PERSONAL COMPUTER OR DESKTOP COMPUTER SOLD TO MEDICAL PRACTITIONERS AND ORGANIZATIONS FOR USE BY THEIR PATIENTS (U.S. CLS. 100 AND 101).

CYNTHIA RINALDI, EXAMINING ATTORNEY

**CLASS 42—(Continued).**

SN 86-178,588. REED ELSEVIER PROPERTIES INC., WILMINGTON, DE. FILED 1-29-2014.

# LEXISNEXIS

THE MARK CONSISTS OF STANDARD CHARACTERS WITHOUT CLAIM TO ANY PARTICULAR FONT, STYLE, SIZE, OR COLOR.

OWNER OF U.S. REG. NOS. 2,370,256, 4,497,457 AND OTHERS.

FOR APPLICATION SERVICE PROVIDER (ASP) FEATURING COMPUTER SOFTWARE FOR PROVIDING, STANDARDIZING, INTEGRATING, MATCHING, VERIFYING, CLEANSING, AUGMENTING AND ACTIVELY MANAGING MEDICAL PROVIDER INFORMATION AND DATA FOR USE IN THE FIELD OF ADMINISTERING AND PROCESSING OF EMPLOYER AND EMPLOYEE INSURANCE AND BENEFITS, ADMINISTERING AND PROCESSING INSURANCE CARRIER SERVICES, ADMINISTERING AND PROCESSING INVOICES AND PAYMENTS TO AND FROM BENEFIT PROVIDERS AND INSURANCE COMPANIES, AND ADMINISTERING AND PROCESSING EMPLOYER AND EMPLOYEE INSURANCE AND BENEFITS FOR USE BY EMPLOYERS, THIRD PARTY ADMINISTRATORS, AND MEDICAL AND DENTAL SERVICE PROVIDERS (U.S. CLS. 100 AND 101).

FIRST USE 9-11-2013; IN COMMERCE 9-11-2013.  
MICHELLE DUBOIS, EXAMINING ATTORNEY

---

SN 86-189,014. FLAGEL, MARK A., BEVERLY HILLS, CA. FILED 2-10-2014.

# PEACH MOMENTS

THE MARK CONSISTS OF STANDARD CHARACTERS WITHOUT CLAIM TO ANY PARTICULAR FONT, STYLE, SIZE, OR COLOR.

FOR PROVIDING AN INTERACTIVE WEBSITE FEATURING TECHNOLOGY THAT ENABLES USERS TO WRITE ABOUT UPLIFTING PERSONAL AND PROFESSIONAL EXPERIENCES, AND TO MAKE COMMENTS AND INTERACT WITH THE ENTRIES MADE BY OTHERS (U.S. CLS. 100 AND 101).

MORGAN WYNNE, EXAMINING ATTORNEY

**CLASS 42—(Continued).**

SN 86-189,707. DENTALFIX RX, LLC, DAVIE, FL. FILED 2-10-2014.



THE COLOR(S) BLACK, GREEN, AND BLUE IS/ARE CLAIMED AS A FEATURE OF THE MARK.

THE MARK CONSISTS OF THE WORD "RUN" IN BLACK TO THE LEFT OF THE INITIALS "DFX" IN BLUE. A RUNNER IS ABOVE THE WORD "RUN" AND IS DEPICTED BY A GREEN DOT REPRESENTING A HEAD AND A GREEN CURVED LINE REPRESENTING ARMS.

FOR PROVIDING ONLINE NON-DOWNLOADABLE COMPUTER SOFTWARE FOR USE IN MANAGING THE MAINTENANCE AND REPAIR OF DENTAL EQUIPMENT AND HAND PIECES (U.S. CLS. 100 AND 101).

FIRST USE 7-2-2013; IN COMMERCE 7-2-2013.  
BRITTANY ESTELL, EXAMINING ATTORNEY

---

SN 86-190,065. BENITEC AUSTRALIA LIMITED, BALMAIN NSW 2041, AUSTRALIA, FILED 2-11-2014.

# BENITEC BIOPHARMA

THE MARK CONSISTS OF STANDARD CHARACTERS WITHOUT CLAIM TO ANY PARTICULAR FONT, STYLE, SIZE, OR COLOR.

OWNER OF AUSTRALIA REG. NO. 1448046, DATED 9-13-2011, EXPIRES 9-13-2021.

NO CLAIM IS MADE TO THE EXCLUSIVE RIGHT TO USE "BIOPHARMA", APART FROM THE MARK AS SHOWN.

FOR BIOLOGICAL RESEARCH; BIOTECHNOLOGY RESEARCH; GENETIC FINGERPRINTING; GENETIC RESEARCH, NAMELY, SCIENTIFIC RESEARCH IN THE FIELD OF GENETICS AND GENETIC TESTING FOR SCIENTIFIC RESEARCH PURPOSES; PROVISION OF SCIENTIFIC RESEARCH INFORMATION IN THE FIELD OF PHARMACEUTICALS AND CLINICAL TRIALS; PROVISION OF SCIENTIFIC INFORMATION IN THE FIELD OF BIOTECHNOLOGY AND GENETICS; PROVISION OF INFORMATION RELATING TO SCIENTIFIC RESEARCH IN THE FIELD OF BIOTECHNOLOGY AND GENETICS; RESEARCH RELATING TO BIOTECHNOLOGY; RESEARCH RELATING TO MOLECULAR SCIENCES; SCIENTIFIC RESEARCH; SCIENTIFIC SERVICES, NAMELY, SCIENTIFIC ANALYSIS IN THE FIELD OF BIOTECHNOLOGY AND GENETICS; TECHNICAL CONSULTATION IN THE FIELD OF BIOTECHNOLOGY AND GENETICS; SCIENTIFIC CONSULTANCY IN THE FIELD OF BIOTECHNOLOGY AND GENETICS; SCIENTIFIC RESEARCH IN THE FIELD OF PHARMACY; SCIENTIFIC RESEARCH RELATING TO BACTERIOLOGY; SCIENTIFIC RESEARCH RELATING TO BIOLOGY; SCIENTIFIC RESEARCH RELATING TO GENETICS; SERVICES FOR ASSESSING THE EFFICIENCY OF PHARMACEUTICALS, NAMELY, PHARMACEUTICAL DRUG DEVELOPMENT, EVALUATION AND TESTING; SERVICES FOR ASSESSING THE SAFETY OF PHARMACEUTICALS, NAMELY, LABORATORY RESEARCH, TESTING AND INSPECTION OF PHARMACEUTICALS (U.S. CLS. 100 AND 101).

JANICE KIM, EXAMINING ATTORNEY

**CLASS 42—(Continued).**

SN 86-191,181. TECHLAND SP. Z O.O., DBA TECHLAND SP. Z O.O., OSTROW WIELKOPOLSKI, POLAND, FILED 2-12-2014.

# HUMALO

THE MARK CONSISTS OF STANDARD CHARACTERS WITHOUT CLAIM TO ANY PARTICULAR FONT, STYLE, SIZE, OR COLOR.

FOR PROVIDING INTERNET SEARCH ENGINES; CREATING AND MAINTAINING WEB SITES FOR THIRD PARTIES; RENTAL OF COMPUTER SOFTWARE; MAINTENANCE OF COMPUTER SOFTWARE; COMPUTER SERVICES, NAMELY, CREATING VIRTUAL COMMUNITIES FOR REGISTERED USERS TO ORGANIZE GROUPS AND EVENTS, PARTICIPATE IN DISCUSSIONS, AND ENGAGE IN SOCIAL, BUSINESS AND COMMUNITY NETWORKING; COMPUTER SERVICES, NAMELY, HOSTING ELECTRONIC FACILITIES FOR THIRD PARTIES FOR ORGANIZING MEETINGS, EVENTS AND INTERACTIVE DISCUSSIONS VIA COMMUNICATION NETWORKS; APPLICATION SERVICE PROVIDER (ASP) SERVICES, NAMELY, HOSTING COMPUTER SOFTWARE APPLICATIONS FOR THIRD PARTIES; APPLICATION SERVICE PROVIDER (ASP) FEATURING SOFTWARE, NAMELY, TO ENABLE THE TEMPORARY USE OF SOFTWARE FOR UPLOADING, DOWNLOADING, STREAMING, POSTING, DISPLAYING, BLOGGING, LINKING, SHARING OR OTHERWISE PROVIDING ELECTRONIC MEDIA OR INFORMATION OVER COMMUNICATION NETWORKS; COMPUTER SERVICES, NAMELY, CREATING COMPUTER INDEXES AND DATABASES, PARTICULARLY CONTAINING TEXTS, ELECTRONIC DOCUMENTS, DATABASES, GRAPHIC AND AUDIOVISUAL INFORMATION, VIA COMPUTER AND COMMUNICATION NETWORKS; COMPUTER SERVICES, NAMELY, DEVELOPING PERSONALIZED WEB PAGES, INCLUDING USER-GENERATED CONTENT OR SPECIFIC CONTENTS, PERSONAL PROFILES, SOUNDS, VIDEOS, DATA IMAGES; COMPUTER SERVICES FOR THE TEMPORARY PROVISION OF NON-DOWNLOADABLE SOFTWARE FOR USING SOCIAL NETWORKS FOR CREATING A VIRTUAL COMMUNITY, AND THE TRANSMISSION OF AUDIO, VIDEO DATA, PHOTOGRAPHIC IMAGES, TEXTS, GRAPHICS (U.S. CLS. 100 AND 101).

KEVIN DINALLO, EXAMINING ATTORNEY

**CLASS 42—(Continued).**

SN 86-205,338. NANT HOLDINGS IP, LLC, CULVER CITY, CA. FILED 2-26-2014.

# GENOMICS WORLD

THE MARK CONSISTS OF STANDARD CHARACTERS WITHOUT CLAIM TO ANY PARTICULAR FONT, STYLE, SIZE, OR COLOR.

NO CLAIM IS MADE TO THE EXCLUSIVE RIGHT TO USE "GENOMICS", APART FROM THE MARK AS SHOWN.

FOR GENOME SEQUENCING SERVICES FOR SCIENTIFIC OR CLINICAL RESEARCH; STRUCTURAL AND FUNCTIONAL ANALYSIS OF GENOMES; GENOME AMPLIFICATION; SCIENTIFIC AND TECHNOLOGICAL SERVICES, NAMELY, PROVIDING GENOME SEQUENCING, DATA ANALYSIS AND INTERPRETATION, ASSAY DEVELOPMENT AND PREPARING, AMPLIFYING, LABELING, DETECTING, ANALYZING AND SEQUENCING NUCLEIC ACIDS AND OTHER BIOLOGICAL MOLECULES, AND RESEARCH AND DESIGN RELATING THERETO, ALL IN THE FIELD OF BIOINFORMATICS, GENOMICS AND GENE EXPRESSION RESEARCH AND DEVELOPMENT; BIOLOGICAL RESEARCH; PROVIDING ONLINE COMPUTER DATABASES FEATURING GENETIC SCIENCE INFORMATION BASED ON AGGREGATED RESULTS OF GENOTYPING, MEDICAL RECORDS, AND/OR GENOMIC SEQUENCING ALL IN THE FIELDS OF GENETICS, GENOMICS, GENOTYPING, PHENOTYPING, AND ANCESTRY; RESEARCH IN THE FIELD OF CHEMISTRY, BIOCHEMISTRY AND BIOLOGY; TECHNOLOGY RESEARCH IN THE FIELD OF BIOTECHNOLOGY, MEDICAL TECHNOLOGY AND ELECTROTECHNOLOGY; SCIENTIFIC RESEARCH RELATING TO GENETICS; SCIENTIFIC CONSULTANCY IN GENOME RESEARCH IN THE LIFE SCIENCES FIELD; SCIENTIFIC, MEDICAL AND PHARMACEUTICAL RESEARCH AND DEVELOPMENT, GENOME ANALYSIS, AND PROVIDING INFORMATION IN THE FIELD OF GENOME ANALYSIS METHODS (U.S. CLS. 100 AND 101).

MARTHA FROMM, EXAMINING ATTORNEY

SN 86-205,668. SENTRY INSURANCE A MUTUAL COMPANY, STEVENS POINT, WI. FILED 2-27-2014.

# SENTRY CONNECT

THE MARK CONSISTS OF STANDARD CHARACTERS WITHOUT CLAIM TO ANY PARTICULAR FONT, STYLE, SIZE, OR COLOR.

OWNER OF U.S. REG. NOS. 1,284,672, 4,371,481 AND OTHERS.

FOR PROVIDING AN INTERACTIVE WEB SITE FEATURING NON-DOWNLOADABLE SOFTWARE FOR MANAGING ACCOUNTS, POLICIES, BILLING, PAYMENTS, CLAIMS AND DOCUMENTS IN THE FIELD OF INSURANCE (U.S. CLS. 100 AND 101).

FIRST USE 12-1-2013; IN COMMERCE 12-1-2013.

LAUREN BURKE, EXAMINING ATTORNEY

**CLASS 42—(Continued).**

SN 86-207,028. INTERACTIVE INTELLIGENCE, INC., INDIANAPOLIS, IN. FILED 2-28-2014.

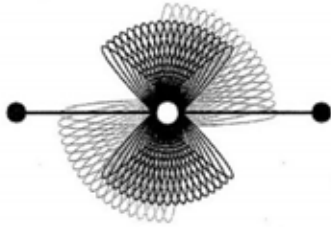

THE MARK CONSISTS OF TWO, OVERLAPPING COIL DESIGNS FORMING A SPIRAL-LIKE SHAPE, INTERSECTED BY A HORIZONTAL LINE WITH A CIRCLE ON EACH END.

FOR PROVIDING USE OF ON-LINE NON-DOWNLOADABLE SOFTWARE AND APPLICATIONS FOR AN ORGANIZATION'S HANDLING AND INTEGRATION OF VOICE AND DATA COMMUNICATION AND COMPUTER TECHNOLOGIES, NAMELY, DIRECTORY SERVICES, OPERATOR SERVICES, ADMINISTRATIVE SERVICES, REPORTING SERVICES, ANSWERING SERVICES, CALL ROUTING, CALL DISTRIBUTION, OUTCALLING SERVICES, VOICE RESPONSE, RECORDING SERVICES, SPEECH ANALYTICS SERVICES, AND CUSTOMIZED, CUSTOMER-SPECIFIC APPLICATIONS; INSTALLATION AND MAINTENANCE OF COMPUTER SOFTWARE; MONITORING OF COMPUTER SYSTEMS, NAMELY, MONITORING OF COMPUTER SYSTEMS TO ENSURE PROPER FUNCTIONING; TECHNICAL SUPPORT SERVICES, NAMELY, TROUBLESHOOTING OF COMPUTER HARDWARE AND SOFTWARE PROBLEMS; PROFESSIONAL SERVICES, NAMELY, COMPUTER PROGRAMMING SERVICES FOR OTHERS IN THE FIELD OF CUSTOMIZATION AND CONFIGURATION OF COMPUTER SOFTWARE (U.S. CLS. 100 AND 101).

MARK SHINER, EXAMINING ATTORNEY

**CLASS 42—(Continued).**

SN 86-209,343. ADVANCED ENGINEERING CONSULTANTS, GRANT-VALKARIA, FL. FILED 3-3-2014.

## Advanced Engineering Consultants

THE MARK CONSISTS OF STANDARD CHARACTERS WITHOUT CLAIM TO ANY PARTICULAR FONT, STYLE, SIZE, OR COLOR.

NO CLAIM IS MADE TO THE EXCLUSIVE RIGHT TO USE "ENGINEERING CONSULTANTS", APART FROM THE MARK AS SHOWN.

SEC. 2(F).

FOR CIVIL ENGINEERING; COMPUTER-AIDED ENGINEERING SERVICES FOR OTHERS; CONSULTING IN THE FIELD OF ENGINEERING; CONSULTING IN THE FIELD OF STRUCTURAL ENGINEERING; CONSULTING IN THE FIELD OF MECHANICAL, CIVIL, ELECTRICAL AND STRUCTURAL ENGINEERING; CONSULTING SERVICES IN THE FIELD OF INDUSTRIAL ENGINEERING; DRAFTING OF PLANS AND ENGINEERING DRAWINGS FOR OTHERS; ENGINEERING DESIGN SERVICES; ENGINEERING SERVICES FOR BUILDING AND PROPERTY CONDITION ASSESSMENT; ENGINEERING SERVICES IN THE FIELD OF MECHANICAL, CIVIL, ELECTRICAL, AND STRUCTURAL; GRAPHIC ILLUSTRATION AND DRAWING SERVICES, NAMELY, PROVIDING GRAPHIC ILLUSTRATIONS AND DRAWINGS OF COMMERCIAL AND INDUSTRIAL BUILDING DESIGNS, AND CONVERTING BUILDING DESIGNS OR MARKUPS TO ELECTRONIC CAD DRAWINGS; INSPECTION SERVICES, NAMELY, DETECTION OF PLUMBING AND ROOF LEAKS, TERMITES, AND ELECTRICAL CONDITIONS IN THE INACCESSIBLE AREAS OF AN EXISTING STRUCTURE OR HOME AND/OR WALL(S) AND VOID(S) BY MEANS OF INFRARED IMAGING UNITS; MECHANICAL ENGINEERING; PLANNING OF BUILDINGS AND INFRASTRUCTURE SYSTEMS FOR BUILDINGS; PRODUCT DEVELOPMENT AND ENGINEERING SERVICES FOR OTHERS; STRUCTURAL ENGINEERING DESIGN SERVICES; TESTING, ANALYZING AND EVALUATING THE STRUCTURAL PROPERTIES OF MASONRY AND CONCRETE STRUCTURES (U.S. CLS. 100 AND 101).

FIRST USE 4-15-2008; IN COMMERCE 4-15-2008.

BARBARA GAYNOR, EXAMINING ATTORNEY

SN 86-210,934. KENNIS RESEARCH GROUP, DBA KENNIS RESEARCH, CONCORD, MA. FILED 3-4-2014.

## KENNIS RESEARCH

THE MARK CONSISTS OF STANDARD CHARACTERS WITHOUT CLAIM TO ANY PARTICULAR FONT, STYLE, SIZE, OR COLOR.

NO CLAIM IS MADE TO THE EXCLUSIVE RIGHT TO USE "RESEARCH", APART FROM THE MARK AS SHOWN. FOR SCIENTIFIC RESEARCH CONSULTING IN THE FIELD OF GENERAL AND BIOMEDICAL SCIENCES (U.S. CLS. 100 AND 101).

FIRST USE 12-1-2005; IN COMMERCE 3-4-2014.

ANDREA BUTLER, EXAMINING ATTORNEY

**CLASS 42—(Continued).**

SN 86-211,557. ITEGRIA, LLC, NORTHBROOK, IL. FILED 3-5-2014.



NO CLAIM IS MADE TO THE EXCLUSIVE RIGHT TO USE "IT", APART FROM THE MARK AS SHOWN.

THE MARK CONSISTS OF THE LETTERS "IT" IN LOWER CASE LETTERS ON A DARK BACKGROUND, WITH A DASH OVER THE LETTER "I".

FOR CONSULTING AND DESIGN SERVICES IN THE FIELD OF INFORMATION TECHNOLOGY FOR SMALL TO MID-SIZED FINANCIAL SERVICES BUSINESSES, NAMELY, COMPUTER SYSTEM DESIGN SERVICES; COMPUTER NETWORK INFRASTRUCTURE DESIGN; TECHNICAL SUPPORT SERVICES FOR SMALL TO MID-SIZED FINANCIAL SERVICES BUSINESSES, NAMELY, TROUBLESHOOTING IN THE NATURE OF DIAGNOSING COMPUTER HARDWARE AND SOFTWARE PROBLEMS; COMPUTER SERVICES FOR SMALL TO MID-SIZED FINANCIAL SERVICES BUSINESSES, NAMELY, COMPUTER SYSTEM ADMINISTRATION; REMOTE ONLINE BACKUP OF COMPUTER DATA FOR SMALL TO MID-SIZED FINANCIAL SERVICES BUSINESSES THAT PROTECTS DATA BY COLLECTING, ENCRYPTING, AND COPYING DATA THROUGH A SECURE INTERNET CONNECTION TO SECURED SERVERS; COMPUTER NETWORK VULNERABILITY SCANNING, AND PENETRATION TESTING (U.S. CLS. 100 AND 101).

JOHN GARTNER, EXAMINING ATTORNEY

SN 86-214,579. BARRACHD INTELLIGENCE SOLUTIONS LIMITED, EDINBURGH, UNITED KINGDOM, FILED 3-7-2014.

# COSAIN

THE MARK CONSISTS OF STANDARD CHARACTERS WITHOUT CLAIM TO ANY PARTICULAR FONT, STYLE, SIZE, OR COLOR.

THE ENGLISH TRANSLATION OF "COSAIN" IN THE MARK IS "TO PROTECT".

FOR SOFTWARE AS A SERVICE (SAAS) SERVICES FEATURING SOFTWARE FOR USE IN MONITORING SOCIAL MEDIA BY END USERS IN PUBLIC SAFETY AGENCIES (U.S. CLS. 100 AND 101).

FIRST USE 12-0-2013; IN COMMERCE 12-0-2013.

REBECCA SMITH, EXAMINING ATTORNEY

**CLASS 42—(Continued).**

SN 86-215,135. BLOOM ENERGY CORPORATION, SUNNYVALE, CA. FILED 3-7-2014.

# BLOOMCONNECT

THE MARK CONSISTS OF STANDARD CHARACTERS WITHOUT CLAIM TO ANY PARTICULAR FONT, STYLE, SIZE, OR COLOR.

FOR PROVIDING AN INTERNET WEBSITE PORTAL THAT ENABLES CUSTOMERS TO MONITOR THE PERFORMANCE AND ENVIRONMENTAL BENEFITS OF ELECTRIC GENERATOR INSTALLATIONS UTILIZING FUEL CELL TECHNOLOGY FOR QUALITY CONTROL PURPOSES (U.S. CLS. 100 AND 101).

BERYL GARDNER, EXAMINING ATTORNEY

SN 86-215,628. ACCESSWEATHER.COM, CELEBRATION, FL. FILED 3-9-2014.

# AccessWeather

THE MARK CONSISTS OF STANDARD CHARACTERS WITHOUT CLAIM TO ANY PARTICULAR FONT, STYLE, SIZE, OR COLOR.

FOR WEATHER INFORMATION SERVICE PROVIDING FORECASTS FOR, BUT NOT LIMITED TO: RADIO, TV, NEWSPAPERS, AVIATION, HOTELS, TRUCKING, MUNICIPALITIES, SCHOOL SYSTEMS, INFORMATION DATABASES AND ON-LINE INTERNET SERVICES (U.S. CLS. 100 AND 101).

FIRST USE 1-1-2000; IN COMMERCE 1-1-2000.

CURTIS FRENCH, EXAMINING ATTORNEY

SN 86-218,374. EPIKKO, INC., CUPERTINO, CA. FILED 3-12-2014.

# Epikko

THE MARK CONSISTS OF STANDARD CHARACTERS WITHOUT CLAIM TO ANY PARTICULAR FONT, STYLE, SIZE, OR COLOR.

THE WORDING "EPIKKO" HAS NO MEANING IN A FOREIGN LANGUAGE.

FOR COMPUTER SOFTWARE SERVICES, NAMELY, PROVIDING A SOFTWARE PLATFORM AS A SERVICE (PAAS) FEATURING COMPUTER SOFTWARE PLATFORMS FOR PROCESSING E-COMMERCE FINANCIAL TRANSACTIONS OVER THE INTERNET AND OTHER GLOBAL COMPUTER NETWORKS (U.S. CLS. 100 AND 101).

SETH DENNIS, EXAMINING ATTORNEY

**CLASS 42—(Continued).**

SN 86-218,923. DIGITAL AND POS ENTERPRISES INC., DORAL, FL. FILED 3-12-2014.



THE COLOR(S) BLUE, RED AND BLACK IS/ARE CLAIMED AS A FEATURE OF THE MARK.

THE MARK CONSISTS OF THE WORD "ADVANCED" IN BLUE FRANKLIN GOTHIC DEMI FONT, ON THE LEFT SIDE THERE ARE 5 BLACK LINES PARALLEL TO THE LETTER "A". IN THE MIDDLE OF THE WORD "ADVANCED" THERE IS A HORIZONTAL RED LINE.

FOR COMPUTER SYSTEM DESIGN; COMPUTER PROGRAMMING; COMPUTER SOFTWARE DESIGN; COMPUTER SOFTWARE CONSULTANCY; INSTALLATION OF COMPUTER SOFTWARE; MAINTENANCE OF COMPUTER SOFTWARE; UPDATING OF COMPUTER SOFTWARE; RENTAL OF COMPUTER SOFTWARE; SOFTWARE AS A SERVICE (SAAS) SERVICES FEATURING SOFTWARE FOR USE IN DATABASE MANAGEMENT, FOR SERVICE DESK MANAGEMENT AND FOR ACCOUNTING (U.S. CLS. 100 AND 101).

ALYSSA STEEL, EXAMINING ATTORNEY

**CLASS 42—(Continued).**

SN 86-219,045. ACTIVELIGHT, INC., NAPLES, FL. FILED 3-12-2014.



THE MARK CONSISTS OF STANDARD CHARACTERS WITHOUT CLAIM TO ANY PARTICULAR FONT, STYLE, SIZE, OR COLOR.

FOR ADVISORY SERVICES IN THE FIELD OF PRODUCT DEVELOPMENT AND QUALITY IMPROVEMENT OF SOFTWARE; APPLICATION SERVICE PROVIDER (ASP) FEATURING SOFTWARE FOR USE MULTIMEDIA ADVERTISING, DIGITAL ADVERTISING, EVENT, PRODUCT OR SERVICE MARKETING; BUSINESS TECHNOLOGY SOFTWARE CONSULTATION SERVICES; CONSULTANCY IN THE FIELD OF SOFTWARE DESIGN; CONSULTING SERVICES IN THE FIELD OF THE DESIGN OF MULTIMEDIA ADVERTISING, DIGITAL ADVERTISING, EVENT, PRODUCT OR SERVICE MARKETING; DESIGN AND DEVELOPMENT OF COMPUTER SOFTWARE FOR MULTIMEDIA ADVERTISING, DIGITAL ADVERTISING, EVENT, PRODUCT OR SERVICE MARKETING; DESIGN AND DEVELOPMENT OF SOFTWARE AND HARDWARE FOR MULTIMEDIA ADVERTISING, DIGITAL ADVERTISING, EVENT, PRODUCT OR SERVICE MARKETING; INSTALLATION AND MAINTENANCE OF COMPUTER SOFTWARE; INSTALLATION AND MAINTENANCE OF MULTIMEDIA ADVERTISING, DIGITAL ADVERTISING, EVENT, PRODUCT OR SERVICE MARKETING SOFTWARE; INSTALLATION, MAINTENANCE AND REPAIR OF COMPUTER SOFTWARE; RENTAL AND MAINTENANCE OF COMPUTER SOFTWARE; RENTING OUT HARDWARE AND SOFTWARE (U.S. CLS. 100 AND 101).

FIRST USE 2-11-2014; IN COMMERCE 2-11-2014.  
ANTHONY RINKER, EXAMINING ATTORNEY

SN 86-219,285. BRAZER, JENNIFER, COSTA MESA, CA. FILED 3-12-2014.



NO CLAIM IS MADE TO THE EXCLUSIVE RIGHT TO USE "CLOUDS.COM", APART FROM THE MARK AS SHOWN.

THE COLOR(S) PINK, BLUE AND WHITE IS/ARE CLAIMED AS A FEATURE OF THE MARK.

THE MARK CONSISTS OF THE WORDING "PINK" IN PINK, "CLOUDZ" IN BLUE, AND ".COM" IN WHITE ON A PINK RECTANGULAR CARRIER, WITH THE STYLIZED IMAGE OF SOME PINK CLOUDS WITH TWO CURVED PINK ARROWS APPEARING TO THE LEFT OF THE WORDING.

FOR CREATING AN ON-LINE COMMUNITY FOR PEOPLE IN RECOVERY; CREATING AN ON-LINE COMMUNITY FOR PEOPLE IN RECOVERY FOR THE PURPOSE OF PARTICIPATING IN DISCUSSIONS, GETTING FEEDBACK FROM OTHER USERS, FORMING VIRTUAL COMMUNITIES, AND CONNECTING WITH OTHERS FOR SUPPORT IN THE RECOVERY PROCESS; HOSTING AN ON-LINE COMMUNITY WEB SITE FEATURING TOPICS OF INTEREST TO PEOPLE IN RECOVERY (U.S. CLS. 100 AND 101).

FIRST USE 3-9-2014; IN COMMERCE 3-9-2014.  
SHAVELL MCPHERSON, EXAMINING ATTORNEY

SN 86-219,024. MSC I INC., NEW YORK, NY. FILED 3-12-2014.



THE MARK CONSISTS OF STANDARD CHARACTERS WITHOUT CLAIM TO ANY PARTICULAR FONT, STYLE, SIZE, OR COLOR.

FOR SOFTWARE AS A SERVICE (SAAS) SERVICES, NAMELY, HOSTING SOFTWARE FOR USE BY OTHERS FOR USE IN FINANCIAL AND INVESTMENT ANALYSIS (U.S. CLS. 100 AND 101).

PAULA MAHONEY, EXAMINING ATTORNEY

**CLASS 42—(Continued).**

SN 86-220,076. PROPOSAL SOFTWARE, INC., WESTPORT, CT. FILED 3-13-2014.

**SearchB%k**  
FROM PROPOSAL SOFTWARE

OWNER OF U.S. REG. NO. 3,644,419.

NO CLAIM IS MADE TO THE EXCLUSIVE RIGHT TO USE "PROPOSAL SOFTWARE", APART FROM THE MARK AS SHOWN.

THE MARK CONSISTS OF THE WORD "SEARCHBOOK" WITH "FROM PROPOSAL SOFTWARE" IN SMALLER LETTERS BELOW "SEARCH", AND THE CHARACTER "%" REPLACING THE LETTERS "OO" IN "BOOK".

FOR PROVIDING TEMPORARY USE OF A NON-DOWNLOADABLE WEB APPLICATION FOR AUTOMATED REVIEW OF INVESTMENT DATA, NAMELY, ASSETS, FINANCIAL PERFORMANCE, ASSET CHARACTERISTICS, AND FEE INFORMATION, AND GENERATING EXECUTIVE SUMMARIES OF REVIEWED INVESTMENT DATA; PROVIDING TEMPORARY USE OF ON-LINE NON-DOWNLOADABLE SOFTWARE AND APPLICATIONS FOR AUTOMATED REVIEW OF INVESTMENT DATA, NAMELY, ASSETS, FINANCIAL PERFORMANCE, ASSET CHARACTERISTICS, AND FEE INFORMATION, AND GENERATING EXECUTIVE SUMMARIES OF REVIEWED INVESTMENT DATA; SOFTWARE AS A SERVICE (SAAS) SERVICES FEATURING SOFTWARE FOR AUTOMATED REVIEW OF INVESTMENT DATA, NAMELY, ASSETS, FINANCIAL PERFORMANCE, ASSET CHARACTERISTICS, AND FEE INFORMATION, AND GENERATING EXECUTIVE SUMMARIES OF REVIEWED INVESTMENT DATA (U.S. CLS. 100 AND 101).

BARBARA RUTLAND, EXAMINING ATTORNEY

SN 86-222,026. MC COMPUTER, INC., BEDFORD, NH. FILED 3-14-2014.



THE COLOR(S) BLACK, BLUE, GRAY AND WHITE IS/ARE CLAIMED AS A FEATURE OF THE MARK.

THE MARK CONSISTS OF THE WORDS "MYCLOUDCURE" WITH THE WORDS "MY" AND "CURE" IN BLACK, "CLOUD" IN WHITE AND A BLACK CLOUD DESIGN INCLUDING A GRAY OVAL UNDERNEATH THE CLOUD, ALL AGAINST A BLUE BACKGROUND.

FOR COMPUTER TECHNICAL SUPPORT SERVICES, NAMELY, 24/7 SERVICE DESK OR HELP DESK SERVICES FOR IT INFRASTRUCTURE, OPERATING SYSTEMS, DATABASE SYSTEMS, AND WEB APPLICATIONS (U.S. CLS. 100 AND 101).

FIRST USE 11-0-2013; IN COMMERCE 11-0-2013.  
TASHIA BUNCH, EXAMINING ATTORNEY

**CLASS 42—(Continued).**

SN 86-222,082. AUGMENTED DEVELOPMENT, LLC, SANTA BARBARA, CA. FILED 3-14-2014.

AugmentedDevelopment

THE MARK CONSISTS OF STANDARD CHARACTERS WITHOUT CLAIM TO ANY PARTICULAR FONT, STYLE, SIZE, OR COLOR.

FOR COMPUTER SOFTWARE CONSULTING (U.S. CLS. 100 AND 101).

FIRST USE 1-20-2014; IN COMMERCE 1-20-2014.  
LAUREN BURKE, EXAMINING ATTORNEY

SN 86-223,631. BOOSTABLE, INC., SAN FRANCISCO, CA. FILED 3-17-2014.



THE MARK CONSISTS OF THE WORD "BOOSTABLE" TO THE RIGHT OF A CIRCULAR IMAGE OF A DIAL WITH A POINTER DIRECTED TO THE UPPER RIGHT OF THE DIAL AND AN INNER CURVE IN THE LEFT HALF OF THE DIAL.

FOR SOFTWARE AS A SERVICE (SAAS) SERVICES FEATURING SOFTWARE FOR USE IN DISSEMINATING ONLINE ADVERTISING AND FOR ANALYZING MARKETING DATA FOR SELLERS ON MARKETPLACES (U.S. CLS. 100 AND 101).

JAMES LOVELACE, EXAMINING ATTORNEY



**CLASS 42—(Continued).**

SN 86-223,785. SLIDEROOM, LLC, DALLAS, TX. FILED 3-17-2014.

LEARNING MACHINE

THE MARK CONSISTS OF STANDARD CHARACTERS WITHOUT CLAIM TO ANY PARTICULAR FONT, STYLE, SIZE, OR COLOR.

FOR PROVIDING TEMPORARY USE OF ONLINE NON-DOWNLOADABLE SOFTWARE FOR STORING, MANAGING, MEASURING, COMBINING, TRACKING, ANALYZING, COMMUNICATING, AND SHARING DATA AND REAL-TIME CONTEXTUAL INSIGHT IN THE FIELDS OF BUSINESS, GOVERNMENT, NOT-FOR-PROFIT, ACADEMIA, GRANT MANAGEMENT, COMPETITIONS, HUMAN RESOURCES, MARKETING, SALES, FINANCE, BUSINESS OPERATIONS, BUSINESS, MANAGEMENT, AND PERSONAL DATA (U.S. CLS. 100 AND 101).

FIRST USE 3-1-2014; IN COMMERCE 3-1-2014.  
APRIL REEVES, EXAMINING ATTORNEY

**CLASS 42—(Continued).**

SN 86-225,942. E-POINT S.A., WARSAW, POLAND, FILED 3-19-2014.



THE COLOR(S) GREEN, BLUE, PURPLE, PINK AND BLACK IS/ARE CLAIMED AS A FEATURE OF THE MARK.

THE MARK CONSISTS OF THE WORDING "VERTABELO" IN BLACK TO THE RIGHT OF A DESIGN THAT CONSISTS OF A BROKEN SHADED TRIANGLE WITH THE FLAT SIDE UP AND THE COLORS GREEN, BLUE, PURPLE AND PINK SHADED VERTICALLY INSIDE THE BROKEN TRIANGLE THAT HAS OPPOSITE VERTICAL SPACES BETWEEN THE COLOR SHADING.

THE WORDING "VERTABELO" HAS NO MEANING IN A FOREIGN LANGUAGE.

FOR WEBSITE DEVELOPMENT SERVICES FOR OTHERS; PROVIDING TEMPORARY USE OF NON-DOWNLOADABLE COMPUTER SOFTWARE VIA THE INTERNET FOR DESIGNING AND MAINTAINING DATABASES (U.S. CLS. 100 AND 101).

FIRST USE 3-12-2014; IN COMMERCE 3-12-2014.  
SETH A. RAPPAPORT, EXAMINING ATTORNEY

SN 86-224,749. BUCKEYE CORRUGATED, INC., AKRON, OH. FILED 3-18-2014.

PORT

THE MARK CONSISTS OF STANDARD CHARACTERS WITHOUT CLAIM TO ANY PARTICULAR FONT, STYLE, SIZE, OR COLOR.

FOR PROVIDING ON-LINE NON-DOWNLOADABLE COMPUTER SOFTWARE FOR USE IN THE PACKAGING INDUSTRY, NAMELY, WEB ENABLED ORDERING, PLANNING, TRACKING, AND REPORTING SOFTWARE (U.S. CLS. 100 AND 101).

LEIGH LOWRY, EXAMINING ATTORNEY

SN 86-226,139. SOMERSAULT ORTHOPEDICS, INC., PLEASANTON, CA. FILED 3-19-2014.

THE VAULT SYSTEM

THE MARK CONSISTS OF STANDARD CHARACTERS WITHOUT CLAIM TO ANY PARTICULAR FONT, STYLE, SIZE, OR COLOR.

NO CLAIM IS MADE TO THE EXCLUSIVE RIGHT TO USE "SYSTEM", APART FROM THE MARK AS SHOWN.

FOR PROVIDING TEMPORARY USE OF ON-LINE NON-DOWNLOADABLE SOFTWARE FOR SURGICAL PLANNING AND SURGICAL TEMPLATE CREATION (U.S. CLS. 100 AND 101).

FIRST USE 9-1-2013; IN COMMERCE 10-23-2013.  
MATTHEW MCDOWELL, EXAMINING ATTORNEY



**CLASS 42—(Continued).**

SN 86-227,017. RC GRAPHICS & CONSULTING, INC., SANTA BARBARA, CA. FILED 3-20-2014.

## RPM Real Portfolio Management

THE MARK CONSISTS OF STANDARD CHARACTERS WITHOUT CLAIM TO ANY PARTICULAR FONT, STYLE, SIZE, OR COLOR.

NO CLAIM IS MADE TO THE EXCLUSIVE RIGHT TO USE "PORTFOLIO MANAGEMENT", APART FROM THE MARK AS SHOWN.

FOR SOFTWARE AS A SERVICE (SAAS) SERVICES FEATURING SOFTWARE FOR MANAGING A COMMERCIAL REAL ESTATE PORTFOLIO (U.S. CLS. 100 AND 101).

FIRST USE 9-1-2013; IN COMMERCE 9-1-2013.  
KAREN K. BUSH, EXAMINING ATTORNEY

SN 86-227,802. BLOKWORX, INC., BURLINGAME, CA. FILED 3-20-2014.



OWNER OF U.S. REG. NO. 3,803,656.  
THE MARK CONSISTS OF THE STYLIZED TEXT "BLOKWORX" IN A MODULAR COMBINATION OF BLOCKS, EACH WITH A LETTER FORMING OR DEPICTING "BLOKWORX".

FOR COMPUTER HARDWARE CONSULTING SERVICES IN THE FIELDS OF COMPUTER SYSTEMS, NETWORKS AND CONNECTIVITY VIA ELECTRONIC COMMUNICATION NETWORKS (U.S. CLS. 100 AND 101).

FIRST USE 5-17-2008; IN COMMERCE 6-28-2008.  
ZACHARY R. SPARER, EXAMINING ATTORNEY

SN 86-228,469. STEELBRICK HOLDINGS, INC., PALO ALTO, CA. FILED 3-21-2014.



THE MARK CONSISTS OF TWO SETS OF SQUARES DIAGONALLY POSITIONED WITH ONE ON TOP OF THE OTHER; NEXT TO THE SQUARES IS THE WORDING "STEEL" STACKED ON TOP OF THE WORDING "BRICK".

FOR SOFTWARE AS A SERVICE (SAAS) SERVICES FEATURING SOFTWARE FOR PRODUCT AND SERVICE CONFIGURATION, PRICING AND QUOTING, AND PROPOSAL GENERATION (U.S. CLS. 100 AND 101).

FIRST USE 3-13-2014; IN COMMERCE 3-13-2014.  
NAAKWAMA ANKRAH, EXAMINING ATTORNEY

**CLASS 42—(Continued).**

SN 86-230,563. GLASS, GRAHAM, SAN FRANCISCO, CA. FILED 3-24-2014.

## MATRIX LMS

THE MARK CONSISTS OF STANDARD CHARACTERS WITHOUT CLAIM TO ANY PARTICULAR FONT, STYLE, SIZE, OR COLOR.

NO CLAIM IS MADE TO THE EXCLUSIVE RIGHT TO USE "LMS", APART FROM THE MARK AS SHOWN.

FOR EDUCATIONAL SERVICES PROVIDED VIA GLOBAL COMPUTER NETWORKS, NAMELY, PROVIDING TEMPORARY USE OF NONDOWNLOADABLE EDUCATIONAL SOFTWARE FOR USE IN ACCESSING AND MANAGING EDUCATIONAL COURSE LISTS, EDUCATIONAL UNITS, EDUCATIONAL LESSONS AND EXERCISES, INFORMATION REGARDING FIELD TRIPS, EDUCATIONAL LESSON AND/OR UNIT-BASED TESTS AND EXPERIMENTS, FOR USE IN PROVIDING STUDENTS, TEACHERS, AND PARENTS WITH ONLINE ACCESS TO SUBMIT, RECEIVE, AND REVIEW CLASSROOM ASSIGNMENTS, COURSE MATERIALS AND CLASS INFORMATION, AND FOR USE IN PROVIDING CLASSROOM MANAGEMENT TOOLS FOR TEACHERS IN THE NATURE OF COURSE CREATION, STUDENT ENROLLMENT TRACKING, DISTRIBUTION OF ASSIGNMENTS, CONDUCTING OF TESTS, AND GRADING (U.S. CLS. 100 AND 101).

RONALD AIKENS, EXAMINING ATTORNEY

SN 86-230,963. IRONSHORE PHARMACEUTICALS & DEVELOPMENT, INC., CAMANA BAY, CAYMAN ISLANDS, FILED 3-25-2014.

## DELEXIS

THE MARK CONSISTS OF STANDARD CHARACTERS WITHOUT CLAIM TO ANY PARTICULAR FONT, STYLE, SIZE, OR COLOR.

FOR PHARMACEUTICAL PRODUCTS DEVELOPMENT (U.S. CLS. 100 AND 101).

DANIEL S. STRINGER, EXAMINING ATTORNEY

**CLASS 42—(Continued).**

SN 86-232,042. ANITIAN CORPORATION, AKA ANITIAN ENTERPRISE SECURITY, BEAVERTON, OR. FILED S.R. 3-25-2014; AM. P.R. 7-1-2014.

# Anitian

THE MARK CONSISTS OF STANDARD CHARACTERS WITHOUT CLAIM TO ANY PARTICULAR FONT, STYLE, SIZE, OR COLOR.

THE WORDING "ANITIAN" HAS NO MEANING IN A FOREIGN LANGUAGE.

FOR COMPUTER SECURITY CONSULTANCY IN THE FIELD OF SCANNING AND PENETRATION TESTING OF COMPUTERS AND NETWORKS TO ASSESS INFORMATION SECURITY VULNERABILITY; DEVELOPMENT OF CUSTOMIZED SOFTWARE FOR OTHERS FOR USE IN RISK ASSESSMENT, INFORMATION SECURITY, BUSINESS ANALYSIS, AUDIT AND AUDIT PLANNING, AND SALES MANAGEMENT; HOSTING AN ONLINE COMMUNITY WEBSITE FEATURING SHARED COMMUNICATIONS BETWEEN COMMUNITY MEMBERS INTERESTED IN PERSONAL AND SMALL BUSINESS COMPUTER INFORMATION SECURITY (U.S. CLS. 100 AND 101).

FIRST USE 10-23-1995; IN COMMERCE 10-23-1995.  
AMY KERTGATE, EXAMINING ATTORNEY

**CLASS 42—(Continued).**

SN 86-233,996. AUTOMATTIC, INC., SAN FRANCISCO, CA. FILED 3-27-2014.

# JETPACK

THE MARK CONSISTS OF STANDARD CHARACTERS WITHOUT CLAIM TO ANY PARTICULAR FONT, STYLE, SIZE, OR COLOR.

FOR APPLICATION SERVICE PROVIDER (ASP) FEATURING SOFTWARE FOR SPECIFIC AND IDENTIFIABLE BLOGGING AND CONTENT MANAGEMENT SYSTEM USED TO FACILITATE BLOGGING AND EDITING, MODIFYING, AND MAINTAINING A WEBSITE, SHARING OF INFORMATION, STATISTICS, AND DATA RELATED TO WEBSITE TRAFFIC, AND UNDERSTANDING AND OPTIMIZING WEBSITE PERFORMANCE AND USAGE (U.S. CLS. 100 AND 101).

FIRST USE 3-0-2011; IN COMMERCE 3-0-2011.  
REBECCA SMITH, EXAMINING ATTORNEY

SN 86-232,286. RTKL ASSOCIATES, INC., BALTIMORE, MD. FILED 3-26-2014.

# URBAN RX

THE MARK CONSISTS OF STANDARD CHARACTERS WITHOUT CLAIM TO ANY PARTICULAR FONT, STYLE, SIZE, OR COLOR.

NO CLAIM IS MADE TO THE EXCLUSIVE RIGHT TO USE "URBAN", APART FROM THE MARK AS SHOWN.

FOR URBAN DESIGN PLANNING SERVICES (U.S. CLS. 100 AND 101).

REBECCA POVARCHUK, EXAMINING ATTORNEY

SN 86-234,079. RX-360 INTERNATIONAL PHARMACEUTICAL SUPPLY CHAIN CONSORTIUM, WASHINGTON, DC. FILED 3-27-2014.

# RX-360

THE MARK CONSISTS OF STANDARD CHARACTERS WITHOUT CLAIM TO ANY PARTICULAR FONT, STYLE, SIZE, OR COLOR.

FOR ORGANIZING AND CONDUCTING A JOINT AUDITING PROGRAM OF PHARMACEUTICAL SUPPLIERS AND SUPPLIERS OF PHARMACEUTICAL INGREDIENTS FOR TECHNICAL ANALYSIS AND EVALUATION OF POTENTIAL RISKS AND SAFEGUARDS; ORGANIZING AND CONDUCTING AN AUDIT SHARING PROGRAM FOR PROVIDING THE RESULTS OF PHARMACEUTICAL SUPPLIER AUDITS FEATURING TECHNICAL ANALYSIS AND EVALUATION OF POTENTIAL RISKS AND SAFEGUARDS; RESEARCH IN THE FIELD OF PHARMACEUTICAL SUPPLY CHAIN SECURITY IN THE NATURE OF TECHNICAL ANALYSIS AND EVALUATION OF POTENTIAL RISKS AND SAFEGUARDS; PROVIDING TECHNICAL ANALYSIS AND EVALUATION INFORMATION OF POTENTIAL RISKS AND SAFEGUARDS IN THE FIELD OF PHARMACEUTICAL SUPPLY CHAIN SECURITY (U.S. CLS. 100 AND 101).

FIRST USE 0-0-2009; IN COMMERCE 0-0-2009.  
KELLEY WELLS, EXAMINING ATTORNEY

SN 86-233,972. SCRIVV, INC., HADDONFIELD, NJ. FILED 3-27-2014.

# SCRIVV

THE MARK CONSISTS OF STANDARD CHARACTERS WITHOUT CLAIM TO ANY PARTICULAR FONT, STYLE, SIZE, OR COLOR.

FOR SOFTWARE AS A SERVICE (SAAS) SERVICES FEATURING SOFTWARE FOR HARVESTING VOICE DATA FOR CUSTOMER RELATIONSHIP MANAGEMENT, SALES MONITORING AND MANAGEMENT, AND POLICY COMPLIANCE MONITORING (U.S. CLS. 100 AND 101).

ROBIN CHOSID, EXAMINING ATTORNEY

**CLASS 42—(Continued).**

SN 86-234,528. INNOVATIONS FOR LEARNING, INC., EVANSTON, IL. FILED 3-27-2014.

# TUTORMATE

THE MARK CONSISTS OF STANDARD CHARACTERS WITHOUT CLAIM TO ANY PARTICULAR FONT, STYLE, SIZE, OR COLOR.

FOR SOFTWARE AS A SERVICE (SAAS) SERVICES FEATURING SOFTWARE FOR EDUCATIONAL PURPOSES, NAMELY, FEATURING INSTRUCTION IN K-8TH GRADE SUBJECTS; SOFTWARE AS A SERVICE (SAAS) SERVICES FEATURING SOFTWARE FOR EDUCATIONAL PURPOSES, NAMELY, FEATURING INTERACTIVE MULTIMEDIA COMPUTER PROGRAMS FOR TUTORING IN K-8TH GRADE SUBJECTS (U.S. CLS. 100 AND 101).

FIRST USE 9-1-2011; IN COMMERCE 9-1-2011.  
ANNE MADDEN, EXAMINING ATTORNEY

---

SN 86-234,669. TPR MEDIA, DBA UBICARE, BOSTON, MA. FILED 3-27-2014.



THE COLOR(S) ORANGE AND BLUE IS/ARE CLAIMED AS A FEATURE OF THE MARK.

THE MARK CONSISTS OF THE DESIGN OF A THREE PART SWIRLING GEOMETRIC DESIGN. THE TWO PIECES ON THE RIGHT ARE ORANGE WHILE THE PIECE ON THE LEFT IS BLUE.

FOR APPLICATION SERVICE PROVIDER (ASP) FEATURING SOFTWARE FOR USE IN PROVIDING A TECHNOLOGY THAT ENABLES THE CREATION AND DISTRIBUTION OF HEALTH-RELATED DATA, AS WELL AS PROVIDING HEALTHCARE PROFESSIONALS WITH A SUBSCRIPTION-BASED ELECTRONIC HEALTHCARE CONTENT MANAGEMENT SYSTEM (U.S. CLS. 100 AND 101).

FIRST USE 10-31-2010; IN COMMERCE 11-1-2010.  
AHSEN KHAN, EXAMINING ATTORNEY

**CLASS 42—(Continued).**

SN 86-235,012. UTILIMARC, INC., ST. LOUIS PARK, MN. FILED 3-28-2014.

# UTILIMARC

THE MARK CONSISTS OF STANDARD CHARACTERS WITHOUT CLAIM TO ANY PARTICULAR FONT, STYLE, SIZE, OR COLOR.

OWNER OF U.S. REG. NO. 2,640,945.  
THE WORDING "UTILIMARC" HAS NO MEANING IN A FOREIGN LANGUAGE.

FOR PROVIDING TEMPORARY USE OF A WEB-BASED SOFTWARE APPLICATION FOR VEHICLE FLEET MANAGEMENT, MONITORING, LOGISTICS AND BENCHMARKING (U.S. CLS. 100 AND 101).

FIRST USE 3-0-2006; IN COMMERCE 3-0-2006.  
BILL DAWE, EXAMINING ATTORNEY

---

SN 86-235,015. MOLTIN LTD, TA MOLTIN, NEWCASTLE UPON TYNE, UNITED KINGDOM, FILED 3-28-2014.

# Moltin

THE MARK CONSISTS OF STANDARD CHARACTERS WITHOUT CLAIM TO ANY PARTICULAR FONT, STYLE, SIZE, OR COLOR.

THE WORDING "MOLTIN" HAS NO MEANING IN A FOREIGN LANGUAGE.

FOR APPLICATION SERVICE PROVIDER FEATURING APPLICATION PROGRAMMING INTERFACE (API) SOFTWARE FOR E-COMMERCE FUNCTIONALITY (U.S. CLS. 100 AND 101).

FIRST USE 4-3-2013; IN COMMERCE 4-3-2013.  
BILL DAWE, EXAMINING ATTORNEY

**CLASS 42—(Continued).**

SN 86-235,050. MOUNTAINTOP CONSULTING, LLC., ARLINGTON, VA. FILED 3-28-2014.

Mountaintop Consulting

THE MARK CONSISTS OF STANDARD CHARACTERS WITHOUT CLAIM TO ANY PARTICULAR FONT, STYLE, SIZE, OR COLOR.

NO CLAIM IS MADE TO THE EXCLUSIVE RIGHT TO USE "CONSULTING", APART FROM THE MARK AS SHOWN.

FOR BUSINESS TECHNOLOGY SOFTWARE CONSULTATION SERVICES; COMPUTER CONSULTATION; COMPUTER CONSULTATION IN THE FIELD OF COMPUTER SECURITY; COMPUTER PROGRAMMING CONSULTANCY; CONSULTANCY IN THE FIELD OF SOFTWARE DESIGN; CONSULTANCY WITH REGARD TO WEBPAGE DESIGN; CONSULTING IN THE FIELD OF CONFIGURATION MANAGEMENT FOR COMPUTER HARDWARE AND SOFTWARE; CONSULTING IN THE FIELD OF INFORMATION TECHNOLOGY; CONSULTING IN THE FIELD OF IT PROJECT MANAGEMENT; CONSULTING IN THE FIELD OF TELECOMMUNICATIONS TECHNOLOGY; CONSULTING SERVICES IN THE FIELD OF CLOUD COMPUTING; CONSULTING SERVICES IN THE FIELD OF COMPUTER-BASED INFORMATION SYSTEMS FOR BUSINESSES; CONSULTING SERVICES IN THE FIELD OF DESIGN AND DEVELOPMENT OF ENGINEERING PROCESSES; CONSULTING SERVICES IN THE FIELD OF PROVIDING ONLINE, NON-DOWNLOADABLE SOFTWARE AND APPLICATIONS; CONSULTING SERVICES IN THE FIELD OF SOFTWARE AS A SERVICE (SAAS); IT CONSULTING SERVICES; WEB SITE DESIGN CONSULTANCY (U.S. CLS. 100 AND 101).

FIRST USE 4-4-2014; IN COMMERCE 4-4-2014.  
JAMES STEIN, EXAMINING ATTORNEY

**CLASS 42—(Continued).**

SN 86-235,150. SCIURID, LLC, DRAPER, UT. FILED 3-28-2014.

LABELPATH

THE MARK CONSISTS OF STANDARD CHARACTERS WITHOUT CLAIM TO ANY PARTICULAR FONT, STYLE, SIZE, OR COLOR.

FOR PROVIDING A WEBSITE FEATURING NON-DOWNLOADABLE SOFTWARE FOR ORGANIZATION OF INTELLECTUAL PROPERTY INFORMATION, DATABASES, AND SERVICES; PROVIDING A WEBSITE FEATURING NON-DOWNLOADABLE SOFTWARE FOR USE IN DATABASE MANAGEMENT; PROVIDING A WEBSITE FEATURING NON-DOWNLOADABLE SOFTWARE TOOLS AND SUPPORT TOOLS FOR USE IN MANAGING TRADEMARK DATA AND INTELLECTUAL PROPERTY COLLABORATION; PROVIDING A WEBSITE FEATURING RESOURCES, NAMELY, NON-DOWNLOADABLE SOFTWARE FOR USE IN TRACKING, MANAGING AND REPORTING ON WORKFLOW PROCESSES, WORKFLOW MANAGEMENT FOR QUALITY AND COMPLIANCE IN CONNECTION WITH PRODUCTS OF OTHERS; PROVIDING ON-LINE NON-DOWNLOADABLE SOFTWARE FOR PROVIDING A SEARCH ENGINE FOR SEARCHING, RETRIEVING, AND ORGANIZING INFORMATION, SITES, DATA AND OTHER RESOURCES AVAILABLE ON A GLOBAL COMPUTER NETWORK (U.S. CLS. 100 AND 101).

FIRST USE 9-1-2013; IN COMMERCE 11-12-2013.  
B. PARADEWELAI, EXAMINING ATTORNEY

SN 86-235,703. GEEKS TECHNICAL SUPPORT LLC, ARLINGTON, VA. FILED 3-28-2014.

geeks | TECHNICAL SUPPORT

NO CLAIM IS MADE TO THE EXCLUSIVE RIGHT TO USE "TECHNICAL SUPPORT", APART FROM THE MARK AS SHOWN.

THE MARK CONSISTS OF THE WORDING "GEEKS TECHNICAL SUPPORT", A VERTICAL LINE, AND PAIR OF EYEGLASSES WITH A HEADSET MICROPHONE, WITH A PORTION OF THE EYEGLASS FRAME FORMING THE TOP HALF OF THE "G" IN "GEEKS". TO THE RIGHT OF THE WORD "GEEKS" IS A VERTICAL LINE AND THE WORDING "TECHNICAL SUPPORT".

FOR TECHNICAL SUPPORT SERVICES, NAMELY, TROUBLESHOOTING OF COMPUTER SOFTWARE PROBLEMS; COMPUTER SOFTWARE CONSULTING SERVICES; TECHNICAL SUPPORT SERVICES FOR COMPUTER HARDWARE CONSISTING OF DESKTOPS, LAPTOPS, MOBILE PHONES, TABLETS, PRINTER, SCANNERS, ROUTERS, MODEMS AND OTHER CONNECTED DEVICES, NAMELY, INFRASTRUCTURE MANAGEMENT AND ADMINISTRATION OF IT SYSTEMS COMPRISED OF THE AFOREMENTIONED COMPUTER HARDWARE; COMPUTER VIRUS PROTECTION SERVICES; COMPUTER SOFTWARE INSTALLATION SERVICES (U.S. CLS. 100 AND 101).

FIRST USE 5-14-2013; IN COMMERCE 5-14-2013.  
AHSEN KHAN, EXAMINING ATTORNEY

**CLASS 42—(Continued).**

SN 86-235,890. CNS VITAL SIGNS, LLC, MORRISVILLE, NC. FILED 3-28-2014.

**COGNITRAX**

THE MARK CONSISTS OF STANDARD CHARACTERS WITHOUT CLAIM TO ANY PARTICULAR FONT, STYLE, SIZE, OR COLOR.

FOR ONLINE NON-DOWNLOADABLE SOFTWARE FOR TESTING AND SCREENING NEUROLOGICAL CONDITIONS (U.S. CLS. 100 AND 101).

FIRST USE 9-6-2013; IN COMMERCE 1-13-2014.  
ANTHONY RINKER, EXAMINING ATTORNEY

SN 86-236,204. ONELOCK, INC., BURBANK, CA. FILED 3-29-2014.

**ONELOCK**

THE MARK CONSISTS OF STANDARD CHARACTERS WITHOUT CLAIM TO ANY PARTICULAR FONT, STYLE, SIZE, OR COLOR.

FOR SOFTWARE AS A SERVICE (SAAS) SERVICES FEATURING SOFTWARE FOR STORING AND MANAGING PASSWORDS AND PERSONAL INFORMATION AND DISTRIBUTING AND ACCESSING THE SAME VIA PERSONAL COMPUTERS AND MOBILE DEVICES (U.S. CLS. 100 AND 101).

ANNE E. GUSTASON, EXAMINING ATTORNEY

SN 86-236,794. FORTHRIGHT ENGINEERING PLLC, RALEIGH, NC. FILED 3-31-2014.

**forthright**  
ENGINEERING PLLC

NO CLAIM IS MADE TO THE EXCLUSIVE RIGHT TO USE "ENGINEERING PLLC", APART FROM THE MARK AS SHOWN.

THE MARK CONSISTS OF THE WORD "FORTHRIGHT" IN LOWERCASE LETTERS WITH THE "O" IN "FORTHRIGHT" FILLED IN EXCEPT FOR AN ARROW POINTING TO THE RIGHT. THE WORDS "ENGINEERING" AND THE LETTERS "PLLC" ARE BELOW THE WORD "FORTHRIGHT".

FOR NEW PRODUCT DESIGN AND DEVELOPMENT; MECHANICAL ENGINEERING SERVICES; ELECTROMECHANICAL ENGINEERING SERVICES; PROTOTYPE FABRICATION OF NEW PRODUCTS FOR OTHERS; PROJECT MANAGEMENT SERVICES IN THE FIELD OF NEW PRODUCT DESIGN AND DEVELOPMENT (U.S. CLS. 100 AND 101).

FIRST USE 7-0-2010; IN COMMERCE 7-0-2010.  
DAVID MURRAY, EXAMINING ATTORNEY

**CLASS 42—(Continued).**

SN 86-236,860. JOE'S DATACENTER, LLC, KANSAS CITY, MO. FILED 3-31-2014.

**Joe's Datacenter**

THE MARK CONSISTS OF STANDARD CHARACTERS WITHOUT CLAIM TO ANY PARTICULAR FONT, STYLE, SIZE, OR COLOR.

NO CLAIM IS MADE TO THE EXCLUSIVE RIGHT TO USE "DATACENTER", APART FROM THE MARK AS SHOWN.

FOR HOSTING WEBSITES, SOFTWARE APPLICATIONS, COMPUTER SOFTWARE, ELECTRONIC DATABASES, DIGITAL CONTENT, AND BUSINESS COMPUTER SOFTWARE APPLICATIONS OF OTHERS ACCESSIBLE VIA THE INTERNET; HOSTING IN THE NATURE OF LEASING, CONFIGURING, UPDATING, MONITORING, OPTIMIZING, AND TROUBLESHOOTING COMPUTER SERVERS AND OTHER COMPUTER HARDWARE THAT SUPPORT HOSTED WEBSITES, SOFTWARE APPLICATIONS, COMPUTER SOFTWARE, ELECTRONIC DATABASES, DIGITAL CONTENT, AND BUSINESS COMPUTER SOFTWARE APPLICATIONS OF OTHERS ACCESSIBLE VIA THE INTERNET; HOSTING IN THE NATURE OF LEASING, CONFIGURING, UPDATING, MONITORING, OPTIMIZING, REPAIRING AND TROUBLESHOOTING COMPUTER SOFTWARE THAT SUPPORTS HOSTED WEBSITES, SOFTWARE APPLICATIONS, COMPUTER SOFTWARE, ELECTRONIC DATABASES, DIGITAL CONTENT, AND BUSINESS SOFTWARE APPLICATIONS OF OTHERS ACCESSIBLE VIA THE INTERNET (U.S. CLS. 100 AND 101).

FIRST USE 7-1-2008; IN COMMERCE 8-19-2008.  
RONALD MCMORROW, EXAMINING ATTORNEY

SN 86-237,039. CLEVER INC., SAN FRANCISCO, CA. FILED 3-31-2014.

**CLEVER**

THE MARK CONSISTS OF STANDARD CHARACTERS WITHOUT CLAIM TO ANY PARTICULAR FONT, STYLE, SIZE, OR COLOR.

FOR APPLICATION SERVICE PROVIDER FEATURING APPLICATION PROGRAMMING INTERFACE (API) SOFTWARE FOR USE IN THE COLLECTION, INTEGRATION AND ACCESS OF STUDENT INFORMATION SYSTEMS DATA IN CONNECTION WITH THIRD PARTY SOFTWARE APPLICATIONS; SOFTWARE AS A SERVICE (SAAS) SERVICES FEATURING SOFTWARE FOR USE IN THE COLLECTION, INTEGRATION AND ACCESS OF STUDENT INFORMATION SYSTEMS DATA IN CONNECTION WITH THIRD PARTY SOFTWARE APPLICATIONS; PROVIDING AN INTERACTIVE INTERNET WEBSITE PORTAL FEATURING SINGLE SIGN ON (SSO) FUNCTIONALITY TECHNOLOGY FOR STUDENTS AND TEACHERS IN CONJUNCTION WITH THIRD PARTY SOFTWARE APPLICATIONS (U.S. CLS. 100 AND 101).

FIRST USE 5-16-2012; IN COMMERCE 5-16-2012.  
DEBORAH MEINERS, EXAMINING ATTORNEY

**CLASS 42—(Continued).**

SN 86-237,614. SHEIKH, FAHAD, RICHMOND, TX. FILED 3-31-2014.



NO CLAIM IS MADE TO THE EXCLUSIVE RIGHT TO USE "24 HRS NETWORK", APART FROM THE MARK AS SHOWN.

THE MARK CONSISTS OF SEVEN CIRCLES OVERLAPPING EACH OTHER WITH IMAGES IN EACH CONSISTING OF A SATELLITE TELEPHONE, MONITOR, COMPUTER, TELEPHONE, CAMERA, HOME THEATER, AND TELEVISION, WITH THE WORDS "24HRS NETWORK" TO THE LEFT OF THE DESIGN.

FOR INSTALLATION, MAINTENANCE AND REPAIR OF INTEGRATED SECURITY SOFTWARE; TECHNICAL SUPPORT SERVICES, NAMELY, 24/7 MONITORING OF NETWORK SYSTEMS, SERVERS AND WEB AND DATABASE APPLICATIONS AND NOTIFICATION OF RELATED EVENTS AND ALERTS; TECHNICAL SUPPORT SERVICES, NAMELY, REMOTE AND ON-SITE INFRASTRUCTURE MANAGEMENT SERVICES FOR MONITORING, ADMINISTRATION AND MANAGEMENT OF PUBLIC AND PRIVATE CLOUD COMPUTING IT AND APPLICATION SYSTEMS (U.S. CLS. 100 AND 101).

FIRST USE 11-18-2009; IN COMMERCE 11-18-2009.  
VIVIAN MICZNIK FIRST, EXAMINING ATTORNEY

SN 86-237,731. SERVWARE, LLC, DAYTON, OH. FILED 3-31-2014.

# ServWare

THE MARK CONSISTS OF STANDARD CHARACTERS WITHOUT CLAIM TO ANY PARTICULAR FONT, STYLE, SIZE, OR COLOR.

FOR NON-DOWNLOADABLE COMPUTER APPLICATION SOFTWARE FOR DESKTOP COMPUTERS AND MOBILE DEVICES, NAMELY, NON-DOWNLOADABLE SOFTWARE FOR TRACKING THE NEEDS OF CHARITABLE ORGANIZATIONS AND THOSE CONNECTED THERETO AND TRACKING OF ASSISTANCE REQUESTS AND FOR USE IN REPORTING ACTIVITIES OF THE ORGANIZATIONS (U.S. CLS. 100 AND 101).

FIRST USE 4-5-2013; IN COMMERCE 10-1-2013.  
BRIDGETT SMITH, EXAMINING ATTORNEY

**CLASS 42—(Continued).**

SN 86-237,916. KNIGHT VISION INSPECTIONS, LLC, YUMA, AZ. FILED 3-31-2014.

## Knight Vision Inspections

THE MARK CONSISTS OF STANDARD CHARACTERS WITHOUT CLAIM TO ANY PARTICULAR FONT, STYLE, SIZE, OR COLOR.

NO CLAIM IS MADE TO THE EXCLUSIVE RIGHT TO USE "INSPECTIONS", APART FROM THE MARK AS SHOWN.

FOR HOME INSPECTIONS (U.S. CLS. 100 AND 101).

FIRST USE 7-3-2012; IN COMMERCE 8-22-2012.

JILLIAN CANTOR, EXAMINING ATTORNEY

SN 86-237,938. KNIGHT VISION INSPECTIONS, LLC, YUMA, AZ. FILED 3-31-2014.



NO CLAIM IS MADE TO THE EXCLUSIVE RIGHT TO USE "INSPECTIONS LLC", APART FROM THE MARK AS SHOWN.

THE COLOR(S) MAROON, BLUE, BROWN, BLACK, WHITE AND GRAY IS/ARE CLAIMED AS A FEATURE OF THE MARK.

THE MARK CONSISTS OF THE DESIGN OF A GRAY, BLACK AND WHITE CASTLE WITH A BROWN DOOR AND TWO MAROON FLAGS, WITH THE WORDING "KNIGHT" IN MAROON INSIDE THE CASTLE, UNDERNEATH WHICH IS THE WORDING "VISION INSPECTIONS LLC" IN BLACK SURROUNDED BY BLUE WATER.

FOR HOME INSPECTIONS (U.S. CLS. 100 AND 101).

FIRST USE 7-3-2012; IN COMMERCE 8-22-2012.

JILLIAN CANTOR, EXAMINING ATTORNEY

**CLASS 42—(Continued).**

SN 86-238,221. TOPTECH SYSTEMS, INC., LONGWOOD, FL. FILED 4-1-2014.

# LOAD2DAY

THE MARK CONSISTS OF STANDARD CHARACTERS WITHOUT CLAIM TO ANY PARTICULAR FONT, STYLE, SIZE, OR COLOR.

FOR PROVIDING TEMPORARY USE OF NON-DOWNLOADABLE SOFTWARE FOR USE IN PROCESSING CUSTOMER INFORMATION TO ENHANCE PRODUCT DELIVERY AT THE CUSTOMER'S FACILITIES (U.S. CLS. 100 AND 101).

DAVID MURRAY, EXAMINING ATTORNEY

SN 86-238,305. GEXA ENERGY, LP, HOUSTON, TX. FILED 4-1-2014.

# GEXA

THE MARK CONSISTS OF STANDARD CHARACTERS WITHOUT CLAIM TO ANY PARTICULAR FONT, STYLE, SIZE, OR COLOR.

OWNER OF U.S. REG. NOS. 2,928,862, 3,943,739 AND 3,943,741.

FOR MEASUREMENT AND VERIFICATION SERVICES IN FIELD OF ENERGY MANAGEMENT AND ENERGY CONSERVATION; CONSULTING SERVICES IN THE FIELDS OF ENERGY MODELING AND ANALYSIS; CONSULTING SERVICES IN DAYLIGHT MODELING AND ANALYSIS; CONSULTANCY SERVICES IN THE FIELD OF THE DEVELOPMENT OF BUILDING ENERGY EFFICIENCY STANDARDS AND BUILDING CODES AND THE DEVELOPMENT OF INDUSTRY STANDARDS; CONSULTING SERVICES IN THE FIELD OF ENVIRONMENTAL ASSESSMENT AND PLANNING, NAMELY, FORMULATING STANDARDS AND BEST PRACTICES FOR THE ENVIRONMENTAL DESIGN, CONSTRUCTION, AND OPERATION OF BUILDINGS; DESIGNING AND IMPLEMENTING ENERGY CONSERVATION PROGRAMS FOR OTHERS; SOFTWARE AS A SERVICE SERVICES FEATURING SOFTWARE FOR DATA ANALYTICS FOR SMART GRID AND ENERGY INFORMATION; ENERGY USAGE MONITORING, METERING, AND ANALYSIS; PROVIDING TEMPORARY USE OF ONLINE NON-DOWNLOADABLE COMPUTER SOFTWARE FOR REMOTE MONITORING, ANALYZING, AND MANAGING OF ENERGY; PROVIDING ONLINE NONDOWNLOADABLE SOFTWARE FOR COMPUTING ENERGY SAVINGS AND MANAGING THE DISTRIBUTION OF ELECTRICAL ENERGY; REMOTE MONITORING AND CONTROLLING OF ENERGY USAGE AND EQUIPMENT AND APPARATUS USED IN ENERGY GENERATION FOR COMMERCIAL, INDUSTRIAL, GOVERNMENT, AND RESIDENTIAL SITES; PROVIDING TEMPORARY USE OF ONLINE NON-DOWNLOADABLE COMPUTER SOFTWARE FOR REMOTE MONITORING, ANALYZING, AND MANAGING OF ENERGY; CONSULTING SERVICES IN THE FIELD OF ENERGY MEASUREMENT TO IMPROVE ENERGY EFFICIENCY AND ENERGY RELIABILITY; UTILITY METER READING SERVICES; PRODUCT DEVELOPMENT CONSULTATION; TECHNICAL CONSULTATION IN THE FIELD OF UTILITY DISTRIBUTION LOAD MANAGEMENT; REMOTE MONITORING SERVICES OF HEATING, VENTILATING AND AIR CONDITIONING APPARATUS; DESIGNING OF MACHINES,

**CLASS 42—(Continued).**

APPARATUS, INSTRUMENTS OR SYSTEMS COMPOSED OF SUCH MACHINES, APPARATUS AND INSTRUMENTS; ELECTRIC METER READING AND DATA ANALYSIS; CONSULTING SERVICES IN THE FIELDS OF ENERGY MEASUREMENT TO IMPROVE ENERGY EFFICIENCY THROUGH COMPUTER OPTIMIZED DELIVERY OF HVAC SERVICES FOR BUILDINGS AND AUTOMATED MANAGEMENT AND REPORTING ON ENERGY COSTS AND ENERGY CONSUMPTION; CONSULTING SERVICES IN THE FIELDS OF COMPUTER SOFTWARE AND PROGRAMS FOR BUILDING ENVIRONMENTAL CONTROL SYSTEMS; DESIGN, INSTALLATION, UPDATING AND MAINTENANCE OF COMPUTER SOFTWARE SYSTEMS; MONITORING OF EVENTS AND ACTIVITIES WHICH INFLUENCE THE ENVIRONMENT AND ENERGY USAGE WITHIN A BUILDING FOR PURPOSES OF MEASURING ENERGY USAGE; REMOTE MONITORING OF HEATING, VENTILATING, AND AIR CONDITIONING APPARATUS, NAMELY, MONITORING AND ANALYZING THE PERFORMANCE OF ENVIRONMENTAL CONTROL SYSTEMS IN BUILDINGS; RECORDING DATA FOR OTHERS ON OPTICAL, DIGITAL, AND MAGNETIC MEDIA FOR ELECTRONIC STORAGE, NAMELY, RECORDING DATA RELATING TO ENERGY CONSUMPTION AND THE OPERATION OF ENVIRONMENTAL CONTROL SYSTEMS IN BUILDINGS; RECORDING DATA RELATING TO ENERGY CONSUMPTION AND THE OPERATION OF ENVIRONMENTAL CONTROL SYSTEMS IN BUILDINGS, NAMELY, GAS, ELECTRIC, AND ENERGY METER DATA MANAGEMENT AND ANALYSIS; PROVISION OF ENGINEERING INFORMATION IN THE FIELD OF ENERGY EFFICIENCY AS IT RELATES TO BUILDING ENERGY USAGE, THE PERFORMANCE OF HVAC SYSTEMS AND OPTIMIZING THE EFFICIENCY AND OPERATIONS OF BUILDING ENVIRONMENTAL CONTROL SYSTEMS (U.S. CLS. 100 AND 101).

MARTHA SANTOMARTINO, EXAMINING ATTORNEY

SN 86-238,342. ACI WORLDWIDE CORP., ELKHORN, NE. FILED 4-1-2014.

# UP

THE MARK CONSISTS OF STANDARD CHARACTERS WITHOUT CLAIM TO ANY PARTICULAR FONT, STYLE, SIZE, OR COLOR.

OWNER OF U.S. REG. NO. 4,497,227.

FOR PROVIDING A FULLY INTEGRATED, END-TO-END ENTERPRISE PAYMENTS PROCESSING SOFTWARE PLATFORM FOR BANKS, PROCESSORS AND RETAILERS THAT ORCHESTRATES ALL ASPECTS OF PAYMENTS PROCESSING FOR ANY PAYMENT TYPE (U.S. CLS. 100 AND 101).

FIRST USE 4-22-2013; IN COMMERCE 4-22-2013.

JASON BLAIR, EXAMINING ATTORNEY

**CLASS 42—(Continued).**

SN 86-238,398. APKUDO LLC, BALTIMORE, MD. FILED 4-1-2014.

# APKUDO

THE MARK CONSISTS OF STANDARD CHARACTERS WITHOUT CLAIM TO ANY PARTICULAR FONT, STYLE, SIZE, OR COLOR.

FOR TESTING, ANALYSIS AND EVALUATION OF MOBILE PHONES, TABLET COMPUTERS, TABLET COMPUTERS, COMPUTER SOFTWARE FOR MOBILE PHONES AND TABLET COMPUTERS, MOBILE PHONE HEADSETS, MOBILE PHONE HEADPHONES, WATCHES, GLASSES, MOBILE PHONE SPEAKERS, MOBILE PHONE HEADSETS, MOBILE PHONE KEYBOARDS, MOBILE PHONE CASES, MOBILE PHONE STRAPS, MOBILE PHONE CHARGERS, MOBILE PHONE SCREEN PROTECTORS, MOBILE PHONE BATTERIES, MOBILE PHONE DOCKING STATIONS, AND MOBILE PHONE MEMORY CARDS (U.S. CLS. 100 AND 101).

FIRST USE 6-16-2011; IN COMMERCE 6-16-2011.  
NAAKWAMA ANKRAH, EXAMINING ATTORNEY

SN 86-238,785. PAPERLESS PCS, LLC, BIRMINGHAM,, AL. FILED 4-1-2014.



NO CLAIM IS MADE TO THE EXCLUSIVE RIGHT TO USE "PAPERLESS PCS", APART FROM THE MARK AS SHOWN.

THE COLOR(S) BLUE, ORANGE, AND WHITE IS/ARE CLAIMED AS A FEATURE OF THE MARK.

THE MARK CONSISTS OF THE WORD ELEMENT "PAPERLESS", WHEREIN "PAPER" IS WRITTEN IN BLUE AND "LESS" IS WRITTEN IN ORANGE, POSITIONED OVER TWIN PARALLEL SHEETS OF PAPER, ONE BLUE AND WHITE AND THE OTHER ORANGE, WITH A SMALLER BLUE "PCS" ELEMENT AT A LOWER RIGHT EDGE OF THE "PAPERLESS" ELEMENT. ABOVE THE BLUE WORD "PAPER" EXTENDING FROM THE LEFT EDGE OF THE BLUE SHEET OF PAPER IS A BLUE HORIZONTAL LINE AND BENEATH THE WORDING "PAPERLESS" EXTENDING FROM THE RIGHT EDGE OF THE ORANGE SHEET OF PAPER IS AN ORANGE HORIZONTAL LINE. THE BLACK BACKGROUND IS USED TO SHOW PLACEMENT, AND IS NOT CLAIMED AS A FEATURE OF THE MARK.

FOR PROVIDING NON-DOWNLOADABLE SOFTWARE, NAMELY, PROVIDING A WEBSITE FEATURING TEMPORARY USE OF NON-DOWNLOADABLE SOFTWARE FOR THE CREATION AND ENTRANCE INTO ELECTRONIC RECORDS SYSTEMS OF PHYSICIAN CERTIFICATION STATEMENTS IN PREPARATION FOR RELEASE AND/OR MOVEMENT OF PATIENTS VIA AMBULATORY TRANSPORTATION SERVICES (U.S. CLS. 100 AND 101).

FIRST USE 10-10-2013; IN COMMERCE 10-10-2013.  
EVIN L. KOZAK, EXAMINING ATTORNEY

**CLASS 42—(Continued).**

SN 86-239,091. KANEMOTO, NATHAN, CHICO, CA. FILED 4-1-2014.

# mycasa

THE MARK CONSISTS OF STANDARD CHARACTERS WITHOUT CLAIM TO ANY PARTICULAR FONT, STYLE, SIZE, OR COLOR.

FOR PROVIDING AN INTERACTIVE WEBSITE IN THE FIELD OF RENOVATING AND CONSTRUCTING HOMES FEATURING TECHNOLOGY THAT ALLOWS USERS TO UPLOAD PHOTOGRAPHS, PROVIDE COMMENTARY ON THEIR RENOVATION AND CONSTRUCTION PROJECTS AND TO LINK TO THIRD PARTY WEBSITES FOR PURCHASING PRODUCTS WHICH MAYBE PICTURED IN THE PHOTOGRAPHS (U.S. CLS. 100 AND 101).

BRENDAN MCCAULEY, EXAMINING ATTORNEY

SN 86-239,382. RITUWALL INC., SAN FRANCISCO, CA. FILED 4-1-2014.

# TheGrid

THE MARK CONSISTS OF STANDARD CHARACTERS WITHOUT CLAIM TO ANY PARTICULAR FONT, STYLE, SIZE, OR COLOR.

FOR PROVIDING TEMPORARY USE OF ONLINE NON-DOWNLOADABLE SOFTWARE FOR ONLINE EDIT AND PUBLICATION SERVICE (U.S. CLS. 100 AND 101).

LINDA E. BLOHM, EXAMINING ATTORNEY

SN 86-239,394. RITUWALL INC., SAN FRANCISCO, CA. FILED 4-1-2014.

# Flowhub

THE MARK CONSISTS OF STANDARD CHARACTERS WITHOUT CLAIM TO ANY PARTICULAR FONT, STYLE, SIZE, OR COLOR.

FOR PROVIDING TEMPORARY USE OF ONLINE NON-DOWNLOADABLE SOFTWARE FOR ONLINE EDIT AND PUBLICATION SERVICE (U.S. CLS. 100 AND 101).

LINDA E. BLOHM, EXAMINING ATTORNEY



**CLASS 42—(Continued).**

SN 86-239,515. COMPUTER WORD PROCESSING SYSTEMS, INC., DBA CONNECTED WORKPLACE SOLUTIONS, INC., CHANTILLY, VA. FILED 4-2-2014.



OWNER OF U.S. REG. NO. 4,345,732.

NO CLAIM IS MADE TO THE EXCLUSIVE RIGHT TO USE "CLOUD ASSIST", APART FROM THE MARK AS SHOWN.

THE COLOR(S) BLUE, RED AND GREY IS/ARE CLAIMED AS A FEATURE OF THE MARK.

THE MARK CONSISTS OF THE LETTERS "CWPS" IN BLUE AND THERE IS A RED LINE BEHIND THE LETTERS WITH AN ARROW HEAD ON THE RIGHT SIDE OF THE LETTER "S" AND THE WORDS "CLOUD ASSIST" IN BLUE WITH A CLOUD OUTLINED IN GREY SURROUNDING THE LETTERS "CWPS", THE RED LINE, ARROW HEAD AND THE WORDS "CLOUD ASSIST".

FOR COMPUTER SERVICES, NAMELY, CLOUD HOSTING PROVIDER SERVICES; COMPUTER SERVICES, NAMELY, INTEGRATION OF PRIVATE AND PUBLIC CLOUD COMPUTING ENVIRONMENTS; CONSULTING SERVICES IN THE FIELD OF CLOUD COMPUTING; PROVIDING VIRTUAL COMPUTER SYSTEMS AND VIRTUAL COMPUTER ENVIRONMENTS THROUGH CLOUD COMPUTING; TECHNICAL CONSULTING SERVICES IN THE FIELDS OF DATACENTER ARCHITECTURE, PUBLIC AND PRIVATE CLOUD COMPUTING SOLUTIONS, AND EVALUATION AND IMPLEMENTATION OF INTERNET TECHNOLOGY AND SERVICES; TECHNICAL SUPPORT SERVICES, NAMELY, REMOTE AND ON-SITE INFRASTRUCTURE MANAGEMENT SERVICES FOR MONITORING, ADMINISTRATION AND MANAGEMENT OF PUBLIC AND PRIVATE CLOUD COMPUTING IT AND APPLICATION SYSTEMS (U.S. CLS. 100 AND 101).

LESLIE RICHARDS, EXAMINING ATTORNEY

SN 86-239,633. FASTRAX, SAN ANTONIO, TX. FILED 4-2-2014.

# FASTRAX

THE MARK CONSISTS OF STANDARD CHARACTERS WITHOUT CLAIM TO ANY PARTICULAR FONT, STYLE, SIZE, OR COLOR.

FOR DESIGN SERVICES IN THE FIELD OF POWER CONTROL SYSTEMS, DISTRIBUTED CONTROL SYSTEMS, POWER AUTOMATION SYSTEMS, SUPERVISORY CONTROL AND DATA ACQUISITION (SCADA) SYSTEMS, AND INDUSTRIAL POWER DISTRIBUTION SYSTEMS THAT ALSO FEATURE THE EVALUATION AND ASSESSMENT OF CUSTOMER NEEDS RELATING TO SAID SYSTEMS (U.S. CLS. 100 AND 101).

FIRST USE 4-1-2014; IN COMMERCE 4-1-2014.

ELISSA GARBER KON, EXAMINING ATTORNEY

**CLASS 42—(Continued).**

SN 86-239,912. RITUWALL INC., SAN FRANCISCO, CA. FILED 4-2-2014.

# Rituwall

THE MARK CONSISTS OF STANDARD CHARACTERS WITHOUT CLAIM TO ANY PARTICULAR FONT, STYLE, SIZE, OR COLOR.

FOR PROVIDING TEMPORARY USE OF ONLINE NON-DOWNLOADABLE SOFTWARE FOR ONLINE EDIT AND PUBLICATION SERVICE (U.S. CLS. 100 AND 101).

LINDA E. BLOHM, EXAMINING ATTORNEY

SN 86-239,982. RITUWALL INC., SAN FRANCISCO, CA. FILED 4-2-2014.



THE COLOR(S) WHITE AND BLUE IS/ARE CLAIMED AS A FEATURE OF THE MARK.

THE MARK CONSISTS OF A CAPITAL LETTER "G" SHOWN IN THE COLOR WHITE IN THE CENTER OF A BLUE SQUARE. THERE ARE FOUR 90 DEGREE L-SHAPED ANGLE DESIGNS, SPACED AROUND THE LETTER "G".

FOR PROVIDING TEMPORARY USE OF ONLINE NON-DOWNLOADABLE SOFTWARE FOR ONLINE EDIT AND PUBLICATION SERVICE (U.S. CLS. 100 AND 101).

LINDA E. BLOHM, EXAMINING ATTORNEY

SN 86-240,356. TKOUT, INC., RESTON, VA. FILED 4-2-2014.

# TKOUT

THE MARK CONSISTS OF STANDARD CHARACTERS WITHOUT CLAIM TO ANY PARTICULAR FONT, STYLE, SIZE, OR COLOR.

FOR PROVIDING A WEBSITE FEATURING A SEARCH ENGINE FOR OBTAINING FOOD AND RESTAURANT INFORMATION (U.S. CLS. 100 AND 101).

FIRST USE 2-12-2014; IN COMMERCE 2-12-2014.

IRA J. GOODSaid, EXAMINING ATTORNEY

**CLASS 42—(Continued).**

SN 86-241,158. BI-LINK METAL SPECIALTIES, INC., BLOOMINGDALE, IL. FILED 4-3-2014.

**THE HARDWARE STORE - BY  
BI-LINK**

THE MARK CONSISTS OF STANDARD CHARACTERS WITHOUT CLAIM TO ANY PARTICULAR FONT, STYLE, SIZE, OR COLOR.

FOR PROVIDING SPECIALIZED FACILITIES FOR DEVELOPING MECHANICAL COMPONENTS, NAMELY, METAL STAMPINGS AND INJECTION MOLD PARTS AND ASSEMBLIES (U.S. CLS. 100 AND 101).

JANET LEE, EXAMINING ATTORNEY

---

SN 86-241,867. GALDI, GREGORY, HAUPPAUGE, NY. FILED 4-3-2014.

**It's Your Cloud - Your  
Choice**

THE MARK CONSISTS OF STANDARD CHARACTERS WITHOUT CLAIM TO ANY PARTICULAR FONT, STYLE, SIZE, OR COLOR.

FOR COMPUTER SERVICES, NAMELY, INTEGRATION OF PRIVATE AND PUBLIC CLOUD COMPUTING ENVIRONMENTS (U.S. CLS. 100 AND 101).

FIRST USE 1-15-2014; IN COMMERCE 1-15-2014.  
NICOLE A NGUYEN, EXAMINING ATTORNEY

---

SN 86-242,137. RITUWALL INC., SAN FRANCISCO, CA. FILED 4-3-2014.



THE MARK CONSISTS OF TWO STYLIZED CAPITAL LETTER "G'S", ONE INSIDE OF THE OTHER CONTAINED IN A DARKENED SQUARE DESIGN

FOR PROVIDING TEMPORARY USE OF ONLINE NON-DOWNLOADABLE SOFTWARE FOR ONLINE EDIT AND PUBLICATION SERVICE (U.S. CLS. 100 AND 101).

LINDA E. BLOHM, EXAMINING ATTORNEY

**CLASS 42—(Continued).**

SN 86-242,705. PHILLIP NATHAN THORNBERRY, CARMEL, IN. FILED 4-4-2014.

**InspectorLab**

THE MARK CONSISTS OF STANDARD CHARACTERS WITHOUT CLAIM TO ANY PARTICULAR FONT, STYLE, SIZE, OR COLOR.

FOR LABORATORY ANALYSIS IN THE FIELD OF INDOOR AIR QUALITY TESTING; QUALITY MANAGEMENT SERVICES, NAMELY, QUALITY EVALUATION AND ANALYSIS, QUALITY ASSURANCE, AND QUALITY CONTROL, IN THE FIELD OF TESTING AND ANALYSIS OF AIR AND SURFACE SAMPLE FOR FUNGI AND BACTERIA, NAMELY CULTURABLE AIR SAMPLES, SPORE TRAP SAMPLES, TAPE BULK, SWAB, AND WATER SAMPLES, ECOLI AND LEGIONELLA ANALYSIS, ANIMAL DANDER, DUST MITES, AND RODENTS; SCIENTIFIC LABORATORY SERVICES (U.S. CLS. 100 AND 101).

FIRST USE 3-15-2014; IN COMMERCE 3-15-2014.  
TIFFANY CHIANG, EXAMINING ATTORNEY

---

SN 86-243,315. 20TWENTY STRATEGIC CONSULTING, INC., MCLEAN, VA. FILED 4-4-2014.

**BECAUSE NOW YOU KNOW**

THE MARK CONSISTS OF STANDARD CHARACTERS WITHOUT CLAIM TO ANY PARTICULAR FONT, STYLE, SIZE, OR COLOR.

FOR DESIGN, DEVELOPMENT AND IMPLEMENTATION OF SOFTWARE FOR OTHERS; INFORMATION TECHNOLOGY CONSULTING SERVICES; PLANNING, DESIGN AND IMPLEMENTATION OF COMPUTER TECHNOLOGIES FOR OTHERS; IT INTEGRATION SERVICES; CONSULTING SERVICES IN THE FIELD OF DESIGN, SELECTION, IMPLEMENTATION AND USE OF COMPUTER SOFTWARE SYSTEMS FOR OTHERS, COMPUTER SOFTWARE PROJECT MANAGEMENT SERVICES (U.S. CLS. 100 AND 101).

FIRST USE 10-20-2010; IN COMMERCE 10-20-2010.  
MICHAEL SOUDERS, EXAMINING ATTORNEY

**CLASS 42—(Continued).**

SN 86-243,869. WADA, HIROSHI, DBA CLOSEUP EXPRESS, SACRAMENTO, CA. FILED 4-6-2014.

# CLOSEUP EXPRESS

THE MARK CONSISTS OF STANDARD CHARACTERS WITHOUT CLAIM TO ANY PARTICULAR FONT, STYLE, SIZE, OR COLOR.

OWNER OF U.S. REG. NO. 4,455,101.  
NO CLAIM IS MADE TO THE EXCLUSIVE RIGHT TO USE "CLOSEUP", APART FROM THE MARK AS SHOWN, FOR PROVIDING A WEBSITE THAT GIVES COMPUTER USERS THE ABILITY TO UPLOAD, EXCHANGE AND SHARE PHOTOS, VIDEOS AND VIDEO LOGS (U.S. CLS. 100 AND 101).  
FIRST USE 6-8-2013; IN COMMERCE 6-8-2013.  
BRIAN PINO, EXAMINING ATTORNEY

**CLASS 42—(Continued).**

SN 86-244,290. KINOKE, LOS GATOS, CA. FILED 4-7-2014.

# KINOKE

THE MARK CONSISTS OF STANDARD CHARACTERS WITHOUT CLAIM TO ANY PARTICULAR FONT, STYLE, SIZE, OR COLOR.

FOR PROVIDING A WEB SITE FEATURING TECHNOLOGY THAT ENABLES USERS TO ARCHIVE TEXT, IMAGES, VIDEOS, SOUND RECORDINGS, AND OTHER ELECTRONIC DATA TO PRESERVE THEIR PERSONAL AND FAMILIAL HISTORIES (U.S. CLS. 100 AND 101).  
WON TEAK OH, EXAMINING ATTORNEY

---

SN 86-244,282. URTSO, MICHAEL, PLANO, TX. AND URTSO, JORDAN, PLANO, TX. FILED 4-7-2014.

# SHAMELESS

THE MARK CONSISTS OF STANDARD CHARACTERS WITHOUT CLAIM TO ANY PARTICULAR FONT, STYLE, SIZE, OR COLOR.

FOR COMPUTER SERVICES, NAMELY, CREATING AN ON-LINE COMMUNITY FOR REGISTERED USERS TO SHARE TEXT, QUOTES, PHOTOGRAPHIC IMAGES, AUDIO AND VIDEO CONTENT; PROVIDING A WEBSITE FEATURING ON-LINE NON-DOWNLOADABLE SOFTWARE THAT ENABLES USERS TO UPLOAD, DOWNLOAD, STREAM, POST, DISPLAY, BLOG, LINK, TRANSMIT AND SHARE TEXT, QUOTES, PHOTOGRAPHIC IMAGES, AUDIO AND VIDEO CONTENT, TO MODIFY THE APPEARANCE AND ENABLE TRANSMISSION OF TEXT, QUOTES, PHOTOGRAPHIC IMAGES, AUDIO AND VIDEO CONTENT, TO HOST ON-LINE WEB FACILITIES AS WEBSITES AND MOBILE SITES THAT ALLOW OTHERS TO SHARE TEXT, QUOTES, PHOTOGRAPHIC IMAGES, AUDIO AND VIDEO CONTENT, AND TO SEARCH INDICES AND DATABASES FOR INFORMATION THAT INCLUDES TEXT, QUOTES, PHOTOGRAPHIC IMAGES, AUDIO AND VIDEO CONTENT (U.S. CLS. 100 AND 101).  
JUSTINE D. PARKER, EXAMINING ATTORNEY

---

SN 86-244,406. MANUFACTURING INFORMATION EXCHANGE SOLUTIONS, INC., AKA MIE SOLUTIONS, INC., GARDEN GROVE, CA. FILED 4-7-2014.

# MIE RFQ

THE MARK CONSISTS OF STANDARD CHARACTERS WITHOUT CLAIM TO ANY PARTICULAR FONT, STYLE, SIZE, OR COLOR.

OWNER OF U.S. REG. NOS. 3,783,587, 3,783,589 AND OTHERS.  
NO CLAIM IS MADE TO THE EXCLUSIVE RIGHT TO USE "RFQ", APART FROM THE MARK AS SHOWN.  
FOR PROVIDING TEMPORARY USE OF ON-LINE, NON-DOWNLOADABLE, CLOUD-BASED SOFTWARE THAT ENABLES USERS TO REQUEST, RECEIVE, COMPARE, AWARD, ACCEPT OR REJECT QUOTATIONS FOR PRODUCTS AND SERVICES (U.S. CLS. 100 AND 101).  
ZACHARY BELLO, EXAMINING ATTORNEY

**CLASS 42—(Continued).**

SN 86-244,702. INFORMEDIKA, INC., SUNNYVALE, CA. FILED 4-7-2014.



NO CLAIM IS MADE TO THE EXCLUSIVE RIGHT TO USE "HEALTH" AND "ONLINE HEALTHCARE MARKETPLACE", APART FROM THE MARK AS SHOWN.

THE MARK CONSISTS OF DESIGN OF SMILING GORILLA TO THE LEFT OF "HEALTH GORILLA" ABOVE "ONLINE HEALTHCARE MARKETPLACE".

FOR SOFTWARE AS A SERVICE (SAAS) FEATURING SOFTWARE FOR USE IN LOCATING HEALTHCARE VENDORS AND FOR USE IN ORDERING, MANAGING AND REVIEWING MEDICAL DIAGNOSTICS AND RESULTS; SOFTWARE AS A SERVICE (SAAS) SERVICES FEATURING SOFTWARE FOR USE IN FACILITATING THE EXCHANGE OF MEDICAL DIAGNOSTICS DATA BETWEEN PHYSICIANS, PATIENTS AND HEALTHCARE VENDORS; PROVIDING A WEBSITE FEATURING ONLINE NON-DOWNLOADABLE SOFTWARE THAT ENABLES USERS TO SEARCH AND LOCATE HEALTHCARE VENDORS AND ORDER, MANAGE AND REVIEW MEDICAL DIAGNOSTICS AND RESULTS; PROVIDING A WEBSITE FEATURING ONLINE NON-DOWNLOADABLE SOFTWARE FOR USE IN FACILITATING THE EXCHANGE OF MEDICAL DIAGNOSTICS DATA BETWEEN PHYSICIANS, PATIENTS AND HEALTHCARE VENDORS (U.S. CLS. 100 AND 101). CHRISTOPHER BUONGIORNO, EXAMINING ATTORNEY

SN 86-245,006. PAPAVERO, EMILY A, MENTONE, CA. AND ZHAO, XIN, MENTONE, CA. FILED 4-7-2014.

## current current

THE MARK CONSISTS OF STANDARD CHARACTERS WITHOUT CLAIM TO ANY PARTICULAR FONT, STYLE, SIZE, OR COLOR.

FOR PROVIDING A WEB SITE FEATURING TECHNOLOGY THAT ENABLES USERS TO EVALUATE PAST ELECTRICAL USAGE, MEASURE A PROPERTY'S SOLAR POTENTIAL, DEVELOP AN ESTIMATE OF FINANCIAL GAIN FROM INSTALLING SOLAR, SEEK BIDS FROM A NETWORK OF LOCAL CONTRACTORS, ASSESS FINANCING OPTIONS, AND SOLICIT FINANCING (U.S. CLS. 100 AND 101).

GIANCARLO CASTRO, EXAMINING ATTORNEY

**CLASS 42—(Continued).**

SN 86-246,234. SHORT, JENNIFER, HENDERSON, NV. FILED 4-8-2014.

## My Master Planner

THE MARK CONSISTS OF STANDARD CHARACTERS WITHOUT CLAIM TO ANY PARTICULAR FONT, STYLE, SIZE, OR COLOR.

FOR PROVIDING A WEBSITE FEATURING NON-DOWNLOADABLE SOFTWARE FOR LIFE COACHING (U.S. CLS. 100 AND 101).

JENNIFER DIXON, EXAMINING ATTORNEY

SN 86-246,301. EAKINS, DARRIN, JACKSONVILLE, FL. FILED 4-8-2014.

## Golden Age Innovations

THE MARK CONSISTS OF STANDARD CHARACTERS WITHOUT CLAIM TO ANY PARTICULAR FONT, STYLE, SIZE, OR COLOR.

FOR GRAPHIC ILLUSTRATION SERVICES FOR OTHERS (U.S. CLS. 100 AND 101).

EMILY CARLSEN, EXAMINING ATTORNEY

SN 86-246,308. JMC ROTA INC., DEL MAR, CA. FILED 4-8-2014.

## JMC Rota

THE MARK CONSISTS OF STANDARD CHARACTERS WITHOUT CLAIM TO ANY PARTICULAR FONT, STYLE, SIZE, OR COLOR.

FOR PROFESSIONAL COMPUTER SERVICES, NAMELY, NETWORK ANALYSIS, LAN/WAN DESIGN, WIRELESS ENGINEERING, VIRTUALIZATION AND COMPUTER PROJECT MANAGEMENT (U.S. CLS. 100 AND 101).

FIRST USE 5-21-2013; IN COMMERCE 5-21-2013. NICOLE A NGUYEN, EXAMINING ATTORNEY

**CLASS 42—(Continued).**

SN 86-246,424. ACOUSYS BIODEVICES INC, PITTSBURGH, PA. FILED 4-8-2014.

# ACOUSYS

THE MARK CONSISTS OF STANDARD CHARACTERS WITHOUT CLAIM TO ANY PARTICULAR FONT, STYLE, SIZE, OR COLOR.

FOR RESEARCH, DESIGN AND DEVELOPMENT IN THE FIELD OF CIRCULATING TUMOR CELLS AND INFECTIOUS DISEASES, NAMELY, RESEARCH, DESIGN AND DEVELOPMENT SERVICES RELATING TO THE DETECTION, ENUMERATION, ANALYSIS, CHARACTERIZATION AND CAPTURE OF CIRCULATING TUMOR CELLS AND PATHOGENS, NAMELY, BACTERIA, FUNGI, PARASITES AND VIRUSES; RESEARCH, DESIGN AND DEVELOPMENT IN THE FIELD OF ENVIRONMENTAL MONITORING OF SEAWATER AND FRESH WATER FOR BIOLOGICAL AND PATHOGENIC ORGANISMS (U.S. CLS. 100 AND 101).

DOUGLAS LEE, EXAMINING ATTORNEY

---

SN 86-246,615. KAUSHAL, VISHAL, DIAMOND BAR, CA. FILED 4-9-2014.

# FlexPool

THE MARK CONSISTS OF STANDARD CHARACTERS WITHOUT CLAIM TO ANY PARTICULAR FONT, STYLE, SIZE, OR COLOR.

FOR IT CONSULTING SERVICES (U.S. CLS. 100 AND 101).

LIEF MARTIN, EXAMINING ATTORNEY

---

SN 86-246,689. KEPWARE, INC., PORTLAND, ME. FILED 4-9-2014.

# KEPCARE

THE MARK CONSISTS OF STANDARD CHARACTERS WITHOUT CLAIM TO ANY PARTICULAR FONT, STYLE, SIZE, OR COLOR.

OWNER OF U.S. REG. NO. 3,119,409.

FOR TECHNICAL SUPPORT SERVICES, NAMELY INSTALLATION, ADMINISTRATION, AND TROUBLESHOOTING OF SOFTWARE APPLICATIONS (U.S. CLS. 100 AND 101).

ANGELA M. MICHELI, EXAMINING ATTORNEY

**CLASS 42—(Continued).**

SN 86-247,434. MAESTRO TECHNOLOGIES INCORPORATED, DBA MAESTRO, WATCHUNG, NJ. AND SUSHEEL BATHLA, AKA SUSHEEL, WATCHUNG, NJ. FILED 4-9-2014.

# The Way to conduct IT

THE MARK CONSISTS OF STANDARD CHARACTERS WITHOUT CLAIM TO ANY PARTICULAR FONT, STYLE, SIZE, OR COLOR.

FOR COMPUTER SERVICES, NAMELY, ON-SITE MANAGEMENT OF INFORMATION TECHNOLOGY (IT) SYSTEMS; COMPUTER SERVICES, NAMELY, REMOTE AND ON-SITE MANAGEMENT OF BIG DATA AND INFORMATION TECHNOLOGIES FOR OTHERS; COMPUTER SERVICES, NAMELY, REMOTE MANAGEMENT OF THE INFORMATION TECHNOLOGY (IT) SYSTEMS OF OTHERS; COMPUTER SERVICES, NAMELY, REMOTE MANAGEMENT OF BIG DATA AND INFORMATION TECHNOLOGIES FOR OTHERS; CONSULTING IN THE FIELD OF INFORMATION TECHNOLOGY; FRANCHISING SERVICES, NAMELY, PLANNING AND DESIGN OF INFORMATION TECHNOLOGY SYSTEMS FOR BUSINESS FRANCHISES; INFORMATION TECHNOLOGY CONSULTING SERVICES; PLANNING, DESIGN AND MANAGEMENT OF INFORMATION TECHNOLOGY SYSTEMS (U.S. CLS. 100 AND 101).

ZACHARY CROMER, EXAMINING ATTORNEY

---

SN 86-247,865. SHENZHEN DANALE TECHNOLOGY CO., LTD, SHENZHEN CITY, CHINA, FILED 4-10-2014.

# Danale

THE MARK CONSISTS OF THE STYLIZED WORD "DANALE".

THE WORDING "DANALE" HAS NO MEANING IN A FOREIGN LANGUAGE.

FOR COMPUTER SOFTWARE DESIGN; CONVERSION OF DATA OR DOCUMENTS FROM PHYSICAL TO ELECTRONIC MEDIA; DUPLICATION OF COMPUTER PROGRAMS; INSTALLATION OF COMPUTER SOFTWARE; MAINTENANCE OF COMPUTER SOFTWARE; MONITORING OF COMPUTER SYSTEMS BY REMOTE ACCESS TO ENSURE PROPER FUNCTIONING; RENTAL OF WEB SERVERS; RESEARCH AND DEVELOPMENT OF COMPUTER SOFTWARE; UPDATING OF COMPUTER SOFTWARE; WEATHER FORECASTING (U.S. CLS. 100 AND 101).

DAWN FELDMAN, EXAMINING ATTORNEY

**CLASS 42—(Continued).**

SN 86-247,958. POSTREL, RICHARD D, MIAMI BEACH, FL. FILED 4-10-2014.

**CLASS 42—(Continued).**

SN 86-248,004. LIVEFROM, INC., MIAMI, FL. FILED 4-10-2014.

# LIVESEAT

THE MARK CONSISTS OF STANDARD CHARACTERS WITHOUT CLAIM TO ANY PARTICULAR FONT, STYLE, SIZE, OR COLOR.

FOR COMPUTER SERVICES, NAMELY, CREATING AN ON-LINE COMMUNITY FOR REGISTERED USERS TO PARTICIPATE IN DISCUSSIONS, GET FEEDBACK FROM THEIR PEERS, FORM VIRTUAL COMMUNITIES, AND ENGAGE IN SOCIAL NETWORKING SERVICES IN THE FIELD OF NEWS, CURRENT EVENTS AND HAPPENINGS; COMPUTER SERVICES, NAMELY, CREATING AN ON-LINE COMMUNITY FOR REGISTERED USERS TO SHARE IMAGES, TEXT, VIDEO AND LINKS RELATED TO EVENTS, HAPPENINGS, NEWS AND CURRENT EVENTS; CREATING AN ON-LINE COMMUNITY FOR USERS FOR THE PURPOSE OF SHARING TEXT, VIDEO AND IMAGES OF EVENTS, NEWS AS WELL AS CURRENT EVENTS; PROVIDING A WEBSITE THAT GIVES USERS THE ABILITY TO REVIEW VARIOUS PRINT, PHOTOGRAPHIC, GRAPHIC IMAGE, AND AUDIO AND VIDEO CONTENT AND UTILIZE A CUSTOM TEMPLATE TO PROVIDE INPUT, LIKES, DISLIKES, EDITS, CHANGES, MODIFICATIONS, OPINIONS, SUGGESTIONS, AND COMMENTS AND ENGAGE IN SOCIAL, BUSINESS AND COMMUNITY NETWORKING; PROVIDING AN ON-LINE NETWORK ENVIRONMENT FEATURING TECHNOLOGY THAT ENABLES USERS TO SHARE DATA IN THE FIELD OF EVENTS, HAPPENINGS, NEWS AND CURRENT EVENTS (U.S. CLS. 100 AND 101).

ROBIN MITTLER, EXAMINING ATTORNEY



NO CLAIM IS MADE TO THE EXCLUSIVE RIGHT TO USE "GENETICS", APART FROM THE MARK AS SHOWN.

THE COLOR(S) BURGUNDY, ORANGE AND BROWN IS/ARE CLAIMED AS A FEATURE OF THE MARK.

THE MARK CONSISTS OF THE COLOR BURGUNDY APPEARS IN THE NAME "VIA" AND "GENETICS" WITH AN ORANGE/BROWN GRADIENT COLORED DNA HELIX BETWEEN "VIA" AND "GENETICS", THE COLOR WHITE REPRESENTS BACKGROUND AND/OR TRANSPARENT AREAS AND IS NOT PART OF THE MARK.

FOR CONSULTING SERVICES IN THE FIELDS OF BIOTECHNOLOGY, PHARMACEUTICAL RESEARCH AND DEVELOPMENT AND GENETIC SCIENCE; GENETIC MAPPING FOR SCIENTIFIC PURPOSES; GENETIC TESTING FOR SCIENTIFIC RESEARCH PURPOSES; GENETIC TESTING OF LABORATORY ANIMALS FOR RESEARCH PURPOSES; PROVIDING INFORMATION IN THE FIELD OF PLANT GENETICS RESEARCH RESOURCES; PROVIDING MEDICAL AND SCIENTIFIC RESEARCH INFORMATION IN THE FIELDS OF PHARMACEUTICALS AND GENETICS; SCIENTIFIC RESEARCH CONSULTING IN THE FIELD OF GENETICS; SCIENTIFIC RESEARCH IN THE FIELD OF GENETICS AND GENETIC ENGINEERING; SCIENTIFIC RESEARCH IN THE FIELD OF GENETICS (U.S. CLS. 100 AND 101).

MARK SPARACINO, EXAMINING ATTORNEY

SN 86-248,519. PHILLIPS, JASON E., NEW YORK, NY. FILED 4-10-2014.

# Marilyn.com

THE MARK CONSISTS OF STANDARD CHARACTERS WITHOUT CLAIM TO ANY PARTICULAR FONT, STYLE, SIZE, OR COLOR.

FOR COMPUTER SERVICES, NAMELY, PROVIDING SEARCH ENGINES FOR OBTAINING DATA, FILES OR DOCUMENTS FROM DATABASES ON A GLOBAL COMPUTER NETWORK (U.S. CLS. 100 AND 101).

FIRST USE 6-21-2013; IN COMMERCE 6-21-2013.

TINA MAI, EXAMINING ATTORNEY

**CLASS 42—(Continued).**

SN 86-248,938. INTERNETSALESRESULTS.COM, INC., CORAL SPRINGS, FL. FILED 4-10-2014.

CONSULT. CREATE. DOMINATE.

THE MARK CONSISTS OF STANDARD CHARACTERS WITHOUT CLAIM TO ANY PARTICULAR FONT, STYLE, SIZE, OR COLOR.

FOR CREATION, DESIGN, DEVELOPMENT AND MAINTENANCE OF WEBSITES FOR OTHERS; CUSTOM DESIGN AND DEVELOPMENT OF COMPUTER SOFTWARE; CONSULTING SERVICES IN THE FIELD OF DESIGN OF NEWSLETTERS (U.S. CLS. 100 AND 101).

FIRST USE 6-3-2008; IN COMMERCE 6-3-2008.  
LEIGH CAROLINE CASE, EXAMINING ATTORNEY



SN 86-249,134. DONUTS INC., BELLEVUE, WA. FILED 4-10-2014.



OWNER OF U.S. REG. NOS. 4,491,466 AND 4,502,837.  
THE MARK CONSISTS OF A LOWER CASE STYLIZED "D" WITH AN OUTLINE AROUND THE CIRCLE PART OF THE LETTER.

FOR DOMAIN REGISTRY OPERATOR SERVICES (U.S. CLS. 100 AND 101).  
FIRST USE 11-12-2013; IN COMMERCE 11-12-2013.  
BERNICE MIDDLETON, EXAMINING ATTORNEY

**CLASS 42—(Continued).**

SN 86-249,672. F/A INTERIOR DESIGN ET DECORATION LLC, SAN FRANCISCO, CA. FILED 4-11-2014.



THE MARK CONSISTS OF AN "F" AND "A" SEPARATED BY A DIAGONAL LINE REACHING ABOVE THE "A".

FOR INTERIOR DECORATION CONSULTATION; INTERIOR DESIGN SERVICES (U.S. CLS. 100 AND 101).  
DAVID COLLIER, EXAMINING ATTORNEY



SN 86-250,080. REDNOVA LABS, INC., WESTWOOD, KS. FILED 4-11-2014.

STOREDGE

THE MARK CONSISTS OF STANDARD CHARACTERS WITHOUT CLAIM TO ANY PARTICULAR FONT, STYLE, SIZE, OR COLOR.

FOR PROVIDING ONLINE, NON-DOWNLOADABLE INTERNET-BASED APPLICATION SOFTWARE TO ASSIST USERS IN MANAGING SELF-STORAGE FACILITIES; AND SOFTWARE AS A SERVICE (SAAS) SERVICES FEATURING SOFTWARE FOR ASSISTING OTHERS IN MANAGING SELF-STORAGE FACILITIES (U.S. CLS. 100 AND 101).

FIRST USE 3-31-2014; IN COMMERCE 3-31-2014.  
JUSTIN SEVERSON, EXAMINING ATTORNEY

**CLASS 42—(Continued).**

SN 86-250,180. BURNETTE SR, MARK LEON, MANASSAS, VA. FILED 4-11-2014.

**FUTURE TALK...**

THE MARK CONSISTS OF STANDARD CHARACTERS WITHOUT CLAIM TO ANY PARTICULAR FONT, STYLE, SIZE, OR COLOR.

FOR PROVIDING A WEBSITE THAT GIVES COMPUTER USERS THE ABILITY TO RECORD, UPLOAD, STORE, ACCESS, POST AND DISPLAY ELECTRONIC MEDIA MESSAGES NAMELY TEXT, VOICE AND VIDEO USING COMPUTER INTERNET DEVICES OR SMART PHONES FOR THE PURPOSE OF ON-DEMAND OR SCHEDULED DELIVERY OF STORED MEDIA MESSAGES VIA COMPUTER DEVICES IN THE FORM OF EMAIL, TEXT, VIDEO OR VOICE (U.S. CLS. 100 AND 101).

FIRST USE 3-24-2014; IN COMMERCE 6-10-2014.  
MICHAEL WIENER, EXAMINING ATTORNEY

SN 86-250,280. PEPPERDASH TECHNOLOGY CORPORATION, ALLSTON, MA. FILED 4-11-2014.

**AV360**

THE MARK CONSISTS OF STANDARD CHARACTERS WITHOUT CLAIM TO ANY PARTICULAR FONT, STYLE, SIZE, OR COLOR.

FOR INFORMATION TECHNOLOGY CONSULTING SERVICES PROVIDED TO BUSINESSES AND NOT INCLUDING HOME AUTOMATION; IT CONSULTING SERVICES PROVIDED TO BUSINESSES AND NOT INCLUDING HOME AUTOMATION (U.S. CLS. 100 AND 101).

FIRST USE 6-1-2013; IN COMMERCE 6-1-2013.  
CURTIS FRENCH, EXAMINING ATTORNEY

SN 86-250,452. AUDACITY, INC., CARLSBAD, CA. FILED 4-11-2014.

**LOUNGE**

THE MARK CONSISTS OF STANDARD CHARACTERS WITHOUT CLAIM TO ANY PARTICULAR FONT, STYLE, SIZE, OR COLOR.

FOR PROVIDING TEMPORARY USE OF A NON-DOWNLOADABLE WEB APPLICATION FOR AGENCY-CLIENT RELATIONSHIP MANAGEMENT THAT MANAGES AND KEEPS TRACK OF COMMUNICATIONS, CORRESPONDENCE, NOTES, ARTWORK AND DOCUMENT FILE SHARING, INVOICING, PROJECT STATUSES, AND TASKS (U.S. CLS. 100 AND 101).

FIRST USE 3-1-2014; IN COMMERCE 3-1-2014.  
TOBY BULLOFF, EXAMINING ATTORNEY

**CLASS 42—(Continued).**

SN 86-251,668. AITECH SOFTWARE CORPORATION, INC., MARGATE, FL. FILED 4-14-2014.

**SettleITsoft**

THE MARK CONSISTS OF STANDARD CHARACTERS WITHOUT CLAIM TO ANY PARTICULAR FONT, STYLE, SIZE, OR COLOR.

FOR PROVIDING A WEBSITE FEATURING NON-DOWNLOADABLE SOFTWARE FOR WEB BASED PLATFORM FEATURING MULTI-SITE AND MOBILE APP DATABASE INTEGRATION, BI-DIRECTIONAL INFORMATION EXCHANGE, TRANSACTIONAL DATA PROCESSING BASED ON COMPLEX ALGORITHMS, STREAMING MEDIA FRAMEWORK, INTUITIVE INTERACTION AND EDUCATIONAL SERVICES WHICH ASSESS CREDITWORTHINESS BASED ON THIRD PARTY CREDIT REPORTING AGENCIES AND USERS' FINANCIAL BEHAVIOR, PROVIDING STATISTICAL HOUSEHOLD FINANCIAL ANALYSIS, CUSTOM REPORTS AND NOTIFICATIONS, CREATING TAILORED FINANCIAL RECOMMENDATIONS TO SETTLE AND REDUCE DEBTS, IN ADDITION TO SOPHISTICATED BUDGET MANAGEMENT TOOLS (U.S. CLS. 100 AND 101).

FIRST USE 9-1-2013; IN COMMERCE 3-1-2014.  
MARK T. MULLEN, EXAMINING ATTORNEY

SN 86-251,846. CHURCH WEB BRANDS, INC., LENOIR CITY, TN. FILED 4-14-2014.

**BRIDGE ELEMENT**

THE MARK CONSISTS OF STANDARD CHARACTERS WITHOUT CLAIM TO ANY PARTICULAR FONT, STYLE, SIZE, OR COLOR.

FOR SOFTWARE AS A SERVICE, NAMELY, HOSTING SOFTWARE FOR USE BY OTHERS FOR USE IN PROCESSING PAYMENTS AND DONATIONS FOR CHARITABLE AND NON-PROFIT ORGANIZATIONS; PROVIDING TEMPORARY USE OF NON-DOWNLOADABLE SOFTWARE FOR USE BY CHARITABLE, NON-PROFIT AND FUNDRAISING ORGANIZATIONS IN PROCESSING PAYMENTS AND DONATIONS FOR CHARITABLE, NON-PROFIT, AND FUND-RAISING ORGANIZATIONS; TECHNICAL SUPPORT SERVICES, NAMELY, TROUBLESHOOTING OF COMPUTER SOFTWARE, WEBSITE, AND MOBILE APP PROBLEMS; CUSTOMIZED SOFTWARE DEVELOPMENT SERVICES; PROVIDING CUSTOMIZED ON-LINE WEB PAGES AND MOBILE APPS FEATURING USER-DEFINED INFORMATION; COMPUTER SOFTWARE PLATFORMS ENABLING FINANCIAL SERVICES FOR ONLINE GIVING, ELECTRONIC GIVING, AND MOBILE GIVING; TEMPLATE-BASED WEBSITE DEVELOPMENT AND HOSTING SERVICES (U.S. CLS. 100 AND 101).

FIRST USE 7-1-2008; IN COMMERCE 7-1-2008.  
GINA HAYES, EXAMINING ATTORNEY



**CLASS 42—(Continued).**

SN 86-251,859. CLOUDY DAYS, INC., PORTLAND, OR.  
FILED 4-14-2014.

# Nouvola

THE MARK CONSISTS OF STANDARD CHARACTERS WITHOUT CLAIM TO ANY PARTICULAR FONT, STYLE, SIZE, OR COLOR.

FOR SOFTWARE AS A SERVICE (SAAS) SERVICES FEATURING SOFTWARE FOR PERFORMANCE TESTING AND PERFORMANCE ANALYTICS FOR CLOUD APPLICATIONS (U.S. CLS. 100 AND 101).

FIRST USE 10-17-2013; IN COMMERCE 10-17-2013.  
MICHAEL SOUDERS, EXAMINING ATTORNEY

---

SN 86-251,874. CLOUDY DAYS, INC., PORTLAND, OR.  
FILED 4-14-2014.

# DiveCloud

THE MARK CONSISTS OF STANDARD CHARACTERS WITHOUT CLAIM TO ANY PARTICULAR FONT, STYLE, SIZE, OR COLOR.

FOR SOFTWARE AS A SERVICE (SAAS) SERVICES FEATURING SOFTWARE FOR PERFORMANCE TESTING AND PERFORMANCE ANALYTICS FOR CLOUD APPLICATIONS (U.S. CLS. 100 AND 101).

FIRST USE 10-17-2013; IN COMMERCE 10-17-2013.  
MICHAEL SOUDERS, EXAMINING ATTORNEY

---

SN 86-251,878. PARK CITY GROUP, SALT LAKE CITY, UT.  
FILED 4-14-2014.

# USE

THE MARK CONSISTS OF STANDARD CHARACTERS WITHOUT CLAIM TO ANY PARTICULAR FONT, STYLE, SIZE, OR COLOR.

FOR CLOUD COMPUTING FEATURING SOFTWARE FOR USE IN EXCHANGING AND COMMUNICATING BUSINESS DATA; SOFTWARE AS A SERVICE (SAAS) SERVICES FEATURING SOFTWARE FOR MANAGING LOGISTICS, REVERSE LOGISTICS, SUPPLY CHAIN SERVICES, SUPPLY CHAIN VISIBILITY AND SYNCHRONIZATION, SUPPLY AND DEMAND FORECASTING AND PRODUCT DISTRIBUTION PROCESSES (U.S. CLS. 100 AND 101).

FIRST USE 5-31-2013; IN COMMERCE 5-31-2013.  
ELLEN B. AWRICH, EXAMINING ATTORNEY

**CLASS 42—(Continued).**

SN 86-252,010. SYNCURITY NETWORKS LLC, ROCHESTER, NY. FILED 4-14-2014.

# Syncurity

THE MARK CONSISTS OF STANDARD CHARACTERS WITHOUT CLAIM TO ANY PARTICULAR FONT, STYLE, SIZE, OR COLOR.

FOR COMPUTER CONSULTATION IN THE FIELD OF COMPUTER SECURITY; COMPUTER NETWORK CONFIGURATION SERVICES; COMPUTER SECURITY CONSULTANCY; COMPUTER SECURITY CONSULTANCY IN THE FIELD OF SCANNING AND PENETRATION TESTING OF COMPUTERS AND NETWORKS TO ASSESS INFORMATION SECURITY VULNERABILITY; COMPUTER SECURITY SERVICE, NAMELY, RESTRICTING ACCESS TO AND BY COMPUTER NETWORKS TO AND OF UNDESIRE WEB SITES, MEDIA AND INDIVIDUALS AND FACILITIES; COMPUTER SECURITY SERVICES, NAMELY, ENFORCING, RESTRICTING AND CONTROLLING ACCESS PRIVILEGES OF USERS OF COMPUTING RESOURCES FOR CLOUD, MOBILE OR NETWORK RESOURCES BASED ON ASSIGNED CREDENTIALS; PROFESSIONAL COMPUTER SERVICES, NAMELY, NETWORK ANALYSIS, LAN/WAN DESIGN, WIRELESS ENGINEERING, VIRTUALIZATION AND COMPUTER PROJECT MANAGEMENT (U.S. CLS. 100 AND 101).

FIRST USE 12-31-2009; IN COMMERCE 1-1-2012.  
JENNIFER DIXON, EXAMINING ATTORNEY

---

SN 86-262,686. VISION DYNAMICS, LLC, LOUISVILLE, KY.  
FILED 4-25-2014.

# OPTICAL DYNAMICS

THE MARK CONSISTS OF STANDARD CHARACTERS WITHOUT CLAIM TO ANY PARTICULAR FONT, STYLE, SIZE, OR COLOR.

NO CLAIM IS MADE TO THE EXCLUSIVE RIGHT TO USE "OPTICAL", APART FROM THE MARK AS SHOWN. FOR DESIGN AND DEVELOPMENT OF COMPONENTS USED IN THE PRODUCTION OF OPHTHALMIC LENSES (U.S. CLS. 100 AND 101).

FIRST USE 11-0-2006; IN COMMERCE 11-0-2006.  
DAVID TAYLOR, EXAMINING ATTORNEY

**CLASS 42—(Continued).**

SN 86-272,995. ELSEVIER INC., NEW YORK, NY. FILED 5-6-2014.

**DISEASEFX**

THE MARK CONSISTS OF STANDARD CHARACTERS WITHOUT CLAIM TO ANY PARTICULAR FONT, STYLE, SIZE, OR COLOR.

FOR PROVIDING ONLINE NON-DOWNLOADABLE COMPUTER SOFTWARE FOR USE BY OTHERS FOR BUILDING AND DISPLAYING MOLECULAR PATHWAYS AND HELPING SCIENTISTS BUILD DATABASES OF INFORMATION IN THE FIELDS OF PROCESSING, MEDICAL INFORMATICS, DRUG DISCOVERY, GENETICS, MOLECULAR BIOLOGY; PROVIDING TEMPORARY USE OF ON-LINE NON-DOWNLOADABLE COMPUTER SOFTWARE FOR USE BY OTHERS FOR AUTOMATED EXTRACTION OF BIOLOGICAL FACTS FROM BIOMEDICAL ABSTRACTS, AND INTERNAL TEXT DOCUMENTS; PROVIDING ONLINE NON-DOWNLOADABLE COMPUTER SOFTWARE FOR USE BY OTHERS THAT COMPILES INFORMATION ABOUT MOLECULAR INTERACTIONS IN A CELL; PROVIDING ONLINE NON-DOWNLOADABLE COMPUTER SOFTWARE FOR USE BY OTHERS IN THE FIELD OF BIOTECHNOLOGY TO STORE, ANALYZE, AND MANAGE INFORMATION ABOUT NUCLEIC ACIDS (U.S. CLS. 100 AND 101).

FIRST USE 8-31-2011; IN COMMERCE 8-31-2011.  
GINA FINK, EXAMINING ATTORNEY

---

SN 86-288,480. RITUWALL INC., SAN FRANCISCO, CA. FILED 5-21-2014.

**DesignAI**

THE MARK CONSISTS OF STANDARD CHARACTERS WITHOUT CLAIM TO ANY PARTICULAR FONT, STYLE, SIZE, OR COLOR.

FOR PROVIDING TEMPORARY USE OF ONLINE NON-DOWNLOADABLE SOFTWARE FOR ONLINE EDIT AND PUBLICATION SERVICE (U.S. CLS. 100 AND 101).

LINDA E. BLOHM, EXAMINING ATTORNEY

**CLASS 42—(Continued).**

SN 86-301,828. CONSERVACO, LLC, DBA CROWD FUNDING PAYS, FORT LAUDERDALE, FL. FILED 6-5-2014.

**Crowd Funding Pays**

THE MARK CONSISTS OF STANDARD CHARACTERS WITHOUT CLAIM TO ANY PARTICULAR FONT, STYLE, SIZE, OR COLOR.

NO CLAIM IS MADE TO THE EXCLUSIVE RIGHT TO USE "CROWD FUNDING", APART FROM THE MARK AS SHOWN.

FOR COMPUTER SERVICES, NAMELY, HOSTING AND MAINTAINING AN ON-LINE WEB SITE FOR OTHERS; COMPUTER SERVICES, NAMELY, PROVIDING ON-LINE SEARCH PLATFORMS THAT ALLOW USERS TO OFFER AND LOCATE GOODS AND SERVICES FOR PRESALE AND PARTICIPATE IN FUNDRAISING FOR CREATIVE PROJECTS; PROVIDING A WEB SITE FEATURING TECHNOLOGY THAT ENABLES USERS TO RAISE MONEY FOR CREATIVE PROJECTS; PROVIDING A WEB SITE FEATURING TECHNOLOGY THAT ENABLES USERS TO OFFER GOODS AND SERVICES FOR PRESALE AND FOR USERS TO PLEDGE TO PURCHASE GOODS AND SERVICES OFFERED BY OTHERS; COMPUTER SERVICES, NAMELY, INTERACTIVE HOSTING SERVICES WHICH ALLOW THE USER TO PUBLISH AND SHARE THEIR OWN CONTENT AND IMAGES ON-LINE; PROVIDING AN ONLINE WEBSITE FOR CREATING AND HOSTING MICRO WEBSITES FOR BUSINESSES (U.S. CLS. 100 AND 101).

FIRST USE 6-1-2014; IN COMMERCE 6-4-2014.  
KATHLEEN M. VANSTON, EXAMINING ATTORNEY

---

SN 86-308,973. ACI WORLDWIDE CORP., ELKHORN, NE. FILED 6-13-2014.

**POSTILION**

THE MARK CONSISTS OF STANDARD CHARACTERS WITHOUT CLAIM TO ANY PARTICULAR FONT, STYLE, SIZE, OR COLOR.

FOR SOFTWARE AS A SERVICE (SAAS) SERVICES FEATURING A CLOUD-BASED SOFTWARE APPLICATION THAT CAPTURES AND AUTHORIZES CUSTOMER PAYMENTS AT THE POINT OF PURCHASE ACROSS MULTIPLE CHANNELS, PERFORMING ANY TRANSACTION TYPE FOR PROCESSING A WIDE VARIETY OF ELECTRONIC PAYMENTS (U.S. CLS. 100 AND 101).

FIRST USE 10-31-1995; IN COMMERCE 10-31-1995.  
JASON BLAIR, EXAMINING ATTORNEY

**CLASS 43—HOTEL AND RESTAURANT SERVICES**

SN 85-513,183. BUGATTI HOTELS & RESORTS LTD., VICTORIA, MAHE, SEYCHELLES, FILED 1-10-2012.

**BUGATTI**

THE MARK CONSISTS OF STANDARD CHARACTERS WITHOUT CLAIM TO ANY PARTICULAR FONT, STYLE, SIZE, OR COLOR.

PRIORITY CLAIMED UNDER SEC. 44(D) ON SEYCHELLES APPLICATION NO. 493/2011, FILED 12-7-2011, REG. NO. 10102, DATED 11-25-2013, EXPIRES 12-7-2018.

PRIORITY CLAIMED UNDER SEC. 44(D) ON SEYCHELLES APPLICATION NO. 492/2011, FILED 12-7-2011, REG. NO. 10101, DATED 11-25-2013, EXPIRES 12-7-2018.

FOR HOTEL SERVICES; RESORT HOTEL SERVICES; PROVISION OF CONFERENCE, EXHIBITION AND MEETING FACILITIES; RESERVATION SERVICES IN RELATION TO HOTELS AND OTHER TEMPORARY ACCOMMODATION; CATERING SERVICES; CONSULTING SERVICES IN THE FIELD OF HOSPITALITY; RESTAURANT SERVICES; OPERATION OF A BAR (U.S. CLS. 100 AND 101).

RAUL CORDOVA, EXAMINING ATTORNEY

**CLASS 43—(Continued).**

SN 85-654,247. IL POSTO MANAGEMENT LLC, NEW YORK, NY. FILED 6-18-2012.



THE MARK CONSISTS OF THE LETTERS "DEL", WITH THE LARGER LETTERS "POSTO" UNDERNEATH, ALL INSIDE A DOUBLE-LINED RECTANGLE HAVING FOUR CIRCLES, ONE AT EACH INSIDE CORNER OF THE RECTANGLE.

THE ENGLISH TRANSLATION OF "DEL POSTO" IN THE MARK IS "OF THE PLACE".

FOR RESTAURANT AND BAR SERVICES (U.S. CLS. 100 AND 101).

FIRST USE 12-0-2005; IN COMMERCE 12-0-2005.

INGA ERVIN, EXAMINING ATTORNEY

SN 85-692,488. MOMOIP LLC, NEW YORK, NY. FILED 8-1-2012.

SN 85-649,743. IL POSTO MANAGEMENT LLC, NEW YORK, NY. FILED 6-12-2012.

**DEL POSTO**

THE MARK CONSISTS OF STANDARD CHARACTERS WITHOUT CLAIM TO ANY PARTICULAR FONT, STYLE, SIZE, OR COLOR.

THE ENGLISH TRANSLATION OF "DEL POSTO" IN THE MARK IS "OF THE PLACE".

FOR RESTAURANT AND BAR SERVICES (U.S. CLS. 100 AND 101).

FIRST USE 12-0-2005; IN COMMERCE 12-0-2005.

INGA ERVIN, EXAMINING ATTORNEY



OWNER OF U.S. REG. NO. 3,637,913.  
THE MARK CONSISTS OF THE FANCIFUL DEPICTION OF A PEACH AND THE WORD "KO".

THE ENGLISH TRANSLATION OF "KO" IN THE MARK IS "SON OF".

FOR BAR SERVICES; RESTAURANT SERVICES, INCLUDING SIT-DOWN SERVICE OF FOOD AND TAKE-OUT RESTAURANT SERVICES (U.S. CLS. 100 AND 101).

FIRST USE 3-9-2008; IN COMMERCE 3-9-2008.

JESSICA FATHY, EXAMINING ATTORNEY

**CLASS 43—(Continued).**

SN 85-879,045. THE GROUCHO CLUB LTD, LONDON W1D 4QB, UNITED KINGDOM, FILED 3-18-2013.

**THE GROUCHO CLUB**

THE MARK CONSISTS OF STANDARD CHARACTERS WITHOUT CLAIM TO ANY PARTICULAR FONT, STYLE, SIZE, OR COLOR.

OWNER OF ERPN CMNTY TM OFC REG. NO. 001313774, DATED 9-17-1999, EXPIRES 9-17-2019.

NO CLAIM IS MADE TO THE EXCLUSIVE RIGHT TO USE "CLUB", APART FROM THE MARK AS SHOWN.

FOR PRIVATE RESIDENCE CLUB SERVICES, NAMELY, PROVIDING CLUB MEMBERS TEMPORARY ACCOMMODATIONS, RESTAURANT AND BAR SERVICES IN COMPANY OWNED OR LEASE PRIVATE RESIDENCES; HOTEL AND CATERING SERVICES (U.S. CLS. 100 AND 101).

AMY C. KEAN, EXAMINING ATTORNEY

SN 85-886,225. BISTRO MD, LLC, NAPLES, FL. FILED 3-26-2013.



NO CLAIM IS MADE TO THE EXCLUSIVE RIGHT TO USE "EATS" AND "TASTY SNACKS", APART FROM THE MARK AS SHOWN.

THE MARK CONSISTS OF A LARGE CIRCLE WITH THE LARGE WORD "EATS" ON TOP OF SMALLER WORDS "ESSENTIAL AND TASTY SNACKS" WITH A SMALL CIRCLE LOCATED ON THE TOP LEFT SIDE OF THE LARGE CIRCLE CONTAINING THE TINE PART OF A FORK WITH THE TINES POINTING UP IN THE MIDDLE OF A HALF CIRCLE WITH SIX EVENLY SPACED TAPERED BAGUETTES ABOVE THE FORK.

FOR FOOD PREPARATION SERVICES; FOOD PREPARATION SERVICES FEATURING HEALTHY MEALS MADE TO ORDER FOR HOME DELIVERY (U.S. CLS. 100 AND 101).

FIRST USE 9-1-2012; IN COMMERCE 9-1-2012.

KATHERINE STOIDES, EXAMINING ATTORNEY

**CLASS 43—(Continued).**

SN 85-910,271. M&SONG INC., IRVINE, CA. FILED 4-21-2013.

**TruSushi 'n Fish**

THE MARK CONSISTS OF STANDARD CHARACTERS WITHOUT CLAIM TO ANY PARTICULAR FONT, STYLE, SIZE, OR COLOR.

NO CLAIM IS MADE TO THE EXCLUSIVE RIGHT TO USE "'N FISH", APART FROM THE MARK AS SHOWN.

FOR RESTAURANT AND CAFE SERVICES; RESTAURANT AND CATERING SERVICES; RESTAURANT SERVICES; RESTAURANT SERVICES FEATURING JAPANESE AND FUSION FOOD AND DRINKS; RESTAURANT SERVICES, INCLUDING SIT-DOWN SERVICE OF FOOD AND TAKE-OUT RESTAURANT SERVICES; RESTAURANT SERVICES, NAMELY, PROVIDING OF FOOD AND BEVERAGES FOR CONSUMPTION ON AND OFF THE PREMISES; SERVING FOOD AND DRINKS (U.S. CLS. 100 AND 101).

FIRST USE 8-0-2012; IN COMMERCE 8-0-2012.

NANCY CLARKE, EXAMINING ATTORNEY

SN 85-922,560. DOMINICK'S BAR & RESTAURANT, INC., BRONX, NY. FILED 5-3-2013.

**DOMINICK'S OF ARTHUR AVENUE**

THE MARK CONSISTS OF STANDARD CHARACTERS WITHOUT CLAIM TO ANY PARTICULAR FONT, STYLE, SIZE, OR COLOR.

NO CLAIM IS MADE TO THE EXCLUSIVE RIGHT TO USE "ARTHUR AVENUE", APART FROM THE MARK AS SHOWN.

FOR RESTAURANT SERVICES (U.S. CLS. 100 AND 101).

FIRST USE 12-31-1962; IN COMMERCE 12-31-1962.

ESTHER A. BORSUK, EXAMINING ATTORNEY

SN 85-959,061. SCHWARTZ COFFEE ENTERPRISES, INC., DEER PARK, NY. FILED 6-13-2013.

**JAVA KING COFFEE COMPANY**

THE MARK CONSISTS OF STANDARD CHARACTERS WITHOUT CLAIM TO ANY PARTICULAR FONT, STYLE, SIZE, OR COLOR.

NO CLAIM IS MADE TO THE EXCLUSIVE RIGHT TO USE "JAVA" AND "COFFEE COMPANY", APART FROM THE MARK AS SHOWN.

FOR COFFEE SUPPLY SERVICES FOR BUSINESS (U.S. CLS. 100 AND 101).

LINDA M. KING, EXAMINING ATTORNEY

**CLASS 43—(Continued).**

SN 86-009,056. SEALS DORIS, MURRIETA, CA. FILED 7-12-2013.

## Chef DJ Seals

THE MARK CONSISTS OF STANDARD CHARACTERS WITHOUT CLAIM TO ANY PARTICULAR FONT, STYLE, SIZE, OR COLOR.

NO CLAIM IS MADE TO THE EXCLUSIVE RIGHT TO USE "CHEF", APART FROM THE MARK AS SHOWN.

"DJ SEALS" IDENTIFIES A LIVING INDIVIDUAL WHOSE CONSENT IS OF RECORD.

FOR FOOD PREPARATION SERVICES (U.S. CLS. 100 AND 101).

FIRST USE 1-15-2013; IN COMMERCE 1-15-2013.  
DAWN HAN, EXAMINING ATTORNEY

**CLASS 43—(Continued).**

SN 86-036,029. TERESA GIUDICE, TOWACO, NJ. FILED 8-13-2013.

## TERESA ENOTECA & RISTORANTE

THE MARK CONSISTS OF STANDARD CHARACTERS WITHOUT CLAIM TO ANY PARTICULAR FONT, STYLE, SIZE, OR COLOR.

NO CLAIM IS MADE TO THE EXCLUSIVE RIGHT TO USE "ENOTECA & RISTORANTE", APART FROM THE MARK AS SHOWN.

THE ENGLISH TRANSLATION OF "ENOTECA & RISTORANTE" IN THE MARK IS "WINE BAR & RESTAURANT".

FOR CAFE AND RESTAURANT SERVICES; CAFETERIA AND RESTAURANT SERVICES; CAFE-RESTAURANTS; CONSULTING IN THE FIELD OF RESTAURANT MENU DEVELOPMENT; RESTAURANT AND HOTEL SERVICES; RESTAURANT AND CATERING SERVICES; RESTAURANT SERVICES; BAR SERVICES; CAFE; RESTAURANT; WINE REPOSITORY SERVICES, NAMELY, WINE BARS; BAR AND RESTAURANT SERVICES; RESTAURANT AND BAR SERVICES (U.S. CLS. 100 AND 101).

DAVID ELTON, EXAMINING ATTORNEY

SN 86-046,330. AZURA, LLC, BOULDER, CO. FILED 8-23-2013.

## MEMORY CARE VILLAGE

THE MARK CONSISTS OF STANDARD CHARACTERS WITHOUT CLAIM TO ANY PARTICULAR FONT, STYLE, SIZE, OR COLOR.

NO CLAIM IS MADE TO THE EXCLUSIVE RIGHT TO USE "MEMORY CARE", APART FROM THE MARK AS SHOWN.

FOR PROVIDING ASSISTED LIVING FACILITIES (U.S. CLS. 100 AND 101).

MICHAEL P EISNACH, EXAMINING ATTORNEY

SN 86-046,349. AZURA, LLC, BOULDER, CO. FILED 8-23-2013.

## DEMENTIA CARE VILLAGE

THE MARK CONSISTS OF STANDARD CHARACTERS WITHOUT CLAIM TO ANY PARTICULAR FONT, STYLE, SIZE, OR COLOR.

NO CLAIM IS MADE TO THE EXCLUSIVE RIGHT TO USE "DEMENTIA CARE", APART FROM THE MARK AS SHOWN.

FOR PROVIDING ASSISTED LIVING FACILITIES (U.S. CLS. 100 AND 101).

MICHAEL P EISNACH, EXAMINING ATTORNEY

SN 86-010,134. MURRIETTA, CECIL, IRVINE, CA. FILED 7-15-2013.



THE COLOR(S) BLUE, RED AND GREEN IS/ARE CLAIMED AS A FEATURE OF THE MARK.

THE MARK CONSISTS OF THE LITERAL ELEMENTS "EL TORO BRAVO" WRITTEN IN RED COLORED IN ARCH FORM WITH THREE BLUE COLORED BULL IMAGES, SURROUNDED BY TWO BLUE COLORED SEMI CIRCLED LINES WHEREIN GREEN COLORED STAIRS LIKE IMAGES WITH THREE RED COLORED TRIANGLES ARE PLACED IN BETWEEN THE SAID SEMI CIRCLED LINES.

THE ENGLISH TRANSLATION OF "EL TORO BRAVO" IN THE MARK IS "THE BRAVE BULL".

FOR RESTAURANT SERVICES FEATURING MEXICAN FOOD, TORTILLAS, TORTILLA CHIPS, CORN AND MEAT PRODUCTS, TACOS; RESTAURANT SERVICES, NAMELY, PROVIDING OF FOOD AND BEVERAGES FOR CONSUMPTION ON AND OFF THE PREMISES (U.S. CLS. 100 AND 101).

FIRST USE 2-1-2013; IN COMMERCE 2-1-2013.  
EDWARD NELSON, EXAMINING ATTORNEY

**CLASS 43—(Continued).**

SN 86-048,232. CPG RESTAURANTS, LLC, CHICAGO, IL. FILED 8-26-2013.

**CHEESIE'S PUB & GRUB**

THE MARK CONSISTS OF STANDARD CHARACTERS WITHOUT CLAIM TO ANY PARTICULAR FONT, STYLE, SIZE, OR COLOR.

NO CLAIM IS MADE TO THE EXCLUSIVE RIGHT TO USE "PUB & GRUB", APART FROM THE MARK AS SHOWN.

FOR BAR AND RESTAURANT SERVICES; FAST-FOOD RESTAURANT SERVICES; MOBILE CAFE SERVICES FOR PROVIDING FOOD AND DRINK; RESTAURANT SERVICES, INCLUDING SIT-DOWN SERVICE OF FOOD AND TAKE-OUT RESTAURANT SERVICES (U.S. CLS. 100 AND 101).

FIRST USE 4-12-2011; IN COMMERCE 4-12-2011.  
SANI KHOURI, EXAMINING ATTORNEY

**CLASS 43—(Continued).**

SN 86-058,782. WATCHTOWER MANAGEMENT, INC., QUEENS, NY. FILED 9-9-2013.



THE COLOR(S) YELLOW, RED, GREEN, GOLD, AND BLUE IS/ARE CLAIMED AS A FEATURE OF THE MARK.

THE MARK CONSISTS OF FIVE PARALLELOGRAMS IN THE COLORS YELLOW, RED, GREEN, GOLD, AND BLUE WITH THE VERTEX OF EACH PARALLELOGRAM ARRANGED AROUND A CENTER POINT SUCH THAT THEY FORM A FIVE POINT STAR, WITH THE WORD "TIMARI" APPEARING IN GOLD BELOW THE STAR, AND BELOW THE WORD "TIMARI" APPEARING THE WORDS "THE TASTE OF ASIA" IN RED.

FOR RESTAURANT SERVICES FEATURING ASIAN CUISINE; RESTAURANT SERVICES, INCLUDING SIT-DOWN SERVICE OF FOOD AND TAKE-OUT RESTAURANT SERVICES (U.S. CLS. 100 AND 101).

ANDREA BUTLER, EXAMINING ATTORNEY

SN 86-054,619. MILLER MC, INC., DBA LARRY H. MILLER MANAGEMENT CORPORATION, SANDY, UT. FILED 9-3-2013.

OWNER OF U.S. REG. NOS. 3,465,572 AND 3,914,868. THE NAME "LARRY H. MILLER" DOES NOT IDENTIFY A LIVING INDIVIDUAL.

THE MARK CONSISTS OF THE WORDS "LARRY H. MILLER" IN CURSIVE WRITING.

FOR CATERING SERVICES; PROVIDING GENERAL PURPOSE CONVENTION AND EXHIBITION FACILITIES (U.S. CLS. 100 AND 101).

LESLIE RICHARDS, EXAMINING ATTORNEY

SN 86-064,153. THE CAMPUS KITCHENS PROJECT, WASHINGTON, DC. FILED 9-13-2013.

**Campus Kitchens Project**

THE MARK CONSISTS OF STANDARD CHARACTERS WITHOUT CLAIM TO ANY PARTICULAR FONT, STYLE, SIZE, OR COLOR.

NO CLAIM IS MADE TO THE EXCLUSIVE RIGHT TO USE "KITCHENS PROJECT", APART FROM THE MARK AS SHOWN.

SEC. 2(F).

FOR CHARITABLE SERVICES, NAMELY, PROVIDING FOOD TO NEEDY PERSONS (U.S. CLS. 100 AND 101).

FIRST USE 1-31-2001; IN COMMERCE 12-31-2001.

KHANH LE, EXAMINING ATTORNEY

**CLASS 43—(Continued).**

SN 86-065,301. ANGRY CHICK, LLC, WEST NEW YORK, NJ.  
FILED 9-16-2013.



NO CLAIM IS MADE TO THE EXCLUSIVE RIGHT TO USE "NEW YORK" OR "WING", APART FROM THE MARK AS SHOWN.

THE MARK CONSISTS OF "NEW YORK WING FACTORY" ACROSS CIRCULAR IMAGE, CHICKEN ON BOTTOM OF CIRCULAR IMAGE, PARALLEL HORIZONTAL STRIPES.

FOR BAR AND RESTAURANT SERVICES (U.S. CLS. 100 AND 101).

FIRST USE 12-1-2013; IN COMMERCE 12-1-2013.

DOMINICK J. SALEMI, EXAMINING ATTORNEY

**CLASS 43—(Continued).**

SN 86-071,620. HJG DWARF HOUSE, INC., ATLANTA, GA.  
FILED 9-23-2013.



OWNER OF U.S. REG. NOS. 2,034,574 AND 3,536,045.

THE MARK CONSISTS OF THE MARK "CHICK-FIL-A" IN CURSIVE WITH A TRUNCATED LETTER "C" STYLIZED TO RESEMBLE THE HEAD OF A ROOSTER NEXT TO THE WORDS "TRUETT'S LUAU" ALL INSIDE A BANNER DECORATED WITH FLOWERS.

FOR RESTAURANT SERVICES (U.S. CLS. 100 AND 101).

JULIE GUTTADAURO, EXAMINING ATTORNEY

SN 86-066,340. GICHOHI, PETER, DBA FLANEE, SHORELINE, WA. FILED 9-17-2013.

# FLANEE

THE MARK CONSISTS OF STANDARD CHARACTERS WITHOUT CLAIM TO ANY PARTICULAR FONT, STYLE, SIZE, OR COLOR.

FOR PROVIDING A WEBSITE FEATURING INFORMATION IN THE FIELD OF HOTELS AND TEMPORARY ACCOMMODATIONS FOR TRAVELERS (U.S. CLS. 100 AND 101).

FIRST USE 6-20-2013; IN COMMERCE 6-20-2013.

KYLE PEETE, EXAMINING ATTORNEY

SN 86-072,704. LAND O'LAKES, INC., ARDEN HILLS, MN.  
FILED 9-24-2013.



**FOODSERVICE**

Simple goodness, made simple.

SN 86-069,002. CASTLE CREOLE, INC, BRANDON, FL.  
FILED 9-19-2013.

# Castle Creole

THE MARK CONSISTS OF STANDARD CHARACTERS WITHOUT CLAIM TO ANY PARTICULAR FONT, STYLE, SIZE, OR COLOR.

FOR RESTAURANT AND CAFE SERVICES (U.S. CLS. 100 AND 101).

FIRST USE 11-5-2010; IN COMMERCE 1-28-2011.

KYLE PEETE, EXAMINING ATTORNEY

OWNER OF U.S. REG. NOS. 2,743,924, 3,151,045 AND 3,550,062.

NO CLAIM IS MADE TO THE EXCLUSIVE RIGHT TO USE "FOODSERVICE", APART FROM THE MARK AS SHOWN.

THE MARK CONSISTS OF AN ARCHED BANNER CONTAINING THE WORDS "LAND O LAKES", WITH A TREE AND LAKE SCENE BELOW THE BANNER. THERE IS A KNEELING INDIAN MAIDEN HOLDING A BUTTER BOX IN THE FOREFRONT. BELOW THE INDIAN MAIDEN ARE THE WORDS "FOODSERVICE", AND BELOW THAT "SIMPLE GOODNESS, MADE SIMPLE."

FOR PROVIDING A WEBSITE FEATURING INFORMATION IN THE FIELD OF RECIPES AND COOKING; PROVIDING A WEBSITE FEATURING NEWS IN THE FIELD OF COOKING AND RECIPES (U.S. CLS. 100 AND 101).

FIRST USE 7-0-2013; IN COMMERCE 7-0-2013.

CAITLIN WATTS-FITZGERALD, EXAMINING ATTORNEY

**CLASS 43—(Continued).**

SN 86-073,586. CARNIVAL CORPORATION, MIAMI, FL. FILED 9-24-2013.



NO CLAIM IS MADE TO THE EXCLUSIVE RIGHT TO USE "AMERICAN", APART FROM THE MARK AS SHOWN.

THE MARK CONSISTS OF THE WORDING "AMERICAN FEAST". THERE ARE HORIZONTAL LINES TO EACH SIDE OF THE WORD "AMERICAN". THE TERM "FEAST" IS BELOW THE TERM "AMERICAN". THE WORDING IN ITS ENTIRETY HAS HORIZONTAL LINES ABOVE AND BELOW IT. A STAR BURST OR RAYS EMANATE FROM THE TOP AND BOTTOM OF THE HORIZONTAL LINES.

FOR PROVIDING OF FOOD AND DRINK; RESTAURANT SERVICES (U.S. CLS. 100 AND 101).

JANICE L. MCMORROW, EXAMINING ATTORNEY

SN 86-074,437. WORLDWIDE GREEKS, LLC, DBA GREEK BOSTON, ARLINGTON, MA. FILED 9-25-2013.

## Greek Boston

THE MARK CONSISTS OF STANDARD CHARACTERS WITHOUT CLAIM TO ANY PARTICULAR FONT, STYLE, SIZE, OR COLOR.

SEC. 2(F).

FOR PROVIDING A WEBSITE FEATURING INFORMATION ABOUT GREEK CULTURE, NAMELY, RECIPE AND COOKING FOOD INFORMATION, AND DINING INFORMATION (U.S. CLS. 100 AND 101).

FIRST USE 1-1-1998; IN COMMERCE 1-1-1998.

VIVIAN MICZNIK FIRST, EXAMINING ATTORNEY

**CLASS 43—(Continued).**

SN 86-074,453. DELIAN 7, INC., DBA LUBITO'S MEXICAN GRILL, SCHERERVILLE, IN. FILED 9-25-2013.

**LUBITO'S MEXICAN GRILL**

THE MARK CONSISTS OF STANDARD CHARACTERS WITHOUT CLAIM TO ANY PARTICULAR FONT, STYLE, SIZE, OR COLOR.

NO CLAIM IS MADE TO THE EXCLUSIVE RIGHT TO USE "MEXICAN GRILL", APART FROM THE MARK AS SHOWN.

THE NAME(S), PORTRAIT(S), AND/OR SIGNATURE(S) SHOWN IN THE MARK DOES NOT IDENTIFY A PARTICULAR LIVING INDIVIDUAL.

THE WORDING "LUBITO" HAS NO MEANING IN A FOREIGN LANGUAGE.

FOR FAST-FOOD RESTAURANT SERVICES (U.S. CLS. 100 AND 101).

FIRST USE 9-16-2013; IN COMMERCE 9-16-2013.

ROBIN MITTLER, EXAMINING ATTORNEY

SN 86-074,825. PR II COCO PALMS LLC, MADISON, NJ. FILED 9-25-2013.

## COCO PALMS

THE MARK CONSISTS OF STANDARD CHARACTERS WITHOUT CLAIM TO ANY PARTICULAR FONT, STYLE, SIZE, OR COLOR.

FOR HOTEL SERVICES; RESORT HOTEL SERVICES; RESTAURANT AND BAR SERVICES; RESERVATION SERVICES FOR HOTEL ACCOMMODATIONS; CATERING SERVICES; PROVISION OF FACILITIES FOR CONVENTIONS (U.S. CLS. 100 AND 101).

BRENDAN MCCAULEY, EXAMINING ATTORNEY

SN 86-075,096. HARRINGTON, LESTER, JACKSONVILLE, FL. FILED 9-26-2013.



"WE HUNGRY"

THE COLOR(S) BLACK, RED, BLUE AND YELLOW IS/ARE CLAIMED AS A FEATURE OF THE MARK.

THE MARK CONSISTS OF LITERAL ELEMENTS "DA-



**CLASS 43—(Continued).**

MUNCHIES WE HUNGRY" WRITTEN IN STYLIZED FORM WHEREIN THE WORDS "DA-MUNCHIES" ARE WRITTEN IN RED COLOR WITH YELLOW BACKGROUND AND OUTLINED BY BLUE COLOR LETTER "S" IS STRETCHED DOWNWARDS TO FORM AN IMAGE OF A NOSE. A SMILEY WITH ITS TONGUE IS COMING OUT FROM THE RIGHT HAND SIDE IN RED COLOR AND OUTLINE BY BLUE COLOR AND IS PLACED BELOW IT AND AT BOTTOM THE WORDS "WE HUNGRY" ARE WRITTEN IN QUOTATION MARKS IN BLACK COLOR.

FOR FOOD TRUCK SERVICES, NAMELY, PROVIDING OF FOOD AND DRINK VIA A MOBILE TRUCK (U.S. CLS. 100 AND 101).

FIRST USE 2-23-2011; IN COMMERCE 2-23-2011.  
TRACY FLETCHER, EXAMINING ATTORNEY

---

SN 86-075,212. THE CITY OF GREENSBORO, GREENSBORO, NC. FILED 9-26-2013.

**GREENSBORO COLISEUM**

THE MARK CONSISTS OF STANDARD CHARACTERS WITHOUT CLAIM TO ANY PARTICULAR FONT, STYLE, SIZE, OR COLOR.

OWNER OF U.S. REG. NO. 4,066,131.

NO CLAIM IS MADE TO THE EXCLUSIVE RIGHT TO USE "COLISEUM", APART FROM THE MARK AS SHOWN. SEC. 2(F).

FOR PROVIDING GENERAL PURPOSE FACILITIES FOR TRADESHOWS, EXHIBITIONS, CONFERENCES, SPORTING AND OTHER ENTERTAINMENT EVENTS (U.S. CLS. 100 AND 101).

FIRST USE 0-0-1974; IN COMMERCE 0-0-1974.  
ANDREA K. NADELMAN, EXAMINING ATTORNEY

---

SN 86-075,219. THE CITY OF GREENSBORO, GREENSBORO, NC. FILED 9-26-2013.

**GREENSBORO COLISEUM COMPLEX**

THE MARK CONSISTS OF STANDARD CHARACTERS WITHOUT CLAIM TO ANY PARTICULAR FONT, STYLE, SIZE, OR COLOR.

OWNER OF U.S. REG. NO. 4,066,131.

NO CLAIM IS MADE TO THE EXCLUSIVE RIGHT TO USE "COLISEUM COMPLEX", APART FROM THE MARK AS SHOWN. SEC. 2(F).

FOR PROVIDING GENERAL PURPOSE FACILITIES FOR TRADESHOWS, EXHIBITIONS, CONFERENCES, SPORTING AND OTHER ENTERTAINMENT EVENTS (U.S. CLS. 100 AND 101).

FIRST USE 0-0-1974; IN COMMERCE 0-0-1974.  
ANDREA K. NADELMAN, EXAMINING ATTORNEY

**CLASS 43—(Continued).**

SN 86-076,041. COOKING CHANNEL, LLC, CINCINNATI, OH. FILED 9-26-2013.

**DEVOUR THE BLOG**

THE MARK CONSISTS OF STANDARD CHARACTERS WITHOUT CLAIM TO ANY PARTICULAR FONT, STYLE, SIZE, OR COLOR.

NO CLAIM IS MADE TO THE EXCLUSIVE RIGHT TO USE "BLOG", APART FROM THE MARK AS SHOWN.

FOR PROVIDING INFORMATION IN THE FIELDS OF FOOD PREPARATION, RECIPES, AND COOKING VIA A GLOBAL COMPUTER NETWORK (U.S. CLS. 100 AND 101).

FIRST USE 4-22-2010; IN COMMERCE 4-22-2010.  
TRACY WHITTAKER-BROWN, EXAMINING ATTORNEY

---

SN 86-077,356. BEN E. KEITH COMPANY, FORT WORTH, TX. FILED 9-27-2013.



THE COLOR(S) GREEN, WHITE, YELLOW, BROWN, BLACK, PINK, TAN, GRAY, BLUE, AND RED IS/ARE CLAIMED AS A FEATURE OF THE MARK.

THE MARK CONSISTS OF A GREEN CIRCLE BORDER WITH THE WORDS "ZOO CREW" IN WHITE IN THE UPPER LEFT-HAND SIDE OF THE CIRCLE. INSIDE THE CIRCLE, AT THE TOP OF THE CIRCLE, IS A COLORFUL DRAWING OF A GIRAFFE THAT IS YELLOW WITH BROWN SPOTS, LIGHT BROWN INNER EARS, LIGHT BROWN CIRCLES AROUND ITS EYES, VERY LIGHT BROWN EYES WITH A DARK BROWN PUPIL, LIGHT BROWN MUZZLE WITH DARK BROWN NOSTRILS, LIGHT BROWN HORN TYPE FEATURES ON ITS HEAD WITH DARK BROWN TIPS, AND A DARK BROWN MANE, GOING CLOCKWISE, THE GIRAFFE IS FOLLOWED BY SOME GREEN AND BLACK FOLIAGE, A PINK HIPPO, A BLACK AND WHITE ZEBRA, WITH BLUE EYES, A TAN LION WITH A DARK BROWN MANE, AND A GREY ELEPHANT WITH BLUE EYES, YELLOW TUSKS, AND A RED MOUTH.

FOR MENU AND FOOD PLANNING SERVICES FOR PRESCHOOLS, NAMELY, CONSULTING IN THE FIELD OF MENU PLANNING FOR OTHERS (U.S. CLS. 100 AND 101).

FIRST USE 1-31-2013; IN COMMERCE 1-31-2013.  
MARK SPARACINO, EXAMINING ATTORNEY

**CLASS 43—(Continued).**

SN 86-079,912. HJG DWARF HOUSE, INC., ATLANTA, GA. FILED 10-1-2013.

**CHICK-FIL-A TRUETT'S LUAU**

THE MARK CONSISTS OF STANDARD CHARACTERS WITHOUT CLAIM TO ANY PARTICULAR FONT, STYLE, SIZE, OR COLOR.

OWNER OF U.S. REG. NOS. 2,034,574 AND 3,536,045. FOR RESTAURANT SERVICES (U.S. CLS. 100 AND 101).

JULIE GUTTADAURO, EXAMINING ATTORNEY

**CLASS 43—(Continued).**

SN 86-090,295. E&E RISTORANTE GROUP, INC., LOS ANGELES, CA. FILED 10-13-2013.



NO CLAIM IS MADE TO THE EXCLUSIVE RIGHT TO USE "HANDCRAFTED PIZZA", APART FROM THE MARK AS SHOWN.

THE MARK CONSISTS OF THE WORD "WOOD" CAPITALIZED ON THE TOP WITH A STYLIZED PIZZA CUTTER UNDER THE WORD "WOOD" AND THE WORDS "HANDCRAFTED PIZZA" IMMEDIATELY BENEATH THE HANDLE PART OF THE PIZZA CUTTER.

FOR RESTAURANT SERVICES (U.S. CLS. 100 AND 101).

FIRST USE 10-1-2013; IN COMMERCE 10-1-2013. ROBIN CHOSID, EXAMINING ATTORNEY

SN 86-083,143. ROSEBUD RESTAURANTS, INC., CHICAGO, IL. FILED 10-4-2013.

**JOE FISH**

THE MARK CONSISTS OF STANDARD CHARACTERS WITHOUT CLAIM TO ANY PARTICULAR FONT, STYLE, SIZE, OR COLOR.

NO CLAIM IS MADE TO THE EXCLUSIVE RIGHT TO USE "FISH", APART FROM THE MARK AS SHOWN.

FOR RESTAURANT SERVICES; CATERING SERVICES; FOOD CARRY-OUT SERVICES (U.S. CLS. 100 AND 101).

SUSAN STIGLITZ, EXAMINING ATTORNEY

SN 86-096,665. DOUBLETAP PUBCADE, LLC, VALRICO, FL. FILED 10-21-2013.

**Pubcade**

SN 86-083,642. KIDSCOOK PRODUCTIONS, LLC, CAMBRIDGE, MA. FILED 10-5-2013.

**KickinNutrition.TV**

THE MARK CONSISTS OF STANDARD CHARACTERS WITHOUT CLAIM TO ANY PARTICULAR FONT, STYLE, SIZE, OR COLOR.

OWNER OF U.S. REG. NO. 4,046,477. FOR PROVIDING A WEB SITE FEATURING CONTENT IN THE FIELD OF HEALTHY EATING AND WELLNESS, NAMELY, INFORMATION ABOUT HEALTHY RECIPES, INGREDIENTS AND COOKING INFORMATION (U.S. CLS. 100 AND 101).

FIRST USE 4-0-2014; IN COMMERCE 4-0-2014. MICHELLE DUBOIS, EXAMINING ATTORNEY

THE MARK CONSISTS OF STANDARD CHARACTERS WITHOUT CLAIM TO ANY PARTICULAR FONT, STYLE, SIZE, OR COLOR.

FOR BAR SERVICES (U.S. CLS. 100 AND 101). GEORGE LORENZO, EXAMINING ATTORNEY

**CLASS 43—(Continued).**

SN 86-103,653. LANE,WENDY,E. AKA ROBBS,WENDY,E,  
SCOTTSDALE, AZ. FILED 10-28-2013.



NO CLAIM IS MADE TO THE EXCLUSIVE RIGHT TO USE "CHEF", APART FROM THE MARK AS SHOWN.  
THE COLOR(S) BLACK, GREY AND HOT PINK IS/ARE CLAIMED AS A FEATURE OF THE MARK.

THE MARK CONSISTS OF A GREY AND HOT PINK COLORED HEART, THE TOP PORTION IS DEFINED IN A HOT PINK SCALLOPED EDGED BRA, IN THE HEART, UNDERNEATH THE BRA, THE WORD "SEXY" IS IN BOLD BLACK LETTERING, AND THE WORD "CHEF" IS BE- NEATH IN BOLD HOT PINK LETTERING.

FOR BAR AND RESTAURANT SERVICES (U.S. CLS. 100 AND 101).

KAREN K. BUSH, EXAMINING ATTORNEY

---

SN 86-104,672. JWC FL, LLC, TAMPA, FL. FILED 10-29-2013.

**MACDINTON'S YARD OF ALE**

THE MARK CONSISTS OF STANDARD CHARACTERS WITHOUT CLAIM TO ANY PARTICULAR FONT, STYLE, SIZE, OR COLOR.

OWNER OF U.S. REG. NO. 4,178,441.

NO CLAIM IS MADE TO THE EXCLUSIVE RIGHT TO USE "YARD OF ALE", APART FROM THE MARK AS SHOWN.

THE NAME(S), PORTRAIT(S), AND/OR SIGNATURE(S) SHOWN IN THE MARK DOES NOT IDENTIFY A PARTI- CULAR LIVING INDIVIDUAL.

FOR BAR SERVICES; PUBS; RESTAURANT SERVICES (U.S. CLS. 100 AND 101).

TRACY FLETCHER, EXAMINING ATTORNEY

**CLASS 43—(Continued).**

SN 86-108,974. JIE WEI, FREDERICKSBURG, VA. FILED 11- 4-2013.



THE MARK CONSISTS OF A TEAPOT AND A LINE BENEATH IN A DARK CIRCLE WHICH IS INSIDE OF A SQUARE AND THE WORD "HUZIHU" UNDER THE SQUARE AND THE CHINESE WORDS OF "HUZIHU" LOCATED BENEATH. THE COLORS BLACK, WHITE AND/OR GRAY REPRESENT BACKGROUND, OUTLIN- ING, SHADING AND/OR TRANSPARENT AREAS AND ARE NOT PART OF THE MARK.

THE ENGLISH TRANSLATION OF "HUZIHU" IN THE MARK IS A "TEAPOT FAMILY".

THE NON-LATIN CHARACTERS IN THE MARK TRANS- LITERATE TO "HUZIHU" AND THIS MEANS "A TEAPOT FAMILY" IN ENGLISH.

FOR BAR AND COCKTAIL LOUNGE SERVICES; BOARDING HOUSES; CAFES; CAFETERIAS; CATER- ING SERVICES; FAST-FOOD RESTAURANTS; HOTEL ACCOMMODATION SERVICES; HOTELS; MAKING RE- SERVATIONS AND BOOKINGS FOR TEMPORARY LODGING; MOTEL SERVICES; PROVIDING OF FOOD AND DRINK VIA A MOBILE TRUCK; PROVIDING TEMPORARY ACCOMMODATION; PROVIDING TEM- PORARY LODGING AT HOLIDAY CAMPS; RENTAL OF ROOMS AS TEMPORARY LIVING ACCOMMODA- TIONS; RESERVATION OF HOTEL ROOMS FOR TRAVELERS; RESTAURANT; RESTAURANTS; SELF- SERVICE RESTAURANTS; TEA BARS (U.S. CLS. 100 AND 101).

SHAVELL MCPHERSON, EXAMINING ATTORNEY

---

SN 86-111,139. FRANK J. ZAMBONI & CO., INC., PARA- MOUNT, CA. FILED 11-5-2013.

**ZAMBONI**

THE MARK CONSISTS OF STANDARD CHARACTERS WITHOUT CLAIM TO ANY PARTICULAR FONT, STYLE, SIZE, OR COLOR.

OWNER OF U.S. REG. NOS. 1,225,136, 2,907,648 AND OTHERS.

SEC. 2(F).

FOR RESTAURANT AND CAFE SERVICES; RESTAU- RANT AND CATERING SERVICES; RESTAURANT SERVICES (U.S. CLS. 100 AND 101).

FIRST USE 8-12-2013; IN COMMERCE 8-12-2013.

MEGHAN REINHART, EXAMINING ATTORNEY

**CLASS 43—(Continued).**

SN 86-112,788. SONG, DAJUAN, PHILADELPHIA, PA. FILED 11-7-2013.



NO CLAIM IS MADE TO THE EXCLUSIVE RIGHT TO USE "DIM SUM" AND THE NON-LATIN CHARACTERS THAT TRANSLATE TO "DIM SUM", APART FROM THE MARK AS SHOWN.

THE MARK CONSISTS OF A STYLIZED WORDING "DIM SUM GARDEN" BELOW THE DESIGN OF A CHINESE-STYLE SPOON HOLDING A JUICY BUN SHOWING A HUMAN FACE. ABOVE THIS DESIGN APPEARS THREE CHINESE CHARACTERS THAT TRANSLITERATE TO "DIAN XIN YUAN", MEANING "DIM SUM GARDEN" IN ENGLISH.

THE NON-LATIN CHARACTERS IN THE MARK TRANSLITERATE TO "DIAN XIN YUAN" AND THEY MEAN "DIM SUM GARDEN" IN ENGLISH.

FOR RESTAURANT SERVICES (U.S. CLS. 100 AND 101).

FIRST USE 1-1-2003; IN COMMERCE 6-1-2013.  
DAWN HAN, EXAMINING ATTORNEY

SN 86-118,897. DC LOFTY LLC, TA CAPITAL VIEW, WASHINGTON, DC. AND MATIUKAS, LINAS, WASHINGTON, DC. FILED S.R. 11-14-2013; AM. P.R. 6-23-2014.



NO CLAIM IS MADE TO THE EXCLUSIVE RIGHT TO USE "HOSTELS", APART FROM THE MARK AS SHOWN.

THE MARK CONSISTS OF A STYLIZED VERSION OF A CAPITOL BUILDING FORMED BY A SERIES OF LINES AND GEOMETRIC SHAPES, A SILHOUETTE OF A PERSON WALKING AND CARRYING A BACKPACK, A SWIRLED LINE APPEARS BENEATH THE BUILDING AND AHEAD OF THE PERSON AND THE WORDS "CAPITAL HOSTELS" APPEARS AT THE BOTTOM.

FOR HOSTELS (U.S. CLS. 100 AND 101).  
FIRST USE 8-8-2008; IN COMMERCE 6-1-2009.  
EDWARD NELSON, EXAMINING ATTORNEY

**CLASS 43—(Continued).**

SN 86-125,707. STATE FARM MUTUAL AUTOMOBILE INSURANCE COMPANY, BLOOMINGTON, IL. FILED 11-21-2013.



OWNER OF U.S. REG. NOS. 4,112,849, 4,211,629 AND OTHERS.

NO CLAIM IS MADE TO THE EXCLUSIVE RIGHT TO USE "CENTER" AND "THEATRE", APART FROM THE MARK AS SHOWN.

THE MARK CONSISTS OF THE WORDS "STATE FARM CENTER" AND "STAR THEATRE" WITH A STYLIZED DEPICTION OF A STADIUM ROOF ABOVE THE WORDS AND THREE OVALS TOUCHING FORMING AN OVERALL TRIANGULAR SHAPE WHERE ONE OVAL APPEARS CENTERED ABOVE THE OTHER TWO OVALS TO THE LEFT OF THE WORDING "STATE FARM". THE WORDS "STAR THEATRE" APPEAR BELOW THE WORDS "STATE FARM CENTER" AND A STAR IS BETWEEN THE WORDS "STAR" AND "THEATRE".

FOR ARENA SERVICES, NAMELY, PROVIDING GENERAL PURPOSE FACILITIES FOR SPORTS, CONCERTS, CONVENTIONS AND EXHIBITIONS (U.S. CLS. 100 AND 101).

FIRST USE 4-29-2013; IN COMMERCE 4-29-2013.  
BRIDGETT SMITH, EXAMINING ATTORNEY

SN 86-128,639. BON ME FOODS, LLC, DBA BON ME, CAMBRIDGE, MA. FILED 11-25-2013.

Bon Me

THE MARK CONSISTS OF STANDARD CHARACTERS WITHOUT CLAIM TO ANY PARTICULAR FONT, STYLE, SIZE, OR COLOR.

THE ENGLISH TRANSLATION OF "BON" IN THE MARK IS "GOOD".

FOR RESTAURANT SERVICES (U.S. CLS. 100 AND 101).

FIRST USE 9-20-2010; IN COMMERCE 4-4-2011.  
ALYSSA STEEL, EXAMINING ATTORNEY

**CLASS 43—(Continued).**

SN 86-135,938. PUPTOWN, LLC, PLYMOUTH, MN. FILED 12-5-2013.

# PUPTOWN

THE MARK CONSISTS OF STANDARD CHARACTERS WITHOUT CLAIM TO ANY PARTICULAR FONT, STYLE, SIZE, OR COLOR.

FOR PET BOARDING SERVICES (U.S. CLS. 100 AND 101).

FIRST USE 1-12-2011; IN COMMERCE 2-1-2011.  
GRETTA YAO, EXAMINING ATTORNEY

**CLASS 43—(Continued).**

COLOR BLUE, THE "F" IN IN THE COLOR GREEN, THE FIRST "O" IN THE COLOR ORANGE, THE SECOND "O" IN THE COLOR TEAL AND THE "D" IN THE COLOR PURPLE, ALL NEXT TO TWO CHINESE CHARACTERS ONE ON TOP OF THE OTHER. THE TOP CHARACTERS ARE IN RED WITH THE CHARACTER ON THE BOTTOM LEFT IN GREEN. THE LOWER CHARACTER APPEARS IN RED WITH BLUE AND YELLOW SHADING IN THE LEFT SQUARES AND THE OTHER TWO SQUARES ARE TRANSPARENT AND GREEN APPEARS ON THE RIGHT SIDE OF THE LOWER STROKE.

THE NON-LATIN CHARACTERS IN THE MARK TRANSLITERATE TO "SHU, GUO" AND THIS MEANS "COMFORT, FRUIT" IN ENGLISH.

FOR RESTAURANT AND CATERING SERVICES (U.S. CLS. 100 AND 101).

NAKWAMA ANKRAH, EXAMINING ATTORNEY

SN 86-137,636. WOWPRIME CORP., TAICHUNG CITY 40354, TAIWAN, FILED 12-6-2013.



NO CLAIM IS MADE TO THE EXCLUSIVE RIGHT TO USE "TEPPAN", APART FROM THE MARK AS SHOWN.

THE COLOR(S) RED, GREEN AND WHITE IS/ARE CLAIMED AS A FEATURE OF THE MARK.

THE MARK CONSISTS OF THE STYLIZED CHARACTERS "HOT 7" IN THE COLOR GREEN ABOVE THE STYLIZED LETTERS "TEPPAN" IN THE COLOR WHITE, ALL FORMED ON A RED BACKGROUND.

FOR RESTAURANT AND CATERING SERVICES (U.S. CLS. 100 AND 101).

NAKWAMA ANKRAH, EXAMINING ATTORNEY

SN 86-138,585. 3PB HOTELS LLC, NEW YORK, NY. FILED 12-9-2013.

# SIXTY SOHO

SN 86-137,647. WOWPRIME CORP., TAICHUNG CITY 40354, TAIWAN, FILED 12-6-2013.



NO CLAIM IS MADE TO THE EXCLUSIVE RIGHT TO USE THE NON-LATIN CHARACTERS IN THE MARK TRANSLITERATE TO "GUO", APART FROM THE MARK AS SHOWN.

THE COLOR(S) RED, BLUE, GREEN, ORANGE, TEAL, PURPLE, AND YELLOW IS/ARE CLAIMED AS A FEATURE OF THE MARK.

THE MARK CONSISTS OF THE LETTERS "SUFOOD" WITH THE "S" IN THE COLOR RED, THE "U" IN THE

THE MARK CONSISTS OF STANDARD CHARACTERS WITHOUT CLAIM TO ANY PARTICULAR FONT, STYLE, SIZE, OR COLOR.

OWNER OF U.S. REG. NO. 3,993,816.

NO CLAIM IS MADE TO THE EXCLUSIVE RIGHT TO USE "SOHO", APART FROM THE MARK AS SHOWN.

FOR BAR AND COCKTAIL LOUNGE SERVICES; HOTEL SERVICES; MAKING RESERVATIONS AND BOOKINGS FOR OTHERS FOR ACCOMMODATIONS AND MEALS AT HOTELS, RESTAURANTS, BARS, COCKTAIL LOUNGES, AND HEALTH SPAS; PROVIDING A WEBSITE FEATURING INFORMATION IN THE FIELD OF HOTELS AND TEMPORARY ACCOMMODATIONS FOR TRAVELERS; PROVIDING EXTENDED-STAY HOTELS; RESORT HOTEL SERVICES; RESTAURANT SERVICES; TAKE-OUT RESTAURANT SERVICES (U.S. CLS. 100 AND 101).

B. PARADEWELAI, EXAMINING ATTORNEY

**CLASS 43—(Continued).**

SN 86-138,597. 3PB HOTELS LLC, NEW YORK, NY. FILED 12-9-2013.

# SIXTY LES

THE MARK CONSISTS OF STANDARD CHARACTERS WITHOUT CLAIM TO ANY PARTICULAR FONT, STYLE, SIZE, OR COLOR.

OWNER OF U.S. REG. NO. 3,993,816.

NO CLAIM IS MADE TO THE EXCLUSIVE RIGHT TO USE "LES", APART FROM THE MARK AS SHOWN.

FOR BAR AND COCKTAIL LOUNGE SERVICES; HOTEL SERVICES; MAKING RESERVATIONS AND BOOKINGS FOR OTHERS FOR ACCOMMODATIONS AND MEALS AT HOTELS, RESTAURANTS, BARS, COCKTAIL LOUNGES, AND HEALTH SPAS; PROVIDING A WEBSITE FEATURING INFORMATION IN THE FIELD OF HOTELS AND TEMPORARY ACCOMMODATIONS FOR TRAVELERS; PROVIDING EXTENDED-STAY HOTELS; RESORT HOTEL SERVICES; RESTAURANT SERVICES; TAKE-OUT RESTAURANT SERVICES (U.S. CLS. 100 AND 101).

B. PARADEWELAI, EXAMINING ATTORNEY

---

SN 86-138,610. 3PB HOTELS LLC, NEW YORK, NY. FILED 12-9-2013.

# SIXTY BEVERLY HILLS

THE MARK CONSISTS OF STANDARD CHARACTERS WITHOUT CLAIM TO ANY PARTICULAR FONT, STYLE, SIZE, OR COLOR.

OWNER OF U.S. REG. NO. 3,993,816.

NO CLAIM IS MADE TO THE EXCLUSIVE RIGHT TO USE "BEVERLY HILLS", APART FROM THE MARK AS SHOWN.

FOR BAR AND COCKTAIL LOUNGE SERVICES; HOTEL SERVICES; MAKING RESERVATIONS AND BOOKINGS FOR OTHERS FOR ACCOMMODATIONS AND MEALS AT HOTELS, RESTAURANTS, BARS, COCKTAIL LOUNGES, AND HEALTH SPAS; PROVIDING A WEBSITE FEATURING INFORMATION IN THE FIELD OF HOTELS AND TEMPORARY ACCOMMODATIONS FOR TRAVELERS; PROVIDING EXTENDED-STAY HOTELS; RESORT HOTEL SERVICES; RESTAURANT SERVICES; TAKE-OUT RESTAURANT SERVICES (U.S. CLS. 100 AND 101).

B. PARADEWELAI, EXAMINING ATTORNEY

**CLASS 43—(Continued).**

SN 86-144,525. SBE HOTEL LICENSING, LLC, LAS VEGAS, NV. FILED 12-16-2013.

# WORLD

THE MARK CONSISTS OF STANDARD CHARACTERS WITHOUT CLAIM TO ANY PARTICULAR FONT, STYLE, SIZE, OR COLOR.

FOR HOTEL SERVICES; HOTEL SERVICES FOR PREFERRED CUSTOMERS; HOTELS; RESORT HOTELS; BAR SERVICES; COCKTAIL LOUNGE SERVICES; RESTAURANT SERVICES; BANQUETS AND BANQUETING SERVICES; BISTRO SERVICES; CAFÉ SERVICES; CAFETERIA SERVICES; COFFEE SHOP SERVICES; CANTEN SERVICES; SNACK BAR SERVICES; WINE BAR SERVICES; TAKE AWAY FOOD SERVICES; CATERING SERVICES; SERVICES FOR PROVIDING FOOD, DRINK AND MEALS; COOKING SERVICES; FOOD PREPARATION SERVICES; TEMPORARY ACCOMMODATION; RESERVATIONS OF TEMPORARY ACCOMMODATIONS; CATERING; PREPARATION OF FOOD, DRINK, MEALS AND REFRESHMENTS; MAKING RESERVATIONS AND BOOKING FOR ACCOMMODATION AND ACCOMMODATION AGENCY SERVICES FOR BOOKING FOR HOTELS FOR HOLIDAY MAKERS, TOURISTS AND TRAVELERS; TEMPORARY ACCOMMODATION RESERVATION SERVICES; TRAVEL AGENCY SERVICES FOR BOOKING AND MAKING ACCOMMODATION AND HOTEL RESERVATIONS; FOOD PREPARATION SERVICES, NAMELY, ARRANGING OF FOOD, DRINK, MEALS AND CATERING FOR WEDDING RECEPTIONS; ARRANGING OF WEDDING RECEPTION VENUES, NAMELY, RENTAL OF BANQUET AND SOCIAL FUNCTION FACILITIES FOR SPECIAL OCCASIONS, NAMELY, PARTY AND WEDDING RECEPTIONS; CHILD CARE AND CHILD MINDING SERVICES; PROVIDING TEMPORARY ACCOMMODATIONS, NAMELY, GUEST HOUSES; HOSPITALITY SERVICES, NAMELY, PROVIDING TEMPORARY ACCOMMODATIONS, FOOD AND DRINK; PROVISION OF FACILITIES FOR CONFERENCES, EXHIBITIONS AND CONVENTIONS; RENTAL AND BOOKING OF CONFERENCE ROOMS AND MEETING ROOMS; RENTAL OF CHAIRS, TABLES, TABLE LINEN, GLASSWARE; RESERVATION OF HOTEL ACCOMMODATION AND MEALS; RESORT SERVICES; BOOKING AND PROVIDING HOTEL AND TEMPORARY ACCOMMODATION AND RESTAURANT PLACES; BOOKING SERVICES FOR HOTELS; INFORMATION, CONSULTANCY AND ADVISORY SERVICES IN RELATION TO THE FOREGOING (U.S. CLS. 100 AND 101).

KEVIN DINALLO, EXAMINING ATTORNEY



**CLASS 43—(Continued).**

SN 86-148,576. PABLO SEBASTIAN MARTINAT, CÓRDOBA, ARGENTINA, FILED 12-19-2013.

# LAPANA

THE MARK CONSISTS OF STANDARD CHARACTERS WITHOUT CLAIM TO ANY PARTICULAR FONT, STYLE, SIZE, OR COLOR.

THE WORDING "LAPANA" HAS NO MEANING IN A FOREIGN LANGUAGE.

FOR RESTAURANT SERVICES, CATERING SERVICES, PREPARATION OF FOOD AND DRINK FOR CONSUMPTION, SELF-SERVING RESTAURANTS, RESTAURANTS, BAR SERVICES, CAFE-RESTAURANTS, CAFETERIAS, BUFFET RESTAURANTS, CANTEEN RESTAURANTS, CATERING SERVICES, EXPRESS SERVICE RESTAURANTS, AND SNACK BARS (U.S. CLS. 100 AND 101).

JENNIFER RICHARDSON, EXAMINING ATTORNEY

SN 86-152,257. MUTUAL WAY TECHNOLOGY CO., LTD, BANDAR SERI BEGAWAN, BRUNEI DARUSSALAM, FILED 12-24-2013.



OWNER OF U.S. REG. NO. 4,305,769.  
THE COLOR(S) ORANGE, RED, WHITE AND BLACK IS/ARE CLAIMED AS A FEATURE OF THE MARK.

THE MARK CONSISTS OF FOUR LARGE BLACK CHINESE CHARACTERS WHICH TRANSLITERATE TO "BA FANG YUN JI" AND WHICH TRANSLATE TO "CONVERGING IN EVERY CORNER" IN ENGLISH SUPERIMPOSED OVER AN ORANGE ABSTRACT TOTEM DESIGN REPRESENTING TWO DRAGON-LIKE DEVICES FACING WITH EACH OTHER ABOVE TWELVE SMALLER BLACK CHINESE CHARACTERS WHICH TRANSLITERATE TO "BA FANG MEI WEI PIAO XIANG", "SI MIAN BIN KE YUN JI" AND "BA FANG" MEANS "ALL DIRECTIONS", "MEI WEI" MEANS "DELICIOUS", "PIAO" MEANS "FLOAT IN AIR", "XIANG" MEANS "FRAGRANT", "SI MIAN" MEANS "SURROUNDED", "BIN KE" MEANS "GUESTS", AND "YUN JI" MEANS "CONVERGE" IN ENGLISH WITH A SMALL BLACK CIRCLE APPEARING IN THE MIDDLE. TO THE LEFT OF A RED RECTANGLE WITH ROUNDED CORNERS CONTAINING FOUR WHITE CHINESE CHARACTERS WHICH TRANSLITERATE TO "BA FANG YUN JI" AND WHICH TRANSLATE TO "CONVERGING IN EVERY CORNER" IN ENGLISH.

THE NON-LATIN CHARACTERS IN THE MARK TRANS-

**CLASS 43—(Continued).**

LITERATE TO "BA FANG YUN JI" AND THIS MEANS "CONVERGING IN EVERY CORNER" IN ENGLISH. THE OTHER SMALL NON-LATIN CHARACTERS IN THE MARK TRANSLITERATE TO "BA FANG MEI WEI PIAO XIANG", "SI MIAN BIN KE YUN JI", AND "BA FANG" MEANS "ALL DIRECTIONS", "MEI WEI" MEANS "DELICIOUS", "PIAO" MEANS "FLOAT IN AIR", "XIANG" MEANS "FRAGRANT", "SI MIAN" MEANS "SURROUNDED", "BIN KE" MEANS "GUESTS", AND "YUN JI" MEANS "CONVERGE" IN ENGLISH.

FOR RESTAURANT SERVICES; RESTAURANTS (U.S. CLS. 100 AND 101).

EUGENIA MARTIN, EXAMINING ATTORNEY

SN 86-160,362. HARD ROCK CAFE INTERNATIONAL (USA), INC., ORLANDO, FL. FILED 1-8-2014.



OWNER OF U.S. REG. NOS. 2,478,328, 3,422,550 AND OTHERS.

THE COLOR(S) WHITE, BLACK, GRAY, TAN, YELLOW, PURPLE, GREEN, PINK AND BLUE IS/ARE CLAIMED AS A FEATURE OF THE MARK.

THE MARK CONSISTS OF A PANDA BEAR WITH A WHITE BODY AND PURPLE ARMS, LEGS AND EARS; WITH PINK EAR SPOTS, ONE PINK EYE SPOT AND PINK ACCENTS; A PURPLE NOSE WITH A BLUE ACCENT; A WHITE AND GREEN PEACE SIGN; A GREEN GARMENT; A PINK NECKLACE WITH A CIRCULAR PURPLE MEDALLION AND A PINK OUTLINE WITH "HARD ROCK" SHOWN IN WHITE LETTERS WITH A PURPLE OUTLINE; A YELLOW, PINK AND PURPLE BUTTERFLY; AND HOLDING A YELLOW, TAN AND GRAY TAMBOURINE. THE PANDA HAS A GRAY SHADOW, AND IS PLAYING A BLACK AND GRAY KEYBOARD WITH PINK BUTTONS AND A CIRCULAR EMBLEM IN PURPLE, PINK AND WHITE WITH "HARD ROCK" IN WHITE LETTERS OUTLINED IN PINK ON FRONT. THERE IS A SMILING YELLOW BELL WITH A PINK MOUTH AND TAN ACCENTS ON THE KEYBOARD. THE WORD "RAZZI" APPEARS IN PURPLE TO THE RIGHT OF THE BEAR.

FOR CHILD CARE SERVICES; RESTAURANT AND HOTEL SERVICES (U.S. CLS. 100 AND 101).

SUSAN LESLIE DUBOIS, EXAMINING ATTORNEY

**CLASS 43—(Continued).**

SN 86-160,373. HARD ROCK CAFE INTERNATIONAL (USA), INC., ORLANDO, FL. FILED 1-8-2014.



OWNER OF U.S. REG. NOS. 2,478,328, 3,422,550 AND OTHERS.

THE COLOR(S) PURPLE, LIME GREEN, DARK ORANGE, PINK, BROWN, GREY, BLACK, WHITE AND TAN IS/ARE CLAIMED AS A FEATURE OF THE MARK.

THE MARK CONSISTS OF A DARK ORANGE LIZARD-LIKE FROG WITH A PINK TONGUE, BROWN SPOTS AND A BROWN BEARD, WHITE SUNGLASSES WITH LIME GREEN LENSES, AND A GRAY AND BROWN HEADSET; WEARING A TAN SHIRT, A BLACK AND PURPLE VEST, BLACK PANTS, BLACK AND GRAY SHOES AND A PURPLE AND WHITE BELT; THE CREATURE IS ALSO WEARING A BLACK FEDORA WITH A PURPLE SASH AND CIRCULAR BLACK EMBLEM WITH A BLACK AND WHITE BORDER AND THE TERM "HARD ROCK" IN WHITE LETTERS WITH A BLACK OUTLINE ACROSS IT. THE WORD "SKIDDLEY" APPEARS IN PURPLE TO THE RIGHT OF THE DESIGN.

FOR CHILD CARE SERVICES; RESTAURANT AND HOTEL SERVICES (U.S. CLS. 100 AND 101).  
SUSAN LESLIE DUBOIS, EXAMINING ATTORNEY

**CLASS 43—(Continued).**

BLACK EMBLEM WITH THE TERM "HARD ROCK" IN WHITE LETTERS WITH A BLACK OUTLINE ON IT. THE DRUM KIT FEATURES A GREEN CRASH CYMBAL; AND TWO SNARES AND A BASE DRUM IN BLACK AND PURPLE, WITH GREEN OUTLINES AND HIGHLIGHTS. THE BASED DRUM HAS A CIRCULAR PURPLE EMBLEM WITH A PURPLE AND WHITE BORDER AND THE TERM "HARD ROCK" IN WHITE LETTERS WITH A PURPLE BORDER ACROSS THE FRONT. THE TERM "BUDDY JR" APPEARS IN PURPLE TO THE RIGHT OF THE DESIGN.

FOR CHILD CARE SERVICES; RESTAURANT AND HOTEL SERVICES (U.S. CLS. 100 AND 101).  
SUSAN LESLIE DUBOIS, EXAMINING ATTORNEY

SN 86-160,426. HARD ROCK CAFE INTERNATIONAL (USA), INC., ORLANDO, FL. FILED 1-8-2014.

SN 86-160,383. HARD ROCK CAFE INTERNATIONAL (USA), INC., ORLANDO, FL. FILED 1-8-2014.



OWNER OF U.S. REG. NOS. 2,478,328, 3,422,550 AND OTHERS.

THE COLOR(S) PURPLE, GREEN, BROWN, TAN, BLUE, GREY, RED, BLACK AND WHITE IS/ARE CLAIMED AS A FEATURE OF THE MARK.

THE MARK CONSISTS OF A TAN AND BROWN CREATURE HOLDING TAN DRUMSTICKS AND SITTING AT A DRUM KIT. THE CREATURE HAS SPIKEY TAN AND BROWN HAIR, A WIDE OPEN MOUTH WITH WHITE TEETH, RED GUMS, A RED TONGUE, AND A BLACK AND BROWN THROAT. IT IS WEARING BLUE PANTS, GRAY SHOES, GREEN AND BLACK WRIST BANDS AND A GREEN AND BLACK ANIMAL-PRINT BANDANA OBSCURING THE EYES. THE BANDANA HAS A CIRCULAR



OWNER OF U.S. REG. NOS. 2,478,328, 3,272,459 AND 3,422,550.

THE COLOR(S) TAN, BLACK, WHITE, GRAY, BLUE, PURPLE AND RED IS/ARE CLAIMED AS A FEATURE OF THE MARK.

THE MARK CONSISTS OF A TAN BEAR WITH A BLUE AND BLACK NOSE AND SEVERAL GRAY EARRINGS; PLAYING A BLACK GUITAR WITH BLUE AND GRAY ACCENTS, BLUE STRINGS AND A GRAY PAW PRINT ON IT; WEARING A BLUE BANDANA STYLE HAT THAT COVERS THE EYES, FEATURING RED AND WHITE BRITISH FLAG-LIKE STRIPES AND THE TERM "HARD ROCK" IN WHITE LETTERS WITH A BLACK OUTLINE OVER A CIRCULAR BLACK EMBLEM WITH A BLACK AND WHITE OUTLINE. THE TERM "SIR KINGSTON" APPEARS IN PURPLE TO THE RIGHT OF THE DESIGN.

FOR CHILD CARE SERVICES; RESTAURANT AND HOTEL SERVICES (U.S. CLS. 100 AND 101).  
SUSAN LESLIE DUBOIS, EXAMINING ATTORNEY



**CLASS 43—(Continued).**

SN 86-163,546. ALLDAY FOODS CO., LTD., BELIZE CITY, BELIZE, FILED 1-13-2014.



NO CLAIM IS MADE TO THE EXCLUSIVE RIGHT TO USE THE NON-LATIN CHARACTERS THAT TRANSLITERATE TO "CHA", APART FROM THE MARK AS SHOWN.

THE MARK CONSISTS OF A STYLIZED "T" ADJACENT THE CHARACTER "4." FORMED ON A CIRCULAR SHADED BACKGROUND ALL ABOVE A SERIES OF CHINESE CHARACTERS.

THE NON-LATIN CHARACTERS IN THE MARK TRANSLITERATE TO "QING; CHA; DA; REN" AND THIS MEANS "PURE"; "CLEAR"; "TEA"; "TO REACH; AND HUMAN BEING" IN ENGLISH.

FOR BAR SERVICES; BOOKING OF TEMPORARY ACCOMMODATION; CAFE SERVICES; CAFETERIA SERVICES; CANTEN SERVICES; FOOD AND DRINK CATERING; RENTAL OF COOKING APPARATUS; CRECHE SERVICES; PROVIDING TEMPORARY LODGING AT HOLIDAY CAMPS; HOTEL SERVICES; BOARDING HOUSES; RENTAL OF CHAIRS, TABLES, TABLE LINEN, GLASSWARE; RENTAL OF DRINKING WATER DISPENSERS; RENTAL OF MEETING ROOMS; RENTAL OF TEMPORARY ACCOMMODATION; RESTAURANT SERVICES; SELF-SERVICE RESTAURANTS; SNACK BAR SERVICES (U.S. CLS. 100 AND 101).

KIMBERLY PARKS, EXAMINING ATTORNEY

SN 86-178,824. CM 76 RESTAURANT GROUP, DBA PIER 76 FISH GRILL, SEAL BEACH, CA. FILED 1-29-2014.



NO CLAIM IS MADE TO THE EXCLUSIVE RIGHT TO USE "FISH GRILL", APART FROM THE MARK AS SHOWN.

THE COLOR(S) BLUE, BROWN, GREEN, RED, WHITE, AND YELLOW IS/ARE CLAIMED AS A FEATURE OF THE MARK.

THE MARK CONSISTS OF AN OCTAGON SHAPED DESIGN OUTLINED IN GREEN COLOR WITH THE COLOR BROWN IN SOLID LINES ABUTTING THIS DESIGN FOLLOWED BY DASH MARKS ALSO IN BROWN COLOR-

**CLASS 43—(Continued).**

ING. ON THE INSIDE OF THE OCTAGON SHAPE, THERE IS STAR DESIGN IN RED COLOR WITH TWO BROWN DASHES LOCATED ON EITHER SIDE. BELOW THE STAR DESIGN, THERE IS THE WORD "PIER" IN BROWN UPPER CASE LETTERS FOLLOWED BY THE NUMBER "76" IN RED COLOR. UNDERNEATH THE "PIER 76", THERE IS AN IMAGE OF A FISH WITH THE COLORS BLUE, YELLOW AND WHITE. UNDERNEATH THE FISH DESIGN ARE THE WORDS "FISH" AND "GRILL" IN RED LETTERING WITH TWO LONGER DASHES UNDERNEATH THESE WORDS.

FOR RESTAURANT, TAKEOUT AND CATERING SERVICES (U.S. CLS. 100 AND 101).

FIRST USE 6-0-2013; IN COMMERCE 6-0-2013.

CURTIS FRENCH, EXAMINING ATTORNEY

SN 86-191,930. PUZO, CLAUDIA L., MAHWAH, NJ. FILED 2-12-2014.

**Mojo's Mex Cafes, LLC**

THE MARK CONSISTS OF STANDARD CHARACTERS WITHOUT CLAIM TO ANY PARTICULAR FONT, STYLE, SIZE, OR COLOR.

NO CLAIM IS MADE TO THE EXCLUSIVE RIGHT TO USE "MEX CAFES, LLC", APART FROM THE MARK AS SHOWN.

FOR MEXICAN RESTAURANT AND BAR SERVICES (U.S. CLS. 100 AND 101).

DEBORAH MEINERS, EXAMINING ATTORNEY

SN 86-204,560. GYPSY CHEF INC., SANTA MONICA, CA. FILED 2-26-2014.

**GYPSY CHEF**

THE MARK CONSISTS OF STANDARD CHARACTERS WITHOUT CLAIM TO ANY PARTICULAR FONT, STYLE, SIZE, OR COLOR.

NO CLAIM IS MADE TO THE EXCLUSIVE RIGHT TO USE "CHEF", APART FROM THE MARK AS SHOWN.

FOR CONSULTING IN THE FIELDS OF CULINARY ARTS AND RESTAURANT CONCEPTS IN THE NATURE OF MENU DEVELOPMENT AND RECIPE DEVELOPMENT (U.S. CLS. 100 AND 101).

MICHAEL TANNER, EXAMINING ATTORNEY

**CLASS 43—(Continued).**

SN 86-204,987. GYPSY CHEF INC., SANTA MONICA, CA. FILED 2-26-2014.

**DAVID MYERS**

THE MARK CONSISTS OF STANDARD CHARACTERS WITHOUT CLAIM TO ANY PARTICULAR FONT, STYLE, SIZE, OR COLOR.

THE NAME(S), PORTRAIT(S), AND/OR SIGNATURE(S) SHOWN IN THE MARK IDENTIFIES "DAVID MYERS", WHOSE CONSENT(S) TO REGISTER IS MADE OF RECORD.

FOR CONSULTING IN THE FIELDS OF CULINARY ARTS AND RESTAURANT CONCEPTS IN THE NATURE OF MENU DEVELOPMENT AND RECIPE DEVELOPMENT (U.S. CLS. 100 AND 101).

MICHAEL TANNER, EXAMINING ATTORNEY

SN 86-205,964. GIOWORLD TRAVEL LLC, MEDFORD, NJ. FILED 2-27-2014.

**GIOWORLD TRAVEL**

THE MARK CONSISTS OF STANDARD CHARACTERS WITHOUT CLAIM TO ANY PARTICULAR FONT, STYLE, SIZE, OR COLOR.

NO CLAIM IS MADE TO THE EXCLUSIVE RIGHT TO USE "TRAVEL", APART FROM THE MARK AS SHOWN.

FOR PROVIDING TRAVEL LODGING INFORMATION SERVICES AND TRAVEL LODGING BOOKING AGENCY SERVICES FOR TRAVELERS (U.S. CLS. 100 AND 101).

SEAN CROWLEY, EXAMINING ATTORNEY

SN 86-209,399. AV-1 MISSION LP, OMAHA, NE. FILED 3-3-2014.

**THE WELSTONE**

THE MARK CONSISTS OF STANDARD CHARACTERS WITHOUT CLAIM TO ANY PARTICULAR FONT, STYLE, SIZE, OR COLOR.

FOR PROVIDING INDEPENDENT LIVING FACILITIES FOR THE ELDERLY (U.S. CLS. 100 AND 101).

APRIL REEVES, EXAMINING ATTORNEY

**CLASS 43—(Continued).**

SN 86-210,669. MOUNTAIN VIEW BREWERY, LLC, ROSELAND, VA. FILED 3-4-2014.

**DEVILS BACKBONE BASECAMP  
BREW PUB**

THE MARK CONSISTS OF STANDARD CHARACTERS WITHOUT CLAIM TO ANY PARTICULAR FONT, STYLE, SIZE, OR COLOR.

OWNER OF U.S. REG. NO. 3,712,371.

NO CLAIM IS MADE TO THE EXCLUSIVE RIGHT TO USE "BREW PUB", APART FROM THE MARK AS SHOWN.

FOR PUBS; BAR SERVICES; RESTAURANT SERVICES (U.S. CLS. 100 AND 101).

FIRST USE 3-3-2014; IN COMMERCE 3-3-2014.

MORGAN WYNNE, EXAMINING ATTORNEY

SN 86-212,523. UP2YOU CAFE INC., SAN DIEGO, CA. FILED 3-6-2014.

**UP2YOU CAFE**

THE MARK CONSISTS OF STANDARD CHARACTERS WITHOUT CLAIM TO ANY PARTICULAR FONT, STYLE, SIZE, OR COLOR.

NO CLAIM IS MADE TO THE EXCLUSIVE RIGHT TO USE "CAFE", APART FROM THE MARK AS SHOWN.

FOR COFFEE-HOUSE AND SNACK-BAR SERVICES; CAFE-RESTAURANTS; RESTAURANT AND CAFE SERVICES; TEA ROOMS (U.S. CLS. 100 AND 101).

C. DIONNE CLYBURN, EXAMINING ATTORNEY

SN 86-214,152. AUGUSTA NATIONAL, INC., AUGUSTA, GA. FILED 3-7-2014.

**MACKENZIE'S PUB**

THE MARK CONSISTS OF STANDARD CHARACTERS WITHOUT CLAIM TO ANY PARTICULAR FONT, STYLE, SIZE, OR COLOR.

NO CLAIM IS MADE TO THE EXCLUSIVE RIGHT TO USE "PUB", APART FROM THE MARK AS SHOWN.

FOR RESTAURANT SERVICES (U.S. CLS. 100 AND 101).

FIRST USE 4-8-2013; IN COMMERCE 4-8-2013.

MICHAEL TANNER, EXAMINING ATTORNEY

**CLASS 43—(Continued).**

SN 86-217,184. CASA DEMARCO, LLC, BOCA RATON, FL.  
FILED 3-11-2014.

---

## ULTIMATE EXUMA

THE MARK CONSISTS OF STANDARD CHARACTERS WITHOUT CLAIM TO ANY PARTICULAR FONT, STYLE, SIZE, OR COLOR.

NO CLAIM IS MADE TO THE EXCLUSIVE RIGHT TO USE "EXUMA", APART FROM THE MARK AS SHOWN.

FOR RESORT LODGING SERVICES; HEALTH RESORT SERVICES, NAMELY, PROVIDING FOOD AND LODGING THAT SPECIALIZE IN PROMOTING PATRONS' GENERAL HEALTH AND WELL-BEING (U.S. CLS. 100 AND 101).

FIRST USE 10-30-2012; IN COMMERCE 10-30-2012.  
KATHERINE CHANG, EXAMINING ATTORNEY

**CLASS 43—(Continued).**

SN 86-222,502. LOZANO, CARLOS, MIAMI SHORES, FL.  
FILED 3-16-2014.



OWNER OF U.S. REG. NOS. 3,531,876, 3,886,138 AND OTHERS.

THE MARK CONSISTS OF THE STYLIZED WORDS "LOS PERROS" WITH THE FIRST LETTER "R" OF "PERROS" BEING REVERSED AND APPEARING BACKWARDS. THE ENTIRETY OF THE MARK APPEARS ON A SHADED BACKGROUND.

THE ENGLISH TRANSLATION OF "LOS PERROS" IN THE MARK IS "THE DOGS".

FOR RESTAURANT; RESTAURANT SERVICES, INCLUDING SIT-DOWN SERVICE OF FOOD AND TAKE-OUT RESTAURANT SERVICES; RESTAURANT SERVICES, NAMELY, PROVIDING OF FOOD AND BEVERAGES FOR CONSUMPTION ON AND OFF THE PREMISES (U.S. CLS. 100 AND 101).

FIRST USE 1-31-2011; IN COMMERCE 1-31-2011.  
LAURA GOLDEN, EXAMINING ATTORNEY

---

SN 86-223,456. GREAT SCOTT TAVERN, LLC, CLEVELAND, OH. FILED 3-17-2014.

## Great Scott Tavern

THE MARK CONSISTS OF STANDARD CHARACTERS WITHOUT CLAIM TO ANY PARTICULAR FONT, STYLE, SIZE, OR COLOR.

NO CLAIM IS MADE TO THE EXCLUSIVE RIGHT TO USE "TAVERN", APART FROM THE MARK AS SHOWN.

FOR BAR SERVICES; RESTAURANT SERVICES (U.S. CLS. 100 AND 101).

ALISON KEELEY, EXAMINING ATTORNEY

---

SN 86-222,450. TNC HOLDING COMPANY, LLC, SAN FRANCISCO, CA. FILED 3-16-2014.

## TSAR NICOULAI CAVIAR CAFE

THE MARK CONSISTS OF STANDARD CHARACTERS WITHOUT CLAIM TO ANY PARTICULAR FONT, STYLE, SIZE, OR COLOR.

OWNER OF U.S. REG. NO. 1,877,777.

NO CLAIM IS MADE TO THE EXCLUSIVE RIGHT TO USE "CAVIAR CAFE", APART FROM THE MARK AS SHOWN.

THE NAME(S), PORTRAIT(S), AND/OR SIGNATURE(S) SHOWN IN THE MARK DOES NOT IDENTIFY A PARTICULAR LIVING INDIVIDUAL.

FOR RESTAURANT SERVICES (U.S. CLS. 100 AND 101).

TINA L. SNAPP, EXAMINING ATTORNEY

---

SN 86-223,787. KAI LLC, SANTA MONICA, CA. FILED 3-17-2014.

## PONO

THE MARK CONSISTS OF STANDARD CHARACTERS WITHOUT CLAIM TO ANY PARTICULAR FONT, STYLE, SIZE, OR COLOR.

OWNER OF U.S. REG. NO. 4,385,356.

THE ENGLISH TRANSLATION OF "PONO" IN THE MARK IS "TO DO THINGS WITH INTEGRITY".

FOR RESTAURANT SERVICES (U.S. CLS. 100 AND 101).

FIRST USE 4-24-2013; IN COMMERCE 4-24-2013.

MARK SPARACINO, EXAMINING ATTORNEY

**CLASS 43—(Continued).**

SN 86-223,790. KAI LLC, SANTA MONICA, CA. FILED 3-17-2014.



OWNER OF U.S. REG. NO. 4,385,356.  
THE MARK CONSISTS OF THE WORD "PONO" INSIDE OF A HEXAGON.

THE ENGLISH TRANSLATION OF "PONO" IN THE MARK IS "TO DO THINGS WITH INTEGRITY".

FOR RESTAURANT SERVICES (U.S. CLS. 100 AND 101).

FIRST USE 3-0-2014; IN COMMERCE 3-0-2014.

MARK SPARACINO, EXAMINING ATTORNEY

SN 86-226,639. SAIF HIRMI, Z, SHELBY TWP, MI. FILED 3-20-2014.



NO CLAIM IS MADE TO THE EXCLUSIVE RIGHT TO USE "FRIES", APART FROM THE MARK AS SHOWN.

THE COLOR(S) PURPLE, YELLOW, BLACK, WHITE, BROWN, PINK, GOLD IS/ARE CLAIMED AS A FEATURE OF THE MARK.

THE MARK CONSISTS OF THE STYLIZED WORDS "MAGIC FRIES" IN GOLD, OUTLINED IN BLACK AND PURPLE, AND PARTIALLY OUTLINED IN PINK. A BLACK TOP HAT FEATURING A WHITE BAND AND CONTAINING YELLOW AND BROWN FRENCH FRIES IS DEPICTED BETWEEN THE WORDS "MAGIC" AND "FRIES". A BLACK LINE EMANATES FROM THE TOP OF THE LETTER "C" IN "MAGIC" AND A SECOND BLACK LINE EMANATES FROM THE TOP OF THE LETTER "F" IN "FRIES". A SERIES OF PINK AND PURPLE STARS APPEAR ABOVE AND BELOW THE WORDING AND TOP HAT DESIGN.

FOR CAFE AND RESTAURANT SERVICES (U.S. CLS. 100 AND 101).

BRIAN CALLAGHAN, EXAMINING ATTORNEY

**CLASS 43—(Continued).**

SN 86-227,557. HOWARD LEE BONDURANT JR, DAYTON, OH. FILED 3-20-2014.

## Supreme Life Foods

THE MARK CONSISTS OF STANDARD CHARACTERS WITHOUT CLAIM TO ANY PARTICULAR FONT, STYLE, SIZE, OR COLOR.

NO CLAIM IS MADE TO THE EXCLUSIVE RIGHT TO USE "FOODS", APART FROM THE MARK AS SHOWN.

FOR HEALTH RESORT SERVICES, NAMELY, PROVIDING FOOD AND LODGING THAT SPECIALIZE IN PROMOTING PATRONS' GENERAL HEALTH AND WELL-BEING (U.S. CLS. 100 AND 101).

DANNEAN HETZEL, EXAMINING ATTORNEY

SN 86-228,093. SOUTHERN KITCHEN NASHVILLE, LLC, NASHVILLE, TN. FILED 3-21-2014.



NO CLAIM IS MADE TO THE EXCLUSIVE RIGHT TO USE "STEAK & OYSTER" AND "NASHVILLE, TN.", APART FROM THE MARK AS SHOWN.

THE MARK CONSISTS OF THE DESIGN OF A RAISED THREE-DIMENSIONAL LETTER "S" WITH THE WORDING "THE SOUTHERN STEAK & OYSTER NASHVILLE, TN. SOUTH OF SOMEWHERE" SUPERIMPOSED THEREON.

FOR RESTAURANT SERVICES (U.S. CLS. 100 AND 101).

FIRST USE 4-0-2012; IN COMMERCE 4-0-2012.

KATINA MISTER, EXAMINING ATTORNEY

SN 86-228,160. DEBORAH LICURSE, SUNNYVALE, CA. FILED 3-21-2014.

## ORGANIC-GO

THE MARK CONSISTS OF STANDARD CHARACTERS WITHOUT CLAIM TO ANY PARTICULAR FONT, STYLE, SIZE, OR COLOR.

FOR FAST-FOOD RESTAURANTS FEATURING ORGANIC FOOD AND DRINKS (U.S. CLS. 100 AND 101).

KAMAL PREET, EXAMINING ATTORNEY

**CLASS 43—(Continued).**

SN 86-229,012. JAMES GILBERT KOENIGSAECKER, REDDING, CA. FILED 3-21-2014.

**KICK START CAFE**

THE MARK CONSISTS OF STANDARD CHARACTERS WITHOUT CLAIM TO ANY PARTICULAR FONT, STYLE, SIZE, OR COLOR.

OWNER OF U.S. REG. NO. 4,458,640.  
NO CLAIM IS MADE TO THE EXCLUSIVE RIGHT TO USE "CAFE", APART FROM THE MARK AS SHOWN.  
FOR COFFEE BARS (U.S. CLS. 100 AND 101).  
FIRST USE 1-1-2007; IN COMMERCE 12-1-2011.  
WILLIAM ROSSMAN, EXAMINING ATTORNEY

**CLASS 43—(Continued).**

SN 86-231,844. GOLDEN FOREST MONGOLIAN BBQ, LOS ANGELES, CA. FILED 3-25-2014.



NO CLAIM IS MADE TO THE EXCLUSIVE RIGHT TO USE "MONGOLIAN BBQ", APART FROM THE MARK AS SHOWN.

THE MARK CONSISTS OF A CIRCLE. AT THE TOP OF THE CIRCLE IS THE WORDING "GOLDEN FOREST". AT THE BOTTOM OF THE CIRCLE IS THE WORDING "MONGOLIAN BBQ". INSIDE THE CIRCLE IS A COW SITTING DOWN WITH A BOWL OF NOODLES, MEAT AND VEGETABLES WITH CHOPSTICKS IN EACH HAND.  
FOR RESTAURANT SERVICES (U.S. CLS. 100 AND 101).  
KERI CANTONE, EXAMINING ATTORNEY

SN 86-229,372. REIGN LLC, DBA COFFEE STUDIO, MERIDIAN, ID. FILED 3-23-2014.



NO CLAIM IS MADE TO THE EXCLUSIVE RIGHT TO USE "COFFEE", APART FROM THE MARK AS SHOWN.

THE COLOR(S) BLACK, GOLD AND BROWN IS/ARE CLAIMED AS A FEATURE OF THE MARK.

THE MARK CONSISTS OF THE STYLIZED WORDING "COFFEE" IN GOLD LETTERING WITH BLACK OUTLINING TO THE LEFT OF THE DESIGN OF A COFFEE CUP ON A SAUCER WITH STEAM RISING OUT OF THE CUP ALL IN THE COLOR BLACK TO THE LEFT OF THE STYLIZED WORDING "STUDIO" IN BROWN LETTERING WITH BLACK OUTLINING.

FOR COFFEE-HOUSE AND SNACK-BAR SERVICES (U.S. CLS. 100 AND 101).

FIRST USE 1-12-2012; IN COMMERCE 8-15-2012.  
AMY C. KEAN, EXAMINING ATTORNEY

SN 86-231,858. WFR STAMFORD LLC, STAMFORD, CT. FILED 3-25-2014.



THE STIPPLING IS FOR SHADING PURPOSES ONLY.  
THE LIKENESS (OR, "PORTRAIT") IN THE MARK IDENTIFIES A LIVING INDIVIDUAL WHOSE CONSENT IS OF RECORD.

THE MARK CONSISTS OF A DESIGN OF A BUST OF A WOMEN'S HEAD WITH A HAIR BAND  
FOR FAST-FOOD RESTAURANT SERVICES; RESTAURANT AND CATERING SERVICES (U.S. CLS. 100 AND 101).

FIRST USE 6-25-2013; IN COMMERCE 6-25-2013.  
PAUL CROWLEY, EXAMINING ATTORNEY

**CLASS 43—(Continued).**

SN 86-231,930. HASHKNIFE ON THE CHISHOLM INC., MINERAL WELLS, TX. FILED 3-25-2014.

### Hashknife restaurants & catering

THE MARK CONSISTS OF STANDARD CHARACTERS WITHOUT CLAIM TO ANY PARTICULAR FONT, STYLE, SIZE, OR COLOR.

NO CLAIM IS MADE TO THE EXCLUSIVE RIGHT TO USE "RESTAURANTS & CATERING", APART FROM THE MARK AS SHOWN.

FOR CATERING SERVICES; RESTAURANT SERVICES, NAMELY, PROVIDING OF FOOD AND BEVERAGES FOR CONSUMPTION ON AND OFF THE PREMISES (U.S. CLS. 100 AND 101).

FIRST USE 6-1-1999; IN COMMERCE 6-1-1999.  
ANDREA CORNWELL, EXAMINING ATTORNEY

---

SN 86-232,694. HART, THOMAS, SCARSDALE, NY. FILED 3-26-2014.

### TOMMY HART'S STEAKHOUSE

THE MARK CONSISTS OF STANDARD CHARACTERS WITHOUT CLAIM TO ANY PARTICULAR FONT, STYLE, SIZE, OR COLOR.

NO CLAIM IS MADE TO THE EXCLUSIVE RIGHT TO USE "STEAKHOUSE", APART FROM THE MARK AS SHOWN.

THE NAME(S), PORTRAIT(S), AND/OR SIGNATURE(S) SHOWN IN THE MARK IDENTIFIES "TOMMY HART", WHOSE CONSENT(S) TO REGISTER IS MADE OF RECORD.

FOR RESTAURANT AND BAR SERVICES (U.S. CLS. 100 AND 101).

TAMARA HUDSON, EXAMINING ATTORNEY

---

SN 86-232,828. MCBLARNEY'S HOLDING, LLC, PROVIDENCE, RI. FILED 3-26-2014.

### MCBLARNEY'S COUNTY TAP

THE MARK CONSISTS OF STANDARD CHARACTERS WITHOUT CLAIM TO ANY PARTICULAR FONT, STYLE, SIZE, OR COLOR.

NO CLAIM IS MADE TO THE EXCLUSIVE RIGHT TO USE "TAP", APART FROM THE MARK AS SHOWN.

FOR BAR AND RESTAURANT SERVICES (U.S. CLS. 100 AND 101).

MIROSLAV NOVAKOVIC, EXAMINING ATTORNEY

**CLASS 43—(Continued).**

SN 86-232,843. MCBLARNEY'S HOLDING, LLC, PROVIDENCE, RI. FILED 3-26-2014.

### MCBLARNEY'S TAP & GRILLE

THE MARK CONSISTS OF STANDARD CHARACTERS WITHOUT CLAIM TO ANY PARTICULAR FONT, STYLE, SIZE, OR COLOR.

NO CLAIM IS MADE TO THE EXCLUSIVE RIGHT TO USE "TAP & GRILLE", APART FROM THE MARK AS SHOWN.

FOR BAR AND RESTAURANT SERVICES (U.S. CLS. 100 AND 101).

MIROSLAV NOVAKOVIC, EXAMINING ATTORNEY

---

SN 86-232,893. MCBLARNEY'S HOLDING, LLC, PROVIDENCE, RI. FILED 3-26-2014.

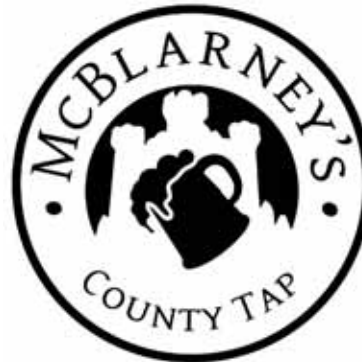

NO CLAIM IS MADE TO THE EXCLUSIVE RIGHT TO USE "TAP", APART FROM THE MARK AS SHOWN.

THE MARK CONSISTS OF A BEER MUG WITHIN AN OUTLINE OF A CASTLE WHICH APPEAR IN AN INNER CONCENTRIC CIRCLE, AND THE WORDING "MCBLARNEY'S" AT THE TOP OF AN OUTER CONCENTRIC CIRCLE AND THE WORDING "COUNTY TAP" AT THE BOTTOM OF THE SAME OUTER CONCENTRIC CIRCLE.

FOR BAR AND RESTAURANT SERVICES (U.S. CLS. 100 AND 101).

MIROSLAV NOVAKOVIC, EXAMINING ATTORNEY

**CLASS 43—(Continued).**

SN 86-233,623. DEL TACO LLC, LAKE FOREST, CA. FILED 3-27-2014.

**MAKIN' IT FRESH**

THE MARK CONSISTS OF STANDARD CHARACTERS WITHOUT CLAIM TO ANY PARTICULAR FONT, STYLE, SIZE, OR COLOR.

OWNER OF U.S. REG. NO. 2,865,565.  
NO CLAIM IS MADE TO THE EXCLUSIVE RIGHT TO USE "FRESH", APART FROM THE MARK AS SHOWN.  
FOR RESTAURANT SERVICES (U.S. CLS. 100 AND 101).

JULIE VEPPUMTHARA, EXAMINING ATTORNEY

---

SN 86-233,745. FLAGSHIP, LLC, OMAHA, NE. FILED 3-27-2014.



NO CLAIM IS MADE TO THE EXCLUSIVE RIGHT TO USE "BEER & TABLE", APART FROM THE MARK AS SHOWN.

THE MARK CONSISTS OF THE STYLIZED WORD "BLATT" AND THE STYLIZED WORDS "BEER & TABLE" BELOW THE WORD "BLATT." TO THE LEFT OF THE WORD "BEER" IS THE END OF AN ARROW AND TO THE RIGHT OF THE WORD "TABLE" IS A FORK.

FOR RESTAURANT AND BAR SERVICES (U.S. CLS. 100 AND 101).

FIRST USE 6-30-2011; IN COMMERCE 6-30-2011.  
HEATHER THOMPSON, EXAMINING ATTORNEY

---

SN 86-233,809. FLAGSHIP, LLC, OMAHA, NE. FILED 3-27-2014.

NO CLAIM IS MADE TO THE EXCLUSIVE RIGHT TO USE "SEAFOOD PROVISIONS", APART FROM THE MARK AS SHOWN.

THE MARK CONSISTS OF THE STYLIZED WORD "PLANK" WITH THE STYLIZED WORDS "SEAFOOD PROVISIONS" BELOW THE WORD "PLANK". THERE IS AN ANCHOR BETWEEN THE WORDS "SEAFOOD PROVISIONS".

FOR RESTAURANT AND BAR SERVICES (U.S. CLS. 100 AND 101).

FIRST USE 5-31-2013; IN COMMERCE 5-31-2013.  
HEATHER THOMPSON, EXAMINING ATTORNEY

**CLASS 43—(Continued).**

SN 86-234,217. FAMILY TOBACCO TRADERS LLC, CORAL GABLES, FL. FILED 3-27-2014.

**THE TANK MIAMI BREWERY**

THE MARK CONSISTS OF STANDARD CHARACTERS WITHOUT CLAIM TO ANY PARTICULAR FONT, STYLE, SIZE, OR COLOR.

NO CLAIM IS MADE TO THE EXCLUSIVE RIGHT TO USE "MIAMI BREWERY", APART FROM THE MARK AS SHOWN.

FOR BREWPUB SERVICES; RESTAURANT SERVICES (U.S. CLS. 100 AND 101).

JASON BLAIR, EXAMINING ATTORNEY

---

SN 86-234,634. LEIBER, DAVID, NEW YORK, NY. FILED 3-27-2014.

**3.14 PIE COMPANY**

THE MARK CONSISTS OF STANDARD CHARACTERS WITHOUT CLAIM TO ANY PARTICULAR FONT, STYLE, SIZE, OR COLOR.

NO CLAIM IS MADE TO THE EXCLUSIVE RIGHT TO USE "PIE COMPANY", APART FROM THE MARK AS SHOWN.

FOR RESTAURANT SERVICES (U.S. CLS. 100 AND 101).

LEIGH LOWRY, EXAMINING ATTORNEY

---

SN 86-234,656. BC RESTAURANT GROUP, DBA BC TACOS, CORAL SPRINGS, FL. FILED 3-27-2014.



NO CLAIM IS MADE TO THE EXCLUSIVE RIGHT TO USE "TACOS", APART FROM THE MARK AS SHOWN.

THE COLOR(S) BLUE, BROWN, YELLOW, GREEN, BLACK, WHITE, RED, CREAM, AND TAN IS/ARE CLAIMED AS A FEATURE OF THE MARK.

THE MARK CONSISTS OF A TAN CAVEWOMAN HOLDING A BROWN CLUB IN HIS RIGHT HAND, IN HIS LEFT HAND HE IS HOLDING A YELLOW TACO SHELL FILLED



**CLASS 43—(Continued).**

WITH GREEN LETTUCE, RED TOMATOES, AND BROWN MEAT. HIS FACE IS SCRUNCHED WITH BLACK BUSHY EYEBROWS AND ONE WHITE TOOTH ON THE LEFT SIDE OF HIS MOUTH, AND A FEW BLACK CHIN HAIRS. HE IS WEARING A YELLOW GARMENT WITH SOME BLACK MARKS. THE CAVEMAN IS STANDING ON TOP OF THE CREAM COLORED STONE LETTERS "B.C." THE WORD UNDERNEATH "B.C." IS "TACOS" AND IS IN A BLACK CRACKED UPPERCASE FONT. ALL ELEMENTS ARE SET AGAINST A BLUE BACKGROUND.

FOR RESTAURANT AND CATERING SERVICES; RESTAURANT SERVICES, INCLUDING SIT-DOWN SERVICE OF FOOD AND TAKE-OUT RESTAURANT SERVICES; RESTAURANT SERVICES, NAMELY, PROVIDING OF FOOD AND BEVERAGES FOR CONSUMPTION ON AND OFF THE PREMISES (U.S. CLS. 100 AND 101).

FIRST USE 3-1-2011; IN COMMERCE 5-18-2011.  
SIDDHARTH JAGANNATHAN, EXAMINING ATTORNEY

---

SN 86-235,080. HISSHO INTERNATIONAL, LLC, CHARLOTTE, NC. FILED 3-28-2014.

**zundo**

THE MARK CONSISTS OF STANDARD CHARACTERS WITHOUT CLAIM TO ANY PARTICULAR FONT, STYLE, SIZE, OR COLOR.

THE ENGLISH TRANSLATION OF "ZUNDO" IS "CYLINDRICAL CONTAINER".

FOR RESTAURANTS (U.S. CLS. 100 AND 101).  
TARAH HARDY, EXAMINING ATTORNEY

---

SN 86-235,117. SIMS, CHARLTON, HOUSTON, TX. FILED 3-28-2014.

**Mikey's Supreme Burgers  
and More**

THE MARK CONSISTS OF STANDARD CHARACTERS WITHOUT CLAIM TO ANY PARTICULAR FONT, STYLE, SIZE, OR COLOR.

NO CLAIM IS MADE TO THE EXCLUSIVE RIGHT TO USE "SUPREME BURGERS", APART FROM THE MARK AS SHOWN.

FOR FAST-FOOD RESTAURANT SERVICES; FAST-FOOD RESTAURANTS; RESTAURANT (U.S. CLS. 100 AND 101).

TARAH HARDY, EXAMINING ATTORNEY

**CLASS 43—(Continued).**

SN 86-235,182. FRANINVEST, LLC, ALEXANDRIA, VA. FILED 3-28-2014.



NO CLAIM IS MADE TO THE EXCLUSIVE RIGHT TO USE "REAL TASTY CHICKEN & SIDES", APART FROM THE MARK AS SHOWN.

THE COLOR(S) RED, YELLOW, BLACK AND WHITE IS/ARE CLAIMED AS A FEATURE OF THE MARK.

THE MARK CONSISTS OF A WEATHER VANE CONSISTING OF A RED CHICKEN OUTLINED IN YELLOW ON A BLACK STAND TO THE LEFT OF THE WORD "THE" WHICH APPEARS IN THE COLOR YELLOW OUTLINED IN BLACK ABOVE THE TERM "CHICKERY" WHICH APPEARS IN THE COLOR RED OUTLINED IN BLACK ABOVE THE WORDING "REAL TASTY CHICKEN & SIDES" WHICH APPEARS IN THE COLOR YELLOW. THE WHOLE MARK APPEARS ON A WHITE BACKGROUND.

FOR RESTAURANT SERVICES, TAKE-OUT RESTAURANT SERVICES, CATERING SERVICES, BAR SERVICES (U.S. CLS. 100 AND 101).

GEOFFREY FOSDICK, EXAMINING ATTORNEY

---

SN 86-235,218. HISSHO INTERNATIONAL, LLC, CHARLOTTE, NC. FILED 3-28-2014.

**zundō**  
ramen | baō | makirritō

NO CLAIM IS MADE TO THE EXCLUSIVE RIGHT TO USE "RAMEN BAO MAKIRRITO", APART FROM THE MARK AS SHOWN.

THE COLOR(S) RED AND BLACK IS/ARE CLAIMED AS A FEATURE OF THE MARK.

THE MARK CONSISTS OF THE WORDING "ZUNDO" AND "RAMEN | BAO | MAKIRRITO" WHERE THE WORD "ZUNDO" IS IN A RED COLOR ON TOP AND THE WORDS "RAMEN | BAO | MAKIRRITO" ARE IN A BLACK COLOR BELOW. THE LETTER "O" IN "ZUNDO" IS STYLIZED AS A PAINT BRUSH STROKE AND A MACRON IN A BLACK COLOR, STYLIZED AS A PAINT BRUSH STROKE, RESTS ABOVE THE "O" IN "ZUNDO". THE WORD "BAO" HAS A MACRON RESTING ABOVE THE "O". THE WORD "MAKIRRITO" ALSO HAS A MACRON RESTING ABOVE THE "O".

THE ENGLISH TRANSLATION OF "ZUNDO" IS "CYLINDRICAL CONTAINER". THE ENGLISH TRANSLATION OF "BAO" IS "PORK BUN". THE ENGLISH TRANSLATION OF "MAKIRRITO" IS "SUSHI BURRITO".

FOR RESTAURANTS (U.S. CLS. 100 AND 101).

TARAH HARDY, EXAMINING ATTORNEY



**CLASS 43—(Continued).**

SN 86-235,853. DMS FOODS, INC., AUSTIN, TX. FILED 3-28-2014.



OWNER OF U.S. REG. NOS. 4,222,925 AND 4,222,926.  
THE MARK CONSISTS OF THE STYLIZED TERM "VERTSKEBAP!" SLOPING UPWARD TO THE EXCLAMATION POINT.

FOR RESTAURANT SERVICES; TAKE-OUT RESTAURANT SERVICES; MOBILE RESTAURANT SERVICES (U.S. CLS. 100 AND 101).

KATHERINE M. DUBRAY, EXAMINING ATTORNEY

SN 86-235,872. DMS FOODS, INC., AUSTIN, TX. FILED 3-28-2014.



OWNER OF U.S. REG. NOS. 4,222,925 AND 4,222,926.  
THE MARK CONSISTS OF THE SILHOUETTE OF A VERTICAL ROTISSERIE NEXT TO THE TERM "VERTSKEBAP!" IN A STYLIZED FONT SLOPING UPWARD TO THE EXCLAMATION POINT.

FOR RESTAURANT SERVICES; TAKE-OUT RESTAURANT SERVICES; MOBILE RESTAURANT SERVICES (U.S. CLS. 100 AND 101).

KATHERINE M. DUBRAY, EXAMINING ATTORNEY

SN 86-235,951. HONG, JOHN, LOS ANGELES, CA. FILED 3-28-2014.

# BBQ CROWN

THE MARK CONSISTS OF STANDARD CHARACTERS WITHOUT CLAIM TO ANY PARTICULAR FONT, STYLE, SIZE, OR COLOR.

NO CLAIM IS MADE TO THE EXCLUSIVE RIGHT TO USE "BBQ", APART FROM THE MARK AS SHOWN.

FOR RESTAURANT AND CATERING SERVICES (U.S. CLS. 100 AND 101).

FIRST USE 1-1-2014; IN COMMERCE 1-1-2014.

CYNTHIA RINALDI, EXAMINING ATTORNEY

**CLASS 43—(Continued).**

SN 86-236,228. BAGEL GUYS LLC, LOS GATOS, CA. FILED 3-29-2014.

# BAGEL GUYS

THE MARK CONSISTS OF STANDARD CHARACTERS WITHOUT CLAIM TO ANY PARTICULAR FONT, STYLE, SIZE, OR COLOR.

NO CLAIM IS MADE TO THE EXCLUSIVE RIGHT TO USE "BAGEL", APART FROM THE MARK AS SHOWN.

FOR RESTAURANTS PROVIDING BAGELS, BAKED GOODS, SANDWICHES, SOUPS, CREAM CHEESE, BEVERAGES, FRUIT, NOVELTY FOOD ITEMS, AND COFFEE FOR CONSUMPTION ON OR OFF THE PREMISES; CATERING SERVICES (U.S. CLS. 100 AND 101).

FIRST USE 2-1-2008; IN COMMERCE 2-1-2008.

JAMES GRIFFIN, EXAMINING ATTORNEY

SN 86-236,429. AMAZING KIDS MANAGEMENT GROUP, INC., PELHAM, AL. FILED 3-30-2014.



NO CLAIM IS MADE TO THE EXCLUSIVE RIGHT TO USE "SCHOOL" AND "KIDS", APART FROM THE MARK AS SHOWN.

THE COLOR(S) WHITE, BLACK, GOLD IS/ARE CLAIMED AS A FEATURE OF THE MARK.

THE MARK CONSISTS OF THE LETTERS "AK" IN GOLD WITH A WHITE BORDER ON A BLACK SHIELD WITH A GOLD BORDER. ON THE SIDES OF THE SHIELD ARE BRANCHES WITH LEAVES ALL IN GOLD WITH BLACK TRIM. BELOW IS A GOLD BANNER WITH THE WORDING "AMAZING KIDS" IN WHITE WITH A BLACK BORDER. THE WORDING "SCHOOL FOR" IS WRITTEN IN BLACK STYLIZED LETTERING ABOVE THE SHIELD.

FOR DAY CARE SERVICES FOR CHILDREN 6 WEEKS TO 6 YEARS OLD (U.S. CLS. 100 AND 101).

LINDA QUIGLEY, EXAMINING ATTORNEY

**CLASS 43—(Continued).**

SN 86-237,176. LOLO'S INC., PHOENIX, AZ. FILED 3-31-2014.



OWNER OF U.S. REG. NO. 4,555,667.

NO CLAIM IS MADE TO THE EXCLUSIVE RIGHT TO USE "CHICKEN &amp; WAFFLES", APART FROM THE MARK AS SHOWN.

THE MARK CONSISTS OF STYLIZED WORDING "LO-LO'S" ABOVE THE STYLIZED WORDS "CHICKEN &amp; WAFFLES".

FOR RESTAURANT AND CATERING SERVICES (U.S. CLS. 100 AND 101).

FIRST USE 8-31-2002; IN COMMERCE 8-31-2002.

KAREN BRACEY, EXAMINING ATTORNEY

SN 86-237,615. CRYSTAL'S CATERING, LLC, WASHINGTON, DC. FILED 3-31-2014.

## Crystal's Catering

THE MARK CONSISTS OF STANDARD CHARACTERS WITHOUT CLAIM TO ANY PARTICULAR FONT, STYLE, SIZE, OR COLOR.

NO CLAIM IS MADE TO THE EXCLUSIVE RIGHT TO USE "CATERING", APART FROM THE MARK AS SHOWN.

FOR BOOKING OF CATERING SERVICES FOR OTHERS; CATERING FOR THE PROVISION OF FOOD AND BEVERAGES; CATERING OF FOOD AND DRINKS; CATERING SERVICES; FOOD AND DRINK CATERING; OUTSIDE CATERING SERVICES (U.S. CLS. 100 AND 101).

ALEX KEAM, EXAMINING ATTORNEY

SN 86-237,790. SUSPENSION CAFE LLC, INDIALANTIC, FL. FILED 3-31-2014.

## Suspension Cafe

THE MARK CONSISTS OF STANDARD CHARACTERS WITHOUT CLAIM TO ANY PARTICULAR FONT, STYLE, SIZE, OR COLOR.

NO CLAIM IS MADE TO THE EXCLUSIVE RIGHT TO USE "CAFE", APART FROM THE MARK AS SHOWN.

FOR CAFE AND RESTAURANT SERVICES (U.S. CLS. 100 AND 101).

JANICE L. MCMORROW, EXAMINING ATTORNEY

**CLASS 43—(Continued).**

SN 86-237,852. SNJ, DBA JOE'S PASTA HOUSE, RIO RANCHO, NM. FILED 3-31-2014.



NO CLAIM IS MADE TO THE EXCLUSIVE RIGHT TO USE "PASTA HOUSE", APART FROM THE MARK AS SHOWN.

THE COLOR(S) BLUE, GREEN, BLACK, RED, ORANGE, WHITE, YELLOW AND BEIGE IS/ARE CLAIMED AS A FEATURE OF THE MARK.

THE MARK CONSISTS OF THE WORDING "JOE'S PASTA HOUSE" IN STYLIZED FONT SUPERIMPOSED OVER AN ITALIAN SEASIDE SCENERY DESIGN. THE TERM "JOE'S" APPEARS IN STYLIZED LETTERING WITH COLOR CHANGING FROM WHITE TO YELLOW TO RED AND THE WORDING "PASTA HOUSE" APPEARS IN STYLIZED LETTERING WITH COLOR CHANGING FROM WHITE TO YELLOW. THE LETTER "P" IN THE TERM "PASTA" IS REPRESENTED BY PASTA NOODLES WHICH GATHER IN A PILE BENEATH THE LETTER. THE SEASIDE DESIGN INCLUDES A BLUE SKY, GREEN TREES, BLACK AND GREEN MOUNTAINS, BLUE WATER, BUILDINGS ALONG THE WATER IN RED, ORANGE, YELLOW, WHITE AND GREEN, AND BEIGE AND RED SAIL BOATS IN THE BACKGROUND.

FOR RESTAURANT (U.S. CLS. 100 AND 101).

FIRST USE 1-10-2009; IN COMMERCE 1-10-2009.

NATALIE POLZER, EXAMINING ATTORNEY

**CLASS 43—(Continued).**

SN 86-237,856. DALET HAMBY, LONG BEACH, CA. AND NORMA CHAVEZ, LONG BEACH, CA. FILED 3-31-2014.

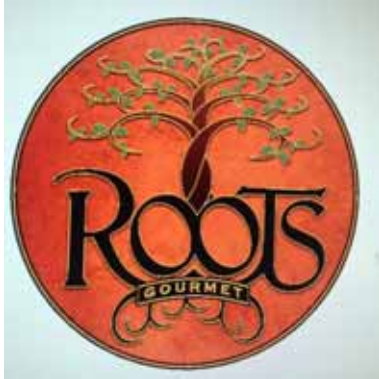

NO CLAIM IS MADE TO THE EXCLUSIVE RIGHT TO USE "GOURMET", APART FROM THE MARK AS SHOWN. THE COLOR(S) ORANGE, GOLD, BLACK, BROWN, AND GREEN IS/ARE CLAIMED AS A FEATURE OF THE MARK.

THE MARK CONSISTS OF THE WORD "ROOTS" IN STYLIZED BLACK LETTERS OUTLINED IN GOLD WITH THE WORD "GOURMET" IN GOLD LETTERS BELOW WITHIN A BLACK BANNER WITH A GOLD BORDER, AND A BROWN TREE OUTLINED IN GOLD WITH GREEN LEAVES ABOVE THE WORD "ROOTS" ALL ON A CIRCULAR ORANGE BACKGROUND WITH A BLACK AND GOLD BORDER.

FOR CAFE AND RESTAURANT SERVICES (U.S. CLS. 100 AND 101).

FIRST USE 0-0-2008; IN COMMERCE 0-0-2008.  
JOHN WILKE, EXAMINING ATTORNEY

SN 86-239,226. VOLTRON ENTERTAINMENT, INC., SHERMAN OAKS, CA. FILED 4-1-2014.

# GIBSIHANA

THE MARK CONSISTS OF STANDARD CHARACTERS WITHOUT CLAIM TO ANY PARTICULAR FONT, STYLE, SIZE, OR COLOR.

THE WORDING "GIBSIHANA" HAS NO MEANING IN A FOREIGN LANGUAGE.

FOR RESTAURANT SERVICES (U.S. CLS. 100 AND 101).

TARAH HARDY, EXAMINING ATTORNEY

**CLASS 43—(Continued).**

SN 86-239,387. DAVIS, PHILLIP B., NORTHFIELD, OH. FILED 4-1-2014.

# i heart waffles

THE MARK CONSISTS OF STANDARD CHARACTERS WITHOUT CLAIM TO ANY PARTICULAR FONT, STYLE, SIZE, OR COLOR.

NO CLAIM IS MADE TO THE EXCLUSIVE RIGHT TO USE "WAFFLES", APART FROM THE MARK AS SHOWN.

FOR FAST-FOOD RESTAURANT SERVICES; RESTAURANT AND CATERING SERVICES; RESTAURANT SERVICES, INCLUDING SIT-DOWN SERVICE OF FOOD AND TAKE-OUT RESTAURANT SERVICES; RESTAURANT SERVICES, NAMELY, PROVIDING OF FOOD AND BEVERAGES FOR CONSUMPTION ON AND OFF THE PREMISES (U.S. CLS. 100 AND 101).

COLLEEN DOMBROW, EXAMINING ATTORNEY

SN 86-241,057. LUGNUTZ CAFÉ, LLC, HOLYOKE, MA. FILED 4-3-2014.

# LugNutz Café Eat Bolt

THE MARK CONSISTS OF STANDARD CHARACTERS WITHOUT CLAIM TO ANY PARTICULAR FONT, STYLE, SIZE, OR COLOR.

NO CLAIM IS MADE TO THE EXCLUSIVE RIGHT TO USE "CAFE" AND "EAT", APART FROM THE MARK AS SHOWN.

FOR RESTAURANT AND CAFE SERVICES (U.S. CLS. 100 AND 101).

FIRST USE 1-30-2014; IN COMMERCE 1-30-2014.

LINDA MICKLEBURGH, EXAMINING ATTORNEY

SN 86-241,307. AER CHAGRIN, INC., CHAGRIN FALLS, OH. FILED 4-3-2014.

# CHAGRIN VALLEY LUCKY DOG CLUB

THE MARK CONSISTS OF STANDARD CHARACTERS WITHOUT CLAIM TO ANY PARTICULAR FONT, STYLE, SIZE, OR COLOR.

NO CLAIM IS MADE TO THE EXCLUSIVE RIGHT TO USE "CHAGRIN VALLEY" AND "DOG CLUB", APART FROM THE MARK AS SHOWN.

FOR KENNEL SERVICES, NAMELY, BOARDING FOR PETS (U.S. CLS. 100 AND 101).

FIRST USE 3-29-2014; IN COMMERCE 3-29-2014.

EMILY CHUO, EXAMINING ATTORNEY

**CLASS 43—(Continued).**

SN 86-242,071. 33 SUBS, INC., EAST HANOVER, NJ. FILED 4-3-2014.

**THE ORIGINAL GREAT WAZU**

THE MARK CONSISTS OF STANDARD CHARACTERS WITHOUT CLAIM TO ANY PARTICULAR FONT, STYLE, SIZE, OR COLOR.

NO CLAIM IS MADE TO THE EXCLUSIVE RIGHT TO USE "THE ORIGINAL", APART FROM THE MARK AS SHOWN.

FOR CAFE SERVICES; DELICATESSEN SERVICES; RESTAURANT SERVICES; TAKE-OUT RESTAURANT SERVICES (U.S. CLS. 100 AND 101).

FIRST USE 0-0-2010; IN COMMERCE 0-0-2010.

ELISSA GARBER KON, EXAMINING ATTORNEY

SN 86-245,366. KC CRAVE, LLC, DBA JAXON SOCIAL, JACKSONVILLE BEACH, FL. FILED 4-8-2014.

**JAXON SOCIAL**

THE MARK CONSISTS OF STANDARD CHARACTERS WITHOUT CLAIM TO ANY PARTICULAR FONT, STYLE, SIZE, OR COLOR.

FOR CATERING SERVICES; RESTAURANT AND BAR SERVICES; RESTAURANT SERVICES; RESTAURANT SERVICES, INCLUDING SIT-DOWN SERVICE OF FOOD AND TAKE-OUT RESTAURANT SERVICES (U.S. CLS. 100 AND 101).

DOMINIC J. FERRAIUOLO, EXAMINING ATTORNEY

**CLASS 43—(Continued).**

SN 86-245,543. TAMIKA FITZPATRICK, DBA THE HEALING AND RENEWING CATERER, HAYWARD, CA. FILED 4-8-2014.



NO CLAIM IS MADE TO THE EXCLUSIVE RIGHT TO USE "CATERER", APART FROM THE MARK AS SHOWN.

THE COLOR(S) RED, WHITE AND PEACH IS/ARE CLAIMED AS A FEATURE OF THE MARK.

THE MARK CONSISTS OF HALF OF A SILHOUETTED PERSON IN RED WITH ARMS UP OVER HER HEAD, HOLDING A COVERED DISH IN RED, WHITE AND PEACH, A LEAF ON EACH SIDE OF THE SILHOUETTE IN LIGHT RED, WHITE AND PEACH, AND A RED AND PEACH UNDERLINE, AND THE WORDING, "THE HEALING & RENEWING CATERER" UNDER EVERYTHING. THE WORDS "THE" AND "CATERER" IN RED AND THE WORDS "HEALING & RENEWING" IN PEACH.

FOR FOOD AND DRINK CATERING (U.S. CLS. 100 AND 101).

WILLIAM VERHOSEK, EXAMINING ATTORNEY

SN 86-245,754. DETERT, YVONNE, SAN FRANCISCO, CA. FILED 4-8-2014.

**OUR PASSION IS YOUR EXPERIENCE**

THE MARK CONSISTS OF STANDARD CHARACTERS WITHOUT CLAIM TO ANY PARTICULAR FONT, STYLE, SIZE, OR COLOR.

FOR HOTEL ACCOMMODATION SERVICES; HOTEL AND RESTAURANT SERVICES; HOTEL SERVICES; HOTELS; MAKING HOTEL RESERVATIONS FOR OTHERS; PROVIDING A WEBSITE FEATURING INFORMATION IN THE FIELD OF HOTELS AND TEMPORARY ACCOMMODATIONS FOR TRAVELERS; PROVIDING EXTENDED-STAY HOTELS; PROVIDING PERSONALIZED INFORMATION ABOUT HOTELS AND TEMPORARY ACCOMMODATIONS FOR TRAVEL VIA THE INTERNET (U.S. CLS. 100 AND 101).

FIRST USE 4-1-2002; IN COMMERCE 4-1-2002.

JACLYN KIDWELL WALKER, EXAMINING ATTORNEY

**CLASS 43—(Continued).**

SN 86-246,196. SUSPENSION CAFE LLC, INDIALANTIC, FL. FILED 4-8-2014.



NO CLAIM IS MADE TO THE EXCLUSIVE RIGHT TO USE "CAFE", APART FROM THE MARK AS SHOWN.

THE MARK CONSISTS OF THE WORDS "SUSPENSION CAFE" IN ALL CAPITAL LETTERS WITH A CHEF'S HAT SITTING OFFSET TO THE LEFT ON THE TOP OF THE FIRST "S" WITH A THREE PRONGED FORK LYING UNDERNEATH THE WORDS.

FOR CAFE AND RESTAURANT SERVICES (U.S. CLS. 100 AND 101).

JANICE L. MCMORROW, EXAMINING ATTORNEY

SN 86-246,503. TWO BICYCLES AND A MAP, LTD, DEERFIELD, WI. FILED 4-8-2014.

## Thank the Cow

THE MARK CONSISTS OF STANDARD CHARACTERS WITHOUT CLAIM TO ANY PARTICULAR FONT, STYLE, SIZE, OR COLOR.

FOR RESTAURANT SERVICES (U.S. CLS. 100 AND 101).

SUNG IN, EXAMINING ATTORNEY

SN 86-246,661. 17100 INC, HARVEY, IL. FILED 4-9-2014.

## ASSETS

THE MARK CONSISTS OF STANDARD CHARACTERS WITHOUT CLAIM TO ANY PARTICULAR FONT, STYLE, SIZE, OR COLOR.

FOR BAR AND NIGHTCLUB SERVICES (U.S. CLS. 100 AND 101).

RAUL CORDOVA, EXAMINING ATTORNEY

**CLASS 43—(Continued).**

SN 86-246,751. R&R BURRITOS, LLC, KILL DEVIL HILLS, NC. FILED 4-9-2014.

## BAD BEAN

THE MARK CONSISTS OF STANDARD CHARACTERS WITHOUT CLAIM TO ANY PARTICULAR FONT, STYLE, SIZE, OR COLOR.

FOR CATERING SERVICES; RESTAURANT; RESTAURANT AND BAR SERVICES; RESTAURANT AND CATERING SERVICES; RESTAURANT SERVICES; RESTAURANTS (U.S. CLS. 100 AND 101).

FIRST USE 4-0-2006; IN COMMERCE 4-0-2006.

DOMINICK J. SALEMI, EXAMINING ATTORNEY

SN 86-246,862. RIO PERLA PROPERTIES, L. P., SAN ANTONIO, TX. FILED 4-9-2014.

## EMMA

THE MARK CONSISTS OF STANDARD CHARACTERS WITHOUT CLAIM TO ANY PARTICULAR FONT, STYLE, SIZE, OR COLOR.

FOR PROVIDING BANQUET AND SOCIAL FUNCTION FACILITIES FOR SPECIAL OCCASIONS; PROVIDING CONFERENCE, EXHIBIT AND MEETING FACILITIES; HOTEL SERVICES (U.S. CLS. 100 AND 101).

THOMAS MANOR, EXAMINING ATTORNEY

SN 86-247,011. AUREA, PHILIP J, LONG BEACH, CA. FILED 4-9-2014.

## TUX AND CHUCKS

THE MARK CONSISTS OF STANDARD CHARACTERS WITHOUT CLAIM TO ANY PARTICULAR FONT, STYLE, SIZE, OR COLOR.

FOR RESTAURANTS; SELF SERVICE RESTAURANTS; CATERING SERVICES (U.S. CLS. 100 AND 101).

BILL DAWE, EXAMINING ATTORNEY

**CLASS 43—(Continued).**

SN 86-247,353. THE SOUPER CAFE, INC., BAY CITY, MI. FILED 4-9-2014.

## The Salad Crisper

THE MARK CONSISTS OF STANDARD CHARACTERS WITHOUT CLAIM TO ANY PARTICULAR FONT, STYLE, SIZE, OR COLOR.

FOR RESTAURANT SERVICES (U.S. CLS. 100 AND 101).

SIDDHARTH JAGANNATHAN, EXAMINING ATTORNEY

---

SN 86-247,363. BUI, ANTHONY, IRVINE, CA. FILED 4-9-2014.

## Pho'n Shaken

THE MARK CONSISTS OF STANDARD CHARACTERS WITHOUT CLAIM TO ANY PARTICULAR FONT, STYLE, SIZE, OR COLOR.

FOR RESTAURANT SERVICES (U.S. CLS. 100 AND 101).

LINDA LAVACHE, EXAMINING ATTORNEY

---

SN 86-247,683. ANTHONY CLARKE, TORRANCE, CA. FILED 4-9-2014.

## GPG

THE MARK CONSISTS OF STANDARD CHARACTERS WITHOUT CLAIM TO ANY PARTICULAR FONT, STYLE, SIZE, OR COLOR.

FOR RESTAURANT SERVICES FEATURING POULTRY; RESTAURANT SERVICES, INCLUDING SIT-DOWN SERVICE OF FOOD AND TAKE-OUT RESTAURANT SERVICES; RESTAURANT SERVICES, NAMELY, PROVIDING OF FOOD AND BEVERAGES FOR CONSUMPTION ON AND OFF THE PREMISES (U.S. CLS. 100 AND 101).

COLLEEN MULCRONE, EXAMINING ATTORNEY

**CLASS 43—(Continued).**

SN 86-248,065. GRAS, LAURENT, NEW YORK, NY. FILED 4-10-2014.

## Laurent Gras

THE MARK CONSISTS OF STANDARD CHARACTERS WITHOUT CLAIM TO ANY PARTICULAR FONT, STYLE, SIZE, OR COLOR.

THE NAME "LAURENT GRAS" IDENTIFIES A LIVING INDIVIDUAL WHOSE CONSENT IS OF RECORD.

FOR CONSULTING IN THE FIELD OF RESTAURANT MENU DEVELOPMENT; CONSULTING SERVICES IN THE FIELD OF CULINARY ARTS; CONSULTING SERVICES IN THE FIELD OF HOSPITALITY (U.S. CLS. 100 AND 101).

RONALD DELGIZZI, EXAMINING ATTORNEY

---

SN 86-248,792. WAHLBURGERS I, LLC, HINGHAM, MA. FILED 4-10-2014.



THE COLOR(S) WHITE, LIGHT GREEN AND GREEN IS/ ARE CLAIMED AS A FEATURE OF THE MARK.

THE MARK CONSISTS OF A STYLIZED "W" IN WHITE WITHIN A GREEN CIRCLE INSIDE A LIGHTER GREEN RING.

FOR RESTAURANT SERVICES (U.S. CLS. 100 AND 101).

FIRST USE 10-21-2011; IN COMMERCE 10-21-2011.

ESTHER A. BORSUK, EXAMINING ATTORNEY

---

SN 86-248,961. DOUGHNUT ENVY, LLC, LAS VEGAS, NV. FILED 4-10-2014.

## THE NAUGHTY DOUGHNUT TRUCK...IS COMING

THE MARK CONSISTS OF STANDARD CHARACTERS WITHOUT CLAIM TO ANY PARTICULAR FONT, STYLE, SIZE, OR COLOR.

FOR PROVIDING OF FOOD AND DRINK VIA A MOBILE TRUCK (U.S. CLS. 100 AND 101).

SUE LAWRENCE, EXAMINING ATTORNEY

**CLASS 43—(Continued).**

SN 86-249,372. CRUCOLI, LLC, DBA DELLA VITI, ROLAND, IA. FILED 4-11-2014.

# DELLA VITI

THE MARK CONSISTS OF STANDARD CHARACTERS WITHOUT CLAIM TO ANY PARTICULAR FONT, STYLE, SIZE, OR COLOR.

THE ENGLISH TRANSLATION OF "DELLA VITI" IN THE MARK IS "OF THE VINES".

FOR BAR SERVICES FEATURING COCKTAILS, BEER, AND WINE (U.S. CLS. 100 AND 101).

FIRST USE 2-25-2012; IN COMMERCE 2-25-2012.  
MICHAEL ENGEL, EXAMINING ATTORNEY

**CLASS 43—(Continued).**

SN 86-251,526. SHMOUNI'S VENTURES, INC., LA MESA, CA. FILED 4-14-2014.

# TIGRIS

THE MARK CONSISTS OF STANDARD CHARACTERS WITHOUT CLAIM TO ANY PARTICULAR FONT, STYLE, SIZE, OR COLOR.

FOR CATERING; CATERING OF FOOD AND DRINKS; CATERING SERVICES; RESTAURANT AND CAFE SERVICES; RESTAURANT AND CATERING SERVICES; RESTAURANT SERVICES; RESTAURANT SERVICES, INCLUDING SIT-DOWN SERVICE OF FOOD AND TAKE-OUT RESTAURANT SERVICES; RESTAURANT, BAR AND CATERING SERVICES; RESTAURANTS FEATURING HOME DELIVERY; TAKE-OUT RESTAURANT SERVICES (U.S. CLS. 100 AND 101).

FIRST USE 11-1-2013; IN COMMERCE 11-1-2013.  
APRIL HESIK, EXAMINING ATTORNEY

SN 86-249,974. SOHA, LLC, ST. LOUIS, MO. FILED 4-11-2014.

# SOHA

THE MARK CONSISTS OF STANDARD CHARACTERS WITHOUT CLAIM TO ANY PARTICULAR FONT, STYLE, SIZE, OR COLOR.

FOR RESTAURANT AND BAR SERVICES (U.S. CLS. 100 AND 101).

FIRST USE 10-0-2012; IN COMMERCE 10-0-2012.  
ANGELA M. MICHELI, EXAMINING ATTORNEY

SN 86-260,391. RIO PERLA PROPERTIES, L. P., SAN ANTONIO, TX. FILED 4-23-2014.

# SWIGGLE KEY

THE MARK CONSISTS OF STANDARD CHARACTERS WITHOUT CLAIM TO ANY PARTICULAR FONT, STYLE, SIZE, OR COLOR.

FOR PROVIDING FOOD AND DRINK (U.S. CLS. 100 AND 101).

THOMAS MANOR, EXAMINING ATTORNEY

SN 86-250,205. AMERASIA CAFE & BAR, COVINGTON, KY. FILED 4-11-2014.

# Kung Food

THE MARK CONSISTS OF STANDARD CHARACTERS WITHOUT CLAIM TO ANY PARTICULAR FONT, STYLE, SIZE, OR COLOR.

FOR RESTAURANT SERVICES (U.S. CLS. 100 AND 101).

FIRST USE 1-1-2012; IN COMMERCE 1-1-2012.  
JOHN WILKE, EXAMINING ATTORNEY

SN 86-262,449. DAVID BURKE, FORT LEE, NJ. FILED 4-25-2014.

# CHEWDOIN

THE MARK CONSISTS OF STANDARD CHARACTERS WITHOUT CLAIM TO ANY PARTICULAR FONT, STYLE, SIZE, OR COLOR.

FOR BAR AND RESTAURANT SERVICES; BAR SERVICES; RESTAURANT; RESTAURANT AND BAR SERVICES; RESTAURANT SERVICES; RESTAURANTS (U.S. CLS. 100 AND 101).

KHANH LE, EXAMINING ATTORNEY

**CLASS 43—(Continued).**

SN 86-278,000. VIVE BENE, LLC, DBA MANGIAMO GELATO, HUNTINGTON BEACH, CA. FILED 5-11-2014.

## Mangiamo Gelato

THE MARK CONSISTS OF STANDARD CHARACTERS WITHOUT CLAIM TO ANY PARTICULAR FONT, STYLE, SIZE, OR COLOR.

NO CLAIM IS MADE TO THE EXCLUSIVE RIGHT TO USE "GELATO", APART FROM THE MARK AS SHOWN.

THE ENGLISH TRANSLATION OF "MANGIAMO" IN THE MARK IS "LOVE TO EAT".

FOR RESTAURANT AND CATERING SERVICES (U.S. CLS. 100 AND 101).

FIRST USE 4-20-2009; IN COMMERCE 4-20-2009.  
KIMBERLY PERRY, EXAMINING ATTORNEY

SN 86-279,665. LYILY PAD, LLC, CLEVELAND, OH. FILED 5-13-2014.

## SLYMAN'S

THE MARK CONSISTS OF STANDARD CHARACTERS WITHOUT CLAIM TO ANY PARTICULAR FONT, STYLE, SIZE, OR COLOR.

FOR RESTAURANT SERVICES (U.S. CLS. 100 AND 101).

FIRST USE 9-11-1974; IN COMMERCE 9-11-1974.  
SARA KUNKLEMAN, EXAMINING ATTORNEY

SN 86-283,052. FAMILY TOBACCO TRADERS LLC, CORAL GABLES, FL. FILED 5-16-2014.

## THE BEER TANK

THE MARK CONSISTS OF STANDARD CHARACTERS WITHOUT CLAIM TO ANY PARTICULAR FONT, STYLE, SIZE, OR COLOR.

NO CLAIM IS MADE TO THE EXCLUSIVE RIGHT TO USE "BEER", APART FROM THE MARK AS SHOWN.

FOR BAR AND RESTAURANT SERVICES; BREWPUB SERVICES (U.S. CLS. 100 AND 101).

JASON BLAIR, EXAMINING ATTORNEY

**CLASS 43—(Continued).**

SN 86-285,571. FOREST COUNTY POTAWATOMI COMMUNITY WISCONSIN, MILWAUKEE, WI. FILED 5-19-2014.

# LOCAVORE

NO CLAIM IS MADE TO THE EXCLUSIVE RIGHT TO USE "LOCAVORE", APART FROM THE MARK AS SHOWN.

THE MARK CONSISTS OF THE WORD "LOCAVORE" WITH A LEAF DESIGN BETWEEN THE "O" AND THE "C".

FOR RESTAURANT SERVICES (U.S. CLS. 100 AND 101).

KATHY DE JONGE, EXAMINING ATTORNEY

SN 86-294,190. GAS MONKEY HOLDINGS, LLC, NORTH HOLLYWOOD, CA. FILED 5-28-2014.



OWNER OF U.S. REG. NOS. 4,492,772, 4,532,015 AND 4,532,118.

NO CLAIM IS MADE TO THE EXCLUSIVE RIGHT TO USE "BAR N GRILL", APART FROM THE MARK AS SHOWN.

THE MARK CONSISTS OF THE STYLIZED TEXT "GAS MONKEY" AND "BAR N GRILL". THERE IS A MONKEY WITH AN ELONGATED, CURVED TONGUE WITH SALIVA-SPRAY AT THE TIP OF THE TONGUE NEXT TO THE STYLIZED TEXT "GAS" AND ABOVE THE STYLIZED TEXT "MONKEY".

FOR RESTAURANT SERVICES, NAMELY, PROVIDING OF FOOD AND BEVERAGES FOR CONSUMPTION ON AND OFF THE PREMISES (U.S. CLS. 100 AND 101).

FIRST USE 7-12-2013; IN COMMERCE 7-12-2013.  
BRIDGETT SMITH, EXAMINING ATTORNEY

SN 86-307,549. PEPSICO, INC., PURCHASE, NY. FILED 6-12-2014.

## KOLA HOUSE

THE MARK CONSISTS OF STANDARD CHARACTERS WITHOUT CLAIM TO ANY PARTICULAR FONT, STYLE, SIZE, OR COLOR.

NO CLAIM IS MADE TO THE EXCLUSIVE RIGHT TO USE "KOLA", APART FROM THE MARK AS SHOWN.

FOR COCKTAIL LOUNGE SERVICES; RESTAURANT SERVICES (U.S. CLS. 100 AND 101).

JENNIFER RICHARDSON, EXAMINING ATTORNEY



**CLASS 43—(Continued).**

SN 86-320,470. PANDA RESTAURANT GROUP, INC., ROSEMEAD, CA. FILED 6-25-2014.

**PANDA KITCHEN**

THE MARK CONSISTS OF STANDARD CHARACTERS WITHOUT CLAIM TO ANY PARTICULAR FONT, STYLE, SIZE, OR COLOR.

NO CLAIM IS MADE TO THE EXCLUSIVE RIGHT TO USE "KITCHEN", APART FROM THE MARK AS SHOWN. FOR RESTAURANT SERVICES (U.S. CLS. 100 AND 101).

EMILY CHUO, EXAMINING ATTORNEY

SN 86-327,709. SEA DOG BRANDS, LLC, SOUTH PORTLAND, ME. FILED 7-3-2014.

**SEA DOG**

THE MARK CONSISTS OF STANDARD CHARACTERS WITHOUT CLAIM TO ANY PARTICULAR FONT, STYLE, SIZE, OR COLOR.

OWNER OF U.S. REG. NOS. 2,810,284, 4,206,889 AND OTHERS.

FOR RESTAURANT SERVICES (U.S. CLS. 100 AND 101).

FIRST USE 12-31-1993; IN COMMERCE 12-31-1993.  
ANNIE NOBLE, EXAMINING ATTORNEY

**CLASS 44—MEDICAL, BEAUTY AND AGRICULTURAL SERVICES**

SN 77-569,932. DISNEY ENTERPRISES, INC., BURBANK, CA. FILED 9-15-2008.



NO CLAIM IS MADE TO THE EXCLUSIVE RIGHT TO USE "CENTER" AND "FAMILY HEALTHCARE", APART FROM THE MARK AS SHOWN.

THE MARK CONSISTS OF LEAVES AND THE WORDS "CENTER FOR LIVING WELL FAMILY HEALTHCARE".

FOR MEDICAL SERVICES; HEALTH CARE SERVICES, NAMELY, WELLNESS PROGRAMS; ALL OF THE FOREGOING FOR DISNEY EMPLOYEES AND THEIR FAMILIES (U.S. CLS. 100 AND 101).

SETH A. RAPPAPORT, EXAMINING ATTORNEY

**CLASS 44—(Continued).**

SN 79-149,031. YI, DONG JIN, REPUBLIC OF KOREA, FILED 3-28-2014.

**TOXNFILL**

THE MARK CONSISTS OF STANDARD CHARACTERS WITHOUT CLAIM TO ANY PARTICULAR FONT, STYLE, SIZE, OR COLOR.

PRIORITY DATE OF 3-7-2014 IS CLAIMED. OWNER OF INTERNATIONAL REGISTRATION 1208552 DATED 3-28-2014, EXPIRES 3-28-2024.

FOR PLASTIC SURGERY; SURGERY; DERMATOLOGY; SKIN CARE SALONS; SKIN BEAUTY SALONS; MAKE-UP APPLICATION SERVICES (U.S. CLS. 100 AND 101).

MAYUR VAGHANI, EXAMINING ATTORNEY

SN 85-257,584. CHARMAINE VAZQUEZ, DBA MVP FITNESS, FAYETTEVILLE, GA. FILED 3-3-2011.



NO CLAIM IS MADE TO THE EXCLUSIVE RIGHT TO USE "FITNESS", APART FROM THE MARK AS SHOWN.

THE COLOR(S) PURPLE, ORANGE IS/ARE CLAIMED AS A FEATURE OF THE MARK.

THE MARK CONSISTS OF AN ORANGE UPPER CASE "M" AND "P" WITH A STYLIZED PURPLE "V" IN BETWEEN. THE PURPLE WORD "FITNESS" IS IN CURSIVE LETTERS UNDER "MVP". THERE IS AN ORANGE BUTTERFLY SITTING IN THE CENTER-TOP PORTION OF THE DESIGN. THE WHITE IN THE MARK IS BACKGROUND AND IS NOT A FEATURE OF THE MARK.

FOR PROVIDING WEIGHT LOSS PROGRAM SERVICES; PROVIDING WEIGHT LOSS PROGRAMS AND COSMETIC BODY CARE SERVICES IN THE NATURE OF NON-SURGICAL BODY CONTOURING; PROVIDING WELLNESS SERVICES, NAMELY, WEIGHT LOSS PROGRAMS OFFERED AT A WELLNESS CENTER; WEIGHT MANAGEMENT SERVICES, NAMELY, PROVIDING WEIGHT LOSS AND/OR WEIGHT MAINTENANCE PROGRAMS (U.S. CLS. 100 AND 101).

ROBIN CHOSID, EXAMINING ATTORNEY

**CLASS 44—(Continued).**

SN 85-381,846. FAMILY FEEDING DYNAMICS LLC, ST. PAUL, MN. FILED 7-27-2011.



THE MARK CONSISTS OF AN IMAGE OF A HEART HAVING A SPIRAL IN THE CENTER WITH THE END OF A SPOON EXTENDING OUT FROM THE BOTTOM LEFT AND THE END OF A FORK EXTENDING FROM THE BOTTOM RIGHT OF THE IMAGE.

FOR CONSULTING SERVICES IN THE FIELD OF CHILDREN'S HEALTH AND NUTRITION; INTERACTIVE COUNSELING SERVICES IN THE FIELD OF CHILDREN'S HEALTH, NUTRITION AND LIFESTYLE WELLNESS (U.S. CLS. 100 AND 101).

FIRST USE 1-31-2009; IN COMMERCE 1-31-2009.  
PRISCILLA MILTON, EXAMINING ATTORNEY

---

SN 85-618,274. REACT WEIGHT MANAGEMENT, INC., JACKSONVILLE, FL. FILED 5-7-2012.

**react**

THE MARK CONSISTS OF STANDARD CHARACTERS WITHOUT CLAIM TO ANY PARTICULAR FONT, STYLE, SIZE, OR COLOR.

OWNER OF U.S. REG. NOS. 3,758,660 AND 3,778,982.  
FOR MEDICAL, PHYSICAL REHABILITATION AND PHYSICAL THERAPY SERVICES (U.S. CLS. 100 AND 101).

FIRST USE 4-1-2012; IN COMMERCE 4-1-2012.  
DAVID TOOLEY, EXAMINING ATTORNEY

**CLASS 44—(Continued).**

SN 85-825,953. ZELTIQ AESTHETICS, INC., PLEASANTON, CA. FILED 1-17-2013.

**DUALSCULPTING**

THE MARK CONSISTS OF STANDARD CHARACTERS WITHOUT CLAIM TO ANY PARTICULAR FONT, STYLE, SIZE, OR COLOR.

FOR MEDICAL SERVICES, NAMELY, PROCEDURES AND SERVICES IN THE NATURE OF TISSUE CONTOURING AND CELLULITE IMPROVEMENT (U.S. CLS. 100 AND 101).

FIRST USE 6-0-2012; IN COMMERCE 6-0-2012.  
ERIN FALK, EXAMINING ATTORNEY

---

SN 85-835,946. ACTIVE LIFE, INC., ALBUQUERQUE, NM. FILED 1-30-2013.

**ACTIVE LIFE**

THE MARK CONSISTS OF STANDARD CHARACTERS WITHOUT CLAIM TO ANY PARTICULAR FONT, STYLE, SIZE, OR COLOR.

FOR ORTHOTIC AND PROSTHETIC CARE SERVICES, NAMELY, MATERIAL ENGINEERING, GAIT ANALYSIS, ANATOMY, PHYSIOLOGY AND USE OF OTHER ORTHOTIC TECHNOLOGIES; FITTING OF PROSTHETICS, ARTIFICIAL LIMBS, ORTHOTICS, ORTHOPEDIC APPLIANCES, COMPRESSION AND MASTECTOMY SERVICES (U.S. CLS. 100 AND 101).

FIRST USE 1-7-2004; IN COMMERCE 1-7-2004.  
THOMAS MANOR, EXAMINING ATTORNEY

**CLASS 44—(Continued).**

SN 85-837,433. ACCENTCARE, INC., DALLAS, TX. FILED 1-31-2013.



**ALERT  
YOUR  
NURSE**

NO CLAIM IS MADE TO THE EXCLUSIVE RIGHT TO USE THE UNIVERSAL PROHIBITION SYMBOL, APART FROM THE MARK AS SHOWN.

THE COLOR(S) BLACK AND RED IS/ARE CLAIMED AS A FEATURE OF THE MARK.

THE MARK CONSISTS OF THE STYLIZED WORDING "ALERT YOUR NURSE" IN BLACK, WITH "ALERT" ON THE FIRST LINE, "YOUR" ON THE SECOND LINE, AND "NURSE" ON THE THIRD LINE. THE UNIVERSAL PROHIBITION SYMBOL IN RED APPEARS OVER THE LETTERS "ER" IN "ALERT".

FOR BEHAVIORAL HEALTH SERVICES; HOME HEALTH CARE SERVICES; MANAGED HEALTH CARE SERVICES; NURSING CARE; NURSING SERVICES; OCCUPATIONAL THERAPY SERVICES; PHYSICAL THERAPY; PROVIDING HEALTH INFORMATION; PROVIDING HEALTHCARE INFORMATION; PROVIDING MEDICAL INFORMATION; SPEECH THERAPY SERVICES (U.S. CLS. 100 AND 101).

ELLEN B. AWRICH, EXAMINING ATTORNEY

**CLASS 44—(Continued).**

SN 85-875,047. PROJECT HEALTHY LIVING, INC., NEW YORK, NY. FILED 3-13-2013.

# ALOHA

THE MARK CONSISTS OF STANDARD CHARACTERS WITHOUT CLAIM TO ANY PARTICULAR FONT, STYLE, SIZE, OR COLOR.

FOR PROVIDING A WEBSITE FEATURING INFORMATION, NEWS AND COMMENTARY REGARDING HEALTH, HEALTHY LIFESTYLES, WELLNESS, BEAUTY AND NUTRITION; PROVIDING AN INTERACTIVE WEBSITE FEATURING INFORMATION AND LINKS RELATING TO HEALTH, HEALTHY LIVING, WEIGHT MAINTENANCE, WEIGHT LOSS, BEAUTY AND NUTRITION; PROVIDING A WEB SITE FEATURING INFORMATION IN THE FIELD OF PHYSICAL AND MENTAL HEALTH, INCLUDING LIVING A HEALTHY AND DISEASE FREE LIFE; PROVIDING AN ON-LINE COMPUTER DATABASE FEATURING INFORMATION REGARDING HEALTH, HEALTHY LIFESTYLES, WELLNESS, BEAUTY AND NUTRITION; BEAUTY CONSULTATION SERVICES; PROVIDING ON-SITE BEAUTY SERVICES, NAMELY, HOLISTIC COSMETIC SKINCARE SERVICES AND COSMETIC BODY CARE, HAIR CARE, HAIRSTYLING, HAIR MAINTENANCE, MAKE-UP, MAKE-UP APPLICATION, AND HYGIENIC CARE; BEAUTY CONSULTATION SERVICES IN THE SELECTION AND USE OF COSMETICS, FRAGRANCES, BEAUTY AIDS, PERSONAL CARE PRODUCTS, AND BATH, BODY AND BEAUTY PRODUCTS; HEALTH SPA SERVICES FOR HEALTH AND WELLNESS OF THE BODY AND SPIRIT OFFERED AT A HEALTH RESORT; MEDSPA SERVICES FOR HEALTH AND BEAUTY OF THE BODY AND SPIRIT (U.S. CLS. 100 AND 101).

JULIE VEPPUMTHARA, EXAMINING ATTORNEY

---

SN 85-902,853. MOSAIC DENTISRY, PC, CHANDLER, AZ. FILED 4-12-2013.

# MOSAIC

THE MARK CONSISTS OF STANDARD CHARACTERS WITHOUT CLAIM TO ANY PARTICULAR FONT, STYLE, SIZE, OR COLOR.

FOR COSMETIC DENTISTRY; DENTAL HYGIENIST SERVICES; DENTAL SERVICES, NAMELY, PERFORMING RESTORATIVE AND COSMETIC PROCEDURES; DENTAL SERVICES, NAMELY, TREATMENT OF PATIENTS WITH SNORING, SLEEP APNEA AND TMJ (TEMPOROMANDIBULAR JOINT) DISORDERS; DENTISTRY; ORAL SURGERY AND DENTAL IMPLANT SERVICES; SPORTS DENTISTRY (U.S. CLS. 100 AND 101).

FIRST USE 1-15-2009; IN COMMERCE 2-12-2009.

TEJBIR SINGH, EXAMINING ATTORNEY

**CLASS 44—(Continued).**

SN 85-963,919. LUNG BIOTECHNOLOGY INC., SILVER SPRING, MD. FILED 6-19-2013.

# RECOLUNG

THE MARK CONSISTS OF STANDARD CHARACTERS WITHOUT CLAIM TO ANY PARTICULAR FONT, STYLE, SIZE, OR COLOR.

FOR SPECIALIZED MEDICAL SERVICES, NAMELY, REHABILITATION OF HUMAN ORGANS FOR SUBSEQUENT TRANSPLANTATION (U.S. CLS. 100 AND 101).  
TINA MAI, EXAMINING ATTORNEY

SN 86-005,030. WAXMAN, HEATHER J, FT. LAUDERDALE, FL. FILED 7-9-2013.

# Transformation Healing Concepts

THE MARK CONSISTS OF STANDARD CHARACTERS WITHOUT CLAIM TO ANY PARTICULAR FONT, STYLE, SIZE, OR COLOR.

NO CLAIM IS MADE TO THE EXCLUSIVE RIGHT TO USE "HEALING", APART FROM THE MARK AS SHOWN.  
FOR HYPNOSIS SERVICES (U.S. CLS. 100 AND 101).  
MICHAEL WEBSTER, EXAMINING ATTORNEY

SN 86-019,117. STEP UP PEDIATRIC AND ADOLESCENT WELLNESS CENTER, PLLC, CLEMMONS, NC. FILED 7-24-2013.

# STEP UP! PEDIATRIC & ADOLESCENT WELLNESS CENTER

THE MARK CONSISTS OF STANDARD CHARACTERS WITHOUT CLAIM TO ANY PARTICULAR FONT, STYLE, SIZE, OR COLOR.

NO CLAIM IS MADE TO THE EXCLUSIVE RIGHT TO USE "PEDIATRIC & ADOLESCENT WELLNESS CENTER", APART FROM THE MARK AS SHOWN.

FOR PHYSICIAN SERVICES; HEALTH CARE; HEALTH CARE SERVICES, NAMELY, WELLNESS PROGRAMS; CONSULTING SERVICES IN THE FIELD OF HEALTH; CONSULTING SERVICES IN THE FIELD OF MEDICAL CARE; CONSULTING SERVICES IN THE FIELD OF HEALTH FOR YOUNG CHILDREN AND ADOLESCENTS; HEALTH ASSESSMENT SERVICES, NAMELY, MEDICAL SCREENING FOR EXISTING COMPLICATIONS STEMMING FROM OBESITY; COUNSELING SERVICES IN THE FIELDS OF HEALTH, NUTRITION AND LIFESTYLE WELLNESS; PROVIDING ASSISTANCE, FITNESS EVALUATIONS AND CONSULTATION FOR INDIVIDUALS TO FACILITATE HEALTH AND WELLNESS IMPROVEMENTS; PROVIDING HEALTHY LIFESTYLE AND NUTRITION SERVICES, NAMELY, PERSONAL ASSESSMENTS, PERSONALIZED ROUTINES, MAINTENANCE SCHEDULES, AND COUNSELING; PROVIDING WELLNESS SERVICES, NAMELY,

**CLASS 44—(Continued).**

WEIGHT LOSS PROGRAMS OFFERED AT A WELLNESS CENTER; WEIGHT MANAGEMENT SERVICES, NAMELY, PROVIDING WEIGHT LOSS AND/OR WEIGHT MAINTENANCE PROGRAMS; WELLNESS AND HEALTH-RELATED CONSULTING SERVICES; PROVIDING A WEB SITE FEATURING MEDICAL AND WELLNESS INFORMATION; PROVIDING HEALTH CARE CONSULTATION AND INFORMATION CONCERNING TREATMENT OF EXISTING CONDITIONS, NAMELY, DIABETES MELLITUS, HYPERTENSION, HYPERCHOLESTEROLEMIA, METABOLIC SYNDROME AND OTHER COMORBIDITIES SECONDARY TO OBESITY; COUNSELING SERVICES IN THE NATURE OF COGNITIVE BEHAVIORAL THERAPY, AND FAMILY THERAPY; COSMETIC SURGERY SERVICES; GYNECOLOGY SERVICES; HEALTH ASSESSMENT SERVICES, NAMELY, PROVIDING METABOLIC ASSESSMENT PROFILES TO CLIENTS OBTAINED BY USING A PORTABLE METABOLIC MEASUREMENT SYSTEM IN THE NATURE OF A UNIQUE HEART-RATE BASED OVERVIEW OF THEIR OWN METABOLISM IN ORDER TO ASSIST IN REACHING WEIGHT LOSS, SPORTS PERFORMANCE, HEALTH, FITNESS, AND WELLNESS-RELATED GOALS; PREGNANCY TESTING SERVICES; HEALTH SPA SERVICES FOR HEALTH AND WELLNESS OF THE BODY AND SPIRIT; PHYSICAL THERAPY; PROVIDING HEALTH CARE CONSULTATION AND INFORMATION CONCERNING BRAIN HEALTH AND WELLNESS, COGNITIVE STIMULATION, STRESS, DEPRESSION, SLEEP DEPRIVATION AND RELEVANT CHRONIC CONDITIONS; HEALTH CARE CONSULTING FOR FAMILY AND PROFESSIONAL CARE PROVIDERS; PROVIDING INFORMATION IN THE FIELDS OF WELLNESS AND HEALTH VIA THE INTERNET, TELEVISION AND RADIO (U.S. CLS. 100 AND 101).

FIRST USE 11-1-2011; IN COMMERCE 11-1-2011.  
SAMUEL E. SHARPER JR., EXAMINING ATTORNEY

SN 86-019,145. STEP UP PEDIATRIC AND ADOLESCENT WELLNESS CENTER, PLLC, CLEMMONS, NC. FILED 7-24-2013.

# STEP UP!

THE MARK CONSISTS OF STANDARD CHARACTERS WITHOUT CLAIM TO ANY PARTICULAR FONT, STYLE, SIZE, OR COLOR.

FOR PHYSICIAN SERVICES; HEALTH CARE; HEALTH CARE SERVICES, NAMELY, WELLNESS PROGRAMS; CONSULTING SERVICES IN THE FIELD OF HEALTH; CONSULTING SERVICES IN THE FIELD OF MEDICAL CARE; CONSULTING SERVICES IN THE FIELD OF HEALTH FOR YOUNG CHILDREN AND ADOLESCENTS; HEALTH ASSESSMENT SERVICES, NAMELY, MEDICAL SCREENING FOR EXISTING COMPLICATIONS STEMMING FROM OBESITY; COUNSELING SERVICES IN THE FIELDS OF HEALTH, NUTRITION AND LIFESTYLE WELLNESS; PROVIDING ASSISTANCE, FITNESS EVALUATIONS AND CONSULTATION FOR INDIVIDUALS TO FACILITATE HEALTH AND WELLNESS IMPROVEMENTS; PROVIDING HEALTHY LIFESTYLE AND NUTRITION SERVICES, NAMELY, PERSONAL ASSESSMENTS, PERSONALIZED ROUTINES, MAINTENANCE SCHEDULES, AND COUNSELING; PROVIDING WELLNESS SERVICES, NAMELY, WEIGHT LOSS PROGRAMS OFFERED AT A WELLNESS CENTER; WEIGHT MANAGEMENT SERVICES, NAMELY, PROVIDING WEIGHT LOSS AND/OR WEIGHT MAINTENANCE PROGRAMS; WELLNESS AND HEALTH-RELATED CONSULTING SERVICES; PROVIDING A WEB SITE FEATURING MEDICAL AND WELLNESS INFORMATION; PROVIDING HEALTH CARE CONSULTATION AND INFORMATION CONCERNING TREATMENT OF EXISTING CONDI-

**CLASS 44—(Continued).**

TIONS, NAMELY, DIABETES MELLITUS, HYPERTENSION, HYPERCHOLESTEROLEMIA, METABOLIC SYNDROME AND OTHER COMORBIDITIES SECONDARY TO OBESITY; COUNSELING SERVICES IN THE NATURE OF COGNITIVE BEHAVIORAL THERAPY, AND FAMILY THERAPY; COSMETIC SURGERY SERVICES; GYNECOLOGY SERVICES; HEALTH ASSESSMENT SERVICES, NAMELY, PROVIDING METABOLIC ASSESSMENT PROFILES TO CLIENTS OBTAINED BY USING A PORTABLE METABOLIC MEASUREMENT SYSTEM IN THE NATURE OF A UNIQUE HEART-RATE BASED OVERVIEW OF THEIR OWN METABOLISM IN ORDER TO ASSIST IN REACHING WEIGHT LOSS, SPORTS PERFORMANCE, HEALTH, FITNESS, AND WELLNESS-RELATED GOALS; PREGNANCY TESTING SERVICES; HEALTH SPA SERVICES FOR HEALTH AND WELLNESS OF THE BODY AND SPIRIT; PHYSICAL THERAPY; PROVIDING HEALTH CARE CONSULTATION AND INFORMATION CONCERNING BRAIN HEALTH AND WELLNESS, COGNITIVE STIMULATION, STRESS, DEPRESSION, SLEEP DEPRIVATION AND RELEVANT CHRONIC CONDITIONS; HEALTH CARE CONSULTING FOR FAMILY AND PROFESSIONAL CARE PROVIDERS; PROVIDING INFORMATION IN THE FIELDS OF WELLNESS AND HEALTH VIA THE INTERNET, TELEVISION AND RADIO (U.S. CLS. 100 AND 101).

FIRST USE 11-1-2011; IN COMMERCE 11-1-2011.  
SAMUEL E. SHARPER JR., EXAMINING ATTORNEY

SN 86-036,352. POUYAN JOHN TABATABAIE, LAGUNA HILLS, CA. FILED 8-13-2013.

**The Holistic Sanctuary**

THE MARK CONSISTS OF STANDARD CHARACTERS WITHOUT CLAIM TO ANY PARTICULAR FONT, STYLE, SIZE, OR COLOR.

NO CLAIM IS MADE TO THE EXCLUSIVE RIGHT TO USE "HOLISTIC", APART FROM THE MARK AS SHOWN.

FOR ADDICTION TREATMENT SERVICES; REHABILITATION FOR SUBSTANCE ABUSE PATIENTS; REHABILITATION OF ALCOHOL ADDICTED PATIENTS; REHABILITATION OF DRUG ADDICTED PATIENTS; REHABILITATION OF NARCOTIC ADDICTED PATIENTS (U.S. CLS. 100 AND 101).

FIRST USE 4-1-2008; IN COMMERCE 4-1-2008.  
ELLEN PERKINS, EXAMINING ATTORNEY

**CLASS 44—(Continued).**

SN 86-040,348. UNIVERSITY OF CHICAGO, THE, CHICAGO, IL. FILED 8-16-2013.

**The University of Chicago  
Medicine**

THE MARK CONSISTS OF STANDARD CHARACTERS WITHOUT CLAIM TO ANY PARTICULAR FONT, STYLE, SIZE, OR COLOR.

OWNER OF U.S. REG. NOS. 1,876,527, 3,091,357 AND 4,468,638.

NO CLAIM IS MADE TO THE EXCLUSIVE RIGHT TO USE "MEDICINE", APART FROM THE MARK AS SHOWN. SEC. 2(F) AS TO "THE UNIVERSITY OF CHICAGO".

FOR HOSPITAL AND HEALTHCARE SERVICES (U.S. CLS. 100 AND 101).

FIRST USE 2-23-2013; IN COMMERCE 2-23-2013.  
KATHERINE CONNOLLY, EXAMINING ATTORNEY

SN 86-040,545. PEDIATRIC HAIR SOLUTIONS CORPORATION, WAXHAW, NC. FILED 8-16-2013.

**PEDIATRIC HAIR SOLUTIONS**

THE MARK CONSISTS OF STANDARD CHARACTERS WITHOUT CLAIM TO ANY PARTICULAR FONT, STYLE, SIZE, OR COLOR.

NO CLAIM IS MADE TO THE EXCLUSIVE RIGHT TO USE "PEDIATRIC HAIR", APART FROM THE MARK AS SHOWN.

FOR LICE REMOVAL FROM HUMANS (U.S. CLS. 100 AND 101).

FIRST USE 8-16-2013; IN COMMERCE 8-16-2013.  
CAROLINE WOOD, EXAMINING ATTORNEY

SN 86-045,378. CEA CAPITAL HOLDINGS, LLC, AKRON, OH. FILED 8-22-2013.

**FOOD FOR LIFE**

THE MARK CONSISTS OF STANDARD CHARACTERS WITHOUT CLAIM TO ANY PARTICULAR FONT, STYLE, SIZE, OR COLOR.

FOR FARMING SERVICES IN THE FIELD OF FRUITS AND VEGETABLES USING HYDROPONICS FOR SUSTAINABLE AGRICULTURE (U.S. CLS. 100 AND 101).

WENDY GOODMAN, EXAMINING ATTORNEY

**CLASS 44—(Continued).**

SN 86-059,997. PEDIATRIC HAIR SOLUTIONS CORPORATION, WAXHAW, NC. FILED 9-10-2013.



**PEDIATRIC**  
HAIR SOLUTIONS

NO CLAIM IS MADE TO THE EXCLUSIVE RIGHT TO USE "PEDIATRIC HAIR", APART FROM THE MARK AS SHOWN.

THE MARK CONSISTS OF THE WORD "PEDIATRIC" SET ABOVE A LONG "S" SHAPED LINE, WHICH CROSSES THROUGH THE LETTER "R" IN "PEDIATRIC", ALL SET ABOVE THE WORDS "HAIR SOLUTIONS".

FOR LICE REMOVAL FROM HUMANS (U.S. CLS. 100 AND 101).

FIRST USE 8-16-2013; IN COMMERCE 8-16-2013.  
CAROLINE WOOD, EXAMINING ATTORNEY

SN 86-061,202. BRITT, ALEISHA, RENTON, WA. FILED 9-11-2013.

**JUST BRONZED**

THE MARK CONSISTS OF STANDARD CHARACTERS WITHOUT CLAIM TO ANY PARTICULAR FONT, STYLE, SIZE, OR COLOR.

NO CLAIM IS MADE TO THE EXCLUSIVE RIGHT TO USE "BRONZED", APART FROM THE MARK AS SHOWN.

FOR BEAUTY SALONS; SKIN TANNING SERVICE FOR HUMANS FOR COSMETIC PURPOSES; HEALTH SPA SERVICES FOR HEALTH AND WELLNESS OF THE BODY AND SPIRIT; HEALTH SPA SERVICES FOR HEALTH AND WELLNESS OF THE BODY AND SPIRIT, NAMELY, PROVIDING MASSAGE, FACIAL AND BODY TREATMENT SERVICES, COSMETIC BODY CARE SERVICES (U.S. CLS. 100 AND 101).

KEVON CHISOLM, EXAMINING ATTORNEY

**CLASS 44—(Continued).**

SN 86-061,713. JML GROUP, LLC, ASHEVILLE, NC. FILED 9-11-2013.

**AWAKEN SKIN & BODY**

THE MARK CONSISTS OF STANDARD CHARACTERS WITHOUT CLAIM TO ANY PARTICULAR FONT, STYLE, SIZE, OR COLOR.

NO CLAIM IS MADE TO THE EXCLUSIVE RIGHT TO USE "SKIN & BODY", APART FROM THE MARK AS SHOWN.

FOR HEALTH CARE CLINIC PROVIDING NON-INVASIVE SKIN AND BODY TREATMENTS USING ULTRASOUND, LASER AND RADIO FREQUENCY DEVICES TO CONTOUR AND TREAT THE BODY BY ABLATING FAT CELLS, TIGHTENING SKIN, REMOVING SKIN DISCOLORATION AND DECREASING WRINKLES (U.S. CLS. 100 AND 101).

GINA FINK, EXAMINING ATTORNEY

SN 86-064,994. BRANDON CONSULTING GROUP, LLC, ATLANTA, GA. FILED 9-15-2013.



**brandon**  
consulting group

NO CLAIM IS MADE TO THE EXCLUSIVE RIGHT TO USE "CONSULTING GROUP", APART FROM THE MARK AS SHOWN.

THE MARK CONSISTS OF THE WORD "BRANDON" WITH THE FIRST TWO LETTERS BEGINNING INSIDE A LARGER LOWER CASE LETTER "B", THE WORDS "CONSULTING GROUP" APPEAR BELOW.

FOR HEALTH CARE DELIVERY AND CONSULTING SERVICES IN THE FIELD OF HEALTH CARE (U.S. CLS. 100 AND 101).

FIRST USE 4-1-2013; IN COMMERCE 4-1-2013.  
KAELIE KUNG, EXAMINING ATTORNEY

SN 86-066,800. SMART PSYCHIATRIC SERVICES, INC., DBA SMARTPSYCH, BOSTON, MA. FILED 9-17-2013.

**SmartPsych**

THE MARK CONSISTS OF STANDARD CHARACTERS WITHOUT CLAIM TO ANY PARTICULAR FONT, STYLE, SIZE, OR COLOR.

FOR PSYCHIATRIC AND BEHAVIORAL HEALTH SERVICES PROVIDED IN PERSON AND VIA COMPUTER, TELEPHONE OR OTHER ELECTRONIC MEANS; CONSULTING SERVICES IN THE FIELD OF PSYCHIATRIC AND BEHAVIORAL HEALTH PROVIDED IN PERSON AND VIA COMPUTER, TELEPHONE OR OTHER ELECTRONIC MEANS (U.S. CLS. 100 AND 101).

FIRST USE 5-0-2013; IN COMMERCE 5-0-2013.  
PATRICIA EVANKO, EXAMINING ATTORNEY

**CLASS 44—(Continued).**

SN 86-071,031. CAMPBELL MCAULEY GROUP LLC, TA CAMPBELL MCAULEY HAIRCARE, LOS ANGELES, CA. FILED 9-20-2013.

CAMPBELL MCAULEY HAIRCARE

THE MARK CONSISTS OF STANDARD CHARACTERS WITHOUT CLAIM TO ANY PARTICULAR FONT, STYLE, SIZE, OR COLOR.

NO CLAIM IS MADE TO THE EXCLUSIVE RIGHT TO USE "HAIRCARE", APART FROM THE MARK AS SHOWN.

THE NAME SHOWN IN THE MARK IDENTIFIES "CAMPBELL MCAULEY" A LIVING INDIVIDUAL WHOSE CONSENT TO REGISTER IS MADE OF RECORD.

FOR PROVIDING ONLINE ADVICE AND INFORMATION IN THE FIELDS OF HAIRSTYLING, HAIRCARE, AND HAIR MAINTENANCE (U.S. CLS. 100 AND 101).

WANDA KAY PRICE, EXAMINING ATTORNEY

**CLASS 44—(Continued).**

SN 86-073,283. ABEL SCREENING, INC., ATLANTA, GA. FILED 9-24-2013.

VRT

THE MARK CONSISTS OF STANDARD CHARACTERS WITHOUT CLAIM TO ANY PARTICULAR FONT, STYLE, SIZE, OR COLOR.

SEC. 2(F).

FOR PSYCHOLOGICAL TESTING SERVICE FOR THE PURPOSE OF GAINING AN OBJECTIVE MEASURE OF SEXUAL INTEREST, ALL BEING PART OF A PROPRIETARY METHOD TO EVALUATE INDIVIDUALS WITH SEXUAL BEHAVIOR PROBLEMS (U.S. CLS. 100 AND 101).

FIRST USE 4-1-1998; IN COMMERCE 4-1-1998.

MICHAEL SOUDERS, EXAMINING ATTORNEY

SN 86-071,474. LARRY GENE WILLIAMS, TRENTON, GA. FILED 9-23-2013.



THE MARK CONSISTS OF A DESIGN OF A GLOBE WITH A DOVE ENCIRCLING THE GLOBE AND A CROSS IN THE CENTER OF THE GLOBE WITH THE STYLIZED TEXT "AGRIMISSIIONS" BENEATH THE GLOBE.

FOR CHARITABLE SERVICES, NAMELY, AGRICULTURAL ASSISTANCE IN THE NATURE OF PROVIDING AGRICULTURAL ADVICE TO POOR FARMERS OF THE WORLD, CHURCHES, RELIGIOUS NONPROFITS, AND COMMUNITIES OF THE UNITED STATES (U.S. CLS. 100 AND 101).

ALLISON HOLTZ, EXAMINING ATTORNEY

SN 86-074,544. GRO ALLIANCE LLC, CUBA CITY, WI. FILED 9-25-2013.



THE MARK CONSISTS OF WAVY LINES POSITIONED ONE ABOVE THE OTHER.

FOR AGRICULTURAL SERVICES, NAMELY, PROVIDING AGRICULTURAL ADVICE IN THE FIELD OF SEED GROWING, SEED PROCESSING, SEED CONDITIONING AND SEED BREEDING, AGRICULTURAL SERVICES, NAMELY, SEED GROWING, SEED PROCESSING AND SEED BREEDING (U.S. CLS. 100 AND 101).

FIRST USE 5-1-2013; IN COMMERCE 6-1-2013.

SHAUNIA CARLYLE, EXAMINING ATTORNEY

**CLASS 44—(Continued).**

SN 86-074,832. PR II COCO PALMS LLC, MADISON, NJ. FILED 9-25-2013.

**COCO PALMS**

THE MARK CONSISTS OF STANDARD CHARACTERS WITHOUT CLAIM TO ANY PARTICULAR FONT, STYLE, SIZE, OR COLOR.

FOR SPA SERVICES, NAMELY, BEAUTY SPA SERVICES IN THE NATURE OF COSMETIC BODY CARE; HEALTH SPA SERVICES FOR HEALTH AND WELLNESS OF THE BODY AND SPIRIT; MEDICAL AND THERAPEUTIC PSYCHOLOGICAL COUNSELING SERVICES; HAIR STYLING AND SALON SERVICES; RESORT, HEALTH AND DAY SPA SERVICES, NAMELY, HEALTH SPA SERVICES FOR HEALTH AND WELLNESS OF THE BODY AND SPIRIT OFFERED AT A HEALTH RESORT; BEAUTY SALON AND HEALTH SPA SERVICES, NAMELY, FACIALS, BODY MASSAGES, MINERAL BATHS, COSMETIC BODY CARE SERVICES, MANICURE AND PEDICURE (U.S. CLS. 100 AND 101).  
BRENDAN MCCAULEY, EXAMINING ATTORNEY

SN 86-079,022. MARTHA LUCERO, GARDEN GROVE, CA. FILED 9-30-2013.



THE MARK CONSISTS OF A STYLIZED IMAGE OF A TOOTH; PROVIDED, HOWEVER, THAT THE BLACK SQUARE SURROUNDING THE TOOTH IS NOT PART OF THE MARK BUT IS THERE MERELY TO DELINEATE THE OUTLINE OF THE MARK.

FOR DENTAL SERVICES, NAMELY, PERFORMING RESTORATIVE AND COSMETIC PROCEDURES (U.S. CLS. 100 AND 101).

FIRST USE 1-1-2009; IN COMMERCE 1-1-2009.

JANICE L. MCMORROW, EXAMINING ATTORNEY

**CLASS 44—(Continued).**

SN 86-082,691. BLYER, SCOTT, ISLANDIA, NY. FILED 10-4-2013.

**Mi Lift**

THE MARK CONSISTS OF STANDARD CHARACTERS WITHOUT CLAIM TO ANY PARTICULAR FONT, STYLE, SIZE, OR COLOR.

NO CLAIM IS MADE TO THE EXCLUSIVE RIGHT TO USE "LIFT", APART FROM THE MARK AS SHOWN.

FOR COSMETIC SURGERY SERVICES (U.S. CLS. 100 AND 101).

FIRST USE 8-1-2013; IN COMMERCE 8-1-2013.

ANNE E. GUSTASON, EXAMINING ATTORNEY

SN 86-091,003. TRACEY CUNNINGHAM, LOS ANGELES, CA. FILED 10-14-2013.

**TRACEY CUNNINGHAM**

THE MARK CONSISTS OF STANDARD CHARACTERS WITHOUT CLAIM TO ANY PARTICULAR FONT, STYLE, SIZE, OR COLOR.

THE NAME(S), PORTRAIT(S), AND/OR SIGNATURE(S) SHOWN IN THE MARK IDENTIFIES "TRACEY CUNNINGHAM", WHOSE CONSENT(S) TO REGISTER IS MADE OF RECORD.

FOR HAIR SALON SERVICES, NAMELY, HAIR CUTTING, HAIR STYLING, HAIR COLORING, HAIR TREATMENT, AND HAIR EXTENSION SERVICES; HAIR COLOR SERVICES, NAMELY, HAIR COLOR CONSULTING SERVICES AND HAIR COLOR EXPERT SERVICES (U.S. CLS. 100 AND 101).

FIRST USE 0-0-1999; IN COMMERCE 0-0-1999.

MICHELE SWAIN, EXAMINING ATTORNEY

SN 86-105,573. LUBA, DANIEL G, DBA PROJECT DNA, MONTEREY, CA. FILED 10-30-2013.

**Project DNA**

THE MARK CONSISTS OF STANDARD CHARACTERS WITHOUT CLAIM TO ANY PARTICULAR FONT, STYLE, SIZE, OR COLOR.

NO CLAIM IS MADE TO THE EXCLUSIVE RIGHT TO USE "DNA", APART FROM THE MARK AS SHOWN.

FOR PROVIDING HEALTHCARE INFORMATION (U.S. CLS. 100 AND 101).

ZACHARY BELLO, EXAMINING ATTORNEY



**CLASS 44—(Continued).**

SN 86-105,727. MURRAY D.M.D. AND ZAHEDI D.D.S. DENTAL CORPORATION, DBA SANTA CLARA DENTAL EXCELLENCE, NEWPORT BEACH, CA. FILED 10-30-2013.



NO CLAIM IS MADE TO THE EXCLUSIVE RIGHT TO USE "SANTA CLARA DENTAL EXCELLENCE", APART FROM THE MARK AS SHOWN.

THE MARK CONSISTS OF THE TERMS "SANTA CLARA" ABOVE THE WORDS "DENTAL EXCELLENCE", ALL OF WHICH IS TO THE RIGHT OF A SILHOUETTE DESIGN OF A TOOTH WITH A TILDE GOING THROUGH THE LOWER CENTER OF THE TOOTH, AND THE BOTTOM OF THE TOOTH CONSISTS OF AN UPWARD CURVE.

FOR DENTIST SERVICES (U.S. CLS. 100 AND 101).

FIRST USE 7-3-2013; IN COMMERCE 7-3-2013.

TINA L. SNAPP, EXAMINING ATTORNEY

**CLASS 44—(Continued).**

SN 86-118,356. NPM FRANCHISING, LLC, PORTLAND, OR. FILED 11-13-2013.

**EARTHWISE PET**

THE MARK CONSISTS OF STANDARD CHARACTERS WITHOUT CLAIM TO ANY PARTICULAR FONT, STYLE, SIZE, OR COLOR.

NO CLAIM IS MADE TO THE EXCLUSIVE RIGHT TO USE "PET", APART FROM THE MARK AS SHOWN.

FOR PET GROOMING SERVICES; PROVIDING SELF-SERVICE PET GROOMING FACILITIES; PROVIDING SELF-SERVICE PET WASHING FACILITIES (U.S. CLS. 100 AND 101).

FIRST USE 10-5-2011; IN COMMERCE 10-5-2011.

B. PARADEWELAI, EXAMINING ATTORNEY

SN 86-110,787. CLEARCHOICEMD, LLC, DBA CLEARCHOICEMD, NEW LONDON, NH. FILED 11-5-2013.

**ClearChoiceMD**

THE MARK CONSISTS OF STANDARD CHARACTERS WITHOUT CLAIM TO ANY PARTICULAR FONT, STYLE, SIZE, OR COLOR.

FOR URGENT MEDICAL CARE CENTERS (U.S. CLS. 100 AND 101).

ANNE E. GUSTASON, EXAMINING ATTORNEY

SN 86-125,239. OTTENBREIT, SHAWN, FOX ISLAND, WA. FILED 11-21-2013.

**THE R.E.S.T. STOP**

THE MARK CONSISTS OF STANDARD CHARACTERS WITHOUT CLAIM TO ANY PARTICULAR FONT, STYLE, SIZE, OR COLOR.

FOR FLOTATION TANK SERVICES, NAMELY, PROVIDING CLIENTS WITH SESSIONS IN A FLOTATION TANK FOR THE PURPOSES OF RELAXATION AND HEALING (U.S. CLS. 100 AND 101).

RONALD DELGIZZI, EXAMINING ATTORNEY

SN 86-110,983. PEACEHEALTH, DBA PEACEHEALTH LABORATORIES, SPRINGFIELD, OR. FILED 11-5-2013.



NO CLAIM IS MADE TO THE EXCLUSIVE RIGHT TO USE "RX" AND "MEDICATION SAFETY PANEL", APART FROM THE MARK AS SHOWN.

THE MARK CONSISTS OF THE STYLIZED LETTERS "RX" ABOVE AND TO THE LEFT OF THE WORD "ADHERE". THE PHRASE "MEDICATION SAFETY PANEL" IS BELOW THE WORD "ADHERE".

FOR MEDICAL TESTING SERVICES, NAMELY, TESTING FOR MEDICAL DIAGNOSTIC PURPOSES; MEDICAL TESTING OF PATIENTS FOR MEDICATION ADHERENCE IN A CLINICAL SETTING AND PROVIDING REPORTS TO CONSULTING PHYSICIANS REGARDING TEST RESULTS (U.S. CLS. 100 AND 101).

CHRISTOPHER REAMS, EXAMINING ATTORNEY

SN 86-134,533. COAST DENTAL SERVICES, INC., TAMPA, FL. FILED 12-4-2013.

**COAST DENTAL KIDS**

THE MARK CONSISTS OF STANDARD CHARACTERS WITHOUT CLAIM TO ANY PARTICULAR FONT, STYLE, SIZE, OR COLOR.

OWNER OF U.S. REG. NOS. 2,891,056, 3,084,892 AND OTHERS.

NO CLAIM IS MADE TO THE EXCLUSIVE RIGHT TO USE "DENTAL KIDS", APART FROM THE MARK AS SHOWN.

FOR PEDIATRIC DENTIST AND ORTHODONTIC SERVICES (U.S. CLS. 100 AND 101).

STEVEN PEREZ, EXAMINING ATTORNEY

**CLASS 44—(Continued).**

SN 86-136,759. DR. MARY LUPO, NEW ORLEANS, LA. FILED 12-6-2013.

# PREJUVE

THE MARK CONSISTS OF STANDARD CHARACTERS WITHOUT CLAIM TO ANY PARTICULAR FONT, STYLE, SIZE, OR COLOR.

FOR MEDICAL SERVICES, NAMELY, PROVIDING LASER THERAPY FOR THE TREATMENT OF SKIN AGING; LAYERING RADIOFREQUENCY AND ULTRASONIC SKIN TIGHTENING PROCEDURES (U.S. CLS. 100 AND 101).

FIRST USE 11-18-2013; IN COMMERCE 11-18-2013.  
TASHIA BUNCH, EXAMINING ATTORNEY

SN 86-136,774. DR. MARY LUPO, NEW ORLEANS, LA. FILED 12-6-2013.

NO CLAIM IS MADE TO THE EXCLUSIVE RIGHT TO USE "ENERGY FACIALS", APART FROM THE MARK AS SHOWN.

THE COLOR(S) TEAL AND GOLD IS/ARE CLAIMED AS A FEATURE OF THE MARK.

THE MARK CONSISTS OF TEAL COLORED STYLIZED LETTERS; INITIAL LETTER UPPER CASE FOLLOWED BY LOWER CASE "PREJUVE"; THE DOT OVER THE LETTER "J" IS GOLD IN COLOR IN THE FORM OF THE TIP OF A WAND, WITH MULTIPLE GOLD DOTS RADIATING FROM THE CENTER IN A STAR DESIGN. A STRAIGHT THIN GOLD LINE EXTENDS HORIZONTALLY FROM THE CENTER DOT OVER THE LETTERS "UVE". BELOW THE WORD "PREJUVE" IN GOLD BLOCK CAPITAL LETTERS ARE THE WORDS, "ENERGY FACIALS". THE MARK IS SET OVER A CLEAR BACKGROUND.

FOR MEDICAL SERVICES, NAMELY, PROVIDING LASER THERAPY FOR THE TREATMENT OF SKIN AGING; LAYERING RADIOFREQUENCY AND ULTRASONIC SKIN TIGHTENING PROCEDURES (U.S. CLS. 100 AND 101).

FIRST USE 11-18-2013; IN COMMERCE 11-18-2013.  
TASHIA BUNCH, EXAMINING ATTORNEY

**CLASS 44—(Continued).**

SN 86-146,973. NETWORK THERAPY SERVICES, LLC, DBA CENTREX REHAB, MINNEAPOLIS, MN. FILED 12-18-2013.

# EverActive

THE MARK CONSISTS OF STANDARD CHARACTERS WITHOUT CLAIM TO ANY PARTICULAR FONT, STYLE, SIZE, OR COLOR.

FOR HEALTH CARE SERVICES, NAMELY, WELLNESS PROGRAMS IN THE NATURE OF PROVIDING THE ELDERLY WITH WHEELCHAIR ANALYSIS, MASSAGE-THERAPY SERVICES, ACCIDENT-PREVENTION SCREENING, AND HEALTH ASSESSMENTS, NAMELY, MEDICAL TESTING IN THE NATURE OF ASSESSING STRENGTH, FLEXIBILITY, AEROBIC ENDURANCE, AND AGILITY/DYNAMIC BALANCE (U.S. CLS. 100 AND 101).

FIRST USE 12-17-2013; IN COMMERCE 12-17-2013.  
LINDA ESTRADA, EXAMINING ATTORNEY

SN 86-148,089. THE CLEVELAND CLINIC FOUNDATION, CLEVELAND, OH. FILED 12-19-2013.

# MYCONSULT

THE MARK CONSISTS OF STANDARD CHARACTERS WITHOUT CLAIM TO ANY PARTICULAR FONT, STYLE, SIZE, OR COLOR.

OWNER OF U.S. REG. NO. 2,911,640.  
FOR TELEMEDICINE SERVICES; INTERNET-BASED MEDICAL DIAGNOSIS OF DISEASES; PROVIDING INFORMATION AND ADVICE REGARDING HEALTH, WELLNESS, AND DISEASE SYMPTOMS, MANAGEMENT AND TREATMENT (U.S. CLS. 100 AND 101).

FIRST USE 8-1-2004; IN COMMERCE 8-1-2004.  
TINA BROWN, EXAMINING ATTORNEY

SN 86-154,658. SOUTH BARK DOG WASH, LLC, SAN DIEGO, CA. FILED 12-30-2013.

# SPREAD THE BLUEBERRY LOVE

THE MARK CONSISTS OF STANDARD CHARACTERS WITHOUT CLAIM TO ANY PARTICULAR FONT, STYLE, SIZE, OR COLOR.

FOR ANIMAL GROOMING SERVICES (U.S. CLS. 100 AND 101).

FIRST USE 9-30-2012; IN COMMERCE 9-30-2012.  
SHAILA LEWIS, EXAMINING ATTORNEY

**CLASS 44—(Continued).**

SN 86-168,970. BRITANNIA PACIFIC PROPERTIES, INC., SACRAMENTO, CA. FILED 1-17-2014.

# EAU SPA

THE MARK CONSISTS OF STANDARD CHARACTERS WITHOUT CLAIM TO ANY PARTICULAR FONT, STYLE, SIZE, OR COLOR.

NO CLAIM IS MADE TO THE EXCLUSIVE RIGHT TO USE "SPA", APART FROM THE MARK AS SHOWN.

THE ENGLISH TRANSLATION OF "EAU" IN THE MARK IS "WATER".

FOR SPA SERVICES, NAMELY, HEALTH SPA SERVICES IN THE NATURE OF BODY WRAPS, MUD TREATMENTS, SEAWEED TREATMENTS AND BODY SCRUBS; BEAUTY SPA SERVICES, NAMELY, COSMETIC BODY CARE; DAY SPA SERVICES, NAMELY, NAIL CARE, MANICURES, PEDICURES, MASSAGES AND NAIL ENHANCEMENTS; HEALTH SPA SERVICES FOR HEALTH AND WELLNESS OF THE BODY AND SPIRIT; MAKING RESERVATIONS AND BOOKINGS FOR OTHERS FOR PHYSICAL AND BEAUTY TREATMENTS AT HEALTH SPAS (U.S. CLS. 100 AND 101).

FIRST USE 3-31-2009; IN COMMERCE 3-31-2009.  
TASHIA BUNCH, EXAMINING ATTORNEY

**CLASS 44—(Continued).**

SN 86-173,383. RAYTRON ENTERPRISES, INC. OF FLORIDA, DBA FANTASTIC SAM'S, CLEARWATER, FL. FILED 1-23-2014.



NO CLAIM IS MADE TO THE EXCLUSIVE RIGHT TO USE "CALL AHEAD" AND "SIGN IN", APART FROM THE MARK AS SHOWN.

THE MARK CONSISTS OF THE WORDS "CALL AHEAD" ON THE TOP OF A CIRCLE IN WHICH A CARTOON TELEPHONE FIGURE IS STANDING WITH A RECEIVER IN ITS RIGHT HAND AND A SIGN IN ITS LEFT HAND THAT SAYS "YOU'RE NEXT" WITH THE WORDS "SIGN IN" UNDERNEATH THE CIRCLE.

FOR HAIR CUTTING, HAIR STYLING, HAIRDRESSING SALONS, AND HAIRDRESSING SERVICES (U.S. CLS. 100 AND 101).

FIRST USE 9-18-1999; IN COMMERCE 9-18-1999.  
JILLIAN CANTOR, EXAMINING ATTORNEY

SN 86-170,205. REBECCA BITZER AND ASSOCIATES, INC., GREENBELT, MD. FILED 1-20-2014.

## Empowered Eating Program

THE MARK CONSISTS OF STANDARD CHARACTERS WITHOUT CLAIM TO ANY PARTICULAR FONT, STYLE, SIZE, OR COLOR.

NO CLAIM IS MADE TO THE EXCLUSIVE RIGHT TO USE "EATING PROGRAM", APART FROM THE MARK AS SHOWN.

FOR DIETITIAN SERVICES (U.S. CLS. 100 AND 101).  
FIRST USE 11-1-2011; IN COMMERCE 11-1-2011.  
ERIN FALK, EXAMINING ATTORNEY

SN 86-182,064. ELUCID BIOIMAGING INC., WENHAM, MA. FILED 2-2-2014.

# VASCUCAP

THE MARK CONSISTS OF STANDARD CHARACTERS WITHOUT CLAIM TO ANY PARTICULAR FONT, STYLE, SIZE, OR COLOR.

FOR MEDICAL SERVICES, NAMELY, QUANTITATING IMAGING SERVICES TO EVALUATE THE SEVERITY OF VASCULAR DISEASE, IN PARTICULAR, ATHEROSCLEROSIS, AND ASSESS LONGITUDINAL THERAPEUTIC RESPONSE TO INVESTIGATIONAL THERAPEUTIC AGENTS TO VASCULAR DISEASE (U.S. CLS. 100 AND 101).

FIRST USE 4-26-2013; IN COMMERCE 4-26-2013.  
MATTHEW EINSTEIN, EXAMINING ATTORNEY

**CLASS 44—(Continued).**

SN 86-187,605. JOHN N MESSERSCHMIDT, DBA POISON IVY PATROL, HIGH FALLS, NY. FILED 2-7-2014.



NO CLAIM IS MADE TO THE EXCLUSIVE RIGHT TO USE "POISON IVY", APART FROM THE MARK AS SHOWN.

THE MARK CONSISTS OF A SHIELD WITH A TWO BORDER OUTLINES. A CIRCLE WITH AN OUTER BORDER OUTLINE APPEARS IN THE MIDDLE OF THE SHIELD. A POISON IVY LEAF APPEARS SUPERIMPOSED OVER THE CIRCLE. A BANNER RIBBON APPEARS ABOVE THE CIRCLE CONTAINING THE WORDS "POISON IVY PATROL" IN STYLIZED LETTERING. THE LETTERING "P.I." IN STYLIZED FONT APPEARS BELOW THE CIRCLE.

FOR GARDENING SERVICES FOR HOMEOWNERS AND MUNICIPALITIES, NAMELY, ERADICATING POISON IVY AND OTHER INVASIVE PLANTS AND WEEDS (U.S. CLS. 100 AND 101).

FIRST USE 9-1-2011; IN COMMERCE 9-1-2011.  
SUE LAWRENCE, EXAMINING ATTORNEY

SN 86-190,541. TASH FITNESS, LLC, CHICAGO, IL. FILED 2-11-2014.

# Tash Fitness

THE MARK CONSISTS OF STANDARD CHARACTERS WITHOUT CLAIM TO ANY PARTICULAR FONT, STYLE, SIZE, OR COLOR.

NO CLAIM IS MADE TO THE EXCLUSIVE RIGHT TO USE "FITNESS", APART FROM THE MARK AS SHOWN.

FOR PROVIDING A WEBSITE FEATURING INFORMATION ABOUT HEALTH, WELLNESS AND NUTRITION; PROVIDING A WEBSITE FEATURING INFORMATION REGARDING HEALTHY LIVING AND LIFESTYLE WELLNESS; PROVIDING ASSISTANCE, FITNESS EVALUATION AND CONSULTATION TO INDIVIDUALS TO HELP THEM MAKE HEALTH, WELLNESS AND NUTRITIONAL CHANGES IN THEIR DAILY LIVING TO IMPROVE HEALTH; PROVIDING HEALTHY LIFESTYLE AND NUTRITION SERVICES, NAMELY, PERSONAL ASSESSMENTS, PERSONALIZED ROUTINES, MAINTENANCE SCHEDULES, AND COUNSELING; PROVIDING INFORMATION IN THE FIELDS OF HEALTH AND WELLNESS; WELLNESS AND HEALTH-RELATED CONSULTING SERVICES (U.S. CLS. 100 AND 101).

BRITTANY ESTELL, EXAMINING ATTORNEY

**CLASS 44—(Continued).**

SN 86-192,008. RESOLUTION HEALTH, LLC, PLANTATION, FL. FILED 2-12-2014.

the freedom to move forward

THE MARK CONSISTS OF STANDARD CHARACTERS WITHOUT CLAIM TO ANY PARTICULAR FONT, STYLE, SIZE, OR COLOR.

FOR PROVIDING WEIGHT LOSS PROGRAM SERVICES (U.S. CLS. 100 AND 101).

FIRST USE 3-1-2013; IN COMMERCE 7-1-2013.  
DAVID C. REIHNER, EXAMINING ATTORNEY

SN 86-196,475. GUNDERSEN LUTHERAN HEALTH SYSTEM, INC., LA CROSSE, WI. FILED 2-18-2014.

## WHERE CARING MEETS EXCELLENCE

THE MARK CONSISTS OF STANDARD CHARACTERS WITHOUT CLAIM TO ANY PARTICULAR FONT, STYLE, SIZE, OR COLOR.

FOR HEALTH CARE AND MEDICAL SERVICES; MEDICAL CONSULTATION AND COUNSELING; SURGERY; EMERGENCY MEDICAL ASSISTANCE AND RESPONSE SERVICES; PHYSICAL REHABILITATION AND THERAPY; MENTAL HEALTH AND PSYCHOLOGICAL TESTING AND COUNSELING; MEDICAL TESTING FOR DIAGNOSTIC OR TREATMENT PURPOSES; NUTRITION COUNSELING; PROVIDING INFORMATION ABOUT HEALTH AND MEDICINE VIA GLOBAL COMPUTER INFORMATION NETWORKS (U.S. CLS. 100 AND 101).

FIRST USE 0-0-2013; IN COMMERCE 0-0-2013.  
KEVIN MITTLER, EXAMINING ATTORNEY

SN 86-198,819. DIRECTMD, LLC, DRAPER, UT. FILED 2-20-2014.

# DirectMD

THE MARK CONSISTS OF STANDARD CHARACTERS WITHOUT CLAIM TO ANY PARTICULAR FONT, STYLE, SIZE, OR COLOR.

FOR PERSONAL MEDICAL CARE SERVICES, NAMELY, PRIMARY CARE EVALUATION AND TREATMENT OF ACUTE AND CHRONIC ILLNESS AND PREVENTIVE MEDICINE, IN A VARIETY OF SETTINGS INCLUDING INDIVIDUAL CLINIC VISITS, GROUP VISITS, TELEPHONE AND EMAIL CONSULTATIONS (U.S. CLS. 100 AND 101).

FIRST USE 9-1-2004; IN COMMERCE 9-1-2004.  
TRACY FLETCHER, EXAMINING ATTORNEY

**CLASS 44—(Continued).**

SN 86-203,653. THERAPY SYSTEMS, INC., NASHVILLE, TN.  
FILED 2-25-2014.

**PRIVATE EDITION**

THE MARK CONSISTS OF STANDARD CHARACTERS WITHOUT CLAIM TO ANY PARTICULAR FONT, STYLE, SIZE, OR COLOR.

OWNER OF U.S. REG. NO. 3,183,777.  
FOR SALON SERVICES, NAMELY, BEAUTY SALON AND SKIN CARE SALON SERVICES; BEAUTY SPA SERVICES, NAMELY, COSMETIC BODY CARE; SALON SERVICES, NAMELY, MASSAGE SERVICES; SALON SERVICES, NAMELY, SPRAY TANNING SALON SERVICES (U.S. CLS. 100 AND 101).

FIRST USE 9-1-1982; IN COMMERCE 9-1-1982.  
DEBORAH LOBO, EXAMINING ATTORNEY

SN 86-207,837. AMID, INC., HOUSTON, TX. FILED 2-28-2014.

**MYIHR**

THE MARK CONSISTS OF STANDARD CHARACTERS WITHOUT CLAIM TO ANY PARTICULAR FONT, STYLE, SIZE, OR COLOR.

FOR PROVIDING PERSONAL HEALTH CARE INFORMATION BY TELEPHONE, GLOBAL COMPUTER NETWORKS, ELECTRONIC MEANS, MOBILE TELEPHONY, AND INTERNET; PROVIDING AN INTERACTIVE WEB SITE FEATURING INDIVIDUAL PERSONAL MEDICAL HISTORY RECORDS, INCLUDING CONDITIONS, TEST RESULTS, MEDICATIONS, ALLERGIES, LEGAL DOCUMENTS, FAMILY HISTORY, CONTACTS, AND INSURANCE (U.S. CLS. 100 AND 101).

FIRST USE 4-15-2012; IN COMMERCE 4-15-2012.  
ERIC SABLE, EXAMINING ATTORNEY

SN 86-208,510. IFLOAT WESTPORT, LLC, DBA IFLOAT, WESTPORT, CT. FILED 3-1-2014.

**iFloat**

THE MARK CONSISTS OF STANDARD CHARACTERS WITHOUT CLAIM TO ANY PARTICULAR FONT, STYLE, SIZE, OR COLOR.

FOR FLOATATION TANK THERAPY USING SENSORY DEPRIVATION TECHNIQUES (U.S. CLS. 100 AND 101).

FIRST USE 12-1-2009; IN COMMERCE 12-1-2009.  
SETH DENNIS, EXAMINING ATTORNEY

**CLASS 44—(Continued).**

SN 86-209,460. LIFETIME PODIATRY PC, NEW YORK, NY.  
FILED 3-3-2014.



THE MARK CONSISTS OF A STYLIZED DESIGN OF A COMBINATION OF FEET AND WINGS. THE FEET ARE AT THE BOTTOM AND AT THE TOP THE FEET TRANSFORM INTO WINGS. THE FEET AND WINGS ARE SUPERIMPOSED ON TWO CONCENTRIC CIRCLES.

FOR NAIL CARE SERVICES; PODIATRY SERVICES (U.S. CLS. 100 AND 101).

FIRST USE 7-1-2011; IN COMMERCE 10-0-2011.  
MARLENE BELL, EXAMINING ATTORNEY

SN 86-211,263. THE TREATMENT CENTERS OF THE PALM BEACHES, LLC, LAKE WORTH, FL. FILED 3-5-2014.



NO CLAIM IS MADE TO THE EXCLUSIVE RIGHT TO USE "TEEN TREATMENT CENTER" AND "PALM BEACHES", APART FROM THE MARK AS SHOWN.

THE COLOR(S) RED AND BLUE IS/ARE CLAIMED AS A FEATURE OF THE MARK.

THE MARK CONSISTS OF A BLUE CIRCLE COMPRISED OF THREE EXTENDED TEARDROPS SURROUNDING A BLUE DOT WITH A PARTIAL REFLECTION OF THE DESIGN BELOW THE DESIGN FOLLOWED BY THE WORDING "TEENTREATMENTCENTER" IN BLUE ABOVE THE WORDING "OF THE PALM BEACHES" IN BLUE ABOVE "WE RESTORE FAMILIES" IN RED. THE COLOR WHITE REPRESENTS TRANSPARENT OR BACKGROUND AND IT NOT INTENDED TO BE A PART OF THE MARK.

FOR REHABILITATION FOR SUBSTANCE ABUSE PATIENTS; REHABILITATION OF ALCOHOL ADDICTED PATIENTS (U.S. CLS. 100 AND 101).

FIRST USE 2-5-2014; IN COMMERCE 2-5-2014.  
DEBORAH MEINERS, EXAMINING ATTORNEY

**CLASS 44—(Continued).**

SN 86-214,340. SYNERGY PSYCHOLOGICAL INC., SIERRA MADRE, CA. FILED 3-7-2014.

**Synergy Psychological**

THE MARK CONSISTS OF STANDARD CHARACTERS WITHOUT CLAIM TO ANY PARTICULAR FONT, STYLE, SIZE, OR COLOR.

NO CLAIM IS MADE TO THE EXCLUSIVE RIGHT TO USE "PSYCHOLOGICAL", APART FROM THE MARK AS SHOWN.

FOR HYPNOTHERAPY SERVICES FOR MEDICAL OR PSYCHOLOGICAL PURPOSES; MUSIC THERAPY FOR PHYSICAL, PSYCHOLOGICAL AND COGNITIVE PURPOSES; PERSONALITY TESTING FOR PSYCHOLOGICAL PURPOSES; PROVIDING PSYCHOLOGICAL PROFILES AND PSYCHOLOGICAL RECORD ANALYSIS AND ASSESSMENTS VIA A WEBSITE THAT ARE DESIGNED TO PROVIDE CUSTOM TAILORED OUTPUTS ABOUT RECOMMENDED RESOURCES AND TREATMENTS ASSOCIATED WITH A DEFINED SET OF SYMPTOMS AND CONCERNS; PSYCHOLOGICAL ASSESSMENT SERVICES; PSYCHOLOGICAL CONSULTATION; PSYCHOLOGICAL COUNSELING; PSYCHOLOGICAL COUNSELING SERVICES IN THE FIELD OF SPORTS; PSYCHOLOGICAL SERVICES, NAMELY, PROVIDING DIAGNOSTIC SERVICES TO CHILDREN WITH SPECIAL NEEDS AND THEIR FAMILIES; PSYCHOLOGICAL SERVICES, NAMELY, PROVIDING THERAPEUTIC SERVICES TO CHILDREN WITH SPECIAL NEEDS AND THEIR FAMILIES (U.S. CLS. 100 AND 101).

FIRST USE 7-26-2009; IN COMMERCE 8-12-2009.  
DANNEAN HETZEL, EXAMINING ATTORNEY

---

SN 86-215,460. CAROLYN MAI, HONOLULU, HI. FILED 3-8-2014.

**MD REFRESH**

THE MARK CONSISTS OF STANDARD CHARACTERS WITHOUT CLAIM TO ANY PARTICULAR FONT, STYLE, SIZE, OR COLOR.

NO CLAIM IS MADE TO THE EXCLUSIVE RIGHT TO USE "MD", APART FROM THE MARK AS SHOWN.

FOR MEDICAL CLINIC PROVIDING WEIGHT LOSS SOLUTIONS, SERVICES AND PROGRAMS, NUTRITION COUNSELING, HORMONE THERAPY, INCLUDING, BIOIDENTICAL HORMONE REPLACEMENT, ANTI AGING THERAPY, AND NATURAL HORMONE THERAPY, MEDICAL AESTHETIC PROCEDURES, INCLUDING, LASER HAIR REMOVAL, LASER PEELS, BOTULINUM TOXIN TREATMENTS, MICRODERMABRASION, LIPOSUCTION, VEIN TREATMENTS, VEIN THERAPY, CELLULITE TREATMENTS, BODY CONTOURING TREATMENTS, INJECTABLE FILLER TREATMENTS, FACIALS, AND SKIN CARE (U.S. CLS. 100 AND 101).

TRACY WHITTAKER-BROWN, EXAMINING ATTORNEY

**CLASS 44—(Continued).**

SN 86-218,098. CHIA CHI KAO, MD, SANTA MONICA, CA. FILED 3-11-2014.

**PONY TAIL LIFT**

THE MARK CONSISTS OF STANDARD CHARACTERS WITHOUT CLAIM TO ANY PARTICULAR FONT, STYLE, SIZE, OR COLOR.

NO CLAIM IS MADE TO THE EXCLUSIVE RIGHT TO USE "LIFT", APART FROM THE MARK AS SHOWN.

FOR COSMETIC AND PLASTIC SURGERY; COSMETIC SURGERY SERVICES; MINIMALLY INVASIVE SURGICAL SERVICES (U.S. CLS. 100 AND 101).

FIRST USE 1-26-2013; IN COMMERCE 1-26-2013.  
MATTHEW GALAN, EXAMINING ATTORNEY

---

SN 86-218,121. CHIA CHI KAO, MD, SANTA MONICA, CA. FILED 3-11-2014.

**PONYTAIL FACELIFT**

THE MARK CONSISTS OF STANDARD CHARACTERS WITHOUT CLAIM TO ANY PARTICULAR FONT, STYLE, SIZE, OR COLOR.

NO CLAIM IS MADE TO THE EXCLUSIVE RIGHT TO USE "FACELIFT", APART FROM THE MARK AS SHOWN.

FOR COSMETIC AND PLASTIC SURGERY; COSMETIC SURGERY SERVICES; MINIMALLY INVASIVE SURGICAL SERVICES (U.S. CLS. 100 AND 101).

MATTHEW GALAN, EXAMINING ATTORNEY

---

SN 86-220,867. ZOLL, MARIKA, AKA DR. MARIKA ZOLL, OJAI, CA. FILED 3-13-2014.

**FRENCH BULLDOGS LA**

THE MARK CONSISTS OF STANDARD CHARACTERS WITHOUT CLAIM TO ANY PARTICULAR FONT, STYLE, SIZE, OR COLOR.

NO CLAIM IS MADE TO THE EXCLUSIVE RIGHT TO USE "FRENCH BULLDOGS", APART FROM THE MARK AS SHOWN.

SEC. 2(F).  
FOR BREEDING AND STUD SERVICES FOR DOGS (U.S. CLS. 100 AND 101).

FIRST USE 1-23-2007; IN COMMERCE 1-23-2007.  
ANGELA M. MICHELI, EXAMINING ATTORNEY

**CLASS 44—(Continued).**

SN 86-221,366. DOUGLAS G. STEIN, M.D., P.A., TAMPA, FL. FILED 3-14-2014.



NO CLAIM IS MADE TO THE EXCLUSIVE RIGHT TO USE "VASECTOMIST", APART FROM THE MARK AS SHOWN.

THE MARK CONSISTS OF THE WORDS "THE" AND "VASECTOMIST" WITH THE LETTER "O" IN "VASECTOMIST" SHAPED IN THE FORM OF A SPERM.

FOR PHYSICIAN SERVICES (U.S. CLS. 100 AND 101).  
FIRST USE 10-18-2013; IN COMMERCE 10-18-2013.  
GRETTA YAO, EXAMINING ATTORNEY

**CLASS 44—(Continued).**

SN 86-224,058. MIT-RAIISHA ENTERPRISES, LLC, JESSUP, MD. FILED 3-18-2014.



NO CLAIM IS MADE TO THE EXCLUSIVE RIGHT TO USE "SPIRITUAL SPA", APART FROM THE MARK AS SHOWN.

THE MARK CONSISTS OF THE STYLIZED WORDING "NIKKI'S" OVER "SPIRITUAL SPA", WITH THE LETTER "S" IN "SPA" CASCADING DOWN THE BACK OF AN IMAGE OF A FEMALE HEAD AND TORSO SILHOUETTE.

FOR DAY SPA SERVICES, NAMELY, NAIL CARE, MANICURES, PEDICURES AND NAIL ENHANCEMENTS; HEALTH SPA SERVICES, NAMELY, COSMETIC BODY CARE SERVICES; HEALTH SPA SERVICES, NAMELY, BODY WRAPS, MUD TREATMENTS, SEAWEED TREATMENTS, HYDROTHERAPY BATHS, AND BODY SCRUBS; MAKE-UP APPLICATION SERVICES; HAIR SALON SERVICES (U.S. CLS. 100 AND 101).  
LAURA KOVALSKY, EXAMINING ATTORNEY

SN 86-224,262. GRANT, TERRY, HEMPSTEAD, NY. FILED 3-18-2014.

SN 86-223,534. ABC DOGS, DALY CITY, CA. FILED 3-17-2014.

ABC Dogs



NO CLAIM IS MADE TO THE EXCLUSIVE RIGHT TO USE "PRE-PAID DENTAL SERVICE PLAN", APART FROM THE MARK AS SHOWN.

THE COLOR(S) BLUE, YELLOW, BLACK, GRAY, WHITE IS/ARE CLAIMED AS A FEATURE OF THE MARK.

THE MARK CONSISTS OF THE BLACK STYLIZED WORDING "PRE-PAID DENTAL SERVICE PLAN". ABOVE THE WORDING IS THE DESIGN OF A TOOTH UNDER A RIBBON THAT IS IN THE SHAPE OF THE OMEGA SYMBOL. THE TOOTH IS WHITE, SHADED IN YELLOW AND BLUE, AND OUTLINED IN BLACK. THE RIBBON IS YELLOW AND WHITE, SHADED IN GRAY, AND OUTLINED IN BLACK.

FOR DENTISTRY (U.S. CLS. 100 AND 101).  
FIRST USE 5-1-2011; IN COMMERCE 5-1-2011.  
BARBARA GAYNOR, EXAMINING ATTORNEY

THE MARK CONSISTS OF STANDARD CHARACTERS WITHOUT CLAIM TO ANY PARTICULAR FONT, STYLE, SIZE, OR COLOR.

NO CLAIM IS MADE TO THE EXCLUSIVE RIGHT TO USE "DOGS", APART FROM THE MARK AS SHOWN.  
FOR DOG WALKING SERVICES (U.S. CLS. 100 AND 101).

FIRST USE 12-12-2011; IN COMMERCE 12-12-2011.  
AISHA CLARKE, EXAMINING ATTORNEY

**CLASS 44—(Continued).**

SN 86-224,539. GAUDETTE, INC., CHARLESTON, SC. FILED 3-18-2014.

**Just Say Know**

THE MARK CONSISTS OF STANDARD CHARACTERS WITHOUT CLAIM TO ANY PARTICULAR FONT, STYLE, SIZE, OR COLOR.

FOR TREATMENT AND REHABILITATION SERVICES FOR PERSONS SUFFERING FROM SUBSTANCE ABUSE AND OTHER CHEMICAL DEPENDENCIES, NAMELY, DRUGS AND ALCOHOL; PSYCHOLOGICAL COUNSELING FOR PERSONS SUFFERING FROM MALADAPTIVE BEHAVIORS, SUBSTANCE ABUSE, AND OTHER CHEMICAL DEPENDENCIES, NAMELY, DRUGS AND ALCOHOL (U.S. CLS. 100 AND 101).

BRIN ANDERSON, EXAMINING ATTORNEY

SN 86-224,893. STANTON, M.D., RYAN, BEVERLY HILLS, CA. FILED 3-18-2014.

**Bio3D-mentional Facelift**

NO CLAIM IS MADE TO THE EXCLUSIVE RIGHT TO USE "FACELIFT", APART FROM THE MARK AS SHOWN.

FOR COSMETIC AND PLASTIC SURGICAL PROCEDURE TO REJUVENATE THE FACE UTILIZING GROWTH FACTORS, PLURIPOTENT CELLS, AND NUTRIENTS FROM THE AMNIOTIC LAYER OF THE PLACENTA COMBINED WITH HYALURONIC ACID THAT IS INJECTED INTO VARIOUS AREAS OF THE FACE, NAMELY, TEMPLES, EYEBROWS, EYELIDS, TEAR TROUGHS, MALARS AND CHEEKS, NASOLABIAL FOLDS, LIPS, CHIN, JOWLS, AND, OR, NECK TO PLUMP AND FILL ATROPHIED AGED TISSUES (U.S. CLS. 100 AND 101).

FIRST USE 10-26-2013; IN COMMERCE 10-26-2013.  
NAKIA HENRY, EXAMINING ATTORNEY

SN 86-225,081. CHELSEA VILLAGE MEDICAL, PC, NEW YORK, NY. FILED 3-18-2014.

**RELATIONSHIP BASED MEDICINE**

THE MARK CONSISTS OF STANDARD CHARACTERS WITHOUT CLAIM TO ANY PARTICULAR FONT, STYLE, SIZE, OR COLOR.

NO CLAIM IS MADE TO THE EXCLUSIVE RIGHT TO USE "MEDICINE", APART FROM THE MARK AS SHOWN. FOR MEDICAL SERVICES (U.S. CLS. 100 AND 101).  
JAY FLOWERS, EXAMINING ATTORNEY

**CLASS 44—(Continued).**

SN 86-226,414. TATTOO AFTERLIFE INC, CENTEREACH, NY. FILED 3-19-2014.

**TATTOO AFTERLIFE**

THE MARK CONSISTS OF STANDARD CHARACTERS WITHOUT CLAIM TO ANY PARTICULAR FONT, STYLE, SIZE, OR COLOR.

NO CLAIM IS MADE TO THE EXCLUSIVE RIGHT TO USE "TATTOO", APART FROM THE MARK AS SHOWN.

FOR COSMETIC TATTOOING SERVICES; PROVIDING MEDICAL INFORMATION AND NEWS ABOUT BODY ART, NAMELY, PIERCING, TATTOOS, SCARIFICATION, SUBINCISION, CASTRATION THROUGH PHOTOS AND VIDEOS; TATTOO PARLORS; TATTOO STUDIOS; TATTOOING; TATTOOING SERVICES (U.S. CLS. 100 AND 101).

FIRST USE 10-18-2012; IN COMMERCE 10-18-2012.  
GINA FINK, EXAMINING ATTORNEY

SN 86-227,964. ONEILL, MICHAEL, BLAINE, MN. FILED 3-21-2014.

**INKOVATION STATION**

THE MARK CONSISTS OF STANDARD CHARACTERS WITHOUT CLAIM TO ANY PARTICULAR FONT, STYLE, SIZE, OR COLOR.

NO CLAIM IS MADE TO THE EXCLUSIVE RIGHT TO USE "STATION", APART FROM THE MARK AS SHOWN.

FOR TATTOO PARLORS; TATTOO STUDIOS (U.S. CLS. 100 AND 101).

DOUGLAS LEE, EXAMINING ATTORNEY

SN 86-228,913. TAMARA TCM ACUPUNCTURE & HERBS, PERRYSBURG, OH. FILED 3-21-2014.



NO CLAIM IS MADE TO THE EXCLUSIVE RIGHT TO USE "TCM ACUPUNCTURE & HERBS", APART FROM THE MARK AS SHOWN.

THE NAME SHOWN IN THE MARK IDENTIFIES A LIVING INDIVIDUAL WHOSE CONSENT IS OF RECORD.

THE MARK CONSISTS OF A TREE IN A YIN/YANG CIRCLE TO THE LEFT OF THE STYLIZED TEXT "TAMARA TCM ACUPUNCTURE & HERBS".

FOR ACUPUNCTURE; HOLISTIC HEALTH SERVICES FEATURING HERBAL MEDICINE; MASSAGE THERAPY SERVICES (U.S. CLS. 100 AND 101).

FIRST USE 9-0-2012; IN COMMERCE 9-0-2012.

JENNIFER RICHARDSON, EXAMINING ATTORNEY



**CLASS 44—(Continued).**

SN 86-228,924. HAIR CLUB FOR MEN, LTD., INC., BOCA RATON, FL. FILED 3-21-2014.



OWNER OF U.S. REG. NOS. 1,317,389, 1,903,844 AND 3,057,215.

NO CLAIM IS MADE TO THE EXCLUSIVE RIGHT TO USE "HAIR", APART FROM THE MARK AS SHOWN.

THE MARK CONSISTS OF THE WORDS "HAIR CLUB" WITH A WAVELIKE LINE THROUGH THE WORDS.

FOR BEAUTY SERVICES, HAIR REPLACEMENT, HAIR WEAVING AND HAIR CARE SERVICES, NAMELY, HAIR SALON SERVICES, HAIR CUTTING SERVICES (U.S. CLS. 100 AND 101).

FIRST USE 12-31-2008; IN COMMERCE 12-31-2008.  
KAMAL PREET, EXAMINING ATTORNEY

**CLASS 44—(Continued).**

SN 86-229,725. MWD MEDICAL P1, LLC, DBA PERSONA DOCTORS, ROCKVILLE, MD. FILED 3-24-2014.

# PersonaDoctors

THE MARK CONSISTS OF STANDARD CHARACTERS WITHOUT CLAIM TO ANY PARTICULAR FONT, STYLE, SIZE, OR COLOR.

FOR CONDUCTING MEDICAL PHYSICAL EVALUATIONS; MEDICAL SERVICES; DISPENSING OF PHARMACEUTICALS; DISPENSING OF PHARMACEUTICALS, NAMELY, INJECTABLES; DISPENSING OF MEDICINES, NAMELY, HORMONE REPLACEMENT THERAPIES; COSMETIC FAT REDUCTION PROCEDURES, NAMELY, NONSURGICAL COSMETIC BODY CARE SERVICES; PHYSICIAN SERVICES (U.S. CLS. 100 AND 101).

FIRST USE 1-11-2014; IN COMMERCE 1-11-2014.  
GILBERT SWIFT, EXAMINING ATTORNEY

SN 86-230,240. SAN ANTONIO COMMUNITY HOSPITAL, UPLAND, CA. FILED 3-24-2014.



## SAN ANTONIO HEALTH

NO CLAIM IS MADE TO THE EXCLUSIVE RIGHT TO USE "SAN ANTONIO HEALTH", APART FROM THE MARK AS SHOWN.

THE MARK CONSISTS OF A SOLID CIRCLE WITH AN IMAGE OF A STEM WITH THREE LEAVES INSIDE THE CIRCLE ALL ABOVE THE WORDS "SAN ANTONIO HEALTH".

FOR MEDICAL SERVICES (U.S. CLS. 100 AND 101).  
ELISSA GARBER KON, EXAMINING ATTORNEY

SN 86-228,969. HUNT SPINE, LLC, LOS ANGELES, CA. FILED 3-21-2014.

# HUNT SPINE

THE MARK CONSISTS OF STANDARD CHARACTERS WITHOUT CLAIM TO ANY PARTICULAR FONT, STYLE, SIZE, OR COLOR.

NO CLAIM IS MADE TO THE EXCLUSIVE RIGHT TO USE "SPINE", APART FROM THE MARK AS SHOWN.

FOR MEDICAL SERVICES, NAMELY, SURGICAL TREATMENT OF THE SPINE; MEDICAL TREATMENT SERVICES, NAMELY, TREATMENT OF THE SPINE INCLUDING TREATMENT OF SPINAL CORD INJURIES, SPINAL TRAUMA, SPINAL DISORDERS, SPINAL DISEASES AND DEGENERATIVE CONDITIONS OF THE NECK AND BACK, SPINAL SCOLIOSIS, DISC REPLACEMENT AND MINIMALLY INVASIVE SPINAL SURGERY (U.S. CLS. 100 AND 101).

FIRST USE 8-30-2006; IN COMMERCE 8-30-2006.  
LOKSYE G LEE RISO, EXAMINING ATTORNEY

SN 86-230,271. SAN ANTONIO COMMUNITY HOSPITAL, UPLAND, CA. FILED 3-24-2014.



## SAN ANTONIO REGIONAL HOSPITAL

NO CLAIM IS MADE TO THE EXCLUSIVE RIGHT TO USE "SAN ANTONIO REGIONAL HOSPITAL", APART FROM THE MARK AS SHOWN.

THE MARK CONSISTS OF A SOLID CIRCLE WITH AN IMAGE OF A STEM WITH THREE LEAVES INSIDE THE CIRCLE ALL TO THE LEFT OF THE WORDS "SAN ANTONIO REGIONAL HOSPITAL".

FOR MEDICAL SERVICES (U.S. CLS. 100 AND 101).  
ELISSA GARBER KON, EXAMINING ATTORNEY

**CLASS 44—(Continued).**

SN 86-230,315. SAN ANTONIO COMMUNITY HOSPITAL, UPLAND, CA. FILED 3-24-2014.



**SAN ANTONIO  
REGIONAL HOSPITAL**

NO CLAIM IS MADE TO THE EXCLUSIVE RIGHT TO USE "SAN ANTONIO REGIONAL HOSPITAL", APART FROM THE MARK AS SHOWN.

THE MARK CONSISTS OF A SOLID CIRCLE WITH AN IMAGE OF A STEM WITH THREE LEAVES INSIDE THE CIRCLE ABOVE THE WORDS "SAN ANTONIO" ALL ABOVE THE WORDS "REGIONAL HOSPITAL".

FOR MEDICAL SERVICES (U.S. CLS. 100 AND 101).  
ELISSA GARBER KON, EXAMINING ATTORNEY

SN 86-231,739. HILL, ANYA, PORTLAND, OR. FILED 3-25-2014.

**Nic-WiPP**

THE MARK CONSISTS OF STANDARD CHARACTERS WITHOUT CLAIM TO ANY PARTICULAR FONT, STYLE, SIZE, OR COLOR.

FOR CONSULTING SERVICES IN THE FIELD OF SMOKING CESSATION TREATMENT (U.S. CLS. 100 AND 101).

KHANH LE, EXAMINING ATTORNEY

SN 86-231,841. DR. VERYL WILLIAMS, AKA BRIDGES RESPITE SERVICES, PLLC, YPSILANTI, MI. FILED 3-25-2014.



THE COLOR(S) RED, BLACK AND WHITE IS/ARE CLAIMED AS A FEATURE OF THE MARK.

THE MARK CONSISTS OF TWO RED STICK FIGURES FORMING A BRIDGE AROUND THE WORDING "BRIDGES". THE "I" IN "BRIDGES" IS COMPRISED OF A

**CLASS 44—(Continued).**

RED STICK FIGURE, WITH THE REMAINING LETTERING BEING BLACK. THE WORD "BRIDGES" IS UNDERLINED IN BLACK. BELOW THE UNDERLINING IS THE WORD "RESPITE" IN BLACK, WITH SIX RED STICK FIGURES SPACED BETWEEN EACH OF THE LETTERS WITH THEIR ARMS CURVED OVER THE LETTERS. BELOW THAT IS THE WORDING "RESPONSIVE EDUCATIONAL SERVICES PURPOSELY IGNITING THERAPEUTIC EQUILIBRIUM" IN BLACK. THE BACKGROUND OF THE MARK IS WHITE.

FOR MENTAL HEALTH THERAPY SERVICES (U.S. CLS. 100 AND 101).

KERI CANTONE, EXAMINING ATTORNEY

SN 86-232,290. HER KARE HOLDINGS, L.L.C., DBA HER KARE, GRAPEVINE, TX. FILED 3-26-2014.



NO CLAIM IS MADE TO THE EXCLUSIVE RIGHT TO USE "KARE", APART FROM THE MARK AS SHOWN.

THE COLOR(S) ROSE AND BLACK IS/ARE CLAIMED AS A FEATURE OF THE MARK.

THE MARK CONSISTS OF THE WORDING "HER KARE" IN RIBBON-LIKE SCRIPT WITH THE LETTERING IN BLACK. THE "K" IN "KARE" IS ROSE OVER BLACK.

FOR CONSULTING SERVICES IN THE FIELD OF HORMONE REPLACEMENT THERAPY; HEALTH CARE SERVICES, NAMELY, HORMONE REPLACEMENT THERAPY (U.S. CLS. 100 AND 101).

FIRST USE 11-1-2013; IN COMMERCE 11-1-2013.  
REBECCA POVARCHUK, EXAMINING ATTORNEY

SN 86-232,469. WILLOW POINT PARTNERS, LLC, INDIANAPOLIS, IN. FILED 3-26-2014.



NO CLAIM IS MADE TO THE EXCLUSIVE RIGHT TO USE HOME CARE, APART FROM THE MARK AS SHOWN.

THE COLOR(S) BLUE AND GREEN IS/ARE CLAIMED AS A FEATURE OF THE MARK.

THE MARK CONSISTS OF THE LITERAL ELEMENT "TOGETHER" IN BLUE FONT POSITIONED ON TOP OF THE LITERAL ELEMENT "HOMECARE" IN GREEN LETTERING, BOTH RIGHT-JUSTIFIED. THE WORDS ARE POSITIONED TO THE RIGHT OF A STYLIZED CIRCLE WITH FOUR CUTOUT SHAPES WITH A CIRCLE IN THE CENTER OF EACH TO FORM THE IMPRESSION OF A STAR WITH THE CUTOUTS ALTERNATING COLORS TWO BLUE, TWO GREEN. THE COLOR WHITE APPEARING IN THE MARK IS NOT CLAIMED AS A FEATURE OF THE MARK

FOR HOME HEALTH CARE SERVICES (U.S. CLS. 100 AND 101).

THOMAS MANOR, EXAMINING ATTORNEY

**CLASS 44—(Continued).**

SN 86-232,685. JAZZY JEWELS, TAMPA, FL. FILED 3-26-2014.



NO CLAIM IS MADE TO THE EXCLUSIVE RIGHT TO USE "MAKE UP HAIR AND PARTIES", APART FROM THE MARK AS SHOWN.

THE MARK CONSISTS OF THE WORDING "JAZZY JEWELS MAKE UP HAIR AND PARTIES" AND THE IMAGE OF A WOMAN. A LARGE LETTER "J" IS SHARED BY THE WORDS "JAZZY" AND "JEWELS" AND A STAR APPEARS AT THE TIP OF THE LETTER "Y" IN "JAZZY".

FOR BEAUTY SALON SERVICES; HAIR SALON SERVICES (U.S. CLS. 100 AND 101).

FIRST USE 5-1-2010; IN COMMERCE 5-1-2010.  
ROSELLE HERRERA, EXAMINING ATTORNEY

SN 86-233,137. MIDTOWN TREE SERVICE, LLC, TULSA, OK. FILED 3-26-2014.

## Midtown Tree Service

THE MARK CONSISTS OF STANDARD CHARACTERS WITHOUT CLAIM TO ANY PARTICULAR FONT, STYLE, SIZE, OR COLOR.

NO CLAIM IS MADE TO THE EXCLUSIVE RIGHT TO USE "TREE SERVICE", APART FROM THE MARK AS SHOWN.

FOR TREE CARE SERVICES, NAMELY, TREE AND SHRUB TRIMMING AND REMOVAL AND STUMP GRINDING (U.S. CLS. 100 AND 101).

FIRST USE 10-9-2012; IN COMMERCE 10-9-2012.  
KEVIN CRENNAN, EXAMINING ATTORNEY

**CLASS 44—(Continued).**

SN 86-233,252. UNIVERSAL NURSING SERVICES, LTD., DBA UNIVERSAL PEDIATRICS, INC., WEST DES MOINES, IA. FILED 3-26-2014.

## Universal Pediatrics

THE MARK CONSISTS OF STANDARD CHARACTERS WITHOUT CLAIM TO ANY PARTICULAR FONT, STYLE, SIZE, OR COLOR.

NO CLAIM IS MADE TO THE EXCLUSIVE RIGHT TO USE "PEDIATRICS", APART FROM THE MARK AS SHOWN.

FOR HOME HEALTH CARE SERVICES (U.S. CLS. 100 AND 101).

JOSETTE BEVERLY, EXAMINING ATTORNEY

SN 86-233,560. MEDSHARE INC., LOUISVILLE, KY. FILED 3-27-2014.

## MEDSHARE HEALTH AND WELLNESS CENTERS

THE MARK CONSISTS OF STANDARD CHARACTERS WITHOUT CLAIM TO ANY PARTICULAR FONT, STYLE, SIZE, OR COLOR.

NO CLAIM IS MADE TO THE EXCLUSIVE RIGHT TO USE "HEALTH AND WELLNESS CENTERS", APART FROM THE MARK AS SHOWN.

FOR MEDICAL CLINIC PROVIDING WEIGHT LOSS SOLUTIONS, SERVICES AND PROGRAMS, NUTRITION COUNSELING, HORMONE THERAPY, INCLUDING, BIOIDENTICAL HORMONE REPLACEMENT, ANTI AGING THERAPY, AND NATURAL HORMONE THERAPY, MEDICAL AESTHETIC PROCEDURES, INCLUDING, LASER HAIR REMOVAL, LASER PEELS, BOTULINUM TOXIN TREATMENTS, MICRODERMABRASION, LIPOSUCTION, VEIN TREATMENTS, VEIN THERAPY, CELLULITE TREATMENTS, BODY CONTOURING TREATMENTS, INJECTABLE FILLER TREATMENTS, FACIALS, AND SKIN CARE; PROVIDING WEIGHT LOSS PROGRAM SERVICES; HEALTH CARE SERVICES, NAMELY, ALLERGY TESTING SERVICES; LASER HAIR REMOVAL SERVICES (U.S. CLS. 100 AND 101).

EDWARD NELSON, EXAMINING ATTORNEY

**CLASS 44—(Continued).**

SN 86-235,672. PLOURDE, MARRION, N PROVIDENCE, RI. FILED 3-28-2014.

## Creative Healing Energy

THE MARK CONSISTS OF STANDARD CHARACTERS WITHOUT CLAIM TO ANY PARTICULAR FONT, STYLE, SIZE, OR COLOR.

NO CLAIM IS MADE TO THE EXCLUSIVE RIGHT TO USE "HEALING ENERGY", APART FROM THE MARK AS SHOWN.

FOR AROMATHERAPY SERVICES; ENERGY HEALING SERVICES, NAMELY, STRESS MANAGEMENT AND STRESS REDUCTION COUNSELING FOR INDIVIDUALS TO ENHANCE THEIR LIVES; PROVIDING A WEBSITE FEATURING INFORMATION CONCERNING ALTERNATIVE HEALTH AND HEALING; PROVIDING IN-PERSON ENERGY HEALING SERVICES; PROVIDING IN-PERSON VIBRATIONAL ENERGY HEALING SERVICES; REIKI HEALING SERVICES (U.S. CLS. 100 AND 101).

DONALD JOHNSON, EXAMINING ATTORNEY

---

SN 86-236,208. ELENA MEYLIKER DDS, INC., DBA ALLURE DENTAL, SAN FRANCISCO, CA. FILED 3-29-2014.

## Allure Dental

THE MARK CONSISTS OF STANDARD CHARACTERS WITHOUT CLAIM TO ANY PARTICULAR FONT, STYLE, SIZE, OR COLOR.

NO CLAIM IS MADE TO THE EXCLUSIVE RIGHT TO USE "DENTAL", APART FROM THE MARK AS SHOWN.

FOR DENTAL SERVICES, NAMELY, PERFORMING RESTORATIVE AND COSMETIC PROCEDURES (U.S. CLS. 100 AND 101).

ANNE E. GUSTASON, EXAMINING ATTORNEY

---

SN 86-236,800. BIJOU'S TOTAL BODY REJUVENATION, INC., WESTBURY, NY. FILED 3-31-2014.

## Bijuvenation

THE MARK CONSISTS OF STANDARD CHARACTERS WITHOUT CLAIM TO ANY PARTICULAR FONT, STYLE, SIZE, OR COLOR.

FOR CONSULTING SERVICES IN THE FIELD OF HEALTH; CONSULTING SERVICES IN THE FIELDS OF HEALTH AND NUTRITION; PROVIDING WEIGHT LOSS PROGRAM SERVICES; WELLNESS AND HEALTH-RELATED CONSULTING SERVICES (U.S. CLS. 100 AND 101).

TINA MAI, EXAMINING ATTORNEY

**CLASS 44—(Continued).**

SN 86-237,736. YANEZ, NADIA, ASTORIA, NY. FILED 3-31-2014.

## Lablosh

THE MARK CONSISTS OF STANDARD CHARACTERS WITHOUT CLAIM TO ANY PARTICULAR FONT, STYLE, SIZE, OR COLOR.

FOR BEAUTY SALON SERVICES; BEAUTY SALONS; BODY WAXING SERVICES; COSMETOLOGY SERVICES; HAIR SALON SERVICES; NAIL CARE SALONS; PROVIDING ON-SITE BEAUTY SERVICES, NAMELY, HAIR STYLING AND MAKE-UP APPLICATION SERVICES (U.S. CLS. 100 AND 101).

COLLEEN DOMBROW, EXAMINING ATTORNEY

---

SN 86-238,739. PENSFORD FINANCIAL GROUP, LLC, DBA SALON 1890, CHARLOTTE, NC. FILED 4-1-2014.

## SALON 1890

THE MARK CONSISTS OF STANDARD CHARACTERS WITHOUT CLAIM TO ANY PARTICULAR FONT, STYLE, SIZE, OR COLOR.

NO CLAIM IS MADE TO THE EXCLUSIVE RIGHT TO USE "SALON", APART FROM THE MARK AS SHOWN.

FOR HAIR STYLING; PROVIDING ON-SITE BEAUTY SERVICES, NAMELY, HAIR STYLING AND MAKE-UP APPLICATION SERVICES (U.S. CLS. 100 AND 101).

MAH ROSENBERG, EXAMINING ATTORNEY

**CLASS 44—(Continued).**

SN 86-238,903. BOARD OF PENSIONS EVANGELICAL LUTHERAN CHURCH OF AMERICA, MINNEAPOLIS, MN. FILED 4-1-2014.



NO CLAIM IS MADE TO THE EXCLUSIVE RIGHT TO USE "SOCIAL/INTERPERSONAL WELL-BEING", "EMOTIONAL WELL-BEING", "PHYSICAL WELL-BEING", "FINANCIAL WELL-BEING", "VOCATIONAL WELL-BEING", "INTELLECTUAL WELL-BEING", AND "SPIRITUAL WELL-BEING", APART FROM THE MARK AS SHOWN. THE COLOR(S) BLUE, GREEN, RED, ORANGE, YELLOW, PURPLE, AND WHITE IS/ARE CLAIMED AS A FEATURE OF THE MARK.

THE MARK CONSISTS OF A CONCENTRIC CIRCLE DESIGN WITH THE BLUE WORDING "IN BAPTISM A NEW CREATION IN CHRIST" ON THE WHITE INNERMOST CIRCLE. THE NEXT CIRCLE CONSISTS OF COLORED SEGMENTS CONTAINING WORDING IN AN EXTREMELY LIGHT SHADE OF THE SAME COLOR AS EACH SEGMENT THE WORDING IS ON. GOING IN A CLOCKWISE DIRECTION, STARTING AT THE THE TOP, THE SEGMENTS ARE BLUE WITH THE WORDING "SOCIAL/INTERPERSONAL WELL BEING", GREEN WITH THE WORDING "EMOTIONAL WELL-BEING", RED WITH THE WORDING "PHYSICAL WELL-BEING", ORANGE WITH THE WORDING "FINANCIAL WELL-BEING", YELLOW WITH THE WORDING "VOCATIONAL WELL-BEING", AND PURPLE WITH THE WORDING "INTELLECTUAL WELL-BEING". THE OUTERMOST CIRCLE IS IN SHADES OF PURPLE CONTAINING THE WORDING "SPIRITUAL WELL-BEING" IN WHITE. THE ENTIRE MARK FEATURES A CURVED MAZE DESIGN, EXCEPT FOR THE INNERMOST WHITE CIRCLE.

FOR PROVIDING INFORMATION, PERSONAL ASSESSMENTS, NEWS AND COMMENTARY IN THE FIELD OF HEALTH AND WELLNESS (U.S. CLS. 100 AND 101).

FIRST USE 3-31-2014; IN COMMERCE 3-31-2014.  
ELLEN B. AWRICH, EXAMINING ATTORNEY

SN 86-239,649. HONEST BODY, LLC, RIPTON, VT. FILED 4-2-2014.

# Honest Body

THE MARK CONSISTS OF STANDARD CHARACTERS WITHOUT CLAIM TO ANY PARTICULAR FONT, STYLE, SIZE, OR COLOR.

FOR NUTRITIONAL THERAPY SERVICES (U.S. CLS. 100 AND 101).

FIRST USE 6-1-2012; IN COMMERCE 6-1-2012.  
DEIRDRE ROBERTSON, EXAMINING ATTORNEY

**CLASS 44—(Continued).**

SN 86-241,311. WUHRMAN, KRISTIN, MEDINA, WA. FILED 4-3-2014.

WAKE UP. BE BRAVE. REPEAT.

THE MARK CONSISTS OF STANDARD CHARACTERS WITHOUT CLAIM TO ANY PARTICULAR FONT, STYLE, SIZE, OR COLOR.

FOR HEALTH COUNSELING; NUTRITION COUNSELING (U.S. CLS. 100 AND 101).

FIRST USE 3-17-2014; IN COMMERCE 3-17-2014.  
BRIAN PINO, EXAMINING ATTORNEY

SN 86-241,566. CONOPCO, INC., ENGLEWOOD CLIFFS, NJ. FILED 4-3-2014.

# HEART MONTHS

THE MARK CONSISTS OF STANDARD CHARACTERS WITHOUT CLAIM TO ANY PARTICULAR FONT, STYLE, SIZE, OR COLOR.

NO CLAIM IS MADE TO THE EXCLUSIVE RIGHT TO USE "HEART", APART FROM THE MARK AS SHOWN.

FOR HEALTH AND NUTRITION COUNSELLING (U.S. CLS. 100 AND 101).

COLLEEN DOMBROW, EXAMINING ATTORNEY

SN 86-244,492. BOSTON MEDICAL CENTER CORPORATION, DBA BOSTON MEDICAL CENTER, BOSTON, MA. FILED 4-7-2014.

# ICOUGH

THE MARK CONSISTS OF STANDARD CHARACTERS WITHOUT CLAIM TO ANY PARTICULAR FONT, STYLE, SIZE, OR COLOR.

FOR HEALTHCARE; PROVIDING HEALTHCARE INFORMATION (U.S. CLS. 100 AND 101).

FIRST USE 8-1-2010; IN COMMERCE 8-1-2010.  
BRIAN NEVILLE, EXAMINING ATTORNEY

**CLASS 44—(Continued).**

SN 86-244,817. TEAMNAKEDFINE, BELLAIRE, TX. FILED 4-7-2014.

**TeamNakedFine**

THE MARK CONSISTS OF STANDARD CHARACTERS WITHOUT CLAIM TO ANY PARTICULAR FONT, STYLE, SIZE, OR COLOR.

FOR PROVIDING A WEBSITE FEATURING INFORMATION AND ADVICE IN THE FIELDS OF DIET, WEIGHT LOSS, DIET PLANNING AND LIFESTYLE WELLNESS; WEIGHT MANAGEMENT SERVICES, NAMELY, PROVIDING WEIGHT LOSS AND/OR WEIGHT MAINTENANCE PROGRAMS (U.S. CLS. 100 AND 101).

FIRST USE 9-11-2013; IN COMMERCE 1-1-2014.  
STEVEN JACKSON, EXAMINING ATTORNEY



SN 86-245,077. VENEZIO, WENDY, BAYVILLE, NJ. FILED 4-7-2014.

**TAN IN MY VAN**

THE MARK CONSISTS OF STANDARD CHARACTERS WITHOUT CLAIM TO ANY PARTICULAR FONT, STYLE, SIZE, OR COLOR.

FOR AIRBRUSH SKIN TANNING SERVICES FOR HUMANS FOR COSMETIC PURPOSES (U.S. CLS. 100 AND 101).

PAULA MAHONEY, EXAMINING ATTORNEY



SN 86-245,105. LIONHEART HOME HEALTH LLC, PORTLAND, OR. FILED 4-7-2014.

**Lionheart**

THE MARK CONSISTS OF STANDARD CHARACTERS WITHOUT CLAIM TO ANY PARTICULAR FONT, STYLE, SIZE, OR COLOR.

FOR HOME HEALTH CARE SERVICES (U.S. CLS. 100 AND 101).

PAULA MAHONEY, EXAMINING ATTORNEY

**CLASS 44—(Continued).**

SN 86-245,444. EARTHADDELIC ENTERPRISES, LLC, KNOXVILLE, TN. FILED 4-8-2014.

**EARTHADDELIC**

THE MARK CONSISTS OF STANDARD CHARACTERS WITHOUT CLAIM TO ANY PARTICULAR FONT, STYLE, SIZE, OR COLOR.

FOR LANDSCAPE DESIGN; LANDSCAPE GARDENING; LAWN CARE (U.S. CLS. 100 AND 101).  
FIRST USE 3-11-2009; IN COMMERCE 3-11-2009.  
CATHERINE TARCU, EXAMINING ATTORNEY



SN 86-245,569. DANIEL J. POPE, INC., DBA POPE FAMILY DENTAL, NAPERVILLE, IL. FILED 4-8-2014.

**ONE VISIT SMILE**

THE MARK CONSISTS OF STANDARD CHARACTERS WITHOUT CLAIM TO ANY PARTICULAR FONT, STYLE, SIZE, OR COLOR.

FOR ORAL SURGERY AND DENTAL IMPLANT SERVICES (U.S. CLS. 100 AND 101).

WILLIAM VERHOSEK, EXAMINING ATTORNEY



SN 86-245,665. EARTHADDELIC ENTERPRISES, LLC, KNOXVILLE, TN. FILED 4-8-2014.



THE MARK CONSISTS OF THE TERM "EARTHADDELIC" WITH THE DESIGN OF A TREE INSIDE A SUN ABOVE THE SECOND "A" AND RAYS EXTENDING FROM THE SUN.

FOR LANDSCAPE DESIGN; LANDSCAPE GARDENING; LAWN CARE (U.S. CLS. 100 AND 101).

FIRST USE 3-11-2009; IN COMMERCE 3-11-2009.  
CATHERINE TARCU, EXAMINING ATTORNEY

**CLASS 44—(Continued).**

SN 86-245,748. SPRING & SPROUT DENTAL MANAGEMENT LLC, DUNDEE, MI. FILED 4-8-2014.

spring & sprout

THE MARK CONSISTS OF THE STYLIZED WORDS SPRING & SPROUT, WITH THE & SYMBOL HAVING A LEAF DESIGN.

FOR PEDIATRIC AND ORTHODONTIC DENTISTRY SERVICES (U.S. CLS. 100 AND 101).

JACLYN KIDWELL WALKER, EXAMINING ATTORNEY

SN 86-245,761. SPRING & SPROUT DENTAL MANAGEMENT LLC, DUNDEE, MI. FILED 4-8-2014.

BIRTH TO BRACES

THE MARK CONSISTS OF STANDARD CHARACTERS WITHOUT CLAIM TO ANY PARTICULAR FONT, STYLE, SIZE, OR COLOR.

FOR PEDIATRIC AND ORTHODONTIC DENTISTRY SERVICES (U.S. CLS. 100 AND 101).

JACLYN KIDWELL WALKER, EXAMINING ATTORNEY

SN 86-245,824. CHARLOTTE CHIROPRACTIC CLINIC, P.A., DBA CHIROCAROLINA, CHARLOTTE, NC. FILED 4-8-2014.

ChiroCarolina

THE MARK CONSISTS OF STANDARD CHARACTERS WITHOUT CLAIM TO ANY PARTICULAR FONT, STYLE, SIZE, OR COLOR.

FOR CHIROPRACTIC SERVICES (U.S. CLS. 100 AND 101).

FIRST USE 3-15-2010; IN COMMERCE 3-15-2010.  
THEODORE MCBRIDE, EXAMINING ATTORNEY

**CLASS 44—(Continued).**

SN 86-245,872. CHILDREN'S HEALTH VENTURES, INC., MIAMI, FL. FILED 4-8-2014.



NO CLAIM IS MADE TO THE EXCLUSIVE RIGHT TO USE "TOP", APART FROM THE MARK AS SHOWN.

THE MARK CONSISTS OF THE WORD "TOP" IN UPPER-CASE LETTERS WITH A CURVING PORTION REMOVED, AND A SYMBOLIC REPRESENTATION OF PLANT LEAVES BETWEEN THE LETTERS O AND P.

FOR MEDICAL DIAGNOSTIC TESTING, MONITORING AND REPORTING SERVICES (U.S. CLS. 100 AND 101).

VERNA BETH RIRIE, EXAMINING ATTORNEY

SN 86-245,964. FUTURECARE HEALTH AND MANAGEMENT CORPORATION, PASADENA, MD. FILED 4-8-2014.

C.A.M.P.

THE MARK CONSISTS OF STANDARD CHARACTERS WITHOUT CLAIM TO ANY PARTICULAR FONT, STYLE, SIZE, OR COLOR.

FOR HOLISTIC PHYSICAL REHABILITATION SERVICES, NAMELY PHYSICAL REHABILITATION, DIETITIAN SERVICES, PSYCHOSOCIAL COUNSELING, WOUND CARE, PHYSICAL THERAPY AND NURSING SERVICES (U.S. CLS. 100 AND 101).

FIRST USE 6-1-2013; IN COMMERCE 6-1-2013.  
ESTHER BELENKER, EXAMINING ATTORNEY

SN 86-246,177. PUBLIC HOSPITAL DISTRICT #1 OF MASON COUNTY, DBA MASON GENERAL HOSPITAL, SHELTON, WA. FILED 4-8-2014.

MyMasonHealth

THE MARK CONSISTS OF STANDARD CHARACTERS WITHOUT CLAIM TO ANY PARTICULAR FONT, STYLE, SIZE, OR COLOR.

FOR HEALTHCARE; PROVIDING HEALTHCARE INFORMATION (U.S. CLS. 100 AND 101).

FIRST USE 4-1-2010; IN COMMERCE 4-1-2010.  
ALLISON SCHRODY, EXAMINING ATTORNEY

**CLASS 44—(Continued).**

SN 86-246,555. RUTKOWSKI, RICK, GOSHEN, NY. FILED 4-9-2014.

# RUNWELL

THE MARK CONSISTS OF STANDARD CHARACTERS WITHOUT CLAIM TO ANY PARTICULAR FONT, STYLE, SIZE, OR COLOR.

FOR PHYSICAL THERAPY SERVICES; PHYSICAL THERAPY EVALUATION, IDENTIFICATION, AND MANAGEMENT OF MOVEMENT DYSFUNCTION TO RESTORE, MAINTAIN, AND PROMOTE OPTIMAL PHYSICAL FUNCTION PREVENTING THE ONSET, SYMPTOMS AND PROGRESSION OF IMPAIRMENTS, FUNCTIONAL LIMITATIONS, AND DISABILITIES RESULTING FROM DISEASE, DISORDERS, CONDITIONS, OR INJURIES (U.S. CLS. 100 AND 101).

PRISCILLA MILTON, EXAMINING ATTORNEY

SN 86-246,804. ANNE ARUNDEL HEALTH SYSTEM, INC., ANNAPOLIS, MD. FILED 4-9-2014.

# SpineTODAY

THE MARK CONSISTS OF STANDARD CHARACTERS WITHOUT CLAIM TO ANY PARTICULAR FONT, STYLE, SIZE, OR COLOR.

FOR MEDICAL SERVICES, NAMELY, BACK AND NECK PAIN TREATMENT; MEDICAL SERVICES, NAMELY, OUTPATIENT PROCEDURES FOR THE TREATMENT OF BACK AND NECK PAIN AND FOR SPINE CARE; MEDICAL SERVICES (U.S. CLS. 100 AND 101).

LINDA M. KING, EXAMINING ATTORNEY

SN 86-247,242. SOUTH COAST MEDICAL MANAGEMENT, LLC, NEWPORT BEACH, CA. FILED 4-9-2014.

## BALBOA SURGERY CENTER

THE MARK CONSISTS OF STANDARD CHARACTERS WITHOUT CLAIM TO ANY PARTICULAR FONT, STYLE, SIZE, OR COLOR.

NO CLAIM IS MADE TO THE EXCLUSIVE RIGHT TO USE "SURGERY CENTER", APART FROM THE MARK AS SHOWN.

FOR PROVIDING MEDICAL EVALUATION OF PERSONAL INJURIES AND COMPREHENSIVE TREATMENT PLANS; MEDICAL CONSULTATION SERVICES RESPECTING PERSONAL INJURY; OPERATION OF A MEDICAL CLINIC AND SURGICAL CARE CLINIC; SURGERY SERVICES (U.S. CLS. 100 AND 101).

LEIGH CAROLINE CASE, EXAMINING ATTORNEY

**CLASS 44—(Continued).**

SN 86-247,269. SOUTH COAST MEDICAL MANAGEMENT, LLC, NEWPORT BEACH, CA. FILED 4-9-2014.

## BALBOA BAY SURGERY CENTER

THE MARK CONSISTS OF STANDARD CHARACTERS WITHOUT CLAIM TO ANY PARTICULAR FONT, STYLE, SIZE, OR COLOR.

NO CLAIM IS MADE TO THE EXCLUSIVE RIGHT TO USE "SURGERY CENTER", APART FROM THE MARK AS SHOWN.

FOR PROVIDING MEDICAL EVALUATION OF PERSONAL INJURIES AND COMPREHENSIVE TREATMENT PLANS; MEDICAL CONSULTATION SERVICES RESPECTING PERSONAL INJURY; OPERATION OF A MEDICAL CLINIC AND SURGICAL CARE CLINIC; SURGERY SERVICES (U.S. CLS. 100 AND 101).

LEIGH CAROLINE CASE, EXAMINING ATTORNEY

SN 86-247,438. REWIRE ME LLC, NEW YORK, NY. FILED 4-9-2014.



THE MARK CONSISTS OF FOUR INTERSECTING CIRCLES WITH DOTS INSIDE.

FOR PROVIDING A WEBSITE FEATURING INFORMATION CONCERNING ALTERNATIVE BEHAVIORAL THERAPIES AND NUTRITION (U.S. CLS. 100 AND 101).

FIRST USE 3-31-2011; IN COMMERCE 2-29-2012.  
ADA HAN, EXAMINING ATTORNEY

SN 86-247,772. EYE LOVE LASHES LLC, PUYALLUP, WA. FILED 4-9-2014.

## EYE LOVE LASHES

THE MARK CONSISTS OF STANDARD CHARACTERS WITHOUT CLAIM TO ANY PARTICULAR FONT, STYLE, SIZE, OR COLOR.

FOR EYELASH EXTENSION SERVICES (U.S. CLS. 100 AND 101).

FIRST USE 7-4-2012; IN COMMERCE 7-4-2012.  
KAPIL BHANOT, EXAMINING ATTORNEY



**CLASS 44—(Continued).**

SN 86-248,545. GREGORY, ALISON, BEDFORD, NY. FILED 4-10-2014.

# QualiEssence

THE MARK CONSISTS OF STANDARD CHARACTERS WITHOUT CLAIM TO ANY PARTICULAR FONT, STYLE, SIZE, OR COLOR.

FOR GERIATRIC HEALTH CARE MANAGEMENT SERVICES; HEALTH CARE SERVICES, NAMELY, PROVIDING A DATABASE IN THE FIELD OF HOME CARE AND NURSING SERVICES INFORMATION AND FEATURING INPUTTING AND COLLECTION OF DATA AND INFORMATION ALL FOR TREATMENT AND DIAGNOSTIC PURPOSES; HOME HEALTH CARE SERVICES, NAMELY, GERIATRIC HEALTH CARE (U.S. CLS. 100 AND 101).

JONATHAN FALK, EXAMINING ATTORNEY

SN 86-249,355. MARY E. ROMERO, MIDDLETOWN, NY. FILED 4-11-2014.

# MINDSET

THE MARK CONSISTS OF STANDARD CHARACTERS WITHOUT CLAIM TO ANY PARTICULAR FONT, STYLE, SIZE, OR COLOR.

FOR COUNSELING IN THE FIELD OF MENTAL HEALTH AND WELLNESS (U.S. CLS. 100 AND 101).

FIRST USE 4-9-2014; IN COMMERCE 4-9-2014.

JOANNA DUKOVIC, EXAMINING ATTORNEY

SN 86-249,382. MARY E. ROMERO, MIDDLETOWN, NY. FILED 4-11-2014.



## MINDSET

THE MARK CONSISTS OF A TREE WITH A GENERALLY ROUND SHAPE WITH THE WORD "MINDSET".

FOR COUNSELING IN THE FIELD OF MENTAL HEALTH AND WELLNESS (U.S. CLS. 100 AND 101).

FIRST USE 4-9-2014; IN COMMERCE 4-9-2014.

JOANNA DUKOVIC, EXAMINING ATTORNEY

**CLASS 44—(Continued).**

SN 86-250,002. KUCHIEVA, NATALIA A, PASADENA, CA. FILED 4-11-2014.

# LASHITUDE

THE MARK CONSISTS OF STANDARD CHARACTERS WITHOUT CLAIM TO ANY PARTICULAR FONT, STYLE, SIZE, OR COLOR.

FOR BEAUTY SALON SERVICES; BEAUTY SPA SERVICES, NAMELY, COSMETIC BODY CARE; BODY WAXING SERVICES; COSMETIC SKIN CARE SERVICES, NAMELY, FACIALS; EYELASH EXTENSION SERVICES (U.S. CLS. 100 AND 101).

SIMON TENG, EXAMINING ATTORNEY

SN 86-250,445. ON THE SPOT HEALTHCARE, PLLC, ANACORTES, WA 98221-03, WA. FILED 4-11-2014.

## FOR THE THINGS YOU DON'T EXPECT

THE MARK CONSISTS OF STANDARD CHARACTERS WITHOUT CLAIM TO ANY PARTICULAR FONT, STYLE, SIZE, OR COLOR.

FOR MEDICAL SERVICES; PROVIDING MEDICAL INFORMATION, CONSULTANCY AND ADVISORY SERVICES; PROVIDING ON-SITE MEDICAL SERVICES TO PATIENTS AT THEIR HOMES, APARTMENTS, SENIOR COMMUNITIES, OFFICES OR OTHER DESIGNATED LOCATIONS; MEDICAL DIAGNOSTIC TESTING, MONITORING AND REPORTING SERVICES (U.S. CLS. 100 AND 101).

SANI KHOURI, EXAMINING ATTORNEY

SN 86-252,315. BIRCHBOX, INC., NEW YORK, NY. FILED 4-15-2014.

## OPEN FOR BEAUTIFUL

THE MARK CONSISTS OF STANDARD CHARACTERS WITHOUT CLAIM TO ANY PARTICULAR FONT, STYLE, SIZE, OR COLOR.

FOR PROVIDING ON-SITE BEAUTY SERVICES, NAMELY, HAIR STYLING, NAIL CARE AND MAKEUP APPLICATION SERVICES AND BEAUTY CONSULTATION SERVICES; PROVIDING A WEBSITE FEATURING ADVICE ABOUT BEAUTY, PERSONAL CARE AND LIFESTYLE PRODUCTS (U.S. CLS. 100 AND 101).

GEORGE LORENZO, EXAMINING ATTORNEY

**CLASS 44—(Continued).**

SN 86-252,365. BOARD OF PENSIONS EVANGELICAL LUTHERAN CHURCH OF AMERICA, MINNEAPOLIS, MN. FILED 4-15-2014.



NO CLAIM IS MADE TO THE EXCLUSIVE RIGHT TO USE "SOCIAL/INTERPERSONAL WELL-BEING", "EMOTIONAL WELL-BEING", "PHYSICAL WELL-BEING", "FINANCIAL WELL-BEING", "VOCATIONAL WELL-BEING", "INTELLECTUAL WELL-BEING", AND "SPIRITUAL WELL-BEING", APART FROM THE MARK AS SHOWN.

THE COLOR(S) NAVY BLUE, GREEN, RED, ORANGE, YELLOW, PURPLE, AND WHITE IS/ARE CLAIMED AS A FEATURE OF THE MARK.

THE MARK CONSISTS OF A CONCENTRIC CIRCLE DESIGN WITH THE NAVY BLUE WORDING "IN BAPTISM A NEW CREATION IN CHRIST" ON THE WHITE INNERMOST CIRCLE. THE NEXT CIRCLE CONSISTS OF COLORED SEGMENTS CONTAINING WHITE WORDING. GOING IN A CLOCKWISE DIRECTION, STARTING AT THE THE TOP, THE SEGMENTS ARE NAVY BLUE WITH THE WORDING "SOCIAL/INTERPERSONAL WELL BEING", GREEN WITH THE WORDING "EMOTIONAL WELL-BEING", RED WITH THE WORDING "PHYSICAL WELL-BEING", ORANGE WITH THE WORDING "FINANCIAL WELL-BEING", YELLOW WITH THE WORDING "VOCATIONAL WELL-BEING", AND PURPLE WITH THE WORDING "INTELLECTUAL WELL-BEING". THE NEXT CIRCLE IS A THIN WHITE CIRCLE. THE OUTERMOST CIRCLE IS A PURPLE CIRCLE CONTAINING THE WORDING "SPIRITUAL WELL-BEING" IN WHITE.

FOR PROVIDING INFORMATION, PERSONAL ASSESSMENTS, NEWS AND COMMENTARY IN THE FIELD OF HEALTH AND WELLNESS (U.S. CLS. 100 AND 101).

FIRST USE 4-8-2014; IN COMMERCE 4-8-2014.  
ELLEN B. AWRICH, EXAMINING ATTORNEY

**CLASS 44—(Continued).**

SN 86-252,438. BOARD OF PENSIONS EVANGELICAL LUTHERAN CHURCH OF AMERICA, MINNEAPOLIS, MN. FILED 4-15-2014.



NO CLAIM IS MADE TO THE EXCLUSIVE RIGHT TO USE "SOCIAL/INTERPERSONAL WELL-BEING", "EMOTIONAL WELL-BEING", "PHYSICAL WELL-BEING", "FINANCIAL WELL-BEING", "VOCATIONAL WELL-BEING", "INTELLECTUAL WELL-BEING", AND "SPIRITUAL WELL-BEING", APART FROM THE MARK AS SHOWN.

THE COLOR(S) NAVY BLUE, GREEN, RED, ORANGE, YELLOW, PURPLE, BLACK, AND WHITE IS/ARE CLAIMED AS A FEATURE OF THE MARK.

THE MARK CONSISTS OF A CONCENTRIC CIRCLE DESIGN WITH THE NAVY BLUE WORDING "IN BAPTISM A NEW CREATION IN CHRIST" IN THE CENTER ON A WHITE AREA WHICH FADES OUTWARD TO THE COLOR SEGMENTS OF THE NEXT CIRCLE. THE NEXT CIRCLE CONSISTS OF COLORED SEGMENTS CONTAINING WHITE WORDING. GOING IN A CLOCKWISE DIRECTION, STARTING AT THE THE TOP, THE SEGMENTS ARE NAVY BLUE WITH THE WORDING "SOCIAL/INTERPERSONAL WELL BEING", GREEN WITH THE WORDING "EMOTIONAL WELL-BEING", RED WITH THE WORDING "PHYSICAL WELL-BEING", ORANGE WITH THE WORDING "FINANCIAL WELL-BEING", YELLOW WITH THE WORDING "VOCATIONAL WELL-BEING", AND PURPLE WITH THE WORDING "INTELLECTUAL WELL-BEING". THE NEXT CIRCLE IS A THIN WHITE CIRCLE. THE OUTERMOST CIRCLE IS A PURPLE CIRCLE CONTAINING THE WORDING "SPIRITUAL WELL-BEING" IN WHITE OUTLINED IN BLACK.

FOR PROVIDING INFORMATION, PERSONAL ASSESSMENTS, NEWS AND COMMENTARY IN THE FIELD OF HEALTH AND WELLNESS (U.S. CLS. 100 AND 101).

FIRST USE 1-1-2014; IN COMMERCE 1-1-2014.  
ELLEN B. AWRICH, EXAMINING ATTORNEY

SN 86-253,637. AHN, LYDIA, CERRITOS, CA. AND AHN, JOHN, CERRITOS, CA. FILED 4-16-2014.

# HomePAL

THE MARK CONSISTS OF STANDARD CHARACTERS WITHOUT CLAIM TO ANY PARTICULAR FONT, STYLE, SIZE, OR COLOR.

FOR HOME HEALTH CARE SERVICES (U.S. CLS. 100 AND 101).

RENEE MCCRAY, EXAMINING ATTORNEY

**CLASS 44—(Continued).**

SN 86-254,918. BIOCORRX INC, TA BICX, SANTA ANA, CA. FILED 4-17-2014.

# Stand Up

THE MARK CONSISTS OF STANDARD CHARACTERS WITHOUT CLAIM TO ANY PARTICULAR FONT, STYLE, SIZE, OR COLOR.

FOR ADDICTION TREATMENT SERVICES (U.S. CLS. 100 AND 101).

SUSAN RICHARDS, EXAMINING ATTORNEY

SN 86-255,911. REBECCA WEISS, PEORIA, AZ. FILED 4-18-2014.



NO CLAIM IS MADE TO THE EXCLUSIVE RIGHT TO USE "MEDSPA", APART FROM THE MARK AS SHOWN.

THE MARK CONSISTS OF THE STYLIZED TEXT "PARADISE" APPEARS ABOVE THE STYLIZED TEXT "MEDSPA". AT THE TOP OF THE IMAGE IS A STYLIZED FLOWER APPEARING INSIDE A STYLIZED CIRCLE.

FOR BEAUTY SPA SERVICES, NAMELY, COSMETIC BODY CARE; COSMETIC BODY CARE SERVICES; HEALTH SPA SERVICES FOR HEALTH AND WELLNESS OF THE BODY AND SPIRIT; HEALTH SPA SERVICES FOR HEALTH AND WELLNESS OF THE BODY AND SPIRIT, NAMELY, PROVIDING MASSAGE, FACIAL AND BODY TREATMENT SERVICES, COSMETIC BODY CARE SERVICES; MEDICAL SPA SERVICES, NAMELY, MINIMALLY AND NON-INVASIVE COSMETIC AND BODY FITNESS THERAPIES; NON-INVASIVE COSMETIC MEDICAL PROCEDURES (U.S. CLS. 100 AND 101).

FIRST USE 2-1-2008; IN COMMERCE 2-1-2008.

REGINA DRUMMOND, EXAMINING ATTORNEY

**CLASS 44—(Continued).**

SN 86-257,977. BOARD OF PENSIONS EVANGELICAL LUTHERAN CHURCH OF AMERICA, MINNEAPOLIS, MN. FILED 4-21-2014.



NO CLAIM IS MADE TO THE EXCLUSIVE RIGHT TO USE "SOCIAL/INTERPERSONAL WELL-BEING", "EMOTIONAL WELL-BEING", "PHYSICAL WELL-BEING", "FINANCIAL WELL-BEING", "VOCATIONAL WELL-BEING", "INTELLECTUAL WELL-BEING", AND "SPIRITUAL WELL-BEING", APART FROM THE MARK AS SHOWN.

THE COLOR(S) NAVY BLUE, GREEN, RED, ORANGE, YELLOW, PURPLE, AND WHITE IS/ARE CLAIMED AS A FEATURE OF THE MARK.

THE MARK CONSISTS OF A CONCENTRIC CIRCLE DESIGN WITH THE INNERMOST CIRCLE BEING WHITE AND THE NEXT CIRCLE CONSISTING OF COLORED SEGMENTS CONTAINING WHITE WORDING. GOING IN A CLOCKWISE DIRECTION, STARTING AT THE THE TOP, THE SEGMENTS ARE NAVY BLUE WITH THE WORDING "SOCIAL/INTERPERSONAL WELL BEING", GREEN WITH THE WORDING "EMOTIONAL WELL-BEING", RED WITH THE WORDING "PHYSICAL WELL-BEING", ORANGE WITH THE WORDING "FINANCIAL WELL-BEING", YELLOW WITH THE WORDING "VOCATIONAL WELL-BEING", AND PURPLE WITH THE WORDING "INTELLECTUAL WELL-BEING". THE NEXT CIRCLE IS A THIN WHITE CIRCLE. THE OUTERMOST CIRCLE IS A PURPLE CIRCLE CONTAINING THE WORDING "SPIRITUAL WELL-BEING" IN WHITE.

FOR PROVIDING INFORMATION, PERSONAL ASSESSMENTS, NEWS AND COMMENTARY IN THE FIELD OF HEALTH AND WELLNESS (U.S. CLS. 100 AND 101).

ELLEN B. AWRICH, EXAMINING ATTORNEY

SN 86-296,737. BIRCHBOX, INC., NEW YORK, NY. FILED 5-30-2014.

# OPEN FOR HANDSOME

THE MARK CONSISTS OF STANDARD CHARACTERS WITHOUT CLAIM TO ANY PARTICULAR FONT, STYLE, SIZE, OR COLOR.

FOR PROVIDING ON-SITE BEAUTY SERVICES, NAMELY, HAIR STYLING, NAIL CARE AND MAKEUP APPLICATION SERVICES AND BEAUTY CONSULTATION SERVICES; PROVIDING A WEBSITE FEATURING ADVICE ABOUT BEAUTY, PERSONAL CARE AND LIFESTYLE PRODUCTS (U.S. CLS. 100 AND 101).

GEORGE LORENZO, EXAMINING ATTORNEY

**CLASS 45—PERSONAL AND LEGAL SERVICES**

SN 76-716,163. FAMILY RESOURCE CENTER, CHICAGO, IL. FILED 4-10-2014.

**CLASS 45—(Continued).**

SN 85-690,923. NATIONAL RUNAWAY SWITCHBOARD, CHICAGO, IL. FILED 7-31-2012.

**OUR HELP. YOUR DECISIONS.**

THE MARK CONSISTS OF STANDARD CHARACTERS WITHOUT CLAIM TO ANY PARTICULAR FONT, STYLE, SIZE, OR COLOR.

FOR ADOPTION PLACEMENT SERVICES; ADOPTION AGENCY SERVICES; ADOPTION COUNSELING SERVICES; AND PROVIDING INFORMATION ABOUT ADOPTING CHILDREN (U.S. CLS. 100 AND 101).

FIRST USE 12-31-1991; IN COMMERCE 12-31-1991.  
ALISON KEELEY, EXAMINING ATTORNEY

**NATIONAL RUNAWAY SAFELINE**

SN 79-119,145. DOTRIP LIMITED, A NEW ZEALAND COMPANY, NEW ZEALAND, FILED 6-8-2012.

# DOTRIP

THE MARK CONSISTS OF STANDARD CHARACTERS WITHOUT CLAIM TO ANY PARTICULAR FONT, STYLE, SIZE, OR COLOR.

PRIORITY DATE OF 2-29-2012 IS CLAIMED.  
OWNER OF INTERNATIONAL REGISTRATION 1132291 DATED 6-8-2012, EXPIRES 6-8-2022.

FOR CREMATORIUM SERVICES, NAMELY, PROVIDING CREMATION SERVICES AND FUNERAL SERVICES ACCOMPANYING CREMATION; LICENSING OF COMPUTER PROGRAMS; SPIRITUAL ADVICE; TRACING OF MISSING PERSONS, NAMELY, TRACKING, LOCATING AND MONITORING SERVICES FOR RECOVERING MISSING PERSONS (U.S. CLS. 100 AND 101).

SETH A. RAPPAPORT, EXAMINING ATTORNEY

THE MARK CONSISTS OF STANDARD CHARACTERS WITHOUT CLAIM TO ANY PARTICULAR FONT, STYLE, SIZE, OR COLOR.

OWNER OF U.S. REG. NOS. 2,820,735 AND 3,088,253.  
NO CLAIM IS MADE TO THE EXCLUSIVE RIGHT TO USE "SAFELINE", APART FROM THE MARK AS SHOWN. SEC. 2(F) AS TO "NATIONAL RUNAWAY".

FOR PERSONAL COUNSELING SERVICES, NAMELY, CRISIS COUNSELING IN THE NATURE OF EMOTIONAL COUNSELING AND EMOTIONAL SUPPORT SERVICES AND EMOTIONAL SUPPORT COUNSELING TO YOUTH WHO HAVE RUN AWAY FROM HOME, YOUTH IN CRISIS, CONCERNED FAMILY MEMBERS AND FRIENDS OF YOUTH IN CRISIS AND YOUTH WHO HAVE RUN AWAY FROM HOME BY MEANS OF A TOLL-FREE TELEPHONE NUMBER; PROVIDING EMOTIONAL COUNSELING FOR YOUTH WHO HAVE RUN AWAY FROM HOME, YOUTH IN CRISIS, CONCERNED FAMILY MEMBERS AND FRIENDS OF YOUTH IN CRISIS AND YOUTH WHO HAVE RUN AWAY FROM HOME COMPRISING INTERVIEWING YOUTH, FRIENDS, AND FAMILY MEMBERS, AND IDENTIFYING PROBLEMS AND SUGGESTING WHERE HELP CAN BE OBTAINED; PERSONAL COUNSELING SERVICES, NAMELY, CRISIS COUNSELING IN THE NATURE OF EMOTIONAL COUNSELING AND PROVIDING CRISIS RELATED INFORMATION IN THE NATURE OF INFORMATION ABOUT EMOTIONAL SUPPORT SERVICES TO YOUTH WHO HAVE RUN AWAY FROM HOME, YOUTH IN CRISIS, CONCERNED FAMILY MEMBERS AND FRIENDS OF YOUTH IN CRISIS AND YOUTH WHO HAVE RUN AWAY FROM HOME (U.S. CLS. 100 AND 101).

FIRST USE 1-15-2013; IN COMMERCE 1-15-2013.  
JUHI KAVEESHVAR, EXAMINING ATTORNEY

SN 79-148,131. WESUMONE SAS, FRANCE, FILED 4-7-2014.

# WESUMONE

THE MARK CONSISTS OF STANDARD CHARACTERS WITHOUT CLAIM TO ANY PARTICULAR FONT, STYLE, SIZE, OR COLOR.

PRIORITY DATE OF 10-9-2013 IS CLAIMED.  
OWNER OF INTERNATIONAL REGISTRATION 1206129 DATED 4-7-2014, EXPIRES 4-7-2024.

FOR SOCIAL NETWORKING SERVICES ONLINE ON THE INTERNET (U.S. CLS. 100 AND 101).

MATTHEW GALAN, EXAMINING ATTORNEY

**CLASS 45—(Continued).**

SN 85-690,925. NATIONAL RUNAWAY SWITCHBOARD, CHICAGO, IL. FILED 7-31-2012.



OWNER OF U.S. REG. NOS. 2,820,735 AND 3,088,253. NO CLAIM IS MADE TO THE EXCLUSIVE RIGHT TO USE "SAFELINE", APART FROM THE MARK AS SHOWN. THE MARK CONSISTS OF THE WORD "NATIONAL" POSITIONED ABOVE THE WORD "RUNAWAY" WHICH IS POSITIONED ABOVE THE WORD "SAFELINE". THE LEFT AND RIGHT SIDES OF THESE WORDS ARE PARTIALLY ENCIRCLED BY CURVED LINES.

SEC. 2(F) AS TO "NATIONAL RUNAWAY".

FOR PERSONAL COUNSELING SERVICES, NAMELY, CRISIS COUNSELING IN THE NATURE OF EMOTIONAL COUNSELING AND EMOTIONAL SUPPORT SERVICES AND EMOTIONAL SUPPORT COUNSELING TO YOUTH WHO HAVE RUN AWAY FROM HOME, YOUTH IN CRISIS, CONCERNED FAMILY MEMBERS AND FRIENDS OF YOUTH IN CRISIS AND YOUTH WHO HAVE RUN AWAY FROM HOME BY MEANS OF A TOLL-FREE TELEPHONE NUMBER; PROVIDING EMOTIONAL COUNSELING FOR YOUTH WHO HAVE RUN AWAY FROM HOME, YOUTH IN CRISIS, CONCERNED FAMILY MEMBERS AND FRIENDS OF YOUTH IN CRISIS AND YOUTH WHO HAVE RUN AWAY FROM HOME COMPRISING INTERVIEWING YOUTH, FRIENDS, AND FAMILY MEMBERS, AND IDENTIFYING PROBLEMS AND SUGGESTING WHERE HELP CAN BE OBTAINED; PERSONAL COUNSELING SERVICES, NAMELY, CRISIS COUNSELING IN THE NATURE OF EMOTIONAL COUNSELING AND PROVIDING CRISIS RELATED INFORMATION IN THE NATURE OF INFORMATION ABOUT EMOTIONAL SUPPORT SERVICES TO YOUTH WHO HAVE RUN AWAY FROM HOME, YOUTH IN CRISIS, CONCERNED FAMILY MEMBERS AND FRIENDS OF YOUTH IN CRISIS AND YOUTH WHO HAVE RUN AWAY FROM HOME (U.S. CLS. 100 AND 101).

FIRST USE 1-15-2013; IN COMMERCE 1-15-2013.  
JUHI KAVEESHVAR, EXAMINING ATTORNEY

SN 85-716,080. WAYNE WRIGHT, LLP, SAN ANTONIO, TX. FILED 8-29-2012.

**YOU DESERVE RESPECT AND JUSTICE SO WE DEMAND IT!**

THE MARK CONSISTS OF STANDARD CHARACTERS WITHOUT CLAIM TO ANY PARTICULAR FONT, STYLE, SIZE, OR COLOR.

FOR LEGAL SERVICES (U.S. CLS. 100 AND 101).  
FIRST USE 9-13-1996; IN COMMERCE 9-13-1996.  
JOHN E. MICHOS, EXAMINING ATTORNEY

**CLASS 45—(Continued).**

SN 85-893,237. JAVA MUSIC CLUB, INC., SURREY, CANADA, FILED 4-2-2013.



THE MARK CONSISTS OF THE WORD "JAVA" ABOVE THE WORD "MUSIC" WHICH IS ABOVE THE WORD "CLUB" INSIDE THE DESIGN OF A MUSICAL NOTE.

FOR ORGANIZING AND CONDUCTING SUPPORT GROUPS IN THE FIELDS OF PSYCHOSOCIAL GROUP SUPPORT OPTIONS, LIFESTYLE HEALTH AND WELLNESS, GRIEF AND BEREAVEMENT, DEATH, STRESS, STRESS REDUCTION, AGING, QUALITY OF LIFE ENHANCEMENT FOR INDIVIDUALS LIVING IN SUPPORTIVE LIVING ENVIRONMENTS, NAMELY, INDEPENDENT LIVING HOMES, LONG-TERM CARE HOMES, ASSISTED LIVING HOMES, MEMORY CARE HOMES, RETIREMENT HOMES AND THOSE RECEIVING HEALTH SERVICES IN THE COMMUNITY, NAMELY, ATTENDING ADULT DAY CENTERS AND SENIOR CENTERS, SELF-HELP, GENERAL HEALTH, SAFETY ISSUES REGARDING DEMENTIA, AGGRESSION, FALLS AND OTHER SAFETY CONCERNS COMMON TO HEALTHCARE FACILITIES, RELIGIOUS FAITH, ANXIETY, DEPRESSION, FEAR CAUSES, FEAR SYMPTOMS, AND FEAR PSYCHOSOCIAL TREATMENT, EXCLUDING MAGAZINES AND JOURNALS FOR VASCULAR ACCESS PROFESSIONALS (U.S. CLS. 100 AND 101).

SIMON TENG, EXAMINING ATTORNEY

SN 85-941,956. SPCA TAMPA BAY, FLORIDA, INC., DBA SPCA TAMPA BAY, LARGO, FL. FILED 5-24-2013.



THE COLOR(S) GREEN, BLUE, PINK, GRAY, BLACK AND WHITE IS/ARE CLAIMED AS A FEATURE OF THE MARK.

THE MARK CONSISTS OF A GRAPHIC OF A GREEN DOG WITH BLUE SPOTS. THE DOG HAS A PINK TONGUE AND GRAY AND WHITE EYES. THE DOG IS OUTLINED IN BLACK.

FOR ANIMAL ADOPTION SERVICE, NAMELY, ARRANGING FOR DOGS AND CATS FROM SHELTERS TO BE PLACED IN HOMES (U.S. CLS. 100 AND 101).

FIRST USE 12-1-2012; IN COMMERCE 12-1-2012.  
ALYSSA STEEL, EXAMINING ATTORNEY

**CLASS 45—(Continued).**

SN 86-056,956. UPRIGHT, NAFISSA SHIREEN, MAPLE RIDGE, CANADA, FILED 9-5-2013.

## Nafissa Shireen

THE MARK CONSISTS OF STANDARD CHARACTERS WITHOUT CLAIM TO ANY PARTICULAR FONT, STYLE, SIZE, OR COLOR.

THE NAME(S), PORTRAIT(S), AND/OR SIGNATURE(S) SHOWN IN THE MARK IDENTIFIES "NAFISSA SHIREEN", WHOSE CONSENT(S) TO REGISTER IS MADE OF RECORD.

FOR PERSONAL LIFESTYLE CONSULTING SERVICES (U.S. CLS. 100 AND 101).

FIRST USE 1-1-2013; IN COMMERCE 1-1-2013.  
MICHAEL WEBSTER, EXAMINING ATTORNEY

**CLASS 45—(Continued).**

SN 86-077,455. ASCENTE BUSINESS CONSULTING, LLC, LAKE SHORE, MN. FILED 9-27-2013.

## ASCENTE FULLY MANAGED IDENTITY THEFT RECOVERY AND RESTORATION SERVICE

THE MARK CONSISTS OF STANDARD CHARACTERS WITHOUT CLAIM TO ANY PARTICULAR FONT, STYLE, SIZE, OR COLOR.

NO CLAIM IS MADE TO THE EXCLUSIVE RIGHT TO USE "FULLY MANAGED IDENTITY THEFT RECOVERY AND RESTORATION SERVICE", APART FROM THE MARK AS SHOWN.

FOR CONSULTATION IN THE FIELD OF DATA THEFT AND IDENTITY THEFT; FINANCIAL IDENTITY MONITORING SERVICES FOR FRAUD PROTECTION PURPOSES; FRAUD AND IDENTITY THEFT PROTECTION SERVICES; MONITORING OF CREDIT REPORTS, THE INTERNET, AND PUBLIC RECORDS TO FACILITATE THE DETECTION AND PREVENTION OF IDENTITY THEFT AND FRAUD (U.S. CLS. 100 AND 101).

FIRST USE 9-1-2013; IN COMMERCE 9-1-2013.  
STEVEN JACKSON, EXAMINING ATTORNEY

SN 86-063,086. KRISHNAMURTHY, VISHWANATH, FOLSOM, CA. AND VISHWANATH, SOUMYA, FOLSOM, CA. FILED 9-12-2013.

## Times of Wisdom

THE MARK CONSISTS OF STANDARD CHARACTERS WITHOUT CLAIM TO ANY PARTICULAR FONT, STYLE, SIZE, OR COLOR.

OWNER OF U.S. REG. NO. 4,167,071.

FOR PROVIDING INFORMATION IN THE FIELD OF PERSONAL DEVELOPMENT, NAMELY, SELF-IMPROVEMENT, SELF-FULFILLMENT, AND INTERPERSONAL COMMUNICATION (U.S. CLS. 100 AND 101).

FIRST USE 12-15-2011; IN COMMERCE 12-15-2011.  
BERYL GARDNER, EXAMINING ATTORNEY

SN 86-077,790. MINCOV LAW CORPORATION, VANCOUVER, BC, CANADA, FILED 9-29-2013.

## TRADEMARK FACTORY

THE MARK CONSISTS OF STANDARD CHARACTERS WITHOUT CLAIM TO ANY PARTICULAR FONT, STYLE, SIZE, OR COLOR.

NO CLAIM IS MADE TO THE EXCLUSIVE RIGHT TO USE "TRADEMARK", APART FROM THE MARK AS SHOWN.

FOR LEGAL SERVICES; LEGAL SERVICES, NAMELY, PREPARATION OF APPLICATIONS FOR TRADEMARK REGISTRATION; LEGAL SERVICES, NAMELY, TRADEMARK MAINTENANCE SERVICES; LEGAL SERVICES, NAMELY, TRADEMARK SEARCHING AND CLEARANCE SERVICES; PROVIDING ASSISTANCE IN THE PROSECUTION OF TRADEMARK APPLICATIONS; PROVIDING INFORMATION IN THE FIELD OF INTELLECTUAL PROPERTY ; PROVIDING ON-LINE INFORMATION IN THE FIELD OF INTELLECTUAL PROPERTY (U.S. CLS. 100 AND 101).

FIRST USE 3-1-2013; IN COMMERCE 3-1-2013.  
LAURIE MAYES, EXAMINING ATTORNEY

**CLASS 45—(Continued).**

SN 86-088,542. HERZFELD & RUBIN, P.C., NEW YORK, NY.  
FILED 10-10-2013.

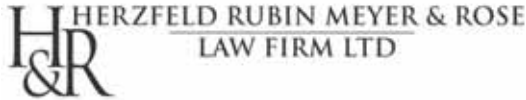

OWNER OF U.S. REG. NO. 4,367,782.  
NO CLAIM IS MADE TO THE EXCLUSIVE RIGHT TO USE "LAW FIRM LTD", APART FROM THE MARK AS SHOWN.

THE MARK CONSISTS OF THE STYLIZED LETTERS AND WORDING "H&R HERZFELD RUBIN MEYER & ROSE LAW FIRM LTD". THE LETTER "H" IS LARGE AND APPEARS ABOVE THE "&". TO THE RIGHT IS THE LETTER "R" THAT IS LARGE AND APPEARS HALF WAY BELOW THE LETTER "H". TO THE RIGHT IS THE WORDING "HERZFELD" WHICH IS ABOVE THE LETTER "R" AND THE WORDING "RUBIN MEYER & ROSE LAW FIRM LTD". BELOW IS A HORIZONTAL LINE AND BELOW THE LINE IS THE WORDING "LAW FIRM LTD".

FOR LEGAL SERVICES (U.S. CLS. 100 AND 101).  
FIRST USE 7-31-2013; IN COMMERCE 7-31-2013.  
CAITLIN WATTS-FITZGERALD, EXAMINING ATTORNEY

SN 86-091,540. STANDIFER, STACIE J, NASHVILLE, TN.  
FILED 10-15-2013.

## Southern Sophisticate

THE MARK CONSISTS OF STANDARD CHARACTERS WITHOUT CLAIM TO ANY PARTICULAR FONT, STYLE, SIZE, OR COLOR.

NO CLAIM IS MADE TO THE EXCLUSIVE RIGHT TO USE "SOUTHERN", APART FROM THE MARK AS SHOWN.  
FOR PROVISION OF A WEB SITE FEATURING INFORMATION ON LIFESTYLES (U.S. CLS. 100 AND 101).

FIRST USE 4-19-2012; IN COMMERCE 4-19-2012.  
BRIAN CALLAGHAN, EXAMINING ATTORNEY

SN 86-109,640. HARTSONG RANCH ANIMAL SANCTUARY,  
GREENWOOD, CA. FILED 11-4-2013.

## every life matters

THE MARK CONSISTS OF STANDARD CHARACTERS WITHOUT CLAIM TO ANY PARTICULAR FONT, STYLE, SIZE, OR COLOR.

FOR ANIMAL RESCUE SERVICES, NAMELY, ARRANGING FOR THE ADOPTION OF RESCUED ANIMALS (U.S. CLS. 100 AND 101).

FIRST USE 10-30-2008; IN COMMERCE 10-30-2008.  
YAT SYE, LEE, EXAMINING ATTORNEY

**CLASS 45—(Continued).**

SN 86-116,016. COMMUNICATION AND SURVEILLANCE SERVICES, LLC, NORTH CHARLESTON, SC. FILED 11-12-2013.

## COMSURV

THE MARK CONSISTS OF STANDARD CHARACTERS WITHOUT CLAIM TO ANY PARTICULAR FONT, STYLE, SIZE, OR COLOR.

FOR SURVEILLANCE SERVICES; SURVEILLANCE SERVICES FEATURING HIGH DEFINITION INSTALLATIONS; CUSTOMIZED SECURITY SURVEILLANCE SERVICES; VIDEO MONITORING OF FACILITIES, VIEWABLE THROUGH A GLOBAL COMPUTER NETWORK FOR SECURITY PURPOSES; PROVIDING A WEBSITE FEATURING ONLINE SURVEILLANCE MONITORING FOR USERS; MONITORING OF SECURITY CAMERAS (U.S. CLS. 100 AND 101).

FIRST USE 1-3-2010; IN COMMERCE 1-3-2010.  
JEFF DEFORD, EXAMINING ATTORNEY

SN 86-142,538. UFIT INDUSTRIES, INC., WILMINGTON, DE. FILED 12-12-2013.

## FitLikeMe

THE MARK CONSISTS OF STANDARD CHARACTERS WITHOUT CLAIM TO ANY PARTICULAR FONT, STYLE, SIZE, OR COLOR.

FOR ONLINE SOCIAL NETWORKING SERVICES IN THE FIELD OF FITNESS AND EXERCISE. (U.S. CLS. 100 AND 101).

MICHAEL WIENER, EXAMINING ATTORNEY

**CLASS 45—(Continued).**

SN 86-158,536. COMPASSION THAT COMPELS, INC., MANDEVILLE, LA. FILED 1-6-2014.



THE MARK CONSISTS OF A DANDELION FLOWER WITH SEEDS BEING BLOWN OFF THE SEED HEAD, WITH THE WORDS "COMPASSION THAT COMPELS.ORG" WITHIN THE FLOATING SEEDS.

FOR CHARITABLE SERVICES, NAMELY, PROVIDING EMOTIONAL SUPPORT SERVICES FOR FEMALE CANCER PATIENTS BY MEANS OF PROVIDING BAGS FILLED WITH USEFUL ITEMS TO ASSIST THEM DURING TREATMENT (U.S. CLS. 100 AND 101).

FIRST USE 9-1-2009; IN COMMERCE 4-1-2013.  
KAPIL BHANOT, EXAMINING ATTORNEY

SN 86-166,473. TRITURA INFORMATION GOVERNANCE LLC, PHILADELPHIA, PA. FILED 1-15-2014.

**TRITURA**

THE MARK CONSISTS OF STANDARD CHARACTERS WITHOUT CLAIM TO ANY PARTICULAR FONT, STYLE, SIZE, OR COLOR.

THE ENGLISH TRANSLATION OF THE WORD "TRITURA" IN THE MARK IS "THRESHING".

FOR COMPUTER-BASED LITIGATION SUPPORT SERVICES; LITIGATION SUPPORT SERVICES, NAMELY, CONSULTATION SERVICES IN THE FIELD OF ELECTRONIC DISCOVERY AND TACTICS (U.S. CLS. 100 AND 101).

WILLIAM ROSSMAN, EXAMINING ATTORNEY

**CLASS 45—(Continued).**

SN 86-167,195. INTERNATIONAL HEALTH SERVICES, SOUTHEASTERN, PA. FILED 1-16-2014.

**IHS GLOBAL**

THE MARK CONSISTS OF STANDARD CHARACTERS WITHOUT CLAIM TO ANY PARTICULAR FONT, STYLE, SIZE, OR COLOR.

NO CLAIM IS MADE TO THE EXCLUSIVE RIGHT TO USE "GLOBAL", APART FROM THE MARK AS SHOWN.

FOR RELIGIOUS SERVICES, NAMELY, CONDUCTING PRAYER MEETINGS FOR HEALTH CARE AND MEDICAL PROFESSIONALS, CHURCH COMMUNITY, BUSINESS COMMUNITY, AND EDUCATIONAL PROFESSIONALS; EVANGELISTIC MINISTERIAL SERVICES; PROVIDING INFORMATION VIA A GLOBAL COMMUNICATIONS NETWORK IN THE FIELDS OF CHRISTIANITY, RELIGION, MINISTRY, EVANGELISM, AND THE INTEGRATION OF FAITH WITH THE MEDICAL AND HEALTH CARE PROFESSIONS, CHURCH, BUSINESS, AND EDUCATION (U.S. CLS. 100 AND 101).

KAREN K. BUSH, EXAMINING ATTORNEY

SN 86-189,973. DAVID D. NOWAK, TOWSON, MD. FILED 2-11-2014.



THE COLOR(S) GOLD AND BLUE IS/ARE CLAIMED AS A FEATURE OF THE MARK.

THE MARK CONSISTS OF THE COLORS GOLD AND BLUE ARE CLAIMED AS A FEATURE OF THE MARK. THE MARK CONSISTS OF THE FOLLOWING: A GOLD MARIJUANA LEAF IN THE CENTER BASE OF PARALLEL GOLD LAUREL LEAVES RISING TO GOLD BORDER SCALES EMANATING FROM CENTER PETAL OF THE MARIJUANA LEAF AND A BLUE BACKGROUND.

FOR LEGAL SERVICES; LEGAL SERVICES, NAMELY, PROVIDING CUSTOMIZED LEGAL INFORMATION, COUNSELING, ADVICE, AND LITIGATION SERVICES IN ALL AREAS OF LAW TO PEOPLE AND FAMILIES OF MODEST INCOMES (U.S. CLS. 100 AND 101).

FIRST USE 6-1-2013; IN COMMERCE 6-1-2013.  
JAY FLOWERS, EXAMINING ATTORNEY



**CLASS 45—(Continued).**

SN 86-191,183. TECHLAND SP. Z O.O., DBA TECHLAND SP. Z O.O., OSTROW WIELKOPOLSKI, POLAND, FILED 2-12-2014.

# HUMALO

THE MARK CONSISTS OF STANDARD CHARACTERS WITHOUT CLAIM TO ANY PARTICULAR FONT, STYLE, SIZE, OR COLOR.

THE WORDING "HUMALO" HAS NO MEANING IN A FOREIGN LANGUAGE.

FOR SOCIAL INTRODUCTION, NETWORKING AND DATING SERVICES; PROVIDING SOCIAL SERVICES, NAMELY, SOCIAL NETWORK SERVICES IN THE FIELD OF PERSONAL DEVELOPMENT, NAMELY, SELF-IMPROVEMENT, PERSONAL GROWTH, CHARITABLE, PHILANTHROPIC, VOLUNTEER ACTIVITIES, PUBLIC AND COMMUNITY SERVICES AND HUMANITARIAN ACTIVITIES; PROVIDING INFORMATION IN THE FIELDS OF PERSONAL DEVELOPMENT, NAMELY, SELF-IMPROVEMENT, PERSONAL GROWTH ON SOCIAL NETWORKING SERVICES (U.S. CLS. 100 AND 101).

KEVIN DINALLO, EXAMINING ATTORNEY

---

SN 86-199,083. BONUS, THOMAS, CLEVELAND, OH. FILED 2-20-2014.

# A MOVEMENT TO RIGHT AMERICA'S DIRECTION

THE MARK CONSISTS OF STANDARD CHARACTERS WITHOUT CLAIM TO ANY PARTICULAR FONT, STYLE, SIZE, OR COLOR.

FOR CHRISTIAN MINISTRY SERVICES; ONLINE SOCIAL NETWORKING SERVICES IN THE FIELD OF CHRISTIANITY; ONLINE SOCIAL NETWORKING SERVICES IN THE FIELD OF CHRISTIANITY PROVIDED VIA A WEBSITE; PROVIDING ON-LINE INFORMATION IN THE FIELD OF SPIRITUALITY, SELF-HELP, AND PERSONAL EMPOWERMENT SUBJECT MATTERS (U.S. CLS. 100 AND 101).

FIRST USE 2-0-2011; IN COMMERCE 2-0-2011.

NATALIE KENEALY, EXAMINING ATTORNEY

**CLASS 45—(Continued).**

SN 86-199,795. TRIPOD TECHNOLOGY GMBH, BERLIN, FED REP GERMANY, FILED 2-21-2014.

# VIVE

THE MARK CONSISTS OF STANDARD CHARACTERS WITHOUT CLAIM TO ANY PARTICULAR FONT, STYLE, SIZE, OR COLOR.

THE ENGLISH TRANSLATION OF THE WORD "VIVE" IN THE MARK IS "TO LIVE", "LONG LIVE", OR "ALIVE". FOR INTERNET BASED SOCIAL INTRODUCTION, NETWORKING AND DATING SERVICES (U.S. CLS. 100 AND 101).

FIRST USE 2-28-2013; IN COMMERCE 2-28-2013.

ZHALEH DELANEY, EXAMINING ATTORNEY

---

SN 86-202,691. PAR 17, LLC, NEW YORK, NY. FILED 2-24-2014.

# EFFORTLESS

THE MARK CONSISTS OF STANDARD CHARACTERS WITHOUT CLAIM TO ANY PARTICULAR FONT, STYLE, SIZE, OR COLOR.

FOR PROVIDING A WEBSITE FEATURING PERSONAL DEVELOPMENT INFORMATION IN THE FIELD OF SELF AWARENESS, SELF MASTERY, AND SELF FULFILLMENT; PROVIDING PERSONAL DEVELOPMENT INFORMATION IN THE FIELD OF PERSONAL IMPROVEMENT, SELF-IMPROVEMENT AND SELF-FULFILLMENT (U.S. CLS. 100 AND 101).

LOURDES AYALA, EXAMINING ATTORNEY

---

SN 86-202,728. PAR 17, LLC, NEW YORK, NY. FILED 2-24-2014.

# EFFORTLESS LIVING

THE MARK CONSISTS OF STANDARD CHARACTERS WITHOUT CLAIM TO ANY PARTICULAR FONT, STYLE, SIZE, OR COLOR.

FOR PROVIDING A WEBSITE FEATURING PERSONAL DEVELOPMENT INFORMATION IN THE FIELD OF SELF AWARENESS, SELF MASTERY, AND SELF FULFILLMENT; PROVIDING PERSONAL DEVELOPMENT INFORMATION IN THE FIELD OF PERSONAL IMPROVEMENT, SELF-IMPROVEMENT AND SELF-FULFILLMENT (U.S. CLS. 100 AND 101).

LOURDES AYALA, EXAMINING ATTORNEY

**CLASS 45—(Continued).**

SN 86-204,162. NEXT GENERATION MEDIATION, GROSSE POINTE, MI. FILED 2-25-2014.

# BRĀV

THE MARK CONSISTS OF STANDARD CHARACTERS WITHOUT CLAIM TO ANY PARTICULAR FONT, STYLE, SIZE, OR COLOR.

FOR ALTERNATIVE DISPUTE RESOLUTION SERVICES (U.S. CLS. 100 AND 101).

FIRST USE 11-17-2007; IN COMMERCE 11-17-2007.

KIMBERLY FRYE, EXAMINING ATTORNEY

SN 86-204,742. HELP AT HOME INC., BOCA RATON, TN. FILED 2-26-2014.



OWNER OF U.S. REG. NO. 3,400,342.

THE MARK CONSISTS OF THE STYLIZED WORDING "PREFERRED CARE AT HOME" WITH THE WORD "PREFERRED" ENLARGED AND THE WORDS "CARE AT HOME" MINIATURIZED SLIGHTLY BELOW IT JUSTIFIED TO THE RIGHT, NEXT TO A STYLIZED DESIGN OF A HAND HOLDING A THREE-LEAFED PLANT TO THE RIGHT OF THE WORDS.

SEC. 2(F) AS TO "PREFERRED CARE AT HOME".

FOR NON-MEDICAL COMPANION CARE, NAMELY, PROVIDING PERSONAL CARE ASSISTANCE OF ACTIVITIES FOR DAILY LIVING, SUCH AS BATHING, GROOMING AND PERSONAL MOBILITY FOR HOMEBOUND SENIORS AND/OR MENTALLY OR PHYSICALLY DISABLED PERSONS (U.S. CLS. 100 AND 101).

FIRST USE 7-15-2007; IN COMMERCE 7-15-2007.

DEBORAH LOBO, EXAMINING ATTORNEY

SN 86-210,410. LOYAL M. HANSON, A PROFESSIONAL LAW CORPORATION, FALLBROOK, CA. FILED 3-4-2014.

# Hanson Law Corporation

THE MARK CONSISTS OF STANDARD CHARACTERS WITHOUT CLAIM TO ANY PARTICULAR FONT, STYLE, SIZE, OR COLOR.

OWNER OF U.S. REG. NOS. 1,998,279, 2,160,054 AND 2,313,597.

NO CLAIM IS MADE TO THE EXCLUSIVE RIGHT TO USE "LAW CORPORATION", APART FROM THE MARK AS SHOWN.

SEC. 2(F).

FOR ATTORNEY-RENDERED LEGAL SERVICES (U.S. CLS. 100 AND 101).

FIRST USE 8-31-1993; IN COMMERCE 8-31-1993.

KEVON CHISOLM, EXAMINING ATTORNEY

**CLASS 45—(Continued).**

SN 86-212,281. KIRWIN NORRIS, P.A., ORLANDO, FL. FILED 3-5-2014.

# One Firm. One Focus. Construction Law.

THE MARK CONSISTS OF STANDARD CHARACTERS WITHOUT CLAIM TO ANY PARTICULAR FONT, STYLE, SIZE, OR COLOR.

NO CLAIM IS MADE TO THE EXCLUSIVE RIGHT TO USE "FIRM" AND "CONSTRUCTION LAW", APART FROM THE MARK AS SHOWN.

FOR LEGAL SERVICES IN THE FIELD OF CONSTRUCTION (U.S. CLS. 100 AND 101).

FIRST USE 1-1-2014; IN COMMERCE 1-1-2014.

PAUL CROWLEY, EXAMINING ATTORNEY

SN 86-212,313. PARSONS, LEIGH, SAN JOSE, CA. FILED 3-5-2014.



# THE VIRTUALDIVORCE

NO CLAIM IS MADE TO THE EXCLUSIVE RIGHT TO USE "VIRTUAL DIVORCE", APART FROM THE MARK AS SHOWN.

THE COLOR(S) BLACK, ORANGE, GREEN AND BLUE IS/ARE CLAIMED AS A FEATURE OF THE MARK.

THE MARK CONSISTS OF A HANDHELD COMPUTER APPEARING IN BLACK WITH TWO STYLIZED HUMAN BEINGS SUPERIMPOSED ON THE COMPUTER. ONE OF THE HUMANS APPEARS IN GREEN WITH AN ORANGE HEAD ON THE LEFT. THE OTHER HUMAN APPEARS IN BLUE WITH AN ORANGE HEAD TO THE RIGHT. BELOW THE COMPUTER IS A BLACK SHADOW. BELOW THE SHADOW ARE THE WORDS "THE VIRTUAL DIVORCE" APPEARING IN BLACK.

FOR LEGAL SERVICES; DIVORCE MEDIATION SERVICES (U.S. CLS. 100 AND 101).

CHARLES L. JENKINS, EXAMINING ATTORNEY

SN 86-221,765. ENGLISH CROSSING, MOORE, SC. FILED 3-14-2014.

# ENGLISH CROSSING

THE MARK CONSISTS OF STANDARD CHARACTERS WITHOUT CLAIM TO ANY PARTICULAR FONT, STYLE, SIZE, OR COLOR.

NO CLAIM IS MADE TO THE EXCLUSIVE RIGHT TO USE "ENGLISH", APART FROM THE MARK AS SHOWN.

FOR MINISTERIAL SERVICES FOR NON-ENGLISH SPEAKING PEOPLE (U.S. CLS. 100 AND 101).

JULIE GUTTADAURO, EXAMINING ATTORNEY

**CLASS 45—(Continued).**

SN 86-226,922. BENJAMIN BLUMENTHAL, ATLANTA, GA. FILED 3-20-2014.

# PatentTank

THE MARK CONSISTS OF STANDARD CHARACTERS WITHOUT CLAIM TO ANY PARTICULAR FONT, STYLE, SIZE, OR COLOR.

FOR PATENT AGENT SERVICES; PATENT AND INDUSTRIAL PROPERTY CONSULTATION; PROVIDING A WEB SITE FEATURING INFORMATION ABOUT PATENTS AND PATENT APPLICATIONS (U.S. CLS. 100 AND 101).

FIRST USE 1-9-2012; IN COMMERCE 3-9-2014.

CHARLES L. JENKINS, EXAMINING ATTORNEY

---

SN 86-228,769. BIG BARK, LLC, CHICAGO, IL. FILED 3-21-2014.



THE MARK CONSISTS OF THE WORD "BIG" APPEARING ABOVE AND TO THE RIGHT OF THE LARGER WORD "BARK" WITH AN IMAGE OF A DOG WEARING A COLLAR FORMING THE "A" IN "BARK".

FOR PROVIDING A WEBSITE FEATURING INFORMATION IN THE FIELD OF RESOURCES FOR LARGE DOG OWNERS, NAMELY, PROVIDING INFORMATION ABOUT PET ADOPTION, IN PARTICULAR, LISTINGS AND PHOTOGRAPHS OF PETS AVAILABLE FOR ADOPTION AND INFORMATION RELATED THERETO; PREPARATION OF CUSTOMIZED GIFT BASKETS WITH SELECTED ITEMS REGARDING A PARTICULAR OCCASION OR THEME, NAMELY, CUSTOM MONTHLY BOXES FEATURING VARIOUS DOG-RELATED ITEMS, NAMELY, TOYS AND TREATS; SOCIAL NETWORKING SERVICES IN THE FIELD OF LARGE DOG OWNERSHIP PROVIDED VIA A WEBSITE (U.S. CLS. 100 AND 101).

FIRST USE 3-4-2012; IN COMMERCE 3-4-2012.

CYNTHIA RINALDI, EXAMINING ATTORNEY

**CLASS 45—(Continued).**

SN 86-229,572. THE SPITZ LAW FIRM, LLC, WARRENSVILLE HEIGHTS, OH. FILED 3-24-2014.



THE MARK CONSISTS OF LADY JUSTICE HAVING WINGS AND HOLDING A SWORD AND SCALES.

FOR LEGAL SERVICES (U.S. CLS. 100 AND 101).

FIRST USE 3-24-2014; IN COMMERCE 3-24-2014.

CHRISTINA SOBRAL, EXAMINING ATTORNEY

---

SN 86-230,110. PEOPLELINK, LLC, SOUTH BEND, IN. FILED 3-24-2014.

# PEOPLELINK

THE MARK CONSISTS OF STANDARD CHARACTERS WITHOUT CLAIM TO ANY PARTICULAR FONT, STYLE, SIZE, OR COLOR.

OWNER OF U.S. REG. NOS. 2,008,114, 2,711,721 AND 4,145,433.

FOR RISK MANAGEMENT CONSULTING SERVICES, NAMELY, PRE-EMPLOYMENT BACKGROUND SCREENING; CONSULTING SERVICES IN THE NATURE OF JOB AND WORK ENVIRONMENT SAFETY RISK ASSESSMENT (U.S. CLS. 100 AND 101).

FIRST USE 5-11-2010; IN COMMERCE 5-11-2010.

KERI CANTONE, EXAMINING ATTORNEY

**CLASS 45—(Continued).**

SN 86-230,310. POINTSERV, INC., BURLINGAME, CA.  
FILED 3-24-2014.

PointServ

THE MARK CONSISTS OF STANDARD CHARACTERS WITHOUT CLAIM TO ANY PARTICULAR FONT, STYLE, SIZE, OR COLOR.

FOR IDENTIFICATION VERIFICATION SERVICES, NAMELY, PROVIDING AUTHENTICATION OF PERSONAL IDENTIFICATION INFORMATION; IDENTIFICATION VERIFICATION SERVICES, NAMELY, PROVIDING AUTHENTICATION OF PERSONAL IDENTIFICATION INFORMATION VIA SECURE STORAGE AND TRANSMITTING SUCH INFORMATION VIA THE INTERNET; PROVIDING AN INTERACTIVE WEB SITE THAT FACILITATES THE VERIFICATION OF A PERSON'S BACKGROUND CREDENTIALS (U.S. CLS. 100 AND 101).

FIRST USE 1-1-2010; IN COMMERCE 1-1-2010.  
TIMOTHY O. SCHIMPF, EXAMINING ATTORNEY

**CLASS 45—(Continued).**

SN 86-232,568. FINGERPRINTING EXPRESS, LLC, RENO, NV. FILED 3-26-2014.

FINGERPRINTING  
**EXPRESS**  
AND MORE!

OWNER OF U.S. REG. NOS. 4,036,611 AND 4,322,456.  
NO CLAIM IS MADE TO THE EXCLUSIVE RIGHT TO USE "FINGERPRINTING", APART FROM THE MARK AS SHOWN.

THE MARK CONSISTS OF A FINGERPRINT DESIGN SURROUNDED BY A SQUARE BORDER WITH THE WORDS "FINGERPRINTING EXPRESS AND MORE!" IN STYLIZED LETTERING.

SEC. 2(F) AS TO "FINGERPRINTING EXPRESS".  
FOR BACKGROUND INVESTIGATION SERVICES; FINGERPRINTING SERVICES; NOTARY PUBLIC SERVICES (U.S. CLS. 100 AND 101).

FIRST USE 2-0-2010; IN COMMERCE 2-0-2010.  
HEATHER THOMPSON, EXAMINING ATTORNEY

SN 86-232,425. FINGERPRINTING EXPRESS, LLC, RENO, NV. FILED 3-26-2014.

FINGERPRINTING EXPRESS

THE MARK CONSISTS OF STANDARD CHARACTERS WITHOUT CLAIM TO ANY PARTICULAR FONT, STYLE, SIZE, OR COLOR.

OWNER OF U.S. REG. NOS. 4,036,611 AND 4,322,456.  
NO CLAIM IS MADE TO THE EXCLUSIVE RIGHT TO USE "FINGERPRINTING", APART FROM THE MARK AS SHOWN.

SEC. 2(F).  
FOR BACKGROUND INVESTIGATION SERVICES; FINGERPRINTING SERVICES; NOTARY PUBLIC SERVICES (U.S. CLS. 100 AND 101).

FIRST USE 10-0-2003; IN COMMERCE 10-0-2003.  
HEATHER THOMPSON, EXAMINING ATTORNEY

SN 86-234,727. NORTHWEST WORKPLACE LAW PLLC, SEATTLE, WA. FILED 3-27-2014.

Northwest Workplace Law

THE MARK CONSISTS OF STANDARD CHARACTERS WITHOUT CLAIM TO ANY PARTICULAR FONT, STYLE, SIZE, OR COLOR.

NO CLAIM IS MADE TO THE EXCLUSIVE RIGHT TO USE "WORKPLACE LAW", APART FROM THE MARK AS SHOWN.

FOR LEGAL SERVICES (U.S. CLS. 100 AND 101).  
FIRST USE 2-22-2013; IN COMMERCE 9-17-2013.  
AMY C. KEAN, EXAMINING ATTORNEY

**CLASS 45—(Continued).**

SN 86-235,084. KERN, AUGUSTINE, CONROY & SCHOPPMANN, P.C., BRIDGEWATER, NJ. FILED 3-28-2014.



THE COLOR(S) BLUE-GREEN, GRAY, WHITE AND BLACK IS/ARE CLAIMED AS A FEATURE OF THE MARK. THE MARK CONSISTS OF A WHITE SNAKE WRAPPED AROUND A CENTER POLE OF THE IMAGE OF THE SCALES OF JUSTICE IN GRAY, SUPERIMPOSED ON A SHIELD WITH A FIELD OF TEAL BLUE-GREEN AND A GRAY AND BLACK BORDER.

FOR PREPAID LEGAL SERVICES FOR THE MEDICAL INDUSTRY (U.S. CLS. 100 AND 101).

FIRST USE 8-0-1990; IN COMMERCE 8-0-1990.  
HANNO RITTNER, EXAMINING ATTORNEY

SN 86-236,037. FILE RIGHT LLC, MIDDLETOWN, DE. FILED 3-28-2014.

INMIGRACION EN TUS MANOS

THE MARK CONSISTS OF STANDARD CHARACTERS WITHOUT CLAIM TO ANY PARTICULAR FONT, STYLE, SIZE, OR COLOR.

NO CLAIM IS MADE TO THE EXCLUSIVE RIGHT TO USE "INMIGRACION", APART FROM THE MARK AS SHOWN.

THE ENGLISH TRANSLATION OF "INMIGRACION EN TUS MANOS" IN THE MARK IS "IMMIGRATION IN YOUR HANDS".

FOR LEGAL DOCUMENT PREPARATION SERVICES; PROVIDING GENERAL IMMIGRATION-RELATED LEGAL INFORMATION VIA A WEBSITE ON GLOBAL COMPUTER NETWORKS (U.S. CLS. 100 AND 101).

BARBARA BROWN, EXAMINING ATTORNEY

**CLASS 45—(Continued).**

SN 86-236,117. WOOD, KRONAH J., OVERLAND PARK, KS. FILED 3-28-2014.

## Metapolymath

THE MARK CONSISTS OF STANDARD CHARACTERS WITHOUT CLAIM TO ANY PARTICULAR FONT, STYLE, SIZE, OR COLOR.

FOR PROVIDING INFORMATION ON TECHNIQUES FOR IMPROVING PERSONAL CREATIVITY (U.S. CLS. 100 AND 101).

FIRST USE 11-4-2011; IN COMMERCE 11-4-2011.  
MARK SPARACINO, EXAMINING ATTORNEY

SN 86-236,494. NEW PARADIGM TECHNOLOGIES, INC., CHICAGO, IL. FILED 3-30-2014.

## The Dating Institute

THE MARK CONSISTS OF STANDARD CHARACTERS WITHOUT CLAIM TO ANY PARTICULAR FONT, STYLE, SIZE, OR COLOR.

NO CLAIM IS MADE TO THE EXCLUSIVE RIGHT TO USE "DATING", APART FROM THE MARK AS SHOWN.

FOR DATING SERVICES; INTERNET BASED SOCIAL NETWORKING, INTRODUCTION, AND DATING SERVICES (U.S. CLS. 100 AND 101).

FIRST USE 3-30-2014; IN COMMERCE 3-30-2014.  
MARK SPARACINO, EXAMINING ATTORNEY

SN 86-236,788. RABUSE, DESIREE C., TULARE, CA. FILED 3-31-2014.

## Style Fox

THE MARK CONSISTS OF STANDARD CHARACTERS WITHOUT CLAIM TO ANY PARTICULAR FONT, STYLE, SIZE, OR COLOR.

NO CLAIM IS MADE TO THE EXCLUSIVE RIGHT TO USE "STYLE", APART FROM THE MARK AS SHOWN.

FOR FASHION INFORMATION; ONLINE SOCIAL NETWORKING SERVICES PROVIDED THROUGH A FASHION COMMUNITY WEBSITE; PROVIDING NEWS AND INFORMATION IN THE FIELD OF FASHION; PROVISION OF A WEB SITE FEATURING INFORMATION ON FASHION (U.S. CLS. 100 AND 101).

FIRST USE 3-1-2011; IN COMMERCE 2-1-2012.  
JAMES GRIFFIN, EXAMINING ATTORNEY

**CLASS 45—(Continued).**

SN 86-237,418. BRIDGE TO LIFE MINISTRIES, SPRING LAKE, MI. FILED 3-31-2014.

**Bridge To Life Ministries**

THE MARK CONSISTS OF STANDARD CHARACTERS WITHOUT CLAIM TO ANY PARTICULAR FONT, STYLE, SIZE, OR COLOR.

NO CLAIM IS MADE TO THE EXCLUSIVE RIGHT TO USE "MINISTRIES", APART FROM THE MARK AS SHOWN.

FOR CHRISTIAN MINISTRY SERVICES; COUNSELING SERVICES IN THE FIELD OF CHRISTIAN CONDUCT IN PERSONAL RELATIONSHIPS; MARRIAGE COUNSELING; PROVIDING A WEBSITE FEATURING INFORMATION FOR LOCAL CHURCH LEADERS IN THE FIELD OF CHRISTIAN GROWTH (U.S. CLS. 100 AND 101).

FIRST USE 4-1-1983; IN COMMERCE 4-1-1983.  
MICHAEL WEBSTER, EXAMINING ATTORNEY

SN 86-237,749. OSWALD, JOHN, VENETIA, PA. FILED 3-31-2014.

**Happy At Home - In Home Care Inc.**

THE MARK CONSISTS OF STANDARD CHARACTERS WITHOUT CLAIM TO ANY PARTICULAR FONT, STYLE, SIZE, OR COLOR.

NO CLAIM IS MADE TO THE EXCLUSIVE RIGHT TO USE "IN HOME CARE INC.", APART FROM THE MARK AS SHOWN.

FOR NON-MEDICAL IN-HOME PERSONAL CARE SERVICES FOR ASSISTING WITH DAILY LIVING ACTIVITIES OF THE ELDERLY AND DISABLED PERSONS (U.S. CLS. 100 AND 101).

FIRST USE 12-20-2013; IN COMMERCE 3-1-2014.  
TOBY BULLOFF, EXAMINING ATTORNEY

SN 86-237,842. STYKU, LOS ANGELES, CA. FILED 3-31-2014.

**fitfyle**

THE MARK CONSISTS OF STANDARD CHARACTERS WITHOUT CLAIM TO ANY PARTICULAR FONT, STYLE, SIZE, OR COLOR.

FOR PROVIDING ONLINE FASHION QUESTIONS TO HELP CONSUMERS DETERMINE THE FIT OF CLOTHING BEST SUITED TO THEIR INDIVIDUAL NEEDS AND PREFERENCES (U.S. CLS. 100 AND 101).

LINDA QUIGLEY, EXAMINING ATTORNEY

**CLASS 45—(Continued).**

SN 86-239,033. USHA SITA, SUNDARAM, EMERYVILLE, CA. FILED 4-1-2014.

**AKASHA SPIRITUAL FAITH**

THE MARK CONSISTS OF STANDARD CHARACTERS WITHOUT CLAIM TO ANY PARTICULAR FONT, STYLE, SIZE, OR COLOR.

NO CLAIM IS MADE TO THE EXCLUSIVE RIGHT TO USE "SPIRITUAL FAITH", APART FROM THE MARK AS SHOWN.

THE ENGLISH TRANSLATION OF "AKASHA" IN THE MARK IS "SKY" OR "ETHEREAL".

FOR SPIRITUAL COUNSELING; PROVIDING SPIRITUAL RETREATS IN THE FIELD OF SPIRITUALITY; PROVIDING SPIRITUAL REHABILITATION SERVICES; MINISTERIAL SERVICES, NAMELY, HOLDING SPIRITUAL RETREATS TO ASSIST RELIGIOUS LEADERS, BOTH CLERGY AND LAY, TO DEVELOP AND ENHANCE THEIR SPIRITUAL LIVES; PROVIDING ONLINE INFORMATION IN THE FIELD OF SPIRITUALITY, SELF-HELP, AND PERSONAL EMPOWERMENT SUBJECT MATTERS; PROVIDING A WEBSITE FEATURING INFORMATION ABOUT MINISTERIAL SERVICES (U.S. CLS. 100 AND 101).

JAMES LOVELACE, EXAMINING ATTORNEY

SN 86-239,119. O.R.Y. WOMEN INC. (OLDER WOMEN REACHING BACK FOR THE YOUNGER WOMEN), COLORADO SPRINGS, CO. FILED 4-1-2014.



NO CLAIM IS MADE TO THE EXCLUSIVE RIGHT TO USE "WOMEN", APART FROM THE MARK AS SHOWN.

THE COLOR(S) WHITE, PURPLE, AND MAGENTA IS/ARE CLAIMED AS A FEATURE OF THE MARK.

THE MARK CONSISTS OF A PURPLE CIRCLE TREE TOP THAT INCLUDES A PURPLE AND WHITE TREE TRUNK WITH A SLIGHT FOUNDATION. THE TREE CIRCLE AND TRUNK ARE PURPLE. THERE IS A WHITE SILHOUETTE OF A WOMAN WITH WHITE ARMS THAT BECOME WHITE TREE BRANCHES AND LEAVES INSIDE THE CIRCLE TREE TOP. THE BOTTOM HALF OF HER BODY IS ALIGNING WITH THE TREE TRUNK. SHE HAS A MAGENTA HEART SHAPE SYMBOL ON THE UPPER RIGHT SIDE OF HER TORSO. BELOW HER IS THE WORDING "O.R.Y. WOMEN" IN MAGENTA BELOW THAT IS THE WORDING "OLDER WOMEN REACHING BACK FOR THE YOUNGER WOMEN" CAPITALIZED AND IN PURPLE.

FOR CHARITABLE SERVICES, NAMELY, PROVIDING EMOTIONAL SUPPORT SERVICES FOR PROVIDING EMOTIONAL SUPPORT FOR YOUNG WOMEN FROM 12 YEARS OF AGE TO 35 BY MEANS OF PROVIDING FAITH-BASED INSPIRATIONAL AND MOTIVATIONAL INFORMATION VIA SOCIAL NETWORKS, EVENTS, AND SPIRITUAL EMPOWERMENT MATERIALS; CHRISTIAN MINISTRY SERVICES; ONLINE SOCIAL NETWORKING SERVICES (U.S. CLS. 100 AND 101).

FIRST USE 3-20-2014; IN COMMERCE 3-20-2014.  
LINDA MICKLEBURGH, EXAMINING ATTORNEY

**CLASS 45—(Continued).**

SN 86-240,061. CUSTOM HOME CARE, INC., CHICAGO, IL.  
FILED 4-2-2014.

# Catered Living

THE MARK CONSISTS OF STANDARD CHARACTERS WITHOUT CLAIM TO ANY PARTICULAR FONT, STYLE, SIZE, OR COLOR.

NO CLAIM IS MADE TO THE EXCLUSIVE RIGHT TO USE "LIVING", APART FROM THE MARK AS SHOWN.

FOR IN-HOME SUPPORT SERVICES TO SENIOR PERSONS, NAMELY, GERIATRIC CARE MANAGEMENT SERVICES IN THE NATURE OF THE COORDINATION OF NECESSARY SERVICES AND PERSONAL CARE FOR OLDER INDIVIDUALS; NON-MEDICAL IN-HOME PERSONAL CARE SERVICES FOR ASSISTING WITH DAILY LIVING ACTIVITIES OF DISABLED PERSONS, THE ELDERLY (U.S. CLS. 100 AND 101).

FIRST USE 3-1-2003; IN COMMERCE 3-1-2003.  
JOANNA FIORELLI, EXAMINING ATTORNEY

---

SN 86-242,825. CK FRANCHISING, INC., DAYTON, OH.  
FILED 4-4-2014.

# LIFESELECT

THE MARK CONSISTS OF STANDARD CHARACTERS WITHOUT CLAIM TO ANY PARTICULAR FONT, STYLE, SIZE, OR COLOR.

FOR IN-HOME SUPPORT SERVICES TO SENIOR PERSONS, NAMELY, GERIATRIC CARE MANAGEMENT SERVICES IN THE NATURE OF THE COORDINATION OF NECESSARY SERVICES AND PERSONAL CARE FOR OLDER INDIVIDUALS; NON-MEDICAL IN-HOME PERSONAL CARE SERVICES FOR ASSISTING WITH DAILY LIVING ACTIVITIES OF SENIORS (U.S. CLS. 100 AND 101).

FIRST USE 7-29-2013; IN COMMERCE 7-29-2013.  
LEIGH LOWRY, EXAMINING ATTORNEY

**CLASS 45—(Continued).**

SN 86-245,159. JENNIFER RAY, CONYERS, GA. FILED 4-7-2014.



THE COLOR(S) PINK, WHITE, BLACK IS/ARE CLAIMED AS A FEATURE OF THE MARK.

THE MARK CONSISTS OF PINK OVAL SHAPE WITH THE WORDS "HOT MOMMIES" WRITTEN IN WHITE AT THE CENTER OF THE PINK OVAL. THE PINK OVAL IS OUTLINED WITH A WHITE BRIM. THE WHITE BRIM IS SURROUNDED IN BLACK WITH A WHITE PERFORATED LINE CREATING AN OUTER LAYER AND A SECOND OVAL AROUND THE PINK OVAL. NEXT THERE IS A WHITE SWIRLING DESIGN STEMMING FROM THE PERFORATED OVAL THAT EXTENDS OUT OF THE UPPER HALF AND LOWER HALF OF THE PERFORATED OVAL. THERE IS A WHITE DOT AT THE TOP AND BOTTOM OF THE SWIRLING DESIGN.

FOR PERSONAL GROWTH AND MOTIVATION CONSULTING SERVICES; PROVIDING A MOTIVATIONAL WEBSITE THE PRIMARY MISSION OF WHICH IS TO INCREASE PERSONAL HAPPINESS IN TERMS OF PERSONAL RELATIONSHIPS, PERSONAL GROWTH AND MOTIVATION, AND SELF-FULFILLMENT; PROVIDING A MOTIVATIONAL WEBSITE THE PRIMARY MISSION OF WHICH IS TO SPREAD LAUGHTER AND SMILES, AND TO RAISE AWARENESS TO THE ISSUE OF SUICIDE AND PROVIDE SUPPORT FOR PEOPLE SUFFERING WITH DEPRESSION; PROVIDING A WEBSITE FEATURING INSPIRATIONAL AND MOTIVATIONAL NEWS STORIES ABOUT WOMEN (U.S. CLS. 100 AND 101).

FIRST USE 5-10-2013; IN COMMERCE 5-10-2013.  
SHAUNIA CARLYLE, EXAMINING ATTORNEY

---

SN 86-245,358. HC DIGITAL MEDIA, INC., WEST HOLLYWOOD, CA. FILED 4-8-2014.

# SPUNK

THE MARK CONSISTS OF STANDARD CHARACTERS WITHOUT CLAIM TO ANY PARTICULAR FONT, STYLE, SIZE, OR COLOR.

FOR ONLINE SOCIAL NETWORKING SERVICES IN THE FIELD OF REVIEWS AND COMMENTARY ON GEOGRAPHIC LOCATIONS, BUSINESSES, AND OTHER PHYSICAL SITES FOR PURPOSES OF SOCIAL INTERACTION, GATHERING, AND RELATIONSHIPS (U.S. CLS. 100 AND 101).

DOMINIC J. FERRAIUOLO, EXAMINING ATTORNEY

**CLASS 45—(Continued).**

SN 86-245,396. SAMUEL, CHARLES, ROSLYN HEIGHTS, NY. FILED 4-8-2014.

**BECAUSE WE CAN**

THE MARK CONSISTS OF STANDARD CHARACTERS WITHOUT CLAIM TO ANY PARTICULAR FONT, STYLE, SIZE, OR COLOR.

FOR ONLINE SOCIAL NETWORKING SERVICES IN THE FIELD OF LINKING ARTISTS WITH CLIENTS PROVIDED VIA A WEBSITE (U.S. CLS. 100 AND 101).  
BARBARA RUTLAND, EXAMINING ATTORNEY

**CLASS 45—(Continued).**

SN 86-245,510. CARRINGTON, COLEMAN, SLOMAN & BLUMENTHAL, L.L.P., DALLAS, TX. FILED 4-8-2014.

**BOOK SMART STREET SMART  
BUSINESS SMART SMARTER  
CHOICE**

THE MARK CONSISTS OF STANDARD CHARACTERS WITHOUT CLAIM TO ANY PARTICULAR FONT, STYLE, SIZE, OR COLOR.

FOR LEGAL SERVICES (U.S. CLS. 100 AND 101).  
FIRST USE 4-3-2014; IN COMMERCE 4-3-2014.  
APRIL HESIK, EXAMINING ATTORNEY

SN 86-245,483. SAMUEL, CHARLES, ROSLYN HEIGHTS, NY. FILED 4-8-2014.



THE COLOR(S) ORANGE, BLUE AND GREEN IS/ARE CLAIMED AS A FEATURE OF THE MARK.

THE MARK CONSISTS OF THREE ADHESIVE NOTES OF VARYING SIZE WITH (FROM LEFT TO RIGHT) ORANGE, BLUE AND GREEN IN COLOR.

FOR ONLINE SOCIAL NETWORKING SERVICES IN THE FIELD OF LINKING ARTISTS WITH CLIENTS PROVIDED VIA A WEBSITE (U.S. CLS. 100 AND 101).  
BARBARA RUTLAND, EXAMINING ATTORNEY

SN 86-245,689. COLLIER LEGAL, PLLC, AKA THE SPIRITED LAWYER, RALEIGH, NC. FILED 4-8-2014.

**The Spirited Lawyer**

THE MARK CONSISTS OF STANDARD CHARACTERS WITHOUT CLAIM TO ANY PARTICULAR FONT, STYLE, SIZE, OR COLOR.

NO CLAIM IS MADE TO THE EXCLUSIVE RIGHT TO USE "LAWYER", APART FROM THE MARK AS SHOWN.

FOR LEGAL SERVICES (U.S. CLS. 100 AND 101).  
FIRST USE 7-4-2013; IN COMMERCE 9-1-2013.  
CAROLINE WOOD, EXAMINING ATTORNEY

SN 86-245,503. CARRINGTON, COLEMAN, SLOMAN & BLUMENTHAL, L.L.P., DALLAS, TX. FILED 4-8-2014.

**SMART IN EVERY SENSE OF  
THE WORD.**

THE MARK CONSISTS OF STANDARD CHARACTERS WITHOUT CLAIM TO ANY PARTICULAR FONT, STYLE, SIZE, OR COLOR.

FOR LEGAL SERVICES (U.S. CLS. 100 AND 101).  
FIRST USE 4-3-2014; IN COMMERCE 4-3-2014.  
APRIL HESIK, EXAMINING ATTORNEY

SN 86-245,962. TRIANGLE VENTURES LLC, CHICAGO, IL. FILED 4-8-2014.

**There is no undo in privacy**

THE MARK CONSISTS OF STANDARD CHARACTERS WITHOUT CLAIM TO ANY PARTICULAR FONT, STYLE, SIZE, OR COLOR.

FOR ELECTRONIC MONITORING SERVICES FOR SECURITY PURPOSES IN THE FIELD OF RANDOMIZED IDENTITY TRACKING (U.S. CLS. 100 AND 101).  
DAVID HOFFMAN, EXAMINING ATTORNEY



**CLASS 45—(Continued).**

SN 86-246,658. COMFORCARE HEALTH CARE HOLDINGS, INC. DBA COMFORCARE SENIOR SERVICES, BLOOMFIELD HILLS, MI. FILED 4-9-2014.

# DementiaWise

THE MARK CONSISTS OF STANDARD CHARACTERS WITHOUT CLAIM TO ANY PARTICULAR FONT, STYLE, SIZE, OR COLOR.

FOR NON-MEDICAL IN-HOME PERSONAL CARE SERVICES FOR ASSISTING WITH DAILY LIVING ACTIVITIES OF THE ELDERLY (U.S. CLS. 100 AND 101).  
FIRST USE 3-11-2014; IN COMMERCE 4-9-2014.  
LINDA M. KING, EXAMINING ATTORNEY

SN 86-246,740. CHENEGA TOTAL ASSET PROTECTION, ASHBURN, VA. FILED 4-9-2014.

# YOUR REPUTATION IS OUR BUSINESS

THE MARK CONSISTS OF STANDARD CHARACTERS WITHOUT CLAIM TO ANY PARTICULAR FONT, STYLE, SIZE, OR COLOR.

FOR SECURITY GUARD SERVICES; SECURITY SERVICES, NAMELY, ARMED AND UNARMED GUARDS, PROVIDING SECURITY ASSESSMENTS OF PHYSICAL LOCATIONS, INFORMATION SYSTEMS, AND WORKING ENVIRONMENTS; SECURITY INSPECTION SERVICES FOR OTHERS; SECURITY CONSULTANCY; VIDEO MONITORING OF FACILITIES, VIEWABLE THROUGH A GLOBAL COMPUTER NETWORK, FOR SECURITY PURPOSES; PROVIDING A WEB SITE FEATURING INFORMATION IN THE FIELD OF SECURITY; MONITORING OF SECURITY SYSTEMS; MONITORING OF TELECOMMUNICATIONS, CCTV AND ALARM SYSTEMS FOR SECURITY PURPOSES (U.S. CLS. 100 AND 101).

FIRST USE 3-31-2014; IN COMMERCE 3-31-2014.  
DOMINICK J. SALEMI, EXAMINING ATTORNEY

**CLASS 45—(Continued).**

SN 86-246,782. WAGNER, STEPHEN, FORT WORTH, TX. FILED 4-9-2014.



NO CLAIM IS MADE TO THE EXCLUSIVE RIGHT TO USE "AMERICAN", APART FROM THE MARK AS SHOWN.

THE MARK CONSISTS OF A STYLIZED CONCENTRIC OVAL. THE OUTER OVAL IS SHADED. THERE ARE TWO STARS IN THE SHADED OVAL. ONE STAR IS ON THE LEFT CENTER PORTION OF THE OVAL AND THE OTHER STAR IS ON THE RIGHT CENTER PORTION OF THE OVAL. THE TOP OF THE SHADED OVAL PRESENTS THE WORD "RANGER" AND THE BOTTOM OF THE SHADED OVAL PRESENTS THE WORD "AMERICAN". THE INNER OVAL PRESENTS AN EIGHT POINTED STAR.

FOR MONITORING OF SECURITY SYSTEMS (U.S. CLS. 100 AND 101).

FIRST USE 7-0-2003; IN COMMERCE 7-0-2003.  
DAVID ALESKOW, EXAMINING ATTORNEY

SN 86-246,795. WAGNER, STEPHEN, FORT WORTH, TX. FILED 4-9-2014.

# RANGER AMERICAN

THE MARK CONSISTS OF STANDARD CHARACTERS WITHOUT CLAIM TO ANY PARTICULAR FONT, STYLE, SIZE, OR COLOR.

NO CLAIM IS MADE TO THE EXCLUSIVE RIGHT TO USE "AMERICAN", APART FROM THE MARK AS SHOWN.

FOR MONITORING OF SECURITY SYSTEMS (U.S. CLS. 100 AND 101).

FIRST USE 7-0-2003; IN COMMERCE 7-0-2003.  
DAVID ALESKOW, EXAMINING ATTORNEY

SN 86-247,001. SPYHERO INC., TORONTO, ONTARIO, CANADA, FILED 4-9-2014.

# SPYHERO

THE MARK CONSISTS OF STANDARD CHARACTERS WITHOUT CLAIM TO ANY PARTICULAR FONT, STYLE, SIZE, OR COLOR.

FOR SURVEILLANCE SERVICES (U.S. CLS. 100 AND 101).

DOUGLAS LEE, EXAMINING ATTORNEY

**CLASS 45—(Continued).**

SN 86-247,016. OLDE TOWNE TITLE & GUARANTY AGENCY, LLC, ST. AUGUSTINE, FL. FILED 4-9-2014.

We Open At 9 And Close All  
Day

THE MARK CONSISTS OF STANDARD CHARACTERS WITHOUT CLAIM TO ANY PARTICULAR FONT, STYLE, SIZE, OR COLOR.

FOR CLOSING SERVICES FOR MORTGAGE LOANS; REAL ESTATE CLOSING SERVICES; REAL ESTATE SETTLEMENT SERVICES (U.S. CLS. 100 AND 101).

FIRST USE 6-1-2008; IN COMMERCE 6-1-2008.

BILL DAWE, EXAMINING ATTORNEY

---

SN 86-247,501. GAMEPLAN, INC., RENO, NV. FILED 4-9-2014.

## VDIGS

THE MARK CONSISTS OF STANDARD CHARACTERS WITHOUT CLAIM TO ANY PARTICULAR FONT, STYLE, SIZE, OR COLOR.

FOR ONLINE SOCIAL NETWORKING SERVICES (U.S. CLS. 100 AND 101).

ALISON KEELEY, EXAMINING ATTORNEY

---

SN 86-247,822. MARYLAND CLAIMS INVESTIGATION, INC., PERRY HALL, MD. FILED 4-9-2014.

## NAVCHECK60

THE MARK CONSISTS OF STANDARD CHARACTERS WITHOUT CLAIM TO ANY PARTICULAR FONT, STYLE, SIZE, OR COLOR.

FOR ACCIDENT INVESTIGATIONS; BACKGROUND INVESTIGATION AND RESEARCH SERVICES; DETECTIVE INVESTIGATIONS; DMV RECORD INVESTIGATION SERVICES; INVESTIGATION SERVICES RELATED TO INSURANCE CLAIMS; PRIVATE INVESTIGATION; SURVEILLANCE SERVICES; WORKERS COMPENSATION FRAUD INVESTIGATION SERVICES (U.S. CLS. 100 AND 101).

FIRST USE 2-0-2014; IN COMMERCE 2-0-2014.

ALYSSA STEEL, EXAMINING ATTORNEY

**CLASS 45—(Continued).**

SN 86-248,346. NATIONS CHECK, RALEIGH, NC. FILED 4-10-2014.

## NationsCheck

THE MARK CONSISTS OF STANDARD CHARACTERS WITHOUT CLAIM TO ANY PARTICULAR FONT, STYLE, SIZE, OR COLOR.

FOR BACKGROUND INVESTIGATION AND RESEARCH SERVICES; DRUG, ALCOHOL AND DNA SCREENING FOR SECURITY AND EMPLOYMENT PURPOSES (U.S. CLS. 100 AND 101).

FIRST USE 4-1-2004; IN COMMERCE 4-1-2004.

ELLEN PERKINS, EXAMINING ATTORNEY

---

SN 86-248,606. PISTONZONE.COM, LLC, PINEVILLE, MO. FILED 4-10-2014.

## PISTONZONE

THE MARK CONSISTS OF STANDARD CHARACTERS WITHOUT CLAIM TO ANY PARTICULAR FONT, STYLE, SIZE, OR COLOR.

FOR INTERNET-BASED SOCIAL NETWORKING SERVICES; ONLINE SOCIAL NETWORKING SERVICES IN THE FIELD OF MOTOR VEHICLES (U.S. CLS. 100 AND 101).

NATALIE KENEALY, EXAMINING ATTORNEY

---

SN 86-248,626. PISTONZONE.COM, LLC, PINEVILLE, MO. FILED 4-10-2014.



THE MARK CONSISTS OF THE WORDS "PISTONZONE" WHEREIN AN ILLUSTRATED PISTON IS USED IN PLACE OF THE "I" WITH FLAMES IN THE BACKGROUND AND PARTIALLY BEHIND THE "P" AND "S".

FOR INTERNET-BASED SOCIAL NETWORKING SERVICES; ONLINE SOCIAL NETWORKING SERVICES IN THE FIELD OF MOTOR VEHICLES (U.S. CLS. 100 AND 101).

NATALIE KENEALY, EXAMINING ATTORNEY

**CLASS 45—(Continued).**

SN 86-248,771. WADA, HIROSHI, DBA CLOSEUP EXPRESS, SACRAMENTO, CA. FILED 4-10-2014.

**CLOSEUP EXPRESS**

THE MARK CONSISTS OF STANDARD CHARACTERS WITHOUT CLAIM TO ANY PARTICULAR FONT, STYLE, SIZE, OR COLOR.

OWNER OF U.S. REG. NO. 4,455,101.

NO CLAIM IS MADE TO THE EXCLUSIVE RIGHT TO USE "CLOSEUP", APART FROM THE MARK AS SHOWN.

FOR INTERNET-BASED DATING, SOCIAL INTRODUCTION AND SOCIAL NETWORKING SERVICES; PROVIDING ON-LINE COMPUTER DATABASES AND ON-LINE SEARCHABLE DATABASES IN THE FIELD OF SOCIAL NETWORKING (U.S. CLS. 100 AND 101).

FIRST USE 6-8-2013; IN COMMERCE 6-8-2013.

BRIAN PINO, EXAMINING ATTORNEY

SN 86-248,796. GARCIA, EDGAR, ANAHEIM, CA. FILED 4-10-2014.

**Married For Life**

THE MARK CONSISTS OF STANDARD CHARACTERS WITHOUT CLAIM TO ANY PARTICULAR FONT, STYLE, SIZE, OR COLOR.

FOR CHRISTIAN MINISTRY SERVICES (U.S. CLS. 100 AND 101).

ESTHER A. BORSUK, EXAMINING ATTORNEY

SN 86-249,356. VAKS, AL, WOODSIDE, CA. FILED 4-11-2014.

**GADABOUTZ**

THE MARK CONSISTS OF STANDARD CHARACTERS WITHOUT CLAIM TO ANY PARTICULAR FONT, STYLE, SIZE, OR COLOR.

FOR INTERNET-BASED SOCIAL NETWORKING SERVICES; ON-LINE SOCIAL NETWORKING SERVICES; ONLINE SOCIAL NETWORKING SERVICES ACCESSIBLE BY MEANS OF DOWNLOADABLE MOBILE APPLICATIONS; PROVIDING ON-LINE COMPUTER DATABASES AND ON-LINE SEARCHABLE DATABASES IN THE FIELD OF SOCIAL NETWORKING (U.S. CLS. 100 AND 101).

GINA HAYES, EXAMINING ATTORNEY

**CLASS 45—(Continued).**

SN 86-249,359. STONKUS, MARK A., DBA HIGHER HOPES LLC, HINGHAM, MA. FILED 4-11-2014.

**Fit Out**

THE MARK CONSISTS OF STANDARD CHARACTERS WITHOUT CLAIM TO ANY PARTICULAR FONT, STYLE, SIZE, OR COLOR.

FOR PERSONAL GROWTH AND MOTIVATION CONSULTING SERVICES (U.S. CLS. 100 AND 101).

FIRST USE 11-30-2012; IN COMMERCE 11-30-2012.

JOHN WILKE, EXAMINING ATTORNEY

SN 86-249,375. LAWCO USA, P.L.L.C., FORT LAUDERDALE, FL. FILED 4-11-2014.

**THE POWER OF MORE**

THE MARK CONSISTS OF STANDARD CHARACTERS WITHOUT CLAIM TO ANY PARTICULAR FONT, STYLE, SIZE, OR COLOR.

FOR LEGAL CONSULTATION SERVICES; LEGAL SERVICES (U.S. CLS. 100 AND 101).

MICHAEL WEBSTER, EXAMINING ATTORNEY

SN 86-249,800. TOMASSO, ROBERT, TUCSON, AZ. FILED 4-11-2014.

**teenertake**

THE MARK CONSISTS OF STANDARD CHARACTERS WITHOUT CLAIM TO ANY PARTICULAR FONT, STYLE, SIZE, OR COLOR.

FOR ON-LINE SOCIAL NETWORKING SERVICES (U.S. CLS. 100 AND 101).

BARBARA GAYNOR, EXAMINING ATTORNEY

**CLASS 45—(Continued).**

SN 86-249,826. THAT GIRL SOLUTIONS, LLC, DBA THAT GIRL CAN DO IT, TAMPA, FL. FILED 4-11-2014.

THAT GIRL CAN DO IT

THE MARK CONSISTS OF STANDARD CHARACTERS WITHOUT CLAIM TO ANY PARTICULAR FONT, STYLE, SIZE, OR COLOR.

FOR PERSONAL CONCIERGE SERVICES FOR OTHERS COMPRISING MAKING REQUESTED PERSONAL ARRANGEMENTS AND RESERVATIONS AND PROVIDING CUSTOMER-SPECIFIC INFORMATION TO MEET INDIVIDUAL NEEDS (U.S. CLS. 100 AND 101).

CAITLIN WATTS-FITZGERALD, EXAMINING ATTORNEY

**CLASS 45—(Continued).**

SN 86-250,573. CHAPLAIN SERVICE PRISON MINISTRY OF VIRGINIA, INC., RICHMOND, VA. FILED 4-12-2014.



THE MARK CONSISTS OF A STYLIZED HUMAN FIGURE DEPICTED FROM THE WAIST UP WITH ARMS OUTSTRETCHED ON A BACKGROUND AREA GENERALLY SQUARE IN SHAPE WITH ROUNDED CORNERS AND INCLUDING THREE RECTANGULAR INDENTATIONS ABOVE AND TO THE RIGHT OF THE STYLIZED HUMAN FIGURE WITH THE STYLIZED WORDS "GRACE INSIDE" TO THE RIGHT OF THE BACKGROUND AREA.

FOR CHRISTIAN MINISTRY SERVICES (U.S. CLS. 100 AND 101).

GINA HAYES, EXAMINING ATTORNEY

SN 86-250,117. NOVAK DRUCE CONNOLLY BOVE + QUIGG LLP, WASHINGTON, DC. FILED 4-11-2014.

SEEING THROUGH THE EYES OF OTHERS

THE MARK CONSISTS OF STANDARD CHARACTERS WITHOUT CLAIM TO ANY PARTICULAR FONT, STYLE, SIZE, OR COLOR.

FOR LEGAL SERVICES; LEGAL SERVICES IN THE FIELD OF INTELLECTUAL PROPERTY AND MEDIATION (U.S. CLS. 100 AND 101).

LEIGH CAROLINE CASE, EXAMINING ATTORNEY

SN 86-250,688. BLACKTOP ALES INC, BURIEN, WA. FILED 4-13-2014.

Make a Pit Stop on your way home!

THE MARK CONSISTS OF STANDARD CHARACTERS WITHOUT CLAIM TO ANY PARTICULAR FONT, STYLE, SIZE, OR COLOR.

FOR LICENSING OF ADVERTISING SLOGANS AND CARTOON CHARACTERS (U.S. CLS. 100 AND 101).

JANICE L. MCMORROW, EXAMINING ATTORNEY

SN 86-250,424. THE LAW OFFICES OF FEELEY & LAROCA, LLC, WINFIELD PARK, NJ. FILED 4-11-2014.

Protecting the Rights of those who Protect the Public

THE MARK CONSISTS OF STANDARD CHARACTERS WITHOUT CLAIM TO ANY PARTICULAR FONT, STYLE, SIZE, OR COLOR.

FOR LEGAL SERVICES (U.S. CLS. 100 AND 101).

ROBERT C. CLARK JR., EXAMINING ATTORNEY

SN 86-250,739. FOSTERING GREAT IDEAS, GREENVILLE, SC. FILED 4-13-2014.

Fostering Great Ideas

THE MARK CONSISTS OF STANDARD CHARACTERS WITHOUT CLAIM TO ANY PARTICULAR FONT, STYLE, SIZE, OR COLOR.

FOR FOSTER CARE (U.S. CLS. 100 AND 101).

FIRST USE 3-14-2011; IN COMMERCE 3-14-2011.

SUNG IN, EXAMINING ATTORNEY

**CLASS 45—(Continued).**

SN 86-251,565. YOUR SAFE HARBOR, INC., NASHVILLE, TN. FILED 4-14-2014.

**CLASS 45—(Continued).**

SN 86-252,356. BOARD OF PENSIONS EVANGELICAL LUTHERAN CHURCH OF AMERICA, MINNEAPOLIS, MN. FILED 4-15-2014.

## YOUR SAFE HARBOR

THE MARK CONSISTS OF STANDARD CHARACTERS WITHOUT CLAIM TO ANY PARTICULAR FONT, STYLE, SIZE, OR COLOR.

FOR INTERNET-BASED SOCIAL NETWORKING SERVICES (U.S. CLS. 100 AND 101).  
JUHI KAVEESHVAR, EXAMINING ATTORNEY

SN 86-252,049. MINCOV LAW CORPORATION, VANCOUVER, CANADA, FILED 4-14-2014.



## IF IT'S REMARKABLE, IT'S TRADEMARKABLE

THE MARK CONSISTS OF STANDARD CHARACTERS WITHOUT CLAIM TO ANY PARTICULAR FONT, STYLE, SIZE, OR COLOR.

FOR CONSULTING IN THE FIELD OF INTELLECTUAL PROPERTY LICENSING; INTELLECTUAL PROPERTY CONSULTATION; INTELLECTUAL PROPERTY WATCH SERVICES; LEGAL SERVICES; LEGAL SERVICES, NAMELY, PREPARATION OF APPLICATIONS FOR TRADEMARK REGISTRATION; LEGAL SERVICES, NAMELY, TRADEMARK MAINTENANCE SERVICES; LEGAL SERVICES, NAMELY, TRADEMARK SEARCHING AND CLEARANCE SERVICES; PROVIDING ASSISTANCE IN THE PROSECUTION OF TRADEMARK APPLICATIONS; PROVIDING INFORMATION ABOUT INTELLECTUAL AND INDUSTRIAL PROPERTY RIGHTS; PROVIDING INFORMATION IN THE FIELD OF INTELLECTUAL PROPERTY LEGAL SERVICES ; PROVIDING INFORMATION IN THE FIELD OF INTELLECTUAL PROPERTY ; PROVIDING ON-LINE INFORMATION IN THE FIELD OF INTELLECTUAL PROPERTY; PROVIDING ON-LINE INFORMATION IN THE FIELD OF INTELLECTUAL PROPERTY LEGAL SERVICES; TRADEMARK MONITORING; TRADEMARK WATCH SERVICES (U.S. CLS. 100 AND 101).  
FIRST USE 7-5-2013; IN COMMERCE 7-5-2013.

JORDAN BAKER, EXAMINING ATTORNEY

THE COLOR(S) NAVY BLUE, GREEN, RED, ORANGE, YELLOW, PURPLE, AND WHITE IS/ARE CLAIMED AS A FEATURE OF THE MARK.

THE MARK CONSISTS OF A CONCENTRIC CIRCLE DESIGN WITH A CENTER WHITE CIRCLE. THE NEXT CIRCLE CONSISTS OF COLORED SEGMENTS. GOING IN A CLOCKWISE DIRECTION, STARTING AT THE THE TOP, THE SEGMENTS ARE NAVY BLUE, GREEN, RED, ORANGE, YELLOW, AND PURPLE. THE NEXT CIRCLE IS A THIN WHITE CIRCLE. THE OUTERMOST CIRCLE IS A PURPLE CIRCLE.

FOR PROVIDING INFORMATION, PERSONAL ASSESSMENTS, NEWS AND COMMENTARY IN THE FIELD OF SPIRITUALITY (U.S. CLS. 100 AND 101).

ELLEN B. AWRICH, EXAMINING ATTORNEY

**CLASS 45—(Continued).**

SN 86-252,371. BOARD OF PENSIONS EVANGELICAL LUTHERAN CHURCH OF AMERICA, MINNEAPOLIS, MN. FILED 4-15-2014.



THE COLOR(S) NAVY BLUE, GREEN, RED, ORANGE, YELLOW, PURPLE, AND WHITE IS/ARE CLAIMED AS A FEATURE OF THE MARK.

THE MARK CONSISTS OF A CONCENTRIC CIRCLE DESIGN WITH A CENTER WHITE CIRCLE WHICH FADES OUTWARD TO THE COLOR SEGMENTS OF THE NEXT CIRCLE. THE NEXT CIRCLE CONSISTS OF COLORED SEGMENTS. GOING IN A CLOCKWISE DIRECTION, STARTING AT THE THE TOP, THE SEGMENTS ARE NAVY BLUE, GREEN, RED, ORANGE, YELLOW, AND PURPLE. THE NEXT CIRCLE IS A THIN WHITE CIRCLE. THE OUTERMOST CIRCLE IS A PURPLE CIRCLE.

FOR PROVIDING INFORMATION, PERSONAL ASSESSMENTS, NEWS AND COMMENTARY IN THE FIELD OF SPIRITUALITY (U.S. CLS. 100 AND 101).

FIRST USE 3-27-2012; IN COMMERCE 3-27-2012.  
ELLEN B. AWRICH, EXAMINING ATTORNEY

**CLASS 45—(Continued).**

SN 86-274,659. JOSEPH A. HARDY & ASSOCIATES, EIGHTY FOUR, PA. FILED 5-7-2014.

# 84 LUMBER

THE MARK CONSISTS OF STANDARD CHARACTERS WITHOUT CLAIM TO ANY PARTICULAR FONT, STYLE, SIZE, OR COLOR.

NO CLAIM IS MADE TO THE EXCLUSIVE RIGHT TO USE "LUMBER", APART FROM THE MARK AS SHOWN.

FOR ONLINE SOCIAL NETWORKING SERVICES IN THE FIELD OF CONSTRUCTION PROVIDED VIA A WEBSITE (U.S. CLS. 100 AND 101).

DAVID COLLIER, EXAMINING ATTORNEY

SN 86-284,521. MONKEYS IN SPACE, LLC, MIAMI, FL. FILED 5-18-2014.

## SOCIAL MEDIA BILL OF RIGHTS

THE MARK CONSISTS OF STANDARD CHARACTERS WITHOUT CLAIM TO ANY PARTICULAR FONT, STYLE, SIZE, OR COLOR.

NO CLAIM IS MADE TO THE EXCLUSIVE RIGHT TO USE "SOCIAL MEDIA", APART FROM THE MARK AS SHOWN.

FOR LEGAL SERVICES, NAMELY, CONSULTING IN THE FIELD OF INTERNET LAW TO INDIVIDUALS, GROUPS OF INDIVIDUALS, ORGANIZATIONS, AND ENTERPRISES (U.S. CLS. 100 AND 101).

MIAH ROSENBERG, EXAMINING ATTORNEY

SN 86-268,453. TOMASSO, ROBERT, TUCSON, AZ. FILED 5-1-2014.



THE MARK CONSISTS OF A DESIGN OF A DESK MICROPHONE WITH GRADUATION CAP ON IT.

FOR ON-LINE SOCIAL NETWORKING SERVICES (U.S. CLS. 100 AND 101).

BARBARA GAYNOR, EXAMINING ATTORNEY

SN 86-290,440. MONS INDUSTRIES, CORP., ROAD TOWN, TORTOLA, BR.VIRGIN ISLANDS, FILED 5-23-2014.

## Global Companions

THE MARK CONSISTS OF STANDARD CHARACTERS WITHOUT CLAIM TO ANY PARTICULAR FONT, STYLE, SIZE, OR COLOR.

NO CLAIM IS MADE TO THE EXCLUSIVE RIGHT TO USE "COMPANIONS", APART FROM THE MARK AS SHOWN.

FOR DATING SERVICES; INTERNET-BASED DATING, SOCIAL INTRODUCTION AND SOCIAL NETWORKING SERVICES (U.S. CLS. 100 AND 101).

FIRST USE 2-14-2014; IN COMMERCE 2-14-2014.  
LAURA GOLDEN, EXAMINING ATTORNEY

SECTION 4.—PRIOR UNITED STATES CLASSIFICATION

APPLICATION IN ONE CLASS

COLLECTIVE MEMBERSHIP MARKS

CLASS 200—COLLECTIVE MEMBERSHIP  
SN 85-971,816. ALOA SECURITY PROFESSIONALS ASSO-  
CIATION, INC., DALLAS, TX. FILED 6-27-2013.

SN 86-177,707. ALPHA CHI NATIONAL COLLEGE HONOR  
SCHOLARSHIP SOCIETY, SEARCY, AR. FILED 1-28-  
2014.

ALOA Institutional  
Locksmith

THE MARK CONSISTS OF STANDARD CHARACTERS  
WITHOUT CLAIM TO ANY PARTICULAR FONT, STYLE,  
SIZE, OR COLOR.

OWNER OF U.S. REG. NOS. 659,476, 3,888,598 AND  
OTHERS.

NO CLAIM IS MADE TO THE EXCLUSIVE RIGHT TO  
USE "INSTITUTIONAL LOCKSMITH", APART FROM THE  
MARK AS SHOWN.

FOR TO INDICATE MEMBERSHIP IN A TRADE  
ASSOCIATION COMPRISED OF LOCKSMITHS AND  
OTHER SECURITY PROFESSIONALS EMPLOYED BY  
LARGE INSTITUTIONS SUCH AS HOSPITALS, HOTELS  
AND UNIVERSITIES.

FIRST USE 1-1-2013; IN COMMERCE 3-1-2013.  
ANDREW LEASER, EXAMINING ATTORNEY

ALPHA CHI

THE MARK CONSISTS OF STANDARD CHARACTERS  
WITHOUT CLAIM TO ANY PARTICULAR FONT, STYLE,  
SIZE, OR COLOR.

FOR TO INDICATE MEMBERSHIP IN A NATIONAL  
HONOR SOCIETY.

FIRST USE 2-22-1934; IN COMMERCE 2-22-1934.  
KRISTIN CARLSON, EXAMINING ATTORNEY

SN 86-177,741. ALPHA CHI NATIONAL COLLEGE HONOR  
SCHOLARSHIP SOCIETY, SEARCY, AR. FILED 1-28-  
2014.

SN 86-061,086. HLMC, LLC, MILWAUKEE, WI. FILED 9-10-  
2013.

HELL'S LOVERS

THE MARK CONSISTS OF STANDARD CHARACTERS  
WITHOUT CLAIM TO ANY PARTICULAR FONT, STYLE,  
SIZE, OR COLOR.

FOR INDICATING MEMBERSHIP IN A MOTOR-  
CYCLE CLUB.

FIRST USE 12-31-1967; IN COMMERCE 12-31-1967.  
LAURIE MAYES, EXAMINING ATTORNEY



NO CLAIM IS MADE TO THE EXCLUSIVE RIGHT TO  
USE "FEB. 22, 1922", APART FROM THE MARK AS SHOWN.

THE MARK CONSISTS OF A SEAL COMPRISED OF TWO  
CONCENTRIC CIRCLES CONTAINING THE WORDS "AL-  
PHA CHI FEB. 22, 1922" WITHIN THE OUTER CIRCLE AND  
A SHIELD WITH A LAMP AND THE LETTERS "AX"  
WITHIN THE INNER CIRCLE.

FOR TO INDICATE MEMBERSHIP IN A NATIONAL  
HONOR SOCIETY .

FIRST USE 12-31-1949; IN COMMERCE 12-31-1949.  
KRISTIN CARLSON, EXAMINING ATTORNEY

SN 86-210,228. MORELOCK, MICHEAL, BRIGHTON, CO. AND HARRIS, JON, BRIGHTON, CO. AND SWEET, LLOYD, BRIGHTON, CO. FILED 3-4-2014.

SN 86-093,868. MAYO FOUNDATION FOR MEDICAL EDUCATION AND RESEARCH, ROCHESTER, MN. FILED 10-17-2013.

## Social Deviants Brotherhood

THE MARK CONSISTS OF STANDARD CHARACTERS WITHOUT CLAIM TO ANY PARTICULAR FONT, STYLE, SIZE, OR COLOR.

NO CLAIM IS MADE TO THE EXCLUSIVE RIGHT TO USE "BROTHERHOOD", APART FROM THE MARK AS SHOWN.

FOR COLLECTIVE MEMBERSHIP MARK FOR INDICATING MEMBERSHIP IN A MOTORCYCLE CLUB.  
MATTHEW GALAN, EXAMINING ATTORNEY

---

SN 86-233,724. SIGMA ALPHA OMEGA CHRISTIAN SORORITY, INC., RICHMOND, VA. FILED 3-27-2014.

## SIGMA ALPHA OMEGA

THE MARK CONSISTS OF STANDARD CHARACTERS WITHOUT CLAIM TO ANY PARTICULAR FONT, STYLE, SIZE, OR COLOR.

OWNER OF U.S. REG. NO. 3,650,842.  
FOR INDICATING MEMBERSHIP IN A CHRISTIAN SERVICE SORORITY.

FIRST USE 1-1-1998; IN COMMERCE 1-1-1998.  
RONALD AIKENS, EXAMINING ATTORNEY

---

SN 86-275,977. LOS VALIENTES INC., ST. PAUL, MN. FILED 5-8-2014.

## Los Valientes

THE MARK CONSISTS OF STANDARD CHARACTERS WITHOUT CLAIM TO ANY PARTICULAR FONT, STYLE, SIZE, OR COLOR.

THE ENGLISH TRANSLATION OF "LOS VALIENTES" IN THE MARK IS "VALIANT ONES".

FOR INDICATING MEMBERSHIP IN AN ASSOCIATION OF MOTORCYCLE RIDERS.

FIRST USE 0-0-1976; IN COMMERCE 0-0-1976.  
SETH DENNIS, EXAMINING ATTORNEY

---

### CERTIFICATION MARKS

#### CLASS A—GOODS

## NEAT

THE MARK CONSISTS OF STANDARD CHARACTERS WITHOUT CLAIM TO ANY PARTICULAR FONT, STYLE, SIZE, OR COLOR.

OWNER OF U.S. REG. NO. 4,444,020.

THE CERTIFICATION MARK, AS INTENDED TO BE USED BY AUTHORIZED PERSONS, IS INTENDED TO CERTIFY THAT THE PRODUCTS INCORPORATE NON-EXERCISE ACTIVITY THERMOGENESIS WEIGHT MANAGEMENT PRINCIPLES.

FOR FOOD AND BEVERAGE PRODUCTS, NUTRITIONAL AND DIETARY SUPPLEMENTS, VITAMINS, FURNITURE, CLOTHING, AND WRITING UTENSILS.

JAY FLOWERS, EXAMINING ATTORNEY

---

#### CLASS B—SERVICES

SN 86-072,753. VALUE INNORUPTION ADVISORS LLC, SEWICKLEY, PA. FILED 9-24-2013.

## CAP

THE MARK CONSISTS OF STANDARD CHARACTERS WITHOUT CLAIM TO ANY PARTICULAR FONT, STYLE, SIZE, OR COLOR.

THE CERTIFICATION MARK, AS USED OR INTENDED TO BE USED BY PERSONS AUTHORIZED BY THE CERTIFIER, CERTIFIES OR IS INTENDED TO CERTIFY THAT THE SERVICES ARE PROVIDED BY AN INDIVIDUAL WHO HAS COMPLETED TRAINING AND HAS TESTED PROFESSIONAL COMPETENCY IN RENDERING BUSINESS CONSULTING SERVICES, NAMELY, PRICING AND VALUE STRATEGY CONSULTING IN THE FIELD OF CHANGE MANAGEMENT AND CHANGE LEADERSHIP SERVICES RELATED TO VALUING AND PRICING PROJECTS.

FOR BUSINESS CONSULTING SERVICES, NAMELY, PRICING AND VALUE STRATEGY CONSULTING IN THE FIELD OF CHANGE MANAGEMENT AND CHANGE LEADERSHIP SERVICES RELATED TO VALUING AND PRICING PROJECTS.

FIRST USE 8-19-2013; IN COMMERCE 8-19-2013.

JENNIFER RICHARDSON, EXAMINING ATTORNEY



SN 86-093,881. MAYO FOUNDATION FOR MEDICAL EDUCATION AND RESEARCH, ROCHESTER, MN. FILED 10-17-2013.

SN 86-130,416. SCRUM ALLIANCE, INC., INDIANAPOLIS, IN. FILED 11-27-2013.

# NEAT

THE MARK CONSISTS OF STANDARD CHARACTERS WITHOUT CLAIM TO ANY PARTICULAR FONT, STYLE, SIZE, OR COLOR.

THE CERTIFICATION MARK, AS INTENDED TO BE USED BY AUTHORIZED PERSONS, IS INTENDED TO CERTIFY THAT THE PROCESSES, BUSINESSES OR SERVICES INCORPORATE NON-EXERCISE ACTIVITY THERMOGENESIS WEIGHT MANAGEMENT PRINCIPLES.

FOR DESIGN, CONSTRUCTION, AND OPERATION OF BUILDINGS; BUSINESSES AND PROCESSES, NAMELY, AGRICULTURE, FORESTRY AND FISHING; MINING, ENERGY AND UTILITIES; CONSTRUCTION; MANUFACTURING; WHOLESALE; RETAIL, HIRE AND REPAIR; TRANSPORT AND DISTRIBUTION; PROFESSIONAL AND BUSINESS SERVICES; FINANCE SERVICES; INSURANCE SERVICES; IT AND TELECOMMUNICATIONS SERVICES; MEDIA AND CREATIVE SERVICES; CATERING AND ACCOMMODATION; HEALTH AND SOCIAL CARE SERVICES; PERSONAL SERVICES; EDUCATION; ARTS, SPORTS AND RECREATION.

JAY FLOWERS, EXAMINING ATTORNEY

SN 86-130,415. SCRUM ALLIANCE, INC., INDIANAPOLIS, IN. FILED 11-27-2013.

# CSPO

THE MARK CONSISTS OF STANDARD CHARACTERS WITHOUT CLAIM TO ANY PARTICULAR FONT, STYLE, SIZE, OR COLOR.

THE CERTIFICATION MARK, AS USED BY AUTHORIZED PERSONS, CERTIFIES THAT THE PERSON DISPLAYING THE MARK HAS DEMONSTRATED QUALIFICATIONS IN THE KNOWLEDGE AND USE OF SPECIFIED PRODUCT DEVELOPMENT PROCESSES IN ACCORDANCE WITH STANDARDS ESTABLISHED BY THE CERTIFIER.

FOR PROVIDING INFORMATION IN THE FIELDS OF PRODUCT DEVELOPMENT, PRODUCT DESIGN AND PRODUCT MANUFACTURING; PROJECT MANAGEMENT SERVICES, PRODUCT DEVELOPMENT SERVICES, PRODUCT DESIGN SERVICES, AND PRODUCT MANUFACTURING SERVICES.

FIRST USE 4-8-2009; IN COMMERCE 4-8-2009.  
DOMINICK J. SALEMI, EXAMINING ATTORNEY

# CSC

THE MARK CONSISTS OF STANDARD CHARACTERS WITHOUT CLAIM TO ANY PARTICULAR FONT, STYLE, SIZE, OR COLOR.

THE CERTIFICATION MARK, AS USED BY AUTHORIZED PERSONS, CERTIFIES THAT THE PERSON DISPLAYING THE MARK HAS DEMONSTRATED QUALIFICATIONS IN THE KNOWLEDGE AND USE OF SPECIFIED PRODUCT DEVELOPMENT PROCESSES IN ACCORDANCE WITH STANDARDS ESTABLISHED BY THE CERTIFIER.

FOR TRAINING, MENTORING, AND CONSULTING SERVICES IN THE FIELDS OF PRODUCT DEVELOPMENT, PRODUCT DESIGN, PRODUCT DEVELOPMENT CONSULTATION, PRODUCT MANUFACTURING CONSULTATION, COMPUTER SOFTWARE DEVELOPMENT AND COMPUTER SOFTWARE DEVELOPMENT MANAGEMENT; EDUCATIONAL SERVICES, NAMELY, CONDUCTING CLASSES, SEMINARS, WORKSHOPS IN THE FIELDS OF PRODUCT DEVELOPMENT, PRODUCT DEVELOPMENT CONSULTATION, PRODUCT MANUFACTURING CONSULTATION, COMPUTER SOFTWARE DEVELOPMENT AND COMPUTER SOFTWARE DEVELOPMENT MANAGEMENT; PROJECT MANAGEMENT SERVICES, PRODUCT DEVELOPMENT SERVICES, PRODUCT DEVELOPMENT AND DESIGN CONSULTATION, AND PRODUCT MANUFACTURING CONSULTATION.

FIRST USE 3-26-2009; IN COMMERCE 3-26-2009.  
DOMINICK J. SALEMI, EXAMINING ATTORNEY

SN 86-238,521. AMERICAN PETROLEUM INSTITUTE, WASHINGTON, DC. FILED 4-1-2014.



OWNER OF U.S. REG. NOS. 677,359, 3,409,522 AND OTHERS.

NO CLAIM IS MADE TO THE EXCLUSIVE RIGHT TO USE "REGISTERED", APART FROM THE MARK AS SHOWN.

THE MARK CONSISTS OF THE WORDS "Q2 API SPEC Q2 REGISTERED" INSIDE OF A BOX. THE "Q" IN THE FIRST OCCURRENCE OF THE TERM "Q2" CONSISTS OF A STYLIZED DESIGN INCORPORATING AN ARROW.

THE CERTIFICATION MARK, AS INTENDED TO BE USED BY PERSONS AUTHORIZED BY THE CERTIFIER, WILL CERTIFY THAT THE PERSONS PERFORMING THE QUALITY ASSURANCE SERVICES HAVE MET THE STANDARDS, QUALIFICATIONS AND TESTING REQUIREMENTS ESTABLISHED BY THE CERTIFIER.

BRENDAN MCCAULEY, EXAMINING ATTORNEY

FOR MANAGEMENT SYSTEM, NAMELY, PRODUCT SERVICING FOR USE IN THE FIELD OF OIL AND GAS EXPLORATION AND DRILLING; MANUFACTURING PROCESSES FOR PRODUCTS, MATERIALS, AND EQUIPMENT FOR USE IN THE FIELDS OF OIL AND GAS EXPLORATION, DRILLING, PRODUCTION, AND TRANSPORTATION; MANAGEMENT SYSTEM, NAMELY, QUALITY ASSURANCE, PRODUCT DESIGN, PRODUCT DEVELOPMENT, AND PRODUCT INSTALLATION, AND PRODUCT SERVICING FOR USE IN THE FIELD OF OIL AND GAS PRODUCTION, TRANSPORTATION, REFINING, AND MARKETING; MANUFACTURING PROCESSES FOR PRODUCTS, MATERIALS, AND EQUIPMENT FOR USE IN THE FIELDS OF OIL AND GAS REFINING, AND MARKETING.

\* \* \* \* \*

# TRADEMARK REGISTRATIONS ISSUED

## PRINCIPAL REGISTER

### SECTION 1.— INTERNATIONAL CLASSIFICATION

The short titles associated below with the international class numbers are terms designed merely for quick identification and are not an official part of the international classification. The full names of international classes are given in section 6.1 of the trademark rules of practice.

The designation "U.S. Cl." appearing in this section refers to the U.S. class in effect prior to Sep. 1, 1973 rather than the international class which applies to applications filed on or after that date. For adoption of international classification see notice in the OFFICIAL GAZETTE of Jun. 26, 1973 (911 O.G. TM 210).

#### CLASS 1—CHEMICALS

- 4,590,653. **GENIUS GUN (STYLIZED)**. SOUDAL, NAAMLOZE VENNOOTSCHAP, MULTIPLE CLASS, (INT. CLS. 1, 17 AND 21), (U.S. CLS. 1, 2, 5, 6, 10, 12, 13, 23, 26, 29, 30, 33, 35, 40, 46 AND 50). SN 79-125,162. PUB. 6-10-2014. FILED 11-30-2012.
- 4,590,654. **GENIUS GUN SOUDAL EASY CONTROL EASY TO USE AND DESIGN**. SOUDAL, NAAMLOZE VENNOOTSCHAP, MULTIPLE CLASS, (INT. CLS. 1, 17 AND 21), (U.S. CLS. 1, 2, 5, 6, 10, 12, 13, 23, 26, 29, 30, 33, 35, 40, 46 AND 50). SN 79-125,163. PUB. 6-10-2014. FILED 11-30-2012.
- 4,590,698. **PRELECT (STANDARD CHARACTER)**. CLAR-IAANT AG, MULTIPLE CLASS, (INT. CLS. 1 AND 2), (U.S. CLS. 1, 5, 6, 10, 11, 16, 26 AND 46). SN 79-132,627. PUB. 6-10-2014. FILED 6-7-2013.
- 4,590,786. **GRAPHENE CITY (STANDARD CHARACTER)**. THE UNIVERSITY OF MANCHESTER, MULTIPLE CLASS, (INT. CLS. 1 AND 35), (U.S. CLS. 1, 5, 6, 10, 26, 46, 100, 101 AND 102). SN 79-136,752. PUB. 6-10-2014. FILED 6-26-2013.
- 4,590,788. **GENECTIVE AND DESIGN**. GENECTIVE, MULTIPLE CLASS, (INT. CLS. 1, 5, 31, 42 AND 44), (U.S. CLS. 1, 5, 6, 10, 18, 26, 44, 46, 51, 52, 100 AND 101). SN 79-136,886. PUB. 6-10-2014. FILED 6-12-2013.
- 4,590,811. **ADHEMARK 13880 (STANDARD CHARACTER)**. ADHETEC, MULTIPLE CLASS, (INT. CLS. 1, 16, 17 AND 40), (U.S. CLS. 1, 2, 5, 6, 10, 12, 13, 22, 23, 26, 29, 35, 37, 38, 46, 50, 100, 103 AND 106). SN 79-138,009. PUB. 6-10-2014. FILED 3-18-2013.
- 4,590,813. **MISCELLANEOUS DESIGN**. BOSTIK SA, MULTIPLE CLASS, (INT. CLS. 1, 16, 17 AND 19), (U.S. CLS. 1, 2, 5, 6, 10, 12, 13, 22, 23, 26, 29, 33, 35, 37, 38, 46 AND 50). SN 79-138,192. PUB. 6-10-2014. FILED 7-22-2013.
- 4,590,815. **MYRAMAZE (STANDARD CHARACTER)**. RAHN AG, MULTIPLE CLASS, (INT. CLS. 1 AND 3), (U.S. CLS. 1, 4, 5, 6, 10, 26, 46, 50, 51 AND 52). SN 79-138,300. PUB. 6-10-2014. FILED 9-4-2013.
- 4,590,824. **MISCELLANEOUS DESIGN**. STATE NUCLEAR POWER TECHNOLOGY CORPORATION LTD., MULTIPLE CLASS, (INT. CLS. 1, 4, 6, 9, 11, 16, 17, 19, 35, 37, 39, 40, 41, 42 AND 45), (U.S. CLS. 1, 2, 5, 6, 10, 12, 13, 14, 15, 21, 22, 23, 25, 26, 29, 31, 33, 34, 35, 36, 37, 38, 46, 50, 100, 101, 102, 103, 105, 106 AND 107). SN 79-138,773. PUB. 6-10-2014. FILED 6-12-2013.
- 4,590,827. **XRUN (STYLIZED)**. SHANGHAI XRUN RESIN CO., LTD., (U.S. CLS. 1, 5, 6, 10, 26 AND 46). SN 79-139,236. PUB. 6-10-2014. FILED 10-8-2013.
- 4,590,838. **MISCELLANEOUS DESIGN**. CHONGQING CHUANDONG CHEMICAL (GROUP) CO., LTD., (U.S. CLS. 1, 5, 6, 10, 26 AND 46). SN 79-139,931. PUB. 6-10-2014. FILED 10-28-2013.
- 4,590,867. **PROQR (STANDARD CHARACTER)**. PROQR THERAPEUTICS B.V., MULTIPLE CLASS, (INT. CLS. 1, 5 AND 42), (U.S. CLS. 1, 5, 6, 10, 18, 26, 44, 46, 51, 52, 100 AND 101). SN 79-141,982. PUB. 6-10-2014. FILED 8-27-2013.
- 4,590,939. **LONGSTAR (STANDARD CHARACTER)**. DONG-BU FARM HANNONG CO., LTD., (U.S. CLS. 1, 5, 6, 10, 26 AND 46). SN 79-146,123. PUB. 6-10-2014. FILED 1-15-2014.
- 4,590,940. **SCAVGUARD (STANDARD CHARACTER)**. CHEM-TRADE WEST LIMITED PARTNERSHIP, (U.S. CLS. 1, 5, 6, 10, 26 AND 46). SN 85-162,115. PUB. 6-10-2014. FILED 10-27-2010.
- 4,590,986. **MASEMUL (STANDARD CHARACTER)**. MUSIM MAS HOLDINGS PTE LTD, (U.S. CLS. 1, 5, 6, 10, 26 AND 46). SN 85-631,006. PUB. 6-10-2014. FILED 5-21-2012.
- 4,591,003. **MONUDIN (STANDARD CHARACTER)**. OXFORD BIOMEDICA PLC, MULTIPLE CLASS, (INT. CLS. 1, 5, 10 AND 42), (U.S. CLS. 1, 5, 6, 10, 18, 26, 39, 44, 46, 51, 52, 100 AND 101). SN 85-693,119. PUB. 10-29-2013. FILED 8-1-2012.
- 4,591,059. **EVO (STANDARD CHARACTER)**. NICOPURE LABS, LLC, MULTIPLE CLASS, (INT. CLS. 1 AND 30), (U.S. CLS. 1, 5, 6, 10, 26 AND 46). SN 85-788,057. PUB. 6-10-2014. FILED 11-27-2012.
- 4,591,083. **PROTOCOLE AND DESIGN**. LE GROUPE INTER-SAND DU CANADA INC., MULTIPLE CLASS, (INT. CLS. 1 AND 31), (U.S. CLS. 1, 5, 6, 10, 26 AND 46). SN 85-805,718. PUB. 6-10-2014. FILED 12-18-2012.
- 4,591,243. **PLANET TURF AND DESIGN**. JAMES CONNOLLY CONSULTING, LTD., (U.S. CLS. 1, 5, 6, 10, 26 AND 46). SN 85-949,171. PUB. 6-10-2014. FILED 6-3-2013.
- 4,591,253. **MIN-DRI (STANDARD CHARACTER)**. ZHOU, HUITANG, MULTIPLE CLASS, (INT. CLS. 1 AND 5), (U.S. CLS. 1, 5, 6, 10, 18, 26, 44, 46, 51 AND 52). SN 85-953,249. PUB. 6-10-2014. FILED 6-7-2013.
- 4,591,340. **ECO-TEK (STANDARD CHARACTER)**. KEM-EN-TEC DIAGNOSTICS A/S, MULTIPLE CLASS, (INT. CLS. 1 AND 5), (U.S. CLS. 1, 5, 6, 10, 18, 26, 44, 46, 51 AND 52). SN 85-970,427. PUB. 12-24-2013. FILED 6-26-2013.
- 4,591,383. **HYLO (STANDARD CHARACTER)**. HYLOMAR LIMITED, MULTIPLE CLASS, (INT. CLS. 1 AND 17), (U.S. CLS. 1, 5, 6, 10, 12, 13, 26, 35, 46 AND 50). SN 85-974,800. PUB. 6-10-2014. FILED 7-1-2013.
- 4,591,398. **FSB1000 FORMULATED SOIL BINDER (STANDARD CHARACTER)**. SOIL-TECH, INC., (U.S. CLS. 1, 5, 6, 10, 26 AND 46). SN 86-000,016. PUB. 6-10-2014. FILED 7-1-2013.
- 4,591,428. **HYATRUE (STYLIZED)**. BLOOMAGE FREDA BIOPHARM CO., LTD., (U.S. CLS. 1, 5, 6, 10, 26 AND 46). SN 86-002,631. PUB. 6-10-2014. FILED 7-3-2013.
- 4,591,505. **LIFTAN (STANDARD CHARACTER)**. LIDL STIFTUNG & CO. KG, MULTIPLE CLASS, (INT. CLS. 1 AND 3), (U.S. CLS. 1, 4, 5, 6, 10, 26, 46, 50, 51 AND 52). SN 86-012,653. PUB. 6-10-2014. FILED 7-17-2013.
- 4,591,540. **TOP FIN (STANDARD CHARACTER)**. PETSMAST STORE SUPPORT GROUP, INC., (U.S. CLS. 1, 5, 6, 10, 26 AND 46). SN 86-024,603. PUB. 6-10-2014. FILED 7-31-2013.
- 4,591,629. **OASIS PRO (STANDARD CHARACTER)**. ECOLAB USA INC., MULTIPLE CLASS, (INT. CLS. 1, 3, 5, 8, 9 AND 21), (U.S. CLS. 1, 2, 4, 5, 6, 10, 13, 18, 21, 23, 26, 28, 29, 30, 33, 36, 38, 40, 44, 46, 50, 51 AND 52). SN 86-047,866. PUB. 6-10-2014. FILED 8-26-2013.
- 4,591,634. **SEPTIC CHOICE (STANDARD CHARACTER)**. MR. ROOTER LLC, (U.S. CLS. 1, 5, 6, 10, 26 AND 46). SN 86-050,222. PUB. 6-10-2014. FILED 8-28-2013.
- 4,591,664. **SERATROL QUALITY SERA, CONSISTENT CONTROLS. AND DESIGN**. GOLDEN WEST BIOLOGICALS, INC., (U.S. CLS. 1, 5, 6, 10, 26 AND 46). SN 86-059,642. PUB. 6-10-2014. FILED 9-9-2013.

- 4,591,696. **CAPITAL WELD CLEANERS (STANDARD CHARACTER)**, CAPITAL STAINLESS, INC., MULTIPLE CLASS, (INT. CLS. 1 AND 7), (U.S. CLS. 1, 5, 6, 10, 13, 19, 21, 23, 26, 31, 34, 35 AND 46). SN 86-069,155. PUB. 6-10-2014. FILED 9-19-2013.
- 4,591,727. **NEW VISION DISPLAY (STANDARD CHARACTER)**, NEW VISION DISPLAY, INC., MULTIPLE CLASS, (INT. CLS. 1 AND 9), (U.S. CLS. 1, 5, 6, 10, 21, 23, 26, 36, 38 AND 46). SN 86-081,171. PUB. 6-10-2014. FILED 10-2-2013.
- 4,591,729. **NVD NEW VISION DISPLAY (STYLIZED)**, NEW VISION DISPLAY, INC., MULTIPLE CLASS, (INT. CLS. 1 AND 9), (U.S. CLS. 1, 5, 6, 10, 21, 23, 26, 36, 38 AND 46). SN 86-081,194. PUB. 6-10-2014. FILED 10-2-2013.
- 4,591,821. **ROGUE COMPOST AND DESIGN**, DRY CREEK LANDFILL, INC., (U.S. CLS. 1, 5, 6, 10, 26 AND 46). SN 86-106,033. PUB. 6-10-2014. FILED 10-30-2013.
- 4,592,036. **AQUA TURF (STANDARD CHARACTER)**, SPRAGREEN LAWN FERTILIZER, LLC, (U.S. CLS. 1, 5, 6, 10, 26 AND 46). SN 86-140,905. PUB. 6-10-2014. FILED 12-11-2013.
- 4,592,046. **INSTAPLATE (STANDARD CHARACTER)**, TRODAT GMBH, (U.S. CLS. 1, 5, 6, 10, 26 AND 46). SN 86-141,626. PUB. 6-10-2014. FILED 12-12-2013.
- 4,592,415. **MI BATCH (STANDARD CHARACTER)**, PLASTICS COLOR CORPORATION, (U.S. CLS. 1, 5, 6, 10, 26 AND 46). SN 86-163,480. PUB. 6-10-2014. FILED 1-13-2014.
- 4,592,517. **JOLT (STANDARD CHARACTER)**, PROX MANAGEMENT, LLC, DBA INNOVA PERFORMANCE PRODUCTS, (U.S. CLS. 1, 5, 6, 10, 26 AND 46). SN 86-167,053. PUB. 6-10-2014. FILED 1-16-2014.
- 4,592,518. **RENUÉ (STANDARD CHARACTER)**, PROX MANAGEMENT, LLC, DBA INNOVA PERFORMANCE PRODUCTS, (U.S. CLS. 1, 5, 6, 10, 26 AND 46). SN 86-167,067. PUB. 6-10-2014. FILED 1-16-2014.
- 4,592,526. **VALET (STANDARD CHARACTER)**, PROX MANAGEMENT, LLC, DBA INNOVA PERFORMANCE PRODUCTS, (U.S. CLS. 1, 5, 6, 10, 26 AND 46). SN 86-167,232. PUB. 6-10-2014. FILED 1-16-2014.
- 4,592,540. **FIXTURE FIX (STANDARD CHARACTER)**, FIXTURE-FIX, LLC, (U.S. CLS. 1, 5, 6, 10, 26 AND 46). SN 86-167,757. PUB. 6-10-2014. FILED 1-16-2014.
- 4,592,630. **VEILEX (STANDARD CHARACTER)**, INTERNATIONAL FLAVORS & FRAGRANCES INC., (U.S. CLS. 1, 5, 6, 10, 26 AND 46). SN 86-174,736. PUB. 6-10-2014. FILED 1-24-2014.
- 4,592,701. **ARCTIC ICE (STANDARD CHARACTER)**, LUDOVICO, INC., (U.S. CLS. 1, 5, 6, 10, 26 AND 46). SN 86-176,198. PUB. 6-10-2014. FILED 1-27-2014.
- 4,592,794. **LEAF-MAX (STANDARD CHARACTER)**, WILCO FARMERS, (U.S. CLS. 1, 5, 6, 10, 26 AND 46). SN 86-177,844. PUB. 6-10-2014. FILED 1-28-2014.
- 4,592,827. **ACCURA (STANDARD CHARACTER)**, LUCIGEN CORPORATION, (U.S. CLS. 1, 5, 6, 10, 26 AND 46). SN 86-178,401. PUB. 6-10-2014. FILED 1-29-2014.
- 4,592,845. **SUNFINE (STANDARD CHARACTER)**, ASAHI KASEI CHEMICALS CORPORATION, (U.S. CLS. 1, 5, 6, 10, 26 AND 46). SN 86-178,756. PUB. 6-10-2014. FILED 1-29-2014.
- 4,592,907. **ENTRY SAFE (STANDARD CHARACTER)**, TETRACHEM DECONTAMINATION SERVICES, LLC, (U.S. CLS. 1, 5, 6, 10, 26 AND 46). SN 86-180,229. PUB. 6-10-2014. FILED 1-30-2014.
- 4,592,992. **XPEDIENT FC AND DESIGN**, AMVAC CHEMICAL CORPORATION, MULTIPLE CLASS, (INT. CLS. 1 AND 5), (U.S. CLS. 1, 5, 6, 10, 18, 26, 44, 46, 51 AND 52). SN 86-212,332. PUB. 6-10-2014. FILED 3-5-2014.
- 4,593,036. **MISCELLANEOUS DESIGN**, LUDOVICO, INC., MULTIPLE CLASS, (INT. CLS. 1 AND 34), (U.S. CLS. 1, 2, 5, 6, 8, 9, 10, 17, 26 AND 46). SN 86-239,066. PUB. 6-10-2014. FILED 4-1-2014.

## CLASS 2—PAINTS

- 4,590,698 ( See Class 1 for this trademark).
- 4,591,539. **PKAF PPG KANSAI AUTOMOTIVE FINISHES AND DESIGN**, PPG KANSAI AUTOMOTIVE FINISHES TECHNOLOGY, LP, (U.S. CLS. 6, 11 AND 16). SN 86-

- 024,383. PUB. 6-10-2014. FILED 7-31-2013.
- 4,591,798. **S AND DESIGN**, GUNSKINS LLC, MULTIPLE CLASS, (INT. CLS. 2 AND 16), (U.S. CLS. 2, 5, 6, 11, 16, 22, 23, 29, 37, 38 AND 50). SN 86-099,939. PUB. 6-10-2014. FILED 10-24-2013.
- 4,591,884. **CONTEGO INTERNATIONAL, INC. AND DESIGN**, CONTEGO INTERNATIONAL, INC., (U.S. CLS. 6, 11 AND 16). SN 86-118,107. PUB. 4-22-2014. FILED 11-13-2013.
- 4,592,750. **ICOLOR (STANDARD CHARACTER)**, NATIONAL OAK DISTRIBUTORS, INC., (U.S. CLS. 6, 11 AND 16). SN 86-177,124. PUB. 6-10-2014. FILED 1-28-2014.
- 4,593,033. **DRIFTWOOD (STANDARD CHARACTER)**, POE, KIMBERLY L., MULTIPLE CLASS, (INT. CLS. 2 AND 3), (U.S. CLS. 1, 4, 6, 11, 16, 50, 51 AND 52). SN 86-235,819. PUB. 6-10-2014. FILED 3-28-2014.

## CLASS 3—COSMETICS AND CLEANING PREPARATIONS

- 4,590,610. **MISCELLANEOUS DESIGN**, DISNEY ENTERPRISES, INC., MULTIPLE CLASS, (INT. CLS. 3, 9, 14, 16, 18, 20, 21, 24 AND 25), (U.S. CLS. 1, 2, 3, 4, 5, 6, 13, 21, 22, 23, 25, 26, 27, 28, 29, 30, 32, 33, 36, 37, 38, 39, 40, 41, 42, 50, 51 AND 52). SN 76-714,301. PUB. 6-10-2014. FILED 6-3-2013.
- 4,590,626. **V AND DESIGN**, JØRGEN KRUISE A/S, MULTIPLE CLASS, (INT. CLS. 3, 5, 10, 18, 20, 21, 25, 28 AND 35), (U.S. CLS. 1, 2, 3, 4, 6, 13, 18, 22, 23, 25, 26, 29, 30, 32, 33, 38, 39, 40, 41, 44, 46, 50, 51, 52, 100, 101 AND 102). SN 79-100,963. PUB. 11-13-2012. FILED 6-10-2011.
- 4,590,693. **DENTASAVE (STANDARD CHARACTER)**, EMKAR ILAC, SANAYI VE TICARET ANONIM SIRKETI, MULTIPLE CLASS, (INT. CLS. 3, 5 AND 21), (U.S. CLS. 1, 2, 4, 6, 13, 18, 23, 29, 30, 33, 40, 44, 46, 50, 51 AND 52). SN 79-132,129. PUB. 6-10-2014. FILED 4-10-2013.
- 4,590,699. **DUCATI SCRAMBLER (STANDARD CHARACTER)**, DUCATI MOTOR HOLDING S.P.A., MULTIPLE CLASS, (INT. CLS. 3, 7, 9, 12, 14, 16, 18, 25 AND 28), (U.S. CLS. 1, 2, 3, 4, 5, 6, 13, 19, 21, 22, 23, 26, 27, 28, 29, 31, 34, 35, 36, 37, 38, 39, 41, 44, 50, 51 AND 52). SN 79-132,788. PUB. 6-10-2014. FILED 4-30-2013.
- 4,590,702. **MISCELLANEOUS DESIGN**, LEINEWEBER GMBH & CO. KG, MULTIPLE CLASS, (INT. CLS. 3, 14, 18 AND 25), (U.S. CLS. 1, 2, 3, 4, 6, 22, 27, 28, 39, 41, 50, 51 AND 52). SN 79-133,135. PUB. 6-10-2014. FILED 5-8-2013.
- 4,590,736. **SEZZ 16 AND DESIGN**, MONSIEUR SHAHÉ KALAJIDJIAN, MULTIPLE CLASS, (INT. CLS. 3, 4, 41, 43 AND 44), (U.S. CLS. 1, 4, 6, 15, 50, 51, 52, 100, 101 AND 107). SN 79-134,625. PUB. 6-10-2014. FILED 6-27-2013.
- 4,590,737. **COOL BLACK (STANDARD CHARACTER)**, COSMICA S.A., (U.S. CLS. 1, 4, 6, 50, 51 AND 52). SN 79-134,679. PUB. 6-10-2014. FILED 7-10-2013.
- 4,590,740. **MISCELLANEOUS DESIGN**, ARA AG, MULTIPLE CLASS, (INT. CLS. 3, 18 AND 25), (U.S. CLS. 1, 2, 3, 4, 6, 22, 39, 41, 50, 51 AND 52). SN 79-134,811. PUB. 6-10-2014. FILED 6-15-2013.
- 4,590,741. **TOTEM (STANDARD CHARACTER)**, DANIELLE REY, (U.S. CLS. 1, 4, 6, 50, 51 AND 52). SN 79-134,872. PUB. 6-10-2014. FILED 7-9-2013.
- 4,590,745. **LIPSTICK QUEEN LIQUID LIPSTICK (STANDARD CHARACTER)**, SPACE BRANDS LIMITED, (U.S. CLS. 1, 4, 6, 50, 51 AND 52). SN 79-135,288. PUB. 6-10-2014. FILED 7-22-2013.
- 4,590,746. **CAMICISSIMA (STANDARD CHARACTER)**, FENICIA S.P.A., MULTIPLE CLASS, (INT. CLS. 3, 9, 14, 18, 24 AND 35), (U.S. CLS. 1, 2, 3, 4, 6, 21, 22, 23, 26, 27, 28, 36, 38, 41, 42, 50, 51, 52, 100, 101 AND 102). SN 79-135,346. PUB. 6-10-2014. FILED 6-21-2013.
- 4,590,747. **ZAGGORA (STANDARD CHARACTER)**, ZAGGORA LIMITED, MULTIPLE CLASS, (INT. CLS. 3, 25, 28, 35, 41 AND 44), (U.S. CLS. 1, 4, 6, 22, 23, 38, 39, 50, 51, 52, 100, 101, 102 AND 107). SN 79-135,390. PUB. 6-10-2014. FILED 1-18-2013.
- 4,590,753. **MISCELLANEOUS DESIGN**, GUANGZHOU CITY BAIYUN LIANJIA FINE CHEMICAL FACTORY, (U.S. CLS. 1, 4, 6, 50, 51 AND 52). SN 79-135,518. PUB. 6-10-2014. FILED 6-22-2013.

- 4,590,781. **RIZETTE AND DESIGN**. LIOELE COSMETIC CO., LTD., (U.S. CLS. 1, 4, 6, 50, 51 AND 52). SN 79-136,522. PUB. 6-10-2014. FILED 7-26-2013.
- 4,590,783. **JARDIN DE LE NÔTRE (STANDARD CHARACTER)**. FONDATION POUR LA SAUVEGARDE ET LE DÉVELOPPEMENT DU DOMAINE DE CHANTILLY, MULTIPLE CLASS, (INT. CLS. 3 AND 4), (U.S. CLS. 1, 4, 6, 15, 50, 51 AND 52). SN 79-136,677. PUB. 6-10-2014. FILED 7-29-2013.
- 4,590,785. **SONICARE AND DESIGN**. KONINKLIJKE PHILIPS N.V., MULTIPLE CLASS, (INT. CLS. 3, 5 AND 21), (U.S. CLS. 1, 2, 4, 6, 13, 18, 23, 29, 30, 33, 40, 44, 46, 50, 51 AND 52). SN 79-136,708. PUB. 6-10-2014. FILED 5-30-2013.
- 4,590,791. **CELLEXIN-PRO (STANDARD CHARACTER)**. ZAKRYTOE AKTSIONERNOE OBSHCHESTVO "PHARM-SINTEZ", MULTIPLE CLASS, (INT. CLS. 3 AND 5), (U.S. CLS. 1, 4, 6, 18, 44, 46, 50, 51 AND 52). SN 79-137,028. PUB. 6-10-2014. FILED 6-20-2013.
- 4,590,812. **LÉA NATURE (STANDARD CHARACTER)**. GROUPE LEA NATURE, MULTIPLE CLASS, (INT. CLS. 3, 5, 29 AND 30), (U.S. CLS. 1, 4, 6, 18, 44, 46, 50, 51 AND 52). SN 79-138,183. PUB. 6-10-2014. FILED 6-12-2013.
- 4,590,815 ( *See Class 1 for this trademark*).
- 4,590,817. **VALENTINA OUD ASSOLUTO AND DESIGN**. VALENTINO S.P.A., (U.S. CLS. 1, 4, 6, 50, 51 AND 52). SN 79-138,468. PUB. 6-10-2014. FILED 9-4-2013.
- 4,590,825. **KENZOHOMME NIGHT AND DESIGN**. KENZO, (U.S. CLS. 1, 4, 6, 50, 51 AND 52). SN 79-138,887. PUB. 6-10-2014. FILED 9-11-2013.
- 4,590,833. **L'ENCLOS AND DESIGN**. LEE, JUNG BOK, (U.S. CLS. 1, 4, 6, 50, 51 AND 52). SN 79-139,559. PUB. 6-10-2014. FILED 10-4-2013.
- 4,590,837. **WUNDERBAR EXPERT'S EXCLUSIVE EDITION (STYLIZED)**. PRO-DUO N.V., (U.S. CLS. 1, 4, 6, 50, 51 AND 52). SN 79-139,918. PUB. 6-10-2014. FILED 9-16-2013.
- 4,590,850. **D UNIFORMS AND DESIGN**. PARFUMS CHRISTIAN DIOR, MULTIPLE CLASS, (INT. CLS. 3 AND 25), (U.S. CLS. 1, 4, 6, 22, 39, 50, 51 AND 52). SN 79-140,717. PUB. 6-10-2014. FILED 10-28-2013.
- 4,590,856. **DISTURBING LONDON (STANDARD CHARACTER)**. DISTURBING LONDON RECORDS; LIMITED, MULTIPLE CLASS, (INT. CLS. 3, 9, 14, 16, 18, 25, 35 AND 41), (U.S. CLS. 1, 2, 3, 4, 5, 6, 21, 22, 23, 26, 27, 28, 29, 36, 37, 38, 39, 41, 50, 51, 52, 100, 101, 102 AND 107). SN 79-141,238. PUB. 6-10-2014. FILED 4-16-2013.
- 4,590,880. **KENZOKI HYDRATANT ANGE GARDIEN AND DESIGN**. KENZO, (U.S. CLS. 1, 4, 6, 50, 51 AND 52). SN 79-142,403. PUB. 6-10-2014. FILED 9-27-2013.
- 4,590,893. **NO NEED TO BE L'HOMME IDEAL ANYMORE, YOU HAVE YOUR FRAGRANCE (STANDARD CHARACTER)**. REY DANIELLE, (U.S. CLS. 1, 4, 6, 50, 51 AND 52). SN 79-142,726. PUB. 6-10-2014. FILED 10-15-2013.
- 4,590,908. **PAPERNET (STANDARD CHARACTER)**. SOFIDEL S.P.A., MULTIPLE CLASS, (INT. CLS. 3, 5, 6, 16, 20 AND 21), (U.S. CLS. 1, 2, 4, 5, 6, 12, 13, 14, 18, 22, 23, 25, 29, 30, 32, 33, 37, 38, 40, 44, 46, 50, 51 AND 52). SN 79-143,317. PUB. 6-10-2014. FILED 1-23-2014.
- 4,591,004. **MAXOLIP (STANDARD CHARACTER)**. TRICORE HEALTH GROUP, INC., (U.S. CLS. 1, 4, 6, 50, 51 AND 52). SN 85-696,063. PUB. 6-10-2014. FILED 8-6-2012.
- 4,591,055. **BODYWISE (STANDARD CHARACTER)**. BODYWISE LIMITED, MULTIPLE CLASS, (INT. CLS. 3, 5 AND 10), (U.S. CLS. 1, 4, 6, 18, 26, 39, 44, 46, 50, 51 AND 52). SN 85-786,056. PUB. 11-26-2013. FILED 11-23-2012.
- 4,591,071. **ROCKITOIL (STANDARD CHARACTER)**. FULL SPEKTREM, LLC, (U.S. CLS. 1, 4, 6, 50, 51 AND 52). SN 85-797,122. PUB. 6-10-2014. FILED 12-7-2012.
- 4,591,081. **THEFACESHOP CHIA SEED (STANDARD CHARACTER)**. THEFACESHOP CO., LTD., (U.S. CLS. 1, 4, 6, 50, 51 AND 52). SN 85-805,361. PUB. 6-10-2014. FILED 12-18-2012.
- 4,591,128. **DUBBLE TRUBBLE (STANDARD CHARACTER)**. SRDG LIMITED, (U.S. CLS. 1, 4, 6, 50, 51 AND 52). SN 85-867,139. PUB. 10-29-2013. FILED 3-5-2013.
- 4,591,182. **MEDICAL INNOVATIONS GROUP AND DESIGN**. MEDICAL INNOVATIONS GROUP HOLDINGS, LTD, MULTIPLE CLASS, (INT. CLS. 3, 5, 10, 11, 12 AND 24), (U.S. CLS. 1, 4, 6, 13, 18, 19, 21, 23, 26, 31, 34, 35, 39, 42, 44, 46, 50, 51 AND 52). SN 85-917,392. PUB. 4-29-2014. FILED 4-29-2013.
- 4,591,283. **KING PROFESSIONAL AND DESIGN**. BEAUTY LAB, INC., (U.S. CLS. 1, 4, 6, 50, 51 AND 52). SN 85-961,805. PUB. 6-10-2014. FILED 6-17-2013.
- 4,591,354. **Z CLEAR (STANDARD CHARACTER)**. TELEPRO-DIRECT, INC., (U.S. CLS. 1, 4, 6, 50, 51 AND 52). SN 85-971,859. PUB. 6-10-2014. FILED 6-27-2013.
- 4,591,448. **BONITA AFRO BALM (STANDARD CHARACTER)**. THE DOUX UNLTD LLC, (U.S. CLS. 1, 4, 6, 50, 51 AND 52). SN 86-004,676. PUB. 6-10-2014. FILED 7-8-2013.
- 4,591,450. **EPICE MARINE (STANDARD CHARACTER)**. COMPTOIR NOUVEAU DE LA PARFUMERIE, (U.S. CLS. 1, 4, 6, 50, 51 AND 52). SN 86-004,959. PUB. 6-10-2014. FILED 7-9-2013.
- 4,591,463. **SPRAY ONCE (STANDARD CHARACTER)**. KRUD KUTTER, INC., (U.S. CLS. 1, 4, 6, 50, 51 AND 52). SN 86-006,328. PUB. 6-10-2014. FILED 7-10-2013.
- 4,591,485. **GOT GLAM (STANDARD CHARACTER)**. ROSS, ELYSA, (U.S. CLS. 1, 4, 6, 50, 51 AND 52). SN 86-010,386. PUB. 6-10-2014. FILED 7-15-2013.
- 4,591,505 ( *See Class 1 for this trademark*).
- 4,591,535. **HEMP ALCHEMY (STANDARD CHARACTER)**. CLAUD, CHRISTOPHER P, (U.S. CLS. 1, 4, 6, 50, 51 AND 52). SN 86-022,436. PUB. 6-10-2014. FILED 7-29-2013.
- 4,591,559. **PARSOL (STANDARD CHARACTER)**. DSM IP ASSETS B.V., (U.S. CLS. 1, 4, 6, 50, 51 AND 52). SN 86-027,698. PUB. 5-6-2014. FILED 8-2-2013.
- 4,591,595. **THEONS (STANDARD CHARACTER)**. CHELLY COSMETIC MANUFACTURING, INC., (U.S. CLS. 1, 4, 6, 50, 51 AND 52). SN 86-037,695. PUB. 6-10-2014. FILED 8-14-2013.
- 4,591,601. **INBALANCE (STANDARD CHARACTER)**. CHEM-SPEC1, LLC, (U.S. CLS. 1, 4, 6, 50, 51 AND 52). SN 86-040,436. PUB. 6-10-2014. FILED 8-16-2013.
- 4,591,629 ( *See Class 1 for this trademark*).
- 4,591,643. **GEORGIA LOUISE AND DESIGN**. GEORGIA LOUISE INC., MULTIPLE CLASS, (INT. CLS. 3, 35 AND 44), (U.S. CLS. 1, 4, 6, 50, 51, 52, 100, 101 AND 102). SN 86-051,539. PUB. 6-10-2014. FILED S.R. 8-29-2013; AM. P.R. 4-8-2014.
- 4,591,653. **GJELLYBOO (STANDARD CHARACTER)**. GJELLYBOO LLC, (U.S. CLS. 1, 4, 6, 50, 51 AND 52). SN 86-053,624. PUB. 6-10-2014. FILED 9-2-2013.
- 4,591,704. **ALTCHKEK MD (STANDARD CHARACTER)**. FSR BEAUTY, LTD, AND ALTCHKEK, DOUGLAS - M.D., (U.S. CLS. 1, 4, 6, 50, 51 AND 52). SN 86-072,890. PUB. 6-10-2014. FILED 9-24-2013.
- 4,591,721. **HAZELWOOD SOAP CO. (STANDARD CHARACTER)**. HAZELWOOD SOAP COMPANY INC, (U.S. CLS. 1, 4, 6, 50, 51 AND 52). SN 86-078,442. PUB. 3-4-2014. FILED 9-30-2013.
- 4,591,722. **HAZELWOOD SOAP CO. AND DESIGN**. HAZELWOOD SOAP COMPANY INC, (U.S. CLS. 1, 4, 6, 50, 51 AND 52). SN 86-078,550. PUB. 3-4-2014. FILED 9-30-2013.
- 4,591,778. **WILD EARTH NATURALS AND DESIGN**. WILD EARTH NATURALS, INC, (U.S. CLS. 1, 4, 6, 50, 51 AND 52). SN 86-096,179. PUB. 6-10-2014. FILED 10-19-2013.
- 4,591,782. **I HEART NAIL ART (STANDARD CHARACTER)**. HALL, JULIA K, DBA I HEART NAIL ART, (U.S. CLS. 1, 4, 6, 50, 51 AND 52). SN 86-097,386. PUB. 6-10-2014. FILED 10-21-2013.
- 4,591,807. **MISCELLANEOUS DESIGN**. ESTEBAN, (U.S. CLS. 1, 4, 6, 50, 51 AND 52). SN 86-103,452. PUB. 6-10-2014. FILED 10-28-2013.
- 4,591,808. **MISCELLANEOUS DESIGN**. ESTEBAN, (U.S. CLS. 1, 4, 6, 50, 51 AND 52). SN 86-103,490. PUB. 6-10-2014. FILED 10-28-2013.
- 4,591,850. **NU YVES SAINT LAURENT (STANDARD CHARACTER)**. YVES SAINT LAURENT PARFUMS, (U.S. CLS. 1, 4, 6, 50, 51 AND 52). SN 86-112,714. PUB. 6-10-2014. FILED 11-7-2013.
- 4,591,946. **PREMIER DELICE (STANDARD CHARACTER)**. L'OREAL, (U.S. CLS. 1, 4, 6, 50, 51 AND 52). SN 86-128,143. PUB. 6-10-2014. FILED 11-25-2013.
- 4,592,040. **UP BEAUTY (STANDARD CHARACTER)**. UP, INC., (U.S. CLS. 1, 4, 6, 50, 51 AND 52). SN 86-141,213. PUB. 6-10-2014. FILED 12-11-2013.

- 4,592,128. **PEELS PLUS (STANDARD CHARACTER)**. PEELS PLUS COMPANY INCORPORATED, (U.S. CLS. 1, 4, 6, 50, 51 AND 52). SN 86-150,932. PUB. 6-10-2014. FILED 12-23-2013.
- 4,592,140. **HAWAIIAN BATH & BODY (STANDARD CHARACTER)**. NORTH SHORE SOAP FACTORY, INC., (U.S. CLS. 1, 4, 6, 50, 51 AND 52). SN 86-151,633. PUB. 6-10-2014. FILED 12-23-2013.
- 4,592,148. **DELICIOUSLY NATURAL (STANDARD CHARACTER)**. NATURALICIOUS, LLC, (U.S. CLS. 1, 4, 6, 50, 51 AND 52). SN 86-152,249. PUB. 6-10-2014. FILED 12-24-2013.
- 4,592,169. **BASICS FOR MEN BY BECKMAN (STANDARD CHARACTER)**. CAMILLE BECKMAN CORPORATION, (U.S. CLS. 1, 4, 6, 50, 51 AND 52). SN 86-153,816. PUB. 6-10-2014. FILED 12-29-2013.
- 4,592,194. **30° AND DESIGN**. NEWPORT APOTHECARY, INC., (U.S. CLS. 1, 4, 6, 50, 51 AND 52). SN 86-155,473. PUB. 6-10-2014. FILED 12-31-2013.
- 4,592,258. **ROOT DOWN BOTANICALS (STANDARD CHARACTER)**. FLOREANI, CHANTE, (U.S. CLS. 1, 4, 6, 50, 51 AND 52). SN 86-158,439. PUB. 6-10-2014. FILED 1-6-2014.
- 4,592,439. **ISLAND PINEAPPLE (STANDARD CHARACTER)**. TRI-COASTAL DESIGN GROUP, INC., (U.S. CLS. 1, 4, 6, 50, 51 AND 52). SN 86-164,611. PUB. 6-10-2014. FILED 1-14-2014.
- 4,592,447. **INSTAGONE PRO (STANDARD CHARACTER)**. INSTAGONE CONSUMER PRODUCTS, LLC, (U.S. CLS. 1, 4, 6, 50, 51 AND 52). SN 86-164,848. PUB. 6-10-2014. FILED 1-14-2014.
- 4,592,479. **MINERAL SPLASH (STANDARD CHARACTER)**. PAPPENHAUSEN, MICHAEL, (U.S. CLS. 1, 4, 6, 50, 51 AND 52). SN 86-165,973. PUB. 6-10-2014. FILED 1-15-2014.
- 4,592,508. **ELAIN AND DESIGN**. LAN, CAROLINE HUNGYU, (U.S. CLS. 1, 4, 6, 50, 51 AND 52). SN 86-166,676. PUB. 6-10-2014. FILED 1-15-2014.
- 4,592,511. **DIZZOLVE BRUSH CLEANER & CONDITIONER (STANDARD CHARACTER)**. O'BRIEN DISTRIBUTING, (U.S. CLS. 1, 4, 6, 50, 51 AND 52). SN 86-166,698. PUB. 6-10-2014. FILED 1-15-2014.
- 4,592,529. **THE "DOWN THERE" OIL (STANDARD CHARACTER)**. ELIZABETH HERRERA, MULTIPLE CLASS, (INT. CLS. 3 AND 5), (U.S. CLS. 1, 4, 6, 18, 44, 46, 50, 51 AND 52). SN 86-167,314. PUB. 6-10-2014. FILED 1-16-2014.
- 4,592,530. **SACRED RENEWAL SPRAY (STANDARD CHARACTER)**. ELIZABETH HERRERA, MULTIPLE CLASS, (INT. CLS. 3 AND 5), (U.S. CLS. 1, 4, 6, 18, 44, 46, 50, 51 AND 52). SN 86-167,320. PUB. 6-10-2014. FILED 1-16-2014.
- 4,592,566. **BUTTER SWEET (STANDARD CHARACTER)**. SALONS UNLIMITED, INC., (U.S. CLS. 1, 4, 6, 50, 51 AND 52). SN 86-169,145. PUB. 6-10-2014. FILED 1-17-2014.
- 4,592,573. **AEROGREEN (STANDARD CHARACTER)**. RUNWAY SERVICES CORPORATION, (U.S. CLS. 1, 4, 6, 50, 51 AND 52). SN 86-171,163. PUB. 6-10-2014. FILED 1-21-2014.
- 4,592,582. **PAMPERED GIRLS (STANDARD CHARACTER)**. LIFESTYLE BRANDS GROUP, INC., (U.S. CLS. 1, 4, 6, 50, 51 AND 52). SN 86-171,850. PUB. 6-10-2014. FILED 1-22-2014.
- 4,592,619. **HEALTHY TIMES AND DESIGN**. HEALTHY TIMES INC., MULTIPLE CLASS, (INT. CLS. 3, 5 AND 30), (U.S. CLS. 1, 4, 6, 18, 44, 46, 50, 51 AND 52). SN 86-174,291. PUB. 6-10-2014. FILED 1-24-2014.
- 4,592,648. **AROMALOGY (STANDARD CHARACTER)**. DAISY'S AROMALOGY, INC., MULTIPLE CLASS, (INT. CLS. 3 AND 4), (U.S. CLS. 1, 4, 6, 15, 50, 51 AND 52). SN 86-175,359. PUB. 6-10-2014. FILED 1-26-2014.
- 4,592,722. **AIRTONIX (STANDARD CHARACTER)**. FITNESS VENTURES INTERNATIONAL, LLC, MULTIPLE CLASS, (INT. CLS. 3 AND 7), (U.S. CLS. 1, 4, 6, 13, 19, 21, 23, 31, 34, 35, 50, 51 AND 52). SN 86-176,720. PUB. 6-10-2014. FILED 1-27-2014.
- 4,592,737. **MAGIC VOYAGE (STANDARD CHARACTER)**. LANCOME PARFUMS ET BEAUTE & CIE, (U.S. CLS. 1, 4, 6, 50, 51 AND 52). SN 86-176,972. PUB. 6-10-2014. FILED 1-28-2014.
- 4,592,743. **PERFECT MY SILHOUETTE (STANDARD CHARACTER)**. PERFECT MY SILHOUETTE, LLC, (U.S. CLS. 1, 4, 6, 50, 51 AND 52). SN 86-177,053. PUB. 6-10-2014. FILED 1-28-2014.
- 4,592,780. **THINKBABY (STANDARD CHARACTER)**. THIN-KOPERATIONS, LLC, MULTIPLE CLASS, (INT. CLS. 3 AND 10), (U.S. CLS. 1, 4, 6, 26, 39, 44, 50, 51 AND 52). SN 86-177,697. PUB. 6-10-2014. FILED 1-28-2014.
- 4,592,785. **THINKSPORT (STANDARD CHARACTER)**. THIN-KOPERATIONS, LLC, (U.S. CLS. 1, 4, 6, 50, 51 AND 52). SN 86-177,761. PUB. 6-10-2014. FILED 1-28-2014.
- 4,592,854. **MISCELLANEOUS DESIGN**. JULIUS SÄMANN LTD., MULTIPLE CLASS, (INT. CLS. 3 AND 28), (U.S. CLS. 1, 4, 6, 22, 23, 38, 50, 51 AND 52). SN 86-178,888. PUB. 6-10-2014. FILED 1-29-2014.
- 4,592,935. **PINKCREDIBLE (STANDARD CHARACTER)**. OCPC, INC., (U.S. CLS. 1, 4, 6, 50, 51 AND 52). SN 86-181,779. PUB. 6-10-2014. FILED 2-1-2014.
- 4,592,966. **MIRACLE DEEP CONDITIONER PLUS KERATIN (STANDARD CHARACTER)**. IT'S A 10, INC., (U.S. CLS. 1, 4, 6, 50, 51 AND 52). SN 86-195,822. PUB. 6-10-2014. FILED 2-17-2014.
- 4,593,033 ( *See Class 2 for this trademark*).
- 4,593,044. **SUGAR SISTERS AND DESIGN**. SUGAR SISTERS LLC, (U.S. CLS. 1, 4, 6, 50, 51 AND 52). SN 86-243,307. PUB. 6-10-2014. FILED 4-4-2014.
- 4,593,046. **PASSION STRUCK (STANDARD CHARACTER)**. VICTORIA'S SECRET STORES BRAND MANAGEMENT, INC., (U.S. CLS. 1, 4, 6, 50, 51 AND 52). SN 86-245,433. PUB. 6-10-2014. FILED 4-8-2014.

---

#### CLASS 4—LUBRICANTS AND FUELS

- 4,590,729. **ABARTH FUORISERIE 695 AND DESIGN**. FIAT GROUP MARKETING & CORPORATE COMMUNICATION S.P.A., MULTIPLE CLASS, (INT. CLS. 4, 12 AND 28), (U.S. CLS. 1, 6, 15, 19, 21, 22, 23, 31, 35, 38, 44 AND 50). SN 79-134,244. PUB. 6-10-2014. FILED 6-17-2013.
- 4,590,734. **ABARTH 695 FUORISERIE AND DESIGN**. FIAT GROUP MARKETING & CORPORATE COMMUNICATION S.P.A., MULTIPLE CLASS, (INT. CLS. 4, 12 AND 28), (U.S. CLS. 1, 6, 15, 19, 21, 22, 23, 31, 35, 38, 44 AND 50). SN 79-134,464. PUB. 6-10-2014. FILED 6-17-2013.
- 4,590,736 ( *See Class 3 for this trademark*).
- 4,590,783 ( *See Class 3 for this trademark*).
- 4,590,824 ( *See Class 1 for this trademark*).
- 4,590,826. **TOTAL THERMAL VISION AND DESIGN**. BARALDI SRL, MULTIPLE CLASS, (INT. CLS. 4 AND 9), (U.S. CLS. 1, 6, 15, 21, 23, 26, 36 AND 38). SN 79-139,178. PUB. 6-10-2014. FILED 9-16-2013.
- 4,591,006. **FOOD ZONE (STANDARD CHARACTER)**. J. WALTER COMPANY LIMITED, (U.S. CLS. 1, 6 AND 15). SN 85-713,837. PUB. 6-10-2014. FILED 8-27-2012.
- 4,591,039. **CHILANTHROPY (STANDARD CHARACTER)**. REY HERRERA, DBA CHILANTHROPY, (U.S. CLS. 1, 6 AND 15). SN 85-776,355. PUB. 10-29-2013. FILED 11-9-2012.
- 4,591,040. **MISCELLANEOUS DESIGN**. REY HERRERA, DBA CHILANTHROPY, (U.S. CLS. 1, 6 AND 15). SN 85-776,356. PUB. 10-29-2013. FILED 11-9-2012.
- 4,591,041. **RELAX. REPEAT. (STANDARD CHARACTER)**. REY HERRERA, DBA CHILANTHROPY, (U.S. CLS. 1, 6 AND 15). SN 85-776,358. PUB. 10-29-2013. FILED 11-9-2012.
- 4,591,396. **PETRA NEMCOVA (STANDARD CHARACTER)**. PETRA NEMCOVA BRAND ENTERPRISES, LLC, (U.S. CLS. 1, 6 AND 15). SN 85-982,544. PUB. 12-4-2012. FILED 6-21-2012.
- 4,592,029. **CRACKLIN' CANDLES (STANDARD CHARACTER)**. T J CRAFTERS, (U.S. CLS. 1, 6 AND 15). SN 86-139,175. PUB. 6-10-2014. FILED 12-10-2013.
- 4,592,168. **ROSEY KAY SCENTED CANDLES (STANDARD CHARACTER)**. J KAYLYNN LLC, DBA ROSEY KAY, (U.S. CLS. 1, 6 AND 15). SN 86-153,809. PUB. 6-10-2014. FILED 12-29-2013.
- 4,592,614. **RED GIANT (STANDARD CHARACTER)**. RED GIANT OIL COMPANY, (U.S. CLS. 1, 6 AND 15). SN 86-174,090. PUB. 6-10-2014. FILED 1-24-2014.
- 4,592,636. **AMP (STANDARD CHARACTER)**. UNITED BRANDS PRODUCTS DESIGN, DEVELOPMENT AND MARKETING, INC., (U.S. CLS. 1, 6 AND 15). SN 86-175,074. PUB. 6-10-2014. FILED 1-24-2014.
- 4,592,648 ( *See Class 3 for this trademark*).

4,592,875. **G (STYLIZED)**. JOHN GIBSON ENTERPRISES, INC., (U.S. CLS. 1, 6 AND 15). SN 86-179,436. PUB. 6-10-2014. FILED 1-30-2014.  
 4,592,956. **IN AND DESIGN**. INTELLIGENT NUTRIENTS, LLC, (U.S. CLS. 1, 6 AND 15). SN 86-190,716. PUB. 6-10-2014. FILED 2-11-2014.

### CLASS 5—PHARMACEUTICALS

4,590,620. **BIOMOR (STANDARD CHARACTER)**. HEALTHY SOURCE, LLC, (U.S. CLS. 6, 18, 44, 46, 51 AND 52). SN 77-523,254. PUB. 6-10-2014. FILED 7-16-2008.  
 4,590,626 ( *See Class 3 for this trademark* ).  
 4,590,642. **GEORINA (STANDARD CHARACTER)**. ARSOA HONSHA CORPORATION, MULTIPLE CLASS, (INT. CLS. 5, 29, 30 AND 32), (U.S. CLS. 6, 18, 44, 45, 46, 48, 51 AND 52). SN 79-122,547. PUB. 8-27-2013. FILED 6-22-2012.  
 4,590,660. **BIOGLIDE (STANDARD CHARACTER)**. REDSCHLAG HOLDING GMBH, (U.S. CLS. 6, 18, 44, 46, 51 AND 52). SN 79-125,923. PUB. 11-12-2013. FILED 12-4-2012.  
 4,590,661. **AQUAGLIDE (STYLIZED)**. REDSCHLAG HOLDING GMBH, (U.S. CLS. 6, 18, 44, 46, 51 AND 52). SN 79-125,946. PUB. 11-12-2013. FILED 12-12-2012.  
 4,590,669. **CLINISTRETCH (STANDARD CHARACTER)**. HADDENHAM HEALTHCARE LIMITED, MULTIPLE CLASS, (INT. CLS. 5, 9, 10, 16, 41 AND 44), (U.S. CLS. 2, 5, 6, 18, 21, 22, 23, 26, 29, 36, 37, 38, 39, 44, 46, 50, 51, 52, 100, 101 AND 107). SN 79-127,777. PUB. 6-10-2014. FILED 10-19-2012.  
 4,590,671. **ADLUMIZ (STANDARD CHARACTER)**. HELSINN HEALTHCARE SA, (U.S. CLS. 6, 18, 44, 46, 51 AND 52). SN 79-128,004. PUB. 6-10-2014. FILED 3-4-2013.  
 4,590,672. **AKEXEV (STANDARD CHARACTER)**. HELSINN HEALTHCARE SA, (U.S. CLS. 6, 18, 44, 46, 51 AND 52). SN 79-128,005. PUB. 6-10-2014. FILED 3-4-2013.  
 4,590,673. **RAZUBO (STANDARD CHARACTER)**. HELSINN HEALTHCARE SA, (U.S. CLS. 6, 18, 44, 46, 51 AND 52). SN 79-128,006. PUB. 6-10-2014. FILED 3-4-2013.  
 4,590,674. **ADLUMYR (STANDARD CHARACTER)**. HELSINN HEALTHCARE SA, (U.S. CLS. 6, 18, 44, 46, 51 AND 52). SN 79-128,007. PUB. 6-10-2014. FILED 3-4-2013.  
 4,590,678. **ABAMUR (STANDARD CHARACTER)**. HELSINN HEALTHCARE SA, (U.S. CLS. 6, 18, 44, 46, 51 AND 52). SN 79-128,353. PUB. 6-10-2014. FILED 3-4-2013.  
 4,590,693 ( *See Class 3 for this trademark* ).  
 4,590,713. **P AND DESIGN**. ZHEJIANG HISOAR PHARMACEUTICAL CO., LTD., (U.S. CLS. 6, 18, 44, 46, 51 AND 52). SN 79-133,411. PUB. 6-10-2014. FILED 5-29-2013.  
 4,590,772. **GLUCOBAY M (STANDARD CHARACTER)**. BAYER INTELLECTUAL PROPERTY GMBH, (U.S. CLS. 6, 18, 44, 46, 51 AND 52). SN 79-136,304. PUB. 6-10-2014. FILED 6-14-2013.  
 4,590,773. **GLUCOBAY AIM (STANDARD CHARACTER)**. BAYER INTELLECTUAL PROPERTY GMBH, (U.S. CLS. 6, 18, 44, 46, 51 AND 52). SN 79-136,305. PUB. 6-10-2014. FILED 6-14-2013.  
 4,590,785 ( *See Class 3 for this trademark* ).  
 4,590,788 ( *See Class 1 for this trademark* ).  
 4,590,791 ( *See Class 3 for this trademark* ).  
 4,590,812 ( *See Class 3 for this trademark* ).  
 4,590,860. **YUYU (STYLIZED)**. SHAOXING KANGKE CAPSULE CO., LTD., (U.S. CLS. 6, 18, 44, 46, 51 AND 52). SN 79-141,561. PUB. 6-10-2014. FILED 9-13-2013.  
 4,590,867 ( *See Class 1 for this trademark* ).  
 4,590,903. **VERASEAL (STANDARD CHARACTER)**. GRIFOLS WORLDWIDE OPERATIONS LIMITED, (U.S. CLS. 6, 18, 44, 46, 51 AND 52). SN 79-143,185. PUB. 6-10-2014. FILED 1-28-2014.  
 4,590,904. **VERATHROM (STANDARD CHARACTER)**. GRIFOLS WORLDWIDE OPERATIONS LIMITED, (U.S. CLS. 6, 18, 44, 46, 51 AND 52). SN 79-143,186. PUB. 6-10-2014. FILED 1-28-2014.  
 4,590,908 ( *See Class 3 for this trademark* ).  
 4,590,913. **XOLAIR AND DESIGN**. NOVARTIS AG, (U.S. CLS. 6, 18, 44, 46, 51 AND 52). SN 79-143,692. PUB. 6-10-2014. FILED 2-5-2014.  
 4,590,916. **ARATHROM (STANDARD CHARACTER)**, GRI-

FOLS WORLDWIDE OPERATIONS LIMITED, (U.S. CLS. 6, 18, 44, 46, 51 AND 52). SN 79-143,865. PUB. 6-10-2014. FILED 1-28-2014.  
 4,590,918. **DEEVEEANT (STANDARD CHARACTER)**. BRADLEY JOHN CHICK, (U.S. CLS. 6, 18, 44, 46, 51 AND 52). SN 79-143,999. PUB. 6-10-2014. FILED 11-18-2013.  
 4,590,919. **POWERNUMB (STANDARD CHARACTER)**. BRADLEY JOHN CHICK, (U.S. CLS. 6, 18, 44, 46, 51 AND 52). SN 79-144,060. PUB. 6-10-2014. FILED 11-15-2013.  
 4,590,924. **SYNJARDY (STANDARD CHARACTER)**. BOEHRINGER INGELHEIM INTERNATIONAL GMBH, (U.S. CLS. 6, 18, 44, 46, 51 AND 52). SN 79-145,490. PUB. 6-10-2014. FILED 2-17-2014.  
 4,590,926. **VEKELTO (STANDARD CHARACTER)**. NOVARTIS AG, (U.S. CLS. 6, 18, 44, 46, 51 AND 52). SN 79-145,755. PUB. 6-10-2014. FILED 3-21-2014.  
 4,590,927. **VYQUELVO (STANDARD CHARACTER)**. NOVARTIS AG, (U.S. CLS. 6, 18, 44, 46, 51 AND 52). SN 79-145,756. PUB. 6-10-2014. FILED 3-21-2014.  
 4,590,928. **ZEVIPTO (STANDARD CHARACTER)**. NOVARTIS AG, (U.S. CLS. 6, 18, 44, 46, 51 AND 52). SN 79-145,757. PUB. 6-10-2014. FILED 3-21-2014.  
 4,590,929. **ZIOXTENZO (STANDARD CHARACTER)**. NOVARTIS AG, (U.S. CLS. 6, 18, 44, 46, 51 AND 52). SN 79-145,758. PUB. 6-10-2014. FILED 3-18-2014.  
 4,590,930. **ARKMENT (STANDARD CHARACTER)**. NOVARTIS AG, (U.S. CLS. 6, 18, 44, 46, 51 AND 52). SN 79-145,759. PUB. 6-10-2014. FILED 3-26-2014.  
 4,590,931. **ATECTURA (STANDARD CHARACTER)**. NOVARTIS AG, (U.S. CLS. 6, 18, 44, 46, 51 AND 52). SN 79-145,760. PUB. 6-10-2014. FILED 3-26-2014.  
 4,590,932. **AUGVERZ (STANDARD CHARACTER)**. NOVARTIS AG, (U.S. CLS. 6, 18, 44, 46, 51 AND 52). SN 79-145,762. PUB. 6-10-2014. FILED 3-26-2014.  
 4,590,933. **ZARPROLENG (STANDARD CHARACTER)**. NOVARTIS AG, (U.S. CLS. 6, 18, 44, 46, 51 AND 52). SN 79-145,816. PUB. 6-10-2014. FILED 3-18-2014.  
 4,590,934. **TIBRENGA (STANDARD CHARACTER)**. NOVARTIS AG, (U.S. CLS. 6, 18, 44, 46, 51 AND 52). SN 79-145,817. PUB. 6-10-2014. FILED 3-21-2014.  
 4,590,935. **AXINART (STANDARD CHARACTER)**. NOVARTIS AG, (U.S. CLS. 6, 18, 44, 46, 51 AND 52). SN 79-145,818. PUB. 6-10-2014. FILED 3-26-2014.  
 4,590,960. **NAVITAS NATURALS AND DESIGN**. NAVITAS LLC, MULTIPLE CLASS, (INT. CLS. 5, 29 AND 30), (U.S. CLS. 6, 18, 44, 46, 51 AND 52). SN 85-453,518. PUB. 6-10-2014. FILED 10-21-2011.  
 4,590,972. **AZIDAY (STANDARD CHARACTER)**. TEVA PHARMACEUTICAL INDUSTRIES LTD., (U.S. CLS. 6, 18, 44, 46, 51 AND 52). SN 85-493,040. PUB. 6-10-2014. FILED 12-12-2011.  
 4,590,973. **AZILECT EN (STANDARD CHARACTER)**. TEVA PHARMACEUTICAL INDUSTRIES LTD., (U.S. CLS. 6, 18, 44, 46, 51 AND 52). SN 85-493,043. PUB. 6-10-2014. FILED 12-12-2011.  
 4,590,978. **PHYTOMUNE (STANDARD CHARACTER)**. CELT CORPORATION, (U.S. CLS. 6, 18, 44, 46, 51 AND 52). SN 85-542,569. PUB. 6-10-2014. FILED 2-14-2012.  
 4,590,980. **KAWELL INNOVACION EN EL CUIDADO DEL CABALLO AND DESIGN**. COMERCIALIZADORA KRAVIVA SPA, (U.S. CLS. 6, 18, 44, 46, 51 AND 52). SN 85-549,331. PUB. 6-10-2014. FILED 2-22-2012.  
 4,591,003 ( *See Class 1 for this trademark* ).  
 4,591,043. **EZECHBONE (STANDARD CHARACTER)**. JOY MEDICAL DEVICES CORPORATION, AKA JMD, (U.S. CLS. 6, 18, 44, 46, 51 AND 52). SN 85-776,642. PUB. 6-10-2014. FILED S.R. 11-12-2012; AM. P.R. 4-17-2013.  
 4,591,055 ( *See Class 3 for this trademark* ).  
 4,591,070. **ENERGY QUIXOTICA (STANDARD CHARACTER)**. FIORE, LISA, (U.S. CLS. 6, 18, 44, 46, 51 AND 52). SN 85-796,794. PUB. 6-10-2014. FILED 12-6-2012.  
 4,591,087. **BLUECLINICAL (STANDARD CHARACTER)**. BLUECLINICAL - INVESTIGACAO E DESENVOLVIMENTO EM SAUDE, LDA, MULTIPLE CLASS, (INT. CLS. 5 AND 42), (U.S. CLS. 6, 18, 44, 46, 51, 52, 100 AND 101). SN 85-807,045. PUB. 9-17-2013. FILED 12-19-2012.  
 4,591,155. **PURELY DRIVEN (STANDARD CHARACTER)**. THORNE RESEARCH, INC., (U.S. CLS. 6, 18, 44, 46, 51

- AND 52). SN 85-892,288. PUB. 6-10-2014. FILED 4-1-2013.
- 4,591,164. **PROTON PILL (STANDARD CHARACTER)**. NEW AGEING INTERNATIONAL PTY LTD, (U.S. CLS. 6, 18, 44, 46, 51 AND 52). SN 85-898,088. PUB. 6-10-2014. FILED 4-8-2013.
- 4,591,182 ( *See Class 3 for this trademark*).
- 4,591,198. **VITA ADIVA (STANDARD CHARACTER)**. VITA ZAHNFABRIK H. RAUTER GMBH & CO. KG, (U.S. CLS. 6, 18, 44, 46, 51 AND 52). SN 85-929,191. PUB. 6-10-2014. FILED 5-10-2013.
- 4,591,253 ( *See Class 1 for this trademark*).
- 4,591,261. **IONIC SPORT WATER 200 AND DESIGN**. SPORT-WATER BEVERAGES LLC, (U.S. CLS. 6, 18, 44, 46, 51 AND 52). SN 85-954,877. PUB. 3-4-2014. FILED 6-10-2013.
- 4,591,289. **MISCELLANEOUS DESIGN**. EDWARD WYNN LLC, (U.S. CLS. 6, 18, 44, 46, 51 AND 52). SN 85-962,697. PUB. 6-10-2014. FILED 6-18-2013.
- 4,591,303. **QUEST (STANDARD CHARACTER)**. QUEST NUTRITION, LLC, MULTIPLE CLASS, (INT. CLS. 5 AND 30), (U.S. CLS. 6, 18, 44, 46, 51 AND 52). SN 85-965,950. PUB. 1-7-2014. FILED 6-20-2013.
- 4,591,320. **BEYOND HUMAN (STANDARD CHARACTER)**. DMET LLC, (U.S. CLS. 6, 18, 44, 46, 51 AND 52). SN 85-967,626. PUB. 6-10-2014. FILED 6-24-2013.
- 4,591,340 ( *See Class 1 for this trademark*).
- 4,591,341. **PURVITALITY (STANDARD CHARACTER)**. STOP AGING NOW, LLC, (U.S. CLS. 6, 18, 44, 46, 51 AND 52). SN 85-970,502. PUB. 6-10-2014. FILED 6-26-2013.
- 4,591,407. **ACTIVE FE (STANDARD CHARACTER)**. VELOCITY CONSULTING SPECIALIST, (U.S. CLS. 6, 18, 44, 46, 51 AND 52). SN 86-001,262. PUB. 6-10-2014. FILED 7-2-2013.
- 4,591,432. **METAMORPHOGEN (STANDARD CHARACTER)**. GLANBIA PLC, (U.S. CLS. 6, 18, 44, 46, 51 AND 52). SN 86-003,031. PUB. 6-10-2014. FILED 7-5-2013.
- 4,591,576. **VECTRA (STANDARD CHARACTER)**. CEVA ANIMAL HEALTH LLC, (U.S. CLS. 6, 18, 44, 46, 51 AND 52). SN 86-032,472. PUB. 12-31-2013. FILED 8-8-2013.
- 4,591,594. **MD ULTRIMIX (STANDARD CHARACTER)**. MD NUTRITION LLC, (U.S. CLS. 6, 18, 44, 46, 51 AND 52). SN 86-037,103. PUB. 6-10-2014. FILED 8-13-2013.
- 4,591,629 ( *See Class 1 for this trademark*).
- 4,591,638. **TRP ADVANCED SOFT CHEW TECHNOLOGY AND DESIGN**. SOGEVAL LABORATORIES, INC., (U.S. CLS. 6, 18, 44, 46, 51 AND 52). SN 86-050,767. PUB. 6-10-2014. FILED 8-28-2013.
- 4,591,652. **MELT-A-WAY (STANDARD CHARACTER)**. SMITH, STEPHANIE M, DBA MEDSHAPE WEIGHT LOSS CLINIC, LLC, (U.S. CLS. 6, 18, 44, 46, 51 AND 52). SN 86-053,463. PUB. 3-4-2014. FILED 9-1-2013.
- 4,591,660. **CRAZY DOGGY JOINT RELIEF GUMMY (STANDARD CHARACTER)**. NATURE'S DYNAMICS, (U.S. CLS. 6, 18, 44, 46, 51 AND 52). SN 86-058,048. PUB. 6-10-2014. FILED 9-6-2013.
- 4,591,773. **INSTANT IMMUNE (STANDARD CHARACTER)**. PACIFIC HEALTH SCIENCES LLC, DBA PACIFIC HEALTH SCIENCES, (U.S. CLS. 6, 18, 44, 46, 51 AND 52). SN 86-094,666. PUB. 6-10-2014. FILED 10-17-2013.
- 4,591,802. **JN-7 BEST (STANDARD CHARACTER)**. VBS DISTRIBUTION, (U.S. CLS. 6, 18, 44, 46, 51 AND 52). SN 86-101,172. PUB. 4-22-2014. FILED 10-25-2013.
- 4,591,889. **DERMABIOLOGICS SKIN RESCUE AND DESIGN**. PEREZ, CEASAR A., (U.S. CLS. 6, 18, 44, 46, 51 AND 52). SN 86-119,224. PUB. 6-10-2014. FILED 11-14-2013.
- 4,591,893. **NURSING WITH HEART (STANDARD CHARACTER)**. SOFT STYLE INC., (U.S. CLS. 6, 18, 44, 46, 51 AND 52). SN 86-119,756. PUB. 6-10-2014. FILED 11-15-2013.
- 4,591,950. **ARDENT (STANDARD CHARACTER)**. IVOCLAR VIVADENT, INC., (U.S. CLS. 6, 18, 44, 46, 51 AND 52). SN 86-128,469. PUB. 6-10-2014. FILED 11-25-2013.
- 4,591,981. **PROTASIA (STANDARD CHARACTER)**. HOLISTIC PET CARE. LLC, (U.S. CLS. 6, 18, 44, 46, 51 AND 52). SN 86-132,432. PUB. 6-10-2014. FILED 12-2-2013.
- 4,592,004. **BEAUTY ENZYMES (STANDARD CHARACTER)**. SUNFOOD, LLC, (U.S. CLS. 6, 18, 44, 46, 51 AND 52). SN 86-136,187. PUB. 6-10-2014. FILED 12-5-2013.
- 4,592,090. **BIOBEADS (STANDARD CHARACTER)**. NATROL, INC., (U.S. CLS. 6, 18, 44, 46, 51 AND 52). SN 86-147,565. PUB. 6-10-2014. FILED 12-18-2013.
- 4,592,186. **ROYALN BALANCE DIET (STANDARD CHARACTER)**. YS HEALTH, (U.S. CLS. 6, 18, 44, 46, 51 AND 52). SN 86-154,791. PUB. 6-10-2014. FILED 12-30-2013.
- 4,592,340. **L.N. PRIZ LABS (STANDARD CHARACTER)**. THE BASIC SCIENCE LABS, LLC, DBA L.N. PRIZ LABS, (U.S. CLS. 6, 18, 44, 46, 51 AND 52). SN 86-161,747. PUB. 6-10-2014. FILED 1-9-2014.
- 4,592,432. **JAYA (STANDARD CHARACTER)**. JAYA WELLNESS LLC, (U.S. CLS. 6, 18, 44, 46, 51 AND 52). SN 86-164,138. PUB. 6-10-2014. FILED 1-13-2014.
- 4,592,491. **MY FAVORITE (STANDARD CHARACTER)**. NATROL, (U.S. CLS. 6, 18, 44, 46, 51 AND 52). SN 86-166,166. PUB. 6-10-2014. FILED 1-15-2014.
- 4,592,529 ( *See Class 3 for this trademark*).
- 4,592,530 ( *See Class 3 for this trademark*).
- 4,592,611. **BERGSTROM NUTRITION (STANDARD CHARACTER)**. CARDINAL ASSOCIATES, DBA BERGSTROM NUTRITION, (U.S. CLS. 6, 18, 44, 46, 51 AND 52). SN 86-173,552. PUB. 6-10-2014. FILED 1-23-2014.
- 4,592,619 ( *See Class 3 for this trademark*).
- 4,592,624. **HEJIAN (STANDARD CHARACTER)**. SHANGHAI HEJIAN ERA E-COMMERCE CO., LTD., (U.S. CLS. 6, 18, 44, 46, 51 AND 52). SN 86-174,447. PUB. 6-10-2014. FILED 1-24-2014.
- 4,592,628. **KEYBIOTICS (STANDARD CHARACTER)**. WHOLE BODY RESEARCH, LLC, (U.S. CLS. 6, 18, 44, 46, 51 AND 52). SN 86-174,580. PUB. 6-10-2014. FILED 1-24-2014.
- 4,592,697. **POWERBOOST (STANDARD CHARACTER)**. OPPORTUNITY HOLDING CO., LLC, (U.S. CLS. 6, 18, 44, 46, 51 AND 52). SN 86-176,140. PUB. 6-10-2014. FILED 1-27-2014.
- 4,592,718. **S1 851 (STYLIZED)**. BESO BIOLOGICAL RESEARCH, INC., (U.S. CLS. 6, 18, 44, 46, 51 AND 52). SN 86-176,607. PUB. 6-10-2014. FILED 1-27-2014.
- 4,592,731. **CRAMPEASE (STANDARD CHARACTER)**. PENPHARM SA (PTY) LTD, (U.S. CLS. 6, 18, 44, 46, 51 AND 52). SN 86-176,865. PUB. 6-10-2014. FILED 1-28-2014.
- 4,592,790. **XL-3 XPECT AND DESIGN**. MARVI ASESORES, S.C., (U.S. CLS. 6, 18, 44, 46, 51 AND 52). SN 86-177,792. PUB. 6-10-2014. FILED 1-28-2014.
- 4,592,791. **XL-3 XTREME AND DESIGN**. MARVI ASESORES, S.C., (U.S. CLS. 6, 18, 44, 46, 51 AND 52). SN 86-177,819. PUB. 6-10-2014. FILED 1-28-2014.
- 4,592,864. **BUY.GAIN.GIVE. (STANDARD CHARACTER)**. CARINA AYDEN, (U.S. CLS. 6, 18, 44, 46, 51 AND 52). SN 86-179,052. PUB. 6-10-2014. FILED 1-29-2014.
- 4,592,877. **DECARA (STANDARD CHARACTER)**. MEDECOR PHARMA, (U.S. CLS. 6, 18, 44, 46, 51 AND 52). SN 86-179,483. PUB. 6-10-2014. FILED 1-30-2014.
- 4,592,887. **MEMORYCHARGE (STANDARD CHARACTER)**. OPPORTUNITY HOLDING CO., LLC, (U.S. CLS. 6, 18, 44, 46, 51 AND 52). SN 86-179,776. PUB. 6-10-2014. FILED 1-30-2014.
- 4,592,892. **FLUFFLES (STANDARD CHARACTER)**. MORAKI, INC., (U.S. CLS. 6, 18, 44, 46, 51 AND 52). SN 86-179,835. PUB. 6-10-2014. FILED 1-30-2014.
- 4,592,938. **LAMBETO (STANDARD CHARACTER)**. SANOFI, (U.S. CLS. 6, 18, 44, 46, 51 AND 52). SN 86-183,493. PUB. 4-29-2014. FILED 2-4-2014.
- 4,592,940. **PROJOE (STANDARD CHARACTER)**. METAGENICS, INC., DBA BARIATRIC ADVANTAGE, (U.S. CLS. 6, 18, 44, 46, 51 AND 52). SN 86-184,336. PUB. 6-10-2014. FILED 2-4-2014.
- 4,592,947. **R GARDEN AND DESIGN**. R-GARDEN, INC., (U.S. CLS. 6, 18, 44, 46, 51 AND 52). SN 86-187,891. PUB. 6-10-2014. FILED 2-7-2014.
- 4,592,992 ( *See Class 1 for this trademark*).
- 4,593,001. **SIMPLICITY (STANDARD CHARACTER)**. DOW AGROSCIENCES LLC, (U.S. CLS. 6, 18, 44, 46, 51 AND 52). SN 86-218,443. PUB. 6-10-2014. FILED 3-12-2014.
- 4,593,017. **INTOLERANCE COMPLEX (STANDARD CHARACTER)**. BOHAGER HOLDINGS, LLC, (U.S. CLS. 6, 18, 44, 46, 51 AND 52). SN 86-224,151. PUB. 6-10-2014. FILED 3-18-2014.



**CLASS 6—METAL GOODS**

- 4,590,606. **CENTRAL SNAP (STANDARD CHARACTER)**. CENTRAL STATES MANUFACTURING, INC., (U.S. CLS. 2, 12, 13, 14, 23, 25 AND 50). SN 76-712,924. PUB. 6-10-2014. FILED 11-26-2012.
- 4,590,643. **STUDER CASEUS (STYLIZED)**. STUDER MASCHINENBAU AG, MULTIPLE CLASS, (INT. CLS. 6, 7 AND 11), (U.S. CLS. 2, 12, 13, 14, 19, 21, 23, 25, 31, 34, 35 AND 50). SN 79-122,909. PUB. 6-10-2014. FILED 9-18-2012.
- 4,590,677. **GORTER AND DESIGN**. GORTER GROUP B.V., MULTIPLE CLASS, (INT. CLS. 6, 19 AND 35), (U.S. CLS. 1, 2, 12, 13, 14, 23, 25, 33, 50, 100, 101 AND 102). SN 79-128,225. PUB. 6-10-2014. FILED 1-17-2013.
- 4,590,777. **PROFILGATE AND DESIGN**. MASCHINENFABRIK HEUTE GMBH & CO. KG, MULTIPLE CLASS, (INT. CLS. 6, 11 AND 21), (U.S. CLS. 2, 12, 13, 14, 21, 23, 25, 29, 30, 31, 33, 34, 40 AND 50). SN 79-136,433. PUB. 6-10-2014. FILED 2-18-2013.
- 4,590,802. **GARTEN[Q] (STANDARD CHARACTER)**. VOGL THOMAS, AND SCHOLZ MARKUS, AND ARMBRÜSTER JENS, MULTIPLE CLASS, (INT. CLS. 6, 19 AND 20), (U.S. CLS. 1, 2, 12, 13, 14, 22, 23, 25, 32, 33 AND 50). SN 79-137,627. PUB. 6-10-2014. FILED 5-17-2013.
- 4,590,803. **RAMPF AND DESIGN**. RAMPF FORMEN GMBH, MULTIPLE CLASS, (INT. CLS. 6, 7, 9, 37 AND 42), (U.S. CLS. 2, 12, 13, 14, 19, 21, 23, 25, 26, 31, 34, 35, 36, 38, 50, 100, 101, 103 AND 106). SN 79-137,653. PUB. 6-10-2014. FILED 9-17-2013.
- 4,590,824 ( *See Class 1 for this trademark*).
- 4,590,830. **A PASIA AND DESIGN**. NOVELLO S.R.L., MULTIPLE CLASS, (INT. CLS. 6, 9 AND 18), (U.S. CLS. 1, 2, 3, 12, 13, 14, 21, 22, 23, 25, 26, 36, 38, 41 AND 50). SN 79-139,392. PUB. 6-10-2014. FILED 6-14-2013.
- 4,590,845. **MISCELLANEOUS DESIGN**. ZHEJIANG TOPSUN LOGISTIC CONTROL CO., LTD., MULTIPLE CLASS, (INT. CLS. 6, 7, 8, 12 AND 22), (U.S. CLS. 1, 2, 7, 12, 13, 14, 19, 21, 22, 23, 25, 28, 31, 34, 35, 42, 44 AND 50). SN 79-140,361. PUB. 6-10-2014. FILED 9-9-2013.
- 4,590,881. **PERMASCAND AND DESIGN**. PERMASCAND AKTIEBOLAG, MULTIPLE CLASS, (INT. CLS. 6, 9, 14, 40 AND 42), (U.S. CLS. 2, 12, 13, 14, 21, 23, 25, 26, 27, 28, 36, 38, 50, 100, 101, 103 AND 106). SN 79-142,443. PUB. 6-10-2014. FILED 7-11-2013.
- 4,590,908 ( *See Class 3 for this trademark*).
- 4,590,936. **CORSPACE (STYLIZED)**. NIPPON STEEL & SUMITOMO METAL CORPORATION, (U.S. CLS. 2, 12, 13, 14, 23, 25 AND 50). SN 79-145,855. PUB. 6-10-2014. FILED 2-3-2014.
- 4,591,031. **STEELSTRONG (STANDARD CHARACTER)**. EBS-CO INDUSTRIES, INC., MULTIPLE CLASS, (INT. CLS. 6, 12 AND 20), (U.S. CLS. 2, 12, 13, 14, 19, 21, 22, 23, 25, 31, 32, 35, 44 AND 50). SN 85-766,660. PUB. 7-30-2013. FILED 10-30-2012.
- 4,591,114. **ALL WEATHER SAFE ROOMS (STANDARD CHARACTER)**. AULT, RICHARD M., MULTIPLE CLASS, (INT. CLS. 6, 35 AND 37), (U.S. CLS. 2, 12, 13, 14, 23, 25, 50, 100, 101, 102, 103 AND 106). SN 85-851,335. PUB. 6-10-2014. FILED 2-15-2013.
- 4,591,299. **Z-MAX (STANDARD CHARACTER)**. FLEXMAASTER CANADA LTD., (U.S. CLS. 2, 12, 13, 14, 23, 25 AND 50). SN 85-965,541. PUB. 6-10-2014. FILED 6-20-2013.
- 4,591,334. **IBOX (STANDARD CHARACTER)**. SOFRIGAM, MULTIPLE CLASS, (INT. CLS. 6, 9 AND 20), (U.S. CLS. 2, 12, 13, 14, 21, 22, 23, 25, 26, 32, 36, 38 AND 50). SN 85-969,386. PUB. 6-10-2014. FILED 6-25-2013.
- 4,591,589. **GIBBS (STYLIZED)**. GIBBS WIRE & STEEL COMPANY, INC., MULTIPLE CLASS, (INT. CLS. 6 AND 40), (U.S. CLS. 2, 12, 13, 14, 23, 25, 50, 100, 103 AND 106). SN 86-035,529. PUB. 6-10-2014. FILED 8-12-2013.
- 4,591,590. **GIBBS (STANDARD CHARACTER)**. GIBBS WIRE & STEEL COMPANY, INC., MULTIPLE CLASS, (INT. CLS. 6 AND 40), (U.S. CLS. 2, 12, 13, 14, 23, 25, 50, 100, 103 AND 106). SN 86-035,534. PUB. 6-10-2014. FILED 8-12-2013.
- 4,591,703. **DECKS THAT GO WHERE YOU GO (STANDARD CHARACTER)**. JNK INNOVATIONS, LLC, (U.S. CLS. 2, 12, 13, 14, 23, 25 AND 50). SN 86-072,884. PUB. 6-10-2014. FILED 9-24-2013.
- 4,591,706. **TRAVEL EASY DECKS AND DESIGN**. JNK IN-

- NOVATIONS, LLC, (U.S. CLS. 2, 12, 13, 14, 23, 25 AND 50). SN 86-074,784. PUB. 6-10-2014. FILED 9-25-2013.
- 4,591,847. **EG AND DESIGN**. EAGLE METALWARE (KUNSHAN) CO.,LTD., (U.S. CLS. 2, 12, 13, 14, 23, 25 AND 50). SN 86-111,166. PUB. 6-10-2014. FILED 11-5-2013.
- 4,591,979. **YARD-BUDDY (STANDARD CHARACTER)**. MCGUIRE, CARL, (U.S. CLS. 2, 12, 13, 14, 23, 25 AND 50). SN 86-132,302. PUB. 6-10-2014. FILED 12-2-2013.
- 4,592,086. **CABLE WINE SYSTEMS AND DESIGN**. CABLE WINE SYSTEMS INC., MULTIPLE CLASS, (INT. CLS. 6 AND 20), (U.S. CLS. 2, 12, 13, 14, 22, 23, 25, 32 AND 50). SN 86-146,801. PUB. 6-10-2014. FILED 12-18-2013.
- 4,592,092. **CURL-LOK (STANDARD CHARACTER)**. NCI GROUP, INC., (U.S. CLS. 2, 12, 13, 14, 23, 25 AND 50). SN 86-147,788. PUB. 6-10-2014. FILED 12-18-2013.
- 4,592,149. **ICE CREAM WRAP ICE CREAM GETS COLD TOO... NO MORE FREEZER BURN! AND DESIGN**. ICE CREAM SKULLS, INC., MULTIPLE CLASS, (INT. CLS. 6 AND 16), (U.S. CLS. 2, 5, 12, 13, 14, 22, 23, 25, 29, 37, 38 AND 50). SN 86-152,316. PUB. 6-10-2014. FILED 12-25-2013.
- 4,592,298. **MOH AND DESIGN**. NIJEL BINNS, (U.S. CLS. 2, 12, 13, 14, 23, 25 AND 50). SN 86-160,180. PUB. 6-10-2014. FILED 1-8-2014.
- 4,592,427. **PROLOK (STANDARD CHARACTER)**. ABL SERVICES, INC., (U.S. CLS. 2, 12, 13, 14, 23, 25 AND 50). SN 86-163,998. PUB. 6-10-2014. FILED 1-13-2014.
- 4,592,741. **311 CYCLING (STANDARD CHARACTER)**. STRAUSS CYCLING LLC, MULTIPLE CLASS, (INT. CLS. 6, 11 AND 12), (U.S. CLS. 2, 12, 13, 14, 19, 21, 23, 25, 31, 34, 35, 44 AND 50). SN 86-177,041. PUB. 6-10-2014. FILED 1-28-2014.
- 4,592,890. **R.I.P. (STANDARD CHARACTER)**. G2 RESEARCH, INC., MULTIPLE CLASS, (INT. CLS. 6 AND 13), (U.S. CLS. 2, 9, 12, 13, 14, 23, 25 AND 50). SN 86-179,817. PUB. 6-10-2014. FILED 1-30-2014.

**CLASS 7—MACHINERY**

- 4,590,634. **HAP STINN HAIRPIN STATOR INNOVATION AND DESIGN**. TECNOMATIC S.P.A., MULTIPLE CLASS, (INT. CLS. 7, 12 AND 42), (U.S. CLS. 13, 19, 21, 23, 31, 34, 35, 44, 100 AND 101). SN 79-118,328. PUB. 6-10-2014. FILED 2-22-2012.
- 4,590,643 ( *See Class 6 for this trademark*).
- 4,590,650. **AIRNAMICS (STANDARD CHARACTER)**. AIRNAMICS, NAPREDNI MEHATRONSKI SISTEMI D.O.O., MULTIPLE CLASS, (INT. CLS. 7, 9, 12 AND 42), (U.S. CLS. 13, 19, 21, 23, 26, 31, 34, 35, 36, 38, 44, 100 AND 101). SN 79-124,116. PUB. 6-10-2014. FILED 8-6-2012.
- 4,590,662. **LINCO (STANDARD CHARACTER)**. LINCO FOOD SYSTEMS A/S, MULTIPLE CLASS, (INT. CLS. 7, 9, 11, 37, 40 AND 41), (U.S. CLS. 13, 19, 21, 23, 26, 31, 34, 35, 36, 38, 100, 101, 103, 106 AND 107). SN 79-126,085. PUB. 6-10-2014. FILED 9-19-2012.
- 4,590,666. **LAB-CLUB (STANDARD CHARACTER)**. MSCIEN-TIFIC; CHROMATOGRAPHIE-HANDEL GMBH, MULTIPLE CLASS, (INT. CLS. 7, 9, 10, 11 AND 35), (U.S. CLS. 13, 19, 21, 23, 26, 31, 34, 35, 36, 38, 39, 44, 100, 101 AND 102). SN 79-127,361. PUB. 6-10-2014. FILED 10-19-2012.
- 4,590,675. **ANGER (STANDARD CHARACTER)**. ANGER MACHINING GMBH, MULTIPLE CLASS, (INT. CLS. 7 AND 42), (U.S. CLS. 13, 19, 21, 23, 31, 34, 35, 100 AND 101). SN 79-128,014. PUB. 6-10-2014. FILED 1-30-2013.
- 4,590,687. **HÄNEL AND DESIGN**. HÄNEL GMBH & CO. KG, MULTIPLE CLASS, (INT. CLS. 7, 37, 41, 42 AND 45), (U.S. CLS. 13, 19, 21, 23, 31, 34, 35, 100, 101, 103, 106 AND 107). SN 79-130,627. PUB. 6-10-2014. FILED 2-7-2013.
- 4,590,697. **FUDEX AND DESIGN**. FUDEX GROUP S.P.A., MULTIPLE CLASS, (INT. CLS. 7 AND 11), (U.S. CLS. 13, 19, 21, 23, 31, 34 AND 35). SN 79-132,484. PUB. 6-10-2014. FILED 6-17-2013.
- 4,590,699 ( *See Class 3 for this trademark*).
- 4,590,705. **FLEX-WELL (STANDARD CHARACTER)**. WELL-TEC A/S, MULTIPLE CLASS, (INT. CLS. 7, 9 AND 37), (U.S. CLS. 13, 19, 21, 23, 26, 31, 34, 35, 36, 38, 100, 103 AND 106). SN 79-133,219. PUB. 6-10-2014. FILED 5-10-2013.
- 4,590,708. **ENERFLARE (STANDARD CHARACTER)**. ENER-

- GEN SOLUTIONS PTY LTD, MULTIPLE CLASS, (INT. CLS. 7 AND 11), (U.S. CLS. 13, 19, 21, 23, 31, 34 AND 35). SN 79-133,317. PUB. 6-10-2014. FILED 6-7-2013.
- 4,590,710. **RAMBOR (STANDARD CHARACTER)**. RAMBOR LOGISTICS & ASSET MANAGEMENT PTY LTD, MULTIPLE CLASS, (INT. CLS. 7, 8 AND 37), (U.S. CLS. 13, 19, 21, 23, 28, 31, 34, 35, 44, 100, 103 AND 106). SN 79-133,395. PUB. 6-10-2014. FILED 2-1-2013.
- 4,590,711. **MISCELLANEOUS DESIGN**. RAMBOR LOGISTICS & ASSET MANAGEMENT PTY LTD, MULTIPLE CLASS, (INT. CLS. 7, 8 AND 37), (U.S. CLS. 13, 19, 21, 23, 28, 31, 34, 35, 44, 100, 103 AND 106). SN 79-133,399. PUB. 6-10-2014. FILED 2-1-2013.
- 4,590,714. **SIROLL CHATTERBLOCK (STANDARD CHARACTER)**. SIEMENS VAI METALS TECHNOLOGIES GMBH, (U.S. CLS. 13, 19, 21, 23, 31, 34 AND 35). SN 79-133,437. PUB. 6-10-2014. FILED 6-24-2013.
- 4,590,727. **STABIDRIVE (STANDARD CHARACTER)**. KUHN S.A., MULTIPLE CLASS, (INT. CLS. 7 AND 12), (U.S. CLS. 13, 19, 21, 23, 31, 34, 35 AND 44). SN 79-134,213. PUB. 6-10-2014. FILED 5-24-2013.
- 4,590,732. **FELO (STANDARD CHARACTER)**. FELO-WERKZEUGFABRIK HOLLAND-LETZ GMBH, MULTIPLE CLASS, (INT. CLS. 7, 8 AND 20), (U.S. CLS. 2, 13, 19, 21, 22, 23, 25, 28, 31, 32, 34, 35, 44 AND 50). SN 79-134,385. PUB. 6-10-2014. FILED 7-9-2013.
- 4,590,738. **AMESON (STYLIZED)**. XIA MEN AI MEI SEN BAO ZHUANG; YOU XIAN GONG SI, (U.S. CLS. 13, 19, 21, 23, 31, 34 AND 35). SN 79-134,733. PUB. 6-10-2014. FILED 7-3-2013.
- 4,590,744. **CELLCUBE (STANDARD CHARACTER)**. CELLSTROM GMBH, MULTIPLE CLASS, (INT. CLS. 7, 9, 11, 37, 39 AND 42), (U.S. CLS. 13, 19, 21, 23, 26, 31, 34, 35, 36, 38, 100, 101, 103, 105 AND 106). SN 79-135,201. PUB. 6-10-2014. FILED 6-12-2013.
- 4,590,754. **BLEX (STANDARD CHARACTER)**. WINGFAN LTD. & CO. KG, MULTIPLE CLASS, (INT. CLS. 7 AND 11), (U.S. CLS. 13, 19, 21, 23, 31, 34 AND 35). SN 79-135,544. PUB. 6-10-2014. FILED 7-29-2013.
- 4,590,758. **POLENTONE (STANDARD CHARACTER)**. MARCO PIROVANO, MULTIPLE CLASS, (INT. CLS. 7, 25, 30 AND 43), (U.S. CLS. 13, 19, 21, 22, 23, 31, 34, 35, 39, 46, 100 AND 101). SN 79-135,690. PUB. 6-10-2014. FILED 7-11-2013.
- 4,590,776. **STEPGUARD (STANDARD CHARACTER)**. SPIRAC ENGINEERING AB, MULTIPLE CLASS, (INT. CLS. 7 AND 11), (U.S. CLS. 13, 19, 21, 23, 31, 34 AND 35). SN 79-136,402. PUB. 6-10-2014. FILED 1-29-2013.
- 4,590,795. **WINBOT (STYLIZED)**. ECOVACS ROBOTICS (SUZHOU) CO., LTD, (U.S. CLS. 13, 19, 21, 23, 31, 34 AND 35). SN 79-137,196. PUB. 6-10-2014. FILED 6-5-2013.
- 4,590,803 ( *See Class 6 for this trademark*).
- 4,590,806. **VDO (STYLIZED)**. CONTINENTAL AUTOMOTIVE GMBH, MULTIPLE CLASS, (INT. CLS. 7, 8, 9, 11, 12, 16, 35, 36, 37 AND 42), (U.S. CLS. 2, 5, 13, 19, 21, 22, 23, 26, 28, 29, 31, 34, 35, 36, 37, 38, 44, 50, 100, 101, 102, 103 AND 106). SN 79-137,909. PUB. 6-10-2014. FILED 12-21-2012.
- 4,590,828. **SUPATURF (STANDARD CHARACTER)**. VITAX LIMITED, (U.S. CLS. 13, 19, 21, 23, 31, 34 AND 35). SN 79-139,298. PUB. 6-10-2014. FILED 6-6-2013.
- 4,590,844. **SERVICE ALL-INCLUSIVE AND DESIGN**. TTS TOOLTECHNIC SYSTEMS AG & CO. KG, MULTIPLE CLASS, (INT. CLS. 7, 35, 36 AND 37), (U.S. CLS. 13, 19, 21, 23, 31, 34, 35, 100, 101, 102, 103 AND 106). SN 79-140,204. PUB. 6-10-2014. FILED 9-25-2013.
- 4,590,845 ( *See Class 6 for this trademark*).
- 4,590,858. **FARMCUBE (STANDARD CHARACTER)**. BRILLIANTSERVICE CO., LTD., MULTIPLE CLASS, (INT. CLS. 7, 9, 11, 20, 21, 31, 41, 42, 44 AND 45), (U.S. CLS. 1, 2, 13, 19, 21, 22, 23, 25, 26, 29, 30, 31, 32, 33, 34, 35, 36, 38, 40, 46, 50, 100, 101 AND 107). SN 79-141,396. PUB. 6-10-2014. FILED 2-22-2013.
- 4,590,885. **VMI (STANDARD CHARACTER)**. VMI HOLLAND B.V., MULTIPLE CLASS, (INT. CLS. 7, 37 AND 42), (U.S. CLS. 13, 19, 21, 23, 31, 34, 35, 100, 101, 103 AND 106). SN 79-142,570. PUB. 6-10-2014. FILED 7-9-2013.
- 4,590,891. **CARRYLINE (STANDARD CHARACTER)**. CARRYLINE AKTIEBOLAG, (U.S. CLS. 13, 19, 21, 23, 31, 34 AND 35). SN 79-142,698. PUB. 6-10-2014. FILED 11-21-2013.
- 4,590,902. **MISCELLANEOUS DESIGN**. BIANCHI VENDING GROUP S.P.A., MULTIPLE CLASS, (INT. CLS. 7, 9 AND 11), (U.S. CLS. 13, 19, 21, 23, 26, 31, 34, 35, 36 AND 38). SN 79-143,160. PUB. 6-10-2014. FILED 9-24-2013.
- 4,590,911. **ROBOMATRIX - FOODMACH AND DESIGN**. FOODMACH PTY LTD, (U.S. CLS. 13, 19, 21, 23, 31, 34 AND 35). SN 79-143,576. PUB. 6-10-2014. FILED 12-11-2013.
- 4,590,952. **SERVO ACCESS BOX (STANDARD CHARACTER)**. DANFOSS DRIVES A/S, MULTIPLE CLASS, (INT. CLS. 7 AND 9), (U.S. CLS. 13, 19, 21, 23, 26, 31, 34, 35, 36 AND 38). SN 85-338,941. PUB. 6-10-2014. FILED 6-6-2011.
- 4,590,963. **RAZOR-BACK MDX (STANDARD CHARACTER)**. ASGCO MANUFACTURING, INC., (U.S. CLS. 13, 19, 21, 23, 31, 34 AND 35). SN 85-464,452. PUB. 6-18-2013. FILED 11-4-2011.
- 4,590,982. **V\* ROTARY AND DESIGN**. LG ELECTRONICS INC., MULTIPLE CLASS, (INT. CLS. 7 AND 11), (U.S. CLS. 13, 19, 21, 23, 31, 34 AND 35). SN 85-570,692. PUB. 1-7-2014. FILED 3-15-2012.
- 4,591,015. **CDT CLEAN DIESEL TECHNOLOGIES AND DESIGN**. CLEAN DIESEL TECHNOLOGIES, INC., (U.S. CLS. 13, 19, 21, 23, 31, 34 AND 35). SN 85-736,153. PUB. 6-10-2014. FILED 9-24-2012.
- 4,591,016. **BLUE.DISC (STANDARD CHARACTER)**. HENGST SE & CO. KG, (U.S. CLS. 13, 19, 21, 23, 31, 34 AND 35). SN 85-739,043. PUB. 6-10-2014. FILED 9-26-2012.
- 4,591,047. **PHOTOREADY (STANDARD CHARACTER)**. TECNAU S.R.L., (U.S. CLS. 13, 19, 21, 23, 31, 34 AND 35). SN 85-780,410. PUB. 6-10-2014. FILED 11-15-2012.
- 4,591,079. **NORTH AMERICA TANA FROM WASTE TO VALUE AND DESIGN**. TANA OY, (U.S. CLS. 13, 19, 21, 23, 31, 34 AND 35). SN 85-801,773. PUB. 11-12-2013. FILED 12-13-2012.
- 4,591,102. **ML.DA. (STANDARD CHARACTER)**. DANIELI & C. OFFICINE MECCANICHE S.P.A., MULTIPLE CLASS, (INT. CLS. 7, 9 AND 11), (U.S. CLS. 13, 19, 21, 23, 26, 31, 34, 35, 36 AND 38). SN 85-825,990. PUB. 12-10-2013. FILED 1-17-2013.
- 4,591,119. **PEPIO (STYLIZED)**. KOMORI CORPORATION, MULTIPLE CLASS, (INT. CLS. 7 AND 9), (U.S. CLS. 13, 19, 21, 23, 26, 31, 34, 35, 36 AND 38). SN 85-855,623. PUB. 6-10-2014. FILED 2-20-2013.
- 4,591,129. **CAVITATOR (STANDARD CHARACTER)**. IBALL INSTRUMENTS LLC, (U.S. CLS. 13, 19, 21, 23, 31, 34 AND 35). SN 85-868,022. PUB. 6-10-2014. FILED 3-6-2013.
- 4,591,148. **FRAM PRO PLUS (STANDARD CHARACTER)**. FRAM GROUP IP, LLC, (U.S. CLS. 13, 19, 21, 23, 31, 34 AND 35). SN 85-885,144. PUB. 6-10-2014. FILED 3-25-2013.
- 4,591,162. **INTERSTATE MUFFLER CO. AND DESIGN**. INTERSTATE MUFFLER LLC, MULTIPLE CLASS, (INT. CLS. 7 AND 37), (U.S. CLS. 13, 19, 21, 23, 31, 34, 35, 100, 103 AND 106). SN 85-897,679. PUB. 6-10-2014. FILED 4-8-2013.
- 4,591,166. **C-DAX (STANDARD CHARACTER)**. C-DAX LIMITED, MULTIPLE CLASS, (INT. CLS. 7, 8 AND 9), (U.S. CLS. 13, 19, 21, 23, 26, 28, 31, 34, 35, 36, 38 AND 44). SN 85-901,129. PUB. 6-10-2014. FILED 4-11-2013.
- 4,591,251. **SPORTS LAUNDRY SYSTEMS AND DESIGN**. CONTINENTAL GIRBAU, INC., MULTIPLE CLASS, (INT. CLS. 7 AND 11), (U.S. CLS. 13, 19, 21, 23, 31, 34 AND 35). SN 85-952,469. PUB. 6-10-2014. FILED 6-6-2013.
- 4,591,266. **ULTRA GLIDE (STANDARD CHARACTER)**. JANOME SEWING MACHINE COMPANY LIMITED, (U.S. CLS. 13, 19, 21, 23, 31, 34 AND 35). SN 85-957,712. PUB. 6-10-2014. FILED 6-12-2013.
- 4,591,288. **DUCTMAKER (STANDARD CHARACTER)**. MESTEK MACHINERY, INC., (U.S. CLS. 13, 19, 21, 23, 31, 34 AND 35). SN 85-962,547. PUB. 6-10-2014. FILED 6-18-2013.
- 4,591,311. **AGGRESSOR (STANDARD CHARACTER)**. QUALITY TRUCK & EQUIPMENT CO., (U.S. CLS. 13, 19, 21, 23, 31, 34 AND 35). SN 85-966,465. PUB. 6-10-2014. FILED 6-21-2013.
- 4,591,382. **TYC (STANDARD CHARACTER)**. T.Y.C. BROTHER INDUSTRIAL CO., LTD., MULTIPLE CLASS, (INT. CLS. 7, 11 AND 12), (U.S. CLS. 13, 19, 21, 23, 31, 34, 35 AND 44). SN 85-974,765. PUB. 6-10-2014. FILED 7-1-2013.
- 4,591,404. **MISCELLANEOUS DESIGN**. SKURKA AEROSPACE INC., (U.S. CLS. 13, 19, 21, 23, 31, 34 AND 35). SN 86-000,825. PUB. 6-10-2014. FILED 7-2-2013.

- 4,591,434. **BLAK BOX (STANDARD CHARACTER)**. REGAL BELOIT AMERICA, INC., (U.S. CLS. 13, 19, 21, 23, 31, 34 AND 35). SN 86-003,263. PUB. 6-10-2014. FILED 7-5-2013.
- 4,591,465. **MARINER (STANDARD CHARACTER)**. REGAL BELOIT AMERICA, INC., (U.S. CLS. 13, 19, 21, 23, 31, 34 AND 35). SN 86-006,657. PUB. 6-10-2014. FILED 7-10-2013.
- 4,591,534. **ADG (STANDARD CHARACTER)**. AUTOMOTIVE DISTRIBUTIONS GROUP, INC., MULTIPLE CLASS, (INT. CLS. 7 AND 9), (U.S. CLS. 13, 19, 21, 23, 26, 31, 34, 35, 36 AND 38). SN 86-022,267. PUB. 6-10-2014. FILED 7-29-2013.
- 4,591,566. **CARRY VAC (STANDARD CHARACTER)**. GUARDAIR CORPORATION, (U.S. CLS. 13, 19, 21, 23, 31, 34 AND 35). SN 86-028,387. PUB. 6-10-2014. FILED 8-5-2013.
- 4,591,585. **RATHOLE KILLER (STANDARD CHARACTER)**. WEATHERFORD/LAMB, INC., (U.S. CLS. 13, 19, 21, 23, 31, 34 AND 35). SN 86-033,989. PUB. 6-10-2014. FILED 8-9-2013.
- 4,591,600. **WAYPOINT POWER (STANDARD CHARACTER)**. RP DELIO AND COMPANY, INC., (U.S. CLS. 13, 19, 21, 23, 31, 34 AND 35). SN 86-040,327. PUB. 6-10-2014. FILED 8-16-2013.
- 4,591,678. **HOPKINS INTERNATIONAL (STANDARD CHARACTER)**. BILLINGTON WELDING & MANUFACTURING, INC., (U.S. CLS. 13, 19, 21, 23, 31, 34 AND 35). SN 86-063,328. PUB. 6-10-2014. FILED 9-12-2013.
- 4,591,679. **BWM/HOPKINS (STANDARD CHARACTER)**. BILLINGTON WELDING & MANUFACTURING, INC., (U.S. CLS. 13, 19, 21, 23, 31, 34 AND 35). SN 86-063,350. PUB. 6-10-2014. FILED 9-12-2013.
- 4,591,685. **AG-GRESSOR (STANDARD CHARACTER)**. QUALITY TRUCK & EQUIPMENT CO., (U.S. CLS. 13, 19, 21, 23, 31, 34 AND 35). SN 86-065,504. PUB. 6-10-2014. FILED 9-16-2013.
- 4,591,696 ( *See Class 1 for this trademark*).
- 4,591,701. **ADD WI (STYLIZED)**. ADVANCED DEVELOPMENT DEPOT INC., MULTIPLE CLASS, (INT. CLS. 7 AND 9), (U.S. CLS. 13, 19, 21, 23, 26, 31, 34, 35, 36 AND 38). SN 86-072,120. PUB. 6-10-2014. FILED 9-23-2013.
- 4,591,760. **PRONA AND DESIGN**. PRONA AIR TOOL MANUFACTURING LIMITED, (U.S. CLS. 13, 19, 21, 23, 31, 34 AND 35). SN 86-089,504. PUB. 6-10-2014. FILED 10-11-2013.
- 4,591,816. **GLACIAL BLASTER (STANDARD CHARACTER)**. GLACIAL BLASTER, INC., (U.S. CLS. 13, 19, 21, 23, 31, 34 AND 35). SN 86-105,622. PUB. 6-10-2014. FILED 10-30-2013.
- 4,591,819. **VERSAFORM (STYLIZED)**. BROWN MACHINE, LLC, (U.S. CLS. 13, 19, 21, 23, 31, 34 AND 35). SN 86-105,672. PUB. 6-10-2014. FILED 10-30-2013.
- 4,591,930. **ALEX (STYLIZED)**. INNOVATIVE PRODUCT ACHIEVEMENTS, LLC, (U.S. CLS. 13, 19, 21, 23, 31, 34 AND 35). SN 86-126,565. PUB. 6-10-2014. FILED 11-22-2013.
- 4,591,937. **PARMITER (STANDARD CHARACTER)**. WILLIAM HACKETT CHAINS LIMITED, (U.S. CLS. 13, 19, 21, 23, 31, 34 AND 35). SN 86-126,896. PUB. 6-10-2014. FILED 11-22-2013.
- 4,591,938. **(IPA) (STANDARD CHARACTER)**. INNOVATIVE PRODUCT ACHIEVEMENTS, LLC, (U.S. CLS. 13, 19, 21, 23, 31, 34 AND 35). SN 86-126,928. PUB. 6-10-2014. FILED 11-22-2013.
- 4,591,970. **SIMMONS (STANDARD CHARACTER)**. SIMMONS ENGINEERING CORPORATION, (U.S. CLS. 13, 19, 21, 23, 31, 34 AND 35). SN 86-131,098. PUB. 6-10-2014. FILED 11-27-2013.
- 4,591,973. **STOL-MILL (STANDARD CHARACTER)**. PROCESS EQUIPMENT SPECIALISTS, (U.S. CLS. 13, 19, 21, 23, 31, 34 AND 35). SN 86-131,611. PUB. 6-10-2014. FILED 11-28-2013.
- 4,591,982. **WEATHER-ARC (STANDARD CHARACTER)**. ROLL-RITE, LLC, (U.S. CLS. 13, 19, 21, 23, 31, 34 AND 35). SN 86-132,637. PUB. 6-10-2014. FILED 12-2-2013.
- 4,591,993. **WHISPERPROP (STANDARD CHARACTER)**. FISCHER PANDA GMBH, (U.S. CLS. 13, 19, 21, 23, 31, 34 AND 35). SN 86-133,859. PUB. 6-10-2014. FILED 12-3-2013.
- 4,592,129. **ROCK BASHER (STANDARD CHARACTER)**. ADVANCED FLOW ENGINEERING, INC., (U.S. CLS. 13, 19, 21, 23, 31, 34 AND 35). SN 86-151,064. PUB. 6-10-2014. FILED 12-23-2013.
- 4,592,242. **SUR-CUT (STANDARD CHARACTER)**. ZUCARO, ANDREW, (U.S. CLS. 13, 19, 21, 23, 31, 34 AND 35). SN 86-157,831. PUB. 6-10-2014. FILED 1-6-2014.
- 4,592,673. **INSITUFORM (STANDARD CHARACTER)**. INA ACQUISITION CORP., (U.S. CLS. 13, 19, 21, 23, 31, 34 AND 35). SN 86-175,703. PUB. 6-10-2014. FILED 1-27-2014.
- 4,592,700. **MICROFLAKER (STANDARD CHARACTER)**. PALMANN MASCHINENFABRIK GMBH & CO. KG, (U.S. CLS. 13, 19, 21, 23, 31, 34 AND 35). SN 86-176,193. PUB. 6-10-2014. FILED 1-27-2014.
- 4,592,722 ( *See Class 3 for this trademark*).
- 4,592,725. **EAT TO TREAT (STANDARD CHARACTER)**. MAGICALBUTTER.COM PBC, (U.S. CLS. 13, 19, 21, 23, 31, 34 AND 35). SN 86-176,784. PUB. 6-10-2014. FILED 1-27-2014.

---

## CLASS 8—HAND TOOLS

- 4,590,629. **POP UP (STANDARD CHARACTER)**. TELLIER, MULTIPLE CLASS, (INT. CLS. 8 AND 21), (U.S. CLS. 2, 13, 23, 28, 29, 30, 33, 40, 44 AND 50). SN 79-112,973. PUB. 6-10-2014. FILED 4-2-2012.
- 4,590,710 ( *See Class 7 for this trademark*).
- 4,590,711 ( *See Class 7 for this trademark*).
- 4,590,732 ( *See Class 7 for this trademark*).
- 4,590,806 ( *See Class 7 for this trademark*).
- 4,590,845 ( *See Class 6 for this trademark*).
- 4,590,869. **PLICA PROTECT AND DESIGN**. IRENE SPAPENS, (U.S. CLS. 23, 28 AND 44). SN 79-142,015. PUB. 6-10-2014. FILED 12-11-2013.
- 4,590,951. **UNBREAKABLE (STANDARD CHARACTER)**. JPW INDUSTRIES INC., (U.S. CLS. 23, 28 AND 44). SN 85-327,107. PUB. 6-10-2014. FILED 5-23-2011.
- 4,591,005. **JESCRAFT (STANDARD CHARACTER)**. JESCO IRON CRAFT, INC., DBA JESCRAFT, MULTIPLE CLASS, (INT. CLS. 8 AND 12), (U.S. CLS. 19, 21, 23, 28, 31, 35 AND 44). SN 85-708,811. PUB. 6-10-2014. FILED 8-21-2012.
- 4,591,056. **SPOT-KNOT ON THE SPOT SLIP KNOT TIE SYSTEM AND DESIGN**. BERD'S INNOVATION'S, LLC, (U.S. CLS. 23, 28 AND 44). SN 85-786,419. PUB. 6-10-2014. FILED 11-25-2012.
- 4,591,166 ( *See Class 7 for this trademark*).
- 4,591,317. **3 OAKS HUNTING AND OUTDOORS AND DESIGN**. AMERICAN DISTRIBUTION COMPANY, LLC, (U.S. CLS. 23, 28 AND 44). SN 85-967,115. PUB. 6-10-2014. FILED 6-21-2013.
- 4,591,629 ( *See Class 1 for this trademark*).
- 4,591,774. **EXTRACTIGATOR (STANDARD CHARACTER)**. EXCLUSIVE MECHANICAL SYSTEMS LTD., (U.S. CLS. 23, 28 AND 44). SN 86-094,669. PUB. 6-10-2014. FILED 10-17-2013.
- 4,591,823. **BIKE SMART (STANDARD CHARACTER)**. HEADLANDS VENTURES, LLC DBA MIKE'S BIKES, MULTIPLE CLASS, (INT. CLS. 8, 11 AND 12), (U.S. CLS. 13, 19, 21, 23, 28, 31, 34, 35 AND 44). SN 86-106,094. PUB. 6-10-2014. FILED 10-30-2013.
- 4,592,615. **TRU-GLIDE (STANDARD CHARACTER)**. TRU-GRIND, INC., (U.S. CLS. 23, 28 AND 44). SN 86-174,156. PUB. 6-10-2014. FILED 1-24-2014.
- 4,592,677. **DEAD DEER (STANDARD CHARACTER)**. DO-ALL TRAPS, LLC, DBA DO-ALL OUTDOORS, LLC, (U.S. CLS. 23, 28 AND 44). SN 86-175,762. PUB. 6-10-2014. FILED 1-27-2014.
- 4,592,809. **VALTEV (STANDARD CHARACTER)**. MICHAEL WILLIAMS, AND SUSAN WILLIAMS, (U.S. CLS. 23, 28 AND 44). SN 86-178,118. PUB. 6-10-2014. FILED 1-29-2014.
- 4,592,819. **C9 CLOUD NINE (STYLIZED)**. MASTER DISTRIBUTOR LIMITED, (U.S. CLS. 23, 28 AND 44). SN 86-178,306. PUB. 6-10-2014. FILED 1-29-2014.
- 4,592,922. **PICK-A-PALOOZA (STANDARD CHARACTER)**. EQUIPT4 LLC, (U.S. CLS. 23, 28 AND 44). SN 86-180,498. PUB. 6-10-2014. FILED 1-30-2014.
- 4,593,014. **DEFCON (STANDARD CHARACTER)**. FENG, KUO CHEN, (U.S. CLS. 23, 28 AND 44). SN 86-223,183. PUB. 6-10-2014. FILED 3-17-2014.
- 4,593,016. **PROELIA (STANDARD CHARACTER)**. FENG, KUO CHEN, (U.S. CLS. 23, 28 AND 44). SN 86-223,217. PUB. 6-10-2014. FILED 3-17-2014.

**CLASS 9—ELECTRICAL AND SCIENTIFIC APPARATUS**

- 4,590,610 ( *See Class 3 for this trademark* ).
- 4,590,632. **MIP (STANDARD CHARACTER)**. REED MIDEM, MULTIPLE CLASS, (INT. CLS. 9, 16, 35, 38 AND 41), (U.S. CLS. 2, 5, 21, 22, 23, 26, 29, 36, 37, 38, 50, 100, 101, 102, 104 AND 107). SN 79-115,309. PUB. 6-10-2014. FILED 11-4-2011.
- 4,590,633. **WIREX (STANDARD CHARACTER)**. EDEVICE, SA, MULTIPLE CLASS, (INT. CLS. 9, 38 AND 42), (U.S. CLS. 21, 23, 26, 36, 38, 100, 101 AND 104). SN 79-118,134. PUB. 3-4-2014. FILED 7-13-2012.
- 4,590,635. **SHOPGUARD (STANDARD CHARACTER)**. AMBRUS SÁNDOR, MULTIPLE CLASS, (INT. CLS. 9, 20 AND 37), (U.S. CLS. 2, 13, 21, 22, 23, 25, 26, 32, 36, 38, 50, 100, 103 AND 106). SN 79-120,731. PUB. 6-10-2014. FILED 4-25-2012.
- 4,590,638. **LYONESS TOGETHER WE ARE STRONG AND DESIGN**. UNITED TRADE MARK LIMITED, MULTIPLE CLASS, (INT. CLS. 9, 35, 38 AND 41), (U.S. CLS. 21, 23, 26, 36, 38, 100, 101, 102, 104 AND 107). SN 79-121,216. PUB. 6-10-2014. FILED 7-2-2012.
- 4,590,640. **1ST-RELIEF (STANDARD CHARACTER)**. ANDREAS LESCH., MULTIPLE CLASS, (INT. CLS. 9, 42 AND 45), (U.S. CLS. 21, 23, 26, 36, 38, 100 AND 101). SN 79-122,082. PUB. 6-10-2014. FILED 10-24-2012.
- 4,590,644. **ORBEGOZO AND DESIGN**. SONIFER, S.A., MULTIPLE CLASS, (INT. CLS. 9, 11 AND 21), (U.S. CLS. 2, 13, 21, 23, 26, 29, 30, 31, 33, 34, 36, 38, 40 AND 50). SN 79-122,942. PUB. 6-10-2014. FILED 10-31-2012.
- 4,590,645. **MISCELLANEOUS DESIGN**. HYGINEX INC., MULTIPLE CLASS, (INT. CLS. 9, 35 AND 42), (U.S. CLS. 21, 23, 26, 36, 38, 100, 101 AND 102). SN 79-123,196. PUB. 6-10-2014. FILED 10-18-2012.
- 4,590,646. **HYPERCAD (STANDARD CHARACTER)**. OPEN MIND TECHNOLOGIES AG, MULTIPLE CLASS, (INT. CLS. 9, 16, 41 AND 42), (U.S. CLS. 2, 5, 21, 22, 23, 26, 29, 36, 37, 38, 50, 100, 101 AND 107). SN 79-123,546. PUB. 6-10-2014. FILED 9-27-2012.
- 4,590,648. **MISCELLANEOUS DESIGN**. KISTLER HOLDING AG, (U.S. CLS. 21, 23, 26, 36 AND 38). SN 79-124,066. PUB. 6-10-2014. FILED 11-19-2012.
- 4,590,649. **MISCELLANEOUS DESIGN**. KISTLER HOLDING AG, (U.S. CLS. 21, 23, 26, 36 AND 38). SN 79-124,067. PUB. 6-10-2014. FILED 11-20-2012.
- 4,590,650 ( *See Class 7 for this trademark* ).
- 4,590,655. **DESIGNING FLUIDITY (STANDARD CHARACTER)**. ALSTOM TRANSPORT SA, MULTIPLE CLASS, (INT. CLS. 9, 12, 16, 18, 25, 35, 37, 38, 39, 40, 41, 42 AND 45), (U.S. CLS. 1, 2, 3, 5, 19, 21, 22, 23, 26, 29, 31, 35, 36, 37, 38, 39, 41, 44, 50, 100, 101, 102, 103, 104, 105, 106 AND 107). SN 79-125,320. PUB. 12-24-2013. FILED 10-5-2012.
- 4,590,656. **DIXIM (STANDARD CHARACTER)**. DIGION, INC., MULTIPLE CLASS, (INT. CLS. 9 AND 42), (U.S. CLS. 21, 23, 26, 36, 38, 100 AND 101). SN 79-125,446. PUB. 6-10-2014. FILED 9-28-2012.
- 4,590,657. **HOMOLOG AND DESIGN**. MUSESTREIZE, SOCIÉTÉ ANONYME, MULTIPLE CLASS, (INT. CLS. 9, 35, 36, 38 AND 42), (U.S. CLS. 21, 23, 26, 36, 38, 100, 101, 102 AND 104). SN 79-125,459. PUB. 6-10-2014. FILED 11-20-2012.
- 4,590,658. **AUDIRVANA (STANDARD CHARACTER)**. HPCI SARL -, HENRI PLISSON CONSEIL ET INVESTISSEMENT, (U.S. CLS. 21, 23, 26, 36 AND 38). SN 79-125,695. PUB. 6-10-2014. FILED 12-4-2012.
- 4,590,659. **SUPER KIWI CASTLE RUN AND DESIGN**. ISCOOL ENTERTAINMENT, MULTIPLE CLASS, (INT. CLS. 9, 41 AND 42), (U.S. CLS. 21, 23, 26, 36, 38, 100, 101 AND 107). SN 79-125,756. PUB. 6-10-2014. FILED 12-14-2012.
- 4,590,662 ( *See Class 7 for this trademark* ).
- 4,590,665. **WUNDERKRAUT (STANDARD CHARACTER)**. WUNDERKRAUT HOLDING S.A., MULTIPLE CLASS, (INT. CLS. 9, 35, 38, 41 AND 42), (U.S. CLS. 21, 23, 26, 36, 38, 100, 101, 102, 104 AND 107). SN 79-127,055. PUB. 6-10-2014. FILED 1-9-2013.
- 4,590,666 ( *See Class 7 for this trademark* ).
- 4,590,668. **ALLBARRY THE DIGITAL LIBRARY AND DESIGN**. XANDRIE, MULTIPLE CLASS, (INT. CLS. 9, 28, 35, 38, 41 AND 42), (U.S. CLS. 21, 22, 23, 26, 36, 38, 50, 100, 101, 102, 104 AND 107). SN 79-127,701. PUB. 6-10-2014. FILED 1-10-2013.
- 4,590,669 ( *See Class 5 for this trademark* ).
- 4,590,679. **SHAMIR SPARK (STANDARD CHARACTER)**. SHAMIR OPTICAL INDUSTRY LTD., (U.S. CLS. 21, 23, 26, 36 AND 38). SN 79-128,647. PUB. 6-10-2014. FILED 2-28-2013.
- 4,590,680. **P PARKNOW AND DESIGN**. BAYERISCHE MOTOREN WERKE; AKTIENGESELLSCHAFT, MULTIPLE CLASS, (INT. CLS. 9, 35, 38 AND 39), (U.S. CLS. 21, 23, 26, 36, 38, 100, 101, 102, 104 AND 105). SN 79-128,932. PUB. 6-10-2014. FILED 2-6-2013.
- 4,590,682. **MEC SWITCHES AND DESIGN**. APEM, (U.S. CLS. 21, 23, 26, 36 AND 38). SN 79-129,156. PUB. 6-10-2014. FILED 3-5-2013.
- 4,590,684. **IL PALATO ITALIANO AND DESIGN**. ENTERPRISE SRL, MULTIPLE CLASS, (INT. CLS. 9, 16, 29, 30, 33, 35, 38, 41 AND 43), (U.S. CLS. 2, 5, 21, 22, 23, 26, 29, 36, 37, 38, 46, 47, 49, 50, 100, 101, 102, 104 AND 107). SN 79-129,476. PUB. 6-10-2014. FILED 1-11-2013.
- 4,590,689. **GREEN AUDIO POWER AND DESIGN**. POWER-SOFT S.P.A., (U.S. CLS. 21, 23, 26, 36 AND 38). SN 79-131,598. PUB. 6-10-2014. FILED 3-28-2013.
- 4,590,690. **KARIFY (STANDARD CHARACTER)**. INNOVATIE PSYCHOLOGISCHE; PSYCHIATRISCHE ZORG B.V., MULTIPLE CLASS, (INT. CLS. 9, 38 AND 44), (U.S. CLS. 21, 23, 26, 36, 38, 100, 101 AND 104). SN 79-131,964. PUB. 6-10-2014. FILED 4-12-2013.
- 4,590,692. **MISCELLANEOUS DESIGN**. FREEDMAN ELECTRONICS PTY LIMITED, (U.S. CLS. 21, 23, 26, 36 AND 38). SN 79-131,987. PUB. 6-10-2014. FILED 9-12-2012.
- 4,590,699 ( *See Class 3 for this trademark* ).
- 4,590,701. **AWOX STRIM (STANDARD CHARACTER)**. AWOX, MULTIPLE CLASS, (INT. CLS. 9 AND 11), (U.S. CLS. 13, 21, 23, 26, 31, 34, 36 AND 38). SN 79-133,101. PUB. 6-10-2014. FILED 4-26-2013.
- 4,590,703. **WORLD OF TANKS BLITZ (STANDARD CHARACTER)**. WARGAMING.NET LLP, MULTIPLE CLASS, (INT. CLS. 9 AND 41), (U.S. CLS. 21, 23, 26, 36, 38, 100, 101 AND 107). SN 79-133,149. PUB. 6-10-2014. FILED 3-1-2013.
- 4,590,705 ( *See Class 7 for this trademark* ).
- 4,590,706. **MISCELLANEOUS DESIGN**. UTV MEDIA (GB) LIMITED, MULTIPLE CLASS, (INT. CLS. 9, 38 AND 41), (U.S. CLS. 21, 23, 26, 36, 38, 100, 101, 104 AND 107). SN 79-133,279. PUB. 6-10-2014. FILED 1-16-2013.
- 4,590,707. **GTO PROFESSIONAL TIMEPIECES AND DESIGN**. MI-TECH, MULTIPLE CLASS, (INT. CLS. 9, 14 AND 18), (U.S. CLS. 1, 2, 3, 21, 22, 23, 26, 27, 28, 36, 38, 41 AND 50). SN 79-133,306. PUB. 6-10-2014. FILED 5-22-2013.
- 4,590,709. **ERICHKRAUSE (STYLIZED)**. ERICH KRAUSE FINLAND OY, MULTIPLE CLASS, (INT. CLS. 9, 16, 18 AND 28), (U.S. CLS. 1, 2, 3, 5, 21, 22, 23, 26, 29, 36, 37, 38, 41 AND 50). SN 79-133,341. PUB. 6-10-2014. FILED 2-25-2013.
- 4,590,712. **NEOSMART (STANDARD CHARACTER)**. DANIEL BENKENSTEIN, MULTIPLE CLASS, (INT. CLS. 9, 35 AND 42), (U.S. CLS. 21, 23, 26, 36, 38, 100, 101 AND 102). SN 79-133,405. PUB. 6-10-2014. FILED 4-29-2013.
- 4,590,717. **VAIO DUO (STANDARD CHARACTER)**. SONY CORPORATION, (U.S. CLS. 21, 23, 26, 36 AND 38). SN 79-133,636. PUB. 6-10-2014. FILED 6-11-2013.
- 4,590,720. **RETHYNC (STANDARD CHARACTER)**. RETHYNC LTD, MULTIPLE CLASS, (INT. CLS. 9, 35, 38 AND 42), (U.S. CLS. 21, 23, 26, 36, 38, 100, 101, 102 AND 104). SN 79-133,891. PUB. 6-10-2014. FILED 3-26-2013.
- 4,590,721. **MERIVAARA (STANDARD CHARACTER)**. MERIVAARA OY, MULTIPLE CLASS, (INT. CLS. 9, 10, 20 AND 37), (U.S. CLS. 2, 13, 21, 22, 23, 25, 26, 32, 36, 38, 39, 44, 50, 100, 103 AND 106). SN 79-134,067. PUB. 6-10-2014. FILED 6-19-2013.
- 4,590,728. **TACTICATH (STANDARD CHARACTER)**. ENDOSSENSE SA, MULTIPLE CLASS, (INT. CLS. 9 AND 10), (U.S. CLS. 21, 23, 26, 36, 38, 39 AND 44). SN 79-134,216. PUB. 6-10-2014. FILED 6-12-2013.
- 4,590,742. **M AND DESIGN**. MERIVAARA CORPORATION, MULTIPLE CLASS, (INT. CLS. 9, 10, 37, 41 AND 42), (U.S. CLS. 21, 23, 26, 36, 38, 39, 44, 100, 101, 103, 106 AND 107). SN 79-135,037. PUB. 6-10-2014. FILED 6-19-2013.
- 4,590,743. **SINOPOLY (STYLIZED)**. SINOPOLY NEW ENERGY INVESTMENT; CO., LTD., (U.S. CLS. 21, 23, 26, 36 AND 38). SN 79-135,139. PUB. 6-10-2014. FILED 6-24-2013.

- 4,590,744 ( *See Class 7 for this trademark.*)  
 4,590,746 ( *See Class 3 for this trademark.*)  
 4,590,752. **MEDSIMULATION (STANDARD CHARACTER)**. KARL STORZ GMBH & CO. KG, MULTIPLE CLASS, (INT. CLS. 9, 35, 37, 41 AND 42), (U.S. CLS. 21, 23, 26, 36, 38, 100, 101, 102, 103, 106 AND 107). SN 79-135,509. PUB. 6-10-2014. FILED 3-11-2013.
- 4,590,762. **MCON MONO (STANDARD CHARACTER)**. TYCO ELECTRONICS AMP GMBH, (U.S. CLS. 21, 23, 26, 36 AND 38). SN 79-135,846. PUB. 6-10-2014. FILED 8-9-2013.
- 4,590,763. **KOR AND DESIGN**. GEOMAGWORLD SA, MULTIPLE CLASS, (INT. CLS. 9, 16, 28, 38, 41 AND 42), (U.S. CLS. 2, 5, 21, 22, 23, 26, 29, 36, 37, 38, 50, 100, 101, 104 AND 107). SN 79-135,866. PUB. 6-10-2014. FILED 6-4-2013.
- 4,590,764. **HAPPY CHEF AND DESIGN**. UAB "NORDCURRENT", MULTIPLE CLASS, (INT. CLS. 9, 16 AND 28), (U.S. CLS. 2, 5, 21, 22, 23, 26, 29, 36, 37, 38 AND 50). SN 79-135,880. PUB. 6-10-2014. FILED 7-18-2013.
- 4,590,766. **LIMECRAFT (STANDARD CHARACTER)**. LIMECRAFT NV, MULTIPLE CLASS, (INT. CLS. 9, 38, 41 AND 42), (U.S. CLS. 21, 23, 26, 36, 38, 100, 101, 104 AND 107). SN 79-135,956. PUB. 6-10-2014. FILED 5-21-2013.
- 4,590,767. **CHAIN IQ (STANDARD CHARACTER)**. CHAIN IQ HOLDING AG, MULTIPLE CLASS, (INT. CLS. 9, 35, 36, 38, 39, 41, 42 AND 45), (U.S. CLS. 21, 23, 26, 36, 38, 100, 101, 102, 104, 105 AND 107). SN 79-136,097. PUB. 3-4-2014. FILED 4-17-2013.
- 4,590,778. **TELSTRA (STANDARD CHARACTER)**. TELSTRA CORPORATION LIMITED, MULTIPLE CLASS, (INT. CLS. 9, 35, 37, 41 AND 42), (U.S. CLS. 21, 23, 26, 36, 38, 100, 101, 102, 103, 106 AND 107). SN 79-136,435. PUB. 6-10-2014. FILED 2-1-2013.
- 4,590,784. **PRODUCTIONMINDS AND DESIGN**. PRODUCTION MINDS SD LIMITED, MULTIPLE CLASS, (INT. CLS. 9 AND 42), (U.S. CLS. 21, 23, 26, 36, 38, 100 AND 101). SN 79-136,697. PUB. 6-10-2014. FILED 2-15-2013.
- 4,590,789. **CHERRY MX (STANDARD CHARACTER)**. ZF FRIEDRICHSHAFEN AG, (U.S. CLS. 21, 23, 26, 36 AND 38). SN 79-136,945. PUB. 6-10-2014. FILED 7-30-2013.
- 4,590,790. **HEDRIVE (STANDARD CHARACTER)**. HOFFMANN-EITLE GBR, MULTIPLE CLASS, (INT. CLS. 9, 35, 38 AND 42), (U.S. CLS. 21, 23, 26, 36, 38, 100, 101, 102 AND 104). SN 79-136,946. PUB. 6-10-2014. FILED 8-27-2013.
- 4,590,792. **HENRY & MAGDA (STANDARD CHARACTER)**. DANIELA ERBSLÖH, MULTIPLE CLASS, (INT. CLS. 9, 18 AND 25), (U.S. CLS. 1, 2, 3, 21, 22, 23, 26, 36, 38, 39 AND 41). SN 79-137,109. PUB. 6-10-2014. FILED 5-22-2013.
- 4,590,793. **MISCELLANEOUS DESIGN**. DANIELA ERBSLÖH, MULTIPLE CLASS, (INT. CLS. 9, 18 AND 25), (U.S. CLS. 1, 2, 3, 21, 22, 23, 26, 36, 38, 39 AND 41). SN 79-137,110. PUB. 6-10-2014. FILED 5-22-2013.
- 4,590,797. **DALLAN (STANDARD CHARACTER)**. DALLAN S.P.A., MULTIPLE CLASS, (INT. CLS. 9, 37 AND 42), (U.S. CLS. 21, 23, 26, 36, 38, 100, 101, 103 AND 106). SN 79-137,396. PUB. 6-10-2014. FILED 8-13-2013.
- 4,590,799. **ICUSHY AND DESIGN**. ECO NOVUM GMBH, MULTIPLE CLASS, (INT. CLS. 9, 36, 38 AND 42), (U.S. CLS. 21, 23, 26, 36, 38, 100, 101, 102 AND 104). SN 79-137,457. PUB. 6-10-2014. FILED 4-24-2013.
- 4,590,801. **VITAL ELEMENT FOR GROWTH AND DESIGN**. N.V. NEDERLANDSCHE APPARATENFABRIEK "NEDAP", MULTIPLE CLASS, (INT. CLS. 9, 35 AND 42), (U.S. CLS. 21, 23, 26, 36, 38, 100, 101 AND 102). SN 79-137,591. PUB. 6-10-2014. FILED 8-26-2013.
- 4,590,803 ( *See Class 6 for this trademark.*)  
 4,590,806 ( *See Class 7 for this trademark.*)  
 4,590,821. **EPLAN FLUID (STYLIZED)**. EPLAN; SOFTWARE & SERVICE GMBH & CO. KG, MULTIPLE CLASS, (INT. CLS. 9, 41 AND 42), (U.S. CLS. 21, 23, 26, 36, 38, 100, 101 AND 107). SN 79-138,602. PUB. 6-10-2014. FILED 9-24-2013.
- 4,590,822. **EPLAN ENGINEERING CENTER (STYLIZED)**. EPLAN SOFTWARE & SERVICE; GMBH & CO. KG, MULTIPLE CLASS, (INT. CLS. 9, 41 AND 42), (U.S. CLS. 21, 23, 26, 36, 38, 100, 101 AND 107). SN 79-138,741. PUB. 6-10-2014. FILED 9-24-2013.
- 4,590,824 ( *See Class 1 for this trademark.*)  
 4,590,826 ( *See Class 4 for this trademark.*)  
 4,590,830 ( *See Class 6 for this trademark.*)
- 4,590,832. **ENACTO (STANDARD CHARACTER)**. ENERGIYCT, AFGEKORT EICT, NAAMLOZE VENNOOTSCHAP, MULTIPLE CLASS, (INT. CLS. 9, 38 AND 42), (U.S. CLS. 21, 23, 26, 36, 38, 100, 101 AND 104). SN 79-139,517. PUB. 6-10-2014. FILED 6-7-2013.
- 4,590,834. **KELDAN (STANDARD CHARACTER)**. KELDAN GMBH, MULTIPLE CLASS, (INT. CLS. 9 AND 11), (U.S. CLS. 13, 21, 23, 26, 31, 34, 36 AND 38). SN 79-139,722. PUB. 6-10-2014. FILED 6-18-2013.
- 4,590,842. **WOBY AND DESIGN**. THE WORLD BIRTHDAY CONNECTION LIMITED, MULTIPLE CLASS, (INT. CLS. 9, 16, 35, 38, 41 AND 45), (U.S. CLS. 2, 5, 21, 22, 23, 26, 29, 36, 37, 38, 50, 100, 101, 102, 104 AND 107). SN 79-140,096. PUB. 6-10-2014. FILED 6-10-2013.
- 4,590,856 ( *See Class 3 for this trademark.*)  
 4,590,858 ( *See Class 7 for this trademark.*)  
 4,590,861. **2R (STANDARD CHARACTER)**. GREEN DESK B.V., MULTIPLE CLASS, (INT. CLS. 9, 12, 16, 25, 35 AND 41), (U.S. CLS. 2, 5, 19, 21, 22, 23, 26, 29, 31, 35, 36, 37, 38, 39, 44, 50, 100, 101, 102 AND 107). SN 79-141,712. PUB. 6-10-2014. FILED 7-22-2013.
- 4,590,870. **PHYSITRACK (STANDARD CHARACTER)**. PHYSITRACK LIMITED, MULTIPLE CLASS, (INT. CLS. 9, 35 AND 38), (U.S. CLS. 21, 23, 26, 36, 38, 100, 101, 102 AND 104). SN 79-142,027. PUB. 6-10-2014. FILED 10-29-2013.
- 4,590,881 ( *See Class 6 for this trademark.*)  
 4,590,890. **FOEDERIS (STYLIZED)**. FOEDERIS, MULTIPLE CLASS, (INT. CLS. 9 AND 42), (U.S. CLS. 21, 23, 26, 36, 38, 100 AND 101). SN 79-142,696. PUB. 6-10-2014. FILED 11-21-2013.
- 4,590,892. **EBESTLIFE AND DESIGN**. GUANGZHOU LUCKYSKY INDUSTRY CO., LTD., (U.S. CLS. 21, 23, 26, 36 AND 38). SN 79-142,706. PUB. 6-10-2014. FILED 12-19-2013.
- 4,590,895. **<T (STANDARD CHARACTER)**. TRUSTONIC LIMITED, MULTIPLE CLASS, (INT. CLS. 9, 16, 41, 42 AND 45), (U.S. CLS. 2, 5, 21, 22, 23, 26, 29, 36, 37, 38, 50, 100, 101 AND 107). SN 79-142,734. PUB. 6-10-2014. FILED 7-5-2013.
- 4,590,896. **INVANTIVE (STANDARD CHARACTER)**. INVANTIVE SOFTWARE BV, (U.S. CLS. 21, 23, 26, 36 AND 38). SN 79-142,864. PUB. 6-10-2014. FILED 12-3-2013.
- 4,590,898. **BLACK ROCKSHOOTER THE GAME AND DESIGN**. GOOD SMILE COMPANY, INC., (U.S. CLS. 21, 23, 26, 36 AND 38). SN 79-142,952. PUB. 6-10-2014. FILED 11-15-2013.
- 4,590,899. **UGLASS (STANDARD CHARACTER)**. NETZSCHGERÄTEBAU GMBH, (U.S. CLS. 21, 23, 26, 36 AND 38). SN 79-142,957. PUB. 6-10-2014. FILED 11-22-2013.
- 4,590,900. **E EDWARDSON AND DESIGN**. M. EDOUARD PASSAQUAY-BOLLÉ, (U.S. CLS. 21, 23, 26, 36 AND 38). SN 79-143,038. PUB. 6-10-2014. FILED 11-14-2013.
- 4,590,902 ( *See Class 7 for this trademark.*)  
 4,590,905. **ORACHECK (STANDARD CHARACTER)**. CYFEX AG, MULTIPLE CLASS, (INT. CLS. 9 AND 10), (U.S. CLS. 21, 23, 26, 36, 38, 39 AND 44). SN 79-143,204. PUB. 6-10-2014. FILED 12-23-2013.
- 4,590,910. **MISCELLANEOUS DESIGN**. ANDOR TECHNOLOGY PLC, MULTIPLE CLASS, (INT. CLS. 9 AND 42), (U.S. CLS. 21, 23, 26, 36, 38, 100 AND 101). SN 79-143,524. PUB. 6-10-2014. FILED 4-10-2013.
- 4,590,920. **CHRONOTARGET (STANDARD CHARACTER)**. STEINERT SENSING SYSTEMS AS, (U.S. CLS. 21, 23, 26, 36 AND 38). SN 79-144,125. PUB. 6-10-2014. FILED 11-18-2013.
- 4,590,944. **PAIRSHARE (STANDARD CHARACTER)**. PAIRSHARE, LLC, (U.S. CLS. 21, 23, 26, 36 AND 38). SN 85-209,576. PUB. 5-3-2011. FILED 1-3-2011.
- 4,590,945. **ICONTROL (STANDARD CHARACTER)**. F5 NETWORKS, INC., (U.S. CLS. 21, 23, 26, 36 AND 38). SN 85-239,128. PUB. 6-10-2014. FILED 2-10-2011.
- 4,590,947. **RBS (STANDARD CHARACTER)**. ONCQUE CORPORATION, (U.S. CLS. 21, 23, 26, 36 AND 38). SN 85-290,477. PUB. 6-10-2014. FILED 4-8-2011.
- 4,590,952 ( *See Class 7 for this trademark.*)  
 4,590,961. **PUCK (STANDARD CHARACTER)**. BARRETT TECHNOLOGY, INC., (U.S. CLS. 21, 23, 26, 36 AND 38). SN 85-453,586. PUB. 6-10-2014. FILED 10-21-2011.
- 4,590,967. **3D POWER AND DESIGN**. GIGA-BYTE TECH-

- NOLOGY CO., LTD., (U.S. CLS. 21, 23, 26, 36 AND 38). SN 85-484,453. PUB. 6-10-2014. FILED 11-30-2011.
- 4,590,977. **JUNGLEE (STANDARD CHARACTER)**, JUNGLEE GAMES, INC. DBA JUNGLEE, (U.S. CLS. 21, 23, 26, 36 AND 38). SN 85-531,044. PUB. 6-10-2014. FILED 2-1-2012.
- 4,590,985. **SECU RETOUR (STANDARD CHARACTER)**, MMC SOFTWARE INTERNATIONAL CORP., MULTIPLE CLASS, (INT. CLS. 9, 35 AND 45), (U.S. CLS. 21, 23, 26, 36, 38, 100, 101 AND 102). SN 85-622,199. PUB. 6-10-2014. FILED 5-10-2012.
- 4,590,988. **IN A BOX SERIES AND DESIGN**, UNITED RADIO INCORPORATED, (U.S. CLS. 21, 23, 26, 36 AND 38). SN 85-647,429. PUB. 6-10-2014. FILED 6-8-2012.
- 4,590,993. **LATTUS (STANDARD CHARACTER)**, QUANTUM CORPORATION, MULTIPLE CLASS, (INT. CLS. 9, 16, 37, 41 AND 42), (U.S. CLS. 2, 5, 21, 22, 23, 26, 29, 36, 37, 38, 50, 100, 101, 103, 106 AND 107). SN 85-654,404. PUB. 6-10-2014. FILED 6-18-2012.
- 4,590,994. **BOTTLE ROCKET (STANDARD CHARACTER)**, BOTTLE ROCKET LLC, MULTIPLE CLASS, (INT. CLS. 9 AND 42), (U.S. CLS. 21, 23, 26, 36, 38, 100 AND 101). SN 85-654,814. PUB. 6-10-2014. FILED 6-18-2012.
- 4,591,000. **ACTIONCASE (STANDARD CHARACTER)**, RAYNAULD LTD., (U.S. CLS. 21, 23, 26, 36 AND 38). SN 85-682,797. PUB. 6-10-2014. FILED 7-20-2012.
- 4,591,001. **TENPAY (STANDARD CHARACTER)**, TENCENT HOLDINGS LIMITED, MULTIPLE CLASS, (INT. CLS. 9, 35, 36, 38, 39, 41 AND 42), (U.S. CLS. 21, 23, 26, 36, 38, 100, 101, 102, 104, 105 AND 107). SN 85-687,231. PUB. 6-10-2014. FILED 7-26-2012.
- 4,591,011. **SAMSUNG FAME (STANDARD CHARACTER)**, SAMSUNG ELECTRONICS CO., LTD., (U.S. CLS. 21, 23, 26, 36 AND 38). SN 85-733,341. PUB. 6-10-2014. FILED 9-19-2012.
- 4,591,014. **DESIGNING EDUCATION (STANDARD CHARACTER)**, LASALLE INTERNATIONAL INC., MULTIPLE CLASS, (INT. CLS. 9, 16 AND 41), (U.S. CLS. 2, 5, 21, 22, 23, 26, 29, 36, 37, 38, 50, 100 AND 107). SN 85-735,006. PUB. 6-10-2014. FILED 9-21-2012.
- 4,591,017. **ISOTERA (STANDARD CHARACTER)**, ISOTERA LIMITED, (U.S. CLS. 21, 23, 26, 36 AND 38). SN 85-740,029. PUB. 6-10-2014. FILED 9-27-2012.
- 4,591,021. **NUECO TRACKER (STANDARD CHARACTER)**, NUECO ENTERPRISES INC., (U.S. CLS. 21, 23, 26, 36 AND 38). SN 85-756,363. PUB. 12-24-2013. FILED 10-17-2012.
- 4,591,028. **D SAMSUNG DININGBOOK (STYLIZED)**, SAMSUNG ELECTRONICS CO., LTD., (U.S. CLS. 21, 23, 26, 36 AND 38). SN 85-764,523. PUB. 6-10-2014. FILED 10-26-2012.
- 4,591,037. **GLAMAZON EXERCISE NUTRITION LIFESTYLE AND DESIGN**, CROTHERS, BEVERLY LILLIAN, MULTIPLE CLASS, (INT. CLS. 9, 16 AND 41), (U.S. CLS. 2, 5, 21, 22, 23, 26, 29, 36, 37, 38, 50, 100, 101 AND 107). SN 85-775,732. PUB. 11-5-2013. FILED 11-9-2012.
- 4,591,046. **SITA E-AIRCRAFT (STANDARD CHARACTER)**, SITA NV, MULTIPLE CLASS, (INT. CLS. 9, 35, 37, 38, 39 AND 42), (U.S. CLS. 21, 23, 26, 36, 38, 100, 101, 102, 103, 104, 105 AND 106). SN 85-779,228. PUB. 6-10-2014. FILED 11-14-2012.
- 4,591,048. **SAMSUNG GALAXY FONBLET (STANDARD CHARACTER)**, SAMSUNG ELECTRONICS CO., LTD., (U.S. CLS. 21, 23, 26, 36 AND 38). SN 85-781,098. PUB. 6-10-2014. FILED 11-16-2012.
- 4,591,058. **DONNIYEN.ASIA (STANDARD CHARACTER)**, BULLET FILMS PRODUCTIONS LIMITED, MULTIPLE CLASS, (INT. CLS. 9, 18 AND 25), (U.S. CLS. 1, 2, 3, 21, 22, 23, 26, 36, 38, 39 AND 41). SN 85-787,994. PUB. 6-10-2014. FILED 11-27-2012.
- 4,591,063. **CLARKDIETRICH WALL TYPE CREATOR (STANDARD CHARACTER)**, CLARKWESTERN DIETRICH BUILDING SYSTEMS LLC, (U.S. CLS. 21, 23, 26, 36 AND 38). SN 85-790,776. PUB. 6-10-2014. FILED 11-29-2012.
- 4,591,068. **PINDROPWORLD (STANDARD CHARACTER)**, PINDROPWORLD, LLC, (U.S. CLS. 21, 23, 26, 36 AND 38). SN 85-794,143. PUB. 5-7-2013. FILED 12-4-2012.
- 4,591,069. **DOMINICAN STUDIES INSTITUTE RESEARCH MONOGRAPH (STANDARD CHARACTER)**, CITY UNIVERSITY OF NEW YORK DOMINICAN STUDIES INSTITUTE, MULTIPLE CLASS, (INT. CLS. 9 AND 41), (U.S. CLS. 21, 23, 26, 36, 38, 100, 101 AND 107). SN 85-794,456. PUB. 6-10-2014. FILED 12-4-2012.
- 4,591,076. **S2R2 (STYLIZED)**, LG ELECTRONICS INC., MULTIPLE CLASS, (INT. CLS. 9, 35 AND 38), (U.S. CLS. 21, 23, 26, 36, 38, 100, 101, 102 AND 104). SN 85-801,012. PUB. 6-10-2014. FILED 12-12-2012.
- 4,591,077. **PRIVATE SOUND MODE AND DESIGN**, LG ELECTRONICS INC., (U.S. CLS. 21, 23, 26, 36 AND 38). SN 85-801,129. PUB. 6-10-2014. FILED 12-12-2012.
- 4,591,085. **BACKHOME (STANDARD CHARACTER)**, VIRBAC, MULTIPLE CLASS, (INT. CLS. 9, 10, 18 AND 45), (U.S. CLS. 1, 2, 3, 21, 22, 23, 26, 36, 38, 39, 41, 44, 100 AND 101). SN 85-806,310. PUB. 6-10-2014. FILED 12-19-2012.
- 4,591,086. **XDR (STANDARD CHARACTER)**, CYBER MEDICAL IMAGING, INC., MULTIPLE CLASS, (INT. CLS. 9, 10, 41 AND 42), (U.S. CLS. 21, 23, 26, 36, 38, 39, 44, 100, 101 AND 107). SN 85-806,884. PUB. 6-10-2014. FILED 12-19-2012.
- 4,591,088. **ICONSIGNMENT (STANDARD CHARACTER)**, BJ BALL LIMITED, MULTIPLE CLASS, (INT. CLS. 9, 16, 35, 38 AND 39), (U.S. CLS. 2, 5, 21, 22, 23, 26, 29, 36, 37, 38, 50, 100, 101, 102, 104 AND 105). SN 85-807,230. PUB. 6-10-2014. FILED 12-20-2012.
- 4,591,097. **STONEY LONESOME PRODUCTIONS (STANDARD CHARACTER)**, CARTOUN, ANDREW, (U.S. CLS. 21, 23, 26, 36 AND 38). SN 85-814,678. PUB. 6-10-2014. FILED 1-3-2013.
- 4,591,098. **MYSTAR MANAGEPOINT (STANDARD CHARACTER)**, SANOFI, (U.S. CLS. 21, 23, 26, 36 AND 38). SN 85-816,741. PUB. 6-10-2014. FILED 1-7-2013.
- 4,591,102 ( *See Class 7 for this trademark*).
- 4,591,103. **APPSPLIT (STANDARD CHARACTER)**, YAHFOUFI, HUSSEIN, DBA APPSPLIT, MULTIPLE CLASS, (INT. CLS. 9 AND 35), (U.S. CLS. 21, 23, 26, 36, 38, 100, 101 AND 102). SN 85-828,156. PUB. 6-10-2014. FILED 1-21-2013.
- 4,591,110. **REVS (STANDARD CHARACTER)**, SIERRA NEVADA CORPORATION, (U.S. CLS. 21, 23, 26, 36 AND 38). SN 85-843,111. PUB. 6-10-2014. FILED 2-7-2013.
- 4,591,118. **ALERT (STANDARD CHARACTER)**, WOLO MANUFACTURING CORP., (U.S. CLS. 21, 23, 26, 36 AND 38). SN 85-853,994. PUB. 6-10-2014. FILED 2-19-2013.
- 4,591,119 ( *See Class 7 for this trademark*).
- 4,591,136. **MISCELLANEOUS DESIGN**, SURVEY SAMPLING INTERNATIONAL, LLC, (U.S. CLS. 21, 23, 26, 36 AND 38). SN 85-878,477. PUB. 6-10-2014. FILED 3-18-2013.
- 4,591,152. **BARUDAN (STYLIZED)**, KABUSHIKIKAIASHA BARUDAN, (U.S. CLS. 21, 23, 26, 36 AND 38). SN 85-889,785. PUB. 6-10-2014. FILED 3-28-2013.
- 4,591,153. **TRIPBAROMETER (STANDARD CHARACTER)**, TRIPADVISOR LLC, MULTIPLE CLASS, (INT. CLS. 9, 35 AND 43), (U.S. CLS. 21, 23, 26, 36, 38, 100, 101 AND 102). SN 85-890,716. PUB. 6-10-2014. FILED 3-29-2013.
- 4,591,165. **DROPPPOINT (STANDARD CHARACTER)**, VERIDIANT, LLC, DBA THINKTASTIC SOFTWARE, MULTIPLE CLASS, (INT. CLS. 9 AND 42), (U.S. CLS. 21, 23, 26, 36, 38, 100 AND 101). SN 85-901,110. PUB. 3-4-2014. FILED 4-12-2013.
- 4,591,166 ( *See Class 7 for this trademark*).
- 4,591,168. **MICRO FOCUS AND DESIGN**, MICRO FOCUS IP DEVELOPMENT LIMITED, MULTIPLE CLASS, (INT. CLS. 9, 41 AND 42), (U.S. CLS. 21, 23, 26, 36, 38, 100, 101 AND 107). SN 85-903,885. PUB. 12-24-2013. FILED 4-15-2013.
- 4,591,170. **ROOTS2THEFUTURE (STANDARD CHARACTER)**, FERNS, PHIL, MULTIPLE CLASS, (INT. CLS. 9, 25, 35, 38, 41, 42 AND 45), (U.S. CLS. 21, 22, 23, 26, 36, 38, 39, 100, 101, 102, 104 AND 107). SN 85-905,969. PUB. 6-10-2014. FILED 4-16-2013.
- 4,591,172. **SAMSUNG LINK AND DESIGN**, SAMSUNG ELECTRONICS CO., LTD., (U.S. CLS. 21, 23, 26, 36 AND 38). SN 85-909,713. PUB. 6-10-2014. FILED 4-19-2013.
- 4,591,173. **IN2SHOPS (STANDARD CHARACTER)**, EXAQT-WORLD, MULTIPLE CLASS, (INT. CLS. 9, 35 AND 38), (U.S. CLS. 21, 23, 26, 36, 38, 100, 101, 102 AND 104). SN 85-910,384. PUB. 4-29-2014. FILED 4-22-2013.
- 4,591,175. **LOGI ANALYTICS AND DESIGN**, LOGI ANALYTICS, INC., (U.S. CLS. 21, 23, 26, 36 AND 38). SN 85-910,559. PUB. 6-10-2014. FILED 4-22-2013.
- 4,591,177. **MOS DEF (STANDARD CHARACTER)**, BEY, YASIIN, (U.S. CLS. 21, 23, 26, 36 AND 38). SN 85-912,494.

- PUB. 3-4-2014. FILED 4-23-2013.
- 4,591,179. **PRECISION TOUCH (STANDARD CHARACTER)**. ACID LABS, LLC, (U.S. CLS. 21, 23, 26, 36 AND 38). SN 85-914,034. PUB. 6-10-2014. FILED 4-24-2013.
- 4,591,192. **CCB STANDARDS THE CLIMATE, COMMUNITY & BIODIVERSITY ALLIANCE AND DESIGN**. CONSERVATION INTERNATIONAL FOUNDATION, (U.S. CLS. 21, 23, 26, 36 AND 38). SN 85-925,765. PUB. 6-10-2014. FILED 5-7-2013.
- 4,591,195. **ILOOME (STANDARD CHARACTER)**. FRANKLIN WIRELESS CORPORATION, (U.S. CLS. 21, 23, 26, 36 AND 38). SN 85-926,981. PUB. 6-10-2014. FILED 5-8-2013.
- 4,591,203. **STEALTH ATTRACTION (STANDARD CHARACTER)**. RLR MEDIA LIMITED, MULTIPLE CLASS, (INT. CLS. 9 AND 41), (U.S. CLS. 21, 23, 26, 36, 38, 100, 101 AND 107). SN 85-933,877. PUB. 4-8-2014. FILED 5-16-2013.
- 4,591,208. **SCLIP (STANDARD CHARACTER)**. JURASOFT AG, MULTIPLE CLASS, (INT. CLS. 9, 35, 38, 42 AND 45), (U.S. CLS. 21, 23, 26, 36, 38, 100, 101, 102 AND 104). SN 85-937,203. PUB. 6-10-2014. FILED 5-20-2013.
- 4,591,215. **THE LODESTONE (STANDARD CHARACTER)**. KABUSHIKI KAISHA SQUARE ENIX (ALSO TRADING AS SQUARE ENIX CO., LTD.), MULTIPLE CLASS, (INT. CLS. 9 AND 41), (U.S. CLS. 21, 23, 26, 36, 38, 100, 101 AND 107). SN 85-940,634. PUB. 6-10-2014. FILED 5-23-2013.
- 4,591,217. **WISE.IO (STYLIZED)**. WISE.IO, INC., (U.S. CLS. 21, 23, 26, 36 AND 38). SN 85-941,283. PUB. 6-10-2014. FILED 5-23-2013.
- 4,591,221. **PALABRAS DE VIDA AND DESIGN**. WORDS OF LIFE CHRISTIAN CENTER, MULTIPLE CLASS, (INT. CLS. 9, 16 AND 45), (U.S. CLS. 2, 5, 21, 22, 23, 26, 29, 36, 37, 38, 50, 100 AND 101). SN 85-942,661. PUB. 6-10-2014. FILED 5-24-2013.
- 4,591,231. **DAIRYLAND ELECTRICAL INDUSTRIES (STANDARD CHARACTER)**. DAIRYLAND ELECTRICAL INDUSTRIES, INC., (U.S. CLS. 21, 23, 26, 36 AND 38). SN 85-946,332. PUB. 6-10-2014. FILED 5-30-2013.
- 4,591,232. **MCIAS (STANDARD CHARACTER)**. TELESOFT TECHNOLOGIES LTD, (U.S. CLS. 21, 23, 26, 36 AND 38). SN 85-946,542. PUB. 6-10-2014. FILED 5-30-2013.
- 4,591,240. **MICROVISION (STANDARD CHARACTER)**. HERMES MICROVISION, INC., (U.S. CLS. 21, 23, 26, 36 AND 38). SN 85-948,566. PUB. 2-25-2014. FILED 6-3-2013.
- 4,591,245. **CORPORATE LEGAL DESKTOP (STANDARD CHARACTER)**. DATACERT, INC., (U.S. CLS. 21, 23, 26, 36 AND 38). SN 85-949,502. PUB. 6-10-2014. FILED 6-3-2013.
- 4,591,247. **POWERHOUSE/WMS (STANDARD CHARACTER)**. QUALITY SOFTWARE SYSTEMS, INC., (U.S. CLS. 21, 23, 26, 36 AND 38). SN 85-950,937. PUB. 6-10-2014. FILED 6-5-2013.
- 4,591,252. **ON THE GO AND DESIGN**. FUHU HOLDINGS, INC., (U.S. CLS. 21, 23, 26, 36 AND 38). SN 85-952,876. PUB. 6-10-2014. FILED 6-6-2013.
- 4,591,254. **OSIM TAI TAI (STANDARD CHARACTER)**. OSIM INTERNATIONAL LTD, (U.S. CLS. 21, 23, 26, 36 AND 38). SN 85-954,074. PUB. 6-10-2014. FILED 6-7-2013.
- 4,591,256. **ADVENTURE SERIES (STANDARD CHARACTER)**. WESTONE LABORATORIES, INC., (U.S. CLS. 21, 23, 26, 36 AND 38). SN 85-954,432. PUB. 6-10-2014. FILED 6-7-2013.
- 4,591,264. **D AND DESIGN**. DAIRYLAND ELECTRICAL INDUSTRIES, INC., (U.S. CLS. 21, 23, 26, 36 AND 38). SN 85-957,382. PUB. 6-10-2014. FILED 6-12-2013.
- 4,591,275. **INTELLI-CAM (STANDARD CHARACTER)**. OMAX CORPORATION, (U.S. CLS. 21, 23, 26, 36 AND 38). SN 85-959,698. PUB. 6-10-2014. FILED 6-14-2013.
- 4,591,295. **EME (STANDARD CHARACTER)**. URS FEDERAL SERVICES, INC., (U.S. CLS. 21, 23, 26, 36 AND 38). SN 85-964,359. PUB. 6-10-2014. FILED 6-19-2013.
- 4,591,300. **ROYAL (STANDARD CHARACTER)**. ROYAL BATTERY DISTRIBUTORS, INC., (U.S. CLS. 21, 23, 26, 36 AND 38). SN 85-965,549. PUB. 6-10-2014. FILED 6-20-2013.
- 4,591,305. **JUST BOSS CHICKS (STANDARD CHARACTER)**. NELLA CHUNKY, MULTIPLE CLASS, (INT. CLS. 9, 25 AND 30), (U.S. CLS. 21, 22, 23, 26, 36, 38, 39 AND 46). SN 85-966,117. PUB. 6-10-2014. FILED 6-21-2013.
- 4,591,309. **PROCALIBRATOR (STANDARD CHARACTER)**. TOTOKU ELECTRIC CO., LTD., MULTIPLE CLASS, (INT. CLS. 9 AND 10), (U.S. CLS. 21, 23, 26, 36, 38, 39 AND 44). SN 85-966,337. PUB. 6-10-2014. FILED 6-21-2013.
- 4,591,312. **PAYFONT (STANDARD CHARACTER)**. PAYFONT LIMITED, MULTIPLE CLASS, (INT. CLS. 9, 35, 36, 42 AND 45), (U.S. CLS. 21, 23, 26, 36, 38, 100, 101 AND 102). SN 85-966,538. PUB. 6-10-2014. FILED 6-21-2013.
- 4,591,316. **SPOTCAST (STANDARD CHARACTER)**. SPOTCAST INC., (U.S. CLS. 21, 23, 26, 36 AND 38). SN 85-966,955. PUB. 6-10-2014. FILED 6-21-2013.
- 4,591,327. **FAMOUS PHOTO (STANDARD CHARACTER)**. ROBERT C. KNUDSEN, (U.S. CLS. 21, 23, 26, 36 AND 38). SN 85-968,533. PUB. 6-10-2014. FILED 6-24-2013.
- 4,591,334 ( *See Class 6 for this trademark*).
- 4,591,358. **ALL IN ONE (STANDARD CHARACTER)**. MED-STREAMING LLC, MULTIPLE CLASS, (INT. CLS. 9 AND 42), (U.S. CLS. 21, 23, 26, 36, 38, 100 AND 101). SN 85-972,365. PUB. 6-10-2014. FILED 6-27-2013.
- 4,591,380. **S VIEW COVER (STANDARD CHARACTER)**. SAMSUNG ELECTRONICS CO., LTD., (U.S. CLS. 21, 23, 26, 36 AND 38). SN 85-974,557. PUB. 6-10-2014. FILED 7-1-2013.
- 4,591,388. **SNOWPLOW (STANDARD CHARACTER)**. SNOWPLOW ANALYTICS LIMITED, MULTIPLE CLASS, (INT. CLS. 9, 35 AND 42), (U.S. CLS. 21, 23, 26, 36, 38, 100, 101 AND 102). SN 85-980,857. PUB. 6-10-2014. FILED 8-22-2012.
- 4,591,424. **AIM HI AMERICANS IN MOTION - HEALTHY INTERVENTIONS AND DESIGN**. AMERICAN ACADEMY OF FAMILY PHYSICIANS, MULTIPLE CLASS, (INT. CLS. 9, 16 AND 44), (U.S. CLS. 2, 5, 21, 22, 23, 26, 29, 36, 37, 38, 50, 100 AND 101). SN 86-002,314. PUB. 6-10-2014. FILED 7-3-2013.
- 4,591,425. **EL GUANTAZO (STANDARD CHARACTER)**. TEL-EVISA, S.A. DE C.V., MULTIPLE CLASS, (INT. CLS. 9 AND 41), (U.S. CLS. 21, 23, 26, 36, 38, 100, 101 AND 107). SN 86-002,401. PUB. 6-10-2014. FILED 7-3-2013.
- 4,591,433. **GLOBECAST AND DESIGN**. GLOBECAST FRANCE, MULTIPLE CLASS, (INT. CLS. 9, 38 AND 42), (U.S. CLS. 21, 23, 26, 36, 38, 100, 101 AND 104). SN 86-003,228. PUB. 6-10-2014. FILED 7-5-2013.
- 4,591,439. **QUADVIEW (STANDARD CHARACTER)**. RGB SPECTRUM, (U.S. CLS. 21, 23, 26, 36 AND 38). SN 86-003,393. PUB. 6-10-2014. FILED S.R. 7-5-2013; AM. P.R. 7-5-2013.
- 4,591,462. **VISION IS OUR MISSION (STANDARD CHARACTER)**. ORLACO PRODUCTS B.V., (U.S. CLS. 21, 23, 26, 36 AND 38). SN 86-006,170. PUB. 6-10-2014. FILED 7-10-2013.
- 4,591,468. **JCM & CO. (STYLIZED)**. DENTON BENTON & STEELE, LLC, MULTIPLE CLASS, (INT. CLS. 9, 25 AND 41), (U.S. CLS. 21, 22, 23, 26, 36, 38, 39, 100, 101 AND 107). SN 86-007,652. PUB. 6-10-2014. FILED 7-11-2013.
- 4,591,475. **SIGHT MASTER (STANDARD CHARACTER)**. TIEMCO, LTD., (U.S. CLS. 21, 23, 26, 36 AND 38). SN 86-008,654. PUB. 6-10-2014. FILED 7-12-2013.
- 4,591,484. **TRUESPORT AND DESIGN**. UNITED STATES ANTI-DOPING AGENCY, AKA USADA, (U.S. CLS. 21, 23, 26, 36 AND 38). SN 86-010,300. PUB. 6-10-2014. FILED 7-15-2013.
- 4,591,503. **KIDS FUN CLUB (STANDARD CHARACTER)**. TABTALE LTD., (U.S. CLS. 21, 23, 26, 36 AND 38). SN 86-012,335. PUB. 6-10-2014. FILED 7-17-2013.
- 4,591,512. **MRI SOFTWARE AND DESIGN**. MRI SOFTWARE LLC, MULTIPLE CLASS, (INT. CLS. 9 AND 42), (U.S. CLS. 21, 23, 26, 36, 38, 100 AND 101). SN 86-013,818. PUB. 6-10-2014. FILED 7-18-2013.
- 4,591,522. **SQUIRREL BOSS AND DESIGN**. VERSACO LLC, MULTIPLE CLASS, (INT. CLS. 9 AND 21), (U.S. CLS. 2, 13, 21, 23, 26, 29, 30, 33, 36, 38, 40 AND 50). SN 86-016,962. PUB. 6-10-2014. FILED 7-22-2013.
- 4,591,525. **TELEDRIFT (STANDARD CHARACTER)**. TELE-DRIIFT COMPANY, (U.S. CLS. 21, 23, 26, 36 AND 38). SN 86-017,386. PUB. 6-10-2014. FILED 7-23-2013.
- 4,591,534 ( *See Class 7 for this trademark*).
- 4,591,537. **PROMOTING FIRST RELATIONSHIPS (STANDARD CHARACTER)**. JEAN KELLY, (U.S. CLS. 21, 23, 26, 36 AND 38). SN 86-022,857. PUB. 6-10-2014. FILED 7-29-2013.
- 4,591,541. **TOP FIN (STANDARD CHARACTER)**. PETSMAST STORE SUPPORT GROUP, INC., (U.S. CLS. 21, 23, 26, 36 AND 38). SN 86-024,633. PUB. 6-10-2014. FILED 7-31-2013.
- 4,591,547. **IHUMAN (STANDARD CHARACTER)**. CODE

- ADN, (U.S. CLS. 21, 23, 26, 36 AND 38). SN 86-025,319. PUB. 6-10-2014. FILED 7-31-2013.
- 4,591,551. **NORTHTRAC AND DESIGN**. VIVISCAPE, MULTIPLE CLASS, (INT. CLS. 9 AND 44), (U.S. CLS. 21, 23, 26, 36, 38, 100 AND 101). SN 86-026,527. PUB. 12-24-2013. FILED 8-1-2013.
- 4,591,569. **LED AIRGUARD (STANDARD CHARACTER)**. REALWHEELS CORPORATION, (U.S. CLS. 21, 23, 26, 36 AND 38). SN 86-028,806. PUB. 6-10-2014. FILED 8-5-2013.
- 4,591,582. **OTUS (STANDARD CHARACTER)**. CARL ZEISS AG, (U.S. CLS. 21, 23, 26, 36 AND 38). SN 86-033,524. PUB. 6-10-2014. FILED 8-9-2013.
- 4,591,591. **TOPLINE (STANDARD CHARACTER)**. TOPLINE PARTNERS, LLC, (U.S. CLS. 21, 23, 26, 36 AND 38). SN 86-035,827. PUB. 6-10-2014. FILED 8-12-2013.
- 4,591,593. **GOLD PAYS (STANDARD CHARACTER)**. ARISTOCRAT TECHNOLOGIES AUSTRALIA PTY LTD., (U.S. CLS. 21, 23, 26, 36 AND 38). SN 86-036,551. PUB. 6-10-2014. FILED 8-13-2013.
- 4,591,596. **COMARK (STANDARD CHARACTER)**. FLUKE PRECISION MEASUREMENT LIMITED, (U.S. CLS. 21, 23, 26, 36 AND 38). SN 86-037,821. PUB. 6-10-2014. FILED 8-14-2013.
- 4,591,605. **GEARIT (STANDARD CHARACTER)**. ICONIC INVESTMENT LLC, (U.S. CLS. 21, 23, 26, 36 AND 38). SN 86-040,709. PUB. 6-10-2014. FILED 8-16-2013.
- 4,591,606. **SHARELY (STANDARD CHARACTER)**. SULLIVAN, JOHN DERMOT, DBA SHARELY, MULTIPLE CLASS, (INT. CLS. 9 AND 42), (U.S. CLS. 21, 23, 26, 36, 38, 100 AND 101). SN 86-040,820. PUB. 6-10-2014. FILED 8-17-2013.
- 4,591,617. **AIRPARROT (STANDARD CHARACTER)**. SQUIRRELS LLC, (U.S. CLS. 21, 23, 26, 36 AND 38). SN 86-044,011. PUB. 3-4-2014. FILED 8-21-2013.
- 4,591,624. **EDI (STANDARD CHARACTER)**. EFFICIENT DRI-VETRAINS, INC., (U.S. CLS. 21, 23, 26, 36 AND 38). SN 86-045,131. PUB. 6-10-2014. FILED 8-22-2013.
- 4,591,629 ( *See Class 1 for this trademark*).
- 4,591,648. **DATSUN AND DESIGN**. NISSAN JIDOSHA KABUSHIKI KAISHA, TA NISSAN MOTOR CO., LTD., (U.S. CLS. 21, 23, 26, 36 AND 38). SN 86-052,171. PUB. 4-22-2014. FILED 8-30-2013.
- 4,591,651. **REELING IN THE WORLD (STYLIZED)**. RUSLYN HOLDINGS PTY LTD, (U.S. CLS. 21, 23, 26, 36 AND 38). SN 86-053,036. PUB. 6-10-2014. FILED 8-30-2013.
- 4,591,655. **PLX (STANDARD CHARACTER)**. PIONEER KABUSHIKI KAISHA, DBA PIONEER CORPORATION, (U.S. CLS. 21, 23, 26, 36 AND 38). SN 86-054,546. PUB. 6-10-2014. FILED 9-3-2013.
- 4,591,662. **S FINDER (STANDARD CHARACTER)**. SAMSUNG ELECTRONICS CO., LTD., (U.S. CLS. 21, 23, 26, 36 AND 38). SN 86-058,898. PUB. 6-10-2014. FILED 9-9-2013.
- 4,591,665. **MAINTENANCE WORKS (STANDARD CHARACTER)**. PROGENY SYSTEMS CORPORATION, MULTIPLE CLASS, (INT. CLS. 9 AND 42), (U.S. CLS. 21, 23, 26, 36, 38, 100 AND 101). SN 86-060,064. PUB. 6-10-2014. FILED 9-10-2013.
- 4,591,687. **JA SUCCESS PARK (STANDARD CHARACTER)**. JUNIOR ACHIEVEMENT USA, (U.S. CLS. 21, 23, 26, 36 AND 38). SN 86-066,537. PUB. 6-10-2014. FILED 9-17-2013.
- 4,591,689. **MCIG (STANDARD CHARACTER)**. MCIG, INC., (U.S. CLS. 21, 23, 26, 36 AND 38). SN 86-067,791. PUB. 2-25-2014. FILED 9-18-2013.
- 4,591,693. **ULTRA BILLBOARD LITE (STANDARD CHARACTER)**. ULTRAVISION HOLDINGS, LLC, (U.S. CLS. 21, 23, 26, 36 AND 38). SN 86-068,438. PUB. 6-10-2014. FILED 9-18-2013.
- 4,591,694. **ULTRA STREET LITE (STANDARD CHARACTER)**. ULTRAVISION HOLDINGS, LLC, (U.S. CLS. 21, 23, 26, 36 AND 38). SN 86-068,476. PUB. 6-10-2014. FILED 9-18-2013.
- 4,591,701 ( *See Class 7 for this trademark*).
- 4,591,716. **LOVE IS ENERGY FEEL IT BREATHE IT BE IT (STANDARD CHARACTER)**. AMERICAN AMARANTH LLC, MULTIPLE CLASS, (INT. CLS. 9, 14, 18, 20 AND 25), (U.S. CLS. 1, 2, 3, 13, 21, 22, 23, 25, 26, 27, 28, 32, 36, 38, 39, 41 AND 50). SN 86-076,970. PUB. 6-10-2014. FILED 9-27-2013.
- 4,591,727 ( *See Class 1 for this trademark*).
- 4,591,728. **JAE AND PRESTIGE ENTERTAINMENT AND DESIGN**. HEMMINGS, CAMEISHA, (U.S. CLS. 21, 23, 26, 36 AND 38). SN 86-081,181. PUB. 6-10-2014. FILED 10-2-2013.
- 4,591,729 ( *See Class 1 for this trademark*).
- 4,591,730. **GO FURTHER WITH YOURTEAM (STANDARD CHARACTER)**. IEWC CORP., MULTIPLE CLASS, (INT. CLS. 9, 16, 35, 39 AND 42), (U.S. CLS. 2, 5, 21, 22, 23, 26, 29, 36, 37, 38, 50, 100, 101, 102 AND 105). SN 86-081,220. PUB. 5-6-2014. FILED 10-2-2013.
- 4,591,734. **CAPTAIN BEYOND (STANDARD CHARACTER)**. CALDWELL, ROBERT E., (U.S. CLS. 21, 23, 26, 36 AND 38). SN 86-081,538. PUB. 6-10-2014. FILED 10-3-2013.
- 4,591,735. **UNITY AIR (STANDARD CHARACTER)**. SATCOM DIRECT, INC., (U.S. CLS. 21, 23, 26, 36 AND 38). SN 86-081,609. PUB. 6-10-2014. FILED 10-3-2013.
- 4,591,747. **MIGHTY STUDIOS (STANDARD CHARACTER)**. MIGHTY STUDIOS LLC, (U.S. CLS. 21, 23, 26, 36 AND 38). SN 86-083,431. PUB. 6-10-2014. FILED 10-4-2013.
- 4,591,750. **MOKIMOBILITY (STANDARD CHARACTER)**. MOKI MOBILITY, INC., MULTIPLE CLASS, (INT. CLS. 9 AND 42), (U.S. CLS. 21, 23, 26, 36, 38, 100 AND 101). SN 86-084,962. PUB. 6-10-2014. FILED 10-7-2013.
- 4,591,751. **MOKIMANAGE (STANDARD CHARACTER)**. MOKI MOBILITY, INC., MULTIPLE CLASS, (INT. CLS. 9 AND 42), (U.S. CLS. 21, 23, 26, 36, 38, 100 AND 101). SN 86-084,974. PUB. 6-10-2014. FILED 10-7-2013.
- 4,591,757. **CLOUDMILLS (STANDARD CHARACTER)**. CLOUDMILLS LLC, (U.S. CLS. 21, 23, 26, 36 AND 38). SN 86-087,807. PUB. 6-10-2014. FILED 10-10-2013.
- 4,591,758. **RAPARMOR (STANDARD CHARACTER)**. PRECISION AUTOWERKS, LLC, DBA RAPARMOR.COM, (U.S. CLS. 21, 23, 26, 36 AND 38). SN 86-088,152. PUB. 6-10-2014. FILED 10-10-2013.
- 4,591,761. **LOS ANGELES SPARKS AND DESIGN**. WNBA ENTERPRISES, LLC, (U.S. CLS. 21, 23, 26, 36 AND 38). SN 86-089,684. PUB. 6-10-2014. FILED 10-11-2013.
- 4,591,769. **SONOLIVER (STANDARD CHARACTER)**. BRACCO SUISSE S.A., MULTIPLE CLASS, (INT. CLS. 9 AND 42), (U.S. CLS. 21, 23, 26, 36, 38, 100 AND 101). SN 86-092,670. PUB. 6-10-2014. FILED 10-16-2013.
- 4,591,792. **GLSU (STANDARD CHARACTER)**. Z OPTION, INC., (U.S. CLS. 21, 23, 26, 36 AND 38). SN 86-099,034. PUB. 6-10-2014. FILED 10-23-2013.
- 4,591,805. **MISCELLANEOUS DESIGN**. MORPHO DETECTION, INC., (U.S. CLS. 21, 23, 26, 36 AND 38). SN 86-102,156. PUB. 6-10-2014. FILED 10-25-2013.
- 4,591,809. **GET A PLAN! GUIDES (STANDARD CHARACTER)**. EMPHASIS ON EXCELLENCE, INC., MULTIPLE CLASS, (INT. CLS. 9 AND 16), (U.S. CLS. 2, 5, 21, 22, 23, 26, 29, 36, 37, 38 AND 50). SN 86-103,540. PUB. 6-10-2014. FILED 10-28-2013.
- 4,591,817. **VO AND DESIGN**. VOLTAGE ENTERTAINMENT USA, INC., (U.S. CLS. 21, 23, 26, 36 AND 38). SN 86-105,655. PUB. 6-10-2014. FILED 10-30-2013.
- 4,591,818. **EADMS AND DESIGN**. ADRYLAN COMMUNICATIONS, INC., (U.S. CLS. 21, 23, 26, 36 AND 38). SN 86-105,669. PUB. 6-10-2014. FILED 10-30-2013.
- 4,591,826. **POWER2PRACTICE (STANDARD CHARACTER)**. AGEOLOGY LLC, (U.S. CLS. 21, 23, 26, 36 AND 38). SN 86-106,901. PUB. 6-10-2014. FILED 10-31-2013.
- 4,591,831. **CMVISION AND DESIGN**. C&M VISION TECHNOLOGIES INC, MULTIPLE CLASS, (INT. CLS. 9 AND 11), (U.S. CLS. 13, 21, 23, 26, 31, 34, 36 AND 38). SN 86-107,357. PUB. 6-10-2014. FILED 10-31-2013.
- 4,591,840. **CONTROL CENTER EAGLE (STANDARD CHARACTER)**. INDIGOVISION LIMITED, TA INDIGOVISION, (U.S. CLS. 21, 23, 26, 36 AND 38). SN 86-109,283. PUB. 6-10-2014. FILED 11-4-2013.
- 4,591,853. **COLLAPSIBLE EYE BOX AND DESIGN**. EDWARD BROCKINGTON, (U.S. CLS. 21, 23, 26, 36 AND 38). SN 86-113,119. PUB. 6-10-2014. FILED 11-7-2013.
- 4,591,855. **N NISSIN (STYLIZED)**. NISSIN DENTAL PRODUCTS, INC., (U.S. CLS. 21, 23, 26, 36 AND 38). SN 86-113,541. PUB. 6-10-2014. FILED 11-8-2013.
- 4,591,858. **ADEM (STANDARD CHARACTER)**. CENTRE CITY DENTAL LABORATORY, INC., DBA PARADIGM DENTAL MODELS, (U.S. CLS. 21, 23, 26, 36 AND 38). SN 86-113,790. PUB. 6-10-2014. FILED 11-8-2013.
- 4,591,863. **TRIGGER TAMER (STANDARD CHARACTER)**.



- THOMAS HUDSON DOZIER, II, DBA MISOPHONIA TREATMENT INSTITUTE, (U.S. CLS. 21, 23, 26, 36 AND 38). SN 86-114,529. PUB. 6-10-2014. FILED 11-9-2013.
- 4,591,869. **APEX BIO (STYLIZED)**. APEX BIOTECHNOLOGY CORPORATION, (U.S. CLS. 21, 23, 26, 36 AND 38). SN 86-115,665. PUB. 6-10-2014. FILED 11-11-2013.
- 4,591,873. **ACHILLA (STANDARD CHARACTER)**. ADP GAUSELMANN GMBH, MULTIPLE CLASS, (INT. CLS. 9 AND 28), (U.S. CLS. 21, 22, 23, 26, 36, 38 AND 50). SN 86-116,232. PUB. 6-10-2014. FILED 11-12-2013.
- 4,591,876. **\*NID (STANDARD CHARACTER)**. OPTICAL ZONU CORPORATION, DBA OPTICAL ZONU CORPORATION, (U.S. CLS. 21, 23, 26, 36 AND 38). SN 86-116,640. PUB. 6-10-2014. FILED 11-12-2013.
- 4,591,881. **MWORKS AND DESIGN**. PROGENY SYSTEMS CORPORATION, MULTIPLE CLASS, (INT. CLS. 9 AND 42), (U.S. CLS. 21, 23, 26, 36, 38, 100 AND 101). SN 86-117,614. PUB. 6-10-2014. FILED 11-13-2013.
- 4,591,892. **MISCELLANEOUS DESIGN**. SUNNYLION LLC, (U.S. CLS. 21, 23, 26, 36 AND 38). SN 86-119,486. PUB. 6-10-2014. FILED 11-14-2013.
- 4,591,920. **DRINKADVISOR (STANDARD CHARACTER)**. RILON LIMITED, MULTIPLE CLASS, (INT. CLS. 9 AND 42), (U.S. CLS. 21, 23, 26, 36, 38, 100 AND 101). SN 86-124,942. PUB. 6-10-2014. FILED 11-21-2013.
- 4,591,928. **DRINK ADVISOR WORLDS BEST BARS & DRINKS GUIDE AND DESIGN**. RILON LIMITED, MULTIPLE CLASS, (INT. CLS. 9 AND 42), (U.S. CLS. 21, 23, 26, 36, 38, 100 AND 101). SN 86-126,245. PUB. 6-10-2014. FILED 11-22-2013.
- 4,591,929. **ARC THE LAD (STANDARD CHARACTER)**. SONY COMPUTER ENTERTAINMENT INC., MULTIPLE CLASS, (INT. CLS. 9 AND 16), (U.S. CLS. 2, 5, 21, 22, 23, 26, 29, 36, 37, 38 AND 50). SN 86-126,314. PUB. 6-10-2014. FILED 11-22-2013.
- 4,591,933. **ITIPMUSIC (STANDARD CHARACTER)**. ITIP MUSIC LLC, (U.S. CLS. 21, 23, 26, 36 AND 38). SN 86-126,772. PUB. 6-10-2014. FILED 11-22-2013.
- 4,591,955. **ADD ESERVER (STANDARD CHARACTER)**. ADVANCED DIGITAL DATA, INC., (U.S. CLS. 21, 23, 26, 36 AND 38). SN 86-129,253. PUB. 6-10-2014. FILED 11-26-2013.
- 4,591,958. **FMF (STYLIZED)**. FLEXCO, LLC, MULTIPLE CLASS, (INT. CLS. 9, 38 AND 41), (U.S. CLS. 21, 23, 26, 36, 38, 100, 101, 104 AND 107). SN 86-129,703. PUB. 6-10-2014. FILED 11-26-2013.
- 4,591,980. **LANGUAGE TRAINER (STANDARD CHARACTER)**. SMARTY EARS, (U.S. CLS. 21, 23, 26, 36 AND 38). SN 86-132,369. PUB. 6-10-2014. FILED 12-2-2013.
- 4,591,994. **STANN SMITH (STANDARD CHARACTER)**. CONNOR, JAMAR, (U.S. CLS. 21, 23, 26, 36 AND 38). SN 86-134,277. PUB. 6-10-2014. FILED 12-3-2013.
- 4,592,001. **SENTAI FILMWORKS (STANDARD CHARACTER)**. SENTAI HOLDINGS, LLC, (U.S. CLS. 21, 23, 26, 36 AND 38). SN 86-135,752. PUB. 6-10-2014. FILED 12-5-2013.
- 4,592,019. **SHAPES & COLORS (STANDARD CHARACTER)**. SHAPES & COLORS LLC, DBA SHAPES & COLORS, MULTIPLE CLASS, (INT. CLS. 9 AND 41), (U.S. CLS. 21, 23, 26, 36, 38, 100, 101 AND 107). SN 86-137,953. PUB. 6-10-2014. FILED S.R. 12-8-2013; AM. P.R. 12-8-2013.
- 4,592,024. **A AND DESIGN**. ASSOCIATED ENVIRONMENTAL SYSTEMS, INC., (U.S. CLS. 21, 23, 26, 36 AND 38). SN 86-138,470. PUB. 6-10-2014. FILED 12-9-2013.
- 4,592,025. **A ASSOCIATED ENVIRONMENTAL SYSTEMS AND DESIGN**. ASSOCIATED ENVIRONMENTAL SYSTEMS, INC., (U.S. CLS. 21, 23, 26, 36 AND 38). SN 86-138,479. PUB. 6-10-2014. FILED 12-9-2013.
- 4,592,048. **CACTUS MCCOY (STANDARD CHARACTER)**. FLIPLINE IDS LLC, (U.S. CLS. 21, 23, 26, 36 AND 38). SN 86-141,780. PUB. 6-10-2014. FILED 12-12-2013.
- 4,592,056. **MISCELLANEOUS DESIGN**. UNIVERSAL CITY STUDIOS LLC, (U.S. CLS. 21, 23, 26, 36 AND 38). SN 86-142,577. PUB. 6-10-2014. FILED 12-12-2013.
- 4,592,076. **ACTIONSPACE BE EFFECTIVE AND DESIGN**. ACTIONSPACE LLC, (U.S. CLS. 21, 23, 26, 36 AND 38). SN 86-144,754. PUB. 6-10-2014. FILED 12-16-2013.
- 4,592,080. **SS AND DESIGN**. MALIK, AMIR, S, AND INDRIZZO, ZACHARY, T, AKA CASPER, (U.S. CLS. 21, 23, 26, 36 AND 38). SN 86-145,242. PUB. 6-10-2014. FILED 12-16-2013.
- 4,592,081. **POGGINZ (STANDARD CHARACTER)**. POGGINZ, LLC, (U.S. CLS. 21, 23, 26, 36 AND 38). SN 86-145,547. PUB. 6-10-2014. FILED 12-17-2013.
- 4,592,114. **LUXTERA AND DESIGN**. LUXTERA INC., (U.S. CLS. 21, 23, 26, 36 AND 38). SN 86-150,245. PUB. 6-10-2014. FILED 12-20-2013.
- 4,592,118. **WHOWANNA (STANDARD CHARACTER)**. WHO-WANNA, INC., (U.S. CLS. 21, 23, 26, 36 AND 38). SN 86-150,481. PUB. 6-10-2014. FILED 12-22-2013.
- 4,592,150. **ONEDA AND DESIGN**. ONEDA HOLDINGS GROUP COMPANY LIMITED, (U.S. CLS. 21, 23, 26, 36 AND 38). SN 86-152,346. PUB. 6-10-2014. FILED 12-25-2013.
- 4,592,151. **COLOR ESSENCE (STANDARD CHARACTER)**. DAI NIPPON INSATSU KABUSHIKI KAISHA, DBA DAI NIPPON PRINTING CO., LTD., MULTIPLE CLASS, (INT. CLS. 9 AND 42), (U.S. CLS. 21, 23, 26, 36, 38, 100 AND 101). SN 86-152,431. PUB. 6-10-2014. FILED 12-26-2013.
- 4,592,183. **VERQU (STANDARD CHARACTER)**. VERQU LLC, (U.S. CLS. 21, 23, 26, 36 AND 38). SN 86-154,718. PUB. 6-10-2014. FILED 12-30-2013.
- 4,592,191. **ATSPOT AND DESIGN**. ATLINK COMMUNICATIONS, INC., (U.S. CLS. 21, 23, 26, 36 AND 38). SN 86-155,230. PUB. 6-10-2014. FILED 12-31-2013.
- 4,592,208. **V GEAR (STANDARD CHARACTER)**. ELITE BRANDS INC., (U.S. CLS. 21, 23, 26, 36 AND 38). SN 86-156,055. PUB. 6-10-2014. FILED 1-2-2014.
- 4,592,219. **LARAVEL (STANDARD CHARACTER)**. OTWELL, TAYLOR W, (U.S. CLS. 21, 23, 26, 36 AND 38). SN 86-156,586. PUB. 6-10-2014. FILED 1-2-2014.
- 4,592,235. **ISCAN (STANDARD CHARACTER)**. LIFESAFETY POWER, INC., (U.S. CLS. 21, 23, 26, 36 AND 38). SN 86-157,480. PUB. 6-10-2014. FILED 1-4-2014.
- 4,592,247. **R NZ AND DESIGN**. RANZ, (U.S. CLS. 21, 23, 26, 36 AND 38). SN 86-158,150. PUB. 6-10-2014. FILED 1-6-2014.
- 4,592,255. **TXSERIES (STANDARD CHARACTER)**. INTERNATIONAL BUSINESS MACHINES CORPORATION, MULTIPLE CLASS, (INT. CLS. 9 AND 16), (U.S. CLS. 2, 5, 21, 22, 23, 26, 29, 36, 37, 38 AND 50). SN 86-158,281. PUB. 6-10-2014. FILED 1-6-2014.
- 4,592,259. **MORRIS WILLIAMS REALTY I-OFFICE (STANDARD CHARACTER)**. MORRIS WILLIAMS CORPORATION, DBA MORRIS WILLIAMS REALTY, (U.S. CLS. 21, 23, 26, 36 AND 38). SN 86-158,446. PUB. 6-10-2014. FILED 1-6-2014.
- 4,592,281. **JERSEY 4 SURE (STANDARD CHARACTER)**. JERSEYFOURSURE LIMITED LIABILITY COMPANY, (U.S. CLS. 21, 23, 26, 36 AND 38). SN 86-159,554. PUB. 6-10-2014. FILED 1-7-2014.
- 4,592,301. **BE BASLER ELECTRIC AND DESIGN**. BASLER ELECTRIC COMPANY, (U.S. CLS. 21, 23, 26, 36 AND 38). SN 86-160,355. PUB. 6-10-2014. FILED 1-8-2014.
- 4,592,304. **DOUBLE GUN DISTORTION (STANDARD CHARACTER)**. WONG, TREVOR S., (U.S. CLS. 21, 23, 26, 36 AND 38). SN 86-160,520. PUB. 6-10-2014. FILED 1-8-2014.
- 4,592,344. **THE SCHAFFER REPLICA (STANDARD CHARACTER)**. SCHAFFER, KENNETH B., (U.S. CLS. 21, 23, 26, 36 AND 38). SN 86-161,851. PUB. 6-10-2014. FILED 1-9-2014.
- 4,592,353. **TR TORO RIDE AND DESIGN**. TORO RIDE, INC., (U.S. CLS. 21, 23, 26, 36 AND 38). SN 86-161,979. PUB. 6-10-2014. FILED 1-9-2014.
- 4,592,355. **SENTRY PODS (STANDARD CHARACTER)**. SMART DIGITAL LLC, (U.S. CLS. 21, 23, 26, 36 AND 38). SN 86-162,096. PUB. 6-10-2014. FILED 1-10-2014.
- 4,592,367. **NAVIOS (STANDARD CHARACTER)**. BECKMAN COULTER, INC., (U.S. CLS. 21, 23, 26, 36 AND 38). SN 86-162,568. PUB. 6-10-2014. FILED 1-10-2014.
- 4,592,383. **B AND DESIGN**. BREAKLINE LLC, (U.S. CLS. 21, 23, 26, 36 AND 38). SN 86-162,788. PUB. 6-10-2014. FILED 1-10-2014.
- 4,592,385. **BINGO DAY (STANDARD CHARACTER)**. BLACKZEN, INC., (U.S. CLS. 21, 23, 26, 36 AND 38). SN 86-162,855. PUB. 6-10-2014. FILED 1-10-2014.
- 4,592,400. **SMARTZONE (STANDARD CHARACTER)**. LIFESAFETY POWER, INC., DBA LIFESAFETY POWER, INC., (U.S. CLS. 21, 23, 26, 36 AND 38). SN 86-163,287. PUB. 6-10-2014. FILED 1-12-2014.
- 4,592,410. **AIRPUL AND DESIGN**. AIRPUL LLC, (U.S. CLS. 21,

- 23, 26, 36 AND 38). SN 86-163,410. PUB. 6-10-2014. FILED 1-13-2014.
- 4,592,422. **APPOINTMENT GENIE (STANDARD CHARACTER)**. OPENMED. MULTIPLE CLASS, (INT. CLS. 9 AND 42), (U.S. CLS. 21, 23, 26, 36, 38, 100 AND 101). SN 86-163,686. PUB. 6-10-2014. FILED 1-13-2014.
- 4,592,435. **ROCKIN' HOUSE AND DESIGN**. ROCKIN' HOUSE RECORDS, INC., (U.S. CLS. 21, 23, 26, 36 AND 38). SN 86-164,319. PUB. 6-10-2014. FILED 1-13-2014.
- 4,592,438. **ACUSIMPLE (STANDARD CHARACTER)**. ACUSIMPLE, LLC, (U.S. CLS. 21, 23, 26, 36 AND 38). SN 86-164,434. PUB. 6-10-2014. FILED 1-13-2014.
- 4,592,458. **SERGIO BY SMARTRG AND DESIGN**. SMARTRG INC., (U.S. CLS. 21, 23, 26, 36 AND 38). SN 86-165,403. PUB. 6-10-2014. FILED 1-14-2014.
- 4,592,462. **MISCELLANEOUS DESIGN**. SMARTRG INC., (U.S. CLS. 21, 23, 26, 36 AND 38). SN 86-165,417. PUB. 6-10-2014. FILED 1-14-2014.
- 4,592,464. **MISCELLANEOUS DESIGN**. SMARTRG INC., (U.S. CLS. 21, 23, 26, 36 AND 38). SN 86-165,437. PUB. 6-10-2014. FILED 1-14-2014.
- 4,592,465. **SERGIO BY SMARTRG (STANDARD CHARACTER)**. SMARTRG INC., (U.S. CLS. 21, 23, 26, 36 AND 38). SN 86-165,455. PUB. 6-10-2014. FILED 1-14-2014.
- 4,592,466. **SERGIO (STANDARD CHARACTER)**. SMARTRG INC., (U.S. CLS. 21, 23, 26, 36 AND 38). SN 86-165,462. PUB. 6-10-2014. FILED 1-14-2014.
- 4,592,480. **WESTSIDE 4 ATHLETES (STANDARD CHARACTER)**. TEE AND ELL WEIGHT LIFTING AND EXERCISE ENTERPRISES, INC., MULTIPLE CLASS, (INT. CLS. 9, 16 AND 41), (U.S. CLS. 2, 5, 21, 22, 23, 26, 29, 36, 37, 38, 50, 100, 101 AND 107). SN 86-165,993. PUB. 6-10-2014. FILED 1-15-2014.
- 4,592,509. **REDFISH INSTRUMENTS (STANDARD CHARACTER)**. REDFISH INSTRUMENTS, INC., (U.S. CLS. 21, 23, 26, 36 AND 38). SN 86-166,691. PUB. 6-10-2014. FILED 1-15-2014.
- 4,592,519. **CREMONA (STANDARD CHARACTER)**. BERTHOLD TYPES LIMITED, (U.S. CLS. 21, 23, 26, 36 AND 38). SN 86-167,075. PUB. 6-10-2014. FILED 1-16-2014.
- 4,592,521. **EVO (STANDARD CHARACTER)**. BERTHOLD TYPES LIMITED, (U.S. CLS. 21, 23, 26, 36 AND 38). SN 86-167,123. PUB. 6-10-2014. FILED 1-16-2014.
- 4,592,522. **FLANGE (STANDARD CHARACTER)**. BERTHOLD TYPES LIMITED, (U.S. CLS. 21, 23, 26, 36 AND 38). SN 86-167,133. PUB. 6-10-2014. FILED 1-16-2014.
- 4,592,578. **OUP' 3 (STANDARD CHARACTER)**. CASTRO, LOUIS A., (U.S. CLS. 21, 23, 26, 36 AND 38). SN 86-171,459. PUB. 6-10-2014. FILED 1-21-2014.
- 4,592,579. **OFTEN AND DESIGN**. SHENZHEN DADITONG TECHNOLOGY CO., LTD., MULTIPLE CLASS, (INT. CLS. 9 AND 25), (U.S. CLS. 21, 22, 23, 26, 36, 38 AND 39). SN 86-171,578. PUB. 6-10-2014. FILED 1-22-2014.
- 4,592,580. **AOSMART AND DESIGN**. AOSMART INC., (U.S. CLS. 21, 23, 26, 36 AND 38). SN 86-171,580. PUB. 6-10-2014. FILED 1-22-2014.
- 4,592,581. **DOODLY DOO (STANDARD CHARACTER)**. PARADIGM INFOTECH INC., (U.S. CLS. 21, 23, 26, 36 AND 38). SN 86-171,670. PUB. 6-10-2014. FILED 1-22-2014.
- 4,592,587. **BUTTON BUILDER (STANDARD CHARACTER)**. BADGE-A-MINIT, LTD., (U.S. CLS. 21, 23, 26, 36 AND 38). SN 86-172,157. PUB. 6-10-2014. FILED 1-22-2014.
- 4,592,591. **FANWISE (STANDARD CHARACTER)**. STAR-MARK INTERNATIONAL, INC., (U.S. CLS. 21, 23, 26, 36 AND 38). SN 86-172,612. PUB. 6-10-2014. FILED 1-22-2014.
- 4,592,592. **MEACI AND DESIGN**. ZHANG PENG, (U.S. CLS. 21, 23, 26, 36 AND 38). SN 86-172,640. PUB. 6-10-2014. FILED 1-22-2014.
- 4,592,593. **BASTO (STANDARD CHARACTER)**. JEF MARTENS, MULTIPLE CLASS, (INT. CLS. 9 AND 25), (U.S. CLS. 21, 22, 23, 26, 36, 38 AND 39). SN 86-172,648. PUB. 6-10-2014. FILED 1-22-2014.
- 4,592,625. **EXOTIC LOCATION RECORDINGS AND DESIGN**. TURKEY ON RYE MUSIC, DBA EXOTIC LOCATION RECORDINGS, MULTIPLE CLASS, (INT. CLS. 9 AND 41), (U.S. CLS. 21, 23, 26, 36, 38, 100, 101 AND 107). SN 86-174,508. PUB. 6-10-2014. FILED 1-24-2014.
- 4,592,632. **TECHSPEC (STANDARD CHARACTER)**. CM ENTERPRISES, (U.S. CLS. 21, 23, 26, 36 AND 38). SN 86-174,912. PUB. 6-10-2014. FILED 1-24-2014.
- 4,592,641. **IPHEMERIS (STANDARD CHARACTER)**. RIBAUDO, CLIFFORD P., (U.S. CLS. 21, 23, 26, 36 AND 38). SN 86-175,172. PUB. 6-10-2014. FILED 1-25-2014.
- 4,592,653. **TAKING THE RESISTANCE OUT OF TECHNOLOGY (STANDARD CHARACTER)**. OHMING TECHNOLOGY, (U.S. CLS. 21, 23, 26, 36 AND 38). SN 86-175,450. PUB. 6-10-2014. FILED 1-26-2014.
- 4,592,660. **EASYPAD (STANDARD CHARACTER)**. WE LOVE APPS S.L., DBA MOVIN'APP, (U.S. CLS. 21, 23, 26, 36 AND 38). SN 86-175,547. PUB. 6-10-2014. FILED 1-27-2014.
- 4,592,696. **BOLD STANDBY (STANDARD CHARACTER)**. SENYX LLC, (U.S. CLS. 21, 23, 26, 36 AND 38). SN 86-176,112. PUB. 6-10-2014. FILED 1-27-2014.
- 4,592,699. **AAM (STANDARD CHARACTER)**. F5 NETWORKS, INC., (U.S. CLS. 21, 23, 26, 36 AND 38). SN 86-176,190. PUB. 6-10-2014. FILED 1-27-2014.
- 4,592,707. **MYCURVES (STANDARD CHARACTER)**. CURVES INTERNATIONAL, INC., (U.S. CLS. 21, 23, 26, 36 AND 38). SN 86-176,316. PUB. 6-10-2014. FILED 1-27-2014.
- 4,592,714. **SDC (STANDARD CHARACTER)**. F5 NETWORKS, INC., (U.S. CLS. 21, 23, 26, 36 AND 38). SN 86-176,480. PUB. 6-10-2014. FILED 1-27-2014.
- 4,592,719. **TRANSCEND (STANDARD CHARACTER)**. THERMO FINNIGAN LLC, (U.S. CLS. 21, 23, 26, 36 AND 38). SN 86-176,613. PUB. 6-10-2014. FILED 1-27-2014.
- 4,592,726. **APPEAL - IT (STANDARD CHARACTER)**. DIGITECH COMPUTER, INC., MULTIPLE CLASS, (INT. CLS. 9 AND 42), (U.S. CLS. 21, 23, 26, 36, 38, 100 AND 101). SN 86-176,789. PUB. 6-10-2014. FILED 1-27-2014.
- 4,592,730. **SURVENT (STANDARD CHARACTER)**. COMPUTERS FOR MARKETING CORPORATION, AKA CFMC, (U.S. CLS. 21, 23, 26, 36 AND 38). SN 86-176,841. PUB. 6-10-2014. FILED 1-28-2014.
- 4,592,732. **TICAM (STANDARD CHARACTER)**. THERMOTEX-KNIX SYSTEMS LTD., (U.S. CLS. 21, 23, 26, 36 AND 38). SN 86-176,879. PUB. 6-10-2014. FILED 1-28-2014.
- 4,592,735. **LPSENSE (STANDARD CHARACTER)**. L&P PROPERTY MANAGEMENT COMPANY, (U.S. CLS. 21, 23, 26, 36 AND 38). SN 86-176,933. PUB. 6-10-2014. FILED 1-28-2014.
- 4,592,736. **S SELNA AND DESIGN**. NIS HOLDINGS LLC, (U.S. CLS. 21, 23, 26, 36 AND 38). SN 86-176,962. PUB. 6-10-2014. FILED 1-28-2014.
- 4,592,747. **\\ VARONIS AND DESIGN**. VARONIS SYSTEMS, INC., MULTIPLE CLASS, (INT. CLS. 9 AND 42), (U.S. CLS. 21, 23, 26, 36, 38, 100 AND 101). SN 86-177,086. PUB. 6-10-2014. FILED 1-28-2014.
- 4,592,789. **XLIN (STANDARD CHARACTER)**. KIM, YOUNGHO, (U.S. CLS. 21, 23, 26, 36 AND 38). SN 86-177,790. PUB. 6-10-2014. FILED 1-28-2014.
- 4,592,813. **O' CARE (STYLIZED)**. CHARDER ELECTRONIC CO., LTD., (U.S. CLS. 21, 23, 26, 36 AND 38). SN 86-178,233. PUB. 6-10-2014. FILED 1-29-2014.
- 4,592,822. **SHIPMAN & GOODWIN LLP COUNSELORS AT LAW AND DESIGN**. SHIPMAN & GOODWIN LLP, (U.S. CLS. 21, 23, 26, 36 AND 38). SN 86-178,346. PUB. 6-10-2014. FILED 1-29-2014.
- 4,592,843. **FORM-U-SHARE (STANDARD CHARACTER)**. SOFTWARE SOLUTIONS INTEGRATED, LLC, (U.S. CLS. 21, 23, 26, 36 AND 38). SN 86-178,717. PUB. 6-10-2014. FILED 1-29-2014.
- 4,592,860. **SELFISH MACHINES (STANDARD CHARACTER)**. SELFISH MACHINES, LLC, MULTIPLE CLASS, (INT. CLS. 9 AND 41), (U.S. CLS. 21, 23, 26, 36, 38, 100, 101 AND 107). SN 86-178,990. PUB. 6-10-2014. FILED 1-29-2014.
- 4,592,874. **STASIS (STANDARD CHARACTER)**. RPI PROPERTIES 102 LLC, DBA STASIS GAMES, (U.S. CLS. 21, 23, 26, 36 AND 38). SN 86-179,306. PUB. 6-10-2014. FILED 1-30-2014.
- 4,592,880. **QUICK2257 (STANDARD CHARACTER)**. LAWRENCE G. WALTERS, P.A., DBA WALTERS LAW GROUP, (U.S. CLS. 21, 23, 26, 36 AND 38). SN 86-179,600. PUB. 6-10-2014. FILED 1-30-2014.
- 4,592,891. **APPJACKET (STANDARD CHARACTER)**. APPJACKET, INC., FORMERLY HOME NETWORKS AND GAMING INC., (U.S. CLS. 21, 23, 26, 36 AND 38). SN 86-179,831. PUB. 6-10-2014. FILED 1-30-2014.
- 4,592,897. **YILLIO (STANDARD CHARACTER)**. YILLIO, INC.,

- MULTIPLE CLASS, (INT. CLS. 9 AND 35), (U.S. CLS. 21, 23, 26, 36, 38, 100, 101 AND 102). SN 86-179,908. PUB. 6-10-2014. FILED 1-30-2014.
- 4,592,913. **AAI (STANDARD CHARACTER)**. THE AMERICAN ASSOCIATION OF IMMUNOLOGISTS, INC., MULTIPLE CLASS, (INT. CLS. 9, 16, 35 AND 41), (U.S. CLS. 2, 5, 21, 22, 23, 26, 29, 36, 37, 38, 50, 100, 101, 102 AND 107). SN 86-180,377. PUB. 6-10-2014. FILED 1-30-2014.
- 4,592,924. **MISCELLANEOUS DESIGN**. UHS OF DELAWARE, INC., MULTIPLE CLASS, (INT. CLS. 9 AND 44), (U.S. CLS. 21, 23, 26, 36, 38, 100 AND 101). SN 86-180,570. PUB. 6-10-2014. FILED 1-31-2014.
- 4,592,927. **MAKERBOT REPLICATOR (STANDARD CHARACTER)**. MAKERBOT INDUSTRIES, LLC, (U.S. CLS. 21, 23, 26, 36 AND 38). SN 86-181,263. PUB. 6-10-2014. FILED 1-31-2014.
- 4,592,944. **WARRIOR (STANDARD CHARACTER)**. ROSENBAUER AMERICA, LLC, (U.S. CLS. 21, 23, 26, 36 AND 38). SN 86-186,065. PUB. 6-10-2014. FILED 2-6-2014.
- 4,592,973. **PUNTO PELOTA (STANDARD CHARACTER)**. SPOTLY INC., (U.S. CLS. 21, 23, 26, 36 AND 38). SN 86-198,984. PUB. 6-10-2014. FILED 2-20-2014.
- 4,592,984. **V O AND DESIGN**. VERUS OPTICAL, (U.S. CLS. 21, 23, 26, 36 AND 38). SN 86-205,761. PUB. 6-10-2014. FILED 2-27-2014.
- 4,592,985. **TETRIS (STANDARD CHARACTER)**. TETRIS HOLDING, LLC, MULTIPLE CLASS, (INT. CLS. 9 AND 41), (U.S. CLS. 21, 23, 26, 36, 38, 100, 101 AND 107). SN 86-205,967. PUB. 6-10-2014. FILED 2-27-2014.
- 4,592,991. **HB HATCHBOX AND DESIGN**. MEGALOWMART HOLDINGS, INC., (U.S. CLS. 21, 23, 26, 36 AND 38). SN 86-210,969. PUB. 6-10-2014. FILED 3-4-2014.
- 4,592,997. **LINERATE (STANDARD CHARACTER)**. F5 NETWORKS, INC., (U.S. CLS. 21, 23, 26, 36 AND 38). SN 86-215,216. PUB. 6-10-2014. FILED 3-7-2014.
- 4,592,998. **TRUECOPY (STANDARD CHARACTER)**. HITACHI DATA SYSTEMS CORPORATION, (U.S. CLS. 21, 23, 26, 36 AND 38). SN 86-215,423. PUB. 6-10-2014. FILED 3-8-2014.
- 4,593,012. **VOWER AND DESIGN**. VYST ENTERPRISES, INC., (U.S. CLS. 21, 23, 26, 36 AND 38). SN 86-222,703. PUB. 6-10-2014. FILED 3-17-2014.
- 4,593,028. **WODISON (STANDARD CHARACTER)**. LI YAO WEN, (U.S. CLS. 21, 23, 26, 36 AND 38). SN 86-229,486. PUB. 6-10-2014. FILED 3-24-2014.
- 4,593,031. **CARMEL (STANDARD CHARACTER)**. BARON T. LTD., DBA CARMEL CAR AND LIMOUSINE SERVICE, (U.S. CLS. 21, 23, 26, 36 AND 38). SN 86-235,151. PUB. 6-10-2014. FILED 3-28-2014.
- 4,593,037. **CW STARRBLING (STANDARD CHARACTER)**. JONES, CYNTHIA, (U.S. CLS. 21, 23, 26, 36 AND 38). SN 86-239,986. PUB. 6-10-2014. FILED 4-2-2014.
- 4,593,039. **CANDYLICIOUS (STANDARD CHARACTER)**. WE LOVE APPS S.L., DBA MOVIN'APP, (U.S. CLS. 21, 23, 26, 36 AND 38). SN 86-240,921. PUB. 6-10-2014. FILED 4-3-2014.
- 4,593,048. **SPITFIRE (STANDARD CHARACTER)**. OPC MARKETING, INC., (U.S. CLS. 21, 23, 26, 36 AND 38). SN 86-246,958. PUB. 6-10-2014. FILED 4-9-2014.
- 4,593,062. **MOBILES SAFE (STANDARD CHARACTER)**. F5 NETWORKS, INC., (U.S. CLS. 21, 23, 26, 36 AND 38). SN 86-975,091. PUB. 6-10-2014. FILED 9-19-2013.
- 4,593,063. **IDENTITY CUBE (STANDARD CHARACTER)**. SAILPOINT TECHNOLOGIES, INC., (U.S. CLS. 21, 23, 26, 36 AND 38). SN 86-975,098. PUB. 6-10-2014. FILED 8-9-2013.
- 4,590,695. **SERVO COMPASS (STANDARD CHARACTER)**. MAQUET CRITICAL CARE AB, (U.S. CLS. 26, 39 AND 44). SN 79-132,250. PUB. 6-10-2014. FILED 5-24-2013.
- 4,590,716. **MALEM (STANDARD CHARACTER)**. MALEM MEDICAL LIMITED, (U.S. CLS. 26, 39 AND 44). SN 79-133,612. PUB. 6-10-2014. FILED 5-22-2013.
- 4,590,718. **E FABENERGY AND DESIGN**. FABE S.R.L., MULTIPLE CLASS, (INT. CLS. 10, 20 AND 24), (U.S. CLS. 2, 13, 22, 25, 26, 32, 39, 42, 44 AND 50). SN 79-133,682. PUB. 6-10-2014. FILED 7-4-2013.
- 4,590,721 ( *See Class 9 for this trademark*).
- 4,590,728 ( *See Class 9 for this trademark*).
- 4,590,730. **HS ALLEGRA (STANDARD CHARACTER)**. HAAG-STREIT HOLDING AG, (U.S. CLS. 26, 39 AND 44). SN 79-134,265. PUB. 6-10-2014. FILED 7-9-2013.
- 4,590,731. **HS HI-R (STANDARD CHARACTER)**. HAAG-STREIT HOLDING AG, (U.S. CLS. 26, 39 AND 44). SN 79-134,266. PUB. 6-10-2014. FILED 7-9-2013.
- 4,590,742 ( *See Class 9 for this trademark*).
- 4,590,757. **NOVUQARE (STANDARD CHARACTER)**. NOVUQARE B.V., (U.S. CLS. 26, 39 AND 44). SN 79-135,602. PUB. 6-10-2014. FILED 6-19-2013.
- 4,590,779. **ZERO ZONE (STANDARD CHARACTER)**. SAFERSONIC; MEDIZINPRODUKTE HANDELS GMBH, MULTIPLE CLASS, (INT. CLS. 10 AND 44), (U.S. CLS. 26, 39, 44, 100 AND 101). SN 79-136,442. PUB. 6-10-2014. FILED 4-24-2013.
- 4,590,810. **MED TEXTILE AND DESIGN**. MEDTEX SWISS GMBH, (U.S. CLS. 26, 39 AND 44). SN 79-137,980. PUB. 6-10-2014. FILED 9-30-2013.
- 4,590,819. **ISBIR BEDDING AND DESIGN**. ISBIR SÜNGER SANAYI ANONIM SİRKETİ, MULTIPLE CLASS, (INT. CLS. 10, 20, 24 AND 35), (U.S. CLS. 2, 13, 22, 25, 26, 32, 39, 42, 44, 50, 100, 101 AND 102). SN 79-138,537. PUB. 6-10-2014. FILED 12-13-2012.
- 4,590,839. **SENSURA MIO (STANDARD CHARACTER)**. COLOPLAST A/S, (U.S. CLS. 26, 39 AND 44). SN 79-139,969. PUB. 6-10-2014. FILED 9-16-2013.
- 4,590,862. **SKORE CONDOMS AND DESIGN**. TTK PROTECTIVE DEVICES LIMITED, (U.S. CLS. 26, 39 AND 44). SN 79-141,805. PUB. 6-10-2014. FILED 11-27-2013.
- 4,590,863. **THERMO "X" CHANGER (STYLIZED)**. ATOM MEDICAL CORPORATION, (U.S. CLS. 26, 39 AND 44). SN 79-141,902. PUB. 6-10-2014. FILED 11-26-2013.
- 4,590,864. **SYRIQ (STANDARD CHARACTER)**. SCHOTT AKTIENGESELLSCHAFT, (U.S. CLS. 26, 39 AND 44). SN 79-141,907. PUB. 6-10-2014. FILED 11-27-2013.
- 4,590,884. **AIR VAPOJET (STYLIZED)**. ATOM MEDICAL CORPORATION, (U.S. CLS. 26, 39 AND 44). SN 79-142,493. PUB. 6-10-2014. FILED 11-26-2013.
- 4,590,905 ( *See Class 9 for this trademark*).
- 4,590,914. **AFFINITI (STYLIZED)**. KONINKLIJKE PHILIPS NV, (U.S. CLS. 26, 39 AND 44). SN 79-143,766. PUB. 6-10-2014. FILED 1-22-2014.
- 4,590,917. **SIMPLYFLO (STYLIZED)**. KONINKLIJKE PHILIPS NV, (U.S. CLS. 26, 39 AND 44). SN 79-143,997. PUB. 6-10-2014. FILED 1-30-2014.
- 4,590,925. **ACROENDO. (STANDARD CHARACTER)**. NIKKISO CO., LTD., (U.S. CLS. 26, 39 AND 44). SN 79-145,708. PUB. 6-10-2014. FILED 1-22-2014.
- 4,591,003 ( *See Class 1 for this trademark*).
- 4,591,055 ( *See Class 3 for this trademark*).
- 4,591,073. **COMEN (STYLIZED)**. SHENZHEN COMEN MEDICAL INSTRUMENTS CO., LTD., (U.S. CLS. 26, 39 AND 44). SN 85-799,308. PUB. 6-10-2014. FILED 12-11-2012.
- 4,591,082. **DUITOM AND DESIGN**. SEGANEST SEGURIDAD MEDICA Y DE ANESTESIA S.A.S-SEGANEST SAS., (U.S. CLS. 26, 39 AND 44). SN 85-805,699. PUB. 6-10-2014. FILED 12-18-2012.
- 4,591,085 ( *See Class 9 for this trademark*).
- 4,591,086 ( *See Class 9 for this trademark*).
- 4,591,133. **LUXOR (STANDARD CHARACTER)**. NOVARTIS AG, (U.S. CLS. 26, 39 AND 44). SN 85-875,053. PUB. 6-10-2014. FILED 3-13-2013.
- 4,591,142. **VETRIX (STANDARD CHARACTER)**. VETRIX, (U.S. CLS. 26, 39 AND 44). SN 85-881,346. PUB. 6-10-2014. FILED 3-20-2013.
- 4,591,182 ( *See Class 3 for this trademark*).

---

## CLASS 10—MEDICAL APPARATUS

- 4,590,626 ( *See Class 3 for this trademark*).
- 4,590,664. **PURE CARAT (STANDARD CHARACTER)**. SIEMENS MEDICAL INSTRUMENTS PTE LTD, (U.S. CLS. 26, 39 AND 44). SN 79-126,740. PUB. 6-10-2014. FILED 1-29-2013.
- 4,590,666 ( *See Class 7 for this trademark*).
- 4,590,669 ( *See Class 5 for this trademark*).
- 4,590,686. **STYLEITALIANO SHADE GUIDES AND DESIGN**. ITS CONSULTING, S.R.O., MULTIPLE CLASS, (INT. CLS. 10 AND 44), (U.S. CLS. 26, 39, 44, 100 AND 101). SN 79-130,406. PUB. 6-10-2014. FILED 3-18-2013.

- 4,591,191. **CAMBRIAN (STANDARD CHARACTER)**. ROBLIN ATHLETIC INC., MULTIPLE CLASS, (INT. CLS. 10 AND 25), (U.S. CLS. 22, 26, 39 AND 44). SN 85-925,712. PUB. 6-10-2014. FILED 5-7-2013.
- 4,591,265. **MINDBRIDGE INNOVATIONS, LLC (STANDARD CHARACTER)**. MINDBRIDGE INNOVATIONS, LLC, (U.S. CLS. 26, 39 AND 44). SN 85-957,699. PUB. 6-10-2014. FILED 6-12-2013.
- 4,591,309 ( *See Class 9 for this trademark*).
- 4,591,355. **OPTI-SPOT (STANDARD CHARACTER)**. IDEXX LABORATORIES, INC., (U.S. CLS. 26, 39 AND 44). SN 85-971,948. PUB. 6-10-2014. FILED 6-27-2013.
- 4,591,400. **ROTOTOME (STANDARD CHARACTER)**. BENJAMIN A. BAPTIST, (U.S. CLS. 26, 39 AND 44). SN 86-000,142. PUB. 6-10-2014. FILED 7-2-2013.
- 4,591,490. **CER.FACE (STANDARD CHARACTER)**. VITA ZAHNFABRIK H. RAUTER GMBH & CO. KG, (U.S. CLS. 26, 39 AND 44). SN 86-010,839. PUB. 6-10-2014. FILED 7-15-2013.
- 4,591,517. **INNOBABY (STANDARD CHARACTER)**. INNOBABY LLC, (U.S. CLS. 26, 39 AND 44). SN 86-015,728. PUB. 6-10-2014. FILED 7-21-2013.
- 4,591,815. **SOOTHENEB AND DESIGN**. FORA CARE INC., (U.S. CLS. 26, 39 AND 44). SN 86-105,063. PUB. 6-10-2014. FILED 10-29-2013.
- 4,591,923. **CURE CATHETER (STANDARD CHARACTER)**. CURE MEDICAL, LLC, (U.S. CLS. 26, 39 AND 44). SN 86-125,386. PUB. 5-6-2014. FILED 11-21-2013.
- 4,592,096. **XRAY2GO (STYLIZED)**. DENTERPRISE INTERNATIONAL, INC., (U.S. CLS. 26, 39 AND 44). SN 86-148,158. PUB. 6-10-2014. FILED 12-19-2013.
- 4,592,199. **STEP 400 GO FORWARD WITH CONFIDENCE..... AND DESIGN**. SPECTRAMED, INC., (U.S. CLS. 26, 39 AND 44). SN 86-155,644. PUB. 6-10-2014. FILED 12-31-2013.
- 4,592,306. **COMODITÀ (STANDARD CHARACTER)**. COMODITA LLC, (U.S. CLS. 26, 39 AND 44). SN 86-160,603. PUB. 6-10-2014. FILED 1-8-2014.
- 4,592,448. **ALEYDIS (STANDARD CHARACTER)**. ALEYDIS CENTERS, LLC, (U.S. CLS. 26, 39 AND 44). SN 86-164,859. PUB. 6-10-2014. FILED 1-14-2014.
- 4,592,510. **HEALTHBEACON SHARPS (STANDARD CHARACTER)**. HEALTHBEACON LIMITED, (U.S. CLS. 26, 39 AND 44). SN 86-166,693. PUB. 6-10-2014. FILED 1-15-2014.
- 4,592,542. **TONY'S TABLE (STANDARD CHARACTER)**. IN-LINE TABLES, (U.S. CLS. 26, 39 AND 44). SN 86-167,770. PUB. 6-10-2014. FILED 1-16-2014.
- 4,592,544. **TONY'S TABLES (STANDARD CHARACTER)**. IN-LINE TABLES, (U.S. CLS. 26, 39 AND 44). SN 86-167,775. PUB. 6-10-2014. FILED 1-16-2014.
- 4,592,545. **T2000 TABLE (STANDARD CHARACTER)**. IN-LINE TABLES, (U.S. CLS. 26, 39 AND 44). SN 86-167,779. PUB. 6-10-2014. FILED 1-16-2014.
- 4,592,599. **NOVOXEL (STANDARD CHARACTER)**. NOVOXEL LTD., (U.S. CLS. 26, 39 AND 44). SN 86-172,855. PUB. 6-10-2014. FILED 1-23-2014.
- 4,592,600. **TIXEL (STANDARD CHARACTER)**. NOVOXEL LTD., (U.S. CLS. 26, 39 AND 44). SN 86-172,860. PUB. 6-10-2014. FILED 1-23-2014.
- 4,592,613. **IMISSEX AND DESIGN**. ANHUI NEWCENTER ELECTRONIC TECHNOLOGY CO., LTD., (U.S. CLS. 26, 39 AND 44). SN 86-173,966. PUB. 6-10-2014. FILED 1-24-2014.
- 4,592,764. **CHEER-THOTIC (STANDARD CHARACTER)**. TOPICAL GEAR LLC, (U.S. CLS. 26, 39 AND 44). SN 86-177,384. PUB. 6-10-2014. FILED 1-28-2014.
- 4,592,780 ( *See Class 3 for this trademark*).
- 4,592,797. **THESILICOMPANY (STYLIZED)**. SILI GOODNESS, INC., (U.S. CLS. 26, 39 AND 44). SN 86-177,876. PUB. 6-10-2014. FILED 1-28-2014.
- 4,592,798. **IT'S NOT A BOTTLE. IT'S A SQUEEZE. (STANDARD CHARACTER)**. SILI GOODNESS, INC., (U.S. CLS. 26, 39 AND 44). SN 86-177,878. PUB. 6-10-2014. FILED 1-28-2014.
- 4,592,816. **O' CARE (STYLIZED)**. CHARDER ELECTRONIC CO., LTD., (U.S. CLS. 26, 39 AND 44). SN 86-178,252. PUB. 6-10-2014. FILED 1-29-2014.
- 4,592,857. **DURATONE-N (STANDARD CHARACTER)**. NEW STETIC S.A., (U.S. CLS. 26, 39 AND 44). SN 86-178,933. PUB. 6-10-2014. FILED 1-29-2014.
- 4,592,881. **DREAMWAVE (STANDARD CHARACTER)**. FIUS DISTRIBUTORS LLC, (U.S. CLS. 26, 39 AND 44). SN 86-179,611. PUB. 6-10-2014. FILED 1-30-2014.
- 4,592,911. **OKARA (STANDARD CHARACTER)**. RICHMIX DISTRIBUTORS, LLC, (U.S. CLS. 26, 39 AND 44). SN 86-180,357. PUB. 6-10-2014. FILED 1-30-2014.
- 4,592,948. **HEAROS (STYLIZED)**. BUMBLE BE HOLDINGS, LLC, (U.S. CLS. 26, 39 AND 44). SN 86-188,179. PUB. 6-10-2014. FILED 2-7-2014.
- 4,592,951. **SLEEP PRETTY IN PINK (STYLIZED)**. BUMBLE BE HOLDINGS, LLC, (U.S. CLS. 26, 39 AND 44). SN 86-189,150. PUB. 6-10-2014. FILED 2-10-2014.
- 4,593,041. **OT-A (STANDARD CHARACTER)**. ORTHOPEDIC SCIENCES, INC., (U.S. CLS. 26, 39 AND 44). SN 86-241,350. PUB. 6-10-2014. FILED 4-3-2014.

---

### CLASS 11—ENVIRONMENTAL CONTROL APPARATUS

- 4,590,643 ( *See Class 6 for this trademark*).
- 4,590,644 ( *See Class 9 for this trademark*).
- 4,590,651. **SEDAL (STANDARD CHARACTER)**. SEDAL, S.L., (U.S. CLS. 13, 21, 23, 31 AND 34). SN 79-124,406. PUB. 6-10-2014. FILED 11-23-2012.
- 4,590,662 ( *See Class 7 for this trademark*).
- 4,590,666 ( *See Class 7 for this trademark*).
- 4,590,697 ( *See Class 7 for this trademark*).
- 4,590,701 ( *See Class 9 for this trademark*).
- 4,590,708 ( *See Class 7 for this trademark*).
- 4,590,744 ( *See Class 7 for this trademark*).
- 4,590,754 ( *See Class 7 for this trademark*).
- 4,590,776 ( *See Class 7 for this trademark*).
- 4,590,777 ( *See Class 6 for this trademark*).
- 4,590,796. **QUIKPLUMB (STYLIZED)**. ZHEJIANG ANHONG PLUMBING CO.,LTD., (U.S. CLS. 13, 21, 23, 31 AND 34). SN 79-137,303. PUB. 6-10-2014. FILED 6-5-2013.
- 4,590,806 ( *See Class 7 for this trademark*).
- 4,590,818. **HANDTE (STANDARD CHARACTER)**. HANDTE UMWELTECHNIK GMBH, MULTIPLE CLASS, (INT. CLS. 11, 37 AND 42), (U.S. CLS. 13, 21, 23, 31, 34, 100, 101, 103 AND 106). SN 79-138,513. PUB. 6-10-2014. FILED 8-14-2013.
- 4,590,824 ( *See Class 1 for this trademark*).
- 4,590,834 ( *See Class 9 for this trademark*).
- 4,590,858 ( *See Class 7 for this trademark*).
- 4,590,902 ( *See Class 7 for this trademark*).
- 4,590,982 ( *See Class 7 for this trademark*).
- 4,591,096. **FUNDO LIGNO (STANDARD CHARACTER)**. WEDI GMBH, MULTIPLE CLASS, (INT. CLS. 11, 17, 19 AND 20), (U.S. CLS. 1, 2, 5, 12, 13, 21, 22, 23, 25, 31, 32, 33, 34, 35 AND 50). SN 85-811,799. PUB. 6-10-2014. FILED 12-28-2012.
- 4,591,102 ( *See Class 7 for this trademark*).
- 4,591,130. **HYPALUME (STANDARD CHARACTER)**. HELLA AUSTRALIA PTY LTD, (U.S. CLS. 13, 21, 23, 31 AND 34). SN 85-868,248. PUB. 6-10-2014. FILED 3-6-2013.
- 4,591,182 ( *See Class 3 for this trademark*).
- 4,591,199. **AUSIMIX (STANDARD CHARACTER)**. GSA INDUSTRIES (AUST.) PTY. LTD., (U.S. CLS. 13, 21, 23, 31 AND 34). SN 85-932,537. PUB. 6-10-2014. FILED 5-15-2013.
- 4,591,251 ( *See Class 7 for this trademark*).
- 4,591,278. **GLORY G (STYLIZED)**. AL-AZMEYAH TRADING ESTABLISHMENT, (U.S. CLS. 13, 21, 23, 31 AND 34). SN 85-960,598. PUB. 6-10-2014. FILED 6-14-2013.
- 4,591,382 ( *See Class 7 for this trademark*).
- 4,591,501. **TOAST-QWIK (STANDARD CHARACTER)**. HATCO CORPORATION, (U.S. CLS. 13, 21, 23, 31 AND 34). SN 86-012,213. PUB. 6-10-2014. FILED 7-17-2013.
- 4,591,542. **TOP FIN (STANDARD CHARACTER)**. PETSMAST STORE SUPPORT GROUP, INC., (U.S. CLS. 13, 21, 23, 31 AND 34). SN 86-024,639. PUB. 6-10-2014. FILED 7-31-2013.
- 4,591,628. **DAN MAR PORTABLE DIP SYSTEM (STANDARD CHARACTER)**. DAN MAR CO., (U.S. CLS. 13, 21, 23, 31 AND 34). SN 86-047,451. PUB. 6-10-2014. FILED 8-26-2013.
- 4,591,639. **INSTANT-TEMP (STANDARD CHARACTER)**. CHRONOMITE LABORATORIES, INC., (U.S. CLS. 13, 21, 23, 31 AND 34). SN 86-050,903. PUB. 6-10-2014. FILED 8-28-

- 2013.
- 4,591,667. **SPOILER (STANDARD CHARACTER)**. AM CONSERVATION GROUP, INC., (U.S. CLS. 13, 21, 23, 31 AND 34). SN 86-060,902. PUB. 6-10-2014. FILED 9-10-2013.
- 4,591,668. **TOILET TUMMY (STANDARD CHARACTER)**. AM CONSERVATION GROUP, INC., (U.S. CLS. 13, 21, 23, 31 AND 34). SN 86-060,927. PUB. 6-10-2014. FILED 9-10-2013.
- 4,591,783. **SOLUTION SERIES (STYLIZED)**. AIR MASTER SYSTEMS, CORP., (U.S. CLS. 13, 21, 23, 31 AND 34). SN 86-097,568. PUB. 6-10-2014. FILED 10-22-2013.
- 4,591,823 ( *See Class 8 for this trademark*).
- 4,591,831 ( *See Class 9 for this trademark*).
- 4,591,871. **EDGE (STANDARD CHARACTER)**. FORUM US, INC., (U.S. CLS. 13, 21, 23, 31 AND 34). SN 86-115,714. PUB. 6-10-2014. FILED 11-11-2013.
- 4,591,940. **SANTA'S WORKSHOP (STANDARD CHARACTER)**. ADJ, INC. (U.S. CLS. 13, 21, 23, 31 AND 34). SN 86-127,322. PUB. 6-10-2014. FILED 11-22-2013.
- 4,591,942. **WITT (STANDARD CHARACTER)**. HEAT TRANSFER PRODUCTS GROUP, LLC. (U.S. CLS. 13, 21, 23, 31 AND 34). SN 86-127,776. PUB. 6-10-2014. FILED 11-24-2013.
- 4,591,951. **COMFORT-AIRE (STYLIZED)**. HEAT CONTROLLER LLC, (U.S. CLS. 13, 21, 23, 31 AND 34). SN 86-128,501. PUB. 6-10-2014. FILED 11-25-2013.
- 4,592,179. **STRIKE (STANDARD CHARACTER)**. CHAUVET & SONS, INC., (U.S. CLS. 13, 21, 23, 31 AND 34). SN 86-154,548. PUB. 6-10-2014. FILED 12-30-2013.
- 4,592,201. **BHI (STYLIZED)**. BHI INTERNATIONAL INC., (U.S. CLS. 13, 21, 23, 31 AND 34). SN 86-155,790. PUB. 6-10-2014. FILED 1-1-2014.
- 4,592,206. **SOLAMIST (STANDARD CHARACTER)**. SMITH, MURRAY, (U.S. CLS. 13, 21, 23, 31 AND 34). SN 86-156,044. PUB. 6-10-2014. FILED 1-2-2014.
- 4,592,283. **LET AND DESIGN**. LIGHT EMISSION TECHNOLOGY, (U.S. CLS. 13, 21, 23, 31 AND 34). SN 86-159,622. PUB. 6-10-2014. FILED 1-7-2014.
- 4,592,482. **BOILERS FOR PEOPLE WHO KNOW AND CARE (STANDARD CHARACTER)**. RENTECH BOILER SYSTEMS, INC., (U.S. CLS. 13, 21, 23, 31 AND 34). SN 86-166,038. PUB. 6-10-2014. FILED 1-15-2014.
- 4,592,520. **THE GALLEY REINVENTING THE KITCHEN AND DESIGN**. THE GALLEY, LLC, (U.S. CLS. 13, 21, 23, 31 AND 34). SN 86-167,105. PUB. 6-10-2014. FILED 1-16-2014.
- 4,592,525. **QUIETFILL (STANDARD CHARACTER)**. LAVELLE INDUSTRIES, INC., (U.S. CLS. 13, 21, 23, 31 AND 34). SN 86-167,223. PUB. 6-10-2014. FILED 1-16-2014.
- 4,592,583. **KLARUS (STYLIZED)**. KLARUS LIGHTING TECHNOLOGY (HONG KONG) CO., LIMITED, (U.S. CLS. 13, 21, 23, 31 AND 34). SN 86-171,854. PUB. 6-10-2014. FILED 1-22-2014.
- 4,592,639. **AQUAVIVA AND DESIGN**. MEGALOWMART HOLDINGS, INC., (U.S. CLS. 13, 21, 23, 31 AND 34). SN 86-175,165. PUB. 6-10-2014. FILED 1-25-2014.
- 4,592,723. **STRATUS (STANDARD CHARACTER)**. SOL NY CORPORATION, (U.S. CLS. 13, 21, 23, 31 AND 34). SN 86-176,736. PUB. 6-10-2014. FILED 1-27-2014.
- 4,592,741 ( *See Class 6 for this trademark*).
- 4,592,749. **ECO-MACHINE (STANDARD CHARACTER)**. JOHN TODD ECOLOGICAL DESIGN, INC., FORMERLY JOHN TODD RESEARCH & DESIGN, INC., (U.S. CLS. 13, 21, 23, 31 AND 34). SN 86-177,121. PUB. 6-10-2014. FILED 1-28-2014.
- 4,592,826. **CLEVERDELIGHTS (STANDARD CHARACTER)**. CASHBASISENTERPRISES LLC, (U.S. CLS. 13, 21, 23, 31 AND 34). SN 86-178,397. PUB. 6-10-2014. FILED 1-29-2014.
- 4,592,832. **TETRIS (STANDARD CHARACTER)**. TETRIS HOLDING, LLC, (U.S. CLS. 13, 21, 23, 31 AND 34). SN 86-178,470. PUB. 6-10-2014. FILED 1-29-2014.
- CLASS, (INT. CLS. 12, 18, 25 AND 35), (U.S. CLS. 1, 2, 3, 19, 21, 22, 23, 31, 35, 39, 41, 44, 100, 101 AND 102). SN 79-114,901. PUB. 6-10-2014. FILED 1-26-2012.
- 4,590,634 ( *See Class 7 for this trademark*).
- 4,590,650 ( *See Class 7 for this trademark*).
- 4,590,655 ( *See Class 9 for this trademark*).
- 4,590,699 ( *See Class 3 for this trademark*).
- 4,590,727 ( *See Class 7 for this trademark*).
- 4,590,729 ( *See Class 4 for this trademark*).
- 4,590,734 ( *See Class 4 for this trademark*).
- 4,590,756. **CELESTE (STANDARD CHARACTER)**. EADS SOGERMA, MULTIPLE CLASS, (INT. CLS. 12 AND 20), (U.S. CLS. 2, 13, 19, 21, 22, 23, 25, 31, 32, 35, 44 AND 50). SN 79-135,590. PUB. 6-10-2014. FILED 7-11-2013.
- 4,590,771. **FACC AND DESIGN**. FACC AG, MULTIPLE CLASS, (INT. CLS. 12, 17 AND 42), (U.S. CLS. 1, 5, 12, 13, 19, 21, 23, 31, 35, 44, 50, 100 AND 101). SN 79-136,288. PUB. 6-10-2014. FILED 2-1-2013.
- 4,590,782. **ELLIPSA (STYLIZED)**. DONG GUAN CROWN SHIN; BABY APPLIANCES CO., LTD., (U.S. CLS. 19, 21, 23, 31, 35 AND 44). SN 79-136,632. PUB. 6-10-2014. FILED 7-5-2013.
- 4,590,806 ( *See Class 7 for this trademark*).
- 4,590,845 ( *See Class 6 for this trademark*).
- 4,590,855. **NOKIAN TYRES GRIP LIKE NEVER BEFORE (STYLIZED)**. NOKIAN TYRES PLC, MULTIPLE CLASS, (INT. CLS. 12 AND 35), (U.S. CLS. 19, 21, 23, 31, 35, 44, 100, 101 AND 102). SN 79-140,902. PUB. 6-10-2014. FILED 9-17-2013.
- 4,590,861 ( *See Class 9 for this trademark*).
- 4,590,868. **BENETTI F-125 (STANDARD CHARACTER)**. AZIMUT-BENETTI S.P.A., (U.S. CLS. 19, 21, 23, 31, 35 AND 44). SN 79-142,005. PUB. 6-10-2014. FILED 11-11-2013.
- 4,590,879. **MISCELLANEOUS DESIGN**. STADLER HOLDING KG, MULTIPLE CLASS, (INT. CLS. 12, 25 AND 35), (U.S. CLS. 19, 21, 22, 23, 31, 35, 39, 44, 100, 101 AND 102). SN 79-142,402. PUB. 6-10-2014. FILED 9-25-2013.
- 4,590,997. **FOOTLOOSE (STYLIZED)**. MANDO CORPORATION, (U.S. CLS. 19, 21, 23, 31, 35 AND 44). SN 85-677,617. PUB. 6-10-2014. FILED 7-16-2012.
- 4,591,005 ( *See Class 8 for this trademark*).
- 4,591,031 ( *See Class 6 for this trademark*).
- 4,591,137. **PACKHORSE (STANDARD CHARACTER)**. IHC HOLLAND IE B.V., (U.S. CLS. 19, 21, 23, 31, 35 AND 44). SN 85-878,640. PUB. 4-22-2014. FILED 3-18-2013.
- 4,591,182 ( *See Class 3 for this trademark*).
- 4,591,382 ( *See Class 7 for this trademark*).
- 4,591,823 ( *See Class 8 for this trademark*).
- 4,591,849. **3SDM (STANDARD CHARACTER)**. 3SDM LTD, (U.S. CLS. 19, 21, 23, 31, 35 AND 44). SN 86-111,911. PUB. 6-10-2014. FILED 11-6-2013.
- 4,591,852. **MUM SPORTS AND DESIGN**. MUM SPORTS LLC, (U.S. CLS. 19, 21, 23, 31, 35 AND 44). SN 86-112,970. PUB. 6-10-2014. FILED 11-7-2013.
- 4,591,939. **GENRIGHT (STANDARD CHARACTER)**. GENRIGHT OFF ROAD, INC., (U.S. CLS. 19, 21, 23, 31, 35 AND 44). SN 86-127,286. PUB. 6-10-2014. FILED 11-22-2013.
- 4,592,131. **VISION WHEEL (STANDARD CHARACTER)**. VISION WHEEL, INC., (U.S. CLS. 19, 21, 23, 31, 35 AND 44). SN 86-151,134. PUB. 6-10-2014. FILED 12-23-2013.
- 4,592,307. **MILANNI (STANDARD CHARACTER)**. VISION WHEEL, INC., (U.S. CLS. 19, 21, 23, 31, 35 AND 44). SN 86-160,621. PUB. 6-10-2014. FILED 1-8-2014.
- 4,592,428. **ROTIFORM (STANDARD CHARACTER)**. ROTIFORM, LLC, (U.S. CLS. 19, 21, 23, 31, 35 AND 44). SN 86-164,001. PUB. 6-10-2014. FILED 1-13-2014.
- 4,592,602. **V AND DESIGN**. VETERAN TIRE AND RUBBER INC., (U.S. CLS. 19, 21, 23, 31, 35 AND 44). SN 86-172,962. PUB. 6-10-2014. FILED 1-23-2014.
- 4,592,649. **ESX (STYLIZED)**. PARLEE CYCLES, INC., (U.S. CLS. 19, 21, 23, 31, 35 AND 44). SN 86-175,371. PUB. 6-10-2014. FILED 1-26-2014.
- 4,592,738. **AGEAGLE (STANDARD CHARACTER)**. SOLUTIONS BY CHILCOTT LLC, (U.S. CLS. 19, 21, 23, 31, 35 AND 44). SN 86-176,996. PUB. 6-10-2014. FILED 1-28-2014.
- 4,592,741 ( *See Class 6 for this trademark*).
- 4,592,859. **SUN SEEKER (STANDARD CHARACTER)**. J & B IMPORTERS, INC, (U.S. CLS. 19, 21, 23, 31, 35 AND 44). SN

## CLASS 12—VEHICLES

- 4,590,623. **ZERO MX (STANDARD CHARACTER)**. ZERO MOTORCYCLES, INC., (U.S. CLS. 19, 21, 23, 31, 35 AND 44). SN 77-757,810. PUB. 3-16-2010. FILED 6-11-2009.
- 4,590,631. **CREATE (STANDARD CHARACTER)**. JASMINDER WALIA, AND JAMES BUTTERFIELD, MULTIPLE

86-178,942. PUB. 6-10-2014. FILED 1-29-2014.  
 4,592,937. **PWJDM (STANDARD CHARACTER)**. PASSWORD INDUSTRIES, INC., (U.S. CLS. 19, 21, 23, 31, 35 AND 44). SN 86-183,255. PUB. 6-10-2014. FILED 2-3-2014.

---

### CLASS 13—FIREARMS

4,591,712. **CMT TAC AND DESIGN**. CROSS MACHINE TOOL CO., INC., (U.S. CLS. 2 AND 9). SN 86-076,469. PUB. 6-10-2014. FILED 9-27-2013.  
 4,591,771. **SPITBALL (STANDARD CHARACTER)**. FIRE-CRAFT PRODUCTS, INC., (U.S. CLS. 2 AND 9). SN 86-093,328. PUB. 6-10-2014. FILED 10-16-2013.  
 4,592,890 ( *See Class 6 for this trademark*).  
 4,592,894. **THE LAST ROUND YOU WILL EVER NEED (STANDARD CHARACTER)**. G2 RESEARCH, INC., (U.S. CLS. 2 AND 9). SN 86-179,840. PUB. 6-10-2014. FILED 1-30-2014.

---

### CLASS 14—JEWELRY

4,590,610 ( *See Class 3 for this trademark*).  
 4,590,636. **TAKING SHAPE TS (STYLIZED)**. TS 14 PLUS AUSTRALIA PTY LTD, MULTIPLE CLASS, (INT. CLS. 14, 18, 25 AND 35), (U.S. CLS. 1, 2, 3, 22, 27, 28, 39, 41, 50, 100, 101 AND 102). SN 79-120,979. PUB. 6-10-2014. FILED 9-7-2012.  
 4,590,637. **VIRTUELLE (STYLIZED)**. TS 14 PLUS AUSTRALIA PTY LTD, MULTIPLE CLASS, (INT. CLS. 14, 18, 25 AND 35), (U.S. CLS. 1, 2, 3, 22, 27, 28, 39, 41, 50, 100, 101 AND 102). SN 79-121,017. PUB. 6-10-2014. FILED 8-10-2012.  
 4,590,694. **URSUL (STYLIZED)**. URSUL, MULTIPLE CLASS, (INT. CLS. 14 AND 18), (U.S. CLS. 1, 2, 3, 22, 27, 28, 41 AND 50). SN 79-132,245. PUB. 6-10-2014. FILED 5-27-2013.  
 4,590,699 ( *See Class 3 for this trademark*).  
 4,590,702 ( *See Class 3 for this trademark*).  
 4,590,707 ( *See Class 9 for this trademark*).  
 4,590,725. **SE SCHWARZ ETIENNE (STYLIZED)**. SCHWARZ ETIENNE S.A., (U.S. CLS. 2, 27, 28 AND 50). SN 79-134,158. PUB. 6-10-2014. FILED 7-16-2013.  
 4,590,746 ( *See Class 3 for this trademark*).  
 4,590,765. **TELLUS (STYLIZED)**. HOVEL CHENORHOKIAN, (U.S. CLS. 2, 27, 28 AND 50). SN 79-135,905. PUB. 6-10-2014. FILED 7-3-2013.  
 4,590,856 ( *See Class 3 for this trademark*).  
 4,590,876. **JASPER CONRAN (STANDARD CHARACTER)**. JASPER CONRAN, MULTIPLE CLASS, (INT. CLS. 14, 18 AND 24), (U.S. CLS. 1, 2, 3, 22, 27, 28, 41, 42 AND 50). SN 79-142,290. PUB. 6-10-2014. FILED 11-8-2013.  
 4,590,881 ( *See Class 6 for this trademark*).  
 4,590,956. **CUTIE AND DESIGN**. ZODIAX A.S., MULTIPLE CLASS, (INT. CLS. 14, 35 AND 40), (U.S. CLS. 2, 27, 28, 50, 100, 101, 102, 103 AND 106). SN 85-422,076. PUB. 6-10-2014. FILED 9-14-2011.  
 4,590,990. **PEERLESS (STANDARD CHARACTER)**. STERLING JEWELERS INC., (U.S. CLS. 2, 27, 28 AND 50). SN 85-649,127. PUB. 6-10-2014. FILED 6-12-2012.  
 4,591,138. **WATCHSTAR LADYSTAR (STANDARD CHARACTER)**. WATCHSTAR, LLC, (U.S. CLS. 2, 27, 28 AND 50). SN 85-878,712. PUB. 6-10-2014. FILED 3-18-2013.  
 4,591,156. **HOUSE OF BLOMBOS (STANDARD CHARACTER)**. HOUSE OF BLOMBOS, LLC, (U.S. CLS. 2, 27, 28 AND 50). SN 85-892,394. PUB. 6-10-2014. FILED 4-1-2013.  
 4,591,201. **MISCELLANEOUS DESIGN**. SHENZHEN HENGXING JEWELRY CO., LTD., MULTIPLE CLASS, (INT. CLS. 14 AND 35), (U.S. CLS. 2, 27, 28, 50, 100, 101 AND 102). SN 85-933,431. PUB. 6-10-2014. FILED 5-15-2013.  
 4,591,202. **YOOSUN (STYLIZED)**. SHENZHEN HENGXING JEWELRY CO., LTD., MULTIPLE CLASS, (INT. CLS. 14 AND 35), (U.S. CLS. 2, 27, 28, 50, 100, 101 AND 102). SN 85-933,445. PUB. 6-10-2014. FILED 5-15-2013.  
 4,591,204. **MISCELLANEOUS DESIGN**. SHENZHEN HENGXING JEWELRY CO., LTD., MULTIPLE CLASS, (INT. CLS.

14 AND 35), (U.S. CLS. 2, 27, 28, 50, 100, 101 AND 102). SN 85-934,723. PUB. 6-10-2014. FILED 5-17-2013.  
 4,591,205. **MISCELLANEOUS DESIGN**. SHENZHEN HENGXING JEWELRY CO., LTD., MULTIPLE CLASS, (INT. CLS. 14 AND 35), (U.S. CLS. 2, 27, 28, 50, 100, 101 AND 102). SN 85-934,724. PUB. 6-10-2014. FILED 5-17-2013.  
 4,591,297. **PDC AND DESIGN**. PRECISION DYNAMICS CORPORATION, AKA PDC, MULTIPLE CLASS, (INT. CLS. 14, 16, 20 AND 35), (U.S. CLS. 2, 5, 13, 22, 23, 25, 27, 28, 29, 32, 37, 38, 50, 100, 101 AND 102). SN 85-965,261. PUB. 6-10-2014. FILED 6-20-2013.  
 4,591,469. **BONES AND FEATHERS COLLECTIVE (STANDARD CHARACTER)**. BONES AND FEATHERS COLLECTIVE, INC., MULTIPLE CLASS, (INT. CLS. 14 AND 35), (U.S. CLS. 2, 27, 28, 50, 100, 101 AND 102). SN 86-007,657. PUB. 6-10-2014. FILED 7-11-2013.  
 4,591,489. **N377 (STYLIZED)**. NEFF, LLC, MULTIPLE CLASS, (INT. CLS. 14 AND 25), (U.S. CLS. 2, 22, 27, 28, 39 AND 50). SN 86-010,818. PUB. 6-10-2014. FILED 7-15-2013.  
 4,591,499. **LA BELLE VIE (STANDARD CHARACTER)**. THE MARFO COMPANY, DBA MARSALA MANUFACTURING COMPANY, (U.S. CLS. 2, 27, 28 AND 50). SN 86-011,756. PUB. 6-10-2014. FILED 7-16-2013.  
 4,591,526. **W AND DESIGN**. BOARD OF REGENTS OF THE UNIVERSITY OF WISCONSIN SYSTEM, MULTIPLE CLASS, (INT. CLS. 14, 16, 21 AND 28), (U.S. CLS. 2, 5, 13, 22, 23, 27, 28, 29, 30, 33, 37, 38, 40 AND 50). SN 86-017,864. PUB. 6-10-2014. FILED 7-23-2013.  
 4,591,531. **ENCLUSIV.ORG (STANDARD CHARACTER)**. MARCUM, COBY, (U.S. CLS. 2, 27, 28 AND 50). SN 86-021,444. PUB. 6-10-2014. FILED 7-26-2013.  
 4,591,570. **WEAR THEIR FUTURE (STANDARD CHARACTER)**. PEACE REHABILITATION CENTER, MULTIPLE CLASS, (INT. CLS. 14 AND 25), (U.S. CLS. 2, 22, 27, 28, 39 AND 50). SN 86-029,524. PUB. 6-10-2014. FILED 8-6-2013.  
 4,591,620. **MOKA + INDIE (STANDARD CHARACTER)**. LYDELL JEWELRY DESIGN STUDIO, INC., (U.S. CLS. 2, 27, 28 AND 50). SN 86-044,779. PUB. 6-10-2014. FILED 8-22-2013.  
 4,591,621. **ELLI + COCO (STANDARD CHARACTER)**. LYDELL JEWELRY DESIGN STUDIO, INC., (U.S. CLS. 2, 27, 28 AND 50). SN 86-044,788. PUB. 6-10-2014. FILED 8-22-2013.  
 4,591,637. **IVY + COCO (STANDARD CHARACTER)**. LYDELL JEWELRY DESIGN STUDIO, INC., (U.S. CLS. 2, 27, 28 AND 50). SN 86-050,590. PUB. 6-10-2014. FILED 8-28-2013.  
 4,591,705. **TAHARA & CO. (STYLIZED)**. JEWELRY BY MICHAEL TAHER LLC, (U.S. CLS. 2, 27, 28 AND 50). SN 86-072,910. PUB. 6-10-2014. FILED 9-24-2013.  
 4,591,716 ( *See Class 9 for this trademark*).  
 4,591,811. **SMILE ON (STANDARD CHARACTER)**. MOREAU TRUST, MULTIPLE CLASS, (INT. CLS. 14, 16, 18, 21 AND 25), (U.S. CLS. 1, 2, 3, 5, 13, 22, 23, 27, 28, 29, 30, 33, 37, 38, 39, 40, 41 AND 50). SN 86-104,453. PUB. 6-10-2014. FILED 10-29-2013.  
 4,591,814. **PERSONALIZED CAUSE (STANDARD CHARACTER)**. ZEPHTEX INDUSTRIES, INC., (U.S. CLS. 2, 27, 28 AND 50). SN 86-105,001. PUB. 6-10-2014. FILED 10-29-2013.  
 4,591,987. **I FAKED IT (STANDARD CHARACTER)**. STAFFORD, ERIN, (U.S. CLS. 2, 27, 28 AND 50). SN 86-133,130. PUB. 6-10-2014. FILED 12-2-2013.  
 4,592,057. **TD TOM DONG (STYLIZED)**. DROW INTERNATIONAL INVESTMENT LTD., (U.S. CLS. 2, 27, 28 AND 50). SN 86-142,686. PUB. 6-10-2014. FILED 12-13-2013.  
 4,592,063. **JH JOHN HARDY AND DESIGN**. JOHN HARDY LIMITED, (U.S. CLS. 2, 27, 28 AND 50). SN 86-143,232. PUB. 6-10-2014. FILED 12-13-2013.  
 4,592,077. **GINTARE (STANDARD CHARACTER)**. KIZYS, GINTARE, DBA GINTARE AND GINTARE JEWELRY, MULTIPLE CLASS, (INT. CLS. 14 AND 42), (U.S. CLS. 2, 27, 28, 50, 100 AND 101). SN 86-144,782. PUB. 6-10-2014. FILED 12-16-2013.  
 4,592,222. **HEALING KNOTS (STANDARD CHARACTER)**. CARGNONI, ROBERT A, (U.S. CLS. 2, 27, 28 AND 50). SN 86-156,923. PUB. 6-10-2014. FILED 1-3-2014.  
 4,592,234. **BONY LEVY (STANDARD CHARACTER)**. LEVY, BONY, (U.S. CLS. 2, 27, 28 AND 50). SN 86-157,370. PUB. 6-10-2014. FILED 1-3-2014.  
 4,592,271. **SUZANNE GAROFALO DESIGN (STANDARD**

**CHARACTER**. SUZANNE GAROFALO DESIGN L.L.C., DBA SUZANNE GAROFALO DESIGN, (U.S. CLS. 2, 27, 28 AND 50). SN 86-158,960. PUB. 6-10-2014. FILED 1-7-2014.

4,592,303. **GAVOX AND DESIGN**. HAPPE, MICHAEL, (U.S. CLS. 2, 27, 28 AND 50). SN 86-160,469. PUB. 6-10-2014. FILED 1-8-2014.

4,592,337. **A WE THE ADORNED (STYLIZED)**. BATTEN, CYNTHIA, AND MCELWEE, TIM, (U.S. CLS. 2, 27, 28 AND 50). SN 86-161,710. PUB. 6-10-2014. FILED 1-9-2014.

4,592,396. **ASHLEY CHILDS (STYLIZED)**. ASHLEY CHILDS, DBA ASHLEY CHILDS, (U.S. CLS. 2, 27, 28 AND 50). SN 86-163,158. PUB. 6-10-2014. FILED 1-11-2014.

4,592,543. **VINEYARD VINES (STANDARD CHARACTER)**. VINEYARD VINES LLC, MULTIPLE CLASS, (INT. CLS. 14, 18 AND 24), (U.S. CLS. 1, 2, 3, 22, 27, 28, 41, 42 AND 50). SN 86-167,773. PUB. 6-10-2014. FILED 1-16-2014.

4,592,549. **VEZA (STYLIZED)**. BAMX ENTERPRISES, (U.S. CLS. 2, 27, 28 AND 50). SN 86-167,957. PUB. 6-10-2014. FILED 1-16-2014.

4,592,594. **GOMI'S HOUSE (STYLIZED)**. KIM, TAE HO, MULTIPLE CLASS, (INT. CLS. 14, 25 AND 26), (U.S. CLS. 2, 22, 27, 28, 37, 39, 40, 42 AND 50). SN 86-172,700. PUB. 6-10-2014. FILED 1-23-2014.

4,592,596. **JEROLLIN (STYLIZED)**. BUYING INTERNATIONAL TRADING CO., LTD, (U.S. CLS. 2, 27, 28 AND 50). SN 86-172,812. PUB. 6-10-2014. FILED 1-23-2014.

4,592,656. **EOZY AND DESIGN**. YIWU JIMAO ELECTRONIC TECHNOLOGY CO., LTD., (U.S. CLS. 2, 27, 28 AND 50). SN 86-175,489. PUB. 6-10-2014. FILED 1-26-2014.

4,592,675. **OLINDA (STANDARD CHARACTER)**. OLINDA ELIZABETH LOPEZ DE GALILEA, MULTIPLE CLASS, (INT. CLS. 14, 18 AND 25), (U.S. CLS. 1, 2, 3, 22, 27, 28, 39, 41 AND 50). SN 86-175,710. PUB. 6-10-2014. FILED 1-27-2014.

4,592,684. **LOVEYOURBLING (STANDARD CHARACTER)**. LOVEYOURBLING, (U.S. CLS. 2, 27, 28 AND 50). SN 86-175,915. PUB. 6-10-2014. FILED 1-27-2014.

4,592,763. **LIVE BREATHE BELIEVE (STANDARD CHARACTER)**. LISA BLONDELL BROWNING, MULTIPLE CLASS, (INT. CLS. 14 AND 25), (U.S. CLS. 2, 22, 27, 28, 39 AND 50). SN 86-177,381. PUB. 6-10-2014. FILED 1-28-2014.

4,592,792. **ROYAL BEAUTY (STANDARD CHARACTER)**. ROYAL BEAUTY INC., (U.S. CLS. 2, 27, 28 AND 50). SN 86-177,822. PUB. 6-10-2014. FILED 1-28-2014.

4,592,828. **BIS JOUX AND DESIGN**. WILZIG, KARIN, (U.S. CLS. 2, 27, 28 AND 50). SN 86-178,402. PUB. 6-10-2014. FILED 1-29-2014.

4,592,831. **D'EARS (STANDARD CHARACTER)**. GRAPHICS 4 GEAR LLC, (U.S. CLS. 2, 27, 28 AND 50). SN 86-178,455. PUB. 6-10-2014. FILED 1-29-2014.

4,592,867. **CARPE DREAM (STANDARD CHARACTER)**. GONZALEZ, LUIS, (U.S. CLS. 2, 27, 28 AND 50). SN 86-179,152. PUB. 6-10-2014. FILED 1-29-2014.

4,592,953. **VCU (STANDARD CHARACTER)**. VIRGINIA COMMONWEALTH UNIVERSITY, MULTIPLE CLASS, (INT. CLS. 14, 16, 21, 24, 25 AND 28), (U.S. CLS. 2, 5, 13, 22, 23, 27, 28, 29, 30, 33, 37, 38, 39, 40, 42 AND 50). SN 86-189,719. PUB. 6-10-2014. FILED 2-10-2014.

4,593,008. **A JEWELER DESIGNED FOR YOU (STANDARD CHARACTER)**. KIT KUHN A JEWELER DESIGNED FOR YOU, INC., (U.S. CLS. 2, 27, 28 AND 50). SN 86-220,023. PUB. 6-10-2014. FILED 3-13-2014.

4,593,047. **PULP (STANDARD CHARACTER)**. PERRY, KELLY-JANE, DBA PULP JEWELRY & GIFTS, (U.S. CLS. 2, 27, 28 AND 50). SN 86-245,687. PUB. 6-10-2014. FILED 4-8-2014.

#### CLASS 15—MUSICAL INSTRUMENTS

4,591,036. **TRUE HOOP (STANDARD CHARACTER)**. DRUM WORKSHOP, INC., (U.S. CLS. 2, 21 AND 36). SN 85-774,724. PUB. 6-10-2014. FILED 11-8-2012.

4,591,466. **YONBERG (STANDARD CHARACTER)**. JEAN-CLAUDE BIBOLLET, (U.S. CLS. 2, 21 AND 36). SN 86-006,690. PUB. 6-10-2014. FILED 7-10-2013.

4,591,836. **MAULOA AND DESIGN**. ZOU JIANQUAN, (U.S. CLS. 2, 21 AND 36). SN 86-108,776. PUB. 6-10-2014. FILED

11-3-2013.

#### CLASS 16—PAPER GOODS AND PRINTED MATTER

4,590,610 ( *See Class 3 for this trademark*).

4,590,618. **THE CHART MART (STANDARD CHARACTER)**. COHEN, MICHAEL, (U.S. CLS. 2, 5, 22, 23, 29, 37, 38 AND 50). SN 76-715,725. PUB. 6-10-2014. FILED 1-27-2014.

4,590,632 ( *See Class 9 for this trademark*).

4,590,646 ( *See Class 9 for this trademark*).

4,590,655 ( *See Class 9 for this trademark*).

4,590,667. **FBS FRANCE BUSINESS SCHOOL AND DESIGN**. SYNDICAT MIXTE DE L'ESCEM, MULTIPLE CLASS, (INT. CLS. 16 AND 41), (U.S. CLS. 2, 5, 22, 23, 29, 37, 38, 50, 100, 101 AND 107). SN 79-127,376. PUB. 6-10-2014. FILED 12-27-2012.

4,590,669 ( *See Class 5 for this trademark*).

4,590,684 ( *See Class 9 for this trademark*).

4,590,699 ( *See Class 3 for this trademark*).

4,590,709 ( *See Class 9 for this trademark*).

4,590,750. **LMC (STYLIZED)**. LMC OXFORD HOLDINGS LIMITED, MULTIPLE CLASS, (INT. CLS. 16, 35 AND 41), (U.S. CLS. 2, 5, 22, 23, 29, 37, 38, 50, 100, 101, 102 AND 107). SN 79-135,502. PUB. 6-10-2014. FILED 2-1-2013.

4,590,763 ( *See Class 9 for this trademark*).

4,590,764 ( *See Class 9 for this trademark*).

4,590,780. **FIRE & FIGHT STREETWEAR AND DESIGN**. ENRICO SCHOLZ, MULTIPLE CLASS, (INT. CLS. 16, 18 AND 25), (U.S. CLS. 1, 2, 3, 5, 22, 23, 29, 37, 38, 39, 41 AND 50). SN 79-136,453. PUB. 6-10-2014. FILED 6-28-2013.

4,590,806 ( *See Class 7 for this trademark*).

4,590,811 ( *See Class 1 for this trademark*).

4,590,813 ( *See Class 1 for this trademark*).

4,590,824 ( *See Class 1 for this trademark*).

4,590,842 ( *See Class 9 for this trademark*).

4,590,856 ( *See Class 3 for this trademark*).

4,590,861 ( *See Class 9 for this trademark*).

4,590,878. **GH AND DESIGN**. GUANGDONG GUANHAO HIGH-TECH CO., LTD, (U.S. CLS. 2, 5, 22, 23, 29, 37, 38 AND 50). SN 79-142,367. PUB. 6-10-2014. FILED 12-17-2013.

4,590,895 ( *See Class 9 for this trademark*).

4,590,908 ( *See Class 3 for this trademark*).

4,590,970. **THE ITTY BITTY KITTY COMMITTEE (STANDARD CHARACTER)**. LAURA CINOTTO, MULTIPLE CLASS, (INT. CLS. 16 AND 41), (U.S. CLS. 2, 5, 22, 23, 29, 37, 38, 50, 100, 101 AND 107). SN 85-488,701. PUB. 5-28-2013. FILED 12-6-2011.

4,590,987. **PADDY POWER (STANDARD CHARACTER)**. PADDY POWER PLC, MULTIPLE CLASS, (INT. CLS. 16, 38, 41 AND 45), (U.S. CLS. 2, 5, 22, 23, 29, 37, 38, 50, 100, 101, 104 AND 107). SN 85-639,479. PUB. 12-3-2013. FILED 5-31-2012.

4,590,992. **PADDY POKER (STANDARD CHARACTER)**. PADDY POWER PLC, MULTIPLE CLASS, (INT. CLS. 16, 38, 41 AND 45), (U.S. CLS. 2, 5, 22, 23, 29, 37, 38, 50, 100, 101, 104 AND 107). SN 85-651,795. PUB. 12-3-2013. FILED 6-14-2012.

4,590,993 ( *See Class 9 for this trademark*).

4,590,998. **ROCK AND ROLL BINGO AND DESIGN**. MARK, MULTIPLE CLASS, (INT. CLS. 16 AND 28), (U.S. CLS. 2, 5, 22, 23, 29, 37, 38 AND 50). SN 85-680,881. PUB. 6-10-2014. FILED 7-18-2012.

4,591,007. **SECRET KINGDOM (STANDARD CHARACTER)**. HOTHOUSE FICTION LTD., (U.S. CLS. 2, 5, 22, 23, 29, 37, 38 AND 50). SN 85-727,064. PUB. 6-10-2014. FILED 9-12-2012.

4,591,013. **BLINGLES GLIMMER (STANDARD CHARACTER)**. MOOSE CREATIVE PTY LTD, MULTIPLE CLASS, (INT. CLS. 16 AND 28), (U.S. CLS. 2, 5, 22, 23, 29, 37, 38 AND 50). SN 85-734,603. PUB. 6-10-2014. FILED S.R. 9-21-2012; AM. P.R. 5-17-2013.

4,591,014 ( *See Class 9 for this trademark*).

4,591,029. **GLOW (STANDARD CHARACTER)**. GLOW MASSAGE, INC., MULTIPLE CLASS, (INT. CLS. 16, 41 AND 44), (U.S. CLS. 2, 5, 22, 23, 29, 37, 38, 50, 100, 101 AND 107). SN 85-766,240. PUB. 6-10-2014. FILED 10-29-2012.

4,591,030. **GLOW MASSAGE & BIRTH SUPPORT (STAN-**

- DARD CHARACTER.** GLOW MESSAGE, INC., MULTIPLE CLASS, (INT. CLS. 16, 41 AND 44), (U.S. CLS. 2, 5, 22, 23, 29, 37, 38, 50, 100, 101 AND 107). SN 85-766,253. PUB. 6-10-2014. FILED 10-29-2012.
- 4,591,037 ( *See Class 9 for this trademark.* )
- 4,591,053. **BONNIE & PEARL (STYLIZED).** HELLO DOLLY LIMITED, MULTIPLE CLASS, (INT. CLS. 16, 25 AND 28), (U.S. CLS. 2, 5, 22, 23, 29, 37, 38, 39 AND 50). SN 85-785,475. PUB. 11-5-2013. FILED 11-21-2012.
- 4,591,064. **NEXGEN PACKAGING (STANDARD CHARACTER).** NEXGEN PACKAGING, LLC, MULTIPLE CLASS, (INT. CLS. 16 AND 24), (U.S. CLS. 2, 5, 22, 23, 29, 37, 38, 42 AND 50). SN 85-790,813. PUB. 6-10-2014. FILED 11-29-2012.
- 4,591,066. **JESUS FILM (STANDARD CHARACTER).** CAMPUS CRUSADE FOR CHRIST, INC., AKA CRU, (U.S. CLS. 2, 5, 22, 23, 29, 37, 38 AND 50). SN 85-793,008. PUB. 6-10-2014. FILED 12-3-2012.
- 4,591,088 ( *See Class 9 for this trademark.* )
- 4,591,210. **BOATING TIMES WE MAKE IT EASY TO HAVE FUN ON YOUR BOAT (STANDARD CHARACTER).** PROMOTION MARKETING MANAGEMENT, LLC, MULTIPLE CLASS, (INT. CLS. 16 AND 41), (U.S. CLS. 2, 5, 22, 23, 29, 37, 38, 50, 100, 101 AND 107). SN 85-937,572. PUB. 6-10-2014. FILED 5-20-2013.
- 4,591,220. **PAPER INKPRESSIONS (STYLIZED).** KOLASINSKI, ANA LUCIA, DBA PAPER INKPRESSIONS, MULTIPLE CLASS, (INT. CLS. 16 AND 40), (U.S. CLS. 2, 5, 22, 23, 29, 37, 38, 50, 100, 103 AND 106). SN 85-942,650. PUB. 6-10-2014. FILED 5-24-2013.
- 4,591,221 ( *See Class 9 for this trademark.* )
- 4,591,238. **KUNG FU PHONICS (STANDARD CHARACTER).** PIMBLEY, WALTER THOMSON, AKA WALT PIMBLEY, (U.S. CLS. 2, 5, 22, 23, 29, 37, 38 AND 50). SN 85-948,192. PUB. 6-10-2014. FILED 5-31-2013.
- 4,591,273. **ONE GOD, ONE CHURCH (STANDARD CHARACTER).** GLASCOE, DEIRDRE C., AND THE MINISTRY OF SECOND TIMOTHY, INC., (U.S. CLS. 2, 5, 22, 23, 29, 37, 38 AND 50). SN 85-959,469. PUB. 10-29-2013. FILED 6-13-2013.
- 4,591,293. **NOTEBOOKING CENTRAL (STANDARD CHARACTER).** DINAH-MIGHT ADVENTURES, LP, (U.S. CLS. 2, 5, 22, 23, 29, 37, 38 AND 50). SN 85-963,659. PUB. 6-10-2014. FILED 6-19-2013.
- 4,591,297 ( *See Class 14 for this trademark.* )
- 4,591,329. **DATSUN (STANDARD CHARACTER).** NISSAN JIDOSHA KABUSHIKI KAISHA, TA NISSAN MOTOR CO., LTD., (U.S. CLS. 2, 5, 22, 23, 29, 37, 38 AND 50). SN 85-968,828. PUB. 5-6-2014. FILED 6-25-2013.
- 4,591,377. **ARCKIT (STANDARD CHARACTER).** MBM BUILDING SYSTEMS LIMITED, MULTIPLE CLASS, (INT. CLS. 16 AND 28), (U.S. CLS. 2, 5, 22, 23, 29, 37, 38 AND 50). SN 85-974,282. PUB. 6-10-2014. FILED 7-1-2013.
- 4,591,424 ( *See Class 9 for this trademark.* )
- 4,591,430. **ZELFLINGS (STANDARD CHARACTER).** MOOSE CREATIVE PTY LTD, MULTIPLE CLASS, (INT. CLS. 16 AND 28), (U.S. CLS. 2, 5, 22, 23, 29, 37, 38 AND 50). SN 86-002,849. PUB. 6-10-2014. FILED S.R. 7-4-2013; AM. P.R. 12-22-2013.
- 4,591,441. **HEMSLEYFRASER (STYLIZED).** HEMSLEY FRASER TRAINING GROUP LIMITED, MULTIPLE CLASS, (INT. CLS. 16, 35 AND 41), (U.S. CLS. 2, 5, 22, 23, 29, 37, 38, 50, 100, 101, 102 AND 107). SN 86-003,460. PUB. 6-10-2014. FILED 7-6-2013.
- 4,591,461. **DELECTABLE DESIGNS AND DESIGN.** DELECTABLE DESIGNS LLC, MULTIPLE CLASS, (INT. CLS. 16 AND 35), (U.S. CLS. 2, 5, 22, 23, 29, 37, 38, 50, 100, 101 AND 102). SN 86-006,131. PUB. 6-10-2014. FILED 7-10-2013.
- 4,591,487. **SHARE YOUR UNIVERSE (STANDARD CHARACTER).** MARVEL CHARACTERS, INC., (U.S. CLS. 2, 5, 22, 23, 29, 37, 38 AND 50). SN 86-010,692. PUB. 6-10-2014. FILED 7-15-2013.
- 4,591,498. **E EHA PRESS AND DESIGN.** GLOBAL CONSCIOUS PTY LIMITED, (U.S. CLS. 2, 5, 22, 23, 29, 37, 38 AND 50). SN 86-011,744. PUB. 6-10-2014. FILED 7-16-2013.
- 4,591,526 ( *See Class 14 for this trademark.* )
- 4,591,567. **EASYVIEW (STANDARD CHARACTER).** ACCO BRANDS CORPORATION, (U.S. CLS. 2, 5, 22, 23, 29, 37, 38 AND 50). SN 86-028,406. PUB. 3-4-2014. FILED 8-5-2013.
- 4,591,586. **LEONARDO HIDALGO (STANDARD CHARACTER).** ART INVASION, MULTIPLE CLASS, (INT. CLS. 16 AND 20), (U.S. CLS. 2, 5, 13, 22, 23, 25, 29, 32, 37, 38 AND 50). SN 86-034,528. PUB. 6-10-2014. FILED 8-10-2013.
- 4,591,626. **ECONOPOLIS (STANDARD CHARACTER).** APPLAUSE LEARNING, INC., (U.S. CLS. 2, 5, 22, 23, 29, 37, 38 AND 50). SN 86-045,970. PUB. 6-10-2014. FILED 8-23-2013.
- 4,591,676. **PROJECT ACCESS PROVIDING PATHWAYS TO INFORMED PARENTING AND DESIGN.** FOSTER AND ADOPTIVE FAMILY SERVICES, MULTIPLE CLASS, (INT. CLS. 16 AND 41), (U.S. CLS. 2, 5, 22, 23, 29, 37, 38, 50, 100, 101 AND 107). SN 86-062,999. PUB. 6-10-2014. FILED 9-12-2013.
- 4,591,683. **AMERICAN BOXHEADS (STANDARD CHARACTER).** MYSZKOWSKI, MARIAN A, (U.S. CLS. 2, 5, 22, 23, 29, 37, 38 AND 50). SN 86-064,889. PUB. 6-10-2014. FILED 9-14-2013.
- 4,591,690. **HEM (STYLIZED).** KYOWA CO., LTD (KYOWA KABUSHIKI KAISHA), MULTIPLE CLASS, (INT. CLS. 16 AND 18), (U.S. CLS. 1, 2, 3, 5, 22, 23, 29, 37, 38, 41 AND 50). SN 86-068,183. PUB. 6-10-2014. FILED 9-18-2013.
- 4,591,720. **FUTURE PHENOM (STANDARD CHARACTER).** RATLIFF ENTERPRISES INC., (U.S. CLS. 2, 5, 22, 23, 29, 37, 38 AND 50). SN 86-078,439. PUB. 6-10-2014. FILED 9-30-2013.
- 4,591,730 ( *See Class 9 for this trademark.* )
- 4,591,744. **MAILPRO (STANDARD CHARACTER).** UNITED STATES POSTAL SERVICE, (U.S. CLS. 2, 5, 22, 23, 29, 37, 38 AND 50). SN 86-082,830. PUB. 6-10-2014. FILED 10-4-2013.
- 4,591,768. **MISCELLANEOUS DESIGN.** JIANG, KELLY, AND WANG, CHI TUNG, (U.S. CLS. 2, 5, 22, 23, 29, 37, 38 AND 50). SN 86-092,484. PUB. 6-10-2014. FILED 10-16-2013.
- 4,591,798 ( *See Class 2 for this trademark.* )
- 4,591,809 ( *See Class 9 for this trademark.* )
- 4,591,811 ( *See Class 14 for this trademark.* )
- 4,591,833. **MOONSHINE UNIVERSITY (STANDARD CHARACTER).** DISTILLED SPIRITS EPICENTER, LLC, MULTIPLE CLASS, (INT. CLS. 16, 18, 21, 25, 28 AND 32), (U.S. CLS. 1, 2, 3, 5, 13, 22, 23, 29, 30, 33, 37, 38, 39, 40, 41, 45, 46, 48 AND 50). SN 86-107,817. PUB. 6-10-2014. FILED 11-1-2013.
- 4,591,903. **BOSTON BAR ASSOCIATION (STANDARD CHARACTER).** BOSTON BAR ASSOCIATION, MULTIPLE CLASS, (INT. CLS. 16, 35, 41 AND 45), (U.S. CLS. 2, 5, 22, 23, 29, 37, 38, 50, 100, 101, 102 AND 107). SN 86-121,755. PUB. 6-10-2014. FILED 11-18-2013.
- 4,591,909. **ARTSLANDIA (STYLIZED).** ARTSLANDIA PUBLISHING, INC., (U.S. CLS. 2, 5, 22, 23, 29, 37, 38 AND 50). SN 86-122,955. PUB. 6-10-2014. FILED 11-19-2013.
- 4,591,929 ( *See Class 9 for this trademark.* )
- 4,591,949. **MADELINE (STANDARD CHARACTER).** LUDWIG BEMELMANS, LLC, MULTIPLE CLASS, (INT. CLS. 16 AND 28), (U.S. CLS. 2, 5, 22, 23, 29, 37, 38 AND 50). SN 86-128,443. PUB. 6-10-2014. FILED 11-25-2013.
- 4,591,966. **AWWCCORDION MEMORY BOOKS (STYLIZED).** ME & RIZ LLC, (U.S. CLS. 2, 5, 22, 23, 29, 37, 38 AND 50). SN 86-130,436. PUB. 6-10-2014. FILED 11-27-2013.
- 4,592,022. **GLORIOUS GIFTS IN A BOX (STANDARD CHARACTER).** THREE SAVED SISTERS, LLC, (U.S. CLS. 2, 5, 22, 23, 29, 37, 38 AND 50). SN 86-138,128. PUB. 6-10-2014. FILED 12-9-2013.
- 4,592,023. **GLORIOUS GIFTS IN A BOX AND DESIGN.** THREE SAVED SISTERS, LLC, (U.S. CLS. 2, 5, 22, 23, 29, 37, 38 AND 50). SN 86-138,140. PUB. 6-10-2014. FILED 12-9-2013.
- 4,592,073. **STABULON (STANDARD CHARACTER).** CGP INDUSTRIES SA, (U.S. CLS. 2, 5, 22, 23, 29, 37, 38 AND 50). SN 86-144,419. PUB. 6-10-2014. FILED 12-16-2013.
- 4,592,104. **SUPERIFICS (STANDARD CHARACTER).** CARLEY, DON M., (U.S. CLS. 2, 5, 22, 23, 29, 37, 38 AND 50). SN 86-149,192. PUB. 6-10-2014. FILED 12-20-2013.
- 4,592,109. **MICROBAN (STANDARD CHARACTER).** MICROBAN PRODUCTS COMPANY, AKA MICROBAN PRODUCTS COMPANY, MULTIPLE CLASS, (INT. CLS. 16 AND 22), (U.S. CLS. 1, 2, 5, 7, 19, 22, 23, 29, 37, 38, 42 AND 50). SN 86-149,874. PUB. 6-10-2014. FILED 12-20-2013.
- 4,592,149 ( *See Class 6 for this trademark.* )
- 4,592,178. **VISION ARTISTRY (STANDARD CHARACTER).** VICK-KALAR, MARILYN, DBA VISION ARTISTRY, (U.S. CLS. 2, 5, 22, 23, 29, 37, 38 AND 50). SN 86-154,527. PUB. 6-10-2014. FILED 12-30-2013.



4,592,205. **JULSTRO (STANDARD CHARACTER)**. DONNELLY, JULIANN, DBA JULSTRO WORLDWIDE, LLC, (U.S. CLS. 2, 5, 22, 23, 29, 37, 38 AND 50). SN 86-155,988. PUB. 6-10-2014. FILED 1-2-2014.

4,592,233. **MIRROR ROAD AND DESIGN**. GARNER, ERIC J, (U.S. CLS. 2, 5, 22, 23, 29, 37, 38 AND 50). SN 86-157,214. PUB. 6-10-2014. FILED 1-3-2014.

4,592,255 ( *See Class 9 for this trademark*).

4,592,270. **MISCELLANEOUS DESIGN**. GREENBRIER IA, INC. MULTIPLE CLASS, (INT. CLS. 16, 18, 21, 25 AND 28), (U.S. CLS. 1, 2, 3, 5, 13, 22, 23, 29, 30, 33, 37, 38, 39, 40, 41 AND 50). SN 86-158,919. PUB. 6-10-2014. FILED 1-7-2014.

4,592,324. **KOKOMOTION.COM (STANDARD CHARACTER)**. DAVIDEK, DIRK R., MULTIPLE CLASS, (INT. CLS. 16, 21 AND 25), (U.S. CLS. 2, 5, 13, 22, 23, 29, 30, 33, 37, 38, 39, 40 AND 50). SN 86-161,476. PUB. 6-10-2014. FILED 1-9-2014.

4,592,341. **EASY CAULK (STANDARD CHARACTER)**. AMUNDSON, GREGORY, DBA GREGORY AMUNDSON, (U.S. CLS. 2, 5, 22, 23, 29, 37, 38 AND 50). SN 86-161,752. PUB. 6-10-2014. FILED 1-9-2014.

4,592,354. **CURIO PRESS (STANDARD CHARACTER)**. ALEXIS AUSTIN, DBA CURIO PRESS, (U.S. CLS. 2, 5, 22, 23, 29, 37, 38 AND 50). SN 86-162,033. PUB. 6-10-2014. FILED 1-9-2014.

4,592,459. **GUIDE TO CONGRESS (STANDARD CHARACTER)**. SAGE PUBLICATIONS, INC., (U.S. CLS. 2, 5, 22, 23, 29, 37, 38 AND 50). SN 86-165,406. PUB. 6-10-2014. FILED 1-14-2014.

4,592,471. **THE DIAPER ONE N DONE (STANDARD CHARACTER)**. DANRYAN INDUSTRIES, INC., DBA DIAPER ONE N DONE, MULTIPLE CLASS, (INT. CLS. 16 AND 21), (U.S. CLS. 2, 5, 13, 22, 23, 29, 30, 33, 37, 38, 40 AND 50). SN 86-165,552. PUB. 6-10-2014. FILED 1-14-2014.

4,592,472. **BTA BUSINESS TRANSITION ACADEMY (STYLIZED)**. BUSINESS TRANSITION ACADEMY, INC., MULTIPLE CLASS, (INT. CLS. 16, 35 AND 41), (U.S. CLS. 2, 5, 22, 23, 29, 37, 38, 50, 100, 101, 102 AND 107). SN 86-165,561. PUB. 6-10-2014. FILED 1-14-2014.

4,592,480 ( *See Class 9 for this trademark*).

4,592,492. **MEDITERRANEAN LONGEVITY (STANDARD CHARACTER)**. VIBRANT CONCEPTS, INC., MULTIPLE CLASS, (INT. CLS. 16, 29 AND 30), (U.S. CLS. 2, 5, 22, 23, 29, 37, 38, 46 AND 50). SN 86-166,180. PUB. 6-10-2014. FILED 1-15-2014.

4,592,574. **MISCELLANEOUS DESIGN**. TOO MARKER PRODUCTS, INC., (U.S. CLS. 2, 5, 22, 23, 29, 37, 38 AND 50). SN 86-171,183. PUB. 6-10-2014. FILED 1-21-2014.

4,592,575. **MISCELLANEOUS DESIGN**. TOO MARKER PRODUCTS, INC., (U.S. CLS. 2, 5, 22, 23, 29, 37, 38 AND 50). SN 86-171,186. PUB. 6-10-2014. FILED 1-21-2014.

4,592,577. **VEHICLEARTZ (STANDARD CHARACTER)**. VEHICLEARTZ LLC, (U.S. CLS. 2, 5, 22, 23, 29, 37, 38 AND 50). SN 86-171,359. PUB. 6-10-2014. FILED 1-21-2014.

4,592,621. **VAL-U-SIZE (STANDARD CHARACTER)**. ORCHIDS PAPER PRODUCTS COMPANY, (U.S. CLS. 2, 5, 22, 23, 29, 37, 38 AND 50). SN 86-174,316. PUB. 6-10-2014. FILED 1-24-2014.

4,592,647. **MELESTORE AND DESIGN**. XIAO SHU, (U.S. CLS. 2, 5, 22, 23, 29, 37, 38 AND 50). SN 86-175,349. PUB. 6-10-2014. FILED 1-26-2014.

4,592,668. **BEEASEL (STANDARD CHARACTER)**. BAJDA, NADI, (U.S. CLS. 2, 5, 22, 23, 29, 37, 38 AND 50). SN 86-175,643. PUB. 6-10-2014. FILED 1-27-2014.

4,592,742. **CHEW (STANDARD CHARACTER)**. LAYMAN, JOHN, (U.S. CLS. 2, 5, 22, 23, 29, 37, 38 AND 50). SN 86-177,051. PUB. 6-10-2014. FILED 1-28-2014.

4,592,760. **MISCELLANEOUS DESIGN**. TOO MARKER PRODUCTS, INC., (U.S. CLS. 2, 5, 22, 23, 29, 37, 38 AND 50). SN 86-177,293. PUB. 6-10-2014. FILED 1-28-2014.

4,592,823. **SHIPMAN & GOODWIN LLP COUNSELORS AT LAW AND DESIGN**. SHIPMAN & GOODWIN LLP, (U.S. CLS. 2, 5, 22, 23, 29, 37, 38 AND 50). SN 86-178,359. PUB. 6-10-2014. FILED 1-29-2014.

4,592,866. **VVAQ (STANDARD CHARACTER)**. FREEDOM VENTURE LLC, (U.S. CLS. 2, 5, 22, 23, 29, 37, 38 AND 50). SN 86-179,147. PUB. 6-10-2014. FILED 1-29-2014.

4,592,913 ( *See Class 9 for this trademark*).

4,592,946. **PIERCE THE VEIL (STANDARD CHARACTER)**.

FUENTES, VICTOR, (U.S. CLS. 2, 5, 22, 23, 29, 37, 38 AND 50). SN 86-187,737. PUB. 6-10-2014. FILED 2-7-2014.

4,592,953 ( *See Class 14 for this trademark*).

4,592,974. **CHASIN' TAIL AND DESIGN**. ASHLEY CROUCH, MULTIPLE CLASS, (INT. CLS. 16 AND 25), (U.S. CLS. 2, 5, 22, 23, 29, 37, 38, 39 AND 50). SN 86-199,399. PUB. 6-10-2014. FILED 2-20-2014.

4,592,986. **R.I.P. (STANDARD CHARACTER)**. G2 RESEARCH, INC., MULTIPLE CLASS, (INT. CLS. 16 AND 25), (U.S. CLS. 2, 5, 22, 23, 29, 37, 38, 39 AND 50). SN 86-206,984. PUB. 6-10-2014. FILED 2-28-2014.

4,592,987. **THE LAST ROUND YOU WILL EVER NEED (STANDARD CHARACTER)**. G2 RESEARCH, INC., MULTIPLE CLASS, (INT. CLS. 16 AND 25), (U.S. CLS. 2, 5, 22, 23, 29, 37, 38, 39 AND 50). SN 86-206,986. PUB. 6-10-2014. FILED 2-28-2014.

---

## CLASS 17—RUBBER GOODS

4,590,653 ( *See Class 1 for this trademark*).

4,590,654 ( *See Class 1 for this trademark*).

4,590,733. **EDVPACKAGING EDV AND DESIGN**. EDV PACKAGING SOLUTIONS, S.A., MULTIPLE CLASS, (INT. CLS. 17, 20 AND 40), (U.S. CLS. 1, 2, 5, 12, 13, 22, 25, 32, 35, 50, 100, 103 AND 106). SN 79-134,408. PUB. 6-10-2014. FILED 5-16-2013.

4,590,751. **TAICA (STYLIZED)**. TAICA CORPORATION, MULTIPLE CLASS, (INT. CLS. 17, 40 AND 42), (U.S. CLS. 1, 5, 12, 13, 35, 50, 100, 101, 103 AND 106). SN 79-135,506. PUB. 6-10-2014. FILED 3-12-2013.

4,590,771 ( *See Class 12 for this trademark*).

4,590,811 ( *See Class 1 for this trademark*).

4,590,813 ( *See Class 1 for this trademark*).

4,590,824 ( *See Class 1 for this trademark*).

4,590,831. **FENIX NTM (STANDARD CHARACTER)**. ARPA INDUSTRIALE S.P.A., MULTIPLE CLASS, (INT. CLS. 17 AND 20), (U.S. CLS. 1, 2, 5, 12, 13, 22, 25, 32, 35 AND 50). SN 79-139,417. PUB. 6-10-2014. FILED 9-26-2013.

4,590,996. **D R I (STYLIZED)**. DAKLAK RUBBER INVESTMENT JOINT STOCK COMPANY, (U.S. CLS. 1, 5, 12, 13, 35 AND 50). SN 85-673,563. PUB. 6-10-2014. FILED 7-11-2012.

4,591,096 ( *See Class 11 for this trademark*).

4,591,206. **P/S 860 (STANDARD CHARACTER)**. PRC-DESOTO INTERNATIONAL, INC., (U.S. CLS. 1, 5, 12, 13, 35 AND 50). SN 85-935,255. PUB. 6-10-2014. FILED 5-17-2013.

4,591,361. **RESHCOR AND DESIGN**. RESHCOR, INC., FORMERLY OMEGA PLASTICS CORP., MULTIPLE CLASS, (INT. CLS. 17, 19, 40 AND 42), (U.S. CLS. 1, 5, 12, 13, 33, 35, 50, 100, 101, 103 AND 106). SN 85-972,730. PUB. 6-10-2014. FILED 6-28-2013.

4,591,383 ( *See Class 1 for this trademark*).

4,591,385. **CLEARBAGS (STANDARD CHARACTER)**. CLEAR IMAGE, INC., DBA IMPACT IMAGES, (U.S. CLS. 1, 5, 12, 13, 35 AND 50). SN 85-974,923. PUB. 6-10-2014. FILED 7-1-2013.

4,591,544. **TOP FIN (STANDARD CHARACTER)**. PETSMART STORE SUPPORT GROUP, INC., (U.S. CLS. 1, 5, 12, 13, 35 AND 50). SN 86-024,645. PUB. 6-10-2014. FILED 7-31-2013.

4,592,332. **AQUIDRY (STANDARD CHARACTER)**. TREDEGAR FILM PRODUCTS CORPORATION, (U.S. CLS. 1, 5, 12, 13, 35 AND 50). SN 86-161,619. PUB. 6-10-2014. FILED 1-9-2014.

4,592,839. **SAFETYTAC AND DESIGN**. CREATIVE SAFETY SUPPLY, (U.S. CLS. 1, 5, 12, 13, 35 AND 50). SN 86-178,651. PUB. 6-10-2014. FILED 1-29-2014.

4,592,995. **INSITUFORM (STANDARD CHARACTER)**. INA ACQUISITION CORP., (U.S. CLS. 1, 5, 12, 13, 35 AND 50). SN 86-214,326. PUB. 6-10-2014. FILED 3-7-2014.

---

## CLASS 18—LEATHER GOODS

4,590,610 ( *See Class 3 for this trademark*).

4,590,626 ( *See Class 3 for this trademark*).

- 4,590,631 ( See Class 12 for this trademark).  
 4,590,636 ( See Class 14 for this trademark).  
 4,590,637 ( See Class 14 for this trademark).  
 4,590,655 ( See Class 9 for this trademark).  
 4,590,694 ( See Class 14 for this trademark).  
 4,590,699 ( See Class 3 for this trademark).  
 4,590,702 ( See Class 3 for this trademark).  
 4,590,707 ( See Class 9 for this trademark).  
 4,590,709 ( See Class 9 for this trademark).  
 4,590,723. **MORE THAN LUX (STANDARD CHARACTER)**. MAURO SERGIO CAGGIANELLI, MULTIPLE CLASS, (INT. CLS. 18, 25 AND 35), (U.S. CLS. 1, 2, 3, 22, 39, 41, 100, 101 AND 102). SN 79-134,145. PUB. 6-10-2014. FILED 7-10-2013.  
 4,590,740 ( See Class 3 for this trademark).  
 4,590,746 ( See Class 3 for this trademark).  
 4,590,760. **ESTEFANIA MARCO (STYLIZED)**. ESTEFANÍA MARCO ALVAREZ, MULTIPLE CLASS, (INT. CLS. 18 AND 25), (U.S. CLS. 1, 2, 3, 22, 39 AND 41). SN 79-135,799. PUB. 6-10-2014. FILED 5-17-2013.  
 4,590,780 ( See Class 16 for this trademark).  
 4,590,792 ( See Class 9 for this trademark).  
 4,590,793 ( See Class 9 for this trademark).  
 4,590,798. **INTRIGATE (STANDARD CHARACTER)**. VALENTINO S.P.A. MULTIPLE CLASS, (INT. CLS. 18 AND 25), (U.S. CLS. 1, 2, 3, 22, 39 AND 41). SN 79-137,415. PUB. 6-10-2014. FILED 8-6-2013.  
 4,590,807. **LICK-FREE (STYLIZED)**. WUXI JUST-PET CO.,LTD, (U.S. CLS. 1, 2, 3, 22 AND 41). SN 79-137,926. PUB. 6-10-2014. FILED 2-22-2013.  
 4,590,809. **GEOX BREATHE AND DESIGN**. GEOX S.P.A. MULTIPLE CLASS, (INT. CLS. 18 AND 25), (U.S. CLS. 1, 2, 3, 22, 39 AND 41). SN 79-137,972. PUB. 6-10-2014. FILED 6-7-2013.  
 4,590,830 ( See Class 6 for this trademark).  
 4,590,856 ( See Class 3 for this trademark).  
 4,590,876 ( See Class 14 for this trademark).  
 4,590,907. **SAMSØE SAMSØE AND DESIGN**. SAMSØE & SAMSØE HOLDING A/S, MULTIPLE CLASS, (INT. CLS. 18 AND 25), (U.S. CLS. 1, 2, 3, 22, 39 AND 41). SN 79-143,253. PUB. 6-10-2014. FILED 11-22-2013.  
 4,590,922. **I-STAY (STANDARD CHARACTER)**. FALCON INNOVATIONS (NORTHAMPTON); LIMITED, (U.S. CLS. 1, 2, 3, 22 AND 41). SN 79-144,180. PUB. 6-10-2014. FILED 11-22-2013.  
 4,590,937. **AGEA (STYLIZED)**. ABDINOV AYAZ, (U.S. CLS. 1, 2, 3, 22 AND 41). SN 79-145,868. PUB. 6-10-2014. FILED 10-14-2013.  
 4,590,946. **GABBY ISABELLA (STANDARD CHARACTER)**. SPANNER LIMITED, MULTIPLE CLASS, (INT. CLS. 18 AND 25), (U.S. CLS. 1, 2, 3, 22, 39 AND 41). SN 85-248,448. PUB. 6-10-2014. FILED 2-22-2011.  
 4,591,027. **PACIFIC SPORTS RESORT (STANDARD CHARACTER)**. W. A. HOLDING COMPANY, LLC, MULTIPLE CLASS, (INT. CLS. 18, 21, 25, 35, 41, 43 AND 44), (U.S. CLS. 1, 2, 3, 13, 22, 23, 29, 30, 33, 39, 40, 41, 50, 100, 101, 102 AND 107). SN 85-762,822. PUB. 6-10-2014. FILED 10-24-2012.  
 4,591,038. **GLAMAZON AND DESIGN**. CROTHERS, BEVERLY LILLIAN, MULTIPLE CLASS, (INT. CLS. 18 AND 25), (U.S. CLS. 1, 2, 3, 22, 39 AND 41). SN 85-775,740. PUB. 11-5-2013. FILED 11-9-2012.  
 4,591,058 ( See Class 9 for this trademark).  
 4,591,080. **MISCELLANEOUS DESIGN**. MAGEE CLOTHING, MULTIPLE CLASS, (INT. CLS. 18, 24 AND 25), (U.S. CLS. 1, 2, 3, 22, 39, 41, 42 AND 50). SN 85-804,603. PUB. 6-10-2014. FILED 12-17-2012.  
 4,591,085 ( See Class 9 for this trademark).  
 4,591,094. **GMT (STYLIZED)**. XIAMEN CITY SPARK IMP. & EXP. CO., LTD., (U.S. CLS. 1, 2, 3, 22 AND 41). SN 85-810,862. PUB. 6-10-2014. FILED 12-27-2012.  
 4,591,101. **MIKE DE BRIE (STYLIZED)**. MIKE DE BRIE (OCEANIA) LIMITED, MULTIPLE CLASS, (INT. CLS. 18 AND 25), (U.S. CLS. 1, 2, 3, 22, 39 AND 41). SN 85-825,273. PUB. 6-10-2014. FILED 1-17-2013.  
 4,591,108. **BOOMBRELLA (STANDARD CHARACTER)**. ZINCOS PRODUCTS INC., DBA WHOLESALE OF PRODUCTS, (U.S. CLS. 1, 2, 3, 22 AND 41). SN 85-839,427. PUB. 6-10-2014. FILED S.R. 2-3-2013; AM. P.R. 5-1-2014.  
 4,591,185. **VIAGGIO (STYLIZED)**. GUCCI AMERICA, INC., (U.S. CLS. 1, 2, 3, 22 AND 41). SN 85-921,552. PUB. 6-10-2014. FILED 5-2-2013.  
 4,591,386. **CLEARBAGS (STANDARD CHARACTER)**. CLEAR IMAGE, INC., DBA IMPACT IMAGES, (U.S. CLS. 1, 2, 3, 22 AND 41). SN 85-974,928. PUB. 6-10-2014. FILED 7-1-2013.  
 4,591,476. **MISCELLANEOUS DESIGN**. RAVENITE, LLC, MULTIPLE CLASS, (INT. CLS. 18, 21 AND 25), (U.S. CLS. 1, 2, 3, 13, 22, 23, 29, 30, 33, 39, 40, 41 AND 50). SN 86-009,062. PUB. 6-10-2014. FILED 7-12-2013.  
 4,591,690 ( See Class 16 for this trademark).  
 4,591,716 ( See Class 9 for this trademark).  
 4,591,799. **SUITICAL (STANDARD CHARACTER)**. SUITICAL INTERNATIONAL BV, (U.S. CLS. 1, 2, 3, 22 AND 41). SN 86-100,006. PUB. 6-10-2014. FILED 10-24-2013.  
 4,591,811 ( See Class 14 for this trademark).  
 4,591,833 ( See Class 16 for this trademark).  
 4,591,971. **GROWING ADVANTAGE THE ALMOND CONFERENCE AND DESIGN**. THE ALMOND BOARD OF CALIFORNIA, MULTIPLE CLASS, (INT. CLS. 18 AND 41), (U.S. CLS. 1, 2, 3, 22, 41, 100, 101 AND 107). SN 86-131,407. PUB. 6-10-2014. FILED 11-27-2013.  
 4,592,052. **MISCELLANEOUS DESIGN**. UNIVERSAL CITY STUDIOS LLC, (U.S. CLS. 1, 2, 3, 22 AND 41). SN 86-142,494. PUB. 6-10-2014. FILED 12-12-2013.  
 4,592,270 ( See Class 16 for this trademark).  
 4,592,351. **DELTA VOYAGER AND DESIGN**. SIMONS, DAVID J., MULTIPLE CLASS, (INT. CLS. 18 AND 25), (U.S. CLS. 1, 2, 3, 22, 39 AND 41). SN 86-161,960. PUB. 6-10-2014. FILED 1-9-2014.  
 4,592,543 ( See Class 14 for this trademark).  
 4,592,657. **VOCHIC (STANDARD CHARACTER)**. LI YAO WEN, (U.S. CLS. 1, 2, 3, 22 AND 41). SN 86-175,524. PUB. 6-10-2014. FILED 1-27-2014.  
 4,592,674. **NENOLIE (STANDARD CHARACTER)**. N. GABRIELE HUNGERFORD, MULTIPLE CLASS, (INT. CLS. 18, 20 AND 25), (U.S. CLS. 1, 2, 3, 13, 22, 25, 32, 39, 41 AND 50). SN 86-175,707. PUB. 6-10-2014. FILED 1-27-2014.  
 4,592,675 ( See Class 14 for this trademark).  
 4,592,812. **OPENING CEREMONY EST. 2002 (STYLIZED)**. OPENING CEREMONY IP LLC, MULTIPLE CLASS, (INT. CLS. 18, 25 AND 35), (U.S. CLS. 1, 2, 3, 22, 39, 41, 100, 101 AND 102). SN 86-178,219. PUB. 6-10-2014. FILED 1-29-2014.  
 4,592,852. **BLACKSEA (STANDARD CHARACTER)**. BLACKSEA COLLECTION INC., (U.S. CLS. 1, 2, 3, 22 AND 41). SN 86-178,869. PUB. 6-10-2014. FILED 1-29-2014.  
 4,592,862. **LIVE LIFE HANDS FREE (STANDARD CHARACTER)**. HIPS-SISTER, INC., (U.S. CLS. 1, 2, 3, 22 AND 41). SN 86-179,029. PUB. 6-10-2014. FILED 1-29-2014.  
 4,592,865. **GOBAND (STYLIZED)**. HIPS-SISTER, INC., (U.S. CLS. 1, 2, 3, 22 AND 41). SN 86-179,089. PUB. 6-10-2014. FILED 1-29-2014.  
 4,592,914. **WAG MORE BARK LESS (STANDARD CHARACTER)**. MELTON-JOHNSON, BRENNAN W., AND MELTON-JOHNSON, JENNIFER M., (U.S. CLS. 1, 2, 3, 22 AND 41). SN 86-180,407. PUB. 6-10-2014. FILED 1-30-2014.  
 4,593,023. **COEUR D'ALENE CASINO AND DESIGN**. COEUR D'ALENE TRIBE, DBA COEUR D'ALENE TRIBAL CASINO, (U.S. CLS. 1, 2, 3, 22 AND 41). SN 86-226,415. PUB. 6-10-2014. FILED 3-19-2014.
- 
- CLASS 19—NON-METALLIC BUILDING MATERIALS**
- 4,590,677 ( See Class 6 for this trademark).  
 4,590,802 ( See Class 6 for this trademark).  
 4,590,813 ( See Class 1 for this trademark).  
 4,590,824 ( See Class 1 for this trademark).  
 4,590,950. **TRIM2TRIM (STANDARD CHARACTER)**. HALISCHUK, CORY, (U.S. CLS. 1, 12, 33 AND 50). SN 85-317,312. PUB. 6-10-2014. FILED 5-10-2011.  
 4,591,095. **TILE TECH PAVERS PAVING AMERICA ONE STEP AT A TIME! AND DESIGN**. TILE TECH INC., (U.S. CLS. 1, 12, 33 AND 50). SN 85-811,647. PUB. 6-10-2014. FILED 12-28-2012.  
 4,591,096 ( See Class 11 for this trademark).

- 4,591,350. **SPLASH COLLECTION AND DESIGN. SURFACES SOUTHEAST, INC.**, (U.S. CLS. 1, 12, 33 AND 50). SN 85-971,527. PUB. 6-10-2014. FILED 6-27-2013.
- 4,591,361 ( *See Class 17 for this trademark*).
- 4,591,543. **TOP FIN (STANDARD CHARACTER). PETSMAST STORE SUPPORT GROUP, INC.**, (U.S. CLS. 1, 12, 33 AND 50). SN 86-024,641. PUB. 6-10-2014. FILED 7-31-2013.
- 4,591,670. **SGI AND DESIGN. SPECIALTY GRANULES INVESTMENTS LLC**, (U.S. CLS. 1, 12, 33 AND 50). SN 86-061,332. PUB. 6-10-2014. FILED 9-11-2013.
- 4,591,671. **SGI (STANDARD CHARACTER). SPECIALTY GRANULES INVESTMENTS LLC**, (U.S. CLS. 1, 12, 33 AND 50). SN 86-061,343. PUB. 6-10-2014. FILED 9-11-2013.
- 4,591,886. **TUFF-SLAB (STANDARD CHARACTER). NYCON CORPORATION**, (U.S. CLS. 1, 12, 33 AND 50). SN 86-118,874. PUB. 6-10-2014. FILED 11-14-2013.
- 4,592,034. **TUFF-MIX (STANDARD CHARACTER). NYCON CORPORATION**, (U.S. CLS. 1, 12, 33 AND 50). SN 86-140,289. PUB. 6-10-2014. FILED 12-11-2013.
- 4,592,209. **CIELO DE ORO (STANDARD CHARACTER). TAB INDIA GRANITES PVT. LTD.**, (U.S. CLS. 1, 12, 33 AND 50). SN 86-156,057. PUB. 6-10-2014. FILED 1-2-2014.
- 4,592,210. **TAB INDIA AND DESIGN. TAB INDIA GRANITES PVT. LTD.**, (U.S. CLS. 1, 12, 33 AND 50). SN 86-156,105. PUB. 6-10-2014. FILED 1-2-2014.
- 4,592,261. **GATOR HANGER (STANDARD CHARACTER). MADE IN AMERICA, LLC**, (U.S. CLS. 1, 12, 33 AND 50). SN 86-158,508. PUB. 6-10-2014. FILED 1-6-2014.
- 4,592,424. **THE MODERNO COLLECTION (STANDARD CHARACTER). HERITAGE OF HARVEST, LLC**, (U.S. CLS. 1, 12, 33 AND 50). SN 86-163,745. PUB. 6-10-2014. FILED 1-13-2014.
- 4,592,440. **PERMALITE (STANDARD CHARACTER). HB&G BUILDING PRODUCTS, INC.**, (U.S. CLS. 1, 12, 33 AND 50). SN 86-164,613. PUB. 6-10-2014. FILED 1-14-2014.
- 4,592,470. **ECO-HUTS AND DESIGN. ROHDE, JUSTIN W., DBA ECO-HUTS**, (U.S. CLS. 1, 12, 33 AND 50). SN 86-165,530. PUB. 6-10-2014. FILED 1-14-2014.
- 4,592,547. **I-HUT (STANDARD CHARACTER). ROHDE, JUSTIN W.**, (U.S. CLS. 1, 12, 33 AND 50). SN 86-167,929. PUB. 6-10-2014. FILED 1-16-2014.
- 4,592,576. **FRENCH CONNECTION (STANDARD CHARACTER). OLD MASTER PRODUCTS, INC.**, (U.S. CLS. 1, 12, 33 AND 50). SN 86-171,333. PUB. 6-10-2014. FILED 1-21-2014.
- 4,592,686. **BUILD AMERICA (STANDARD CHARACTER). WINDSOR HOLDING COMPANY**, (U.S. CLS. 1, 12, 33 AND 50). SN 86-175,954. PUB. 6-10-2014. FILED 1-27-2014.
- 4,592,720. **MISCELLANEOUS DESIGN. WINDSOR HOLDING COMPANY**, (U.S. CLS. 1, 12, 33 AND 50). SN 86-176,629. PUB. 6-10-2014. FILED 1-27-2014.
- 4,592,788. **HOMESTEAD (STANDARD CHARACTER). INFINITY LAWN AND GARDEN, INC.**, (U.S. CLS. 1, 12, 33 AND 50). SN 86-177,780. PUB. 6-10-2014. FILED 1-28-2014.
- 4,592,795. **EVEREST (STANDARD CHARACTER). INFINITY LAWN AND GARDEN, INC.**, (U.S. CLS. 1, 12, 33 AND 50). SN 86-177,850. PUB. 6-10-2014. FILED 1-28-2014.
- DARD CHARACTER). IAN JAMES BURDEN, MULTIPLE CLASS, (INT. CLS. 20 AND 35), (U.S. CLS. 2, 13, 22, 25, 32, 50, 100, 101 AND 102). SN 79-140,162. PUB. 6-10-2014. FILED 10-31-2013.**
- 4,590,853. **P.G.T. RECLAIMED AND DESIGN. IAN JAMES BURDEN, MULTIPLE CLASS, (INT. CLS. 20 AND 35), (U.S. CLS. 2, 13, 22, 25, 32, 50, 100, 101 AND 102). SN 79-140,751. PUB. 6-10-2014. FILED 3-13-2013.**
- 4,590,858 ( *See Class 7 for this trademark*).
- 4,590,888. **JUUL (STANDARD CHARACTER). N. EILERSEN A/S**, (U.S. CLS. 2, 13, 22, 25, 32 AND 50). SN 79-142,645. PUB. 6-10-2014. FILED 12-11-2013.
- 4,590,908 ( *See Class 3 for this trademark*).
- 4,590,938. **IMATT (STANDARD CHARACTER). DAS GESUNDHEITSHAUS GMBH**, (U.S. CLS. 2, 13, 22, 25, 32 AND 50). SN 79-146,109. PUB. 6-10-2014. FILED 1-22-2014.
- 4,591,031 ( *See Class 6 for this trademark*).
- 4,591,054. **PET DREAMS AND DESIGN. PET DREAMS INTERNATIONAL, INC.**, (U.S. CLS. 2, 13, 22, 25, 32 AND 50). SN 85-785,834. PUB. 6-10-2014. FILED 11-21-2012.
- 4,591,096 ( *See Class 11 for this trademark*).
- 4,591,297 ( *See Class 14 for this trademark*).
- 4,591,313. **V SLEEP MATTRESS SYSTEMS (STYLIZED). LAT ENTERPRISES, LLC**, (U.S. CLS. 2, 13, 22, 25, 32 AND 50). SN 85-966,587. PUB. 6-10-2014. FILED 6-21-2013.
- 4,591,334 ( *See Class 6 for this trademark*).
- 4,591,397. **KITTYSMART (STANDARD CHARACTER). KITTYSMART LLC**, (U.S. CLS. 2, 13, 22, 25, 32 AND 50). SN 86-000,014. PUB. 6-10-2014. FILED 7-1-2013.
- 4,591,586 ( *See Class 16 for this trademark*).
- 4,591,625. **GRAVITY-TUBE (STANDARD CHARACTER). GO PAPA, LLLP**, (U.S. CLS. 2, 13, 22, 25, 32 AND 50). SN 86-045,196. PUB. 6-10-2014. FILED 8-22-2013.
- 4,591,716 ( *See Class 9 for this trademark*).
- 4,592,086 ( *See Class 6 for this trademark*).
- 4,592,087. **KOZY CUSHIONS AND DESIGN. KOZY CUSHIONS**, (U.S. CLS. 2, 13, 22, 25, 32 AND 50). SN 86-146,859. PUB. 6-10-2014. FILED 12-18-2013.
- 4,592,100. **MIRRORMAXX (STANDARD CHARACTER). PANORAMIC ENTERPRISE, LLC**, (U.S. CLS. 2, 13, 22, 25, 32 AND 50). SN 86-148,476. PUB. 6-10-2014. FILED 12-19-2013.
- 4,592,116. **DB DECOBROTHERS (STYLIZED). PRETTY STAR STORE LLC, MULTIPLE CLASS, (INT. CLS. 20 AND 21), (U.S. CLS. 2, 13, 22, 23, 25, 29, 30, 32, 33, 40 AND 50). SN 86-150,318. PUB. 6-10-2014. FILED 12-21-2013.**
- 4,592,419. **CANTWELL MATTRESS CM EST. 1920 HANDMADE AND DESIGN. CANTWELL MATTRESS COMPANY**, (U.S. CLS. 2, 13, 22, 25, 32 AND 50). SN 86-163,621. PUB. 6-10-2014. FILED 1-13-2014.
- 4,592,455. **BRISA (STANDARD CHARACTER). L&P PROPERTY MANAGEMENT COMPANY**, (U.S. CLS. 2, 13, 22, 25, 32 AND 50). SN 86-165,252. PUB. 6-10-2014. FILED 1-14-2014.
- 4,592,481. **HEAT-A-SEAT (STANDARD CHARACTER). THE LUCCI CORP.**, (U.S. CLS. 2, 13, 22, 25, 32 AND 50). SN 86-166,011. PUB. 6-10-2014. FILED 1-15-2014.
- 4,592,674 ( *See Class 18 for this trademark*).
- 4,592,954. **CLOUD SLEEP (STYLIZED). XILINMEN FURNITURE CO., LTD.**, MULTIPLE CLASS, (INT. CLS. 20 AND 24), (U.S. CLS. 2, 13, 22, 25, 32, 42 AND 50). SN 86-189,902. PUB. 6-10-2014. FILED 2-11-2014.
- 4,592,983. **PERFORMANCE WOOL (STANDARD CHARACTER). BEDGEAR LLC, MULTIPLE CLASS, (INT. CLS. 20 AND 24), (U.S. CLS. 2, 13, 22, 25, 32, 42 AND 50). SN 86-204,607. PUB. 6-10-2014. FILED 2-26-2014.**

---

#### CLASS 20—FURNITURE AND ARTICLES NOT OTHERWISE CLASSIFIED

- 4,590,610 ( *See Class 3 for this trademark*).
- 4,590,626 ( *See Class 3 for this trademark*).
- 4,590,635 ( *See Class 9 for this trademark*).
- 4,590,718 ( *See Class 10 for this trademark*).
- 4,590,721 ( *See Class 9 for this trademark*).
- 4,590,732 ( *See Class 7 for this trademark*).
- 4,590,733 ( *See Class 17 for this trademark*).
- 4,590,748. **REALE (STANDARD CHARACTER). EUROPEAN INTELLECTUAL PROPERTY SA, MULTIPLE CLASS, (INT. CLS. 20 AND 24), (U.S. CLS. 2, 13, 22, 25, 32, 42 AND 50). SN 79-135,408. PUB. 6-10-2014. FILED 1-3-2013.**
- 4,590,756 ( *See Class 12 for this trademark*).
- 4,590,802 ( *See Class 6 for this trademark*).
- 4,590,819 ( *See Class 10 for this trademark*).
- 4,590,831 ( *See Class 17 for this trademark*).
- 4,590,843. **PGT RECLAIMED STRETCH BEDDING (STAN-**

---

#### CLASS 21—HOUSEWARES AND GLASS

- 4,590,610 ( *See Class 3 for this trademark*).
- 4,590,626 ( *See Class 3 for this trademark*).
- 4,590,629 ( *See Class 8 for this trademark*).
- 4,590,644 ( *See Class 9 for this trademark*).
- 4,590,653 ( *See Class 1 for this trademark*).
- 4,590,654 ( *See Class 1 for this trademark*).
- 4,590,693 ( *See Class 3 for this trademark*).
- 4,590,719. **HIGHGLASS AND DESIGN. STEKLARNA HRASTNIK D.O.O.**, MULTIPLE CLASS, (INT. CLS. 21, 34, 35, 40

AND 42), (U.S. CLS. 2, 8, 9, 13, 17, 23, 29, 30, 33, 40, 50, 100, 101, 102, 103 AND 106). SN 79-133,870. PUB. 6-10-2014. FILED 6-7-2013.

4,590,769. **ICEPOOL (STANDARD CHARACTER)**. WINE NOT, (U.S. CLS. 2, 13, 23, 29, 30, 33, 40 AND 50). SN 79-136,142. PUB. 6-10-2014. FILED 8-14-2013.

4,590,777 ( *See Class 6 for this trademark*).

4,590,785 ( *See Class 3 for this trademark*).

4,590,800. **CLUB WHIZZ (STANDARD CHARACTER)**. LM GOLF AUSTRALIA PTY LTD, (U.S. CLS. 2, 13, 23, 29, 30, 33, 40 AND 50). SN 79-137,580. PUB. 6-10-2014. FILED 9-11-2013.

4,590,823. **STÄHLEMÜHLE (STANDARD CHARACTER)**. CHRISTOPH KELLER, MULTIPLE CLASS, (INT. CLS. 21, 32 AND 33), (U.S. CLS. 2, 13, 23, 29, 30, 33, 40, 45, 46, 47, 48, 49 AND 50). SN 79-138,753. PUB. 6-10-2014. FILED 10-11-2013.

4,590,858 ( *See Class 7 for this trademark*).

4,590,908 ( *See Class 3 for this trademark*).

4,590,968. **AQUAPALOOZA (STANDARD CHARACTER)**. BRUNSWICK CORPORATION, (U.S. CLS. 2, 13, 23, 29, 30, 33, 40 AND 50). SN 85-484,905. PUB. 6-10-2014. FILED 12-1-2011.

4,590,971. **TENURA (STANDARD CHARACTER)**. HESKINS LTD., MULTIPLE CLASS, (INT. CLS. 21 AND 27), (U.S. CLS. 2, 13, 19, 20, 23, 29, 30, 33, 37, 40, 42 AND 50). SN 85-489,797. PUB. 6-10-2014. FILED 12-7-2011.

4,590,979. **NOVOGRATZ (STANDARD CHARACTER)**. NOVOGRATZ, ROBERT, AND NOVOGRATZ, CORTNEY, MULTIPLE CLASS, (INT. CLS. 21 AND 24), (U.S. CLS. 2, 13, 23, 29, 30, 33, 40, 42 AND 50). SN 85-542,792. PUB. 6-10-2014. FILED 2-14-2012.

4,591,027 ( *See Class 18 for this trademark*).

4,591,189. **K ANNABEL KARMEL AND DESIGN**. ANNABEL KARMEL GROUP HOLDINGS LTD, (U.S. CLS. 2, 13, 23, 29, 30, 33, 40 AND 50). SN 85-924,216. PUB. 6-10-2014. FILED 5-6-2013.

4,591,200. **KARDASHIAN KOLLECTION (STANDARD CHARACTER)**. KIMSAPRINCESS INC., AND 2DIE4KOURT, AND KHLOMONEY INC., (U.S. CLS. 2, 13, 23, 29, 30, 33, 40 AND 50). SN 85-933,297. PUB. 6-10-2014. FILED 5-15-2013.

4,591,387. **CLEARBAGS (STANDARD CHARACTER)**. CLEAR IMAGE, INC., DBA IMPACT IMAGES, (U.S. CLS. 2, 13, 23, 29, 30, 33, 40 AND 50). SN 85-974,935. PUB. 6-10-2014. FILED 7-1-2013.

4,591,476 ( *See Class 18 for this trademark*).

4,591,522 ( *See Class 9 for this trademark*).

4,591,526 ( *See Class 14 for this trademark*).

4,591,629 ( *See Class 1 for this trademark*).

4,591,673. **CHILLWARMER AND DESIGN**. MIND4RENT LLC, (U.S. CLS. 2, 13, 23, 29, 30, 33, 40 AND 50). SN 86-062,090. PUB. 6-10-2014. FILED 9-11-2013.

4,591,699. **QUATTROSELECT (STANDARD CHARACTER)**. DIVERSEY, INC., (U.S. CLS. 2, 13, 23, 29, 30, 33, 40 AND 50). SN 86-069,724. PUB. 6-10-2014. FILED 9-19-2013.

4,591,746. **TS AND DESIGN**. TASTEFULLY SIMPLE, INC., MULTIPLE CLASS, (INT. CLS. 21, 25, 29, 30, 32 AND 35), (U.S. CLS. 2, 13, 22, 23, 29, 30, 33, 39, 40, 45, 46, 48, 50, 100, 101 AND 102). SN 86-083,316. PUB. 6-10-2014. FILED 10-4-2013.

4,591,804. **TRAMONTINA PROLINE (STANDARD CHARACTER)**. TRAMONTINA S.A., CUTLERIA, (U.S. CLS. 2, 13, 23, 29, 30, 33, 40 AND 50). SN 86-101,805. PUB. 6-10-2014. FILED 10-25-2013.

4,591,811 ( *See Class 14 for this trademark*).

4,591,832. **DISTILLED SPIRITS EPICENTER (STANDARD CHARACTER)**. DISTILLED SPIRITS EPICENTER, LLC, MULTIPLE CLASS, (INT. CLS. 21 AND 25), (U.S. CLS. 2, 13, 22, 23, 29, 30, 33, 39, 40 AND 50). SN 86-107,716. PUB. 6-10-2014. FILED 11-1-2013.

4,591,833 ( *See Class 16 for this trademark*).

4,591,913. **GMAS DESIGN (STANDARD CHARACTER)**. GMAS DESIGN LLC, (U.S. CLS. 2, 13, 23, 29, 30, 33, 40 AND 50). SN 86-123,330. PUB. 6-10-2014. FILED 11-19-2013.

4,591,977. **WOW SPORT (STANDARD CHARACTER)**. FUSION ONE GLOBAL, LLC, (U.S. CLS. 2, 13, 23, 29, 30, 33, 40 AND 50). SN 86-132,080. PUB. 6-10-2014. FILED 11-30-2013.

4,592,116 ( *See Class 20 for this trademark*).

4,592,173. **ACCESSIBLEGARDENS AND DESIGN**. LAROC-

QUE, ANNE MARIE, DBA ACCESSIBLE GARDENS, (U.S. CLS. 2, 13, 23, 29, 30, 33, 40 AND 50). SN 86-154,218. PUB. 6-10-2014. FILED 12-30-2013.

4,592,237. **BLUEWAVE AND DESIGN**. BLUEWAVE WATER BOTTLES, INC., (U.S. CLS. 2, 13, 23, 29, 30, 33, 40 AND 50). SN 86-157,684. PUB. 6-10-2014. FILED 1-5-2014.

4,592,270 ( *See Class 16 for this trademark*).

4,592,314. **MEMORY ANGELS AND DESIGN**. ESPOSITO, HEATHER J, DBA MEMORY ANGELS, (U.S. CLS. 2, 13, 23, 29, 30, 33, 40 AND 50). SN 86-161,150. PUB. 6-10-2014. FILED 1-9-2014.

4,592,324 ( *See Class 16 for this trademark*).

4,592,331. **VINLUXE (STANDARD CHARACTER)**. CUMMINGS, BEN, (U.S. CLS. 2, 13, 23, 29, 30, 33, 40 AND 50). SN 86-161,613. PUB. 6-10-2014. FILED 1-9-2014.

4,592,471 ( *See Class 16 for this trademark*).

4,592,869. **WAG MORE BARK LESS (STANDARD CHARACTER)**. MELTON-JOHNSON, BRENNAN W., AND MELTON-JOHNSON, JENNIFER M., (U.S. CLS. 2, 13, 23, 29, 30, 33, 40 AND 50). SN 86-179,164. PUB. 6-10-2014. FILED 1-29-2014.

4,592,870. **SKOY (STANDARD CHARACTER)**. SKOY ENTERPRISES, LLC, AKA SKOY, (U.S. CLS. 2, 13, 23, 29, 30, 33, 40 AND 50). SN 86-179,189. PUB. 6-10-2014. FILED 1-29-2014.

4,592,953 ( *See Class 14 for this trademark*).

4,593,058. **CLOROX AND DESIGN**. THE CLOROX COMPANY, (U.S. CLS. 2, 13, 23, 29, 30, 33, 40 AND 50). SN 86-254,287. PUB. 6-10-2014. FILED 4-16-2014.

4,593,060. **BARRE BARRE (STANDARD CHARACTER)**. MARTINEZ TAYLOR, JOSE EDUARDO, (U.S. CLS. 2, 13, 23, 29, 30, 33, 40 AND 50). SN 86-975,060. PUB. 6-10-2014. FILED 8-5-2013.

---

## CLASS 22—CORDAGE AND FIBERS

4,590,759. **HYDROWARMER (STYLIZED)**. FIRBEST CO., LTD., MULTIPLE CLASS, (INT. CLS. 22, 23, 24 AND 25), (U.S. CLS. 1, 2, 7, 19, 22, 39, 42, 43 AND 50). SN 79-135,717. PUB. 6-10-2014. FILED 2-21-2013.

4,590,845 ( *See Class 6 for this trademark*).

4,591,234. **V-STRAP (STANDARD CHARACTER)**. DENNIS M. AMBROSE, (U.S. CLS. 1, 2, 7, 19, 22, 42 AND 50). SN 85-947,398. PUB. 6-10-2014. FILED 5-31-2013.

4,591,493. **NOBARLINER (STANDARD CHARACTER)**. CORRPAK BULK PACKAGING SYSTEMS, (U.S. CLS. 1, 2, 7, 19, 22, 42 AND 50). SN 86-011,573. PUB. 6-10-2014. FILED 7-16-2013.

4,591,934. **SUPERIASD (STANDARD CHARACTER)**. INVISTA NORTH AMERICA S.A R.L., (U.S. CLS. 1, 2, 7, 19, 22, 42 AND 50). SN 86-126,810. PUB. 6-10-2014. FILED 11-22-2013.

4,592,109 ( *See Class 16 for this trademark*).

---

## CLASS 23—YARNS AND THREADS

4,590,755. **BESTE (STYLIZED)**. BESTE S.P.A., MULTIPLE CLASS, (INT. CLS. 23 AND 24), (U.S. CLS. 42, 43 AND 50). SN 79-135,559. PUB. 6-10-2014. FILED 12-19-2012.

4,590,759 ( *See Class 22 for this trademark*).

4,590,848. **ICE CREPE AND DESIGN**. EMILCOTONI S.P.A., (U.S. CL. 43). SN 79-140,600. PUB. 6-10-2014. FILED 10-4-2013.

4,592,620. **BABY BEE SWEET DELIGHT (STANDARD CHARACTER)**. HOBBY LOBBY STORES, INC., (U.S. CL. 43). SN 86-174,312. PUB. 6-10-2014. FILED 1-24-2014.

---

## CLASS 24—FABRICS

4,590,610 ( *See Class 3 for this trademark*).

4,590,715. **LIGHTEX (STANDARD CHARACTER)**. WOOREE NANOPHIL CO., LTD., (U.S. CLS. 42 AND 50). SN 79-133,571. PUB. 6-10-2014. FILED 6-5-2013.

- 4,590,718 ( *See Class 10 for this trademark.*)  
 4,590,746 ( *See Class 3 for this trademark.*)  
 4,590,748 ( *See Class 20 for this trademark.*)  
 4,590,755 ( *See Class 23 for this trademark.*)  
 4,590,759 ( *See Class 22 for this trademark.*)  
 4,590,819 ( *See Class 10 for this trademark.*)  
 4,590,876 ( *See Class 14 for this trademark.*)  
 4,590,979 ( *See Class 21 for this trademark.*)  
 4,590,995. **MALIBU SURF SHACK AND DESIGN.** MALIBU ADVENTURES INC., DBA MALIBU SURF SHACK, MULTIPLE CLASS, (INT. CLS. 24, 25, 28 AND 41), (U.S. CLS. 22, 23, 38, 39, 42, 50, 100, 101 AND 107). SN 85-672,045. PUB. 6-10-2014. FILED 7-9-2012.  
 4,591,025. **VAPORTEX (STANDARD CHARACTER).** TEXOLINI, INC., MULTIPLE CLASS, (INT. CLS. 24 AND 25), (U.S. CLS. 22, 39, 42 AND 50). SN 85-760,936. PUB. 6-10-2014. FILED 10-23-2012.  
 4,591,064 ( *See Class 16 for this trademark.*)  
 4,591,080 ( *See Class 18 for this trademark.*)  
 4,591,147. **BELLA BUNDLES AND DESIGN.** JULIE FELDMAN, DBA BELLA BUNDLES, (U.S. CLS. 42 AND 50). SN 85-882,623. PUB. 9-17-2013. FILED 3-21-2013.  
 4,591,182 ( *See Class 3 for this trademark.*)  
 4,591,723. **MESSAGE IN A BLANKET (STANDARD CHARACTER).** BOOBADOBA, LLC, (U.S. CLS. 42 AND 50). SN 86-079,127. PUB. 6-10-2014. FILED 9-30-2013.  
 4,591,742. **SNUGGLE DOODLE AND DESIGN.** TISKIEWIC, HANA, (U.S. CLS. 42 AND 50). SN 86-082,495. PUB. 6-10-2014. FILED 10-3-2013.  
 4,592,147. **EST CALIFORNIA 2001 PCT AND DESIGN.** AMRAPUR OVERSEAS INCORPORATED, (U.S. CLS. 42 AND 50). SN 86-152,173. PUB. 6-10-2014. FILED 12-24-2013.  
 4,592,543 ( *See Class 14 for this trademark.*)  
 4,592,588. **K AND DESIGN.** KASHWERE L.L.C., MULTIPLE CLASS, (INT. CLS. 24, 25, 28 AND 35), (U.S. CLS. 22, 23, 38, 39, 42, 50, 100, 101 AND 102). SN 86-172,160. PUB. 6-10-2014. FILED 1-22-2014.  
 4,592,638. **TACKY TABLECLOTH AND DESIGN.** PAVLICK MARKETING, INC., (U.S. CLS. 42 AND 50). SN 86-175,154. PUB. 6-10-2014. FILED 1-25-2014.  
 4,592,824. **ALL FOR YOU AND DESIGN.** CHEN, BIAO, AND HU, LIYAN, (U.S. CLS. 42 AND 50). SN 86-178,367. PUB. 6-10-2014. FILED 1-29-2014.  
 4,592,847. **COZYSWADDLE (STYLIZED).** LAMBS & IVY, INC., (U.S. CLS. 42 AND 50). SN 86-178,802. PUB. 6-10-2014. FILED 1-29-2014.  
 4,592,953 ( *See Class 14 for this trademark.*)  
 4,592,954 ( *See Class 20 for this trademark.*)  
 4,592,983 ( *See Class 20 for this trademark.*)

## CLASS 25—CLOTHING

- 4,590,607. **LUVLIFE AND DESIGN.** DILLINGHAM, KEITH, (U.S. CLS. 22 AND 39). SN 76-713,230. PUB. 6-10-2014. FILED 1-14-2013.  
 4,590,610 ( *See Class 3 for this trademark.*)  
 4,590,611. **STRONG ARM SPORTS AND DESIGN.** WILLIAMS, MORDECAI P., JR., (U.S. CLS. 22 AND 39). SN 76-714,381. PUB. 6-10-2014. FILED 6-13-2013.  
 4,590,625. **RED DRAGON (STANDARD CHARACTER).** CENTRE SKATEBOARD DISTRIBUTION LTD., (U.S. CLS. 22 AND 39). SN 78-478,821. PUB. 6-10-2014. FILED 9-3-2004.  
 4,590,626 ( *See Class 3 for this trademark.*)  
 4,590,631 ( *See Class 12 for this trademark.*)  
 4,590,636 ( *See Class 14 for this trademark.*)  
 4,590,637 ( *See Class 14 for this trademark.*)  
 4,590,639. **WORLD IN UNION (STANDARD CHARACTER).** RUGBY WORLD CUP LIMITED, MULTIPLE CLASS, (INT. CLS. 25, 28 AND 41), (U.S. CLS. 22, 23, 38, 39, 50, 100, 101 AND 107). SN 79-121,993. PUB. 6-10-2014. FILED 1-16-2012.  
 4,590,641. **CASINOSOCKERKING (STANDARD CHARACTER).** MANFRED EBERHARD, MULTIPLE CLASS, (INT. CLS. 25, 28 AND 41), (U.S. CLS. 22, 23, 38, 39, 50, 100, 101 AND 107). SN 79-122,535. PUB. 6-10-2014. FILED 5-22-2012.  
 4,590,655 ( *See Class 9 for this trademark.*)  
 4,590,699 ( *See Class 3 for this trademark.*)  
 4,590,702 ( *See Class 3 for this trademark.*)  
 4,590,723 ( *See Class 18 for this trademark.*)  
 4,590,740 ( *See Class 3 for this trademark.*)  
 4,590,747 ( *See Class 3 for this trademark.*)  
 4,590,758 ( *See Class 7 for this trademark.*)  
 4,590,759 ( *See Class 22 for this trademark.*)  
 4,590,760 ( *See Class 18 for this trademark.*)  
 4,590,780 ( *See Class 16 for this trademark.*)  
 4,590,792 ( *See Class 9 for this trademark.*)  
 4,590,793 ( *See Class 9 for this trademark.*)  
 4,590,798 ( *See Class 18 for this trademark.*)  
 4,590,808. **FRAU (STANDARD CHARACTER).** CALZATURIFICIO FRAU S.P.A., (U.S. CLS. 22 AND 39). SN 79-137,970. PUB. 6-10-2014. FILED 12-31-2012.  
 4,590,809 ( *See Class 18 for this trademark.*)  
 4,590,835. **AYUMI PLUS AND DESIGN.** TOKUTAKE INDUSTRY CO., LTD., (U.S. CLS. 22 AND 39). SN 79-139,903. PUB. 6-10-2014. FILED 10-4-2013.  
 4,590,849. **MISCELLANEOUS DESIGN.** ECCO SKO A/S, (U.S. CLS. 22 AND 39). SN 79-140,684. PUB. 6-10-2014. FILED 11-6-2013.  
 4,590,850 ( *See Class 3 for this trademark.*)  
 4,590,851. **FOLLOW ME CASHMERE BY COMPTOIR DES COTONNIERS (STANDARD CHARACTER).** CREATIONS NELSON, (U.S. CLS. 22 AND 39). SN 79-140,722. PUB. 6-10-2014. FILED 9-4-2013.  
 4,590,856 ( *See Class 3 for this trademark.*)  
 4,590,857. **MISCELLANEOUS DESIGN.** EDGE BLUE, INC., (U.S. CLS. 22 AND 39). SN 79-141,393. PUB. 6-10-2014. FILED 11-1-2013.  
 4,590,859. **MISCELLANEOUS DESIGN.** EDGE BLUE, INC., (U.S. CLS. 22 AND 39). SN 79-141,466. PUB. 6-10-2014. FILED 11-1-2013.  
 4,590,861 ( *See Class 9 for this trademark.*)  
 4,590,874. **BITURI AND DESIGN.** SUNG HO DONG, (U.S. CLS. 22 AND 39). SN 79-142,269. PUB. 6-10-2014. FILED 8-14-2013.  
 4,590,879 ( *See Class 12 for this trademark.*)  
 4,590,887. **CHATTYFEET AND DESIGN.** CHATTYWEAR LTD, (U.S. CLS. 22 AND 39). SN 79-142,600. PUB. 6-10-2014. FILED 12-3-2013.  
 4,590,897. **HENGSONG (STYLIZED).** LIN JIANSAN, (U.S. CLS. 22 AND 39). SN 79-142,904. PUB. 6-10-2014. FILED 11-6-2013.  
 4,590,907 ( *See Class 18 for this trademark.*)  
 4,590,915. **LADYFENSE (STANDARD CHARACTER).** EMMAUEL WILMES, MULTIPLE CLASS, (INT. CLS. 25, 28, 32, 35 AND 41), (U.S. CLS. 22, 23, 38, 39, 45, 46, 48, 50, 100, 101, 102 AND 107). SN 79-143,774. PUB. 6-10-2014. FILED 8-8-2013.  
 4,590,946 ( *See Class 18 for this trademark.*)  
 4,590,969. **SMOOTHIES (STANDARD CHARACTER).** MALIBU DESIGN GROUP, (U.S. CLS. 22 AND 39). SN 85-484,933. PUB. 6-10-2014. FILED 12-1-2011.  
 4,590,981. **NI (STYLIZED).** NINTH INNING BASEBALL, LLC, (U.S. CLS. 22 AND 39). SN 85-569,196. PUB. 12-24-2013. FILED 3-14-2012.  
 4,590,995 ( *See Class 24 for this trademark.*)  
 4,591,022. **MY BOYFRIEND IS OUT OF TOWN (STANDARD CHARACTER).** PEACE UNITED, MULTIPLE CLASS, (INT. CLS. 25, 41 AND 43), (U.S. CLS. 22, 39, 100, 101 AND 107). SN 85-757,668. PUB. 6-10-2014. FILED 10-18-2012.  
 4,591,025 ( *See Class 24 for this trademark.*)  
 4,591,026. **MISSISSIPPI STATE AND DESIGN.** MISSISSIPPI STATE UNIVERSITY, MULTIPLE CLASS, (INT. CLS. 25 AND 41), (U.S. CLS. 22, 39, 100, 101 AND 107). SN 85-762,780. PUB. 6-10-2014. FILED 10-24-2012.  
 4,591,027 ( *See Class 18 for this trademark.*)  
 4,591,038 ( *See Class 18 for this trademark.*)  
 4,591,053 ( *See Class 16 for this trademark.*)  
 4,591,057. **BILTWELL (STYLIZED).** BILTWELL CUSTOM MOTORCYCLE CORP., DBA BILTWELL, INC., MULTIPLE CLASS, (INT. CLS. 25 AND 26), (U.S. CLS. 22, 37, 39, 40, 42 AND 50). SN 85-787,569. PUB. 6-10-2014. FILED 11-26-2012.  
 4,591,058 ( *See Class 9 for this trademark.*)  
 4,591,065. **CHAPTER (STYLIZED).** BEANS + BLINTZES,

- LLC, (U.S. CLS. 22 AND 39). SN 85-791,117. PUB. 6-10-2014. FILED 11-29-2012.
- 4,591,072. **SANTISI BROTHERS (STANDARD CHARACTER)**. P D J & ASSOCIATES INC., MULTIPLE CLASS, (INT. CLS. 25 AND 43), (U.S. CLS. 22, 39, 100 AND 101). SN 85-798,656. PUB. 6-10-2014. FILED 12-10-2012.
- 4,591,080 ( *See Class 18 for this trademark*).
- 4,591,093. **MANITO AND DESIGN. TOTAL KIDS CORP.**, (U.S. CLS. 22 AND 39). SN 85-810,628. PUB. 6-10-2014. FILED 12-26-2012.
- 4,591,099. **BETTER BITES (STANDARD CHARACTER)**. DOUBLE D HOLDINGS, LLC, DBA BETTER BITES, MULTIPLE CLASS, (INT. CLS. 25 AND 43), (U.S. CLS. 22, 39, 100 AND 101). SN 85-819,601. PUB. 6-10-2014. FILED 1-9-2013.
- 4,591,101 ( *See Class 18 for this trademark*).
- 4,591,106. **MISCELLANEOUS DESIGN. KIKOYNY, LLC**, (U.S. CLS. 22 AND 39). SN 85-832,831. PUB. 6-10-2014. FILED 1-25-2013.
- 4,591,109. **VAULT BREWING (STANDARD CHARACTER)**. VAULT BREWING COMPANY, MULTIPLE CLASS, (INT. CLS. 25, 32 AND 43), (U.S. CLS. 22, 39, 45, 46, 48, 100 AND 101). SN 85-842,573. PUB. 3-4-2014. FILED S.R. 2-6-2013; AM. P.R. 12-6-2013.
- 4,591,151. **FOF AND DESIGN. THRILLA CLOTHING COMPANY**, (U.S. CLS. 22 AND 39). SN 85-889,389. PUB. 6-10-2014. FILED 3-28-2013.
- 4,591,170 ( *See Class 9 for this trademark*).
- 4,591,178. **CAMBRIAN ANATOMICAL (STANDARD CHARACTER)**. ROBLIN ATHLETIC INC., (U.S. CLS. 22 AND 39). SN 85-913,790. PUB. 6-10-2014. FILED 4-24-2013.
- 4,591,180. **J R BUCKLEY (STANDARD CHARACTER)**. JEFFERY R. BUCKLEY, (U.S. CLS. 22 AND 39). SN 85-914,592. PUB. 11-5-2013. FILED 4-25-2013.
- 4,591,191 ( *See Class 10 for this trademark*).
- 4,591,196. **SAVE AMERICA'S CHILDREN AND DESIGN. DEW, DAVID L., JR.**, MULTIPLE CLASS, (INT. CLS. 25 AND 41), (U.S. CLS. 22, 39, 100, 101 AND 107). SN 85-927,985. PUB. 6-10-2014. FILED 5-9-2013.
- 4,591,223. **FLYING BROS (STYLIZED)**. MANTESSOFILHO, FLAVIO, DBA FLYING BROS, (U.S. CLS. 22 AND 39). SN 85-942,930. PUB. 6-10-2014. FILED 5-26-2013.
- 4,591,262. **KNOTTY CO. (STANDARD CHARACTER)**. ALLISON, PATRICK, (U.S. CLS. 22 AND 39). SN 85-955,163. PUB. 6-10-2014. FILED 6-10-2013.
- 4,591,274. **KINGZ (STANDARD CHARACTER)**. FIGHTER'S MARKET INC., (U.S. CLS. 22 AND 39). SN 85-959,571. PUB. 6-10-2014. FILED 6-13-2013.
- 4,591,276. **FUNKY JEANS (STANDARD CHARACTER)**. ASHER, SHALOM, (U.S. CLS. 22 AND 39). SN 85-959,723. PUB. 6-10-2014. FILED 6-14-2013.
- 4,591,286. **SEE U SOON (STANDARD CHARACTER)**. U ART RICH, LLC, (U.S. CLS. 22 AND 39). SN 85-962,168. PUB. 6-10-2014. FILED 6-17-2013.
- 4,591,290. **STYLE IS NOT ABOUT SIZE, IT'S ABOUT ATTITUDE (STANDARD CHARACTER)**. GREENSTEIN, RENEE, (U.S. CLS. 22 AND 39). SN 85-962,778. PUB. 6-10-2014. FILED 6-18-2013.
- 4,591,304. **TINKSKY (STYLIZED)**. SHENZHEN SHIDAI ZHONGCHUANG INVESTMENT CO., LTD., (U.S. CLS. 22 AND 39). SN 85-966,057. PUB. 6-10-2014. FILED 6-21-2013.
- 4,591,305 ( *See Class 9 for this trademark*).
- 4,591,337. **SACRED HEART UNIVERSITY (STANDARD CHARACTER)**. SACRED HEART UNIVERSITY, INCORPORATED, (U.S. CLS. 22 AND 39). SN 85-969,513. PUB. 1-7-2014. FILED 6-25-2013.
- 4,591,345. **IT'S IN MY HEART (STANDARD CHARACTER)**. MXC, LLC., (U.S. CLS. 22 AND 39). SN 85-970,765. PUB. 6-10-2014. FILED 6-26-2013.
- 4,591,356. **BAMBOWTIE (STANDARD CHARACTER)**. BAMB ECOLOGICAL TECHNOLOGY, INC., (U.S. CLS. 22 AND 39). SN 85-972,021. PUB. 6-10-2014. FILED 6-27-2013.
- 4,591,372. **MISCELLANEOUS DESIGN. MICHAEL J. CONNORS**, MULTIPLE CLASS, (INT. CLS. 25 AND 41), (U.S. CLS. 22, 39, 100, 101 AND 107). SN 85-973,349. PUB. 6-10-2014. FILED 6-28-2013.
- 4,591,373. **BARRECORE AND DESIGN. BARRECORE LIMITED**, MULTIPLE CLASS, (INT. CLS. 25 AND 41), (U.S. CLS. 22, 39, 100, 101 AND 107). SN 85-973,778. PUB. 6-10-2014. FILED 6-30-2013.
- 4,591,374. **BE FABULOUS BE FEARLESS B KOUTURE (STANDARD CHARACTER)**. B KOUTURE LLC, (U.S. CLS. 22 AND 39). SN 85-973,937. PUB. 6-10-2014. FILED 7-1-2013.
- 4,591,379. **ZENA (STANDARD CHARACTER)**. R.D. SIMPSON, INC., (U.S. CLS. 22 AND 39). SN 85-974,475. PUB. 6-10-2014. FILED 7-1-2013.
- 4,591,384. **JM SPORT (STANDARD CHARACTER)**. REGENT-SUTTON, LLC, (U.S. CLS. 22 AND 39). SN 85-974,863. PUB. 6-10-2014. FILED 7-1-2013.
- 4,591,409. **GO DEEP 365 (STANDARD CHARACTER)**. GO DEEP GEAR LLC, (U.S. CLS. 22 AND 39). SN 86-001,295. PUB. 6-10-2014. FILED 7-2-2013.
- 4,591,431. **YMC AND DESIGN. MORRISON HOLDINGS, LLC**, (U.S. CLS. 22 AND 39). SN 86-002,928. PUB. 6-10-2014. FILED 7-5-2013.
- 4,591,440. **XTREME NARCOSIS AND DESIGN. SANTANDER, JORGE L.**, (U.S. CLS. 22 AND 39). SN 86-003,445. PUB. 6-10-2014. FILED 7-6-2013.
- 4,591,447. **STOLEN GOODS (STANDARD CHARACTER)**. WHITNEY FOSTER, (U.S. CLS. 22 AND 39). SN 86-004,668. PUB. 6-10-2014. FILED 7-8-2013.
- 4,591,468 ( *See Class 9 for this trademark*).
- 4,591,476 ( *See Class 18 for this trademark*).
- 4,591,489 ( *See Class 14 for this trademark*).
- 4,591,495. **STAY LO (STANDARD CHARACTER)**. JORDAN, MALEEK, (U.S. CLS. 22 AND 39). SN 86-011,632. PUB. 6-10-2014. FILED 7-16-2013.
- 4,591,519. **E EMPREINTE AND DESIGN. EMPREINTE**, (U.S. CLS. 22 AND 39). SN 86-016,607. PUB. 6-10-2014. FILED 7-22-2013.
- 4,591,520. **WISCONSIN (STANDARD CHARACTER)**. BOARD OF REGENTS OF THE UNIVERSITY OF WISCONSIN SYSTEM, MULTIPLE CLASS, (INT. CLS. 25 AND 41), (U.S. CLS. 22, 39, 100, 101 AND 107). SN 86-016,610. PUB. 6-10-2014. FILED 7-22-2013.
- 4,591,561. **MISCELLANEOUS DESIGN. BACKCOUNTRY GARAGE, LLC**, (U.S. CLS. 22 AND 39). SN 86-027,885. PUB. 6-10-2014. FILED 8-2-2013.
- 4,591,562. **APPENDAGE (STANDARD CHARACTER)**. APPENDAGE, (U.S. CLS. 22 AND 39). SN 86-028,254. PUB. 6-10-2014. FILED 8-4-2013.
- 4,591,563. **SEE YOU IN THE WATER (STANDARD CHARACTER)**. SOLSWELL, (U.S. CLS. 22 AND 39). SN 86-028,256. PUB. 6-10-2014. FILED 8-4-2013.
- 4,591,564. **BORN DRIVEN (STANDARD CHARACTER)**. PINHEIRO, THYAGO, (U.S. CLS. 22 AND 39). SN 86-028,357. PUB. 12-31-2013. FILED 8-5-2013.
- 4,591,570 ( *See Class 14 for this trademark*).
- 4,591,575. **MISCELLANEOUS DESIGN. GORDON, STEVE**, (U.S. CLS. 22 AND 39). SN 86-031,416. PUB. 6-10-2014. FILED 8-7-2013.
- 4,591,592. **VESTEM AND DESIGN. VESTEM INDÚSTRIA E COMÉRCIO DE CONFECÇÕES LTDA**, (U.S. CLS. 22 AND 39). SN 86-035,838. PUB. 6-10-2014. FILED 8-12-2013.
- 4,591,599. **LOU & GREY (STYLIZED)**. ANNCO, INC., (U.S. CLS. 22 AND 39). SN 86-040,317. PUB. 6-10-2014. FILED 8-16-2013.
- 4,591,630. **GYPSY 05 MADE IN HOLLYWOOD (STANDARD CHARACTER)**. GYPSY 05, INC., (U.S. CLS. 22 AND 39). SN 86-048,156. PUB. 2-25-2014. FILED 8-26-2013.
- 4,591,647. **BAR BROKE (STANDARD CHARACTER)**. ROBINSON, TANNER G., (U.S. CLS. 22 AND 39). SN 86-052,067. PUB. 6-10-2014. FILED 8-29-2013.
- 4,591,677. **STELLA & DOT (STANDARD CHARACTER)**. STELLA & DOT LLC, (U.S. CLS. 22 AND 39). SN 86-063,258. PUB. 2-25-2014. FILED 9-12-2013.
- 4,591,716 ( *See Class 9 for this trademark*).
- 4,591,746 ( *See Class 21 for this trademark*).
- 4,591,811 ( *See Class 14 for this trademark*).
- 4,591,832 ( *See Class 21 for this trademark*).
- 4,591,833 ( *See Class 16 for this trademark*).
- 4,591,835. **PLATINUM STILETTOS (STANDARD CHARACTER)**. CITY WIDE PROMOTIONS, INC. DBA PLATINUM STILETTOS, (U.S. CLS. 22 AND 39). SN 86-108,430. PUB. 6-10-2014. FILED 11-1-2013.
- 4,591,857. **MUSCLE MILITIA AND DESIGN. MUSCLE MILI-**

- TIA LLC., (U.S. CLS. 22 AND 39). SN 86-113,612. PUB. 6-10-2014. FILED 11-8-2013.
- 4,591,860. **DOUBTFUL AS DOUBLE (STANDARD CHARACTER)**. NAGAO, TOMOAKI, (U.S. CLS. 22 AND 39). SN 86-114,222. PUB. 6-10-2014. FILED 11-8-2013.
- 4,591,866. **WADDLE AND DESIGN**. LAKEVIEW INNOVATIONS, (U.S. CLS. 22 AND 39). SN 86-115,061. PUB. 6-10-2014. FILED 11-11-2013.
- 4,591,872. **DOING IT BETTER. (STANDARD CHARACTER)**. CONQUER GEAR INC., (U.S. CLS. 22 AND 39). SN 86-116,183. PUB. 6-10-2014. FILED 11-12-2013.
- 4,591,943. **GREEN 6.2 (STANDARD CHARACTER)**. RACE ASSIST. LLC, DBA RA SPORTS MANAGEMENT, LLC, MULTIPLE CLASS, (INT. CLS. 25 AND 41), (U.S. CLS. 22, 39, 100, 101 AND 107). SN 86-127,915. PUB. 6-10-2014. FILED 11-25-2013.
- 4,591,959. **DUNKIN' DONUTS (STANDARD CHARACTER)**. DD IP HOLDER LLC, MULTIPLE CLASS, (INT. CLS. 25, 29, 30, 32, 35 AND 43), (U.S. CLS. 22, 39, 45, 46, 48, 100, 101 AND 102). SN 86-129,719. PUB. 6-10-2014. FILED 11-26-2013.
- 4,591,965. **TWO WHEEL LIFE (STANDARD CHARACTER)**. FORREST, DAN, (U.S. CLS. 22 AND 39). SN 86-130,429. PUB. 6-10-2014. FILED 11-27-2013.
- 4,591,990. **I RIDE A BIKE (STANDARD CHARACTER)**. BALLIETT, SETH, (U.S. CLS. 22 AND 39). SN 86-133,563. PUB. 4-22-2014. FILED 12-3-2013.
- 4,592,000. **KINGS OF NY (STANDARD CHARACTER)**. HERNANDEZ, DANIEL, (U.S. CLS. 22 AND 39). SN 86-135,507. PUB. 6-10-2014. FILED 12-4-2013.
- 4,592,031. **ELEASE DONOVAN (STANDARD CHARACTER)**. ELEASE DONOVAN SWIMWEAR, INC., (U.S. CLS. 22 AND 39). SN 86-139,346. PUB. 6-10-2014. FILED 12-10-2013.
- 4,592,044. **MOB STAR AND DESIGN**. VICTOR HERNANDEZ, DBA MOBSTAR INDUSTRIES, (U.S. CLS. 22 AND 39). SN 86-141,416. PUB. 6-10-2014. FILED 12-12-2013.
- 4,592,049. **THE COLORS YOU BLEED (STANDARD CHARACTER)**. SPORT YOUR COLOR, LLC, (U.S. CLS. 22 AND 39). SN 86-141,885. PUB. 6-10-2014. FILED 12-12-2013.
- 4,592,051. **MISCELLANEOUS DESIGN**. UNIVERSAL CITY STUDIOS LLC, (U.S. CLS. 22 AND 39). SN 86-142,396. PUB. 6-10-2014. FILED 12-12-2013.
- 4,592,058. **TD TOM DONG (STYLIZED)**. DROW INTERNATIONAL INVESTMENT LTD., (U.S. CLS. 22 AND 39). SN 86-142,767. PUB. 6-10-2014. FILED 12-13-2013.
- 4,592,068. **HARDWODDER (STANDARD CHARACTER)**. HARD WODDER ATHLETICS, LLC, (U.S. CLS. 22 AND 39). SN 86-143,931. PUB. 6-10-2014. FILED 12-15-2013.
- 4,592,108. **PRO BIKER RACING EQUIPMENT AND DESIGN**. PROBIKER CORP., (U.S. CLS. 22 AND 39). SN 86-149,700. PUB. 6-10-2014. FILED 12-20-2013.
- 4,592,112. **PRAIRIE ROSE (STANDARD CHARACTER)**. GRENSOURCE BRAND APPAREL, INC., DBA GREEN-SOURCE, (U.S. CLS. 22 AND 39). SN 86-150,115. PUB. 6-10-2014. FILED 12-20-2013.
- 4,592,145. **PEOPLE'S CHOICE APPAREL (STYLIZED)**. PEOPLE'S CHOICE APPAREL, INC., (U.S. CLS. 22 AND 39). SN 86-152,077. PUB. 6-10-2014. FILED S.R. 12-24-2013; AM. P.R. 12-24-2013.
- 4,592,165. **NINE LINE AND DESIGN**. 9 LINE APPAREL LLC, (U.S. CLS. 22 AND 39). SN 86-153,645. PUB. 6-10-2014. FILED 12-28-2013.
- 4,592,195. **PITTIE CHICKS AND DESIGN**. PITTIE CHICKS, (U.S. CLS. 22 AND 39). SN 86-155,489. PUB. 6-10-2014. FILED 12-31-2013.
- 4,592,224. **FIGHT THE STEREOTYPE (STANDARD CHARACTER)**. ORLOFF, DANIEL, (U.S. CLS. 22 AND 39). SN 86-156,995. PUB. 6-10-2014. FILED 1-3-2014.
- 4,592,225. **WORLD OF KREAM AND DESIGN**. THE WORLD OF KREAM LLC, (U.S. CLS. 22 AND 39). SN 86-157,004. PUB. 6-10-2014. FILED 1-3-2014.
- 4,592,270 ( *See Class 16 for this trademark*).
- 4,592,312. **FELIPE'S MEXICAN TAQUERIA (STANDARD CHARACTER)**. FELIPE'S VENTURES, L.L.C., MULTIPLE CLASS, (INT. CLS. 25 AND 43), (U.S. CLS. 22, 39, 100 AND 101). SN 86-161,001. PUB. 6-10-2014. FILED 1-9-2014.
- 4,592,324 ( *See Class 16 for this trademark*).
- 4,592,351 ( *See Class 18 for this trademark*).
- 4,592,401. **LEONEL MANZANO (STANDARD CHARACTER)**. LEONEL MANZANO LLC, (U.S. CLS. 22 AND 39). SN 86-163,304. PUB. 6-10-2014. FILED 1-12-2014.
- 4,592,402. **MISCELLANEOUS DESIGN**. LEONEL MANZANO LLC, (U.S. CLS. 22 AND 39). SN 86-163,314. PUB. 6-10-2014. FILED 1-12-2014.
- 4,592,405. **P.JAMES (STANDARD CHARACTER)**. MANAS, MARIA, ESPERANZA, AKA DIAZ, MARIA, ESPERANZA, (U.S. CLS. 22 AND 39). SN 86-163,352. PUB. 6-10-2014. FILED 1-12-2014.
- 4,592,444. **EKU W N S AND DESIGN**. EASTERN KENTUCKY UNIVERSITY, (U.S. CLS. 22 AND 39). SN 86-164,663. PUB. 6-10-2014. FILED 1-14-2014.
- 4,592,468. **AVA JAMES (STANDARD CHARACTER)**. C-QUEST, INC., (U.S. CLS. 22 AND 39). SN 86-165,504. PUB. 6-10-2014. FILED 1-14-2014.
- 4,592,504. **BLUE GILL (STYLIZED)**. BRANNON LEHANE, (U.S. CLS. 22 AND 39). SN 86-166,570. PUB. 6-10-2014. FILED 1-15-2014.
- 4,592,506. **CROWNE COMFORTEUR AND DESIGN**. PEDI-LUXE FOOTWEAR, (U.S. CLS. 22 AND 39). SN 86-166,651. PUB. 6-10-2014. FILED 1-15-2014.
- 4,592,523. **CONNOISSEUR LIFE CLOTHING (STANDARD CHARACTER)**. STAFFORD, WILLIAM, (U.S. CLS. 22 AND 39). SN 86-167,189. PUB. 6-10-2014. FILED 1-16-2014.
- 4,592,528. **THE SOLE OF CHEER (STANDARD CHARACTER)**. ZOE MARKETING, INC., MULTIPLE CLASS, (INT. CLS. 25 AND 35), (U.S. CLS. 22, 39, 100, 101 AND 102). SN 86-167,248. PUB. 6-10-2014. FILED 1-16-2014.
- 4,592,538. **NOBLE COLLECTIVE (STANDARD CHARACTER)**. NOBLE COLLECTIVE LLC, (U.S. CLS. 22 AND 39). SN 86-167,603. PUB. 6-10-2014. FILED 1-16-2014.
- 4,592,570. **CARBON38 (STANDARD CHARACTER)**. CARBON 38, INC., (U.S. CLS. 22 AND 39). SN 86-169,310. PUB. 6-10-2014. FILED 1-18-2014.
- 4,592,579 ( *See Class 9 for this trademark*).
- 4,592,588 ( *See Class 24 for this trademark*).
- 4,592,593 ( *See Class 9 for this trademark*).
- 4,592,594 ( *See Class 14 for this trademark*).
- 4,592,626. **JINGER JUNKIE (STANDARD CHARACTER)**. ASCENDED LIFE SOLUTIONS INCORPORATED, (U.S. CLS. 22 AND 39). SN 86-174,525. PUB. 6-10-2014. FILED 1-24-2014.
- 4,592,633. **D'JANDRO (STANDARD CHARACTER)**. MANTILLA DIAZ, MARCO, (U.S. CLS. 22 AND 39). SN 86-174,913. PUB. 6-10-2014. FILED 1-24-2014.
- 4,592,637. **PENNY BRAVE (STANDARD CHARACTER)**. PENNY BRAVE, (U.S. CLS. 22 AND 39). SN 86-175,137. PUB. 6-10-2014. FILED 1-25-2014.
- 4,592,643. **FOVL FORTVNE (STANDARD CHARACTER)**. ALFONS HARRIS, (U.S. CLS. 22 AND 39). SN 86-175,275. PUB. 6-10-2014. FILED 1-25-2014.
- 4,592,644. **MISCELLANEOUS DESIGN**. ALFONS HARRIS, (U.S. CLS. 22 AND 39). SN 86-175,282. PUB. 6-10-2014. FILED 1-25-2014.
- 4,592,659. **BRING SLOOTS (STANDARD CHARACTER)**. SCHMIDT, MAXWELL, (U.S. CLS. 22 AND 39). SN 86-175,543. PUB. 6-10-2014. FILED 1-27-2014.
- 4,592,661. **PUPPHAT (STANDARD CHARACTER)**. SWARTZ, ADAM, (U.S. CLS. 22 AND 39). SN 86-175,569. PUB. 6-10-2014. FILED 1-27-2014.
- 4,592,671. **FRAXURE (STANDARD CHARACTER)**. FRAXURE, (U.S. CLS. 22 AND 39). SN 86-175,688. PUB. 6-10-2014. FILED 1-27-2014.
- 4,592,674 ( *See Class 18 for this trademark*).
- 4,592,675 ( *See Class 14 for this trademark*).
- 4,592,698. **KCMOX AND DESIGN**. THE BUNKER INC., (U.S. CLS. 22 AND 39). SN 86-176,184. PUB. 6-10-2014. FILED 1-27-2014.
- 4,592,702. **JOHN STEPHEN (STANDARD CHARACTER)**. BMG IMPORT EXPORTS, INC., (U.S. CLS. 22 AND 39). SN 86-176,213. PUB. 6-10-2014. FILED 1-27-2014.
- 4,592,705. **EB EMERALD BLACK APPAREL COMPANY (STYLIZED)**. F & L GROUP, INC., (U.S. CLS. 22 AND 39). SN 86-176,263. PUB. 6-10-2014. FILED 1-27-2014.
- 4,592,717. **LOVE, NICKIE LEW (STANDARD CHARACTER)**. WILD HORSES APPAREL, LLC, (U.S. CLS. 22 AND 39). SN 86-176,569. PUB. 6-10-2014. FILED 1-27-2014.
- 4,592,729. **MISCELLANEOUS DESIGN**. LOPEZ, EDUARDO,

(U.S. CLS. 22 AND 39). SN 86-176,817. PUB. 6-10-2014. FILED 1-28-2014.  
 4,592,763 ( *See Class 14 for this trademark* ).  
 4,592,769. **VIRGINIA COMMONWEALTH UNIVERSITY 1838 MCV RPI VCU AND DESIGN**. VIRGINIA COMMONWEALTH UNIVERSITY, (U.S. CLS. 22 AND 39). SN 86-177,487. PUB. 6-10-2014. FILED 1-28-2014.  
 4,592,793. **LA VIDA ES DEPORTE (STANDARD CHARACTER)**. LIFE IS SPORTS LLC, (U.S. CLS. 22 AND 39). SN 86-177,842. PUB. 6-10-2014. FILED 1-28-2014.  
 4,592,806. **WHATWEARS AND DESIGN**. LI LIE, (U.S. CLS. 22 AND 39). SN 86-178,043. PUB. 6-10-2014. FILED 1-28-2014.  
 4,592,812 ( *See Class 18 for this trademark* ).  
 4,592,834. **LIVELIFY (STANDARD CHARACTER)**. LIVELIFY, (U.S. CLS. 22 AND 39). SN 86-178,503. PUB. 6-10-2014. FILED 1-29-2014.  
 4,592,836. **PINETAR (STANDARD CHARACTER)**. KIM DALZELL INCORPORATED, (U.S. CLS. 22 AND 39). SN 86-178,566. PUB. 6-10-2014. FILED 1-29-2014.  
 4,592,841. **MISCELLANEOUS DESIGN**. VICTORIA'S SECRET STORES BRAND MANAGEMENT, INC., (U.S. CLS. 22 AND 39). SN 86-178,703. PUB. 6-10-2014. FILED 1-29-2014.  
 4,592,863. **TIES & VIBES (STANDARD CHARACTER)**. TIES AND VIBES, DBA TIES AND VIBES, (U.S. CLS. 22 AND 39). SN 86-179,040. PUB. 6-10-2014. FILED 1-29-2014.  
 4,592,888. **DRAMASTICS (STANDARD CHARACTER)**. DRAMASTICS, (U.S. CLS. 22 AND 39). SN 86-179,786. PUB. 6-10-2014. FILED 1-30-2014.  
 4,592,895. **DRIBBLE BIBBLE (STANDARD CHARACTER)**. ROTHSCHILD, DEBORAH V., (U.S. CLS. 22 AND 39). SN 86-179,853. PUB. 6-10-2014. FILED 1-30-2014.  
 4,592,900. **SHEFISHES2 (STANDARD CHARACTER)**. CLEVER CLICKS, LLC, MULTIPLE CLASS, (INT. CLS. 25 AND 41), (U.S. CLS. 22, 39, 100, 101 AND 107). SN 86-180,117. PUB. 6-10-2014. FILED 1-30-2014.  
 4,592,901. **OKOBOATIN' (STANDARD CHARACTER)**. WELTE, DIANE, (U.S. CLS. 22 AND 39). SN 86-180,123. PUB. 6-10-2014. FILED 1-30-2014.  
 4,592,902. **HAIL STATE (STANDARD CHARACTER)**. MISSISSIPPI STATE UNIVERSITY, MULTIPLE CLASS, (INT. CLS. 25 AND 41), (U.S. CLS. 22, 39, 100, 101 AND 107). SN 86-180,130. PUB. 6-10-2014. FILED 1-30-2014.  
 4,592,905. **THEYSKENS (STANDARD CHARACTER)**. OTS B.V., (U.S. CLS. 22 AND 39). SN 86-180,211. PUB. 6-10-2014. FILED 1-30-2014.  
 4,592,906. **TMCA (STANDARD CHARACTER)**. TRAVIS-MATHEW, LLC, (U.S. CLS. 22 AND 39). SN 86-180,221. PUB. 6-10-2014. FILED 1-30-2014.  
 4,592,923. **MISCELLANEOUS DESIGN**. TIES AND VIBES, DBA TIES AND VIBES, (U.S. CLS. 22 AND 39). SN 86-180,512. PUB. 6-10-2014. FILED 1-30-2014.  
 4,592,925. **BEVERLY HILLS VAPOR AND DESIGN**. BEVERLY HILLS VAPOR, MULTIPLE CLASS, (INT. CLS. 25 AND 34), (U.S. CLS. 2, 8, 9, 17, 22 AND 39). SN 86-180,692. PUB. 6-10-2014. FILED 1-31-2014.  
 4,592,953 ( *See Class 14 for this trademark* ).  
 4,592,974 ( *See Class 16 for this trademark* ).  
 4,592,986 ( *See Class 16 for this trademark* ).  
 4,592,987 ( *See Class 16 for this trademark* ).  
 4,593,000. **VICTORIA'S SECRET TEASE (STANDARD CHARACTER)**. VICTORIA'S SECRET STORES BRAND MANAGEMENT, INC., (U.S. CLS. 22 AND 39). SN 86-218,345. PUB. 6-10-2014. FILED 3-11-2014.  
 4,593,021. **CIRCLING RAVEN GOLF CLUB AND DESIGN**. COEUR D'ALENE CASINO, (U.S. CLS. 22 AND 39). SN 86-226,395. PUB. 6-10-2014. FILED 3-19-2014.  
 4,593,026. **ASILIO (STANDARD CHARACTER)**. THE MADE GROUP, (U.S. CLS. 22 AND 39). SN 86-227,215. PUB. 6-10-2014. FILED 3-20-2014.  
 4,593,029. **MISCELLANEOUS DESIGN**. LIFE IS SPORTS LLC, (U.S. CLS. 22 AND 39). SN 86-229,701. PUB. 6-10-2014. FILED 3-24-2014.  
 4,593,042. **RESPECT HER HUSTLE (STANDARD CHARACTER)**. LUCAS, KRISTEN, AND WELLS, DEE, (U.S. CLS. 22 AND 39). SN 86-241,963. PUB. 6-10-2014. FILED 4-3-2014.

**CLASS 26—FANCY GOODS**

4,591,057 ( *See Class 25 for this trademark* ).  
 4,592,297. **SIMPLESS WEAVE (STANDARD CHARACTER)**. CAROL FRAZIER, (U.S. CLS. 37, 39, 40, 42 AND 50). SN 86-160,100. PUB. 6-10-2014. FILED 1-8-2014.  
 4,592,493. **MAGNETUCK (STANDARD CHARACTER)**. BUNTING, PHILIP G., (U.S. CLS. 37, 39, 40, 42 AND 50). SN 86-166,226. PUB. 6-10-2014. FILED 1-15-2014.  
 4,592,594 ( *See Class 14 for this trademark* ).

**CLASS 27—FLOOR COVERINGS**

4,590,971 ( *See Class 21 for this trademark* ).  
 4,591,100. **DIRTY DOG DOORMAT (STANDARD CHARACTER)**. NANO PET PRODUCTS, LLC, (U.S. CLS. 19, 20, 37, 42 AND 50). SN 85-820,423. PUB. 6-10-2014. FILED 1-10-2013.  
 4,592,502. **MARIE RICCI COLLECTION (STANDARD CHARACTER)**. MARIE RICCI COLLECTION, INC., (U.S. CLS. 19, 20, 37, 42 AND 50). SN 86-166,485. PUB. 6-10-2014. FILED 1-15-2014.

**CLASS 28—TOYS AND SPORTING GOODS**

4,590,626 ( *See Class 3 for this trademark* ).  
 4,590,639 ( *See Class 25 for this trademark* ).  
 4,590,641 ( *See Class 25 for this trademark* ).  
 4,590,668 ( *See Class 9 for this trademark* ).  
 4,590,699 ( *See Class 3 for this trademark* ).  
 4,590,709 ( *See Class 9 for this trademark* ).  
 4,590,729 ( *See Class 4 for this trademark* ).  
 4,590,734 ( *See Class 4 for this trademark* ).  
 4,590,747 ( *See Class 3 for this trademark* ).  
 4,590,763 ( *See Class 9 for this trademark* ).  
 4,590,764 ( *See Class 9 for this trademark* ).  
 4,590,841. **FUJIKURA AND DESIGN**. FUJIKURA GOMU KOGYO KABUSHIKI KAISHA ALSO TRADING AS FUJIKURA RUBBER LTD., (U.S. CLS. 22, 23, 38 AND 50). SN 79-140,056. PUB. 6-10-2014. FILED 10-16-2013.  
 4,590,915 ( *See Class 25 for this trademark* ).  
 4,590,995 ( *See Class 24 for this trademark* ).  
 4,590,998 ( *See Class 16 for this trademark* ).  
 4,591,009. **5TH ST. GYM (STANDARD CHARACTER)**. BAIA-MONTE, MATTHEW, MULTIPLE CLASS, (INT. CLS. 28 AND 41), (U.S. CLS. 22, 23, 38, 50, 100, 101 AND 107). SN 85-727,341. PUB. 6-10-2014. FILED 9-12-2012.  
 4,591,013 ( *See Class 16 for this trademark* ).  
 4,591,032. **AB BED (STANDARD CHARACTER)**. DURHAM FITNESS INNOVATIONS, LLC, (U.S. CLS. 22, 23, 38 AND 50). SN 85-767,088. PUB. 6-10-2014. FILED 10-30-2012.  
 4,591,034. **ANISE WORM (STANDARD CHARACTER)**. BASS RIVER OUTDOORS, LLC, (U.S. CLS. 22, 23, 38 AND 50). SN 85-773,313. PUB. 6-10-2014. FILED 11-7-2012.  
 4,591,053 ( *See Class 16 for this trademark* ).  
 4,591,105. **NUMEN TRACE (STANDARD CHARACTER)**. BRUNING, LYNNE A., (U.S. CLS. 22, 23, 38 AND 50). SN 85-830,848. PUB. 6-10-2014. FILED 1-24-2013.  
 4,591,169. **LITTLE TIKES. BIG PLAY. (STYLIZED)**. THE LITTLE TIKES COMPANY, (U.S. CLS. 22, 23, 38 AND 50). SN 85-904,931. PUB. 6-10-2014. FILED 4-15-2013.  
 4,591,229. **FUNBALLZ (STANDARD CHARACTER)**. FUNBALLZ APS, (U.S. CLS. 22, 23, 38 AND 50). SN 85-944,781. PUB. 6-10-2014. FILED 5-29-2013.  
 4,591,364. **K ROYAL AND DESIGN**. KUO KAU PAPER PRODUCTS CO., LTD., (U.S. CLS. 22, 23, 38 AND 50). SN 85-972,871. PUB. 6-10-2014. FILED 6-28-2013.  
 4,591,365. **SHOOT-A-WAY (STANDARD CHARACTER)**. SHOOT-A-WAY, INC., (U.S. CLS. 22, 23, 38 AND 50). SN 85-972,921. PUB. 6-10-2014. FILED 6-28-2013.  
 4,591,370. **SK8MAFIA (STANDARD CHARACTER)**. CONNELLY, DAN, AND PRIEBE, JOSH, (U.S. CLS. 22, 23, 38 AND 50). SN 85-973,156. PUB. 6-10-2014. FILED 6-28-2013.  
 4,591,377 ( *See Class 16 for this trademark* ).  
 4,591,419. **ROTOR BONES (STANDARD CHARACTER)**.



- FLITE TEST, LLC, (U.S. CLS. 22, 23, 38 AND 50). SN 86-001,942. PUB. 6-10-2014. FILED 7-3-2013.  
4,591,430 ( *See Class 16 for this trademark* ).
- 4,591,442. **FRIENDLY RACERS (STANDARD CHARACTER)**. MATTEL, INC., (U.S. CLS. 22, 23, 38 AND 50). SN 86-003,902. PUB. 6-10-2014. FILED 7-8-2013.
- 4,591,492. **ELECTRIC BOOGALOO (STANDARD CHARACTER)**. ARISTOCRAT TECHNOLOGIES AUSTRALIA, PTY LTD., (U.S. CLS. 22, 23, 38 AND 50). SN 86-011,485. PUB. 6-10-2014. FILED 7-16-2013.
- 4,591,526 ( *See Class 14 for this trademark* ).
- 4,591,607. **GOLDEN FESTIVAL (STANDARD CHARACTER)**. ARISTOCRAT TECHNOLOGIES AUSTRALIA PTY LTD., (U.S. CLS. 22, 23, 38 AND 50). SN 86-041,411. PUB. 6-10-2014. FILED 8-19-2013.
- 4,591,608. **CELTIC QUEEN (STANDARD CHARACTER)**. ARISTOCRAT TECHNOLOGIES AUSTRALIA PTY LTD., (U.S. CLS. 22, 23, 38 AND 50). SN 86-041,492. PUB. 6-10-2014. FILED 8-19-2013.
- 4,591,623. **T TYGJ AND DESIGN**. CHANG CHIEN, TIEN-HO, (U.S. CLS. 22, 23, 38 AND 50). SN 86-045,048. PUB. 6-10-2014. FILED 8-22-2013.
- 4,591,636. **CP (STYLIZED)**. CANEY PUTTERWORKS LLC, (U.S. CLS. 22, 23, 38 AND 50). SN 86-050,405. PUB. 6-10-2014. FILED 8-28-2013.
- 4,591,681. **DURAFLOCK (STANDARD CHARACTER)**. RHINO SPORTS GROUP, LLC, (U.S. CLS. 22, 23, 38 AND 50). SN 86-064,504. PUB. 6-10-2014. FILED 9-13-2013.
- 4,591,682. **OPTIBRIGHT (STANDARD CHARACTER)**. RHINO SPORTS GROUP, LLC, (U.S. CLS. 22, 23, 38 AND 50). SN 86-064,524. PUB. 6-10-2014. FILED 9-13-2013.
- 4,591,709. **GOLDEN RULE MARBLE (STANDARD CHARACTER)**. VALLMAR STUDIOS LLC, MULTIPLE CLASS, (INT. CLS. 28 AND 41), (U.S. CLS. 22, 23, 38, 50, 100, 101 AND 107). SN 86-075,799. PUB. 6-10-2014. FILED 9-26-2013.
- 4,591,743. **DOODLEBOOM AND DESIGN**. TISKIEWIC, HANA, (U.S. CLS. 22, 23, 38 AND 50). SN 86-082,504. PUB. 6-10-2014. FILED 10-4-2013.
- 4,591,767. **ILLUMI-CUP (STANDARD CHARACTER)**. THE TORO COMPANY, (U.S. CLS. 22, 23, 38 AND 50). SN 86-092,152. PUB. 6-10-2014. FILED 10-15-2013.
- 4,591,833 ( *See Class 16 for this trademark* ).
- 4,591,873 ( *See Class 9 for this trademark* ).
- 4,591,917. **MISCELLANEOUS DESIGN**. U.S. KIDS GOLF LLC, (U.S. CLS. 22, 23, 38 AND 50). SN 86-124,185. PUB. 6-10-2014. FILED 11-20-2013.
- 4,591,949 ( *See Class 16 for this trademark* ).
- 4,592,028. **THE BALLSCRATCHER (STYLIZED)**. HOMECOL-OGY, INC., DBA HEDGEHOG LACROSSE, (U.S. CLS. 22, 23, 38 AND 50). SN 86-138,974. PUB. 6-10-2014. FILED 12-9-2013.
- 4,592,054. **MISCELLANEOUS DESIGN**. UNIVERSAL CITY STUDIOS LLC, (U.S. CLS. 22, 23, 38 AND 50). SN 86-142,528. PUB. 6-10-2014. FILED 12-12-2013.
- 4,592,160. **SKUNK FUSION (STANDARD CHARACTER)**. FARR OUTDOORS INC., (U.S. CLS. 22, 23, 38 AND 50). SN 86-153,126. PUB. 6-10-2014. FILED 12-27-2013.
- 4,592,202. **RYOKU (STANDARD CHARACTER)**. KIMURA, KRIS H., (U.S. CLS. 22, 23, 38 AND 50). SN 86-155,832. PUB. 6-10-2014. FILED 1-2-2014.
- 4,592,270 ( *See Class 16 for this trademark* ).
- 4,592,279. **JERSEY 4 SURE (STANDARD CHARACTER)**. JERSEYFOURSURE LIMITED LIABILITY COMPANY, (U.S. CLS. 22, 23, 38 AND 50). SN 86-159,526. PUB. 6-10-2014. FILED 1-7-2014.
- 4,592,334. **AWESOME ISLAND (STANDARD CHARACTER)**. CHAMPLAIN COLLEGE, INCORPORATED, (U.S. CLS. 22, 23, 38 AND 50). SN 86-161,643. PUB. 6-10-2014. FILED 1-9-2014.
- 4,592,363. **BRINGTHEHOOPLA LLC AND DESIGN**. BRINGTHEHOOPLA, MULTIPLE CLASS, (INT. CLS. 28 AND 41), (U.S. CLS. 22, 23, 38, 50, 100, 101 AND 107). SN 86-162,357. PUB. 6-10-2014. FILED 1-10-2014.
- 4,592,407. **PILLOW FIGHTERS (STANDARD CHARACTER)**. THROWBOY, (U.S. CLS. 22, 23, 38 AND 50). SN 86-163,363. PUB. 6-10-2014. FILED 1-12-2014.
- 4,592,412. **ZUP (STANDARD CHARACTER)**. ZUP, LLC, FORMERLY GLEN WADE DUFF, (U.S. CLS. 22, 23, 38 AND 50). SN 86-163,461. PUB. 6-10-2014. FILED 1-13-2014.
- 4,592,446. **PRE (STANDARD CHARACTER)**. CARBON INNO-VATIONS, LLC, (U.S. CLS. 22, 23, 38 AND 50). SN 86-164,822. PUB. 6-10-2014. FILED 1-14-2014.
- 4,592,463. **NOSEJOB (STANDARD CHARACTER)**. EASTSIDE LONGBOARDS LLC, DBA EASTSIDE LONGBOARDS, (U.S. CLS. 22, 23, 38 AND 50). SN 86-165,436. PUB. 6-10-2014. FILED 1-14-2014.
- 4,592,556. **G AND DESIGN**. RED STEER GLOVE COMPANY, (U.S. CLS. 22, 23, 38 AND 50). SN 86-168,658. PUB. 6-10-2014. FILED 1-17-2014.
- 4,592,588 ( *See Class 24 for this trademark* ).
- 4,592,605. **BIXLE (STANDARD CHARACTER)**. BIXLE LLC, (U.S. CLS. 22, 23, 38 AND 50). SN 86-173,065. PUB. 6-10-2014. FILED 1-23-2014.
- 4,592,635. **HANDBAND PRO (STANDARD CHARACTER)**. DANIELLE PETTIFOR, DBA CREATION FITNESS, (U.S. CLS. 22, 23, 38 AND 50). SN 86-175,071. PUB. 6-10-2014. FILED 1-24-2014.
- 4,592,669. **CHASING THE TRUTH AND DESIGN**. CHASING THE TRUTH INC., (U.S. CLS. 22, 23, 38 AND 50). SN 86-175,667. PUB. 6-10-2014. FILED 1-27-2014.
- 4,592,688. **ARTIFACT (STANDARD CHARACTER)**. MAGAZINE EXCHANGE, INC., (U.S. CLS. 22, 23, 38 AND 50). SN 86-176,010. PUB. 6-10-2014. FILED 1-27-2014.
- 4,592,711. **ISLE SURF & SUP (STANDARD CHARACTER)**. INTERNATIONAL SURF VENTURES INC., (U.S. CLS. 22, 23, 38 AND 50). SN 86-176,419. PUB. 6-10-2014. FILED 1-27-2014.
- 4,592,784. **IMPACT (STYLIZED)**. SHANGHAI SANFEI FIT-NESS CO., LTD., (U.S. CLS. 22, 23, 38 AND 50). SN 86-177,758. PUB. 6-10-2014. FILED 1-28-2014.
- 4,592,854 ( *See Class 3 for this trademark* ).
- 4,592,926. **WAG MORE BARK LESS (STANDARD CHARAC-TER)**. MELTON-JOHNSON, BRENNAN W., AND MEL-TON-JOHNSON, JENNIFER M., (U.S. CLS. 22, 23, 38 AND 50). SN 86-181,197. PUB. 6-10-2014. FILED 1-31-2014.
- 4,592,953 ( *See Class 14 for this trademark* ).
- 4,593,015. **EPOCH LACROSSE (STANDARD CHARACTER)**. EPOCH LACROSSE LLC, (U.S. CLS. 22, 23, 38 AND 50). SN 86-223,194. PUB. 6-10-2014. FILED 3-17-2014.
- 4,593,022. **CIRCLING RAVEN GOLF CLUB AND DESIGN**. COEUR D'ALENE CASINO, (U.S. CLS. 22, 23, 38 AND 50). SN 86-226,403. PUB. 6-10-2014. FILED 3-19-2014.

---

## CLASS 29—MEATS AND PROCESSED FOODS

- 4,590,608. **MISCELLANEOUS DESIGN**. STEIDINGER MEAT PROCESSING, INC., (U.S. CL. 46). SN 76-713,910. PUB. 6-10-2014. FILED 4-11-2013.
- 4,590,630. **SÜDTIROL SPECK ALTO ADIGE I.G.P. SÜDTIROLER SPECK G.G.A. INDICAZIONE GEOGRAFICA PROTETTA GESCHÜTZTE GEOGRAPHISCHE ANGABE AND DESIGN**. CONSORZIO TUTELA SPECK ALTO ADIGE - SÜDTIROLER SPECK CONSORTIUM, (U.S. CL. 46). SN 79-114,304. PUB. 6-10-2014. FILED 2-22-2012.
- 4,590,642 ( *See Class 5 for this trademark* ).
- 4,590,684 ( *See Class 9 for this trademark* ).
- 4,590,770. **KILIÇ AND DESIGN**. KILIC DENIZ URUNLERI URETIMI IHRACAT; ITHALAT VE TICARET ANONIM SIRKETI, MULTIPLE CLASS, (INT. CLS. 29 AND 31), (U.S. CLS. 1 AND 46). SN 79-136,168. PUB. 6-10-2014. FILED 6-19-2013.
- 4,590,794. **ITALIAN BAR FERRERO (STYLIZED)**. SOREMARTEC S.A., MULTIPLE CLASS, (INT. CLS. 29, 30 AND 32), (U.S. CLS. 45, 46 AND 48). SN 79-137,152. PUB. 6-10-2014. FILED 7-18-2013.
- 4,590,812 ( *See Class 3 for this trademark* ).
- 4,590,829. **HAPPY VILLAGE AND DESIGN**. ISIK TARIM ÜRÜNLERI; SANAYI VE TICARET ANONIM SIRKETI, MULTIPLE CLASS, (INT. CLS. 29, 30 AND 35), (U.S. CLS. 46, 100, 101 AND 102). SN 79-139,376. PUB. 6-10-2014. FILED 4-1-2013.
- 4,590,866. **POLARICA AND DESIGN**. POLARICA AB, (U.S. CL. 46). SN 79-141,958. PUB. 6-10-2014. FILED 12-20-2013.
- 4,590,889. **SCHARFER MORIZZ (STANDARD CHARACTER)**.

SCHWYZER MILCHHUUS AG, (U.S. CL. 46). SN 79-142,655. PUB. 6-10-2014. FILED 11-28-2013.

4,590,906. **FRUITY MINDS (STANDARD CHARACTER)**. F&B MASTERS INTERNATIONAL B.V., MULTIPLE CLASS, (INT. CLS. 29 AND 32), (U.S. CLS. 45, 46 AND 48). SN 79-143,215. PUB. 6-10-2014. FILED 11-29-2013.

4,590,960 ( *See Class 5 for this trademark*).

4,591,321. **SAFE EGGS (STANDARD CHARACTER)**. NATIONAL PASTEURIZED EGGS, LLC, (U.S. CL. 46). SN 85-967,706. PUB. 6-10-2014. FILED 6-24-2013.

4,591,339. **YOU'LL NEVER BITE A BURGER BETTER THAN A BUBBA! (STANDARD CHARACTER)**. BUBBA FOODS, LLC, (U.S. CL. 46). SN 85-970,355. PUB. 6-10-2014. FILED 6-26-2013.

4,591,550. **OCEAN'S PRIDE (STANDARD CHARACTER)**. PT CENTRAL PROTEINAPRIMA TBK, (U.S. CL. 46). SN 86-026,520. PUB. 6-10-2014. FILED 8-1-2013.

4,591,552. **OCEAN'S PRIDE AND DESIGN**. PT CENTRAL PROTEINAPRIMA TBK, (U.S. CL. 46). SN 86-026,571. PUB. 6-10-2014. FILED 8-1-2013.

4,591,714. **FLOWER AND DESIGN**. TUT'S INTERNATIONAL EXPORT AND IMPORT CO., INC., (U.S. CL. 46). SN 86-076,793. PUB. 6-10-2014. FILED 9-27-2013.

4,591,736. **FARMTOBOTTLE (STANDARD CHARACTER)**. FARMTOBOTTLE, LLC, MULTIPLE CLASS, (INT. CLS. 29 AND 32), (U.S. CLS. 45, 46 AND 48). SN 86-081,647. PUB. 6-10-2014. FILED 10-3-2013.

4,591,746 ( *See Class 21 for this trademark*).

4,591,765. **THE CRAZY NUTZ COMPANY (STANDARD CHARACTER)**. THE CRAZY NUTZ COMPANY, LLC, (U.S. CL. 46). SN 86-090,381. PUB. 6-10-2014. FILED 10-14-2013.

4,591,777. **TAZAH AND DESIGN**. KARABETIAN IMPORT & DISTRIBUTION, INC., MULTIPLE CLASS, (INT. CLS. 29 AND 32), (U.S. CLS. 45, 46 AND 48). SN 86-096,128. PUB. 6-10-2014. FILED 10-19-2013.

4,591,796. **ECO PEZ SPECIALTY SEAFOOD AND DESIGN**. UNIVERSAL SEAFOOD, INC., (U.S. CL. 46). SN 86-099,782. PUB. 6-10-2014. FILED 10-23-2013.

4,591,959 ( *See Class 25 for this trademark*).

4,591,961. **RAILROAD CAMP SHRIMP (STANDARD CHARACTER)**. TAHOE JOE'S, INC., (U.S. CL. 46). SN 86-129,774. PUB. 6-10-2014. FILED 11-26-2013.

4,592,010. **MISCELLANEOUS DESIGN**. MORNING SUN AUSTRALIA PTY LTD, MULTIPLE CLASS, (INT. CLS. 29 AND 30), (U.S. CL. 46). SN 86-137,136. PUB. 6-10-2014. FILED 12-6-2013.

4,592,035. **MISSION HILL BISTRO AND DESIGN**. STAMPEDE MEAT, INC., (U.S. CL. 46). SN 86-140,433. PUB. 4-29-2014. FILED 12-11-2013.

4,592,069. **FIRST DUCK AND DESIGN**. ZHONG'AO HOLDINGS GROUP CO., LTD, (U.S. CL. 46). SN 86-144,131. PUB. 6-10-2014. FILED 12-16-2013.

4,592,074. **HERMAN'S NUT HOUSE AND DESIGN**. MARATHON VENTURES INC., DBA HERMAN'S NUT HOUSE, (U.S. CL. 46). SN 86-144,440. PUB. 6-10-2014. FILED 12-16-2013.

4,592,158. **BIG! FACE! AND DESIGN**. NANJING BIGEFEISI COMMERCIAL & TRADE CO., LTD., (U.S. CL. 46). SN 86-152,966. PUB. 6-10-2014. FILED 12-27-2013.

4,592,163. **GREEN DIRT FARM (STANDARD CHARACTER)**. GREEN DIRT FARM, L.L.C., (U.S. CL. 46). SN 86-153,255. PUB. 6-10-2014. FILED 12-27-2013.

4,592,264. **BIG TEXAS FLAVOR IN EVERY BITE (STANDARD CHARACTER)**. SWIFT BRANDS COMPANY, (U.S. CL. 46). SN 86-158,560. PUB. 6-10-2014. FILED 1-6-2014.

4,592,330. **PICASSO AND DESIGN**. RHOD WILLIAMS, (U.S. CL. 46). SN 86-161,599. PUB. 6-10-2014. FILED 1-9-2014.

4,592,398. **CALL IT YOURS CASSEROLES (STANDARD CHARACTER)**. CALL IT YOURS CASSEROLES, LLC, MULTIPLE CLASS, (INT. CLS. 29, 30 AND 43), (U.S. CLS. 46, 100 AND 101). SN 86-163,185. PUB. 6-10-2014. FILED 1-11-2014.

4,592,492 ( *See Class 16 for this trademark*).

4,592,645. **ADANMU (STYLIZED)**. YONGKANG QINGWU INDUSTRY & TRADE CO., LTD, (U.S. CL. 46). SN 86-175,331. PUB. 6-10-2014. FILED 1-26-2014.

4,592,767. **SPECIAL RECIPE (STANDARD CHARACTER)**.

THE J. M. SMUCKER COMPANY, (U.S. CL. 46). SN 86-177,454. PUB. 6-10-2014. FILED 1-28-2014.

4,592,799. **MIRAKALE (STANDARD CHARACTER)**. ANCHOR AVENUE COMPANY, LLC, (U.S. CL. 46). SN 86-177,889. PUB. 6-10-2014. FILED 1-28-2014.

4,592,848. **FLAVOR-REDI (STANDARD CHARACTER)**. TYSON FOODS, INC., (U.S. CL. 46). SN 86-178,823. PUB. 6-10-2014. FILED 1-29-2014.

4,592,879. **LA PAULINA (STANDARD CHARACTER)**. MOLFINO HERMANOS SOCIEDAD ANÓNIMA, (U.S. CL. 46). SN 86-179,559. PUB. 6-10-2014. FILED 1-30-2014.

4,592,929. **ZOTES (STANDARD CHARACTER)**. Z BRAND MARKETING, LLC, (U.S. CL. 46). SN 86-181,411. PUB. 6-10-2014. FILED 1-31-2014.

4,592,932. **EATRAGEOUS (STANDARD CHARACTER)**. ANDREW WADE GITLIN, MULTIPLE CLASS, (INT. CLS. 29 AND 30), (U.S. CL. 46). SN 86-181,522. PUB. 6-10-2014. FILED 1-31-2014.

4,592,962. **EL CAMPERO (STANDARD CHARACTER)**. C & F FOODS, INC., MULTIPLE CLASS, (INT. CLS. 29 AND 30), (U.S. CL. 46). SN 86-193,208. PUB. 6-10-2014. FILED 2-13-2014.

4,592,970. **EDIBLE NUMBERS (STANDARD CHARACTER)**. EDIBLE ARRANGEMENTS, LLC, (U.S. CL. 46). SN 86-197,498. PUB. 6-10-2014. FILED 2-19-2014.

4,592,989. **TAI FA CAI AND DESIGN**. BEST FOOD SERVICES, INC., (U.S. CL. 46). SN 86-207,709. PUB. 6-10-2014. FILED 2-28-2014.

---

#### CLASS 30—STAPLE FOODS

4,590,624. **VIETNAM SOUTHERN FOOD CORPORATION VINAFOOD I AND DESIGN**. VIETNAM SOUTHERN FOOD CORPORATION, (U.S. CL. 46). SN 77-846,281. PUB. 6-10-2014. FILED 10-12-2009.

4,590,628. **LLAOLLAO. (STYLIZED)**. LLAO LLAO, S.L., MULTIPLE CLASS, (INT. CLS. 30 AND 43), (U.S. CLS. 46, 100 AND 101). SN 79-110,459. PUB. 6-10-2014. FILED 2-29-2012.

4,590,642 ( *See Class 5 for this trademark*).

4,590,684 ( *See Class 9 for this trademark*).

4,590,758 ( *See Class 7 for this trademark*).

4,590,794 ( *See Class 29 for this trademark*).

4,590,804. **TWIGGLES (STYLIZED)**. EURO PATISSERIE HOLDING B.V., (U.S. CL. 46). SN 79-137,666. PUB. 6-10-2014. FILED 8-7-2013.

4,590,812 ( *See Class 3 for this trademark*).

4,590,820. **ROOBAR AND DESIGN**. KURABIINICA OOD, (U.S. CL. 46). SN 79-138,555. PUB. 6-10-2014. FILED 9-9-2013.

4,590,829 ( *See Class 29 for this trademark*).

4,590,872. **ANTICO MOLINO ROSSO (STANDARD CHARACTER)**. MIRANDOLA GAETANO, (U.S. CL. 46). SN 79-142,077. PUB. 6-10-2014. FILED 9-10-2013.

4,590,882. **É (STYLIZED)**. CAFÉS NOVELL, S.A., (U.S. CL. 46). SN 79-142,473. PUB. 6-10-2014. FILED 11-4-2013.

4,590,949. **SHAHRZAD AND DESIGN**. LT OVERSEAS NORTH AMERICA, INC., (U.S. CL. 46). SN 85-312,546. PUB. 6-10-2014. FILED 5-4-2011.

4,590,957. **SIMPLYFOOD (STANDARD CHARACTER)**. LANDSTROM, DARRYL, DBA COLLEEN & COMPANY INC., (U.S. CL. 46). SN 85-428,247. PUB. 3-4-2014. FILED 9-21-2011.

4,590,960 ( *See Class 5 for this trademark*).

4,591,023. **CRUMB & GET IT COOKIE COMPANY (STANDARD CHARACTER)**. CRUMB & GET IT COOKIE COMPANY INC., (U.S. CL. 46). SN 85-757,773. PUB. 4-23-2013. FILED 10-18-2012.

4,591,059 ( *See Class 1 for this trademark*).

4,591,107. **OATS ANY TIME (STANDARD CHARACTER)**. OATS ANY TIME, (U.S. CL. 46). SN 85-833,772. PUB. 6-10-2014. FILED 1-28-2013.

4,591,125. **SALT FOR LIFE (STANDARD CHARACTER)**. S & P INGREDIENT DEVELOPMENT, LLC, (U.S. CL. 46). SN 85-866,054. PUB. 6-10-2014. FILED 3-4-2013.

4,591,134. **BEACHY CREAM (STANDARD CHARACTER)**. BEACHY CREAM, LLC, (U.S. CL. 46). SN 85-875,455.

- PUB. 6-10-2014. FILED 3-13-2013.
- 4,591,139. **PIZZA EAST (STANDARD CHARACTER)**. SOHO HOUSE LIMITED, MULTIPLE CLASS, (INT. CLS. 30, 41 AND 43), (U.S. CLS. 46, 100, 101 AND 107). SN 85-878,900. PUB. 3-25-2014. FILED 3-18-2013.
- 4,591,141. **KIWI BURST AND DESIGN**. KIWI BURST, LLC, MULTIPLE CLASS, (INT. CLS. 30 AND 43), (U.S. CLS. 46, 100 AND 101). SN 85-880,849. PUB. 8-27-2013. FILED 3-20-2013.
- 4,591,209. **NORSAL (STANDARD CHARACTER)**. NORTE SALINEIRA SA IND. E COM. - NORSAL, (U.S. CL. 46). SN 85-937,348. PUB. 10-29-2013. FILED 5-20-2013.
- 4,591,249. **ZWEETME (STANDARD CHARACTER)**. INGENIO DEL CAUCA S.A. INCAUCA S.A., (U.S. CL. 46). SN 85-952,222. PUB. 6-10-2014. FILED 6-6-2013.
- 4,591,303 ( *See Class 5 for this trademark*).
- 4,591,305 ( *See Class 9 for this trademark*).
- 4,591,308. **FROM SOIL TO CUP, FERTILE SOIL TEAS AND DESIGN**. FERTILE SOIL TEAS, LLC, (U.S. CL. 46). SN 85-966,304. PUB. 6-10-2014. FILED 6-21-2013.
- 4,591,444. **BLONOSMOKE AND DESIGN**. DENNIS ROBINSON, MULTIPLE CLASS, (INT. CLS. 30 AND 34), (U.S. CLS. 2, 8, 9, 17 AND 46). SN 86-004,102. PUB. 6-10-2014. FILED 7-8-2013.
- 4,591,508. **E.Z. JAMMERS (STANDARD CHARACTER)**. ALBIE'S FOODS, INC., (U.S. CL. 46). SN 86-012,946. PUB. 6-10-2014. FILED 7-17-2013.
- 4,591,523. **GOOD JOE AND DESIGN**. HESS CORPORATION, MULTIPLE CLASS, (INT. CLS. 30 AND 35), (U.S. CLS. 46, 100, 101 AND 102). SN 86-017,204. PUB. 6-10-2014. FILED 7-23-2013.
- 4,591,574. **WAN HUA FOODS INC. (STANDARD CHARACTER)**. WAN HUA FOODS INC, (U.S. CL. 46). SN 86-030,472. PUB. 6-10-2014. FILED 8-6-2013.
- 4,591,650. **THE ORGANIC COFFEE CO. AND DESIGN**. JBR, INC., MULTIPLE CLASS, (INT. CLS. 30 AND 43), (U.S. CLS. 46, 100 AND 101). SN 86-052,676. PUB. 6-10-2014. FILED 8-30-2013.
- 4,591,700. **COCO MAGOU COFFEE COCO MAGOU COFFEE AND DESIGN**. ZHANG, JUN, (U.S. CL. 46). SN 86-071,194. PUB. 6-10-2014. FILED 9-21-2013.
- 4,591,746 ( *See Class 21 for this trademark*).
- 4,591,788. **ADIOS (STANDARD CHARACTER)**. FANTASIA DISTRIBUTION, INC., MULTIPLE CLASS, (INT. CLS. 30 AND 34), (U.S. CLS. 2, 8, 9, 17 AND 46). SN 86-097,994. PUB. 6-10-2014. FILED 10-22-2013.
- 4,591,806. **DECORIA ENJOY LOOKS & TASTE AND DESIGN**. DECORIA CONFECTIONERY CO., LTD., (U.S. CL. 46). SN 86-102,942. PUB. 6-10-2014. FILED 10-28-2013.
- 4,591,810. **THE AMAZING CAKES BAKERY EST. 2004 AND DESIGN**. AMAZING CAKES, INCORPORATED, AKA THE AMAZING CAKES BAKERY, (U.S. CL. 46). SN 86-103,824. PUB. 6-10-2014. FILED 10-29-2013.
- 4,591,834. **THE PHOEBE SNOW COMPANY AND DESIGN**. PHOEBE SNOW COMPANY INC., (U.S. CL. 46). SN 86-108,125. PUB. 6-10-2014. FILED 11-1-2013.
- 4,591,841. **THE FARINATA PROJECT (STANDARD CHARACTER)**. THE FARINATA PROJECT, LLC, (U.S. CL. 46). SN 86-109,404. PUB. 6-10-2014. FILED 11-4-2013.
- 4,591,900. **SWEET BBQ SAUCE AND DESIGN**. SONNY'S FRANCHISE COMPANY, (U.S. CL. 46). SN 86-121,230. PUB. 6-10-2014. FILED 11-18-2013.
- 4,591,906. **TOKERS TEA CO. (STANDARD CHARACTER)**. CAFFE VITA, INC., (U.S. CL. 46). SN 86-122,025. PUB. 6-10-2014. FILED 11-18-2013.
- 4,591,912. **TASTE (STANDARD CHARACTER)**. TASTE, LLC, (U.S. CL. 46). SN 86-123,204. PUB. 6-10-2014. FILED 11-19-2013.
- 4,591,916. **TEXAS BRIGADE AND DESIGN**. TEXAS BRIGADE BBQ, LLC, (U.S. CL. 46). SN 86-123,779. PUB. 6-10-2014. FILED 11-20-2013.
- 4,591,941. **BLISS BALLS (STANDARD CHARACTER)**. LIFE ELEMENTS, INC., (U.S. CL. 46). SN 86-127,741. PUB. 6-10-2014. FILED 11-24-2013.
- 4,591,959 ( *See Class 25 for this trademark*).
- 4,591,960. **NEVADA CHEESECAKE (STANDARD CHARACTER)**. TAHOE JOE'S, INC., (U.S. CL. 46). SN 86-129,772. PUB. 6-10-2014. FILED 11-26-2013.
- 4,591,967. **JOYOUS DAISY (STANDARD CHARACTER)**. EDIBLE ARRANGEMENTS, LLC, (U.S. CL. 46). SN 86-130,638. PUB. 6-10-2014. FILED 11-27-2013.
- 4,591,997. **LEIDENHEIMER BAKING CO. GOOD TO THE LAST CRUMB SINCE 1896 AND DESIGN**. G. H. LEIDENHEIMER BAKING CO., LTD., (U.S. CL. 46). SN 86-134,784. PUB. 6-10-2014. FILED 12-4-2013.
- 4,592,010 ( *See Class 29 for this trademark*).
- 4,592,021. **D'BEST SEASONING AND DESIGN**. MYERS, DONALD KEITH, JR., (U.S. CL. 46). SN 86-138,098. PUB. 6-10-2014. FILED 12-9-2013.
- 4,592,071. **DETOX WITH ME (STANDARD CHARACTER)**. PAROMI TEA, LLC, (U.S. CL. 46). SN 86-144,357. PUB. 5-6-2014. FILED 12-16-2013.
- 4,592,135. **CATERPILLAR EUJICE AND DESIGN**. CATERPILLAR EUJICE INC, (U.S. CL. 46). SN 86-151,264. PUB. 6-10-2014. FILED 12-23-2013.
- 4,592,143. **MISCELLANEOUS DESIGN**. LITTLE BAKERY IN THE GROVE, LLC, (U.S. CL. 46). SN 86-151,902. PUB. 6-10-2014. FILED 12-24-2013.
- 4,592,236. **RAINBOW CONFECTIONS (STANDARD CHARACTER)**. THE RAINBOW CONFECTION, LLC, DBA RAINBOW CONFECTIONS, (U.S. CL. 46). SN 86-157,645. PUB. 6-10-2014. FILED 1-5-2014.
- 4,592,293. **SANCHO MIGUEL'S SALSA (STANDARD CHARACTER)**. HAMPTON, MIGUEL, (U.S. CL. 46). SN 86-160,038. PUB. 6-10-2014. FILED 1-8-2014.
- 4,592,343. **COOKIE CRUSH BAKERY (STANDARD CHARACTER)**. GEORGE DELALLO COMPANY, INC., (U.S. CL. 46). SN 86-161,780. PUB. 6-10-2014. FILED 1-9-2014.
- 4,592,350. **BOONVILLE PIMENT D'VILLE (STANDARD CHARACTER)**. SCOMMEGNA, ROGER, (U.S. CL. 46). SN 86-161,942. PUB. 6-10-2014. FILED 1-9-2014.
- 4,592,359. **MISSISSIPPI GROGG (STANDARD CHARACTER)**. ROASTING SOLUTIONS, LLC, (U.S. CL. 46). SN 86-162,145. PUB. 6-10-2014. FILED 1-10-2014.
- 4,592,372. **TRAINING TREATS FOR HUSBANDS (STANDARD CHARACTER)**. TRAINING TREATS, LLC, (U.S. CL. 46). SN 86-162,623. PUB. 6-10-2014. FILED 1-10-2014.
- 4,592,398 ( *See Class 29 for this trademark*).
- 4,592,431. **SCHMILK (STANDARD CHARACTER)**. CHOCOLATE HOLLOW LLC., (U.S. CL. 46). SN 86-164,132. PUB. 6-10-2014. FILED 1-13-2014.
- 4,592,461. **TEA WITCH TEA (STANDARD CHARACTER)**. LAVECK, PATRICIA, (U.S. CL. 46). SN 86-165,412. PUB. 6-10-2014. FILED 1-14-2014.
- 4,592,478. **HERBAL RETREAT (STANDARD CHARACTER)**. TEA FORTE, INC., (U.S. CL. 46). SN 86-165,854. PUB. 6-10-2014. FILED 1-15-2014.
- 4,592,492 ( *See Class 16 for this trademark*).
- 4,592,503. **MAURY'S HIVE TEA (STANDARD CHARACTER)**. NAMTTIP LLC, (U.S. CL. 46). SN 86-166,540. PUB. 6-10-2014. FILED 1-15-2014.
- 4,592,507. **SWIZZLE BANANAS (STANDARD CHARACTER)**. EDIBLE ARRANGEMENTS, LLC, (U.S. CL. 46). SN 86-166,660. PUB. 6-10-2014. FILED 1-15-2014.
- 4,592,514. **DONUT RISING (STANDARD CHARACTER)**. DONUT RISING LLC, (U.S. CL. 46). SN 86-166,894. PUB. 6-10-2014. FILED 1-16-2014.
- 4,592,536. **RUSTING IN SEATTLE (STANDARD CHARACTER)**. STEPHANIE KO, AKA STEPHANIE R. W. KO, (U.S. CL. 46). SN 86-167,481. PUB. 6-10-2014. FILED 1-16-2014.
- 4,592,552. **THE WESTBEAN COFFEE ROASTERS (STANDARD CHARACTER)**. THE WESTBEAN COFFEE ROASTERS INC., (U.S. CL. 46). SN 86-168,337. PUB. 6-10-2014. FILED 1-17-2014.
- 4,592,568. **JAILHOUSE COFFEE MAKE A BREAK FOR IT AND DESIGN**. FLAM, ROBERT, (U.S. CL. 46). SN 86-169,279. PUB. 6-10-2014. FILED 1-17-2014.
- 4,592,619 ( *See Class 3 for this trademark*).
- 4,592,634. **SO LIGHT, THEY MIGHT FLOAT OFF YOUR PLATE! (STANDARD CHARACTER)**. LILY FROM THE VILLAGE, LLC, DBA LILY FROM THE VILLAGE, (U.S. CL. 46). SN 86-174,951. PUB. 6-10-2014. FILED 1-24-2014.
- 4,592,650. **PIZZAREV (STANDARD CHARACTER)**. PIZZAREV IP HOLDINGS, LLC, (U.S. CL. 46). SN 86-175,383. PUB. 6-10-2014. FILED 1-26-2014.
- 4,592,666. **THE VAPORATORY (STANDARD CHARACTER)**.

THE VAPORATORY, LLC, (U.S. CL. 46). SN 86-175,624. PUB. 6-10-2014. FILED 1-27-2014.

4,592,683. **PA'S PISTOLS (STANDARD CHARACTER)**. PA'S PISTOLS BAR-B-QUE SAUCE, (U.S. CL. 46). SN 86-175,885. PUB. 6-10-2014. FILED 1-27-2014.

4,592,685. **RAILHOUSE THOUSAND ISLAND (STANDARD CHARACTER)**. AMC BURGERS, INC., (U.S. CL. 46). SN 86-175,931. PUB. 6-10-2014. FILED 1-27-2014.

4,592,765. **EGGO (STANDARD CHARACTER)**. KELLOGG NORTH AMERICA COMPANY, (U.S. CL. 46). SN 86-177,391. PUB. 6-10-2014. FILED 1-28-2014.

4,592,776. **YOUNG MOUNTAIN TEA (STANDARD CHARACTER)**. YOUNG MOUNTAIN TEA, LLC, (U.S. CL. 46). SN 86-177,634. PUB. 6-10-2014. FILED 1-28-2014.

4,592,807. **THE UN-PRETZEL (STANDARD CHARACTER)**. MORLEY CANDY MAKERS, INC., (U.S. CL. 46). SN 86-178,058. PUB. 6-10-2014. FILED 1-28-2014.

4,592,844. **SBOONS (STANDARD CHARACTER)**. SJG LLC, (U.S. CL. 46). SN 86-178,744. PUB. 6-10-2014. FILED 1-29-2014.

4,592,883. **SCOTTY B'S (STANDARD CHARACTER)**. GOOD EATZ GOURMET CORP., (U.S. CL. 46). SN 86-179,647. PUB. 6-10-2014. FILED 1-30-2014.

4,592,889. **SPECIALTY'S@HOME (STANDARD CHARACTER)**. SPECIALTY'S CAFE & BAKERY, INC., (U.S. CL. 46). SN 86-179,787. PUB. 6-10-2014. FILED 1-30-2014.

4,592,898. **OZMO (STANDARD CHARACTER)**. SOLEN CIKOLATA GIDA SANAYI VE TICARET ANONIM SIRKETI, (U.S. CL. 46). SN 86-179,941. PUB. 6-10-2014. FILED 1-30-2014.

4,592,908. **FOLLOW YOUR GUT! (STANDARD CHARACTER)**. HEALTH-ADE LLC, (U.S. CL. 46). SN 86-180,300. PUB. 6-10-2014. FILED 1-30-2014.

4,592,930. **ZOTES (STANDARD CHARACTER)**. Z BRAND MARKETING, LLC, (U.S. CL. 46). SN 86-181,439. PUB. 6-10-2014. FILED 1-31-2014.

4,592,932 ( *See Class 29 for this trademark*).

4,592,945. **TWIST & SHOUT (STANDARD CHARACTER)**. WAL-MART STORES, INC., (U.S. CL. 46). SN 86-186,680. PUB. 6-10-2014. FILED 2-6-2014.

4,592,962 ( *See Class 29 for this trademark*).

4,592,976. **FRUIT-TASTIC (STANDARD CHARACTER)**. KELLOGG NORTH AMERICA COMPANY, (U.S. CL. 46). SN 86-203,095. PUB. 6-10-2014. FILED 2-25-2014.

4,592,980. **THE SNACKING CRUNCH WITH A PUNCH (STANDARD CHARACTER)**. KELLOGG NORTH AMERICA COMPANY, (U.S. CL. 46). SN 86-203,839. PUB. 6-10-2014. FILED 2-25-2014.

4,593,052. **BERRIES IN HEAT (STANDARD CHARACTER)**. GOOD EATZ GOURMET CORP., (U.S. CL. 46). SN 86-248,589. PUB. 6-10-2014. FILED 4-10-2014.

4,593,053. **NEMESIS (STANDARD CHARACTER)**. GOOD EATZ GOURMET CORP., (U.S. CL. 46). SN 86-248,597. PUB. 6-10-2014. FILED 4-10-2014.

4,593,054. **ARCH NEMESIS (STANDARD CHARACTER)**. GOOD EATZ GOURMET CORP., (U.S. CL. 46). SN 86-248,654. PUB. 6-10-2014. FILED 4-10-2014.

### CLASS 31—NATURAL AGRICULTURAL PRODUCTS

4,590,770 ( *See Class 29 for this trademark*).

4,590,788 ( *See Class 1 for this trademark*).

4,590,858 ( *See Class 7 for this trademark*).

4,590,991. **SIMPLICITY PLUS (STANDARD CHARACTER)**. NORMERICA INC., AKA NORTHDOWN INDUSTRIES INC., (U.S. CLS. 1 AND 46). SN 85-650,965. PUB. 6-10-2014. FILED 6-13-2012.

4,591,002. **POTATOES WITH PERSONALITY (STANDARD CHARACTER)**. THE LITTLE POTATO COMPANY LTD., (U.S. CLS. 1 AND 46). SN 85-687,744. PUB. 6-10-2014. FILED 7-26-2012.

4,591,024. **ULTRA PRECIOUS CAT (STANDARD CHARACTER)**. PRECIOUS CAT, INC., (U.S. CLS. 1 AND 46). SN 85-757,998. PUB. 6-10-2014. FILED 10-18-2012.

4,591,049. **BUCKLEY (STANDARD CHARACTER)**. BOULDER

ORGANICS LLC, DBA ORGANIC PET SUPERFOOD, MULTIPLE CLASS, (INT. CLS. 31 AND 35), (U.S. CLS. 1, 46, 100, 101 AND 102). SN 85-781,148. PUB. 6-10-2014. FILED 11-16-2012.

4,591,083 ( *See Class 1 for this trademark*).

4,591,150. **GUSTO AND DESIGN**. CLAUSE, (U.S. CLS. 1 AND 46). SN 85-889,185. PUB. 6-10-2014. FILED 3-28-2013.

4,591,197. **CLEMCOTT (STANDARD CHARACTER)**. CARPA DORADA, S.L., (U.S. CLS. 1 AND 46). SN 85-928,897. PUB. 2-11-2014. FILED 5-10-2013.

4,591,545. **TOP FIN (STANDARD CHARACTER)**. PETSMAST STORE SUPPORT GROUP, INC., (U.S. CLS. 1 AND 46). SN 86-024,784. PUB. 6-10-2014. FILED 7-31-2013.

4,591,616. **V.I.P. PETFOODS AND DESIGN**. V.I.P. PET FOODS PTY LTD, (U.S. CLS. 1 AND 46). SN 86-043,787. PUB. 6-10-2014. FILED 8-21-2013.

4,591,642. **EMPTY VASE (STANDARD CHARACTER)**. THE EMPTY VASE, INC., MULTIPLE CLASS, (INT. CLS. 31 AND 39), (U.S. CLS. 1, 46, 100 AND 105). SN 86-051,445. PUB. 6-10-2014. FILED 8-29-2013.

4,591,902. **SELECT-WAY AND DESIGN**. MIDWAY FARMS AND FORAGE, (U.S. CLS. 1 AND 46). SN 86-121,688. PUB. 6-10-2014. FILED 11-18-2013.

4,591,921. **ANDEAN NATURALS (STANDARD CHARACTER)**. ANDEAN NATURALS, INC., (U.S. CLS. 1 AND 46). SN 86-125,126. PUB. 6-10-2014. FILED 11-21-2013.

4,591,922. **BABY QUINOA (STANDARD CHARACTER)**. ANDEAN NATURALS, INC., (U.S. CLS. 1 AND 46). SN 86-125,130. PUB. 6-10-2014. FILED 11-21-2013.

4,592,221. **LOCAL PROVENANCE AND DESIGN**. PINELANDS NURSERY, INC., AKA PINELANDS NURSERY AND SUPPLY, (U.S. CLS. 1 AND 46). SN 86-156,886. PUB. 6-10-2014. FILED 1-3-2014.

4,592,893. **DOG STAR BARKERY (STANDARD CHARACTER)**. DOG STAR BARKERY, LLC, (U.S. CLS. 1 AND 46). SN 86-179,839. PUB. 6-10-2014. FILED 1-30-2014.

4,593,061. **SIMVITRO (STANDARD CHARACTER)**. J.R. SIMPLOT COMPANY, (U.S. CLS. 1 AND 46). SN 86-975,088. PUB. 6-10-2014. FILED 1-21-2014.

### CLASS 32—LIGHT BEVERAGES

4,590,642 ( *See Class 5 for this trademark*).

4,590,794 ( *See Class 29 for this trademark*).

4,590,823 ( *See Class 21 for this trademark*).

4,590,901. **STRANGELOVE (STANDARD CHARACTER)**. STRANGELOVE IP LICENSING PTY LTD, (U.S. CLS. 45, 46 AND 48). SN 79-143,151. PUB. 6-10-2014. FILED 12-11-2012.

4,590,906 ( *See Class 29 for this trademark*).

4,590,915 ( *See Class 25 for this trademark*).

4,590,976. **BUFFALO BILL'S BREWERY (STANDARD CHARACTER)**. STEINBECK BREWING COMPANY, (U.S. CLS. 45, 46 AND 48). SN 85-524,195. PUB. 6-10-2014. FILED 1-24-2012.

4,591,089. **CLOUD CHASER (STANDARD CHARACTER)**. SOVEREIGN BRANDS, LLC, MULTIPLE CLASS, (INT. CLS. 32, 33 AND 43), (U.S. CLS. 45, 46, 47, 48, 49, 100 AND 101). SN 85-807,618. PUB. 12-24-2013. FILED 12-20-2012.

4,591,109 ( *See Class 25 for this trademark*).

4,591,186. **BREWERY VIVANT (STANDARD CHARACTER)**. ONE BEER AT A TIME, LLC, (U.S. CLS. 45, 46 AND 48). SN 85-921,640. PUB. 6-10-2014. FILED 5-2-2013.

4,591,418. **HIJINX BREWING COMPANY AND DESIGN**. HBC, LLC, (U.S. CLS. 45, 46 AND 48). SN 86-001,854. PUB. 6-10-2014. FILED 7-3-2013.

4,591,496. **MONTAGE (STANDARD CHARACTER)**. MONTAGE HOTELS & RESORTS, LLC, (U.S. CLS. 45, 46 AND 48). SN 86-011,638. PUB. 6-10-2014. FILED 7-16-2013.

4,591,527. **SMALL TOWN BREWERY (STANDARD CHARACTER)**. INNOVATIVE BREWING, LLC, MULTIPLE CLASS, (INT. CLS. 32, 33, 35 AND 40), (U.S. CLS. 45, 46, 47, 48, 49, 100, 101, 102, 103 AND 106). SN 86-018,058. PUB. 6-10-2014. FILED 7-23-2013.

4,591,554. **ORGANIC PHARMER (STANDARD CHARACTER)**. 2DOCSORGANIC, LLC, MULTIPLE CLASS, (INT. CLS. 32

- AND 35), (U.S. CLS. 45, 46, 48, 100, 101 AND 102). SN 86-026,969. PUB. 6-10-2014. FILED 8-2-2013.
- 4,591,602. **GHOST DRIFTER (STANDARD CHARACTER)**. ODYSSEY BEERWERKS, LLC. (U.S. CLS. 45, 46 AND 48). SN 86-040,534. PUB. 6-10-2014. FILED 8-16-2013.
- 4,591,603. **CLAN WARRIOR (STANDARD CHARACTER)**. ODYSSEY BEERWERKS, LLC. (U.S. CLS. 45, 46 AND 48). SN 86-040,556. PUB. 6-10-2014. FILED 8-16-2013.
- 4,591,609. **CA AND DESIGN**. CLUB DE FUTBOL AMERICA, S.A. DE C.V., (U.S. CLS. 45, 46 AND 48). SN 86-041,580. PUB. 6-10-2014. FILED 8-19-2013.
- 4,591,736 ( *See Class 29 for this trademark*).
- 4,591,746 ( *See Class 21 for this trademark*).
- 4,591,756. **KING ST BREWING COMPANY ALASKA AND DESIGN**. KING STREET BREWING LLC, DBA KING STREET BREWING COMPANY, (U.S. CLS. 45, 46 AND 48). SN 86-087,661. PUB. 3-4-2014. FILED 10-9-2013.
- 4,591,777 ( *See Class 29 for this trademark*).
- 4,591,833 ( *See Class 16 for this trademark*).
- 4,591,905. **SUIZA PREMIUM - SALUD EN CADA VASO DE JUGO AND DESIGN**. SUIZA FRUIT CORPORATION, (U.S. CLS. 45, 46 AND 48). SN 86-121,943. PUB. 6-10-2014. FILED 11-18-2013.
- 4,591,926. **10 DAY SCOTTISH ALE AND DESIGN**. FLIX ENTERTAINMENT LLC, (U.S. CLS. 45, 46 AND 48). SN 86-125,688. PUB. 6-10-2014. FILED 11-21-2013.
- 4,591,959 ( *See Class 25 for this trademark*).
- 4,591,963. **PISGAH AND DESIGN**. PISGAH BREWING COMPANY, (U.S. CLS. 45, 46 AND 48). SN 86-129,817. PUB. 6-10-2014. FILED 11-26-2013.
- 4,592,018. **DARK RIDER (STANDARD CHARACTER)**. ALLEN, ERICH STEPHAN, (U.S. CLS. 45, 46 AND 48). SN 86-137,785. PUB. 6-10-2014. FILED 12-7-2013.
- 4,592,139. **BAJA MICHELADAS (STANDARD CHARACTER)**. GARCIA, VICTOR, (U.S. CLS. 45, 46 AND 48). SN 86-151,615. PUB. 6-10-2014. FILED 12-23-2013.
- 4,592,141. **BAJA MICHELADAS AND DESIGN**. GARCIA, VICTOR, (U.S. CLS. 45, 46 AND 48). SN 86-151,638. PUB. 6-10-2014. FILED 12-23-2013.
- 4,592,142. **ENJOY THE BITE! AND DESIGN**. GARCIA, VICTOR, (U.S. CLS. 45, 46 AND 48). SN 86-151,692. PUB. 6-10-2014. FILED 12-23-2013.
- 4,592,640. **ELEVATE LIFE (STANDARD CHARACTER)**. LKN BEVERAGES, LLC, (U.S. CLS. 45, 46 AND 48). SN 86-175,170. PUB. 6-10-2014. FILED 1-25-2014.
- 4,592,658. **AINONI (STYLIZED)**. CHANGSHA HAGEN BIOTECHNOLOGY CO., LTD., (U.S. CLS. 45, 46 AND 48). SN 86-175,530. PUB. 6-10-2014. FILED 1-27-2014.
- 4,592,687. **DUTY HONOR AMERICA'S VETERANS FOREVER (STANDARD CHARACTER)**. AMERICA FOREVER PRODUCTIONS, LLC, (U.S. CLS. 45, 46 AND 48). SN 86-175,962. PUB. 6-10-2014. FILED 1-27-2014.
- 4,592,755. **TERMINATOR (STANDARD CHARACTER)**. MCMENAMINS, INC., (U.S. CLS. 45, 46 AND 48). SN 86-177,215. PUB. 6-10-2014. FILED 1-28-2014.
- 4,592,856. **BINA (STANDARD CHARACTER)**. NDN STAR, (U.S. CLS. 45, 46 AND 48). SN 86-178,909. PUB. 6-10-2014. FILED 1-29-2014.
- 4,592,952. **DRINK OFF THE BEATEN CRAFT (STANDARD CHARACTER)**. CARTON BREWING COMPANY, LLC, (U.S. CLS. 45, 46 AND 48). SN 86-189,330. PUB. 6-10-2014. FILED 2-10-2014.
- 4,593,013. **MISCELLANEOUS DESIGN**. ALLAGASH BREWING COMPANY, (U.S. CLS. 45, 46 AND 48). SN 86-222,753. PUB. 6-10-2014. FILED 3-17-2014.
- 4,590,684 ( *See Class 9 for this trademark*).
- 4,590,696. **AUCHNAGIE (STANDARD CHARACTER)**. LDC (SCOTLAND) LTD, (U.S. CLS. 47 AND 49). SN 79-132,259. PUB. 6-10-2014. FILED 6-4-2013.
- 4,590,722. **NUMINA (STANDARD CHARACTER)**. SALENTEIN ARGENTINA B.V., (U.S. CLS. 47 AND 49). SN 79-134,136. PUB. 6-10-2014. FILED 6-14-2013.
- 4,590,739. **SIGNATURE DE LOIRE (STANDARD CHARACTER)**. JOSEPH VERDIER, (U.S. CLS. 47 AND 49). SN 79-134,801. PUB. 6-10-2014. FILED 4-30-2013.
- 4,590,823 ( *See Class 21 for this trademark*).
- 4,590,836. **TERRE DE VIGNERONS AND DESIGN**. TERRE DE VIGNERONS-UNION PRODIFFU, MULTIPLE CLASS, (INT. CLS. 33, 35, 39 AND 41), (U.S. CLS. 47, 49, 100, 101, 102, 105 AND 107). SN 79-139,916. PUB. 6-10-2014. FILED 8-27-2013.
- 4,590,840. **CLUB DE CANTINEROS (STANDARD CHARACTER)**. BACARDI & COMPANY LIMITED, MULTIPLE CLASS, (INT. CLS. 33, 41 AND 43), (U.S. CLS. 47, 49, 100, 101 AND 107). SN 79-140,042. PUB. 6-10-2014. FILED 10-4-2013.
- 4,590,846. **BROCHET (STANDARD CHARACTER)**. AMPELLIDAE SARL, (U.S. CLS. 47 AND 49). SN 79-140,473. PUB. 6-10-2014. FILED 10-23-2013.
- 4,590,852. **BEAUVIGNAC (STANDARD CHARACTER)**. CAVE LES COSTIERES DE POMEROLS (SOCIETE COOPERATIVE AGRICOLE DE VINIFICATION), (U.S. CLS. 47 AND 49). SN 79-140,726. PUB. 6-10-2014. FILED 10-21-2013.
- 4,590,865. **& VODKA AND DESIGN**. PHILIP JAMES CLARK, AND PETER DAVID DARROCH, (U.S. CLS. 47 AND 49). SN 79-141,945. PUB. 6-10-2014. FILED 12-11-2013.
- 4,590,877. **CASA BELFI (STANDARD CHARACTER)**. CANTINA VINI ARMANI A. - TERRE; DOMINICI SOCIETÀ A RESPONSABILITÀ; LIMITATA IN SIGLA "CANTINA VINI; ARMANI A. - TERRE DOMINICI SOCIETÀ; A RESPONSABILITÀ LIMITATA IN SIGLA; "CANTINA VINI ARMANI A. S.R.L." E; "TERRE DOMINICI S.R.L.", (U.S. CLS. 47 AND 49). SN 79-142,359. PUB. 6-10-2014. FILED 10-23-2013.
- 4,590,909. **BLACKPITTS (STANDARD CHARACTER)**. TEELING WHISKEY COMPANY LTD, (U.S. CLS. 47 AND 49). SN 79-143,355. PUB. 6-10-2014. FILED 1-27-2014.
- 4,590,975. **FINCA FLICHMAN GRAND VINEYARDS (STANDARD CHARACTER)**. FINCA FLICHMAN, S.A., (U.S. CLS. 47 AND 49). SN 85-518,892. PUB. 6-10-2014. FILED 1-18-2012.
- 4,590,983. **LA PECHERA (STANDARD CHARACTER)**. BODEGAS SAN HUBERTO S.A., (U.S. CLS. 47 AND 49). SN 85-608,640. PUB. 6-10-2014. FILED 4-26-2012.
- 4,590,999. **NOW INE (STANDARD CHARACTER)**. COOPERATIVA AGRÍCOLA PISQUERA ELQUI LIMITADA, (U.S. CLS. 47 AND 49). SN 85-681,458. PUB. 6-10-2014. FILED 7-19-2012.
- 4,591,089 ( *See Class 32 for this trademark*).
- 4,591,244. **D'USSE AND DESIGN**. D'USSE LLC, (U.S. CLS. 47 AND 49). SN 85-949,402. PUB. 6-10-2014. FILED 6-3-2013.
- 4,591,318. **"THE BOOM" (STANDARD CHARACTER)**. GENOA CELLARS LLC, (U.S. CLS. 47 AND 49). SN 85-967,248. PUB. 6-10-2014. FILED 6-22-2013.
- 4,591,353. **IMPERIAL COLLECTION (STANDARD CHARACTER)**. PREMIER LIQUEUR GROUP LIMITED, (U.S. CLS. 47 AND 49). SN 85-971,818. PUB. 6-10-2014. FILED 6-27-2013.
- 4,591,420. **8 MESAS AND DESIGN**. RELLO LARA ENRIQUE, (U.S. CLS. 47 AND 49). SN 86-002,073. PUB. 6-10-2014. FILED 7-3-2013.
- 4,591,527 ( *See Class 32 for this trademark*).
- 4,591,580. **S SINFIRE AND DESIGN**. HOOD RIVER DISTILLERS, INC., (U.S. CLS. 47 AND 49). SN 86-033,110. PUB. 6-10-2014. FILED 8-8-2013.
- 4,591,646. **RAPA NUI (STANDARD CHARACTER)**. D & M NEW WORLD MANAGEMENT, INC., (U.S. CLS. 47 AND 49). SN 86-051,957. PUB. 6-10-2014. FILED 8-29-2013.
- 4,591,698. **THE JEM AND DESIGN**. ASSEMBLED INVESTMENTS (PROPRIETARY) LIMITED, (U.S. CLS. 47 AND 49). SN 86-069,615. PUB. 6-10-2014. FILED 9-19-2013.
- 4,591,738. **THE GREAT RIFT VALLEY (STANDARD CHARACTER)**. BRAND PHOENIX LIMITED, (U.S. CLS. 47 AND 49). SN 86-081,754. PUB. 6-10-2014. FILED 10-3-2013.
- 4,591,755. **AUDELSSA (STANDARD CHARACTER)**. RIGHT

### CLASS 33—WINES AND SPIRITS

- 4,590,670. **MAXIME TRIJOL AND DESIGN**. ETS MAXIME TRIJOL, (U.S. CLS. 47 AND 49). SN 79-127,779. PUB. 6-10-2014. FILED 2-19-2013.
- 4,590,676. **WWM WORLD WINE MEETINGS (STANDARD CHARACTER)**. ADHESION GROUP, MULTIPLE CLASS, (INT. CLS. 33, 35, 38 AND 41), (U.S. CLS. 47, 49, 100, 101, 102, 104 AND 107). SN 79-128,120. PUB. 6-10-2014. FILED 10-25-2012.

- SIDE, LLC, (U.S. CLS. 47 AND 49). SN 86-087,660. PUB. 6-10-2014. FILED 10-9-2013.
- 4,591,837. **SANTA ELVIRA (STANDARD CHARACTER)**. ANTONINO, NIGRELLI, (U.S. CLS. 47 AND 49). SN 86-108,836. PUB. 6-10-2014. FILED 11-3-2013.
- 4,591,856. **BLANC FOUSSY (STANDARD CHARACTER)**. LACHETEAU, (U.S. CLS. 47 AND 49). SN 86-113,593. PUB. 6-10-2014. FILED 11-8-2013.
- 4,591,910. **CANTONA 100% AGAVE (STANDARD CHARACTER)**. BALTICO SPIRITS LLC, (U.S. CLS. 47 AND 49). SN 86-123,035. PUB. 6-10-2014. FILED 11-19-2013.
- 4,591,986. **TROY & SONS PLATINUM WHISKEY (STANDARD CHARACTER)**. BLUE RIDGE SPIRITS BRANDS JVI, LLC, (U.S. CLS. 47 AND 49). SN 86-133,061. PUB. 6-10-2014. FILED 12-2-2013.
- 4,591,996. **TROY & SONS OAK RESERVE WHISKEY (STANDARD CHARACTER)**. BLUE RIDGE SPIRITS BRANDS JVI, LLC, (U.S. CLS. 47 AND 49). SN 86-134,720. PUB. 6-10-2014. FILED 12-4-2013.
- 4,592,248. **NEW HAVEN MISSOURI PINCKNEY BEND DISTILLERY AND DESIGN**. ARTISAN SPIRITS LLC, (U.S. CLS. 47 AND 49). SN 86-158,170. PUB. 6-10-2014. FILED 1-6-2014.
- 4,592,421. **THE WORLD'S MOST POPULAR WINE (STANDARD CHARACTER)**. THE WINE GROUP LLC, (U.S. CLS. 47 AND 49). SN 86-163,672. PUB. 6-10-2014. FILED 1-13-2014.
- 4,592,500. **PAMPELONNE (STANDARD CHARACTER)**. PAMPELONNE LLC, (U.S. CLS. 47 AND 49). SN 86-166,444. PUB. 6-10-2014. FILED 1-15-2014.
- 4,592,595. **THIRSTY OAK (STANDARD CHARACTER)**. SCHREUS, HANS W, (U.S. CLS. 47 AND 49). SN 86-172,807. PUB. 6-10-2014. FILED 1-23-2014.
- 4,592,708. **COOL FISH (STANDARD CHARACTER)**. SMITH-ANDERSON ENTERPRISES, INC., (U.S. CLS. 47 AND 49). SN 86-176,328. PUB. 6-10-2014. FILED 1-27-2014.
- 4,592,734. **IDOL RIDGE WINERY (STANDARD CHARACTER)**. MARTIN'S HONEY FARM & MEADERY, LLC, DBA IDOL RIDGE WINERY, (U.S. CLS. 47 AND 49). SN 86-176,905. PUB. 6-10-2014. FILED 1-28-2014.
- 4,592,758. **SOLOMON HILLS (STANDARD CHARACTER)**. EBM ASSOCIATES, LLC, (U.S. CLS. 47 AND 49). SN 86-177,241. PUB. 6-10-2014. FILED 1-28-2014.
- 4,592,774. **SPICE TRAIL (STANDARD CHARACTER)**. LAKE CHALICE WINES LTD, (U.S. CLS. 47 AND 49). SN 86-177,577. PUB. 6-10-2014. FILED 1-28-2014.
- 4,592,918. **MISCELLANEOUS DESIGN**. POMO RIDGE DISTRIBUTION, LLC, (U.S. CLS. 47 AND 49). SN 86-180,474. PUB. 6-10-2014. FILED 1-30-2014.
- 4,592,958. **MISCELLANEOUS DESIGN**. THE ABSOLUT COMPANY AKTIEBOLAG, (U.S. CLS. 47 AND 49). SN 86-191,332. PUB. 6-10-2014. FILED 2-12-2014.
- 4,592,964. **HOOT 2012 PINOT BLANC SANTA MARIA VALLEY, CALIFORNIA AND DESIGN**. PHOENIX VINTNERS, LLC, DBA TRAVELING VINEYARD, (U.S. CLS. 47 AND 49). SN 86-194,413. PUB. 6-10-2014. FILED 2-14-2014.
- 4,593,024. **MISCELLANEOUS DESIGN**. DIAGEO NORTH AMERICA, INC., (U.S. CLS. 47 AND 49). SN 86-226,873. PUB. 6-10-2014. FILED 3-20-2014.
- 4,593,030. **BOZEMAN SPIRITS DISTILLERY B TRADE MARK AND DESIGN**. BOZEMAN SPIRITS, LLC, (U.S. CLS. 47 AND 49). SN 86-232,714. PUB. 6-10-2014. FILED 3-26-2014.

---

#### CLASS 34—SMOKERS' ARTICLES

- 4,590,663. **BT (STANDARD CHARACTER)**. AKTSIONERNO DROUJESTVO; "BULGARTABAC-HOLDING", (U.S. CLS. 2, 8, 9 AND 17). SN 79-126,455. PUB. 6-10-2014. FILED 1-18-2013.
- 4,590,719 ( *See Class 21 for this trademark*).
- 4,591,444 ( *See Class 30 for this trademark*).
- 4,591,536. **THE CIGAR GUYS AND DESIGN**. THE CIGAR GUYS INTERNATIONAL, (U.S. CLS. 2, 8, 9 AND 17). SN 86-022,678. PUB. 6-10-2014. FILED 7-29-2013.
- 4,591,587. **MOXIE (STANDARD CHARACTER)**. COOPER & COMPANY, INC., (U.S. CLS. 2, 8, 9 AND 17). SN 86-035,328. PUB. 1-7-2014. FILED 8-12-2013.
- 4,591,788 ( *See Class 30 for this trademark*).
- 4,592,241. **MISCELLANEOUS DESIGN**. PHANTOM SMOKE, CO., (U.S. CLS. 2, 8, 9 AND 17). SN 86-157,830. PUB. 6-10-2014. FILED 1-6-2014.
- 4,592,443. **Z PALMA AND DESIGN**. SHOW CIGARS, INC., (U.S. CLS. 2, 8, 9 AND 17). SN 86-164,655. PUB. 6-10-2014. FILED 1-14-2014.
- 4,592,655. **MOX (STYLIZED)**. SHENZHEN JIAPENG JIYU DESIGN CO., LTD., (U.S. CLS. 2, 8, 9 AND 17). SN 86-175,483. PUB. 6-10-2014. FILED 1-26-2014.
- 4,592,721. **DUNE (STANDARD CHARACTER)**. MUZAIC, GEORGE, (U.S. CLS. 2, 8, 9 AND 17). SN 86-176,710. PUB. 6-10-2014. FILED 1-27-2014.
- 4,592,878. **G (STYLIZED)**. JOHN GIBSON ENTERPRISES, INC., (U.S. CLS. 2, 8, 9 AND 17). SN 86-179,518. PUB. 6-10-2014. FILED 1-30-2014.
- 4,592,925 ( *See Class 25 for this trademark*).
- 4,592,928. **THE BIG PAYBACK (STANDARD CHARACTER)**. CONSPIRACY INC., (U.S. CLS. 2, 8, 9 AND 17). SN 86-181,399. PUB. 6-10-2014. FILED 1-31-2014.
- 4,592,981. **DEUS (STYLIZED)**. HONGKONG WILLRAISE INTERGRATED CIRCUIT CO., LIMITED, (U.S. CLS. 2, 8, 9 AND 17). SN 86-204,214. PUB. 6-10-2014. FILED 2-26-2014.
- 4,592,982. **EDMAR (STYLIZED)**. HONGKONG WILLRAISE INTERGRATED CIRCUIT CO., LIMITED, (U.S. CLS. 2, 8, 9 AND 17). SN 86-204,217. PUB. 6-10-2014. FILED 2-26-2014.
- 4,593,036 ( *See Class 1 for this trademark*).
- 4,593,038. **LEROY (STANDARD CHARACTER)**. CONSPIRACY INC., (U.S. CLS. 2, 8, 9 AND 17). SN 86-240,384. PUB. 6-10-2014. FILED 4-2-2014.
- 4,593,043. **TRUCE (STANDARD CHARACTER)**. THE TRUCE COMPANY, (U.S. CLS. 2, 8, 9 AND 17). SN 86-243,181. PUB. 6-10-2014. FILED 4-4-2014.

---

#### SERVICE MARKS

#### CLASS 35—ADVERTISING AND BUSINESS

- 4,590,604. **VANTAGE DATA CENTERS AND DESIGN**. SIREN DATA MANAGEMENT COMPANY LLC, MULTIPLE CLASS, (INT. CLS. 35, 36 AND 42), (U.S. CLS. 100, 101 AND 102). SN 76-705,856. PUB. 6-10-2014. FILED 1-3-2011.
- 4,590,605. **CFPB CONSUMER FINANCIAL PROTECTION BUREAU AND DESIGN**. CONSUMER FINANCIAL PROTECTION BUREAU, MULTIPLE CLASS, (INT. CLS. 35, 36 AND 41), (U.S. CLS. 100, 101, 102 AND 107). SN 76-708,879. PUB. 6-10-2014. FILED 8-25-2011.
- 4,590,609. **RUNWAY MANHATTAN (STANDARD CHARACTER)**. TRYON MEDIA, LLC, (U.S. CLS. 100, 101 AND 102). SN 76-714,227. PUB. 6-10-2014. FILED 5-24-2013.
- 4,590,612. **PLAY IT COY LIFE WELL PLAYED. AND DESIGN**. LIFE AFTER SPORTS AGENCY, LLC, (U.S. CLS. 100, 101 AND 102). SN 76-714,455. PUB. 6-10-2014. FILED 6-26-2013.
- 4,590,613. **BOWIE BAKERY AND DESIGN**. MARQUEZ, JUAN, AND MARQUEZ, ERIKA, (U.S. CLS. 100, 101 AND 102). SN 76-715,365. PUB. 6-10-2014. FILED 11-15-2013.
- 4,590,616. **HOOTGRAM (STANDARD CHARACTER)**. HOOTGRAM, LLC, (U.S. CLS. 100, 101 AND 102). SN 76-715,548. PUB. 6-10-2014. FILED 12-16-2013.
- 4,590,621. **IPA A&I AND DESIGN**. INTERNATIONAL PROFIT ASSOCIATES, INC., MULTIPLE CLASS, (INT. CLS. 35 AND 36), (U.S. CLS. 100, 101 AND 102). SN 77-724,037. PUB. 6-10-2014. FILED 4-28-2009.
- 4,590,622. **I-SITE (STANDARD CHARACTER)**. I-SITE, INC., (U.S. CLS. 100, 101 AND 102). SN 77-750,175. PUB. 6-10-2014. FILED 6-2-2009.
- 4,590,626 ( *See Class 3 for this trademark*).
- 4,590,631 ( *See Class 12 for this trademark*).
- 4,590,632 ( *See Class 9 for this trademark*).
- 4,590,636 ( *See Class 14 for this trademark*).
- 4,590,637 ( *See Class 14 for this trademark*).
- 4,590,638 ( *See Class 9 for this trademark*).
- 4,590,645 ( *See Class 9 for this trademark*).
- 4,590,647. **KN LOGIN (STANDARD CHARACTER)**. KÜHNE

- + NAGEL INTERNATIONAL AG, MULTIPLE CLASS, (INT. CLS. 35, 36 AND 39), (U.S. CLS. 100, 101, 102 AND 105). SN 79-123,671. PUB. 6-10-2014. FILED 10-8-2012.
- 4,590,652. **EVENTISIMO AND DESIGN**. EVENTISIMO, S.L., MULTIPLE CLASS, (INT. CLS. 35, 39 AND 41), (U.S. CLS. 100, 101, 102, 105 AND 107). SN 79-124,985. PUB. 6-10-2014. FILED 12-27-2012.
- 4,590,655 ( *See Class 9 for this trademark*).
- 4,590,657 ( *See Class 9 for this trademark*).
- 4,590,665 ( *See Class 9 for this trademark*).
- 4,590,666 ( *See Class 7 for this trademark*).
- 4,590,668 ( *See Class 9 for this trademark*).
- 4,590,676 ( *See Class 33 for this trademark*).
- 4,590,677 ( *See Class 6 for this trademark*).
- 4,590,680 ( *See Class 9 for this trademark*).
- 4,590,681. **G GENERATOR AND DESIGN**. GENERATOR HOSTELS LTD, MULTIPLE CLASS, (INT. CLS. 35, 38, 39, 41 AND 43), (U.S. CLS. 100, 101, 102, 104, 105 AND 107). SN 79-129,122. PUB. 6-10-2014. FILED 12-3-2012.
- 4,590,684 ( *See Class 9 for this trademark*).
- 4,590,691. **THE LIP (STYLIZED)**. LABELUX GROUP GMBH, MULTIPLE CLASS, (INT. CLS. 35 AND 36), (U.S. CLS. 100, 101 AND 102). SN 79-131,976. PUB. 6-10-2014. FILED 5-22-2013.
- 4,590,700. **LUXURY IN PROGRESS LABELUX GROUP AND DESIGN**. LABELUX GROUP GMBH, MULTIPLE CLASS, (INT. CLS. 35 AND 36), (U.S. CLS. 100, 101 AND 102). SN 79-132,882. PUB. 6-10-2014. FILED 5-22-2013.
- 4,590,704. **MEDIA QUARTER (STANDARD CHARACTER)**. J.V.P. CONSULTING (ISRAEL) LTD., MULTIPLE CLASS, (INT. CLS. 35, 36 AND 41), (U.S. CLS. 100, 101, 102 AND 107). SN 79-133,161. PUB. 6-10-2014. FILED 6-6-2013.
- 4,590,712 ( *See Class 9 for this trademark*).
- 4,590,719 ( *See Class 21 for this trademark*).
- 4,590,720 ( *See Class 9 for this trademark*).
- 4,590,723 ( *See Class 18 for this trademark*).
- 4,590,726. **ESSE (STYLIZED)**. ESSE EV ÜRÜNLERİ PAZARLAMA; SANAYİ VE TİCARET ANONİM ŞİRKETİ, (U.S. CLS. 100, 101 AND 102). SN 79-134,170. PUB. 6-10-2014. FILED 5-31-2013.
- 4,590,746 ( *See Class 3 for this trademark*).
- 4,590,747 ( *See Class 9 for this trademark*).
- 4,590,749. **SANDY (STANDARD CHARACTER)**. JOSÉ VICENTE CRESPO NAVARRO, (U.S. CLS. 100, 101 AND 102). SN 79-135,416. PUB. 6-10-2014. FILED 4-25-2013.
- 4,590,750 ( *See Class 16 for this trademark*).
- 4,590,752 ( *See Class 9 for this trademark*).
- 4,590,761. **MISCELLANEOUS DESIGN**. TARP TEAM HOLDING APS, MULTIPLE CLASS, (INT. CLS. 35 AND 41), (U.S. CLS. 100, 101, 102 AND 107). SN 79-135,800. PUB. 6-10-2014. FILED 6-22-2013.
- 4,590,767 ( *See Class 9 for this trademark*).
- 4,590,774. **LIDAN (STANDARD CHARACTER)**. LIDAN MARINE AB, MULTIPLE CLASS, (INT. CLS. 35, 37 AND 42), (U.S. CLS. 100, 101, 102, 103 AND 106). SN 79-136,397. PUB. 6-10-2014. FILED 8-19-2013.
- 4,590,775. **LIDAN MARINE (STANDARD CHARACTER)**. LIDAN MARINE AB, MULTIPLE CLASS, (INT. CLS. 35, 37 AND 42), (U.S. CLS. 100, 101, 102, 103 AND 106). SN 79-136,398. PUB. 6-10-2014. FILED 8-19-2013.
- 4,590,778 ( *See Class 9 for this trademark*).
- 4,590,786 ( *See Class 1 for this trademark*).
- 4,590,787. **CALASIA (STANDARD CHARACTER)**. CALASIA GROUP PTE. LTD., (U.S. CLS. 100, 101 AND 102). SN 79-136,842. PUB. 6-10-2014. FILED 8-22-2013.
- 4,590,790 ( *See Class 9 for this trademark*).
- 4,590,801 ( *See Class 9 for this trademark*).
- 4,590,805. **AIRSPIRIT.COM (STYLIZED)**. ALTAIR, MULTIPLE CLASS, (INT. CLS. 35 AND 38), (U.S. CLS. 100, 101, 102 AND 104). SN 79-137,700. PUB. 6-10-2014. FILED 9-13-2013.
- 4,590,806 ( *See Class 7 for this trademark*).
- 4,590,819 ( *See Class 10 for this trademark*).
- 4,590,824 ( *See Class 1 for this trademark*).
- 4,590,829 ( *See Class 29 for this trademark*).
- 4,590,836 ( *See Class 33 for this trademark*).
- 4,590,842 ( *See Class 9 for this trademark*).
- 4,590,843 ( *See Class 20 for this trademark*).
- 4,590,844 ( *See Class 7 for this trademark*).
- 4,590,853 ( *See Class 20 for this trademark*).
- 4,590,854. **EVERTIQ (STANDARD CHARACTER)**. EVERTIQ NEW MEDIA AB, MULTIPLE CLASS, (INT. CLS. 35 AND 41), (U.S. CLS. 100, 101, 102 AND 107). SN 79-140,880. PUB. 6-10-2014. FILED 4-16-2013.
- 4,590,855 ( *See Class 12 for this trademark*).
- 4,590,856 ( *See Class 3 for this trademark*).
- 4,590,861 ( *See Class 9 for this trademark*).
- 4,590,870 ( *See Class 9 for this trademark*).
- 4,590,873. **SFP SELECTED FOOD PACKAGING AND DESIGN**. SVEN BOILLAT, (U.S. CLS. 100, 101 AND 102). SN 79-142,266. PUB. 6-10-2014. FILED 10-22-2013.
- 4,590,875. **EP ENTERPRISE PARTNERS (STYLIZED)**. STHREE IP LIMITED, (U.S. CLS. 100, 101 AND 102). SN 79-142,276. PUB. 6-10-2014. FILED 12-16-2013.
- 4,590,879 ( *See Class 12 for this trademark*).
- 4,590,894. **JL (STYLIZED)**. RICHEMONT INTERNATIONAL SA, (U.S. CLS. 100, 101 AND 102). SN 79-142,727. PUB. 6-10-2014. FILED 11-26-2013.
- 4,590,912. **TRUVER (STANDARD CHARACTER)**. YAREMENKO SERHII VASYLOVYCH, (U.S. CLS. 100, 101 AND 102). SN 79-143,687. PUB. 6-10-2014. FILED 11-26-2013.
- 4,590,915 ( *See Class 25 for this trademark*).
- 4,590,923. **HATCHAA (STANDARD CHARACTER)**. INVESTOM, UAB, (U.S. CLS. 100, 101 AND 102). SN 79-145,204. PUB. 6-10-2014. FILED 1-28-2014.
- 4,590,942. **MUNICIPAL DATAWORKS (STANDARD CHARACTER)**. ONTARIO GOOD ROADS ASSOCIATION, MULTIPLE CLASS, (INT. CLS. 35, 36 AND 42), (U.S. CLS. 100, 101 AND 102). SN 85-195,155. PUB. 6-10-2014. FILED 12-10-2010.
- 4,590,943. **MDW (STANDARD CHARACTER)**. ONTARIO GOOD ROADS ASSOCIATION, MULTIPLE CLASS, (INT. CLS. 35, 36 AND 42), (U.S. CLS. 100, 101 AND 102). SN 85-195,196. PUB. 6-10-2014. FILED 12-10-2010.
- 4,590,956 ( *See Class 14 for this trademark*).
- 4,590,958. **SERVIENTREGA (STANDARD CHARACTER)**. SERVIENTREGA S.A., (U.S. CLS. 100, 101 AND 102). SN 85-431,526. PUB. 6-10-2014. FILED 9-26-2011.
- 4,590,962. **UNITED STATES FORMULA 3 CHAMPIONSHIP AND DESIGN**. TOSA, MARK, (U.S. CLS. 100, 101 AND 102). SN 85-461,868. PUB. 6-10-2014. FILED 11-1-2011.
- 4,590,965. **MOBILE NATIONS AND DESIGN**. AXEL LTD. CO., (U.S. CLS. 100, 101 AND 102). SN 85-473,765. PUB. 6-10-2014. FILED 11-16-2011.
- 4,590,985 ( *See Class 9 for this trademark*).
- 4,590,989. **SIGN SMART AND DESIGN**. SIGN SMART LLC, (U.S. CLS. 100, 101 AND 102). SN 85-648,236. PUB. 6-10-2014. FILED 6-11-2012.
- 4,591,001 ( *See Class 9 for this trademark*).
- 4,591,008. **TRONICSXCHANGE AND DESIGN**. TRONICSXCHANGE, INC., MULTIPLE CLASS, (INT. CLS. 35 AND 37), (U.S. CLS. 100, 101, 102, 103 AND 106). SN 85-727,155. PUB. 6-10-2014. FILED 9-12-2012.
- 4,591,018. **SOCIAL HOUSE (STANDARD CHARACTER)**. SOCIAL HOUSE, INC., (U.S. CLS. 100, 101 AND 102). SN 85-744,269. PUB. 3-26-2013. FILED 10-2-2012.
- 4,591,019. **CRUMB & GET IT COOKIE COMPANY (STANDARD CHARACTER)**. CRUMB & GET IT COOKIE COMPANY INC., (U.S. CLS. 100, 101 AND 102). SN 85-750,540. PUB. 4-23-2013. FILED 10-10-2012.
- 4,591,027 ( *See Class 18 for this trademark*).
- 4,591,033. **MY HAUTE CLOSET (STANDARD CHARACTER)**. TROCHE, MILYSAN, DBA MYHAUTCLOSET.COM, (U.S. CLS. 100, 101 AND 102). SN 85-768,224. PUB. 6-10-2014. FILED 10-31-2012.
- 4,591,046 ( *See Class 9 for this trademark*).
- 4,591,049 ( *See Class 31 for this trademark*).
- 4,591,050. **TRANSIT WIRELESS (STANDARD CHARACTER)**. TRANSIT WIRELESS, LLC, (U.S. CLS. 100, 101 AND 102). SN 85-781,971. PUB. 6-10-2014. FILED 11-16-2012.
- 4,591,051. **HEALTHSTAT (STANDARD CHARACTER)**. HEALTHSTAT, INC., MULTIPLE CLASS, (INT. CLS. 35, 36 AND 44), (U.S. CLS. 100, 101 AND 102). SN 85-785,392. PUB. 6-10-2014. FILED 11-21-2012.
- 4,591,062. **BILTWELL INC. QUALITY COUNTS AND DESIGN**. BILTWELL CUSTOM MOTORCYCLE CORP., DBA BILTWELL INC., (U.S. CLS. 100, 101 AND 102). SN 85-

- 789,465. PUB. 6-10-2014. FILED 11-28-2012.  
 4,591,076 ( *See Class 9 for this trademark* ).  
 4,591,088 ( *See Class 9 for this trademark* ).  
 4,591,103 ( *See Class 9 for this trademark* ).  
 4,591,111. **COMMONWELL HEALTH ALLIANCE (STANDARD CHARACTER)**. COMMONWELL HEALTH ALLIANCE INC., MULTIPLE CLASS, (INT. CLS. 35, 42 AND 44), (U.S. CLS. 100, 101 AND 102). SN 85-844,919. PUB. 6-10-2014. FILED 2-8-2013.  
 4,591,114 ( *See Class 6 for this trademark* ).  
 4,591,115. **FUSION MARKETING (STANDARD CHARACTER)**. FUSION PERFORMANCE MARKETING, LLC, (U.S. CLS. 100, 101 AND 102). SN 85-851,642. PUB. 6-10-2014. FILED 2-15-2013.  
 4,591,116. **BROADCAST YOUR BUSINESS (STANDARD CHARACTER)**. THINKGLOBAL INC., (U.S. CLS. 100, 101 AND 102). SN 85-851,918. PUB. 6-10-2014. FILED 2-16-2013.  
 4,591,120. **ENERGY UPGRADE CALIFORNIA AND DESIGN**. CALIFORNIA PUBLIC UTILITIES COMMISSION, AND CALIFORNIA ENERGY COMMISSION, (U.S. CLS. 100, 101 AND 102). SN 85-859,360. PUB. 6-10-2014. FILED 2-25-2013.  
 4,591,122. **VISION MANAGEMENT (STANDARD CHARACTER)**. MEYERS, LEANNE, (U.S. CLS. 100, 101 AND 102). SN 85-862,220. PUB. 6-10-2014. FILED 2-27-2013.  
 4,591,126. **RENEWAGE (STANDARD CHARACTER)**. RENEWAGE ENERGY SOLUTIONS, INC., MULTIPLE CLASS, (INT. CLS. 35 AND 42), (U.S. CLS. 100, 101 AND 102). SN 85-866,313. PUB. 2-25-2014. FILED 3-4-2013.  
 4,591,143. **EZLEASE AND DESIGN**. FRANCO TYP-POSTALIA, INC., DBA FP MAILING SOLUTIONS, (U.S. CLS. 100, 101 AND 102). SN 85-881,599. PUB. 6-10-2014. FILED 3-20-2013.  
 4,591,145. **EZLEASE (STANDARD CHARACTER)**. FRANCO TYP-POSTALIA, INC., DBA FP MAILING SOLUTIONS, (U.S. CLS. 100, 101 AND 102). SN 85-882,104. PUB. 6-10-2014. FILED 3-21-2013.  
 4,591,149. **COLIN COWIE (STANDARD CHARACTER)**. COLIN COWIE TRADEMARKS, LLC, (U.S. CLS. 100, 101 AND 102). SN 85-885,464. PUB. 6-10-2014. FILED 3-25-2013.  
 4,591,153 ( *See Class 9 for this trademark* ).  
 4,591,160. **CONFIDENT WOMEN (STANDARD CHARACTER)**. WOMEN ON A MISSION TO EARN COMMISSION, DBA WOAMTEC, (U.S. CLS. 100, 101 AND 102). SN 85-896,255. PUB. 6-10-2014. FILED 4-5-2013.  
 4,591,167. **ID LUBRICANTS (STANDARD CHARACTER)**. WESTRIDGE LABORATORIES, INC., (U.S. CLS. 100, 101 AND 102). SN 85-901,864. PUB. 6-10-2014. FILED 4-11-2013.  
 4,591,170 ( *See Class 9 for this trademark* ).  
 4,591,171. **ANIME CONJI (STANDARD CHARACTER)**. THE SOCIETY FOR THE PROMOTION OF JAPANESE ANIMATION, AKA SPJA, MULTIPLE CLASS, (INT. CLS. 35 AND 41), (U.S. CLS. 100, 101, 102 AND 107). SN 85-908,760. PUB. 6-10-2014. FILED 4-18-2013.  
 4,591,173 ( *See Class 9 for this trademark* ).  
 4,591,181. **WHITETAIL PROPERTIES (STANDARD CHARACTER)**. WHITETAIL PROPERTIES REAL ESTATE, LLC, MULTIPLE CLASS, (INT. CLS. 35 AND 41), (U.S. CLS. 100, 101, 102 AND 107). SN 85-916,891. PUB. 6-10-2014. FILED 4-28-2013.  
 4,591,183. **MY-STREETART (STANDARD CHARACTER)**. MY ART AND INNOVATION STUDIOS LLC, (U.S. CLS. 100, 101 AND 102). SN 85-918,953. PUB. 6-10-2014. FILED 4-30-2013.  
 4,591,187. **MASTER Z'S CUE CLUB 8 9 6 5 10 AND DESIGN**. MIDWEST RECREATIONAL PRODUCTS, INC., (U.S. CLS. 100, 101 AND 102). SN 85-922,717. PUB. 6-10-2014. FILED 5-3-2013.  
 4,591,188. **NATIONAL ALLIANCE ON MENTAL ILLNESS (STANDARD CHARACTER)**. NAMI, DBA NATIONAL ALLIANCE ON MENTAL ILLNESS, (U.S. CLS. 100, 101 AND 102). SN 85-922,962. PUB. 6-10-2014. FILED 5-3-2013.  
 4,591,201 ( *See Class 14 for this trademark* ).  
 4,591,202 ( *See Class 14 for this trademark* ).  
 4,591,204 ( *See Class 14 for this trademark* ).  
 4,591,205 ( *See Class 14 for this trademark* ).  
 4,591,208 ( *See Class 9 for this trademark* ).  
 4,591,218. **SIBASPORTS (STANDARD CHARACTER)**. SIBA, LLC, DBA SIBA SPORTS, (U.S. CLS. 100, 101 AND 102). SN 85-941,569. PUB. 6-10-2014. FILED 5-24-2013.  
 4,591,219. **AA4S (STANDARD CHARACTER)**. ANTEA USA, INC., (U.S. CLS. 100, 101 AND 102). SN 85-942,187. PUB. 6-10-2014. FILED 5-24-2013.  
 4,591,222. **FLYING BROS (STYLIZED)**. MANTESSOFILHO, FLAVIO, DBA FLYING BROS, (U.S. CLS. 100, 101 AND 102). SN 85-942,913. PUB. 6-10-2014. FILED 5-26-2013.  
 4,591,225. **PHYSICIANSFAST PROTEIN SPARING MODIFIED FAST AND DESIGN**. PHYSICIANS WEIGHT LOSS CENTERS OF AMERICA, INC., (U.S. CLS. 100, 101 AND 102). SN 85-943,841. PUB. 6-10-2014. FILED 5-28-2013.  
 4,591,233. **PRIORITY PAYMENT SYSTEMS AND DESIGN**. PRIORITY PAYMENT SYSTEMS LLC, MULTIPLE CLASS, (INT. CLS. 35, 36 AND 45), (U.S. CLS. 100, 101 AND 102). SN 85-946,549. PUB. 6-10-2014. FILED 5-30-2013.  
 4,591,242. **ARTOURA (STANDARD CHARACTER)**. ARTOURA, INC, MULTIPLE CLASS, (INT. CLS. 35, 41 AND 42), (U.S. CLS. 100, 101, 102 AND 107). SN 85-949,168. PUB. 6-10-2014. FILED 6-3-2013.  
 4,591,248. **ST SUPERTEC (STYLIZED)**. SUPERTEC MACHINERY INC., (U.S. CLS. 100, 101 AND 102). SN 85-952,183. PUB. 6-10-2014. FILED 6-6-2013.  
 4,591,257. **OOPS OUTLET (STANDARD CHARACTER)**. WASHBURN & CO., (U.S. CLS. 100, 101 AND 102). SN 85-954,571. PUB. 6-10-2014. FILED 6-8-2013.  
 4,591,260. **CLIMAFY (STANDARD CHARACTER)**. CLIMAFY.COM, INC, MULTIPLE CLASS, (INT. CLS. 35, 41 AND 42), (U.S. CLS. 100, 101, 102 AND 107). SN 85-954,803. PUB. 6-10-2014. FILED 6-10-2013.  
 4,591,263. **UPWIND SOLUTIONS (STANDARD CHARACTER)**. UPWIND SOLUTIONS, INC., MULTIPLE CLASS, (INT. CLS. 35, 37, 40 AND 42), (U.S. CLS. 100, 101, 102, 103 AND 106). SN 85-956,521. PUB. 6-10-2014. FILED 6-11-2013.  
 4,591,268. **WIN LOCAL (STANDARD CHARACTER)**. MOBILE REAL ESTATE, LLC, (U.S. CLS. 100, 101 AND 102). SN 85-957,967. PUB. 6-10-2014. FILED 6-12-2013.  
 4,591,270. **ISPORTSMEDIA (STANDARD CHARACTER)**. ISPORTSMEDIA, LLC, MULTIPLE CLASS, (INT. CLS. 35 AND 42), (U.S. CLS. 100, 101 AND 102). SN 85-958,247. PUB. 6-10-2014. FILED 6-12-2013.  
 4,591,271. **RADDA WAKE (STANDARD CHARACTER)**. RILEE, JESSICA JANE, (U.S. CLS. 100, 101 AND 102). SN 85-958,699. PUB. 6-10-2014. FILED 6-13-2013.  
 4,591,277. **PLANETARY (STANDARD CHARACTER)**. PLANETARY GROUP, LLC, THE, DBA THE PLANETARY GROUP, MULTIPLE CLASS, (INT. CLS. 35, 41 AND 42), (U.S. CLS. 100, 101, 102 AND 107). SN 85-959,856. PUB. 6-10-2014. FILED 6-14-2013.  
 4,591,285. **PTG PENSIONPRO (STANDARD CHARACTER)**. PENSION TECHNOLOGY GROUP, INC., MULTIPLE CLASS, (INT. CLS. 35 AND 42), (U.S. CLS. 100, 101 AND 102). SN 85-962,156. PUB. 6-10-2014. FILED 6-17-2013.  
 4,591,287. **TRIBE CALLED CURL (STANDARD CHARACTER)**. DAWSON, IMANI, MULTIPLE CLASS, (INT. CLS. 35 AND 41), (U.S. CLS. 100, 101, 102 AND 107). SN 85-962,322. PUB. 6-10-2014. FILED 6-18-2013.  
 4,591,297 ( *See Class 14 for this trademark* ).  
 4,591,306. **FAIR TRADE USA (STANDARD CHARACTER)**. TRANSFAIR USA, DBA FAIR TRADE USA, MULTIPLE CLASS, (INT. CLS. 35, 36, 41 AND 42), (U.S. CLS. 100, 101, 102 AND 107). SN 85-966,224. PUB. 6-10-2014. FILED 6-21-2013.  
 4,591,307. **FAIR TRADE USA AND DESIGN**. TRANSFAIR USA, DBA FAIR TRADE USA, MULTIPLE CLASS, (INT. CLS. 35, 36, 41 AND 42), (U.S. CLS. 100, 101, 102 AND 107). SN 85-966,231. PUB. 6-10-2014. FILED 6-21-2013.  
 4,591,310. **ARCH ADVANTAGE (STANDARD CHARACTER)**. ARCHADVANTAGE, LLC, MULTIPLE CLASS, (INT. CLS. 35 AND 36), (U.S. CLS. 100, 101 AND 102). SN 85-966,462. PUB. 6-10-2014. FILED 6-21-2013.  
 4,591,312 ( *See Class 9 for this trademark* ).  
 4,591,322. **GOMOBL (STANDARD CHARACTER)**. GO WIRELESS, INC., (U.S. CLS. 100, 101 AND 102). SN 85-967,876. PUB. 6-10-2014. FILED 6-24-2013.  
 4,591,324. **NATIONAL CENTER FOR ENERGY MANAGEMENT AND BUILDING TECHNOLOGIES (STANDARD CHARACTER)**. TRUSTEES OF THE NATIONAL ENERGY MANAGEMENT INSTITUTE COMMITTEE ("NEMIC") AS



- A JOINTLY ADMINISTERED TAFT-HARTLEY LABOR MANAGEMENT TRUST ESTABLISHED BY THE SHEET METAL WORKERS INTERNATIONAL ASSOCIATION ("SMWIA") AND THE SHEET METAL AIR CONDITIONING CONTRACTORS NATIONAL ASSOCIATION ("SMACNA"), (U.S. CLS. 100, 101 AND 102). SN 85-968,011. PUB. 6-10-2014. FILED 6-24-2013.
- 4,591,331. **FISHUSA.COM (STANDARD CHARACTER)**. FISHUSA, INC., (U.S. CLS. 100, 101 AND 102). SN 85-969,072. PUB. 6-10-2014. FILED 6-25-2013.
- 4,591,335. **SOUTH CAROLINA OVARIAN CANCER FOUNDATION AND DESIGN**. SOUTH CAROLINA OVARIAN CANCER FOUNDATION, (U.S. CLS. 100, 101 AND 102). SN 85-969,435. PUB. 6-10-2014. FILED 6-25-2013.
- 4,591,338. **STAR OF GEORGIA FOUNDATION CHAMPIONS FOR THE UNDERPRIVILEGED AND DESIGN**. STAR OF GEORGIA FOUNDATION, INC. DBA STAR OF GEORGIA FOUNDATION, (U.S. CLS. 100, 101 AND 102). SN 85-969,961. PUB. 6-10-2014. FILED 6-25-2013.
- 4,591,346. **OPPORTUNITY (STANDARD CHARACTER)**. OPPORTUNITY DETROIT LLC, (U.S. CLS. 100, 101 AND 102). SN 85-970,818. PUB. 6-10-2014. FILED 6-26-2013.
- 4,591,363. **FOLLOWME (STANDARD CHARACTER)**. SINGLE TOUCH INTERACTIVE, INC., (U.S. CLS. 100, 101 AND 102). SN 85-972,802. PUB. 6-10-2014. FILED 6-28-2013.
- 4,591,369. **PIGGYBACK LETTERPRESS (STANDARD CHARACTER)**. ALDINE, INC., MULTIPLE CLASS, (INT. CLS. 35 AND 40), (U.S. CLS. 100, 101, 102, 103 AND 106). SN 85-973,136. PUB. 6-10-2014. FILED 6-28-2013.
- 4,591,371. **SCRIPTED (STANDARD CHARACTER)**. SCRIPTED, INC., MULTIPLE CLASS, (INT. CLS. 35 AND 41), (U.S. CLS. 100, 101, 102 AND 107). SN 85-973,262. PUB. 6-10-2014. FILED 6-28-2013.
- 4,591,375. **GREEN TOPIA AND DESIGN**. FRIENDS OF THE GARDENAERIAL, INC., MULTIPLE CLASS, (INT. CLS. 35, 36 AND 41), (U.S. CLS. 100, 101, 102 AND 107). SN 85-973,993. PUB. 6-10-2014. FILED 7-1-2013.
- 4,591,381. **STEM CORPS (STANDARD CHARACTER)**. VICTORY MEDIA, INC., DBA VICTORY TECH, (U.S. CLS. 100, 101 AND 102). SN 85-974,718. PUB. 6-10-2014. FILED 7-1-2013.
- 4,591,388 ( *See Class 9 for this trademark*).
- 4,591,390. **SAFELITE ADVANTAGE AND DESIGN**. SAFELITE GROUP, INC., MULTIPLE CLASS, (INT. CLS. 35 AND 37), (U.S. CLS. 100, 101, 102, 103 AND 106). SN 85-981,645. PUB. 6-10-2014. FILED 12-27-2012.
- 4,591,391. **D-TOWN (STANDARD CHARACTER)**. DETROIT BLACK COMMUNITY FOOD SECURITY NETWORK, AKA DBCFSN, MULTIPLE CLASS, (INT. CLS. 35 AND 41), (U.S. CLS. 100, 101, 102 AND 107). SN 85-981,746. PUB. 6-10-2014. FILED 12-6-2012.
- 4,591,392. **AMOVEO (STANDARD CHARACTER)**. AMOVEO PRODUCTIONS, INC., (U.S. CLS. 100, 101 AND 102). SN 85-982,075. PUB. 7-2-2013. FILED 2-7-2013.
- 4,591,401. **P2I BABY AND DESIGN**. THE FORUM, (U.S. CLS. 100, 101 AND 102). SN 86-000,470. PUB. 6-10-2014. FILED 7-2-2013.
- 4,591,402. **P2I (STANDARD CHARACTER)**. THE FORUM, (U.S. CLS. 100, 101 AND 102). SN 86-000,479. PUB. 6-10-2014. FILED 7-2-2013.
- 4,591,408. **NEW MILLENNIUM RECORDS (STANDARD CHARACTER)**. NEW MILLENNIUM RECORDS, (U.S. CLS. 100, 101 AND 102). SN 86-001,283. PUB. 6-10-2014. FILED 7-2-2013.
- 4,591,413. **MY EMPOWERED LIFESTYLE (STANDARD CHARACTER)**. DAoust, CHRISTIAN, (U.S. CLS. 100, 101 AND 102). SN 86-001,466. PUB. 6-10-2014. FILED 7-3-2013.
- 4,591,421. **ASYMMETRIC TECHNOLOGIES (STANDARD CHARACTER)**. ASYMMETRIC TECHNOLOGIES, LLC, (U.S. CLS. 100, 101 AND 102). SN 86-002,105. PUB. 6-10-2014. FILED 7-3-2013.
- 4,591,423. **ASYMMETRIC TECHNOLOGIES AND DESIGN**. ASYMMETRIC TECHNOLOGIES, LLC, (U.S. CLS. 100, 101 AND 102). SN 86-002,114. PUB. 6-10-2014. FILED 7-3-2013.
- 4,591,426. **PLAWZA (STANDARD CHARACTER)**. EFTEKHARI, AFSHIN, (U.S. CLS. 100, 101 AND 102). SN 86-002,412. PUB. 6-10-2014. FILED 7-3-2013.
- 4,591,435. **ECI HEALTHCARE PARTNERS (STANDARD CHARACTER)**. ECI HEALTHCARE PARTNERS CORP., MULTIPLE CLASS, (INT. CLS. 35 AND 44), (U.S. CLS. 100, 101 AND 102). SN 86-003,300. PUB. 6-10-2014. FILED 7-5-2013.
- 4,591,436. **ECI HEALTHCARE PARTNERS AND DESIGN**. ECI HEALTHCARE PARTNERS CORP., MULTIPLE CLASS, (INT. CLS. 35 AND 44), (U.S. CLS. 100, 101 AND 102). SN 86-003,312. PUB. 6-10-2014. FILED 7-5-2013.
- 4,591,437. **HEALTHCARE WITH PEOPLE IN MIND (STANDARD CHARACTER)**. ECI HEALTHCARE PARTNERS CORP., MULTIPLE CLASS, (INT. CLS. 35 AND 44), (U.S. CLS. 100, 101 AND 102). SN 86-003,317. PUB. 6-10-2014. FILED 7-5-2013.
- 4,591,438. **S4G (STANDARD CHARACTER)**. ALLEN PROFESSIONAL GRAPHICS GROUP, LLC, DBA S4G, (U.S. CLS. 100, 101 AND 102). SN 86-003,351. PUB. 6-10-2014. FILED 7-5-2013.
- 4,591,441 ( *See Class 16 for this trademark*).
- 4,591,443. **EDTECHTEACHER LEADING CHANGE IN CHANGING TIMES AND DESIGN**. EDTECHTEACHER, INC., MULTIPLE CLASS, (INT. CLS. 35 AND 41), (U.S. CLS. 100, 101, 102 AND 107). SN 86-004,004. PUB. 6-10-2014. FILED 7-8-2013.
- 4,591,449. **AMERICAN COLLEGE OF BOARD CERTIFIED ATTORNEYS ACBCA (STANDARD CHARACTER)**. BROOKS, GARY LEON, DBA AMERICAN COLLEGE OF BOARD CERTIFIED ATTORNEYS, AND BROOKS, DEBRA ANN, DBA AMERICAN COLLEGE OF BOARD CERTIFIED ATTORNEYS, (U.S. CLS. 100, 101 AND 102). SN 86-004,768. PUB. 6-10-2014. FILED 7-8-2013.
- 4,591,452. **DBX (STANDARD CHARACTER)**. DROPBOX, INC., (U.S. CLS. 100, 101 AND 102). SN 86-005,190. PUB. 6-10-2014. FILED 7-9-2013.
- 4,591,457. **OPTION ONE ENERGY AND DESIGN**. OPTION ONE ENERGY, LLC., (U.S. CLS. 100, 101 AND 102). SN 86-005,603. PUB. 6-10-2014. FILED 7-9-2013.
- 4,591,461 ( *See Class 16 for this trademark*).
- 4,591,469 ( *See Class 14 for this trademark*).
- 4,591,470. **CPR CONTINGENCY PLANNING AND RECOVERY AND DESIGN**. CRI SOLUTIONS, INC., MULTIPLE CLASS, (INT. CLS. 35 AND 42), (U.S. CLS. 100, 101 AND 102). SN 86-007,882. PUB. 6-10-2014. FILED 7-11-2013.
- 4,591,473. **RAPID CHOICE (STANDARD CHARACTER)**. LIEBERMAN RESEARCH WORLDWIDE, LLC, (U.S. CLS. 100, 101 AND 102). SN 86-008,495. PUB. 6-10-2014. FILED 7-12-2013.
- 4,591,477. **KARMA CANDY (STANDARD CHARACTER)**. KARMA CANDY INC., (U.S. CLS. 100, 101 AND 102). SN 86-009,461. PUB. 6-10-2014. FILED 7-12-2013.
- 4,591,479. **PIONEERING THE DELIVERY OF CARE (STANDARD CHARACTER)**. ENVISION HEALTHCARE CORPORATION, (U.S. CLS. 100, 101 AND 102). SN 86-010,081. PUB. 6-10-2014. FILED 7-15-2013.
- 4,591,486. **RAD VINTAGE (STANDARD CHARACTER)**. GEYMAN, RONALD, (U.S. CLS. 100, 101 AND 102). SN 86-010,486. PUB. 6-10-2014. FILED 7-15-2013.
- 4,591,497. **ACTION GROUP STAFFING AND DESIGN**. DRAKE NELSON LLC, (U.S. CLS. 100, 101 AND 102). SN 86-011,687. PUB. 6-10-2014. FILED 7-16-2013.
- 4,591,507. **INSTACARE LIMITED WARRANTY AND DESIGN**. INSTA-CREDIT AUTO MART, INC., MULTIPLE CLASS, (INT. CLS. 35 AND 36), (U.S. CLS. 100, 101 AND 102). SN 86-012,760. PUB. 6-10-2014. FILED 7-17-2013.
- 4,591,511. **COMPLIANCE GUARDIAN (STANDARD CHARACTER)**. AMERICAN ASSOCIATED DRUGGISTS, INC., DBA UNITED DRUGS, MULTIPLE CLASS, (INT. CLS. 35 AND 45), (U.S. CLS. 100, 101 AND 102). SN 86-013,756. PUB. 6-10-2014. FILED 7-18-2013.
- 4,591,514. **WE WILL NEVER FORGET (STANDARD CHARACTER)**. JEREMY WAYNE SOLES, (U.S. CLS. 100, 101 AND 102). SN 86-014,277. PUB. 6-10-2014. FILED 7-18-2013.
- 4,591,515. **NEW YORK EARLY MUSIC CELEBRATION (STANDARD CHARACTER)**. EARLY MUSIC FOUNDATION, INC., (U.S. CLS. 100, 101 AND 102). SN 86-014,455. PUB. 6-10-2014. FILED 7-18-2013.
- 4,591,518. **POINT OF SALE CORNER (STANDARD CHARACTER)**. KIELY, SHAUN, (U.S. CLS. 100, 101 AND 102). SN 86-015,840. PUB. 6-10-2014. FILED 7-22-2013.

- 4,591,523 ( *See Class 30 for this trademark*).
- 4,591,527 ( *See Class 32 for this trademark*).
- 4,591,528. **FISHUSA.COM AND DESIGN**. FISHUSA, INC., (U.S. CLS. 100, 101 AND 102). SN 86-018,415. PUB. 6-10-2014. FILED 7-24-2013.
- 4,591,554 ( *See Class 32 for this trademark*).
- 4,591,556. **VESPANOMICS (STANDARD CHARACTER)**. PIAGGIO & C. S.P.A., (U.S. CLS. 100, 101 AND 102). SN 86-027,168. PUB. 6-10-2014. FILED 8-2-2013.
- 4,591,558. **C CAPACITY TRUCKS AND DESIGN**. CAPACITY OF TEXAS, INC., DBA CAPACITY TRUCKS, INC., MULTIPLE CLASS, (INT. CLS. 35 AND 40), (U.S. CLS. 100, 101, 102, 103 AND 106). SN 86-027,598. PUB. 6-10-2014. FILED 8-2-2013.
- 4,591,584. **RI AND DESIGN**. EXIGEN SERVICES, LTD., (U.S. CLS. 100, 101 AND 102). SN 86-033,912. PUB. 12-31-2013. FILED 8-9-2013.
- 4,591,611. **MISCELLANEOUS DESIGN**. ENVISION HEALTHCARE CORPORATION, (U.S. CLS. 100, 101 AND 102). SN 86-043,410. PUB. 6-10-2014. FILED 8-20-2013.
- 4,591,627. **TEXTMYBRAIN (STANDARD CHARACTER)**. EDGEWORKS CORP., (U.S. CLS. 100, 101 AND 102). SN 86-047,261. PUB. 6-10-2014. FILED 8-25-2013.
- 4,591,632. **RADAR DIGITAL (STANDARD CHARACTER)**. MORELAND-PEARCE, KENNETH, DBA RADAR DIGITAL, (U.S. CLS. 100, 101 AND 102). SN 86-049,689. PUB. 6-10-2014. FILED 8-27-2013.
- 4,591,640. **T TRENDY TOTS AND DESIGN**. TRENDY TOTS, INC., (U.S. CLS. 100, 101 AND 102). SN 86-051,311. PUB. 6-10-2014. FILED 8-29-2013.
- 4,591,641. **SELL YOUR CAR HERE.NET AND DESIGN**. BENISTI, RICHARD, (U.S. CLS. 100, 101 AND 102). SN 86-051,432. PUB. 6-10-2014. FILED 8-29-2013.
- 4,591,643 ( *See Class 3 for this trademark*).
- 4,591,645. **SAVINGS FOR THOSE WHO SERVE (STANDARD CHARACTER)**. GOVX, INC., MULTIPLE CLASS, (INT. CLS. 35 AND 41), (U.S. CLS. 100, 101, 102 AND 107). SN 86-051,607. PUB. 6-10-2014. FILED 8-29-2013.
- 4,591,656. **NEW ORLEANS INTERNATIONAL BEER FESTIVAL AND DESIGN**. RED MOUNTAIN ENTERTAINMENT, (U.S. CLS. 100, 101 AND 102). SN 86-054,704. PUB. 6-10-2014. FILED 9-3-2013.
- 4,591,657. **LIFETIME WINDOWS AND SIDING AND DESIGN**. LIFETIME WINDOWS AND SIDING, INC., MULTIPLE CLASS, (INT. CLS. 35 AND 37), (U.S. CLS. 100, 101, 102, 103 AND 106). SN 86-054,870. PUB. 3-4-2014. FILED 9-3-2013.
- 4,591,663. **AG ADS (STANDARD CHARACTER)**. BIG RIG NETWORK, LLC, (U.S. CLS. 100, 101 AND 102). SN 86-058,934. PUB. 6-10-2014. FILED 9-9-2013.
- 4,591,666. **MAJOR SURPLUS (STANDARD CHARACTER)**. MAJOR SURPLUS AND SURVIVAL, (U.S. CLS. 100, 101 AND 102). SN 86-060,702. PUB. 6-10-2014. FILED 9-10-2013.
- 4,591,672. **THE BULK-PRICED FOOD SHOPPE (STANDARD CHARACTER)**. THE BULK-PRICED FOOD SHOPPE, LLC, (U.S. CLS. 100, 101 AND 102). SN 86-061,660. PUB. 6-10-2014. FILED 9-11-2013.
- 4,591,674. **PRICELINE SPONSORED LISTINGS (STANDARD CHARACTER)**. PRICELINE.COM LLC, MULTIPLE CLASS, (INT. CLS. 35 AND 42), (U.S. CLS. 100, 101 AND 102). SN 86-062,510. PUB. 6-10-2014. FILED 9-12-2013.
- 4,591,680. **CVS PHARMACY (STYLIZED)**. CVS PHARMACY, INC., (U.S. CLS. 100, 101 AND 102). SN 86-064,266. PUB. 6-10-2014. FILED 9-13-2013.
- 4,591,688. **AIS AUTO INSURANCE SPECIALISTS AGENCY (STANDARD CHARACTER)**. AUTO INSURANCE SPECIALISTS LLC, (U.S. CLS. 100, 101 AND 102). SN 86-067,064. PUB. 6-10-2014. FILED 9-17-2013.
- 4,591,710. **FLOATING MOTION (STANDARD CHARACTER)**. CHRISTOPHER LEIGH STUDIOS, LLC, (U.S. CLS. 100, 101 AND 102). SN 86-076,389. PUB. 6-10-2014. FILED 9-27-2013.
- 4,591,718. **PAUL'S PEACE A MHAP FOR LIFE'S JOURNEY FOUNDATION FOR MENTAL HEALTH AWARENESS & PREPAREDNESS ROUTE 6 HIGHWAY 11 ROUTE 96 HIGHWAY 16 AND DESIGN**. PAUL'S PEACE, INC., (U.S. CLS. 100, 101 AND 102). SN 86-078,063. PUB. 6-10-2014. FILED 9-30-2013.
- 4,591,724. **BRIDGER INSIGHT (STANDARD CHARACTER)**. LEXISNEXIS RISK SOLUTIONS INC., MULTIPLE CLASS, (INT. CLS. 35, 36 AND 45), (U.S. CLS. 100, 101 AND 102). SN 86-079,245. PUB. 6-10-2014. FILED 10-1-2013.
- 4,591,725. **WEDOCOWS! (STANDARD CHARACTER)**. LEEDSTONE, LLC, (U.S. CLS. 100, 101 AND 102). SN 86-079,855. PUB. 6-10-2014. FILED 10-1-2013.
- 4,591,726. **4 AND DESIGN**. 4INTERNET, LLC, (U.S. CLS. 100, 101 AND 102). SN 86-080,391. PUB. 6-10-2014. FILED 10-2-2013.
- 4,591,730 ( *See Class 9 for this trademark*).
- 4,591,741. **CLIENT CENTRIC COMMUNICATIONS AND DESIGN**. TENENZ, INC., MULTIPLE CLASS, (INT. CLS. 35, 41 AND 42), (U.S. CLS. 100, 101, 102 AND 107). SN 86-082,357. PUB. 6-10-2014. FILED 10-3-2013.
- 4,591,745. **UGAM SOLUTIONS (STANDARD CHARACTER)**. UGAM SOLUTIONS PRIVATE LIMITED, (U.S. CLS. 100, 101 AND 102). SN 86-082,960. PUB. 6-10-2014. FILED 10-4-2013.
- 4,591,746 ( *See Class 21 for this trademark*).
- 4,591,749. **SKY TRAMPOLINE ARENA AND DESIGN**. SKY-WALKER HAVEN LLC, DBA SKY TRAMPOLINE ARENA, MULTIPLE CLASS, (INT. CLS. 35 AND 41), (U.S. CLS. 100, 101, 102 AND 107). SN 86-084,769. PUB. 3-4-2014. FILED 10-7-2013.
- 4,591,753. **PROJECT CLEAR (STANDARD CHARACTER)**. THE METROPOLITAN ST. LOUIS SEWER DISTRICT, MULTIPLE CLASS, (INT. CLS. 35 AND 44), (U.S. CLS. 100, 101 AND 102). SN 86-086,859. PUB. 6-10-2014. FILED 10-9-2013.
- 4,591,754. **PROJECT CLEAR GET THE RAIN OUT WITH MSD AND DESIGN**. THE METROPOLITAN ST. LOUIS SEWER DISTRICT, (U.S. CLS. 100, 101 AND 102). SN 86-086,900. PUB. 6-10-2014. FILED 10-9-2013.
- 4,591,762. **LABOKAY (STANDARD CHARACTER)**. FOREST CAPITAL PARTNERS, LLC, MULTIPLE CLASS, (INT. CLS. 35 AND 36), (U.S. CLS. 100, 101 AND 102). SN 86-089,884. PUB. 6-10-2014. FILED 10-11-2013.
- 4,591,763. **LABOKAY NATURAL RESOURCES (STANDARD CHARACTER)**. FOREST CAPITAL PARTNERS, LLC, MULTIPLE CLASS, (INT. CLS. 35 AND 36), (U.S. CLS. 100, 101 AND 102). SN 86-089,894. PUB. 6-10-2014. FILED 10-11-2013.
- 4,591,764. **LABOKAY NATURAL RESOURCES AND DESIGN**. FOREST CAPITAL PARTNERS, LLC, MULTIPLE CLASS, (INT. CLS. 35 AND 36), (U.S. CLS. 100, 101 AND 102). SN 86-089,906. PUB. 6-10-2014. FILED 10-11-2013.
- 4,591,772. **MISCELLANEOUS DESIGN**. LEG AVENUE, INC., (U.S. CLS. 100, 101 AND 102). SN 86-093,473. PUB. 6-10-2014. FILED 10-16-2013.
- 4,591,775. **ONYX PAYMENTS (STANDARD CHARACTER)**. PEGASUS BUSINESS INTELLIGENCE, LP, MULTIPLE CLASS, (INT. CLS. 35 AND 36), (U.S. CLS. 100, 101 AND 102). SN 86-095,641. PUB. 6-10-2014. FILED 10-18-2013.
- 4,591,780. **CLINICAL LAB EXPO (STANDARD CHARACTER)**. AMERICAN ASSOCIATION FOR CLINICAL CHEMISTRY, INC., (U.S. CLS. 100, 101 AND 102). SN 86-096,737. PUB. 6-10-2014. FILED 10-21-2013.
- 4,591,790. **PET PRODUCTS 4LESS (STANDARD CHARACTER)**. WEB RIVER GROUP, INC., DBA WEB RIVER GROUP, (U.S. CLS. 100, 101 AND 102). SN 86-098,692. PUB. 6-10-2014. FILED 10-22-2013.
- 4,591,793. **RICKY'S NYC LOOKING GOOD! FEELING GOOD! PUP-UP SHOP AND DESIGN**. RICKY'S TRADEMARK HOLDINGS, INC., (U.S. CLS. 100, 101 AND 102). SN 86-099,301. PUB. 6-10-2014. FILED 10-23-2013.
- 4,591,797. **LOVE YOU INC. (STANDARD CHARACTER)**. KIRKLAND, REAGEN C., (U.S. CLS. 100, 101 AND 102). SN 86-099,856. PUB. 6-10-2014. FILED 10-23-2013.
- 4,591,822. **YTEL (STANDARD CHARACTER)**. YTEL, INC., MULTIPLE CLASS, (INT. CLS. 35, 38 AND 42), (U.S. CLS. 100, 101, 102 AND 104). SN 86-106,062. PUB. 6-10-2014. FILED 10-30-2013.
- 4,591,824. **ONE CENT FLIGHTS AND DESIGN**. ONE CENT TECHNOLOGIES HOLDINGS PTY LTD, MULTIPLE CLASS, (INT. CLS. 35 AND 39), (U.S. CLS. 100, 101, 102 AND 105). SN 86-106,384. PUB. 6-10-2014. FILED 10-31-2013.
- 4,591,825. **GALCO AND DESIGN**. GALCO INDUSTRIAL ELECTRONICS, MULTIPLE CLASS, (INT. CLS. 35, 37 AND 42), (U.S. CLS. 100, 101, 102, 103 AND 106). SN 86-

- 106,649. PUB. 6-10-2014. FILED 10-31-2013.
- 4,591,827. **MISCELLANEOUS DESIGN**. REMY COINTREAU, (U.S. CLS. 100, 101 AND 102). SN 86-106,924. PUB. 6-10-2014. FILED 10-31-2013.
- 4,591,839. **ONTHESPOTSALE AND DESIGN**. UNIFIED CELLULAR, INC., (U.S. CLS. 100, 101 AND 102). SN 86-109,234. PUB. 6-10-2014. FILED 11-4-2013.
- 4,591,843. **BEHOOVEME BE MORE THAN A RÉSUMÉ (STANDARD CHARACTER)**. YOU B-YOU, DBA BEHOOVEME, (U.S. CLS. 100, 101 AND 102). SN 86-110,245. PUB. 6-10-2014. FILED 11-5-2013.
- 4,591,845. **EPBZR (STYLIZED)**. EPBZR, LLC, (U.S. CLS. 100, 101 AND 102). SN 86-110,337. PUB. 6-10-2014. FILED 11-5-2013.
- 4,591,848. **PAR HAITI POUR HAITI (STANDARD CHARACTER)**. HAITI ORIGINALE LLC, (U.S. CLS. 100, 101 AND 102). SN 86-111,637. PUB. 6-10-2014. FILED 11-6-2013.
- 4,591,859. **PHARMCARE (STANDARD CHARACTER)**. BARNEY KENT ABBOTT, (U.S. CLS. 100, 101 AND 102). SN 86-114,088. PUB. 6-10-2014. FILED 11-8-2013.
- 4,591,864. **NATIONAL ASSOCIATION OF PEOPLE WITH AIDS (STANDARD CHARACTER)**. COMMUNITY EDUCATION GROUP, INC., MULTIPLE CLASS, (INT. CLS. 35 AND 41), (U.S. CLS. 100, 101, 102 AND 107). SN 86-114,722. PUB. 6-10-2014. FILED 11-10-2013.
- 4,591,877. **BEOND POWERED BY BUZZTIME AND DESIGN**. NTN BUZZTIME, INC., MULTIPLE CLASS, (INT. CLS. 35 AND 41), (U.S. CLS. 100, 101, 102 AND 107). SN 86-116,776. PUB. 6-10-2014. FILED 11-12-2013.
- 4,591,879. **DOOBLE (STANDARD CHARACTER)**. DOOBLE INC., (U.S. CLS. 100, 101 AND 102). SN 86-117,011. PUB. 6-10-2014. FILED 11-12-2013.
- 4,591,880. **MAKERBOT ACADEMY (STANDARD CHARACTER)**. MAKERBOT INDUSTRIES, LLC, MULTIPLE CLASS, (INT. CLS. 35 AND 36), (U.S. CLS. 100, 101 AND 102). SN 86-117,385. PUB. 6-10-2014. FILED 11-13-2013.
- 4,591,885. **JAC ASSOCIATES ENERGY EFFICIENT LIGHTING AND ILLUMINATION AND DESIGN**. JAC ASSOCIATES, (U.S. CLS. 100, 101 AND 102). SN 86-118,181. PUB. 6-10-2014. FILED 11-13-2013.
- 4,591,891. **BREAK THE STIGMA (STANDARD CHARACTER)**. FOUNDATIONS RECOVERY NETWORK, LLC, (U.S. CLS. 100, 101 AND 102). SN 86-119,324. PUB. 6-10-2014. FILED 11-14-2013.
- 4,591,896. **COMPUTER UPGRADE KING AND DESIGN**. COMPUTER UPGRADE KING LLC, (U.S. CLS. 100, 101 AND 102). SN 86-120,387. PUB. 6-10-2014. FILED 11-15-2013.
- 4,591,899. **BEAUTY BREAKTHROUGHS (STANDARD CHARACTER)**. ADVANCE MAGAZINE PUBLISHERS INC., MULTIPLE CLASS, (INT. CLS. 35 AND 44), (U.S. CLS. 100, 101 AND 102). SN 86-121,126. PUB. 6-10-2014. FILED 11-18-2013.
- 4,591,903 ( *See Class 16 for this trademark*).
- 4,591,915. **AUTISM FRIENDLY LOCATIONS WE'RE A OK AND DESIGN**. AUTISM CENTER OF TULSA, INC., (U.S. CLS. 100, 101 AND 102). SN 86-123,752. PUB. 6-10-2014. FILED 11-20-2013.
- 4,591,925. **WORKSPACEDESIGN AND DESIGN**. AMY SCHMIDT HAMILTON, (U.S. CLS. 100, 101 AND 102). SN 86-125,590. PUB. 6-10-2014. FILED 11-21-2013.
- 4,591,927. **MACNEILL GROUP (STANDARD CHARACTER)**. FOCUS HOLDINGS, LLC, MULTIPLE CLASS, (INT. CLS. 35 AND 36), (U.S. CLS. 100, 101 AND 102). SN 86-125,948. PUB. 6-10-2014. FILED 11-21-2013.
- 4,591,935. **FOUNDATION DIGITAL (STANDARD CHARACTER)**. FOUNDATION DIGITAL, MULTIPLE CLASS, (INT. CLS. 35 AND 42), (U.S. CLS. 100, 101 AND 102). SN 86-126,818. PUB. 6-10-2014. FILED 11-22-2013.
- 4,591,944. **TEAM FOOD CHAIN (STANDARD CHARACTER)**. KAMEN, CHAD, (U.S. CLS. 100, 101 AND 102). SN 86-128,022. PUB. 6-10-2014. FILED 11-25-2013.
- 4,591,945. **NEW ENGLAND FARMS (STANDARD CHARACTER)**. NEW ENGLAND FARMS, INC., (U.S. CLS. 100, 101 AND 102). SN 86-128,104. PUB. 6-10-2014. FILED 11-25-2013.
- 4,591,954. **ALLEN GLOBAL COMPANIES (STANDARD CHARACTER)**. ALLEN GLOBAL, LLC, (U.S. CLS. 100, 101 AND 102). SN 86-129,150. PUB. 6-10-2014. FILED 11-26-2013.
- 4,591,956. **DIAMOND WIRELESS (STANDARD CHARACTER)**. DIAMOND WIRELESS, LLC, MULTIPLE CLASS, (INT. CLS. 35, 36 AND 38), (U.S. CLS. 100, 101, 102 AND 104). SN 86-129,284. PUB. 6-10-2014. FILED 11-26-2013.
- 4,591,959 ( *See Class 25 for this trademark*).
- 4,591,962. **SPIES IN BLACK TIES (STANDARD CHARACTER)**. ASSOCIATION OF FORMER INTELLIGENCE OFFICERS, INC., MULTIPLE CLASS, (INT. CLS. 35 AND 41), (U.S. CLS. 100, 101, 102 AND 107). SN 86-129,791. PUB. 6-10-2014. FILED 11-26-2013.
- 4,591,968. **PAKORE AND DESIGN**. PAKORE LLC, MULTIPLE CLASS, (INT. CLS. 35 AND 42), (U.S. CLS. 100, 101 AND 102). SN 86-130,956. PUB. 6-10-2014. FILED 11-27-2013.
- 4,591,969. **NEW ENGLAND FARMS AND DESIGN**. NEW ENGLAND FARMS, INC., (U.S. CLS. 100, 101 AND 102). SN 86-131,077. PUB. 6-10-2014. FILED 11-27-2013.
- 4,591,978. **DEVRIGHT (STYLIZED)**. DEVRIGHT LLC, (U.S. CLS. 100, 101 AND 102). SN 86-132,206. PUB. 6-10-2014. FILED 12-1-2013.
- 4,591,984. **SK AND DESIGN**. SK HOLDINGS CO., LTD., (U.S. CLS. 100, 101 AND 102). SN 86-132,796. PUB. 6-10-2014. FILED 12-2-2013.
- 4,591,991. **BARGAIN HUNTERS (STANDARD CHARACTER)**. BARGAIN HUNTERS, INC., (U.S. CLS. 100, 101 AND 102). SN 86-133,653. PUB. 6-10-2014. FILED 12-3-2013.
- 4,591,995. **MCCLURE, BROWN & ASSOCIATES AND DESIGN**. MCCLURE, BROWN, & ASSOCIATES LLC, (U.S. CLS. 100, 101 AND 102). SN 86-134,407. PUB. 6-10-2014. FILED 12-4-2013.
- 4,592,003. **THE MONSTER CYCLE (STANDARD CHARACTER)**. MACNEAL, MICHAEL, MULTIPLE CLASS, (INT. CLS. 35 AND 41), (U.S. CLS. 100, 101, 102 AND 107). SN 86-135,994. PUB. 6-10-2014. FILED 12-5-2013.
- 4,592,005. **CONCORDIA (STANDARD CHARACTER)**. FRAC-TAL ANALYTICS, INC., (U.S. CLS. 100, 101 AND 102). SN 86-136,225. PUB. 6-10-2014. FILED 12-5-2013.
- 4,592,013. **AD ADMARKET & ADMARKET LIST AVO ADVERTISING AND FREE CLASSIFIEDS AND DESIGN**. AVO ADMARKET & ADMARKET LIST, INC., (U.S. CLS. 100, 101 AND 102). SN 86-137,510. PUB. 6-10-2014. FILED 12-6-2013.
- 4,592,014. **I AM A PROFESSIONAL. I AM LICENSED. (STANDARD CHARACTER)**. PROFESSIONAL BEAUTY ASSOCIATION, (U.S. CLS. 100, 101 AND 102). SN 86-137,526. PUB. 6-10-2014. FILED 12-6-2013.
- 4,592,032. **92101 CONDO GURU .COM AND DESIGN**. 92101 CONDO GURU INC., (U.S. CLS. 100, 101 AND 102). SN 86-139,527. PUB. 6-10-2014. FILED 12-10-2013.
- 4,592,037. **CARJOHNNY.COM AND DESIGN**. DEALERS ONLY, LLC, (U.S. CLS. 100, 101 AND 102). SN 86-140,914. PUB. 6-10-2014. FILED 12-11-2013.
- 4,592,038. **MOA MARYLAND OPTOMETRIC ASSOCIATION AND DESIGN**. MARYLAND OPTOMETRIC ASSOCIATION, MULTIPLE CLASS, (INT. CLS. 35, 41 AND 44), (U.S. CLS. 100, 101, 102 AND 107). SN 86-140,917. PUB. 6-10-2014. FILED 12-11-2013.
- 4,592,059. **U.S.-EGYPT BUSINESS COUNSEL AND DESIGN**. CHAMBER OF COMMERCE OF THE UNITED STATES OF AMERICA, (U.S. CLS. 100, 101 AND 102). SN 86-142,770. PUB. 6-10-2014. FILED 12-13-2013.
- 4,592,060. **BETTERWORLDBOOKS AND DESIGN**. QUMPUS, INC., (U.S. CLS. 100, 101 AND 102). SN 86-142,840. PUB. 6-10-2014. FILED 12-13-2013.
- 4,592,061. **SENVOL (STANDARD CHARACTER)**. SENVOL LLC, (U.S. CLS. 100, 101 AND 102). SN 86-143,010. PUB. 6-10-2014. FILED 12-13-2013.
- 4,592,062. **LEGAL SURE (STANDARD CHARACTER)**. LEGAL SURE, LLC, (U.S. CLS. 100, 101 AND 102). SN 86-143,048. PUB. 6-10-2014. FILED 12-13-2013.
- 4,592,065. **REACTION MANAGEMENT (STANDARD CHARACTER)**. REACTION MANAGEMENT, INC., AKA RMI, (U.S. CLS. 100, 101 AND 102). SN 86-143,311. PUB. 6-10-2014. FILED 12-13-2013.
- 4,592,066. **RESOLUTION HEALTH (STANDARD CHARACTER)**. RESOLUTION HEALTH, INC., MULTIPLE CLASS, (INT. CLS. 35, 39 AND 44), (U.S. CLS. 100, 101, 102 AND 105). SN 86-143,605. PUB. 6-10-2014. FILED 12-13-2013.
- 4,592,075. **RMI (STANDARD CHARACTER)**. REACTION

- MANAGEMENT, INC., AKA RMI, (U.S. CLS. 100, 101 AND 102). SN 86-144,517. PUB. 6-10-2014. FILED 12-16-2013.
- 4,592,084. **PCPARTPICKER (STANDARD CHARACTER)**. PCPARTPICKER, LLC, (U.S. CLS. 100, 101 AND 102). SN 86-146,591. PUB. 6-10-2014. FILED 12-17-2013.
- 4,592,085. **TOTALVANTAGE (STANDARD CHARACTER)**. WORKFLOWONE LLC, (U.S. CLS. 100, 101 AND 102). SN 86-146,708. PUB. 6-10-2014. FILED 12-18-2013.
- 4,592,088. **LIVEANSWER (STANDARD CHARACTER)**. LIVEANSWER, INC., (U.S. CLS. 100, 101 AND 102). SN 86-147,384. PUB. 6-10-2014. FILED 12-18-2013.
- 4,592,089. **LIVEANSWER AND DESIGN**. LIVEANSWER, INC., (U.S. CLS. 100, 101 AND 102). SN 86-147,515. PUB. 6-10-2014. FILED 12-18-2013.
- 4,592,101. **NADART (STANDARD CHARACTER)**. NATIONAL AUTOMOBILE DEALERS ASSOCIATION, MULTIPLE CLASS, (INT. CLS. 35 AND 36), (U.S. CLS. 100, 101 AND 102). SN 86-148,495. PUB. 6-10-2014. FILED 12-19-2013.
- 4,592,103. **SPRIZA (STANDARD CHARACTER)**. SPRIZA INC, MULTIPLE CLASS, (INT. CLS. 35 AND 42), (U.S. CLS. 100, 101 AND 102). SN 86-148,741. PUB. 6-10-2014. FILED 12-19-2013.
- 4,592,106. **VAPE HQ (STANDARD CHARACTER)**. THE VAPE HEADQUARTERS, (U.S. CLS. 100, 101 AND 102). SN 86-149,545. PUB. 6-10-2014. FILED 12-20-2013.
- 4,592,107. **BROADWAYBOX (STANDARD CHARACTER)**. BROADWAYBOX, INC., MULTIPLE CLASS, (INT. CLS. 35, 41 AND 42), (U.S. CLS. 100, 101, 102 AND 107). SN 86-149,663. PUB. 6-10-2014. FILED 12-20-2013.
- 4,592,110. **ANSWER 24 LIVE .COM AND DESIGN**. SEVEN ONE, INC., (U.S. CLS. 100, 101 AND 102). SN 86-149,937. PUB. 6-10-2014. FILED 12-20-2013.
- 4,592,115. **AMERIHEALTH CARITAS AND DESIGN**. INDEPENDENCE BLUE CROSS, MULTIPLE CLASS, (INT. CLS. 35 AND 36), (U.S. CLS. 100, 101 AND 102). SN 86-150,281. PUB. 6-10-2014. FILED 12-20-2013.
- 4,592,117. **ESTEPP ENERGY AND DESIGN**. ESTEPP ENERGY LLC, DBA ESTEPP ENERGY, LLC, (U.S. CLS. 100, 101 AND 102). SN 86-150,423. PUB. 6-10-2014. FILED 12-21-2013.
- 4,592,121. **PURCHASING POWER PLUS (STANDARD CHARACTER)**. PURCHASING POWER PLUS, LLC, (U.S. CLS. 100, 101 AND 102). SN 86-150,759. PUB. 6-10-2014. FILED 12-23-2013.
- 4,592,122. **MISCELLANEOUS DESIGN**. DAILWILLIAMS, NIEESHA, AND WILLIAMS, TREMAYNE, (U.S. CLS. 100, 101 AND 102). SN 86-150,778. PUB. 6-10-2014. FILED 12-23-2013.
- 4,592,124. **RETAIL ADVANTAGE GROUP (STANDARD CHARACTER)**. PURCHASING POWER PLUS, LLC, (U.S. CLS. 100, 101 AND 102). SN 86-150,782. PUB. 6-10-2014. FILED 12-23-2013.
- 4,592,126. **WORLD GROUP WGPAS.COM PROPERTY ADVERTISING SALES AND DESIGN**. ALMEIDA, ROBERTO, (U.S. CLS. 100, 101 AND 102). SN 86-150,870. PUB. 6-10-2014. FILED 12-23-2013.
- 4,592,138. **NEW COMMUNITIES PROGRAM (STANDARD CHARACTER)**. LOCAL INITIATIVES SUPPORT CORPORATION, MULTIPLE CLASS, (INT. CLS. 35 AND 36), (U.S. CLS. 100, 101 AND 102). SN 86-151,458. PUB. 6-10-2014. FILED 12-23-2013.
- 4,592,144. **UNI URBAN -N - ISLAND AND DESIGN**. COUSMOOR GIFTS, LLC, (U.S. CLS. 100, 101 AND 102). SN 86-152,030. PUB. 6-10-2014. FILED 12-24-2013.
- 4,592,155. **PROJECTION DIGITAL (STANDARD CHARACTER)**. PROJECTION DIGITAL LLC, (U.S. CLS. 100, 101 AND 102). SN 86-152,864. PUB. 6-10-2014. FILED 12-26-2013.
- 4,592,159. **LIBRA NETWORK (STANDARD CHARACTER)**. MODERNO MEDIA, INC., (U.S. CLS. 100, 101 AND 102). SN 86-153,049. PUB. 6-10-2014. FILED 12-27-2013.
- 4,592,161. **TOMCORBETTFORGOVERNOR.COM (STANDARD CHARACTER)**. TOM CORBETT FOR GOVERNOR, MULTIPLE CLASS, (INT. CLS. 35 AND 36), (U.S. CLS. 100, 101 AND 102). SN 86-153,160. PUB. 6-10-2014. FILED 12-27-2013.
- 4,592,164. **SITEPLICITY (STANDARD CHARACTER)**. MT3 MARKETING LLC, MULTIPLE CLASS, (INT. CLS. 35, 41 AND 42), (U.S. CLS. 100, 101, 102 AND 107). SN 86-153,524. PUB. 6-10-2014. FILED 12-27-2013.
- 4,592,176. **SEA TO SEA: CYCLING TO END POVERTY (STANDARD CHARACTER)**. WORLD RENEW, MULTIPLE CLASS, (INT. CLS. 35, 36 AND 41), (U.S. CLS. 100, 101, 102 AND 107). SN 86-154,404. PUB. 6-10-2014. FILED 12-30-2013.
- 4,592,187. **ICON UNION (STANDARD CHARACTER)**. ICON UNION, INC., (U.S. CLS. 100, 101 AND 102). SN 86-154,938. PUB. 6-10-2014. FILED 12-31-2013.
- 4,592,197. **SOUL FOOD CYPHER (STANDARD CHARACTER)**. SOUL FOOD CYPHER LLC, (U.S. CLS. 100, 101 AND 102). SN 86-155,499. PUB. 6-10-2014. FILED 12-31-2013.
- 4,592,198. **OPERATION BBQ RELIEF (STANDARD CHARACTER)**. OPERATION BBQ RELIEF, MULTIPLE CLASS, (INT. CLS. 35 AND 36), (U.S. CLS. 100, 101 AND 102). SN 86-155,518. PUB. 6-10-2014. FILED 12-31-2013.
- 4,592,207. **ANIMAL WELFARE CERTIFIED SCIENCE BASED AND DESIGN**. VERASSURE LLC, A WHOLLY OWNED SUBSIDIARY OF FROST PLLC, DBA FACTA, (U.S. CLS. 100, 101 AND 102). SN 86-156,053. PUB. 6-10-2014. FILED 1-2-2014.
- 4,592,211. **BOWLING GREEN KENTUCKY GEARED FOR FUN! AND DESIGN**. BOWLING GREEN AREA CONVENTION & VISITORS BUREAU, (U.S. CLS. 100, 101 AND 102). SN 86-156,114. PUB. 6-10-2014. FILED 1-2-2014.
- 4,592,215. **TVC (STYLIZED)**. TVC HOLDING, INC., (U.S. CLS. 100, 101 AND 102). SN 86-156,262. PUB. 6-10-2014. FILED 1-2-2014.
- 4,592,216. **MEDICAL-SUPPLIES.COM AND DESIGN**. MARCOAH GROUP USA, LLC, (U.S. CLS. 100, 101 AND 102). SN 86-156,285. PUB. 6-10-2014. FILED 1-2-2014.
- 4,592,220. **SETBUY (STANDARD CHARACTER)**. RHC TRADING INC, (U.S. CLS. 100, 101 AND 102). SN 86-156,852. PUB. 6-10-2014. FILED 1-3-2014.
- 4,592,227. **INSITE MANAGED SOLUTIONS AND DESIGN**. INSITE MANAGED SOLUTIONS, (U.S. CLS. 100, 101 AND 102). SN 86-157,065. PUB. 6-10-2014. FILED 1-3-2014.
- 4,592,230. **THE SPANISH RED (STANDARD CHARACTER)**. RUIZ, FRANCISCO, (U.S. CLS. 100, 101 AND 102). SN 86-157,115. PUB. 6-10-2014. FILED 1-3-2014.
- 4,592,240. **BLONDIE'S TOFFEE (STANDARD CHARACTER)**. GALLAGHER, CYNTHIA, (U.S. CLS. 100, 101 AND 102). SN 86-157,811. PUB. 6-10-2014. FILED 1-6-2014.
- 4,592,244. **PAPA (STANDARD CHARACTER)**. PRO-AM PINBALL ASSOCIATION, INC., (U.S. CLS. 100, 101 AND 102). SN 86-157,882. PUB. 6-10-2014. FILED 1-6-2014.
- 4,592,245. **TOOL CONTROL, FROM THE EXPERTS FOR THE EXPERTS (STANDARD CHARACTER)**. HUTCHENS, SEAN, (U.S. CLS. 100, 101 AND 102). SN 86-158,108. PUB. 6-10-2014. FILED 1-6-2014.
- 4,592,246. **WINSOR STAFFING AND DESIGN**. WINSOR TEMPS OF NEW YORK, INC., (U.S. CLS. 100, 101 AND 102). SN 86-158,145. PUB. 6-10-2014. FILED 1-6-2014.
- 4,592,250. **JOB LISTING AND DESIGN**. JOBLISTING, INC., (U.S. CLS. 100, 101 AND 102). SN 86-158,205. PUB. 6-10-2014. FILED 1-6-2014.
- 4,592,252. **SPLICE AND DESIGN**. SOCIETY OF PRODUCT LICENSORS COMMITTED TO EXCELLENCE, MULTIPLE CLASS, (INT. CLS. 35 AND 41), (U.S. CLS. 100, 101, 102 AND 107). SN 86-158,238. PUB. 6-10-2014. FILED 1-6-2014.
- 4,592,254. **CERTIFIED RESIDENT AND DESIGN**. RENTPATH, INC., (U.S. CLS. 100, 101 AND 102). SN 86-158,256. PUB. 6-10-2014. FILED 1-6-2014.
- 4,592,256. **ALOHA JAM AND DESIGN**. DIVERSION ENTERPRISES, LLC, (U.S. CLS. 100, 101 AND 102). SN 86-158,302. PUB. 6-10-2014. FILED 1-6-2014.
- 4,592,257. **APC BOOKKEEPING COLOR HELPS ENTREPRENEURS GROW AND DESIGN**. APC BOOKKEEPING LLC, (U.S. CLS. 100, 101 AND 102). SN 86-158,398. PUB. 6-10-2014. FILED 1-6-2014.
- 4,592,263. **ROYAL VAPOR (STANDARD CHARACTER)**. LOVING, NEIL, (U.S. CLS. 100, 101 AND 102). SN 86-158,550. PUB. 6-10-2014. FILED 1-6-2014.
- 4,592,265. **BISCOMERICA (STANDARD CHARACTER)**. BISCOMERICA CORPORATION, MULTIPLE CLASS, (INT. CLS. 35, 39 AND 40), (U.S. CLS. 100, 101, 102, 103, 105 AND 106). SN 86-158,604. PUB. 6-10-2014. FILED 1-6-2014.
- 4,592,266. **QUALITY IS OUR FAMILY TRADITION (STAN-**

- DARD CHARACTER**). BISCOMERICA CORPORATION, MULTIPLE CLASS, (INT. CLS. 35, 39 AND 40), (U.S. CLS. 100, 101, 102, 103, 105 AND 106). SN 86-158,611. PUB. 6-10-2014. FILED 1-6-2014.
- 4,592,272. **PHI (STANDARD CHARACTER)**. PHI, INCORPORATED, (U.S. CLS. 100, 101 AND 102). SN 86-159,026. PUB. 6-10-2014. FILED 1-7-2014.
- 4,592,273. **SP BANCORP (STANDARD CHARACTER)**. SP BANCORP, INC., (U.S. CLS. 100, 101 AND 102). SN 86-159,073. PUB. 6-10-2014. FILED 1-7-2014.
- 4,592,274. **BEN BAY (STANDARD CHARACTER)**. GIRGENTI, SALVATORE, MULTIPLE CLASS, (INT. CLS. 35 AND 36), (U.S. CLS. 100, 101 AND 102). SN 86-159,077. PUB. 6-10-2014. FILED 1-7-2014.
- 4,592,275. **BEN BAY AND DESIGN**. GIRGENTI, SALVATORE, MULTIPLE CLASS, (INT. CLS. 35 AND 36), (U.S. CLS. 100, 101 AND 102). SN 86-159,093. PUB. 6-10-2014. FILED 1-7-2014.
- 4,592,287. **CALI GIRL CAKES (STANDARD CHARACTER)**. CALI GIRL CAKES LLC, (U.S. CLS. 100, 101 AND 102). SN 86-159,852. PUB. 6-10-2014. FILED 1-8-2014.
- 4,592,290. **G MART ADS SHARING IS GREATER THAN MARKETING AND DESIGN**. GMART ADS LLC, (U.S. CLS. 100, 101 AND 102). SN 86-160,029. PUB. 6-10-2014. FILED 1-8-2014.
- 4,592,308. **MISCELLANEOUS DESIGN**. WOD OUTLET, (U.S. CLS. 100, 101 AND 102). SN 86-160,650. PUB. 6-10-2014. FILED 1-8-2014.
- 4,592,310. **BIG JOHN'S (STANDARD CHARACTER)**. BIG JOHNS ACE, LLC, MULTIPLE CLASS, (INT. CLS. 35 AND 37), (U.S. CLS. 100, 101, 102, 103 AND 106). SN 86-160,772. PUB. 6-10-2014. FILED 1-8-2014.
- 4,592,325. **PLT HEALTH SOLUTIONS (STANDARD CHARACTER)**. P.L. THOMAS & CO., INC., (U.S. CLS. 100, 101 AND 102). SN 86-161,493. PUB. 6-10-2014. FILED 1-9-2014.
- 4,592,327. **CROSS CULTURAL MANAGEMENT (STANDARD CHARACTER)**. HYRAX INTERNATIONAL, LLC, (U.S. CLS. 100, 101 AND 102). SN 86-161,568. PUB. 6-10-2014. FILED 1-9-2014.
- 4,592,328. **HYRAX INTERNATIONAL, LLC (STYLIZED)**. HYRAX INTERNATIONAL, LLC, (U.S. CLS. 100, 101 AND 102). SN 86-161,574. PUB. 6-10-2014. FILED 1-9-2014.
- 4,592,329. **HYRAX INTERNATIONAL, LLC (STANDARD CHARACTER)**. HYRAX INTERNATIONAL, LLC, (U.S. CLS. 100, 101 AND 102). SN 86-161,581. PUB. 6-10-2014. FILED 1-9-2014.
- 4,592,338. **NAPCP EST. 2009 . NATIONAL . ASSOCIATION . OF PROFESSIONAL . CHILD . PHOTOGRAPHERS . AND DESIGN**. NAPCP, INC., (U.S. CLS. 100, 101 AND 102). SN 86-161,715. PUB. 6-10-2014. FILED 1-9-2014.
- 4,592,352. **CUSTOM MAT BUILDER AND DESIGN**. CUSTOM MAT COMPANY, INC., (U.S. CLS. 100, 101 AND 102). SN 86-161,975. PUB. 6-10-2014. FILED 1-9-2014.
- 4,592,370. **BB COMMERCIAL SOLUTIONS AND DESIGN**. BUDGET BLINDS, INC., (U.S. CLS. 100, 101 AND 102). SN 86-162,587. PUB. 6-10-2014. FILED 1-10-2014.
- 4,592,373. **PUBLIC WORKS PARTNERS (STANDARD CHARACTER)**. PUBLIC WORKS PARTNERS LLC, MULTIPLE CLASS, (INT. CLS. 35 AND 36), (U.S. CLS. 100, 101 AND 102). SN 86-162,647. PUB. 6-10-2014. FILED 1-10-2014.
- 4,592,376. **MOLECULE (STANDARD CHARACTER)**. MOLECULE-AMERICA, L.L.C., (U.S. CLS. 100, 101 AND 102). SN 86-162,663. PUB. 6-10-2014. FILED 1-10-2014.
- 4,592,379. **OPTIMIZED360 (STANDARD CHARACTER)**. FAHIMI SEAN A, (U.S. CLS. 100, 101 AND 102). SN 86-162,753. PUB. 6-10-2014. FILED 1-10-2014.
- 4,592,380. **GO AUTO EXCHANGE (STANDARD CHARACTER)**. GFC LENDING, LLC, (U.S. CLS. 100, 101 AND 102). SN 86-162,761. PUB. 6-10-2014. FILED 1-10-2014.
- 4,592,381. **GO AUTO EXCHANGE AND DESIGN**. GFC LENDING, LLC, (U.S. CLS. 100, 101 AND 102). SN 86-162,769. PUB. 6-10-2014. FILED 1-10-2014.
- 4,592,384. **R-COMM MEDIA (STANDARD CHARACTER)**. THOMAS BLAINE ROGERS, (U.S. CLS. 100, 101 AND 102). SN 86-162,824. PUB. 6-10-2014. FILED 1-10-2014.
- 4,592,387. **PMA FULFILLMENT (STANDARD CHARACTER)**. GREEN LIGHT DIRECT SERVICES, INC., (U.S. CLS. 100, 101 AND 102). SN 86-162,885. PUB. 6-10-2014. FILED 1-10-2014.
- 4,592,388. **CULMINATION PROJECT (STANDARD CHARACTER)**. CULMINATION PROJECT, LLC, (U.S. CLS. 100, 101 AND 102). SN 86-162,906. PUB. 6-10-2014. FILED 1-10-2014.
- 4,592,389. **ARCHITECTS OF THE LIVE BRAND EXPERIENCE (STANDARD CHARACTER)**. 360 LIVE MEDIA, LLC, (U.S. CLS. 100, 101 AND 102). SN 86-162,910. PUB. 6-10-2014. FILED 1-10-2014.
- 4,592,390. **REAL VENDORS (STANDARD CHARACTER)**. JANSSENS SALES, INC., (U.S. CLS. 100, 101 AND 102). SN 86-162,927. PUB. 6-10-2014. FILED 1-10-2014.
- 4,592,394. **S B AND DESIGN**. CHRIS FARMAND & COMPANY, PLLC, (U.S. CLS. 100, 101 AND 102). SN 86-163,128. PUB. 6-10-2014. FILED 1-11-2014.
- 4,592,395. **SMALL BATCH STANDARD (STANDARD CHARACTER)**. CHRIS FARMAND & COMPANY, PLLC, (U.S. CLS. 100, 101 AND 102). SN 86-163,129. PUB. 6-10-2014. FILED 1-11-2014.
- 4,592,399. **CP AND DESIGN**. CULMINATION PROJECT, LLC, (U.S. CLS. 100, 101 AND 102). SN 86-163,249. PUB. 6-10-2014. FILED 1-11-2014.
- 4,592,409. **A TO Z DENTAL GO AHEAD...SMILE WITH CONFIDENCE AND DESIGN**. ZADOYAN, ARMENAK, AND SHAKHGELDYAN, VAHE, (U.S. CLS. 100, 101 AND 102). SN 86-163,385. PUB. 6-10-2014. FILED 1-12-2014.
- 4,592,414. **SPORTIQUE BRANDS (STANDARD CHARACTER)**. THORRINGTON CAPITAL, LLC, (U.S. CLS. 100, 101 AND 102). SN 86-163,479. PUB. 6-10-2014. FILED 1-13-2014.
- 4,592,417. **YES WE SCAN (STANDARD CHARACTER)**. SCAN MAILBOXES SOLUTIONS, LLC, (U.S. CLS. 100, 101 AND 102). SN 86-163,535. PUB. 6-10-2014. FILED 1-13-2014.
- 4,592,418. **GLOBALMAXCLUB (STANDARD CHARACTER)**. GLOBAL MAX UNLIMITED GROUP, CORP, (U.S. CLS. 100, 101 AND 102). SN 86-163,566. PUB. 6-10-2014. FILED 1-13-2014.
- 4,592,420. **REFLECTIONS URNS & MEMORIALS (STANDARD CHARACTER)**. STARDUST MEMORIALS, LLC, (U.S. CLS. 100, 101 AND 102). SN 86-163,653. PUB. 6-10-2014. FILED 1-13-2014.
- 4,592,423. **VAPE DYNASTY (STANDARD CHARACTER)**. RADIA, NICK, (U.S. CLS. 100, 101 AND 102). SN 86-163,736. PUB. 6-10-2014. FILED 1-13-2014.
- 4,592,425. **NATIONAL COMPASSION FUND (STANDARD CHARACTER)**. NATIONAL CENTER FOR VICTIMS OF CRIME, MULTIPLE CLASS, (INT. CLS. 35 AND 36), (U.S. CLS. 100, 101 AND 102). SN 86-163,891. PUB. 6-10-2014. FILED 1-13-2014.
- 4,592,430. **BUILDERS WAREHOUSE AND DESIGN**. BATC FOUNDATION, (U.S. CLS. 100, 101 AND 102). SN 86-164,121. PUB. 6-10-2014. FILED 1-13-2014.
- 4,592,454. **WALWORTH COUNTY EST. 1839 WISCONSIN AND DESIGN**. WALWORTH COUNTY, WISCONSIN A WISCONSIN MUNICIPAL CORPORATION, (U.S. CLS. 100, 101 AND 102). SN 86-165,247. PUB. 6-10-2014. FILED 1-14-2014.
- 4,592,469. **1234567 RATE TRADES AND DESIGN**. ELIANT, INC., (U.S. CLS. 100, 101 AND 102). SN 86-165,511. PUB. 6-10-2014. FILED 1-14-2014.
- 4,592,472 ( *See Class 16 for this trademark*).
- 4,592,475. **BTA BUSINESS TRANSITION ACADEMY MENTORS (STYLIZED)**. BUSINESS TRANSITION ACADEMY, INC., MULTIPLE CLASS, (INT. CLS. 35 AND 41), (U.S. CLS. 100, 101, 102 AND 107). SN 86-165,712. PUB. 6-10-2014. FILED 1-15-2014.
- 4,592,476. **BTA BUSINESS TRANSITION ACADEMY ROADMAP (STYLIZED)**. BUSINESS TRANSITION ACADEMY, INC., MULTIPLE CLASS, (INT. CLS. 35 AND 41), (U.S. CLS. 100, 101, 102 AND 107). SN 86-165,717. PUB. 6-10-2014. FILED 1-15-2014.
- 4,592,477. **JEWELS FOR THE KING AND QUEEN IN ALL OF US (STANDARD CHARACTER)**. THE GOLDEN EYE LLC, (U.S. CLS. 100, 101 AND 102). SN 86-165,837. PUB. 6-10-2014. FILED 1-15-2014.
- 4,592,494. **GREERWALKER (STANDARD CHARACTER)**. GREERWALKER LLP, (U.S. CLS. 100, 101 AND 102). SN 86-166,315. PUB. 6-10-2014. FILED 1-15-2014.
- 4,592,496. **GREERWALKER CERTIFIED PUBLIC ACCOUN-**

- TANTS AND DESIGN. GREERWALKER LLP, (U.S. CLS. 100, 101 AND 102). SN 86-166,346. PUB. 6-10-2014. FILED 1-15-2014.
- 4,592,501. SOUTHLAND SAFETY AND DESIGN. SOUTHLAND SAFETY, LLC, (U.S. CLS. 100, 101 AND 102). SN 86-166,466. PUB. 6-10-2014. FILED 1-15-2014.
- 4,592,527. FEARLESSLIVING WITH JULIA WILSON AND DESIGN. WILSON, JULIA A., (U.S. CLS. 100, 101 AND 102). SN 86-167,238. PUB. 6-10-2014. FILED 1-16-2014.
- 4,592,528 ( See Class 25 for this trademark).
- 4,592,531. SCANNER MONKEY (STANDARD CHARACTER). SCANNER MONKEY, LLC, MULTIPLE CLASS, (INT. CLS. 35 AND 41), (U.S. CLS. 100, 101, 102 AND 107). SN 86-167,342. PUB. 6-10-2014. FILED 1-16-2014.
- 4,592,532. ORGANIZED KNOWLEDGE (STANDARD CHARACTER). TRANSITION-PATH INC., (U.S. CLS. 100, 101 AND 102). SN 86-167,369. PUB. 6-10-2014. FILED 1-16-2014.
- 4,592,533. SCANNER MONKEY AND DESIGN. SCANNER MONKEY, LLC, MULTIPLE CLASS, (INT. CLS. 35 AND 41), (U.S. CLS. 100, 101, 102 AND 107). SN 86-167,424. PUB. 6-10-2014. FILED 1-16-2014.
- 4,592,534. CITY AUTO SALES AND DESIGN. MCFARLAND, CLARENCE EUGENE, (U.S. CLS. 100, 101 AND 102). SN 86-167,476. PUB. 6-10-2014. FILED 1-16-2014.
- 4,592,535. DEATH VALLEY RECORDS (STANDARD CHARACTER). LITTLE HURRICANE, (U.S. CLS. 100, 101 AND 102). SN 86-167,479. PUB. 6-10-2014. FILED 1-16-2014.
- 4,592,541. THE CHICKEN SHACK HOME OF THE BARGAIN BIRD AND DESIGN. HOLLAND LADY, INC., (U.S. CLS. 100, 101 AND 102). SN 86-167,769. PUB. 6-10-2014. FILED 1-16-2014.
- 4,592,554. MIDWEST APPLIANCE PARTS (STANDARD CHARACTER). MIDWEST APPLIANCE PARTS CO. INC., (U.S. CLS. 100, 101 AND 102). SN 86-168,463. PUB. 6-10-2014. FILED 1-17-2014.
- 4,592,555. WISDOM FOR WEALTH. FOR LIFE. (STANDARD CHARACTER). RONALD BLUE & CO., MULTIPLE CLASS, (INT. CLS. 35 AND 36), (U.S. CLS. 100, 101 AND 102). SN 86-168,657. PUB. 6-10-2014. FILED 1-17-2014.
- 4,592,557. RONALD BLUE & CO. (STANDARD CHARACTER). RONALD BLUE & CO., MULTIPLE CLASS, (INT. CLS. 35 AND 36), (U.S. CLS. 100, 101 AND 102). SN 86-168,665. PUB. 6-10-2014. FILED 1-17-2014.
- 4,592,558. DEBT SYNC (STANDARD CHARACTER). MARKET VIEW LLC, (U.S. CLS. 100, 101 AND 102). SN 86-168,802. PUB. 6-10-2014. FILED 1-17-2014.
- 4,592,562. STAIRLIFT HEADQUARTERS (STANDARD CHARACTER). ACCESS & MOBILITY SOLUTIONS, LLC, MULTIPLE CLASS, (INT. CLS. 35 AND 37), (U.S. CLS. 100, 101, 102, 103 AND 106). SN 86-169,000. PUB. 6-10-2014. FILED 1-17-2014.
- 4,592,563. SPARROW (STANDARD CHARACTER). SPARROW STRATEGY, LLC., (U.S. CLS. 100, 101 AND 102). SN 86-169,040. PUB. 6-10-2014. FILED 1-17-2014.
- 4,592,565. PAPER BLOOMS (STANDARD CHARACTER). PAPER BLOOMS, (U.S. CLS. 100, 101 AND 102). SN 86-169,068. PUB. 6-10-2014. FILED 1-17-2014.
- 4,592,588 ( See Class 24 for this trademark).
- 4,592,589. RSC (STANDARD CHARACTER). PETOSKEY PLASTICS, INC., DBA RSC SALES COMPANY, (U.S. CLS. 100, 101 AND 102). SN 86-172,281. PUB. 6-10-2014. FILED 1-22-2014.
- 4,592,604. THE SEARCH IS OVER (STANDARD CHARACTER). DAWG, INC., (U.S. CLS. 100, 101 AND 102). SN 86-173,062. PUB. 6-10-2014. FILED 1-23-2014.
- 4,592,609. BEST OF SAN ANTONIO (STANDARD CHARACTER). EUCLID MEDIA GROUP LLC, (U.S. CLS. 100, 101 AND 102). SN 86-173,240. PUB. 6-10-2014. FILED 1-23-2014.
- 4,592,610. H HORNE FOCUSED ON YOU AND DESIGN. HORNE LLP, MULTIPLE CLASS, (INT. CLS. 35, 36 AND 45), (U.S. CLS. 100, 101 AND 102). SN 86-173,273. PUB. 6-10-2014. FILED 1-23-2014.
- 4,592,612. PIPEVINE (STANDARD CHARACTER). PIPEVINE, LLC, (U.S. CLS. 100, 101 AND 102). SN 86-173,809. PUB. 6-10-2014. FILED 1-23-2014.
- 4,592,646. YOUSEXMAS (STYLIZED). JIANHU YONG JIE FOREIGN TRADE CO., LTD., (U.S. CLS. 100, 101 AND 102). SN 86-175,336. PUB. 6-10-2014. FILED 1-26-2014.
- 4,592,652. APPALACHIA PROUD (STANDARD CHARACTER). KENTUCKY DEPARTMENT OF AGRICULTURE, (U.S. CLS. 100, 101 AND 102). SN 86-175,397. PUB. 6-10-2014. FILED 1-26-2014.
- 4,592,662. FUNHURTS (STANDARD CHARACTER). SPEER, MICHAEL, (U.S. CLS. 100, 101 AND 102). SN 86-175,574. PUB. 6-10-2014. FILED 1-27-2014.
- 4,592,670. FRONCARE (STANDARD CHARACTER). FRONCARE INC., (U.S. CLS. 100, 101 AND 102). SN 86-175,684. PUB. 6-10-2014. FILED 1-27-2014.
- 4,592,678. LIFE IS SHORT. STAY AWAKE FOR IT. (STANDARD CHARACTER). ARABICA FUNDING, INC., (U.S. CLS. 100, 101 AND 102). SN 86-175,771. PUB. 6-10-2014. FILED 1-27-2014.
- 4,592,681. GENACAST (STANDARD CHARACTER). GENACAST VENTURES, LLC, MULTIPLE CLASS, (INT. CLS. 35 AND 36), (U.S. CLS. 100, 101 AND 102). SN 86-175,835. PUB. 6-10-2014. FILED 1-27-2014.
- 4,592,713. FLIGHTPATH (STANDARD CHARACTER). FLIGHTPATH, INC., MULTIPLE CLASS, (INT. CLS. 35 AND 42), (U.S. CLS. 100, 101 AND 102). SN 86-176,426. PUB. 6-10-2014. FILED 1-27-2014.
- 4,592,739. THE VELVET SHOESTRING (STANDARD CHARACTER). THE VELVET SHOESTRING, INC., (U.S. CLS. 100, 101 AND 102). SN 86-177,005. PUB. 6-10-2014. FILED 1-28-2014.
- 4,592,746. PERFECT MY SILHOUETTE (STANDARD CHARACTER). PERFECT MY SILHOUETTE, LLC, (U.S. CLS. 100, 101 AND 102). SN 86-177,075. PUB. 6-10-2014. FILED 1-28-2014.
- 4,592,751. ACT (STANDARD CHARACTER). THUNDERBIRD SCHOOL OF GLOBAL MANAGEMENT, (U.S. CLS. 100, 101 AND 102). SN 86-177,144. PUB. 6-10-2014. FILED 1-28-2014.
- 4,592,752. IFLYACY (STANDARD CHARACTER). SOUTH JERSEY TRANSPORTATION AUTHORITY, (U.S. CLS. 100, 101 AND 102). SN 86-177,168. PUB. 6-10-2014. FILED 1-28-2014.
- 4,592,753. MISCELLANEOUS DESIGN. A BOTTLED AFFAIR, LLC, MULTIPLE CLASS, (INT. CLS. 35 AND 41), (U.S. CLS. 100, 101, 102 AND 107). SN 86-177,178. PUB. 6-10-2014. FILED 1-28-2014.
- 4,592,757. YOUR WAY ON THE PARKWAY (STANDARD CHARACTER). CAPITOL AUTO GROUP, INC., MULTIPLE CLASS, (INT. CLS. 35 AND 37), (U.S. CLS. 100, 101, 102, 103 AND 106). SN 86-177,234. PUB. 6-10-2014. FILED 1-28-2014.
- 4,592,759. BUILD A BETTER CHRISTMAS (STANDARD CHARACTER). CARHARTT, INC., (U.S. CLS. 100, 101 AND 102). SN 86-177,278. PUB. 6-10-2014. FILED 1-28-2014.
- 4,592,772. MISCELLANEOUS DESIGN. BETTYE HARRIS LARYNX CANCER AWARENESS CENTER, (U.S. CLS. 100, 101 AND 102). SN 86-177,520. PUB. 6-10-2014. FILED 1-28-2014.
- 4,592,773. FINOVATE (STANDARD CHARACTER). THE FINOVATE GROUP, INC., (U.S. CLS. 100, 101 AND 102). SN 86-177,542. PUB. 6-10-2014. FILED 1-28-2014.
- 4,592,777. M AND DESIGN. MY SCRAP NETWORK LLC, (U.S. CLS. 100, 101 AND 102). SN 86-177,671. PUB. 6-10-2014. FILED 1-28-2014.
- 4,592,778. XOTIC XTRAS (STANDARD CHARACTER). EXOTIC EXTRAS LTD, (U.S. CLS. 100, 101 AND 102). SN 86-177,672. PUB. 6-10-2014. FILED 1-28-2014.
- 4,592,810. KATYLIST (STANDARD CHARACTER). SHELLBACK TACTICAL INC, (U.S. CLS. 100, 101 AND 102). SN 86-178,125. PUB. 6-10-2014. FILED 1-29-2014.
- 4,592,812 ( See Class 18 for this trademark).
- 4,592,825. BLAKE & PENDLETON (STANDARD CHARACTER). BLAKE & PENDLETON, INC., MULTIPLE CLASS, (INT. CLS. 35 AND 37), (U.S. CLS. 100, 101, 102, 103 AND 106). SN 86-178,375. PUB. 6-10-2014. FILED 1-29-2014.
- 4,592,838. THEDIFFERENCE (STANDARD CHARACTER). THE DIFFERENCE A2C LLC, (U.S. CLS. 100, 101 AND 102). SN 86-178,644. PUB. 6-10-2014. FILED 1-29-2014.
- 4,592,840. SM AND DESIGN. SHALIK, MORRIS & COMPANY, LLP, (U.S. CLS. 100, 101 AND 102). SN 86-178,678. PUB. 6-10-2014. FILED 1-29-2014.
- 4,592,842. IG FEATURES (STANDARD CHARACTER). IG

SHOUTOUT NETWORK LLC, (U.S. CLS. 100, 101 AND 102). SN 86-178,704. PUB. 6-10-2014. FILED 1-29-2014.

4,592,853. **F FABULOUS FOUR (STYLIZED)**, UNITED STATES BOWLING CONGRESS, INC., MULTIPLE CLASS, (INT. CLS. 35 AND 41), (U.S. CLS. 100, 101, 102 AND 107). SN 86-178,885. PUB. 6-10-2014. FILED 1-29-2014.

4,592,855. **TLS AUTO RECYCLING AND DESIGN**, T.L.S. PARTS, INC., (U.S. CLS. 100, 101 AND 102). SN 86-178,889. PUB. 6-10-2014. FILED 1-29-2014.

4,592,868. **MISCELLANEOUS DESIGN**, ORANGE HARP, INC., (U.S. CLS. 100, 101 AND 102). SN 86-179,163. PUB. 6-10-2014. FILED 1-29-2014.

4,592,871. **MISCELLANEOUS DESIGN**, GREEN DOT BANK, MULTIPLE CLASS, (INT. CLS. 35 AND 36), (U.S. CLS. 100, 101 AND 102). SN 86-179,191. PUB. 6-10-2014. FILED 1-29-2014.

4,592,873. **FOR WHATEVER BLOWS YOUR SKIRT UP (STANDARD CHARACTER)**, CANADY, KAREN S., DBA BIKIE GIRL BLOOMERS, (U.S. CLS. 100, 101 AND 102). SN 86-179,251. PUB. 6-10-2014. FILED 1-30-2014.

4,592,882. **K KATYLIST AND DESIGN**, SHELLBACK TACTICAL INC, (U.S. CLS. 100, 101 AND 102). SN 86-179,615. PUB. 6-10-2014. FILED 1-30-2014.

4,592,884. **SCOTTY B'S (STANDARD CHARACTER)**, GOOD EATZ GOURMET CORP., (U.S. CLS. 100, 101 AND 102). SN 86-179,657. PUB. 6-10-2014. FILED 1-30-2014.

4,592,896. **MISCELLANEOUS DESIGN**, RATE-MONITOR, INC., (U.S. CLS. 100, 101 AND 102). SN 86-179,903. PUB. 6-10-2014. FILED 1-30-2014.

4,592,897 ( *See Class 9 for this trademark*).

4,592,909. **SERBAGS (STANDARD CHARACTER)**, CIVLAK, ALI, (U.S. CLS. 100, 101 AND 102). SN 86-180,320. PUB. 6-10-2014. FILED 1-30-2014.

4,592,912. **SHOPIST (STANDARD CHARACTER)**, MAP THE BRAND, INC., (U.S. CLS. 100, 101 AND 102). SN 86-180,366. PUB. 6-10-2014. FILED 1-30-2014.

4,592,913 ( *See Class 9 for this trademark*).

4,592,949. **IMPROVING OUTCOME AND QUALITY OF LIFE (STANDARD CHARACTER)**, CARLSON, JUSTIN, MULTIPLE CLASS, (INT. CLS. 35 AND 42), (U.S. CLS. 100, 101 AND 102). SN 86-188,225. PUB. 6-10-2014. FILED 2-7-2014.

4,592,955. **WINVELOPE (STANDARD CHARACTER)**, PATENT INVESTMENT & LICENSING COMPANY, (U.S. CLS. 100, 101 AND 102). SN 86-190,108. PUB. 6-10-2014. FILED 2-11-2014.

4,592,957. **SOLDIERS TO SCIENTISTS (STANDARD CHARACTER)**, CARLSON, JUSTIN, (U.S. CLS. 100, 101 AND 102). SN 86-190,792. PUB. 6-10-2014. FILED 2-11-2014.

4,592,959. **CHARACTER, RESULTS, INNOVATION, HUMANITY (STANDARD CHARACTER)**, CARLSON, JUSTIN, MULTIPLE CLASS, (INT. CLS. 35 AND 42), (U.S. CLS. 100, 101 AND 102). SN 86-191,935. PUB. 6-10-2014. FILED 2-12-2014.

4,592,963. **BB AND DESIGN**, THE BARBARA BUSH FOUNDATION FOR FAMILY LITERACY, INC., (U.S. CLS. 100, 101 AND 102). SN 86-194,412. PUB. 6-10-2014. FILED 2-14-2014.

4,592,972. **QUAD SQUAD (STANDARD CHARACTER)**, APPSURDITY, INC., (U.S. CLS. 100, 101 AND 102). SN 86-198,862. PUB. 6-10-2014. FILED 2-20-2014.

4,592,988. **PROTECTING YOUR FREEDOM TO FISH (STANDARD CHARACTER)**, COASTAL CONSERVATION ASSOCIATION, (U.S. CLS. 100, 101 AND 102). SN 86-207,546. PUB. 6-10-2014. FILED 2-28-2014.

4,592,999. **SOLDIERS TO STEM (STANDARD CHARACTER)**, CARLSON, JUSTIN, (U.S. CLS. 100, 101 AND 102). SN 86-216,083. PUB. 6-10-2014. FILED 3-10-2014.

4,593,032. **COMFORT THE ENVIRONMENT (STANDARD CHARACTER)**, CHEESEBOY PROPERTIES LLC, (U.S. CLS. 100, 101 AND 102). SN 86-235,408. PUB. 6-10-2014. FILED 3-28-2014.

4,593,051. **BRIDGING THE GAP BETWEEN EMPLOYERS AND VETERANS (STANDARD CHARACTER)**, CARLSON, JUSTIN, (U.S. CLS. 100, 101 AND 102). SN 86-247,916. PUB. 6-10-2014. FILED 4-10-2014.

4,593,057. **SPARKPR (STANDARD CHARACTER)**, SPARK PUBLIC RELATIONS, LLC, DBA SPARKPR, (U.S. CLS. 100, 101 AND 102). SN 86-254,125. PUB. 6-10-2014. FILED 4-

16-2014.

**CLASS 36—INSURANCE AND FINANCIAL**

4,590,603. **FIRSTSECURITY BANK OF ARKANSAS AND DESIGN**, FIRST SECURITY BANCORP, (U.S. CLS. 100, 101 AND 102). SN 76-455,928. PUB. 6-10-2014. FILED 10-4-2002.

4,590,604 ( *See Class 35 for this trademark*).

4,590,605 ( *See Class 35 for this trademark*).

4,590,614. **KIDNEY ACTION DAY (STANDARD CHARACTER)**, AMERICAN KIDNEY FUND, INC., MULTIPLE CLASS, (INT. CLS. 36 AND 44), (U.S. CLS. 100, 101 AND 102). SN 76-715,503. PUB. 6-10-2014. FILED 12-5-2013.

4,590,615. **KIDNEY ACTION DAY WALK (STANDARD CHARACTER)**, AMERICAN KIDNEY FUND, INC., MULTIPLE CLASS, (INT. CLS. 36 AND 44), (U.S. CLS. 100, 101 AND 102). SN 76-715,504. PUB. 6-10-2014. FILED 12-5-2013.

4,590,621 ( *See Class 35 for this trademark*).

4,590,647 ( *See Class 35 for this trademark*).

4,590,657 ( *See Class 9 for this trademark*).

4,590,685. **ONE MIZUHO BUILDING THE FUTURE WITH YOU (STYLIZED)**, MIZUHO FINANCIAL GROUP, INC., (U.S. CLS. 100, 101 AND 102). SN 79-129,697. PUB. 6-10-2014. FILED 3-25-2013.

4,590,691 ( *See Class 35 for this trademark*).

4,590,700 ( *See Class 35 for this trademark*).

4,590,704 ( *See Class 35 for this trademark*).

4,590,724. **BIG TELEMATICS (STANDARD CHARACTER)**, ITB TELEMATICS SOLUTIONS LLP, (U.S. CLS. 100, 101 AND 102). SN 79-134,147. PUB. 6-10-2014. FILED 7-18-2013.

4,590,735. **ADVANTAGE MY VIEW (STANDARD CHARACTER)**, SIEMENS SCHWEIZ AG, MULTIPLE CLASS, (INT. CLS. 36, 37 AND 42), (U.S. CLS. 100, 101, 102, 103 AND 106). SN 79-134,621. PUB. 6-10-2014. FILED 6-17-2013.

4,590,767 ( *See Class 9 for this trademark*).

4,590,799 ( *See Class 9 for this trademark*).

4,590,806 ( *See Class 7 for this trademark*).

4,590,844 ( *See Class 7 for this trademark*).

4,590,871. **SPIKE (STANDARD CHARACTER)**, METAPS INC., (U.S. CLS. 100, 101 AND 102). SN 79-142,042. PUB. 6-10-2014. FILED 11-27-2013.

4,590,886. **SAXOSELECT (STANDARD CHARACTER)**, SAXO BANK A/S, (U.S. CLS. 100, 101 AND 102). SN 79-142,587. PUB. 6-10-2014. FILED 11-19-2013.

4,590,942 ( *See Class 35 for this trademark*).

4,590,943 ( *See Class 35 for this trademark*).

4,590,974. **BNX (STANDARD CHARACTER)**, ICE FUTURES EUROPE, (U.S. CLS. 100, 101 AND 102). SN 85-513,148. PUB. 6-10-2014. FILED 1-10-2012.

4,591,001 ( *See Class 9 for this trademark*).

4,591,051 ( *See Class 35 for this trademark*).

4,591,061. **G THE GUARANTEE AND DESIGN**, THE GUARANTEE COMPANY OF NORTH AMERICA USA, (U.S. CLS. 100, 101 AND 102). SN 85-788,809. PUB. 6-10-2014. FILED 11-27-2012.

4,591,091. **MULTICULTURAL INTEGRATED KIDNEY EDUCATION PROGRAM MIKE PROGRAM AND DESIGN**, MULTICULTURAL INTEGRATED KIDNEY EDUCATION PROGRAM, DBA MIKE PROGRAM, MULTIPLE CLASS, (INT. CLS. 36 AND 41), (U.S. CLS. 100, 101, 102 AND 107). SN 85-809,710. PUB. 6-10-2014. FILED 12-21-2012.

4,591,092. **MIKE PROGRAM MULTICULTURAL INTEGRATED KIDNEY EDUCATION PROGRAM AND DESIGN**, MULTICULTURAL INTEGRATED KIDNEY EDUCATION PROGRAM, DBA MIKE PROGRAM, MULTIPLE CLASS, (INT. CLS. 36 AND 41), (U.S. CLS. 100, 101, 102 AND 107). SN 85-809,716. PUB. 6-10-2014. FILED 12-21-2012.

4,591,123. **THE GLEANER LIFE FOUNDATION SERIES (STANDARD CHARACTER)**, GLEANER LIFE INSURANCE SOCIETY, (U.S. CLS. 100, 101 AND 102). SN 85-864,410. PUB. 6-10-2014. FILED 3-1-2013.

4,591,176. **IQCOPAY AND DESIGN**, IQCOPAY PATIENT PAYMENT SYSTEMS, LLC, (U.S. CLS. 100, 101 AND 102). SN 85-910,563. PUB. 6-10-2014. FILED 4-22-2013.

4,591,233 ( *See Class 35 for this trademark*).

- 4,591,255. **2 GUYS LOANS (STANDARD CHARACTER)**. 2 GUYS LOANS, LLC, (U.S. CLS. 100, 101 AND 102). SN 85-954,229. PUB. 6-10-2014. FILED 6-7-2013.
- 4,591,269. **RAIN AND HAIL (STANDARD CHARACTER)**. RAIN AND HAIL INSURANCE SERVICE, INC., (U.S. CLS. 100, 101 AND 102). SN 85-958,144. PUB. 6-10-2014. FILED 6-12-2013.
- 4,591,306 ( *See Class 35 for this trademark*).
- 4,591,307 ( *See Class 35 for this trademark*).
- 4,591,310 ( *See Class 35 for this trademark*).
- 4,591,312 ( *See Class 9 for this trademark*).
- 4,591,326. **STATES OF THE WORLD WEALTH MANAGEMENT AND DESIGN**. OMEGA FINANCIAL GROUP, (U.S. CLS. 100, 101 AND 102). SN 85-968,262. PUB. 6-10-2014. FILED 6-24-2013.
- 4,591,352. **TOAST OUR VETS (STANDARD CHARACTER)**. TOAST OUR VETS FOUNDATION, (U.S. CLS. 100, 101 AND 102). SN 85-971,725. PUB. 6-10-2014. FILED 6-27-2013.
- 4,591,360. **RECYCLING RUMBLE (STANDARD CHARACTER)**. ENVIRONMENT RECLAMATION SERVICES, LLC, (U.S. CLS. 100, 101 AND 102). SN 85-972,662. PUB. 6-10-2014. FILED 6-28-2013.
- 4,591,362. **P PREFERRED PROTECTION PLAN AND DESIGN**. SERVICE GUARD INSURANCE AGENCY, L.L.P., (U.S. CLS. 100, 101 AND 102). SN 85-972,747. PUB. 6-10-2014. FILED 6-28-2013.
- 4,591,375 ( *See Class 35 for this trademark*).
- 4,591,394. **PARSEMUS FOUNDATION (STANDARD CHARACTER)**. PARSEMUS FOUNDATION, (U.S. CLS. 100, 101 AND 102). SN 85-982,448. PUB. 1-1-2013. FILED 2-24-2012.
- 4,591,395. **PARSEMUS (STANDARD CHARACTER)**. PARSEMUS FOUNDATION, (U.S. CLS. 100, 101 AND 102). SN 85-982,449. PUB. 1-1-2013. FILED 2-24-2012.
- 4,591,406. **EX-SAKER STUDENTS ASSOCIATION U.S.A, INC. (STANDARD CHARACTER)**. EX-SAKER STUDENTS ASSOCIATION, U.S.A, INC., (U.S. CLS. 100, 101 AND 102). SN 86-001,165. PUB. 6-10-2014. FILED 7-2-2013.
- 4,591,415. **THE AUTOX (STANDARD CHARACTER)**. THE AUTO EXCHANGE, LLC, (U.S. CLS. 100, 101 AND 102). SN 86-001,514. PUB. 6-10-2014. FILED 7-3-2013.
- 4,591,416. **THE AUTOXL GO BIG. (STANDARD CHARACTER)**. THE AUTO EXCHANGE, LLC, (U.S. CLS. 100, 101 AND 102). SN 86-001,530. PUB. 6-10-2014. FILED 7-3-2013.
- 4,591,417. **THE AUTOX AND DESIGN**. THE AUTO EXCHANGE, LLC, (U.S. CLS. 100, 101 AND 102). SN 86-001,543. PUB. 6-10-2014. FILED 7-3-2013.
- 4,591,464. **COMPLIANCETRACK (STANDARD CHARACTER)**. AVMETRICS, (U.S. CLS. 100, 101 AND 102). SN 86-006,609. PUB. 6-10-2014. FILED 7-10-2013.
- 4,591,502. **SSB&T (STANDARD CHARACTER)**. STEELE STREET BANK & TRUST, (U.S. CLS. 100, 101 AND 102). SN 86-012,282. PUB. 6-10-2014. FILED 7-17-2013.
- 4,591,507 ( *See Class 35 for this trademark*).
- 4,591,516. **KOK LAND MANAGEMENT SERVICES INC AND DESIGN**. KOK LAND MANAGEMENT SERVICES, INC., (U.S. CLS. 100, 101 AND 102). SN 86-014,756. PUB. 6-10-2014. FILED 7-19-2013.
- 4,591,521. **JOHN WAYNE CANCER FIGHTERS (STANDARD CHARACTER)**. JOHN WAYNE CANCER FOUNDATION, (U.S. CLS. 100, 101 AND 102). SN 86-016,813. PUB. 6-10-2014. FILED 7-22-2013.
- 4,591,533. **JETCASH (STANDARD CHARACTER)**. CUMMINS-ALLISON CORP., (U.S. CLS. 100, 101 AND 102). SN 86-022,265. PUB. 6-10-2014. FILED 7-29-2013.
- 4,591,548. **GIANT QUACKY (STANDARD CHARACTER)**. GREAT AMERICAN DUCK RACES, INC., DBA GAME: GREAT AMERICAN MERCHANDISE AND EVENTS, (U.S. CLS. 100, 101 AND 102). SN 86-026,150. PUB. 6-10-2014. FILED 8-1-2013.
- 4,591,615. **CIFO (STANDARD CHARACTER)**. CISNEROS FONTANALS ART FOUNDATION, DBA CIFO, (U.S. CLS. 100, 101 AND 102). SN 86-043,636. PUB. 6-10-2014. FILED 8-21-2013.
- 4,591,675. **SERKET RACING AND DESIGN**. SERKET RACING LLC, (U.S. CLS. 100, 101 AND 102). SN 86-062,791. PUB. 6-10-2014. FILED 9-12-2013.
- 4,591,692. **NGM INSURANCE COMPANY AND DESIGN**. MAIN STREET AMERICA GROUP, INC., (U.S. CLS. 100, 101 AND 102). SN 86-068,355. PUB. 6-10-2014. FILED 9-18-2013.
- 4,591,697. **ACUITY WEALTH MANAGEMENT (STANDARD CHARACTER)**. ACUITY WEALTH MANAGEMENT, LLC, (U.S. CLS. 100, 101 AND 102). SN 86-069,494. PUB. 3-4-2014. FILED 9-19-2013.
- 4,591,707. **CLARITY STATEMENT (STANDARD CHARACTER)**. BANK OF AMERICA CORPORATION, (U.S. CLS. 100, 101 AND 102). SN 86-075,362. PUB. 6-10-2014. FILED 9-26-2013.
- 4,591,708. **NEW MEXICO STUDENT LOANS (STANDARD CHARACTER)**. THE NEW MEXICO EDUCATIONAL ASSISTANCE FOUNDATION, (U.S. CLS. 100, 101 AND 102). SN 86-075,371. PUB. 6-10-2014. FILED 9-26-2013.
- 4,591,724 ( *See Class 35 for this trademark*).
- 4,591,762 ( *See Class 35 for this trademark*).
- 4,591,763 ( *See Class 35 for this trademark*).
- 4,591,764 ( *See Class 35 for this trademark*).
- 4,591,775 ( *See Class 35 for this trademark*).
- 4,591,776. **BEST WINERY CHEFS SONOMA COUNTY AND DESIGN**. SANTA ROSA SUNRISE ROTARY CLUB, (U.S. CLS. 100, 101 AND 102). SN 86-095,949. PUB. 6-10-2014. FILED 10-18-2013.
- 4,591,784. **RENT DITTMAR (STANDARD CHARACTER)**. DITTMAR COMPANY, (U.S. CLS. 100, 101 AND 102). SN 86-097,780. PUB. 6-10-2014. FILED 10-22-2013.
- 4,591,829. **SHAPING ACADEMIC FUTURES (STANDARD CHARACTER)**. THE GO PROJECT, INC., MULTIPLE CLASS, (INT. CLS. 36, 41 AND 45), (U.S. CLS. 100, 101, 102 AND 107). SN 86-107,075. PUB. 6-10-2014. FILED 10-31-2013.
- 4,591,830. **ANNUITY DOCTOR (STANDARD CHARACTER)**. BERWICK INSURANCE GROUP LLC, (U.S. CLS. 100, 101 AND 102). SN 86-107,155. PUB. 6-10-2014. FILED 10-31-2013.
- 4,591,867. **NEST SEEKERS INTERNATIONAL (STYLIZED)**. NEST SEEKERS LLC, (U.S. CLS. 100, 101 AND 102). SN 86-115,570. PUB. 6-10-2014. FILED 11-11-2013.
- 4,591,870. **NEST SEEKERS INTERNATIONAL (STANDARD CHARACTER)**. NEST SEEKERS LLC, (U.S. CLS. 100, 101 AND 102). SN 86-115,698. PUB. 6-10-2014. FILED 11-11-2013.
- 4,591,880 ( *See Class 35 for this trademark*).
- 4,591,897. **N AND DESIGN**. NEST SEEKERS LLC, (U.S. CLS. 100, 101 AND 102). SN 86-120,453. PUB. 6-10-2014. FILED 11-15-2013.
- 4,591,904. **BOSTON BAR FOUNDATION (STANDARD CHARACTER)**. BOSTON BAR ASSOCIATION, (U.S. CLS. 100, 101 AND 102). SN 86-121,768. PUB. 6-10-2014. FILED 11-18-2013.
- 4,591,908. **GCCS 1963 AND DESIGN**. GULF COAST ADJUSTMENT SERVICE OF HOUSTON, INC., DBA GULF COAST CLAIMS SERVICE, (U.S. CLS. 100, 101 AND 102). SN 86-122,834. PUB. 6-10-2014. FILED 11-19-2013.
- 4,591,927 ( *See Class 35 for this trademark*).
- 4,591,952. **THE MOUNTAIN STANDS BEHIND YOU. (STANDARD CHARACTER)**. MOUNTAIN STATES MUTUAL CASUALTY COMPANY, (U.S. CLS. 100, 101 AND 102). SN 86-128,781. PUB. 6-10-2014. FILED 11-25-2013.
- 4,591,956 ( *See Class 35 for this trademark*).
- 4,591,988. **SHARESPOST INVESTMENT MANAGEMENT (STANDARD CHARACTER)**. SHARESPOST, INC., (U.S. CLS. 100, 101 AND 102). SN 86-133,147. PUB. 6-10-2014. FILED 12-2-2013.
- 4,591,989. **TALKMARKETS AND DESIGN**. TALKMARKETS, LLC, (U.S. CLS. 100, 101 AND 102). SN 86-133,282. PUB. 6-10-2014. FILED 12-4-2013.
- 4,591,998. **HAMPTONS ESCAPE (STANDARD CHARACTER)**. HAMPTONS ESCAPE, INC., MULTIPLE CLASS, (INT. CLS. 36 AND 43), (U.S. CLS. 100, 101 AND 102). SN 86-134,785. PUB. 6-10-2014. FILED 12-4-2013.
- 4,592,008. **RFIG ROYAL FINANCIAL INVESTMENT GROUP GRAND ADVICE FOR THE COMMON INVESTOR AND DESIGN**. ROYAL FINANCIAL INVESTMENT GROUP LLC, (U.S. CLS. 100, 101 AND 102). SN 86-136,960. PUB. 6-10-2014. FILED 12-6-2013.
- 4,592,078. **REAL ESTATE ARTISAN (STANDARD CHARACTER)**. REALITY REALTY PROFESSIONALS, LLC, (U.S. CLS. 100, 101 AND 102). SN 86-144,821. PUB. 6-10-2014. FILED 12-16-2013.
- 4,592,101 ( *See Class 35 for this trademark*).
- 4,592,115 ( *See Class 35 for this trademark*).



- 4,592,138 ( *See Class 35 for this trademark* ).  
 4,592,161 ( *See Class 35 for this trademark* ).  
 4,592,174. **LBPM AND DESIGN**. LB PROPERTY MANAGEMENT, INC., (U.S. CLS. 100, 101 AND 102). SN 86-154,258. PUB. 6-10-2014. FILED 12-30-2013.  
 4,592,176 ( *See Class 35 for this trademark* ).  
 4,592,198 ( *See Class 35 for this trademark* ).  
 4,592,243. **SETTLERS LIFE IT'S ABOUT PEOPLE. AND DESIGN**. SETTLERS LIFE INSURANCE COMPANY, (U.S. CLS. 100, 101 AND 102). SN 86-157,836. PUB. 6-10-2014. FILED 1-6-2014.  
 4,592,249. **MORRIS WILLIAMS REALTY (STANDARD CHARACTER)**. MORRIS WILLIAMS CORPORATION, DBA MORRIS WILLIAMS REALTY, (U.S. CLS. 100, 101 AND 102). SN 86-158,202. PUB. 6-10-2014. FILED 1-6-2014.  
 4,592,274 ( *See Class 35 for this trademark* ).  
 4,592,275 ( *See Class 35 for this trademark* ).  
 4,592,294. **STREET SMART VEHICLE PROTECTION (STANDARD CHARACTER)**. CREDITGUARD CORPORATION, (U.S. CLS. 100, 101 AND 102). SN 86-160,041. PUB. 6-10-2014. FILED 1-8-2014.  
 4,592,295. **MARI REALTY (STANDARD CHARACTER)**. EAST TEXAS PROPERTY SEARCH, INC., (U.S. CLS. 100, 101 AND 102). SN 86-160,043. PUB. 6-10-2014. FILED 1-8-2014.  
 4,592,315. **SOURCE INTERNATIONAL (STANDARD CHARACTER)**. SOURCE INTERNATIONAL, INC., (U.S. CLS. 100, 101 AND 102). SN 86-161,151. PUB. 6-10-2014. FILED 1-9-2014.  
 4,592,317. **NFL PLAYER CARE FOUNDATION AND DESIGN**. NATIONAL FOOTBALL LEAGUE, (U.S. CLS. 100, 101 AND 102). SN 86-161,209. PUB. 6-10-2014. FILED 1-9-2014.  
 4,592,349. **MVP REALTY (STANDARD CHARACTER)**. MVP REALTY ASSOCIATES, DBA MVP REALTY, (U.S. CLS. 100, 101 AND 102). SN 86-161,929. PUB. 6-10-2014. FILED 1-9-2014.  
 4,592,356. **ERGAWEALTH (STANDARD CHARACTER)**. IAN LATERREUR INC., (U.S. CLS. 100, 101 AND 102). SN 86-162,123. PUB. 6-10-2014. FILED 1-10-2014.  
 4,592,357. **GREATER ALABAMA MLS SEARCH REAL ESTATE LIKE A PRO AND DESIGN**. GREATER ALABAMA MULTIPLE LISTING SERVICE, INC., (U.S. CLS. 100, 101 AND 102). SN 86-162,139. PUB. 6-10-2014. FILED 1-10-2014.  
 4,592,358. **GREATER ALABAMA MLS AND DESIGN**. GREATER ALABAMA MULTIPLE LISTING SERVICE, INC., (U.S. CLS. 100, 101 AND 102). SN 86-162,142. PUB. 6-10-2014. FILED 1-10-2014.  
 4,592,373 ( *See Class 35 for this trademark* ).  
 4,592,375. **CLI CAPITAL AND DESIGN**. CHURCH LOANS & INVESTMENTS TRUST, (U.S. CLS. 100, 101 AND 102). SN 86-162,657. PUB. 6-10-2014. FILED 1-10-2014.  
 4,592,408. **NYCB PURCHASE ACCELERATOR (STANDARD CHARACTER)**. NEW YORK COMMUNITY BANCORP, INC., (U.S. CLS. 100, 101 AND 102). SN 86-163,380. PUB. 6-10-2014. FILED 1-12-2014.  
 4,592,425 ( *See Class 35 for this trademark* ).  
 4,592,433. **INSYNC ANALYTICS (STANDARD CHARACTER)**. INSYNC ANALYTICS LLC, (U.S. CLS. 100, 101 AND 102). SN 86-164,204. PUB. 6-10-2014. FILED 1-13-2014.  
 4,592,441. **12 14 FOUNDATION AND DESIGN**. 1214 FOUNDATION, INC., (U.S. CLS. 100, 101 AND 102). SN 86-164,633. PUB. 6-10-2014. FILED 1-14-2014.  
 4,592,474. **MATRIMONEY METHOD (STANDARD CHARACTER)**. RICHARDSON, MAUREEN, (U.S. CLS. 100, 101 AND 102). SN 86-165,664. PUB. 6-10-2014. FILED 1-15-2014.  
 4,592,524. **ALTRUISTA (STANDARD CHARACTER)**. NASSER, ALI, (U.S. CLS. 100, 101 AND 102). SN 86-167,194. PUB. 6-10-2014. FILED 1-16-2014.  
 4,592,537. **CARLISLE INSURANCE - SINCE 1925 - TAKE PRIDE AND DESIGN**. CARLISLE INSURANCE AGENCY, INC., (U.S. CLS. 100, 101 AND 102). SN 86-167,598. PUB. 6-10-2014. FILED 1-16-2014.  
 4,592,539. **CARLISLE INSURANCE SINCE 1925 (STANDARD CHARACTER)**. CARLISLE INSURANCE AGENCY, INC., (U.S. CLS. 100, 101 AND 102). SN 86-167,617. PUB. 6-10-2014. FILED 1-16-2014.  
 4,592,555 ( *See Class 35 for this trademark* ).  
 4,592,557 ( *See Class 35 for this trademark* ).  
 4,592,561. **MSI AND DESIGN**. CHARLES ANTON GEORGE, (U.S. CLS. 100, 101 AND 102). SN 86-168,974. PUB. 6-10-2014. FILED 1-17-2014.  
 4,592,567. **STRAIGHT FROM THE TAPE (STANDARD CHARACTER)**. TROFAST MEDIA LLC, (U.S. CLS. 100, 101 AND 102). SN 86-169,157. PUB. 6-10-2014. FILED 1-17-2014.  
 4,592,571. **FEED4MORE (STANDARD CHARACTER)**. WHOLE FOODS MARKET IP, L.P., (U.S. CLS. 100, 101 AND 102). SN 86-170,237. PUB. 6-10-2014. FILED 1-20-2014.  
 4,592,585. **ONE HEALTHY STEP FOR MAN... ONE GIANT LEAP FOR THE HEALTH OF MAN KIND. (STANDARD CHARACTER)**. TIMOTHY TELYMONDE, (U.S. CLS. 100, 101 AND 102). SN 86-171,992. PUB. 6-10-2014. FILED 1-22-2014.  
 4,592,610 ( *See Class 35 for this trademark* ).  
 4,592,629. **CURIAN (STANDARD CHARACTER)**. JACKSON NATIONAL LIFE INSURANCE COMPANY, (U.S. CLS. 100, 101 AND 102). SN 86-174,682. PUB. 6-10-2014. FILED 1-24-2014.  
 4,592,681 ( *See Class 35 for this trademark* ).  
 4,592,693. **THINK DIFFERENTLY. INVEST TACTICALLY. (STANDARD CHARACTER)**. YIELDQUEST SECURITIES, (U.S. CLS. 100, 101 AND 102). SN 86-176,054. PUB. 6-10-2014. FILED 1-27-2014.  
 4,592,694. **NEW WAYS OF THINKING (STANDARD CHARACTER)**. PUTNAM INVESTMENTS, LLC, (U.S. CLS. 100, 101 AND 102). SN 86-176,055. PUB. 6-10-2014. FILED 1-27-2014.  
 4,592,709. **CC (STYLIZED)**. CAPITAL IMPACT PARTNERS, (U.S. CLS. 100, 101 AND 102). SN 86-176,362. PUB. 6-10-2014. FILED 1-27-2014.  
 4,592,710. **JENNIFER ANN MCTIGUE (STANDARD CHARACTER)**. NEKAI CORP, (U.S. CLS. 100, 101 AND 102). SN 86-176,391. PUB. 6-10-2014. FILED 1-27-2014.  
 4,592,712. **JEFFREY ALLAN BRODE (STANDARD CHARACTER)**. SOLAS CORPORATION, (U.S. CLS. 100, 101 AND 102). SN 86-176,425. PUB. 6-10-2014. FILED 1-27-2014.  
 4,592,728. **SHOOT FOR THE STARS (STANDARD CHARACTER)**. SHEEHAN, JOHN C., (U.S. CLS. 100, 101 AND 102). SN 86-176,813. PUB. 6-10-2014. FILED 1-27-2014.  
 4,592,756. **TIPQUICK (STANDARD CHARACTER)**. TIPQUICK PARTNERS LLC, (U.S. CLS. 100, 101 AND 102). SN 86-177,228. PUB. 6-10-2014. FILED 1-28-2014.  
 4,592,781. **UMIALIK (STANDARD CHARACTER)**. WESTERN NATIONAL MUTUAL INSURANCE COMPANY, (U.S. CLS. 100, 101 AND 102). SN 86-177,714. PUB. 6-10-2014. FILED 1-28-2014.  
 4,592,786. **EARTHWAYS (STANDARD CHARACTER)**. EARTHWAYS FOUNDATION, (U.S. CLS. 100, 101 AND 102). SN 86-177,764. PUB. 6-10-2014. FILED 1-28-2014.  
 4,592,871 ( *See Class 35 for this trademark* ).  
 4,592,886. **GIVING COMFORT (STANDARD CHARACTER)**. MCKESSON FOUNDATION INC., (U.S. CLS. 100, 101 AND 102). SN 86-179,770. PUB. 6-10-2014. FILED 1-30-2014.  
 4,593,059. **MISCELLANEOUS DESIGN**. WBI INVESTMENTS, INC., (U.S. CLS. 100, 101 AND 102). SN 86-254,712. PUB. 6-10-2014. FILED 4-17-2014.
- 
- CLASS 37—CONSTRUCTION AND REPAIR**
- 4,590,635 ( *See Class 9 for this trademark* ).  
 4,590,655 ( *See Class 9 for this trademark* ).  
 4,590,662 ( *See Class 7 for this trademark* ).  
 4,590,683. **PREPATINA AND DESIGN**. RHEINZINK GMBH & CO. KG, MULTIPLE CLASS, (INT. CLS. 37 AND 42), (U.S. CLS. 100, 101, 103 AND 106). SN 79-129,229. PUB. 6-10-2014. FILED 11-9-2012.  
 4,590,687 ( *See Class 7 for this trademark* ).  
 4,590,705 ( *See Class 7 for this trademark* ).  
 4,590,710 ( *See Class 7 for this trademark* ).  
 4,590,711 ( *See Class 7 for this trademark* ).  
 4,590,721 ( *See Class 9 for this trademark* ).  
 4,590,735 ( *See Class 36 for this trademark* ).  
 4,590,742 ( *See Class 9 for this trademark* ).  
 4,590,744 ( *See Class 7 for this trademark* ).  
 4,590,752 ( *See Class 9 for this trademark* ).  
 4,590,774 ( *See Class 35 for this trademark* ).

- 4,590,775 ( *See Class 35 for this trademark.*)  
 4,590,778 ( *See Class 9 for this trademark.*)  
 4,590,797 ( *See Class 9 for this trademark.*)  
 4,590,803 ( *See Class 6 for this trademark.*)  
 4,590,806 ( *See Class 7 for this trademark.*)  
 4,590,818 ( *See Class 11 for this trademark.*)  
 4,590,824 ( *See Class 1 for this trademark.*)  
 4,590,844 ( *See Class 7 for this trademark.*)  
 4,590,885 ( *See Class 7 for this trademark.*)  
 4,590,993 ( *See Class 9 for this trademark.*)  
 4,591,008 ( *See Class 35 for this trademark.*)  
 4,591,046 ( *See Class 9 for this trademark.*)  
 4,591,114 ( *See Class 6 for this trademark.*)  
 4,591,162 ( *See Class 7 for this trademark.*)  
 4,591,190. **KAI TOTAL PAVEMENT MANAGEMENT AND DESIGN.** KANSAS ASPHALT, INC., (U.S. CLS. 100, 103 AND 106). SN 85-925,543. PUB. 6-10-2014. FILED 5-7-2013.  
 4,591,212. **DADDONA CONSTRUCTION (STANDARD CHARACTER).** DADDONA, MICHAEL, (U.S. CLS. 100, 103 AND 106). SN 85-938,849. PUB. 6-10-2014. FILED 5-21-2013.  
 4,591,213. **RATIONAL SUSTAINABILITY (STANDARD CHARACTER).** WOODMEISTER MASTER BUILDERS, INC., (U.S. CLS. 100, 103 AND 106). SN 85-939,144. PUB. 6-10-2014. FILED 5-22-2013.  
 4,591,214. **FM 2 A SERVICE OF LEE COMPANY AND DESIGN.** LEE COMPANY, MULTIPLE CLASS, (INT. CLS. 37 AND 42), (U.S. CLS. 100, 101, 103 AND 106). SN 85-939,791. PUB. 6-10-2014. FILED 5-22-2013.  
 4,591,216. **WOODMEISTER (STANDARD CHARACTER).** WOODMEISTER MASTER BUILDERS, INC., (U.S. CLS. 100, 103 AND 106). SN 85-941,250. PUB. 6-10-2014. FILED 5-23-2013.  
 4,591,263 ( *See Class 35 for this trademark.*)  
 4,591,294. **SCHELL BROTHERS (STANDARD CHARACTER).** SCHELL BROTHERS LLC, TA SCHELL BROTHERS, (U.S. CLS. 100, 103 AND 106). SN 85-963,840. PUB. 6-10-2014. FILED 6-19-2013.  
 4,591,330. **NEXT STEP LIVING (STANDARD CHARACTER).** NEXT STEP LIVING, INC., (U.S. CLS. 100, 103 AND 106). SN 85-968,856. PUB. 6-10-2014. FILED 6-25-2013.  
 4,591,357. **RAY ST. CLAIR ROOFING AND DESIGN.** RAY ST. CLAIR ROOFING, INC., (U.S. CLS. 100, 103 AND 106). SN 85-972,103. PUB. 6-10-2014. FILED 6-27-2013.  
 4,591,376. **TICK BUSTERS (STANDARD CHARACTER).** TICK BUSTERS, LLC, DBA TICK BUSTERS LLC, (U.S. CLS. 100, 103 AND 106). SN 85-974,147. PUB. 6-10-2014. FILED 7-1-2013.  
 4,591,390 ( *See Class 35 for this trademark.*)  
 4,591,399. **FSB1000 FORMULATED SOIL BINDER (STANDARD CHARACTER).** SOIL-TECH, INC., (U.S. CLS. 100, 103 AND 106). SN 86-000,021. PUB. 6-10-2014. FILED 7-1-2013.  
 4,591,467. **COLORADO BARRICADE (STANDARD CHARACTER).** COLORADO BARRICADE COMPANY, LLC, (U.S. CLS. 100, 103 AND 106). SN 86-006,866. PUB. 6-10-2014. FILED 7-10-2013.  
 4,591,478. **CB AND DESIGN.** COLORADO BARRICADE COMPANY, LLC, (U.S. CLS. 100, 103 AND 106). SN 86-009,479. PUB. 6-10-2014. FILED 7-12-2013.  
 4,591,506. **TOTALLY TANKER INTERIORS AND DESIGN.** TOTALLY TANKER INTERIORS, INC, DBA TOTALLY TANKER INTERIORS, INC., (U.S. CLS. 100, 103 AND 106). SN 86-012,680. PUB. 6-10-2014. FILED 7-17-2013.  
 4,591,560. **FLO-RITE (STANDARD CHARACTER).** DOUGLAS G. CHONG SERVICES, LLC, AKA DGC SERVICES LLC, (U.S. CLS. 100, 103 AND 106). SN 86-027,854. PUB. 6-10-2014. FILED 8-2-2013.  
 4,591,657 ( *See Class 35 for this trademark.*)  
 4,591,658. **24-7 COOPERATIVE (STANDARD CHARACTER).** 24-7 TELCOM, INC., MULTIPLE CLASS, (INT. CLS. 37, 38, 42 AND 45), (U.S. CLS. 100, 101, 103, 104 AND 106). SN 86-056,002. PUB. 6-10-2014. FILED 9-4-2013.  
 4,591,715. **MISCELLANEOUS DESIGN.** POSEIDON BARGE CORPORATION, MULTIPLE CLASS, (INT. CLS. 37 AND 39), (U.S. CLS. 100, 103, 105 AND 106). SN 86-076,961. PUB. 6-10-2014. FILED 9-27-2013.  
 4,591,731. **HARMON (STANDARD CHARACTER).** PRISM ASSURANCE, LTD., (U.S. CLS. 100, 103 AND 106). SN 86-081,495. PUB. 6-10-2014. FILED 10-3-2013.  
 4,591,759. **TEEWASH (STANDARD CHARACTER).** GASVENTURE 1, LLC, (U.S. CLS. 100, 103 AND 106). SN 86-088,249. PUB. 6-10-2014. FILED 10-10-2013.  
 4,591,820. **MOREVENT HEATING COOLING PLUMBING AND DESIGN.** MORVENT AIR CONDITIONING & HEATING, LLC, (U.S. CLS. 100, 103 AND 106). SN 86-105,808. PUB. 6-10-2014. FILED 10-30-2013.  
 4,591,825 ( *See Class 35 for this trademark.*)  
 4,591,932. **SHE PAINTS AND DESIGN.** REBECCA AND JAMES PICKENS AND ASSOCIATES, LLC, DBA SHE PAINTS PHILLY, (U.S. CLS. 100, 103 AND 106). SN 86-126,634. PUB. 6-10-2014. FILED 11-22-2013.  
 4,591,957. **CRTS AND DESIGN.** CRTS, INC., (U.S. CLS. 100, 103 AND 106). SN 86-129,665. PUB. 6-10-2014. FILED 11-26-2013.  
 4,591,972. **MAR(BACKWARDS K) CEMENT CONTRACTORS (STYLIZED).** M. LEUZZI, JR & V. LEUZZI CEMENT CONTRACTORS, LLC, (U.S. CLS. 100, 103 AND 106). SN 86-131,489. PUB. 6-10-2014. FILED 11-27-2013.  
 4,591,976. **M.T. DUNN PLUMBING AND DESIGN.** MICHAEL T. DUNN, DBA MICHAEL T. DUNN PLUMBING, (U.S. CLS. 100, 103 AND 106). SN 86-132,075. PUB. 6-10-2014. FILED 11-30-2013.  
 4,591,999. **A HEALTHY HOME CRAWLSPACE SOLUTIONS (STYLIZED).** CRAWLSPACE SOLUTIONS A HEALTHY HOME, LLC, (U.S. CLS. 100, 103 AND 106). SN 86-135,395. PUB. 6-10-2014. FILED 12-4-2013.  
 4,592,011. **SERGTEC CORP. (STANDARD CHARACTER).** SERGTEC CORPORATION, (U.S. CLS. 100, 103 AND 106). SN 86-137,184. PUB. 6-10-2014. FILED 12-6-2013.  
 4,592,026. **DIRK'S (STANDARD CHARACTER).** KANG, SHIN-KU, (U.S. CLS. 100, 103 AND 106). SN 86-138,919. PUB. 6-10-2014. FILED 12-9-2013.  
 4,592,050. **PANDA CARPET & TILE CLEANING (STANDARD CHARACTER).** BAILEY, BRAD, (U.S. CLS. 100, 103 AND 106). SN 86-142,095. PUB. 6-10-2014. FILED 12-12-2013.  
 4,592,053. **REPAIR PRO (STANDARD CHARACTER).** SHOGUN SERVICES LLC, DBA SHOGUN SERVICES, (U.S. CLS. 100, 103 AND 106). SN 86-142,522. PUB. 6-10-2014. FILED 12-12-2013.  
 4,592,130. **ANYWHERE BICYCLE REPAIR (STANDARD CHARACTER).** STU CLOTT, (U.S. CLS. 100, 103 AND 106). SN 86-151,101. PUB. 6-10-2014. FILED 12-23-2013.  
 4,592,203. **HALEY & ALDRICH CONSTRUCTION SERVICES AND DESIGN.** HALEY & ALDRICH CONSTRUCTION SERVICES, INC., (U.S. CLS. 100, 103 AND 106). SN 86-155,879. PUB. 6-10-2014. FILED 1-2-2014.  
 4,592,218. **SAFE SOLUTIONS (STANDARD CHARACTER).** SAFE SOLUTIONS CARPET CLEANING, (U.S. CLS. 100, 103 AND 106). SN 86-156,525. PUB. 6-10-2014. FILED 1-2-2014.  
 4,592,276. **Z ZIMMERMANN HOMES (STYLIZED).** ZIMMERMANN HOMES, LLC, (U.S. CLS. 100, 103 AND 106). SN 86-159,343. PUB. 6-10-2014. FILED 1-7-2014.  
 4,592,305. **TITANZ PLUMBING INC. TZ AND DESIGN.** TITANZ PLUMBING INC., (U.S. CLS. 100, 103 AND 106). SN 86-160,555. PUB. 6-10-2014. FILED 1-8-2014.  
 4,592,309. **WHEN COMFORT CAN'T WAIT (STANDARD CHARACTER).** DALLAS UNIQUE INDOOR COMFORT, LTD., (U.S. CLS. 100, 103 AND 106). SN 86-160,689. PUB. 6-10-2014. FILED 1-8-2014.  
 4,592,310 ( *See Class 35 for this trademark.*)  
 4,592,311. **DISTINCT URBAN LIVING (STANDARD CHARACTER).** CAPITAL CITY REAL ESTATE, (U.S. CLS. 100, 103 AND 106). SN 86-160,982. PUB. 6-10-2014. FILED 1-9-2014.  
 4,592,345. **OUTDOOR LIVING DESIGNED AROUND YOU (STANDARD CHARACTER).** SYSTEMS PAVING, INC., DBA SYSTEM PAVERS, MULTIPLE CLASS, (INT. CLS. 37, 42 AND 44), (U.S. CLS. 100, 101, 103 AND 106). SN 86-161,871. PUB. 6-10-2014. FILED 1-9-2014.  
 4,592,364. **VALUE DRY (STANDARD CHARACTER).** JMS CONSTRUCTORS, INC., DBA VALUE DRY, (U.S. CLS. 100, 103 AND 106). SN 86-162,375. PUB. 6-10-2014. FILED 1-10-2014.  
 4,592,382. **MISCELLANEOUS DESIGN.** PEST SHIELD PEST CONTROL SERVICES, INC., (U.S. CLS. 100, 103 AND 106).

- SN 86-162,785. PUB. 6-10-2014. FILED 1-10-2014.
- 4,592,386. **TEMPORARY REPAIR LLC THE GREEN TARP TEAM AND DESIGN**. TEMPORARY REPAIR LLC, (U.S. CLS. 100, 103 AND 106). SN 86-162,862. PUB. 6-10-2014. FILED 1-10-2014.
- 4,592,416. **OXBUILT CONSTRUCTION (STANDARD CHARACTER)**. OXBUILT CONSTRUCTION, LLC, (U.S. CLS. 100, 103 AND 106). SN 86-163,512. PUB. 6-10-2014. FILED 1-13-2014.
- 4,592,516. **PYRAMIDS IN FLORIDA (STANDARD CHARACTER)**. HOENTZSCH GERTRAUD, MULTIPLE CLASS, (INT. CLS. 37 AND 43), (U.S. CLS. 100, 101, 103 AND 106). SN 86-166,977. PUB. 6-10-2014. FILED 1-16-2014.
- 4,592,551. **UHS BUILDING SOLUTIONS (STANDARD CHARACTER)**. UHS OF DELAWARE, INC., MULTIPLE CLASS, (INT. CLS. 37 AND 42), (U.S. CLS. 100, 101, 103 AND 106). SN 86-168,220. PUB. 6-10-2014. FILED 1-17-2014.
- 4,592,562 ( *See Class 35 for this trademark*).
- 4,592,608. **WE PUT THE "WOW" IN WINDOWS! (STANDARD CHARACTER)**. WINDOWS, LLC, DBA RENEWAL BY ANDERSEN, (U.S. CLS. 100, 103 AND 106). SN 86-173,171. PUB. 6-10-2014. FILED 1-23-2014.
- 4,592,627. **RUCRACKED? (STANDARD CHARACTER)**. RUCRACKED?, LLC, (U.S. CLS. 100, 103 AND 106). SN 86-174,567. PUB. 6-10-2014. FILED 1-24-2014.
- 4,592,665. **MISCELLANEOUS DESIGN**. TRIPLE S ENTERPRISES INC., (U.S. CLS. 100, 103 AND 106). SN 86-175,598. PUB. 6-10-2014. FILED 1-27-2014.
- 4,592,689. **BAKER ROOFING COMPANY (STANDARD CHARACTER)**. BAKER ROOFING COMPANY, (U.S. CLS. 100, 103 AND 106). SN 86-176,015. PUB. 6-10-2014. FILED 1-27-2014.
- 4,592,757 ( *See Class 35 for this trademark*).
- 4,592,796. **SUMMIT CREEK (STANDARD CHARACTER)**. LYONS GATE, LLC, (U.S. CLS. 100, 103 AND 106). SN 86-177,858. PUB. 6-10-2014. FILED 1-28-2014.
- 4,592,804. **WAVE CONNECTS (STANDARD CHARACTER)**. WAVE CONNECTS, INC., (U.S. CLS. 100, 103 AND 106). SN 86-178,021. PUB. 6-10-2014. FILED 1-28-2014.
- 4,592,825 ( *See Class 35 for this trademark*).
- 4,592,851. **BIOTECHS (STANDARD CHARACTER)**. SWAT ENTERPRISE, LLC, DBA BIOTECHS, (U.S. CLS. 100, 103 AND 106). SN 86-178,856. PUB. 6-10-2014. FILED 1-29-2014.
- 4,592,971. **SLIP SAVERS SAFETY FLOOR & BATH TREATMENTS AND DESIGN**. SLIP SAVERS LLC, FORMERLY EMES, LLC, (U.S. CLS. 100, 103 AND 106). SN 86-198,131. PUB. 6-10-2014. FILED 2-19-2014.
- 4,592,996. **INSITUFORM (STANDARD CHARACTER)**. INA ACQUISITION CORP., (U.S. CLS. 100, 103 AND 106). SN 86-214,345. PUB. 6-10-2014. FILED 3-7-2014.
- 4,593,018. **SYSTEM PAVERS (STANDARD CHARACTER)**. SYSTEMS PAVING, INC., DBA SYSTEM PAVERS, MULTIPLE CLASS, (INT. CLS. 37, 42 AND 44), (U.S. CLS. 100, 101, 103 AND 106). SN 86-224,968. PUB. 6-10-2014. FILED 3-18-2014.
- 4,590,766 ( *See Class 9 for this trademark*).
- 4,590,767 ( *See Class 9 for this trademark*).
- 4,590,790 ( *See Class 9 for this trademark*).
- 4,590,799 ( *See Class 9 for this trademark*).
- 4,590,805 ( *See Class 35 for this trademark*).
- 4,590,832 ( *See Class 9 for this trademark*).
- 4,590,842 ( *See Class 9 for this trademark*).
- 4,590,870 ( *See Class 9 for this trademark*).
- 4,590,987 ( *See Class 16 for this trademark*).
- 4,590,992 ( *See Class 16 for this trademark*).
- 4,591,001 ( *See Class 9 for this trademark*).
- 4,591,046 ( *See Class 9 for this trademark*).
- 4,591,067. **JESUS FILM (STANDARD CHARACTER)**. CAMPUS CRUSADE FOR CHRIST, INC., AKA CRU, (U.S. CLS. 100, 101 AND 104). SN 85-793,477. PUB. 6-10-2014. FILED 12-3-2012.
- 4,591,076 ( *See Class 9 for this trademark*).
- 4,591,078. **THE WEEKLY FEED AND DESIGN**. LOUISVILLE PUBLIC MEDIA, INC., MULTIPLE CLASS, (INT. CLS. 38 AND 41), (U.S. CLS. 100, 101, 104 AND 107). SN 85-801,202. PUB. 6-10-2014. FILED 12-12-2012.
- 4,591,088 ( *See Class 9 for this trademark*).
- 4,591,121. **N7 AND DESIGN**. DEUTSCHE BORSE AG, (U.S. CLS. 100, 101 AND 104). SN 85-861,350. PUB. 6-10-2014. FILED 2-27-2013.
- 4,591,144. **PINKMAIL.ORG (STYLIZED)**. BROCK, MICHAEL, (U.S. CLS. 100, 101 AND 104). SN 85-881,641. PUB. 6-10-2014. FILED 3-20-2013.
- 4,591,170 ( *See Class 9 for this trademark*).
- 4,591,173 ( *See Class 9 for this trademark*).
- 4,591,208 ( *See Class 9 for this trademark*).
- 4,591,228. **TV CHILE AND DESIGN**. TELEVISIÓN NACIONAL DE CHILE, (U.S. CLS. 100, 101 AND 104). SN 85-944,607. PUB. 6-10-2014. FILED 5-29-2013.
- 4,591,347. **LIFE LIVES HERE (STANDARD CHARACTER)**. SCRIPPS NETWORKS, LLC, MULTIPLE CLASS, (INT. CLS. 38 AND 41), (U.S. CLS. 100, 101, 104 AND 107). SN 85-970,894. PUB. 5-20-2014. FILED 6-26-2013.
- 4,591,433 ( *See Class 9 for this trademark*).
- 4,591,456. **THE NEW AMERICAN VETERAN (STANDARD CHARACTER)**. GALLANTFEW, INC., (U.S. CLS. 100, 101 AND 104). SN 86-005,446. PUB. 6-10-2014. FILED 7-9-2013.
- 4,591,565. **POWERMEDED AND DESIGN**. POWERMEDED LLC, (U.S. CLS. 100, 101 AND 104). SN 86-028,368. PUB. 6-10-2014. FILED 8-5-2013.
- 4,591,583. **DISASTER RECOVERYNOW AND DESIGN**. O4IT USA, LLC, (U.S. CLS. 100, 101 AND 104). SN 86-033,624. PUB. 6-10-2014. FILED S.R. 8-9-2013; AM. P.R. 5-1-2014.
- 4,591,604. **ALL DEF DIGITAL (STANDARD CHARACTER)**. DJR HOLDINGS, LLC, (U.S. CLS. 100, 101 AND 104). SN 86-040,596. PUB. 6-10-2014. FILED 8-16-2013.
- 4,591,658 ( *See Class 37 for this trademark*).
- 4,591,803. **CARCHIVE (STANDARD CHARACTER)**. TOYOTA JIDOSHA KABUSHIKI KAISHA, TA TOYOTA MOTOR CORPORATION, MULTIPLE CLASS, (INT. CLS. 38, 42 AND 45), (U.S. CLS. 100, 101 AND 104). SN 86-101,542. PUB. 6-10-2014. FILED 10-25-2013.
- 4,591,822 ( *See Class 35 for this trademark*).
- 4,591,882. **CHARTER SPECTRUM TV|INTERNET|VOICE AND DESIGN**. CHARTER COMMUNICATIONS HOLDING COMPANY L.L.C., MULTIPLE CLASS, (INT. CLS. 38, 39 AND 42), (U.S. CLS. 100, 101, 104 AND 105). SN 86-117,895. PUB. 6-10-2014. FILED 11-13-2013.
- 4,591,956 ( *See Class 35 for this trademark*).
- 4,591,958 ( *See Class 9 for this trademark*).
- 4,592,175. **TELNEXUS (STANDARD CHARACTER)**. TELNEXUS INVESTMENTS, LLC, (U.S. CLS. 100, 101 AND 104). SN 86-154,276. PUB. 6-10-2014. FILED 12-30-2013.
- 4,592,184. **TUNNEL GUARD (STANDARD CHARACTER)**. GUARDED HORIZONS INC., (U.S. CLS. 100, 101 AND 104). SN 86-154,746. PUB. 6-10-2014. FILED 12-30-2013.
- 4,592,449. **TELEPHONICAPPEARANCE AND DESIGN**. APPEARBY, LLC, (U.S. CLS. 100, 101 AND 104). SN 86-164,866. PUB. 6-10-2014. FILED 1-14-2014.
- 4,592,553. **SIMPLY MAGIC PRODUCTIONS (STANDARD CHARACTER)**. TELEPHONETICS, INC., (U.S. CLS. 100, 101 AND 104). SN 86-168,428. PUB. 6-10-2014. FILED 1-17-2014.

---

## CLASS 38—COMMUNICATION

- 4,592,695. **ON HOLD ON THE GO (STANDARD CHARACTER)**. TELEPHONETICS, INC., (U.S. CLS. 100, 101 AND 104). SN 86-176,105. PUB. 6-10-2014. FILED 1-27-2014.
- 4,592,846. **KIDS EMAIL (STANDARD CHARACTER)**. RUBY WEB LLC, DBA KIDSEMAIL.ORG, (U.S. CLS. 100, 101 AND 104). SN 86-178,797. PUB. 6-10-2014. FILED 1-29-2014.
- 4,592,876. **LSX (STANDARD CHARACTER)**. IBASIS, (U.S. CLS. 100, 101 AND 104). SN 86-179,447. PUB. 6-10-2014. FILED 1-30-2014.
- 4,592,934. **GRIZZLY ADAMS (STANDARD CHARACTER)**. GRIZZLY ADAMS, LLC, (U.S. CLS. 100, 101 AND 104). SN 86-181,745. PUB. 6-10-2014. FILED 1-31-2014.

### CLASS 39—TRANSPORTATION AND STORAGE

- 4,590,647 ( *See Class 35 for this trademark* ).
- 4,590,652 ( *See Class 35 for this trademark* ).
- 4,590,655 ( *See Class 9 for this trademark* ).
- 4,590,680 ( *See Class 9 for this trademark* ).
- 4,590,681 ( *See Class 35 for this trademark* ).
- 4,590,744 ( *See Class 7 for this trademark* ).
- 4,590,767 ( *See Class 9 for this trademark* ).
- 4,590,824 ( *See Class 1 for this trademark* ).
- 4,590,836 ( *See Class 33 for this trademark* ).
- 4,590,847. **SPARBER GROUP AND DESIGN**. SPARBER TRANSPORT, S.A., (U.S. CLS. 100 AND 105). SN 79-140,556. PUB. 6-10-2014. FILED 11-22-2013.
- 4,591,001 ( *See Class 9 for this trademark* ).
- 4,591,046 ( *See Class 9 for this trademark* ).
- 4,591,084. **GROUP-EASE (STANDARD CHARACTER)**. THE CORYN GROUP II, LLC, MULTIPLE CLASS, (INT. CLS. 39 AND 43), (U.S. CLS. 100, 101 AND 105). SN 85-806,167. PUB. 6-10-2014. FILED 12-19-2012.
- 4,591,088 ( *See Class 9 for this trademark* ).
- 4,591,280. **MEDALLION INTERNATIONAL AND DESIGN**. MEDALLION TRANSPORTATION HOLDINGS INC., (U.S. CLS. 100 AND 105). SN 85-961,631. PUB. 6-10-2014. FILED 6-17-2013.
- 4,591,281. **ACE HEAVY HAUL, LLC AND DESIGN**. MEDALLION TRANSPORTATION HOLDINGS INC., (U.S. CLS. 100 AND 105). SN 85-961,692. PUB. 6-10-2014. FILED 6-17-2013.
- 4,591,282. **MEDALLION TRANSPORT & LOGISTICS SINCE 1964 AND DESIGN**. MEDALLION TRANSPORTATION HOLDINGS INC., (U.S. CLS. 100 AND 105). SN 85-961,756. PUB. 6-10-2014. FILED 6-17-2013.
- 4,591,284. **THE HEALTHCARD (STANDARD CHARACTER)**. HEALTHCAPABLE, (U.S. CLS. 100 AND 105). SN 85-962,030. PUB. 6-10-2014. FILED 6-17-2013.
- 4,591,414. **RIVER RIDIN' (STANDARD CHARACTER)**. ATKINS, CHANDLER, (U.S. CLS. 100 AND 105). SN 86-001,494. PUB. 6-10-2014. FILED 7-3-2013.
- 4,591,480. **PIONEERING THE DELIVERY OF CARE (STANDARD CHARACTER)**. ENVISION HEALTHCARE CORPORATION, (U.S. CLS. 100 AND 105). SN 86-010,087. PUB. 6-10-2014. FILED 7-15-2013.
- 4,591,581. **PIXIE & PIRATE DESTINATIONS AND DESIGN**. PIXIE AND PIRATE DESTINATIONS LLC, MULTIPLE CLASS, (INT. CLS. 39 AND 43), (U.S. CLS. 100, 101 AND 105). SN 86-033,275. PUB. 3-4-2014. FILED 8-9-2013.
- 4,591,588. **GET HERE. GET THERE. GET HOME. (STANDARD CHARACTER)**. KENTON COUNTY AIRPORT BOARD, DBA CINCINNATI/NORTHERN KENTUCKY INTERNATIONAL AIRPORT, (U.S. CLS. 100 AND 105). SN 86-035,456. PUB. 12-31-2013. FILED 8-12-2013.
- 4,591,610. **AEROWORLD TRAVEL (STANDARD CHARACTER)**. SUNRISE TOURS & TRAVEL, INC., (U.S. CLS. 100 AND 105). SN 86-042,900. PUB. 6-10-2014. FILED 8-20-2013.
- 4,591,612. **MISCELLANEOUS DESIGN**. ENVISION HEALTHCARE CORPORATION, (U.S. CLS. 100 AND 105). SN 86-043,411. PUB. 6-10-2014. FILED 8-20-2013.
- 4,591,642 ( *See Class 31 for this trademark* ).
- 4,591,684. **YOUR PRIVATE ITALY AND DESIGN**. YOUR PRIVATE ITALY, LLC, (U.S. CLS. 100 AND 105). SN 86-065,373. PUB. 6-10-2014. FILED 9-16-2013.
- 4,591,702. **ENVIA MI COMPRA (STANDARD CHARACTER)**. ZUKERMAN, DAVID BENADERET, MULTIPLE CLASS, (INT. CLS. 39 AND 45), (U.S. CLS. 100, 101 AND 105). SN 86-072,442. PUB. 6-10-2014. FILED 9-23-2013.
- 4,591,715 ( *See Class 37 for this trademark* ).
- 4,591,730 ( *See Class 9 for this trademark* ).
- 4,591,824 ( *See Class 35 for this trademark* ).
- 4,591,882 ( *See Class 38 for this trademark* ).
- 4,591,911. **PAVLUS (STANDARD CHARACTER)**. PAVLUS TRAVEL & CRUISE, INC., (U.S. CLS. 100 AND 105). SN 86-123,104. PUB. 6-10-2014. FILED 11-19-2013.
- 4,591,936. **SCOOTER SQUAD (STANDARD CHARACTER)**. BEAUCHAMP, MICHAEL T, DBA SCOOTER SQUAD, (U.S. CLS. 100 AND 105). SN 86-126,846. PUB. 6-10-2014. FILED 11-22-2013.
- 4,592,039. **OPERATION: DOG TAG FOSTERING TRANSPORTING AND DESIGN**. OPERATION DOG TAG, (U.S. CLS. 100 AND 105). SN 86-141,028. PUB. 6-10-2014. FILED 12-11-2013.
- 4,592,066 ( *See Class 35 for this trademark* ).
- 4,592,113. **BY THE SEAT OF MY SKIRT (STANDARD CHARACTER)**. WETHERINGTON, KELLY, MULTIPLE CLASS, (INT. CLS. 39 AND 41), (U.S. CLS. 100, 101, 105 AND 107). SN 86-150,172. PUB. 6-10-2014. FILED 12-20-2013.
- 4,592,123. **FOOD STORIES TRAVEL (STANDARD CHARACTER)**. CB HOSPITALITY SERVICES LLC, (U.S. CLS. 100 AND 105). SN 86-150,780. PUB. 6-10-2014. FILED 12-23-2013.
- 4,592,152. **SPEED. CHOICE. CONTROL. (STANDARD CHARACTER)**. VANGUARD TRADEMARK HOLDINGS USA LLC, (U.S. CLS. 100 AND 105). SN 86-152,474. PUB. 6-10-2014. FILED 12-26-2013.
- 4,592,213. **CF AND DESIGN**. COSMO FREIGHT SOLUTIONS, INC., (U.S. CLS. 100 AND 105). SN 86-156,218. PUB. 6-10-2014. FILED 1-2-2014.
- 4,592,217. **THE AUTO HELP LINE OF AMERICA AND DESIGN**. TVC HOLDING, INC., (U.S. CLS. 100 AND 105). SN 86-156,354. PUB. 6-10-2014. FILED 1-2-2014.
- 4,592,228. **BEHR PRO AND DESIGN**. BEHR PROCESS CORPORATION, (U.S. CLS. 100 AND 105). SN 86-157,089. PUB. 6-10-2014. FILED 1-3-2014.
- 4,592,231. **5 SENSES TOUR (STANDARD CHARACTER)**. YANIV, WENDY, (U.S. CLS. 100 AND 105). SN 86-157,126. PUB. 6-10-2014. FILED 1-3-2014.
- 4,592,265 ( *See Class 35 for this trademark* ).
- 4,592,266 ( *See Class 35 for this trademark* ).
- 4,592,318. **SALTWATER SAVAGES (STANDARD CHARACTER)**. MCGOWAN, JACOB WILLIAM, (U.S. CLS. 100 AND 105). SN 86-161,224. PUB. 6-10-2014. FILED 1-9-2014.
- 4,592,371. **COME BACK NEW (STANDARD CHARACTER)**. PRINCESS CRUISE LINES, LTD., DBA PRINCESS CRUISES, MULTIPLE CLASS, (INT. CLS. 39, 41, 43 AND 44), (U.S. CLS. 100, 101, 105 AND 107). SN 86-162,595. PUB. 6-10-2014. FILED 1-10-2014.
- 4,592,377. **PRINCESS CRUISES COME BACK NEW AND DESIGN**. PRINCESS CRUISE LINES, LTD., DBA PRINCESS CRUISES, MULTIPLE CLASS, (INT. CLS. 39, 41, 43 AND 44), (U.S. CLS. 100, 101, 105 AND 107). SN 86-162,692. PUB. 6-10-2014. FILED 1-10-2014.
- 4,592,499. **MAZZA HEALTHCARE (STANDARD CHARACTER)**. MAZZA HEALTHCARE, LLC, (U.S. CLS. 100 AND 105). SN 86-166,431. PUB. 6-10-2014. FILED 1-15-2014.
- 4,592,598. **WE PICK UP. WE STORE. WE DELIVER. (STANDARD CHARACTER)**. CITYSTASH HOLDINGS, LLC, (U.S. CLS. 100 AND 105). SN 86-172,840. PUB. 6-10-2014. FILED 1-23-2014.
- 4,592,622. **WE DELIVER CONFIDENCE (STANDARD CHARACTER)**. NEW JERSEY LAWYERS SERVICE, LLC, AKA NJLS COURIERS, (U.S. CLS. 100 AND 105). SN 86-174,363. PUB. 6-10-2014. FILED 1-24-2014.
- 4,592,727. **BOHEMIAN EXPERIENCE (STANDARD CHARACTER)**. MICHAELA MOKROSOVA, (U.S. CLS. 100 AND 105). SN 86-176,795. PUB. 6-10-2014. FILED 1-27-2014.
- 4,592,931. **GOODFRIEND (STANDARD CHARACTER)**. POST MANAGEMENT SELF-STORAGE, (U.S. CLS. 100 AND 105). SN 86-181,440. PUB. 6-10-2014. FILED 1-31-2014.
- 4,592,961. **ALEGRIA (STANDARD CHARACTER)**. BORQUET, COURTNEY G, (U.S. CLS. 100 AND 105). SN 86-192,149. PUB. 6-10-2014. FILED 2-12-2014.

**CLASS 40—MATERIAL TREATMENT**

- 4,590,655 ( *See Class 9 for this trademark.*)  
 4,590,662 ( *See Class 7 for this trademark.*)  
 4,590,688. **VISARIO AND DESIGN. RUMPELT, TINO, TA VISARIO**, (U.S. CLS. 100, 103 AND 106). SN 79-130,693. PUB. 6-10-2014. FILED 3-1-2013.  
 4,590,719 ( *See Class 21 for this trademark.*)  
 4,590,733 ( *See Class 17 for this trademark.*)  
 4,590,751 ( *See Class 17 for this trademark.*)  
 4,590,811 ( *See Class 1 for this trademark.*)  
 4,590,824 ( *See Class 1 for this trademark.*)  
 4,590,881 ( *See Class 6 for this trademark.*)  
 4,590,956 ( *See Class 14 for this trademark.*)  
 4,591,220 ( *See Class 16 for this trademark.*)  
 4,591,230. **EYE ON SHEET METAL (STANDARD CHARACTER). INTERNATIONAL TRAINING INSTITUTE FOR THE SHEET METAL AND AIR CONDITIONING INDUSTRY, AKA ITI TRUST**, (U.S. CLS. 100, 103 AND 106). SN 85-946,159. PUB. 6-10-2014. FILED 5-30-2013.  
 4,591,263 ( *See Class 35 for this trademark.*)  
 4,591,319. **MY GOODIE SPOT AND DESIGN. MY GOODIE SPOT, INC.**, (U.S. CLS. 100, 103 AND 106). SN 85-967,583. PUB. 6-10-2014. FILED 6-24-2013.  
 4,591,361 ( *See Class 17 for this trademark.*)  
 4,591,366. **FOUNDRY 2.0 (STANDARD CHARACTER). GLOBALFOUNDRIES INC., MULTIPLE CLASS, (INT. CLS. 40 AND 42)**, (U.S. CLS. 100, 101, 103 AND 106). SN 85-973,009. PUB. 6-10-2014. FILED 6-28-2013.  
 4,591,369 ( *See Class 35 for this trademark.*)  
 4,591,527 ( *See Class 32 for this trademark.*)  
 4,591,558 ( *See Class 35 for this trademark.*)  
 4,591,589 ( *See Class 6 for this trademark.*)  
 4,591,590 ( *See Class 6 for this trademark.*)  
 4,591,732. **HARMON (STANDARD CHARACTER). PRISM ASSURANCE, LTD.**, (U.S. CLS. 100, 103 AND 106). SN 86-081,506. PUB. 6-10-2014. FILED 10-3-2013.  
 4,591,737. **I-PAINT (STANDARD CHARACTER). I-PAINT S.R.L.**, (U.S. CLS. 100, 103 AND 106). SN 86-081,743. PUB. 6-10-2014. FILED 10-3-2013.  
 4,592,006. **BLACKSTONE COFFEE COMPANY FRESH ROASTED AND DESIGN. BLACKSTONE COFFEE, MULTIPLE CLASS, (INT. CLS. 40 AND 43)**, (U.S. CLS. 100, 101, 103 AND 106). SN 86-136,327. PUB. 6-10-2014. FILED 12-5-2013.  
 4,592,055. **WE MAKE AMAZING THINGS HAPPEN. (STANDARD CHARACTER). NATEL ENGINEERING CO., INC., MULTIPLE CLASS, (INT. CLS. 40 AND 42)**, (U.S. CLS. 100, 101, 103 AND 106). SN 86-142,562. PUB. 6-10-2014. FILED 12-12-2013.  
 4,592,265 ( *See Class 35 for this trademark.*)  
 4,592,266 ( *See Class 35 for this trademark.*)  
 4,592,268. **ADEX (STANDARD CHARACTER). ADEX MACHINING TECHNOLOGIES, LLC**, (U.S. CLS. 100, 103 AND 106). SN 86-158,716. PUB. 6-10-2014. FILED 1-6-2014.  
 4,592,269. **ADEX MACHINING (STANDARD CHARACTER). ADEX MACHINING, LLC**, (U.S. CLS. 100, 103 AND 106). SN 86-158,722. PUB. 6-10-2014. FILED 1-6-2014.  
 4,592,320. **PRINTEDUNION.COM AND DESIGN. FINALOPTION CORP.**, (U.S. CLS. 100, 103 AND 106). SN 86-161,352. PUB. 6-10-2014. FILED 1-9-2014.  
 4,592,597. **MORF3D (STANDARD CHARACTER). MORF3D, INC.**, MULTIPLE CLASS, (INT. CLS. 40 AND 42), (U.S. CLS. 100, 101, 103 AND 106). SN 86-172,836. PUB. 6-10-2014. FILED 1-23-2014.  
 4,592,817. **MISCELLANEOUS DESIGN. F. ATLEE DODGE AIRCRAFT SERVICES, LLC**, (U.S. CLS. 100, 103 AND 106). SN 86-178,272. PUB. 6-10-2014. FILED 1-29-2014.  
 4,590,641 ( *See Class 25 for this trademark.*)  
 4,590,646 ( *See Class 9 for this trademark.*)  
 4,590,652 ( *See Class 35 for this trademark.*)  
 4,590,655 ( *See Class 9 for this trademark.*)  
 4,590,659 ( *See Class 9 for this trademark.*)  
 4,590,662 ( *See Class 7 for this trademark.*)  
 4,590,665 ( *See Class 9 for this trademark.*)  
 4,590,667 ( *See Class 16 for this trademark.*)  
 4,590,668 ( *See Class 9 for this trademark.*)  
 4,590,669 ( *See Class 5 for this trademark.*)  
 4,590,676 ( *See Class 33 for this trademark.*)  
 4,590,681 ( *See Class 35 for this trademark.*)  
 4,590,684 ( *See Class 9 for this trademark.*)  
 4,590,687 ( *See Class 7 for this trademark.*)  
 4,590,703 ( *See Class 9 for this trademark.*)  
 4,590,704 ( *See Class 35 for this trademark.*)  
 4,590,706 ( *See Class 9 for this trademark.*)  
 4,590,736 ( *See Class 3 for this trademark.*)  
 4,590,742 ( *See Class 9 for this trademark.*)  
 4,590,747 ( *See Class 3 for this trademark.*)  
 4,590,750 ( *See Class 16 for this trademark.*)  
 4,590,752 ( *See Class 9 for this trademark.*)  
 4,590,761 ( *See Class 35 for this trademark.*)  
 4,590,763 ( *See Class 9 for this trademark.*)  
 4,590,766 ( *See Class 9 for this trademark.*)  
 4,590,767 ( *See Class 9 for this trademark.*)  
 4,590,778 ( *See Class 9 for this trademark.*)  
 4,590,816. **EMPA-REG PIO (STANDARD CHARACTER). BOEHRINGER INGELHEIM INTERNATIONAL GMBH, MULTIPLE CLASS, (INT. CLS. 41 AND 42)**, (U.S. CLS. 100, 101 AND 107). SN 79-138,325. PUB. 6-10-2014. FILED 9-17-2013.  
 4,590,821 ( *See Class 9 for this trademark.*)  
 4,590,822 ( *See Class 9 for this trademark.*)  
 4,590,824 ( *See Class 1 for this trademark.*)  
 4,590,836 ( *See Class 33 for this trademark.*)  
 4,590,840 ( *See Class 33 for this trademark.*)  
 4,590,842 ( *See Class 9 for this trademark.*)  
 4,590,854 ( *See Class 35 for this trademark.*)  
 4,590,856 ( *See Class 3 for this trademark.*)  
 4,590,858 ( *See Class 7 for this trademark.*)  
 4,590,861 ( *See Class 9 for this trademark.*)  
 4,590,883. **YESTERDAYWORLD AND DESIGN. RINI DAMMEN**, (U.S. CLS. 100, 101 AND 107). SN 79-142,484. PUB. 6-10-2014. FILED 11-14-2013.  
 4,590,895 ( *See Class 9 for this trademark.*)  
 4,590,915 ( *See Class 25 for this trademark.*)  
 4,590,954. **FOOTBALL GAMEPLAN.COM "WHERE FOOTBALL MAKES SENSE" AND DESIGN. HUNT JR., EMORY, DBA FOOTBALL GAMEPLAN LLC**, (U.S. CLS. 100, 101 AND 107). SN 85-367,457. PUB. 6-10-2014. FILED 7-10-2011.  
 4,590,959. **SNOOP YOUTH FOOTBALL LEAGUE (STANDARD CHARACTER). BROADUS, CALVIN**, (U.S. CLS. 100, 101 AND 107). SN 85-436,509. PUB. 5-14-2013. FILED 9-30-2011.  
 4,590,964. **BUILDING A NATION OF NEIGHBORS (STANDARD CHARACTER). WELCOMING AMERICA, INC.**, (U.S. CLS. 100, 101 AND 107). SN 85-472,614. PUB. 6-10-2014. FILED 11-15-2011.  
 4,590,970 ( *See Class 16 for this trademark.*)  
 4,590,984. **DECOMPRESSION PROJECT (STANDARD CHARACTER). STREITER, RUTH**, MULTIPLE CLASS, (INT. CLS. 41 AND 44), (U.S. CLS. 100, 101 AND 107). SN 85-613,970. PUB. 6-10-2014. FILED 5-2-2012.  
 4,590,987 ( *See Class 16 for this trademark.*)  
 4,590,992 ( *See Class 16 for this trademark.*)  
 4,590,993 ( *See Class 9 for this trademark.*)  
 4,590,995 ( *See Class 24 for this trademark.*)  
 4,591,001 ( *See Class 9 for this trademark.*)  
 4,591,009 ( *See Class 28 for this trademark.*)  
 4,591,010. **THE MONEY MACHINE (STANDARD CHARACTER). WAYNE QUIRK**, (U.S. CLS. 100, 101 AND 107). SN 85-729,448. PUB. 6-10-2014. FILED 9-14-2012.  
 4,591,012. **GOLDHAR (STANDARD CHARACTER). GOLDHAR LEARNING SYSTEMS, INC.**, (U.S. CLS. 100, 101 AND 107). SN 85-733,671. PUB. 6-10-2014. FILED 9-20-2012.  
 4,591,014 ( *See Class 9 for this trademark.*)  
 4,591,022 ( *See Class 25 for this trademark.*)

**CLASS 41—EDUCATION AND ENTERTAINMENT**

- 4,590,605 ( *See Class 35 for this trademark.*)  
 4,590,632 ( *See Class 9 for this trademark.*)  
 4,590,638 ( *See Class 9 for this trademark.*)  
 4,590,639 ( *See Class 25 for this trademark.*)

- 4,591,026 ( *See Class 25 for this trademark.* )  
 4,591,027 ( *See Class 18 for this trademark.* )  
 4,591,029 ( *See Class 16 for this trademark.* )  
 4,591,030 ( *See Class 16 for this trademark.* )  
 4,591,037 ( *See Class 9 for this trademark.* )  
 4,591,042. **LOS MALPORTADO DE ARTURO OCHOA AND DESIGN.** OCHOA MARQUEZ, JESUS ARTURO, AND ALDERETE, JACQUELINE, AND ROBLES, DELIA J, (U.S. CLS. 100, 101 AND 107). SN 85-776,497. PUB. 6-10-2014. FILED 11-11-2012.  
 4,591,044. **BEYOND OCD RESOURCES TO GET THERE AND DESIGN.** BEYOND OCD, (U.S. CLS. 100, 101 AND 107). SN 85-777,777. PUB. 6-10-2014. FILED 11-13-2012.  
 4,591,045. **FISHING UNIVERSITY (STANDARD CHARACTER).** FISHING UNIVERSITY INC, (U.S. CLS. 100, 101 AND 107). SN 85-778,438. PUB. 6-10-2014. FILED 11-13-2012.  
 4,591,069 ( *See Class 9 for this trademark.* )  
 4,591,074. **ECOSYSTEM (STANDARD CHARACTER).** LES SERVICES ÉNERGÉTIQUES ECOSYSTEM INC, (U.S. CLS. 100, 101 AND 107). SN 85-800,124. PUB. 6-10-2014. FILED 12-11-2012.  
 4,591,075. **ECOSYSTEM AND DESIGN.** LES SERVICES ÉNERGÉTIQUES ECOSYSTEM INC, (U.S. CLS. 100, 101 AND 107). SN 85-800,167. PUB. 6-10-2014. FILED 12-11-2012.  
 4,591,078 ( *See Class 38 for this trademark.* )  
 4,591,086 ( *See Class 9 for this trademark.* )  
 4,591,090. **SHENOLOGY (STANDARD CHARACTER).** SHENERGY HOLDINGS INC, MULTIPLE CLASS, (INT. CLS. 41, 44 AND 45), (U.S. CLS. 100, 101 AND 107). SN 85-809,525. PUB. 6-10-2014. FILED 12-21-2012.  
 4,591,091 ( *See Class 36 for this trademark.* )  
 4,591,092 ( *See Class 36 for this trademark.* )  
 4,591,104. **HILLBILLY HERALD (STANDARD CHARACTER).** HERALD, JAMES, (U.S. CLS. 100, 101 AND 107). SN 85-829,147. PUB. 6-10-2014. FILED 1-22-2013.  
 4,591,113. **GOVERNOR'S CUP CASE (STANDARD CHARACTER).** VIRGINIA WINERIES ASSOCIATION, THE, (U.S. CLS. 100, 101 AND 107). SN 85-847,978. PUB. 6-10-2014. FILED 2-12-2013.  
 4,591,117. **FANTASYHD (STANDARD CHARACTER).** SSC GROUP, LLC, (U.S. CLS. 100, 101 AND 107). SN 85-852,977. PUB. 6-10-2014. FILED 2-18-2013.  
 4,591,124. **PRANACYCLE (STANDARD CHARACTER).** BRINGMAN, ELLIOTT GORDON, DBA PRANACYCLE, (U.S. CLS. 100, 101 AND 107). SN 85-865,171. PUB. 6-10-2014. FILED 3-2-2013.  
 4,591,127. **LEGALWATCH (STANDARD CHARACTER).** JEAN JOHNSON, MULTIPLE CLASS, (INT. CLS. 41 AND 45), (U.S. CLS. 100, 101 AND 107). SN 85-867,047. PUB. 6-10-2014. FILED 3-5-2013.  
 4,591,131. **JERSEY OFF SUIT ON (STANDARD CHARACTER).** BRANDON LONDON, (U.S. CLS. 100, 101 AND 107). SN 85-869,376. PUB. 6-10-2014. FILED 3-7-2013.  
 4,591,139 ( *See Class 30 for this trademark.* )  
 4,591,140. **PROFOUND MYSTICAL MEDITATION (STANDARD CHARACTER).** THE EXECUTORS OF FRANCISCO COLL MONGE ESTATE, FORMERLY FRANCISCO COLL, (U.S. CLS. 100, 101 AND 107). SN 85-880,650. PUB. 6-10-2014. FILED 3-19-2013.  
 4,591,154. **IN THE GROOVE AND DESIGN.** IN THE GROOVE MUSIC LLC, MULTIPLE CLASS, (INT. CLS. 41 AND 45), (U.S. CLS. 100, 101 AND 107). SN 85-891,541. PUB. 6-10-2014. FILED 4-1-2013.  
 4,591,159. **SALISH CLIFFS GOLF CLUB (STANDARD CHARACTER).** SQUAXIN ISLAND TRIBE, (U.S. CLS. 100, 101 AND 107). SN 85-895,508. PUB. 1-7-2014. FILED 4-4-2013.  
 4,591,163. **BATTLE BROTHERHOOD MMA (STANDARD CHARACTER).** BATTLE BROTHERHOOD LTD, (U.S. CLS. 100, 101 AND 107). SN 85-897,685. PUB. 6-10-2014. FILED 4-8-2013.  
 4,591,168 ( *See Class 9 for this trademark.* )  
 4,591,170 ( *See Class 9 for this trademark.* )  
 4,591,171 ( *See Class 35 for this trademark.* )  
 4,591,174. **EAR HEART MUSIC (STANDARD CHARACTER).** EAR HEART MUSIC, (U.S. CLS. 100, 101 AND 107). SN 85-910,451. PUB. 6-10-2014. FILED 4-22-2013.  
 4,591,181 ( *See Class 35 for this trademark.* )  
 4,591,196 ( *See Class 25 for this trademark.* )  
 4,591,203 ( *See Class 9 for this trademark.* )  
 4,591,210 ( *See Class 16 for this trademark.* )  
 4,591,215 ( *See Class 9 for this trademark.* )  
 4,591,226. **MIND360 (STANDARD CHARACTER).** FEEL GOLF COMPANY, INC., (U.S. CLS. 100, 101 AND 107). SN 85-944,540. PUB. 6-10-2014. FILED 5-29-2013.  
 4,591,242 ( *See Class 35 for this trademark.* )  
 4,591,260 ( *See Class 35 for this trademark.* )  
 4,591,267. **MYHITS (STANDARD CHARACTER).** BIG LEAGUE ANALYSIS, LLC, (U.S. CLS. 100, 101 AND 107). SN 85-957,731. PUB. 6-10-2014. FILED 6-12-2013.  
 4,591,277 ( *See Class 35 for this trademark.* )  
 4,591,279. **1872 AND DESIGN.** DOANE COLLEGE, (U.S. CLS. 100, 101 AND 107). SN 85-961,604. PUB. 6-10-2014. FILED 6-17-2013.  
 4,591,287 ( *See Class 35 for this trademark.* )  
 4,591,296. **CASINOS AT SEA REWARDS (STANDARD CHARACTER).** NCL CORPORATION LTD., (U.S. CLS. 100, 101 AND 107). SN 85-965,249. PUB. 6-10-2014. FILED 6-20-2013.  
 4,591,298. **CASINOS AT SEA PLAYERS CLUB (STANDARD CHARACTER).** NCL CORPORATION LTD., (U.S. CLS. 100, 101 AND 107). SN 85-965,273. PUB. 6-10-2014. FILED 6-20-2013.  
 4,591,301. **SNEAK&EAT (STANDARD CHARACTER).** ADED WEAR, INC., (U.S. CLS. 100, 101 AND 107). SN 85-965,705. PUB. 6-10-2014. FILED 6-20-2013.  
 4,591,306 ( *See Class 35 for this trademark.* )  
 4,591,307 ( *See Class 35 for this trademark.* )  
 4,591,325. **FIRSTHAND AND DESIGN.** BERRY COLLEGE, INC., (U.S. CLS. 100, 101 AND 107). SN 85-968,181. PUB. 6-10-2014. FILED 6-24-2013.  
 4,591,332. **S NETWORKING SEMINARS (STYLIZED).** NETWORKING SEMINARS INC., (U.S. CLS. 100, 101 AND 107). SN 85-969,229. PUB. 6-10-2014. FILED 6-25-2013.  
 4,591,342. **STAY ABOVE THE LINE (STANDARD CHARACTER).** MORGAN, DIANA, (U.S. CLS. 100, 101 AND 107). SN 85-970,539. PUB. 6-10-2014. FILED 6-26-2013.  
 4,591,343. **TOURISM ORLANDO LEADERSHIP PROGRAM AND DESIGN.** FLORIDA CENTER CHAMBER OF COMMERCE INCORPORATED, DBA INTERNATIONAL DRIVE RESORT AREA CHAMBER OF COMMERCE, (U.S. CLS. 100, 101 AND 107). SN 85-970,597. PUB. 6-10-2014. FILED 6-26-2013.  
 4,591,344. **FRENCHLY YOURS (STANDARD CHARACTER).** VICTOIRE FIGOTIN, DBA FRENCHLY YOURS, (U.S. CLS. 100, 101 AND 107). SN 85-970,751. PUB. 6-10-2014. FILED 6-26-2013.  
 4,591,347 ( *See Class 38 for this trademark.* )  
 4,591,348. **STEPS THERAPY (STANDARD CHARACTER).** STEPS THERAPY, INC., MULTIPLE CLASS, (INT. CLS. 41 AND 44), (U.S. CLS. 100, 101 AND 107). SN 85-971,318. PUB. 6-10-2014. FILED 6-27-2013.  
 4,591,349. **STEPS THERAPY AND DESIGN.** STEPS THERAPY, INC., MULTIPLE CLASS, (INT. CLS. 41 AND 44), (U.S. CLS. 100, 101 AND 107). SN 85-971,331. PUB. 6-10-2014. FILED 6-27-2013.  
 4,591,351. **LEADING LIKE A LADY (STANDARD CHARACTER).** BROWN, NADIA YVETTE, DBA DOYENNE LEADERSHIP INSTITUTE, (U.S. CLS. 100, 101 AND 107). SN 85-971,633. PUB. 6-10-2014. FILED 6-27-2013.  
 4,591,367. **MOMMY TO MOGUL RADIO SHOW (STANDARD CHARACTER).** MAS UNIVERSAL, LLC, DBA KNOW THE RADIO SHOW, MOMMY TO MOGUL, (U.S. CLS. 100, 101 AND 107). SN 85-973,028. PUB. 6-10-2014. FILED 6-28-2013.  
 4,591,371 ( *See Class 35 for this trademark.* )  
 4,591,372 ( *See Class 25 for this trademark.* )  
 4,591,373 ( *See Class 25 for this trademark.* )  
 4,591,375 ( *See Class 35 for this trademark.* )  
 4,591,391 ( *See Class 35 for this trademark.* )  
 4,591,393. **AMOVEO (STANDARD CHARACTER).** AMOVEO PRODUCTIONS, INC., (U.S. CLS. 100, 101 AND 107). SN 85-982,076. PUB. 7-2-2013. FILED 2-7-2013.  
 4,591,410. **NOFAP (STANDARD CHARACTER).** RHODES, ALEXANDER JULIAN, (U.S. CLS. 100, 101 AND 107). SN 86-001,394. PUB. 6-10-2014. FILED 7-3-2013.  
 4,591,411. **FIREBALL NETWORK (STANDARD CHARACTER).** DEENA BAIKOWITZ, (U.S. CLS. 100, 101 AND 107). SN 86-001,427. PUB. 6-10-2014. FILED 7-3-2013.

- 4,591,412. **SPARK YOUR NETWORK. IGNITE YOUR BUSINESS.** (STANDARD CHARACTER). DEENA BAIKOWITZ, (U.S. CLS. 100, 101 AND 107). SN 86-001,429. PUB. 6-10-2014. FILED 7-3-2013.
- 4,591,422. **GRACIOUS HOSPITALITY** (STANDARD CHARACTER), THE BILTMORE COMPANY, (U.S. CLS. 100, 101 AND 107). SN 86-002,108. PUB. 6-10-2014. FILED 7-3-2013.
- 4,591,425 ( *See Class 9 for this trademark.*).
- 4,591,427. **THE SANFORD HARMONY PROGRAM** (STANDARD CHARACTER). ARIZONA BOARD OF REGENTS FOR AND ON BEHALF OF ARIZONA STATE UNIVERSITY, (U.S. CLS. 100, 101 AND 107). SN 86-002,583. PUB. 6-10-2014. FILED 7-3-2013.
- 4,591,441 ( *See Class 16 for this trademark.*).
- 4,591,443 ( *See Class 35 for this trademark.*).
- 4,591,445. **CHAIN FITNESS** (STANDARD CHARACTER). TAYLOR RAMSDELL CREATIONS, LLC, (U.S. CLS. 100, 101 AND 107). SN 86-004,545. PUB. 6-10-2014. FILED 7-8-2013.
- 4,591,446. **TAYLOR RAMSDELL'S CHAIN FITNESS EST. 2009 AND DESIGN.** TAYLOR RAMSDELL CREATIONS, LLC, (U.S. CLS. 100, 101 AND 107). SN 86-004,633. PUB. 6-10-2014. FILED 7-8-2013.
- 4,591,453. **DBX** (STANDARD CHARACTER). DROPBOX, INC., (U.S. CLS. 100, 101 AND 107). SN 86-005,194. PUB. 6-10-2014. FILED 7-9-2013.
- 4,591,458. **RAPID INQUIRY-DRIVEN CHANGE CYCLE** (STANDARD CHARACTER). EDUCATION NORTHWEST, (U.S. CLS. 100, 101 AND 107). SN 86-005,687. PUB. 6-10-2014. FILED 7-9-2013.
- 4,591,459. **RICC** (STANDARD CHARACTER). EDUCATION NORTHWEST, (U.S. CLS. 100, 101 AND 107). SN 86-005,737. PUB. 6-10-2014. FILED 7-9-2013.
- 4,591,460. **EARTHSTATION** (STANDARD CHARACTER). BANGING TIMPANI, LLC, (U.S. CLS. 100, 101 AND 107). SN 86-005,828. PUB. 6-10-2014. FILED 7-9-2013.
- 4,591,468 ( *See Class 9 for this trademark.*).
- 4,591,471. **WEST COAST WING CHUN AUTHENTIC IP MAN KUNG FU AND DESIGN.** WEST COAST WING CHUN, (U.S. CLS. 100, 101 AND 107). SN 86-007,986. PUB. 6-10-2014. FILED 7-11-2013.
- 4,591,472. **KNIT THE BRIDGE** (STANDARD CHARACTER). FIBERARTS GUILD OF PITTSBURGH, INC., (U.S. CLS. 100, 101 AND 107). SN 86-008,462. PUB. 6-10-2014. FILED 7-12-2013.
- 4,591,474. **MISCELLANEOUS DESIGN.** FIBERARTS GUILD OF PITTSBURGH, INC., (U.S. CLS. 100, 101 AND 107). SN 86-008,498. PUB. 6-10-2014. FILED 7-12-2013.
- 4,591,481. **PIONEERING THE DELIVERY OF CARE** (STANDARD CHARACTER). ENVISION HEALTHCARE CORPORATION, (U.S. CLS. 100, 101 AND 107). SN 86-010,093. PUB. 6-10-2014. FILED 7-15-2013.
- 4,591,483. **COLLEGE RECOVERY COUNSELORS U AND DESIGN.** RECOVERY EDU, LLC, (U.S. CLS. 100, 101 AND 107). SN 86-010,156. PUB. 6-10-2014. FILED 7-15-2013.
- 4,591,491. **TOUR 18 AND DESIGN.** WSG TOUR 18 IV, LP, (U.S. CLS. 100, 101 AND 107). SN 86-011,063. PUB. 6-10-2014. FILED 7-16-2013.
- 4,591,500. **LIVE WITH LORI** (STANDARD CHARACTER). DREAMS IN GLASS, INC., (U.S. CLS. 100, 101 AND 107). SN 86-012,146. PUB. 6-10-2014. FILED 7-17-2013.
- 4,591,504. **AGRICULTURAL COMMUNITY ENGAGEMENT** (STANDARD CHARACTER). PROFESSIONAL DAIRY PRODUCERS OF WISCONSIN, (U.S. CLS. 100, 101 AND 107). SN 86-012,628. PUB. 6-10-2014. FILED 7-17-2013.
- 4,591,509. **SPOT LIFE LESSONS AND DESIGN.** CLARK ATLANTA UNIVERSITY, INC., (U.S. CLS. 100, 101 AND 107). SN 86-013,051. PUB. 6-10-2014. FILED 7-17-2013.
- 4,591,510. **GIGAFIT** (STANDARD CHARACTER). JACK MCKRACKEN LLC, (U.S. CLS. 100, 101 AND 107). SN 86-013,649. PUB. 6-10-2014. FILED 7-18-2013.
- 4,591,513. **ACTIVE VOICE** (STANDARD CHARACTER). COMMUNITY INITIATIVES, (U.S. CLS. 100, 101 AND 107). SN 86-013,999. PUB. 6-10-2014. FILED 7-18-2013.
- 4,591,520 ( *See Class 25 for this trademark.*).
- 4,591,524. **WSOP.COM WORLD SERIES OF POKER AND DESIGN.** CAESARS INTERACTIVE ENTERTAINMENT, INC., (U.S. CLS. 100, 101 AND 107). SN 86-017,259. PUB. 6-10-2014. FILED 7-23-2013.
- 4,591,530. **JASPER COAL ORGANIZED MARCH 17 2004 AND DESIGN.** JASPER COAL ENTERTAINMENT, LLC, (U.S. CLS. 100, 101 AND 107). SN 86-018,827. PUB. 6-10-2014. FILED 7-24-2013.
- 4,591,532. **OFFF OVER FIFTY FIERCE AND FABULOUS** (STANDARD CHARACTER). HOLYFIELD, NORVELL A., AKA OVER FIFTY FIERCE AND FABULOUS, (U.S. CLS. 100, 101 AND 107). SN 86-021,822. PUB. 6-10-2014. FILED 7-28-2013.
- 4,591,546. **UNDERGROUND PERFORMANCE AND DESIGN.** UNDERGROUND PERFORMANCE LLC, (U.S. CLS. 100, 101 AND 107). SN 86-024,990. PUB. 6-10-2014. FILED 7-31-2013.
- 4,591,555. **LETSRUMBL** (STANDARD CHARACTER). SYNKT GAMES, INC, (U.S. CLS. 100, 101 AND 107). SN 86-027,154. PUB. 6-10-2014. FILED 8-2-2013.
- 4,591,557. **JEANIUS** (STANDARD CHARACTER). ADVANCE MAGAZINE PUBLISHERS, INC., (U.S. CLS. 100, 101 AND 107). SN 86-027,404. PUB. 6-10-2014. FILED 8-2-2013.
- 4,591,573. **JUSTADDOBSTER** (STANDARD CHARACTER). BLACK POINT SEAFOOD INC., (U.S. CLS. 100, 101 AND 107). SN 86-030,386. PUB. 6-10-2014. FILED 8-6-2013.
- 4,591,579. **ACTIVELY NORTHWEST** (STANDARD CHARACTER). PREMIERA BLUE CROSS, MULTIPLE CLASS, (INT. CLS. 41 AND 44), (U.S. CLS. 100, 101 AND 107). SN 86-033,038. PUB. 6-10-2014. FILED 8-8-2013.
- 4,591,597. **ARABIAN HORSE ASSOCIATION OF ARIZONA** (STANDARD CHARACTER). ARABIAN HORSE ASSOCIATION OF ARIZONA, (U.S. CLS. 100, 101 AND 107). SN 86-038,863. PUB. 6-10-2014. FILED 8-15-2013.
- 4,591,598. **CURVES AND CHAOS** (STANDARD CHARACTER). FRAUSTO, MONIQUE, (U.S. CLS. 100, 101 AND 107). SN 86-039,894. PUB. 6-10-2014. FILED 8-16-2013.
- 4,591,613. **MISCELLANEOUS DESIGN.** ENVISION HEALTHCARE CORPORATION, (U.S. CLS. 100, 101 AND 107). SN 86-043,412. PUB. 6-10-2014. FILED 8-20-2013.
- 4,591,622. **MARGINALIA** (STANDARD CHARACTER). LAW, TIMOTHY MICHAEL, (U.S. CLS. 100, 101 AND 107). SN 86-044,961. PUB. 6-10-2014. FILED 8-22-2013.
- 4,591,645 ( *See Class 35 for this trademark.*).
- 4,591,649. **TUTORVILLE** (STANDARD CHARACTER). TUTORVILLE, LLC, AKA TUTORVILLE, (U.S. CLS. 100, 101 AND 107). SN 86-052,636. PUB. 3-11-2014. FILED 8-30-2013.
- 4,591,661. **GOURMET GRANDE DAME** (STANDARD CHARACTER). BETH FORMAN, (U.S. CLS. 100, 101 AND 107). SN 86-058,082. PUB. 6-10-2014. FILED 9-6-2013.
- 4,591,676 ( *See Class 16 for this trademark.*).
- 4,591,691. **ROSE HILL BAND** (STANDARD CHARACTER). ROSE HILL BAND, (U.S. CLS. 100, 101 AND 107). SN 86-068,324. PUB. 6-10-2014. FILED 9-18-2013.
- 4,591,695. **DRINK UP SUMMER** (STANDARD CHARACTER). CICI ENTERPRISES, LP, MULTIPLE CLASS, (INT. CLS. 41 AND 43), (U.S. CLS. 100, 101 AND 107). SN 86-069,093. PUB. 6-10-2014. FILED 9-19-2013.
- 4,591,709 ( *See Class 28 for this trademark.*).
- 4,591,711. **CAPTURE** (STANDARD CHARACTER). UNCOMMON CONTENT PARTNERS LLC, (U.S. CLS. 100, 101 AND 107). SN 86-076,443. PUB. 6-10-2014. FILED 9-27-2013.
- 4,591,739. **CONCEPTS IN CARE CONFERENCE** (STANDARD CHARACTER). ALZHEIMER'S FOUNDATION OF AMERICA, INC., MULTIPLE CLASS, (INT. CLS. 41 AND 44), (U.S. CLS. 100, 101 AND 107). SN 86-081,855. PUB. 2-25-2014. FILED 10-3-2013.
- 4,591,740. **A MAGICAL HISTORY TOUR** (STANDARD CHARACTER). DIGGING RECORDS, INC., (U.S. CLS. 100, 101 AND 107). SN 86-081,929. PUB. 6-10-2014. FILED 10-3-2013.
- 4,591,741 ( *See Class 35 for this trademark.*).
- 4,591,749 ( *See Class 35 for this trademark.*).
- 4,591,766. **THE ROLL MODEL** (STANDARD CHARACTER). TUNE UP FITNESS WORLDWIDE INC., (U.S. CLS. 100, 101 AND 107). SN 86-090,634. PUB. 6-10-2014. FILED 10-14-2013.
- 4,591,770. **RACHEL CRUZE** (STANDARD CHARACTER). LAMPO LICENSING, LLC, (U.S. CLS. 100, 101 AND 107). SN 86-092,981. PUB. 6-10-2014. FILED 10-16-2013.
- 4,591,779. **ASTUDY** (STANDARD CHARACTER). EXPLORIUS EDUCATION AB, (U.S. CLS. 100, 101 AND 107). SN 86-096,407. PUB. 6-10-2014. FILED 10-21-2013.

- 4,591,781. **ROYAL NORTEÑO (STANDARD CHARACTER)**. VASQUEZ, OSCAR M. AND MITCHELL VIRRUETA, ALAN, AND ANDRADE, IRVIN FABIAN, (U.S. CLS. 100, 101 AND 107). SN 86-097,304. PUB. 6-10-2014. FILED 10-21-2013.
- 4,591,786. **INDIGITOUS (STANDARD CHARACTER)**. CAMPUS CRUSADE FOR CHRIST, INC., (U.S. CLS. 100, 101 AND 107). SN 86-097,914. PUB. 6-10-2014. FILED 10-22-2013.
- 4,591,787. **INDIGITOUS AND DESIGN**. CAMPUS CRUSADE FOR CHRIST, INC., AKA CRU, (U.S. CLS. 100, 101 AND 107). SN 86-097,940. PUB. 6-10-2014. FILED 10-22-2013.
- 4,591,789. **TROOPS INTO TRANSPORTATION THE CDL SCHOOL AND DESIGN**. HANLEY III, ALBERT V., (U.S. CLS. 100, 101 AND 107). SN 86-098,287. PUB. 6-10-2014. FILED 10-22-2013.
- 4,591,795. **THE REALITY OF IT IS... (STANDARD CHARACTER)**. SHABAZZ, KEVIN, (U.S. CLS. 100, 101 AND 107). SN 86-099,427. PUB. 6-10-2014. FILED 10-23-2013.
- 4,591,800. **MR. AMORE STABLES (STANDARD CHARACTER)**. MR. AMORE STABLES, LLC, (U.S. CLS. 100, 101 AND 107). SN 86-100,204. PUB. 6-10-2014. FILED 10-24-2013.
- 4,591,801. **AMORE AND DESIGN**. MR. AMORE STABLES, LLC, (U.S. CLS. 100, 101 AND 107). SN 86-100,220. PUB. 6-10-2014. FILED 10-24-2013.
- 4,591,828. **GO PROJECT (STANDARD CHARACTER)**. THE GO PROJECT, INC., MULTIPLE CLASS, (INT. CLS. 41 AND 45), (U.S. CLS. 100, 101 AND 107). SN 86-107,043. PUB. 6-10-2014. FILED 10-31-2013.
- 4,591,829 ( *See Class 36 for this trademark*).
- 4,591,842. **ABC SPANISH IN MOTION AND DESIGN**. LANGUAGE IN MOTION, INC., DBA ABC SPANISH IN MOTION, (U.S. CLS. 100, 101 AND 107). SN 86-109,527. PUB. 6-10-2014. FILED 11-4-2013.
- 4,591,844. **SERVED INSIDE THE STORY OF OUR FOOD AND DESIGN**. MARICOPA COUNTY COMMUNITY COLLEGE DISTRICT, (U.S. CLS. 100, 101 AND 107). SN 86-110,311. PUB. 6-10-2014. FILED 11-5-2013.
- 4,591,846. **EIC AND DESIGN**. EDUCATION INTERNATIONAL COOPERATION (EIC) GROUP LTD, (U.S. CLS. 100, 101 AND 107). SN 86-110,388. PUB. 6-10-2014. FILED 11-5-2013.
- 4,591,851. **VIRTUS (STANDARD CHARACTER)**. VIRTUS STRENGTH AND CONDITIONING, (U.S. CLS. 100, 101 AND 107). SN 86-112,860. PUB. 6-10-2014. FILED 11-7-2013.
- 4,591,854. **WHAT WOULD YOU FIGHT FOR? (STANDARD CHARACTER)**. UNIVERSITY OF NOTRE DAME DU LAC, (U.S. CLS. 100, 101 AND 107). SN 86-113,292. PUB. 6-10-2014. FILED 11-8-2013.
- 4,591,862. **TLH THE LANGUAGE HOUSE TEFL AND DESIGN**. THE LANGUAGE HOUSE TEFL LANGUAGE S.R.O., (U.S. CLS. 100, 101 AND 107). SN 86-114,312. PUB. 6-10-2014. FILED 11-8-2013.
- 4,591,864 ( *See Class 35 for this trademark*).
- 4,591,865. **THE KOVER AND DESIGN**. MARCEL BARREIRO, (U.S. CLS. 100, 101 AND 107). SN 86-115,059. PUB. 6-10-2014. FILED 11-11-2013.
- 4,591,868. **BIZ PIE BLOG AND DESIGN**. NORA PALLER, (U.S. CLS. 100, 101 AND 107). SN 86-115,659. PUB. 6-10-2014. FILED 11-11-2013.
- 4,591,874. **PEOPLES CLUB OF NIGERIA INTERNATIONAL AND DESIGN**. PEOPLES CLUB OF NIGERIA INTERNATIONAL, (U.S. CLS. 100, 101 AND 107). SN 86-116,372. PUB. 6-10-2014. FILED 11-12-2013.
- 4,591,877 ( *See Class 35 for this trademark*).
- 4,591,878. **THE POLE PALACE (STANDARD CHARACTER)**. THE POLE PALACE LLC, (U.S. CLS. 100, 101 AND 107). SN 86-116,841. PUB. 6-10-2014. FILED 11-12-2013.
- 4,591,883. **CONTINUING THE TRADITION (STANDARD CHARACTER)**. NEW JERSEY WATERFOWLERS ASSOCIATION, INC., (U.S. CLS. 100, 101 AND 107). SN 86-118,078. PUB. 6-10-2014. FILED 11-13-2013.
- 4,591,887. **EASIFY AND DESIGN**. EASIFY, INC., (U.S. CLS. 100, 101 AND 107). SN 86-119,005. PUB. 6-10-2014. FILED 11-14-2013.
- 4,591,890. **GENHERATION (STANDARD CHARACTER)**. GENHERATION, (U.S. CLS. 100, 101 AND 107). SN 86-119,257. PUB. 6-10-2014. FILED 11-14-2013.
- 4,591,898. **EXCELLENCE FOR ALL WORLD-CLASS INSTRUCTIONAL SYSTEMS FOR OUR SCHOOLS AND DESIGN**. NATIONAL CENTER ON EDUCATION AND THE ECONOMY, (U.S. CLS. 100, 101 AND 107). SN 86-120,492. PUB. 6-10-2014. FILED 11-15-2013.
- 4,591,903 ( *See Class 16 for this trademark*).
- 4,591,914. **CORN AND DESIGN**. CORN PUBLISHING, (U.S. CLS. 100, 101 AND 107). SN 86-123,641. PUB. 6-10-2014. FILED 11-20-2013.
- 4,591,918. **THE BATH SALT ZOMBIES (STANDARD CHARACTER)**. GRAHAM WOODARD, AND ZANE BOWMAN, (U.S. CLS. 100, 101 AND 107). SN 86-124,468. PUB. 6-10-2014. FILED 11-20-2013.
- 4,591,924. **CAMP MIKDASH BUILDING LIVES WITH HEART AND DESIGN**. MENUCHA CHESED SERVICES, CORP., (U.S. CLS. 100, 101 AND 107). SN 86-125,407. PUB. 6-10-2014. FILED 11-21-2013.
- 4,591,931. **NOM DE PLUME STUDIO (STANDARD CHARACTER)**. KREBSBACH, RENA, (U.S. CLS. 100, 101 AND 107). SN 86-126,577. PUB. 6-10-2014. FILED 11-22-2013.
- 4,591,943 ( *See Class 25 for this trademark*).
- 4,591,947. **DINOSAURIA EXPERIENCE (STANDARD CHARACTER)**. INTERNATIONAL GEM & JEWELRY SHOW, INC., (U.S. CLS. 100, 101 AND 107). SN 86-128,180. PUB. 6-10-2014. FILED 11-25-2013.
- 4,591,948. **MARQUIS THEATRE (STANDARD CHARACTER)**. MARQUIS THEATRE ASSOCIATES, (U.S. CLS. 100, 101 AND 107). SN 86-128,404. PUB. 6-10-2014. FILED 11-25-2013.
- 4,591,958 ( *See Class 9 for this trademark*).
- 4,591,962 ( *See Class 35 for this trademark*).
- 4,591,971 ( *See Class 18 for this trademark*).
- 4,591,974. **YELLOW DOG PILATES (STANDARD CHARACTER)**. KAPLAN, JENNIFER BETH, DBA YELLOW DOG PILATES, (U.S. CLS. 100, 101 AND 107). SN 86-131,844. PUB. 6-10-2014. FILED 11-29-2013.
- 4,591,975. **DIAMONDS GENTLEMAN'S CLUB (STANDARD CHARACTER)**. ARAYOS LLC, DBA DIAMONDS GENTLEMAN'S CLUB, MULTIPLE CLASS, (INT. CLS. 41 AND 43), (U.S. CLS. 100, 101 AND 107). SN 86-132,064. PUB. 5-6-2014. FILED 11-30-2013.
- 4,592,002. **BIG WRASSE DIVERS INC. AND DESIGN**. BIG WRASSE DIVERS, INC., (U.S. CLS. 100, 101 AND 107). SN 86-135,758. PUB. 6-10-2014. FILED 12-5-2013.
- 4,592,003 ( *See Class 35 for this trademark*).
- 4,592,007. **TRAINING THINK TANK (STANDARD CHARACTER)**. COACH MAX AZ LLC, DBA TRAINING THINK TANK, (U.S. CLS. 100, 101 AND 107). SN 86-136,794. PUB. 6-10-2014. FILED 12-6-2013.
- 4,592,012. **CYBERBODYSHOP (STANDARD CHARACTER)**. CYBERBODYSHOP, (U.S. CLS. 100, 101 AND 107). SN 86-137,206. PUB. 6-10-2014. FILED 12-6-2013.
- 4,592,015. **NKT (STANDARD CHARACTER)**. NEW KADAMPA TRADITION - INTERNATIONAL KADAMPA BUDDHIST UNION, MULTIPLE CLASS, (INT. CLS. 41 AND 45), (U.S. CLS. 100, 101 AND 107). SN 86-137,672. PUB. 6-10-2014. FILED 12-6-2013.
- 4,592,016. **SHAMANIC DE-ARMORING (STANDARD CHARACTER)**. SHAMANIC DE-ARMORING, LLC, (U.S. CLS. 100, 101 AND 107). SN 86-137,781. PUB. 6-10-2014. FILED 12-7-2013.
- 4,592,017. **SHAMANIC DEARMORING (STANDARD CHARACTER)**. SHAMANIC DE-ARMORING, LLC, (U.S. CLS. 100, 101 AND 107). SN 86-137,784. PUB. 6-10-2014. FILED 12-7-2013.
- 4,592,019 ( *See Class 9 for this trademark*).
- 4,592,027. **MISCELLANEOUS DESIGN**. UNIVERSAL CITY STUDIOS LLC, (U.S. CLS. 100, 101 AND 107). SN 86-138,926. PUB. 6-10-2014. FILED 12-9-2013.
- 4,592,038 ( *See Class 35 for this trademark*).
- 4,592,041. **NEW KADAMPA TRADITION (STANDARD CHARACTER)**. NEW KADAMPA TRADITION - INTERNATIONAL KADAMPA BUDDHIST UNIO, MULTIPLE CLASS, (INT. CLS. 41 AND 45), (U.S. CLS. 100, 101 AND 107). SN 86-141,337. PUB. 6-10-2014. FILED 12-11-2013.
- 4,592,042. **MYTUTOR INC. (STANDARD CHARACTER)**. MYTUTOR INC., (U.S. CLS. 100, 101 AND 107). SN 86-141,365. PUB. 6-10-2014. FILED 12-11-2013.
- 4,592,043. **MYTUTOR INC. AND DESIGN**. MYTUTOR INC., (U.S. CLS. 100, 101 AND 107). SN 86-141,377. PUB. 6-10-2014.



- FILED 12-11-2013.
- 4,592,045. **FIND YOUR BEAUTIFUL LIFE PLAN (STANDARD CHARACTER)**. LAVIN, ELIZABETH, (U.S. CLS. 100, 101 AND 107). SN 86-141,611. PUB. 6-10-2014. FILED 12-12-2013.
- 4,592,047. **AMATEUR RADIO IN SPACE AMSAT AND DESIGN**. RADIO AMATEUR SATELLITE CORPORATION, (U.S. CLS. 100, 101 AND 107). SN 86-141,654. PUB. 6-10-2014. FILED 12-12-2013.
- 4,592,067. **HERITAGE AUDIO VISUAL AND DESIGN**. CROSSROADS ENTERPRISES, LLC, DBA HERITAGE AUDIO VISUAL, (U.S. CLS. 100, 101 AND 107). SN 86-143,632. PUB. 6-10-2014. FILED 12-13-2013.
- 4,592,070. **COLOR ME CANVAS (STANDARD CHARACTER)**. COLOR ME MINE ENTERPRISES, INC., DBA COLOR ME MINE, (U.S. CLS. 100, 101 AND 107). SN 86-144,224. PUB. 6-10-2014. FILED 12-16-2013.
- 4,592,079. **HOOPS LIFE (STYLIZED)**. HOOPS PAT BURKE'S TRAINING FACILITY, LLC, FORMERLY HOOPS 31, LLC, MULTIPLE CLASS, (INT. CLS. 41 AND 45), (U.S. CLS. 100, 101 AND 107). SN 86-144,988. PUB. 6-10-2014. FILED 12-16-2013.
- 4,592,083. **HEARSOME (STANDARD CHARACTER)**. JOUST 12 PRODUCTIONS, (U.S. CLS. 100, 101 AND 107). SN 86-146,454. PUB. 6-10-2014. FILED 12-17-2013.
- 4,592,093. **WHYDOIDATE THE PLACE WHERE SINGLES LAUGH & SHARE THE TRIUMPHS AND TRAGEDIES OF DATING WHYDOIDATE.COM AND DESIGN**. BLONDE BYTES, DBA WHYDOIDATE, (U.S. CLS. 100, 101 AND 107). SN 86-147,825. PUB. 6-10-2014. FILED 12-19-2013.
- 4,592,094. **WHYDOIDATE (STANDARD CHARACTER)**. BLONDE BYTES, DBA WHYDOIDATE, (U.S. CLS. 100, 101 AND 107). SN 86-147,826. PUB. 6-10-2014. FILED 12-19-2013.
- 4,592,099. **MRS. U.S. GLOBE (STANDARD CHARACTER)**. KEMBLE, TRACY, (U.S. CLS. 100, 101 AND 107). SN 86-148,465. PUB. 6-10-2014. FILED 12-19-2013.
- 4,592,102. **SPECTACTICAL LASER TAG AND DESIGN**. MBH RECREATION, LLC, (U.S. CLS. 100, 101 AND 107). SN 86-148,733. PUB. 6-10-2014. FILED 12-19-2013.
- 4,592,105. **RAKTIVIST (STANDARD CHARACTER)**. THE RANDOM ACTS OF KINDNESS FOUNDATION, (U.S. CLS. 100, 101 AND 107). SN 86-149,454. PUB. 6-10-2014. FILED 12-20-2013.
- 4,592,107 ( *See Class 35 for this trademark*).
- 4,592,111. **ATLETICO S R AND DESIGN**. ATLETICO SANTA ROSA, (U.S. CLS. 100, 101 AND 107). SN 86-150,110. PUB. 6-10-2014. FILED 12-20-2013.
- 4,592,113 ( *See Class 39 for this trademark*).
- 4,592,120. **EMERGENT SOUL (STYLIZED)**. KAM ENTERPRISES INC, (U.S. CLS. 100, 101 AND 107). SN 86-150,726. PUB. 6-10-2014. FILED 12-23-2013.
- 4,592,132. **WHATABURGER FIELD CORPUS CHRISTI AND DESIGN**. TRES AGUILAS ENTERPRISES LLC, (U.S. CLS. 100, 101 AND 107). SN 86-151,142. PUB. 6-10-2014. FILED 12-23-2013.
- 4,592,133. **GRACE CAMO & LACE (STANDARD CHARACTER)**. SUSAN ARMSTRONG, (U.S. CLS. 100, 101 AND 107). SN 86-151,192. PUB. 6-10-2014. FILED 12-23-2013.
- 4,592,134. **EPIC QUEST OF AWESOME (STANDARD CHARACTER)**. LEVEL UP ENTERPRISES, INC., DBA NERD FITNESS, (U.S. CLS. 100, 101 AND 107). SN 86-151,241. PUB. 6-10-2014. FILED 12-23-2013.
- 4,592,146. **THE L.I.F.T. METHOD LIGAMENT INFLUENCED FASCIAL TECHNIQUE (STANDARD CHARACTER)**. THE BODY SHOPPE, (U.S. CLS. 100, 101 AND 107). SN 86-152,171. PUB. 6-10-2014. FILED 12-24-2013.
- 4,592,156. **NASHVILLE MUSIC GARDEN AND DESIGN**. THE COMMUNITY FOUNDATION OF MIDDLE TENNESSEE, (U.S. CLS. 100, 101 AND 107). SN 86-152,904. PUB. 6-10-2014. FILED 12-26-2013.
- 4,592,164 ( *See Class 35 for this trademark*).
- 4,592,166. **LPC LUCKY PARADISE CASINOS YOU'RE ALWAYS LUCKY WITH PARADISE AND DESIGN**. MICHAEL BROOKS, (U.S. CLS. 100, 101 AND 107). SN 86-153,703. PUB. 6-10-2014. FILED 12-28-2013.
- 4,592,172. **DAVE HODGES THE COMMON SENSE SHOW FREEING AMERICA ONE ENSLAVED MIND AT A TIME (STANDARD CHARACTER)**. HODGES, DAVID, AND HODGES, NORA, MULTIPLE CLASS, (INT. CLS. 41 AND 42), (U.S. CLS. 100, 101 AND 107). SN 86-153,973. PUB. 6-10-2014. FILED 12-30-2013.
- 4,592,176 ( *See Class 35 for this trademark*).
- 4,592,181. **KEHILLA (STANDARD CHARACTER)**. CONSERVATIVE FOUNDATION, (U.S. CLS. 100, 101 AND 107). SN 86-154,610. PUB. 6-10-2014. FILED 12-30-2013.
- 4,592,182. **PRACTICAL PALEO (STANDARD CHARACTER)**. BALANCED BITES LLC, (U.S. CLS. 100, 101 AND 107). SN 86-154,670. PUB. 6-10-2014. FILED 12-30-2013.
- 4,592,189. **SELECTED STUDY GROUPS AND DESIGN**. SELECTED INDEPENDENT FUNERAL HOMES, (U.S. CLS. 100, 101 AND 107). SN 86-155,188. PUB. 6-10-2014. FILED 12-31-2013.
- 4,592,190. **SELECTED STUDY GROUPS AND DESIGN**. SELECTED INDEPENDENT FUNERAL HOMES, (U.S. CLS. 100, 101 AND 107). SN 86-155,212. PUB. 6-10-2014. FILED 12-31-2013.
- 4,592,200. **BRILLIANT BUS (STANDARD CHARACTER)**. PYFROM, ESTELLA, (U.S. CLS. 100, 101 AND 107). SN 86-155,694. PUB. 6-10-2014. FILED 12-31-2013.
- 4,592,232. **PROGRESSIVE MUSIC CENTER (STANDARD CHARACTER)**. PROGRESSIVE PERCUSSION DRUM STUDIOS, INC., (U.S. CLS. 100, 101 AND 107). SN 86-157,161. PUB. 6-10-2014. FILED 1-3-2014.
- 4,592,251. **HUB CITY BIKE WEEK (STANDARD CHARACTER)**. 2UP LLC, (U.S. CLS. 100, 101 AND 107). SN 86-158,231. PUB. 6-10-2014. FILED 1-6-2014.
- 4,592,252 ( *See Class 35 for this trademark*).
- 4,592,253. **THE POWER PLAYERS CLUB (STANDARD CHARACTER)**. TRU TRANSFORMATION COACHING, LLC, (U.S. CLS. 100, 101 AND 107). SN 86-158,248. PUB. 6-10-2014. FILED 1-6-2014.
- 4,592,262. **MANAGEMENT BY FIRE (STANDARD CHARACTER)**. PROACTIVE TRAINING SOLUTIONS, INC., (U.S. CLS. 100, 101 AND 107). SN 86-158,547. PUB. 6-10-2014. FILED 1-6-2014.
- 4,592,278. **CHRISTIAN BOOK OF THE YEAR (STANDARD CHARACTER)**. EVANGELICAL CHRISTIAN PUBLISHERS ASSOCIATION, (U.S. CLS. 100, 101 AND 107). SN 86-159,462. PUB. 6-10-2014. FILED 1-7-2014.
- 4,592,285. **THE DOUBLECLICKS (STANDARD CHARACTER)**. THE DOUBLECLICKS LLC, (U.S. CLS. 100, 101 AND 107). SN 86-159,716. PUB. 6-10-2014. FILED 1-7-2014.
- 4,592,286. **PHIL 'N THE VOID (STANDARD CHARACTER)**. DE LUCIA, ANTHONY, JR., (U.S. CLS. 100, 101 AND 107). SN 86-159,720. PUB. 6-10-2014. FILED 1-7-2014.
- 4,592,288. **NESHAMA INTERFAITH CENTER (STANDARD CHARACTER)**. NESHAMA INTERFAITH CENTER INC., (U.S. CLS. 100, 101 AND 107). SN 86-159,955. PUB. 6-10-2014. FILED 1-8-2014.
- 4,592,289. **IMSA AND DESIGN**. INTERNATIONAL MOTOR SPORTS ASSOCIATION LLC, (U.S. CLS. 100, 101 AND 107). SN 86-159,961. PUB. 6-10-2014. FILED 1-8-2014.
- 4,592,291. **CHARACTER LAB (STANDARD CHARACTER)**. THE CHARACTER LAB INC., (U.S. CLS. 100, 101 AND 107). SN 86-160,034. PUB. 6-10-2014. FILED 1-8-2014.
- 4,592,292. **NESHAMA INTERFAITH CENTER ONE RIVER, MANY STREAMS AND DESIGN**. NESHAMA INTERFAITH CENTER INC., (U.S. CLS. 100, 101 AND 107). SN 86-160,035. PUB. 6-10-2014. FILED 1-8-2014.
- 4,592,296. **DESIGN YOU COACHING (STANDARD CHARACTER)**. TANEA FLANDERS, DBA DESIGN YOU COACHING, (U.S. CLS. 100, 101 AND 107). SN 86-160,051. PUB. 6-10-2014. FILED 1-8-2014.
- 4,592,299. **ORIGINAL YOU (STANDARD CHARACTER)**. ORIGINAL STRENGTH SYSTEMS, LLC, (U.S. CLS. 100, 101 AND 107). SN 86-160,235. PUB. 6-10-2014. FILED 1-8-2014.
- 4,592,300. **LIFESTYLE ATHLETICS (STANDARD CHARACTER)**. CORONEL, MARC, DBA LIFESTYLE ATHLETICS, (U.S. CLS. 100, 101 AND 107). SN 86-160,321. PUB. 6-10-2014. FILED 1-8-2014.
- 4,592,322. **CHICKS WITH PICKS AND DESIGN**. FREELANCE ADVENTURES INC., DBA CHICKS WITH PICKS, (U.S. CLS. 100, 101 AND 107). SN 86-161,432. PUB. 6-10-2014. FILED 1-9-2014.
- 4,592,323. **USHARBORS AND DESIGN**. MAINE BOATS, HOMES & HARBORS, INC., (U.S. CLS. 100, 101 AND 107).

- SN 86-161,456. PUB. 6-10-2014. FILED 1-9-2014.
- 4,592,326. **HEAT ATHLETICS (STANDARD CHARACTER)**. HEAT ATHLETICS ALL-STARS LLC, (U.S. CLS. 100, 101 AND 107). SN 86-161,540. PUB. 6-10-2014. FILED 1-9-2014.
- 4,592,335. **CHICKS ROCK AND DESIGN**. FREELANCE ADVENTURES INC., (U.S. CLS. 100, 101 AND 107). SN 86-161,659. PUB. 6-10-2014. FILED 1-9-2014.
- 4,592,347. **THE PREPARED PERFORMER (STANDARD CHARACTER)**. MAHONEY, MOLLY, (U.S. CLS. 100, 101 AND 107). SN 86-161,884. PUB. 6-10-2014. FILED 1-9-2014.
- 4,592,348. **BEVERLY HILLS TENNIS AND DESIGN**. THE TENNIS PLACE, INC. (U.S. CLS. 100, 101 AND 107). SN 86-161,922. PUB. 6-10-2014. FILED 1-9-2014.
- 4,592,362. **PURPOSE 2PLAY.COM (STANDARD CHARACTER)**. PURPOSE 2 PLAY.COM, (U.S. CLS. 100, 101 AND 107). SN 86-162,292. PUB. 6-10-2014. FILED 1-10-2014.
- 4,592,363 ( *See Class 28 for this trademark*).
- 4,592,368. **CONSCIOUS GIRLFRIEND (STANDARD CHARACTER)**. CONSCIOUS GIRLFRIEND, DBA HEALERS LIFE, (U.S. CLS. 100, 101 AND 107). SN 86-162,574. PUB. 6-10-2014. FILED 1-10-2014.
- 4,592,371 ( *See Class 39 for this trademark*).
- 4,592,374. **TOTAL HEALTH INSTITUTE (STANDARD CHARACTER)**. TOTAL HEALTH MINISTRIES, INC., MULTIPLE CLASS, (INT. CLS. 41, 44 AND 45), (U.S. CLS. 100, 101 AND 107). SN 86-162,654. PUB. 6-10-2014. FILED 1-10-2014.
- 4,592,377 ( *See Class 39 for this trademark*).
- 4,592,378. **FATHERLY (STANDARD CHARACTER)**. IR MEDIA VENTURES, LLC, (U.S. CLS. 100, 101 AND 107). SN 86-162,733. PUB. 6-10-2014. FILED 1-10-2014.
- 4,592,403. **LEAN TEACHING AND DESIGN**. EMILIANI, MARIO L, DBA THE CLBM, LLC, (U.S. CLS. 100, 101 AND 107). SN 86-163,321. PUB. 6-10-2014. FILED 1-12-2014.
- 4,592,404. **CHICKS CLIMBING AND DESIGN**. FREELANCE ADVENTURES INC., (U.S. CLS. 100, 101 AND 107). SN 86-163,339. PUB. 6-10-2014. FILED 1-12-2014.
- 4,592,426. **CAREER WISDOM INSTITUTE AND DESIGN**. CAREER WISDOM INSTITUTE, (U.S. CLS. 100, 101 AND 107). SN 86-163,962. PUB. 6-10-2014. FILED 1-13-2014.
- 4,592,429. **TAKE A KID BIRDING AND DESIGN**. THE NEW JERSEY AUDUBON SOCIETY, (U.S. CLS. 100, 101 AND 107). SN 86-164,053. PUB. 6-10-2014. FILED 1-13-2014.
- 4,592,445. **DBTI (STANDARD CHARACTER)**. DESIGN/BUILD TENANT IMPROVEMENTS, (U.S. CLS. 100, 101 AND 107). SN 86-164,680. PUB. 6-10-2014. FILED 1-14-2014.
- 4,592,452. **SAFEWAY DRIVING AND DESIGN**. SAFEWAY DRIVING SYSTEMS, LLC, (U.S. CLS. 100, 101 AND 107). SN 86-165,146. PUB. 6-10-2014. FILED 1-14-2014.
- 4,592,467. **MALCO THEATRES (STANDARD CHARACTER)**. MALCO THEATRES, INC., (U.S. CLS. 100, 101 AND 107). SN 86-165,490. PUB. 6-10-2014. FILED 1-14-2014.
- 4,592,472 ( *See Class 16 for this trademark*).
- 4,592,475 ( *See Class 35 for this trademark*).
- 4,592,476 ( *See Class 35 for this trademark*).
- 4,592,480 ( *See Class 9 for this trademark*).
- 4,592,485. **MISCELLANEOUS DESIGN**. SAVANNAH MUSIC FESTIVAL, INC., (U.S. CLS. 100, 101 AND 107). SN 86-166,081. PUB. 6-10-2014. FILED 1-15-2014.
- 4,592,487. **SAVANNAH MUSIC FESTIVAL (STANDARD CHARACTER)**. SAVANNAH MUSIC FESTIVAL, INC., (U.S. CLS. 100, 101 AND 107). SN 86-166,099. PUB. 6-10-2014. FILED 1-15-2014.
- 4,592,488. **SWING CENTRAL JAZZ (STANDARD CHARACTER)**. SAVANNAH MUSIC FESTIVAL, INC., (U.S. CLS. 100, 101 AND 107). SN 86-166,108. PUB. 6-10-2014. FILED 1-15-2014.
- 4,592,490. **LAND OF MAKE BELIEVE (STANDARD CHARACTER)**. CHRISTOPHER MAIER, DBA LAND OF MAKE BELIEVE, (U.S. CLS. 100, 101 AND 107). SN 86-166,160. PUB. 6-10-2014. FILED 1-15-2014.
- 4,592,505. **BODY MIND SYSTEMS (STANDARD CHARACTER)**. CULLETON, FRANK E., DBA BODY MIND SYSTEMS, (U.S. CLS. 100, 101 AND 107). SN 86-166,630. PUB. 6-10-2014. FILED 1-15-2014.
- 4,592,513. **KISS MY AXE! (STANDARD CHARACTER)**. FREELANCE ADVENTURES INC., (U.S. CLS. 100, 101 AND 107). SN 86-166,780. PUB. 6-10-2014. FILED 1-15-2014.
- 4,592,515. **LUMINARY LEADER (STANDARD CHARACTER)**. PEOPLE-SIDE SOLUTIONS, (U.S. CLS. 100, 101 AND 107). SN 86-166,930. PUB. 6-10-2014. FILED 1-16-2014.
- 4,592,531 ( *See Class 35 for this trademark*).
- 4,592,533 ( *See Class 35 for this trademark*).
- 4,592,572. **PROJECT NURSERY AND DESIGN**. PROJECT NURSERY, LLC, (U.S. CLS. 100, 101 AND 107). SN 86-170,705. PUB. 6-10-2014. FILED 1-21-2014.
- 4,592,584. **PERFORMFIT 360 (STANDARD CHARACTER)**. GUARDIAN PREMIER SOLUTIONS, (U.S. CLS. 100, 101 AND 107). SN 86-171,944. PUB. 6-10-2014. FILED 1-22-2014.
- 4,592,586. **TICKETLAB AND DESIGN**. TICKETLAB LLC, (U.S. CLS. 100, 101 AND 107). SN 86-172,133. PUB. 6-10-2014. FILED 1-22-2014.
- 4,592,590. **MADE-N-AMERICA (STANDARD CHARACTER)**. LEHNER, MARK P., DBA MADE-N-AMERICA, (U.S. CLS. 100, 101 AND 107). SN 86-172,298. PUB. 6-10-2014. FILED 1-22-2014.
- 4,592,603. **DORRANCE (STANDARD CHARACTER)**. DORRANCE PUBLISHING COMPANY, INC., (U.S. CLS. 100, 101 AND 107). SN 86-173,027. PUB. 6-10-2014. FILED 1-23-2014.
- 4,592,606. **MISCELLANEOUS DESIGN**. DORRANCE PUBLISHING COMPANY, INC., (U.S. CLS. 100, 101 AND 107). SN 86-173,074. PUB. 6-10-2014. FILED 1-23-2014.
- 4,592,616. **SCHOOL OF HUMAN POTENTIAL (STANDARD CHARACTER)**. AMIVERIS ENTERPRISE, INC., (U.S. CLS. 100, 101 AND 107). SN 86-174,190. PUB. 6-10-2014. FILED 1-24-2014.
- 4,592,618. **FIVE SECONDS TO FREEDOM (STANDARD CHARACTER)**. MATTHEW JOHN BADEN, AND ROBERT VINCENT LIBERATI 3RD, AND BRENDAN JOHN MARTIN, AND JOSEPH MALCOM SPRINGER, AND TYLER MICHAEL STEINBAUER, (U.S. CLS. 100, 101 AND 107). SN 86-174,224. PUB. 6-10-2014. FILED 1-24-2014.
- 4,592,623. **HITFU (STANDARD CHARACTER)**. HITFU, INC., (U.S. CLS. 100, 101 AND 107). SN 86-174,408. PUB. 6-10-2014. FILED 1-24-2014.
- 4,592,625 ( *See Class 9 for this trademark*).
- 4,592,642. **THEATREZONE (STANDARD CHARACTER)**. THEATREZONE INC., (U.S. CLS. 100, 101 AND 107). SN 86-175,174. PUB. 6-10-2014. FILED 1-25-2014.
- 4,592,663. **LONGEVITY IS LIFE (STANDARD CHARACTER)**. CHEKALSKA, NATALIYA, (U.S. CLS. 100, 101 AND 107). SN 86-175,575. PUB. 6-10-2014. FILED 1-27-2014.
- 4,592,672. **PRACTICALLY SPEAKING (STANDARD CHARACTER)**. SEI INVESTMENTS DEVELOPMENTS, INC., (U.S. CLS. 100, 101 AND 107). SN 86-175,690. PUB. 6-10-2014. FILED 1-27-2014.
- 4,592,676. **FITIN45 (STANDARD CHARACTER)**. BUCKHEAD JIU-JITSU, (U.S. CLS. 100, 101 AND 107). SN 86-175,721. PUB. 6-10-2014. FILED 1-27-2014.
- 4,592,679. **ENERGY (STANDARD CHARACTER)**. ENERGY INTERACTIVE FITNESS, (U.S. CLS. 100, 101 AND 107). SN 86-175,810. PUB. 6-10-2014. FILED 1-27-2014.
- 4,592,704. **LEXICON (STANDARD CHARACTER)**. LEXICON INTERACTIVE, INC., (U.S. CLS. 100, 101 AND 107). SN 86-176,226. PUB. 6-10-2014. FILED 1-27-2014.
- 4,592,706. **GPBHM (STANDARD CHARACTER)**. GREAT PLAINS BLACK HISTORY MUSEUM, ARCHIVES AND INTERPRETATIVE CENTER, INC., (U.S. CLS. 100, 101 AND 107). SN 86-176,294. PUB. 6-10-2014. FILED 1-27-2014.
- 4,592,715. **IT'S TIME TO BE A PARENT AGAIN (STANDARD CHARACTER)**. BREVARD COUNTY SHERIFF'S OFFICE, (U.S. CLS. 100, 101 AND 107). SN 86-176,522. PUB. 6-10-2014. FILED 1-27-2014.
- 4,592,716. **MISCELLANEOUS DESIGN**. FAMILY DEVELOPMENT RESOURCES, INC., (U.S. CLS. 100, 101 AND 107). SN 86-176,541. PUB. 6-10-2014. FILED 1-27-2014.
- 4,592,724. **WE HEAT THE BODY NOT THE ROOM (STANDARD CHARACTER)**. 3X30 YOGA, LLC, (U.S. CLS. 100, 101 AND 107). SN 86-176,780. PUB. 6-10-2014. FILED 1-27-2014.
- 4,592,733. **GET HIGH (STANDARD CHARACTER)**. REFORMED BODIES, INC., (U.S. CLS. 100, 101 AND 107). SN 86-176,895. PUB. 6-10-2014. FILED 1-28-2014.
- 4,592,748. **GORILLA RILLA (STANDARD CHARACTER)**. ACASIO, MARK, (U.S. CLS. 100, 101 AND 107). SN 86-177,091. PUB. 6-10-2014. FILED 1-28-2014.
- 4,592,753 ( *See Class 35 for this trademark*).

- 4,592,754. **PARTY MACHINE (STANDARD CHARACTER)**. EMERALD CITY BAND, INC., (U.S. CLS. 100, 101 AND 107). SN 86-177,194. PUB. 6-10-2014. FILED 1-28-2014.
- 4,592,761. **WE'RE NOT BUYING IT (STANDARD CHARACTER)**. NATIONAL COUNCIL ON ALCOHOLISM AND DRUG DEPENDENCE OF MIDDLESEX COUNTY, INC., (U.S. CLS. 100, 101 AND 107). SN 86-177,351. PUB. 6-10-2014. FILED 1-28-2014.
- 4,592,766. **KASTLE (STANDARD CHARACTER)**. KASTLE LLC, (U.S. CLS. 100, 101 AND 107). SN 86-177,440. PUB. 6-10-2014. FILED 1-28-2014.
- 4,592,768. **VOICES OF THE DEAD (STANDARD CHARACTER)**. MCGURL, SCOT, (U.S. CLS. 100, 101 AND 107). SN 86-177,479. PUB. 6-10-2014. FILED 1-28-2014.
- 4,592,770. **IN THE CAR (STANDARD CHARACTER)**. IN THE CAR, (U.S. CLS. 100, 101 AND 107). SN 86-177,503. PUB. 6-10-2014. FILED 1-28-2014.
- 4,592,779. **REAL WOMEN RUN (STANDARD CHARACTER)**. YOUNG WOMEN'S CHRISTIAN ASSOCIATION OF SALT LAKE CITY, (U.S. CLS. 100, 101 AND 107). SN 86-177,687. PUB. 6-10-2014. FILED 1-28-2014.
- 4,592,782. **4 GRANDS 8 HANDS (STANDARD CHARACTER)**. BZDEK, CAZ, (U.S. CLS. 100, 101 AND 107). SN 86-177,718. PUB. 6-10-2014. FILED 1-28-2014.
- 4,592,783. **TWIN GALAXIES (STANDARD CHARACTER)**. HALL DIGITAL FILMS, INC., (U.S. CLS. 100, 101 AND 107). SN 86-177,735. PUB. 6-10-2014. FILED 1-28-2014.
- 4,592,787. **CAD-ARTISTRY (STANDARD CHARACTER)**. VASQUEZ, JAVIER EDUARDO, (U.S. CLS. 100, 101 AND 107). SN 86-177,765. PUB. 6-10-2014. FILED 1-28-2014.
- 4,592,800. **SERIOUSLY FOR REAL? (STANDARD CHARACTER)**. FS INDUSTRIES LLC, (U.S. CLS. 100, 101 AND 107). SN 86-177,890. PUB. 6-10-2014. FILED 1-28-2014.
- 4,592,801. **CANVAS & CLAY (STANDARD CHARACTER)**. CANVAS & CLAY, (U.S. CLS. 100, 101 AND 107). SN 86-177,987. PUB. 6-10-2014. FILED 1-28-2014.
- 4,592,803. **LIFESTYLE ATHLETICS AND DESIGN**. CORONEL, MARC, DBA LIFESTYLE ATHLETICS, (U.S. CLS. 100, 101 AND 107). SN 86-178,004. PUB. 6-10-2014. FILED 1-28-2014.
- 4,592,808. **JERICHO AND DESIGN**. FOXHOUND URBAN ADVENTURES, INC., (U.S. CLS. 100, 101 AND 107). SN 86-178,082. PUB. 6-10-2014. FILED 1-28-2014.
- 4,592,811. **ANCHORS AND AMMO (STANDARD CHARACTER)**. PETERSON, CHRISTY L, (U.S. CLS. 100, 101 AND 107). SN 86-178,164. PUB. 6-10-2014. FILED 1-29-2014.
- 4,592,814. **HOUSE OF HARPER (STANDARD CHARACTER)**. KNAPP, CAROLINE, (U.S. CLS. 100, 101 AND 107). SN 86-178,234. PUB. 6-10-2014. FILED 1-29-2014.
- 4,592,820. **SHIPMAN & GOODWIN LLP COUNSELORS AT LAW AND DESIGN**. SHIPMAN & GOODWIN LLP, (U.S. CLS. 100, 101 AND 107). SN 86-178,324. PUB. 6-10-2014. FILED 1-29-2014.
- 4,592,833. **PROJECT REAL AND DESIGN**. THE BARTER FOUNDATION, INCORPORATED, (U.S. CLS. 100, 101 AND 107). SN 86-178,497. PUB. 6-10-2014. FILED 1-29-2014.
- 4,592,835. **IMPACTSTRONG (STANDARD CHARACTER)**. STEVEN C. DOSS, DBA IMPACTSTRONG, (U.S. CLS. 100, 101 AND 107). SN 86-178,546. PUB. 6-10-2014. FILED 1-29-2014.
- 4,592,853 ( *See Class 35 for this trademark*).
- 4,592,860 ( *See Class 9 for this trademark*).
- 4,592,861. **NO JUDGMENT. JUST LOVE. (STANDARD CHARACTER)**. REA, SHARON, (U.S. CLS. 100, 101 AND 107). SN 86-178,996. PUB. 6-10-2014. FILED 1-29-2014.
- 4,592,900 ( *See Class 25 for this trademark*).
- 4,592,902 ( *See Class 25 for this trademark*).
- 4,592,913 ( *See Class 9 for this trademark*).
- 4,592,916. **JOURNEY OF PROFOUND HEALING (STANDARD CHARACTER)**. SAI MAA, LLC, (U.S. CLS. 100, 101 AND 107). SN 86-180,448. PUB. 6-10-2014. FILED 1-30-2014.
- 4,592,917. **JOURNEY OF PROFOUND AWAKENING (STANDARD CHARACTER)**. SAI MAA, LLC, (U.S. CLS. 100, 101 AND 107). SN 86-180,460. PUB. 6-10-2014. FILED 1-30-2014.
- 4,592,919. **PROFOUND UNION FOR LOVERS (STANDARD CHARACTER)**. SAI MAA, LLC, (U.S. CLS. 100, 101 AND 107). SN 86-180,476. PUB. 6-10-2014. FILED 1-30-2014.
- 4,592,920. **GIVE ME 15 MINUTES AND I'LL GIVE YOU AMERICA (STANDARD CHARACTER)**. WEINER, DR. MICHAEL A., (U.S. CLS. 100, 101 AND 107). SN 86-180,477. PUB. 6-10-2014. FILED 1-30-2014.
- 4,592,921. **JOURNEY OF PROFOUND ABUNDANCE (STANDARD CHARACTER)**. SAI MAA, LLC, (U.S. CLS. 100, 101 AND 107). SN 86-180,491. PUB. 6-10-2014. FILED 1-30-2014.
- 4,592,933. **IB&WS AND DESIGN**. INTERNATIONAL BUSINESS & WINE SOCIETY LLC, (U.S. CLS. 100, 101 AND 107). SN 86-181,736. PUB. 6-10-2014. FILED 1-31-2014.
- 4,592,939. **FEAR EXPERIMENT (STANDARD CHARACTER)**. MAC & CHEESE PRODUCTIONS, (U.S. CLS. 100, 101 AND 107). SN 86-183,779. PUB. 6-10-2014. FILED 2-4-2014.
- 4,592,942. **YOGA JOURNAL LIVE! (STANDARD CHARACTER)**. CRUZ BAY PUBLISHING, INC., (U.S. CLS. 100, 101 AND 107). SN 86-185,182. PUB. 6-10-2014. FILED 2-5-2014.
- 4,592,943. **YOGA JOURNAL LIVE! (STYLIZED)**. CRUZ BAY PUBLISHING, INC., (U.S. CLS. 100, 101 AND 107). SN 86-185,233. PUB. 6-10-2014. FILED 2-5-2014.
- 4,592,950. **RED-YELLOW-GREEN (STANDARD CHARACTER)**. LEADLINE, LLC, (U.S. CLS. 100, 101 AND 107). SN 86-188,847. PUB. 6-10-2014. FILED 2-10-2014.
- 4,592,960. **T TROFAST MEDIA AND DESIGN**. TROFAST MEDIA LLC, (U.S. CLS. 100, 101 AND 107). SN 86-192,131. PUB. 6-10-2014. FILED 2-12-2014.
- 4,592,965. **SAFE SENIORS 50+ PROGRAM - WE CHANGES LIVES (STANDARD CHARACTER)**. TEXEIRA, KIRK, (U.S. CLS. 100, 101 AND 107). SN 86-195,106. PUB. 6-10-2014. FILED 2-17-2014.
- 4,592,969. **PINNACLE ENTERTAINMENT (STYLIZED)**. PINNACLE ENTERTAINMENT, INC., (U.S. CLS. 100, 101 AND 107). SN 86-197,009. PUB. 6-10-2014. FILED 2-18-2014.
- 4,592,979. **CREATIVE SPIRITS (STANDARD CHARACTER)**. CREATIVE SPIRITS, INC., (U.S. CLS. 100, 101 AND 107). SN 86-203,480. PUB. 6-10-2014. FILED 2-25-2014.
- 4,592,985 ( *See Class 9 for this trademark*).
- 4,592,990. **SINCE 1957 EAGLE LAKE CAMPS AND DESIGN**. THE NAVIGATORS, (U.S. CLS. 100, 101 AND 107). SN 86-208,897. PUB. 6-10-2014. FILED 3-3-2014.
- 4,593,010. **MISCELLANEOUS DESIGN**. PUEBLO OF ISLETA, (U.S. CLS. 100, 101 AND 107). SN 86-220,685. PUB. 6-10-2014. FILED 3-13-2014.
- 4,593,011. **HIGH CALIBER WOMEN AND DESIGN**. JACKSON HOLE SHOOTING, LLC, (U.S. CLS. 100, 101 AND 107). SN 86-222,120. PUB. 6-10-2014. FILED 3-14-2014.
- 4,593,020. **THE TASTING ROOM WINE BAR & SHOP BOXWOOD ESTATE WINERY AND DESIGN**. BOXWOOD WINERY, L.L.C., MULTIPLE CLASS, (INT. CLS. 41 AND 43), (U.S. CLS. 100, 101 AND 107). SN 86-225,770. PUB. 6-10-2014. FILED 3-19-2014.
- 4,593,025. **INSTABRACKET (STANDARD CHARACTER)**. TURNER SPORTS, INC., (U.S. CLS. 100, 101 AND 107). SN 86-226,981. PUB. 6-10-2014. FILED 3-20-2014.
- 4,593,027. **SCHOOL OF HUMAN POTENTIAL MIND, BODY, SPIRIT AND DESIGN**. AMIVERIS ENTERPRISE, INC., (U.S. CLS. 100, 101 AND 107). SN 86-227,814. PUB. 6-10-2014. FILED 3-20-2014.
- 4,593,034. **PRIMITIVE SURVIVAL RATING (STANDARD CHARACTER)**. DISCOVERY COMMUNICATIONS, LLC, (U.S. CLS. 100, 101 AND 107). SN 86-237,059. PUB. 6-10-2014. FILED 3-31-2014.
- 4,593,045. **RED INOCENTE (STYLIZED)**. CALIFORNIA WESTERN SCHOOL OF LAW, (U.S. CLS. 100, 101 AND 107). SN 86-245,098. PUB. 6-10-2014. FILED 4-7-2014.
- 4,593,049. **90 DAY FIANCÉ (STANDARD CHARACTER)**. DISCOVERY COMMUNICATIONS, LLC, (U.S. CLS. 100, 101 AND 107). SN 86-247,416. PUB. 6-10-2014. FILED 4-9-2014.
- 4,593,050. **SEX SENT ME TO THE ER (STANDARD CHARACTER)**. DISCOVERY COMMUNICATIONS, LLC, (U.S. CLS. 100, 101 AND 107). SN 86-247,422. PUB. 6-10-2014. FILED 4-9-2014.
- 4,593,056. **RED INOCENTE (STANDARD CHARACTER)**. CALIFORNIA WESTERN SCHOOL OF LAW, (U.S. CLS. 100, 101 AND 107). SN 86-250,628. PUB. 6-10-2014. FILED 4-12-2014.

**CLASS 42—SCIENTIFIC AND COMPUTER SERVICES**

- 4,590,604 ( *See Class 35 for this trademark.* )  
4,590,619. **ANALYSISPLUS AND DESIGN**. PHILLIPS 66 COMPANY, (U.S. CLS. 100 AND 101). SN 77-090,335. PUB. 6-10-2014. FILED 1-24-2007.  
4,590,633 ( *See Class 9 for this trademark.* )  
4,590,634 ( *See Class 7 for this trademark.* )  
4,590,640 ( *See Class 9 for this trademark.* )  
4,590,645 ( *See Class 9 for this trademark.* )  
4,590,646 ( *See Class 9 for this trademark.* )  
4,590,650 ( *See Class 7 for this trademark.* )  
4,590,655 ( *See Class 9 for this trademark.* )  
4,590,656 ( *See Class 9 for this trademark.* )  
4,590,657 ( *See Class 9 for this trademark.* )  
4,590,659 ( *See Class 9 for this trademark.* )  
4,590,665 ( *See Class 9 for this trademark.* )  
4,590,668 ( *See Class 9 for this trademark.* )  
4,590,675 ( *See Class 7 for this trademark.* )  
4,590,683 ( *See Class 37 for this trademark.* )  
4,590,687 ( *See Class 7 for this trademark.* )  
4,590,712 ( *See Class 9 for this trademark.* )  
4,590,719 ( *See Class 21 for this trademark.* )  
4,590,720 ( *See Class 9 for this trademark.* )  
4,590,735 ( *See Class 36 for this trademark.* )  
4,590,742 ( *See Class 9 for this trademark.* )  
4,590,744 ( *See Class 7 for this trademark.* )  
4,590,751 ( *See Class 17 for this trademark.* )  
4,590,752 ( *See Class 9 for this trademark.* )  
4,590,763 ( *See Class 9 for this trademark.* )  
4,590,766 ( *See Class 9 for this trademark.* )  
4,590,767 ( *See Class 9 for this trademark.* )  
4,590,771 ( *See Class 12 for this trademark.* )  
4,590,774 ( *See Class 35 for this trademark.* )  
4,590,775 ( *See Class 35 for this trademark.* )  
4,590,778 ( *See Class 9 for this trademark.* )  
4,590,784 ( *See Class 9 for this trademark.* )  
4,590,788 ( *See Class 1 for this trademark.* )  
4,590,790 ( *See Class 9 for this trademark.* )  
4,590,797 ( *See Class 9 for this trademark.* )  
4,590,799 ( *See Class 9 for this trademark.* )  
4,590,801 ( *See Class 9 for this trademark.* )  
4,590,803 ( *See Class 6 for this trademark.* )  
4,590,806 ( *See Class 7 for this trademark.* )  
4,590,816 ( *See Class 41 for this trademark.* )  
4,590,818 ( *See Class 11 for this trademark.* )  
4,590,821 ( *See Class 9 for this trademark.* )  
4,590,822 ( *See Class 9 for this trademark.* )  
4,590,824 ( *See Class 1 for this trademark.* )  
4,590,832 ( *See Class 9 for this trademark.* )  
4,590,858 ( *See Class 7 for this trademark.* )  
4,590,867 ( *See Class 1 for this trademark.* )  
4,590,881 ( *See Class 6 for this trademark.* )  
4,590,885 ( *See Class 7 for this trademark.* )  
4,590,890 ( *See Class 9 for this trademark.* )  
4,590,895 ( *See Class 9 for this trademark.* )  
4,590,910 ( *See Class 9 for this trademark.* )  
4,590,941. **TALKING TOM CAT (STANDARD CHARACTER)**. OUT FIT 7 LIMITED, (U.S. CLS. 100 AND 101). SN 85-189,060. PUB. 6-10-2014. FILED 12-2-2010.  
4,590,942 ( *See Class 35 for this trademark.* )  
4,590,943 ( *See Class 35 for this trademark.* )  
4,590,955. **URBANIMMERSIVE (STANDARD CHARACTER)**. URBANIMMERSIVE INC., (U.S. CLS. 100 AND 101). SN 85-418,256. PUB. 6-10-2014. FILED 9-8-2011.  
4,590,966. **FERMENTRICS (STANDARD CHARACTER)**. RITCHIE FEED & SEED INC., (U.S. CLS. 100 AND 101). SN 85-480,296. PUB. 6-10-2014. FILED 11-23-2011.  
4,590,993 ( *See Class 9 for this trademark.* )  
4,590,994 ( *See Class 9 for this trademark.* )  
4,591,001 ( *See Class 9 for this trademark.* )  
4,591,003 ( *See Class 1 for this trademark.* )  
4,591,046 ( *See Class 9 for this trademark.* )  
4,591,086 ( *See Class 9 for this trademark.* )  
4,591,087 ( *See Class 5 for this trademark.* )  
4,591,111 ( *See Class 35 for this trademark.* )  
4,591,112. **FROST (STANDARD CHARACTER)**. FROST PRODUCTS LIMITED, (U.S. CLS. 100 AND 101). SN 85-847,386. PUB. 6-10-2014. FILED 2-12-2013.  
4,591,126 ( *See Class 35 for this trademark.* )  
4,591,135. **THE SWIFT INNOVATION CORP (STANDARD CHARACTER)**. THE SWIFT INNOVATION CORP, (U.S. CLS. 100 AND 101). SN 85-878,097. PUB. 12-31-2013. FILED 3-16-2013.  
4,591,165 ( *See Class 9 for this trademark.* )  
4,591,168 ( *See Class 9 for this trademark.* )  
4,591,170 ( *See Class 9 for this trademark.* )  
4,591,193. **QUESTFLEX (STANDARD CHARACTER)**. QUEST MEDIA & SUPPLIES, INC., (U.S. CLS. 100 AND 101). SN 85-925,796. PUB. 6-10-2014. FILED 5-7-2013.  
4,591,194. **INVEST IN THE CAPABILITY NOT THE PRODUCT (STANDARD CHARACTER)**. QUEST MEDIA & SUPPLIES, INC., (U.S. CLS. 100 AND 101). SN 85-925,799. PUB. 6-10-2014. FILED 5-7-2013.  
4,591,208 ( *See Class 9 for this trademark.* )  
4,591,211. **BABEL SENTRY (STANDARD CHARACTER)**. BABEL STREET, LLC, (U.S. CLS. 100 AND 101). SN 85-938,215. PUB. 6-10-2014. FILED 5-21-2013.  
4,591,214 ( *See Class 37 for this trademark.* )  
4,591,227. **ALGORITHMRX (STANDARD CHARACTER)**. ALGORITHMRX, LLC, (U.S. CLS. 100 AND 101). SN 85-944,555. PUB. 6-10-2014. FILED 5-29-2013.  
4,591,235. **LUBE INSIGHTS SUITE (STANDARD CHARACTER)**. SAGGEZZA, INC., (U.S. CLS. 100 AND 101). SN 85-947,772. PUB. 6-10-2014. FILED 5-31-2013.  
4,591,236. **LUBE INSIGHTS (STANDARD CHARACTER)**. SAGGEZZA, INC., (U.S. CLS. 100 AND 101). SN 85-947,831. PUB. 6-10-2014. FILED 5-31-2013.  
4,591,237. **LUBE VISUALS (STANDARD CHARACTER)**. SAGGEZZA, INC., (U.S. CLS. 100 AND 101). SN 85-947,851. PUB. 6-10-2014. FILED 5-31-2013.  
4,591,242 ( *See Class 35 for this trademark.* )  
4,591,246. **CORPORATE LEGAL DESKTOP (STANDARD CHARACTER)**. DATACERT, INC., (U.S. CLS. 100 AND 101). SN 85-949,538. PUB. 6-10-2014. FILED 6-3-2013.  
4,591,250. **QUANT5 (STYLIZED)**. QUANT5, INC., (U.S. CLS. 100 AND 101). SN 85-952,402. PUB. 6-10-2014. FILED 6-6-2013.  
4,591,260 ( *See Class 35 for this trademark.* )  
4,591,263 ( *See Class 35 for this trademark.* )  
4,591,270 ( *See Class 35 for this trademark.* )  
4,591,277 ( *See Class 35 for this trademark.* )  
4,591,285 ( *See Class 35 for this trademark.* )  
4,591,291. **TITAN LABORATORIES COMPLETE FLUIDS ANALYSIS AND DESIGN**. SIEGEL OIL COMPANY, (U.S. CLS. 100 AND 101). SN 85-963,561. PUB. 6-10-2014. FILED 6-19-2013.  
4,591,306 ( *See Class 35 for this trademark.* )  
4,591,307 ( *See Class 35 for this trademark.* )  
4,591,312 ( *See Class 9 for this trademark.* )  
4,591,314. **SOVEE (STANDARD CHARACTER)**. SOVEE, LLC, (U.S. CLS. 100 AND 101). SN 85-966,722. PUB. 6-10-2014. FILED 6-21-2013.  
4,591,315. **HYDROSTRUCTURES (STANDARD CHARACTER)**. HYDROSTRUCTURES, P.A., (U.S. CLS. 100 AND 101). SN 85-966,731. PUB. 6-10-2014. FILED 6-21-2013.  
4,591,328. **GOVPROIT (STANDARD CHARACTER)**. GOVPROIT, INC, (U.S. CLS. 100 AND 101). SN 85-968,686. PUB. 6-10-2014. FILED 6-24-2013.  
4,591,333. **AERIE BRIDGE SOLUTIONS (STANDARD CHARACTER)**. AERIE BRIDGE SOLUTIONS, INC., (U.S. CLS. 100 AND 101). SN 85-969,365. PUB. 6-10-2014. FILED 6-25-2013.  
4,591,336. **MISCELLANEOUS DESIGN**. AERIE BRIDGE SOLUTIONS, INC., (U.S. CLS. 100 AND 101). SN 85-969,446. PUB. 6-10-2014. FILED 6-25-2013.  
4,591,358 ( *See Class 9 for this trademark.* )  
4,591,361 ( *See Class 17 for this trademark.* )  
4,591,366 ( *See Class 40 for this trademark.* )  
4,591,378. **SOFTWAREMATCH AND DESIGN**. CAPTERRA, INC., (U.S. CLS. 100 AND 101). SN 85-974,378. PUB. 6-10-2014. FILED 7-1-2013.  
4,591,388 ( *See Class 9 for this trademark.* )  
4,591,433 ( *See Class 9 for this trademark.* )  
4,591,454. **SMARTDRAW (STANDARD CHARACTER)**. SMARTDRAW, LLC, (U.S. CLS. 100 AND 101). SN 86-

- 005,237. PUB. 6-10-2014. FILED 7-9-2013.  
4,591,470 ( *See Class 35 for this trademark* ).  
4,591,494. **KNOCK (STANDARD CHARACTER)**. KNOCK, INC., (U.S. CLS. 100 AND 101). SN 86-011,585. PUB. 12-24-2013. FILED 7-16-2013.  
4,591,512 ( *See Class 9 for this trademark* ).  
4,591,571. **SHIEL (STANDARD CHARACTER)**. SHIEL MEDICAL LABORATORY, (U.S. CLS. 100 AND 101). SN 86-029,732. PUB. 6-10-2014. FILED 8-6-2013.  
4,591,577. **CONTRIBUTION MAP (STANDARD CHARACTER)**. GATSBY TECHNOLOGIES, LLC, (U.S. CLS. 100 AND 101). SN 86-032,856. PUB. 6-10-2014. FILED 8-8-2013.  
4,591,578. **RIZE TECHNOLOGY (STANDARD CHARACTER)**. RIZE TECHNOLOGY CORPORATION, (U.S. CLS. 100 AND 101). SN 86-032,977. PUB. 6-10-2014. FILED 8-8-2013.  
4,591,606 ( *See Class 9 for this trademark* ).  
4,591,619. **FINDABILITY PLATFORM (STANDARD CHARACTER)**. FINDABILITY SCIENCES LLC, (U.S. CLS. 100 AND 101). SN 86-044,464. PUB. 6-10-2014. FILED 8-21-2013.  
4,591,658 ( *See Class 37 for this trademark* ).  
4,591,665 ( *See Class 9 for this trademark* ).  
4,591,669. **NATIONWIDE EVICTION (STANDARD CHARACTER)**. NATIONWIDE EVICTION SERVICES, LLC, (U.S. CLS. 100 AND 101). SN 86-061,196. PUB. 6-10-2014. FILED 9-11-2013.  
4,591,674 ( *See Class 35 for this trademark* ).  
4,591,730 ( *See Class 9 for this trademark* ).  
4,591,733. **HARMON (STANDARD CHARACTER)**. PRISM ASSURANCE, LTD., (U.S. CLS. 100 AND 101). SN 86-081,518. PUB. 6-10-2014. FILED 10-3-2013.  
4,591,741 ( *See Class 35 for this trademark* ).  
4,591,750 ( *See Class 9 for this trademark* ).  
4,591,751 ( *See Class 9 for this trademark* ).  
4,591,769 ( *See Class 9 for this trademark* ).  
4,591,803 ( *See Class 38 for this trademark* ).  
4,591,813. **MISCELLANEOUS DESIGN**. VISUAL SUPPLY CO., (U.S. CLS. 100 AND 101). SN 86-104,925. PUB. 2-25-2014. FILED 10-29-2013.  
4,591,822 ( *See Class 35 for this trademark* ).  
4,591,825 ( *See Class 35 for this trademark* ).  
4,591,838. **MYGUARD (STANDARD CHARACTER)**. CONTINENTAL GREEN, INC., (U.S. CLS. 100 AND 101). SN 86-109,004. PUB. 6-10-2014. FILED 11-4-2013.  
4,591,875. **RISKMATCH (STANDARD CHARACTER)**. RISKMATCH, LLC, (U.S. CLS. 100 AND 101). SN 86-116,630. PUB. 6-10-2014. FILED 11-12-2013.  
4,591,881 ( *See Class 9 for this trademark* ).  
4,591,882 ( *See Class 38 for this trademark* ).  
4,591,907. **STEEL CITY NDT LLC AND DESIGN**. STEEL CITY NDT, LLC, (U.S. CLS. 100 AND 101). SN 86-122,810. PUB. 6-10-2014. FILED 11-19-2013.  
4,591,919. **WISDOM CLOUD (STANDARD CHARACTER)**. STEM SYSTEMS GROUP, INC., (U.S. CLS. 100 AND 101). SN 86-124,589. PUB. 6-10-2014. FILED 11-20-2013.  
4,591,920 ( *See Class 9 for this trademark* ).  
4,591,928 ( *See Class 9 for this trademark* ).  
4,591,935 ( *See Class 35 for this trademark* ).  
4,591,964. **NEWSDOCK (STANDARD CHARACTER)**. NEWSDOCK LIMITED, (U.S. CLS. 100 AND 101). SN 86-129,988. PUB. 6-10-2014. FILED 11-26-2013.  
4,591,968 ( *See Class 35 for this trademark* ).  
4,591,983. **APACT (STANDARD CHARACTER)**. CELGENE CORPORATION, (U.S. CLS. 100 AND 101). SN 86-132,794. PUB. 6-10-2014. FILED 12-2-2013.  
4,591,985. **APACT AND DESIGN**. CELGENE CORPORATION, (U.S. CLS. 100 AND 101). SN 86-132,816. PUB. 6-10-2014. FILED 12-2-2013.  
4,592,009. **CARDIAC RESEARCH INSTITUTE AT MMRL AND DESIGN**. MASONIC MEDICAL RESEARCH LABORATORY, DBA CARDIAC RESEARCH INSTITUTE, (U.S. CLS. 100 AND 101). SN 86-137,022. PUB. 6-10-2014. FILED 12-6-2013.  
4,592,030. **TECH3 (STYLIZED)**. TECH3 BUSINESS SYSTEMS, LLC, (U.S. CLS. 100 AND 101). SN 86-139,187. PUB. 6-10-2014. FILED 12-10-2013.  
4,592,033. **WHOELSE (STANDARD CHARACTER)**. WHOELSE UG, (U.S. CLS. 100 AND 101). SN 86-139,530. PUB. 6-10-2014. FILED 12-10-2013.  
4,592,055 ( *See Class 40 for this trademark* ).  
4,592,077 ( *See Class 14 for this trademark* ).  
4,592,082. **THE DATE DETECTIVE (STANDARD CHARACTER)**. THE DATE DETECTIVE, LLC, (U.S. CLS. 100 AND 101). SN 86-146,248. PUB. 6-10-2014. FILED 12-17-2013.  
4,592,091. **AUTHENTIC WEB PRESENCE (STANDARD CHARACTER)**. MOVE OUT OF THE BOX LLC, (U.S. CLS. 100 AND 101). SN 86-147,581. PUB. 6-10-2014. FILED 12-18-2013.  
4,592,095. **KANBANIZE AND DESIGN**. BUSINESSMAP LTD., (U.S. CLS. 100 AND 101). SN 86-147,929. PUB. 6-10-2014. FILED 12-19-2013.  
4,592,097. **TENDASH (STANDARD CHARACTER)**. 1010DATA, INC., (U.S. CLS. 100 AND 101). SN 86-148,236. PUB. 6-10-2014. FILED 12-19-2013.  
4,592,098. **VOGNITION (STANDARD CHARACTER)**. WHAT ARE MINDS FOR, INC., (U.S. CLS. 100 AND 101). SN 86-148,449. PUB. 6-10-2014. FILED 12-19-2013.  
4,592,103 ( *See Class 35 for this trademark* ).  
4,592,107 ( *See Class 35 for this trademark* ).  
4,592,151 ( *See Class 9 for this trademark* ).  
4,592,153. **F{A} FACULTY ANALYTICS AND DESIGN**. INTERLUNIA, INC., (U.S. CLS. 100 AND 101). SN 86-152,806. PUB. 6-10-2014. FILED 12-26-2013.  
4,592,154. **R.E.S.T JNO DESIGNS AND DESIGN**. JNO DESIGN LLC, DBA JNO DESIGNS, (U.S. CLS. 100 AND 101). SN 86-152,811. PUB. 6-10-2014. FILED 12-26-2013.  
4,592,164 ( *See Class 35 for this trademark* ).  
4,592,172 ( *See Class 41 for this trademark* ).  
4,592,177. **GREEN BUSINESS ALLIANCE (STANDARD CHARACTER)**. GREEN BUSINESS ALLIANCE, INC., (U.S. CLS. 100 AND 101). SN 86-154,434. PUB. 6-10-2014. FILED 12-30-2013.  
4,592,180. **BETTER2GETHER DESIGNS (STANDARD CHARACTER)**. NICHOLS, JENNA, (U.S. CLS. 100 AND 101). SN 86-154,592. PUB. 6-10-2014. FILED 12-30-2013.  
4,592,185. **CLASSROOM AUTHORS (STANDARD CHARACTER)**. TRI-STATE ASSOCIATED SERVICES, INC., (U.S. CLS. 100 AND 101). SN 86-154,790. PUB. 6-10-2014. FILED 12-30-2013.  
4,592,212. **UNDER THE SUN SOLAR INNOVATIVE ENERGY SOLUTIONS INC. AND DESIGN**. RICHARD C, RAPP III, AKA UNDER THE SUN SOLAR, (U.S. CLS. 100 AND 101). SN 86-156,135. PUB. 6-10-2014. FILED 1-2-2014.  
4,592,223. **IF THIS THEN THAT (STANDARD CHARACTER)**. IFTTT, INC., (U.S. CLS. 100 AND 101). SN 86-156,966. PUB. 6-10-2014. FILED 1-3-2014.  
4,592,226. **IFTTT (STANDARD CHARACTER)**. IFTTT, INC., (U.S. CLS. 100 AND 101). SN 86-157,012. PUB. 6-10-2014. FILED 1-3-2014.  
4,592,239. **LAWCOUNTABILITY (STANDARD CHARACTER)**. UCOUNTICS LLC, (U.S. CLS. 100 AND 101). SN 86-157,796. PUB. 6-10-2014. FILED 1-6-2014.  
4,592,267. **CHEMICAL INTELLIGENCE (STANDARD CHARACTER)**. SAFETEC COMPLIANCE SYSTEMS, (U.S. CLS. 100 AND 101). SN 86-158,644. PUB. 6-10-2014. FILED 1-6-2014.  
4,592,282. **EXPERIMMUNE AND DESIGN**. TEXAS TECH UNIVERSITY HEALTH SCIENCES CENTER, (U.S. CLS. 100 AND 101). SN 86-159,564. PUB. 6-10-2014. FILED 1-7-2014.  
4,592,319. **ENTRANCE AND DESIGN**. ENTRANCE CONSULTING SERVICES, INC., (U.S. CLS. 100 AND 101). SN 86-161,253. PUB. 6-10-2014. FILED 1-9-2014.  
4,592,345 ( *See Class 37 for this trademark* ).  
4,592,393. **ILLUMNOVATE AND DESIGN**. ILLUMNOVATE, LLC, (U.S. CLS. 100 AND 101). SN 86-163,105. PUB. 6-10-2014. FILED 1-11-2014.  
4,592,397. **XPRESS APM (STANDARD CHARACTER)**. XPRESSDOCS PARTNERS, LTD., (U.S. CLS. 100 AND 101). SN 86-163,170. PUB. 6-10-2014. FILED 1-11-2014.  
4,592,422 ( *See Class 9 for this trademark* ).  
4,592,436. **ANSWERX NAME CONTROLS (STANDARD CHARACTER)**. XEROCOLE, INC., (U.S. CLS. 100 AND 101). SN 86-164,325. PUB. 6-10-2014. FILED 1-13-2014.  
4,592,451. **WHITESTONE TEC (STANDARD CHARACTER)**. WHITESTONE TEC, DBA WHITESTONE TEC, (U.S. CLS. 100 AND 101). SN 86-165,120. PUB. 6-10-2014. FILED 1-14-

- 2014.
- 4,592,456. **PRISM (STANDARD CHARACTER)**. COMPUTER EVIDENCE SPECIALISTS, LLC, (U.S. CLS. 100 AND 101). SN 86-165,333. PUB. 6-10-2014. FILED 1-14-2014.
- 4,592,460. **TCG (STYLIZED)**. TURNER CONSULTING GROUP, INC., (U.S. CLS. 100 AND 101). SN 86-165,411. PUB. 6-10-2014. FILED 1-14-2014.
- 4,592,495. **HNB-BC (STANDARD CHARACTER)**. AMERICAN HOLISTIC NURSES CREDENTIALING CORPORATION, DBA THE AMERICAN HOLISTIC NURSES CREDENTIALING CORPORATION, (U.S. CLS. 100 AND 101). SN 86-166,322. PUB. 6-10-2014. FILED 1-15-2014.
- 4,592,497. **TISCH MS RESEARCH CENTER OF NEW YORK AND DESIGN**. TISCH MULTIPLE SCLEROSIS CENTER OF NEW YORK, INC., (U.S. CLS. 100 AND 101). SN 86-166,396. PUB. 6-10-2014. FILED 1-15-2014.
- 4,592,548. **SAVVYDESKTOP (STANDARD CHARACTER)**. B2B INDUSTRIES, LLC, (U.S. CLS. 100 AND 101). SN 86-167,951. PUB. 6-10-2014. FILED 1-16-2014.
- 4,592,551 ( *See Class 37 for this trademark*).
- 4,592,569. **DASHRIDE (STANDARD CHARACTER)**. SOBRIO, LLC, (U.S. CLS. 100 AND 101). SN 86-169,309. PUB. 6-10-2014. FILED 1-18-2014.
- 4,592,597 ( *See Class 40 for this trademark*).
- 4,592,601. **ESQ.ME AND DESIGN**. KAUSHIK, SOMYA, (U.S. CLS. 100 AND 101). SN 86-172,884. PUB. 6-10-2014. FILED 1-23-2014.
- 4,592,631. **SLOANE ROW (STANDARD CHARACTER)**. SLOANE ROW, LLC, (U.S. CLS. 100 AND 101). SN 86-174,820. PUB. 6-10-2014. FILED 1-24-2014.
- 4,592,651. **DIGISQUID (STANDARD CHARACTER)**. DIGISQUID STUDIOS, INC., DBA DIGISQUID, (U.S. CLS. 100 AND 101). SN 86-175,387. PUB. 6-10-2014. FILED 1-26-2014.
- 4,592,654. **MAKING BOOKS DISCOVERABLE (STANDARD CHARACTER)**. JARED & PERRY METADATA, LLC, (U.S. CLS. 100 AND 101). SN 86-175,470. PUB. 6-10-2014. FILED 1-26-2014.
- 4,592,667. **SYNCBITS (STANDARD CHARACTER)**. SILVERWIZ LTD., (U.S. CLS. 100 AND 101). SN 86-175,635. PUB. 6-10-2014. FILED 1-27-2014.
- 4,592,680. **ASCENTERA (STANDARD CHARACTER)**. ASCENTERA INC., (U.S. CLS. 100 AND 101). SN 86-175,829. PUB. 6-10-2014. FILED 1-27-2014.
- 4,592,682. **MONTHLYSTAR (STANDARD CHARACTER)**. ABRAHAMS, LARRY, (U.S. CLS. 100 AND 101). SN 86-175,841. PUB. 6-10-2014. FILED 1-27-2014.
- 4,592,690. **POWER3WEB (STANDARD CHARACTER)**. POWER THREE WEB, LTDA., (U.S. CLS. 100 AND 101). SN 86-176,023. PUB. 6-10-2014. FILED 1-27-2014.
- 4,592,691. **SUCCEED ADVANTAGE (STANDARD CHARACTER)**. SUCCEED MANAGEMENT SOLUTIONS, LLC, (U.S. CLS. 100 AND 101). SN 86-176,039. PUB. 6-10-2014. FILED 1-27-2014.
- 4,592,703. **READY 4 ACTION (STANDARD CHARACTER)**. CAMARGO PHARMACEUTICAL SERVICES, LLC, (U.S. CLS. 100 AND 101). SN 86-176,215. PUB. 6-10-2014. FILED 1-27-2014.
- 4,592,713 ( *See Class 35 for this trademark*).
- 4,592,726 ( *See Class 9 for this trademark*).
- 4,592,740. **EQUIX (STANDARD CHARACTER)**. THE MOSTERT GROUP, LLC, (U.S. CLS. 100 AND 101). SN 86-177,025. PUB. 6-10-2014. FILED 1-28-2014.
- 4,592,747 ( *See Class 9 for this trademark*).
- 4,592,818. **MARISA JILL DESIGN (STANDARD CHARACTER)**. MARISA JILL LLC, (U.S. CLS. 100 AND 101). SN 86-178,286. PUB. 6-10-2014. FILED 1-29-2014.
- 4,592,830. **GET REAL HEALTH (STANDARD CHARACTER)**. INETXPRTS CORP., DBA GET REAL HEALTH, (U.S. CLS. 100 AND 101). SN 86-178,439. PUB. 6-10-2014. FILED 1-29-2014.
- 4,592,837. **BUILDING THE NEXT GENERATION OF ESSENTIAL MATERIALS (STANDARD CHARACTER)**. ESSENTIUM MATERIALS, (U.S. CLS. 100 AND 101). SN 86-178,631. PUB. 6-10-2014. FILED 1-29-2014.
- 4,592,849. **TRANSEND (STANDARD CHARACTER)**. MOTIONPOINT CORPORATION, (U.S. CLS. 100 AND 101). SN 86-178,832. PUB. 6-10-2014. FILED 1-29-2014.
- 4,592,850. **PUGGIN.IT (STANDARD CHARACTER)**. JONES, ANNIE L, (U.S. CLS. 100 AND 101). SN 86-178,841. PUB. 6-10-2014. FILED 1-29-2014.
- 4,592,858. **RAKSMART.COM (STANDARD CHARACTER)**. PEG TECH INC., (U.S. CLS. 100 AND 101). SN 86-178,934. PUB. 6-10-2014. FILED 1-29-2014.
- 4,592,899. **GOHCLABELS (STANDARD CHARACTER)**. GARY L. SHARPE, (U.S. CLS. 100 AND 101). SN 86-180,023. PUB. 6-10-2014. FILED 1-30-2014.
- 4,592,949 ( *See Class 35 for this trademark*).
- 4,592,959 ( *See Class 35 for this trademark*).
- 4,592,977. **GLOBALNIMBUS (STANDARD CHARACTER)**. MOTIONPOINT CORPORATION, (U.S. CLS. 100 AND 101). SN 86-203,132. PUB. 6-10-2014. FILED 2-25-2014.
- 4,593,018 ( *See Class 37 for this trademark*).
- 4,593,040. **OCEAN RIDERS ENGINEERING (STANDARD CHARACTER)**. OCEAN RIDERS ENGINEERING, INC., (U.S. CLS. 100 AND 101). SN 86-241,013. PUB. 6-10-2014. FILED 4-3-2014.

---

### CLASS 43—HOTEL AND RESTAURANT SERVICES

- 4,590,628 ( *See Class 30 for this trademark*).
- 4,590,681 ( *See Class 35 for this trademark*).
- 4,590,684 ( *See Class 9 for this trademark*).
- 4,590,736 ( *See Class 3 for this trademark*).
- 4,590,758 ( *See Class 7 for this trademark*).
- 4,590,840 ( *See Class 33 for this trademark*).
- 4,590,953. **HOME OF THE GOODBURGER GOODBURGER AND DESIGN**. 43RD STREET RESTAURANT, LLC, (U.S. CLS. 100 AND 101). SN 85-339,231. PUB. 6-10-2014. FILED 6-20-2011.
- 4,591,022 ( *See Class 25 for this trademark*).
- 4,591,027 ( *See Class 18 for this trademark*).
- 4,591,072 ( *See Class 25 for this trademark*).
- 4,591,084 ( *See Class 39 for this trademark*).
- 4,591,089 ( *See Class 32 for this trademark*).
- 4,591,099 ( *See Class 25 for this trademark*).
- 4,591,109 ( *See Class 25 for this trademark*).
- 4,591,139 ( *See Class 30 for this trademark*).
- 4,591,141 ( *See Class 30 for this trademark*).
- 4,591,153 ( *See Class 9 for this trademark*).
- 4,591,224. **BIG D'S AND DESIGN**. SERFLING, DALE R. SERFLING, LINDA M., DBA BIG D'S PIZZA, LLC, (U.S. CLS. 100 AND 101). SN 85-943,602. PUB. 6-10-2014. FILED 5-28-2013.
- 4,591,258. **ALTAMAREA (STANDARD CHARACTER)**. ALTAMAREA INTELLECTUAL PROPERTY, LLC, (U.S. CLS. 100 AND 101). SN 85-954,608. PUB. 6-10-2014. FILED 6-8-2013.
- 4,591,259. **ALTAMAREA GROUP (STANDARD CHARACTER)**. ALTAMAREA INTELLECTUAL PROPERTY, LLC, (U.S. CLS. 100 AND 101). SN 85-954,610. PUB. 6-10-2014. FILED 6-8-2013.
- 4,591,292. **MACK'S CHOW (STANDARD CHARACTER)**. MACK EVENT PRODUCTIONS LLC, (U.S. CLS. 100 AND 101). SN 85-963,602. PUB. 12-24-2013. FILED 6-19-2013.
- 4,591,302. **BNG AND DESIGN**. BAGELS N GREENS CONEY LLC, (U.S. CLS. 100 AND 101). SN 85-965,811. PUB. 6-10-2014. FILED 6-20-2013.
- 4,591,323. **MASTRO'S CITY HALL STEAKHOUSE (STANDARD CHARACTER)**. MASTRO'S RESTAURANTS, LLC, (U.S. CLS. 100 AND 101). SN 85-968,010. PUB. 6-10-2014. FILED 6-24-2013.
- 4,591,368. **RUBICON BREWING COMPANY (STANDARD CHARACTER)**. STRAYHAN INVESTMENTS, INC, DBA RUBICON BREWING COMPANY, (U.S. CLS. 100 AND 101). SN 85-973,135. PUB. 6-10-2014. FILED 6-28-2013.
- 4,591,389. **PREZZA (STYLIZED)**. ANTHONY J. CATURANO, (U.S. CLS. 100 AND 101). SN 85-981,539. PUB. 6-10-2014. FILED 5-16-2013.
- 4,591,488. **THE DELI LLAMA AND DESIGN**. JUST KEEP SWIMMING INC., (U.S. CLS. 100 AND 101). SN 86-010,733. PUB. 1-7-2014. FILED 7-15-2013.
- 4,591,581 ( *See Class 39 for this trademark*).
- 4,591,644. **EARLY YEARS AND DESIGN**. THE EARLY

- YEARS, INC., AKA EARLY YEARS CHILD CARE, (U.S. CLS. 100 AND 101). SN 86-051,582. PUB. 6-10-2014. FILED 8-29-2013.
- 4,591,650 ( *See Class 30 for this trademark*).
- 4,591,654. CAMERON'S DELI (STANDARD CHARACTER). CAMERON'S DELI INC., DBA CAMERON'S DELI, (U.S. CLS. 100 AND 101). SN 86-054,406. PUB. 6-10-2014. FILED 9-3-2013.
- 4,591,695 ( *See Class 41 for this trademark*).
- 4,591,719. PEYOTE (STANDARD CHARACTER). MAHARAJA LIFE LIMITED, (U.S. CLS. 100 AND 101). SN 86-078,124. PUB. 6-10-2014. FILED 9-30-2013.
- 4,591,959 ( *See Class 25 for this trademark*).
- 4,591,975 ( *See Class 41 for this trademark*).
- 4,591,998 ( *See Class 36 for this trademark*).
- 4,592,006 ( *See Class 40 for this trademark*).
- 4,592,020. HAPPYLEMON AND DESIGN. RBT ENTERPRISES LIMITED, (U.S. CLS. 100 AND 101). SN 86-138,007. PUB. 6-10-2014. FILED 12-9-2013.
- 4,592,125. PARQ BAR (STANDARD CHARACTER). MONTAGE HOTELS & RESORTS, LLC, (U.S. CLS. 100 AND 101). SN 86-150,792. PUB. 6-10-2014. FILED 12-23-2013.
- 4,592,157. BIG! FACE! AND DESIGN. NANJING BIGEFEISI COMMERCIAL & TRADE CO.,LTD., (U.S. CLS. 100 AND 101). SN 86-152,961. PUB. 6-10-2014. FILED 12-27-2013.
- 4,592,167. NAKED GOURMET AND DESIGN. TERRELL, ALICE G., (U.S. CLS. 100 AND 101). SN 86-153,788. PUB. 6-10-2014. FILED 12-29-2013.
- 4,592,192. THE ORIGINAL OMELETTE MAN (STANDARD CHARACTER). HARRISON, RALPH C., DBA HARRISON CATERERS, (U.S. CLS. 100 AND 101). SN 86-155,250. PUB. 6-10-2014. FILED 12-31-2013.
- 4,592,260. WING IT! AND DESIGN. CHOL WANG, INC., DBA WING IT!, (U.S. CLS. 100 AND 101). SN 86-158,456. PUB. 6-10-2014. FILED 1-6-2014.
- 4,592,277. ESTILO GAÚCHO BRAZILIAN STEAKHOUSE AND DESIGN. BAHTCHE LLC, (U.S. CLS. 100 AND 101). SN 86-159,375. PUB. 6-10-2014. FILED 1-7-2014.
- 4,592,312 ( *See Class 25 for this trademark*).
- 4,592,336. OYSTERS XO (STANDARD CHARACTER). OYSTERS XO LLC, AKA OYSTERS XO, (U.S. CLS. 100 AND 101). SN 86-161,668. PUB. 6-10-2014. FILED 1-9-2014.
- 4,592,339. DHC DAVIDSON HOTELS & RESORTS AND DESIGN. DAVIDSON HOTEL COMPANY LLC, (U.S. CLS. 100 AND 101). SN 86-161,721. PUB. 6-10-2014. FILED 1-9-2014.
- 4,592,342. DAVIDSON HOTELS & RESORTS (STANDARD CHARACTER). DAVIDSON HOTEL COMPANY LLC, (U.S. CLS. 100 AND 101). SN 86-161,765. PUB. 6-10-2014. FILED 1-9-2014.
- 4,592,360. OVATION BRANDS AND DESIGN. BUFFETS, INC., DBA OVATION BRANDS, (U.S. CLS. 100 AND 101). SN 86-162,147. PUB. 6-10-2014. FILED 1-10-2014.
- 4,592,361. OVATION BRANDS (STANDARD CHARACTER). BUFFETS, INC., DBA OVATION BRANDS, (U.S. CLS. 100 AND 101). SN 86-162,148. PUB. 6-10-2014. FILED 1-10-2014.
- 4,592,365. MIZADO COCINA AND DESIGN. TASTE BUDS, INC., (U.S. CLS. 100 AND 101). SN 86-162,444. PUB. 6-10-2014. FILED 1-10-2014.
- 4,592,366. MIZADO COCINA (STYLIZED). TASTE BUDS, INC., (U.S. CLS. 100 AND 101). SN 86-162,453. PUB. 6-10-2014. FILED 1-10-2014.
- 4,592,369. MIG'S PIZZA CASTLE (STANDARD CHARACTER). MIGDALES, THOMAS, (U.S. CLS. 100 AND 101). SN 86-162,579. PUB. 6-10-2014. FILED 1-10-2014.
- 4,592,371 ( *See Class 39 for this trademark*).
- 4,592,377 ( *See Class 39 for this trademark*).
- 4,592,398 ( *See Class 29 for this trademark*).
- 4,592,411. M THE OLD MINE CIDERY & BREWPUB AND DESIGN. THE OLD MINE BREWING COMPANY, DBA THE OLD MINE, (U.S. CLS. 100 AND 101). SN 86-163,449. PUB. 6-10-2014. FILED 1-13-2014.
- 4,592,413. BAY BAYS CHICKEN & WAFFLES (STANDARD CHARACTER). KAESHUA RESTAURANT GROUP, (U.S. CLS. 100 AND 101). SN 86-163,470. PUB. 6-10-2014. FILED 1-13-2014.
- 4,592,442. TOMATO BAR PIZZA BAKERY AND DESIGN. TOMATO BAR LLC, (U.S. CLS. 100 AND 101). SN 86-164,653. PUB. 6-10-2014. FILED 1-14-2014.
- 4,592,498. WELCOME TO AMERICA'S DINER (STANDARD CHARACTER). DFO, LLC, (U.S. CLS. 100 AND 101). SN 86-166,425. PUB. 6-10-2014. FILED 1-15-2014.
- 4,592,512. JULIUS' AND DESIGN. BUFORD, HELEN, (U.S. CLS. 100 AND 101). SN 86-166,708. PUB. 6-10-2014. FILED 1-15-2014.
- 4,592,516 ( *See Class 37 for this trademark*).
- 4,592,617. THE STANFORD COURT (STANDARD CHARACTER). STANFORD 8 OWNER, LLC, (U.S. CLS. 100 AND 101). SN 86-174,215. PUB. 6-10-2014. FILED 1-24-2014.
- 4,592,692. SLIGHTLY SALTY AND DESIGN. SLIGHTLY SALTY LLC., (U.S. CLS. 100 AND 101). SN 86-176,042. PUB. 6-10-2014. FILED 1-27-2014.
- 4,592,762. ÈLEVAGE NOSTALGIA MEETS NOUVEAU (STYLIZED). MAINSAIL EPICUREAN HOTEL, LLLP, (U.S. CLS. 100 AND 101). SN 86-177,368. PUB. 6-10-2014. FILED 1-28-2014.
- 4,592,771. EDGE SOCIAL DRINKERY (STYLIZED). MAINSAIL EPICUREAN HOTEL, LLLP, (U.S. CLS. 100 AND 101). SN 86-177,519. PUB. 6-10-2014. FILED 1-28-2014.
- 4,592,805. SOUPREMACY (STANDARD CHARACTER). CRIMSON CIRCLE LLC, (U.S. CLS. 100 AND 101). SN 86-178,041. PUB. 6-10-2014. FILED 1-28-2014.
- 4,592,829. PELLEGRINO'S DELI CAFE SUBS SOUPS SALADS BURGERS AND DESIGN. CLUBHOUSE GRILL INC., (U.S. CLS. 100 AND 101). SN 86-178,417. PUB. 6-10-2014. FILED 1-29-2014.
- 4,592,904. EAT, LITTLE BIRD (STANDARD CHARACTER). BERTHOU, THANH THI, (U.S. CLS. 100 AND 101). SN 86-180,199. PUB. 6-10-2014. FILED 1-30-2014.
- 4,592,936. WHERE COMFORT & VALUE MATTER (STANDARD CHARACTER). STAY EXPRESS WORLDWIDE, INC., (U.S. CLS. 100 AND 101). SN 86-182,773. PUB. 6-10-2014. FILED 2-3-2014.
- 4,592,968. PINNACLE ENTERTAINMENT (STYLIZED). PINNACLE ENTERTAINMENT, INC., (U.S. CLS. 100 AND 101). SN 86-196,843. PUB. 6-10-2014. FILED 2-18-2014.
- 4,592,975. BAGGER DAVE'S BURGER TAVERN (STANDARD CHARACTER). AMC BURGERS, INC., (U.S. CLS. 100 AND 101). SN 86-201,978. PUB. 6-10-2014. FILED 2-24-2014.
- 4,592,978. BAGGER DAVE'S BURGER TAVERN AND DESIGN. AMC BURGERS, INC., (U.S. CLS. 100 AND 101). SN 86-203,386. PUB. 6-10-2014. FILED 2-25-2014.
- 4,593,002. COMFORT STARTS HERE (STANDARD CHARACTER). CHEESEBOY PROPERTIES LLC, (U.S. CLS. 100 AND 101). SN 86-218,791. PUB. 6-10-2014. FILED 3-12-2014.
- 4,593,003. TRAVEL COMFORTABLY (STANDARD CHARACTER). CHEESEBOY PROPERTIES LLC, (U.S. CLS. 100 AND 101). SN 86-218,804. PUB. 6-10-2014. FILED 3-12-2014.
- 4,593,004. COMFORT ON THE RUN (STANDARD CHARACTER). CHEESEBOY PROPERTIES LLC, (U.S. CLS. 100 AND 101). SN 86-218,821. PUB. 6-10-2014. FILED 3-12-2014.
- 4,593,005. SIGNATURE COMFORTS (STANDARD CHARACTER). CHEESEBOY PROPERTIES LLC, (U.S. CLS. 100 AND 101). SN 86-218,828. PUB. 6-10-2014. FILED 3-12-2014.
- 4,593,006. CLASSIC COMFORTS (STANDARD CHARACTER). CHEESEBOY PROPERTIES LLC, (U.S. CLS. 100 AND 101). SN 86-218,834. PUB. 6-10-2014. FILED 3-12-2014.
- 4,593,007. MORNING COMFORTS (STANDARD CHARACTER). CHEESEBOY PROPERTIES LLC, (U.S. CLS. 100 AND 101). SN 86-218,865. PUB. 6-10-2014. FILED 3-12-2014.
- 4,593,020 ( *See Class 41 for this trademark*).
- 4,593,055. BAJA FLATS (STANDARD CHARACTER). COMPASS GROUP USA, INC., (U.S. CLS. 100 AND 101). SN 86-249,726. PUB. 6-10-2014. FILED 4-11-2014.
- 4,593,064. BARLEY MOW BREWING COMPANY (STANDARD CHARACTER). BARLEY MOW BREWING COMPANY II, LLC, (U.S. CLS. 100 AND 101). SN 86-975,435. PUB. 4-8-2014. FILED 10-25-2013.

---

#### CLASS 44—MEDICAL, BEAUTY AND AGRICULTURAL SERVICES

- 4,590,614 ( *See Class 36 for this trademark*).
- 4,590,615 ( *See Class 36 for this trademark*).

- 4,590,669 ( See Class 5 for this trademark).  
 4,590,686 ( See Class 10 for this trademark).  
 4,590,690 ( See Class 9 for this trademark).  
 4,590,736 ( See Class 3 for this trademark).  
 4,590,747 ( See Class 3 for this trademark).  
 4,590,779 ( See Class 10 for this trademark).  
 4,590,788 ( See Class 1 for this trademark).  
 4,590,858 ( See Class 7 for this trademark).  
 4,590,948. **CONCIERGE AND DESIGN**. WASHINGTON HOSPITAL CENTER CORPORATION, (U.S. CLS. 100 AND 101). SN 85-296,025. PUB. 4-17-2012. FILED 4-15-2011.  
 4,590,984 ( See Class 41 for this trademark).  
 4,591,020. **AYA (STYLIZED)**. AESTHETIC PRODUCTS, LLC, (U.S. CLS. 100 AND 101). SN 85-752,453. PUB. 6-10-2014. FILED 10-12-2012.  
 4,591,027 ( See Class 18 for this trademark).  
 4,591,029 ( See Class 16 for this trademark).  
 4,591,030 ( See Class 16 for this trademark).  
 4,591,051 ( See Class 35 for this trademark).  
 4,591,052. **HEALTHSTAT (STANDARD CHARACTER)**. HEALTHSTAT, INC., (U.S. CLS. 100 AND 101). SN 85-785,401. PUB. 6-10-2014. FILED 11-21-2012.  
 4,591,090 ( See Class 41 for this trademark).  
 4,591,111 ( See Class 35 for this trademark).  
 4,591,158. **RENALOGIC (STANDARD CHARACTER)**. DCC, INC., (U.S. CLS. 100 AND 101). SN 85-894,607. PUB. 6-10-2014. FILED 4-3-2013.  
 4,591,207. **EDR PALM BEACH INSTITUTE EATING DISORDER RECOVERY AND DESIGN**. PB INSTITUTE PARTNERS LIMITED PARTNERSHIP, (U.S. CLS. 100 AND 101). SN 85-936,694. PUB. 6-10-2014. FILED 5-20-2013.  
 4,591,348 ( See Class 41 for this trademark).  
 4,591,349 ( See Class 41 for this trademark).  
 4,591,403. **HIGHPOINT LAWN SERVICE AND DESIGN**. JOHN C. PRUSA, (U.S. CLS. 100 AND 101). SN 86-000,762. PUB. 6-10-2014. FILED 7-2-2013.  
 4,591,405. **THE BEST MINDS WORKING AS ONE (STANDARD CHARACTER)**. SCOTT & WHITE HEALTHCARE, (U.S. CLS. 100 AND 101). SN 86-001,092. PUB. 6-10-2014. FILED 7-2-2013.  
 4,591,424 ( See Class 9 for this trademark).  
 4,591,435 ( See Class 35 for this trademark).  
 4,591,436 ( See Class 35 for this trademark).  
 4,591,437 ( See Class 35 for this trademark).  
 4,591,451. **KELLEY BAKER BROWS AND DESIGN**. KELLEY BAKER, (U.S. CLS. 100 AND 101). SN 86-005,147. PUB. 6-10-2014. FILED 7-9-2013.  
 4,591,455. **REGIONAL HAND CENTER OF CENTRAL CALIFORNIA AND DESIGN**. RANDI A. GALLI, M.D., INC., (U.S. CLS. 100 AND 101). SN 86-005,301. PUB. 6-10-2014. FILED 7-9-2013.  
 4,591,482. **PIONEERING THE DELIVERY OF CARE (STANDARD CHARACTER)**. ENVISION HEALTHCARE CORPORATION, (U.S. CLS. 100 AND 101). SN 86-010,098. PUB. 6-10-2014. FILED 7-15-2013.  
 4,591,529. **ALL THERAPY (STANDARD CHARACTER)**. ALL THERAPY, (U.S. CLS. 100 AND 101). SN 86-018,698. PUB. 6-10-2014. FILED 7-24-2013.  
 4,591,551 ( See Class 9 for this trademark).  
 4,591,553. **THE FREEDOM CARE PROGRAM (STANDARD CHARACTER)**. UHS OF DELAWARE, INC., (U.S. CLS. 100 AND 101). SN 86-026,889. PUB. 6-10-2014. FILED 8-2-2013.  
 4,591,572. **HEALING WARRIORS PROGRAM (STANDARD CHARACTER)**. HEALING WARRIORS PROGRAM, (U.S. CLS. 100 AND 101). SN 86-029,895. PUB. 6-10-2014. FILED 8-6-2013.  
 4,591,579 ( See Class 41 for this trademark).  
 4,591,614. **MISCELLANEOUS DESIGN**. ENVISION HEALTHCARE CORPORATION, (U.S. CLS. 100 AND 101). SN 86-043,413. PUB. 6-10-2014. FILED 8-20-2013.  
 4,591,635. **CRAFTING THE FUTURE OF FOOD (STANDARD CHARACTER)**. MK CUISINE GLOBAL LLC, DBA MATTHEW KENNEY CUISINE, (U.S. CLS. 100 AND 101). SN 86-050,403. PUB. 6-10-2014. FILED 8-28-2013.  
 4,591,643 ( See Class 3 for this trademark).  
 4,591,686. **SAGE EDUCATIONAL PSYCHOLOGY (STANDARD CHARACTER)**. TINSLEY, KATHRYN, (U.S. CLS. 100 AND 101). SN 86-065,594. PUB. 3-4-2014. FILED 9-16-2013.  
 4,591,713. **Z ZONE 24 LANDSCAPING AND DESIGN**. Z24 LANDSCAPING INC., (U.S. CLS. 100 AND 101). SN 86-076,503. PUB. 6-10-2014. FILED 9-27-2013.  
 4,591,739 ( See Class 41 for this trademark).  
 4,591,753 ( See Class 35 for this trademark).  
 4,591,812. **T2 BIOSYSTEMS AND DESIGN**. T2 BIOSYSTEMS, INC., (U.S. CLS. 100 AND 101). SN 86-104,468. PUB. 6-10-2014. FILED 10-29-2013.  
 4,591,888. **RIVISION (STANDARD CHARACTER)**. HAR-EL RIVI, (U.S. CLS. 100 AND 101). SN 86-119,095. PUB. 6-10-2014. FILED 11-14-2013.  
 4,591,894. **TRIDENTUSA MOBILE CLINICAL SERVICES AND DESIGN**. MX USA, INC., (U.S. CLS. 100 AND 101). SN 86-120,014. PUB. 6-10-2014. FILED 11-15-2013.  
 4,591,895. **TRIDENTUSA MOBILE CLINICAL SERVICES AND DESIGN**. MX USA, INC., (U.S. CLS. 100 AND 101). SN 86-120,032. PUB. 6-10-2014. FILED 11-15-2013.  
 4,591,899 ( See Class 35 for this trademark).  
 4,591,901. **AUTISM COMPANION (STANDARD CHARACTER)**. GRIMES, JANE, (U.S. CLS. 100 AND 101). SN 86-121,634. PUB. 6-10-2014. FILED 11-18-2013.  
 4,591,953. **CARING NEVER CHANGES (STANDARD CHARACTER)**. EASTERN CONNECTICUT HEALTH NETWORK, INC., (U.S. CLS. 100 AND 101). SN 86-129,138. PUB. 6-10-2014. FILED 11-26-2013.  
 4,591,992. **BAMBOO ISLE MASSAGE (STANDARD CHARACTER)**. BAMBOO ISLE MASSAGE LLC, (U.S. CLS. 100 AND 101). SN 86-133,853. PUB. 6-10-2014. FILED 12-3-2013.  
 4,592,038 ( See Class 35 for this trademark).  
 4,592,064. **MADISON COUNSELING SOLUTIONS SET YOURSELF FREE AND DESIGN**. MADISON COUNSELING SOLUTIONS LLC, (U.S. CLS. 100 AND 101). SN 86-143,275. PUB. 6-10-2014. FILED 12-13-2013.  
 4,592,066 ( See Class 35 for this trademark).  
 4,592,072. **AESTHETIC BODY SHOP (STANDARD CHARACTER)**. MARTIN, PAULA, (U.S. CLS. 100 AND 101). SN 86-144,376. PUB. 6-10-2014. FILED 12-16-2013.  
 4,592,119. **PETER DAVID (STANDARD CHARACTER)**. KLEIN LABORATORIES INC, (U.S. CLS. 100 AND 101). SN 86-150,602. PUB. 6-10-2014. FILED 12-23-2013.  
 4,592,127. **NAGGIAR VINEYARDS (STANDARD CHARACTER)**. NAGGIAR VINEYARDS, LLC, (U.S. CLS. 100 AND 101). SN 86-150,881. PUB. 6-10-2014. FILED 12-23-2013.  
 4,592,137. **UNIVERSITY PEDIATRIC DENTISTRY AND DESIGN**. UNIVERSITY PEDIATRIC DENTISTRY, P.C., (U.S. CLS. 100 AND 101). SN 86-151,432. PUB. 6-10-2014. FILED 12-23-2013.  
 4,592,170. **ESTREL WELLNESS CENTERS (STANDARD CHARACTER)**. ESTREL CENTERS, (U.S. CLS. 100 AND 101). SN 86-153,908. PUB. 6-10-2014. FILED 12-30-2013.  
 4,592,171. **ESTREL WELLNESS CENTERS AND DESIGN**. ESTREL CENTERS, (U.S. CLS. 100 AND 101). SN 86-153,915. PUB. 6-10-2014. FILED 12-30-2013.  
 4,592,238. **GOT SWELLING (STANDARD CHARACTER)**. MAULDIN, PATRICIA ANN, (U.S. CLS. 100 AND 101). SN 86-157,767. PUB. 6-10-2014. FILED 1-6-2014.  
 4,592,284. **ERIK ALAN DAVIS SALON (STANDARD CHARACTER)**. EAD COSMETICS LLC, (U.S. CLS. 100 AND 101). SN 86-159,635. PUB. 6-10-2014. FILED 1-7-2014.  
 4,592,302. **MISCELLANEOUS DESIGN**. OPHTHALMIC AND OCULOPLASTIC SURGERY, INC., DBA KELLIS EYE CENTER, (U.S. CLS. 100 AND 101). SN 86-160,438. PUB. 6-10-2014. FILED 1-8-2014.  
 4,592,313. **EAST TENNESSEE CHILDREN'S HOSPITAL AND DESIGN**. EAST TENNESSEE CHILDREN'S HOSPITAL ASSOCIATION, INC., (U.S. CLS. 100 AND 101). SN 86-161,050. PUB. 6-10-2014. FILED 1-9-2014.  
 4,592,316. **ORDINARY DOGS, EXTRAORDINARY SERVICE (STANDARD CHARACTER)**. DIVINE CANINES, (U.S. CLS. 100 AND 101). SN 86-161,196. PUB. 6-10-2014. FILED 1-9-2014.  
 4,592,321. **AFFILIATED GENETICS (STANDARD CHARACTER)**. AFFILIATED GENETICS, INC., (U.S. CLS. 100 AND 101). SN 86-161,380. PUB. 6-10-2014. FILED 1-9-2014.  
 4,592,333. **HOSPITAL STRENGTH INDEX (STANDARD CHARACTER)**. IVANTAGE HEALTH ANALYTICS, INC., (U.S. CLS. 100 AND 101). SN 86-161,625. PUB. 6-10-2014.



FILED 1-9-2014.  
 4,592,345 ( *See Class 37 for this trademark.*)  
 4,592,371 ( *See Class 39 for this trademark.*)  
 4,592,374 ( *See Class 41 for this trademark.*)  
 4,592,377 ( *See Class 39 for this trademark.*)  
 4,592,406. **DEFINING NUTRITION (STANDARD CHARACTER)**. REAGAN, SUSAN BECKMAN, (U.S. CLS. 100 AND 101). SN 86-163,353. PUB. 6-10-2014. FILED 1-12-2014.  
 4,592,437. **PURE DENTISTRY (STANDARD CHARACTER)**. SLATE DENTAL CORPORATION, (U.S. CLS. 100 AND 101). SN 86-164,433. PUB. 6-10-2014. FILED 1-13-2014.  
 4,592,453. **UH-OH PEDIATRIC URGENT CARE (STANDARD CHARACTER)**. UNITED INVESTMENT GROUP OF LOUISIANA, LLC, (U.S. CLS. 100 AND 101). SN 86-165,169. PUB. 6-10-2014. FILED 1-14-2014.  
 4,592,457. **AOK ATHLETIC ORTHOPEDICS & KNEE CENTER FOOT & ANKLE | HAND | PAIN | SHOULDER | SPINE AND DESIGN**. JENSEN, JACK, (U.S. CLS. 100 AND 101). SN 86-165,371. PUB. 6-10-2014. FILED 1-14-2014.  
 4,592,484. **MISCELLANEOUS DESIGN**. UHS OF DELAWARE, INC., (U.S. CLS. 100 AND 101). SN 86-166,065. PUB. 6-10-2014. FILED 1-15-2014.  
 4,592,486. **MENTISCORE (STANDARD CHARACTER)**. MENTISCORE SOLUTIONS LIMITED, (U.S. CLS. 100 AND 101). SN 86-166,083. PUB. 6-10-2014. FILED 1-15-2014.  
 4,592,546. **PROJECT ACTIVATE (STANDARD CHARACTER)**. BRILLIANT AGING, (U.S. CLS. 100 AND 101). SN 86-167,890. PUB. 6-10-2014. FILED 1-16-2014.  
 4,592,550. **SNORE CRUSHERS (STANDARD CHARACTER)**. GILLUM, RICHARD, (U.S. CLS. 100 AND 101). SN 86-168,119. PUB. 6-10-2014. FILED 1-17-2014.  
 4,592,559. **MEDSCRIPT PHARMACY (STANDARD CHARACTER)**. MEDSCRIPT PHARMACY, LLC, (U.S. CLS. 100 AND 101). SN 86-168,936. PUB. 6-10-2014. FILED 1-17-2014.  
 4,592,560. **MEDSCRIPT AND DESIGN**. MEDSCRIPT PHARMACY, LLC, (U.S. CLS. 100 AND 101). SN 86-168,943. PUB. 6-10-2014. FILED 1-17-2014.  
 4,592,607. **MISCELLANEOUS DESIGN**. O'CONNOR PROFESSIONAL GROUP, LLC, (U.S. CLS. 100 AND 101). SN 86-173,107. PUB. 6-10-2014. FILED 1-23-2014.  
 4,592,664. **DISCOVER THE DIFFERENCE FAMILY-OWNED MAKES (STANDARD CHARACTER)**. RAE-ANN HOLDINGS, INC., DBA RAE-ANN SKILLED NURSING AND REHABILITATION CENTERS, (U.S. CLS. 100 AND 101). SN 86-175,576. PUB. 6-10-2014. FILED 1-27-2014.  
 4,592,775. **EVANGELINE A DELECTABLE SPA AND DESIGN**. MAINSAIL EPICUREAN HOTEL, LLLP, (U.S. CLS. 100 AND 101). SN 86-177,600. PUB. 6-10-2014. FILED 1-28-2014.  
 4,592,802. **AOK SPINE & PAIN AND DESIGN**. JENSEN, JACK, (U.S. CLS. 100 AND 101). SN 86-177,992. PUB. 6-10-2014. FILED 1-28-2014.  
 4,592,872. **A HAPPY MOUTH IS A HEALTHY MOUTH (STANDARD CHARACTER)**. CHETAN PATIL, (U.S. CLS. 100 AND 101). SN 86-179,195. PUB. 6-10-2014. FILED 1-29-2014.  
 4,592,903. **EYE WANT (STANDARD CHARACTER)**. EYE WANT, INC., (U.S. CLS. 100 AND 101). SN 86-180,154. PUB. 6-10-2014. FILED 1-30-2014.  
 4,592,915. **EQUU8 AND DESIGN**. EQUU8 HORSEMANSHIP & THERAPEUTIC RIDING, DBA EQUU8, (U.S. CLS. 100 AND 101). SN 86-180,410. PUB. 6-10-2014. FILED 1-30-2014.  
 4,592,924 ( *See Class 9 for this trademark.*)  
 4,592,941. **ACCU-CHEK CONNECT (STANDARD CHARACTER)**. ROCHE DIAGNOSTICS GMBH, (U.S. CLS. 100 AND 101). SN 86-185,123. PUB. 5-6-2014. FILED 2-5-2014.  
 4,592,967. **PINNACLE ENTERTAINMENT (STYLIZED)**. PINNACLE ENTERTAINMENT, INC., (U.S. CLS. 100 AND 101). SN 86-196,753. PUB. 6-10-2014. FILED 2-18-2014.  
 4,592,993. **UH-OH PEDIATRIC URGENT CARE AND DESIGN**. UNITED INVESTMENT GROUP OF LOUISIANA, LLC, (U.S. CLS. 100 AND 101). SN 86-213,773. PUB. 6-10-2014. FILED 3-6-2014.  
 4,592,994. **MENTI (STANDARD CHARACTER)**. MENTISCORE SOLUTIONS LIMITED, (U.S. CLS. 100 AND 101). SN 86-213,972. PUB. 6-10-2014. FILED 3-7-2014.  
 4,593,009. **CETELIFE (STANDARD CHARACTER)**. CETELIFE, (U.S. CLS. 100 AND 101). SN 86-220,308. PUB. 6-10-2014. FILED 3-13-2014.

4,593,018 ( *See Class 37 for this trademark.*)  
 4,593,035. **MEDSTAR HEART INSTITUTE (STANDARD CHARACTER)**. MEDSTAR HEALTH, INC., (U.S. CLS. 100 AND 101). SN 86-237,265. PUB. 6-10-2014. FILED 3-31-2014.

---

## CLASS 45—PERSONAL AND LEGAL SERVICES

4,590,617. **LL AND DESIGN**. THE LAIRE GROUP, INC., (U.S. CLS. 100 AND 101). SN 76-715,692. PUB. 6-10-2014. FILED 1-22-2014.  
 4,590,627 ( *See Class 38 for this trademark.*)  
 4,590,640 ( *See Class 9 for this trademark.*)  
 4,590,655 ( *See Class 9 for this trademark.*)  
 4,590,687 ( *See Class 7 for this trademark.*)  
 4,590,767 ( *See Class 9 for this trademark.*)  
 4,590,768. **SAPHERIOR (STANDARD CHARACTER)**. SAPHERIOR GMBH & CO.KG, (U.S. CLS. 100 AND 101). SN 79-136,141. PUB. 6-10-2014. FILED 8-12-2013.  
 4,590,814. **TBK (STANDARD CHARACTER)**. TBK GBR (VERTRETUNGSBERECHTIGTER GESELLSCHAFTER: MATTHIAS GRILL), (U.S. CLS. 100 AND 101). SN 79-138,297. PUB. 6-10-2014. FILED 8-14-2013.  
 4,590,824 ( *See Class 1 for this trademark.*)  
 4,590,842 ( *See Class 9 for this trademark.*)  
 4,590,858 ( *See Class 7 for this trademark.*)  
 4,590,895 ( *See Class 9 for this trademark.*)  
 4,590,921. **LEGALSTREET (STANDARD CHARACTER)**. LEGAL STREET LIMITED, (U.S. CLS. 100 AND 101). SN 79-144,132. PUB. 6-10-2014. FILED 1-25-2014.  
 4,590,985 ( *See Class 9 for this trademark.*)  
 4,590,987 ( *See Class 16 for this trademark.*)  
 4,590,992 ( *See Class 16 for this trademark.*)  
 4,591,035. **SPECIALIZED RISK AND DESIGN**. HAYNES, STEVEN E., DBA SPECIALIZED RISK, (U.S. CLS. 100 AND 101). SN 85-773,938. PUB. 6-10-2014. FILED 11-7-2012.  
 4,591,060. **GIFTSTER (STANDARD CHARACTER)**. MYGIFTSTER CORPORATION, (U.S. CLS. 100 AND 101). SN 85-788,180. PUB. 6-10-2014. FILED 11-27-2012.  
 4,591,085 ( *See Class 9 for this trademark.*)  
 4,591,090 ( *See Class 41 for this trademark.*)  
 4,591,127 ( *See Class 41 for this trademark.*)  
 4,591,132. **CPC CARRIER PERFORMANCE CHECK AND DESIGN**. WORLDWIDE EQUIPMENT EXCHANGE, LLC, (U.S. CLS. 100 AND 101). SN 85-872,175. PUB. 6-10-2014. FILED 3-11-2013.  
 4,591,146. **OUT MINISTRIES (STANDARD CHARACTER)**. ROBERSON, HALLEY, (U.S. CLS. 100 AND 101). SN 85-882,517. PUB. 6-10-2014. FILED 3-21-2013.  
 4,591,154 ( *See Class 41 for this trademark.*)  
 4,591,157. **SAMSARA CONSULTING (STANDARD CHARACTER)**. SAMSARA CONSULTING, (U.S. CLS. 100 AND 101). SN 85-893,968. PUB. 6-10-2014. FILED 4-3-2013.  
 4,591,161. **THESE ARE THE TIMES THAT TRY MEN'S SOULS IN HOC SIGNO VINCES VENI VIDI VICI FIGG ATF AND DESIGN**. PRINCE LAW OFFICES, PC, DBA FIREARMS INDUSTRY COUNSULTING GROUP, (U.S. CLS. 100 AND 101). SN 85-896,609. PUB. 6-10-2014. FILED 4-5-2013.  
 4,591,170 ( *See Class 9 for this trademark.*)  
 4,591,184. **THERAPY DOGS INTERNATIONAL PAWS AWHILE FOR LOVE AND DESIGN**. THERAPY DOGS INTERNATIONAL, INC., (U.S. CLS. 100 AND 101). SN 85-920,150. PUB. 6-10-2014. FILED 5-1-2013.  
 4,591,208 ( *See Class 9 for this trademark.*)  
 4,591,221 ( *See Class 9 for this trademark.*)  
 4,591,233 ( *See Class 35 for this trademark.*)  
 4,591,239. **GOD IS A BRAND NAME (STANDARD CHARACTER)**. THE MINISTRY OF SECOND TIMOTHY, INC., AND GLASCOE, DEIRDRE C., (U.S. CLS. 100 AND 101). SN 85-948,231. PUB. 10-29-2013. FILED 6-1-2013.  
 4,591,241. **MANHOOD IN THE MANGER (STANDARD CHARACTER)**. NOBLE WARRIORS, INC., (U.S. CLS. 100 AND 101). SN 85-948,918. PUB. 6-10-2014. FILED 6-3-2013.  
 4,591,272. **ROYALE COMPANY AND DESIGN**. ROYALE CONCIERGE, INC., (U.S. CLS. 100 AND 101). SN 85-

- 959,203. PUB. 6-10-2014. FILED 6-13-2013.  
 4,591,312 ( *See Class 9 for this trademark* ).  
 4,591,359. **ALWAYS A SMOOTH SETTLEMENT (STANDARD CHARACTER)**. COLE CORPORATION INC., DBA TITLE EXCELLENCE, (U.S. CLS. 100 AND 101). SN 85-972,474. PUB. 6-10-2014. FILED 6-28-2013.  
 4,591,429. **POWER (STANDARD CHARACTER)**. RELIGIOUS TECHNOLOGY CENTER, (U.S. CLS. 100 AND 101). SN 86-002,673. PUB. 6-10-2014. FILED 7-4-2013.  
 4,591,511 ( *See Class 35 for this trademark* ).  
 4,591,568. **RIGHT CONNECTION ASSOCIATION . A LEADERSHIP ASSOCIATION . AND DESIGN**. RIGHT CONNECTION MINISTRIES INTERNATIONAL, INC., (U.S. CLS. 100 AND 101). SN 86-028,659. PUB. 6-10-2014. FILED 8-5-2013.  
 4,591,618. **MENTESLEGALES (STANDARD CHARACTER)**. TICKTIN, PETER, (U.S. CLS. 100 AND 101). SN 86-044,399. PUB. 6-10-2014. FILED 8-21-2013.  
 4,591,631. **THE HARD PLACES COMMUNITY. A GLIMPSE OF HOPE FOR THE HOPELESS IN THE DARKEST CORNERS OF THIS WORLD. AND DESIGN**. THE HARD PLACES COMMUNITY, AKA WALK AGAINST TRAFFICK, (U.S. CLS. 100 AND 101). SN 86-048,812. PUB. 6-10-2014. FILED 8-27-2013.  
 4,591,633. **SHOOT SHARE SELL (STANDARD CHARACTER)**. JUKIN MEDIA, INC., (U.S. CLS. 100 AND 101). SN 86-049,930. PUB. 6-10-2014. FILED 8-28-2013.  
 4,591,658 ( *See Class 37 for this trademark* ).  
 4,591,659. **ZING LEGAL (STYLIZED)**. KRAMER, KAREN M., DBA ZING LEGAL, (U.S. CLS. 100 AND 101). SN 86-057,092. PUB. 6-10-2014. FILED 9-5-2013.  
 4,591,702 ( *See Class 39 for this trademark* ).  
 4,591,717. **SAFETYSTORE (STANDARD CHARACTER)**. CRISIS MANAGEMENT SYSTEMS, INC., (U.S. CLS. 100 AND 101). SN 86-077,189. PUB. 6-10-2014. FILED 9-27-2013.  
 4,591,724 ( *See Class 35 for this trademark* ).  
 4,591,748. **ELCOCK FUNERAL HOME YOUR FAITH, OUR HOME (STANDARD CHARACTER)**. ELCOCK FUNERAL HOME, INC., (U.S. CLS. 100 AND 101). SN 86-083,454. PUB. 6-10-2014. FILED 10-4-2013.  
 4,591,752. **SENIOR RECRUITERS (STANDARD CHARACTER)**. SENIOR RECRUITERS, INC., (U.S. CLS. 100 AND 101). SN 86-085,932. PUB. 6-10-2014. FILED 10-8-2013.  
 4,591,785. **INDIGITOUS (STANDARD CHARACTER)**. CAMPUS CRUSADE FOR CHRIST, INC., (U.S. CLS. 100 AND 101). SN 86-097,907. PUB. 6-10-2014. FILED 10-22-2013.  
 4,591,791. **DEAF BIBLE AND DESIGN**. HOSANNA, (U.S. CLS. 100 AND 101). SN 86-099,005. PUB. 6-10-2014. FILED 10-23-2013.  
 4,591,794. **COLON CANCER ALLIANCE (STANDARD CHARACTER)**. COLON CANCER ALLIANCE, (U.S. CLS. 100 AND 101). SN 86-099,340. PUB. 6-10-2014. FILED 10-23-2013.  
 4,591,803 ( *See Class 38 for this trademark* ).  
 4,591,828 ( *See Class 41 for this trademark* ).  
 4,591,829 ( *See Class 36 for this trademark* ).  
 4,591,861. **GIRLS NITE IN INTERNATIONAL AND DESIGN**. GIRLS NITE IN INTERNATIONAL, (U.S. CLS. 100 AND 101). SN 86-114,277. PUB. 6-10-2014. FILED 11-8-2013.  
 4,591,903 ( *See Class 16 for this trademark* ).  
 4,592,015 ( *See Class 41 for this trademark* ).  
 4,592,041 ( *See Class 41 for this trademark* ).  
 4,592,079 ( *See Class 41 for this trademark* ).  
 4,592,136. **URBAN PARADISE (STANDARD CHARACTER)**. BOURNE LOGISTICS MARKETING, LTD., (U.S. CLS. 100 AND 101). SN 86-151,294. PUB. 6-10-2014. FILED 12-23-2013.  
 4,592,188. **CARING FOR THE HUMAN SPIRIT (STANDARD CHARACTER)**. THE HEALTHCARE CHAPLAINCY NETWORK., (U.S. CLS. 100 AND 101). SN 86-155,104. PUB. 6-10-2014. FILED 12-31-2013.  
 4,592,193. **PSYCHIC POWER NETWORK (STANDARD CHARACTER)**. SPRING LAKE COMMUNICATIONS LLC, (U.S. CLS. 100 AND 101). SN 86-155,400. PUB. 6-10-2014. FILED 12-31-2013.  
 4,592,196. **J'NICHE (STYLIZED)**. J'NICHE LLC, (U.S. CLS. 100 AND 101). SN 86-155,493. PUB. 6-10-2014. FILED 12-31-2013.  
 4,592,204. **EVALFASTER (STANDARD CHARACTER)**. ADVENTUM ENTERPRISES, LLC, (U.S. CLS. 100 AND 101). SN 86-155,924. PUB. 6-10-2014. FILED 1-2-2014.  
 4,592,214. **TVC AND DESIGN**. TVC HOLDING, INC., (U.S. CLS. 100 AND 101). SN 86-156,252. PUB. 6-10-2014. FILED 1-2-2014.  
 4,592,229. **C U C . O R G THE CHURCH EST. 33 A.D. CHRISTIANS UNITED FOR CHRIST AND DESIGN**. BERRY, JAMES, (U.S. CLS. 100 AND 101). SN 86-157,103. PUB. 6-10-2014. FILED 1-3-2014.  
 4,592,280. **WRIT LEGAL (STANDARD CHARACTER)**. WRIT LEGAL, (U.S. CLS. 100 AND 101). SN 86-159,550. PUB. 6-10-2014. FILED 1-7-2014.  
 4,592,346. **WRIT LEGAL NATIONWIDE SERVICE OF PROCESS AND DESIGN**. WRIT LEGAL, (U.S. CLS. 100 AND 101). SN 86-161,879. PUB. 6-10-2014. FILED 1-9-2014.  
 4,592,374 ( *See Class 41 for this trademark* ).  
 4,592,392. **A DOVE'S NEST (STANDARD CHARACTER)**. DOVES NEST ENTERPRISES LLC, DBA DOVES NEST ENTERPRISES LLC, (U.S. CLS. 100 AND 101). SN 86-162,981. PUB. 6-10-2014. FILED 1-10-2014.  
 4,592,434. **FAMILY LAW HEADQUARTERS (STANDARD CHARACTER)**. STANGE LAW FIRM, PC, (U.S. CLS. 100 AND 101). SN 86-164,318. PUB. 6-10-2014. FILED 1-13-2014.  
 4,592,450. **STRATEGIC GLOBAL ASSISTANCE (STANDARD CHARACTER)**. STRATEGIC GLOBAL ASSISTANCE, INC., (U.S. CLS. 100 AND 101). SN 86-165,043. PUB. 6-10-2014. FILED 1-14-2014.  
 4,592,473. **PATENT INTERCEPTION (STANDARD CHARACTER)**. IRON DOME LLC, (U.S. CLS. 100 AND 101). SN 86-165,581. PUB. 6-10-2014. FILED 1-14-2014.  
 4,592,483. **MEDIATING FOR RESULTS (STANDARD CHARACTER)**. SMITH, ROBERT M., (U.S. CLS. 100 AND 101). SN 86-166,044. PUB. 6-10-2014. FILED 1-15-2014.  
 4,592,489. **INVENTION MINE (STANDARD CHARACTER)**. INVENTION MINE LLC, (U.S. CLS. 100 AND 101). SN 86-166,139. PUB. 6-10-2014. FILED 1-15-2014.  
 4,592,564. **R AND DESIGN**. RED SQUARE HOLDINGS LLC, (U.S. CLS. 100 AND 101). SN 86-169,050. PUB. 6-10-2014. FILED 1-17-2014.  
 4,592,610 ( *See Class 35 for this trademark* ).  
 4,592,744. **DEMARCOIP AND DESIGN**. DEMARCO INTELLECTUAL PROPERTY, LLC, (U.S. CLS. 100 AND 101). SN 86-177,067. PUB. 6-10-2014. FILED 1-28-2014.  
 4,592,745. **MISCELLANEOUS DESIGN**. DEMARCO INTELLECTUAL PROPERTY, LLC, (U.S. CLS. 100 AND 101). SN 86-177,071. PUB. 6-10-2014. FILED 1-28-2014.  
 4,592,815. **WORDS HAVE MEANINGS, PRINCIPLES HAVE CONSEQUENCES, CHARACTER COUNTS. (STANDARD CHARACTER)**. BLACKSTOCK, JAMES F, DBA JAMES F BLACKSTOCK PLLC, (U.S. CLS. 100 AND 101). SN 86-178,240. PUB. 6-10-2014. FILED 1-29-2014.  
 4,592,821. **SHIPMAN & GOODWIN LLP COUNSELORS AT LAW AND DESIGN**. SHIPMAN & GOODWIN LLP, (U.S. CLS. 100 AND 101). SN 86-178,333. PUB. 6-10-2014. FILED 1-29-2014.  
 4,592,885. **TOTEM (STANDARD CHARACTER)**. WHITE, RACHEL, (U.S. CLS. 100 AND 101). SN 86-179,736. PUB. 6-10-2014. FILED 1-30-2014.  
 4,592,910. **SCENEKIDS (STANDARD CHARACTER)**. GRAVITY BOULEVARD, LLC, (U.S. CLS. 100 AND 101). SN 86-180,324. PUB. 6-10-2014. FILED 1-30-2014.  
 4,593,019. **MAKE THE RIGHT CHOICE (STANDARD CHARACTER)**. N. FRED THIAGARAJAH, (U.S. CLS. 100 AND 101). SN 86-225,123. PUB. 6-10-2014. FILED 3-18-2014.

\* \* \* \* \*

SECTION 2.—PRIOR UNITED STATES CLASSIFICATION

COLLECTIVE MEMBERSHIP MARKS

**CLASS 200—COLLECTIVE MEMBERSHIP**

4,592,162. **UMMOA (STANDARD CHARACTER)**, CESIDIO TALLINI, SN 86-153,190. PUB. 6-10-2014. FILED 12-27-2013.

4,592,391. **RUTHLESS RIDERZ MC (STANDARD CHARACTER)**, CLAYTON KIMBROUGH, SN 86-162,939. PUB. 6-10-2014. FILED 1-10-2014.

CERTIFICATION MARKS

CLASS B—SERVICES

4,591,538. **BCTMB (STANDARD CHARACTER)**, NATIONAL CERTIFICATION BOARD FOR THERAPEUTIC MASSAGE & BODYWORK, INC., SN 86-023,990. PUB. 6-10-2014. FILED 7-30-2013.

4,591,549. **NATIONAL CERTIFICATION BOARD FOR THERAPEUTIC MASSAGE & BODYWORK BCTMB BOARD CERTIFIED IN THERAPEUTIC MASSAGE & BODYWORK AND DESIGN**, NATIONAL CERTIFICATION BOARD FOR THERAPEUTIC MASSAGE & BODYWORK, INC., SN 86-026,390. PUB. 6-10-2014. FILED 8-1-2013.

---

\* \* \* \* \*

# TRADEMARK REGISTRATIONS ISSUED UNDER SECTION 1(d)

The following marks have registered on the Principal Register pursuant to the intent-to-use provisions of Section 1(d) of the Trademark Act of 1946, as amended.

## SECTION 1.— INTERNATIONAL CLASSIFICATION

The short titles associated below with the international class numbers are terms designed merely for quick identification and are not an official part of the international classification. The full names of international classes are given in section 6.1 of the trademark rules of practice.

The designation "U.S. Cl." appearing in this section refers to the U.S. class in effect prior to Sep. 1, 1973 rather than the international class which applies to applications filed on or after that date. For adoption of international classification see notice in the OFFICIAL GAZETTE of Jun. 26, 1973 (911 O.G. TM 210).

### Application in more than one class

4,593,067. TANGLA HOTELS & RESORTS WORLDWIDE CO. LIMITED, DES VOEUX ROAD C CENTRAL, HONG KONG. SN 76-713,770. PUB. 6-11-2013, FILED 3-19-2013.



OWNER OF U.S. REG. NO. 3,899,460.  
NO CLAIM IS MADE TO THE EXCLUSIVE RIGHT TO USE "URBAN BOUTIQUE", APART FROM THE MARK AS SHOWN.

THE DESIGN CONSISTS OF CONSISTS OF THE WORDS "TANGLA URBAN BOUTIQUE" UNDERNEATH A STYLIZED DESIGN OF A MISCELLANEOUS DESIGN WITH AN OVERALL TRIANGULAR SHAPE.

#### CLASS 35—ADVERTISING AND BUSINESS

FOR ADMINISTRATIVE HOTEL MANAGEMENT; ASSOCIATION SERVICES, NAMELY, PROMOTING DIVERSITY IN THE RESTAURANT AND HOTEL INDUSTRIES ON BEHALF OF EMPLOYEES, VENDORS, MANAGEMENT AND OWNERS; BUSINESS MANAGEMENT OF HOTELS AND HOTEL MANAGEMENT FOR OTHERS; ARRANGING AND CONDUCTING PROMOTIONAL EVENTS FOR OTHERS; CONSULTATIONS SERVICES, NAMELY, CREATIVE AND STRATEGIC CONSULTATION REGARDING DEVELOPMENT AND PRODUCTION OF MARKETING CAMPAIGNS FOR OTHERS; DIRECT MARKETING ADVERTISING FOR OTHERS; EVENT PLANNING AND MANAGEMENT FOR MARKETING, BRANDING, PROMOTING OR ADVERTISING THE GOODS AND SERVICES OF OTHERS AND MARKETING SERVICES FOR THE HOTELS OF OTHERS (U.S. CLS. 100, 101 AND 102).

FIRST USE 11-1-2013; IN COMMERCE 11-1-2013.

#### CLASS 43—HOTEL AND RESTAURANT SERVICES

FOR RESORT HOTEL SERVICES (U.S. CLS. 100 AND 101).  
FIRST USE 11-1-2013; IN COMMERCE 11-1-2013.

4,593,079. THE OLIVER WHITE HILL FOUNDATION, RICHMOND, VA. SN 77-755,026. PUB. 4-26-2011, FILED 6-9-2009.

#### THE OLIVER WHITE HILL FOUNDATION

THE MARK CONSISTS OF STANDARD CHARACTERS WITHOUT CLAIM TO ANY PARTICULAR FONT, STYLE, SIZE, OR COLOR.

NO CLAIM IS MADE TO THE EXCLUSIVE RIGHT TO USE "FOUNDATION", APART FROM THE MARK AS SHOWN.

THE NAME(S), PORTRAIT(S), AND/OR SIGNATURE(S) SHOWN IN THE MARK DOES NOT IDENTIFY A PARTICULAR LIVING INDIVIDUAL.

#### CLASS 35—ADVERTISING AND BUSINESS

FOR PROMOTING PUBLIC AWARENESS IN THE AREAS OF CIVIL RIGHTS THROUGH STRATEGIC RELATIONSHIPS WITH FOUNDATIONS, CORPORATIONS AND MULTILATERAL ORGANIZATIONS AND THROUGH THE DEVELOPMENT OF PARTNERSHIPS WITH BAR ASSOCIATIONS, LAW FIRMS, LAW SCHOOLS, AND NON-GOVERNMENTAL ORGANIZATIONS COMMITTED TO THE DEVELOPMENT OF THE INSTITUTIONS OF A CIVIL SOCIETY (U.S. CLS. 100, 101 AND 102).

FIRST USE 6-20-2014; IN COMMERCE 6-10-2014.

**CLASS 36—INSURANCE AND FINANCIAL**

FOR CHARITABLE SERVICES, NAMELY, PROMOTING THE AWARENESS AND STUDY OF CIVIL RIGHTS BY PROVIDING GRANTS TO INDIVIDUALS, SELECT BUSINESSES, EDUCATIONAL INSTITUTIONS, NON-PROFIT ORGANIZATIONS, COMMUNITY ORGANIZATIONS AND THINK TANKS FOR LECTURES, SEMINARS, RESEARCH, CONFERENCES AND WORKSHOPS ON THE TOPICS OF CIVIL RIGHTS, AND FUND RAISING SERVICES (U.S. CLS. 100, 101 AND 102).

FIRST USE 6-20-2014; IN COMMERCE 6-20-2014.

**CLASS 41—EDUCATION AND ENTERTAINMENT**

FOR EDUCATION SERVICES, NAMELY, ARRANGING AND CONDUCTING TOURS, COURSES, SEMINARS, FELLOWSHIPS, LECTURES, PROGRAMS AND WORKSHOPS CONCERNING HISTORICAL AND CULTURAL TOPICS; DEVELOPMENT AND DISSEMINATION OF EDUCATIONAL MATERIALS FOR OTHERS CONCERNING CIVIL RIGHTS (U.S. CLS. 100, 101 AND 107).

FIRST USE 6-20-2014; IN COMMERCE 6-20-2014.

**CLASS 38—COMMUNICATION**

FOR PROVIDING ACCESS TO COMPUTER, ELECTRONIC AND ONLINE DATABASES; TELECOMMUNICATIONS SERVICES, NAMELY, ELECTRONIC TRANSMISSION OF DATA, MESSAGES AND INFORMATION; PROVIDING ONLINE FORUMS FOR COMMUNICATION ON TOPICS OF GENERAL INTEREST; PROVIDING ONLINE COMMUNICATIONS LINKS WHICH TRANSFER WEB SITE USERS TO OTHER LOCAL AND GLOBAL WEB PAGES; PROVIDING ONLINE CHAT ROOMS AND ELECTRONIC BULLETIN BOARDS FOR TRANSMISSION OF MESSAGES AMONG USERS IN THE FIELD OF GENERAL INTEREST; AUDIO, TEXT AND VIDEO BROADCASTING SERVICES OVER COMPUTER OR OTHER COMMUNICATION NETWORKS NAMELY, ELECTRONICALLY TRANSMITTING DATA, INFORMATION, AUDIO AND VIDEO IMAGES; PROVIDING ACCESS TO THE INTERNET, NAMELY, FACILITATING ACCESS TO THIRD PARTY WEB SITES VIA A UNIVERSAL LOGIN; PEER-TO-PEER PHOTO SHARING SERVICES, NAMELY, ELECTRONIC TRANSMISSION OF DIGITAL PHOTO FILES AMONG INTERNET USERS (U.S. CLS. 100, 101 AND 104).

FIRST USE 6-16-2014; IN COMMERCE 6-16-2014.

4,593,088. WU, JASON, NEW YORK, NY. SN 77-900,304. PUB. 5-10-2011, FILED 12-23-2009.

# JASON WU

THE MARK CONSISTS OF STANDARD CHARACTERS WITHOUT CLAIM TO ANY PARTICULAR FONT, STYLE, SIZE, OR COLOR.

OWNER OF U.S. REG. NO. 3,851,718.

THE NAME "JASON WU" IDENTIFIES A LIVING INDIVIDUAL WHOSE CONSENT IS OF RECORD.

**CLASS 9—ELECTRICAL AND SCIENTIFIC APPARATUS**

FOR SUNGLASSES; EYEGLASSES; EYEGGLASS FRAMES (U.S. CLS. 21, 23, 26, 36 AND 38).

FIRST USE 9-0-2010; IN COMMERCE 9-0-2010.

**CLASS 18—LEATHER GOODS**

FOR HANDBAGS; SHOULDER BAGS (U.S. CLS. 1, 2, 3, 22 AND 41).

FIRST USE 10-0-2010; IN COMMERCE 10-0-2010.

4,593,090. COOVIT, INC., NEW YORK, NY. SN 77-945,633. PUB. 5-24-2011, FILED 2-26-2010.

# Coovit

THE MARK CONSISTS OF STANDARD CHARACTERS WITHOUT CLAIM TO ANY PARTICULAR FONT, STYLE, SIZE, OR COLOR.

**CLASS 42—SCIENTIFIC AND COMPUTER SERVICES**

FOR COMPUTER SERVICES, NAMELY, HOSTING ELECTRONIC FACILITIES FOR OTHERS FOR ORGANIZING AND CONDUCTING MEETINGS, EVENTS AND INTERACTIVE DISCUSSIONS VIA COMMUNICATION NETWORKS; APPLICATION SERVICE PROVIDER (ASP) SERVICES, NAMELY, HOSTING COMPUTER SOFTWARE APPLICATIONS OF OTHERS; APPLICATION SERVICE PROVIDER (ASP) FEATURING SOFTWARE TO ENABLE OR FACILITATE THE UPLOADING, DOWNLOADING, STREAMING, POSTING, DISPLAYING, BLOGGING, LINKING, SHARING OR OTHERWISE PROVIDING ELECTRONIC MEDIA OR INFORMATION OVER COMMUNICATION NETWORKS; PROVIDING AN ONLINE NETWORK SERVICE THAT ENABLES USERS TO TRANSFER PERSONAL IDENTITY DATA TO AND SHARE PERSONAL IDENTITY DATA WITH AND AMONG MULTIPLE WEBSITES; PROVIDING A WEB SITE FEATURING TECHNOLOGY THAT ENABLES ONLINE USERS TO CREATE PERSONAL PROFILES FEATURING SOCIAL NETWORKING INFORMATION AND TO TRANSFER AND SHARE SUCH INFORMATION AMONG MULTIPLE WEBSITES; PROVIDING TEMPORARY USE OF NON-DOWNLOADABLE SOFTWARE APPLICATIONS FOR SOCIAL NETWORKING, CREATING A VIRTUAL COMMUNITY, AND TRANSMISSION OF AUDIO, VIDEO, PHOTOGRAPHIC IMAGES, TEXT, GRAPHICS AND DATA; COMPUTER SERVICES IN THE NATURE OF CUSTOMIZED WEB PAGES FEATURING USER-DEFINED OR SPECIFIED INFORMATION, PERSONAL PROFILES, AUDIO, VIDEO, PHOTOGRAPHIC IMAGES, TEXT, GRAPHICS AND DATA; PROVIDING A WEB SITE FEATURING TEMPORARY USE OF NON-DOWNLOADABLE SOFTWARE ALLOWING WEB SITE USERS TO UPLOAD ON-LINE VIDEOS FOR SHARING WITH OTHERS FOR ENTERTAINMENT PURPOSES; PEER-TO-BROWSER PHOTO SHARING SERVICES, NAMELY, PROVIDING A WEBSITE FEATURING TECHNOLOGY ENABLING USERS TO UPLOAD, VIEW, AND DOWNLOAD DIGITAL PHOTOS; PROVIDING A WEB SITE THAT GIVES COMPUTER USERS THE ABILITY TO UPLOAD AND SHARE USER-GENERATED ESSAYS AND ARTICLES ON A WIDE VARIETY OF TOPICS AND SUBJECTS; COMPUTER SERVICES, NAMELY, CREATING VIRTUAL COMMUNITIES FOR REGISTERED USERS TO ORGANIZE GROUPS AND EVENTS, PARTICIPATE IN DISCUSSIONS, AND ENGAGE IN SOCIAL NETWORKING FEATURING THE EXCHANGE OF MEDIA AND INFORMATION; PROVIDING A WEBSITE FEATURING NON-DOWNLOADABLE SOFTWARE FOR USE IN PREPARING, POSTING AND RESPONDING TO ON-LINE CLASSIFIED ADVERTISING, FORMING VIRTUAL COMMUNITIES, SOCIAL NETWORKING, PHOTO SHARING, VIDEO SHARING AND TRANSMISSION OF PHOTOGRAPHIC IMAGES; COMPUTER SERVICES, NAMELY, CREATING VIR-

TUAL COMMUNITIES FOR REGISTERED USERS TO ORGANIZE GROUPS AND EVENTS, PARTICIPATE IN DISCUSSIONS, AND ENGAGE IN SOCIAL, BUSINESS AND COMMUNITY NETWORKING; COMPUTER SERVICES, NAMELY, HOSTING ELECTRONIC FACILITIES FOR OTHERS FOR ORGANIZING AND CONDUCTING MEETINGS, EVENTS AND INTERACTIVE DISCUSSIONS VIA COMMUNICATION NETWORKS; APPLICATION SERVICE PROVIDER FEATURING APPLICATION PROGRAMMING INTERFACE (API) SOFTWARE FOR ALLOWING DATA RETRIEVAL, UPLOAD, ACCESS AND MANAGEMENT (U.S. CLS. 100 AND 101).

FIRST USE 6-16-2014; IN COMMERCE 6-16-2014.

#### **CLASS 45—PERSONAL AND LEGAL SERVICES**

FOR ON-LINE SOCIAL NETWORKING SERVICES; CONDUCTING ON-LINE PERSONAL LIFESTYLE PERFORMANCE ASSESSMENTS AND SKILL ENHANCEMENT PROGRAMS, INCLUDING GOAL SETTING AND GOAL ATTAINMENT (U.S. CLS. 100 AND 101).

FIRST USE 6-16-2014; IN COMMERCE 6-16-2014.

---

4,593,093. VINCENT TULL COMPANY, LLC, HENDERSON, NV. SN 78-922,188. PUB. 4-30-2013, FILED 7-4-2006.

# VEGAS



OWNER OF U.S. REG. NOS. 1,790,454 AND 2,972,269.

#### **CLASS 25—CLOTHING**

FOR CAPS; POLO SHIRTS; T-SHIRTS (U.S. CLS. 22 AND 39).

FIRST USE 6-2-2014; IN COMMERCE 6-2-2014.

#### **CLASS 33—WINES AND SPIRITS**

FOR VODKA (U.S. CLS. 47 AND 49).

FIRST USE 6-2-2014; IN COMMERCE 6-2-2014.

---

4,593,096. FRY'S ELECTRONICS, INC., SAN JOSE, CA. SN 85-030,125. PUB. 4-19-2011, FILED 5-4-2010.

# CYBERCATS

THE MARK CONSISTS OF STANDARD CHARACTERS WITHOUT CLAIM TO ANY PARTICULAR FONT, STYLE, SIZE, OR COLOR.

#### **CLASS 9—ELECTRICAL AND SCIENTIFIC APPARATUS**

FOR COMPUTER ACCESSORIES AND RELATED MERCHANDISE, NAMELY, MOUSE PADS AND LAPTOP CARRYING CASES; BLANK STORAGE MEDIA, NAMELY, FLASH DRIVES (U.S. CLS. 21, 23, 26, 36 AND 38).

FIRST USE 6-14-2014; IN COMMERCE 6-14-2014.

#### **CLASS 16—PAPER GOODS AND PRINTED MATTER**

FOR NOTEBOOK PAPER; POSTERS (U.S. CLS. 2, 5, 22, 23, 29, 37, 38 AND 50).

FIRST USE 6-14-2014; IN COMMERCE 6-14-2014.

#### **CLASS 25—CLOTHING**

FOR HATS AND CAPS (U.S. CLS. 22 AND 39).

FIRST USE 6-14-2014; IN COMMERCE 6-14-2014.

#### **CLASS 28—TOYS AND SPORTING GOODS**

FOR SPORTING GOODS AND EQUIPMENT, NAMELY, MINIATURE TOY SOUVENIR SPORTS HELMETS; MINIATURE AND STANDARD SIZED FOOTBALLS; PARTY FAVORS IN THE NATURE OF NOISEMAKERS (U.S. CLS. 22, 23, 38 AND 50).

FIRST USE 6-14-2014; IN COMMERCE 6-14-2014.

#### **CLASS 32—LIGHT BEVERAGES**

FOR BEVERAGES, NAMELY, BOTTLED WATER (U.S. CLS. 45, 46 AND 48).

FIRST USE 6-14-2014; IN COMMERCE 6-14-2014.

---

4,593,097. SWEDISH ORPHAN BIOVITRUM AB (PUBL), STOCKHOLM, SWEDEN. SN 85-035,739. PUB. 11-1-2011, FILED 5-11-2010.

# SOBI

THE MARK CONSISTS OF STANDARD CHARACTERS WITHOUT CLAIM TO ANY PARTICULAR FONT, STYLE, SIZE, OR COLOR.

THE WORDING "SOBI" HAS NO MEANING IN A FOREIGN LANGUAGE.

#### **CLASS 5—PHARMACEUTICALS**

FOR PHARMACEUTICAL PREPARATIONS IN THE FIELD OF HUMAN MEDICINE FOR THE PREVENTION AND TREATMENT OF HEMATOLOGICAL DISEASES, INTESTINAL FAT MALABSORPTION DISEASES, INFLAMMATORY DISEASES, RHEUMATOID ARTHRITIS, CANCER, INHERITED METABOLIC DISEASES AND CYSTIC FIBROSIS, ALL OF THE FOREGOING EXCLUDING VITAMIN AND MINERAL PREPARATIONS AND VITAMINIZED TONIC DRINKS FOR MEDICAL PURPOSES; PHARMACEUTICAL PREPARATIONS FOR THE TREATMENT OF INJURY TO EPITHELIAL CELLS AND TISSUES AND FOR STIMULATING BLOOD CELL PRODUCTION, EXCLUDING VITAMIN AND MINERAL PREPARATIONS AND VITAMINIZED TONIC DRINKS FOR MEDICAL PURPOSES (U.S. CLS. 6, 18, 44, 46, 51 AND 52).

FIRST USE 6-0-2010; IN COMMERCE 6-0-2010.

**CLASS 10—MEDICAL APPARATUS**

FOR SURGICAL INSTRUMENTS AND APPARATUS; MEDICAL APPARATUS AND INSTRUMENTS FOR USE IN GENERAL SURGERY; MEDICAL APPARATUS AND INSTRUMENTS, NAMELY, MEDICAL APPARATUS FOR INTRODUCING PHARMACEUTICAL PREPARATIONS INTO THE HUMAN BODY AND FACILITATING THE INHALATION OF PHARMACEUTICAL PREPARATIONS AND MEDICAL INFUSION AND INJECTION DEVICES FOR ADMINISTERING DRUGS (U.S. CLS. 26, 39 AND 44).

FIRST USE 6-0-2010; IN COMMERCE 6-0-2010.

**CLASS 35—ADVERTISING AND BUSINESS**

FOR MARKETING AND ADVERTISING OF MEDICAL AND PHARMACEUTICAL PRODUCTS; RETAIL DISTRIBUTORSHIP SERVICES IN THE FIELD OF PHARMACEUTICALS, MEDICAL PREPARATIONS, DIAGNOSTICS AND MEDICAL DEVICES (U.S. CLS. 100, 101 AND 102).

FIRST USE 6-0-2010; IN COMMERCE 6-0-2010.

**CLASS 42—SCIENTIFIC AND COMPUTER SERVICES**

FOR SCIENTIFIC RESEARCH; INDUSTRIAL RESEARCH IN THE MEDICAL AND PHARMACEUTICAL FIELDS (U.S. CLS. 100 AND 101).

FIRST USE 6-0-2010; IN COMMERCE 6-0-2010.

**CLASS 45—PERSONAL AND LEGAL SERVICES**

FOR LICENSING WITHIN THE FIELD OF MEDICINES; LICENSING OF INTELLECTUAL PROPERTY (U.S. CLS. 100 AND 101).

FIRST USE 6-0-2010; IN COMMERCE 6-0-2010.

**CLASS 5—PHARMACEUTICALS**

FOR PHARMACEUTICAL PREPARATIONS IN THE FIELD OF HUMAN MEDICINE FOR THE PREVENTION AND TREATMENT OF HEMATOLOGICAL DISEASES, INTESTINAL FAT MALABSORPTION DISEASES, INFLAMMATORY DISEASES, RHEUMATOID ARTHRITIS, CANCER, INHERITED METABOLIC DISEASES AND CYSTIC FIBROSIS, ALL OF THE FOREGOING EXCLUDING VITAMIN AND MINERAL PREPARATIONS AND VITAMINIZED TONIC DRINKS FOR MEDICAL PURPOSES; PHARMACEUTICAL PREPARATIONS FOR THE TREATMENT OF INJURY TO EPITHELIAL CELLS AND TISSUES AND FOR STIMULATING BLOOD CELL PRODUCTION, EXCLUDING VITAMIN AND MINERAL PREPARATIONS AND VITAMINIZED TONIC DRINKS FOR MEDICAL PURPOSES (U.S. CLS. 6, 18, 44, 46, 51 AND 52).

FIRST USE 6-0-2010; IN COMMERCE 6-0-2010.

**CLASS 10—MEDICAL APPARATUS**

FOR SURGICAL INSTRUMENTS AND APPARATUS; MEDICAL APPARATUS AND INSTRUMENTS FOR USE IN GENERAL SURGERY; MEDICAL APPARATUS AND INSTRUMENTS, NAMELY, MEDICAL APPARATUS FOR INTRODUCING PHARMACEUTICAL PREPARATIONS INTO THE HUMAN BODY AND FACILITATING THE INHALATION OF PHARMACEUTICAL PREPARATIONS AND MEDICAL INFUSION AND INJECTION DEVICES FOR ADMINISTERING DRUGS (U.S. CLS. 26, 39 AND 44).

FIRST USE 6-0-2010; IN COMMERCE 6-0-2010.

**CLASS 35—ADVERTISING AND BUSINESS**

FOR MARKETING AND ADVERTISING OF MEDICAL AND PHARMACEUTICAL PRODUCTS; RETAIL DISTRIBUTORSHIP SERVICES IN THE FIELD OF PHARMACEUTICALS, MEDICAL PREPARATIONS, DIAGNOSTICS AND MEDICAL DEVICES (U.S. CLS. 100, 101 AND 102).

FIRST USE 6-0-2010; IN COMMERCE 6-0-2010.

**CLASS 42—SCIENTIFIC AND COMPUTER SERVICES**

FOR SCIENTIFIC RESEARCH; INDUSTRIAL RESEARCH IN THE MEDICAL AND PHARMACEUTICAL FIELDS (U.S. CLS. 100 AND 101).

FIRST USE 6-0-2010; IN COMMERCE 6-0-2010.

**CLASS 45—PERSONAL AND LEGAL SERVICES**

FOR LICENSING WITHIN THE FIELD OF MEDICINES; LICENSING OF INTELLECTUAL PROPERTY (U.S. CLS. 100 AND 101).

FIRST USE 6-0-2010; IN COMMERCE 6-0-2010.

4,593,098. SWEDISH ORPHAN BIOVITRUM AB (PUBL), STOCKHOLM, SWEDEN. SN 85-036,483. PUB. 11-29-2011, FILED 5-12-2010.

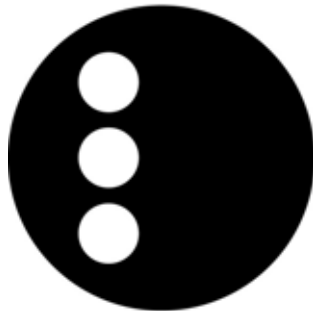

THE MARK CONSISTS OF A LARGER SHADED CIRCLE WITH THREE SMALLER UNSHADED CIRCLES ARRANGED VERTICALLY ON THE LEFT SIDE OF THE LARGER SHADED CIRCLE.

4,593,100. FWD MEDIA, INC., NEW YORK, NY. SN 85-039,178. PUB. 4-26-2011, FILED 5-14-2010.

Where learning gets  
animated

THE MARK CONSISTS OF STANDARD CHARACTERS WITHOUT CLAIM TO ANY PARTICULAR FONT, STYLE, SIZE, OR COLOR.

**CLASS 41—EDUCATION AND ENTERTAINMENT**

FOR PROVIDING AN ONLINE COMPUTER WEBSITE THAT PROVIDES PRINTABLE EDUCATIONAL INFORMATION IN THE FIELDS OF LANGUAGE ARTS, WORLD HISTORY AND CULTURE, HEALTH, SCIENCE, TECHNOLOGY MATTERS FOR THE PURPOSE OF ACADEMIC STUDY AND LEARNING; EDUCATIONAL INTERACTIVE SERVICES, NAMELY, INSTRUCTION BY PROVIDING LIVE, WEBSITE AND ONLINE CLASSES, WORKSHOP, AND INTERACTIVE LESSONS IN THE FIELDS OF HEALTH, SCIENCE, MATHEMATICS, ART, MUSIC, LANGUAGE ARTS, HEALTH AND TECHNOLOGY AND DISTRIBUTION OF COURSE MATERIALS IN CONNECTION THEREWITH; PRODUCTION AND DISTRIBUTION OF INTERACTIVE ANIMATED EDUCATIONAL MOVIES VIA THE INTERNET; GLOBAL COMPUTER NETWORK SERVICES, NAMELY, PROVIDING ONLINE EDUCATIONAL INFORMATION IN THE FIELDS OF HEALTH, SCIENCE, MATHEMATICS, ART, MUSIC, LANGUAGE ARTS, AND TECHNOLOGY FOR THE PURPOSE OF ACADEMIC STUDY AND LEARNING; PROVIDING SUBSCRIPTION BASED USE OF ON-LINE NON-DOWNLOADABLE EDUCATIONAL COMPUTER GAMES OVER A GLOBAL COMPUTER NETWORK IN THE FIELDS OF SCIENCE, MATHEMATICS, ART, MUSIC, LANGUAGE ARTS, HEALTH AND TECHNOLOGY FOR THE PURPOSE OF ACADEMIC STUDY AND LEARNING (U.S. CLS. 100, 101 AND 107).

FIRST USE 7-1-2008; IN COMMERCE 7-1-2008.

**CLASS 42—SCIENTIFIC AND COMPUTER SERVICES**

FOR PROVIDING SUBSCRIPTION BASED USE OF ON-LINE NON-DOWNLOADABLE EDUCATIONAL SOFTWARE OVER A GLOBAL COMPUTER NETWORK IN THE FIELDS OF SCIENCE, MATHEMATICS, ART, MUSIC, LANGUAGE ARTS, HEALTH AND TECHNOLOGY FOR THE PURPOSE OF ACADEMIC STUDY AND LEARNING (U.S. CLS. 100 AND 101).

FIRST USE 7-1-2008; IN COMMERCE 7-1-2008.

4,593,109. TYCO ELECTRONICS CORPORATION, BERYN, PA. SN 85-055,059. PUB. 5-10-2011, FILED 6-4-2010.

# SOLARLOK

THE MARK CONSISTS OF STANDARD CHARACTERS WITHOUT CLAIM TO ANY PARTICULAR FONT, STYLE, SIZE, OR COLOR.

OWNER OF U.S. REG. NO. 2,825,888.

**CLASS 8—HAND TOOLS**

FOR HAND TOOLS, NAMELY, CRIMP TOOLS AND WIRE STRIPPERS (U.S. CLS. 23, 28 AND 44).

FIRST USE 12-31-2012; IN COMMERCE 12-31-2012.

**CLASS 9—ELECTRICAL AND SCIENTIFIC APPARATUS**

FOR ELECTRICAL CONNECTORS; ELECTRICAL CABLES; ELECTRICAL CABLE ASSEMBLIES COMPRISING ELECTRICAL CABLES AND ELECTRICAL CABLE CONNECTORS; JUNCTION BOXES; JUNCTION BOX ASSEMBLIES COMPRISING ELECTRICAL JUNCTION BOXES AND BOX HOUSING; ELECTRICAL DISTRIBUTION BOXES WITH ELECTRICAL COMBINERS FOR CONNECTING ELECTRIC CABLES; ELECTRICAL SWITCHES; METAL GROUNDING CLIPS FOR USE AS PARTS AND FITTINGS FOR ELECTRICAL CABLES; METAL CLAMPS; JUNCTION BOXES CONTAINING ELECTRONIC COMBINERS; DUST COVERS FOR ELECTRICAL CONNECTORS (U.S. CLS. 21, 23, 26, 36 AND 38).

FIRST USE 12-31-2012; IN COMMERCE 12-31-2012.

**CLASS 16—PAPER GOODS AND PRINTED MATTER**

FOR PAPER LABELS FOR USE ON SOLAR POWER EQUIPMENT AND WIRING (U.S. CLS. 2, 5, 22, 23, 29, 37, 38 AND 50).

FIRST USE 12-31-2012; IN COMMERCE 12-31-2012.

**CLASS 20—FURNITURE AND ARTICLES NOT OTHERWISE CLASSIFIED**

FOR NON-METAL CLAMPS; PLASTIC LABELS FOR USE ON SOLAR POWER EQUIPMENT AND WIRING (U.S. CLS. 2, 13, 22, 25, 32 AND 50).

FIRST USE 12-31-2012; IN COMMERCE 12-31-2012.

4,593,110. SIERRA ENERGY, DAVIS, CA. SN 85-056,255. PUB. 5-17-2011, FILED 6-7-2010.

# FASTOX

THE MARK CONSISTS OF STANDARD CHARACTERS WITHOUT CLAIM TO ANY PARTICULAR FONT, STYLE, SIZE, OR COLOR.

**CLASS 7—MACHINERY**

FOR NOZZLES FOR USE IN GASIFIERS; GASIFIERS (U.S. CLS. 13, 19, 21, 23, 31, 34 AND 35).

FIRST USE 4-1-2014; IN COMMERCE 4-1-2014.

**CLASS 42—SCIENTIFIC AND COMPUTER SERVICES**

FOR DESIGN OF EQUIPMENT FOR GASIFICATION OF MATERIALS, NAMELY, BIOMASS, COAL, OIL SHALE, AND SOLID WASTE; DESIGN OF EQUIPMENT FOR CONVERTING METALLIC OXIDE ORES INTO MOLTEN METALS; ENGINEERING SERVICES IN THE TECHNOLOGY FIELD OF GASIFICATION; TECHNOLOGICAL CONSULTATION IN THE TECHNOLOGY FIELD OF CONVERTING METALLIC OXIDE ORES INTO MOLTEN METALS (U.S. CLS. 100 AND 101).

FIRST USE 4-1-2014; IN COMMERCE 4-1-2014.



4,593,111. ELDER RESOURCE CENTER, LLC, COOPER CITY, FL. SN 85-056,498. PUB. 5-17-2011, FILED 6-7-2010.

ElderHelper.com

THE MARK CONSISTS OF THE WORDS "ELDERHELPER" AND "COM" SEPARATED BY A SMILEY FACE WEARING GLASSES WITHIN A CIRCLE.

#### CLASS 35—ADVERTISING AND BUSINESS

FOR ADVERTISING SERVICES, NAMELY, PROMOTING THE INTERESTS OF SPECIALIZED PROVIDERS OF ELDER CARE GOODS AND SERVICES IN THE FIELDS OF ACCOUNTING, ALZHEIMER'S CARE, ASSISTED LIVING, CANCER CARE, COMPANION CARE, ESTATE PLANNING, ESTATE SALES, FINAL ARRANGEMENTS IN THE NATURE OF FUNERAL, BURIAL AND CREMATION SERVICES, FINANCIAL PLANNING AND MANAGEMENT, GERIATRIC CARE MANAGEMENT, GOVERNMENT INFORMATION SERVICES AND AGENCY LINKS, HOME CUSTODIAL CARE IN THE NATURE OF HOUSE KEEPING AND LAUNDRY SERVICES, HOME-DELIVERED GROCERIES, HOME DELIVERED MEALS, HOME HEALTH CARE, HOSPICE CARE, INSURANCE SERVICES, LEGAL SERVICES, MEDICAL SERVICES, MEDICAL EQUIPMENT, MEDICAL SUPPLIES, MEDICATIONS, NURSING HOME CARE, PLACEMENT SERVICES, REAL ESTATE, RESPITE CARE, TRANSPORTATION, AND TAX SERVICES; PROVIDING A WEBSITE ON THE GLOBAL COMPUTER INFORMATION NETWORK FEATURING INFORMATION OF INTEREST TO SENIOR CITIZENS, THEIR FAMILIES AND THEIR CAREGIVERS IN THE FIELD OF ACCOUNTING; PROVIDING A WEBSITE ON THE GLOBAL COMPUTER INFORMATION NETWORK FEATURING INFORMATION OF INTEREST TO SENIOR CITIZENS, THEIR FAMILIES AND THEIR CAREGIVERS IN THE FIELD OF ESTATE PLANNING AND ESTATE SALES; PROVIDING A WEBSITE ON THE GLOBAL COMPUTER INFORMATION NETWORK FEATURING INFORMATION OF INTEREST TO SENIOR CITIZENS, THEIR FAMILIES AND THEIR CAREGIVERS IN THE FIELD OF TAX SERVICES, NAMELY, TAX ADVISORY SERVICES, TAX PLANNING" ADVICE, INFORMATION AND CONSULTANCY AND TAX FILING SERVICES (U.S. CLS. 100, 101 AND 102).

FIRST USE 7-9-2014; IN COMMERCE 7-9-2014.

#### CLASS 44—MEDICAL, BEAUTY AND AGRICULTURAL SERVICES

FOR PROVIDING A WEBSITE ON THE GLOBAL COMPUTER INFORMATION NETWORK FEATURING INFORMATION OF INTEREST TO SENIOR CITIZENS, THEIR FAMILIES AND THEIR CAREGIVERS IN THE FIELD OF MENTAL HEALTH CARE, SPECIALIZING IN ALZHEIMER'S CARE; PROVIDING A WEBSITE ON THE GLOBAL COMPUTER INFORMATION NETWORK FEATURING INFORMATION OF INTEREST TO SENIOR CITIZENS, THEIR FAMILIES AND THEIR CAREGIVERS IN THE FIELD OF CANCER CARE AND GERIATRIC HEALTH CARE MANAGEMENT SERVICES, HOME HEALTH CARE SERVICES, HOSPICE CARE AND MEDICAL SERVICES; PROVIDING A WEBSITE ON THE GLOBAL COMPUTER INFORMATION

NETWORK FEATURING INFORMATION OF INTEREST TO SENIOR CITIZENS, THEIR FAMILIES AND THEIR CAREGIVERS IN THE FIELD OF PHARMACEUTICAL ADVICE AND DISPENSING OF PHARMACEUTICALS; PROVIDING A WEBSITE ON THE GLOBAL COMPUTER INFORMATION NETWORK FEATURING INFORMATION OF INTEREST TO SENIOR CITIZENS, THEIR FAMILIES AND THEIR CAREGIVERS IN THE FIELD OF NURSING HOMES AND HOME NURSING AID SERVICES; PROVIDING A WEBSITE ON THE GLOBAL COMPUTER INFORMATION NETWORK FEATURING INFORMATION OF INTEREST TO SENIOR CITIZENS, THEIR FAMILIES AND THEIR CARE GIVERS IN THE FIELD OF RESPITE CARE, NAMELY, SHORT-TERM, TEMPORARY ASSISTANCE TO THOSE WHO ARE CARING FOR FAMILY MEMBERS WHO MIGHT OTHERWISE REQUIRE PERMANENT PLACEMENT IN A FACILITY OUTSIDE OF THE HOME; PROVIDING A WEBSITE ON THE GLOBAL COMPUTER INFORMATION NETWORK FEATURING INFORMATION OF INTEREST TO SENIOR CITIZENS, THEIR FAMILIES AND THEIR CARE GIVERS IN THE FIELD OF MEDICAL EQUIPMENT AND MEDICAL SUPPLIES, NAMELY, RENTAL AND PURCHASE OF MEDICAL EQUIPMENT AND MEDICAL SUPPLIES (U.S. CLS. 100 AND 101).

FIRST USE 7-9-2014; IN COMMERCE 7-9-2014.

4,593,112. ELDER RESOURCE CENTER, LLC, COOPER CITY, FL. SN 85-056,505. PUB. 5-17-2011, FILED 6-7-2010.

ELDER HELPER

THE MARK CONSISTS OF STANDARD CHARACTERS WITHOUT CLAIM TO ANY PARTICULAR FONT, STYLE, SIZE, OR COLOR.

#### CLASS 35—ADVERTISING AND BUSINESS

FOR ADVERTISING SERVICES, NAMELY, PROMOTING THE INTERESTS OF SPECIALIZED PROVIDERS OF ELDER CARE GOODS AND SERVICES IN THE FIELDS OF ACCOUNTING, ALZHEIMER'S CARE, ASSISTED LIVING, CANCER CARE, COMPANION CARE, ESTATE PLANNING, ESTATE SALES, FINAL ARRANGEMENTS IN THE NATURE OF FUNERAL, BURIAL AND CREMATION SERVICES, FINANCIAL PLANNING AND MANAGEMENT, GERIATRIC CARE MANAGEMENT, GOVERNMENT INFORMATION SERVICES AND AGENCY LINKS, HOME CUSTODIAL CARE IN THE NATURE OF HOUSE KEEPING AND LAUNDRY SERVICES, HOME-DELIVERED GROCERIES, HOME DELIVERED MEALS, HOME HEALTH CARE, HOSPICE CARE, INSURANCE SERVICES, LEGAL SERVICES, MEDICAL SERVICES, MEDICAL EQUIPMENT, MEDICAL SUPPLIES, MEDICATIONS, NURSING HOME CARE, PLACEMENT SERVICES, REAL ESTATE, RESPITE CARE, TRANSPORTATION, AND TAX SERVICES; PROVIDING A WEBSITE ON THE GLOBAL COMPUTER INFORMATION NETWORK FEATURING INFORMATION OF INTEREST TO SENIOR CITIZENS, THEIR FAMILIES AND THEIR CAREGIVERS IN THE FIELD OF ACCOUNTING; PROVIDING A WEBSITE ON THE GLOBAL COMPUTER INFORMATION NETWORK FEATURING INFORMATION OF INTEREST TO SENIOR CITIZENS, THEIR FAMILIES AND THEIR CAREGIVERS IN THE FIELD OF ESTATE PLANNING AND ESTATE SALES; PROVIDING A WEBSITE ON THE GLOBAL COMPUTER INFORMATION NETWORK FEATURING INFORMATION OF INTEREST TO SENIOR CITIZENS, THEIR FAMILIES AND THEIR CAREGIVERS IN THE FIELD OF TAX SERVICES, NAMELY, TAX ADVISORY SERVICES, TAX PLANNING ADVICE, INFORMATION AND CONSULTANCY AND TAX FILING SERVICES (U.S. CLS. 100, 101 AND 102).

FIRST USE 6-26-2014; IN COMMERCE 6-26-2014.

**CLASS 44—MEDICAL, BEAUTY AND AGRICULTURAL SERVICES**

FOR PROVIDING A WEBSITE ON THE GLOBAL COMPUTER INFORMATION NETWORK FEATURING INFORMATION OF INTEREST TO SENIOR CITIZENS, THEIR FAMILIES AND THEIR CAREGIVERS IN THE FIELD OF MENTAL HEALTH CARE, SPECIALIZING IN ALZHEIMER'S CARE; PROVIDING A WEBSITE ON THE GLOBAL COMPUTER INFORMATION NETWORK FEATURING INFORMATION OF INTEREST TO SENIOR CITIZENS, THEIR FAMILIES AND THEIR CAREGIVERS IN THE FIELD OF CANCER CARE AND GERIATRIC HEALTH CARE MANAGEMENT SERVICES, HOME HEALTH CARE SERVICES, HOSPICE CARE AND MEDICAL SERVICES; PROVIDING A WEBSITE ON THE GLOBAL COMPUTER INFORMATION NETWORK FEATURING INFORMATION OF INTEREST TO SENIOR CITIZENS, THEIR FAMILIES AND THEIR CAREGIVERS IN THE FIELD OF PHARMACEUTICAL ADVICE AND DISPENSING OF PHARMACEUTICALS; PROVIDING A WEBSITE ON THE GLOBAL COMPUTER INFORMATION NETWORK FEATURING INFORMATION OF INTEREST TO SENIOR CITIZENS, THEIR FAMILIES AND THEIR CAREGIVERS IN THE FIELD OF NURSING HOMES AND HOME NURSING AID SERVICES; PROVIDING A WEBSITE ON THE GLOBAL COMPUTER INFORMATION NETWORK FEATURING INFORMATION OF INTEREST TO SENIOR CITIZENS, THEIR FAMILIES AND THEIR CARE GIVERS IN THE FIELD OF RESPITE CARE, NAMELY, SHORT-TERM, TEMPORARY ASSISTANCE TO THOSE WHO ARE CARING FOR FAMILY MEMBERS WHO MIGHT OTHERWISE REQUIRE PERMANENT PLACEMENT IN A FACILITY OUTSIDE OF THE HOME; PROVIDING A WEBSITE ON THE GLOBAL COMPUTER INFORMATION NETWORK FEATURING INFORMATION OF INTEREST TO SENIOR CITIZENS, THEIR FAMILIES AND THEIR CARE GIVERS IN THE FIELD OF MEDICAL EQUIPMENT AND MEDICAL SUPPLIES, NAMELY, RENTAL AND PURCHASE OF MEDICAL EQUIPMENT AND MEDICAL SUPPLIES (U.S. CLS. 100 AND 101).

FIRST USE 6-26-2014; IN COMMERCE 6-26-2014.

**CLASS 35—ADVERTISING AND BUSINESS**

FOR ADVERTISING SERVICES, NAMELY, PROMOTING THE INTERESTS OF SPECIALIZED PROVIDERS OF ELDER CARE GOODS AND SERVICES IN THE FIELDS OF ACCOUNTING, ALZHEIMER'S CARE, ASSISTED LIVING, CANCER CARE, COMPANION CARE, ESTATE PLANNING, ESTATE SALES, FINAL ARRANGEMENTS IN THE NATURE OF FUNERAL, BURIAL AND CREMATION SERVICES, FINANCIAL PLANNING AND MANAGEMENT, GERIATRIC CARE MANAGEMENT, GOVERNMENT INFORMATION SERVICES AND AGENCY LINKS, HOME CUSTODIAL CARE IN THE NATURE OF HOUSE KEEPING AND LAUNDRY SERVICES, HOME-DELIVERED GROCERIES, HOME DELIVERED MEALS, HOME HEALTH CARE, HOSPICE CARE, INSURANCE SERVICES, LEGAL SERVICES, MEDICAL SERVICES, MEDICAL EQUIPMENT, MEDICAL SUPPLIES, MEDICATIONS, NURSING HOME CARE, PLACEMENT SERVICES, REAL ESTATE, RESPITE CARE, TRANSPORTATION, AND TAX SERVICES; PROVIDING A WEBSITE ON THE GLOBAL COMPUTER INFORMATION NETWORK FEATURING INFORMATION OF INTEREST TO SENIOR CITIZENS, THEIR FAMILIES AND THEIR CAREGIVERS IN THE FIELD OF ACCOUNTING; PROVIDING A WEBSITE ON THE GLOBAL COMPUTER INFORMATION NETWORK FEATURING INFORMATION OF INTEREST TO SENIOR CITIZENS, THEIR FAMILIES AND THEIR CAREGIVERS IN THE FIELD OF ESTATE PLANNING AND ESTATE SALES; PROVIDING A WEBSITE ON THE GLOBAL COMPUTER INFORMATION NETWORK FEATURING INFORMATION OF INTEREST TO SENIOR CITIZENS, THEIR FAMILIES AND THEIR CAREGIVERS IN THE FIELD OF TAX SERVICES, NAMELY, TAX ADVISORY SERVICES, TAX PLANNING ADVICE, INFORMATION AND CONSULTANCY AND TAX FILING SERVICES (U.S. CLS. 100, 101 AND 102).

FIRST USE 6-26-2014; IN COMMERCE 6-26-2014.

**CLASS 44—MEDICAL, BEAUTY AND AGRICULTURAL SERVICES**

FOR PROVIDING A WEBSITE ON THE GLOBAL COMPUTER INFORMATION NETWORK FEATURING INFORMATION OF INTEREST TO SENIOR CITIZENS, THEIR FAMILIES AND THEIR CAREGIVERS IN THE FIELD OF MENTAL HEALTH CARE, SPECIALIZING IN ALZHEIMER'S CARE; PROVIDING A WEBSITE ON THE GLOBAL COMPUTER INFORMATION NETWORK FEATURING INFORMATION OF INTEREST TO SENIOR CITIZENS, THEIR FAMILIES AND THEIR CAREGIVERS IN THE FIELD OF CANCER CARE AND GERIATRIC HEALTH CARE MANAGEMENT SERVICES, HOME HEALTH CARE SERVICES, HOSPICE CARE AND MEDICAL SERVICES; PROVIDING A WEBSITE ON THE GLOBAL COMPUTER INFORMATION NETWORK FEATURING INFORMATION OF INTEREST TO SENIOR CITIZENS, THEIR FAMILIES AND THEIR CAREGIVERS IN THE FIELD OF PHARMACEUTICAL ADVICE AND DISPENSING OF PHARMACEUTICALS; PROVIDING A WEBSITE ON THE GLOBAL COMPUTER INFORMATION NETWORK FEATURING INFORMATION OF INTEREST TO SENIOR CITIZENS, THEIR FAMILIES AND THEIR CAREGIVERS IN THE FIELD OF NURSING HOMES AND HOME NURSING AID SERVICES; PROVIDING A WEBSITE ON THE GLOBAL COMPUTER INFORMATION NETWORK FEATURING INFORMATION OF INTEREST TO SENIOR CITIZENS, THEIR FAMILIES AND THEIR CARE GIVERS IN THE FIELD OF RESPITE CARE, NAMELY, SHORT-TERM, TEMPORARY ASSISTANCE TO THOSE WHO ARE CARING FOR FAMILY MEMBERS WHO MIGHT OTHERWISE REQUIRE PERMANENT PLACEMENT IN A FACILITY OUTSIDE OF THE HOME; PROVIDING A WEBSITE ON THE GLOBAL COMPUTER INFORMATION NETWORK FEATURING INFORMATION OF INTEREST TO SENIOR CITIZENS, THEIR FAMILIES AND THEIR CARE GIVERS IN THE FIELD OF MEDICAL EQUIPMENT AND MEDICAL SUPPLIES, NAMELY, RENTAL AND PURCHASE OF MEDICAL EQUIPMENT AND MEDICAL SUPPLIES (U.S. CLS. 100 AND 101).

FIRST USE 6-26-2014; IN COMMERCE 6-26-2014.

4,593,113. ELDER RESOURCE CENTER, LLC, COOPER CITY, FL. SN 85-056,509. PUB. 5-17-2011, FILED 6-7-2010.



THE MARK CONSISTS OF A SMILEY FACE WEARING GLASSES WITHIN A CIRCLE.

4,593,114. SHAFFER, W. BENJAMIN, GALENA, OH. SN 85-057,929. PUB. 11-2-2010, FILED 6-8-2010.

## REGNUM INFINITUM

OWNER OF U.S. REG. NO. 3,842,869.

THE MARK CONSISTS OF THE WORDS "REGNUM INFINITUM".

THE ENGLISH TRANSLATION OF "REGNUM INFINITUM" IN THE MARK IS "KINGDOM WITHOUT END". THIS, HOWEVER, IS NOT THE ONLY VALID INTERPRETATION.

### CLASS 9—ELECTRICAL AND SCIENTIFIC APPARATUS

FOR AUDIO AND VIDEO RECORDINGS FEATURING MUSIC AND ARTISTIC PERFORMANCES; COMPACT DISCS FEATURING MUSIC; DIGITAL MUSIC DOWNLOADABLE FROM THE INTERNET; DOWNLOADABLE MP3 FILES, MP3 RECORDINGS, ON-LINE DISCUSSION BOARDS, WEBCASTS, WEBINARS AND PODCASTS FEATURING MUSIC, AUDIO BOOKS AND NEWS BROADCASTS; EYEWEAR; EYEWEAR CASES; PROTECTIVE COVERS AND CASES FOR CELL PHONES, LAPTOPS AND PORTABLE MEDIA PLAYERS (U.S. CLS. 21, 23, 26, 36 AND 38).

FIRST USE 8-13-2009; IN COMMERCE 9-7-2009.

### CLASS 16—PAPER GOODS AND PRINTED MATTER

FOR ART PRINTS; GENERAL FEATURE MAGAZINES; PHOTOGRAPHIC PRINTS; PHOTOGRAPHS; PICTURE BOOKS; PICTURES; PRINTS (U.S. CLS. 2, 5, 22, 23, 29, 37, 38 AND 50).

FIRST USE 8-13-2009; IN COMMERCE 9-7-2009.

### CLASS 18—LEATHER GOODS

FOR ALL-PURPOSE ATHLETIC BAGS; ALL-PURPOSE CARRYING BAGS; BACKPACKS; BILLFOLDS; BRIEF-CASE-TYPE PORTFOLIOS; BRIEFCASES; CLUTCH BAGS; GYM BAGS; HANDBAGS; LUGGAGE; PURSES; SHOULDER BAGS; TOTE BAGS; TRAVEL BAGS; UMBRELLAS; WALLETS (U.S. CLS. 1, 2, 3, 22 AND 41).

FIRST USE 8-13-2009; IN COMMERCE 9-7-2009.

4,593,118. LONGEVITY BIOTECH, INC., PHILADELPHIA, PA. SN 85-061,282. PUB. 5-10-2011, FILED 6-11-2010.

## HYBRIDTIDE

THE MARK CONSISTS OF STANDARD CHARACTERS WITHOUT CLAIM TO ANY PARTICULAR FONT, STYLE, SIZE, OR COLOR.

### CLASS 1—CHEMICALS

FOR CHEMICAL, BIOCHEMICAL, BIOLOGICAL AND BIOTECHNOLOGICAL KITS AND COMPOSITIONS, NAMELY, KITS CONSISTING PRIMARILY OF POLYPEPTIDES FOR THE APPLICATION OF POLYPEPTIDE CHEMISTRY, POLYPEPTIDE DESIGN, AND POLYPEPTIDE MANIPULATION IN SCIENTIFIC RESEARCH (U.S. CLS. 1, 5, 6, 10, 26 AND 46).

FIRST USE 3-31-2012; IN COMMERCE 3-31-2012.

### CLASS 5—PHARMACEUTICALS

FOR PHARMACEUTICAL PRODUCTS, PREPARATIONS AND SUBSTANCES, NAMELY, POLYPEPTIDES AND PROTEINS FOR THE TREATMENT AND DIAGNOSIS OF CARDIOVASCULAR DISEASE, NEUROLOGICAL DISEASE, ONCOLOGY DISEASE, INFLAMMATORY DISEASE, INFECTIOUS DISEASE, METABOLIC DISEASE (U.S. CLS. 6, 18, 44, 46, 51 AND 52).

FIRST USE 3-31-2012; IN COMMERCE 3-31-2012.

4,593,132. COPIA INTERACTIVE, LLC, NEW YORK, NY. SN 85-109,871. PUB. 4-12-2011, FILED 8-17-2010.

## Learn Better Together

THE MARK CONSISTS OF STANDARD CHARACTERS WITHOUT CLAIM TO ANY PARTICULAR FONT, STYLE, SIZE, OR COLOR.

### CLASS 38—COMMUNICATION

FOR TRANSMISSION OF INSTRUCTIONAL CONTENT, NAMELY, TEXT, IMAGES, VIDEO AND SOUND, THROUGH PORTABLE AND HANDHELD ELECTRONIC DEVICES; COMPUTER SERVICES, NAMELY, PROVIDING ON-LINE FACILITIES FOR REAL TIME INTERACTION WITH OTHER COMPUTER USERS CONCERNING TOPICS OF EDUCATION (U.S. CLS. 100, 101 AND 104).

FIRST USE 6-6-2014; IN COMMERCE 6-6-2014.

### CLASS 42—SCIENTIFIC AND COMPUTER SERVICES

FOR COMPUTER SERVICES, NAMELY, CREATING AN ON-LINE COMMUNITY FOR REGISTERED USERS TO PARTICIPATE IN DISCUSSIONS, GET FEEDBACK FROM THEIR PEERS, FORM VIRTUAL COMMUNITIES, AND ENGAGE IN SOCIAL NETWORKING FEATURING SOCIAL MEDIA AND TOPICS ON EDUCATION AND EDUCATIONAL PUBLICATIONS, NAMELY, BOOKS, MAGAZINES, NEWSPAPERS, PERIODICALS, VIDEO AND MULTIMEDIA PRESENTATIONS; PROVIDING A WEBSITE THAT ENABLES USERS TO COMMENT ON AND TO PARTICIPATE IN DISCUSSIONS ON INSTRUCTIONAL CONTENT (U.S. CLS. 100 AND 101).

FIRST USE 6-6-2014; IN COMMERCE 6-6-2014.

4,593,142. GUARDIAN INDUSTRIES CORP., AUBURN HILLS, MI. SN 85-171,805. PUB. 5-10-2011, FILED 11-8-2010.

## DECOCRISTAL

THE MARK CONSISTS OF STANDARD CHARACTERS WITHOUT CLAIM TO ANY PARTICULAR FONT, STYLE, SIZE, OR COLOR.

### CLASS 19—NON-METALLIC BUILDING MATERIALS

FOR GLASS FOR USE IN THE ARCHITECTURAL FIELD, NAMELY, BUILDING GLASS; GLASS PANELS AND SHEETS FOR COMMERCIAL AND RESIDENTIAL BUILDINGS FOR BUILDING AND CONSTRUCTION PURPOSES; FLAT OR CONTOURED GLASS PANELS AND SHEETS FOR COMMERCIAL AND RESIDENTIAL BUILDINGS AND FOR USE IN PARTITION WALLS FOR BUILDING AND CONSTRUCTION PURPOSES (U.S. CLS. 1, 12, 33 AND 50).

FIRST USE 12-0-2011; IN COMMERCE 12-0-2011.

### CLASS 20—FURNITURE AND ARTICLES NOT OTHERWISE CLASSIFIED

FOR FINISHED OR TEMPERED GLASS FOR USE IN FURNITURE (U.S. CLS. 2, 13, 22, 25, 32 AND 50).

FIRST USE 12-0-2011; IN COMMERCE 12-0-2011.

4,593,143. QUIST-NEWINS, MARY, EDINA, MN. SN 85-171,936. PUB. 4-19-2011, FILED 11-8-2010.

## MONEYWEAVE

THE MARK CONSISTS OF STANDARD CHARACTERS WITHOUT CLAIM TO ANY PARTICULAR FONT, STYLE, SIZE, OR COLOR.

### CLASS 16—PAPER GOODS AND PRINTED MATTER

FOR WRITTEN ARTICLES IN THE FIELD OF FINANCE; NEWSLETTERS IN THE FIELD OF FINANCE (U.S. CLS. 2, 5, 22, 23, 29, 37, 38 AND 50).

FIRST USE 5-1-2014; IN COMMERCE 5-1-2014.

### CLASS 36—INSURANCE AND FINANCIAL

FOR FINANCIAL ADVICE AND CONSULTANCY SERVICES; PROVIDING ON-LINE FINANCIAL CALCULATORS (U.S. CLS. 100, 101 AND 102).

FIRST USE 5-1-2014; IN COMMERCE 5-1-2014.

### CLASS 41—EDUCATION AND ENTERTAINMENT

FOR EDUCATIONAL SERVICES, NAMELY, CONDUCTING SEMINARS IN THE FIELD OF FINANCE AND DISTRIBUTION OF COURSE MATERIAL IN CONNECTION THEREWITH (U.S. CLS. 100, 101 AND 107).

FIRST USE 5-1-2014; IN COMMERCE 5-1-2014.

4,593,144. AURORA ALGAE, INC., HAYWARD, CA. SN 85-172,947. PUB. 7-26-2011, FILED 11-9-2010.

## AURORA ALGAE

THE MARK CONSISTS OF STANDARD CHARACTERS WITHOUT CLAIM TO ANY PARTICULAR FONT, STYLE, SIZE, OR COLOR.

NO CLAIM IS MADE TO THE EXCLUSIVE RIGHT TO USE "ALGAE", APART FROM THE MARK AS SHOWN.

### CLASS 1—CHEMICALS

FOR BIOMASS (NAMELY, A RENEWABLE BIOLOGICAL MATERIAL FROM LIVING OR PREVIOUSLY LIVING ORGANISMS) DERIVED CULTURES OF MICROORGANISMS OTHER THAN FOR MEDICAL AND VETERINARY USE. BIOMASS (NAMELY, A RENEWABLE BIOLOGICAL MATERIAL FROM LIVING OR PREVIOUSLY LIVING ORGANISMS) DERIVED CHEMICALS USED IN THE MANUFACTURE OF PHARMACEUTICALS, NUTRACEUTICALS, DIETARY SUPPLEMENTS AND ADDITIVES (U.S. CLS. 1, 5, 6, 10, 26 AND 46).

FIRST USE 3-30-2011; IN COMMERCE 4-23-2013.

### CLASS 5—PHARMACEUTICALS

FOR DIETARY SUPPLEMENTS; NUTRITIONAL ADDITIVES FOR MEDICAL PURPOSES FOR USE IN DIETARY SUPPLEMENTS FOR HUMAN CONSUMPTION; NUTRITIONAL SUPPLEMENTS; NUTRITIONAL OILS; OMEGA 3 OILS; OMEGA 3 EPA; OMEGA 3 FATTY ACIDS, ALGAL OILS AND PHARMACEUTICAL PREPARATIONS, NAMELY, OMEGA 3 OILS, OMEGA 3 FATTY ACIDS AND OMEGA 3 EPA ADAPTED FOR MEDICAL USE (U.S. CLS. 6, 18, 44, 46, 51 AND 52).

FIRST USE 3-30-2011; IN COMMERCE 4-23-2013.

### CLASS 29—MEATS AND PROCESSED FOODS

FOR EDIBLE OILS; NUTRITIONAL OILS; OMEGA 3 OILS; OMEGA 3 EPA; OMEGA 3 FATTY ACIDS; ALGAL OILS; PROCESSED ALGAE FOR HUMAN CONSUMPTION (U.S. CL. 46).

FIRST USE 3-30-2011; IN COMMERCE 4-23-2013.

4,593,145. AURORA ALGAE, INC., HAYWARD, CA. SN 85-172,998. PUB. 11-15-2011, FILED 11-9-2010.

**Aurora|algae**

NO CLAIM IS MADE TO THE EXCLUSIVE RIGHT TO USE "ALGAE", APART FROM THE MARK AS SHOWN.

THE MARK CONSISTS OF THE INITIAL TERM "AURORA" SEPARATED BY A VERTICAL LINE FROM THE SUBSEQUENT TERM "ALGAE".

**CLASS 1—CHEMICALS**

FOR BIOMASS, NAMELY, A RENEWABLE BIOLOGICAL MATERIAL FROM LIVING OR PREVIOUSLY LIVING ORGANISMS DERIVED CULTURES OF MICROORGANISMS OTHER THAN FOR MEDICAL AND VETERINARY USE. BIOMASS, NAMELY, A RENEWABLE BIOLOGICAL MATERIAL FROM LIVING OR PREVIOUSLY LIVING ORGANISMS DERIVED CHEMICALS USED IN THE MANUFACTURE OF PHARMACEUTICALS, NUTRACEUTICALS, DIETARY SUPPLEMENTS AND ADDITIVES (U.S. CLS. 1, 5, 6, 10, 26 AND 46).

FIRST USE 3-30-2011; IN COMMERCE 4-23-2013.

**CLASS 5—PHARMACEUTICALS**

FOR ALGAE-DERIVED DIETARY SUPPLEMENTS; ALGAE-DERIVED NUTRITIONAL ADDITIVES FOR MEDICAL PURPOSES FOR USE IN DIETARY SUPPLEMENTS FOR HUMAN CONSUMPTION; ALGAE-DERIVED NUTRITIONAL SUPPLEMENTS, NAMELY, NUTRITIONAL OILS, OMEGA 3 OILS, OMEGA 3 EPA, OMEGA 3 FATTY ACIDS, ALGAL OILS, ALGAE-DERIVED PHARMACEUTICAL PREPARATIONS, NAMELY, OMEGA 3 OILS, OMEGA 3 FATTY ACIDS AND OMEGA 3 EPA ADAPTED FOR MEDICAL USE (U.S. CLS. 6, 18, 44, 46, 51 AND 52).

FIRST USE 3-30-2011; IN COMMERCE 4-23-2013.

**CLASS 29—MEATS AND PROCESSED FOODS**

FOR EDIBLE OILS; NUTRITIONAL OILS; OMEGA 3 OILS; OMEGA 3 EPA; OMEGA 3 FATTY ACIDS; ALGAL OILS; PROCESSED ALGAE FOR HUMAN CONSUMPTION (U.S. CL. 46).

FIRST USE 3-30-2011; IN COMMERCE 4-23-2013.

4,593,157. STOCKPILE, INC., PALO ALTO, CA. SN 85-189,708. PUB. 5-3-2011, FILED 12-2-2010.

# STOCKPILE

THE MARK CONSISTS OF STANDARD CHARACTERS WITHOUT CLAIM TO ANY PARTICULAR FONT, STYLE, SIZE, OR COLOR.

**CLASS 35—ADVERTISING AND BUSINESS**

FOR PROMOTIONAL SERVICES, NAMELY, PROMOTING THE GOODS AND SERVICES OF OTHERS BY MEANS OF PROVIDING STOCKS, SECURITIES AND EQUITIES; ADMINISTRATION OF CUSTOMER LOYALTY AND REWARDS PROGRAMS TO PROMOTE GOODS AND SERVICES OF OTHERS; ADMINISTERING COUPONS, REBATES AND VOUCHERS PROMOTING THE GOODS AND SERVICES OF OTHERS; ADVERTISING SERVICES FOR PROMOTING THE BROKERAGE OF STOCKS, SECURITIES AND EQUITIES; RECORDING AND REGISTERING THE TRANSFER OF STOCKS, SECURITIES AND EQUITIES; COMPILING FINANCIAL, SECURITIES, STOCK EXCHANGE, TRADE AND QUOTE, AND OTHER FINANCIAL MARKET INFORMATION FOR BUSINESS PURPOSES; ISSUANCE AND MANAGEMENT OF GIFT CARDS AND GIFT CERTIFICATES EXCHANGEABLE FOR AND BACKED BY STOCKS, SECURITIES AND EQUITIES (U.S. CLS. 100, 101 AND 102).

FIRST USE 6-19-2014; IN COMMERCE 6-25-2014.

**CLASS 36—INSURANCE AND FINANCIAL**

FOR BROKERAGE SERVICES FOR STOCKS, SECURITIES AND EQUITIES; FINANCIAL SERVICES, NAMELY, ASSISTING OTHERS WITH THE COMPLETION OF FINANCIAL TRANSACTIONS FOR STOCKS, SECURITIES AND EQUITIES; PROVIDING INFORMATION IN THE FIELD OF FINANCIAL STOCK AND EQUITY MARKETS (U.S. CLS. 100, 101 AND 102).

FIRST USE 6-19-2014; IN COMMERCE 6-19-2014.

4,593,160. STREETLINKS LLC, KANSAS CITY, MO. SN 85-195,183. PUB. 4-26-2011, FILED 12-10-2010.

# I V M

THE MARK CONSISTS OF STANDARD CHARACTERS WITHOUT CLAIM TO ANY PARTICULAR FONT, STYLE, SIZE, OR COLOR.

**CLASS 9—ELECTRICAL AND SCIENTIFIC APPARATUS**

FOR COMPUTER SOFTWARE PROGRAM FOR VERIFICATION OF RESIDENTIAL REAL ESTATE APPRAISALS (U.S. CLS. 21, 23, 26, 36 AND 38).

FIRST USE 6-17-2014; IN COMMERCE 6-17-2014.

**CLASS 36—INSURANCE AND FINANCIAL**

FOR APPRAISAL SERVICES, NAMELY, PROVIDING A SECOND OPINION FOR REAL ESTATE APPRAISALS AND VERIFICATION OF REAL ESTATE APPRAISALS; REAL ESTATE VALUATION SERVICES (U.S. CLS. 100, 101 AND 102).

FIRST USE 6-17-2014; IN COMMERCE 6-17-2014.

4,593,180. THE RONALD REAGAN PRESIDENTIAL LIBRARY FOUNDATION, SIMI VALLEY, CA. SN 85-233,487. PUB. 3-12-2013, FILED 2-3-2011.

# GUIDECAM

THE MARK CONSISTS OF STANDARD CHARACTERS WITHOUT CLAIM TO ANY PARTICULAR FONT, STYLE, SIZE, OR COLOR.

SEC. 2(F).

**CLASS 9—ELECTRICAL AND SCIENTIFIC APPARATUS**

FOR WIRELESS DEVICES FEATURING SOFTWARE FOR FACILITATION OF TOURS OF MUSEUMS; INTERACTIVE WIRELESS DEVICES FOR CAPTURING AND UPLOADING DIGITAL IMAGES FOR FUTURE USE (U.S. CLS. 21, 23, 26, 36 AND 38).

FIRST USE 5-1-2013; IN COMMERCE 5-1-2013.

**CLASS 39—TRANSPORTATION AND STORAGE**

FOR PROVIDING SELF-GUIDED TOUR SERVICES VIA WIRELESS DEVICES FEATURING PRERECORDED INFORMATION ABOUT MUSEUM EXHIBITS (U.S. CLS. 100 AND 105).

FIRST USE 2-7-2011; IN COMMERCE 2-7-2011.

4,593,185. BAND JAM IT, LLC, WILMINGTON, DE. SN 85-274,049. PUB. 1-22-2013, FILED 3-22-2011.

# Band Jam It

THE MARK CONSISTS OF STANDARD CHARACTERS WITHOUT CLAIM TO ANY PARTICULAR FONT, STYLE, SIZE, OR COLOR.

NO CLAIM IS MADE TO THE EXCLUSIVE RIGHT TO USE "BAND", APART FROM THE MARK AS SHOWN.

**CLASS 38—COMMUNICATION**

FOR PROVIDING AN ON-LINE FORUM FOR MUSIC; PROVIDING ON-LINE CHAT ROOMS AND ELECTRONIC BULLETIN BOARDS FOR TRANSMISSION OF MESSAGES AMONG USERS IN THE FIELD OF MUSIC (U.S. CLS. 100, 101 AND 104).

FIRST USE 10-1-2011; IN COMMERCE 10-1-2011.

**CLASS 41—EDUCATION AND ENTERTAINMENT**

FOR PROVIDING A WEBSITE FEATURING MUSIC INFORMATION (U.S. CLS. 100, 101 AND 107).

FIRST USE 10-1-2011; IN COMMERCE 10-1-2011.

**CLASS 42—SCIENTIFIC AND COMPUTER SERVICES**

FOR PROVIDING A WEB SITE FEATURING TECHNOLOGY THAT ENABLES USERS TO SHARE, BOOKMARK, INDEX, STORE, COLLECT AND SHOWCASE CONTENT IN ELECTRONIC FORM IN THE NATURE AND FIELD OF MUSIC; PROVIDING A WEB SITE FEATURING TEMPORARY USE OF NON-DOWNLOADABLE SOFTWARE ALLOWING WEB SITE USERS TO UPLOAD, POST AND DISPLAY ONLINE VIDEOS FOR SHARING WITH OTHERS FOR ENTERTAINMENT PURPOSES; PROVIDING A WEB SITE FEATURING TEMPORARY USE OF NONDOWNLOADABLE SOFTWARE FOR COLLECTING AND DISPLAYING USER'S MUSIC VIDEOS AS WELL AS AUDIO, PHOTOGRAPHIC AND PROSE PRESENTATIONS (U.S. CLS. 100 AND 101).

FIRST USE 10-1-2011; IN COMMERCE 10-1-2011.

4,593,186. SERVICE EXCHANGE SOLUTIONS ENTERPRISE, INC., MISSISSAUGA, ONTARIO, CANADA. SN 85-276,717. PUB. 8-7-2012, FILED 3-25-2011.

# Counselor Exchange

THE MARK CONSISTS OF STANDARD CHARACTERS

WITHOUT CLAIM TO ANY PARTICULAR FONT, STYLE, SIZE, OR COLOR.

NO CLAIM IS MADE TO THE EXCLUSIVE RIGHT TO USE "COUNSELOR", APART FROM THE MARK AS SHOWN.

**CLASS 9—ELECTRICAL AND SCIENTIFIC APPARATUS**

FOR DOWNLOADABLE ELECTRONIC PUBLICATIONS, NAMELY, ARTICLES, NEWSLETTERS, JOURNALS, MAGAZINES AND NEWSPAPERS IN THE FIELDS OF PSYCHOLOGY, SOCIAL WORK, AND HEALTHCARE; COMPUTER SOFTWARE APPLICATION FOR VIDEO CONFERENCING, ON-LINE COUNSELING AND DATA MANAGEMENT THAT ENABLES BUSINESSES, ASSOCIATIONS, UNIVERSITIES AND INSTITUTIONAL USERS TO OFFER THE SERVICES OF SOCIAL WORKERS, PSYCHOLOGISTS, AND OTHER LICENSED MENTAL HEALTH AND EMOTIONAL HEALTH PROFESSIONALS TO EMPLOYEES, STUDENTS AND MEMBERS (U.S. CLS. 21, 23, 26, 36 AND 38).

FIRST USE 11-15-2013; IN COMMERCE 11-15-2013.

**CLASS 35—ADVERTISING AND BUSINESS**

FOR ON-LINE ADVERTISING SERVICES FOR SOCIAL WORKERS, PSYCHOLOGISTS, AND OTHER LICENSED MENTAL HEALTH AND EMOTIONAL HEALTH PROFESSIONALS (U.S. CLS. 100, 101 AND 102).

FIRST USE 11-15-2013; IN COMMERCE 11-15-2013.

**CLASS 36—INSURANCE AND FINANCIAL**

FOR COLLECTING PAYMENT FEES AND PROCESSING SALES TAX AND VALUE ADDED TAX PAYMENTS ON BEHALF OF OTHERS (U.S. CLS. 100, 101 AND 102).

FIRST USE 11-15-2013; IN COMMERCE 11-15-2013.

**CLASS 41—EDUCATION AND ENTERTAINMENT**

FOR EDUCATIONAL SERVICES IN THE FIELDS OF PSYCHOLOGY, SOCIAL WORK, AND HEALTHCARE, NAMELY, TRAINING IN THE FIELDS OF PSYCHOLOGY, SOCIAL WORK, AND HEALTHCARE, THE PRESENTATION OF PANEL DISCUSSIONS IN THE FIELDS OF PSYCHOLOGY, SOCIAL WORK, AND HEALTHCARE; PROVIDING ONLINE JOURNALS, NAMELY, BLOGS IN THE FIELDS OF PSYCHOLOGY, SOCIAL WORK, AND HEALTHCARE, PROVIDING LIVE ONLINE SEMINARS IN THE NATURE OF WEBINARS IN THE FIELDS OF PSYCHOLOGY, SOCIAL WORK, AND HEALTHCARE; PROVIDING ON-LINE PUBLICATIONS, NAMELY, ARTICLES, NEWSLETTERS, JOURNALS, MAGAZINES AND NEWSPAPERS IN THE FIELDS OF PSYCHOLOGY, SOCIAL WORK, AND HEALTHCARE; MEMBERSHIP CLUB SERVICES, NAMELY, PROVIDING TRAINING TO MEMBERS IN THE FIELD OF PROFESSIONAL DEVELOPMENT (U.S. CLS. 100, 101 AND 107).

FIRST USE 11-15-2013; IN COMMERCE 11-15-2013.

**CLASS 42—SCIENTIFIC AND COMPUTER SERVICES**

FOR PROVIDING AN INTERACTIVE WEBSITE FEATURING TECHNOLOGY THAT ENABLES SOCIAL WORKERS, PSYCHOLOGISTS, AND OTHER LICENSED MENTAL HEALTH AND EMOTIONAL HEALTH PROFESSIONALS TO ENTER, ACCESS, TRACK, MANAGE, MONITOR, STORE, AND GENERATE INFORMATION AND REPORTS; PROVIDING TEMPORARY USE OF ON-LINE NON-DOWNLOADABLE SERVICES FOR ON-LINE BOOKING OF MEETINGS AND APPOINTMENTS; PROVIDING TEMPORARY USE OF AN ON-LINE, NON-DOWNLOADABLE SOFTWARE APPLICATION FOR VIDEO CONFERENCING, ON-LINE COUNSELING AND DATA MANAGEMENT THAT ENABLES BUSINESSES, ASSOCIATIONS, UNIVERSITIES AND INSTITUTIONAL USERS TO OFFER THE SERVICES OF SOCIAL WORKERS, PSYCHOLOGISTS, AND OTHER LICENSED MENTAL HEALTH AND EMOTIONAL HEALTH PROFESSIONALS TO EMPLOYEES, STUDENTS AND MEMBERS (U.S. CLS. 100 AND 101).

FIRST USE 11-15-2013; IN COMMERCE 11-15-2013.

**CLASS 45—PERSONAL AND LEGAL SERVICES**

FOR ONLINE SOCIAL NETWORKING SERVICES IN THE FIELDS OF PSYCHOLOGY, SOCIAL WORK, AND HEALTHCARE PROVIDED VIA A WEBSITE (U.S. CLS. 100 AND 101).

FIRST USE 11-15-2013; IN COMMERCE 11-15-2013.

4,593,203. HEALTHFIRST, INC., NEW YORK, NY. SN 85-338,722. PUB. 5-15-2012, FILED 6-6-2011.



THE COLOR(S) GREEN AND BLACK IS/ARE CLAIMED AS A FEATURE OF THE MARK.

THE MARK CONSISTS OF THE STYLIZED BLACK WORDING "HF", WITH A GREEN LEAF DESIGN APPEARING ABOVE THE LETTER "H".

**CLASS 35—ADVERTISING AND BUSINESS**

FOR CONSULTING SERVICES RELATED TO CONSUMER INFORMATION REGARDING HEALTH CARE PLAN OPTIONS, PRODUCTS AND PROGRAMS IN THE FIELD OF MANAGED CARE AND STATE AND FEDERAL MEDICAL CARE PROGRAMS; COST MANAGEMENT FOR THE HEALTH BENEFIT PLANS OF OTHERS (U.S. CLS. 100, 101 AND 102).

FIRST USE 3-30-2012; IN COMMERCE 3-30-2012.

**CLASS 36—INSURANCE AND FINANCIAL**

FOR ADMINISTRATION OF PRE-PAID HEALTH CARE PLANS; ORGANIZING PRE-PAID HEALTH CARE PLANS; HEALTH INSURANCE UNDERWRITING; HEALTH INSURANCE ADMINISTRATION (U.S. CLS. 100, 101 AND 102).

FIRST USE 3-30-2012; IN COMMERCE 3-30-2012.

**CLASS 44—MEDICAL, BEAUTY AND AGRICULTURAL SERVICES**

FOR MANAGED HEALTH CARE SERVICES; HEALTH CARE SERVICES (U.S. CLS. 100 AND 101).

FIRST USE 3-30-2012; IN COMMERCE 3-30-2012.

4,593,207. RB DISTRIBUTION, INC., COLMAR, PA. SN 85-343,649. PUB. 4-9-2013, FILED 6-10-2011.

**OE SOLUTIONS**

THE MARK CONSISTS OF STANDARD CHARACTERS WITHOUT CLAIM TO ANY PARTICULAR FONT, STYLE, SIZE, OR COLOR.

NO CLAIM IS MADE TO THE EXCLUSIVE RIGHT TO USE "OE", APART FROM THE MARK AS SHOWN.

**CLASS 7—MACHINERY**

FOR LAND VEHICLE ENGINE PARTS AND EQUIPMENT, NAMELY, AIR FILTER BOXES, CAMSHAFT SYNCHRONIZERS, EXHAUST MANIFOLDS, ELECTRONIC FAN CLUTCH, FAN PULLEY BRACKETS, HARMONIC BALANCERS FOR CRANKSHAFTS TO REDUCE RESONANCE, IGNITION DISTRIBUTORS, INTAKE MANIFOLDS, OIL COOLER LINES, OIL PANS, OIL COOLER CONNECTORS, NAMELY, LINES, HOSES AND FITTINGS, RADIATOR COOLING SYSTEM CONNECTORS, NAMELY, LINES, HOSES AND FITTINGS, RADIATOR FAN ASSEMBLIES, SMOG PUMP PULLIES, TIMING BELT COVERS, WINDOW LIFT MOTORS, WINDOW WIPER MOTORS (U.S. CLS. 13, 19, 21, 23, 31, 34 AND 35).

FIRST USE 2-7-2014; IN COMMERCE 2-7-2014.

**CLASS 12—VEHICLES**

FOR LAND VEHICLE PARTS AND EQUIPMENT, NAMELY, AIR DOOR ACTUATORS, BRAKE CALIPER ASSEMBLIES, CLOCK SPRING CONNECTORS FOR AIR BAG UNITS, CONTROL ARMS FOR STEERING AND SUSPENSION SYSTEMS, CV JOINT BOOTS, DOOR LOCK ACTUATORS, FLUID RESERVOIRS, FOUR WHEEL DRIVE COMPONENTS, NAMELY, ACTUATORS AND TRANSFER CASE MOTORS, FUEL LINES, FUEL SENDING UNITS, NAMELY, FOR MEASURING FUEL IN FUEL TANKS, FUEL TANKS, HYDRAULIC CLUTCH LINES, LATCHES FOR WINDOWS, HOODS AND FUEL TANKS, POWER STEERING PULLEYS, FUEL LINE REPAIR KITS COMPRISED PRIMARILY OF FUEL LINES AND HOSES AND CONNECTORS AND FITTINGS THEREFOR, TRANSMISSION LINE CONNECTORS, NAMELY, LINES, HOSES AND FITTINGS, FUEL LINE CONNECTORS AND RETAINERS, NAMELY, LINES, HOSES AND FITTINGS, REAR AXLE SHAFTS, SIDE VIEW MIRROR ASSEMBLIES, TRANSMISSION LINE ASSEMBLIES IN THE NATURE OF CONNECTORS, FITTINGS, INLETS AND OUTLETS, TRANSMISSION SHIFT SOLENOID PACKS FOR SHIFTING OIL FLOW TO APPROPRIATE COMPONENTS; WINDOW REGULATORS, WINDOW WIPER TRANSMISSION LINKAGES IN THE NATURE OF LINKAGES BETWEEN THE WIPER MOTOR AND WIPER ARMS (U.S. CLS. 19, 21, 23, 31, 35 AND 44).

FIRST USE 2-7-2014; IN COMMERCE 2-7-2014.

4,593,212. NILES STEEL TANK COMPANY, NILES, MI. SN 85-353,953. PUB. 5-1-2012, FILED 6-23-2011.

4,593,225. P&L INDUSTRIES, INC., COTTONWOOD, AZ. SN 85-390,743. PUB. 2-12-2013, FILED 8-5-2011.

## TANK DEFENDER

THE MARK CONSISTS OF STANDARD CHARACTERS WITHOUT CLAIM TO ANY PARTICULAR FONT, STYLE, SIZE, OR COLOR.

NO CLAIM IS MADE TO THE EXCLUSIVE RIGHT TO USE "TANK", APART FROM THE MARK AS SHOWN.

### CLASS 6—METAL GOODS

FOR METAL STORAGE TANKS (U.S. CLS. 2, 12, 13, 14, 23, 25 AND 50).  
FIRST USE 3-0-2014; IN COMMERCE 3-0-2014.

### CLASS 11—ENVIRONMENTAL CONTROL APPARATUS

FOR HOT WATER TANKS; FITTED LINERS FOR HOT WATER TANKS; HOT WATER HEATERS (U.S. CLS. 13, 21, 23, 31 AND 34).

FIRST USE 3-0-2014; IN COMMERCE 3-0-2014.

4,593,220. TRASCHER, KENNETH G., MONROE, LA. SN 85-377,625. PUB. 5-29-2012, FILED 7-21-2011.

## IFB

THE MARK CONSISTS OF STANDARD CHARACTERS WITHOUT CLAIM TO ANY PARTICULAR FONT, STYLE, SIZE, OR COLOR.

### CLASS 6—METAL GOODS

FOR SYSTEM FOR THE ERECTION OF A BUILDING MADE PRIMARILY OF METAL FROM PREASSEMBLED COMPONENTS TRANSPORTED TO THE BUILDING SITE IN A SHIPPING CONTAINER, COMPRISED PRIMARILY OF MODULAR METALLIC BUILDING MATERIALS, NAMELY, BUILDING WALL FRAMING MADE PRIMARILY FROM METAL, REINFORCING MATERIALS OF METAL FOR BUILDING PURPOSES, COMPOSITE PANELS COMPOSED PRIMARILY OF METAL, METAL ROOF TRUSSES, METAL ROOFING PANELS AND METAL CLADDING FOR CONSTRUCTION AND BUILDING (U.S. CLS. 2, 12, 13, 14, 23, 25 AND 50).  
FIRST USE 1-12-2013; IN COMMERCE 1-12-2013.

### CLASS 37—CONSTRUCTION AND REPAIR

FOR BUILDING CONSTRUCTION SERVICES (U.S. CLS. 100, 103 AND 106).  
FIRST USE 8-9-2012; IN COMMERCE 8-9-2012.

## LASERLYTE

THE MARK CONSISTS OF STANDARD CHARACTERS WITHOUT CLAIM TO ANY PARTICULAR FONT, STYLE, SIZE, OR COLOR.

OWNER OF U.S. REG. NO. 3,306,495.  
SEC. 2(F).

### CLASS 8—HAND TOOLS

FOR BAYONETS (U.S. CLS. 23, 28 AND 44).  
FIRST USE 1-0-2009; IN COMMERCE 1-0-2009.

### CLASS 9—ELECTRICAL AND SCIENTIFIC APPARATUS

FOR OPTICAL OR TELESCOPIC SIGHTS MOUNTABLE TO A WEAPON THAT INCORPORATE A LASER USED TO AIM THE WEAPON, ALIGN THE WEAPON OR ALIGN A SCOPE MOUNTED TO THE WEAPON; LASER POINTERS; BATTERIES; PROTECTIVE CASES SPECIALLY ADAPTED FOR OPTICAL OR TELESCOPIC SIGHTS; LASER CARTRIDGES FOR GUNS, NAMELY, LASER CARTRIDGES THAT ARE RECEIVED IN THE BARREL OF A GUN AND ACTIVATE WHEN THE FIRING PIN OF THE GUN IS ACTIVATED; ON-OFF SWITCHES FOR OPTICAL OR TELESCOPIC SIGHTS MOUNTED TO A WEAPON; GUN ALIGNMENT SIGHTS, NAMELY, SIGHTERS TO ALIGN THE BORE OF A GUN WITH A SIGHTING DEVICE; LASER TARGETING DEVICES FOR WEAPONS, NAMELY, TARGETS THAT REGISTER STRIKES FROM LASER LIGHT (U.S. CLS. 21, 23, 26, 36 AND 38).  
FIRST USE 5-0-2001; IN COMMERCE 5-0-2001.

### CLASS 13—FIREARMS

FOR FIREARM SIGHTS, NAMELY, BORE SIGHTERS; FIREARM ATTACHMENTS, NAMELY, MOUNTS FOR ATTACHING LASER SIGHTING DEVICES TO A FIREARM; ADAPTERS TO FIT SIGHTING DEVICES TO GUNS (U.S. CLS. 2 AND 9).

FIRST USE 5-0-2001; IN COMMERCE 5-0-2001.

### CLASS 25—CLOTHING

FOR CLOTHING AND APPAREL, NAMELY, T-SHIRTS AND BASEBALL CAPS (U.S. CLS. 22 AND 39).  
FIRST USE 5-0-2001; IN COMMERCE 5-0-2001.

4,593,232. AMERICAN SPORTFISHING ASSOCIATION, ALEXANDRIA, VA. SN 85-428,047. PUB. 10-23-2012, FILED 9-21-2011.

## FISHSMART

THE MARK CONSISTS OF STANDARD CHARACTERS WITHOUT CLAIM TO ANY PARTICULAR FONT, STYLE, SIZE, OR COLOR.



**CLASS 16—PAPER GOODS AND PRINTED MATTER**

FOR NEWSLETTERS, MAGAZINES, LEAFLETS, BROCHURES, AND HAND-OUTS; PRINTED INSTRUCTIONAL MATERIALS ON FISHING TECHNIQUES TO MINIMIZE FISH MORTALITY; THE FOREGOING NOT SPECIFICALLY REGARDING FISHING LURES (U.S. CLS. 2, 5, 22, 23, 29, 37, 38 AND 50).

FIRST USE 3-27-2012; IN COMMERCE 3-27-2012.

**CLASS 25—CLOTHING**

FOR CLOTHING, NAMELY, HEADWEAR, FISHING VESTS, JACKETS, SWEATERS, SWEAT-SHIRTS, T-SHIRTS, SHIRTS (U.S. CLS. 22 AND 39).

FIRST USE 6-12-2014; IN COMMERCE 6-12-2014.

**CLASS 35—ADVERTISING AND BUSINESS**

FOR ASSOCIATION SERVICES, NAMELY, PROMOTING THE INTERESTS OF FISHERMAN AND THOSE IN THE FISHING INDUSTRY; PROMOTING PUBLIC AWARENESS FISHING AND MINIMIZING FISH MORTALITY (U.S. CLS. 100, 101 AND 102).

FIRST USE 7-12-2012; IN COMMERCE 7-12-2012.

**CLASS 41—EDUCATION AND ENTERTAINMENT**

FOR ELECTRONIC NEWSLETTERS AND ONLINE INFORMATIONAL DATABASES IN THE FIELD OF FISHING; PROVIDING INSTRUCTIONS ON FISHING EQUIPMENT USE; THE FOREGOING NOT SPECIFICALLY REGARDING FISHING LURES (U.S. CLS. 100, 101 AND 107).

FIRST USE 3-29-2011; IN COMMERCE 3-29-2011.

4,593,237. POINTSERVE, INC., DBA MOBI, AUSTIN, TX. SN 85-446,029. PUB. 4-2-2013, FILED 10-12-2011.

# MOBI.INSIGHT

THE MARK CONSISTS OF STANDARD CHARACTERS WITHOUT CLAIM TO ANY PARTICULAR FONT, STYLE, SIZE, OR COLOR.

**CLASS 9—ELECTRICAL AND SCIENTIFIC APPARATUS**

FOR SOFTWARE APPLICATIONS, NAMELY, SOFTWARE APPLICATIONS FOR PRESENTING AND ANALYZING COST AND PERFORMANCE TRENDS BASED ON GPS DATA AND OPERATIONAL BUSINESS METRICS (U.S. CLS. 21, 23, 26, 36 AND 38).

FIRST USE 9-28-2011; IN COMMERCE 9-28-2011.

**CLASS 42—SCIENTIFIC AND COMPUTER SERVICES**

FOR NON-DOWNLOADABLE PROPRIETARY SOFTWARE ACCESSED VIA A NETWORK TO PRESENT AND ANALYZE COST AND PERFORMANCE TRENDS BASED ON GPS DATA AND OPERATIONAL BUSINESS METRICS (U.S. CLS. 100 AND 101).

FIRST USE 9-28-2011; IN COMMERCE 9-28-2011.

4,593,236. POINTSERVE, INC., DBA MOBI, AUSTIN, TX. SN 85-446,027. PUB. 4-2-2013, FILED 10-12-2011.

# MOBI.DISPATCH

THE MARK CONSISTS OF STANDARD CHARACTERS WITHOUT CLAIM TO ANY PARTICULAR FONT, STYLE, SIZE, OR COLOR.

**CLASS 9—ELECTRICAL AND SCIENTIFIC APPARATUS**

FOR SOFTWARE APPLICATIONS, NAMELY, SOFTWARE APPLICATIONS FOR GUIDING SERVICE PLANNERS THROUGH SAME-DAY SCHEDULE CHANGES, NEW ORDERS AND ROUTE RE-ASSIGNMENTS (U.S. CLS. 21, 23, 26, 36 AND 38).

FIRST USE 9-28-2011; IN COMMERCE 9-28-2011.

**CLASS 42—SCIENTIFIC AND COMPUTER SERVICES**

FOR NON-DOWNLOADABLE PROPRIETARY SOFTWARE ACCESSED VIA A NETWORK TO GUIDE SERVICE PLANNERS THROUGH SAME-DAY SCHEDULE CHANGES, NEW ORDERS AND ROUTE RE-ASSIGNMENTS (U.S. CLS. 100 AND 101).

FIRST USE 9-28-2011; IN COMMERCE 9-28-2011.

4,593,238. WORKSHOP XI, INC., SAN RAFAEL, CA. SN 85-447,915. PUB. 4-24-2012, FILED 10-14-2011.

# ACRE

THE MARK CONSISTS OF STANDARD CHARACTERS WITHOUT CLAIM TO ANY PARTICULAR FONT, STYLE, SIZE, OR COLOR.

**CLASS 18—LEATHER GOODS**

FOR ALL PURPOSE SPORT BAGS; ALL-PURPOSE ATHLETIC BAGS; ALL-PURPOSE CARRYING BAGS; ALL-PURPOSE REUSABLE CARRYING BAGS; ATHLETIC BAGS; BACKPACKS; BACKPACKS, BOOK BAGS, SPORTS BAGS, BUM BAGS, WALLETS AND HANDBAGS; BAGS AND HOLDALLS FOR SPORTS CLOTHING; BEACH BAGS; DUFFEL BAGS; GYM BAGS; MESSENGER BAGS; SHOULDER BAGS; SPORT BAGS; WAIST BAGS (U.S. CLS. 1, 2, 3, 22 AND 41).

FIRST USE 8-27-2013; IN COMMERCE 8-27-2013.

**CLASS 28—TOYS AND SPORTING GOODS**

FOR BAGS ESPECIALLY DESIGNED FOR BIKING EQUIPMENT (U.S. CLS. 22, 23, 38 AND 50).

FIRST USE 8-27-2013; IN COMMERCE 8-27-2013.

4,593,241. EXTRAVAGANCE MUSIC MANAGEMENT LIMITED, HERTFORDSHIRE HP4 1TD, UNITED KINGDOM. SN 85-459,106. PUB. 11-6-2012, FILED 10-28-2011.



THE MARK CONSISTS OF A MASK DESIGN PLACED OVER THE WORD "DÉHASSE".

THE WORDING "DÉHASSE" HAS NO MEANING IN A FOREIGN LANGUAGE.

#### CLASS 9—ELECTRICAL AND SCIENTIFIC APPARATUS

FOR SOUND AND VISUAL RECORDINGS FEATURING MUSIC; SOUND AND VISUAL RECORDINGS FEATURING MUSIC PROVIDED BY DOWNLOADING AND STREAMING VIA COMMUNICATIONS NETWORKS (U.S. CLS. 21, 23, 26, 36 AND 38).

FIRST USE 1-0-2011; IN COMMERCE 1-0-2011.

#### CLASS 41—EDUCATION AND ENTERTAINMENT

FOR ENTERTAINMENT, NAMELY, LIVE MUSIC CONCERTS; PRESENTATION OF LIVE SHOW PERFORMANCES AND LIVE PERFORMANCES BY MUSIC GROUPS; ORGANISATION AND PRODUCTION OF LIVE MUSIC SHOWS AND TELEVISION SHOWS; ENTERTAINMENT SERVICES, NAMELY, PERFORMING OF MUSIC; ENTERTAINMENT IN THE NATURE OF AUDIO VISUAL PERFORMANCES (U.S. CLS. 100, 101 AND 107).

FIRST USE 1-0-2011; IN COMMERCE 1-0-2011.

4,593,242. V-DAY CORPORATION, NEW YORK, NY. SN 85-459,321. PUB. 6-11-2013, FILED 10-28-2011.

# V-GIRLS

THE MARK CONSISTS OF STANDARD CHARACTERS WITHOUT CLAIM TO ANY PARTICULAR FONT, STYLE, SIZE, OR COLOR.

OWNER OF U.S. REG. NOS. 3,922,736 AND 4,080,857.

#### CLASS 14—JEWELRY

FOR RUBBER OR SILICON WRISTBANDS IN THE NATURE OF A BRACELET (U.S. CLS. 2, 27, 28 AND 50).

FIRST USE 6-30-2012; IN COMMERCE 6-30-2012.

#### CLASS 26—FANCY GOODS

FOR ORNAMENTAL NOVELTY PINS AND BUTTONS (U.S. CLS. 37, 39, 40, 42 AND 50).

FIRST USE 10-31-2012; IN COMMERCE 10-31-2012.

4,593,243. GOOGLE INC., MOUNTAIN VIEW, CA. SN 85-461,965. PUB. 6-5-2012, FILED 11-1-2011.



PRIORITY CLAIMED UNDER SEC. 44(D) ON JAMAICA APPLICATION NO. 58662, FILED 8-15-2011.

THE MARK CONSISTS OF SILHOUETTE OF HOUSE WITH ARCH FOR FRONT DOOR.

#### CLASS 9—ELECTRICAL AND SCIENTIFIC APPARATUS

FOR THERMOSTATS; CLIMATE CONTROL SYSTEM CONSISTING OF A DIGITAL THERMOSTAT THAT CAN BE CONTROLLED WIRELESSLY FROM A REMOTE LOCATION; SOFTWARE APPLICATION FOR USE ON COMPUTERS AND HAND-HELD DEVICES TO CONTROL CLIMATE AND ENERGY USAGE IN HOMES AND BUSINESSES FROM A REMOTE LOCATION (U.S. CLS. 21, 23, 26, 36 AND 38).

FIRST USE 10-25-2011; IN COMMERCE 10-25-2011.

#### CLASS 35—ADVERTISING AND BUSINESS

FOR PROMOTIONAL SERVICES, NAMELY, CREATING ADVERTISING MESSAGES AND CREATING PROMOTIONAL INCENTIVES FOR ENERGY USERS TO REDUCE THEIR ENERGY USE (U.S. CLS. 100, 101 AND 102).

FIRST USE 10-25-2011; IN COMMERCE 10-25-2011.

#### CLASS 38—COMMUNICATION

FOR ELECTRONIC TRANSMISSION OF MESSAGES (U.S. CLS. 100, 101 AND 104).

FIRST USE 2-11-2014; IN COMMERCE 2-11-2014.

4,593,245. MY WEBOLUTION LLC, DUNN LORING, VA. SN 85-470,189. PUB. 11-12-2013, FILED 11-11-2011.

# WEBREEL

THE MARK CONSISTS OF STANDARD CHARACTERS WITHOUT CLAIM TO ANY PARTICULAR FONT, STYLE,

SIZE, OR COLOR.

**CLASS 42—SCIENTIFIC AND COMPUTER SERVICES**

FOR SOCIAL MEDIA SERVICES, NAMELY, SOCIAL BOOKMARKING WEBSITE SERVICES IN THE NATURE OF PROVIDING A WEBSITE FEATURING TECHNOLOGY THAT ENABLES USERS TO ORGANIZE, STORE, MANAGE, SHARE AND SEARCH FOR BOOKMARKS OF RESOURCES; ONLINE COMMUNITY SERVICES, NAMELY, CREATING AN ONLINE COMMUNITY FOR REGISTERED USERS TO PARTICIPATE IN DISCUSSIONS, GET FEEDBACK FROM THEIR PEERS, SHARE BOOKMARKS, FORM VIRTUAL COMMUNITIES, AND ENGAGE IN SOCIAL NETWORKING (U.S. CLS. 100 AND 101).

FIRST USE 7-0-2013; IN COMMERCE 4-23-2014.

**CLASS 45—PERSONAL AND LEGAL SERVICES**

FOR ONLINE SOCIAL NETWORKING SERVICES (U.S. CLS. 100 AND 101).

FIRST USE 7-0-2013; IN COMMERCE 4-23-2014.

4,593,249. CERNER INNOVATION, INC., KANSAS CITY, KS. SN 85-476,792. PUB. 9-18-2012, FILED 11-18-2011.



OWNER OF U.S. REG. NOS. 1,458,174, 3,772,468, AND OTHERS.

THE COLOR(S) BLUE AND GREEN IS/ARE CLAIMED AS A FEATURE OF THE MARK.

THE MARK CONSISTS OF THE WORDING "CERNER" TO THE LEFT OF WHICH IS A PARTIALLY CLOSED BLUE CIRCULAR FORM WHEREIN THE LEFT BORDER OF THE CIRCLE DOES NOT CONNECT BUT RATHER CONVERGES INTO TWO CURVING GREEN PARALLEL LINES EXTENDING OUTSIDE OF THE CIRCULAR FORM TOWARDS THE WORDING.

**CLASS 42—SCIENTIFIC AND COMPUTER SERVICES**

FOR PROVIDING ONLINE NON-DOWNLOADABLE COMPUTER SOFTWARE FOR USE IN THE HEALTHCARE FIELD, NAMELY, SOFTWARE FOR MANAGING, STORING, ANALYZING, MAINTAINING, PROCESSING, STRUCTURING, REVIEWING, BUILDING, EDITING, DISTRIBUTING, COMMUNICATING, ORGANIZING, SHARING, REFERENCING, MONITORING AND INTEGRATING HEALTHCARE INFORMATION; PROVIDING ONLINE NON-DOWNLOADABLE COMPUTER SOFTWARE FOR AUTOMATING CLINICAL, FINANCIAL AND ADMINISTRATIVE HEALTHCARE PROCESSES AND CONDUCTING HEALTH RELATED TRANSACTIONS VIA COMPUTER AND COMMUNICATION NETWORKS; DESIGN FOR OTHERS OF COMPUTER SOFTWARE FOR USE IN THE HEALTHCARE FIELD; IMPLEMENTATION, MAINTENANCE AND REPAIR OF COMPUTER SOFTWARE FOR USE IN THE HEALTHCARE FIELD; TECHNICAL SUPPORT SERVICES, NAMELY, TROUBLESHOOTING OF HEALTHCARE SOFTWARE VIA TELEPHONE, ELECTRONIC AND ON-SITE COMMUNICATION (U.S. CLS. 100 AND 101).

FIRST USE 11-1-2013; IN COMMERCE 11-1-2013.

**CLASS 44—MEDICAL, BEAUTY AND AGRICULTURAL SERVICES**

FOR HEALTHCARE CONSULTATION SERVICES (U.S. CLS. 100 AND 101).

FIRST USE 11-1-2013; IN COMMERCE 11-1-2013.

4,593,262. MORELLO FORNI DI MORELLO MARCO & C. S.A.S., CERANESI (GENOA), ITALY. SN 85-497,797. PUB. 4-2-2013, FILED 12-16-2011.



NO CLAIM IS MADE TO THE EXCLUSIVE RIGHT TO USE "FORNI", APART FROM THE MARK AS SHOWN.

THE MARK CONSISTS OF "MF" WITHIN A GLOBE AND "MORELLO FORNI" IN STYLIZED LETTERS.

THE ENGLISH TRANSLATION OF "FORNI" IN THE MARK IS "OVENS".

**CLASS 7—MACHINERY**

FOR MACHINES FOR THE MANIPULATION OF ALIMENTARY PASTE, NAMELY, ELECTRIC PASTA MAKERS FOR DOMESTIC USE (U.S. CLS. 13, 19, 21, 23, 31, 34 AND 35).

FIRST USE 9-0-1994; IN COMMERCE 0-0-1995.

**CLASS 11—ENVIRONMENTAL CONTROL APPARATUS**

FOR OVENS, NAMELY, STATIC COOKING OVENS AND ROTARY COOKING OVENS; COOKING OVENS; WOOD BURNING STOVES; PIZZA COOKING OVENS; ELECTRICAL AND GAS PIZZA COOKING OVENS; KITCHENS, STOVES AND OVENS OPERATING WITH GAS AND ELECTRICITY, NAMELY, STATIC COOKING OVENS AND ROTARY COOKING OVENS; SMOKE ASPIRATORS, NAMELY, VENTILATION HOODS, SMOKE EXTRACTOR HOODS FOR KITCHENS; BARBECUE GRILLS; MACHINES, NAMELY, PROFESSIONAL AND NON-PROFESSIONAL COOKING OVENS (U.S. CLS. 13, 21, 23, 31 AND 34).

FIRST USE 9-0-1994; IN COMMERCE 0-0-1995.

4,593,267. KCETLINK, BURBANK, CA. SN 85-515,457. PUB. 11-20-2012, FILED 1-12-2012.

**YOUR TURN TO CARE**

THE MARK CONSISTS OF STANDARD CHARACTERS WITHOUT CLAIM TO ANY PARTICULAR FONT, STYLE, SIZE, OR COLOR.

**CLASS 41—EDUCATION AND ENTERTAINMENT**

FOR NEWS AND ENTERTAINMENT SERVICES, NAMELY, A CONTINUING PROGRAM SERIES PROVIDING NEWS, INFORMATION, INTERVIEWS AND DOCUMENTARIES IN THE FIELDS OF FAMILY ISSUES, FAMILY SUPPORT SERVICES AND RESOURCES, AND ELDER ISSUES PROVIDED THROUGH CABLE AND BROADCAST TELEVISION; PROVIDING NON-DOWNLOADABLE PUBLICATIONS IN THE NATURE OF ARTICLES AND BLOGS IN THE FIELDS OF FAMILY ISSUES, FAMILY SUPPORT SERVICES AND RESOURCES, AND ELDER ISSUES THROUGH A WEBSITE AND TO MOBILE COMMUNICATIONS DEVICES ON THE GLOBAL COMPUTER NETWORK AND WIRELESS NETWORKS; ONLINE JOURNALS, NAMELY, BLOGS FEATURING DISCUSSION IN THE FIELDS OF FAMILY ISSUES, FAMILY SUPPORT SERVICES AND RESOURCES, AND ELDER ISSUES (U.S. CLS. 100, 101 AND 107).

FIRST USE 3-7-2012; IN COMMERCE 3-7-2012.

**CLASS 45—PERSONAL AND LEGAL SERVICES**

FOR NEWS AND ENTERTAINMENT SERVICES, NAMELY, PROVIDING NEWS AND INFORMATION, ARTICLES, REVIEWS, INTERVIEWS, EDITORIALS, RESOURCES, AUDIO FILES, VIDEO FILES, AND OTHER MULTIMEDIA MATERIAL IN THE FIELDS OF FAMILY INTERACTION ISSUES, FAMILY SUPPORT SERVICES AND RESOURCES, AND ELDER CARE ISSUES (U.S. CLS. 100 AND 101).

FIRST USE 3-7-2012; IN COMMERCE 3-7-2012.

4,593,282. PROSA PRODUCTOS NATURALES, S.A. DE C.V., MÉXICO DF, MEXICO. SN 85-539,400. PUB. 10-29-2013, FILED 2-10-2012.



THE COLOR(S) GREEN IS/ARE CLAIMED AS A FEATURE OF THE MARK.

THE MARK CONSISTS OF A STYLIZED FLOWER DESIGN, OUTLINED IN GREEN, OVER THE WORD "PROSA", IN GREEN CAPITAL LETTERS. THE WHITE AREAS WITHIN THE DESIGN AND BEHIND THE LETTERS ARE BACKGROUND, AND ARE NOT CLAIMED AS PART OF THE MARK.

THE ENGLISH TRANSLATION OF "PROSA" IN THE MARK IS "PROSE".

**CLASS 3—COSMETICS AND CLEANING PREPARATIONS**

FOR BAR SOAP; COSMETICS; SKIN LOTION (U.S. CLS. 1, 4, 6, 50, 51 AND 52).

FIRST USE 6-23-2014; IN COMMERCE 6-23-2014.

**CLASS 5—PHARMACEUTICALS**

FOR DIETARY AND NUTRITIONAL SUPPLEMENTS; DIETARY SUPPLEMENTAL DRINKS; TOPICAL ANALGESICS (U.S. CLS. 6, 18, 44, 46, 51 AND 52).

FIRST USE 6-23-2014; IN COMMERCE 6-23-2014.

4,593,285. STACY GOLDBERG'S WHAT'S IN YOUR CART?, LLC, DBA SAVORFULL, DETROIT, MI. SN 85-548,610. PUB. 8-7-2012, FILED 2-21-2012.

# SAVORFULL

THE MARK CONSISTS OF STANDARD CHARACTERS WITHOUT CLAIM TO ANY PARTICULAR FONT, STYLE, SIZE, OR COLOR.

**CLASS 35—ADVERTISING AND BUSINESS**

FOR COMPUTERIZED ON-LINE ORDERING SERVICES IN THE FIELD OF ALLERGY-FREE AND OTHER SPECIALTY FOODS; ELECTRONIC CATALOG SERVICES FEATURING ALLERGY-FREE AND OTHER SPECIALTY FOODS; PROMOTIONAL SERVICES, NAMELY, DISTRIBUTION OF ADVERTISING FLYERS, COUPONS, CATALOGS AND PROMOTIONAL ITEMS OF OTHERS; RETAIL AND ON-LINE GROCERY STORE SERVICES FEATURING HOME DELIVERY SERVICE; WEB-BASED CATALOG SERVICES FEATURING ALLERGY-FREE AND OTHER SPECIALTY FOODS (U.S. CLS. 100, 101 AND 102).

FIRST USE 6-0-2012; IN COMMERCE 4-1-2014.

**CLASS 44—MEDICAL, BEAUTY AND AGRICULTURAL SERVICES**

FOR COUNSELING SERVICES IN THE FIELDS OF HEALTH, NUTRITION AND LIFESTYLE WELLNESS; PROVIDING A WEBSITE FEATURING INFORMATION ABOUT HEALTH, WELLNESS AND NUTRITION; PROVIDING AN ON-LINE COMPUTER DATABASE FEATURING INFORMATION REGARDING HEALTH AND NUTRITION; PROVIDING HEALTHY LIFESTYLE AND NUTRITION SERVICES, NAMELY, PERSONAL ASSESSMENTS, PERSONALIZED ROUTINES, MAINTENANCE SCHEDULES, AND COUNSELING; PROVIDING INFORMATION, NEWS AND COMMENTARY IN THE FIELD OF NUTRITION, HEALTH AND WELLNESS; PROVIDING ON-LINE INFORMATION, NEWS AND COMMENTARY IN THE FIELD OF HEALTH AND WELLNESS RELATING TO DIET, NUTRITION AND FOOD CHOICES (U.S. CLS. 100 AND 101).

FIRST USE 2-0-2012; IN COMMERCE 2-0-2012.

4,593,288. MOEN INCORPORATED, NORTH OLMSTED, OH. SN 85-556,539. PUB. 2-19-2013, FILED 2-29-2012.



OWNER OF U.S. REG. NOS. 3,756,439, 3,756,440, AND OTHERS.

NO CLAIM IS MADE TO THE EXCLUSIVE RIGHT TO USE "HOME", APART FROM THE MARK AS SHOWN.

THE MARK CONSISTS OF TWO CROSSED WATER DROPS FOLLOWED BY THE WORD "MOEN" WITH THE WORDS "HOME CARE" UNDERNEATH WITH A 4 PART CIRCLE DESIGN IN BETWEEN THE WORDS "HOME" AND "CARE".

SEC. 2(F) AS TO "HOME CARE".

#### CLASS 6—METAL GOODS

FOR METAL BATHTUB AND SHOWER HAND GRIPS; METAL BATHTUB AND SHOWER GRAB BARS AND GRAB BAR ANCHORING SYSTEMS THEREFOR COMPOSED PRIMARILY OF METAL, NAMELY, FASTENING ANCHORS, SLEEVES, SCREWS, BOLTS, WASHERS AND PLATES; BATHTUB SAFETY BARS COMPOSED PRIMARILY OF METAL; AND TOILET RAILS COMPOSED PRIMARILY OF METAL; METAL BATHTUB AND SHOWER GRAB BARS WITH INTEGRATED TOWEL BAR, METAL BATHTUB AND SHOWER GRAB BARS WITH INTEGRATED SHELF, METAL BATHTUB AND SHOWER GRAB BARS WITH INTEGRATED TOILET TISSUE HOLDER (U.S. CLS. 2, 12, 13, 14, 23, 25 AND 50).

FIRST USE 7-1-2012; IN COMMERCE 7-1-2012.

#### CLASS 11—ENVIRONMENTAL CONTROL APPARATUS

FOR SHOWER AND BATHTUB FIXTURES, NAMELY, HAND HELD SHOWER HEADS AND SHOWER HOLDERS THEREFOR; TOILET SAFETY SEATS, ELEVATED TOILET SEATS; TOILET SAFETY SEATS AND ELEVATED TOILET SEATS AND ARMRESTS THEREFOR SOLD AS A UNIT; ARMRESTS FOR USE WITH TOILET SAFETY SEATS, AND ELEVATED TOILET SEATS; AND PORTABLE COMMODOES (U.S. CLS. 13, 21, 23, 31 AND 34).

FIRST USE 7-1-2012; IN COMMERCE 7-1-2012.

#### CLASS 17—RUBBER GOODS

FOR NON-SLIP ADHESIVE-BACKED BATHTUB AND SHOWER APPLIQUES (U.S. CLS. 1, 5, 12, 13, 35 AND 50).

FIRST USE 7-1-2012; IN COMMERCE 7-1-2012.

#### CLASS 20—FURNITURE AND ARTICLES NOT OTHERWISE CLASSIFIED

FOR NON-METAL BATHROOM SAFETY PRODUCTS, NAMELY, BATHTUB AND SHOWER HAND GRIPS AND BATHTUB GRIPS FOR ASSISTANCE OF INDIVIDUALS ENTERING AND EXITING BATHTUBS; SHOWER AND BATHTUB SEATING PRODUCTS, NAMELY, SEATS, BENCH SEATS AND CHAIRS AND TRANSFER BENCHES; SHOWER AND BATHTUB SEATING PRODUCTS, NAMELY, TRANSFER BENCHES, THE FOREGOING SOLD AS A UNIT WITH ACCESSORIES IN THE NATURE OF ARMRESTS, BASKETS, AND SHOWER HOLDERS; ARMRESTS AND ACCESSORIES IN THE NATURE OF BASKETS AND SHOWER HOLDERS, THE FOREGOING FITTED FOR USE WITH SHOWER AND BATHTUB SEATING PRODUCTS, NAMELY, SEATS, BENCH SEATS, TRANSFER BENCHES, AND CHAIRS (U.S. CLS. 2, 13, 22, 25, 32 AND 50).

FIRST USE 7-1-2012; IN COMMERCE 7-1-2012.

#### CLASS 21—HOUSEWARES AND GLASS

FOR BATHROOM ACCESSORIES, NAMELY, TOWEL BARS WITH INTEGRATED SHELF, TOWEL BARS WITH INTEGRATED TOILET TISSUE HOLDER, BATHTUB AND SHOWER GRAB BARS WITH INTEGRATED TOWEL BAR, BATHTUB AND SHOWER GRAB BARS WITH INTEGRATED SHELF, BATHTUB AND SHOWER GRAB BARS WITH INTEGRATED TOILET TISSUE HOLDER, AND TOILET TISSUE HOLDERS; AND SOAP DISHES (U.S. CLS. 2, 13, 23, 29, 30, 33, 40 AND 50).

FIRST USE 7-1-2012; IN COMMERCE 7-1-2012.

#### CLASS 27—FLOOR COVERINGS

FOR NON-SLIP BATHTUB MATS (U.S. CLS. 19, 20, 37, 42 AND 50).

FIRST USE 7-1-2012; IN COMMERCE 7-1-2012.

4,593,293. CEQUENT PERFORMANCE PRODUCTS, INC., PLYMOUTH, MI. SN 85-560,426. PUB. 3-18-2014, FILED 3-5-2012.

## PRO SERIES

THE MARK CONSISTS OF STANDARD CHARACTERS WITHOUT CLAIM TO ANY PARTICULAR FONT, STYLE, SIZE, OR COLOR.

OWNER OF U.S. REG. NO. 3,448,400.

NO CLAIM IS MADE TO THE EXCLUSIVE RIGHT TO USE "SERIES", APART FROM THE MARK AS SHOWN.

#### CLASS 8—HAND TOOLS

FOR MANUALLY-OPERATED JACKS FOR LAND VEHICLES (U.S. CLS. 23, 28 AND 44).

FIRST USE 2-1-2009; IN COMMERCE 2-1-2009.

#### CLASS 9—ELECTRICAL AND SCIENTIFIC APPARATUS

FOR ELECTRONIC BRAKE CONTROLLERS FOR VEHICLE TRAILERS; TRAILER BREAKAWAY KITS COMPRISED OF A CUT-OUT SWITCH, BATTERY, BATTERY CASE AND OPTIONAL BATTERY CHARGER (U.S. CLS. 21, 23, 26, 36 AND 38).

FIRST USE 6-1-2010; IN COMMERCE 6-1-2010.

#### CLASS 12—VEHICLES

FOR TRAILER HITCHES; MECHANICAL SWAY CONTROLS TO BE USED AS AN INTEGRAL COMPONENT OF TRAILERS; METAL LOCKING DEVICE FOR TRAILER HITCH COUPLERS; BICYCLE CARRIERS AND CARGO CARRIERS FOR VEHICLES; STRUCTURAL COMPONENT PARTS OF TRAILER HITCHES, NAMELY, COUPLERS, PIN BOXES AND PINTLE HOOKS (U.S. CLS. 19, 21, 23, 31, 35 AND 44).

FIRST USE 4-1-2010; IN COMMERCE 4-1-2010.

4,593,303. DIAGEO NORTH AMERICA, INC., NORWALK, CT. SN 85-577,730. PUB. 7-16-2013, FILED 3-23-2012.

## CAPTAIN MORGAN

THE MARK CONSISTS OF STANDARD CHARACTERS WITHOUT CLAIM TO ANY PARTICULAR FONT, STYLE, SIZE, OR COLOR.

OWNER OF U.S. REG. NOS. 972,985, 3,509,465, AND OTHERS.

**CLASS 35—ADVERTISING AND BUSINESS**

FOR RETAIL STORE SERVICES FEATURING RUM AND RUM BASED PRODUCTS AND ALSO FEATURING BRANDED MERCHANDISE INCLUDING APPAREL AND APPAREL ACCESSORIES, HOUSEWARES, JEWELRY, GIFT NOVELTIES, AND OFFICE AND STATIONERY SUPPLIES (U.S. CLS. 100, 101 AND 102).

FIRST USE 4-24-2012; IN COMMERCE 4-24-2012.

**CLASS 41—EDUCATION AND ENTERTAINMENT**

FOR EDUCATIONAL AND ENTERTAINMENT SERVICES, NAMELY, GUIDED TOURS OF A RUM DISTILLERY AND ADJOINING VISITOR CENTER FEATURING INFORMATION REGARDING ALCOHOLIC BEVERAGES, BRAND HISTORY AND DISTILLATION PROCESSES (U.S. CLS. 100, 101 AND 107).

FIRST USE 4-24-2012; IN COMMERCE 4-24-2012.

---

4,593,306. FASHIONETTE DOLLSWEAR LTD., LONDON, UNITED KINGDOM. SN 85-584,798. PUB. 10-23-2012, FILED 3-30-2012.

# FASHIONETTE

THE MARK CONSISTS OF STANDARD CHARACTERS WITHOUT CLAIM TO ANY PARTICULAR FONT, STYLE, SIZE, OR COLOR.

**CLASS 18—LEATHER GOODS**

FOR REUSABLE SHOPPING BAGS; CANVAS SHOPPING BAGS (U.S. CLS. 1, 2, 3, 22 AND 41).

FIRST USE 11-18-2009; IN COMMERCE 6-12-2014.

**CLASS 28—TOYS AND SPORTING GOODS**

FOR DOLL'S CLOTHING AND ACCESSORIES, NAMELY, BANDANAS, SCARVES, SASHES, FUR STOLE, DETACHABLE COLLARS, BELTS, SHOULDER WRAPS, COLLARS, COLLAR PROTECTORS, SHAWLS, SWEATERS, SHIRTS, SHIRT YOKES, SHIRT FRONTS, UNDERSHIRTS, FURS, GABARDINES, RAINCOATS, SKIRTS, COATS, TROUSERS, JEANS, OVERCOATS, DRESSES, KNITWEAR, JACKETS, LEGGINGS (U.S. CLS. 22, 23, 38 AND 50).

FIRST USE 11-18-2009; IN COMMERCE 2-7-2013.

---

4,593,309. MAXXSONICS USA, INC., LAKE ZURICH, IL. SN 85-594,590. PUB. 5-21-2013, FILED 4-11-2012.

# MAXXLINK

THE MARK CONSISTS OF STANDARD CHARACTERS WITHOUT CLAIM TO ANY PARTICULAR FONT, STYLE, SIZE, OR COLOR.

OWNER OF U.S. REG. NOS. 2,792,058 AND 3,318,379.

**CLASS 9—ELECTRICAL AND SCIENTIFIC APPARATUS**

FOR AUDIO PRODUCTS AND ACCESSORIES, NAMELY, AMPLIFIER INSTALLATION KITS COMPRISED OF ELECTRICAL WIRE, ELECTRIC SIGNAL CABLE, FUSE HOLDERS AND FUSES; POWER WIRES; ELECTRIC WIRE AND CABLES; ELECTRIC GROUND WIRE, ELECTRIC SIGNAL CABLES; PRIMARY ELECTRIC WIRE; FUSE HOLDERS; ELECTRICAL POWER DISTRIBUTION BLOCKS; FUSED ELECTRICAL POWER DISTRIBUTION BLOCKS; ELECTRICAL CONNECTORS, NAMELY, GROUND LUGS, BUTT TERMINALS, SPLICE TERMINALS, RING TERMINALS AND FORK TERMINALS; FUSES; SUBWOOFER ENCLOSURES; SPEAKER ENCLOSURES; ELECTRIC LINE OUTPUT CONVERTERS; OEM INTEGRATION DEVICES, NAMELY, ELECTRONIC INTERFACES FOR AUDIO SPEAKERS; CAPACITORS; ELECTRICAL CONNECTORS; BATTERY TERMINALS IN THE NATURE OF ELECTRIC CONNECTORS FOR CONNECTING BATTERIES; ELECTRICAL CONNECTORS (U.S. CLS. 21, 23, 26, 36 AND 38).

FIRST USE 1-0-2012; IN COMMERCE 1-0-2012.

**CLASS 17—RUBBER GOODS**

FOR SOUND DEADENERS AND SOUND DAMPENERS IN THE NATURE OF ACOUSTIC PRODUCTS, NAMELY, SOUND ABSORBERS AND DIFFUSERS (U.S. CLS. 1, 5, 12, 13, 35 AND 50).

FIRST USE 1-0-2012; IN COMMERCE 1-0-2012.

---

4,593,312. STRING KING LACROSSE LLC, LOS ANGELES, CA. SN 85-603,579. PUB. 10-2-2012, FILED 4-20-2012.



NO CLAIM IS MADE TO THE EXCLUSIVE RIGHT TO USE "LACROSSE EST. 2011", APART FROM THE MARK AS SHOWN.

THE MARK CONSISTS OF THE TEXT "STRINGKING" ARCHED AT THE TOP, BELOW AND LEFT OF THAT IS THE TEXT "EST.", AN ABSTRACT DESIGN AT THE CENTER, THE TEXT "2011" TO THE RIGHT OF THE DESIGN, AND THE TEXT "LACROSSE" AT THE BOTTOM.

**CLASS 25—CLOTHING**

FOR ATHLETIC APPAREL, NAMELY, SHIRTS, HATS, AND CAPS (U.S. CLS. 22 AND 39).

FIRST USE 2-1-2013; IN COMMERCE 2-26-2013.

**CLASS 28—TOYS AND SPORTING GOODS**

FOR LACROSSE STICK STRINGS (U.S. CLS. 22, 23, 38 AND 50).

FIRST USE 2-1-2013; IN COMMERCE 2-26-2013.

**CLASS 41—EDUCATION AND ENTERTAINMENT**

FOR EDUCATION SERVICES, NAMELY, PROVIDING WEB-BASED EDUCATIONAL TUTORIALS AND INSTRUCTION IN THE FIELD OF LACROSSE STICK STRINGING (U.S. CLS. 100, 101 AND 107).

FIRST USE 1-15-2013; IN COMMERCE 2-26-2013.

4,593,313. STYLEWHILE LTD., HELSINKI, FINLAND. SN 85-609,953. PUB. 3-11-2014, FILED 4-27-2012.

# Stylewhile

THE MARK CONSISTS OF STANDARD CHARACTERS WITHOUT CLAIM TO ANY PARTICULAR FONT, STYLE, SIZE, OR COLOR.

PRIORITY CLAIMED UNDER SEC. 44(D) ON ERP CMNTY TM OFC APPLICATION NO. 010780096, FILED 4-2-2012.

**CLASS 9—ELECTRICAL AND SCIENTIFIC APPARATUS**

FOR COMPUTER SOFTWARE PLATFORMS FOR COMPUTER PROGRAMS TO USE FOR UTILIZATION OF HUMAN AND MACHINE INTELLIGENCE ON-DEMAND IN THE FIELD OF COMMERCIAL TASKS; COMPUTER SOFTWARE FOR CREATING, STORING AND SHARING CONTENT BETWEEN INTERNET CONNECTED DEVICES, COMPUTERS AND COMPUTER NETWORKS AND BETWEEN MOBILE DEVICES; COMPUTER SOFTWARE TO ALLOW USERS TO ACCESS INTERNET BASED CONTENT, DIGITAL CONTENT, CONTENT FROM THIRD PARTY SOURCES AND USER GENERATED CONTENT THROUGH ELECTRONIC DEVICES, COMPUTER SOFTWARE FOR SOCIAL NETWORKING (U.S. CLS. 21, 23, 26, 36 AND 38).

FIRST USE 9-0-2013; IN COMMERCE 9-0-2013.

**CLASS 35—ADVERTISING AND BUSINESS**

FOR OPERATING AN ONLINE SHOPPING SITE IN THE FIELD OF CLOTHING AND FASHION ACCESSORIES FEATURING ONLINE MERCHANDISE DISPLAYS OF COMBINATIONS OF RETAILERS' CLOTHING AND FASHION ACCESSORIES; ADVERTISING SERVICES, NAMELY, PROMOTING THE SERVICES OF OTHERS BY PROVIDING A WEB PAGE FEATURING LINKS TO THE WEBSITES OF OTHERS; PROMOTING THE GOODS AND SERVICES OF OTHERS BY PROVIDING A WEBSITE FEATURING CREATION AND SHARING STYLES IN THE FIELD OF CLOTHING AND FASHION ACCESSORIES; PROVISION OF A WEBSITE FEATURING INFORMATION ON SHOPPING IN THE FIELD OF CLOTHING AND FASHION ACCESSORIES; DEMONSTRATION OF GOODS AND SERVICES BY ELECTRONIC MEANS; ADVERTISING AND PROMOTIONAL SERVICES (U.S. CLS. 100, 101 AND 102).

FIRST USE 1-1-2013; IN COMMERCE 1-1-2013.

4,593,322. GIANLUCA MECH S.P.A., ASIGLIANO VENETO, ITALY. SN 85-622,087. PUB. 10-8-2013, FILED 5-10-2012.

# GIANLUCA MECH

THE MARK CONSISTS OF STANDARD CHARACTERS

WITHOUT CLAIM TO ANY PARTICULAR FONT, STYLE, SIZE, OR COLOR.

THE NAME(S), PORTRAIT(S), AND/OR SIGNATURE(S) SHOWN IN THE MARK IDENTIFIES "GIANLUCA MECH", WHOSE CONSENT(S) TO REGISTER IS MADE OF RECORD.

THE WORDING "GIANLUCA MECH" HAS NO MEANING IN A FOREIGN LANGUAGE.

**CLASS 5—PHARMACEUTICALS**

FOR DIETARY FOOD SUPPLEMENTS, DIETETIC FOODS, NAMELY, PROCESSED FOOD BASED ON HERBS AND PROTEINS IN THE NATURE OF SOUPS, OMELETS, BISCUITS, POTATO PUREE, PIZZA, SHAKES, SPREADABLE CREAM, CREAM, PUDDING, FLAN, CUSTARD, YOGURTS, MUFFINS, POTATO CHIPS, TACO CHIPS, CORN CHIPS, PITA CHIPS, CUSTARDS, DRINKS, NAMELY, SOFT DRINKS AND FRUIT JUICES, BREADS, PASTA, CRACKERS, NUT AND BEAN-BASED SNACK FOODS, PLUMCAKES, SOY-BASED AND CEREAL BASED FOOD BARS, PROCESSED CEREALS, SNACK MIX CONSISTING PRIMARILY OF SOY-BASED SNACK FOODS, CHEESE-FLAVORED SNACKS, CEREAL BASED SNACKS, MELBA TOAST, COOKING AND DIPPING SAUCES, NATURAL AND SUGAR FREE ARTIFICIAL SWEETENERS, ICE CREAM AND TEA ADAPTED FOR MEDICAL USE, DIETARY FOOD SUPPLEMENTS OF PROTEIN; HERBAL COMPOUNDS NAMELY, PILLS, POWDERS, TABLETS, CAPSULES, DROPS AND LIQUID EXTRACTS FOR USE AS DIETETIC ADDITIVES FOR MEDICAL PURPOSES; NATURAL HERBAL SUPPLEMENTS, MEDICINAL HERB EXTRACTS (U.S. CLS. 6, 18, 44, 46, 51 AND 52).

FIRST USE 7-23-2013; IN COMMERCE 7-23-2013.

**CLASS 30—STAPLE FOODS**

FOR HERBAL FOOD BEVERAGES; HERBAL INFUSIONS; HERBAL TEA FOR FOOD PURPOSES; PROCESSED HERBS; COFFEE, TEA, COCOA, SUGAR, RICE, TAPIOCA, FLOUR AND PREPARATIONS MADE FROM CEREALS, NAMELY, CEREAL-BASED SNACK FOODS, READY-TO-EAT CEREAL-DERIVED FOOD BARS, BREAKFAST CEREALS, BREAD, PASTRY AND CONFECTIONERY, NAMELY, CAKES, COOKIES, CANDY; ICES, NAMELY, FRUIT ICES AND FLAVORED ICES; HONEY; TREACLE; YEAST; SALT; MUSTARD; VINEGAR; SAUCES; CONDIMENTS, NAMELY, PEPPER SAUCE, KETCHUP; SPICES (U.S. CL. 46).

FIRST USE 7-23-2013; IN COMMERCE 7-23-2013.

**CLASS 32—LIGHT BEVERAGES**

FOR HERBAL JUICES, NON-ALCOHOLIC DRINKS, NAMELY, SOFT DRINKS; FRUIT DRINKS AND FRUIT JUICES; SYRUPS FOR MAKING BEVERAGES; PREPARATIONS FOR MAKING BEVERAGES, NAMELY, FRUIT DRINKS AND FRUIT, HERBAL AND SPICE FLAVORED SOFT DRINKS (U.S. CLS. 45, 46 AND 48).

FIRST USE 7-23-2013; IN COMMERCE 7-23-2013.

4,593,323. GIANLUCA MECH S.P.A., ASIGLIANO VENETO, ITALY. SN 85-622,153. PUB. 10-8-2013, FILED 5-10-2012.

# MECH DIET

THE MARK CONSISTS OF STANDARD CHARACTERS WITHOUT CLAIM TO ANY PARTICULAR FONT, STYLE, SIZE, OR COLOR.

NO CLAIM IS MADE TO THE EXCLUSIVE RIGHT TO USE "DIET", APART FROM THE MARK AS SHOWN.

THE WORDING "MECH" HAS NO MEANING IN A FOREIGN LANGUAGE.

**CLASS 5—PHARMACEUTICALS**

FOR DIETARY FOOD SUPPLEMENTS, DIETETIC FOODS, NAMELY, PROCESSED FOOD BASED ON HERBS AND PROTEINS IN THE NATURE OF SOUPS, OMELETS, BISCUITS, POTATO PURÉE, PIZZA, SHAKES, SPREADABLE CREAM, CREAM, PUDDING, FLAN, CUSTARD, YOGURTS, MUFFINS, POTATO CHIPS, TACO CHIPS, CORN CHIPS, PITA CHIPS, CUSTARDS, DRINKS, NAMELY, SOFT DRINKS AND FRUIT JUICES, BREADS, PASTA, CRACKERS, NUT AND BEAN-BASED SNACK FOODS, PLUMCAKES, SOY-BASED AND CEREAL BASED FOOD BARS, PROCESSED CEREALS, SNACK MIX CONSISTING PRIMARILY OF SOY-BASED SNACK FOODS, CHEESE-FLAVORED SNACKS, CEREAL BASED SNACKS, MELBA TOAST, COOKING AND DIPPING SAUCES, NATURAL AND SUGAR FREE ARTIFICIAL SWEETENERS, ICE CREAM AND TEA ADAPTED FOR MEDICAL USE, DIETARY FOOD SUPPLEMENTS OF PROTEIN; HERBAL COMPOUNDS NAMELY, PILLS, POWDERS, TABLETS, CAPSULES, DROPS AND LIQUID EXTRACTS FOR USE AS DIETETIC ADDITIVES FOR MEDICAL PURPOSES; NATURAL HERBAL SUPPLEMENTS, MEDICINAL HERB EXTRACTS (U.S. CLS. 6, 18, 44, 46, 51 AND 52).

FIRST USE 6-19-2013; IN COMMERCE 6-19-2013.

**CLASS 30—STAPLE FOODS**

FOR HERBAL FOOD BEVERAGES; HERBAL INFUSIONS; HERBAL TEA FOR FOOD PURPOSES; PROCESSED HERBS; COFFEE, TEA, COCOA, SUGAR, RICE, TAPIOCA, FLOUR AND PREPARATIONS MADE FROM CEREALS, NAMELY, CEREAL-BASED SNACK FOODS, READY-TO-EAT CEREAL-DERIVED FOOD BARS, BREAKFAST CEREALS, BREAD, PASTRY AND CONFECTIONERY, NAMELY, CAKES, COOKIES, CANDY; ICES, NAMELY, FRUIT ICES AND FLAVORED ICES; HONEY; TREACLE; YEAST; SALT; MUSTARD; VINEGAR; SAUCES; CONDIMENTS, NAMELY, PEPPER SAUCE, KETCHUP; SPICES (U.S. CL. 46).

FIRST USE 6-19-2013; IN COMMERCE 6-19-2013.

**CLASS 32—LIGHT BEVERAGES**

FOR HERBAL JUICES, NON-ALCOHOLIC DRINKS, NAMELY, SOFT DRINKS; FRUIT DRINKS AND FRUIT JUICES; SYRUPS FOR MAKING BEVERAGES; PREPARATIONS FOR MAKING BEVERAGES, NAMELY, FRUIT DRINKS AND FRUIT, HERBAL AND SPICE FLAVORED SOFT DRINKS (U.S. CLS. 45, 46 AND 48).

FIRST USE 6-19-2013; IN COMMERCE 6-19-2013.

4,593,331. AFRO FUSION CUISINE BRANDS LLC, DBA AFRO FUSION CUISINE, WAUWATOSA, WI. SN 85-630,505. PUB. 10-30-2012, FILED 5-21-2012.

**Afro Fusion Cuisine**  
Experience the thrill of a  
culinary safari!

THE MARK CONSISTS OF STANDARD CHARACTERS WITHOUT CLAIM TO ANY PARTICULAR FONT, STYLE, SIZE, OR COLOR.

NO CLAIM IS MADE TO THE EXCLUSIVE RIGHT TO USE "AFRO FUSION CUISINE" IN INTERNATIONAL CLASSES 9, 16, 30, 40 AND 43 AND "AFRO" IN INTERNATIONAL CLASSES 24 AND 25, APART FROM THE MARK AS SHOWN.

**CLASS 9—ELECTRICAL AND SCIENTIFIC APPARATUS**

FOR DOWNLOADABLE ELECTRONIC DATA FILES FEATURING RECIPES (U.S. CLS. 21, 23, 26, 36 AND 38).  
FIRST USE 8-4-2012; IN COMMERCE 8-4-2012.

**CLASS 16—PAPER GOODS AND PRINTED MATTER**

FOR PRINTED RECIPE CARDS; RECIPE BOOKS (U.S. CLS. 2, 5, 22, 23, 29, 37, 38 AND 50).  
FIRST USE 8-4-2012; IN COMMERCE 8-4-2012.

**CLASS 24—FABRICS**

FOR CLOTH BANNERS; CLOTH COASTERS; CLOTHS USED FOR WRAPPING GOODS; COTTON CLOTH; DISH CLOTHS; ELASTIC FABRICS FOR CLOTHING; FACE CLOTHS; FELT CLOTH; FLAX CLOTH; KITCHEN LINENS; KITCHEN TOWELS; LABELS OF CLOTH; TABLE CLOTH OF TEXTILE; TABLE CLOTHS NOT OF PAPER; TEXTILE FABRICS FOR THE MANUFACTURE OF CLOTHING; WRAPPING CLOTH FOR GENERAL PURPOSES (U.S. CLS. 42 AND 50).

FIRST USE 8-4-2012; IN COMMERCE 8-4-2012.

**CLASS 25—CLOTHING**

FOR APRONS (U.S. CLS. 22 AND 39).  
FIRST USE 8-4-2012; IN COMMERCE 8-4-2012.

**CLASS 30—STAPLE FOODS**

FOR ARTICHOKE SAUCE; BAKING SPICES; BARBECUE DRY RUB; BARBECUE SAUCE; CHEESE SAUCE; CHICKEN WING SAUCE; CHILI SAUCE; CHIMICHURRI SAUCE; CINNAMON POWDER; CLOVE POWDER; CONDIMENT, NAMELY, OYSTER SAUCE; CONDIMENT, NAMELY, PEPPER SAUCE; COOKING SAUCES; CURRY; CURRY POWDER; CURRY SAUCE; DIPPING SAUCES; DRY SPICE RUB FOR MEATS AND FISH; EDIBLE SPICES; FISH SAUCE; FRUIT SAUCES EXCLUDING CRANBERRY SAUCE AND APPLESAUCE; GINGER; GRILLING SAUCES; HOT PEPPER POWDER; HOT SAUCE; JAPANESE HORSERADISH POWDER SPICE (WASABI POWDER); MARINADE MIXES; MARINADES; ORGANIC CURRY SAUCES; PEPPER; PEPPER POWDER; PEPPER SPICE; PICANTE SAUCE; SAUCE MIXES; SAUCES; SAUCES FOR BARBECUED MEAT; SPICE BLENDS; SPICE RUBS; TOMATO SAUCE (U.S. CL. 46).

FIRST USE 8-4-2012; IN COMMERCE 8-4-2012.

**CLASS 40—MATERIAL TREATMENT**

FOR CUSTOM FLAVORING OF SAUCES AND DRY SEASONINGS (U.S. CLS. 100, 103 AND 106).  
FIRST USE 8-4-2012; IN COMMERCE 8-4-2012.

**CLASS 43—HOTEL AND RESTAURANT SERVICES**

FOR PROVIDING A DATABASE IN THE FIELD OF RECIPES AND COOKING INFORMATION; PROVIDING AN INTERACTIVE WEB SITE FEATURING INFORMATION IN THE FIELD OF RECIPES FOR ALCOHOLIC BEVERAGES AND COCKTAILS; PROVIDING AN ONLINE COMPUTER DATABASE TO CONSUMERS FEATURING INFORMATION ABOUT RECIPES, INGREDIENTS AND COOKING INFORMATION (U.S. CLS. 100 AND 101).

FIRST USE 8-4-2012; IN COMMERCE 8-4-2012.



4,593,335. DISCOVERREADY, LLC, NEW YORK, NY. SN 85-633,834. PUB. 4-2-2013, FILED 5-24-2012.

## SAMPLYZER

THE MARK CONSISTS OF STANDARD CHARACTERS WITHOUT CLAIM TO ANY PARTICULAR FONT, STYLE, SIZE, OR COLOR.

### CLASS 42—SCIENTIFIC AND COMPUTER SERVICES

FOR PROVIDING ONLINE NON-DOWNLOADABLE SOFTWARE FOR ORGANIZING, MANAGING, SEARCHING, AND ANALYZING DOCUMENTS AND FILES FOR USE IN THE FIELDS OF LITIGATION SUPPORT AND ELECTRONIC DISCOVERY; PROVIDING TEMPORARY USE OF ONLINE NON-DOWNLOADABLE SOFTWARE FOR USE IN DATABASE AND INFORMATION MANAGEMENT, COMPUTER-BASED LITIGATION SUPPORT, AND ELECTRONIC DISCOVERY; PROVIDING ONLINE NON-DOWNLOADABLE SOFTWARE FOR USE IN THE FIELDS OF LITIGATION SUPPORT AND ELECTRONIC DISCOVERY TO ANALYZE, CALCULATE, AND OBTAIN METRICS CHARACTERIZING ELECTRONIC DISCOVERY WORKFLOW AND GENERATE INTERACTIVE REPORTS FOR THE PURPOSES OF QUALITY CONTROL AND SYSTEM AND PROCESS EFFICIENCY (U.S. CLS. 100 AND 101).  
FIRST USE 1-15-2013; IN COMMERCE 1-15-2013.

### CLASS 45—PERSONAL AND LEGAL SERVICES

FOR LITIGATION SUPPORT SERVICES, NAMELY, CONDUCTING ELECTRONIC LEGAL DISCOVERY IN THE NATURE OF REVIEW, MANAGEMENT, STATISTICAL SAMPLING, AND ANALYSIS OF ELECTRONICALLY STORED INFORMATION THAT COULD BE RELEVANT EVIDENCE IN A LAWSUIT (U.S. CLS. 100 AND 101).  
FIRST USE 1-15-2013; IN COMMERCE 1-15-2013.

4,593,342. GORDON TRUCKING, INC., PACIFIC, WA. SN 85-635,861. PUB. 5-21-2013, FILED 5-25-2012.



NO CLAIM IS MADE TO THE EXCLUSIVE RIGHT TO USE "TRUCKING INC." AND "SINCE 1946", APART FROM THE MARK AS SHOWN.

THE MARK CONSISTS OF THE STYLIZED LETTERS "GTI" SUPERIMPOSED ON AN ASYMMETRICAL TRIANGLE, NEXT TO THE STYLIZED WORDING "GORDON TRUCKING INC." WHICH APPEARS OVER A HORIZONTAL LINE OVER THE WORDS "SAFETY, SERVICE AND SUSTAINABILITY SINCE 1946".

### CLASS 35—ADVERTISING AND BUSINESS

FOR TRANSPORTATION MANAGEMENT AND LOGISTICS SERVICES, NAMELY, ARRANGING THE TRANSPORTATION OF GOODS FOR OTHERS (U.S. CLS. 100, 101 AND 102).  
FIRST USE 8-6-2009; IN COMMERCE 8-6-2009.

### CLASS 39—TRANSPORTATION AND STORAGE

FOR GLOBAL TRANSPORTATION OF FREIGHT FOR OTHERS BY ALL AVAILABLE MEANS (U.S. CLS. 100 AND 105).

FIRST USE 8-6-2009; IN COMMERCE 8-6-2009.

4,593,344. CRUMBS & COMFORT BY GRAZIELLA, LLC, DBA CRUMBS & COMFORT BY GRAZIELLA; CRUMBS & COMFORT, LLC; CRUMBS AND COMFORT, STONE RIDGE, VA. SN 85-636,716. PUB. 10-30-2012, FILED 5-28-2012.

## Crumbs & Comfort

THE MARK CONSISTS OF STANDARD CHARACTERS WITHOUT CLAIM TO ANY PARTICULAR FONT, STYLE, SIZE, OR COLOR.

### CLASS 30—STAPLE FOODS

FOR BAKED GOODS, NAMELY, CRUMBLES; BAKERY DESSERTS; BAKERY GOODS; BAKERY GOODS AND DESSERT ITEMS, NAMELY, CHEESECAKES FOR RETAIL AND WHOLESALE DISTRIBUTION AND CONSUMPTION ON OR OFF THE PREMISES; BAKERY PRODUCTS; BAKERY PRODUCTS, NAMELY, SWEET BAKERY GOODS; BISCOTTI; BISCUITS AND BREAD; BREAD; BREAD AND BUNS; BREAD AND PASTRY; CHOCOLATE COVERED COOKIES; COOKIES; MUFFINS; PASTRIES; PASTRIES WITH FRUIT; PASTRY; PASTRY CREAM; PASTRY SHELLS; SCONES; WITH ALL OF THE FOREGOING EXCLUDING CUPCAKES (U.S. CL. 46).  
FIRST USE 12-20-2012; IN COMMERCE 12-20-2012.

### CLASS 40—MATERIAL TREATMENT

FOR BAKERY SERVICES, NAMELY, THE MANUFACTURE OF BAKERY PRODUCTS TO ORDER AND/OR SPECIFICATION OF OTHERS, EXCLUDING THE MANUFACTURE OF CUPCAKES (U.S. CLS. 100, 103 AND 106).  
FIRST USE 12-20-2012; IN COMMERCE 12-20-2012.

4,593,347. TERRE D'OC CREATIONS, MANOSQUE (VILLENEUVE), FRANCE. SN 85-638,930. PUB. 5-21-2013, FILED 5-30-2012.

## mémoired'uninstant

THE MARK CONSISTS OF THE TERM "MÉMOIRE D'UN INSTANT" IN STYLIZED FONT.

THE ENGLISH TRANSLATION OF "MÉMOIRE D'UN INSTANT" IN THE MARK IS "MEMORY OF A MOMENT".

**CLASS 3—COSMETICS AND CLEANING PREPARATIONS**

FOR EXTRACTS OF FLOWERS FOR USE WITH PERFUMERY; BASES FOR FLOWER PERFUMES, NAMELY, ESSENTIAL OILS; ESSENTIAL OILS FOR PERSONAL USE; PERFUME MADE FROM EXTRACT OF FLOWERS; PERFUMERY; FUMIGATING PREPARATIONS IN THE NATURE OF INCENSE; OILS FOR PERFUMES AND SCENTS; INCENSES; SCENTED INCENSE; SCENTED WOOD; SACHETS FOR PERFUMING LINEN; SCENTED CERAMIC STONES; DEODORANTS FOR PERSONAL USE (U.S. CLS. 1, 4, 6, 50, 51 AND 52).  
FIRST USE 12-16-2013; IN COMMERCE 12-16-2013.

**CLASS 4—LUBRICANTS AND FUELS**

FOR PERFUMED CANDLES OF PERFUMED WAX; CANDLES; SCENTED CANDLES; CANDLES FOR NIGHT LIGHTS; TEXTILE OIL (U.S. CLS. 1, 6 AND 15).  
FIRST USE 12-16-2013; IN COMMERCE 12-16-2013.

**CLASS 21—HOUSEWARES AND GLASS**

FOR GLASS, UNWORKED OR SEMI-WORKED, EXCEPT BUILDING GLASS; OPAL GLASS; WORKS OF ART, OF PORCELAIN, TERRA-COTTA OR GLASS; BOXES OF GLASS; PAINTED GLASSWARE FOR HOLDING PERFUMED CANDLES; GLASS RECEPTACLES, NAMELY, GLASS STORAGE JARS AND GLASS CONTAINERS FOR HOUSE HOLD USE; FLASKS NOT OF PRECIOUS METAL; VASES NOT OF PRECIOUS METAL; SMALL DISHES NOT OF PRECIOUS METAL; BOWLS NOT OF PRECIOUS METAL; CANDLESTICKS FOR USE WITH CANDELABRA CANDLESTICKS AND NOT OF PRECIOUS METAL; PERFUME BURNER NOT OF PRECIOUS METAL; INCENSE BURNER NOT OF PRECIOUS METAL; PERFUME VAPORIZERS, ATOMIZERS AND SPRAYERS NOT OF PRECIOUS METAL, ALL SOLD EMPTY; GLASS JARS, NAMELY, CARBOYS (U.S. CLS. 2, 13, 23, 29, 30, 33, 40 AND 50).  
FIRST USE 12-16-2013; IN COMMERCE 12-16-2013.

4,593,350. SYNTHOMER DEUTSCHLAND GMBH, MARL, FED REP GERMANY. SN 85-642,104. PUB. 5-28-2013, FILED 6-4-2012.

**PLEXTOL**

THE MARK CONSISTS OF STANDARD CHARACTERS WITHOUT CLAIM TO ANY PARTICULAR FONT, STYLE, SIZE, OR COLOR.

**CLASS 1—CHEMICALS**

FOR SYNTHETIC RESIN DISPERSIONS FOR INDUSTRIAL USE; SYNTHETIC RESIN EMULSIONS FOR INDUSTRIAL USE; AQUEOUS DISPERSIONS, IN PARTICULAR AQUEOUS DISPERSIONS OF ACRYLIC POLYMER, ACRYLIC COPOLYMER, ACRYLIC ESTER COPOLYMER; ACRYLIC RESIN DISPERSIONS, PARTICULARLY FOR USE IN THE MANUFACTURE OF PAINTS, VARNISHES, LACQUERS, COATINGS; DISPERSIONS, IN PARTICULAR COLLOIDAL DISPERSIONS OF MACROMOLECULES, NAMELY, ACRYLIC POLYMER DISPERSIONS, ACRYLIC COPOLYMER DISPERSIONS, ACRYLIC ESTER COPOLYMER DISPERSIONS; BINDER DISPERSIONS, NAMELY, ACRYLIC POLYMER DISPERSIONS, ACRYLIC COPOLYMER DISPERSIONS, ACRYLIC ESTER COPOLYMER DISPERSIONS; BINDERS, NAMELY, ACRYLIC POLYMER DISPERSIONS, ACRYLIC COPOLYMER DISPERSIONS, ACRYLIC ESTER COPOLYMER DISPERSIONS; EMULSIONS, IN PARTICULAR AQUEOUS EMULSIONS OF MACROMOLECULES, NAMELY, ACRYLIC POLYMER EMULSIONS, ACRYLIC COPOLYMER EMULSIONS, ACRYLIC ESTER COPOLYMER EMULSIONS; ACRYLIC RESIN EMULSIONS, PARTICULARLY FOR USE IN THE MANUFACTURE OF PAINTS, VARNISHES, LACQUERS; CHEMICAL IMPREGNATIONS, NAMELY, SYNTHETIC RESIN DISPERSIONS AND POLYMER DISPERSIONS FOR IMPREGNATING OF TEXTILES, NON-WOVENS AND FABRICS; IMPREGNATING CHEMICALS, NAMELY, SYNTHETIC RESIN DISPERSIONS AND POLYMER DISPERSIONS FOR THE IMPREGNATING OF TEXTILES, NON-WOVENS AND FABRICS; ADHESIVES USED IN INDUSTRY; CHEMICAL THICKENERS FOR USE IN THE MANUFACTURE OF ADHESIVES, PAINTS, VARNISHES, LACQUERS, COATINGS; CHEMICAL ADDITIVES FOR ADHESIVES; UNPROCESSED ARTIFICIAL RESINS FOR INDUSTRIAL USE; CHEMICAL ADDITIVES FOR BITUMEN; VULCANISATION ACCELERATORS; VULCANISING PREPARATIONS IN THE NATURE OF CHEMICALS FOR USE IN INDUSTRY AND SCIENCE; CHEMICAL ADDITIVES FOR USE IN THE MANUFACTURE OF PAINTS, VARNISHES, LACQUERS; CHEMICALS FOR RUBBER PROCESSING APPLICATIONS, NAMELY, CHEMICAL INTENSIFIERS FOR RUBBER; CHEMICAL ADDITIVES FOR RUBBER SOLUTIONS; UNPROCESSED PLASTICS DISPERSIONS; UNPROCESSED PLASTICS (U.S. CLS. 1, 5, 6, 10, 26 AND 46).  
FIRST USE 3-8-2001; IN COMMERCE 3-8-2001.

**CLASS 2—PAINTS**

FOR PAINTS, VARNISHES, LACQUERS; PRESERVATIVES AGAINST RUST IN THE NATURE OF A COATING; PRESERVATIVES AGAINST DETERIORATION OF WOOD; COLORANTS; RAW NATURAL RESINS; ANTI-CORROSIVE PREPARATIONS IN THE NATURE OF A COATING, WOOD PRESERVATIVES; BINDING PREPARATIONS FOR COATINGS, PAINTS, VARNISHES AND LACQUERS (U.S. CLS. 6, 11 AND 16).  
FIRST USE 3-8-2001; IN COMMERCE 3-8-2001.

4,593,352. COLLINS, MICHAEL, BLANCHARD, OK. SN 85-642,268. PUB. 11-6-2012, FILED 6-4-2012.

**SUBSHOT**

THE MARK CONSISTS OF STANDARD CHARACTERS WITHOUT CLAIM TO ANY PARTICULAR FONT, STYLE, SIZE, OR COLOR.

**CLASS 13—FIREARMS**

FOR BARREL INSERTS FOR SHOTGUNS; COMPONENT PARTS FOR SHOTGUNS (U.S. CLS. 2 AND 9).  
FIRST USE 6-20-2014; IN COMMERCE 6-20-2014.

4,593,354. LORUSSO LAW FIRM, PC, ATLANTA, GA. SN 85-642,522. PUB. 6-4-2013, FILED 6-4-2012.

**CLASS 28—TOYS AND SPORTING GOODS**

FOR TARGET LAUNCHERS FOR SKEETS AND CLAY PIGEONS; CLAY PIGEON TRAPS; CLAY PIGEONS; TARGETS (U.S. CLS. 22, 23, 38 AND 50).  
FIRST USE 6-20-2014; IN COMMERCE 6-20-2014.



OWNER OF U.S. REG. NO. 3,925,175.  
NO CLAIM IS MADE TO THE EXCLUSIVE RIGHT TO USE "LAWYER" IN CLASS 45, APART FROM THE MARK AS SHOWN.

THE COLOR(S) BLUE, WHITE AND BLACK IS/ARE CLAIMED AS A FEATURE OF THE MARK.

THE MARK CONSISTS OF THE WORDS "BLUE LINE" WITH LETTERS IN WHITE ON A BLUE GRADIENT RECTANGULAR BACKGROUND; THE WORD "LAWYER" WITH LETTERS IN BLACK ON A WHITE BACKGROUND; THE SILHOUETTE OF A MAN IN A BUSINESS SUIT WITH A SHIRT AND TIE IS DRAWN THROUGH THE WORDS AT THE LETTER "I" IN "LINE" AND BETWEEN THE "Y" AND "E" IN THE WORD "LAWYER". THE LETTER "I" IN WHITE FORMS THE WHITE SHIRT ON THE SILHOUETTE.

4,593,353. KOI CONCEPTS, LLC, DUARTE, CA. SN 85-642,445. PUB. 4-30-2013, FILED 6-4-2012.

RX SLEEVE

THE MARK CONSISTS OF STANDARD CHARACTERS WITHOUT CLAIM TO ANY PARTICULAR FONT, STYLE, SIZE, OR COLOR.

NO CLAIM IS MADE TO THE EXCLUSIVE RIGHT TO USE "SLEEVE", APART FROM THE MARK AS SHOWN.

**CLASS 10—MEDICAL APPARATUS**

FOR ADULT SEXUAL AIDS, NAMELY, HARNESES FOR NON-ELECTRIC MASSAGE DEVICES AND ACCESSORIES THEREFOR FOR USE IN MASSAGING OR VIBRATING PORTIONS OF THE FACE AND BODY; IMITATION SEXUAL ORGANS, NAMELY, PENISES, PENISES AND TESTICLES, AND DILDOS; DEVICES FOR AIDING IN SEXUAL INTERCOURSE AND MASTURBATION, NAMELY, REPRODUCTIONS OF PARTS OF THE MALE AND FEMALE ANATOMY; BODY TAPE ACCOMPANYING ADULT SEXUAL AIDS; STIMULATION DEVICES FOR AIDING IN SEXUAL AROUSAL AND SEXUAL PERFORMANCE; VIBRATOR SLEEVES; ERECTION AND ORGASM-ENHANCING ARTICLES FOR IMMEDIATE APPLICATION TO THE HUMAN BODY, NAMELY, PENIS ENLARGERS (U.S. CLS. 26, 39 AND 44).  
FIRST USE 4-26-2012; IN COMMERCE 4-26-2012.

**CLASS 35—ADVERTISING AND BUSINESS**

FOR ON-LINE RETAIL STORE SERVICES FEATURING ADULT SEXUAL AIDS, NAMELY, HARNESES, BODY TAPE, PENIS EXTENDERS, PENIS ENHANCEMENT SLEEVES, IMITATION SEXUAL ORGANS, NAMELY, PENISES, PENISES AND TESTICLES, AND ERECTION AND ORGASM-ENHANCING ARTICLES FOR IMMEDIATE APPLICATION TO THE HUMAN BODY (U.S. CLS. 100, 101 AND 102).  
FIRST USE 4-26-2012; IN COMMERCE 4-26-2012.

**CLASS 21—HOUSEWARES AND GLASS**

FOR HOUSEWARES AND GLASS, NAMELY, COFFEE MUGS, DRINKING GLASSES, AND INSULATED CONTAINERS FOR BEVERAGES FOR DOMESTIC USE (U.S. CLS. 2, 13, 23, 29, 30, 33, 40 AND 50).  
FIRST USE 3-12-2014; IN COMMERCE 3-12-2014.

**CLASS 25—CLOTHING**

FOR CLOTHING, NAMELY, SHIRTS, JACKETS, AND HATS (U.S. CLS. 22 AND 39).  
FIRST USE 6-27-2012; IN COMMERCE 6-27-2012.

**CLASS 45—PERSONAL AND LEGAL SERVICES**

FOR ONLINE REPORTING OF NEWS AND OPINIONS REGARDING LEGAL ISSUES FOR LAW ENFORCEMENT PERSONNEL (U.S. CLS. 100 AND 101).  
FIRST USE 8-6-2012; IN COMMERCE 8-6-2012.

4,593,358. JEUNESSE GLOBAL HOLDINGS, LLC, ALTA-MONTE SPRINGS, FL. SN 85-646,104. PUB. 10-30-2012, FILED 6-7-2012.

REDEFINING YOUTH

THE MARK CONSISTS OF STANDARD CHARACTERS WITHOUT CLAIM TO ANY PARTICULAR FONT, STYLE, SIZE, OR COLOR.

**CLASS 3—COSMETICS AND CLEANING PREPARATIONS**

FOR SKIN CARE PRODUCTS, NAMELY, NON-MEDICATED SKIN SERUM (U.S. CLS. 1, 4, 6, 50, 51 AND 52).  
FIRST USE 6-0-2012; IN COMMERCE 6-0-2012.

**CLASS 5—PHARMACEUTICALS**

FOR DIETARY AND NUTRITIONAL SUPPLEMENTS (U.S. CLS. 6, 18, 44, 46, 51 AND 52).  
FIRST USE 6-0-2012; IN COMMERCE 6-0-2012.

4,593,363. CARIS MPI, INC., PHOENIX, AZ. SN 85-648,491.  
PUB. 5-14-2013, FILED 6-11-2012.

**MOLECULAR INTELLIGENCE**

THE MARK CONSISTS OF STANDARD CHARACTERS WITHOUT CLAIM TO ANY PARTICULAR FONT, STYLE, SIZE, OR COLOR.

NO CLAIM IS MADE TO THE EXCLUSIVE RIGHT TO USE "MOLECULAR", APART FROM THE MARK AS SHOWN.

**CLASS 42—SCIENTIFIC AND COMPUTER SERVICES**

FOR MEDICAL RESEARCH, NAMELY, ASSESSMENT OF CLINICAL DATA; MEDICAL RESEARCH, NAMELY, ANNOTATION OF INDIVIDUALIZED CLINICAL DATA WITH PUBLISHED CLINICAL DATA RESULTS (U.S. CLS. 100 AND 101).

FIRST USE 1-28-2013; IN COMMERCE 1-28-2013.

**CLASS 44—MEDICAL, BEAUTY AND AGRICULTURAL SERVICES**

FOR MEDICAL SCREENING SERVICES IN THE FIELD OF CANCER; MEDICAL DIAGNOSTIC TESTING, MONITORING AND REPORTING SERVICES; PATHOLOGY DIAGNOSTIC SERVICES FOR MEDICAL PURPOSES; PROGNOSTIC ANALYSIS SERVICES FOR MEDICAL PURPOSES; THERANOSTIC ANALYSIS SERVICES FOR MEDICAL PURPOSES; MOLECULAR DIAGNOSTIC SERVICES FOR MEDICAL PURPOSES (U.S. CLS. 100 AND 101).

FIRST USE 1-28-2013; IN COMMERCE 1-28-2013.

4,593,367. DRYBAR HOLDINGS LLC, DALLAS, TX. SN 85-652,271. PUB. 11-6-2012, FILED 6-14-2012.

**PEACE, LOVE & BLOWOUTS!**

THE MARK CONSISTS OF THE WORDS "PEACE, LOVE & BLOWOUTS!" IN CAPITAL LETTERS, WITH A HEART IN PLACE OF THE FIRST LETTER "O" IN "BLOWOUTS".

**CLASS 3—COSMETICS AND CLEANING PREPARATIONS**

FOR HAIR SHAMPOOS AND CONDITIONERS; HAIR SPRAYS AND HAIR GELS; HAIR STYLING PREPARATIONS (U.S. CLS. 1, 4, 6, 50, 51 AND 52).

FIRST USE 10-31-2013; IN COMMERCE 10-31-2013.

**CLASS 8—HAND TOOLS**

FOR FLAT IRONS FOR STYLING HAIR; HAIR CURLING IRONS; HAIR DRYERS; BLOWDRYERS; HAIR-BRUSHES (U.S. CLS. 23, 28 AND 44).  
FIRST USE 12-31-2012; IN COMMERCE 12-31-2012.

4,593,370. ELECNR, S.A., BILBAO, SPAIN. SN 85-655,102.  
PUB. 12-31-2013, FILED 6-19-2012.



NO CLAIM IS MADE TO THE EXCLUSIVE RIGHT TO USE "GROUP", APART FROM THE MARK AS SHOWN.

THE COLOR(S) BLUE AND ORANGE IS/ARE CLAIMED AS A FEATURE OF THE MARK.

THE MARK CONSISTS OF AN ORANGE COLORED CURVED BAND ABOVE THE WORD "BELCO" AND THE WORDS "ELECNR GROUP" BELOW THE WORD "BELCO". WITH ALL LETTERS IN ALL WORDS BEING IN BLUE COLOR AND LOWER CASE, THE WORD "BELCO" BEING IN LARGER FONT THAN THE WORDS "ELECNR GROUP", THE WORDS "BELCO" AND "ELECNR" BEING IN BOLD FONT.

**CLASS 37—CONSTRUCTION AND REPAIR**

FOR CONSTRUCTION SERVICES, NAMELY, THE CONSTRUCTION AND MAINTENANCE OF BUILDINGS, INDUSTRIAL PLANTS, WIND AND SOLAR ENERGY FARMS; CONSTRUCTION AND MAINTENANCE OF ELECTRICAL AND TELECOMMUNICATIONS INFRASTRUCTURES, NAMELY, TELECOMMUNICATIONS TOWERS, AND CONSTRUCTION AND MAINTENANCE OF BUILDINGS AND INDUSTRIAL PLANTS, AND WIND AND SOLAR FARMS (U.S. CLS. 100, 103 AND 106).

FIRST USE 6-23-2014; IN COMMERCE 6-23-2014.

**CLASS 42—SCIENTIFIC AND COMPUTER SERVICES**

FOR ENGINEERING SERVICES FOR THE DESIGN, CONSTRUCTION AND ASSEMBLY OF ELECTRICAL AND TELECOMMUNICATIONS INFRASTRUCTURES, AS WELL AS FOR BUILDINGS, INDUSTRIAL PLANTS, WIND AND SOLAR ENERGY FARMS (U.S. CLS. 100 AND 101).

FIRST USE 6-23-2014; IN COMMERCE 6-23-2014.

4,593,379. CORN PRODUCTS DEVELOPMENT, INC., WESTCHESTER, IL. SN 85-658,812. PUB. 11-20-2012, FILED 6-22-2012.

**DEVELOPING  
IDEAS.DELIVERING SOLUTIONS**

THE MARK CONSISTS OF STANDARD CHARACTERS WITHOUT CLAIM TO ANY PARTICULAR FONT, STYLE, SIZE, OR COLOR.

OWNER OF U.S. REG. NOS. 3,873,775 AND 4,552,194.

**CLASS 1—CHEMICALS**

FOR INDUSTRIAL STARCH, DEXTRIN, CORN SYRUPS, POLYMERS AND POLYMERIC ADDITIVES AND ARTIFICIAL AND SYNTHETIC RESINS FOR USE IN THE MANUFACTURE OF PAPER, PAPERBOARD, LINERBOARD, TEXTILES, FOAMED PRODUCTS, ADHESIVES, BUILDING MATERIALS, CONSTRUCTION MATERIALS, PERSONAL CARE PRODUCTS, CLEANING PRODUCTS, PACKAGING MATERIALS AND PHARMACEUTICALS; INDUSTRIAL STARCHES, HYDROCOLLOIDS, FLOURS, EMULSIFIERS, AND THICKENERS FOR THE MANUFACTURE OF FOODS AND BEVERAGES; INDUSTRIAL STARCHES FOR THE ENCAPSULATION OF FLAVORS, VITAMINS AND SPICES; NATURAL SWEETENERS, GLUCOSE, DEXTROSE AND CORN SYRUP AND EXCIPIENTS, STARCH, POLYOLS, PLANT DERIVED CALCIUM AND MINERALS FOR USE IN THE MANUFACTURE OF PHARMACEUTICALS, INFANT FOOD, NUTRITIONAL SUPPLEMENTS FOR ANIMALS; INDUSTRIAL STARCH SYRUPS, CORN SYRUPS, DEXTRIN, STARCHES HYDROCOLLOIDS, FLOURS, EMULSIFIERS, NATURAL SWEETENERS, GLUCOSE, DEXTROSE, POLYOLS, DIETARY FIBERS, PREBIOTIC FIBERS, INULIN FIBERS, PLANT DERIVED CALCIUM AND MINERALS, THICKENERS FOR USE IN THE MANUFACTURE OF FOODS AND BEVERAGES FOR USE IN THE MANUFACTURE OF ANIMAL FEED AND NUTRITIONAL SUPPLEMENTS (U.S. CLS. 1, 5, 6, 10, 26 AND 46).

FIRST USE 6-30-2012; IN COMMERCE 6-30-2012.

**CLASS 5—PHARMACEUTICALS**

FOR DIETARY FIBER FOR USE IN TREATING CONSTIPATION, DIABETES, HEART DISEASE AND GASTROINTESTINAL DISORDERS, TO AID IN DIGESTION, WEIGHT MANAGEMENT, AND ENERGY LEVELS FOR USE IN THE MANUFACTURE OF PHARMACEUTICALS, INFANT FOOD, NUTRITIONAL SUPPLEMENTS AND DIETETIC SUBSTANCES FOR MEDICAL USE, AND FOR USE IN THE MANUFACTURE OF FOOD AND BEVERAGES AND FOR USE IN THE MANUFACTURE OF ANIMAL FEED AND NUTRITIONAL SUPPLEMENTS FOR ANIMALS; PREBIOTIC FIBERS AND INULIN FIBERS FOR USE IN TREATING CONSTIPATION, DIABETES, HEART DISEASE AND GASTROINTESTINAL DISORDERS, TO AID IN DIGESTION, WEIGHT MANAGEMENT, AND ENERGY LEVELS FOR USE IN THE MANUFACTURE OF INFANT FOOD, NUTRITIONAL SUPPLEMENTS AND DIETETIC SUBSTANCES FOR MEDICAL USE AND FOR USE IN THE MANUFACTURE OF FOOD AND BEVERAGES; DIETETIC SUGAR SUBSTITUTES, GLUCOSE, LACTOSE AND MILK SUGAR ALL FOR MEDICAL USE (U.S. CLS. 6, 18, 44, 46, 51 AND 52).

FIRST USE 6-30-2012; IN COMMERCE 6-30-2012.

**CLASS 42—SCIENTIFIC AND COMPUTER SERVICES**

FOR SCIENTIFIC AND TECHNOLOGICAL CONSULTING SERVICES, RESEARCH AND DESIGN, INDUSTRIAL ANALYSIS AND DEVELOPMENT FOR MANUFACTURERS OF FOOD, BEVERAGES, PAPER, PAPERBOARD, LINERBOARD, TEXTILES, FOAMED PRODUCTS, ADHESIVES, BUILDING MATERIALS, CONSTRUCTION MATERIALS, PERSONAL CARE PRODUCTS, CLEANING PRODUCTS, PACKAGING MATERIALS, PHARMACEUTICALS, INFANT FOOD, NUTRITIONAL SUPPLEMENTS, NUTRITIONAL FOODS AND BEVERAGES AND ANIMAL FEED (U.S. CLS. 100 AND 101).

FIRST USE 6-30-2012; IN COMMERCE 6-30-2012.

4,593,381. PI DELTA PSI FRATERNITY, INC., FLUSHING, NY. SN 85-660,151. PUB. 4-8-2014, FILED 6-25-2012.



NO CLAIM IS MADE TO THE EXCLUSIVE RIGHT TO USE "1994", APART FROM THE MARK AS SHOWN.

THE COLOR(S) RED, GOLD, BLACK, WHITE, GRAY, GREEN, BROWN AND TAN IS/ARE CLAIMED AS A FEATURE OF THE MARK.

THE MARK CONSISTS OF A WHITE CREST WITH GRAY SHADING IN THE SHAPE OF A SHIELD, WITH A BORDER IN GOLD OUTLINED IN BLACK, AND GOLD LINES OUTLINED IN BLACK FORMING A CROSS, DIVIDING THE SHIELD INTO FOUR QUADRANTS, WITH A RED STRIPE OUTLINED IN BLACK RUNNING FROM THE UPPER LEFT CORNER TO THE LOWER RIGHT CORNER, AND A BLACK AND WHITE YIN YANG SYMBOL IN THE MIDDLE. THE UPPER LEFT QUADRANT CONTAINS A WHITE SCROLL OUTLINED IN BLACK. THE UPPER RIGHT QUADRANT CONTAINS A BALANCING SCALE IN GRAY AND BLACK. THE LOWER LEFT QUADRANT CONTAINS A HANDSHAKE BETWEEN TWO TAN HANDS OUTLINED IN BLACK WITH GRAY SHIRT CUFFS OUTLINED IN BLACK. THE LOWER RIGHT QUADRANT CONTAINS A PICTURE OF A TREE WITH GREEN LEAVES OUTLINED IN BLACK AND A BROWN TRUNK AND BRANCHES OUTLINED IN BLACK. A SMALL WHITE BANNER WITH BROWN SHADING AND OUTLINED IN BLACK IS AT THE BOTTOM OF THE CREST WITH THE YEAR "1994" IN THE MIDDLE OF THE BANNER IN BLACK.

**CLASS 25—CLOTHING**

FOR T-SHIRTS, SHORTS, COATS, JACKETS, VESTS, SWEATSHIRTS, SWEATPANTS, JERSEYS, SPORTSWEAR, NAMELY, SHIRTS, JACKETS, PANTS, WARM-UP SUITS, PULLOVERS, HATS, CAPS, POLO SHIRTS, TANKTOPS, SWEATERS, RAINCOATS, SWIMWEAR, ROBES AND PAJAMAS, NECKWEAR, NECKTIES, SCARVES, GLOVES, MITTENS (U.S. CLS. 22 AND 39).

FIRST USE 7-1-2012; IN COMMERCE 7-1-2012.

**CLASS 35—ADVERTISING AND BUSINESS**

FOR ASSOCIATION SERVICES, NAMELY, ORGANIZING CHAPTERS OF A FRATERNITY AND PROMOTING THE INTERESTS OF THE MEMBERS THEREOF (U.S. CLS. 100, 101 AND 102).

FIRST USE 7-1-2012; IN COMMERCE 7-1-2012.

4,593,383. INFUSED COMPANY, DENVER, CO. SN 85-660,728. PUB. 12-4-2012, FILED 6-25-2012.

4,593,394. CARDINAL MCCLOSKEY SCHOOL AND HOME FOR CHILDREN, VALHALLA, NY. SN 85-671,821. PUB. 12-17-2013, FILED 7-9-2012.

# INFUSED

THE MARK CONSISTS OF STANDARD CHARACTERS WITHOUT CLAIM TO ANY PARTICULAR FONT, STYLE, SIZE, OR COLOR.

## CLASS 35—ADVERTISING AND BUSINESS

FOR BUSINESS CONSULTING REGARDING BUSINESS INNOVATION AND GROUP DYNAMICS (U.S. CLS. 100, 101 AND 102).

FIRST USE 1-15-2012; IN COMMERCE 3-15-2012.

## CLASS 41—EDUCATION AND ENTERTAINMENT

FOR EDUCATION SERVICES, NAMELY, PROVIDING CLASSES, WORKSHOPS AND SEMINARS IN THE FIELDS OF INNOVATION AND GROUP DYNAMICS, EDUCATION SERVICES, NAMELY, MENTORING IN THE FIELD OF INNOVATION AND GROUP DYNAMICS (U.S. CLS. 100, 101 AND 107).

FIRST USE 1-15-2012; IN COMMERCE 3-15-2012.

---

4,593,393. JERVIS, KALI DAY, DBA KALI DAY, BROOKLYN, NY. SN 85-671,217. PUB. 12-4-2012, FILED 7-8-2012.

# Kali Day

THE MARK CONSISTS OF STANDARD CHARACTERS WITHOUT CLAIM TO ANY PARTICULAR FONT, STYLE, SIZE, OR COLOR.

THE NAME "KALI DAY" IDENTIFIES A LIVING INDIVIDUAL WHOSE CONSENT IS OF RECORD.

## CLASS 14—JEWELRY

FOR JEWELRY (U.S. CLS. 2, 27, 28 AND 50).  
FIRST USE 10-1-2005; IN COMMERCE 5-26-2012.

## CLASS 25—CLOTHING

FOR WOMEN'S CLOTHING, NAMELY, SHIRTS, DRESSES, SKIRTS, BLOUSES (U.S. CLS. 22 AND 39).  
FIRST USE 10-1-2005; IN COMMERCE 7-23-2013.



Cardinal McCloskey  
COMMUNITY SERVICES

NO CLAIM IS MADE TO THE EXCLUSIVE RIGHT TO USE "COMMUNITY SERVICES", APART FROM THE MARK AS SHOWN.

THE NAME "CARDINAL MCCLOSKEY" DOES NOT IDENTIFY A LIVING INDIVIDUAL.

THE MARK CONSISTS OF THE WORDS "CARDINAL MCCLOSKEY COMMUNITY SERVICES" BENEATH A LOGO IN THE FORM OF A STYLIZED HEART WITHIN A HEART.

## CLASS 35—ADVERTISING AND BUSINESS

FOR ENHANCING THE QUALITY OF LIFE FOR CHILDREN WITH DEVELOPMENTAL PROBLEMS AND THEIR FAMILY MEMBERS BY PROVIDING INFORMATION REGARDING CAREER OPPORTUNITIES (U.S. CLS. 100, 101 AND 102).

FIRST USE 5-21-2014; IN COMMERCE 5-21-2014.

## CLASS 36—INSURANCE AND FINANCIAL

FOR ENHANCING THE QUALITY OF LIFE FOR CHILDREN WITH DEVELOPMENTAL PROBLEMS AND THEIR FAMILY MEMBERS BY PROVIDING ASSISTANCE IN OBTAINING RESIDENTIAL REAL ESTATE QUARTERS AND PROVIDING FINANCIAL ASSISTANCE IN THE NATURE OF RENT, FOOD AND CLOTHING STIPENDS TO HELP MAINTAIN INTACT FAMILY UNITS (U.S. CLS. 100, 101 AND 102).

FIRST USE 5-21-2014; IN COMMERCE 5-21-2014.

## CLASS 41—EDUCATION AND ENTERTAINMENT

FOR ENHANCING THE QUALITY OF LIFE FOR CHILDREN WITH DEVELOPMENTAL PROBLEMS AND THEIR FAMILY MEMBERS BY PROVIDING INFORMATION ON VOCATIONAL TRAINING AND HIGHER EDUCATION, PROVIDING EDUCATIONAL SERVICES IN THE NATURE OF CLASSES, SEMINARS AND INDIVIDUAL TUTORING TO IMPROVE BEHAVIORAL AND DISABILITY PROBLEMS, PROVIDING EDUCATIONAL SERVICES IN THE NATURE OF CLASSES, SEMINARS AND INDIVIDUAL TUTORING FOR PROMOTING INDEPENDENCE AND PRODUCTIVITY OF INDIVIDUALS, AND PROVIDING ENHANCED EDUCATIONAL SERVICES IN THE NATURE OF CLASSES, SEMINARS AND INDIVIDUAL TUTORING GEARED TOWARD FINDING EMPLOYMENT TO PERSONS WITH DEVELOPMENTAL DISABILITIES (U.S. CLS. 100, 101 AND 107).

FIRST USE 5-21-2014; IN COMMERCE 5-21-2014.

**CLASS 43—HOTEL AND RESTAURANT SERVICES**

FOR ENHANCING THE QUALITY OF LIFE FOR CHILDREN WITH DEVELOPMENTAL PROBLEMS AND THEIR FAMILY MEMBERS BY PROVIDING HALFWAY HOUSES FOR TRANSITION FROM FOSTER CARE TO SELF-SUFFICIENCY, PROVIDING TEMPORARY SHELTER AND FOOD FOR HOMELESS RUN-AWAY AND AT-RISK YOUTH, PROVIDING FOOD TO FAMILIES IN NEED, PROVIDING TEMPORARY EMERGENCY RESIDENCES FOR ABUSED OR NEGLECTED CHILDREN, PROVIDING TEMPORARY RESIDENCES TO YOUNG WOMEN WHO HAVE BEEN PHYSICALLY AND SEXUALLY ABUSED, PROVIDING PRESCHOOL AND INFANT CARE AT DAYCARE CENTERS (U.S. CLS. 100 AND 101).

FIRST USE 5-21-2014; IN COMMERCE 5-21-2014.

**CLASS 44—MEDICAL, BEAUTY AND AGRICULTURAL SERVICES**

FOR ENHANCING THE QUALITY OF LIFE FOR CHILDREN WITH DEVELOPMENTAL PROBLEMS AND THEIR FAMILY MEMBERS BY PROVIDING SPECIALIZED HEALTHCARE FOR THE TREATMENT OF PHYSICAL AND SEXUAL ABUSE, PROVIDING IN DEPTH MEDICAL COUNSELING TO FAMILIES WITH CHILDREN HAVING SPECIAL MEDICAL AND DEVELOPMENTAL NEEDS, PROVIDING PSYCHOLOGICAL COUNSELING SERVICES TO ASSIST IN IMPROVING BEHAVIORAL AND DISCIPLINARY PROBLEMS, PROVIDING PSYCHOLOGICAL COUNSELING SERVICES TO ASSIST IN HELPING TO MAINTAIN INTACT FAMILY UNITS, AND PROVIDING PSYCHOLOGICAL COUNSELING FOR ASSISTING INDIVIDUALS BY PROMOTING INDEPENDENCE AND PRODUCTIVITY (U.S. CLS. 100 AND 101).

FIRST USE 5-21-2014; IN COMMERCE 5-21-2014.

**CLASS 45—PERSONAL AND LEGAL SERVICES**

FOR ENHANCING THE QUALITY OF LIFE FOR CHILDREN WITH DEVELOPMENTAL PROBLEMS AND THEIR FAMILY MEMBERS BY PROVIDING FOSTER CARE, PROVIDING ADOPTION PLACEMENT, PROVIDING MEDICAL CASE MANAGEMENT SERVICES IN THE NATURE OF COORDINATION OF NECESSARY MEDICAL SERVICES TO FAMILIES WITH CHILDREN HAVING SPECIAL MEDICAL NEEDS, PROVIDING COMPREHENSIVE MEDICAL AND MEDICAL CLINICAL CARE TO CHILDREN AND THEIR FAMILIES WITH PHYSICAL AND EMOTIONAL DISTURBANCES, AND PROVIDING COUNSELING IN THE FIELD OF IMPROVEMENT OF SOCIAL SKILLS TO FOSTER GROWTH IN PERSONAL DEVELOPMENT, SOCIAL SKILLS AND VOCATIONAL READINESS FOR INDIVIDUALS WITH DEVELOPMENTAL DISABILITIES (U.S. CLS. 100 AND 101).

FIRST USE 5-21-2014; IN COMMERCE 5-21-2014.

**CLASS 35—ADVERTISING AND BUSINESS**

FOR ENHANCING THE QUALITY OF LIFE FOR CHILDREN WITH DEVELOPMENTAL PROBLEMS AND THEIR FAMILY MEMBERS BY PROVIDING INFORMATION REGARDING CAREER OPPORTUNITIES (U.S. CLS. 100, 101 AND 102).

FIRST USE 5-21-2014; IN COMMERCE 5-21-2014.

**CLASS 36—INSURANCE AND FINANCIAL**

FOR ENHANCING THE QUALITY OF LIFE FOR CHILDREN WITH DEVELOPMENTAL PROBLEMS AND THEIR FAMILY MEMBERS BY PROVIDING ASSISTANCE IN OBTAINING RESIDENTIAL REAL ESTATE QUARTERS AND PROVIDING FINANCIAL ASSISTANCE IN THE NATURE OF RENT, FOOD AND CLOTHING STIPENDS TO HELP MAINTAIN INTACT FAMILY UNITS (U.S. CLS. 100, 101 AND 102).

FIRST USE 5-21-2014; IN COMMERCE 5-21-2014.

**CLASS 41—EDUCATION AND ENTERTAINMENT**

FOR ENHANCING THE QUALITY OF LIFE FOR CHILDREN WITH DEVELOPMENTAL PROBLEMS AND THEIR FAMILY MEMBERS BY PROVIDING INFORMATION ON VOCATIONAL TRAINING AND HIGHER EDUCATION, PROVIDING EDUCATIONAL SERVICES IN THE NATURE OF CLASSES, SEMINARS AND INDIVIDUAL TUTORING TO IMPROVE BEHAVIORAL AND DISABILITY PROBLEMS, PROVIDING EDUCATIONAL SERVICES IN THE NATURE OF CLASSES, SEMINARS AND INDIVIDUAL TUTORING FOR PROMOTING INDEPENDENCE AND PRODUCTIVITY OF INDIVIDUALS, AND PROVIDING ENHANCED EDUCATIONAL SERVICES IN THE NATURE OF CLASSES, SEMINARS AND INDIVIDUAL TUTORING GEARED TOWARD FINDING EMPLOYMENT TO PERSONS WITH DEVELOPMENTAL DISABILITIES (U.S. CLS. 100, 101 AND 107).

FIRST USE 5-21-2014; IN COMMERCE 5-21-2014.

**CLASS 43—HOTEL AND RESTAURANT SERVICES**

FOR ENHANCING THE QUALITY OF LIFE FOR CHILDREN WITH DEVELOPMENTAL PROBLEMS AND THEIR FAMILY MEMBERS BY PROVIDING HALFWAY HOUSES FOR TRANSITION FROM FOSTER CARE TO SELF-SUFFICIENCY, PROVIDING TEMPORARY SHELTER AND FOOD FOR HOMELESS RUN-AWAY AND AT-RISK YOUTH, PROVIDING FOOD TO FAMILIES IN NEED, PROVIDING TEMPORARY EMERGENCY RESIDENCES FOR ABUSED OR NEGLECTED CHILDREN, PROVIDING TEMPORARY RESIDENCES TO YOUNG WOMEN WHO HAVE BEEN PHYSICALLY AND SEXUALLY ABUSED, PROVIDING PRESCHOOL AND INFANT CARE AT DAYCARE CENTERS (U.S. CLS. 100 AND 101).

FIRST USE 5-21-2014; IN COMMERCE 5-21-2014.

**CLASS 44—MEDICAL, BEAUTY AND AGRICULTURAL SERVICES**

FOR ENHANCING THE QUALITY OF LIFE FOR CHILDREN WITH DEVELOPMENTAL PROBLEMS AND THEIR FAMILY MEMBERS BY PROVIDING SPECIALIZED HEALTHCARE FOR THE TREATMENT OF PHYSICAL AND SEXUAL ABUSE, PROVIDING IN DEPTH MEDICAL COUNSELING TO FAMILIES WITH CHILDREN HAVING SPECIAL MEDICAL AND DEVELOPMENTAL NEEDS, PROVIDING PSYCHOLOGICAL COUNSELING SERVICES TO ASSIST IN IMPROVING BEHAVIORAL AND DISCIPLINARY PROBLEMS, PROVIDING PSYCHOLOGICAL COUNSELING SERVICES TO ASSIST IN HELPING TO MAINTAIN INTACT FAMILY UNITS, AND PROVIDING PSYCHOLOGICAL COUNSELING FOR ASSISTING INDIVIDUALS BY PROMOTING INDEPENDENCE AND PRODUCTIVITY (U.S. CLS. 100 AND 101).

FIRST USE 5-21-2014; IN COMMERCE 5-21-2014.

4,593,395. CARDINAL MCCLOSKEY SCHOOL AND HOME FOR CHILDREN, VALHALLA, NY. SN 85-671,853. PUB. 11-26-2013, FILED 7-9-2012.

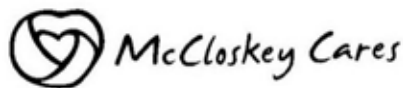

THE MARK CONSISTS OF THE WORDS "MCCLOSKEY CARES" ADJACENT A STYLIZED FIGURE OF A HEART WITHIN A HEART.

**CLASS 45—PERSONAL AND LEGAL SERVICES**

FOR ENHANCING THE QUALITY OF LIFE FOR CHILDREN WITH DEVELOPMENTAL PROBLEMS AND THEIR FAMILY MEMBERS BY PROVIDING FOSTER CARE, PROVIDING ADOPTION PLACEMENT, PROVIDING MEDICAL CASE MANAGEMENT SERVICES IN THE NATURE OF COORDINATION OF NECESSARY MEDICAL SERVICES TO FAMILIES WITH CHILDREN HAVING SPECIAL MEDICAL NEEDS, PROVIDING COMPREHENSIVE MEDICAL AND MEDICAL CLINICAL CARE TO CHILDREN AND THEIR FAMILIES WITH PHYSICAL AND EMOTIONAL DISTURBANCES, AND PROVIDING COUNSELING IN THE FIELD OF IMPROVEMENT OF SOCIAL SKILLS TO FOSTER GROWTH IN PERSONAL DEVELOPMENT, SOCIAL SKILLS AND VOCATIONAL READINESS FOR INDIVIDUALS WITH DEVELOPMENTAL DISABILITIES (U.S. CLS. 100 AND 101).

FIRST USE 5-21-2014; IN COMMERCE 5-21-2014.

4,593,398. INTEGR8 FUELS INC., MAJURO, MARSHALL ISLANDS. SN 85-672,433. PUB. 8-13-2013, FILED 7-10-2012.

# INTEGR8

**CLASS 4—LUBRICANTS AND FUELS**

FOR DIESEL OIL, FUEL OIL, GAS OIL, LUBRICATING OILS, ENGINE OIL FOR MARINE VEHICLES (U.S. CLS. 1, 6 AND 15).

FIRST USE 6-17-2013; IN COMMERCE 6-17-2013.

**CLASS 35—ADVERTISING AND BUSINESS**

FOR ADVERTISING; BUSINESS MANAGEMENT AND ADMINISTRATION; PROVIDING OFFICE FUNCTIONS; WHOLESALE AND RETAIL STORE SERVICES FEATURING DIESEL OIL, FUEL OIL, GAS OIL, LUBRICATING OILS AND ENGINE OIL FOR MARINE VEHICLES (U.S. CLS. 100, 101 AND 102).

FIRST USE 6-17-2013; IN COMMERCE 6-17-2013.

4,593,403. KITCHENSIDE LLC, SAN DIEGO, CA. SN 85-677,044. PUB. 5-14-2013, FILED 7-13-2012.

# Curious Fork

THE MARK CONSISTS OF STANDARD CHARACTERS WITHOUT CLAIM TO ANY PARTICULAR FONT, STYLE, SIZE, OR COLOR.

NO CLAIM IS MADE TO THE EXCLUSIVE RIGHT TO USE "FORK", APART FROM THE MARK AS SHOWN.

**CLASS 35—ADVERTISING AND BUSINESS**

FOR RETAIL STORE SERVICES, COMPUTERIZED ON-LINE RETAIL STORE SERVICES, AND ELECTRONIC CATALOG SERVICES, ALL FEATURING FOODS, CUTLERY, KITCHEN GADGETS, KITCHEN APPLIANCES, KITCHEN UTENSILS, KITCHENWARE, COOKWARE, GIFTWARE, FLATWARE, AND COOKBOOKS; RETAIL FOOD STORE SERVICES; RETAIL STORE SERVICES FEATURE FINE FOOD AND KITCHENWARE (U.S. CLS. 100, 101 AND 102).

FIRST USE 6-12-2014; IN COMMERCE 6-12-2014.

**CLASS 41—EDUCATION AND ENTERTAINMENT**

FOR EDUCATIONAL SERVICES, NAMELY, PROVIDING CLASSES AND ONLINE INSTRUCTION IN THE FIELD OF CULINARY ARTS; EDUCATIONAL SERVICES, NAMELY, CONDUCTING COURSES, SEMINARS, AND WORKSHOPS IN THE FIELD OF FOOD AND BEVERAGE PREPARATION AND RECIPES AND PREPARATION DEMONSTRATIONS (U.S. CLS. 100, 101 AND 107).

FIRST USE 6-12-2014; IN COMMERCE 6-12-2014.

**CLASS 43—HOTEL AND RESTAURANT SERVICES**

FOR RESTAURANT SERVICES; PROVIDING INFORMATION ONLINE REGARDING FOOD, WINE, BEVERAGES, COOKING, BAKING, RECIPES, DINING AND RESTAURANT INFORMATION; CATERING SERVICES (U.S. CLS. 100 AND 101).

FIRST USE 6-12-2014; IN COMMERCE 6-12-2014.

4,593,408. JILL STEPHENS, SEAL BEACH, CA. SN 85-683,334. PUB. 1-22-2013, FILED 7-20-2012.

# my dog nose it

THE MARK CONSISTS OF STANDARD CHARACTERS WITHOUT CLAIM TO ANY PARTICULAR FONT, STYLE, SIZE, OR COLOR.

**CLASS 3—COSMETICS AND CLEANING PREPARATIONS**

FOR PREPARATIONS FOR REPELLING SUN, NAMELY, NON-MEDICATED SUN SCREEN FOR DOGS (U.S. CLS. 1, 4, 6, 50, 51 AND 52).

FIRST USE 7-7-2014; IN COMMERCE 7-11-2014.

**CLASS 5—PHARMACEUTICALS**

FOR NOSE DROPS FOR CATS AND DOGS; PREPARATIONS FOR REPELLING SUN, NAMELY, MEDICATED SUN SCREEN FOR DOGS (U.S. CLS. 6, 18, 44, 46, 51 AND 52).

FIRST USE 7-7-2014; IN COMMERCE 7-11-2014.



4,593,417. MAYR-MELNHOF KARTON AG, VIENNA, AUSTRIA. SN 85-688,338. PUB. 6-4-2013, FILED 7-27-2012.

## MM Packaging

THE MARK CONSISTS OF STANDARD CHARACTERS WITHOUT CLAIM TO ANY PARTICULAR FONT, STYLE, SIZE, OR COLOR.

OWNER OF U.S. REG. NO. 3,120,996.

NO CLAIM IS MADE TO THE EXCLUSIVE RIGHT TO USE "PACKAGING", APART FROM THE MARK AS SHOWN.

### CLASS 35—ADVERTISING AND BUSINESS

FOR RETAIL SERVICES BY DIRECT SOLICITATION BY SALES AGENTS OR DISTRIBUTORS IN THE FIELD OF CARTON PACKAGES AND FOLDING BOXES MADE OF CARTON (U.S. CLS. 100, 101 AND 102).

FIRST USE 0-0-2005; IN COMMERCE 6-29-2011.

### CLASS 42—SCIENTIFIC AND COMPUTER SERVICES

FOR DEVELOPMENT OF NEW TECHNOLOGY FOR OTHERS IN THE FIELD OF CARTON TECHNOLOGY; DEVELOPMENT OF NEW PRODUCTS FOR OTHERS IN THE FIELD OF FOLDING BOXES MADE OF CARTON (U.S. CLS. 100 AND 101).

FIRST USE 0-0-2005; IN COMMERCE 6-29-2011.

4,593,423. WORLD WRESTLING ENTERTAINMENT, INC., STAMFORD, CT. SN 85-697,614. PUB. 11-5-2013, FILED 8-7-2012.



THE MARK CONSISTS OF A LETTER "B" FOLLOWED BY A PERIOD AND THE LETTER "A" FOLLOWED BY A PERIOD FOLLOWED BY A STAR DESIGN, ALL WITHIN A SHADED RECTANGULAR BORDER, WITH THE WORDS "BE A STAR" UNDERNEATH.

### CLASS 41—EDUCATION AND ENTERTAINMENT

FOR EDUCATIONAL SERVICES, NAMELY, CONDUCTING TRAINING, WORKSHOPS, CONFERENCES AND TUTORING IN THE FIELD OF ANTI-BULLYING AND DISTRIBUTION OF EDUCATIONAL MATERIALS IN CONNECTION THEREWITH (U.S. CLS. 100, 101 AND 107).

FIRST USE 4-30-2011; IN COMMERCE 4-30-2011.

### CLASS 45—PERSONAL AND LEGAL SERVICES

FOR PROVIDING A WEBSITE FEATURING INFORMATION IN THE FIELD OF ANTI-BULLYING (U.S. CLS. 100 AND 101).

FIRST USE 4-30-2011; IN COMMERCE 4-30-2011.

4,593,427. MOBILEBITS CORP., SARASOTA, CA. SN 85-702,084. PUB. 4-9-2013, FILED 8-13-2012.

## SAMY

THE MARK CONSISTS OF STANDARD CHARACTERS WITHOUT CLAIM TO ANY PARTICULAR FONT, STYLE, SIZE, OR COLOR.

### CLASS 9—ELECTRICAL AND SCIENTIFIC APPARATUS

FOR COMPUTER SOFTWARE FOR ELECTRONIC DEVICES, NAMELY, MOBILE PHONES, TABLET COMPUTERS, PERSONAL COMPUTERS, LAPTOP COMPUTERS, ELECTRONIC READERS THAT CONSOLIDATE AND TRACK CONSUMER ELECTRONIC AND VIRTUAL GIFT CARDS, LOYALTY AND AFFINITY CARDS AND PROGRAMS, PUNCH CARDS, RECEIPTS, REBATES, COUPONS, PROMOTIONS, CUSTOMER REWARDS AND OFFERS FOR RETAIL AND CONSUMER GOODS AND SERVICES; COMPUTER SOFTWARE FOR ELECTRONIC DEVICES NAMELY, MOBILE PHONES, TABLET COMPUTERS, PERSONAL COMPUTERS, LAPTOP COMPUTERS, AND ELECTRONIC READERS FOR RECORDING, ORGANIZING, TRANSMITTING, MANIPULATING, AND REVIEWING TEXT, DATA, IMAGE, AND AUDIO FILES, FOR PROVIDING TARGETED CONSUMER ELECTRONIC AND VIRTUAL GIFT CARDS, LOYALTY AND AFFINITY CARDS AND PROGRAMS, RECEIPTS, REBATES, COUPONS, PROMOTIONS, CUSTOMER REWARDS AND OFFERS TO CONSUMERS BASED UPON CONSUMER INFORMATION, NAMELY, CONSUMER REGISTRATION, CONSUMER REQUESTS, NEEDS AND INTEREST OF THE CONSUMER, CONSUMER DEMOGRAPHICS AND PERSONAL INFORMATION, REAL-TIME GEOGRAPHIC LOCATION INFORMATION OF THE CONSUMERS ELECTRONIC DEVICE AND THE PURCHASING AND SHOPPING HABITS OF THE USER OF THE ELECTRONIC DEVICE, IN THE RETAIL AND CONSUMER MARKET; COMPUTER SOFTWARE FOR ELECTRONIC DEVICES, NAMELY, MOBILE PHONES, TABLET COMPUTERS, PERSONAL COMPUTERS, LAPTOP COMPUTERS, ELECTRONIC READERS FOR PROVIDING PAYMENT TRANSACTION PROCESSING AND THE AUTHENTICATION OF PAYMENT TRANSACTIONS FOR RETAIL AND CONSUMER GOODS AND SERVICES; COMPUTER SOFTWARE FOR ELECTRONIC DEVICES, NAMELY, MOBILE PHONES, TABLET COMPUTERS, PERSONAL COMPUTERS, LAPTOP COMPUTERS, ELECTRONIC READERS FOR PROVIDING TICKET PURCHASING; COMPUTER SOFTWARE FOR ELECTRONIC DEVICES, NAMELY, MOBILE PHONES, TABLET COMPUTERS, PERSONAL COMPUTERS, LAPTOP COMPUTERS, ELECTRONIC READERS FOR PROVIDING AUTHENTICATION FOR THE USE OF CONSUMER ELECTRONIC AND VIRTUAL GIFT CARDS, LOYALTY AND AFFINITY CARDS AND PROGRAMS, PUNCH CARDS, REBATES, COUPONS, PROMOTIONS, CUSTOMER REWARDS AND OFFERS UPON USE AND FOR MONITORING USAGE OF OFFERS AND DISCOUNTS AND PREVENTING UNAUTHORIZED USE OF LIMITED TIME OR LIMITED USE OFFERS FOR RETAIL AND CONSUMER GOODS AND SERVICES; COMPUTER SOFTWARE FOR ELECTRONIC DEVICES, NAMELY, MOBILE PHONES, TABLET COMPUTERS, PERSONAL COMPUTERS, LAPTOP COMPUTERS,

ELECTRONIC READERS FOR DISPLAYING COUPONS, OFFERS, REBATES AND OTHER DISCOUNTS ON DIGITAL SIGNAGE FOR RETAIL AND CONSUMER GOODS AND SERVICES (U.S. CLS. 21, 23, 26, 36 AND 38).

FIRST USE 5-27-2010; IN COMMERCE 8-29-2012.

#### CLASS 35—ADVERTISING AND BUSINESS

FOR PROVIDING ADVERTISEMENT AND PROMOTIONAL SERVICES FOR RETAIL AND CONSUMER BUSINESSES BY DISSEMINATING TO CONSUMER ELECTRONIC DEVICES VIA GLOBAL COMPUTER NETWORKS CONSUMER ELECTRONIC AND VIRTUAL GIFT CARDS, LOYALTY AND AFFINITY CARDS AND PROGRAMS, PUNCH CARDS, RECEIPTS, REBATES, COUPONS, PROMOTIONS, CUSTOMER REWARDS, TICKETS AND OTHER DISCOUNTS AND OFFERS TO USERS TO CONSUMER ELECTRONIC DEVICES VIA A GLOBAL NETWORK, BASED UPON CONSUMER INFORMATION, NAMELY, CONSUMER REGISTRATION, CONSUMER REQUESTS, NEEDS AND INTEREST OF A CONSUMER, CONSUMER DEMOGRAPHICS AND PERSONAL INFORMATION, THE REAL-TIME GEOGRAPHIC LOCATION OF A USER'S ELECTRONIC DEVICE AND THE PURCHASING AND SHOPPING HABITS OF A USER; MONITORING USAGE OF CONSUMER ELECTRONIC AND VIRTUAL GIFT CARDS, LOYALTY AND AFFINITY CARDS AND PROGRAMS, PUNCH CARDS, RECEIPTS, REBATES, COUPONS, PROMOTIONS, CUSTOMER REWARDS AND OFFERS FOR RETAIL AND CONSUMER BUSINESSES; PROVIDING DATA ANALYTICS AND TRACKING INFORMATION FOR RETAIL AND CONSUMER BUSINESSES RELATED TO CONSUMER BUYING HABITS, CONSUMER FEEDBACK, CONSUMER NEEDS AND INTERESTS PROVIDED WITH THE HELP OF SENSORIALITY AND QUANTITY-RELATED DATA, NAMELY, PERSONAL AND DEMOGRAPHIC DATA, INTEGRATED TRACKING OF COMMERCIAL TRANSACTIONS RELATED TO GOODS AND SERVICES FOR OTHERS, SALE VOLUME TRACKING, GIFT CARD PURCHASE AND GIFT CARD USE TRACKING, LOYALTY PROGRAM ENROLLMENT AND BENEFIT USE TRACKING FOR OTHERS, REBATE AND PROMOTION USE TRACKING FOR OTHERS, AND PROVIDING DATA REGARDING A CONSUMER'S RECEIPT OF A PARTICULAR PROMOTIONAL OFFER, NAMELY, IDENTIFYING WHICH DATA ANALYTICS CAUSED THE CONSUMER TO RECEIVE THE PROMOTIONAL OFFER AND INFORMATION REGARDING COMMERCIAL TRANSACTIONS RELATED TO PROMOTIONS, OFFERS, REBATES, COUPONS, AND CONSUMER LOYALTY PROGRAMS (U.S. CLS. 100, 101 AND 102).

FIRST USE 5-27-2010; IN COMMERCE 8-29-2012.

#### CLASS 45—PERSONAL AND LEGAL SERVICES

FOR PROVIDING USER AUTHENTICATION SERVICES FOR CONSUMER ELECTRONIC AND VIRTUAL GIFT CARDS, LOYALTY AND AFFINITY CARDS AND PROGRAMS, PUNCH CARDS, RECEIPTS, REBATES, COUPONS, PROMOTIONS, CUSTOMER REWARDS AND OFFERS AND PREVENTING THE UNAUTHORIZED USE OF LIMITED TIME AND LIMITED USE OFFERS THERETO (U.S. CLS. 100 AND 101).

FIRST USE 5-27-2010; IN COMMERCE 8-29-2012.

4,593,431. THE WELLCARE MANAGEMENT GROUP, INC., TAMPA, FL. SN 85-710,211. PUB. 4-30-2013, FILED 8-22-2012.

#### THE COMMUNITY COMMITMENT

THE MARK CONSISTS OF STANDARD CHARACTERS WITHOUT CLAIM TO ANY PARTICULAR FONT, STYLE, SIZE, OR COLOR.

#### CLASS 36—INSURANCE AND FINANCIAL

FOR CHARITABLE SERVICES, NAMELY, PROVIDING INFORMATION IN THE FIELD OF FINANCIAL ASSISTANCE FOR PUBLIC HEALTH PROGRAMS AND INITIATIVES; PROVIDING GRANTS FOR CREATING LOCAL PUBLIC ASSISTANCE HEALTH PROGRAMS AND INITIATIVE; PROVIDING ADVICE AND ASSISTANCE IN OBTAINING GRANTS FOR CREATING LOCAL PUBLIC ASSISTANCE HEALTH PROGRAMS AND INITIATIVE (U.S. CLS. 100, 101 AND 102).

FIRST USE 11-0-2011; IN COMMERCE 11-0-2011.

#### CLASS 41—EDUCATION AND ENTERTAINMENT

FOR PROVIDING RECOGNITION BY THE WAY OF AWARDS TO DEMONSTRATE EXCELLENCE IN THE FIELD OF PUBLIC ASSISTANCE HEALTH PROGRAMS AND INITIATIVES (U.S. CLS. 100, 101 AND 107).

FIRST USE 11-0-2011; IN COMMERCE 11-0-2011.

4,593,449. THE BODY EVOLUTION, INC., OGDEN, UT. SN 85-722,698. PUB. 8-13-2013, FILED 9-6-2012.



THE MARK CONSISTS OF THE STYLIZED LETTERS "B E" WITH THE LETTER "B" PARTIALLY OVERLAPPING THE LETTER "E".

#### CLASS 5—PHARMACEUTICALS

FOR DIETARY AND NUTRITIONAL SUPPLEMENTS; DIETARY FOOD SUPPLEMENTS; MINERAL SUPPLEMENTS; PROTEIN SUPPLEMENTS; VITAMIN SUPPLEMENTS; WEIGHT MANAGEMENT SUPPLEMENTS; WHEY PROTEIN SUPPLEMENTS (U.S. CLS. 6, 18, 44, 46, 51 AND 52).

FIRST USE 9-11-2001; IN COMMERCE 9-11-2001.

#### CLASS 25—CLOTHING

FOR CLOTHING, NAMELY, TOPS, BOTTOMS, HATS, SHIRTS, PANTS, GLOVES, UNDERWEAR, COATS, YOGA PANTS, SWEAT SHIRTS, SWEAT PANTS, SHORTS, SHOES, SOCKS, BOOTS, BELTS (U.S. CLS. 22 AND 39).

FIRST USE 9-1-2008; IN COMMERCE 9-1-2008.

4,593,453. ITSON INC., REDWOOD CITY, CA. SN 85-728,773.  
PUB. 9-3-2013, FILED 9-13-2012.

## ITSON SMART SERVICES

THE MARK CONSISTS OF STANDARD CHARACTERS WITHOUT CLAIM TO ANY PARTICULAR FONT, STYLE, SIZE, OR COLOR.

NO CLAIM IS MADE TO THE EXCLUSIVE RIGHT TO USE "SERVICES", APART FROM THE MARK AS SHOWN.

### CLASS 38—COMMUNICATION

FOR TELECOMMUNICATIONS SERVICES, NAMELY, THE TRANSMISSION OF VOICE, DATA, IMAGES, AUDIO, VIDEO, AND INFORMATION VIA TELEPHONE, SATELLITE, AND GLOBAL COMPUTER NETWORKS; PERSONAL COMMUNICATIONS SERVICES; WIRELESS ROAMING SERVICES; CONNECTION BY TELECOMMUNICATIONS TO A GLOBAL COMPUTER NETWORK (U.S. CLS. 100, 101 AND 104).

FIRST USE 5-13-2013; IN COMMERCE 5-13-2013.

### CLASS 42—SCIENTIFIC AND COMPUTER SERVICES

FOR SOFTWARE AND DEVICE ASSISTED SERVICES FOR HANDHELD AND MOBILE ELECTRONIC DEVICES, NAMELY, COMPUTER PROGRAMMING FOR HANDHELD AND MOBILE ELECTRONIC DEVICES, PROGRAMMING HANDHELD AND MOBILE ELECTRONIC DEVICES FOR THE FOLLOWING PURPOSES: REMOTE ACTIVATION, CONTROL, MONITORING, NOTIFICATION, INTERFACING, AND BILLING, AND COMPUTER ENGINEERING SERVICES FOR HANDHELD AND MOBILE ELECTRONIC DEVICES (U.S. CLS. 100 AND 101).

FIRST USE 5-13-2013; IN COMMERCE 5-13-2013.

4,593,456. CITY STUMBLER, LOS ANGELES, CA. SN 85-732,253. PUB. 5-28-2013, FILED 9-18-2012.



THE COLOR(S) RED, SILVER AND BLACK IS/ARE CLAIMED AS A FEATURE OF THE MARK.

THE MARK CONSISTS OF THE FOLLOWING: THE WORDING "CITYSTUMBLER" IN BLACK AND AN IMAGE OF FIVE DIFFERENT SIZED SQUARES ABOVE THE TEXT. TWO SQUARES APPEAR IN THE COLOR RED, TWO IN THE COLOR SILVER, AND ONE IN THE COLOR BLACK.

### CLASS 9—ELECTRICAL AND SCIENTIFIC APPARATUS

FOR COMPUTER SOFTWARE, NAMELY, CONSUMER DATA STORAGE SOFTWARE IN THE AREA OF REAL ESTATE, APARTMENT AND RESIDENTIAL RENTALS, CONSUMER GOODS AND CONSUMER SERVICES; COMPUTER DATABASE SOFTWARE FEATURING INFORMATION IN THE FIELD OF REAL ESTATE, APARTMENT AND RESIDENTIAL RENTALS, CONSUMER GOODS AND CONSUMER SERVICES; COMPUTER SOFTWARE, NAMELY, APPLICATION PROGRAMMING INTERFACE (API) FOR ACCESSING AND PRESENTING INFORMATION IN THE FIELD OF REAL ESTATE, CONSUMER GOODS AND CONSUMER SERVICES; COMPUTER SOFTWARE FOR SEARCHING, RETRIEVING, VIEWING AND PROVIDING INFORMATION RELATED TO REAL ESTATE MARKETS, TRENDS, PROPERTIES, LISTINGS, PRICING, OPEN HOUSES, AGENTS AND BROKERS; COMPUTER APPLICATION SOFTWARE FOR MOBILE PHONES, PORTABLE MEDIA PLAYERS, TABLET AND HANDHELD COMPUTERS, NAMELY, SOFTWARE FOR ADVERTISING, SEARCHING, RETRIEVING, VIEWING AND PROVIDING INFORMATION RELATED TO REAL ESTATE MARKETS, TRENDS, PROPERTIES, LISTINGS, PRICING, OPEN HOUSES, AGENTS AND BROKERS, AND CONSUMER GOODS AND CONSUMER SERVICES; COMPUTER SOFTWARE FOR SHARING DATA ABOUT REAL ESTATE, APARTMENTS, AND RESIDENTIAL RENTALS ON SOCIAL NETWORKING SITES; COMPUTER SOFTWARE, NAMELY, WIDGETS IN THE FIELDS OF REAL ESTATE, AND APARTMENT AND RESIDENTIAL RENTALS; COMPUTER SOFTWARE, NAMELY, SOFTWARE PLUG-INS FOR USE IN SOCIAL MEDIA SITES IN THE FIELDS OF REAL ESTATE, AND APARTMENT AND RESIDENTIAL RENTALS, COMPUTER SOFTWARE FOR SEARCHING AND ACCESSING INTERACTIVE MAPS AND INFORMATION ON LOCAL LANDMARKS, SCHOOLS, RESTAURANTS, GROCERY STORES, AND OTHER AMENITIES; COMPUTER APPLICATION SOFTWARE FOR MOBILE PHONES, PORTABLE MEDIA PLAYERS, TABLET AND HANDHELD COMPUTERS, NAMELY, SOFTWARE FOR SEARCHING AND ACCESSING INTERACTIVE MAPS AND INFORMATION ON LOCAL LANDMARKS, SCHOOLS, RESTAURANTS, GROCERY STORES, AND OTHER AMENITIES (U.S. CLS. 21, 23, 26, 36 AND 38).

FIRST USE 4-1-2013; IN COMMERCE 4-1-2013.

### CLASS 35—ADVERTISING AND BUSINESS

FOR ADVERTISING OF COMMERCIAL OR RESIDENTIAL REAL ESTATE; ADVERTISING BY TRANSMISSION OF ONLINE PUBLICITY FOR THIRD PARTIES THROUGH ELECTRONIC COMMUNICATIONS NETWORKS IN THE FIELD OF REAL ESTATE; REAL ESTATE ADVERTISING SERVICES; DESIGN OF ADVERTISING MATERIALS FOR OTHERS; DESIGN OF INTERNET ADVERTISING; PROVIDING MARKETING SERVICES FOR REAL ESTATE PROFESSIONALS; REAL ESTATE MARKETING SERVICES IN THE FIELD OF CONDOMINIUMS, APARTMENTS, LUXURY APARTMENTS, HOMES; REAL ESTATE SALES MANAGEMENT; REAL ESTATE MARKETING SERVICES, NAMELY, ON-LINE SERVICES FEATURING TOURS OF RESIDENTIAL AND COMMERCIAL REAL ESTATE; PROVIDING REAL ESTATE VIDEO TOURS FOR MARKETING PURPOSES; PROVIDING AN ON-LINE SHOWROOM FOR THE GOODS OF OTHERS IN THE FIELD OF REAL ESTATE, APARTMENTS, AND RESIDENTIAL RENTALS; OPERATING ONLINE MARKETPLACES FOR SELLERS OF GOODS AND SERVICES IN THE FIELD OF REAL ESTATE, APARTMENTS, AND RESIDENTIAL RENTALS, AND POTENTIAL BUYERS; PROVIDING AN INTERACTIVE REAL ESTATE WEBSITE WHICH PROMOTES HOUSING AND APARTMENT PROPERTIES THROUGH OFFERING PROSPECTIVE TENANTS VIDEO WALK THROUGH, PROPERTY DESCRIPTIONS, TEXT, PRICE, LOCATION, MAPS AND OTHER INFORMATION THAT WOULD BE INFLUENTIAL TO A PROSPECTIVE CLIENT IN MAKING A TRANSACTIONAL DECISION; MATCHING CONSUMERS WITH REAL ESTATE PROFESSIONALS IN THE FIELD OF REAL ESTATE SERVICES VIA COMPUTER NETWORK; MATCHING CONSUMERS WITH PROFESSIONALS IN THE FIELD OF REAL ESTATE; REFERRAL SERVICES IN THE FIELD OF REAL ESTATE; MATCH-

ING BORROWERS WITH POTENTIAL LENDERS IN THE FIELD OF MORTGAGE LENDING; PROVIDING REAL ESTATE LEADS FOR PROSPECTIVE PURCHASERS; PROMOTING THE GOODS AND SERVICES OF OTHERS BY MEANS OF LINKING THE WEB SITE TO OTHER WEB SITES FEATURING REAL ESTATE, CONSUMER GOODS AND CONSUMER SERVICES; ADVERTISING AND MARKETING SERVICES IN THE FIELDS OF REAL ESTATE, APARTMENTS, RESIDENTIAL RENTALS, RETAIL SERVICES, FINANCIAL SERVICES, MORTGAGE SERVICES, HOME EQUITY SERVICES, INSURANCE SERVICES, ESCROW SERVICES, REAL ESTATE APPRAISAL SERVICES, LEGAL SERVICES, TITLE SERVICES, NOTARY SERVICES, REAL ESTATE AGENCY SERVICES, PROPERTY MANAGEMENT SERVICES, MOVING AND RELOCATION SERVICES, HOME INSPECTION SERVICES, ARCHITECTURAL SERVICES, LANDSCAPING SERVICES, INTERIOR DESIGN SERVICES, BUILDING CONTRACTORS, HOME BUILDING AND REPAIR SERVICES, HOME IMPROVEMENT SERVICES, PAINTING SERVICES, PLUMBING SERVICES, INTERIOR DESIGN SERVICES, STAGING SERVICES, AND HOME FURNISHINGS; MAKING REFERRALS IN THE FIELDS OF RETAIL SERVICES, FINANCIAL SERVICES, MORTGAGE SERVICES, HOME EQUITY SERVICES, INSURANCE SERVICES, ESCROW SERVICES, APPRAISAL SERVICES, LEGAL SERVICES, TITLE SERVICES, NOTARY SERVICES, REAL ESTATE AGENCY SERVICES, PROPERTY MANAGEMENT SERVICES, MOVING SERVICES, HOME INSPECTION SERVICES, ARCHITECTURAL SERVICES, LANDSCAPING SERVICES, INTERIOR DESIGN SERVICES, BUILDING CONTRACTORS, HOME BUILDING AND REPAIR SERVICES, HOME IMPROVEMENT SERVICES, CARPENTRY SERVICES, ENGINEERING SERVICES, PAINTING SERVICES, PLUMBING SERVICES, INTERIOR DESIGN SERVICES, STAGING SERVICES, AND HOME FURNISHINGS; BUSINESS AND CONSUMER RESEARCH SERVICES IN THE FIELD OF REAL ESTATE; PROVIDING STATISTICAL INFORMATION AND INDEXES OF MORTGAGES, INTERESTS, AND PRICES FOR OTHERS; COMMERCIAL INFORMATION SERVICES, NAMELY, PROVIDING DEMOGRAPHIC DATA; PROVIDING INFORMATION ABOUT NEIGHBORHOODS AND NEIGHBORHOOD AMENITIES, NAMELY, MATCHING CONSUMERS WITH PROFESSIONAL IN THE FIELD OF RESIDENTIAL AND COMMERCIAL SERVICES; PROVIDING CONSUMER INFORMATION IN THE FIELD OF HOME IMPROVEMENT COMPARISONS; BUSINESS SERVICES, NAMELY, ORGANIZING THIRD-PARTY VENDORS, SUPPLIERS, AND CONTRACTORS, AND DOCUMENTATION AND INFORMATION ON BEHALF OF OTHERS IN THE FIELD OF REAL ESTATE; PROMOTING THE GOODS AND SERVICES OF OTHERS BY MEANS OF LINKING THE WEB SITE TO OTHER WEB SITES FEATURING APARTMENT AND RESIDENTIAL RENTAL LISTINGS; PROMOTING THE GOODS AND SERVICES OF OTHERS BY PLACING ADVERTISEMENTS AND PROMOTIONAL DISPLAYS IN AN ELECTRONIC SITE ACCESSED THROUGH COMPUTER NETWORKS AND THROUGH AN INTERACTIVE WEB SITE FEATURING REAL ESTATE INFORMATION AND LISTINGS; PROMOTING THE WEB SITES OF OTHERS, NAMELY, DISSEMINATION OF ADVERTISING FOR OTHERS VIA AN ON-LINE ELECTRONIC COMMUNICATIONS NETWORK; PROVIDING A WEBSITE WHERE USERS CAN POST RATINGS, REVIEWS AND RECOMMENDATIONS IN THE FIELD OF HOME FURNISHINGS, HOME IMPROVEMENT CONSTRUCTION, GENERAL BUILDING CONTRACTOR SERVICES, CARPENTRY SERVICES, HOME BUILDING, HOME REPAIR, PAINTING, PLUMBING SERVICES, RETAIL SERVICES, MOVING AND RELOCATION SERVICES, NAMELY, PLANNING AND IMPLEMENTING MOVES OF HOMES OF OTHERS, AND HOME IMPROVEMENT SERVICES, NAMELY, RENOVATION, CONSTRUCTION, AND REPAIR OF HOUSES, APARTMENTS, AND CONDOMINIUMS FOR COMMERCIAL PURPOSES; ALLOWING USERS OF AN ONLINE

CONSUMER INFORMATION SERVICE TO COMPARE AND RATE HOMES AND HOME IMPROVEMENTS; PROVIDING ON-LINE DIRECTORY INFORMATION SERVICES ALSO FEATURING HYPERLINKS TO OTHER WEB SITES; PROVIDING AN ONLINE COMMERCIAL INFORMATION DIRECTORY ON THE INTERNET; MARKET RESEARCH SERVICES IN THE FIELD OF REAL ESTATE, NAMELY, SEARCHING, RETRIEVING, SUMMARIZING AND PROVIDING INFORMATION RELATED TO REAL ESTATE MARKETS, TRENDS, PROPERTIES, LISTINGS AND PRICING (U.S. CLS. 100, 101 AND 102).

FIRST USE 4-1-2013; IN COMMERCE 4-1-2013.

### CLASS 36—INSURANCE AND FINANCIAL

FOR CLASSIFIED REAL ESTATE LISTINGS OF APARTMENT RENTALS AND HOUSING RENTALS; COMMERCIAL AND RESIDENTIAL REAL ESTATE AGENCY SERVICES; PROVIDING A DATABASE OF INFORMATION ABOUT RESIDENTIAL REAL ESTATE LISTINGS IN DIFFERENT NEIGHBORHOODS AND COMMUNITIES; PROVIDING A DATABASE OF RESIDENTIAL REAL ESTATE LISTINGS WITHIN NEIGHBORHOODS AND COMMUNITIES SPECIFICALLY IDENTIFIED BY USERS; PROVIDING AN INTERNET WEBSITE PORTAL OFFERING INFORMATION IN THE FIELDS OF REAL ESTATE CONCERNING THE PURCHASE AND SALE OF NEW AND RESALE HOMES AND CONDOS; PROVIDING REAL ESTATE LISTINGS AND REAL ESTATE INFORMATION VIA THE INTERNET; REAL ESTATE AGENCIES; REAL ESTATE BROKERAGE; REAL ESTATE LISTINGS; REAL ESTATE LISTING SERVICES FOR HOUSING RENTALS AND APARTMENT RENTALS; REAL ESTATE RENTAL SERVICES, NAMELY, RENTAL OF RESIDENTIAL HOUSING; REAL ESTATE SERVICES, NAMELY, PROVIDING ONLINE QUESTIONS TO HELP USERS DETERMINE THE BEST NEIGHBORHOODS AND COMMUNITIES SUITED TO THEIR INDIVIDUAL NEEDS AND PREFERENCES; RESIDENTIAL REAL ESTATE AGENCY SERVICES; REAL ESTATE VALUATION SERVICES, FINANCIAL VALUATION OF REAL ESTATE; PROVIDING INFORMATION IN THE FIELD OF REAL ESTATE; FINANCIAL SERVICES, NAMELY, MORTGAGE AND HOME EQUITY LOAN PLANNING; PROVIDING MORTGAGE AND HOME EQUITY LOAN QUOTATIONS TO OTHERS AND PROVIDING ANONYMOUS MORTGAGE AND HOME EQUITY LOAN QUOTATIONS TO OTHERS; PROVIDING INFORMATION, ANALYSIS, AND ADVICE IN THE FIELDS OF MORTGAGE LENDING AND HOME EQUITY LENDING; CREDIT SCORE ESTIMATE SERVICES, NAMELY, PROVIDING AN ONLINE CALCULATOR THAT PROVIDES AN ESTIMATE OF USERS' CREDIT SCORE BASED ON ANSWERS PROVIDED; PROVIDING AN ON-LINE COMPUTER DATABASE IN THE FIELD OF CREDIT RATING; PROVIDING ONLINE AN INTERACTIVE CONSUMER CREDIT SCORE SIMULATOR WHICH PERMITS AN INDIVIDUAL TO SIMULATE HIS OR HER CREDIT SCORE BY SELECTING DATA VARIABLES TO SHOW THE EFFECT OF THE DIFFERENT VARIABLES UPON THE INDIVIDUAL'S CREDIT SCORE; APARTMENT AND RESIDENTIAL RENTAL FINANCIAL VALUATION SERVICES; FINANCIAL VALUATION OF APARTMENTS AND RESIDENTIAL RENTALS; PROVIDING INFORMATION IN THE FIELD OF REAL ESTATE AND PROVIDING A WEB SITE WHERE USERS CAN POST RATINGS, REVIEWS, AND RECOMMENDATIONS IN THE FIELDS OF REAL ESTATE MANAGEMENT, REAL ESTATE LEASING, REAL ESTATE APPRAISALS, REAL ESTATE LISTING, REAL ESTATE AGENTS, APARTMENT RENTALS, RESIDENTIAL RENTALS, FINANCIAL SERVICES, MORTGAGE LENDING SERVICES, HOME EQUITY LOAN SERVICES, INSURANCE SERVICES, REAL ESTATE ESCROW SERVICES, REAL ESTATE APPRAISAL SERVICES, REAL ESTATE TITLE INSURANCE UNDER-

WRITING SERVICES, REAL ESTATE AGENCY SERVICES, AND REAL PROPERTY MANAGEMENT SERVICES; FINANCIAL RESEARCH SERVICES IN THE FIELD OF REAL ESTATE; PROVIDING COMPUTER DATABASES FEATURING SEARCHABLE INDEXES OF INFORMATION, REAL ESTATE PROPERTY LISTINGS, THIRD-PARTY WEB SITES AND LINKS, AND OTHER RESOURCES AVAILABLE ON COMPUTER NETWORKS IN THE FIELD OF REAL ESTATE; PROVIDING AN ONLINE COMPUTER DATABASE AND INFORMATION IN THE FIELD OF REAL ESTATE (U.S. CLS. 100, 101 AND 102).

FIRST USE 4-1-2013; IN COMMERCE 4-1-2013.

#### CLASS 42—SCIENTIFIC AND COMPUTER SERVICES

FOR PROVIDING TEMPORARY USE OF NON-DOWNLOADABLE SOFTWARE THAT ALLOWS OTHERS TO DESIGN AND CREATE WEBSITES; HOSTING WEBSITES AND DIGITAL CONTENT FOR OTHERS ON THE INTERNET; WEB SITE DESIGN; WEB SITE DEVELOPMENT FOR OTHERS; PROVIDING TEMPORARY USE OF NON-DOWNLOADABLE COMPUTER SOFTWARE IN THE FIELDS OF REAL ESTATE, APARTMENTS, RESIDENTIAL RENTALS, MORTGAGES, AND CONSUMER GOODS AND CONSUMER SERVICES; NON-DOWNLOADABLE COMPUTER DATABASE SOFTWARE FEATURING INFORMATION AND ADVERTISING IN THE FIELDS OF REAL ESTATE, APARTMENTS AND RESIDENTIAL RENTALS, MORTGAGES, CONSUMER GOODS, AND CONSUMER SERVICES; COMPUTER SERVICES, NAMELY, SEARCH ENGINE OPTIMIZATION; PROVIDING A WEBSITE WHERE USERS CAN POST RATINGS, REVIEWS AND RECOMMENDATIONS IN THE FIELD OF HOME INSPECTION SERVICES FOR THE PURPOSES OF HOME REPAIR AND HOME RESTORATION, ENGINEERING SERVICES, INTERIOR DESIGN SERVICES AND INTERIOR DECORATING SERVICES, APARTMENT, CONDOMINIUM AND HOME STAGING SERVICES FOR THE PURPOSE OF INCREASING THE APPEAL OF THE PROPERTY TO PROSPECTIVE BUYERS AND/OR RENTERS, AND HOME FURNISHINGS; COMPUTER SERVICES, NAMELY, PROVIDING A WEBSITE FEATURING A SEARCH ENGINE FOR OBTAINING DATA, NAMELY, REAL ESTATE INFORMATION, ACCESSED VIA A GLOBAL COMPUTER NETWORK, WIDE AREA NETWORKS AND LOCAL AREA NETWORKS (U.S. CLS. 100 AND 101).

FIRST USE 4-1-2013; IN COMMERCE 4-1-2013.

4,593,457. ITSON INC., REDWOOD CITY, CA. SN 85-732,271. PUB. 9-3-2013, FILED 9-18-2012.

## SMART SERVICES

THE MARK CONSISTS OF STANDARD CHARACTERS WITHOUT CLAIM TO ANY PARTICULAR FONT, STYLE, SIZE, OR COLOR.

NO CLAIM IS MADE TO THE EXCLUSIVE RIGHT TO USE "SERVICES", APART FROM THE MARK AS SHOWN.

#### CLASS 38—COMMUNICATION

FOR TELECOMMUNICATIONS SERVICES, NAMELY, THE TRANSMISSION OF VOICE, DATA, IMAGES, AUDIO, VIDEO, AND INFORMATION VIA TELEPHONE, SATELLITE, AND GLOBAL COMPUTER NETWORKS; PERSONAL COMMUNICATIONS SERVICES; WIRELESS ROAMING SERVICES; CONNECTION BY TELECOMMUNICATIONS TO A GLOBAL COMPUTER NETWORK (U.S. CLS. 100, 101 AND 104).

FIRST USE 5-13-2013; IN COMMERCE 5-13-2013.

#### CLASS 42—SCIENTIFIC AND COMPUTER SERVICES

FOR SOFTWARE AND DEVICE ASSISTED SERVICES FOR HANDHELD AND MOBILE ELECTRONIC DEVICES, NAMELY, COMPUTER PROGRAMMING FOR HANDHELD AND MOBILE ELECTRONIC DEVICES, PROGRAMMING HANDHELD AND MOBILE ELECTRONIC DEVICES FOR THE FOLLOWING PURPOSES: REMOTE ACTIVATION, CONTROL, MONITORING, NOTIFICATION, INTERFACING, AND BILLING, AND COMPUTER ENGINEERING SERVICES FOR HANDHELD AND MOBILE ELECTRONIC DEVICES (U.S. CLS. 100 AND 101).

FIRST USE 5-13-2013; IN COMMERCE 5-13-2013.

4,593,459. PREMIER HEALTHCARE ALLIANCE, LP, CHARLOTTE, NC. SN 85-733,799. PUB. 2-19-2013, FILED 9-20-2012.



OWNER OF U.S. REG. NOS. 3,597,963, 3,666,078, AND OTHERS.

THE COLOR(S) PURPLE, GREEN, BLUE AND GRAY IS/ARE CLAIMED AS A FEATURE OF THE MARK.

THE MARK CONSISTS OF A TRIANGLE WITH CURVED OUTER AND INTERIOR SIDES IN SHADES OF PURPLE, GREEN AND BLUE, AND THE WORDING "PREMIER" IN GRAY BELOW THE TRIANGLE; THE WHITE INTERIOR OF THE TRIANGLE IS BACKGROUND AND NOT PART OF THE MARK.

#### CLASS 35—ADVERTISING AND BUSINESS

FOR PROCUREMENT, NAMELY, PURCHASING A WIDE VARIETY OF MEDICAL SUPPLIES, OFFICE SUPPLIES, PHARMACEUTICALS AND HEALTHCARE PRODUCTS FOR OTHERS; HOSPITAL MANAGEMENT CONSULTING SERVICES IN THE FIELD OF HEALTH CARE COST CONTAINMENT, SUPPLY CHAIN MANAGEMENT, HEALTH CARE OPERATIONAL PRODUCTIVITY AND HEALTHCARE SUPPLY PRICING; PROVIDING AN ONLINE COMPUTER DATABASE FEATURING BUSINESS MANAGEMENT INFORMATION FOR ANALYZING AND ASSESSING HEALTH CARE COST CONTAINMENT, HEALTH CARE QUALITY AND SAFETY, ACCOUNTING, LABOR ASSESSMENT, OPERATIONAL PRODUCTIVITY DATA, HEALTH CARE CONTRACT OPTIMIZATION, PRICE VERIFICATION, PRICE BENCHMARKING, PRICING AND OVERHEAD COST REDUCTION, SPENDING PATTERNS, PURCHASING OPTIMIZATION, AND SUPPLY CHAIN INFORMATION MANAGEMENT; HOSPITAL MANAGEMENT INFORMATION SERVICES, NAMELY, ACQUIRING, ANALYZING, AND FURNISHING BUSINESS INFORMATION RELATING TO PRODUCTIVITY, PROFITABILITY AND COST ACCOUNTING DATA RELATING TO THE FIELD OF HOSPITAL MANAGEMENT AND BUSINESS OPERATIONS OF HEALTH CARE FACILITIES (U.S. CLS. 100, 101 AND 102).

FIRST USE 5-24-2012, THE MARK WAS FIRST USED ANYWHERE IN A DIFFERENT FORM OTHER THAN THAT SOUGHT TO BE REGISTERED AT LEAST AS EARLY AS 01/00/1996.; IN COMMERCE 5-24-2012, THE MARK WAS FIRST USED IN COMMERCE IN A DIFFERENT FORM OTHER THAN THAT SOUGHT TO BE REGISTERED AT LEAST AS EARLY AS 01/00/1996..

**CLASS 36—INSURANCE AND FINANCIAL**

FOR FINANCIAL MANAGEMENT AND ADMINISTRATION OF RISK RETENTION GROUPS FOR HEALTHCARE PROFESSIONAL LIABILITY; FINANCIAL CONSULTATION SERVICES, NAMELY, PROVIDING FINANCIAL ANALYSIS RELATING TO PROFITABILITY AND COST ACCOUNTING DATA IN THE FIELD OF HOSPITAL MANAGEMENT (U.S. CLS. 100, 101 AND 102).

FIRST USE 5-24-2012, THE MARK WAS FIRST USED ANYWHERE IN A DIFFERENT FORM OTHER THAN THAT SOUGHT TO BE REGISTERED AT LEAST AS EARLY AS 01/00/1996.; IN COMMERCE 5-24-2012, THE MARK WAS FIRST USED IN COMMERCE IN A DIFFERENT FORM OTHER THAN THAT SOUGHT TO BE REGISTERED AT LEAST AS EARLY AS 01/00/1996..

**CLASS 44—MEDICAL, BEAUTY AND AGRICULTURAL SERVICES**

FOR CONSULTING SERVICES IN THE FIELD OF HEALTHCARE INFORMATION; PROVIDING AN ONLINE COMPUTER DATABASE IN THE FIELDS OF HEALTH CARE INFORMATION AND CLINICAL AND OPERATIONAL COMPARATIVE PATIENT, SYNDROME, HEALTH SYSTEMS PERFORMANCE, AND PATIENT SATISFACTION DATA; MEDICAL INFORMATION SERVICES, NAMELY, ACQUIRING, ANALYZING AND FURNISHING CLINICAL DATA FOR MEDICAL COUNSELING PURPOSES (U.S. CLS. 100 AND 101).

FIRST USE 5-24-2012, THE MARK WAS FIRST USED ANYWHERE IN A DIFFERENT FORM OTHER THAN THAT SOUGHT TO BE REGISTERED AT LEAST AS EARLY AS 01/00/1996.; IN COMMERCE 5-24-2012, THE MARK WAS FIRST USED IN COMMERCE IN A DIFFERENT FORM OTHER THAN THAT SOUGHT TO BE REGISTERED AT LEAST AS EARLY AS 01/00/1996..

**CLASS 9—ELECTRICAL AND SCIENTIFIC APPARATUS**

FOR ELECTROMECHANICALLY MOVABLE TELECOMMUNICATION SYSTEMS, NAMELY, ROBOTS OF THE KIND HAVING A DISPLAY THAT SHOWS AN IMAGE OF A REMOTE OPERATOR AND A SPEAKER FOR THE REMOTE OPERATOR TO BE HEARD TO PROVIDE THE REMOTE OPERATOR WITH A PRESENCE AT THE LOCATION OF THE ROBOT, AND A CAMERA AND MICROPHONE FOR THE ROBOT TO COLLECT IMAGE AND SOUND DATA FROM ITS SURROUNDINGS AND PROVIDE BACK TO THE REMOTE OPERATOR, AND THEIR FRAMES AND ROBOTIC COMPONENTS FOR IMPARTING MOVEMENT, ANY TRANSPORTATION ACCESSORIES, NAMELY, ROBOTIC ARMS, ONBOARD COMPUTERS, ONBOARD STEERING SOFTWARE, ONBOARD VIDEO OR VOICE CAPTURE AND OUTPUT COMMUNICATION HARDWARE AND SOFTWARE, ONBOARD RECEPTION AND TRANSMISSION SOFTWARE FOR WIRELESS RECEPTION AND TRANSMISSION OF STEERING, VIDEO AND VOICE DATA, AUTOMATIC VERSION UPDATE SOFTWARE FOR ONBOARD SOFTWARE, AND ONBOARD POWER STORAGE AND RECHARGING COMPONENTS; POWER STATIONS FOR RECHARGING OF ELECTROMECHANICALLY MOVABLE TELECOM SYSTEMS; REMOTE CONTROL SOFTWARE, NAMELY, SOFTWARE MODULES FOR REMOTE STEERING OF ELECTROMECHANICALLY MOVABLE TELECOM SYSTEMS, SOFTWARE MODULES FOR REMOTE VIDEO OR VOICE CAPTURE AND OUTPUT, AND REMOTE TRANSMISSION AND RECEPTION OF STEERING, VOICE AND VIDEO DATA OVER A NETWORK TO AND FROM ONE OR MORE ELECTROMECHANICALLY MOVABLE TELECOM SYSTEMS; SERVER COMPUTERS AND THEIR SOFTWARE FOR MANAGING COMMUNICATIONS BETWEEN ELECTROMECHANICALLY MOVABLE TELECOM SYSTEMS AND REMOTE CONTROL COMPUTERS, INCLUDING DOWNLOADABLE SOFTWARE FOR USE BY ONBOARD COMPUTERS BY ELECTROMECHANICALLY MOVABLE TELECOM SYSTEMS, DOWNLOADABLE SOFTWARE FOR USE BY REMOTE CONTROL COMPUTERS, A DATABASE AND CONNECTION LOGIC FOR MAKING CONNECTIONS BETWEEN MULTIPLE ELECTROMECHANICALLY MOVABLE TELECOM SYSTEMS AND MULTIPLE REMOTE CONTROL COMPUTERS, AND FACILITY ACCESS CONTROL SOFTWARE THAT ALLOWS AND CONTROLS ACCESS BY REMOTE CONTROL COMPUTERS TO SELECTED ELECTROMECHANICALLY MOVABLE TELECOM SYSTEMS HELD AT A FACILITY AND CONTROLS CHARGING OF THE ELECTROMECHANICALLY MOVABLE TELECOM SYSTEMS (U.S. CLS. 21, 23, 26, 36 AND 38).

FIRST USE 9-25-2012; IN COMMERCE 9-25-2012.

4,593,468. SUITABLE TECHNOLOGIES, INC., PALO ALTO, CA. SN 85-739,083. PUB. 10-8-2013, FILED 9-26-2012.

**SUITABLE TECHNOLOGIES**

THE MARK CONSISTS OF STANDARD CHARACTERS WITHOUT CLAIM TO ANY PARTICULAR FONT, STYLE, SIZE, OR COLOR.

NO CLAIM IS MADE TO THE EXCLUSIVE RIGHT TO USE "TECHNOLOGIES", APART FROM THE MARK AS SHOWN.

**CLASS 41—EDUCATION AND ENTERTAINMENT**

FOR TRAINING IN USE AND OPERATION OF ELECTROMECHANICALLY MOVABLE TELECOM SYSTEMS AND THEIR FRAMES AND ROBOTIC COMPONENTS FOR IMPARTING MOVEMENT, ANY TRANSPORTATION ACCESSORIES SUCH AS ROBOTIC ARMS, ONBOARD COMPUTERS, ONBOARD STEERING SOFTWARE, ONBOARD VIDEO OR VOICE CAPTURE AND OUTPUT COMMUNICATION HARDWARE AND SOFTWARE, ONBOARD RECEPTION AND TRANSMISSION SOFTWARE FOR WIRELESS RECEPTION AND TRANSMISSION OF STEERING, VIDEO AND VOICE DATA, AUTOMATIC VERSION UPDATE SOFTWARE, ONBOARD POWER STORAGE AND RECHARGING ROBOTIC COMPONENTS, POWER STATIONS FOR RECHARGING OF ELECTROMECHANICALLY MOVABLE TELECOM SYSTEMS, AND HOSTED AND ON-SITE FACILITY ACCESS CONTROL SOFTWARE THAT ALLOWS AND CONTROLS ACCESS BY REMOTE CONTROL COMPUTERS TO SELECTED ELECTROMECHANICALLY MOVABLE TELECOM SYSTEMS HELD AT A FACILITY AND CONTROLS CHARGING OF THE ELECTROMECHANICALLY MOVABLE TELECOM SYSTEMS (U.S. CLS. 100, 101 AND 107).

FIRST USE 9-25-2012; IN COMMERCE 9-25-2012.

**CLASS 42—SCIENTIFIC AND COMPUTER SERVICES**

FOR INSTALLATION AND MAINTENANCE OF ELECTROMECHANICALLY MOVABLE TELECOM SYSTEMS AND THEIR FRAMES AND ROBOTIC COMPONENTS FOR IMPARTING MOVEMENT, ANY TRANSPORTATION ACCESSORIES SUCH AS ROBOTIC ARMS, ONBOARD COMPUTERS, ONBOARD STEERING SOFTWARE, ONBOARD VIDEO OR VOICE CAPTURE AND OUTPUT COMMUNICATION HARDWARE AND SOFTWARE, ONBOARD RECEPTION AND TRANSMISSION SOFTWARE FOR WIRELESS RECEPTION AND TRANSMISSION OF STEERING, VIDEO AND VOICE DATA, AUTOMATIC VERSION UPDATE SOFTWARE, ONBOARD POWER STORAGE AND RECHARGING ROBOTIC COMPONENTS, POWER STATIONS FOR RECHARGING OF ELECTROMECHANICALLY MOVABLE TELECOM SYSTEMS, AND HOSTED AND ON-SITE FACILITY ACCESS CONTROL SOFTWARE THAT ALLOWS AND CONTROLS ACCESS BY REMOTE CONTROL COMPUTERS TO SELECTED ELECTROMECHANICALLY MOVABLE TELECOM SYSTEMS HELD AT A FACILITY AND CONTROLS CHARGING OF THE ELECTROMECHANICALLY MOVABLE TELECOM SYSTEMS; HOSTING OF DOWNLOADABLE SOFTWARE OF OTHERS FOR USE BY ONBOARD COMPUTERS BY ELECTROMECHANICALLY MOVABLE TELECOM SYSTEMS; PROVIDING REMOTE USERS ACCESS TO REMOTE CONTROL SOFTWARE SUCH AS SOFTWARE MODULES FOR REMOTE STEERING OF ELECTROMECHANICALLY MOVABLE TELECOM SYSTEMS, SOFTWARE MODULES FOR REMOTE VIDEO OR VOICE CAPTURE AND OUTPUT, AND REMOTE TRANSMISSION AND RECEPTION OF STEERING, VOICE AND VIDEO DATA OVER A NETWORK TO AND FROM ONE OR MORE ELECTROMECHANICALLY MOVABLE TELECOM SYSTEMS; HOSTING DOWNLOADABLE SOFTWARE OF OTHERS FOR USE BY REMOTE CONTROL COMPUTERS; HOSTING A CONNECTION SERVICE THAT INCLUDES A DATABASE AND CONNECTION LOGIC FOR MAKING CONNECTIONS BETWEEN AND MULTIPLE REMOTE CONTROL COMPUTERS AND MULTIPLE ELECTROMECHANICALLY MOVABLE TELECOM SYSTEMS OR FACILITY ACCESS CONTROL SOFTWARE THAT ALLOWS AND CONTROLS ACCESS BY REMOTE CONTROL COMPUTERS TO SELECTED ELECTROMECHANICALLY MOVABLE TELECOM SYSTEMS HELD AT A FACILITY (U.S. CLS. 100 AND 101).

FIRST USE 9-25-2012; IN COMMERCE 9-25-2012.

**CLASS 9—ELECTRICAL AND SCIENTIFIC APPARATUS**

FOR ELECTROMECHANICALLY MOVABLE TELECOMMUNICATION SYSTEMS, NAMELY, ROBOTS OF THE KIND HAVING A DISPLAY THAT SHOWS AN IMAGE OF A REMOTE OPERATOR AND A SPEAKER FOR THE REMOTE OPERATOR TO BE HEARD TO PROVIDE THE REMOTE OPERATOR WITH A PRESENCE AT THE LOCATION OF THE ROBOT, AND A CAMERA AND MICROPHONE FOR THE ROBOT TO COLLECT IMAGE AND SOUND DATA FROM ITS SURROUNDINGS AND PROVIDE BACK TO THE REMOTE OPERATOR, AND THEIR FRAMES AND ROBOTIC COMPONENTS FOR IMPARTING MOVEMENT, ANY TRANSPORTATION ACCESSORIES SUCH AS ROBOTIC ARMS, ONBOARD COMPUTERS, ONBOARD STEERING SOFTWARE, ONBOARD VIDEO OR VOICE CAPTURE AND OUTPUT COMMUNICATION HARDWARE AND SOFTWARE, ONBOARD RECEPTION AND TRANSMISSION SOFTWARE FOR WIRELESS RECEPTION AND TRANSMISSION OF STEERING, VIDEO AND VOICE DATA, AUTOMATIC VERSION UPDATE SOFTWARE, ONBOARD POWER STORAGE AND RECHARGING ROBOTIC COMPONENTS, POWER STATIONS FOR RECHARGING OF ELECTROMECHANICALLY MOVABLE TELECOM SYSTEMS, AND HOSTED AND ON-SITE FACILITY ACCESS CONTROL SOFTWARE THAT ALLOWS AND CONTROLS ACCESS BY REMOTE CONTROL COMPUTERS TO SELECTED ELECTROMECHANICALLY MOVABLE TELECOM SYSTEMS HELD AT A FACILITY AND CONTROLS CHARGING OF THE ELECTROMECHANICALLY MOVABLE TELECOM SYSTEMS; HOSTING OF DOWNLOADABLE SOFTWARE FOR USE BY ONBOARD COMPUTERS BY ELECTROMECHANICALLY MOVABLE TELECOM SYSTEMS; PROVIDING REMOTE USERS WITH REMOTE CONTROL SOFTWARE, NAMELY, SOFTWARE MODULES FOR REMOTE STEERING OF ELECTROMECHANICALLY MOVABLE TELECOM SYSTEMS, SOFTWARE MODULES FOR REMOTE VIDEO OR VOICE CAPTURE AND OUTPUT, AND REMOTE TRANSMISSION AND RECEPTION OF STEERING, VOICE AND VIDEO DATA OVER A NETWORK TO AND FROM ONE OR MORE ELECTROMECHANICALLY MOVABLE TELECOM SYSTEMS; HOSTING DOWNLOADABLE SOFTWARE FOR USE BY REMOTE CONTROL COMPUTERS; HOSTING A CONNECTION SERVICE THAT INCLUDES A DATABASE AND CONNECTION LOGIC FOR MAKING CONNECTIONS BETWEEN AND MULTIPLE REMOTE CONTROL COMPUTERS AND MULTIPLE ELECTROMECHANICALLY MOVABLE TELECOM SYSTEMS OR FACILITY ACCESS CONTROL SOFTWARE THAT ALLOWS AND CONTROLS ACCESS BY REMOTE CONTROL COMPUTERS TO SELECTED ELECTROMECHANICALLY MOVABLE TELECOM SYSTEMS HELD AT A FACILITY (U.S. CLS. 21, 23, 26, 36 AND 38).

FIRST USE 9-25-2012; IN COMMERCE 9-25-2012.

4,593,469. SUITABLE TECHNOLOGIES, INC., PALO ALTO, CA. SN 85-739,094. PUB. 10-8-2013, FILED 9-26-2012.

**BEAM**

THE MARK CONSISTS OF STANDARD CHARACTERS WITHOUT CLAIM TO ANY PARTICULAR FONT, STYLE, SIZE, OR COLOR.

**CLASS 41—EDUCATION AND ENTERTAINMENT**

FOR TRAINING IN USE AND OPERATION OF ELECTROMECHANICALLY MOVABLE TELECOM SYSTEMS AND THEIR FRAMES AND ROBOTIC COMPONENTS FOR IMPARTING MOVEMENT, ANY TRANSPORTATION ACCESSORIES SUCH AS ROBOTIC ARMS, ONBOARD COMPUTERS, ONBOARD STEERING SOFTWARE, ONBOARD VIDEO OR VOICE CAPTURE AND OUTPUT COMMUNICATION HARDWARE AND SOFTWARE, ONBOARD RECEPTION AND TRANSMISSION SOFTWARE FOR WIRELESS RECEPTION AND TRANSMISSION OF STEERING, VIDEO AND VOICE DATA, AUTOMATIC VERSION UPDATE SOFTWARE, ONBOARD POWER STORAGE AND RECHARGING ROBOTIC COMPONENTS, POWER STATIONS FOR RECHARGING OF ELECTROMECHANICALLY MOVABLE TELECOM SYSTEMS, AND HOSTED AND ON-SITE FACILITY ACCESS CONTROL SOFTWARE THAT ALLOWS AND CONTROLS ACCESS BY REMOTE CONTROL COMPUTERS TO SELECTED ELECTROMECHANICALLY MOVABLE TELECOM SYSTEMS HELD AT A FACILITY AND CONTROLS CHARGING OF THE ELECTROMECHANICALLY MOVABLE TELECOM SYSTEMS (U.S. CLS. 100, 101 AND 107).

FIRST USE 9-25-2012; IN COMMERCE 9-25-2012.

**CLASS 42—SCIENTIFIC AND COMPUTER SERVICES**

FOR INSTALLATION AND MAINTENANCE OF ELECTROMECHANICALLY MOVABLE TELECOM SYSTEMS AND THEIR FRAMES AND ROBOTIC COMPONENTS FOR IMPARTING MOVEMENT, ANY TRANSPORTATION ACCESSORIES SUCH AS ROBOTIC ARMS, ONBOARD COMPUTERS, ONBOARD STEERING SOFTWARE, ONBOARD VIDEO OR VOICE CAPTURE AND OUTPUT COMMUNICATION HARDWARE AND SOFTWARE, ONBOARD RECEPTION AND TRANSMISSION SOFTWARE FOR WIRELESS RECEPTION AND TRANSMISSION OF STEERING, VIDEO AND VOICE DATA, AUTOMATIC VERSION UPDATE SOFTWARE, ONBOARD POWER STORAGE AND RECHARGING ROBOTIC COMPONENTS, POWER STATIONS FOR RECHARGING OF ELECTROMECHANICALLY MOVABLE TELECOM SYSTEMS, AND HOSTED AND ON-SITE FACILITY ACCESS CONTROL SOFTWARE THAT ALLOWS AND CONTROLS ACCESS BY REMOTE CONTROL COMPUTERS TO SELECTED ELECTROMECHANICALLY MOVABLE TELECOM SYSTEMS HELD AT A FACILITY AND CONTROLS CHARGING OF THE ELECTROMECHANICALLY MOVABLE TELECOM SYSTEMS; HOSTING OF DOWNLOADABLE SOFTWARE OF OTHERS FOR USE BY ONBOARD COMPUTERS BY ELECTROMECHANICALLY MOVABLE TELECOM SYSTEMS; PROVIDING REMOTE USERS ACCESS TO WITH REMOTE CONTROL SOFTWARE SUCH AS SOFTWARE MODULES FOR REMOTE STEERING OF ELECTROMECHANICALLY MOVABLE TELECOM SYSTEMS, SOFTWARE MODULES FOR REMOTE VIDEO OR VOICE CAPTURE AND OUTPUT, AND REMOTE TRANSMISSION AND RECEPTION OF STEERING, VOICE AND VIDEO DATA OVER A NETWORK TO AND FROM ONE OR MORE ELECTROMECHANICALLY MOVABLE TELECOM SYSTEMS; HOSTING DOWNLOADABLE SOFTWARE OF OTHERS FOR USE BY REMOTE CONTROL COMPUTERS; HOSTING A CONNECTION SERVICE THAT INCLUDES A DATABASE AND CONNECTION LOGIC FOR MAKING CONNECTIONS BETWEEN AND MULTIPLE REMOTE CONTROL COMPUTERS AND MULTIPLE ELECTROMECHANICALLY MOVABLE TELECOM SYSTEMS OR FACILITY ACCESS CONTROL SOFTWARE THAT ALLOWS AND CONTROLS ACCESS BY REMOTE CONTROL COMPUTERS TO SELECTED ELECTROMECHANICALLY MOVABLE TELECOM SYSTEMS HELD AT A FACILITY (U.S. CLS. 100 AND 101).  
FIRST USE 9-25-2012; IN COMMERCE 9-25-2012.

**CLASS 17—RUBBER GOODS**

FOR WATER SOLUBLE FILMS, NAMELY, WATER SOLUBLE PLASTIC FILMS FOR USE IN MANUFACTURING OF WATER SOLUBLE BAGS FOR HOUSEHOLD AND AGRICULTURAL USE, NAMELY, FOR USE IN PACKAGING FOR DETERGENTS AND AGRICHEMICALS, AND FOR GENERAL INDUSTRIAL USE; PLASTIC MATERIAL IN THE FORM OF FILM FOR USE IN MANUFACTURING; AND PLASTIC MATERIAL IN EXTRUDED FORM FOR USE IN PRODUCTION; POLYVINYL ALCOHOL WATER SOLUBLE FILM FOR USE AS A BACKING OR TOPPING TO SUPPORT EMBROIDERY ON TEXTILES AND APPAREL; WATER SOLUBLE FILMS, NAMELY, WATER SOLUBLE PLASTIC FILMS FOR USE AS A SUPPORT FOR EMBROIDERY OR SEWING ON TEXTILES AND APPAREL, AND AS A BACKING FOR EMBROIDERY OR SEWING ON TEXTILES AND APPAREL (U.S. CLS. 1, 5, 12, 13, 35 AND 50).  
FIRST USE 1-24-2012; IN COMMERCE 1-24-2012.

**CLASS 40—MATERIAL TREATMENT**

FOR MANUFACTURE OF WATER SOLUBLE FILMS MADE OF PLASTIC OR POLYVINYL ALCOHOL, TO ORDER AND/OR SPECIFICATION OF OTHERS (U.S. CLS. 100, 103 AND 106).  
FIRST USE 1-24-2012; IN COMMERCE 1-24-2012.

**CLASS 42—SCIENTIFIC AND COMPUTER SERVICES**

FOR PROVIDING TESTING AND ANALYSIS SERVICES FOR OTHERS OF WATER SOLUBLE FILMS MADE OF PLASTIC OR POLYVINYL ALCOHOL (U.S. CLS. 100 AND 101).  
FIRST USE 1-24-2012; IN COMMERCE 1-24-2012.

4,593,471. NEW YORK UNIVERSITY, NEW YORK, NY. SN 85-742,020. PUB. 4-23-2013, FILED 9-29-2012.

4,593,470. MONOSOL LLC, MERRILLVILLE, IN. SN 85-739,317. PUB. 3-5-2013, FILED 9-26-2012.

**CONVENIENCE INSPIRED**

THE MARK CONSISTS OF STANDARD CHARACTERS WITHOUT CLAIM TO ANY PARTICULAR FONT, STYLE, SIZE, OR COLOR.

**ConsultGeri**

THE MARK CONSISTS OF STANDARD CHARACTERS WITHOUT CLAIM TO ANY PARTICULAR FONT, STYLE, SIZE, OR COLOR.

**CLASS 38—COMMUNICATION**

FOR PROVIDING ON-LINE FACILITIES FOR REAL TIME INTERACTION WITH OTHER COMPUTER USERS, IN THE FIELD OF GERIATRIC HEALTHCARE (U.S. CLS. 100, 101 AND 104).  
FIRST USE 6-6-2014; IN COMMERCE 6-6-2014.

**CLASS 41—EDUCATION AND ENTERTAINMENT**

FOR EDUCATIONAL SERVICES, NAMELY, PROVIDING ON-LINE CLASSES, SEMINARS AND WORKSHOPS AND NON-DOWNLOADABLE JOURNALS IN THE FIELD OF GERIATRIC HEALTHCARE (U.S. CLS. 100, 101 AND 107).  
FIRST USE 6-6-2014; IN COMMERCE 6-6-2014.



**CLASS 44—MEDICAL, BEAUTY AND AGRICULTURAL SERVICES**

FOR SERVICES IN PROVIDING CONSULTATION TO AND EVALUATION OF GERIATRIC PATIENTS TO ASSIST IN MAKING HEALTH, WELLNESS AND NUTRITIONAL DECISIONS; WEBSITE FEATURING INFORMATION IN THE FIELD OF GERIATRIC HEALTHCARE; PROVIDING AN INTERACTIVE WEBSITE FEATURING INFORMATION AND LINKS RELATED TO GERIATRIC PATIENTS AND GERIATRIC HEALTHCARE (U.S. CLS. 100 AND 101).

FIRST USE 6-6-2014; IN COMMERCE 6-6-2014.

4,593,473. NETWORK BEAUTY & FASHION COSMÉTICA LTDA, SÃO PAULO-SP, BRAZIL. SN 85-742,317. PUB. 9-17-2013, FILED 10-1-2012.



THE MARK CONSISTS OF THE WORDING "ITALIAN HAIRTECH" IN STYLIZED LETTERS. THE WORD "ITALIAN" APPEARS IN BIGGER, SIZE AND THE WORD "HAIRTECH" IN SMALLER SIZE. TWO HORIZONTAL LINES PRECEDE THE WORD "HAIRTECH".

**CLASS 3—COSMETICS AND CLEANING PREPARATIONS**

FOR COSMETICS AND COSMETIC PREPARATIONS; HAIR CARE CREAMS; HAIR CARE KITS COMPRISING NON-MEDICATED HAIR CARE PREPARATIONS, NAMELY, SPLIT END REPAIR PREPARATIONS; HAIR CARE LOTIONS; HAIR CARE PREPARATIONS; HAIR CARE PRODUCTS, NAMELY, HEAT PROTECTION SPRAYS; HAIR CLEANING PREPARATIONS; HAIR COLOR; HAIR COLOR REMOVERS; HAIR COLORANTS; HAIR COLORING PREPARATIONS; HAIR COLOURANTS; HAIR COLOURING; HAIR COLOURING AND DYES; HAIR COLOURING PREPARATIONS; HAIR CREAMS; HAIR CURLING PREPARATIONS; HAIR DECOLORANTS; HAIR DYES; HAIR EMOLLIENTS; HAIR LOTIONS; HAIR MASCARA; HAIR MASKS; HAIR NOURISHERS; HAIR POMADES; HAIR RELAXERS; HAIR RELAXING PREPARATIONS; HAIR RINSES; HAIR SHAMPOOS AND CONDITIONERS; HAIR SHEEN SPRAY; HAIR STRAIGHTENING PREPARATIONS; HAIR WAVING LOTION; HAIR WAVING PREPARATIONS; NON-MEDICATED HAIR RESTORATION LOTIONS; NON-MEDICATED HAIR SERUMS; NON-MEDICATED LEAVE IN SERUMS AND SPLIT END REPAIR AND RESTORATION HAIR CARE PREPARATIONS; PREPARATIONS FOR PERMANENT HAIR WAVES (U.S. CLS. 1, 4, 6, 50, 51 AND 52).

FIRST USE 3-31-2012; IN COMMERCE 2-26-2012.

**CLASS 35—ADVERTISING AND BUSINESS**

FOR DISTRIBUTORSHIP SERVICES IN THE FIELD OF COSMETICS, PERFUMES AND PERFUMERY AND PERSONAL HYGIENE PRODUCTS; EXPORT AND IMPORT AGENCIES IN THE FIELD OF COSMETICS, PERFUMES AND PERFUMERY AND PERSONAL HYGIENE PRODUCTS; ON-LINE RETAIL STORE SERVICES FEATURING COSMETICS, PERFUMES AND PERFUMERY AND PERSONAL HYGIENE PRODUCTS; RETAIL STORE SERVICES FEATURING COSMETICS, PERFUMES AND PERFUMERY AND PERSONAL HYGIENE PRODUCTS; WHOLESALE DISTRIBUTORSHIPS FEATURING COSMETICS, PERFUMES AND PERFUMERY AND PERSONAL HYGIENE PRODUCTS (U.S. CLS. 100, 101 AND 102).

FIRST USE 3-31-2012; IN COMMERCE 2-26-2014.

4,593,478. ASSET HEALTH, INC., TROY, MI. SN 85-746,103. PUB. 4-2-2013, FILED 10-4-2012.

**ASSET HEALTH REWARDS**

THE MARK CONSISTS OF STANDARD CHARACTERS WITHOUT CLAIM TO ANY PARTICULAR FONT, STYLE, SIZE, OR COLOR.

OWNER OF U.S. REG. NO. 3,360,564.

NO CLAIM IS MADE TO THE EXCLUSIVE RIGHT TO USE "HEALTH REWARDS", APART FROM THE MARK AS SHOWN.

**CLASS 35—ADVERTISING AND BUSINESS**

FOR BUSINESS CONSULTING AND INFORMATION SERVICES IN THE FIELD OF EMPLOYEE WELLNESS, EMPLOYEE BENEFITS, EMPLOYEE HEALTHCARE AND EMPLOYEE COST MANAGEMENT; COST MANAGEMENT FOR THE HEALTH AND EMPLOYEE BENEFIT PLANS OF OTHERS (U.S. CLS. 100, 101 AND 102).

FIRST USE 4-1-2014; IN COMMERCE 4-1-2014.

**CLASS 41—EDUCATION AND ENTERTAINMENT**

FOR EDUCATION AND TRAINING SERVICES, NAMELY, PROVIDING ON-LINE TUTORIAL SESSIONS RELATING TO EMPLOYEE WELLNESS, BENEFITS, HEALTHCARE, HEALTH PROMOTION, PREVENTATIVE HEALTHCARE, DISEASE MANAGEMENT, HEALTH RISK ASSESSMENT AND HEALTHCARE COSTS (U.S. CLS. 100, 101 AND 107).

FIRST USE 4-1-2014; IN COMMERCE 4-1-2014.

**CLASS 42—SCIENTIFIC AND COMPUTER SERVICES**

FOR PROVIDING ONLINE NON-DOWNLOADABLE SOFTWARE FOR ADMINISTERING EMPLOYEE BENEFIT AND WELLNESS PROGRAMS, FOR MANAGING, TRACKING AND REDUCING EMPLOYEE COSTS, FOR EDUCATING AND CHANGING EMPLOYEE BEHAVIOR REGARDING WELLNESS ISSUES AND FOR PROVIDING INDIVIDUAL AND GROUP TRAINING RELATING TO WELLNESS ISSUES; PROVIDING ONLINE NON-DOWNLOADABLE SOFTWARE FOR DISPLAYING AND TRACKING DATA AND INFORMATION AND EDUCATING EMPLOYEES IN THE FIELDS OF EMPLOYEE WELLNESS, BENEFITS, HEALTHCARE, HEALTH PROMOTION, PREVENTATIVE HEALTHCARE, DISEASE MANAGEMENT, HEALTH RISK ASSESSMENT AND HEALTHCARE COSTS (U.S. CLS. 100 AND 101).

FIRST USE 4-1-2014; IN COMMERCE 4-1-2014.

4,593,480. DELICION, LLC, SIOUX FALLS, SD. SN 85-746,841. PUB. 3-12-2013, FILED 10-5-2012.

delicion

THE MARK CONSISTS OF STANDARD CHARACTERS WITHOUT CLAIM TO ANY PARTICULAR FONT, STYLE, SIZE, OR COLOR.

**CLASS 9—ELECTRICAL AND SCIENTIFIC APPARATUS**

FOR DOWNLOADABLE ELECTRONIC DATA FILES FEATURING RECIPES; DOWNLOADABLE SOFTWARE IN THE NATURE OF A MOBILE APPLICATION FOR PERSONAL AND PROFESSIONAL USE OF DEVELOPED RECIPES AND COOKING INFORMATION (U.S. CLS. 21, 23, 26, 36 AND 38).

FIRST USE 4-1-2013; IN COMMERCE 5-1-2013.

**CLASS 43—HOTEL AND RESTAURANT SERVICES**

FOR PROVIDING A DATABASE IN THE FIELD OF RECIPES AND COOKING INFORMATION; PROVIDING AN ONLINE COMPUTER DATABASE TO CONSUMERS FEATURING INFORMATION ABOUT RECIPES, INGREDIENTS AND COOKING INFORMATION (U.S. CLS. 100 AND 101).

FIRST USE 4-1-2013; IN COMMERCE 5-1-2013.

4,593,494. CAVE SPRINGS, INC., WILMINGTON, DE. SN 85-757,402. PUB. 4-23-2013, FILED 10-18-2012.



OWNER OF U.S. REG. NOS. 3,117,924, 4,186,873, AND OTHERS.

NO CLAIM IS MADE TO THE EXCLUSIVE RIGHT TO USE "MATERNITY", APART FROM THE MARK AS SHOWN.

THE MARK CONSISTS OF TWO HEARTS PARTIALLY OVERLAPPING OVER THE PHRASE "TWO HEARTS MATERNITY" WITH THE PHRASE "BY DESTINATION MATERNITY" UNDERNEATH IN LESS PROMINENT FONT.

**CLASS 25—CLOTHING**

FOR MATERNITY CLOTHING, NAMELY, BLOUSES, TOPS, TUNICS, DRESSES, JACKETS, LONG AND SHORT COATS, SWEATERS, LINGERIE, SWIMWEAR, SKIRTS, JEANS, SHORTS, SHORT SETS, PANT SETS COMPRISED OF PANTS SOLD TOGETHER WITH SHIRTS, JACKETS OR SWEATERS, EXERCISE WEAR, NAMELY, SWEATSHIRTS, SWEAT PANTS, T-SHIRTS, SPORTS BRAS, JOGGING SUITS; AND BABY NURSING APPAREL, NAMELY, INFANT LAYETTE (U.S. CLS. 22 AND 39).

FIRST USE 3-31-2013; IN COMMERCE 3-31-2013.

**CLASS 35—ADVERTISING AND BUSINESS**

FOR RETAIL STORE AND ONLINE RETAIL STORE SERVICES FEATURING WOMEN'S CLOTHING, MATERNITY CLOTHING, BABY NURSING APPAREL, AND BABY NURSING APPAREL ACCESSORIES (U.S. CLS. 100, 101 AND 102).

FIRST USE 3-31-2013; IN COMMERCE 3-31-2013.

4,593,495. ATA RETAIL SERVICES, INC., PLEASANTON, CA. SN 85-757,731. PUB. 10-8-2013, FILED 10-18-2012.

CRAVE

THE MARK CONSISTS OF STANDARD CHARACTERS WITHOUT CLAIM TO ANY PARTICULAR FONT, STYLE, SIZE, OR COLOR.

**CLASS 9—ELECTRICAL AND SCIENTIFIC APPARATUS**

FOR MEASURING CUPS, MEASURING SPOONS (U.S. CLS. 21, 23, 26, 36 AND 38).

FIRST USE 9-3-2013; IN COMMERCE 9-3-2013.

**CLASS 16—PAPER GOODS AND PRINTED MATTER**

FOR DECORATIVE BOXES MADE OF PAPER FOR BAKED GOODS (U.S. CLS. 2, 5, 22, 23, 29, 37, 38 AND 50).

FIRST USE 9-24-2013; IN COMMERCE 9-24-2013.

**CLASS 21—HOUSEWARES AND GLASS**

FOR PAPER BAKING CUPS, MINIATURE PAPER BAKING CUPS, LOAF PANS, PASTRY BAGS, CONFECTIONERS' DEVICES FOR DECORATING FOODS, NAMELY, FROSTING AND ICING PIPING BAGS, FROSTING AND ICING PRESSES WITH DECORATIVE TIPS (U.S. CLS. 2, 13, 23, 29, 30, 33, 40 AND 50).

FIRST USE 10-29-2013; IN COMMERCE 10-29-2013.

4,593,500. LYNX GRILLS, INC., DOWNEY, CA. SN 85-760,577. PUB. 1-7-2014, FILED 10-22-2012.

MOM FRIENDLY, DAD READY

THE MARK CONSISTS OF STANDARD CHARACTERS WITHOUT CLAIM TO ANY PARTICULAR FONT, STYLE, SIZE, OR COLOR.

**CLASS 6—METAL GOODS**

FOR ACCESS DOORS FOR GRILLS, UTILITY DRAWERS FOR GRILLS, WARMING DRAWERS SOLD AS INDIVIDUAL UNITS (U.S. CLS. 2, 12, 13, 14, 23, 25 AND 50).

FIRST USE 3-1-2013; IN COMMERCE 3-1-2013.

**CLASS 11—ENVIRONMENTAL CONTROL APPARATUS**

FOR BARBECUE GRILLS, GAS GRILLS, AND ELECTRIC GRILLS; ACCESSORIES AND COMPLEMENTARY PRODUCTS FOR BARBECUE GRILLS, GAS GRILLS, AND ELECTRIC GRILLS, NAMELY, SIDE BURNERS, POWER BURNERS, COCKTAIL STATIONS WITH ICE STORAGE, SINKS WITH FAUCETS, FAUCET FILTERS, DRAINBOARDS, BOTTLE STORAGE COMPARTMENTS AND SPEED RAILS FOR GRILLS, DOUBLE SIDE BURNERS WITH PREP CENTERS, REFRIGERATORS, BEVERAGE DISPENSERS, WOK AND GRIDDLE PLATE ACCESSORIES FOR GRILLS, VENTILATION FOR GRILLS, AND OUTDOOR HEATERS (U.S. CLS. 13, 21, 23, 31 AND 34).

FIRST USE 3-1-2013; IN COMMERCE 3-1-2013.

**CLASS 21—HOUSEWARES AND GLASS**

FOR COVERS FOR GRILLS (U.S. CLS. 2, 13, 23, 29, 30, 33, 40 AND 50).

FIRST USE 3-1-2013; IN COMMERCE 3-1-2013.

4,593,503. LIU, XIANG, BEIJING, CHINA. SN 85-761,835. PUB. 10-8-2013, FILED 10-24-2012.

JSSHAN

THE MARK CONSISTS OF STANDARD CHARACTERS WITHOUT CLAIM TO ANY PARTICULAR FONT, STYLE, SIZE, OR COLOR.

THE NAME(S), PORTRAIT(S), AND/OR SIGNATURE(S) SHOWN IN THE MARK DOES NOT IDENTIFY A PARTICULAR LIVING INDIVIDUAL.

**CLASS 25—CLOTHING**

FOR BLOUSES; BRIDESMAID DRESSES; CLOTHING, NAMELY, WRAP-AROUNDS; DRESSES; EVENING DRESSES; GLOVES; SHIRTS; SKIRTS; TURBANS; WEDDING DRESSES; WOMEN'S CEREMONIAL DRESSES (U.S. CLS. 22 AND 39).

FIRST USE 11-1-2012; IN COMMERCE 11-1-2012.

**CLASS 35—ADVERTISING AND BUSINESS**

FOR ADVERTISING, MARKETING AND PROMOTION SERVICES; ARRANGING AND CONDUCTING OF FAIRS AND EXHIBITIONS FOR BUSINESS AND ADVERTISING PURPOSES; DESIGN OF ADVERTISING MATERIALS FOR OTHERS; DESIGN OF INTERNET ADVERTISING; DIRECT MAIL ADVERTISING SERVICES; IMPORT-EXPORT AGENCIES IN THE FIELD OF CLOTHING; ON-LINE ADVERTISING ON COMPUTER NETWORKS; ORGANIZATION OF FASHION SHOWS FOR COMMERCIAL PURPOSES; PUBLICATION OF PUBLICITY TEXTS; RETAIL SHOP WINDOW DISPLAY ARRANGEMENT SERVICES (U.S. CLS. 100, 101 AND 102).

FIRST USE 11-1-2012; IN COMMERCE 11-1-2012.

4,593,505. WILLIAMS-SONOMA, INC., SAN FRANCISCO, CA. SN 85-763,464. PUB. 10-29-2013, FILED 10-25-2012.

— west elm —  
**MARKET**

OWNER OF U.S. REG. NOS. 2,725,772, 2,845,444, AND OTHERS.

NO CLAIM IS MADE TO THE EXCLUSIVE RIGHT TO USE "MARKET", APART FROM THE MARK AS SHOWN.

THE MARK CONSISTS OF THE WORDS "WEST ELM" PLACED BETWEEN HORIZONTAL LINES, ABOVE THE WORD "MARKET".

**CLASS 21—HOUSEWARES AND GLASS**

FOR CONTAINERS MADE OF NON-PRECIOUS METAL, GLASS, PORCELAIN AND EARTHEN WARE FOR HOUSEHOLD AND KITCHEN USE; BAKING DISHES; BROOMS; KITCHEN COOKWARE, NAMELY, POTS AND PANS; DISHES; BOWLS; CUPS; BEVERAGE GLASSWARE; ICE BUCKETS; TABLEWARE, NAMELY, KNIVES, SERVING FORKS AND SERVING SPOONS; KNIFE BLOCKS; KITCHEN CONTAINERS; COFFEE POTS NOT OF PRECIOUS METAL; TEAPOTS NOT OF PRECIOUS METAL AND TEA KETTLES; TRIVETS; TRAYS, NAMELY, FOR DOMESTIC PURPOSES; SPICE RACKS; WINE RACKS; LAUNDRY BASKETS; BASKETS OF WICKER AND WOOD FOR HOUSEHOLD USE; BUCKETS; SCRUBBING BRUSHES; SOAP DISPENSERS; CLOTHES AND DISH DRYING RACKS; TOWEL HOLDERS, NAMELY, TOWEL RAILS AND RINGS; TRASH CANS; FLOWER POTS; GARDENING GLOVES; GARDEN HOSE SPRAYERS; GENERAL PURPOSE STORAGE BINS FOR HOUSEHOLD USE; UTENSILS FOR BARBECUES, NAMELY, FORKS, TONGS, TURNERS; WOOD CHOPPING BOARDS FOR KITCHEN USE (U.S. CLS. 2, 13, 23, 29, 30, 33, 40 AND 50).

FIRST USE 2-0-2012; IN COMMERCE 2-0-2012.

**CLASS 35—ADVERTISING AND BUSINESS**

FOR RETAIL STORE SERVICES, ON-LINE RETAIL STORE SERVICES AND CATALOG MAIL ORDER SERVICES FEATURING HOUSE WARES, HOME ACCESSORIES, INDOOR AND OUTDOOR FURNITURE, LAMPS AND LIGHTING FIXTURES, CURTAINS, BATH LINENS, SKIN CARE LOTIONS AND OILS, BASKETS MADE OF WICKER, INTERIOR DECORATING BOOKS, BATH RUGS, TOWELS, SHOWER CURTAINS, LIGHTING, TOYS, BOOKS, HARDWARE, NAMELY, FURNITURE HARDWARE, BATHROOM HARDWARE, CULINARY EQUIPMENT, COOKWARE, BAKEWARE, CUTLERY, KITCHEN GADGETS, UTENSILS, DINNERWARE, TABLEWARE, GLASSWARE, FLATWARE, SERVING TRAYS, CERAMICS, ELECTRIC KITCHEN APPLIANCES, COOKBOOKS, GOURMET FOODS, TABLE LINENS, KITCHEN TOWELS, BASKETS, BROOMS, BRUSHES AND DUSTERS FOR CLEANING, BARBECUES AND BARBECUE ACCESSORIES, PICNIC ACCESSORIES, HOSES, PLANTERS, PLANT STANDS, PLANTING SOIL, WATERING CANS, GARDEN TROWELS, GARDEN PRUNERS (U.S. CLS. 100, 101 AND 102).

FIRST USE 2-0-2012; IN COMMERCE 2-0-2012.

4,593,506. WILLIAMS-SONOMA, INC., SAN FRANCISCO, CA. SN 85-763,466. PUB. 10-29-2013, FILED 10-25-2012.

4,593,507. NET HEALTH SYSTEMS, INC., PITTSBURGH, PA. SN 85-763,792. PUB. 10-8-2013, FILED 10-25-2012.

## WEST ELM MARKET

THE MARK CONSISTS OF STANDARD CHARACTERS WITHOUT CLAIM TO ANY PARTICULAR FONT, STYLE, SIZE, OR COLOR.

OWNER OF U.S. REG. NOS. 2,725,772, 2,845,444, AND OTHERS.

NO CLAIM IS MADE TO THE EXCLUSIVE RIGHT TO USE "MARKET", APART FROM THE MARK AS SHOWN.

### CLASS 21—HOUSEWARES AND GLASS

FOR CONTAINERS MADE OF NON-PRECIOUS METAL, GLASS, PORCELAIN AND EARTHEN WARE FOR HOUSEHOLD AND KITCHEN USE; BAKING DISHES; BROOMS; KITCHEN COOKWARE, NAMELY, POTS AND PANS; DISHES; BOWLS; CUPS; BEVERAGE GLASSWARE; ICE BUCKETS; TABLEWARE, NAMELY, KNIVES, SERVING FORKS AND SERVING SPOONS; KNIFE BLOCKS; KITCHEN CONTAINERS; COFFEE POTS NOT OF PRECIOUS METAL; TEAPOTS NOT OF PRECIOUS METAL AND TEA KETTLES; TRIVETS; TRAYS, NAMELY, TRAYS FOR DOMESTIC PURPOSES; SPICE RACKS; WINE RACKS; LAUNDRY BASKETS; BASKETS OF WICKER AND WOOD FOR HOUSEHOLD USE; BUCKETS; SCRUBBING BRUSHES; SOAP DISPENSERS; CLOTHES AND DISH DRYING RACKS; TOWEL HOLDERS, NAMELY, TOWEL RAILS AND RINGS; TRASH CANS; FLOWER POTS; GARDENING GLOVES; GARDEN HOSE SPRAYERS; GENERAL PURPOSE STORAGE BINS FOR HOUSEHOLD USE; UTENSILS FOR BARBECUES, NAMELY, FORKS, TONGS, TURNERS; WOOD CHOPPING BOARDS FOR KITCHEN USE (U.S. CLS. 2, 13, 23, 29, 30, 33, 40 AND 50).  
FIRST USE 2-0-2012; IN COMMERCE 2-0-2012.

### CLASS 35—ADVERTISING AND BUSINESS

FOR RETAIL STORE SERVICES, ON-LINE RETAIL STORE SERVICES AND CATALOG MAIL ORDER SERVICES FEATURING HOUSE WARES, HOME ACCESSORIES, INDOOR AND OUTDOOR FURNITURE, LAMPS AND LIGHTING FIXTURES, CURTAINS, BATH LINENS, SKIN CARE LOTIONS AND OILS, BASKETS MADE OF WICKER, INTERIOR DECORATING BOOKS, BATH RUGS, TOWELS, SHOWER CURTAINS, LIGHTING, TOYS, BOOKS, HARDWARE, NAMELY, FURNITURE HARDWARE, BATHROOM HARDWARE, CULINARY EQUIPMENT, COOKWARE, BAKEWARE, CUTLERY, KITCHEN GADGETS, UTENSILS, DINNERWARE, TABLEWARE, GLASSWARE, FLATWARE, SERVING TRAYS, CERAMICS, ELECTRIC KITCHEN APPLIANCES, COOKBOOKS, GOURMET FOODS, TABLE LINENS, KITCHEN TOWELS, BASKETS, BROOMS, BRUSHES AND DUSTERS FOR CLEANING, BARBECUES AND BARBECUE ACCESSORIES, PICNIC ACCESSORIES, HOSES, PLANTERS, PLANT STANDS, PLANTING SOIL, WATERING CANS, GARDEN TOWELS, GARDEN PRUNERS (U.S. CLS. 100, 101 AND 102).  
FIRST USE 2-0-2012; IN COMMERCE 2-0-2012.

## WOUNDEXPERT

THE MARK CONSISTS OF STANDARD CHARACTERS WITHOUT CLAIM TO ANY PARTICULAR FONT, STYLE, SIZE, OR COLOR.

OWNER OF U.S. REG. NO. 2,488,698.

### CLASS 9—ELECTRICAL AND SCIENTIFIC APPARATUS

FOR COMPUTER SOFTWARE FOR HEALTHCARE MANAGEMENT (U.S. CLS. 21, 23, 26, 36 AND 38).  
FIRST USE 7-0-1999; IN COMMERCE 7-0-1999.

### CLASS 16—PAPER GOODS AND PRINTED MATTER

FOR COMPUTER SOFTWARE MANUALS (U.S. CLS. 2, 5, 22, 23, 29, 37, 38 AND 50).  
FIRST USE 7-0-1999; IN COMMERCE 7-0-1999.

### CLASS 21—HOUSEWARES AND GLASS

FOR MUGS (U.S. CLS. 2, 13, 23, 29, 30, 33, 40 AND 50).  
FIRST USE 1-0-2002; IN COMMERCE 1-0-2002.

### CLASS 41—EDUCATION AND ENTERTAINMENT

FOR EDUCATION, NAMELY, CLASSES AND TRAINING SERVICES IN THE FIELD OF SOFTWARE FOR HEALTHCARE MANAGEMENT (U.S. CLS. 100, 101 AND 107).  
FIRST USE 7-0-1999; IN COMMERCE 7-0-1999.

4,593,520. BEAZLEY PLC, LONDON, UNITED KINGDOM. SN 85-767,513. PUB. 10-22-2013, FILED 10-30-2012.

## ECLIPSE

THE MARK CONSISTS OF STANDARD CHARACTERS WITHOUT CLAIM TO ANY PARTICULAR FONT, STYLE, SIZE, OR COLOR.

OWNER OF U.S. REG. NO. 4,022,420.

### CLASS 16—PAPER GOODS AND PRINTED MATTER

FOR PRINTED PUBLICATIONS, NAMELY, MAGAZINES, NEWSLETTERS, NEWSPAPERS, PERIODICALS, JOURNALS, CATALOGUES, PAMPHLETS, LEAFLETS AND POSTERS IN THE FIELD OF INSURANCE OR RE-INSURANCE OR INSURANCE OR RE-INSURANCE SERVICES; WRITING INSTRUMENTS; PENS; PENCILS (U.S. CLS. 2, 5, 22, 23, 29, 37, 38 AND 50).  
FIRST USE 8-0-2010; IN COMMERCE 8-0-2010.

**CLASS 35—ADVERTISING AND BUSINESS**

FOR BUSINESS ADMINISTRATION AND MANAGEMENT; PROVISION OF BUSINESS ADVICE PERTAINING TO INSURANCE, RE-INSURANCE, RISK MANAGEMENT, AND MEDIATION; INFORMATION AND ADVISORY SERVICES RELATING TO THE AFORESAID SERVICES (U.S. CLS. 100, 101 AND 102).

FIRST USE 8-0-2010; IN COMMERCE 8-0-2010.

**CLASS 36—INSURANCE AND FINANCIAL**

FOR INSURANCE SERVICES, NAMELY, UNDERWRITING, ISSUANCE AND ADMINISTRATION OF LIFE, ACCIDENT, CASUALTY, HEALTH, MARINE, POLITICAL RISK AND CONTINGENCY, PROPERTY, REINSURANCE, PROFESSIONAL LIABILITY, MANAGEMENT LIABILITY, ENVIRONMENTAL AND AVIATION INSURANCE; FINANCIAL SERVICES IN THE FIELD OF INSURANCE, NAMELY, INSURANCE SETTLEMENT SERVICES AND FINANCIAL EVALUATION FOR INSURANCE PURPOSES; PRIVATE CLIENT INSURANCE SERVICES, NAMELY, UNDERWRITING, ISSUANCE AND ADMINISTRATION OF LIFE, ACCIDENT, HEALTH, POLITICAL RISK AND CONTINGENCY, PROPERTY, REINSURANCE, PROFESSIONAL LIABILITY, MANAGEMENT LIABILITY AND ENVIRONMENTAL INSURANCE; INSURANCE BROKERAGE; RE-INSURANCE BROKERAGE; INSURANCE AND RE-INSURANCE AGENCY SERVICES; INSURANCE AND RE-INSURANCE CONSULTATION; PROVIDING INSURANCE INFORMATION SERVICES, NAMELY, PROVIDING INFORMATION RELATED TO INSURANCE POLICIES, INSURANCE CLAIMS AND REINSURANCE STRATEGIES AND PLANS; INSURANCE UNDERWRITING SERVICES; FINANCIAL ADVISORY, CONSULTATION, PLANNING AND INFORMATION SERVICES; ACTUARIAL SERVICES; FINANCIAL RISK MANAGEMENT, ASSESSMENT, CONTROL AND CONSULTANCY SERVICES; INSURANCE CLAIMS ADMINISTRATION; ELECTRONIC PROCESSING OF INSURANCE CLAIMS AND PAYMENT DATA; APPRAISALS FOR INSURANCE CLAIMS; INSURANCE CLAIMS PROCESSING; FINANCIAL ANALYSIS AND CONSULTATION IN THE FIELD OF INSURANCE PREMIUMS AND CLAIMS; FINANCIAL EVALUATION FOR INSURANCE PURPOSES; FINANCIAL MANAGEMENT FOR INSURANCE PURPOSES; FINANCIAL PLANNING FOR INSURANCE PURPOSES; FINANCIAL PORTFOLIO MANAGEMENT FOR INSURANCE PURPOSES (U.S. CLS. 100, 101 AND 102).

FIRST USE 8-0-2010; IN COMMERCE 8-0-2010.

4,593,522. BUIITIME LLC, WESTLAKE, OH. SN 85-768,480. PUB. 4-9-2013, FILED 10-31-2012.

**BUIITIME**

THE MARK CONSISTS OF STANDARD CHARACTERS WITHOUT CLAIM TO ANY PARTICULAR FONT, STYLE, SIZE, OR COLOR.

**CLASS 35—ADVERTISING AND BUSINESS**

FOR ON-LINE BUSINESS NETWORKING SERVICES; OPERATING ON-LINE MARKETPLACES FEATURING THE PURCHASING AND SELLING OF TIME SLOTS FOR USERS TO MEET, SPEAK, INTERACT OR CONDUCT BUSINESS TRANSACTIONS IN THE FIELD OF BUSINESS DEVELOPMENT AND THEIR RESPECTIVE INDUSTRIES (U.S. CLS. 100, 101 AND 102).

FIRST USE 6-2-2014; IN COMMERCE 6-2-2014.

**CLASS 38—COMMUNICATION**

FOR PROVIDING PRIVATE AND SECURE REAL TIME ELECTRONIC COMMUNICATION OVER A COMPUTER NETWORK; TRANSMISSION OF INFORMATION BY ELECTRONIC COMMUNICATIONS NETWORKS (U.S. CLS. 100, 101 AND 104).

FIRST USE 6-2-2014; IN COMMERCE 6-2-2014.

**CLASS 42—SCIENTIFIC AND COMPUTER SERVICES**

FOR PROVIDING A WEB SITE FEATURING TECHNOLOGY THAT ENABLES USERS TO CREATE, SCHEDULE, MARKET, PURCHASE AND SELL SLOTS OF TIME, TO SURVEY AND SOLICIT FEEDBACK FROM INTERACTIONS BETWEEN USERS, AND TO FACILITATE THE PROCESSING OF TIME SLOT PAYMENTS AMONG USERS; SOFTWARE AS A SERVICE (SAAS) SERVICES FEATURING SOFTWARE FOR OPERATING AN ONLINE MARKETPLACE, FOR ENABLING USERS TO CREATE, SCHEDULE, MARKET, PURCHASE AND SELL SLOTS OF TIME, TO SURVEY AND SOLICIT FEEDBACK FROM INTERACTIONS BETWEEN USERS, AND TO FACILITATE THE PROCESSING OF TIME SLOT PAYMENTS AMONG USERS (U.S. CLS. 100 AND 101).

FIRST USE 6-2-2014; IN COMMERCE 6-2-2014.

4,593,523. JINI BABY INTERNATIONAL CO., LTD., CHANGHUA COUNTY, TAIWAN. SN 85-768,754. PUB. 11-12-2013, FILED 11-1-2012.



THE MARK CONSISTS OF A GRAPHIC DEPICTION OF A BABY DUCK WITH THE WORDS "KU.KU DUCKBILL" IN STYLIZED FONT PLACED BENEATH IT.

**CLASS 5—PHARMACEUTICALS**

FOR FOOD FOR BABIES; BABY MILK POWDER; BREAST-NURSING PADS; COD LIVER OIL; VITAMINS; NUTRITIONAL FOOD ADDITIVES FOR MEDICAL PURPOSES IN THE NATURE OF NATURAL FOOD EXTRACTS DERIVED FROM FISH; DEPURATIVES FOR THE BODY; ANTI-HORSEFLY OILS; SANITIZING WIPES; SANITARY NAPKINS (U.S. CLS. 6, 18, 44, 46, 51 AND 52).

FIRST USE 5-13-2014; IN COMMERCE 5-13-2014.

**CLASS 10—MEDICAL APPARATUS**

FOR BABY BOTTLE NIPPLES; BABY BOTTLES; BREAST PUMPS; CLINICAL THERMOMETERS; MEDICAL ICE PACKS; PACIFIER CLIPS; TEATS; NURSING BOTTLES; ABDOMINAL CORSETS (U.S. CLS. 26, 39 AND 44).

FIRST USE 5-13-2014; IN COMMERCE 5-13-2014.

**CLASS 25—CLOTHING**

FOR UNDERWEAR; SHAPEWEAR, NAMELY, LADIES FOUNDATION GARMENTS AND BRAS; GIRDLES; SOCKS; DRESSES; BATHING CAPS; SHOES; CAPS; CHILDREN'S AND INFANTS' CLOTH BIBS; INFANT WEAR (U.S. CLS. 22 AND 39).

FIRST USE 5-13-2014; IN COMMERCE 5-13-2014.

4,593,537. HUNG, TACHUN, HSINCHU CITY, TAIWAN. SN 85-775,010. PUB. 11-5-2013, FILED 11-8-2012.

4,593,536. WHOLESOME GENERATION, AUSTIN, TX. SN 85-774,308. PUB. 4-23-2013, FILED 11-8-2012.

**WHOLESOME GENERATION**

THE MARK CONSISTS OF STANDARD CHARACTERS WITHOUT CLAIM TO ANY PARTICULAR FONT, STYLE, SIZE, OR COLOR.

**CLASS 41—EDUCATION AND ENTERTAINMENT**

FOR EDUCATION SERVICES IN THE NATURE OF EARLY CHILDHOOD INSTRUCTION; EDUCATIONAL SERVICES, NAMELY, CONDUCTING CONFERENCES, CLASSES, SEMINARS, WORKSHOPS, WEB CONFERENCES, AND TELEPHONE CONFERENCES IN THE FIELD OF NUTRITION, HEALTHY EATING, HEALTHY LIVING, AND WELLNESS FOR TEACHERS AND THE GENERAL PUBLIC; EDUCATION SERVICES, NAMELY, DEVELOPING CURRICULUMS FOR OTHERS IN THE FIELDS OF NUTRITION, HEALTHY EATING, HEALTHY LIVING, AND WELLNESS; EDUCATION SERVICES, NAMELY, PROVIDING KINDERGARTEN THROUGH 5TH GRADE (K-5) CLASSROOM INSTRUCTION INFORMATION IN THE FIELD OF PARENTING CONCERNING EDUCATION OF CHILDREN; PROVIDING EDUCATION COURSES IN THE FIELD OF NUTRITION, HEALTHY EATING, HEALTHY LIVING, AND WELLNESS FOR TEACHERS AND THE GENERAL PUBLIC; EDUCATION SERVICES, NAMELY, DEVELOPING CURRICULUMS FOR OTHERS IN THE FIELDS OF NUTRITION, HEALTHY EATING, HEALTHY LIVING, AND WELLNESS OFFERED THROUGH ONLINE, NON-DOWNLOADABLE VIDEOS AND INSTRUCTOR ASSISTANCE; PHYSICAL EDUCATION SERVICES; PROVIDING A WEBSITE FEATURING INFORMATION IN THE FIELDS OF EDUCATION FOR CHILDREN; PROVIDING INFORMATION IN THE FIELD OF CHILDREN'S EDUCATION (U.S. CLS. 100, 101 AND 107).

FIRST USE 10-0-2013; IN COMMERCE 3-0-2014.

**CLASS 43—HOTEL AND RESTAURANT SERVICES**

FOR CHILD CARE; CHILD CARE CENTERS; CHILD CARE SERVICES; DAY CARE CENTERS (U.S. CLS. 100 AND 101).

FIRST USE 10-0-2013; IN COMMERCE 3-0-2014.

# INNOR

THE MARK CONSISTS OF STANDARD CHARACTERS WITHOUT CLAIM TO ANY PARTICULAR FONT, STYLE, SIZE, OR COLOR.

THE WORDING "INNOR" HAS NO MEANING IN A FOREIGN LANGUAGE.

**CLASS 9—ELECTRICAL AND SCIENTIFIC APPARATUS**

FOR TELEPHONE, PHONE CASE, IN-CAR TELEPHONE HANDSET CRADLE, MOBILE PHONE, PROTECTOR, NAMELY, PROTECTIVE COVERS SPECIALLY ADAPTED FOR MOBILE PHONES, MOBILE PHONE HOLDER, NAMELY, DETACHABLE CELL PHONE HOLDERS, PHONE HANDS-FREE DEVICE, MOBILE PHONE STRAP, AND MOBILE PHONE CASE (U.S. CLS. 21, 23, 26, 36 AND 38).

FIRST USE 12-31-2013; IN COMMERCE 2-23-2014.

**CLASS 12—VEHICLES**

FOR BICYCLES AND STRUCTURAL PARTS FOR BICYCLES, NAMELY, BICYCLE PEDAL, BICYCLE HANDLEBAR STEM, BICYCLE SILL JOINT, FRONT FORK, BICYCLE PARKING BRACKET, BICYCLE SPOKE, BICYCLE MOTOR, BICYCLE CRANK, BICYCLE WHEEL, BASKETS ADAPTED FOR BICYCLES, BICYCLE FRAME, SEAT POST, BICYCLE TRANSMISSION GEAR SET COMPRISED OF GEARS AND OTHER STRUCTURAL COMPONENTS SOLD AS A UNIT, ELECTRIC BICYCLES, SCOOTER, ELECTRIC SCOOTER, MOVING TRICYCLE, PANNIER BAGS FOR BICYCLES, AND OTHER ELECTRIC VEHICLE, NAMELY, MOTORCYCLES (U.S. CLS. 19, 21, 23, 31, 35 AND 44).

FIRST USE 12-31-2013; IN COMMERCE 2-23-2014.

**CLASS 42—SCIENTIFIC AND COMPUTER SERVICES**

FOR NEW PRODUCT DESIGN SERVICES, INDUSTRIAL DESIGN SERVICES, NAMELY, PRODUCT APPEARANCE AND STRUCTURE DESIGN, COMPUTER HARDWARE DESIGN, CONSULTATION SERVICES FOR COMPUTER HARDWARE DESIGN AND DEVELOPMENT, PACKAGING DESIGN, GRAPHIC DESIGN, FASHION PRODUCT DESIGN, AND TECHNOLOGICAL INFORMATION SERVICES RELATED TO FASHION PRODUCT DESIGN (U.S. CLS. 100 AND 101).

FIRST USE 12-31-2013; IN COMMERCE 12-31-2013.

4,593,538. HUNG, TACHUN, HSINCHU CITY, TAIWAN. SN 85-775,038. PUB. 10-29-2013, FILED 11-8-2012.

4,593,543. WHOKNOWS, INC., MOUNTAIN VIEW, CA. SN 85-776,702. PUB. 5-7-2013, FILED 11-12-2012.

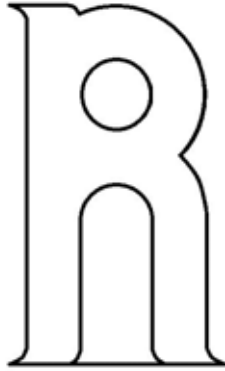

THE MARK CONSISTS OF STYLIZED CAPITAL LETTER "R" OVERLAPPING WITH A SMALL STYLIZED LETTER "I", WHICH IS PLACED IN THE MIDDLE OF THE STYLIZED CAPITAL LETTER "R".

#### CLASS 9—ELECTRICAL AND SCIENTIFIC APPARATUS

FOR TELEPHONE, PHONE CASE, IN-CAR TELEPHONE HANDSET CRADLE, MOBILE PHONE PROTECTOR, NAMELY, PROTECTIVE COVERS SPECIALLY ADAPTED FOR MOBILE PHONES, MOBILE PHONE HOLDER, NAMELY, DETACHABLE CELL PHONE HOLDERS, PHONE HANDS-FREE DEVICE, MOBILE PHONE STRAP, MOBILE PHONE CASE (U.S. CLS. 21, 23, 26, 36 AND 38).

FIRST USE 12-31-2013; IN COMMERCE 2-23-2014.

#### CLASS 12—VEHICLES

FOR BICYCLES AND STRUCTURAL PARTS FOR BICYCLES, NAMELY, BICYCLE PEDAL, BICYCLE HANDLEBAR STEM, BICYCLE SILL JOINT, FRONT FORK, BICYCLE PARKING BRACKET, BICYCLE SPOKE, BICYCLE MOTOR, BICYCLE CRANK, BICYCLE WHEEL, BASKETS ADAPTED FOR BICYCLES, BICYCLE FRAME, SEAT POST, BICYCLE TRANSMISSION GEAR SET COMPRISED OF GEARS AND OTHER STRUCTURAL COMPONENTS SOLD AS A UNIT, ELECTRIC BICYCLES, SCOOTER, ELECTRIC SCOOTER, MOVING TRICYCLE, AND PANNIER BAGS FOR BICYCLES, AND OTHER ELECTRIC VEHICLE, NAMELY, MOTORCYCLES (U.S. CLS. 19, 21, 23, 31, 35 AND 44).

FIRST USE 12-31-2013; IN COMMERCE 2-23-2014.

#### CLASS 42—SCIENTIFIC AND COMPUTER SERVICES

FOR NEW PRODUCT DESIGN SERVICES; INDUSTRIAL DESIGN SERVICES, NAMELY, PRODUCT APPEARANCE AND STRUCTURE DESIGN, COMPUTER HARDWARE DESIGN, CONSULTATION SERVICES FOR COMPUTER HARDWARE DESIGN AND DEVELOPMENT, PACKAGING DESIGN, GRAPHIC DESIGN, FASHION PRODUCT DESIGN, AND TECHNOLOGICAL INFORMATION SERVICES RELATED TO FASHION PRODUCT DESIGN (U.S. CLS. 100 AND 101).

FIRST USE 12-31-2013; IN COMMERCE 12-31-2013.

## WHOKNOWS

THE MARK CONSISTS OF STANDARD CHARACTERS WITHOUT CLAIM TO ANY PARTICULAR FONT, STYLE, SIZE, OR COLOR.

#### CLASS 9—ELECTRICAL AND SCIENTIFIC APPARATUS

FOR COMPUTER SOFTWARE FOR PROVIDING AUTOMATIC EXPERTISE DISCOVERY INFORMATION; COMPUTER HARDWARE (U.S. CLS. 21, 23, 26, 36 AND 38).

FIRST USE 11-30-2012; IN COMMERCE 11-30-2012.

#### CLASS 42—SCIENTIFIC AND COMPUTER SERVICES

FOR PROVIDING A WEBSITE FEATURING NON-DOWNLOADABLE SOFTWARE FOR USE IN ACCESSING AN AUTOMATIC EXPERTISE DISCOVERY PLATFORM; COMPUTER SERVICES, NAMELY, PROVIDING SEARCH PLATFORMS TO ALLOW USERS TO ACCESS, SEARCH, AND USE AN AUTOMATIC EXPERTISE DISCOVERY DATABASE; PLATFORM AS A SERVICE (PAAS) FEATURING COMPUTER SOFTWARE PLATFORMS FOR ALLOWING USERS TO ACCESS, SEARCH, AND USE AN AUTOMATIC EXPERTISE DISCOVERY DATABASE; COMPUTER SERVICES, NAMELY, PROVIDING SEARCH PLATFORMS TO ALLOW USERS TO ACCESS, SEARCH, AND USE EXPERTISE DISCOVERY DATABASES; PLATFORM AS A SERVICE (PAAS) FEATURING COMPUTER SOFTWARE PLATFORMS FOR ALLOWING USERS TO ACCESS, SEARCH, AND USE EXPERTISE DISCOVERY DATABASES; APPLICATION SERVICE PROVIDER FEATURING APPLICATION PROGRAMMING INTERFACE (API) SOFTWARE FOR API PLUGINS AND BUILT-IN CONNECTORS FOR INTEGRATING WITH THIRD-PARTY SOFTWARE AND SERVICES FOR EXPERTISE DISCOVERY; COMPUTER SERVICES, NAMELY, PROVIDING A WEBSITE FEATURING NON-DOWNLOADABLE SOFTWARE FOR USE IN SOLVING THE PROBLEM OF ACCURATE EXPERTISE DISCOVERY AND KNOWLEDGE RETENTION, AND INTERPRET RANKINGS AND PROPRIETARY BEHAVIORAL SIGNALS TO PRESENT AN ACCURATE AND CONSISTENT SHOWCASE OF CORPORATE EXPERTISE (U.S. CLS. 100 AND 101).

FIRST USE 11-30-2012; IN COMMERCE 11-30-2012.

4,593,546. FLATS LLC, CHICAGO, IL. SN 85-779,336. PUB. 11-5-2013, FILED 11-14-2012.



EST. ALWAYS

FLATS

CHICAGO

NO CLAIM IS MADE TO THE EXCLUSIVE RIGHT TO USE "FLATS CHICAGO", APART FROM THE MARK AS

SHOWN.

THE MARK CONSISTS OF THE IMAGE OF A DOG IN PROFILE. BELOW THE DOG IMAGE IS THE PHRASE "EST. ALWAYS" IN A MEDIUM-SIZED TYPE. BELOW "EST. ALWAYS" IS THE WORD "FLATS" IN A LARGER-SIZED TYPE. BELOW "FLATS" IS THE WORD "CHICAGO" IN A MEDIUM-SIZED TYPE.

#### CLASS 36—INSURANCE AND FINANCIAL

FOR RENTING OF REAL-ESTATE; RENTING OF BUILDINGS; RENTING OF APARTMENTS; RENTING OF OFFICE SPACE; RENTING OF RETAIL SPACE; LEASING OF REAL-ESTATE; LEASING OF BUILDINGS; LEASING OF APARTMENTS; LEASING OF OFFICE SPACE; LEASING OF RETAIL SPACE; REAL ESTATE AGENCIES; REAL ESTATE AGENCIES FEATURING BUILDINGS, APARTMENTS, OFFICE SPACE, AND RETAIL SPACE; BUILDING MANAGEMENT; APARTMENT HOUSE MANAGEMENT; PROVIDING REAL ESTATE LISTINGS AND REAL ESTATE INFORMATION VIA THE INTERNET (U.S. CLS. 100, 101 AND 102).  
FIRST USE 5-21-2012; IN COMMERCE 5-21-2012.

#### CLASS 43—HOTEL AND RESTAURANT SERVICES

FOR HOTEL SERVICES; RESIDENTIAL HOTEL SERVICES; RENTAL OF BUILDINGS FOR TEMPORARY OCCUPANCY (U.S. CLS. 100 AND 101).  
FIRST USE 5-21-2012; IN COMMERCE 5-21-2012.

---

4,593,549. NIMBLETV, INC., NEW YORK, NY. SN 85-781,262. PUB. 9-24-2013, FILED 11-16-2012.

# NIMBLETV

THE MARK CONSISTS OF STANDARD CHARACTERS WITHOUT CLAIM TO ANY PARTICULAR FONT, STYLE, SIZE, OR COLOR.

#### CLASS 9—ELECTRICAL AND SCIENTIFIC APPARATUS

FOR SOFTWARE FOR USE IN ELECTRONIC TRANSMISSION AND STREAMING OF DIGITAL MEDIA CONTENT FOR OTHERS VIA COMPUTERS, TABLETS, MOBILE PHONES, TELEVISION, WIRED AND WIRELESS COMMUNICATION DEVICES, AND OPTICAL AND ELECTRONIC COMMUNICATIONS NETWORKS; SOFTWARE FOR USE IN STREAMING OF AUDIO AND AUDIO-VISUAL MEDIA CONTENT IN THE FIELDS OF NEWS, ENTERTAINMENT, SPORTS, COMEDY, DRAMA, MUSIC, AND MUSIC VIDEOS VIA COMPUTERS, TABLETS, MOBILE PHONES, TELEVISIONS, WIRED AND WIRELESS COMMUNICATION DEVICES, AND OPTICAL AND ELECTRONIC COMMUNICATIONS NETWORKS (U.S. CLS. 21, 23, 26, 36 AND 38).  
FIRST USE 12-0-2013; IN COMMERCE 12-0-2013.

#### CLASS 38—COMMUNICATION

FOR ELECTRONIC TRANSMISSION AND STREAMING OF DIGITAL MEDIA CONTENT FOR OTHERS VIA OPTICAL AND ELECTRONIC COMMUNICATIONS NETWORKS; STREAMING OF AUDIO AND AUDIO-VISUAL MEDIA CONTENT IN THE FIELDS OF NEWS, ENTERTAINMENT, SPORTS, COMEDY, DRAMA, MUSIC, AND MUSIC VIDEOS VIA OPTICAL AND ELECTRONIC COMMUNICATIONS NETWORKS; WEBCASTING SERVICES; VIDEO-ON DEMAND TRANSMISSION SERVICES; PROVIDING ON-LINE FORUMS FOR TRANSMISSION OF MESSAGES AMONG COMPUTER USERS (U.S. CLS. 100, 101 AND 104).  
FIRST USE 12-0-2013; IN COMMERCE 12-0-2013.

#### CLASS 42—SCIENTIFIC AND COMPUTER SERVICES

FOR PROVIDING TEMPORARY USE OF NONDOWNLOADABLE SOFTWARE FOR USE IN ELECTRONIC TRANSMISSION AND STREAMING OF DIGITAL MEDIA CONTENT FOR OTHERS VIA COMPUTERS, TABLETS, MOBILE PHONES, TELEVISION, WIRED AND WIRELESS COMMUNICATION DEVICES, AND OPTICAL AND ELECTRONIC COMMUNICATIONS NETWORKS; PROVIDING TEMPORARY USE OF NONDOWNLOADABLE SOFTWARE FOR USE IN STREAMING OF AUDIO AND AUDIO-VISUAL MEDIA CONTENT IN THE FIELDS OF NEWS, ENTERTAINMENT, SPORTS, COMEDY, DRAMA, MUSIC, AND MUSIC VIDEOS VIA COMPUTERS, TABLETS, MOBILE PHONES, TELEVISION, WIRED AND WIRELESS COMMUNICATION DEVICES, AND OPTICAL AND ELECTRONIC COMMUNICATIONS NETWORKS (U.S. CLS. 100 AND 101).  
FIRST USE 12-0-2013; IN COMMERCE 12-0-2013.

---

4,593,564. INNOVATIVE SPORTS LIMITED, KOWLOON, HONG KONG. SN 85-787,623. PUB. 11-12-2013, FILED 11-26-2012.



THE MARK CONSISTS OF THE STYLIZED LOWER CASE LETTER WORDING "IN-GAUGE" AND A STYLIZED DESIGN OF A BICYCLE GEAR.

#### CLASS 6—METAL GOODS

FOR BICYCLE LOCKS; LOCKS OF METAL; PAD-LOCKS OF METAL; SECURITY DEVICES, NAMELY, LOCKS OF METAL FOR VEHICLES; METAL STRUCTURES FOR BICYCLES, NAMELY, METAL STANDS IN THE NATURE OF STORAGE RACKS; METAL BICYCLE STORAGE RACKS (U.S. CLS. 2, 12, 13, 14, 23, 25 AND 50).  
FIRST USE 5-0-2013; IN COMMERCE 5-0-2013.



**CLASS 9—ELECTRICAL AND SCIENTIFIC APPARATUS**

FOR ARTICLES OF PROTECTIVE CLOTHING FOR WEAR BY CYCLISTS FOR PROTECTION AGAINST ACCIDENT OR INJURY; PROTECTIVE EYEWEAR, NAMELY, PROTECTIVE SUNGLASSES FOR BICYCLE RIDERS; PROTECTIVE HEADGEAR, NAMELY, BICYCLE HELMETS; PROTECTIVE HEADGEAR FOR CYCLISTS, NAMELY, BICYCLE HELMETS; PROTECTIVE HELMETS FOR CYCLISTS; BICYCLE HELMETS; PROTECTION HELMETS FOR SPORTS; PROTECTIVE FACE SHIELDS FOR PROTECTIVE HELMETS; BICYCLES SPEEDOMETERS; PROTECTIVE SPORTS HELMET ACCESSORIES THAT ATTACH TO THE HELMETS, NAMELY, MOUTH GUARDS, EAR PADS, THROAT PROTECTORS, CHIN STRAPS, FACE MASKS, JAW PADS AND EYE SHIELDS (U.S. CLS. 21, 23, 26, 36 AND 38).

FIRST USE 5-0-2013; IN COMMERCE 5-0-2013.

**CLASS 11—ENVIRONMENTAL CONTROL APPARATUS**

FOR BICYCLE LIGHTS; LIGHT BULBS FOR DIRECTION INDICATORS FOR CYCLES; HEADLAMPS FOR USE ON CYCLES; DYNAMO LIGHTS FOR VEHICLES; SOLAR-POWERED LIGHTS FOR USE IN BICYCLES (U.S. CLS. 13, 21, 23, 31 AND 34).

FIRST USE 5-0-2013; IN COMMERCE 5-0-2013.

**CLASS 12—VEHICLES**

FOR STRUCTURAL PARTS FOR BICYCLES, NAMELY, METAL KICKSTANDS; TURN SIGNALS FOR DIRECTION INDICATORS FOR CYCLES; BICYCLES; BICYCLE SADDLES; COVERS FOR BICYCLE SADDLES; SAFETY PADS FOR BICYCLES; PUMPS FOR BICYCLES; TIRE PUMPS FOR INFLATING MOTORCYCLE TIRES; AIR PUMPS FOR BICYCLES FOR THE INFLATION OF TIRES; TIRE PUMPS; BELLS FOR BICYCLES, CYCLES; BICYCLE KICKSTANDS; COVERS FOR FOOT PEDALS ON CYCLES, NAMELY, BICYCLE PEDAL CLEATS; PEDALS FOR BICYCLES; BAG CARRIERS FOR CYCLES, NAMELY, BAGS SPECIALLY ADAPTED FOR TRANSPORTING BICYCLES; BICYCLE CARRIERS, NAMELY, RACKS FOR VEHICLES FOR BICYCLES; LUGGAGE CARRIERS FOR BICYCLES; CYCLE MUDGUARDS; BICYCLE BRAKES; BICYCLE PARTS, NAMELY, BRAKE SHOES; BRAKE SHOES FOR LAND VEHICLES; BRAKES FOR BICYCLES, CYCLES; BRAKING SYSTEMS FOR BICYCLES AND PARTS THEREOF; CHAINS FOR BICYCLES, CYCLES; FRAMES FOR BICYCLES; GEARS FOR BICYCLES; HANDLEBARS FOR BICYCLES, CYCLES; WHEEL HUBS FOR BICYCLES; INNER TUBES FOR CYCLES; TUBELESS TIRES FOR BICYCLES, CYCLES; BICYCLE PARTS, NAMELY, TUBES AND CONNECTORS FOR BICYCLE FRAMES; STANDS FOR BICYCLES; STANDS FOR CYCLES, NAMELY, METAL STANDS FOR HOLDING STATIONARY MOTORCYCLES IN AN UPRIGHT POSITION; REARVIEW MIRRORS; PUNCTURE REPAIR KITS FOR BICYCLE TIRES AND INNER TUBES FOR TIRES COMPRISED PRIMARILY OF TIRE REPAIR PATCHES AND TIRE PUNCTURE SEALANT; BAGS SPECIALLY ADAPTED FOR USE WITH BICYCLES, NAMELY, SEAT BAGS, SADDLE BAGS, HANDLEBAR BAGS, STEM BAGS, FRAME BAGS, RACK BAGS, PANNIERS, TRUNK BAGS, WATER CARRYING BAGS; BOTTLE CAGES FOR BICYCLES; WHEELS BEING PARTS OF BICYCLES; TRAILERS; CHILD CARRYING TRAILERS FOR USE IN TRANSPORTING CHILDREN WHILE HIKING, JOGGING, WALKING; BIKE TRAILERS; CHILD CARRYING STROLLERS FOR USE IN TRANSPORTING CHILDREN WHILE HIKING, JOGGING, WALKING; BABY STROLLERS; JOGGING STROLLERS; WAGONS; CARGO BOATS; CARGO TRUCKS (U.S. CLS. 19, 21, 23, 31, 35 AND 44).

FIRST USE 5-0-2013; IN COMMERCE 5-0-2013.

4,593,567. COUPONS.COM INCORPORATED, MOUNTAIN VIEW, CA. SN 85-789,206. PUB. 5-7-2013, FILED 11-28-2012.

# KITCHME

THE MARK CONSISTS OF STANDARD CHARACTERS WITHOUT CLAIM TO ANY PARTICULAR FONT, STYLE, SIZE, OR COLOR.

**CLASS 9—ELECTRICAL AND SCIENTIFIC APPARATUS**

FOR DOWNLOADABLE COMPUTER SOFTWARE FOR PROVIDING SHOPPING LISTS FOR CONSUMER PACKAGED GOODS IN WHICH ITEMS ARE ASSOCIATED WITH STORE SPECIALS, COUPONS AND/OR PERSONALIZED RECOMMENDATIONS FOR RECIPES; DOWNLOADABLE COMPUTER SOFTWARE FOR DISPLAYING GROCERY DEALS, SPECIALS AND/OR COUPONS IN ASSOCIATION WITH PERSONALIZED RECOMMENDATIONS FOR RECIPES AND OTHER CONSUMER PACKAGED GOODS; DOWNLOADABLE COMPUTER SOFTWARE FOR TRACKING CONSUMER MEAL PREPARATION AND SHOPPING DECISIONS RELATING TO CONSUMER PACKAGED GOODS (U.S. CLS. 21, 23, 26, 36 AND 38).

FIRST USE 6-27-2013; IN COMMERCE 6-27-2013.

**CLASS 42—SCIENTIFIC AND COMPUTER SERVICES**

FOR PROVIDING TEMPORARY USE OF NON-DOWNLOADABLE COMPUTER SOFTWARE FOR PROVIDING SHOPPING LISTS FOR CONSUMER PACKAGED GOODS IN WHICH ITEMS ARE ASSOCIATED WITH LOCALLY AVAILABLE IN-STORE SPECIALS AND COUPONS AND WITH PERSONALIZED RECOMMENDATIONS FOR RECIPES; PROVIDING TEMPORARY USE OF NON-DOWNLOADABLE COMPUTER SOFTWARE FOR MATCHING LOCALLY AVAILABLE GROCERY DEALS WITH PERSONALIZED RECOMMENDATIONS FOR RECIPES AND OTHER CONSUMER PACKAGED GOODS; PROVIDING TEMPORARY USE OF NON-DOWNLOADABLE COMPUTER SOFTWARE FOR TRACKING CONSUMER MEAL PREPARATION AND SHOPPING DECISIONS RELATING TO CONSUMER PACKAGED GOODS (U.S. CLS. 100 AND 101).

FIRST USE 4-30-2011; IN COMMERCE 4-30-2011.

4,593,573. THINK TELEVISUAL LLC, CHICAGO, IL. SN 85-789,788. PUB. 7-23-2013, FILED 11-28-2012.

# TOUCHVISION

THE MARK CONSISTS OF STANDARD CHARACTERS WITHOUT CLAIM TO ANY PARTICULAR FONT, STYLE, SIZE, OR COLOR.

**CLASS 9—ELECTRICAL AND SCIENTIFIC APPARATUS**

FOR COMPUTER SOFTWARE FOR INTERACTIVE ENTERTAINMENT, WHICH ALLOWS USERS TO CUSTOMIZE THE VIEWING, LISTENING, AND PLAYING EXPERIENCE OF NEWS AND INFORMATION VIDEO CONTENT BY SELECTING AND ARRANGING THE DISPLAY AND PERFORMANCE OF THE AUDIO, VIDEO AND AUDIOVISUAL ELEMENTS ON THEIR TELEVISIONS, COMPUTERS, TABLETS AND MOBILE PHONES (U.S. CLS. 21, 23, 26, 36 AND 38).

FIRST USE 7-3-2013; IN COMMERCE 7-3-2013.

**CLASS 38—COMMUNICATION**

FOR MOBILE MEDIA SERVICES IN THE NATURE OF ELECTRONIC TRANSMISSION, WIRELESS BROADCASTING AND ELECTRONIC DELIVERY OF AUDIO, VIDEO AND MULTIMEDIA ENTERTAINMENT CONTENT, NAMELY, TEXT, DATA, IMAGES, AUDIO, VIDEO AND AUDIOVISUAL FILES PROVIDED VIA THE INTERNET, WIRELESS COMMUNICATION, ELECTRONIC COMMUNICATIONS NETWORKS AND COMPUTER NETWORKS; VIDEO BROADCASTING SERVICES OVER THE INTERNET OR OTHER COMMUNICATIONS NETWORK, NAMELY, SHOWING, DISPLAYING, AND ELECTRONICALLY TRANSMITTING VIDEO CLIPS; INTERNET BROADCASTING SERVICES; PROVIDING STREAMING OF AUDIO AND VIDEO IN THE NATURE OF NEWS, EDITORIAL CONTENT AND INFORMATION, NAMELY, AUDIO, VISUAL AND AUDIOVISUAL MATERIAL FOR OTHERS VIA GLOBAL COMPUTER NETWORKS; TRANSMISSION OF NEWS; PROVIDING ON-LINE CHAT ROOMS AND ELECTRONIC BULLETIN BOARDS FOR TRANSMISSION OF MESSAGES AMONG USERS IN THE FIELD OF GENERAL INTEREST (U.S. CLS. 100, 101 AND 104).

FIRST USE 7-1-2013; IN COMMERCE 7-1-2013.

**CLASS 41—EDUCATION AND ENTERTAINMENT**

FOR ENTERTAINMENT SERVICES IN THE NATURE OF PROVIDING ENTERTAINMENT PROGRAMS AND CONTENT, NAMELY, ON-GOING TELEVISION PROGRAMS RELATING TO CURRENT EVENTS AND ENTERTAINMENT NEWS VIA THE INTERNET, ELECTRONIC COMMUNICATIONS NETWORKS, COMPUTER NETWORKS AND WIRELESS COMMUNICATIONS NETWORKS AND ON-GOING TELEVISION PROGRAMS FEATURING CLIPS, GRAPHICS AND INFORMATION RELATING TO CURRENT EVENTS AND ENTERTAINMENT NEWS, VIA THE INTERNET, ELECTRONIC COMMUNICATIONS NETWORKS, COMPUTER NETWORKS AND WIRELESS COMMUNICATIONS NETWORKS (U.S. CLS. 100, 101 AND 107).

FIRST USE 7-1-2013; IN COMMERCE 10-1-2013.

**CLASS 42—SCIENTIFIC AND COMPUTER SERVICES**

FOR PROVIDING A WEBSITE FEATURING TECHNOLOGY THAT ENABLES USERS TO UPLOAD AND SHARE USER-GENERATED VIDEOS ON A WIDE VARIETY OF TOPICS AND SUBJECTS (U.S. CLS. 100 AND 101).

FIRST USE 7-1-2013; IN COMMERCE 7-1-2013.

4,593,576. FULTON, JAMES WESLEY, SAN PEDRO, CA. SN 85-790,347. PUB. 5-7-2013, FILED 11-29-2012.

# KomPATi

THE MARK CONSISTS OF STANDARD CHARACTERS WITHOUT CLAIM TO ANY PARTICULAR FONT, STYLE, SIZE, OR COLOR.

**CLASS 9—ELECTRICAL AND SCIENTIFIC APPARATUS**

FOR COMPUTER APPLICATION SOFTWARE FOR MOBILE PHONES, PORTABLE MEDIA PLAYERS, HANDHELD COMPUTERS, NAMELY, SOFTWARE FOR CALCULATING THE COMPATIBILITY OF A PERSON, SERVICE, OR PRODUCT TO THE GOALS ESTABLISHED BY THE SOFTWARE USER (U.S. CLS. 21, 23, 26, 36 AND 38).

FIRST USE 12-16-2013; IN COMMERCE 12-16-2013.

**CLASS 42—SCIENTIFIC AND COMPUTER SERVICES**

FOR SOFTWARE AS A SERVICE (SAAS) SERVICES FEATURING SOFTWARE FOR CALCULATING THE COMPATIBILITY OF A PERSON, SERVICE, OR PRODUCT TO THE GOALS ESTABLISHED BY THE SOFTWARE USER (U.S. CLS. 100 AND 101).

FIRST USE 12-16-2013; IN COMMERCE 12-16-2013.

4,593,577. THE SUNSHINE STORY, LLC, LAKELAND, FL. SN 85-790,517. PUB. 11-5-2013, FILED 11-29-2012.



NO CLAIM IS MADE TO THE EXCLUSIVE RIGHT TO USE "FLORIDA TANGERINES" FOR INTERNATIONAL CLASS 31, APART FROM THE MARK AS SHOWN.

THE MARK CONSISTS OF THE WORDS "LEGEND OF SUN LION FLORIDA TANGERINES UNLOCK YOUR SHINE!" OVER A TREE WITH ADDITIONAL TREES IN THE BACKGROUND WITH A PANTHER KITTEN IN THE FOREGROUND HOLDING A TANGERINE AND CHASING A BOAR THROUGH GRASS.

**CLASS 16—PAPER GOODS AND PRINTED MATTER**

FOR POSTERS (U.S. CLS. 2, 5, 22, 23, 29, 37, 38 AND 50).

FIRST USE 2-9-2013; IN COMMERCE 2-9-2013.

**CLASS 31—NATURAL AGRICULTURAL PRODUCTS**

FOR FRESH CITRUS FRUITS (U.S. CLS. 1 AND 46).  
FIRST USE 2-9-2013; IN COMMERCE 2-9-2013.

4,593,580. SIX FLAGS THEME PARKS, INC., GRAND PRAIRIE, TX. SN 85-791,275. PUB. 10-29-2013, FILED 11-30-2012.



OWNER OF U.S. REG. NOS. 1,049,376, 3,861,377, AND 4,114,989.

NO CLAIM IS MADE TO THE EXCLUSIVE RIGHT TO USE "SAFARI" AND "OFF ROAD ADVENTURE", APART FROM THE MARK AS SHOWN.

THE COLOR(S) WHITE, BLACK, BROWN, RED, ORANGE, YELLOW AND GREEN IS/ARE CLAIMED AS A FEATURE OF THE MARK.

THE MARK CONSISTS OF THE WORDS "SIX FLAGS" IN STYLIZED FONT IN THE COLORS WHITE WITH BLACK BORDERS. BELOW THE FOREGOING IS THE WORD "SAFARI" IN STYLIZED FONT IN THE COLORS YELLOW AND ORANGE WITH BLACK BORDERS. BELOW THE FOREGOING ARE THE WORDS "OFF ROAD ADVENTURE" IN STYLIZED FONT IN THE COLORS YELLOW AND ORANGE WITH BLACK BORDERS. BEHIND ALL OF THE FOREGOING IS A DIAMOND SHAPE BACKGROUND CONTAINING THE COLORS WHITE, BLACK, BROWN, RED, ORANGE AND YELLOW AND WITHIN WHICH ARE FIGURES OF ANIMALS NEXT TO A JEEP. THE FOREGOING DIAMOND SHAPE IS SURROUNDED BY A DESIGN ELEMENT DEPICTING LEAVES IN THE COLOR GREEN.

**CLASS 6—METAL GOODS**

FOR METAL PRODUCTS, NAMELY, METAL KEY CHAINS AND KEY FOBS OF COMMON METAL (U.S. CLS. 2, 12, 13, 14, 23, 25 AND 50).  
FIRST USE 5-23-2013; IN COMMERCE 5-23-2013.

**CLASS 9—ELECTRICAL AND SCIENTIFIC APPARATUS**

FOR PRERECORDED DVDS, VIDEO AND AUDIO TAPES AND VIDEO AND AUDIO DISKS FEATURING INFORMATION RELATING TO AMUSEMENT AND THEME PARK ATTRACTIONS; COMPUTER PROGRAMS FOR PRERECORDED GAMES, ELECTRONIC GAME PROGRAMS; GAME SOFTWARE, AND CD-ROMS FEATURING COMPUTER GAMES; MAGNETS AND SUNGLASSES (U.S. CLS. 21, 23, 26, 36 AND 38).  
FIRST USE 5-23-2013; IN COMMERCE 5-23-2013.

**CLASS 20—FURNITURE AND ARTICLES NOT OTHERWISE CLASSIFIED**

FOR PICTURE AND PHOTOGRAPH FRAMES (U.S. CLS. 2, 13, 22, 25, 32 AND 50).  
FIRST USE 5-23-2013; IN COMMERCE 5-23-2013.

**CLASS 21—HOUSEWARES AND GLASS**

FOR BEVERAGE WARE (U.S. CLS. 2, 13, 23, 29, 30, 33, 40 AND 50).  
FIRST USE 5-23-2013; IN COMMERCE 5-23-2013.

**CLASS 25—CLOTHING**

FOR CLOTHING AND APPAREL, NAMELY, T-SHIRTS, SWEATSHIRTS, TANK TOPS, POLO SHIRTS, SWEATPANTS, PAJAMAS, VESTS AND HEADWEAR (U.S. CLS. 22 AND 39).  
FIRST USE 5-23-2013; IN COMMERCE 5-23-2013.

**CLASS 28—TOYS AND SPORTING GOODS**

FOR TOYS, NAMELY, SNOW GLOBES, STUFFED ANIMALS, PLUSH TOYS, TOY VEHICLES AND ACTION FIGURES; PUZZLES; PLAYING CARDS; SPORTING GOODS, ATHLETIC EQUIPMENT AND EXERCISE EQUIPMENT, NAMELY, PLAYGROUND BALLS AND BASKETBALLS; CHRISTMAS TREE ORNAMENTS (U.S. CLS. 22, 23, 38 AND 50).  
FIRST USE 5-23-2013; IN COMMERCE 5-23-2013.

**CLASS 41—EDUCATION AND ENTERTAINMENT**

FOR AMUSEMENT AND THEME PARK SERVICES (U.S. CLS. 100, 101 AND 107).  
FIRST USE 5-23-2013; IN COMMERCE 5-23-2013.

4,593,586. ROCKWALL INDEPENDENT SCHOOL DISTRICT, ROCKWALL, TX. SN 85-794,567. PUB. 5-7-2013, FILED 12-4-2012.



THE MARK CONSISTS OF A CARICATURE OF A YELLOWJACKET.

**CLASS 25—CLOTHING**

FOR CLOTHING, NAMELY, T-SHIRTS, SWEAT SHIRTS, ATHLETIC UNIFORMS, PANTS, TANK TOPS, JERSEY SHORTS, SHORTS, GOLF SHIRTS, CAPS, VESTS, HATS, SPORT SHIRTS, RUGBY SHIRTS, SWEATERS, BELTS, TIES, NIGHT SHIRTS, WARM-UP SUITS, JACKETS, PARKAS, COATS, CLOTH BIBS, HEAD BANDS, AND WRIST BANDS (U.S. CLS. 22 AND 39).  
FIRST USE 1-1-2010; IN COMMERCE 1-1-2010.

**CLASS 41—EDUCATION AND ENTERTAINMENT**

FOR EDUCATION SERVICES, NAMELY, PROVIDING HIGH SCHOOL INSTRUCTION THROUGH THE CLASSROOM PROVIDED THROUGH THE SCHOOL DISTRICT; EDUCATION SERVICES NAMELY, PROVIDING HIGH SCHOOL EXTRACURRICULAR COURSES OF INSTRUCTION IN THE FIELDS OF ATHLETICS, BAND, CHOIR, SPEECH, DRAMA, DANCE, STUDENT COUNCIL, AND DRILL TEAM (U.S. CLS. 100, 101 AND 107).  
FIRST USE 1-1-2010; IN COMMERCE 1-1-2010.

**CLASS 6—METAL GOODS**

FOR TRAILER WHEEL CHOCKS MADE PRIMARILY OF METAL; TRAILER LOADING RAMPS MADE PRIMARILY OF METAL; TRAILER SAFETY CABLES, NAMELY, NON-ELECTRIC METAL CABLES (U.S. CLS. 2, 12, 13, 14, 23, 25 AND 50).  
FIRST USE 4-30-2013; IN COMMERCE 4-30-2013.

**CLASS 8—HAND TOOLS**

FOR NON-HYDRAULIC TRAILER JACKS (U.S. CLS. 23, 28 AND 44).  
FIRST USE 4-30-2013; IN COMMERCE 4-30-2013.

**CLASS 9—ELECTRICAL AND SCIENTIFIC APPARATUS**

FOR ELECTRICAL VEHICLE TRAILER WIRING KITS COMPRISING WIRES FOR CONDUCTING ELECTRICITY, CONNECTORS FOR CONDUCTING ELECTRICITY, AND HARDWARE FOR SECURING COMPONENTS TO THE TRAILER AND THE VEHICLE (U.S. CLS. 21, 23, 26, 36 AND 38).  
FIRST USE 4-30-2013; IN COMMERCE 4-30-2013.

**CLASS 11—ENVIRONMENTAL CONTROL APPARATUS**

FOR VEHICLE AUXILIARY LIGHTS; ASSEMBLIES AND KITS FOR MAKING TRAILER LIGHTS FOR VEHICLES (U.S. CLS. 13, 21, 23, 31 AND 34).  
FIRST USE 4-30-2013; IN COMMERCE 4-30-2013.

**CLASS 12—VEHICLES**

FOR VEHICLE TOWING RECEIVER HITCHES; VEHICLE BALL MOUNTS; VEHICLE HITCH BALLS; VEHICLE HITCH PINS; VEHICLE HITCH MOUNTED BIKE RACKS; VEHICLE HITCH MOUNTED CARGO PLATFORMS; VEHICLE HITCH MOUNTED STEP; VEHICLE TOW BARS; VEHICLE CARGO RACKS; TRAILER COUPLERS; TRAILER SAFETY CHAINS; TRAILER WHEEL BEARINGS; TRAILER WHEEL BEARING PROTECTORS (U.S. CLS. 19, 21, 23, 31, 35 AND 44).  
FIRST USE 4-30-2013; IN COMMERCE 4-30-2013.

**CLASS 20—FURNITURE AND ARTICLES NOT OTHERWISE CLASSIFIED**

FOR TRAILER WHEEL CHOCKS MADE PRIMARILY OF PLASTIC; TRAILER LOADING RAMPS PRIMARILY MADE OF RESIN COMPOSITE (U.S. CLS. 2, 13, 22, 25, 32 AND 50).  
FIRST USE 4-30-2013; IN COMMERCE 4-30-2013.

4,593,588. BJ'S WHOLESALE CLUB, INC., WESTBOROUGH, MA. SN 85-795,585. PUB. 4-30-2013, FILED 12-5-2012.

**THE TIME TO MAKE A DIFFERENCE IS NOW**

THE MARK CONSISTS OF STANDARD CHARACTERS WITHOUT CLAIM TO ANY PARTICULAR FONT, STYLE, SIZE, OR COLOR.

**CLASS 5—PHARMACEUTICALS**

FOR DISPOSABLE DAIPERS FOR BABIES (U.S. CLS. 6, 18, 44, 46, 51 AND 52).  
FIRST USE 4-20-2013; IN COMMERCE 4-20-2013.

**CLASS 8—HAND TOOLS**

FOR PLASTIC CUTLERY, NAMELY, KNIVES, FORKS AND SPOONS (U.S. CLS. 23, 28 AND 44).  
FIRST USE 10-31-2013; IN COMMERCE 10-31-2013.

**CLASS 16—PAPER GOODS AND PRINTED MATTER**

FOR PAPER TOWELS, NAPKINS, BATH TISSUE (U.S. CLS. 2, 5, 22, 23, 29, 37, 38 AND 50).  
FIRST USE 12-8-2012; IN COMMERCE 12-8-2012.

**CLASS 21—HOUSEWARES AND GLASS**

FOR PAPER PLATES AND CUPS (U.S. CLS. 2, 13, 23, 29, 30, 33, 40 AND 50).  
FIRST USE 2-9-2013; IN COMMERCE 2-9-2013.

4,593,606. BURNING GLASS INTERNATIONAL, INC., BOSTON, MA. SN 85-800,800. PUB. 10-8-2013, FILED 12-12-2012.

**LENS/PRISM**

THE MARK CONSISTS OF STANDARD CHARACTERS WITHOUT CLAIM TO ANY PARTICULAR FONT, STYLE, SIZE, OR COLOR.

4,593,604. WINSTON PRODUCTS LLC, CLEVELAND, OH. SN 85-800,546. PUB. 10-1-2013, FILED 12-12-2012.

**TOWSMART**

THE MARK CONSISTS OF STANDARD CHARACTERS WITHOUT CLAIM TO ANY PARTICULAR FONT, STYLE, SIZE, OR COLOR.

**CLASS 9—ELECTRICAL AND SCIENTIFIC APPARATUS**

FOR DOWNLOADABLE COMPUTER SOFTWARE IN THE FIELD OF EMPLOYMENT AND THE LABOR MARKET WHICH PAIRS CANDIDATES' SKILLS, EXPERIENCE AND CAREER GOALS WITH POTENTIAL EMPLOYERS' NEEDS (U.S. CLS. 21, 23, 26, 36 AND 38).  
FIRST USE 11-1-2012; IN COMMERCE 11-1-2012.

**CLASS 42—SCIENTIFIC AND COMPUTER SERVICES**

FOR TEMPORARY USE OF NON-DOWNLOADABLE SOFTWARE IN THE FIELD OF EMPLOYMENT AND THE LABOR MARKET WHICH PAIRS CANDIDATES' SKILLS, EXPERIENCE AND CAREER GOALS WITH POTENTIAL EMPLOYERS' NEEDS (U.S. CLS. 100 AND 101).  
FIRST USE 3-10-2014; IN COMMERCE 3-10-2014.

**CLASS 3—COSMETICS AND CLEANING PREPARATIONS**

FOR COSMETIC PRODUCTS FOR PERSONAL CARE; COSMETICS BASED ON ENCAPSULATED ACTIVE INGREDIENTS; NON-MEDICATED COSMETICS FOR PROTECTION FROM ULTRAVIOLET RAYS; NON-MEDICATED COSMETICS FOR PROTECTION FROM SUN LIGHT AND SOLAR RADIATION FOR THE SKIN AND FOR THE HAIR; NON-MEDICATED COSMETICS FOR SKIN BURN PROTECTION AND HAIR CARE COLOR PROTECTION (U.S. CLS. 1, 4, 6, 50, 51 AND 52).  
FIRST USE 4-13-2012; IN COMMERCE 7-31-2013.

4,593,619. GREENHUNTER WATER, LLC, GRAPEVINE, TX. SN 85-803,263. PUB. 5-14-2013, FILED 12-14-2012.

4,593,607. AIR PRODUCTS AND CHEMICALS, INC., ALLENTOWN, PA. SN 85-801,639. PUB. 10-15-2013, FILED 12-13-2012.

Dermoprotectyl

THE MARK CONSISTS OF STANDARD CHARACTERS WITHOUT CLAIM TO ANY PARTICULAR FONT, STYLE, SIZE, OR COLOR.

**CLASS 1—CHEMICALS**

FOR ENCAPSULATED ACTIVE CHEMICAL INGREDIENTS FOR USE IN THE MANUFACTURE OF PERSONAL CARE PRODUCTS; A FORMULATED CHEMICAL RAW MATERIAL CONTAINING A COMBINATION OF TWO OR MORE INGREDIENT DELIVERY SYSTEMS ENCAPSULATING TWO OR MORE DIFFERENT ACTIVE CHEMICAL INGREDIENTS AND DELIVERING THESE INGREDIENTS TO TWO OR MORE TARGET SITES ON OR WITHIN THE SKIN OR HAIR FOR USE IN THE MANUFACTURE OF PERSONAL CARE PRODUCTS; A FORMULATED CHEMICAL RAW MATERIAL CONTAINING BOTH HYDROPHILIC, CHARGED VESICLES ENCAPSULATING ULTRAVIOLET RADIATION FILTERS AND LIPOSOMAL VESICLES ENCAPSULATING ANTIOXIDANTS FOR USE IN THE MANUFACTURE OF PERSONAL CARE PRODUCTS; ENCAPSULATED ACTIVE CHEMICAL INGREDIENTS USED IN THE MANUFACTURE OF PERSONAL CARE PRODUCTS AND COSMETICS SPECIFICALLY PROVIDING PROTECTION FROM SOLAR RADIATION FOR THE SKIN AND FOR THE HAIR, AND ASSOCIATED BENEFITS INCLUDING FREE RADICAL PROTECTION BENEFITS; CHEMICALS USED IN THE MANUFACTURE OF COSMETIC AND PHARMACEUTICAL PRODUCTS; CHEMICALS FOR INDUSTRIAL PURPOSES (U.S. CLS. 1, 5, 6, 10, 26 AND 46).  
FIRST USE 4-13-2012; IN COMMERCE 7-31-2013.

THE MARK CONSISTS OF STANDARD CHARACTERS WITHOUT CLAIM TO ANY PARTICULAR FONT, STYLE, SIZE, OR COLOR.

NO CLAIM IS MADE TO THE EXCLUSIVE RIGHT TO USE "TANK", APART FROM THE MARK AS SHOWN.

**CLASS 12—VEHICLES**

FOR MOBILE STORAGE TANKS; PORTABLE TANKS FOR OIL EXPLORATION, PORTABLE TANKS FOR OIL PRODUCTION, PORTABLE WATER STORAGE TANKS, CONTAINER TANKS, TANK CONTAINERS AND GENERAL PURPOSE TANKS, ALL IN THE NATURE OF MOBILE STORAGE TANKS (U.S. CLS. 19, 21, 23, 31, 35 AND 44).  
FIRST USE 6-0-2013; IN COMMERCE 6-0-2013.

**CLASS 39—TRANSPORTATION AND STORAGE**

FOR RENTAL OF PORTABLE TANKS (U.S. CLS. 100 AND 105).  
FIRST USE 6-0-2013; IN COMMERCE 6-0-2013.

4,593,626. HEALTH SERVICES GROUP, INC., PORTLAND, OR. SN 85-806,879. PUB. 6-4-2013, FILED 12-19-2012.



NO CLAIM IS MADE TO THE EXCLUSIVE RIGHT TO USE "HEALTH", APART FROM THE MARK AS SHOWN.

THE MARK CONSISTS OF A DESIGN AND THE WORDS "MODA" AND "HEALTH". UNDER THE LETTERS "D" AND "A" IS THE WORD "HEALTH". ABOVE THE LETTER "D" IS AN UPWARD POINTING ARROW.

**CLASS 36—INSURANCE AND FINANCIAL**

FOR INSURANCE SERVICES, NAMELY, UNDERWRITING, ISSUANCE AND ADMINISTRATION IN THE FIELDS OF HEALTH INSURANCE, REINSURANCE AND STOP LOSS AND PHARMACEUTICAL BENEFITS (U.S. CLS. 100, 101 AND 102).

FIRST USE 5-6-2013; IN COMMERCE 5-0-2013.

**CLASS 44—MEDICAL, BEAUTY AND AGRICULTURAL SERVICES**

FOR HEALTH CARE SERVICES, NAMELY, WELLNESS PROGRAMS AND PROVIDING HEALTHCARE PROGRAMS FOR MEMBERS OF CONTRACTING GROUPS (U.S. CLS. 100 AND 101).

FIRST USE 5-6-2013; IN COMMERCE 5-0-2013.

4,593,627. HEALTH SERVICES GROUP, INC., PORTLAND, OR. SN 85-806,885. PUB. 6-4-2013, FILED 12-19-2012.



THE MARK CONSISTS OF A DESIGN CONSISTS AND THE WORD "MODA". ABOVE THE LETTER "D" IS AN UPWARD POINTING ARROW.

**CLASS 36—INSURANCE AND FINANCIAL**

FOR INSURANCE SERVICES, NAMELY, UNDERWRITING, ISSUANCE AND ADMINISTRATION IN THE FIELDS OF HEALTH INSURANCE, REINSURANCE AND STOP LOSS AND PHARMACEUTICAL BENEFITS (U.S. CLS. 100, 101 AND 102).

FIRST USE 5-6-2013; IN COMMERCE 5-0-2013.

**CLASS 44—MEDICAL, BEAUTY AND AGRICULTURAL SERVICES**

FOR HEALTH CARE SERVICES, NAMELY, WELLNESS PROGRAMS AND PROVIDING HEALTHCARE PROGRAMS FOR MEMBERS OF CONTRACTING GROUPS (U.S. CLS. 100 AND 101).

FIRST USE 5-6-2013; IN COMMERCE 5-0-2013.

4,593,628. HEALTH SERVICES GROUP, INC., PORTLAND, OR. SN 85-806,892. PUB. 6-4-2013, FILED 12-19-2012.



THE MARK CONSISTS OF STANDARD CHARACTERS WITHOUT CLAIM TO ANY PARTICULAR FONT, STYLE, SIZE, OR COLOR.

NO CLAIM IS MADE TO THE EXCLUSIVE RIGHT TO USE "HEALTH", APART FROM THE MARK AS SHOWN.

**CLASS 36—INSURANCE AND FINANCIAL**

FOR INSURANCE SERVICES, NAMELY, UNDERWRITING, ISSUANCE AND ADMINISTRATION IN THE FIELDS OF HEALTH INSURANCE, REINSURANCE AND STOP LOSS AND PHARMACEUTICAL BENEFITS (U.S. CLS. 100, 101 AND 102).

FIRST USE 5-6-2013; IN COMMERCE 5-0-2013.

**CLASS 44—MEDICAL, BEAUTY AND AGRICULTURAL SERVICES**

FOR HEALTH CARE SERVICES, NAMELY, WELLNESS PROGRAMS AND PROVIDING HEALTHCARE PROGRAMS FOR MEMBERS OF CONTRACTING GROUPS (U.S. CLS. 100 AND 101).

FIRST USE 5-6-2013; IN COMMERCE 5-0-2013.

4,593,629. AMPLISINE LABS LLC, LUBBOCK, TX. SN 85-807,078. PUB. 5-14-2013, FILED 12-19-2012.



THE MARK CONSISTS OF STANDARD CHARACTERS WITHOUT CLAIM TO ANY PARTICULAR FONT, STYLE, SIZE, OR COLOR.

**CLASS 9—ELECTRICAL AND SCIENTIFIC APPARATUS**

FOR AUTOMATION SOFTWARE, NAMELY, SOFTWARE TO REMOTELY MONITOR, CONTROL, OPTIMIZE, TRACK PROBLEMS AND GENERATE PRODUCTION REPORTS FOR FLUID BASED SYSTEMS, OIL AND GAS PRODUCTION, WIRELESS NETWORKS, AND INDUSTRIAL SYSTEMS; INDUSTRIAL AUTOMATION CONTROLS; COMPUTER APPLICATION SOFTWARE FOR MOBILE PHONES AND/OR HANDHELD COMPUTERS, NAMELY, SOFTWARE FOR USE IN DATABASE MANAGEMENT AND ELECTRONIC STORAGE OF DATA; COMPUTER SOFTWARE FOR WIRELESS CONTENT DELIVERY (U.S. CLS. 21, 23, 26, 36 AND 38).

FIRST USE 6-19-2014; IN COMMERCE 6-19-2014.

**CLASS 38—COMMUNICATION**

FOR COMMUNICATION SERVICES, NAMELY, TRANSMISSION OF VOICE, AUDIO, VISUAL IMAGES AND DATA BY TELECOMMUNICATIONS NETWORKS, WIRELESS COMMUNICATION NETWORKS, THE INTERNET, INFORMATION SERVICES NETWORKS AND DATA NETWORKS; DIGITAL NETWORK TELECOMMUNICATIONS SERVICES; ELECTRONIC EXCHANGE OF DATA STORED IN DATABASES ACCESSIBLE VIA WIRELESS TELECOMMUNICATIONS NETWORKS; WIRELESS TELECOMMUNICATIONS SERVICES, NAMELY, PROVIDING REAL-TIME, MULTIMEDIA AND MULTIPARTY COMMUNICATIONS AND ACCESS TO SITE PROCESS INFORMATION OVER COMPUTER NETWORKS (U.S. CLS. 100, 101 AND 104).

FIRST USE 6-19-2014; IN COMMERCE 6-19-2014.

**CLASS 42—SCIENTIFIC AND COMPUTER SERVICES**

FOR DATA AUTOMATION AND COLLECTION SERVICE USING PROPRIETARY SOFTWARE TO EVALUATE, ANALYZE AND COLLECT SERVICE DATA; PROVIDING TEMPORARY USE OF A WEB-BASED SOFTWARE APPLICATION FOR USE IN DATABASE MANAGEMENT AND ELECTRONIC STORAGE OF DATA; DEVELOPMENT OF TECHNOLOGIES FOR THE FABRICATION OF CIRCUITS FOR WIRELESS COMMUNICATION AND ELECTRONIC DATA PROCESSING; REMOTE DIAGNOSTIC SERVICES IN THE FIELD OF FLUID BASED SYSTEMS, OIL AND GAS PRODUCTION, WIRELESS NETWORKS, AND INDUSTRIAL SYSTEMS; COMPUTER DIAGNOSTIC SERVICES (U.S. CLS. 100 AND 101).

FIRST USE 6-19-2014; IN COMMERCE 6-19-2014.

**CLASS 42—SCIENTIFIC AND COMPUTER SERVICES**

FOR DATA AUTOMATION AND COLLECTION SERVICE USING PROPRIETARY SOFTWARE TO EVALUATE, ANALYZE AND COLLECT SERVICE DATA; PROVIDING TEMPORARY USE OF A WEB-BASED SOFTWARE APPLICATION FOR USE IN DATABASE MANAGEMENT AND ELECTRONIC STORAGE OF DATA; DEVELOPMENT OF TECHNOLOGIES FOR THE FABRICATION OF CIRCUITS FOR WIRELESS COMMUNICATION AND ELECTRONIC DATA PROCESSING; REMOTE DIAGNOSTIC SERVICES IN THE FIELD OF FLUID BASED SYSTEMS, OIL AND GAS PRODUCTION, WIRELESS NETWORKS, AND INDUSTRIAL SYSTEMS; COMPUTER DIAGNOSTIC SERVICES (U.S. CLS. 100 AND 101).

FIRST USE 11-4-2009; IN COMMERCE 11-4-2009.

4,593,630. AMPLISINE LABS LLC, LUBBOCK, TX. SN 85-807,082. PUB. 5-14-2013, FILED 12-19-2012.

4,593,634. CONVERSION CAPITAL, LLC, NEW YORK, NY. SN 85-807,827. PUB. 5-14-2013, FILED 12-20-2012.

# AMPLISINE

THE MARK CONSISTS OF STANDARD CHARACTERS WITHOUT CLAIM TO ANY PARTICULAR FONT, STYLE, SIZE, OR COLOR.

**CLASS 9—ELECTRICAL AND SCIENTIFIC APPARATUS**

FOR AUTOMATION SOFTWARE, NAMELY, SOFTWARE TO REMOTELY MONITOR, CONTROL, OPTIMIZE, TRACK PROBLEMS AND GENERATE PRODUCTION REPORTS FOR FLUID BASED SYSTEMS, OIL AND GAS PRODUCTION, WIRELESS NETWORKS, AND INDUSTRIAL SYSTEMS; INDUSTRIAL AUTOMATION CONTROLS; COMPUTER APPLICATION SOFTWARE FOR MOBILE PHONES AND/OR HANDHELD COMPUTERS, NAMELY, SOFTWARE FOR USE IN DATABASE MANAGEMENT AND ELECTRONIC STORAGE OF DATA; COMPUTER SOFTWARE FOR WIRELESS CONTENT DELIVERY (U.S. CLS. 21, 23, 26, 36 AND 38).

FIRST USE 3-31-2012; IN COMMERCE 3-31-2012.

**CLASS 38—COMMUNICATION**

FOR COMMUNICATION SERVICES, NAMELY, TRANSMISSION OF VOICE, AUDIO, VISUAL IMAGES AND DATA BY TELECOMMUNICATIONS NETWORKS, WIRELESS COMMUNICATION NETWORKS, THE INTERNET, INFORMATION SERVICES NETWORKS AND DATA NETWORKS; DIGITAL NETWORK TELECOMMUNICATIONS SERVICES; ELECTRONIC EXCHANGE OF DATA STORED IN DATABASES ACCESSIBLE VIA WIRELESS TELECOMMUNICATIONS NETWORKS; WIRELESS TELECOMMUNICATIONS SERVICES, NAMELY, PROVIDING REAL-TIME, MULTIMEDIA AND MULTIPARTY COMMUNICATIONS AND ACCESS TO SITE PROCESS INFORMATION OVER COMPUTER NETWORKS (U.S. CLS. 100, 101 AND 104).

FIRST USE 3-1-2012; IN COMMERCE 3-1-2012.

# CONVERSION

THE MARK CONSISTS OF STANDARD CHARACTERS WITHOUT CLAIM TO ANY PARTICULAR FONT, STYLE, SIZE, OR COLOR.

**CLASS 35—ADVERTISING AND BUSINESS**

FOR BUSINESS ADMINISTRATION SERVICES; BUSINESS CONSULTING SERVICES; BUSINESS INCUBATOR SERVICES, NAMELY, MARKETING, MANAGEMENT, AND DEVELOPMENT SERVICES IN THE FORM OF START-UP SUPPORT FOR EMERGING BUSINESSES AND START-UPS OF OTHERS; BUSINESS NETWORKING SERVICES (U.S. CLS. 100, 101 AND 102).

FIRST USE 6-0-2013; IN COMMERCE 6-0-2013.

**CLASS 36—INSURANCE AND FINANCIAL**

FOR VENTURE CAPITAL SERVICES, NAMELY, PROVIDING FINANCING TO COMPANIES AND ENTREPRENEURS; VENTURE CAPITAL ADVISORY SERVICES; FORMING VENTURE CAPITAL INVESTMENT FUNDS TO INVEST IN COMPANIES AND ENTREPRENEURS, MANAGING VENTURE CAPITAL INVESTMENT FUNDS; BUSINESS INCUBATOR SERVICES, NAMELY, PROVIDING FINANCING OF EMERGING AND START-UP COMPANIES; FINANCIAL ADVICE AND CONSULTANCY SERVICES; FINANCIAL INVESTMENT SERVICES IN THE FIELD OF VENTURE CAPITAL (U.S. CLS. 100, 101 AND 102).

FIRST USE 3-0-2013; IN COMMERCE 3-0-2013.

4,593,635. INGURAN, LLC, DBA SEXING TECHNOLOGIES, NAVASOTA, TX. SN 85-807,900. PUB. 10-29-2013, FILED 12-20-2012.



OWNER OF U.S. REG. NOS. 3,564,718 AND 3,617,594.

THE MARK CONSISTS OF A CIRCLE WITH A SMALL ARROW PROJECTING UPWARDLY FROM THE UPPER PERIMETER OF THE CIRCLE, THE CIRCLE BEING ATTACHED AT ITS LOWER PERIMETER TO THE UPPER PERIMETER OF AN OVAL THAT HAS A CROSS PROJECTING FROM ITS LOWER PERIMETER.

#### CLASS 5—PHARMACEUTICALS

FOR ISOLATED OR PROCESSED ANIMAL REPRODUCTIVE CELLS, NAMELY, ANIMAL SEMEN; ANIMAL SPERM, SPERM SOLUTIONS, AND OOCYTES (U.S. CLS. 6, 18, 44, 46, 51 AND 52).

FIRST USE 11-1-2008; IN COMMERCE 11-1-2008.

#### CLASS 31—NATURAL AGRICULTURAL PRODUCTS

FOR ANIMAL EMBRYOS (U.S. CLS. 1 AND 46).  
FIRST USE 11-1-2011; IN COMMERCE 11-1-2011.

#### CLASS 44—MEDICAL, BEAUTY AND AGRICULTURAL SERVICES

FOR SPERM SORTING SERVICES FOR OTHERS, NAMELY, SORTING OR SEX SELECTING ANIMAL SEMEN FOR USE IN ARTIFICIAL INSEMINATION AND IN VITRO FERTILIZATION (U.S. CLS. 100 AND 101).

FIRST USE 11-1-2011; IN COMMERCE 11-1-2011.

4,593,641. VIAPLAY, LOS ANGELES, CA. SN 85-810,292. PUB. 5-21-2013, FILED 12-26-2012.

VIAPLAY

THE MARK CONSISTS OF STANDARD CHARACTERS WITHOUT CLAIM TO ANY PARTICULAR FONT, STYLE, SIZE, OR COLOR.

#### CLASS 9—ELECTRICAL AND SCIENTIFIC APPARATUS

FOR COMPUTER CURSOR CONTROL DEVICES, NAMELY, COMPUTER MOUSE; COMPUTER CURSOR CONTROL DEVICES, NAMELY, DIGITIZER TABLETS; COMPUTER CURSOR CONTROL DEVICES, NAMELY, LIGHT PENS; COMPUTER CURSOR CONTROL DEVICES, NAMELY, TOUCH PADS; COMPUTER CURSOR CONTROL DEVICES, NAMELY, TRACKBALLS; COMPUTER GAME PROGRAMS; COMPUTER GAME SOFTWARE; COMPUTER GAME SOFTWARE FOR PERSONAL COMPUTERS AND HOME VIDEO GAME CONSOLES; COMPUTER HARDWARE AND COMPUTER PERIPHERALS; COMPUTER HARDWARE AND COMPUTER SOFTWARE PROGRAMS FOR THE INTEGRATION OF TEXT, AUDIO, GRAPHICS, STILL IMAGES AND MOVING PICTURES INTO AN INTERACTIVE DELIVERY FOR MULTIMEDIA APPLICATIONS; COMPUTER KEYBOARD CONTROLLERS; KEYBOARDS FOR MOBILE PHONES; REMOTE CONTROLS FOR TELEVISIONS, COMPUTERS, SET-TOP BOXES, MULTI-MEDIA PLAYERS, COMPUTER PERIPHERALS; SET-TOP BOXES; WIRELESS COMPUTER MICE; WIRELESS COMPUTER PERIPHERALS; WIRELESS PRESENTER IN THE NATURE OF A WIRELESS REMOTE POINTER (U.S. CLS. 21, 23, 26, 36 AND 38).  
FIRST USE 7-16-2013; IN COMMERCE 8-3-2013.

#### CLASS 28—TOYS AND SPORTING GOODS

FOR COMPUTER GAME CONSOLES FOR USE WITH AN EXTERNAL DISPLAY SCREEN OR MONITOR; COMPUTER GAME JOYSTICKS; GAME CONTROLLERS FOR COMPUTER GAMES; JOYSTICKS FOR VIDEO GAMES; VIDEO GAME INTERACTIVE HAND HELD REMOTE CONTROLS FOR PLAYING ELECTRONIC GAMES; VIDEO GAME INTERACTIVE REMOTE CONTROL UNITS (U.S. CLS. 22, 23, 38 AND 50).  
FIRST USE 7-16-2013; IN COMMERCE 8-3-2013.

4,593,642. 1C LIMITED LIABILITY COMPANY, AKA 1C LLC, MOSCOW, RUSSIAN FED.. SN 85-810,599. PUB. 11-12-2013, FILED 12-26-2012.

1C:Enterprise

THE MARK CONSISTS OF STANDARD CHARACTERS WITHOUT CLAIM TO ANY PARTICULAR FONT, STYLE, SIZE, OR COLOR.

#### CLASS 9—ELECTRICAL AND SCIENTIFIC APPARATUS

FOR COMPUTER SOFTWARE FOR USE AS A BUSINESS APPLICATION FOR MANAGING BILLING AND PAYMENTS, FOR INVENTORY MANAGEMENT, FOR MANAGING OF OPERATIONS BY RECEIVING AND SHIPPING GOODS, FOR MANAGING AND CONTROLLING OVER THE EXECUTION OF TRANSACTIONS AND CALCULATIONS ON IT, FOR MANAGING CREDIT MEMOS AND REFUNDS, FOR MANAGING BANK RECONCILIATIONS, FOR CREATING AND MANAGING REPORTING AND INFORMATION ON THE BALANCE SHEET, FOR MANAGING INCOME STATEMENT, CASH FLOW, TRIAL BALANCE, TAX CALCULATION IN THE FIELD OF ACCOUNTING, AUDITING, TAXATION, MANAGEMENT ACCOUNTING, FINANCIAL ANALYSIS, PAYROLL, BUDGETING, TRANSPORTATION AND WAREHOUSING, ACCOUNT OF PERSONAL FINANCE, MANAGEMENT OF TRADE AND SERVICE ENTERPRISES (U.S. CLS. 21, 23, 26, 36 AND 38).  
FIRST USE 6-27-2005; IN COMMERCE 8-19-2013.



**CLASS 42—SCIENTIFIC AND COMPUTER SERVICES**

FOR SOFTWARE AS A SERVICE (SAAS) SERVICES FEATURING SOFTWARE FOR USE AS A BUSINESS APPLICATION FOR MANAGING BILLING AND PAYMENTS, INVENTORY MANAGEMENT, MANAGING OPERATIONS BY RECEIVING AND SHIPPING GOODS, MANAGING CONTROL OVER THE EXECUTION OF TRANSACTIONS AND CALCULATIONS ON IT, MANAGEMENT OF CREDIT MEMOS AND REFUNDS, MANAGEMENT OF BANK RECONCILIATIONS, CREATING AND MANAGING REPORTING AND INFORMATION ON THE BALANCE SHEET, INCOME STATEMENT, CASH FLOW, TRIAL BALANCE, TAX CALCULATION IN THE FIELD OF ACCOUNTING, AUDITING, TAXATION, MANAGEMENT ACCOUNTING, FINANCIAL ANALYSIS, PAYROLL, BUDGETING, TRANSPORTATION AND WAREHOUSING, ACCOUNT OF PERSONAL FINANCE, MANAGEMENT OF TRADE AND SERVICE ENTERPRISES (U.S. CLS. 100 AND 101).

FIRST USE 6-27-2005; IN COMMERCE 8-19-2013.

4,593,643. ADAM EVERS, ALLEN, TX. SN 85-811,466. PUB. 5-21-2013, FILED 12-27-2012.

# SENS

THE MARK CONSISTS OF STANDARD CHARACTERS WITHOUT CLAIM TO ANY PARTICULAR FONT, STYLE, SIZE, OR COLOR.

**CLASS 5—PHARMACEUTICALS**

FOR DIETARY SUPPLEMENT DRINKS (U.S. CLS. 6, 18, 44, 46, 51 AND 52).

FIRST USE 5-1-2014; IN COMMERCE 5-1-2014.

**CLASS 32—LIGHT BEVERAGES**

FOR ENERGY DRINKS (U.S. CLS. 45, 46 AND 48).

FIRST USE 5-1-2014; IN COMMERCE 5-1-2014.

4,593,647. SKULLCANDY, INC., PARK CITY, UT. SN 85-812,017. PUB. 11-12-2013, FILED 12-28-2012.

# PLYR

THE MARK CONSISTS OF STANDARD CHARACTERS WITHOUT CLAIM TO ANY PARTICULAR FONT, STYLE, SIZE, OR COLOR.

**CLASS 9—ELECTRICAL AND SCIENTIFIC APPARATUS**

FOR DEVICES FOR HANDS-FREE USE OF MOBILE PHONES; EARPHONES; HEADPHONES; HEADSETS FOR USE WITH COMPUTERS; HEADSETS FOR USE WITH COMPUTERS, NAMELY, TABLET COMPUTERS AND PORTABLE MEDIA PLAYERS (U.S. CLS. 21, 23, 26, 36 AND 38).

FIRST USE 11-12-2012; IN COMMERCE 11-12-2012.

**CLASS 28—TOYS AND SPORTING GOODS**

FOR HEADSETS FOR USE IN PLAYING VIDEO GAMES; HEADSETS FOR USE WITH GAME CONSOLES; GAMING PERIPHERALS OR ACCESSORIES FOR COMPUTER GAMES, NAMELY, GAME CONTROLLER ADAPTERS AND GAME CONTROLLER ADAPTERS HAVING AN AUDIO OUTPUT PORT AND AN AUDIO INPUT PORT (U.S. CLS. 22, 23, 38 AND 50).

FIRST USE 11-12-2012; IN COMMERCE 11-12-2012.

4,593,648. SKULLCANDY, INC., PARK CITY, UT. SN 85-812,018. PUB. 11-12-2013, FILED 12-28-2012.

# SLYR

THE MARK CONSISTS OF STANDARD CHARACTERS WITHOUT CLAIM TO ANY PARTICULAR FONT, STYLE, SIZE, OR COLOR.

**CLASS 9—ELECTRICAL AND SCIENTIFIC APPARATUS**

FOR DEVICES FOR HANDS-FREE USE OF MOBILE PHONES; EARPHONES; HEADPHONES; HEADSETS FOR USE WITH COMPUTERS; HEADSETS FOR USE WITH COMPUTERS, NAMELY, TABLET COMPUTERS AND PORTABLE MEDIA PLAYERS (U.S. CLS. 21, 23, 26, 36 AND 38).

FIRST USE 9-13-2012; IN COMMERCE 9-13-2012.

**CLASS 28—TOYS AND SPORTING GOODS**

FOR HEADSETS FOR USE IN PLAYING VIDEO GAMES; HEADSETS FOR USE WITH GAME CONSOLES; GAMING PERIPHERALS OR ACCESSORIES FOR COMPUTER GAMES, NAMELY, GAME CONTROLLER ADAPTERS AND GAME CONTROLLER ADAPTERS HAVING AN AUDIO OUTPUT PORT AND AN AUDIO INPUT PORT (U.S. CLS. 22, 23, 38 AND 50).

FIRST USE 9-13-2012; IN COMMERCE 9-13-2012.

4,593,654. BABE YOU LLC, BARRINGTON, RI. SN 85-814,759. PUB. 5-28-2013, FILED 1-3-2013.

THE MARK CONSISTS OF THE STYLIZED LETTERS "B" AND "Y" WITH THE "B" FORMING THE PROFILE OF A WOMAN.

**CLASS 3—COSMETICS AND CLEANING PREPARATIONS**

FOR COSMETICS, BODY PRODUCTS, NAMELY, BODY LOTION, BODY CREAM, BODY OIL, BODY POWDER, BODY SPRAYS, BODY WASHES FOR HUMANS, COSMETIC PREPARATIONS FOR BODY CARE; HAIR PRODUCTS, NAMELY, COSMETIC PREPARATIONS FOR THE HAIR AND SCALP, HAIR CARE PREPARATIONS, HAIR COLOR, HAIR CLEANING PREPARATIONS; FACE PRODUCTS, NAMELY, FACE CREAMS, FACE LOTIONS, FACE POWDERS, MAKE-UP FOR THE FACE, PERFUME, COLOGNE, SOAPS FOR PERSONAL USE; BAR SOAPS (U.S. CLS. 1, 4, 6, 50, 51 AND 52).

FIRST USE 1-14-2014; IN COMMERCE 1-14-2014.

**CLASS 14—JEWELRY**

FOR JEWELRY MADE OF METAL OR FABRIC (U.S. CLS. 2, 27, 28 AND 50).

FIRST USE 1-14-2014; IN COMMERCE 1-14-2014.

**CLASS 18—LEATHER GOODS**

FOR HANDBAGS AND TOTE BAGS (U.S. CLS. 1, 2, 3, 22 AND 41).

FIRST USE 1-14-2014; IN COMMERCE 1-14-2014.

**CLASS 25—CLOTHING**

FOR CLOTHING, NAMELY, TOPS, BOTTOMS, JACKETS, SHRUGS, DRESSES, SHAWLS, LINGERIE, LOUNGEWEAR, BRAS, UNDERWEAR, NIGHTWEAR, ROBES, SCARVES, BODY SHAPERS, FOOTWEAR, STOCKINGS, GARTERS, GARTER BELTS, BELTS, GLOVES (U.S. CLS. 22 AND 39).

FIRST USE 1-14-2014; IN COMMERCE 1-14-2014.

4,593,669. VAUGHN GROOMING, LLC, MIAMI, FL. SN 85-821,110. PUB. 5-14-2013, FILED 1-11-2013.

V76

THE MARK CONSISTS OF STANDARD CHARACTERS WITHOUT CLAIM TO ANY PARTICULAR FONT, STYLE, SIZE, OR COLOR.

**CLASS 3—COSMETICS AND CLEANING PREPARATIONS**

FOR SHAMPOOS AND CONDITIONERS, ENERGIZING AND REJUVENATING SHAMPOOS, HYDRATING AND REJUVENATING CONDITIONERS; MOISTURIZING AND CONDITIONING SHAMPOOS, MOISTURIZING AND FORTIFYING CONDITIONERS, BRIGHTENING AND SILVER SHAMPOO AND CONDITIONER, HAIR CREAMS AND HAIR GELS, STRONG-HOLD HAIR CONDITIONING GEL, FLEXIBLE CONDITIONING GEL FOR HAIR, MEDIUM-HOLD HAIR STYLING CREAM, HAIR GROOMING CREAM, HAIR WAXES AND POMADES, NATURAL WAXPOMADE, HAIR MOLDING PASTE, MATTE ROCK STYLE MOLDING PASTE FOR HAIR, HAIR SPRAYS AND HAIR OILS, HAIR PREP STYLING SPRAY, SHAVE FOAM AND SHAVE CREAM, DETAILING SHAVE OIL, NON-MEDICATED LIP BALM AND LIP MOISTURIZER, CLEAR TALCUM POWDER, BAR SOAP, BODY WASH, NON-MEDICATED REFRESHING HAIR AND FACE MIST (U.S. CLS. 1, 4, 6, 50, 51 AND 52).

FIRST USE 12-30-2013; IN COMMERCE 12-30-2013.

**CLASS 35—ADVERTISING AND BUSINESS**

FOR PROVIDING CONSUMER PRODUCT INFORMATION ON MEN'S HAIR GROOMING, STYLE AND PERSONAL CARE ITEMS VIA A GLOBAL COMPUTER NETWORK (U.S. CLS. 100, 101 AND 102).

FIRST USE 12-30-2013; IN COMMERCE 12-30-2013.

4,593,678. FOOT PETALS, INC., PICKERINGTON, OH. SN 85-825,595. PUB. 5-7-2013, FILED 1-17-2013.

foot  petals

OWNER OF U.S. REG. NOS. 3,008,330, 3,865,684, AND 3,898,704.

THE MARK CONSISTS OF THE WORDING "FOOT PETALS" IN STYLIZED FONT. A STYLIZED DESIGN OF A FLOWER WITH SIX PETALS APPEARS BETWEEN "FOOT" AND "PETALS".

**CLASS 25—CLOTHING**

FOR SHOE INSERTS FOR PRIMARILY NON-ORTHOPEDIC PURPOSES, NAMELY, SHOE CUSHIONS; HEEL PADS; HEEL CUSHIONS; BALL OF FOOT CUSHIONS; ARCH CUSHIONS; INSOLES; HEEL INSERTS; INSERTS IN THE FORM OF APPLIQUES TO PREVENT SHOES FROM SLIPPING; STRAP CUSHIONS TO BE ADHERED TO THE STRAPS OF SHOES; PADS FOR SHOE STRAPS; SOCKS; SHOES; SLIPPERS; FLIP-FLOPS; ANTI-SLIP APPLIQUES FOR THE SOLES OF SHOES; KITS COMPRISED OF SHOE INSERTS FOR PRIMARILY NON-ORTHOPEDIC PURPOSES, NAMELY, SHOE INSOLES, BALL OF FOOT CUSHIONS, HEEL CUSHIONS, PADS FOR SHOE STRAPS, AND ADHESIVE NON-SKID APPLIQUES FOR SHOES (U.S. CLS. 22 AND 39).

FIRST USE 10-0-2013; IN COMMERCE 10-0-2013.

**CLASS 35—ADVERTISING AND BUSINESS**

FOR ONLINE RETAIL STORE SERVICES FEATURING ALL OF THE FOLLOWING: FOOT CARE AND FOOTWEAR PRODUCTS AND ACCESSORIES; SHOE INSERTS FOR PRIMARILY NON-ORTHOPEDIC PURPOSES, NAMELY, SHOE CUSHIONS; HEEL PADS; HEEL CUSHIONS; BALL OF FOOT CUSHIONS; ARCH CUSHIONS; INSOLES; HEEL INSERTS; INSERTS IN THE FORM OF APPLIQUES TO PREVENT SHOES FROM SLIPPING; STRAP CUSHIONS TO BE ADHERED TO THE STRAPS OF SHOES; PADS FOR SHOE STRAPS; ANTI-SLIP APPLIQUES FOR THE SOLES OF SHOES; AND KITS COMPRISED OF SAME; SOCKS; SHOES; SLIPPERS; FLIP-FLOPS; SHOE POUCHES; INFLATABLE BOOT SHAPERS (U.S. CLS. 100, 101 AND 102).

FIRST USE 10-0-2013; IN COMMERCE 10-0-2013.

4,593,679. CONTINENTAL ACCESSORY CORPORATION, AMITYVILLE, NY. SN 85-825,841. PUB. 11-5-2013, FILED 1-17-2013.

TEACHERS CORNER

THE MARK CONSISTS OF STANDARD CHARACTERS

WITHOUT CLAIM TO ANY PARTICULAR FONT, STYLE, SIZE, OR COLOR.

NO CLAIM IS MADE TO THE EXCLUSIVE RIGHT TO USE "TEACHERS", APART FROM THE MARK AS SHOWN.

#### **CLASS 16—PAPER GOODS AND PRINTED MATTER**

FOR EDUCATIONAL DECORATIVE PAPER BANNERS AND BORDERS; STICKERS; PAPER IDENTIFICATION NAME TAGS; PAPER NAME PLATES; PRINTED PUNCH CHARTS AND PRINTED INCENTIVE CHARTS; BOOKMARKS; PRINTED HALL PASSES; PRINTED REWARD CERTIFICATES; PAPER DIE-CUT SHAPES; PAPER SENTENCE STRIPS; PAPER PRINTED POCKET CHARTS; PRINTED DAILY CLASS SCHEDULES; MEMO PADS (U.S. CLS. 2, 5, 22, 23, 29, 37, 38 AND 50).

FIRST USE 7-0-2013; IN COMMERCE 7-0-2013.

#### **CLASS 20—FURNITURE AND ARTICLES NOT OTHERWISE CLASSIFIED**

FOR NON-PAPER IDENTIFICATION NAME TAGS; NONMETAL NAME PLATES; NON-PAPER EDUCATIONAL DECORATIVE BANNERS AND BORDERS; NON-PAPER STICKERS; NON-PAPER IDENTIFICATION NAME TAGS; NON-PAPER NAME PLATES; NON-PAPER PRINTED PUNCH CHARTS AND PRINTED INCENTIVE CHARTS; NON-PAPER BOOKMARKS; NON-PAPER PRINTED HALL PASSES; NON-PAPER PRINTED REWARD CERTIFICATES; NON-PAPER DIE-CUT SHAPES; NON-PAPER MEMO PADS; NON-PAPER SENTENCE STRIPS; NON-PAPER PRINTED POCKET CHARTS; NON-PAPER PRINTED DAILY CLASS SCHEDULES; DRY-ERASE PLASTIC REUSABLE TRANSPARENT COVERS FOR PAPERS (U.S. CLS. 2, 13, 22, 25, 32 AND 50).

FIRST USE 7-0-2013; IN COMMERCE 7-0-2013.

4,593,685. JEFFERSON STREET SIGNAGE DISTRICT, LLC, PHOENIX, AZ. SN 85-829,367. PUB. 10-8-2013, FILED 1-22-2013.

## **LEGENDS LIVE**

THE MARK CONSISTS OF STANDARD CHARACTERS WITHOUT CLAIM TO ANY PARTICULAR FONT, STYLE, SIZE, OR COLOR.

OWNER OF U.S. REG. NOS. 4,082,494 AND 4,082,495.

NO CLAIM IS MADE TO THE EXCLUSIVE RIGHT TO USE "LIVE", APART FROM THE MARK AS SHOWN.

#### **CLASS 35—ADVERTISING AND BUSINESS**

FOR ADVERTISING SERVICES, NAMELY, PROMOTING AND MARKETING THE GOODS AND SERVICES OF OTHERS IN THE FIELD OF CONCERTS, LIVE ENTERTAINMENT, AND CULTURAL EVENTS VIA PRINT AND ELECTRONIC MEDIA; EVENT PLANNING AND MANAGEMENT FOR MARKETING, BRANDING, PROMOTING OR ADVERTISING THE GOODS AND SERVICES OF OTHERS; PROMOTING VISUAL AND PERFORMING ARTS EVENTS BY MEANS OF PROVIDING AN ONLINE EVENTS CALENDAR, ORIGINAL ARTICLES, INTERVIEWS, AND INFORMATION ABOUT ART, ARTISTS AND ARTS EVENTS VIA AN INTERNET WEB SITE, ALL FOR PROMOTIONAL PURPOSES (U.S. CLS. 100, 101 AND 102).

FIRST USE 6-3-2014; IN COMMERCE 6-3-2014.

#### **CLASS 41—EDUCATION AND ENTERTAINMENT**

FOR ORGANIZING COMMUNITY SPORTING AND CULTURAL EVENTS; PROVIDING AN INTERNET WEBSITE PORTAL IN THE FIELD OF ENTERTAINMENT, CULTURAL AND SPORTING EVENTS; PROVIDING ON-LINE NEWSLETTERS IN THE FIELD OF CONCERTS, LIVE ENTERTAINMENT, AND CULTURAL EVENTS (U.S. CLS. 100, 101 AND 107).

FIRST USE 6-3-2014; IN COMMERCE 6-3-2014.

4,593,691. UNITED SEATING & MOBILITY, LLC, HAZELWOOD, MO. SN 85-834,415. PUB. 6-25-2013, FILED 1-28-2013.



THE MARK CONSISTS OF A DARK CIRCLE AND WITHIN THAT CIRCLE, IN WHITE, THE LOWERCASE LETTER "N" WITH THE DOWNSTROKE OF THE "N" FORMING THE BEGINNING OF THE LETTER "U".

#### **CLASS 7—MACHINERY**

FOR STAIR LIFTS; WHEEL CHAIR LIFTS FOR USE IN THE HOME (U.S. CLS. 13, 19, 21, 23, 31, 34 AND 35).

FIRST USE 5-1-2013; IN COMMERCE 5-1-2013.

#### **CLASS 10—MEDICAL APPARATUS**

FOR WALKERS FOR USE BY MOBILITY-IMPAIRED INDIVIDUALS; WALKERS TO AID IN MOBILITY; WALKING AIDS FOR DISABLED PERSONS, NAMELY, WALKING FRAMES (U.S. CLS. 26, 39 AND 44).

FIRST USE 5-1-2013; IN COMMERCE 5-1-2013.

#### **CLASS 12—VEHICLES**

FOR CHAIR LIFTS; MOTORISED WHEELCHAIRS FOR THE DISABLED AND THOSE WITH MOBILITY DIFFICULTIES; MOTORIZED PERSONAL MOBILITY SCOOTERS; MOTORIZED, ELECTRIC-POWERED, SELF-PROPELLED, SELF-BALANCING, WHEELED PERSONAL MOBILITY, TRANSPORTATION DEVICE; MOTORIZED, SELF-PROPELLED, WHEELED PERSONAL MOBILITY DEVICE, NAMELY, SCOOTERS; POWER TRANSFER SEATS FOR VEHICLES TO PROVIDE EASIER INGRESS TO AND EGRESS FROM A VEHICLE FOR DISABLED OR MOBILITY IMPAIRED PEOPLE; VEHICLES FOR THE PHYSICALLY HANDICAPPED AND THOSE OF REDUCED MOBILITY; WHEEL CHAIRS; WHEELCHAIRS (U.S. CLS. 19, 21, 23, 31, 35 AND 44).

FIRST USE 5-1-2013; IN COMMERCE 5-1-2013.

**CLASS 37—CONSTRUCTION AND REPAIR**

FOR MAINTENANCE AND/OR REPAIR OF CUSTOMIZED MEDICAL SEATING EQUIPMENT, POSITIONAL EQUIPMENT, AND MOBILITY EQUIPMENT FOR DISABLED PERSONS AND MOBILITY IMPAIRED PERSONS (U.S. CLS. 100, 103 AND 106).

FIRST USE 5-1-2013; IN COMMERCE 5-1-2013.

**CLASS 39—TRANSPORTATION AND STORAGE**

FOR DISTRIBUTION SERVICES, NAMELY, DELIVERY OF CUSTOMIZED MEDICAL SEATING EQUIPMENT, POSITIONAL EQUIPMENT, AND MOBILITY EQUIPMENT FOR DISABLED PERSONS AND MOBILITY IMPAIRED PERSONS (U.S. CLS. 100 AND 105).

FIRST USE 5-1-2013; IN COMMERCE 5-1-2013.

**CLASS 40—MATERIAL TREATMENT**

FOR ASSEMBLY OF PRODUCTS FOR OTHERS (U.S. CLS. 100, 103 AND 106).

FIRST USE 5-1-2013; IN COMMERCE 5-1-2013.

**CLASS 41—EDUCATION AND ENTERTAINMENT**

FOR EDUCATION SERVICES, NAMELY, PROVIDING CLASSES, WORKSHOPS, SEMINARS AND TRAINING TO DISABLED AND MOBILITY IMPAIRED PERSONS, MEDICAL STAFF, CLINICAL STAFF, CARE GIVERS AND FAMILIES IN THE FIELD OF PROPER CUSTOMIZATION, MODIFICATION, ADJUSTMENT AND USE OF CUSTOMIZED MEDICAL SEATING EQUIPMENT, POSITIONAL EQUIPMENT, AND MOBILITY EQUIPMENT FOR DISABLED PERSONS AND MOBILITY IMPAIRED PERSONS (U.S. CLS. 100, 101 AND 107).

FIRST USE 5-1-2013; IN COMMERCE 5-1-2013.

---

4,593,697. SUMMIT AGRO USA, LLC, CARY, NC. SN 85-838,576. PUB. 9-3-2013, FILED 2-1-2013.

# REFER

THE MARK CONSISTS OF STANDARD CHARACTERS WITHOUT CLAIM TO ANY PARTICULAR FONT, STYLE, SIZE, OR COLOR.

**CLASS 1—CHEMICALS**

FOR CHEMICALS FOR USE IN AGRICULTURE, NAMELY, DESICCANTS (U.S. CLS. 1, 5, 6, 10, 26 AND 46).

FIRST USE 6-12-2014; IN COMMERCE 6-12-2014.

**CLASS 5—PHARMACEUTICALS**

FOR CHEMICALS FOR USE IN AGRICULTURE, NAMELY, HERBICIDES (U.S. CLS. 6, 18, 44, 46, 51 AND 52).

FIRST USE 6-12-2014; IN COMMERCE 6-12-2014.

4,593,698. UNITED SEATING & MOBILITY, LLC, HAZELWOOD, MO. SN 85-839,724. PUB. 6-25-2013, FILED 2-4-2013.

## Mobility starts here.

THE MARK CONSISTS OF STANDARD CHARACTERS WITHOUT CLAIM TO ANY PARTICULAR FONT, STYLE, SIZE, OR COLOR.

**CLASS 7—MACHINERY**

FOR STAIR LIFTS; WHEEL CHAIR LIFTS FOR USE IN THE HOME (U.S. CLS. 13, 19, 21, 23, 31, 34 AND 35).

FIRST USE 5-1-2013; IN COMMERCE 5-1-2013.

**CLASS 10—MEDICAL APPARATUS**

FOR WALKERS FOR USE BY MOBILITY-IMPAIRED INDIVIDUALS; WALKERS TO AID IN MOBILITY; WALKING AIDS FOR DISABLED PERSONS, NAMELY, WALKING FRAMES (U.S. CLS. 26, 39 AND 44).

FIRST USE 5-1-2013; IN COMMERCE 5-1-2013.

**CLASS 12—VEHICLES**

FOR CHAIR LIFTS; MOTORISED WHEELCHAIRS FOR THE DISABLED AND THOSE WITH MOBILITY DIFFICULTIES; MOTORIZED PERSONAL MOBILITY SCOOTERS; MOTORIZED, ELECTRIC-POWERED, SELF-PROPELLED, SELF-BALANCING, WHEELED PERSONAL MOBILITY, TRANSPORTATION DEVICE; MOTORIZED, SELF-PROPELLED, WHEELED PERSONAL MOBILITY DEVICE, NAMELY, SCOOTERS; POWER TRANSFER SEATS FOR VEHICLES TO PROVIDE EASIER INGRESS TO AND EGRESS FROM A VEHICLE FOR DISABLED OR MOBILITY IMPAIRED PEOPLE; VEHICLES FOR THE PHYSICALLY HANDICAPPED AND THOSE OF REDUCED MOBILITY; WHEEL CHAIRS; WHEELCHAIRS (U.S. CLS. 19, 21, 23, 31, 35 AND 44).

FIRST USE 5-1-2013; IN COMMERCE 5-1-2013.

**CLASS 37—CONSTRUCTION AND REPAIR**

FOR MAINTENANCE AND/OR REPAIR OF CUSTOMIZED MEDICAL SEATING EQUIPMENT, POSITIONAL EQUIPMENT, AND MOBILITY EQUIPMENT FOR DISABLED PERSONS AND MOBILITY IMPAIRED PERSONS (U.S. CLS. 100, 103 AND 106).

FIRST USE 5-1-2013; IN COMMERCE 5-1-2013.

**CLASS 39—TRANSPORTATION AND STORAGE**

FOR DISTRIBUTION SERVICES, NAMELY, DELIVERY OF CUSTOMIZED MEDICAL SEATING EQUIPMENT, POSITIONAL EQUIPMENT, AND MOBILITY EQUIPMENT FOR DISABLED PERSONS AND MOBILITY IMPAIRED PERSONS (U.S. CLS. 100 AND 105).

FIRST USE 5-1-2013; IN COMMERCE 5-1-2013.

**CLASS 40—MATERIAL TREATMENT**

FOR ASSEMBLY OF PRODUCTS FOR OTHERS (U.S. CLS. 100, 103 AND 106).

FIRST USE 5-1-2013; IN COMMERCE 5-1-2013.

**CLASS 41—EDUCATION AND ENTERTAINMENT**

FOR EDUCATION SERVICES, NAMELY, PROVIDING CLASSES, WORKSHOPS, SEMINARS AND TRAINING TO DISABLED AND MOBILITY IMPAIRED PERSONS, MEDICAL STAFF, CLINICAL STAFF, CARE GIVERS AND FAMILIES IN THE FIELD OF PROPER CUSTOMIZATION, MODIFICATION, ADJUSTMENT AND USE OF CUSTOMIZED MEDICAL SEATING EQUIPMENT, POSITIONAL EQUIPMENT, AND MOBILITY EQUIPMENT FOR DISABLED PERSONS AND MOBILITY IMPAIRED PERSONS (U.S. CLS. 100, 101 AND 107).

FIRST USE 5-1-2013; IN COMMERCE 5-1-2013.

4,593,724. POTOMAC METALS, INC., STERLING, VA. SN 85-849,912. PUB. 2-11-2014, FILED 2-14-2013.



4,593,708. 2 SCOOPS, LLC, BEVERLY, MA. SN 85-843,890. PUB. 2-4-2014, FILED 2-7-2013.



NO CLAIM IS MADE TO THE EXCLUSIVE RIGHT TO USE "ICE CREAM", APART FROM THE MARK AS SHOWN.

THE MARK CONSISTS OF THE STYLIZED WORD "2SCOOPS" WITH AN ICE CREAM SCOOP APPEARING AS THE LETTER "P" ABOVE THE STYLIZED PHRASE "I SCREAM!"

**CLASS 30—STAPLE FOODS**

FOR ICE CREAM, SORBET AND FROZEN CONFECTIONS (U.S. CL. 46).

FIRST USE 4-30-2013; IN COMMERCE 4-30-2013.

**CLASS 43—HOTEL AND RESTAURANT SERVICES**

FOR RESTAURANT SERVICES; RESTAURANT SERVICES FEATURING ICE CREAM, SORBET, CUPCAKES, BEVERAGES AND THE LIKE; ICE CREAM PARLOR SERVICES; ICE CREAM SHOP SERVICES IN THE NATURE OF A RESTAURANT (U.S. CLS. 100 AND 101).

FIRST USE 4-30-2013; IN COMMERCE 4-30-2013.

NO CLAIM IS MADE TO THE EXCLUSIVE RIGHT TO USE "METALS" AND "INCORPORATED" AND THE UNIVERSAL RECYCLE SYMBOL, APART FROM THE MARK AS SHOWN.

THE MARK CONSISTS OF A CIRCULAR RING FRAMED BY A RIM AND WITH THE WORDS "POTOMAC METALS" IN ALL CAPITAL LETTERS ON TOP OF THE UPPER HALF OF THE RING AND THE WORD "INCORPORATED" IN ALL CAPITAL LETTERS ON TOP OF THE LOWER HALF OF THE RING AND WITH A RIM CLOSER TO THE CENTER FRAMING A CIRCLE WITH A UNIVERSALLY USED SYMBOL OF RECYCLING AND THE UPPER CASE LETTERS "PMI" ABOVE A DEPICTION OF THE SPHERE OF THE EARTH WITH NORTH AMERICA FROM THE SOUTH WESTERN COAST OF THE UNITED STATES TO EASTERN COAST LINE OF NORTH AMERICA, CENTRAL AMERICA AND THE NORTHERN AND WESTERN COAST OF SOUTH AMERICA VISIBLE ALONG WITH THE ATLANTIC OCEAN AND THE WESTERN COAST OF AFRICA AND THE SOUTH WESTERN COAST OF EUROPE (PORTUGAL AND SPAIN).

**CLASS 6—METAL GOODS**

FOR WASTE MATERIALS STORAGE BINS OF METAL; GENERAL PURPOSE METAL STORAGE UNITS, NAMELY, METAL SKIPS FOR COLLECTION AND STORAGE (U.S. CLS. 2, 12, 13, 14, 23, 25 AND 50).

FIRST USE 1-0-2007; IN COMMERCE 1-0-2007.

**CLASS 35—ADVERTISING AND BUSINESS**

FOR RETAIL STORE SERVICES AND WHOLESALE DISTRIBUTORSHIPS FEATURING SCRAP METALS AND RECYCLED METALS; COMMERCIAL CONSULTANCY IN THE FIELD OF THE RETAIL AND WHOLESALE SALE OF SCRAP METALS AND RECYCLED METALS (U.S. CLS. 100, 101 AND 102).

FIRST USE 1-0-2007; IN COMMERCE 1-0-2007.

**CLASS 36—INSURANCE AND FINANCIAL**

FOR BROKERAGE OF SCRAP METALS AND RECYCLED METALS; INFORMATION, ADVISORY AND CONSULTANCY SERVICES IN RELATION TO THE AFORESAID SERVICES (U.S. CLS. 100, 101 AND 102).

FIRST USE 1-0-2007; IN COMMERCE 1-0-2007.

**CLASS 37—CONSTRUCTION AND REPAIR**

FOR DISPOSAL OF METALS, WASTE, REFUSE AND GARBAGE FOR OTHERS; COLLECTION OF SCRAP METAL FOR RECYCLING; COLLECTION OF METAL AND REFUSE FOR RECYCLING; SOLID WASTE COLLECTION OF METALS FOR OTHERS FOR RECYCLING; INFORMATION, ADVISORY AND CONSULTANCY SERVICES IN RELATION TO THE AFORESAID SERVICES (U.S. CLS. 100, 103 AND 106).

FIRST USE 1-0-2007; IN COMMERCE 1-0-2007.

**CLASS 39—TRANSPORTATION AND STORAGE**

FOR TRANSPORTATION OF WASTE MATERIALS AND WASTE PRODUCTS; RECYCLING TRANSPORTATION SERVICES; FREIGHT TRANSPORTATION OF SCRAP METALS FOR OTHERS; FREIGHT TRANSPORTATION PROVIDED FOR THE DISPOSAL OF WASTE MATERIALS FOR OTHERS; STORAGE, DISTRIBUTION, AND TRANSPORTATION OF METALS; WASTE AND REFUSE COLLECTION IN THE NATURE OF GARBAGE COLLECTION; INFORMATION, ADVISORY AND CONSULTANCY SERVICES IN RELATION TO THE AFORESAID SERVICES (U.S. CLS. 100 AND 105).

FIRST USE 1-0-2007; IN COMMERCE 1-0-2007.

**CLASS 40—MATERIAL TREATMENT**

FOR PROCESSING OF SCRAP METAL AND RECYCLING OF SCRAP METAL; PROCESSING AND RECYCLING OF WASTE AND WASTE MATERIALS; MATERIAL TREATMENT SERVICES IN CONNECTION WITH RECYCLING; METAL RECLAMATION SERVICES; RECYCLING; RECYCLING PROCESS SERVICES; PROCESSING AND TREATING REFUSE AND WASTE FOR THE RECOVERY OF MATERIALS; SORTING OF WASTE AND RECYCLABLE MATERIAL; WASTE MANAGEMENT; DESTRUCTION OF WASTE; ENVIRONMENTAL REMEDIATION SERVICES, NAMELY, METAL, REFUSE AND WASTE DISPOSAL; INDUSTRIAL TOXIC WASTE DISPOSAL; CONSULTING SERVICES IN THE FIELDS OF SCRAP METAL PROCESSING AND RECYCLING; INFORMATION, ADVISORY AND CONSULTANCY SERVICES IN RELATION TO THE AFORESAID SERVICES (U.S. CLS. 100, 103 AND 106).

FIRST USE 1-0-2007; IN COMMERCE 1-0-2007.

**CLASS 35—ADVERTISING AND BUSINESS**

FOR RETAIL STORE SERVICES AND WHOLESALE DISTRIBUTORSHIPS FEATURING SCRAP METALS AND RECYCLED METALS; COMMERCIAL CONSULTANCY IN THE FIELD OF THE RETAIL AND WHOLESALE SALE OF SCRAP METALS AND RECYCLED METALS (U.S. CLS. 100, 101 AND 102).

FIRST USE 4-3-1998; IN COMMERCE 4-3-1998.

**CLASS 36—INSURANCE AND FINANCIAL**

FOR BROKERAGE OF SCRAP METALS AND RECYCLED METALS; INFORMATION, ADVISORY AND CONSULTANCY SERVICES IN RELATION TO THE AFORESAID SERVICES (U.S. CLS. 100, 101 AND 102).

FIRST USE 4-3-1998; IN COMMERCE 4-3-1998.

**CLASS 37—CONSTRUCTION AND REPAIR**

FOR DISPOSAL OF METALS, WASTE, REFUSE AND GARBAGE FOR OTHERS; COLLECTION OF SCRAP METAL; COLLECTION OF METAL AND REFUSE FOR RECYCLING; COLLECTION OF METALS AND WASTE FOR OTHERS; INFORMATION, ADVISORY AND CONSULTANCY SERVICES IN RELATION TO THE AFORESAID SERVICES (U.S. CLS. 100, 103 AND 106).

FIRST USE 4-3-1998; IN COMMERCE 4-3-1998.

**CLASS 39—TRANSPORTATION AND STORAGE**

FOR TRANSPORTATION OF WASTE MATERIALS AND WASTE PRODUCTS; RECYCLING TRANSPORTATION SERVICES; FREIGHT TRANSPORTATION OF SCRAP METALS FOR OTHERS; FREIGHT TRANSPORTATION PROVIDED FOR THE DISPOSAL OF WASTE MATERIALS FOR OTHERS; STORAGE, DISTRIBUTION, AND TRANSPORTATION OF METALS; GARBAGE, WASTE, AND REFUSE COLLECTION; INFORMATION, ADVISORY AND CONSULTANCY SERVICES IN RELATION TO THE AFORESAID SERVICES (U.S. CLS. 100 AND 105).

FIRST USE 4-3-1998; IN COMMERCE 4-3-1998.

**CLASS 40—MATERIAL TREATMENT**

FOR PROCESSING OF SCRAP METAL AND RECYCLING OF SCRAP METAL; PROCESSING AND RECYCLING OF WASTE AND WASTE MATERIALS; MATERIAL TREATMENT SERVICES IN CONNECTION WITH RECYCLING; METAL RECLAMATION SERVICES; RECYCLING; RECYCLING PROCESS SERVICES; PROCESSING AND TREATING REFUSE AND WASTE FOR THE RECOVERY OF MATERIALS; SORTING OF WASTE AND RECYCLABLE MATERIAL; WASTE MANAGEMENT; DESTRUCTION OF WASTE; ENVIRONMENTAL REMEDIATION SERVICES, NAMELY, METAL, REFUSE AND WASTE DISPOSAL; INDUSTRIAL TOXIC WASTE DISPOSAL; CONSULTING SERVICES IN THE FIELDS OF SCRAP METAL PROCESSING AND RECYCLING; INFORMATION, ADVISORY AND CONSULTANCY SERVICES IN RELATION TO THE AFORESAID SERVICES (U.S. CLS. 100, 103 AND 106).

FIRST USE 4-3-1998; IN COMMERCE 4-3-1998.

4,593,725. POTOMAC METALS, INC., STERLING, VA. SN 85-849,924. PUB. 2-11-2014, FILED 2-14-2013.

**POTOMAC METALS**

THE MARK CONSISTS OF STANDARD CHARACTERS WITHOUT CLAIM TO ANY PARTICULAR FONT, STYLE, SIZE, OR COLOR.

NO CLAIM IS MADE TO THE EXCLUSIVE RIGHT TO USE "METALS", APART FROM THE MARK AS SHOWN.

**CLASS 6—METAL GOODS**

FOR WASTE MATERIALS STORAGE BINS OF METAL; GENERAL PURPOSE METAL STORAGE UNITS, NAMELY, METAL SKIPS FOR COLLECTION AND STORAGE (U.S. CLS. 2, 12, 13, 14, 23, 25 AND 50).

FIRST USE 4-3-1998; IN COMMERCE 4-3-1998.

4,593,730. VIVID MEDICAL INC., PALO ALTO, CA. SN 85-855,887. PUB. 5-7-2013, FILED 2-21-2013.

**WWW.VIVIDMED.COM**

THE MARK CONSISTS OF STANDARD CHARACTERS WITHOUT CLAIM TO ANY PARTICULAR FONT, STYLE,

SIZE, OR COLOR.

### CLASS 9—ELECTRICAL AND SCIENTIFIC APPARATUS

FOR COMPUTER AND APPLICATION SOFTWARE FOR USE IN MEDICAL PROCEDURES, NAMELY, FOR RECEIVING BY WIRED OR WIRELESS TRANSMISSION, CAPTURING, PROCESSING AND DISPLAYING VIDEO AND IMAGES OBTAINED DURING MEDICAL INTUBATION, ENDOSCOPY, DENTISTRY, PATHOLOGY, DERMATOLOGY, MICROSCOPY MEDICAL AND SCIENTIFIC PROCEDURES; COMPUTER APPLICATION SOFTWARE FOR DISPLAY DEVICES, CELL PHONES, MOBILE PHONES, PORTABLE ELECTRONICS DEVICES AND TABLETS, NAMELY, SOFTWARE FOR PROCESSING AND DISPLAYING TWO- OR THREE-DIMENSIONAL IMAGES IN MEDICAL AND SCIENTIFIC APPARATUS INCLUDING VIDEO ENDOSCOPES, VIDEO LARYNGOSCOPES, VIDEO BRONCHOSCOPES, VIDEO MICROSCOPES, VIDEO CAMERAS, AND VIDEO INSTRUMENTS (U.S. CLS. 21, 23, 26, 36 AND 38).

FIRST USE 9-1-2011; IN COMMERCE 7-31-2012.

### CLASS 10—MEDICAL APPARATUS

FOR MEDICAL INTUBATION EQUIPMENT; ENDOSCOPES; LARYNGOSCOPES; BRONCHOSCOPES; INTUBATION STYLETS; MICROSCOPES, DENTAL, DERMATOLOGY, PATHOLOGY, SURGICAL AND MEDICAL APPARATUS AND INSTRUMENTS FOR USE IN TWO- OR THREE-DIMENSIONAL VISUALIZATION OF ENDOTRACHEAL INTUBATION, SURGERY, MEDICAL OR SCIENTIFIC EXAMINATION, NAMELY, VIDEO ENDOSCOPES, VIDEO BRONCHOSCOPES, VIDEO LARYNGOSCOPES, VIDEO INTUBATION STYLETS; VIDEO INTUBATION DEVICES, SINGLE-USE VIDEO INTUBATION DEVICES; VIDEO ENDOSCOPES; VIDEO DENTAL AND ORAL CAMERAS; VIDEO DERMATOLOGY DEVICES; PATHOLOGY VIDEO IMAGING DEVICES; SURGICAL AND MEDICAL VIDEO IMAGING DEVICES, VIDEO SYSTEMS AND IMAGING CAMERAS FOR USE IN MEDICAL INTUBATION, ENDOSCOPY, DERMATOLOGY, DENTISTRY, AND OTHER MEDICAL AND SCIENTIFIC IMAGING INSTRUMENTATION (U.S. CLS. 26, 39 AND 44).

FIRST USE 7-31-2012; IN COMMERCE 7-31-2012.

4,593,736. KATANYA, L.L.C., FAR HILLS, NJ. SN 85-859,764. PUB. 5-7-2013, FILED 2-25-2013.

## PLAY THE WORLD

THE MARK CONSISTS OF STANDARD CHARACTERS WITHOUT CLAIM TO ANY PARTICULAR FONT, STYLE, SIZE, OR COLOR.

### CLASS 18—LEATHER GOODS

FOR ALL-PURPOSE CARRYING BAGS; PURSES; UMBRELLAS (U.S. CLS. 1, 2, 3, 22 AND 41).

FIRST USE 4-1-2013; IN COMMERCE 4-1-2013.

### CLASS 25—CLOTHING

FOR COATS; DRESSES; GOLF CAPS; GOLF SHIRTS; GOLF SHOES; GOLF SHORTS; GOLF TROUSERS; JACKETS; SCARVES; SHOES; SHORTS; SKIRTS; SLACKS; SOCKS; SWEATERS; TOPS; UNDERGARMENTS; UNDERWEAR; WOMEN'S HATS AND HOODS (U.S. CLS. 22 AND 39).

FIRST USE 4-1-2013; IN COMMERCE 4-1-2013.

4,593,739. AIR PRODUCTS AND CHEMICALS, INC., ALLENTOWN, PA. SN 85-861,763. PUB. 3-18-2014, FILED 2-27-2013.

## Dermohydrine

THE MARK CONSISTS OF STANDARD CHARACTERS WITHOUT CLAIM TO ANY PARTICULAR FONT, STYLE, SIZE, OR COLOR.

### CLASS 1—CHEMICALS

FOR COSMETIC RAW MATERIALS FOR INDUSTRIAL PURPOSES, NAMELY, CHEMICAL ADDITIVES FOR USE IN THE MANUFACTURE OF COSMETICS AND PERSONAL CARE PRODUCTS; A COMPLEX OF INGREDIENTS FOR USE IN THE MANUFACTURE OF PERSONAL CARE PRODUCTS, NAMELY, ACTIVE CHEMICAL INGREDIENTS PROMOTING HYDRATION, MOISTURIZATION, MOISTURE DONATION, AND SOFTENING BENEFITS; LIPID-BASED VESICLES ENCAPSULATING INGREDIENTS, NAMELY, ACTIVE CHEMICAL MOISTURIZING INGREDIENTS FOR USE IN THE MANUFACTURE OF PERSONAL CARE PRODUCTS, NAMELY, COSMETIC PRODUCTS (U.S. CLS. 1, 5, 6, 10, 26 AND 46).

FIRST USE 4-9-2013; IN COMMERCE 8-20-2013.

### CLASS 3—COSMETICS AND CLEANING PREPARATIONS

FOR PREPARATIONS FOR BODY AND COSMETICS, NAMELY, OILS, CREAMS, MILKS, LOTIONS, SERUMS, GELS, SPRAYS, AND POWDERS; COSMETIC PREPARATIONS AND SUBSTANCES FOR THE GROOMING AND THE APPEARANCE OF SKIN, BODY, FACE, EYES, HAIR, TEETH AND NAILS, NAMELY, SKIN AND BODY LOTION AND CREAMS; PERFUMERY, ESSENTIAL OILS, MAKE-UP PREPARATIONS; COSMETIC SUN-TANNING AND SUNSCREEN PREPARATIONS; COSMETIC PREPARATIONS FOR CLEANING, CARE, MOISTURIZATION, AND BEAUTIFICATION OF THE SKIN, HAIR OR NAIL; CLEANSING LOTIONS AND CLEANSING MILK, SKIN REVIVAL SUBSTANCES, NAMELY, SKIN CREAM, BODY LOTION, SKIN MOISTURIZERS, FACE AND BODY BEAUTY MASKS; BATH AND SHOWER OILS, GELS, CREAMS AND FOAM; TISSUES IMPREGNATED WITH COSMETIC LOTIONS; COSMETIC PREPARATIONS INCORPORATING A HYDRATION, MOISTURIZATION, MOISTURE DONATION, OR SOFTENING BENEFITS, OR COMBINATION THEREOF (U.S. CLS. 1, 4, 6, 50, 51 AND 52).

FIRST USE 4-9-2013; IN COMMERCE 9-20-2013.

4,593,743. MICROGRID SOLAR ENERGY, LLC, EARTH CITY, MO. SN 85-863,513. PUB. 10-8-2013, FILED 2-28-2013.

## POWER YOUR LIFE WITH SUN

THE MARK CONSISTS OF STANDARD CHARACTERS WITHOUT CLAIM TO ANY PARTICULAR FONT, STYLE, SIZE, OR COLOR.

OWNER OF U.S. REG. NO. 1,844,026.

**CLASS 35—ADVERTISING AND BUSINESS**

FOR MARKETING SERVICES RELATING TO PRODUCTS THAT PRODUCE SOLAR GENERATED ELECTRICITY, RETAIL STORE SERVICES FEATURING PRODUCTS THAT PRODUCE SOLAR GENERATED ELECTRICITY, MAIL ORDER SERVICES FEATURING PRODUCTS THAT PRODUCE SOLAR GENERATED ELECTRICITY, AND ON-LINE RETAIL STORE SERVICES FEATURING PRODUCTS THAT PRODUCE SOLAR GENERATED ELECTRICITY (U.S. CLS. 100, 101 AND 102).

FIRST USE 2-28-2013; IN COMMERCE 2-28-2013.

**CLASS 37—CONSTRUCTION AND REPAIR**

FOR INSTALLATION OF PRODUCTS THAT PRODUCE SOLAR GENERATED ELECTRICITY (U.S. CLS. 100, 103 AND 106).

FIRST USE 2-28-2013; IN COMMERCE 2-28-2013.

4,593,746. FOUNDATIONDB, LLC, VIENNA, VA. SN 85-866,209. PUB. 2-25-2014, FILED 3-4-2013.



THE COLOR(S) BLUE IS/ARE CLAIMED AS A FEATURE OF THE MARK.

THE MARK CONSISTS OF A STYLIZED DESIGN OF TWO BUILDINGS COMPRISED OF SHADED RECTANGLE FORMS IN THREE SHADES OF BLUE. THE BUILDING ON THE LEFT IS TWO STORIES, WITH THE LOWER STORY IN DARK BLUE AND THE TOP STORY IN AQUA BLUE. THE BUILDING ON THE RIGHT IS THREE STORIES, WITH THE LOWER STORY IN DARK BLUE, THE MIDDLE STORY IN AQUA BLUE, AND THE TOP STORY IN LIGHT BLUE. THE COLOR WHITE REPRESENTS BACKGROUND, OUTLINING, SHADING, AND/OR TRANSPARENT AREAS AND IS NOT PART OF THE MARK.

**CLASS 9—ELECTRICAL AND SCIENTIFIC APPARATUS**

FOR COMPUTER SOFTWARE FOR DATABASE MANAGEMENT AND DEVELOPMENT (U.S. CLS. 21, 23, 26, 36 AND 38).

FIRST USE 1-2-2012; IN COMMERCE 1-2-2012.

**CLASS 42—SCIENTIFIC AND COMPUTER SERVICES**

FOR SOFTWARE AS A SERVICE (SAAS) SERVICES FEATURING SOFTWARE FOR DATABASE MANAGEMENT AND DEVELOPMENT (U.S. CLS. 100 AND 101).

FIRST USE 8-20-2013; IN COMMERCE 8-20-2013.

4,593,758. MORIN, GERMAIN, EAST BRUNSWICK, NJ. SN 85-875,674. PUB. 3-11-2014, FILED 3-14-2013.

# NETCON5

THE MARK CONSISTS OF STANDARD CHARACTERS WITHOUT CLAIM TO ANY PARTICULAR FONT, STYLE, SIZE, OR COLOR.

**CLASS 9—ELECTRICAL AND SCIENTIFIC APPARATUS**

FOR SYSTEMS FOR PUBLIC SAFETY CALL TAKING AND EMERGENCY DISPATCH COMPRISING TELEPHONES, COMPUTER HARDWARE AND ASSOCIATED SOFTWARE, ALL SOLD TOGETHER AS A UNIT (U.S. CLS. 21, 23, 26, 36 AND 38).

FIRST USE 3-7-2013; IN COMMERCE 3-7-2013.

**CLASS 38—COMMUNICATION**

FOR TELECOMMUNICATIONS SERVICES, NAMELY, EMERGENCY DISPATCH AND SECONDARY NOTIFICATION SERVICES IN THE NATURE OF TRANSMISSION OF AUDIO AND TEXT TO WIRELESS SYSTEMS, COMPUTERS, MOBILE PHONES AND RADIO PAGERS (U.S. CLS. 100, 101 AND 104).

FIRST USE 3-7-2013; IN COMMERCE 3-7-2013.

4,593,760. SARIANA LLC, SAN DIEGO, CA. SN 85-877,929. PUB. 4-1-2014, FILED 3-15-2013.

# IDESK

THE MARK CONSISTS OF STANDARD CHARACTERS WITHOUT CLAIM TO ANY PARTICULAR FONT, STYLE, SIZE, OR COLOR.

**CLASS 9—ELECTRICAL AND SCIENTIFIC APPARATUS**

FOR ELECTRONIC CARD READERS; ELECTRONIC MEMORY CARD READERS; FLASH CARD READERS; STANDS FOR HANDHELD DIGITAL ELECTRONIC DEVICES, NAMELY, MOBILE PHONES; USB HUBS (U.S. CLS. 21, 23, 26, 36 AND 38).

FIRST USE 12-27-2013; IN COMMERCE 12-27-2013.

**CLASS 16—PAPER GOODS AND PRINTED MATTER**

FOR DESKTOP BUSINESS CARD HOLDERS; DESKTOP ORGANIZERS; DOCUMENT HOLDERS; HOLDERS FOR DESK ACCESSORIES; LETTER OPENERS; NOTE PAD HOLDERS; PEN OR PENCIL HOLDERS (U.S. CLS. 2, 5, 22, 23, 29, 37, 38 AND 50).

FIRST USE 12-27-2013; IN COMMERCE 12-27-2013.



4,593,767. FIELDING, LAWRENCE A., AKA FIELDING, LARRY, PRINCE GEORGE, B.C., CANADA. SN 85-880,678. PUB. 8-6-2013, FILED 3-20-2013.

## THE X TAILS

THE MARK CONSISTS OF STANDARD CHARACTERS WITHOUT CLAIM TO ANY PARTICULAR FONT, STYLE, SIZE, OR COLOR.

### CLASS 9—ELECTRICAL AND SCIENTIFIC APPARATUS

FOR DOWNLOADABLE ELECTRONIC PUBLICATIONS IN THE NATURE OF BOOKS IN THE FIELD OF CHILDREN'S LITERATURE; DOWNLOADABLE SERIES OF FICTION BOOKS; ELECTRONIC PUBLICATIONS, NAMELY, BOOKS FEATURING CHILDREN'S LITERATURE RECORDED ON COMPUTER MEDIA; DOWNLOADABLE IMAGE FILES CONTAINING CHILDREN'S ILLUSTRATIONS (U.S. CLS. 21, 23, 26, 36 AND 38).

FIRST USE 4-1-2013; IN COMMERCE 10-10-2013.

### CLASS 16—PAPER GOODS AND PRINTED MATTER

FOR A SERIES OF BOOKS AND WRITTEN ARTICLES IN THE FIELD OF CHILDREN'S LITERATURE; CHILDREN'S BOOKS; PICTURE BOOKS (U.S. CLS. 2, 5, 22, 23, 29, 37, 38 AND 50).

FIRST USE 4-1-2013; IN COMMERCE 9-28-2013.

4,593,768. CUSTOM MOLDED PRODUCTS, INC., NEWNAN, GA. SN 85-880,809. PUB. 10-22-2013, FILED 3-20-2013.

## AQUAELEMENTS

THE MARK CONSISTS OF STANDARD CHARACTERS WITHOUT CLAIM TO ANY PARTICULAR FONT, STYLE, SIZE, OR COLOR.

### CLASS 1—CHEMICALS

FOR SWIMMING POOL WATER TESTING, TREATING, AND CLARIFYING CHEMICALS; REPAIR KITS AND VINYL REPAIR KITS COMPRISING GLUE FOR USE IN THE VINYL REPAIR INDUSTRY AND PATCHES FOR USE IN THE VINYL REPAIR INDUSTRY (U.S. CLS. 1, 5, 6, 10, 26 AND 46).

FIRST USE 7-31-2013; IN COMMERCE 7-31-2013.

### CLASS 6—METAL GOODS

FOR TOOLS, PARTS, AND ACCESSORIES FOR USE WITH SWIMMING POOLS AND SPAS, NAMELY, METAL TELESCOPING POLES; TOOLS, PARTS, AND ACCESSORIES FOR USE WITH SWIMMING POOLS AND SPAS, NAMELY, POOL TOOL ORGANIZERS AND POOL TOOL HANGERS MADE OF METAL FOR ORGANIZING AND HANGING HOSES AND TELESCOPING POLES (U.S. CLS. 2, 12, 13, 14, 23, 25 AND 50).

FIRST USE 7-31-2013; IN COMMERCE 7-31-2013.

### CLASS 9—ELECTRICAL AND SCIENTIFIC APPARATUS

FOR TOOLS, PARTS, AND ACCESSORIES FOR USE WITH SWIMMING POOLS AND SPAS, NAMELY, SAFETY ROPES HAVING FLOATS THEREON FOR SWIMMING POOLS; THERMOMETERS (U.S. CLS. 21, 23, 26, 36 AND 38).

FIRST USE 7-31-2013; IN COMMERCE 7-31-2013.

### CLASS 21—HOUSEWARES AND GLASS

FOR TOOLS, PARTS, AND ACCESSORIES FOR USE WITH SWIMMING POOLS AND SPAS, NAMELY, CLEANING BRUSHES AND DISPENSERS FOR USE IN DISPENSING CLEANING AND DISINFECTING SOLUTIONS, ALL FOR USE IN CONNECTION WITH SWIMMING POOLS AND SPAS (U.S. CLS. 2, 13, 23, 29, 30, 33, 40 AND 50).

FIRST USE 7-31-2013; IN COMMERCE 7-31-2013.

### CLASS 22—CORDAGE AND FIBERS

FOR TOOLS, PARTS, AND ACCESSORIES FOR USE WITH SWIMMING POOLS AND SPAS, NAMELY, DEEP LEAF NETS AND SKIMMING NETS (U.S. CLS. 1, 2, 7, 19, 22, 42 AND 50).

FIRST USE 7-31-2013; IN COMMERCE 7-31-2013.

4,593,773. IFW TRAINING, LLC, ANTHEM, AZ. SN 85-881,780. PUB. 10-15-2013, FILED 3-20-2013.

## ONE FIT WIDOW

THE MARK CONSISTS OF STANDARD CHARACTERS WITHOUT CLAIM TO ANY PARTICULAR FONT, STYLE, SIZE, OR COLOR.

NO CLAIM IS MADE TO THE EXCLUSIVE RIGHT TO USE "WIDOW", APART FROM THE MARK AS SHOWN.

### CLASS 25—CLOTHING

FOR ATHLETIC PANTS; ATHLETIC SHIRTS; ATHLETIC SHORTS; JACKETS; SWEATPANTS; SWEATSHIRTS (U.S. CLS. 22 AND 39).

FIRST USE 5-15-2013; IN COMMERCE 5-15-2013.

### CLASS 41—EDUCATION AND ENTERTAINMENT

FOR EDUCATION SERVICES, NAMELY, PROVIDING LIVE AND ON-LINE CLASSES, SEMINARS, CAMPS, WORKSHOPS, AND RETREATS IN THE FIELD OF PERSONAL FITNESS, CONDITIONING, EXERCISE IMPROVEMENT, GRIEVING, LOSS, AND BEREAVEMENT; LIFE COACHING SERVICES IN THE FIELD OF GRIEVING, LOSS, AND BEREAVEMENT; PERSONAL FITNESS TRAINING SERVICES AND CONSULTANCY; PROVIDING ASSISTANCE, PERSONAL TRAINING AND PHYSICAL FITNESS CONSULTATION TO INDIVIDUALS TO HELP THEM MAKE PHYSICAL FITNESS, STRENGTH, CONDITIONING, AND EXERCISE IMPROVEMENT IN THEIR DAILY LIVING (U.S. CLS. 100, 101 AND 107).

FIRST USE 1-22-2012; IN COMMERCE 1-22-2012.

4,593,781. GRAPEVINEONE LLC, CHICAGO, IL. SN 85-886,945. PUB. 3-11-2014, FILED 3-26-2013.

# TIXE

THE MARK CONSISTS OF STANDARD CHARACTERS WITHOUT CLAIM TO ANY PARTICULAR FONT, STYLE, SIZE, OR COLOR.

## CLASS 9—ELECTRICAL AND SCIENTIFIC APPARATUS

FOR COMPUTER APPLICATION SOFTWARE FOR MOBILE PHONES, NAMELY, SOFTWARE FOR LOCATION TRACKING OF USERS, DOCUMENTING USER EVENT HISTORY, AND/OR NOTIFICATION TO EMERGENCY CONTACTS FOR PURPOSES OF ENSURING USER SAFETY AND WELL BEING (U.S. CLS. 21, 23, 26, 36 AND 38).

FIRST USE 9-5-2011; IN COMMERCE 8-14-2013.

## CLASS 42—SCIENTIFIC AND COMPUTER SERVICES

FOR PROVIDING A WEBSITE FEATURING TECHNOLOGY THAT ALLOWS COMPUTER USERS TO PERFORM LOCATION TRACKING OF USERS, DOCUMENT USER EVENT HISTORY, AND/OR PROVIDE NOTIFICATION TO EMERGENCY CONTACTS FOR PURPOSES OF ENSURING USER SAFETY AND WELL BEING (U.S. CLS. 100 AND 101).

FIRST USE 9-5-2011; IN COMMERCE 8-14-2013.

---

4,593,794. JOCKEY INTERNATIONAL, INC., KENOSHA, WI. SN 85-896,563. PUB. 3-18-2014, FILED 4-5-2013.

## The Fit That Speaks Volumes

THE MARK CONSISTS OF STANDARD CHARACTERS WITHOUT CLAIM TO ANY PARTICULAR FONT, STYLE, SIZE, OR COLOR.

## CLASS 25—CLOTHING

FOR BRAS (U.S. CLS. 22 AND 39).  
FIRST USE 7-1-2013; IN COMMERCE 7-1-2013.

## CLASS 35—ADVERTISING AND BUSINESS

FOR ONLINE RETAIL STORE SERVICES, CATALOG ORDERING SERVICES, MAIL ORDER CATALOG SERVICES AND RETAIL STORE SERVICES ALL IN THE FIELD OF APPAREL (U.S. CLS. 100, 101 AND 102).

FIRST USE 7-1-2013; IN COMMERCE 7-1-2013.

## CLASS 45—PERSONAL AND LEGAL SERVICES

FOR FASHION CONSULTING SERVICES, NAMELY, APPAREL FITTING SERVICES (U.S. CLS. 100 AND 101).  
FIRST USE 7-1-2013; IN COMMERCE 7-1-2013.

4,593,797. QUAL CHEM, LLC, AKRON, OH. SN 85-898,634. PUB. 10-15-2013, FILED 4-9-2013.



OWNER OF U.S. REG. NOS. 4,291,295 AND 4,340,971.

THE MARK CONSISTS OF THE WORD "NANOSHEENOLOGY" WITH A TEARDROP SHAPE BETWEEN THE LETTERS "O" AND "S" ABOVE THREE LAYERS OF BUBBLES.

## CLASS 3—COSMETICS AND CLEANING PREPARATIONS

FOR CAR WASH CHEMICALS, NAMELY, AUTOMOBILE CLEANERS, AND POLYMER SEALANTS FOR CLEANING, SHINING AND PROTECTING AUTOMOBILE EXTERIOR SURFACES (U.S. CLS. 1, 4, 6, 50, 51 AND 52).

FIRST USE 3-0-2013; IN COMMERCE 3-0-2013.

## CLASS 7—MACHINERY

FOR MACHINERY FOR APPLYING CAR WASH CHEMICALS, NAMELY, POWER OPERATED SPRAYERS (U.S. CLS. 13, 19, 21, 23, 31, 34 AND 35).

FIRST USE 3-0-2013; IN COMMERCE 3-0-2013.

---

4,593,798. QUAL CHEM, LLC, AKRON, OH. SN 85-898,672. PUB. 10-15-2013, FILED 4-9-2013.

# NANOSHEENOLOGY

THE MARK CONSISTS OF STANDARD CHARACTERS WITHOUT CLAIM TO ANY PARTICULAR FONT, STYLE, SIZE, OR COLOR.

OWNER OF U.S. REG. NOS. 4,291,295 AND 4,340,971.

## CLASS 3—COSMETICS AND CLEANING PREPARATIONS

FOR CAR WASH CHEMICALS, NAMELY, AUTOMOBILE CLEANERS, AND POLYMER SEALANTS FOR CLEANING, SHINING AND PROTECTING AUTOMOBILE EXTERIOR SURFACES (U.S. CLS. 1, 4, 6, 50, 51 AND 52).

FIRST USE 3-0-2013; IN COMMERCE 3-0-2013.

## CLASS 7—MACHINERY

FOR MACHINERY FOR APPLYING CAR WASH CHEMICALS, NAMELY, POWER OPERATED SPRAYERS (U.S. CLS. 13, 19, 21, 23, 31, 34 AND 35).  
FIRST USE 3-0-2013; IN COMMERCE 3-0-2013.

4,593,802. INTELLIGENT MEDICAL OBJECTS, INC.,  
NORTHBROOK, IL. SN 85-900,239. PUB. 3-11-2014,  
FILED 4-10-2013.

## IMO ANYWHERE

THE MARK CONSISTS OF STANDARD CHARACTERS  
WITHOUT CLAIM TO ANY PARTICULAR FONT, STYLE,  
SIZE, OR COLOR.

OWNER OF U.S. REG. NOS. 2,453,920, 4,310,653, AND  
4,310,654.

### CLASS 9—ELECTRICAL AND SCIENTIFIC APPARATUS

FOR COMPUTER HARDWARE AND SOFTWARE FOR  
USE IN MAINTAINING ELECTRONIC MEDICAL RE-  
CORDS AND MANAGING MEDICAL TREATMENT FOR  
PATIENTS (U.S. CLS. 21, 23, 26, 36 AND 38).

FIRST USE 9-13-2013; IN COMMERCE 9-13-2013.

### CLASS 42—SCIENTIFIC AND COMPUTER SERVICES

FOR COMPUTER CONSULTING AND SOFTWARE  
DESIGN SERVICES IN THE FIELDS OF MEDICAL  
EDUCATION, MEDICAL TREATMENT AND MEDICAL  
RECORD MANAGEMENT (U.S. CLS. 100 AND 101).

FIRST USE 9-13-2013; IN COMMERCE 9-13-2013.

4,593,806. DOCUSIGN, INC., SEATTLE, WA. SN 85-903,910.  
PUB. 7-16-2013, FILED 4-15-2013.

## KEEP BUSINESS DIGITAL

THE MARK CONSISTS OF STANDARD CHARACTERS  
WITHOUT CLAIM TO ANY PARTICULAR FONT, STYLE,  
SIZE, OR COLOR.

### CLASS 38—COMMUNICATION

FOR DELIVERY OF MESSAGES BY ELECTRONIC  
TRANSMISSION; ON-LINE DOCUMENT DELIVERY  
VIA A GLOBAL COMPUTER NETWORK (U.S. CLS. 100,  
101 AND 104).

FIRST USE 5-0-2013; IN COMMERCE 5-0-2013.

### CLASS 42—SCIENTIFIC AND COMPUTER SERVICES

FOR PROVIDING A WEBSITE FEATURING NON-  
DOWNLOADABLE SOFTWARE FOR USE WITH ELEC-  
TRONIC DATA VERIFICATION AND SECURE DIGITAL  
TRANSACTIONS VIA GLOBAL INFORMATION NET-  
WORKS; PROVIDING A WEBSITE FEATURING TECH-  
NOLOGY THAT ENABLES USERS TO UPLOAD,  
ELECTRONICALLY AUTHENTICATE, STORE AND SE-  
CURELY DISTRIBUTE A DOCUMENT OR FILE VIA  
GLOBAL INFORMATION NETWORKS (U.S. CLS. 100  
AND 101).

FIRST USE 5-0-2013; IN COMMERCE 5-0-2013.

### CLASS 45—PERSONAL AND LEGAL SER- VICES

FOR PROVIDING USER AUTHENTICATION SER-  
VICES IN E-COMMERCE TRANSACTIONS (U.S. CLS.  
100 AND 101).

FIRST USE 5-0-2013; IN COMMERCE 5-0-2013.

4,593,828. INTELLIGENTSIA COFFEE INC., CHICAGO, IL.  
SN 85-914,365. PUB. 10-22-2013, FILED 4-25-2013.



OWNER OF U.S. REG. NO. 3,433,987.

THE MARK CONSISTS OF A SINGLE FIVE POINT STAR  
ABOVE A STYLIZED WING DESIGN WHICH HAS A CUP  
OF COFFEE IN THE MIDDLE OF IT.

### CLASS 21—HOUSEWARES AND GLASS

FOR MUGS, TRAVEL MUGS, TRAVEL TUMBLERS,  
AND ESPRESSO CUPS (U.S. CLS. 2, 13, 23, 29, 30, 33, 40  
AND 50).

FIRST USE 10-0-2006; IN COMMERCE 10-0-2006.

### CLASS 30—STAPLE FOODS

FOR COFFEE AND COFFEE BEANS; TEA (U.S. CL.  
46).

FIRST USE 10-0-2006; IN COMMERCE 10-0-2006.

### CLASS 40—MATERIAL TREATMENT

FOR COFFEE ROASTING AND PROCESSING (U.S.  
CLS. 100, 103 AND 106).

FIRST USE 10-0-2006; IN COMMERCE 10-0-2006.

### CLASS 43—HOTEL AND RESTAURANT SER- VICES

FOR CAFE SERVICES (U.S. CLS. 100 AND 101).

FIRST USE 10-0-2006; IN COMMERCE 10-0-2006.

4,593,841. MARC MERTENS, LOS ANGELES, CA. SN 85-  
918,702. PUB. 11-26-2013, FILED 4-30-2013.

## A Hundred Years

THE MARK CONSISTS OF STANDARD CHARACTERS  
WITHOUT CLAIM TO ANY PARTICULAR FONT, STYLE,  
SIZE, OR COLOR.

**CLASS 35—ADVERTISING AND BUSINESS**

FOR ADVERTISEMENT AND PUBLICITY SERVICES BY PROMOTING THE GOODS, SERVICES, BRAND IDENTITY, COMMERCIAL INFORMATION AND NEWS OF THIRD PARTIES THROUGH PRINT, AUDIO, VIDEO, DIGITAL AND ON-LINE MEDIA; ADVERTISING AGENCY SPECIALIZING IN THE DESIGN AND EXECUTION OF WORD OF MOUTH, VIRAL, BUZZ AND EXPERIENTIAL MARKETING PROGRAMS; ADVERTISING AND BUSINESS MANAGEMENT CONSULTANCY; ADVERTISING AND COMMERCIAL INFORMATION SERVICES, VIA THE INTERNET; ADVERTISING AND PROMOTION SERVICES AND RELATED CONSULTING; ADVERTISING AND PUBLICITY SERVICES, NAMELY, PROMOTING THE GOODS, SERVICES, BRAND IDENTITY AND COMMERCIAL INFORMATION AND NEWS OF THIRD PARTIES THROUGH PRINT, AUDIO, VIDEO, DIGITAL AND ON-LINE MEDIUM; ADVERTISING SERVICES; ADVERTISING SERVICES, NAMELY, CREATING CORPORATE AND BRAND IDENTITY FOR OTHERS; ADVERTISING SERVICES, NAMELY, PROMOTING THE BRANDS, GOODS AND SERVICES OF OTHERS; ADVERTISING, MARKETING AND PROMOTION SERVICES; ARRANGING AND CONDUCTING MARKETING PROMOTIONAL EVENTS FOR OTHERS; BRAND CONCEPT AND BRAND DEVELOPMENT SERVICES FOR CORPORATE AND INDIVIDUAL CLIENTS; BRAND CONCEPT AND BRAND DEVELOPMENT SERVICES FOR CORPORATE CLIENTS; BRANDING SERVICES, NAMELY, CONSULTING, DEVELOPMENT, MANAGEMENT AND MARKETING OF BRANDS FOR BUSINESSES AND/OR INDIVIDUALS; BUSINESS CONSULTING SERVICES, NAMELY, PROVIDING ASSISTANCE IN DEVELOPMENT OF BUSINESS STRATEGIES AND CREATIVE IDEATION; BUSINESS DEVELOPMENT SERVICES; BUSINESS MARKETING CONSULTING SERVICES; DESIGN OF INTERNET ADVERTISING; DEVELOPMENT OF MARKETING STRATEGIES AND CONCEPTS; DEVELOPMENT OF MARKETING STRATEGIES, CONCEPTS AND TACTICS, NAMELY, AUDIENCE DEVELOPMENT, BRAND AWARENESS, ONLINE COMMUNITY BUILDING AND DIGITAL WORD OF MOUTH COMMUNICATIONS; MARKETING AND BRANDING SERVICES, NAMELY, PROVIDING CUSTOMIZED COMMUNICATION PROGRAMS TO OBTAIN CONSUMER INSIGHTS AND DEVELOP BRANDING STRATEGIES; MARKETING CONSULTING; MARKETING CONSULTING SERVICES RELATING TO LONG-TERM BUSINESS STRATEGY DEVELOPMENT FOR NON-PROFIT ORGANIZATIONS; ON-LINE ADVERTISING ON COMPUTER COMMUNICATION NETWORKS; PROMOTING THE PARTIES AND SPECIAL EVENTS OF OTHERS; PROMOTING, ADVERTISING AND MARKETING OF THE BRANDS, PRODUCTS, SERVICES AND ONLINE WEBSITES OF INDIVIDUALS, BUSINESSES AND NONPROFIT ORGANIZATIONS; SOCIAL MEDIA STRATEGY AND MARKETING CONSULTANCY FOCUSING ON HELPING CLIENTS CREATE AND EXTEND THEIR PRODUCT AND BRAND STRATEGIES BY BUILDING VIRALLY ENGAGING MARKETING SOLUTIONS (U.S. CLS. 100, 101 AND 102).

FIRST USE 5-1-2013; IN COMMERCE 5-24-2013.

**CLASS 42—SCIENTIFIC AND COMPUTER SERVICES**

FOR BUILDING AND MAINTAINING WEBSITES; COMPUTER SERVICES, NAMELY, CREATING, MAINTAINING, DESIGNING AND IMPLEMENTING WEB SITES FOR OTHERS; COMPUTER SERVICES, NAMELY, DESIGNING AND IMPLEMENTING WEB SITES FOR OTHERS; COMPUTER SERVICES, NAMELY, DESIGNING AND IMPLEMENTING INTERACTIVE WEBSITES FOR OTHERS; COMPUTER SERVICES, NAMELY, HOSTING ON-LINE WEB FACILITIES FOR OTHERS FOR ORGANIZING AND CONDUCTING ONLINE MEETINGS, GATHERINGS, AND INTERACTIVE DISCUSSIONS; COMPUTER SERVICES, NAMELY, PROVIDING AN INTERACTIVE WEB SITE FEATURING TECHNOLOGY THAT ALLOWS USERS TO COLLECT, STORE, MANAGE, DELIVER AND SHOWCASE ELECTRONIC AND PAPER-BASED CONTENT; COMPUTER SERVICES, NAMELY, PROVIDING CUSTOMIZED WEB PAGES FEATURING USER-DEFINED INFORMATION; COMPUTER-AIDED DESIGN SERVICES; COMPUTER-AIDED ENGINEERING SERVICES FOR OTHERS; CON-

SULTING SERVICES IN CONNECTION WITH DESIGNING INTERACTIVE WEBSITES FOR USE BY OTHERS FOR THE PURPOSE OF DEVELOPING BRAND IDENTITY AND BRAND MARKETING STRATEGIES; CONSULTING SERVICES IN THE DESIGN AND IMPLEMENTATION OF COMPUTER-BASED INFORMATION SYSTEMS FOR BUSINESSES; DESIGN OF HOMEPAGES AND WEBSITES; DESIGN, CREATION, HOSTING, MAINTENANCE OF WEBSITES FOR OTHERS; DESIGNING WEBSITES FOR OTHERS; INNOVATION CONSULTING SERVICES, NAMELY, ADVISING OTHERS IN THE AREAS OF PRODUCT DEVELOPMENT; PROVIDING COMPUTER PROGRAMMING SERVICES TO CUSTOMERS THAT ENABLES THEM TO PROVIDE VIDEO AND AUDIO CONTENT ON THEIR WEB SITES (U.S. CLS. 100 AND 101).

FIRST USE 5-1-2013; IN COMMERCE 5-24-2013.

4,593,842. MARC MERTENS, LOS ANGELES, CA. SN 85-918,733. PUB. 11-26-2013, FILED 4-30-2013.

# 100YRS

THE MARK CONSISTS OF STANDARD CHARACTERS WITHOUT CLAIM TO ANY PARTICULAR FONT, STYLE, SIZE, OR COLOR.

**CLASS 35—ADVERTISING AND BUSINESS**

FOR ADVERTISEMENT AND PUBLICITY SERVICES BY PROMOTING THE GOODS, SERVICES, BRAND IDENTITY, COMMERCIAL INFORMATION AND NEWS OF THIRD PARTIES THROUGH PRINT, AUDIO, VIDEO, DIGITAL AND ON-LINE MEDIA; ADVERTISING AGENCY SPECIALIZING IN THE DESIGN AND EXECUTION OF WORD OF MOUTH, VIRAL, BUZZ AND EXPERIENTIAL MARKETING PROGRAMS; ADVERTISING AND BUSINESS MANAGEMENT CONSULTANCY; ADVERTISING AND COMMERCIAL INFORMATION SERVICES, VIA THE INTERNET; ADVERTISING AND PROMOTION SERVICES AND RELATED CONSULTING; ADVERTISING AND PUBLICITY SERVICES, NAMELY, PROMOTING THE GOODS, SERVICES, BRAND IDENTITY AND COMMERCIAL INFORMATION AND NEWS OF THIRD PARTIES THROUGH PRINT, AUDIO, VIDEO, DIGITAL AND ON-LINE MEDIUM; ADVERTISING SERVICES; ADVERTISING SERVICES, NAMELY, CREATING CORPORATE AND BRAND IDENTITY FOR OTHERS; ADVERTISING SERVICES, NAMELY, PROMOTING THE BRANDS, GOODS AND SERVICES OF OTHERS; ADVERTISING, MARKETING AND PROMOTION SERVICES; ARRANGING AND CONDUCTING MARKETING PROMOTIONAL EVENTS FOR OTHERS; BRAND CONCEPT AND BRAND DEVELOPMENT SERVICES FOR CORPORATE AND INDIVIDUAL CLIENTS; BRAND CONCEPT AND BRAND DEVELOPMENT SERVICES FOR CORPORATE CLIENTS; BRANDING SERVICES, NAMELY, CONSULTING, DEVELOPMENT, MANAGEMENT AND MARKETING OF BRANDS FOR BUSINESSES AND/OR INDIVIDUALS; BUSINESS CONSULTING SERVICES, NAMELY, PROVIDING ASSISTANCE IN DEVELOPMENT OF BUSINESS STRATEGIES AND CREATIVE IDEATION; BUSINESS DEVELOPMENT SERVICES; BUSINESS MARKETING CONSULTING SERVICES; DESIGN OF INTERNET ADVERTISING; DEVELOPMENT OF MARKETING STRATEGIES AND CONCEPTS; DEVELOPMENT OF MARKETING STRATEGIES, CONCEPTS AND TACTICS, NAMELY, AUDIENCE DEVELOPMENT, BRAND AWARENESS, ONLINE COMMUNITY BUILDING AND DIGITAL WORD OF MOUTH COMMUNICATIONS; MARKETING AND BRANDING SERVICES, NAMELY, PROVIDING CUSTOMIZED COMMUNICATION PROGRAMS TO OBTAIN CONSUMER INSIGHTS AND DEVELOP BRANDING STRATEGIES; MARKETING CONSULTING; MARKETING CONSULTING SERVICES

RELATING TO LONG-TERM BUSINESS STRATEGY DEVELOPMENT FOR NON-PROFIT ORGANIZATIONS; ON-LINE ADVERTISING ON COMPUTER COMMUNICATION NETWORKS; PROMOTING THE PARTIES AND SPECIAL EVENTS OF OTHERS; PROMOTING, ADVERTISING AND MARKETING OF THE BRANDS, PRODUCTS, SERVICES AND ONLINE WEBSITES OF INDIVIDUALS, BUSINESSES AND NONPROFIT ORGANIZATIONS; SOCIAL MEDIA STRATEGY AND MARKETING CONSULTANCY FOCUSING ON HELPING CLIENTS CREATE AND EXTEND THEIR PRODUCT AND BRAND STRATEGIES BY BUILDING VIRALLY ENGAGING MARKETING SOLUTIONS (U.S. CLS. 100, 101 AND 102).

FIRST USE 5-1-2013; IN COMMERCE 5-24-2013.

#### **CLASS 42—SCIENTIFIC AND COMPUTER SERVICES**

FOR BUILDING AND MAINTAINING WEBSITES; COMPUTER SERVICES, NAMELY, CREATING, MAINTAINING, DESIGNING AND IMPLEMENTING WEB SITES FOR OTHERS; COMPUTER SERVICES, NAMELY, DESIGNING AND IMPLEMENTING WEB SITES FOR OTHERS; COMPUTER SERVICES, NAMELY, DESIGNING AND IMPLEMENTING INTERACTIVE WEBSITES FOR OTHERS; COMPUTER SERVICES, NAMELY, HOSTING ON-LINE WEB FACILITIES FOR OTHERS FOR ORGANIZING AND CONDUCTING ONLINE MEETINGS, GATHERINGS, AND INTERACTIVE DISCUSSIONS; COMPUTER SERVICES, NAMELY, PROVIDING AN INTERACTIVE WEB SITE FEATURING TECHNOLOGY THAT ALLOWS USERS TO COLLECT, STORE, MANAGE, DELIVER AND SHOWCASE ELECTRONIC AND PAPER-BASED CONTENT; COMPUTER SERVICES, NAMELY, PROVIDING CUSTOMIZED WEB PAGES FEATURING USER-DEFINED INFORMATION; COMPUTER-AIDED DESIGN SERVICES; COMPUTER-AIDED ENGINEERING SERVICES FOR OTHERS; CONSULTING SERVICES IN CONNECTION WITH DESIGNING INTERACTIVE WEBSITES FOR USE BY OTHERS FOR THE PURPOSE OF DEVELOPING BRAND IDENTITY AND BRAND MARKETING STRATEGIES; CONSULTING SERVICES IN THE DESIGN AND IMPLEMENTATION OF COMPUTER-BASED INFORMATION SYSTEMS FOR BUSINESSES; DESIGN OF HOMEPAGES AND WEBSITES; DESIGN, CREATION, HOSTING, MAINTENANCE OF WEBSITES FOR OTHERS; DESIGNING WEBSITES FOR OTHERS; INNOVATION CONSULTING SERVICES, NAMELY, ADVISING OTHERS IN THE AREAS OF PRODUCT DEVELOPMENT; PROVIDING COMPUTER PROGRAMMING SERVICES TO CUSTOMERS THAT ENABLES THEM TO PROVIDE VIDEO AND AUDIO CONTENT ON THEIR WEB SITES (U.S. CLS. 100 AND 101).

FIRST USE 5-1-2013; IN COMMERCE 5-24-2013.

4,593,848. 0960980 B.C. LTD., DAWSON CREEK, BC, CANADA. SN 85-919,703. PUB. 11-19-2013, FILED 5-1-2013.

### **WILD FOREVER ALLIANCE**

THE MARK CONSISTS OF STANDARD CHARACTERS WITHOUT CLAIM TO ANY PARTICULAR FONT, STYLE, SIZE, OR COLOR.

NO CLAIM IS MADE TO THE EXCLUSIVE RIGHT TO USE "ALLIANCE", APART FROM THE MARK AS SHOWN.

#### **CLASS 35—ADVERTISING AND BUSINESS**

FOR PROVIDING A WEBSITE FEATURING A DISCOUNT PROGRAM TO ENABLE MEMBERS TO OBTAIN ACCESS TO DISCOUNTS AND REWARDS ALL RELATED TO HUNTING TOURS (U.S. CLS. 100, 101 AND 102).

FIRST USE 7-20-2013; IN COMMERCE 7-20-2013.

#### **CLASS 41—EDUCATION AND ENTERTAINMENT**

FOR GUIDED HUNTING TOURS; HUNTING GUIDE SERVICES; PROVIDING OUTDOOR RECREATIONAL FACILITIES AND CONDUCTING INSTRUCTIONAL SEMINARS FOR HUNTING, CAMPING AND SHOOTING; RECREATIONAL SERVICES IN THE NATURE OF OUTDOOR CAMPING GUIDE SERVICES AND WILD ANIMAL WATCHING GUIDE SERVICES; PROVIDING A WEBSITE FEATURING INFORMATION ABOUT HUNTING; PROVIDING A WEBSITE FEATURING INFORMATION ABOUT GUIDED HUNTING TOURS (U.S. CLS. 100, 101 AND 107).

FIRST USE 7-20-2013; IN COMMERCE 7-20-2013.

4,593,849. SOF LEI' LI, LLC, ATLANTA, GA. SN 85-919,776. PUB. 10-1-2013, FILED 5-1-2013.

## **SOF LEI' LI**

THE MARK CONSISTS OF STANDARD CHARACTERS WITHOUT CLAIM TO ANY PARTICULAR FONT, STYLE, SIZE, OR COLOR.

THE ENGLISH TRANSLATION OF "SOF LEI' LI" IN THE MARK IS "END OF MY NIGHT".

#### **CLASS 41—EDUCATION AND ENTERTAINMENT**

FOR ENTERTAINMENT SERVICES, NAMELY, A MUSIC LOUNGE FEATURING LIVE PERFORMANCES BY SINGERS AND MUSICIANS, DJS, NON-DOWNLOADABLE PRERECORDED MUSIC ENTERTAINMENT, AND AUDIO AND VISUAL MUSICAL PERFORMANCES, NAMELY, THE SHOWING OF PRERECORDED MUSICAL PERFORMANCES (U.S. CLS. 100, 101 AND 107).

FIRST USE 10-0-2013; IN COMMERCE 10-0-2013.

#### **CLASS 43—HOTEL AND RESTAURANT SERVICES**

FOR COCKTAIL LOUNGE SERVICES FEATURING FOOD, DRINK, AND MUSIC (U.S. CLS. 100 AND 101).

FIRST USE 10-0-2013; IN COMMERCE 10-0-2013.

4,593,850. THE CENTER FOR COGNITIVE SPORTS PERFORMANCE, INC., PORTLAND, ME. SN 85-920,071. PUB. 10-1-2013, FILED 5-1-2013.

## **COGSPORTS**

THE MARK CONSISTS OF STANDARD CHARACTERS

WITHOUT CLAIM TO ANY PARTICULAR FONT, STYLE, SIZE, OR COLOR.

4,593,853. SWIRLIFY, LLC, SAN LUIS OBISPO, CA. SN 85-920,665. PUB. 10-15-2013, FILED 5-1-2013.

# SWIRLIFY

## CLASS 35—ADVERTISING AND BUSINESS

FOR CONSULTING SERVICES IN BUSINESS LEADERSHIP DEVELOPMENT AND BUSINESS MANAGEMENT; CONSULTING SERVICES IN THE AREA OF SUSTAINABLE BUSINESS SOLUTIONS; CONSULTING SERVICES IN THE FIELD OF HIGHER EDUCATION ADMINISTRATION; CONSULTING SERVICES IN THE FIELD OF HUMAN RESOURCES DEVELOPMENT, NAMELY, FOR THE PROMOTION OF EMPLOYEE RETENTION, CAREER GROWTH, AND INCREASED PRODUCTIVITY FOR EMPLOYEES AND EMPLOYERS; CONSULTING SERVICES IN THE FIELD OF HUMAN RESOURCES DEVELOPMENT, NAMELY, UTILIZING TECHNOLOGY FOR THE PROMOTION OF EMPLOYEE RETENTION, CAREER GROWTH AND INCREASED PRODUCTIVITY FOR EMPLOYEES AND EMPLOYERS; HUMAN CAPITAL MANAGEMENT OUTSOURCING SERVICES; HUMAN RESOURCE ANALYSIS AND CONSULTING SERVICES; PERSONNEL SELECTION USING PSYCHOLOGICAL TESTING; PROMOTING THE INTERESTS OF PEOPLE INVOLVED AND CONCERNED WITH YOUTH SPORTS; PSYCHOLOGICAL TESTING FOR THE SELECTION OF PERSONNEL (U.S. CLS. 100, 101 AND 102).

FIRST USE 5-7-2013; IN COMMERCE 8-14-2013.

## CLASS 41—EDUCATION AND ENTERTAINMENT

FOR AMATEUR YOUTH SPORTS SERVICES, NAMELY, ORGANIZING AND PROVIDING YOUTH SPORTS ACTIVITIES; BUSINESS TRAINING; BUSINESS TRAINING CONSULTANCY SERVICES; BUSINESS TRAINING IN THE FIELD OF LEADERSHIP DEVELOPMENT, EXECUTIVE COACHING, PSYCHOLOGICAL PROFILING, TEAM BUILDING, AND EMOTIONAL INTELLIGENCE; COACHING IN THE FIELD OF SPORTS; EDUCATION SERVICES, NAMELY, PROVIDING ONLINE COGNITIVE ASSESSMENTS AND TRAINING PROGRAMS THAT HELP IDENTIFY COGNITIVE STRENGTHS AND WEAKNESSES OF AN INDIVIDUAL; EDUCATIONAL SERVICES, NAMELY, CONDUCTING CLASSES, SEMINARS, CONFERENCES, WORKSHOPS, FIELD TRIPS, ON-LINE CLASSES, AND ON-LINE INTERACTIVE WORKSHOPS IN THE FIELD OF SPORTS EDUCATION, COACHING, TEAM BUILDING, AND EMOTIONAL INTELLIGENCE AND DISTRIBUTION OF TRAINING MATERIAL IN CONNECTION THEREWITH; EDUCATIONAL SERVICES, NAMELY, PROVIDING A LEARNING AND INNOVATION CENTER FEATURING FULLY CUSTOMIZED LEADERSHIP, MOTIVATIONAL, EDUCATIONAL, AND BRAINSTORMING TRAINING; ENCOURAGING AMATEUR SPORTS AND PHYSICAL EDUCATION BY ORGANIZING, SANCTIONING, CONDUCTING, REGULATING AND GOVERNING AMATEUR ATHLETIC PROGRAMS AND ACTIVITIES; ENTERTAINMENT AND EDUCATIONAL SERVICES IN THE NATURE OF COMPETITIONS IN THE FIELD OF ENTERTAINMENT, EDUCATION, CULTURE, SPORTS, AND OTHER NON-BUSINESS AND NON-COMMERCIAL FIELDS; PROVIDING A WEB SITE FEATURING INFORMATION ON YOUTH SPORTS; PROVIDING INFORMATION RELATING TO SPORTS AND SPORTING EVENTS; SPORTS INSTRUCTION SERVICES; SPORTS TRAINING SERVICES (U.S. CLS. 100, 101 AND 107).

FIRST USE 5-7-2013; IN COMMERCE 8-14-2013.

THE MARK CONSISTS OF STANDARD CHARACTERS WITHOUT CLAIM TO ANY PARTICULAR FONT, STYLE, SIZE, OR COLOR.

## CLASS 35—ADVERTISING AND BUSINESS

FOR ADVERTISING SERVICES, NAMELY, PROMOTING THE WINE OF OTHERS; MATCHING INDIVIDUALS WITH WINE PREFERENCES THROUGH PROFILING SURVEYS AND ANALYSIS; PROVIDING A WEBSITE AND WEB-BASED APPLICATION FEATURING THE RATINGS, REVIEWS AND RECOMMENDATIONS POSTED BY CONSUMERS ON WINE FOR COMMERCIAL PURPOSES (U.S. CLS. 100, 101 AND 102).

FIRST USE 4-4-2013; IN COMMERCE 4-1-2014.

## CLASS 42—SCIENTIFIC AND COMPUTER SERVICES

FOR PROVIDING TEMPORARY USE OF A WEB-BASED SOFTWARE APPLICATION FOR POSTING RATINGS, REVIEWS AND RECOMMENDATIONS ON WINES BY CONSUMERS (U.S. CLS. 100 AND 101).

FIRST USE 4-4-2013; IN COMMERCE 4-1-2014.

## CLASS 43—HOTEL AND RESTAURANT SERVICES

FOR PROVIDING INFORMATION ABOUT WINE CHARACTERISTICS; PROVIDING A WEBSITE FEATURING THE RATINGS, REVIEWS AND RECOMMENDATIONS ON WINES FOR WINE APPRECIATION PURPOSES POSTED BY CONSUMERS (U.S. CLS. 100 AND 101).

FIRST USE 4-4-2013; IN COMMERCE 4-1-2014.

---

4,593,866. DESTINY HEALTH, INC., CHICAGO, IL. SN 85-923,913. PUB. 10-15-2013, FILED 5-6-2013.

# VITALITY INSTITUTE

THE MARK CONSISTS OF STANDARD CHARACTERS WITHOUT CLAIM TO ANY PARTICULAR FONT, STYLE, SIZE, OR COLOR.

NO CLAIM IS MADE TO THE EXCLUSIVE RIGHT TO USE "INSTITUTE", APART FROM THE MARK AS SHOWN.

## CLASS 16—PAPER GOODS AND PRINTED MATTER

FOR PRINTED MATERIALS, NAMELY, RESEARCH REPORTS, CONFERENCE REPORTS, SURVEYS, BOOKS, JOURNALS AND POLICY BRIEFS FEATURING ISSUES RELATING TO HEALTH PROMOTION AND GROUP OR INDIVIDUAL HEALTH AND WELLNESS PROGRAMS (U.S. CLS. 2, 5, 22, 23, 29, 37, 38 AND 50).

FIRST USE 12-31-2013; IN COMMERCE 12-31-2013.

**CLASS 35—ADVERTISING AND BUSINESS**

FOR PROMOTING PUBLIC AWARENESS OF HEALTH AND WELLNESS ISSUES THAT AFFECT HEALTH PROMOTION AND GROUP OR INDIVIDUAL HEALTH AND WELLNESS PROGRAMS (U.S. CLS. 100, 101 AND 102).

FIRST USE 12-31-2013; IN COMMERCE 12-31-2013.

**CLASS 41—EDUCATION AND ENTERTAINMENT**

FOR EDUCATIONAL SERVICES, NAMELY, ORGANIZING AND CONDUCTING WORKSHOPS, CONFERENCES AND SYMPOSIA RELATING TO HEALTH PROMOTION AND GROUP OR INDIVIDUAL HEALTH AND WELLNESS ISSUES (U.S. CLS. 100, 101 AND 107).

FIRST USE 12-31-2013; IN COMMERCE 12-31-2013.

4,593,872. SOAR NO MORE, LLC, NAMPA, ID. SN 85-924,713. PUB. 2-11-2014, FILED 5-6-2013.

SOAR NO MORE

THE MARK CONSISTS OF STANDARD CHARACTERS WITHOUT CLAIM TO ANY PARTICULAR FONT, STYLE, SIZE, OR COLOR.

**CLASS 25—CLOTHING**

FOR HATS; SHIRTS (U.S. CLS. 22 AND 39).  
FIRST USE 5-31-2009; IN COMMERCE 5-31-2009.

**CLASS 28—TOYS AND SPORTING GOODS**

FOR GAME STRAPS USED IN BIRD HUNTING; HUNTING DECOY BAGS; HUNTING GAME CALLS; WILD GAME HUNTING DECOYS (U.S. CLS. 22, 23, 38 AND 50).

FIRST USE 10-31-2013; IN COMMERCE 10-31-2013.

4,593,873. PHILADELPHIA PARKING AUTHORITY, PHILADELPHIA, PA. SN 85-924,934. PUB. 11-5-2013, FILED 5-7-2013.



OWNER OF U.S. REG. NO. 3,792,167.

NO CLAIM IS MADE TO THE EXCLUSIVE RIGHT TO USE "PARKING AUTHORITY", APART FROM THE MARK AS SHOWN.

THE COLOR(S) BLUE, RED AND GREY IS/ARE CLAIMED AS A FEATURE OF THE MARK.

THE MARK CONSISTS OF A BLUE LETTER "P", A RED LETTER "A" AND A BLUE LETTER "A" SET AGAINST A GREY CITY SKYLINE WITH EACH LETTER PARTIALLY OVERLAPPING EACH OTHER, "PHILADELPHIA" IN BLUE

POSITIONED UNDER THE SECOND "P" AND "A", AND "PARKING AUTHORITY" IN BLUE POSITIONED UNDER "PHILADELPHIA". THE WHITE RECTANGLE REPRESENTS BACKGROUND AND IS NOT PART OF THE MARK.

SEC. 2(F) AS TO "PHILADELPHIA PARKING AUTHORITY".

**CLASS 35—ADVERTISING AND BUSINESS**

FOR VEHICLE AUCTION SERVICES (U.S. CLS. 100, 101 AND 102).

FIRST USE 3-5-2013; IN COMMERCE 3-5-2013.

**CLASS 39—TRANSPORTATION AND STORAGE**

FOR PARKING LOT SERVICES; VEHICLE AND LOAD TOWING SERVICES (U.S. CLS. 100 AND 105).

FIRST USE 3-5-2013; IN COMMERCE 3-5-2013.

**CLASS 45—PERSONAL AND LEGAL SERVICES**

FOR POLICE AND CIVIL PROTECTION SERVICES, NAMELY, PARKING SERVICES IN THE NATURE OF MANAGEMENT AND OVERSIGHT OF PARKING METERS AND MUNICIPAL PARKING SPACES, ON-STREET PARKING REGULATION AND ENFORCEMENT SERVICES, TRAFFIC ENFORCEMENT SERVICES, AUTOMOBILE IMPOUNDING SERVICES, TAXI AND LIMOUSINE REGULATION AND ENFORCEMENT SERVICES; REVIEWING STANDARDS AND PRACTICES TO ASSURE COMPLIANCE WITH PARKING LAWS AND REGULATIONS AND TAXI AND LIMOUSINE LAWS AND REGULATIONS (U.S. CLS. 100 AND 101).

FIRST USE 3-5-2013; IN COMMERCE 3-5-2013.

4,593,877. MINDJET, LLC, SAN FRANCISCO, CA. SN 85-925,760. PUB. 10-8-2013, FILED 5-7-2013.

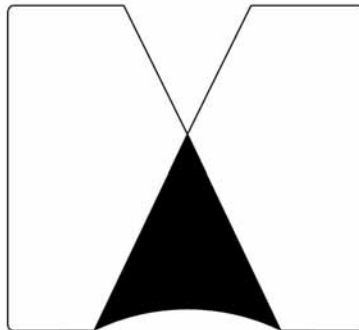

THE MARK CONSISTS OF A STYLIZED REPRESENTATION OF THE LETTER M.

**CLASS 9—ELECTRICAL AND SCIENTIFIC APPARATUS**

FOR COMPUTER SOFTWARE FOR USE IN SOCIAL TASK MANAGEMENT AND COLLABORATIVE WORK MANAGEMENT, NAMELY, PROJECT AND TASK PLANNING, PROJECT AND TASK BRAINSTORMING, PROJECT ORGANIZATION, PROJECT AND TASK MANAGEMENT, TASK ASSIGNMENT, TRACKING PROGRESS OF PROJECTS AND TASKS AND GROUP COLLABORATION; COMPUTER SOFTWARE FOR USE IN RECORDING, VISUALIZING, STRUCTURING, CLASSIFYING AND ORGANIZING INFORMATION AND MIND MAPPING (U.S. CLS. 21, 23, 26, 36 AND 38).

FIRST USE 9-0-2012; IN COMMERCE 10-0-2012.

**CLASS 42—SCIENTIFIC AND COMPUTER SERVICES**

FOR PROVIDING TEMPORARY USE OF NON-DOWNLOADABLE COMPUTER SOFTWARE FOR USE IN SOCIAL TASK MANAGEMENT AND COLLABORATIVE WORK MANAGEMENT, NAMELY, PROJECT AND TASK PLANNING, PROJECT AND TASK BRAINSTORMING, PROJECT ORGANIZATION, PROJECT AND TASK MANAGEMENT, TASK ASSIGNMENT, TRACKING PROGRESS OF PROJECTS AND TASKS AND GROUP COLLABORATION VIA WIRELESS, ELECTRONIC AND OPTICAL COMMUNICATIONS NETWORKS; PROVIDING TEMPORARY USE OF NON-DOWNLOADABLE COMPUTER SOFTWARE FOR USE IN RECORDING, VISUALIZING, STRUCTURING, CLASSIFYING AND ORGANIZING INFORMATION AND MIND MAPPING VIA WIRELESS, ELECTRONIC AND OPTICAL COMMUNICATIONS NETWORKS (U.S. CLS. 100 AND 101).

FIRST USE 9-0-2012; IN COMMERCE 9-0-2012.

**CLASS 35—ADVERTISING AND BUSINESS**

FOR ADVICE IN THE RUNNING OF ESTABLISHMENTS AS FRANCHISES; FRANCHISING, NAMELY, CONSULTATION AND ASSISTANCE IN BUSINESS MANAGEMENT, ORGANIZATION AND PROMOTION; FRANCHISING, NAMELY, OFFERING BUSINESS MANAGEMENT ASSISTANCE IN THE ESTABLISHMENT AND/OR OPERATION OF REAL ESTATE APPRAISAL SERVICES (U.S. CLS. 100, 101 AND 102).

FIRST USE 3-1-2013; IN COMMERCE 3-1-2013.

**CLASS 36—INSURANCE AND FINANCIAL**

FOR FRANCHISING SERVICES, NAMELY, PROVIDING FINANCIAL INFORMATION AND ADVICE REGARDING THE ESTABLISHMENT AND/OR OPERATION OF REAL ESTATE APPRAISAL SERVICES; REAL ESTATE APPRAISAL AND VALUATION (U.S. CLS. 100, 101 AND 102).

FIRST USE 3-1-2013; IN COMMERCE 3-1-2013.

---

4,593,878. VITAL JUICE CO, INC., SEATTLE, WA. SN 85-925,772. PUB. 10-1-2013, FILED 5-7-2013.

**VITAL FACTS**

THE MARK CONSISTS OF STANDARD CHARACTERS WITHOUT CLAIM TO ANY PARTICULAR FONT, STYLE, SIZE, OR COLOR.

**CLASS 29—MEATS AND PROCESSED FOODS**

FOR VEGETABLE AND FRUIT BASED FOOD BEVERAGES (U.S. CL. 46).

FIRST USE 2-0-2013; IN COMMERCE 7-0-2013.

**CLASS 32—LIGHT BEVERAGES**

FOR FRUIT AND VEGETABLE JUICES (U.S. CLS. 45, 46 AND 48).

FIRST USE 2-0-2013; IN COMMERCE 7-0-2013.

---

4,593,883. ACCURITY VALCO, LLC, SCOTTSDALE, AZ. SN 85-927,477. PUB. 10-8-2013, FILED 5-9-2013.

**ACCURITY**

THE MARK CONSISTS OF STANDARD CHARACTERS WITHOUT CLAIM TO ANY PARTICULAR FONT, STYLE, SIZE, OR COLOR.

---

4,593,887. SHANGHAI JINKA FLOORING TECHNOLOGY CO., LTD., SHANGHAI 201806, CHINA. SN 85-929,363. PUB. 11-19-2013, FILED 5-11-2013.

**POSTILE**

THE MARK CONSISTS OF STANDARD CHARACTERS WITHOUT CLAIM TO ANY PARTICULAR FONT, STYLE, SIZE, OR COLOR.

THE WORDING "POSTILE" HAS NO MEANING IN A FOREIGN LANGUAGE.

**CLASS 19—NON-METALLIC BUILDING MATERIALS**

FOR ATHLETIC FLOORING; BOARD MATERIAL MADE OF POLYETHYLENE USED AS A WOOD SUBSTITUTE; BUILDING MATERIALS, NAMELY, COMPOSITE PANELS COMPOSED PRIMARILY OF NONMETAL MATERIALS; CONSTRUCTION MATERIALS, NAMELY, NON-METAL FLOORING MATERIALS; FABRIC FOR UNDERLAYMENT OF FLOORING; FLOORBOARDS; FLOORING COMPRISED OF RUBBER OR PVC ADAPTED FOR PHYSICAL FITNESS ACTIVITIES; MODULAR PLASTIC DECKING TO SERVE AS A GROUND COVER; MULTILAYER PANELS OF PLASTIC FOR USE IN BUILDING; NON-METAL BUILDING MATERIALS, NAMELY, RUBBER, PLASTIC AND TEXTILE TILES, VENEER AND PANELS USED ON FLOOR, WALL AND OTHER SURFACE; NON-METAL CONSTRUCTION MATERIALS, NAMELY, RUBBER, PLASTIC AND TEXTILES PANELS USED ON FLOOR, WALL AND OTHER SURFACE; NON-METAL FLOOR PANELS; NON-METAL FLOOR TILES; NON-METAL FLOORS; NON-METAL TILES; NON-METAL TILES FOR WALLS, FLOORS OR CEILINGS; PLASTIC FLOORBOARDS; PLASTIC TILES; PVC ROOFING MEMBRANE; RUBBER AND SYNTHETIC NON-METAL TILES FOR USE ON INDOOR AND OUTDOOR FLOORS; RUBBER FLOOR TILES; RUBBER FLOORING; SYNTHETIC FLOORING MATERIALS OR WALL-CLADDINGS; VINYL FLOORING; VINYL TILES (U.S. CLS. 1, 12, 33 AND 50).

FIRST USE 2-10-2010; IN COMMERCE 5-18-2010.



**CLASS 27—FLOOR COVERINGS**

FOR ADHESIVE COATED CONTAMINATION CONTROL FLOOR MAT MADE OF POLYPROPYLENE THAT CAPTURES PARTICULATES; ANTI-SLIP FLOOR MATS MADE PRIMARILY OF RUBBER, PLASTIC OR TEXTILES; ANTI-STATIC FLOOR MATS MADE PRIMARILY OF RUBBER, PLASTIC OR TEXTILES; CARPET TILES FOR COVERING FLOORS; CORK FOR USE AS A FLOOR OR WALL COVERING; COVERINGS FOR EXISTING FLOORS; DECORATIVE SLIP-RESISTANT FLOOR COVERING IN SHEET FORM; FLOOR COVERINGS MADE OF RUBBER, PLASTIC OR TEXTILES; FLOOR COVERINGS OF RUBBER AND SYNTHETIC RUBBER; FLOOR COVERINGS, NAMELY, FLOOR RUNNERS; FLOOR MATS USED IN INDUSTRIAL APPLICATIONS MADE PRIMARILY OF RUBBER, PLASTIC OR TEXTILES; GYMNASIUM FLOOR COVERINGS; HARD SURFACE COVERINGS FOR FLOORS; PROTECTIVE FLOOR COVERINGS; RESILIENT HARD SURFACE COVERING FOR FLOORS, WALLS AND OTHER SURFACES; SHEETS OF PLASTIC FOR COVERING WALLS; VINYL FLOOR COVERINGS; VINYL FLOOR MATS FOR INDOOR OR OUTDOOR USE (U.S. CLS. 19, 20, 37, 42 AND 50).

FIRST USE 2-10-2010; IN COMMERCE 5-18-2010.

4,593,908. THE BRADBURY COMPANY, INC., MOUND-DRIDGE, KS. SN 85-933,250. PUB. 11-5-2013, FILED 5-15-2013.

# BOW SCOUT

THE MARK CONSISTS OF STANDARD CHARACTERS WITHOUT CLAIM TO ANY PARTICULAR FONT, STYLE, SIZE, OR COLOR.

**CLASS 7—MACHINERY**

FOR METAL PROCESSING MACHINES; METAL FORMING MACHINES; METAL FLATTENING MACHINES; MACHINES FOR FORMING SHEET METAL; LEVELING MACHINES USED TO FLATTEN METAL; LEVELING MACHINES USED TO FLATTEN METAL FOR USE IN STEEL PROCESSING LINES (U.S. CLS. 13, 19, 21, 23, 31, 34 AND 35).

FIRST USE 3-21-2013; IN COMMERCE 3-21-2013.

**CLASS 9—ELECTRICAL AND SCIENTIFIC APPARATUS**

FOR ELECTRICAL AND COMPUTER HARDWARE AND SOFTWARE FOR USE IN CONTROLLING METAL FORMING AND MEASURING MACHINERY AND SYSTEMS; PROGRAMMABLE ELECTRICAL CONTROLLER FOR METAL FORMING AND METAL FLATTENING MACHINERY; AND PROGRAMMABLE ELECTRICAL CONTROLLER FOR LEVELERS (U.S. CLS. 21, 23, 26, 36 AND 38).

FIRST USE 3-21-2013; IN COMMERCE 3-21-2013.

4,593,912. GRATITUDE INTERACTIVE LLC, DBA GRATITUDE INTERACTIVE, SEATTLE, WA. SN 85-935,116. PUB. 11-5-2013, FILED 5-17-2013.

# love to thank

THE MARK CONSISTS OF STANDARD CHARACTERS WITHOUT CLAIM TO ANY PARTICULAR FONT, STYLE, SIZE, OR COLOR.

**CLASS 9—ELECTRICAL AND SCIENTIFIC APPARATUS**

FOR DOWNLOADABLE MOBILE APPLICATION SOFTWARE FOR POSTING AND SENDING FEEDBACK AND REVIEWS ON PRODUCTS AND SERVICES OF OTHERS; DOWNLOADABLE MOBILE APPLICATION SOFTWARE FOR ONLINE ADVERTISING AND BUSINESS PROMOTION (U.S. CLS. 21, 23, 26, 36 AND 38).

FIRST USE 6-3-2014; IN COMMERCE 6-3-2014.

**CLASS 35—ADVERTISING AND BUSINESS**

FOR PROMOTING THE GOODS AND SERVICES OF OTHERS BY PROVIDING AN INTERACTIVE WEBSITE FOR POSTING AND SENDING FEEDBACK AND REVIEWS ON PRODUCTS AND SERVICES OF OTHERS; PROVIDING AN INTERACTIVE WEBSITE FOR ONLINE ADVERTISING AND BUSINESS PROMOTION; BUSINESS CONSULTING IN THE FIELD OF ADVERTISING PERFORMANCE, EVALUATION AND ANALYSIS; BUSINESS CONSULTING IN THE FIELD OF PUBLIC RELATIONS- RELATED PERFORMANCE, EVALUATION AND ANALYSIS; BUSINESS CONSULTING IN THE FIELD OF HUMAN RESOURCES-RELATED PERFORMANCE, EVALUATION AND ANALYSIS (U.S. CLS. 100, 101 AND 102).

FIRST USE 6-3-2014; IN COMMERCE 6-3-2014.

4,593,915. KNEZEVIC, MARIJA, BEDFORD HILLS, NY. SN 85-935,614. PUB. 10-8-2013, FILED 5-17-2013.

# Bubo and me

THE MARK CONSISTS OF STANDARD CHARACTERS WITHOUT CLAIM TO ANY PARTICULAR FONT, STYLE, SIZE, OR COLOR.

**CLASS 35—ADVERTISING AND BUSINESS**

FOR ADVERTISING AND BUSINESS MANAGEMENT CONSULTANCY; ADVERTISING AND MARKETING; ADVERTISING AND PROMOTION SERVICES AND RELATED CONSULTING; ADVERTISING COPYWRITING; BUSINESS MANAGEMENT; CREATIVE MARKETING DESIGN SERVICES; PROMOTION AND MARKETING SERVICES AND RELATED CONSULTING; PROVIDING OFFICE FUNCTIONS; PROVIDING OFFICE SUPPORT STAFF SERVICES (U.S. CLS. 100, 101 AND 102).

FIRST USE 12-3-2013; IN COMMERCE 12-3-2013.

**CLASS 42—SCIENTIFIC AND COMPUTER SERVICES**

FOR ANIMATION AND SPECIAL-EFFECTS DESIGN FOR OTHERS; CONSULTANCY WITH REGARD TO WEBPAGE DESIGN; CONSULTING IN THE FIELD OF GRAPHIC ART DESIGN; CONSULTING SERVICES IN THE FIELD OF DESIGN OF NEWSLETTERS; DESIGN AND MAINTENANCE OF WEB SITES FOR OTHERS; DESIGN OF CUSTOM PAINTINGS; DESIGN OF CUSTOMIZED BOOKS; GRAPHIC DESIGN; GRAPHIC ILLUSTRATION SERVICES FOR OTHERS; WEB SITE DESIGN; WEBSITE DESIGN CONSULTANCY (U.S. CLS. 100 AND 101).

FIRST USE 12-3-2013; IN COMMERCE 12-3-2013.

4,593,917. VITAL JUICE CO, INC., SEATTLE, WA. SN 85-935,686. PUB. 10-1-2013, FILED 5-17-2013.

# MR. SQUEEZE

THE MARK CONSISTS OF STANDARD CHARACTERS WITHOUT CLAIM TO ANY PARTICULAR FONT, STYLE, SIZE, OR COLOR.

**CLASS 29—MEATS AND PROCESSED FOODS**

FOR VEGETABLE AND FRUIT BASED FOOD BEVERAGES (U.S. CL. 46).

FIRST USE 5-0-2013; IN COMMERCE 4-0-2014.

**CLASS 32—LIGHT BEVERAGES**

FOR FRUIT AND VEGETABLE JUICES (U.S. CLS. 45, 46 AND 48).

FIRST USE 5-0-2013; IN COMMERCE 4-0-2014.

4,593,918. VITAL JUICE CO, INC., SEATTLE, WA. SN 85-935,693. PUB. 10-8-2013, FILED 5-17-2013.

# MRS. BEET

THE MARK CONSISTS OF STANDARD CHARACTERS WITHOUT CLAIM TO ANY PARTICULAR FONT, STYLE, SIZE, OR COLOR.

**CLASS 29—MEATS AND PROCESSED FOODS**

FOR VEGETABLE AND FRUIT BASED FOOD BEVERAGES (U.S. CL. 46).

FIRST USE 7-0-2013; IN COMMERCE 4-0-2014.

**CLASS 32—LIGHT BEVERAGES**

FOR FRUIT AND VEGETABLE JUICES (U.S. CLS. 45, 46 AND 48).

FIRST USE 7-0-2013; IN COMMERCE 4-0-2014.

4,593,922. CACCAVALE, GINO, NEW YORK, NY. SN 85-936,633. PUB. 10-15-2013, FILED 5-20-2013.



The logo for REZISY features the word "REZISY" in a bold, sans-serif font. The letter "Z" is significantly larger than the other letters. The letter "T" is replaced by a stylized stick figure with its arms raised, forming the vertical stem of the letter.

THE MARK CONSISTS OF THE WORDING "REZIST" IN ALL UPPER CASE LETTERS WITH THE "Z" LARGER THAN THE OTHER LETTERS AND THE "T" CONSISTING OF AN ABSTRACT RENDERING OF A STICK FIGURE.

**CLASS 9—ELECTRICAL AND SCIENTIFIC APPARATUS**

FOR DIGITAL MEDIA, NAMELY, PRE-RECORDED DVDS AND DOWNLOADABLE VIDEO RECORDINGS IN THE FIELD OF EXERCISE AND FITNESS (U.S. CLS. 21, 23, 26, 36 AND 38).

FIRST USE 2-1-2014; IN COMMERCE 2-1-2014.

**CLASS 16—PAPER GOODS AND PRINTED MATTER**

FOR BOOKS AND PAMPHLETS IN THE FIELD OF EXERCISE AND FITNESS (U.S. CLS. 2, 5, 22, 23, 29, 37, 38 AND 50).

FIRST USE 2-1-2014; IN COMMERCE 2-1-2014.

4,593,931. SUK YEE SMITH, MECHANICSBURG, PA. SN 85-937,210. PUB. 10-15-2013, FILED 5-20-2013.

# GOT PINK POWER?

THE MARK CONSISTS OF STANDARD CHARACTERS WITHOUT CLAIM TO ANY PARTICULAR FONT, STYLE, SIZE, OR COLOR.

**CLASS 16—PAPER GOODS AND PRINTED MATTER**

FOR PRINTED EDUCATIONAL MATERIALS IN THE FIELD OF SELF-EMPOWERMENT (U.S. CLS. 2, 5, 22, 23, 29, 37, 38 AND 50).

FIRST USE 1-18-2013; IN COMMERCE 1-18-2013.

**CLASS 41—EDUCATION AND ENTERTAINMENT**

FOR PROVIDING CLASSES, WORKSHOPS, SEMINARS AND CAMPS IN THE FIELDS OF FITNESS, KARATE, AND MIXED MARTIAL ARTS; PROVIDING FITNESS AND EXERCISE STUDIO SERVICES, NAMELY, KARATE AND MIXED MARTIAL ARTS; PROVIDING A WEBSITE FEATURING INFORMATION ON EXERCISE AND FITNESS (U.S. CLS. 100, 101 AND 107).

FIRST USE 1-18-2013; IN COMMERCE 1-18-2013.

**CLASS 45—PERSONAL AND LEGAL SERVICES**

FOR PROVIDING INFORMATION IN THE FIELD OF SELF-DEFENSE (U.S. CLS. 100 AND 101).

FIRST USE 1-18-2013; IN COMMERCE 1-18-2013.

4,593,935. EXO-GALACTIC ENGINEERING L.L.C., EAGAN, MN. SN 85-937,973. PUB. 10-15-2013, FILED 5-21-2013.



THE MARK CONSISTS OF THE WORD "EXOGAL" IN BLOCK LETTERS WHERE THE LETTER "O" IS REPLACED WITH A SMALL SPHERE SURROUNDED BY FOUR SMALLER SPHERES ATTACHED TO EACH OF WHICH IS AN LINE IN AN ARCUATE SHAPE.

#### CLASS 9—ELECTRICAL AND SCIENTIFIC APPARATUS

FOR COMPUTER SOFTWARE, NAMELY, DIGITAL TO ANALOG CONVERSION SOFTWARE FOR STREAMING CONVERTED DATA SUCH AS DIGITAL AUDIO (MP3S) FROM A COMPUTER OVER A HIGH-SPEED, HIGHLY SYNCHRONOUS AND DETERMINISTIC NETWORK TO COMPATIBLE DIGITAL AMPLIFIERS, USING A WIRELESS CONTROLLER FROM DESKTOP AND MOBILE DEVICES (U.S. CLS. 21, 23, 26, 36 AND 38).  
FIRST USE 4-1-2014; IN COMMERCE 5-1-2014.

#### CLASS 42—SCIENTIFIC AND COMPUTER SERVICES

FOR SOFTWARE AS A SERVICE FEATURING DIGITAL AUDIO SERVICES, NAMELY, PROVIDING DIGITAL TO ANALOG CONVERSION ABILITIES FOR STREAMING CONVERTED DATA SUCH AS DIGITAL AUDIO (MP3S) FROM A COMPUTER OVER A HIGH-SPEED, HIGHLY SYNCHRONOUS AND DETERMINISTIC NETWORK TO COMPATIBLE DIGITAL AMPLIFIERS, USING A WIRELESS CONTROLLER FROM DESKTOP AND MOBILE DEVICES (U.S. CLS. 100 AND 101).  
FIRST USE 4-1-2014; IN COMMERCE 5-1-2014.

4,593,937. DUNCAN ENTERPRISES, INC., DBA ILOVE-TOCREATE, FRESNO, CA. SN 85-938,040. PUB. 11-12-2013, FILED 5-21-2013.



THE COLOR(S) WHITE, PURPLE, GOLD, FUCHSIA, PINK, ORANGE, YELLOW, LIGHT GREEN, GREEN AND BLUE IS/ARE CLAIMED AS A FEATURE OF THE MARK.

THE MARK CONSISTS OF A CIRCULAR DESIGN WITH THE WORDS "RAINBOW ROCK" IN WHITE BLOCK LETTERS CONTAINED WITHIN THE PURPLE OUTER-MOST RING OF THE CIRCLE, WHICH IS SURROUNDED BY A THIN RING OF WHITE AND OUTLINED IN GOLD. A MULTI-COLORED STRIPED ROCK FORMATION EX-

TENDS UPWARDS FROM THE LOWER PORTION OF THE CIRCLE AND A WHITE NEGATIVE SPACE SURROUNDS THE TOP PORTION OF THE ROCK FORMATION, SEPARATING IT FROM THE RING CONTAINING THE WORDING. THE COLORS APPEAR FROM BOTTOM TO TOP AS FOLLOWS: BLUE, GREEN, LIGHT GREEN, YELLOW, ORANGE, PINK, AND OUTLINED AND SHADED IN FUCHSIA.

#### CLASS 2—PAINTS

FOR FABRIC PAINTS; FABRIC DYES; TIE-DYE KITS COMPRISED PRIMARILY OF DYES, COLOR FIXERS, LATEX GLOVES AND RUBBER BANDS OF TIE-DYING FABRICS AND TEXTILES (U.S. CLS. 6, 11 AND 16).  
FIRST USE 5-1-2014; IN COMMERCE 5-1-2014.

#### CLASS 28—TOYS AND SPORTING GOODS

FOR HOBBY CRAFT KITS FOR TIE-DYE COMPRISED PRIMARILY OF DYES, MIXING BOTTLES, COLOR FIXERS, LATEX GLOVES AND RUBBER BANDS, SPECIFICALLY FOR DYING FABRICS AND TEXTILES (U.S. CLS. 22, 23, 38 AND 50).  
FIRST USE 5-1-2014; IN COMMERCE 5-1-2014.

4,593,939. DRVITA, INC., LAS VEGAS, NV. SN 85-938,192. PUB. 10-15-2013, FILED 5-21-2013.

# Nature's Lab

THE MARK CONSISTS OF STANDARD CHARACTERS WITHOUT CLAIM TO ANY PARTICULAR FONT, STYLE, SIZE, OR COLOR.

#### CLASS 3—COSMETICS AND CLEANING PREPARATIONS

FOR AROMATIC BODY CARE PRODUCTS, NAMELY, BODY LOTION, SHOWER GEL, CUTICLE CREAM, SHAMPOO, CONDITIONER, NON-MEDICATED LIP BALM, SOAP, BODY POLISH, BODY AND FOOT SCRUB AND NON-MEDICATED FOOT CREAM; BODY AND BEAUTY CARE COSMETICS; COSMETIC PREPARATIONS FOR THE CARE OF MOUTH AND TEETH; NON-MEDICATED HERBAL BODY CARE PRODUCTS, NAMELY, BODY OILS, SALVES, AND LIP BALMS; NON-MEDICATED SKIN CARE PREPARATIONS, NAMELY, CREAMS, LOTIONS, GELS, TONERS, CLEANSERS AND PEELS; NON-MEDICATED SKIN CREAMS WITH ESSENTIAL OILS FOR USE IN AROMATHERAPY (U.S. CLS. 1, 4, 6, 50, 51 AND 52).  
FIRST USE 2-20-2014; IN COMMERCE 2-20-2014.

**CLASS 5—PHARMACEUTICALS**

FOR DIETARY AND NUTRITIONAL SUPPLEMENTS; DIETARY AND NUTRITIONAL SUPPLEMENTS FOR ENDURANCE SPORTS; DIETARY AND NUTRITIONAL SUPPLEMENTS USED FOR WEIGHT LOSS; DIETARY BEVERAGE SUPPLEMENTS FOR HUMAN CONSUMPTION IN LIQUID AND DRY MIX FORM FOR THERAPEUTIC PURPOSES; DIETARY FIBER FOR TREATING CONSTIPATION; DIETARY SUPPLEMENT DRINK MIXES; DIETARY SUPPLEMENTS FOR ANIMALS; DIETARY SUPPLEMENTS IN THE NATURE OF WEIGHT LOSS POWDERS; ENZYME DIETARY SUPPLEMENTS; FLAXSEED DIETARY SUPPLEMENTS; HERBAL SUPPLEMENTS; HOMEOPATHIC SUPPLEMENTS; LIQUID HERBAL SUPPLEMENTS; LIQUID VITAMIN SUPPLEMENTS; NUTRACEUTICALS FOR USE AS A DIETARY SUPPLEMENT; NUTRITIONAL SUPPLEMENT SHAKES; NUTRITIONAL SUPPLEMENTS IN LOTION FORM SOLD AS A COMPONENT OF NUTRITIONAL SKIN CARE PRODUCTS; POWDERED NUTRITIONAL SUPPLEMENT DRINK MIX AND CONCENTRATE; PROTEIN SUPPLEMENT SHAKES; VITAMIN AND MINERAL SUPPLEMENTS; WEIGHT MANAGEMENT SUPPLEMENTS (U.S. CLS. 6, 18, 44, 46, 51 AND 52).

FIRST USE 2-20-2014; IN COMMERCE 2-20-2014.

4,593,940. TERRYBEAR, INC., ST. PAUL, MN. SN 85-938,283. PUB. 2-4-2014, FILED 5-21-2013.



OWNER OF U.S. REG. NO. 3,781,613.

NO CLAIM IS MADE TO THE EXCLUSIVE RIGHT TO USE "PERSONALIZED", APART FROM THE MARK AS SHOWN.

THE COLOR(S) GRAY, BLACK, WHITE, RED, GREEN, BLUE, BROWN AND ORANGE IS/ARE CLAIMED AS A FEATURE OF THE MARK.

THE MARK CONSISTS OF A GRAY TAG WITH THE WORDS "A PET'S LIFE PERSONALIZED MEMORIES"; TO THE RIGHT OF THE TAG IS A GREAT DANE WITH BLACK AND WHITE COLORING, A PARROT ON TOP OF THE GREAT DANE WITH RED, ORANGE, GREEN, BLUE FEATHERS, A BLUE FISH AT THE TAIL OF THE GREAT DANE AND A FISH BELOW NEAR THE HIND LEG OF THE GREAT DANE; A BROWN DOG, A BLACK AND WHITE RABBIT AND A BLACK AND WHITE CAT BELOW THE GREAT DANE.

**CLASS 18—LEATHER GOODS**

FOR PERSONALIZED PET ACCESSORIES AND MEMORIALS, NAMELY, IMITATION LEATHER BOXES (U.S. CLS. 1, 2, 3, 22 AND 41).

FIRST USE 8-16-2012; IN COMMERCE 8-21-2012.

**CLASS 20—FURNITURE AND ARTICLES NOT OTHERWISE CLASSIFIED**

FOR PERSONALIZED PET ACCESSORIES AND MEMORIALS, NAMELY, WOOD COMPOSITE BOXES, PHOTO BOXES, PHOTO FRAMES AND PLACARDS (U.S. CLS. 2, 13, 22, 25, 32 AND 50).

FIRST USE 8-16-2012; IN COMMERCE 8-21-2012.

**CLASS 21—HOUSEWARES AND GLASS**

FOR PERSONALIZED PET ACCESSORIES AND MEMORIALS, NAMELY, CERAMIC MUGS, BRASS URNS, METAL ALLOY URNS AND MARBLE URNS (U.S. CLS. 2, 13, 23, 29, 30, 33, 40 AND 50).

FIRST USE 8-16-2012; IN COMMERCE 8-21-2012.

4,593,957. ECLAT TEXTILE CO., LTD., TAIPEI, TAIWAN. SN 85-940,779. PUB. 10-22-2013, FILED 5-23-2013.

# Aqua Guide

THE MARK CONSISTS OF THE WORDS "AQUA GUIDE" CONTAINED IN A RECTANGULAR BOX SHAPE WITH A CO-SIGN SHAPED FORM TAPERED AT EACH END AND INTERCEPTING THE TOP OF THE LETTER "U" AND COMPLETING IN THE CENTER OF THE LETTER "E".

**CLASS 23—YARNS AND THREADS**

FOR COIR THREAD; COIR YARN; COTTON THREAD AND YARN; EMBROIDERY THREAD AND YARN; HEMP THREAD AND YARN; JUTE THREAD AND YARN; LINEN THREAD AND YARN; RAYON THREAD; RAYON YARN; SILK THREADS AND YARNS; SPUN COTTON; SPUN SILK; SPUN THREAD AND YARN; THREAD; YARN (U.S. CL. 43).

FIRST USE 6-5-2014; IN COMMERCE 6-5-2014.

**CLASS 24—FABRICS**

FOR BED SHEETS; BROCADE; CALICO; COTTON FABRIC; CURTAIN FABRIC; FABRICS FOR THE MANUFACTURE OF LINGERIE; FIBERGLASS FABRIC FOR TEXTILE USE; FLANNEL; FUSTIAN; GAUZE FABRIC; HEMP CLOTH; JERSEY MATERIAL; LINEN LINING FABRIC FOR SHOES; RAYON FABRIC; SILK CLOTH; TABLE CLOTHS NOT OF PAPER; TABLE LINEN; TAFFETA; TEXTILE USED AS LINING FOR CLOTHING; WOOLEN FABRIC; ZEPHYR FABRIC (U.S. CLS. 42 AND 50).

FIRST USE 6-5-2014; IN COMMERCE 6-5-2014.

**CLASS 25—CLOTHING**

FOR APRONS; ATHLETIC SHOES; BABY BIBS NOT OF PAPER; BASEBALL CAPS; BATHING CAPS; BATHROBES; BELTS; BOOTS; BOW TIES; CAPES; CHILDREN'S CLOTH EATING BIBS; CLOTH BIBS; COATS; DRESSING GOWNS; EAR MUFFS; FOOTBALL SHOES; GLOVES; GYMNASTIC SHOES; HOODS; JACKETS; JEANS; MUFFLERS; NECKTIES; NIGHT GOWNS; OVERALLS; OVERCOATS; PAJAMAS; PANTS; PINAFORES; PLASTIC BABY BIBS; RAINCOATS; ROBES; SCARFS; SHIRTS; SHOES; SHOWER CAPS; SINGLET; SKI GLOVES; SKIRTS; SNOWBOARD GLOVES; SOCKS; SUITS; SWEATERS; SWIM CAPS; SWIM WEAR; SWIMSUITS; T-SHIRTS; TURBANS; UNDERPANTS; UNDERWEAR; WRAPS (U.S. CLS. 22 AND 39).

FIRST USE 6-5-2014; IN COMMERCE 6-5-2014.

4,593,965. DIAMOND HONG, INC., BROOKLYN, NY. SN 85-941,640. PUB. 11-26-2013, FILED 5-24-2013.

红  
標

THE MARK CONSISTS OF TWO NON-LATIN CHARACTERS RUNNING VERTICALLY.

THE NON-LATIN CHARACTERS IN THE MARK TRANSLITERATE TO "HONG" AND "BIAO" AND THIS MEANS "RED SIGN OR INDICATION" IN ENGLISH.

#### CLASS 5—PHARMACEUTICALS

FOR DIETARY FOOD SUPPLEMENTS; MEDICINAL HERBS AND HERBAL TEA FOR MEDICINAL PURPOSES; MEDICATED CANDIES; GINSENG FOR MEDICINAL USE (U.S. CLS. 6, 18, 44, 46, 51 AND 52).  
FIRST USE 1-31-2013; IN COMMERCE 2-28-2013.

#### CLASS 30—STAPLE FOODS

FOR PROCESSED HERBS; DRIED HERBS; PROCESSED GINSENG USED AS AN HERB; HERBAL FOOD BEVERAGES AND TEA (U.S. CL. 46).  
FIRST USE 1-31-2013; IN COMMERCE 2-28-2013.

4,593,966. GIBSON BRANDS, INC., NASHVILLE, TN. SN 85-941,930. PUB. 10-29-2013, FILED 5-24-2013.

GIBSON BRANDS

THE MARK CONSISTS OF STANDARD CHARACTERS WITHOUT CLAIM TO ANY PARTICULAR FONT, STYLE, SIZE, OR COLOR.

OWNER OF U.S. REG. NOS. 510,594, 3,257,493, AND 3,877,181.

NO CLAIM IS MADE TO THE EXCLUSIVE RIGHT TO USE "BRANDS", APART FROM THE MARK AS SHOWN.

SEC. 2(F) AS TO "GIBSON".

#### CLASS 9—ELECTRICAL AND SCIENTIFIC APPARATUS

FOR CONSUMER ELECTRONIC EQUIPMENT, NAMELY, AUDIO MIXERS, DIGITAL AUDIO RECORDERS, AUDIO PLAYBACK MACHINES, AUDIO AMPLIFIERS; AUDIO SPEAKERS; ELECTRONIC SOUND PROCESSING AND EFFECTS EQUIPMENT, NAMELY, GUITAR EFFECTS PROCESSORS (U.S. CLS. 21, 23, 26, 36 AND 38).  
FIRST USE 6-11-2013; IN COMMERCE 6-11-2013.

#### CLASS 15—MUSICAL INSTRUMENTS

FOR MUSICAL INSTRUMENTS (U.S. CLS. 2, 21 AND 36).

FIRST USE 6-11-2013; IN COMMERCE 6-11-2013.

4,593,967. DIAMOND HONG, INC., BROOKLYN, NY. SN 85-941,946. PUB. 11-26-2013, FILED 5-24-2013.

金  
標

THE MARK CONSISTS OF TWO NON-LATIN CHARACTERS ARRANGED VERTICALLY.

THE NON-LATIN CHARACTERS IN THE MARK TRANSLITERATE TO "JIN" AND "BIAO" AND THIS MEANS "GOLD SIGN OR INDICATION" IN ENGLISH.

#### CLASS 5—PHARMACEUTICALS

FOR DIETARY FOOD SUPPLEMENT; MEDICINAL HERBS AND HERBAL TEA FOR MEDICINAL PURPOSES; MEDICATED CANDIES; GINSENG FOR MEDICINAL USE (U.S. CLS. 6, 18, 44, 46, 51 AND 52).  
FIRST USE 1-31-2013; IN COMMERCE 2-28-2013.

#### CLASS 30—STAPLE FOODS

FOR PROCESSED HERBS; DRIED HERBS; PROCESSED GINSENG USED AS AN HERB; HERBAL FOOD BEVERAGES AND TEA (U.S. CL. 46).  
FIRST USE 1-31-2013; IN COMMERCE 2-28-2013.

4,593,970. TECHNOFORM CAPRANO + BRUNNHOFER GMBH, 34117 KASSEL, FED REP GERMANY. SN 85-942,483. PUB. 1-14-2014, FILED 5-24-2013.

TECHNOFORM

THE MARK CONSISTS OF STANDARD CHARACTERS WITHOUT CLAIM TO ANY PARTICULAR FONT, STYLE, SIZE, OR COLOR.

OWNER OF U.S. REG. NOS. 2,956,767 AND 3,174,335.

**CLASS 6—METAL GOODS**

FOR METAL BUILDING MATERIALS, NAMELY, WALL FRAMING, FLASHING, SOFFITS, FASCIA; METAL CLADDING FOR BUILDING CONSTRUCTION; METAL ROOF VENTS FOR VENTILATION IN RESIDENTIAL AND COMMERCIAL BUILDINGS; METAL TRIM FOR BUILDINGS; METAL COUNTERTOPS FOR FURTHER INSTALLATION; REINFORCING MATERIALS OF METAL FOR BUILDING PURPOSES AND COMPOSITE PANELS COMPOSED PRIMARILY OF METAL; GOODS OF COMMON METAL, NAMELY, METAL BELLS AND INGOTS OF COMMON METAL (U.S. CLS. 2, 12, 13, 14, 23, 25 AND 50).

FIRST USE 8-4-2004; IN COMMERCE 8-4-2004.

**CLASS 19—NON-METALLIC BUILDING MATERIALS**

FOR NON-METALLIC BUILDING MATERIALS, NAMELY, WALL BOARDS, CELLULAR PVC TRIM, COMPOSITE PANELS, FASCIA, SOFFITS, AND REINFORCING MATERIALS ALL FOR BUILDING PURPOSES; BUILDING GLASS; ASPHALT FELT; BUILDING STONE; LUMBER; NON-METAL FLASHING; NON-METAL CLADDING FOR BUILDING CONSTRUCTION; NON-METAL ROOF VENTS FOR VENTILATION IN RESIDENTIAL AND COMMERCIAL BUILDINGS; NON-METAL TRIM FOR BUILDINGS; NON-METAL COUNTERTOPS FOR FURTHER INSTALLATION; NON-METAL ARCHITECTURAL MOLDINGS AND FINISH TRIM; NON-METALLIC RIGID PIPES FOR BUILDING (U.S. CLS. 1, 12, 33 AND 50).

FIRST USE 8-4-2004; IN COMMERCE 8-4-2004.

4,593,979. APPLIED SCIENCES AND INFORMATION SYSTEMS, INC., VIRGINIA BEACH, VA. SN 85-943,559. PUB. 10-22-2013, FILED 5-28-2013.

**I-SPORTSMAN**

THE MARK CONSISTS OF STANDARD CHARACTERS WITHOUT CLAIM TO ANY PARTICULAR FONT, STYLE, SIZE, OR COLOR.

OWNER OF U.S. REG. NO. 3,372,481.

**CLASS 9—ELECTRICAL AND SCIENTIFIC APPARATUS**

FOR DOWNLOADABLE SOFTWARE IN THE NATURE OF A MOBILE APPLICATION FOR AUTOMATION OF THE CHECK IN, CHECK-OUT AND PERMITTING PROCESSES FOR RECREATIONAL SPORTS, HUNTING AND FISHING; DOWNLOADABLE SOFTWARE IN THE NATURE OF A MOBILE APPLICATION FOR THE COLLECTION, EDITING, ORGANIZING, MODIFYING, TRANSMISSION, STORAGE AND SHARING OF DATA AND INFORMATION (U.S. CLS. 21, 23, 26, 36 AND 38).

FIRST USE 2-12-2007; IN COMMERCE 2-22-2007.

**CLASS 42—SCIENTIFIC AND COMPUTER SERVICES**

FOR PROVIDING TEMPORARY USE OF ON-LINE NON-DOWNLOADABLE SOFTWARE FOR AUTOMATION OF THE CHECK IN, CHECK-OUT AND PERMITTING PROCESSES FOR RECREATIONAL SPORTS, HUNTING AND FISHING; PROVIDING TEMPORARY USE OF ON-LINE NON-DOWNLOADABLE SOFTWARE FOR THE COLLECTION, EDITING, ORGANIZING, MODIFYING, TRANSMISSION, STORAGE AND SHARING OF DATA AND INFORMATION (U.S. CLS. 100 AND 101).

FIRST USE 2-12-2007; IN COMMERCE 2-22-2007.

4,593,982. TURTLE STONE CO., LTD., KANAGAWA-KEN, JAPAN. SN 85-943,829. PUB. 11-5-2013, FILED 5-28-2013.



THE MARK CONSISTS OF OF THE WORD "OKIRAKU" IN STYLIZED PARTLY-SUPERIMPOSED LETTERS OF DIFFERENT HEIGHTS, FORMING A TRIANGULAR SHAPE, WITH THE LETTER "A" BEING THE TALLEST.

THE ENGLISH TRANSLATION OF "OKIRAKU" IN THE MARK IS "CAREFREE ABANDON".

**CLASS 18—LEATHER GOODS**

FOR TOTE BAGS; REUSABLE SHOPPING BAGS (U.S. CLS. 1, 2, 3, 22 AND 41).

FIRST USE 8-1-2002; IN COMMERCE 5-22-2013.

**CLASS 25—CLOTHING**

FOR CLOTHING, NAMELY, SHIRTS, PANTS, SKIRTS, BLOUSES, DRESSES, JACKETS, COATS, SWEATERS; UNDERWEAR; FOOTWEAR (U.S. CLS. 22 AND 39).

FIRST USE 8-1-2002; IN COMMERCE 5-22-2013.

4,593,990. NICE TIGHT WHITE ASH, LLC, FAIRHOPE, AL. SN 85-945,742. PUB. 10-22-2013, FILED 5-29-2013.

**NICE TIGHT WHITE ASH**

THE MARK CONSISTS OF STANDARD CHARACTERS WITHOUT CLAIM TO ANY PARTICULAR FONT, STYLE, SIZE, OR COLOR.

**CLASS 25—CLOTHING**

FOR BOOTS; HATS; HEADWEAR; JACKETS; LEISURE SHOES; PANTS; PARKAS; RAINWEAR; SHIRTS; SWEATERS; SWEATSHIRTS; VESTS (U.S. CLS. 22 AND 39).  
FIRST USE 5-22-2014; IN COMMERCE 5-22-2014.

**CLASS 34—SMOKERS' ARTICLES**

FOR CIGAR CUTTERS; CIGAR HOLDERS; CIGAR HUMIDIFIERS; CIGAR LIGHTERS; CIGAR TUBES; CIGAR WRAPS; CIGARS (U.S. CLS. 2, 8, 9 AND 17).  
FIRST USE 5-22-2014; IN COMMERCE 5-22-2014.

4,593,995. TALBOT LIFTING & SECURITY EUROPE LIMITED, CLONSKEAGH DUBLIN 4, IRELAND. SN 85-946,247. PUB. 11-5-2013, FILED 5-30-2013.

# QUICKFLEX

THE MARK CONSISTS OF STANDARD CHARACTERS WITHOUT CLAIM TO ANY PARTICULAR FONT, STYLE, SIZE, OR COLOR.

**CLASS 6—METAL GOODS**

FOR POT HOOKS OF METAL; BELTS STRETCHERS OF METAL; WIRE STRETCHERS, NAMELY, METAL TENSION LINKS; BELT STRAPS OF METAL; BELT CABLES OF METAL; STRAPS OF METAL FOR HANDLING LOADS AND FIXING LOADS; STRAPS OF METAL FOR HANDLING LOADS AND FIXING BOATS ON LOADING PALLET OR TRAILER; CABLES OF METAL, NON-ELECTRIC FOR HANDLING AND FIXING LOADS; CABLES OF METAL, NON-ELECTRIC FOR HANDLING AND FIXING BOATS ON LOADING PALLET OR TRAILER (U.S. CLS. 2, 12, 13, 14, 23, 25 AND 50).  
FIRST USE 5-27-2013; IN COMMERCE 6-1-2014.

**CLASS 22—CORDAGE AND FIBERS**

FOR STRAPS, NOT OF METAL FOR HANDLING LOADS AND FIXING LOADS; STRAPS, NOT OF METAL FOR HANDLING LOADS AND FIXING BOATS ON PALLET OR TRAILER; CABLES, NOT OF METAL, NON-ELECTRIC FOR HANDLING AND FIXING LOADS; CABLES, NOT OF METAL, NON-ELECTRIC FOR HANDLING AND FIXING BOATS ON LOADING PALLET OR TRAILER (U.S. CLS. 1, 2, 7, 19, 22, 42 AND 50).  
FIRST USE 5-27-2013; IN COMMERCE 6-1-2014.

4,593,996. ROGUE PLAY, INC., IRVINE, CA. SN 85-946,516. PUB. 10-22-2013, FILED 5-30-2013.

# Rogue Play

THE MARK CONSISTS OF STANDARD CHARACTERS WITHOUT CLAIM TO ANY PARTICULAR FONT, STYLE, SIZE, OR COLOR.

**CLASS 9—ELECTRICAL AND SCIENTIFIC APPARATUS**

FOR COMPUTER GAME CARTRIDGES AND DISCS; COMPUTER GAME SOFTWARE; COMPUTER GAME SOFTWARE FOR PERSONAL COMPUTERS AND HOME VIDEO GAME CONSOLES; COMPUTER GAME SOFTWARE FOR USE ON MOBILE AND CELLULAR PHONES; DOWNLOADABLE COMPUTER GAME SOFTWARE VIA A GLOBAL COMPUTER NETWORK AND WIRELESS DEVICES; ELECTRONIC GAME SOFTWARE FOR HANDHELD ELECTRONIC DEVICES; ELECTRONIC GAME SOFTWARE FOR WIRELESS DEVICES; VIDEO GAME CARTRIDGES AND DISCS (U.S. CLS. 21, 23, 26, 36 AND 38).  
FIRST USE 5-16-2014; IN COMMERCE 5-16-2014.

**CLASS 42—SCIENTIFIC AND COMPUTER SERVICES**

FOR DESIGNING AND DEVELOPING COMPUTER GAME SOFTWARE AND VIDEO GAME SOFTWARE FOR USE WITH COMPUTERS, VIDEO GAME PROGRAM SYSTEMS AND COMPUTER NETWORKS (U.S. CLS. 100 AND 101).  
FIRST USE 5-16-2014; IN COMMERCE 5-16-2014.

4,593,997. KUEHN, HAGEN, TABARZ, FED REP GERMANY. SN 85-946,627. PUB. 10-22-2013, FILED 5-30-2013.

# Trovler

THE MARK CONSISTS OF STANDARD CHARACTERS WITHOUT CLAIM TO ANY PARTICULAR FONT, STYLE, SIZE, OR COLOR.

**CLASS 39—TRANSPORTATION AND STORAGE**

FOR ON-LINE TRANSPORTATION RESERVATION AND TRAVEL TICKET RESERVATION SERVICES; PROVIDING AN ON-LINE SEARCHABLE COMPUTER DATABASE FEATURING INFORMATION ON TRAVEL; PROVIDING INFORMATION, NEWS AND COMMENTARY IN THE FIELD OF TRAVEL; PROVIDING TRAVEL INFORMATION TO TRAVELERS REGARDING FARES, TIMETABLES AND PUBLIC TRANSPORT; TRAVEL GUIDE AND TRAVEL INFORMATION SERVICES; TRAVEL PLANNING FOR INDIVIDUALS, FAMILIES, AND GROUPS FOR SPECIAL OCCASIONS SUCH AS DESTINATION WEDDINGS AND HONEYMOONS (U.S. CLS. 100 AND 105).  
FIRST USE 11-12-2013; IN COMMERCE 11-12-2013.

**CLASS 42—SCIENTIFIC AND COMPUTER SERVICES**

FOR COMPUTER SERVICES, NAMELY, HOSTING ON-LINE INTERACTIVE PUBLIC CALENDARS THAT ALLOW MULTIPLE PARTICIPANTS TO SHARE EVENT SCHEDULES AND FACILITY RESERVATIONS; PROVIDING A WEB SITE FEATURING TECHNOLOGY THAT ENABLES INTERNET USERS TO BOOK TRAVEL (U.S. CLS. 100 AND 101).  
FIRST USE 11-12-2013; IN COMMERCE 11-12-2013.

4,593,998. NIKI BARR ENTERPRISES, LLC, ANNAPOLIS, MD. SN 85-947,099. PUB. 11-5-2013, FILED 5-31-2013.

THE LAST YEAR

THE MARK CONSISTS OF "THE LAST YEAR" IN UPPER CASE STYLIZED TEXT.

**CLASS 9—ELECTRICAL AND SCIENTIFIC APPARATUS**

FOR SOUND AND VIDEO RECORDINGS FEATURING MUSIC; DOWNLOADABLE SOUND AND VIDEO RECORDINGS FEATURING MUSIC; ELECTRONIC SOUND AND VIDEO RECORDINGS FEATURING MUSIC (U.S. CLS. 21, 23, 26, 36 AND 38).

FIRST USE 9-2-2013; IN COMMERCE 9-2-2013.

**CLASS 41—EDUCATION AND ENTERTAINMENT**

FOR ENTERTAINMENT SERVICES IN THE NATURE OF A LIVE MUSICAL GROUP; ENTERTAINMENT SERVICES IN THE NATURE OF A LIVE VOCAL AND INSTRUMENTAL MUSICAL GROUP; ENTERTAINMENT, NAMELY, LIVE PERFORMANCES BY A MUSICAL GROUP; LIVE PERFORMANCES BY A MUSICAL GROUP; ENTERTAINMENT SERVICES, NAMELY, PROVIDING NON-DOWNLOADABLE PLAYBACK OF MUSIC AND MUSICAL VIDEOS, RELATED FILM CLIPS, PHOTOGRAPHS, AND OTHER MULTIMEDIA MATERIALS FEATURING A MUSICAL GROUP VIA GLOBAL COMMUNICATIONS NETWORKS; ENTERTAINMENT SERVICES, NAMELY, PROVIDING A WEB SITE FEATURING NON-DOWNLOADABLE MUSICAL PERFORMANCES, MUSICAL VIDEOS, RELATED FILM CLIPS, PHOTOGRAPHS, AND OTHER MULTIMEDIA MATERIALS FEATURING A MUSICAL GROUP; ENTERTAINMENT SERVICES, NAMELY, PROVIDING ONLINE, NON-DOWNLOADABLE PRERECORDED SOUND AND VIDEO RECORDINGS FEATURING MUSIC VIA A GLOBAL COMPUTER NETWORK (U.S. CLS. 100, 101 AND 107).

FIRST USE 9-2-2013; IN COMMERCE 9-2-2013.

4,593,999. COLON HYDROPREP SOLUTIONS, LLC, SOUTH LAKE TAHOE, CA. SN 85-947,442. PUB. 10-22-2013, FILED 5-31-2013.

HydroPrep

THE MARK CONSISTS OF STANDARD CHARACTERS WITHOUT CLAIM TO ANY PARTICULAR FONT, STYLE, SIZE, OR COLOR.

**CLASS 41—EDUCATION AND ENTERTAINMENT**

FOR EDUCATIONAL SERVICES, NAMELY, CONDUCTING TRAINING OF LICENSED MEDICAL PROFESSIONALS IN THE FIELD OF ADMINISTRATION OF COLONIC TREATMENTS AND DISTRIBUTION OF TRAINING MATERIAL IN CONNECTION THEREWITH (U.S. CLS. 100, 101 AND 107).

FIRST USE 5-28-2013; IN COMMERCE 5-28-2013.

**CLASS 44—MEDICAL, BEAUTY AND AGRICULTURAL SERVICES**

FOR COLONIC TREATMENTS, NAMELY, IRRIGATION OF THE COLON FOR CLEANSING PURPOSES BY INJECTING LARGE AMOUNTS OF FLUID HIGH INTO THE COLON (U.S. CLS. 100 AND 101).

FIRST USE 5-28-2013; IN COMMERCE 5-28-2013.

4,594,008. HEALTH NEW ENGLAND, INC., SPRINGFIELD, MA. SN 85-948,956. PUB. 12-3-2013, FILED 6-3-2013.



OWNER OF U.S. REG. NOS. 2,814,598, 4,332,448, AND OTHERS.

NO CLAIM IS MADE TO THE EXCLUSIVE RIGHT TO USE "HEALTH NEW ENGLAND", APART FROM THE MARK AS SHOWN.

THE MARK CONSISTS OF THE PROFILE OF TWO HEADS AND AN ARM ABOVE THE WORDS "HNE HEALTH NEW ENGLAND" INSCRIBED WITHIN A CIRCLE, WITH THE WORDS "HOW CAN WE HELP?" RUNNING ALONG THE EXTERIOR CIRCUMFERENCE OF THE CIRCLE.

**CLASS 36—INSURANCE AND FINANCIAL**

FOR MEDICAL INSURANCE, NAMELY, UNDERWRITING AND ADMINISTRATION (U.S. CLS. 100, 101 AND 102).

FIRST USE 1-1-2013; IN COMMERCE 1-1-2013.

**CLASS 44—MEDICAL, BEAUTY AND AGRICULTURAL SERVICES**

FOR OPERATING A HEALTH MAINTENANCE ORGANIZATION WHICH ADDRESSES HEALTH AND MEDICAL CARE FOR ITS MEMBERS THROUGH A NETWORK OF SELECTED HEALTH CARE PROVIDERS (U.S. CLS. 100 AND 101).

FIRST USE 1-1-2013; IN COMMERCE 1-1-2013.

4,594,024. LEARNER FIRST LLC, BELLEVUE, WA. SN 85-952,039. PUB. 10-29-2013, FILED 6-6-2013.

The Learner First

THE MARK CONSISTS OF STANDARD CHARACTERS WITHOUT CLAIM TO ANY PARTICULAR FONT, STYLE,



SIZE, OR COLOR.

#### **CLASS 16—PAPER GOODS AND PRINTED MATTER**

FOR PRINTED MATERIAL, NAMELY, SURVEYS AND ASSESSMENTS IN THE FIELD OF EDUCATOR TRAINING AND PERFORMANCE (U.S. CLS. 2, 5, 22, 23, 29, 37, 38 AND 50).

FIRST USE 12-20-2012; IN COMMERCE 12-20-2012.

#### **CLASS 35—ADVERTISING AND BUSINESS**

FOR BUSINESS CONSULTATION IN THE FIELD OF EDUCATION LEADERSHIP DEVELOPMENT; CONSULTING SERVICES IN THE FIELD OF HIGHER EDUCATION ADMINISTRATION (U.S. CLS. 100, 101 AND 102).

FIRST USE 12-20-2012; IN COMMERCE 12-20-2012.

#### **CLASS 41—EDUCATION AND ENTERTAINMENT**

FOR CONSULTATION IN THE FIELD OF K-12 EDUCATIONAL SYSTEMS; EDUCATIONAL AND ENTERTAINMENT SERVICES, NAMELY, PROVIDING MOTIVATIONAL AND EDUCATIONAL SPEAKERS; EDUCATIONAL SERVICES, NAMELY, DEVELOPING CURRICULUM FOR EDUCATORS; EDUCATIONAL SERVICES, NAMELY, OFFERING OF ASSESSMENTS AND SURVEYS IN THE FIELD OF EDUCATOR TRAINING AND PERFORMANCE FOR THE PURPOSE OF IMPROVING TEACHING PROCEDURES; INFORMATION IN THE FIELD OF PARENTING CONCERNING EDUCATION OF CHILDREN; LEADERSHIP DEVELOPMENT TRAINING FOR EDUCATORS; PROVIDING ADVICE AND INFORMATION IN THE FIELD OF EDUCATIONAL AND ENTERTAINMENT ACTIVITIES AND EVENTS FOR CHILDREN; PROVIDING INFORMATION ABOUT EDUCATION; PROVIDING INFORMATION AND NEWS IN THE FIELD OF TEACHING METHODOLOGY AND EDUCATION; PROVIDING INFORMATION IN THE FIELD OF CHILDREN'S EDUCATION; PROVIDING INFORMATION RELATING TO EDUCATIONAL SERVICES; EDUCATIONAL EXAMINATION SERVICES; PROVIDING ON-LINE RESOURCE GUIDES FOR RELATIVES CONCERNING CHILDREN IN THE FIELDS OF EDUCATION, RECREATION, AND ENTERTAINMENT (U.S. CLS. 100, 101 AND 107).

FIRST USE 12-20-2012; IN COMMERCE 12-20-2012.

#### **CLASS 35—ADVERTISING AND BUSINESS**

FOR SUPPLY CHAIN MANAGEMENT SERVICES; MANAGEMENT OF TRANSPORTATION LOGISTICS SERVICES, NAMELY, PLANNING AND SCHEDULING SHIPMENTS FOR USERS OF TRANSPORTATION SERVICES AND ARRANGING THE TRANSPORTATION OF GOODS FOR OTHERS; COMMERCIAL MAIL RECEIVING AGENCY, NAMELY, PROVIDING SPECIALIZED MAIL MANAGEMENT SERVICES; MANAGEMENT AND ADMINISTRATION OF NON-CORE FUNCTIONS, NAMELY, MAILING AND SHIPPING, RECORDS MANAGEMENT, INFORMATION SERVICES, SHIPMENT PROCESSING, PREPARING SHIPPING DOCUMENTS AND INVOICES; ORDER FULFILLMENT SERVICES; PROVIDING PRODUCT RETURNS DATA; MONITORING AND TRACKING OF SHIPMENTS; BUSINESS MANAGEMENT SERVICES, NAMELY, MANAGING LOGISTICS, REVERSE LOGISTICS, INVENTORY, SUPPLY AND DEMAND FORECASTING AND PRODUCT DISTRIBUTION PROCESSES FOR OTHERS; BUSINESS CONSULTING SERVICES RELATING TO ALL OF THE FOREGOING SERVICES AND PRODUCT DISTRIBUTION, OPERATIONS MANAGEMENT SERVICES, LOGISTICS, REVERSE LOGISTICS, AND PRODUCTION SYSTEMS AND DISTRIBUTION SOLUTIONS (U.S. CLS. 100, 101 AND 102).

FIRST USE 6-6-2013; IN COMMERCE 6-6-2013.

#### **CLASS 39—TRANSPORTATION AND STORAGE**

FOR SUPPLY CHAIN LOGISTICS AND REVERSE LOGISTICS SERVICES, NAMELY, STORAGE, TRANSPORTATION AND DELIVERY OF GOODS FOR OTHERS; SHIPPING AND DELIVERY SERVICES, NAMELY, PICKUP, TRANSPORTATION, AND DELIVERY OF PACKAGES; PACKAGING AND PARCELING OF GOODS FOR TRANSPORT PURPOSES (U.S. CLS. 100 AND 105).

FIRST USE 6-6-2013; IN COMMERCE 6-6-2013.

#### **CLASS 40—MATERIAL TREATMENT**

FOR ASSEMBLY OF PRODUCTS AND KITS, NAMELY, GOODS PROVIDED BY OTHERS (U.S. CLS. 100, 103 AND 106).

FIRST USE 6-6-2013; IN COMMERCE 6-6-2013.

#### **CLASS 42—SCIENTIFIC AND COMPUTER SERVICES**

FOR SOFTWARE AS A SERVICE (SAAS) SERVICES FEATURING SOFTWARE FOR PREPARING, ADMINISTERING, AND MANAGING THE SHIPMENT AND RETURN OF MERCHANDISE PARCELS AND PACKAGES, FOR PRODUCING AND PRINTING SHIPMENT MANIFESTS AND LABELS FOR THE SHIPMENT AND RETURN OF MERCHANDISE PARCELS AND PACKAGES, AND FOR DATA PROCESSING, REPORTING, AND BILLING IN THE FIELD OF SHIPPING AND RETURNING MERCHANDISE PARCELS AND PACKAGES; SOFTWARE AS A SERVICE (SAAS) SERVICES FEATURING SOFTWARE FOR PROVIDING REAL-TIME, INTEGRATED BUSINESS MANAGEMENT INTELLIGENCE BY COMBINING INFORMATION FROM VARIOUS DATABASES AND PRESENTING IT IN AN EASY-TO-UNDERSTAND FORMAT FOR THE USER IN THE FIELDS OF ORDER FULFILLMENT, INVENTORY MANAGEMENT, LOGISTICS MANAGEMENT, AND RETURNS MANAGEMENT; SOFTWARE AS A SERVICE (SAAS) SERVICES FEATURING SOFTWARE FOR PLACING ORDERS, TRACKING AND MONITORING FULFILLMENT OF ORDERS, MONITORING DISTRIBUTION AND DELIVERY OF PARCELS AND PACKAGES; SOFTWARE AS A SERVICE (SAAS) SERVICES FEATURING SOFTWARE FOR COORDINATING AIR AND GROUND TRANSPORT, LOGISTICS, SUPPLY CHAIN MANAGEMENT, WAREHOUSE MANAGEMENT, ORDER FULFILLMENT; DESIGNING, CREATING, MAINTAINING, AND HOSTING ELECTRONIC COMMERCE WEBSITES FOR OTHERS (U.S. CLS. 100 AND 101).

FIRST USE 6-6-2013; IN COMMERCE 6-6-2013.

4,594,048. NEWGISTICS, INC., AUSTIN, TX. SN 85-955,254.  
PUB. 10-29-2013, FILED 6-10-2013.

### **WHERE END-TO-END E-COMMERCE BEGINS**

THE MARK CONSISTS OF STANDARD CHARACTERS WITHOUT CLAIM TO ANY PARTICULAR FONT, STYLE, SIZE, OR COLOR.

NO CLAIM IS MADE TO THE EXCLUSIVE RIGHT TO USE "END-TO-END E-COMMERCE", APART FROM THE MARK AS SHOWN.

4,594,078. PORCH LIFE COOLERS L.L.C., SUMMERVILLE, SC. SN 85-959,165. PUB. 11-5-2013, FILED 6-13-2013.

## PORCH LIFE

THE MARK CONSISTS OF STANDARD CHARACTERS WITHOUT CLAIM TO ANY PARTICULAR FONT, STYLE, SIZE, OR COLOR.

### CLASS 16—PAPER GOODS AND PRINTED MATTER

FOR BUMPER STICKERS; DECALS; DECORATIVE DECALS FOR VEHICLE WINDOWS; POSTCARDS; STICKERS (U.S. CLS. 2, 5, 22, 23, 29, 37, 38 AND 50). FIRST USE 6-0-2013; IN COMMERCE 6-0-2013.

### CLASS 21—HOUSEWARES AND GLASS

FOR FOAM DRINK HOLDERS; INSULATED CONTAINERS FOR FOOD OR BEVERAGE FOR DOMESTIC USE; INSULATING SLEEVE HOLDERS FOR BEVERAGE CANS; PORTABLE BEVERAGE COOLERS; PORTABLE COOLERS (U.S. CLS. 2, 13, 23, 29, 30, 33, 40 AND 50). FIRST USE 6-0-2013; IN COMMERCE 6-0-2013.

### CLASS 25—CLOTHING

FOR HATS; SHIRTS AND SHORT-SLEEVED SHIRTS (U.S. CLS. 22 AND 39). FIRST USE 6-0-2013; IN COMMERCE 6-0-2013.

### CLASS 43—HOTEL AND RESTAURANT SERVICES

FOR CHARITABLE SERVICES, NAMELY, PROVIDING FOOD TO THE NEEDY (U.S. CLS. 100 AND 101). FIRST USE 3-23-2014; IN COMMERCE 3-23-2014.

4,594,091. DACO CORPORATION, KENT, WA. SN 85-961,379. PUB. 3-25-2014, FILED 6-17-2013.

## WORKHORSE

THE MARK CONSISTS OF STANDARD CHARACTERS WITHOUT CLAIM TO ANY PARTICULAR FONT, STYLE, SIZE, OR COLOR.

### CLASS 7—MACHINERY

FOR WRAPPING MACHINES; MATERIAL HANDLING MACHINES, NAMELY, ELECTRIC AND HYDRAULIC PALLET JACKS (U.S. CLS. 13, 19, 21, 23, 31, 34 AND 35). FIRST USE 8-6-2013; IN COMMERCE 8-6-2013.

### CLASS 12—VEHICLES

FOR PALLET TRUCKS (U.S. CLS. 19, 21, 23, 31, 35 AND 44). FIRST USE 8-6-2013; IN COMMERCE 8-6-2013.

4,594,084. FEEDING AMERICA SAN DIEGO, SAN DIEGO, CA. SN 85-960,500. PUB. 11-5-2013, FILED 6-14-2013.



THE MARK CONSISTS OF AN IMAGE OF A TRUCK AND IMAGES OF AN APPLE, CARROT AND WEDGE OF CHEESE WITH TWO EYES AND SMILE.

### CLASS 39—TRANSPORTATION AND STORAGE

FOR WAREHOUSING SERVICES, NAMELY, DISTRIBUTION AND DELIVERY OF SURPLUS AND SALVAGEABLE FOOD (U.S. CLS. 100 AND 105). FIRST USE 9-16-2013; IN COMMERCE 9-16-2013.

4,594,101. ASHWORTH, LLC, CARLSBAD, CA. SN 85-963,219. PUB. 11-19-2013, FILED 6-18-2013.



OWNER OF U.S. REG. NOS. 1,940,723, 4,064,615, AND OTHERS.

THE MARK CONSISTS OF A DEPICTION OF A MAN CARRYING A GOLF BAG.

### CLASS 18—LEATHER GOODS

FOR LUGGAGE, CARRY-ALL BAGS, DUFFEL BAGS, GARMENT BAGS FOR TRAVEL, BACKPACKS (U.S. CLS. 1, 2, 3, 22 AND 41).

FIRST USE 11-15-2013; IN COMMERCE 11-15-2013.

**CLASS 25—CLOTHING**

FOR FOOTWEAR; CLOTHING, NAMELY, SHORTS, PANTS, SKORTS, SHIRTS, TOPS, VESTS, SWEATERS, SWEATSHIRTS, PULLOVERS, COATS, JACKETS, RAINWEAR, SOCKS, BELTS; HEADWEAR (U.S. CLS. 22 AND 39).

FIRST USE 6-1-2014; IN COMMERCE 6-1-2014.

**CLASS 28—TOYS AND SPORTING GOODS**

FOR GOLF BAGS (U.S. CLS. 22, 23, 38 AND 50).  
FIRST USE 6-1-2014; IN COMMERCE 6-1-2014.

4,594,121. THE ANNEXUS GROUP, LLC, SCOTTSDALE, AZ.  
SN 85-968,546. PUB. 4-1-2014, FILED 6-24-2013.

**ANNEXUS RESEARCH INSTITUTE**

THE MARK CONSISTS OF STANDARD CHARACTERS WITHOUT CLAIM TO ANY PARTICULAR FONT, STYLE, SIZE, OR COLOR.

OWNER OF U.S. REG. NOS. 4,226,576, 4,396,278, AND 4,396,279.

NO CLAIM IS MADE TO THE EXCLUSIVE RIGHT TO USE "RESEARCH INSTITUTE", APART FROM THE MARK AS SHOWN.

**CLASS 16—PAPER GOODS AND PRINTED MATTER**

FOR PRINTED INSTRUCTIONAL, EDUCATIONAL, AND TEACHING MATERIALS IN THE FIELD OF WEALTH MANAGEMENT AND RETIREMENT PLANNING (U.S. CLS. 2, 5, 22, 23, 29, 37, 38 AND 50).

FIRST USE 1-0-2014; IN COMMERCE 1-0-2014.

**CLASS 36—INSURANCE AND FINANCIAL**

FOR PROVIDING ON-LINE INFORMATION FOR INVESTMENT ADVISORS AND THEIR CLIENTS IN THE FIELD OF WEALTH MANAGEMENT AND RETIREMENT PLANNING (U.S. CLS. 100, 101 AND 102).

FIRST USE 1-0-2014; IN COMMERCE 1-0-2014.

**CLASS 41—EDUCATION AND ENTERTAINMENT**

FOR EDUCATION SERVICES, NAMELY, PROVIDING SEMINARS AND WORKSHOPS IN THE FIELD OF WEALTH MANAGEMENT AND RETIREMENT PLANNING (U.S. CLS. 100, 101 AND 107).

FIRST USE 1-0-2014; IN COMMERCE 1-0-2014.

4,594,122. THE ANNEXUS GROUP, LLC, SCOTTSDALE, AZ.  
SN 85-968,550. PUB. 4-1-2014, FILED 6-24-2013.

**ANNEXUS**

THE MARK CONSISTS OF STANDARD CHARACTERS

WITHOUT CLAIM TO ANY PARTICULAR FONT, STYLE, SIZE, OR COLOR.

OWNER OF U.S. REG. NOS. 4,226,576, 4,396,278, AND 4,396,279.

**CLASS 16—PAPER GOODS AND PRINTED MATTER**

FOR PRINTED INSTRUCTIONAL, EDUCATIONAL, AND TEACHING MATERIALS IN THE FIELD OF WEALTH MANAGEMENT AND RETIREMENT PLANNING (U.S. CLS. 2, 5, 22, 23, 29, 37, 38 AND 50).

FIRST USE 1-0-2014; IN COMMERCE 1-0-2014.

**CLASS 36—INSURANCE AND FINANCIAL**

FOR PROVIDING ON-LINE INFORMATION FOR INVESTMENT ADVISORS AND THEIR CLIENTS IN THE FIELD OF WEALTH MANAGEMENT AND RETIREMENT PLANNING (U.S. CLS. 100, 101 AND 102).

FIRST USE 1-0-2014; IN COMMERCE 1-0-2014.

**CLASS 41—EDUCATION AND ENTERTAINMENT**

FOR EDUCATION SERVICES, NAMELY, PROVIDING SEMINARS AND WORKSHOPS IN THE FIELD OF WEALTH MANAGEMENT AND RETIREMENT PLANNING (U.S. CLS. 100, 101 AND 107).

FIRST USE 1-0-2014; IN COMMERCE 1-0-2014.

4,594,134. THORO-PACKAGING, CORONA, CA. SN 85-970,496. PUB. 12-3-2013, FILED 6-26-2013.

**THOROPROTOTYPE**

THE MARK CONSISTS OF STANDARD CHARACTERS WITHOUT CLAIM TO ANY PARTICULAR FONT, STYLE, SIZE, OR COLOR.

OWNER OF U.S. REG. NO. 2,096,792.

**CLASS 16—PAPER GOODS AND PRINTED MATTER**

FOR PRE-PRINTED, PRE-FABRICATED PACKAGING MATERIALS, NAMELY, CARDBOARD, CORRUGATED AND PAPERBOARD BOXES; PAPER BAGS; CARDBOARD AND PAPER ENVELOPES AND PAPER WRAPPINGS, ALL FOR PACKAGING OF GOODS (U.S. CLS. 2, 5, 22, 23, 29, 37, 38 AND 50).

FIRST USE 5-21-2013; IN COMMERCE 5-21-2013.

**CLASS 40—MATERIAL TREATMENT**

FOR CUSTOM MANUFACTURE OF PRODUCT PACKAGING; PRINTING; EMBOSsing SERVICES, NAMELY, EMBOSsing WORDS, DESIGNS OR IMAGES ON PRODUCT PACKAGING (U.S. CLS. 100, 103 AND 106).

FIRST USE 5-21-2013; IN COMMERCE 5-21-2013.

**CLASS 42—SCIENTIFIC AND COMPUTER SERVICES**

FOR PACKAGING DESIGN; GRAPHIC DESIGN (U.S. CLS. 100 AND 101).

FIRST USE 5-21-2013; IN COMMERCE 5-21-2013.

4,594,155. MARY KAY INC., ADDISON, TX. SN 85-974,731. PUB. 10-29-2013, FILED 7-1-2013.

**DISCOVER WHAT YOU LOVE**

THE MARK CONSISTS OF STANDARD CHARACTERS WITHOUT CLAIM TO ANY PARTICULAR FONT, STYLE, SIZE, OR COLOR.

**CLASS 3—COSMETICS AND CLEANING PREPARATIONS**

FOR COSMETICS, NON-MEDICATED TOILETRIES, NON-MEDICATED SKIN CARE PREPARATIONS AND FRAGRANCES FOR PERSONAL USE (U.S. CLS. 1, 4, 6, 50, 51 AND 52).  
FIRST USE 2-14-2014; IN COMMERCE 2-14-2014.

**CLASS 16—PAPER GOODS AND PRINTED MATTER**

FOR PRINTED BUSINESS SUPPLIES, MARKETING MATERIALS AND SALES AIDS, NAMELY, CATALOGS, MAGAZINES, BUSINESS CARDS, LETTERHEAD, ENVELOPES, STATIONERY AND BROCHURES, ALL IN THE FIELDS OF COSMETICS AND BEAUTY CARE AND DIRECT SALES OF COSMETICS AND BEAUTY CARE PRODUCTS; PLASTIC AND PAPER COSMETIC BAGS SOLD EMPTY (U.S. CLS. 2, 5, 22, 23, 29, 37, 38 AND 50).  
FIRST USE 2-14-2014; IN COMMERCE 2-14-2014.

4,594,158. SEVEN WELLS, LLC, DBA I. E. DISTRIBUTION, COSTA MESA, CA. SN 85-980,607. PUB. 2-19-2013, FILED 10-17-2012.



THE MARK CONSISTS OF A SHADED CIRCLE WITH CROSSED LIGHTNING BOLTS CENTERED IN THE MIDDLE OF THE SHADED CIRCLE, WITH THE LETTER "W" CENTERED INSIDE OF THE TOP PORTION OF THE SHADED CIRCLE, WITH THE LETTER "L" CENTERED TO THE RIGHT EDGE PORTION OF THE SHADED CIRCLE, WITH THE LETTER "D" CENTERED AT THE BOTTOM PORTION OF THE SHADED CIRCLE, AND WITH THE LETTER "R" CENTERED TO THE LEFT EDGE PORTION OF THE SHADED CIRCLE.

**CLASS 25—CLOTHING**

FOR CLOTHING, NAMELY T-SHIRTS, TANK TOPS, TOPS, SWEATERS, JACKETS, BOXER SHORTS, PANTS, JEANS, SHORTS, SWEAT SHIRTS, SWEAT PANTS; HEADGEAR, NAMELY BEANIES, CAPS, AND HATS; AND FOOTWEAR (U.S. CLS. 22 AND 39).  
FIRST USE 1-31-2013; IN COMMERCE 1-31-2013.

**CLASS 28—TOYS AND SPORTING GOODS**

FOR GAMES, PLAYTHINGS, AND SPORTING GOODS, NAMELY, SKATEBOARD DECKS, SKATEBOARD WHEELS, SKATEBOARDS, SKIS, SNOW SAUCERS, SNOW SKIS, SNOW SLEDS FOR RECREATIONAL USE, SNOWBOARD DECKS, SNOWBOARDS, WAKEBOARDS, WATERSKIS, SOFT SCULPTURE DOLLS, ELECTRONICALLY OPERATED TOY MOTOR VEHICLES, KITES, BODY BOARDS (U.S. CLS. 22, 23, 38 AND 50).  
FIRST USE 1-31-2013; IN COMMERCE 1-31-2013.

4,594,159. WHOLE FOODS MARKET IP, L.P., AUSTIN, TX. SN 85-981,865. PUB. 4-9-2013, FILED 1-5-2012.

**WHOLE JOURNEYS**

THE MARK CONSISTS OF STANDARD CHARACTERS WITHOUT CLAIM TO ANY PARTICULAR FONT, STYLE, SIZE, OR COLOR.

NO CLAIM IS MADE TO THE EXCLUSIVE RIGHT TO USE "JOURNEYS", APART FROM THE MARK AS SHOWN.

**CLASS 35—ADVERTISING AND BUSINESS**

FOR PROVIDING TRAVEL MANAGEMENT SERVICES (U.S. CLS. 100, 101 AND 102).  
FIRST USE 10-0-2012; IN COMMERCE 10-0-2012.

**CLASS 39—TRANSPORTATION AND STORAGE**

FOR TRAVEL SERVICES, NAMELY, ESCORTING OF TRAVELERS, TRANSPORT OF TRAVELERS AND THEIR LUGGAGE, AND CONSULTATION IN THE FIELD OF TRAVEL DESTINATIONS; TRAVEL AGENCY SERVICES, NAMELY, MAKING AND COORDINATING TRAVEL ARRANGEMENTS FOR OTHERS; ARRANGING TRAVEL FOR OTHERS; ARRANGING TRAVEL TOURS; MAKING RESERVATIONS AND BOOKINGS FOR TRANSPORTATION FOR OTHERS; PROVISION OF TRAVEL INFORMATION; COORDINATING TRAVEL ARRANGEMENTS FOR INDIVIDUALS AND FOR GROUPS; PROVIDING INFORMATION ONLINE IN THE FIELDS OF TRAVEL, TOURISM TRAVEL SERVICES, AND TRAVEL DESTINATIONS (U.S. CLS. 100 AND 105).  
FIRST USE 10-0-2012; IN COMMERCE 10-0-2012.

**CLASS 42—SCIENTIFIC AND COMPUTER SERVICES**

FOR COMPUTER SERVICES, NAMELY, PROVIDING A WEBSITE FEATURING TECHNOLOGY THAT ENABLES INTERNET USERS TO BOOK TRAVEL RESERVATIONS AND ARRANGEMENTS, PROVIDING A WEBSITE THAT ENABLES USERS TO SUBSCRIBE TO NEWSLETTERS AND UPDATES REGARDING TRAVEL, PROVIDING A WEBSITE THAT GIVES USERS THE ABILITY TO POST BLOGS, VIDEOS, MOVIES, COMMENTS, REVIEWS, PHOTOGRAPHS AND PICTURES, AND PROVIDING A WEBSITE THAT GIVES USERS THE ABILITY TO REVIEW VARIOUS PRINT, PHOTOGRAPHIC, GRAPHIC IMAGE, AND AUDIO AND VIDEO CONTENT AND UTILIZE A CUSTOM TEMPLATE TO PROVIDE INPUT, LIKES, DISLIKES, EDITS, CHANGES, MODIFICATIONS, OPINIONS, SUGGESTIONS, AND COMMENTS AND ENGAGE IN SOCIAL, BUSINESS AND COMMUNITY NETWORKING (U.S. CLS. 100 AND 101).

FIRST USE 10-0-2012; IN COMMERCE 10-0-2012.

**CLASS 43—HOTEL AND RESTAURANT SERVICES**

FOR TRAVEL AGENCY SERVICES, NAMELY, MAKING RESERVATIONS AND BOOKING FOR TEMPORARY LODGING; PROVIDING INFORMATION ONLINE TO TRAVELERS AND TOURISTS IN THE FIELDS OF RESTAURANTS, TEMPORARY LODGINGS, AND LOCAL FOOD AND DRINK (U.S. CLS. 100 AND 101).

FIRST USE 10-0-2012; IN COMMERCE 10-0-2012.

4,594,163. FLUFF MONKEY ENTERPRISES, LLC, SEVEN VALLEYS, PA. SN 85-982,033. PUB. 12-6-2011, FILED 4-15-2011.

**FLUFF MONKEY**

THE MARK CONSISTS OF STANDARD CHARACTERS WITHOUT CLAIM TO ANY PARTICULAR FONT, STYLE, SIZE, OR COLOR.

OWNER OF U.S. REG. NO. 3,937,449.

**CLASS 3—COSMETICS AND CLEANING PREPARATIONS**

FOR SHOE SHINE KITS COMPRISED OF SHOE POLISHES AND CREAMS AND A SHOE SHINE APPARATUS MADE OF FABRIC ASSEMBLED IN A POM-POM LIKE FASHION (U.S. CLS. 1, 4, 6, 50, 51 AND 52).

FIRST USE 6-27-2012; IN COMMERCE 8-4-2012.

**CLASS 6—METAL GOODS**

FOR METAL KEYCHAINS; METAL CARABINER CLIPS (U.S. CLS. 2, 12, 13, 14, 23, 25 AND 50).

FIRST USE 2-24-2011; IN COMMERCE 3-0-2011.

**CLASS 9—ELECTRICAL AND SCIENTIFIC APPARATUS**

FOR CELLULAR PHONE ACCESSORY CHARMS (U.S. CLS. 21, 23, 26, 36 AND 38).

FIRST USE 11-4-2012; IN COMMERCE 11-4-2012.

**CLASS 14—JEWELRY**

FOR JEWELRY; CHARMS FOR USE AS PERSONAL JEWELRY (U.S. CLS. 2, 27, 28 AND 50).

FIRST USE 6-0-2012; IN COMMERCE 7-11-2012.

**CLASS 16—PAPER GOODS AND PRINTED MATTER**

FOR PACKAGED KITS COMPOSED PRIMARILY OF PRINTED INSTRUCTIONAL MATERIALS FOR THE ASSEMBLY OF APPARATI MADE OF FABRIC ASSEMBLED IN A POM-POM LIKE FASHION (U.S. CLS. 2, 5, 22, 23, 29, 37, 38 AND 50).

FIRST USE 9-6-2012; IN COMMERCE 9-6-2012.

**CLASS 18—LEATHER GOODS**

FOR LUGGAGE TAGS; BACKPACKS; CLOTHING FOR DOMESTIC PETS; PET COLLAR ACCESSORIES, NAMELY, BOWS AND CHARMS; PURSE CHARMS; PURSE ACCESSORY, NAMELY, AN APPARATUS MADE OF FABRIC AND ASSEMBLED IN A POM-POM LIKE FASHION THAT ATTACHES TO THE OUTSIDE OF A WOMAN'S PURSE AS A DECORATIVE ACCESSORY; BACKPACK ACCESSORY, NAMELY, AN APPARATUS MADE OF FABRIC AND ASSEMBLED IN A POM-POM LIKE FASHION THAT ATTACHES TO THE OUTSIDE OF A BACKPACK (U.S. CLS. 1, 2, 3, 22 AND 41).

FIRST USE 2-24-2011; IN COMMERCE 3-0-2011.

**CLASS 21—HOUSEWARES AND GLASS**

FOR DUSTING GLOVES; SHOE SHINE CLOTHS (U.S. CLS. 2, 13, 23, 29, 30, 33, 40 AND 50).

FIRST USE 2-24-2011; IN COMMERCE 3-0-2011.

**CLASS 24—FABRICS**

FOR BEACH TOWELS; BED COVERS; WASHING GLOVES (U.S. CLS. 42 AND 50).

FIRST USE 2-24-2011; IN COMMERCE 3-0-2011.

**CLASS 25—CLOTHING**

FOR HATS; FLIP FLOPS; CLOTHING, NAMELY, T-SHIRTS; HEADBANDS (U.S. CLS. 22 AND 39).

FIRST USE 9-24-2011; IN COMMERCE 1-0-2012.

**CLASS 26—FANCY GOODS**

FOR SHOELACES; PONYTAIL HOLDERS; CLOTHING ACCESSORIES, NAMELY, CHARMS FOR ATTACHMENT TO ZIPPER PULLS AND BUTTONS; CHARMS FOR SHOES; BELT ACCESSORY, NAMELY, AN APPARATUS MADE OF FABRIC AND ASSEMBLED IN A POM-POM LIKE FASHION THAT ATTACHES TO THE CLIP OF A BELT USED FOR CLOTHING (U.S. CLS. 37, 39, 40, 42 AND 50).

FIRST USE 6-28-2011; IN COMMERCE 6-28-2011.

**CLASS 28—TOYS AND SPORTING GOODS**

FOR PARTY FAVORS IN THE NATURE OF SMALL TOYS; PET TOYS; GAMES, NAMELY, A TOSS AND PITCH GAME USING AN APPARATUS MADE OF FABRIC ASSEMBLED IN A POM-POM LIKE FASHION; STRESS RELIEF APPARATUS MADE OF FABRIC AND ASSEMBLED IN A POM-POM LIKE FASHION FOR HAND EXERCISE (U.S. CLS. 22, 23, 38 AND 50).

FIRST USE 2-24-2011; IN COMMERCE 3-0-2011.

4,594,164. SEVENTH GENERATION, INC., BURLINGTON, VT. SN 85-982,046. PUB. 9-18-2012, FILED 2-10-2012.

**CARING TODAY FOR SEVEN  
GENERATIONS OF TOMORROWS.**

THE MARK CONSISTS OF STANDARD CHARACTERS WITHOUT CLAIM TO ANY PARTICULAR FONT, STYLE, SIZE, OR COLOR.

**CLASS 3—COSMETICS AND CLEANING PREPARATIONS**

FOR NON-MEDICATED SOAPS, BODY WASHES FOR INFANTS, CHILDREN AND ADULTS, NON-MEDICATED SKIN CARE PREPARATIONS; NON-MEDICATED SKIN LOTIONS, CREAMS, OILS AND GELS FOR INFANTS, CHILDREN AND ADULTS; PRE-MOISTENED, NON-MEDICATED BABY WIPES; FABRIC SOFTENER FOR LAUNDRY USE; DISHWASHER RINSE AID; BATH SOAP, TOILET SOAP, LAUNDRY BLEACH, LAUNDRY CLEANING PREPARATIONS, LAUNDRY STAIN REMOVAL PREPARATIONS; AUTOMATIC DISHWASHER DETERGENTS; DISH WASHING PREPARATIONS, GLASS CLEANING PREPARATIONS, TOILET CLEANING PREPARATIONS, ALL-PURPOSE CLEANING PREPARATIONS, HOUSEHOLD SURFACE CLEANING PREPARATIONS; HOUSEHOLD CLEANING PREPARATIONS FOR USE IN NURSERIES; GLASS CLEANING PREPARATIONS; TUB AND TILE CLEANING PREPARATIONS; SHOWER CLEANING PREPARATIONS; CLEANERS FOR METAL HOUSEHOLD SURFACES; CLEANERS FOR CERAMIC HOUSEHOLD SURFACES; CLEANERS FOR STONE HOUSEHOLD SURFACES (U.S. CLS. 1, 4, 6, 50, 51 AND 52).

FIRST USE 3-1-2013; IN COMMERCE 3-1-2013.

**CLASS 5—PHARMACEUTICALS**

FOR FEMININE HYGIENE PADS AND PANTY LINERS; BABIES' DIAPERS OF PAPER; DISPOSABLE BABY DIAPERS (U.S. CLS. 6, 18, 44, 46, 51 AND 52).

FIRST USE 5-1-2013; IN COMMERCE 5-1-2013.

**CLASS 16—PAPER GOODS AND PRINTED MATTER**

FOR PAPER TOWELS, TOILET PAPER, FACIAL TISSUES, GROCERY BAGS, PLASTIC TRASH BAGS, PAPER NAPKINS; DISPOSABLE CHILDREN'S TRAINING PANTS (U.S. CLS. 2, 5, 22, 23, 29, 37, 38 AND 50).

FIRST USE 6-1-2013; IN COMMERCE 6-1-2013.

4,594,169. ELLIOT, MICHAEL, LOS ANGELES, CA. SN 85-982,094. PUB. 10-1-2013, FILED 4-26-2013.

**Hammer & Nails - Nail Shop  
for Guys**

THE MARK CONSISTS OF STANDARD CHARACTERS WITHOUT CLAIM TO ANY PARTICULAR FONT, STYLE, SIZE, OR COLOR.

NO CLAIM IS MADE TO THE EXCLUSIVE RIGHT TO USE "NAIL SHOP FOR GUYS", APART FROM THE MARK AS SHOWN.

**CLASS 3—COSMETICS AND CLEANING PREPARATIONS**

FOR COSMETICS, NAMELY, HAND LOTION AND FOOT LOTION (U.S. CLS. 1, 4, 6, 50, 51 AND 52).

FIRST USE 1-8-2014; IN COMMERCE 1-8-2014.

**CLASS 44—MEDICAL, BEAUTY AND AGRICULTURAL SERVICES**

FOR BEAUTY SERVICES, NAMELY, PROVIDING MANICURES, PEDICURES, FACIALS AND WAXING (U.S. CLS. 100 AND 101).

FIRST USE 11-5-2013; IN COMMERCE 11-9-2013.

4,594,170. OT MOBILITY, INC., CUPERTINO, CA. SN 85-982,159. PUB. 11-5-2013, FILED 5-11-2013.

**OT MOBILITY**

THE MARK CONSISTS OF STANDARD CHARACTERS WITHOUT CLAIM TO ANY PARTICULAR FONT, STYLE, SIZE, OR COLOR.

**CLASS 9—ELECTRICAL AND SCIENTIFIC APPARATUS**

FOR DOWNLOADABLE SOFTWARE IN THE NATURE OF A MOBILE APPLICATION FOR APPOINTMENT SCHEDULING AND BOOKING, CALENDARING, TRANSPORTATION STATUS UPDATES, ELECTRONIC MAP DISPLAY, AND TRIP PLANNING (U.S. CLS. 21, 23, 26, 36 AND 38).

FIRST USE 2-27-2014; IN COMMERCE 2-27-2014.

**CLASS 38—COMMUNICATION**

FOR TELECOMMUNICATIONS SERVICES, NAMELY, EMAIL NOTIFICATION ALERTS VIA THE INTERNET, SHORT MESSAGE SERVICE MESSAGES, TWO WAY MESSAGING MESSAGES, AND PUSH-NOTIFICATIONS TO USERS OF PORTABLE ELECTRONIC DEVICES (U.S. CLS. 100, 101 AND 104).

FIRST USE 2-27-2014; IN COMMERCE 2-27-2014.

4,594,171. OT MOBILITY, INC., CUPERTINO, CA. SN 85-982,160. PUB. 11-5-2013, FILED 5-10-2013.

**SPOT ON TIME**

THE MARK CONSISTS OF STANDARD CHARACTERS WITHOUT CLAIM TO ANY PARTICULAR FONT, STYLE, SIZE, OR COLOR.

**CLASS 9—ELECTRICAL AND SCIENTIFIC APPARATUS**

FOR DOWNLOADABLE SOFTWARE IN THE NATURE OF A MOBILE APPLICATION FOR APPOINTMENT SCHEDULING AND BOOKING, CALENDARING, TRANSPORTATION STATUS UPDATES, ELECTRONIC MAP DISPLAY, AND TRIP PLANNING (U.S. CLS. 21, 23, 26, 36 AND 38).

FIRST USE 2-27-2014; IN COMMERCE 2-27-2014.

**CLASS 38—COMMUNICATION**

FOR TELECOMMUNICATIONS SERVICES, NAMELY, EMAIL NOTIFICATION ALERTS VIA THE INTERNET, SHORT MESSAGE SERVICE MESSAGES, TWO WAY MESSAGING MESSAGES, AND PUSH-NOTIFICATIONS TO USERS OF PORTABLE ELECTRONIC DEVICES (U.S. CLS. 100, 101 AND 104).

FIRST USE 2-27-2014; IN COMMERCE 2-27-2014.

---

4,594,177. WHOLE FOODS MARKET IP, L.P., AUSTIN, TX.  
SN 85-982,213. PUB. 4-2-2013, FILED 12-15-2011.

# DARK RYE

THE MARK CONSISTS OF STANDARD CHARACTERS WITHOUT CLAIM TO ANY PARTICULAR FONT, STYLE, SIZE, OR COLOR.

**CLASS 9—ELECTRICAL AND SCIENTIFIC APPARATUS**

FOR COMPUTER APPLICATION SOFTWARE FOR MOBILE DEVICES TO ENABLE USERS TO ACCESS AND INTERACT WITH LIVE AND PRE-RECORDED PROGRAMS, AUDIO AND VIDEO RECORDINGS, DIGITAL MEDIA, AND DIGITAL MAGAZINES IN THE FIELDS OF COOKING, NUTRITION, SHOPPING, LEISURE, LIFESTYLE, PERSONAL IMPROVEMENT, FITNESS, NATURE, GARDENING, ENVIRONMENTAL ISSUES, CONSERVATION, FOOD, WINE, DIET, HEALTH, WELLNESS, POPULAR CULTURE, AND TOPICS OF GENERAL INTEREST, AND TO ACCESS AND INTERACT WITH CURRENT EVENT NEWS-RELATED INFORMATION, ENTERTAINMENT-RELATED INFORMATION, EDUCATION INFORMATION, AND INFORMATION IN THE FIELDS OF COOKING, NUTRITION, SHOPPING, LEISURE, LIFESTYLE, PERSONAL IMPROVEMENT, FITNESS, NATURE, GARDENING, ENVIRONMENTAL ISSUES, CONSERVATION, FOOD, WINE, DIET, HEALTH, WELLNESS, POPULAR CULTURE, AND TOPICS OF GENERAL INTEREST; PRE-RECORDED AUDIO AND VIDEO RECORDINGS, TELEVISION PROGRAMS, AND DIGITAL MEDIA IN THE FIELDS OF COOKING, NUTRITION, SHOPPING, LEISURE, LIFESTYLE, PERSONAL IMPROVEMENT, FITNESS, NATURE, GARDENING, ENVIRONMENTAL ISSUES, CONSERVATION, FOOD, WINE, DIET, HEALTH, WELLNESS, POPULAR CULTURE, AND TOPICS OF GENERAL INTEREST; DOWNLOADABLE ELECTRONIC PUBLICATIONS IN THE NATURE OF DIGITAL MAGAZINES, NEWSLETTERS, ARTICLES, INFORMATION SHEETS AND MOBILE APPLICATIONS IN THE FIELDS OF COOKING, NUTRITION, SHOPPING, LEISURE, LIFESTYLE, PERSONAL IMPROVEMENT, FITNESS, NATURE, GARDENING, ENVIRONMENTAL ISSUES, CONSERVATION, FOOD, WINE, DIET, HEALTH, WELLNESS, POPULAR CULTURE, AND TOPICS OF GENERAL INTEREST (U.S. CLS. 21, 23, 26, 36 AND 38).

FIRST USE 3-10-2012; IN COMMERCE 3-10-2012.

**CLASS 41—EDUCATION AND ENTERTAINMENT**

FOR ENTERTAINMENT AND EDUCATIONAL SERVICES, NAMELY, PROVIDING ONGOING PROGRAMS, SEGMENTS, SHOWS, AND NON-DOWNLOADABLE ONLINE VIDEO MAGAZINE FEATURING NEWS, COMEDY, ACTION, COMMENTARY, ADVICE, INTERVIEWS, DOCUMENTARY INFORMATION AND STORIES IN THE FIELDS OF COOKING, NUTRITION, SHOPPING, LEISURE, LIFESTYLE, PERSONAL IMPROVEMENT, FITNESS, NATURE, GARDENING, ENVIRONMENTAL ISSUES, CONSERVATION, FOOD, WINE, DIET, HEALTH, WELLNESS, POPULAR CULTURE, AND TOPICS OF GENERAL INTEREST DISTRIBUTED VIA VARIOUS PLATFORMS ACROSS MULTIPLE FORMS OF TRANSMISSION MEDIA; ENTERTAINMENT SERVICES, NAMELY, PRODUCTION AND DISTRIBUTION OF TELEVISION PROGRAMS AND MULTIMEDIA PROGRAMS; ENTERTAINMENT SERVICES, NAMELY, PRODUCTION AND DISTRIBUTION OF ELECTRONIC, DIGITAL VIDEO AND FILM; MEDIA PRODUCTION AND DISTRIBUTION SERVICES, NAMELY, VIDEO AND FILM PRODUCTION AND DISTRIBUTION, AND COMPUTER ANIMATION PRODUCTION SERVICES; PROVIDING INFORMATION ONLINE IN THE FIELDS OF FITNESS, LEISURE ACTIVITIES, AND POPULAR CULTURE (U.S. CLS. 100, 101 AND 107).

FIRST USE 3-10-2012; IN COMMERCE 3-10-2012.

**CLASS 43—HOTEL AND RESTAURANT SERVICES**

FOR PROVIDING INFORMATION ONLINE IN THE FIELDS OF COOKING, FOOD PREPARATION, WINE CHARACTERISTICS AND WINE AND FOOD PAIRINGS, INGREDIENTS AND RECIPES (U.S. CLS. 100 AND 101).

FIRST USE 3-10-2012; IN COMMERCE 3-10-2012.

**CLASS 44—MEDICAL, BEAUTY AND AGRICULTURAL SERVICES**

FOR PROVIDING INFORMATION ONLINE IN THE FIELDS OF NUTRITION, DIET, HEALTH, WELLNESS, MAINTAINING A HEALTHY LIFESTYLE, AND GARDENING (U.S. CLS. 100 AND 101).

FIRST USE 3-10-2012; IN COMMERCE 3-10-2012.

---

4,594,179. CHOISR INTERNET GMBH, BERLIN, FED REP GERMANY. SN 85-982,277. PUB. 10-15-2013, FILED 2-18-2013.

# Choisr

THE MARK CONSISTS OF STANDARD CHARACTERS WITHOUT CLAIM TO ANY PARTICULAR FONT, STYLE, SIZE, OR COLOR.

**CLASS 35—ADVERTISING AND BUSINESS**

FOR ADVERTISING AND PROMOTIONAL SERVICES; ADVERTISING AND MARKETING SERVICES, NAMELY, PROMOTING THE PRODUCTS AND SERVICES OF OTHERS; PROMOTING THE GOODS AND SERVICES OF OTHERS BY PROVIDING HYPERTEXT LINKS TO THE WEBSITES OF OTHERS (U.S. CLS. 100, 101 AND 102).

FIRST USE 8-19-2013; IN COMMERCE 8-19-2013.

**CLASS 42—SCIENTIFIC AND COMPUTER SERVICES**

FOR PROVIDING A WEBSITE FEATURING TECHNOLOGY THAT ENABLES INTERNET USERS TO CREATE, UPLOAD, BOOKMARK, VIEW, ANNOTATE, EVALUATE AND SHARE DATA, INFORMATION AND MULTIMEDIA CONTENT; COMPUTER SERVICES, NAMELY, CREATING AN ONLINE COMMUNITY FOR REGISTERED USERS TO PARTICIPATE IN DISCUSSIONS, GET FEEDBACK FROM THEIR PEERS, FORM VIRTUAL COMMUNITIES, AND ENGAGE IN SOCIAL NETWORKING SERVICES IN THE FIELD OF GENERAL INTEREST; HOSTING AN INTERACTIVE PLATFORM AND ONLINE NON-DOWNLOADABLE SOFTWARE FOR UPLOADING, POSTING, SHOWING, DISPLAYING, TAGGING, SHARING, EVALUATING AND TRANSMITTING MESSAGES, COMMENTS, MULTIMEDIA CONTENT, PHOTOS, PICTURES, IMAGES, TEXT, INFORMATION, AND OTHER USER-GENERATED CONTENT; PLATFORM AND FACILITY FOR MOBILE DEVICE COMMUNICATION, NAMELY, PROVIDING NON-DOWNLOADABLE SOFTWARE THAT FACILITATES SHARING AND DISCOVERING INFORMATION AND MEDIA CONTENT VIA MOBILE DEVICES; PLATFORM AND FACILITY FOR NETWORKED COMMUNICATIONS, NAMELY, PROVIDING NON-DOWNLOADABLE SOFTWARE THAT FACILITATES SHARING AND DISCOVERING INFORMATION AND MEDIA CONTENT VIA LOCAL AND GLOBAL COMPUTER, MOBILE, CELLULAR, WIRELESS AND DATA COMMUNICATIONS NETWORKS (U.S. CLS. 100 AND 101).

FIRST USE 8-19-2013; IN COMMERCE 8-19-2013.

**CLASS 45—PERSONAL AND LEGAL SERVICES**

FOR ONLINE SOCIAL NETWORKING SERVICES; PROVIDING ONLINE SOCIAL NETWORKING SERVICES FOR PURPOSES OF COMMENTARY, COMPARISON, COLLABORATION, CONSULTATION, EVALUATION, ADVICE, DISCUSSION, INFORMATION SHARING, ENTERTAINMENT OR GENERAL INTEREST (U.S. CLS. 100 AND 101).

FIRST USE 8-19-2013; IN COMMERCE 8-19-2013.

**CLASS 41—EDUCATION AND ENTERTAINMENT**

FOR MEDICAL TEACHING AND TRAINING; TRAINING OTHERS TO BECOME CERTIFIED ALCOHOLISM AND DRUG TREATMENT COUNSELORS; EDUCATION SERVICES, NAMELY, PROVIDING PERSONAL MEETINGS, SEMINARS, AND LECTURES TO PATIENTS, CLIENTS, HEALTH CARE PROVIDERS, AND COMMUNITY MEMBERS IN THE FIELD OF HEALTH; EDUCATION SERVICES, NAMELY, PROVIDING WEBINARS IN THE FIELD OF MEDICINE, HEALTH, AND WELLNESS; PROVIDING ON-LINE NEWSLETTERS IN THE FIELD OF MEDICINE, HEALTHCARE, HEALTH, AND DRUG AND ADDICTION TREATMENT AND RECOVERY (U.S. CLS. 100, 101 AND 107).

FIRST USE 6-16-2014; IN COMMERCE 6-16-2014.

**CLASS 42—SCIENTIFIC AND COMPUTER SERVICES**

FOR MEDICAL LABORATORY SERVICES; LABORATORY ANALYSIS IN THE FIELD OF TESTING FOR DRUGS, ALCOHOL, AND MEDICAL ILLNESSES; MEDICAL AND SCIENTIFIC RESEARCH IN THE FIELD OF DRUG AND ALCOHOL ADDICTION (U.S. CLS. 100 AND 101).

FIRST USE 6-16-2014; IN COMMERCE 6-16-2014.

**CLASS 44—MEDICAL, BEAUTY AND AGRICULTURAL SERVICES**

FOR DRUG TESTING FOR SUBSTANCE ABUSE; MEDICAL TESTING FOR DIAGNOSTIC OR TREATMENT PURPOSES; REHABILITATION OF DRUG ADDICTED PATIENTS; REHABILITATION OF ALCOHOL ADDICTED PATIENTS; MEDICAL ASSISTANCE SERVICES; MEDICAL SERVICES IN THE FIELDS OF PRIMARY CARE, PSYCHIATRIC AND PSYCHOLOGICAL CARE, TREATMENT OF SEXUALLY TRANSMITTED DISEASES, DRUG AND ALCOHOL DETOXIFICATION SERVICES, TREATMENT OF RESPIRATORY DISEASE, MENTAL HEALTH SERVICES, AND DRUG AND ALCOHOL REHABILITATION; MEDICAL, PHYSICAL REHABILITATION AND PHYSICAL THERAPY SERVICES; PSYCHOLOGICAL COUNSELING; RECREATIONAL THERAPY; COGNITIVE AND SKILL-BASED THERAPY; CONDUCTING MEDICAL PHYSICAL EVALUATIONS; MEDICAL CARE, NAMELY, PRIMARY CARE, PSYCHIATRIC CARE, PHYSIOLOGICAL CARE, AND DRUG AND ALCOHOL REHABILITATION; PROVIDING MEDICAL ADVICE IN THE FIELD OF PRIMARY CARE, PSYCHIATRIC CARE, PHYSIOLOGICAL CARE, AND DRUG AND ALCOHOL REHABILITATION; PROVIDING MEDICAL INFORMATION IN THE FIELD OF PRIMARY CARE, PSYCHIATRIC CARE, PHYSIOLOGICAL CARE, AND DRUG AND ALCOHOL REHABILITATION; COGNITIVE THERAPY SERVICES; PROVIDING MENTAL REHABILITATION FACILITIES; PROVIDING PHYSICAL REHABILITATION FACILITIES; MEDICAL REHABILITATION, NAMELY, MEDICAL, PHARMACOLOGICAL, AND BEHAVIORAL SERVICES FOR PATIENTS WITH SUBSTANCE USE DISORDERS AND CO-OCCURRING MEDICAL AND PSYCHOLOGICAL DISABILITIES; PROVIDING RESIDENTIAL TREATMENT FACILITIES FOR THE TREATMENT OF DRUG AND ALCOHOL ADDICTION AND DETOXIFICATION (U.S. CLS. 100 AND 101).

FIRST USE 6-16-2014; IN COMMERCE 6-16-2014.

4,594,180. START TREATMENT & RECOVERY CENTERS, INC., BROOKLYN, NY. SN 85-982,290. PUB. 10-22-2013, FILED 4-15-2013.

THE RIGHT WAY TO TREAT  
PEOPLE

THE MARK CONSISTS OF STANDARD CHARACTERS WITHOUT CLAIM TO ANY PARTICULAR FONT, STYLE, SIZE, OR COLOR.

**CLASS 9—ELECTRICAL AND SCIENTIFIC APPARATUS**

FOR COMPUTER SOFTWARE FOR CONTROLLING AND MANAGING PATIENT MEDICAL INFORMATION (U.S. CLS. 21, 23, 26, 36 AND 38).

FIRST USE 6-16-2014; IN COMMERCE 6-16-2014.

**CLASS 45—PERSONAL AND LEGAL SERVICES**

FOR CASE MANAGEMENT SERVICES, NAMELY, COORDINATION OF LEGAL, PHYSICAL, SOCIAL, AND PSYCHOLOGICAL SERVICES FOR PEOPLE SUFFERING FROM DRUG AND ALCOHOL ADDICTION AND ILLNESSES (U.S. CLS. 100 AND 101).

FIRST USE 6-16-2014; IN COMMERCE 6-16-2014.



4,594,189. ZYGOTE MEDIA GROUP, INC., AMERICAN FORK, UT. SN 85-982,497. PUB. 10-23-2012, FILED 11-7-2011.

## ZYGOTE BODY

THE MARK CONSISTS OF STANDARD CHARACTERS WITHOUT CLAIM TO ANY PARTICULAR FONT, STYLE, SIZE, OR COLOR.

NO CLAIM IS MADE TO THE EXCLUSIVE RIGHT TO USE "BODY", APART FROM THE MARK AS SHOWN.

### CLASS 9—ELECTRICAL AND SCIENTIFIC APPARATUS

FOR COMPUTER SOFTWARE FOR MOBILE DEVICES, PERSONAL COMPUTERS, CONSOLES AND TABLETS, NAMELY, COMPUTER SOFTWARE FOR ALLOWING USERS TO VIEW DIGITAL THREE DIMENSIONAL IMAGES OF THE ANATOMY; SOFTWARE FOR PROCESSING DIGITAL THREE DIMENSIONAL IMAGES OF THE ANATOMY (U.S. CLS. 21, 23, 26, 36 AND 38).

FIRST USE 1-0-2012; IN COMMERCE 1-0-2012.

### CLASS 41—EDUCATION AND ENTERTAINMENT

FOR EDUCATIONAL SERVICES, NAMELY, PROVIDING ONLINE INSTRUCTION IN THE FIELD HUMAN ANATOMY VIA AN ONLINE WEBSITE (U.S. CLS. 100, 101 AND 107).

FIRST USE 1-0-2012; IN COMMERCE 1-0-2012.

### CLASS 42—SCIENTIFIC AND COMPUTER SERVICES

FOR PROVIDING A WEBSITE FEATURING TECHNOLOGY ENABLING USERS TO EXPLORE HUMAN ANATOMY VIA A THREE DIMENSIONAL BROWSER THAT INCLUDES LAYER OPTIONS SUCH AS SKIN, TISSUE, AND BONE; ONLINE COMPUTER SERVICES, NAMELY, PROVIDING A WEBSITE FEATURING TECHNOLOGY ENABLING USERS TO EXPLORE HUMAN ANATOMY VIA A THREE DIMENSIONAL BROWSER THAT INCLUDES LAYER OPTIONS SUCH AS SKIN, TISSUE, AND BONE; PROVIDING AN INTERACTIVE WEBSITE FEATURING TECHNOLOGY THAT ALLOWS USERS TO EXPLORE HUMAN ANATOMY VIA A THREE DIMENSIONAL BROWSER THAT INCLUDES LAYER OPTIONS SUCH AS SKIN, TISSUE, AND BONE; COMPUTER GRAPHICS DESIGN SERVICES, NAMELY, CREATING 3D COMPUTER MODELS AND ANIMATIONS (U.S. CLS. 100 AND 101).

FIRST USE 1-0-2012; IN COMMERCE 1-0-2012.

4,594,190. PEAK PERFORMANCE CHIROPRACTIC, PLLC, GRAND RAPIDS, MI. SN 85-982,508. PUB. 11-12-2013, FILED 12-5-2012.

## I-CHIRO

THE MARK CONSISTS OF STANDARD CHARACTERS WITHOUT CLAIM TO ANY PARTICULAR FONT, STYLE, SIZE, OR COLOR.

### CLASS 35—ADVERTISING AND BUSINESS

FOR FRANCHISE SERVICES, NAMELY, OFFERING BUSINESS MANAGEMENT ASSISTANCE IN THE ESTABLISHMENT AND OPERATION OF CHIROPRACTIC, MEDICAL, MASSAGE THERAPY, AROMATHERAPY AND DAY SPA SERVICE PROVIDERS (U.S. CLS. 100, 101 AND 102).

FIRST USE 11-0-2012; IN COMMERCE 1-0-2013.

### CLASS 44—MEDICAL, BEAUTY AND AGRICULTURAL SERVICES

FOR CHIROPRACTIC SERVICES; HEALTH SPA SERVICES FOR HEALTH AND WELLNESS OF THE BODY AND SPIRIT, NAMELY, PROVIDING MASSAGE, FACIAL AND BODY TREATMENT SERVICES, COSMETIC BODY CARE SERVICES; DAY SPA SERVICES, NAMELY, BODY WRAPS, DETOXIFICATION SERVICES, NUTRITIONAL THERAPY AND GUIDANCE, PROVIDING WEIGHT LOSS PROGRAMS, AND FOOT BATH SERVICES; MEDICAL SPA SERVICES, NAMELY, MINIMALLY AND NON-INVASIVE COSMETIC AND BODY FITNESS THERAPIES (U.S. CLS. 100 AND 101).

FIRST USE 11-0-2012; IN COMMERCE 1-0-2013.

4,594,191. PRECIOUS MOMENTS, INC., CARTHAGE, MO. SN 85-982,537. PUB. 11-26-2013, FILED 5-24-2013.

## PRETTY AS A PRINCESS

THE MARK CONSISTS OF STANDARD CHARACTERS WITHOUT CLAIM TO ANY PARTICULAR FONT, STYLE, SIZE, OR COLOR.

OWNER OF U.S. REG. NO. 3,168,723.

### CLASS 15—MUSICAL INSTRUMENTS

FOR MUSICAL BOXES (U.S. CLS. 2, 21 AND 36).  
FIRST USE 9-15-2010; IN COMMERCE 9-15-2010.

### CLASS 16—PAPER GOODS AND PRINTED MATTER

FOR BABY BOOKS; BALLPOINT PENS; BLANK WRITING JOURNALS; BOOK ENDS; BOOK MARKS; CARDS, NAMELY, NOTECARDS, GREETING CARDS; CHARTS FOR DISPLAYING DATA ABOUT HUMAN HEIGHT AND ALSO DISPLAYING A RULER FOR MEASURING A PERSON'S HEIGHT; CHILDREN'S ACTIVITY BOOKS; CHILDREN'S BOOKS; COLORING BOOKS; DESK CALENDARS; MEMORY BOOKS; MEMORY BOXES, NAMELY, CARDBOARD BOXES CONTAINING CARDBOARD CARDS FOR DISPLAYING AND STORING BABY/INFANT, SCHOOL KEEPSAKES AND MEMENTOS; NOTE BOOKS; PAPER STATIONERY; PEN AND PENCIL CASES AND BOXES; PEN AND PENCIL HOLDERS; PEN AND PENCIL TRAYS; PENCIL SHARPENERS; PENCILS; SCHOOL SUPPLY KITS CONTAINING VARIOUS COMBINATIONS OF SELECTED SCHOOL SUPPLIES, NAMELY, WRITING INSTRUMENTS, PENS, PENCILS, MECHANICAL PENCILS, ERASERS, MARKERS, CRAYONS, HIGHLIGHTER PENS, FOLDERS, NOTEBOOKS, PAPER, PROTRACTORS, PAPER CLIPS, PENCIL SHARPENERS, WRITING GRIPS, GLUE AND BOOK MARKS; SCRAP BOOKS; STATIONERY WRITING PAPER AND ENVELOPES; STICKERS; STORY BOOKS; WALL CALENDARS (U.S. CLS. 2, 5, 22, 23, 29, 37, 38 AND 50).

FIRST USE 5-9-2006; IN COMMERCE 5-9-2006.

**CLASS 20—FURNITURE AND ARTICLES NOT OTHERWISE CLASSIFIED**

FOR COLD CAST RESIN FIGURINES; DECORATIVE BOXES MADE OF WOOD; FURNITURE FOR HOUSE, OFFICE AND GARDEN; FURNITURE, MIRRORS, PICTURE FRAMES; FURNITURE, NAMELY, DRESSERS; TOY BOXES; WALL PLAQUES MADE OF RESIN OR WOOD; WORKS OF ART OF RESIN OR WOOD (U.S. CLS. 2, 13, 22, 25, 32 AND 50).

FIRST USE 9-15-2010; IN COMMERCE 9-15-2013.

**CLASS 21—HOUSEWARES AND GLASS**

FOR CERAMIC FIGURINES; DISHES; DRINKING GLASSES, NAMELY, TUMBLERS; MUGS; WALL PLAQUES MADE OF PORCELAIN; WORKS OF ART OF PORCELAIN (U.S. CLS. 2, 13, 23, 29, 30, 33, 40 AND 50).

FIRST USE 9-15-2010; IN COMMERCE 9-15-2010.

4,594,197. LIQUIDPRACTICE LLC, ALBUQUERQUE, NM.  
SN 86-001,890. PUB. 12-10-2013, FILED 7-3-2013.



NO CLAIM IS MADE TO THE EXCLUSIVE RIGHT TO USE "ATTACHEDAPPS.COM", APART FROM THE MARK AS SHOWN.

THE MARK CONSISTS OF A STYLIZED LETTER LOWER CASE "A" IN THE SHAPE OF A PAPERCLIP INSIDE A SHADED CIRCLE TO THE LEFT OF THE COMBINED WORD "ATTACHEDAPPS" WITH ".COM" BELOW THE WORD AT THE FAR RIGHT.

**CLASS 9—ELECTRICAL AND SCIENTIFIC APPARATUS**

FOR COMPUTER APPLICATION SOFTWARE FOR SMART PHONES, TABLET COMPUTERS, AND COMPUTERS, NAMELY, SOFTWARE FOR ANALYZING, CREATING, MANAGING, REPORTING, STORING AND TRACKING DATA IN THE FIELDS OF CUSTOMER RELATIONSHIP MANAGEMENT, EMPLOYEE EFFICIENCY, MARKETING, PRODUCT SUPPORT, PROMOTION, SALES, SALES SUPPORT, SCHEDULING, SECURITY, SERVICES, TASK MANAGEMENT AND TRACKING, TIME MANAGEMENT AND TRACKING, VENDOR INFORMATION, VENDOR RELATIONSHIP MANAGEMENT; COMPUTER SOFTWARE FOR APPLICATION AND DATABASE INTEGRATION; COMPUTER SOFTWARE FOR ANALYZING, CREATING, MANAGING, REPORTING, STORING AND TRACKING DATA IN THE FIELDS OF CUSTOMER RELATIONSHIP MANAGEMENT, EMPLOYEE EFFICIENCY, MARKETING, PRODUCT SUPPORT, PROMOTION, SALES, SALES SUPPORT, SCHEDULING, SECURITY, SERVICES, TASK MANAGEMENT AND TRACKING, TIME MANAGEMENT AND TRACKING, VENDOR INFORMATION, VENDOR RELATIONSHIP MANAGEMENT AND INSTRUMENTAL USER GUIDES SOLD AS A UNIT; COMPUTER SOFTWARE FOR ANALYZING, CREATING, MANAGING, REPORTING, STORING AND TRACKING DATA IN THE FIELDS OF CUSTOMER RELATIONSHIP MANAGEMENT, EMPLOYEE EFFICIENCY, MARKETING, PRODUCT SUPPORT, PROMOTION, SALES, SALES SUPPORT, SCHEDULING, SECURITY, SERVICES, TASK MANAGEMENT AND TRACKING, TIME MANAGEMENT AND TRACKING, VENDOR INFORMATION, VENDOR RELATIONSHIP MANAGEMENT; COMPUTER SOFTWARE FOR ANALYZING, CREATING, MANAGING, REPORTING, STORING AND TRACKING DATA IN THE FIELDS OF CUSTOMER RELATIONSHIP MANAGEMENT, EMPLOYEE EFFICIENCY, MARKETING, PRODUCT SUPPORT, PROMOTION, SALES, SALES SUPPORT, SCHEDULING, SECURITY, SERVICES, TASK MANAGEMENT AND TRACKING, TIME MANAGEMENT AND TRACKING, VENDOR INFORMATION, VENDOR RELATIONSHIP MANAGEMENT; COMPUTER SOFTWARE FOR ANALYZING, CREATING, MANAGING, REPORTING, STORING AND TRACKING DATA IN THE FIELDS OF CUSTOMER RELATIONSHIP MANAGEMENT, EMPLOYEE EFFICIENCY, MARKETING, PRODUCT SUPPORT, PROMOTION, SALES, SALES SUPPORT, SCHEDULING, SECURITY, SERVICES, TASK MANAGEMENT AND TRACKING, TIME MANAGEMENT AND TRACKING, VENDOR INFORMATION, VENDOR RE-

LATIONSHIP MANAGEMENT THAT MAY BE DOWNLOADED FROM A GLOBAL COMPUTER NETWORK; COMPUTER SOFTWARE PLATFORMS FOR FACILITATING AND COMMUNICATING AMONG PEER PROFESSIONALS IN THE ACCOUNTING, ADVERTISING, ARCHITECTURE, CONSTRUCTION, FINANCIAL SERVICES, LEGAL SERVICES, MARKETING, REAL ESTATE AND BUSINESS SERVICES FIELDS, AND FOR CUSTOMIZING COMPUTER APPLICATION USER INTERFACES; COMPUTER SOFTWARE THAT PROVIDES REAL-TIME, INTEGRATED BUSINESS MANAGEMENT INTELLIGENCE BY COMBINING INFORMATION FROM VARIOUS DATABASES AND PRESENTING IT IN AN EASY-TO-UNDERSTAND USER INTERFACE; COMPUTER SOFTWARE THAT PROVIDES WEB-BASED ACCESS TO APPLICATIONS AND SERVICES THROUGH A WEB OPERATING SYSTEM OR PORTAL INTERFACE; DOWNLOADABLE CLOUD COMPUTER SOFTWARE FOR ANALYZING, CREATING, MANAGING, REPORTING, STORING AND TRACKING DATA IN THE FIELDS OF CUSTOMER RELATIONSHIP MANAGEMENT, EMPLOYEE EFFICIENCY, MARKETING, PRODUCT SUPPORT, PROMOTION, SALES, SALES SUPPORT, SCHEDULING, SECURITY, SERVICES, TASK MANAGEMENT AND TRACKING, TIME MANAGEMENT AND TRACKING, VENDOR INFORMATION, VENDOR RELATIONSHIP MANAGEMENT; DOWNLOADABLE COMPUTER SOFTWARE FOR ANALYZING, CREATING, MANAGING, REPORTING, STORING AND TRACKING DATA IN THE FIELDS OF CUSTOMER RELATIONSHIP MANAGEMENT, EMPLOYEE EFFICIENCY, MARKETING, PRODUCT SUPPORT, PROMOTION, SALES, SALES SUPPORT, SCHEDULING, SECURITY, SERVICES, TASK MANAGEMENT AND TRACKING, TIME MANAGEMENT AND TRACKING, VENDOR INFORMATION, VENDOR RELATIONSHIP MANAGEMENT; DOWNLOADABLE MOBILE APPLICATIONS FOR ANALYZING, CREATING, MANAGING, REPORTING, STORING AND TRACKING DATA IN THE FIELDS OF CUSTOMER RELATIONSHIP MANAGEMENT, EMPLOYEE EFFICIENCY, MARKETING, PRODUCT SUPPORT, PROMOTION, SALES, SALES SUPPORT, SCHEDULING, SECURITY, SERVICES, TASK MANAGEMENT AND TRACKING, TIME MANAGEMENT AND TRACKING, VENDOR INFORMATION, VENDOR RELATIONSHIP MANAGEMENT (U.S. CLS. 21, 23, 26, 36 AND 38).

FIRST USE 7-1-2013; IN COMMERCE 7-15-2013.

**CLASS 42—SCIENTIFIC AND COMPUTER SERVICES**

FOR APPLICATION SERVICE PROVIDER (ASP) FEATURING SOFTWARE FOR USE AMONG PEER PROFESSIONALS IN THE ACCOUNTING, ADVERTISING, ARCHITECTURE, CONSTRUCTION, FINANCIAL SERVICES, LEGAL SERVICES, MARKETING, REAL ESTATE AND BUSINESS SERVICES FIELDS FOR ANALYZING, CREATING, MANAGING, REPORTING, STORING AND TRACKING DATA IN THE FIELDS OF CUSTOMER RELATIONSHIP MANAGEMENT, EMPLOYEE EFFICIENCY, MARKETING, PRODUCT SUPPORT, PROMOTION, SALES, SALES SUPPORT, SCHEDULING, SECURITY, SERVICES, TASK MANAGEMENT AND TRACKING, AND FOR CUSTOMIZING COMPUTER APPLICATION USER INTERFACES; APPLICATION SERVICE PROVIDER FEATURING APPLICATION PROGRAMMING INTERFACE (API) SOFTWARE FOR ANALYZING, CREATING, MANAGING, REPORTING, STORING AND TRACKING DATA IN THE FIELDS OF CUSTOMER RELATIONSHIP MANAGEMENT, EMPLOYEE EFFICIENCY, MARKETING, PRODUCT SUPPORT, PROMOTION, SALES, SALES SUPPORT, SCHEDULING, SECURITY, SERVICES, TASK MANAGEMENT AND TRACKING, TIME MANAGEMENT AND TRACKING, VENDOR INFORMATION, VENDOR RELATIONSHIP MANAGEMENT; COMPUTER SERVICES, NAMELY, ACTING AS AN APPLICATION SERVICE PROVIDER IN THE FIELD OF INFORMATION MANAGEMENT TO HOST COMPUTER APPLICATION SOFTWARE FOR THE PURPOSE OF ANALYZING, CREATING, MANAGING, REPORTING, STORING AND TRACKING DATA IN THE FIELDS OF CUSTOMER RELATIONSHIP MANAGEMENT, EMPLOYEE EFFICIENCY, MARKETING, PRODUCT SUPPORT, PROMOTION, SALES, SALES SUPPORT, SCHEDULING, SECURITY, SERVICES, TASK MANAGEMENT AND TRACKING, TIME MANAGEMENT AND TRACKING,

VENDOR INFORMATION, VENDOR RELATIONSHIP MANAGEMENT; PROVIDING AN ONLINE NON-DOWNLOADABLE INTERNET-BASED SYSTEM APPLICATION FEATURING TECHNOLOGY ENABLING USERS TO ANALYZE, CREATE, MANAGE, REPORT, STORE AND TRACK DATA IN THE FIELDS OF CUSTOMER RELATIONSHIP MANAGEMENT, EMPLOYEE EFFICIENCY, MARKETING, PRODUCT SUPPORT, PROMOTION, SALES, SALES SUPPORT, SCHEDULING, SECURITY, SERVICES, TASK MANAGEMENT AND TRACKING, TIME MANAGEMENT AND TRACKING, VENDOR INFORMATION, VENDOR RELATIONSHIP MANAGEMENT; PROVIDING TEMPORARY USE OF A WEB-BASED SOFTWARE APPLICATION FOR ANALYZING, CREATING, MANAGING, REPORTING, STORING AND TRACKING DATA IN THE FIELDS OF CUSTOMER RELATIONSHIP MANAGEMENT, EMPLOYEE EFFICIENCY, MARKETING, PRODUCT SUPPORT, PROMOTION, SALES, SALES SUPPORT, SCHEDULING, SECURITY, SERVICES, TASK MANAGEMENT AND TRACKING, TIME MANAGEMENT AND TRACKING, VENDOR INFORMATION, VENDOR RELATIONSHIP MANAGEMENT; PROVIDING TEMPORARY USE OF ON-LINE NON-DOWNLOADABLE SOFTWARE AND APPLICATIONS FOR ANALYZING, CREATING, MANAGING, REPORTING, STORING AND TRACKING DATA IN THE FIELDS OF CUSTOMER RELATIONSHIP MANAGEMENT, EMPLOYEE EFFICIENCY, MARKETING, PRODUCT SUPPORT, PROMOTION, SALES, SALES SUPPORT, SCHEDULING, SECURITY, SERVICES, TASK MANAGEMENT AND TRACKING, TIME MANAGEMENT AND TRACKING, VENDOR INFORMATION, VENDOR RELATIONSHIP MANAGEMENT (U.S. CLS. 100 AND 101).  
FIRST USE 7-1-2013; IN COMMERCE 7-15-2013.

---

4,594,198. BUILDER'S BEST, INC., JACKSON, FL. SN 86-002,286. PUB. 4-29-2014, FILED 7-3-2013.



OWNER OF U.S. REG. NOS. 1,795,755, 2,757,034, AND OTHERS.

NO CLAIM IS MADE TO THE EXCLUSIVE RIGHT TO USE "BUILDER'S BEST", APART FROM THE MARK AS SHOWN.

THE MARK CONSISTS OF THE WORDING "BUILDER'S BEST" WITH AN IMAGE OF A ROOFTOP AND A DESIGN STRIPE OVER THE WORDING AND UNDERNEATH THE ROOFTOP IMAGE.

#### CLASS 6—METAL GOODS

FOR METAL VENTILATION DUCT COMPONENTS FOR BUILDINGS, NAMELY, FLEXIBLE METALLIC DUCTS, ELBOWS, VENTS AND CLAMPS (U.S. CLS. 2, 12, 13, 14, 23, 25 AND 50).

FIRST USE 4-17-2013; IN COMMERCE 4-17-2013.

#### CLASS 19—NON-METALLIC BUILDING MATERIALS

FOR NON-METAL VENTILATION DUCT COMPONENTS FOR BUILDINGS, NAMELY, FLEXIBLE POLYMERIC DUCTS, ELBOWS, VENTS AND CLAMPS (U.S. CLS. 1, 12, 33 AND 50).

FIRST USE 4-17-2013; IN COMMERCE 4-17-2013.

4,594,200. BOO'S BUCKET LIST, LLC, RYE, NH. SN 86-002,387. PUB. 11-26-2013, FILED 7-3-2013.

## LASTINGMATTERS

THE MARK CONSISTS OF STANDARD CHARACTERS WITHOUT CLAIM TO ANY PARTICULAR FONT, STYLE, SIZE, OR COLOR.

#### CLASS 9—ELECTRICAL AND SCIENTIFIC APPARATUS

FOR DOWNLOADABLE ELECTRONIC PUBLICATIONS IN THE NATURE OF WORKBOOKS DIRECTED TO ORGANIZING AND RECORDING ONE'S PERSONAL INFORMATION (U.S. CLS. 21, 23, 26, 36 AND 38).

FIRST USE 5-16-2014; IN COMMERCE 5-16-2014.

#### CLASS 16—PAPER GOODS AND PRINTED MATTER

FOR WORKBOOKS DIRECTED TO ORGANIZING AND RECORDING ONE'S PERSONAL INFORMATION (U.S. CLS. 2, 5, 22, 23, 29, 37, 38 AND 50).

FIRST USE 5-19-2014; IN COMMERCE 5-19-2014.

#### CLASS 45—PERSONAL AND LEGAL SERVICES

FOR PERSONAL CONCIERGE SERVICES FOR OTHERS COMPRISING ASSISTING OTHERS WITH THE PROCESS OF ORGANIZING AND RECORDING THEIR PERSONAL INFORMATION (U.S. CLS. 100 AND 101).

FIRST USE 5-16-2014; IN COMMERCE 5-16-2014.

---

4,594,227. DOODLE ENTERPRISES LLC, DETROIT, MI. SN 86-010,485. PUB. 10-29-2013, FILED 7-15-2013.

## dPOP!

THE MARK CONSISTS OF STANDARD CHARACTERS WITHOUT CLAIM TO ANY PARTICULAR FONT, STYLE, SIZE, OR COLOR.

#### CLASS 35—ADVERTISING AND BUSINESS

FOR RETAIL STORE SERVICES FEATURING FURNITURE AND DECORATIVE ACCESSORIES FOR COMMERCIAL SPACE (U.S. CLS. 100, 101 AND 102).

FIRST USE 9-0-2013; IN COMMERCE 9-0-2013.

#### CLASS 39—TRANSPORTATION AND STORAGE

FOR MOVING COMPANY SERVICES, NAMELY, COMMERCIAL MOVING SERVICES (U.S. CLS. 100 AND 105).

FIRST USE 9-0-2013; IN COMMERCE 9-0-2013.

#### CLASS 42—SCIENTIFIC AND COMPUTER SERVICES

FOR SPACE PLANNING AND INTERIOR DESIGN SERVICES (U.S. CLS. 100 AND 101).

FIRST USE 9-0-2013; IN COMMERCE 9-0-2013.

4,594,237. MGFB PROPERTIES, INC., PENSACOLA, FL. SN 86-013,291. PUB. 3-18-2014, FILED 7-17-2013.



OWNER OF U.S. REG. NO. 4,272,440.

THE MARK CONSISTS OF IN THE FRONT CENTER, A SKULL; HALF OF THE SKULL IS DARK-SHADED WITH A LIGHTER COLORED EYE SOCKET, AND THE OTHER HALF IS LIGHTER WITH A DARK EYE SOCKET. BEHIND THE SKULL ARE A GUITAR AND A FISHING ROD, BOTH OF WHICH ARE PARTIALLY DARKLY-SHADOWED, CROSSED IN AN "X" SHAPE. THE BODY OF THE GUITAR AND THE REEL OF THE FISHING ROD ARE NEAREST THE BOTTOM OF THE SKULL. ABOVE THIS IMAGE IS THE WORDING "FLORA-BAMA" AND BENEATH THE IMAGE ARE THE WORDS "YACHT CLUB".

#### CLASS 21—HOUSEWARES AND GLASS

FOR BEVERAGE GLASSWARE; THERMAL INSULATED WRAP FOR CANS TO KEEP THE CONTENTS COLD OR HOT (U.S. CLS. 2, 13, 23, 29, 30, 33, 40 AND 50).  
FIRST USE 6-21-2013; IN COMMERCE 6-1-2014.

#### CLASS 25—CLOTHING

FOR SHIRTS; HATS; JACKETS; SUN VISORS (U.S. CLS. 22 AND 39).  
FIRST USE 6-21-2013; IN COMMERCE 6-21-2013.

4,594,238. SGT, INC., AKA STINGER GHAFFARIAN TECHNOLOGIES, INC., GREENBELT, MD. SN 86-013,529. PUB. 2-25-2014, FILED 7-18-2013.



NO CLAIM IS MADE TO THE EXCLUSIVE RIGHT TO USE "TECHNOLOGIES", APART FROM THE MARK AS SHOWN.

THE COLOR(S) TEAL, BLACK, AND WHITE IS/ARE CLAIMED AS A FEATURE OF THE MARK.

THE MARK CONSISTS OF THE LETTERS "SGT" IN WHITE SUPERIMPOSED ON ONE ANOTHER ON A TEAL SQUARE OUTLINED IN WHITE AND BLACK. TO THE RIGHT OF THE SQUARE IS THE BLACK WORDING "STINGER GHAFFARIAN TECHNOLOGIES". UNDERNEATH ALL OF THE AFOREMENTIONED, IS THE BLACK WORDING "ACHIEVING RESULTSEXCEEDING EXPECTATIONS".

#### CLASS 35—ADVERTISING AND BUSINESS

FOR CONSULTING IN THE FIELD OF PROCURING GOVERNMENT CONTRACTS FOR THE PURCHASE OF GOODS AND LABOR CONTRACTING SERVICES; GOVERNMENT RELATIONS CONSULTANCY SERVICES; PROVIDING ADVICE AND ASSISTANCE TO COMMERCIAL ENTITIES RELATING TO THE ESTABLISHMENT AND MAINTENANCE OF BUSINESS AND CONTRACTUAL RELATIONSHIPS WITH FEDERAL, STATE AND LOCAL GOVERNMENTS (U.S. CLS. 100, 101 AND 102).  
FIRST USE 5-2-2006; IN COMMERCE 10-15-2008.

#### CLASS 42—SCIENTIFIC AND COMPUTER SERVICES

FOR COMPUTER PROJECT MANAGEMENT SERVICES; COMPUTER SERVICES, NAMELY, ON-SITE MANAGEMENT OF INFORMATION TECHNOLOGY (IT) SYSTEMS; COMPUTER SERVICES, NAMELY, REMOTE MANAGEMENT OF THE INFORMATION TECHNOLOGY (IT) SYSTEMS OF OTHERS; PLANNING, DESIGN AND MANAGEMENT OF INFORMATION TECHNOLOGY SYSTEMS (U.S. CLS. 100 AND 101).  
FIRST USE 5-2-2006; IN COMMERCE 3-20-2010.

4,594,240. HER JUSTICE INC., NEW YORK, NY. SN 86-013,878. PUB. 3-4-2014, FILED 7-18-2013.

## SHIFT THE POWER

THE MARK CONSISTS OF STANDARD CHARACTERS WITHOUT CLAIM TO ANY PARTICULAR FONT, STYLE, SIZE, OR COLOR.

#### CLASS 36—INSURANCE AND FINANCIAL

FOR CHARITABLE FUND RAISING SERVICES TO RAISE FUNDS FOR LEGAL SERVICES FOR LOW INCOME WOMEN (U.S. CLS. 100, 101 AND 102).  
FIRST USE 11-12-2013; IN COMMERCE 11-12-2013.

#### CLASS 45—PERSONAL AND LEGAL SERVICES

FOR LEGAL SERVICES (U.S. CLS. 100 AND 101).  
FIRST USE 11-12-2013; IN COMMERCE 11-12-2013.

4,594,251. THE EDUCATION CENTER, LLC, GREENSBORO, NC. SN 86-018,946. PUB. 2-11-2014, FILED 7-24-2013.



OWNER OF U.S. REG. NOS. 1,954,722 AND 2,099,569.  
THE MARK CONSISTS OF A DRAWING OF A MAILBOX ATOP GRASS.

#### **CLASS 16—PAPER GOODS AND PRINTED MATTER**

FOR PRINTED INSTRUCTIONAL AND EDUCATIONAL MATERIALS FEATURING TEACHING IDEAS, LITERATURE-BASED ACTIVITIES, ART ACTIVITIES, GAMES, MANIPULATIVES, BULLETIN BOARD SUGGESTIONS, ACTIVITY CARDS, TEACHER RESOURCE BOOKS AND REPRODUCIBLES (U.S. CLS. 2, 5, 22, 23, 29, 37, 38 AND 50).

FIRST USE 10-1-2013; IN COMMERCE 10-1-2013.

#### **CLASS 41—EDUCATION AND ENTERTAINMENT**

FOR PROVIDING ONLINE EDUCATIONAL INFORMATION IN THE FIELD OF EARLY CHILDHOOD EDUCATION; PROVIDING ONLINE PUBLICATIONS IN THE NATURE OF EDUCATION RESOURCE MATERIALS FOR USE IN TEACHING, NAMELY, LITERATURE BASED ACTIVITIES, ART ACTIVITIES, GAMES, MANIPULATIVES, BULLETIN BOARD SUGGESTIONS, ACTIVITY CARDS, TEACHER RESOURCE BOOKS (U.S. CLS. 100, 101 AND 107).

FIRST USE 3-1-2014; IN COMMERCE 3-1-2014.

#### **CLASS 42—SCIENTIFIC AND COMPUTER SERVICES**

FOR COMPUTER SERVICES, NAMELY, HOSTING AN INTERACTIVE WEBSITE THAT ALLOWS USER TO ACCESS EDUCATIONAL RESOURCE MATERIALS FOR USE IN TEACHING, NAMELY, LITERATURE BASED ACTIVITIES, ART ACTIVITIES, GAMES, MANIPULATIVES, BULLETIN BOARD SUGGESTIONS, ACTIVITY CARDS, TEACHER RESOURCE BOOKS (U.S. CLS. 100 AND 101).

FIRST USE 3-1-2014; IN COMMERCE 3-1-2014.

4,594,253. DUNCAN ENTERPRISES, INC, DBA ILOVE-TOCREATE, FRESNO, CA. SN 86-019,142. PUB. 11-26-2013, FILED 7-24-2013.

## Create Basics

THE MARK CONSISTS OF STANDARD CHARACTERS WITHOUT CLAIM TO ANY PARTICULAR FONT, STYLE, SIZE, OR COLOR.

#### **CLASS 2—PAINTS**

FOR FABRIC PAINTS; FABRIC DYES; KITS COMPRISED PRIMARILY OF FABRIC DYES AND PAINTS, PAINT FIXERS, RUBBER BANDS AND LATEX GLOVES FOR HOBBY AND CRAFT USE IN TIE-DYING FABRICS AND TEXTILES (U.S. CLS. 6, 11 AND 16).

FIRST USE 5-1-2014; IN COMMERCE 5-1-2014.

#### **CLASS 16—PAPER GOODS AND PRINTED MATTER**

FOR IRON-ON TRANSFERS FOR CRAFT AND HOBBY USE ON FABRICS AND TEXTILES; ARTS AND CRAFTS KITS USED PRIMARILY FOR THE PURPOSE OF TIE-DYING FABRICS AND TEXTILES (U.S. CLS. 2, 5, 22, 23, 29, 37, 38 AND 50).

FIRST USE 5-1-2014; IN COMMERCE 5-1-2014.

4,594,258. NEWGISTICS, INC., AUSTIN, TX. SN 86-024,119. PUB. 10-29-2013, FILED 7-30-2013.

## NEWGISTICS

THE MARK CONSISTS OF STANDARD CHARACTERS WITHOUT CLAIM TO ANY PARTICULAR FONT, STYLE, SIZE, OR COLOR.

OWNER OF U.S. REG. NOS. 2,776,146 AND 3,766,924.

#### **CLASS 35—ADVERTISING AND BUSINESS**

FOR MANAGEMENT OF TRANSPORTATION LOGISTICS SERVICES, NAMELY, PLANNING AND SCHEDULING SHIPMENTS FOR USERS OF TRANSPORTATION SERVICES AND ARRANGING THE TRANSPORTATION OF GOODS FOR OTHERS; COMMERCIAL MAIL RECEIVING AGENCY, NAMELY, PROVIDING SPECIALIZED MAIL MANAGEMENT SERVICES; MANAGEMENT AND ADMINISTRATION OF NON-CORE FUNCTIONS, NAMELY, MAILING AND SHIPPING, RECORDS MANAGEMENT, INFORMATION SERVICES, SHIPMENT PROCESSING, PREPARING SHIPPING DOCUMENTS AND INVOICES; MONITORING AND TRACKING OF SHIPMENTS; BUSINESS MANAGEMENT SERVICES, NAMELY, MANAGING LOGISTICS, REVERSE LOGISTICS, INVENTORY, SUPPLY AND DEMAND FORECASTING AND PRODUCT DISTRIBUTION PROCESSES FOR OTHERS; BUSINESS CONSULTING SERVICES RELATING TO ALL OF THE FOREGOING SERVICES AND PRODUCT DISTRIBUTION, OPERATIONS MANAGEMENT SERVICES, LOGISTICS, REVERSE LOGISTICS, AND PRODUCTION SYSTEMS AND DISTRIBUTION SOLUTIONS (U.S. CLS. 100, 101 AND 102).

FIRST USE 7-24-2000; IN COMMERCE 9-4-2000.

**CLASS 39—TRANSPORTATION AND STORAGE**

FOR SUPPLY CHAIN LOGISTICS AND REVERSE LOGISTICS SERVICES, NAMELY, STORAGE, TRANSPORTATION AND DELIVERY OF GOODS FOR OTHERS; SHIPPING AND DELIVERY SERVICES, NAMELY, PICKUP, TRANSPORTATION, AND DELIVERY OF PACKAGES (U.S. CLS. 100 AND 105).  
FIRST USE 7-24-2000; IN COMMERCE 9-4-2000.

**CLASS 40—MATERIAL TREATMENT**

FOR ASSEMBLY OF PRODUCTS AND KITS, NAMELY, GOODS PROVIDED BY OTHERS (U.S. CLS. 100, 103 AND 106).  
FIRST USE 4-26-2013; IN COMMERCE 4-26-2013.

**CLASS 42—SCIENTIFIC AND COMPUTER SERVICES**

FOR SOFTWARE AS A SERVICE (SAAS) SERVICES FEATURING SOFTWARE FOR PREPARING, ADMINISTERING, AND MANAGING THE SHIPMENT AND RETURN OF MERCHANDISE PARCELS AND PACKAGES, FOR PRODUCING AND PRINTING SHIPMENT MANIFESTS AND LABELS FOR THE SHIPMENT AND RETURN OF MERCHANDISE PARCELS AND PACKAGES, AND FOR DATA PROCESSING, REPORTING, AND BILLING IN THE FIELD OF SHIPPING AND RETURNING MERCHANDISE PARCELS AND PACKAGES; SOFTWARE AS A SERVICE (SAAS) SERVICES FEATURING SOFTWARE FOR PROVIDING REAL-TIME, INTEGRATED BUSINESS MANAGEMENT INTELLIGENCE BY COMBINING INFORMATION FROM VARIOUS DATABASES AND PRESENTING IT IN AN EASY-TO-UNDERSTAND FORMAT FOR THE USER IN THE FIELDS OF ORDER FULFILLMENT, INVENTORY MANAGEMENT, LOGISTICS MANAGEMENT, AND RETURNS MANAGEMENT; SOFTWARE AS A SERVICE (SAAS) SERVICES FEATURING SOFTWARE FOR PLACING ORDERS, TRACKING AND MONITORING FULFILLMENT OF ORDERS, MONITORING DISTRIBUTION AND DELIVERY OF PARCELS AND PACKAGES; SOFTWARE AS A SERVICE (SAAS) SERVICES FEATURING SOFTWARE FOR COORDINATING AIR AND GROUND TRANSPORT, LOGISTICS, SUPPLY CHAIN MANAGEMENT, WAREHOUSE MANAGEMENT, ORDER FULFILLMENT; DESIGNING, CREATING, MAINTAINING, AND HOSTING ELECTRONIC COMMERCE WEBSITES FOR OTHERS (U.S. CLS. 100 AND 101).  
FIRST USE 7-24-2000; IN COMMERCE 9-4-2000.

4,594,265. BODEGA 11 LLC, PHOENIX, AZ. SN 86-029,261.  
PUB. 3-18-2014, FILED 8-5-2013.

# SYDNEY'S

THE MARK CONSISTS OF STANDARD CHARACTERS WITHOUT CLAIM TO ANY PARTICULAR FONT, STYLE, SIZE, OR COLOR.

**CLASS 35—ADVERTISING AND BUSINESS**

FOR RETAIL MARKETS FEATURING FOOD AND FOOD-RELATED GOODS; RETAIL MARKETS FEATURING FRESH AND PREPACKAGED FOODS-TO-GO AND EMPANADAS (U.S. CLS. 100, 101 AND 102).  
FIRST USE 8-1-2013; IN COMMERCE 5-17-2014.

**CLASS 43—HOTEL AND RESTAURANT SERVICES**

FOR RESTAURANT SERVICES; BAR SERVICES; CATERING SERVICES; SERVICES RENDERED BY CAFETERIAS, CAFES, SNACK BARS, SANDWICH BARS, CANTEENS, COFFEE BARS, COFFEE SHOPS AND TEA ROOMS; CONSULTING IN THE FIELD OF RESTAURANT SERVICES (U.S. CLS. 100 AND 101).  
FIRST USE 8-1-2013; IN COMMERCE 5-17-2014.

4,594,269. COYLE, DOUGLAS, AUSTIN, TX. AND HARRISON, ERIC, AUSTIN, TX. SN 86-030,508. PUB. 12-31-2013, FILED 8-6-2013.

# Fine Lion

THE MARK CONSISTS OF STANDARD CHARACTERS WITHOUT CLAIM TO ANY PARTICULAR FONT, STYLE, SIZE, OR COLOR.

**CLASS 9—ELECTRICAL AND SCIENTIFIC APPARATUS**

FOR MUSICAL RECORDINGS (U.S. CLS. 21, 23, 26, 36 AND 38).  
FIRST USE 10-16-2013; IN COMMERCE 10-20-2013.

**CLASS 41—EDUCATION AND ENTERTAINMENT**

FOR ENTERTAINMENT IN THE NATURE OF LIVE MUSICAL PERFORMANCES (U.S. CLS. 100, 101 AND 107).  
FIRST USE 10-16-2013; IN COMMERCE 10-20-2013.

4,594,281. NEW ALBERTSON'S, INC., BOISE, ID. SN 86-034,237. PUB. 2-18-2014, FILED 8-9-2013.

# MYRXCARE

THE MARK CONSISTS OF STANDARD CHARACTERS WITHOUT CLAIM TO ANY PARTICULAR FONT, STYLE, SIZE, OR COLOR.

**CLASS 35—ADVERTISING AND BUSINESS**

FOR RETAIL PHARMACY SERVICES, RETAIL GROCERY STORE SERVICES (U.S. CLS. 100, 101 AND 102).  
FIRST USE 10-9-2013; IN COMMERCE 10-9-2013.

**CLASS 44—MEDICAL, BEAUTY AND AGRICULTURAL SERVICES**

FOR HEALTH SCREENING SERVICES IN THE FIELD OF BLOOD PRESSURE, CHOLESTEROL, THYROID AND DIABETES; PHARMACEUTICAL SERVICES, NAMELY, MEDICATION DISPENSING, MEDICATION COUNSELING AND IMMUNIZING (U.S. CLS. 100 AND 101).

FIRST USE 6-17-2014; IN COMMERCE 6-17-2014.

---

4,594,286. LIFE TECHNOLOGIES CORPORATION, CARLSBAD, CA. SN 86-035,561. PUB. 12-31-2013, FILED 8-12-2013.

**IBIND**

THE MARK CONSISTS OF STANDARD CHARACTERS WITHOUT CLAIM TO ANY PARTICULAR FONT, STYLE, SIZE, OR COLOR.

**CLASS 1—CHEMICALS**

FOR ELECTROPHORESIS GEL AND CHROMATOGRAPHY CHEMICALS, BUFFERS, AND SOLUTIONS FOR SCIENTIFIC RESEARCH (U.S. CLS. 1, 5, 6, 10, 26 AND 46).

FIRST USE 8-15-2013; IN COMMERCE 8-16-2013.

**CLASS 9—ELECTRICAL AND SCIENTIFIC APPARATUS**

FOR ELECTROPHORESIS APPARATUS NOT FOR MEDICAL PURPOSES, WHICH USES MEMBRANES, GEL MATRIX, AND AN INTEGRATED POWER SUPPLY, FOR LIFE SCIENCES RESEARCH (U.S. CLS. 21, 23, 26, 36 AND 38).

FIRST USE 8-15-2013; IN COMMERCE 8-16-2013.

---

4,594,296. BANKERS FIDELITY LIFE INSURANCE COMPANY, ATLANTA, GA. SN 86-041,620. PUB. 2-18-2014, FILED 8-19-2013.

**BOLT**  
BANKERS ONLINE TRAINING

NO CLAIM IS MADE TO THE EXCLUSIVE RIGHT TO USE "BANKERS ONLINE TRAINING", APART FROM THE MARK AS SHOWN.

COLOR IS NOT CLAIMED AS A FEATURE OF THE MARK.

THE MARK CONSISTS OF THE WORD "BOLT" WITH A LIGHTENING THROUGH "BOLT" ABOVE THE WORDS "BANKERS ONLINE TRAINING".

**CLASS 41—EDUCATION AND ENTERTAINMENT**

FOR INTERACTIVE PASSWORD PROTECTED ON-LINE TRAINING SERVICES OF AGENTS IN THE FIELD OF INSURANCE SERVICES, NAMELY, BROKERAGE, UNDERWRITING, ADMINISTRATION AND CLAIMS PROCESSING OF LIFE INSURANCE, SHORT-TERM CARE INSURANCE, DISABILITY INSURANCE, HEALTH INSURANCE, MEDICARE SUPPLEMENT INSURANCE, PAYROLL INSURANCE, PAYROLL TAX DEBITING SERVICES, DISCOUNT PROGRAMS, PRESCRIPTION DRUG PROGRAMS; PROVIDING PASSWORD PROTECTED ON-LINE TRAINING COURSES, SEMINARS, WORKSHOPS, CLASSES TO AGENTS IN THE FIELD OF INSURANCE SERVICES, NAMELY, BROKERAGE, UNDERWRITING, ADMINISTRATION AND CLAIMS PROCESSING OF LIFE INSURANCE, SHORT-TERM CARE INSURANCE, DISABILITY INSURANCE, HEALTH INSURANCE, MEDICARE SUPPLEMENT INSURANCE, PAYROLL INSURANCE, PAYROLL TAX DEBITING SERVICES, DISCOUNT PROGRAMS, PRESCRIPTION DRUG PROGRAMS (U.S. CLS. 100, 101 AND 107).

FIRST USE 11-6-2013; IN COMMERCE 11-6-2013.

**CLASS 42—SCIENTIFIC AND COMPUTER SERVICES**

FOR PROVIDING TEMPORARY USE OF ON-LINE NON-DOWNLOADABLE USER INTERFACE SOFTWARE FOR THE EXCHANGE OF SALES-RELATED DATA VIA A PASSWORD PROTECTED SITE (U.S. CLS. 100 AND 101).

FIRST USE 11-6-2013; IN COMMERCE 11-6-2013.

---

4,594,308. SYSTEMFORWARD AMERICA, INC., LAFAYETTE, LA. SN 86-045,357. PUB. 10-29-2013, FILED 8-22-2013.

**AMERICA'S MOST TRUSTED  
TEAM OF LOCKSMITHS**

THE MARK CONSISTS OF STANDARD CHARACTERS WITHOUT CLAIM TO ANY PARTICULAR FONT, STYLE, SIZE, OR COLOR.

**CLASS 37—CONSTRUCTION AND REPAIR**

FOR SECURITY SERVICES, NAMELY, INSTALLATION, REPAIR, MAINTENANCE, AND REPLACEMENT OF LOCKS, DOORS, DOOR COMPONENTS, DOOR HARDWARE, AND ALARM SYSTEMS (U.S. CLS. 100, 103 AND 106).

FIRST USE 8-1-2011; IN COMMERCE 8-1-2011.

**CLASS 45—PERSONAL AND LEGAL SERVICES**

FOR SECURITY SERVICES, NAMELY, SECURITY INSPECTION SERVICES FOR OTHERS (U.S. CLS. 100 AND 101).

FIRST USE 8-1-2011; IN COMMERCE 8-1-2011.

4,594,312. INC INTERNATIONAL COMPANY, KENNETT SQUARE, PA. SN 86-047,130. PUB. 3-4-2014, FILED 8-24-2013.

# HART

THE MARK CONSISTS OF STANDARD CHARACTERS WITHOUT CLAIM TO ANY PARTICULAR FONT, STYLE, SIZE, OR COLOR.

## CLASS 9—ELECTRICAL AND SCIENTIFIC APPARATUS

FOR BASEBALL BATTING HELMETS; BICYCLE HELMETS; CATCHERS' HELMETS; CRASH HELMETS; DIVING HELMETS; FOOTBALL HELMETS; HELMETS FOR BICYCLES; HELMETS FOR MOTORCYCLISTS; HOCKEY HELMETS; MOTORCYCLE HELMETS; PROTECTIVE HELMETS; PROTECTIVE HELMETS FOR BOXING; RIDING HELMETS; SAFETY HELMETS (U.S. CLS. 21, 23, 26, 36 AND 38).

FIRST USE 6-30-2014; IN COMMERCE 6-30-2014.

## CLASS 25—CLOTHING

FOR HELMET LINERS; SHIRTS (U.S. CLS. 22 AND 39).  
FIRST USE 6-30-2014; IN COMMERCE 6-30-2014.

## CLASS 28—TOYS AND SPORTING GOODS

FOR ATHLETIC PROTECTIVE PADS FOR FOOTBALL, BASEBALL, BASKETBALL, SOCCER, SKATEBOARDING, KARATE, WRESTLING, LACROSSE, HORSEBACK RIDING; PROTECTIVE PADDING FOR PLAYING FOOTBALL, BASEBALL, BASKETBALL, SOCCER, SKATEBOARDING, KARATE, WRESTLING, LACROSSE, HORSEBACK RIDING; SAFETY PADDING FOR FOOTBALL, BASEBALL, BASKETBALL, SOCCER, SKATEBOARDING, KARATE, WRESTLING, LACROSSE, HORSEBACK RIDING (U.S. CLS. 22, 23, 38 AND 50).  
FIRST USE 6-30-2014; IN COMMERCE 6-30-2014.

4,594,315. JOHNSON, JESSICA J., NEWPORT BEACH, CA. SN 86-048,468. PUB. 4-1-2014, FILED 8-26-2013.

# MOMMY CHIC

THE MARK CONSISTS OF STANDARD CHARACTERS WITHOUT CLAIM TO ANY PARTICULAR FONT, STYLE, SIZE, OR COLOR.

NO CLAIM IS MADE TO THE EXCLUSIVE RIGHT TO USE "MOMMY", APART FROM THE MARK AS SHOWN.

## CLASS 41—EDUCATION AND ENTERTAINMENT

FOR ON-LINE JOURNALS, NAMELY, BLOGS FEATURING NEWS AND COMMENTARY ON PERSONAL LIFESTYLE CHOICES, EDITING, AND LINKS TO OTHER WEBSITES (U.S. CLS. 100, 101 AND 107).

FIRST USE 9-19-2013; IN COMMERCE 9-19-2013.

## CLASS 45—PERSONAL AND LEGAL SERVICES

FOR PERSONAL LIFESTYLE CONSULTING SERVICES, INCLUDING PERSONAL STYLIST SERVICES; PROVIDING A WEBSITE FEATURING PERSONAL LIFESTYLE CHOICES (U.S. CLS. 100 AND 101).  
FIRST USE 9-19-2013; IN COMMERCE 9-19-2013.

4,594,319. GUTIER, MICKY, PHOENIX, AZ. SN 86-050,613. PUB. 2-18-2014, FILED 8-28-2013.

# XYBOY

THE MARK CONSISTS OF STANDARD CHARACTERS WITHOUT CLAIM TO ANY PARTICULAR FONT, STYLE, SIZE, OR COLOR.

OWNER OF U.S. REG. NOS. 2,909,091 AND 2,921,574.

## CLASS 3—COSMETICS AND CLEANING PREPARATIONS

FOR NON-MEDICATED SKIN CARE PREPARATIONS FOR MEN; COSMETICS (U.S. CLS. 1, 4, 6, 50, 51 AND 52).  
FIRST USE 5-15-2014; IN COMMERCE 5-15-2014.

## CLASS 25—CLOTHING

FOR APPAREL, NAMELY, UNDERWEAR, T-SHIRTS, SHIRTS, PANTS, SWEATSHIRTS AND HATS (U.S. CLS. 22 AND 39).

FIRST USE 6-17-2014; IN COMMERCE 6-17-2014.

4,594,337. READY PAC PRODUCE, INC., IRWINDALE, CA. SN 86-060,168. PUB. 3-18-2014, FILED 9-10-2013.

# READY PAC

THE MARK CONSISTS OF STANDARD CHARACTERS WITHOUT CLAIM TO ANY PARTICULAR FONT, STYLE, SIZE, OR COLOR.

OWNER OF U.S. REG. NOS. 1,317,157, 2,173,981, AND OTHERS.

NO CLAIM IS MADE TO THE EXCLUSIVE RIGHT TO USE "PACK", APART FROM THE MARK AS SHOWN.

## CLASS 29—MEATS AND PROCESSED FOODS

FOR SALAD KITS CONSISTING PRIMARILY OF PROCESSED LETTUCE AND ALSO CONTAINING SALAD DRESSING, AND ONE OR MORE OF VEGETABLES, FRUIT, NUTS, EGGS, CHEESE, MEAT, POULTRY, CROUTONS, TORTILLA CHIPS, FLAT BREAD CHIPS; PACKAGED VEGETABLE SALADS; PACKAGED CUT FRUIT; PACKAGED CUT FRUIT WITH DIPS; PACKAGED CUT VEGETABLES; PACKAGED CUT VEGETABLES WITH DIPS; PACKAGED MEALS CONSISTING OF MEAT AND ONE OR MORE OF EGGS, FRUITS, VEGETABLES; SOUPS; PREPARED FOOD KITS CONSISTING OF SOUPS AND SALADS (U.S. CL. 46).

FIRST USE 8-0-1988; IN COMMERCE 8-0-1988.



**CLASS 30—STAPLE FOODS**

FOR WRAP SANDWICH KITS CONSISTING PRIMARILY OF EGGS, MEAT OR POULTRY, AND VEGETABLES AND TORTILLAS (U.S. CL. 46).

FIRST USE 3-0-2014; IN COMMERCE 3-0-2014.

---

4,594,341. INC INTERNATIONAL COMPANY, KENNETT SQUARE, PA. SN 86-061,738. PUB. 1-28-2014, FILED 9-11-2013.

**ACCELLERON**

THE MARK CONSISTS OF STANDARD CHARACTERS WITHOUT CLAIM TO ANY PARTICULAR FONT, STYLE, SIZE, OR COLOR.

**CLASS 9—ELECTRICAL AND SCIENTIFIC APPARATUS**

FOR CHIN STRAPS FOR FOOTBALL HELMETS; PROTECTIVE HELMETS; SAFETY HELMETS (U.S. CLS. 21, 23, 26, 36 AND 38).

FIRST USE 6-30-2014; IN COMMERCE 6-30-2014.

**CLASS 25—CLOTHING**

FOR SHIRTS (U.S. CLS. 22 AND 39).

FIRST USE 6-30-2014; IN COMMERCE 6-30-2014.

**CLASS 28—TOYS AND SPORTING GOODS**

FOR PADS FOR USE IN FOOTBALL, BASEBALL, HOCKEY, SOCCER, BASKETBALL, LACROSSE, SNOWBOARDING, SKATEBOARDING, HORSEBACK RIDING, WRESTLING, KARATE; PROTECTIVE PADDING FOR PLAYING FOOTBALL, BASEBALL, HOCKEY, SOCCER, BASKETBALL, LACROSSE, SNOWBOARDING, SKATEBOARDING, HORSEBACK RIDING, WRESTLING, KARATE; SAFETY PADDING FOR FOOTBALL, BASEBALL, HOCKEY, SOCCER, BASKETBALL, LACROSSE, SNOWBOARDING, SKATEBOARDING, HORSEBACK RIDING, WRESTLING, KARATE (U.S. CLS. 22, 23, 38 AND 50).

FIRST USE 6-30-2014; IN COMMERCE 6-30-2014.

---

4,594,342. INC INTERNATIONAL COMPANY, KENNETT SQUARE, PA. SN 86-061,748. PUB. 1-28-2014, FILED 9-11-2013.

**IMPACSHIELD**

THE MARK CONSISTS OF STANDARD CHARACTERS WITHOUT CLAIM TO ANY PARTICULAR FONT, STYLE, SIZE, OR COLOR.

**CLASS 9—ELECTRICAL AND SCIENTIFIC APPARATUS**

FOR PROTECTIVE HELMETS; SAFETY HELMETS (U.S. CLS. 21, 23, 26, 36 AND 38).

FIRST USE 6-30-2014; IN COMMERCE 6-30-2014.

**CLASS 28—TOYS AND SPORTING GOODS**

FOR PADS FOR USE IN FOOTBALL, BASEBALL, HOCKEY, SOCCER, BASKETBALL, LACROSSE, SNOWBOARDING, SKATEBOARDING, HORSEBACK RIDING, WRESTLING, KARATE; PROTECTIVE PADDING FOR PLAYING FOOTBALL, BASEBALL, HOCKEY, SOCCER, BASKETBALL, LACROSSE, SNOWBOARDING, SKATEBOARDING, HORSEBACK RIDING, WRESTLING, KARATE; SAFETY PADDING FOR FOOTBALL, BASEBALL, HOCKEY, SOCCER, BASKETBALL, LACROSSE, SNOWBOARDING, SKATEBOARDING, HORSEBACK RIDING, WRESTLING, KARATE (U.S. CLS. 22, 23, 38 AND 50).

FIRST USE 6-30-2014; IN COMMERCE 6-30-2014.

---

4,594,350. SANA PHARMA AS, OSLO, NORWAY. SN 86-065,296. PUB. 3-11-2014, FILED 9-16-2013.

**NBG24:7**

THE MARK CONSISTS OF STANDARD CHARACTERS WITHOUT CLAIM TO ANY PARTICULAR FONT, STYLE, SIZE, OR COLOR.

OWNER OF NORWAY REG. NO. 271220, DATED 6-21-2013, EXPIRES 3-15-2023.

**CLASS 3—COSMETICS AND CLEANING PREPARATIONS**

FOR COSMETIC CREAM, COSMETIC PREPARATIONS FOR SKIN CARE, FACE CREAM, HAND CREAM, BODY LOTION, SHAMPOO, COSMETIC SUN PROTECTING PREPARATIONS, AFTER SUN LOTIONS (U.S. CLS. 1, 4, 6, 50, 51 AND 52).

FIRST USE 1-1-2006; IN COMMERCE 1-1-2006.

**CLASS 5—PHARMACEUTICALS**

FOR DIETARY SUPPLEMENTS, VITAMIN PREPARATIONS (U.S. CLS. 6, 18, 44, 46, 51 AND 52).

FIRST USE 1-1-2006; IN COMMERCE 1-1-2006.

4,594,359. MEDINA, SYLVIA M, DBA GREEN KIDS CLUB, INC., IDAHO FALLS, ID. SN 86-068,171. PUB. 3-4-2014, FILED 9-18-2013.



NO CLAIM IS MADE TO THE EXCLUSIVE RIGHT TO USE "GREEN KIDS", APART FROM THE MARK AS SHOWN.

THE MARK CONSISTS OF FIGURES OF A BOY ON THE LEFT, A GIRL ON THE RIGHT, WITH AN EAGLE IN THE CENTER WITH ITS WINGS SHOWING BEHIND THE SHOULDERS OF THE BOY AND GIRL. THE BOY AND GIRL ARE HOLDING A GLOBE OF THE EARTH SHOWING THE CONTINENT OF NORTH AMERICA AND PART OF SOUTH AMERICA. BELOW THE FIGURES AND THE GLOBE APPEAR THE WORDS "GREEN KIDS CLUB".

#### CLASS 16—PAPER GOODS AND PRINTED MATTER

FOR CHILDREN'S BOOKS (U.S. CLS. 2, 5, 22, 23, 29, 37, 38 AND 50).  
FIRST USE 1-1-2012; IN COMMERCE 1-1-2013.

#### CLASS 28—TOYS AND SPORTING GOODS

FOR DOLLS AND DOLL ACCESSORIES, NAMELY, CLOTHING FOR DOLLS, DOLL ROOMS, DOLL BEDS, DOLL HOUSES, TOY FABRICS AND LINENS FOR DOLLS AND STROLLERS FOR DOLLS; DOLLS AND DOLLS' CLOTHING; PLUSH DOLLS; TOY ANIMALS AND ACCESSORIES THEREFOR (U.S. CLS. 22, 23, 38 AND 50).  
FIRST USE 12-15-2013; IN COMMERCE 2-24-2014.

4,594,361. BIKE BARN, L.P., HOUSTON, TX. SN 86-069,141. PUB. 4-22-2014, FILED 9-19-2013.



OWNER OF U.S. REG. NO. 3,919,222.

NO CLAIM IS MADE TO THE EXCLUSIVE RIGHT TO USE "BIKE" AND "HOUSTON, TEXAS", APART FROM THE MARK AS SHOWN.

THE MARK CONSISTS OF "BIK" WITH A MACRON OVER THE "I" AND "BIKE BARN HOUSTON TEXAS", ALL WITHIN AN OVAL BORDER.

#### CLASS 12—VEHICLES

FOR BICYCLE PARTS, NAMELY, PEDALS, BRAKES, BRAKE SHOES, CHAINS, BICYCLE FRAMES, HANDLE-BAR GRIPS, GEARS, TUBES FOR BICYCLE FRAMES AND INNER TUBES FOR BICYCLES, GEAR WHEELS AND BICYCLE WHEELS, FORKS, HANDLE BAR STEMS, HANDLE BAR ENDS, SADDLES, SEAT POSTS, RIMS AND STRUCTURAL PARTS FOR WHEELS, SPOKES FOR BICYCLE WHEELS, WHEEL HUBS FOR BICYCLES, HANDLE BARS; METAL AND NON-METAL BICYCLE RACKS FOR VEHICLES, FRONT AND REAR BICYCLE RACK PACKS, BICYCLE PUMPS, TIRE INFLATORS, TRAINERS IN THE NATURE OF BICYCLE TRAINING HARNESSSES, BICYCLE BELLS, HANDLE-BAR GRIP TAPE, BICYCLE HORNS, BICYCLE KICK-STANDS, BICYCLE TRAILERS, BICYCLE TRAINING WHEELS, BICYCLE WATER BOTTLE CAGES, BICYCLE-MOUNTED PET SEATS, MUD GUARDS FOR BICYCLES, FITTED BIKE COVERS, BASKETS ADAPTED FOR BICYCLES, BICYCLE STANDS; BICYCLES (U.S. CLS. 19, 21, 23, 31, 35 AND 44).  
FIRST USE 3-10-2014; IN COMMERCE 3-10-2014.

#### CLASS 16—PAPER GOODS AND PRINTED MATTER

FOR BUMPER STICKERS, DECALS, DECORATIVE DECALS FOR VEHICLE WINDOWS (U.S. CLS. 2, 5, 22, 23, 29, 37, 38 AND 50).  
FIRST USE 3-10-2014; IN COMMERCE 3-10-2014.

#### CLASS 25—CLOTHING

FOR BICYCLING CLOTHING, NAMELY, BICYCLING JERSEYS, BICYCLING SHORTS AND BIB SHORTS, BICYCLING GLOVES, BICYCLING SOCKS, BICYCLING JACKETS AND VESTS, BICYCLING ARM, KNEE AND LEG WARMERS, BICYCLING TIGHTS, BICYCLING HATS, CAPS, HEADBANDS, SKULL CAPS AND BALACLAVAS, BICYCLING TOE AND SHOE FITTED COVERS USED TO PROTECT THE SHOES FROM WATER OR OTHER DAMAGE, BICYCLING SKIN SUITS, BICYCLE MECHANIC APRONS, BICYCLING UNDERGARMENTS AND BICYCLING SHOES; T-SHIRTS (U.S. CLS. 22 AND 39).  
FIRST USE 3-10-2014; IN COMMERCE 3-10-2014.

4,594,369. WELLNESS CREATIONS, LLC, NEW YORK, NY. SN 86-073,149. PUB. 2-18-2014, FILED 9-24-2013.

## WELLPATH

THE MARK CONSISTS OF STANDARD CHARACTERS WITHOUT CLAIM TO ANY PARTICULAR FONT, STYLE, SIZE, OR COLOR.

#### CLASS 5—PHARMACEUTICALS

FOR DIETARY SUPPLEMENTS AND VITAMINS DEVELOPED TO ADDRESS SPECIFIC DIETARY GOALS (U.S. CLS. 6, 18, 44, 46, 51 AND 52).  
FIRST USE 5-20-2014; IN COMMERCE 5-20-2014.

#### CLASS 40—MATERIAL TREATMENT

FOR CUSTOM MANUFACTURE OF DIETARY SUPPLEMENTS AND VITAMINS (U.S. CLS. 100, 103 AND 106).  
FIRST USE 5-20-2014; IN COMMERCE 5-20-2014.

**CLASS 42—SCIENTIFIC AND COMPUTER SERVICES**

FOR PRODUCT RESEARCH AND DEVELOPMENT IN THE FIELD OF NUTRITIONAL PRODUCTS (U.S. CLS. 100 AND 101).

FIRST USE 5-20-2014; IN COMMERCE 5-20-2014.

**CLASS 44—MEDICAL, BEAUTY AND AGRICULTURAL SERVICES**

FOR DIETARY AND NUTRITIONAL GUIDANCE (U.S. CLS. 100 AND 101).

FIRST USE 5-20-2014; IN COMMERCE 5-20-2014.

4,594,420. IOWA-DES MOINES SUPPLY, INC., DES MOINES, IA. SN 86-090,422. PUB. 4-1-2014, FILED 10-14-2013.



NO CLAIM IS MADE TO THE EXCLUSIVE RIGHT TO USE "COFFEE 100% ARABICA BEANS" AND "DES MOINES ROASTED", APART FROM THE MARK AS SHOWN.

THE COLOR(S) WHITE, BLUE, GREEN, BROWN, AND ORANGE IS/ARE CLAIMED AS A FEATURE OF THE MARK.

THE MARK CONSISTS OF A WHITE DIAMOND SHAPE WITH BORDER COLORS OF GREEN AND BROWN; A BROWN BANNER OUTLINED IN GREEN APPEARS OVER THE LOWER POINT OF THE DIAMOND, WITH THE WORDS "DES MOINES ROASTED" IN WHITE INSIDE THE BANNER; THE WORD "RIVERWALK" APPEARS WITHIN THE DIAMOND IN GREEN; UNDER "RIVERWALK" APPEARS THE WORDS "COFFEE 100% ARABICA BEANS" IN GREEN; ABOVE "RIVERWALK" IS A PICTURE OF A CITYSCAPE IN GREEN WITH A PARTIAL ORANGE SUN APPEARING IN THE HORIZON; AND A WAVY LINE IN BLUE DEPICTING A RIVER.

**CLASS 30—STAPLE FOODS**

FOR ARABICA COFFEE BEANS (U.S. CL. 46).  
FIRST USE 11-20-2013; IN COMMERCE 11-20-2013.

**CLASS 43—HOTEL AND RESTAURANT SERVICES**

FOR COFFEE SHOPS (U.S. CLS. 100 AND 101).  
FIRST USE 3-31-2014; IN COMMERCE 3-31-2014.

4,594,426. CEDARLANE NATURAL FOODS, INC., CARSON, CA. SN 86-091,766. PUB. 4-1-2014, FILED 10-15-2013.



OWNER OF U.S. REG. NOS. 3,319,992, 4,415,658, AND OTHERS.

NO CLAIM IS MADE TO THE EXCLUSIVE RIGHT TO USE "FRESH" AND "FOOD COMPANY", APART FROM THE MARK AS SHOWN.

THE MARK CONSISTS OF TWO LEAVES AT THE LEFT OF "FRANKLY FRESH" SURROUNDED BY A RECTANGULAR SHAPE WITH ROUNDED ENDS; THE WORDS "A CEDARLANE FOOD COMPANY" CENTERED BELOW AND OUTSIDE THE RECTANGULAR SHAPE.

**CLASS 29—MEATS AND PROCESSED FOODS**

FOR PREPARED, PACKAGED AND REFRIGERATED AND/OR FROZEN ENTREES CONSISTING PRIMARILY OF MEAT, FISH, POULTRY, VEGETABLES; PREPARED, PACKAGED AND REFRIGERATED AND/OR FROZEN SIDE DISHES CONSISTING PRIMARILY OF BAKED YAM CASSEROLE, CREAMED SPINACH, MASHED POTATOES, AND SCALLOPED POTATOES; PREPARED, PACKAGED AND REFRIGERATED AND/OR FROZEN SOUPS; PREPARED, PACKAGED AND REFRIGERATED SALADS CONSISTING PRIMARILY OF MEAT, POULTRY, FISH, VEGETABLES, DRESSINGS, FRUITS, AND CHEESES; PREPARED, PACKAGED AND REFRIGERATED SANDWICHES AND WRAPS CONSISTING PRIMARILY OF MEAT, POULTRY, VEGETABLES, CHEESES AND DRESSING (U.S. CL. 46).

FIRST USE 10-22-2013; IN COMMERCE 10-22-2013.

**CLASS 30—STAPLE FOODS**

FOR PREPARED, PACKAGED AND REFRIGERATED AND/OR FROZEN ENTREES CONSISTING OF PASTAS AND RICE, INCLUDING LASAGNAS, ENCHILADAS, MACARONI AND CHEESE; PREPARED, PACKAGED AND REFRIGERATED AND/OR FROZEN SIDE DISHES CONSISTING PRIMARILY OF BREAD STUFFING; PREPARED, PACKAGED AND REFRIGERATED SALADS CONSISTING OF PASTAS, RICE, AND GRAINS; PREPARED, PACKAGED AND/OR REFRIGERATED DIPS INCLUDING HUMMUS, RANCH DIP, ONION DIP, EGGPLANT DIP, TZATZIKI, CUCUMBER AND YOGURT; PREPARED AND PACKAGED SAUCES AND GRAVIES (U.S. CL. 46).

FIRST USE 10-22-2013; IN COMMERCE 10-22-2013.

4,594,446. HER JUSTICE INC., NEW YORK, NY. SN 86-099,317. PUB. 4-8-2014, FILED 10-23-2013.



NO CLAIM IS MADE TO THE EXCLUSIVE RIGHT TO USE "JUSTICE", APART FROM THE MARK AS SHOWN.

THE MARK CONSISTS OF THE WORDING "HER JUSTICE", WITH A STYLIZED BOX BETWEEN "HER" AND "JUSTICE".

**CLASS 36—INSURANCE AND FINANCIAL**

FOR CHARITABLE FUND RAISING SERVICES TO RAISE FUNDS FOR LEGAL SERVICES FOR LOW INCOME WOMEN (U.S. CLS. 100, 101 AND 102).  
FIRST USE 11-12-2013; IN COMMERCE 11-12-2013.

**CLASS 45—PERSONAL AND LEGAL SERVICES**

FOR LEGAL SERVICES (U.S. CLS. 100 AND 101).  
FIRST USE 11-12-2013; IN COMMERCE 11-12-2013.

4,594,460. JANUS DEVELOPMENTAL SERVICES, INC., NOBLESVILLE, IN. SN 86-102,896. PUB. 4-15-2014, FILED 10-29-2013.



THE MARK CONSISTS OF A DRAWING OF TWO STICK FIGURE PEOPLE HOLDING HANDS, FORMING THE SHAPE OF A HEART IN BETWEEN THE TWO FIGURES.

4,594,447. FÉ FIT LLC, ROUND ROCK, TX. SN 86-099,358. PUB. 4-8-2014, FILED 10-23-2013.

**CLASS 35—ADVERTISING AND BUSINESS**

FOR JOB PLACEMENT, NAMELY, PROVIDING EMPLOYMENT OPPORTUNITIES TO INDIVIDUALS WITH INTELLECTUAL AND DEVELOPMENTAL DISABILITIES; JOB PLACEMENT FOR INDIVIDUALS WITH INTELLECTUAL AND DEVELOPMENTAL DISABILITIES THROUGH PARTNERSHIPS WITH LOCAL BUSINESSES (U.S. CLS. 100, 101 AND 102).  
FIRST USE 10-26-2013; IN COMMERCE 10-26-2013.

**CLASS 41—EDUCATION AND ENTERTAINMENT**

FOR PROVIDING EDUCATIONAL AND PREVOCAATIONAL COURSES TO PERSONS WITH INTELLECTUAL AND DEVELOPMENTAL DISABILITIES IN THE FIELD OF DAILY LIVING SKILLS, COMMUNITY READINESS SKILLS TRAINING, RECREATION SKILLS DEVELOPMENT, COMMUNICATION AND SOCIAL SKILLS DEVELOPMENT, AND BEHAVIOR MANAGEMENT (U.S. CLS. 100, 101 AND 107).  
FIRST USE 10-26-2013; IN COMMERCE 10-26-2013.

NO CLAIM IS MADE TO THE EXCLUSIVE RIGHT TO USE "FIT", APART FROM THE MARK AS SHOWN.  
THE MARK CONSISTS OF THE WORDS "FÉ FIT" IN STYLIZED FONT INSIDE A CIRCLE.

**CLASS 9—ELECTRICAL AND SCIENTIFIC APPARATUS**

FOR DIGITAL MEDIA, NAMELY, DVDS, HIGH DEFINITION DIGITAL VIDEO DISCS, AND DOWNLOADABLE AUDIO-VISUAL RECORDINGS IN THE FIELDS OF EXERCISE AND PHYSICAL FITNESS (U.S. CLS. 21, 23, 26, 36 AND 38).  
FIRST USE 11-28-2013; IN COMMERCE 11-28-2013.

**CLASS 41—EDUCATION AND ENTERTAINMENT**

FOR PROVIDING MULTI-MEDIA ONLINE INFORMATION, VIDEOS, PHOTOS, NEWS, AND COMMENTARY IN THE FIELDS OF EXERCISE AND PHYSICAL FITNESS (U.S. CLS. 100, 101 AND 107).  
FIRST USE 11-3-2012; IN COMMERCE 11-3-2012.

4,594,475. BIG PINKY, LLC, TEMECULA, CA. SN 86-108,413. PUB. 4-15-2014, FILED 11-1-2013.

# WILD PEPPER

THE MARK CONSISTS OF STANDARD CHARACTERS WITHOUT CLAIM TO ANY PARTICULAR FONT, STYLE, SIZE, OR COLOR.

**CLASS 18—LEATHER GOODS**

FOR BAGS, NAMELY, TOTE BAGS, GYM BAGS, SHOULDER BAGS AND BACKPACKS (U.S. CLS. 1, 2, 3, 22 AND 41).  
FIRST USE 5-2-2014; IN COMMERCE 5-2-2014.

**CLASS 25—CLOTHING**

FOR CLOTHING APPAREL, NAMELY, BOTTOMS, PANTS, SWEATPANTS, SHORTS, SKIRTS, SKORTS, TOPS, BLOUSES, SHIRTS, T-SHIRTS, JACKETS, SWEATSHIRTS, HOODED SWEATSHIRTS, BRAS, DRESSES, SWIMWEAR AND SWIMWEAR COVER-UPS, HATS, AND LEG AND KNEE WARMERS; ACTIVEWEAR AND VOLLEYBALL APPAREL, NAMELY, SPORT TOPS, TANK TOPS, SPORT BRAS AND BOTTOMS; FOOTWEAR, NAMELY, SHOES, SANDALS AND SOCKS (U.S. CLS. 22 AND 39).

FIRST USE 5-2-2014; IN COMMERCE 5-2-2014.

4,594,487. INSURANCE ZEBRA INC., AUSTIN, TX. SN 86-113,474. PUB. 4-1-2014, FILED 11-8-2013.

# THE ZEBRA

THE MARK CONSISTS OF STANDARD CHARACTERS WITHOUT CLAIM TO ANY PARTICULAR FONT, STYLE, SIZE, OR COLOR.

**CLASS 35—ADVERTISING AND BUSINESS**

FOR INSURANCE LEAD COLLECTION AND MATCHING SERVICES, NAMELY, MATCHING CONSUMER REQUESTS FOR INSURANCE POLICY QUOTES COLLECTED OVER THE INTERNET TO PRE-QUALIFIED INSURANCE BROKERS, AGENTS AND AGENCIES INTERESTED IN THOSE REQUESTS (U.S. CLS. 100, 101 AND 102).

FIRST USE 1-0-2012; IN COMMERCE 1-0-2012.

**CLASS 36—INSURANCE AND FINANCIAL**

FOR INSURANCE AGENCIES; INSURANCE SERVICES, PROVIDING PREMIUM RATE QUOTES VIA ON-LINE, TELEPHONE AND MAIL MEANS (U.S. CLS. 100, 101 AND 102).

FIRST USE 1-0-2012; IN COMMERCE 1-0-2012.

4,594,518. EARTHSCAPE USA LLC, MESA, AZ. SN 86-127,823. PUB. 4-22-2014, FILED 11-25-2013.

# STEMulate

THE MARK CONSISTS OF STANDARD CHARACTERS WITHOUT CLAIM TO ANY PARTICULAR FONT, STYLE, SIZE, OR COLOR.

**CLASS 1—CHEMICALS**

FOR ARTIFICIAL PLANT-CULTIVATION SOIL; COMPOST; FERTILISER FOR SOIL AND POTTING SOIL; FERTILISERS FOR SOIL AND POTTING SOIL; FERTILIZERS; FERTILIZERS FOR AGRICULTURAL USE; FERTILIZERS FOR DOMESTIC USE; GROWING MEDIA FOR PLANTS; HORTICULTURAL SOIL AMENDMENTS THAT ARE INCORPORATED INTO OR ONTO A TURF, LAWN OR SOIL PROFILE; NATURAL FERTILIZERS; NON-CHEMICAL BIO-FERTILIZERS; NUTRITIVE ADDITIVE TO ENHANCE THE BIOLOGICAL ACTIVITY OF WATER, SOIL, SEEDS AND PLANTS FOR PURPOSES OF FERTILIZATION AND BIOREMEDIATION OF POLLUTANTS; ORGANIC FERTILIZERS; SOIL ADDITIVES; SOIL AMENDMENTS; SOIL IMPROVING AGENTS; SOIL STABILIZERS FOR ROADS, PONDS AND LAKES; SOIL STABILIZERS FOR USE IN ROAD CONSTRUCTION; SOIL SURFACTANT USED TO PROMOTE UNIFORM MOVEMENT OF WATER IN SOIL; SUBSTANCES FOR REGULATING PLANT GROWTH (U.S. CLS. 1, 5, 6, 10, 26 AND 46).

FIRST USE 12-5-2013; IN COMMERCE 5-1-2014.

**CLASS 22—CORDAGE AND FIBERS**

FOR COCONUT FIBERS; HORTICULTURAL BAGS AND SACKS, NAMELY, BAGS AND SACKS MADE OF WOVEN SYNTHETIC OR NATURAL FIBERS OR PLASTICS MATERIALS, ALL FOR USE IN GROWING ANY TYPE OF PLANT, SHRUB OR TREE; PLASTIC-COVERED MESH FABRIC GROWING BAGS FOR GROWING PLANTS AND TREES (U.S. CLS. 1, 2, 7, 19, 22, 42 AND 50).

FIRST USE 12-5-2013; IN COMMERCE 5-1-2014.

4,594,527. ORR CORPORATION, LOUISVILLE, KY. SN 86-134,792. PUB. 4-29-2014, FILED 12-4-2013.

# Mission Critical Fire Protection Experts

THE MARK CONSISTS OF STANDARD CHARACTERS WITHOUT CLAIM TO ANY PARTICULAR FONT, STYLE, SIZE, OR COLOR.

NO CLAIM IS MADE TO THE EXCLUSIVE RIGHT TO USE "FIRE PROTECTION EXPERTS", APART FROM THE MARK AS SHOWN.

**CLASS 35—ADVERTISING AND BUSINESS**

FOR DISTRIBUTORSHIP SERVICES IN THE FIELD OF FIRE AND EXPLOSION PROTECTION EQUIPMENT (U.S. CLS. 100, 101 AND 102).

FIRST USE 5-0-2014; IN COMMERCE 5-0-2014.

**CLASS 37—CONSTRUCTION AND REPAIR**

FOR INSTALLATION AND MAINTENANCE OF FIRE ALARM, DETECTION, AND SUPPRESSION SYSTEMS AND EXPLOSION PROTECTION SYSTEMS (U.S. CLS. 100, 103 AND 106).

FIRST USE 5-0-2014; IN COMMERCE 5-0-2014.

**CLASS 42—SCIENTIFIC AND COMPUTER SERVICES**

FOR DESIGN AND INSPECTION OF FIRE DETECTION AND SUPPRESSION SYSTEMS AND EXPLOSION PROTECTION SYSTEMS (U.S. CLS. 100 AND 101).

FIRST USE 5-0-2014; IN COMMERCE 5-0-2014.

4,594,528. ELECTRONIC TRANSACTIONS ASSOCIATION, WASHINGTON, DC. SN 86-135,028. PUB. 4-22-2014, FILED 12-4-2013.

# TRANSACT

THE MARK CONSISTS OF STANDARD CHARACTERS WITHOUT CLAIM TO ANY PARTICULAR FONT, STYLE, SIZE, OR COLOR.

### CLASS 35—ADVERTISING AND BUSINESS

FOR ARRANGING AND CONDUCTING TRADE SHOW EXHIBITIONS IN THE FIELD OF THE ELECTRONIC TRANSACTIONS INDUSTRY (U.S. CLS. 100, 101 AND 102).  
FIRST USE 4-8-2014; IN COMMERCE 4-8-2014.

### CLASS 41—EDUCATION AND ENTERTAINMENT

FOR EDUCATIONAL SERVICES, NAMELY, ARRANGING AND CONDUCTING EDUCATIONAL CONFERENCES IN THE FIELD OF ELECTRONIC TRANSACTIONS AND THE ELECTRONIC TRANSACTIONS INDUSTRY (U.S. CLS. 100, 101 AND 107).  
FIRST USE 4-8-2014; IN COMMERCE 4-8-2014.

4,594,535. PROFILE PRODUCTS LLC, BUFFALO GROVE, IL. SN 86-143,068. PUB. 4-29-2014, FILED 12-13-2013.

# POWERGUARD

THE MARK CONSISTS OF STANDARD CHARACTERS WITHOUT CLAIM TO ANY PARTICULAR FONT, STYLE, SIZE, OR COLOR.

### CLASS 19—NON-METALLIC BUILDING MATERIALS

FOR HYDRAULICALLY-APPLIED, FLEXIBLE EROSION CONTROL BLANKETS COMPOSED OF LONG STRAND, THERMALLY PROCESSED WOOD FIBERS, CRIMPED INTERLOCKING FIBERS AND PERFORMANCE ENHANCING ADDITIVES; ABSORBENT, EROSION RESISTANT BLANKETS FOR RAPID GERMINATION AND ACCELERATED PLANT GROWTH (U.S. CLS. 1, 12, 33 AND 50).  
FIRST USE 4-21-2014; IN COMMERCE 4-21-2014.

### CLASS 31—NATURAL AGRICULTURAL PRODUCTS

FOR MULCH (U.S. CLS. 1 AND 46).  
FIRST USE 4-21-2014; IN COMMERCE 4-21-2014.

4,594,544. INC INTERNATIONAL COMPANY, KENNETT SQUARE, PA. SN 86-163,195. PUB. 4-15-2014, FILED 1-11-2014.

# UNCAP

THE MARK CONSISTS OF STANDARD CHARACTERS WITHOUT CLAIM TO ANY PARTICULAR FONT, STYLE, SIZE, OR COLOR.

### CLASS 9—ELECTRICAL AND SCIENTIFIC APPARATUS

FOR PROTECTIVE HELMETS; PROTECTIVE HELMETS FOR SPORTS; SAFETY HELMETS (U.S. CLS. 21, 23, 26, 36 AND 38).  
FIRST USE 6-30-2014; IN COMMERCE 6-29-2014.

### CLASS 28—TOYS AND SPORTING GOODS

FOR ATHLETIC PROTECTIVE PADS FOR FOOTBALL, BASKETBALL, HOCKEY, SNOWBOARDING, SKATEBOARDING, WRESTLING, HORSEBACK RIDING, BICYCLING, BASEBALL; PADS FOR USE IN FOOTBALL, BASKETBALL, HOCKEY, SNOWBOARDING, SKATEBOARDING, WRESTLING, HORSEBACK RIDING, BICYCLING, BASEBALL; SAFETY PADDING FOR FOOTBALL, BASKETBALL, HOCKEY, SNOWBOARDING, SKATEBOARDING, WRESTLING, HORSEBACK RIDING, BICYCLING, BASEBALL (U.S. CLS. 22, 23, 38 AND 50).  
FIRST USE 6-30-2014; IN COMMERCE 6-30-2014.

## SECTION 2.— INTERNATIONAL CLASSIFICATION

The short titles associated below with the international class numbers are terms designed merely for quick identification and are not an official part of the international classification. The full names of international classes are given in section 6.1 of the trademark rules of practice.

The designation "U.S. Cl." appearing in this section refers to the U.S. class in effect prior to Sep. 1, 1973 rather than the international class which applies to applications filed on or after that date. For adoption of international classification see notice in the OFFICIAL GAZETTE of Jun. 26, 1973 (911 O.G. TM 210).

### Application in one class

#### CLASS 1—CHEMICALS

4,593,178. TEXAS RESEARCH INTERNATIONAL, INC., AUSTIN, TX. SN 85-228,045. PUB. 3-5-2013, FILED 1-27-2011.

Proteckt

THE MARK CONSISTS OF STANDARD CHARACTERS WITHOUT CLAIM TO ANY PARTICULAR FONT, STYLE, SIZE, OR COLOR.

FOR POLYMERS AND POLYMERIC ADDITIVES FOR USE IN THE MANUFACTURE OF PHARMACEUTICAL PREPARATIONS, MEDICAL DEVICES, COSMETICS, PERSONAL CARE PRODUCTS; HIGH TEMPERATURE ABRASION RESISTANT COATINGS FOR AIRCRAFT AND HEAVY INDUSTRIAL AND MILITARY MACHINERY, ADHESIVES AND LUBRICANTS; ALL OF THE BEFORE MENTIONED GOODS NOT FOR USE IN THE AREA OF CORROSION PROTECTION, BUILDING PROTECTION AND HYDROPHOBATION (U.S. CLS. 1, 5, 6, 10, 26 AND 46).

FIRST USE 6-3-2013; IN COMMERCE 6-3-2013.

4,593,251. CONSTRUCTION RESEARCH & TECHNOLOGY GMBH, TROSTBERG, FED REP GERMANY. SN 85-477,520. PUB. 5-1-2012, FILED 11-21-2011.

MASTERWELD

THE MARK CONSISTS OF STANDARD CHARACTERS WITHOUT CLAIM TO ANY PARTICULAR FONT, STYLE, SIZE, OR COLOR.

FOR ADHESIVES FOR CONCRETE (U.S. CLS. 1, 5, 6, 10, 26 AND 46).

FIRST USE 6-20-2014; IN COMMERCE 6-20-2014.

#### CLASS 1—(Continued).

4,593,621. LINCOLN GLOBAL, INC., CITY OF INDUSTRY, CA. SN 85-803,680. PUB. 4-23-2013, FILED 12-15-2012.

842-H

THE MARK CONSISTS OF STANDARD CHARACTERS WITHOUT CLAIM TO ANY PARTICULAR FONT, STYLE, SIZE, OR COLOR.

FOR FLUXES FOR ARC WELDING OPERATIONS (U.S. CLS. 1, 5, 6, 10, 26 AND 46).

FIRST USE 12-15-2012; IN COMMERCE 12-15-2012.

4,593,668. MIDTECH R&D, INC., FAIRMONT, MN. SN 85-820,414. PUB. 5-7-2013, FILED 1-10-2013.

UPRISE COMPLETE

THE MARK CONSISTS OF STANDARD CHARACTERS WITHOUT CLAIM TO ANY PARTICULAR FONT, STYLE, SIZE, OR COLOR.

NO CLAIM IS MADE TO THE EXCLUSIVE RIGHT TO USE "COMPLETE", APART FROM THE MARK AS SHOWN.

FOR SEED COATING APPLIED TO CORN, SOY-BEANS, WHEAT AND ALFALFA SEEDS TO IMPROVE STANDS, SEEDLING HEALTH AND YIELD (U.S. CLS. 1, 5, 6, 10, 26 AND 46).

FIRST USE 2-28-2013; IN COMMERCE 2-28-2013.

**CLASS 1—(Continued).**

4,593,700. BLUE PACIFIC FLAVORS & FRAGRANCES, INC., CITY OF INDUSTRY, CA. SN 85-841,475. PUB. 4-30-2013, FILED 2-5-2013.

## SimplyFiber

THE MARK CONSISTS OF STANDARD CHARACTERS WITHOUT CLAIM TO ANY PARTICULAR FONT, STYLE, SIZE, OR COLOR.

FOR WHOLE RICE BRAN FIBER FOR USE IN THE MANUFACTURE OF FOODS AND BEVERAGES (U.S. CLS. 1, 5, 6, 10, 26 AND 46).

FIRST USE 11-7-2013; IN COMMERCE 11-7-2013.

**CLASS 1—(Continued).**

4,593,833. DOVE BIOTECH INC., NEW YORK, NY. SN 85-916,317. PUB. 12-10-2013, FILED 4-26-2013.

## CWP-121

THE MARK CONSISTS OF STANDARD CHARACTERS WITHOUT CLAIM TO ANY PARTICULAR FONT, STYLE, SIZE, OR COLOR.

FOR ORGANIC CHEMICAL BASED SOLUTION FOR WASTE WATER TREATMENT (U.S. CLS. 1, 5, 6, 10, 26 AND 46).

FIRST USE 11-1-2008; IN COMMERCE 7-13-2012.

4,593,701. BLUE PACIFIC FLAVORS & FRAGRANCES, INC., CITY OF INDUSTRY, CA. SN 85-841,500. PUB. 4-30-2013, FILED 2-5-2013.

## SimplyFermented

THE MARK CONSISTS OF STANDARD CHARACTERS WITHOUT CLAIM TO ANY PARTICULAR FONT, STYLE, SIZE, OR COLOR.

FOR FERMENTATION EXTRACTS (U.S. CLS. 1, 5, 6, 10, 26 AND 46).

FIRST USE 2-18-2014; IN COMMERCE 2-18-2014.

4,593,914. CLEAN WATER SERVICES, HILLSBORO, OR. SN 85-935,450. PUB. 10-22-2013, FILED 5-17-2013.

## CLEAN WATER GROW

THE MARK CONSISTS OF STANDARD CHARACTERS WITHOUT CLAIM TO ANY PARTICULAR FONT, STYLE, SIZE, OR COLOR.

FOR FERTILIZERS (U.S. CLS. 1, 5, 6, 10, 26 AND 46).

FIRST USE 3-0-2013; IN COMMERCE 3-0-2014.

4,593,780. XITEBIO TECHNOLOGIES, INC., WINNIPEG, MANITOBA, CANADA. SN 85-886,926. PUB. 8-13-2013, FILED 3-26-2013.

## AGPT

THE MARK CONSISTS OF STANDARD CHARACTERS WITHOUT CLAIM TO ANY PARTICULAR FONT, STYLE, SIZE, OR COLOR.

FOR PLANT INOCULANTS, NAMELY, BIOLOGICAL MICROORGANISMS USED FOR PLANT GROWTH (U.S. CLS. 1, 5, 6, 10, 26 AND 46).

FIRST USE 2-0-2011; IN COMMERCE 2-0-2011.

4,593,919. OPTIMA WORLDWIDE LTD., KOLOA, HI. SN 85-936,207. PUB. 2-11-2014, FILED 5-19-2013.

## Guardian Gel

THE MARK CONSISTS OF STANDARD CHARACTERS WITHOUT CLAIM TO ANY PARTICULAR FONT, STYLE, SIZE, OR COLOR.

FOR ACTIVE CHEMICAL INGREDIENTS FOR USE IN THE MANUFACTURE OF PHARMACEUTICALS FOR TREATING SEXUALLY TRANSMITTED DISEASES AND INFECTIONS (U.S. CLS. 1, 5, 6, 10, 26 AND 46).

FIRST USE 6-1-2000; IN COMMERCE 6-1-2000.



**CLASS 1—(Continued).**

4,594,076. COUNCIL FOR SCIENTIFIC AND INDUSTRIAL RESEARCH, PRETORIA, GAUTENG, SOUTH AFRICA. SN 85-958,773. PUB. 11-12-2013, FILED 6-13-2013.

# MAGRESYN

THE MARK CONSISTS OF STANDARD CHARACTERS WITHOUT CLAIM TO ANY PARTICULAR FONT, STYLE, SIZE, OR COLOR.

FOR MAGNETIC POLYMER MICROSPHERES (U.S. CLS. 1, 5, 6, 10, 26 AND 46).

FIRST USE 7-27-2012; IN COMMERCE 3-28-2014.

---

4,594,221. BIOWORKS, INC., VICTOR, NY. SN 86-008,930. PUB. 9-17-2013, FILED 7-12-2013.

# VitalSource

THE MARK CONSISTS OF STANDARD CHARACTERS WITHOUT CLAIM TO ANY PARTICULAR FONT, STYLE, SIZE, OR COLOR.

FOR FERTILIZERS (U.S. CLS. 1, 5, 6, 10, 26 AND 46).

FIRST USE 1-1-2014; IN COMMERCE 3-18-2014.

---

4,594,225. BIOWORKS, INC., VICTOR, NY. SN 86-010,201. PUB. 9-24-2013, FILED 7-15-2013.

# Organic VitalSource

THE MARK CONSISTS OF STANDARD CHARACTERS WITHOUT CLAIM TO ANY PARTICULAR FONT, STYLE, SIZE, OR COLOR.

NO CLAIM IS MADE TO THE EXCLUSIVE RIGHT TO USE "ORGANIC", APART FROM THE MARK AS SHOWN.

FOR ORGANIC FERTILIZERS (U.S. CLS. 1, 5, 6, 10, 26 AND 46).

FIRST USE 1-1-2014; IN COMMERCE 5-27-2014.

**CLASS 1—(Continued).**

4,594,239. SELECTIVE MICRO TECHNOLOGIES, COLUMBUS, OH. SN 86-013,659. PUB. 12-10-2013, FILED 7-18-2013.

# SelectroFresh

THE MARK CONSISTS OF THE STYLIZED TEXT "SELECTROFRESH" WITH THE LETTER "H" HAVING A LEAF SYMBOL AT THE END. THE WORDS "SELECTRO" AND "FRESH" HAVE DISTINCTIVE, SEPARATE APPEARANCES.

FOR CHEMICAL ADDITIVES FOR USE IN THE MANUFACTURE OF CHLORINE DIOXIDE TO BE USED IN FOOD PROCESSING FACILITIES AND AS A RAW AGRICULTURAL COMMODITY WASH (U.S. CLS. 1, 5, 6, 10, 26 AND 46).

FIRST USE 6-9-2014; IN COMMERCE 6-9-2014.

---

4,594,305. PROFILE PRODUCTS LLC, BUFFALO GROVE, IL. SN 86-044,930. PUB. 4-29-2014, FILED 8-22-2013.

# PRO LEAGUE CHAMPION BROWN

THE MARK CONSISTS OF STANDARD CHARACTERS WITHOUT CLAIM TO ANY PARTICULAR FONT, STYLE, SIZE, OR COLOR.

OWNER OF U.S. REG. NOS. 2,449,549 AND 3,949,282.

NO CLAIM IS MADE TO THE EXCLUSIVE RIGHT TO USE "BROWN", APART FROM THE MARK AS SHOWN.

FOR SOIL CONDITIONERS FOR USE ON ATHLETIC FIELDS (U.S. CLS. 1, 5, 6, 10, 26 AND 46).

FIRST USE 12-9-2013; IN COMMERCE 12-9-2013.

---

4,594,413. LIFE TECHNOLOGIES CORPORATION, CARLSBAD, CA. SN 86-088,257. PUB. 1-28-2014, FILED 10-10-2013.

# FLUOVOLT

THE MARK CONSISTS OF STANDARD CHARACTERS WITHOUT CLAIM TO ANY PARTICULAR FONT, STYLE, SIZE, OR COLOR.

FOR CHEMICALS FOR USE IN FLUORESCENT ANALYSIS FOR SCIENTIFIC RESEARCH PURPOSES, KITS COMPRISED OF CHEMICALS FOR USE IN FLUORESCENT ANALYSIS, AND PRINTED MATERIAL PROVIDED IN CONNECTION THEREWITH (U.S. CLS. 1, 5,

6, 10, 26 AND 46).

FIRST USE 11-15-2013; IN COMMERCE 11-15-2013.

**CLASS 1—(Continued).**

4,594,428. JOSEPH JAMES FEWER, AYLMER, ONTARIO, CANADA. SN 86-092,618. PUB. 3-11-2014, FILED 10-16-2013.

## AGRABURST

THE MARK CONSISTS OF STANDARD CHARACTERS WITHOUT CLAIM TO ANY PARTICULAR FONT, STYLE, SIZE, OR COLOR.

FOR SUBSTANCES FOR REGULATING PLANT GROWTH (U.S. CLS. 1, 5, 6, 10, 26 AND 46).  
FIRST USE 2-18-2014; IN COMMERCE 2-18-2014.

4,594,541. NEOGEN CORPORATION, LANSING, MI. SN 86-153,387. PUB. 4-22-2014, FILED 12-27-2013.

## AQUAPRIME

THE MARK CONSISTS OF STANDARD CHARACTERS WITHOUT CLAIM TO ANY PARTICULAR FONT, STYLE, SIZE, OR COLOR.

FOR CHEMICALS, MINERAL AND ACIDS FOR USE IN PURIFICATION OF WATER FOR VETERINARY USE; CHEMICALS, MINERALS AND ACIDS FOR USE IN PURIFYING WATER FOR VETERINARY USE (U.S. CLS. 1, 5, 6, 10, 26 AND 46).

FIRST USE 12-23-2013; IN COMMERCE 12-23-2013.

**CLASS 2—PAINTS**

4,593,086. HENRY COMPANY LLC, EL SEGUNDO, CA. SN 77-871,826. PUB. 6-7-2011, FILED 11-13-2009.

## EL PREFERIDO DE LOS PROFESIONALES

THE MARK CONSISTS OF STANDARD CHARACTERS WITHOUT CLAIM TO ANY PARTICULAR FONT, STYLE, SIZE, OR COLOR.

OWNER OF U.S. REG. NO. 1,992,242.

THE ENGLISH TRANSLATION OF "EL PREFERIDO DE LOS PROFESIONALES" IN THE MARK IS #1 CHOICE OF PROFESSIONALS.

**CLASS 2—(Continued).**

SEC. 2(F).

FOR WATERPROOFING COATINGS, NAMELY, FIBRATED AND NON-FIBRATED ASPHALTIC AND RESINOUS COATINGS APPLIED TO WALLS AND FOUNDATIONS; AND AIR BARRIER COATINGS, NAMELY, FIBRATED AND NON-FIBRATED ASPHALTIC AND RESIN-BASED COATINGS FOR APPLICATION TO CONCRETE, CONCRETE BLOCK, AND DRYWALL SHEATHING IN INDUSTRIAL/COMMERCIAL RAIN SCREENWALL APPLICATIONS; ELASTOMERIC-BASED COATINGS FOR USE ON ROOFS, WALLS, AND BUILDING FOUNDATIONS; ROOF PAINTS AND PRIMERS; ALUMINUM PAINTS AND COATINGS FOR ROOFS AND BUILDINGS; SEALANTS, COATINGS, RESURFACERS AND FILLERS FOR COATING AND REPAIR OF FOUNDATIONS, CONCRETE MASONRY, SURFACES AND FLOORS, PROTECTIVE COATINGS AND SEALERS FOR DRIVEWAYS; PAINTS AND PROTECTIVE COATINGS FOR ROOFS; PROTECTIVE SEALERS IN THE FORM OF COATINGS FOR CONCRETE, PAVING STONES AND MASONRY; ELASTOMERIC ACRYLIC BASED ROOF COATINGS; CEMENTITIOUS REPAIR, MAINTENANCE AND COATING PRODUCTS, NAMELY, POLYMER BASED SEALANTS FOR CONCRETE, PAVING STONES, MASONRY AND WALLS; FIBRATED AND NON-FIBRATED RESIN-BASED COATINGS FOR ROOFS, FOUNDATIONS AND WALLS (U.S. CLS. 6, 11 AND 16).

FIRST USE 3-0-2013; IN COMMERCE 3-0-2013.

4,593,277. MCWANE, INC., BIRMINGHAM, AL. SN 85-532,522. PUB. 10-30-2012, FILED 2-2-2012.

## TUF-BOND

THE MARK CONSISTS OF STANDARD CHARACTERS WITHOUT CLAIM TO ANY PARTICULAR FONT, STYLE, SIZE, OR COLOR.

FOR CORROSION INHIBITANTS IN THE NATURE OF A COATING; ANTI-CORROSIVE COATINGS FOR FIRE HYDRANTS; ANTI-CORROSIVE COATINGS FOR DUCTILE IRON (U.S. CLS. 6, 11 AND 16).

FIRST USE 2-1-2012; IN COMMERCE 2-1-2012.

4,593,308. ECO PRODUCT GROUP, LLC, PITTSBURGH, PA. SN 85-592,707. PUB. 8-21-2012, FILED 4-9-2012.

## SILVERARMOR

THE MARK CONSISTS OF STANDARD CHARACTERS WITHOUT CLAIM TO ANY PARTICULAR FONT, STYLE, SIZE, OR COLOR.

FOR INTERIOR PAINT CONTAINING SILVER AS AN INGREDIENT FOR WALLS AND WOODWORK; POLYURETHANE COATING CONTAINING SILVER AS AN INGREDIENT FOR USE AS SEALANT (U.S. CLS. 6, 11 AND 16).

FIRST USE 6-20-2014; IN COMMERCE 6-20-2014.

**CLASS 2—(Continued).**

4,593,861. ULTRATECH INTERNATIONAL, INC., JACKSONVILLE, FL. SN 85-922,829. PUB. 7-16-2013, FILED 5-3-2013.

**ULTRA ALWAYS DRY**

THE MARK CONSISTS OF STANDARD CHARACTERS WITHOUT CLAIM TO ANY PARTICULAR FONT, STYLE, SIZE, OR COLOR.

OWNER OF U.S. REG. NOS. 2,304,078, 3,866,001, AND OTHERS.

FOR ANTI-CORROSIVE AND FIRE RETARDANT COATINGS; ANTI-TARNISHING PREPARATIONS FOR COATING METALS; ARCHITECTURAL PROTECTIVE COATINGS; COATING PREPARATIONS HAVING WATER REPELLENT PROPERTIES; COATINGS IN THE NATURE OF INDUSTRIAL SEALANTS FOR WATERPROOFING AND SURFACE HARDENING; CONCRETE MOISTURE BARRIER COATING; CONCRETE SEALERS IN THE FORM OF A COATING; CORROSION INHIBITING PAINT TYPE COATINGS FOR COMMERCIAL MARINE USE; CORROSION INHIBITING PAINT TYPE COATINGS FOR USE IN THE OIL AND/OR GAS DRILLING INDUSTRY; CORROSION INHIBITORS IN THE NATURE OF A COATING; EXTERIOR SURFACE PROTECTIVE COATINGS; FLOOR COATINGS; RUST PREVENTATIVES IN THE NATURE OF A COATING; VEHICLE CORROSION INHIBITING PREPARATIONS IN THE NATURE OF A COATING; WATERPROOF PAINTS; WEATHERPROOFING COATINGS (U.S. CLS. 6, 11 AND 16).

FIRST USE 3-0-2014; IN COMMERCE 3-0-2014.

4,594,009. FLEET WHOLESALE SUPPLY CO., INC., APPLETON, WI. SN 85-949,112. PUB. 11-5-2013, FILED 6-3-2013.

**BUNKER-HILL PAINT CO.**

THE MARK CONSISTS OF STANDARD CHARACTERS WITHOUT CLAIM TO ANY PARTICULAR FONT, STYLE, SIZE, OR COLOR.

NO CLAIM IS MADE TO THE EXCLUSIVE RIGHT TO USE "PAINT CO.", APART FROM THE MARK AS SHOWN. FOR PAINTS (U.S. CLS. 6, 11 AND 16). FIRST USE 4-1-2014; IN COMMERCE 4-1-2014.

**CLASS 2—(Continued).**

4,594,292. THE VALSPAR CORPORATION, MINNEAPOLIS, MN. SN 86-039,756. PUB. 1-7-2014, FILED 8-16-2013.

**COLORFINITY**

THE MARK CONSISTS OF STANDARD CHARACTERS WITHOUT CLAIM TO ANY PARTICULAR FONT, STYLE, SIZE, OR COLOR.

FOR PAINTS (U.S. CLS. 6, 11 AND 16). FIRST USE 11-30-2013; IN COMMERCE 11-30-2013.

4,594,293. THE VALSPAR CORPORATION, MINNEAPOLIS, MN. SN 86-039,791. PUB. 1-7-2014, FILED 8-16-2013.

**COLORFINITY**

THE MARK CONSISTS OF THE WORD "COLORFINITY" WITH THE LETTER "N" REPLACED BY AN INFINITY SYMBOL.

FOR PAINTS (U.S. CLS. 6, 11 AND 16). FIRST USE 11-30-2013; IN COMMERCE 11-30-2013.

4,594,297. THE VALSPAR CORPORATION, MINNEAPOLIS, MN. SN 86-041,843. PUB. 1-7-2014, FILED 8-19-2013.

**COVER & GO**

THE MARK CONSISTS OF STANDARD CHARACTERS WITHOUT CLAIM TO ANY PARTICULAR FONT, STYLE, SIZE, OR COLOR.

FOR PAINTS (U.S. CLS. 6, 11 AND 16). FIRST USE 10-25-2013; IN COMMERCE 10-25-2013.

**CLASS 2—(Continued).**

4,594,348. THE VALSPAR CORPORATION, MINNEAPOLIS, MN. SN 86-063,650. PUB. 1-7-2014, FILED 9-13-2013.

**RESERVE**

THE MARK CONSISTS OF STANDARD CHARACTERS WITHOUT CLAIM TO ANY PARTICULAR FONT, STYLE, SIZE, OR COLOR.

FOR PAINTS (U.S. CLS. 6, 11 AND 16).  
FIRST USE 4-1-2014; IN COMMERCE 4-1-2014.

---

4,594,410. GDB INTERNATIONAL INC., NEW BRUNSWICK, NJ. SN 86-087,781. PUB. 3-4-2014, FILED 10-10-2013.

**EVOLVE**

THE MARK CONSISTS OF STANDARD CHARACTERS WITHOUT CLAIM TO ANY PARTICULAR FONT, STYLE, SIZE, OR COLOR.

FOR RECYCLED PAINT FOR USE IN INDUSTRIAL BUILDING CONSTRUCTION; RECYCLED HOUSE PAINT (U.S. CLS. 6, 11 AND 16).  
FIRST USE 1-1-2014; IN COMMERCE 1-1-2014.

---

4,594,411. GDB INTERNATIONAL INC., NEW BRUNSWICK, NJ. SN 86-087,785. PUB. 3-4-2014, FILED 10-10-2013.



THE MARK CONSISTS OF THE LITERAL ELEMENT "EVOLVE" WRITTEN IN STYLIZED FORM WHEREIN THERE IS AN IMAGE OF LEAF IS PLACED ABOVE THE LETTER "O" OF "EVOLVE".

FOR RECYCLED PAINT FOR USE IN INDUSTRIAL BUILDING CONSTRUCTION; RECYCLED HOUSE PAINT (U.S. CLS. 6, 11 AND 16).  
FIRST USE 1-1-2014; IN COMMERCE 1-1-2014.

**CLASS 3—COSMETICS AND CLEANING PREPARATIONS****CLASS 3—(Continued).**

4,593,092. TOOTH TASTES, INC., MANHATTAN BEACH, CA. SN 78-590,656. PUB. 2-11-2014, FILED 3-18-2005.

**BABY BLING**

THE MARK CONSISTS OF STANDARD CHARACTERS WITHOUT CLAIM TO ANY PARTICULAR FONT, STYLE, SIZE, OR COLOR.

OWNER OF U.S. REG. NO. 3,005,085.  
NO CLAIM IS MADE TO THE EXCLUSIVE RIGHT TO USE "BABY", APART FROM THE MARK AS SHOWN.  
FOR CHILDREN'S TOOTHPASTE (U.S. CLS. 1, 4, 6, 50, 51 AND 52).  
FIRST USE 5-6-2006; IN COMMERCE 5-8-2006.

---

4,593,128. PET PRODUCTS DISTRIBUTION, LLC, SAN DIEGO, CA. SN 85-077,538. PUB. 6-21-2011, FILED 7-2-2010.



THE MARK CONSISTS OF A THREE DIMENSIONAL CONTAINER SHAPED LIKE A BONE.

FOR ORGANIC PET CARE PRODUCTS, NAMELY, SHAMPOO, CONDITIONER AND BODY SPRAY (U.S. CLS. 1, 4, 6, 50, 51 AND 52).  
FIRST USE 3-2-2011; IN COMMERCE 3-2-2011.

---

4,593,239. DORCICH, DAVID, LOS ANGELES, CA. AND SAUNDERS, PAULINE, LOS ANGELES, CA. SN 85-452,589. PUB. 7-9-2013, FILED 10-20-2011.

**Goth Block Sunscreen**

THE MARK CONSISTS OF STANDARD CHARACTERS WITHOUT CLAIM TO ANY PARTICULAR FONT, STYLE, SIZE, OR COLOR.

**CLASS 3—(Continued).**

NO CLAIM IS MADE TO THE EXCLUSIVE RIGHT TO USE "BLOCK SUNSCREEN", APART FROM THE MARK AS SHOWN.

FOR SUN BLOCK (U.S. CLS. 1, 4, 6, 50, 51 AND 52).  
FIRST USE 6-27-2014; IN COMMERCE 6-27-2014.

**CLASS 3—(Continued).**

4,593,374. ABERCROMBIE & FITCH TRADING CO., NEW ALBANY, OH. SN 85-657,883. PUB. 11-6-2012, FILED 6-21-2012.

4,593,271. XTREME TOOLS INTERNATIONAL, INC., MIA-MI, FL. SN 85-524,645. PUB. 6-19-2012, FILED 1-25-2012.

**SHORECLIFF BEACH****Girls Girls Girls**

THE MARK CONSISTS OF STANDARD CHARACTERS WITHOUT CLAIM TO ANY PARTICULAR FONT, STYLE, SIZE, OR COLOR.

FOR HAIR BLEACHES; HAIR CARE CREAMS; HAIR CARE LOTIONS; HAIR COLORANTS; HAIR CONDITIONERS; HAIR GEL AND HAIR MOUSSE; HAIR GELS; HAIR LOTION; HAIR OILS; HAIR RELAXERS; HAIR RELAXING PREPARATIONS; HAIR RINSES; HAIR SHAMPOO; HAIR SHAMPOOS AND CONDITIONERS; HAIR SPRAYS AND HAIR GELS; HAIR STRAIGHTENING PREPARATIONS; HAIR STYLING FIXATIVE IN THE NATURE OF HAIR WAX; HAIR STYLING PREPARATIONS; HAIR STYLING SPRAY; HAIR WAX; HAIR-WASHING POWDER (U.S. CLS. 1, 4, 6, 50, 51 AND 52).

FIRST USE 2-3-2014; IN COMMERCE 2-3-2014.

THE MARK CONSISTS OF STANDARD CHARACTERS WITHOUT CLAIM TO ANY PARTICULAR FONT, STYLE, SIZE, OR COLOR.

FOR BODY SPRAY USED AS A PERSONAL DEODORANT AND AS FRAGRANCE; BODY SPRAYS; DEODORANTS FOR PERSONAL USE; FRAGRANCES FOR PERSONAL USE (U.S. CLS. 1, 4, 6, 50, 51 AND 52).  
FIRST USE 1-9-2013; IN COMMERCE 1-9-2013.

4,593,404. UNILEVER PLC, MERSEYSIDE ENGLAND, UNITED KINGDOM. SN 85-680,050. PUB. 3-25-2014, FILED 7-18-2012.

4,593,310. TURTLE WAX, INC., WILLOWBROOK, IL. SN 85-595,649. PUB. 10-30-2012, FILED 4-12-2012.

**ON THE REBOUND****THE SMARTER WAY TO SHINE**

THE MARK CONSISTS OF STANDARD CHARACTERS WITHOUT CLAIM TO ANY PARTICULAR FONT, STYLE, SIZE, OR COLOR.

FOR CLEANING, WASHING, WAXING, POLISHING AND RESTORING PREPARATIONS FOR VEHICLES (U.S. CLS. 1, 4, 6, 50, 51 AND 52).  
FIRST USE 4-1-2012; IN COMMERCE 4-1-2012.

THE MARK CONSISTS OF STANDARD CHARACTERS WITHOUT CLAIM TO ANY PARTICULAR FONT, STYLE, SIZE, OR COLOR.

FOR SOAPS; PERFUMERY; ESSENTIAL OILS; DEODORANTS AND ANTIPERSPIRANTS; HAIR CARE PREPARATIONS; HAIR COLORANTS, HAIR DYES, HAIR LOTIONS, HAIR WAVING PREPARATIONS, SHAMPOOS, CONDITIONERS, HAIR SPRAYS, HAIR DRESSINGS, HAIR LACQUERS, HAIR MOUSSES, HAIR GLAZES, HAIR GELS, HAIR MOISTURIZERS, HAIR PRESERVATION TREATMENTS, NAMELY, HAIR CONDITIONERS, HAIR OILS, HAIR TONIC, HAIR CREAMS, HAIR OILS, HAIR TONIC, HAIR CREAMS, NON-MEDICATED PREPARATIONS FOR THE BATH AND/OR SHOWER; NON-MEDICATED SKIN CARE PREPARATIONS; COSMETICS (U.S. CLS. 1, 4, 6, 50, 51 AND 52).  
FIRST USE 3-0-2013; IN COMMERCE 3-0-2013.

**CLASS 3—(Continued).**

4,593,491. AG GLOBAL PRODUCTS, LLC, LOS ANGELES, CA. SN 85-755,805. PUB. 3-18-2014, FILED 10-16-2012.

## HOT SAUCE

THE MARK CONSISTS OF STANDARD CHARACTERS WITHOUT CLAIM TO ANY PARTICULAR FONT, STYLE, SIZE, OR COLOR.

FOR CONDITIONERS; HAIR CARE PREPARATIONS; HAIR STYLING PREPARATIONS; NON-MEDICATED HAIR TREATMENT PREPARATIONS FOR COSMETIC PURPOSES; SHAMPOOS (U.S. CLS. 1, 4, 6, 50, 51 AND 52).

FIRST USE 1-0-2006; IN COMMERCE 1-0-2006.

4,593,510. RAFIH, SEBASTIEN, NICE, FRANCE. SN 85-764,195. PUB. 4-23-2013, FILED 10-26-2012.

## ÉTIENNE RAFF PARIS

THE MARK CONSISTS OF STANDARD CHARACTERS WITHOUT CLAIM TO ANY PARTICULAR FONT, STYLE, SIZE, OR COLOR.

NO CLAIM IS MADE TO THE EXCLUSIVE RIGHT TO USE "PARIS", APART FROM THE MARK AS SHOWN.

THE NAME(S), PORTRAIT(S), AND/OR SIGNATURE(S) SHOWN IN THE MARK DOES NOT IDENTIFY A PARTICULAR LIVING INDIVIDUAL.

FOR AFTER-SHAVE; BEAUTY MASKS; COLOGNES, PERFUMES AND COSMETICS; ESSENTIAL OILS; HAIR LOTIONS; LIPSTICKS; SHAVING CREAMS; SHAVING GELS; SHAVING LOTIONS; SHAVING PREPARATIONS; SKIN CLEANSING CREAM; SOAPS FOR PERSONAL USE; TOILET WATERS (U.S. CLS. 1, 4, 6, 50, 51 AND 52).

FIRST USE 1-1-2014; IN COMMERCE 1-1-2014.

4,593,624. ZIRC COMPANY, BUFFALO, MN. SN 85-805,242. PUB. 5-14-2013, FILED 12-18-2012.

## Mirror Magic

THE MARK CONSISTS OF STANDARD CHARACTERS WITHOUT CLAIM TO ANY PARTICULAR FONT, STYLE, SIZE, OR COLOR.

NO CLAIM IS MADE TO THE EXCLUSIVE RIGHT TO USE "MIRROR", APART FROM THE MARK AS SHOWN.

FOR ANTI-FOG SOLUTION FOR REMOVING AND PREVENTING FOG ON DENTAL MOUTH MIRRORS (U.S. CLS. 1, 4, 6, 50, 51 AND 52).

FIRST USE 6-20-2014; IN COMMERCE 6-20-2014.

**CLASS 3—(Continued).**

4,593,625. L'OREAL USA CREATIVE, INC., NEW YORK, NY. SN 85-806,853. PUB. 5-7-2013, FILED 12-19-2012.

## MASTER KAJAL

THE MARK CONSISTS OF STANDARD CHARACTERS WITHOUT CLAIM TO ANY PARTICULAR FONT, STYLE, SIZE, OR COLOR.

OWNER OF U.S. REG. NOS. 4,112,649, 4,151,011, AND 4,155,406.

NO CLAIM IS MADE TO THE EXCLUSIVE RIGHT TO USE "KAJAL", APART FROM THE MARK AS SHOWN.

FOR EYE MAKEUP (U.S. CLS. 1, 4, 6, 50, 51 AND 52).

FIRST USE 6-1-2014; IN COMMERCE 6-1-2014.

4,593,661. THE TETRA CORPORATION, EATON RAPIDS, MI. SN 85-817,295. PUB. 4-9-2013, FILED 1-7-2013.

## KAMEA

THE MARK CONSISTS OF STANDARD CHARACTERS WITHOUT CLAIM TO ANY PARTICULAR FONT, STYLE, SIZE, OR COLOR.

FOR BODY CREAM; COSMETIC CREAMS; COSMETIC CREAMS FOR SKIN CARE; COSMETIC PREPARATIONS; COSMETIC PREPARATIONS FOR BODY CARE; COSMETIC PREPARATIONS FOR SKIN CARE; COSMETIC PREPARATIONS FOR SKIN RENEWAL; EXFOLIANT CREAMS; EXFOLIANTS FOR SKIN; MOISTURIZING CREAMS; MOISTURIZING PREPARATIONS FOR THE SKIN; NON-MEDICATED SKIN CARE PREPARATIONS; NON-MEDICATED SKIN CARE PREPARATIONS, NAMELY, CREAMS, LOTIONS, GELS, TONERS, CLEANERS AND PEELS; NON-MEDICATED SKIN CREAMS; SKIN CONDITIONERS; SKIN CONDITIONING CREAMS FOR COSMETIC PURPOSES; SKIN EMOLLIENTS; SKIN MOISTURIZER (U.S. CLS. 1, 4, 6, 50, 51 AND 52).

FIRST USE 1-14-2014; IN COMMERCE 1-14-2014.

**CLASS 3—(Continued).**

4,593,662. COLGATE-PALMOLIVE COMPANY, NEW YORK, NY. SN 85-818,248. PUB. 5-7-2013, FILED 1-8-2013.

**GEAR**

THE MARK CONSISTS OF STANDARD CHARACTERS WITHOUT CLAIM TO ANY PARTICULAR FONT, STYLE, SIZE, OR COLOR.  
FOR DEODORANTS AND ANTIPERSPIRANTS FOR PERSONAL USE (U.S. CLS. 1, 4, 6, 50, 51 AND 52).  
FIRST USE 1-15-2014; IN COMMERCE 1-15-2014.

4,593,684. COLGATE-PALMOLIVE COMPANY, NEW YORK, NY. SN 85-829,141. PUB. 6-11-2013, FILED 1-22-2013.

**DRYCORE**

THE MARK CONSISTS OF STANDARD CHARACTERS WITHOUT CLAIM TO ANY PARTICULAR FONT, STYLE, SIZE, OR COLOR.  
FOR DEODORANTS AND ANTIPERSPIRANTS FOR PERSONAL USE (U.S. CLS. 1, 4, 6, 50, 51 AND 52).  
FIRST USE 1-15-2014; IN COMMERCE 1-15-2014.

4,593,689. COLGATE-PALMOLIVE COMPANY, NEW YORK, NY. SN 85-831,628. PUB. 6-11-2013, FILED 1-24-2013.

**FRESHCORE**

THE MARK CONSISTS OF STANDARD CHARACTERS WITHOUT CLAIM TO ANY PARTICULAR FONT, STYLE, SIZE, OR COLOR.  
FOR DEODORANTS AND ANTIPERSPIRANTS FOR PERSONAL USE (U.S. CLS. 1, 4, 6, 50, 51 AND 52).  
FIRST USE 1-6-2014; IN COMMERCE 1-6-2014.

**CLASS 3—(Continued).**

4,593,696. MSD CONSUMER CARE, INC., MEMPHIS, TN. SN 85-837,562. PUB. 6-18-2013, FILED 1-31-2013.

**DREAMWALK**

THE MARK CONSISTS OF STANDARD CHARACTERS WITHOUT CLAIM TO ANY PARTICULAR FONT, STYLE, SIZE, OR COLOR.  
FOR NON-MEDICATED FOOT CREAMS; NON-MEDICATED FOOT LOTIONS; NON-MEDICATED FOOT SCRUBS; NON-MEDICATED FOOT SOAKS; PUMICE STONES FOR PERSONAL USE; NON-MEDICATED FOOT PREPARATION TO PROTECT SKIN FROM IRRITATION AND RUBBING AND TO PREVENT BLISTERS; FOOT DEODORANT SPRAY; FOOT POWDER (U.S. CLS. 1, 4, 6, 50, 51 AND 52).  
FIRST USE 4-1-2014; IN COMMERCE 4-1-2014.

4,593,705. COLGATE-PALMOLIVE COMPANY, NEW YORK, NY. SN 85-843,842. PUB. 6-11-2013, FILED 2-7-2013.

**COOL MOTION**

THE MARK CONSISTS OF STANDARD CHARACTERS WITHOUT CLAIM TO ANY PARTICULAR FONT, STYLE, SIZE, OR COLOR.  
OWNER OF U.S. REG. NOS. 2,952,971, 3,684,132, AND OTHERS.  
FOR DEODORANTS AND ANTIPERSPIRANTS FOR PERSONAL USE (U.S. CLS. 1, 4, 6, 50, 51 AND 52).  
FIRST USE 1-15-2014; IN COMMERCE 1-15-2014.

4,593,744. COLGATE-PALMOLIVE COMPANY, NEW YORK, NY. SN 85-864,546. PUB. 5-7-2013, FILED 3-1-2013.

**SPEED STICK GEAR**

THE MARK CONSISTS OF STANDARD CHARACTERS WITHOUT CLAIM TO ANY PARTICULAR FONT, STYLE, SIZE, OR COLOR.  
OWNER OF U.S. REG. NOS. 2,464,025, 3,030,115, AND OTHERS.  
NO CLAIM IS MADE TO THE EXCLUSIVE RIGHT TO USE "STICK", APART FROM THE MARK AS SHOWN.  
FOR DEODORANTS AND ANTIPERSPIRANTS FOR PERSONAL USE (U.S. CLS. 1, 4, 6, 50, 51 AND 52).  
FIRST USE 1-15-2014; IN COMMERCE 1-15-2014.

**CLASS 3—(Continued).**

4,593,808. SOFT GOLD GHEE, INC., SAN FRANCISCO, CA. SN 85-905,941. PUB. 10-15-2013, FILED 4-16-2013.

**Bell+Ghee**

THE MARK CONSISTS OF STANDARD CHARACTERS WITHOUT CLAIM TO ANY PARTICULAR FONT, STYLE, SIZE, OR COLOR.

FOR COSMETIC CREAMS FOR SKIN CARE CONTAINING GHEE; FRAGRANCED SKIN CARE PREPARATIONS CONTAINING GHEE, NAMELY, SKIN CLEANSERS AND SKIN MOISTURIZERS; NON-MEDICATED SKIN CARE PREPARATIONS CONTAINING GHEE, NAMELY, CREAMS, LOTIONS, GELS, TONERS, CLEANERS AND PEELS (U.S. CLS. 1, 4, 6, 50, 51 AND 52).

FIRST USE 5-1-2014; IN COMMERCE 5-1-2014.

4,593,816. GINN, ALEXIS, DYER, IN. SN 85-910,070. PUB. 1-7-2014, FILED 4-20-2013.



THE MARK CONSISTS OF A PATTERN OF CURVED LINES INSIDE A CIRCLE.

FOR ARTIFICIAL FINGERNAILS; FINGERNAIL DECALS; THREE-DIMENSIONAL FINGERNAIL DECALS; FINGERNAIL EMBELLISHMENTS; FINGERNAIL JEWELRY; NAIL POLISH; NAIL STRENGTHENERS; NAIL POLISH REMOVERS; NAIL CARE PREPARATIONS; ADHESIVES FOR ATTACHING ARTIFICIAL FINGERNAILS (U.S. CLS. 1, 4, 6, 50, 51 AND 52).

FIRST USE 5-9-2014; IN COMMERCE 5-9-2014.

**CLASS 3—(Continued).**

4,593,817. ALEXIS GINN, DYER, IN. SN 85-910,071. PUB. 2-18-2014, FILED 4-20-2013.

**STATIC NAILS**

THE MARK CONSISTS OF STANDARD CHARACTERS WITHOUT CLAIM TO ANY PARTICULAR FONT, STYLE, SIZE, OR COLOR.

NO CLAIM IS MADE TO THE EXCLUSIVE RIGHT TO USE "NAILS", APART FROM THE MARK AS SHOWN.

FOR ARTIFICIAL FINGERNAILS; FINGERNAIL DECALS; THREE-DIMENSIONAL FINGERNAIL DECALS; FINGERNAIL EMBELLISHMENTS; FINGERNAIL JEWELRY; NAIL POLISH; NAIL STRENGTHENERS; NAIL POLISH REMOVERS; NAIL CARE PREPARATIONS; ADHESIVES FOR ATTACHING ARTIFICIAL FINGERNAILS (U.S. CLS. 1, 4, 6, 50, 51 AND 52).

FIRST USE 5-9-2014; IN COMMERCE 5-9-2014.

4,593,837. THE PROCTER & GAMBLE COMPANY, CINCINNATI, OH. SN 85-917,353. PUB. 10-29-2013, FILED 4-29-2013.



OWNER OF U.S. REG. NOS. 2,855,103 AND 4,162,256. THE MARK CONSISTS OF THE WORD "SECRET" IN SCRIPT ON A FOUR PETAL FLOWER DESIGN.

FOR ANTIPERSPIRANT AND DEODORANTS FOR PERSONAL USE; BODY SPRAY (U.S. CLS. 1, 4, 6, 50, 51 AND 52).

FIRST USE 10-31-2013; IN COMMERCE 10-31-2013.

4,593,869. L'OREAL, PARIS, FRANCE. SN 85-924,027. PUB. 10-15-2013, FILED 5-6-2013.

**DE-CONSTRUCTED**

THE MARK CONSISTS OF STANDARD CHARACTERS WITHOUT CLAIM TO ANY PARTICULAR FONT, STYLE, SIZE, OR COLOR.

FOR HAIR STYLING PREPARATIONS (U.S. CLS. 1, 4, 6, 50, 51 AND 52).

FIRST USE 12-1-2013; IN COMMERCE 12-1-2013.



**CLASS 3—(Continued).**

4,593,885. TAKAO ASAYAMA, MOUNTAIN VIEW, CA. SN 85-928,425. PUB. 10-8-2013, FILED 5-10-2013.

**CRYSTAL GUARD**

THE MARK CONSISTS OF STANDARD CHARACTERS WITHOUT CLAIM TO ANY PARTICULAR FONT, STYLE, SIZE, OR COLOR.

FOR POLYMER SEALANT FOR GLOSSING AND PROTECTING EXTERIOR SURFACES OF MOTOR VEHICLES; POLYMER SEALANT FOR GLOSSING, LUBRICATING AND PROTECTING EXTERIOR SURFACES OF MUSICAL INSTRUMENTS (U.S. CLS. 1, 4, 6, 50, 51 AND 52).

FIRST USE 11-30-2013; IN COMMERCE 11-30-2013.

4,593,906. HED ENTERPRISES, INC., LAS VEGAS, NV. SN 85-933,226. PUB. 10-15-2013, FILED 5-15-2013.

**PHPERFECT**

THE MARK CONSISTS OF STANDARD CHARACTERS WITHOUT CLAIM TO ANY PARTICULAR FONT, STYLE, SIZE, OR COLOR.

FOR HAIR CARE PREPARATIONS (U.S. CLS. 1, 4, 6, 50, 51 AND 52).

FIRST USE 6-2-2014; IN COMMERCE 6-2-2014.

4,593,955. L'OREAL, PARIS, FRANCE. SN 85-940,551. PUB. 10-29-2013, FILED 5-23-2013.

**MOISTURE BLUR**

THE MARK CONSISTS OF STANDARD CHARACTERS WITHOUT CLAIM TO ANY PARTICULAR FONT, STYLE, SIZE, OR COLOR.

NO CLAIM IS MADE TO THE EXCLUSIVE RIGHT TO USE "MOISTURE", APART FROM THE MARK AS SHOWN.

FOR NON-MEDICATED FACIAL SKINCARE PREPARATIONS (U.S. CLS. 1, 4, 6, 50, 51 AND 52).

FIRST USE 1-1-2014; IN COMMERCE 1-1-2014.

**CLASS 3—(Continued).**

4,593,960. CLINIQUE LABORATORIES, LLC, NEW YORK, NY. SN 85-941,059. PUB. 10-29-2013, FILED 5-23-2013.

**CLINIQUE  
FOR MEN**

OWNER OF U.S. REG. NOS. 859,445, 892,987, AND OTHERS.

NO CLAIM IS MADE TO THE EXCLUSIVE RIGHT TO USE "FOR MEN", APART FROM THE MARK AS SHOWN.

THE MARK CONSISTS OF THE WORDS "CLINIQUE FOR MEN", WHICH APPEAR IN-BETWEEN TWO HORIZONTAL LINES.

FOR NON-MEDICATED SKIN CARE PREPARATIONS (U.S. CLS. 1, 4, 6, 50, 51 AND 52).

FIRST USE 3-28-2014; IN COMMERCE 3-28-2014.

4,593,969. EMMA 1997 CO., LTD., TAIPEI CITY, TAIWAN. SN 85-942,425. PUB. 11-19-2013, FILED 5-24-2013.



NO CLAIM IS MADE TO THE EXCLUSIVE RIGHT TO USE "1997", APART FROM THE MARK AS SHOWN.

THE MARK CONSISTS OF THE WORD "EMMA" IN LOWER CASE CURSIVE WHERE THE LETTER "E" IS CONSIDERABLY LARGER THAN THE OTHER LETTERS AND THE NUMBERS "1997" IN A BLOCK IS ABOVE THE LETTERS "MMA" OF "EMMA".

FOR FACIAL LOTION; LOTIONS FOR FACE AND BODY CARE; MAKE-UP REMOVING MILK, GEL, LOTIONS AND CREAMS; MASCARAS; EYE SHADOWS; COSMETIC CREAMS; COSMETIC HAND CREAMS; FACIAL MASKS; COSMETIC CREAMS FOR SKIN CARE; BABY HAND SOAP (U.S. CLS. 1, 4, 6, 50, 51 AND 52).

FIRST USE 11-16-2006; IN COMMERCE 9-7-2011.

4,593,988. PARIS PRESENTS INCORPORATED, GURNEE, IL. SN 85-945,178. PUB. 10-22-2013, FILED 5-29-2013.

**REAL TECHNIQUES**

THE MARK CONSISTS OF STANDARD CHARACTERS WITHOUT CLAIM TO ANY PARTICULAR FONT, STYLE, SIZE, OR COLOR.

**CLASS 3—(Continued).**

OWNER OF U.S. REG. NO. 4,017,264.  
FOR BLUSH; EYE MAKE-UP; FOUNDATION; LIP  
BALM; LIP GLOSS (U.S. CLS. 1, 4, 6, 50, 51 AND 52).  
FIRST USE 4-16-2014; IN COMMERCE 4-16-2014.

4,594,033. THE PROCTER & GAMBLE COMPANY, CINCIN-  
NATI, OH. SN 85-952,754. PUB. 11-5-2013, FILED 6-6-2013.

**FINISHING MINT**

THE MARK CONSISTS OF STANDARD CHARACTERS  
WITHOUT CLAIM TO ANY PARTICULAR FONT, STYLE,  
SIZE, OR COLOR.

NO CLAIM IS MADE TO THE EXCLUSIVE RIGHT TO  
USE "MINT", APART FROM THE MARK AS SHOWN.

FOR DENTIFRICES, COSMETIC TOOTH WHITENERS  
(U.S. CLS. 1, 4, 6, 50, 51 AND 52).

FIRST USE 1-6-2014; IN COMMERCE 1-6-2014.

4,594,034. THE PROCTER & GAMBLE COMPANY, CINCIN-  
NATI, OH. SN 85-952,760. PUB. 11-5-2013, FILED 6-6-2013.

**MESMERIZING MINT**

THE MARK CONSISTS OF STANDARD CHARACTERS  
WITHOUT CLAIM TO ANY PARTICULAR FONT, STYLE,  
SIZE, OR COLOR.

NO CLAIM IS MADE TO THE EXCLUSIVE RIGHT TO  
USE "MINT", APART FROM THE MARK AS SHOWN.

FOR DENTIFRICES (U.S. CLS. 1, 4, 6, 50, 51 AND 52).  
FIRST USE 1-6-2014; IN COMMERCE 1-6-2014.

4,594,037. BC INTERNATIONAL COSMETIC & IMAGE  
SERVICES, INC., ORLANDO, FL. SN 85-952,930. PUB. 4-8-  
2014, FILED 6-6-2013.

**BTEXTREME**

THE MARK CONSISTS OF STANDARD CHARACTERS  
WITHOUT CLAIM TO ANY PARTICULAR FONT, STYLE,  
SIZE, OR COLOR.

FOR NON-MEDICATED SKIN CARE PREPARATIONS  
(U.S. CLS. 1, 4, 6, 50, 51 AND 52).

FIRST USE 3-1-2014; IN COMMERCE 3-1-2014.

**CLASS 3—(Continued).**

4,594,039. TAB LABORATORIES, INC., HUNTINGTON  
BEACH, CA. SN 85-953,094. PUB. 10-29-2013, FILED 6-6-  
2013.



THE COLOR(S) WHITE AND BLUE IS/ARE CLAIMED AS  
A FEATURE OF THE MARK.

THE MARK CONSISTS OF THE WORD "TAB-LAB" IN  
UPPERCASE, IN A WHITE FONT, INSIDE A SOLID BLUE  
OVAL.

FOR TEETH WHITENING KIT; TOOTH WHITENING  
GELS (U.S. CLS. 1, 4, 6, 50, 51 AND 52).

FIRST USE 1-1-2014; IN COMMERCE 1-1-2014.

4,594,073. BIOELEMENTS, INC., COLORADO SPRINGS, CO.  
SN 85-958,463. PUB. 11-5-2013, FILED 6-13-2013.

**MADE TO FADE**

THE MARK CONSISTS OF STANDARD CHARACTERS  
WITHOUT CLAIM TO ANY PARTICULAR FONT, STYLE,  
SIZE, OR COLOR.

FOR COSMETIC PREPARATIONS FOR PROTECTING  
THE SKIN FROM THE SUN'S RAYS; COSMETIC PRE-  
PARATIONS FOR SKIN CARE; COSMETIC PREPARA-  
TIONS FOR SKIN RENEWAL (U.S. CLS. 1, 4, 6, 50, 51  
AND 52).

FIRST USE 9-5-2013; IN COMMERCE 9-5-2013.

4,594,113. L'OREAL, PARIS, FRANCE. SN 85-966,228. PUB. 4-  
1-2014, FILED 6-21-2013.

**ORDER**

THE MARK CONSISTS OF STANDARD CHARACTERS  
WITHOUT CLAIM TO ANY PARTICULAR FONT, STYLE,  
SIZE, OR COLOR.

OWNER OF U.S. REG. NO. 4,170,202.  
FOR HAIR STYLING PREPARATIONS (U.S. CLS. 1, 4,  
6, 50, 51 AND 52).

FIRST USE 10-10-2013; IN COMMERCE 10-10-2013.

**CLASS 3—(Continued).**

4,594,182. DISNEY ENTERPRISES, INC., BURBANK, CA. SN 85-982,301. PUB. 6-12-2012, FILED 1-17-2012.

**BEAUTIFULLY DISNEY**

THE MARK CONSISTS OF STANDARD CHARACTERS WITHOUT CLAIM TO ANY PARTICULAR FONT, STYLE, SIZE, OR COLOR.

OWNER OF U.S. REG. NOS. 3,548,154, 4,067,997, AND OTHERS.

FOR COSMETICS (U.S. CLS. 1, 4, 6, 50, 51 AND 52).  
FIRST USE 2-28-2013; IN COMMERCE 2-28-2013.

4,594,185. RETAIL ROYALTY COMPANY, LAS VEGAS, NV. SN 85-982,358. PUB. 5-14-2013, FILED 12-27-2012.

**AEO VINTAGE**

THE MARK CONSISTS OF STANDARD CHARACTERS WITHOUT CLAIM TO ANY PARTICULAR FONT, STYLE, SIZE, OR COLOR.

OWNER OF U.S. REG. NOS. 1,877,686, 4,257,752, AND OTHERS.

FOR COSMETICS (U.S. CLS. 1, 4, 6, 50, 51 AND 52).  
FIRST USE 6-0-2014; IN COMMERCE 6-0-2014.

4,594,212. MANVEENA'S SOLUTIONS, LLC., MOYOCK, NC. SN 86-006,393. PUB. 12-3-2013, FILED 7-10-2013.



THE NAME(S), PORTRAIT(S), AND/OR SIGNATURE(S) SHOWN IN THE MARK DOES NOT IDENTIFY A PARTICULAR LIVING INDIVIDUAL.

**CLASS 3—(Continued).**

THE MARK CONSISTS OF A DESIGN THAT DEPICTS THE CHARACTER "M" IN STYLIZED FONT. WITHIN THE MIDDLE PORTION OF THE DESIGN IS AN OUTLINED DESIGN THAT DEPICTS A RAIN DROP. DIRECTLY BELOW THE DESIGN IS THE WORDING "MANVEENA'S SOLUTIONS" IN STYLIZED FONT.

FOR BODY LOTIONS; COSMETIC CREAMS; COSMETIC CREAMS FOR SKIN CARE; COSMETIC MASKS; COSMETIC PREPARATIONS; COSMETIC PREPARATIONS FOR BATH AND SHOWER; COSMETIC PREPARATIONS FOR BODY CARE; COSMETIC PREPARATIONS FOR SKIN CARE; COSMETICS; NON-MEDICATED HAIR SERUMS (U.S. CLS. 1, 4, 6, 50, 51 AND 52).

FIRST USE 1-1-2013; IN COMMERCE 3-15-2013.

4,594,262. AVON PRODUCTS, INC., NEW YORK, NY. SN 86-027,032. PUB. 11-26-2013, FILED 8-2-2013.

**AVON INSTINCT**

THE MARK CONSISTS OF STANDARD CHARACTERS WITHOUT CLAIM TO ANY PARTICULAR FONT, STYLE, SIZE, OR COLOR.

OWNER OF U.S. REG. NOS. 633,318, 692,928, AND OTHERS.

FOR AFTER-SHAVE; AFTER-SHAVE LOTIONS; BODY LOTION; EAU DE PERFUME; SHOWER AND BATH GEL (U.S. CLS. 1, 4, 6, 50, 51 AND 52).

FIRST USE 12-19-2013; IN COMMERCE 12-19-2013.

4,594,275. THINK TRADING, INC., PALM BEACH GARDENS, FL. SN 86-032,467. PUB. 12-3-2013, FILED 8-8-2013.

**STENCIL OFF**

THE MARK CONSISTS OF STANDARD CHARACTERS WITHOUT CLAIM TO ANY PARTICULAR FONT, STYLE, SIZE, OR COLOR.

NO CLAIM IS MADE TO THE EXCLUSIVE RIGHT TO USE "STENCIL". APART FROM THE MARK AS SHOWN.

FOR STENCIL TRANSFER SOLUTION INTENDED FOR USE IN THE TATTOO INDUSTRY (U.S. CLS. 1, 4, 6, 50, 51 AND 52).

FIRST USE 2-1-2014; IN COMMERCE 2-1-2014.

**CLASS 3—(Continued).**

4,594,306. CLINIQUE LABORATORIES, LLC, NEW YORK, NY. SN 86-045,125. PUB. 10-29-2013, FILED 8-22-2013.

**CLINIQUE SMART**

THE MARK CONSISTS OF STANDARD CHARACTERS WITHOUT CLAIM TO ANY PARTICULAR FONT, STYLE, SIZE, OR COLOR.

OWNER OF U.S. REG. NOS. 878,877, 904,834, AND 1,626,589.

FOR NON-MEDICATED SKIN CARE PREPARATIONS (U.S. CLS. 1, 4, 6, 50, 51 AND 52).

FIRST USE 6-8-2014; IN COMMERCE 6-8-2014.

---

4,594,343. AVON PRODUCTS, INC., NEW YORK, NY. SN 86-061,861. PUB. 11-26-2013, FILED 9-11-2013.

**AVON PASSION**

THE MARK CONSISTS OF STANDARD CHARACTERS WITHOUT CLAIM TO ANY PARTICULAR FONT, STYLE, SIZE, OR COLOR.

OWNER OF U.S. REG. NOS. 633,318, 692,928, AND OTHERS.

FOR BODY LOTION; EAU DE PARFUM; SHOWER GEL (U.S. CLS. 1, 4, 6, 50, 51 AND 52).

FIRST USE 10-10-2013; IN COMMERCE 10-10-2013.

---

4,594,380. CITY OF MIAMI BEACH, MIAMI BEACH, FL. SN 86-077,280. PUB. 4-15-2014, FILED 9-27-2013.



NO CLAIM IS MADE TO THE EXCLUSIVE RIGHT TO USE "MIAMI BEACH", APART FROM THE MARK AS SHOWN.

THE MARK CONSISTS OF THE LETTERS "MB" IN STYLIZED FONT WITH THE WORDS "MIAMIBEACH" IN STYLIZED FONT BELOW.

FOR NON-MEDICATED SUN CARE PREPARATIONS; NON-MEDICATED SKIN CARE PREPARATIONS; HAIR CARE PREPARATIONS (U.S. CLS. 1, 4, 6, 50, 51 AND 52).  
FIRST USE 11-10-2013; IN COMMERCE 11-10-2013.

**CLASS 3—(Continued).**

4,594,381. CITY OF MIAMI BEACH, MIAMI BEACH, FL. SN 86-077,286. PUB. 4-15-2014, FILED 9-27-2013.

**MB MIAMI BEACH**

THE MARK CONSISTS OF STANDARD CHARACTERS WITHOUT CLAIM TO ANY PARTICULAR FONT, STYLE, SIZE, OR COLOR.

NO CLAIM IS MADE TO THE EXCLUSIVE RIGHT TO USE "MIAMI BEACH", APART FROM THE MARK AS SHOWN.

FOR NON-MEDICATED SUN CARE PREPARATIONS; NON-MEDICATED SKIN CARE PREPARATIONS; HAIR CARE PREPARATIONS (U.S. CLS. 1, 4, 6, 50, 51 AND 52).  
FIRST USE 11-10-2013; IN COMMERCE 11-10-2013.

---

4,594,452. DEMERT BRANDS, INC., LUTZ, FL. SN 86-100,707. PUB. 4-1-2014, FILED 10-24-2013.

**PLUMP FOR JOY**

THE MARK CONSISTS OF STANDARD CHARACTERS WITHOUT CLAIM TO ANY PARTICULAR FONT, STYLE, SIZE, OR COLOR.

FOR SPRAY HAIR GEL (U.S. CLS. 1, 4, 6, 50, 51 AND 52).

FIRST USE 12-0-2013; IN COMMERCE 12-0-2013.

---

4,594,453. DEMERT BRANDS, INC., LUTZ, FL. SN 86-100,742. PUB. 4-1-2014, FILED 10-24-2013.

**INTENSIVE HAIR UNIT**

THE MARK CONSISTS OF STANDARD CHARACTERS WITHOUT CLAIM TO ANY PARTICULAR FONT, STYLE, SIZE, OR COLOR.

FOR HAIR CONDITIONER (U.S. CLS. 1, 4, 6, 50, 51 AND 52).

FIRST USE 12-0-2013; IN COMMERCE 12-0-2013.

**CLASS 3—(Continued).**

4,594,473. THE PROCTER & GAMBLE COMPANY, CINCINNATI, OH. SN 86-108,191. PUB. 4-22-2014, FILED 11-1-2013.

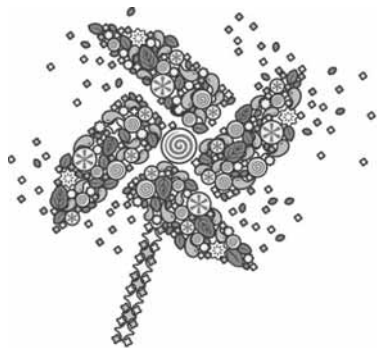

THE MARK CONSISTS OF LEAVES, TEARDROPS, SQUARES, DIAMONDS, CIRCLES AND A SWIRLED PEPPERMINT CANDY IN THE CENTER ALL OF WHICH FORMS A PINWHEEL WITH DIAMONDS REVOLVING AROUND THE PINWHEEL

FOR DENTIFRICES (U.S. CLS. 1, 4, 6, 50, 51 AND 52).  
FIRST USE 1-6-2014; IN COMMERCE 1-6-2014.

**CLASS 3—(Continued).**

4,594,500. AWESOME PRODUCTS, INC., BUENA PARK, CA. SN 86-119,458. PUB. 4-8-2014, FILED 11-14-2013.

# VIBRANCE

THE MARK CONSISTS OF STANDARD CHARACTERS WITHOUT CLAIM TO ANY PARTICULAR FONT, STYLE, SIZE, OR COLOR.

FOR LAUNDRY DETERGENT (U.S. CLS. 1, 4, 6, 50, 51 AND 52).

FIRST USE 1-2-2014; IN COMMERCE 1-2-2014.

4,594,491. B BEAUTIFUL, LLC, AZUSA, CA. SN 86-114,227. PUB. 4-1-2014, FILED 11-8-2013.

# LUV2KISS

THE MARK CONSISTS OF STANDARD CHARACTERS WITHOUT CLAIM TO ANY PARTICULAR FONT, STYLE, SIZE, OR COLOR.

FOR A TRANSPARENT, WATERPROOF LIP LINER THAT DEFINES THE SHAPE OF THE LIPS AND PREVENTS LIP GLOSS AND LIPSTICK FROM BLEEDING OR FEATHERING (U.S. CLS. 1, 4, 6, 50, 51 AND 52).

FIRST USE 3-1-2014; IN COMMERCE 3-1-2014.

4,594,507. CURT'S SPICE CO. & OILERIE, LLC, FISH CREEK, WI. SN 86-122,358. PUB. 4-15-2014, FILED 11-19-2013.



4,594,495. ROBERT, EVELYN, SAN FRANCISCO, CA. SN 86-117,496. PUB. 4-8-2014, FILED 11-13-2013.

# ALCHEMICA BOTANICA

THE MARK CONSISTS OF STANDARD CHARACTERS WITHOUT CLAIM TO ANY PARTICULAR FONT, STYLE, SIZE, OR COLOR.

NO CLAIM IS MADE TO THE EXCLUSIVE RIGHT TO USE "BOTANICA", APART FROM THE MARK AS SHOWN.

FOR ESSENTIAL OILS (U.S. CLS. 1, 4, 6, 50, 51 AND 52).

FIRST USE 6-1-2014; IN COMMERCE 6-1-2014.

THE COLOR(S) GREEN AND PURPLE IS/ARE CLAIMED AS A FEATURE OF THE MARK.

THE MARK CONSISTS OF TWO STYLIZED OLIVES, ONE ON TOP OF THE OTHER, FORMING A HEART, THE FRONT OLIVE BEING GREEN AND THE BOTTOM OLIVE BEING PURPLE, ON TOP OF THE WORD "AMORE" IN PURPLE, WHICH IS STACKED ON TOP OF THE WORDS "DI NONNA" IN PURPLE.

THE ENGLISH TRANSLATION OF "AMORE DI NONNA" IN THE MARK IS "GRANDMA'S LOVE".

FOR HAIR CARE CREAMS; LOTIONS FOR HAIR AND SKIN; SKIN CREAMS; SOAPS FOR HAIR AND SKIN CARE (U.S. CLS. 1, 4, 6, 50, 51 AND 52).

FIRST USE 4-17-2014; IN COMMERCE 4-17-2014.

**CLASS 3—(Continued).**

4,594,526. MAESA, INC., NEW YORK, NY. SN 86-134,279. PUB. 3-4-2014, FILED 12-3-2013.

**THE ART OF GLAMOUR**

THE MARK CONSISTS OF STANDARD CHARACTERS WITHOUT CLAIM TO ANY PARTICULAR FONT, STYLE, SIZE, OR COLOR.  
FOR COSMETICS (U.S. CLS. 1, 4, 6, 50, 51 AND 52).  
FIRST USE 4-15-2014; IN COMMERCE 4-15-2014.

4,594,543. THE SUN PRODUCTS CORPORATION, WILTON, CT. SN 86-162,492. PUB. 4-22-2014, FILED 1-10-2014.

**SNUGGLE SCENT BOOSTERS**

THE MARK CONSISTS OF STANDARD CHARACTERS WITHOUT CLAIM TO ANY PARTICULAR FONT, STYLE, SIZE, OR COLOR.  
OWNER OF U.S. REG. NOS. 1,246,754, 2,717,343, AND OTHERS.

NO CLAIM IS MADE TO THE EXCLUSIVE RIGHT TO USE "SCENT BOOSTERS", APART FROM THE MARK AS SHOWN.

FOR LAUNDRY ADDITIVE IN THE NATURE OF FRAGRANCE ENHANCERS (U.S. CLS. 1, 4, 6, 50, 51 AND 52).

FIRST USE 12-31-2013; IN COMMERCE 12-31-2013.

**CLASS 4—LUBRICANTS AND FUELS**

4,593,125. J. BAXTER BRINKMANN INTERNATIONAL CORPORATION, DALLAS, TX. SN 85-077,507. PUB. 6-7-2011, FILED 7-2-2010.

**MALIBU OUTDOOR LIVING**

THE MARK CONSISTS OF STANDARD CHARACTERS WITHOUT CLAIM TO ANY PARTICULAR FONT, STYLE, SIZE, OR COLOR.

OWNER OF U.S. REG. NOS. 816,551, 3,424,575, AND OTHERS.

NO CLAIM IS MADE TO THE EXCLUSIVE RIGHT TO USE "OUTDOOR LIVING", APART FROM THE MARK AS SHOWN.

FOR CHARCOAL LIGHTER FLUID; CHARCOAL BRIQUETTES; WOOD CHIPS FOR SMOKING, GRILLING, AND FLAVORING FOODS (U.S. CLS. 1, 6 AND 15).

FIRST USE 5-19-2014; IN COMMERCE 5-19-2014.

**CLASS 4—(Continued).**

4,593,210. CANDLE LAMP COMPANY, LLC, CORONA, CA. SN 85-346,227. PUB. 11-27-2012, FILED 6-14-2011.

**SAFE HEAT GREEN**

THE MARK CONSISTS OF STANDARD CHARACTERS WITHOUT CLAIM TO ANY PARTICULAR FONT, STYLE, SIZE, OR COLOR.

OWNER OF U.S. REG. NOS. 1,749,759, 3,843,513, AND OTHERS.

NO CLAIM IS MADE TO THE EXCLUSIVE RIGHT TO USE "HEAT" AND "GREEN", APART FROM THE MARK AS SHOWN.

FOR CHAFING DISH FUEL (U.S. CLS. 1, 6 AND 15).  
FIRST USE 2-4-2012; IN COMMERCE 2-4-2012.

4,594,324. SHELL TRADEMARK MANAGEMENT BV, THE HAGUE, NETHERLANDS. SN 86-052,793. PUB. 2-25-2014, FILED 8-30-2013.

**TOMORROW'S FUEL TODAY**

THE MARK CONSISTS OF STANDARD CHARACTERS WITHOUT CLAIM TO ANY PARTICULAR FONT, STYLE, SIZE, OR COLOR.

NO CLAIM IS MADE TO THE EXCLUSIVE RIGHT TO USE "FUEL", APART FROM THE MARK AS SHOWN.

FOR LIQUEFIED NATURAL GAS (U.S. CLS. 1, 6 AND 15).

FIRST USE 8-1-2013; IN COMMERCE 5-15-2014.

**CLASS 5—PHARMACEUTICALS**

4,593,115. GLOBAL PROTECTION CORP., BOSTON, MA. SN 85-058,087. PUB. 5-10-2011, FILED 6-9-2010.

**DUO**

THE MARK CONSISTS OF STANDARD CHARACTERS WITHOUT CLAIM TO ANY PARTICULAR FONT, STYLE, SIZE, OR COLOR.

FOR PERSONAL LUBRICANTS (U.S. CLS. 6, 18, 44, 46, 51 AND 52).

FIRST USE 7-2-2014; IN COMMERCE 7-2-2014.

**CLASS 5—(Continued).**

4,593,138. SKINVISIBLE PHARMACEUTICALS, INC., LAS VEGAS, NV. SN 85-152,719. PUB. 3-22-2011, FILED 10-14-2010.

# Justcare

THE MARK CONSISTS OF STANDARD CHARACTERS WITHOUT CLAIM TO ANY PARTICULAR FONT, STYLE, SIZE, OR COLOR.

FOR ACNE TREATMENT PREPARATIONS; COLD SORE TREATMENT PREPARATIONS; DERMATOLOGICAL PHARMACEUTICAL PRODUCTS; FACE CREAMS AND CLEANSERS CONTAINING BENZOYL PEROXIDE FOR MEDICAL PURPOSES, NAMELY, THE TREATMENT OF ACNE; HEMORRHOID TREATMENT PREPARATIONS; NAIL FUNGUS TREATMENT PREPARATIONS; NON-MEDICATED, THERAPEUTIC SKIN CREAMS FOR THE TREATMENT OF SKIN CONDITIONS; PARAPHARMACEUTICAL PRODUCTS FOR USE IN DERMATOLOGY; PHARMACEUTICAL PREPARATIONS AND SUBSTANCES FOR THE TREATMENT OF DAMAGED SKIN AND TISSUE; PHARMACEUTICAL PREPARATIONS FOR THE TREATMENT AND PREVENTION OF SKIN CONDITIONS; RETINOL FOR MEDICAL PURPOSES FOR THE TREATMENT OF SKIN CONDITIONS; THERAPEUTIC PHARMACEUTICAL FOR THE TREATMENT OF SKIN CONDITIONS; TOPICAL GEL FOR MEDICAL AND THERAPEUTIC TREATMENT OF SKIN CONDITIONS (U.S. CLS. 6, 18, 44, 46, 51 AND 52).

FIRST USE 4-3-2012; IN COMMERCE 9-20-2013.

4,593,175. ANIKA THERAPEUTICS, INC., BEDFORD, MA. SN 85-223,616. PUB. 5-31-2011, FILED 1-21-2011.

# CINGAL

THE MARK CONSISTS OF STANDARD CHARACTERS WITHOUT CLAIM TO ANY PARTICULAR FONT, STYLE, SIZE, OR COLOR.

FOR THERAPEUTIC AGENT FOR THE TREATMENT OF ARTICULAR DISCOMFORT OR DYSFUNCTION (U.S. CLS. 6, 18, 44, 46, 51 AND 52).

FIRST USE 5-8-2013; IN COMMERCE 5-8-2013.

**CLASS 5—(Continued).**

4,593,176. BLISTEX INC., OAK BROOK, IL. SN 85-227,096. PUB. 11-22-2011, FILED 1-26-2011.

# BLISSFUL BUTTERS

THE MARK CONSISTS OF STANDARD CHARACTERS WITHOUT CLAIM TO ANY PARTICULAR FONT, STYLE, SIZE, OR COLOR.

OWNER OF U.S. REG. NO. 3,829,379.

NO CLAIM IS MADE TO THE EXCLUSIVE RIGHT TO USE "BUTTERS", APART FROM THE MARK AS SHOWN.

FOR MEDICATED LIP CARE PREPARATIONS, MEDICATED TOPICAL CREAMS, LOTIONS, GELS, BALMS, AND OINTMENTS FOR HUMAN USE FOR LIP AND SKIN DRYNESS, COLD SORES, AND FOR LIP AND SKIN CARE (U.S. CLS. 6, 18, 44, 46, 51 AND 52).

FIRST USE 5-1-2014; IN COMMERCE 5-1-2014.

4,593,182. MARTHA STEWART LIVING OMNIMEDIA, INC., NEW YORK, NY. SN 85-238,153. PUB. 7-19-2011, FILED 2-9-2011.

# MARTHA STEWART

THE MARK CONSISTS OF STANDARD CHARACTERS WITHOUT CLAIM TO ANY PARTICULAR FONT, STYLE, SIZE, OR COLOR.

OWNER OF U.S. REG. NOS. 3,435,783, 3,709,397, AND OTHERS.

THE NAME(S), PORTRAIT(S), AND/OR SIGNATURE(S) SHOWN IN THE MARK IDENTIFIES "MARTHA STEWART", WHOSE CONSENT(S) TO REGISTER IS MADE OF RECORD.

FOR HEALTHY LIVING PRODUCTS, NAMELY, VITAMINS; HERBAL PRODUCTS, NAMELY, HERBAL DIETARY SUPPLEMENTS AND BOTANICAL SUPPLEMENTS; HOMEOPATHIC SUPPLEMENTS (U.S. CLS. 6, 18, 44, 46, 51 AND 52).

FIRST USE 8-0-2013; IN COMMERCE 9-0-2013.

**CLASS 5—(Continued).**

4,593,183. NATUREX-DBS LLC, S. HACKENSACK, NJ. SN 85-247,545. PUB. 6-28-2011, FILED 2-21-2011.

**Cransulin**

THE MARK CONSISTS OF STANDARD CHARACTERS WITHOUT CLAIM TO ANY PARTICULAR FONT, STYLE, SIZE, OR COLOR.

FOR NUTRACEUTICALS FOR USE AS A DIETARY SUPPLEMENT (U.S. CLS. 6, 18, 44, 46, 51 AND 52).  
FIRST USE 6-23-2014; IN COMMERCE 6-23-2014.

**CLASS 5—(Continued).**

4,593,229. BIOGEN IDEC MA INC., CAMBRIDGE, MA. SN 85-411,805. PUB. 12-6-2011, FILED 8-31-2011.

**ALPROLIX**

THE MARK CONSISTS OF STANDARD CHARACTERS WITHOUT CLAIM TO ANY PARTICULAR FONT, STYLE, SIZE, OR COLOR.

FOR PHARMACEUTICAL PREPARATIONS FOR THE TREATMENT OF HEMOPHILIA (U.S. CLS. 6, 18, 44, 46, 51 AND 52).  
FIRST USE 5-5-2014; IN COMMERCE 5-5-2014.

4,593,189. HYPER NETWORK SOLUTIONS OF FLORIDA, LLC, WEST PALM BEACH, FL. SN 85-295,709. PUB. 8-23-2011, FILED 4-14-2011.

**FORPLAY**

THE MARK CONSISTS OF STANDARD CHARACTERS WITHOUT CLAIM TO ANY PARTICULAR FONT, STYLE, SIZE, OR COLOR.

FOR DIETARY AND NUTRITIONAL SUPPLEMENTS (U.S. CLS. 6, 18, 44, 46, 51 AND 52).  
FIRST USE 2-18-2014; IN COMMERCE 2-18-2014.

4,593,254. CLOVERSHIELD, INC., LA JOLLA, CA. SN 85-480,272. PUB. 11-19-2013, FILED 11-23-2011.

**VAPORTHERAPY**

THE MARK CONSISTS OF STANDARD CHARACTERS WITHOUT CLAIM TO ANY PARTICULAR FONT, STYLE, SIZE, OR COLOR.

FOR NATURAL AND SYNTHETIC SUBSTANCES, NAMELY, MEDICATED OILS CONTAINING HERBS, BOTANICALS AND FRAGRANCE THAT RELEASE INGREDIENTS WHEN HEATED TO PROVIDE RELIEF THROUGH NASAL AND/OR ORAL INTRODUCTION, FOR ALLOPATHIC PURPOSES (U.S. CLS. 6, 18, 44, 46, 51 AND 52).  
FIRST USE 6-2-2014; IN COMMERCE 6-2-2014.

4,593,224. THE PROCTER & GAMBLE COMPANY, CINCINNATI, OH. SN 85-390,497. PUB. 1-17-2012, FILED 8-5-2011.

**SEAMLESS FIT**

THE MARK CONSISTS OF STANDARD CHARACTERS WITHOUT CLAIM TO ANY PARTICULAR FONT, STYLE, SIZE, OR COLOR.

FOR CATAMENIAL PRODUCTS, NAMELY, MAXI PADS, MINI PADS, AND PANTILINERS (U.S. CLS. 6, 18, 44, 46, 51 AND 52).  
FIRST USE 4-2-2012; IN COMMERCE 4-2-2012.

4,593,255. GENOMMA LAB INTERNACIONAL, S.A.B. DE C.V., MEXICO, D.F., MEXICO. SN 85-482,000. PUB. 5-8-2012, FILED 11-28-2011.

**LAGICAM V**

THE MARK CONSISTS OF STANDARD CHARACTERS WITHOUT CLAIM TO ANY PARTICULAR FONT, STYLE, SIZE, OR COLOR.

FOR VAGINAL PREPARATIONS, NAMELY, ANTI-FUNGALS (U.S. CLS. 6, 18, 44, 46, 51 AND 52).  
FIRST USE 2-28-2014; IN COMMERCE 2-28-2014.



**CLASS 5—(Continued).**

4,593,279. NUTRACLICK, LLC, BOSTON, MA. SN 85-537,534.  
PUB. 10-15-2013, FILED 2-8-2012.

---

**BRX**

THE MARK CONSISTS OF STANDARD CHARACTERS WITHOUT CLAIM TO ANY PARTICULAR FONT, STYLE, SIZE, OR COLOR.

FOR MINERAL SUPPLEMENTS; VITAMIN AND MINERAL SUPPLEMENTS; DIETARY SUPPLEMENT DRINK MIXES; HERBAL SUPPLEMENTS; NUTRITIONALLY FORTIFIED BEVERAGES; FOOD SUPPLEMENTS (U.S. CLS. 6, 18, 44, 46, 51 AND 52).

FIRST USE 4-4-2012; IN COMMERCE 4-4-2012.

---

4,593,339. SCHIFF NUTRITION INTERNATIONAL, INC., SALT LAKE CITY, UT. SN 85-634,998. PUB. 5-7-2013, FILED 5-24-2012.

**Schiff**

OWNER OF U.S. REG. NOS. 2,225,004, 3,708,271, AND 3,781,901.

THE MARK CONSISTS OF THE WORD "SCHIFF" IN STYLIZED FORM.

SEC. 2(F).

FOR A LINE OF DIETARY SUPPLEMENTS; A LINE OF VITAMIN AND MINERAL SUPPLEMENTS; A LINE OF VITAMINS; DIETARY SUPPLEMENTS; VITAMIN AND MINERAL SUPPLEMENTS VITAMINS; NUTRITIONAL SUPPLEMENTS; DIETARY SUPPLEMENTS IN THE FORM OF TABLETS; VITAMIN TABLETS (U.S. CLS. 6, 18, 44, 46, 51 AND 52).

FIRST USE 4-30-2013; IN COMMERCE 4-30-2013.

---

4,593,346. DIETARY PROS, INC. AKA DP LABS, WAUSAU, WI. SN 85-638,812. PUB. 11-13-2012, FILED 5-30-2012.

**Party Recovery**

THE MARK CONSISTS OF STANDARD CHARACTERS WITHOUT CLAIM TO ANY PARTICULAR FONT, STYLE, SIZE, OR COLOR.

**CLASS 5—(Continued).**

NO CLAIM IS MADE TO THE EXCLUSIVE RIGHT TO USE "RECOVERY", APART FROM THE MARK AS SHOWN.  
FOR DIETARY SUPPLEMENTS (U.S. CLS. 6, 18, 44, 46, 51 AND 52).  
FIRST USE 5-21-2014; IN COMMERCE 5-21-2014.

---

4,593,365. SIMON, LARRY, QUOGUE, NY. SN 85-650,318.  
PUB. 9-17-2013, FILED 6-13-2012.

**StaySlim Mist**

THE MARK CONSISTS OF STANDARD CHARACTERS WITHOUT CLAIM TO ANY PARTICULAR FONT, STYLE, SIZE, OR COLOR.

NO CLAIM IS MADE TO THE EXCLUSIVE RIGHT TO USE "MIST", APART FROM THE MARK AS SHOWN.

FOR APPETITE SUPPRESSANTS; THERAPEUTIC AGENTS FOR WEIGHT CONTROL AND APPETITE SUPPRESSION (U.S. CLS. 6, 18, 44, 46, 51 AND 52).

FIRST USE 3-7-2014; IN COMMERCE 3-7-2014.

---

4,593,366. SOGEVAL LABORATORIES, INC., IRVING, TX. SN 85-650,835. PUB. 11-26-2013, FILED 6-13-2012.

**GENTLESEB**

THE MARK CONSISTS OF STANDARD CHARACTERS WITHOUT CLAIM TO ANY PARTICULAR FONT, STYLE, SIZE, OR COLOR.

FOR MEDICATED SHAMPOO FOR DOGS CONTAINING SULFUR AND SALICYLIC ACID (U.S. CLS. 6, 18, 44, 46, 51 AND 52).

FIRST USE 7-31-2012; IN COMMERCE 7-31-2012.

---

4,593,442. THE BODY EVOLUTION, INC., OGDEN, UT. SN 85-715,319. PUB. 3-11-2014, FILED 8-28-2012.

**RECALIBRATE BLENDED WHEY  
PROTEIN**

THE MARK CONSISTS OF STANDARD CHARACTERS WITHOUT CLAIM TO ANY PARTICULAR FONT, STYLE, SIZE, OR COLOR.

**CLASS 5—(Continued).**

NO CLAIM IS MADE TO THE EXCLUSIVE RIGHT TO USE "BLENDED WHEY PROTEIN", APART FROM THE MARK AS SHOWN.

FOR DIETARY AND NUTRITIONAL SUPPLEMENTS CONTAINING BLENDED WHEY PROTEIN (U.S. CLS. 6, 18, 44, 46, 51 AND 52).

FIRST USE 9-1-2012; IN COMMERCE 9-1-2012.

---

4,593,443. THE BODY EVOLUTION, INC., OGDEN, UT. SN 85-715,348. PUB. 8-20-2013, FILED 8-28-2012.

**CALIBRATE MEAL REPLACEMENT**

THE MARK CONSISTS OF STANDARD CHARACTERS WITHOUT CLAIM TO ANY PARTICULAR FONT, STYLE, SIZE, OR COLOR.

NO CLAIM IS MADE TO THE EXCLUSIVE RIGHT TO USE "MEAL REPLACEMENT", APART FROM THE MARK AS SHOWN.

FOR DIETARY AND NUTRITIONAL SUPPLEMENTS (U.S. CLS. 6, 18, 44, 46, 51 AND 52).

FIRST USE 9-1-2012; IN COMMERCE 9-1-2012.

---

4,593,447. MARKET WATCH FRANCHISE & CONSULTING, INC., LAS VEGAS, NV. SN 85-717,655. PUB. 10-23-2012, FILED 8-30-2012.

**MITOCHRON**

THE MARK CONSISTS OF STANDARD CHARACTERS WITHOUT CLAIM TO ANY PARTICULAR FONT, STYLE, SIZE, OR COLOR.

FOR NUTRITIONAL SUPPLEMENTS (U.S. CLS. 6, 18, 44, 46, 51 AND 52).

FIRST USE 6-9-2014; IN COMMERCE 6-9-2014.

---

4,593,526. NATURAL FACTORS NUTRITIONAL PRODUCTS LTD., COQUITLAM, BC, CANADA. SN 85-770,968. PUB. 10-15-2013, FILED 11-4-2012.

**CEREBROVITAL PQQ-10**

THE MARK CONSISTS OF STANDARD CHARACTERS WITHOUT CLAIM TO ANY PARTICULAR FONT, STYLE, SIZE, OR COLOR.

**CLASS 5—(Continued).**

PRIORITY CLAIMED UNDER SEC. 44(D) ON CANADA APPLICATION NO. 1600984, FILED 11-4-2012.

NO CLAIM IS MADE TO THE EXCLUSIVE RIGHT TO USE "PQQ-10", APART FROM THE MARK AS SHOWN.

FOR DIETARY AND NUTRITIONAL SUPPLEMENTS; DIETARY FOOD SUPPLEMENTS; FOOD SUPPLEMENTS; HEALTH FOOD SUPPLEMENTS; HERBAL SUPPLEMENTS; MINERAL SUPPLEMENTS; NUTRACEUTICALS FOR USE AS A DIETARY SUPPLEMENT; VITAMIN AND MINERAL SUPPLEMENTS; ALL CONTAINING PQQ (PYRROLOQUINOLINE QUINONE) (U.S. CLS. 6, 18, 44, 46, 51 AND 52).

FIRST USE 10-9-2013; IN COMMERCE 11-15-2013.

---

4,593,550. BAYER HEALTHCARE LLC, PITTSBURGH, PA. SN 85-781,286. PUB. 4-9-2013, FILED 11-16-2012.

**BEETLE SHIELD**

THE MARK CONSISTS OF STANDARD CHARACTERS WITHOUT CLAIM TO ANY PARTICULAR FONT, STYLE, SIZE, OR COLOR.

NO CLAIM IS MADE TO THE EXCLUSIVE RIGHT TO USE "BEETLE", APART FROM THE MARK AS SHOWN.

FOR INSECTICIDES (U.S. CLS. 6, 18, 44, 46, 51 AND 52).

FIRST USE 1-2-2013; IN COMMERCE 1-2-2013.

---

4,593,574. NIPPON SODA CO., LTD., CHIYODA-KU, TOKYO, JAPAN. SN 85-790,224. PUB. 4-30-2013, FILED 11-29-2012.

**CERCOBIN**

THE MARK CONSISTS OF STANDARD CHARACTERS WITHOUT CLAIM TO ANY PARTICULAR FONT, STYLE, SIZE, OR COLOR.

FOR FUNGICIDES FOR AGRICULTURAL AND HORTICULTURAL USE; FUNGICIDES (U.S. CLS. 6, 18, 44, 46, 51 AND 52).

FIRST USE 4-15-2014; IN COMMERCE 4-15-2014.

**CLASS 5—(Continued).**

4,593,632. STALLERGENES SA, 92160 ANTONY, FRANCE.  
SN 85-807,637. PUB. 5-14-2013, FILED 12-20-2012.

# ORALAIR

THE MARK CONSISTS OF STANDARD CHARACTERS WITHOUT CLAIM TO ANY PARTICULAR FONT, STYLE, SIZE, OR COLOR.

OWNER OF U.S. REG. NO. 3,194,354.  
FOR PHARMACEUTICAL PREPARATIONS FOR THE TREATMENT OF ALLERGIES (U.S. CLS. 6, 18, 44, 46, 51 AND 52).

FIRST USE 5-14-2014; IN COMMERCE 5-14-2014.

4,593,637. BIOTROPICS MALAYSIA BERHAD, KUALA LUMPUR, MALAYSIA. SN 85-809,011. PUB. 11-12-2013, FILED 12-21-2012.

# CERPLUS

THE MARK CONSISTS OF STANDARD CHARACTERS WITHOUT CLAIM TO ANY PARTICULAR FONT, STYLE, SIZE, OR COLOR.

FOR DIETARY SUPPLEMENTS; DIETETIC FOOD, NAMELY, HERBS, ADAPTED FOR MEDICAL USE; DIETARY SUPPLEMENT BEVERAGES, NAMELY, LIQUID HERBAL SUPPLEMENTS FOR ANTIOXIDANT, BEAUTY AND LONGEVITY; NUTRITIONAL SUPPLEMENTS; MEDICINAL HERB EXTRACTS; MEDICINAL PLANT EXTRACTS; HERBAL MEDICINES, NAMELY, HERBAL SUPPLEMENTS AND PILLS AND CAPSULES FOR IMPROVING COGNITION; NUTRACEUTICALS; BOTANICAL PREPARATIONS TO BE TAKEN ORALLY IN THE NATURE OF TABLETS, CAPSULES, LIQUID, POWDER FOR PROMOTING GENERAL HEALTH (U.S. CLS. 6, 18, 44, 46, 51 AND 52).

FIRST USE 11-1-2013; IN COMMERCE 1-1-2014.

4,593,695. SAMSON AL, DBA ALSAMSON FUNCTIONAL SALES & CONSULTING, HOBOKEN, NJ. SN 85-837,081. PUB. 10-29-2013, FILED 1-30-2013.

# Joe Lean, Jo Lean

THE MARK CONSISTS OF STANDARD CHARACTERS WITHOUT CLAIM TO ANY PARTICULAR FONT, STYLE, SIZE, OR COLOR.

**CLASS 5—(Continued).**

THE NAME(S), PORTRAIT(S), AND/OR SIGNATURE(S) SHOWN IN THE MARK DOES NOT IDENTIFY A PARTICULAR LIVING INDIVIDUAL.

FOR DIETARY AND NUTRITIONAL SUPPLEMENTS; DIETARY AND NUTRITIONAL SUPPLEMENTS FOR ENDURANCE SPORTS; DIETARY AND NUTRITIONAL SUPPLEMENTS USED FOR WEIGHT LOSS; DIETARY SUPPLEMENT DRINK MIXES; DIETARY SUPPLEMENTS; DIETARY SUPPLEMENTS FOR HUMAN CONSUMPTION; NUTRITIONAL SUPPLEMENT IN THE NATURE OF A NUTRIENT-DENSE, PROTEIN-BASED DRINK MIX; NUTRITIONAL SUPPLEMENTS; POWDERED NUTRITIONAL SUPPLEMENT DRINK MIX; PROTEIN DIETARY SUPPLEMENTS; PROTEIN SUPPLEMENTS (U.S. CLS. 6, 18, 44, 46, 51 AND 52).

FIRST USE 4-1-2013; IN COMMERCE 4-13-2013.

4,593,729. WILDLIFE RESEARCH CENTER, INC., RAMSEY, MN. SN 85-854,628. PUB. 12-24-2013, FILED 2-20-2013.

# SCENT KILLER

THE MARK CONSISTS OF STANDARD CHARACTERS WITHOUT CLAIM TO ANY PARTICULAR FONT, STYLE, SIZE, OR COLOR.

OWNER OF U.S. REG. NOS. 1,757,030, 4,184,334, AND OTHERS.

NO CLAIM IS MADE TO THE EXCLUSIVE RIGHT TO USE "SCENT", APART FROM THE MARK AS SHOWN. SEC. 2(F).

FOR ODOR REDUCING PREPARATIONS FOR USE ON BACKPACKS, KNAPSACKS, DRY BAGS, DUFFLE BAGS, AND ALL PURPOSE SPORT BAGS (U.S. CLS. 6, 18, 44, 46, 51 AND 52).

FIRST USE 6-24-2014; IN COMMERCE 6-24-2014.

4,593,731. MAX ZELLER SOHNE AKTIENGESELLSCHAFT, ROMANSHORN, SWITZERLAND. SN 85-855,972. PUB. 8-13-2013, FILED 2-21-2013.

# ZE339

THE MARK CONSISTS OF STANDARD CHARACTERS WITHOUT CLAIM TO ANY PARTICULAR FONT, STYLE, SIZE, OR COLOR.

FOR ALLERGY CAPSULES; ALLERGY MEDICATIONS; ALLERGY RELIEF MEDICATION; ALLERGY TABLETS; PLANT EXTRACTS FOR MEDICAL, VETERINARY AND PHARMACEUTICAL PURPOSES (U.S. CLS. 6, 18, 44, 46, 51 AND 52).

FIRST USE 8-22-2013; IN COMMERCE 8-22-2013.

**CLASS 5—(Continued).**

4,593,741. CORMATRIX CARDIOVASCULAR, INC., ROSWELL, GA. SN 85-862,668. PUB. 7-30-2013, FILED 2-28-2013.

# iECM

THE MARK CONSISTS OF STANDARD CHARACTERS WITHOUT CLAIM TO ANY PARTICULAR FONT, STYLE, SIZE, OR COLOR.

OWNER OF U.S. REG. NO. 3,658,620.  
FOR MEDICAL PRODUCTS, NAMELY, PROCESSED EXTRACELLULAR MATRIX NATURAL BIOMATERIALS FOR THE RECONSTRUCTION AND REPAIR OF CARDIOVASCULAR TISSUE, CARDIAC PATCHES, VASCULAR GRAFTS, AND FOR USE AS AN INJECTABLE EXTRACELLULAR MATRIX COMPOSITION (U.S. CLS. 6, 18, 44, 46, 51 AND 52).

FIRST USE 1-15-2014; IN COMMERCE 1-15-2014.

4,593,829. INNOVUS PHARMACEUTICALS, INC., SAN DIEGO, CA. SN 85-914,704. PUB. 10-1-2013, FILED 4-25-2013.

# EJECTDELAY

THE MARK CONSISTS OF STANDARD CHARACTERS WITHOUT CLAIM TO ANY PARTICULAR FONT, STYLE, SIZE, OR COLOR.

FOR PHARMACEUTICAL PREPARATIONS FOR USE IN UROLOGY; PHARMACEUTICAL PREPARATIONS FOR MAINTAINING EJACULATORY CONTROL AND/OR SEXUAL SENSATION; PHARMACEUTICAL SKIN LOTIONS; PHARMACEUTICALS FOR THE TREATMENT OF ERECTILE DYSFUNCTION (U.S. CLS. 6, 18, 44, 46, 51 AND 52).

FIRST USE 11-1-2013; IN COMMERCE 2-4-2014.

4,593,924. DR. JAMES D. KRYSOSIK, NORTHFIELD, OH. SN 85-936,816. PUB. 4-8-2014, FILED 5-20-2013.

# KICK ACID

THE MARK CONSISTS OF STANDARD CHARACTERS WITHOUT CLAIM TO ANY PARTICULAR FONT, STYLE, SIZE, OR COLOR.

**CLASS 5—(Continued).**

NO CLAIM IS MADE TO THE EXCLUSIVE RIGHT TO USE "ACID", APART FROM THE MARK AS SHOWN.

FOR DIETARY FOOD SUPPLEMENTS; NUTRITIONAL SUPPLEMENT ENERGY BARS; NATURAL FOOD PRODUCTS, NAMELY, DIETARY SUPPLEMENTS FORMED AND PACKAGED AS BARS; ALL THE FOREGOING DESIGNED TO REDUCE ACID WASTE IN THE BODY (U.S. CLS. 6, 18, 44, 46, 51 AND 52).

FIRST USE 1-2-2014; IN COMMERCE 1-2-2014.

4,593,981. UNITED PHOSPHORUS, INC., KING OF PRUSSIA, PA. SN 85-943,675. PUB. 7-30-2013, FILED 5-28-2013.

# BROADLOOM

THE MARK CONSISTS OF STANDARD CHARACTERS WITHOUT CLAIM TO ANY PARTICULAR FONT, STYLE, SIZE, OR COLOR.

FOR HERBICIDES (U.S. CLS. 6, 18, 44, 46, 51 AND 52).

FIRST USE 6-12-2014; IN COMMERCE 6-12-2014.

4,593,987. HOFFMAN HAACK, ROBIN, CAPISTRANO BEACH, CA. SN 85-944,936. PUB. 10-22-2013, FILED 5-29-2013.

# CLAR8TY

THE MARK CONSISTS OF STANDARD CHARACTERS WITHOUT CLAIM TO ANY PARTICULAR FONT, STYLE, SIZE, OR COLOR.

FOR NUTRITIONAL SUPPLEMENTS IN THE FORM OF POWDER (U.S. CLS. 6, 18, 44, 46, 51 AND 52).

FIRST USE 4-28-2014; IN COMMERCE 4-28-2014.

**CLASS 5—(Continued).**

4,594,015. GRUPO CAROSI, S.A., AVENTURA, FL. SN 85-950,578. PUB. 10-29-2013, FILED 6-4-2013.

**VIAMITAN**

THE MARK CONSISTS OF STANDARD CHARACTERS WITHOUT CLAIM TO ANY PARTICULAR FONT, STYLE, SIZE, OR COLOR.

FOR DIETARY AND NUTRITIONAL SUPPLEMENTS; DIETARY SUPPLEMENTS; NUTRITIONAL SUPPLEMENTS; VITAMIN AND MINERAL SUPPLEMENTS (U.S. CLS. 6, 18, 44, 46, 51 AND 52).

FIRST USE 1-2-2014; IN COMMERCE 1-2-2014.

4,594,016. GRUPO CAROSI, S.A., AVENTURA, FL. SN 85-950,599. PUB. 10-29-2013, FILED 6-4-2013.

**LIPOGLUCAN**

THE MARK CONSISTS OF STANDARD CHARACTERS WITHOUT CLAIM TO ANY PARTICULAR FONT, STYLE, SIZE, OR COLOR.

FOR DIETARY AND NUTRITIONAL SUPPLEMENTS; DIETARY SUPPLEMENTS; NUTRITIONAL SUPPLEMENTS; VITAMIN AND MINERAL SUPPLEMENTS (U.S. CLS. 6, 18, 44, 46, 51 AND 52).

FIRST USE 1-2-2014; IN COMMERCE 1-2-2014.

4,594,017. WISE CHOICE PRODUCTS, INC., EL CAJON, CA. SN 85-950,672. PUB. 10-29-2013, FILED 6-4-2013.

**ARMeD**

THE MARK CONSISTS OF STANDARD CHARACTERS WITHOUT CLAIM TO ANY PARTICULAR FONT, STYLE, SIZE, OR COLOR.

FOR DIETARY AND NUTRITIONAL SUPPLEMENTS (U.S. CLS. 6, 18, 44, 46, 51 AND 52).

FIRST USE 7-15-2013; IN COMMERCE 8-13-2013.

**CLASS 5—(Continued).**

4,594,051. CA IP HOLDINGS, LLC, BOYNTON BEACH, FL. SN 85-956,230. PUB. 10-29-2013, FILED 6-11-2013.

**KING MASS**

THE MARK CONSISTS OF STANDARD CHARACTERS WITHOUT CLAIM TO ANY PARTICULAR FONT, STYLE, SIZE, OR COLOR.

FOR DIETARY AND NUTRITIONAL SUPPLEMENTS; DIETARY AND NUTRITIONAL SUPPLEMENTS USED FOR WEIGHT GAIN (U.S. CLS. 6, 18, 44, 46, 51 AND 52).

FIRST USE 6-25-2013; IN COMMERCE 6-25-2013.

4,594,116. HINES, RYAN, FRANKLIN, KY. SN 85-968,151. PUB. 3-4-2014, FILED 6-24-2013.

**AUXOLOGY LABS**

THE MARK CONSISTS OF STANDARD CHARACTERS WITHOUT CLAIM TO ANY PARTICULAR FONT, STYLE, SIZE, OR COLOR.

NO CLAIM IS MADE TO THE EXCLUSIVE RIGHT TO USE "LABS", APART FROM THE MARK AS SHOWN.

FOR DIETARY AND NUTRITIONAL SUPPLEMENTS (U.S. CLS. 6, 18, 44, 46, 51 AND 52).

FIRST USE 11-18-2013; IN COMMERCE 11-18-2013.

4,594,119. ACTAVIS, INC., PARSIPPANY, NJ. SN 85-968,346. PUB. 11-12-2013, FILED 6-24-2013.



OWNER OF U.S. REG. NO. 2,764,846.

NO CLAIM IS MADE TO THE EXCLUSIVE RIGHT TO USE "FOR WOMEN", APART FROM THE MARK AS SHOWN.

THE MARK CONSISTS OF A WOMAN STANDING BESIDE THE STYLIZED WORD "OXYTROL" AND HAVING HER LEFT HAND WRAPPED AROUND THE UPPER LEFT PORTION OF THE "O". THE WORDS "FOR WOMEN" APPEAR UNDER THE WORD "OXYTROL" STARTING AT THE "Y" AND ENDING AT THE "L".

FOR PHARMACEUTICAL PREPARATIONS, NAMELY, MEDICAL TRANSDERMAL PATCHES FOR THE DELIVERY OF ANTICHOLINERGIC AGENTS (U.S. CLS. 6, 18, 44, 46, 51 AND 52).

FIRST USE 9-25-2013; IN COMMERCE 9-25-2013.

**CLASS 5—(Continued).**

4,594,139. LUDMAN FIT CORPORATION, MONTCLAIR, NJ. SN 85-971,343. PUB. 1-14-2014, FILED 6-27-2013.

**Verebey Joint Support**

THE MARK CONSISTS OF STANDARD CHARACTERS WITHOUT CLAIM TO ANY PARTICULAR FONT, STYLE, SIZE, OR COLOR.

NO CLAIM IS MADE TO THE EXCLUSIVE RIGHT TO USE "JOINT SUPPORT", APART FROM THE MARK AS SHOWN.

THE WORDING "VEREBEY" HAS NO MEANING IN A FOREIGN LANGUAGE.

FOR NUTRITIONAL SUPPLEMENTS (U.S. CLS. 6, 18, 44, 46, 51 AND 52).

FIRST USE 5-15-2014; IN COMMERCE 5-15-2014.

4,594,160. BODYWISE LIMITED, ISLE OF WIGHT, UNITED KINGDOM. SN 85-982,016. PUB. 11-26-2013, FILED 11-23-2012.

**BODYWISE**

THE MARK CONSISTS OF STANDARD CHARACTERS WITHOUT CLAIM TO ANY PARTICULAR FONT, STYLE, SIZE, OR COLOR.

PRIORITY CLAIMED UNDER SEC. 44(D) ON ERP N CMNTY TM OFC APPLICATION NO. 11216331, FILED 9-26-2012, REG. NO. 11216331, DATED 3-26-2013, EXPIRES 9-26-2022.

FOR PERSONAL LUBRICANTS AND GELS; HYGIENIC LUBRICANTS (U.S. CLS. 6, 18, 44, 46, 51 AND 52).

FIRST USE 12-0-1997; IN COMMERCE 12-0-1997.

4,594,181. MEDIVERSE INTERNATIONAL, INC., ARCADIA, CA. SN 85-982,297. PUB. 2-11-2014, FILED 7-18-2012.

**Utopia**

THE MARK CONSISTS OF STANDARD CHARACTERS WITHOUT CLAIM TO ANY PARTICULAR FONT, STYLE, SIZE, OR COLOR.

FOR NUTRITIONAL SUPPLEMENTS; DIETARY SUPPLEMENTS; INFANT FORMULA (U.S. CLS. 6, 18, 44, 46, 51 AND 52).

FIRST USE 4-1-2013; IN COMMERCE 9-1-2013.

**CLASS 5—(Continued).**

4,594,223. HI-HEALTH SUPERMART CORPORATION, DBA HI-HEALTH, SCOTTSDALE, AZ. SN 86-009,351. PUB. 10-15-2013, FILED 7-12-2013.

**HYDRATE YOUR PASSION**

THE MARK CONSISTS OF STANDARD CHARACTERS WITHOUT CLAIM TO ANY PARTICULAR FONT, STYLE, SIZE, OR COLOR.

FOR DIETARY SUPPLEMENTAL DRINKS (U.S. CLS. 6, 18, 44, 46, 51 AND 52).

FIRST USE 12-23-2013; IN COMMERCE 1-30-2014.

4,594,268. EOSC LTD, WASHINGTON DEPOT, CT. SN 86-030,426. PUB. 10-15-2013, FILED 8-6-2013.

**HAUTE LUXURY**

THE MARK CONSISTS OF STANDARD CHARACTERS WITHOUT CLAIM TO ANY PARTICULAR FONT, STYLE, SIZE, OR COLOR.

FOR ANTI-INSECT SPRAY; INSECT REPELLENT AGENTS; INSECT REPELLENTS; PREPARATIONS FOR REPELLING INSECTS (U.S. CLS. 6, 18, 44, 46, 51 AND 52).

FIRST USE 10-18-2013; IN COMMERCE 10-18-2013.

4,594,288. VESSAL, CARALYN, VILLANOVA, PA. SN 86-037,620. PUB. 2-4-2014, FILED 8-14-2013.

**Sufficient-C**

THE MARK CONSISTS OF STANDARD CHARACTERS WITHOUT CLAIM TO ANY PARTICULAR FONT, STYLE, SIZE, OR COLOR.

FOR DIETARY SUPPLEMENT DRINK MIXES CONTAINING VITAMIN C; VITAMIN C PREPARATIONS (U.S. CLS. 6, 18, 44, 46, 51 AND 52).

FIRST USE 9-1-2013; IN COMMERCE 10-1-2013.

**CLASS 5—(Continued).**

4,594,303. HANGZHOU SKYHERB TECHNOLOGIES CO.,LTD., HANGZHOU, CHINA. SN 86-044,705. PUB. 2-18-2014, FILED 8-22-2013.

# SKYHERB

THE MARK CONSISTS OF STANDARD CHARACTERS WITHOUT CLAIM TO ANY PARTICULAR FONT, STYLE, SIZE, OR COLOR.

FOR PLANT EXTRACTS FOR MEDICAL, VETERINARY AND PHARMACEUTICAL PURPOSES; NUTRITIONAL FOOD ADDITIVES FOR MEDICAL PURPOSES IN THE NATURE OF NATURAL FOOD EXTRACTS DERIVED FROM FRUITS AND VEGETABLES (U.S. CLS. 6, 18, 44, 46, 51 AND 52).

FIRST USE 9-1-2013; IN COMMERCE 9-1-2013.

**CLASS 5—(Continued).**

4,594,336. SIMILASAN AG, JONEN, SWITZERLAND. SN 86-058,855. PUB. 2-11-2014, FILED 9-9-2013.



THE COLOR(S) GRAY, GREEN AND WHITE IS/ARE CLAIMED AS A FEATURE OF THE MARK.

THE MARK CONSISTS OF A GRAY SWISS CROSS WITH A GREEN LEAF IN THE UPPER RIGHT HAND QUADRANT FORMED BY THE CROSS, ALL ON A WHITE BACKGROUND.

FOR FULL LINE OF HOMEOPATHIC PHARMACEUTICAL PREPARATIONS (U.S. CLS. 6, 18, 44, 46, 51 AND 52).

FIRST USE 7-1-2013; IN COMMERCE 7-1-2013.

4,594,309. NORDIC NATURALS, INC., WATSONVILLE, CA. SN 86-045,795. PUB. 12-3-2013, FILED 8-22-2013.

# Omega Boost

THE MARK CONSISTS OF STANDARD CHARACTERS WITHOUT CLAIM TO ANY PARTICULAR FONT, STYLE, SIZE, OR COLOR.

NO CLAIM IS MADE TO THE EXCLUSIVE RIGHT TO USE "OMEGA", APART FROM THE MARK AS SHOWN.

FOR DIETARY AND NUTRITIONAL SUPPLEMENTS CONTAINING OMEGAS; DIETARY SUPPLEMENTS FOR HUMAN CONSUMPTION CONTAINING OMEGAS (U.S. CLS. 6, 18, 44, 46, 51 AND 52).

FIRST USE 1-6-2014; IN COMMERCE 1-6-2014.

4,594,344. TAMBRANDS, INC., CINCINNATI, OH. SN 86-062,704. PUB. 2-11-2014, FILED 9-12-2013.



THE MARK CONSISTS OF A TAMPON WRAPPED BY A MEASURING TAPE CONTAINING THE WORDING "SLENDERFIT".

FOR TAMPONS (U.S. CLS. 6, 18, 44, 46, 51 AND 52).

FIRST USE 4-1-2014; IN COMMERCE 4-1-2014.

**CLASS 5—(Continued).**

4,594,366. MOCHI LLC, SCOTTSDALE, AZ. SN 86-071,333.  
PUB. 3-18-2014, FILED 9-22-2013.

## Vegas Strips

THE MARK CONSISTS OF STANDARD CHARACTERS WITHOUT CLAIM TO ANY PARTICULAR FONT, STYLE, SIZE, OR COLOR.

NO CLAIM IS MADE TO THE EXCLUSIVE RIGHT TO USE "STRIPS", APART FROM THE MARK AS SHOWN.

FOR HERBAL MALE ENHANCEMENT CAPSULES (U.S. CLS. 6, 18, 44, 46, 51 AND 52).

FIRST USE 3-1-2014; IN COMMERCE 5-1-2014.

---

4,594,374. NUTRACLICK, LLC, BOSTON, MA. SN 86-076,033.  
PUB. 2-18-2014, FILED 9-26-2013.

## VolcaNO

THE MARK CONSISTS OF STANDARD CHARACTERS WITHOUT CLAIM TO ANY PARTICULAR FONT, STYLE, SIZE, OR COLOR.

FOR DIETARY SUPPLEMENTS THAT BOOST THE BODY'S PRODUCTION OF NITRIC OXIDE; DIETARY AND NUTRITIONAL SUPPLEMENTS CONTAINING NITRIC OXIDE; DIETARY AND NUTRITIONAL SUPPLEMENTS; DIETARY SUPPLEMENT; NUTRITIONAL SUPPLEMENT (U.S. CLS. 6, 18, 44, 46, 51 AND 52).

FIRST USE 1-2-2014; IN COMMERCE 1-2-2014.

---

4,594,391. ANTI L'AGE INC., RIVERSIDE, CA. SN 86-080,189.  
PUB. 3-25-2014, FILED 10-1-2013.

## X-CELL FORTE AMINOS

THE MARK CONSISTS OF STANDARD CHARACTERS WITHOUT CLAIM TO ANY PARTICULAR FONT, STYLE, SIZE, OR COLOR.

NO CLAIM IS MADE TO THE EXCLUSIVE RIGHT TO USE "AMINOS", APART FROM THE MARK AS SHOWN.

FOR DIETARY AND NUTRITIONAL SUPPLEMENTS CONTAINING AMINO ACIDS; AMINO ACIDS FOR NUTRITIONAL PURPOSES (U.S. CLS. 6, 18, 44, 46, 51 AND 52).

FIRST USE 10-1-2013; IN COMMERCE 10-1-2013.

**CLASS 5—(Continued).**

4,594,398. CARGILL THE NETHERLANDS HOLDING B.V.,  
1118 CZ SCHIPHOL, NETHERLANDS. SN 86-083,987. PUB.  
1-7-2014, FILED 10-7-2013.

## PROHACID

THE MARK CONSISTS OF STANDARD CHARACTERS WITHOUT CLAIM TO ANY PARTICULAR FONT, STYLE, SIZE, OR COLOR.

FOR ANIMAL FEED ADDITIVE FOR USE AS A NUTRITIONAL SUPPLEMENT FOR MEDICAL PURPOSES (U.S. CLS. 6, 18, 44, 46, 51 AND 52).

FIRST USE 9-16-2013; IN COMMERCE 9-16-2013.

---

4,594,434. K10 HOLDINGS, LLC, NEW YORK, NY. SN 86-  
094,761. PUB. 3-4-2014, FILED 10-17-2013.

## THERE MUST BE SOMETHING IN THE WATER

THE MARK CONSISTS OF STANDARD CHARACTERS WITHOUT CLAIM TO ANY PARTICULAR FONT, STYLE, SIZE, OR COLOR.

FOR DIETARY SUPPLEMENTS FOR PETS (U.S. CLS. 6, 18, 44, 46, 51 AND 52).

FIRST USE 10-31-2013; IN COMMERCE 10-31-2013.

---

4,594,481. NUTRITHORITY LLC, WICHITA, KS. SN 86-  
109,541. PUB. 4-1-2014, FILED 11-4-2013.

## NUTRITHORITY

THE MARK CONSISTS OF STANDARD CHARACTERS WITHOUT CLAIM TO ANY PARTICULAR FONT, STYLE, SIZE, OR COLOR.

FOR DIETARY AND NUTRITIONAL SUPPLEMENTS (U.S. CLS. 6, 18, 44, 46, 51 AND 52).

FIRST USE 3-0-2014; IN COMMERCE 3-0-2014.



**CLASS 5—(Continued).**

4,594,486. UNIVERA, INC., SEATTLE, WA. SN 86-113,000.  
PUB. 4-22-2014, FILED 11-7-2013.

**CLARICOR OMEGA**

THE MARK CONSISTS OF STANDARD CHARACTERS WITHOUT CLAIM TO ANY PARTICULAR FONT, STYLE, SIZE, OR COLOR.

NO CLAIM IS MADE TO THE EXCLUSIVE RIGHT TO USE "OMEGA", APART FROM THE MARK AS SHOWN.

FOR DIETARY SUPPLEMENTS FEATURING OMEGA FATTY ACIDS (U.S. CLS. 6, 18, 44, 46, 51 AND 52).

FIRST USE 6-9-2014; IN COMMERCE 6-9-2014.

4,594,488. PRISTINE BAY, LLC, DBA VIANDA, CINCINNATI, OH. SN 86-113,803. PUB. 4-22-2014, FILED 11-8-2013.

**MIGHTY KIDZ**

THE MARK CONSISTS OF STANDARD CHARACTERS WITHOUT CLAIM TO ANY PARTICULAR FONT, STYLE, SIZE, OR COLOR.

NO CLAIM IS MADE TO THE EXCLUSIVE RIGHT TO USE "KIDS", APART FROM THE MARK AS SHOWN.

FOR MULTIVITAMIN PREPARATIONS (U.S. CLS. 6, 18, 44, 46, 51 AND 52).

FIRST USE 3-14-2014; IN COMMERCE 3-14-2014.

4,594,489. PRISTINE BAY, LLC, DBA VIANDA, CINCINNATI, OH. SN 86-113,820. PUB. 4-22-2014, FILED 11-8-2013.

**WITTY KIDZ**

THE MARK CONSISTS OF STANDARD CHARACTERS WITHOUT CLAIM TO ANY PARTICULAR FONT, STYLE, SIZE, OR COLOR.

NO CLAIM IS MADE TO THE EXCLUSIVE RIGHT TO USE "KIDS", APART FROM THE MARK AS SHOWN.

FOR DIETARY SUPPLEMENTS (U.S. CLS. 6, 18, 44, 46, 51 AND 52).

FIRST USE 3-18-2014; IN COMMERCE 3-18-2014.

**CLASS 5—(Continued).**

4,594,506. FORM-A-FEED, INC., STEWART, MN. SN 86-121,692. PUB. 4-22-2014, FILED 11-18-2013.

**GLO-N-SHINE**

THE MARK CONSISTS OF STANDARD CHARACTERS WITHOUT CLAIM TO ANY PARTICULAR FONT, STYLE, SIZE, OR COLOR.

FOR DIETARY SUPPLEMENTS FOR BINDING LIVESTOCK FEED IN THE MANUFACTURING PROCESS (U.S. CLS. 6, 18, 44, 46, 51 AND 52).

FIRST USE 11-25-2013; IN COMMERCE 11-25-2013.

4,594,514. EBI, LLC, PARSIPPANY, NJ. SN 86-125,825. PUB. 4-29-2014, FILED 11-21-2013.

**TRINNECT**

THE MARK CONSISTS OF STANDARD CHARACTERS WITHOUT CLAIM TO ANY PARTICULAR FONT, STYLE, SIZE, OR COLOR.

FOR ALLOGRAFT BONE SPACER FOR USE IN SPINAL SURGERY; BONE GRAFTS PROCESSED FROM HUMAN TISSUE FOR USE IN SPINAL SURGERY (U.S. CLS. 6, 18, 44, 46, 51 AND 52).

FIRST USE 5-31-2014; IN COMMERCE 5-31-2014.

4,594,520. GUARDIAN SUPPLY COMPNAY LLC, BRISTOL, CT. SN 86-129,510. PUB. 4-22-2014, FILED 11-26-2013.

**PRO-PELL**

THE MARK CONSISTS OF STANDARD CHARACTERS WITHOUT CLAIM TO ANY PARTICULAR FONT, STYLE, SIZE, OR COLOR.

FOR ANIMAL REPELLENTS (U.S. CLS. 6, 18, 44, 46, 51 AND 52).

FIRST USE 1-1-2014; IN COMMERCE 1-1-2014.

**CLASS 6—METAL GOODS**

**CLASS 6—(Continued).**

4,593,068. ROUGH BROTHERS, INC., CINCINNATI, OH. SN 76-713,918. PUB. 9-10-2013, FILED 4-12-2013.



OWNER OF U.S. REG. NO. 2,301,581.  
NO CLAIM IS MADE TO THE EXCLUSIVE RIGHT TO USE "INC.", APART FROM THE MARK AS SHOWN.  
THE MARK CONSISTS OF THE LETTERS "RBI" IN A STYLIZED FONT TO THE LEFT OF THE REPRESENTATION OF A GREENHOUSE CONTAINING A SINGLE LEAF, ALL ABOVE THE WORDS "ROUGH BROTHERS, INC." IN A STYLIZED FONT.  
FOR PERMANENT PRE-FABRICATED GREENHOUSE BUILDINGS HAVING METAL FRAMES (U.S. CLS. 2, 12, 13, 14, 23, 25 AND 50).  
FIRST USE 10-30-2013; IN COMMERCE 10-30-2013.

4,593,204. MAYNE COATINGS CORP., LANGLEY, CANADA. SN 85-342,206. PUB. 1-15-2013, FILED 6-9-2011.

**LONGBOARD**

THE MARK CONSISTS OF STANDARD CHARACTERS WITHOUT CLAIM TO ANY PARTICULAR FONT, STYLE, SIZE, OR COLOR.  
PRIORITY CLAIMED UNDER SEC. 44(D) ON CANADA APPLICATION NO. 1516511, FILED 2-23-2011, REG. NO. TMA837090, DATED 11-27-2012, EXPIRES 11-27-2027.  
FOR PREMIUM ARCHITECTURAL MATERIALS FOR USE IN CONSTRUCTION, NAMELY, METAL SOFFITS, METAL RAILINGS FOR BALCONIES IN THE NATURE OF PRIVACY SCREENS, METAL SIDING, METAL CLADDING, AND METAL WALL SYSTEMS COMPRISED OF ARCHITECTURAL PANEL SYSTEMS FOR USE AS EXTERIOR BUILDING CLADDING (U.S. CLS. 2, 12, 13, 14, 23, 25 AND 50).  
FIRST USE 7-31-2012; IN COMMERCE 7-31-2012.

**CLASS 6—(Continued).**

4,593,235. TILCOR ROOFING SYSTEMS LIMITED, DBA TILCOR ROOFING SYSTEMS LIMITED, AUCKLAND, NEW ZEALAND. SN 85-440,384. PUB. 4-30-2013, FILED 10-5-2011.

**TILCOR**

THE MARK CONSISTS OF STANDARD CHARACTERS WITHOUT CLAIM TO ANY PARTICULAR FONT, STYLE, SIZE, OR COLOR.  
PRIORITY CLAIMED UNDER SEC. 44(D) ON NEW ZEALAND APPLICATION NO. 847014, FILED 8-4-2011, REG. NO. 847014, DATED 2-7-2012, EXPIRES 2-7-2022.  
FOR ROOF TILES OF METAL; TILES OF METAL FOR BUILDINGS; NAILS (U.S. CLS. 2, 12, 13, 14, 23, 25 AND 50).  
FIRST USE 2-27-2014; IN COMMERCE 2-27-2014.

4,593,372. CHAD M. LARSON, SAVAGE, MN. SN 85-655,804. PUB. 11-13-2012, FILED 6-19-2012.

**TNA**

THE MARK CONSISTS OF STANDARD CHARACTERS WITHOUT CLAIM TO ANY PARTICULAR FONT, STYLE, SIZE, OR COLOR.  
FOR METAL FASTENERS, NAMELY, BOLTS (U.S. CLS. 2, 12, 13, 14, 23, 25 AND 50).  
FIRST USE 6-26-2014; IN COMMERCE 6-26-2014.

4,593,432. PILEPRO LLC, CREEDMOOR, TX. SN 85-710,279. PUB. 5-14-2013, FILED 8-22-2012.

**ANY-Z**

THE MARK CONSISTS OF STANDARD CHARACTERS WITHOUT CLAIM TO ANY PARTICULAR FONT, STYLE, SIZE, OR COLOR.  
FOR PILING SHEETS, OF METAL; SHEET PILES, OF METAL; PROFILED PILING SECTIONS, OF METAL; CONNECTING ELEMENTS FOR SHEET PILES OF METAL, NAMELY, METAL SHEET PILE CONNECTORS; AND METAL CONNECTING PROFILES AND WELDING CORNERS FOR SHEET PILES OF METAL OR PLASTIC (U.S. CLS. 2, 12, 13, 14, 23, 25 AND 50).  
FIRST USE 2-0-2013; IN COMMERCE 2-0-2013.

**CLASS 6—(Continued).**

4,593,557. DAB DOOR COMPANY, INC., HIALEAH GARDENS, FL. SN 85-784,284. PUB. 5-7-2013, FILED 11-20-2012.



OWNER OF U.S. REG. NO. 2,882,966.

THE MARK CONSISTS OF THE STYLIZED WORDING "HURRICANE MASTER BY DAB" WITH THE WORD "HURRICANE" APPEARING ABOVE THE WORD "MASTER". THE WORDING "BY DAB" APPEARING BELOW THE LETTER "R" IN "MASTER". AND WITH A STYLIZED CURVED LINE DEPICTING MOTION RUNNING RIGHT TO LEFT FROM BEHIND THE WORD "HURRICANE" THROUGH THE LETTER "A" IN "MASTER".

FOR METAL GARAGE DOORS; METAL GARAGE DOORS AND ELECTRIC MOTOR-POWERED GARAGE DOOR OPENERS THEREFOR, SOLD TOGETHER AS A UNIT (U.S. CLS. 2, 12, 13, 14, 23, 25 AND 50).

FIRST USE 11-28-2012; IN COMMERCE 3-4-2013.

**CLASS 6—(Continued).**

4,594,346. HAMPTON PRODUCTS INTERNATIONAL CORPORATION, FOOTHILL RANCH, CA. SN 86-062,925. PUB. 3-4-2014, FILED 9-12-2013.

ZX-15

THE MARK CONSISTS OF STANDARD CHARACTERS WITHOUT CLAIM TO ANY PARTICULAR FONT, STYLE, SIZE, OR COLOR.

FOR METAL LOCKS FEATURING A RUST PREVENTIVE COATING AS AN INTEGRAL COMPONENT (U.S. CLS. 2, 12, 13, 14, 23, 25 AND 50).

FIRST USE 3-24-2014; IN COMMERCE 3-24-2014.

4,593,699. ERGOTRON, INC., ST. PAUL, MN. SN 85-840,112. PUB. 10-22-2013, FILED 2-4-2013.

EZMOUNT

THE MARK CONSISTS OF STANDARD CHARACTERS WITHOUT CLAIM TO ANY PARTICULAR FONT, STYLE, SIZE, OR COLOR.

FOR HARDWARE MOUNTING SYSTEM COMPRISED PARTIALLY OF METAL, NAMELY, METAL WALL PLATES, METAL WALL DISCS, METAL MECHANICAL LATCHES, METAL BARS AND CABLES, SPACER BRACKETS OF METAL, AND METAL SCREWS FOR WALL MOUNTING OF TELEVISIONS (U.S. CLS. 2, 12, 13, 14, 23, 25 AND 50).

FIRST USE 7-0-2010; IN COMMERCE 7-0-2010.

4,594,480. SHAN DONG TENGDA STAINLESS STEEL PRODUCTS CO., LTD., SHANDONG, CHINA. SN 86-108,998. PUB. 4-1-2014, FILED 11-4-2013.



THE MARK CONSISTS OF A CIRCLE DIVIDED INTO UPPER AND LOWER PORTION, WITH THE WORD "TENGDA" BETWEEN THEM, AND TWO CHINESE CHARACTERS THAT TRANSLITERATE INTO "TENG DA" INSIDE THE LOWER PORTION.

THE ENGLISH TRANSLATION OF "TENGDA" IN THE MARK IS "FLY REACH".

THE NON-LATIN CHARACTERS IN THE MARK TRANSLITERATE TO "TENG DA" AND THIS MEANS "FLY REACH" IN ENGLISH.

FOR BUCKLES OF COMMON METAL; METAL BOLTS; METAL HARDWARE, NAMELY, WASHERS; METAL HOOKS; METAL NUTS; METAL RIVETS; METAL SCREWS; METAL THREADED FASTENERS; NAILS; THREADED METAL RODS (U.S. CLS. 2, 12, 13, 14, 23, 25 AND 50).

FIRST USE 10-16-2003; IN COMMERCE 11-4-2013.

4,593,771. TRINITY HIGHWAY PRODUCTS, LLC, DALLAS, TX. SN 85-881,377. PUB. 12-24-2013, FILED 3-20-2013.

SYTP

THE MARK CONSISTS OF STANDARD CHARACTERS WITHOUT CLAIM TO ANY PARTICULAR FONT, STYLE, SIZE, OR COLOR.

FOR METAL GUARDRAIL AND END TERMINAL POSTS (U.S. CLS. 2, 12, 13, 14, 23, 25 AND 50).

FIRST USE 10-29-2013; IN COMMERCE 10-29-2013.

**CLASS 6—(Continued).**

4,594,524. BONDED TECHNOLOGY CORPORATION, ROGERS, MN. SN 86-133,883. PUB. 4-22-2014, FILED 12-3-2013.

# BONDTEK

THE MARK CONSISTS OF STANDARD CHARACTERS WITHOUT CLAIM TO ANY PARTICULAR FONT, STYLE, SIZE, OR COLOR.

FOR BUILDING MATERIALS, NAMELY, COMPOSITE PANELS COMPOSED PRIMARILY OF METAL (U.S. CLS. 2, 12, 13, 14, 23, 25 AND 50).

FIRST USE 4-29-2014; IN COMMERCE 4-29-2014.

**CLASS 7—MACHINERY**

4,593,069. BETTCHER INDUSTRIES, INC., BIRMINGHAM, OH. SN 76-713,983. PUB. 12-3-2013, FILED 4-19-2013.

# BETTCHER QUANTUM

THE MARK CONSISTS OF STANDARD CHARACTERS WITHOUT CLAIM TO ANY PARTICULAR FONT, STYLE, SIZE, OR COLOR.

OWNER OF U.S. REG. NO. 882,786.

FOR HAND-HELD, MOTOR-DRIVEN ROTARY KNIVES; ELECTRIC AND PNEUMATIC DRIVE MOTORS FOR HAND-HELD, MOTOR-DRIVEN ROTARY KNIVES; AND FLEXIBLE DRIVE TRANSMISSIONS WHICH ROTATABLY DRIVE A BLADE OF A HAND-HELD, MOTOR-DRIVEN ROTARY KNIFE (U.S. CLS. 13, 19, 21, 23, 31, 34 AND 35).

FIRST USE 12-0-2013; IN COMMERCE 12-0-2013.

4,593,071. BETTCHER INDUSTRIES, INC., BIRMINGHAM, OH. SN 76-713,986. PUB. 11-26-2013, FILED 4-19-2013.

# WHIZARD QUANTUM

THE MARK CONSISTS OF STANDARD CHARACTERS WITHOUT CLAIM TO ANY PARTICULAR FONT, STYLE, SIZE, OR COLOR.

OWNER OF U.S. REG. NO. 879,445.

FOR HAND-HELD, MOTOR-DRIVEN ROTARY KNIVES; ELECTRIC AND PNEUMATIC DRIVE MOTORS FOR HAND-HELD, MOTOR-DRIVEN ROTARY KNIVES; AND FLEXIBLE DRIVE TRANSMISSIONS WHICH ROTATABLY DRIVE A BLADE OF A HAND-HELD, MOTOR-DRIVEN ROTARY KNIFE (U.S. CLS. 13, 19, 21, 23, 31, 34 AND 35).

FIRST USE 12-0-2013; IN COMMERCE 12-0-2013.

**CLASS 7—(Continued).**

4,593,119. APPLIED MATERIALS, INC., SANTA CLARA, CA. SN 85-063,846. PUB. 5-10-2011, FILED 6-15-2010.

# NLIGHTEN

THE MARK CONSISTS OF STANDARD CHARACTERS WITHOUT CLAIM TO ANY PARTICULAR FONT, STYLE, SIZE, OR COLOR.

FOR SEMICONDUCTOR MANUFACTURING MACHINES, SEMICONDUCTOR SUBSTRATE MANUFACTURING MACHINES AND SEMICONDUCTOR WAFER PROCESSING MACHINES AND EQUIPMENT, NAMELY, FOR THE PROCESSING, PRODUCTION, POLISHING AND CLEANING OF SEMICONDUCTOR SUBSTRATES, THIN FILMS, SILICON DISCS AND WAFERS (U.S. CLS. 13, 19, 21, 23, 31, 34 AND 35).

FIRST USE 6-15-2010; IN COMMERCE 6-15-2010.

4,593,126. J. BAXTER BRINKMANN INTERNATIONAL CORPORATION, DALLAS, TX. SN 85-077,519. PUB. 6-28-2011, FILED 7-2-2010.

# MALIBU OUTDOOR LIVING

THE MARK CONSISTS OF STANDARD CHARACTERS WITHOUT CLAIM TO ANY PARTICULAR FONT, STYLE, SIZE, OR COLOR.

OWNER OF U.S. REG. NOS. 816,551, 3,424,575, AND OTHERS.

NO CLAIM IS MADE TO THE EXCLUSIVE RIGHT TO USE "OUTDOOR LIVING", APART FROM THE MARK AS SHOWN.

FOR VACUUM CLEANERS AND THEIR COMPONENTS, NAMELY, BRUSHES, CREVICE TOOLS, DUST FILTERS AND BAGS, CLEANER BAGS, CLEANER HOSES, HOSE ADAPTERS, PUMPS, SUCTION NOZZLES, AND EXTENSION WANDS (U.S. CLS. 13, 19, 21, 23, 31, 34 AND 35).

FIRST USE 5-19-2014; IN COMMERCE 5-19-2014.

**CLASS 7—(Continued).**

4,593,226. TECHTRONIC FLOOR CARE TECHNOLOGY LIMITED, ROAD TOWN, TORTOLA, BR.VIRGIN ISLANDS. SN 85-393,950. PUB. 5-1-2012, FILED 8-10-2011.

## PROFILE

THE MARK CONSISTS OF STANDARD CHARACTERS WITHOUT CLAIM TO ANY PARTICULAR FONT, STYLE, SIZE, OR COLOR.

FOR VACUUM CLEANERS; CARPET CLEANING MACHINES, NAMELY, CARPET EXTRACTORS; POWER OPERATED FLOOR BURNISHERS; AND FLOOR POLISHERS (U.S. CLS. 13, 19, 21, 23, 31, 34 AND 35).  
FIRST USE 6-16-2012; IN COMMERCE 6-16-2012.

---

4,593,578. CLOVER ONE, LLC, WILMINGTON, DE. SN 85-791,049. PUB. 11-5-2013, FILED 11-29-2012.

## OUTERWALL

THE MARK CONSISTS OF STANDARD CHARACTERS WITHOUT CLAIM TO ANY PARTICULAR FONT, STYLE, SIZE, OR COLOR.

FOR VENDING MACHINES (U.S. CLS. 13, 19, 21, 23, 31, 34 AND 35).  
FIRST USE 10-0-2013; IN COMMERCE 10-0-2013.

---

4,593,688. FRAM GROUP IP, LLC, LAKE FOREST, IL. SN 85-831,462. PUB. 4-30-2013, FILED 1-24-2013.



THE COLOR(S) ORANGE, WHITE AND BLACK IS/ARE CLAIMED AS A FEATURE OF THE MARK.

THE MARK CONSISTS OF THE WORD "AUTOLITE" WITH "AUTO" IN ORANGE AND "LITE" IN BLACK, DIVIDED BY A WHITE LIGHTENING BOLT DESIGN.

FOR SPARK PLUGS; SPARK PLUG WIRES FOR LAND VEHICLES (U.S. CLS. 13, 19, 21, 23, 31, 34 AND 35).  
FIRST USE 3-1-2014; IN COMMERCE 3-1-2014.

**CLASS 7—(Continued).**

4,593,710. VELCON FILTERS, LLC, COLORADO SPRINGS, CO. SN 85-845,183. PUB. 10-15-2013, FILED 2-8-2013.



NO CLAIM IS MADE TO THE EXCLUSIVE RIGHT TO USE "CLEANDIESEL", APART FROM THE MARK AS SHOWN.

THE MARK CONSISTS OF THE TERMS "VELCON CLEANDIESEL" IN STYLIZED LETTERING, WITH THE WORD "VELCON" ON THE TOP, OFF CENTERED TO THE LEFT, IN SOLID, CAPITALIZED LETTERS, AND UNDERNEATH IS THE TERM "CLEANDIESEL", WITH THE WORD "CLEAN" IN CAPITALIZED, BLOCK LETTERS THAT ARE OUTLINED BUT NOT FILLED IN, AND THE WORD "DIESEL" IN SOLID TEXT WITH A CAPITAL "D" AND THE REMAINING LETTERS IN LOWER CASE.

FOR FUEL FILTRATION SYSTEMS COMPRISING FUEL FILTERS, FUEL FILTER HOUSINGS, FILTER VESSELS AND FUEL CONDITION MONITORING PRODUCTS (U.S. CLS. 13, 19, 21, 23, 31, 34 AND 35).

FIRST USE 8-31-2012; IN COMMERCE 8-31-2012.

---

4,593,813. WINTERS, GLENN, NEW LEBANON, NY. SN 85-907,606. PUB. 9-10-2013, FILED 4-18-2013.

## Wort Monster

THE MARK CONSISTS OF STANDARD CHARACTERS WITHOUT CLAIM TO ANY PARTICULAR FONT, STYLE, SIZE, OR COLOR.

NO CLAIM IS MADE TO THE EXCLUSIVE RIGHT TO USE "WORT", APART FROM THE MARK AS SHOWN.

FOR BEER MAKING MACHINES AND AERATED BEER MAKING MACHINES (U.S. CLS. 13, 19, 21, 23, 31, 34 AND 35).

FIRST USE 4-10-2013; IN COMMERCE 9-15-2013.

---

4,593,831. AMBUSH HEADS LLC, DBA AMBUSH HEADS, LLC, CLOVIS, CA. SN 85-915,879. PUB. 4-8-2014, FILED 4-26-2013.

## The Original WeedShark PRO

THE MARK CONSISTS OF STANDARD CHARACTERS WITHOUT CLAIM TO ANY PARTICULAR FONT, STYLE, SIZE, OR COLOR.

**CLASS 7—(Continued).**

NO CLAIM IS MADE TO THE EXCLUSIVE RIGHT TO USE "THE ORIGINAL", APART FROM THE MARK AS SHOWN. FOR LAWN AND GARDEN STRING TRIMMER SPOOLS (U.S. CLS. 13, 19, 21, 23, 31, 34 AND 35). FIRST USE 6-0-2013; IN COMMERCE 6-0-2013.

---

4,593,832. AMBUSH HEADS LLC, DBA AMBUSH HEADS, LLC, CLOVIS, CA. SN 85-915,889. PUB. 4-8-2014, FILED 4-26-2013.

The Original WeedShark  
MightyMax

THE MARK CONSISTS OF STANDARD CHARACTERS WITHOUT CLAIM TO ANY PARTICULAR FONT, STYLE, SIZE, OR COLOR.

NO CLAIM IS MADE TO THE EXCLUSIVE RIGHT TO USE "THE ORIGINAL", APART FROM THE MARK AS SHOWN.

FOR LAWN AND GARDEN STRING TRIMMER SPOOLS (U.S. CLS. 13, 19, 21, 23, 31, 34 AND 35). FIRST USE 6-0-2013; IN COMMERCE 6-0-2013.

---

4,593,874. MATRIX PACKAGING MACHINERY LLC, SAUKVILLE, WI. SN 85-924,967. PUB. 10-8-2013, FILED 5-7-2013.

METIS

THE MARK CONSISTS OF STANDARD CHARACTERS WITHOUT CLAIM TO ANY PARTICULAR FONT, STYLE, SIZE, OR COLOR.

FOR PACKAGING MACHINES (U.S. CLS. 13, 19, 21, 23, 31, 34 AND 35). FIRST USE 9-23-2013; IN COMMERCE 9-23-2013.

**CLASS 7—(Continued).**

4,593,925. ITT ENIDINE INC., ORCHARD PARK, NY. SN 85-936,870. PUB. 10-22-2013, FILED 5-20-2013.

ENICOTE

THE MARK CONSISTS OF STANDARD CHARACTERS WITHOUT CLAIM TO ANY PARTICULAR FONT, STYLE, SIZE, OR COLOR.

FOR INDUSTRIAL SHOCK ABSORBERS, NAMELY, IMPACT DAMPERS (U.S. CLS. 13, 19, 21, 23, 31, 34 AND 35).

FIRST USE 1-1-2012; IN COMMERCE 1-1-2012.

---

4,594,001. VEECO INSTRUMENTS INC., PLAINVIEW, NY. SN 85-947,907. PUB. 10-29-2013, FILED 5-31-2013.

GENXPLORE

THE MARK CONSISTS OF STANDARD CHARACTERS WITHOUT CLAIM TO ANY PARTICULAR FONT, STYLE, SIZE, OR COLOR.

FOR MOLECULAR BEAM EPITAXY SYSTEMS, NAMELY, MACHINERY FOR GROWING EPITAXIAL LAYERS ON SUBSTRATES, AND COMPONENT PARTS THEREFOR (U.S. CLS. 13, 19, 21, 23, 31, 34 AND 35).

FIRST USE 8-19-2013; IN COMMERCE 8-19-2013.

---

4,594,056. ALPHA TECHNOLOGY U.S.A. CORPORATION, DBA FUTURECOW, LONGWOOD, FL. SN 85-956,514. PUB. 11-5-2013, FILED 6-11-2013.



THE COLOR(S) GREEN, BLACK, PINK AND WHITE IS/ ARE CLAIMED AS A FEATURE OF THE MARK.

THE MARK CONSISTS OF THE WORD "FUTURE" IN GREEN STANDARD FONT WITH THE EXCEPTION OF THE "U" IN THE WORD "FUTURE" BEING A MORE STYLISH FONT. THE "U" IN THE WORD "FUTURE" FORMS THE UDDER OF A COW FROM THE REAR VIEW

**CLASS 7—(Continued).**

WITH THE COW'S HEAD LOOKING BACK. THE UDDER IS SHADED PINK WITH THE REST OF THE COW BEING BLACK AND WHITE; FOLLOWED DIRECTLY BY THE WORD "COW" IN BLACK STANDARD FONT WITH THE EXCEPTION OF THE "W" IN THE WORD "COW" BEING A MORE STYLISH FONT. THE "W" IN THE WORD "COW" FORMS THE UDDER OF A COW FROM THE REAR VIEW WITH THE COW'S HEAD LOOKING BACK. THE UDDER IS SHADED PINK WITH THE REST OF THE COW BEING BLACK AND WHITE.

FOR MACHINES FOR UDDER CLEANING AND WASHING OF DAIRY COWS (U.S. CLS. 13, 19, 21, 23, 31, 34 AND 35).

FIRST USE 5-31-2014; IN COMMERCE 5-31-2014.

---

4,594,127. ALUMINUMSOLUTION.COM, BRAZORIA, TX. SN 85-969,817. PUB. 12-3-2013, FILED 6-25-2013.

## The Ghost Deer Feeder

THE MARK CONSISTS OF STANDARD CHARACTERS WITHOUT CLAIM TO ANY PARTICULAR FONT, STYLE, SIZE, OR COLOR.

NO CLAIM IS MADE TO THE EXCLUSIVE RIGHT TO USE "DEER FEEDER", APART FROM THE MARK AS SHOWN.

FOR MECHANIZED FEEDERS FOR DEER; MECHANIZED LIVESTOCK FEEDERS (U.S. CLS. 13, 19, 21, 23, 31, 34 AND 35).

FIRST USE 2-1-2014; IN COMMERCE 2-1-2014.

---

4,594,267. MAYTAG PROPERTIES, LLC. ST. JOSEPH, MI. SN 86-029,886. PUB. 12-31-2013, FILED 8-6-2013.

## PowerBlast

THE MARK CONSISTS OF STANDARD CHARACTERS WITHOUT CLAIM TO ANY PARTICULAR FONT, STYLE, SIZE, OR COLOR.

FOR DISHWASHERS (U.S. CLS. 13, 19, 21, 23, 31, 34 AND 35).

FIRST USE 6-2-2014; IN COMMERCE 6-2-2014.

**CLASS 7—(Continued).**

4,594,291. THE TORO COMPANY, BLOOMINGTON, MN. SN 86-039,222. PUB. 4-8-2014, FILED 8-15-2013.

## QUICKFIND

THE MARK CONSISTS OF STANDARD CHARACTERS WITHOUT CLAIM TO ANY PARTICULAR FONT, STYLE, SIZE, OR COLOR.

OWNER OF U.S. REG. NOS. 2,967,845 AND 3,726,105.

FOR COMPONENT PARTS OF TURF CARE EQUIPMENT, NAMELY, AN ELECTRONIC CONTROL PANEL CONSOLE FOR THE OPERATION OF OUTDOOR POWER EQUIPMENT IN THE NATURE OF SPRAYERS (U.S. CLS. 13, 19, 21, 23, 31, 34 AND 35).

FIRST USE 2-0-2014; IN COMMERCE 2-0-2014.

---

4,594,400. VAUGHAN CO., INC., MONTESANO, WA. SN 86-085,386. PUB. 4-8-2014, FILED 10-8-2013.



NO CLAIM IS MADE TO THE EXCLUSIVE RIGHT TO USE "CHOPPER", APART FROM THE MARK AS SHOWN.

THE MARK CONSISTS OF A DEPICTION OF A MECHANICAL IMPELLER FOLLOWED BY THE WORD "CHOPPER" IN STYLIZED LETTERS. THE PUMP AND WORD ARE UNDERLINED.

FOR PUMPING MACHINES FOR LIQUIDS AND SLURRIES AND REPLACEMENT PARTS THEREFOR (U.S. CLS. 13, 19, 21, 23, 31, 34 AND 35).

FIRST USE 7-10-2013; IN COMMERCE 10-7-2013.

---

4,594,402. VAUGHAN CO., INC., MONTESANO, WA. SN 86-085,515. PUB. 3-4-2014, FILED 10-8-2013.



OWNER OF U.S. REG. NO. 2,813,550.

THE MARK CONSISTS OF A DEPICTION OF A MECHANICAL IMPELLER FOLLOWED BY THE WORD "ROTAMIX" IN STYLIZED LETTERS. THE IMPELLER AND WORD ARE UNDERLINED.

FOR PUMPING MACHINES FOR LIQUIDS AND SLURRIES AND REPLACEMENT PARTS THEREFOR (U.S. CLS. 13, 19, 21, 23, 31, 34 AND 35).

FIRST USE 7-10-2013; IN COMMERCE 10-7-2013.

**CLASS 7—(Continued).**

4,594,404. VAUGHAN CO., INC., MONTESANO, WA. SN 86-085,551. PUB. 3-4-2014, FILED 10-8-2013.



OWNER OF U.S. REG. NO. 2,717,956.  
THE MARK CONSISTS OF A DEPICTION OF A MECHANICAL IMPELLER FOLLOWED BY THE WORD "TRITON" IN STYLIZED LETTERS. THE PUMP AND WORD ARE UNDERLINED.

FOR PUMPING MACHINES FOR LIQUIDS AND SLURRIES AND REPLACEMENT PARTS THEREFOR (U.S. CLS. 13, 19, 21, 23, 31, 34 AND 35).

FIRST USE 7-10-2013; IN COMMERCE 10-7-2013.

4,594,405. VAUGHAN CO., INC., MONTESANO, WA. SN 86-085,588. PUB. 3-4-2014, FILED 10-8-2013.



OWNER OF U.S. REG. NO. 1,634,659.  
THE MARK CONSISTS OF A DEPICTION OF A VORTEX LOCATED ON AND COMPLETING THE UPPER LEFT CORNER OF THE LETTER "V" IN THE WORD "VAUGHAN". THE WORDS "UNMATCHED RELIABILITY" ARE SET FORTH ABOVE "VAUGHAN". THE WORDS ARE IN STYLIZED LETTERS.

FOR PUMPING MACHINES FOR LIQUIDS AND SLURRIES AND REPLACEMENT PARTS THEREFOR (U.S. CLS. 13, 19, 21, 23, 31, 34 AND 35).

FIRST USE 7-10-2013; IN COMMERCE 10-7-2013.

4,594,536. ALEGACY GROUP, LLC, WALLER, TX. SN 86-144,426. PUB. 4-29-2014, FILED 12-16-2013.

# ALEGACY

THE MARK CONSISTS OF STANDARD CHARACTERS WITHOUT CLAIM TO ANY PARTICULAR FONT, STYLE, SIZE, OR COLOR.

FOR GAS COMPRESSORS (U.S. CLS. 13, 19, 21, 23, 31, 34 AND 35).

FIRST USE 11-25-2013; IN COMMERCE 11-25-2013.

**CLASS 7—(Continued).**

4,594,537. ALEGACY GROUP, LLC, WALLER, TX. SN 86-144,430. PUB. 4-29-2014, FILED 12-16-2013.



THE MARK CONSISTS OF A STYLIZED CAPITAL "A" WITH THE WORD "LEGACY" TO THE RIGHT IN SMALLER CAPITAL LETTERS.

FOR GAS COMPRESSORS (U.S. CLS. 13, 19, 21, 23, 31, 34 AND 35).

FIRST USE 11-25-2013; IN COMMERCE 11-25-2013.

**CLASS 8—HAND TOOLS**

4,593,127. J. BAXTER BRINKMANN INTERNATIONAL CORPORATION, DALLAS, TX. SN 85-077,523. PUB. 6-14-2011, FILED 7-2-2010.

## MALIBU OUTDOOR LIVING

THE MARK CONSISTS OF STANDARD CHARACTERS WITHOUT CLAIM TO ANY PARTICULAR FONT, STYLE, SIZE, OR COLOR.

OWNER OF U.S. REG. NOS. 816,551, 3,424,575, AND OTHERS.

NO CLAIM IS MADE TO THE EXCLUSIVE RIGHT TO USE "OUTDOOR LIVING", APART FROM THE MARK AS SHOWN.

FOR HAND TOOLS, NAMELY, DIGGING TOOLS FOR BURYING CABLES IN THE NATURE OF TROWELS, FILES, ICE PICKS, TONGS, NON-ELECTRIC CAN OPENERS, PLIERS, FISH SCALERS, AND MEAT HOOKS; ACCESSORIES FOR GRILLING PRODUCTS, NAMELY, CLEANING TOOLS IN THE NATURE OF GRILL SCRAPERS AND HAND-OPERATED COMBINATION TOOLS COMPRISING A GRILL SCRAPER, SCRUBBER OR BRUSH (U.S. CLS. 23, 28 AND 44).

FIRST USE 5-19-2014; IN COMMERCE 5-19-2014.

4,593,221. PERIO, INC., DUBLIN, OH. SN 85-380,346. PUB. 12-20-2011, FILED 7-25-2011.

## BARBASOL

THE MARK CONSISTS OF STANDARD CHARACTERS WITHOUT CLAIM TO ANY PARTICULAR FONT, STYLE, SIZE, OR COLOR.



**CLASS 8—(Continued).**

OWNER OF U.S. REG. NOS. 135,022 AND 712,264.  
FOR DISPOSABLE RAZORS; RAZORS AND RAZOR  
BLADES (U.S. CLS. 23, 28 AND 44).  
FIRST USE 6-26-2014; IN COMMERCE 6-26-2014.

4,593,222. PERIO, INC., DUBLIN, OH. SN 85-380,350. PUB. 12-  
20-2011, FILED 7-25-2011.

**PURE SILK**

THE MARK CONSISTS OF STANDARD CHARACTERS  
WITHOUT CLAIM TO ANY PARTICULAR FONT, STYLE,  
SIZE, OR COLOR.

OWNER OF U.S. REG. NO. 1,956,686.  
FOR DISPOSABLE RAZORS; RAZORS AND RAZOR  
BLADES (U.S. CLS. 23, 28 AND 44).  
FIRST USE 6-26-2014; IN COMMERCE 6-26-2014.

4,593,338. STEPHEN WALDEN, PHOENIX, AZ. SN 85-634,794.  
PUB. 11-6-2012, FILED 5-24-2012.

**Handle-It**

THE MARK CONSISTS OF STANDARD CHARACTERS  
WITHOUT CLAIM TO ANY PARTICULAR FONT, STYLE,  
SIZE, OR COLOR.

FOR HAND TOOLS, NAMELY, SHOVELS, SNOW  
SHOVELS, RAKES, HOES, AND TROWELS, WEEDING  
FORKS, AND SPADES (U.S. CLS. 23, 28 AND 44).  
FIRST USE 9-11-2013; IN COMMERCE 9-11-2013.

4,593,373. BEAUTY HOLDING LLC, DENTON, TX. SN 85-  
656,559. PUB. 7-30-2013, FILED 6-20-2012.

**STYLER HD**

THE MARK CONSISTS OF STANDARD CHARACTERS  
WITHOUT CLAIM TO ANY PARTICULAR FONT, STYLE,  
SIZE, OR COLOR.

NO CLAIM IS MADE TO THE EXCLUSIVE RIGHT TO  
USE "STYLER", APART FROM THE MARK AS SHOWN.  
FOR ELECTRIC IRONS FOR STYLING HAIR (U.S.  
CLS. 23, 28 AND 44).  
FIRST USE 9-18-2012; IN COMMERCE 9-18-2012.

**CLASS 8—(Continued).**

4,593,551. EB GIFTWARE LLC, ELMSFORD, NY. SN 85-  
781,664. PUB. 11-5-2013, FILED 11-16-2012.

**The Ice Terminator**

THE MARK CONSISTS OF STANDARD CHARACTERS  
WITHOUT CLAIM TO ANY PARTICULAR FONT, STYLE,  
SIZE, OR COLOR.

NO CLAIM IS MADE TO THE EXCLUSIVE RIGHT TO  
USE "ICE", APART FROM THE MARK AS SHOWN.

FOR HAND HELD ICE SCRAPER (U.S. CLS. 23, 28  
AND 44).

FIRST USE 3-6-2013; IN COMMERCE 8-21-2013.

4,593,694. DEBRA ALOUISE, SAN DIEGO, CA. SN 85-837,066.  
PUB. 7-9-2013, FILED 1-30-2013.

**File Wise Nail File "Don't  
Poke Your Fingers & Toes"**

THE MARK CONSISTS OF STANDARD CHARACTERS  
WITHOUT CLAIM TO ANY PARTICULAR FONT, STYLE,  
SIZE, OR COLOR.

NO CLAIM IS MADE TO THE EXCLUSIVE RIGHT TO  
USE "FILE" AND "NAIL FILE", APART FROM THE MARK  
AS SHOWN.

FOR NAIL FILES (U.S. CLS. 23, 28 AND 44).

FIRST USE 5-7-2014; IN COMMERCE 5-10-2014.

4,593,722. SPELLBINDERS PAPER ARTS COMPANY, LLC,  
PHOENIX, AZ. SN 85-849,161. PUB. 10-29-2013, FILED 2-13-  
2013.

**ARTISAN X-PLORER**

THE MARK CONSISTS OF STANDARD CHARACTERS  
WITHOUT CLAIM TO ANY PARTICULAR FONT, STYLE,  
SIZE, OR COLOR.

NO CLAIM IS MADE TO THE EXCLUSIVE RIGHT TO  
USE "ARTISAN", APART FROM THE MARK AS SHOWN.

FOR HAND OPERATED PRESS FOR DIE CUTTING  
AND EMBOSING (U.S. CLS. 23, 28 AND 44).

FIRST USE 12-0-2012; IN COMMERCE 1-15-2013.

**CLASS 8—(Continued).**

4,593,814. PROTOGENZ LLC., CARNATION, WA. SN 85-908,792. PUB. 9-10-2013, FILED 4-18-2013.

# RotoCinch

THE MARK CONSISTS OF STANDARD CHARACTERS WITHOUT CLAIM TO ANY PARTICULAR FONT, STYLE, SIZE, OR COLOR.

FOR MANUALLY-OPERATED WINCHES (U.S. CLS. 23, 28 AND 44).

FIRST USE 1-1-2014; IN COMMERCE 6-1-2014.

---

4,593,875. STORY, DANA, WESTLAKE VILLAGE, CA. SN 85-925,065. PUB. 10-8-2013, FILED 5-7-2013.

# THERMATRU

THE MARK CONSISTS OF STANDARD CHARACTERS WITHOUT CLAIM TO ANY PARTICULAR FONT, STYLE, SIZE, OR COLOR.

FOR ELECTRIC IRONS FOR STYLING HAIR; INFRARED HEAT COMPONENT SOLD AS A FEATURE OF ELECTRIC IRONS FOR STYLING HAIR (U.S. CLS. 23, 28 AND 44).

FIRST USE 6-5-2013; IN COMMERCE 6-5-2013.

---

4,593,913. FARRELL, ROBERT, WALL, NJ. SN 85-935,193. PUB. 10-15-2013, FILED 5-17-2013.

# MAXXIMUS-REXX

THE MARK CONSISTS OF STANDARD CHARACTERS WITHOUT CLAIM TO ANY PARTICULAR FONT, STYLE, SIZE, OR COLOR.

FOR HAND TOOLS, NAMELY, ADZES (U.S. CLS. 23, 28 AND 44).

FIRST USE 5-16-2013; IN COMMERCE 5-16-2013.

**CLASS 8—(Continued).**

4,594,108. GAMO OUTDOOR USA, INC., FORT LAUDERDALE, FL. SN 85-964,436. PUB. 11-5-2013, FILED 6-19-2013.

# JOKER

THE MARK CONSISTS OF STANDARD CHARACTERS WITHOUT CLAIM TO ANY PARTICULAR FONT, STYLE, SIZE, OR COLOR.

FOR KNIVES FOR HUNTING AND SPORT (U.S. CLS. 23, 28 AND 44).

FIRST USE 9-13-2013; IN COMMERCE 9-13-2013.

---

4,594,442. KELLER MANUFACTURING COMPANY, DBA GARDEX, ST. LOUIS, MO. SN 86-098,520. PUB. 4-8-2014, FILED 10-22-2013.

# GARDEX DISASTER CLEAN-UP RAKE

THE MARK CONSISTS OF STANDARD CHARACTERS WITHOUT CLAIM TO ANY PARTICULAR FONT, STYLE, SIZE, OR COLOR.

OWNER OF U.S. REG. NOS. 1,737,962 AND 2,259,165.

NO CLAIM IS MADE TO THE EXCLUSIVE RIGHT TO USE "DISASTER CLEAN-UP RAKE", APART FROM THE MARK AS SHOWN.

FOR RAKES (U.S. CLS. 23, 28 AND 44).

FIRST USE 3-19-2014; IN COMMERCE 3-19-2014.

---

**CLASS 9—ELECTRICAL AND SCIENTIFIC APPARATUS**

**CLASS 9—(Continued).**

4,593,065. ESSLOR OF AMERICA, INC., DALLAS, TX. SN 76-708,638. PUB. 10-29-2013, FILED 8-8-2011.



THE MARK CONSISTS OF STANDARD CHARACTERS WITHOUT CLAIM TO ANY PARTICULAR FONT, STYLE, SIZE, OR COLOR.

FOR CHEMICALS FOR MAKING TRANSPARENT OPTICAL LENSES SOLD AS AN INTEGRAL COMPONENT OF EYEGLASS LENSES; CURABLE ARTIFICIAL RESINS FOR MAKING TRANSPARENT OPTICAL LENSES SOLD AS AN INTEGRAL COMPONENT OF EYEGLASS LENSES; AND NATURAL RESIN THAT OCCURS NATURALLY AS A RESIN IN NATURE SOLD AS AN INTEGRAL COMPONENT OF EYEGLASS LENSES (U.S. CLS. 21, 23, 26, 36 AND 38).

FIRST USE 9-20-2011; IN COMMERCE 9-20-2011.

---

4,593,078. RCF S.P.A., 42124 REGGIO EMILIA, ITALY. SN 77-725,023. PUB. 1-21-2014, FILED 4-29-2009.



THE MARK CONSISTS OF THE STYLIZED LETTERS "TT" WITH A PLUS SIGN.

FOR HIGH FIDELITY VIDEO PRODUCTS COMPRISING VIDEO MONITORS; COMPACT DISC PLAYERS; COMPACT DISC REMOTE CONTROLS AND STRUCTURAL PARTS THEREFOR; HIGH FIDELITY SOUND REPRODUCTION AND HOME CINEMA EQUIPMENT, NAMELY, AMPLIFIERS, PRE-AMPLIFIERS, AUDIO AND VIDEO RECEIVERS, STEREO AND TELEVISION TUNERS, RADIOS AND LOUDSPEAKERS; DVD-PLAYERS, SOUND PROCESSORS (U.S. CLS. 21, 23, 26, 36 AND 38).

FIRST USE 6-14-2006; IN COMMERCE 6-14-2006.

**CLASS 9—(Continued).**

4,593,080. RELATIVITY MEDIA, LLC, BEVERLY HILLS, CA. SN 77-765,692. PUB. 5-18-2010, FILED 6-23-2009.

## RELATIVITY MEDIA

THE MARK CONSISTS OF STANDARD CHARACTERS WITHOUT CLAIM TO ANY PARTICULAR FONT, STYLE, SIZE, OR COLOR.

NO CLAIM IS MADE TO THE EXCLUSIVE RIGHT TO USE "MEDIA", APART FROM THE MARK AS SHOWN.

FOR AUDIO RECORDINGS FEATURING MUSIC; COMPACT DISCS FEATURING MUSIC; COMPUTER GAME SOFTWARE; COMPUTER PROGRAMS FOR VIDEO AND COMPUTER GAMES; COMPUTER SOFTWARE FEATURING MUSICAL SOUND RECORDINGS AND MUSICAL VIDEO RECORDINGS; COMPUTER SOFTWARE THAT PROVIDES WEB-BASED ACCESS TO APPLICATIONS AND SERVICES THROUGH A WEB OPERATING SYSTEM OR PORTAL INTERFACE; DIGITAL MUSIC DOWNLOADABLE FROM THE INTERNET; DOWNLOADABLE FILMS AND TELEVISION PROGRAMS FEATURING ACTION, ADVENTURE, COMPETITION, FAMILY, FASHION, LIFESTYLES, MYSTERY, NEWS, FILM NOIR, COMEDY, DRAMA, WESTERNS, WAR, DANCE, CRIME, HISTORICAL, BIOGRAPHICAL, SUSPENSE, THRILLER, FANTASY, HORROR, MUSIC, SPORTS, MUSICALS, ROMANCE, REALITY, SCIENCE FICTION, EDUCATIONAL, DOCUMENTARY, MOCKUMENTARY AND ANIMATION TOPICS AND THEMES PROVIDED VIA A VIDEO-ON-DEMAND SERVICE; DOWNLOADABLE MP3 FILES AND MP3 RECORDINGS FEATURING MOVIES, SHOWS, GAMES AND MUSIC; DOWNLOADABLE MULTIMEDIA FILE CONTAINING ARTWORK, TEXT, AUDIO, VIDEO, GAMES, AND INTERNET WEB LINKS RELATING TO SPORTS, POP CULTURE, TELEVISION, NEWS, FASHION, CULTURE, ENTERTAINMENT, MEDIA, THE ARTS, COMEDY, HISTORY, MUSIC AND LIFESTYLES; DOWNLOADABLE MUSICAL SOUND RECORDINGS; DOWNLOADABLE VIDEO RECORDINGS FEATURING MOVIES, SHOWS, GAMES AND MUSIC; DOWNLOADABLE MOVIES, SHOWS, MULTIMEDIA, AUDIO, VIDEO, GAMES AND MUSIC VIA THE INTERNET AND WIRELESS DEVICES; ELECTRONIC GAME PROGRAMS; ELECTRONIC GAME SOFTWARE; GAME SOFTWARE; INTERACTIVE MULTIMEDIA COMPUTER GAME PROGRAM; INTERACTIVE VIDEO GAME PROGRAMS; MUSICAL SOUND RECORDINGS; MUSICAL VIDEO RECORDINGS; VIDEO AND COMPUTER GAME PROGRAMS; VIDEO GAME CARTRIDGES AND DISCS; VIDEO GAME SOFTWARE; VIRTUAL REALITY GAME SOFTWARE (U.S. CLS. 21, 23, 26, 36 AND 38).

FIRST USE 4-28-2006; IN COMMERCE 4-28-2006.

---

4,593,103. AEROVIRONMENT, INC., MONROVIA, CA. SN 85-052,971. PUB. 5-10-2011, FILED 6-2-2010.

## AEROVIRONMENT

THE MARK CONSISTS OF STANDARD CHARACTERS WITHOUT CLAIM TO ANY PARTICULAR FONT, STYLE, SIZE, OR COLOR.

**CLASS 9—(Continued).**

OWNER OF U.S. REG. NOS. 1,999,292, 3,535,416, AND 3,600,261.

FOR ELECTRIC VEHICLE BATTERY CHARGING APPARATUS AND PARTS THEREFOR (U.S. CLS. 21, 23, 26, 36 AND 38).

FIRST USE 3-31-2010; IN COMMERCE 3-31-2010.

**CLASS 9—(Continued).**

4,593,151. MURRAY SALES, INC., MONTREAL, CANADA. SN 85-183,776. PUB. 11-8-2011, FILED 11-23-2010.

4,593,105. AEROVIRONMENT, INC., MONROVIA, CA. SN 85-053,233. PUB. 5-10-2011, FILED 6-2-2010.



OWNER OF U.S. REG. NOS. 1,999,292, 3,535,416, AND 3,600,261.

THE MARK CONSISTS OF STYLIZED UPPER CASE LETTERS "AV" ABOVE LOWER CASE WORD "AEROVIR-ONMENT".

FOR ELECTRIC VEHICLE BATTERY CHARGING APPARATUS AND PARTS THEREFOR (U.S. CLS. 21, 23, 26, 36 AND 38).

FIRST USE 3-31-2010; IN COMMERCE 3-31-2010.

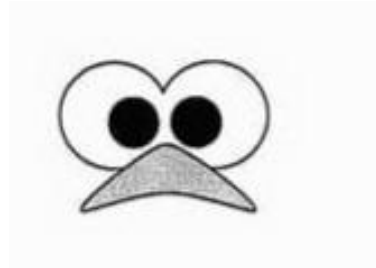

THE MARK CONSISTS OF THE DESIGN OF TWO EYES AND A BEAK.

FOR EGG TIMERS (U.S. CLS. 21, 23, 26, 36 AND 38). FIRST USE 5-30-2014; IN COMMERCE 5-30-2014.

4,593,154. MODKIT, LLC, CAMBRIDGE, MA. SN 85-184,951. PUB. 4-19-2011, FILED 11-24-2010.

4,593,131. GUIDEPOSTS A CHURCH CORPORATION, DAN-BURY, CT. SN 85-083,332. PUB. 4-26-2011, FILED 7-13-2010.

**HOPE SPRINGS**

THE MARK CONSISTS OF STANDARD CHARACTERS WITHOUT CLAIM TO ANY PARTICULAR FONT, STYLE, SIZE, OR COLOR.

FOR CARRYING CASES FOR LAPTOPS AND E-BOOKS (U.S. CLS. 21, 23, 26, 36 AND 38).

FIRST USE 5-31-2011; IN COMMERCE 5-31-2011.

**MODKIT**

THE MARK CONSISTS OF STANDARD CHARACTERS WITHOUT CLAIM TO ANY PARTICULAR FONT, STYLE, SIZE, OR COLOR.

FOR COMPUTER HARDWARE AND RELATED USER MANUALS DISTRIBUTED THEREWITH; COMPUTER SOFTWARE DEVELOPMENT TOOLS AND RELATED USER MANUALS DISTRIBUTED THEREWITH; COMPUTER SOFTWARE FOR THE ELECTRONIC DESIGN OF COMPUTER HARDWARE, NAMELY, PRINTED CIRCUIT BOARDS AND OTHER ELECTRONIC SYSTEMS, AND RELATED USER MANUALS DISTRIBUTED THEREWITH (U.S. CLS. 21, 23, 26, 36 AND 38).

FIRST USE 5-31-2011; IN COMMERCE 5-31-2011.

**CLASS 9—(Continued).**

4,593,179. FLIR SYSTEMS, INC., WILSONVILLE, OR. SN 85-230,525. PUB. 6-21-2011, FILED 1-31-2011.

# LEPTON

THE MARK CONSISTS OF STANDARD CHARACTERS WITHOUT CLAIM TO ANY PARTICULAR FONT, STYLE, SIZE, OR COLOR.

FOR OPTICAL, CINEMATOGRAPHIC, AND PHOTOGRAPHIC APPARATUS AND INSTRUMENTS, NAMELY, MICROBOLOMETER BASED INFRARED CAMERAS COMPRISED OF MICROBOLOMETER FOCAL PLANE ARRAYS (FPAS), PROCESSING ELECTRONICS, A CALIBRATION DEVICE AND LENS; CAMERA APPARATUS FOR DETECTING, MEASURING, RECORDING, TRANSMITTING, ANALYZING, AND REPRODUCING IMAGES, NAMELY, MICROBOLOMETER BASED INFRARED CAMERAS COMPRISED OF MICROBOLOMETER FOCAL PLANE ARRAYS (FPAS), PROCESSING ELECTRONICS, A CALIBRATION DEVICE AND LENS; IMAGING SYSTEMS COMPRISING MICROBOLOMETER BASED INFRARED CAMERAS COMPRISED OF MICROBOLOMETER FOCAL PLANE ARRAYS (FPAS), PROCESSING ELECTRONICS, A CALIBRATION DEVICE AND LENS; IMAGE PROCESSING HARDWARE AND SOFTWARE (U.S. CLS. 21, 23, 26, 36 AND 38).

FIRST USE 1-6-2014; IN COMMERCE 3-31-2014.

4,593,184. CAPCOM GAME STUDIO VANCOUVER, INC., BRITISH COLUMBIA, CANADA. SN 85-263,300. PUB. 10-8-2013, FILED 3-10-2011.



THE COLOR(S) BLUE AND YELLOW IS/ARE CLAIMED AS A FEATURE OF THE MARK.

**CLASS 9—(Continued).**

THE MARK CONSISTS OF THE LETTERS "C" AND "V" INSIDE A THREE-DIMENSIONAL BOX. THE LETTERS "C" AND "V" APPEAR IN BLUE AND ARE OUTLINED IN YELLOW. THE BOX APPEARS IN BLUE AND IS OUTLINED IN YELLOW.

FOR COMPUTER GAME SOFTWARE; COMPUTER GAMES IN THE FORM OF CARTRIDGES, CASSETTES, DISCS OR TAPES; VIDEO GAME CARTRIDGES; VIDEO GAME MACHINES FOR USE WITH TELEVISION RECEIVERS; DOWNLOADABLE GAME SOFTWARE; DOWNLOADABLE COMPUTER GAMES; DOWNLOADABLE GAME PROGRAM FOR PLAYING ON MOBILE PHONES; DOWNLOADABLE GAME SOFTWARE FOR PLAYING ON MOBILE PHONES; SCREEN SAVER SOFTWARE AND WALLPAPER SOFTWARE; DOWNLOADABLE SCREEN SAVER SOFTWARE AND WALLPAPER SOFTWARE FOR MOBILE PHONES; DOWNLOADABLE GRAPHICS AND MUSIC VIA A GLOBAL COMPUTER NETWORK; DOWNLOADABLE GRAPHICS, MUSIC AND RING TONES FOR MOBILE PHONES (U.S. CLS. 21, 23, 26, 36 AND 38).

FIRST USE 10-11-2011; IN COMMERCE 10-11-2011.

4,593,190. SANDISK ENTERPRISE IP LLC, MILPITAS, CA. SN 85-299,471. PUB. 6-28-2011, FILED 4-20-2011.

# FLASHGUARD

THE MARK CONSISTS OF STANDARD CHARACTERS WITHOUT CLAIM TO ANY PARTICULAR FONT, STYLE, SIZE, OR COLOR.

FOR SOLID STATE DRIVES (U.S. CLS. 21, 23, 26, 36 AND 38).

FIRST USE 10-13-2011; IN COMMERCE 10-13-2011.

4,593,193. IGT, RENO, NV. SN 85-303,914. PUB. 8-23-2011, FILED 4-25-2011.

# MISS RED

THE MARK CONSISTS OF STANDARD CHARACTERS WITHOUT CLAIM TO ANY PARTICULAR FONT, STYLE, SIZE, OR COLOR.

FOR GAMING MACHINES, NAMELY, DEVICES WHICH ACCEPT A WAGER (U.S. CLS. 21, 23, 26, 36 AND 38).

FIRST USE 4-4-2012; IN COMMERCE 4-4-2012.

**CLASS 9—(Continued).**

4,593,198. ABBOTT INFORMATICS CORPORATION, HOLLYWOOD, FL. SN 85-323,171. PUB. 5-15-2012, FILED 5-17-2011.

**STARLIMS FUSION**

THE MARK CONSISTS OF STANDARD CHARACTERS WITHOUT CLAIM TO ANY PARTICULAR FONT, STYLE, SIZE, OR COLOR.

OWNER OF U.S. REG. NO. 3,173,865.

FOR SOFTWARE PROGRAMS SPECIFICALLY FOR USE IN RESEARCH AND DIAGNOSTIC LABORATORIES, IN PARTICULAR TO ENABLE DATA INTERFACING BETWEEN LABORATORY INSTRUMENTS AND APPARATUS AND LABORATORY INFORMATION SYSTEMS, BILLING SYSTEMS, PHYSICIAN PRACTICES, DOCUMENT IMAGING SYSTEMS, RESEARCH SOFTWARE, LABORATORY INFORMATION MANAGEMENT SYSTEMS, HOSPITAL INFORMATION SYSTEMS, ELECTRONIC MEDICAL RECORDS, BLOOD BANK SYSTEMS, PATHOLOGY SYSTEMS, PATIENT TESTING DEVICES, PATIENT ADMINISTRATION SYSTEMS, CLINICAL TRIAL MANAGEMENT SYSTEMS, ELECTRONIC DATA CAPTURE SYSTEMS, MIDDLEWARE SYSTEMS, LABORATORY AUTOMATION SYSTEMS, INTERFACE ENGINES, FLEXIBLE INTERFACE ENGINES, RFID INTERFACES, TEMPERATURE MONITORING SYSTEMS, EQUIPMENT MONITORING SYSTEMS, PRINTERS, BARCODE PRINTERS, DATA MANAGEMENT SYSTEMS, PDF FILES, PARSING SYSTEMS, COMPUTER SPREADSHEET FILES, COMMA SEPARATED VALUE FILES, FLAT FILES, CANCER APPLICATIONS CHECKLISTS, PORTABLE MEDICAL ANALYZERS, STATISTICAL ANALYSIS SOFTWARE, ENTERPRISE RESOURCE MANAGEMENT SYSTEMS, ENTERPRISE SOFTWARE FOR MANAGING BUSINESS PROCESSES AND CUSTOMER RELATIONS, ENTERPRISE RESOURCE PLANNING SOFTWARE, MACHINES USED FOR INTERFACE MONITORING, DATA LOGGERS, COMPUTER HARDWARE DEVICES RECEIVING DATA, MANUFACTURING RESOURCE PLANNING SOFTWARE AND AUTOMATED WAREHOUSING TOOLS (U.S. CLS. 21, 23, 26, 36 AND 38).

FIRST USE 5-31-2012; IN COMMERCE 5-31-2012.

**CLASS 9—(Continued).**

4,593,208. KCD, INC., MULTIDISCIPLINED CREATIVE SOURCE, WILLIAMSTOWN, KY. SN 85-344,755. PUB. 11-1-2011, FILED 6-13-2011.

**Mindful Me**

THE MARK CONSISTS OF STANDARD CHARACTERS WITHOUT CLAIM TO ANY PARTICULAR FONT, STYLE, SIZE, OR COLOR.

FOR DOWNLOADABLE ELECTRONIC PUBLICATIONS, NAMELY, BOOKS, GUIDEBOOKS, EDUCATIONAL CURRICULA, AND DIGITALLY-RECORDED MATERIALS, NAMELY, DOWNLOADABLE AUDIO AND MULTIMEDIA FILES, DOWNLOADABLE INTERACTIVE MULTIMEDIA FILES, AND EDUCATIONAL SOFTWARE, ALL THE FOREGOING FEATURING A COMBINATION OF THE SUBJECTS OF DEVELOPMENTAL PSYCHOLOGY, CHILD DEVELOPMENT AND PROGRESSIVE PARENTING TO ADVANCE KNOW-HOW FOR NURTURING OPTIMAL EMOTIONAL WELLNESS IN CHILDREN (U.S. CLS. 21, 23, 26, 36 AND 38).

FIRST USE 12-18-2006; IN COMMERCE 3-12-2014.

4,593,215. L-3 COMMUNICATIONS SECURITY AND DETECTION SYSTEMS, INC., WOBURN, MA. SN 85-370,443. PUB. 5-15-2012, FILED 7-13-2011.

**CX-Portal**

THE MARK CONSISTS OF STANDARD CHARACTERS WITHOUT CLAIM TO ANY PARTICULAR FONT, STYLE, SIZE, OR COLOR.

OWNER OF U.S. REG. NO. 3,444,407.

FOR X-RAY IMAGING INSPECTION SYSTEM COMPRISED OF X-RAY SCANNERS FOR SCREENING CARGO, VEHICLES AND CONTAINERS (U.S. CLS. 21, 23, 26, 36 AND 38).

FIRST USE 10-0-2013; IN COMMERCE 11-0-2013.

4,593,219. SCOSCHE INDUSTRIES, INC., OXNARD, CA. SN 85-376,371. PUB. 12-6-2011, FILED 7-20-2011.

**BOOMBARS**

THE MARK CONSISTS OF STANDARD CHARACTERS WITHOUT CLAIM TO ANY PARTICULAR FONT, STYLE, SIZE, OR COLOR.

FOR LOUDSPEAKERS WITH BUILT IN AMPLIFIERS (U.S. CLS. 21, 23, 26, 36 AND 38).

FIRST USE 4-0-2014; IN COMMERCE 4-0-2014.

**CLASS 9—(Continued).**

4,593,228. KEEPSAYK, LLC, CHICAGO, IL. SN 85-400,302. PUB. 1-24-2012, FILED 8-17-2011.



THE COLOR(S) BLACK AND WHITE IS/ARE CLAIMED AS A FEATURE OF THE MARK.

THE MARK CONSISTS OF THE WORD "KEEPSAYK" WITH THE WORD COMPONENT "KEEP" APPEARING IN WHITE LETTERING ADJACENT ON THE LEFT EMBODIED IN A BLACK CIRCLE, AND THE WORD COMPONENT "SAYK" APPEARING IN BLACK LETTERING ADJACENT ON THE RIGHT.

FOR COMPUTER SOFTWARE FOR ORGANIZING AND VIEWING DIGITAL IMAGES AND PHOTOGRAPHS; COMPUTER SOFTWARE FOR THE COLLECTION, EDITING, ORGANIZING, MODIFYING, BOOK MARKING, TRANSMISSION, STORAGE AND SHARING OF DATA AND INFORMATION (U.S. CLS. 21, 23, 26, 36 AND 38).

FIRST USE 6-26-2014; IN COMMERCE 6-26-2014.

---

4,593,234. QUALCOMM INCORPORATED, SAN DIEGO, CA. SN 85-435,038. PUB. 3-13-2012, FILED 9-29-2011.



THE COLOR(S) ORANGE, RED, BURGUNDY AND GREY IS/ARE CLAIMED AS A FEATURE OF THE MARK.

THE MARK CONSISTS OF THE LETTERS "IZAT" IN STYLIZED LETTERS WITH A PUSHPIN ABOVE THE LETTER "Z". THE LETTER "I" IS IN ORANGE, THE LETTERS "Z" AND "A" ARE IN SHADES OF RED, THE LETTER "T" AND THE HEAD OF THE PUSHPIN ARE IN SHADES OF BURGUNDY, AND THE PIN PORTION OF THE PUSHPIN AND ITS SHADOW ARE GREY.

FOR SILICON CHIPS; COMPUTER SOFTWARE FOR USE IN LOCATION TRACKING, CONTROLLING GLOBAL POSITIONING SYSTEM (GPS) APPLICATIONS, AND PROVIDING, GATHERING, AND STORING LOCATION DATA (U.S. CLS. 21, 23, 26, 36 AND 38).

FIRST USE 12-20-2012; IN COMMERCE 12-20-2012.

**CLASS 9—(Continued).**

4,593,253. ASSURED SOFTWARE LIMITED, KELOWNA, BC, CANADA. SN 85-480,155. PUB. 2-26-2013, FILED 11-23-2011.

ASSURED PACKOUT

THE MARK CONSISTS OF STANDARD CHARACTERS WITHOUT CLAIM TO ANY PARTICULAR FONT, STYLE, SIZE, OR COLOR.

PRIORITY CLAIMED UNDER SEC. 44(D) ON CANADA APPLICATION NO. 1550794, FILED 11-4-2011, REG. NO. TMA835298, DATED 10-29-2012, EXPIRES 10-29-2027.

NO CLAIM IS MADE TO THE EXCLUSIVE RIGHT TO USE "PACKOUT", APART FROM THE MARK AS SHOWN.

FOR COMPUTER SOFTWARE THAT CREATES ELECTRONIC DATABASES USED TO TRACK, LOG AND MANAGE THE REMOVAL AND REPLACEMENT OF CONTENTS, NAMELY, FROM RESTORATION PROJECTS WITHIN THE RESTORATION SERVICES INDUSTRY; DOWNLOADABLE ELECTRONIC PUBLICATIONS OFFERING INFORMATION IN THE FIELD OF COMPUTER SOFTWARE, NAMELY, BROCHURES, USER MANUALS AND PAMPHLETS (U.S. CLS. 21, 23, 26, 36 AND 38).

FIRST USE 7-22-2013; IN COMMERCE 7-22-2013.

---

4,593,261. UNIVERSAL CITY STUDIOS LLC, UNIVERSAL CITY, CA. SN 85-497,225. PUB. 11-20-2012, FILED 12-16-2011.



OWNER OF U.S. REG. NOS. 874,303, 4,135,572, AND OTHERS.

**CLASS 9—(Continued).**

THE MARK CONSISTS OF THE WORD "UNIVERSAL" SUPERIMPOSED UPON A STYLIZED GLOBE DESIGN.

FOR PRE-RECORDED DVDS AND CD ROM PROGRAMS FEATURING MOTION PICTURES AND TELEVISION PROGRAMS IN THE FIELDS OF ACTION, ADVENTURE, ANIMATION, COMEDY, DOCUMENTARY, DRAMA, FANTASY, HORROR, MUSICAL, MYSTERY, ROMANCE, SCIENCE FICTION, AND/OR WESTERN GENRES; PRE-RECORDED COMPUTER SOFTWARE PROGRAMS FEATURING MOTION PICTURES AND TELEVISION PROGRAMS IN THE FIELDS OF ACTION, ADVENTURE, ANIMATION, COMEDY, DOCUMENTARY, DRAMA, FANTASY, HORROR, MUSICAL, MYSTERY, ROMANCE, SCIENCE FICTION AND/OR WESTERN GENRES; DOWNLOADABLE VIDEOS, TELEVISION PROGRAMS AND MOTION PICTURE FILMS IN THE FIELDS OF ACTION, ADVENTURE, ANIMATION, COMEDY, DOCUMENTARY, DRAMA, FANTASY, HORROR, MUSICAL, MYSTERY, ROMANCE, SCIENCE FICTION AND/OR WESTERN GENRES; PRERECORDED COMPACT DISCS FEATURING MUSIC; INTERACTIVE MULTIMEDIA SOFTWARE PROGRAMS FEATURING EDUCATIONAL AND ENTERTAINMENT CONTENT FROM MOTION PICTURES AND TELEVISION PROGRAMS IN THE FIELDS OF ACTION, ADVENTURE, ANIMATION, COMEDY, DOCUMENTARY, DRAMA, FANTASY, HORROR, MUSICAL, MYSTERY, ROMANCE, SCIENCE FICTION AND/OR WESTERN GENRES; INTERACTIVE MULTI-MEDIA SOFTWARE FOR PLAYING GAMES (U.S. CLS. 21, 23, 26, 36 AND 38).

FIRST USE 4-30-2012; IN COMMERCE 4-30-2012.

**CLASS 9—(Continued).**

THE MARK CONSISTS OF THE WORD "UNIVERSAL" SUPERIMPOSED UPON A STYLIZED GLOBE DESIGN.

FOR PRE-RECORDED DVDS AND CD ROM PROGRAMS FEATURING MOTION PICTURES AND TELEVISION PROGRAMS IN THE FIELDS OF ACTION, ADVENTURE, ANIMATION, COMEDY, DOCUMENTARY, DRAMA, FANTASY, HORROR, MUSICAL, MYSTERY, ROMANCE, SCIENCE FICTION, AND/OR WESTERN GENRES; PRE-RECORDED COMPUTER SOFTWARE PROGRAMS FEATURING MOTION PICTURES AND TELEVISION PROGRAMS IN THE FIELDS OF ACTION, ADVENTURE, ANIMATION, COMEDY, DOCUMENTARY, DRAMA, FANTASY, HORROR, MUSICAL, MYSTERY, ROMANCE, SCIENCE FICTION AND/OR WESTERN GENRES; DOWNLOADABLE VIDEOS, TELEVISION PROGRAMS AND MOTION PICTURE FILMS IN THE FIELDS OF ACTION, ADVENTURE, ANIMATION, COMEDY, DOCUMENTARY, DRAMA, FANTASY, HORROR, MUSICAL, MYSTERY, ROMANCE, SCIENCE FICTION AND/OR WESTERN GENRES; PRERECORDED COMPACT DISCS FEATURING MUSIC; INTERACTIVE MULTIMEDIA SOFTWARE PROGRAMS FEATURING EDUCATIONAL AND ENTERTAINMENT CONTENT FROM MOTION PICTURES AND TELEVISION PROGRAMS IN THE FIELDS OF ACTION, ADVENTURE, ANIMATION, COMEDY, DOCUMENTARY, DRAMA, FANTASY, HORROR, MUSICAL, MYSTERY, ROMANCE, SCIENCE FICTION AND/OR WESTERN GENRES; INTERACTIVE MULTI-MEDIA SOFTWARE FOR PLAYING GAMES (U.S. CLS. 21, 23, 26, 36 AND 38).

FIRST USE 4-30-2012; IN COMMERCE 4-30-2012.

4,593,263. UNIVERSAL CITY STUDIOS LLC, UNIVERSAL CITY, CA. SN 85-497,838. PUB. 11-20-2012, FILED 12-16-2011.



OWNER OF U.S. REG. NOS. 874,303, 4,135,572, AND OTHERS.

4,593,286. OKI ELECTRIC INDUSTRY CO., LTD., TOKYO, JAPAN. SN 85-553,338. PUB. 8-13-2013, FILED 2-27-2012.

# OKI

OWNER OF U.S. REG. NOS. 1,578,683, 3,840,953, AND OTHERS.

THE MARK CONSISTS OF THE STYLIZED PRESENTATION OF THE TERM "OKI".

THE WORDING "OKI" HAS NO MEANING IN A FOREIGN LANGUAGE.

FOR FACSIMILE MACHINES; COMPUTER PERIPHERALS; ELECTRIC WIRES AND CABLES; PRINTED CIRCUIT BOARDS; REED SWITCH FOR USE WITH IC TESTERS, HOME SECURITY EQUIPMENT, HOME APPLIANCES SUCH AS REFRIGERATORS, WASHING MACHINES AND RICE COOKERS; ELECTRODE WIRE FOR ELECTRIC DISCHARGE MACHINES, NAMELY, MACHINES FOR CUTTING METALS AS THE WORKPIECES BY GENERATING AN ELECTRICAL DISCHARGE BETWEEN THE METALS AND THE WIRE AS ELECTRODES WHICH IS CONTINUOUSLY FED; PHOTOCOPIING MACHINES; COMPUTER PRINTERS; SCANNERS (U.S. CLS. 21, 23, 26, 36 AND 38).

FIRST USE 12-31-2004; IN COMMERCE 12-31-2004.



**CLASS 9—(Continued).**

4,593,291. EVEREADY BATTERY COMPANY, INC., ST. LOUIS, MO. SN 85-558,449. PUB. 5-8-2012, FILED 3-2-2012.

**CLASS 9—(Continued).**

4,593,301. GLOBAL CELLULAR, INC., ALPHARETTA, GA. SN 85-567,251. PUB. 9-18-2012, FILED 3-12-2012.

**THAT'S POSITIVENERGY**

THE MARK CONSISTS OF STANDARD CHARACTERS WITHOUT CLAIM TO ANY PARTICULAR FONT, STYLE, SIZE, OR COLOR.

FOR BATTERY CHARGERS (U.S. CLS. 21, 23, 26, 36 AND 38).

FIRST USE 2-10-2014; IN COMMERCE 2-10-2014.

**TRILOGY**

THE MARK CONSISTS OF STANDARD CHARACTERS WITHOUT CLAIM TO ANY PARTICULAR FONT, STYLE, SIZE, OR COLOR.

FOR CASES AND COVERS FOR WIRELESS DEVICES, NAMELY, PROTECTIVE COVERS AND CASES FOR CELL PHONES, PORTABLE MEDIA PLAYERS, ELECTRONIC READING DEVICES, AND PDAS (U.S. CLS. 21, 23, 26, 36 AND 38).

FIRST USE 3-31-2014; IN COMMERCE 3-31-2014.

4,593,297. MONSTER, INC., BRISBANE, CA. SN 85-564,424. PUB. 9-3-2013, FILED 3-8-2012.

**MONSTER DNA**

THE MARK CONSISTS OF STANDARD CHARACTERS WITHOUT CLAIM TO ANY PARTICULAR FONT, STYLE, SIZE, OR COLOR.

OWNER OF U.S. REG. NOS. 2,575,745, 3,761,292, AND OTHERS.

FOR HEADPHONES, HEADPHONE EARCUPS, HEADPHONE BANDS, HEADPHONE CABLES, AND INTERCHANGEABLE DECORATIVE HEADPHONE BANDS (U.S. CLS. 21, 23, 26, 36 AND 38).

FIRST USE 9-13-2012; IN COMMERCE 9-13-2012.

4,593,317. TWENTIETH CENTURY FOX FILM CORPORATION, LOS ANGELES, CA. SN 85-615,640. PUB. 10-2-2012, FILED 5-3-2012.

**HOW TO LIVE WITH YOUR  
PARENTS FOR THE REST OF  
YOUR LIFE**

4,593,298. KENKO TOKINA USA, INC., HUNTINGTON BEACH, CA. SN 85-565,971. PUB. 9-24-2013, FILED 3-9-2012.

**EVO**

THE MARK CONSISTS OF STANDARD CHARACTERS WITHOUT CLAIM TO ANY PARTICULAR FONT, STYLE, SIZE, OR COLOR.

FOR PORTABLE PHOTOGRAPHY EQUIPMENT, NAMELY, OPTICAL GLASS FILTERS, UV FILTERS, PROTECTOR FILTERS AND CIRCULAR POLARIZER FILTERS (U.S. CLS. 21, 23, 26, 36 AND 38).

FIRST USE 3-0-2012; IN COMMERCE 3-0-2012.

THE MARK CONSISTS OF STANDARD CHARACTERS WITHOUT CLAIM TO ANY PARTICULAR FONT, STYLE, SIZE, OR COLOR.

FOR DOWNLOADABLE AUDIO AND VIDEO RECORDINGS FEATURING COMEDY; DOWNLOADABLE TELEVISION SHOWS AND VIDEO RECORDINGS FEATURING COMEDY (U.S. CLS. 21, 23, 26, 36 AND 38).

FIRST USE 4-4-2013; IN COMMERCE 4-4-2013.

**CLASS 9—(Continued).**

4,593,319. ECHOBIT, LLC, GOLDEN VALLEY, MN. SN 85-620,019. PUB. 4-30-2013, FILED 5-8-2012.

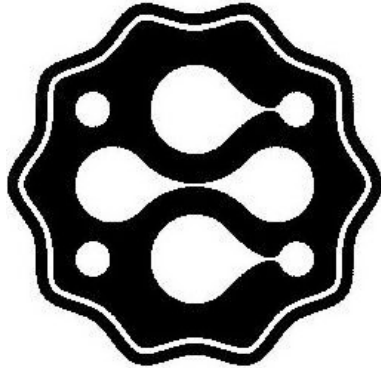

THE MARK CONSISTS OF A CIRCULAR SHAPE WITH A SCALLOPED EDGE, APPEARING AS A SEAL CONTAINING ABSTRACT SHAPES: TWO SMALL CIRCLES APPEAR WITHIN THE LEFT SIDE OF THE CIRCLE, TWO SHAPES RESEMBLING HORIZONTAL EXCLAMATION POINTS PLACED AT THE TOP AND BOTTOM AREAS OF THE CIRCLE, AND TWO HORIZONTAL TEARDROP SHAPES, APPEARING TO CONNECT AT THE TIPS, IN THE CENTER OF THE CIRCLE.

FOR COMPUTER GAME SOFTWARE FOR PERSONAL COMPUTING DEVICES AND VIDEO GAME CONSOLES; VIDEO GAME SOFTWARE (U.S. CLS. 21, 23, 26, 36 AND 38).

FIRST USE 1-0-2011; IN COMMERCE 1-0-2011.

4,593,320. ECHOBIT, LLC, GOLDEN VALLEY, MN. SN 85-620,031. PUB. 4-30-2013, FILED 5-8-2012.

**QUIT PLAYING WITH YOURSELF**

THE MARK CONSISTS OF STANDARD CHARACTERS WITHOUT CLAIM TO ANY PARTICULAR FONT, STYLE, SIZE, OR COLOR.

FOR COMPUTER GAME SOFTWARE FOR PERSONAL COMPUTING DEVICES AND VIDEO GAME CONSOLES; VIDEO GAME SOFTWARE (U.S. CLS. 21, 23, 26, 36 AND 38).

FIRST USE 9-12-2009; IN COMMERCE 9-12-2009.

**CLASS 9—(Continued).**

4,593,321. ECHOBIT, LLC, GOLDEN VALLEY, MN. SN 85-620,038. PUB. 4-23-2013, FILED 5-8-2012.

**DARWIN WAS A GAMER**

THE MARK CONSISTS OF STANDARD CHARACTERS WITHOUT CLAIM TO ANY PARTICULAR FONT, STYLE, SIZE, OR COLOR.

FOR COMPUTER GAME SOFTWARE FOR PERSONAL COMPUTING DEVICES AND VIDEO GAME CONSOLES; VIDEO GAME SOFTWARE (U.S. CLS. 21, 23, 26, 36 AND 38).

FIRST USE 12-0-2009; IN COMMERCE 12-0-2009.

4,593,328. AUCTION PROFILE ANALYTICS, LLC, NORFOLK, VA. SN 85-627,760. PUB. 10-23-2012, FILED 5-17-2012.

**AUCTION PROFILE**

THE MARK CONSISTS OF STANDARD CHARACTERS WITHOUT CLAIM TO ANY PARTICULAR FONT, STYLE, SIZE, OR COLOR.

NO CLAIM IS MADE TO THE EXCLUSIVE RIGHT TO USE "AUCTION", APART FROM THE MARK AS SHOWN.

FOR DOWNLOADABLE SOFTWARE FOR ANALYSIS OF STOCKS, OPTIONS, FUTURES, CURRENCIES, COMMODITIES, FOREIGN EXCHANGE AND OTHER TRADEABLE FINANCIAL INSTRUMENTS; DOWNLOADABLE SOFTWARE FOR ASSESSING AND EVALUATING TRADING DATA; DOWNLOADABLE SOFTWARE FOR EDUCATION AND TRAINING IN THE FIELDS OF STOCK, OPTION, FUTURES, CURRENCY, COMMODITY, FOREIGN EXCHANGE AND OTHER SECURITIES TRADING (U.S. CLS. 21, 23, 26, 36 AND 38).

FIRST USE 5-1-2014; IN COMMERCE 5-1-2014.

**CLASS 9—(Continued).**

4,593,355. XALT ENERGY, LLC, WILMINGTON, DE. SN 85-642,652. PUB. 4-30-2013, FILED 6-4-2012.

# XALT

THE MARK CONSISTS OF STANDARD CHARACTERS WITHOUT CLAIM TO ANY PARTICULAR FONT, STYLE, SIZE, OR COLOR.

FOR BATTERY PACKS; BATTERY SYSTEMS TO PROVIDE BACKUP POWER; BATTERY SYSTEMS COMPRISING LITHIUM-ION BATTERY CELLS, STRUCTURAL ENCLOSURES, THERMAL MANAGEMENT SYSTEMS AND CONTROL SYSTEMS (U.S. CLS. 21, 23, 26, 36 AND 38).

FIRST USE 3-5-2014; IN COMMERCE 3-5-2014.

4,593,362. PFIP, LLC, NEWINGTON, NH. SN 85-647,213. PUB. 5-14-2013, FILED 6-8-2012.



OWNER OF U.S. REG. NOS. 3,977,164, 3,989,040, AND 4,058,640.

THE COLOR(S) PURPLE, YELLOW, WHITE, AND BLACK IS/ARE CLAIMED AS A FEATURE OF THE MARK.

THE MARK CONSISTS OF WORDS AND GRAPHICS SURROUNDING THE SCREEN OF A COMPUTER MONITOR TERMINAL. THE PRECISE SHAPE OF THE OUTER FRAME OF THE MONITOR, AND THE INNER FRAME OF MONITOR'S SCREEN, DEPICTED IN BROKEN LINES, ARE NOT CLAIMED BUT SERVE ONLY TO SHOW THE PLACEMENT OF THE MARK. THE COLOR BLACK APPEARS IN THE DESIGN OF THE STYLIZED MECHANICAL GEARS BEHIND THE WORDS "PLANET FITNESS". THE COLOR WHITE APPEARS IN THE WORDING "PLANET FITNESS". THE COLOR YELLOW APPEARS IN THE LOWER LEFT AND RIGHT CORNERS OF THE BORDER, IN THE OVAL AT THE BOTTOM OF THE SCREEN, IN THE STYLIZED THUMBS, AND THE LETTERING "VISIONARY". THE COLOR PURPLE APPEARS IN THE BORDER AND IN THE CIRCLE INSIDE THE MECHANICAL GEARS.

FOR COMPUTER HARDWARE AND SOFTWARE, NAMELY, INTERACTIVE COMPUTER TERMINALS FEATURING SOFTWARE USED FOR DATA MANAGEMENT, COMMUNICATION, AND ADMINISTRATIVE MANAGEMENT IN THE FIELD OF HEALTH AND FITNESS TRAINING AND CLUBS (U.S. CLS. 21, 23, 26, 36 AND 38).

FIRST USE 8-27-2013; IN COMMERCE 8-27-2013.

**CLASS 9—(Continued).**

4,593,369. SIMPLIVITY CORPORATION, WESTBOROUGH, MA. SN 85-654,383. PUB. 11-13-2012, FILED 6-18-2012.

# OMNISTACK

THE MARK CONSISTS OF STANDARD CHARACTERS WITHOUT CLAIM TO ANY PARTICULAR FONT, STYLE, SIZE, OR COLOR.

FOR COMPUTER HARDWARE AND SOFTWARE FOR COMPUTER SERVER AND DATA STORAGE VIRTUALIZATION (U.S. CLS. 21, 23, 26, 36 AND 38).

FIRST USE 4-23-2013; IN COMMERCE 4-23-2013.

4,593,382. SKYERA, INC., SAN JOSE, CA. SN 85-660,719. PUB. 11-6-2012, FILED 6-25-2012.



THE MARK CONSISTS OF A BROKEN DIAMOND DESIGN SURROUNDING A SOLID DIAMOND DESIGN.

FOR SILICON CHIPS, COMPUTER SOFTWARE FOR ENTERPRISE SOLID-STATE STORAGE SYSTEMS (U.S. CLS. 21, 23, 26, 36 AND 38).

FIRST USE 12-0-2012; IN COMMERCE 12-0-2012.

4,593,387. JOSEPH F. BASMAJI, WATERFORD, MI. SN 85-665,800. PUB. 5-21-2013, FILED 6-29-2012.

# iKonnnect

THE MARK CONSISTS OF STANDARD CHARACTERS WITHOUT CLAIM TO ANY PARTICULAR FONT, STYLE, SIZE, OR COLOR.

THE WORDING "IKONNECT" HAS NO MEANING IN A FOREIGN LANGUAGE.

FOR CARRYING CASES FOR ELECTRONIC EQUIPMENT, NAMELY, CELL PHONES, PDA'S, CAMERAS (U.S. CLS. 21, 23, 26, 36 AND 38).

FIRST USE 5-2-2014; IN COMMERCE 5-26-2014.

**CLASS 9—(Continued).**

4,593,399. NCSTAR INC., CITY OF INDUSTRY, CA. SN 85-674,633. PUB. 8-27-2013, FILED 7-11-2012.

**NCSTAR**

THE MARK CONSISTS OF STANDARD CHARACTERS WITHOUT CLAIM TO ANY PARTICULAR FONT, STYLE, SIZE, OR COLOR.

OWNER OF U.S. REG. NO. 2,604,348.  
 FOR GOLF SCOPES; GUN SCOPES; OPTICAL LENS SIGHTS; OPTICAL OR TELESCOPIC LENS SIGHTS; RIFLE SCOPES; SPOTTING SCOPES; TACTICAL LASER SIGHTS; TELESCOPIC GUN SIGHTS; TELESCOPIC LENS SIGHTS; TELESCOPIC SIGHTS (U.S. CLS. 21, 23, 26, 36 AND 38).  
 FIRST USE 2-18-2013; IN COMMERCE 2-18-2013.

**CLASS 9—(Continued).**

4,593,416. BUDGET CASHFLOW KING LLC, CLIO, MI. SN 85-688,264. PUB. 5-7-2013, FILED 7-26-2012.



NO CLAIM IS MADE TO THE EXCLUSIVE RIGHT TO USE "BUDGET CASH FLOW", APART FROM THE MARK AS SHOWN.

THE MARK CONSISTS OF A CROWN WITH THE WORDS "BUDGET CASHFLOW" AND A DOLLAR SIGN ABOVE THE CROWN, THE WORD "KING" BELOW THE CROWN, AND FIREWORKS LEADING FROM THE CROWN.

FOR SOFTWARE TO MANAGE, PROJECT AND ANALYZE A BUDGET, A CASH-FLOW, AND A GLOBAL CASH-FLOW (U.S. CLS. 21, 23, 26, 36 AND 38).  
 FIRST USE 11-7-2012; IN COMMERCE 4-13-2014.

4,593,415. BUDGET CASHFLOW KING LLC, CLIO, MI. SN 85-688,260. PUB. 5-7-2013, FILED 7-26-2012.

**BUDGET CASHFLOW KING**

4,593,422. EARL J. PEQUEEN, WATSONVILLE, CA. SN 85-694,227. PUB. 1-8-2013, FILED 8-2-2012.

**ViewTube**

THE MARK CONSISTS OF STANDARD CHARACTERS WITHOUT CLAIM TO ANY PARTICULAR FONT, STYLE, SIZE, OR COLOR.

NO CLAIM IS MADE TO THE EXCLUSIVE RIGHT TO USE "BUDGET CASH FLOW", APART FROM THE MARK AS SHOWN.

FOR SOFTWARE TO MANAGE, PROJECT AND ANALYZE A BUDGET, A CASH-FLOW, AND A GLOBAL CASH-FLOW (U.S. CLS. 21, 23, 26, 36 AND 38).  
 FIRST USE 11-7-2012; IN COMMERCE 4-13-2014.

THE MARK CONSISTS OF STANDARD CHARACTERS WITHOUT CLAIM TO ANY PARTICULAR FONT, STYLE, SIZE, OR COLOR.

FOR VIEWFINDERS (U.S. CLS. 21, 23, 26, 36 AND 38).  
 FIRST USE 6-5-2012; IN COMMERCE 8-28-2013.

**CLASS 9—(Continued).**

4,593,428. DIGITS2WORDS, GREENCASTLE, IN. SN 85-704,775. PUB. 1-22-2013, FILED 8-15-2012.

# Digits2Words

THE MARK CONSISTS OF STANDARD CHARACTERS WITHOUT CLAIM TO ANY PARTICULAR FONT, STYLE, SIZE, OR COLOR.

FOR COMPUTER GAME SOFTWARE FOR USE ON MOBILE AND CELLULAR PHONES; VIDEO AND COMPUTER GAME PROGRAMS (U.S. CLS. 21, 23, 26, 36 AND 38).

FIRST USE 12-1-2012; IN COMMERCE 12-1-2012.

4,593,429. CHENG USA, INC., SOUTH SAN FRANCISCO, CA. SN 85-706,944. PUB. 2-12-2013, FILED 8-17-2012.

# Primecharge

THE MARK CONSISTS OF STANDARD CHARACTERS WITHOUT CLAIM TO ANY PARTICULAR FONT, STYLE, SIZE, OR COLOR.

FOR BATTERIES AND BATTERY CHARGERS; BATTERY CHARGE DEVICES; BATTERY CHARGERS; BATTERY MONITORS; BATTERY TESTERS; CHARGERS FOR BATTERIES; CHARGERS FOR ELECTRIC BATTERIES; CONSUMER ELECTRONIC PRODUCTS, NAMELY, AUDIO AMPLIFIERS, AUDIO SPEAKERS, AUDIO RECEIVERS, AUDIO DECODERS, VIDEO DECODERS, SPEAKERS, POWER CONVERSION DEVICES, POWER CONVERTERS, AND POWER INVERTERS; CONVERTERS; DC/AC POWER CONVERTERS; ELECTRIC CONVERTERS; ELECTRIC POWER CONVERTERS (U.S. CLS. 21, 23, 26, 36 AND 38).

FIRST USE 8-17-2012; IN COMMERCE 12-1-2013.

4,593,434. RICHARD WENDELL ARNESON III, RANCHO SANTA FE, CA. SN 85-710,474. PUB. 4-30-2013, FILED 8-22-2012.

# MAKAI PRESS

THE MARK CONSISTS OF STANDARD CHARACTERS WITHOUT CLAIM TO ANY PARTICULAR FONT, STYLE, SIZE, OR COLOR.

NO CLAIM IS MADE TO THE EXCLUSIVE RIGHT TO USE "PRESS", APART FROM THE MARK AS SHOWN.

**CLASS 9—(Continued).**

THE ENGLISH TRANSLATION OF "MAKAI" IN THE MARK IS "TOWARD OR BY THE SEA" OR "SEAWARD".

FOR ELECTRONIC PUBLICATIONS, NAMELY, DOWNLOADABLE E-BOOKS RELATING TO THE SPORT OF SAILING; ELECTRONIC PUBLICATIONS, NAMELY, BOOKS RELATING TO THE SPORT OF SAILING RECORDED ON COMPUTER MEDIA (U.S. CLS. 21, 23, 26, 36 AND 38).

FIRST USE 5-20-2014; IN COMMERCE 5-20-2014.

4,593,454. NOVASENTIS, INC., BURLINGAME, CA. SN 85-730,168. PUB. 2-19-2013, FILED 9-16-2012.

# CLIC

THE MARK CONSISTS OF STANDARD CHARACTERS WITHOUT CLAIM TO ANY PARTICULAR FONT, STYLE, SIZE, OR COLOR.

FOR APPARATUS AND INSTRUMENTS FOR CONDUCTING, SWITCHING, TRANSFORMING, ACCUMULATING, STORING, REGULATING OR CONTROLLING ELECTRICITY, NAMELY, ELECTRIC ACTUATORS FOR USE IN MOTION CONTROL; ELECTRIC ACTUATORS FEATURING HAPTIC TECHNOLOGY; ELECTRIC ACTUATORS FOR SIMULATING TACTILE FEEDBACK; ELECTRIC TRANSDUCERS; ELECTRICAL TRANSDUCERS FOR USE IN MOTION CONTROL; ELECTRIC ACTUATORS FEATURING ACOUSTIC TECHNOLOGY; ELECTRIC ACTUATORS FEATURING CAPACITIVE TECHNOLOGY; ELECTRIC ACTUATORS FEATURING SENSOR TECHNOLOGY (U.S. CLS. 21, 23, 26, 36 AND 38).

FIRST USE 1-2-2014; IN COMMERCE 1-2-2014.

4,593,464. NOK NOK LABS, INC., PALO ALTO, CA. SN 85-737,990. PUB. 6-4-2013, FILED 9-25-2012.

# NOK NOK LABS

THE MARK CONSISTS OF STANDARD CHARACTERS WITHOUT CLAIM TO ANY PARTICULAR FONT, STYLE, SIZE, OR COLOR.

**CLASS 9—(Continued).**

NO CLAIM IS MADE TO THE EXCLUSIVE RIGHT TO USE "LABS", APART FROM THE MARK AS SHOWN.

FOR COMPUTER SOFTWARE FOR USE IN COMPUTER NETWORK SECURITY AND COMPUTER NETWORK USER AUTHENTICATION; COMPUTER SOFTWARE FOR USE IN AUTHENTICATING COMPUTER USERS, COMPUTER HARDWARE, AND COMPUTER SOFTWARE, ALL FOR STORING AND TRANSMISSION OF ELECTRONIC DATA FOR USE AS A STRONG AUTHENTICATION IDENTIFICATION SYSTEM; COMPUTER SOFTWARE FOR USER AUTHENTICATION AND COMPUTER HARDWARE AUTHENTICATION FOR E-COMMERCE TRANSACTIONS, SENDING AND RECEIVING OF DIGITAL DATA, VOICE, MUSIC, AND VIDEO, AND FOR USER AUTHENTICATION AND COMPUTER HARDWARE AUTHENTICATION FOR ELECTRONIC FUNDS TRANSFER, CREDIT AND DEBIT CARD AND ELECTRONIC CHECK TRANSACTIONS VIA A GLOBAL COMPUTER NETWORK; COMPUTER SOFTWARE FOR OPERATING AND MANAGING BIOMETRIC OR SECURITY TOKEN COMPUTER SYSTEMS, TELEPHONES, AND COMMUNICATION HARDWARE; COMPUTER SOFTWARE FOR RESTRICTING ACCESS TO AND BY COMPUTERS, COMPUTER SOFTWARE, COMPUTER HARDWARE, COMPUTER USERS, AND COMPUTER NETWORKS WITH UNDESIREED WEB SITES, SOFTWARE AND COMPUTER HARDWARE (U.S. CLS. 21, 23, 26, 36 AND 38).

FIRST USE 3-27-2013; IN COMMERCE 3-27-2013.

---

4,593,465. NOK NOK LABS, INC., PALO ALTO, CA. SN 85-737,995. PUB. 6-4-2013, FILED 9-25-2012.

# NOK NOK

THE MARK CONSISTS OF STANDARD CHARACTERS WITHOUT CLAIM TO ANY PARTICULAR FONT, STYLE, SIZE, OR COLOR.

FOR COMPUTER SOFTWARE FOR USE IN COMPUTER NETWORK SECURITY AND COMPUTER NETWORK USER AUTHENTICATION; COMPUTER SOFTWARE FOR USE IN AUTHENTICATING COMPUTER USERS, COMPUTER HARDWARE, AND COMPUTER SOFTWARE, ALL FOR STORING AND TRANSMISSION OF ELECTRONIC DATA FOR USE AS A STRONG AUTHENTICATION IDENTIFICATION SYSTEM; COMPUTER SOFTWARE FOR USER AUTHENTICATION AND COMPUTER HARDWARE AUTHENTICATION FOR E-COMMERCE TRANSACTIONS, SENDING AND RECEIVING OF DIGITAL DATA, VOICE, MUSIC, AND VIDEO, AND FOR USER AUTHENTICATION AND COMPUTER HARDWARE AUTHENTICATION FOR ELECTRONIC FUNDS TRANSFER, CREDIT AND DEBIT CARD AND ELECTRONIC CHECK TRANSACTIONS VIA A GLOBAL COMPUTER NETWORK; COMPUTER SOFTWARE FOR OPERATING AND MANAGING BIOMETRIC OR SECURITY TOKEN COMPUTER SYSTEMS, TELEPHONES, AND COMMUNICATION HARDWARE; COMPUTER SOFTWARE FOR RESTRICTING ACCESS TO AND BY COMPUTERS, COMPUTER SOFTWARE, COMPUTER HARDWARE, COMPUTER USERS, AND COMPUTER NETWORKS WITH UNDESIREED WEB SITES, SOFTWARE AND COMPUTER HARDWARE (U.S. CLS. 21, 23, 26, 36 AND 38).

FIRST USE 10-15-2013; IN COMMERCE 10-15-2013.

**CLASS 9—(Continued).**

4,593,466. NOK NOK LABS, INC., PALO ALTO, CA. SN 85-737,999. PUB. 6-4-2013, FILED 9-25-2012.

# NNL

THE MARK CONSISTS OF STANDARD CHARACTERS WITHOUT CLAIM TO ANY PARTICULAR FONT, STYLE, SIZE, OR COLOR.

FOR COMPUTER SOFTWARE FOR USE IN COMPUTER NETWORK SECURITY AND COMPUTER NETWORK USER AUTHENTICATION; COMPUTER SOFTWARE FOR USE IN AUTHENTICATING COMPUTER USERS, COMPUTER HARDWARE, AND COMPUTER SOFTWARE, ALL FOR STORING AND TRANSMISSION OF ELECTRONIC DATA FOR USE AS A STRONG AUTHENTICATION IDENTIFICATION SYSTEM; COMPUTER SOFTWARE FOR USER AUTHENTICATION AND COMPUTER HARDWARE AUTHENTICATION FOR E-COMMERCE TRANSACTIONS, SENDING AND RECEIVING OF DIGITAL DATA, VOICE, MUSIC, AND VIDEO, AND FOR USER AUTHENTICATION AND COMPUTER HARDWARE AUTHENTICATION FOR ELECTRONIC FUNDS TRANSFER, CREDIT AND DEBIT CARD AND ELECTRONIC CHECK TRANSACTIONS VIA A GLOBAL COMPUTER NETWORK; COMPUTER SOFTWARE FOR OPERATING AND MANAGING BIOMETRIC OR SECURITY TOKEN COMPUTER SYSTEMS, TELEPHONES, AND COMMUNICATION HARDWARE; COMPUTER SOFTWARE FOR RESTRICTING ACCESS TO AND BY COMPUTERS, COMPUTER SOFTWARE, COMPUTER HARDWARE, COMPUTER USERS, AND COMPUTER NETWORKS WITH UNDESIREED WEB SITES, SOFTWARE AND COMPUTER HARDWARE (U.S. CLS. 21, 23, 26, 36 AND 38).

FIRST USE 3-19-2013; IN COMMERCE 3-19-2013.

---

4,593,467. PHILIGHT SOFTWARE INTERNATIONAL PTY LTD, MARANGAROO WA 6064, AUSTRALIA. SN 85-738,412. PUB. 6-4-2013, FILED 9-25-2012.



OWNER OF AUSTRALIA REG. NO. 1440963, DATED 8-5-2011, EXPIRES 8-5-2021.

THE COLOR(S) BLACK, GREEN, BLUE, PURPLE, ORANGE, RED, YELLOW AND PINK IS/ARE CLAIMED AS A FEATURE OF THE MARK.

THE MARK CONSISTS OF RAYS IN GREEN, BLUE, PURPLE, ORANGE, RED, YELLOW AND PINK TO THE RIGHT OF "SHARPERLIGHT" IN BLACK LETTERING.

FOR COMPUTER SOFTWARE, NAMELY, SOFTWARE PRODUCTS FOR BUSINESS APPLICATIONS, NAMELY, COMPUTER SOFTWARE FOR ANALYSIS AND REPORTING (U.S. CLS. 21, 23, 26, 36 AND 38).

FIRST USE 5-30-2013; IN COMMERCE 5-30-2013.

**CLASS 9—(Continued).**

4,593,476. SUPERGIANT GAMES, LLC, SAN FRANCISCO, CA. SN 85-745,220. PUB. 4-30-2013, FILED 10-3-2012.

**CLASS 9—(Continued).**

4,593,497. NAKIHEI, ROBERT, LYNNWOOD, WA. SN 85-759,351. PUB. 3-26-2013, FILED 10-20-2012.

**TRANSISTOR**

THE MARK CONSISTS OF STANDARD CHARACTERS WITHOUT CLAIM TO ANY PARTICULAR FONT, STYLE, SIZE, OR COLOR.

FOR COMPUTER GAME SOFTWARE; VIDEO GAME SOFTWARE; COMPUTER AND VIDEO GAME SOFTWARE FOR USE ON PERSONAL COMPUTERS; COMPUTER AND VIDEO GAME SOFTWARE FOR GAME CONSOLES; COMPUTER AND VIDEO GAME SOFTWARE FOR USE ON GLOBAL COMMUNICATIONS NETWORK CAPABLE AND CONNECTABLE SYSTEMS FOR INDIVIDUAL, PEER-TO-PEER, ONLINE AND MULTIPLAYER PLAY; COMPUTER GAME PROGRAMS FOR USE IN CONNECTION WITH SINGLE PLAYER AND MULTIPLAYER INTERACTIVE GAMES PLAYED OVER A GLOBAL COMMUNICATION NETWORK; COMPUTER GAME APPLICATION SOFTWARE FOR MOBILE PHONES, TABLET COMPUTERS AND OTHER WIRELESS ELECTRONIC DEVICES (U.S. CLS. 21, 23, 26, 36 AND 38).

FIRST USE 5-20-2014; IN COMMERCE 5-20-2014.

**Tribal Order**

THE MARK CONSISTS OF STANDARD CHARACTERS WITHOUT CLAIM TO ANY PARTICULAR FONT, STYLE, SIZE, OR COLOR.

FOR MUSICAL RECORDINGS (U.S. CLS. 21, 23, 26, 36 AND 38).

FIRST USE 11-1-2012; IN COMMERCE 11-1-2012.

4,593,483. PLAYDATE DIGITAL INC., NEW YORK, NY. SN 85-751,384. PUB. 4-30-2013, FILED 10-11-2012.



NO CLAIM IS MADE TO THE EXCLUSIVE RIGHT TO USE "DIGITAL", APART FROM THE MARK AS SHOWN.

THE MARK CONSISTS OF THE WORD "PLAYDATE" IN LOWER CASE, HAVING A PUZZLE PIECE WITH A SMILING FACE BETWEEN "PLAY" AND "DATE", AND WITH THE WORD "DIGITAL" IN UPPER CASE BELOW IT.

FOR DOWNLOADABLE COMPUTER SOFTWARE AND GRAPHICS FOR MOBILE PHONES AND OTHER COMPUTING DEVICES, FEATURING EDUCATIONAL INFORMATION, BOOKS AND GAMES FOR CHILDREN; DIGITAL MEDIA, NAMELY, AUDIO AND VIDEO FILES FEATURING TEXT, GRAPHICS, ANIMATION, AUDIO, VIDEO AND MULTIMEDIA RECORDINGS FOR DOWNLOAD ON MOBILE PHONES AND OTHER COMPUTING DEVICES IN THE FIELD OF EDUCATIONAL INFORMATION, BOOKS AND GAMES FOR CHILDREN; DOWNLOADABLE MULTIMEDIA RECORDINGS AND SOFTWARE APPLICATIONS FEATURING CONTENT IN THE FIELDS OF EDUCATIONAL INFORMATION, BOOKS AND GAMES FOR CHILDREN (U.S. CLS. 21, 23, 26, 36 AND 38).

FIRST USE 6-14-2013; IN COMMERCE 6-14-2013.

4,593,508. MHMB LLC, WEST HOLLYWOOD, CA. SN 85-763,983. PUB. 11-5-2013, FILED 10-25-2012.

**STYLEPIC**

THE MARK CONSISTS OF STANDARD CHARACTERS WITHOUT CLAIM TO ANY PARTICULAR FONT, STYLE, SIZE, OR COLOR.

FOR COMPUTER APPLICATION SOFTWARE FOR MOBILE PHONES, COMPUTERS, AND PORTABLE MEDIA PLAYERS, NAMELY, FASHION-INDUSTRY SOFTWARE FOR USERS TO CREATE, UPLOAD, AND SHARE CONTENT FOR FASHION RETAILERS AND THOSE IN THE FASHION BUSINESS (U.S. CLS. 21, 23, 26, 36 AND 38).

FIRST USE 4-6-2014; IN COMMERCE 4-6-2014.

**CLASS 9—(Continued).**

4,593,509. MHMB LLC, WEST HOLLYWOOD, CA. SN 85-764,011. PUB. 11-5-2013, FILED 10-25-2012.

STYLE  PIC

THE MARK CONSISTS OF THE LETTERS "STYLE" FOLLOWED BY A POINT-AND-SHOOT CAMERA FOLLOWED BY THE LETTERS "PIC".

FOR COMPUTER APPLICATION SOFTWARE FOR MOBILE PHONES, COMPUTERS, AND PORTABLE MEDIA PLAYERS, NAMELY, FASHION-INDUSTRY SOFTWARE FOR USERS TO CREATE, UPLOAD, AND SHARE CONTENT FOR FASHION RETAILERS AND THOSE IN THE FASHION BUSINESS (U.S. CLS. 21, 23, 26, 36 AND 38).

FIRST USE 4-6-2014; IN COMMERCE 4-6-2014.

4,593,524. CORNING OPTICAL COMMUNICATIONS BRANDS, INC., WILMINGTON, DE. SN 85-768,961. PUB. 12-24-2013, FILED 11-1-2012.

3.  optical

THE MARK CONSISTS OF THE NUMBER "3", FOLLOWED BY A PERIOD, WHICH IN TURN IS FOLLOWED BY THE WORD "OPTICAL" WHERE THE "O" IN "OPTICAL" IS RENDERED IN THE FORM OF A DESIGN COMPRISED OF TWO SOLID SEMI-CIRCLES FACING EACH OTHER.

FOR OPTICAL CABLE ASSEMBLIES AND THE COMPONENT PARTS THEREOF (U.S. CLS. 21, 23, 26, 36 AND 38).

FIRST USE 5-30-2014; IN COMMERCE 5-30-2014.

**CLASS 9—(Continued).**

4,593,530. AAC TECHNOLOGIES HOLDINGS INC., GRAND CAYMAN KY1-1111, CAYMAN ISLANDS. SN 85-772,180. PUB. 10-22-2013, FILED 11-6-2012.



NO CLAIM IS MADE TO THE EXCLUSIVE RIGHT TO USE "DB", APART FROM THE MARK AS SHOWN.

THE MARK CONSISTS OF A DESIGN. THE LEFT PORTION OF THE DESIGN RESEMBLES A STYLIZED LETTER "D." THE RIGHT PORTION OF THE DESIGN RESEMBLES A STYLIZED LETTER "B". THE TWO PORTIONS ARE ARRANGED SYMMETRICALLY ON A GEOMETRIC-SHAPED BACKGROUND WITH TWO OUTER SIDES OF THE LETTER "D" AND "B" RESEMBLING A PAIR OF EARPHONES.

FOR AERIALS; EARPHONES; ELECTRIC ACCUMULATORS; ELECTRIC SENSORS; HORNS FOR LOUD-SPEAKERS; INTEGRATED CIRCUITS; MICROPHONES; OPTICAL LENSES; PERSONAL STEREOS; SOUND TRANSMITTING APPARATUS (U.S. CLS. 21, 23, 26, 36 AND 38).

FIRST USE 2-6-2013; IN COMMERCE 2-6-2013.

4,593,545. CALIBER TRUCK CO., LLC, CAPITOLA, CA. SN 85-778,429. PUB. 10-1-2013, FILED 11-13-2012.

CALIBER

THE MARK CONSISTS OF STANDARD CHARACTERS WITHOUT CLAIM TO ANY PARTICULAR FONT, STYLE, SIZE, OR COLOR.

FOR CASES FOR EYEGLASSES AND SUNGLASSES; CASES FOR SPECTACLES AND SUNGLASSES; CHAINS FOR SPECTACLES AND FOR SUNGLASSES; DUST PROTECTIVE GOGGLES AND MASKS; EYEWEAR, NAMELY, SUNGLASSES, EYEGLASSES AND OPHTHALMIC FRAMES AND CASES THEREFOR; EYEWEAR, NAMELY, SUNGLASSES; FRAMES FOR SPECTACLES AND SUNGLASSES; GOGGLES FOR SPORTS; LENSES FOR SUNGLASSES; MOTORCYCLE GOGGLES; NOSE GUARDS WHICH CAN BE WORN BY ATTACHMENT TO EYEWEAR SUCH AS SUNGLASSES AND SKI GOGGLES; SKI GOGGLES; SNOW GOGGLES; SPECTACLES AND SUNGLASSES; SPORT GOGGLES FOR USE IN ACTION SPORTS; SUNGLASS CHAINS AND CORDS; SUNGLASS LENSES; SUNGLASSES; SUNGLASSES AND SPECTACLES (U.S. CLS. 21, 23, 26, 36 AND 38).

FIRST USE 4-16-2012; IN COMMERCE 4-16-2012.



**CLASS 9—(Continued).**

4,593,548. MPHASIS LIMITED, MAHADEVAPURA, BANGALOR, INDIA. SN 85-780,272. PUB. 10-29-2013, FILED 11-15-2012.



THE MARK CONSISTS OF THE LITERAL ELEMENTS "MPHASIS ACCELON" IN STYLIZED FORM FOLLOWED BY TWO ARROWS.

FOR RECORDED SOFTWARE RELATING TO FINANCIAL AND BANKING SERVICES VIA A URL AND A MANUAL USER ID/ PASSWORD (U.S. CLS. 21, 23, 26, 36 AND 38).

FIRST USE 11-2-2012; IN COMMERCE 11-2-2012.

**CLASS 9—(Continued).**

DOWNLOADABLE PRINTING FONTS; PRINTING FONTS THAT CAN BE DOWNLOADED PROVIDED BY MEANS OF ELECTRONIC TRANSMISSION; COMPUTER OPERATING SYSTEMS; OPERATING SYSTEM PROGRAMS; OPTICAL CHARACTER READERS; OPTICAL CHARACTER RECOGNITION APPARATUS; OPTICAL READERS; SOFTWARE FOR OPTICAL CHARACTER RECOGNITION; RENEWABLE BATTERY SYSTEM TO PROVIDE BACKUP POWER; SOFTWARE FOR THE OPERATIONAL MANAGEMENT OF PORTABLE MAGNETIC AND ELECTRONIC CARDS; COMPUTER FIRMWARE, COMPUTER PROGRAMS, AND COMPUTER SOFTWARE THAT MAY BE DOWNLOADED FROM A GLOBAL COMPUTER NETWORK FOR USE IN DATABASE MANAGEMENT, DATABASE SEARCHING, FOR USE AS SPREADSHEETS, FOR WORD PROCESSING, AND FOR USE AS GAMES; INFORMATION SECURITY COMPUTER FIRMWARE, NAMELY, DATA ENCRYPTION AND DECRYPTION FIRMWARE; COMPUTER OPERATING SYSTEM SOFTWARE (U.S. CLS. 21, 23, 26, 36 AND 38).

FIRST USE 1-1-1990; IN COMMERCE 10-22-2013.

4,593,561. AGILE 3 SOLUTIONS LLC, SAN FRANCISCO, CA. SN 85-785,091. PUB. 10-1-2013, FILED 11-21-2012.



THE MARK CONSISTS OF STANDARD CHARACTERS WITHOUT CLAIM TO ANY PARTICULAR FONT, STYLE, SIZE, OR COLOR.

FOR COMPUTER SOFTWARE AND SOFTWARE TOOLS, NAMELY, A COMPUTER SOFTWARE SUITE CONSISTING OF GOVERNANCE DASHBOARDS, SOFTWARE ASSESSMENT TOOLS AND SOFTWARE BENCHMARKING TOOLS THAT INTEGRATE WITH BUSINESS PROCESS MODELING TOOLS TO ENABLE ORGANIZATIONS TO REALIZE IMPROVEMENTS IN BUSINESS PROCESS EFFICIENCIES AND TO PROVIDE BUSINESS LEADERS WITH INFORMATION ON BUSINESS PROCESSES AND OPERATIONS PERFORMANCE, AND WITH COMPLIANCE AND GOVERNANCE MATURITY TO ENABLE STRATEGIC BUSINESS DECISIONS (U.S. CLS. 21, 23, 26, 36 AND 38).

FIRST USE 8-1-2009; IN COMMERCE 8-1-2009.

4,593,553. DYNACOMWARE TAIWAN INC., TAIPEI, TAIWAN. SN 85-782,339. PUB. 10-8-2013, FILED 11-19-2012.



THE MARK CONSISTS OF STANDARD CHARACTERS WITHOUT CLAIM TO ANY PARTICULAR FONT, STYLE, SIZE, OR COLOR.

FOR TYPEFACES, TYPEFONTS, AND TYPE DESIGNS OF ALPHANUMERIC CHARACTERS AND TYPOGRAPHICAL SYMBOLS RECORDED AS LATENT IMAGES IN DATA STORAGE MEDIA, NAMELY, MAGNETIC TAPE, MAGNETIC DISC, OPTICAL MEMORIES AND INTEGRATED CIRCUIT MEMORIES, NAMELY, ROMS, PROMS AND EPROMS; SOFTWARE FOR CREATING TYPEFONTS; TYPEFACE FONT COMPUTER SOFTWARE, NAMELY, COMPUTER PROGRAMS FOR GENERATING CHARACTER FONTS; COMPUTER SOFTWARE, NAMELY, SOFTWARE FOR USE IN CONNECTION WITH FONT FORMAT CONVERSION; COMPUTER SOFTWARE FOR FONT CREATION AND MANIPULATION WHICH CONTAINS A DATABASE OF FONTS; SOFTWARE PROGRAMMABLE MICROPROCESSORS; DATA CARRIERS CONTAINING STORED TYPOGRAPHIC TYPEFACES; TYPEFACE FONTS RECORDED ON MAGNETIC MEDIA AND CD-ROM;

4,593,572. PEOPLE PEOPLE AB, 118 47 STOCKHOLM, SWEDEN. SN 85-789,557. PUB. 4-30-2013, FILED 11-28-2012.



THE MARK CONSISTS OF STANDARD CHARACTERS WITHOUT CLAIM TO ANY PARTICULAR FONT, STYLE, SIZE, OR COLOR.

FOR LOUDSPEAKERS AND COMPONENTS THEREFOR (U.S. CLS. 21, 23, 26, 36 AND 38).

FIRST USE 11-11-2011; IN COMMERCE 6-11-2014.

**CLASS 9—(Continued).**

4,593,595. NAOMI JOHNSON, MONTCLAIR, NJ. SN 85-796,924. PUB. 9-10-2013, FILED 12-6-2012.

# Noneillah

THE MARK CONSISTS OF STANDARD CHARACTERS WITHOUT CLAIM TO ANY PARTICULAR FONT, STYLE, SIZE, OR COLOR.

FOR AUDIO AND VIDEO RECORDINGS FEATURING MUSIC AND ARTISTIC PERFORMANCES (U.S. CLS. 21, 23, 26, 36 AND 38).

FIRST USE 1-2-2013; IN COMMERCE 1-2-2013.

**CLASS 9—(Continued).**

4,593,614. AHNLAB, INC., GYEONGGI-DO, REPUBLIC OF KOREA. SN 85-803,091. PUB. 11-5-2013, FILED 12-14-2012.

# AHNLAB CMC

THE MARK CONSISTS OF STANDARD CHARACTERS WITHOUT CLAIM TO ANY PARTICULAR FONT, STYLE, SIZE, OR COLOR.

OWNER OF U.S. REG. NO. 2,795,323.

FOR COMPUTER NETWORK SECURITY DEVICES, NAMELY, COMPUTER NETWORK ADAPTERS, HUBS, ROUTERS, AND SWITCHES; COMPUTER SOFTWARE FOR SECURITY PURPOSES, NAMELY, PROTECTING DATA AND INFORMATION BY PREVENTING UNAUTHORIZED USERS FROM ACCESSING THEM; DOWNLOADABLE COMPUTER SOFTWARE FOR SECURITY PURPOSES, NAMELY, PROTECTING DATA AND INFORMATION BY PREVENTING UNAUTHORIZED USERS FROM ACCESSING THEM; DOWNLOADABLE COMPUTER SOFTWARE FOR SECURITY OF MOBILE DEVICES, NAMELY, PROTECTING DATA AND INFORMATION BY PREVENTING UNAUTHORIZED USERS FROM ACCESSING THEM; COMPUTER SOFTWARE THAT MONITORS, DETECTS, INTERCEPTS, DIAGNOSES AND REPAIRS COMPUTER VIRUSES, ALL FOR COMPUTER SECURITY PURPOSES; COMPUTERS INSTALLED WITH COMPUTER SOFTWARE THAT MONITORS, DETECTS, INTERCEPTS, DIAGNOSES AND REPAIRS COMPUTER VIRUSES, ALL FOR COMPUTER SECURITY PURPOSES; ENCODED SMART CARDS CONTAINING PROGRAMMING USED TO MONITOR, DETECT, INTERCEPT, DIAGNOSE AND REPAIR COMPUTER VIRUSES FOR COMPUTER SECURITY PURPOSES; COMPUTER SOFTWARE THAT MONITORS, DETECTS, INTERCEPTS, DIAGNOSES AND REPAIRS VIRUSES OF MOBILE DEVICES, FOR SECURITY PURPOSES (U.S. CLS. 21, 23, 26, 36 AND 38).

FIRST USE 3-10-2012; IN COMMERCE 12-10-2012.

4,593,613. AHNLAB, INC., GYEONGGI-DO, REPUBLIC OF KOREA. SN 85-803,048. PUB. 11-5-2013, FILED 12-14-2012.

# AHNLAB MDS

THE MARK CONSISTS OF STANDARD CHARACTERS WITHOUT CLAIM TO ANY PARTICULAR FONT, STYLE, SIZE, OR COLOR.

OWNER OF U.S. REG. NO. 2,795,323.

FOR COMPUTER NETWORK SECURITY DEVICES, NAMELY, COMPUTER NETWORK ADAPTERS, HUBS, ROUTERS, AND SWITCHES; COMPUTER SOFTWARE FOR SECURITY PURPOSES, NAMELY, PROTECTING DATA AND INFORMATION BY PREVENTING UNAUTHORIZED USERS FROM ACCESSING THEM; DOWNLOADABLE COMPUTER SOFTWARE FOR SECURITY PURPOSES, NAMELY, PROTECTING DATA AND INFORMATION BY PREVENTING UNAUTHORIZED USERS FROM ACCESSING THEM; DOWNLOADABLE COMPUTER SOFTWARE FOR SECURITY OF MOBILE DEVICES, NAMELY, PROTECTING DATA AND INFORMATION BY PREVENTING UNAUTHORIZED USERS FROM ACCESSING THEM; COMPUTER SOFTWARE THAT MONITORS, DETECTS, INTERCEPTS, DIAGNOSES AND REPAIRS COMPUTER VIRUSES, ALL FOR COMPUTER SECURITY PURPOSES; COMPUTERS INSTALLED WITH COMPUTER SOFTWARE THAT MONITORS, DETECTS, INTERCEPTS, DIAGNOSES AND REPAIRS COMPUTER VIRUSES, ALL FOR COMPUTER SECURITY PURPOSES; ENCODED SMART CARDS CONTAINING PROGRAMMING USED TO MONITOR, DETECT, INTERCEPT, DIAGNOSE AND REPAIR COMPUTER VIRUSES FOR COMPUTER SECURITY PURPOSES; COMPUTER SOFTWARE THAT MONITORS, DETECTS, INTERCEPTS, DIAGNOSES AND REPAIRS VIRUSES OF MOBILE DEVICES, FOR SECURITY PURPOSES (U.S. CLS. 21, 23, 26, 36 AND 38).

FIRST USE 3-10-2012; IN COMMERCE 12-10-2012.

4,593,615. AHNLAB, INC., GYEONGGI-DO, REPUBLIC OF KOREA. SN 85-803,108. PUB. 11-5-2013, FILED 12-14-2012.

# AHNLAB ACS

THE MARK CONSISTS OF STANDARD CHARACTERS WITHOUT CLAIM TO ANY PARTICULAR FONT, STYLE, SIZE, OR COLOR.

**CLASS 9—(Continued).**

OWNER OF U.S. REG. NO. 2,795,323.

FOR COMPUTER NETWORK SECURITY DEVICES, NAMELY, COMPUTER NETWORK ADAPTERS, HUBS, ROUTERS, AND SWITCHES; COMPUTER SOFTWARE FOR SECURITY PURPOSES, NAMELY, PROTECTING DATA AND INFORMATION BY PREVENTING UNAUTHORIZED USERS FROM ACCESSING THEM; DOWNLOADABLE COMPUTER SOFTWARE FOR SECURITY PURPOSES, NAMELY, PROTECTING DATA AND INFORMATION BY PREVENTING UNAUTHORIZED USERS FROM ACCESSING THEM; DOWNLOADABLE COMPUTER SOFTWARE FOR SECURITY OF MOBILE DEVICES, NAMELY, PROTECTING DATA AND INFORMATION BY PREVENTING UNAUTHORIZED USERS FROM ACCESSING THEM; COMPUTER SOFTWARE THAT MONITORS, DETECTS, INTERCEPTS, DIAGNOSES AND REPAIRS COMPUTER VIRUSES, ALL FOR COMPUTER SECURITY PURPOSES; COMPUTERS INSTALLED WITH COMPUTER SOFTWARE THAT MONITORS, DETECTS, INTERCEPTS, DIAGNOSES AND REPAIRS COMPUTER VIRUSES, ALL FOR COMPUTER SECURITY PURPOSES; ENCODED SMART CARDS CONTAINING PROGRAMMING USED TO MONITOR, DETECT, INTERCEPT, DIAGNOSE AND REPAIR COMPUTER VIRUSES FOR COMPUTER SECURITY PURPOSES; COMPUTER SOFTWARE THAT MONITORS, DETECTS, INTERCEPTS, DIAGNOSES AND REPAIRS VIRUSES OF MOBILE DEVICES, FOR SECURITY PURPOSES (U.S. CLS. 21, 23, 26, 36 AND 38).

FIRST USE 3-10-2012; IN COMMERCE 12-10-2012.

---

4,593,617. AHNLAB, INC., GYEONGGI-DO, REPUBLIC OF KOREA. SN 85-803,128. PUB. 10-29-2013, FILED 12-14-2012.

# AHNLAB ADS

THE MARK CONSISTS OF STANDARD CHARACTERS WITHOUT CLAIM TO ANY PARTICULAR FONT, STYLE, SIZE, OR COLOR.

OWNER OF U.S. REG. NO. 2,795,323.

FOR COMPUTER NETWORK SECURITY DEVICES, NAMELY, COMPUTER NETWORK ADAPTERS, HUBS, ROUTERS, AND SWITCHES; COMPUTER SOFTWARE FOR SECURITY PURPOSES, NAMELY, PROTECTING DATA AND INFORMATION BY PREVENTING UNAUTHORIZED USERS FROM ACCESSING THEM; DOWNLOADABLE COMPUTER SOFTWARE FOR SECURITY PURPOSES, NAMELY, PROTECTING DATA AND INFORMATION BY PREVENTING UNAUTHORIZED USERS FROM ACCESSING THEM; DOWNLOADABLE COMPUTER SOFTWARE FOR SECURITY OF MOBILE DEVICES, NAMELY, PROTECTING DATA AND INFORMATION BY PREVENTING UNAUTHORIZED USERS FROM ACCESSING THEM; COMPUTER SOFTWARE THAT MONITORS, DETECTS, INTERCEPTS, DIAGNOSES AND REPAIRS COMPUTER VIRUSES, ALL FOR COMPUTER SECURITY PURPOSES; COMPUTERS INSTALLED WITH COMPUTER SOFTWARE THAT MONITORS, DETECTS, INTERCEPTS, DIAGNOSES AND REPAIRS COMPUTER VIRUSES, ALL FOR COMPUTER SECURITY PURPOSES; ENCODED SMART CARDS CONTAINING PROGRAMMING USED TO MONITOR, DETECT, INTERCEPT, DIAGNOSE AND REPAIR COMPUTER VIRUSES FOR COMPUTER SECURITY PURPOSES; COMPUTER SOFTWARE THAT MONITORS, DETECTS, INTERCEPTS, DIAGNOSES AND REPAIRS VIRUSES OF MOBILE DEVICES, FOR SECURITY PURPOSES (U.S. CLS. 21, 23, 26, 36 AND 38).

FIRST USE 3-10-2012; IN COMMERCE 12-10-2012.

**CLASS 9—(Continued).**

4,593,620. EPSON AMERICA, INC., LONG BEACH, CA. SN 85-803,448. PUB. 10-1-2013, FILED 12-14-2012.

# OMNILINK

THE MARK CONSISTS OF STANDARD CHARACTERS WITHOUT CLAIM TO ANY PARTICULAR FONT, STYLE, SIZE, OR COLOR.

FOR POINT OF SALE TERMINALS; POINT OF SALE COMPUTER HARDWARE AND PERIPHERALS; POINT OF SALE COMPUTER OPERATING SOFTWARE; POINT OF SALE DEVICES, NAMELY, PRINTERS WITH CAPABILITY VIA ETHERNET OR WIRELESS NETWORKS TO CONNECT TO LOCAL OR CLOUD-BASED SERVERS; COMPUTER SOFTWARE FOR DATA PARSING AND EXTRACTING RECEIPT DATA INFORMATION, CONNECTING BUILT-IN SERVER TO MOBILE DEVICES, SUPPORTING DRIVERLESS PRINTING FROM INTERNET-BASED SOFTWARE APPLICATIONS RUNNING ON MOBILE DEVICES, AND CONTROLLING MULTIPLE DEVICES, NAMELY, DRIVING TOUCH PANELS OR SLAVE PRINTERS (U.S. CLS. 21, 23, 26, 36 AND 38).

FIRST USE 5-0-2013; IN COMMERCE 5-0-2013.

---

4,593,645. SKULLCANDY, INC., PARK CITY, UT. SN 85-811,999. PUB. 10-29-2013, FILED 12-28-2012.

# FIX

THE MARK CONSISTS OF STANDARD CHARACTERS WITHOUT CLAIM TO ANY PARTICULAR FONT, STYLE, SIZE, OR COLOR.

FOR DEVICES FOR HANDS-FREE USE OF MOBILE PHONES; EARPHONES; HEADPHONES; HEADSETS FOR USE WITH MOBILE DEVICES, NAMELY, MOBILE PHONES, ELECTRONIC BOOK READERS, TABLET COMPUTERS, AND DIGITAL MEDIA PLAYERS (U.S. CLS. 21, 23, 26, 36 AND 38).

FIRST USE 5-9-2011; IN COMMERCE 5-9-2011.

**CLASS 9—(Continued).**

4,593,646. SKULLCANDY, INC., PARK CITY, UT. SN 85-812,011. PUB. 10-29-2013, FILED 12-28-2012.

# CHOPS

THE MARK CONSISTS OF STANDARD CHARACTERS WITHOUT CLAIM TO ANY PARTICULAR FONT, STYLE, SIZE, OR COLOR.

FOR DEVICES FOR HANDS-FREE USE OF MOBILE PHONES; EARPHONES; HEADPHONES; HEADSETS FOR USE WITH MOBILE DEVICES, NAMELY, MOBILE PHONES, ELECTRONIC BOOK READERS, TABLET COMPUTERS, AND DIGITAL MEDIA PLAYERS (U.S. CLS. 21, 23, 26, 36 AND 38).

FIRST USE 1-3-2008; IN COMMERCE 1-3-2008.

4,593,651. SITIME CORPORATION, SUNNYVALE, CA. SN 85-814,146. PUB. 11-26-2013, FILED 1-2-2013.

# TEMPFLAT

THE MARK CONSISTS OF STANDARD CHARACTERS WITHOUT CLAIM TO ANY PARTICULAR FONT, STYLE, SIZE, OR COLOR.

FOR SEMICONDUCTORS, SILICON WAFERS, PACKAGED OSCILLATORS, AND INTEGRATED CIRCUITS; ELECTRONIC DEVICES FOR MEASURING, TESTING AND GENERATING ELECTRONIC AND ELECTRICAL TIMING OR CLOCK SIGNALS IN SILICON CHIPS AND SIGNAL CONDITIONING CIRCUITRY (U.S. CLS. 21, 23, 26, 36 AND 38).

FIRST USE 6-3-2013; IN COMMERCE 6-3-2013.

4,593,652. SITIME CORPORATION, SUNNYVALE, CA. SN 85-814,152. PUB. 11-26-2013, FILED 1-2-2013.

# TEMPFLAT MEMS

THE MARK CONSISTS OF STANDARD CHARACTERS WITHOUT CLAIM TO ANY PARTICULAR FONT, STYLE, SIZE, OR COLOR.

**CLASS 9—(Continued).**

NO CLAIM IS MADE TO THE EXCLUSIVE RIGHT TO USE "MEMS", APART FROM THE MARK AS SHOWN.

FOR SEMICONDUCTORS, SILICON WAFERS, PACKAGED OSCILLATORS, AND INTEGRATED CIRCUITS; ELECTRONIC DEVICES FOR MEASURING, TESTING AND GENERATING ELECTRONIC AND ELECTRICAL TIMING OR CLOCK SIGNALS IN SILICON CHIPS AND SIGNAL CONDITIONING CIRCUITRY (U.S. CLS. 21, 23, 26, 36 AND 38).

FIRST USE 6-3-2013; IN COMMERCE 6-3-2013.

4,593,660. EBATES PERFORMANCE MARKETING, INC., SAN FRANCISCO, CA. SN 85-816,755. PUB. 11-19-2013, FILED 1-7-2013.



OWNER OF U.S. REG. NOS. 3,852,239, 3,858,927, AND 3,858,928.

THE COLOR(S) YELLOW AND BLACK IS/ARE CLAIMED AS A FEATURE OF THE MARK.

THE MARK CONSISTS OF THE WORD "EBATES" IN A YELLOW STYLIZED FONT DESIGN WITH A BLACK BACKGROUND.

FOR CONSUMER COUPONS DOWNLOADED FROM A GLOBAL COMPUTER NETWORK (U.S. CLS. 21, 23, 26, 36 AND 38).

FIRST USE 6-30-2009; IN COMMERCE 6-30-2009.

4,593,664. COHEN, MORGAN, DBA COHEN SYSTEMS, BASEL, SWITZERLAND. SN 85-819,305. PUB. 5-28-2013, FILED 1-9-2013.

# ISITKOSHER

THE MARK CONSISTS OF STANDARD CHARACTERS WITHOUT CLAIM TO ANY PARTICULAR FONT, STYLE, SIZE, OR COLOR.

FOR COMPUTER APPLICATION SOFTWARE FOR MOBILE DEVICES, NAMELY, SOFTWARE FOR PROVIDING CONSUMERS WITH PRODUCT INFORMATION RELATING TO DIETARY RESTRICTIONS (U.S. CLS. 21, 23, 26, 36 AND 38).

FIRST USE 9-15-2013; IN COMMERCE 9-15-2013.

**CLASS 9—(Continued).**

4,593,683. AHNLAB, INC., GYEONGGI-DO, REPUBLIC OF KOREA. SN 85-828,968. PUB. 10-29-2013, FILED 1-22-2013.

## AHNLAB DPS

THE MARK CONSISTS OF STANDARD CHARACTERS WITHOUT CLAIM TO ANY PARTICULAR FONT, STYLE, SIZE, OR COLOR.

OWNER OF U.S. REG. NO. 2,795,323.

FOR COMPUTER NETWORK SECURITY DEVICES, NAMELY, COMPUTER NETWORK ADAPTERS, HUBS, ROUTERS, AND SWITCHES; COMPUTER SOFTWARE FOR SECURITY PURPOSES, NAMELY, PROTECTING DATA AND INFORMATION BY PREVENTING UNAUTHORIZED USERS FROM ACCESSING THEM; DOWNLOADABLE COMPUTER SOFTWARE FOR SECURITY PURPOSES, NAMELY, PROTECTING DATA AND INFORMATION BY PREVENTING UNAUTHORIZED USERS FROM ACCESSING THEM; DOWNLOADABLE COMPUTER SOFTWARE FOR SECURITY OF MOBILE DEVICES, NAMELY, PROTECTING DATA AND INFORMATION BY PREVENTING UNAUTHORIZED USERS FROM ACCESSING THEM; COMPUTER SOFTWARE THAT MONITORS, DETECTS, INTERCEPTS, DIAGNOSES AND REPAIRS COMPUTER VIRUSES, ALL FOR COMPUTER SECURITY PURPOSES; COMPUTERS INSTALLED WITH COMPUTER SOFTWARE THAT MONITORS, DETECTS, INTERCEPTS, DIAGNOSES AND REPAIRS COMPUTER VIRUSES, ALL FOR COMPUTER SECURITY PURPOSES; ENCODED SMART CARDS CONTAINING PROGRAMMING USED TO MONITOR, DETECT, INTERCEPT, DIAGNOSE AND REPAIR COMPUTER VIRUSES FOR COMPUTER SECURITY PURPOSES; COMPUTER SOFTWARE THAT MONITORS, DETECTS, INTERCEPTS, DIAGNOSES AND REPAIRS VIRUSES OF MOBILE DEVICES, FOR SECURITY PURPOSES (U.S. CLS. 21, 23, 26, 36 AND 38).

FIRST USE 2-12-2013; IN COMMERCE 2-25-2013.

4,593,703. HURTADO, NICHOLAS, STUDIO CITY, CA. AND CASILLAS, SCOTT, STUDIO CITY, CA. SN 85-842,005. PUB. 6-25-2013, FILED 2-6-2013.

## Inventor

THE MARK CONSISTS OF STANDARD CHARACTERS WITHOUT CLAIM TO ANY PARTICULAR FONT, STYLE, SIZE, OR COLOR.

FOR COMPACT DISCS FEATURING MUSIC; DOWNLOADABLE MUSIC FILES; MUSICAL RECORDINGS (U.S. CLS. 21, 23, 26, 36 AND 38).

FIRST USE 5-20-2013; IN COMMERCE 5-20-2013.

**CLASS 9—(Continued).**

4,593,732. VIEVU, LLC, SEATTLE, WA. SN 85-857,275. PUB. 8-6-2013, FILED 2-22-2013.



OWNER OF U.S. REG. NO. 3,732,011. THE COLOR(S) GREEN AND WHITE IS/ARE CLAIMED AS A FEATURE OF THE MARK.

THE MARK CONSISTS OF THE WORD "VIEVU" WITH THE LETTERS "VIE" IN GREEN TO THE LEFT OF THE LETTERS "VU" IN WHITE INSIDE A GREEN BOX. THERE IS A WHITE SUPERScript "2" TO THE RIGHT OF THE GREEN BOX. THE BLACK IN THE DRAWING REPRESENTS TRANSPARENT BACKGROUND AREA AND IS NOT A PART OF THE MARK.

FOR AUDIO RECORDERS; DIGITAL AUDIO AND VIDEO RECORDERS AND PLAYERS; DIGITAL VIDEO RECORDERS; VIDEO CAMERAS (U.S. CLS. 21, 23, 26, 36 AND 38).

FIRST USE 10-15-2013; IN COMMERCE 10-15-2013.

4,593,734. NEWTELL SOLUTIONS, LLC, MIRAMAR, FL. SN 85-858,313. PUB. 7-16-2013, FILED 2-23-2013.

## NEWTELL

THE MARK CONSISTS OF STANDARD CHARACTERS WITHOUT CLAIM TO ANY PARTICULAR FONT, STYLE, SIZE, OR COLOR.

FOR COMPUTER SOFTWARE FOR AUTOMATED TELLER MACHINES (U.S. CLS. 21, 23, 26, 36 AND 38).

FIRST USE 5-6-2013; IN COMMERCE 5-6-2013.

4,593,735. NEWTELL SOLUTIONS, LLC, MIRAMAR, FL. SN 85-858,315. PUB. 7-16-2013, FILED 2-23-2013.



THE MARK CONSISTS OF A CIRCULAR SWIRL OF THREE SOLID LINES WHERE EACH OF THE SOLID LINES BEGINS AT ONE OF THREE POINTS AT THE EXTERIOR OF THE CIRCLE, APPROXIMATELY 45 DEGREES, AP-

**CLASS 9—(Continued).**

PROXIMATELY 180 DEGREES, AND APPROXIMATELY 315 DEGREES, AND WHICH SOLID LINES ARE ARRANGED IN A CIRCULAR FASHION WHEREBY THE RADIUS OF EACH CIRCLE FORMED BY EACH SOLID LINE DECREASES UNTIL EACH SOLID LINE REACHES AN END POINT CLOSER TO THE CENTER OF THE CIRCLE, WHICH END POINTS ARE LOCATED IN THE INTERIOR OF THE CIRCLE AT APPROXIMATELY 45 DEGREES, APPROXIMATELY 180 DEGREES, AND APPROXIMATELY 315 DEGREES, THUS CREATING A HOLE IN THE CENTER OF THE CIRCLE, SAID HOLE HAVING A DIAMETER EQUAL TO APPROXIMATELY THE DISTANCE BETWEEN EACH END POINT AND ITS CORRESPONDING POINT OF ORIGIN.

FOR COMPUTER SOFTWARE AND HARDWARE FOR AUTOMATED TELLER MACHINES (U.S. CLS. 21, 23, 26, 36 AND 38).

FIRST USE 5-6-2013; IN COMMERCE 5-6-2013.

---

4,593,737. YUTRON CO., LTD., NEW TAIPEI CITY 235, TAIWAN. SN 85-860,164. PUB. 11-5-2013, FILED 2-26-2013.



THE MARK CONSISTS OF THE STYLIZED WORDING "FUGLE".

THE ENGLISH TRANSLATION OF "FUGLE" IN THE MARK IS "GUIDE" OR "LEADER".

FOR MOBILE PHONE PROTECTION CASES; COMPUTER TABLET PROTECTION CASES; MOBILE PHONE POUCHES; CHARGERS FOR MOBILE PHONES; HOLDERS FOR MOBILE PHONES; MOBILE PHONE SCREEN PROTECTORS; ELECTRONIC CABLES FOR MOBILE PHONES; INPUT TOUCH PENS FOR MOBILE PHONES; INPUT TOUCH PENS FOR COMPUTER TABLETS; KEYBOARDS FOR TABLETS; KEYBOARDS FOR MOBILE PHONES; CHARGERS FOR TABLETS; POUCHES SPECIALLY ADAPTED FOR COMPUTER TABLETS; MOBILE HEADPHONES; PORTABLE SPEAKERS FOR MOBILE PHONES; BATTERY CHARGERS FOR ELECTRONIC GAMES; ACCESSORIES FOR USE WITH COMPUTER SOFTWARE GAMES, DOWNLOADABLE SOFTWARE GAMES, AND VIDEO DISC GAMES, NAMELY, ELECTRONIC CABLES, INPUT TOUCH PENS, KEYBOARDS, HEADPHONES AND PORTABLE SPEAKERS (U.S. CLS. 21, 23, 26, 36 AND 38).

FIRST USE 7-15-2013; IN COMMERCE 1-6-2014.

**CLASS 9—(Continued).**

4,593,765. DACA DESIGN LLC, GARDEN CITY, NY. SN 85-879,277. PUB. 11-26-2013, FILED 3-18-2013.

## SMART CATCH

THE MARK CONSISTS OF STANDARD CHARACTERS WITHOUT CLAIM TO ANY PARTICULAR FONT, STYLE, SIZE, OR COLOR.

FOR AN ELASTOMERIC APPARATUS ATTACHABLE TO A MOBILE ELECTRONIC DEVICE FOR SECURING A MOBILE ELECTRONIC DEVICE TO A USER OR THEIR GEAR; A CELL PHONE SECUREMENT APPARATUS, NAMELY, AN ELASTOMERIC APPARATUS FOR SECURING A CELL PHONE TO THE USER OR THEIR GEAR; MOBILE ELECTRONIC DEVICE SECUREMENT APPARATUS, AN ELASTOMERIC APPARATUS FOR SECURING A MOBILE DEVICE TO THE USER OR THEIR GEAR (U.S. CLS. 21, 23, 26, 36 AND 38).

FIRST USE 7-15-2013; IN COMMERCE 7-15-2013.

---

4,593,775. INVESTMENT RECOVERY ASSOCIATION, KANSAS CITY, MO. SN 85-882,830. PUB. 3-11-2014, FILED 3-21-2013.



OWNER OF U.S. REG. NO. 2,273,738.

NO CLAIM IS MADE TO THE EXCLUSIVE RIGHT TO USE "ASSOCIATION", APART FROM THE MARK AS SHOWN.

THE MARK CONSISTS OF A TRIANGLE DESIGN ABOVE THE WORD "INVESTMENT" ABOVE THE WORD "RECOVERY" ABOVE THE WORD "ASSOCIATION".

SEC. 2(F) "INVESTMENT RECOVERY ASSOCIATION".

FOR DOWNLOADABLE ELECTRONIC PUBLICATIONS, NAMELY, MEMBERSHIP ROSTERS, MEMBERSHIP DIRECTORIES, HANDBOOKS, JOURNALS AND NEWSLETTERS CONCERNING INVESTMENT RECOVERY, ASSOCIATION FLYERS AND INFORMATION BROCHURES CONCERNING INVESTMENT RECOVERY AND INFORMATION AND EVENTS RELATED THERETO, CONFERENCE PLANNING GUIDES EXPLAINING HOW TO ORGANIZE INVESTMENT RECOVERY CONFERENCES, CONFERENCE AGENDA AND BIOGRAPHIES OF SPEAKERS (U.S. CLS. 21, 23, 26, 36 AND 38).

FIRST USE 10-27-1995; IN COMMERCE 10-27-1995.

**CLASS 9—(Continued).**

4,593,788. FLOP STUDIOS, INC., GREENWOOD VILLAGE, CO. SN 85-891,073. PUB. 9-3-2013, FILED 3-30-2013.

**Basketball Paper Flick PRO**

THE MARK CONSISTS OF STANDARD CHARACTERS WITHOUT CLAIM TO ANY PARTICULAR FONT, STYLE, SIZE, OR COLOR.

NO CLAIM IS MADE TO THE EXCLUSIVE RIGHT TO USE "BASKETBALL PAPER FLICK", APART FROM THE MARK AS SHOWN.

FOR GAMING APPLICATION SOFTWARE, MOBILE GAME SOFTWARE, VIDEO GAME SOFTWARE, VIDEO GAME PROGRAMS, VIDEO GAME CARTRIDGES, ELECTRONIC GAME SOFTWARE, ELECTRONIC GAME PROGRAMS, ELECTRONIC GAME CARTRIDGES (U.S. CLS. 21, 23, 26, 36 AND 38).

FIRST USE 5-1-2013; IN COMMERCE 5-1-2013.

4,593,792. BITLIT MEDIA INC., VANCOUVER, BC, CANADA. SN 85-894,050. PUB. 12-3-2013, FILED 4-3-2013.

**BitLit**

THE MARK CONSISTS OF STANDARD CHARACTERS WITHOUT CLAIM TO ANY PARTICULAR FONT, STYLE, SIZE, OR COLOR.

FOR COMPUTER APPLICATION SOFTWARE FOR MOBILE PHONES, NAMELY, SOFTWARE FOR RECOGNITION AND REGISTRATION OF PHYSICAL BOOKS, AND SALE OF EBOOKS (U.S. CLS. 21, 23, 26, 36 AND 38).

FIRST USE 12-12-2013; IN COMMERCE 1-15-2014.

4,593,799. COMPASS INTERNATIONAL CORPORATION LIMITED, CHAI WAN, HONG KONG. SN 85-899,775. PUB. 11-5-2013, FILED 4-10-2013.



NO CLAIM IS MADE TO THE EXCLUSIVE RIGHT TO USE "ARMOR", APART FROM THE MARK AS SHOWN.

**CLASS 9—(Continued).**

THE MARK CONSISTS OF THE STYLIZED LETTERS "C", "A" ON THE LEFT AND THE WORDS "COMPASS ARMOR" ON THE RIGHT.

FOR BULLET-PROOF WAISTCOATS; CLOTHING FOR PROTECTION AGAINST ACCIDENTS, IRRADIATION AND FIRE; LIFE SAVING RAFTS; PROTECTING MASKS; PROTECTIVE HELMETS; PROTECTIVE SUITS FOR AVIATORS; PROTECTIVE WORK GLOVES; RESPIRATORY MASKS FOR NON-MEDICAL PURPOSES; SAFETY NETS; SHOES FOR PROTECTION AGAINST ACCIDENTS AND FIRE (U.S. CLS. 21, 23, 26, 36 AND 38).

FIRST USE 11-20-2012; IN COMMERCE 5-15-2013.

4,593,800. BOOTS & COOTS, INC., HOUSTON, TX. SN 85-900,024. PUB. 1-14-2014, FILED 4-10-2013.

**WELLCALL**

THE MARK CONSISTS OF STANDARD CHARACTERS WITHOUT CLAIM TO ANY PARTICULAR FONT, STYLE, SIZE, OR COLOR.

FOR COMPUTER APPLICATION SOFTWARE FOR CELL PHONES, NAMELY, SOFTWARE CONTAINING SPECIFIC BLOWOUT CONTINGENCY PLANS AND PROCEDURES FOR USE IN AN OIL OR GAS WELL EMERGENCY AS WELL AS CONTACT INFORMATION FOR RESPONSE ASSISTANCE TO AN OIL OR GAS WELL EMERGENCY (U.S. CLS. 21, 23, 26, 36 AND 38).

FIRST USE 9-16-2013; IN COMMERCE 9-16-2013.

4,593,815. HEWLETT-PACKARD DEVELOPMENT COMPANY, L.P., HOUSTON, TX. SN 85-909,290. PUB. 11-5-2013, FILED 4-19-2013.

**HP TRUST CIRCLES**

THE MARK CONSISTS OF STANDARD CHARACTERS WITHOUT CLAIM TO ANY PARTICULAR FONT, STYLE, SIZE, OR COLOR.

OWNER OF U.S. REG. NOS. 1,842,724, 2,958,220, AND OTHERS.

FOR COMPUTER SOFTWARE FOR ENCRYPTION; COMPUTER SOFTWARE FOR ORGANIZING AND MANAGING DIGITAL FILES; COMPUTER SOFTWARE FOR ORGANIZING AND MANAGING DOCUMENT SECURITY AND FILE ACCESS PERMISSIONS (U.S. CLS. 21, 23, 26, 36 AND 38).

FIRST USE 9-23-2013; IN COMMERCE 9-23-2013.

**CLASS 9—(Continued).**

4,593,835. MEHLENBACHER, JONATHAN L, MEMPHIS, TN.  
SN 85-916,635. PUB. 10-8-2013, FILED 4-26-2013.

# Jonny Atma

THE MARK CONSISTS OF STANDARD CHARACTERS WITHOUT CLAIM TO ANY PARTICULAR FONT, STYLE, SIZE, OR COLOR.

THE NAME(S), PORTRAIT(S), AND/OR SIGNATURE(S) SHOWN IN THE MARK IDENTIFIES JONATHAN MEHLENBACHER, WHOSE CONSENT(S) TO REGISTER IS MADE OF RECORD.

FOR AUDIO AND VIDEO RECORDINGS FEATURING MUSIC AND ARTISTIC PERFORMANCES (U.S. CLS. 21, 23, 26, 36 AND 38).

FIRST USE 5-1-2012; IN COMMERCE 6-5-2013.

4,593,838. AHIMSA CREATIONS L.L.C., SUGAR LAND, TX.  
SN 85-917,803. PUB. 10-1-2013, FILED 4-29-2013.

# NONVIOLENZE

THE MARK CONSISTS OF STANDARD CHARACTERS WITHOUT CLAIM TO ANY PARTICULAR FONT, STYLE, SIZE, OR COLOR.

FOR AUDIO RECORDINGS FEATURING MUSIC; AUDIO TAPES FEATURING MUSIC; DOWNLOADABLE MUSICAL SOUND RECORDINGS; DOWNLOADABLE RING TONES, GRAPHICS AND MUSIC VIA A GLOBAL COMPUTER NETWORK AND WIRELESS DEVICES; MUSICAL SOUND RECORDINGS; MUSICAL VIDEO RECORDINGS; PRE-RECORDED CDS, VIDEO TAPES, LASER DISKS AND DVDS FEATURING MUSIC AND MUSIC VIDEOS; SOUND RECORDINGS FEATURING MUSIC; VIDEO RECORDINGS FEATURING MUSIC AND MUSIC VIDEOS (U.S. CLS. 21, 23, 26, 36 AND 38).

FIRST USE 7-25-2013; IN COMMERCE 7-25-2013.

4,593,844. GREEN INVESTMENTS, LLC, PHOENIX, AZ. SN  
85-919,366. PUB. 10-8-2013, FILED 4-30-2013.

# MAX EFFORT RECRUITS

THE MARK CONSISTS OF STANDARD CHARACTERS WITHOUT CLAIM TO ANY PARTICULAR FONT, STYLE, SIZE, OR COLOR.

**CLASS 9—(Continued).**

NO CLAIM IS MADE TO THE EXCLUSIVE RIGHT TO USE "RECRUITS", APART FROM THE MARK AS SHOWN.

FOR DOWNLOADABLE SOFTWARE IN THE NATURE OF A MOBILE APPLICATION FOR USE IN ATHLETIC RECRUITING (U.S. CLS. 21, 23, 26, 36 AND 38).

FIRST USE 5-21-2014; IN COMMERCE 5-21-2014.

4,593,852. GREEN LIGHT INNOVATIONS, LAKE SAINT LOUIS, MO. SN 85-920,663. PUB. 11-5-2013, FILED 5-1-2013.



THE MARK CONSISTS OF STYLIZED "G".  
FOR ELECTRIC SIGNS (U.S. CLS. 21, 23, 26, 36 AND 38).

FIRST USE 7-1-2013; IN COMMERCE 7-1-2013.

4,593,855. CORE CARE MEDICAL LLC, SPARTANBURG, SC. SN 85-921,098. PUB. 11-5-2013, FILED 5-2-2013.

# CORE CARE

THE MARK CONSISTS OF STANDARD CHARACTERS WITHOUT CLAIM TO ANY PARTICULAR FONT, STYLE, SIZE, OR COLOR.

NO CLAIM IS MADE TO THE EXCLUSIVE RIGHT TO USE "CARE", APART FROM THE MARK AS SHOWN.

FOR COMPUTER SOFTWARE FOR USE IN CONDUCTING SURVEYS, DOCTOR-PATIENT INTERVIEWS, AND ANNUAL WELLNESS VISITS IN THE MEDICAL FIELD (U.S. CLS. 21, 23, 26, 36 AND 38).

FIRST USE 5-1-2013; IN COMMERCE 5-1-2013.



**CLASS 9—(Continued).**

4,593,858. PORTIA INTERNATIONAL TRADING LIMITED, NEW TERRITORIES, HONG KONG. SN 85-922,162. PUB. 10-8-2013, FILED 5-2-2013.



THE MARK CONSISTS OF THE WORD "TRUFFOL" BELOW A STYLIZED BLACK SQUARE WITH ROUNDED CORNERS.

FOR AMPLIFIERS; BAGS ADAPTED FOR LAPTOPS; BATTERIES, ELECTRIC; BATTERY BOXES, ACCUMULATOR BOXES; BATTERY CHARGERS; BATTERY PACKS FOR VIDEO CAMERAS, LAPTOPS, TABLET COMPUTERS, COMPACT DISC PLAYERS, MP3 PLAYERS, PORTABLE MEDIA PLAYERS, TELEPHONES, CELLULAR TELEPHONES, PERSONAL DIGITAL ASSISTANTS; BRIEFCASES SPECIALLY ADAPTED FOR HOLDING LAPTOP COMPUTERS; PHOTOGRAPHY CAMERAS; CASES FOR MUSIC, AUDIO AND RELATED ELECTRONIC EQUIPMENT, NAMELY, CASES FOR AUDIO TUNERS, AUDIO RECEIVERS, AMPLIFIERS, TAPE PLAYERS, COMPACT DISC PLAYERS, MP3 CONTROLLERS AND PLAYERS, AUDIO MIXERS, AUDIO SPEAKERS IN THE NATURE OF MUSIC STUDIO MONITORS, MICROPHONES, AUDIO SPEAKERS, COMPACT DISCS, AUDIO TAPES, PORTABLE COMPUTERS, ANTENNAS, PHONOGRAPHIC RECORD PLAYERS, AUDIO RECORDING EQUIPMENT, AND THE CABLES ASSOCIATED WITH ALL OF THE FOREGOING EQUIPMENT; CASES FOR TELEPHONES; CASES ESPECIALLY MADE FOR PHOTOGRAPHIC APPARATUS AND INSTRUMENTS; CARRYING CASES FOR MOBILE COMPUTERS; CHARGERS FOR ELECTRIC BATTERIES; COMPUTER PERIPHERAL DEVICES; COMPUTERS; DECORATIVE ORNAMENTS FOR CELLULAR TELEPHONES; DISPLAY SCREEN PROTECTORS FOR PROVIDING SHADE AND PRIVACY SPECIALLY ADAPTED TO ELECTRONIC DEVICES, NAMELY, LAPTOPS, TABLET COMPUTERS, CELL PHONES, PERSONAL DIGITAL ASSISTANTS, EXCLUDING GAMING APPARATUS; FITTED PLASTIC FILMS KNOWN AS SKINS FOR COVERING AND PROVIDING A SCRATCH PROOF BARRIER OR PROTECTION FOR ELECTRONIC DEVICES, NAMELY, MP3 PLAYERS, MOBILE TELEPHONES, SMART TELEPHONES, LAPTOPS, TABLET COMPUTERS, DIGITAL CAMERAS, GLOBAL POSITIONING SYSTEMS AND PERSONAL DIGITAL ASSISTANTS; HANDS FREE KITS FOR PHONES; HEADPHONES; HEADSETS FOR TELEPHONES; LAPTOP COMPUTERS; LOUDSPEAKERS; MICROPHONES; NAVIGATIONAL INSTRUMENTS; PORTABLE TELEPHONES; PORTABLE MEDIA PLAYERS; PROTECTIVE COVERS AND CASES FOR CELL PHONES, LAPTOPS AND PORTABLE MEDIA PLAYERS; PROTECTIVE COVERS AND CASES FOR TABLET COMPUTERS; RADIOS; STRAPS FOR MOBILE PHONES AND TELEPHONE APPARATUS (U.S. CLS. 21, 23, 26, 36 AND 38).

FIRST USE 4-13-2013; IN COMMERCE 4-13-2013.

**CLASS 9—(Continued).**

4,593,889. ROCK SECURITY, LLC, DETROIT, MI. SN 85-929,930. PUB. 10-22-2013, FILED 5-13-2013.

# 360-365

THE MARK CONSISTS OF STANDARD CHARACTERS WITHOUT CLAIM TO ANY PARTICULAR FONT, STYLE, SIZE, OR COLOR.

FOR COMPUTER SOFTWARE TO ENABLE THE TRANSMISSION OF MAPPING, NAVIGATION, TRAFFIC, WEATHER AND POINT-OF-INTEREST INFORMATION TO TELECOMMUNICATIONS NETWORKS, CELLULAR TELEPHONES AND NAVIGATION DEVICE; SOFTWARE FOR SMARTPHONES THAT PROVIDES USERS THE ABILITY TO REMOTELY CONTROL FEATURES OF THEIR MOTOR VEHICLE, NAMELY, LOCKING AND UNLOCKING VEHICLE DOORS AND STARTING AND TURNING OFF THE VEHICLE; SOFTWARE FOR SMARTPHONES THAT PROVIDES USERS THE ABILITY TO REMOTELY CHECK STATUSES OF MOTOR VEHICLE OPERATING SYSTEMS, NAMELY, ENGINE OIL LIFE, FUEL LEVEL, TIRE PRESSURE AND BATTERY CHARGE; SOFTWARE FOR SMARTPHONES THAT PROVIDES USERS THE ABILITY TO CONNECT TO A TELECOMMUNICATIONS SERVICE ADVISOR AT A CALL CENTER; ELECTRONIC NAVIGATIONAL DEVICES, NAMELY, GLOBAL POSITIONING SATELLITE (GPS) BASED NAVIGATION RECEIVERS; ELECTRONIC DEPTH SOUNDERS; PORTABLE COMMUNICATION DEVICES, NAMELY, RADIO TRANSCEIVERS AND WIRELESS TELEPHONES; PRE-RECORDED CD-ROMS AND CARTRIDGES FEATURING DIGITAL MAP DATA AND SOFTWARE FOR FACILITATING USE OF GPS BASED NAVIGATION RECEIVERS, RADIO TRANSCEIVERS AND WIRELESS TELEPHONES (U.S. CLS. 21, 23, 26, 36 AND 38).

FIRST USE 2-0-2014; IN COMMERCE 2-0-2014.

4,593,921. NIPPON DENKI KABUSHIKI KAISHA, DBA NEC CORPORATION, TOKYO, JAPAN. SN 85-936,582. PUB. 12-3-2013, FILED 5-20-2013.

## INFOFRAME ELASTIC RELATIONAL STORE

THE MARK CONSISTS OF STANDARD CHARACTERS WITHOUT CLAIM TO ANY PARTICULAR FONT, STYLE, SIZE, OR COLOR.

NO CLAIM IS MADE TO THE EXCLUSIVE RIGHT TO USE "ELASTIC RELATIONAL STORE", APART FROM THE MARK AS SHOWN.

FOR COMPUTER SOFTWARE FOR USE IN INFORMATION MANAGEMENT, INFORMATION ANALYSIS AND DATABASE MANAGEMENT (U.S. CLS. 21, 23, 26, 36 AND 38).

FIRST USE 9-22-2013; IN COMMERCE 9-22-2013.

**CLASS 9—(Continued).**

4,593,932. HACH COMPANY, LOVELAND, CO. SN 85-937,234. PUB. 11-5-2013, FILED 5-20-2013.

# QUIKCHEM

THE MARK CONSISTS OF STANDARD CHARACTERS WITHOUT CLAIM TO ANY PARTICULAR FONT, STYLE, SIZE, OR COLOR.

FOR AUTOMATED FLOW INJECTION QUANTITATIVE ANALYSIS SYSTEM COMPRISED OF A SAMPLER IN THE NATURE OF A BAILER, AN INJECTOR, A REACTION MANIFOLD, A FILLING LEVEL DETECTOR, SOFTWARE FOR INSTRUMENT CONTROL AND DATA ACQUISITION, A COMPUTER, AND A PRINTER, ALL FOR USE IN ANALYZING PH LEVELS, THE PRESENCE AND LEVELS OF DISSOLVED SOLIDS, METALS, CHEMICALS, AND GASES, AND THE PRESENCE AND LEVELS OF BACTERIA AND SINGLE-CELLED LIVING ORGANISMS IN DRINKING WATER, WASTEWATER, SEAWATER, BRACKISH WATER, INDUSTRIAL WATER, INDUSTRIAL BRINE AND CAUSTIC FLUID MATRICES, SURFACE WATER, DAIRY AND BEVERAGE FLUID MATRICES, AGRICULTURAL SOIL EXTRACTS, AQUARIUM WATER, AND HYDROPONIC FLUIDS (U.S. CLS. 21, 23, 26, 36 AND 38).

FIRST USE 2-1-1981; IN COMMERCE 2-1-1981.

**CLASS 9—(Continued).**

4,593,942. THE PROFESSIONAL CONNECTION INCORPORATED, DBA FLYINSTYLE, FORT LAUDERDALE, FL. SN 85-938,498. PUB. 10-15-2013, FILED 5-21-2013.

# FlyInStyle

THE MARK CONSISTS OF STANDARD CHARACTERS WITHOUT CLAIM TO ANY PARTICULAR FONT, STYLE, SIZE, OR COLOR.

FOR COMPUTER APPLICATION SOFTWARE FOR INTERNET ENABLED COMPUTERS, MOBILE PHONES, TABLETS AND OTHER DEVICES, NAMELY, SOFTWARE FOR PRESENTING ADVERTISING SERVICES AND PROMOTIONAL OFFERS (U.S. CLS. 21, 23, 26, 36 AND 38).

FIRST USE 3-5-2014; IN COMMERCE 3-5-2014.

4,593,936. SNAPONE, INC., PRINCETON, NJ. SN 85-937,975. PUB. 10-29-2013, FILED 5-21-2013.



OWNER OF U.S. REG. NOS. 4,061,424, 4,182,548, AND OTHERS.

NO CLAIM IS MADE TO THE EXCLUSIVE RIGHT TO USE "PLAY", APART FROM THE MARK AS SHOWN.

THE MARK CONSISTS OF A STYLIZED PINWHEEL DESIGN ON THE LEFT WITH THE STYLIZED TEXT "SNAP PLAY" TO THE RIGHT. THE STYLIZED PINWHEEL DESIGN CONSISTS OF FIVE STYLIZED BLADES EMANATING FROM THE CENTER OF THE DESIGN IN PINWHEEL FASHION.

FOR DOWNLOADABLE SOFTWARE IN THE NATURE OF A MOBILE APPLICATION FOR STREAMING DIGITAL MUSIC FROM A HOME COMPUTER OR CLOUD SERVICE TO A MOBILE PHONE OR OTHER INTERNET CONNECTED DEVICES (U.S. CLS. 21, 23, 26, 36 AND 38).

FIRST USE 6-10-2014; IN COMMERCE 6-10-2014.

4,593,951. CAPITAL ONE FINANCIAL CORPORATION, RICHMOND, VA. SN 85-939,951. PUB. 10-15-2013, FILED 5-22-2013.

# SURESWIPE

THE MARK CONSISTS OF STANDARD CHARACTERS WITHOUT CLAIM TO ANY PARTICULAR FONT, STYLE, SIZE, OR COLOR.

FOR MOBILE DEVICE APPLICATION SOFTWARE, NAMELY, SECURITY SOFTWARE (U.S. CLS. 21, 23, 26, 36 AND 38).

FIRST USE 9-16-2012; IN COMMERCE 9-16-2012.

**CLASS 9—(Continued).**

4,593,963. WALI ELECTRIC, INC., HAYWARD, CA. SN 85-941,441. PUB. 10-22-2013, FILED 5-23-2013.

# WALI

THE MARK CONSISTS OF STANDARD CHARACTERS WITHOUT CLAIM TO ANY PARTICULAR FONT, STYLE, SIZE, OR COLOR.

FOR BATTERIES; BATTERY CABLES; BATTERY CASES; BATTERY CHARGE DEVICES; BATTERY CHARGERS; BATTERY PACKS FOR LAPTOPS, CELL PHONES, AND HANDHELD COMPUTERS; CELL PHONE BATTERY CHARGERS; CELL PHONE BATTERY CHARGERS FOR USE IN VEHICLES; ELECTRIC POWER CONVERTERS; MOBILE TELEPHONE BATTERIES; POWER ADAPTERS; POWER ADAPTERS FOR COMPUTERS; RECHARGEABLE ELECTRIC BATTERIES; RENEWABLE BATTERY SYSTEM TO PROVIDE BACKUP POWER (U.S. CLS. 21, 23, 26, 36 AND 38).  
FIRST USE 3-23-2013; IN COMMERCE 3-23-2013.

---

4,593,973. D3F, LLC, NEW YORK, NY. SN 85-942,668. PUB. 10-22-2013, FILED 5-24-2013.

# HUNGRY FAN

THE MARK CONSISTS OF STANDARD CHARACTERS WITHOUT CLAIM TO ANY PARTICULAR FONT, STYLE, SIZE, OR COLOR.

OWNER OF U.S. REG. NO. 4,243,443.  
FOR DOWNLOADABLE SOFTWARE IN THE NATURE OF A MOBILE APPLICATION FOR REVIEWING AND ACCESSING INFORMATION CONCERNING RESTAURANTS, FOOD AND DINING OPTIONS, MENUS AND SPORTS VENUES (U.S. CLS. 21, 23, 26, 36 AND 38).  
FIRST USE 11-4-2013; IN COMMERCE 11-4-2013.

---

4,593,976. AVANZA CORPORATION, SHENZHEN, GUANGDONG, CHINA. SN 85-943,191. PUB. 11-5-2013, FILED 5-28-2013.

# Avanza

THE MARK CONSISTS OF STANDARD CHARACTERS WITHOUT CLAIM TO ANY PARTICULAR FONT, STYLE, SIZE, OR COLOR.

**CLASS 9—(Continued).**

THE ENGLISH TRANSLATION OF THE SPANISH WORD "AVANZA" IN THE MARK IS "IT ADVANCES".

FOR AUDIO-RECEIVERS AND VIDEO-RECEIVERS; CAMCORDERS; CINEMATOGRAPHIC CAMERAS; CINEMATOGRAPHIC PROJECTORS; COMPUTER MEMORY HARDWARE; DATA PROCESSORS; DOWNLOADABLE IMAGE FILE CONTAINING ARTWORK, TEXT, AUDIO, VIDEO, GAMES AND INTERNET WEB LINKS RELATING TO SPORTING AND CULTURAL ACTIVITIES; EDITING APPLIANCES FOR CINEMATOGRAPHIC FILMS; FLASHLIGHTS FOR USE IN PHOTOGRAPHY; INTERFACES FOR COMPUTERS; LASER DEVICE FOR PROJECTING A VISIBLE LINE ON A WORK PIECE TO BE CUT BY A ROTARY POWER SAW; LIQUID CRYSTAL DISPLAY (LCD) PROJECTORS; MAGIC LANTERNS; MOVIE EDITING PROJECTORS; MOVIE PROJECTORS; MULTIMEDIA PROJECTORS; PHOTOGRAPHIC FILTERS; PHOTOGRAPHIC PROJECTORS; PHOTOGRAPHIC SLIDE TRANSPARENCIES; PICTURE PROJECTORS; PLANETARIUM PROJECTORS; PROJECTION SCREENS; PROJECTORS PARTICULARLY PROJECTORS FOR THE ENTERTAINMENT INDUSTRY; SELF-ACTING FOCUSING PROJECTORS; SLIDE PROJECTORS; SOUND PROJECTORS AND AMPLIFIERS; SOUND REPRODUCTION APPARATUS; SOUND TRANSMITTING APPARATUS; TRANSPARENCY PROJECTION APPARATUS; VIDEO PROJECTORS (U.S. CLS. 21, 23, 26, 36 AND 38).

FIRST USE 6-10-2013; IN COMMERCE 9-3-2013.

---

4,593,991. PRNT ENTERPRISES, LLC, FORT LAUDERDALE, FL. SN 85-945,875. PUB. 11-5-2013, FILED 5-30-2013.

# 3BEE

THE MARK CONSISTS OF STANDARD CHARACTERS WITHOUT CLAIM TO ANY PARTICULAR FONT, STYLE, SIZE, OR COLOR.

FOR COMPUTER SYSTEMS, NAMELY, COMPUTER HARDWARE AND SOFTWARE FOR MARKETING FOR USE WITH WIRELESS PROXIMITY MARKETING SYSTEMS; COMPUTER HARDWARE AND SOFTWARE FOR MARKETING FOR USE WITH WIRELESS PROXIMITY MARKETING SYSTEMS (U.S. CLS. 21, 23, 26, 36 AND 38).

FIRST USE 6-23-2014; IN COMMERCE 6-23-2014.

**CLASS 9—(Continued).**

4,593,992. PRNT ENTERPRISES, LLC, FORT LAUDERDALE, FL. SN 85-945,876. PUB. 11-5-2013, FILED 5-30-2013.



THE MARK CONSISTS OF THE ARTISTIC RENDERING OF A BEE DRAWN WITH A HUMAN FACE.

FOR COMPUTER SYSTEMS, NAMELY, COMPUTER HARDWARE AND SOFTWARE FOR MARKETING FOR USE WITH WIRELESS PROXIMITY MARKETING SYSTEMS; COMPUTER HARDWARE AND SOFTWARE FOR MARKETING FOR USE WITH WIRELESS PROXIMITY MARKETING SYSTEMS (U.S. CLS. 21, 23, 26, 36 AND 38).

FIRST USE 6-23-2014; IN COMMERCE 6-23-2014.

4,593,993. PRNT ENTERPRISES, LLC, FORT LAUDERDALE, FL. SN 85-945,878. PUB. 11-5-2013, FILED 5-30-2013.

WHEN YOU SEE THE BEE, WIFI  
IS FREE

THE MARK CONSISTS OF STANDARD CHARACTERS WITHOUT CLAIM TO ANY PARTICULAR FONT, STYLE, SIZE, OR COLOR.

FOR COMPUTER SYSTEMS, NAMELY, COMPUTER HARDWARE AND SOFTWARE FOR MARKETING FOR USE WITH WIRELESS PROXIMITY MARKETING SYSTEMS; COMPUTER HARDWARE AND SOFTWARE FOR MARKETING FOR USE WITH WIRELESS PROXIMITY MARKETING SYSTEMS (U.S. CLS. 21, 23, 26, 36 AND 38).

FIRST USE 6-23-2014; IN COMMERCE 6-23-2014.

**CLASS 9—(Continued).**

4,594,000. MILESTONE AV TECHNOLOGIES LLC, EDEN PRAIRIE, MN. SN 85-947,876. PUB. 11-5-2013, FILED 5-31-2013.

**FOR YOUR IMAGE**

THE MARK CONSISTS OF STANDARD CHARACTERS WITHOUT CLAIM TO ANY PARTICULAR FONT, STYLE, SIZE, OR COLOR.

FOR VIDEO PROJECTION SCREENS AND VIDEO CAMERAS; AUDIO, VIDEO, AND HOME THEATER FURNISHINGS, NAMELY, STANDS SPECIALLY ADAPTED FOR AUDIO SPEAKERS; STANDS SPECIALLY ADAPTED FOR AUDIO AND VIDEO EQUIPMENT (U.S. CLS. 21, 23, 26, 36 AND 38).

FIRST USE 6-11-2013; IN COMMERCE 6-11-2013.

4,594,063. METRO CREATIVE GRAPHICS, INC., NEW YORK, NY. SN 85-957,426. PUB. 11-12-2013, FILED 6-12-2013.

**MiAD**

THE MARK CONSISTS OF STANDARD CHARACTERS WITHOUT CLAIM TO ANY PARTICULAR FONT, STYLE, SIZE, OR COLOR.

FOR DOWNLOADABLE MOBILE APPLICATIONS FOR THE CREATION OF ADVERTISEMENTS AND ADVERTISING LAYOUTS (U.S. CLS. 21, 23, 26, 36 AND 38).

FIRST USE 5-23-2013; IN COMMERCE 5-23-2013.

4,594,080. CODE STRICT LLC, LOS ANGELES, CA. SN 85-959,765. PUB. 11-12-2013, FILED 6-14-2013.

**Code Strict LLC**

THE MARK CONSISTS OF STANDARD CHARACTERS WITHOUT CLAIM TO ANY PARTICULAR FONT, STYLE, SIZE, OR COLOR.

NO CLAIM IS MADE TO THE EXCLUSIVE RIGHT TO USE "LLC", APART FROM THE MARK AS SHOWN.

FOR COMPUTER SOFTWARE DEVELOPMENT TOOLS (U.S. CLS. 21, 23, 26, 36 AND 38).

FIRST USE 6-5-2013; IN COMMERCE 6-5-2013.

**CLASS 9—(Continued).**

4,594,102. V-MARK ENTERPRISES LTD., VANCOUVER, CANADA. SN 85-963,272. PUB. 11-5-2013, FILED 6-18-2013.

V-MARK

THE MARK CONSISTS OF STANDARD CHARACTERS WITHOUT CLAIM TO ANY PARTICULAR FONT, STYLE, SIZE, OR COLOR.

FOR CLIMATE CONTROL SYSTEMS CONSISTING OF DIGITAL THERMOSTATS FOR COOLING EQUIPMENT, AND A PROGRAMMABLE LOGIC CONTROLLER (PLC) WITH INPUT AND OUTPUT FEATURES FOR TEMPERATURE AND HUMIDITY, WHICH WORKS WITH A REMOTE DIGITAL READ OUT CONTROLLER; CLIMATE CONTROL SYSTEMS CONSISTING OF DIGITAL THERMOSTATS, AIR CONDITIONING, HEATING, VENTILATION AND DRYING CONTROL DEVICES; LABELS CARRYING MAGNETICALLY, OPTICALLY, OR ELECTRONICALLY RECORDED OR ENCODED INFORMATION; TEMPERATURE METERS NOT FOR MEDICAL USE; WEIGHING SCALES; WIRELESS TRANSCEIVERS WITH COLLECTION AND DISPLAY TECHNOLOGY FOR THE STATUS AND TRACKING OF RETAIL GOODS FROM THE BACKDOOR TO THE SHELF (U.S. CLS. 21, 23, 26, 36 AND 38).  
FIRST USE 11-18-2013; IN COMMERCE 12-8-2013.

**CLASS 9—(Continued).**

4,594,103. V-MARK ENTERPRISES LTD., VANCOUVER, B.C., CANADA. SN 85-963,359. PUB. 11-5-2013, FILED 6-18-2013.



THE MARK CONSISTS OF A TRIANGLE AT UPPER LEFT, TRAPEZOID AT UPPER RIGHT, A STYLIZED LETTER "M" AT BOTTOM, BELOW WHICH IS THE WORD "V-MARK" AND ALL IN RECTANGULAR BACKGROUND IN WHITE.

FOR CLIMATE CONTROL SYSTEMS CONSISTING OF DIGITAL THERMOSTATS FOR COOLING EQUIPMENT, AND A PROGRAMMABLE LOGIC CONTROLLER (PLC) WITH INPUT AND OUTPUT FEATURES FOR TEMPERATURE AND HUMIDITY, WHICH WORKS WITH A REMOTE DIGITAL READ OUT CONTROLLER; CLIMATE CONTROL SYSTEMS CONSISTING OF DIGITAL THERMOSTATS, AIR CONDITIONING, HEATING, VENTILATION AND DRYING CONTROL DEVICES; LABELS CARRYING MAGNETICALLY, OPTICALLY, OR ELECTRONICALLY RECORDED OR ENCODED INFORMATION; TEMPERATURE METERS NOT FOR MEDICAL USE; WEIGHING SCALES; WIRELESS TRANSCEIVERS WITH COLLECTION AND DISPLAY TECHNOLOGY FOR THE STATUS AND TRACKING OF RETAIL GOODS FROM THE BACKDOOR TO THE SHELF (U.S. CLS. 21, 23, 26, 36 AND 38).  
FIRST USE 11-18-2013; IN COMMERCE 12-8-2013.

4,594,105. ST. CHARLES CONSULTING GROUP LLC, ST. CHARLES, IL. SN 85-963,862. PUB. 11-5-2013, FILED 6-19-2013.

RapidMapper

THE MARK CONSISTS OF STANDARD CHARACTERS WITHOUT CLAIM TO ANY PARTICULAR FONT, STYLE, SIZE, OR COLOR.

FOR COMPUTER SOFTWARE FOR BUSINESS PROCESS MAPPING (U.S. CLS. 21, 23, 26, 36 AND 38).  
FIRST USE 10-24-2013; IN COMMERCE 10-24-2013.

**CLASS 9—(Continued).**

4,594,124. SOFTCAMP CO., LTD., SEOUL, REPUBLIC OF KOREA. SN 85-969,651. PUB. 11-12-2013, FILED 6-25-2013.

# MAXEON

THE MARK CONSISTS OF STANDARD CHARACTERS WITHOUT CLAIM TO ANY PARTICULAR FONT, STYLE, SIZE, OR COLOR.

FOR COMPUTER SOFTWARE FOR STORING, SHARING, TRANSMITTING DIGITAL DOCUMENTS AND FILES; COMPUTER SOFTWARE FOR USE IN MANAGEMENT OF CLOUD-BASED FILE STORAGE, TRANSFER, AND SHARING; COMPUTER SOFTWARE DEVELOPMENT TOOLS; COMPUTER SOFTWARE FOR USE IN MANAGEMENT OF USER IDENTITIES, ACCESS PERMISSIONS, AUTHENTICATION, SECURE COMMUNICATION AND PROTECTION OF BUSINESS AND PERSONAL INFORMATION FOR MOBILE AND WIRELESS COMMUNICATION DEVICES; COMPUTER SOFTWARE FOR PROVIDING WEB-BASED ACCESS TO APPLICATIONS AND SERVICES THROUGH A WEB OPERATING SYSTEM OR PORTAL INTERFACE; COMPUTER SOFTWARE FOR SECURITY, MANAGEMENT, DATA SHARING, COLLABORATION, AND ACCESS BETWEEN ENTERPRISE COMPUTER SYSTEMS, NETWORKS, ELECTRONIC AND OPTICAL COMMUNICATION NETWORKS, AND MOBILE WIRELESS DEVICES; COMPUTER SOFTWARE FOR DEVELOPING MOBILE INTERFACE APPLICATIONS AND CLIENT INTERFACES (U.S. CLS. 21, 23, 26, 36 AND 38).

FIRST USE 5-1-2013; IN COMMERCE 5-1-2013.

4,594,125. SOFTCAMP CO., LTD., SEOUL, REPUBLIC OF KOREA. SN 85-969,673. PUB. 11-12-2013, FILED 6-25-2013.

# SHIELDEX

THE MARK CONSISTS OF STANDARD CHARACTERS WITHOUT CLAIM TO ANY PARTICULAR FONT, STYLE, SIZE, OR COLOR.

FOR COMPUTER SOFTWARE FOR STORING, SHARING, TRANSMITTING DIGITAL DOCUMENTS AND FILES; COMPUTER SOFTWARE FOR USE IN MANAGEMENT OF CLOUD-BASED FILE STORAGE, TRANSFER, AND SHARING; COMPUTER SOFTWARE DEVELOPMENT TOOLS; COMPUTER SOFTWARE FOR USE IN MANAGEMENT OF USER IDENTITIES, ACCESS PERMISSIONS, AUTHENTICATION, SECURE COMMUNICATION AND PROTECTION OF BUSINESS AND PERSONAL INFORMATION FOR MOBILE AND WIRELESS COMMUNICATION DEVICES; COMPUTER SOFTWARE FOR PROVIDING WEB-BASED ACCESS TO APPLICATIONS AND SERVICES THROUGH A WEB OPERATING SYSTEM OR PORTAL INTERFACE; COMPUTER SOFTWARE FOR SECURITY, MANAGEMENT, DATA SHARING, COLLABORATION, AND ACCESS BETWEEN ENTERPRISE COMPUTER SYSTEMS, NETWORKS, ELECTRONIC AND OPTICAL COMMUNICATION NETWORKS, AND MOBILE WIRELESS DEVICES; COMPUTER SOFTWARE FOR DEVELOPING MOBILE INTERFACE APPLICATIONS AND CLIENT INTERFACES (U.S. CLS. 21, 23, 26, 36 AND 38).

FIRST USE 9-1-2013; IN COMMERCE 9-1-2013.

**CLASS 9—(Continued).**

4,594,143. VILLARREAL, VIVIAN DAVID, GONZALES, LA. SN 85-972,831. PUB. 11-19-2013, FILED 6-28-2013.

# HUSTLE LANE RECORDS

THE MARK CONSISTS OF STANDARD CHARACTERS WITHOUT CLAIM TO ANY PARTICULAR FONT, STYLE, SIZE, OR COLOR.

NO CLAIM IS MADE TO THE EXCLUSIVE RIGHT TO USE "RECORDS", APART FROM THE MARK AS SHOWN, FOR DIGITAL MATERIALS, NAMELY, CDS FEATURING MUSICAL RECORDINGS; DOWNLOADABLE MUSIC FILES; DOWNLOADABLE MUSICAL SOUND RECORDINGS; MUSICAL RECORDINGS; PRE-RECORDED CDS FEATURING MUSICAL RECORDINGS (U.S. CLS. 21, 23, 26, 36 AND 38).

FIRST USE 5-0-2008; IN COMMERCE 5-0-2008.

4,594,146. E-FILLIATE, INC., RANCHO CORDOVA, CA. SN 85-973,396. PUB. 10-8-2013, FILED 6-28-2013.

# STREET BUDS

THE MARK CONSISTS OF STANDARD CHARACTERS WITHOUT CLAIM TO ANY PARTICULAR FONT, STYLE, SIZE, OR COLOR.

NO CLAIM IS MADE TO THE EXCLUSIVE RIGHT TO USE "BUDS", APART FROM THE MARK AS SHOWN.

FOR HEADPHONES, EARPHONES AND EARBUDS (U.S. CLS. 21, 23, 26, 36 AND 38).

FIRST USE 1-30-2014; IN COMMERCE 5-22-2014.

4,594,147. WELLTOK, INC., DENVER, CO. SN 85-973,464. PUB. 11-19-2013, FILED 6-28-2013.

# Momentum

THE MARK CONSISTS OF STANDARD CHARACTERS WITHOUT CLAIM TO ANY PARTICULAR FONT, STYLE, SIZE, OR COLOR.

FOR COMPUTER APPLICATION SOFTWARE FOR MOBILE PHONES, MOBILE DEVICES, AND HANDHELD COMPUTERS, NAMELY, SOFTWARE FOR CREATING, ADDING, ORGANIZING, COLLECTING, AND SHARING PHOTOS, QUOTES, THOUGHTS, CHALLENGES, TIPS, AND ACHIEVEMENTS (U.S. CLS. 21, 23, 26, 36 AND 38).

FIRST USE 12-0-2013; IN COMMERCE 12-0-2013.

**CLASS 9—(Continued).**

4,594,150. LIVINGPLUG, INC., SAN FRANCISCO, CA. SN 85-974,137. PUB. 4-15-2014, FILED 7-1-2013.

# LivingPlug

THE MARK CONSISTS OF STANDARD CHARACTERS WITHOUT CLAIM TO ANY PARTICULAR FONT, STYLE, SIZE, OR COLOR.

FOR ELECTRICAL OUTLET PLATES; COMPUTER HARDWARE; EXTENSION CORDS; ELECTRICAL OUTLET APPARATUS, NAMELY, A MULTI-FUNCTION OUTLET ATTACHMENT, NAMELY, OUTLET FACE-PLATE COVER AND CHILD SAFE OUTLET COVER (U.S. CLS. 21, 23, 26, 36 AND 38).

FIRST USE 6-12-2014; IN COMMERCE 6-12-2014.

4,594,152. ZIPSTEAL LLC, MORRIS PLAINS, NJ. SN 85-974,316. PUB. 11-19-2013, FILED 7-1-2013.

# Maxessory

THE MARK CONSISTS OF STANDARD CHARACTERS WITHOUT CLAIM TO ANY PARTICULAR FONT, STYLE, SIZE, OR COLOR.

THE NAME(S), PORTRAIT(S), AND/OR SIGNATURE(S) SHOWN IN THE MARK DOES NOT IDENTIFY A PARTICULAR LIVING INDIVIDUAL.

THE WORDING "MAXESSORY" HAS NO MEANING IN A FOREIGN LANGUAGE.

FOR CARRYING CASES FOR CELL PHONES; CELL PHONE BACKPLATES; CELL PHONE CASES; CELL PHONE COVERS; CELL PHONE FACEPLATES; PROTECTIVE COVERS AND CASES FOR CELL PHONES, LAPTOPS AND PORTABLE MEDIA PLAYERS; PROTECTIVE COVERS AND CASES FOR TABLET COMPUTERS (U.S. CLS. 21, 23, 26, 36 AND 38).

FIRST USE 7-1-2013; IN COMMERCE 10-1-2013.

4,594,157. AMTRAN TECHNOLOGY CO., LTD., NEW TAIPEI CITY, TAIWAN. SN 85-978,928. PUB. 11-12-2013, FILED 6-7-2011.

# I.C.E

THE MARK CONSISTS OF STANDARD CHARACTERS WITHOUT CLAIM TO ANY PARTICULAR FONT, STYLE, SIZE, OR COLOR.

**CLASS 9—(Continued).**

PRIORITY CLAIMED UNDER SEC. 44(D) ON CHINA APPLICATION NO. 9370082. FILED 4-21-2011, REG. NO. 9370082. DATED 9-7-2012, EXPIRES 9-6-2022.

FOR TELEVISIONS AND MONITORS; TELEVISION SETS; LIQUID CRYSTAL DISPLAY (LCD) TELEVISIONS; PORTABLE TELEVISIONS; PLASMA TELEVISION (U.S. CLS. 21, 23, 26, 36 AND 38).

FIRST USE 9-9-2012; IN COMMERCE 9-9-2012.

4,594,175. DREAMWORKS ANIMATION L.L.C., GLENDALE, CA. SN 85-982,206. PUB. 11-8-2011, FILED 4-25-2011.

# DREAMWORKS DRAGONS: GIFT OF THE NIGHT FURY

THE MARK CONSISTS OF STANDARD CHARACTERS WITHOUT CLAIM TO ANY PARTICULAR FONT, STYLE, SIZE, OR COLOR.

OWNER OF U.S. REG. NOS. 2,326,951, 2,457,467, AND OTHERS.

FOR PRE-RECORDED DVDS FEATURING ANIMATED MOTION PICTURES; PRE-RECORDED VIDEO DISKS AND DVDS FEATURING ANIMATED MOTION PICTURES (U.S. CLS. 21, 23, 26, 36 AND 38).

FIRST USE 11-15-2011; IN COMMERCE 11-15-2011.

4,594,178. MEETME, INC., NEW HOPE, PA. SN 85-982,218. PUB. 3-25-2014, FILED 5-23-2013.

# CHOOSY

THE MARK CONSISTS OF STANDARD CHARACTERS WITHOUT CLAIM TO ANY PARTICULAR FONT, STYLE, SIZE, OR COLOR.

FOR SOFTWARE FOR USE IN MOBILE DEVICES WHICH ALLOWS USERS TO COMMUNICATE VIA TEXTUAL CONTENT, VIDEO, PHOTOS AND AUDIO-VISUAL MEANS, INCLUDING VIA SOCIAL NETWORKING PLATFORMS; DOWNLOADABLE SOFTWARE IN THE NATURE OF A MOBILE APPLICATION FOR ANALYZING DATA AND TRANSMISSION OF PHOTOGRAPHS; COMPUTER SOFTWARE FOR THE COLLECTION, EDITING, ORGANIZING, MODIFYING, TRANSMISSION, STORAGE AND SHARING OF DATA AND INFORMATION; COMPUTER SOFTWARE TO ENABLE UPLOADING, DOWNLOADING, ACCESSING, POSTING, DISPLAYING, TAGGING, BLOGGING, STREAMING, LINKING, SHARING OR OTHERWISE PROVIDING ELECTRONIC MEDIA OR INFORMATION VIA COMPUTER AND COMMUNICATION NETWORKS; APPLICATION PROGRAMMING INTERFACE (API) FOR COMPUTER SOFTWARE WHICH FACILITATES ONLINE SERVICES FOR SOCIAL NETWORKING, BUILDING SOCIAL NETWORKING APPLICATIONS AND FOR ALLOWING DATA RETRIEVAL, UPLOAD, DOWNLOAD, ACCESS AND MANAGEMENT (U.S. CLS. 21, 23, 26, 36 AND 38).

FIRST USE 12-18-2013; IN COMMERCE 12-18-2013.

**CLASS 9—(Continued).**

4,594,184. HUIMIO OY, ESPOO, FINLAND. SN 85-982,354.  
PUB. 10-29-2013, FILED 11-26-2012.

# TUNEMIO

THE MARK CONSISTS OF STANDARD CHARACTERS WITHOUT CLAIM TO ANY PARTICULAR FONT, STYLE, SIZE, OR COLOR.

THE WORDING "TUNEMIO" HAS NO MEANING IN A FOREIGN LANGUAGE.

FOR DOWNLOADABLE SOFTWARE FOR PLAYING, LEARNING AND PRACTICING MUSIC, FOR CREATING MUSICAL CONTENT, FOR SHARING AND DISTRIBUTING THE CONTENT AND INTERACTING WITH OTHER USERS (U.S. CLS. 21, 23, 26, 36 AND 38).

FIRST USE 4-11-2013; IN COMMERCE 4-11-2013.

**CLASS 9—(Continued).**

4,594,204. CARPE, DAVID, LEXINGTON, MA. SN 86-003,396.  
PUB. 12-17-2013, FILED 7-5-2013.

# Furgazm

THE MARK CONSISTS OF STANDARD CHARACTERS WITHOUT CLAIM TO ANY PARTICULAR FONT, STYLE, SIZE, OR COLOR.

FOR CARRYING CASES SPECIALLY ADAPTED FOR ELECTRONIC EQUIPMENT, NAMELY, CELL PHONES, LAPTOPS, PORTABLE MEDIA PLAYERS, TABLET COMPUTERS, SMARTPHONES (U.S. CLS. 21, 23, 26, 36 AND 38).

FIRST USE 1-1-2014; IN COMMERCE 6-1-2014.

---

4,594,202. FORTWAY LIMITED, ROAD TOWN, TORTOLA, BR. VIRGIN ISLANDS. SN 86-002,644. PUB. 10-29-2013, FILED 7-3-2013.



THE MARK CONSISTS OF A SQUARE WITH CURVED ANGLES, WITH A DESIGN CONSISTING A TRIANGLE WITH CURVED SIDES AND CURVED LINES INSIDE THE TRIANGLE, AND THE STYLIZED WORD SPINNAKER. THE LOWER PORTION OF THE SQUARE IS FILLED, THE TRIANGLE DESIGN IS INSIDE THE UPPER PORTION OF THE SQUARE AND THE WORD SPINNAKER IS INSIDE THE LOWER PORTION OF THE SQUARE.

FOR CASES FOR EYEGLASSES AND SUNGLASSES; FRAMES FOR GLASSES AND PINCE-NEZ; OPTICAL GLASSES; SPECTACLE FRAMES; SPECTACLE LENSES; SUNGLASSES (U.S. CLS. 21, 23, 26, 36 AND 38).

FIRST USE 4-2-2014; IN COMMERCE 4-2-2014.

---

4,594,216. OMNI CABLE CORPORATION, WEST CHESTER, PA. SN 86-007,623. PUB. 12-3-2013, FILED 7-11-2013.

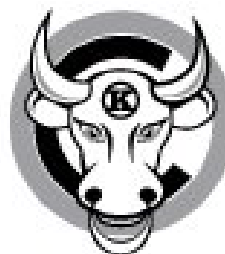

THE MARK CONSISTS OF THE LETTER "O" ENCLOSING THE LETTER "C," ON TOP OF WHICH IS A DRAWING OF A BULL'S HEAD. THE DEPICTION OF BULL'S HEAD INCLUDES AN ENCIRCLED LETTER "K" ON THE BULL'S FOREHEAD.

FOR ELECTRIC CABLES, WIRES, CONDUCTORS AND CONNECTION FITTINGS THEREFOR (U.S. CLS. 21, 23, 26, 36 AND 38).

FIRST USE 3-6-2013; IN COMMERCE 3-6-2013.



**CLASS 9—(Continued).**

4,594,217. HARDEEN, DAMIAN, BAYSIDE, NY. SN 86-007,647. PUB. 12-3-2013, FILED 7-11-2013.



THE MARK CONSISTS OF THE STYLIZED TEXT "PIC-TRAITS".

FOR VIDEO RECORDINGS FEATURING PHOTOGRAPHY INSTRUCTION (U.S. CLS. 21, 23, 26, 36 AND 38).

FIRST USE 7-3-2013; IN COMMERCE 6-17-2014.

**CLASS 9—(Continued).**

4,594,255. INTRALOT, INC., DULUTH, GA. SN 86-023,750. PUB. 10-15-2013, FILED 7-30-2013.



THE MARK CONSISTS OF STANDARD CHARACTERS WITHOUT CLAIM TO ANY PARTICULAR FONT, STYLE, SIZE, OR COLOR.

FOR COMPUTER SOFTWARE AND FIRMWARE FOR LOTTERIES AND GAMES OF CHANCE ON ANY COMPUTERIZED PLATFORM, INCLUDING DEDICATED GAMING CONSOLES, VIDEO BASED MACHINES, AND VIDEO LOTTERY TERMINALS FOR SALE TO LOTTERY AND GAMING AUTHORITIES AND THEIR AUTHORIZED AGENTS (U.S. CLS. 21, 23, 26, 36 AND 38).

FIRST USE 9-14-2013; IN COMMERCE 9-14-2013.

4,594,218. ANS DIGITAL CORP, TA NIXXELL, METUCHEN, NJ. SN 86-007,739. PUB. 2-25-2014, FILED 7-11-2013.



THE MARK CONSISTS OF STANDARD CHARACTERS WITHOUT CLAIM TO ANY PARTICULAR FONT, STYLE, SIZE, OR COLOR.

FOR ACCESSORIES FOR CELL PHONES, GPS AND CAMERAS, NAMELY, CARRYING CASES, PROTECTIVE CASES, CAR WINDSHIELD SUCTION MOUNTS, CAR DASHBOARD SUCTION MOUNTS, USB CABLES, BATTERY CHARGERS, POWER SUPPLY ADAPTERS, CAMERA BATTERIES, CAMERA TRIPODS, CAMERA LENS FILTERS (U.S. CLS. 21, 23, 26, 36 AND 38).

FIRST USE 10-15-2013; IN COMMERCE 10-15-2013.

4,594,266. A.C. ZINCS, INC., SEMINOLE, FL. SN 86-029,567. PUB. 1-21-2014, FILED 8-6-2013.



4,594,244. EMPIRIX INC., BILLERICA, MA. SN 86-015,192. PUB. 11-12-2013, FILED 7-19-2013.



THE MARK CONSISTS OF STANDARD CHARACTERS WITHOUT CLAIM TO ANY PARTICULAR FONT, STYLE, SIZE, OR COLOR.

FOR COMPUTER HARDWARE AND SOFTWARE FOR TESTING AND MONITORING COMPUTER NETWORK INFRASTRUCTURE AND TELECOMMUNICATION NETWORKS INFRASTRUCTURE, APPLICATIONS, AND EQUIPMENT, FOR TELECOMMUNICATIONS SERVICE PROVIDERS (U.S. CLS. 21, 23, 26, 36 AND 38).

FIRST USE 9-12-2013; IN COMMERCE 9-12-2013.

THE MARK CONSISTS OF STANDARD CHARACTERS WITHOUT CLAIM TO ANY PARTICULAR FONT, STYLE, SIZE, OR COLOR.

NO CLAIM IS MADE TO THE EXCLUSIVE RIGHT TO USE "CORROSION", APART FROM THE MARK AS SHOWN.

FOR SACRIFICIAL ANODE FOR AIR CONDITIONERS (U.S. CLS. 21, 23, 26, 36 AND 38).

FIRST USE 1-17-2006; IN COMMERCE 1-17-2006.

**CLASS 9—(Continued).**

4,594,298. TAPJOY, INC., SAN FRANCISCO, CA. SN 86-042,728. PUB. 1-21-2014, FILED 8-20-2013.



THE MARK CONSISTS OF THE WORDING "MY" WITHIN A CIRCLE AND THE STYLIZED WORDING "TAPJOY". FOR DOWNLOADABLE COMPUTER SOFTWARE FOR USE WITH MOBILE COMPUTING DEVICES FOR USE IN VIEWING DATA INCLUDING REWARDS RECEIVED FROM OTHER COMPUTER PROGRAM APPLICATIONS (U.S. CLS. 21, 23, 26, 36 AND 38).

FIRST USE 8-28-2013; IN COMMERCE 8-28-2013.

4,594,301. 337 TECHNOLOGY LIMITED, BEIJING, CHINA. SN 86-044,690. PUB. 10-29-2013, FILED 8-22-2013.

## Clash of Kings

THE MARK CONSISTS OF STANDARD CHARACTERS WITHOUT CLAIM TO ANY PARTICULAR FONT, STYLE, SIZE, OR COLOR.

FOR COMPUTER GAME PROGRAMMES; COMPUTER GAME PROGRAMMES DOWNLOADABLE VIA THE INTERNET; COMPUTER GAME SOFTWARE; COMPUTER GAME SOFTWARE FOR USE ON MOBILE AND CELLULAR PHONES (U.S. CLS. 21, 23, 26, 36 AND 38).

FIRST USE 5-20-2014; IN COMMERCE 5-20-2014.

4,594,302. 337 TECHNOLOGY LIMITED, BEIJING, CHINA. SN 86-044,696. PUB. 10-29-2013, FILED 8-22-2013.

## Clash of Spartan

THE MARK CONSISTS OF STANDARD CHARACTERS WITHOUT CLAIM TO ANY PARTICULAR FONT, STYLE, SIZE, OR COLOR.

FOR COMPUTER GAME PROGRAMMES; COMPUTER GAME PROGRAMMES DOWNLOADABLE VIA THE INTERNET; COMPUTER GAME SOFTWARE; COMPUTER GAME SOFTWARE FOR USE ON MOBILE AND CELLULAR PHONES (U.S. CLS. 21, 23, 26, 36 AND 38).

FIRST USE 12-18-2013; IN COMMERCE 12-18-2013.

**CLASS 9—(Continued).**

4,594,307. TREW GROUP, INC., DBA TREW MARKETING, AUSTIN, TX. SN 86-045,336. PUB. 2-25-2014, FILED 8-22-2013.

## Smart Marketing for Engineers

THE MARK CONSISTS OF STANDARD CHARACTERS WITHOUT CLAIM TO ANY PARTICULAR FONT, STYLE, SIZE, OR COLOR.

NO CLAIM IS MADE TO THE EXCLUSIVE RIGHT TO USE "MARKETING FOR ENGINEERS", APART FROM THE MARK AS SHOWN.

FOR DOWNLOADABLE ELECTRONIC BOOKS IN THE FIELD OF MARKETING (U.S. CLS. 21, 23, 26, 36 AND 38).

FIRST USE 1-1-2014; IN COMMERCE 1-1-2014.

4,594,318. PANAMA JACK INTERNATIONAL, INC., ORLANDO, FL. SN 86-050,332. PUB. 10-29-2013, FILED 8-28-2013.

## OUT ISLAND BY PANAMA JACK

THE MARK CONSISTS OF STANDARD CHARACTERS WITHOUT CLAIM TO ANY PARTICULAR FONT, STYLE, SIZE, OR COLOR.

OWNER OF U.S. REG. NOS. 2,700,520, 4,235,451, AND OTHERS.

THE NAME "PANAMA JACK" DOES NOT IDENTIFY A LIVING INDIVIDUAL.

FOR SUNGLASSES, SUNGLASS CASES, EYEGLASSES, EYEGLASS FRAMES, EYEWEAR AND SUNGLASS ACCESSORIES, NAMELY, CASES, CORDS AND NOSE PADS (U.S. CLS. 21, 23, 26, 36 AND 38).

FIRST USE 12-1-2013; IN COMMERCE 12-1-2013.

4,594,330. CIENA CORPORATION, HANOVER, MD. SN 86-057,222. PUB. 2-11-2014, FILED 9-5-2013.

## THE MUX

THE MARK CONSISTS OF STANDARD CHARACTERS WITHOUT CLAIM TO ANY PARTICULAR FONT, STYLE, SIZE, OR COLOR.

FOR MOBILE APPLICATION THAT BRINGS TOGETHER THE TELECOM AND TECHNOLOGY RSS FEEDS FROM ACROSS INDUSTRIES AND ALLOWS A USER TO CUSTOMIZE FEEDS, SAVE AND SHARE ARTICLES (U.S. CLS. 21, 23, 26, 36 AND 38).

FIRST USE 6-1-2013; IN COMMERCE 6-1-2013.

**CLASS 9—(Continued).**

4,594,347. VISION SOURCE L.P., KINGWOOD, TX. SN 86-063,428. PUB. 1-28-2014, FILED 9-12-2013.

**CLASS 9—(Continued).**

4,594,394. CHETANA WILLIAMSON, SANTA MONICA, CA. SN 86-081,342. PUB. 4-8-2014, FILED 10-2-2013.

# FRESH DAY

THE MARK CONSISTS OF STANDARD CHARACTERS WITHOUT CLAIM TO ANY PARTICULAR FONT, STYLE, SIZE, OR COLOR.

FOR CONTACT LENSES (U.S. CLS. 21, 23, 26, 36 AND 38).

FIRST USE 6-23-2014; IN COMMERCE 6-23-2014.

---

4,594,370. ALRAHIB, AKRUM, MISSION VIEJO, CA. SN 86-073,443. PUB. 2-18-2014, FILED 9-24-2013.

## Students With A Grades

THE MARK CONSISTS OF STANDARD CHARACTERS WITHOUT CLAIM TO ANY PARTICULAR FONT, STYLE, SIZE, OR COLOR.

FOR HEADSETS FOR CELLULAR OR MOBILE PHONES; HEADSETS FOR MOBILE TELEPHONES (U.S. CLS. 21, 23, 26, 36 AND 38).

FIRST USE 2-10-2013; IN COMMERCE 2-10-2013.

---

4,594,385. DELICIOUS 62 LLC, SEATTLE, WA. SN 86-078,238. PUB. 2-25-2014, FILED 9-30-2013.

# Snapling

THE MARK CONSISTS OF STANDARD CHARACTERS WITHOUT CLAIM TO ANY PARTICULAR FONT, STYLE, SIZE, OR COLOR.

FOR COMPUTER GAME SOFTWARE FOR USE ON MOBILE AND CELLULAR PHONES (U.S. CLS. 21, 23, 26, 36 AND 38).

FIRST USE 8-1-2013; IN COMMERCE 11-15-2013.



NO CLAIM IS MADE TO THE EXCLUSIVE RIGHT TO USE "BAG WORKS", APART FROM THE MARK AS SHOWN.

THE NAME(S), PORTRAIT(S), AND/OR SIGNATURE(S) SHOWN IN THE MARK DOES NOT IDENTIFY A PARTICULAR LIVING INDIVIDUAL.

THE MARK CONSISTS OF THE LETTERS "JB" IN A STYLIZED DESIGN AND THE WORDS "JENNY'S BAG WORKS" BENEATH THE DESIGN.

FOR BAGS AND CASES SPECIALLY ADAPTED FOR HOLDING OR CARRYING PORTABLE TELEPHONES AND TELEPHONE EQUIPMENT AND ACCESSORIES (U.S. CLS. 21, 23, 26, 36 AND 38).

FIRST USE 12-2-2013; IN COMMERCE 12-2-2013.

**CLASS 9—(Continued).**

4,594,397. NEWPORT COMPUTER SERVICES, INC., DBA NCS GLOBAL, ROCHESTER, NH. SN 86-083,337. PUB. 12-10-2013, FILED 10-4-2013.

**CLASS 9—(Continued).**

4,594,425. ARGENTO SC, NEW YORK, NY. SN 86-091,487. PUB. 3-11-2014, FILED 10-15-2013.

What you need, when you  
need IT.

**BLKSMITH**

THE MARK CONSISTS OF STANDARD CHARACTERS WITHOUT CLAIM TO ANY PARTICULAR FONT, STYLE, SIZE, OR COLOR.

FOR BACKUP DRIVES FOR COMPUTERS; BLANK COMPUTER DISCS; CENTRAL PROCESSING UNITS (CPU); COMPUTER CABLES; COMPUTER CARD ADAPTER; COMPUTER CENTRAL PROCESSING UNITS; COMPUTER CHASSIS; COMPUTER CHIPS; COMPUTER CURSOR CONTROL DEVICES, NAMELY, COMPUTER MOUSE; COMPUTER CURSOR CONTROL DEVICES, NAMELY, DIGITIZER TABLETS; COMPUTER CURSOR CONTROL DEVICES, NAMELY, LIGHT PENS; COMPUTER CURSOR CONTROL DEVICES, NAMELY, TOUCH PADS; COMPUTER CURSOR CONTROL DEVICES, NAMELY, TRACKBALLS; COMPUTER DISC DRIVES; COMPUTER DOCKING STATIONS; COMPUTER EQUIPMENT, NAMELY, WIRELESS CARDS; COMPUTER EXPANSION BOARDS; COMPUTER GRAPHICS BOARDS; COMPUTER HARDWARE; COMPUTER HARDWARE AND PERIPHERALS; COMPUTER HEAT SINKS; COMPUTER KEYBOARD CONTROLLERS; COMPUTER KEYBOARDS; COMPUTER MICE; COMPUTER MONITORS; COMPUTER MOTHERBOARDS AND DAUGHTERBOARDS; COMPUTER NETWORK ADAPTERS, SWITCHES, ROUTERS AND HUBS; COMPUTER NETWORK SERVER; COMPUTER TERMINALS, KEYBOARDS AND PRINTERS (U.S. CLS. 21, 23, 26, 36 AND 38).

FIRST USE 9-1-2013; IN COMMERCE 9-1-2013.

THE MARK CONSISTS OF STANDARD CHARACTERS WITHOUT CLAIM TO ANY PARTICULAR FONT, STYLE, SIZE, OR COLOR.

FOR PROTECTIVE CARRYING CASES FOR PORTABLE ELECTRONIC LISTENING DEVICES AND MUSIC PLAYERS, NAMELY, MP3 PLAYERS, AND FOR PORTABLE COMPUTERS, GLOBAL POSITIONING SYSTEMS (GPS), MOBILE AND CELLULAR TELEPHONES, PORTABLE MEDIA PLAYERS, SMART PHONES, AND PERSONAL DIGITAL ASSISTANTS (U.S. CLS. 21, 23, 26, 36 AND 38).

FIRST USE 5-12-2014; IN COMMERCE 6-2-2014.

4,594,432. ENSPERITY VENTURES INCORPORATED, ROAD TOWN, TORTOLA, BR.VIRGIN ISLANDS. SN 86-093,260. PUB. 4-1-2014, FILED 10-16-2013.

4,594,421. OMRON HEALTHCARE, INC., LAKE FOREST, IL. SN 86-090,613. PUB. 4-1-2014, FILED 10-14-2013.



**Alvita**

THE MARK CONSISTS OF STANDARD CHARACTERS WITHOUT CLAIM TO ANY PARTICULAR FONT, STYLE, SIZE, OR COLOR.

THE WORDING "ALVITA" HAS NO MEANING IN A FOREIGN LANGUAGE.

FOR PEDOMETERS (U.S. CLS. 21, 23, 26, 36 AND 38). FIRST USE 3-6-2014; IN COMMERCE 3-6-2014.

THE MARK CONSISTS OF THE WORD "SHOBINGG", WITH AN IMAGE OF A BAG WITH A HANDLE OVER THE WORD, AND WITH MULTIPLE CIRCLES NEXT TO AND PARTIALLY OVERLAPPING THE BAG.

FOR SOFTWARE FOR COMPUTERS, MOBILE PHONES, AND COMPUTER TABLETS FOR CREATING, MANAGING, ACCESSING, AND ANALYZING SEARCHABLE DATABASES OF CUSTOMER INFORMATION AND DATA AND PROVIDING USER ACCESS TO DISCOUNTS AND REWARDS FOR CUSTOMER LOYALTY, REWARDS, AND INCENTIVES PROGRAMS (U.S. CLS. 21, 23, 26, 36 AND 38).

FIRST USE 2-8-2014; IN COMMERCE 2-8-2014.

**CLASS 9—(Continued).**

4,594,433. BRIDWELL, NORMAN, EDGARTOWN, MA. SN 86-093,619. PUB. 3-11-2014, FILED 10-17-2013.

**CLIFFORD THE BIG RED DOG**

THE MARK CONSISTS OF STANDARD CHARACTERS WITHOUT CLAIM TO ANY PARTICULAR FONT, STYLE, SIZE, OR COLOR.

OWNER OF U.S. REG. NOS. 1,897,994, 2,743,654, AND OTHERS.

FOR DOWNLOADABLE MOVIES AND TELEVISION SHOWS FEATURING CHILDREN'S ENTERTAINMENT (U.S. CLS. 21, 23, 26, 36 AND 38).

FIRST USE 4-10-2014; IN COMMERCE 4-10-2014.

4,594,439. GIGA-BYTE TECHNOLOGY CO., LTD., NEW TAIPEI CITY, TAIWAN. SN 86-097,447. PUB. 4-15-2014, FILED 10-22-2013.

**G1 Gaming**

THE MARK CONSISTS OF STANDARD CHARACTERS WITHOUT CLAIM TO ANY PARTICULAR FONT, STYLE, SIZE, OR COLOR.

OWNER OF U.S. REG. NOS. 4,370,615, 4,370,617, AND OTHERS.

NO CLAIM IS MADE TO THE EXCLUSIVE RIGHT TO USE "GAMING", APART FROM THE MARK AS SHOWN.

FOR MOTHERBOARDS (U.S. CLS. 21, 23, 26, 36 AND 38).

FIRST USE 4-1-2014; IN COMMERCE 4-1-2014.

4,594,483. UTUPA, INC., BELLEVUE, WA. SN 86-111,049. PUB. 4-1-2014, FILED 11-5-2013.

**UTUPA**

THE MARK CONSISTS OF STANDARD CHARACTERS WITHOUT CLAIM TO ANY PARTICULAR FONT, STYLE, SIZE, OR COLOR.

FOR COMPUTER APPLICATION SOFTWARE FOR MOBILE APPLICATIONS, LAPTOPS AND PCS, NAMELY, SOFTWARE FOR PHOTO SHARING (U.S. CLS. 21, 23, 26, 36 AND 38).

FIRST USE 3-1-2014; IN COMMERCE 3-1-2014.

**CLASS 9—(Continued).**

4,594,517. MAKERBOT INDUSTRIES, LLC, BROOKLYN, NY. SN 86-126,511. PUB. 4-22-2014, FILED 11-22-2013.

**MAKERBOT MULTISCAN**

THE MARK CONSISTS OF STANDARD CHARACTERS WITHOUT CLAIM TO ANY PARTICULAR FONT, STYLE, SIZE, OR COLOR.

OWNER OF U.S. REG. NOS. 3,761,183 AND 4,397,067. FOR COMPUTER SOFTWARE FOR CREATING 3D IMAGES (U.S. CLS. 21, 23, 26, 36 AND 38).

FIRST USE 11-20-2013; IN COMMERCE 11-20-2013.

4,594,531. HODAPP, EDWARD ELLIS, TEMECULA, CA. SN 86-137,777. PUB. 4-29-2014, FILED 12-7-2013.

**CAGE-E**

THE MARK CONSISTS OF STANDARD CHARACTERS WITHOUT CLAIM TO ANY PARTICULAR FONT, STYLE, SIZE, OR COLOR.

FOR CELLPHONE HOLDER (U.S. CLS. 21, 23, 26, 36 AND 38).

FIRST USE 6-24-2014; IN COMMERCE 6-24-2014.

4,594,540. ADRIAN CHEN, DBA SILICON VALLEY IMAGING CORPORATION, FREMONT, CA. SN 86-145,820. PUB. 4-29-2014, FILED 12-17-2013.



OWNER OF U.S. REG. NO. 3,180,411. THE COLOR(S) BLUE AND BLACK IS/ARE CLAIMED AS A FEATURE OF THE MARK.

THE MARK CONSISTS OF THE WORDING "SVP" IN BLACK. AROUND THE WORDING IN BLUE IS AN UNFINISHED OVAL DESIGN.

FOR CAMERAS; COMPUTER CAMERAS; DIGITAL CAMERAS; DIGITAL CELLULAR PHONES; DIGITAL FILM SCANNERS; DIGITAL INPUT AND OUTPUT SCANNERS; DIGITAL MEDIA STREAMING DEVICES; DIGITAL TELEPHONES; DIGITAL VIDEO CAMERAS; FISH-EYE CONVERSION LENSES FOR CAMERAS; PC TABLETS; PROTECTIVE COVERS AND CASES FOR TABLET COMPUTERS; TABLET COMPUTER (U.S. CLS. 21, 23, 26, 36 AND 38).

FIRST USE 6-26-2014; IN COMMERCE 6-26-2014.

**CLASS 10—MEDICAL APPARATUS**

4,593,070. EXSURCO MEDICAL, INC., BIRMINGHAM, OH.  
SN 76-713,984. PUB. 3-18-2014, FILED 4-19-2013.

**DERMASHARP**

THE MARK CONSISTS OF STANDARD CHARACTERS WITHOUT CLAIM TO ANY PARTICULAR FONT, STYLE, SIZE, OR COLOR.

FOR REPLACEMENT BLADES FOR HAND-HELD, POWER-DRIVEN DERMATOMES FOR USE IN CONNECTION WITH PERFORMING MEDICAL AND SURGICAL PROCEDURES AND TISSUE AND BONE RECOVERY PROCEDURES, PARTICULARLY, TISSUE REMOVAL, CUTTING AND TRIMMING OF SKIN TISSUE, CONNECTIVE TISSUE SUCH AS LIGAMENTS, TENDONS, AND CARTILAGE, AND BONES, ADIPOSE DEBRIDING AND WOUND DEBRIDING (U.S. CLS. 26, 39 AND 44).

FIRST USE 8-0-2013; IN COMMERCE 8-0-2013.

---

4,593,099. INTERNATIONAL BIOMEDICAL, AUSTIN, TX.  
SN 85-039,046. PUB. 10-19-2010, FILED 5-14-2010.

**PUFFIN**

THE MARK CONSISTS OF STANDARD CHARACTERS WITHOUT CLAIM TO ANY PARTICULAR FONT, STYLE, SIZE, OR COLOR.

FOR PATIENT BREATHING SYSTEM FOR IN-PATIENT EMERGENCY RESUSCITATION IN EMERGENCY ROOMS OR NEWBORN INTENSIVE CARE UNITS OR HOSPITAL FACILITIES, USED TO CLEAR PATIENT AIRWAY AND PROVIDE VARIOUS LEVELS OF SHORT-TERM BREATHING SUPPORT FROM SUPPLEMENTAL "BLOW-BY" OXYGEN TO MANUAL OR ASSISTED BREATHING (U.S. CLS. 26, 39 AND 44).

FIRST USE 12-11-2013; IN COMMERCE 12-11-2013.

---

4,593,231. TOPERA, INC., SCOTTSDALE, AZ. SN 85-427,624.  
PUB. 3-27-2012, FILED 9-20-2011.

**RHYTHMVIEW**

THE MARK CONSISTS OF STANDARD CHARACTERS WITHOUT CLAIM TO ANY PARTICULAR FONT, STYLE, SIZE, OR COLOR.

FOR MEDICAL DEVICES FOR ABNORMAL HEART RHYTHM DIAGNOSIS (U.S. CLS. 26, 39 AND 44).

FIRST USE 11-12-2013; IN COMMERCE 11-12-2013.

**CLASS 10—(Continued).**

4,593,248. PRENATAL DIAGNOSTIC PRODUCTS, LLC, LOS ANGELES, CA. SN 85-474,810. PUB. 5-1-2012, FILED 11-17-2011.

**VillusCath**

THE MARK CONSISTS OF STANDARD CHARACTERS WITHOUT CLAIM TO ANY PARTICULAR FONT, STYLE, SIZE, OR COLOR.

FOR MEDICAL AND SURGICAL CATHETERS (U.S. CLS. 26, 39 AND 44).

FIRST USE 11-17-2011; IN COMMERCE 5-26-2014.

---

4,593,273. C. R. BARD, INC., MURRAY HILL, NJ. SN 85-528,377. PUB. 6-19-2012, FILED 1-30-2012.

**CHECKER**

THE MARK CONSISTS OF STANDARD CHARACTERS WITHOUT CLAIM TO ANY PARTICULAR FONT, STYLE, SIZE, OR COLOR.

FOR MEDICAL DEVICES AND APPARATUS, NAMELY, CATHETERS AND COMPONENTS OF CATHETERS, AND PARTS AND FITTINGS THEREFOR (U.S. CLS. 26, 39 AND 44).

FIRST USE 4-18-2014; IN COMMERCE 4-18-2014.

**CLASS 10—(Continued).**

4,593,284. ZUMA DENTAL, LLC, LOS ANGELES, CA. SN 85-547,719. PUB. 11-20-2012, FILED 2-20-2012.

# Z-RAY

THE MARK CONSISTS OF STANDARD CHARACTERS WITHOUT CLAIM TO ANY PARTICULAR FONT, STYLE, SIZE, OR COLOR.

FOR DENTAL X-RAY APPARATUS; MOUNTS FOR DENTAL X-RAY NEGATIVE; MOUNTS FOR X-RAY NEGATIVES FOR DENTAL PURPOSES; X-RAY APPARATUS FOR DENTAL USE; X-RAY APPARATUS FOR DENTAL IMAGING; X-RAY APPLIANCES FOR DENTAL USE; X-RAY CT SCANNERS; X-RAY DIAGNOSTIC APPARATUS; X-RAY TUBES FOR DENTAL PURPOSES; MOUNTS FOR DIGITAL SENSOR USED FOR TAKING DIGITAL DENTAL RADIOGRAPHS; DIGITAL SENSOR USED FOR TAKING DIGITAL DENTAL RADIOGRAPHS; HOLDERS FOR DIGITAL SENSOR USED FOR TAKING DIGITAL DENTAL RADIOGRAPHS; POSITIONING DEVICE FOR POSITIONING X-RAY APPARATUS WITH RESPECT TO A PATIENT; HOLDERS FOR X-RAY FILMS; ALIGNMENT DEVICE FOR ALIGNING X-RAY APPARATUS WITH RESPECT TO A PATIENT (U.S. CLS. 26, 39 AND 44).

FIRST USE 6-2-2014; IN COMMERCE 6-2-2014.

**CLASS 10—(Continued).**

THE MARK CONSISTS OF A PICTORIAL REPRESENTATION OF A HUMAN HEAD AND TORSO WITH THE TERM "HEADACHE" IN PLACE OF THE HEAD AND THE WORDING "MIGRAINES 951-ACHE" AND A TELEPHONE DESIGN ON THE TORSO. ON THE TOP OF THE HEAD ARE LIGHTNING BOLTS, AND THERE ARE ZIG-ZAG LINES ON THE SIDES OF THE NECK.

FOR MEDICAL DEVICES FOR THE MANAGEMENT AND TREATMENT OF NEUROLOGICAL DISORDERS, DISEASES AND CONDITIONS; MEDICAL DEVICES FOR THE MANAGEMENT AND TREATMENT OF PAIN; MEDICAL DEVICES FOR THE MANAGEMENT AND TREATMENT OF MIGRAINES AND HEADACHES; MEDICAL DEVICES USED IN CONJUNCTION WITH DRUG ADMINISTRATION FOR THE MANAGEMENT AND TREATMENT OF NEUROLOGICAL DISORDERS, DISEASES AND CONDITIONS; THERAPEUTIC PILLOWS, NAMELY, PILLOWS FOR MEDICAL USE RELATING TO HEADACHES, MIGRAINES, AND NEUROLOGICAL DISORDERS (U.S. CLS. 26, 39 AND 44).

FIRST USE 5-8-2014; IN COMMERCE 5-8-2014.

4,593,674. SOUTHERN SPINE, LLC, MACON, GA. SN 85-822,132. PUB. 11-5-2013, FILED 1-14-2013.



NO CLAIM IS MADE TO THE EXCLUSIVE RIGHT TO USE "PRECISION GUIDED" AND THE PICTORIAL REPRESENTATION OF A SURGICAL INSTRUMENT, APART FROM THE MARK AS SHOWN.

THE MARK CONSISTS OF A STYLIZED DRAWING OF A SURGICAL INSTRUMENT ADJACENT TO THE LETTERS "P," "G" IN LARGE FONT ABOVE THE WORDS "PRECISION GUIDED" IN A MUCH SMALLER FONT. TO THE LEFT OF THE WORDS "PRECISION GUIDED" ARE THREE CIRCLES TOUCHING EACH OTHER LINED UP HORIZONTALLY TO THE WORDING.

FOR SURGICAL INSTRUMENTS USED FOR THE INSERTION OF SPINAL IMPLANTS (U.S. CLS. 26, 39 AND 44).

FIRST USE 4-1-2013; IN COMMERCE 4-1-2013.

4,593,556. ANSARINIA PROFESSIONAL CORPORATION, LAS VEGAS, NV. SN 85-784,208. PUB. 9-3-2013, FILED 11-20-2012.



NO CLAIM IS MADE TO THE EXCLUSIVE RIGHT TO USE "HEADACHE MIGRAINES 951-ACHE", APART FROM THE MARK AS SHOWN.

4,593,702. DJO, LLC, VISTA, CA. SN 85-841,650. PUB. 11-12-2013, FILED 2-5-2013.

## MATCH POINT SYSTEM

THE MARK CONSISTS OF STANDARD CHARACTERS WITHOUT CLAIM TO ANY PARTICULAR FONT, STYLE, SIZE, OR COLOR.

**CLASS 10—(Continued).**

NO CLAIM IS MADE TO THE EXCLUSIVE RIGHT TO USE "SYSTEM", APART FROM THE MARK AS SHOWN.  
FOR SHOULDER IMPLANTS MADE OF ARTIFICIAL MATERIALS (U.S. CLS. 26, 39 AND 44).  
FIRST USE 9-30-2013; IN COMMERCE 11-30-2013.

---

4,593,714. VIORA LTD., HERZLIAH PITUACH, ISRAEL. SN 85-846,042. PUB. 10-8-2013, FILED 2-11-2013.

# VTOUCH

THE MARK CONSISTS OF STANDARD CHARACTERS WITHOUT CLAIM TO ANY PARTICULAR FONT, STYLE, SIZE, OR COLOR.

FOR COSMETIC APPARATUS USING FRACTIONAL RADIOFREQUENCY AND SWITCHING, VACUUMING AND COOLING TECHNOLOGIES FOR PERFORMING AESTHETIC SKIN TREATMENT PROCEDURES; MEDICAL AND SURGICAL APPARATUS AND INSTRUMENTS, NAMELY, DERMATOLOGICAL AND AESTHETIC DEVICES, APPARATUS AND INSTRUMENTS UTILIZING FRACTIONAL RADIOFREQUENCY AND SWITCHING, VACUUMING AND COOLING TECHNOLOGIES AND BI POLAR RADIOFREQUENCY TECHNOLOGY FOR USE IN DERMABRASION SKIN RENEWAL, COAGULATION AND ABLATION OF SOFT TISSUES, SKIN EXFOLIATION AND REDUCTION OF SKIN WRINKLING, AND SKIN TIGHTENING, AND STRUCTURAL PARTS AND ACCESSORIES (U.S. CLS. 26, 39 AND 44).

FIRST USE 3-20-2012; IN COMMERCE 3-20-2012.

---

4,593,751. COVIDIEN LP, MANSFIELD, MA. SN 85-870,634. PUB. 8-6-2013, FILED 3-8-2013.

# EMPRINT

THE MARK CONSISTS OF STANDARD CHARACTERS WITHOUT CLAIM TO ANY PARTICULAR FONT, STYLE, SIZE, OR COLOR.

FOR SURGICAL AND MEDICAL APPARATUS AND INSTRUMENTS FOR USE IN GENERAL SURGERY (U.S. CLS. 26, 39 AND 44).  
FIRST USE 5-18-2014; IN COMMERCE 5-18-2014.

**CLASS 10—(Continued).**

4,593,777. JOINT SMART, LLC, TRAVERSE CITY, MI. SN 85-884,117. PUB. 11-5-2013, FILED 3-22-2013.

## SHOULDEREVOLUTION

THE MARK CONSISTS OF STANDARD CHARACTERS WITHOUT CLAIM TO ANY PARTICULAR FONT, STYLE, SIZE, OR COLOR.

FOR MEDICAL BRACES FOR SHOULDER (U.S. CLS. 26, 39 AND 44).  
FIRST USE 6-29-2014; IN COMMERCE 6-29-2014.

---

4,594,032. TEVA WOMEN'S HEALTH, INC., WOODCLIFF LAKE, NJ. SN 85-952,706. PUB. 11-12-2013, FILED 6-6-2013.



OWNER OF U.S. REG. NO. 1,505,716.

NO CLAIM IS MADE TO THE EXCLUSIVE RIGHT TO USE "INTRAUTERINE COPPER CONTRACEPTIVE", APART FROM THE MARK AS SHOWN.

THE MARK CONSISTS OF THE WORD "PARAGARD" NEXT TO A SMALLER "T380A" ABOVE THE WORDING "INTRAUTERINE COPPER CONTRACEPTIVE". TO THE RIGHT OF THE WORDING IS A TRIANGULAR SHAPED DESIGN FORMED BY FOUR SEPARATE SHADED GEOMETRIC SHAPES.

FOR CONTRACEPTIVES, NAMELY, INTRAUTERINE DEVICES (U.S. CLS. 26, 39 AND 44).

FIRST USE 7-31-2013; IN COMMERCE 7-31-2013.

---

4,594,036. TEVA WOMEN'S HEALTH, INC., WOODCLIFF LAKE, NJ. SN 85-952,804. PUB. 11-12-2013, FILED 6-6-2013.



OWNER OF U.S. REG. NO. 1,505,716.

NO CLAIM IS MADE TO THE EXCLUSIVE RIGHT TO USE "INTRAUTERINE COPPER CONTRACEPTIVE", APART FROM THE MARK AS SHOWN.



**CLASS 10—(Continued).**

THE COLOR(S) BLACK, PINK, AND PURPLE IS/ARE CLAIMED AS A FEATURE OF THE MARK.

THE MARK CONSISTS OF THE WORD "PARAGARD" IN BOLD BLACK FONT, NEXT TO A SMALLER "T380A" ALSO IN BLACK, ABOVE THE WORDING "INTRAUTERINE COPPER CONTRACEPTIVE" WRITTEN IN PINK. TO THE RIGHT OF THE WORDING IS A TRIANGULAR SHAPED DESIGN IN SHADES OF PINK AND PURPLE FORMED BY FOUR SEPARATE SHADED GEOMETRIC SHAPES.

FOR CONTRACEPTIVES, NAMELY, INTRAUTERINE DEVICES (U.S. CLS. 26, 39 AND 44).

FIRST USE 7-31-2013; IN COMMERCE 7-31-2013.

**CLASS 10—(Continued).**

4,594,270. VITAL CONNECT, INC., CAMPBELL, CA. SN 86-030,750. PUB. 12-31-2013, FILED 8-7-2013.

# HealthPatch

THE MARK CONSISTS OF STANDARD CHARACTERS WITHOUT CLAIM TO ANY PARTICULAR FONT, STYLE, SIZE, OR COLOR.

FOR VITAL SIGN MONITORING DEVICES IN A PAD OR SHIELD OF CLOTH FORM THAT ANALYZE AND TRANSMIT VITAL SIGN HEALTH INFORMATION, NAMELY, BLOOD PRESSURE, BLOOD GLUCOSE, BLOOD PROPERTIES, LUNG FUNCTION, ACTIVITY LEVEL, STRESS LEVEL, SLEEP MONITORING, RESPIRATORY EVENTS, ELECTROCARDIOGRAM DATA, HEART RATE, PULSE RATE VIA WIRE OR WIRELESS TO RELAY HAND-HELD MOBILE UNITS AND CLOUD COMPUTERS (U.S. CLS. 26, 39 AND 44).

FIRST USE 4-29-2014; IN COMMERCE 4-29-2014.

4,594,038. REV MEDX, INC., WILSONVILLE, OR. SN 85-953,016. PUB. 10-29-2013, FILED 6-6-2013.

# AIRWRAP

THE MARK CONSISTS OF STANDARD CHARACTERS WITHOUT CLAIM TO ANY PARTICULAR FONT, STYLE, SIZE, OR COLOR.

FOR COMPRESSION BANDAGES; ELASTIC BANDAGES (U.S. CLS. 26, 39 AND 44).

FIRST USE 8-12-2013; IN COMMERCE 5-9-2014.

4,594,351. ROYAL MEDICAL SOLUTIONS, INC., SAN ANTONIO, TX. SN 86-065,326. PUB. 3-4-2014, FILED 9-16-2013.

4,594,068. METAVENTION, INC., EDEN PRAIRIE, MN. SN 85-957,695. PUB. 10-29-2013, FILED 6-12-2013.

# METAVENTION

THE MARK CONSISTS OF STANDARD CHARACTERS WITHOUT CLAIM TO ANY PARTICULAR FONT, STYLE, SIZE, OR COLOR.

FOR MEDICAL APPARATUS AND INSTRUMENTS FOR USE IN SURGERY; MEDICAL DEVICES TO TREAT INTRAVASCULAR SITES; SURGICAL INSTRUMENTS FOR USE IN NEUROMODULATION (U.S. CLS. 26, 39 AND 44).

FIRST USE 7-31-2013; IN COMMERCE 5-28-2014.



NO CLAIM IS MADE TO THE EXCLUSIVE RIGHT TO USE "TOT TEMPS DIGITAL CHARACTER THERMOMETER", APART FROM THE MARK AS SHOWN.

THE MARK CONSISTS OF THE LITERAL ELEMENTS "TOT TEMPS DIGITAL CHARACTER THERMOMETER" WRITTEN IN STYLIZED FORM WHEREIN AN IMAGE OF A BEAR FACE RESEMBLING LETTER "O" IS PLACED BETWEEN THE LETTERS "TT" AND LITERAL ELEMENTS "TT TEMPS" ARE PLACED ABOVE THE WORDS "DIGITAL CHARACTER THERMOMETER".

FOR THERMOMETERS FOR MEDICAL PURPOSES (U.S. CLS. 26, 39 AND 44).

FIRST USE 1-6-2014; IN COMMERCE 1-6-2014.

**CLASS 10—(Continued).**

4,594,498. VIBRATEX, INC., NAPA, CA. SN 86-118,607. PUB. 4-8-2014, FILED 11-14-2013.

ADORABLE. NOT INNOCENT.

THE MARK CONSISTS OF STANDARD CHARACTERS WITHOUT CLAIM TO ANY PARTICULAR FONT, STYLE, SIZE, OR COLOR.  
FOR ADULT SEXUAL STIMULATION AIDS, NAMELY, VIBRATORS (U.S. CLS. 26, 39 AND 44).  
FIRST USE 1-11-2014; IN COMMERCE 1-11-2014.

**CLASS 11—ENVIRONMENTAL CONTROL APPARATUS**

4,593,085. MICHAEL J. BEHM, EDEN PRAIRE, MN. SN 77-859,779. PUB. 4-26-2011, FILED 10-28-2009.

FINAL APPROACH

THE MARK CONSISTS OF STANDARD CHARACTERS WITHOUT CLAIM TO ANY PARTICULAR FONT, STYLE, SIZE, OR COLOR.  
FOR LIGHTING SYSTEM AND LIGHT COMPONENTS COMPRISED OF MARINE LIGHTING FIXTURES AND DOCK LIGHTING FIXTURES (U.S. CLS. 13, 21, 23, 31 AND 34).  
FIRST USE 6-30-2012; IN COMMERCE 6-20-2014.

4,593,116. METAL-FAB, INC., WICHITA, KS. SN 85-058,558. PUB. 12-3-2013, FILED 6-9-2010.

HYDROMAX

THE MARK CONSISTS OF STANDARD CHARACTERS WITHOUT CLAIM TO ANY PARTICULAR FONT, STYLE, SIZE, OR COLOR.  
FOR AIR CLEANERS, NAMELY, AIR FILTERING UNITS FOR COMMERCIAL, DOMESTIC AND INDUSTRIAL USE (U.S. CLS. 13, 21, 23, 31 AND 34).  
FIRST USE 11-19-2010; IN COMMERCE 11-19-2010.

**CLASS 11—(Continued).**

4,593,181. MITSUBISHI CHEMICAL CORPORATION, MINATO-KU, TOKYO, JAPAN. SN 85-234,849. PUB. 11-1-2011, FILED 2-4-2011.

VELVE

THE MARK CONSISTS OF STANDARD CHARACTERS WITHOUT CLAIM TO ANY PARTICULAR FONT, STYLE, SIZE, OR COLOR.  
FOR ELECTRIC LAMPS; LIGHTING APPARATUS AND INSTALLATIONS, NAMELY, ELECTRIC LIGHT BULBS AND TRACK LIGHTING LAMPS, LAMPS, LAMP HOLDERS, LAMP HOLDERS FOR ELECTRIC BULBS, LIGHTING APPARATUS, NAMELY, LIGHTING INSTALLATIONS (U.S. CLS. 13, 21, 23, 31 AND 34).  
FIRST USE 7-31-2011; IN COMMERCE 8-31-2012.

4,593,380. RUPRECHT, PAMELA R., LAKELAND, MN. SN 85-659,132. PUB. 11-13-2012, FILED 6-22-2012.

RAPIDPURE

THE MARK CONSISTS OF STANDARD CHARACTERS WITHOUT CLAIM TO ANY PARTICULAR FONT, STYLE, SIZE, OR COLOR.  
FOR WATER PURIFICATION AND FILTRATION APPARATUS; WATER FILTERS; WATER BAGS FOR WATER PURIFICATION AND FILTRATION APPARATUS (U.S. CLS. 13, 21, 23, 31 AND 34).  
FIRST USE 3-31-2014; IN COMMERCE 3-31-2014.

4,593,397. CHARTMATE INC., KAOHSIUNG, TAIWAN. SN 85-672,359. PUB. 1-29-2013, FILED 7-10-2012.

LuxPad

THE MARK CONSISTS OF STANDARD CHARACTERS WITHOUT CLAIM TO ANY PARTICULAR FONT, STYLE, SIZE, OR COLOR.  
FOR FLAT PANEL LIGHTING APPARATUS (U.S. CLS. 13, 21, 23, 31 AND 34).  
FIRST USE 1-11-2013; IN COMMERCE 9-14-2013.

**CLASS 11—(Continued).**

4,593,472. KONINKLIJKE PHILIPS ELECTRONICS N.V., 5656 AE EINDHOVEN, NETHERLANDS. SN 85-742,273. PUB. 5-28-2013, FILED 9-30-2012.

# AQPC

THE MARK CONSISTS OF STANDARD CHARACTERS WITHOUT CLAIM TO ANY PARTICULAR FONT, STYLE, SIZE, OR COLOR.

PRIORITY CLAIMED UNDER SEC. 44(D) ON BENELUX APPLICATION NO. 1244946, FILED 3-30-2012, REG. NO. 0917555, DATED 7-10-2012, EXPIRES 3-30-2022.

FOR ELECTRIC LAMPS, PARTS OF THE AFORE-SAID GOODS (U.S. CLS. 13, 21, 23, 31 AND 34).

FIRST USE 3-0-2012; IN COMMERCE 6-0-2012.

---

4,593,558. FAN FI INTERNATIONAL, INC., SPARKS, NV. SN 85-784,353. PUB. 4-9-2013, FILED 11-20-2012.

# SHOWERDUO

THE MARK CONSISTS OF STANDARD CHARACTERS WITHOUT CLAIM TO ANY PARTICULAR FONT, STYLE, SIZE, OR COLOR.

FOR SHOWERHEADS (U.S. CLS. 13, 21, 23, 31 AND 34).

FIRST USE 3-0-2014; IN COMMERCE 3-0-2014.

---

4,593,590. ROTH, MORDCHAI, UPPER SADDLE RIVER, NJ. SN 85-796,587. PUB. 11-19-2013, FILED 12-6-2012.

# EUROLUX

THE MARK CONSISTS OF STANDARD CHARACTERS WITHOUT CLAIM TO ANY PARTICULAR FONT, STYLE, SIZE, OR COLOR.

FOR ELECTRIC TOASTER OVENS; ELECTRIC COFFEE MAKERS; ELECTRIC CORDLESS TEA KETTLES WITH ELECTRIC HOT PLATES; HOT PLATES; ELECTRIC COOKWARE, NAMELY, ROASTERS AND BROILERS (U.S. CLS. 13, 21, 23, 31 AND 34).

FIRST USE 5-1-2014; IN COMMERCE 5-1-2014.

**CLASS 11—(Continued).**

4,593,591. ROTH, MORDCHAI, UPPER SADDLE RIVER, NJ. SN 85-796,637. PUB. 11-19-2013, FILED 12-6-2012.



NO CLAIM IS MADE TO THE EXCLUSIVE RIGHT TO USE "MILL", APART FROM THE MARK AS SHOWN.

THE MARK CONSISTS OF THE WORDS "MAGIC MILL" AND A SQUARE-LIKE DESIGN WITH ROUNDED CORNERS CONTAINING A DESIGN OF WHEAT.

FOR ELECTRIC COFFEE MAKERS; ELECTRIC TEA KETTLES; ELECTRIC TEA POTS; ELECTRIC COOKWARE, NAMELY, ROASTERS AND BROILERS; HOT PLATES; COOKING OVENS, ELECTRIC OVENS; MICROWAVE OVENS; GAS OVENS; ELECTRIC SLOW COOKERS (U.S. CLS. 13, 21, 23, 31 AND 34).

FIRST USE 5-1-2014; IN COMMERCE 5-1-2014.

---

4,593,618. COOL GEAR INTERNATIONAL, LLC., JENKINTOWN, PA. SN 85-803,131. PUB. 3-11-2014, FILED 12-14-2012.



OWNER OF U.S. REG. NOS. 1,497,764, 3,655,486, AND OTHERS.

NO CLAIM IS MADE TO THE EXCLUSIVE RIGHT TO USE "GEAR", APART FROM THE MARK AS SHOWN.

THE MARK CONSISTS OF THE WORD "COOL" ON TOP OF THE WORD "GEAR" BOTH IN LOWER CASE PUFFED LETTERS ON A DARKER BACKGROUND WITH TWO FILLED INVERTED WATER DROPLET SHAPES BETWEEN THE "O"S IN THE WORD "COOL".

FOR WATER FILTRATION BOTTLES SOLD EMPTY; REPLACEMENT FILTERS FOR WATER FILTRATION BOTTLES (U.S. CLS. 13, 21, 23, 31 AND 34).

FIRST USE 11-5-2009; IN COMMERCE 11-5-2009.

**CLASS 11—(Continued).**

4,593,656. FLANDERS CORPORATION, WASHINGTON, NC. SN 85-814,937. PUB. 5-21-2013, FILED 1-3-2013.

# FCP

THE MARK CONSISTS OF STANDARD CHARACTERS WITHOUT CLAIM TO ANY PARTICULAR FONT, STYLE, SIZE, OR COLOR.

FOR AIR FILTERS FOR INDUSTRIAL AND DOMESTIC INSTALLATIONS (U.S. CLS. 13, 21, 23, 31 AND 34). FIRST USE 2-1-2014; IN COMMERCE 2-1-2014.

---

4,593,763. DEEC, INC., BELLEVUE, WA. SN 85-879,066. PUB. 10-15-2013, FILED 3-18-2013.

# DEEC

THE MARK CONSISTS OF STANDARD CHARACTERS WITHOUT CLAIM TO ANY PARTICULAR FONT, STYLE, SIZE, OR COLOR.

FOR OXYGEN-HYDROGEN PLASMA GENERATORS USED IN THE AUTOMOTIVE, TRUCKING AND MARINE INDUSTRIES; OXYGEN-HYDROGEN GENERATORS USED IN THE AUTOMOTIVE, TRUCKING AND MARINE INDUSTRIES; OXYGEN GENERATORS USED IN THE AUTOMOTIVE, TRUCKING AND MARINE INDUSTRIES; HYDROGEN GENERATORS; OXYGEN-HYDROGEN-GENERATION EQUIPMENT AND COMPONENTS, NAMELY, OXYGEN-HYDROGEN ELECTROLYSIS GENERATORS USED WITH INTERNAL COMBUSTION ENGINES (U.S. CLS. 13, 21, 23, 31 AND 34).

FIRST USE 2-0-2013; IN COMMERCE 8-0-2013.

---

4,593,795. ROBERN, INC., BRISTOL, PA. SN 85-898,163. PUB. 4-1-2014, FILED 4-8-2013.

# EYEZON

THE MARK CONSISTS OF STANDARD CHARACTERS WITHOUT CLAIM TO ANY PARTICULAR FONT, STYLE, SIZE, OR COLOR.

FOR ELECTRIC LIGHTING FIXTURES FOR THE BATHROOM (U.S. CLS. 13, 21, 23, 31 AND 34). FIRST USE 4-30-2013; IN COMMERCE 4-30-2013.

**CLASS 11—(Continued).**

4,593,851. GREEN LIGHT INNOVATIONS, LAKE SAINT LOUIS, MO. SN 85-920,662. PUB. 10-8-2013, FILED 5-1-2013.

# SUNFLARE

THE MARK CONSISTS OF STANDARD CHARACTERS WITHOUT CLAIM TO ANY PARTICULAR FONT, STYLE, SIZE, OR COLOR.

FOR FLASHLIGHTS, OUTDOOR PORTABLE LIGHTING PRODUCTS, NAMELY, HEAD LAMPS, SPOT LIGHTS, AND LED LIGHT BULBS (U.S. CLS. 13, 21, 23, 31 AND 34).

FIRST USE 8-31-2013; IN COMMERCE 8-31-2013.

---

4,593,892. FILTRATION ADVICE, INC., DELRAY BEACH, FL. SN 85-931,112. PUB. 10-15-2013, FILED 5-14-2013.

# AIRTREAT

THE MARK CONSISTS OF STANDARD CHARACTERS WITHOUT CLAIM TO ANY PARTICULAR FONT, STYLE, SIZE, OR COLOR.

FOR AIR FILTERS FOR HEATING, AIR CONDITIONING AND FORCED-AIR VENTILATION AND AIR FILTRATION SYSTEMS (U.S. CLS. 13, 21, 23, 31 AND 34).

FIRST USE 10-31-2013; IN COMMERCE 10-31-2013.

---

4,594,311. SODERWORLD ENTERPRISES, LLC, WILLOW-BROOK, IL. SN 86-046,650. PUB. 1-14-2014, FILED 8-23-2013.

# RAGLITE

light anywhere

THE MARK CONSISTS OF THE WORD "RAGLITE" APPEARING ABOVE THE WORDS "LIGHT ANYWHERE".

FOR LED LIGHT STRIPS WOVEN INTO FABRIC (U.S. CLS. 13, 21, 23, 31 AND 34). FIRST USE 1-31-2014; IN COMMERCE 1-31-2014.

**CLASS 11—(Continued).**

4,594,314. SODERWORLD ENTERPRISES, LLC, WILLOW-BROOK, IL. SN 86-048,110. PUB. 1-14-2014, FILED 8-26-2013.

**RAGLITE LIGHT ANYWHERE**

THE MARK CONSISTS OF STANDARD CHARACTERS WITHOUT CLAIM TO ANY PARTICULAR FONT, STYLE, SIZE, OR COLOR.

FOR LED LIGHT STRIPS WOVEN INTO FABRIC (U.S. CLS. 13, 21, 23, 31 AND 34).

FIRST USE 1-31-2014; IN COMMERCE 1-31-2014.

4,594,551. INQ-ENERGY, INC., STAFFORD, TX. SN 86-975,254. PUB. 1-14-2014, FILED 8-22-2013.

**INQ-ENERGY**

THE MARK CONSISTS OF STANDARD CHARACTERS WITHOUT CLAIM TO ANY PARTICULAR FONT, STYLE, SIZE, OR COLOR.

FOR LED LIGHTING FIXTURES FOR INDOOR AND OUTDOOR LIGHTING APPLICATIONS; SOLAR LIGHT FIXTURES, NAMELY, INDOOR AND OUTDOOR SOLAR POWERED LIGHTING UNITS AND FIXTURES (U.S. CLS. 13, 21, 23, 31 AND 34).

FIRST USE 12-13-2013; IN COMMERCE 12-13-2013.

**CLASS 12—VEHICLES**

4,593,272. THULE IP AB, MALMO, SWEDEN. SN 85-527,170. PUB. 7-23-2013, FILED 1-27-2012.

**SPEED-LINK**

THE MARK CONSISTS OF STANDARD CHARACTERS WITHOUT CLAIM TO ANY PARTICULAR FONT, STYLE, SIZE, OR COLOR.

FOR MOUNTING SYSTEM COMPRISED OF BAND GRIPS AND CYLINDER LOCK HOUSING FOR MOUNTING AN ACCESSORY TO A VEHICLE ROOF OR VEHICLE ROOF RACK (U.S. CLS. 19, 21, 23, 31, 35 AND 44).

FIRST USE 3-1-2011; IN COMMERCE 3-1-2011.

**CLASS 12—(Continued).**

4,593,388. MACSPORTS INC., LA VERNE, CA. SN 85-666,411. PUB. 9-24-2013, FILED 7-2-2012.

**THE BIG KAHUNA**

THE MARK CONSISTS OF STANDARD CHARACTERS WITHOUT CLAIM TO ANY PARTICULAR FONT, STYLE, SIZE, OR COLOR.

FOR FOLDABLE WAGONS FOR CARRYING PERSONAL EFFECTS TO THE BEACH AND NOT INTENDED FOR CARRYING CHILDREN (U.S. CLS. 19, 21, 23, 31, 35 AND 44).

FIRST USE 7-1-2013; IN COMMERCE 7-1-2013.

4,593,414. FORD MOTOR COMPANY, DEARBORN, MI. SN 85-687,689. PUB. 11-6-2012, FILED 7-26-2012.

**LLEGA MAS LEJOS**

THE MARK CONSISTS OF STANDARD CHARACTERS WITHOUT CLAIM TO ANY PARTICULAR FONT, STYLE, SIZE, OR COLOR.

THE ENGLISH TRANSLATION OF "LLEGA MAS LEJOS" IN THE MARK IS "GO FURTHER".

FOR MOTOR VEHICLES, NAMELY, AUTOMOBILES, TRUCKS, VANS, SPORT UTILITY VEHICLES (U.S. CLS. 19, 21, 23, 31, 35 AND 44).

FIRST USE 9-30-2012; IN COMMERCE 9-30-2012.

4,593,693. DARFON INNOVATION CORPORATION, NEIHU DIST, TAIPEI CTY, TAIWAN. SN 85-836,439. PUB. 2-4-2014, FILED 1-30-2013.

**EXCIMER**  
POWER DRIVE

NO CLAIM IS MADE TO THE EXCLUSIVE RIGHT TO USE "POWER DRIVE", APART FROM THE MARK AS SHOWN.

**CLASS 12—(Continued).**

THE MARK CONSISTS OF THE STYLIZED WORD "EX-CIMER" AND THE PHRASE "POWER DRIVE". THE LETTER "X" IS THE COMBINATION OF A CURVE AND TWO SQUARES, AND THE LETTER "R" IS IN LOWER CASE. THE PHRASE "POWER DRIVE" IS AT THE BOTTOM OF THE MARK.

FOR MOTORIZED BICYCLES; BICYCLES; BICYCLE STANDS ; MUDGUARDS OF BICYCLES; RIMS FOR BICYCLE WHEELS; BICYCLE SADDLES; BICYCLE BRAKES; MOTORS FOR BICYCLES; BICYCLE PARTS, NAMELY, HANDLE BAR STEMS, DERAILLEURS (U.S. CLS. 19, 21, 23, 31, 35 AND 44).

FIRST USE 3-20-2013; IN COMMERCE 9-18-2013.



4,593,756. GOWER, JIM, JEMEZ SPRINGS, NM. SN 85-874,453. PUB. 8-6-2013, FILED 3-13-2013.

**SCUMBAGBIKER**

THE MARK CONSISTS OF STANDARD CHARACTERS WITHOUT CLAIM TO ANY PARTICULAR FONT, STYLE, SIZE, OR COLOR.

FOR MOTORCYCLES AND STRUCTURAL PARTS THEREFOR (U.S. CLS. 19, 21, 23, 31, 35 AND 44).

FIRST USE 6-1-2013; IN COMMERCE 6-1-2013.



4,593,789. ZIKE, LLC, GREENVILLE, SC. SN 85-891,262. PUB. 8-20-2013, FILED 3-31-2013.

**GET UP, GET OUT, GET ZIKED**

THE MARK CONSISTS OF STANDARD CHARACTERS WITHOUT CLAIM TO ANY PARTICULAR FONT, STYLE, SIZE, OR COLOR.

FOR NON-MOTORIZED SCOOTERS (U.S. CLS. 19, 21, 23, 31, 35 AND 44).

FIRST USE 11-30-2013; IN COMMERCE 11-30-2013.

**CLASS 12—(Continued).**

4,593,807. NINGBO SUNLIGHT MOTOR PARTS CO., LTD., 315175, CHINA. SN 85-905,089. PUB. 12-31-2013, FILED 4-16-2013.



THE MARK CONSISTS OF A STYLIZED LETTER "Q" ABOVE A NON-LATIN CHARACTER DESIGN AND THE LITERAL ELEMENT "QIANMING".

THE ENGLISH TRANSLATION OF THE TWO CHINESE CHARACTERS IN THE MARK IS "SKY" "NEXT". THE WORDING "QIANMING" HAS NO MEANING IN A FOREIGN LANGUAGE.

THE NON-LATIN CHARACTERS IN THE MARK TRANSLITERATE TO "QIAN" "MING" AND THIS MEANS "SKY" "NEXT" IN ENGLISH.

FOR SUN-BLINDS ADAPTED FOR AUTOMOBILES; HEAD-RESTS FOR VEHICLE SEATS; HUBS FOR VEHICLE WHEELS; SEAT COVERS FOR VEHICLES; VEHICLE SUSPENSION SPRINGS; ANTI-DAZZLE DEVICES FOR VEHICLES; STEERING WHEELS FOR VEHICLES; CAPS FOR VEHICLE PETROL TANKS; COVERS FOR VEHICLE STEERING WHEELS; UPHOLSTERY FOR VEHICLES (U.S. CLS. 19, 21, 23, 31, 35 AND 44).

FIRST USE 3-1-2014; IN COMMERCE 3-1-2014.



4,593,950. LITTORAL MARINE, LLC, WILDWOOD, FL. SN 85-939,602. PUB. 10-22-2013, FILED 5-22-2013.

**CREVALLE**

THE MARK CONSISTS OF STANDARD CHARACTERS WITHOUT CLAIM TO ANY PARTICULAR FONT, STYLE, SIZE, OR COLOR.

FOR BOAT HULLS; BOATS; STRUCTURAL PARTS FOR BOATS (U.S. CLS. 19, 21, 23, 31, 35 AND 44).

FIRST USE 11-1-2013; IN COMMERCE 11-1-2013.

**CLASS 12—(Continued).**

4,594,326. CHINA MANUFACTURERS ALLIANCE, LLC, MONROVIA, CA. SN 86-055,694. PUB. 3-18-2014, FILED 9-4-2013.

# MOZZO

THE MARK CONSISTS OF STANDARD CHARACTERS WITHOUT CLAIM TO ANY PARTICULAR FONT, STYLE, SIZE, OR COLOR.

THE ENGLISH TRANSLATION OF "MOZZO" IN THE MARK IS "HUB".

FOR TIRES FOR VEHICLES (U.S. CLS. 19, 21, 23, 31, 35 AND 44).

FIRST USE 1-1-2014; IN COMMERCE 1-1-2014.

4,594,401. JOY UNIVERSAL LIMITED, ROAD TOWN, TORTOLA, BR.VIRGIN ISLANDS. SN 86-085,514. PUB. 3-25-2014, FILED 10-8-2013.

# Nash Motors

THE MARK CONSISTS OF STANDARD CHARACTERS WITHOUT CLAIM TO ANY PARTICULAR FONT, STYLE, SIZE, OR COLOR.

NO CLAIM IS MADE TO THE EXCLUSIVE RIGHT TO USE "MOTORS", APART FROM THE MARK AS SHOWN.

FOR AUTOMOBILES (U.S. CLS. 19, 21, 23, 31, 35 AND 44).

FIRST USE 3-1-2014; IN COMMERCE 3-1-2014.

4,594,467. CHINA MANUFACTURERS ALLIANCE, LLC, MONROVIA, CA. SN 86-106,146. PUB. 1-28-2014, FILED 10-30-2013.

# Neolin

THE MARK CONSISTS OF STANDARD CHARACTERS WITHOUT CLAIM TO ANY PARTICULAR FONT, STYLE, SIZE, OR COLOR.

FOR TIRES (U.S. CLS. 19, 21, 23, 31, 35 AND 44).

FIRST USE 5-1-2014; IN COMMERCE 5-1-2014.

**CLASS 13—FIREARMS**

**CLASS 13—(Continued).**

4,593,479. STURM, RUGER & COMPANY, INC., SOUTHPORT, CT. SN 85-746,290. PUB. 2-19-2013, FILED 10-4-2012.



OWNER OF U.S. REG. NOS. 618,055, 3,846,257, AND OTHERS.

THE MARK CONSISTS OF AN IMAGE OF AN EAGLE WITH SPREAD WINGS WITH THE LETTER "R" IN THE MIDDLE AND THE WORD "RUGER" TO THE RIGHT OF THE IMAGE.

FOR FIREARMS (U.S. CLS. 2 AND 9).

FIRST USE 6-2-2014; IN COMMERCE 6-2-2014.

4,594,128. PAYNE, DAVID M, STAR, ID. SN 85-969,984. PUB. 11-26-2013, FILED 6-26-2013.

# Zero Carry

THE MARK CONSISTS OF STANDARD CHARACTERS WITHOUT CLAIM TO ANY PARTICULAR FONT, STYLE, SIZE, OR COLOR.

NO CLAIM IS MADE TO THE EXCLUSIVE RIGHT TO USE "CARRY", APART FROM THE MARK AS SHOWN.

FOR HAND GUN ACCESSORIES, NAMELY, BELT CLIPS FOR SECURING A GUN WITHOUT THE USE OF A HOLSTER (U.S. CLS. 2 AND 9).

FIRST USE 4-18-2013; IN COMMERCE 4-18-2013.

4,594,455. AHL, INC., ASHLAND, VA. SN 86-101,268. PUB. 3-18-2014, FILED 10-25-2013.

# BROTHERS FOREVER

THE MARK CONSISTS OF STANDARD CHARACTERS WITHOUT CLAIM TO ANY PARTICULAR FONT, STYLE, SIZE, OR COLOR.

FOR FIREARMS (U.S. CLS. 2 AND 9).

FIRST USE 6-25-2014; IN COMMERCE 6-25-2014.

**CLASS 14—JEWELRY**

**CLASS 14—(Continued).**

4,593,161. SKECHERS U.S.A., INC. II, MANHATTAN BEACH, CA. SN 85-199,901. PUB. 4-19-2011, FILED 12-16-2010.

**TWINKLE BANDS**

THE MARK CONSISTS OF STANDARD CHARACTERS WITHOUT CLAIM TO ANY PARTICULAR FONT, STYLE, SIZE, OR COLOR.

FOR BRACELETS; JEWELRY (U.S. CLS. 2, 27, 28 AND 50).  
FIRST USE 2-25-2011; IN COMMERCE 2-25-2011.

---

4,593,368. RICHLINE GROUP, INC., NEW YORK, NY. SN 85-653,054. PUB. 10-23-2012, FILED 6-15-2012.

**OCEAN TREASURES**

THE MARK CONSISTS OF STANDARD CHARACTERS WITHOUT CLAIM TO ANY PARTICULAR FONT, STYLE, SIZE, OR COLOR.

FOR JEWELRY (U.S. CLS. 2, 27, 28 AND 50).  
FIRST USE 4-1-2013; IN COMMERCE 4-1-2013.

---

4,593,375. SOURCE INTERLINK MAGAZINES, LLC, EL SEGUNDO, CA. SN 85-658,058. PUB. 11-13-2012, FILED 6-21-2012.

**LOWRIDER**

THE MARK CONSISTS OF STANDARD CHARACTERS WITHOUT CLAIM TO ANY PARTICULAR FONT, STYLE, SIZE, OR COLOR.

OWNER OF U.S. REG. NOS. 1,557,901, 2,798,772, AND OTHERS.

FOR BRACELETS; JEWELRY; JEWELRY, NAMELY, DOG TAGS FOR WEAR BY HUMANS FOR DECORATIVE PURPOSES; NECK CHAINS; NECKLACES (U.S. CLS. 2, 27, 28 AND 50).

FIRST USE 1-21-2013; IN COMMERCE 1-21-2013.

**CLASS 14—(Continued).**

4,593,376. SOURCE INTERLINK MAGAZINES, LLC, EL SEGUNDO, CA. SN 85-658,073. PUB. 11-13-2012, FILED 6-21-2012.



OWNER OF U.S. REG. NOS. 1,743,113, 3,893,988, AND OTHERS.

THE MARK CONSISTS OF A CHARACTER PORTRAITURE OF A MAN'S SINGLE LINE CIRCLE HEAD FACING FORWARD WITH A MUSTACHE WEARING DARK SQUARE SUNGLASSES BELOW BRIM OF A TOP CENTER INDENTED HAT WITH A DARK BAND AROUND IT AND A SHINE INDICATED ON THE FAR RIGHT SIDE OF THE BAND.

FOR BRACELETS; JEWELRY; JEWELRY, NAMELY, DOG TAGS FOR WEAR BY HUMANS FOR DECORATIVE PURPOSES; NECK CHAINS; NECKLACES (U.S. CLS. 2, 27, 28 AND 50).

FIRST USE 1-21-2013; IN COMMERCE 1-21-2013.

---

4,593,671. NO. 131 HOLDINGS INC., BROOKLYN, NY. SN 85-821,898. PUB. 12-10-2013, FILED 1-12-2013.

**SOPHY**

THE MARK CONSISTS OF STANDARD CHARACTERS WITHOUT CLAIM TO ANY PARTICULAR FONT, STYLE, SIZE, OR COLOR.

FOR JEWELRY (U.S. CLS. 2, 27, 28 AND 50).

FIRST USE 5-30-2014; IN COMMERCE 5-30-2014.

---

4,593,680. NO. 131 HOLDINGS INC., BROOKLYN, NY. SN 85-825,884. PUB. 12-10-2013, FILED 1-17-2013.

**SOPHY NEW YORK**

THE MARK CONSISTS OF STANDARD CHARACTERS WITHOUT CLAIM TO ANY PARTICULAR FONT, STYLE, SIZE, OR COLOR.

NO CLAIM IS MADE TO THE EXCLUSIVE RIGHT TO USE "NEW YORK", APART FROM THE MARK AS SHOWN.

FOR JEWELRY (U.S. CLS. 2, 27, 28 AND 50).

FIRST USE 7-9-2013; IN COMMERCE 7-9-2013.



**CLASS 14—(Continued).**

4,593,834. MARCONDES, GIL, DAVIE, FL. SN 85-916,438.  
PUB. 9-24-2013, FILED 4-26-2013.

# ARETERIA

THE MARK CONSISTS OF STANDARD CHARACTERS WITHOUT CLAIM TO ANY PARTICULAR FONT, STYLE, SIZE, OR COLOR.

FOR COSTUME JEWELRY (U.S. CLS. 2, 27, 28 AND 50).  
FIRST USE 8-15-2013; IN COMMERCE 10-28-2013.

---

4,593,857. JASON DIPIETRO, EAST PROVIDENCE, RI. SN 85-921,894. PUB. 10-1-2013, FILED 5-2-2013.

# MAGNETROS

THE MARK CONSISTS OF STANDARD CHARACTERS WITHOUT CLAIM TO ANY PARTICULAR FONT, STYLE, SIZE, OR COLOR.

FOR JEWELRY (U.S. CLS. 2, 27, 28 AND 50).  
FIRST USE 1-0-2014; IN COMMERCE 1-0-2014.

---

4,593,888. BREWSTER, IVAN, BROOKLYN, NY. SN 85-929,777. PUB. 10-8-2013, FILED 5-13-2013.

# INSTACLOCKS

THE MARK CONSISTS OF THE STYLIZED WORDS "INSTACLOCKS".  
FOR CLOCKS (U.S. CLS. 2, 27, 28 AND 50).  
FIRST USE 4-6-2014; IN COMMERCE 5-7-2014.

**CLASS 14—(Continued).**

4,593,904. KIKI MCDONOUGH, LONDON, UNITED KINGDOM. SN 85-933,114. PUB. 2-25-2014, FILED 5-15-2013.

# KIKI MCDONOUGH

THE MARK CONSISTS OF STANDARD CHARACTERS WITHOUT CLAIM TO ANY PARTICULAR FONT, STYLE, SIZE, OR COLOR.

THE NAME "KIKI MCDONOUGH" IDENTIFIES A LIVING INDIVIDUAL WHOSE CONSENT IS OF RECORD.  
FOR JEWELRY; EARRINGS, NECKLACES, BRACELETS AND RINGS (U.S. CLS. 2, 27, 28 AND 50).  
FIRST USE 6-0-1985; IN COMMERCE 5-0-2012.

---

4,594,007. DEL MILAGRO PHILBROOK REIKI STONES, INC., COOPER CITY, FL. SN 85-948,950. PUB. 10-29-2013, FILED 6-3-2013.



DEL MILAGRO PHILBROOK REIKI STONES, INC.  
*Miracle Crystals, Your Call To Consciousness*

NO CLAIM IS MADE TO THE EXCLUSIVE RIGHT TO USE "REIKI STONES, INC." AND "CRYSTALS", APART FROM THE MARK AS SHOWN.

THE MARK CONSISTS OF A CIRCULAR GLOWING DESIGN WITH WINGS, WITH THE WORDING "DEL MILAGRO PHILBROOK REIKI STONES, INC." AND "MIRACLE CRYSTALS, YOUR CALL TO CONSCIOUSNESS" SEPARATED BY A HORIZONTAL LINE AND APPEARING BELOW THE DESIGN.

THE ENGLISH TRANSLATION OF "DEL MILAGRO" IN THE MARK IS "OF THE MIRACLE".

FOR JEWELRY; PENDANTS; SEMI-PRECIOUS AND PRECIOUS STONES (U.S. CLS. 2, 27, 28 AND 50).  
FIRST USE 5-0-2014; IN COMMERCE 5-0-2014.

**CLASS 14—(Continued).**

4,594,135. VACVAL, JURAJ, NASSAU, BAHAMAS. SN 85-970,720. PUB. 11-19-2013, FILED 6-26-2013.

# DRONE

THE MARK CONSISTS OF STANDARD CHARACTERS WITHOUT CLAIM TO ANY PARTICULAR FONT, STYLE, SIZE, OR COLOR.

FOR JEWELLERY, CLOCKS, WATCHES AND PARTS FOR WATCHES AND CLOCKS (U.S. CLS. 2, 27, 28 AND 50).

FIRST USE 4-7-2014; IN COMMERCE 4-7-2014.

4,594,458. THE HUNDREDS IS HUGE, INC., VERNON, CA. SN 86-101,902. PUB. 4-22-2014, FILED 10-25-2013.



OWNER OF U.S. REG. NOS. 3,390,623 AND 4,180,159. THE MARK CONSISTS OF THE DESIGN OF A BOMB WITH A HUMAN FACE, WITH SPARKS COMING OUT OF THE TOP OF THE BOMB.

FOR WATCHES (U.S. CLS. 2, 27, 28 AND 50).  
FIRST USE 6-5-2008; IN COMMERCE 6-5-2008.

4,594,501. FOULADIAN, JEAN PIERRE, WOODLAND HILLS, CA. SN 86-119,679. PUB. 4-15-2014, FILED 11-15-2013.

## JEAN-PIERRE JEWELERS

THE MARK CONSISTS OF STANDARD CHARACTERS WITHOUT CLAIM TO ANY PARTICULAR FONT, STYLE, SIZE, OR COLOR.

NO CLAIM IS MADE TO THE EXCLUSIVE RIGHT TO USE "JEWELERS", APART FROM THE MARK AS SHOWN.

**CLASS 14—(Continued).**

THE NAME(S), PORTRAIT(S), AND/OR SIGNATURE(S) SHOWN IN THE MARK IDENTIFIES "JEAN-PIERRE", WHOSE CONSENT(S) TO REGISTER IS MADE OF RECORD.

FOR JEWELRY; DIAMONDS; DIAMOND JEWELRY; DIAMOND STUDS; FINE JEWELRY (U.S. CLS. 2, 27, 28 AND 50).

FIRST USE 10-1-2013; IN COMMERCE 10-1-2013.

**CLASS 15—MUSICAL INSTRUMENTS**

4,594,360. AUGUST D. MARTIN, ALBUQUERQUE, NM. SN 86-068,790. PUB. 2-11-2014, FILED 9-19-2013.

# ULTIMOUNT

THE MARK CONSISTS OF STANDARD CHARACTERS WITHOUT CLAIM TO ANY PARTICULAR FONT, STYLE, SIZE, OR COLOR.

FOR DRUM PARTS, NAMELY, MOUNTING HARDWARE FOR DRUM COMPONENTS; DRUM PARTS, NAMELY, A STRUCTURAL FRAMEWORK COUPLING THE DRUM HEAD TO THE DRUM SHELL; MUSICAL INSTRUMENT TUNING APPARATUS, NAMELY, A DRUM MOUNT PROVIDING ADJUSTABLE TENSION ON THE DRUM SHELL AND/OR DRUM HEAD; MUSICAL INSTRUMENTS, NAMELY, DRUMS WITH SPECIALIZED MOUNTING HARDWARE PERMITTING UNIMPEDED RESONANCE OF THE DRUM SHELL (U.S. CLS. 2, 21 AND 36).

FIRST USE 6-21-2014; IN COMMERCE 6-21-2014.

4,594,395. ANDY GRAHAM, SANTA ROSA, CA. SN 86-082,157. PUB. 2-25-2014, FILED 10-3-2013.

# SlapStick

THE MARK CONSISTS OF STANDARD CHARACTERS WITHOUT CLAIM TO ANY PARTICULAR FONT, STYLE, SIZE, OR COLOR.

FOR ELECTRIC AND ELECTRONIC MUSICAL INSTRUMENTS (U.S. CLS. 2, 21 AND 36).

FIRST USE 4-1-2014; IN COMMERCE 5-1-2014.

**CLASS 16—PAPER GOODS AND PRINTED MATTER**

**CLASS 16—(Continued).**

4,593,152. DJ ASHBA, WEST HOLLYWOOD, CA. SN 85-184,005. PUB. 4-26-2011, FILED 11-23-2010.

# DJ ASHBA

THE MARK CONSISTS OF STANDARD CHARACTERS WITHOUT CLAIM TO ANY PARTICULAR FONT, STYLE, SIZE, OR COLOR.

THE NAME "DJ ASHBA" IDENTIFIES A LIVING INDIVIDUAL WHOSE CONSENT IS OF RECORD.

FOR POSTERS, AUTOGRAPH BOOKS, DECALS, STICKERS AND PICTURES (U.S. CLS. 2, 5, 22, 23, 29, 37, 38 AND 50).

FIRST USE 4-13-2003; IN COMMERCE 4-13-2003.

4,593,167. THE COLORS OF MALENT, LLC, NASHUA, NH. SN 85-208,191. PUB. 5-10-2011, FILED 12-30-2010.



THE COLOR(S) BLUE, GREEN, GOLD, BLACK, AND GRAY IS/ARE CLAIMED AS A FEATURE OF THE MARK.

THE MARK CONSISTS OF A CIRCLE CUT INTO THREE PIECES. THE PIECES ARE SLIGHTLY SEPARATED. THE LEFTMOST THIRD IS BLUE, THE MIDDLE IS GREEN, AND THE RIGHTMOST THIRD IS GOLD. THE STYLIZED WORDS "THE COLORS OF MALENT" OVERLAY THE THREE PARTS OF THE CIRCLE, AND THE LETTERS ARE BLACK AND OUTLINED WITH GRAY.

FOR SERIES OF FICTION WORKS, NAMELY, NOVELS AND BOOKS (U.S. CLS. 2, 5, 22, 23, 29, 37, 38 AND 50).

FIRST USE 8-18-2010; IN COMMERCE 3-25-2011.

**CLASS 16—(Continued).**

4,593,170. NATIONAL GEOGRAPHIC SOCIETY, WASHINGTON, DC. SN 85-211,859. PUB. 4-26-2011, FILED 1-6-2011.



OWNER OF U.S. REG. NOS. 2,775,405, 3,393,110, AND OTHERS.

THE MARK CONSISTS OF THE WORDS NATIONAL GEOGRAPHIC AND A RECTANGULAR BORDER DESIGN WHICH APPEAR CENTERED OVER THE WORD EXPLORER. THE LETTER "O" IN THE WORD EXPLORER IS ENLARGED AND APPEARS WITH A SHADED OUTLINE. THE SHADING IS MERELY A FEATURE OF THE DESIGN AND IS NOT INTENDED TO DEPICT COLOR.

FOR PERIODICAL PUBLICATIONS, NAMELY, EDUCATIONAL MAGAZINES FOR CHILDREN AND PRINTED TEACHING GUIDES ASSOCIATED THEREWITH (U.S. CLS. 2, 5, 22, 23, 29, 37, 38 AND 50).

FIRST USE 3-0-2011; IN COMMERCE 3-0-2011.

4,593,247. YUPO CORPORATION, TOKYO, JAPAN. SN 85-474,447. PUB. 2-11-2014, FILED 11-16-2011.

# YUPOJELLY

THE MARK CONSISTS OF STANDARD CHARACTERS WITHOUT CLAIM TO ANY PARTICULAR FONT, STYLE, SIZE, OR COLOR.

FOR PAPER AND CARDBOARD: SYNTHETIC PAPER; GOODS MADE FROM PAPER AND CARDBOARD, NAMELY, PAPER GIFT BAGS, PAPER CARDS, BOOK COVERS, MAGAZINE COVERS, PRINTED MAP COVERS, DRAWING TEMPLATES, DRAFTING TEMPLATES, MARKING TEMPLATES, PAPER REPORT COVERS, AND SALES SHEETS; PRINTED MATTER, NAMELY, BROCHURES, BOOKS, MAGAZINES, AND MANUALS FEATURING THE PAPER INDUSTRY AND THE SYNTHETIC PAPER INDUSTRY; PRINTED MATTER, NAMELY, TAGS, SIGNS, LABELS, WINDOW SIGNS, OUTDOOR SIGNS, CROSSWORD PUZZLES, MENU SIGNS, PAPER MENU DISPLAY CARDS, OVERLAY DRAWINGS, POSTERS, POINT OF PURCHASE MATERIALS, BANNERS, EMERGENCY SIGNS, DIRECTIONAL SIGNS, AND INSTRUCTIONAL SIGNS; BOOK-BINDING MATERIAL; PHOTOGRAPHS; STATIONERY; ADHESIVES FOR STATIONERY OR HOUSEHOLD PURPOSES; ARTISTS' MATERIALS, NAMELY, PAINT TRAYS, PAINT ROLLERS, AND PAINT BRUSHES; TYPEWRITERS AND OFFICE REQUISITES, NAMELY, ENVELOPE SEALING MACHINES; PRINTED INSTRUCTIONAL AND TEACHING MATERIAL, NAMELY, TRAINING MANUALS, INSTRUCTIONAL MANUALS, AND TEACHING MANUALS; PLASTIC MATERIALS FOR PACKAGING, NAMELY, PLASTIC CLING FILM FOR PACKAGING; PRINTERS' TYPE; PRINTING BLOCKS (U.S. CLS. 2, 5, 22, 23, 29, 37, 38 AND 50).

FIRST USE 6-8-2010; IN COMMERCE 4-3-2012.

**CLASS 16—(Continued).**

4,593,327. GROM, CHRIS V, MANSFIELD, TX. SN 85-626,792. PUB. 4-30-2013, FILED 5-16-2012.

# Hootybee

THE MARK CONSISTS OF STANDARD CHARACTERS WITHOUT CLAIM TO ANY PARTICULAR FONT, STYLE, SIZE, OR COLOR.

FOR CHILDREN'S BOOKS; PUBLICATIONS, NAMELY, A SERIES IN THE FIELDS OF CHILDREN'S BOOKS (U.S. CLS. 2, 5, 22, 23, 29, 37, 38 AND 50). FIRST USE 1-1-2014; IN COMMERCE 4-1-2014.

---

4,593,435. RICHARD WENDELL ARNESON III, RANCHO SANTA FE, CA. SN 85-710,484. PUB. 4-30-2013, FILED 8-22-2012.

# MAKAI PRESS

THE MARK CONSISTS OF STANDARD CHARACTERS WITHOUT CLAIM TO ANY PARTICULAR FONT, STYLE, SIZE, OR COLOR.

NO CLAIM IS MADE TO THE EXCLUSIVE RIGHT TO USE "PRESS", APART FROM THE MARK AS SHOWN.

THE ENGLISH TRANSLATION OF "MAKAI" IN THE MARK IS "TOWARD OR BY THE SEA" OR "SEAWARD".

FOR PUBLICATIONS, NAMELY, BOOKS RELATING TO THE SPORT OF SAILING (U.S. CLS. 2, 5, 22, 23, 29, 37, 38 AND 50).

FIRST USE 4-28-2014; IN COMMERCE 4-28-2014.

---

4,593,437. MARVEL CHARACTERS, INC., BURBANK, CA. SN 85-711,690. PUB. 6-11-2013, FILED 8-23-2012.

# IRON PATRIOT

THE MARK CONSISTS OF STANDARD CHARACTERS WITHOUT CLAIM TO ANY PARTICULAR FONT, STYLE, SIZE, OR COLOR.

FOR COMIC BOOKS; PUBLICATIONS, NAMELY, MAGAZINES AND PRINTED PERIODICALS, FEATURING COMIC BOOK STORIES AND ARTWORK (U.S. CLS. 2, 5, 22, 23, 29, 37, 38 AND 50).

FIRST USE 3-26-2014; IN COMMERCE 3-26-2014.

**CLASS 16—(Continued).**

4,593,439. BLANCHARD TRAINING AND DEVELOPMENT, INC., ESCONDIDO, CA. SN 85-711,992. PUB. 11-13-2012, FILED 8-24-2012.



OWNER OF U.S. REG. NO. 1,584,015.

THE MARK CONSISTS OF THE DESIGNATION "SLLL" IN A SQUARE COMPOSED OF BROKEN LINES.

FOR PUBLICATIONS, NAMELY, CATALOGS, WORKBOOKS, INSTRUCTIONAL BOOKS, HANDOUTS, SLIDE GUIDE BOOKLETS, AND PRINTED INSTRUCTIONAL MATERIALS IN THE FIELDS OF EMPLOYEE DEVELOPMENT, BUSINESS MANAGEMENT AND LEADERSHIP (U.S. CLS. 2, 5, 22, 23, 29, 37, 38 AND 50).

FIRST USE 10-31-2013; IN COMMERCE 10-31-2013.

---

4,593,441. DAEWON MEDIA CO., LTD., SEOUL, REPUBLIC OF KOREA. SN 85-712,459. PUB. 1-29-2013, FILED 8-24-2012.

# GON

THE MARK CONSISTS OF STANDARD CHARACTERS WITHOUT CLAIM TO ANY PARTICULAR FONT, STYLE, SIZE, OR COLOR.

FOR COMIC BOOKS AND MAGAZINES, CARTOONS, POSTERS AND STATIONERY, GLUE FOR HOUSEHOLD PURPOSES, CALENDARS, FOUNTAIN PENS, PAINT BOXES, NOTEBOOKS (U.S. CLS. 2, 5, 22, 23, 29, 37, 38 AND 50).

FIRST USE 2-23-1995; IN COMMERCE 8-30-2011.

**CLASS 16—(Continued).**

4,593,448. THOMAS, RITA LEIGH, VALENCIA, CA. SN 85-719,649. PUB. 2-5-2013, FILED 9-4-2012.

*Seriously Speaking*

THE MARK CONSISTS OF THE STYLIZED TEXT "SERIOUSLY SPEAKING".  
FOR CALENDARS; GREETING CARDS; POSTERS (U.S. CLS. 2, 5, 22, 23, 29, 37, 38 AND 50).  
FIRST USE 8-6-2013; IN COMMERCE 8-6-2013.

4,593,450. GENERALIST INK, LLC, RIDGEFIELD, CT. SN 85-722,882. PUB. 4-30-2013, FILED 9-7-2012.

**GENERALIST INK**

THE MARK CONSISTS OF STANDARD CHARACTERS WITHOUT CLAIM TO ANY PARTICULAR FONT, STYLE, SIZE, OR COLOR.  
FOR BOOKS ON A WIDE VARIETY OF EDUCATIONAL TOPICS (U.S. CLS. 2, 5, 22, 23, 29, 37, 38 AND 50).  
FIRST USE 6-3-2014; IN COMMERCE 6-3-2014.

4,593,486. CLEARWATER PAPER CORPORATION, SPOKANE, WA. SN 85-753,089. PUB. 4-2-2013, FILED 10-12-2012.

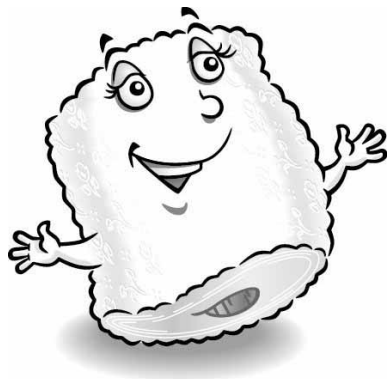

THE MARK CONSISTS OF A BLACK OUTLINE OF A

**CLASS 16—(Continued).**

ROLL OF TOILET PAPER WITH HUMAN-LIKE QUALITIES, SPECIFICALLY, FACE AND ARMS. THE MARK IS SHADED NEAR THE EDGES, SPECIFICALLY AT THE ARMS, FACIAL FEATURES, SIDES OF THE PAPER ROLL, BOTTOM OF THE PAPER ROLL, AND THE SHADOWING BELOW THE PAPER ROLL. THE MARK IS SHADED AT THE EYELIDS. THE EDGES ON THE SIDES OF THE TORSO CONTAIN STYLIZED FLOWERS AND A DOT GEOMETRIC DESIGN. THE MARK IS SHADED AT THE MOUTH. THE CENTER OF THE ROLL IS SHADED.  
FOR BATHROOM TISSUE (U.S. CLS. 2, 5, 22, 23, 29, 37, 38 AND 50).  
FIRST USE 10-14-2013; IN COMMERCE 10-14-2013.

4,593,488. DIVERSIFIED DYNAMICS CORPORATION, MINNEAPOLIS, MN. SN 85-754,016. PUB. 4-30-2013, FILED 10-15-2012.

**Gap Wheel**

NO CLAIM IS MADE TO THE EXCLUSIVE RIGHT TO USE "GAP" AND "WHEEL", APART FROM THE MARK AS SHOWN.

THE MARK CONSISTS OF THE WORDING "GAP WHEEL" WITH A WHEEL IN BETWEEN THE TWO WORDS.  
FOR HANDLED-PADS WITH CENTRAL WHEEL FOR APPLYING PAINT OR STAIN SOLD AS AN INTEGRAL COMPONENT OF MANUALLY OPERATED, HANDHELD PAINT AND STAIN APPLICATORS (U.S. CLS. 2, 5, 22, 23, 29, 37, 38 AND 50).  
FIRST USE 6-30-2013; IN COMMERCE 6-30-2013.

4,593,504. E&B GIFTWARE LLC, ELMSFORD, NY. SN 85-762,968. PUB. 11-5-2013, FILED 10-25-2012.

**Fashion Works**

THE MARK CONSISTS OF STANDARD CHARACTERS WITHOUT CLAIM TO ANY PARTICULAR FONT, STYLE, SIZE, OR COLOR.

FOR DESK ACCESSORIES, NAMELY, TAPE DISPENSERS; NOTEPAD HOLDERS, AND PEN AND PENCIL HOLDERS; HOLDERS FOR DESK ACCESSORIES (U.S. CLS. 2, 5, 22, 23, 29, 37, 38 AND 50).  
FIRST USE 3-7-2013; IN COMMERCE 9-16-2013.

**CLASS 16—(Continued).**

4,593,554. BJ'S WHOLESALE CLUB, INC., WESTBOROUGH, MA. SN 85-783,047. PUB. 4-23-2013, FILED 11-19-2012.

**WE ARE TREE POSITIVE**

THE MARK CONSISTS OF STANDARD CHARACTERS WITHOUT CLAIM TO ANY PARTICULAR FONT, STYLE, SIZE, OR COLOR.

FOR PAPER PRODUCTS, NAMELY, BATH TISSUE, PAPER NAPKINS AND PAPER TOWELS (U.S. CLS. 2, 5, 22, 23, 29, 37, 38 AND 50).

FIRST USE 12-8-2012; IN COMMERCE 12-8-2012.

4,593,603. HINDUSTAN PENCILS PRIVATE LIMITED, MUMBAI, INDIA. SN 85-800,512. PUB. 11-5-2013, FILED 12-12-2012.

**SIVO**

THE MARK CONSISTS OF STANDARD CHARACTERS WITHOUT CLAIM TO ANY PARTICULAR FONT, STYLE, SIZE, OR COLOR.

FOR WOOD CASED WRITING PENCILS, ERASERS, PENCIL SHARPENERS, GRADUATED RULERS, MECHANICAL PENCILS, LEADS FOR MECHANICAL PENCILS, COLOR PENCILS, WATER SOLUBLE COLOR PENCILS, WAX CRAYONS, BALL POINT PENS, MATHEMATICAL INSTRUMENT SET COMPRISING DRAFTING AND DRAWING COMPASS, DRAFTING INSTRUMENT IN THE NATURE OF A DIVIDER, PROTRACTOR, DRAWING AND DRAFTING SQUARES IN THE NATURE OF A SET SQUARE 45° AND SET SQUARE 60°, MATHEMATICAL INSTRUMENTS, NAMELY, DRAFTING AND DRAWING COMPASSES, DRAFTING INSTRUMENTS IN THE NATURE OF DIVIDERS, PROTRACTORS, DRAWING AND DRAFTING SQUARES IN THE NATURE OF SET SQUARES; COPYING PENCILS, GLASS MARKING PENCILS, CHECKING PENCILS (U.S. CLS. 2, 5, 22, 23, 29, 37, 38 AND 50).

FIRST USE 6-19-2014; IN COMMERCE 6-19-2014.

4,593,644. CURB, LINDA, NASHVILLE, TN. SN 85-811,807. PUB. 12-24-2013, FILED 12-28-2012.

**PATRIOTIC PETS**

THE MARK CONSISTS OF STANDARD CHARACTERS WITHOUT CLAIM TO ANY PARTICULAR FONT, STYLE, SIZE, OR COLOR.

**CLASS 16—(Continued).**

NO CLAIM IS MADE TO THE EXCLUSIVE RIGHT TO USE "PETS", APART FROM THE MARK AS SHOWN.

FOR GREETING CARDS (U.S. CLS. 2, 5, 22, 23, 29, 37, 38 AND 50).

FIRST USE 1-5-2014; IN COMMERCE 1-5-2014.

4,593,670. WARREN LEVINSON, DENVER, CO. SN 85-821,607. PUB. 6-4-2013, FILED 1-11-2013.

**DR Q**

THE MARK CONSISTS OF STANDARD CHARACTERS WITHOUT CLAIM TO ANY PARTICULAR FONT, STYLE, SIZE, OR COLOR.

FOR COMIC STRIPS (U.S. CLS. 2, 5, 22, 23, 29, 37, 38 AND 50).

FIRST USE 4-0-2013; IN COMMERCE 4-0-2013.

4,593,745. TINY DOG PRESS, BALTIMORE, MD. SN 85-865,609. PUB. 12-3-2013, FILED 3-4-2013.

**Tiny Dog Press**

THE MARK CONSISTS OF STANDARD CHARACTERS WITHOUT CLAIM TO ANY PARTICULAR FONT, STYLE, SIZE, OR COLOR.

OWNER OF U.S. REG. NO. 8,586,560.

NO CLAIM IS MADE TO THE EXCLUSIVE RIGHT TO USE "PRESS", APART FROM THE MARK AS SHOWN.

FOR PRINTED INVITATIONS; STATIONERY (U.S. CLS. 2, 5, 22, 23, 29, 37, 38 AND 50).

FIRST USE 5-1-2013; IN COMMERCE 9-1-2013.

**CLASS 16—(Continued).**

4,593,796. GUANGXI JINGUI PULP&PAPER CO.,LTD., GUANGXI, CHINA. SN 85-898,516. PUB. 12-3-2013, FILED 4-9-2013.



THE MARK CONSISTS OF THE WORDING "GALAXY" IN STYLIZED FONT BELOW A FANCIFUL DESIGN OF A GALAXY SHOWING CURVED BANDS TO REPRESENT VARIOUS ORBITS.

FOR PAPER BOARDS; CARDBOARD (U.S. CLS. 2, 5, 22, 23, 29, 37, 38 AND 50).

FIRST USE 2-24-2014; IN COMMERCE 2-24-2014.

4,593,870. TOPCO HOLDINGS, INC., ELK GROVE VILLAGE, IL. SN 85-924,167. PUB. 10-8-2013, FILED 5-6-2013.

**ABSOLUTE SOFT**

THE MARK CONSISTS OF STANDARD CHARACTERS WITHOUT CLAIM TO ANY PARTICULAR FONT, STYLE, SIZE, OR COLOR.

NO CLAIM IS MADE TO THE EXCLUSIVE RIGHT TO USE "SOFT", APART FROM THE MARK AS SHOWN.

FOR FACIAL TISSUE (U.S. CLS. 2, 5, 22, 23, 29, 37, 38 AND 50).

FIRST USE 10-0-2013; IN COMMERCE 10-0-2013.

4,593,905. KISSLETOE, LLC, PARK CITY, UT. SN 85-933,152. PUB. 10-15-2013, FILED 5-15-2013.

**KISSLETOE**

THE MARK CONSISTS OF STANDARD CHARACTERS WITHOUT CLAIM TO ANY PARTICULAR FONT, STYLE, SIZE, OR COLOR.

FOR GREETING CARDS (U.S. CLS. 2, 5, 22, 23, 29, 37, 38 AND 50).

FIRST USE 3-20-2014; IN COMMERCE 3-29-2014.

**CLASS 16—(Continued).**

4,593,930. M & G PARTNERS, LLP, MILWAUKEE, WI. SN 85-937,044. PUB. 10-15-2013, FILED 5-20-2013.

**CHROMA STIX**

THE MARK CONSISTS OF STANDARD CHARACTERS WITHOUT CLAIM TO ANY PARTICULAR FONT, STYLE, SIZE, OR COLOR.

FOR CRAYONS (U.S. CLS. 2, 5, 22, 23, 29, 37, 38 AND 50).

FIRST USE 5-21-2014; IN COMMERCE 5-21-2014.

4,593,938. DUNCAN ENTERPRISES, INC., DBA ILOVE-TOCREATE, FRESNO, CA. SN 85-938,107. PUB. 11-12-2013, FILED 5-21-2013.

**Tulip Dual-Tip Fabric Markers**

THE MARK CONSISTS OF STANDARD CHARACTERS WITHOUT CLAIM TO ANY PARTICULAR FONT, STYLE, SIZE, OR COLOR.

OWNER OF U.S. REG. NOS. 3,815,379, 4,083,600, AND OTHERS.

NO CLAIM IS MADE TO THE EXCLUSIVE RIGHT TO USE "DUAL-TIP FABRIC MARKERS", APART FROM THE MARK AS SHOWN.

FOR PERMANENT FELT TIP MARKERS FOR CRAFT AND HOBBY APPLICATION ON FABRICS AND TEXTILES FEATURING TIPS OF VARYING THICKNESS ON BOTH ENDS OF THE MARKER (U.S. CLS. 2, 5, 22, 23, 29, 37, 38 AND 50).

FIRST USE 5-1-2014; IN COMMERCE 5-1-2014.

4,593,971. BE OUR GUEST, LLC, HALEIWA, HI. SN 85-942,659. PUB. 10-22-2013, FILED 5-24-2013.

**SEEK SPOT**

THE MARK CONSISTS OF STANDARD CHARACTERS WITHOUT CLAIM TO ANY PARTICULAR FONT, STYLE, SIZE, OR COLOR.

FOR PRINTED DIRECTORIES OF VACATION ACTIVITIES, ATTRACTIONS, AND RENTALS (U.S. CLS. 2, 5, 22, 23, 29, 37, 38 AND 50).

FIRST USE 12-1-2013; IN COMMERCE 12-1-2013.

**CLASS 16—(Continued).**

4,594,019. FORSHER, JAMES M., BAINBRIDGE ISLAND, WA. SN 85-950,846. PUB. 12-3-2013, FILED 6-4-2013.

**Nostalgia\*Gram**  
**The Entertaining Greeting**  
**Card**

THE MARK CONSISTS OF STANDARD CHARACTERS WITHOUT CLAIM TO ANY PARTICULAR FONT, STYLE, SIZE, OR COLOR.

NO CLAIM IS MADE TO THE EXCLUSIVE RIGHT TO USE "GREETING CARD", APART FROM THE MARK AS SHOWN.

FOR GREETING CARDS; GREETING CARDS FEATURING DVD AND BOOKS (U.S. CLS. 2, 5, 22, 23, 29, 37, 38 AND 50).

FIRST USE 5-24-2014; IN COMMERCE 5-24-2014.

---

4,594,123. HIGEAR INNOVATIONS, LLC, FREDERICKTOWN, MO. SN 85-969,199. PUB. 11-12-2013, FILED 6-25-2013.

**VITALBOARD**

THE MARK CONSISTS OF STANDARD CHARACTERS WITHOUT CLAIM TO ANY PARTICULAR FONT, STYLE, SIZE, OR COLOR.

FOR DRY ERASE WRITING BOARDS AND WRITING SURFACES; STICK-ON WHITEBOARDS AND DRY-ERASE BOARDS (U.S. CLS. 2, 5, 22, 23, 29, 37, 38 AND 50).

FIRST USE 5-1-2013; IN COMMERCE 9-1-2013.

---

4,594,165. THE WELL COMMUNITY CHURCH, FRESNO, CA. SN 85-982,049. PUB. 4-23-2013, FILED 11-21-2012.

**ANATOMY OF A DISCIPLE**

THE MARK CONSISTS OF STANDARD CHARACTERS WITHOUT CLAIM TO ANY PARTICULAR FONT, STYLE, SIZE, OR COLOR.

FOR PUBLICATIONS, NAMELY, BOOKS (U.S. CLS. 2, 5, 22, 23, 29, 37, 38 AND 50).

FIRST USE 12-11-2013; IN COMMERCE 12-11-2013.

**CLASS 16—(Continued).**

4,594,183. KISS CATALOG, LTD., PINE BROOK, NJ. SN 85-982,303. PUB. 6-11-2013, FILED 1-4-2013.

**KISS KIDS**

THE MARK CONSISTS OF STANDARD CHARACTERS WITHOUT CLAIM TO ANY PARTICULAR FONT, STYLE, SIZE, OR COLOR.

OWNER OF U.S. REG. NOS. 1,894,876, 4,276,064, AND OTHERS.

NO CLAIM IS MADE TO THE EXCLUSIVE RIGHT TO USE "KIDS", APART FROM THE MARK AS SHOWN.

FOR COMIC BOOKS (U.S. CLS. 2, 5, 22, 23, 29, 37, 38 AND 50).

FIRST USE 4-10-2013; IN COMMERCE 4-10-2013.

---

4,594,340. SHIGEMATSU, SETSU, CORONA, CA. SN 86-060,965. PUB. 1-28-2014, FILED 9-10-2013.

**GUARDIAN PRINCESSES**

THE MARK CONSISTS OF STANDARD CHARACTERS WITHOUT CLAIM TO ANY PARTICULAR FONT, STYLE, SIZE, OR COLOR.

FOR CHILDREN'S BOOKS; CHILDREN'S INTERACTIVE EDUCATIONAL BOOKS; EDUCATIONAL BOOKS FEATURING ELEMENTARY LEVEL CHILDREN'S LANGUAGE ARTS; EDUCATIONAL KITS SOLD AS A UNIT IN THE FIELD OF ELEMENTARY LEVEL CHILDREN'S LANGUAGE ARTS CONSISTING PRIMARILY OF EDUCATIONAL BOOKS AND ALSO INCLUDING DVDS AND T-SHIRTS; EDUCATIONAL KITS SOLD AS A UNIT IN THE FIELD OF ELEMENTARY LEVEL CHILDREN'S LANGUAGE ARTS CONSISTING PRIMARILY OF BOOKS AND ALSO INCLUDING DVDS; EDUCATIONAL PUBLICATIONS, NAMELY, EDUCATIONAL LEARNING CARDS, FLASH CARDS, ACTIVITY CARDS, WORKBOOKS, TEXTBOOKS, ACTIVITY BOOKS, STORY BOOKS, PUZZLE BOOKS, PRINTED PUZZLES, TEACHER GUIDES, MANUALS, POSTERS AND EDUCATIONAL BOOKLETS IN THE FIELD OF ELEMENTARY LEVEL CHILDREN'S LANGUAGE ARTS; PRINTED PAMPHLETS, BROCHURES, MANUALS, BOOKS, BOOKLETS, LEAFLETS, INFORMATIONAL FLYERS, INFORMATIONAL SHEETS AND NEWSLETTERS, ADHESIVE BACKED STICKERS, AND KITS COMPRISING ONE OR MORE OF THE FOREGOING MATERIALS IN THE FIELD OF ELEMENTARY LEVEL CHILDREN'S LANGUAGE ARTS (U.S. CLS. 2, 5, 22, 23, 29, 37, 38 AND 50).

FIRST USE 12-15-2013; IN COMMERCE 12-15-2013.



**CLASS 16—(Continued).**

4,594,416. SERGEANT'S PET CARE PRODUCTS, INC., ALLEGAN, ME. SN 86-089,447. PUB. 3-18-2014, FILED 10-11-2013.

# GO! BAGS

THE MARK CONSISTS OF STANDARD CHARACTERS WITHOUT CLAIM TO ANY PARTICULAR FONT, STYLE, SIZE, OR COLOR.

NO CLAIM IS MADE TO THE EXCLUSIVE RIGHT TO USE "BAGS", APART FROM THE MARK AS SHOWN.

FOR PLASTIC BAGS FOR DISPOSING OF PET WASTE (U.S. CLS. 2, 5, 22, 23, 29, 37, 38 AND 50).

FIRST USE 1-2-2014; IN COMMERCE 1-2-2014.

**CLASS 16—(Continued).**

4,594,502. THE CYNJA L.L.C., WASHINGTON, DC. SN 86-119,831. PUB. 4-15-2014, FILED 11-15-2013.

# THE CYNJA

THE MARK CONSISTS OF STANDARD CHARACTERS WITHOUT CLAIM TO ANY PARTICULAR FONT, STYLE, SIZE, OR COLOR.

FOR CHILDREN'S ACTIVITY BOOKS; CHILDREN'S BOOKS; CHILDREN'S INTERACTIVE EDUCATIONAL BOOKS; COMIC BOOKS; EDUCATIONAL BOOKS FEATURING CYBERSECURITY AND COMPUTER TOPICS; EDUCATIONAL PUBLICATIONS, NAMELY, EDUCATIONAL LEARNING CARDS, FLASH CARDS, ACTIVITY CARDS, WORKBOOKS, TEXTBOOKS, ACTIVITY BOOKS, STORY BOOKS, PUZZLE BOOKS, PRINTED PUZZLES, TEACHER GUIDES, MANUALS, POSTERS AND EDUCATIONAL BOOKLETS IN THE FIELD OF CYBERSECURITY AND COMPUTER TOPICS; PRINTED PAMPHLETS, BROCHURES, MANUALS, BOOKS, BOOKLETS, LEAFLETS, INFORMATIONAL FLYERS, INFORMATIONAL SHEETS AND NEWSLETTERS, ADHESIVE BACKED STICKERS, AND KITS COMPRISING ONE OR MORE OF THE FOREGOING MATERIALS IN THE FIELD OF CYBERSECURITY AND COMPUTER TOPICS; SERIES OF FICTION WORKS, NAMELY, NOVELS AND BOOKS; SERIES OF NON-FICTION BOOKS IN THE FIELD OF CYBERSECURITY AND COMPUTER TOPICS (U.S. CLS. 2, 5, 22, 23, 29, 37, 38 AND 50).

FIRST USE 7-22-2013; IN COMMERCE 1-25-2014.

4,594,499. ALLISON L. POHL, WINTER PARK, FL. SN 86-118,961. PUB. 4-15-2014, FILED 11-14-2013.



OWNER OF U.S. REG. NO. 4,231,574.  
THE MARK CONSISTS OF STYLIZED OUTLINE OF FEMALE WAIST, HIPS AND THIGHS.  
FOR SILK SCREEN PRINTS; WORKS OF ART MADE OF PAPER (U.S. CLS. 2, 5, 22, 23, 29, 37, 38 AND 50).  
FIRST USE 1-1-2009; IN COMMERCE 2-1-2014.

4,594,523. COUGHLIN, CHRIS, GLENDALE, AZ. SN 86-131,627. PUB. 4-22-2014, FILED 11-28-2013.

# EMT CRASH-CARDS 360

THE MARK CONSISTS OF STANDARD CHARACTERS WITHOUT CLAIM TO ANY PARTICULAR FONT, STYLE, SIZE, OR COLOR.

NO CLAIM IS MADE TO THE EXCLUSIVE RIGHT TO USE "EMT", APART FROM THE MARK AS SHOWN.

FOR FLASH CARDS (U.S. CLS. 2, 5, 22, 23, 29, 37, 38 AND 50).

FIRST USE 1-1-2013; IN COMMERCE 1-1-2013.

**CLASS 16—(Continued).**

4,594,534. CAVALLINI PAPERS & CO, INC., SOUTH SAN FRANCISCO, CA. SN 86-141,847. PUB. 4-29-2014, FILED 12-12-2013.

**JOURNALINO**

THE MARK CONSISTS OF STANDARD CHARACTERS WITHOUT CLAIM TO ANY PARTICULAR FONT, STYLE, SIZE, OR COLOR.

FOR BLANK LEATHER BOUND WRITING BOOKS (U.S. CLS. 2, 5, 22, 23, 29, 37, 38 AND 50).  
FIRST USE 1-9-2014; IN COMMERCE 1-9-2014.

**CLASS 17—RUBBER GOODS**

4,593,289. FLEXITALLIC INVESTMENTS, INC., KINGWOOD, TX. SN 85-557,248. PUB. 11-19-2013, FILED 3-1-2012.

**CHANGE**

THE MARK CONSISTS OF STANDARD CHARACTERS WITHOUT CLAIM TO ANY PARTICULAR FONT, STYLE, SIZE, OR COLOR.

FOR SPIRAL WOUND GASKETS COMPRISED OF VERMICULITE, GRAPHITE AND OTHER NON-METAL MATERIALS, ALSO CONTAINING METAL, WITH FACINGS ON BOTH SIDES OF NON-METALLIC GASKET MATERIAL FOR USE IN INDUSTRIAL APPLICATIONS, NOT FOR USE ON INTERNAL COMBUSTION ENGINES; PIPE GASKETS (U.S. CLS. 1, 5, 12, 13, 35 AND 50).

FIRST USE 2-0-2012; IN COMMERCE 10-0-2012.

**CLASS 17—(Continued).**

4,593,290. FLEXITALLIC INVESTMENTS, INC., KINGWOOD, TX. SN 85-557,250. PUB. 11-12-2013, FILED 3-1-2012.



THE MARK CONSISTS OF A STYLIZED WORDING OF THE TERM "CHANGE" IN LOWERCASE LETTERS, WITH THE LETTER "E" APPEARING IN THE SHAPE OF A CIRCLE THAT IS BISECTED HORIZONTALLY, WITH A VERTICAL LINE CONNECTING THE BOTTOM OF THE CIRCLE WITH THE BISECTING HORIZONTAL LINE.

FOR SPIRAL WOUND GASKETS COMPRISED OF VERMICULITE, GRAPHITE AND OTHER NON-METAL MATERIALS, ALSO CONTAINING METAL, WITH FACINGS ON BOTH SIDES OF NON-METALLIC GASKET MATERIAL FOR USE IN INDUSTRIAL APPLICATIONS, NOT FOR USE ON INTERNAL COMBUSTION ENGINES; PIPE GASKETS (U.S. CLS. 1, 5, 12, 13, 35 AND 50).

FIRST USE 2-0-2012; IN COMMERCE 10-0-2012.

4,593,460. SWAN PRODUCTS, LLC, NEW YORK, NY. SN 85-734,863. PUB. 10-8-2013, FILED 9-21-2012.

**WATERWORKS**

THE MARK CONSISTS OF STANDARD CHARACTERS WITHOUT CLAIM TO ANY PARTICULAR FONT, STYLE, SIZE, OR COLOR.

FOR GARDEN HOSES; LAWN HOSES (U.S. CLS. 1, 5, 12, 13, 35 AND 50).

FIRST USE 8-1-1988; IN COMMERCE 8-1-1988.

4,593,666. GEERFAB, LLC, MILWAUKEE, WI. SN 85-820,168. PUB. 11-5-2013, FILED 1-10-2013.

**ROOMZORBERS**

THE MARK CONSISTS OF STANDARD CHARACTERS WITHOUT CLAIM TO ANY PARTICULAR FONT, STYLE, SIZE, OR COLOR.

FOR ARCHITECTURAL ACOUSTIC PRODUCTS FOR SOUND ABSORPTION AND CONTROL, NAMELY, SOUND ABSORBERS AND DIFFUSERS (U.S. CLS. 1, 5, 12, 13, 35 AND 50).

FIRST USE 3-26-2013; IN COMMERCE 3-26-2013.

**CLASS 17—(Continued).**

4,593,667. GEERFAB, LLC, MILWAUKEE, WI. SN 85-820,180.  
PUB. 11-5-2013, FILED 1-10-2013.

**MULTIZORBER**

THE MARK CONSISTS OF STANDARD CHARACTERS WITHOUT CLAIM TO ANY PARTICULAR FONT, STYLE, SIZE, OR COLOR.

FOR ARCHITECTURAL ACOUSTIC PRODUCTS FOR SOUND ABSORPTION AND CONTROL, NAMELY, SOUND ABSORBERS AND DIFFUSERS (U.S. CLS. 1, 5, 12, 13, 35 AND 50).

FIRST USE 3-26-2013; IN COMMERCE 3-26-2013.

**CLASS 17—(Continued).**

4,594,379. ISOLA USA CORP., CHANDLER, AZ. SN 86-077,080. PUB. 12-3-2013, FILED 9-27-2013.

**TERRAGREEN**

THE MARK CONSISTS OF STANDARD CHARACTERS WITHOUT CLAIM TO ANY PARTICULAR FONT, STYLE, SIZE, OR COLOR.

FOR RESIN CONTAINING LAMINATES WITH AND WITHOUT METAL CLADDING FOR USE IN THE MANUFACTURE OF PRINTED CIRCUIT BOARDS (U.S. CLS. 1, 5, 12, 13, 35 AND 50).

FIRST USE 11-25-2013; IN COMMERCE 11-25-2013.

4,594,254. OX ENGINEERED PRODUCTS, LLC, CHARLESTON, IL. SN 86-022,018. PUB. 1-14-2014, FILED 7-29-2013.

**ISO RED CI**

THE MARK CONSISTS OF STANDARD CHARACTERS WITHOUT CLAIM TO ANY PARTICULAR FONT, STYLE, SIZE, OR COLOR.

NO CLAIM IS MADE TO THE EXCLUSIVE RIGHT TO USE "CI", APART FROM THE MARK AS SHOWN.

FOR FOAM INSULATION FOR USE AS BUILDING INSULATION (U.S. CLS. 1, 5, 12, 13, 35 AND 50).

FIRST USE 1-24-2014; IN COMMERCE 1-24-2014.

4,594,466. SWIFT RESPONSE, LLC, WESTON, FL. SN 86-105,996. PUB. 4-15-2014, FILED 10-30-2013.

**FLEX SHOT**

THE MARK CONSISTS OF STANDARD CHARACTERS WITHOUT CLAIM TO ANY PARTICULAR FONT, STYLE, SIZE, OR COLOR.

FOR LIQUID RUBBER ADHESIVE SEALANT FOR GENERAL USE (U.S. CLS. 1, 5, 12, 13, 35 AND 50).

FIRST USE 1-4-2014; IN COMMERCE 1-4-2014.

4,594,377. ISOLA USA CORP., CHANDLER, AZ. SN 86-077,038. PUB. 12-3-2013, FILED 9-27-2013.

**STRATUS**

THE MARK CONSISTS OF STANDARD CHARACTERS WITHOUT CLAIM TO ANY PARTICULAR FONT, STYLE, SIZE, OR COLOR.

FOR FILMS AND SHEETS MADE OUT OF RESIN FOR USE IN THE MANUFACTURE OF CIRCUIT BOARDS (U.S. CLS. 1, 5, 12, 13, 35 AND 50).

FIRST USE 4-28-2014; IN COMMERCE 4-28-2014.

**CLASS 18—LEATHER GOODS**

4,593,091. BG DIRECT, LLC, SHELTON, CT. SN 77-961,845. PUB. 5-3-2011, FILED 3-18-2010.

**DOODADZZ COUTURE**

THE MARK CONSISTS OF STANDARD CHARACTERS WITHOUT CLAIM TO ANY PARTICULAR FONT, STYLE, SIZE, OR COLOR.

NO CLAIM IS MADE TO THE EXCLUSIVE RIGHT TO USE "COUTURE", APART FROM THE MARK AS SHOWN.

FOR PET ACCESSORIES, NAMELY, CHARMS USED ON COLLARS; ANIMAL COLLARS (U.S. CLS. 1, 2, 3, 22 AND 41).

FIRST USE 6-23-2014; IN COMMERCE 6-23-2014.

**CLASS 18—(Continued).**

4,593,134. ZIGI ENTERPRISES, INC., NEW YORK, NY. SN 85-123,132. PUB. 5-3-2011, FILED 9-3-2010.

# ZLONDON

THE MARK CONSISTS OF STANDARD CHARACTERS WITHOUT CLAIM TO ANY PARTICULAR FONT, STYLE, SIZE, OR COLOR.

FOR BAGS, NAMELY, HANDBAGS AND PURSES; ALL OF THE FOREGOING DESIGNED IN LONDON, ENGLAND (U.S. CLS. 1, 2, 3, 22 AND 41).

FIRST USE 8-31-2013; IN COMMERCE 8-31-2013.

**CLASS 18—(Continued).**

4,593,316. LAVIN, RICHARD, DBA CARAFINA COLLECTIONS, SOUTH PASADENA, CA. AND OROZCO LAVIN, MARIBEL, DBA CARAFINA COLLECTIONS, SOUTH PASADENA, CA. SN 85-613,989. PUB. 11-6-2012, FILED 5-2-2012.

# Carafina

THE MARK CONSISTS OF STANDARD CHARACTERS WITHOUT CLAIM TO ANY PARTICULAR FONT, STYLE, SIZE, OR COLOR.

THE ENGLISH TRANSLATION OF "CARAFINA" IN THE MARK IS "ELEGANT LOOK" OR "BEAUTIFUL FACE".

FOR HANDBAGS, PURSES AND WALLETS; LEATHER PURSES; MULTI-PURPOSE PURSES (U.S. CLS. 1, 2, 3, 22 AND 41).

FIRST USE 1-31-2013; IN COMMERCE 6-1-2013.

4,593,147. BANANA EQUIPMENT, INC., MINNEAPOLIS, MN. SN 85-173,966. PUB. 4-26-2011, FILED 11-10-2010.



NO CLAIM IS MADE TO THE EXCLUSIVE RIGHT TO USE "EQUIPMENT" AND "MADE IN THE U.S.A.", APART FROM THE MARK AS SHOWN.

THE MARK CONSISTS OF THE WORDING "BANANA EQUIPMENT", "MADE IN THE USA", AND "PRODUCTS WITH A PEEL" AND A STYLIZED DESIGN OF A GORILLA HIKER WALKING ALONG A MOUNTAIN RIDGE AND CARRYING A BANANA IN THE LEFT HAND AND A SEWING MACHINE IN THE RIGHT HAND, AND SURROUNDED BY A RECTANGULAR DOUBLE LINE BOX FEATURING A ROUNDED CORNER DESIGN RISING UP AND TO THE RIGHT FROM THE LOWER LEFT HAND CORNER OF THE BOX.

FOR LUGGAGE, NAMELY, BACKPACKS, DUFFEL BAGS, TOTE BAGS, SUITCASES AND CARGO BAGS, NAMELY, ALL PURPOSE CARRYING BAGS; AND WALLETS (U.S. CLS. 1, 2, 3, 22 AND 41).

FIRST USE 6-1-2014; IN COMMERCE 6-1-2014.

4,593,359. MYSTERY RANCH, LTD., BOZEMAN, MT. SN 85-646,275. PUB. 11-13-2012, FILED 6-7-2012.

# TERRAPLANE

THE MARK CONSISTS OF STANDARD CHARACTERS WITHOUT CLAIM TO ANY PARTICULAR FONT, STYLE, SIZE, OR COLOR.

FOR BACKPACKS, DAYPACKS, DUFFEL BAGS, LUGGAGE, BRIEFCASES AND BOOK BAGS (U.S. CLS. 1, 2, 3, 22 AND 41).

FIRST USE 7-0-2013; IN COMMERCE 3-7-2014.

4,593,361. FUN, FIERCE & FABULOUS, LLC, PHILADELPHIA, PA. SN 85-646,613. PUB. 11-20-2012, FILED 6-8-2012.

# ARM CHARMS

THE MARK CONSISTS OF STANDARD CHARACTERS WITHOUT CLAIM TO ANY PARTICULAR FONT, STYLE, SIZE, OR COLOR.

**CLASS 18—(Continued).**

NO CLAIM IS MADE TO THE EXCLUSIVE RIGHT TO USE "CHARMS", APART FROM THE MARK AS SHOWN.

FOR ALL PURPOSE SPORT BAGS; ALL-PURPOSE ATHLETIC BAGS; ALL-PURPOSE CARRYING BAGS; ALL-PURPOSE REUSABLE CARRYING BAGS; AMENITY BAGS SOLD EMPTY; ANIMAL CARRIERS; ANIMAL GAME BAGS; ATHLETIC BAGS; ATTACHE CASES; ATTACHE CASES MADE OF IMITATION LEATHER; ATTACHE CASES MADE OF LEATHER; BABY CARRYING BAGS; BACKPACKS, BOOK BAGS, SPORTS BAGS, BUM BAGS, WALLETS AND HANDBAGS; BAGS FOR CARRYING BABIES' ACCESSORIES; BAGS FOR UMBRELLAS; BARREL BAGS; BEACH BAGS; BELT BAGS; BELT BAGS AND HIP BAGS; BOOK BAGS; BRIEFCASES AND ATTACHE CASES; BUSINESS CARD CASES; BUSINESS CASES; CALLING CARD CASES; CANVAS SHOPPING BAGS; CARRIERS FOR SUITS, SHIRTS AND DRESSES; CARRY-ALL BAGS; CARRY-ON BAGS; CARRYING CASES; CARRYING CASES FOR DOCUMENTS; CASES FOR KEYS; CASES OF IMITATION LEATHER; CATALOG CASES; CELLULOSE FOOD CASINGS; CHAIN MESH PURSES; CHALK BAGS; CHANGE PURSES; CHARM BAGS (OMAMORIRE); CLOTHING FOR DOMESTIC PETS; CLUTCH BAGS; CLUTCH PURSES; CLUTCHES; COIN PURSES; COIN PURSES NOT MADE OF PRECIOUS METAL; COIN PURSES, NOT OF PRECIOUS METALS; COLLARS FOR PETS BEARING MEDICAL INFORMATION; COSMETIC BAGS SOLD EMPTY; COSMETIC CARRYING CASES SOLD EMPTY; COSMETIC CASES SOLD EMPTY; CREDIT CARD CASES; CREDIT CARD CASES AND HOLDERS; DIAPER BAGS; DOCUMENT CASES; DOCUMENT SUITCASES; DOLLY BAGS; DRAWSTRING BAGS; DRY BAGS; DUFFEL BAGS; DUFFEL BAGS FOR TRAVEL; DUFFLE BAGS; EVENING BAGS; EVENING HANDBAGS; FASHION HANDBAGS; FITTED PROTECTIVE COVERS FOR HANDBAGS, BRIEFCASES, VALISES, SUITCASES, AND BRIEFCASE-LIKE PORTFOLIOS; FLIGHT BAGS; GARMENT BAGS FOR TRAVEL; GARMENT BAGS FOR TRAVEL MADE OF LEATHER; GARMENTS FOR PETS; GENERAL PURPOSE BAGS FOR CARRYING YOGA EQUIPMENT; GENERAL PURPOSE BAGS FOR HOLDING DANCE EQUIPMENT; GENERAL PURPOSE SPORT TROLLEY BAGS; GENTLEMEN'S HANDBAGS; GLADSTONE BAGS; GUT FOR MAKING FOOD CASINGS; GUT FOR MAKING SAUSAGE CASINGS; GYM BAGS; HANDBAG FRAMES; HANDBAGS; HANDBAGS FOR LADIES; HANDBAGS FOR MEN; HANDBAGS, PURSES AND WALLETS; HIP BAGS; HOBO BAGS; HORSE TAIL BAGS; INTERCHANGEABLE DECORATIVE COVERS FOR ACCESSORIZATION PURPOSES THAT ARE SPECIALLY ADAPTED TO HANDBAGS; KEY BAGS; KEY CASES; KEY CASES OF LEATHER OR IMITATION LEATHER; KEY-CASES OF LEATHER AND SKINS; KIT BAGS; KNITTED BAGS, NOT OF PRECIOUS METALS; KORI WICKER TRUNKS; LEATHER AND IMITATION LEATHER BAGS; LEATHER AND IMITATION LEATHER SPORT BAGS AND GENERAL PURPOSE TROLLEY BAGS; LEATHER BAGS AND WALLETS; LEATHER BAGS FOR MERCHANDISE PACKAGING; LEATHER BAGS, SUITCASES AND WALLETS; LEATHER CASES; LEATHER CASES FOR KEYS; LEATHER CREDIT CARD CASES; LEATHER HANDBAGS; LEATHER KEY CASES; LEATHER PURSES; LEATHER SHOPPING BAGS; LUGGAGE; LUGGAGE AND TRUNKS; LUGGAGE INSERTS, NAMELY, PACKING CUBES; LUGGAGE LABEL HOLDERS; LUGGAGE TAGS; MAKE-UP BAGS SOLD EMPTY; MEN'S CLUTCH BAGS; MESH SHOPPING BAGS; MESSENGER BAGS; MILITARY DUFFLE BAGS, GARMENT BAGS FOR TRAVEL, TOTE BAGS, SHOULDER BAGS AND BACKPACKS; MINAUDIERES IN THE NATURE OF SMALL CLUTCH PURSES; MULTI-PURPOSE PURSES; MULTI-STRANDED, BEADED CLIP THAT ATTACHES TO THE OUTSIDE OF A WOMEN'S PURSE AS A DECORATIVE ACCESSORY; NAME CARD CASES; NON-MOTORIZED, COLLAPSIBLE LUGGAGE CARTS; OVERNIGHT BAGS; OVERNIGHT CASES; OVERNIGHT SUITCASES; PAPER-REINFORCED CELLULOSE FOOD CASINGS; PET ACCESSORIES, NAMELY, CANVAS, VINYL AND LEATHER POUCHES FOR HOLDING DISPOSABLE BAGS TO PLACE PET WASTE IN, PET ACCESSORIES, NAMELY, SPECIALLY DESIGNED CANVAS, VINYL OR LEATHER BAGS ATTACHED TO ANIMAL LEASHES FOR HOLDING SMALL ITEMS SUCH AS KEYS, CREDIT CARDS, MONEY OR DISPOSABLE BAGS FOR DIS-

**CLASS 18—(Continued).**

POSING OF PET WASTE; PET CLOTHING; PET COLLAR ACCESSORIES, NAMELY, BELLS, SILENCERS, SAFETY LIGHTS AND BLINKERS, PENDANTS AND CHARMS; PET COLLAR ACCESSORIES, NAMELY, BOWS AND CHARMS; PET COLLAR ACCESSORIES, NAMELY, CHARMS; PET HAIR ORNAMENTS; PET PRODUCTS IN THE NATURE OF A RESTRAINING DEVICE, NAMELY, TIE-OUT STAKES AND TIE-OUT CHAINS; PET PRODUCTS, NAMELY, PET RESTRAINING DEVICES CONSISTING OF LEASHES, COLLARS, HARNESSSES, RESTRAINING STRAPS, AND LEASHES WITH LOCKING DEVICES; PET RESTRAINING DEVICES CONSISTING OF HARNESSSES AND/OR RESTRAINING STRAPS, FOR USE IN PET GROOMING OR VETERINARY CARE; PET TAGS SPECIALLY ADAPTED FOR ATTACHING TO PET LEASHES OR COLLARS; PLASTIC LUGGAGE LABELS; POUCHES; POMMEL BAGS; POUCHES AND BAGS SOLD EMPTY FOR ATTACHMENT TO BACKPACKS; PROTECTIVE FITTED LINERS FOR BACKPACKS AND LUGGAGE; PURSE CHARMS; PURSE FRAMES; PURSES; PURSES AND WALLETS; PURSES AND WALLETS OF PRECIOUS METAL; PURSES MADE OF PRECIOUS METAL; PURSES NOT MADE OF PRECIOUS METAL; PURSES OF PRECIOUS METAL; PURSES, NOT OF PRECIOUS METAL; REUSABLE SHOPPING BAGS; REUSABLE TEXTILE PRODUCE BAGS TO CARRY PRODUCE FROM GROCERY STORES AND FARMER'S MARKETS; ROLL BAGS; SACK PACKS, NAMELY, DRAWSTRING BAGS USED AS BACKPACKS; SADDLE HORN BAGS; SADDLERY, NAMELY, HORN BAGS; SCHOOL BAGS; SCHOOL BOOK BAGS; SHAVING BAGS SOLD EMPTY; SHOE BAGS FOR TRAVEL; SHOPPING BAGS MADE OF SKIN; SHOPPING BAGS WITH WHEELS ATTACHED; SHOULDER BAGS; SLING BAGS; SLING BAGS FOR CARRYING INFANTS; SMALL BAGS FOR MEN, SMALL CLUTCH PURSES; SMALL PURSES; SMALL SUITCASES; SOUVENIR BAGS; SPORT BAGS; SPORTS BAGS; SPORTSMAN'S HUNTING BAGS; STRAPS FOR CARRYING CASES; STRAPS FOR HANDBAGS; STRAPS FOR LUGGAGE; STRING BAGS FOR SHOPPING; SUIT BAGS; SUIT CARRIERS; SUITCASE HANDLES; SUITCASES; TEXTILE SHOPPING BAGS; TIE CASES; TOILETRY BAGS SOLD EMPTY; TOILETRY CASES SOLD EMPTY; TOOL BAGS SOLD EMPTY; TOTE BAGS; TRAIN CASES; TRAVEL BAGS; TRAVEL CASES; TRAVELING BAGS; TRAVELLING BAGS; TRAVELLING CASES OF LEATHER; TRAVELLING TRUNKS; TRUNKS; TRUNKS AND SUITCASES; UNFITTED VANITY CASES; VANITY CASES SOLD EMPTY; WAIST BAGS; WASH BAGS FOR CARRYING TOILETRIES; WHEELED BAGS; WHEELED DUFFLE BAGS; WHEELED MESSENGER BAGS; WHEELED SHOPPING BAGS; WHEELED TOTE BAGS; WINE BAGS WITH HANDLES FOR CARRYING OR HOLDING WINE; WINE CARRYING CASES; WRIST MOUNTED CARRYALL BAGS; WRIST MOUNTED PURSES; WRISTLET BAGS (U.S. CLS. 1, 2, 3, 22 AND 41).

FIRST USE 7-1-2014; IN COMMERCE 7-1-2014.

4,593,770. BRIGGS & RILEY TRAVELWARE, LLC, HAUPAUGE, NY. SN 85-881,357. PUB. 10-1-2013, FILED 3-20-2013.

# TORQ

THE MARK CONSISTS OF STANDARD CHARACTERS WITHOUT CLAIM TO ANY PARTICULAR FONT, STYLE, SIZE, OR COLOR.

FOR ROLLING LUGGAGE (U.S. CLS. 1, 2, 3, 22 AND 41).

FIRST USE 5-0-2013; IN COMMERCE 5-0-2013.

**CLASS 18—(Continued).**

4,593,772. BRIGGS & RILEY TRAVELWARE, LLC, HAUPAUGE, NY. SN 85-881,387. PUB. 10-1-2013, FILED 3-20-2013.

**T O R Q**

THE MARK CONSISTS OF THE WORD "TORQ" IN STYLIZED LETTERS.

FOR ROLLING LUGGAGE (U.S. CLS. 1, 2, 3, 22 AND 41).

FIRST USE 5-0-2013; IN COMMERCE 5-0-2013.

4,594,186. NO FEAR USA LIMITED, SHIREBROOK, UNITED KINGDOM. SN 85-982,386. PUB. 4-17-2012, FILED 1-13-2012.



THE MARK CONSISTS OF A STYLIZED IMAGE OF A SET OF EYES.

FOR LUGGAGE; DUFFLE BAGS, GYM BAGS, ALL-PURPOSE SPORT BAGS AND BACKPACKS; SPORTS LUGGAGE AND GYM BAGS (U.S. CLS. 1, 2, 3, 22 AND 41).

FIRST USE 10-31-2013; IN COMMERCE 10-31-2013.

4,594,356. RIMOWA GMBH, COLOGNE, FED REP GERMANY. SN 86-066,782. PUB. 12-31-2013, FILED 9-17-2013.

**SALSA DELUXE**

THE MARK CONSISTS OF STANDARD CHARACTERS WITHOUT CLAIM TO ANY PARTICULAR FONT, STYLE, SIZE, OR COLOR.

**CLASS 18—(Continued).**

NO CLAIM IS MADE TO THE EXCLUSIVE RIGHT TO USE "DELUXE", APART FROM THE MARK AS SHOWN.

FOR LUGGAGE BOXES, NAMELY, TRUNKS AND SUITCASES; TRAVELING TRUNKS; VALISES; TRAVELING BAGS; TROLLEY SUITCASES; VANITY CASES, NOT FITTED AND SOLD EMPTY; ATTACHE CASES; SUITCASES AND PARTS THEREFOR, NAMELY, VALISE HANDLES, TELESCOPE HANDLES AND WHEELS; BRIEFCASE; BACKPACKS; BILLFOLDS; POCKET WALLET; WEARABLE STRAP-ON BELT POUCHES; LEATHERWARE TRAVELING BAG SETS; GARMENT BAGS FOR TRAVEL; SPORT BAGS; TRAVEL KIT BAGS SOLD EMPTY; WEARABLE STRAP-ON WAIST POUCHES; BOOK BAGS; LEATHER AND IMITATION LEATHER; GOODS MADE FROM LEATHER AND IMITATION LEATHER, NAMELY, PROTECTIVE COVERS FOR LAPTOPS, CELL PHONES AND TABLET COMPUTERS; LUGGAGE STRAPS; LUGGAGE TAGS; LUGGAGE AND UMBRELLAS (U.S. CLS. 1, 2, 3, 22 AND 41).

FIRST USE 1-1-2008; IN COMMERCE 1-1-2008.

4,594,538. STEVEN MADDEN, LTD., LONG ISLAND CITY, NY. SN 86-145,585. PUB. 4-15-2014, FILED 12-17-2013.



OWNER OF U.S. REG. NOS. 2,087,866, 3,608,879, AND OTHERS.

NO CLAIM IS MADE TO THE EXCLUSIVE RIGHT TO USE "NEW YORK", APART FROM THE MARK AS SHOWN.

THE NAME "STEVE MADDEN" IDENTIFIES A LIVING INDIVIDUAL WHOSE CONSENT IS OF RECORD.

THE MARK CONSISTS OF THE WORDING "STEVE MADDEN" ABOVE THE WORDING "BARNETT AVENUE", ABOVE THE WORDING "NEW YORK", ALL OF WHICH IS SURROUNDED BY A SINGLE-LINE RECTANGULAR BORDER.

FOR BAGS, NAMELY, HANDBAGS, WALLETS, SHOULDER BAGS, TOTE BAGS, BACK PACKS, CLUTCHES, MESSENGER BAGS, CARRY-ON BAGS (U.S. CLS. 1, 2, 3, 22 AND 41).

FIRST USE 6-10-2014; IN COMMERCE 6-10-2014.

**CLASS 18—(Continued).**

4,594,539. STEVEN MADDEN, LTD., LONG ISLAND CITY, NY. SN 86-145,593. PUB. 4-15-2014, FILED 12-17-2013.



OWNER OF U.S. REG. NOS. 2,087,866, 3,608,879, AND OTHERS.

THE NAME "STEVE MADDEN" IDENTIFIES A LIVING INDIVIDUAL WHOSE CONSENT IS OF RECORD.

THE MARK CONSISTS OF A MOUNTAIN DESIGN, BELOW WHICH APPEARS THE WORDING "STEVE MADDEN BARNETT AVENUE", ALL OF WHICH IS SURROUNDED BY A THREE-LINE RECTANGULAR BORDER.

FOR BAGS, NAMELY, HANDBAGS, WALLETS, SHOULDER BAGS, TOTE BAGS, BACK PACKS, CLUTCHES, MESSENGER BAGS, CARRY-ON BAGS (U.S. CLS. 1, 2, 3, 22 AND 41).

FIRST USE 6-10-2014; IN COMMERCE 6-10-2014.

**CLASS 19—NON-METALLIC BUILDING MATERIALS**

4,593,174. PERKINS+ WILL, INC., SAN FRANCISCO, CA. SN 85-220,831. PUB. 6-7-2011, FILED 1-19-2011.



THE MARK CONSISTS OF A SPRIG BETWEEN THE WORDS "SPROUT" AND "SPACE".

FOR MODULAR BUILDINGS MADE PRIMARILY OF NON-METAL MATERIALS (U.S. CLS. 1, 12, 33 AND 50). FIRST USE 3-2-2013; IN COMMERCE 3-2-2013.

4,593,385. UNILIN FLOORING NC, LLC, CALHOUN, GA. SN 85-663,729. PUB. 4-30-2013, FILED 6-28-2012.

**INSTYLE FLOORS BY MOHAWK**

THE MARK CONSISTS OF STANDARD CHARACTERS WITHOUT CLAIM TO ANY PARTICULAR FONT, STYLE, SIZE, OR COLOR.

OWNER OF U.S. REG. NOS. 1,099,660, 2,521,092, AND OTHERS.

NO CLAIM IS MADE TO THE EXCLUSIVE RIGHT TO USE "INSTYLE FLOORS", APART FROM THE MARK AS SHOWN.

FOR HARDWOOD FLOORING; LAMINATE FLOORING (U.S. CLS. 1, 12, 33 AND 50).

FIRST USE 1-1-2014; IN COMMERCE 1-1-2014.

**CLASS 19—(Continued).**

4,593,458. HERCUTECH, INC., PHOENIX, AZ. SN 85-733,343. PUB. 9-24-2013, FILED 9-19-2012.

**ShearStrip**

THE MARK CONSISTS OF STANDARD CHARACTERS WITHOUT CLAIM TO ANY PARTICULAR FONT, STYLE, SIZE, OR COLOR.

FOR NON-METAL FORMING SYSTEMS FOR CONCRETE AND OTHER CURABLE CONSTRUCTION MATERIALS COMPRISED OF NON-METAL MODULAR CASTING FORMS (U.S. CLS. 1, 12, 33 AND 50).

FIRST USE 4-11-2011; IN COMMERCE 1-2-2014.

4,593,774. TAPCO INTERNATIONAL CORPPORATION, WIXOM, MI. SN 85-882,707. PUB. 9-10-2013, FILED 3-21-2013.

**DINESOL**

THE MARK CONSISTS OF STANDARD CHARACTERS WITHOUT CLAIM TO ANY PARTICULAR FONT, STYLE, SIZE, OR COLOR.

FOR NON-METALLIC BUILDING PRODUCTS, NAMELY, VINYL SIDING AND VINYL SIDING ACCESSORIES IN THE NATURE OF NON-METAL SHUTTERS, GABLE VENTS AND MOUNTING BLOCKS (U.S. CLS. 1, 12, 33 AND 50).

FIRST USE 8-6-2008; IN COMMERCE 8-6-2008.

4,594,365. AGRU/AMERICA, INC., GEORGETOWN, SC. SN 86-070,042. PUB. 3-4-2014, FILED 9-20-2013.

**AGRULINE**

THE MARK CONSISTS OF STANDARD CHARACTERS WITHOUT CLAIM TO ANY PARTICULAR FONT, STYLE, SIZE, OR COLOR.

OWNER OF U.S. REG. NO. 1,831,332.

FOR NON-METAL PIPE COUPLINGS AND JOINTS; NON-METAL PIPE FITTINGS; NON-METAL SEWER PIPES; NON-METAL WATER PIPES; RIGID PIPES, NOT OF METAL; SEWER PIPES, NOT OF METAL; WATER-PIPE VALVES, NOT OF METAL OR PLASTIC; WATER-PIPES, NOT OF METAL (U.S. CLS. 1, 12, 33 AND 50).

FIRST USE 6-15-2014; IN COMMERCE 6-15-2014.

**CLASS 20—FURNITURE AND ARTICLES NOT OTHERWISE CLASSIFIED**

4,593,199. JANUS ET CIE, WEST HOLLYWOOD, CA. SN 85-324,339. PUB. 10-1-2013, FILED 5-18-2011.

JANUSFIBER: OUR  
GENERATION-NEXT HANDWOVEN  
WEATHER RESISTANT FIBER

THE MARK CONSISTS OF STANDARD CHARACTERS WITHOUT CLAIM TO ANY PARTICULAR FONT, STYLE, SIZE, OR COLOR.

OWNER OF U.S. REG. NO. 3,951,382.

NO CLAIM IS MADE TO THE EXCLUSIVE RIGHT TO USE "HANDWOVEN WEATHER RESISTANT FIBER", APART FROM THE MARK AS SHOWN.

FOR HANDWOVEN WEATHER RESISTANT SYNTHETIC FIBERS SOLD AS A COMPONENT OF FURNITURE AND HOME ACCESSORIES (U.S. CLS. 2, 13, 22, 25, 32 AND 50).

FIRST USE 2-1-2011; IN COMMERCE 2-1-2011.

4,593,489. JBI MANUFACTURING LLC, AURORA, CO. SN 85-754,423. PUB. 3-26-2013, FILED 10-15-2012.

# Paws Rest

THE MARK CONSISTS OF STANDARD CHARACTERS WITHOUT CLAIM TO ANY PARTICULAR FONT, STYLE, SIZE, OR COLOR.

FOR PET CASKETS (U.S. CLS. 2, 13, 22, 25, 32 AND 50).  
FIRST USE 10-23-2013; IN COMMERCE 10-23-2013.

4,593,555. TISCH, UNLIMITED LLC, CHICAGO, IL. SN 85-783,072. PUB. 10-29-2013, FILED 11-19-2012.

TISCH ELEVATING THE BUFFET  
TO NEW HEIGHTS

THE MARK CONSISTS OF STANDARD CHARACTERS WITHOUT CLAIM TO ANY PARTICULAR FONT, STYLE, SIZE, OR COLOR.

NO CLAIM IS MADE TO THE EXCLUSIVE RIGHT TO USE "TISCH", APART FROM THE MARK AS SHOWN.

THE ENGLISH TRANSLATION OF THE WORD "TISCH" IN THE MARK IS "TABLE".

FOR TABLES (U.S. CLS. 2, 13, 22, 25, 32 AND 50).  
FIRST USE 1-2-2014; IN COMMERCE 1-2-2014.

**CLASS 20—(Continued).**

4,593,692. WELDSALE COMPANY LLC, PHILA, PA. SN 85-834,721. PUB. 6-25-2013, FILED 1-29-2013.

# ACORN PLATEN TABLE

THE MARK CONSISTS OF STANDARD CHARACTERS WITHOUT CLAIM TO ANY PARTICULAR FONT, STYLE, SIZE, OR COLOR.

NO CLAIM IS MADE TO THE EXCLUSIVE RIGHT TO USE "PLATEN TABLE", APART FROM THE MARK AS SHOWN.

FOR WELDING PLATEN TABLE (U.S. CLS. 2, 13, 22, 25, 32 AND 50).

FIRST USE 6-25-2014; IN COMMERCE 6-25-2014.

4,593,759. HAWORTH, INC., HOLLAND, MI. SN 85-876,011. PUB. 8-6-2013, FILED 3-14-2013.

# WINDOWSEAT

THE MARK CONSISTS OF STANDARD CHARACTERS WITHOUT CLAIM TO ANY PARTICULAR FONT, STYLE, SIZE, OR COLOR.

FOR FURNITURE (U.S. CLS. 2, 13, 22, 25, 32 AND 50).  
FIRST USE 6-10-2013; IN COMMERCE 6-10-2013.

4,593,762. HALLIBURTON ENERGY SERVICES, INC., CARROLLTON, TX. SN 85-878,600. PUB. 9-3-2013, FILED 3-18-2013.

# SOLUPORT

THE MARK CONSISTS OF STANDARD CHARACTERS WITHOUT CLAIM TO ANY PARTICULAR FONT, STYLE, SIZE, OR COLOR.

FOR OIL AND GAS WELL COMPLETION TOOLS, NAMELY, PORT PLUG PROTECTORS IN THE NATURE OF A PORT SLEEVE COMPRISED OF POLYGLYCOLIC ACID (PGA) AND THERMOPLASTIC POLYMER WHICH IS BIODEGRADABLE AND DISSOLVES OVER TIME USED TO CONTROL PRESSURE OR FLUIDS DOWN-HOLE IN ORDER TO ALLOW FOR CONTINUOUS PUMPING IN MULTI-ZONE TREATMENTS (U.S. CLS. 2, 13, 22, 25, 32 AND 50).

FIRST USE 4-18-2013; IN COMMERCE 4-18-2013.



**CLASS 20—(Continued).**

4,593,824. ZINUS INC., SAN LEANDRO, CA. SN 85-912,553. PUB. 11-5-2013, FILED 4-23-2013.

# ViscoGeltex

THE MARK CONSISTS OF STANDARD CHARACTERS WITHOUT CLAIM TO ANY PARTICULAR FONT, STYLE, SIZE, OR COLOR.

OWNER OF U.S. REG. NO. 4,211,630.  
FOR MATTRESS TOPPERS, MATTRESSES AND PILLOWS MADE IN WHOLE OR SIGNIFICANT PART OF ELASTIC FOAM GEL (U.S. CLS. 2, 13, 22, 25, 32 AND 50).  
FIRST USE 5-1-2013; IN COMMERCE 7-15-2013.

4,593,876. BARON, MICHAEL, CORRALES, NM. SN 85-925,188. PUB. 10-29-2013, FILED 5-7-2013.



NO CLAIM IS MADE TO THE EXCLUSIVE RIGHT TO USE "FURNITURE", APART FROM THE MARK AS SHOWN.

THE STIPPLING IS FOR SHADING PURPOSES ONLY.  
THE MARK CONSISTS OF ALL WORDS SPELLED OUT WITH THE USE OF DOWEL PIECES, "ART OF DOWEL" IN CAPS, "FURNITURE & MORE" IN LOWER CASE, USING AN AMPERSAND FOR AND. A THIN LINE SWIRLS THROUGH THIS BUSINESS NAME.

FOR FURNITURE; MOVABLE WALL PARTITIONS; NON-METAL NAME PLATES; TABLES (U.S. CLS. 2, 13, 22, 25, 32 AND 50).  
FIRST USE 5-1-2013; IN COMMERCE 5-1-2013.

4,594,041. INNOCOR, INC., WEST LONG BRANCH, NJ. SN 85-953,526. PUB. 10-8-2013, FILED 6-7-2013.

# ABSOLUTE COMFORT

THE MARK CONSISTS OF STANDARD CHARACTERS WITHOUT CLAIM TO ANY PARTICULAR FONT, STYLE, SIZE, OR COLOR.

OWNER OF U.S. REG. NO. 2,471,859.  
FOR MATTRESS TOPPERS AND PILLOWS (U.S. CLS. 2, 13, 22, 25, 32 AND 50).  
FIRST USE 7-0-1999; IN COMMERCE 7-0-1999.

**CLASS 20—(Continued).**

4,594,153. PANAMA JACK INTERNATIONAL, INC., ORLANDO, FL. SN 85-974,391. PUB. 10-29-2013, FILED 7-1-2013.

# ISLAND COVE BY PANAMA JACK

THE MARK CONSISTS OF STANDARD CHARACTERS WITHOUT CLAIM TO ANY PARTICULAR FONT, STYLE, SIZE, OR COLOR.

OWNER OF U.S. REG. NOS. 1,328,519, 3,565,257, AND OTHERS.

THE NAME(S), PORTRAIT(S), AND/OR SIGNATURE(S) SHOWN IN THE MARK DOES NOT IDENTIFY A PARTICULAR LIVING INDIVIDUAL.

FOR FURNITURE, OUTDOOR FURNITURE, PILLOWS, BEDS, BENCHES, CHAIRS, CUSHIONS; SCREENS; STOOLS; AND WALL DECORATIONS MADE OF WOOD, WAX, PLASTER OR PLASTIC (U.S. CLS. 2, 13, 22, 25, 32 AND 50).  
FIRST USE 2-1-2014; IN COMMERCE 2-1-2014.

4,594,173. THE SUN PRODUCTS CORPORATION, WILTON, CT. SN 85-982,189. PUB. 2-26-2013, FILED 10-3-2012.

# SNUGGLE HOME

THE MARK CONSISTS OF STANDARD CHARACTERS WITHOUT CLAIM TO ANY PARTICULAR FONT, STYLE, SIZE, OR COLOR.

OWNER OF U.S. REG. NOS. 1,246,754, 2,701,266, AND OTHERS.

NO CLAIM IS MADE TO THE EXCLUSIVE RIGHT TO USE "HOME", APART FROM THE MARK AS SHOWN.  
FOR MATTRESSES AND PILLOWS (U.S. CLS. 2, 13, 22, 25, 32 AND 50).  
FIRST USE 7-1-2013; IN COMMERCE 7-1-2013.

4,594,214. GRACO CHILDREN'S PRODUCTS INC., ATLANTA, GA. SN 86-006,628. PUB. 10-29-2013, FILED 7-10-2013.

# READY2DINE

THE MARK CONSISTS OF STANDARD CHARACTERS WITHOUT CLAIM TO ANY PARTICULAR FONT, STYLE, SIZE, OR COLOR.

FOR HIGH CHAIRS AND BOOSTER SEATS FOR INFANTS AND CHILDREN (U.S. CLS. 2, 13, 22, 25, 32 AND 50).  
FIRST USE 1-31-2014; IN COMMERCE 1-31-2014.

**CLASS 20—(Continued).**

4,594,242. PACIFIC COAST FEATHER COMPANY, SEATTLE, WA. SN 86-014,430. PUB. 12-10-2013, FILED 7-18-2013.

## PhysioForm

THE MARK CONSISTS OF STANDARD CHARACTERS WITHOUT CLAIM TO ANY PARTICULAR FONT, STYLE, SIZE, OR COLOR.

FOR PILLOWS (U.S. CLS. 2, 13, 22, 25, 32 AND 50).  
FIRST USE 4-1-2014; IN COMMERCE 4-1-2014.

---

4,594,259. SOUTHERN SALES & MARKETING GROUP, INC., ATLANTA, GA. SN 86-024,499. PUB. 11-12-2013, FILED 7-31-2013.

## SOUTHERN HALLOWEEN

THE MARK CONSISTS OF STANDARD CHARACTERS WITHOUT CLAIM TO ANY PARTICULAR FONT, STYLE, SIZE, OR COLOR.

NO CLAIM IS MADE TO THE EXCLUSIVE RIGHT TO USE "HALLOWEEN", APART FROM THE MARK AS SHOWN.

FOR OUTDOOR HOLIDAY DECORATIONS, NAMELY, INFLATABLE SCULPTURES (U.S. CLS. 2, 13, 22, 25, 32 AND 50).

FIRST USE 9-6-2013; IN COMMERCE 9-6-2013.

---

4,594,384. WICKEN, CHRISTOPHER J., WESTMINSTER, CO. SN 86-078,054. PUB. 2-25-2014, FILED 9-30-2013.

## BOBBER MAXX

THE MARK CONSISTS OF STANDARD CHARACTERS WITHOUT CLAIM TO ANY PARTICULAR FONT, STYLE, SIZE, OR COLOR.

FOR ADVERTISING BALLOONS; INFLATABLE PUBLICITY OBJECTS (U.S. CLS. 2, 13, 22, 25, 32 AND 50).  
FIRST USE 8-15-2013; IN COMMERCE 8-15-2013.

**CLASS 20—(Continued).**

4,594,386. WICKEN, CHRISTOPHER J., WESTMINSTER, CO. SN 86-078,696. PUB. 2-25-2014, FILED 9-30-2013.

## PERMASHINE

THE MARK CONSISTS OF STANDARD CHARACTERS WITHOUT CLAIM TO ANY PARTICULAR FONT, STYLE, SIZE, OR COLOR.

FOR ADVERTISING BALLOONS; INFLATABLE PUBLICITY OBJECTS (U.S. CLS. 2, 13, 22, 25, 32 AND 50).  
FIRST USE 6-13-2014; IN COMMERCE 6-13-2014.

---

4,594,465. WWRD, INC, WINDSOR, CA. SN 86-104,932. PUB. 4-15-2014, FILED 10-29-2013.

## CAPABUBBLES

THE MARK CONSISTS OF STANDARD CHARACTERS WITHOUT CLAIM TO ANY PARTICULAR FONT, STYLE, SIZE, OR COLOR.

FOR NON-METAL AND NON-PAPER CLOSURES, NAMELY, REUSABLE SPARKLING WINE, CHAMPAGNE OR WINE BOTTLE CAP (U.S. CLS. 2, 13, 22, 25, 32 AND 50).

FIRST USE 5-21-2014; IN COMMERCE 5-21-2014.

---

4,594,508. ROCO RESCUE, INC., BATON ROUGE, LA. SN 86-122,908. PUB. 5-6-2014, FILED 11-19-2013.



OWNER OF U.S. REG. NOS. 2,790,411 AND 3,860,108.

**CLASS 20—(Continued).**

THE MARK CONSISTS OF THE WORD "RDX" IN A STYLIZED FONT BELOW A VERTICAL RECTANGLE SURROUNDED BY A PAIR OF INTERESTING LINES, AND A WORD "ROCO" IN A STYLIZED FONT POSITIONED ABOVE THE WORD "RDX".

FOR NON-METAL HARDWARE FOR USE IN DESCENDING ROPES, NAMELY, DESCENDERS (U.S. CLS. 2, 13, 22, 25, 32 AND 50).

FIRST USE 12-15-2013; IN COMMERCE 12-15-2013.

**CLASS 21—(Continued).**

4,593,396. VALUEVISION MEDIA, INC., EDEN PRAIRIE, MN. SN 85-672,075. PUB. 4-30-2013, FILED 7-9-2012.

**COOK'S TRADITION****CLASS 21—HOUSEWARES AND GLASS**

4,593,120. JANSON, PAUL A, GEORGETOWN, MA. AND JANSON, MARY F. GEORGETOWN, MA. SN 85-066,123. PUB. 1-25-2011, FILED 6-18-2010.

**Save the Planet One Meal  
At a Time**

THE MARK CONSISTS OF STANDARD CHARACTERS WITHOUT CLAIM TO ANY PARTICULAR FONT, STYLE, SIZE, OR COLOR.

FOR COLLAPSIBLE FABRIC STORAGE CONTAINER FOR DOMESTIC USE; COLLAPSIBLE STORAGE CONTAINERS FOR DOMESTIC USE; CONTAINERS FOR HOUSEHOLD OR KITCHEN USE; CONTAINERS FOR HOUSEHOLD USE; HOUSEHOLD CONTAINERS FOR FOODS; INSULATED CONTAINERS FOR FOOD OR BEVERAGE FOR DOMESTIC USE; PLASTIC STORAGE CONTAINERS FOR HOUSEHOLD USE (U.S. CLS. 2, 13, 23, 29, 30, 33, 40 AND 50).

FIRST USE 3-1-2009; IN COMMERCE 2-17-2014.

THE MARK CONSISTS OF STANDARD CHARACTERS WITHOUT CLAIM TO ANY PARTICULAR FONT, STYLE, SIZE, OR COLOR.

NO CLAIM IS MADE TO THE EXCLUSIVE RIGHT TO USE "COOK'S", APART FROM THE MARK AS SHOWN.

FOR BAKEWARE; CONTAINERS FOR HOUSEHOLD OR KITCHEN USE; COOKWARE, NAMELY, POTS AND PANS; COOKWARE, NAMELY, COOKING UTENSILS, NAMELY, FORKS, SPOONS, SPATULAS, LADLES, KNIVES, TURNERS, SKEWERS, TONGS, CHOPPERS, SCRAPERS, NON-ELECTRIC MIXERS, DUTCH OVENS, RAMEKINS, JARS, FRYING PANS, SKILLETS; HOUSEHOLD UTENSILS, NAMELY, FORKS, SPOONS, SPATULAS, LADLES, KNIVES, TURNERS, SKEWERS, TONGS, CHOPPERS, SCRAPERS, NON-ELECTRIC MIXERS, DUTCH OVENS, RAMEKINS, JARS, FRYING PANS, SKILLETS; KITCHEN UTENSILS, NAMELY, SPATULAS, LADLES, TURNERS, SKEWERS, TONGS, NON-ELECTRIC MIXERS, DUTCH OVENS, RAMEKINS, JARS, FRYING PANS, SKILLETS; NON-ELECTRIC KITCHEN TOOLS, NAMELY, SPATULAS, LADLES, TURNERS, SKEWERS, TONGS, NON-ELECTRIC FOOD MIXERS, DUTCH OVENS, RAMEKINS, JARS FOR STORING FOOD, FRYING PANS, SKILLETS (U.S. CLS. 2, 13, 23, 29, 30, 33, 40 AND 50).

FIRST USE 12-13-2012; IN COMMERCE 12-13-2012.

4,593,351. MEADWESTVACO CORPORATION, RICHMOND, VA. SN 85-642,168. PUB. 10-30-2012, FILED 6-4-2012.

4,593,532. STARBOARD COLLECTION, LLC, SOUTH BURLINGTON, VT. SN 85-773,358. PUB. 5-28-2013, FILED 11-7-2012.

**ERGOSOL**

THE MARK CONSISTS OF STANDARD CHARACTERS WITHOUT CLAIM TO ANY PARTICULAR FONT, STYLE, SIZE, OR COLOR.

FOR MANUALLY ACTUATED PUMP DISPENSERS FOR ATTACHMENT TO CONTAINERS FOR USE IN DISPENSING LIQUIDS (U.S. CLS. 2, 13, 23, 29, 30, 33, 40 AND 50).

FIRST USE 5-29-2014; IN COMMERCE 5-29-2014.

**STARBOARD COLLECTION**

THE MARK CONSISTS OF STANDARD CHARACTERS WITHOUT CLAIM TO ANY PARTICULAR FONT, STYLE, SIZE, OR COLOR.

NO CLAIM IS MADE TO THE EXCLUSIVE RIGHT TO USE "COLLECTION", APART FROM THE MARK AS SHOWN.

FOR HOUSEWARES FOR USE IN BOAT GALLEYS, NAMELY, BOWLS, PLATES, MEAL AND SERVING TRAYS (U.S. CLS. 2, 13, 23, 29, 30, 33, 40 AND 50).

FIRST USE 4-1-2014; IN COMMERCE 4-1-2014.

**CLASS 21—(Continued).**

4,593,598. THE MEMORY COMPANY, LLC, PHENIX CITY, AL. SN 85-798,755. PUB. 5-7-2013, FILED 12-10-2012.

**CLASS 21—(Continued).**

4,593,713. DR PEPPER/SEVEN UP, INC., PLANO, TX. SN 85-845,876. PUB. 4-30-2013, FILED 2-11-2013.

# Either Or

THE MARK CONSISTS OF STANDARD CHARACTERS WITHOUT CLAIM TO ANY PARTICULAR FONT, STYLE, SIZE, OR COLOR.

FOR INSULATING SLEEVE HOLDER FOR BOTTLES; INSULATING SLEEVE HOLDERS FOR BEVERAGE CANS (U.S. CLS. 2, 13, 23, 29, 30, 33, 40 AND 50). FIRST USE 3-11-2013; IN COMMERCE 3-11-2013.

# DR PEPPER

THE MARK CONSISTS OF STANDARD CHARACTERS WITHOUT CLAIM TO ANY PARTICULAR FONT, STYLE, SIZE, OR COLOR.

OWNER OF U.S. REG. NOS. 3,044,406, 3,209,272, AND 3,304,880. FOR CUPS (U.S. CLS. 2, 13, 23, 29, 30, 33, 40 AND 50). FIRST USE 4-1-2014; IN COMMERCE 4-1-2014.

4,593,605. BILL LODEN, PLANO, TX. SN 85-800,716. PUB. 5-7-2013, FILED 12-12-2012.

4,593,733. S. C. JOHNSON & SON, INC., RACINE, WI. SN 85-857,347. PUB. 4-30-2013, FILED 2-22-2013.

# SPIKED

THE MARK CONSISTS OF STANDARD CHARACTERS WITHOUT CLAIM TO ANY PARTICULAR FONT, STYLE, SIZE, OR COLOR.

FOR COCKTAIL SHAKERS (U.S. CLS. 2, 13, 23, 29, 30, 33, 40 AND 50). FIRST USE 4-23-2012; IN COMMERCE 4-23-2012.

# ZIPLOC TO GO

THE MARK CONSISTS OF STANDARD CHARACTERS WITHOUT CLAIM TO ANY PARTICULAR FONT, STYLE, SIZE, OR COLOR.

OWNER OF U.S. REG. NOS. 1,994,033 AND 4,108,889. FOR PLASTIC CONTAINERS FOR HOUSEHOLD USE (U.S. CLS. 2, 13, 23, 29, 30, 33, 40 AND 50). FIRST USE 4-28-2013; IN COMMERCE 4-28-2013.

4,593,676. GREAT NH RESTAURANTS, INC., BEDFORD, NH. SN 85-823,868. PUB. 7-16-2013, FILED 1-15-2013.

# CHEF NICOLE'S

THE MARK CONSISTS OF STANDARD CHARACTERS WITHOUT CLAIM TO ANY PARTICULAR FONT, STYLE, SIZE, OR COLOR.

OWNER OF U.S. REG. NO. 3,766,162. THE NAME(S), PORTRAIT(S), AND/OR SIGNATURE(S) SHOWN IN THE MARK IDENTIFIES "NICOLE" BARREIRA, WHOSE CONSENT(S) TO REGISTER IS MADE OF RECORD.

FOR HOUSEHOLD UTENSILS, NAMELY, SPATULAS, SERVING SPOONS, WHISKS, TONGS, AND SERVING FORKS (U.S. CLS. 2, 13, 23, 29, 30, 33, 40 AND 50). FIRST USE 1-10-2013; IN COMMERCE 6-1-2014.

# I'm Here to Erase Normal

THE MARK CONSISTS OF STANDARD CHARACTERS WITHOUT CLAIM TO ANY PARTICULAR FONT, STYLE, SIZE, OR COLOR.

4,593,821. PACKED HOUSE PUBLICATIONS, LLC, GRAND PRAIRIE, TX. SN 85-912,244. PUB. 1-28-2014, FILED 4-23-2013.

**CLASS 21—(Continued).**

OWNER OF U.S. REG. NO. 4,512,390.

FOR BEER JUGS; BEER MUGS; BEVERAGE GLASSWARE; BEVERAGE WARE; BOTTLE OPENERS; BOTTLE SLEEVES COMPOSED OF LIQUID-ABSORBING MICRO FIBER FABRIC; BOTTLES, SOLD EMPTY; BOWLS; COASTERS, NOT OF PAPER AND OTHER THAN TABLE LINEN; COCKTAIL GLASSES; COFFEE CUPS; COFFEE CUPS, TEA CUPS AND MUGS; COFFEE MUGS; COFFEE POTS; COOKIE JARS; COOLERS FOR WINE; COOLING BUCKETS FOR WINE; CROCKERY, NAMELY, POTS, DISHES, DRINKING CUPS AND SAUCERS, BOWLS, SERVING BOWLS AND TRAYS; CUPS; CUPS AND MUGS; CUPS, NOT OF PRECIOUS METAL; SAUCERS; DRINKING CUPS; DRINKING CUPS AND SAUCERS; DRINKING CUPS FOR BABIES AND CHILDREN AND PARTS AND FITTINGS THEREFOR, NAMELY, CUPS FOR BABIES AND CHILDREN SOLD AS A UNIT WITH VALVES AND LIDS; DRINKING CUPS FOR CHILDREN AND PARTS AND FITTINGS THEREFOR, NAMELY, DRINKING CUPS FOR CHILDREN SOLD AS A UNIT WITH NON-INSULATED LIDS; DRINKING CUPS FOR INFANTS AND PARTS AND FITTINGS THEREFOR, NAMELY, VALVES AND LIDS SOLD AS A UNIT; DRINKING GLASSES, NAMELY, TUMBLERS; DRINKING STRAWS OF GLASS; DRINKING VESSELS; EARTHENWARE MUGS; FIGURINES OF GLASS; CERAMIC AND PORCELAIN CUPS AND MUGS (U.S. CLS. 2, 13, 23, 29, 30, 33, 40 AND 50).

FIRST USE 8-31-2013; IN COMMERCE 8-31-2013.

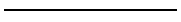

4,593,898. PRESTAGON LLC, PALO ALTO, CA. SN 85-931,728. PUB. 10-22-2013, FILED 5-14-2013.

# Bowl Topper

THE MARK CONSISTS OF STANDARD CHARACTERS WITHOUT CLAIM TO ANY PARTICULAR FONT, STYLE, SIZE, OR COLOR.

NO CLAIM IS MADE TO THE EXCLUSIVE RIGHT TO USE "BOWL", APART FROM THE MARK AS SHOWN.

FOR PLASTIC STORAGE CONTAINERS FOR HOUSEHOLD OR DOMESTIC USE (U.S. CLS. 2, 13, 23, 29, 30, 33, 40 AND 50).

FIRST USE 5-1-2013; IN COMMERCE 8-23-2013.

**CLASS 21—(Continued).**

4,593,909. LUCKY CONCH, LLC, KEY WEST, FL. SN 85-933,722. PUB. 10-15-2013, FILED 5-16-2013.



THE MARK CONSISTS OF A DRAWING OF A SHELL WITH THE WORD "CONCH" UNDERNEATH.

FOR DRINKING GLASSES, MUGS, STEINS AND SHOT GLASSES MADE OF GLASS, PLASTIC, CERAMIC AND EARTHENWARE; INSULATED SLEEVE HOLDERS FOR CANS AND BOTTLES (U.S. CLS. 2, 13, 23, 29, 30, 33, 40 AND 50).

FIRST USE 10-1-2012; IN COMMERCE 11-21-2013.

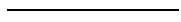

4,593,934. LEAPFROG PRODUCT DEVELOPMENT LLC, CHICAGO, IL. SN 85-937,456. PUB. 11-5-2013, FILED 5-20-2013.

# ZULU

THE MARK CONSISTS OF STANDARD CHARACTERS WITHOUT CLAIM TO ANY PARTICULAR FONT, STYLE, SIZE, OR COLOR.

FOR PLASTIC DRINKWARE SOLD EMPTY, NAMELY, REUSABLE WATER BOTTLES, TRAVEL MUGS, SPORTS BOTTLES; STAINLESS STEEL DRINKWARE SOLD EMPTY, NAMELY, REUSABLE WATER BOTTLES, TRAVEL MUGS AND SPORTS BOTTLES; AND GLASS DRINKWARE SOLD EMPTY, NAMELY, REUSABLE WATER BOTTLES, TRAVEL MUGS AND SPORTS BOTTLES (U.S. CLS. 2, 13, 23, 29, 30, 33, 40 AND 50).

FIRST USE 7-1-2013; IN COMMERCE 7-1-2013.

**CLASS 21—(Continued).**

4,593,975. KYLE G. MUIR, SALT LAKE CITY, UT. SN 85-942,820. PUB. 10-22-2013, FILED 5-25-2013.

# swoob

THE MARK CONSISTS OF STANDARD CHARACTERS WITHOUT CLAIM TO ANY PARTICULAR FONT, STYLE, SIZE, OR COLOR.

FOR BOTTLES, SOLD EMPTY; EMPTY WATER BOTTLES FOR BICYCLES; NEOPRENE ZIPPERED BOTTLE HOLDERS; PLASTIC DRINK BOTTLE IDENTIFICATION TAG; PLASTIC WATER BOTTLES SOLD EMPTY; RECYCLABLE FLEXIBLE PLASTIC POUCHES SOLD EMPTY FOR HOLDING WATER OR NUTRITIONAL LIQUIDS; REUSABLE PLASTIC WATER BOTTLES SOLD EMPTY; REUSABLE STAINLESS STEEL WATER BOTTLES SOLD EMPTY; SPORTS BOTTLES SOLD EMPTY; SQUEEZE BOTTLE SOLD EMPTY; WATER BOTTLES SOLD EMPTY (U.S. CLS. 2, 13, 23, 29, 30, 33, 40 AND 50).  
FIRST USE 9-30-2012; IN COMMERCE 7-8-2013.

4,594,025. NANCY A. BOLANIS, ARLINGTON, VA. SN 85-952,241. PUB. 11-12-2013, FILED 6-6-2013.



THE COLOR(S) BLACK, GREEN, PINK, RED, WHITE, YELLOW, BROWN, LIGHT BROWN AND DARK BROWN IS/ARE CLAIMED AS A FEATURE OF THE MARK.

THE MARK CONSISTS OF THE WORDS "WILLOW-MIA PIG", IN GREEN STYLIZED WRITING. ABOVE THE "I" IN "WILLOW" IS A PINK AND GREEN FLOWER. THE "O" OF "WILLOW" IS REPRESENTED BY A FLOWER WITH A LIGHT AND DARK BROWN CENTER AND YELLOW LEAVES. THE "I" IN "MIA" IS A PINK AND YELLOW FLOWER. BELOW THE WORDS "WILLOW-MIA" IS A BRANCH WITH THE COLORS BROWN AND HAVING GREEN LEAVES. BELOW THE BRANCH IS A PIG. THE PIG IS PINK, BLACK AND WHITE AND FACING TO THE LEFT. THE PIG IS WEARING A FLOWER NECKLACE. THE NECKLACE CONSISTS OF PINK AND RED FLOWERS AND GREEN LEAVES. TO THE RIGHT OF THE PIG IS THE WORD "PIG" IN THE COLOR GREEN. AT THE BOTTOM IS THE WORDING "I IN 100 MILLION" IN THE COLOR GREEN. THE BACKGROUND IS NOT CLAIMED AS A FEATURE OF THE MARK.

FOR MUGS (U.S. CLS. 2, 13, 23, 29, 30, 33, 40 AND 50).  
FIRST USE 10-31-2013; IN COMMERCE 10-31-2013.

**CLASS 21—(Continued).**

4,594,026. NANCY A. BOLANIS, ARLINGTON, VA. SN 85-952,296. PUB. 11-12-2013, FILED 6-6-2013.



THE COLOR(S) GREEN, WHITE, BLACK, PINK AND RED IS/ARE CLAIMED AS A FEATURE OF THE MARK.

THE MARK CONSISTS OF THE WORDING "YOU MY GIRL?" IN GREEN AT THE TOP. BELOW THE WORDING FACING SIDWAYS AND TO THE LEFT IS A DESIGN OF "WILLOW-MIA" THE PIG. WILLOW-MIA THE PIG IS PRESENTED IN PINK, WHITE AND BLACK AND AROUND HER HEAD IS A COLLAR AND A LEASE IN RED. BELOW THE PIG IS THE WORDING "WILLOW-MIA PIG" IN GREEN. THE BACKGROUND IS NOT CLAIMED AS A FEATURE OF THE MARK.

FOR MUGS (U.S. CLS. 2, 13, 23, 29, 30, 33, 40 AND 50).  
FIRST USE 10-31-2013; IN COMMERCE 10-31-2013.

4,594,027. NANCY A. BOLANIS, ARLINGTON, VA. SN 85-952,347. PUB. 11-5-2013, FILED 6-6-2013.



THE COLOR(S) GREEN, YELLOW, DARK BROWN, LIGHT BROWN, WHITE, BLACK AND PINK IS/ARE CLAIMED AS A FEATURE OF THE MARK.

THE MARK CONSISTS OF THE WORDING "FACTORY FARMS ARE NOT" IN GREEN AT THE TOP. BELOW THE WORDING IS A FLOWER DESIGN IN SHADES OF YELLOW, DARK BROWN AND LIGHT BROWN. THE FLOWER

**CLASS 21—(Continued).**

HAS A GREEN SHADED STEM. TO THE LEFT OF FLOWER DESIGN IS A PIG DESIGN. THE PIG IS PRESENTED IN THE COLORS PINK AND WHITE WITH BLACK EYES, MARKINGS AND OUTLINING WITH A WHITE AND BLACK TAG IN HER RIGHT EAR WITH THE NUMBER "228". BELOW THE PIG ARE BLADES OF GRASS IN SHADES OF GREEN WITH BLACK SHADOWING. BELOW THE GRASS ARE THE WORDS "SOVEREIGN STATES" IN GREEN. THE BACKGROUND IS NOT CLAIMED AS A FEATURE OF THE MARK.

FOR MUGS (U.S. CLS. 2, 13, 23, 29, 30, 33, 40 AND 50).  
FIRST USE 10-31-2013; IN COMMERCE 10-31-2013.

4,594,028. CONAIR CORPORATION, STAMFORD, CT. SN 85-952,370. PUB. 11-5-2013, FILED 6-6-2013.

**CONAIR TOURMALINE SMOOTHERS**

THE MARK CONSISTS OF STANDARD CHARACTERS WITHOUT CLAIM TO ANY PARTICULAR FONT, STYLE, SIZE, OR COLOR.

OWNER OF U.S. REG. NO. 3,277,360.

NO CLAIM IS MADE TO THE EXCLUSIVE RIGHT TO USE "TOURMALINE", APART FROM THE MARK AS SHOWN.

FOR HAIRBRUSHES (U.S. CLS. 2, 13, 23, 29, 30, 33, 40 AND 50).

FIRST USE 5-26-2014; IN COMMERCE 5-26-2014.

4,594,029. NANCY A. BOLANIS, ARLINGTON, VA. SN 85-952,384. PUB. 11-5-2013, FILED 6-6-2013.



THE COLOR(S) GREEN, DARK BROWN, LIGHT BROWN, RED, WHITE, BLACK AND PINK IS/ARE CLAIMED AS A FEATURE OF THE MARK.

THE MARK CONSISTS OF THE WORDING ""PIG ON!"" IN GREEN ON THE TOP OUTLINED IN BLACK. BELOW THE WORDING IS A PIG DESIGN. THE PIG IS PRESENTED IN THE COLORS PINK AND WHITE WITH LIGHT BROWN HOOVES, SHE IS RUNNING TO THE LEFT AND WEARING A RED HARNESS. THE PIG AND HARNESS ARE OUTLINED IN BLACK, AND THE PIG HAS BLACK EYES, MARKINGS AND SHADING. BELOW THE PIG IS A REPRESENTATION OF DARK AND LIGHT BROWN DIRT WITH A FEW BLADES OF GREEN GRASS AND FLYING BITS OF BROWN AND BLACK DIRT. AT THE BOTTOM ARE THE WORDS "WILLOW-MIA PIG" IN THE COLOR GREEN. THE BACKGROUND IS NOT CLAIMED AS A FEATURE OF THE MARK.

FOR MUGS (U.S. CLS. 2, 13, 23, 29, 30, 33, 40 AND 50).  
FIRST USE 10-31-2013; IN COMMERCE 10-31-2013.

**CLASS 21—(Continued).**

4,594,053. CAROLINE SUSAN BARON, NEW YORK, NY. SN 85-956,314. PUB. 10-29-2013, FILED 6-11-2013.

# MENURKEY

THE MARK CONSISTS OF STANDARD CHARACTERS WITHOUT CLAIM TO ANY PARTICULAR FONT, STYLE, SIZE, OR COLOR.

FOR MENORAHS IN THE FORM OF A TURKEY (U.S. CLS. 2, 13, 23, 29, 30, 33, 40 AND 50).

FIRST USE 9-0-2013; IN COMMERCE 9-0-2013.

4,594,055. LOS ANGELES POTTERY, INC., WILMINGTON, CA. SN 85-956,489. PUB. 10-29-2013, FILED 6-11-2013.

# MISTRAL

THE MARK CONSISTS OF STANDARD CHARACTERS WITHOUT CLAIM TO ANY PARTICULAR FONT, STYLE, SIZE, OR COLOR.

FOR BOWLS; MUGS; PLATES (U.S. CLS. 2, 13, 23, 29, 30, 33, 40 AND 50).

FIRST USE 10-0-2013; IN COMMERCE 10-0-2013.

4,594,156. NATGAS RESOURCES LLC, PITTSBURGH, PA. SN 85-977,952. PUB. 3-26-2013, FILED 9-8-2011.

# NATGAS

THE MARK CONSISTS OF STANDARD CHARACTERS WITHOUT CLAIM TO ANY PARTICULAR FONT, STYLE, SIZE, OR COLOR.

FOR CUPS, MUGS, BEVERAGE GLASSWARE (U.S. CLS. 2, 13, 23, 29, 30, 33, 40 AND 50).

FIRST USE 7-9-2014; IN COMMERCE 7-9-2014.

**CLASS 21—(Continued).**

4,594,280. T BOVEE PRODUCTS LLC, COLEMAN, MI. SN 86-033,969. PUB. 2-4-2014, FILED 8-9-2013.

# DripzN

THE MARK CONSISTS OF STANDARD CHARACTERS WITHOUT CLAIM TO ANY PARTICULAR FONT, STYLE, SIZE, OR COLOR.

FOR DRIP COLLARS SPECIALLY ADAPTED FOR USE AROUND SPIGOTS OR NOZZLES OF PORTABLE BEVERAGE DISPENSERS (U.S. CLS. 2, 13, 23, 29, 30, 33, 40 AND 50).

FIRST USE 5-18-2014; IN COMMERCE 5-18-2014.

**CLASS 23—YARNS AND THREADS**

4,594,129. ZHEJIANG XINAO TEXTILES INC., ZHEJIANG PROVINCE, CHINA. SN 85-970,053. PUB. 11-19-2013, FILED 6-26-2013.

# LANABLEND

THE MARK CONSISTS OF STANDARD CHARACTERS WITHOUT CLAIM TO ANY PARTICULAR FONT, STYLE, SIZE, OR COLOR.

THE ENGLISH TRANSLATION OF "LANA" IN THE MARK IS "WOOL".

FOR ELASTIC THREAD AND YARN FOR TEXTILE USE; LINEN THREAD AND YARN; RAYON THREAD; SPUN COTTON; SPUN SILK; SPUN WOOL; SYNTHETIC THREAD; THREAD; WOOLLEN THREAD AND YARN; YARN (U.S. CL. 43).

FIRST USE 9-5-2007; IN COMMERCE 11-3-2007.

4,594,131. ZHEJIANG XINAO TEXTILES INC., ZHEJIANG PROVINCE, CHINA. SN 85-970,055. PUB. 3-4-2014, FILED 6-26-2013.



NO CLAIM IS MADE TO THE EXCLUSIVE RIGHT TO USE "BLEND", APART FROM THE MARK AS SHOWN.

THE MARK CONSISTS OF TWO INTERSECTING POLYGONS WITH THE WORDS "LANA" AND "BLEND" INSIDE.

THE ENGLISH TRANSLATION OF "LANA" IN THE MARK IS "WOOL".

FOR ELASTIC THREAD AND YARN FOR TEXTILE USE; LINEN THREAD AND YARN; RAYON THREAD; SPUN COTTON; SPUN SILK; SPUN WOOL; SYNTHETIC THREAD; THREAD; WOOLLEN THREAD AND YARN; YARN (U.S. CL. 43).

FIRST USE 12-3-2007; IN COMMERCE 8-10-2008.

**CLASS 24—FABRICS**

4,593,123. J. BAXTER BRINKMANN INTERNATIONAL CORPORATION, DALLAS, TX. SN 85-077,450. PUB. 5-24-2011, FILED 7-2-2010.

# MALIBU

THE MARK CONSISTS OF STANDARD CHARACTERS WITHOUT CLAIM TO ANY PARTICULAR FONT, STYLE, SIZE, OR COLOR.

OWNER OF U.S. REG. NOS. 816,551, 3,424,575, AND OTHERS.

FOR OVEN MITTS; AND SWAGS FOR ELECTRIC LIGHT FIXTURES (U.S. CLS. 42 AND 50).

FIRST USE 5-19-2014; IN COMMERCE 5-19-2014.

4,593,129. J. BAXTER BRINKMANN INTERNATIONAL CORPORATION, DALLAS, TX. SN 85-077,541. PUB. 6-28-2011, FILED 7-2-2010.

# MALIBU OUTDOOR LIVING

THE MARK CONSISTS OF STANDARD CHARACTERS WITHOUT CLAIM TO ANY PARTICULAR FONT, STYLE, SIZE, OR COLOR.

OWNER OF U.S. REG. NOS. 816,551, 3,424,575, AND OTHERS.

NO CLAIM IS MADE TO THE EXCLUSIVE RIGHT TO USE "OUTDOOR LIVING", APART FROM THE MARK AS SHOWN.

FOR OVEN MITTS; AND SWAGS FOR ELECTRIC LIGHT FIXTURES (U.S. CLS. 42 AND 50).

FIRST USE 5-19-2014; IN COMMERCE 5-19-2014.

4,593,148. DOWDELL, JENNIFER, CLARENCE, NY. SN 85-179,335. PUB. 11-1-2011, FILED 11-17-2010.

# DENIM AGAIN

THE MARK CONSISTS OF STANDARD CHARACTERS WITHOUT CLAIM TO ANY PARTICULAR FONT, STYLE, SIZE, OR COLOR.

NO CLAIM IS MADE TO THE EXCLUSIVE RIGHT TO USE "DENIM", APART FROM THE MARK AS SHOWN.

FOR BEDDING ITEMS, NAMELY, DUVETS, DUVET COVERS AND SHAMS; KITCHEN TEXTILE ITEMS, NAMELY, CHAIR CUSHION COVERS, TABLE CLOTHS, TABLE RUNNERS, AND PLACEMATS; ALL AFOREMENTIONED GOODS MADE WHOLLY OR IN PART OF DENIM (U.S. CLS. 42 AND 50).

FIRST USE 6-2-2014; IN COMMERCE 6-2-2014.



**CLASS 24—(Continued).**

4,593,217. WELSPUN GLOBAL BRANDS LIMITED, MUMBAI 400013, INDIA. SN 85-370,657. PUB. 5-8-2012, FILED 7-13-2011.

# MAXGRIP

THE MARK CONSISTS OF STANDARD CHARACTERS WITHOUT CLAIM TO ANY PARTICULAR FONT, STYLE, SIZE, OR COLOR.

FOR MATTRESS PADS (U.S. CLS. 42 AND 50).  
FIRST USE 6-5-2014; IN COMMERCE 6-5-2014.

---

4,593,218. COACH SERVICES, INC., NEW YORK, NY. SN 85-374,358. PUB. 6-5-2012, FILED 7-18-2011.

# COACH NEW YORK

THE MARK CONSISTS OF STANDARD CHARACTERS WITHOUT CLAIM TO ANY PARTICULAR FONT, STYLE, SIZE, OR COLOR.

OWNER OF U.S. REG. NOS. 2,451,168, 3,157,972, AND 3,554,448.

NO CLAIM IS MADE TO THE EXCLUSIVE RIGHT TO USE "NEW YORK", APART FROM THE MARK AS SHOWN.

FOR BATH TOWELS; BEACH TOWELS (U.S. CLS. 42 AND 50).

FIRST USE 5-1-2014; IN COMMERCE 5-1-2014.

---

4,593,230. SHERMAN SAMUEL, SARAH, LOS ANGELES, CA. SN 85-412,337. PUB. 2-14-2012, FILED 8-31-2011.

# A Sunny Afternoon

THE MARK CONSISTS OF STANDARD CHARACTERS WITHOUT CLAIM TO ANY PARTICULAR FONT, STYLE, SIZE, OR COLOR.

FOR BANNERS OF TEXTILE; BED BLANKETS; TABLE CLOTH OF TEXTILE; TEA TOWELS (U.S. CLS. 42 AND 50).

FIRST USE 9-15-2013; IN COMMERCE 9-15-2013.

**CLASS 24—(Continued).**

4,593,723. HMS INTERNATIONAL FABRICS CORP., SECAUCUS, NJ. SN 85-849,738. PUB. 5-7-2013, FILED 2-14-2013.

# IT'S ONLY NATURAL

THE MARK CONSISTS OF STANDARD CHARACTERS WITHOUT CLAIM TO ANY PARTICULAR FONT, STYLE, SIZE, OR COLOR.

FOR NATURALLY DERIVED TEXTILE FABRICS FOR USE IN THE MANUFACTURE OF CLOTHING, HANDBAGS, WALLETS AND LUGGAGE; NATURALLY DERIVED TEXTILE FABRICS FOR HOME AND COMMERCIAL INTERIORS, NAMELY, FOR FURNITURE UPHOLSTERY AND FOR MAKING HOUSEHOLD FURNISHINGS (U.S. CLS. 42 AND 50).

FIRST USE 6-18-2014; IN COMMERCE 6-18-2014.

---

4,593,779. ELLISON FIRST ASIA, LLC, NEW YORK, NY. SN 85-885,687. PUB. 12-31-2013, FILED 3-25-2013.

# ELLISON AMERICAN CLASSIC

THE MARK CONSISTS OF STANDARD CHARACTERS WITHOUT CLAIM TO ANY PARTICULAR FONT, STYLE, SIZE, OR COLOR.

OWNER OF U.S. REG. NO. 2,732,881.  
NO CLAIM IS MADE TO THE EXCLUSIVE RIGHT TO USE "AMERICAN CLASSIC", APART FROM THE MARK AS SHOWN.

FOR BED SHEETS, PILLOW CASES (U.S. CLS. 42 AND 50).

FIRST USE 11-27-2013; IN COMMERCE 11-27-2013.

**CLASS 24—(Continued).**

4,593,946. MR. R.J.C., INC., DBA RJR FASHION FABRICS, TORRANCE, CA. SN 85-938,706. PUB. 11-12-2013, FILED 5-21-2013.



NO CLAIM IS MADE TO THE EXCLUSIVE RIGHT TO USE "COTTON", "EST. 2013" AND "AUTHENTIC", APART FROM THE MARK AS SHOWN.

THE MARK CONSISTS OF "STEEL + COTTON" IN LARGE BLOCK LETTERING BETWEEN HORIZONTAL LINES, WITH "EST. 2013" AND "AUTHENTIC" WRITTEN ABOVE AND BELOW IN SMALLER LETTERS WITHIN A RAW COTTON DESIGN ELEMENT.

FOR FABRICS MADE IN SIGNIFICANT PART OF COTTON FOR THE MANUFACTURE OF QUILTS AND HOME SEWING (U.S. CLS. 42 AND 50).

FIRST USE 5-30-2014; IN COMMERCE 5-30-2014.

4,594,252. SAM SALEM & SON, LLC, NEW YORK CITY, NY. SN 86-018,959. PUB. 1-14-2014, FILED 7-24-2013.

**POSH HOME**

THE MARK CONSISTS OF STANDARD CHARACTERS WITHOUT CLAIM TO ANY PARTICULAR FONT, STYLE, SIZE, OR COLOR.

NO CLAIM IS MADE TO THE EXCLUSIVE RIGHT TO USE "HOME", APART FROM THE MARK AS SHOWN.

FOR BED BLANKETS; BED SHEETS; COMFORTERS; PILLOW CASES; THROWS; TOWELS (U.S. CLS. 42 AND 50).

FIRST USE 10-2-2013; IN COMMERCE 10-2-2013.

**CLASS 25—CLOTHING****CLASS 25—(Continued).**

4,593,074. WOLVERINE WORLD WIDE, INC., ROCKFORD, MI. SN 77-597,960. PUB. 2-3-2009, FILED 10-22-2008.

**WOLVERINE 1000 MILE**

THE MARK CONSISTS OF STANDARD CHARACTERS WITHOUT CLAIM TO ANY PARTICULAR FONT, STYLE, SIZE, OR COLOR.

FOR BELTS (U.S. CLS. 22 AND 39).

FIRST USE 9-0-2012; IN COMMERCE 9-0-2012.

4,593,087. CLARKE, CONRAD CHRISTOPHER, DBA CIDEA SOLUTIONS, EAST ISLIP, NY. SN 77-892,297. PUB. 11-2-2010, FILED 12-13-2009.



THE MARK CONSISTS OF A GRAPHIC ELEMENT DEPICTING THE FACE OF AN EXTRATERRESTRIAL WEARING A HOODED GARMENT, AS IF IN DISGUISE. THE MARK IS FOLLOWED BY THE BRAND NAME: "ALIENGEAR", AND THE BRAND SLOGAN: "DON'T FEAR IT, WEAR IT."

FOR A-SHIRTS; ANKLE SOCKS; ANKLETS; ANTI-PERSPIRANT SOCKS; ATHLETIC APPAREL, NAMELY, SHIRTS, PANTS, JACKETS, FOOTWEAR, HATS AND CAPS, ATHLETIC UNIFORMS; ATHLETIC FOOTWEAR; BABY BOTTOMS; BABY LAYETTES FOR CLOTHING; BABY TOPS; BANDANAS; BASEBALL CAPS; BASELAYER BOTTOMS; BASELAYER TOPS; BATHING SUITS; BATHING SUITS FOR MEN; BATHING TRUNKS; BATHROBES; BEACH FOOTWEAR; BEACH SHOES; BELTS; BELTS FOR CLOTHING; BELTS MADE FROM IMITATION LEATHER; BELTS MADE OF LEATHER; BELTS MADE OUT OF CLOTH; BELTS OF TEXTILE; BIBS NOT OF CLOTH OR PAPER; BIBS NOT OF PAPER; BODY SHIRTS; BODY SUITS; BOOTS; BOOTS FOR MOTORCYCLING; BOOTS FOR SPORT; BOTTOMS; BOW TIES; BOXER BRIEFS; BOXER SHORTS; BRACES; BRAS; BRIEFS; BRIEFS; CAMISOLES; CAPS; CAPS WITH VISORS; CARGO PANTS; CHILDREN'S AND INFANT'S APPAREL, NAMELY, JUMPERS, OVERALL SLEEPWEAR, PAJAMAS, ROMPERS AND ONE-PIECE GARMENTS; CHILDREN'S AND INFANTS' CLOTH BIBS; CHILDREN'S CLOTH EATING BIBS; CHILDREN'S HEADWEAR; CLOTH BIBS; CLOTHING, NAMELY, WRAP-AROUNDS; COATS; COATS FOR MEN AND WOMEN; COATS MADE OF COTTON; COATS OF DENIM; CREW NECK SWEATERS; CROP TOPS; DENIM JACKETS; DENIMS; DOWN JACKETS; DRESS SHIRTS; DRESS SUITS; DRESSES; DRESSING

**CLASS 25—(Continued).**

GOWNS; DRESSING GOWNS AND BATH ROBES; DRY SUITS; DUST COATS; EVENING DRESSES; FABRIC BELTS; FLIP FLOPS; FOOTBALL BOOTS AND STUDS THEREFOR; FOOTBALL SHOES; FOOTWEAR; FOOTWEAR FOR MEN; FOOTWEAR FOR MEN AND WOMEN; FOOTWEAR FOR TRACK AND FIELD ATHLETICS; FOOTWEAR FOR WOMEN; FOOTWEAR NOT FOR SPORTS; FUR COATS; FUR COATS AND JACKETS; FUR HATS; FUR JACKETS; GLOVES INCLUDING THOSE MADE OF SKIN, HIDE OR FUR; GOLF CAPS; GOLF PANTS, SHIRTS AND SKIRTS; GOLF SHIRTS; GOLF SHOES; GOLF SHORTS; GOLF TROUSERS; GYM PANTS; GYM SHORTS; GYM SUITS; HALTER TOPS; HAT BANDS; HATS; HATS FOR INFANTS, BABIES, TODDLERS AND CHILDREN; HEAD SCARVES; HEAD SWEATBANDS; HEAD WEAR; HEADBANDS; HEADBANDS AGAINST SWEATING; HEADBANDS FOR CLOTHING; HEADWEAR; HEAVY COATS; HEAVY JACKETS; HOODED PULLOVERS; HOODED SWEAT SHIRTS; HOODS; HOODS; INFANT AND TODDLER ONE PIECE CLOTHING; INFANT WEAR; INFANTS' SHOES AND BOOTS; INFANTS' TROUSERS; JACKETS; JACKETS AND SOCKS; JEANS; JERSEYS; JOGGING OUTFITS; JOGGING PANTS; JOGGING SUITS; KNIT SHIRTS; KNITTED CAPS; KNITTED GLOVES; KNITTED UNDERWEAR; LAB COATS; LADIES' BOOTS; LADIES' SUITS; LADIES' UNDERWEAR; LEATHER BELTS; LEATHER COATS; LEATHER HEADWEAR; LEATHER JACKETS; LEATHER PANTS; LEATHER SHOES; LEATHER SLIPPERS; LEISURE SUITS; LIGHT-REFLECTING COATS; LIGHT-REFLECTING JACKETS; LINGERIE; LONG JACKETS; LONG SLEEVE PULLOVERS; LONG SLEEVED VESTS; LONG UNDERWEAR; LONG-SLEEVED SHIRTS; LOUNGE PANTS; MASQUERADE COSTUMES; MASQUERADE COSTUMES AND MASKS SOLD IN CONNECTION THEREWITH; MEN'S AND WOMEN'S JACKETS, COATS, TROUSERS, VESTS; MEN'S DRESS SOCKS; MEN'S SOCKS; MEN'S SUITS; MEN'S SUITS, WOMEN'S SUITS; MEN'S UNDERWEAR; MOCK TURTLE-NECK SWEATERS; MOISTURE-WICKING SPORTS BRAS; MOISTURE-WICKING SPORTS PANTS; MOISTURE-WICKING SPORTS SHIRTS; MORNING COATS; MOTORCYCLE GLOVES; MOTORCYCLE JACKETS; MOTORCYCLE RAIN SUITS; MUSCLE TOPS; NECKERCHIEFS; NIGHT SHIRTS; ONE PIECE GARMENT FOR INFANTS AND TODDLERS; ONE-PIECE PLAY SUITS; OPEN-NECKED SHIRTS; OUTER JACKETS; OVER COATS; OVER SHIRTS; OVER-TROUSERS; PADDED JACKETS; PADDING JACKETS; PAJAMA BOTTOMS; PAJAMAS; PANTIES, SHORTS AND BRIEFS; PANTS; PLAY SUITS; PLEATED SKIRTS FOR FORMAL KIMONOS (HAKAMA); POLO SHIRTS; PRAM SUITS; RAIN COATS; RAIN JACKETS; RAIN SUITS; RAIN-PROOF JACKETS; REVERSIBLE JACKETS; RIDING BOOTS; RIDING COATS; RIDING GLOVES; RIDING SHOES; RUGBY SHIRTS; RUGBY TOPS; SANDALS; SANDALS AND BEACH SHOES; SCARFS; SCARVES; SCIENTIFIC AND TECHNOLOGICAL APPAREL, NAMELY, SHIRTS, PANTS, JACKETS, FOOTWEAR, HATS AND CAPS, UNIFORMS; SHIRTS; SHIRTS AND SHORT-SLEEVED SHIRTS; SHIRTS FOR INFANTS, BABIES, TODDLERS AND CHILDREN; SHIRTS FOR SUITS; SHORT-SLEEVED OR LONG-SLEEVED T-SHIRTS; SHORT-SLEEVED SHIRTS; SHOULDER SCARVES; SHOULDER WRAPS; SHOULDER WRAPS FOR CLOTHING; SILK SCARVES; SKI GLOVES; SKI JACKETS; SKI MASKS; SKI PANTS; SKI SUITS; SKI SUITS FOR COMPETITION; SKI TROUSERS; SKI WEAR; SKIRT SUITS; SKIRTS; SKIRTS AND DRESSES; SKULL CAPS; SKULLIES; SLEEP SHIRTS; SLEEVED OR SLEEVELESS JACKETS; SLEEVELESS JERSEYS; SMALL HATS; SNOW BOARDING SUITS; SNOW PANTS; SNOW SUITS; SNOWBOARD PANTS; SOCK SUSPENDERS; SOCKS; SOCKS AND STOCKINGS; SPORT COATS; SPORT SHIRTS; SPORTS BRA; SPORTS BRAS; SPORTS JACKETS; SPORTS JERSEYS; SPORTS JERSEYS AND BREECHES FOR SPORTS; SPORTS PANTS; SPORTS SHIRTS; SPORTS SHIRTS WITH SHORT SLEEVES; STRAPLESS BRAS; STRETCH PANTS; STUFF JACKETS; SUEDE JACKETS; SUIT COATS; SUITS; SUITS OF LEATHER; SUSPENDER BELTS; SUSPENDER BELTS FOR MEN; SUSPENDER BELTS FOR WOMEN; SUSPENDERS; SUSPENDERS; SWEAT JACKETS; SWEAT PANTS; SWEAT SHIRTS; SWEAT SUITS; SWEATERS; SWIM TRUNKS; SWIM WEAR; SWIM WEAR FOR GENTLEMEN AND LADIES; SWIMMING TRUNKS; T-

**CLASS 25—(Continued).**

SHIRTS; TANK TOPS; TANK-TOPS; TEE SHIRTS; TENNIS DRESSES; THERMAL SOCKS; THERMAL UNDERWEAR; THONGS; TIES; TOP COATS; TOPS; TRACK JACKETS; TRACK PANTS; TRACK SUITS; TRAINING SUITS; TRENCH COATS; TRIATHLON CLOTHING, NAMELY, TRIATHLON TIGHTS, TRIATHLON SHORTS, TRIATHLON SINGLET, TRIATHLON SHIRTS, TRIATHLON SUITS; TROUSERS OF LEATHER; TRUNKS; TUBE TOPS; TURTLE NECK SHIRTS; TURTLENECK SWEATERS; UNDERPANTS; UNDERWEAR; UNDERWEAR, NAMELY, BOY SHORTS; V-NECK SWEATERS; VESTED SUITS; VESTS; WARM UP SUITS; WATER SOCKS; WATERPROOF JACKETS AND PANTS; WEARABLE GARMENTS AND CLOTHING, NAMELY, SHIRTS; WET SUIT GLOVES; WET SUITS; WET SUITS FOR WATER-SKIING AND SUB-AQUA; WIND COATS; WIND RESISTANT JACKETS; WIND SHIRTS; WIND VESTS; WIND-JACKETS; WOMEN'S HATS AND HOODS; WOMEN'S TOPS, NAMELY, CAMIS; WOMEN'S UNDERWEAR; WOOLLEN SOCKS; WOVEN OR KNITTED UNDERWEAR; WRAP BELTS FOR KIMONOS (DATEMAKI); WRAPS; YOGA PANTS; YOGA SHIRTS (U.S. CLS. 22 AND 39).

FIRST USE 6-23-2009; IN COMMERCE 4-9-2011.

4,593,121. TONE IT UP, LLC, HERMOSA BEACH, CA. SN 85-068,196. PUB. 5-17-2011, FILED 6-22-2010.

---

## TONE IT UP

THE MARK CONSISTS OF STANDARD CHARACTERS WITHOUT CLAIM TO ANY PARTICULAR FONT, STYLE, SIZE, OR COLOR.

FOR YOGA PANTS, CAPRI PANTS, SHORTS, SWIMWEAR (U.S. CLS. 22 AND 39).

FIRST USE 6-12-2012; IN COMMERCE 6-18-2014.

---

4,593,162. ABERCROMBIE & FITCH TRADING CO., NEW ALBANY, OH. SN 85-207,255. PUB. 5-3-2011, FILED 12-29-2010.

## HOLLISTER CALIF

THE MARK CONSISTS OF STANDARD CHARACTERS WITHOUT CLAIM TO ANY PARTICULAR FONT, STYLE, SIZE, OR COLOR.

OWNER OF U.S. REG. NOS. 3,310,650, 3,605,286, AND OTHERS.

NO CLAIM IS MADE TO THE EXCLUSIVE RIGHT TO USE "CALIF", APART FROM THE MARK AS SHOWN.

FOR BOTTOMS; COATS; JACKETS; SLEEPWEAR; TOPS (U.S. CLS. 22 AND 39).

FIRST USE 12-0-2004; IN COMMERCE 12-0-2004.

**CLASS 25—(Continued).**

4,593,163. ABERCROMBIE & FITCH TRADING CO., NEW ALBANY, OH. SN 85-207,287. PUB. 5-17-2011, FILED 12-29-2010.

**HOLLISTER MALIBU**

THE MARK CONSISTS OF STANDARD CHARACTERS WITHOUT CLAIM TO ANY PARTICULAR FONT, STYLE, SIZE, OR COLOR.

OWNER OF U.S. REG. NOS. 3,310,650, 3,605,286, AND OTHERS.

NO CLAIM IS MADE TO THE EXCLUSIVE RIGHT TO USE "MALIBU", APART FROM THE MARK AS SHOWN.

FOR BOTTOMS; SLEEPWEAR; TOPS (U.S. CLS. 22 AND 39).

FIRST USE 12-0-2004; IN COMMERCE 12-0-2004.

---

4,593,164. ABERCROMBIE & FITCH TRADING CO., NEW ALBANY, OH. SN 85-207,296. PUB. 5-17-2011, FILED 12-29-2010.

**HOLLISTER DEL MAR**

THE MARK CONSISTS OF STANDARD CHARACTERS WITHOUT CLAIM TO ANY PARTICULAR FONT, STYLE, SIZE, OR COLOR.

OWNER OF U.S. REG. NOS. 3,310,650, 3,605,286, AND OTHERS.

NO CLAIM IS MADE TO THE EXCLUSIVE RIGHT TO USE "DEL MAR", APART FROM THE MARK AS SHOWN.

FOR BOTTOMS; SLEEPWEAR; TOPS (U.S. CLS. 22 AND 39).

FIRST USE 9-0-2009; IN COMMERCE 9-0-2009.

---

4,593,165. ABERCROMBIE & FITCH TRADING CO., NEW ALBANY, OH. SN 85-207,302. PUB. 5-3-2011, FILED 12-29-2010.

**HOLLISTER GUARD DIV**

THE MARK CONSISTS OF STANDARD CHARACTERS WITHOUT CLAIM TO ANY PARTICULAR FONT, STYLE, SIZE, OR COLOR.

OWNER OF U.S. REG. NOS. 3,310,650, 3,605,286, AND OTHERS.

FOR TOPS (U.S. CLS. 22 AND 39).

FIRST USE 1-4-2012; IN COMMERCE 1-4-2012.

**CLASS 25—(Continued).**

4,593,172. 15 FOOTER, LLC, CONYERS, GA. SN 85-215,688. PUB. 5-24-2011, FILED 1-12-2011.



THE MARK CONSISTS OF A STYLIZED LETTER "T" INSIDE A CIRCLE.

FOR FOOTWEAR (U.S. CLS. 22 AND 39).

FIRST USE 10-0-2009; IN COMMERCE 10-0-2009.

---

4,593,173. DELUNA BY DESIGN, INC., NEW YORK, NY. SN 85-220,383. PUB. 5-24-2011, FILED 1-18-2011.

**MARISOL DELUNA**

THE MARK CONSISTS OF STANDARD CHARACTERS WITHOUT CLAIM TO ANY PARTICULAR FONT, STYLE, SIZE, OR COLOR.

THE NAME(S), PORTRAIT(S), AND/OR SIGNATURE(S) SHOWN IN THE MARK IDENTIFIES "MARISOL DELUNA", WHOSE CONSENT(S) TO REGISTER IS MADE OF RECORD.

FOR BANDANAS (U.S. CLS. 22 AND 39).

FIRST USE 2-4-2013; IN COMMERCE 1-1-1997.

---

4,593,187. BANDAI NAMCO GAMES INC., TOKYO, JAPAN. SN 85-282,340. PUB. 6-14-2011, FILED 3-31-2011.

**GALAGA**

THE MARK CONSISTS OF STANDARD CHARACTERS WITHOUT CLAIM TO ANY PARTICULAR FONT, STYLE, SIZE, OR COLOR.

**CLASS 25—(Continued).**

OWNER OF U.S. REG. NOS. 1,746,475, 3,234,043, AND OTHERS.

FOR BOXER SHORTS; CAPS; HEADWEAR; LOUNGE PANTS; PARKAS; SLEEPWEAR; T-SHIRTS; WRISTBANDS (U.S. CLS. 22 AND 39).

FIRST USE 0-0-1981; IN COMMERCE 0-0-1981.

**CLASS 25—(Continued).**

OWNER OF U.S. REG. NOS. 3,006,302, 3,929,005, AND OTHERS.

FOR HOSIERY (U.S. CLS. 22 AND 39).

FIRST USE 6-1-2011; IN COMMERCE 6-1-2011.

---

4,593,188. SWIM STRONG FOUNDATION, INC., EAST ELMHURST, NY. SN 85-292,915. PUB. 9-6-2011, FILED 4-12-2011.

**SWIM STRONG**

THE MARK CONSISTS OF STANDARD CHARACTERS WITHOUT CLAIM TO ANY PARTICULAR FONT, STYLE, SIZE, OR COLOR.

NO CLAIM IS MADE TO THE EXCLUSIVE RIGHT TO USE "SWIM", APART FROM THE MARK AS SHOWN.

FOR BEACH COVER-UPS; PANTS; SHORTS; SWEAT PANTS; SWEAT SHIRTS; T-SHIRTS (U.S. CLS. 22 AND 39).

FIRST USE 2-28-2006; IN COMMERCE 2-28-2006.

---

4,593,191. VITAMIN A ENTERPRISES, INC., COSTA MESA, CA. SN 85-300,992. PUB. 9-27-2011, FILED 4-21-2011.

**VITAMIN A**

THE MARK CONSISTS OF STANDARD CHARACTERS WITHOUT CLAIM TO ANY PARTICULAR FONT, STYLE, SIZE, OR COLOR.

OWNER OF U.S. REG. NO. 2,599,891.

FOR LINGERIE (U.S. CLS. 22 AND 39).

FIRST USE 2-0-1996; IN COMMERCE 6-17-2014.

---

4,593,223. GILDAN USA INC., CHARLESTON, SC. SN 85-382,427. PUB. 11-1-2011, FILED 7-27-2011.

**AQUA FX ZONE**

THE MARK CONSISTS OF STANDARD CHARACTERS WITHOUT CLAIM TO ANY PARTICULAR FONT, STYLE, SIZE, OR COLOR.

---

4,593,227. STUART, HELENA, NEW YORK, NY. SN 85-396,558. PUB. 1-17-2012, FILED 8-12-2011.

**LILAC WINE**

THE MARK CONSISTS OF STANDARD CHARACTERS WITHOUT CLAIM TO ANY PARTICULAR FONT, STYLE, SIZE, OR COLOR.

FOR CLOTHING, NAMELY, LINGERIE, BRAS, UNDERPANTS, BODY SUITS, CAMISOLES, GARTERS, HOSIERY, T-SHIRTS, DRESSES, LEGGINGS, CARDIGANS, BLOUSES, SKIRTS, AND PANTS (U.S. CLS. 22 AND 39).

FIRST USE 9-25-2013; IN COMMERCE 5-6-2014.

---

4,593,233. ULTIMATE APOCALYPSE APPAREL LLC, PORT SAINT LUCIE, FL. SN 85-433,633. PUB. 2-11-2014, FILED 9-28-2011.

**APOCALYPSE MMA**

THE MARK CONSISTS OF STANDARD CHARACTERS WITHOUT CLAIM TO ANY PARTICULAR FONT, STYLE, SIZE, OR COLOR.

NO CLAIM IS MADE TO THE EXCLUSIVE RIGHT TO USE "MMA", APART FROM THE MARK AS SHOWN.

FOR CLOTHING, NAMELY, T-SHIRTS, SHORTS, HATS, PANTS, SWEATSHIRTS, SHIRTS, UNDERWEAR, CAPS, BEANIES, SKULL CAPS, TANK TOPS, JERSEYS, BRIEFS, WRISTBANDS, BELTS AND JACKETS (U.S. CLS. 22 AND 39).

FIRST USE 12-1-2009; IN COMMERCE 12-1-2009.

**CLASS 25—(Continued).**

4,593,244. LABORDE, CAROL-ANN, ROYAL PALM BEACH, FL. AND LABORDE, RALPH, ROYAL PALM BEACH, FL. SN 85-469,554. PUB. 10-29-2013, FILED 11-10-2011.



THE COLOR(S) RED IS/ARE CLAIMED AS A FEATURE OF THE MARK.

THE MARK CONSISTS OF THE WORD "SWAGU" IN A STYLIZED RED FONT. THE LETTER "U" IN "SWAGU" HAS AN ACCENT. THE BOTTOM OF THE WORD "SWAGU" PRESENTS THE IMAGE OF RED DRIPPINGS DRIPPING OFF OF THE LETTERS OF THE WORD.

THE WORDING "SWAGU" HAS NO MEANING IN A FOREIGN LANGUAGE.

FOR BLOUSES; BOXER SHORTS; BRAS; COATS; HOODED SWEATSHIRTS; JACKETS; JEANS; LEGGINGS; PANTIES; PANTS; SHIRTS; SHOES; SHORTS; SOCKS; TANK TOPS; TIES; TUBE TOPS (U.S. CLS. 22 AND 39).

FIRST USE 1-7-2012; IN COMMERCE 1-7-2012.

4,593,260. DOUGLAS BLAINE, PALMYRA, NJ. SN 85-496,079. PUB. 5-22-2012, FILED 12-15-2011.



THE NAME(S), PORTRAIT(S), AND/OR SIGNATURE(S) SHOWN IN THE MARK DOES NOT IDENTIFY A PARTICULAR LIVING INDIVIDUAL.

THE MARK CONSISTS OF THE WORDING "TITZLINGER" BENEATH THE PORTRAIT OF A MAN IN SILHOUETTE WEARING A CAP.

FOR WOMEN'S LINGERIE AND UNDERWEAR, NAMELY, BIKINIS, BRASSIERES, CAMISETTES, CAMISOLES, CORSELETS, FOUNDATION GARMENTS, G-STRINGS, MATERNITY BRAS, MATERNITY LINGERIE, NEGLIGÉES, PANTIES, SHORTS, AND BRIEFS, PEIGNOIRS, NIGHTWEAR, PETTICOATS, SLIPS, AND UNDERWEAR THONGS; WOMEN'S HOSIERY AND PANTY HOSE, SKIRTS, AND DRESSES; MEN'S AND WOMEN'S CLOTHING, NAMELY, JACKETS, COATS, TROUSERS, VESTS, JEANS, SWEATSHIRTS AND HOODED SWEATSHIRTS, SHIRTS AND SHORT-SLEEVED SHIRTS, T-SHIRTS, SHORTS, JERSEYS, CLOTHING TOPS AND SWIMWEAR, HATS AND FOOTWEAR; MEN'S UNDERWEAR AND MUSCLE TOPS (U.S. CLS. 22 AND 39).

FIRST USE 7-16-2014; IN COMMERCE 7-16-2014.

**CLASS 25—(Continued).**

4,593,269. PERMARA LLC, DAKOTA DUNES, SD. SN 85-519,326. PUB. 11-6-2012, FILED 1-18-2012.



THE MARK CONSISTS OF A PARTIAL CIRCLE WHEREBY THE LEFT ARC OF THE CIRCLE TERMINATES IN AN ARROW, AND FURTHER PROVIDING A VERTICAL LINE DISSECTING THE ARC OF THE CIRCLE.

FOR CLOTHING, NAMELY, SOCKS, UNDERGARMENTS, T-SHIRTS, TREATED WITH ANTIMICROBIAL COMPOUND (U.S. CLS. 22 AND 39).

FIRST USE 5-13-2013; IN COMMERCE 5-13-2013.

4,593,336. STEPHEN J. COHEN, UPPER SADDLE RIVER, NJ. SN 85-634,095. PUB. 10-23-2012, FILED 5-24-2012.



THE MARK CONSISTS OF THE WORD "ME" FOLLOWED BY A PLUS SIGN, AN EQUAL SIGN AND A HEART.

FOR APPAREL, NAMELY, T-SHIRTS, SWEATPANTS, SWEATSHIRTS, SHORTS, CAPS, PAJAMAS, UNDERWEAR AND HEAD BANDS (U.S. CLS. 22 AND 39).

FIRST USE 6-16-2014; IN COMMERCE 6-16-2014.

4,593,343. BUCKLE BRANDS, INC., KEARNEY, NE. SN 85-636,110. PUB. 5-7-2013, FILED 5-25-2012.

**SOLELY BLACK BY BKE**

THE MARK CONSISTS OF STANDARD CHARACTERS WITHOUT CLAIM TO ANY PARTICULAR FONT, STYLE, SIZE, OR COLOR.

OWNER OF U.S. REG. NOS. 2,447,957, 4,082,735, AND OTHERS.

**CLASS 25—(Continued).**

NO CLAIM IS MADE TO THE EXCLUSIVE RIGHT TO USE "BLACK", APART FROM THE MARK AS SHOWN.  
FOR FOOTWEAR, SHOES (U.S. CLS. 22 AND 39).  
FIRST USE 10-3-2012; IN COMMERCE 10-3-2012.

4,593,360. KIRK HAMMETT, LOS ANGELES, CA. SN 85-646,604. PUB. 3-26-2013, FILED 6-8-2012.



KIRK VON HAMMETT IDENTIFIES THE PSEUDONYM OF KIRK HAMMETT, A LIVING INDIVIDUAL WHOSE CONSENT IS OF RECORD.

THE MARK CONSISTS OF A CARTOON DRAWING OF A MONSTER, SPECIFICALLY, A MENACING, SUIT-CLAD GHOUL WITH LONG CURLY HAIR AND A THIN MOUSTACHE, ELONGATED HANDS AND NAILS, AN EXAGGERATED SMILE, FANGED TEETH, POINTED SHOULDERS, AND TWO BULGING EYES, THE EYE ON THE LEFT (IN THE "STAGE RIGHT" POSITION) BEING SUBSTANTIALLY LARGER, WITH THE OUTLINE OF THE GHOUL SHADOWED AGAINST A PARTIALLY OBSCURED OVAL-SHAPED BACKGROUND AND THE TEXT "KIRK VON HAMMETT" CENTERED ABOVE THE GHOUL'S HEAD.

FOR CLOTHING, NAMELY, T-SHIRTS (U.S. CLS. 22 AND 39).  
FIRST USE 10-1-2012; IN COMMERCE 10-1-2012.

4,593,389. EMILIO PUCCI INTERNATIONAL B.V., BAARN, NETHERLANDS. SN 85-667,116. PUB. 12-4-2012, FILED 7-2-2012.

**EMILIO PUCCI**

THE MARK CONSISTS OF STANDARD CHARACTERS WITHOUT CLAIM TO ANY PARTICULAR FONT, STYLE, SIZE, OR COLOR.

OWNER OF U.S. REG. NOS. 1,687,909, 3,382,298, AND OTHERS.

**CLASS 25—(Continued).**

THE NAME(S), PORTRAIT(S), AND/OR SIGNATURE(S) SHOWN IN THE MARK DOES NOT IDENTIFY A PARTICULAR LIVING INDIVIDUAL.

FOR CLOTHING NAMELY, SHIRTS, T-SHIRTS, PULL-OVERS, SKIRTS, DRESSES, TROUSERS, COATS, JACKETS, BELTS FOR CLOTHING, SCARVES, SASHES, AND BATHING SUITS; FOOTWEAR; HEADWEAR (U.S. CLS. 22 AND 39).

FIRST USE 12-0-1949; IN COMMERCE 12-0-1949.

4,593,401. CHANGA CLINTON INGRAM, COLUMBIA, MD. AND JESSE INGRAM, COLUMBIA, MD. AND DAMANI KONATA INGRAM, COLUMBIA, MD. SN 85-674,852. PUB. 10-15-2013, FILED 7-12-2012.

**DEBANA**

THE MARK CONSISTS OF STANDARD CHARACTERS WITHOUT CLAIM TO ANY PARTICULAR FONT, STYLE, SIZE, OR COLOR.

THE ENGLISH TRANSLATION OF THE WORD "DEBANA" IN THE MARK IS "OPPORTUNITY".

FOR ATHLETIC APPAREL, NAMELY, SHIRTS, PANTS, JACKETS, FOOTWEAR, HATS AND CAPS, ATHLETIC UNIFORMS (U.S. CLS. 22 AND 39).

FIRST USE 10-10-2012; IN COMMERCE 10-10-2012.

4,593,410. ACI INTERNATIONAL, LOS ANGELES, CA. SN 85-685,245. PUB. 11-6-2012, FILED 7-24-2012.

**CYCLE OF HOPE**

THE MARK CONSISTS OF STANDARD CHARACTERS WITHOUT CLAIM TO ANY PARTICULAR FONT, STYLE, SIZE, OR COLOR.

FOR FOOTWEAR (U.S. CLS. 22 AND 39).

FIRST USE 4-10-2014; IN COMMERCE 4-10-2014.

4,593,424. VARSITY SPIRIT CORPORATION, MEMPHIS, TN. SN 85-698,025. PUB. 10-23-2012, FILED 8-8-2012.

**VARSIY DANCE**

THE MARK CONSISTS OF STANDARD CHARACTERS WITHOUT CLAIM TO ANY PARTICULAR FONT, STYLE, SIZE, OR COLOR.

**CLASS 25—(Continued).**

OWNER OF U.S. REG. NOS. 1,680,452, 2,293,083, AND OTHERS.

NO CLAIM IS MADE TO THE EXCLUSIVE RIGHT TO USE "DANCE", APART FROM THE MARK AS SHOWN.

FOR CLOTHING, NAMELY, UNIFORMS FOR DRILL TEAMS, DANCE TEAMS AND POM POM SQUADS (U.S. CLS. 22 AND 39).

FIRST USE 12-31-1994; IN COMMERCE 12-31-1994.

**CLASS 25—(Continued).**

4,593,499. MINDFUL PALATE, KATY, TX. SN 85-759,762. PUB. 3-26-2013, FILED 10-22-2012.

## Spoon Mage

THE MARK CONSISTS OF STANDARD CHARACTERS WITHOUT CLAIM TO ANY PARTICULAR FONT, STYLE, SIZE, OR COLOR.

FOR APRONS; HATS; NECKTIES; SCARVES; T-SHIRTS (U.S. CLS. 22 AND 39).

FIRST USE 1-1-2012; IN COMMERCE 12-17-2012.

4,593,461. BOARD OF REGENTS OF THE UNIVERSITY OF NEBRASKA, LINCOLN, NE. SN 85-735,170. PUB. 4-9-2013, FILED 9-21-2012.



OWNER OF U.S. REG. NOS. 2,081,720, 3,267,445, AND OTHERS.

THE MARK CONSISTS OF A STYLIZED "N" WITH THE TERM "IRON" ACROSS THE MIDDLE OF THE "N".

FOR SHIRTS, POLO SHIRTS, T-SHIRTS, SWEATSHIRTS, JERSEYS, HEADGEAR, NAMELY, CAPS AND KNIT HATS (U.S. CLS. 22 AND 39).

FIRST USE 9-29-2012; IN COMMERCE 9-29-2012.

4,593,534. THEE LEFT HAND BLACK LLC, NEW YORK, NY. SN 85-773,716. PUB. 4-16-2013, FILED 11-7-2012.

## NORTH MANUAL VOCATIONAL

THE MARK CONSISTS OF STANDARD CHARACTERS WITHOUT CLAIM TO ANY PARTICULAR FONT, STYLE, SIZE, OR COLOR.

FOR T-SHIRTS, SHIRTS, SHORTS, PANTS AND JEANS; JACKETS AND VESTS MADE OF DENIM, LEATHER, CLOTH AND SUEDE; ATHLETIC CLOTHING, NAMELY, TRACK SUITS, SWEATSHIRTS, SWEATPANTS AND SWIMWEAR; FOOTWEAR CONSISTING OF ATHLETIC SHOES, DRESS SHOES AND SNEAKERS; AND HATS AND CAPS (U.S. CLS. 22 AND 39).

FIRST USE 12-20-2013; IN COMMERCE 12-20-2013.

4,593,484. GSI WORLD, GRAND PRAIRIE, TX. SN 85-752,093. PUB. 3-26-2013, FILED 10-11-2012.

## Run The Walk

THE MARK CONSISTS OF STANDARD CHARACTERS WITHOUT CLAIM TO ANY PARTICULAR FONT, STYLE, SIZE, OR COLOR.

FOR HATS; JACKETS; POLO SHIRTS; SHORTS; SOCKS; SWEATSHIRTS; T-SHIRTS (U.S. CLS. 22 AND 39).

FIRST USE 3-24-2012; IN COMMERCE 1-1-2014.

4,593,547. LOUIS M. ROBINSON, PORTAGE, MI. AND SUSAN GONZALES, LAWTON, MI. SN 85-779,881. PUB. 4-23-2013, FILED 11-15-2012.

## SPANISH QUEEN

THE MARK CONSISTS OF STANDARD CHARACTERS WITHOUT CLAIM TO ANY PARTICULAR FONT, STYLE, SIZE, OR COLOR.

FOR WOMEN'S CLOTHING, NAMELY, SHIRTS, T-SHIRTS, LONG-SLEEVED SHIRTS, SWEAT SHIRTS AND TANK-TOPS; HATS; SCARVES, BANDANAS; PANTS; JEANS; DRESSES (U.S. CLS. 22 AND 39).

FIRST USE 7-20-2013; IN COMMERCE 1-26-2014.



**CLASS 25—(Continued).**

4,593,552. VAVA SHOES, INC., DBA J. MICHAEL SHOES, SYRACUSE, NY. SN 85-782,179. PUB. 4-23-2013, FILED 11-18-2012.

IF IT'S HOT... IT'S HERE!

THE MARK CONSISTS OF STANDARD CHARACTERS WITHOUT CLAIM TO ANY PARTICULAR FONT, STYLE, SIZE, OR COLOR.

FOR COATS FOR MEN AND WOMEN; DENIMS; FOOTWEAR FOR MEN; HATS; JACKETS; JEANS; LEATHER SHOES; MEN'S AND WOMEN'S JACKETS, COATS, TROUSERS, VESTS; RUBBER SHOES; SANDALS AND BEACH SHOES; SCARVES; SHIRTS; SWEATERS; T-SHIRTS; TENNIS SHOES; WOMEN'S CLOTHING, NAMELY, SHIRTS, DRESSES, SKIRTS, BLOUSES; WOMEN'S SHOES (U.S. CLS. 22 AND 39).

FIRST USE 5-30-2014; IN COMMERCE 5-30-2014.

4,593,568. EISENHARDT, JODIE SUE, HOUSTON, TX. SN 85-789,245. PUB. 5-14-2013, FILED 11-28-2012.



NO CLAIM IS MADE TO THE EXCLUSIVE RIGHT TO USE "AUSTIN", APART FROM THE MARK AS SHOWN.

THE MARK CONSISTS OF A 5 PRONGED STAR SET IN FRONT OF A CIRCLE WITH MUSICAL NOTES ADJACENT BOTH SIDES OF THE STAR. THE STAR IS RECESSED INTO A SQUIGGLY SHAPED PATTERN ABOVE THE WORDS "AWESOME IN AUSTIN".

FOR CLOTHING, NAMELY, T-SHIRTS, HOODED SWEATSHIRTS, SWEAT SHIRTS, HATS, SANDALS, PANTS, AND SHORTS (U.S. CLS. 22 AND 39).

FIRST USE 8-11-2012; IN COMMERCE 4-0-2012.

**CLASS 25—(Continued).**

4,593,569. EISENHARDT, JODIE SUE, HOUSTON, TX. SN 85-789,249. PUB. 5-14-2013, FILED 11-28-2012.

AWESOME IN AUSTIN

THE MARK CONSISTS OF STANDARD CHARACTERS WITHOUT CLAIM TO ANY PARTICULAR FONT, STYLE, SIZE, OR COLOR.

NO CLAIM IS MADE TO THE EXCLUSIVE RIGHT TO USE "AUSTIN", APART FROM THE MARK AS SHOWN.

FOR CLOTHING, NAMELY, T-SHIRTS, HOODED SWEATSHIRTS, SWEAT SHIRTS, HATS, SANDALS, PANTS, AND SHORTS (U.S. CLS. 22 AND 39).

FIRST USE 6-23-2012; IN COMMERCE 4-0-2014.

4,593,593. ADAGBADA, MUHAMMED, BRONX, NY. AND BURWELL, TYRRELL, BRONX, NY. SN 85-796,805. PUB. 11-5-2013, FILED 12-6-2012.

marc lure verified

THE MARK CONSISTS OF STANDARD CHARACTERS WITHOUT CLAIM TO ANY PARTICULAR FONT, STYLE, SIZE, OR COLOR.

THE NAME "MARC LURE" IN THE MARK DOES NOT IDENTIFY A LIVING INDIVIDUAL.

FOR LONG UNDERWEAR; SOCKS; T-SHIRTS; TANK TOPS; UNDERWEAR (U.S. CLS. 22 AND 39).

FIRST USE 2-1-2014; IN COMMERCE 2-1-2014.

4,593,594. AUBURN UNIVERSITY, AUBURN, AL. SN 85-796,845. PUB. 6-4-2013, FILED 12-6-2012.

In Gus We Trust

THE MARK CONSISTS OF STANDARD CHARACTERS WITHOUT CLAIM TO ANY PARTICULAR FONT, STYLE, SIZE, OR COLOR.

FOR CLOTHING AND PERSONAL ITEMS, NAMELY, SHIRTS, PANTS, AND HATS (U.S. CLS. 22 AND 39).

FIRST USE 12-4-2012; IN COMMERCE 12-4-2012.

**CLASS 25—(Continued).**

4,593,599. ROGER GARMENTS, LLC, MONTEBELLO, CA. SN 85-799,228. PUB. 5-7-2013, FILED 12-10-2012.

**LBK**

THE MARK CONSISTS OF STANDARD CHARACTERS WITHOUT CLAIM TO ANY PARTICULAR FONT, STYLE, SIZE, OR COLOR.

FOR BOTTOMS; DRESSES; JACKETS; TOPS (U.S. CLS. 22 AND 39).

FIRST USE 1-0-2013; IN COMMERCE 4-30-2013.

4,593,600. IMUS MACABEE, LLC, MILPITAS, CA. SN 85-799,293. PUB. 4-30-2013, FILED 12-11-2012.

**FOLLE'**

THE MARK CONSISTS OF STANDARD CHARACTERS WITHOUT CLAIM TO ANY PARTICULAR FONT, STYLE, SIZE, OR COLOR.

THE WORDING "FOLLE'" HAS NO MEANING IN A FOREIGN LANGUAGE.

FOR WOMEN'S FOOTWEAR (U.S. CLS. 22 AND 39).

FIRST USE 3-1-2014; IN COMMERCE 3-1-2014.

4,593,622. HERIVAUX, FERGUSON, BOSTON, MA. SN 85-804,396. PUB. 10-1-2013, FILED 12-17-2012.

**OMG it's OG**

THE MARK CONSISTS OF STANDARD CHARACTERS WITHOUT CLAIM TO ANY PARTICULAR FONT, STYLE, SIZE, OR COLOR.

FOR APPAREL, NAMELY, SHIRTS, SKIRTS, PANTS, JACKETS, FOOTWEAR, HATS AND CAPS; SNEAKERS; HATS; CLOTHING ACCESSORIES, NAMELY, BELTS AND HEADBANDS (U.S. CLS. 22 AND 39).

FIRST USE 7-0-2012; IN COMMERCE 7-0-2012.

**CLASS 25—(Continued).**

4,593,653. PELES, JOSEPH, TEMPE, AZ. SN 85-814,470. PUB. 5-28-2013, FILED 1-3-2013.

**\$H&cKøFW°°D**

THE MARK CONSISTS OF A STYLIZED FORM OF THE WORD "SH&CKOFWOOD". THE LETTER "S" IS REPRESENTED BY A DOLLAR SIGN. THE LETTER "A" IS REPRESENTED BY AN AMPERSAND. THE FIRST LETTER "C" HAS A DIAGONAL LINE INTERSECTING THE LETTER. THE LETTER FIRST LETTER "O" HAS A DIAGONAL LINE INTERSECTING THROUGH IT. THE LETTER "W" HAS TWO HORIZONTAL LINES DISPLAYED ACROSS THE LETTER. THE SECOND AND THIRD LETTERS "O" ARE PRESENTED IN A SMALLER FONT AND ARE PRESENTED AT THE VERY TOP OF THE WORD.

FOR HATS; HOODED SWEATSHIRTS; SHIRTS; SWEAT SHIRTS; T-SHIRTS (U.S. CLS. 22 AND 39).

FIRST USE 10-0-2013; IN COMMERCE 10-0-2013.

4,593,657. HEFFLIN, TIMOTHY, GAITHERSBURG, MD. SN 85-815,413. PUB. 11-5-2013, FILED 1-4-2013.

**MARSHMELLOWS BABIES**

THE MARK CONSISTS OF STANDARD CHARACTERS WITHOUT CLAIM TO ANY PARTICULAR FONT, STYLE, SIZE, OR COLOR.

NO CLAIM IS MADE TO THE EXCLUSIVE RIGHT TO USE "BABIES", APART FROM THE MARK AS SHOWN.

FOR T-SHIRTS AND HATS (U.S. CLS. 22 AND 39).

FIRST USE 4-1-2014; IN COMMERCE 4-1-2014.

4,593,663. HBI BRANDED APPAREL ENTERPRISES, LLC, WINSTON-SALEM, NC. SN 85-818,988. PUB. 11-26-2013, FILED 1-9-2013.

**GEO MATRIX**

THE MARK CONSISTS OF STANDARD CHARACTERS WITHOUT CLAIM TO ANY PARTICULAR FONT, STYLE, SIZE, OR COLOR.

FOR FOOTWEAR (U.S. CLS. 22 AND 39).

FIRST USE 7-31-2013; IN COMMERCE 7-31-2013.

**CLASS 25—(Continued).**

4,593,747. MARINE SAFETY PRODUCTS, LLC, KISSIMMEE, FL. SN 85-866,467. PUB. 8-27-2013, FILED 3-4-2013.

# AEGIS

THE MARK CONSISTS OF STANDARD CHARACTERS WITHOUT CLAIM TO ANY PARTICULAR FONT, STYLE, SIZE, OR COLOR.

FOR WEARABLE GARMENTS AND CLOTHING, NAMELY, SURFING WEAR, BOARD SHORTS, DRESSES, JACKETS, JEANS, PANTS, RASH GUARDS, SHIRTS, VESTS, SHORTS, SKIRTS, SWEATERS, SWEAT-SHIRTS, SWIMWEAR, T-SHIRTS, TANK TOPS, WALKING SHORTS, AND WET SUITS; FOOTWEAR FOR MEN, WOMEN AND CHILDREN, NAMELY, BOOTIES, SANDALS, ATHLETIC SHOES, SLIPPERS, SPORTING FOOTWEAR, AND WATER SHOES; HEADGEAR FOR MEN, WOMEN AND CHILDREN, NAMELY, BEANIES, BANDANAS, HATS, HEADBANDS AND VISORS (U.S. CLS. 22 AND 39).

FIRST USE 2-14-2014; IN COMMERCE 2-14-2014.

4,593,749. LIQUIPEL IP, LLC., SANTA ANA, CA. SN 85-868,802. PUB. 8-27-2013, FILED 3-6-2013.

# LIQUIPEL

THE MARK CONSISTS OF STANDARD CHARACTERS WITHOUT CLAIM TO ANY PARTICULAR FONT, STYLE, SIZE, OR COLOR.

OWNER OF U.S. REG. NOS. 4,202,513, 4,332,663, AND OTHERS.

FOR FOOTWEAR; HATS; SHIRTS; SHORT-SLEEVED SHIRTS; SHORTS; SOCKS; SWEAT SHIRTS; SWEATERS; SWIMWEAR; TANK TOPS; TEE SHIRTS; WATERPROOF FOOTWEAR; WATERPROOF JACKETS AND PANTS (U.S. CLS. 22 AND 39).

FIRST USE 3-17-2011; IN COMMERCE 5-21-2012.

**CLASS 25—(Continued).**

4,593,750. BOINNARD, LUDOVIC, SAN DIEGO, CA. AND BLANCHARD, MARC, SAN DIEGO, CA. SN 85-869,829. PUB. 5-14-2013, FILED 3-7-2013.

# ITRACK

THE MARK CONSISTS OF STANDARD CHARACTERS WITHOUT CLAIM TO ANY PARTICULAR FONT, STYLE, SIZE, OR COLOR.

FOR GLOVES; MOTORCYCLE GLOVES (U.S. CLS. 22 AND 39).

FIRST USE 11-1-2013; IN COMMERCE 11-1-2013.

4,593,793. HAWABI, INC., SEMINOLE, FL. SN 85-896,151. PUB. 9-10-2013, FILED 4-5-2013.



THE COLOR(S) BLACK, ORANGE AND WHITE IS/ARE CLAIMED AS A FEATURE OF THE MARK.

THE MARK CONSISTS OF THE WORD "HAWABI" IN LOWER CASE BLACK LETTERING ON A WHITE BACKGROUND, THE LETTER "I" IS DOTTED WITH AN ORANGE DOT AND SURROUNDING THE WORDING IS AN IMAGE DEPICTING A STYLIZED ANGLED THREE PEAK MOUNTAIN IN BLACK THICK OUTLINING.

FOR COMBINATIONS; HEADBANDS FOR CLOTHING; HOODS; JACKETS; JERSEYS; SHORT SETS; TOPS; WEARABLE GARMENTS AND CLOTHING, NAMELY, SHIRTS; WOMEN'S CLOTHING, NAMELY, SHIRTS, DRESSES, SKIRTS, BLOUSES (U.S. CLS. 22 AND 39).

FIRST USE 6-13-2013; IN COMMERCE 6-13-2013.

4,593,801. LOVE GIVE LIVE, LITITZ, PA. SN 85-900,029. PUB. 3-4-2014, FILED 4-10-2013.

# Love.Give.Live.

THE MARK CONSISTS OF STANDARD CHARACTERS WITHOUT CLAIM TO ANY PARTICULAR FONT, STYLE, SIZE, OR COLOR.

FOR T-SHIRTS (U.S. CLS. 22 AND 39).

FIRST USE 4-1-2013; IN COMMERCE 5-8-2013.

**CLASS 25—(Continued).**

4,593,804. SUNDRY CLOTHING, INC, CULVER CITY, CA. SN 85-902,127. PUB. 9-3-2013, FILED 4-11-2013.

# SUNDRY

THE MARK CONSISTS OF STANDARD CHARACTERS WITHOUT CLAIM TO ANY PARTICULAR FONT, STYLE, SIZE, OR COLOR.

FOR CLOTHING, NAMELY, MEN'S, WOMEN'S, MIS-SY'S, JUNIORS', CHILDREN'S AND INFANTS' JEANS, PANTS, TROUSERS, CAPRIS, LEGGINGS, SHORTS, SKORTS, OVERALLS, SHORTALLS, SKIRTS, DRESSES, TOPS, T-SHIRTS, SWEATSHIRTS, BLOUSES, SHIRTS, JACKETS, COATS, SWEATERS, VESTS, CARDIGANS, SCARVES, SOCKS, BANDANAS, NECKTIES, BELTS, BOOTS, SANDALS, FOOTWEAR, HATS, CAPS, HEADWEAR, UNDERWEAR, SWIMWEAR, GLOVES AND TIES (U.S. CLS. 22 AND 39).

FIRST USE 4-1-2011; IN COMMERCE 5-1-2011.

4,593,884. ROAD PLAYER, RAMONA, CA. SN 85-927,519. PUB. 10-15-2013, FILED 5-9-2013.



THE MARK CONSISTS OF A DESIGN THAT DEPICTS A SIGN WITH A BORDER. WITHIN THE SIGN IS A DESIGN THAT DEPICTS A PERSON PLAYING POOL.

FOR HATS; HOODED SWEATSHIRTS; JACKETS; PANTS; SHOES; SHORT-SLEEVED OR LONG-SLEEVED T-SHIRTS; SHORTS; SKIRTS; SOCKS; SWEATERS; SWEATSHIRTS; T-SHIRTS; TANK TOPS (U.S. CLS. 22 AND 39).

FIRST USE 5-9-2013; IN COMMERCE 5-9-2013.

**CLASS 25—(Continued).**

4,593,899. MATHIS, TYRE, NEWPORT NEWS, VA. AND MATHIS, DARRILL, BROOKLYN, NY. SN 85-931,765. PUB. 10-15-2013, FILED 5-14-2013.



THE MARK CONSISTS OF THE STYLIZED LETTERS "BH." THE LETTERS ARE ON A STYLIZED DESIGN.

FOR BANDANAS; HATS; SHIRTS; SKULL CAPS; SWEAT PANTS; SWEAT SHIRTS; SWEAT SUITS; T-SHIRTS; WRISTBANDS (U.S. CLS. 22 AND 39).

FIRST USE 1-0-2014; IN COMMERCE 1-0-2014.

4,593,900. MATHIS, TYRE, NEWPORT NEWS, VA. AND MATHIS, DARRILL, BROOKLYN, NY. SN 85-931,901. PUB. 10-15-2013, FILED 5-14-2013.



NO CLAIM IS MADE TO THE EXCLUSIVE RIGHT TO USE "BKLYN", APART FROM THE MARK AS SHOWN.

THE MARK CONSISTS OF THE STYLIZED LETTERS "BH." THE LETTER "B" IS BACKWARDS. BELOW IS THE STYLIZED TERM "BKLYN." THE LETTER "B" IS BACKWARDS. AT THE BOTTOM IS THE TERM "HOUSE" IN STYLIZED FONT.

FOR BANDANAS; SHIRTS; SKULL CAPS; SWEAT PANTS; SWEAT SHIRTS; SWEAT SUITS; T-SHIRTS; WRISTBANDS (U.S. CLS. 22 AND 39).

FIRST USE 1-0-2014; IN COMMERCE 1-0-2014.

**CLASS 25—(Continued).**

4,593,923. SNRWORX.COM LLC, OVERLAND PARK, KS. SN 85-936,761. PUB. 10-15-2013, FILED 5-20-2013.

CAESAR SETTLED FOR A SALAD

THE MARK CONSISTS OF STANDARD CHARACTERS WITHOUT CLAIM TO ANY PARTICULAR FONT, STYLE, SIZE, OR COLOR.

FOR A-SHIRTS; APRONS; ATHLETIC APPAREL, NAMELY, SHIRTS, HATS AND CAPS; ATHLETIC SHIRTS; BANDANAS; BASEBALL CAPS; BOXER BRIEFS; BOXER SHORTS; GOLF PANTS, SHIRTS AND SKIRTS; HATS; HOODED PULLOVERS; HOODED SWEAT SHIRTS; HOODED SWEATSHIRTS; LINGERIE; PANTIES; PANTIES, SHORTS AND BRIEFS; SPORTS BRAS; SWEATSHIRTS; T-SHIRTS; TANK TOPS; TOPS; TUBE TOPS; WOMEN'S CLOTHING, NAMELY, SHIRTS (U.S. CLS. 22 AND 39).

FIRST USE 4-1-2005; IN COMMERCE 1-1-2013.

4,593,958. REPUBLIK OF KALIFORNIA, INC., HERMOSA, CA. SN 85-940,823. PUB. 10-22-2013, FILED 5-23-2013.

BRAVE WEST

THE MARK CONSISTS OF STANDARD CHARACTERS WITHOUT CLAIM TO ANY PARTICULAR FONT, STYLE, SIZE, OR COLOR.

FOR FLEECE TOPS; HEADWEAR; SHIRTS; SWEATSHIRTS; T-SHIRTS (U.S. CLS. 22 AND 39).

FIRST USE 2-20-2014; IN COMMERCE 2-20-2014.

4,593,974. KYLE G. MUIR, SALT LAKE CITY, UT. SN 85-942,812. PUB. 11-5-2013, FILED 5-25-2013.

SWOOBFIT

THE MARK CONSISTS OF STANDARD CHARACTERS WITHOUT CLAIM TO ANY PARTICULAR FONT, STYLE, SIZE, OR COLOR.

FOR APPAREL FOR DANCERS, NAMELY, TEE SHIRTS, SWEATSHIRTS, PANTS, LEGGINGS, SHORTS AND JACKETS; ATHLETIC APPAREL, NAMELY, SHIRTS, PANTS, JACKETS, FOOTWEAR, HATS AND CAPS, ATHLETIC UNIFORMS; BATHING COSTUMES FOR WOMEN; SWEATSHIRTS FOR WOMEN; T-SHIRTS FOR WOMEN; WOMEN'S ATHLETIC TOPS WITH BUILT-IN BRAS; WOMEN'S CLOTHING, NAMELY, SHIRTS, DRESSES, SKIRTS, BLOUSES; WOMEN'S TOPS, NAMELY, CAMIS; WOMEN'S UNDERWEAR (U.S. CLS. 22 AND 39).

FIRST USE 9-30-2012; IN COMMERCE 7-8-2013.

**CLASS 25—(Continued).**

4,593,983. MUNIZ, RICARDO, NEW YORK, NY. SN 85-944,075. PUB. 10-22-2013, FILED 5-28-2013.

CHULO 

THE MARK CONSISTS OF THE STYLIZED TEXT "CHULO" WITH A GRAPHIC DRAWING CONTAINED IN THE LETTER "O" IN THE WORD "CHULO" REPRESENTING THE "COQUI," AN INDIGENOUS SPECIES OF FROG NATIVE TO PUERTO RICO.

THE ENGLISH TRANSLATION OF THE PUERTO RICAN SPANISH WORD CHULO IN THE MARK IS "PRETTY BOY OR "HUNK" OR "CUTIE".

FOR CLOTHING, NAMELY, UNDERWEAR, T-SHIRTS, TANKS, SWIMWEAR, HOODIES, SHIRTS, SWEATS, PANTS, SHORTS, SOCKS, BELTS, CAPS, TIES, JACKETS, SUITS, DRESSES, SKIRTS, BLAZERS, SWEATERS, VESTS, SHAWLS, ROBES, SUSPENDERS, COATS AND BANDANAS (U.S. CLS. 22 AND 39).

FIRST USE 1-1-2004; IN COMMERCE 1-1-2006.

4,593,989. ALL ACCESS APPAREL, INC., MONTEBELLO, CA. SN 85-945,647. PUB. 10-22-2013, FILED 5-29-2013.

NEON SOUL

THE MARK CONSISTS OF STANDARD CHARACTERS WITHOUT CLAIM TO ANY PARTICULAR FONT, STYLE, SIZE, OR COLOR.

FOR BOTTOMS; DRESSES; JACKETS; TOPS (U.S. CLS. 22 AND 39).

FIRST USE 1-0-2014; IN COMMERCE 1-0-2014.

4,594,002. NUÑO, JORGE, DBA ROSARIO, LOS ANGELES, CA. SN 85-947,955. PUB. 11-5-2013, FILED 5-31-2013.

ROSARIO

THE MARK CONSISTS OF STANDARD CHARACTERS WITHOUT CLAIM TO ANY PARTICULAR FONT, STYLE, SIZE, OR COLOR.

**CLASS 25—(Continued).**

THE ENGLISH TRANSLATION OF "ROSARIO" IN THE MARK IS "ROSARY".

FOR CLOTHING FOR USE BY MEN AND WOMEN, NAMELY, DRESSES, SKIRTS, BLOUSES, PANTS, JACKETS, COATS, BATHING SUITS, HOSIERY, BATHROBES, BELTS, BLAZERS, BLOUSONS, BODY SUITS, BOLEROS, CAPES, CARDIGANS, CHEMISES, FUR COATS, SUIT COATS, CORSELETS, CULOTTES, HALTER TOPS, HEADBANDS, JEANS, JOGGING SUITS, JUMPERS, JUMPSUITS, KIMONOS, LEGGINGS, LEOTARDS, LOUNGEWEAR, NECKTIES, NECKWEAR, PANTSUITS, POCKET SQUARES, PONCHOS, PULLOVERS, RAINCOATS, SCARVES, SHAWLS, SHORTS, SLACKS, SPORT COATS, SPORT SHIRTS, SUITS, SUSPENDERS, SWEAT PANTS, SWEAT SHIRTS, T-SHIRTS, TROUSERS, VESTS, TUXEDOS, VESTED SUITS, WARM-UP BLAZERS, BOXER SHORTS, BRIEFS, OVERALLS, PAJAMAS; PLAY-SUITS, PULLOVERS; UNDERGARMENTS FOR MEN AND WOMEN, NAMELY, BOXER SHORTS, CAMISOLES, SOCKS, NIGHTGOWNS, UNDERSHIRTS, UNDERWEAR; GLOVES, HEADWEAR, AND HATS (U.S. CLS. 22 AND 39).

FIRST USE 10-1-2013; IN COMMERCE 10-1-2013.

**CLASS 25—(Continued).**

4,594,066. COLUCCI, KATHRYN, MADISON, WI. AND COLUCCI, LAMONT, MADISON, WI. SN 85-957,522. PUB. 11-12-2013, FILED 6-12-2013.



THE MARK CONSISTS OF THE STYLIZED TERMS "NOT A HUGGER." BELOW IS A STYLIZED DESIGN OF A CIRCLE WITH A BAR THROUGH IT. THERE IS AN ABSTRACT CHARACTER IN THE CENTER.

FOR HATS; HOODED SWEAT SHIRTS; LONG-SLEEVED SHIRTS; MATERNITY CLOTHING, NAMELY, SHIRTS, SWEATSHIRTS, LONG SLEEVED SHIRTS AND SWIMWEAR; POLO SHIRTS; SHIRTS; SWEAT SHIRTS; SWIMWEAR; T-SHIRTS (U.S. CLS. 22 AND 39).

FIRST USE 6-1-2014; IN COMMERCE 6-1-2014.

4,594,047. GULICK, DAVID R., BROOKLYN, NY. SN 85-955,147. PUB. 10-29-2013, FILED 6-10-2013.

## SUMMER RENTAL

THE MARK CONSISTS OF STANDARD CHARACTERS WITHOUT CLAIM TO ANY PARTICULAR FONT, STYLE, SIZE, OR COLOR.

FOR BASEBALL CAPS AND HATS; CAPS; HATS; HOODED PULLOVERS; HOODED SWEAT SHIRTS; HOODS; SHIRTS AND SHORT-SLEEVED SHIRTS; SHORT-SLEEVED OR LONG-SLEEVED T-SHIRTS; SURF WEAR; SWEATSHIRTS; T-SHIRTS; TEE SHIRTS (U.S. CLS. 22 AND 39).

FIRST USE 8-0-2012; IN COMMERCE 8-0-2012.

4,594,085. FIT AND TUFF LLC, AKA F.A.T, CORONA, NY. SN 85-960,521. PUB. 11-5-2013, FILED 6-14-2013.

## Fit And Tuff

THE MARK CONSISTS OF STANDARD CHARACTERS WITHOUT CLAIM TO ANY PARTICULAR FONT, STYLE, SIZE, OR COLOR.

FOR A-SHIRTS; ANTI-SWEAT UNDERWEAR; ATHLETIC APPAREL, NAMELY, SHIRTS, PANTS, JACKETS, FOOTWEAR, HATS AND CAPS, ATHLETIC UNIFORMS; ATHLETIC PANTS; ATHLETIC SHIRTS; ATHLETIC SHORTS; BASEBALL CAPS AND HATS; CAPS; CAPS WITH VISORS; COMPRESSION GARMENTS FOR ATHLETIC OR OTHER NON-MEDICAL USE, NAMELY, COMPRESSION SHORTS, SOCKS, TIGHTS, LEGGINGS, SHIRTS, TANKS, SLEEVES; CYCLING SHORTS; GYM SHORTS; HEADGEAR, NAMELY, HATS, CAPS, BANDANAS, SWEATBANDS, HEADBANDS; HOODED SWEAT SHIRTS; JOGGING PANTS; KNITTED CAPS; LONG-SLEEVED SHIRTS; MOISTURE-WICKING SPORTS SHIRTS; RUNNING SHOES; SHORT-SLEEVED OR LONG-SLEEVED T-SHIRTS; SHORTS; SKULL CAPS; SNEAKERS; SOCKS; SPORT SHIRTS; SPORTS CAPS AND HATS; SPORTS PANTS; SUN PROTECTIVE CLOTHING, NAMELY, T-SHIRTS, TANK TOPS, SHORTS, PANTS; SWEAT PANTS; SWEAT SHIRTS; SWIM CAPS; SWIMMING CAPS; T-SHIRTS; T-SHIRTS FOR BABIES, TODDLERS, CHILDREN, ADULTS, MEN, WOMEN; TANK TOPS; TANK-TOPS; TRIATHLON CLOTHING, NAMELY, TRIATHLON TIGHTS, TRIATHLON SHORTS, TRIATHLON SINGLET, TRIATHLON SHIRTS, TRIATHLON SUITS; UNDERWEAR; YOGA PANTS; YOGA SHIRTS (U.S. CLS. 22 AND 39).

FIRST USE 6-1-2013; IN COMMERCE 6-1-2013.

**CLASS 25—(Continued).**

4,594,097. TEXTILE WORLD1, DBA UP2DATE FASHION, MONMOUTH JUNCTION, NJ. SN 85-962,971. PUB. 11-12-2013, FILED 6-18-2013.

## Tabszy Sleepwear

THE MARK CONSISTS OF STANDARD CHARACTERS WITHOUT CLAIM TO ANY PARTICULAR FONT, STYLE, SIZE, OR COLOR.

NO CLAIM IS MADE TO THE EXCLUSIVE RIGHT TO USE "SLEEPWEAR", APART FROM THE MARK AS SHOWN.

THE WORDING "TABSZY" HAS NO MEANING IN A FOREIGN LANGUAGE.

FOR WEARABLE GARMENTS AND CLOTHING, NAMELY, SHIRTS (U.S. CLS. 22 AND 39).

FIRST USE 6-18-2014; IN COMMERCE 6-18-2014.

---

4,594,104. SOLOSOL MOVEMENT, LLC, MANHATTAN BEACH, CA. SN 85-963,707. PUB. 11-19-2013, FILED 6-19-2013.

## SOLOSOL MOVEMENT

THE MARK CONSISTS OF STANDARD CHARACTERS WITHOUT CLAIM TO ANY PARTICULAR FONT, STYLE, SIZE, OR COLOR.

THE ENGLISH TRANSLATION OF THE WORD "SOLOSOL" IN THE MARK IS "ONLY SUN".

FOR ATHLETIC APPAREL, NAMELY, PANTS, LEGGINGS, TIGHTS, SHIRTS, T-SHIRTS, TANK TOPS, SPORTS BRAS, SHORTS, SWEATSHIRTS, SWEATPANTS, SOCKS, JACKETS, HOODED SWEATSHIRTS, COATS, HEADBANDS, AND HATS (U.S. CLS. 22 AND 39).

FIRST USE 5-0-2014; IN COMMERCE 5-0-2014.

---

4,594,106. KLOUD 9 KIX, HOUSTON, TX. SN 85-964,038. PUB. 11-12-2013, FILED 6-19-2013.

## Kloud 9 Kix

THE MARK CONSISTS OF STANDARD CHARACTERS WITHOUT CLAIM TO ANY PARTICULAR FONT, STYLE, SIZE, OR COLOR.

FOR HATS; JEANS; SHIRTS; SHOES; SOCKS; SWEATPANTS (U.S. CLS. 22 AND 39).

FIRST USE 11-1-2013; IN COMMERCE 11-1-2013.

**CLASS 25—(Continued).**

4,594,110. SAFFORD, WILLIAM, SAN DIEGO, CA. SN 85-965,256. PUB. 11-5-2013, FILED 6-20-2013.

## ORDER & PROGRESS

THE MARK CONSISTS OF STANDARD CHARACTERS WITHOUT CLAIM TO ANY PARTICULAR FONT, STYLE, SIZE, OR COLOR.

FOR ATHLETIC APPAREL, NAMELY, SHIRTS, PANTS, JACKETS, FOOTWEAR, HATS AND CAPS, ATHLETIC UNIFORMS (U.S. CLS. 22 AND 39).

FIRST USE 6-20-2013; IN COMMERCE 2-1-2014.

---

4,594,130. ZHEJIANG XINAO TEXTILES INC., ZHEJIANG PROVINCE, CHINA. SN 85-970,054. PUB. 11-19-2013, FILED 6-26-2013.

## LANABLEND

THE MARK CONSISTS OF STANDARD CHARACTERS WITHOUT CLAIM TO ANY PARTICULAR FONT, STYLE, SIZE, OR COLOR.

THE ENGLISH TRANSLATION OF "LANA" IN THE MARK IS "WOOL".

FOR BABY LAYETTES FOR CLOTHING; CHILDREN'S AND INFANT'S APPAREL, NAMELY, JUMPERS, OVERALL SLEEPWEAR, PAJAMAS, ROMPERS AND ONE-PIECE GARMENTS; FUR JACKETS; GLOVES AS CLOTHING; HATS; HOSIERY; JACKETS; KNIT JACKETS; SCARFS; SHOES; UNDERWEAR (U.S. CLS. 22 AND 39).

FIRST USE 2-27-2008; IN COMMERCE 7-20-2009.

---

4,594,132. ZHEJIANG XINAO TEXTILES INC., ZHEJIANG PROVINCE, CHINA. SN 85-970,064. PUB. 3-4-2014, FILED 6-26-2013.



NO CLAIM IS MADE TO THE EXCLUSIVE RIGHT TO USE "BLEND", APART FROM THE MARK AS SHOWN.

THE MARK CONSISTS OF TWO INTERSECTING POLYGONS WITH THE WORDS "LANA" AND "BLEND" INSIDE.

**CLASS 25—(Continued).**

THE ENGLISH TRANSLATION OF "LANA" IN THE MARK IS "WOOL".

FOR BABY LAYETTES FOR CLOTHING; CHILDREN'S AND INFANT'S APPAREL, NAMELY, JUMPERS, OVERALL SLEEPWEAR, PAJAMAS, ROMPERS AND ONE-PIECE GARMENTS; FUR JACKETS; GLOVES AS CLOTHING; HATS; HOSIERY; JACKETS; KNIT JACKETS; SCARFS; SHOES; UNDERWEAR (U.S. CLS. 22 AND 39).

FIRST USE 2-27-2008; IN COMMERCE 7-20-2009.

---

4,594,151. SMALL, PEGGY, KALISPELL, MT. AND SMALL, LARRY, KALISPELL, MT. SN 85-974,232. PUB. 12-10-2013, FILED 7-1-2013.

### OFFICIAL MAN'S "eating shirt"

THE MARK CONSISTS OF STANDARD CHARACTERS WITHOUT CLAIM TO ANY PARTICULAR FONT, STYLE, SIZE, OR COLOR.

NO CLAIM IS MADE TO THE EXCLUSIVE RIGHT TO USE "MAN'S EATING SHIRT", APART FROM THE MARK AS SHOWN.

FOR CLOTH BIBS; T-SHIRTS (U.S. CLS. 22 AND 39).  
FIRST USE 1-31-2014; IN COMMERCE 3-31-2014.

---

4,594,172. NATIONAL HOT ROD ASSOCIATION, GLEN-DORA, CA. SN 85-982,162. PUB. 10-30-2012, FILED 6-6-2012.



OWNER OF U.S. REG. NOS. 3,072,072, 3,300,206, AND 3,300,207.

THE MARK CONSISTS OF A STYLIZED REPRESENTATION OF TWO AUTOMOBILES AND THE WORDS "NATIONAL HOT ROD ASSOCIATION DEDICATED TO SAFETY".

FOR JACKETS; SHIRTS (U.S. CLS. 22 AND 39).  
FIRST USE 2-8-2007; IN COMMERCE 2-8-2007.

**CLASS 25—(Continued).**

4,594,187. NO FEAR USA LIMITED, SHIREBROOK, UNITED KINGDOM. SN 85-982,387. PUB. 4-10-2012, FILED 1-13-2012.



THE MARK CONSISTS OF A STYLIZED IMAGE OF A SET OF EYES.

FOR GLOVES; HEADWEAR; HATS AND CAPS; SURF WEAR (U.S. CLS. 22 AND 39).

FIRST USE 10-31-2013; IN COMMERCE 10-31-2013.

---

4,594,207. STEPHANIE RODNEZ, PLANTATION, FL. SN 86-004,371. PUB. 1-7-2014, FILED 7-8-2013.

### Godlywood Girl

THE MARK CONSISTS OF STANDARD CHARACTERS WITHOUT CLAIM TO ANY PARTICULAR FONT, STYLE, SIZE, OR COLOR.

NO CLAIM IS MADE TO THE EXCLUSIVE RIGHT TO USE GIRL, APART FROM THE MARK AS SHOWN.

FOR WOMEN'S CLOTHING, NAMELY, SHIRTS, DRESSES, SKIRTS, BLOUSES (U.S. CLS. 22 AND 39).

FIRST USE 7-1-2013; IN COMMERCE 1-1-2014.

---

4,594,210. LEVI STRAUSS & CO., SAN FRANCISCO, CA. SN 86-005,940. PUB. 10-8-2013, FILED 7-9-2013.

### WELLTHREAD

THE MARK CONSISTS OF STANDARD CHARACTERS WITHOUT CLAIM TO ANY PARTICULAR FONT, STYLE, SIZE, OR COLOR.

FOR OUTER JACKETS; PANTS; SHIRTS; SPORT COATS; T-SHIRTS (U.S. CLS. 22 AND 39).

FIRST USE 2-17-2014; IN COMMERCE 2-17-2014.



**CLASS 25—(Continued).**

4,594,213. NEW & LINGWOOD LIMITED, ETON, WINDSOR, BERKSHIRE, UNITED KINGDOM. SN 86-006,481. PUB. 12-3-2013, FILED 7-10-2013.



THE MARK CONSISTS OF THE LETTER "N" WITH AN OVERLAPPING STYLIZED "L".

FOR ARTICLES OF CLOTHING FOR MEN, NAMELY, SHIRTS, SHOES, BOOTS, TIES, UNDERWEAR, SOCKS, KNITWEAR, NAMELY, WOOL AND CASHMERE SWEATERS, CARDIGANS AND PULLOVERS (U.S. CLS. 22 AND 39).

FIRST USE 12-31-1991; IN COMMERCE 12-31-1991.

4,594,246. MUDDY COUTURE, JACKSONVILLE, TX. SN 86-015,320. PUB. 1-7-2014, FILED 7-19-2013.

## Muddy Couture

THE MARK CONSISTS OF STANDARD CHARACTERS WITHOUT CLAIM TO ANY PARTICULAR FONT, STYLE, SIZE, OR COLOR.

NO CLAIM IS MADE TO THE EXCLUSIVE RIGHT TO USE "COUTURE", APART FROM THE MARK AS SHOWN.

FOR MEN'S, WOMEN'S, AND CHILDREN'S T-SHIRTS, TANK TOPS, SWEATSHIRTS, HOODED SWEATSHIRTS, WOVEN SHIRTS, LONG SLEEVE SHIRTS, POLO STYLE SHIRTS, VESTS, PANTS, WADERS, SHORTS, HATS, HEADBANDS, BANDANAS, CAPS, RAIN WEAR, SHOES, SOCKS, UNDERWEAR, KOOZIES, WRISTBANDS, DECALS, AND LANYARDS (U.S. CLS. 22 AND 39).

FIRST USE 6-1-2013; IN COMMERCE 7-1-2013.

**CLASS 25—(Continued).**

4,594,256. DELLA ROSA, ALESSANDRO, NEW YORK, NY. SN 86-024,008. PUB. 10-29-2013, FILED 7-30-2013.

## Just Say No

THE MARK CONSISTS OF STANDARD CHARACTERS WITHOUT CLAIM TO ANY PARTICULAR FONT, STYLE, SIZE, OR COLOR.

FOR CAPS; HATS; JACKETS; SHIRTS; SWEAT SHIRTS; T-SHIRTS (U.S. CLS. 22 AND 39).

FIRST USE 7-30-2013; IN COMMERCE 6-20-2014.

4,594,257. DELLA ROSA, ALESSANDRO, NEW YORK, NY. SN 86-024,022. PUB. 10-29-2013, FILED 7-30-2013.

## Just Say Whatever

THE MARK CONSISTS OF STANDARD CHARACTERS WITHOUT CLAIM TO ANY PARTICULAR FONT, STYLE, SIZE, OR COLOR.

FOR CAPS; HATS; JACKETS; SHIRTS; SWEAT SHIRTS; T-SHIRTS (U.S. CLS. 22 AND 39).

FIRST USE 7-30-2013; IN COMMERCE 6-20-2014.

4,594,323. MRGRAPH LLC, PARKER, CO. SN 86-052,401. PUB. 4-1-2014, FILED 8-30-2013.

## Smile Each Mile

THE MARK CONSISTS OF STANDARD CHARACTERS WITHOUT CLAIM TO ANY PARTICULAR FONT, STYLE, SIZE, OR COLOR.

FOR APPAREL AND CLOTHING, NAMELY, T-SHIRTS, RUNNING SHIRTS AND HATS (U.S. CLS. 22 AND 39).

FIRST USE 9-25-2013; IN COMMERCE 9-25-2013.

**CLASS 25—(Continued).**

4,594,367. SIUFFE, RYAN, SANTA BARBARA, CA. SN 86-072,265. PUB. 2-18-2014, FILED 9-23-2013.

# ± SUMMER

THE MARK CONSISTS OF THE LITERAL ELEMENTS FOR THE PLUS-MINUS SIGN "±" AND THE WORD "SUMMER".

FOR BASEBALL CAPS AND HATS; BELTS; BOOTS; BOTTOMS; CAPS; COATS; DRESS SHIRTS; DRESSES; FLEECE BOTTOMS; FOOTWEAR; GLOVES; HATS; HOODED SWEATSHIRTS; JACKETS; JEANS; NECKTIES; NECKWEAR; PANTS; SHIRTS; SHOES; SHORTS; SOCKS; SUITS; SWEATERS; SWEATSHIRTS; T-SHIRTS; TANK TOPS (U.S. CLS. 22 AND 39).

FIRST USE 2-21-2014; IN COMMERCE 4-4-2014.

---

4,594,371. MATTHEW KEENE, DOVER, NH. SN 86-074,070. PUB. 3-18-2014, FILED 9-25-2013.

## SWAG SOLD SEPARATELY

THE MARK CONSISTS OF STANDARD CHARACTERS WITHOUT CLAIM TO ANY PARTICULAR FONT, STYLE, SIZE, OR COLOR.

FOR CLOTHING, NAMELY, T-SHIRTS, TANK TOPS, SWEATSHIRTS, HOODED SWEAT SHIRTS, HATS, CAPS (U.S. CLS. 22 AND 39).

FIRST USE 8-2-2012; IN COMMERCE 5-2-2014.

---

4,594,440. SECHREST, TODD, PEORIA, AZ. AND BRYAN, DYLAN, PEORIA, AZ. SN 86-097,637. PUB. 3-18-2014, FILED 10-22-2013.

## Do You Stay True Lifestyles

THE MARK CONSISTS OF STANDARD CHARACTERS WITHOUT CLAIM TO ANY PARTICULAR FONT, STYLE, SIZE, OR COLOR.

FOR COLLARED SHIRTS; HATS; SWEATERS; T-SHIRTS; WRISTBANDS (U.S. CLS. 22 AND 39).

FIRST USE 1-0-2014; IN COMMERCE 1-0-2014.

**CLASS 25—(Continued).**

4,594,459. LIAO, XINHUI, SHEN ZHEN, CANADA. SN 86-102,432. PUB. 3-18-2014, FILED 10-26-2013.

# ANSELF

THE MARK CONSISTS OF STANDARD CHARACTERS WITHOUT CLAIM TO ANY PARTICULAR FONT, STYLE, SIZE, OR COLOR.

FOR CLOTHING; NAMELY, ANORAKS, APRONS, ATHLETIC TIGHTS, BABIES' PANTS, BABY BODY-SUITS, BABY BOTTOMS, BABY TOPS, BALACLAVAS, BALL GOWNS, BALLOON PANTS, BANDEAU TOPS, BASELAYER BOTTOMS, BASELAYER TOPS, BATHING SUITS, BATHING TRUNKS, BATHROBES, BEACHWEAR, BELTS, BIKINIS, BLAZERS, BLOUSONS, BODY LINEN, BODY SHIRTS, BODY STOCKINGS, BODY SUITS, BOTTOMS, BOW TIES, BOXER SHORTS, BRAS, BRIEFS, CAPES, COATS, COLLARED SHIRTS, CREW NECK SWEATERS, DOWN JACKETS, DOWN SUITS, DRESS PANTS, DRESS SHIRTS, DRESS SUITS, DRESSES, DRESSING GOWNS, FLEECE BOTTOMS, FLEECE PULLOVERS, FLEECE TOPS, FLEECE VESTS, GLOVES, HALTER TOPS, HOODED SWEAT SHIRTS, INFANT WEAR, JACKETS, JEANS, KNEE HIGHS, LADIES' UNDERWEAR, LEISURE SUITS, LINGERIE, LONG JOHNS, MATERNITY BRAS, MEN'S SOCKS, MEN'S SUITS, MEN'S UNDERWEAR, NECKTIES, NEGLIGENCES, NIGHT GOWNS, NON-SLIP SOCKS, ONE PIECE GARMENT FOR INFANTS AND TODDLERS, OVER COATS, OVERALLS, PAJAMAS, PANTYHOSE, PARKAS, PIQUE SHIRTS, PLAY SUITS, POLO SHIRTS, PONCHOS, PULLOVERS, RAINWEAR, ROBES, RUGBY SHIRTS, SARONGS, SCARVES, SHIRTS, SHORTS, SKIRTS, SKIWEAR, SLEEPWEAR, SOCKS, SPORT SHIRTS, SPORTS BRAS, SPORTS PANTS, SPORT SHIRTS, STOCKINGS, SUNDRESSES, SUSPENDERS, SWEATERS, SWIM WEAR, TANK TOPS, TEE SHIRTS, TIGHTS, TROUSERS, TURTLE NECK SHIRTS, UNDERWEAR, VESTS, AND WOMEN'S UNDERWEAR; FOOTWEAR; HEADGEAR, NAMELY, HATS AND CAPS (U.S. CLS. 22 AND 39).

FIRST USE 9-1-2013; IN COMMERCE 9-1-2013.

---

4,594,461. M.EURYSTTHEE CLOTHING LLC, HOUSTON, TX. SN 86-103,976. PUB. 2-11-2014, FILED 10-29-2013.

## It's A Conceited Feel

THE MARK CONSISTS OF STANDARD CHARACTERS WITHOUT CLAIM TO ANY PARTICULAR FONT, STYLE, SIZE, OR COLOR.

FOR HATS; JEANS; SHIRTS (U.S. CLS. 22 AND 39).

FIRST USE 4-1-2014; IN COMMERCE 4-1-2014.

**CLASS 25—(Continued).**

4,594,468. CENETRA LATOYA HUGHES, DBA O'SWAN, CHESTER, SC. SN 86-106,191. PUB. 3-25-2014, FILED 10-30-2013.



THE MARK CONSISTS OF LARGE SCRIPT "O" WITH A SWAN INSIDE, AND "SWAN" IN LOWERCASE SCRIPT LETTERS.

FOR ADULT NOVELTY GAG CLOTHING ITEM, NAMELY, SOCKS; BABIES' PANTS; BABY LAYETTES FOR CLOTHING; BELTS; BELTS FOR CLOTHING; BELTS MADE OUT OF CLOTH; BIBS NOT OF CLOTH OR PAPER; BOTTOMS; CHILDREN'S AND INFANTS' CLOTH BIBS; CHILDREN'S CLOTH EATING BIBS; CLOTH BIBS; CLOTH BIBS FOR ADULT DINERS; CLOTH BIBS FOR USE BY SENIOR CITIZENS OR PHYSICALLY- OR MENTALLY-CHALLENGED PERSONS; CLOTHING EXTENSION USED TO EXTEND THE NORMAL SIZE RANGE OF CLOTHING ITEMS TO ACCOMMODATE PREGNANCY SIZE CHANGES; CLOTHING FOR ATHLETIC USE, NAMELY, PADDED ELBOW COMPRESSION SLEEVES BEING PART OF AN ATHLETIC GARMENT; CLOTHING FOR ATHLETIC USE, NAMELY, PADDED PANTS; CLOTHING FOR ATHLETIC USE, NAMELY, PADDED SHIRTS; CLOTHING FOR ATHLETIC USE, NAMELY, PADDED SHORTS; CLOTHING FOR BABIES, TODDLERS AND CHILDREN, TREATED WITH FIRE AND HEAT RETARDANTS, NAMELY, PAJAMAS, JACKETS, SHIRTS, PANTS, JUMPERS; CLOTHING FOR WEAR IN JUDO PRACTICES; CLOTHING FOR WEAR IN WRESTLING GAMES; CLOTHING ITEMS, NAMELY, ADHESIVE POCKETS THAT MAY BE AFFIXED DIRECTLY TO THE BODY AS A DECORATIVE PIECE OF CLOTHING WITH UTILITY; CLOTHING ITEMS, NAMELY, ADHESIVE POCKETS THAT MAY BE AFFIXED DIRECTLY TO THE INSIDE OF CLOTHING FOR STORAGE AND SAFEKEEPING OF PERSONAL ITEMS; CLOTHING ITEMS, NAMELY, BLINDFOLDS WORN OVER THE EYES; CLOTHING ITEMS, NAMELY, GAGS WORN OVER THE MOUTH; CLOTHING SHIELDS, NAMELY, PADS APPLIED TO THE UNDERARMS OF SHIRTS, BLOUSES AND SWEATERS; CLOTHING, NAMELY, ARM WARMERS; CLOTHING, NAMELY, ATHLETIC SLEEVES; CLOTHING, NAMELY, BASE LAYERS; CLOTHING, NAMELY, COWLS AND SMOKE RING SCARVES; CLOTHING, NAMELY, CROPS; CLOTHING, NAMELY, FOLK COSTUMES; CLOTHING, NAMELY, HAND-WARMERS; CLOTHING, NAMELY, KHAKIS; CLOTHING, NAMELY, KNEE WARMERS; CLOTHING, NAMELY, MATERNITY BANDS; CLOTHING, NAMELY, NECK TUBES; CLOTHING, NAMELY, THOBES; CLOTHING, NAMELY, WRAP-AROUNDS; COMBINATIONS; CORSETS; DRAWERS; DUSTERS; EYESHADES; FOU-LARDS; GLOVES AS CLOTHING; HEAD WRAPS; HEADBANDS FOR CLOTHING; HOODS; INFANT AND TODDLER ONE PIECE CLOTHING; JACKETS; JERSEYS; LEATHER BELTS; MANTLES; MUFFLERS; NON-DIS-

**CLASS 25—(Continued).**

POSABLE CLOTH TRAINING PANTS; PAPER HATS FOR USE AS CLOTHING ITEMS; PARTS OF CLOTHING, NAMELY, GUSSETS FOR TIGHTS, GUSSETS FOR STOCKINGS, GUSSETS FOR BATHING SUITS, GUSSETS FOR UNDERWEAR, GUSSETS FOR LEOTARDS AND GUSSETS FOR FOOTLETS; PARTS OF CLOTHING, NAMELY, UNDERARM GUSSETS; PERSPIRATION ABSORBENT UNDERWEAR CLOTHING; POCKET SQUARES; POCKETS FOR CLOTHING; SHIRTS; SHORT SETS; SHOULDER WRAPS; SHOULDER WRAPS FOR CLOTHING; SWADDLING CLOTHES; TIES; TOPS; TRAVEL CLOTHING CONTAINED IN A PACKAGE COMPRISING REVERSIBLE JACKETS, PANTS, SKIRTS, TOPS AND A BELT OR SCARF; TRIATHLON CLOTHING, NAMELY, TRIATHLON TIGHTS, TRIATHLON SHORTS, TRIATHLON SINGLET, TRIATHLON SHIRTS, TRIATHLON SUITS; UNDERARM CLOTHING SHIELDS; WEARABLE GARMENTS AND CLOTHING, NAMELY, SHIRTS; WOMEN'S CLOTHING, NAMELY, SHIRTS, DRESSES, SKIRTS, BLOUSES; WRAPS; WRIST BANDS; WRISTBANDS (U.S. CLS. 22 AND 39).  
FIRST USE 12-20-2013; IN COMMERCE 2-12-2014.

4,594,471. 13 & B TRADING, DBA TRICHOTOMY CLOTHING, LEVITTOWN, NY. SN 86-107,730. PUB. 4-22-2014, FILED 11-1-2013.

THE MARK CONSISTS OF THE WORD "TRICHOTOMY" IN A STYLIZED FONT.

FOR ATHLETIC APPAREL, NAMELY, SHIRTS, PANTS, JACKETS, FOOTWEAR, HATS AND CAPS, ATHLETIC UNIFORMS; ATHLETIC SHIRTS; BODY SHIRTS; BUTTON DOWN SHIRTS; CARGO PANTS; DENIMS; HOODED SWEATSHIRTS; SWEATSHIRTS (U.S. CLS. 22 AND 39).

FIRST USE 6-27-2014; IN COMMERCE 6-27-2014.

4,594,482. LANIADO, MOSHE, KEYPORT, NJ. SN 86-110,363. PUB. 4-1-2014, FILED 11-5-2013.

THE MARK CONSISTS OF STANDARD CHARACTERS WITHOUT CLAIM TO ANY PARTICULAR FONT, STYLE, SIZE, OR COLOR.

FOR SWIMWEAR (U.S. CLS. 22 AND 39).  
FIRST USE 9-1-2013; IN COMMERCE 1-14-2014.

**CLASS 25—(Continued).**

4,594,493. JONES, MIKE, NOVI, MI. SN 86-117,225. PUB. 4-8-2014, FILED 11-13-2013.

# MAFOOSE

THE MARK CONSISTS OF STANDARD CHARACTERS WITHOUT CLAIM TO ANY PARTICULAR FONT, STYLE, SIZE, OR COLOR.

FOR CLOTHING, NAMELY, T-SHIRTS, SHIRTS, TOPS, SWEATERS, SWEATSHIRTS, HOODED SWEATSHIRTS; COATS, JERSEYS, JACKETS; BOTTOMS, PANTS, TROUSERS, JEANS, SHORTS, SWEATPANTS, PAJAMAS; DRESSES; SKIRTS; BLOUSES; UNDERWEAR; SWIMWEAR; HEADWEAR; FOOTWEAR; BELTS, TIES, GLOVES, SOCKS (U.S. CLS. 22 AND 39).

FIRST USE 3-1-2014; IN COMMERCE 3-1-2014.

---

4,594,497. SANCHES, KYLIE, NEDERLAND, TX. SN 86-118,470. PUB. 4-8-2014, FILED 11-14-2013.

# YOU PLAY . I PRAY

THE MARK CONSISTS OF STANDARD CHARACTERS WITHOUT CLAIM TO ANY PARTICULAR FONT, STYLE, SIZE, OR COLOR.

FOR CLOTHING, NAMELY, TOPS, BOTTOMS, SHIRTS, TEE-SHIRTS, HATS, SWEATSHIRTS, JACKETS, PANTS, TANKS (U.S. CLS. 22 AND 39).

FIRST USE 4-1-2014; IN COMMERCE 4-1-2014.

---

4,594,503. ALAN HAYMES, NEW YORK, NY. SN 86-120,429. PUB. 4-15-2014, FILED 11-15-2013.



THE MARK CONSISTS OF THE LETTERS "AP" INTERWINED WITH THE "P" AND THE "A" SHARING VERTICAL AND HORIZONTAL LINES. THE UPPER HORIZONTAL LINE OF THE LETTER "P" EXTENDS FURTHER TO THE LEFT THAN A TRADITIONAL LETTER "P". THE "AP" IS SLANTED TO THE RIGHT. BENEATH "AP" APPEARS "ALPHA PERFORMANCE" IN STYLIZED FONT.

FOR ATHLETIC PANTS; ATHLETIC SHIRTS; ATHLETIC SHORTS (U.S. CLS. 22 AND 39).

FIRST USE 9-0-2012; IN COMMERCE 9-0-2012.

**CLASS 25—(Continued).**

4,594,516. YOO, KENNY K., LOS ANGELES, CA. SN 86-126,228. PUB. 4-22-2014, FILED 11-22-2013.

# Maronie

THE MARK CONSISTS OF STANDARD CHARACTERS WITHOUT CLAIM TO ANY PARTICULAR FONT, STYLE, SIZE, OR COLOR.

FOR ATHLETIC PANTS; ATHLETIC SKIRTS; BLOUSES; DENIM JACKETS; DENIMS; DOWN JACKETS; DRESS PANTS; DRESS SHIRTS; DRESS SUITS; DRESSES; EVENING DRESSES; FLEECE TOPS; FUR COATS AND JACKETS; FUR JACKETS; GOLF PANTS, SHIRTS AND SKIRTS; GYM PANTS; JACKETS; JOGGING PANTS; JUMPER DRESSES; KNIT DRESSES; KNIT JACKETS; KNIT SHIRTS; KNIT SKIRTS; KNIT TOPS; KOREAN OUTER JACKETS WORN OVER BASIC GARMENT; LEATHER JACKETS; LEATHER PANTS; LEATHER SKIRTS; LONG JACKETS; OVER COATS; PANTS; SKIRT SUITS; SKIRTS; SKIRTS AND DRESSES; STRETCH PANTS; SWEAT PANTS; SWEATERS; TANK TOPS; TURTLENECK SWEATERS; V-NECK SWEATERS; WOMEN'S CEREMONIAL DRESSES; WOMEN'S CLOTHING, NAMELY, SHIRTS, DRESSES, SKIRTS, BLOUSES (U.S. CLS. 22 AND 39).

FIRST USE 6-25-2014; IN COMMERCE 6-25-2014.

---

4,594,519. LORETO, CARLOS, NEW YORK, NY. SN 86-128,171. PUB. 4-29-2014, FILED 11-25-2013.

# Carlos Loreto

THE MARK CONSISTS OF STANDARD CHARACTERS WITHOUT CLAIM TO ANY PARTICULAR FONT, STYLE, SIZE, OR COLOR.

THE NAME "CARLOS LORETO" IDENTIFIES A LIVING INDIVIDUAL WHOSE CONSENT IS OF RECORD.

FOR FOOTWEAR (U.S. CLS. 22 AND 39).

FIRST USE 5-1-2014; IN COMMERCE 5-1-2014.

**CLASS 25—(Continued).**

4,594,530. MERLIV HOLDINGS, LLC, HILLIARD, OH. SN 86-135,818. PUB. 4-29-2014, FILED 12-5-2013.



THE MARK CONSISTS OF THE WORD "BEND" IN LOWER CASE LETTERING WITH THREE, STACKED AND SLIGHTLY SPACED APART, POINTED CONVEX ARCS EXTENDING BETWEEN THE "B" IN "BEND" AND THE "D" IN "BEND" ABOVE THE "EN" IN "BEND", THE MIDDLE ARC BEING SLIGHTLY LONGER THAN THE OTHER TWO ARCS.

FOR ATHLETIC SHIRTS; ATHLETIC SHORTS; ATHLETIC TOPS AND BOTTOMS FOR YOGA; HOODED SWEATSHIRTS; STRETCH PANTS; SWEATSHIRTS; T-SHIRTS (U.S. CLS. 22 AND 39).

FIRST USE 4-25-2014; IN COMMERCE 4-25-2014.

4,594,533. DE WEERD BEHEER B.V., 1191 HD, NETHERLANDS. SN 86-141,488. PUB. 4-29-2014, FILED 12-12-2013.



THE MARK CONSISTS OF STANDARD CHARACTERS WITHOUT CLAIM TO ANY PARTICULAR FONT, STYLE, SIZE, OR COLOR.

FOR BLOUSES; PANTS; POLO SHIRTS; SHIRTS; T-SHIRTS; UNDERWEAR (U.S. CLS. 22 AND 39).

FIRST USE 2-15-2011; IN COMMERCE 9-25-2013.

4,594,554. MONODICA, SPARKS, NV. SN 86-975,527. PUB. 10-29-2013, FILED 7-23-2013.



THE MARK CONSISTS OF STANDARD CHARACTERS WITHOUT CLAIM TO ANY PARTICULAR FONT, STYLE, SIZE, OR COLOR.

FOR ATHLETIC SHIRTS; BLOUSES; BODY SHIRTS; BUTTON DOWN SHIRTS; CAPRI PANTS; CAPS; CARGO PANTS; COLLARED SHIRTS; DRESS PANTS; DRESS SHIRTS; DRESSES; GOLF CAPS; GOLF SHIRTS; HATS; LONG-SLEEVED SHIRTS; NIGHT SHIRTS; PANTS; POLO SHIRTS; SHIRTS; SOCKS; SWEAT JACKETS; SWEAT PANTS; SWEAT SHIRTS; SWEAT SHORTS; SWEAT SUITS; T-SHIRTS (U.S. CLS. 22 AND 39).

FIRST USE 5-31-2014; IN COMMERCE 5-31-2014.

**CLASS 26—FANCY GOODS**

4,593,609. MAY IEV, DBA PINNUPS, HAWTHORNE, CA. SN 85-802,542. PUB. 5-14-2013, FILED 12-13-2012.



THE MARK CONSISTS OF STANDARD CHARACTERS WITHOUT CLAIM TO ANY PARTICULAR FONT, STYLE, SIZE, OR COLOR.

FOR BOBBY PINS; HAIR BARRETTES; HAIR PINS AND GRIPS; ORIENTAL HAIR PINS (U.S. CLS. 37, 39, 40, 42 AND 50).

FIRST USE 2-1-2012; IN COMMERCE 5-1-2014.

4,593,830. BERKSHIRE PPM, INC., LITCHFIELD, CT. SN 85-915,305. PUB. 11-5-2013, FILED 4-25-2013.



THE MARK CONSISTS OF STANDARD CHARACTERS WITHOUT CLAIM TO ANY PARTICULAR FONT, STYLE, SIZE, OR COLOR.

FOR BELT BUCKLES (U.S. CLS. 37, 39, 40, 42 AND 50).

FIRST USE 11-15-2013; IN COMMERCE 11-15-2013.

4,594,368. LOX EXTENSIONS LLC, DBA LOX EXTENSIONS LLC, SHELBY TWP, MI. SN 86-072,881. PUB. 2-18-2014, FILED 9-24-2013.



THE MARK CONSISTS OF STANDARD CHARACTERS WITHOUT CLAIM TO ANY PARTICULAR FONT, STYLE, SIZE, OR COLOR.

NO CLAIM IS MADE TO THE EXCLUSIVE RIGHT TO USE "LOCKS", APART FROM THE MARK AS SHOWN.

FOR HAIR EXTENSIONS (U.S. CLS. 37, 39, 40, 42 AND 50).

FIRST USE 6-1-2013; IN COMMERCE 10-22-2013.

**CLASS 26—(Continued).**

4,594,396. LOX EXTENSIONS LLC, DBA LOX EXTENSIONS LLC, SHELBY TWP, MI. SN 86-082,753. PUB. 2-18-2014, FILED 10-4-2013.

---

## Fiberlite Technology

THE MARK CONSISTS OF STANDARD CHARACTERS WITHOUT CLAIM TO ANY PARTICULAR FONT, STYLE, SIZE, OR COLOR.

NO CLAIM IS MADE TO THE EXCLUSIVE RIGHT TO USE "TECHNOLOGY", APART FROM THE MARK AS SHOWN.

FOR HAIR EXTENSIONS (U.S. CLS. 37, 39, 40, 42 AND 50).

FIRST USE 6-1-2013; IN COMMERCE 10-22-2013.

**CLASS 27—FLOOR COVERINGS**

4,593,124. J. BAXTER BRINKMANN INTERNATIONAL CORPORATION, DALLAS, TX. SN 85-077,455. PUB. 6-7-2011, FILED 7-2-2010.

---

## MALIBU

THE MARK CONSISTS OF STANDARD CHARACTERS WITHOUT CLAIM TO ANY PARTICULAR FONT, STYLE, SIZE, OR COLOR.

OWNER OF U.S. REG. NOS. 816,551, 3,424,575, AND OTHERS.

FOR GRILL MATS, NAMELY, FLOOR MATS FOR USE UNDER BARBEQUE GRILLS (U.S. CLS. 19, 20, 37, 42 AND 50).

FIRST USE 5-19-2014; IN COMMERCE 5-19-2014.

4,593,130. J. BAXTER BRINKMANN INTERNATIONAL CORPORATION, DALLAS, TX. SN 85-077,544. PUB. 6-7-2011, FILED 7-2-2010.

---

## MALIBU OUTDOOR LIVING

THE MARK CONSISTS OF STANDARD CHARACTERS WITHOUT CLAIM TO ANY PARTICULAR FONT, STYLE, SIZE, OR COLOR.

OWNER OF U.S. REG. NOS. 816,551, 3,424,575, AND OTHERS.

**CLASS 27—(Continued).**

NO CLAIM IS MADE TO THE EXCLUSIVE RIGHT TO USE "OUTDOOR LIVING", APART FROM THE MARK AS SHOWN.

FOR GRILL MATS, NAMELY, FLOOR MATS FOR USE UNDER BARBEQUE GRILLS (U.S. CLS. 19, 20, 37, 42 AND 50).

FIRST USE 5-19-2014; IN COMMERCE 5-19-2014.

4,593,295. DEFLECTO, LLC, INDIANAPOLIS, IN. SN 85-561,793. PUB. 7-24-2012, FILED 3-6-2012.

---

## FREE & CLEAR

THE MARK CONSISTS OF STANDARD CHARACTERS WITHOUT CLAIM TO ANY PARTICULAR FONT, STYLE, SIZE, OR COLOR.

FOR UNDER-CHAIR FLOOR PROTECTOR, NAMELY, CHAIR MATS (U.S. CLS. 19, 20, 37, 42 AND 50).

FIRST USE 7-31-2013; IN COMMERCE 7-31-2013.

4,593,650. ICON DE HOLDINGS LLC, WILMINGTON, DE. SN 85-813,129. PUB. 5-21-2013, FILED 12-31-2012.

---

## WAVERLY

THE MARK CONSISTS OF STANDARD CHARACTERS WITHOUT CLAIM TO ANY PARTICULAR FONT, STYLE, SIZE, OR COLOR.

OWNER OF U.S. REG. NOS. 709,694, 2,222,219, AND OTHERS.

FOR BATH MATS (U.S. CLS. 19, 20, 37, 42 AND 50).

FIRST USE 1-1-2013; IN COMMERCE 1-1-2013.

4,594,220. HELLAS CONSTRUCTION, INC., AUSTIN, TX. SN 86-007,917. PUB. 10-29-2013, FILED 7-11-2013.

---

## TRIAD

THE MARK CONSISTS OF STANDARD CHARACTERS WITHOUT CLAIM TO ANY PARTICULAR FONT, STYLE, SIZE, OR COLOR.

FOR SYNTHETIC TURF (U.S. CLS. 19, 20, 37, 42 AND 50).

FIRST USE 1-31-2012; IN COMMERCE 1-31-2012.

**CLASS 27—(Continued).**

4,594,445. THE NEWARK GROUP, INC., CRANFORD, NJ. SN 86-099,017. PUB. 2-25-2014, FILED 10-23-2013.

**CENTURION DETECPROTEC**

THE MARK CONSISTS OF STANDARD CHARACTERS WITHOUT CLAIM TO ANY PARTICULAR FONT, STYLE, SIZE, OR COLOR.

OWNER OF U.S. REG. NO. 4,317,013.  
FOR MATTING FEATURING A PAPERBOARD LAYER WITH WHITE OVERLAY FOR PROTECTING FLOORS (U.S. CLS. 19, 20, 37, 42 AND 50).  
FIRST USE 4-7-2014; IN COMMERCE 4-7-2014.

**CLASS 28—(Continued).**

4,593,259. CORSAN INVENTIONS CORP., AGUADILLA, PUERTO RICO. SN 85-493,660. PUB. 5-22-2012, FILED 12-13-2011.

**CLASS 28—TOYS AND SPORTING GOODS**

4,593,107. MATTEL, INC., EL SEGUNDO, CA. SN 85-053,871. PUB. 5-10-2011, FILED 6-3-2010.

**BOOM BOX**

THE MARK CONSISTS OF STANDARD CHARACTERS WITHOUT CLAIM TO ANY PARTICULAR FONT, STYLE, SIZE, OR COLOR.

FOR TOYS, GAMES AND PLAYTHINGS, NAMELY, TOY VEHICLES AND ACCESSORIES THEREFOR (U.S. CLS. 22, 23, 38 AND 50).  
FIRST USE 4-1-2014; IN COMMERCE 4-1-2014.

THE MARK CONSISTS OF A CIRCLE WITH A DOUBLE OUTERLINE. INSIDE OF SAID CIRCLE THERE'S THE WORD "THE" ON THE UPPER RIGHT SIDE. RIGHT UNDER SAID WORD THERE'S A LETTER "S" FORMED BY A GEOMETRIC FIGURES FONT DOUBLED OUTLINED. THE LETTER "S" IS FOLLOWED BY A DOT. TO THE RIGHT OF SAID DOT, THE LETTER "P" ALSO FORMED BY GEOMETRIC FIGURES FOLLOWED BY A DOT. THIS LETTER "P" HAS A SMALL POLE EXTENDING VERTICALLY FROM THE UPPER AND LOWER PORTION OF THE LETTER, FOLLOWED BY A HORIZONTAL POLE ENDING WITH A BOXING GLOVE.

FOR SPORTS EQUIPMENT FOR BOXING AND MARTIAL ARTS, NAMELY, BOXING GLOVES, BOXING BAGS, PUNCHING MITTS, BELLY PROTECTORS, GROIN PROTECTORS AND SHIN GUARDS; TRAINING APPARATUS FOR BOXING, MARTIAL ARTS, AND SIMILAR SPORTS (U.S. CLS. 22, 23, 38 AND 50).  
FIRST USE 3-1-2014; IN COMMERCE 3-1-2014.

4,593,213. ARIZONA MANUFACTURING & EMBROIDERY, INC., TEMPE, AZ. SN 85-361,205. PUB. 11-22-2011, FILED 6-30-2011.

**BRAVO**

THE MARK CONSISTS OF STANDARD CHARACTERS WITHOUT CLAIM TO ANY PARTICULAR FONT, STYLE, SIZE, OR COLOR.

FOR COVERS FOR GOLF CLUBS; FITTED HEAD COVERS FOR GOLF CLUBS; GOLF CLUB COVERS; HEAD COVERS FOR GOLF CLUBS; ALL THE FOREGOING NOT RELATING TO SPORTS EXCEPT GOLF OR TO A SPORTS TEAM, LEAGUE, MASCOT OR STADIUM (U.S. CLS. 22, 23, 38 AND 50).  
FIRST USE 8-31-2011; IN COMMERCE 8-31-2011.

4,593,264. FRICK, ANDREW, AFTON, MO. SN 85-504,358. PUB. 10-29-2013, FILED 12-27-2011.

**BACKYARD BLOCK PARTY**

THE MARK CONSISTS OF STANDARD CHARACTERS WITHOUT CLAIM TO ANY PARTICULAR FONT, STYLE, SIZE, OR COLOR.

NO CLAIM IS MADE TO THE EXCLUSIVE RIGHT TO USE "BLOCK", APART FROM THE MARK AS SHOWN.  
FOR GAMES (U.S. CLS. 22, 23, 38 AND 50).  
FIRST USE 5-0-2014; IN COMMERCE 5-0-2014.

**CLASS 28—(Continued).**

4,593,276. DO OUTDOORS, INC., SPRINGFIELD, MO. SN 85-531,124. PUB. 4-1-2014, FILED 2-1-2012.

**MR. TROUT**

THE MARK CONSISTS OF STANDARD CHARACTERS WITHOUT CLAIM TO ANY PARTICULAR FONT, STYLE, SIZE, OR COLOR.

THE NAME "MR. TROUT" DOES NOT IDENTIFY A LIVING INDIVIDUAL.

FOR FISHING REELS; FISHING RODS (U.S. CLS. 22, 23, 38 AND 50).

FIRST USE 6-9-2014; IN COMMERCE 6-9-2014.

---

4,593,278. MARGARET MARILYN SMITH, WATERFORD, VA. SN 85-534,064. PUB. 1-22-2013, FILED S.R. 2-4-2012; AM. P.R. 11-24-2012.

**Once Upon A Breeze**

THE MARK CONSISTS OF STANDARD CHARACTERS WITHOUT CLAIM TO ANY PARTICULAR FONT, STYLE, SIZE, OR COLOR.

FOR TOYS, NAMELY, KITES AND ACCESSORIES FOR KITES, NAMELY, KITE HANDLES, KITE LINES, KITE REELS, KITE STRING AND KITE TAILS (U.S. CLS. 22, 23, 38 AND 50).

FIRST USE 6-16-2014; IN COMMERCE 6-16-2014.

---

4,593,418. ELLIOTT, BRANDON, WILLIMANTIC, CT. SN 85-691,085. PUB. 4-30-2013, FILED 7-31-2012.

**Elliott Groove Sharpening  
Golf Tee**

THE MARK CONSISTS OF STANDARD CHARACTERS WITHOUT CLAIM TO ANY PARTICULAR FONT, STYLE, SIZE, OR COLOR.

NO CLAIM IS MADE TO THE EXCLUSIVE RIGHT TO USE "GROOVE SHARPENING GOLF TEE", APART FROM THE MARK AS SHOWN.

FOR MULTI-PURPOSE GOLF TEES, NAMELY, A GOLF TEE THAT SHARPENS THE GROOVES OF THE GOLF CLUB FACE (U.S. CLS. 22, 23, 38 AND 50).

FIRST USE 6-24-2014; IN COMMERCE 6-24-2014.

**CLASS 28—(Continued).**

4,593,438. SAFRON, JEREMY, MAKAWOA, HI. SN 85-711,697. PUB. 3-4-2014, FILED 8-23-2012.

**UNPREDICTIBALL**

THE MARK CONSISTS OF STANDARD CHARACTERS WITHOUT CLAIM TO ANY PARTICULAR FONT, STYLE, SIZE, OR COLOR.

FOR CHILDREN'S EDUCATIONAL TOYS FOR DEVELOPING MARIAL ARTS SKILLS (U.S. CLS. 22, 23, 38 AND 50).

FIRST USE 10-0-2012; IN COMMERCE 10-0-2012.

---

4,593,481. JUSTIN MCCLURE, WICHITA, KS. SN 85-749,260. PUB. 11-5-2013, FILED 10-9-2012.

**LAUNCH LASER**

THE MARK CONSISTS OF STANDARD CHARACTERS WITHOUT CLAIM TO ANY PARTICULAR FONT, STYLE, SIZE, OR COLOR.

NO CLAIM IS MADE TO THE EXCLUSIVE RIGHT TO USE "LASER", APART FROM THE MARK AS SHOWN.

FOR SPORTS TRAINING EQUIPMENT SWING AID APPARATUS FOR INSTRUCTING ON PROPER SWING TECHNIQUES FOR SWINGING BASEBALL BATS, SOFTBALL BATS, GOLF CLUBS OR HOCKEY STICKS WHICH ATTACHES THERETO AND EMITS A LASER BEAM FOR PROVIDING REFERENCE FOR PROPER SWINGING TECHNIQUE (U.S. CLS. 22, 23, 38 AND 50).

FIRST USE 5-1-2013; IN COMMERCE 5-1-2013.

---

4,593,487. POLLARD BANKNOTE LIMITED PARTNERSHIP, WINNIPEG, MB, CANADA. SN 85-753,347. PUB. 10-22-2013, FILED 10-12-2012.

**\$50 SHADES OF GREEN**

THE MARK CONSISTS OF STANDARD CHARACTERS WITHOUT CLAIM TO ANY PARTICULAR FONT, STYLE, SIZE, OR COLOR.

NO CLAIM IS MADE TO THE EXCLUSIVE RIGHT TO USE "\$50", APART FROM THE MARK AS SHOWN.

FOR LOTTERY TICKETS (U.S. CLS. 22, 23, 38 AND 50).

FIRST USE 2-11-2013; IN COMMERCE 2-11-2013.



**CLASS 28—(Continued).**

4,593,492. BALLY GAMING, INC., DBA BALLY TECHNOLOGIES, LAS VEGAS, NV. SN 85-756,962. PUB. 3-26-2013, FILED 10-17-2012.

**Visitors from Planet Z**

THE MARK CONSISTS OF STANDARD CHARACTERS WITHOUT CLAIM TO ANY PARTICULAR FONT, STYLE, SIZE, OR COLOR.

FOR GAMING MACHINES, NAMELY, DEVICES WHICH ACCEPT A WAGER (U.S. CLS. 22, 23, 38 AND 50).

FIRST USE 2-4-2013; IN COMMERCE 2-4-2013.

4,593,493. BALLY GAMING, INC., DBA BALLY TECHNOLOGIES, LAS VEGAS, NV. SN 85-756,966. PUB. 3-26-2013, FILED 10-17-2012.

**Romantic Eyes**

THE MARK CONSISTS OF STANDARD CHARACTERS WITHOUT CLAIM TO ANY PARTICULAR FONT, STYLE, SIZE, OR COLOR.

FOR GAMING MACHINES, NAMELY, DEVICES WHICH ACCEPT A WAGER (U.S. CLS. 22, 23, 38 AND 50).

FIRST USE 5-6-2013; IN COMMERCE 5-6-2013.

4,593,513. JAKKS PACIFIC, INC., MALIBU, CA. SN 85-765,491. PUB. 10-15-2013, FILED 10-28-2012.

**POWERTRAINS**   
COLLECT >>> CONNECT >>> EXPAND

NO CLAIM IS MADE TO THE EXCLUSIVE RIGHT TO USE "POWER TRAINS" AND "CONNECT" AND "EXPAND", APART FROM THE MARK AS SHOWN.

THE MARK CONSISTS OF THE WORD "POWERTRAINS" FOLLOWED BY AN INCOMPLETE CIRCLE CONTAINING AN ARROW IN OUTLINE; BENEATH WHICH WORD APPEAR THE WORDS: "COLLECT", FOLLOWED BY THREE ANGULAR BRACKETS; "CONNECT", FOLLOWED BY THREE ANGULAR BRACKETS; AND THE WORD "EXPAND".

FOR TOYS GAMES AND PLAYTHINGS, NAMELY, TOY TRAINS AND PARTS AND ACCESSORIES THEREFOR (U.S. CLS. 22, 23, 38 AND 50).

FIRST USE 10-12-2012; IN COMMERCE 10-12-2012.

**CLASS 28—(Continued).**

4,593,542. MEGABASS INC., SHIZUOKA 431-3115, JAPAN. SN 85-776,149. PUB. 10-22-2013, FILED 11-9-2012.

**OROCHI**

THE MARK CONSISTS OF STANDARD CHARACTERS WITHOUT CLAIM TO ANY PARTICULAR FONT, STYLE, SIZE, OR COLOR.

THE ENGLISH TRANSLATION OF "OROCHI" IN THE MARK IS "EIGHT-FORKED SERPENT".

FOR FISHING TACKLE, NAMELY, LURES, FISHING RODS, FISHING LINES, FISHING HOOKS, FLOATS, SINKERS, REELS, CREELS, FISHING SPEARS, AND SOFT ARTIFICIAL BAIT (U.S. CLS. 22, 23, 38 AND 50).

FIRST USE 4-30-2010; IN COMMERCE 7-31-2010.

4,593,565. WIORA, JOHN, NAPERVILLE, IL. AND WIORA, NANCY, NAPERVILLE, IL. SN 85-788,774. PUB. 5-14-2013, FILED 11-27-2012.

**The Party Ref**

THE MARK CONSISTS OF STANDARD CHARACTERS WITHOUT CLAIM TO ANY PARTICULAR FONT, STYLE, SIZE, OR COLOR.

FOR AMUSEMENT AND GAME APPARATUS, NAMELY, GAMES AND PLAYTHINGS, NAMELY, PARLOR GAMES (U.S. CLS. 22, 23, 38 AND 50).

FIRST USE 5-27-2014; IN COMMERCE 5-27-2014.

4,593,570. LEON COUNTY, FLORIDA, TALLAHASSEE, FL. SN 85-789,435. PUB. 4-30-2013, FILED 11-28-2012.

**Let's**   
**Balance** 

OWNER OF U.S. REG. NO. 3,275,039.

NO CLAIM IS MADE TO THE EXCLUSIVE RIGHT TO USE "LEON" AND THE REPRESENTATION OF THE MAP OF FLORIDA, APART FROM THE MARK AS SHOWN.

THE MARK CONSISTS OF THE WORDS "LET'S BALANCE" FOLLOWED BY AN EXCLAMATION POINT THAT HAS AS THE PERIOD IN THE EXCLAMATION POINT TWO CONCENTRIC CIRCLES, A MAP OF FLORIDA, AND THE WORD "LEON".

FOR BOARD GAMES (U.S. CLS. 22, 23, 38 AND 50).

FIRST USE 6-23-2014; IN COMMERCE 6-23-2014.

**CLASS 28—(Continued).**

4,593,583. KONAMI GAMING, INC., LAS VEGAS, NV. SN 85-792,545. PUB. 4-9-2013, FILED 12-2-2012.

**LEGEND OF CAPTAIN**

THE MARK CONSISTS OF STANDARD CHARACTERS WITHOUT CLAIM TO ANY PARTICULAR FONT, STYLE, SIZE, OR COLOR.

OWNER OF U.S. REG. NOS. 3,140,283, 4,191,490, AND OTHERS.

FOR ELECTRONIC GAMING MACHINES, NAMELY, DEVICES WHICH ACCEPT A WAGER; GAMING DEVICES, NAMELY, GAMING MACHINES, SLOT MACHINES, BINGO MACHINES, WITH OR WITHOUT VIDEO OUTPUT; GAMING EQUIPMENT, NAMELY, SLOT MACHINES WITH OR WITHOUT VIDEO OUTPUT; GAMING MACHINES; GAMING MACHINES FEATURING A DEVICE THAT ACCEPTS WAGERS; GAMING MACHINES INCLUDING SLOT MACHINES OR VIDEO LOTTERY TERMINALS; GAMING MACHINES THAT GENERATE OR DISPLAY WAGER OUTCOMES; GAMING MACHINES, NAMELY, SLOT MACHINES AND VIDEO LOTTERY TERMINALS; GAMING MACHINES, NAMELY, DEVICES WHICH ACCEPT A WAGER; GAMING MACHINES, NAMELY, ELECTRONIC SLOT AND BINGO MACHINES; MACHINES FOR PLAYING GAMES OF CHANCE; RECONFIGURABLE CASINO AND LOTTERY GAMING EQUIPMENT, NAMELY, GAMING MACHINES AND OPERATIONAL COMPUTER GAME SOFTWARE THEREFOR SOLD AS A UNIT; SLOT MACHINES (U.S. CLS. 22, 23, 38 AND 50).  
FIRST USE 6-1-2014; IN COMMERCE 6-1-2014.

4,593,584. KONAMI GAMING, INC., LAS VEGAS, NV. SN 85-792,550. PUB. 4-9-2013, FILED 12-2-2012.

**GLAMOROUS PEACOCK**

THE MARK CONSISTS OF STANDARD CHARACTERS WITHOUT CLAIM TO ANY PARTICULAR FONT, STYLE, SIZE, OR COLOR.

**CLASS 28—(Continued).**

OWNER OF U.S. REG. NO. 4,158,396.

FOR ELECTRONIC GAMING MACHINES, NAMELY, DEVICES WHICH ACCEPT A WAGER; GAMING DEVICES, NAMELY, GAMING MACHINES, SLOT MACHINES, BINGO MACHINES, WITH OR WITHOUT VIDEO OUTPUT; GAMING EQUIPMENT, NAMELY, SLOT MACHINES WITH OR WITHOUT VIDEO OUTPUT; GAMING MACHINES; GAMING MACHINES FEATURING A DEVICE THAT ACCEPTS WAGERS; GAMING MACHINES INCLUDING SLOT MACHINES OR VIDEO LOTTERY TERMINALS; GAMING MACHINES THAT GENERATE OR DISPLAY WAGER OUTCOMES; GAMING MACHINES, NAMELY, SLOT MACHINES AND VIDEO LOTTERY TERMINALS; GAMING MACHINES, NAMELY, DEVICES WHICH ACCEPT A WAGER; GAMING MACHINES, NAMELY, ELECTRONIC SLOT AND BINGO MACHINES; MACHINES FOR PLAYING GAMES OF CHANCE; RECONFIGURABLE CASINO AND LOTTERY GAMING EQUIPMENT, NAMELY, GAMING MACHINES AND OPERATIONAL COMPUTER GAME SOFTWARE THEREFOR SOLD AS A UNIT; SLOT MACHINES (U.S. CLS. 22, 23, 38 AND 50).  
FIRST USE 6-1-2014; IN COMMERCE 6-1-2014.

4,593,589. MULTIMEDIA GAMES, INC., AUSTIN, TX. SN 85-796,144. PUB. 11-12-2013, FILED 12-6-2012.

**Mardi Gras In The Big Easy**

THE MARK CONSISTS OF STANDARD CHARACTERS WITHOUT CLAIM TO ANY PARTICULAR FONT, STYLE, SIZE, OR COLOR.

FOR GAMING DEVICES, NAMELY, GAMING MACHINES, SLOT MACHINES, BINGO MACHINES, WITH OR WITHOUT VIDEO OUTPUT; GAMING MACHINES THAT GENERATE OR DISPLAY WAGER OUTCOMES; RECONFIGURABLE CASINO AND LOTTERY GAMING EQUIPMENT, NAMELY, GAMING MACHINES AND OPERATIONAL COMPUTER GAME SOFTWARE THEREFOR SOLD AS A UNIT (U.S. CLS. 22, 23, 38 AND 50).  
FIRST USE 5-11-2014; IN COMMERCE 5-11-2014.

**CLASS 28—(Continued).**

4,593,687. KONAMI GAMING, INC., LAS VEGAS, NV. SN 85-829,656. PUB. 4-9-2013, FILED 1-23-2013.

**ADORNED PEACOCK**

THE MARK CONSISTS OF STANDARD CHARACTERS WITHOUT CLAIM TO ANY PARTICULAR FONT, STYLE, SIZE, OR COLOR.

FOR ELECTRONIC GAMING MACHINES, NAMELY, DEVICES WHICH ACCEPT A WAGER; GAMING DEVICES, NAMELY, GAMING MACHINES, SLOT MACHINES, BINGO MACHINES, WITH OR WITHOUT VIDEO OUTPUT; GAMING EQUIPMENT, NAMELY, SLOT MACHINES WITH OR WITHOUT VIDEO OUTPUT; GAMING MACHINES; GAMING MACHINES FEATURING A DEVICE THAT ACCEPTS WAGERS; GAMING MACHINES INCLUDING SLOT MACHINES OR VIDEO LOTTERY TERMINALS; GAMING MACHINES THAT GENERATE OR DISPLAY WAGER OUTCOMES; GAMING MACHINES, NAMELY, SLOT MACHINES AND VIDEO LOTTERY TERMINALS; GAMING MACHINES, NAMELY, DEVICES WHICH ACCEPT A WAGER; GAMING MACHINES, NAMELY, ELECTRONIC SLOT AND BINGO MACHINES; MACHINES FOR PLAYING GAMES OF CHANCE; RECONFIGURABLE CASINO AND LOTTERY GAMING EQUIPMENT, NAMELY, GAMING MACHINES AND OPERATIONAL COMPUTER GAME SOFTWARE THEREFOR SOLD AS A UNIT; SLOT MACHINES (U.S. CLS. 22, 23, 38 AND 50).

FIRST USE 6-1-2014; IN COMMERCE 6-1-2014.

---

4,593,706. MATTEL, INC., EL SEGUNDO, CA. SN 85-843,863. PUB. 12-3-2013, FILED 2-7-2013.

**POPPY O'HAIR**

THE MARK CONSISTS OF STANDARD CHARACTERS WITHOUT CLAIM TO ANY PARTICULAR FONT, STYLE, SIZE, OR COLOR.

THE NAME(S), PORTRAIT(S), AND/OR SIGNATURE(S) SHOWN IN THE MARK DOES NOT IDENTIFY A PARTICULAR LIVING INDIVIDUAL.

FOR TOYS, GAMES AND PLAYTHINGS, NAMELY, DOLLS, DOLL CLOTHING AND DOLL ACCESSORIES (U.S. CLS. 22, 23, 38 AND 50).

FIRST USE 6-10-2014; IN COMMERCE 6-10-2014.

**CLASS 28—(Continued).**

4,593,707. MATTEL, INC., EL SEGUNDO, CA. SN 85-843,869. PUB. 12-3-2013, FILED 2-7-2013.

**HOLLY O'HAIR**

THE MARK CONSISTS OF STANDARD CHARACTERS WITHOUT CLAIM TO ANY PARTICULAR FONT, STYLE, SIZE, OR COLOR.

THE NAME(S), PORTRAIT(S), AND/OR SIGNATURE(S) SHOWN IN THE MARK DOES NOT IDENTIFY A PARTICULAR LIVING INDIVIDUAL.

FOR TOYS, GAMES AND PLAYTHINGS, NAMELY, DOLLS, DOLL CLOTHING AND DOLL ACCESSORIES (U.S. CLS. 22, 23, 38 AND 50).

FIRST USE 6-10-2014; IN COMMERCE 6-10-2014.

---

4,593,717. MATTEL, INC., EL SEGUNDO, CA. SN 85-848,040. PUB. 12-3-2013, FILED 2-12-2013.

**JUST RIGHT, NEVER WRONG**

THE MARK CONSISTS OF STANDARD CHARACTERS WITHOUT CLAIM TO ANY PARTICULAR FONT, STYLE, SIZE, OR COLOR.

FOR TOYS, GAMES AND PLAYTHINGS, NAMELY, DOLLS, DOLL CLOTHING AND DOLL ACCESSORIES (U.S. CLS. 22, 23, 38 AND 50).

FIRST USE 2-14-2014; IN COMMERCE 2-14-2014.

---

4,593,718. MATTEL, INC., EL SEGUNDO, CA. SN 85-848,043. PUB. 11-26-2013, FILED 2-12-2013.

**HONEST TO GOODNESS**

THE MARK CONSISTS OF STANDARD CHARACTERS WITHOUT CLAIM TO ANY PARTICULAR FONT, STYLE, SIZE, OR COLOR.

FOR TOYS, GAMES AND PLAYTHINGS, NAMELY, DOLLS, DOLL CLOTHING AND DOLL ACCESSORIES (U.S. CLS. 22, 23, 38 AND 50).

FIRST USE 6-11-2014; IN COMMERCE 6-11-2014.

**CLASS 28—(Continued).**

4,593,785. ZEENIE DOLLZ LLC, GARDEN GROVE, CA. SN 85-889,404. PUB. 2-25-2014, FILED 3-28-2013.

## Eco Warriors Zeenie

THE MARK CONSISTS OF STANDARD CHARACTERS WITHOUT CLAIM TO ANY PARTICULAR FONT, STYLE, SIZE, OR COLOR.  
FOR DOLLS (U.S. CLS. 22, 23, 38 AND 50).  
FIRST USE 6-26-2013; IN COMMERCE 6-26-2013.

4,593,867. YELJIM FISHING LURES LLC, RUSHSYLVANIA, OH. SN 85-923,922. PUB. 10-1-2013, FILED 5-6-2013.



THE MARK CONSISTS OF AN ELONGATED POLYGON WITH SIX EDGES AND SIX VERTICES HAVING A BISECTING LINE THEREIN, AND AN ISOSCELES TRAPEZOID EXTENDING FROM ONE OF THE SIX VERTICES OF THE ELONGATED POLYGON.  
FOR FISHING LURES (U.S. CLS. 22, 23, 38 AND 50).  
FIRST USE 7-8-2013; IN COMMERCE 7-8-2013.

4,593,890. MINDWARE HOLDINGS, INC., ROSEVILLE, MN. SN 85-930,063. PUB. 10-8-2013, FILED 5-13-2013.

## PIVIT

THE MARK CONSISTS OF STANDARD CHARACTERS WITHOUT CLAIM TO ANY PARTICULAR FONT, STYLE, SIZE, OR COLOR.  
FOR TABLETOP GAMES (U.S. CLS. 22, 23, 38 AND 50).  
FIRST USE 9-10-2013; IN COMMERCE 9-10-2013.

**CLASS 28—(Continued).**

4,593,916. THE MARKETING STORE, LLC, CHICAGO, IL. SN 85-935,618. PUB. 10-15-2013, FILED 5-17-2013.

## FLYX

THE MARK CONSISTS OF STANDARD CHARACTERS WITHOUT CLAIM TO ANY PARTICULAR FONT, STYLE, SIZE, OR COLOR.  
FOR LAUNCHABLE TOY FIGURES AND TARGET GAMES (U.S. CLS. 22, 23, 38 AND 50).  
FIRST USE 1-1-2013; IN COMMERCE 1-1-2013.

4,593,933. MATTEL, INC., EL SEGUNDO, CA. SN 85-937,306. PUB. 10-22-2013, FILED 5-20-2013.

## SLOMAN "SLO MO" MORTAVITCH

THE MARK CONSISTS OF STANDARD CHARACTERS WITHOUT CLAIM TO ANY PARTICULAR FONT, STYLE, SIZE, OR COLOR.  
THE NAME(S), PORTRAIT(S), AND/OR SIGNATURE(S) SHOWN IN THE MARK DOES NOT IDENTIFY A PARTICULAR LIVING INDIVIDUAL.  
FOR DOLLS, DOLL CLOTHING AND DOLL ACCESSORIES (U.S. CLS. 22, 23, 38 AND 50).  
FIRST USE 5-6-2014; IN COMMERCE 5-6-2014.

4,593,941. PETER NYARI, CARLSBAD, CA. AND KLARA NYARI, CARLSBAD, CA. SN 85-938,496. PUB. 10-22-2013, FILED 5-21-2013.

## BELLE DE CLAIRE

THE MARK CONSISTS OF STANDARD CHARACTERS WITHOUT CLAIM TO ANY PARTICULAR FONT, STYLE, SIZE, OR COLOR.  
THE NAME(S), PORTRAIT(S), AND/OR SIGNATURE(S) SHOWN IN THE MARK DOES NOT IDENTIFY A PARTICULAR LIVING INDIVIDUAL.  
THE ENGLISH TRANSLATION OF "BELLE DE CLAIRE" IN THE MARK IS "OYSTER BEAUTY".  
FOR HOBBY CRAFT KIT COMPRISING HEMP CORDAGE AND BEADS (U.S. CLS. 22, 23, 38 AND 50).  
FIRST USE 5-1-2014; IN COMMERCE 5-1-2014.

**CLASS 28—(Continued).**

4,593,961. KARGER, ELIZABETH, OAKLAND, CA. SN 85-941,073. PUB. 10-22-2013, FILED 5-23-2013.



THE COLOR(S) PURPLE, GREEN, BLACK, WHITE, BLUE, ORANGE, RED AND GRAY IS/ARE CLAIMED AS A FEATURE OF THE MARK.

THE MARK CONSISTS OF A PURPLE FUZZY CREATURE WITH GREEN, GRAY, WHITE AND BLACK EYES, ABOVE THE STYLIZED WORD "SMUGGLES", THE LETTERS IN A VARIETY OF COLORS. "S" IS BLUE, "M" IS GREEN, "U" IN ORANGE, "G" IN PURPLE FEATURING A WHITE AND BLACK EYE, THE NEXT "G" IN RED FEATURING A WHITE AND BLACK EYE, "L" IN BLUE, "E" IN GREEN AND "S" IN ORANGE. THE WORD IS SHADOWED IN GRAY.

FOR STUFFED TOY ANIMALS (U.S. CLS. 22, 23, 38 AND 50).

FIRST USE 4-1-2014; IN COMMERCE 4-1-2014.

4,593,978. OLSON, LESLIE, ORLANDO, FL. SN 85-943,509. PUB. 10-22-2013, FILED 5-28-2013.

## Slave Hours

THE MARK CONSISTS OF STANDARD CHARACTERS WITHOUT CLAIM TO ANY PARTICULAR FONT, STYLE, SIZE, OR COLOR.

FOR BOARD GAMES (U.S. CLS. 22, 23, 38 AND 50).  
FIRST USE 6-5-2014; IN COMMERCE 6-7-2014.

4,594,010. SOH, JOHNSON, SINGAPORE, SINGAPORE. SN 85-949,786. PUB. 11-12-2013, FILED 6-4-2013.

## POWER YOUR SWIM

THE MARK CONSISTS OF STANDARD CHARACTERS WITHOUT CLAIM TO ANY PARTICULAR FONT, STYLE, SIZE, OR COLOR.

FOR SWIMMING ARTICLES NAMELY, KICKBOARDS, SWIMMING PADDLES, FLOTATION DEVICES FOR USE IN SWIMMING, NAMELY, SWIM FLOATS; INFLATABLE BANDS FOR SWIMMING; PULL BUOYS FOR SWIM TRAINING; FINGER BRACES FOR USE IN SWIMMING; SWIMMING FINS AND FLIPPERS; SWIMMING BELTS (U.S. CLS. 22, 23, 38 AND 50).  
FIRST USE 7-1-2013; IN COMMERCE 7-1-2013.

**CLASS 28—(Continued).**

4,594,023. CUSH FAMILY HOLDINGS PTY LTD., NOOSAVILLE QLD, AUSTRALIA. SN 85-951,722. PUB. 11-12-2013, FILED 6-5-2013.



NO CLAIM IS MADE TO THE EXCLUSIVE RIGHT TO USE "LURES", APART FROM THE MARK AS SHOWN.

THE MARK CONSISTS OF THE WORDS "DUGONG LURES" WITH A STYLIZED LURE ABOVE "DUGONG".

FOR ARTIFICIAL FISHING BAIT; ARTIFICIAL FISHING LURES; FISHING LURES (U.S. CLS. 22, 23, 38 AND 50).

FIRST USE 5-17-2014; IN COMMERCE 5-17-2014.

4,594,058. TRUE FITNESS TECHNOLOGY, INC., O'FALLON, MO. SN 85-956,628. PUB. 10-29-2013, FILED 6-11-2013.

## EMERGE

THE MARK CONSISTS OF STANDARD CHARACTERS WITHOUT CLAIM TO ANY PARTICULAR FONT, STYLE, SIZE, OR COLOR.

FOR EXERCISE EQUIPMENT COMPONENT SOLD AS PART OF THE FINAL PRODUCT, NAMELY, CONSOLE FOR AUTOMATIC VARIABLE SPEED, GRADE CONTROL AND CARDIAC HEART MONITORING (U.S. CLS. 22, 23, 38 AND 50).

FIRST USE 9-30-2013; IN COMMERCE 9-30-2013.

4,594,059. TRUE FITNESS TECHNOLOGY, INC., O'FALLON, MO. SN 85-956,651. PUB. 10-29-2013, FILED 6-11-2013.

## TRANSCEND

THE MARK CONSISTS OF STANDARD CHARACTERS WITHOUT CLAIM TO ANY PARTICULAR FONT, STYLE, SIZE, OR COLOR.

FOR EXERCISE EQUIPMENT COMPONENT SOLD AS PART OF THE FINAL PRODUCT, NAMELY, CONSOLE FOR AUTOMATIC VARIABLE SPEED, GRADE CONTROL AND CARDIAC HEART MONITORING (U.S. CLS. 22, 23, 38 AND 50).

FIRST USE 9-30-2013; IN COMMERCE 9-30-2013.

**CLASS 28—(Continued).**

4,594,077. HASBRO, INC., PAWTUCKET, RI. SN 85-959,030. PUB. 11-5-2013, FILED 6-13-2013.

**RAINBOW ROCKS**

THE MARK CONSISTS OF STANDARD CHARACTERS WITHOUT CLAIM TO ANY PARTICULAR FONT, STYLE, SIZE, OR COLOR.

FOR TOY PONIES AND ACCESSORIES FOR USE THEREWITH; DOLLS, DOLL CLOTHING AND DOLL ACCESSORIES (U.S. CLS. 22, 23, 38 AND 50).

FIRST USE 12-31-2013; IN COMMERCE 12-31-2013.

4,594,081. PARETO LAB, LLC, CARLSBAD, CA. SN 85-960,037. PUB. 11-5-2013, FILED 6-14-2013.

**PHOQUE**

THE MARK CONSISTS OF STANDARD CHARACTERS WITHOUT CLAIM TO ANY PARTICULAR FONT, STYLE, SIZE, OR COLOR.

THE ENGLISH TRANSLATION OF "PHOQUE" IN THE MARK IS "SEAL".

FOR SKATEBOARDS; BAGS FOR SKATEBOARDS; BALL BEARINGS FOR SKATEBOARDS; SKATEBOARD DECKS; SKATEBOARD TRUCKS; SKATEBOARD WHEELS; STAND-UP PADDLE BOARDS; BAGS FOR STAND-UP PADDLE BOARDS; LEASHES FOR STAND-UP PADDLE BOARDS; STAND-UP PADDLE BOARD FINS; STAND-UP PADDLE BOARD PADDLES; STAND-UP PADDLE BOARD RAIL PROTECTORS; SURFBOARDS; BAGS ESPECIALLY DESIGNED FOR SURFBOARDS; LEASHES FOR SURFBOARDS; SURFBOARD FINS; SURFBOARD STOMP PADS; SURFBOARD TRACTION PADS; SURFBOARD WAX; DECK GRIPS FOR SPORTS EQUIPMENT BOARDS, NAMELY, SKATEBOARDS, STAND UP PADDLE BOARDS AND SURFBOARDS; TRACTION PADS FOR SPORTS EQUIPMENT BOARDS, NAMELY, SKATEBOARDS, STAND UP PADDLE BOARDS AND SURFBOARDS; ELBOW PADS FOR ATHLETIC USE; KNEE PADS FOR ATHLETIC USE; WRIST GUARDS FOR ATHLETIC USE (U.S. CLS. 22, 23, 38 AND 50).

FIRST USE 12-20-2013; IN COMMERCE 12-20-2013.

**CLASS 28—(Continued).**

4,594,083. WORLD WRESTLING ENTERTAINMENT, INC., STAMFORD, CT. SN 85-960,470. PUB. 10-29-2013, FILED 6-14-2013.

**WWE SLAM CITY**

THE MARK CONSISTS OF STANDARD CHARACTERS WITHOUT CLAIM TO ANY PARTICULAR FONT, STYLE, SIZE, OR COLOR.

FOR TOYS, NAMELY, ACTION FIGURES, ACCESSORIES THEREFOR; DOLLS; CASES FOR ACTION FIGURES; TOY WRESTLING RINGS; PLAYSETS; TOY VEHICLES; BOARD GAMES; TABLETOP ACTION SKILL GAMES; PLAYING CARDS; PUZZLES; STUFFED TOYS; PLUSH TOYS; TOY BELTS; TOY FOAM HANDS; COSTUME MASKS; COSTUME MASKS; NOVELTY FACE MASKS; CHRISTMAS TREE DECORATIONS (U.S. CLS. 22, 23, 38 AND 50).

FIRST USE 12-31-2013; IN COMMERCE 12-31-2013.

4,594,090. INCREDIBLE TECHNOLOGIES, INC., VERNON HILLS, IL. SN 85-961,251. PUB. 11-5-2013, FILED 6-17-2013.

**WOLFPACK**

THE MARK CONSISTS OF STANDARD CHARACTERS WITHOUT CLAIM TO ANY PARTICULAR FONT, STYLE, SIZE, OR COLOR.

FOR GAMING DEVICES, NAMELY, GAMING MACHINES, SLOT MACHINES, BINGO MACHINES, WITH OR WITHOUT VIDEO OUTPUT (U.S. CLS. 22, 23, 38 AND 50).

FIRST USE 9-1-2013; IN COMMERCE 9-1-2013.

4,594,167. AEROPOSTALE WEST, INC., NEW YORK, NY. SN 85-982,067. PUB. 10-4-2011, FILED 4-29-2011.

**JIMMY'Z**

THE MARK CONSISTS OF STANDARD CHARACTERS WITHOUT CLAIM TO ANY PARTICULAR FONT, STYLE, SIZE, OR COLOR.

OWNER OF U.S. REG. NOS. 1,411,390, 3,240,506, AND OTHERS.

FOR SURFBOARDS, SKATEBOARDS, SNOWBOARDS, BODYBOARDS, WAKE BOARDS, ROLLER SKATES, IN-LINE SKATES, BEACH BALLS, BAGS FOR SKATEBOARDS, BAGS ESPECIALLY DESIGNED FOR SURFBOARDS (U.S. CLS. 22, 23, 38 AND 50).

FIRST USE 5-17-2013; IN COMMERCE 5-17-2013.

**CLASS 28—(Continued).**

4,594,188. DREAMWORKS ANIMATION L.L.C., GLENDALE, CA. SN 85-982,447. PUB. 11-8-2011, FILED 4-22-2011.

**STORMFLY**

THE MARK CONSISTS OF STANDARD CHARACTERS WITHOUT CLAIM TO ANY PARTICULAR FONT, STYLE, SIZE, OR COLOR.

FOR ACTION FIGURES AND ACCESSORIES THEREFOR; BENDABLE PLAY FIGURES; PLUSH TOYS; STUFFED TOYS (U.S. CLS. 22, 23, 38 AND 50).  
FIRST USE 5-13-2014; IN COMMERCE 5-13-2014.

**CLASS 28—(Continued).**

4,594,229. MATTEL, INC., EL SEGUNDO, CA. SN 86-011,221. PUB. 12-3-2013, FILED 7-16-2013.

**UNNAMED ONE**

THE MARK CONSISTS OF STANDARD CHARACTERS WITHOUT CLAIM TO ANY PARTICULAR FONT, STYLE, SIZE, OR COLOR.

FOR TOY ACTION FIGURES AND ACCESSORIES THEREFOR (U.S. CLS. 22, 23, 38 AND 50).  
FIRST USE 3-31-2014; IN COMMERCE 3-31-2014.

4,594,205. MATTEL, INC., EL SEGUNDO, CA. SN 86-003,906. PUB. 11-26-2013, FILED 7-8-2013.

**RED CARPET**

THE MARK CONSISTS OF STANDARD CHARACTERS WITHOUT CLAIM TO ANY PARTICULAR FONT, STYLE, SIZE, OR COLOR.

FOR DOLLS, DOLL CLOTHING AND DOLL ACCESSORIES (U.S. CLS. 22, 23, 38 AND 50).  
FIRST USE 11-14-2013; IN COMMERCE 11-14-2013.

4,594,206. MATTEL, INC., EL SEGUNDO, CA. SN 86-003,997. PUB. 11-26-2013, FILED 7-8-2013.

**BLACK CARPET**

THE MARK CONSISTS OF STANDARD CHARACTERS WITHOUT CLAIM TO ANY PARTICULAR FONT, STYLE, SIZE, OR COLOR.

FOR DOLLS, DOLL CLOTHING AND DOLL ACCESSORIES (U.S. CLS. 22, 23, 38 AND 50).  
FIRST USE 6-10-2014; IN COMMERCE 6-10-2014.

4,594,230. MATTEL, INC., EL SEGUNDO, CA. SN 86-011,224. PUB. 12-3-2013, FILED 7-16-2013.

**DANGER BRIDGE**

THE MARK CONSISTS OF STANDARD CHARACTERS WITHOUT CLAIM TO ANY PARTICULAR FONT, STYLE, SIZE, OR COLOR.

NO CLAIM IS MADE TO THE EXCLUSIVE RIGHT TO USE "BRIDGE", APART FROM THE MARK AS SHOWN.  
FOR TOY VEHICLES AND ACCESSORIES THEREFOR, TOY VEHICLE TRACK SETS AND ACCESSORIES THEREFOR (U.S. CLS. 22, 23, 38 AND 50).  
FIRST USE 6-17-2014; IN COMMERCE 6-17-2014.

4,594,378. CLOUD B, INC., GARDENA, CA. SN 86-077,079. PUB. 2-11-2014, FILED 9-27-2013.

**FRANKIE THE FOX**

THE MARK CONSISTS OF STANDARD CHARACTERS WITHOUT CLAIM TO ANY PARTICULAR FONT, STYLE, SIZE, OR COLOR.

NO CLAIM IS MADE TO THE EXCLUSIVE RIGHT TO USE "FOX", APART FROM THE MARK AS SHOWN.  
FOR TOYS, NAMELY, PLUSH TOYS (U.S. CLS. 22, 23, 38 AND 50).  
FIRST USE 5-16-2014; IN COMMERCE 5-16-2014.

**CLASS 28—(Continued).**

4,594,485. PATCH PRODUCTS, INC., BELOIT, WI. SN 86-112,636. PUB. 4-22-2014, FILED 11-7-2013.

# Bouncy Bop

THE MARK CONSISTS OF STANDARD CHARACTERS WITHOUT CLAIM TO ANY PARTICULAR FONT, STYLE, SIZE, OR COLOR.

NO CLAIM IS MADE TO THE EXCLUSIVE RIGHT TO USE "BOUNCY", APART FROM THE MARK AS SHOWN.

FOR CHILDREN'S EDUCATIONAL TOYS FOR DEVELOPING COGNITIVE AND FINE MOTOR SKILLS (U.S. CLS. 22, 23, 38 AND 50).

FIRST USE 6-24-2014; IN COMMERCE 6-24-2014.

**CLASS 28—(Continued).**

4,594,505. IGT, RENO, NV. SN 86-120,587. PUB. 4-8-2014, FILED 11-15-2013.

# PROWLING PANTHER

THE MARK CONSISTS OF STANDARD CHARACTERS WITHOUT CLAIM TO ANY PARTICULAR FONT, STYLE, SIZE, OR COLOR.

FOR GAMING MACHINES, NAMELY, DEVICES WHICH ACCEPT A WAGER (U.S. CLS. 22, 23, 38 AND 50).

FIRST USE 4-25-2014; IN COMMERCE 5-5-2014.

4,594,494. MISSION PRODUCT HOLDINGS, INC., NEW YORK, NY. SN 86-117,285. PUB. 4-22-2014, FILED 11-13-2013.

# SHOCK GRIP

THE MARK CONSISTS OF STANDARD CHARACTERS WITHOUT CLAIM TO ANY PARTICULAR FONT, STYLE, SIZE, OR COLOR.

OWNER OF U.S. REG. NO. 4,265,352.

NO CLAIM IS MADE TO THE EXCLUSIVE RIGHT TO USE "GRIP", APART FROM THE MARK AS SHOWN.

FOR SHRINK-TO-FIT RUBBER GRIP THAT MOLDS TO THE HANDLE OF SPORTING GOODS (U.S. CLS. 22, 23, 38 AND 50).

FIRST USE 2-1-2014; IN COMMERCE 2-1-2014.

4,594,542. BUC-EE'S, LTD., LAKE JACKSON, TX. SN 86-161,040. PUB. 4-8-2014, FILED 1-9-2014.

# BUC-EE BOARDS

THE MARK CONSISTS OF STANDARD CHARACTERS WITHOUT CLAIM TO ANY PARTICULAR FONT, STYLE, SIZE, OR COLOR.

OWNER OF U.S. REG. NOS. 3,763,277, 4,007,063, AND 4,316,457.

NO CLAIM IS MADE TO THE EXCLUSIVE RIGHT TO USE "BOARDS", APART FROM THE MARK AS SHOWN.

FOR SURFBOARDS, PADDLE BOARDS, KNEEBOARDS, AND WAKEBOARDS (U.S. CLS. 22, 23, 38 AND 50).

FIRST USE 5-11-2014; IN COMMERCE 5-11-2014.

4,594,504. IGT, RENO, NV. SN 86-120,553. PUB. 4-8-2014, FILED 11-15-2013.

# LEGEND OF THE GAUCHO

THE MARK CONSISTS OF STANDARD CHARACTERS WITHOUT CLAIM TO ANY PARTICULAR FONT, STYLE, SIZE, OR COLOR.

FOR GAMING MACHINES, NAMELY, DEVICES WHICH ACCEPT A WAGER (U.S. CLS. 22, 23, 38 AND 50).

FIRST USE 5-27-2014; IN COMMERCE 5-27-2014.

**CLASS 29—MEATS AND PROCESSED FOODS**

4,593,146. CLEAVER COMPANY, INC., THE, NEW YORK, NY. SN 85-173,253. PUB. 7-26-2011, FILED 11-10-2010.

# The Green Table

THE MARK CONSISTS OF STANDARD CHARACTERS WITHOUT CLAIM TO ANY PARTICULAR FONT, STYLE, SIZE, OR COLOR.

FOR PRE-PACKAGED ENTREES CONSISTING PRIMARILY OF SUSTAINABLY-SOURCED MEAT, FISH, POULTRY OR VEGETABLES (U.S. CL. 46).

FIRST USE 4-1-2014; IN COMMERCE 4-1-2014.



**CLASS 29—(Continued).**

4,593,257. FAIRLIFE, LLC, CHICAGO, IL. SN 85-485,118. PUB. 5-15-2012, FILED 12-1-2011.

**FROM GRASS TO GLASS**

THE MARK CONSISTS OF STANDARD CHARACTERS WITHOUT CLAIM TO ANY PARTICULAR FONT, STYLE, SIZE, OR COLOR.

FOR BEVERAGES CONSISTING PRINCIPALLY OF MILK; BEVERAGES HAVING A MILK BASE; CHOCOLATE MILK; COWS' MILK; DAIRY PRODUCTS EXCLUDING ICE CREAM, ICE MILK AND FROZEN YOGURT; DAIRY-BASED BEVERAGES; MILK; MILK BEVERAGES WITH HIGH MILK CONTENT (U.S. CL. 46).

FIRST USE 2-15-2014; IN COMMERCE 2-15-2014.

4,593,266. ONION CRUNCH, INC., NEW YORK, NY. SN 85-510,072. PUB. 9-18-2012, FILED 1-6-2012.

**POTATO CRUNCH**

THE MARK CONSISTS OF STANDARD CHARACTERS WITHOUT CLAIM TO ANY PARTICULAR FONT, STYLE, SIZE, OR COLOR.

OWNER OF U.S. REG. NOS. 3,933,065 AND 3,969,368. NO CLAIM IS MADE TO THE EXCLUSIVE RIGHT TO USE "POTATO", APART FROM THE MARK AS SHOWN. FOR PROCESSED POTATOES (U.S. CL. 46). FIRST USE 3-20-2014; IN COMMERCE 3-20-2014.

4,593,307. FRITO-LAY NORTH AMERICA, INC., PLANO, TX. SN 85-586,790. PUB. 8-14-2012, FILED 4-2-2012.

**TASTES OF SUMMER**

THE MARK CONSISTS OF STANDARD CHARACTERS WITHOUT CLAIM TO ANY PARTICULAR FONT, STYLE, SIZE, OR COLOR.

FOR POTATO-BASED SNACK FOODS (U.S. CL. 46). FIRST USE 5-0-2014; IN COMMERCE 5-0-2014.

**CLASS 29—(Continued).**

4,593,333. BONAMAR CORPORATION, DORAL, FL. SN 85-632,502. PUB. 5-21-2013, FILED 5-23-2012.

**KAROL**

THE MARK CONSISTS OF STANDARD CHARACTERS WITHOUT CLAIM TO ANY PARTICULAR FONT, STYLE, SIZE, OR COLOR.

FOR SEAFOOD (U.S. CL. 46). FIRST USE 4-1-2013; IN COMMERCE 4-1-2013.

4,593,409. DEL MONTE FOODS, INC., SAN FRANCISCO, CA. SN 85-684,798. PUB. 10-23-2012, FILED 7-23-2012.

**BURSTING WITH LIFE**

THE MARK CONSISTS OF STANDARD CHARACTERS WITHOUT CLAIM TO ANY PARTICULAR FONT, STYLE, SIZE, OR COLOR.

FOR CANNED FRUITS; CANNED FRUITS AND VEGETABLES; CANNED TOMATOES; CANNED, COOKED OR OTHERWISE PROCESSED TOMATOES; DICED TOMATOES; PEELED TOMATOES; PROCESSED VEGETABLES AND FRUITS (U.S. CL. 46). FIRST USE 6-15-2014; IN COMMERCE 6-15-2014.

4,593,562. ORGANIC FRESH FINGERS, INC., SALEM, OR. SN 85-785,141. PUB. 10-29-2013, FILED 11-21-2012.

**WHOLESOME BAKES**

THE MARK CONSISTS OF STANDARD CHARACTERS WITHOUT CLAIM TO ANY PARTICULAR FONT, STYLE, SIZE, OR COLOR.

NO CLAIM IS MADE TO THE EXCLUSIVE RIGHT TO USE "WHOLESOME", APART FROM THE MARK AS SHOWN.

FOR PREPARED AND PREPACKAGED MEALS CONSISTING PRIMARILY OF MEAT, FISH, POULTRY OR VEGETABLES (U.S. CL. 46). FIRST USE 1-1-2014; IN COMMERCE 1-1-2014.

**CLASS 29—(Continued).**

4,593,677. FAIRLIFE, LLC, CHICAGO, IL. SN 85-825,446. PUB. 6-4-2013, FILED 1-17-2013.

# FAIRLIFE

THE MARK CONSISTS OF STANDARD CHARACTERS WITHOUT CLAIM TO ANY PARTICULAR FONT, STYLE, SIZE, OR COLOR.

FOR BEVERAGES CONSISTING PRINCIPALLY OF MILK; BEVERAGES HAVING A MILK BASE; CHOCOLATE MILK; DAIRY PRODUCTS EXCLUDING ICE CREAM, ICE MILK AND FROZEN YOGURT; DAIRY-BASED BEVERAGES; DAIRY-BASED SNACK FOODS EXCLUDING ICE CREAM, ICE MILK AND FROZEN YOGURT; GREEK YOGURT; MILK; MILK BEVERAGES WITH HIGH MILK CONTENT; MILK SHAKES; MILK-BASED BEVERAGES WITH CHOCOLATE; MILK-BASED ENERGY DRINKS; PROTEIN MILK; STRAWBERRY MILK; VANILLA MILK; YOGURT (U.S. CL. 46). FIRST USE 2-15-2014; IN COMMERCE 2-15-2014.

4,593,812. TJ SEVEN INCORPORATION, PINOLE, CA. SN 85-907,345. PUB. 4-1-2014, FILED 4-17-2013.



NO CLAIM IS MADE TO THE EXCLUSIVE RIGHT TO USE "BEST NEST" AND "CHAO", APART FROM THE MARK AS SHOWN.

THE MARK CONSISTS OF AN IMAGE OF TWO SWALLOWS IN FLIGHT, ABOVE THE WORDS "BEST NEST", IN BLOCK UPPER CASE LETTERING, WITH THE LETTERS "B" AND "N" IN A SOMEWHAT LARGER FONT, WITH TWO CHINESE CHARACTERS BELOW THE TERM "BEST", AND TWO SMALLER SWALLOWS IN FLIGHT TO THE RIGHT OF THE CHINESE CHARACTERS.

THE ENGLISH TRANSLATION OF THE CHINESE CHARACTERS IN THE MARK IS "CAVE SWALLOW HOME".

THE NON-LATIN CHARACTERS IN THE MARK TRANSLITERATE TO "DONG CHAO" AND THIS MEANS "CAVE SWALLOW HOME" IN ENGLISH.

FOR EDIBLE BIRD'S NESTS (U.S. CL. 46). FIRST USE 4-15-2014; IN COMMERCE 4-15-2014.

**CLASS 29—(Continued).**

4,593,901. DUTTON III, DAVID H, HILTON HEAD, SC. SN 85-932,025. PUB. 10-22-2013, FILED 5-14-2013.

# CEMENT PICKLES

THE MARK CONSISTS OF STANDARD CHARACTERS WITHOUT CLAIM TO ANY PARTICULAR FONT, STYLE, SIZE, OR COLOR.

NO CLAIM IS MADE TO THE EXCLUSIVE RIGHT TO USE "PICKLES", APART FROM THE MARK AS SHOWN. FOR PICKLED CUCUMBERS; PICKLES (U.S. CL. 46). FIRST USE 6-1-2011; IN COMMERCE 5-1-2014.

4,593,986. DIRECT M. FRESH, S.A. DE C.V., SANTA CATARINA, MEXICO. SN 85-944,829. PUB. 10-22-2013, FILED 5-29-2013.

# MADE WITH A SMILE

THE MARK CONSISTS OF STANDARD CHARACTERS WITHOUT CLAIM TO ANY PARTICULAR FONT, STYLE, SIZE, OR COLOR.

FOR DEHYDRATED FRUIT SNACKS; DRIED FRUIT AND VEGETABLES; DRIED FRUIT MIXES; DRIED FRUIT-BASED SNACKS (U.S. CL. 46). FIRST USE 4-9-2014; IN COMMERCE 4-9-2014.

4,594,045. DAMON MEYER, ASHLAND, OH. SN 85-953,939. PUB. 10-29-2013, FILED 6-7-2013.

# HOMESTEAD SPRINGS

THE MARK CONSISTS OF STANDARD CHARACTERS WITHOUT CLAIM TO ANY PARTICULAR FONT, STYLE, SIZE, OR COLOR.

FOR FISH, NOT LIVE; PORK (U.S. CL. 46). FIRST USE 2-6-2014; IN COMMERCE 2-6-2014.

**CLASS 29—(Continued).**

4,594,141. INDUSTRIAS LACTEAS SAN VICENTE, S.A.,  
24193 NAVATEJERA(LEON), SPAIN. SN 85-971,805. PUB.  
12-10-2013, FILED 6-27-2013.

**CONDE DUQUE**

THE MARK CONSISTS OF STANDARD CHARACTERS  
WITHOUT CLAIM TO ANY PARTICULAR FONT, STYLE,  
SIZE, OR COLOR.

OWNER OF ERPN CMNTY TM OFC REG. NO. 9897984,  
DATED 9-19-2011, EXPIRES 4-15-2021.

THE ENGLISH TRANSLATION OF "CONDE DUQUE" IN  
THE MARK IS "COUNT DUKE".

FOR CHEESES (U.S. CL. 46).

FIRST USE 5-1-2014; IN COMMERCE 5-1-2014.

**CLASS 29—(Continued).**

4,594,484. BUC-EE'S, LTD., LAKE JACKSON, TX. SN 86-  
111,488. PUB. 4-8-2014, FILED 11-6-2013.

**BEAVER CHIPS**

THE MARK CONSISTS OF STANDARD CHARACTERS  
WITHOUT CLAIM TO ANY PARTICULAR FONT, STYLE,  
SIZE, OR COLOR.

OWNER OF U.S. REG. NO. 3,844,978.

NO CLAIM IS MADE TO THE EXCLUSIVE RIGHT TO  
USE "CHIPS", APART FROM THE MARK AS SHOWN.

FOR POTATO CHIPS (U.S. CL. 46).

FIRST USE 2-24-2014; IN COMMERCE 2-24-2014.

4,594,245. FRANK BRUNCKHORST CO., L.L.C., BROOK-  
LYN, NY. SN 86-015,267. PUB. 10-1-2013, FILED 7-19-2013.

**REAL TURKEY. NO SURPRISES.**

THE MARK CONSISTS OF STANDARD CHARACTERS  
WITHOUT CLAIM TO ANY PARTICULAR FONT, STYLE,  
SIZE, OR COLOR.

NO CLAIM IS MADE TO THE EXCLUSIVE RIGHT TO  
USE "TURKEY", APART FROM THE MARK AS SHOWN.

FOR PROCESSED MEAT (U.S. CL. 46).

FIRST USE 9-30-2013; IN COMMERCE 9-30-2013.

4,594,512. MOSEFUND FARM, LLC, BRANCHVILLE, NJ. SN  
86-125,272. PUB. 4-15-2014, FILED 11-21-2013.



NO CLAIM IS MADE TO THE EXCLUSIVE RIGHT TO  
USE "MANGALITSA", APART FROM THE MARK AS  
SHOWN.

THE STIPPLING IS A FEATURE OF THE MARK.

THE COLOR(S) RED, YELLOW, GRAY AND BLACK IS/  
ARE CLAIMED AS A FEATURE OF THE MARK.

THE MARK CONSISTS OF THE ARTISTIC RENDERING  
OF A PIG IN BLACK AND GRAY. THE PIG IS DRAWN TO  
APPEAR WEARING A CROWN IN BLACK AND RED.  
BENEATH THE PIG ARE THE STYLIZED WORDS "MAN-  
GALITSA BY MØSEFUND" IN RED. ALL THE AFORE-  
MENTIONED APPEARS ON A YELLOW BACKGROUND.

THE ENGLISH TRANSLATION OF "MOSEFUND" IN  
THE MARK IS "FROM THE SWAMP".

FOR UNCOOKED HAMBURGER PATTIES; BACON;  
BRATWURST; HAM; FRESH MEAT (U.S. CL. 46).

FIRST USE 6-27-2014; IN COMMERCE 6-27-2014.

**HAPPYMUNCHIES**

THE MARK CONSISTS OF STANDARD CHARACTERS  
WITHOUT CLAIM TO ANY PARTICULAR FONT, STYLE,  
SIZE, OR COLOR.

OWNER OF U.S. REG. NO. 4,150,832.

FOR FREEZE-DRIED FRUITS AND VEGETABLES IN  
THE FORM OF A CHIP (U.S. CL. 46).

FIRST USE 1-31-2013; IN COMMERCE 1-31-2013.

**CLASS 30—STAPLE FOODS**

**CLASS 30—(Continued).**

4,593,139. MRS. LAURALICIOUS, LLC, WEST LINN, OR. SN 85-163,603. PUB. 7-5-2011, FILED 10-28-2010.

**BAKE A-LICIOUS**

THE MARK CONSISTS OF STANDARD CHARACTERS WITHOUT CLAIM TO ANY PARTICULAR FONT, STYLE, SIZE, OR COLOR.

NO CLAIM IS MADE TO THE EXCLUSIVE RIGHT TO USE "BAKE", APART FROM THE MARK AS SHOWN.

FOR FLOUR-BASED MIXES FOR BAKERY GOODS; MIXES FOR BAKERY GOODS; PANCAKE MIXES; PIZZA CRUST MIXES (U.S. CL. 46).

FIRST USE 12-21-2012; IN COMMERCE 12-21-2012.

4,593,140. MRS. LAURALICIOUS, LLC, WEST LINN, OR. SN 85-163,753. PUB. 4-19-2011, FILED 10-28-2010.



THE NAME "MRS. LAURALICIOUS" IDENTIFIES A LIVING INDIVIDUAL WHOSE CONSENT IS OF RECORD.

THE MARK CONSISTS OF THE WORDS "MRS. LAURALICIOUS" IN WHITE LETTERING ATOP A BLACK OVAL SHAPE SURROUNDED BY A WAVY GRAY BORDER. WHITE STARS APPEAR ABOVE THE IS IN "LAURALICIOUS," AND THE WORDS "SCRUMPTIOUS FOODS FOR CHANGING DIETS" APPEAR IN WHITE LETTERING ALONG THE LOWER BORDER OF THE OVAL.

FOR FLOUR-BASED MIXES FOR BAKERY GOODS; MIXES FOR BAKERY GOODS; PIZZA CRUST MIXES; PANCAKE MIXES (U.S. CL. 46).

FIRST USE 12-21-2012; IN COMMERCE 12-21-2012.

4,593,200. LA TAPATIA TORTILLERIA, INC., FRESNO, CA. SN 85-325,494. PUB. 10-25-2011, FILED 5-19-2011.

**OPCIONES MAS SALUDABLES**

THE MARK CONSISTS OF STANDARD CHARACTERS WITHOUT CLAIM TO ANY PARTICULAR FONT, STYLE, SIZE, OR COLOR.

NO CLAIM IS MADE TO THE EXCLUSIVE RIGHT TO USE "SALUDABLES", APART FROM THE MARK AS SHOWN.

**CLASS 30—(Continued).**

THE ENGLISH TRANSLATION OF "OPCIONES MAS SALUDABLES" IN THE MARK IS "MORE HEALTHY OPTIONS".

FOR TORTILLA CHIPS (U.S. CL. 46).  
FIRST USE 7-1-2014; IN COMMERCE 7-1-2014.

4,593,201. LA TAPATIA TORTILLERIA, INC., FRESNO, CA. SN 85-325,496. PUB. 9-27-2011, FILED 5-19-2011.

**HEALTHIER OPTIONS**

THE MARK CONSISTS OF STANDARD CHARACTERS WITHOUT CLAIM TO ANY PARTICULAR FONT, STYLE, SIZE, OR COLOR.

FOR TORTILLA CHIPS (U.S. CL. 46).  
FIRST USE 7-1-2014; IN COMMERCE 7-1-2014.

4,593,246. TEA SECTION, AUSTIN, TX. SN 85-472,356. PUB. 4-24-2012, FILED 11-14-2011.

**Tea Section**

THE MARK CONSISTS OF STANDARD CHARACTERS WITHOUT CLAIM TO ANY PARTICULAR FONT, STYLE, SIZE, OR COLOR.

NO CLAIM IS MADE TO THE EXCLUSIVE RIGHT TO USE "TEA", APART FROM THE MARK AS SHOWN.

FOR TEA, BLACK TEA, TEA BAGS, GREEN TEA, ORGANIC TEA, INSTANT TEA, LOOSE TEA, ICE TEA, FRUIT TEA, HERBAL TEA (U.S. CL. 46).

FIRST USE 11-1-2012; IN COMMERCE 11-14-2012.

4,593,384. KONOPELSKI, STEVEN, BAYVILLE, NY. SN 85-662,633. PUB. 11-20-2012, FILED 6-27-2012.

**CANNOLIO**

THE MARK CONSISTS OF STANDARD CHARACTERS WITHOUT CLAIM TO ANY PARTICULAR FONT, STYLE, SIZE, OR COLOR.

FOR COOKIES; PASTRIES (U.S. CL. 46).  
FIRST USE 6-0-2012; IN COMMERCE 5-0-2014.

**CLASS 30—(Continued).**

4,593,566. BIANCO, MARY, LAS VEGAS, NV. AND BIANCO, MALEAH, LAS VEGAS, NV. SN 85-789,053. PUB. 10-22-2013, FILED 11-28-2012.



NO CLAIM IS MADE TO THE EXCLUSIVE RIGHT TO USE "SINCE 1952" AND "ITALIAN DRESSINGS", APART FROM THE MARK AS SHOWN.

THE COLOR(S) TURQUOISE, BLACK, DARK RED, AND WHITE IS/ARE CLAIMED AS A FEATURE OF THE MARK.

THE MARK CONSISTS OF A VERTICAL BLACK BAR OVERLAPPED BY THREE RECTANGLES OUTLINED IN BLACK. INSIDE THE TOP RECTANGLE IS THE DARK RED STYLIZED TEXT "BIANCO'S" UNDERLINED IN TURQUOISE. INSIDE THE SECOND RECTANGLE IS THE DARK RED STYLIZED TEXT "ITALIAN". INSIDE THE THIRD RECTANGLE IS THE DARK RED STYLIZED TEXT "DRESSINGS". TO THE RIGHT OF THE BLACK BAR IS A TURQUOISE ARROW. ABOVE THE TOP RECTANGLE IS A RECTANGLE OUTLINED IN BLACK CONTAINING THE DARK RED STYLIZED TEXT "SINCE 1952". ABOVE THIS RECTANGLE IS A BLACK LINE ATTACHED TO A TURQUOISE CIRCLE. ALL THE IMAGES AND TEXT ARE CONTAINED IN A TURQUOISE OVAL WITH A WHITE BACKGROUND.

FOR GARLIC ITALIAN SALAD DRESSINGS; THOUSAND ISLAND SALAD DRESSINGS; BLUE CHEESE SALAD DRESSINGS (U.S. CL. 46).

FIRST USE 11-1-2012; IN COMMERCE 12-1-2012.

4,593,610. LAND OF THOUSAND HILLS COFFEE COMPANY, INC., ROSWELL, GA. SN 85-802,767. PUB. 11-19-2013, FILED 12-14-2012.



OWNER OF U.S. REG. NOS. 3,668,238, 3,981,608, AND 4,082,258.

**CLASS 30—(Continued).**

THE MARK CONSISTS OF THE LETTERS "CT" ENCOMPASSED BY A CIRCLE WITH A PAIR OF ARROWS.

FOR COFFEE; COFFEE AND TEA; COFFEE BASED BEVERAGES; COFFEE BEANS; COFFEE PODS; GROUND COFFEE BEANS; ROASTED COFFEE BEANS; UNROASTED COFFEE (U.S. CL. 46).

FIRST USE 7-15-2013; IN COMMERCE 7-31-2013.

4,593,681. BELL FOODS INTERNATIONAL, INC., GERVIAS, OR. SN 85-826,294. PUB. 6-18-2013, FILED 1-17-2013.

## Mr. Jalapeno

THE MARK CONSISTS OF STANDARD CHARACTERS WITHOUT CLAIM TO ANY PARTICULAR FONT, STYLE, SIZE, OR COLOR.

NO CLAIM IS MADE TO THE EXCLUSIVE RIGHT TO USE "JALAPENO", APART FROM THE MARK AS SHOWN. FOR HOT SAUCE; PICANTE SAUCE; PICO DE GALLO SAUCE; SALSA (U.S. CL. 46).

FIRST USE 3-1-2014; IN COMMERCE 6-1-2014.

4,593,690. WIESER & ZELZNICK, INC., CHICAGO, IL. SN 85-833,805. PUB. 6-25-2013, FILED 1-28-2013.

## S. Paul's Beauté de la mer

THE MARK CONSISTS OF STANDARD CHARACTERS WITHOUT CLAIM TO ANY PARTICULAR FONT, STYLE, SIZE, OR COLOR.

THE NAME "S. PAUL" IDENTIFIES A LIVING INDIVIDUAL WHOSE CONSENT IS OF RECORD.

THE ENGLISH TRANSLATION OF "BEAUTE DE LA MER" IN THE MARK IS "BEAUTY OF THE SEA".

FOR SAUCES (U.S. CL. 46).

FIRST USE 6-8-2014; IN COMMERCE 6-8-2014.

**CLASS 30—(Continued).**

4,593,818. D-MAC MARKETING, LLC., BETHLEHEM, PA. SN 85-910,243. PUB. 4-1-2014, FILED 4-21-2013.

## Simply Less

THE MARK CONSISTS OF STANDARD CHARACTERS WITHOUT CLAIM TO ANY PARTICULAR FONT, STYLE, SIZE, OR COLOR.

FOR SALT (U.S. CL. 46).

FIRST USE 12-27-2013; IN COMMERCE 12-27-2013.

---

4,593,822. JOBLING, PETER G., OAKVILLE, ONTARIO, CANADA. SN 85-912,333. PUB. 10-15-2013, FILED 4-23-2013.

## CAMLLOW

THE MARK CONSISTS OF STANDARD CHARACTERS WITHOUT CLAIM TO ANY PARTICULAR FONT, STYLE, SIZE, OR COLOR.

OWNER OF CANADA REG. NO. TMA849443, DATED 4-25-2013, EXPIRES 4-25-2028.

THE WORDING "CAMLLOW" HAS NO MEANING IN A FOREIGN LANGUAGE.

FOR FOOD ADDITIVES, NAMELY, SALT SUBSTITUTES AND MSG SUBSTITUTES FOR USE AS A FLAVORING FOR FOOD; FOOD ADDITIVES, NAMELY, SALT SUBSTITUTES AND MSG SUBSTITUTES FOR NON-NUTRITIONAL PURPOSES FOR USE AS A FLAVORING FOR FOOD; FLAVOR ENHANCERS USED IN FOOD AND BEVERAGE PRODUCTS; FLAVORING ADITIVES FOR NON-NUTRITIONAL PURPOSES; FOOD FLAVORINGS (U.S. CL. 46).

FIRST USE 9-20-2011; IN COMMERCE 4-23-2014.

---

4,593,823. WEAVER POPCORN COMPANY, INC., NOBLESVILLE, IN. SN 85-912,465. PUB. 9-24-2013, FILED 4-23-2013.

## CRISPY POPS

THE MARK CONSISTS OF STANDARD CHARACTERS WITHOUT CLAIM TO ANY PARTICULAR FONT, STYLE, SIZE, OR COLOR.

NO CLAIM IS MADE TO THE EXCLUSIVE RIGHT TO USE "CRISPY", APART FROM THE MARK AS SHOWN.

FOR POPPED POPCORN (U.S. CL. 46).

FIRST USE 7-16-2013; IN COMMERCE 7-16-2013.

**CLASS 30—(Continued).**

4,593,840. LOVE HENS, ORANGE, CA. SN 85-918,316. PUB. 4-15-2014, FILED 4-30-2013.

## LOVE HENS

THE MARK CONSISTS OF STANDARD CHARACTERS WITHOUT CLAIM TO ANY PARTICULAR FONT, STYLE, SIZE, OR COLOR.

FOR CEREAL PREPARATIONS, NAMELY, BREAKFAST CEREAL; CEREAL-BASED SNACK FOOD; SNACK BARS, NAMELY, GRANOLA-BASED SNACK BARS; SALAD DRESSINGS; MIXES FOR MAKING BAKING BATTERS; MUFFINS; BREAD; FOOD BARS, NAMELY, READY TO EAT, CEREAL DERIVED FOOD BARS; RICE AND OATMEAL PORRIDGE (U.S. CL. 46).

FIRST USE 2-12-2014; IN COMMERCE 2-12-2014.

---

4,593,902. DUTTON III, DAVID H, HILTON HEAD, SC. SN 85-932,028. PUB. 10-22-2013, FILED 5-14-2013.

## CEMENT PICKLE RELISH

THE MARK CONSISTS OF STANDARD CHARACTERS WITHOUT CLAIM TO ANY PARTICULAR FONT, STYLE, SIZE, OR COLOR.

NO CLAIM IS MADE TO THE EXCLUSIVE RIGHT TO USE "PICKLE RELISH", APART FROM THE MARK AS SHOWN.

FOR PICKLE RELISH; RELISH (U.S. CL. 46).

FIRST USE 6-1-2011; IN COMMERCE 5-1-2014.

---

4,593,994. MORRIS INTERNATIONAL, INC., DAVIDSON, NC. SN 85-946,052. PUB. 11-5-2013, FILED 5-30-2013.

## NOAH EMERGENCY MEDICAL MEAL PLAN

THE MARK CONSISTS OF STANDARD CHARACTERS WITHOUT CLAIM TO ANY PARTICULAR FONT, STYLE, SIZE, OR COLOR.

NO CLAIM IS MADE TO THE EXCLUSIVE RIGHT TO USE "EMERGENCY MEDICAL MEAL PLAN", APART FROM THE MARK AS SHOWN.

FOR DISASTER PREPAREDNESS SUPPLIES AND EMERGENCY SURVIVAL SUPPLIES KIT COMPRISING OF INSTANT OATMEAL, INSTANT DRIED MILK, CEREAL, SOUPS, CHILI, TACOS, FREEZE-DRIED DICED CHICKEN AND GROUND BEEF, WATER, TEA, SODA, LEMONADE, BEEF BROTH, CHICKEN BROTH, PUDDING, POWDERED EGGS, LONG GRAIN RICE, UNPROCESSED PINTO BEANS, DRIED PINTO BEANS, SEA SALT FOR COOKING, SUGAR, GROUND COFFEE BEANS, AND FREEZE-DRIED INSTANT MEALS (U.S. CL. 46).

FIRST USE 2-0-2013; IN COMMERCE 2-0-2013.

**CLASS 30—(Continued).**

4,594,064. S-L SNACKS NATIONAL, LLC, CHARLOTTE, NC.  
SN 85-957,437. PUB. 11-5-2013, FILED 6-12-2013.

**DUNK YOUR D'ORO**

THE MARK CONSISTS OF STANDARD CHARACTERS WITHOUT CLAIM TO ANY PARTICULAR FONT, STYLE, SIZE, OR COLOR.

OWNER OF U.S. REG. NOS. 2,180,713, 3,092,963, AND 4,192,872.

THE ENGLISH TRANSLATION OF "D'ORO" IN THE MARK IS "OF GOLD".

FOR BISCOTTI; BREADSTICKS; COOKIES (U.S. CL. 46).

FIRST USE 8-31-2013; IN COMMERCE 8-31-2013.

4,594,065. S-L SNACKS NATIONAL, LLC, CHARLOTTE, NC.  
SN 85-957,448. PUB. 11-5-2013, FILED 6-12-2013.

**HOW DO YOU DUNK YOUR D'ORO?**

THE MARK CONSISTS OF STANDARD CHARACTERS WITHOUT CLAIM TO ANY PARTICULAR FONT, STYLE, SIZE, OR COLOR.

OWNER OF U.S. REG. NOS. 2,180,713, 3,092,963, AND 4,192,872.

THE ENGLISH TRANSLATION OF "D'ORO" IN THE MARK IS "OF GOLD".

FOR BISCOTTI; BREADSTICKS; COOKIES (U.S. CL. 46).

FIRST USE 8-31-2013; IN COMMERCE 8-31-2013.

4,594,095. GOURMENT BEVERAGES, L.L.C., MISSOULA, MT.  
SN 85-962,520. PUB. 11-5-2013, FILED 6-18-2013.



The logo for Mountain Perk features the words "Mountain Perk" in a dark brown, slightly irregular, handwritten-style font. To the right of the word "Perk" is a stylized coffee cup icon with a small steam bubble rising from it. The cup is dark brown with a white interior and a white steam bubble.

THE COLOR(S) DARK BROWN, REDDISH BROWN AND GRAY IS/ARE CLAIMED AS A FEATURE OF THE MARK.

THE MARK CONSISTS OF THE WORDING "MOUNTAIN PERKS" WITH THE WORD "MOUNTAIN" IN A DARK BROWN COLOR AND THE WORD "PERKS" IN REDDISH BROWN COLOR WITH THE STYLIZED S AS THE HANDLE OF A STYLIZED COFFEE CUP ALONG WITH A GRAY TOP OF COFFEE CUP WITH A GRAY STEAM SYMBOL APPEARING ABOVE THE STYLIZED COFFEE CUP.

FOR COFFEE; TEA; CAPPUCCINO; HOT CHOCOLATE; WHOLE BEAN COFFEE; AND GROUND COFFEE (U.S. CL. 46).

FIRST USE 10-12-2013; IN COMMERCE 2-11-2014.

**CLASS 30—(Continued).**

4,594,107. MEATBALL MANAGEMENT LLC, BROOKLYN, NY.  
SN 85-964,106. PUB. 11-12-2013, FILED 6-19-2013.



OWNER OF U.S. REG. NOS. 3,862,272, 4,037,569, AND 4,225,456.

NO CLAIM IS MADE TO THE EXCLUSIVE RIGHT TO USE "MEATBALL SHOP", APART FROM THE MARK AS SHOWN.

THE MARK CONSISTS OF IN ALL CAPITAL LETTERS, THE WORD "THE" IS ABOVE THE BLOCK LETTERS "TMS" WHICH ARE SHADED WITH DIAGONAL LINES AND THE WORD "SHOP" IS DIRECTLY BELOW THE LETTERS "TMS". THE WORD "MEATBALL" IS IN BOLD AND IS FRAMED IN FILAGREE ON TOP OF THE LETTERS "TMS".

FOR TOMATO SAUCE; SAUCES CONTAINING MEATBALLS (U.S. CL. 46).

FIRST USE 2-1-2014; IN COMMERCE 4-1-2014.

4,594,114. TOPCO HOLDINGS, INC., ELK GROVE VILLAGE, IL.  
SN 85-967,805. PUB. 10-8-2013, FILED 6-24-2013.

**SEA BUDDIES**

THE MARK CONSISTS OF STANDARD CHARACTERS WITHOUT CLAIM TO ANY PARTICULAR FONT, STYLE, SIZE, OR COLOR.

FOR CRACKERS (U.S. CL. 46).

FIRST USE 2-0-2014; IN COMMERCE 2-0-2014.

4,594,115. TOPCO HOLDINGS, INC., ELK GROVE VILLAGE, IL.  
SN 85-967,818. PUB. 10-8-2013, FILED 6-24-2013.

**NOSTIMO**

THE MARK CONSISTS OF STANDARD CHARACTERS WITHOUT CLAIM TO ANY PARTICULAR FONT, STYLE, SIZE, OR COLOR.

OWNER OF U.S. REG. NO. 4,226,441.

FOR FROZEN YOGURT; FROZEN YOGURT CONFECTIONS (U.S. CL. 46).

FIRST USE 7-0-2013; IN COMMERCE 7-0-2013.

**CLASS 30—(Continued).**

4,594,118. ROBBINS RICE COMPANY, COLUSA, CA. SN 85-968,280. PUB. 11-26-2013, FILED 6-24-2013.

**BLACK FOX BRAND**

THE MARK CONSISTS OF STANDARD CHARACTERS WITHOUT CLAIM TO ANY PARTICULAR FONT, STYLE, SIZE, OR COLOR.

NO CLAIM IS MADE TO THE EXCLUSIVE RIGHT TO USE "BRAND", APART FROM THE MARK AS SHOWN. FOR RICE (U.S. CL. 46).  
FIRST USE 2-1-2014; IN COMMERCE 6-5-2014.

4,594,133. POST FOODS, LLC, PARSIPPANY, NJ. SN 85-970,406. PUB. 11-12-2013, FILED 6-26-2013.

**ATTUNE FOODS**

THE MARK CONSISTS OF STANDARD CHARACTERS WITHOUT CLAIM TO ANY PARTICULAR FONT, STYLE, SIZE, OR COLOR.

OWNER OF U.S. REG. NOS. 3,287,144, 3,336,806, AND 4,324,732.

NO CLAIM IS MADE TO THE EXCLUSIVE RIGHT TO USE "FOODS", APART FROM THE MARK AS SHOWN. FOR CHOCOLATE BARS; CRACKERS; BREAKFAST CEREALS; READY-TO-EAT CEREALS; PROCESSED CEREALS; GRANOLA (U.S. CL. 46).  
FIRST USE 10-31-2006; IN COMMERCE 10-31-2006.

4,594,199. KELLOGG NORTH AMERICA COMPANY, BATTLE CREEK, MI. SN 86-002,386. PUB. 11-12-2013, FILED 7-3-2013.

**MUNCH ZONE**

THE MARK CONSISTS OF STANDARD CHARACTERS WITHOUT CLAIM TO ANY PARTICULAR FONT, STYLE, SIZE, OR COLOR.

FOR BREAKFAST CEREALS; CEREAL-BASED SNACK FOODS; PROCESSED CEREAL-BASED FOOD TO BE USED AS A BREAKFAST FOOD, SNACK FOOD OR INGREDIENT FOR MAKING OTHER FOODS (U.S. CL. 46).  
FIRST USE 11-30-2013; IN COMMERCE 11-30-2013.

**CLASS 30—(Continued).**

4,594,203. RUIZ FOOD PRODUCTS, INC., DINUBA, CA. SN 86-003,294. PUB. 11-26-2013, FILED 7-5-2013.

**SIERRA GRANDE**

THE MARK CONSISTS OF STANDARD CHARACTERS WITHOUT CLAIM TO ANY PARTICULAR FONT, STYLE, SIZE, OR COLOR.

FOR MEXICAN FOOD PRODUCTS, NAMELY, TAQUITOS (U.S. CL. 46).  
FIRST USE 1-20-2014; IN COMMERCE 1-20-2014.

4,594,209. IMPACT CONFECTIONS, INC., LITTLETON, CO. SN 86-005,218. PUB. 12-17-2013, FILED 7-9-2013.

**PUCKER PACKS**

THE MARK CONSISTS OF STANDARD CHARACTERS WITHOUT CLAIM TO ANY PARTICULAR FONT, STYLE, SIZE, OR COLOR.

NO CLAIM IS MADE TO THE EXCLUSIVE RIGHT TO USE "PACKS", APART FROM THE MARK AS SHOWN. FOR CANDY (U.S. CL. 46).  
FIRST USE 1-1-2014; IN COMMERCE 1-1-2014.

4,594,278. GRUMA, S.A.B. DE C.V., SAN PEDRO GARZA GARCÍA, N.L., MEXICO. SN 86-033,494. PUB. 12-31-2013, FILED 8-9-2013.



THE MARK CONSISTS OF A CHARACTER DESIGN WHICH IS CIRCULAR IN SHAPE HAVING A FACE, TWO ARMS AND TWO FEET.

FOR TOSTADAS (U.S. CL. 46).  
FIRST USE 2-0-2014; IN COMMERCE 2-0-2014.



**CLASS 30—(Continued).**

4,594,287. ROCCO & LOLA, AUSTIN, TX. SN 86-036,935. PUB. 1-28-2014, FILED 8-13-2013.

**Rocco & Lola Fine Foods**

THE MARK CONSISTS OF STANDARD CHARACTERS WITHOUT CLAIM TO ANY PARTICULAR FONT, STYLE, SIZE, OR COLOR.

NO CLAIM IS MADE TO THE EXCLUSIVE RIGHT TO USE "FINE FOODS", APART FROM THE MARK AS SHOWN.

FOR BREAD CRUMBS; SEASONED COATING FOR MEAT, FISH, POULTRY; SEASONED COATING MIXTURES FOR FOODS (U.S. CL. 46).

FIRST USE 9-19-2013; IN COMMERCE 9-19-2013.

**CLASS 30—(Continued).**

4,594,382. CAPITAL RICE CO., LTD., BANGKOK 10600, THAILAND. SN 86-077,341. PUB. 3-25-2014, FILED 9-27-2013.

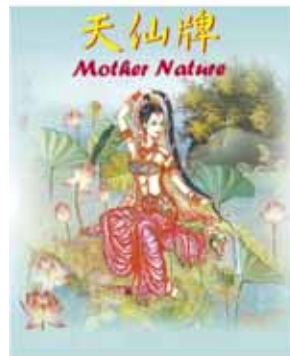

THE NAME(S), PORTRAIT(S), AND/OR SIGNATURE(S) SHOWN IN THE MARK DOES NOT IDENTIFY A PARTICULAR LIVING INDIVIDUAL.

THE COLOR(S) BLACK, RED, GREEN, BLUE AND YELLOW IS/ARE CLAIMED AS A FEATURE OF THE MARK.

THE MARK CONSISTS OF AN IMAGE OF A SEATED WOMAN WITH BLACK HAIR WEARING RED PANTS AND A GREEN BIKINI TOP, WITH JEWELS AND JEWELRY ON THE CLOTHING AND ON THE WOMAN, SURROUNDED BY GREEN PLANTS AND RED FLOWERS AGAINST A BLUE SKY BACKGROUND; ABOVE THE IMAGE ARE YELLOW CHINESE LETTERS OUTLINED IN RED AND THE WORDS "MOTHER NATURE" IN RED LETTERS.

THE NON-LATIN CHARACTERS IN THE MARK TRANSLITERATE TO TIAN ZIAN AND THIS MEANS ANGEL IN ENGLISH.

FOR RICE (U.S. CL. 46).

FIRST USE 1-31-2012; IN COMMERCE 1-31-2012.

4,594,329. FANSHAWE FOODS LLC, NEW YORK, NY. SN 86-056,739. PUB. 11-5-2013, FILED 9-5-2013.

**Yum Bunny**

THE MARK CONSISTS OF STANDARD CHARACTERS WITHOUT CLAIM TO ANY PARTICULAR FONT, STYLE, SIZE, OR COLOR.

FOR DULCE DE LECHE (U.S. CL. 46).

FIRST USE 9-1-2013; IN COMMERCE 9-1-2013.

4,594,406. RED DIAMOND, INC., MOODY, AL. SN 86-086,691. PUB. 3-25-2014, FILED 10-9-2013.

**THE WORLD'S MOST REFRESHING TEA**

4,594,352. JTM FOODS LLC, ERIE, PA. SN 86-065,371. PUB. 3-25-2014, FILED 9-16-2013.

**TID-BITS MINI SNACK PIES**

THE MARK CONSISTS OF STANDARD CHARACTERS WITHOUT CLAIM TO ANY PARTICULAR FONT, STYLE, SIZE, OR COLOR.

NO CLAIM IS MADE TO THE EXCLUSIVE RIGHT TO USE "MINI SNACK PIES", APART FROM THE MARK AS SHOWN.

FOR FRUIT PIES (U.S. CL. 46).

FIRST USE 1-29-2014; IN COMMERCE 1-29-2014.

THE MARK CONSISTS OF STANDARD CHARACTERS WITHOUT CLAIM TO ANY PARTICULAR FONT, STYLE, SIZE, OR COLOR.

NO CLAIM IS MADE TO THE EXCLUSIVE RIGHT TO USE "TEA", APART FROM THE MARK AS SHOWN.

FOR TEA (U.S. CL. 46).

FIRST USE 11-4-2013; IN COMMERCE 11-4-2013.

**CLASS 30—(Continued).**

4,594,407. COGNITEA, LLC, NEEDHAM, MA. SN 86-086,706. PUB. 3-11-2014, FILED 10-9-2013.

# COGNITEA

THE MARK CONSISTS OF STANDARD CHARACTERS WITHOUT CLAIM TO ANY PARTICULAR FONT, STYLE, SIZE, OR COLOR.

FOR TEA; TEA-BASED BEVERAGES (U.S. CL. 46).  
FIRST USE 3-7-2014; IN COMMERCE 3-7-2014.

4,594,435. NASSAU CANDY DISTRIBUTORS, INC., HICKSVILLE, NY. SN 86-096,204. PUB. 3-11-2014, FILED 10-20-2013.



NO CLAIM IS MADE TO THE EXCLUSIVE RIGHT TO USE "CANDY", APART FROM THE MARK AS SHOWN.

THE MARK CONSISTS OF THE WORDS "CLEVER CANDY" IN STYLIZED FONT APPEARING WITHIN A CLOUD-SHAPED BUBBLE. AN IMAGE OF A LIGHT BULB IS POSITIONED OVER THE "V" IN "CLEVER", AND AN IMAGE OF A MOUTH AND TONGUE ARE POSITIONED UNDER THE "V" IN "CLEVER".

FOR CHOCOLATE AND CHOCOLATES; CHOCOLATE BARS; CANDY MINTS; GUMMY CANDIES; CANDY, NAMELY, CARAMEL DROPS (U.S. CL. 46).

FIRST USE 10-31-2013; IN COMMERCE 10-31-2013.

4,594,438. SINGLE CUP COFFEE LIMITED, OTTAWA, ONTARIO, CANADA. SN 86-097,409. PUB. 4-15-2014, FILED 10-22-2013.

# GUY'S AMERICAN DINER BLEND

THE MARK CONSISTS OF STANDARD CHARACTERS WITHOUT CLAIM TO ANY PARTICULAR FONT, STYLE, SIZE, OR COLOR.

NO CLAIM IS MADE TO THE EXCLUSIVE RIGHT TO USE "AMERICAN DINER BLEND", APART FROM THE MARK AS SHOWN.

FOR COFFEE (U.S. CL. 46).

FIRST USE 1-19-2014; IN COMMERCE 1-19-2014.

**CLASS 30—(Continued).**

4,594,448. SMARTPRICE SALES AND MARKETING, NORTHBROOK, IL. SN 86-099,445. PUB. 4-15-2014, FILED 10-23-2013.



NO CLAIM IS MADE TO THE EXCLUSIVE RIGHT TO USE "DOLCE", APART FROM THE MARK AS SHOWN.

THE COLOR(S) WHITE, NAVY BLUE, GOLD, LIGHT PURPLE IS/ARE CLAIMED AS A FEATURE OF THE MARK.

THE MARK CONSISTS OF THE WORDS "DOLCE TUSCANO" IN A STYLIZED WHITE FONT. THE WORDS ARE PRESENTED IN A NAVY BLUE SHADED RECTANGULAR LIKE IMAGE. THE WORD "DOLCE" IS PRESENTED ABOVE THE WORD "TUSCANO". TO THE LEFT AND RIGHT OF THE WORD "DOLCE" ARE TWO LIGHT PURPLE CURVED LIKE IMAGE SHAPES. THE RECTANGULAR IMAGE IS OUTLINED IN GOLD. THE TOP OF THE RECTANGULAR SHAPE PRESENTS A GOLD ORNATE CROWN LIKE IMAGE.

THE ENGLISH TRANSLATION OF THE WORD "DOLCE" IN THE MARK IS "SWEET". THE WORDING "TUSCANO" HAS NO MEANING IN A FOREIGN LANGUAGE.

FOR CAKES; CHOCOLATE; CHOCOLATE COVERED NUTS; CHOCOLATE-BASED SPREAD ALSO CONTAINING NUTS; CINNAMON-COATED NUTS; COFFEE; COOKIES; CRACKERS; CREAM PUFFS; ECLAIRS; GOLDEN SYRUP; MAPLE SYRUP; MOLASSES SYRUP; PANCAKE SYRUP; PASTRIES; STARCH SYRUP; SUGARED NUTS; TRAIL MIX CONSISTING PRIMARILY OF GRANOLA, AND ALSO INCLUDING DRIED FRUIT, CHOCOLATE, PROCESSED NUTS; TRAIL MIX CONSISTING PRIMARILY OF PRETZELS, POPCORN, AND CRACKERS, AND ALSO INCLUDING DRIED FRUIT, CHOCOLATE, PROCESSED NUTS (U.S. CL. 46).

FIRST USE 2-1-2014; IN COMMERCE 2-1-2014.

4,594,521. ANGELIC BAKEHOUSE, INC., CUDAHY, WI. SN 86-130,778. PUB. 4-22-2014, FILED 11-27-2013.

# FLATZZA

THE MARK CONSISTS OF STANDARD CHARACTERS WITHOUT CLAIM TO ANY PARTICULAR FONT, STYLE, SIZE, OR COLOR.

FOR BAKERY GOODS MADE FROM FLOUR AND/OR WHOLE OR SPROUTED GRAINS (U.S. CL. 46).

FIRST USE 9-30-2013; IN COMMERCE 12-6-2013.

**CLASS 30—(Continued).**

4,594,529. CAROLINE'S, INC., SPARTANBURG, SC. SN 86-135,349. PUB. 3-18-2014, FILED 12-4-2013.

Any way you slice it

THE MARK CONSISTS OF STANDARD CHARACTERS WITHOUT CLAIM TO ANY PARTICULAR FONT, STYLE, SIZE, OR COLOR.

FOR CAKES; CUP CAKES; PASTRIES; SANDWICHES (U.S. CL. 46).

FIRST USE 11-1-2013; IN COMMERCE 11-1-2013.

4,594,552. 3 ZEROS CORP, BIRMINGHAM, MI. SN 86-975,281. PUB. 12-17-2013, FILED 7-30-2013.

3 Zeros

THE MARK CONSISTS OF STANDARD CHARACTERS WITHOUT CLAIM TO ANY PARTICULAR FONT, STYLE, SIZE, OR COLOR.

FOR SALAD DRESSING; SALAD DRESSINGS; SALAD SAUCES (U.S. CL. 46).

FIRST USE 10-1-2013; IN COMMERCE 10-1-2013.

**CLASS 31—NATURAL AGRICULTURAL PRODUCTS**

4,593,544. EXPORTADORA RIO BLANCO LTDA., SANTIAGO, CHILE. SN 85-777,063. PUB. 4-16-2013, FILED 11-12-2012.

NORTFRUT

THE MARK CONSISTS OF STANDARD CHARACTERS WITHOUT CLAIM TO ANY PARTICULAR FONT, STYLE, SIZE, OR COLOR.

FOR FRESH FRUITS AND VEGETABLES (U.S. CLS. 1 AND 46).

FIRST USE 12-23-2013; IN COMMERCE 12-23-2013.

**CLASS 31—(Continued).**

4,593,631. FLORISTS' TRANSWORLD DELIVERY, INC., DOWNERS GROVE, IL. SN 85-807,180. PUB. 10-29-2013, FILED 12-19-2012.

THE FTD ROSE

THE MARK CONSISTS OF STANDARD CHARACTERS WITHOUT CLAIM TO ANY PARTICULAR FONT, STYLE, SIZE, OR COLOR.

NO CLAIM IS MADE TO THE EXCLUSIVE RIGHT TO USE "ROSE", APART FROM THE MARK AS SHOWN.

FOR FLOWERS, NAMELY, LIVE ROSES, ROSE BOUQUETS AND ARRANGEMENTS (U.S. CLS. 1 AND 46).

FIRST USE 1-0-2013; IN COMMERCE 1-0-2013.

4,593,742. ATLANTIC PRODUCE EXCHANGE, LLC, TALLAHASSEE, FL. SN 85-862,990. PUB. 4-22-2014, FILED 2-28-2013.

Sweet Ones

THE MARK CONSISTS OF STANDARD CHARACTERS WITHOUT CLAIM TO ANY PARTICULAR FONT, STYLE, SIZE, OR COLOR.

NO CLAIM IS MADE TO THE EXCLUSIVE RIGHT TO USE "SWEET", APART FROM THE MARK AS SHOWN.

FOR FRUITS, NAMELY, FRESH WATERMELON (U.S. CLS. 1 AND 46).

FIRST USE 3-1-2013; IN COMMERCE 5-1-2013.

4,593,920. ROLF C. HAGEN INC., MONTREAL, QUEBEC, CANADA. SN 85-936,430. PUB. 1-21-2014, FILED 5-20-2013.

NUTRIENCE

THE MARK CONSISTS OF STANDARD CHARACTERS WITHOUT CLAIM TO ANY PARTICULAR FONT, STYLE, SIZE, OR COLOR.

OWNER OF U.S. REG. NOS. 1,571,451, 1,592,224, AND 2,731,392.

SEC. 2(F).

FOR PET FOOD (U.S. CLS. 1 AND 46).

FIRST USE 3-0-2014; IN COMMERCE 3-0-2014.

**CLASS 31—(Continued).**

4,594,021. A. DUDA & SONS, INC., OVIEDO, FL. SN 85-951,260. PUB. 10-29-2013, FILED 6-5-2013.

### NATURALLY SWEETER & CRISPIER

THE MARK CONSISTS OF STANDARD CHARACTERS WITHOUT CLAIM TO ANY PARTICULAR FONT, STYLE, SIZE, OR COLOR.

FOR FRESH FRUITS AND FRESH VEGETABLES (U.S. CLS. 1 AND 46).

FIRST USE 5-0-2013; IN COMMERCE 5-0-2013.

---

4,594,117. PROGRESSIVE PRODUCE CORPORATION, LOS ANGELES, CA. SN 85-968,156. PUB. 12-3-2013, FILED 6-24-2013.

### MICRO BAKER BITES

THE MARK CONSISTS OF STANDARD CHARACTERS WITHOUT CLAIM TO ANY PARTICULAR FONT, STYLE, SIZE, OR COLOR.

OWNER OF U.S. REG. NO. 2,963,292.  
NO CLAIM IS MADE TO THE EXCLUSIVE RIGHT TO USE "BITES", APART FROM THE MARK AS SHOWN.

FOR FRESH VEGETABLES (U.S. CLS. 1 AND 46).

FIRST USE 9-24-2013; IN COMMERCE 9-24-2014.

---

4,594,231. SUSTAINABLE SWINE RESOURCES, LLC, LAKE MILLS, WI. SN 86-011,477. PUB. 12-24-2013, FILED 7-16-2013.



NO CLAIM IS MADE TO THE EXCLUSIVE RIGHT TO USE "SUSTAINABLE SWINE", APART FROM THE MARK AS SHOWN.

THE MARK CONSISTS OF THE WORDS "SUSTAINABLE SWINE RESOURCES" UNDERNEATH A PIG AND SUN DESIGN.

FOR ANIMAL FEED (U.S. CLS. 1 AND 46).

FIRST USE 6-27-2014; IN COMMERCE 6-27-2014.

**CLASS 31—(Continued).**

4,594,274. THE IAMS COMPANY, CINCINNATI, OH. SN 86-032,452. PUB. 10-29-2013, FILED 8-8-2013.

### EUKANUBA RESILIENCE

THE MARK CONSISTS OF STANDARD CHARACTERS WITHOUT CLAIM TO ANY PARTICULAR FONT, STYLE, SIZE, OR COLOR.

OWNER OF U.S. REG. NOS. 970,296, 3,418,989, AND 3,644,236.

FOR ANIMAL FOODSTUFFS (U.S. CLS. 1 AND 46).

FIRST USE 1-6-2014; IN COMMERCE 1-6-2014.

---

4,594,313. C. L. HENDERSON PRODUCE, LLC, HENDERSONVILLE, NC. SN 86-047,900. PUB. 1-14-2014, FILED 8-26-2013.

### LITTLE CRUNCHERS

THE MARK CONSISTS OF STANDARD CHARACTERS WITHOUT CLAIM TO ANY PARTICULAR FONT, STYLE, SIZE, OR COLOR.

FOR UNPROCESSED APPLES; PACKAGED UNPROCESSED APPLES; FRESH FRUIT; UNPROCESSED FRUIT; PACKAGED FRESH FRUIT; FRESH VEGETABLES; UNPROCESSED VEGETABLES; AND PACKAGED FRESH VEGETABLES (U.S. CLS. 1 AND 46).

FIRST USE 6-19-2014; IN COMMERCE 6-19-2014.

---

4,594,322. ROACH, LYNDSEY, SAN CLEMENTE, CA. AND ANDERSON, MICAH, SAN CLEMENTE, CA. SN 86-052,153. PUB. 2-25-2014, FILED 8-30-2013.

### PALEO PAW

THE MARK CONSISTS OF STANDARD CHARACTERS WITHOUT CLAIM TO ANY PARTICULAR FONT, STYLE, SIZE, OR COLOR.

NO CLAIM IS MADE TO THE EXCLUSIVE RIGHT TO USE "PALEO", APART FROM THE MARK AS SHOWN.

FOR DOG FOOD; DOG TREATS; PET FOOD (U.S. CLS. 1 AND 46).

FIRST USE 12-7-2013; IN COMMERCE 12-7-2013.

**CLASS 32—LIGHT BEVERAGES**

**CLASS 32—(Continued).**

4,593,089. ENVASADORA AGUIDA, S.A. DE C.V., DOLORES HIDALGO, GTO, MEXICO. SN 77-928,419. PUB. 5-3-2011, FILED 2-4-2010.

## RANCHO NATURA

THE MARK CONSISTS OF STANDARD CHARACTERS WITHOUT CLAIM TO ANY PARTICULAR FONT, STYLE, SIZE, OR COLOR.

OWNER OF MEXICO REG. NO. 680455, DATED 8-18-2000, EXPIRES 8-18-2020.

THE ENGLISH TRANSLATION OF "RANCHO NATURA" IN THE MARK IS "NATURE RANCH".

FOR MINERAL AND AERATED WATER; SOFT DRINKS; FRUIT DRINKS; FRUIT JUICES; SYRUPS FOR MAKING SOFT DRINKS AND FRUIT DRINKS (U.S. CLS. 45, 46 AND 48).

FIRST USE 6-10-2014; IN COMMERCE 6-10-2014.

---

4,593,171. OLD WORLD QUALITY FOODS, LLC., ELK GROVE VILLAGE, IL. SN 85-214,483. PUB. 8-13-2013, FILED 1-10-2011.

## TIGER ENERGY DRINK

THE MARK CONSISTS OF STANDARD CHARACTERS WITHOUT CLAIM TO ANY PARTICULAR FONT, STYLE, SIZE, OR COLOR.

NO CLAIM IS MADE TO THE EXCLUSIVE RIGHT TO USE "ENERGY DRINK", APART FROM THE MARK AS SHOWN.

FOR ENERGY DRINKS; SPORTS DRINKS, NAMELY, ENERGY DRINKS (U.S. CLS. 45, 46 AND 48).

FIRST USE 3-1-2005; IN COMMERCE 3-1-2005.

---

4,593,192. BB ENDEAVORS LLC, NEW YORK, NY. SN 85-303,740. PUB. 10-9-2012, FILED 4-25-2011.

## SKINNYGIRL

THE MARK CONSISTS OF STANDARD CHARACTERS WITHOUT CLAIM TO ANY PARTICULAR FONT, STYLE, SIZE, OR COLOR.

OWNER OF U.S. REG. NO. 3,795,804.

FOR NON-ALCOHOLIC BEVERAGES, NAMELY, CARBONATED BEVERAGES; NON-ALCOHOLIC BEVERAGES CONTAINING FRUIT JUICES (U.S. CLS. 45, 46 AND 48).

FIRST USE 11-0-2013; IN COMMERCE 11-0-2013.

**CLASS 32—(Continued).**

4,593,205. PURE PRODUCT GMBH, HAMBURG, FED REP GERMANY. SN 85-342,484. PUB. 5-22-2012, FILED 6-9-2011.

## OCÓO

THE MARK CONSISTS OF STANDARD CHARACTERS WITHOUT CLAIM TO ANY PARTICULAR FONT, STYLE, SIZE, OR COLOR.

THE WORDING "OCÓO" HAS NO MEANING IN A FOREIGN LANGUAGE.

FOR BEAUTY BEVERAGES, NAMELY, FRUIT BASED SOFT DRINKS; BEAUTY BEVERAGES, NAMELY, FRUIT JUICE AND ENERGY DRINKS ENHANCED WITH BERRIES, MINERALS, AND VITAMINS, AND FLAVORED WITH TEA, AND FRUIT-BASED BEVERAGES CONTAINING FRUIT CONCENTRATE AND NUTRITIONAL SUPPLEMENTS (U.S. CLS. 45, 46 AND 48).

FIRST USE 5-1-2010; IN COMMERCE 1-24-2014.

---

4,593,270. CILURZO, VINNIE, SANTA ROSA, CA. AND CILURZO, NATALIE, SANTA ROSA, CA. SN 85-524,114. PUB. 6-19-2012, FILED 1-24-2012.

## PROCTOR

THE MARK CONSISTS OF STANDARD CHARACTERS WITHOUT CLAIM TO ANY PARTICULAR FONT, STYLE, SIZE, OR COLOR.

FOR BEER (U.S. CLS. 45, 46 AND 48).

FIRST USE 6-21-2014; IN COMMERCE 6-21-2014.

---

4,593,274. CILURZO, VINNIE, SANTA ROSA, CA. AND CILURZO, NATALIE, SANTA ROSA, CA. SN 85-530,003. PUB. 6-26-2012, FILED 1-31-2012.

## AMASA

THE MARK CONSISTS OF STANDARD CHARACTERS WITHOUT CLAIM TO ANY PARTICULAR FONT, STYLE, SIZE, OR COLOR.

FOR BEER (U.S. CLS. 45, 46 AND 48).

FIRST USE 6-21-2014; IN COMMERCE 6-21-2014.

**CLASS 32—(Continued).**

4,593,311. NATURAL MOTIVES LLC, CORAL GABLES, FL. SN 85-597,463. PUB. 9-4-2012, FILED 4-13-2012.

# ENERBEE

THE MARK CONSISTS OF STANDARD CHARACTERS WITHOUT CLAIM TO ANY PARTICULAR FONT, STYLE, SIZE, OR COLOR.  
FOR ENERGY DRINKS (U.S. CLS. 45, 46 AND 48).  
FIRST USE 6-23-2014; IN COMMERCE 6-23-2014.

**CLASS 32—(Continued).**

4,593,727. LUHMAN, JOSEPH, WAUKEE, IA. SN 85-853,614. PUB. 4-15-2014, FILED 2-19-2013.

# Perradise

THE MARK CONSISTS OF STANDARD CHARACTERS WITHOUT CLAIM TO ANY PARTICULAR FONT, STYLE, SIZE, OR COLOR.  
FOR BEER (U.S. CLS. 45, 46 AND 48).  
FIRST USE 6-1-2014; IN COMMERCE 6-1-2014.

4,593,636. MICHIELS BREWING, LLC, ADA, MI. SN 85-808,104. PUB. 5-21-2013, FILED 12-20-2012.



NO CLAIM IS MADE TO THE EXCLUSIVE RIGHT TO USE "CRAFT BREWERY & SUPPLY", APART FROM THE MARK AS SHOWN.

THE MARK CONSISTS OF THE OUTLINE OF AN OVAL, FROM THE TOP LEFT OF WHICH IS THE SILHOUETTED FIGURE OF A BRANCH, WITH A MAN SWINGING ON A ROPE FROM THE BRANCH; TO THE RIGHT OF THE FIGURE ARE THE WORDS "GRAVEL" (ABOVE) "BOTTOM" (ABOVE) "CRAFT BREWERY & SUPPLY".

FOR BEER (U.S. CLS. 45, 46 AND 48).  
FIRST USE 9-7-2013; IN COMMERCE 9-7-2013.

4,593,761. FERMENTED PROJECT LLC, DBA SIDE PROJECT BREWING, SAINT LOUIS, MO. SN 85-878,284. PUB. 8-6-2013, FILED 3-17-2013.



THE MARK CONSISTS OF STYLIZED LETTERING WHERE THE WORD "SIDE" IS UNDERLINED AND LOCATED TO THE UPPER LEFT AND THE WORD "PROJECT" IS UNDERLINED AND LOCATED TO THE LOWER RIGHT. A STYLIZED IMAGE OF A LIGHTBULB HANGS BETWEEN THE WORDS "SIDE" AND "PROJECT".

FOR BEER, ALE, LAGER, STOUT, PORTER, SHANDY, MALT LIQUOR (U.S. CLS. 45, 46 AND 48).

FIRST USE 9-28-2013; IN COMMERCE 9-28-2013.

4,593,640. STONY CREEK BREWERY, LLC, BRANFORD, CT. SN 85-809,766. PUB. 5-14-2013, FILED 12-22-2012.

# 239

THE MARK CONSISTS OF STANDARD CHARACTERS WITHOUT CLAIM TO ANY PARTICULAR FONT, STYLE, SIZE, OR COLOR.  
FOR BEER (U.S. CLS. 45, 46 AND 48).  
FIRST USE 6-18-2014; IN COMMERCE 6-18-2014.

4,593,843. YARDS BREWING COMPANY, LLC, PHILADELPHIA, PA. SN 85-919,256. PUB. 1-14-2014, FILED 4-30-2013.

# CICADA

THE MARK CONSISTS OF STANDARD CHARACTERS WITHOUT CLAIM TO ANY PARTICULAR FONT, STYLE, SIZE, OR COLOR.  
FOR BEER, ALE AND PORTER (U.S. CLS. 45, 46 AND 48).  
FIRST USE 8-23-2013; IN COMMERCE 8-23-2013.

**CLASS 32—(Continued).**

4,593,903. AMERICAN DWARF HOP ASSOCIATION, LLC, MOXEE, WA. SN 85-932,141. PUB. 10-15-2013, FILED 5-14-2013.

# AZACCA

THE MARK CONSISTS OF STANDARD CHARACTERS WITHOUT CLAIM TO ANY PARTICULAR FONT, STYLE, SIZE, OR COLOR.

FOR EXTRACTS OF HOPS FOR MAKING BEER; HOP EXTRACTS FOR MANUFACTURING BEER; PROCESSED HOPS FOR USE IN MAKING BEER (U.S. CLS. 45, 46 AND 48).

FIRST USE 10-1-2013; IN COMMERCE 10-1-2013.

4,594,004. HAMDAN, TARIK D, TUCSON, AZ. SN 85-948,289. PUB. 10-29-2013, FILED 6-1-2013.

# Electric Blue

THE MARK CONSISTS OF STANDARD CHARACTERS WITHOUT CLAIM TO ANY PARTICULAR FONT, STYLE, SIZE, OR COLOR.

FOR ENERGY DRINKS ENHANCED WITH HERBS, VITAMINS AND MINERALS TO PROMOTE MENS HEALTH AND SEXUAL DRIVE (U.S. CLS. 45, 46 AND 48).

FIRST USE 1-1-2014; IN COMMERCE 3-1-2014.

4,594,040. SIP ON PRODUCTIONS, LLC, LYNWOOD, CA. SN 85-953,502. PUB. 11-5-2013, FILED 6-7-2013.

# Avec

THE MARK CONSISTS OF STANDARD CHARACTERS WITHOUT CLAIM TO ANY PARTICULAR FONT, STYLE, SIZE, OR COLOR.

THE ENGLISH TRANSLATION OF "AVEC" IN THE MARK IS "WITH".

FOR CONCENTRATES, SYRUPS OR POWDERS USED IN THE PREPARATION OF SPORTS AND ENERGY DRINKS; ENERGY DRINKS; FRUIT FLAVORED DRINKS; FRUIT FLAVOURED CARBONATED DRINKS; FRUIT-FLAVORED BEVERAGES; ISOTONIC BEVERAGES; ISOTONIC NON-ALCOHOLIC DRINKS; NON-ALCOHOLIC BEVERAGES, NAMELY, CARBONATED BEVERAGES; SPORTS DRINKS; SPORTS DRINKS, NAMELY, PERFORMANCE DRINKS (U.S. CLS. 45, 46 AND 48).

FIRST USE 6-21-2013; IN COMMERCE 10-25-2013.

**CLASS 32—(Continued).**

4,594,093. DIAGEO IRELAND, DUBLIN, IRELAND. SN 85-961,451. PUB. 9-10-2013, FILED 6-17-2013.



OWNER OF U.S. REG. NOS. 3,034,149, 3,115,920, AND 3,144,140.

THE MARK CONSISTS OF AN OUTLINED IMAGE OF A CASTLE WITH THE WORD "SMITHWICK'S" APPEARING ON THE INSIDE UPPER HALF OF THE CASTLE.

FOR BEER (U.S. CLS. 45, 46 AND 48).

FIRST USE 5-31-2013; IN COMMERCE 5-31-2013.

4,594,168. CERVECERIA MODELO, S. DE R.L. DE C.V., C.P. 11320 MÉXICO CITY, MEXICO. SN 85-982,074. PUB. 11-22-2011, FILED 6-23-2011.

# CORONARITA

THE MARK CONSISTS OF STANDARD CHARACTERS WITHOUT CLAIM TO ANY PARTICULAR FONT, STYLE, SIZE, OR COLOR.

OWNER OF U.S. REG. NOS. 2,489,710, 3,388,558, AND OTHERS.

FOR BEER (U.S. CLS. 45, 46 AND 48).

FIRST USE 7-15-2014; IN COMMERCE 7-15-2014.

**CLASS 32—(Continued).**

4,594,250. CREATURE COMFORTS BREWING COMPANY LLC, ATHENS, GA. SN 86-017,278. PUB. 2-25-2014, FILED 7-23-2013.

# Tropicália

THE MARK CONSISTS OF STANDARD CHARACTERS WITHOUT CLAIM TO ANY PARTICULAR FONT, STYLE, SIZE, OR COLOR.

FOR BEER; BEER WORT; BEER, ALE AND LAGER; BEER, ALE AND PORTER; BEER, ALE, LAGER, STOUT AND PORTER; BEER, ALE, LAGER, STOUT, PORTER, SHANDY; BEERS; BREWED MALT-BASED ALCOHOLIC BEVERAGE IN THE NATURE OF A BEER; FLAVORED BEERS; MALT BEER; PALE BEER (U.S. CLS. 45, 46 AND 48).

FIRST USE 4-13-2014; IN COMMERCE 4-13-2014.

4,594,320. GIVN GOODS INC., ATLANTA, GA. SN 86-050,673. PUB. 1-14-2014, FILED 8-28-2013.

# givn

THE MARK CONSISTS OF STANDARD CHARACTERS WITHOUT CLAIM TO ANY PARTICULAR FONT, STYLE, SIZE, OR COLOR.

FOR BOTTLED DRINKING WATER; DISTILLED DRINKING WATER; DRINKING WATER; DRINKING WATER WITH VITAMINS; DRINKING WATERS; PURIFIED BOTTLED DRINKING WATER (U.S. CLS. 45, 46 AND 48).

FIRST USE 3-7-2014; IN COMMERCE 4-9-2014.

4,594,469. CLARK FOODS, INC., NEW ALBANY, IN. SN 86-106,929. PUB. 4-15-2014, FILED 10-31-2013.

# GINGER REAL

THE MARK CONSISTS OF STANDARD CHARACTERS WITHOUT CLAIM TO ANY PARTICULAR FONT, STYLE, SIZE, OR COLOR.

OWNER OF U.S. REG. NO. 3,159,442.  
NO CLAIM IS MADE TO THE EXCLUSIVE RIGHT TO USE "GINGER", APART FROM THE MARK AS SHOWN.  
THE ENGLISH TRANSLATION OF THE WORD "REAL" IN THE MARK IS "ROYAL".

FOR NON-ALCOHOLIC COCKTAIL MIXES; SYRUPS FOR MAKING FRUIT-FLAVORED DRINKS (U.S. CLS. 45, 46 AND 48).

FIRST USE 4-30-2014; IN COMMERCE 4-30-2014.

**CLASS 32—(Continued).**

4,594,509. COPPERTAIL BREWING CO LLC, TAMPA, FL. SN 86-123,397. PUB. 3-4-2014, FILED 11-19-2013.

# NIGHT SWIM

THE MARK CONSISTS OF STANDARD CHARACTERS WITHOUT CLAIM TO ANY PARTICULAR FONT, STYLE, SIZE, OR COLOR.

FOR BEER, ALE, LAGER, STOUT AND PORTER (U.S. CLS. 45, 46 AND 48).

FIRST USE 5-2-2014; IN COMMERCE 5-2-2014.

4,594,546. ODELL BREWING COMPANY, FORT COLLINS, CO. SN 86-166,625. PUB. 4-22-2014, FILED 1-15-2014.

# JAUNT

THE MARK CONSISTS OF STANDARD CHARACTERS WITHOUT CLAIM TO ANY PARTICULAR FONT, STYLE, SIZE, OR COLOR.

FOR ALE; BEER (U.S. CLS. 45, 46 AND 48).

FIRST USE 5-14-2014; IN COMMERCE 5-14-2014.

4,594,547. THE THREE RING BREWING CO., LLC, ASHEVILLE, NC. SN 86-181,654. PUB. 5-6-2014, FILED 1-31-2014.

# Man Eater

THE MARK CONSISTS OF STANDARD CHARACTERS WITHOUT CLAIM TO ANY PARTICULAR FONT, STYLE, SIZE, OR COLOR.

FOR BEER (U.S. CLS. 45, 46 AND 48).

FIRST USE 3-7-2014; IN COMMERCE 3-7-2014.

**CLASS 33—WINES AND SPIRITS**



## CLASS 33—(Continued).

4,593,081. ROCK N ROLL IMPORTS, STOCKTON, CA. SN 77-768,254. PUB. 9-10-2013, FILED 6-25-2009.

# ROCK 'N ROLL

THE MARK CONSISTS OF STANDARD CHARACTERS WITHOUT CLAIM TO ANY PARTICULAR FONT, STYLE, SIZE, OR COLOR.

FOR TEQUILA (U.S. CLS. 47 AND 49).  
FIRST USE 1-0-2012; IN COMMERCE 1-0-2012.

---

4,593,159. DEVAUGHN, JAMES, BURKBURNETT, TX. SN 85-193,404. PUB. 1-29-2013, FILED 12-8-2010.



The logo features the word "Flag" in a large, elegant, cursive script. Below it, the words "SERIES" and "VODKA" are written in a smaller, clean, sans-serif font, stacked vertically.

NO CLAIM IS MADE TO THE EXCLUSIVE RIGHT TO USE "SERIES VODKA", APART FROM THE MARK AS SHOWN.

FOR DISTILLED SPIRITS; LIQUOR; SPIRITS; SPIRITS AND LIQUEURS; VODKA (U.S. CLS. 47 AND 49).  
FIRST USE 8-1-2012; IN COMMERCE 8-1-2012.

---

4,593,169. SONOMA WINE COMPANY, GRATON, CA. SN 85-210,334. PUB. 4-5-2011, FILED 1-4-2011.

# Brainstorm

THE MARK CONSISTS OF STANDARD CHARACTERS WITHOUT CLAIM TO ANY PARTICULAR FONT, STYLE, SIZE, OR COLOR.

FOR WINE; WINES (U.S. CLS. 47 AND 49).  
FIRST USE 5-23-2014; IN COMMERCE 5-23-2014.

## CLASS 33—(Continued).

4,593,194. SOCIEDAD AGRICOLA REQUINGUA LIMITADA, SANTIAGO, CHILE. SN 85-304,903. PUB. 9-13-2011, FILED 4-26-2011.

# LAKU

THE MARK CONSISTS OF STANDARD CHARACTERS WITHOUT CLAIM TO ANY PARTICULAR FONT, STYLE, SIZE, OR COLOR.

FOR WINE (U.S. CLS. 47 AND 49).  
FIRST USE 10-29-2013; IN COMMERCE 10-29-2013.

---

4,593,216. CULT OF 8, INC., MONTEREY, CA. SN 85-370,519. PUB. 12-6-2011, FILED 7-13-2011.

# STATE OF ART

THE MARK CONSISTS OF STANDARD CHARACTERS WITHOUT CLAIM TO ANY PARTICULAR FONT, STYLE, SIZE, OR COLOR.

FOR WINES (U.S. CLS. 47 AND 49).  
FIRST USE 11-30-2012; IN COMMERCE 11-30-2012.

---

4,593,268. CONSTELLATION BRANDS U.S. OPERATIONS, INC., CANANDAIGUA, NY. SN 85-518,517. PUB. 10-15-2013, FILED 1-17-2012.

# V.NO

THE MARK CONSISTS OF STANDARD CHARACTERS WITHOUT CLAIM TO ANY PARTICULAR FONT, STYLE, SIZE, OR COLOR.

THE WORDING "V.NO" HAS NO MEANING IN A FOREIGN LANGUAGE.  
FOR WINE (U.S. CLS. 47 AND 49).  
FIRST USE 6-0-2013; IN COMMERCE 6-0-2013.

**CLASS 33—(Continued).**

4,593,283. WILLIAM GRANT & SONS IRISH BRANDS LIMITED, DUBLIN, IRELAND. SN 85-543,084. PUB. 8-13-2013, FILED 2-15-2012.



NO CLAIM IS MADE TO THE EXCLUSIVE RIGHT TO USE "RHUBARB TEA" AND "CERTIFIED ORGANIC NEUTRAL SPIRITS WITH RHUBARB & OTHER BOTANICALS NATIVE TO RURAL NORTH AMERICA" AND "ORGANIC INGREDIENTS: RHUBARB, BEETS, CARROTS, LEMON, PETITGRAIN, CARDAMOM, PINK PEPPERCORN, CORIANDER, VANILLA AND PURE CANE SUGAR," AND "SPIRIT" AND "RECIPE FOR RHUBARB TEA" AND "SHAKE WELL BEFORE ENJOYING," AND THE "USDA ORGANIC" SEAL DESIGN, APART FROM THE MARK AS SHOWN.

THE NAME(S), PORTRAIT(S), AND/OR SIGNATURE(S) SHOWN IN THE MARK DOES NOT IDENTIFY A PARTICULAR LIVING INDIVIDUAL.

THE MARK CONSISTS OF A DESIGN FEATURING CALIPERS INSIDE A COG WHEEL WITH THE NUMBER "19" ABOVE A HORIZONTAL BAR ON THE CALIPERS AND THE NUMBER "36" BELOW THE BAR, WITH AN EYE IN BETWEEN THE TWO PRONGS OF THE CALIPERS. THE WORDING "ART IN THE AGE" IS PRESENTED IMMEDIATELY BELOW THE DESIGN, UNDER WHICH THE TERM "RHUBARB" IS DEPICTED OVER "(TEA)" BETWEEN TWO HORIZONTAL LINES. THE WORDING "CERTIFIED ORGANIC NEUTRAL SPIRITS" IS BELOW THE LAST HORIZONTAL LINE, UNDER WHICH IS THE WORDING "WITH RHUBARB & OTHER BOTANICALS NATIVE TO RURAL NORTH AMERICA." A PARAGRAPH CONSISTING OF THE WORDING "ORGANIC INGREDIENTS: RHUBARB, BEETS, CARROTS, LEMON, PETITGRAIN, CARDAMOM, PINK PEPPERCORN, CORIANDER, VANILLA AND PURE CANE SUGAR." THE WORDING "THIS SINGULAR SPIRIT IS BASED ON AN OLD PHILADELPHIA RECIPE FOR RHUBARB TEA THAT BEGAN IN THE LATE 1700S WHEN BENJAMIN FRANKLIN FIRST INTRODUCED RHUBARB TO AMERICA." IS BELOW THE FIRST PARAGRAPH, AND IS FOLLOWED BY A PARAGRAPH CONSISTING OF THE WORDING "A DELICIOUS PART OF THE ORGANIC EXPERIENCE IS OCCASIONAL SEDIMENT. SHAKE WELL BEFORE ENJOYING." THE "USDA ORGANIC" SYMBOL IS AT THE BOTTOM OF THE MARK.

FOR ORGANIC LIQUEURS (U.S. CLS. 47 AND 49).  
FIRST USE 1-27-2014; IN COMMERCE 1-27-2014.

**CLASS 33—(Continued).**

4,593,329. RMRH ENTERPRISES, LLC, DBA EAST TENNESSEE DISTILLERY, PINEY FLATS, TN. SN 85-627,896. PUB. 10-23-2012, FILED 5-17-2012.

## ROBERSON'S TENNESSEE MELLOMOON

THE MARK CONSISTS OF STANDARD CHARACTERS WITHOUT CLAIM TO ANY PARTICULAR FONT, STYLE, SIZE, OR COLOR.

NO CLAIM IS MADE TO THE EXCLUSIVE RIGHT TO USE "TENNESSEE", APART FROM THE MARK AS SHOWN.

THE NAME(S), PORTRAIT(S), AND/OR SIGNATURE(S) SHOWN IN THE MARK IDENTIFIES NEIL ROBERSON, WHOSE CONSENT(S) TO REGISTER IS MADE OF RECORD.

FOR DISTILLED SPIRITS (U.S. CLS. 47 AND 49).  
FIRST USE 10-1-2012; IN COMMERCE 5-1-2014.

4,593,407. NEGOCIANTS NEW ZEALAND LIMITED, REMUERA, AUCKLAND, NEW ZEALAND. SN 85-681,888. PUB. 1-29-2013, FILED 7-19-2012.



OWNER OF U.S. REG. NO. 3,445,468.  
THE MARK CONSISTS OF A DARKENED PARTIAL MOON ABOVE THE WORD "OPAWA".

THE ENGLISH TRANSLATION OF "OPAWA" IN THE MARK IS "SMOKY RIVER".

FOR WINES (U.S. CLS. 47 AND 49).  
FIRST USE 5-0-2012; IN COMMERCE 3-7-2013.

**CLASS 33—(Continued).**

4,593,426. WINERY EXCHANGE, INC., NOVATO, CA. SN 85-701,757. PUB. 12-11-2012, FILED 8-13-2012.

# TABLOID

THE MARK CONSISTS OF STANDARD CHARACTERS WITHOUT CLAIM TO ANY PARTICULAR FONT, STYLE, SIZE, OR COLOR.

FOR FLAVORED BREWED MALT BEVERAGE (U.S. CLS. 47 AND 49).  
FIRST USE 4-0-2014; IN COMMERCE 4-0-2014.

4,593,498. HERON, LESLEY A., LOUISVILLE, KY. SN 85-759,449. PUB. 4-2-2013, FILED 10-21-2012.

# BR&NDY

THE MARK CONSISTS OF STANDARD CHARACTERS WITHOUT CLAIM TO ANY PARTICULAR FONT, STYLE, SIZE, OR COLOR.

FOR BRANDY (U.S. CLS. 47 AND 49).  
FIRST USE 1-1-2014; IN COMMERCE 6-1-2014.

4,593,529. KOLEV, KOLIO, DES PLAINES, IL. SN 85-771,939. PUB. 4-16-2013, FILED 11-5-2012.

LIFE IS TOO SHORT TO DRINK  
CHEAP RAKIA

THE MARK CONSISTS OF STANDARD CHARACTERS WITHOUT CLAIM TO ANY PARTICULAR FONT, STYLE, SIZE, OR COLOR.

FOR BRANDY (U.S. CLS. 47 AND 49).  
FIRST USE 7-20-2013; IN COMMERCE 7-20-2013.

**CLASS 33—(Continued).**

4,593,638. DEAR, INC., ATLANTA, GA. SN 85-809,170. PUB. 5-21-2013, FILED 12-21-2012.

# BUONGIORNO

THE MARK CONSISTS OF STANDARD CHARACTERS WITHOUT CLAIM TO ANY PARTICULAR FONT, STYLE, SIZE, OR COLOR.

THE ENGLISH TRANSLATION OF "BUON GIORNO" IN THE MARK IS "GOOD DAY".

FOR WINES (U.S. CLS. 47 AND 49).  
FIRST USE 4-0-2014; IN COMMERCE 4-0-2014.

4,593,791. UNHINGED PRODUCTIONS, LLC, LUBBOCK, TX. SN 85-892,183. PUB. 8-20-2013, FILED 4-1-2013.

# TreyMark

THE MARK CONSISTS OF STANDARD CHARACTERS WITHOUT CLAIM TO ANY PARTICULAR FONT, STYLE, SIZE, OR COLOR.

FOR ALCOHOLIC BEVERAGES EXCEPT BEERS (U.S. CLS. 47 AND 49).

FIRST USE 10-1-2013; IN COMMERCE 10-1-2013.

4,593,811. DONNELL, ROBERT, SEBASTOPOL, CA. SN 85-907,115. PUB. 9-24-2013, FILED 4-17-2013.

# Screen Door Cellars

THE MARK CONSISTS OF STANDARD CHARACTERS WITHOUT CLAIM TO ANY PARTICULAR FONT, STYLE, SIZE, OR COLOR.

NO CLAIM IS MADE TO THE EXCLUSIVE RIGHT TO USE "CELLARS", APART FROM THE MARK AS SHOWN.

FOR WINE (U.S. CLS. 47 AND 49).  
FIRST USE 5-16-2013; IN COMMERCE 11-27-2013.

**CLASS 33—(Continued).**

4,593,820. CARMIN, FLORENT, LOS ANGELES, CA. SN 85-911,123. PUB. 10-1-2013, FILED 4-22-2013.



THE MARK CONSISTS OF A FLEUR DE LIS IN THE CENTER WITH STYLIZED WINGS ON BOTH SIDES.

FOR ALCOHOLIC BEVERAGES EXCEPT BEERS; ALCOHOLIC BEVERAGES, NAMELY, DIGESTIFS; POTABLE SPIRITS; ALCOHOLIC EXTRACTS OR ESSENCES; ALCOHOLIC BEVERAGES CONTAINING FRUIT OR PLANTS OR HERBS; ALCOHOLIC FRUIT EXTRACTS; ALCOHOLIC BEVERAGES WITH PLANT EXTRACTS; ALCOHOLIC BEVERAGES WITH HERB EXTRACTS; DISTILLED ALCOHOLIC BEVERAGES; DISTILLED SPIRITS; ABSINTHE (U.S. CLS. 47 AND 49).

FIRST USE 12-11-2013; IN COMMERCE 12-11-2013.

**CLASS 33—(Continued).**

4,593,927. VERISMO WINE LLC, NAPA, CA. SN 85-937,001. PUB. 10-15-2013, FILED 5-20-2013.



THE MARK CONSISTS OF A STYLIZED DESIGN OF A CLUSTER OF GRAPES CONSISTING OF GROUP OF SEVEN (7) NONUNIFORM, IRREGULAR CIRCLES ALONG WITH AN IRREGULAR STEM.

FOR WINES (U.S. CLS. 47 AND 49).

FIRST USE 12-1-2012; IN COMMERCE 12-1-2012.

4,593,862. CHATEAU DIANA LLC, HEALDSBURG, CA. SN 85-923,153. PUB. 7-16-2013, FILED 5-3-2013.

**JAWBREAKER**

THE MARK CONSISTS OF STANDARD CHARACTERS WITHOUT CLAIM TO ANY PARTICULAR FONT, STYLE, SIZE, OR COLOR.

FOR WINE (U.S. CLS. 47 AND 49).

FIRST USE 4-16-2014; IN COMMERCE 4-16-2014.

4,593,928. VERISMO WINE LLC, NAPA, CA. SN 85-937,006. PUB. 10-29-2013, FILED 5-20-2013.

4,593,926. VERISMO WINE LLC, NAPA, CA. SN 85-936,983. PUB. 10-29-2013, FILED 5-20-2013.



NO CLAIM IS MADE TO THE EXCLUSIVE RIGHT TO USE "VINEYARDS", APART FROM THE MARK AS SHOWN.

THE MARK CONSISTS OF THE DESIGN OF A GRAPE VINE WITH TWO HORIZONTALLY OUTSTRETCHED LIMBS WITH THE WORD "D'AMBROSIO" IN STYLIZED FONT ABOVE BOTH LIMBS AND THE WORD "VINEYARDS" IN STYLIZED FONT BENEATH THE RIGHT LIMB.

FOR WINES (U.S. CLS. 47 AND 49).

FIRST USE 12-1-2012; IN COMMERCE 12-1-2012.



THE NAME AND/OR LIKENESS IN THE MARK DOES NOT REFER TO ANY LIVING INDIVIDUAL.

THE MARK CONSISTS OF A MAN WEARING A CROWN SMOKING A CIGAR WITH SMOKE ARISING FROM THE CIGAR. THE SMOKE CONSISTS OF THE WORD "FRANK" IN MIRROR IMAGE AND IN STYLIZED FONT.

FOR WINES (U.S. CLS. 47 AND 49).

FIRST USE 12-1-2012; IN COMMERCE 12-1-2012.

**CLASS 33—(Continued).**

4,593,929. VERISMO WINE LLC, NAPA, CA. SN 85-937,023.  
PUB. 10-15-2013, FILED 5-20-2013.

## ESSERE FRANCO

THE MARK CONSISTS OF STANDARD CHARACTERS WITHOUT CLAIM TO ANY PARTICULAR FONT, STYLE, SIZE, OR COLOR.

THE ENGLISH TRANSLATION OF "ESSERE FRANCO" IN THE MARK IS "TO BE FRANK".  
FOR WINES (U.S. CLS. 47 AND 49).  
FIRST USE 12-1-2012; IN COMMERCE 12-1-2012.

**CLASS 33—(Continued).**

4,594,042. DURBIN FAMILY WINES, LLC, FURLONG, PA.  
SN 85-953,624. PUB. 10-29-2013, FILED 6-7-2013.

## SEA BIRD

THE MARK CONSISTS OF STANDARD CHARACTERS WITHOUT CLAIM TO ANY PARTICULAR FONT, STYLE, SIZE, OR COLOR.

FOR ALCOHOLIC BEVERAGES EXCEPT BEERS (U.S. CLS. 47 AND 49).  
FIRST USE 4-5-2014; IN COMMERCE 4-5-2014.

4,593,949. THACKREY, SEAN HALEY, BOLINAS, CA. SN 85-939,539. PUB. 10-22-2013, FILED 5-22-2013.

## FIFI

THE MARK CONSISTS OF STANDARD CHARACTERS WITHOUT CLAIM TO ANY PARTICULAR FONT, STYLE, SIZE, OR COLOR.

FOR GRAPE WINE (U.S. CLS. 47 AND 49).  
FIRST USE 6-13-2014; IN COMMERCE 6-13-2014.

4,594,043. DURBIN FAMILY WINES, LLC, FURLONG, PA.  
SN 85-953,634. PUB. 10-29-2013, FILED 6-7-2013.

## GREAT VINES TO GREAT TIMES

THE MARK CONSISTS OF STANDARD CHARACTERS WITHOUT CLAIM TO ANY PARTICULAR FONT, STYLE, SIZE, OR COLOR.

FOR ALCOHOLIC BEVERAGES EXCEPT BEERS (U.S. CLS. 47 AND 49).  
FIRST USE 4-5-2014; IN COMMERCE 4-5-2014.

4,594,003. KAIZER CORP., TAMARAC, FL. SN 85-947,983.  
PUB. 10-29-2013, FILED 5-31-2013.

## WARBLOOD

THE MARK CONSISTS OF STANDARD CHARACTERS WITHOUT CLAIM TO ANY PARTICULAR FONT, STYLE, SIZE, OR COLOR.

FOR WINES (U.S. CLS. 47 AND 49).  
FIRST USE 6-23-2014; IN COMMERCE 6-23-2014.

4,594,094. KAIZER CORP., TAMARAC, FL. SN 85-962,467.  
PUB. 10-29-2013, FILED 6-18-2013.

## LANNISTER

THE MARK CONSISTS OF STANDARD CHARACTERS WITHOUT CLAIM TO ANY PARTICULAR FONT, STYLE, SIZE, OR COLOR.

FOR BOURBON; GIN; VODKA; WHISKEY; WINES (U.S. CLS. 47 AND 49).  
FIRST USE 6-23-2014; IN COMMERCE 6-23-2014.

**CLASS 33—(Continued).**

4,594,112. VILLANUEVA HOLDING COMPANY, LLC, HOUSTON, TX. SN 85-966,139. PUB. 11-12-2013, FILED 6-21-2013.

**SANTA ANGELA**

THE MARK CONSISTS OF STANDARD CHARACTERS WITHOUT CLAIM TO ANY PARTICULAR FONT, STYLE, SIZE, OR COLOR.

THE ENGLISH TRANSLATION OF "SANTA" IN THE MARK IS "SAINT".

FOR LIQUEURS (U.S. CLS. 47 AND 49).

FIRST USE 3-3-2014; IN COMMERCE 3-3-2014.

**CLASS 33—(Continued).**

4,594,174. MIDWEST CUSTOM BOTTLING, LLC, PEWAUKEE, WI. SN 85-982,192. PUB. 9-25-2012, FILED 4-21-2012.

**TIPPY COW**

THE MARK CONSISTS OF STANDARD CHARACTERS WITHOUT CLAIM TO ANY PARTICULAR FONT, STYLE, SIZE, OR COLOR.

FOR LIQUOR AND LIQUEURS (U.S. CLS. 47 AND 49).

FIRST USE 1-30-2014; IN COMMERCE 2-6-2014.

4,594,138. CROSS CREEK ENTERPRISES, INC., RANCHO CUCAMONGA, CA. SN 85-971,187. PUB. 11-12-2013, FILED 6-26-2013.



Real De Oaxaca

OWNER OF U.S. REG. NOS. 4,167,245 AND 4,346,077.

NO CLAIM IS MADE TO THE EXCLUSIVE RIGHT TO USE "OAXACA", APART FROM THE MARK AS SHOWN.

THE MARK CONSISTS OF OF STYLIZED WORDING "REAL DE OAXACA". THE DESIGN CONSISTS OF A TURKEY WITH EIGHT FEATHERS IN ITS TAIL. TWO WINGS CROSS THE TAIL FEATHERS.

THE ENGLISH TRANSLATION OF REAL DE OAXACA IN THE MARK IS ROYAL OF OAXACA.

FOR DISTILLED SPIRITS (U.S. CLS. 47 AND 49).

FIRST USE 5-10-2014; IN COMMERCE 5-10-2014.

4,594,192. CJS BEVERAGE CORP., NEW YORK, NY. SN 85-982,538. PUB. 5-7-2013, FILED 11-29-2012.



THE MARK CONSISTS OF A HORSESHOE DESIGN ABOVE THE WORD "PINHOOK".

FOR SPIRITS, BOURBON (U.S. CLS. 47 AND 49).

FIRST USE 2-25-2014; IN COMMERCE 2-25-2014.

4,594,140. DURBIN FAMILY WINES, LLC, FURLONG, PA. SN 85-971,512. PUB. 10-29-2013, FILED 6-27-2013.



THE MARK CONSISTS OF THE IMAGE OF A SEA BIRD. FOR ALCOHOLIC BEVERAGES EXCEPT BEERS (U.S. CLS. 47 AND 49).

FIRST USE 4-5-2014; IN COMMERCE 4-5-2014.

4,594,193. CJS BEVERAGE CORP., NEW YORK, NY. SN 85-982,539. PUB. 4-30-2013, FILED 11-29-2012.

**PINHOOK**

THE MARK CONSISTS OF STANDARD CHARACTERS WITHOUT CLAIM TO ANY PARTICULAR FONT, STYLE, SIZE, OR COLOR.

FOR SPIRITS, BOURBON (U.S. CLS. 47 AND 49).

FIRST USE 2-25-2014; IN COMMERCE 2-25-2014.

**CLASS 33—(Continued).**

4,594,215. SUTCLIFFE & SON LLC, IRVINE, CA. SN 86-007,547. PUB. 1-28-2014, FILED 7-11-2013.

**THE EXCEPTIONAL BY  
SUTCLIFFE & SON**

THE MARK CONSISTS OF STANDARD CHARACTERS WITHOUT CLAIM TO ANY PARTICULAR FONT, STYLE, SIZE, OR COLOR.

NO CLAIM IS MADE TO THE EXCLUSIVE RIGHT TO USE "EXCEPTIONAL" AND "& SON", APART FROM THE MARK AS SHOWN.

FOR DISTILLED SPIRITS (U.S. CLS. 47 AND 49).  
FIRST USE 5-1-2013; IN COMMERCE 5-1-2013.

**CLASS 33—(Continued).**

4,594,363. CANOPY LICENSING, LLC, NAPA, CA. SN 86-069,830. PUB. 5-6-2014, FILED 9-19-2013.

**THE GIRL AND DRAGON**

THE MARK CONSISTS OF STANDARD CHARACTERS WITHOUT CLAIM TO ANY PARTICULAR FONT, STYLE, SIZE, OR COLOR.

FOR ALCOHOLIC BEVERAGES EXCEPT BEERS (U.S. CLS. 47 AND 49).

FIRST USE 5-6-2014; IN COMMERCE 5-6-2014.

4,594,224. BACARDI & COMPANY LIMITED, VADUZ, LIECHTENSTEIN. SN 86-009,621. PUB. 10-29-2013, FILED 7-13-2013.

**CAZADORES**

OWNER OF U.S. REG. NOS. 1,863,882, 3,534,985, AND OTHERS.

THE ENGLISH TRANSLATION OF "CAZADORES" IN THE MARK IS "LIGHT INFANTRY".

FOR ALCOHOLIC BEVERAGES EXCEPT BEERS (U.S. CLS. 47 AND 49).

FIRST USE 6-18-2014; IN COMMERCE 6-18-2014.

4,594,364. CANOPY MANAGEMENT, LLC, NAPA, CA. SN 86-069,836. PUB. 4-29-2014, FILED 9-19-2013.

**LADY LA FEMME**

THE MARK CONSISTS OF STANDARD CHARACTERS WITHOUT CLAIM TO ANY PARTICULAR FONT, STYLE, SIZE, OR COLOR.

THE ENGLISH TRANSLATION OF "LA FEMME" IN THE MARK IS "WOMEN".

FOR ALCOHOLIC BEVERAGES EXCEPT BEERS (U.S. CLS. 47 AND 49).

FIRST USE 6-19-2014; IN COMMERCE 6-19-2014.

4,594,249. KLINKER BRICK WINERY, INC., LODI, CA. SN 86-016,706. PUB. 10-15-2013, FILED 7-22-2013.

**TRANZIND**

THE MARK CONSISTS OF STANDARD CHARACTERS WITHOUT CLAIM TO ANY PARTICULAR FONT, STYLE, SIZE, OR COLOR.

FOR ALCOHOLIC BEVERAGES EXCEPT BEERS (U.S. CLS. 47 AND 49).

FIRST USE 4-22-2014; IN COMMERCE 4-22-2014.

4,594,423. ALLIED BLENDEES AND DISTILLERS PRIVATE LIMITED, MUMBAI, INDIA. SN 86-091,019. PUB. 3-4-2014, FILED 10-14-2013.

**OFFICER'S CHOICE**

THE MARK CONSISTS OF STANDARD CHARACTERS WITHOUT CLAIM TO ANY PARTICULAR FONT, STYLE, SIZE, OR COLOR.

FOR ALCOHOLIC BEVERAGES EXCEPT BEERS; BLENDED SPIRITS; BRANDY; DISTILLED SPIRITS; GIN; LIQUEURS; RUM; VODKA; WHISKEY; WINES (U.S. CLS. 47 AND 49).

FIRST USE 10-13-1988; IN COMMERCE 2-18-2014.

**CLASS 33—(Continued).**

4,594,424. OX-EYE VINEYARDS LLC, STAUNTON, VA. SN 86-091,471. PUB. 4-8-2014, FILED 10-15-2013.

## Scale House Reserve

THE MARK CONSISTS OF STANDARD CHARACTERS WITHOUT CLAIM TO ANY PARTICULAR FONT, STYLE, SIZE, OR COLOR.

NO CLAIM IS MADE TO THE EXCLUSIVE RIGHT TO USE "HOUSE RESERVE", APART FROM THE MARK AS SHOWN.

FOR WINES (U.S. CLS. 47 AND 49).  
FIRST USE 1-10-2014; IN COMMERCE 6-2-2014.

**CLASS 34—SMOKERS' ARTICLES**

4,593,166. FAIRMONT HOLDINGS, INC., DANIA, FL. SN 85-207,838. PUB. 5-3-2011, FILED 12-30-2010.

## POST EMBARGO

THE MARK CONSISTS OF STANDARD CHARACTERS WITHOUT CLAIM TO ANY PARTICULAR FONT, STYLE, SIZE, OR COLOR.

FOR CIGARS, TOBACCO, CIGAR BOXES, CIGAR CUTTERS AND CIGAR TUBES (U.S. CLS. 2, 8, 9 AND 17).

FIRST USE 6-25-2014; IN COMMERCE 6-27-2014.

4,593,177. FAIRMONT HOLDINGS, INC., DANIA, FL. SN 85-227,481. PUB. 5-3-2011, FILED 1-27-2011.

## Alchemy

THE MARK CONSISTS OF STANDARD CHARACTERS WITHOUT CLAIM TO ANY PARTICULAR FONT, STYLE, SIZE, OR COLOR.

FOR CIGARS, TOBACCO, CIGAR BOXES, CIGAR CUTTERS AND CIGAR TUBES (U.S. CLS. 2, 8, 9 AND 17).

FIRST USE 6-25-2014; IN COMMERCE 6-25-2014.

**CLASS 34—(Continued).**

4,593,776. GREAT LAKES ELECTRONIC CIGARETTES, LLC, SPARROWS POINT, MD. SN 85-883,712. PUB. 9-10-2013, FILED 3-22-2013.



NO CLAIM IS MADE TO THE EXCLUSIVE RIGHT TO USE "VAPOR SPOUT", APART FROM THE MARK AS SHOWN.

THE COLOR(S) GRAY AND BLUE IS/ARE CLAIMED AS A FEATURE OF THE MARK.

THE MARK CONSISTS OF THE GRAY WORDING "VAPOR" AND BLUE WORDING "SPOUT" IN STYLIZED FONT. BETWEEN THEN APPEARS THE DESIGN OF A BLUE CURVE LINE BELOW A GRAY OVERALL-TRIANGULAR DESIGN THAT INCORPORATES A CYCLONE DESIGN IN THE MIDDLE.

FOR ELECTRONIC CIGARETTES (U.S. CLS. 2, 8, 9 AND 17).

FIRST USE 7-1-2013; IN COMMERCE 8-1-2013.

4,593,947. CHASAM TOBACCO, LLC, MIAMI, FL. SN 85-939,027. PUB. 12-3-2013, FILED 5-22-2013.

## LUCHADOR

THE MARK CONSISTS OF STANDARD CHARACTERS WITHOUT CLAIM TO ANY PARTICULAR FONT, STYLE, SIZE, OR COLOR.

THE ENGLISH TRANSLATION OF "LUCHADOR" IN THE MARK IS "WRESTLER".

FOR CIGARS (U.S. CLS. 2, 8, 9 AND 17).

FIRST USE 4-23-2014; IN COMMERCE 4-23-2014.

4,594,035. SPARK INDUSTRIES, LLC, CAMARILLO, CA. SN 85-952,801. PUB. 11-5-2013, FILED 6-6-2013.

## VOOKAH

THE MARK CONSISTS OF STANDARD CHARACTERS WITHOUT CLAIM TO ANY PARTICULAR FONT, STYLE, SIZE, OR COLOR.

FOR ELECTRONIC CIGARETTES (U.S. CLS. 2, 8, 9 AND 17).

FIRST USE 7-31-2013; IN COMMERCE 7-31-2013.



**CLASS 34—(Continued).**

4,594,060. KUMAR, KAMAL, TOMS RIVER, NJ. SN 85-956,892. PUB. 10-29-2013, FILED 6-11-2013.

# SKYFOG

THE MARK CONSISTS OF STANDARD CHARACTERS WITHOUT CLAIM TO ANY PARTICULAR FONT, STYLE, SIZE, OR COLOR.

FOR ELECTRONIC CIGARETTES (U.S. CLS. 2, 8, 9 AND 17).

FIRST USE 1-0-2014; IN COMMERCE 1-0-2014.

---

4,594,211. M&C AKERS INC., IUKA, MS. SN 86-006,322. PUB. 4-8-2014, FILED 7-10-2013.

# IMAGE

THE MARK CONSISTS OF STANDARD CHARACTERS WITHOUT CLAIM TO ANY PARTICULAR FONT, STYLE, SIZE, OR COLOR.

FOR ELECTRONIC CIGARETTES; ELECTRONIC CIGARETTE REFILL CARTRIDGES SOLD EMPTY; ELECTRONIC CIGARS; ELECTRONIC CIGAR REFILL CARTRIDGES SOLD EMPTY; ELECTRONIC CIGARETTES FOR USE AS AN ALTERNATIVE TO TRADITIONAL CIGARETTES; ELECTRONIC CIGARETTE KITS COMPRISED OF ELECTRONIC CIGARETTES, ELECTRONIC CIGARETTE REFILL CARTRIDGES SOLD EMPTY, AND BATTERY CHARGERS, ALL SOLD AS A UNIT (U.S. CLS. 2, 8, 9 AND 17).

FIRST USE 1-0-2012; IN COMMERCE 1-0-2012.

---

4,594,354. SHIELDS, JOHN, CLERMONT, FL. SN 86-065,731. PUB. 3-11-2014, FILED 9-16-2013.

# XISTIX

THE MARK CONSISTS OF STANDARD CHARACTERS WITHOUT CLAIM TO ANY PARTICULAR FONT, STYLE, SIZE, OR COLOR.

FOR SMOKERS' ARTICLES, NAMELY, CIGAR HOLDERS COMPRISED OF A CLIP THAT ATTACHES TO THE BAND OF THE CIGAR AND A STAND THAT ALLOWS THE CIGAR TO BE PLACED ON A FLAT SURFACE AND ALLOWS THE USER TO SMOKE THE CIGAR BY HOLDING THE CIGAR HOLDER (U.S. CLS. 2, 8, 9 AND 17).

FIRST USE 1-27-2014; IN COMMERCE 1-27-2014.

**CLASS 34—(Continued).**

4,594,463. CLEAN SMOKE, LLC, SARASOTA, FL. SN 86-104,402. PUB. 4-15-2014, FILED 10-29-2013.

# Do your lungs a flavor

THE MARK CONSISTS OF STANDARD CHARACTERS WITHOUT CLAIM TO ANY PARTICULAR FONT, STYLE, SIZE, OR COLOR.

FOR ELECTRIC CIGARETTES; ELECTRONIC CIGARETTES; AND ELECTRONIC CIGARETTES FOR USE AS AN ALTERNATIVE TO TRADITIONAL CIGARETTES (U.S. CLS. 2, 8, 9 AND 17).

FIRST USE 10-24-2013; IN COMMERCE 10-24-2013.

---

4,594,477. PASTEL, STEVEN HSI, COVINA, CA. SN 86-108,960. PUB. 4-1-2014, FILED 11-4-2013.

# Skeleton Key

THE MARK CONSISTS OF STANDARD CHARACTERS WITHOUT CLAIM TO ANY PARTICULAR FONT, STYLE, SIZE, OR COLOR.

FOR ELECTRONIC CIGARETTES (U.S. CLS. 2, 8, 9 AND 17).

FIRST USE 2-4-2014; IN COMMERCE 2-4-2014.

**CLASS 34—(Continued).**

4,594,478. PASTEL, STEVEN HSI, COVINA, CA. SN 86-108,965. PUB. 4-1-2014, FILED 11-4-2013.



THE MARK CONSISTS OF A STYLIZED SKELETON KEY WITH A CREST WITH A CROWN, TWO OPPOSING GRIFFINS, TWO CROSSED KEYS, ORNAMENTAL DECORATION ADORNING THE TOP OF THE KEY AND ON THE BOTTOM, TWO STYLIZED CHECK MARKS WITH A SLANTED RECTANGLE AT THE TOP, WHICH IS COMBINED WITH AN UPSIDE DOWN CURVED LINE THAT IS SQUARED AT THE TOP AND ROUNDED AT THE BOTTOM.

FOR ELECTRONIC CIGARETTES (U.S. CLS. 2, 8, 9 AND 17).

FIRST USE 2-4-2014; IN COMMERCE 2-4-2014.

4,594,479. PASTEL, STEVEN HSI, COVINA, CA. SN 86-108,967. PUB. 4-1-2014, FILED 11-4-2013.



THE MARK CONSISTS OF TWO STYLIZED CHECK MARKS WITH A SLANTED RECTANGLE AT THE TOP, WHICH IS COMBINED WITH AN UPSIDE DOWN CURVED LINE THAT IS SQUARED AT THE TOP AND ROUNDED AT THE BOTTOM.

FOR ELECTRONIC CIGARETTES (U.S. CLS. 2, 8, 9 AND 17).

FIRST USE 2-4-2014; IN COMMERCE 2-4-2014.

**CLASS 34—(Continued).**

4,594,490. LEIGA IMPORT CORPORATION, IRVINE, CA. SN 86-114,179. PUB. 4-15-2014, FILED 11-8-2013.

# LEIGA

THE MARK CONSISTS OF STANDARD CHARACTERS WITHOUT CLAIM TO ANY PARTICULAR FONT, STYLE, SIZE, OR COLOR.

THE WORDING "LEIGA" HAS NO MEANING IN A FOREIGN LANGUAGE.

FOR LIGHTERS FOR SMOKERS, NAMELY, CIGARETTE LIGHTERS AND MULTIPURPOSE UTILITY LIGHTERS (U.S. CLS. 2, 8, 9 AND 17).

FIRST USE 11-1-2013; IN COMMERCE 3-1-2014.

4,594,548. OLIVEROS, INC., MIAMI, FL. SN 86-186,898. PUB. 5-6-2014, FILED 2-6-2014.

# La Boheme

THE MARK CONSISTS OF STANDARD CHARACTERS WITHOUT CLAIM TO ANY PARTICULAR FONT, STYLE, SIZE, OR COLOR.

THE ENGLISH TRANSLATION OF "LA BOHEME" IN THE MARK IS A WOMAN FROM THE HISTORICAL COUNTRY OF CENTRAL EUROPE, OCCUPYING THE WESTERN TWO-THIRDS OF THE TRADITIONAL CZECH LANDS. IT IS LOCATED IN THE CONTEMPORARY CZECH REPUBLIC WITH ITS CAPITAL IN PRAGUE. IN A BROADER MEANING, IT OFTEN REFERS TO THE ENTIRE CZECH TERRITORY, INCLUDING MORAVIA AND CZECH SILESIA.

FOR CIGARS (U.S. CLS. 2, 8, 9 AND 17).

FIRST USE 5-6-2014; IN COMMERCE 5-21-2014.

**SERVICE MARKS**

**CLASS 35—ADVERTISING AND BUSINESS**

**CLASS 35—(Continued).**

4,593,073. WYNN RESORTS HOLDINGS, LLC, LAS VEGAS, NV. SN 77-238,853. PUB. 8-10-2010, FILED 7-25-2007.

# ENCORE

THE MARK CONSISTS OF STANDARD CHARACTERS WITHOUT CLAIM TO ANY PARTICULAR FONT, STYLE, SIZE, OR COLOR.

FOR RETAIL STORE SERVICES FEATURING A WIDE VARIETY OF CONSUMER GOODS OF OTHERS (U.S. CLS. 100, 101 AND 102).

FIRST USE 12-22-2008; IN COMMERCE 12-22-2008.

---

4,593,117. MYKIDBRAINIAIC, INC., DBA MY MUSIC SKOOL, CASTLE PINES NORTH, CO. SN 85-059,377. PUB. 11-6-2012, FILED 6-10-2010.

# My Music Skool

THE MARK CONSISTS OF STANDARD CHARACTERS WITHOUT CLAIM TO ANY PARTICULAR FONT, STYLE, SIZE, OR COLOR.

NO CLAIM IS MADE TO THE EXCLUSIVE RIGHT TO USE "MUSIC", APART FROM THE MARK AS SHOWN.

FOR FRANCHISING, NAMELY, CONSULTATION AND ASSISTANCE IN BUSINESS MANAGEMENT, ORGANIZATION AND PROMOTION (U.S. CLS. 100, 101 AND 102).

FIRST USE 5-20-2014; IN COMMERCE 5-20-2014.

---

4,593,136. MT GROUP LTD., DALLAS, TX. SN 85-145,389. PUB. 5-3-2011, FILED 10-5-2010.

BIG SAVINGS. MORE FLOORING

THE MARK CONSISTS OF STANDARD CHARACTERS WITHOUT CLAIM TO ANY PARTICULAR FONT, STYLE, SIZE, OR COLOR.

FOR WHOLESALE AND RETAIL STORE SERVICES FEATURING TILE AND FLOORING (U.S. CLS. 100, 101 AND 102).

FIRST USE 7-31-2012; IN COMMERCE 7-31-2012.

**CLASS 35—(Continued).**

4,593,137. MT GROUP LTD., DALLAS, TX. SN 85-145,410. PUB. 4-26-2011, FILED 10-5-2010.

GRANDES AHORROS. MAS PISO

THE MARK CONSISTS OF STANDARD CHARACTERS WITHOUT CLAIM TO ANY PARTICULAR FONT, STYLE, SIZE, OR COLOR.

THE ENGLISH TRANSLATION OF "GRANDES AHORROS. MAS PISO" IN THE MARK IS "BIG SAVINGS. MORE FLOORING".

FOR WHOLESALE AND RETAIL STORE SERVICES FEATURING TILE AND FLOORING (U.S. CLS. 100, 101 AND 102).

FIRST USE 7-31-2012; IN COMMERCE 7-31-2012.

---

4,593,149. INNOVENTIVE POWER LLC, SOUTH ORANGE, NJ. SN 85-179,807. PUB. 10-25-2011, FILED 11-18-2010.

# DRCC

THE MARK CONSISTS OF STANDARD CHARACTERS WITHOUT CLAIM TO ANY PARTICULAR FONT, STYLE, SIZE, OR COLOR.

OWNER OF U.S. REG. NOS. 3,993,137 AND 3,993,138.

FOR BUSINESS CONSULTING SERVICES FOR THE ELECTRIC ENERGY INDUSTRY; CONSULTING SERVICES IN THE FIELD OF ENERGY USAGE MANAGEMENT AND ENERGY EFFICIENCY; BUSINESS SERVICES, NAMELY, MONITORING ENERGY USAGE AND COORDINATING ELECTRICITY LOAD SHIFTING AND LOAD CURTAILMENT AMONG UTILITY PROVIDERS; PROVIDING A WEB-BASED ON-LINE PORTAL THAT PROVIDES CUSTOMER ACCESS TO THEIR ENERGY USAGE PATTERN INFORMATION, ENERGY LOAD-SHIFTING AND LOAD-CURTAILMENT INFORMATION, AND ENERGY CONSUMPTION AND USAGE DATA, FOR PURPOSES OF UTILITY ACCOUNT BUSINESS MANAGEMENT AND ENERGY USAGE MANAGEMENT (U.S. CLS. 100, 101 AND 102).

FIRST USE 10-0-2011; IN COMMERCE 10-0-2011.

**CLASS 35—(Continued).**

4,593,150. BAKER & TAYLOR, INC., CHARLOTTE, NC. SN 85-180,437. PUB. 4-24-2012, FILED 11-18-2010.

**CUSTOMREACH**

THE MARK CONSISTS OF STANDARD CHARACTERS WITHOUT CLAIM TO ANY PARTICULAR FONT, STYLE, SIZE, OR COLOR.

FOR PROVIDING ADVERTISING SERVICES IN THE NATURE OF PROMOTING AND MARKETING THE SERVICES OF RETAIL BOOKSTORES AND LIBRARIES OF OTHERS THROUGH ALL PUBLIC COMMUNICATION MEANS; PROVIDING MARKETING SERVICES FOR RETAIL BOOKSTORES AND LIBRARIES, NAMELY, DIRECT MARKETING AND MARKETING DESIGN SERVICES (U.S. CLS. 100, 101 AND 102).

FIRST USE 7-0-2011; IN COMMERCE 7-0-2011.

**CLASS 35—(Continued).**

4,593,195. WAMAFRAMA ENTERTAINMENT, LLC, HENDERSON, NV. SN 85-317,182. PUB. 11-1-2011, FILED 5-10-2011.

**WAMAFRAMA**

THE MARK CONSISTS OF STANDARD CHARACTERS WITHOUT CLAIM TO ANY PARTICULAR FONT, STYLE, SIZE, OR COLOR.

FOR BUSINESS MANAGEMENT CONSULTING CONCERNING THE COMMERCIAL ENTERPRISES OF AUTHORS, MUSICIANS, ARTISTS, PRODUCERS, SCREENPLAY WRITERS, DIRECTORS AND ACTORS; PERSONAL MANAGEMENT SERVICES FOR AUTHORS, MUSICIANS, ARTISTS, PRODUCERS, SCREENPLAY WRITERS, DIRECTORS AND ACTORS; ENTERTAINMENT MANAGEMENT; PERSONAL MANAGEMENT SERVICES FOR ENTERTAINERS; DISTRIBUTORSHIP SERVICES IN THE FIELD OF PRE-RECORDED VIDEOCASSETTES AND VIDEODISCS FEATURING MUSIC AND ENTERTAINMENT IN THE NATURE OF PERFORMANCES BY A MUSICAL BAND; DISTRIBUTORSHIPS IN THE FIELD MUSICAL SOUND RECORDINGS AND VIDEO RECORDINGS; ADVERTISING AND PROMOTION SERVICES AND RELATED CONSULTING SERVICES; ADVERTISING AND PUBLICITY SERVICES; ASSOCIATION SERVICES, NAMELY, PROMOTING THE INTERESTS OF MUSICIANS, SINGERS, SONGWRITERS, MUSICAL PERFORMERS AND ARTISTS; COMPUTERIZED ON-LINE ORDERING FEATURING GENERAL MERCHANDISE AND GENERAL CONSUMER GOODS; COMPUTERIZED ON-LINE ORDERING SERVICES IN THE FIELD OF MUSIC; COMPUTERIZED ONLINE RETAIL STORE SERVICES IN THE FIELD OF MUSIC; ON-LINE RETAIL STORE SERVICES FEATURING DOWNLOADABLE PRE-RECORDED MUSIC AND AUDIO-VISUAL CONTENT, CLOTHING, AND GENERAL MERCHANDISE; ORGANIZATION OF PROMOTIONS USING AUDIO-VISUAL MEDIA; PREPARING AUDIO-VISUAL DISPLAYS IN THE FIELD OF MUSIC ADVERTISING; PREPARING AUDIO VISUAL PRESENTATIONS FOR USE IN ADVERTISING; PROMOTING THE CONCERTS OF OTHERS; PROMOTING THE GOODS AND SERVICES OF OTHERS BY ARRANGING FOR SPONSORS TO AFFILIATE THEIR GOODS AND SERVICES WITH CONCERTS AND MUSICAL EVENTS; PROMOTING THE GOODS OF OTHERS BY PREPARING AND PLACING ADVERTISEMENTS IN AN ELECTRONIC MAGAZINE ACCESSED THROUGH A GLOBAL COMPUTER NETWORK; PROVIDING INFORMATION ABOUT THE GOODS AND SERVICES OF OTHERS VIA A GLOBAL COMPUTER NETWORK; RETAIL STORE SERVICES AVAILABLE THROUGH COMPUTER COMMUNICATION NETWORKS FEATURING, CASSETTES, DVDS AND VIDEOCASSETTES FEATURING MUSIC AND ARTISTIC PERFORMANCES, CLOTHING; COMMERCIAL ADMINISTRATION OF THE LICENSING OF MUSICAL SOUND RECORDINGS OF OTHERS (U.S. CLS. 100, 101 AND 102).

FIRST USE 12-27-2010; IN COMMERCE 6-6-2014.

4,593,155. BARTON, CHRISTINE M, DBA QUAIL AND POPPY, NINE MILE FALLS, WA. SN 85-185,771. PUB. 4-12-2011, FILED 11-28-2010.

**Quail and Poppy**

THE MARK CONSISTS OF STANDARD CHARACTERS WITHOUT CLAIM TO ANY PARTICULAR FONT, STYLE, SIZE, OR COLOR.

FOR RETAIL GIFT SHOPS (U.S. CLS. 100, 101 AND 102).

FIRST USE 9-15-2011; IN COMMERCE 5-15-2013.

4,593,168. SAVING PROMISE INC., WASHINGTON, DC. SN 85-210,175. PUB. 5-3-2011, FILED 1-4-2011.

**BetweenUs**

THE MARK CONSISTS OF STANDARD CHARACTERS WITHOUT CLAIM TO ANY PARTICULAR FONT, STYLE, SIZE, OR COLOR.

FOR PROMOTING PUBLIC AWARENESS OF THE CAUSES OF AND RESPONSES TO DOMESTIC VIOLENCE (U.S. CLS. 100, 101 AND 102).

FIRST USE 12-3-2013; IN COMMERCE 12-3-2013.

**CLASS 35—(Continued).**

4,593,196. GALERIE DE POP CO., LTD., TOKYO, JAPAN. SN 85-318,808. PUB. 5-22-2012, FILED 5-12-2011.

sage de cret

THE MARK CONSISTS OF STANDARD CHARACTERS WITHOUT CLAIM TO ANY PARTICULAR FONT, STYLE, SIZE, OR COLOR.

THE ENGLISH TRANSLATION OF "SAGE DE CRET" IN THE MARK IS "SENSIBLE STATEMENT" OR "SENSIBLE ASSERTION".

FOR WHOLESALE AND RETAIL STORE SERVICES FEATURING HATS AND CAPS, BELTS AND SHOES (U.S. CLS. 100, 101 AND 102).

FIRST USE 5-15-2001; IN COMMERCE 4-17-2013.

**CLASS 35—(Continued).**

HAVING A BLACK BORDER. THE WORDING "COURTEOUS COMMUTER" APPEARS IN CAPITALIZED BLACK LETTERS OVER THE WORDING "ON BOARD" IN CAPITALIZED BLACK LETTERS OF A SMALLER FONT (COMPARED TO THE FONT OF "COURTEOUS COMMUTER"). A BLACK FIGURE RESEMBLING A SMILING MOUTH APPEARS OVER THE WORD "COURTEOUS". THREE HORIZONTAL STRAIGHT LINES EXTEND FROM THE LEFT SIDE OF THE MOUTH TO THE BORDER OF THE QUADRANGLE, FADING FROM GRAY TO WHITE.

FOR PROMOTING THE GOODS AND SERVICES OF OTHERS BY PROVIDING A WEBSITE FEATURING COUPONS, REBATES, PRICE COMPARISON INFORMATION, PRODUCT REVIEWS, ADVERTISEMENTS, LINKS TO THE RETAIL WEBSITES OF OTHERS, AND DISCOUNT INFORMATION; PROMOTING PUBLIC AWARENESS OF THE NEED TO PARTICIPATE IN SOCIALLY-CONSCIOUS SAFE VEHICLE DRIVING VIA THE DISSEMINATION OF CONSUMER INFORMATION FROM A WEBSITE; PROVIDING A WEBSITE FEATURING CONSUMER INFORMATION IN THE FORM OF NON-DOWNLOADABLE VIDEO AND AUDIO RECORDINGS CONCERNING TOPICS RELATING TO SAFE VEHICLE DRIVING (U.S. CLS. 100, 101 AND 102).

FIRST USE 7-1-2014; IN COMMERCE 7-1-2014.

4,593,252. AITHERENA LTD., LONDON, UNITED KINGDOM. SN 85-480,096. PUB. 5-29-2012, FILED 11-23-2011.

Aitherena

4,593,250. RYAN, PATRICK, TROY, NY. SN 85-477,470. PUB. 11-13-2012, FILED 11-21-2011.



NO CLAIM IS MADE TO THE EXCLUSIVE RIGHT TO USE "COMMUTER", APART FROM THE MARK AS SHOWN.

THE COLOR(S) BLACK, YELLOW, WHITE AND GRAY IS/ARE CLAIMED AS A FEATURE OF THE MARK.

THE MARK CONSISTS OF A YELLOW QUADRANGLE

THE MARK CONSISTS OF STANDARD CHARACTERS WITHOUT CLAIM TO ANY PARTICULAR FONT, STYLE, SIZE, OR COLOR.

FOR COMPUTERIZED ON-LINE ORDERING SERVICES IN THE FIELD OF VISUAL ART, INCLUDING PAINTINGS, WATER COLORS, PHOTOGRAPHIC PRINTS, ART PRINTS, SCULPTURE, CRAFTS, VIRTUAL ART AND VIDEO ART; ON-LINE TRADING SERVICES IN THE FIELD OF VISUAL ART IN WHICH SELLER POSTS PRODUCTS TO BE AUCTIONED AND BIDDING IS DONE VIA THE INTERNET; OPERATING ON-LINE MARKETPLACES FOR SELLERS OF GOODS IN THE FIELD OF VISUAL ART, INCLUDING PAINTINGS, WATER COLORS, PHOTOGRAPHIC PRINTS, ART PRINTS, SCULPTURE, CRAFTS, VIRTUAL ART AND VIDEO ART; ADVERTISING AND PUBLICITY SERVICES PROVIDED VIA TELECOMMUNICATIONS NETWORKS, WIRELESS COMMUNICATION NETWORKS, AND THE INTERNET, NAMELY, PROVIDING INFORMATION REGARDING ARTWORK AVAILABLE FOR PURCHASE; PROVIDING INFORMATION PERTAINING TO PURCHASING ART; PROVIDING AN ONLINE SEARCHABLE DATABASE FEATURING ARTWORK BEING OFFERED FOR SALE AND BUYER AND SELLER CONTACT INFORMATION; PROVIDING A WEBSITE FEATURING PRODUCTS AND SERVICES RATINGS OF OTHERS IN THE FIELD OF ARTWORK AND ARTIST SERVICES RECOMMENDED BY CONSUMERS; CONDUCTING PROMOTIONAL CONTESTS TO PROMOTE ARTWORK OF OTHERS; ON-LINE PROFESSIONAL NETWORKING SERVICES FOR ARTISTS, ART COLLECTORS AND ART RESELLERS; PROVIDING CONSUMER INFORMATION IN THE FIELD OF ARTWORK VIA THE INTERNET (U.S. CLS. 100, 101 AND 102).

FIRST USE 6-1-2014; IN COMMERCE 6-1-2014.

**CLASS 35—(Continued).**

4,593,258. R&R NOVELTIES, INC., OKLAHOMA CITY, OK.  
SN 85-490,947. PUB. 5-15-2012, FILED 12-8-2011.

# CARLIE'S

THE MARK CONSISTS OF STANDARD CHARACTERS WITHOUT CLAIM TO ANY PARTICULAR FONT, STYLE, SIZE, OR COLOR.

FOR RETAIL STORE SERVICES FEATURING LINGERIE, SHOES, GREETING CARDS, LOTIONS, OILS, LUBRICANTS, BOOKS, MAGAZINES, DVDS, GAG GIFTS, ADULT NOVELTIES, BEDROOM TOYS, AND GENERAL MERCHANDISE (U.S. CLS. 100, 101 AND 102).

FIRST USE 7-1-2014; IN COMMERCE 7-1-2014.

---

4,593,357. WEBB, NICHOLAS, REDDING, CA. SN 85-645,830.  
PUB. 4-30-2013, FILED 6-7-2012.

# SOUL OF THE CUSTOMER

THE MARK CONSISTS OF STANDARD CHARACTERS WITHOUT CLAIM TO ANY PARTICULAR FONT, STYLE, SIZE, OR COLOR.

FOR BUSINESS CONSULTATION SERVICES IN THE FIELD OF BUSINESS ANALYTICS (U.S. CLS. 100, 101 AND 102).

FIRST USE 1-1-2013; IN COMMERCE 1-1-2013.

---

4,593,377. EZHEALTHCHOICE.COM, LTD., CANTON, OH.  
SN 85-658,212. PUB. 4-30-2013, FILED 6-21-2012.

# EZHealthChoice

THE MARK CONSISTS OF STANDARD CHARACTERS WITHOUT CLAIM TO ANY PARTICULAR FONT, STYLE, SIZE, OR COLOR.

FOR PROVIDING A WEBSITE FEATURING CONSUMER INFORMATION ABOUT HEALTHCARE GOODS AND SERVICES, NAMELY, THE AVAILABILITY, COST, QUALITY AND ALTERNATIVES FOR HEALTHCARE PRODUCTS AND SERVICES (U.S. CLS. 100, 101 AND 102).

FIRST USE 6-30-2009; IN COMMERCE 2-28-2014.

**CLASS 35—(Continued).**

4,593,378. EZHEALTHCHOICE.COM, LTD., CANTON, OH.  
SN 85-658,232. PUB. 5-7-2013, FILED 6-21-2012.

# EZHC

THE MARK CONSISTS OF STANDARD CHARACTERS WITHOUT CLAIM TO ANY PARTICULAR FONT, STYLE, SIZE, OR COLOR.

FOR PROVIDING A WEBSITE FEATURING CONSUMER INFORMATION ABOUT HEALTHCARE GOODS AND SERVICES, NAMELY, THE AVAILABILITY, COST, QUALITY AND ALTERNATIVES FOR HEALTHCARE PRODUCTS AND SERVICES (U.S. CLS. 100, 101 AND 102).

FIRST USE 10-31-2011; IN COMMERCE 2-28-2014.

---

4,593,402. ERIC MOWER AND ASSOCIATES, INC., BUFFALO, NY. SN 85-676,112. PUB. 12-24-2013, FILED 7-13-2012.

# ERIC MOWER + ASSOCIATES

THE MARK CONSISTS OF STANDARD CHARACTERS WITHOUT CLAIM TO ANY PARTICULAR FONT, STYLE, SIZE, OR COLOR.

NO CLAIM IS MADE TO THE EXCLUSIVE RIGHT TO USE "ASSOCIATES", APART FROM THE MARK AS SHOWN.

THE NAME(S), PORTRAIT(S), AND/OR SIGNATURE(S) SHOWN IN THE MARK IDENTIFIES A LIVING INDIVIDUAL, WHOSE CONSENT(S) TO REGISTER IS MADE OF RECORD.

FOR ADVERTISING AND MARKETING SERVICES; PUBLIC RELATIONS; CREATING CORPORATE AND BRAND IDENTITY FOR OTHERS; ADVERTISING THROUGH ALL PUBLIC COMMUNICATIONS MEANS (U.S. CLS. 100, 101 AND 102).

FIRST USE 6-0-2012. THE MARK WAS FIRST USED ANYWHERE IN A DIFFERENT FORM OTHER THAN THAT SOUGHT TO BE REGISTERED AT LEAST AS EARLY AS 01/01/1981.; IN COMMERCE 6-0-2012. THE MARK WAS FIRST USED IN COMMERCE IN A DIFFERENT FORM OTHER THAN THAT SOUGHT TO BE REGISTERED AT LEAST AS EARLY AS 00/00/1981. .

**CLASS 35—(Continued).**

4,593,412. BGASC, LLC, CALABASAS, CA. SN 85-685,925. PUB. 5-14-2013, FILED 7-24-2012.

# BGASC

THE MARK CONSISTS OF STANDARD CHARACTERS WITHOUT CLAIM TO ANY PARTICULAR FONT, STYLE, SIZE, OR COLOR.

FOR ON-LINE RETAIL STORE SERVICES FEATURING COIN SUPPLIES; RETAIL OUTLETS FEATURING COIN SUPPLIES; RETAIL STORE SERVICES FEATURING COIN SUPPLIES; WHOLESALE STORE SERVICES FEATURING COIN SUPPLIES (U.S. CLS. 100, 101 AND 102).

FIRST USE 2-1-2013; IN COMMERCE 2-1-2013.

**CLASS 35—(Continued).**

4,593,436. NEW BALANCE TORONTO LTD., TORONTO, ONTARIO, CANADA. SN 85-711,171. PUB. 3-12-2013, FILED 8-23-2012.

# FIT4BALANCE

THE MARK CONSISTS OF STANDARD CHARACTERS WITHOUT CLAIM TO ANY PARTICULAR FONT, STYLE, SIZE, OR COLOR.

FOR ON-LINE RETAIL STORE SERVICES FEATURING SHOES AND RELATED CLOTHING AND FOOTWEAR PRODUCTS (U.S. CLS. 100, 101 AND 102).

FIRST USE 8-0-2013; IN COMMERCE 8-0-2013.

---

4,593,421. EMILIO PUCCI INTERNATIONAL B.V., NL-3743KN BAARN, NETHERLANDS. SN 85-693,659. PUB. 5-14-2013, FILED 8-2-2012.

# PUCCI

THE MARK CONSISTS OF STANDARD CHARACTERS WITHOUT CLAIM TO ANY PARTICULAR FONT, STYLE, SIZE, OR COLOR.

PRIORITY CLAIMED UNDER SEC. 44(D) ON ITALY APPLICATION NO. FI2012C00054, FILED 4-11-2012.

OWNER OF U.S. REG. NOS. 2,760,935, 3,899,489, AND OTHERS.

THE NAME(S), PORTRAIT(S), AND/OR SIGNATURE(S) SHOWN IN THE MARK DOES NOT IDENTIFY A PARTICULAR LIVING INDIVIDUAL.

SEC. 2(F).

FOR RETAIL STORE SERVICES AND ON-LINE RETAIL STORE SERVICES FEATURING CLOTHING, FOOTWEAR, HEADWEAR, LEATHERWEAR, BAGS, PURSES, EYEWEAR, JEWELRY; MAIL ORDER SERVICES FEATURING CLOTHING, FOOTWEAR, HEADWEAR, LEATHERWEAR, BAGS, PURSES, EYEWEAR, JEWELRY ; RETAIL STORE SERVICES AND ON-LINE RETAIL STORE SERVICES FEATURING CLOTHING, FOOTWEAR, HEADWEAR, LEATHERWEAR, BAGS, PURSES, EYEWEAR, JEWELRY, THAT ARE ACCESSIBLE THROUGH COMPUTER COMMUNICATIONS, ON-LINE, BY MAIL ORDER, BY CATALOG, AND ALL OTHER MEANS OF COMMUNICATION FOR RETAIL SALES PURPOSE (U.S. CLS. 100, 101 AND 102).

FIRST USE 12-0-2002; IN COMMERCE 12-0-2002.

---

4,593,446. VITAMIN COTTAGE NATURAL FOOD MARKETS, INC., DBA NATURAL GROCERS BY VITAMIN COTTAGE, LAKEWOOD, CO. SN 85-717,359. PUB. 12-3-2013, FILED 8-30-2012.

# EDAP - Every Day Affordable Price

THE MARK CONSISTS OF STANDARD CHARACTERS WITHOUT CLAIM TO ANY PARTICULAR FONT, STYLE, SIZE, OR COLOR.

NO CLAIM IS MADE TO THE EXCLUSIVE RIGHT TO USE "EVERY DAY AFFORDABLE PRICE", APART FROM THE MARK AS SHOWN.

FOR RETAIL STORE SERVICES AND ON-LINE RETAIL STORE SERVICES FEATURING GROCERIES, COSMETICS, VITAMINS, SPORT AND HEALTH NUTRITION SUPPLEMENTS, BOOKS AND EDUCATIONAL MATERIALS ON NUTRITION AND HEALTH, AND ORGANIC FOODS (U.S. CLS. 100, 101 AND 102).

FIRST USE 6-23-2013; IN COMMERCE 6-23-2013.

**CLASS 35—(Continued).**

4,593,477. UNITEDHEALTH GROUP INCORPORATED, MINNETONKA, MN. SN 85-745,882. PUB. 5-21-2013, FILED 10-4-2012.

**MYMEDSREVIEW**

THE MARK CONSISTS OF STANDARD CHARACTERS WITHOUT CLAIM TO ANY PARTICULAR FONT, STYLE, SIZE, OR COLOR.

FOR MEDICATION THERAPY MANAGEMENT SERVICES, NAMELY, MEDICATION CONSULTATIONS, MEDICATION THERAPY REVIEWS, AND ASSESSING MEDICATION UTILIZATION, AND HISTORY, PERSONAL MEDICATION RECORD KEEPING AND THE DEVELOPMENT OF MEDICATION-RELATED ACTION PLANS, ALL FOR COST MANAGEMENT PURPOSES; PROVIDING INFORMATION IN THE FIELD OF MEDICATION UTILIZATION, NAMELY, PROVIDING INFORMATION REGARDING MEDICATION COST MANAGEMENT (U.S. CLS. 100, 101 AND 102).

FIRST USE 2-8-2013; IN COMMERCE 2-8-2013.

4,593,490. PREFERRED GUEST, INC., STAMFORD, CT. SN 85-754,478. PUB. 10-1-2013, FILED 10-15-2012.

**CROSSOVER REWARDS**

THE MARK CONSISTS OF STANDARD CHARACTERS WITHOUT CLAIM TO ANY PARTICULAR FONT, STYLE, SIZE, OR COLOR.

NO CLAIM IS MADE TO THE EXCLUSIVE RIGHT TO USE "REWARDS", APART FROM THE MARK AS SHOWN.

FOR CUSTOMER LOYALTY SERVICES, NAMELY, INCENTIVE PROGRAMS TO PROMOTE FREQUENT CUSTOMER PATRONAGE THROUGH REWARDS GIVEN TO HOTEL GUESTS (U.S. CLS. 100, 101 AND 102).

FIRST USE 2-1-2013; IN COMMERCE 2-1-2013.

**CLASS 35—(Continued).**

4,593,496. FISHER SCIENTIFIC COMPANY L.L.C., PITTSBURGH, PA. SN 85-757,799. PUB. 10-8-2013, FILED 10-18-2012.

**BETTER LIVING BEGINS IN THE LAB**

THE MARK CONSISTS OF STANDARD CHARACTERS WITHOUT CLAIM TO ANY PARTICULAR FONT, STYLE, SIZE, OR COLOR.

FOR PROVIDING CONSUMER INFORMATION IN THE FIELDS OF LABORATORY PRODUCTS AND SERVICES, MEDICAL SUPPLIES, PERSONAL PROTECTION PRODUCTS, CLINICAL TESTING AND TEST RESULTS (U.S. CLS. 100, 101 AND 102).

FIRST USE 0-0-2013; IN COMMERCE 0-0-2013.

4,593,511. SUSTAINED MOTION CAR COLLECTION, LLC, NAPLES, FL. SN 85-764,385. PUB. 4-16-2013, FILED 10-26-2012.

**SUSTAINED MOTION CAR COLLECTION**

THE MARK CONSISTS OF STANDARD CHARACTERS WITHOUT CLAIM TO ANY PARTICULAR FONT, STYLE, SIZE, OR COLOR.

NO CLAIM IS MADE TO THE EXCLUSIVE RIGHT TO USE "CAR COLLECTION", APART FROM THE MARK AS SHOWN.

FOR DEALERSHIP SERVICES IN THE FIELD OF AUTOMOBILES, CLASSIC AUTOMOBILES AND ANTIQUE AUTOMOBILES; AUTOMOBILE DEALERSHIPS (U.S. CLS. 100, 101 AND 102).

FIRST USE 2-1-2013; IN COMMERCE 2-2-2013.

4,593,512. SUSTAINED MOTION CAR COLLECTION, LLC, NAPLES, FL. SN 85-764,399. PUB. 5-14-2013, FILED 10-26-2012.



THE COLOR(S) BLUE, RED, YELLOW AND SILVER IS/ ARE CLAIMED AS A FEATURE OF THE MARK.



**CLASS 35—(Continued).**

THE MARK CONSISTS OF THE STYLIZED WORD "SUSTAINED" IN THE COLOR BLUE WITH SILVER HORIZONTAL LINES AND SHADOWING, WITH THE STYLIZED WORD "MOTION" DIRECTLY UNDERNEATH IN THE COLOR RED WITH SILVER HORIZONTAL LINES AND SHADOWING, WITH A CIRCLE DESIGN ON THE RIGHT IN THE COLORS RED AND BLUE AND SILVER WITH A YELLOW CENTER AND THE LETTERS "SM" IN SILVER AND UNDERLINED IN SILVER WITHIN THE YELLOW CENTER.

FOR DEALERSHIP SERVICES IN THE FIELD OF AUTOMOBILES, CLASSIC AUTOMOBILES AND ANTIQUE AUTOMOBILES; AUTOMOBILE DEALERSHIPS (U.S. CLS. 100, 101 AND 102).

FIRST USE 2-1-2013; IN COMMERCE 2-1-2013.

---

4,593,515. SUSTAINED MOTION CAR COLLECTION, LLC, NAPLES, FL. SN 85-765,955. PUB. 4-2-2013, FILED 10-29-2012.

**SUSTAINED MOTION**

THE MARK CONSISTS OF STANDARD CHARACTERS WITHOUT CLAIM TO ANY PARTICULAR FONT, STYLE, SIZE, OR COLOR.

FOR DEALERSHIP SERVICES IN THE FIELD OF AUTOMOBILES, CLASSIC AUTOMOBILES AND ANTIQUE AUTOMOBILES; AUTOMOBILE DEALERSHIPS (U.S. CLS. 100, 101 AND 102).

FIRST USE 2-1-2013; IN COMMERCE 2-1-2013.

---

4,593,517. PATRIOT BUICK PONTIAC GMC, INC., BOYERTOWN, PA. SN 85-766,834. PUB. 4-16-2013, FILED 10-30-2012.



THE MARK CONSISTS OF THE LETTERS "PH" IN A STYLIZED FORMAT WITH A ROOF ABOVE THEM, WHICH FORMS A HOUSE.

FOR ONLINE STORE SERVICES FEATURING MOTOR VEHICLE PARTS AND MOTOR VEHICLE ACCESSORIES (U.S. CLS. 100, 101 AND 102).

FIRST USE 9-24-2009; IN COMMERCE 9-24-2009.

**CLASS 35—(Continued).**

4,593,525. STERLING RESTAURANT SUPPLY, LLC, STERLING, VA. SN 85-770,624. PUB. 10-1-2013, FILED 11-2-2012.

**SRS**

THE MARK CONSISTS OF STANDARD CHARACTERS WITHOUT CLAIM TO ANY PARTICULAR FONT, STYLE, SIZE, OR COLOR.

FOR RETAIL STORE SERVICES AND ONLINE RETAIL STORE SERVICES FEATURING FLATWARE, DINNERWARE, BEVERAGE GLASSWARE AND STEMWARE, COOKWARE, SERVINGWARE FOR SERVING FOOD AND DRINKS, AND HOUSEWARES (U.S. CLS. 100, 101 AND 102).

FIRST USE 8-24-2012; IN COMMERCE 8-24-2012.

---

4,593,540. WILLIAMS-SONOMA, INC., SAN FRANCISCO, CA. SN 85-776,020. PUB. 10-29-2013, FILED 11-9-2012.

**we love**

OWNER OF U.S. REG. NO. 4,043,221.

THE COLOR(S) RED AND BLACK IS/ARE CLAIMED AS A FEATURE OF THE MARK.

THE MARK CONSISTS OF THE BLACK WORDS, "WE LOVE", WITH A RED HEART USED IN PLACE OF THE LETTER "O".

FOR ONLINE RETAIL STORE SERVICES, RETAIL STORE SERVICES, AND CATALOG MAIL ORDER SERVICES FEATURING HOUSE WARES, HOME ACCESSORIES, INDOOR AND OUTDOOR FURNITURE, PILLOWS, SLIPCOVERS, RUGS, LAMPS AND LIGHTING FIXTURES, CURTAINS, CURTAIN RODS, BED LINENS, BATH LINENS, CANDLE HOLDERS, CANDLES, PICTURE FRAMES, MIRRORS, VASES, DINNERWARE, GLASSWARE, TRAYS, BASKETS MADE OF WICKER, INTERIOR DECORATING BOOKS, WALL COVERINGS, WINDOW COVERINGS, WINDOW SHADES, FABRIC, NAMELY, CURTAIN FABRIC, UPHOLSTERY FABRIC, FABRIC MADE OF COTTON AND FABRIC MADE OF GAUZE, BEDDING, BATH RUGS, TOWELS, SHOWER CURTAINS, LIGHTING, BOOKS, HARDWARE, NAMELY, DRAPERY HARDWARE, FURNITURE HARDWARE, BATHROOM HARDWARE, CLOCKS, STATUES AND FIGURINES, SNOW GLOBES, PAPERWEIGHTS, BOOKENDS, JEWELRY BOXES, BOXES, PERFUME BOTTLES, HOME SCENTS, PAPER SUPPLIES, OFFICE PRODUCTS, BARWARE, NAPKINS, COASTERS, BREAD BOARDS, CHEESE KNIVES, DISHES, AND SALT AND PEPPER SHAKERS (U.S. CLS. 100, 101 AND 102).

FIRST USE 1-0-2013; IN COMMERCE 1-0-2013.

**CLASS 35—(Continued).**

4,593,559. MACHELEDT, JEAN M, AKA GVTRADINGCOMPANY.COM, FORT COLLINS, CO. SN 85-784,393. PUB. 10-29-2013, FILED 11-20-2012.

## Gros Ventre Trading Co.

THE MARK CONSISTS OF STANDARD CHARACTERS WITHOUT CLAIM TO ANY PARTICULAR FONT, STYLE, SIZE, OR COLOR.

NO CLAIM IS MADE TO THE EXCLUSIVE RIGHT TO USE "TRADING CO.", APART FROM THE MARK AS SHOWN.

THE ENGLISH TRANSLATION OF "GROS VENTRE" IN THE MARK IS "BIG BELLY".

FOR RETAIL STORE SERVICES FEATURING STATIONERY, NAMELY, POSTCARDS AND NOTE CARDS; PERSONAL ACCESSORIES, NAMELY, JEWELRY; SPORTS APPAREL, NAMELY, T-SHIRTS, AND TANK TOPS; GIFTS, NAMELY, MAGNETS, STICKERS, AND GADGETS ACCESSIBLE ON-LINE AND BY TELEPHONE ORDER (U.S. CLS. 100, 101 AND 102).

FIRST USE 3-18-2013; IN COMMERCE 8-5-2013.

4,593,563. CONCORD CONSULTING CORPORATION, SHERWOOD PARK, ALBERTA, CANADA. SN 85-787,554. PUB. 3-25-2014, FILED 11-26-2012.

## PRO.FILE

THE MARK CONSISTS OF STANDARD CHARACTERS WITHOUT CLAIM TO ANY PARTICULAR FONT, STYLE, SIZE, OR COLOR.

OWNER OF U.S. REG. NOS. 3,534,454 AND 3,924,785.

FOR ON-LINE HUMAN RESOURCE ASSESSMENT AND DEVELOPMENT BY WAY OF PROVISION TO EMPLOYERS OF AN ON-LINE QUESTIONNAIRE TO IDENTIFY THE PERSONALITY CHARACTERISTICS AND BEHAVIORS NECESSARY IN DIFFERENT EMPLOYMENT AREAS; ON-LINE HUMAN RESOURCE ASSESSMENT AND DEVELOPMENT, NAMELY, THE SELECTION, RECRUITMENT, PROMOTION AND EVALUATION OF EMPLOYEES, MANAGERS AND EXECUTIVES BY WAY OF THE PROVISION OF AN ON-LINE SURVEY TO IDENTIFY THEIR PERSONALITY CHARACTERISTICS AND BEHAVIORS SO AS TO MORE ACCURATELY ASSESS THEIR POTENTIAL FOR EMPLOYMENT; ON-LINE PERSONNEL MANAGEMENT AND CONSULTATION IN THE AREA OF MATCHING PERSONNEL WITH OCCUPATIONAL REQUIREMENTS; ON-LINE BUSINESS MANAGEMENT CONSULTATION IN THE AREA OF MATCHING PERSONNEL WITH OCCUPATIONAL REQUIREMENTS (U.S. CLS. 100, 101 AND 102).

FIRST USE 1-1-2012; IN COMMERCE 1-1-2014.

**CLASS 35—(Continued).**

4,593,585. SFV VENTURES, INC., GRANADA HILLS, CA. SN 85-794,188. PUB. 5-21-2013, FILED 12-4-2012.

## PET-I-TUDE

THE MARK CONSISTS OF STANDARD CHARACTERS WITHOUT CLAIM TO ANY PARTICULAR FONT, STYLE, SIZE, OR COLOR.

FOR ONLINE RETAIL STORE SERVICES FEATURING PET FOOD AND PET ACCESSORIES AND RETAIL STORE SERVICES FEATURING PET FOOD AND PET ACCESSORIES (U.S. CLS. 100, 101 AND 102).

FIRST USE 5-0-2014; IN COMMERCE 5-0-2014.

4,593,616. UNITED FISHING ADVENTURES, LLC, LOXAHATCHEE, FL. SN 85-803,125. PUB. 10-29-2013, FILED 12-14-2012.

## UNITED FISHING ADVENTURES

THE MARK CONSISTS OF STANDARD CHARACTERS WITHOUT CLAIM TO ANY PARTICULAR FONT, STYLE, SIZE, OR COLOR.

NO CLAIM IS MADE TO THE EXCLUSIVE RIGHT TO USE "FISHING ADVENTURES", APART FROM THE MARK AS SHOWN.

FOR PROVIDING AN ONLINE DIRECTORY INFORMATION SERVICE FEATURING INFORMATION REGARDING FISHING TOURS AND OTHER FISHING RELATED ACTIVITIES (U.S. CLS. 100, 101 AND 102).

FIRST USE 7-31-2013; IN COMMERCE 7-31-2013.

4,593,623. ORIOLE MEDIA CORP., TORONTO, CANADA. SN 85-804,972. PUB. 10-15-2013, FILED 12-18-2012.

## NECTAR

THE MARK CONSISTS OF STANDARD CHARACTERS WITHOUT CLAIM TO ANY PARTICULAR FONT, STYLE, SIZE, OR COLOR.

FOR ON-LINE REVERSE AUCTION SERVICES IN WHICH PUBLISHERS BID ON ADVERTISING CAMPAIGNS, ALLOCATE THE BIDDING INVENTORY, NAMELY, THE ADVERTISING CAMPAIGNS BASED ON A RATING SYSTEM, DELIVER THE DATA COLLECTED FROM BIDDING PROCESS AND ANALYZE AND DELIVER DATA FROM THE AUDIENCE REGARDING THE ADVERTISING CAMPAIGN (U.S. CLS. 100, 101 AND 102).

FIRST USE 5-21-2013; IN COMMERCE 5-21-2013.

**CLASS 35—(Continued).**

4,593,633. ABILENE MACHINE, INC., ABILENE, KS. SN 85-807,821. PUB. 5-14-2013, FILED 12-20-2012.

# FARM TUFF

THE MARK CONSISTS OF STANDARD CHARACTERS WITHOUT CLAIM TO ANY PARTICULAR FONT, STYLE, SIZE, OR COLOR.

NO CLAIM IS MADE TO THE EXCLUSIVE RIGHT TO USE "FARM", APART FROM THE MARK AS SHOWN.

FOR RETAIL AND WHOLESALE STORE SERVICES FEATURING NEW AND USED FARM MACHINERY AND PARTS THEREOF (U.S. CLS. 100, 101 AND 102).

FIRST USE 6-16-2014; IN COMMERCE 6-16-2014.

4,593,658. PFIZER INC., NEW YORK, NY. SN 85-815,889. PUB. 10-15-2013, FILED 1-4-2013.

# PFIZER RXPATHWAYS

THE MARK CONSISTS OF STANDARD CHARACTERS WITHOUT CLAIM TO ANY PARTICULAR FONT, STYLE, SIZE, OR COLOR.

FOR ADMINISTRATION OF A PROGRAM TO PROVIDE MEDICINES AT LOW OR NO COST TO UNDERSERVED POPULATIONS; ADMINISTRATION OF A PROGRAM TO PROVIDE DISCOUNTS ON PRESCRIPTION MEDICINES (U.S. CLS. 100, 101 AND 102).

FIRST USE 4-1-2014; IN COMMERCE 4-1-2014.

4,593,682. CASTRO PETERSEN, INC., LONG BEACH, CA. SN 85-827,322. PUB. 3-11-2014, FILED 1-18-2013.



NO CLAIM IS MADE TO THE EXCLUSIVE RIGHT TO USE "CREATIVE" OR "PRODUCTIONS", APART FROM THE MARK AS SHOWN.

**CLASS 35—(Continued).**

THE COLOR(S) RED, BLACK, AND WHITE IS/ARE CLAIMED AS A FEATURE OF THE MARK.

THE MARK CONSISTS OF THE DESIGN OF THREE LIGHT BULBS WITH LINES REPRESENTING LIGHT, IN WHITE, ON A BLACK RECTANGLE. ABOVE THE RECTANGLE IS THE WORD "CREATIVE" IN BLACK, AND BELOW IS THE WORD "PRODUCTIONS" IN BLACK, AND UNDER THE "O" IN "PRODUCTIONS" IS A BLACK TRIANGLE. ALL WITHIN A WHITE RECTANGLE OUTLINED IN BLACK AND RED.

FOR ADVERTISING AND MARKETING CONSULTANCY; ADVERTISING AND PROMOTION SERVICES AND RELATED CONSULTING (U.S. CLS. 100, 101 AND 102).

FIRST USE 9-1-1992; IN COMMERCE 9-1-1992.

4,593,721. AMERICAN TIRE DISTRIBUTORS, INC., HUNTERVILLE, NC. SN 85-849,099. PUB. 11-5-2013, FILED 2-13-2013.



OWNER OF U.S. REG. NOS. 3,024,766, 4,284,277, AND OTHERS.

NO CLAIM IS MADE TO THE EXCLUSIVE RIGHT TO USE "TIRE DISTRIBUTORS", APART FROM THE MARK AS SHOWN.

THE MARK CONSISTS OF THE STYLIZED LETTERS "ATD" IN LARGE FONT DISPLAYED ABOVE THE WORDING "AMERICAN TIRE DISTRIBUTORS". THE WORDING "MILES AHEAD" IS BELOW "DISTRIBUTORS".

SEC. 2(F) AS TO "AMERICAN".

FOR DISTRIBUTORSHIP SERVICES IN THE FIELD OF AUTOMOTIVE AND VEHICLE TIRES, WHEELS, EQUIPMENT, AFTER-MARKET ACCESSORIES AND REPLACEMENT PARTS (U.S. CLS. 100, 101 AND 102).

FIRST USE 4-29-2013; IN COMMERCE 4-29-2013.

4,593,748. VACO, LLC, BRENTWOOD, TN. SN 85-867,348. PUB. 11-19-2013, FILED 3-5-2013.

# VACO HEALTHCARE

THE MARK CONSISTS OF STANDARD CHARACTERS WITHOUT CLAIM TO ANY PARTICULAR FONT, STYLE, SIZE, OR COLOR.

OWNER OF U.S. REG. NOS. 3,595,980, 3,686,763, AND OTHERS.

**CLASS 35—(Continued).**

NO CLAIM IS MADE TO THE EXCLUSIVE RIGHT TO USE "HEALTHCARE", APART FROM THE MARK AS SHOWN.  
 FOR BUSINESS CONSULTATION SERVICES; EMPLOYMENT AGENCY SERVICES, NAMELY, TEMPORARY PROFESSIONAL EMPLOYMENT STAFFING, EMPLOYMENT DIRECT HIRE PLACEMENT, RECRUITMENT AND SEARCH SERVICES IN THE FIELDS OF HEALTHCARE, HEALTHCARE INFORMATION TECHNOLOGY AND CLINICAL (U.S. CLS. 100, 101 AND 102).  
 FIRST USE 1-6-2014; IN COMMERCE 1-6-2014.

---

4,593,757. A.B. CLOSING CORPORATION, ORLANDO, FL.  
 SN 85-875,151. PUB. 9-10-2013, FILED 3-13-2013.

# Knight Federal

THE MARK CONSISTS OF STANDARD CHARACTERS WITHOUT CLAIM TO ANY PARTICULAR FONT, STYLE, SIZE, OR COLOR.

NO CLAIM IS MADE TO THE EXCLUSIVE RIGHT TO USE "FEDERAL", APART FROM THE MARK AS SHOWN.

FOR BUSINESS CONSULTATION IN THE FIELD OF BUSINESS PROCESS TECHNOLOGY, CHANGE MANAGEMENT, OPERATIONAL SUSTAINABILITY; EMPLOYMENT HIRING, RECRUITING, PLACEMENT, STAFFING AND CAREER NETWORKING SERVICES; EMPLOYMENT STAFFING THE FIELD OF INFORMATION TECHNOLOGY; BUSINESS MANAGEMENT AND CONSULTING SERVICES IN THE FIELDS OF GOVERNMENT AND MILITARY AGENCY INFORMATION TECHNOLOGY PROJECTS, AND BUSINESS OPERATIONS; SERVICES FOR GOVERNMENT AND MILITARY AGENCIES, NAMELY, BUSINESS ADMINISTRATION AND MANAGEMENT; GOVERNMENT AND MILITARY BUSINESS CONSULTING SERVICES IN THE FIELD OF OPERATIONS MANAGEMENT; EMPLOYMENT HIRING, RECRUITING, PLACEMENT AND STAFFING SERVICES (U.S. CLS. 100, 101 AND 102).

FIRST USE 2-4-2013; IN COMMERCE 5-1-2014.

**CLASS 35—(Continued).**

4,593,766. ALABS CORP. DBA ACCUMEN, SAN DIEGO, CA.  
 SN 85-880,541. PUB. 4-8-2014, FILED 3-19-2013.

# ACCUMEN

THE MARK CONSISTS OF STANDARD CHARACTERS WITHOUT CLAIM TO ANY PARTICULAR FONT, STYLE, SIZE, OR COLOR.

FOR MANAGEMENT AND BUSINESS CONSULTING SERVICES FOR HOSPITALS AND MEDICAL LABORATORIES, NAMELY, ASSESSING AND CONSULTING ON MEDICAL LABORATORY SERVICE LINES, SUPPLY CHAIN EFFICIENCY FOR MEDICAL LABORATORIES, TESTING PROCEDURES OFFERED BY MEDICAL LABORATORIES, MANAGEMENT OF BLOOD PRODUCTS IN MEDICAL LABORATORIES, REPORTING MEDICAL LABORATORY TEST RESULTS, DEVELOPMENT OF MEDICAL LABORATORY OUTREACH PROGRAMS, CUSTOMER SERVICE FOR MEDICAL LABORATORIES, INVENTORY MANAGEMENT FOR MEDICAL LABORATORIES AND BILLING PRACTICES FOR MEDICAL LABORATORIES, ALL FOR COMMERCIAL AND BUSINESS PURPOSES (U.S. CLS. 100, 101 AND 102).

FIRST USE 9-29-2013; IN COMMERCE 9-29-2013.

---

4,593,810. L.O.F. INC., ELKHART, IN. SN 85-907,019. PUB. 9-10-2013, FILED 4-17-2013.

# ILOVEMYTRUCK.COM

THE MARK CONSISTS OF STANDARD CHARACTERS WITHOUT CLAIM TO ANY PARTICULAR FONT, STYLE, SIZE, OR COLOR.

FOR DISTRIBUTORSHIP SERVICES IN THE FIELD OF VEHICLE PARTS AND ACCESSORIES, NAMELY, AUTOMOTIVE, SUV, AND TRUCK PARTS AND ACCESSORIES (U.S. CLS. 100, 101 AND 102).

FIRST USE 5-2-2014; IN COMMERCE 5-2-2014.

---

4,593,825. WHITESTONE WORKS, LLC, DBA WHITESTONE WORKS, NEW YORK, NY. SN 85-912,633. PUB. 4-1-2014, FILED 4-23-2013.



# WHITESTONE — WORKS —

THE COLOR(S) WHITE AND BLUE IS/ARE CLAIMED AS A FEATURE OF THE MARK.

**CLASS 35—(Continued).**

THE MARK CONSISTS OF A WHITE STYLIZED LIGHTHOUSE OUTLINED IN DARK BLUE WITH TWO DIAGONAL MEDIUM BLUE LINES ACROSS THE BOTTOM PORTION. TO THE RIGHT OF THE LIGHTHOUSE APPEARS THE STYLIZED WORDING "WHITESTONE WORKS". THE WORD "WHITE" APPEARS IN DARK BLUE, FOLLOWED BY "STONE" IN MEDIUM BLUE AND "WORKS" LISTED BELOW IN MEDIUM BLUE. TWO DARK BLUE TAPERED LINES EXTEND HORIZONTALLY FROM THE WORD "WORKS" TO THE LEFT AND RIGHT.

FOR ADVERTISING AND PROMOTIONAL SERVICES (U.S. CLS. 100, 101 AND 102).

FIRST USE 7-15-2013; IN COMMERCE 7-15-2013.

**WHITESTONE WORKS**

THE MARK CONSISTS OF STANDARD CHARACTERS WITHOUT CLAIM TO ANY PARTICULAR FONT, STYLE, SIZE, OR COLOR.

FOR ADVERTISING AND PROMOTIONAL SERVICES (U.S. CLS. 100, 101 AND 102).

FIRST USE 7-15-2013; IN COMMERCE 7-15-2013.

4,593,827. DANA POSSICK, CANTON, GA. SN 85-914,074. PUB. 9-17-2013, FILED 4-24-2013.

**Here 2 Work**

THE MARK CONSISTS OF STANDARD CHARACTERS WITHOUT CLAIM TO ANY PARTICULAR FONT, STYLE, SIZE, OR COLOR.

FOR BUSINESS SERVICES, NAMELY, PROVIDING A WEBSITE THAT CONNECTS SERVICE PROVIDERS WITH CONSUMERS (U.S. CLS. 100, 101 AND 102).

FIRST USE 6-1-2013; IN COMMERCE 6-1-2013.

**CLASS 35—(Continued).**

4,593,856. EDWARD HINES LUMBER, BUFFALO GROVE, IL. SN 85-921,455. PUB. 4-15-2014, FILED 5-2-2013.

**SUPPLYING SOLUTIONS**

THE MARK CONSISTS OF STANDARD CHARACTERS WITHOUT CLAIM TO ANY PARTICULAR FONT, STYLE, SIZE, OR COLOR.

FOR WHOLESALE AND RETAIL STORE SERVICES FEATURING WINDOWS, DOORS, MILLWORK, LUMBER, COMPONENTS, ROOFING, SIDING, AND BUILDING CONSTRUCTION MATERIALS (U.S. CLS. 100, 101 AND 102).

FIRST USE 7-17-2013; IN COMMERCE 7-17-2013.

4,593,880. ACOSTA, INC., JACKSONVILLE, FL. SN 85-927,304. PUB. 12-3-2013, FILED 5-9-2013.

**HUNTER STRAKER**

THE MARK CONSISTS OF STANDARD CHARACTERS WITHOUT CLAIM TO ANY PARTICULAR FONT, STYLE, SIZE, OR COLOR.

FOR ADVERTISING AND MARKETING CONSULTANCY; ADVERTISING AND MARKETING SERVICES, NAMELY, PROMOTING THE GOODS AND SERVICES OF OTHERS (U.S. CLS. 100, 101 AND 102).

FIRST USE 9-14-2013; IN COMMERCE 9-14-2013.

**CLASS 35—(Continued).**

4,593,886. INSTITUTE FOR FAMILY-CENTERED CARE, INC., DBA INSTITUTE FOR PATIENT- AND FAMILY-CENTERED CARE, BETHESDA, MD. SN 85-929,100. PUB. 10-8-2013, FILED 5-10-2013.



THE MARK CONSISTS OF A GRAPHIC ELEMENT OF TRIANGLES IN A CIRCULAR CONFIGURATION RESEMBLING A PINWHEEL OUT FROM WHICH A LINE EXTENDS TO THE RIGHT. ABOVE THE LINE IS THE LITERAL ELEMENT "BETTER TOGETHER" AND BELOW THE LINE IS THE LITERAL ELEMENT "PARTNERING WITH FAMILIES".

FOR PROMOTING PUBLIC AWARENESS AND CHANGE IN HEALTH CARE POLICIES AND PRACTICES SO THAT FAMILIES ARE VIEWED AS CARE PARTNERS AND ALLIES FOR QUALITY AND SAFETY, ACCORDING TO PATIENT PREFERENCE, AND NOT AS VISITORS (U.S. CLS. 100, 101 AND 102).

FIRST USE 6-24-2014; IN COMMERCE 6-24-2014.

4,593,893. WILD IRISHMAN ADVISORY, LLC, GREENWOOD VILLAGE, CO. SN 85-931,200. PUB. 10-22-2013, FILED 5-14-2013.



NO CLAIM IS MADE TO THE EXCLUSIVE RIGHT TO USE "ADVISORY", APART FROM THE MARK AS SHOWN. THE MARK CONSISTS OF A STYLIZED DESIGN OF A DOUBLE MOUNTAIN PEAK WITH A LARGE SETTING SUN ABOVE THE WORDS "WILD IRISHMAN" SEPARATED BY A LINE AND OVER THE WORD "ADVISORY".

FOR BRANDING SERVICES, NAMELY, CONSULTING, DEVELOPMENT, MANAGEMENT AND MARKETING OF BRANDS FOR BUSINESSES AND/OR INDIVIDUALS; BUSINESS CONSULTING AND INFORMATION SERVICES; BUSINESS MARKETING CONSULTING SERVICES (U.S. CLS. 100, 101 AND 102).

FIRST USE 1-28-2014; IN COMMERCE 1-28-2014.

**CLASS 35—(Continued).**

4,593,895. CENTRIC BRAND COLLECTIVE, INC., SEATTLE, WA. SN 85-931,316. PUB. 10-8-2013, FILED 5-14-2013.

**HOLISTECH LIVING**

THE MARK CONSISTS OF STANDARD CHARACTERS WITHOUT CLAIM TO ANY PARTICULAR FONT, STYLE, SIZE, OR COLOR.

FOR RETAIL STORE SERVICES FEATURING HEALTH AND WELLNESS TECHNOLOGY AND PRODUCTS (U.S. CLS. 100, 101 AND 102).

FIRST USE 10-1-2013; IN COMMERCE 10-1-2013.

4,593,907. DOUG EDMONDS, PHILOMATH, OR. AND JACQUE LUSK, PHILOMATH, OR. SN 85-933,248. PUB. 10-29-2013, FILED 5-15-2013.



THE COLOR(S) BROWN, BLACK, YELLOW, PEACH, BLUE AND GREY IS/ARE CLAIMED AS A FEATURE OF THE MARK.

THE MARK CONSISTS OF A STYLIZED PERSON WEARING BROWN SHOES, BLACK PANTS AND YELLOW T SHIRT WITH THE LETTERS "BiL" IN BLACK. THE STYLIZED PERSON HAS PEACH SKIN, BLUE EYES WITH BLACK PUPILS AND GREY SCLERA, BLACK NOSE AND MOUTH, AND BROWN HAIR, AND A BLACK LINE OUTLINE.

FOR ADVERTISING AND DIRECTORY SERVICES, NAMELY, PROMOTING THE SERVICES OF OTHERS BY PROVIDING A WEB PAGE FEATURING LINKS TO THE WEBSITES OF OTHERS; ON-LINE PROMOTION OF COMPUTER NETWORKS AND WEBSITES; PROMOTING THE GOODS AND SERVICES OF OTHERS BY MEANS OF OPERATING AN ON-LINE SHOPPING MALL WITH LINKS TO THE RETAIL WEB SITES OF OTHERS; PROMOTING THE GOODS AND SERVICES OF OTHERS BY PROVIDING A WEB SITE FEATURING LINKS TO THE WEBSITES OR SOCIAL MEDIA PAGES OF LOCAL BUSINESSES; PROMOTING THE GOODS AND SERVICES OF OTHERS BY PROVIDING A WEBSITE FEATURING COUPONS, REBATES, PRICE-COMPARISON INFORMATION, PRODUCT REVIEWS, LINKS TO THE RETAIL WEBSITES OF OTHERS, AND DISCOUNT INFORMATION; PROMOTING THE GOODS AND SERVICES OF OTHERS BY PROVIDING AN INTERACTIVE WEBSITE WHERE USERS CAN INCREASE THE CURRENT VALUE OF AN ONLINE DISCOUNT BEING OFFERED BY PURCHASING THE GOODS AND SERVICES ASSOCIATED WITH THAT DISCOUNT IN THE FORM OF AN ONLINE COUPON,

**CLASS 35—(Continued).**

VOUCHER OR GIFT CARD; PROMOTING THE GOODS AND SERVICES OF OTHERS BY PROVIDING HYPERTEXT LINKS TO THE WEB SITES OF OTHERS; PROMOTING, ADVERTISING AND MARKETING OF THE BRANDS, PRODUCTS, SERVICES AND ONLINE WEBSITES OF INDIVIDUALS, BUSINESSES AND NONPROFIT ORGANIZATIONS; PROMOTING, ADVERTISING AND MARKETING ON-LINE WEB SITES OF OTHERS; PROVIDING A SEARCHABLE ON-LINE ADVERTISING WEBSITE AND GUIDE FEATURING THE GOODS AND SERVICES OF OTHER VENDORS VIA THE INTERNET; PROVIDING A SEARCHABLE ONLINE ADVERTISING WEBSITE AND INFORMATIONAL GUIDE FEATURING THE GOODS AND SERVICES OF OTHER VENDORS VIA THE INTERNET IN THE FIELD OF CONSUMER PRODUCTS AND SERVICES, AND/OR ANY PRODUCTS AND SERVICES THAT ARE LOCAL TO A USER OF THE WEBSITE; PROVIDING A SEARCHABLE WEBSITE FEATURING THE GOODS AND SERVICES OF OTHER VENDORS; PROVIDING A WEB SITE FEATURING THE RATINGS, REVIEWS AND RECOMMENDATIONS ON PRODUCTS AND SERVICES FOR COMMERCIAL PURPOSES POSTED BY USERS; PROVIDING A WEB SITE THAT FEATURES AN ON-LINE MARKET FOR USERS TO LIST OFFERED OR WANTED PERSONAL AND BUSINESS ASSETS AND SKILLS FOR HIRE, RENT, SALE OR AUCTION TRANSACTED ON THE BASIS OF PREDEFINED PERFORMANCE AND CLOSING TERMS AND CONDITIONS; PROVIDING A WEB SITE WHICH FEATURES ADVERTISEMENTS FOR THE GOODS AND SERVICES OF OTHERS ON A GLOBAL COMPUTER NETWORK; PROVIDING A WEB-BASED SYSTEM AND ONLINE PORTALS IN THE FIELD OF CONSUMER-TO-BUSINESS COMMERCE FOR CONSUMERS TO ENTER, MANAGE AND MODIFY THEIR CONSUMER PREFERENCE INFORMATION FOR USE BY MERCHANTS TO CREATE AND MANAGE OFFERS FOR DELIVERY TO CONSUMERS; PROVIDING A WEBSITE FEATURING A LIST OF ITEMS AND SERVICES AVAILABLE FOR RENT BY OTHERS; PROVIDING A WEBSITE FEATURING AN ONLINE MARKETPLACE FOR EXCHANGING GOODS AND SERVICES WITH OTHER USERS; PROVIDING AN INTERNET WEBSITE PORTAL FEATURING PROMOTION AND ADVERTISING FOR HOME SERVICE PROVIDERS AND PRODUCT MANUFACTURERS; PROVIDING ON-LINE DIRECTORY INFORMATION SERVICES ALSO FEATURING HYPERLINKS TO OTHER WEB SITES; PROVIDING SPACE AT A WEB SITE FOR THE ADVERTISEMENT OF THE GOODS AND SERVICES OF OTHERS; PROVISION OF A WEB SITE FEATURING COMMERCIAL INFORMATION ON SHOPPING; PROVISION OF SPACE ON WEBSITES FOR ADVERTISING GOODS AND SERVICES; RENTAL OF ADVERTISING SPACE ON WEB SITES (U.S. CLS. 100, 101 AND 102).

FIRST USE 6-17-2014; IN COMMERCE 6-17-2014.

**CLASS 35—(Continued).**

4,593,910. SHOP SMART, LLC, CHICAGO, IL. SN 85-933,907. PUB. 2-11-2014, FILED 5-16-2013.



NO CLAIM IS MADE TO THE EXCLUSIVE RIGHT TO USE "SAVINGS SINCE 2001" AND "DEALS", APART FROM THE MARK AS SHOWN.

THE NAME(S), PORTRAIT(S), AND/OR SIGNATURE(S) SHOWN IN THE MARK IDENTIFIES "BRADLEY P. WILSON", WHOSE CONSENT(S) TO REGISTER IS MADE OF RECORD.

THE MARK CONSISTS OF A CIRCLE CONTAINING THE WORDS "HANDPICKED SAVINGS" AT THE TOP OF THE CIRCLE AND "SINCE 2001" AT THE BOTTOM OF THE CIRCLE WITH THE WORDS "BRAD'S DEALS" IN THE MIDDLE OF THE CIRCLE.

FOR PROVIDING A SEARCHABLE ON-LINE ADVERTISING WEBSITE AND GUIDE FEATURING THE GOODS AND SERVICES OF OTHER VENDORS VIA THE INTERNET (U.S. CLS. 100, 101 AND 102).

FIRST USE 5-23-2013; IN COMMERCE 5-23-2013.

4,593,943. CRT MEDICAL SYSTEMS, INC., NOVI, MI. SN 85-938,516. PUB. 10-29-2013, FILED 5-21-2013.

## CRT Medical Systems' FiscalCare

THE MARK CONSISTS OF STANDARD CHARACTERS WITHOUT CLAIM TO ANY PARTICULAR FONT, STYLE, SIZE, OR COLOR.

NO CLAIM IS MADE TO THE EXCLUSIVE RIGHT TO USE "MEDICAL SYSTEMS' FISCAL CARE", APART FROM THE MARK AS SHOWN.

FOR HEALTHCARE PRACTICE MANAGEMENT AND ADMINISTRATIVE SUPPORT SERVICES; MEDICAL BILLING SUPPORT SERVICES (U.S. CLS. 100, 101 AND 102).

FIRST USE 5-5-2014; IN COMMERCE 5-5-2014.



**CLASS 35—(Continued).**

4,593,953. TAGWHALE, INC., BROOKLYN, NY. SN 85-940,311. PUB. 10-22-2013, FILED 5-23-2013.

# TagWhale

THE MARK CONSISTS OF STANDARD CHARACTERS WITHOUT CLAIM TO ANY PARTICULAR FONT, STYLE, SIZE, OR COLOR.

FOR ON-LINE RETAIL STORE SERVICES FEATURING PHYSICAL AND VIRTUAL MERCHANDISE FOR USE BY MEMBERS OF AN ONLINE COMMUNITY IN CONNECTION WITH A DESIGNATED WEBSITE FEATURING FICTIONAL CHARACTERS; PROVIDING A WEBSITE FOR CONNECTING SELLERS WITH BUYERS; PROVISION OF SPACE ON WEBSITES FOR ADVERTISING GOODS AND SERVICES (U.S. CLS. 100, 101 AND 102).

FIRST USE 6-1-2014; IN COMMERCE 6-1-2014.

4,593,954. PINEAPPLE PARADE, LLC, BELLAIRE, TX. SN 85-940,541. PUB. 10-29-2013, FILED 5-23-2013.



THE COLOR(S) GREEN, BLACK, AND YELLOW IS/ARE CLAIMED AS A FEATURE OF THE MARK.

THE MARK CONSISTS OF A BLACK RECTANGLE CONTAINING A STYLIZED YELLOW AND GREEN PINEAPPLE. THE TERM "PINEAPPLE" APPEARS IN YELLOW TO THE RIGHT OF THE STYLIZED PINEAPPLE, BELOW THE TERM "PINEAPPLE" APPEARS THE STYLIZED TERM "PARADE" IN YELLOW BLOCK FONT.

FOR ONLINE RETAIL STORE SERVICES FEATURING JEWELRY, CLOTHES, PURSES, AND ACCESSORIES THEREFOR (U.S. CLS. 100, 101 AND 102).

FIRST USE 5-30-2013; IN COMMERCE 5-30-2013.

4,593,959. STARTUP WEEKEND, SEATTLE, WA. SN 85-940,925. PUB. 11-26-2013, FILED 5-23-2013.

# UP GLOBAL

THE MARK CONSISTS OF STANDARD CHARACTERS WITHOUT CLAIM TO ANY PARTICULAR FONT, STYLE, SIZE, OR COLOR.

**CLASS 35—(Continued).**

NO CLAIM IS MADE TO THE EXCLUSIVE RIGHT TO USE "GLOBAL", APART FROM THE MARK AS SHOWN.

FOR ARRANGING AND CONDUCTING SPECIAL EVENTS FOR BUSINESS PURPOSES; BUSINESS DEVELOPMENT SERVICES, NAMELY, PROVIDING START-UP SUPPORT FOR BUSINESSES OF OTHERS (U.S. CLS. 100, 101 AND 102).

FIRST USE 5-23-2013; IN COMMERCE 5-23-2013.

4,593,962. RAGLAND, ELDON, ARVADA, CO. SN 85-941,356. PUB. 10-29-2013, FILED 5-23-2013.

# Eagle Freedom Photography

THE MARK CONSISTS OF STANDARD CHARACTERS WITHOUT CLAIM TO ANY PARTICULAR FONT, STYLE, SIZE, OR COLOR.

NO CLAIM IS MADE TO THE EXCLUSIVE RIGHT TO USE "PHOTOGRAPHY", APART FROM THE MARK AS SHOWN.

FOR ON-LINE RETAIL STORE SERVICES FEATURING ART AND PHOTOGRAPHS (U.S. CLS. 100, 101 AND 102).

FIRST USE 5-1-2013; IN COMMERCE 1-1-2014.

4,593,972. BE OUR GUEST, LLC, HALEIWA, HI. SN 85-942,663. PUB. 10-22-2013, FILED 5-24-2013.

# SEEK SPOT

THE MARK CONSISTS OF STANDARD CHARACTERS WITHOUT CLAIM TO ANY PARTICULAR FONT, STYLE, SIZE, OR COLOR.

FOR PROVIDING AN ON-LINE DIRECTORY INFORMATION SERVICE FEATURING INFORMATION REGARDING VACATION ACTIVITIES, ATTRACTIONS, AND RENTALS (U.S. CLS. 100, 101 AND 102).

FIRST USE 12-1-2013; IN COMMERCE 12-1-2013.



**CLASS 35—(Continued).**

4,593,984. GAAD FASHION CREATION LIMITED, NASSAU, BAHAMAS. SN 85-944,190. PUB. 11-12-2013, FILED 5-28-2013.

**CAROLINNA ESPINOSA**

THE MARK CONSISTS OF STANDARD CHARACTERS WITHOUT CLAIM TO ANY PARTICULAR FONT, STYLE, SIZE, OR COLOR.

OWNER OF U.S. REG. NO. 3,970,990.

THE NAME(S), PORTRAIT(S), AND/OR SIGNATURE(S) SHOWN IN THE MARK DOES NOT IDENTIFY A PARTICULAR LIVING INDIVIDUAL.

FOR RETAIL STORE SERVICES, WHOLESALE STORE SERVICES, MAIL ORDER CATALOGUE SERVICES, AND ON-LINE RETAIL STORE SERVICES, ALL FEATURING PURSES, HANDBAGS, CLUTCH BAGS, FOOTWEAR, NAMELY, BOOTS, SHOES, SANDALS AND SLIPPERS (U.S. CLS. 100, 101 AND 102).

FIRST USE 1-18-2009; IN COMMERCE 6-0-2013.

4,594,044. MOROCH PARTNERS, L.P., DALLAS, TX. SN 85-953,753. PUB. 10-29-2013, FILED 6-7-2013.

**BE SIGNIFICANT**

THE MARK CONSISTS OF STANDARD CHARACTERS WITHOUT CLAIM TO ANY PARTICULAR FONT, STYLE, SIZE, OR COLOR.

FOR ADVERTISING AND MARKETING SERVICES (U.S. CLS. 100, 101 AND 102).

FIRST USE 4-0-2013; IN COMMERCE 7-1-2013.

4,594,052. PROSPECTAS LLC, COLLEYVILLE, TX. SN 85-956,246. PUB. 10-29-2013, FILED 6-11-2013.



THE COLOR(S) RED, BLACK, GRAY, AND WHITE IS/ ARE CLAIMED AS A FEATURE OF THE MARK.

**CLASS 35—(Continued).**

THE MARK CONSISTS OF THE LETTER "P" IN WHITE INSIDE OF A RED CIRCLE OUTLINED WITH A GRAY LINE THAT FADES TO BLACK AT THE BOTTOM; A SMALLER GRAY CIRCLE WITH A SMALL WHITE OVAL AT ITS TOP APPEARS TO THE RIGHT OF THE RED CIRCLE, AND A LINE CURVES ACROSS THE RED CIRCLE AND FADES FROM GRAY TO BLACK; UNDERNEATH THE RED CIRCLE APPEARS THE WORDING "PROSPECTAS" IN GRAY.

FOR BUSINESS CONSULTATION IN THE FIELD OF HUMAN RESOURCES (U.S. CLS. 100, 101 AND 102).  
FIRST USE 5-1-2014; IN COMMERCE 5-1-2014.

4,594,062. TOFIXIT!, INC., PHOENIX, AZ. SN 85-957,098. PUB. 11-12-2013, FILED 6-11-2013.

**TC REFERRALS**

THE MARK CONSISTS OF STANDARD CHARACTERS WITHOUT CLAIM TO ANY PARTICULAR FONT, STYLE, SIZE, OR COLOR.

NO CLAIM IS MADE TO THE EXCLUSIVE RIGHT TO USE "REFERRALS", APART FROM THE MARK AS SHOWN.

FOR PROVIDING CONSUMER INFORMATION ABOUT AND MAKING REFERRALS IN THE FIELDS OF CONSTRUCTION, REPAIR AND MAINTENANCE OF RESIDENTIAL AND COMMERCIAL PROPERTIES, AUTOMOBILE SERVICE AND REPAIR, FINANCIAL SERVICES, ACCOUNTING AND BOOKKEEPING SERVICES, ESTATE PLANNING SERVICES, FINANCIAL PLANNING SERVICES, INSURANCE SERVICES, INVESTMENT SERVICES, MORTGAGE SERVICES, TAX PREPARATION SERVICES, COMPUTER SERVICES, CONCIERGE AND ERRAND SERVICES, DOG TRAINING SERVICES, PET BOARDING SERVICES, PET GROOMING SERVICES, PRINTING SERVICES, MAID SERVICES, HOME THEATER AND SATELLITE TELEVISION SALES AND SERVICES, MOVING SERVICES, REALTY SERVICES, PEST CONTROL SERVICES, AND LANDSCAPING SERVICES (U.S. CLS. 100, 101 AND 102).

FIRST USE 1-22-2014; IN COMMERCE 1-22-2014.

4,594,071. BELK STORES SERVICES, INC., CHARLOTTE, NC. SN 85-958,051. PUB. 11-5-2013, FILED 6-12-2013.



OWNER OF U.S. REG. NOS. 3,969,941, 3,970,689, AND OTHERS.

THE MARK CONSISTS OF THE WORD "SO". ON A PARTIAL FLOWER PETAL AND THE WORD "MOD"., ALL ABOVE THE WORDS "MODERN SOUTHERN BEAUTY".

FOR RETAIL DEPARTMENT STORE SERVICES (U.S. CLS. 100, 101 AND 102).

FIRST USE 10-9-2013; IN COMMERCE 10-9-2013.

**CLASS 35—(Continued).**

4,594,079. INSPIRIT GROWTH, LLC, BLUE BELL, PA. SN 85-959,658. PUB. 11-5-2013, FILED 6-14-2013.

## The Owner Reflective Perspective

THE MARK CONSISTS OF STANDARD CHARACTERS WITHOUT CLAIM TO ANY PARTICULAR FONT, STYLE, SIZE, OR COLOR.

FOR BUSINESS ADVISORY SERVICES IN THE FIELD OF MULTIPLIED GROWTH STRATEGY AND EXECUTION; BUSINESS ASSISTANCE, ADVISORY AND CONSULTING SERVICES IN THE FIELD OF MULTIPLIED GROWTH STRATEGY AND EXECUTION; BUSINESS MANAGEMENT CONSULTANCY AND ADVISORY SERVICES; BUSINESS MANAGEMENT CONSULTING AND ADVISORY SERVICES; CONSULTANCY AND ADVISORY SERVICES IN THE FIELD OF BUSINESS STRATEGY; MANAGEMENT CONSULTING AND ADVISORY SERVICES IN THE AREAS OF CORPORATE GROWTH STRATEGY, INNOVATION AND GROWTH PROCESSES, ORGANIZATIONAL TRANSFORMATION, AND TALENT MANAGEMENT AND DEVELOPMENT STRATEGIES; PROVIDING BUSINESS MANAGEMENT INFORMATION IN CONNECTION WITH CONSULTING AND ADVISORY SERVICES IN THE FIELD OF STRATEGIC PLANNING (U.S. CLS. 100, 101 AND 102).

FIRST USE 5-1-2012; IN COMMERCE 6-9-2014.

4,594,082. INSPIRIT GROWTH, LLC, BLUE BELL, PA. SN 85-960,283. PUB. 11-5-2013, FILED 6-14-2013.

## The Lifetime Expander

THE MARK CONSISTS OF STANDARD CHARACTERS WITHOUT CLAIM TO ANY PARTICULAR FONT, STYLE, SIZE, OR COLOR.

FOR BUSINESS ADVISORY SERVICES IN THE FIELD OF MULTIPLIED GROWTH STRATEGY AND EXECUTION; BUSINESS ASSISTANCE, ADVISORY AND CONSULTING SERVICES IN THE FIELD OF MULTIPLIED GROWTH STRATEGY AND EXECUTION; BUSINESS MANAGEMENT CONSULTANCY AND ADVISORY SERVICES; BUSINESS MANAGEMENT CONSULTING AND ADVISORY SERVICES; CONSULTANCY AND ADVISORY SERVICES IN THE FIELD OF BUSINESS STRATEGY; MANAGEMENT CONSULTING AND ADVISORY SERVICES IN THE AREAS OF CORPORATE GROWTH STRATEGY, INNOVATION AND GROWTH PROCESSES, ORGANIZATIONAL TRANSFORMATION, AND TALENT MANAGEMENT AND DEVELOPMENT STRATEGIES; PROVIDING BUSINESS MANAGEMENT INFORMATION IN CONNECTION WITH CONSULTING AND ADVISORY SERVICES IN THE FIELD OF STRATEGIC PLANNING (U.S. CLS. 100, 101 AND 102).

FIRST USE 5-1-2012; IN COMMERCE 6-9-2014.

**CLASS 35—(Continued).**

4,594,086. KRISTENSEN, KARON C., DBA LULUKATE, LLC, METAIRIE, LA. SN 85-960,644. PUB. 11-12-2013, FILED 6-14-2013.

# lulukate

THE MARK CONSISTS OF STANDARD CHARACTERS WITHOUT CLAIM TO ANY PARTICULAR FONT, STYLE, SIZE, OR COLOR.

FOR ON-LINE RETAIL GIFT SHOPS (U.S. CLS. 100, 101 AND 102).

FIRST USE 7-1-2013; IN COMMERCE 7-1-2013.

4,594,087. KRISTENSEN, KARON C., DBA LULUKATE, LLC, METAIRIE, LA. SN 85-960,698. PUB. 11-12-2013, FILED 6-14-2013.



THE MARK CONSISTS OF THE WORDING "LULUKATE" WITH 2 SMALL BIRDS, ONE BIRD SITTING ON THE SECOND "L" AND THE SECOND BIRD SITTING ON AN EXTENDED LETTER "T".

FOR ON-LINE RETAIL GIFT SHOPS (U.S. CLS. 100, 101 AND 102).

FIRST USE 7-1-2013; IN COMMERCE 7-1-2013.

4,594,089. DERUSHIA, BRIAN, MOUNT PLEASANT, MI. SN 85-961,126. PUB. 11-5-2013, FILED 6-17-2013.

## GLORY 2 HIM

THE MARK CONSISTS OF STANDARD CHARACTERS WITHOUT CLAIM TO ANY PARTICULAR FONT, STYLE, SIZE, OR COLOR.

FOR ON-LINE RETAIL STORE SERVICES FEATURING CLOTHING, JEWELRY, STICKERS, ORNAMENTS, POSTERS, MAGNETS AND OTHER CHRISTIAN RELATED GOODS; RETAIL SHOPS FEATURING CLOTHING, JEWELRY, STICKERS, ORNAMENTS, POSTERS, MAGNETS AND OTHER CHRISTIAN RELATED GOODS (U.S. CLS. 100, 101 AND 102).

FIRST USE 12-0-2013; IN COMMERCE 12-0-2013.

**CLASS 35—(Continued).**

4,594,096. YARDI SYSTEMS, INC., GOLETA, CA. SN 85-962,969. PUB. 10-29-2013, FILED 6-18-2013.

# VENDORCAFÉ

THE MARK CONSISTS OF STANDARD CHARACTERS WITHOUT CLAIM TO ANY PARTICULAR FONT, STYLE, SIZE, OR COLOR.

FOR PROVIDING A SEARCHABLE WEBSITE FEATURING THIRD-PARTY VENDORS AND SUPPLIERS; PROVIDING A WEBSITE FOR CONNECTING VENDORS AND CUSTOMERS THAT ALLOWS VENDORS TO SUBMIT, MANAGE, AND REVIEW DOCUMENTS, ITEMS, PRICE LISTS, PURCHASE ORDERS, PROPOSALS AND CONTRACTS; PROVIDING A WEBSITE FOR MANAGING VENDOR AND SUPPLIER RELATIONSHIPS, LIABILITY INSURANCE AND GOVERNMENTAL FORMS AND FILINGS (U.S. CLS. 100, 101 AND 102).

FIRST USE 10-31-2012; IN COMMERCE 10-31-2012.

4,594,099. KRAVET INC., BETHPAGE, NY. SN 85-963,000. PUB. 10-8-2013, FILED 6-18-2013.



OWNER OF U.S. REG. NOS. 2,821,173, 3,495,169, AND OTHERS.

THE MARK CONSISTS OF A STYLIZED DESIGN OF TWO LETTERS "K".

FOR ONLINE STORE SERVICES FEATURING HOME GOODS, HOME ACCESSORIES, BEDDING, DRAPERY, LIGHTING, DRAPERY HARDWARE, MIRRORS, WALL ART, TABLETOP ITEMS AND FURNITURE; ONLINE STORE SERVICES FEATURING FABRICS AND TEXTILES FOR USE IN THE MANUFACTURE OF HOME FURNISHINGS, NAMELY, UPHOLSTERY, FURNITURE, DRAPERIES, WALL COVERINGS, LINENS, CURTAINS, PILLOWS, BEDSHEETS, QUILTS AND CURTAIN TIE-BACKS; ONLINE STORE SERVICES FEATURING WOVEN, PRINTED, NATURAL AND SYNTHETIC FIBER DECORATIVE FABRICS; ONLINE STORE SERVICES FEATURING FABRIC AND FURNISHING TRIMMINGS, NAMELY, ORNAMENTAL RIBBONS MADE OF TEXTILES, LACE TRIMMING, TASSELS, BRAIDS, FRINGES AND DECORATIVE CORDS; ONLINE STORE SERVICES FEATURING WALLPAPER, NON-TEXTILE WALL COVERINGS, NAMELY, WALL COVERINGS MADE OF PAPER, GRASS CLOTH, VINYL, POLYMERS OR FABRIC; ONLINE STORE SERVICES FEATURING CARPETING, RUGS, BROADLOOM CARPETS, AREA RUGS, FLOOR MATS, AND MATTING FOR COVERING EXISTING FLOORS; PROVIDING A WEBSITE FEATURING LINKS TO THE ECOMMERCE WEBSITES OF OTHERS (U.S. CLS. 100, 101 AND 102).

FIRST USE 8-9-2000; IN COMMERCE 8-9-2000.

**CLASS 35—(Continued).**

4,594,100. KRAVET INC., BETHPAGE, NY. SN 85-963,041. PUB. 10-8-2013, FILED 6-18-2013.

# KRAVET

THE MARK CONSISTS OF STANDARD CHARACTERS WITHOUT CLAIM TO ANY PARTICULAR FONT, STYLE, SIZE, OR COLOR.

OWNER OF U.S. REG. NOS. 1,240,403, 4,249,215, AND OTHERS.

SEC. 2(F).

FOR ONLINE STORE SERVICES FEATURING HOME GOODS, HOME ACCESSORIES, BEDDING, DRAPERY, LIGHTING, DRAPERY HARDWARE, MIRRORS, WALL ART, TABLETOP ITEMS AND FURNITURE; ONLINE STORE SERVICES FEATURING FABRICS AND TEXTILES FOR USE IN THE MANUFACTURE OF HOME FURNISHINGS, NAMELY, UPHOLSTERY, FURNITURE, DRAPERIES, WALL COVERINGS, LINENS, CURTAINS, PILLOWS, BEDSHEETS, QUILTS AND CURTAIN TIE-BACKS; ONLINE STORE SERVICES FEATURING WOVEN, PRINTED, NATURAL AND SYNTHETIC FIBER DECORATIVE FABRICS; ONLINE STORE SERVICES FEATURING FABRIC AND FURNISHING TRIMMINGS, NAMELY, ORNAMENTAL RIBBONS MADE OF TEXTILES, LACE TRIMMING, TASSELS, BRAIDS, FRINGES AND DECORATIVE CORDS; ONLINE STORE SERVICES FEATURING WALLPAPER, NON-TEXTILE WALL COVERINGS, NAMELY, WALL COVERINGS MADE OF PAPER, GRASS CLOTH, VINYL, POLYMERS OR FABRIC; ONLINE STORE SERVICES FEATURING CARPETING, RUGS, BROADLOOM CARPETS, AREA RUGS, FLOOR MATS, AND MATTING FOR COVERING EXISTING FLOORS; PROVIDING A WEBSITE FEATURING LINKS TO THE ECOMMERCE WEBSITES OF OTHERS (U.S. CLS. 100, 101 AND 102).

FIRST USE 8-9-2000; IN COMMERCE 8-9-2000.

4,594,136. AKADIA TAX RECRUITING LLC, NEW YORK, NY. SN 85-970,927. PUB. 11-19-2013, FILED 6-26-2013.

# AKADIA

THE MARK CONSISTS OF STANDARD CHARACTERS WITHOUT CLAIM TO ANY PARTICULAR FONT, STYLE, SIZE, OR COLOR.

FOR EXECUTIVE RECRUITING SERVICES (U.S. CLS. 100, 101 AND 102).

FIRST USE 7-1-2013; IN COMMERCE 7-1-2013.

**CLASS 35—(Continued).**

4,594,137. AKADIA TAX RECRUITING LLC, NEW YORK, NY. SN 85-970,954. PUB. 12-3-2013, FILED 6-26-2013.

**AKADIA TAX RECRUITING**

THE MARK CONSISTS OF STANDARD CHARACTERS WITHOUT CLAIM TO ANY PARTICULAR FONT, STYLE, SIZE, OR COLOR.

NO CLAIM IS MADE TO THE EXCLUSIVE RIGHT TO USE "TAX RECRUITING", APART FROM THE MARK AS SHOWN.

FOR EXECUTIVE RECRUITING SERVICES (U.S. CLS. 100, 101 AND 102).

FIRST USE 7-1-2013; IN COMMERCE 7-1-2013.

4,594,142. DITTMAN INCENTIVE MARKETING CORPORATION, NEW BRUNSWICK, NJ. SN 85-972,585. PUB. 11-19-2013, FILED 6-28-2013.

**MADE TO MEASURE MOTIVATION**

THE MARK CONSISTS OF STANDARD CHARACTERS WITHOUT CLAIM TO ANY PARTICULAR FONT, STYLE, SIZE, OR COLOR.

FOR DESIGN DEVELOPMENT AND CONDUCTING ALL ASPECTS OF INCENTIVE PROGRAMS AND CONTESTS FOR OTHERS; CONDUCTING EMPLOYEE AND SALES CONSULTANT INCENTIVE AWARD PROGRAMS TO PROMOTE ON THE JOB PERFORMANCE (U.S. CLS. 100, 101 AND 102).

FIRST USE 12-3-2013; IN COMMERCE 12-3-2013.

**CLASS 35—(Continued).**

4,594,144. INSPIRIT GROWTH, LLC, FORMERLY ACCEL-EX, LLC, BLUE BELL, PA. SN 85-973,160. PUB. 11-5-2013, FILED 6-28-2013.

**The Wisdom Continuum**

THE MARK CONSISTS OF STANDARD CHARACTERS WITHOUT CLAIM TO ANY PARTICULAR FONT, STYLE, SIZE, OR COLOR.

FOR BUSINESS ADVISORY SERVICES IN THE FIELD OF MULTIPLIED GROWTH STRATEGY AND EXECUTION; BUSINESS ASSISTANCE, ADVISORY AND CONSULTING SERVICES IN THE FIELD OF MULTIPLIED GROWTH STRATEGY AND EXECUTION; BUSINESS MANAGEMENT CONSULTANCY AND ADVISORY SERVICES; CONSULTANCY AND ADVISORY SERVICES IN THE FIELD OF BUSINESS STRATEGY; MANAGEMENT CONSULTING AND ADVISORY SERVICES IN THE AREAS OF CORPORATE GROWTH STRATEGY, INNOVATION AND GROWTH PROCESSES, ORGANIZATIONAL TRANSFORMATION, AND TALENT MANAGEMENT AND DEVELOPMENT STRATEGIES; PROVIDING BUSINESS MANAGEMENT INFORMATION IN CONNECTION WITH CONSULTING AND ADVISORY SERVICES IN THE FIELD OF STRATEGIC PLANNING (U.S. CLS. 100, 101 AND 102).

FIRST USE 2-1-2013; IN COMMERCE 6-9-2014.

4,594,149. J.K. INTERNATIONALE, LLC, OVERLAND PARK, KS. SN 85-973,735. PUB. 11-26-2013, FILED 6-29-2013.



NO CLAIM IS MADE TO THE EXCLUSIVE RIGHT TO USE "INTERNATIONALE KANSAS CTIY", APART FROM THE MARK AS SHOWN.

THE MARK CONSISTS OF AN AIRPLANE FLYING IN THE AIR WITH A BANNER WHICH STATES "JK INTERNATIONALE" IN LARGER FONT, WITHIN THE SAME BANNER AND ON THE SECOND FOLD OF THE BANNER IT STATES "KANSAS CITY" IN SMALLER FONT.

THE ENGLISH TRANSLATION OF "INTERNATIONALE" IN THE MARK IS "INTERNATIONAL".

FOR IMPORT AGENCY SERVICES IN THE FIELD OF ALCOHOLIC BEVERAGE (U.S. CLS. 100, 101 AND 102).

FIRST USE 3-5-2014; IN COMMERCE 3-5-2014.

**CLASS 35—(Continued).**

4,594,176. WAGGENER EDSTROM WORLDWIDE, INC., LAKE OSWEGO, OR. SN 85-982,207. PUB. 4-30-2013, FILED 11-19-2012.



OWNER OF U.S. REG. NOS. 2,524,897, 3,135,391, AND OTHERS.

NO CLAIM IS MADE TO THE EXCLUSIVE RIGHT TO USE "COMMUNICATIONS", APART FROM THE MARK AS SHOWN.

THE MARK CONSISTS OF THE LETTERS "W" AND "E" IN A STYLIZED FORMAT NEXT TO THE WORDS "WAGGENER EDSTROM COMMUNICATIONS" ALSO IN A STYLIZED FONT.

FOR PUBLIC RELATIONS SERVICES; MARKET RESEARCH SERVICES; MARKETING SERVICES, NAMELY, PLANNING PRODUCT LAUNCH CAMPAIGNS AND DEVELOPMENT OF BRANDS AND PRODUCT IDENTITY; CONSULTATIONS IN SALES AND CHANNEL MANAGEMENT; DEVELOPMENT OF COLLATERAL AND PROMOTIONAL MATERIALS AND PRESS KITS FOR OTHERS; BUSINESS CONSULTING WITH REGARD TO TRADE SHOWS AND PRODUCT LAUNCH EVENT MANAGEMENT; BUSINESS MONITORING, ANALYTICS, AND CONSULTING SERVICES IN THE FIELDS OF STRATEGY AND MARKETING USING ANALYTIC MODELS FOR THE UNDERSTANDING AND PREDICTING OF ONLINE COMMUNICATIONS AND MARKET TRENDS AND ACTIONS BASED ON THOSE COMMUNICATIONS, AND TO MEASURE THE IMPACT AND INFLUENCE OF ONLINE COMMUNICATIONS ON BRANDS AND BUSINESSES; BUSINESS MONITORING, ANALYTICS, AND CONSULTING SERVICES IN THE FIELD OF ONLINE COMMUNICATIONS PERTAINING TO BUSINESSES (U.S. CLS. 100, 101 AND 102).

FIRST USE 1-16-2014; IN COMMERCE 1-16-2014.

4,594,195. IZEA, INC., WINTER PARK, FL. SN 86-000,540. PUB. 11-26-2013, FILED 7-2-2013.

**NATIVE AD EXCHANGE**

THE MARK CONSISTS OF STANDARD CHARACTERS WITHOUT CLAIM TO ANY PARTICULAR FONT, STYLE, SIZE, OR COLOR.

NO CLAIM IS MADE TO THE EXCLUSIVE RIGHT TO USE "AD EXCHANGE", APART FROM THE MARK AS SHOWN.

FOR DISSEMINATION OF ADVERTISEMENTS (U.S. CLS. 100, 101 AND 102).

FIRST USE 2-28-2014; IN COMMERCE 2-28-2014.

**CLASS 35—(Continued).**

4,594,208. SUPPLY CHAIN FINANCE INC., DBA SUPPLY CHAIN FINANCE, OMAHA, NE. SN 86-004,718. PUB. 12-3-2013, FILED 7-8-2013.



THE MARK CONSISTS OF INCOMPLETE CIRCLE WITH BLACK BACKGROUND AND WHITE OVERLAY THAT SPLIT CIRCLE IN THE 1:00 POSITION AND THE 7:00 POSITION (IN TERMS OF A CLOCK). THE OVERLAY IS ARRANGED TO CREATE AN ABSTRACT 'S'.

FOR ACCOUNT AUDITING; AUDIT SUPPORT SERVICES, NAMELY, REVIEW AND ANALYSIS OF A COMPANY'S SALES, AS WELL AS THE PREPARATION, ORGANIZATION AND PRESENTATION OF THE DOCUMENTS AND DATA REQUESTED BY A GOVERNMENT BODY, AND ADVICE ON GOVERNMENT AUDIT PROCESSES, POLICIES AND STRATEGY; AUDITING UTILITY RATES FOR OTHERS; BUSINESS AUDITING (U.S. CLS. 100, 101 AND 102).

FIRST USE 3-1-2013; IN COMMERCE 3-1-2013.

4,594,219. GREY PNEUMATIC CORP., MENOMONIE, WI. SN 86-007,805. PUB. 12-24-2013, FILED 7-11-2013.

**Everything Impact**

THE MARK CONSISTS OF STANDARD CHARACTERS WITHOUT CLAIM TO ANY PARTICULAR FONT, STYLE, SIZE, OR COLOR.

NO CLAIM IS MADE TO THE EXCLUSIVE RIGHT TO USE "IMPACT", APART FROM THE MARK AS SHOWN.

FOR ON-LINE WHOLESALE STORE SERVICES FEATURING SOCKETS FOR IMPACT WRENCHES, SOCKET SETS FOR IMPACT WRENCHES, AND IMPACT SOCKET WRENCH ADAPTERS, EXTENSIONS, AND ATTACHMENTS, AND HAND TOOLS, NAMELY, SOCKET WRENCHES, SOCKET SETS, RATCHETS AND LEVERAGE BARS FOR ATTACHMENT TO MANUALLY OPERATED WRENCHES, ADAPTERS WHICH FIT BETWEEN AND ALLOW CONNECTION OF A HANDLE AND A WRENCH SOCKET OR SOCKET, EXTENSIONS WHICH FIT BETWEEN AND ALLOW CONNECTION OF A HANDLE AND A WRENCH SOCKET OR SOCKET, UNIVERSAL JOINTS WHICH FIT BETWEEN AND ALLOW CONNECTION OF A HANDLE AND A WRENCH SOCKET OR SOCKET; WHOLESALE DISTRIBUTORSHIPS FEATURING SOCKETS FOR IMPACT WRENCHES, SOCKET SETS FOR IMPACT WRENCHES, AND IMPACT SOCKET WRENCH ADAPTERS, EXTENSIONS, AND ATTACHMENTS, AND HAND TOOLS, NAMELY, SOCKET WRENCHES, SOCKET SETS,

**CLASS 35—(Continued).**

RATCHETS AND LEVERAGE BARS FOR ATTACHMENT TO MANUALLY OPERATED WRENCHES, ADAPTERS WHICH FIT BETWEEN AND ALLOW CONNECTION OF A HANDLE AND A WRENCH SOCKET OR SOCKET, EXTENSIONS WHICH FIT BETWEEN AND ALLOW CONNECTION OF A HANDLE AND A WRENCH SOCKET OR SOCKET, UNIVERSAL JOINTS WHICH FIT BETWEEN AND ALLOW CONNECTION OF A HANDLE AND A WRENCH SOCKET OR SOCKET; WHOLESALE STORE SERVICES FEATURING SOCKETS FOR IMPACT WRENCHES, SOCKET SETS FOR IMPACT WRENCHES, AND IMPACT SOCKET WRENCH ADAPTERS, EXTENSIONS, AND ATTACHMENTS, AND HAND TOOLS, NAMELY, SOCKET WRENCHES, SOCKET SETS, RATCHETS AND LEVERAGE BARS FOR ATTACHMENT TO MANUALLY OPERATED WRENCHES, ADAPTERS WHICH FIT BETWEEN AND ALLOW CONNECTION OF A HANDLE AND A WRENCH SOCKET OR SOCKET, EXTENSIONS WHICH FIT BETWEEN AND ALLOW CONNECTION OF A HANDLE AND A WRENCH SOCKET OR SOCKET, UNIVERSAL JOINTS WHICH FIT BETWEEN AND ALLOW CONNECTION OF A HANDLE AND A WRENCH SOCKET OR SOCKET (U.S. CLS. 100, 101 AND 102).  
FIRST USE 7-11-2013; IN COMMERCE 7-11-2013.

---

4,594,226. MICHAEL KANTROW, NEW YORK, NY. SN 86-010,456. PUB. 4-1-2014, FILED 7-15-2013.

**MAKEABLE**

THE MARK CONSISTS OF STANDARD CHARACTERS WITHOUT CLAIM TO ANY PARTICULAR FONT, STYLE, SIZE, OR COLOR.

FOR BUSINESS CONSULTING AND INFORMATION SERVICES; ADVERTISING AND MARKETING CONSULTING; BUSINESS STRATEGIC PLANNING SERVICES AND MARKETING PLAN DEVELOPMENT SERVICES IN THE FIELD OF PRODUCT INNOVATION; BUSINESS CONSULTING SERVICES IN THE FIELD OF BRAND CREATION, BRAND DEVELOPMENT, BRAND EVALUATION, BRAND MARKETING AND BRAND IDENTITY; BUSINESS CONSULTING SERVICES IN THE FIELDS OF ADVERTISING, MARKETING, CORPORATE IDENTITY DEVELOPMENT, STRATEGIC BRANDING, BRAND POSITIONING AND PRODUCT PROMOTION; ADVERTISING, PUBLIC RELATIONS AND THE DESIGN OF ADVERTISING AND POINT OF SALE PROMOTIONAL MATERIALS, CONSUMER RESEARCH, AND BUSINESS CONSULTING RELATING TO SALES STRATEGY; BUSINESS ADVERTISING AND MARKETING SERVICES, NAMELY, OFFERING BUSINESS ADVERTISING AND MARKETING SERVICES IN THE FIELDS OF SOCIAL MEDIA STRATEGY, DIGITAL STRATEGY, ONLINE STRATEGY; ADVERTISING AND MARKETING SERVICES, NAMELY, CREATION OF STRATEGY, PLANNING AND EXECUTION OF ONLINE MARKETING AND ADVERTISING CAMPAIGNS; BUSINESS CONSULTING SERVICES IN THE FIELD OF STRATEGY DEFINITION, CONTENT DEVELOPMENT; BUSINESS DEVELOPMENT SERVICES IN THE FIELDS OF SOCIAL COMMERCE, ECOMMERCE, MCOMMERCE AND CMS STRATEGY; PROVIDING INFORMATION IN THE FIELDS OF BUSINESS INNOVATION PROCESS, BUSINESS MANAGEMENT AND BUSINESS OPPORTUNITIES; ARRANGING AND CONDUCTING OF EXHIBITIONS FOR BUSINESS AND ADVERTISING PURPOSES FOR OTHERS; BUSINESS CONSULTING SERVICES IN THE FIELD OF BUSINESS INNOVATION PROCESS (U.S. CLS. 100, 101 AND 102).  
FIRST USE 9-18-2013; IN COMMERCE 9-18-2013.

**CLASS 35—(Continued).**

4,594,235. VELOPOWER CONSULTING LLC, DBA ROAM-PLATE, SARATOGA SPRINGS, NY. SN 86-012,870. PUB. 12-10-2013, FILED 7-17-2013.



THE COLOR(S) BLACK, WHITE AND AQUA IS/ARE CLAIMED AS A FEATURE OF THE MARK.

THE MARK CONSISTS OF THE WORD "ROAMPLATE" IN BLACK, CAPITAL LETTERS ON A WHITE BACKGROUND, WITH THE "R" AND THE "P" IN LARGER FONT THAN THE REMAINING LETTERS. THE "R" INCLUDES SILHOUETTES OF SHOES IN A WALKING STRIDE, WITH ONE SHOE AT THE BOTTOM OF EACH OF THE "R"'S DOWN STROKES. THE CHARACTER "P" INCLUDES THE SILHOUETTE OF A DINNER FORK AT THE BOTTOM OF THE "P" DOWN STROKE. THE FOUR TINES OF THE FORK POINT DOWN AND SLIGHTLY TO THE LEFT, TERMINATING AT THE CENTER OF A CIRCULAR, AQUA AND BLACK DINNER PLATE. THE PLATE IS DISPLAYED IN THREE DIMENSIONAL PERSPECTIVE AS CONCENTRIC OVALS WITH SHADING ALONG THE INSIDE TOP OF THE INNER OVAL.

FOR PROMOTIONAL SERVICES, NAMELY, PROMOTING THE GOODS OF OTHERS BY PROVIDING ONLINE RESTAURANT SPECIALS MENUS, COUPONS AND DISCOUNTED ITEMS (U.S. CLS. 100, 101 AND 102).  
FIRST USE 5-1-2014; IN COMMERCE 5-1-2014.

---

4,594,243. OSMAN YUSUF, AUSTIN, TX. SN 86-015,028. PUB. 12-10-2013, FILED 7-19-2013.

**PETROBOSS**

THE MARK CONSISTS OF STANDARD CHARACTERS WITHOUT CLAIM TO ANY PARTICULAR FONT, STYLE, SIZE, OR COLOR.

FOR BUSINESS CONSULTING SERVICES FOR THE ENERGY INDUSTRY (U.S. CLS. 100, 101 AND 102).  
FIRST USE 2-27-2014; IN COMMERCE 2-27-2014.

**CLASS 35—(Continued).**

4,594,247. RACK ROOM SHOES OF VIRGINIA, LLC, CHARLOTTE, NC. SN 86-015,501. PUB. 10-15-2013, FILED 7-19-2013.

## the CLOSET

THE MARK CONSISTS OF STANDARD CHARACTERS WITHOUT CLAIM TO ANY PARTICULAR FONT, STYLE, SIZE, OR COLOR.

FOR ON-LINE RETAIL STORE SERVICES FEATURING FOOTWEAR AND FOOTWEAR ACCESSORIES (U.S. CLS. 100, 101 AND 102).

FIRST USE 12-24-2013; IN COMMERCE 12-24-2013.

---

4,594,261. HOMEGOODS, INC., FRAMINGHAM, MA. SN 86-027,025. PUB. 11-5-2013, FILED 8-2-2013.

## AN ORGANIZED HOME IS A HAPPY HOME

THE MARK CONSISTS OF STANDARD CHARACTERS WITHOUT CLAIM TO ANY PARTICULAR FONT, STYLE, SIZE, OR COLOR.

OWNER OF U.S. REG. NOS. 3,829,144, 3,971,157, AND OTHERS.

FOR RETAIL DEPARTMENT STORE SERVICES (U.S. CLS. 100, 101 AND 102).

FIRST USE 9-9-2013; IN COMMERCE 9-9-2013.

---

4,594,276. IDAHO HEALTH INSURANCE EXCHANGE, BOISE, ID. SN 86-033,179. PUB. 1-28-2014, FILED 8-8-2013.



NO CLAIM IS MADE TO THE EXCLUSIVE RIGHT TO USE "IDAHO" AND THE DESIGN OF THE STATE OF IDAHO, APART FROM THE MARK AS SHOWN.

THE MARK CONSISTS OF THE DESIGN OF THE STATE OF IDAHO. TO THE LEFT OF THE DESIGN IS THE WORDING "YOUR HEALTH IDAHO" WITH "IDAHO" BELOW "YOUR HEALTH."

FOR PROVIDING HEALTH INSURANCE EXCHANGES IN THE NATURE OF A MARKETPLACE THAT OFFERS PURCHASERS OF HEALTH INSURANCE A VARIETY OF PLANS FROM DIFFERENT INSURANCE PROVIDERS (U.S. CLS. 100, 101 AND 102). FIRST USE 8-20-2013; IN COMMERCE 8-20-2013.

**CLASS 35—(Continued).**

4,594,283. IDAHO HEALTH INSURANCE EXCHANGE, BOISE, ID. SN 86-034,414. PUB. 12-31-2013, FILED 8-9-2013.

## Your Health Idaho

THE MARK CONSISTS OF STANDARD CHARACTERS WITHOUT CLAIM TO ANY PARTICULAR FONT, STYLE, SIZE, OR COLOR.

NO CLAIM IS MADE TO THE EXCLUSIVE RIGHT TO USE "IDAHO", APART FROM THE MARK AS SHOWN.

FOR PROVIDING HEALTH INSURANCE EXCHANGES IN THE NATURE OF A MARKETPLACE THAT OFFERS PURCHASERS OF HEALTH INSURANCE A VARIETY OF PLANS FROM DIFFERENT INSURANCE PROVIDERS (U.S. CLS. 100, 101 AND 102). FIRST USE 8-20-2013; IN COMMERCE 8-20-2013.

---

4,594,284. TRUE SOURCE HONEY, LLC, WASHINGTON, DC. SN 86-034,495. PUB. 2-11-2014, FILED 8-10-2013.



OWNER OF U.S. REG. NOS. 4,116,139, 4,134,507, AND OTHERS.

NO CLAIM IS MADE TO THE EXCLUSIVE RIGHT TO USE "TRUE SOURCE HONEY", APART FROM THE MARK AS SHOWN.

THE COLOR(S) GREEN, YELLOW, BLACK AND WHITE IS/ARE CLAIMED AS A FEATURE OF THE MARK.

THE MARK CONSISTS OF A HORIZONTAL RECTANGLE WITH A GREEN BORDER, WITH A THIN GREEN VERTICAL LINE BEGINNING AT THE BOTTOM BORDER EXTENDING HALFWAY UP IN THE MIDDLE OF THE RECTANGLE, DIVIDING THE RECTANGLE IN HALF. IN THE LEFT HALF OF THE RECTANGLE, THE WORD "TRUE" AND BELOW IT, THE WORD "SOURCE" APPEAR IN GREEN CAPITAL LETTERS; BETWEEN THE WORDS "TRUE SOURCE" AND THE CENTER LINE, IS A DRAWING OF A HONEY BEE, WITH A SEGMENTED YELLOW BODY AND HEAD WITH EACH SEGMENT OUTLINED IN BLACK, AND WHITE WINGS OUTLINED IN BLACK. ON THE RIGHT SIDE OF THE RECTANGLE, THE WORD "HONEY" APPEARS IN GREEN. THE COLOR WHITE APPEARS IN THE BACKGROUND OF THE RECTANGLE.

FOR ASSOCIATION SERVICES, NAMELY, PROMOTING THE INTERESTS OF UNITED STATES HONEY PRODUCERS; PROMOTING PUBLIC AWARENESS OF THE BENEFITS OF DOMESTICALLY PRODUCED HONEY AND THE DANGERS TO SAFETY AND PURITY OF HONEY OBTAINED OR IMPORTED IN CIRCUMVENTION OF U.S. LAW (U.S. CLS. 100, 101 AND 102). FIRST USE 10-9-2013; IN COMMERCE 10-9-2013.

**CLASS 35—(Continued).**

4,594,321. VERTESS HOLDINGS, LLC, TUCSON, AZ. SN 86-051,985. PUB. 2-25-2014, FILED 8-29-2013.

# VERTESS

THE MARK CONSISTS OF STANDARD CHARACTERS WITHOUT CLAIM TO ANY PARTICULAR FONT, STYLE, SIZE, OR COLOR.

FOR BUSINESS CONSULTING AND ADVISORY SERVICES IN THE FIELDS OF BUSINESS MANAGEMENT, BUSINESS STRATEGY, BUSINESS LEADERSHIP, BUYING AND SELLING OF BUSINESSES, MERGERS AND ACQUISITIONS, AND HEALTH CARE (U.S. CLS. 100, 101 AND 102).

FIRST USE 11-1-2013; IN COMMERCE 11-1-2013.

4,594,325. PAVAO, VINNIE, FALL RIVER, MA. SN 86-053,800. PUB. 1-21-2014, FILED 9-3-2013.

# SOMNIUM

THE MARK CONSISTS OF STANDARD CHARACTERS WITHOUT CLAIM TO ANY PARTICULAR FONT, STYLE, SIZE, OR COLOR.

FOR ART GALLERY SERVICES (U.S. CLS. 100, 101 AND 102).

FIRST USE 4-1-2014; IN COMMERCE 4-1-2014.

**CLASS 35—(Continued).**

4,594,327. SOUTH BASIN MAYORS AND REEVES INC., DBA LAKE FRIENDLY, WINNIPEG, MANITOBA, CANADA. SN 86-055,734. PUB. 1-28-2014, FILED 9-4-2013.

## Become an Aquavist

THE MARK CONSISTS OF STANDARD CHARACTERS WITHOUT CLAIM TO ANY PARTICULAR FONT, STYLE, SIZE, OR COLOR.

FOR ASSOCIATION SERVICES, NAMELY, PROMOTING PUBLIC AWARENESS OF WATER SUSTAINABILITY; CHARITABLE SERVICES, NAMELY, ORGANIZING AND DEVELOPING PROJECTS TO PROMOTE AWARENESS OF TREE AND ENVIRONMENTAL CONSERVATION; CHARITABLE SERVICES, NAMELY, PROMOTING PUBLIC AWARENESS OF WATER SUSTAINABILITY; PROMOTING PUBLIC AWARENESS OF ENVIRONMENTAL ISSUES AND INITIATIVES; PROMOTING PUBLIC AWARENESS OF NEPHROTIC SYNDROME AND FOCAL SEGMENTAL GLOMERULOSCLEROSIS (FSGS); PROMOTING PUBLIC AWARENESS OF THE NEED FOR WATER SUSTAINABILITY; PROMOTING PUBLIC AWARENESS OF WATER SUSTAINABILITY; PROMOTING PUBLIC AWARENESS OF WATER SUSTAINABILITY; PUBLIC ADVOCACY TO PROMOTE AWARENESS OF WATER SUSTAINABILITY (U.S. CLS. 100, 101 AND 102).

FIRST USE 9-10-2013; IN COMMERCE 9-10-2013.

4,594,328. TRAVISMATHEW, LLC, HUNTINGTON BEACH, CA. SN 86-056,107. PUB. 2-18-2014, FILED 9-4-2013.

# TRAVISMATHEW

THE MARK CONSISTS OF STANDARD CHARACTERS WITHOUT CLAIM TO ANY PARTICULAR FONT, STYLE, SIZE, OR COLOR.

OWNER OF U.S. REG. NO. 4,248,730.

THE NAME(S), PORTRAIT(S), AND/OR SIGNATURE(S) SHOWN IN THE MARK DOES NOT IDENTIFY A PARTICULAR LIVING INDIVIDUAL.

FOR COMPUTERIZED ON-LINE RETAIL STORE SERVICES IN THE FIELD OF GOLF APPAREL, MENS APPAREL, WOMEN'S APPAREL, KIDS APPAREL, GOLF ACCESSORIES, CLOTHING ACCESSORIES, FOOTWEAR, BAGS, LUGGAGE; ON-LINE RETAIL STORE SERVICES FEATURING GOLF APPAREL, MENS APPAREL, WOMEN'S APPAREL, KIDS APPAREL, GOLF ACCESSORIES, CLOTHING ACCESSORIES, FOOTWEAR, BAGS, LUGGAGE; RETAIL APPAREL STORES; RETAIL CLOTHING BOUTIQUES; RETAIL STORE SERVICES FEATURING GOLF APPAREL, MENS APPAREL, WOMEN'S APPAREL, KIDS APPAREL, GOLF ACCESSORIES, CLOTHING ACCESSORIES, FOOTWEAR, BAGS, LUGGAGE (U.S. CLS. 100, 101 AND 102).

FIRST USE 10-0-2007; IN COMMERCE 1-1-2008.



**CLASS 35—(Continued).**

4,594,353. YUSUF, OSMAN, AUSTIN, TX. SN 86-065,716. PUB. 2-25-2014, FILED 9-16-2013.



THE COLOR(S) RED, BLACK, AND WHITE IS/ARE CLAIMED AS A FEATURE OF THE MARK.

THE MARK CONSISTS OF THE STYLIZED RED LETTERS "PB" WITHIN A BLACK AND WHITE CIRCULAR DESIGN.

FOR BUSINESS CONSULTING SERVICES FOR THE ENERGY INDUSTRY (U.S. CLS. 100, 101 AND 102).

FIRST USE 2-27-2014; IN COMMERCE 2-27-2014.

**CLASS 35—(Continued).**

4,594,393. ABRAMS, JAMES, SHAKER HEIGHTS, OH. SN 86-080,624. PUB. 3-25-2014, FILED 10-2-2013.

**THE ALTRUISM SOCIETY**

THE MARK CONSISTS OF STANDARD CHARACTERS WITHOUT CLAIM TO ANY PARTICULAR FONT, STYLE, SIZE, OR COLOR.

NO CLAIM IS MADE TO THE EXCLUSIVE RIGHT TO USE "SOCIETY", APART FROM THE MARK AS SHOWN.

FOR CHARITABLE SERVICES, NAMELY, PROMOTING PUBLIC AWARENESS OF HEALTH AND WELLNESS, EDUCATION, HUNGER, POVERTY, SHELTERS, INFECTIOUS DISEASES, AGRICULTURAL DEVELOPMENT, EMERGENCY RESPONSE, FAMILY PLANNING, FINANCIAL SERVICES FOR THE POOR, GLOBAL LIBRARIES, NUTRITION, VACCINE DELIVERY, WATER, SANITATION AND HYGIENE; DEVELOPING AND COORDINATING VOLUNTEER PROJECTS FOR CHARITABLE ORGANIZATIONS; ORGANIZING AND CONDUCTING CHARITY AUCTIONS FOR CHARITABLE FUNDRAISING PURPOSES; CHARITABLE SERVICES, NAMELY, ORGANIZING AND DEVELOPING PROJECTS THAT AIM TO IMPROVE THE LIVES OF UNDERPRIVILEGED AND IMPOVERISHED PEOPLE; CHARITABLE SERVICES, NAMELY, ORGANIZING AND CONDUCTING VOLUNTEER PROGRAMS AND COMMUNITY SERVICE PROJECTS (U.S. CLS. 100, 101 AND 102).

FIRST USE 1-15-2000; IN COMMERCE 2-15-2000.

4,594,355. BROCOR XCHANGE INC., MINNEAPOLIS, MN. SN 86-066,313. PUB. 3-4-2014, FILED 9-17-2013.

brocorXchange

THE MARK CONSISTS OF THE TERM "BROCOR" IN LOWER CASE, IMMEDIATELY FOLLOWED BY A CAPITAL "X", IMMEDIATELY FOLLOWED BY THE TERM "CHANGE" IN LOWER CASE; WHERE THE "X" IS ENLARGED AND APPEARS AS IF FORMED FROM A "GREATER THAN" CHARACTER IN FRONT OF AND PARTIALLY OVERLAPPING A "LESS THAN" CHARACTER.

FOR PROVIDING HEALTH INSURANCE EXCHANGES IN THE NATURE OF A MARKETPLACE THAT OFFERS PURCHASERS OF HEALTH INSURANCE A VARIETY OF PLANS FROM DIFFERENT INSURANCE PROVIDERS (U.S. CLS. 100, 101 AND 102).

FIRST USE 11-1-2013; IN COMMERCE 11-1-2013.

4,594,408. OSMAN YUSUF, AUSTIN, TX. SN 86-086,933. PUB. 12-10-2013, FILED 10-9-2013.

**Turning Contractors into Stakeholders**

THE MARK CONSISTS OF STANDARD CHARACTERS WITHOUT CLAIM TO ANY PARTICULAR FONT, STYLE, SIZE, OR COLOR.

FOR BUSINESS CONSULTING SERVICES FOR THE ENERGY INDUSTRY (U.S. CLS. 100, 101 AND 102).

FIRST USE 2-27-2014; IN COMMERCE 2-27-2014.

**CLASS 35—(Continued).**

4,594,429. REPUBLIC SERVICES, INC., PHOENIX, AZ. SN 86-092,665. PUB. 3-11-2014, FILED 10-16-2013.

**REPUBLIC REWARDS**

THE MARK CONSISTS OF STANDARD CHARACTERS WITHOUT CLAIM TO ANY PARTICULAR FONT, STYLE, SIZE, OR COLOR.

OWNER OF U.S. REG. NOS. 4,084,686, 4,246,843, AND OTHERS.

NO CLAIM IS MADE TO THE EXCLUSIVE RIGHT TO USE "REWARDS", APART FROM THE MARK AS SHOWN.

FOR ARRANGING AND CONDUCTING CUSTOMER LOYALTY PROGRAM AND INCENTIVE REWARDS PROGRAMS TO PROMOTE RECYCLING (U.S. CLS. 100, 101 AND 102).

FIRST USE 2-7-2014; IN COMMERCE 2-7-2014.

---

4,594,431. AWL & SUNDRY, NORTH BERGEN, NJ. SN 86-093,023. PUB. 3-11-2014, FILED 10-16-2013.

**Awl & Sundry**

THE MARK CONSISTS OF STANDARD CHARACTERS WITHOUT CLAIM TO ANY PARTICULAR FONT, STYLE, SIZE, OR COLOR.

FOR ON-LINE RETAIL STORE SERVICES FEATURING CUSTOM SHOES, BELTS AND OTHER ACCESSORIES (U.S. CLS. 100, 101 AND 102).

FIRST USE 3-24-2014; IN COMMERCE 3-24-2014.

---

4,594,436. AGRIREP, LLC, SPENCER, IA. SN 86-097,074. PUB. 4-8-2014, FILED 10-21-2013.

**AGRIREP**

THE MARK CONSISTS OF STANDARD CHARACTERS WITHOUT CLAIM TO ANY PARTICULAR FONT, STYLE, SIZE, OR COLOR.

FOR COOPERATIVE ADVERTISING AND MARKETING FOR INDEPENDENT MANUFACTURERS IN THE FIELD OF AGRICULTURAL PRODUCTS AND SERVICES; ONLINE RETAIL STORE SERVICES FEATURING AGRICULTURAL PRODUCTS; DISTRIBUTORSHIP SERVICES IN THE FIELD OF AGRICULTURAL PRODUCTS; ONLINE RETAIL CONSIGNMENT STORES FEATURING AGRICULTURAL PRODUCTS (U.S. CLS. 100, 101 AND 102).

FIRST USE 11-1-2013; IN COMMERCE 11-1-2013.

**CLASS 35—(Continued).**

4,594,437. AGRIREP, LLC, SPENCER, IA. SN 86-097,075. PUB. 4-8-2014, FILED 10-21-2013.



THE COLOR(S) YELLOW, ORANGE, RED AND DARK GREY IS/ARE CLAIMED AS A FEATURE OF THE MARK.

THE MARK CONSISTS OF SIX BARS DIAGONALLY POSITIONED IN SETS OF TWO; FIRST SET OF BARS ARE YELLOW IN COLOR AND ARE AT THE TOP, THE BAR TO THE RIGHT SITS HIGHER AND BAR TO THE LEFT IS POSITIONED SO THAT IT IS JUST BELOW THE ENDING POINT OF THE RIGHT BAR; THE NEXT SET OF TWO BARS ARE ORANGE IN COLOR AND THE RIGHT BAR SITS HIGHER THAN THE LEFT AND THE LEFT BAR IS POSITIONED SO IT IS JUST BELOW THE ENDING POINT OF THE RIGHT BAR; THE LAST SET OF THREE BARS IS RED IN COLOR AND THE BAR TO THE RIGHT SITS HIGHER THAN THE LEFT AND THE LEFT BAR SITS JUST AT THE END POINT OF THE RIGHT BAR; BELOW THE SIX BARS ARE THE LETTERS "AGRIREP" IN A DARK GREY COLOR, THE "A" IN "AGRI" AND THE "R" IN "REP" ARE LARGER IN SIZE COMPARED TO THE "GRI" IN AGRI AND THE "EP" IN "REP".

FOR COOPERATIVE ADVERTISING AND MARKETING FOR INDEPENDENT MANUFACTURERS IN THE FIELD OF AGRICULTURAL PRODUCTS AND SERVICES; ONLINE RETAIL STORE SERVICES FEATURING AGRICULTURAL PRODUCTS; DISTRIBUTORSHIP SERVICES IN THE FIELD OF AGRICULTURAL PRODUCTS; ONLINE RETAIL CONSIGNMENT STORES FEATURING AGRICULTURAL PRODUCTS (U.S. CLS. 100, 101 AND 102).

FIRST USE 11-1-2013; IN COMMERCE 11-1-2013.

**CLASS 35—(Continued).**

4,594,451. KALE, CHRISTI, HENDERSON, NV. SN 86-100,195.  
PUB. 4-8-2014, FILED 10-24-2013.



THE MARK CONSISTS OF A POLAR BEAR WEARING SUNGLASSES, SITTING IN A CHAIR, UNDER AN UMBRELLA, HOLDING A DRINK IN ONE HAND AND A FAN IN THE OTHER HAND.

FOR ON-LINE RETAIL STORE SERVICES FEATURING TSHIRTS, TOYS, STUFFED ANIMALS, AND PORTABLE CAR SEAT COOLING DEVICE (U.S. CLS. 100, 101 AND 102).

FIRST USE 7-23-2013; IN COMMERCE 7-23-2013.

**CLASS 35—(Continued).**

THE MARK CONSISTS OF A BLUE RECTANGLE CONTAINING THE WORDING "THE PERFECT PATIENT FUNNEL SYSTEM" IN WHITE TO THE LEFT OF FOUR GOLD BARS LINED IN WHITE.

FOR ADMINISTRATION OF A CONSUMER MEMBERSHIP PROGRAM FOR ENABLING PARTICIPANTS TO RECEIVE PRODUCT SAMPLES AND DISCOUNTS IN THE FIELD OF HEALTHCARE; ADVERTISING AND BUSINESS MANAGEMENT CONSULTANCY; ADVERTISING AND MARKETING CONSULTANCY; ADVERTISING AND PROMOTION SERVICES AND RELATED CONSULTING; ADVERTISING CONSULTATION; ASSISTANCE, ADVISORY SERVICES AND CONSULTANCY WITH REGARD TO BUSINESS PLANNING, BUSINESS ANALYSIS, BUSINESS MANAGEMENT, BUSINESS ORGANIZATION, MARKETING AND CUSTOMER ANALYSIS; BUSINESS ADVISORY SERVICES, CONSULTANCY AND INFORMATION; BUSINESS AND MANAGEMENT CONSULTING FOR HEALTHCARE PROVIDERS AND RELATED BUSINESSES; CONSULTING IN THE FIELD OF SALES METHODS, SALES MANAGEMENT, AND SALES IMPROVEMENT; CONSULTING SERVICES IN BUSINESS ORGANIZATION AND MANAGEMENT; CONSULTING SERVICES IN THE FIELD OF DENTAL PRACTICE MANAGEMENT; CONSULTING SERVICES IN THE FIELD OF INTERNET MARKETING; CONSULTING SERVICES IN THE FIELD OF MARKETING OF EDUCATIONAL TRAINING; CONSULTING SERVICES IN THE FIELD OF MEDICAL PRACTICE MANAGEMENT FOR OTHERS IN THE FIELD OF MEDICINE, CHIROPRACTIC, DENTISTRY; CONSULTING SERVICES IN THE FIELD OF PATIENT RELATIONSHIP MANAGEMENT FOR HEALTHCARE PROVIDERS; CONSULTING SERVICES RELATING TO PUBLICITY; CORPORATE IMAGE CONSULTING SERVICES; DIRECT MARKETING CONSULTING SERVICES; DOCTOR REFERRALS; MARKET RESEARCH CONSULTATION; MARKETING CONSULTATION IN THE FIELD OF HEALTHCARE; MARKETING CONSULTING (U.S. CLS. 100, 101 AND 102).

FIRST USE 10-29-2013; IN COMMERCE 11-7-2013.

4,594,474. PERFORM GROUP, LLC, YORK, PA. SN 86-108,283. PUB. 4-1-2014, FILED 11-1-2013.

4,594,456. THE LIFE HOUSE CHIROPRACTIC, CHAPPAQUA, NY. SN 86-101,294. PUB. 4-8-2014, FILED 10-25-2013.



NO CLAIM IS MADE TO THE EXCLUSIVE RIGHT TO USE "THE PERFECT PATIENT FUNNEL SYSTEM", APART FROM THE MARK AS SHOWN.

THE COLOR(S) BLUE, GOLD, WHITE IS/ARE CLAIMED AS A FEATURE OF THE MARK.

**BUY WITH CONFIDENCE**

THE MARK CONSISTS OF STANDARD CHARACTERS WITHOUT CLAIM TO ANY PARTICULAR FONT, STYLE, SIZE, OR COLOR.

FOR WHOLESALE ORDERING SERVICES IN THE FIELD OF GYMNASTICS APPAREL AND ACCESSORIES (U.S. CLS. 100, 101 AND 102).

FIRST USE 12-29-2013; IN COMMERCE 12-29-2013.

**CLASS 35—(Continued).**

4,594,476. BKLYN1834, LLC, NEW YORK, NY. SN 86-108,701. PUB. 4-15-2014, FILED 11-2-2013.



NO CLAIM IS MADE TO THE EXCLUSIVE RIGHT TO USE "BKLYN", APART FROM THE MARK AS SHOWN.

THE MARK CONSISTS OF THE NUMBER "18" ABOVE THE WORD "BKLYN" ABOVE THE NUMBER "34", WITH HORIZONTAL LINES ABOVE AND BELOW THE WORD "BKLYN".

FOR ON-LINE RETAIL STORE SERVICES FEATURING CLOTHING, DRINKING GLASSES, BAGS, AND GENERAL CONSUMER MERCHANDISE (U.S. CLS. 100, 101 AND 102).

FIRST USE 3-31-2014; IN COMMERCE 3-31-2014.

4,594,492. TABLE 12 PRODUCTIONS, INC., BROOKLYN, NY. SN 86-116,263. PUB. 4-22-2014, FILED 11-12-2013.

**SUNSHINE & MIRABELLE**

THE MARK CONSISTS OF STANDARD CHARACTERS WITHOUT CLAIM TO ANY PARTICULAR FONT, STYLE, SIZE, OR COLOR.

THE NAME(S), PORTRAIT(S), AND/OR SIGNATURE(S) SHOWN IN THE MARK DOES NOT IDENTIFY A PARTICULAR LIVING INDIVIDUAL.

FOR RETAIL STORE SERVICES AND COMPUTERIZED ONLINE RETAIL STORE SERVICES FEATURING A WIDE VARIETY OF VINTAGE GOODS, HAND-CRAFTED GOODS, AND FOOD PRODUCTS (U.S. CLS. 100, 101 AND 102).

FIRST USE 1-30-2014; IN COMMERCE 1-30-2014.

**CLASS 35—(Continued).**

4,594,496. WALK AGAINST TRAFFICK, AKA W.A.T., JACKSON, MS. SN 86-117,877. PUB. 4-29-2014, FILED 11-13-2013.



THE COLOR(S) RED AND WHITE IS/ARE CLAIMED AS A FEATURE OF THE MARK.

THE MARK CONSISTS OF THE WORDING "WALK AGAINST TRAFFICK" IN RED WITH WHITE SPECKLES WITH THE WORDING "A JOURNEY TO END SEX TRAFFICKING" BELOW IT IN RED AND THE IMAGE OF A RED AND WHITE TEMPLE ABOVE IT.

FOR CHARITABLE SERVICES, NAMELY, ORGANIZING AND DEVELOPING PROJECTS THAT AIM TO PROMOTE GLOBAL AWARENESS ABOUT HUMAN TRAFFICKING AND COMMERCIAL SEX INDUSTRY (U.S. CLS. 100, 101 AND 102).

FIRST USE 10-1-2013; IN COMMERCE 11-1-2013.

4,594,513. SEARS BRANDS, LLC, HOFFMAN ESTATES, IL. SN 86-125,704. PUB. 3-18-2014, FILED 11-21-2013.

**KICKING GRASS AND TAKING NAMES**

THE MARK CONSISTS OF STANDARD CHARACTERS WITHOUT CLAIM TO ANY PARTICULAR FONT, STYLE, SIZE, OR COLOR.

FOR RETAIL DEPARTMENT STORE SERVICES AND ONLINE RETAIL DEPARTMENT STORE SERVICES FEATURING LAWN AND GARDEN EQUIPMENT (U.S. CLS. 100, 101 AND 102).

FIRST USE 2-0-2014; IN COMMERCE 2-0-2014.

4,594,515. AMAIN.COM, INC., CHICO, CA. SN 86-125,903. PUB. 4-22-2014, FILED 11-21-2013.

**Performance Hobbies**

THE MARK CONSISTS OF STANDARD CHARACTERS WITHOUT CLAIM TO ANY PARTICULAR FONT, STYLE, SIZE, OR COLOR.

OWNER OF U.S. REG. NO. 3,190,808.

**CLASS 35—(Continued).**

NO CLAIM IS MADE TO THE EXCLUSIVE RIGHT TO USE "HOBBIES", APART FROM THE MARK AS SHOWN.

FOR COMPUTERIZED ON-LINE RETAIL STORE SERVICES IN THE FIELD OF PROFESSIONAL GRADE AND HOBBY GRADE REMOTE CONTROLLED VEHICLES INCLUDING CARS, HELICOPTERS, PLANES, OTHER VEHICLE MODELS AND ACCESSORIES THEREOF; ON-LINE RETAIL STORE SERVICES FEATURING PROFESSIONAL GRADE AND HOBBY GRADE REMOTE CONTROLLED VEHICLES INCLUDING CARS, HELICOPTERS, PLANES, OTHER VEHICLE MODELS AND ACCESSORIES THEREOF; RETAIL STORE SERVICES FEATURING PROFESSIONAL GRADE AND HOBBY GRADE REMOTE CONTROLLED VEHICLES INCLUDING CARS, HELICOPTERS, PLANES, OTHER VEHICLE MODELS AND ACCESSORIES THEREOF (U.S. CLS. 100, 101 AND 102).

FIRST USE 11-15-2013; IN COMMERCE 11-15-2013.

---

4,594,525. ZILKNATION, REDWOOD CITY, CA. SN 86-134,145. PUB. 4-22-2014, FILED 12-3-2013.

# FR35H

THE MARK CONSISTS OF STANDARD CHARACTERS WITHOUT CLAIM TO ANY PARTICULAR FONT, STYLE, SIZE, OR COLOR.

FOR RETAIL STORE SERVICES FEATURING CLOTHING, KEY CHAINS, STICKERS, CELL PHONES CASES, LAPTOP CASES (U.S. CLS. 100, 101 AND 102).

FIRST USE 12-3-2013; IN COMMERCE 2-1-2014.

---

4,594,545. SPINGO SOLUTIONS, INC., AKA SPINGO SOLUTIONS, LLC, DRAPER, UT. SN 86-166,020. PUB. 4-22-2014, FILED 1-15-2014.

# Event Engine

THE MARK CONSISTS OF STANDARD CHARACTERS WITHOUT CLAIM TO ANY PARTICULAR FONT, STYLE, SIZE, OR COLOR.

NO CLAIM IS MADE TO THE EXCLUSIVE RIGHT TO USE "EVENT", APART FROM THE MARK AS SHOWN.

FOR PROVIDING A SEARCHABLE ONLINE ADVERTISING WEBSITE THAT FEATURES THE UPCOMING EVENTS OF OTHERS, AND ALSO COMPILES AND DISSEMINATES THE ADVERTISING OF OTHERS VIA PUBLIC AND PRIVATE WIRELESS NETWORKS (U.S. CLS. 100, 101 AND 102).

FIRST USE 6-18-2014; IN COMMERCE 6-18-2014.

**CLASS 36—INSURANCE AND FINANCIAL****CLASS 36—(Continued).**

4,593,077. IRON-STARR EXCESS AGENCY LTD., HAMILTON HM 19, BERMUDA. SN 77-699,904. PUB. 9-17-2013, FILED 3-26-2009.

# IRON-STARR

THE MARK CONSISTS OF STANDARD CHARACTERS WITHOUT CLAIM TO ANY PARTICULAR FONT, STYLE, SIZE, OR COLOR.

FOR INSURANCE UNDERWRITING SERVICES IN THE FIELDS OF EXCESS CASUALTY AND EXCESS FINANCIAL LINES (U.S. CLS. 100, 101 AND 102).

FIRST USE 4-30-2009; IN COMMERCE 4-30-2009.

---

4,593,102. BLUE CROSS AND BLUE SHIELD OF FLORIDA, INC., JACKSONVILLE, FL. SN 85-042,295. PUB. 11-2-2010, FILED 5-19-2010.

# THE FUTURE OF HEALTH CARE IS RIGHT AROUND THE CORNER

THE MARK CONSISTS OF STANDARD CHARACTERS WITHOUT CLAIM TO ANY PARTICULAR FONT, STYLE, SIZE, OR COLOR.

FOR INSURANCE SERVICES, NAMELY, UNDERWRITING, ISSUING AND ADMINISTRATION OF HEALTH, DENTAL AND LIFE INSURANCE (U.S. CLS. 100, 101 AND 102).

FIRST USE 12-19-2013; IN COMMERCE 12-19-2013.

---

4,593,133. BRIDGEWAY CAPITAL, INC., PITTSBURGH, PA. SN 85-119,776. PUB. 2-18-2014, FILED 8-31-2010.



NO CLAIM IS MADE TO THE EXCLUSIVE RIGHT TO USE "CAPITAL", APART FROM THE MARK AS SHOWN.

THE MARK CONSISTS OF A DESIGN OF A BRIDGE WITH THE ROADWAY EXTENDING TO THE RIGHT IN THE FORM OF A HORIZONTAL LINE. ABOVE THE LINE IS THE WORD "BRIDGEWAY" AND BELOW THE LINE IS THE WORD "CAPITAL".

FOR FINANCIAL SERVICES IN THE NATURE OF DEBT FINANCING AND EQUITY INVESTMENTS FOR ENTREPRENEURS, GROWING ENTERPRISES AND COMMUNITY FACILITIES, NONPROFIT ORGANIZATIONS, AND REAL ESTATE PROJECTS FOR ECONOMIC REVITALIZATION AND COMMUNITY DEVELOPMENT (U.S. CLS. 100, 101 AND 102).

FIRST USE 8-1-2010; IN COMMERCE 8-1-2010.



**CLASS 36—(Continued).**

4,593,135. F.N.B. CORPORATION, NAPLES, FL. SN 85-130,427. PUB. 12-13-2011, FILED 9-15-2010.



OWNER OF U.S. REG. NOS. 3,571,126, 4,026,821, AND OTHERS.

NO CLAIM IS MADE TO THE EXCLUSIVE RIGHT TO USE "BANK" AND "PRIVATE BANKING GROUP", APART FROM THE MARK AS SHOWN.

THE COLOR(S) BLUE, WHITE & GRAY IS/ARE CLAIMED AS A FEATURE OF THE MARK.

THE MARK CONSISTS OF A STYLIZED DEPICTION OF THE TOP LEFT CORNER OF AN AMERICAN FLAG WITH FIVE WITH STARS IN A BLUE BACKGROUND, GRAY STRIPES AND TWO HANDS SHAKING ONE ANOTHER IN BLUE, WHEREIN THE SLEEVE OF THE RIGHT HAND BREAKS OFF INTO THE THREE GRAY STRIPES OF THE FLAG ALL ABOVE THE PHRASE "FIRST NATIONAL BANK" IN BLUE ABOVE THE STYLIZED PHRASE "PRIVATE BANKING GROUP" IN GRAY. THE COLOR WHITE APPEARS IN THE STARS, HANDS, CUFFS OF THE SHIRTS, IN THE GRAY STRIPED ARM, AND IN THE BACKGROUND.

SEC. 2(F) AS TO "FIRST NATIONAL".

FOR DEPOSITORY SERVICES, NAMELY, ADMINISTRATION OF HOLIDAY AND VACATION CLUB ACCOUNTS, AUTOMATED TELLER MACHINE SERVICES; BANKING SERVICES; CHECKING ACCOUNT SERVICES, CREDIT CARD SERVICES, DEBIT CARD SERVICES; BANKING SERVICES, NAMELY, DIRECT DEPOSIT SERVICES, ELECTRONIC INTERACTIVE BANKING SERVICES, FINANCIAL INFORMATION PROVIDED BY ELECTRONIC MEANS, FINANCIAL MANAGEMENT SERVICES, FINANCIAL CLEARING HOUSE SERVICES, FINANCIAL GUARANTEE AND SURETY SERVICES, FINANCIAL VALUATION OF PERSONAL PROPERTY AND REAL ESTATE, FINANCIAL ANALYSIS AND CONSULTATION, FINANCIAL FORECASTING SERVICES, FINANCIAL EXCHANGE SERVICES, FINANCIAL PORTFOLIO MANAGEMENT, FINANCIAL PLANNING, FINANCING SERVICES, FINANCING FOR LOW AND MODERATE INCOME PERSONS, HOME EQUITY LOANS, PROVIDING INDIVIDUAL RETIREMENT ACCOUNTS, PROVIDING SELF EMPLOYED QUALIFIED RETIREMENT PLANS, INTERNET BANKING SERVICES, INTERNET BILL PAYMENT, LEASE-PURCHASE FINANCING, LENDING SERVICES, NAMELY, MORTGAGE, CONSUMER, RETAIL AND COMMERCIAL LOANS, LOAN FINANCING, MONEY MARKET ACCOUNT SERVICES, NIGHT DEPOSIT BOX SERVICES, PROVIDING FINANCIAL INFORMATION IN THE NATURE OF RATES OF EXCHANGE, REMOTE DEPOSIT SERVICES, RENT SECURITY ACCOUNTS, SAFE DEPOSIT BOX SERVICES, SAVINGS ACCOUNT SERVICES, TELEPHONE BANKING SERVICES, WIRE TRANSFER SERVICES OF MONEY, INFORMATION SERVICES FOR ALL OF THE FOREGOING PROVIDED VIA A GLOBAL COMPUTER NETWORK; FINANCIAL ADVICE AND BROKERAGE SERVICES IN CONNECTION WITH INDIVIDUAL RETIREMENT ACCOUNTS; FINANCIAL ADVICE AND BROKERAGE SERVICES IN CONNECTION WITH SELF EMPLOYED QUALIFIED RETIREMENT PLANS; CAPITAL INVESTMENT CONSULTATION AND ADVICE; CAPITAL INVESTMENT SERVICES; FINANCIAL INFORMATION PROVIDED BY ELECTRONIC/INTERACTIVE MEANS; ELECTRONIC FINANCIAL PLANNING AND BANKING SERVICES; FINANCIAL INVESTMENT ADVICE AND CONSULTATION; FINANCIAL PORTFOLIO MANAGEMENT; FINANCIAL PLANNING; FINANCIAL INFORMATION PROVIDED BY ELECTRONIC MEANS; FINANCIAL RESEARCH; FINANCIAL VALUATION OF INVESTMENT PORTFOLIO; FINANCIAL IN-

**CLASS 36—(Continued).**

FORMATION IN THE NATURE OF RATES OF EXCHANGE, FINANCIAL EXCHANGE, FINANCIAL INFORMATION IN THE NATURE OF FINANCIAL FORECASTING AND FINANCIAL GUARANTEE AND SURETY, FINANCIAL ANALYSIS AND CONSULTATION; FINANCIAL AND INVESTMENT MANAGEMENT; FUND INVESTMENT CONSULTATION; FUNDS INVESTMENT; INDIVIDUAL INVESTMENT ADVISORY SERVICES; INVESTMENT ADVICE AND BROKERAGE SERVICES IN THE FIELD OF FIXED AND VARIABLE ANNUITIES; INTERNET INVESTMENT AND BROKERAGE SERVICES, INVESTMENT ADVICE, INVESTMENT CONSULTATION, INVESTMENT MANAGEMENT, INVESTMENT ADVICE AND BROKERAGE SERVICES IN THE FIELD OF MUTUAL FUNDS AND SECURITIES; MANAGEMENT AND ADMINISTRATION OF DEFINED BENEFIT PLANS, PROFIT SHARING PLANS AND NON-QUALIFIED RETIREMENT PLANS; ADMINISTRATION OF MUNICIPAL AND COUNTY GOVERNMENT EMPLOYEE PENSION SERVICES; MUTUAL FUND BROKERAGE, DISTRIBUTION AND INVESTMENT SERVICES; FINANCIAL RISK MANAGEMENT AND CONSULTATION AND PLANNING IN THE FIELDS OF HEALTH CARE, DISABILITY, LONG-TERM CARE AND LIFE INSURANCE; SECURITIES BROKERAGE SERVICES, STOCK AND BOND PORTFOLIO MANAGEMENT AND ADVICE, INFORMATION SERVICES FOR ALL OF THE FOREGOING PROVIDED VIA A GLOBAL COMPUTER NETWORK; CONSUMER FINANCING SERVICES AND LOAN FINANCING; ELECTRONIC CONSUMER FINANCE SERVICES; FINANCIAL VALUATION OF PERSONAL PROPERTY AND REAL ESTATE; FINANCING HOUSING FOR MODERATE INCOME CITIZENS; INTERNET CONSUMER FINANCING SERVICES; LEASE-PURCHASE FINANCING; LENDING SERVICES, NAMELY, MORTGAGE, CONSUMER, RETAIL AND COMMERCIAL LOANS, LOAN FINANCING, BROKERAGE OF SUBORDINATED NOTES, NAMELY, SHORT-TERM DEBT SECURITIES, CASH FLOW SERVICES, NAMELY, PROVIDING CASH TO MORTGAGE NOTE HOLDERS IN RETURN FOR OWNERSHIP OF THE NOTE; INFORMATION SERVICES FOR ALL OF THE FOREGOING PROVIDED VIA A GLOBAL COMPUTER NETWORK; INSURANCE ACTUARIAL SERVICES INCLUDING APPRAISAL, ADMINISTRATION, AGENCY, BROKERAGE, CONSULTATION, AND SUBROGATION IN THE FIELDS OF AUTO, LIFE, HEALTH, LONG TERM CARE, PROPERTY, CASUALTY, ACCIDENT, FIRE, MARINE, MEDICAL, PRE-PAID HEALTHCARE; APPRAISALS AND EVALUATION OF INSURANCE COVERAGES OF PERSONAL PROPERTY AND REAL ESTATE; INFORMATION SERVICES FOR ALL OF THE FOREGOING PROVIDED VIA A GLOBAL COMPUTER NETWORK; BUSINESS SUCCESSOR'S FINANCIAL PLANNING; FINANCIAL PLANNING FOR RETIREMENT; MAINTAINING AND ADMINISTERING CORPORATE ESCROW SERVICES AND CUSTODIAL SERVICES; CORPORATE TRUST AND BOND TRANSFER AGENCY SERVICES; FINANCIAL DEPOSITORY SERVICES RELATED TO TRUST AND BENEFIT ACCOUNTS; EDUCATION FINANCIAL PLANNING; PROVIDING EDUCATIONAL FUNDING IN THE NATURE OF (529)I ACCOUNTS; ELECTRONIC INTERACTIVE FINANCIAL TRUST MANAGEMENT ACCOUNT SERVICES; FINANCIAL ADMINISTRATION OF EMPLOYER RETIREMENT ACCOUNTS; ESTATE PLANNING; TRUST MANAGEMENT ACCOUNTS SERVICES AS TRUSTEE, EXECUTOR AND TRUST UNDER WILL; ESTATE PLANNING SERVICES INCLUDING LIVING, TESTAMENTARY AND CHARITABLE REMAINDER TRUSTS; ESTATE PLANNING, SETTLEMENT AND ADMINISTRATION; FIDUCIARY REPRESENTATIVE SERVICES AND TRUST ADMINISTRATION; FINANCIAL MANAGEMENT IN THE NATURE OF INSTITUTIONAL CUSTODIAL SERVICES; INTERNET TRUST MANAGEMENT ACCOUNT SERVICES; ESTATE PLANNING FOR TAX DEDUCTION AND GIFTING PROGRAMS; TRUST SERVICES, NAMELY, INVESTMENT AND TRUST COMPANY SERVICES; AND INFORMATION SERVICES FOR ALL OF THE FOREGOING PROVIDED VIA A GLOBAL COMPUTER NETWORK (U.S. CLS. 100, 101 AND 102).

FIRST USE 7-1-2011; IN COMMERCE 7-1-2011.

**CLASS 36—(Continued).**

4,593,209. PERSHING INVESTMENTS LLC, NEWARK, DE. SN 85-345,778. PUB. 6-4-2013, FILED 6-14-2011.

**NEW MODEL CUSTODIAN**

THE MARK CONSISTS OF STANDARD CHARACTERS WITHOUT CLAIM TO ANY PARTICULAR FONT, STYLE, SIZE, OR COLOR.

NO CLAIM IS MADE TO THE EXCLUSIVE RIGHT TO USE "CUSTODIAN", APART FROM THE MARK AS SHOWN.

FOR FINANCIAL CONSULTATION SERVICES; FINANCIAL SERVICES, NAMELY, ACTING AS CUSTODIAN OF ASSETS FOR REGISTERED INVESTMENT ADVISORS; PROVIDING AN INTERNET WEBSITE PORTAL OFFERING INFORMATION IN THE FIELD OF FINANCIAL INVESTMENTS AND FEATURING WEALTH MANAGEMENT AND ANALYSIS TOOLS; PROVIDING INFORMATION AND ADVICE REGARDING FINANCIAL INVESTMENT SERVICES AND INVESTMENT PRODUCTS (U.S. CLS. 100, 101 AND 102).  
FIRST USE 3-31-2011; IN COMMERCE 3-31-2011.

**CLASS 36—(Continued).**

4,593,315. TRANSAMERICA FINANCIAL LIFE INSURANCE COMPANY, HARRISON, NY. SN 85-613,878. PUB. 10-15-2013, FILED 5-1-2012.

**TFLIC FINANCIAL FOUNDATION  
IUL**

THE MARK CONSISTS OF STANDARD CHARACTERS WITHOUT CLAIM TO ANY PARTICULAR FONT, STYLE, SIZE, OR COLOR.

NO CLAIM IS MADE TO THE EXCLUSIVE RIGHT TO USE "FINANCIAL" AND "IUL", APART FROM THE MARK AS SHOWN.

FOR UNDERWRITING AND ADMINISTRATION OF INDEXED UNIVERSAL LIFE INSURANCE; UNDERWRITING AND ADMINISTRATION OF LIFE INSURANCE (U.S. CLS. 100, 101 AND 102).  
FIRST USE 11-14-2012; IN COMMERCE 11-14-2012.

4,593,314. WESTERN RESERVE LIFE ASSURANCE CO. OF OHIO, ST. PETERSBURG, FL. SN 85-613,876. PUB. 10-15-2013, FILED 5-1-2012.

**WRL FINANCIAL FOUNDATION  
IUL**

THE MARK CONSISTS OF STANDARD CHARACTERS WITHOUT CLAIM TO ANY PARTICULAR FONT, STYLE, SIZE, OR COLOR.

OWNER OF U.S. REG. NOS. 1,892,346, 2,986,868, AND OTHERS.

NO CLAIM IS MADE TO THE EXCLUSIVE RIGHT TO USE "FINANCIAL" AND "IUL", APART FROM THE MARK AS SHOWN.

FOR UNDERWRITING AND ADMINISTRATION OF INDEXED UNIVERSAL LIFE INSURANCE; UNDERWRITING AND ADMINISTRATION OF LIFE INSURANCE (U.S. CLS. 100, 101 AND 102).  
FIRST USE 2-27-2013; IN COMMERCE 2-27-2013.

4,593,332. THE WELLCARE MANAGEMENT GROUP, INC., TAMPA, FL. SN 85-630,686. PUB. 5-7-2013, FILED 5-21-2012.

**WELLCARE EXTRA**

THE MARK CONSISTS OF STANDARD CHARACTERS WITHOUT CLAIM TO ANY PARTICULAR FONT, STYLE, SIZE, OR COLOR.

OWNER OF U.S. REG. NOS. 1,343,516, 4,032,248, AND OTHERS.

FOR PRESCRIPTION DRUG INSURANCE UNDERWRITING AND ADMINISTRATION, NAMELY, PROVIDING A MEDICARE PART D PRESCRIPTION DRUG PLAN (U.S. CLS. 100, 101 AND 102).  
FIRST USE 7-0-2013; IN COMMERCE 7-0-2013.

**CLASS 36—(Continued).**

4,593,340. FIRST NIAGARA FINANCIAL GROUP, INC., BUFFALO, NY. SN 85-635,708. PUB. 4-23-2013, FILED 5-25-2012.

**CROSS-SOLVE**

THE MARK CONSISTS OF STANDARD CHARACTERS WITHOUT CLAIM TO ANY PARTICULAR FONT, STYLE, SIZE, OR COLOR.

FOR BANKING SERVICES, FINANCIAL SERVICES, NAMELY, FINANCIAL AND INVESTMENT PLANNING, CONSULTING, MANAGEMENT, AND ADVISORY SERVICES; INVESTMENT SERVICES, NAMELY, INVESTMENT AND SECURITIES BROKERAGE SERVICES, ANNUITY SALES AND SERVICE, AND PROVIDING INFORMATION ON INVESTMENT AND SECURITIES PERFORMANCE; AND INSURANCE SERVICES, NAMELY, INSURANCE BROKERAGE, INSURANCE AGENCY, INSURANCE ADMINISTRATION, AND INSURANCE AND RISK CONSULTATION IN THE FIELDS OF PROPERTY AND CASUALTY, ACCIDENT, HEALTH, LIFE, WORKERS COMPENSATION, SURETY AND OTHER INSURANCE (U.S. CLS. 100, 101 AND 102).  
FIRST USE 12-19-2013; IN COMMERCE 12-19-2013.

**CLASS 36—(Continued).**

4,593,348. PRONTO MONEY TRANSFER INC., MANHATTAN BEACH, CA. SN 85-639,085. PUB. 2-11-2014, FILED 5-30-2012.



NO CLAIM IS MADE TO THE EXCLUSIVE RIGHT TO USE "MONEY TRANSFER", APART FROM THE MARK AS SHOWN.

THE MARK CONSISTS OF THE WORDS "PRONTO MONEY TRANSFER", WITH THE "S" IN "TRANSFER" BEING A FANCIFUL DOLLAR SIGN, AND WITH AN ABSTRACT LINE DESIGN BELOW PART OF THE WORD "PRONTO".

FOR PROVIDING DIVERSIFIED FINANCIAL SERVICES, NAMELY, MONEY TRANSFER, MONEY REMITTANCE, CREDIT CONSULTATION, AND CHECK CASHING (U.S. CLS. 100, 101 AND 102).

FIRST USE 2-0-2005; IN COMMERCE 2-0-2005.

4,593,341. FIRST NIAGARA FINANCIAL GROUP, INC., BUFFALO, NY. SN 85-635,848. PUB. 4-23-2013, FILED 5-25-2012.

**CROSS-SOLVING**

THE MARK CONSISTS OF STANDARD CHARACTERS WITHOUT CLAIM TO ANY PARTICULAR FONT, STYLE, SIZE, OR COLOR.

FOR BANKING SERVICES, FINANCIAL SERVICES, NAMELY, FINANCIAL AND INVESTMENT PLANNING, CONSULTING, MANAGEMENT, AND ADVISORY SERVICES; INVESTMENT SERVICES, NAMELY, INVESTMENT AND SECURITIES BROKERAGE SERVICES, ANNUITY SALES AND SERVICE, AND PROVIDING INFORMATION ON INVESTMENT AND SECURITIES PERFORMANCE; AND INSURANCE SERVICES, NAMELY, INSURANCE BROKERAGE, INSURANCE AGENCY, INSURANCE ADMINISTRATION, AND INSURANCE AND RISK CONSULTATION IN THE FIELDS OF PROPERTY AND CASUALTY, ACCIDENT, HEALTH, LIFE, WORKERS COMPENSATION, SURETY AND OTHER INSURANCE (U.S. CLS. 100, 101 AND 102).  
FIRST USE 12-19-2013; IN COMMERCE 12-19-2013.

4,593,411. HUMANA INC., LOUISVILLE, KY. SN 85-685,373. PUB. 11-13-2012, FILED 7-24-2012.

**DENTAL SAVINGS PLUS**

THE MARK CONSISTS OF STANDARD CHARACTERS WITHOUT CLAIM TO ANY PARTICULAR FONT, STYLE, SIZE, OR COLOR.

NO CLAIM IS MADE TO THE EXCLUSIVE RIGHT TO USE "DENTAL SAVINGS", APART FROM THE MARK AS SHOWN.

FOR ADMINISTERING DISCOUNT FEE-FOR-SERVICE DENTAL PLANS; ADMINISTERING DISCOUNT FEE-FOR-SERVICE VISION PLANS; ADMINISTERING DISCOUNT PHARMACEUTICAL PLANS; ADMINISTERING DISCOUNT FEE-FOR-SERVICE HEARING PLAN; ADMINISTERING DISCOUNT COMPLEMENTARY AND ALTERNATIVE MEDICINE (CAM) PLAN, NAMELY, ACUPUNCTURE SERVICES, CHIROPRACTIC CARE AND MASSAGE THERAPY (U.S. CLS. 100, 101 AND 102).  
FIRST USE 1-1-2012; IN COMMERCE 2-1-2012.



**CLASS 36—(Continued).**

4,593,433. TONY MARREN, PROVO, UT. SN 85-710,373. PUB. 2-12-2013, FILED 8-22-2012.

## 30-Day Chump Change Challenge

THE MARK CONSISTS OF STANDARD CHARACTERS WITHOUT CLAIM TO ANY PARTICULAR FONT, STYLE, SIZE, OR COLOR.

NO CLAIM IS MADE TO THE EXCLUSIVE RIGHT TO USE "30-DAY" AND "CHALLENGE", APART FROM THE MARK AS SHOWN.

FOR CHARITABLE FUNDRAISING SERVICES (U.S. CLS. 100, 101 AND 102).  
FIRST USE 8-22-2012; IN COMMERCE 4-14-2014.

4,593,444. SEVEN CORNERS, INC., CARMEL, IN. SN 85-716,778. PUB. 2-19-2013, FILED 8-30-2012.

## STUDENT EXPRESS

THE MARK CONSISTS OF STANDARD CHARACTERS WITHOUT CLAIM TO ANY PARTICULAR FONT, STYLE, SIZE, OR COLOR.

NO CLAIM IS MADE TO THE EXCLUSIVE RIGHT TO USE "STUDENT", APART FROM THE MARK AS SHOWN.

FOR INSURANCE SERVICES, NAMELY, UNDERWRITING, ISSUANCE AND ADMINISTRATION OF AN INTERNATIONAL HEALTH BENEFIT INSURANCE PLAN FOR STUDENTS (U.S. CLS. 100, 101 AND 102).  
FIRST USE 6-10-2014; IN COMMERCE 6-10-2014.

4,593,445. GORDON \* HOWARD ASSOCIATES, INC., LITTLETON, CO. SN 85-716,939. PUB. 4-2-2013, FILED 8-30-2012.



OWNER OF U.S. REG. NOS. 2,989,184, 3,385,298, AND OTHERS.

THE COLOR(S) BLACK, GRAY, AND YELLOW IS/ARE CLAIMED AS A FEATURE OF THE MARK.

**CLASS 36—(Continued).**

THE MARK CONSISTS OF THE WORD "ELITE" IN GRAY CURSIVE SCRIPT, UNDERLINED IN YELLOW, AND THE WORD "PASSTIME" IN BLACK STYLIZED CHARACTERS, SITUATED TO THE UPPER LEFT OF THE WORD "ELITE". THE LETTER "I" IN THE WORD "PASSTIME" IS YELLOW AND CREATES THE NEEDLE ON A YELLOW SPEDOMETER THAT FORMS A SEMI-CIRCLE OVER THE WORD "PASSTIME". THE END OF WHICH FLOWS INTO THE CURSIVE SCRIPT OF THE LETTER "E" IN THE WORD "ELITE".

FOR PROVIDING A VEHICLE PAYMENT TRACKING AND ENFORCEMENT SYSTEM, NAMELY, ELECTRONIC PROCESSING AND TRANSMISSION OF BILL PAYMENT VERIFICATION DATA TO ALLOW OR DENY USE OF VEHICLE (U.S. CLS. 100, 101 AND 102).

FIRST USE 12-31-2012; IN COMMERCE 12-31-2012.

4,593,541. HOMESTEADERS LIFE COMPANY, WEST DES MOINES, IA. SN 85-776,078. PUB. 4-16-2013, FILED 11-9-2012.

## HOMESTEADERS ASSURANCE TRUST

THE MARK CONSISTS OF STANDARD CHARACTERS WITHOUT CLAIM TO ANY PARTICULAR FONT, STYLE, SIZE, OR COLOR.

NO CLAIM IS MADE TO THE EXCLUSIVE RIGHT TO USE "ASSURANCE TRUST", APART FROM THE MARK AS SHOWN.

FOR INSURANCE UNDERWRITING SERVICES IN THE FIELD OF WHOLE LIFE INSURANCE FOR USE IN THE PRE-NEED FUNERAL MARKET TO FUND PRE-NEED OR PRE-ARRANGEMENT AGREEMENTS, AND DESIGNED TO BE FUNDED WITH FUNERAL HOME TRUST FUNDS (U.S. CLS. 100, 101 AND 102).

FIRST USE 9-1-2013; IN COMMERCE 9-1-2013.

4,593,639. FARMERS GROUP, INC., LOS ANGELES, CA. SN 85-809,414. PUB. 5-21-2013, FILED 12-21-2012.

## WE ARE FARMERS

THE MARK CONSISTS OF STANDARD CHARACTERS WITHOUT CLAIM TO ANY PARTICULAR FONT, STYLE, SIZE, OR COLOR.

OWNER OF U.S. REG. NOS. 1,837,037, 4,150,905, AND OTHERS.

FOR INSURANCE UNDERWRITING SERVICES IN THE FIELD OF PROPERTY, CASUALTY, LIFE, AUTOMOBILE, BOAT, FARM AND RANCH, FLOOD, WORKERS COMPENSATION, RENTERS, TOWNHOUSE, CONDOMINIUM, AND HOMEOWNERS; INSURANCE CLAIMS PROCESSING, INSURANCE ADMINISTRATION, AND INSURANCE AGENCY SERVICES; PROVIDING INFORMATION IN INSURANCE MATTERS (U.S. CLS. 100, 101 AND 102).

FIRST USE 3-0-2014; IN COMMERCE 3-0-2014.

**CLASS 36—(Continued).**

4,593,659. MOVENCORP INC., NEW YORK, NY. SN 85-816,215. PUB. 4-30-2013, FILED 1-5-2013.

# MONEYPATH

THE MARK CONSISTS OF STANDARD CHARACTERS WITHOUT CLAIM TO ANY PARTICULAR FONT, STYLE, SIZE, OR COLOR.

FOR BANKING SERVICES (U.S. CLS. 100, 101 AND 102).

FIRST USE 3-6-2013; IN COMMERCE 3-6-2013.

4,593,704. SOUTHEAST BANK, ATHENS, TN. SN 85-842,023. PUB. 7-2-2013, FILED 2-6-2013.



OWNER OF U.S. REG. NO. 2,647,170.  
NO CLAIM IS MADE TO THE EXCLUSIVE RIGHT TO USE "BANK" AND "COMMUNITY BANK", APART FROM THE MARK AS SHOWN.

THE COLOR(S) GREEN, BLUE, BLACK AND WHITE IS/ARE CLAIMED AS A FEATURE OF THE MARK.

THE MARK CONSISTS OF A WHITE BACKGROUND WITH THE WORDS "SOUTHEAST" APPEARING IN LARGE LETTERING WITH THE WORD "SOUTH" IN GREEN AND THE WORD "EAST" IN BLUE, WITH THE WORD "BANK" APPEARING IN SMALLER LOWER CASE LETTERING IN BLACK BENEATH THE WORD "EAST", AND THE SLOGAN "YOUR COMMUNITY BANK WHEREVER YOU ARE" APPEARING IN SMALLER LETTERING BENEATH THE WORDS "SOUTHEAST BANK" WITH THE WORDS "YOUR COMMUNITY BANK" IN GREEN, FOLLOWED BY A BLACK DOT, AND FOLLOWED BY THE WORDS "WHEREVER YOU ARE" IN BLUE.

FOR BANKING AND FINANCIAL SERVICES (U.S. CLS. 100, 101 AND 102).

FIRST USE 3-1-2013; IN COMMERCE 3-1-2013.

**CLASS 36—(Continued).**

4,593,711. THE WUNDERGLO FOUNDATION, LOS ANGELES, CA. SN 85-845,285. PUB. 10-22-2013, FILED 2-8-2013.

## THE WUNDERGLO FOUNDATION

THE MARK CONSISTS OF STANDARD CHARACTERS WITHOUT CLAIM TO ANY PARTICULAR FONT, STYLE, SIZE, OR COLOR.

NO CLAIM IS MADE TO THE EXCLUSIVE RIGHT TO USE "FOUNDATION", APART FROM THE MARK AS SHOWN.

FOR CHARITABLE FUNDRAISING SERVICES (U.S. CLS. 100, 101 AND 102).

FIRST USE 7-31-2011; IN COMMERCE 7-31-2011.

4,593,712. THE WUNDERGLO FOUNDATION, LOS ANGELES, CA. SN 85-845,361. PUB. 10-22-2013, FILED 2-8-2013.



NO CLAIM IS MADE TO THE EXCLUSIVE RIGHT TO USE "FOUNDATION", APART FROM THE MARK AS SHOWN.

THE MARK CONSISTS OF A SHADED RECTANGLE CONTAINING THE STYLIZED WORDS "THE WUNDERGLO FOUNDATION" WITH THE WORD "THE" ON TOP OF THE WORD "WUNDERGLO", AND THE WORD "FOUNDATION" ON THE BOTTOM.

FOR CHARITABLE FUNDRAISING SERVICES (U.S. CLS. 100, 101 AND 102).

FIRST USE 7-31-2011; IN COMMERCE 7-31-2011.

4,593,738. SUNTRUST BANKS, INC., ATLANTA, GA. SN 85-861,755. PUB. 8-20-2013, FILED 2-27-2013.



THE COLOR(S) BLUE, WHITE, ORANGE AND RED IS/ARE CLAIMED AS A FEATURE OF THE MARK.

THE MARK CONSISTS OF THE WORD "LIGHTSTREAM" IN STYLIZED BLUE LETTERING, WITH AN ORANGE AND RED SUN RAY PATTERN CONSISTING OF FIVE RAYS FLARING OUT TO THE LEFT OF THE WORD, GROWING LARGER AS THEY MOVE FROM TOP TO BOTTOM, ALL ON A WHITE BACKGROUND.

FOR FINANCIAL SERVICES, NAMELY, CONSUMER LOAN SERVICES (U.S. CLS. 100, 101 AND 102).

FIRST USE 3-18-2013; IN COMMERCE 3-18-2013.

**CLASS 36—(Continued).**

4,593,754. ATHENE ANNUITY & LIFE ASSURANCE COMPANY, GREENVILLE, SC. SN 85-871,761. PUB. 11-5-2013, FILED 3-8-2013.

ATHENE PERFORMANCE ELITE

THE MARK CONSISTS OF STANDARD CHARACTERS WITHOUT CLAIM TO ANY PARTICULAR FONT, STYLE, SIZE, OR COLOR.

OWNER OF U.S. REG. NOS. 4,293,512 AND 4,294,747.

NO CLAIM IS MADE TO THE EXCLUSIVE RIGHT TO USE "ELITE", APART FROM THE MARK AS SHOWN.

FOR ANNUITY UNDERWRITING; UNDERWRITING, ISSUANCE AND ADMINISTRATION OF ANNUITIES (U.S. CLS. 100, 101 AND 102).

FIRST USE 4-10-2013; IN COMMERCE 4-10-2013.

4,593,839. OREGON'S HEALTH CO-OP, PORTLAND, OR. SN 85-918,076. PUB. 11-19-2013, FILED 4-29-2013.

SIMPLEBRONZE

THE MARK CONSISTS OF STANDARD CHARACTERS WITHOUT CLAIM TO ANY PARTICULAR FONT, STYLE, SIZE, OR COLOR.

FOR INSURANCE SERVICES, NAMELY, UNDERWRITING, ISSUANCE AND ADMINISTRATION OF HEALTH INSURANCE FOR OTHERS (U.S. CLS. 100, 101 AND 102).

FIRST USE 9-30-2013; IN COMMERCE 9-30-2013.

4,593,845. LEE, ERICA P., UPPER MARLBORO, MD. SN 85-919,481. PUB. 10-8-2013, FILED 4-30-2013.

  
PARTICULAR PROPERTIES  
REAL ESTATE, LLC

NO CLAIM IS MADE TO THE EXCLUSIVE RIGHT TO USE "PROPERTIES REAL ESTATE, LLC", APART FROM THE MARK AS SHOWN.

THE MARK CONSISTS OF THE STYLIZED WORDING IN BLACK "PARTICULAR PROPERTIES REAL ESTATE, LLC" WITH THE WORDS "REAL ESTATE, LLC" IN SMALLER FONT POSITIONED UNDER THE WORDS "PARTICULAR PROPERTIES". ON TOP OF THE WORDING "PARTICULAR PROPERTIES" IS THE OUTLINE OF A HOUSE INSIDE THE SPHERICAL GLASS OF A MAGNIFYING GLASS.

FOR REAL ESTATE BROKERAGE (U.S. CLS. 100, 101 AND 102).

FIRST USE 12-15-2013; IN COMMERCE 12-15-2013.

**CLASS 36—(Continued).**

4,593,846. OREGON'S HEALTH CO-OP, PORTLAND, OR. SN 85-919,495. PUB. 11-19-2013, FILED 4-30-2013.

SIMPLESILVER

THE MARK CONSISTS OF STANDARD CHARACTERS WITHOUT CLAIM TO ANY PARTICULAR FONT, STYLE, SIZE, OR COLOR.

FOR INSURANCE SERVICES, NAMELY, UNDERWRITING, ISSUANCE AND ADMINISTRATION OF HEALTH INSURANCE FOR OTHERS (U.S. CLS. 100, 101 AND 102).

FIRST USE 10-4-2013; IN COMMERCE 10-4-2013.

4,593,847. OREGON'S HEALTH CO-OP, PORTLAND, OR. SN 85-919,502. PUB. 11-19-2013, FILED 4-30-2013.

SIMPLEGOLD

THE MARK CONSISTS OF STANDARD CHARACTERS WITHOUT CLAIM TO ANY PARTICULAR FONT, STYLE, SIZE, OR COLOR.

FOR INSURANCE SERVICES, NAMELY, UNDERWRITING, ISSUANCE AND ADMINISTRATION OF HEALTH INSURANCE FOR OTHERS (U.S. CLS. 100, 101 AND 102).

FIRST USE 9-30-2013; IN COMMERCE 9-30-2013.

4,593,860. AKITA, INC., WILMINGTON, DE. SN 85-922,620. PUB. 10-15-2013, FILED 5-3-2013.

  
win  
warranty information network

NO CLAIM IS MADE TO THE EXCLUSIVE RIGHT TO USE "WARRANTY INFORMATION NETWORK", APART FROM THE MARK AS SHOWN.

THE MARK CONSISTS OF THE LETTER "W" WITHIN A SHADED CIRCLE TILTED TO THE LEFT. TO THE RIGHT OF THE DESIGN APPEARS THE TERM "WIN". BELOW APPEARS THE WORDING "WARRANTY INFORMATION NETWORK".

FOR WARRANTY CLAIMS ADMINISTRATION SERVICES, NAMELY, PROCESSING WARRANTY CLAIMS FOR CONSUMER ELECTRONICS (U.S. CLS. 100, 101 AND 102).

FIRST USE 8-0-2012; IN COMMERCE 8-0-2012.

**CLASS 36—(Continued).**

4,593,881. CROWNWHEEL PARTNERS, LLC, MENLO PARK, CA. SN 85-927,371. PUB. 11-5-2013, FILED 5-9-2013.

**CROWNWHEEL PARTNERS**

THE MARK CONSISTS OF STANDARD CHARACTERS WITHOUT CLAIM TO ANY PARTICULAR FONT, STYLE, SIZE, OR COLOR.

NO CLAIM IS MADE TO THE EXCLUSIVE RIGHT TO USE "PARTNERS", APART FROM THE MARK AS SHOWN. FOR FINANCIAL INVESTMENT BROKERAGE SERVICES; FINANCIAL ADVISORY AND CONSULTANCY SERVICES; FINANCIAL ANALYSIS AND RESEARCH SERVICES (U.S. CLS. 100, 101 AND 102).

FIRST USE 6-12-2013; IN COMMERCE 6-12-2013.

**CLASS 36—(Continued).**

4,593,948. CAPITAL ONE FINANCIAL CORPORATION, RICHMOND, VA. SN 85-939,315. PUB. 10-15-2013, FILED 5-22-2013.

**SURESWIPE**

THE MARK CONSISTS OF STANDARD CHARACTERS WITHOUT CLAIM TO ANY PARTICULAR FONT, STYLE, SIZE, OR COLOR.

FOR BANKING SERVICES (U.S. CLS. 100, 101 AND 102).

FIRST USE 9-16-2012; IN COMMERCE 9-16-2012.

4,593,968. JPMORGAN CHASE & CO., NEW YORK, NY. SN 85-942,159. PUB. 3-11-2014, FILED 5-24-2013.

**J.P. MORGAN MARKETS**

THE MARK CONSISTS OF STANDARD CHARACTERS WITHOUT CLAIM TO ANY PARTICULAR FONT, STYLE, SIZE, OR COLOR.

OWNER OF U.S. REG. NOS. 3,335,070, 3,752,981, AND 4,062,449.

NO CLAIM IS MADE TO THE EXCLUSIVE RIGHT TO USE "MARKETS", APART FROM THE MARK AS SHOWN.

THE NAME "J.P. MORGAN" DOES NOT IDENTIFY A PARTICULAR LIVING INDIVIDUAL.

FOR BANKING AND FINANCIAL SERVICES, NAMELY, INVESTMENT SERVICES IN THE FIELDS OF RESEARCH, TRADING AND POST TRADE SUPPORT (U.S. CLS. 100, 101 AND 102).

FIRST USE 1-7-2013; IN COMMERCE 1-7-2013.

4,593,911. DUTTINE-CAVATAIO FUND, PITTSBURGH, PA. SN 85-934,213. PUB. 10-15-2013, FILED 5-16-2013.



THE MARK CONSISTS OF A STYLIZED IMAGE WITH AN INNER AND OUTER CIRCLE. THE WORDS DROP THE PUCK ON CANCER ARE CONTAINED IN THE INNER CIRCLE. A HOCKEY STICK COMBINED WITH A RIBBON IS BELOW THE WORDS "ON CANCER" AND OVERLAPS THE INNER AND OUTER CIRCLES.

FOR CHARITABLE FUNDRAISING SERVICES BY MEANS OF ORGANIZING AND CONDUCTING SPECIAL EVENTS (U.S. CLS. 100, 101 AND 102).

FIRST USE 1-31-2012; IN COMMERCE 1-31-2012.

4,593,977. BROWN & BROWN, INC., TAMPA, FL. SN 85-943,410. PUB. 11-5-2013, FILED 5-28-2013.



OWNER OF U.S. REG. NOS. 2,411,257, 4,063,491, AND OTHERS.

NO CLAIM IS MADE TO THE EXCLUSIVE RIGHT TO USE "INSURANCE" AND "EMPLOYEE BENEFITS MARKETPLACE", APART FROM THE MARK AS SHOWN.

THE COLOR(S) BLUE, BLACK, WHITE AND RED IS/ARE CLAIMED AS A FEATURE OF THE MARK.

**CLASS 36—(Continued).**

THE MARK CONSISTS OF THE WORDING "BROWN & BROWN INSURANCE EMPLOYEE BENEFITS MARKETPLACE", WITH "BROWN & BROWN" APPEARING IN WHITE WITHIN A BLUE-SHADED, RECTANGULAR-SHAPED CARRIER WITH ITS LOWER HORIZONTAL EDGE APPEARING IN RED, WITH THE WORD "INSURANCE" APPEARING IN BLACK IMMEDIATELY BELOW, AND LOCATED TO THE RIGHT OF THESE ELEMENTS ARE THE WORDS "EMPLOYEE" IN BLUE AND "BENEFITS MARKETPLACE" IN RED.

FOR INSURANCE BROKERAGE; CONSULTING SERVICES IN THE FIELD OF EMPLOYEE FINANCIAL AND INSURANCE BENEFIT PLANS (U.S. CLS. 100, 101 AND 102).

FIRST USE 6-0-2013; IN COMMERCE 6-0-2013.

---

4,594,030. OAK FINANCIAL SOFTWARE CORP., SOUTH BEND, IN. SN 85-952,572. PUB. 10-29-2013, FILED 6-6-2013.



THE MARK CONSISTS OF A GRASSHOPPER. FOR FINANCIAL SERVICES, NAMELY, PREPAID, CREDIT AND DEBIT CARD SERVICES (U.S. CLS. 100, 101 AND 102).

FIRST USE 3-31-2014; IN COMMERCE 5-22-2014.

---

4,594,031. OAK FINANCIAL SOFTWARE CORP., SOUTH BEND, IN. SN 85-952,574. PUB. 11-12-2013, FILED 6-6-2013.

# CHAPULIN

THE MARK CONSISTS OF STANDARD CHARACTERS WITHOUT CLAIM TO ANY PARTICULAR FONT, STYLE, SIZE, OR COLOR.

THE ENGLISH TRANSLATION OF "CHAPULIN" IN THE MARK IS "GRASSHOPPER".

FOR FINANCIAL SERVICES, NAMELY, PREPAID, CREDIT AND DEBIT CARD SERVICES (U.S. CLS. 100, 101 AND 102).

FIRST USE 3-31-2014; IN COMMERCE 5-22-2014.

**CLASS 36—(Continued).**

4,594,145. KCG HOLDINGS, INC., JERSEY CITY, NJ. SN 85-973,189. PUB. 4-1-2014, FILED 6-28-2013.

# KCG HOTSPOT

THE MARK CONSISTS OF STANDARD CHARACTERS WITHOUT CLAIM TO ANY PARTICULAR FONT, STYLE, SIZE, OR COLOR.

FOR FINANCIAL SERVICES, NAMELY, FOREIGN CURRENCY TRADING OVER THE INTERNET (U.S. CLS. 100, 101 AND 102).

FIRST USE 7-1-2013; IN COMMERCE 7-1-2013.

---

4,594,228. JEWISH FEDERATION OF GREATER SEATTLE, SEATTLE, WA. SN 86-010,807. PUB. 12-31-2013, FILED 7-15-2013.

# J-KICK

THE MARK CONSISTS OF STANDARD CHARACTERS WITHOUT CLAIM TO ANY PARTICULAR FONT, STYLE, SIZE, OR COLOR.

FOR CHARITABLE FUNDRAISING SERVICES FOR PROJECTS VIA AN ONLINE COMMUNITY WEBSITE; ONLINE CHARITABLE FUNDRAISING SERVICES (U.S. CLS. 100, 101 AND 102).

FIRST USE 11-4-2013; IN COMMERCE 11-4-2013.

---

4,594,299. HEALTH CARE SERVICE CORPORATION, CHICAGO, IL. SN 86-044,066. PUB. 2-11-2014, FILED 8-21-2013.

# LIFESTYLE ASSURANCE

THE MARK CONSISTS OF STANDARD CHARACTERS WITHOUT CLAIM TO ANY PARTICULAR FONT, STYLE, SIZE, OR COLOR.

NO CLAIM IS MADE TO THE EXCLUSIVE RIGHT TO USE "ASSURANCE", APART FROM THE MARK AS SHOWN.

FOR INSURANCE SERVICES, NAMELY, UNDERWRITING, ADMINISTRATION AND BROKERAGE OF CRITICAL ILLNESS INSURANCE (U.S. CLS. 100, 101 AND 102).

FIRST USE 5-0-2014; IN COMMERCE 5-0-2014.

**CLASS 36—(Continued).**

4,594,316. BONDED BUILDERS SERVICE CORP., ST. PETERSBURG, FL. SN 86-048,591. PUB. 1-21-2014, FILED 8-27-2013.

**BUILDERXPRESS**

THE MARK CONSISTS OF STANDARD CHARACTERS WITHOUT CLAIM TO ANY PARTICULAR FONT, STYLE, SIZE, OR COLOR.

FOR WARRANTY CLAIMS ADMINISTRATION SERVICES, NAMELY, PROCESSING WARRANTY CLAIMS FOR HOME BUILDERS (U.S. CLS. 100, 101 AND 102).  
FIRST USE 3-21-2013; IN COMMERCE 3-21-2013.

4,594,317. BONDED BUILDERS SERVICE CORP., ST. PETERSBURG, FL. SN 86-048,593. PUB. 2-25-2014, FILED 8-27-2013.

**BUILDER EXPRESS**

THE MARK CONSISTS OF STANDARD CHARACTERS WITHOUT CLAIM TO ANY PARTICULAR FONT, STYLE, SIZE, OR COLOR.

NO CLAIM IS MADE TO THE EXCLUSIVE RIGHT TO USE "BUILDER", APART FROM THE MARK AS SHOWN.

FOR WARRANTY CLAIMS ADMINISTRATION SERVICES, NAMELY, PROCESSING WARRANTY CLAIMS FOR HOME BUILDERS (U.S. CLS. 100, 101 AND 102).  
FIRST USE 3-21-2013; IN COMMERCE 3-21-2013.

4,594,332. FIRST CITIZENS BANCSHARES, INC., RALEIGH, NC. SN 86-057,774. PUB. 2-25-2014, FILED 9-6-2013.



OWNER OF U.S. REG. NOS. 3,514,733, 3,637,721, AND OTHERS.

**CLASS 36—(Continued).**

THE COLOR(S) RED, BLUE, AND SILVER IS/ARE CLAIMED AS A FEATURE OF THE MARK.

THE MARK CONSISTS OF A RED FLAG DESIGN OUTLINED IN SILVER WITHIN A BLUE SQUARE.

FOR BANKING SERVICES; FINANCIAL SERVICES, NAMELY, EQUIPMENT FINANCING, FINANCIAL LOAN CONSULTATION, FINANCIAL RISK MANAGEMENT CONSULTATION, FINANCIAL VALUATIONS, FINANCING SERVICES, FINANCIAL PLANNING AND MANAGEMENT, MONEY LENDING, MORTGAGE REFINANCING, FINANCIAL PLANNING FOR RETIREMENT, WEALTH MANAGEMENT SERVICES, FINANCIAL ADVICE AND CONSULTATION SERVICES, MERCHANT FINANCIAL SERVICES, NAMELY, PAYMENT TRANSACTION PROCESSING SERVICES, FINANCIAL ASSET MANAGEMENT, FINANCIAL FORECASTING, FINANCIAL INVESTMENT BROKERAGE, FINANCIAL TRUST PLANNING, ESTATE PLANNING AND WEALTH TRANSFER ADVICE, FINANCIAL STRATEGIES FOR TAX MANAGEMENT (U.S. CLS. 100, 101 AND 102).

FIRST USE 9-20-2013; IN COMMERCE 9-20-2013.

4,594,333. FIRST CITIZENS BANCSHARES, INC., RALEIGH, NC. SN 86-057,778. PUB. 2-25-2014, FILED 9-6-2013.



OWNER OF U.S. REG. NOS. 3,514,733, 3,637,721, AND OTHERS.

THE MARK CONSISTS OF A WAVY FLAG DESIGN WITHIN A SQUARE.

FOR BANKING SERVICES; FINANCIAL SERVICES, NAMELY, EQUIPMENT FINANCING, FINANCIAL LOAN CONSULTATION, FINANCIAL RISK MANAGEMENT CONSULTATION, FINANCIAL VALUATIONS, FINANCING SERVICES, FINANCIAL PLANNING AND MANAGEMENT, MONEY LENDING, MORTGAGE REFINANCING, FINANCIAL PLANNING FOR RETIREMENT, WEALTH MANAGEMENT SERVICES, FINANCIAL ADVICE AND CONSULTATION SERVICES, MERCHANT FINANCIAL SERVICES, NAMELY, PAYMENT TRANSACTION PROCESSING SERVICES, FINANCIAL ASSET MANAGEMENT, FINANCIAL FORECASTING, FINANCIAL INVESTMENT BROKERAGE, FINANCIAL TRUST PLANNING, ESTATE PLANNING AND WEALTH TRANSFER ADVICE, FINANCIAL STRATEGIES FOR TAX MANAGEMENT (U.S. CLS. 100, 101 AND 102).

FIRST USE 9-20-2013; IN COMMERCE 9-20-2013.

**CLASS 36—(Continued).**

4,594,339. WYNDHAM HOTELS AND RESORTS, LLC, PAR-SIPPANY, NJ. SN 86-060,915. PUB. 3-4-2014, FILED 9-10-2013.

**WYNDHAM CLUB PASS**

THE MARK CONSISTS OF STANDARD CHARACTERS WITHOUT CLAIM TO ANY PARTICULAR FONT, STYLE, SIZE, OR COLOR.

OWNER OF U.S. REG. NOS. 2,859,133, 4,111,176, AND OTHERS.

NO CLAIM IS MADE TO THE EXCLUSIVE RIGHT TO USE "CLUB PASS", APART FROM THE MARK AS SHOWN.

FOR VACATION REAL ESTATE TIME SHARE EXCHANGE SERVICES; VACATION REAL ESTATE TIME-SHARE SERVICES (U.S. CLS. 100, 101 AND 102).

FIRST USE 6-1-2014; IN COMMERCE 6-1-2014.

4,594,345. AQUARII, INC., CAMILLUS, NY. SN 86-062,907. PUB. 4-1-2014, FILED 9-12-2013.

**Aquarii's Enlightened  
Financing**

THE MARK CONSISTS OF STANDARD CHARACTERS WITHOUT CLAIM TO ANY PARTICULAR FONT, STYLE, SIZE, OR COLOR.

NO CLAIM IS MADE TO THE EXCLUSIVE RIGHT TO USE "FINANCING", APART FROM THE MARK AS SHOWN.

FOR FINANCIAL SERVICES, NAMELY, ASSISTING CUSTOMERS IN OBTAINING FINANCING FOR LOANS IN CONNECTION WITH THE PURCHASE OF LED (LIGHT EMITTING DIODE) LIGHTING FIXTURES, RELATED EQUIPMENT AND CONTROLS, AND IN CONNECTION WITH OBTAINING INSTALLATION SERVICES, ASSOCIATED ENGINEERING SERVICES AND PROJECT MANAGEMENT SERVICES, ALL IN CONNECTION WITH THE PURCHASE OF LED (LIGHT EMITTING DIODE) LIGHTING FIXTURES AND EQUIPMENT (U.S. CLS. 100, 101 AND 102).

FIRST USE 11-14-2013; IN COMMERCE 11-14-2013.

4,594,349. AMERICAN INTERNATIONAL GROUP, INC., NEW YORK, NY. SN 86-064,500. PUB. 2-18-2014, FILED 9-13-2013.

**BANKERS PROFESSIONAL EDGE**

THE MARK CONSISTS OF STANDARD CHARACTERS WITHOUT CLAIM TO ANY PARTICULAR FONT, STYLE, SIZE, OR COLOR.

OWNER OF U.S. REG. NOS. 3,339,160, 3,970,773, AND OTHERS.

**CLASS 36—(Continued).**

NO CLAIM IS MADE TO THE EXCLUSIVE RIGHT TO USE "BANKERS PROFESSIONAL", APART FROM THE MARK AS SHOWN.

FOR INSURANCE UNDERWRITING IN THE FIELD OF PROFESSIONAL LIABILITY INSURANCE OFFERED TO BANKERS AND FINANCIAL INSTITUTIONS (U.S. CLS. 100, 101 AND 102).

FIRST USE 9-0-2013; IN COMMERCE 9-0-2013.

4,594,372. FIRST FINANCIAL LEASING & FINANCE, INC., FORT LAUDERDALE, FL. SN 86-074,178. PUB. 3-11-2014, FILED 9-25-2013.

**RAFT**

THE MARK CONSISTS OF STANDARD CHARACTERS WITHOUT CLAIM TO ANY PARTICULAR FONT, STYLE, SIZE, OR COLOR.

FOR INVESTING CONSULTING, NAMELY, ASSISTING INDIVIDUALS WITH ROLLING OVER THEIR RETIREMENT FUNDS INTO BUSINESS START-UPS (U.S. CLS. 100, 101 AND 102).

FIRST USE 9-25-2013; IN COMMERCE 9-25-2013.

4,594,383. RABO AGRIFINANCE, INC., ST. LOUIS, MO. SN 86-077,431. PUB. 2-18-2014, FILED 9-27-2013.

**WE STAND BY OUR CUSTOMERS  
OVER TIME**

THE MARK CONSISTS OF STANDARD CHARACTERS WITHOUT CLAIM TO ANY PARTICULAR FONT, STYLE, SIZE, OR COLOR.

FOR FINANCING AND LOAN SERVICES (U.S. CLS. 100, 101 AND 102).

FIRST USE 2-3-2014; IN COMMERCE 2-3-2014.



**CLASS 36—(Continued).**

4,594,387. AARC, LLC, SPARTANBURG, SC. SN 86-078,706.  
PUB. 2-18-2014, FILED 9-30-2013.

**ANYTIME WALLET**

THE MARK CONSISTS OF STANDARD CHARACTERS WITHOUT CLAIM TO ANY PARTICULAR FONT, STYLE, SIZE, OR COLOR.

FOR FINANCIAL SERVICES, NAMELY, MONEY LENDING; ELECTRONIC LOAN ORIGINATION SERVICES; ELECTRONIC LOAN PREPARATION SERVICES; PROVIDING A WEBSITE FOR THE ORIGINATION OF LOANS; ARRANGING OF LOANS; CONSUMER LENDING SERVICES (U.S. CLS. 100, 101 AND 102).  
FIRST USE 3-10-2014; IN COMMERCE 3-10-2014.

4,594,388. AARC, LLC, SPARTANBURG, SC. SN 86-078,785.  
PUB. 3-11-2014, FILED 9-30-2013.



THE MARK CONSISTS OF A DARK SHADED RECTANGLE WITH ANOTHER LIGHT SHADED RECTANGLE PARTIALLY VISIBLE AND EXTENDING OUT FROM THE TOP LEFT EDGE OF THE DARK SHADED RECTANGLE AT AN ANGLE. INSIDE THE FIRST RECTANGLE APPEARS THE STYLIZED WORD "ANYTIME" IN LOWER CASE LETTERS WITH THE WORD "WALLET" APPEARING DIRECTLY BELOW "ANYTIME".

FOR FINANCIAL SERVICES, NAMELY, MONEY LENDING; ELECTRONIC LOAN ORIGINATION SERVICES; ELECTRONIC LOAN PREPARATION SERVICES; PROVIDING A WEBSITE FOR THE ORIGINATION OF LOANS; ARRANGING OF LOANS; CONSUMER LENDING SERVICES (U.S. CLS. 100, 101 AND 102).  
FIRST USE 3-10-2014; IN COMMERCE 3-10-2014.

**CLASS 36—(Continued).**

4,594,464. SONNY'S FRANCHISE COMPANY, WINTER PARK, FL. SN 86-104,810. PUB. 3-25-2014, FILED 10-29-2013.

**RANDOM ACTS OF BBQ**

THE MARK CONSISTS OF STANDARD CHARACTERS WITHOUT CLAIM TO ANY PARTICULAR FONT, STYLE, SIZE, OR COLOR.

FOR CHARITABLE FUNDRAISING SERVICES (U.S. CLS. 100, 101 AND 102).  
FIRST USE 9-0-2013; IN COMMERCE 10-0-2013.

4,594,470. SUPER G FUNDING, LLC, NEWPORT BEACH, CA. SN 86-107,274. PUB. 4-15-2014, FILED 10-31-2013.

**OPPORTUNITY CAPITAL**

THE MARK CONSISTS OF STANDARD CHARACTERS WITHOUT CLAIM TO ANY PARTICULAR FONT, STYLE, SIZE, OR COLOR.

NO CLAIM IS MADE TO THE EXCLUSIVE RIGHT TO USE "CAPITAL", APART FROM THE MARK AS SHOWN. FOR MAKING BUSINESS LOANS TO PUBLIC AND PRIVATE COMPANIES (U.S. CLS. 100, 101 AND 102).  
FIRST USE 6-17-2014; IN COMMERCE 6-17-2014.

4,594,472. ATLANTIC CAPITAL BANCSHARES, INC., ATLANTA, GA. SN 86-107,924. PUB. 4-1-2014, FILED 11-1-2013.

**BANK IN THE RIGHT DIRECTION**

THE MARK CONSISTS OF STANDARD CHARACTERS WITHOUT CLAIM TO ANY PARTICULAR FONT, STYLE, SIZE, OR COLOR.

FOR BANKING SERVICES (U.S. CLS. 100, 101 AND 102).  
FIRST USE 6-30-2014; IN COMMERCE 6-30-2014.



**CLASS 36—(Continued).**

4,594,532. ATLANTIC CAPITAL BANCSHARES, INC., ATLANTA, GA. SN 86-139,492. PUB. 4-22-2014, FILED 12-10-2013.



NO CLAIM IS MADE TO THE EXCLUSIVE RIGHT TO USE "CAPITAL", APART FROM THE MARK AS SHOWN. THE COLOR(S) BLUE AND BLACK IS/ARE CLAIMED AS A FEATURE OF THE MARK.

THE MARK CONSISTS OF THE WORDS "ATLANTIC CAPITAL" IN THE COLOR BLACK BELOW A BIRD-SHAPED DESIGN COMPRISED OF OVERLAPPING TRIANGLES IN VARIOUS SHADES OF THE COLOR BLUE.

FOR BANKING SERVICES (U.S. CLS. 100, 101 AND 102).

FIRST USE 6-2-2014; IN COMMERCE 6-2-2014.

**CLASS 37—(Continued).**

4,593,106. AEROVIRONMENT, INC., MONROVIA, CA. SN 85-053,248. PUB. 5-10-2011, FILED 6-2-2010.



OWNER OF U.S. REG. NOS. 1,999,292, 3,535,416, AND 3,600,261.

THE MARK CONSISTS OF STYLIZED UPPER CASE LETTERS "AV" ABOVE LOWER CASE WORD "AEROVIRONMENT".

FOR RÉPAIR SERVICES FOR RESIDENTIAL AND COMMERCIAL ELECTRIC VEHICLE BATTERY CHARGING STATIONS; ELECTRICAL CONTRACTING SERVICES; BUILDING SITE ASSESSMENT, ALSO KNOWN AS COMMERCIAL REAL ESTATE SITE SELECTION FOR SUCH STATIONS; INSTALLATION SERVICES IN THE FIELD OF RESIDENTIAL AND COMMERCIAL ELECTRIC VEHICLE BATTERY CHARGING STATIONS; SERVICES ASSOCIATED WITH RESIDENTIAL AND COMMERCIAL ELECTRIC VEHICLE BATTERY CHARGING STATIONS, NAMELY, REPAIR AND INSTALLATION SERVICES (U.S. CLS. 100, 103 AND 106).

FIRST USE 4-30-2014; IN COMMERCE 4-30-2014.

4,593,156. GREEN BAY PACKERS, INC., GREEN BAY, WI. SN 85-185,938. PUB. 4-26-2011, FILED 11-29-2010.

**CLASS 37—CONSTRUCTION AND REPAIR**

4,593,104. AEROVIRONMENT, INC., MONROVIA, CA. SN 85-052,991. PUB. 5-10-2011, FILED 6-2-2010.

AEROVIRONMENT

THE MARK CONSISTS OF STANDARD CHARACTERS WITHOUT CLAIM TO ANY PARTICULAR FONT, STYLE, SIZE, OR COLOR.

OWNER OF U.S. REG. NOS. 1,999,292, 3,535,416, AND 3,600,261.

FOR RÉPAIR SERVICES FOR RESIDENTIAL AND COMMERCIAL ELECTRIC VEHICLE BATTERY CHARGING STATIONS; ELECTRICAL CONTRACTING SERVICES; BUILDING SITE ASSESSMENT, ALSO KNOWN AS COMMERCIAL REAL ESTATE SITE SELECTION FOR SUCH STATIONS; INSTALLATION SERVICES IN THE FIELD OF RESIDENTIAL AND COMMERCIAL ELECTRIC VEHICLE BATTERY CHARGING STATIONS; SERVICES ASSOCIATED WITH RESIDENTIAL AND COMMERCIAL ELECTRIC VEHICLE BATTERY CHARGING STATIONS, NAMELY, REPAIR AND INSTALLATION SERVICES (U.S. CLS. 100, 103 AND 106).

FIRST USE 4-30-2014; IN COMMERCE 4-30-2014.

TITLETOWN

THE MARK CONSISTS OF STANDARD CHARACTERS WITHOUT CLAIM TO ANY PARTICULAR FONT, STYLE, SIZE, OR COLOR.

OWNER OF U.S. REG. NO. 1,802,761.

FOR REAL ESTATE DEVELOPMENT (U.S. CLS. 100, 103 AND 106).

FIRST USE 1-26-2011; IN COMMERCE 1-26-2011.

4,593,753. FM INDUSTRIES, LLC, LA CANADA, CA. SN 85-871,424. PUB. 9-10-2013, FILED 3-8-2013.

Blinds World

THE MARK CONSISTS OF STANDARD CHARACTERS WITHOUT CLAIM TO ANY PARTICULAR FONT, STYLE, SIZE, OR COLOR.

**CLASS 37—(Continued).**

NO CLAIM IS MADE TO THE EXCLUSIVE RIGHT TO USE "BLINDS", APART FROM THE MARK AS SHOWN.

FOR INSTALLATION OF WINDOW COVERINGS AND TREATMENTS, NAMELY, BLINDS, SHUTTERS, LOUVERS, DRAPERIES, CURTAINS, SHEERS, SWAGS AND VALANCES (U.S. CLS. 100, 103 AND 106).

FIRST USE 5-1-2013; IN COMMERCE 5-1-2013.

---

## GARAGE SQUAD

4,593,891. MGD ENTERPRISES, INC., SPRINGFIELD, MO.  
SN 85-930,102. PUB. 10-8-2013, FILED 5-13-2013.

THE MARK CONSISTS OF STANDARD CHARACTERS WITHOUT CLAIM TO ANY PARTICULAR FONT, STYLE, SIZE, OR COLOR.

NO CLAIM IS MADE TO THE EXCLUSIVE RIGHT TO USE "GARAGE", APART FROM THE MARK AS SHOWN.

FOR CLEANING OF GARAGES AND INDOOR VEHICULAR STORAGE SPACES; ELECTRICAL REPAIRS AND INSTALLATION OF GARAGE DOOR AND GATE OPENERS AND CONTROLS; INSTALLATION OF GARAGE FLOOR COATINGS; INSTALLATION, MAINTENANCE AND REPAIR OF DOORS (U.S. CLS. 100, 103 AND 106).

FIRST USE 6-3-2014; IN COMMERCE 6-3-2014.

4,593,952. PINNACLE POTASH INTERNATIONAL, LTD., AUSTIN, TX. SN 85-940,206. PUB. 10-22-2013, FILED 5-22-2013.



THE MARK CONSISTS OF THE LETTERS "PPI" IN A LOWER CASE FONT. BELOW THE LETTERS ARE THREE CURVED LINES THAT EXTEND TO THE RIGHT OF THE LETTERS AND DIP BENEATH THE LETTERS "PP".

FOR MINING SERVICES, NAMELY, THE EXTRACTION OF POTASH (U.S. CLS. 100, 103 AND 106).

FIRST USE 10-0-2013; IN COMMERCE 10-0-2013.

**CLASS 37—(Continued).**

4,594,046. RODEOROOTER AND PLUMBING, SUNNYVALE, CA. SN 85-954,456. PUB. 4-8-2014, FILED 6-8-2013.

---

## Rodeo Rooter And Plumbing

THE MARK CONSISTS OF STANDARD CHARACTERS WITHOUT CLAIM TO ANY PARTICULAR FONT, STYLE, SIZE, OR COLOR.

NO CLAIM IS MADE TO THE EXCLUSIVE RIGHT TO USE "ROOTER AND PLUMBING", APART FROM THE MARK AS SHOWN.

FOR PLUMBING CONTRACTOR SERVICES (U.S. CLS. 100, 103 AND 106).

FIRST USE 1-1-2014; IN COMMERCE 1-1-2014.

4,594,092. MAID RIGHT FRANCHISING, LLC, ALPHARETTA, GA. SN 85-961,416. PUB. 11-5-2013, FILED 6-17-2013.

---

## MAID RIGHT TRACKER

THE MARK CONSISTS OF STANDARD CHARACTERS WITHOUT CLAIM TO ANY PARTICULAR FONT, STYLE, SIZE, OR COLOR.

FOR CLEANING OF RESIDENTIAL, COMMERCIAL, VACATION RENTAL AND NEW CONSTRUCTION BUILDINGS (U.S. CLS. 100, 103 AND 106).

FIRST USE 6-17-2013; IN COMMERCE 4-25-2014.

4,594,098. BLUEPOINT ALERT SOLUTIONS, LLC, ELGIN, IL. SN 85-962,997. PUB. 11-5-2013, FILED 6-18-2013.

---

## BLUEPOINT

THE MARK CONSISTS OF STANDARD CHARACTERS WITHOUT CLAIM TO ANY PARTICULAR FONT, STYLE, SIZE, OR COLOR.

FOR INSTALLATION AND MAINTENANCE OF ALARM, DETECTION, AND NOTIFICATION SYSTEMS (U.S. CLS. 100, 103 AND 106).

FIRST USE 8-15-2013; IN COMMERCE 8-15-2013.

**CLASS 37—(Continued).**

4,594,279. A & M PROFESSIONAL POOL RENOVATIONS, LLC, PORT CHARLOTTE, FL. SN 86-033,775. PUB. 2-25-2014, FILED 8-9-2013.

**RESURRECTION POOLS**

THE MARK CONSISTS OF STANDARD CHARACTERS WITHOUT CLAIM TO ANY PARTICULAR FONT, STYLE, SIZE, OR COLOR.

NO CLAIM IS MADE TO THE EXCLUSIVE RIGHT TO USE "POOLS", APART FROM THE MARK AS SHOWN.

FOR SWIMMING POOL MAINTENANCE (U.S. CLS. 100, 103 AND 106).

FIRST USE 3-4-2014; IN COMMERCE 3-4-2014.

4,594,304. PILKINGTON, GEORGE, VIRGINIA BEACH, VA. SN 86-044,718. PUB. 2-25-2014, FILED 8-22-2013.

**THE INSULATION DOCTOR**

THE MARK CONSISTS OF STANDARD CHARACTERS WITHOUT CLAIM TO ANY PARTICULAR FONT, STYLE, SIZE, OR COLOR.

NO CLAIM IS MADE TO THE EXCLUSIVE RIGHT TO USE "INSULATION", APART FROM THE MARK AS SHOWN.

FOR INSTALLATION AND MAINTENANCE OF BUILDING INSULATION; REMOVING CONTAMINATED INSULATION (U.S. CLS. 100, 103 AND 106).

FIRST USE 3-1-2013; IN COMMERCE 3-1-2013.

4,594,430. URBAN DEVELOPMENT CORPORATION, PHILADELPHIA, PA. SN 86-092,668. PUB. 4-8-2014, FILED 10-16-2013.

**PROPERTY RECOVERY 911**

THE MARK CONSISTS OF STANDARD CHARACTERS WITHOUT CLAIM TO ANY PARTICULAR FONT, STYLE, SIZE, OR COLOR.

**CLASS 37—(Continued).**

NO CLAIM IS MADE TO THE EXCLUSIVE RIGHT TO USE "PROPERTY RECOVERY", APART FROM THE MARK AS SHOWN.

FOR EMERGENCY CONSTRUCTION REPAIRS, NAMELY, RESTORATION SERVICES IN THE FIELD OF WATER, SMOKE AND FIRE DAMAGED PROPERTY; DRAIN AND SEWER CLEANING AND ROOTERING SERVICES; BUILDING CONSTRUCTION, REMODELING AND REPAIR; BUILDING RESTORATION; RENOVATION AND RESTORATION OF BUILDINGS; RESTORATION IN THE FIELD OF RESIDENTIAL HOUSING; INDUSTRIAL, COMMERCIAL, AND RESIDENTIAL ELECTRICAL CONTRACTING, SERVICING, AND REPAIR; PLUMBING SERVICES; MAINTENANCE AND/OR REPAIR OF DRYWALL; INSTALLATION, MAINTENANCE AND REPAIR OF FOUNDATIONS, BASEMENTS, CONCRETE WALLS, FLOORING, DRAINAGE SYSTEMS, HUMIDITY CONTROL SYSTEMS AND SUMP PUMPS (U.S. CLS. 100, 103 AND 106).

FIRST USE 12-0-2013; IN COMMERCE 12-0-2013.

**CLASS 38—COMMUNICATION**

4,593,482. EMC CORPORATION, HOPKINTON, MA. SN 85-751,291. PUB. 11-5-2013, FILED 10-11-2012.

**EMCTV**

THE MARK CONSISTS OF STANDARD CHARACTERS WITHOUT CLAIM TO ANY PARTICULAR FONT, STYLE, SIZE, OR COLOR.

OWNER OF U.S. REG. NOS. 2,142,157, 2,623,553, AND OTHERS.

FOR VIDEO AND AUDIO BROADCASTING SERVICES; WEBCASTING SERVICES; SIMULCASTING SERVICES, NAMELY, TRANSMISSION OF AUDIO, VIDEO, PHOTOGRAPHIC AND MULTIMEDIA CONTENT VIA THE INTERNET, CABLE NETWORKS, WIRELESS NETWORKS, SATELLITE, OR INTERACTIVE MULTIMEDIA NETWORKS; COMMUNICATION SERVICES, NAMELY, TRANSMISSION OF VOICE, AUDIO, VISUAL IMAGES AND DATA BY TELECOMMUNICATIONS NETWORKS, WIRELESS COMMUNICATION NETWORKS, THE INTERNET, INFORMATION SERVICES NETWORKS AND DATA NETWORKS (U.S. CLS. 100, 101 AND 104).

FIRST USE 5-8-2011; IN COMMERCE 5-8-2011.

**CLASS 38—(Continued).**

4,593,686. SOFTFOUNDRY TECHNOLOGY (NINGBO) CO., LTD., NINGBO, ZHEJIANG, CHINA. SN 85-829,622. PUB. 10-8-2013, FILED 1-22-2013.

**CLASS 38—(Continued).**

4,594,088. TRANSLATION RIGHT-LEFT, LLC, TRENTON, NJ. SN 85-960,746. PUB. 11-12-2013, FILED 6-14-2013.

# FacePro

THE MARK CONSISTS OF THE WORDING "FACEPRO" IN STYLIZED FONT.

FOR CABLE TELEVISION BROADCASTING; COMMUNICATIONS BY FIBRE-OPTIC NETWORKS; ELECTRONIC MAIL; MESSAGE SENDING AND RECEIVING SERVICES; RADIO BROADCASTING; SATELLITE TRANSMISSION; TELEGRAPH SERVICES; TELEVISION BROADCASTING; WIRELESS BROADCASTING (U.S. CLS. 100, 101 AND 104).

FIRST USE 1-1-1999; IN COMMERCE 1-1-2000.

# DIGAZI

THE MARK CONSISTS OF STANDARD CHARACTERS WITHOUT CLAIM TO ANY PARTICULAR FONT, STYLE, SIZE, OR COLOR.

FOR AUDIO AND VIDEO BROADCASTING SERVICES OVER THE INTERNET; BROADCASTING OF VIDEO AND AUDIO PROGRAMMING OVER THE INTERNET; BROADCASTING PROGRAMS VIA A GLOBAL COMPUTER NETWORK; BROADCASTING SERVICES AND PROVISION OF TELECOMMUNICATION ACCESS TO FILMS AND TELEVISION PROGRAMMES PROVIDED VIA A VIDEO-ON-DEMAND SERVICE; BROADCASTING SERVICES AND PROVISION OF TELECOMMUNICATION ACCESS TO VIDEO AND AUDIO CONTENT PROVIDED VIA A VIDEO-ON-DEMAND SERVICE VIA THE INTERNET; COMMUNICATION SERVICES, NAMELY, ELECTRONIC TRANSMISSION OF DATA AND DOCUMENTS AMONG USERS OF COMPUTERS; COMMUNICATION SERVICES, NAMELY, PROVIDING ELECTRONIC TRANSMISSION OF INFORMATION STORED IN A DATABASE VIA INTERACTIVELY COMMUNICATING COMPUTER SYSTEMS; COMMUNICATIONS SERVICES, NAMELY, TRANSMITTING STREAMED SOUND AND AUDIOVISUAL RECORDINGS VIA THE INTERNET; DATA TRANSMISSION AND RECEPTION SERVICES VIA TELECOMMUNICATION MEANS; DELIVERY OF DIGITAL MUSIC BY ELECTRONIC TRANSMISSION; ELECTRONIC TRANSMISSION AND STREAMING OF DIGITAL MEDIA CONTENT FOR OTHERS VIA GLOBAL AND LOCAL COMPUTER NETWORKS; ELECTRONIC TRANSMISSION OF DATA AND DOCUMENTS VIA COMPUTER TERMINALS; ELECTRONIC TRANSMISSION OF DATA AND DOCUMENTS VIA COMPUTER TERMINALS AND ELECTRONIC DEVICES; INTERNET BROADCASTING SERVICES; ON-LINE DOCUMENT DELIVERY VIA A GLOBAL COMPUTER NETWORK; PEER-TO-PEER NETWORK COMPUTER SERVICES, NAMELY, ELECTRONIC TRANSMISSION OF AUDIO, VIDEO AND OTHER DATA AND DOCUMENTS AMONG COMPUTERS; PEER-TO-PEER PHOTO SHARING SERVICES, NAMELY, ELECTRONIC TRANSMISSION OF DIGITAL PHOTO FILES AMONG INTERNET USERS; PROVIDING ACCESS TO DIGITAL MUSIC WEBSITES ON THE INTERNET; PROVISION OF ACCESS TO DATA OR DOCUMENTS STORED ELECTRONICALLY IN CENTRAL FILES FOR REMOTE CONSULTATION; STREAMING OF AUDIO MATERIAL ON THE INTERNET; STREAMING OF AUDIO, VISUAL AND AUDIOVISUAL MATERIAL VIA A GLOBAL COMPUTER NETWORK; STREAMING OF VIDEO MATERIAL ON THE INTERNET; TRANSMISSION AND DISTRIBUTION OF DATA OR AUDIO VISUAL IMAGES VIA A GLOBAL COMPUTER NETWORK OR THE INTERNET; TRANSMISSION AND RECEPTION OF DATABASE INFORMATION VIA THE TELECOMMUNICATION NETWORK; TRANSMISSION OF DATABASE INFORMATION VIA TELECOMMUNICATIONS NETWORKS; TRANSMISSION OF DIGITAL FILES; TRANSMISSION OF INFORMATION BY DATA COMMUNICATIONS FOR ASSISTING DECI-

4,594,018. GUTIERREZ, RAFAEL, LOS ANGELES, CA. SN 85-950,693. PUB. 10-29-2013, FILED 6-4-2013.

# AMVISION

THE MARK CONSISTS OF STANDARD CHARACTERS WITHOUT CLAIM TO ANY PARTICULAR FONT, STYLE, SIZE, OR COLOR.

FOR BROADCASTING OF RADIO PROGRAMS AND TELEVISION PROGRAMS (U.S. CLS. 100, 101 AND 104).

FIRST USE 6-23-2014; IN COMMERCE 6-23-2014.

**CLASS 38—(Continued).**

SION MAKING; TRANSMISSION OF SOUND, PICTURE AND DATA SIGNALS; TRANSMISSION OF SOUND, VIDEO AND INFORMATION; VIDEO BROADCASTING; VIDEO BROADCASTING AND TRANSMISSION SERVICES VIA THE INTERNET, FEATURING FILMS AND MOVIES; VIDEO BROADCASTING SERVICES OVER THE INTERNET OR OTHER COMMUNICATIONS NETWORK FEATURING THE UPLOADED, POSTED AND TAGGED VIDEOS OF OTHERS; VIDEO BROADCASTING SERVICES OVER THE INTERNET OR OTHER COMMUNICATIONS NETWORK, NAMELY, ELECTRONICALLY TRANSMITTING VIDEO CLIPS; VIDEO BROADCASTING SERVICES VIA THE INTERNET; VIDEO ON DEMAND TRANSMISSIONS; VIDEO STREAMING SERVICES VIA THE INTERNET, FEATURING INDEPENDENT FILMS AND MOVIES; VIDEO TRANSMISSION OVER DIGITAL NETWORKS; VIDEO-ON-DEMAND TRANSMISSION SERVICES; VIDEO-ON-DEMAND TRANSMISSION SERVICES VIA THE INTERNET; WEB CASTING SERVICES; WEBCASTING SERVICES (U.S. CLS. 100, 101 AND 104).

FIRST USE 11-1-2013; IN COMMERCE 11-1-2013.

4,594,154. D2MP MEDIA, LLC, CLEVELAND, OH. SN 85-974,564. PUB. 9-17-2013, FILED 7-1-2013.



THE COLOR(S) RED, DARK RED, AND WHITE IS/ARE CLAIMED AS A FEATURE OF THE MARK.

THE MARK CONSISTS OF A SQUARE BACKGROUND IMAGE CONSISTING OF THE BACK OF A RED ENVELOPE (RED ON TOP, DARK RED ON BOTTOM) OVERLAYED WITH A LARGE WHITE "D" LETTER IN THE CENTER CONSISTING OF EVENLY BROKEN WHITE LINES THAT EVOKE A TARGET-LIKE IMAGE.

FOR ELECTRONIC MAIL SERVICES (U.S. CLS. 100, 101 AND 104).

FIRST USE 6-3-2013; IN COMMERCE 11-10-2013.

**CLASS 38—(Continued).**

4,594,294. TOONUP SNIPPETS, INC., WAYNE, PA. SN 86-040,260. PUB. 11-5-2013, FILED 8-16-2013.

**BETTERWORLDIANS**

THE MARK CONSISTS OF STANDARD CHARACTERS WITHOUT CLAIM TO ANY PARTICULAR FONT, STYLE, SIZE, OR COLOR.

FOR INTERNET RADIO BROADCASTING SERVICES (U.S. CLS. 100, 101 AND 104).

FIRST USE 10-0-2013; IN COMMERCE 10-0-2013.

4,594,550. BODYTRACE HOLDINGS LIMITED, TST EAST, HONG KONG. SN 86-975,210. PUB. 2-4-2014, FILED 9-13-2013.



THE MARK CONSISTS OF THE WORDING "BODY-TRACE" TO THE RIGHT OF A STYLIZED SQUARE SCALE SEEN FROM ABOVE WITH A MISSING LOWER RIGHT CORNER.

FOR DIGITAL NETWORK TELECOMMUNICATIONS SERVICES (U.S. CLS. 100, 101 AND 104).

FIRST USE 1-0-2013; IN COMMERCE 1-0-2013.

**CLASS 39—TRANSPORTATION AND STORAGE**

4,593,292. TWENTIETH CENTURY FOX FILM CORPORATION, LOS ANGELES, CA. SN 85-559,324. PUB. 11-12-2013, FILED 3-2-2012.

**FOX STUDIOS**

THE MARK CONSISTS OF STANDARD CHARACTERS WITHOUT CLAIM TO ANY PARTICULAR FONT, STYLE, SIZE, OR COLOR.

OWNER OF U.S. REG. NO. 2,140,779.

**CLASS 39—(Continued).**

NO CLAIM IS MADE TO THE EXCLUSIVE RIGHT TO USE "STUDIOS", APART FROM THE MARK AS SHOWN.

FOR TRANSPORTATION SERVICES FOR FILM PRODUCTIONS, NAMELY, DELIVERY OF CAMERA, LIGHTING, GRIP, CATERING AND POWER GENERATOR EQUIPMENT, COSTUMES, FILM AND TELEVISION PROPS, FOOD, TRAILERS, AND MOVIE AND TELEVISION SETS; MOVIE SET AND FILM TRANSPORTATION SERVICES, NAMELY, FREIGHT TRANSPORTATION BY TRUCKS, TRACTORS AND AIR; TRANSPORTATION SERVICES FOR FILM PRODUCTIONS, NAMELY, PROVIDING SHUTTLE SERVICES AND VEHICLES FOR PASSENGERS (U.S. CLS. 100 AND 105).

FIRST USE 2-15-2002; IN COMMERCE 2-15-2002.

**CLASS 39—(Continued).**

4,593,326. WASTEZERO, INC., RALEIGH, NC. SN 85-625,954.  
PUB. 7-10-2012, FILED 5-15-2012.

WasteZero Retail Store  
Distribution

4,593,305. TWENTIETH CENTURY FOX FILM CORPORATION, LOS ANGELES, CA. SN 85-584,164. PUB. 10-22-2013, FILED 3-29-2012.



OWNER OF U.S. REG. NO. 2,140,779.  
NO CLAIM IS MADE TO THE EXCLUSIVE RIGHT TO USE "STUDIOS", APART FROM THE MARK AS SHOWN.

THE MARK CONSISTS OF THE WORD "FOX" IN THREE-DIMENSIONAL LETTERING ON A PLATFORM ABOVE THE WORD "STUDIOS" IN THREE-DIMENSIONAL LETTERING, ALL OF WHICH IS ON TOP OF A PEDESTAL STRUCTURE SURROUNDED BY KLIEG LIGHTS EMITTING RAYS STRETCHING UPWARD.

FOR TRANSPORTATION SERVICES FOR FILM PRODUCTIONS, NAMELY, DELIVERY OF CAMERA, LIGHTING, GRIP, CATERING AND POWER GENERATOR EQUIPMENT, COSTUMES, FILM AND TELEVISION PROPS, FOOD, TRAILERS, AND MOVIE AND TELEVISION SETS; MOVIE SET AND FILM TRANSPORTATION SERVICES, NAMELY, FREIGHT TRANSPORTATION BY TRUCKS, TRACTORS AND AIR; TRANSPORTATION SERVICES FOR FILM PRODUCTIONS, NAMELY, PROVIDING SHUTTLE SERVICES AND VEHICLES FOR PASSENGERS (U.S. CLS. 100 AND 105).

FIRST USE 2-15-2002; IN COMMERCE 2-15-2002.

THE MARK CONSISTS OF STANDARD CHARACTERS WITHOUT CLAIM TO ANY PARTICULAR FONT, STYLE, SIZE, OR COLOR.

OWNER OF U.S. REG. NO. 3,734,926.

NO CLAIM IS MADE TO THE EXCLUSIVE RIGHT TO USE "RETAIL STORE DISTRIBUTION", APART FROM THE MARK AS SHOWN.

FOR WHOLESALE AND RETAIL DISTRIBUTION SERVICES IN THE FIELD OF RECYCLING, SOLID WASTE MANAGEMENT, AND TRASH METERING SUPPLIES (U.S. CLS. 100 AND 105).

FIRST USE 1-27-2012; IN COMMERCE 1-27-2012.

4,593,769. REVSPRING, INC., WIXOM, MI. SN 85-881,270.  
PUB. 10-15-2013, FILED 3-20-2013.

REVDIGITAL

THE MARK CONSISTS OF STANDARD CHARACTERS WITHOUT CLAIM TO ANY PARTICULAR FONT, STYLE, SIZE, OR COLOR.

FOR ONLINE ARCHIVAL SERVICES IN THE FIELD OF BILLING COMMUNICATIONS AND PAYMENTS, NAMELY, STORAGE OF ELECTRONIC DOCUMENTS, DOCUMENT DELIVERY AND ELECTRONIC DOCUMENT AND E-MAIL ARCHIVING SERVICES (U.S. CLS. 100 AND 105).

FIRST USE 6-27-2013; IN COMMERCE 6-27-2013.

**CLASS 39—(Continued).**

4,593,783. MOGULDOM MEDIA GROUP, NEW YORK, NY. SN 85-887,578. PUB. 8-13-2013, FILED 3-27-2013.

# AFKTravel

THE MARK CONSISTS OF STANDARD CHARACTERS WITHOUT CLAIM TO ANY PARTICULAR FONT, STYLE, SIZE, OR COLOR.

FOR TRAVEL INFORMATION SERVICES; PROVIDING AN ON-LINE COMPUTER DATABASE IN THE FIELD OF TRAVEL INFORMATION SERVICES PERTAINING TO TRAVEL RELATING TO AFRICA; PROVIDING REVIEWS OF TRAVEL SERVICE PROVIDERS, TRAVEL DESTINATIONS, AND LOCAL ATTRACTIONS RELATING TO AFRICA VIA A GLOBAL COMPUTER NETWORK; PROVIDING AN ONLINE TRAVEL PLATFORM THAT PROVIDES TRAVEL INFORMATION INCLUDING USER AND PROFESSIONAL REVIEWS; PROVIDING AN ONLINE TRAVEL PLATFORM THAT PROCESSES HOTEL, FLIGHT, AND VACATION RENTAL TRANSACTIONS PERTAINING TO TRAVEL RELATED TO AFRICA (U.S. CLS. 100 AND 105).

FIRST USE 6-16-2014; IN COMMERCE 6-16-2014.

**CLASS 39—(Continued).**

4,593,863. 247.COM LLC, HENDERSON, NV. SN 85-923,385. PUB. 10-15-2013, FILED 5-3-2013.



NO CLAIM IS MADE TO THE EXCLUSIVE RIGHT TO USE ".COM" AND "LAS VEGAS", APART FROM THE MARK AS SHOWN.

THE MARK CONSISTS OF AN IMAGE IN THE SHAPE OF A SPADE, WITH CURVED LINES EMANATING FROM THE BOTTOM CENTER AND CURVING LEFT TO RIGHT TOWARD THE UPPER RIGHT SIDE. THE DESIGN IS POSITIONED TO THE LEFT OF THE TEXT "LV247", WITH THE TEXT ".COM" AT AN ANGLE TO THE RIGHT OF THE "7". UNDER THE TEXT "LV247.COM" IS THE TEXT "YOUR CONNECTION IN LAS VEGAS".

FOR TRAVEL AGENCY SERVICES, NAMELY, MAKING RESERVATIONS AND BOOKINGS FOR TRANSPORTATION; TRAVEL AND TRANSPORT INFORMATION SERVICE (U.S. CLS. 100 AND 105).

FIRST USE 6-12-2013; IN COMMERCE 6-12-2013.

4,593,836. MCMILLEN, SANDRA L., DBA ORDINARY COUPLE TRAVELS, WINDSOR, CO. SN 85-917,147. PUB. 4-8-2014, FILED 4-29-2013.

# ORDINARY COUPLE

THE MARK CONSISTS OF STANDARD CHARACTERS WITHOUT CLAIM TO ANY PARTICULAR FONT, STYLE, SIZE, OR COLOR.

FOR ORGANIZATION OF TRAVEL; PROVIDING INFORMATION, NEWS, AND COMMENTARY IN THE FIELD OF TRAVEL; PROVIDING REVIEW OF TRAVEL SERVICE PROVIDERS; PROVISION OF TRAVEL INFORMATION; TRAVEL AGENCY SERVICES, NAMELY, MAKING RESERVATIONS AND BOOKINGS FOR TRANSPORTATION; TRAVEL INFORMATION SERVICES; TRAVEL GUIDE SERVICES; PERSONAL TRAVEL TOUR GUIDE SERVICES; ONLINE TRAVEL TRANSPORTATION RESERVATION SERVICES AND TRAVEL TICKET RESERVATION SERVICES; ARRANGING TRAVEL TOURS; PROVIDING PERSONALIZED INFORMATION ABOUT TRAVEL VIA THE INTERNET; PROVIDING A WEBSITE FEATURING TRANSPORTATION INFORMATION RESOURCES FOR TRAVEL (U.S. CLS. 100 AND 105).

FIRST USE 10-1-2013; IN COMMERCE 10-1-2013.

4,593,879. OUTDOOR TRAVEL ADVENTURES INC., SAN DIEGO, CA. SN 85-926,958. PUB. 10-29-2013, FILED 5-8-2013.

# BULE

THE MARK CONSISTS OF STANDARD CHARACTERS WITHOUT CLAIM TO ANY PARTICULAR FONT, STYLE, SIZE, OR COLOR.

THE ENGLISH TRANSLATION OF "BULE" IN THE MARK IS "FOREIGNER".

FOR ONLINE TRANSPORTATION RESERVATION AND TRAVEL TICKET RESERVATION SERVICES FOR AIRLINE, CAR RENTAL AND TOUR PACKAGE RESERVATIONS SERVICES PROVIDED VIA A GLOBAL COMPUTER NETWORK; PROVIDING AIRLINE, CAR RENTAL, TOUR PACKAGE, AND GENERAL TRAVEL INFORMATION VIA A GLOBAL COMPUTER NETWORK (U.S. CLS. 100 AND 105).

FIRST USE 6-15-2014; IN COMMERCE 6-15-2014.

**CLASS 39—(Continued).**

4,594,241. SPLIT ROCK SUPPLY CHAIN SOLUTIONS INC, GRAND RAPIDS, MI. SN 86-014,102. PUB. 4-29-2014, FILED 7-18-2013.

Everything other trucking  
companies aren't

THE MARK CONSISTS OF STANDARD CHARACTERS WITHOUT CLAIM TO ANY PARTICULAR FONT, STYLE, SIZE, OR COLOR.

FOR FREIGHT AND TRANSPORT BROKERAGE (U.S. CLS. 100 AND 105).

FIRST USE 1-23-2014; IN COMMERCE 1-23-2014.

---

4,594,277. VALERO ENERGY PARTNERS GP LLC, SAN ANTONIO, TX. SN 86-033,483. PUB. 3-25-2014, FILED 8-9-2013.



NO CLAIM IS MADE TO THE EXCLUSIVE RIGHT TO USE "ENERGY PARTNERS LP", APART FROM THE MARK AS SHOWN.

THE MARK CONSISTS OF A CURVED LINE INTERLOCKING AND ENTWINING THE LETTER "V" ABOVE THE WORD "VALERO" AND THE WORDS "ENERGY PARTNERS LP".

FOR STORAGE, DISTRIBUTION, TRANSPORTATION, SHIPPING AND DELIVERY OF OIL, PRODUCTS DERIVED FROM OIL, RENEWABLE FUELS SUCH AS ETHANOL AND BIO-DIESEL, AND OTHER HYDRO-CARBON-BASED PRODUCTS VIA PIPELINES, TRUCKS, RAILCARS, AND MARINE VESSELS (U.S. CLS. 100 AND 105).

FIRST USE 12-16-2013; IN COMMERCE 12-16-2013.

**CLASS 39—(Continued).**

4,594,389. CAESARS LICENSE COMPANY, LLC, LAS VEGAS, NV. SN 86-079,397. PUB. 12-31-2013, FILED 10-1-2013.

Save. Travel. Earn. Repeat.

THE MARK CONSISTS OF STANDARD CHARACTERS WITHOUT CLAIM TO ANY PARTICULAR FONT, STYLE, SIZE, OR COLOR.

FOR PROVIDING TRAVEL AND TOUR RESERVATION SERVICES, NAMELY, ARRANGING TRAVEL TOURS, TRAVEL TOUR GUIDE SERVICES, AND MAKING TRAVEL RESERVATIONS AND BOOKINGS FOR TRANSPORTATION; TRAVEL GUIDE AND TRAVEL INFORMATION SERVICES; TRAVEL BOOKING AGENCY SERVICES; ARRANGING AND COORDINATING TRAVEL ARRANGEMENT FOR INDIVIDUALS AND GROUPS, NAMELY, DESTINATION STAYS, WEDDINGS, HONEYMOONS, FAMILY AND FRIEND VACATIONS, GOLF VACATIONS, REUNIONS AND SPECIAL EVENTS AND CELEBRATIONS; TRAVEL AGENCY SERVICES FEATURING A TRAVEL MEMBERSHIP PROGRAM WHICH UTILIZES CREDITS WHICH MAY BE REDEEMED FOR TRAVEL RELATED SERVICES IN THE NATURE OF RESERVATIONS AND BOOKING FOR TRANSPORTATION; ON-LINE TRAVEL AGENCY SERVICES, NAMELY, MAKING RESERVATIONS AND BOOKINGS FOR TRANSPORTATION BY MEANS OF A GLOBAL COMPUTER NETWORK (U.S. CLS. 100 AND 105).

FIRST USE 4-1-2013; IN COMMERCE 4-1-2013.

---

4,594,392. SWAIN AUSTRALIAN TOURS (2003), INC., ARDMORE, PA. SN 86-080,543. PUB. 3-18-2014, FILED 10-2-2013.

SWAIN DESTINATIONS

THE MARK CONSISTS OF STANDARD CHARACTERS WITHOUT CLAIM TO ANY PARTICULAR FONT, STYLE, SIZE, OR COLOR.

OWNER OF U.S. REG. NOS. 1,625,248, 3,518,731, AND OTHERS.

NO CLAIM IS MADE TO THE EXCLUSIVE RIGHT TO USE "DESTINATIONS", APART FROM THE MARK AS SHOWN.

FOR TRAVEL AGENCY SERVICES, NAMELY, MAKING RESERVATIONS AND BOOKINGS FOR TRANSPORTATION (U.S. CLS. 100 AND 105).

FIRST USE 1-10-2014; IN COMMERCE 1-10-2014.



**CLASS 39—(Continued).**

4,594,549. SEAPORT AIRLINES, INC., PORTLAND, OR. SN 86-187,071. PUB. 4-22-2014, FILED 2-7-2014.

**HOMETOWN SERVICE.  
WORLDWIDE CONNECTIONS.**

THE MARK CONSISTS OF STANDARD CHARACTERS WITHOUT CLAIM TO ANY PARTICULAR FONT, STYLE, SIZE, OR COLOR.

FOR AIRLINE AND SHIPPING SERVICES; AIRLINE TRANSPORTATION SERVICES; AIR TRANSPORTATION OF PASSENGERS AND FREIGHT (U.S. CLS. 100 AND 105).

FIRST USE 3-24-2014; IN COMMERCE 3-24-2014.

**CLASS 40—MATERIAL TREATMENT**

4,593,579. CLOVER ONE, LLC, WILMINGTON, DE. SN 85-791,064. PUB. 4-30-2013, FILED 11-29-2012.

**OUTERWALL**

THE MARK CONSISTS OF STANDARD CHARACTERS WITHOUT CLAIM TO ANY PARTICULAR FONT, STYLE, SIZE, OR COLOR.

FOR RECYCLING SERVICES (U.S. CLS. 100, 103 AND 106).

FIRST USE 9-30-2013; IN COMMERCE 9-30-2013.

4,594,162. CARLISLE WIDE PLANK FLOORS, INC., STODDARD, NH. SN 85-982,023. PUB. 3-26-2013, FILED 12-7-2012.

**SLOWCRAFT**

THE MARK CONSISTS OF STANDARD CHARACTERS WITHOUT CLAIM TO ANY PARTICULAR FONT, STYLE, SIZE, OR COLOR.

FOR CUSTOM MANUFACTURE OF WOOD FLOORING, WOOD STAIR COMPONENTS, NAMELY, STAIR TREADS, RISERS AND NOSING, WOOD PANELING, WOOD BEAMS, WOOD FLOOR VENT COVERS FOR HVAC DUCTS (U.S. CLS. 100, 103 AND 106).

FIRST USE 12-0-2012; IN COMMERCE 12-0-2012.

**CLASS 41—EDUCATION AND ENTERTAINMENT****CLASS 41—(Continued).**

4,593,066. HOUGHTON MIFFLIN HARCOURT PUBLISHING COMPANY, BOSTON, MA. SN 76-712,804. PUB. 11-19-2013, FILED 11-9-2012.



NO CLAIM IS MADE TO THE EXCLUSIVE RIGHT TO USE "PERSONAL MATH TRAINER", APART FROM THE MARK AS SHOWN.

THE MARK CONSISTS OF THE WORDING "PERSONAL MATH TRAINER" TO THE RIGHT OF A DESIGN BOARD WITH PLUS, MINUS, DIVISION AND MULTIPLICATION SIGNS ON IT AND WEARING A NECKLACE AROUND IT WITH A WHISTLE ON IT AND WEARING A BASEBALL CAP ATOP IT.

FOR EDUCATIONAL SERVICES, NAMELY, PROVIDING PRACTICE, ASSESSMENT, REMEDIATION AND TUTORIAL ASSISTANCE IN THE FIELD OF MATHEMATICS PROVIDED BY MEANS OF AN INTERACTIVE WEBSITE VIA THE INTERNET, NAMELY, PROVIDING EDUCATIONAL INFORMATION AND TEST QUESTIONS IN THE ACADEMIC FIELD OF MATHEMATICS (U.S. CLS. 100, 101 AND 107).

FIRST USE 6-1-2013; IN COMMERCE 6-1-2013.

4,593,108. BRONCO BALL, LLC, FRISCO, TX. SN 85-054,072. PUB. 5-3-2011, FILED 6-3-2010.

**Bronco Ball**

THE MARK CONSISTS OF STANDARD CHARACTERS WITHOUT CLAIM TO ANY PARTICULAR FONT, STYLE, SIZE, OR COLOR.

NO CLAIM IS MADE TO THE EXCLUSIVE RIGHT TO USE "BALL", APART FROM THE MARK AS SHOWN.

FOR ENTERTAINMENT IN THE NATURE OF HORSEBACK BALL GAMES FEATURING RIDERS THROWING AND CATCHING A BALL WITH TEAMMATES (U.S. CLS. 100, 101 AND 107).

FIRST USE 6-27-2014; IN COMMERCE 6-27-2014.

**CLASS 41—(Continued).**

4,593,197. FIVE MORE MINUTES, LLC, EAST CHTHAM, NY. SN 85-322,220. PUB. 10-30-2012, FILED 5-16-2011.

five more minutes

THE MARK CONSISTS OF STANDARD CHARACTERS WITHOUT CLAIM TO ANY PARTICULAR FONT, STYLE, SIZE, OR COLOR.

FOR FILM AND VIDEO PRODUCTION CONSULTING SERVICES; MULTIMEDIA ENTERTAINMENT SERVICES IN THE NATURE OF DEVELOPMENT, PRODUCTION AND POST-PRODUCTION SERVICES IN THE FIELDS OF VIDEO AND FILMS; SCRIPT WRITING SERVICES (U.S. CLS. 100, 101 AND 107).

FIRST USE 6-24-2014; IN COMMERCE 6-24-2014.

4,593,206. SCRUBLIFE, INC., PRINCETON, NJ. SN 85-343,515. PUB. 1-15-2013, FILED 6-10-2011.

SCRUBLIFE

THE MARK CONSISTS OF STANDARD CHARACTERS WITHOUT CLAIM TO ANY PARTICULAR FONT, STYLE, SIZE, OR COLOR.

FOR PRODUCTION OF MUSICAL SOUND RECORDINGS; RECORD PRODUCTION; PRODUCTION OF MUSIC VIDEO RECORDINGS; AUDIO AND VIDEO RECORDING AND PRODUCTION; MUSICAL AUDIO AND VIDEO RECORDING, PRODUCTION, AND PUBLISHING (U.S. CLS. 100, 101 AND 107).

FIRST USE 3-1-2011; IN COMMERCE 3-1-2011.

4,593,214. BRUCE KAUFMAN, NORTHBROOK, IL. SN 85-367,761. PUB. 4-30-2013, FILED 7-11-2011.

MR. MOW-IT-ALL

THE MARK CONSISTS OF STANDARD CHARACTERS WITHOUT CLAIM TO ANY PARTICULAR FONT, STYLE, SIZE, OR COLOR.

**CLASS 41—(Continued).**

THE NAME "MR. MOW-IT-ALL" IDENTIFIES THE STAGE NAME OF APPLICANT BRUCE KAUFMAN, A LIVING INDIVIDUAL, WHOSE CONSENT IS IMPLIED BY THE FACT THAT THE MARK IS IN THE APPLICANT'S STAGE NAME.

FOR ENTERTAINMENT SERVICES, NAMELY, PERSONAL APPEARANCES BY A TELEVISION AND SPORTS CELEBRITY; PROVIDING INFORMATION IN THE FIELD OF LAWN MOWER RACING (U.S. CLS. 100, 101 AND 107).

FIRST USE 4-30-1998; IN COMMERCE 4-30-1998.

4,593,240. NP IP HOLDINGS LLC, LAS VEGAS, NV. SN 85-454,379. PUB. 2-21-2012, FILED 10-24-2011.

MY | PLAY

NO CLAIM IS MADE TO THE EXCLUSIVE RIGHT TO USE "PLAY", APART FROM THE MARK AS SHOWN.

THE MARK CONSISTS OF THE WORDS MY PLAY WHERE A VERTICAL LINE IS FEATURED BETWEEN THE WORD MY AND THE WORD PLAY. THE MARK CONSISTS OF STANDARD CHARACTERS, WITHOUT CLAIM TO ANY PARTICULAR FONT, STYLE, SIZE OR COLOR.

FOR ENTERTAINMENT SERVICES, NAMELY, CASINO GAMING (U.S. CLS. 100, 101 AND 107).

FIRST USE 6-18-2008; IN COMMERCE 6-18-2008.

4,593,256. RANCHITO ESCONDIDO LLC, BRYAN, TX. SN 85-484,267. PUB. 11-6-2012, FILED 11-30-2011.

Escondido Polo

THE MARK CONSISTS OF STANDARD CHARACTERS WITHOUT CLAIM TO ANY PARTICULAR FONT, STYLE, SIZE, OR COLOR.

NO CLAIM IS MADE TO THE EXCLUSIVE RIGHT TO USE "POLO", APART FROM THE MARK AS SHOWN.

**CLASS 41—(Continued).**

THE ENGLISH TRANSLATION OF "ESCONDIDO" IN THE MARK IS HIDDEN.

FOR POLO CLUB SERVICES; ENTERTAINMENT SERVICES, NAMELY, POLO EXHIBITIONS AND COMPETITIONS; EQUESTRIAN EXHIBITIONS AND COMPETITIONS; PROVIDING FACILITIES FOR EQUESTRIAN EXHIBITIONS AND COMPETITIONS; PROVIDING FACILITIES FOR POLO EXHIBITIONS AND COMPETITIONS; HORSE SHOWING AND HORSE TRAINING SERVICES (U.S. CLS. 100, 101 AND 107).

FIRST USE 9-30-2009; IN COMMERCE 9-30-2009.

---

4,593,275. DIAMOND MINDS BASEBALL ACADEMY, LLC, THREE BRIDGES, NJ. SN 85-530,035. PUB. 7-3-2012, FILED 1-31-2012.



THE MARK CONSISTS OF THE IMAGE OF A BASEBALL UPON WHICH IS A MORTARBOARD CAP.

FOR ATHLETIC TRAINING SERVICES; EDUCATION SERVICES, NAMELY, PROVIDING ON-LINE CLASSES, SEMINARS AND WORKSHOPS IN THE FIELD OF ATHLETICS AND SPORTS; SPORTS TRAINING SERVICES; TRAINING SERVICES IN THE FIELD OF ATHLETICS AND SPORTS (U.S. CLS. 100, 101 AND 107).

FIRST USE 7-2-2014; IN COMMERCE 7-2-2014.

---

4,593,280. SUZANNE EVANS COACHING OF SOUTH CAROLINA, LLC, MURRELLS INLET, SC. SN 85-537,885. PUB. 10-15-2013, FILED 2-9-2012.

**HELL YEAH STUDIOS**

THE MARK CONSISTS OF STANDARD CHARACTERS WITHOUT CLAIM TO ANY PARTICULAR FONT, STYLE, SIZE, OR COLOR.

**CLASS 41—(Continued).**

NO CLAIM IS MADE TO THE EXCLUSIVE RIGHT TO USE "STUDIOS", APART FROM THE MARK AS SHOWN.

FOR FILM AND VIDEO PRODUCTION OF BUSINESS MARKETING VIDEOS EXCLUDING THE FIELD OF MUSIC; PRODUCTION OF WEBINARS AND BUSINESS MARKETING VIDEOS FOR BUSINESS OR COMMERCIAL PURPOSES FOR OTHERS; FILM AND VIDEO PRODUCTION CONSULTING SERVICES RELATING TO BUSINESS MARKETING VIDEOS; FILM EDITING OF BUSINESS MARKETING VIDEOS; FILM STUDIOS FOR PRODUCING BUSINESS MARKETING VIDEOS; PHOTOGRAPHY SERVICES RELATING TO BUSINESS MARKETING (U.S. CLS. 100, 101 AND 107).

FIRST USE 8-1-2011; IN COMMERCE 8-1-2011.

---

4,593,294. LIEBERMAN COMPANIES, INC., BLOOMINGTON, MN. SN 85-560,950. PUB. 7-24-2012, FILED 3-5-2012.

**ELSIE'S**

THE MARK CONSISTS OF STANDARD CHARACTERS WITHOUT CLAIM TO ANY PARTICULAR FONT, STYLE, SIZE, OR COLOR.

FOR CASINO SERVICES (U.S. CLS. 100, 101 AND 107).  
FIRST USE 5-21-2014; IN COMMERCE 5-21-2014.

---

4,593,296. SPARTAN RACE, INC., BOSTON, MA. SN 85-564,408. PUB. 1-1-2013, FILED 3-8-2012.

**SPARTAN COACHING**

THE MARK CONSISTS OF STANDARD CHARACTERS WITHOUT CLAIM TO ANY PARTICULAR FONT, STYLE, SIZE, OR COLOR.

NO CLAIM IS MADE TO THE EXCLUSIVE RIGHT TO USE "COACHING", APART FROM THE MARK AS SHOWN.

FOR CONDUCTING FITNESS CLASSES; CONSULTING SERVICES IN THE FIELDS OF FITNESS AND EXERCISE; COUNSELING SERVICES IN THE FIELD OF PHYSICAL FITNESS; PHYSICAL FITNESS INSTRUCTION; PROVIDING A WEBSITE FEATURING INFORMATION ON EXERCISE AND FITNESS; PROVIDING ASSISTANCE, PERSONAL TRAINING AND PHYSICAL FITNESS CONSULTATION TO INDIVIDUALS TO HELP THEM MAKE PHYSICAL FITNESS, STRENGTH, CONDITIONING, AND EXERCISE IMPROVEMENT IN THEIR DAILY LIVING (U.S. CLS. 100, 101 AND 107).

FIRST USE 8-8-2012; IN COMMERCE 8-8-2012.

**CLASS 41—(Continued).**

4,593,304. LIFE OF PURPOSE LLC, BOCA RATON, FL. SN 85-581,285. PUB. 8-14-2012, FILED 3-27-2012.

**LIFE OF PURPOSE**

THE MARK CONSISTS OF STANDARD CHARACTERS WITHOUT CLAIM TO ANY PARTICULAR FONT, STYLE, SIZE, OR COLOR.

FOR EDUCATIONAL SERVICES, NAMELY, CONDUCTING CLASSES, SEMINARS, CONFERENCES AND WORKSHOPS IN THE FIELD OF COUNSELING, RECOGNIZING AND TREATING ALCOHOL, DRUG AND CHEMICAL ADDICTIONS (U.S. CLS. 100, 101 AND 107).  
FIRST USE 6-1-2013; IN COMMERCE 12-5-2013.

4,593,318. INVESTOR BISTRO, LLC, RICHMOND, VT. SN 85-616,188. PUB. 11-5-2013, FILED 5-3-2012.

**INVESTOR BISTRO**

THE MARK CONSISTS OF STANDARD CHARACTERS WITHOUT CLAIM TO ANY PARTICULAR FONT, STYLE, SIZE, OR COLOR.

NO CLAIM IS MADE TO THE EXCLUSIVE RIGHT TO USE "INVESTOR", APART FROM THE MARK AS SHOWN.

FOR PROVIDING A WEBSITE FEATURING BLOGS, NON-DOWNLOADABLE PUBLICATIONS, NON-DOWNLOADABLE NEWSLETTERS AND NON-DOWNLOADABLE ARTICLES IN THE FIELD OF INVESTMENT STRATEGIES, FINANCIAL PLANNING AND INVESTOR EDUCATION FOR INDIVIDUAL INVESTORS; ON-LINE JOURNALS, NAMELY, BLOGS FEATURING INVESTOR EDUCATION, INVESTMENT STRATEGIES, FINANCIAL PLANNING STRATEGIES AND INVESTOR EDUCATION FOR INDIVIDUAL INVESTORS; EDUCATIONAL SERVICES, NAMELY, CONDUCTING INFORMAL ON-LINE PROGRAMS IN THE FIELDS OF INVESTOR EDUCATION, INVESTMENT STRATEGIES AND FINANCIAL PLANNING FOR INDIVIDUAL INVESTORS AND PRINTABLE MATERIALS DISTRIBUTED THEREWITH (U.S. CLS. 100, 101 AND 107).

FIRST USE 12-31-2013; IN COMMERCE 12-31-2013.

**CLASS 41—(Continued).**

4,593,330. LIGHT OF TOMORROW, CHICAGO, IL. SN 85-629,561. PUB. 11-6-2012, FILED 5-18-2012.

**LIGHT OF TOMORROW**

THE MARK CONSISTS OF STANDARD CHARACTERS WITHOUT CLAIM TO ANY PARTICULAR FONT, STYLE, SIZE, OR COLOR.

FOR EDUCATIONAL SERVICES, NAMELY, CONDUCTING SEMINARS RELATING TO DRUG ABUSE PREVENTION, AND DISTRIBUTION OF COURSE MATERIALS IN CONNECTION THEREWITH (U.S. CLS. 100, 101 AND 107).

FIRST USE 1-1-2013; IN COMMERCE 1-1-2013.

4,593,349. LAS VEGAS SANDS CORP., LAS VEGAS, NV. SN 85-640,803. PUB. 5-21-2013, FILED 6-1-2012.

**LIGHT OF VENICE**

THE MARK CONSISTS OF STANDARD CHARACTERS WITHOUT CLAIM TO ANY PARTICULAR FONT, STYLE, SIZE, OR COLOR.

FOR ENTERTAINMENT SERVICES, NAMELY, A THREE DIMENSIONAL LIGHT SHOW PERFORMANCE USING DIGITAL TECHNOLOGY (U.S. CLS. 100, 101 AND 107).

FIRST USE 11-21-2011; IN COMMERCE 11-21-2011.

4,593,356. BIERFISH RESTAURANT PARTNERS, LP, PHILADELPHIA, PA. SN 85-644,899. PUB. 5-7-2013, FILED 6-6-2012.

**DUNKEL DARE**

THE MARK CONSISTS OF STANDARD CHARACTERS WITHOUT CLAIM TO ANY PARTICULAR FONT, STYLE, SIZE, OR COLOR.

NO CLAIM IS MADE TO THE EXCLUSIVE RIGHT TO USE "DUNKEL", APART FROM THE MARK AS SHOWN.

**CLASS 41—(Continued).**

THE ENGLISH TRANSLATION OF "DUNKEL" IN THE MARK IS "DARK".

FOR ENTERTAINMENT SERVICES, NAMELY, A CONTINUING QUESTION AND ANSWER GAME SHOW INVOLVING PHYSICAL CHALLENGES BROADCAST OVER TELEVISION, SATELLITE, AUDIO AND VIDEO MEDIA; PRESENTATION OF LIVE SHOW PERFORMANCES, NAMELY, LIVE QUESTION AND ANSWER GAME SHOWS INVOLVING PHYSICAL CHALLENGES (U.S. CLS. 100, 101 AND 107).

FIRST USE 6-0-2012; IN COMMERCE 6-0-2012.

4,593,371. JOHNSON, KEVIN, RICHMOND, CA. AND KOHTZ, PETER, EL CERRITO, CA. SN 85-655,343. PUB. 11-13-2012, FILED 6-19-2012.

## Shiver Twins

THE MARK CONSISTS OF STANDARD CHARACTERS WITHOUT CLAIM TO ANY PARTICULAR FONT, STYLE, SIZE, OR COLOR.

FOR ENTERTAINMENT SERVICES IN THE NATURE OF LIVE MUSICAL PERFORMANCES; LIVE PERFORMANCES BY A MUSICAL GROUP (U.S. CLS. 100, 101 AND 107).

FIRST USE 6-23-2014; IN COMMERCE 6-23-2014.

4,593,392. OOBLAGA, MONTREUIL SOUS BOIS, FRANCE. SN 85-669,104. PUB. 12-4-2012, FILED 7-5-2012.

## The Breedies

THE MARK CONSISTS OF STANDARD CHARACTERS WITHOUT CLAIM TO ANY PARTICULAR FONT, STYLE, SIZE, OR COLOR.

FOR ENTERTAINMENT SERVICES, NAMELY, PROVIDING ONLINE VIDEO GAMES; ENTERTAINMENT SERVICES, NAMELY, PROVIDING TEMPORARY USE OF NON-DOWNLOADABLE VIDEO GAMES; PROVIDING A WEB SITE THROUGH WHICH PEOPLE LOCATE INFORMATION ABOUT TOURNAMENTS, EVENTS, AND COMPETITIONS IN THE VIDEO GAME FIELD; PROVIDING RATINGS FOR TELEVISION, MOVIE, MUSIC, VIDEO, AND VIDEO GAME CONTENT (U.S. CLS. 100, 101 AND 107).

FIRST USE 7-0-2012; IN COMMERCE 7-0-2012.

**CLASS 41—(Continued).**

4,593,430. THE CORPORATION OF MERCER UNIVERSITY, MACON, GA. SN 85-709,008. PUB. 10-15-2013, FILED 8-21-2012.



NO CLAIM IS MADE TO THE EXCLUSIVE RIGHT TO USE "HEALTH SCIENCES CENTER", APART FROM THE MARK AS SHOWN.

THE COLOR(S) BLUE, LIGHT BLUE, GREEN, LIGHT GREEN, YELLOW, LIGHT YELLOW, ORANGE, LIGHT ORANGE, BLACK AND WHITE IS/ARE CLAIMED AS A FEATURE OF THE MARK.

THE MARK CONSISTS OF FLOWER DESIGN COMPRISED OF FOUR FLOWER PETALS FORMING A STYLIZED SQUARE WITH EACH PETAL EXTENDING OUTWARD FROM THE CENTER TOWARDS THE CORNERS OF THE SQUARE. THE PETALS ARE COMPRISED OF TWO HALVES WITH ONE HALF BEING DARKER THAN THE OTHER, WITH A CENTRAL VEIN IN WHITE SEPARATING EACH HALF. THE UPPER LEFT-HAND PETAL APPEARS IN BLUE AND LIGHT BLUE, THE UPPER RIGHT-HAND PETAL APPEARS IN GREEN AND LIGHT GREEN, THE LOWER RIGHT-HAND PETAL APPEARS IN YELLOW AND LIGHT YELLOW, AND THE LOWER LEFT-HAND PETAL APPEARS IN ORANGE AND LIGHT ORANGE. A TRANSPARENT WHITE CIRCLE IS POSITIONED IN THE CENTRAL OF THE LOGO AND EXTENDS HALFWAY THROUGH THE PETALS. THE WORDS "MERCER HEALTH" POSITIONED OVER THE WORDS "SCIENCES CENTER", APPEAR IN BLACK LETTERS TO THE RIGHT OF THE DESIGN.

FOR EDUCATION SERVICES, NAMELY, PROVIDING CLASSES IN THE FIELDS OF MEDICINE, NURSING AND PHARMACY; EDUCATION SERVICES, NAMELY, EDUCATION SERVICES PROVIDED BY A MEDICAL SCHOOL, A NURSING SCHOOL, AND A PHARMACY SCHOOL (U.S. CLS. 100, 101 AND 107).

FIRST USE 7-1-2012; IN COMMERCE 7-1-2012.

4,593,440. BLANCHARD TRAINING AND DEVELOPMENT, INC., ESCONDIDO, CA. SN 85-711,999. PUB. 11-13-2012, FILED 8-24-2012.



OWNER OF U.S. REG. NO. 1,584,015.

**CLASS 41—(Continued).**

THE MARK CONSISTS OF THE DESIGNATION "SLII" IN A SQUARE COMPOSED OF BROKEN LINES.

FOR EDUCATIONAL SERVICES, NAMELY, CONDUCTING WORKSHOPS, SEMINARS AND TRAINING SESSIONS RELATING TO MANAGEMENT SKILLS, EMPLOYEE DEVELOPMENT AND LEADERSHIP (U.S. CLS. 100, 101 AND 107).

FIRST USE 11-11-2013; IN COMMERCE 11-11-2013.

**CLASS 41—(Continued).**

NO CLAIM IS MADE TO THE EXCLUSIVE RIGHT TO USE "STUDIOS", APART FROM THE MARK AS SHOWN.

FOR ENTERTAINMENT SERVICES, NAMELY, PRODUCTION AND DISTRIBUTION OF MULTI-MEDIA PROGRAMMING, AUDIO-VISUAL PROGRAMMING, TELEVISION PROGRAMMING, AND FILMS (U.S. CLS. 100, 101 AND 107).

FIRST USE 2-3-2014; IN COMMERCE 2-3-2014.

---

4,593,474. AMNESIA INTERNATIONAL, LLC, AVENTURA, FL. SN 85-743,507. PUB. 11-26-2013, FILED 10-2-2012.

---

4,593,519. PHILIP D. GOLE, GRAND RAPIDS, MI. SN 85-767,007. PUB. 2-4-2014, FILED 10-30-2012.

# STORY

THE MARK CONSISTS OF STANDARD CHARACTERS WITHOUT CLAIM TO ANY PARTICULAR FONT, STYLE, SIZE, OR COLOR.

FOR NIGHTCLUB SERVICES (U.S. CLS. 100, 101 AND 107).

FIRST USE 12-26-2012; IN COMMERCE 12-26-2012.

# SURGICAL METROLOGY

THE MARK CONSISTS OF STANDARD CHARACTERS WITHOUT CLAIM TO ANY PARTICULAR FONT, STYLE, SIZE, OR COLOR.

NO CLAIM IS MADE TO THE EXCLUSIVE RIGHT TO USE "SURGICAL", APART FROM THE MARK AS SHOWN. FOR MEDICAL TRAINING, TEACHING, AND LECTURING IN THE FIELD OF PROSTHETIC IMPLANT TECHNIQUES (U.S. CLS. 100, 101 AND 107).

FIRST USE 5-15-2014; IN COMMERCE 5-15-2014.

---

4,593,501. TWIN CITIES PUBLIC TELEVISION, INC., ST. PAUL, MN. SN 85-760,680. PUB. 11-5-2013, FILED 10-23-2012.

# SPARTICL

THE MARK CONSISTS OF STANDARD CHARACTERS WITHOUT CLAIM TO ANY PARTICULAR FONT, STYLE, SIZE, OR COLOR.

FOR EDUCATION AND ENTERTAINMENT SERVICES, NAMELY, PROVIDING A WEBSITE PORTAL FEATURING GAMES, EDUCATIONAL ACTIVITIES IN THE NATURE OF GAMES, QUIZZES AND SCIENCE FAIR PROJECTS, AND EDUCATIONAL MATERIALS OF OTHERS IN THE FIELDS OF SCIENCE, TECHNOLOGY, ENGINEERING AND MATH, DELIVERED VIA THE INTERNET AND WIRELESS COMMUNICATION DEVICES (U.S. CLS. 100, 101 AND 107).

FIRST USE 10-1-2013; IN COMMERCE 10-1-2013.

---

4,593,527. MEGA MY PIXEL, LLC, NASHVILLE, TN. SN 85-771,506. PUB. 4-16-2013, FILED 11-5-2012.

# MEGA MY PIXEL

---

4,593,518. NBCUNIVERSAL MEDIA, LLC, NEW YORK, NY. SN 85-766,855. PUB. 11-12-2013, FILED 10-30-2012.

# WILSHIRE STUDIOS

THE MARK CONSISTS OF STANDARD CHARACTERS WITHOUT CLAIM TO ANY PARTICULAR FONT, STYLE, SIZE, OR COLOR.

THE MARK CONSISTS OF STANDARD CHARACTERS WITHOUT CLAIM TO ANY PARTICULAR FONT, STYLE, SIZE, OR COLOR.

FOR PHOTOGRAPHY SERVICES (U.S. CLS. 100, 101 AND 107).

FIRST USE 4-9-2014; IN COMMERCE 4-9-2014.

**CLASS 41—(Continued).**

4,593,528. MEGA MY PIXEL, LLC, NASHVILLE, TN. SN 85-771,532. PUB. 4-16-2013, FILED 11-5-2012.



THE MARK CONSISTS OF A SQUARE WITH MULTIPLE SQUARES INSIDE WITH AN IMAGE OF A CAMERA OVER THE SQUARES ALL TO THE LEFT OF THE WORD "MEGA" OVER THE WORDS "MY PIXEL" ALL INSIDE A RECTANGULAR SHAPE.

FOR PHOTOGRAPHY SERVICES (U.S. CLS. 100, 101 AND 107).

FIRST USE 4-9-2014; IN COMMERCE 4-9-2014.

---

4,593,571. IMG PRODUCTIONS, INC., NEW YORK, NY. SN 85-789,490. PUB. 4-30-2013, FILED 11-28-2012.

**SURVIVAL OF THE FITTEST**

THE MARK CONSISTS OF STANDARD CHARACTERS WITHOUT CLAIM TO ANY PARTICULAR FONT, STYLE, SIZE, OR COLOR.

FOR ENTERTAINMENT SERVICES IN THE NATURE OF AN ON-GOING REALITY BASED TELEVISION PROGRAM (U.S. CLS. 100, 101 AND 107).

FIRST USE 5-0-2012; IN COMMERCE 5-0-2012.

---

4,593,575. CBS RADIO INC., NEW YORK, NY. SN 85-790,325. PUB. 11-5-2013, FILED 11-29-2012.

**JUKEBOX JURY**

THE MARK CONSISTS OF STANDARD CHARACTERS WITHOUT CLAIM TO ANY PARTICULAR FONT, STYLE, SIZE, OR COLOR.

FOR ENTERTAINMENT SERVICES, NAMELY, PROVIDING A WEBSITE FEATURING NON-DOWNLOADABLE VIDEOS ABOUT MUSIC (U.S. CLS. 100, 101 AND 107).

FIRST USE 1-8-2013; IN COMMERCE 1-8-2013.

**CLASS 41—(Continued).**

4,593,587. MANUEL ARREGUIN, TLALNEPANTLA DE BAZ MX, MEXICO. SN 85-794,798. PUB. 5-7-2013, FILED 12-5-2012.



THE MARK CONSISTS OF THE WORD "YENYERE" WITH LETTERS SLANTING INTO THE MIDDLE OF THE WORD. ABOVE THE WORD IS A DESIGN LOOKS LIKE A LETTER C ABOVE THE FIRST LETTER "E" AND THE LETTER "N" IN "YENYERE" AND A BACKWARDS LETTER C ABOVE THE SECOND LETTER "E" AND THE LETTER "R" IN YENYERE AND A STAR ABOVE THE SECOND LETTER "Y" IN YENYERE. BELOW THE WORD, A BAR LINKS THE LETTERS "N" AND "R". FOUR LINES RUN THROUGH THE LETTERS OF "YENYERE".

FOR ENTERTAINMENT SERVICES, NAMELY, LIVE PERFORMANCES AS A DISC JOCKEY (DJ) FOR PARTIES, NIGHTCLUBS, CONCERTS AND SPECIAL EVENTS (U.S. CLS. 100, 101 AND 107).

FIRST USE 1-1-1984; IN COMMERCE 7-1-2014.

---

4,593,597. BROUILLETTE, DENISE, SAN FRANCISCO, CA. SN 85-798,270. PUB. 5-7-2013, FILED 12-9-2012.

**TAKE ONE SMALL ACTION**

THE MARK CONSISTS OF STANDARD CHARACTERS WITHOUT CLAIM TO ANY PARTICULAR FONT, STYLE, SIZE, OR COLOR.

FOR EDUCATION SERVICES, NAMELY, PROVIDING LIVE AND ON-LINE INDIVIDUAL INSTRUCTION, CLASSES, SEMINARS AND WORKSHOPS IN THE FIELD OF PROFESSIONAL AND PERSONAL LEADERSHIP DEVELOPMENT (U.S. CLS. 100, 101 AND 107).

FIRST USE 6-29-2014; IN COMMERCE 6-29-2014.

---

4,593,611. LAS VEGAS SANDS CORP., LAS VEGAS, NV. SN 85-802,992. PUB. 4-30-2013, FILED 12-14-2012.

**RUBY DRAGON BACCARAT TOURNAMENT**

THE MARK CONSISTS OF STANDARD CHARACTERS WITHOUT CLAIM TO ANY PARTICULAR FONT, STYLE, SIZE, OR COLOR.

**CLASS 41—(Continued).**

NO CLAIM IS MADE TO THE EXCLUSIVE RIGHT TO USE "BACCARAT TOURNAMENT", APART FROM THE MARK AS SHOWN.

FOR CASINO SERVICES, ENTERTAINMENT SERVICES, NAMELY, CONDUCTING LIVE BACCARAT GAMES AND TOURNAMENTS; CONDUCTING AND PROVIDING FACILITIES FOR SPECIAL EVENTS FEATURING CASINO AND GAMING CONTESTS AND TOURNAMENTS (U.S. CLS. 100, 101 AND 107).

FIRST USE 12-22-2012; IN COMMERCE 12-22-2012.

---

4,593,612. LAS VEGAS SANDS CORP., LAS VEGAS, NV. SN 85-802,994. PUB. 4-30-2013, FILED 12-14-2012.

### ROYAL DRAGON BACCARAT TOURNAMENT

THE MARK CONSISTS OF STANDARD CHARACTERS WITHOUT CLAIM TO ANY PARTICULAR FONT, STYLE, SIZE, OR COLOR.

NO CLAIM IS MADE TO THE EXCLUSIVE RIGHT TO USE "BACCARAT TOURNAMENT", APART FROM THE MARK AS SHOWN.

FOR CASINO SERVICES, ENTERTAINMENT SERVICES, NAMELY, CONDUCTING LIVE BACCARAT GAMES AND TOURNAMENTS; CONDUCTING AND PROVIDING FACILITIES FOR SPECIAL EVENTS FEATURING CASINO AND GAMING CONTESTS AND TOURNAMENTS (U.S. CLS. 100, 101 AND 107).

FIRST USE 12-31-2012; IN COMMERCE 12-31-2012.

---

4,593,649. ATHLETIC ARTIST TRAINING, COVINA, CA. SN 85-812,449. PUB. 6-4-2013, FILED 12-28-2012.

### Athletic Artist Training

THE MARK CONSISTS OF STANDARD CHARACTERS WITHOUT CLAIM TO ANY PARTICULAR FONT, STYLE, SIZE, OR COLOR.

NO CLAIM IS MADE TO THE EXCLUSIVE RIGHT TO USE "ARTIST TRAINING", APART FROM THE MARK AS SHOWN.

FOR TRAINING SERVICES IN THE FIELD OF DANCE AND MARTIAL ARTS (U.S. CLS. 100, 101 AND 107).

FIRST USE 4-1-2013; IN COMMERCE 4-1-2013.

**CLASS 41—(Continued).**

4,593,715. WARNER BROS. ENTERTAINMENT INC., BURBANK, CA. SN 85-846,650. PUB. 5-14-2013, FILED 2-11-2013.

## FAMOUS IN 12

THE MARK CONSISTS OF STANDARD CHARACTERS WITHOUT CLAIM TO ANY PARTICULAR FONT, STYLE, SIZE, OR COLOR.

FOR ENTERTAINMENT IN THE NATURE OF ON-GOING TELEVISION PROGRAMS IN THE FIELD OF LIVE-ACTION, COMEDY, DRAMA AND FAMILY RELATIONSHIPS; ENTERTAINMENT IN THE NATURE OF AN ON-GOING LIVE-ACTION, COMEDY, AND DRAMA SHOW FEATURING FAMILY RELATIONSHIPS BROADCAST OVER TELEVISION; SATELLITE, AUDIO, AND VIDEO MEDIA; ENTERTAINMENT SERVICES IN THE NATURE OF AN ON-GOING REALITY BASED TELEVISION PROGRAM; ENTERTAINMENT SERVICES IN THE NATURE OF A NON-FICTION TELEVISION PROGRAMMING SERIES ON TOPICS RELATING TO FAMILY RELATIONSHIPS; ENTERTAINMENT SERVICES, NAMELY, PRODUCTION AND DISTRIBUTION OF ON-GOING TELEVISION PROGRAMS IN THE FIELD OF LIVE-ACTION, COMEDY, DRAMA AND FAMILY RELATIONSHIPS; PRODUCTION AND DISTRIBUTION OF TELEVISION SHOWS (U.S. CLS. 100, 101 AND 107).

FIRST USE 6-3-2014; IN COMMERCE 6-3-2014.

---

4,593,719. RIVERA, RICKY L, PITTSFIELD, MA. SN 85-848,862. PUB. 8-6-2013, FILED 2-13-2013.

## Ricky Bats

THE MARK CONSISTS OF STANDARD CHARACTERS WITHOUT CLAIM TO ANY PARTICULAR FONT, STYLE, SIZE, OR COLOR.

THE NAME "RICKY BATS" IS NOT THE NAME OF A LIVING INDIVIDUAL.

FOR ARRANGING FOR TICKET RESERVATIONS FOR SHOWS AND OTHER ENTERTAINMENT EVENTS; ARRANGING, ORGANIZING, CONDUCTING, AND HOSTING SOCIAL ENTERTAINMENT EVENTS; CONDUCTING ENTERTAINMENT EXHIBITIONS IN THE NATURE OF MUSICAL CONCERTS; CONSULTATION IN THE FIELD OF SPECIAL EVENT PLANNING FOR SOCIAL ENTERTAINMENT PURPOSES; ENTERTAINMENT EVENT BOOKING AGENCIES; ENTERTAINMENT IN THE NATURE OF LIVE PERFORMANCES BY A MUSICIAN; ENTERTAINMENT IN THE NATURE OF LIVE RADIO PERSONALITY PERFORMANCES; ENTERTAINMENT IN THE NATURE OF LIVE STAGE PERFORMANCES IN THE NATURE OF CONCERTS IN THE FIELD OF MUSIC BY AN INDIVIDUAL; ENTERTAINMENT IN THE NATURE OF ON-GOING TELEVISION PROGRAMS IN THE FIELD OF VARIETY; ENTERTAINMENT IN THE NATURE OF VISUAL AND AUDIO PERFORMANCES BY MUSICAL INDIVIDUALS OR GROUPS; ENTERTAINMENT IN THE NATURE OF VISUAL AND AUDIO PERFORMANCES, AND MUSICAL, VARIETY, NEWS AND COMEDY SHOWS; ENTERTAINMENT IN THE NATURE OF VISUAL AND AUDIO PERFORMANCES, NAMELY, MUSICAL BAND, ROCK GROUP, GYMNASTIC, DANCE, AND BALLET PERFORMANCES; ENTERTAINMENT IN THE NATURE OF



**CLASS 41—(Continued).**

VISUAL AND AUDIO PERFORMANCES BY AN ACTOR; ENTERTAINMENT IN THE NATURE OF LIVE PERFORMANCES; ENTERTAINMENT MEDIA PRODUCTION SERVICES FOR MOTION PICTURES, TELEVISION AND INTERNET; ENTERTAINMENT SERVICES BY A MUSICAL ARTIST AND PRODUCER, NAMELY, MUSICAL COMPOSITION FOR OTHERS AND PRODUCTION OF MUSICAL SOUND RECORDINGS; ENTERTAINMENT SERVICES IN THE NATURE OF LIVE MUSICAL PERFORMANCES; ENTERTAINMENT SERVICES IN THE NATURE OF PRESENTING LIVE MUSICAL PERFORMANCES; ENTERTAINMENT SERVICES IN THE NATURE OF RECORDING, PRODUCTION AND POST-PRODUCTION SERVICES IN THE FIELD OF MUSIC; ENTERTAINMENT SERVICES IN THE NATURE OF MUSICAL PERFORMANCES; ENTERTAINMENT SERVICES, NAMELY, AN ON-LINE ACTIVITY WHERE YOU CREATE YOUR OWN MUSIC VIDEOS; ENTERTAINMENT SERVICES, NAMELY, DANCE EVENTS BY A RECORDING ARTIST; ENTERTAINMENT SERVICES, NAMELY, LIVE, TELEVISED AND MOVIE APPEARANCES BY A PROFESSIONAL ENTERTAINER; ENTERTAINMENT SERVICES, NAMELY, PROVIDING INFORMATION ABOUT A RECORDING ARTIST VIA AN ONLINE NETWORK; ENTERTAINMENT SERVICES, NAMELY, PROVIDING LIVE ENTERTAINMENT BY DANCERS VIA THE INTERNET; ENTERTAINMENT, NAMELY, LIVE PERFORMANCES BY A MUSICAL BAND; ENTERTAINMENT, NAMELY, LIVE PERFORMANCES BY MUSICAL BANDS; ENTERTAINMENT, NAMELY, LIVE PERFORMANCES BY ROCK GROUPS; ENTERTAINMENT, NAMELY, PRODUCTION OF MUSICAL SOUND RECORDINGS; MULTIMEDIA ENTERTAINMENT SERVICES IN THE NATURE OF DEVELOPMENT, PRODUCTION AND POST-PRODUCTION SERVICES IN THE FIELDS OF VIDEO AND FILMS; MULTIMEDIA ENTERTAINMENT SERVICES IN THE NATURE OF RECORDING, PRODUCTION AND POST-PRODUCTION SERVICES IN THE FIELDS OF MUSIC, VIDEO, AND FILMS; ORGANIZATION OF EXHIBITIONS FOR MUSICAL ENTERTAINMENT; ORGANIZATION OF FASHION SHOWS FOR ENTERTAINMENT PURPOSES; ORGANIZING AND ARRANGING EXHIBITIONS FOR ENTERTAINMENT PURPOSES; PROVIDING A WEBSITE FEATURING ENTERTAINMENT INFORMATION; PROVIDING A WEBSITE FEATURING INFORMATION IN THE FIELD OF MUSIC AND ENTERTAINMENT (U.S. CLS. 100, 101 AND 107).

FIRST USE 1-1-2012; IN COMMERCE 5-1-2012.

**CLASS 41—(Continued).**

4,593,720. RIVERA, RICKY L, PITTSFIELD, MA. SN 85-848,954. PUB. 8-6-2013, FILED 2-13-2013.

**B A T S Born A True Spitter**

THE MARK CONSISTS OF STANDARD CHARACTERS WITHOUT CLAIM TO ANY PARTICULAR FONT, STYLE, SIZE, OR COLOR.

FOR ARRANGING FOR TICKET RESERVATIONS FOR SHOWS AND OTHER ENTERTAINMENT EVENTS; ARRANGING, ORGANIZING, CONDUCTING, AND HOSTING SOCIAL ENTERTAINMENT EVENTS; CONDUCTING ENTERTAINMENT EXHIBITIONS IN THE NATURE OF MUSICAL CONCERTS; CONSULTATION IN THE FIELD OF SPECIAL EVENT PLANNING FOR SOCIAL ENTERTAINMENT PURPOSES; ENTERTAINMENT EVENT BOOKING AGENCIES; ENTERTAINMENT IN THE NATURE OF LIVE PERFORMANCES BY A MUSICIAN; ENTERTAINMENT IN THE NATURE OF LIVE RADIO PERSONALITY PERFORMANCES; ENTERTAINMENT IN THE NATURE OF LIVE STAGE PERFORMANCES IN THE NATURE OF CONCERTS IN THE FIELD OF MUSIC BY AN INDIVIDUAL; ENTERTAINMENT IN THE NATURE OF ON-GOING TELEVISION PROGRAMS IN THE FIELD OF VARIETY; ENTERTAINMENT IN THE NATURE OF VISUAL AND AUDIO PERFORMANCES BY MUSICAL INDIVIDUALS OR GROUPS; ENTERTAINMENT IN THE NATURE OF VISUAL AND AUDIO PERFORMANCES, AND MUSICAL, VARIETY, NEWS AND COMEDY SHOWS; ENTERTAINMENT IN THE NATURE OF VISUAL AND AUDIO PERFORMANCES, NAMELY, MUSICAL BAND, ROCK GROUP, GYMNASTIC, DANCE, AND BALLET PERFORMANCES; ENTERTAINMENT IN THE NATURE OF VISUAL AND AUDIO PERFORMANCES BY AN ACTOR; ENTERTAINMENT IN THE NATURE OF LIVE PERFORMANCES; ENTERTAINMENT MEDIA PRODUCTION SERVICES FOR MOTION PICTURES, TELEVISION AND INTERNET; ENTERTAINMENT SERVICES BY A MUSICAL ARTIST AND PRODUCER, NAMELY, MUSICAL COMPOSITION FOR OTHERS AND PRODUCTION OF MUSICAL SOUND RECORDINGS; ENTERTAINMENT SERVICES IN THE NATURE OF LIVE MUSICAL PERFORMANCES; ENTERTAINMENT SERVICES IN THE NATURE OF PRESENTING LIVE MUSICAL PERFORMANCES; ENTERTAINMENT SERVICES IN THE NATURE OF RECORDING, PRODUCTION AND POST-PRODUCTION SERVICES IN THE FIELD OF MUSIC; ENTERTAINMENT SERVICES IN THE NATURE OF MUSICAL PERFORMANCES; ENTERTAINMENT SERVICES, NAMELY, AN ON-LINE ACTIVITY WHERE YOU CREATE YOUR OWN MUSIC VIDEOS; ENTERTAINMENT SERVICES, NAMELY, DANCE EVENTS BY A RECORDING ARTIST; ENTERTAINMENT SERVICES, NAMELY, LIVE, TELEVISED AND MOVIE APPEARANCES BY A PROFESSIONAL ENTERTAINER; ENTERTAINMENT SERVICES, NAMELY, PROVIDING INFORMATION ABOUT A RECORDING ARTIST VIA AN ONLINE NETWORK; ENTERTAINMENT SERVICES, NAMELY, PROVIDING LIVE ENTERTAINMENT BY DANCERS VIA THE IN-

**CLASS 41—(Continued).**

TERNET; ENTERTAINMENT, NAMELY, LIVE PERFORMANCES BY A MUSICAL BAND; ENTERTAINMENT, NAMELY, LIVE PERFORMANCES BY MUSICAL BANDS; ENTERTAINMENT, NAMELY, LIVE PERFORMANCES BY ROCK GROUPS; ENTERTAINMENT, NAMELY, PRODUCTION OF MUSIC SOUND RECORDINGS; MULTIMEDIA ENTERTAINMENT SERVICES IN THE NATURE OF DEVELOPMENT, PRODUCTION AND POST-PRODUCTION SERVICES IN THE FIELDS OF VIDEO AND FILMS; MULTIMEDIA ENTERTAINMENT SERVICES IN THE NATURE OF RECORDING, PRODUCTION AND POST-PRODUCTION SERVICES IN THE FIELDS OF MUSIC, VIDEO, AND FILMS; ORGANIZATION OF EXHIBITIONS FOR MUSICAL ENTERTAINMENT; ORGANIZATION OF FASHION SHOWS FOR ENTERTAINMENT PURPOSES; ORGANIZING AND ARRANGING EXHIBITIONS FOR ENTERTAINMENT PURPOSES; PROVIDING A WEBSITE FEATURING ENTERTAINMENT INFORMATION; PROVIDING A WEBSITE FEATURING INFORMATION IN THE FIELD OF MUSIC AND ENTERTAINMENT (U.S. CLS. 100, 101 AND 107).

FIRST USE 1-1-2012; IN COMMERCE 5-1-2012.

---

4,593,726. DELICION, LLC, AKA DELICION, SIOUX FALLS, SD. SN 85-852,371. PUB. 7-30-2013, FILED 2-18-2013.



NO CLAIM IS MADE TO THE EXCLUSIVE RIGHT TO USE "STAGE", APART FROM THE MARK AS SHOWN.

THE MARK CONSISTS OF A STYLIZED IMAGE OF A PLACE SETTING FEATURING A FORK, PLATE AND KNIFE, TO THE LEFT OF THE WORDING "STAGE IT" APPEARING IN A STYLIZED FONT.

FOR EDUCATIONAL SERVICES, NAMELY, PROVIDING DISPLAYS AND EXHIBITS IN THE FIELD OF COOKING AND MEAL PRESENTATION (U.S. CLS. 100, 101 AND 107).

FIRST USE 5-1-2012; IN COMMERCE 5-1-2012.

---

4,593,755. KURIAN, SHELLEY, GRAPEVINE, TX. SN 85-873,618. PUB. 10-29-2013, FILED 3-12-2013.

**SHELLEY K EVENTS**

THE MARK CONSISTS OF STANDARD CHARACTERS WITHOUT CLAIM TO ANY PARTICULAR FONT, STYLE, SIZE, OR COLOR.

NO CLAIM IS MADE TO THE EXCLUSIVE RIGHT TO USE "EVENTS", APART FROM THE MARK AS SHOWN.

THE NAME "SHELLEY K" IDENTIFIES A LIVING INDIVIDUAL WHOSE CONSENT IS OF RECORD.

FOR SPECIAL EVENT CONSULTATION AND SPECIAL EVENT PLANNING SERVICES, NAMELY, FOR WEDDINGS, FASHION SPECIAL EVENTS, PARTIES, AND PHILANTHROPIC SPECIAL EVENTS (U.S. CLS. 100, 101 AND 107).

FIRST USE 7-1-2013; IN COMMERCE 7-1-2013.

**CLASS 41—(Continued).**

4,593,782. TRAVEL DAILY NEWS, INC., WASHINGTON, DC. SN 85-887,000. PUB. 6-25-2013, FILED 3-26-2013.

**DEVIL IN THE DETAILS**

THE MARK CONSISTS OF STANDARD CHARACTERS WITHOUT CLAIM TO ANY PARTICULAR FONT, STYLE, SIZE, OR COLOR.

FOR ENTERTAINMENT AND EDUCATIONAL SERVICES IN THE NATURE OF TELEVISION AND MULTIMEDIA PROGRAM SERIES FEATURING SUBJECTS OF GENERAL HUMAN INTEREST DISTRIBUTED VIA VARIOUS PLATFORMS ACROSS MULTIPLE FORMS OF TRANSMISSION MEDIA; PROVIDING ENTERTAINMENT INFORMATION TO OTHERS VIA A GLOBAL COMPUTER NETWORK (U.S. CLS. 100, 101 AND 107).

FIRST USE 6-14-2014; IN COMMERCE 6-14-2014.

---

4,593,786. FOURTH WAVE STRATEGY INC., DARTMOUTH, NOVA SCOTIA, CANADA. SN 85-889,937. PUB. 8-27-2013, FILED 3-29-2013.

**TEN DIRECTIONS**

THE MARK CONSISTS OF STANDARD CHARACTERS WITHOUT CLAIM TO ANY PARTICULAR FONT, STYLE, SIZE, OR COLOR.

FOR EDUCATIONAL SERVICES, NAMELY, CONDUCTING CLASSES, SEMINARS, CONFERENCES, WORKSHOPS AND TELECOURSES IN THE FIELDS OF FACILITATION TRAINING, DEVELOPMENT AND CERTIFICATION PROGRAMS AND DISTRIBUTION OF TRAINING MATERIALS IN CONNECTION THEREWITH; EDUCATIONAL SERVICES, NAMELY, CONDUCTING CLASSES, SEMINARS, CONFERENCES, WORKSHOPS AND TELECOURSES IN THE FIELD OF FACILITATION TRAINING, DEVELOPMENT AND CERTIFICATION PROGRAMS AND DISTRIBUTION OF EDUCATIONAL MATERIALS IN CONNECTION THEREWITH (U.S. CLS. 100, 101 AND 107).

FIRST USE 6-30-2014; IN COMMERCE 6-30-2014.

**CLASS 41—(Continued).**

4,593,805. LITTLE BRIDGE, BROOKLYN, NY. SN 85-903,625.  
PUB. 9-24-2013, FILED 4-14-2013.

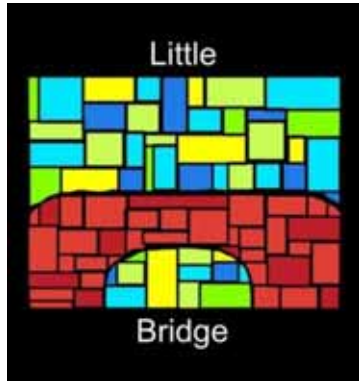

THE COLOR(S) LIGHT RED, DARK RED, YELLOW, BLACK, WHITE, LIGHT GREEN, DARK GREEN, LIGHT BLUE, AND DARK BLUE IS/ARE CLAIMED AS A FEATURE OF THE MARK.

THE MARK CONSISTS OF A RECTANGULAR DESIGN COMPRISED OF MOSAIC TILES DEPICTING AN ARCH BRIDGE. THE BRIDGE IS COMPRISED OF UNEVEN MOSAIC TILES PLACED HORIZONTALLY AND VERTICALLY IN A RANDOM PATTERN APPEARING IN LIGHT RED AND DARK RED COLOR. ABOVE THE BRIDGE AND UNDERNEATH THE ARCH OF THE BRIDGE ARE UNEVEN MOSAIC TILES PLACED HORIZONTALLY AND VERTICALLY IN A RANDOM PATTERN APPEARING IN THE COLORS LIGHT GREEN, DARK GREEN, YELLOW, LIGHT BLUE, AND DARK BLUE. THE BRIDGE AND MOSAIC TILES HAVE BLACK BORDERS. ABOVE THE RECTANGLE DESIGN IS THE STYLIZED WHITE WORD "LITTLE" ON A BLACK BACKGROUND. BELOW THE RECTANGLE DESIGN IS THE STYLIZED WHITE WORD "BRIDGE" ON A BLACK BACKGROUND.

FOR NURSERY SCHOOLS (U.S. CLS. 100, 101 AND 107).

FIRST USE 2-1-2014; IN COMMERCE 3-29-2014.

4,593,859. THE DETROIT ZOOLOGICAL SOCIETY, ROYAL OAK, MI. SN 85-922,314. PUB. 11-19-2013, FILED 5-3-2013.



OWNER OF U.S. REG. NOS. 2,553,547, 3,683,854, AND OTHERS.

NO CLAIM IS MADE TO THE EXCLUSIVE RIGHT TO USE "ZOO", APART FROM THE MARK AS SHOWN.

**CLASS 41—(Continued).**

THE COLOR(S) BLACK, WHITE, RED, BLUE, GRAY, PURPLE, ORANGE, YELLOW, GREEN AND PINK IS/ARE CLAIMED AS A FEATURE OF THE MARK.

THE MARK CONSISTS OF A COLOR DRAWING OF A PENGUIN USING BLACK, WHITE, ORANGE, YELLOW AND BLUE, WITHIN A CIRCLE CONTAINING A WINTER LANDSCAPE BACKGROUND COMPOSED OF HILLS, STARS, SPHERES AND TREES IN BLACK, WHITE, BLUE, GREY, PURPLE, ORANGE, YELLOW, GREEN AND PINK ALL ABOVE THE WORDS "WILD LIGHTS" WRITTEN IN A STYLIZED FONT IN WHITE AND DECORATED WITH BLUE SPHERES AND YELLOW STARS ON A RED BANNER ALL ABOVE THE WORDS "AT THE DETROIT ZOO" WRITTEN IN BLACK WHERE THE WHITE BACKGROUND IS NOT OTHERWISE A PART OF THE MARK.

SEC. 2(F) AS TO "DETROIT".

FOR ANIMAL EXHIBITIONS; EDUCATION SERVICES, NAMELY, PROVIDING CLASSES, SEMINARS AND WORKSHOPS IN THE FIELD OF CONSERVATION, ECOLOGY AND ZOOLOGY; RECREATIONAL PARK SERVICES; ZOOS (U.S. CLS. 100, 101 AND 107).

FIRST USE 6-0-2013; IN COMMERCE 6-0-2013.

4,593,864. 247.COM LLC, HENDERSON, NV. SN 85-923,391.  
PUB. 10-15-2013, FILED 5-3-2013.



NO CLAIM IS MADE TO THE EXCLUSIVE RIGHT TO USE ".COM" AND "LAS VEGAS", APART FROM THE MARK AS SHOWN.

THE MARK CONSISTS OF AN IMAGE IN THE SHAPE OF A SPADE, WITH CURVED LINES EMANATING FROM THE BOTTOM CENTER AND CURVING LEFT TO RIGHT TOWARD THE UPPER RIGHT SIDE. THE DESIGN IS POSITIONED TO THE LEFT OF THE TEXT "LV247", WITH THE TEXT ".COM" AT AN ANGLE TO THE RIGHT OF THE "7". UNDER THE TEXT "LV247.COM" IS THE TEXT "YOUR CONNECTION IN LAS VEGAS".

FOR ARRANGING FOR TICKET RESERVATIONS FOR SHOWS AND OTHER ENTERTAINMENT EVENTS (U.S. CLS. 100, 101 AND 107).

FIRST USE 6-12-2013; IN COMMERCE 6-12-2013.

4,593,868. RICOT, PATRICK, EVERETT, MA. SN 85-923,948.  
PUB. 10-22-2013, FILED 5-6-2013.



NO CLAIM IS MADE TO THE EXCLUSIVE RIGHT TO USE "THE JOINT MAGAZINE", APART FROM THE MARK AS SHOWN.

**CLASS 41—(Continued).**

THE MARK CONSISTS OF A MAN SITTING DOWN WITH HIS HEAD DOWN BEHIND JAIL BARS. TO THE RIGHT OF THE JAIL BARS IS THE WORDING IN THE MARK, "THE JOINT MAGAZINE", WITH THE WORD "JOINT" PLACED ABOVE THE WORD "MAGAZINE". THE WORD "THE" IS INSIDE THE "O" IN "JOINT". THE DOT ON THE "I" IN "JOINT" IS SLANTED.

FOR PROVIDING ON-LINE MAGAZINES IN THE FIELD OF HIP HOP AND RAP, WITH PRISON THEMES (U.S. CLS. 100, 101 AND 107).

FIRST USE 6-11-2014; IN COMMERCE 6-11-2014.

---

4,593,944. JACKSON, MATTIE D., BRENTWOOD, TN. SN 85-938,692. PUB. 10-15-2013, FILED 5-21-2013.

**VOLUPTUOUS VINES**

THE MARK CONSISTS OF STANDARD CHARACTERS WITHOUT CLAIM TO ANY PARTICULAR FONT, STYLE, SIZE, OR COLOR.

FOR ENTERTAINMENT SERVICES, NAMELY, WINE TASTINGS (U.S. CLS. 100, 101 AND 107).

FIRST USE 4-5-2014; IN COMMERCE 4-5-2014.

---

4,593,980. ONE WORLD IN CONCERT, INC., NEW YORK, NY. SN 85-943,627. PUB. 11-5-2013, FILED 5-28-2013.

**SHIFTINGS**

THE MARK CONSISTS OF STANDARD CHARACTERS WITHOUT CLAIM TO ANY PARTICULAR FONT, STYLE, SIZE, OR COLOR.

FOR PRODUCTION OF LIVE ENTERTAINMENT EVENTS, NAMELY, LIVE CONCERTS, FESTIVALS, THEATRICAL SHOWS, EDUCATIONAL EXHIBITIONS AND CULTURAL EXHIBITIONS; ENTERTAINMENT SERVICES IN THE NATURE OF ORGANIZING LIVE MUSICAL, THEATRICAL, EDUCATIONAL AND CULTURAL EXHIBITIONS; PROVIDING A WEBSITE FEATURING INFORMATION ON CULTURAL EVENTS (U.S. CLS. 100, 101 AND 107).

FIRST USE 5-16-2014; IN COMMERCE 5-16-2014.

**CLASS 41—(Continued).**

4,594,012. IQ INNOVATIONS, LLC, COLUMBUS, OH. SN 85-950,272. PUB. 11-12-2013, FILED 6-4-2013.

**POWERCORE**

THE MARK CONSISTS OF STANDARD CHARACTERS WITHOUT CLAIM TO ANY PARTICULAR FONT, STYLE, SIZE, OR COLOR.

FOR EDUCATIONAL SERVICES, NAMELY, DEVELOPING, ARRANGING, AND CONDUCTING EDUCATIONAL PROGRAMS AND PROVIDING COURSES OF INSTRUCTION AT THE K-12 LEVELS (U.S. CLS. 100, 101 AND 107).

FIRST USE 7-10-2013; IN COMMERCE 7-10-2013.

---

4,594,014. WILLIAMS, KRISTEN, TOMBALL, TX. SN 85-950,554. PUB. 10-29-2013, FILED 6-4-2013.

**My Friends Are Fiction**

THE MARK CONSISTS OF STANDARD CHARACTERS WITHOUT CLAIM TO ANY PARTICULAR FONT, STYLE, SIZE, OR COLOR.

FOR ON-LINE JOURNALS, NAMELY, BLOGS FEATURING REVIEWS AND INFORMATION ON BOOKS (U.S. CLS. 100, 101 AND 107).

FIRST USE 12-18-2012; IN COMMERCE 12-18-2012.

---

4,594,020. GLENNA C. BAILEY, CHANDLER, AZ. SN 85-950,863. PUB. 10-29-2013, FILED 6-4-2013.

**BOOKWILD**

THE MARK CONSISTS OF STANDARD CHARACTERS WITHOUT CLAIM TO ANY PARTICULAR FONT, STYLE, SIZE, OR COLOR.

FOR PROVIDING A WEBSITE FEATURING INFORMATION IN THE FIELD OF FICTION WRITING; PROVIDING INFORMATION IN THE FIELD OF FICTION WRITING (U.S. CLS. 100, 101 AND 107).

FIRST USE 8-4-2013; IN COMMERCE 8-4-2013.

**CLASS 41—(Continued).**

4,594,050. SCHEELS ALL SPORTS, INC., FARGO, ND. SN 85-955,984. PUB. 12-10-2013, FILED 6-10-2013.

FOR THE LIFE OF ME

THE MARK CONSISTS OF STANDARD CHARACTERS WITHOUT CLAIM TO ANY PARTICULAR FONT, STYLE, SIZE, OR COLOR.

FOR PROVIDING A WEBSITE FEATURING INFORMATION IN THE FIELDS OF SPORTS, GOLFING, RUNNING, HUNTING, BOW HUNTING, ARCHERY, BASEBALL, BIKING, FISHING, CAMPING, AND FITNESS EXERCISES; PROVIDING A WEBSITE FEATURING BLOGS IN THE FIELDS OF SPORTS, GOLFING, RUNNING, HUNTING, BOW HUNTING, ARCHERY, BASEBALL, BIKING, FISHING, CAMPING, AND FITNESS EXERCISES (U.S. CLS. 100, 101 AND 107).  
FIRST USE 7-1-2013; IN COMMERCE 7-1-2013.

4,594,067. BASIS EDUCATIONAL GROUP, INC., TUCSON, AZ. SN 85-957,591. PUB. 10-29-2013, FILED 6-12-2013.

BASIS

THE MARK CONSISTS OF STANDARD CHARACTERS WITHOUT CLAIM TO ANY PARTICULAR FONT, STYLE, SIZE, OR COLOR.

FOR EDUCATIONAL SERVICES, NAMELY, PROVIDING COURSES OF INSTRUCTION IN CHARTER SCHOOLS AT THE ELEMENTARY, MIDDLE SCHOOL AND HIGH SCHOOL LEVEL (U.S. CLS. 100, 101 AND 107).  
FIRST USE 7-31-2010; IN COMMERCE 7-31-2010.

**CLASS 41—(Continued).**

4,594,069. GENERATION READY INC., NEW YORK, NY. SN 85-957,815. PUB. 10-29-2013, FILED 6-12-2013.

GENERATION READY

THE MARK CONSISTS OF STANDARD CHARACTERS WITHOUT CLAIM TO ANY PARTICULAR FONT, STYLE, SIZE, OR COLOR.

FOR EDUCATIONAL SERVICES, NAMELY, PROVIDING WEB-BASED, ON-SITE, AND INTERACTIVE CONSULTANCY, CLASSROOM TRAINING, AND PROFESSIONAL DEVELOPMENT FOR TEACHERS AND EDUCATORS TO IMPROVE STUDENT ACHIEVEMENT BY IMPROVING TEACHER PERFORMANCE; EDUCATIONAL SERVICES, NAMELY, PROVIDING AN ON-LINE LIBRARY OF RESOURCES FOR TEACHERS AND EDUCATORS INCLUDING ON-LINE CLASSES, WORKSHOPS, VIDEO MODELS, AND COURSES IN THE FIELD OF PROFESSIONAL DEVELOPMENT (U.S. CLS. 100, 101 AND 107).  
FIRST USE 7-16-2013; IN COMMERCE 7-16-2013.

4,594,070. GENERATION READY INC., NEW YORK, NY. SN 85-957,827. PUB. 10-29-2013, FILED 6-12-2013.

PARTNERING FOR SCHOOL SUCCESS

THE MARK CONSISTS OF STANDARD CHARACTERS WITHOUT CLAIM TO ANY PARTICULAR FONT, STYLE, SIZE, OR COLOR.

FOR EDUCATIONAL SERVICES, NAMELY, PROVIDING WEB-BASED, ON-SITE, AND INTERACTIVE CONSULTANCY, CLASSROOM TRAINING, AND PROFESSIONAL DEVELOPMENT FOR TEACHERS AND EDUCATORS TO IMPROVE STUDENT ACHIEVEMENT BY IMPROVING TEACHER PERFORMANCE; EDUCATIONAL SERVICES, NAMELY, PROVIDING AN ON-LINE LIBRARY OF RESOURCES FOR TEACHERS AND EDUCATORS INCLUDING ON-LINE CLASSES, WORKSHOPS, VIDEO MODELS, AND COURSES IN THE FIELD OF PROFESSIONAL DEVELOPMENT (U.S. CLS. 100, 101 AND 107).  
FIRST USE 7-16-2013; IN COMMERCE 7-16-2013.

**CLASS 41—(Continued).**

4,594,109. SCHEELS ALL SPORTS, INC., FARGO, ND. SN 85-964,930. PUB. 11-12-2013, FILED 6-20-2013.

**CLASS 41—(Continued).**

4,594,161. MONKEYS INDA MIDDLE, LLC, WILMINGTON, DE. SN 85-982,019. PUB. 10-16-2012, FILED 10-24-2011.

# For the Life of Me

THE MARK CONSISTS OF THE WORDS "FOR THE LIFE OF ME" IN STYLIZED LETTERING WITH THE APPEARANCE OF HANDWRITTEN AND BOLDED CHARACTERS.

FOR PROVIDING A WEBSITE FEATURING INFORMATION IN THE FIELDS OF SPORTS, GOLFING, RUNNING, HUNTING, BOW HUNTING, ARCHERY, BASEBALL, BIKING, FISHING, CAMPING, AND FITNESS EXERCISES; PROVIDING A WEBSITE FEATURING BLOGS AND NON-DOWNLOADABLE PUBLICATIONS, NAMELY, ARTICLES IN THE FIELDS OF SPORTS, GOLFING, RUNNING, HUNTING, BOW HUNTING, ARCHERY, BASEBALL, BIKING, FISHING, CAMPING, AND FITNESS EXERCISES (U.S. CLS. 100, 101 AND 107).

FIRST USE 7-1-2013; IN COMMERCE 7-1-2013.

## MONKEYS INDA MIDDLE

THE MARK CONSISTS OF STANDARD CHARACTERS WITHOUT CLAIM TO ANY PARTICULAR FONT, STYLE, SIZE, OR COLOR.

FOR INTERNET WEBSITE FEATURING MUSIC, ENTERTAINMENT AND SOCIAL COMMENTARY; ENTERTAINMENT SERVICES IN THE NATURE OF LIVE MUSICAL PERFORMANCES (U.S. CLS. 100, 101 AND 107).

FIRST USE 2-0-2013; IN COMMERCE 2-0-2013.

---

4,594,120. GENERATION READY INC., NEW YORK, NY. SN 85-968,502. PUB. 10-29-2013, FILED 6-24-2013.

---

4,594,166. THE WELL COMMUNITY CHURCH, FRESNO, CA. SN 85-982,050. PUB. 5-21-2013, FILED 11-21-2012.

# READYPATH

THE MARK CONSISTS OF STANDARD CHARACTERS WITHOUT CLAIM TO ANY PARTICULAR FONT, STYLE, SIZE, OR COLOR.

FOR EDUCATIONAL SERVICES, NAMELY, PROVIDING WEB-BASED, ON-SITE, AND INTERACTIVE CONSULTANCY, CLASSROOM TRAINING, AND PROFESSIONAL DEVELOPMENT FOR TEACHERS AND EDUCATORS TO IMPROVE STUDENT ACHIEVEMENT BY IMPROVING TEACHER PERFORMANCE; EDUCATIONAL SERVICES, NAMELY, PROVIDING AN ON-LINE LIBRARY OF RESOURCES FOR TEACHERS AND EDUCATORS INCLUDING ON-LINE CLASSES, WORKSHOPS, VIDEO MODELS, AND COURSES IN THE FIELD OF PROFESSIONAL DEVELOPMENT (U.S. CLS. 100, 101 AND 107).

FIRST USE 7-16-2013; IN COMMERCE 7-16-2013.

## ANATOMY OF A DISCIPLE

THE MARK CONSISTS OF STANDARD CHARACTERS WITHOUT CLAIM TO ANY PARTICULAR FONT, STYLE, SIZE, OR COLOR.

FOR EDUCATION SERVICES, NAMELY, PROVIDING ONLINE COGNITIVE ASSESSMENTS IN THE FIELD OF RELIGION AND SPIRITUAL ASSESSMENT AND DEVELOPMENT (U.S. CLS. 100, 101 AND 107).

FIRST USE 12-11-2013; IN COMMERCE 12-11-2013.

**CLASS 41—(Continued).**

4,594,232. GRAND CITRUS GROUP, LLC, HUNTINGTON BEACH, CA. SN 86-011,544. PUB. 2-4-2014, FILED 7-16-2013.



THE MARK CONSISTS OF A CIRCLE, REPRESENTING A CONCEPTUAL ORANGE, FORMED BY TWO SWIRLING WAVES, HOLLOW IN THE MIDDLE, WITH A LEAF AND STEM ATTACHED.

FOR MULTI-ARTS ENTERTAINMENT SERVICES, NAMELY, CONDUCTING COMMUNITY FESTIVALS FEATURING A VARIETY OF ACTIVITIES, NAMELY, ART AND SCULPTURE GARDEN EXHIBITIONS, AND LIVE MUSIC PERFORMANCES FOR ENTERTAINMENT, CULTURAL, AND EDUCATIONAL PURPOSES (U.S. CLS. 100, 101 AND 107).  
FIRST USE 9-19-2013; IN COMMERCE 9-19-2013.

4,594,234. UNIVERSAL CITY STUDIOS LLC, UNIVERSAL CITY, CA. SN 86-011,846. PUB. 10-29-2013, FILED 7-16-2013.

**SILLY SWIRLY**

THE MARK CONSISTS OF STANDARD CHARACTERS WITHOUT CLAIM TO ANY PARTICULAR FONT, STYLE, SIZE, OR COLOR.

FOR AMUSEMENT PARK AND THEME PARK SERVICES (U.S. CLS. 100, 101 AND 107).  
FIRST USE 4-2-2014; IN COMMERCE 4-2-2014.

4,594,248. SCHOLASTIC INC., NEW YORK, NY. SN 86-016,207. PUB. 12-17-2013, FILED 7-22-2013.

**SCIENCEFLIX**

THE MARK CONSISTS OF STANDARD CHARACTERS WITHOUT CLAIM TO ANY PARTICULAR FONT, STYLE, SIZE, OR COLOR.

**CLASS 41—(Continued).**

OWNER OF U.S. REG. NOS. 3,399,135, 3,479,195, AND 3,998,136.

FOR PROVIDING AN ON-LINE EDUCATIONAL PROGRAM IN THE FIELD OF SCIENCE VIA A GLOBAL COMPUTER NETWORK (U.S. CLS. 100, 101 AND 107).  
FIRST USE 6-2-2014; IN COMMERCE 6-2-2014.

4,594,260. DANGEROUS CURVES, LLC, MEMPHIS, TN. SN 86-025,757. PUB. 12-24-2013, FILED 8-1-2013.

**DDDonna.com**

THE MARK CONSISTS OF STANDARD CHARACTERS WITHOUT CLAIM TO ANY PARTICULAR FONT, STYLE, SIZE, OR COLOR.

FOR ENTERTAINMENT SERVICES, NAMELY, PROVIDING A WEB SITE FEATURING PHOTOGRAPHIC, AUDIO, VIDEO AND PROSE PRESENTATIONS FEATURING EXERCISE AND FITNESS (U.S. CLS. 100, 101 AND 107).

FIRST USE 6-1-2013; IN COMMERCE 6-1-2013.

4,594,263. ENDGAME ENTERPRISES, LLC, WESTMINSTER, CO. SN 86-028,662. PUB. 12-24-2013, FILED 8-5-2013.

**DUMBER TOGETHER**

THE MARK CONSISTS OF STANDARD CHARACTERS WITHOUT CLAIM TO ANY PARTICULAR FONT, STYLE, SIZE, OR COLOR.

FOR EDUCATIONAL AND ENTERTAINMENT SERVICES, NAMELY, A CONTINUING PROGRAM ABOUT POLITICAL AND SOCIAL SATIRE ACCESSIBLE BY MEANS OF SATELLITE AND COMPUTER NETWORKS; PROVIDING A WEBSITE FEATURING NON-DOWNLOADABLE PUBLICATIONS IN THE NATURE OF COMIC STRIPS AND BLOGS IN THE FIELD OF POLITICAL AND SOCIAL SATIRE (U.S. CLS. 100, 101 AND 107).

FIRST USE 1-2-2014; IN COMMERCE 1-2-2014.

**CLASS 41—(Continued).**

4,594,264. ENDGAME ENTERPRISES, LLC, WESTMINSTER, CO. SN 86-028,663. PUB. 12-24-2013, FILED 8-5-2013.

**CUR & CRONY**

THE MARK CONSISTS OF STANDARD CHARACTERS WITHOUT CLAIM TO ANY PARTICULAR FONT, STYLE, SIZE, OR COLOR.

FOR EDUCATIONAL AND ENTERTAINMENT SERVICES, NAMELY, A CONTINUING PROGRAM ABOUT POLITICAL AND SOCIAL SATIRE ACCESSIBLE BY MEANS OF SATELLITE AND COMPUTER NETWORKS; PROVIDING A WEBSITE FEATURING NON-DOWNLOADABLE PUBLICATIONS IN THE NATURE OF COMIC STRIPS AND BLOGS IN THE FIELD OF POLITICAL AND SOCIAL SATIRE (U.S. CLS. 100, 101 AND 107).

FIRST USE 1-2-2014; IN COMMERCE 1-2-2014.

4,594,271. WORLD WRESTLING ENTERTAINMENT, INC., STAMFORD, CT. SN 86-030,966. PUB. 11-12-2013, FILED 8-7-2013.

**ALEX RILEY**

THE MARK CONSISTS OF STANDARD CHARACTERS WITHOUT CLAIM TO ANY PARTICULAR FONT, STYLE, SIZE, OR COLOR.

THE NAME "ALEX RILEY" DOES NOT IDENTIFY A LIVING INDIVIDUAL.

FOR ENTERTAINMENT SERVICES, NAMELY, WRESTLING EXHIBITIONS AND PERFORMANCES BY PROFESSIONAL WRESTLERS AND ENTERTAINERS RENDERED LIVE AND THROUGH BROADCAST MEDIA INCLUDING TELEVISION AND RADIO, AND VIA THE INTERNET OR COMMERCIAL ONLINE SERVICE; PROVIDING INFORMATION IN THE FIELDS OF SPORTS AND ENTERTAINMENT VIA AN ONLINE COMMUNITY PORTAL; PROVIDING A WEBSITE IN THE FIELD OF SPORTS ENTERTAINMENT; FAN CLUB SERVICES; ORGANIZING AND STAGING SOCIAL ENTERTAINMENT EVENTS WITH FAN CLUB MEMBERS; PROVIDING ONLINE NEWSLETTERS IN THE FIELDS OF SPORTS ENTERTAINMENT; ONLINE JOURNALS, NAMELY, BLOGS, IN THE FIELDS OF SPORTS ENTERTAINMENT (U.S. CLS. 100, 101 AND 107).

FIRST USE 12-31-2008; IN COMMERCE 12-31-2008.

**CLASS 41—(Continued).**

4,594,300. RESIGNATION HOLDINGS, LLC, FORMERLY RESIGNATION BREWERY LLC, ALTADENA, CA. SN 86-044,582. PUB. 3-18-2014, FILED 8-21-2013.

**Resignation Brewery**

THE MARK CONSISTS OF STANDARD CHARACTERS WITHOUT CLAIM TO ANY PARTICULAR FONT, STYLE, SIZE, OR COLOR.

FOR ENTERTAINMENT SERVICES, NAMELY, PROVIDING AN INTERACTIVE WEBSITE FEATURING NON-DOWNLOADABLE PHOTOGRAPHS OF OTHERS IN THE FIELD OF DRINKING BEER AND CELEBRATING (U.S. CLS. 100, 101 AND 107).

FIRST USE 10-15-2013; IN COMMERCE 10-15-2013.

4,594,357. OMNI PARTNERS, LLC, ATLANTA, GA. SN 86-066,912. PUB. 2-11-2014, FILED 9-17-2013.

**I FOUND IT.**

THE MARK CONSISTS OF STANDARD CHARACTERS WITHOUT CLAIM TO ANY PARTICULAR FONT, STYLE, SIZE, OR COLOR.

FOR ONLINE RELIGIOUS SERVICES, NAMELY, RELIGIOUS INSTRUCTION SERVICES (U.S. CLS. 100, 101 AND 107).

FIRST USE 4-15-2014; IN COMMERCE 4-15-2014.

4,594,375. ENDGAME ENTERPRISES, LLC, WESTMINSTER, CO. SN 86-076,085. PUB. 12-31-2013, FILED 9-26-2013.

**THE SILLY SENTINEL**

THE MARK CONSISTS OF STANDARD CHARACTERS WITHOUT CLAIM TO ANY PARTICULAR FONT, STYLE, SIZE, OR COLOR.

FOR EDUCATIONAL AND ENTERTAINMENT SERVICES, NAMELY, A CONTINUING PROGRAM ABOUT POLITICAL AND SOCIAL SATIRE ACCESSIBLE BY MEANS OF SATELLITE AND COMPUTER NETWORKS; PROVIDING A WEBSITE FEATURING NON-DOWNLOADABLE PUBLICATIONS IN THE NATURE OF COMIC STRIPS AND BLOGS IN THE FIELD OF POLITICAL AND SOCIAL SATIRE (U.S. CLS. 100, 101 AND 107).

FIRST USE 1-2-2014; IN COMMERCE 1-2-2014.



**CLASS 41—(Continued).**

4,594,376. ENDGAME ENTERPRISES, LLC, WESTMINSTER, CO. SN 86-076,089. PUB. 12-24-2013, FILED 9-26-2013.

**LAME SPIN**

THE MARK CONSISTS OF STANDARD CHARACTERS WITHOUT CLAIM TO ANY PARTICULAR FONT, STYLE, SIZE, OR COLOR.

FOR EDUCATIONAL AND ENTERTAINMENT SERVICES, NAMELY, A CONTINUING PROGRAM ABOUT POLITICAL AND SOCIAL SATIRE ACCESSIBLE BY MEANS OF SATELLITE AND COMPUTER NETWORKS; PROVIDING A WEBSITE FEATURING NON-DOWNLOADABLE PUBLICATIONS IN THE NATURE OF COMIC STRIPS AND BLOGS IN THE FIELD OF POLITICAL AND SOCIAL SATIRE (U.S. CLS. 100, 101 AND 107).

FIRST USE 1-2-2014; IN COMMERCE 1-2-2014.

---

4,594,403. STOP, LLC, LAS VEGAS, NV. SN 86-085,524. PUB. 3-25-2014, FILED 10-8-2013.



SAFETY TRAINING OPERATORS PROGRAM

NO CLAIM IS MADE TO THE EXCLUSIVE RIGHT TO USE "SAFETY TRAINING OPERATORS PROGRAM", APART FROM THE MARK AS SHOWN.

THE MARK CONSISTS OF A STOP SIGN WITH THE LETTERS "STOP" INSIDE. BELOW THERE IS THE STYLIZED TEXT "SAFETY TRAINING OPERATORS PROGRAM".

FOR TRAINING SERVICES IN THE FIELD OF DRIVER SAFETY (U.S. CLS. 100, 101 AND 107).

FIRST USE 9-30-2013; IN COMMERCE 9-30-2013.

---

4,594,414. FUSION MEDIA NETWORK, LLC, BURBANK, CA. SN 86-088,376. PUB. 1-14-2014, FILED 10-10-2013.

**A.M. TONIGHT**

THE MARK CONSISTS OF STANDARD CHARACTERS WITHOUT CLAIM TO ANY PARTICULAR FONT, STYLE, SIZE, OR COLOR.

FOR ENTERTAINMENT SERVICES, NAMELY, AN ONGOING TELEVISION PROGRAM THAT COVERS THE INTERSECTION OF POP CULTURE AND POLITICS (U.S. CLS. 100, 101 AND 107).

FIRST USE 10-28-2013; IN COMMERCE 10-28-2013.

**CLASS 41—(Continued).**

4,594,415. FUSION MEDIA NETWORK, LLC, BURBANK, CA. SN 86-088,403. PUB. 2-11-2014, FILED 10-10-2013.

**SOCCER GODS**

THE MARK CONSISTS OF STANDARD CHARACTERS WITHOUT CLAIM TO ANY PARTICULAR FONT, STYLE, SIZE, OR COLOR.

NO CLAIM IS MADE TO THE EXCLUSIVE RIGHT TO USE "SOCCER", APART FROM THE MARK AS SHOWN.

FOR ENTERTAINMENT SERVICES, NAMELY, AN ONGOING TELEVISION SPORTS PROGRAM (U.S. CLS. 100, 101 AND 107).

FIRST USE 5-14-2014; IN COMMERCE 5-14-2014.

---

4,594,441. MARINA BOURANTONIS, BRADENTON, FL. SN 86-097,953. PUB. 4-8-2014, FILED 10-22-2013.



OWNER OF U.S. REG. NO. 4,297,599.

THE COLOR(S) BLACK, RED, LIGHT TAN, AND DARK TAN IS/ARE CLAIMED AS A FEATURE OF THE MARK.

THE MARK CONSISTS OF LIGHT AND DARK TAN LOTUS FLOWER WITH WORDING "THAVMA" ACROSS IN BLACK LETTERS, WITH THE "V" AND A FLAME IN RED.

THE ENGLISH TRANSLATION OF THE WORD "THAVMA" IN THE MARK IS "MIRACLE".

FOR YOGA INSTRUCTION (U.S. CLS. 100, 101 AND 107).

FIRST USE 10-1-2013; IN COMMERCE 3-1-2014.

**CLASS 41—(Continued).**

4,594,449. REINHART, DAVID S., HOLDEN, MA. SN 86-100,034. PUB. 4-8-2014, FILED 10-24-2013.



NO CLAIM IS MADE TO THE EXCLUSIVE RIGHT TO USE "PRESS", APART FROM THE MARK AS SHOWN.

THE COLOR(S) RED, BLACK, YELLOW, AND WHITE IS/ARE CLAIMED AS A FEATURE OF THE MARK.

THE MARK CONSISTS OF A MALE CARDINAL BIRD HEAD APPEARING IN RED AND BLACK WITH A BLACK OUTLINE, YELLOW BEAK AND WHITE EYE WITH A BLACK EYE PUPIL. THE WORDING "CARDINAL PRESS" IS UNDERNEATH THE CARDINAL BIRD DESIGN IN RED STYLIZED LETTERING.

FOR PUBLISHING OF BOOKS AND MAGAZINES (U.S. CLS. 100, 101 AND 107).

FIRST USE 5-7-2014; IN COMMERCE 5-7-2014.

4,594,454. MELODYWED, MOUNTAIN VIEW, CA. SN 86-101,058. PUB. 4-8-2014, FILED 10-24-2013.

# MelodyWed

THE MARK CONSISTS OF STANDARD CHARACTERS WITHOUT CLAIM TO ANY PARTICULAR FONT, STYLE, SIZE, OR COLOR.

FOR CUSTOM WRITING SERVICES FOR NON-ADVERTISING PURPOSES; POEM AND LYRIC WRITING; SONG WRITING SERVICES FOR NON-ADVERTISING PURPOSES (U.S. CLS. 100, 101 AND 107).

FIRST USE 1-1-2014; IN COMMERCE 1-1-2014.

**CLASS 41—(Continued).**

4,594,457. BEYOND THE MIX INC., GARDEN CITY, NY. SN 86-101,605. PUB. 4-1-2014, FILED 10-25-2013.

# Beyond The Mix

THE MARK CONSISTS OF STANDARD CHARACTERS WITHOUT CLAIM TO ANY PARTICULAR FONT, STYLE, SIZE, OR COLOR.

FOR DISC JOCKEYS FOR PARTIES AND SPECIAL EVENTS (U.S. CLS. 100, 101 AND 107).

FIRST USE 8-1-2013; IN COMMERCE 11-2-2013.

**CLASS 42—SCIENTIFIC AND COMPUTER SERVICES**

4,593,076. KNOVATION, INC., CINCINNATI, OH. SN 77-656,567. PUB. 5-27-2014, FILED 1-26-2009.

# EDUDYM

THE MARK CONSISTS OF STANDARD CHARACTERS WITHOUT CLAIM TO ANY PARTICULAR FONT, STYLE, SIZE, OR COLOR.

FOR PROVIDING TEMPORARY USE OF NON-DOWNLOADABLE COMPUTER SOFTWARE FOR THE INTERACTIVE RETRIEVAL AND EXCHANGE OF DATA (U.S. CLS. 100 AND 101).

FIRST USE 8-1-2009; IN COMMERCE 10-15-2009.

**CLASS 42—(Continued).**

4,593,083. GENOR BIOPHARMA CO. LTD., PUDONG, SHANGHAI, CHINA. SN 77-796,294. PUB. 5-3-2011, FILED 8-4-2009.

# GENOR

THE MARK CONSISTS OF STANDARD CHARACTERS WITHOUT CLAIM TO ANY PARTICULAR FONT, STYLE, SIZE, OR COLOR.

FOR SCIENTIFIC AND TECHNOLOGICAL RESEARCH SERVICES AND RESEARCH OF BACTERIOLOGY; BIOLOGICAL RESEARCH; RESEARCH IN THE AREA OF VACCINES, MONOCLONAL ANTIBODIES, RECOMBINANT PHARMACEUTICALS, PROTEIN PHARMACEUTICALS, AND BIOTECHNOLOGICAL PHARMACEUTICALS; PROVIDING QUALITY CONTROL AND QUALITY ASSURANCE SERVICES IN THE FIELD OF BIOTECHNOLOGICAL PHARMACEUTICALS; TECHNOLOGY CONSULTATION IN THE FIELD OF BIOTECHNOLOGICAL PHARMACEUTICALS (U.S. CLS. 100 AND 101).

FIRST USE 12-20-2009; IN COMMERCE 12-20-2009.

4,593,084. NIMVIA, LLC, CHARLOTTE, NC. SN 77-833,586. PUB. 11-23-2010, FILED 9-23-2009.



THE MARK CONSISTS OF THE WORD "NIMVIA", WITH A DIAGONAL OVAL CIRCLING THE LETTER "N" AND CROSSING THROUGH THE DOT OF THE FIRST LETTER "I".

THE WORDING "NIMVIA" HAS NO MEANING IN A FOREIGN LANGUAGE.

FOR SOFTWARE AS A SERVICE (SAAS) SERVICES FEATURING PRACTICE MANAGEMENT SOFTWARE FOR USE BY PATENT PRACTITIONERS IN INTERACTING WITH ONLINE COMPUTER SYSTEMS OF THE U.S. PATENT AND TRADEMARK OFFICE IN THE FIELD OF PATENT PROSECUTION BEFORE THE U.S. PATENT AND TRADEMARK OFFICE (U.S. CLS. 100 AND 101).

FIRST USE 1-21-2014; IN COMMERCE 1-21-2014.

**CLASS 42—(Continued).**

4,593,094. UNIFIED COMMUNICATIONS INTEROPERABILITY FORUM, INC., MILFORD, DE. SN 85-006,620. PUB. 5-10-2011, FILED 4-5-2010.



THE MARK CONSISTS OF THREE CIRCLES AT THE PERIMETER OF A CIRCULAR PATTERN SEPARATED BY SEMI-CIRCULAR LINES AND HAVING A CENTER SPOKE.

FOR DEVELOPING VOLUNTARY STANDARDS FOR INTEROPERABILITY OF COMMUNICATION HARDWARE AND SOFTWARE IN ORDER TO FACILITATE VIDEO CONFERENCING AND APPLICATION SHARING ACROSS ENTERPRISES, SERVICE PROVIDERS AND CONSUMER CLOUDS; ESTABLISHMENT OF TESTING PROCEDURES FOR CERTIFYING COMMUNICATION HARDWARE AND SOFTWARE IN THE FIELD OF VIDEO CONFERENCING AND APPLICATION SHARING (U.S. CLS. 100 AND 101).

FIRST USE 9-29-2010; IN COMMERCE 9-29-2010.

4,593,095. UNIFIED COMMUNICATIONS INTEROPERABILITY FORUM, INC., MILFORD, DE. SN 85-006,624. PUB. 5-10-2011, FILED 4-5-2010.

# UCI FORUM

THE MARK CONSISTS OF STANDARD CHARACTERS WITHOUT CLAIM TO ANY PARTICULAR FONT, STYLE, SIZE, OR COLOR.

NO CLAIM IS MADE TO THE EXCLUSIVE RIGHT TO USE "FORUM", APART FROM THE MARK AS SHOWN.

FOR DEVELOPING VOLUNTARY STANDARDS FOR INTEROPERABILITY OF COMMUNICATION HARDWARE AND SOFTWARE IN ORDER TO FACILITATE VIDEO CONFERENCING AND APPLICATION SHARING ACROSS ENTERPRISES, SERVICE PROVIDERS AND CONSUMER CLOUDS; ESTABLISHMENT OF TESTING PROCEDURES FOR CERTIFYING COMMUNICATION HARDWARE AND SOFTWARE IN THE FIELD OF VIDEO CONFERENCING AND APPLICATION SHARING (U.S. CLS. 100 AND 101).

FIRST USE 9-29-2010; IN COMMERCE 9-29-2010.

**CLASS 42—(Continued).**

4,593,101. UNIFIED COMMUNICATIONS INTEROPERABILITY FORUM, INC., MILFORD, DE. SN 85-041,338. PUB. 5-10-2011, FILED 5-18-2010.

# UCIF

THE MARK CONSISTS OF STANDARD CHARACTERS WITHOUT CLAIM TO ANY PARTICULAR FONT, STYLE, SIZE, OR COLOR.

FOR DEVELOPING VOLUNTARY STANDARDS FOR INTEROPERABILITY OF COMMUNICATION HARDWARE AND SOFTWARE IN ORDER TO FACILITATE VIDEO CONFERENCING AND APPLICATION SHARING ACROSS ENTERPRISES, SERVICE PROVIDERS AND CONSUMER CLOUDS; ESTABLISHMENT OF TESTING PROCEDURES FOR CERTIFYING COMMUNICATION HARDWARE AND SOFTWARE IN THE FIELD OF VIDEO CONFERENCING AND APPLICATION SHARING (U.S. CLS. 100 AND 101).

FIRST USE 9-29-2010; IN COMMERCE 9-29-2010.

4,593,141. CRF, INC., DBA CRF HEALTH, PLYMOUTH MEETING, PA. SN 85-166,863. PUB. 5-3-2011, FILED 11-2-2010.

# TRIALMAX TOUCH

THE MARK CONSISTS OF STANDARD CHARACTERS WITHOUT CLAIM TO ANY PARTICULAR FONT, STYLE, SIZE, OR COLOR.

OWNER OF U.S. REG. NOS. 3,114,603 AND 3,421,470.

NO CLAIM IS MADE TO THE EXCLUSIVE RIGHT TO USE "TOUCH", APART FROM THE MARK AS SHOWN.

FOR SOFTWARE AS A SERVICE (SAAS) SERVICES FEATURING SOFTWARE FOR THE COLLECTION, EDITING, ORGANIZING, MODIFYING, BOOK MARKING, TRANSMISSION, STORAGE AND SHARING OF PATIENT REPORTED OUTCOMES ON HANDHELD AND PDAS (U.S. CLS. 100 AND 101).

FIRST USE 5-1-2014; IN COMMERCE 5-1-2014.

4,593,158. DAVAR, ALI, VANCOUVER, BC, CANADA. SN 85-189,735. PUB. 5-10-2011, FILED 12-2-2010.

# theReel

THE MARK CONSISTS OF STANDARD CHARACTERS WITHOUT CLAIM TO ANY PARTICULAR FONT, STYLE, SIZE, OR COLOR.

**CLASS 42—(Continued).**

PRIORITY CLAIMED UNDER SEC. 44(D) ON CANADA APPLICATION NO. 1,502,976. FILED 11-8-2010.

FOR COMPUTER SERVICES, NAMELY, CREATING AN ON-LINE COMMUNITY FOR REGISTERED USERS TO PARTICIPATE IN DISCUSSIONS, GET FEEDBACK FROM THEIR PEERS, FORM VIRTUAL COMMUNITIES, AND ENGAGE IN SOCIAL NETWORKING; COMPUTER SERVICES, NAMELY, CREATING AN ON-LINE COMMUNITY FOR REGISTERED USERS TO PARTICIPATE IN DISCUSSIONS, GET FEEDBACK FROM THEIR PEERS, FORM VIRTUAL COMMUNITIES, AND ENGAGE IN SOCIAL NETWORKING IN THE ENTERTAINMENT INDUSTRY (U.S. CLS. 100 AND 101).

FIRST USE 7-4-2014; IN COMMERCE 7-4-2014.

4,593,202. EYEMAGINATIONS, INC., TOWSON, MD. SN 85-327,424. PUB. 11-19-2013, FILED 5-23-2011.

# ECHO

THE MARK CONSISTS OF STANDARD CHARACTERS WITHOUT CLAIM TO ANY PARTICULAR FONT, STYLE, SIZE, OR COLOR.

FOR SOFTWARE AS A SERVICE (SAAS) SERVICES FEATURING SOFTWARE FOR MEDICAL PROFESSIONALS, EDUCATIONAL INSTITUTIONS, AND HEALTHCARE MANUFACTURERS, FOR MARKETING AND EDUCATION PURPOSES, NAMELY, SOFTWARE THAT PROVIDES EXPLANATIONS OF MEDICAL CONDITIONS, PRODUCTS AND PROCEDURES, AND PROVIDES MEDICAL EDUCATION AND ENTERTAINMENT (U.S. CLS. 100 AND 101).

FIRST USE 4-20-2013; IN COMMERCE 4-20-2013.

4,593,324. RELATIVE EMOTION ENTERPRISES, INC., GREAT NECK, NY. SN 85-623,313. PUB. 10-30-2012, FILED 5-11-2012.

# collaborizm

THE MARK CONSISTS OF STANDARD CHARACTERS WITHOUT CLAIM TO ANY PARTICULAR FONT, STYLE, SIZE, OR COLOR.

FOR PROVIDING AN ONLINE NON-DOWNLOADABLE INTERNET-BASED SOFTWARE APPLICATION FOR PUBLISHING AND SHARING DIGITAL MEDIA AND INFORMATION VIA GLOBAL COMPUTER AND COMMUNICATIONS NETWORKS (U.S. CLS. 100 AND 101).

FIRST USE 4-1-2014; IN COMMERCE 4-1-2014.

**CLASS 42—(Continued).**

4,593,325. RELATIVE EMOTION ENTERPRISES, INC., GREAT NECK, NY. SN 85-623,382. PUB. 10-30-2012, FILED 5-11-2012.



THE MARK CONSISTS OF A LETTER "C" AND A LIGHTNING BOLT CONTAINED WITHIN A SHADED CIRCLE.

FOR PROVIDING AN ONLINE NON-DOWNLOADABLE INTERNET-BASED SOFTWARE APPLICATION FOR PUBLISHING AND SHARING DIGITAL MEDIA AND INFORMATION VIA GLOBAL COMPUTER AND COMMUNICATIONS NETWORKS (U.S. CLS. 100 AND 101).

FIRST USE 4-1-2014; IN COMMERCE 4-1-2014.

**CLASS 42—(Continued).**

4,593,345. VOISPOT, LLC, BOCA RATON, FL. SN 85-638,672. PUB. 10-30-2012, FILED 5-30-2012.

# VOISPOT

THE MARK CONSISTS OF STANDARD CHARACTERS WITHOUT CLAIM TO ANY PARTICULAR FONT, STYLE, SIZE, OR COLOR.

FOR COMPUTER SERVICES, NAMELY, HOSTING ON-LINE WEB FACILITIES FOR OTHERS FOR ORGANIZING AND CONDUCTING ONLINE MEETINGS, GATHERINGS, AND INTERACTIVE DISCUSSIONS; COMPUTER SERVICES, NAMELY, PROVIDING CUSTOMIZED ONLINE WEB PAGES FEATURING USER-DEFINED INFORMATION; COMPUTER SERVICES, NAMELY, PROVIDING A WEBSITE FOR USERS TO ASK AND ANSWER QUESTIONS ON A VARIETY OF TOPICS OF GENERAL INTEREST, CREATING AN ONLINE COMMUNITY FOR REGISTERED USERS TO PARTICIPATE IN DISCUSSIONS, GET FEEDBACK FROM THEIR PEERS, FORM VIRTUAL COMMUNITIES, AND ENGAGE IN SOCIAL NETWORKING; COMPUTER SERVICES, NAMELY, CREATING INDEXES OF INFORMATION, SITES AND OTHER RESOURCES AVAILABLE ON COMPUTER NETWORKS; PROVIDING TEMPORARY USE OF NON-DOWNLOADABLE SOFTWARE APPLICATIONS FOR ENABLING, FACILITATING, OR ENHANCING SOCIAL NETWORKING, CREATING A VIRTUAL COMMUNITY, AND TRANSMISSION OF AUDIO, PHOTOGRAPHIC IMAGES, TEXT, GRAPHICS AND DATA; PROVIDING A WEB SITE FEATURING TECHNOLOGY THAT ENABLES USERS TO UPLOAD AND SHARE, PHOTOS, TEXT, GRAPHICS AND DATA (U.S. CLS. 100 AND 101).

FIRST USE 9-20-2012; IN COMMERCE 9-20-2012.

4,593,334. DAUGHERTY SYSTEMS, INC., ST. LOUIS, MO. SN 85-633,242. PUB. 11-19-2013, FILED 5-23-2012.

## DAUGHERTY MOBILE SUITE

THE MARK CONSISTS OF STANDARD CHARACTERS WITHOUT CLAIM TO ANY PARTICULAR FONT, STYLE, SIZE, OR COLOR.

OWNER OF U.S. REG. NOS. 1,823,411, 2,734,281, AND 4,285,489.

NO CLAIM IS MADE TO THE EXCLUSIVE RIGHT TO USE "MOBILE SUITE", APART FROM THE MARK AS SHOWN.

SEC. 2(F) AS TO "DAUGHERTY".

FOR SOFTWARE AS A SERVICE (SAAS) SERVICES FEATURING SOFTWARE FOR WORKFORCE MANAGEMENT, WORKFORCE COMMUNICATION, WORKFORCE SUPERVISION, WORKFORCE LOCATION TRACKING, WORKFORCE TASK SCHEDULING, REPORT GENERATION, AND FOR PROVIDING WORKERS WITH MOBILE ACCESS TO ASSIGNED TASKS, INSTRUCTIONS, WORK ORDERS, QUESTIONNAIRES, FORMS, SURVEYS, AND NOTIFICATIONS (U.S. CLS. 100 AND 101).

FIRST USE 5-0-2014; IN COMMERCE 5-0-2014.

**CLASS 42—(Continued).**

4,593,364. WHO CUTS, LLC, ATLANTA, GA. SN 85-650,298.  
PUB. 11-6-2012, FILED 6-13-2012.



THE MARK CONSISTS OF THE COMPOSITE WORD "WHOCUTS," IN WHICH THE SECOND UPRIGHT POST OF THE LETTER "H" IS EXTENDED TO TWICE THE HEIGHT OF THE WORD AND TOPPED WITH THE CARTOON IMAGE OF AN OWL WITH ITS RIGHT WING EXTENDED.

FOR COMPUTER SERVICES IN THE NATURE OF CUSTOMIZED WEB PAGES FEATURING USER-DEFINED INFORMATION, PERSONAL PROFILES AND INFORMATION; COMPUTER SERVICES, NAMELY, HOSTING ONLINE WEB FACILITIES FOR OTHERS FOR ORGANIZING AND CONDUCTING ONLINE MEETINGS AND INTERACTIVE DISCUSSIONS; APPLICATION SERVICE PROVIDER (ASP) FEATURING SOFTWARE TO ENABLE UPLOADING, POSTING, SHOWING, DISPLAYING, TAGGING, BLOGGING, SHARING OR OTHERWISE PROVIDING DIGITAL MEDIA AND INFORMATION OVER THE INTERNET; PROVIDING TEMPORARY USE OF NON-DOWNLOADABLE SOFTWARE APPLICATIONS FOR CLASSIFIEDS, VIRTUAL COMMUNITY, SOCIAL NETWORKING, PHOTO SHARING, AND TRANSMISSION OF PHOTOGRAPHIC IMAGES; PROVIDING ON-LINE COMPUTER DATABASES AND ON-LINE SEARCHABLE DATABASES IN THE FIELD OF VIRTUAL COMMUNITY (U.S. CLS. 100 AND 101).

FIRST USE 5-19-2012; IN COMMERCE 3-31-2014.

4,593,386. EXELON CORPORATION, PHILADELPHIA, PA.  
SN 85-664,070. PUB. 12-11-2012, FILED 6-28-2012.

VIRTUWATT LINK

THE MARK CONSISTS OF STANDARD CHARACTERS WITHOUT CLAIM TO ANY PARTICULAR FONT, STYLE, SIZE, OR COLOR.

OWNER OF U.S. REG. NOS. 3,962,886 AND 4,088,630.

**CLASS 42—(Continued).**

NO CLAIM IS MADE TO THE EXCLUSIVE RIGHT TO USE "LINK", APART FROM THE MARK AS SHOWN.

FOR PROVIDING TEMPORARY USE OF ONLINE NON-DOWNLOADABLE SOFTWARE FOR AUTOMATED LOAD CONTROL AND DEMAND RESPONSE PROGRAMS; PROVIDING TEMPORARY USE OF ON-LINE NON-DOWNLOADABLE SOFTWARE FOR USE IN PROVIDING ENERGY PRICING AND USAGE INFORMATION, PARTICIPATING IN ENERGY AUCTIONS, MONITORING ENERGY USAGE AND SUPPLY, MANAGING AND REDUCING ENERGY LOAD AND USAGE, ENERGY AUDITING, RESPONDING TO CURTAILMENT EVENTS CALLED BY THE LOCAL INDEPENDENT SYSTEM OPERATOR (ISO), THE ENERGY SUPPLIER OR SELF-SCHEDULED EVENTS, AND PROVIDING CUSTOMIZED REPORTS RELATED THERETO (U.S. CLS. 100 AND 101).

FIRST USE 12-10-2012; IN COMMERCE 12-10-2012.

4,593,390. EASY E-JUNKIE LLC, BLACKSBURG, VA. SN 85-668,155. PUB. 12-4-2012, FILED 7-3-2012.

cartWiz

THE MARK CONSISTS OF STANDARD CHARACTERS WITHOUT CLAIM TO ANY PARTICULAR FONT, STYLE, SIZE, OR COLOR.

FOR COMPUTER PROGRAMMING SERVICES FOR OTHERS IN THE FIELD OF ECOMMERCE; PROVIDING TEMPORARY USE OF ON-LINE NON-DOWNLOADABLE SOFTWARE AND APPLICATIONS FOR USE LINKING TO ON-LINE SOFTWARE AND APPLICATIONS FOR THE PURPOSE OF TRANSFERRING TRANSACTION DATA AND PRODUCT DATA, AND FOR USE CREATING, STORING, MODIFYING, ANALYZING, AND REPORTING TRANSACTION DATA AND PRODUCT DATA, AND FOR USE MANAGING ON-LINE MERCHANT SALES AND PRE-SALES AND POST-SALES ACTIVITIES (U.S. CLS. 100 AND 101).

FIRST USE 6-17-2014; IN COMMERCE 6-17-2014.

4,593,405. SYINC LLC, MECHANICSBURG, PA. SN 85-681,186. PUB. 2-19-2013, FILED 7-19-2012.

iritzi

THE MARK CONSISTS OF STANDARD CHARACTERS WITHOUT CLAIM TO ANY PARTICULAR FONT, STYLE, SIZE, OR COLOR.

**CLASS 42—(Continued).**

THE ENGLISH TRANSLATION OF "IRITZI" IN THE MARK IS "OPINION".

FOR APPLICATION SERVICE PROVIDER (ASP) FEATURING SOFTWARE FOR USE IN THE DIGITIZATION AND AUTOMATION OF THE PROCESSES OF AN INSTITUTIONAL REVIEW BOARD, INCLUDING STUDY MANAGEMENT, PROTOCOL MANAGEMENT, VIRTUALIZATION OF MEETINGS AND INSTITUTION LEVEL OVERVIEWS, IN THE FIELD OF INSTITUTIONAL REVIEW BOARD MANAGEMENT (U.S. CLS. 100 AND 101).

FIRST USE 5-22-2014; IN COMMERCE 5-22-2014.

**CLASS 42—(Continued).**

4,593,419. JAMZOO TECHNOLOGY CO., LTD., DA'AN DIST. TAIPEI CITY, TAIWAN. SN 85-692,919. PUB. 10-15-2013, FILED 8-1-2012.

# JamZoo

THE MARK CONSISTS OF STANDARD CHARACTERS WITHOUT CLAIM TO ANY PARTICULAR FONT, STYLE, SIZE, OR COLOR.

FOR COMPUTER PROGRAMMING; DESIGN OF COMPUTER SOFTWARE; MAINTENANCE OF COMPUTER SOFTWARE; RENTAL OF COMPUTER SOFTWARE; PROVIDING INFORMATION IN THE FIELDS OF TECHNOLOGY AND SOFTWARE DEVELOPMENT VIA THE GLOBAL COMPUTER NETWORKS; CONSULTATION FOR DESIGN OF COMPUTER SOFTWARE; COMPUTER SYSTEMS ANALYSIS; DESIGN OF COMPUTER SYSTEMS; COMPUTER SOFTWARE INSTALLATION; PROVIDING TEMPORARY USE OF NON-DOWNLOADABLE COMPUTER SOFTWARE FOR USERS TO DEVELOP APPLICATIONS FOR MOBILE PHONES OVER COMPUTER NETWORKS, INTRANETS AND THE INTERNET; COMPUTER SERVICES, NAMELY, ELECTRONIC DIGITIZING OF PHYSICAL INFORMATION, NAMELY, PHOTOGRAPHIC IMAGES, ARTWORK, PAINTINGS, AND DOCUMENTS; DATA CONVERSION OF COMPUTER PROGRAMS AND DATA, NOT PHYSICAL CONVERSION; RENTAL OF WEB SERVER SPACE; RENTAL OF WEB SERVER; PLANNING AND BUILDING WEBSITES; MAINTAINING WEBSITES FOR OTHERS; COMPUTER CO-LOCATION SERVICES, NAMELY, PROVIDING FACILITIES FOR THE LOCATION OF COMPUTER SERVERS WITH THE EQUIPMENT OF OTHERS (U.S. CLS. 100 AND 101).  
FIRST USE 9-4-2012; IN COMMERCE 9-4-2012.

4,593,406. GOLDMARK STUDIOS INC., VANCOUVER, BC, V6E 4C2, CANADA. SN 85-681,860. PUB. 6-18-2013, FILED 7-19-2012.

## GOLDMARK STUDIOS

4,593,420. JAMZOO TECHNOLOGY CO., LTD., DA'AN DIST. TAIPEI CTY, TAIWAN. SN 85-692,979. PUB. 10-8-2013, FILED 8-1-2012.

# 醬子

THE MARK CONSISTS OF STANDARD CHARACTERS WITHOUT CLAIM TO ANY PARTICULAR FONT, STYLE, SIZE, OR COLOR.

NO CLAIM IS MADE TO THE EXCLUSIVE RIGHT TO USE "STUDIOS", APART FROM THE MARK AS SHOWN.

FOR DESIGN AND DEVELOPMENT OF SOFTWARE, COMPUTER GAMES, AND OTHER INTERACTIVE MEDIA AND APPLICATIONS FOR COMPUTERS, ONLINE, AND MOBILE DEVICES (U.S. CLS. 100 AND 101).  
FIRST USE 8-0-2012; IN COMMERCE 8-0-2012.

THE MARK CONSISTS OF TWO LARGE CHINESE CHARACTERS.

**CLASS 42—(Continued).**

THE NON-LATIN CHARACTERS IN THE MARK TRANSLITERATE TO "JIAN ZI" AND THIS MEANS "SAUCE SON" IN ENGLISH.

FOR COMPUTER PROGRAMMING; DESIGN OF COMPUTER SOFTWARE; MAINTENANCE OF COMPUTER SOFTWARE; RENTAL OF COMPUTER SOFTWARE; PROVIDING INFORMATION IN THE FIELDS OF TECHNOLOGY AND SOFTWARE DEVELOPMENT VIA THE GLOBAL COMPUTER NETWORKS; CONSULTATION FOR DESIGN OF COMPUTER SOFTWARE; COMPUTER SYSTEMS ANALYSIS; DESIGN OF COMPUTER SYSTEMS; COMPUTER SOFTWARE INSTALLATION; PROVIDING TEMPORARY USE OF NON-DOWNLOADABLE COMPUTER SOFTWARE FOR USERS TO DEVELOP APPLICATIONS FOR MOBILE PHONES OVER COMPUTER NETWORKS, INTRANETS AND THE INTERNET; COMPUTER SERVICES, NAMELY, ELECTRONIC DIGITIZING OF PHYSICAL INFORMATION, NAMELY, PHOTOGRAPHIC IMAGES, ARTWORK, PAINTINGS, AND DOCUMENTS; DATA CONVERSION OF COMPUTER PROGRAMS AND DATA, NOT PHYSICAL CONVERSION; RENTAL OF WEB SERVER SPACE; RENTAL OF WEB SERVER; PLANNING AND BUILDING WEBSITES; MAINTAINING WEBSITES FOR OTHERS; COMPUTER CO-LOCATION SERVICES, NAMELY, PROVIDING FACILITIES FOR THE LOCATION OF COMPUTER SERVERS WITH THE EQUIPMENT OF OTHERS (U.S. CLS. 100 AND 101).  
FIRST USE 9-4-2012; IN COMMERCE 9-4-2012.

**CLASS 42—(Continued).**

4,593,462. NOK NOK LABS, INC., PALO ALTO, CA. SN 85-737,983. PUB. 6-4-2013, FILED 9-25-2012.

# NOK NOK

---

4,593,451. UNITED RENTALS, INC., STAMFORD, CT. SN 85-724,478. PUB. 1-15-2013, FILED 9-10-2012.

## RENT LESS. DO MORE.

THE MARK CONSISTS OF STANDARD CHARACTERS WITHOUT CLAIM TO ANY PARTICULAR FONT, STYLE, SIZE, OR COLOR.

FOR PROVIDING TEMPORARY USE OF NON-DOWNLOADABLE COMPUTER SOFTWARE FOR MANAGEMENT, TRACKING AND ACCOUNTING IN THE FIELD OF RENTAL EQUIPMENT, RENTAL TRANSACTIONS AND EQUIPMENT REPAIR (U.S. CLS. 100 AND 101).  
FIRST USE 10-28-2011; IN COMMERCE 10-28-2011.

THE MARK CONSISTS OF STANDARD CHARACTERS WITHOUT CLAIM TO ANY PARTICULAR FONT, STYLE, SIZE, OR COLOR.

FOR SOFTWARE AS A SERVICE (SAAS) SERVICES FEATURING SOFTWARE FOR USE IN COMPUTER NETWORK SECURITY AND COMPUTER NETWORK USER AUTHENTICATION; SOFTWARE AS A SERVICE (SAAS) SERVICES FEATURING SOFTWARE FOR USE IN AUTHENTICATING COMPUTER USERS, COMPUTER HARDWARE, AND COMPUTER SOFTWARE, ALL FOR STORING AND TRANSMISSION OF ELECTRONIC DATA FOR USE AS A STRONG AUTHENTICATION IDENTIFICATION SYSTEM; SOFTWARE AS A SERVICE (SAAS) SERVICES FEATURING SOFTWARE FOR USE IN USER AUTHENTICATION AND COMPUTER HARDWARE AUTHENTICATION FOR E-COMMERCE TRANSACTIONS, SENDING AND RECEIVING OF DIGITAL DATA, VOICE, MUSIC, AND VIDEO, AND FOR USER AUTHENTICATION AND COMPUTER HARDWARE AUTHENTICATION FOR ELECTRONIC FUNDS TRANSFER, CREDIT AND DEBIT CARD AND ELECTRONIC CHECK TRANSACTIONS VIA A GLOBAL COMPUTER NETWORK; COMPUTER SOFTWARE FOR OPERATING AND MANAGING STRONG AUTHENTICATION OR SECURITY TOKEN COMPUTER IDENTIFICATION SYSTEMS, TELEPHONES, AND COMMUNICATION HARDWARE; SOFTWARE AS A SERVICE (SAAS) SERVICES FEATURING SOFTWARE FOR USE IN RESTRICTING ACCESS TO AND BY COMPUTERS, COMPUTER SOFTWARE, COMPUTER HARDWARE, COMPUTER USERS, AND COMPUTER NETWORKS WITH UNDESIRE WEB SITES, SOFTWARE AND COMPUTER HARDWARE (U.S. CLS. 100 AND 101).

FIRST USE 2-12-2012; IN COMMERCE 2-12-2012.



**CLASS 42—(Continued).**

4,593,463. NOK NOK LABS, INC., PALO ALTO, CA. SN 85-737,986. PUB. 6-4-2013, FILED 9-25-2012.

# NNL

THE MARK CONSISTS OF STANDARD CHARACTERS WITHOUT CLAIM TO ANY PARTICULAR FONT, STYLE, SIZE, OR COLOR.

FOR SOFTWARE AS A SERVICE (SAAS) SERVICES FEATURING SOFTWARE FOR USE IN COMPUTER NETWORK SECURITY AND COMPUTER NETWORK USER AUTHENTICATION; SOFTWARE AS A SERVICE (SAAS) SERVICES FEATURING SOFTWARE FOR USE IN AUTHENTICATING COMPUTER USERS, COMPUTER HARDWARE, AND COMPUTER SOFTWARE, ALL FOR STORING AND TRANSMISSION OF ELECTRONIC DATA FOR USE AS A STRONG AUTHENTICATION IDENTIFICATION SYSTEM; SOFTWARE AS A SERVICE (SAAS) SERVICES FEATURING SOFTWARE FOR USE IN USER AUTHENTICATION AND COMPUTER HARDWARE AUTHENTICATION FOR E-COMMERCE TRANSACTIONS, SENDING AND RECEIVING OF DIGITAL DATA, VOICE, MUSIC, AND VIDEO, AND FOR USER AUTHENTICATION AND COMPUTER HARDWARE AUTHENTICATION FOR ELECTRONIC FUNDS TRANSFER, CREDIT AND DEBIT CARD AND ELECTRONIC CHECK TRANSACTIONS VIA A GLOBAL COMPUTER NETWORK; COMPUTER SOFTWARE FOR OPERATING AND MANAGING STRONG AUTHENTICATION OR SECURITY TOKEN COMPUTER IDENTIFICATION SYSTEMS, TELEPHONES, AND COMMUNICATION HARDWARE; SOFTWARE AS A SERVICE (SAAS) SERVICES FEATURING SOFTWARE FOR USE IN RESTRICTING ACCESS TO AND BY COMPUTERS, COMPUTER SOFTWARE, COMPUTER HARDWARE, COMPUTER USERS, AND COMPUTER NETWORKS WITH UNDESIRE WEB SITES, SOFTWARE AND COMPUTER HARDWARE (U.S. CLS. 100 AND 101).

FIRST USE 2-13-2014; IN COMMERCE 2-13-2014.

---

4,593,475. LIVE FULLY ENGAGED LLC, COLORADO SPRINGS, CO. SN 85-743,976. PUB. 10-15-2013, FILED 10-2-2012.

## THE COMMUNICATION CURE

THE MARK CONSISTS OF STANDARD CHARACTERS WITHOUT CLAIM TO ANY PARTICULAR FONT, STYLE, SIZE, OR COLOR.

NO CLAIM IS MADE TO THE EXCLUSIVE RIGHT TO USE "COMMUNICATION", APART FROM THE MARK AS SHOWN.

FOR PROVIDING AN INTERACTIVE WEB SITE FEATURING TECHNOLOGY THAT ALLOWS USERS TO UPLOAD, DOWNLOAD AND STREAM CONTENT, VIDEOS, PHOTOGRAPHS, AND INFORMATION FOR QUIZZES FOR BUILDING RELATIONSHIPS WITH OTHER PEOPLE (U.S. CLS. 100 AND 101).

FIRST USE 10-0-2011; IN COMMERCE 10-0-2011.

**CLASS 42—(Continued).**

4,593,514. SOLUTIONS BY DESIGN, INC., DBA SOLUTIONS BY DESIGN, INC., NEW YORK, NY. SN 85-765,648. PUB. 11-12-2013, FILED 10-29-2012.

# Journal to Health

THE MARK CONSISTS OF STANDARD CHARACTERS WITHOUT CLAIM TO ANY PARTICULAR FONT, STYLE, SIZE, OR COLOR.

NO CLAIM IS MADE TO THE EXCLUSIVE RIGHT TO USE "JOURNAL", APART FROM THE MARK AS SHOWN.

FOR PROVIDING AN INTERACTIVE WEBSITE FEATURING TECHNOLOGY THAT ALLOWS USERS TO CREATE AN ONLINE JOURNAL OR DIARY (U.S. CLS. 100 AND 101).

FIRST USE 6-1-2014; IN COMMERCE 6-1-2014.

---

4,593,533. BDM IT SOLUTIONS INC., CALGARY, AB, CANADA. SN 85-773,503. PUB. 10-22-2013, FILED 11-7-2012.

# BDM

THE MARK CONSISTS OF STANDARD CHARACTERS WITHOUT CLAIM TO ANY PARTICULAR FONT, STYLE, SIZE, OR COLOR.

FOR APPLICATION SERVICE PROVIDER FEATURING SOFTWARE FOR USE IN PHARMACY MANAGEMENT, NAMELY, SOFTWARE FOR MANAGING PATIENT MEDICATION ORDER INFORMATION, DRUG DISTRIBUTION, INVENTORY AND BILLING, FOR USE IN IMPROVING PRODUCTIVITY AND ENHANCING PATIENT CARE (U.S. CLS. 100 AND 101).

FIRST USE 2-15-2013; IN COMMERCE 2-15-2013.

**CLASS 42—(Continued).**

4,593,535. ANABIOS CORPORATION, FORMERLY ANABIO-CARDIA CORPORATION, SAN DIEGO, CA. SN 85-773,795. PUB. 4-16-2013, FILED 11-7-2012.

# Phase X

THE MARK CONSISTS OF STANDARD CHARACTERS WITHOUT CLAIM TO ANY PARTICULAR FONT, STYLE, SIZE, OR COLOR.

FOR BIOMEDICAL RESEARCH SERVICES; CONSULTING SERVICES IN THE FIELDS OF BIOTECHNOLOGY, PHARMACEUTICAL RESEARCH AND DEVELOPMENT, LABORATORY TESTING, DIAGNOSTICS, AND PHARMACOGENETICS; LABORATORY RESEARCH IN THE FIELD OF PHARMACEUTICALS AND TOXINS; MEDICAL AND SCIENTIFIC RESEARCH, NAMELY, CONDUCTING CLINICAL TRIALS FOR OTHERS; MEDICAL RESEARCH; PHARMACEUTICAL RESEARCH AND DEVELOPMENT; RESEARCH AND DEVELOPMENT IN THE FIELD OF DRUG SAFETY AND TOXICITY; RESEARCH AND DEVELOPMENT IN THE PHARMACEUTICAL AND BIOTECHNOLOGY FIELDS; TOXICOLOGY SERVICES (U.S. CLS. 100 AND 101).

FIRST USE 8-1-2010; IN COMMERCE 9-1-2010.

**CLASS 42—(Continued).**

4,593,582. SIGGITT LLC, LAS VEGAS, NV. SN 85-792,278. PUB. 5-7-2013, FILED 11-30-2012.

# Can you dig it? Then Siggitt!

THE MARK CONSISTS OF STANDARD CHARACTERS WITHOUT CLAIM TO ANY PARTICULAR FONT, STYLE, SIZE, OR COLOR.

FOR CUSTOM DESIGN AND DEVELOPMENT OF E-MAIL SIGNATURES; PROVIDING AN INTERACTIVE WEBSITE FEATURING TECHNOLOGY THAT ALLOWS USERS TO CREATE CUSTOM E-MAIL SIGNATURES AND ATTACH ART, CULTURE, MUSIC, AND BRAND IMAGES AND LINKS TO E-MAIL SIGNATURES; SOFTWARE AS A SERVICE (SAAS) SERVICES FEATURING SOFTWARE FOR CREATING CUSTOM E-MAIL SIGNATURES AND TRACKING DATA OBTAINED FROM E-MAIL SIGNATURES AND IMBEDDED LINKS (U.S. CLS. 100 AND 101).

FIRST USE 6-20-2014; IN COMMERCE 6-20-2014.

---

4,593,581. SIGGITT LLC, LAS VEGAS, NV. SN 85-792,274. PUB. 5-7-2013, FILED 11-30-2012.

# Siggitt

THE MARK CONSISTS OF STANDARD CHARACTERS WITHOUT CLAIM TO ANY PARTICULAR FONT, STYLE, SIZE, OR COLOR.

FOR CUSTOM DESIGN AND DEVELOPMENT OF E-MAIL SIGNATURES; PROVIDING AN INTERACTIVE WEBSITE FEATURING TECHNOLOGY THAT ALLOWS USERS TO CREATE CUSTOM E-MAIL SIGNATURES AND ATTACH ART, CULTURE, MUSIC, AND BRAND IMAGES AND LINKS TO E-MAIL SIGNATURES; SOFTWARE AS A SERVICE (SAAS) SERVICES FEATURING SOFTWARE FOR CREATING CUSTOM E-MAIL SIGNATURES AND TRACKING DATA OBTAINED FROM E-MAIL SIGNATURES AND IMBEDDED LINKS (U.S. CLS. 100 AND 101).

FIRST USE 6-20-2014; IN COMMERCE 6-20-2014.

---

4,593,592. MADEQUEST, DECATUR, GA. SN 85-796,773. PUB. 5-21-2013, FILED 12-6-2012.

# MadeQuest

THE MARK CONSISTS OF STANDARD CHARACTERS WITHOUT CLAIM TO ANY PARTICULAR FONT, STYLE, SIZE, OR COLOR.

FOR PROVIDING TEMPORARY USE OF A WEB-BASED SOFTWARE APPLICATION FOR CONSUMERS TO REQUEST, DESCRIBE, OR DESIGN A PRODUCT VIA DESCRIPTION OR PICTURE AND DESIGNERS MAY BID TO FILL OR GRANT THE REQUEST OR ORDER, THEREFORE CONNECTING QUALIFIED SERVICE PROVIDERS WITH CONSUMERS (U.S. CLS. 100 AND 101).

FIRST USE 8-0-2012; IN COMMERCE 12-0-2013.

**CLASS 42—(Continued).**

4,593,596. LAIYA ENTERPRISES INC., PARADISE VALLEY, AZ. SN 85-797,151. PUB. 6-4-2013, FILED 12-7-2012.

# bcarrot

THE MARK CONSISTS OF STANDARD CHARACTERS WITHOUT CLAIM TO ANY PARTICULAR FONT, STYLE, SIZE, OR COLOR.

FOR SOFTWARE AS A SERVICE (SAAS), NAMELY, HOSTING SOFTWARE FOR USE BY OTHERS FOR ACCESSING ONLINE, NON-DOWNLOADABLE SOFTWARE FOR CONDUCTING A PROGRAM TO FACILITATE EMPLOYER RECOGNITION OF EMPLOYEE ACHIEVEMENTS (U.S. CLS. 100 AND 101).

FIRST USE 11-1-2013; IN COMMERCE 11-1-2013.

4,593,602. BENAROYA RESEARCH INSTITUTE AT VIRGINIA MASON, SEATTLE, WA. SN 85-799,861. PUB. 11-12-2013, FILED 12-11-2012.

# BRInG It On

THE MARK CONSISTS OF STANDARD CHARACTERS WITHOUT CLAIM TO ANY PARTICULAR FONT, STYLE, SIZE, OR COLOR.

FOR MEDICAL AND SCIENTIFIC RESEARCH AND CONDUCTING CLINICAL TRIALS IN THE FIELD OF THE CAUSES AND CURES OF HUMAN DISEASES (U.S. CLS. 100 AND 101).

FIRST USE 6-15-2013; IN COMMERCE 7-2-2013.

4,593,665. INNOVATION TAP LLC, DRESHER, PA. SN 85-819,746. PUB. 5-28-2013, FILED 1-10-2013.

# POWERFEED

THE MARK CONSISTS OF STANDARD CHARACTERS WITHOUT CLAIM TO ANY PARTICULAR FONT, STYLE, SIZE, OR COLOR.

FOR SOFTWARE AS A SERVICE (SAAS) SERVICES FEATURING SOFTWARE FOR USE IN PROVIDING LOW LATENCY DATA, INFORMATION AND ANALYSIS USED IN THE ENERGY AND COMMODITIES TRADING (U.S. CLS. 100 AND 101).

FIRST USE 1-13-2014; IN COMMERCE 1-13-2014.

**CLASS 42—(Continued).**

4,593,675. ADVICENT SOLUTIONS, LP, MILWAUKEE, WI. SN 85-822,792. PUB. 9-24-2013, FILED 1-14-2013.

# NAVIPRO

THE MARK CONSISTS OF STANDARD CHARACTERS WITHOUT CLAIM TO ANY PARTICULAR FONT, STYLE, SIZE, OR COLOR.

FOR PROVIDING TEMPORARY USE OF ON-LINE NON-DOWNLOADABLE SOFTWARE FOR USE IN FINANCIAL PLANNING (U.S. CLS. 100 AND 101).

FIRST USE 1-19-2013; IN COMMERCE 1-28-2013.

4,593,728. HUMAN CAPITAL MANAGEMENT SOLUTIONS, INC., DBA HIREWELL, CHICAGO, IL. SN 85-854,034. PUB. 8-6-2013, FILED 2-19-2013.

# TECH YOURSELF

THE MARK CONSISTS OF STANDARD CHARACTERS WITHOUT CLAIM TO ANY PARTICULAR FONT, STYLE, SIZE, OR COLOR.

FOR PROVIDING A WEBSITE FEATURING ON-LINE NON-DOWNLOADABLE SOFTWARE FOR TESTING COMPETENCIES OF JOB CANDIDATES (U.S. CLS. 100 AND 101).

FIRST USE 3-8-2013; IN COMMERCE 3-23-2014.

4,593,787. ALTEC LIMITED CONSULTING, GROVE CITY, OH. SN 85-890,348. PUB. 12-24-2013, FILED 3-29-2013.



NO CLAIM IS MADE TO THE EXCLUSIVE RIGHT TO USE "GREEN FLEET", APART FROM THE MARK AS SHOWN.

THE COLOR(S) BRIGHT GREEN, LIGHT GREEN, GREEN, DARK GREEN, LIGHT GRAY, GRAY, AND DARK GRAY IS/ARE CLAIMED AS A FEATURE OF THE MARK.

THE MARK CONSISTS OF THE LITERAL ELEMENT "GREEN FLEET". THE WORD "GREEN" IS IN THE UPPER LEFT AND IS IN BRIGHT GREEN STYLIZED LETTERS. THE WORD "FLEET" IS IN THE LOWER RIGHT AND IS IN STYLIZED DARK GRAY LETTERS. ALL OF THE LETTERS IN "GREEN" AND "FLEET" HAVE GRAY OUTLINING ON THE RIGHT SIDE. BETWEEN THE WORDS "GREEN" AND "FLEET" IS A DESIGN ELEMENT CONSISTING OF A

**CLASS 42—(Continued).**

RIGHT-FACING FUEL PUMP HANDLE AND NOZZLE WHICH IS LIGHT GRAY IN COLOR WITH A CURVED DARK GREEN LINE WHICH STARTS FROM THE BOTTOM OF THE PUMP HANDLE, CURVES AROUND AND THEN FORMS THE STEM AND CENTER LINE OF A LEAF THAT IS BELOW THE FUEL PUMP NOZZLE AND HANDLE DESIGN. THE LEAF IS OUTLINED IN DARK GREEN WITH THE INSIDE BEING LIGHT GREEN AT THE TIP AND SLOWLY BECOMING GREEN AT THE BOTTOM. UNDER THE LEAF IS AN OVAL SHAPED SHADOW WHICH IS LIGHT GRAY AT THE OUTER EDGES AND GRAY IN THE MIDDLE. THE COLOR WHITE IN THE MARK IS TRANSPARENT BACKGROUND AND IT NOT A PART OF THE MARK.

FOR SOFTWARE AS A SERVICE (SAAS) SERVICES FEATURING SOFTWARE FOR PLANNING, MANAGING AND IMPLEMENTING ALTERNATIVE FUEL SYSTEMS AND TECHNOLOGIES FOR COMMERCIAL VEHICLES, FLEET VEHICLES (U.S. CLS. 100 AND 101).  
FIRST USE 1-5-2012; IN COMMERCE 1-5-2012.

---

4,593,790. RUN BUSINESS SOLUTIONS, INC., AMARILLO, TX. SN 85-891,535. PUB. 11-5-2013, FILED 4-1-2013.

# RunSync

THE MARK CONSISTS OF STANDARD CHARACTERS WITHOUT CLAIM TO ANY PARTICULAR FONT, STYLE, SIZE, OR COLOR.

FOR COMPUTER SERVICES, NAMELY, HOSTING AN INTERACTIVE WEB SITE THAT ALLOWS YOU TO SEND TEXT MESSAGES TO YOUR SUBSCRIBERS, PUBLISH INFORMATION TO YOUR WEBSITE, MOBILE APP, SOCIAL NETWORKING AND MICROBLOGGING SITES FROM A SINGLE CONVENIENT WEB OR MOBILE INTERFACE (U.S. CLS. 100 AND 101).

FIRST USE 10-1-2013; IN COMMERCE 10-1-2013.

---

4,593,809. GREAT LAKES MEDICAL BILLING & PRACTICE MANAGEMENT, LLC, CHESTERFIELD, MI. SN 85-906,489. PUB. 9-17-2013, FILED 4-17-2013.

# avantMD

THE MARK CONSISTS OF STANDARD CHARACTERS WITHOUT CLAIM TO ANY PARTICULAR FONT, STYLE, SIZE, OR COLOR.

FOR PROVIDING ON-LINE, NON-DOWNLOADABLE, INTERNET-BASED SOFTWARE APPLICATION FOR MEDICAL BILLING FOR PHYSICIANS AND HEALTH CARE INSTITUTIONS (U.S. CLS. 100 AND 101).

FIRST USE 3-1-2013; IN COMMERCE 3-15-2013.

**CLASS 42—(Continued).**

4,593,854. GENOME ID GROUP, LLC, GREENVILLE, NC. SN 85-920,893. PUB. 10-8-2013, FILED 5-1-2013.

## SOLVING DNA MIXTURES GENOME WIDE

THE MARK CONSISTS OF STANDARD CHARACTERS WITHOUT CLAIM TO ANY PARTICULAR FONT, STYLE, SIZE, OR COLOR.

FOR DNA SCREENING FOR FORENSIC ANALYSIS AND RESEARCH PURPOSES; DNA PROFILING AND ANALYSIS SERVICES FOR FORENSIC ANALYSIS AND RESEARCH PURPOSES; CONSULTING SERVICES IN THE FIELD OF DNA FORENSICS (U.S. CLS. 100 AND 101).

FIRST USE 1-14-2014; IN COMMERCE 1-14-2014.

---

4,593,882. LIGHTYEAR TECHNOLOGIES, INC., MCLEAN, VA. SN 85-927,426. PUB. 10-8-2013, FILED 5-9-2013.

# ALTAMIRA

THE MARK CONSISTS OF STANDARD CHARACTERS WITHOUT CLAIM TO ANY PARTICULAR FONT, STYLE, SIZE, OR COLOR.

FOR CONSULTING IN THE FIELD OF INFORMATION TECHNOLOGY; CONSULTING IN THE FIELD OF TELECOMMUNICATIONS TECHNOLOGY (U.S. CLS. 100 AND 101).

FIRST USE 6-18-2013; IN COMMERCE 6-18-2013.

---

4,593,897. KASPAR HAUSER CORP., VENICE, CA. SN 85-931,509. PUB. 10-8-2013, FILED 5-14-2013.

# HATCHEREE

THE MARK CONSISTS OF STANDARD CHARACTERS WITHOUT CLAIM TO ANY PARTICULAR FONT, STYLE, SIZE, OR COLOR.

FOR PROVIDING AN ONLINE NON-DOWNLOADABLE INTERNET-BASED SYSTEM APPLICATION FEATURING TECHNOLOGY ENABLING USERS TO DEVELOP, MANAGE, AND COLLABORATE WITH COMMUNITIES OF THEIR FANS / FOLLOWERS (U.S. CLS. 100 AND 101).

FIRST USE 11-8-2013; IN COMMERCE 11-8-2013.

**CLASS 42—(Continued).**

4,593,956. AIRCARE LABS LLC, PHILADELPHIA, PA. SN 85-940,771. PUB. 10-22-2013, FILED 5-23-2013.

# AIRCARE

THE MARK CONSISTS OF STANDARD CHARACTERS WITHOUT CLAIM TO ANY PARTICULAR FONT, STYLE, SIZE, OR COLOR.

FOR PROVIDING A WEBSITE FEATURING NON-DOWNLOADABLE SOFTWARE FOR REMOTE MEDICAL CONSULTATION IN THE FIELD OF TELEMEDICINE; PROVIDING A WEBSITE FEATURING NON-DOWNLOADABLE SOFTWARE FOR THE REMOTE MONITORING OF DATA INDICATIVE OF THE HEALTH OR CONDITION OF AN INDIVIDUAL OR GROUP OF INDIVIDUALS FOR MEDICAL DIAGNOSIS AND TREATMENT PURPOSES (U.S. CLS. 100 AND 101).  
FIRST USE 10-0-2013; IN COMMERCE 10-0-2013.

4,593,985. MINDBODY, INC., SAN LUIS OBISPO, CA. SN 85-944,646. PUB. 11-5-2013, FILED 5-29-2013.

## POWERED BY MINDBODY

THE MARK CONSISTS OF STANDARD CHARACTERS WITHOUT CLAIM TO ANY PARTICULAR FONT, STYLE, SIZE, OR COLOR.

OWNER OF U.S. REG. NOS. 3,387,526 AND 3,873,251.  
FOR PROVIDING TEMPORARY USE OF NON-DOWNLOADABLE BUSINESS MANAGEMENT SOFTWARE DELIVERED VIA INTERNET WEB BROWSER AND APPLICATION PROGRAMMING INTERFACE (API) FOR YOGA AND PILATES STUDIOS, HEALTH CLUBS, DAY SPAS, RESORTS, RETREAT CENTERS, DANCE STUDIOS, BEAUTY SALONS, PERSONAL TRAINERS, SPORTS TRAINERS AND OTHER HEALTH AND WELLNESS BUSINESSES; SOFTWARE SERVICES DELIVERED VIA AN INTERNET WEB BROWSER AND APPLICATION PROGRAMMING INTERFACE (API), NAMELY, PROVIDING TEMPORARY USE OF NON-DOWNLOADABLE COMPUTER SOFTWARE TO MANAGE CLASSES AND EVENTS, SCHEDULE RESOURCES AND APPOINTMENTS, AND TO ACCESS BUSINESS REPORTS; PROVIDING TEMPORARY USE OF NON-DOWNLOADABLE MERCHANT ACCOUNT SOFTWARE AND APPLICATION PROGRAMMING INTERFACE (API) SOFTWARE ALL FOR USE IN BILLING AND RECONCILING ACCOUNTS FOR YOGA AND PILATES STUDIOS, HEALTH CLUBS, DAY SPAS, RESORTS, RETREAT CENTERS, DANCE STUDIOS, BEAUTY SALONS, PERSONAL TRAINERS, SPORTS TRAINERS AND OTHER HEALTH AND BUSINESSES; AND WEBSITE DEVELOPMENT FOR OTHERS (U.S. CLS. 100 AND 101).  
FIRST USE 11-8-2011; IN COMMERCE 11-8-2011.

**CLASS 42—(Continued).**

4,594,005. PINEAU, BRAD, STRATFORD, PEI, CANADA. SN 85-948,665. PUB. 10-29-2013, FILED 6-3-2013.



THE MARK CONSISTS OF AN ABSTRACT MINIMALIST RENDERING OF A WATCHTOWER TO THE LEFT OF THE WORD "WATCHTOWER".

FOR SOFTWARE AS A SERVICE (SAAS) SERVICES FEATURING SOFTWARE THAT ALLOWS MANAGERS TO COLLECT FEEDBACK FROM THEIR TEAM (U.S. CLS. 100 AND 101).  
FIRST USE 11-19-2013; IN COMMERCE 11-19-2013.

4,594,194. TITAN MANAGEMENT GROUP, LLC, BRENTWOOD, TN. SN 85-982,543. PUB. 10-15-2013, FILED 10-30-2012.

# TITAN

THE MARK CONSISTS OF STANDARD CHARACTERS WITHOUT CLAIM TO ANY PARTICULAR FONT, STYLE, SIZE, OR COLOR.

FOR PROVIDING TEMPORARY USE OF ONLINE NON-DOWNLOADABLE SOFTWARE FOR FUEL MANAGEMENT, COMPLIANCE MANAGEMENT AND FACILITY MANAGEMENT; PROVIDING SOFTWARE SUPPORT SERVICES IN THE NATURE OF REMOTE MONITORING AND TROUBLESHOOTING SOFTWARE PROBLEMS RELATING TO FUEL MANAGEMENT, COMPLIANCE MANAGEMENT AND FACILITY MANAGEMENT; PROVIDING ONLINE NON-DOWNLOADABLE CLOUD-BASED SOFTWARE THAT REMOTELY FACILITATES THE MANAGEMENT OF AUTOMATIC FUEL TANK GAUGES AND MONITORS AUTOMATIC TANK GAUGES TO DETECT AND PREVENT ENVIRONMENTAL RELEASES; AND SOFTWARE AS A SERVICE (SAAS) SERVICES FEATURING SOFTWARE FOR SUBSCRIPTION-BASED MANAGEMENT OF ENVIRONMENTAL, FUEL, AND FUEL FACILITY-RELATED ASSETS, COMPLIANCE AND MAINTENANCE; AND PROVIDING TEMPORARY USE OF ONLINE NON-DOWNLOADABLE SOFTWARE OFFERED OVER A GLOBAL COMPUTER NETWORK FOR SUBSCRIPTION-BASED MANAGEMENT OF ENVIRONMENTAL, FUEL, AND FUEL FACILITY-RELATED ASSETS, COMPLIANCE AND MAINTENANCE (U.S. CLS. 100 AND 101).

FIRST USE 7-1-2008; IN COMMERCE 7-1-2008.

**CLASS 42—(Continued).**

4,594,272. THE OUTFIT, INC., BEVERLY, MA. SN 86-031,067.  
PUB. 3-4-2014, FILED 8-7-2013.

**BIG BOARD**

THE MARK CONSISTS OF STANDARD CHARACTERS WITHOUT CLAIM TO ANY PARTICULAR FONT, STYLE, SIZE, OR COLOR.

FOR SOFTWARE AS A SERVICE (SAAS) SERVICES FEATURING SOFTWARE FOR REPORTING, AGGREGATING, CURATING, VISUALIZING AND COLLABORATION OF DATA FROM THIRD PARTY SERVICES AND FIRST-PARTY API SUBMISSIONS FOR DATA REPORTING, INFORMATION SHARING, PROJECT MANAGEMENT, PRODUCT MANAGEMENT, ACCOUNTING, SALES, CALENDARS, BUSINESS PLANNING, BUSINESS MONITORING, BUSINESS ANALYSIS, BUSINESS INTELLIGENCE, CLIENT MANAGEMENT, SOCIAL NETWORK INTELLIGENCE, ISSUE TRACKING, WORK REPOSITORIES, CODE REPOSITORIES, ANALYTICS, INTERNAL AND EXTERNAL COMMUNICATIONS (U.S. CLS. 100 AND 101).

FIRST USE 3-27-2014; IN COMMERCE 3-27-2014.

4,594,282. MAKE DESIGN, DBA PIPPA & CO., ALAMEDA, CA. SN 86-034,338. PUB. 3-4-2014, FILED 8-9-2013.

**pippa & co.**

THE MARK CONSISTS OF STANDARD CHARACTERS WITHOUT CLAIM TO ANY PARTICULAR FONT, STYLE, SIZE, OR COLOR.

NO CLAIM IS MADE TO THE EXCLUSIVE RIGHT TO USE "& CO.", APART FROM THE MARK AS SHOWN.

FOR SPECIAL EVENT STYLING (U.S. CLS. 100 AND 101).

FIRST USE 1-16-2014; IN COMMERCE 1-16-2014.

**CLASS 42—(Continued).**

4,594,285. COLEMAN, MICK, CHINO VALLEY, AZ. SN 86-034,732. PUB. 12-31-2013, FILED 8-12-2013.

**EMSADVANCED**

THE MARK CONSISTS OF STANDARD CHARACTERS WITHOUT CLAIM TO ANY PARTICULAR FONT, STYLE, SIZE, OR COLOR.

FOR PROVIDING ON-LINE NON-DOWNLOADABLE SOFTWARE FOR MANAGEMENT OF HEAVY CONSTRUCTION EQUIPMENT AND EQUIPMENT COMPONENTS SUCH AS OIL CHANGES, FUEL USE, TIRE AND TRACK WEAR AND GENERAL MAINTENANCE (U.S. CLS. 100 AND 101).

FIRST USE 4-26-2014; IN COMMERCE 4-26-2014.

4,594,310. AL-KAOURI, MOSTAFA, SALWA, LEBANON. SN 86-045,950. PUB. 1-14-2014, FILED 8-23-2013.

**YOUAUGMENT**

THE MARK CONSISTS OF STANDARD CHARACTERS WITHOUT CLAIM TO ANY PARTICULAR FONT, STYLE, SIZE, OR COLOR.

FOR DESIGN, DEVELOPMENT AND IMPLEMENTATION OF SOFTWARE; DESIGN, DEVELOPMENT, AND IMPLEMENTATION OF SOFTWARE FOR ENABLING AUGMENTED REALITY APPLICATIONS (U.S. CLS. 100 AND 101).

FIRST USE 10-15-2013; IN COMMERCE 10-15-2013.

4,594,335. MILLER, ROBY, IOWA CITY, IA. SN 86-058,732. PUB. 4-1-2014, FILED 9-9-2013.

**OUTSCRIPTING**

THE MARK CONSISTS OF STANDARD CHARACTERS WITHOUT CLAIM TO ANY PARTICULAR FONT, STYLE, SIZE, OR COLOR.

FOR UPDATING OF COMPUTER SOFTWARE; PROVIDING TEMPORARY USE OF ON-LINE NON-DOWNLOADABLE SOFTWARE THAT ENABLES A PHARMACY OWNER TO HIRE ANOTHER PHARMACIST TO OPERATE HIS OR HER STORE; PROVIDING A WEBSITE FEATURING ON-LINE NON-DOWNLOADABLE SOFTWARE THAT ENABLES A PHARMACY OWNER TO HIRE ANOTHER PHARMACIST TO OPERATE HIS OR HER STORE (U.S. CLS. 100 AND 101).

FIRST USE 8-31-2012; IN COMMERCE 8-31-2012.

**CLASS 42—(Continued).**

4,594,338. EXPENSEWATCH, INC., PLYMOUTH MEETING, PA. SN 86-060,689. PUB. 2-11-2014, FILED 9-10-2013.



THE MARK CONSISTS OF A BENJAMIN FRANKLIN CARTOON IMAGE WHO IS WEARING PINCE-NEZ GLASSES. THE IMAGE HAS AN OVERSIZED HEAD RELATIVE TO A SMALLER, PORTLY BODY WITH A PUZZLE PIECE LOGO ON HIS LAPEL. HE IS HOLDING A KITE WITH RIBBONS ON THE TAIL AND AT THE END OF THE TAIL IS A KEY CONTAINING THE LETTERS "E" AND "W" ON THE BLADE OF THE KEY.

FOR PROVIDING ON-LINE NON-DOWNLOADABLE SOFTWARE PROGRAMS TO PROVIDE AUTOMATION, VISIBILITY, AND CONTROL OF COMPANY SPENDING PROCESSES BY ENABLING USERS TO CREATE, REVIEW, APPROVE, CATEGORIZE AND ANALYZE SPEND TRANSACTIONS INCLUDING EXPENSE REPORTS, PURCHASE REQUISITIONS AND PAYABLE INVOICES (U.S. CLS. 100 AND 101).

FIRST USE 8-20-2013; IN COMMERCE 5-5-2014.

4,594,390. PERFORMANCE REVIEW INSTITUTE, WARREN-DALE, PA. SN 86-079,765. PUB. 4-1-2014, FILED 10-1-2013.

**MEDACCRED**

THE MARK CONSISTS OF STANDARD CHARACTERS WITHOUT CLAIM TO ANY PARTICULAR FONT, STYLE, SIZE, OR COLOR.

FOR TECHNICAL ANALYSIS AND EVALUATION, NAMELY, CONDUCTING TECHNICAL AUDITS OF MEDICAL DEVICE INDUSTRY SUPPLIERS TO DETERMINE THEIR ABILITY TO PROVIDE AND MAINTAIN TECHNICAL SERVICES AT AN ACCEPTABLE LEVEL OF PERFORMANCE (U.S. CLS. 100 AND 101).

FIRST USE 10-1-2013; IN COMMERCE 10-1-2013.

**CLASS 42—(Continued).**

4,594,409. SILVERSTONE GROUP, INCORPORATED, OMAHA, NE. SN 86-087,121. PUB. 2-11-2014, FILED 10-9-2013.

**BENEFITSQUE**

THE MARK CONSISTS OF STANDARD CHARACTERS WITHOUT CLAIM TO ANY PARTICULAR FONT, STYLE, SIZE, OR COLOR.

FOR PROVIDING TEMPORARY USE OF A WEB-BASED SOFTWARE APPLICATION CONSISTING OF HEALTH ENROLLMENT AND DECISION TOOLS FOR ASSISTING WITH ENROLLMENT IN EMPLOYEE HEALTH AND WELFARE BENEFIT PLANS (U.S. CLS. 100 AND 101).

FIRST USE 10-17-2013; IN COMMERCE 10-17-2013.

4,594,417. ABSIO CORPORATION, HIGHLANDS RANCH, CO. SN 86-089,753. PUB. 3-4-2014, FILED 10-11-2013.

**TAKE CONTROL OF YOUR  
DIGITAL WORLD**

THE MARK CONSISTS OF STANDARD CHARACTERS WITHOUT CLAIM TO ANY PARTICULAR FONT, STYLE, SIZE, OR COLOR.

FOR COMPUTER SOFTWARE DEVELOPMENT; CONSULTING IN THE FIELD OF INFORMATION TECHNOLOGY; DESIGN AND DEVELOPMENT OF COMPUTER SOFTWARE; DESIGN AND DEVELOPMENT OF COMPUTER SOFTWARE FOR PROTECTION AND DISTRIBUTION OF DIGITAL CONTENT; SOFTWARE AS A SERVICE (SAAS) SERVICES FEATURING SOFTWARE FOR ENSURING THE SECURITY OF ELECTRONIC MAIL; SOFTWARE AS A SERVICE (SAAS) SERVICES FEATURING SOFTWARE FOR USE IN THE FIELD OF SECURITY OF ELECTRONIC MAIL; SOFTWARE DEVELOPMENT IN THE FIELD OF PROTECTION AND DISTRIBUTION OF DIGITAL CONTENT (U.S. CLS. 100 AND 101).

FIRST USE 10-30-2013; IN COMMERCE 10-30-2013.

**CLASS 42—(Continued).**

4,594,418. ABSIO CORPORATION, HIGHLANDS RANCH, CO. SN 86-089,763. PUB. 3-4-2014, FILED 10-11-2013.

**TAKE CONTROL OF YOUR  
DIGITAL LIFE**

THE MARK CONSISTS OF STANDARD CHARACTERS WITHOUT CLAIM TO ANY PARTICULAR FONT, STYLE, SIZE, OR COLOR.

FOR COMPUTER SOFTWARE DEVELOPMENT; CONSULTING IN THE FIELD OF INFORMATION TECHNOLOGY; DESIGN AND DEVELOPMENT OF COMPUTER SOFTWARE; DESIGN AND DEVELOPMENT OF COMPUTER SOFTWARE FOR PROTECTION AND DISTRIBUTION OF DIGITAL CONTENT; SOFTWARE AS A SERVICE (SAAS) SERVICES FEATURING SOFTWARE FOR ENSURING THE SECURITY OF ELECTRONIC MAIL; SOFTWARE AS A SERVICE (SAAS) SERVICES FEATURING SOFTWARE FOR USE IN THE FIELD OF SECURITY OF ELECTRONIC MAIL; SOFTWARE DEVELOPMENT IN THE FIELD OF PROTECTION AND DISTRIBUTION OF DIGITAL CONTENT (U.S. CLS. 100 AND 101).

FIRST USE 10-30-2013; IN COMMERCE 10-30-2013.

---

4,594,419. ABSIO CORPORATION, HIGHLANDS RANCH, CO. SN 86-089,767. PUB. 3-4-2014, FILED 10-11-2013.

**TAKE CONTROL OF YOUR  
DIGITAL PROPERTY**

THE MARK CONSISTS OF STANDARD CHARACTERS WITHOUT CLAIM TO ANY PARTICULAR FONT, STYLE, SIZE, OR COLOR.

FOR COMPUTER SOFTWARE DEVELOPMENT; CONSULTING IN THE FIELD OF INFORMATION TECHNOLOGY; DESIGN AND DEVELOPMENT OF COMPUTER SOFTWARE; DESIGN AND DEVELOPMENT OF COMPUTER SOFTWARE FOR PROTECTION AND DISTRIBUTION OF DIGITAL CONTENT; SOFTWARE AS A SERVICE (SAAS) SERVICES FEATURING SOFTWARE FOR ENSURING THE SECURITY OF ELECTRONIC MAIL; SOFTWARE AS A SERVICE (SAAS) SERVICES FEATURING SOFTWARE FOR USE IN THE FIELD OF SECURITY OF ELECTRONIC MAIL; SOFTWARE DEVELOPMENT IN THE FIELD OF PROTECTION AND DISTRIBUTION OF DIGITAL CONTENT (U.S. CLS. 100 AND 101).

FIRST USE 10-30-2013; IN COMMERCE 10-30-2013.

**CLASS 42—(Continued).**

4,594,422. ABSIO CORPORATION, HIGHLANDS RANCH, CO. SN 86-091,016. PUB. 3-4-2014, FILED 10-14-2013.

**MY DATA, MY RULES**

THE MARK CONSISTS OF STANDARD CHARACTERS WITHOUT CLAIM TO ANY PARTICULAR FONT, STYLE, SIZE, OR COLOR.

FOR COMPUTER SOFTWARE DEVELOPMENT; CONSULTING IN THE FIELD OF INFORMATION TECHNOLOGY; DESIGN AND DEVELOPMENT OF COMPUTER SOFTWARE; DESIGN AND DEVELOPMENT OF COMPUTER SOFTWARE FOR PROTECTION AND DISTRIBUTION OF DIGITAL CONTENT; SOFTWARE AS A SERVICE (SAAS) SERVICES FEATURING SOFTWARE FOR ENSURING THE SECURITY OF ELECTRONIC MAIL; SOFTWARE AS A SERVICE (SAAS) SERVICES FEATURING SOFTWARE FOR USE IN THE FIELD OF SECURITY OF ELECTRONIC MAIL; SOFTWARE DEVELOPMENT IN THE FIELD OF PROTECTION AND DISTRIBUTION OF DIGITAL CONTENT (U.S. CLS. 100 AND 101).

FIRST USE 6-9-2014; IN COMMERCE 6-9-2014.

---

4,594,427. PHH VEHICLE MANAGEMENT SERVICES, LLC, SPARKS, MD. SN 86-092,005. PUB. 3-11-2014, FILED 10-15-2013.

**PHH XPLORE**

THE MARK CONSISTS OF STANDARD CHARACTERS WITHOUT CLAIM TO ANY PARTICULAR FONT, STYLE, SIZE, OR COLOR.

OWNER OF U.S. REG. NO. 3,235,973.  
FOR PROVIDING AN ONLINE NON-DOWNLOADABLE INTERNET-BASED SYSTEM APPLICATION FEATURING TECHNOLOGY ENABLING USERS TO PERFORM DATA ANALYSIS AND BENCHMARKING REGARDING THEIR COMMERCIAL FLEET VEHICLE OPERATIONS (U.S. CLS. 100 AND 101).

FIRST USE 11-20-2013; IN COMMERCE 11-20-2013.



**CLASS 42—(Continued).**

4,594,462. THERA-LINK LLC, RICHARDSON, TX. SN 86-103,994. PUB. 3-25-2014, FILED 10-29-2013.

# thera-LINK

THE MARK CONSISTS OF STANDARD CHARACTERS WITHOUT CLAIM TO ANY PARTICULAR FONT, STYLE, SIZE, OR COLOR.

FOR ONLINE, NON-DOWNLOADABLE COMPUTER APPLICATION SOFTWARE FOR MOBILE PHONES, TABLET COMPUTERS, LAPTOP COMPUTERS, AND DESKTOP COMPUTERS, NAMELY, ONLINE, NON-DOWNLOADABLE SOFTWARE FOR PROVIDING A PLATFORM FOR THERAPISTS TO HAVE MOBILE THERAPY SESSIONS THROUGH VIDEO CONFERENCES WITH CLIENTS (U.S. CLS. 100 AND 101).

FIRST USE 10-1-2013; IN COMMERCE 3-8-2014.

**CLASS 42—(Continued).**

4,594,553. SAFEGUARD PROPERTIES MANAGEMENT, LLC, VALLEY VIEW, OH. SN 86-975,436. PUB. 4-1-2014, FILED 11-1-2013.

# MAPALERT

THE MARK CONSISTS OF STANDARD CHARACTERS WITHOUT CLAIM TO ANY PARTICULAR FONT, STYLE, SIZE, OR COLOR.

FOR SOFTWARE AS A SERVICE (SAAS) SERVICES FEATURING SOFTWARE FOR ORGANIZING INFORMATION BY GEOGRAPHIC LOCATION (U.S. CLS. 100 AND 101).

FIRST USE 11-6-2013; IN COMMERCE 11-6-2013.

**CLASS 43—HOTEL AND RESTAURANT SERVICES**

4,593,072. KW BRANDS, LLC, WEST MONROE, LA. SN 76-715,246. PUB. 3-4-2014, FILED 10-24-2013.

# HUMANITY

THE MARK CONSISTS OF STANDARD CHARACTERS WITHOUT CLAIM TO ANY PARTICULAR FONT, STYLE, SIZE, OR COLOR.

FOR SOFTWARE AS A SERVICE (SAAS) SERVICES, NAMELY, HOSTING SOFTWARE FOR USE BY OTHERS FOR USE IN WORKFORCE AND GROUP MANAGEMENT SUCH AS SCHEDULING, TIME AND ATTENDANCE, LEAVE MANAGEMENT, PERFORMANCE REVIEWS, ON-BOARDING, TRAINING, APPLICANT TRACKING, COMMUNICATION, REPORTING, PAY-ROLL, METRICS AND VISUAL DASHBOARD, CALENDARING, EVENT MANAGEMENT AND BOOKINGS, TRAINING, TASK MANAGEMENT; PLATFORM AS A SERVICE (PAAS) FEATURING COMPUTER SOFTWARE PLATFORMS FOR BUILDING, HOSTING AND DISTRIBUTING APPLICATIONS TO USERS (U.S. CLS. 100 AND 101).

FIRST USE 1-15-2014; IN COMMERCE 1-15-2014.



THE LIKENESS (OR, PORTRAIT) IN THE MARK IDENTIFIES WILLIE ROBERTSON A LIVING INDIVIDUAL WHOSE CONSENT IS OF RECORD.

THE MARK CONSISTS OF THE DRAWING OF A MAN'S HEAD WITH A FULL BEARD AND SUNGLASSES AND A BANDANA DISPLAYING A REPRESENTATIVE DESIGN OF THE STARS AND STRIPES OF THE USA FLAG.

FOR RESTAURANT SERVICES (U.S. CLS. 100 AND 101).

FIRST USE 10-25-2013; IN COMMERCE 10-25-2013.

**CLASS 43—(Continued).**

4,593,082. TASTY COCKTAILS, LLC, HENDERSON, NV. SN 77-773,522. PUB. 3-4-2014, FILED 7-2-2009.

# NUMB

THE MARK CONSISTS OF STANDARD CHARACTERS WITHOUT CLAIM TO ANY PARTICULAR FONT, STYLE, SIZE, OR COLOR.  
FOR RESTAURANT AND BAR SERVICES (U.S. CLS. 100 AND 101).  
FIRST USE 7-20-2010; IN COMMERCE 7-20-2010.

4,593,153. GREEN BAY PACKERS, INC., GREEN BAY, WI. SN 85-184,656. PUB. 4-26-2011, FILED 11-24-2010.

# TITLETOWN

THE MARK CONSISTS OF STANDARD CHARACTERS WITHOUT CLAIM TO ANY PARTICULAR FONT, STYLE, SIZE, OR COLOR.  
OWNER OF U.S. REG. NO. 1,802,761.  
FOR ARENA SERVICES, NAMELY, PROVIDING FACILITIES FOR SPORTS, CONCERTS, CONVENTIONS AND EXHIBITIONS; HOTEL, BAR AND RESTAURANT SERVICES (U.S. CLS. 100 AND 101).  
FIRST USE 6-28-2010; IN COMMERCE 7-29-2010.

4,593,265. DANG BANH MI LLC, AUSTIN, TX. SN 85-509,907. PUB. 12-11-2012, FILED 1-5-2012.

# Dang Bánh Mì

THE MARK CONSISTS OF STANDARD CHARACTERS WITHOUT CLAIM TO ANY PARTICULAR FONT, STYLE, SIZE, OR COLOR.  
NO CLAIM IS MADE TO THE EXCLUSIVE RIGHT TO USE "BANH MI", APART FROM THE MARK AS SHOWN.  
THE ENGLISH TRANSLATION OF "BANH MI" IN THE MARK IS "BREAD".  
FOR RESTAURANT SERVICES, INCLUDING SIT-DOWN SERVICE OF FOOD AND TAKE-OUT RESTAURANT SERVICES (U.S. CLS. 100 AND 101).  
FIRST USE 7-21-2014; IN COMMERCE 7-21-2014.

**CLASS 43—(Continued).**

4,593,287. RESTAURANT INVESTORS, LLC, GREENSBORO, NC. SN 85-554,425. PUB. 11-19-2013, FILED 2-28-2012.

# Marshall Free House

THE MARK CONSISTS OF STANDARD CHARACTERS WITHOUT CLAIM TO ANY PARTICULAR FONT, STYLE, SIZE, OR COLOR.  
NO CLAIM IS MADE TO THE EXCLUSIVE RIGHT TO USE "FREE HOUSE", APART FROM THE MARK AS SHOWN.  
THE NAME DOES NOT IDENTIFY A PARTICULAR LIVING INDIVIDUAL.  
FOR RESTAURANT SERVICES (U.S. CLS. 100 AND 101).  
FIRST USE 5-26-2014; IN COMMERCE 5-26-2014.

4,593,413. SHOGA, WAIL, HUNTINGTON BEACH, CA. SN 85-686,349. PUB. 1-15-2013, FILED 7-25-2012.

# MotorSport Cafe

THE MARK CONSISTS OF STANDARD CHARACTERS WITHOUT CLAIM TO ANY PARTICULAR FONT, STYLE, SIZE, OR COLOR.  
NO CLAIM IS MADE TO THE EXCLUSIVE RIGHT TO USE "CAFE", APART FROM THE MARK AS SHOWN.  
FOR CAFE SERVICES (U.S. CLS. 100 AND 101).  
FIRST USE 9-1-2013; IN COMMERCE 9-1-2013.

4,593,425. DUNNAM, FREDERICK TODD, VICTORIA, TX. SN 85-699,797. PUB. 4-9-2013, FILED 8-9-2012.

# TIN SPUR RANCH

THE MARK CONSISTS OF STANDARD CHARACTERS WITHOUT CLAIM TO ANY PARTICULAR FONT, STYLE, SIZE, OR COLOR.  
FOR PROVIDING BANQUET AND SOCIAL FUNCTION FACILITIES FOR SPECIAL OCCASIONS SUCH AS WEDDINGS, QUINCEANERAS, AND BIRTHDAY PARTIES; RENTAL OF BANQUET AND SOCIAL FUNCTION FACILITIES FOR SPECIAL OCCASIONS, NAMELY, WEDDING RECEPTIONS, QUINCEANERAS, AND BIRTHDAY PARTIES (U.S. CLS. 100 AND 101).  
FIRST USE 1-1-2013; IN COMMERCE 1-1-2013.

**CLASS 43—(Continued).**

4,593,502. PC FESTIVUS, LLC C/O LASALLE HOTEL PROPERTIES, BETHESDA, MD. SN 85-760,730. PUB. 4-23-2013, FILED 10-23-2012.

WESTHOUSE HOTEL NEW YORK

THE MARK CONSISTS OF STANDARD CHARACTERS WITHOUT CLAIM TO ANY PARTICULAR FONT, STYLE, SIZE, OR COLOR.

NO CLAIM IS MADE TO THE EXCLUSIVE RIGHT TO USE "HOTEL NEW YORK", APART FROM THE MARK AS SHOWN.

FOR HOTEL SERVICES; RESTAURANT, BAR AND LOUNGE SERVICES (U.S. CLS. 100 AND 101).

FIRST USE 12-27-2013; IN COMMERCE 12-27-2013.

4,593,516. MONTEREY BAY AQUARIUM FOUNDATION, MONTEREY, CA. SN 85-765,970. PUB. 9-24-2013, FILED 10-29-2012.

CINDY'S WATERFRONT

THE MARK CONSISTS OF STANDARD CHARACTERS WITHOUT CLAIM TO ANY PARTICULAR FONT, STYLE, SIZE, OR COLOR.

NO CLAIM IS MADE TO THE EXCLUSIVE RIGHT TO USE "WATERFRONT", APART FROM THE MARK AS SHOWN.

THE NAME "CINDY'S" IDENTIFIES THE NICKNAME OF CYNTHIA PAWLKYN, A LIVING INDIVIDUAL WHOSE CONSENT IS OF RECORD.

FOR RESTAURANT SERVICES (U.S. CLS. 100 AND 101).

FIRST USE 4-27-2013; IN COMMERCE 4-27-2013.

4,593,539. PROTEUS PARTNERS, LLC, AUSTELL, GA. SN 85-775,535. PUB. 2-5-2013, FILED 11-9-2012.



NO CLAIM IS MADE TO THE EXCLUSIVE RIGHT TO USE "HOTEL", APART FROM THE MARK AS SHOWN.

THE COLOR(S) BLUE, WHITE AND YELLOW IS/ARE CLAIMED AS A FEATURE OF THE MARK.

**CLASS 43—(Continued).**

THE MARK CONSISTS OF THE LITERAL ELEMENT "SHUT EYE HOTEL" IN WHITE LETTERING EXCEPT FOR A YELLOW "O" IN "HOTEL", SITUATED BELOW A YELLOW ANGLE AND ABOVE A YELLOW HORIZONTAL LINE AND CONTAINED ENTIRELY WITHIN A BLUE RECTANGLE WITH ROUNDED EDGES.

FOR PROVIDING EXTENDED-STAY HOTELS; PROVIDING TEMPORARY HOUSING ACCOMMODATIONS; RESTAURANT AND HOTEL SERVICES; SERVING FOOD AND DRINKS (U.S. CLS. 100 AND 101).

FIRST USE 4-1-2013; IN COMMERCE 4-1-2013.

4,593,601. JMWILLIAMS LLC, NEW YORK, NY. SN 85-799,354. PUB. 1-21-2014, FILED 12-11-2012.

BUVETTE GASTROTHÈQUE

THE MARK CONSISTS OF STANDARD CHARACTERS WITHOUT CLAIM TO ANY PARTICULAR FONT, STYLE, SIZE, OR COLOR.

OWNER OF U.S. REG. NO. 3,996,324.

THE ENGLISH TRANSLATION OF THE WORD "BUVETTE" IN THE MARK IS "ROADSIDE CAFE". THE WORDING "GASTROTHÈQUE" HAS NO MEANING IN A FOREIGN LANGUAGE.

FOR RESTAURANT SERVICES FEATURING UPSCALE CUISINE AND EXCLUDING ROADSIDE CAFE SERVICES (U.S. CLS. 100 AND 101).

FIRST USE 1-21-2011; IN COMMERCE 1-21-2011.

4,593,608. THE ROUND TABLE FRANCHISE CORPORATION, CONCORD, CA. SN 85-802,336. PUB. 8-13-2013, FILED 12-13-2012.

FRESH PIXX

THE MARK CONSISTS OF STANDARD CHARACTERS WITHOUT CLAIM TO ANY PARTICULAR FONT, STYLE, SIZE, OR COLOR.

NO CLAIM IS MADE TO THE EXCLUSIVE RIGHT TO USE "FRESH", APART FROM THE MARK AS SHOWN.

FOR RESTAURANT SERVICES (U.S. CLS. 100 AND 101).

FIRST USE 6-11-2014; IN COMMERCE 6-11-2014.

**CLASS 43—(Continued).**

4,593,778. SPORTING LIFE BAR GROUP, LLC, BEVERLY HILLS, CA. SN 85-885,285. PUB. 9-3-2013, FILED 3-25-2013.



NO CLAIM IS MADE TO THE EXCLUSIVE RIGHT TO USE "BAR", APART FROM THE MARK AS SHOWN.

THE MARK CONSISTS OF THE STYLIZED TEXT "SPORTING LIFE BAR" WITH THE WORD "LIFE" EXTENDING ABOVE THE WORD "BAR". THE LETTERS OF THE WORD "BAR" ARE SUPERIMPOSED ON PARTIALLY OVERLAPPING RECTANGLES WITH ROUNDED CORNERS. THE FIRST RECTANGLE IS TILTED SLIGHTLY TO THE LEFT, THE SECOND RECTANGLE IS NOT TILTED, AND THE THIRD RECTANGLE IS TILTED SLIGHTLY TO THE RIGHT. A FOOTBALL, BASEBALL, TED GOLF BALL, SOCCER BALL, BASEBALL, HOCKEY PUCK AND BASKETBALL ARE POSITIONED HORIZONTALLY BELOW THE WORD "SPORTING" AND TO THE LEFT OF THE FIRST RECTANGLE. A HORIZONTAL LINE EXTENDS FROM JUST BELOW AND TO THE LEFT OF THE FOOTBALL TO JUST BELOW AND TO THE RIGHT OF THE BASKETBALL.

FOR BAR SERVICES; CATERING SERVICES; PROVIDING BANQUET AND SOCIAL FUNCTION FACILITIES FOR SPECIAL OCCASIONS; PUBS; RESTAURANT SERVICES; TAKE-OUT RESTAURANT SERVICES; TAVERN SERVICES (U.S. CLS. 100 AND 101).

FIRST USE 6-3-2014; IN COMMERCE 6-3-2014.

4,593,865. 247.COM LLC, HENDERSON, NV. SN 85-923,396. PUB. 10-15-2013, FILED 5-3-2013.



NO CLAIM IS MADE TO THE EXCLUSIVE RIGHT TO USE ".COM" AND "LAS VEGAS", APART FROM THE MARK AS SHOWN.

THE MARK CONSISTS OF AN IMAGE IN THE SHAPE OF A SPADE, WITH CURVED LINES EMANATING FROM THE BOTTOM CENTER AND CURVING LEFT TO RIGHT TOWARD THE UPPER RIGHT SIDE. THE DESIGN IS POSITIONED TO THE LEFT OF THE TEXT "LV247", WITH THE TEXT ".COM" AT AN ANGLE TO THE RIGHT OF THE "7". UNDER THE TEXT "LV247.COM" IS THE TEXT "YOUR CONNECTION IN LAS VEGAS".

FOR TRAVEL AGENCY SERVICES, NAMELY, MAKING RESERVATIONS AND BOOKING FOR TEMPORARY LODGING; TRAVEL AGENCY SERVICES, NAMELY, MAKING RESERVATIONS AND BOOKINGS FOR RESTAURANTS AND MEALS (U.S. CLS. 100 AND 101).

FIRST USE 6-12-2013; IN COMMERCE 6-12-2013.

**CLASS 43—(Continued).**

4,593,894. PALM FOODS, LLC, GREENWICH, CT. SN 85-931,204. PUB. 10-15-2013, FILED 5-14-2013.

## PALMWICH

THE MARK CONSISTS OF STANDARD CHARACTERS WITHOUT CLAIM TO ANY PARTICULAR FONT, STYLE, SIZE, OR COLOR.

FOR BAR SERVICES; PROVIDING OF FOOD AND DRINK; RESTAURANT SERVICES (U.S. CLS. 100 AND 101).

FIRST USE 5-20-2014; IN COMMERCE 5-20-2014.

4,593,945. JACKSON, MATTIE D., BRENTWOOD, TN. SN 85-938,697. PUB. 10-15-2013, FILED 5-21-2013.

## VOLUPTUOUS VINES

THE MARK CONSISTS OF STANDARD CHARACTERS WITHOUT CLAIM TO ANY PARTICULAR FONT, STYLE, SIZE, OR COLOR.

FOR PROVIDING INFORMATION ABOUT WINE CHARACTERISTICS; SOMMELIER SERVICES, NAMELY, PROVIDING ADVICE ON WINE AND WINE AND FOOD PAIRING (U.S. CLS. 100 AND 101).

FIRST USE 1-31-2013; IN COMMERCE 1-31-2013.

4,593,964. SIX CONTINENTS HOTELS, INC., ATLANTA, GA. SN 85-941,576. PUB. 10-29-2013, FILED 5-24-2013.

## HISTORIA COLLECTION

THE MARK CONSISTS OF STANDARD CHARACTERS WITHOUT CLAIM TO ANY PARTICULAR FONT, STYLE, SIZE, OR COLOR.

NO CLAIM IS MADE TO THE EXCLUSIVE RIGHT TO USE "COLLECTION", APART FROM THE MARK AS SHOWN.

THE ENGLISH TRANSLATION OF THE WORD "HISTORIA" IN THE MARK IS "HISTORY".

FOR HOTEL SERVICES (U.S. CLS. 100 AND 101).  
FIRST USE 6-25-2013; IN COMMERCE 6-25-2013.

**CLASS 43—(Continued).**

4,594,013. THE TRUSTEES OF THE VALASKANTJIS FAMILY TRUST, SAN CLEMENTE, CA. SN 85-950,291. PUB. 11-5-2013, FILED 6-4-2013.

**FAST DINING MADE FRESH**

THE MARK CONSISTS OF STANDARD CHARACTERS WITHOUT CLAIM TO ANY PARTICULAR FONT, STYLE, SIZE, OR COLOR.

FOR RESTAURANT SERVICES (U.S. CLS. 100 AND 101).

FIRST USE 8-0-2013; IN COMMERCE 8-0-2013.

4,594,049. GROWLERU FRANCO, LLC, CENTENNIAL, CO. SN 85-955,794. PUB. 11-12-2013, FILED 6-10-2013.

**Growler University**

THE MARK CONSISTS OF STANDARD CHARACTERS WITHOUT CLAIM TO ANY PARTICULAR FONT, STYLE, SIZE, OR COLOR.

NO CLAIM IS MADE TO THE EXCLUSIVE RIGHT TO USE "GROWLER", APART FROM THE MARK AS SHOWN.

FOR TAPROOM SERVICES FEATURING DRAFT BEER (U.S. CLS. 100 AND 101).

FIRST USE 12-24-2013; IN COMMERCE 12-24-2013.

4,594,054. UNIVERSAL CITY STUDIOS LLC, UNIVERSAL CITY, CA. SN 85-956,443. PUB. 10-29-2013, FILED 6-11-2013.

**DESPICABLE DELIGHTS**

THE MARK CONSISTS OF STANDARD CHARACTERS WITHOUT CLAIM TO ANY PARTICULAR FONT, STYLE, SIZE, OR COLOR.

FOR CAFE SERVICES; PROVIDING OF FOOD AND DRINK; RESTAURANT SERVICES; SNACK BAR SERVICES (U.S. CLS. 100 AND 101).

FIRST USE 3-28-2014; IN COMMERCE 3-28-2014.

**CLASS 43—(Continued).**

4,594,057. RTR FOOD CONCEPTS INC., SAN FRANCISCO, CA. SN 85-956,579. PUB. 11-12-2013, FILED 6-11-2013.



NO CLAIM IS MADE TO THE EXCLUSIVE RIGHT TO USE "PIZZA", APART FROM THE MARK AS SHOWN.

THE MARK CONSISTS OF AN OUTER CIRCLE OUTLINE, WITHIN THE OUTLINE ARE THE WORDS "TAKE ONE PIZZA", WITH "TAKE ONE" AT THE TOP AND "PIZZA" ON THE BOTTOM. CURVED TO FOLLOW THE OUTLINE, WITHIN THE OUTLINE ON THE LEFT AND RIGHT ARE MOVIE REELS, THERE IS A SHADED CENTER CIRCLE, IN THE CENTER OF THE MARK IS A CLAPPERBOARD IN THE OPEN POSITION, THE PHRASE "READY IN 3...2...1!" APPEARS ON THE CLAPPERBOARD, THE BOTTOM LEFT CORNER OF THE CLAPPERBOARD IS STICKING INTO A PIZZA WITH TOPPINGS.

FOR PIZZA PARLORS; RESTAURANT SERVICES (U.S. CLS. 100 AND 101).

FIRST USE 6-11-2013; IN COMMERCE 3-31-2014.

4,594,061. HARFER ENTERPRISES, LLC, DISTRICT HEIGHTS, MD. SN 85-957,035. PUB. 11-12-2013, FILED 6-11-2013.

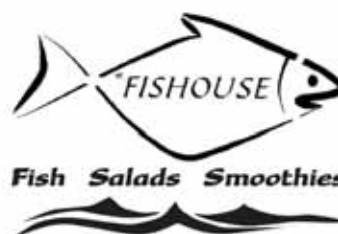

NO CLAIM IS MADE TO THE EXCLUSIVE RIGHT TO USE "FISHHOUSE" AND "FISH SALADS SMOOTHIES", APART FROM THE MARK AS SHOWN.

THE MARK CONSISTS OF A STYLIZED FISH CONTAINING THE WORDING "HF— FISHHOUSE" ALONG WITH THE WORDING "FISH SALADS SMOOTHIES" THAT APPEARS BELOW THE FISH. THERE ARE 3 WAVES WITH THREE CRESTS FOUND BELOW THE WORDING.

FOR RESTAURANT SERVICES, INCLUDING SIT-DOWN SERVICE OF FOOD AND TAKE-OUT RESTAURANT SERVICES; TAKE-OUT RESTAURANT SERVICES (U.S. CLS. 100 AND 101).

FIRST USE 5-1-2013; IN COMMERCE 6-14-2014.

**CLASS 43—(Continued).**

4,594,072. BLACK FOREST HOSPITALITY GROUP LLC, BROOKLYN, NY. SN 85-958,125. PUB. 9-24-2013, FILED 6-12-2013.

**BLACK FOREST BROOKLYN**

THE MARK CONSISTS OF STANDARD CHARACTERS WITHOUT CLAIM TO ANY PARTICULAR FONT, STYLE, SIZE, OR COLOR.

NO CLAIM IS MADE TO THE EXCLUSIVE RIGHT TO USE "BROOKLYN", APART FROM THE MARK AS SHOWN.

FOR RESTAURANT SERVICES (U.S. CLS. 100 AND 101).

FIRST USE 12-6-2013; IN COMMERCE 12-6-2013.

4,594,074. R&D ENTERPRISES, LLC, PLANO, TX. SN 85-958,467. PUB. 11-5-2013, FILED 6-13-2013.

**WILD PITCH**

THE MARK CONSISTS OF STANDARD CHARACTERS WITHOUT CLAIM TO ANY PARTICULAR FONT, STYLE, SIZE, OR COLOR.

FOR BAR SERVICES; RESTAURANT SERVICES (U.S. CLS. 100 AND 101).

FIRST USE 3-31-2014; IN COMMERCE 3-31-2014.

4,594,075. R&D ENTERPRISES, LLC, PLANO, TX. SN 85-958,470. PUB. 11-12-2013, FILED 6-13-2013.



THE MARK CONSISTS OF A BASEBALL AND TRAILING SHADOW WITH THE STYLIZED WORDS "WILD PITCH" ON THE RIGHT SIDE.

FOR BAR SERVICES; RESTAURANT SERVICES (U.S. CLS. 100 AND 101).

FIRST USE 3-31-2014; IN COMMERCE 3-31-2014.

**CLASS 43—(Continued).**

4,594,111. EMERIK HOTEL, LLC, BEVERLY HILLS, CA. SN 85-965,737. PUB. 11-5-2013, FILED 6-20-2013.

**STAFFORD + MATHIS**

THE MARK CONSISTS OF STANDARD CHARACTERS WITHOUT CLAIM TO ANY PARTICULAR FONT, STYLE, SIZE, OR COLOR.

FOR RESTAURANT, BAR AND LOUNGE SERVICES (U.S. CLS. 100 AND 101).

FIRST USE 1-21-2014; IN COMMERCE 1-21-2014.

4,594,222. FISH DADDY'S, LLC, COLLEGE STATION, TX. SN 86-009,135. PUB. 12-3-2013, FILED 7-12-2013.

**FD'S GRILL HOUSE**

THE MARK CONSISTS OF STANDARD CHARACTERS WITHOUT CLAIM TO ANY PARTICULAR FONT, STYLE, SIZE, OR COLOR.

NO CLAIM IS MADE TO THE EXCLUSIVE RIGHT TO USE "GRILL HOUSE", APART FROM THE MARK AS SHOWN.

FOR RESTAURANT AND BAR SERVICES (U.S. CLS. 100 AND 101).

FIRST USE 6-1-2014; IN COMMERCE 6-1-2014.

4,594,233. AL PARTNERS, LLC, SCOTTSDALE, AZ. SN 86-011,777. PUB. 1-7-2014, FILED 7-16-2013.

**ZELLA'S PIZZA & CHEESESTEAKS**

THE MARK CONSISTS OF STANDARD CHARACTERS WITHOUT CLAIM TO ANY PARTICULAR FONT, STYLE, SIZE, OR COLOR.

NO CLAIM IS MADE TO THE EXCLUSIVE RIGHT TO USE "PIZZA & CHEESESTEAKS", APART FROM THE MARK AS SHOWN.

FOR CATERING SERVICES; RESTAURANT SERVICES (U.S. CLS. 100 AND 101).

FIRST USE 10-7-2013; IN COMMERCE 10-7-2013.

**CLASS 43—(Continued).**

4,594,290. CHIKARANOMOTO HOLDINGS CO., LTD, FUKUOKA CITY, FUKUOKA, JAPAN. SN 86-038,769. PUB. 2-11-2014, FILED 8-15-2013.



麵王  
M E N - O H

NO CLAIM IS MADE TO THE EXCLUSIVE RIGHT TO USE THE NON-LATIN CHARACTERS THAT TRANSLITERATE AND MEAN "RAMEN", APART FROM THE MARK AS SHOWN.

THE MARK CONSISTS OF JAPANESE CHARACTERS OVER THE WORDS "MEN-OH".

THE ENGLISH TRANSLATION OF "MEN-OH" IN THE MARK IS "RAMEN KING".

THE NON-LATIN CHARACTERS IN THE MARK TRANSLITERATE TO MEN-OH AND THIS MEANS RAMEN KING IN ENGLISH.

FOR RESTAURANT AND CAFE SERVICES (U.S. CLS. 100 AND 101).

FIRST USE 2-12-2014; IN COMMERCE 2-12-2014.

4,594,334. LATIN VALLEY 2130, LLC, PHILADELPHIA, PA. SN 86-058,094. PUB. 1-28-2014, FILED 9-6-2013.

ROSA BLANCA

THE MARK CONSISTS OF STANDARD CHARACTERS WITHOUT CLAIM TO ANY PARTICULAR FONT, STYLE, SIZE, OR COLOR.

THE ENGLISH TRANSLATION OF ROSA BLANCA IN THE MARK IS WHITE ROSE.

FOR BAR SERVICES; RESTAURANT SERVICES (U.S. CLS. 100 AND 101).

FIRST USE 12-15-2013; IN COMMERCE 12-15-2013.

4,594,373. HOMESTYLE DINING LLC, PLANO, TX. SN 86-075,433. PUB. 12-17-2013, FILED 9-26-2013.

Bo's Steak & Grill

THE MARK CONSISTS OF STANDARD CHARACTERS WITHOUT CLAIM TO ANY PARTICULAR FONT, STYLE, SIZE, OR COLOR.

**CLASS 43—(Continued).**

NO CLAIM IS MADE TO THE EXCLUSIVE RIGHT TO USE "STEAK & GRILL", APART FROM THE MARK AS SHOWN. FOR RESTAURANT SERVICES, NAMELY, PROVIDING OF FOOD AND BEVERAGES FOR CONSUMPTION ON AND OFF THE PREMISES (U.S. CLS. 100 AND 101). FIRST USE 9-26-2013; IN COMMERCE 4-10-2014.

4,594,443. WAGGING TAILS PET RESORT INCORPORATED, EAGAN, MN. SN 86-098,981. PUB. 3-18-2014, FILED 10-23-2013.

happy dogs play here

THE MARK CONSISTS OF STANDARD CHARACTERS WITHOUT CLAIM TO ANY PARTICULAR FONT, STYLE, SIZE, OR COLOR.

FOR BOARDING FOR ANIMALS; KENNEL SERVICES, NAMELY, BOARDING FOR PETS; PET BOARDING SERVICES; PET DAY CARE SERVICES; PET HOTEL SERVICES (U.S. CLS. 100 AND 101).

FIRST USE 6-1-2014; IN COMMERCE 6-1-2014.

4,594,444. WAGGING TAILS PET RESORT INCORPORATED, EAGAN, MN. SN 86-099,004. PUB. 3-18-2014, FILED 10-23-2013.



THE MARK CONSISTS OF A STYLIZED LETTER "W" WITH AN OUTLINE OF AN ANIMAL (DOG) INCORPORATED INTO THE LETTER.

FOR BOARDING FOR ANIMALS; KENNEL SERVICES, NAMELY, BOARDING FOR PETS; PET BOARDING SERVICES; PET DAY CARE SERVICES; PET HOTEL SERVICES (U.S. CLS. 100 AND 101).

FIRST USE 6-1-2014; IN COMMERCE 6-1-2014.

**CLASS 43—(Continued).**

4,594,511. SYAL, RAJ, LAKE FOREST, CA. SN 86-124,926. PUB. 4-1-2014, FILED 11-21-2013.

**CLASS 44—(Continued).**

4,593,299. GROUP DCA, LLC, PARSIPPANY, NJ. SN 85-567,130. PUB. 2-19-2013, FILED 3-12-2012.

**ROCKFIRE GRILL**

THE MARK CONSISTS OF STANDARD CHARACTERS WITHOUT CLAIM TO ANY PARTICULAR FONT, STYLE, SIZE, OR COLOR.

NO CLAIM IS MADE TO THE EXCLUSIVE RIGHT TO USE "GRILL", APART FROM THE MARK AS SHOWN.

FOR RESTAURANT, BAR AND CATERING SERVICES (U.S. CLS. 100 AND 101).

FIRST USE 11-2-2013; IN COMMERCE 3-1-2014.

**CLASS 44—MEDICAL, BEAUTY AND AGRICULTURAL SERVICES**

4,593,075. HEARTMILES L.L.C., ALISO VIEJO, CA. SN 77-655,531. PUB. 3-9-2010, FILED 1-23-2009.

**FITPRINT**

THE MARK CONSISTS OF STANDARD CHARACTERS WITHOUT CLAIM TO ANY PARTICULAR FONT, STYLE, SIZE, OR COLOR.

FOR COMPILING AND ANALYZING DATA ON INDIVIDUAL AND GROUP PHYSICAL FITNESS FOR HEALTH PURPOSES; PROVIDING SUBSCRIBERS WITH CUSTOM-TAILORED INFORMATION ON CURRENT, HISTORIC, AND/OR COMPARATIVE LEVELS OF INDIVIDUAL OR GROUP PHYSICAL FITNESS FOR HEALTH PURPOSES (U.S. CLS. 100 AND 101).

FIRST USE 5-8-2013; IN COMMERCE 5-8-2013.

4,593,281. REWIRE ME LLC, NEW YORK, NY. SN 85-539,036. PUB. 8-14-2012, FILED 2-10-2012.

**REWIRE ME**

THE MARK CONSISTS OF STANDARD CHARACTERS WITHOUT CLAIM TO ANY PARTICULAR FONT, STYLE, SIZE, OR COLOR.

FOR PROVIDING A WEBSITE FEATURING INFORMATION CONCERNING ALTERNATIVE BEHAVIORAL THERAPIES AND NUTRITION (U.S. CLS. 100 AND 101).

FIRST USE 7-20-2010; IN COMMERCE 7-20-2010.

**PD ONE**

THE MARK CONSISTS OF STANDARD CHARACTERS WITHOUT CLAIM TO ANY PARTICULAR FONT, STYLE, SIZE, OR COLOR.

FOR PROVISION OF INFORMATION CONCERNING PHARMACEUTICAL PRODUCTS AND THEIR USES, NAMELY, PROVIDING INFORMATION RELATING TO DIAGNOSTIC, PROPHYLACTIC AND THERAPEUTIC PROPERTIES OF PHARMACEUTICALS TO HEALTH-CARE PROFESSIONALS VIA SECURE INTERNET NETWORK (U.S. CLS. 100 AND 101).

FIRST USE 5-15-2012; IN COMMERCE 5-15-2012.

4,593,300. GROUP DCA, LLC, PARSIPPANY, NJ. SN 85-567,143. PUB. 3-19-2013, FILED 3-12-2012.



THE MARK CONSISTS OF A SQUARE CONTAINING THE STYLIZED LETTERS "PD". A SHADOW APPEARS BELOW THE SQUARE. THE STYLIZED WORD "ONE" IS SITUATED TO THE RIGHT OF THE SQUARE. THE SHADED BACKGROUND IS TO SHOW PLACEMENT OF THE MARK AND IS NOT CLAIMED AS A FEATURE OF IT.

FOR PROVISION OF INFORMATION CONCERNING PHARMACEUTICAL PRODUCTS AND THEIR USES, NAMELY, PROVIDING INFORMATION RELATING TO DIAGNOSTIC, PROPHYLACTIC AND THERAPEUTIC PROPERTIES OF PHARMACEUTICALS TO HEALTH-CARE PROFESSIONALS VIA SECURE INTERNET NETWORK (U.S. CLS. 100 AND 101).

FIRST USE 5-15-2012; IN COMMERCE 5-15-2012.



**CLASS 44—(Continued).**

4,593,391. KING COUNTY PUBLIC HOSPITAL DISTRICT NO. 2, KIRKLAND, WA. SN 85-668,484. PUB. 7-9-2013, FILED 7-3-2012.



THE MARK CONSISTS OF A STYLIZED TREE TO THE LEFT OF THE WORDING "EVERGREENHEALTH".

FOR HOSPITAL SERVICES, NAMELY, CANCER CARE, CARDIAC CARE, AND SURGICAL SERVICES; AMBULANT MEDICAL CARE; EMERGENCY MEDICAL ASSISTANCE; PRIMARY CARE CLINIC SERVICES; FREE-STANDING EMERGENCY ROOM SERVICES; NEURO-SCIENCE DIAGNOSIS AND TREATMENT SERVICES; PARKINSON'S DIAGNOSIS AND TREATMENT SERVICES; PROVIDING AN INTERNET WEBSITE FOR MEDICAL PROFESSIONALS AND MEDICAL PATIENTS FEATURING MEDICAL INFORMATION FROM REMOTE LOCATIONS VIA ELECTRONIC PATIENT MONITORING DEVICES THAT FEED INFORMATION TO THE WEB SITE THAT CAN BE ACCESSED IN REAL-TIME BY MEDICAL PROFESSIONALS FOR PURPOSES OF MONITORING AND DIAGNOSING MEDICAL CONDITIONS; PROVIDING AN ON-LINE, PATIENT-INITIATED, PATIENT-AUTHORIZED, FEE-FOR-SERVICE, MEDICAL PROFILE AND MEDICAL RECORD ANALYSIS SERVICE DESIGNED TO PROVIDE PATIENTS WITH CUSTOM TAILORED INFORMATION ABOUT THE RANGE OF POSSIBLE DIAGNOSES AND THERAPIES ASSOCIATED WITH A DEFINED SET OF SYMPTOMS; PROVIDING LASER THERAPY FOR TREATING MEDICAL CONDITIONS; PROVIDING LIMITED IN-HOME PERSONAL MEDICAL SERVICES FOR INDIVIDUALS, NAMELY, CHECKING VITAL SIGNS, MEDICATION COMPLIANCE AND INDIVIDUAL HYGIENE, SCHEDULING DOCTOR APPOINTMENTS, PICKING UP PRESCRIPTIONS, CHECKING MEDICAL EQUIPMENT AND SUPPLIES, AND PROVIDING ON-LINE INFORMATION RELATED TO THESE PERSONAL MEDICAL SERVICES; PROVISION OF HEALTH CARE AND MEDICAL SERVICES BY HEALTH CARE PROFESSIONALS VIA THE INTERNET OR TELECOMMUNICATION NETWORKS (U.S. CLS. 100 AND 101).

FIRST USE 3-9-2012; IN COMMERCE 3-9-2012.

4,593,452. RASMUSSEN, KYLE ROBERT, LITCHFIELD, MN. SN 85-728,157. PUB. 2-19-2013, FILED 9-13-2012.

## Guest Experience Maximization

THE MARK CONSISTS OF STANDARD CHARACTERS WITHOUT CLAIM TO ANY PARTICULAR FONT, STYLE, SIZE, OR COLOR.

FOR HEALTHCARE (U.S. CLS. 100 AND 101).  
FIRST USE 3-1-2012; IN COMMERCE 3-1-2012.

**CLASS 44—(Continued).**

4,593,455. AMYLIN PHARMACEUTICALS, LLC, SAN DIEGO, CA. SN 85-730,966. PUB. 4-23-2013, FILED 9-17-2012.

## STEADY SUPPORT PROGRAM

THE MARK CONSISTS OF STANDARD CHARACTERS WITHOUT CLAIM TO ANY PARTICULAR FONT, STYLE, SIZE, OR COLOR.

OWNER OF U.S. REG. NO. 4,199,058.

NO CLAIM IS MADE TO THE EXCLUSIVE RIGHT TO USE "SUPPORT PROGRAM", APART FROM THE MARK AS SHOWN.

FOR MEDICAL INFORMATION SERVICES IN THE FIELD OF DIABETES (U.S. CLS. 100 AND 101).

FIRST USE 5-0-2014; IN COMMERCE 5-0-2014.

4,593,531. WELLS, LUANNE, BETTENDORF, IA. SN 85-772,368. PUB. 11-5-2013, FILED 11-6-2012.

## Natural Adjustments

THE MARK CONSISTS OF STANDARD CHARACTERS WITHOUT CLAIM TO ANY PARTICULAR FONT, STYLE, SIZE, OR COLOR.

NO CLAIM IS MADE TO THE EXCLUSIVE RIGHT TO USE "ADJUSTMENTS", APART FROM THE MARK AS SHOWN.

FOR ACUPUNCTURE; ACUPUNCTURE SERVICES; ANTI-SMOKING THERAPY; ART THERAPY; BODY-WORK THERAPY SERVICES, NAMELY, STRUCTURAL INTEGRATION THERAPY AND MOVEMENT THERAPY; CHIROPRACTIC SERVICES; CHIROPRACTICS; CLINICAL MENTAL HEALTH COUNSELING SERVICES; CONDUCTING TELEPHONE AND IN-PERSON PERSONAL LIFESTYLE WELLNESS ASSESSMENTS; CONSULTING IN THE FIELD OF HEALTH AND WELLNESS TO BRING ABOUT PERSONAL HAPPINESS; CONSULTING SERVICES IN THE FIELD OF MENTAL FITNESS; CONSULTING SERVICES IN THE FIELD OF MENTAL HEALTH AND WELLNESS; COUNSELING SERVICES IN THE FIELDS OF HEALTH, HERBALISM, AND LIFESTYLE WELLNESS; COUNSELING SERVICES IN THE FIELDS OF HEALTH, NUTRITION AND LIFESTYLE WELLNESS; HEALTH ASSESSMENT SERVICES, NAMELY, PROVIDING METABOLIC ASSESSMENT PROFILES (MAP) TO CLIENTS OBTAINED BY USING A PORTABLE METABOLIC MEASUREMENT SYSTEM IN THE NATURE OF A UNIQUE, HEART-RATE BASED OVERVIEW OF THEIR OWN METABOLISM IN ORDER TO ASSIST IN REACHING WEIGHT LOSS, SPORTS PERFORMANCE, HEALTH, FITNESS, AND WELLNESS-RELATED GOALS; HEALTH CARE SERVICES, NAMELY, HEALTH AND WELLNESS PROGRAMS IN FIELD OF CHILDHOOD OBESITY; HEALTH CARE SERVICES, NAMELY, WELLNESS PROGRAMS; HEALTH SPA SERVICES FOR HEALTH AND WELLNESS OF THE BODY AND SPIRIT; MASSAGE; MASSAGE THERAPY SERVICES; MEDICAL CLINIC PROVIDING WEIGHT LOSS SOLUTIONS, SERVICES AND PROGRAMS, NUTRITION COUNSELING, HORMONE THERAPY, INCLUDING, BIOIDENTICAL HORMONE REPLACEMENT, ANTI AGING THERAPY, AND NATURAL HORMONE THERAPY, MEDICAL AESTHETIC PROCEDURES, INCLUDING, LASER HAIR

**CLASS 44—(Continued).**

REMOVAL, LASER PEELS, BOTULINUM TOXIN TREATMENTS, MICRODERMABRASION, LIPOSUCTION, VEIN TREATMENTS, VEIN THERAPY, CELLULITE TREATMENTS, BODY CONTOURING TREATMENTS, INJECTABLE FILLER TREATMENTS, FACIALS, AND SKIN CARE; MEDICAL COUNSELING; MEDICAL TESTING SERVICES, NAMELY, FITNESS EVALUATION; MEDICAL, PHYSICAL REHABILITATION AND PHYSICAL THERAPY SERVICES; MENTAL HEALTH COUNSELING AND PSYCHOTHERAPY AS IT RELATES TO RELATIONSHIPS; NUTRITION COUNSELING; NUTRITIONAL THERAPY SERVICES; PHYSICAL THERAPY; PROVIDING A WEB SITE FEATURING INFORMATION IN THE FIELD OF MENTAL HEALTH AND WELLNESS; PROVIDING A WEBSITE FEATURING CONTENT REGARDING HEALTHY LIVING AND LIFESTYLE WELLNESS; PROVIDING A WEBSITE FEATURING INFORMATION ABOUT HEALTH AND WELLNESS; PROVIDING A WEBSITE FEATURING INFORMATION ABOUT HEALTH, WELLNESS AND NUTRITION; PROVIDING A WEBSITE FEATURING INFORMATION AND ADVICE IN THE FIELDS OF DIET, WEIGHT LOSS, DIET PLANNING AND LIFESTYLE WELLNESS; PROVIDING ASSISTANCE, FITNESS EVALUATION AND CONSULTATION TO CORPORATE CLIENTS TO HELP THEIR EMPLOYEES MAKE HEALTH, WELLNESS AND NUTRITIONAL CHANGES IN THEIR DAILY LIVING TO IMPROVE HEALTH; PROVIDING ASSISTANCE, FITNESS EVALUATION AND CONSULTATION TO INDIVIDUALS TO HELP THEM MAKE HEALTH, WELLNESS AND NUTRITIONAL CHANGES IN THEIR DAILY LIVING TO IMPROVE HEALTH; PROVIDING HEALTHY LIFESTYLE AND NUTRITION SERVICES, NAMELY, PERSONAL ASSESSMENTS, PERSONALIZED ROUTINES, MAINTENANCE SCHEDULES, AND COUNSELING; PROVIDING INFORMATION, NEWS AND COMMENTARY IN THE FIELD OF NUTRITION, HEALTH AND WELLNESS; PROVIDING LASER THERAPY FOR TREATING MEDICAL CONDITIONS; PROVIDING WELLNESS SERVICES, NAMELY, PERSONAL ASSESSMENTS, PERSONALIZED ROUTINES, MAINTENANCE SCHEDULES, AND COUNSELING; PROVIDING WELLNESS SERVICES, NAMELY, WEIGHT LOSS PROGRAMS OFFERED AT A WELLNESS CENTER; PSYCHOLOGICAL COUNSELING; PSYCHOLOGICAL COUNSELING SERVICES IN THE FIELD OF SPORTS; RELAXATION THERAPY IN THE NATURE OF AUTOGENOUS TRAINING; STRESS REDUCTION THERAPY; VITAMIN THERAPY; WEIGHT REDUCTION DIET PLANNING AND SUPERVISION (U.S. CLS. 100 AND 101).

FIRST USE 3-1-2014; IN COMMERCE 3-1-2014.

4,593,560. SUNEJA, RANDEEP, KATY, TX. SN 85-784,763. PUB. 4-23-2013, FILED 11-21-2012.

I TREAT, HE CURES.

THE MARK CONSISTS OF STANDARD CHARACTERS WITHOUT CLAIM TO ANY PARTICULAR FONT, STYLE, SIZE, OR COLOR.

FOR MEDICAL SERVICES (U.S. CLS. 100 AND 101).  
FIRST USE 2-26-2014; IN COMMERCE 2-26-2014.

**CLASS 44—(Continued).**

4,593,672. JOHNSON & JOHNSON, NEW BRUNSWICK, NJ. SN 85-822,121. PUB. 12-24-2013, FILED 1-14-2013.

REAL FACTS REAL RELIEF

THE MARK CONSISTS OF STANDARD CHARACTERS WITHOUT CLAIM TO ANY PARTICULAR FONT, STYLE, SIZE, OR COLOR.

FOR PROVISION OF HEALTH INFORMATION REGARDING PREVENTION AND TREATMENT OF COLDS AND ALLERGIES (U.S. CLS. 100 AND 101).

FIRST USE 4-1-2014; IN COMMERCE 4-1-2014.

4,593,673. JOHNSON & JOHNSON, NEW BRUNSWICK, NJ. SN 85-822,122. PUB. 12-24-2013, FILED 1-14-2013.

THE MARK CONSISTS OF THE WORDS "REAL FACTS" ON TOP OF THE WORDS "REAL RELIEF" AND A CURVED DOTTED LINE.

FOR PROVISION OF HEALTH INFORMATION REGARDING PREVENTION AND TREATMENT OF COLDS AND ALLERGIES (U.S. CLS. 100 AND 101).

FIRST USE 4-1-2014; IN COMMERCE 4-1-2014.

4,593,709. SEVEN MANAGEMENT SERVICES, INC., BEVERLY HILLS, CA. SN 85-844,848. PUB. 8-20-2013, FILED 2-8-2013.

W METHOD

THE MARK CONSISTS OF STANDARD CHARACTERS WITHOUT CLAIM TO ANY PARTICULAR FONT, STYLE, SIZE, OR COLOR.

NO CLAIM IS MADE TO THE EXCLUSIVE RIGHT TO USE "METHOD", APART FROM THE MARK AS SHOWN.

FOR REHABILITATION OF DRUG ADDICTED PATIENTS, NAMELY, OPIATE DETOXIFICATION (U.S. CLS. 100 AND 101).

FIRST USE 3-30-2013; IN COMMERCE 3-30-2013.

**CLASS 44—(Continued).**

4,593,716. NEW STANLEY ASSOCIATES, LLLP, ESTES PARK, CO. SN 85-846,733. PUB. 4-30-2013, FILED 2-11-2013.

# STANLEY

THE MARK CONSISTS OF STANDARD CHARACTERS WITHOUT CLAIM TO ANY PARTICULAR FONT, STYLE, SIZE, OR COLOR.

OWNER OF U.S. REG. NOS. 3,179,149, 3,762,592, AND OTHERS.

FOR HEALTH SPA SERVICES FOR HEALTH AND WELLNESS OF THE BODY AND SPIRIT, AND HEALTH SPA SERVICES NAMELY, COSMETIC BODY CARE SERVICES (U.S. CLS. 100 AND 101).

FIRST USE 6-23-2014; IN COMMERCE 6-23-2014.

4,593,740. AGNESIAN HEALTHCARE, INC., FOND DU LAC, WI. SN 85-862,201. PUB. 8-6-2013, FILED 2-27-2013.



OWNER OF U.S. REG. NOS. 3,201,186, 3,212,736, AND OTHERS.

NO CLAIM IS MADE TO THE EXCLUSIVE RIGHT TO USE "CONVENIENT CARE CLINIC", APART FROM THE MARK AS SHOWN.

THE MARK CONSISTS OF THE WORDS "AGNESIAN CONVENIENT CARE CLINIC" WITH HORIZONTAL LINES BEFORE AND AFTER THE WORD "CLINIC", AND A DESIGN ELEMENT ADJACENT TO THE WORD "AGNESIAN" COMPRISED OF A DESIGN IN THE OVERALL SHAPE OF A DIAMOND WITH THREE TRIANGLES INSIDE THE CORNERS OF THE DIAMOND AND A REPRESENTATION OF A RISING SUN IN THE FOURTH CORNER.

FOR HEALTHCARE; MEDICAL CLINICS (U.S. CLS. 100 AND 101).

FIRST USE 5-16-2014; IN COMMERCE 5-16-2014.

4,593,764. SIGNATURE HEALTHCARE, LLC, LOUISVILLE, KY. SN 85-879,201. PUB. 10-1-2013, FILED 3-18-2013.



NO CLAIM IS MADE TO THE EXCLUSIVE RIGHT TO USE "ACCELERATED CARE", APART FROM THE MARK AS SHOWN.

THE COLOR(S) RED, BLACK, PINK, ORANGE, PURPLE, BLUE, GRAY IS/ARE CLAIMED AS A FEATURE OF THE MARK.

**CLASS 44—(Continued).**

THE MARK CONSISTS OF A STYLIZED LOWERCASE "E" FORMED BY AN ARROW AND THE WORDING "EXCELERATED CARE". THE "E" IS PRESENTED IN GRADUATED COLOR THAT APPEARS FROM THE BOTTOM OF THE "E" FORWARD AS FOLLOWS: RED, ORANGE, PINK, PURPLE, AND BLUE. THE "E" IS UNDERLINE GRAY. RIGHT OF THE "E" IS THE BLACK WORD "EXCELERATED" AND THE RED WORD "CARE".

FOR POST ACUTE HEALTH CARE SERVICES (U.S. CLS. 100 AND 101).

FIRST USE 12-31-2012; IN COMMERCE 12-31-2012.

4,593,784. DYANN P. TIDY, MALIBU, CA. SN 85-888,903. PUB. 8-20-2013, FILED 3-28-2013.

# GLAMIFORNIA

THE MARK CONSISTS OF STANDARD CHARACTERS WITHOUT CLAIM TO ANY PARTICULAR FONT, STYLE, SIZE, OR COLOR.

FOR HYGIENIC AND BEAUTY CARE (U.S. CLS. 100 AND 101).

FIRST USE 5-19-2014; IN COMMERCE 5-19-2014.

4,593,819. GLOBAL ADVANCED IMAGING, LLC, LITTLE ROCK, AR. SN 85-910,494. PUB. 11-5-2013, FILED 4-22-2013.



NO CLAIM IS MADE TO THE EXCLUSIVE RIGHT TO USE "GLOBAL ADVANCED IMAGING, LLC", APART FROM THE MARK AS SHOWN.

THE MARK CONSISTS OF A GLOBE WITH 3 ELECTRONS/ELECTRON PATHS REVOLVING AROUND IT. TO THE RIGHT OF THE GLOBE THERE IS THE STYLIZED TEXT "GAI" AND ALONG THE BOTTOM THERE IS THE STYLIZED TEXT "GLOBAL ADVANCED IMAGING, LLC".

FOR MEDICAL SERVICES, NAMELY, TELERADIOLOGY NUCLEAR MEDICINE INTERPRETATION AND REPORTING; PROVIDING ON-SITE RADIOTHERAPIES (U.S. CLS. 100 AND 101).

FIRST USE 9-16-2013; IN COMMERCE 9-16-2013.

**CLASS 44—(Continued).**

4,593,896. ANYDAY DENTAL, LLC, ALPINE, UT. SN 85-931,403. PUB. 10-29-2013, FILED 5-14-2013.

**ANYDAY DENTAL**

THE MARK CONSISTS OF STANDARD CHARACTERS WITHOUT CLAIM TO ANY PARTICULAR FONT, STYLE, SIZE, OR COLOR.

NO CLAIM IS MADE TO THE EXCLUSIVE RIGHT TO USE "DENTAL", APART FROM THE MARK AS SHOWN. FOR DENTAL SERVICES; GENERAL DENTISTRY; DENTAL SURGERY; PROVIDING INFORMATION IN THE FIELD OF DENTISTRY AND DENTAL SERVICES; PROVIDING A WEBSITE FEATURING INFORMATION IN THE FIELD OF DENTISTRY (U.S. CLS. 100 AND 101). FIRST USE 6-23-2014; IN COMMERCE 6-23-2014.

4,594,006. BELAIR MANAGEMENT SERVICES, LLC, DBA THE VEIN GUYS, EVANS, GA. SN 85-948,698. PUB. 10-29-2013, FILED 6-3-2013.

**MAKE EVERY STEP COUNT**

THE MARK CONSISTS OF STANDARD CHARACTERS WITHOUT CLAIM TO ANY PARTICULAR FONT, STYLE, SIZE, OR COLOR.

FOR MEDICAL SERVICES (U.S. CLS. 100 AND 101). FIRST USE 8-15-2013; IN COMMERCE 8-15-2013.

4,594,011. PLANNED PARENTHOOD/ORANGE AND SAN BERNARDINO COUNTIES, INC., ORANGE, CA. SN 85-949,941. PUB. 11-5-2013, FILED 6-4-2013.

**MELODY WOMEN'S HEALTH**

THE MARK CONSISTS OF STANDARD CHARACTERS WITHOUT CLAIM TO ANY PARTICULAR FONT, STYLE, SIZE, OR COLOR.

NO CLAIM IS MADE TO THE EXCLUSIVE RIGHT TO USE "WOMEN'S HEALTH", APART FROM THE MARK AS SHOWN.

FOR PRIMARY CARE MEDICAL SERVICES FOR WOMEN (U.S. CLS. 100 AND 101). FIRST USE 3-1-2014; IN COMMERCE 3-1-2014.

**CLASS 44—(Continued).**

4,594,022. JASON FURIA, SPRINGFIELD, NJ. SN 85-951,406. PUB. 10-29-2013, FILED 6-5-2013.

**IMPROVE**

THE MARK CONSISTS OF STANDARD CHARACTERS WITHOUT CLAIM TO ANY PARTICULAR FONT, STYLE, SIZE, OR COLOR.

FOR PHYSICAL THERAPY (U.S. CLS. 100 AND 101). FIRST USE 12-0-2013; IN COMMERCE 12-0-2013.

4,594,126. SADDLEFIRE HOLDINGS, LLC, DBA SADDLEFIRE VENTURES, BETHESDA, MD. SN 85-969,696. PUB. 11-26-2013, FILED 6-25-2013.

**MINDOULA**

THE MARK CONSISTS OF STANDARD CHARACTERS WITHOUT CLAIM TO ANY PARTICULAR FONT, STYLE, SIZE, OR COLOR.

FOR HEALTH CARE MANAGEMENT SERVICES IN THE FIELD OF BEHAVIORAL HEALTH (U.S. CLS. 100 AND 101).

FIRST USE 6-14-2014; IN COMMERCE 6-14-2013.

4,594,148. KEEPSAKE BEAUTY LLC, ROCKVILLE, MD. SN 85-973,476. PUB. 12-3-2013, FILED 6-28-2013.

**Keepsake Beauty**

THE MARK CONSISTS OF STANDARD CHARACTERS WITHOUT CLAIM TO ANY PARTICULAR FONT, STYLE, SIZE, OR COLOR.

NO CLAIM IS MADE TO THE EXCLUSIVE RIGHT TO USE "BEAUTY", APART FROM THE MARK AS SHOWN.

FOR BODY WAXING SERVICES; HAIR COLOR SALON SERVICES; HAIR CUTTING; HAIR STYLING; MAKE-UP APPLICATION SERVICES (U.S. CLS. 100 AND 101).

FIRST USE 5-4-2013; IN COMMERCE 5-15-2013.

**CLASS 44—(Continued).**

4,594,196. SLEEP DATA SERVICES, LLC, SAN DIEGO, CA. SN 86-000,786. PUB. 11-26-2013, FILED 7-2-2013.

# OptiSom

THE MARK CONSISTS OF STANDARD CHARACTERS WITHOUT CLAIM TO ANY PARTICULAR FONT, STYLE, SIZE, OR COLOR.

FOR MEDICAL DIAGNOSIS AND TREATMENT OF SLEEP DISORDERS, SLEEP APNEA, INSOMNIA AND RESTLESS LEG SYNDROME (U.S. CLS. 100 AND 101).

FIRST USE 6-3-2013; IN COMMERCE 7-9-2013.

4,594,236. IDEAL IMAGE DEVELOPMENT CORPORATION, DBA IDEAL IMAGE, TAMPA, FL. SN 86-012,969. PUB. 1-14-2014, FILED 7-17-2013.

# IDEAL IMAGE

THE MARK CONSISTS OF STANDARD CHARACTERS WITHOUT CLAIM TO ANY PARTICULAR FONT, STYLE, SIZE, OR COLOR.

OWNER OF U.S. REG. NOS. 2,966,922, 3,193,543, AND 3,985,005.

FOR COSMETIC PROCEDURES, NAMELY, LASER TREATMENTS FOR ACNE, SKIN, TATTOOS, SCARS, HAIR REMOVAL; MEDICAL SERVICES, NAMELY, PERFORMING LIPOPLASTY TECHNIQUES AND PROCEDURES ON PATIENTS FOR PURPOSES OF BODY SCULPTING AND SHAPING; INJECTABLE FILLER TREATMENTS; WRINKLE REDUCTION SERVICES, NAMELY, WRINKLE REDUCTION INJECTIONS AND LASER WRINKLE REDUCTION SERVICES; LASER SKIN REJUVENATION AND RESURFACING; PROVIDING WEIGHT LOSS PROGRAM SERVICES; HEALTHCARE SERVICES, NAMELY, WELLNESS PROGRAMS AND CONSULTING IN THE FIELD OF WELLNESS TO BRING ABOUT PERSONAL HAPPINESS (U.S. CLS. 100 AND 101).

FIRST USE 8-31-2013; IN COMMERCE 8-31-2013.

**CLASS 44—(Continued).**

4,594,295. STEVE NGUYEN, M.D., P.A., ORLANDO, FL. SN 86-040,261. PUB. 1-7-2014, FILED 8-16-2013.

# OPTIMOTION

THE MARK CONSISTS OF STANDARD CHARACTERS WITHOUT CLAIM TO ANY PARTICULAR FONT, STYLE, SIZE, OR COLOR.

FOR ORTHOPEDIC SURGERY SERVICES (U.S. CLS. 100 AND 101).

FIRST USE 8-20-2013; IN COMMERCE 8-20-2013.

4,594,331. DINH, TU XUAN, PHILADELPHIA, PA. SN 86-057,492. PUB. 2-4-2014, FILED 9-6-2013.

# TREND EYE CARE

THE MARK CONSISTS OF STANDARD CHARACTERS WITHOUT CLAIM TO ANY PARTICULAR FONT, STYLE, SIZE, OR COLOR.

NO CLAIM IS MADE TO THE EXCLUSIVE RIGHT TO USE "EYE CARE", APART FROM THE MARK AS SHOWN. FOR OPTOMETRY SERVICES (U.S. CLS. 100 AND 101).

FIRST USE 11-14-2013; IN COMMERCE 11-14-2013.

4,594,450. MASSAGE DELIVERY, INC., NEW EGYPT, NJ. SN 86-100,146. PUB. 3-18-2014, FILED 10-24-2013.

# TrailSpa

THE MARK CONSISTS OF STANDARD CHARACTERS WITHOUT CLAIM TO ANY PARTICULAR FONT, STYLE, SIZE, OR COLOR.

FOR MASSAGE THERAPY SERVICES (U.S. CLS. 100 AND 101).

FIRST USE 1-1-2014; IN COMMERCE 2-1-2014.

**CLASS 44—(Continued).**

4,594,510. LIM ACUPUNCTURE AND HERBS CLINIC, LOS ANGELES, CA. SN 86-123,983. PUB. 4-29-2014, FILED 11-20-2013.

**CLASS 45—(Continued).**

4,593,211. E-ELIGIBILITY, INC., LOS ALTOS, CA. SN 85-347,752. PUB. 11-15-2011, FILED 6-16-2011.

# Tab Acupuncture

# CALLSIGN

THE MARK CONSISTS OF STANDARD CHARACTERS WITHOUT CLAIM TO ANY PARTICULAR FONT, STYLE, SIZE, OR COLOR.

NO CLAIM IS MADE TO THE EXCLUSIVE RIGHT TO USE "ACUPUNCTURE", APART FROM THE MARK AS SHOWN.

FOR MEDICAL SERVICES, NAMELY, ORIENTAL MEDICINE SERVICES IN THE NATURE OF ACUPUNCTURE THAT USES HANDS OR POINTY TOOLS BUT NOT NEEDLES ON THE SAME ACUPUNCTURE POINTS WHERE NEEDLES ARE TRADITIONALLY PLACED TO TREAT PATIENTS (U.S. CLS. 100 AND 101).

FIRST USE 6-20-2014; IN COMMERCE 6-20-2014.

THE MARK CONSISTS OF STANDARD CHARACTERS WITHOUT CLAIM TO ANY PARTICULAR FONT, STYLE, SIZE, OR COLOR.

FOR FRAUD AND IDENTITY THEFT PROTECTION SERVICES; PROVIDING FINANCIAL FRAUD PROTECTION AND PREVENTION; PROVIDING FRAUD DETECTION SERVICES FOR ELECTRONIC FUNDS TRANSFER, CREDIT AND DEBIT CARD AND ELECTRONIC CHECK TRANSACTIONS VIA A GLOBAL COMPUTER NETWORK; AND FRAUD DETECTION SERVICES, NAMELY, MONITORING FINANCIAL TRANSACTIONS AND EVALUATING THE LIKELIHOOD OF FRAUD IN THE FIELD OF ELECTRONIC FUND TRANSFER AND PAYMENT PROCESSING SERVICES (U.S. CLS. 100 AND 101).

FIRST USE 2-8-2014; IN COMMERCE 2-8-2014.

**CLASS 45—PERSONAL AND LEGAL SERVICES**

4,593,122. SARAH BROKAW, VENICE, CA. SN 85-073,157. PUB. 5-24-2011, FILED 6-28-2010.

4,593,337. PROUDFIT, CHARLES, CINCINNATI, OH. SN 85-634,209. PUB. 4-30-2013, FILED 5-24-2012.

# FORTYTUDE

# return on involvement

THE MARK CONSISTS OF STANDARD CHARACTERS WITHOUT CLAIM TO ANY PARTICULAR FONT, STYLE, SIZE, OR COLOR.

FOR PROVIDING ONLINE INFORMATION IN THE FIELDS OF SELF-HELP AND PERSONAL EMPOWERMENT IN ACHIEVING PERSONAL AND PROFESSIONAL GOALS (U.S. CLS. 100 AND 101).

FIRST USE 3-1-2011; IN COMMERCE 3-1-2011.

THE MARK CONSISTS OF STANDARD CHARACTERS WITHOUT CLAIM TO ANY PARTICULAR FONT, STYLE, SIZE, OR COLOR.

FOR CHRISTIAN MINISTRY SERVICES (U.S. CLS. 100 AND 101).

FIRST USE 3-1-2014; IN COMMERCE 3-1-2014.

**CLASS 45—(Continued).**

4,593,400. WORLD BUDDHIST-HANMI ASSOCIATION, THE, DBA DARI RULAI TEMPLE, LA PUENTE, CA. SN 85-674,701. PUB. 4-23-2013, FILED 7-11-2012.



NO CLAIM IS MADE TO THE EXCLUSIVE RIGHT TO USE "TEMPLE", APART FROM THE MARK AS SHOWN. THE COLOR(S) RED, YELLOW, BLACK, AND ORANGE IS/ARE CLAIMED AS A FEATURE OF THE MARK.

THE MARK CONSISTS OF THE WORDING "DARI RULAI TEMPLE" IN BLACK ABOVE THE WORDING "KNOW YOURSELF, CHANGE YOURSELF, CONQUER YOURSELF", IN BLACK. ALL THE WORDING APPEARS ABOVE A DESIGN CONSISTING OF A RED BUDDHA, TWO ORANGE AND YELLOW SANSKRIT SYMBOLS WITH RED BACKGROUNDS, AND YELLOW AND ORANGE SUNS IN A DIAMOND PATTERN, ALL ON A YELLOW AND ORANGE BACKGROUND.

THE ENGLISH TRANSLATION OF "DARI RULAI" IN THE MARK IS THE GREAT ENLIGHTENER.

THE NON-LATIN CHARACTERS IN THE MARK TRANSLITERATE TO "AH" AND "WAH" AND THIS MEANS "CALL" AND "ADMIRATION" IN ENGLISH.

FOR CONDUCTING RELIGIOUS PRAYER AND MEDITATION SERVICES, PROVIDING RELIGIOUS AND SPIRITUAL GATHERINGS AND RETREATS TO DEVELOP AND ENHANCE THE SPIRITUAL LIVES OF INDIVIDUALS VIA BUDDHIST TEMPLES (U.S. CLS. 100 AND 101).

FIRST USE 3-1-2003; IN COMMERCE 3-1-2003.

4,593,485. BAROSS, BETH, RIDGEWOOD, NJ. SN 85-752,594. PUB. 12-10-2013, FILED 10-12-2012.



THE MARK CONSISTS OF A STYLIZED TELEPHONE HANDSET POSITIONED ABOVE A SQUARE, HOUSE-LIKE CRADLE. THE CRADLE INCLUDES A CONCAVE CURVED

**CLASS 45—(Continued).**

CUT-OUT AT EACH UPPER CORNER AND ROUNDED BOTTOM CORNERS. AS VIEWED, A RECTANGULAR SHAPED DOOR CUT-OUT IS POSITIONED AT THE RIGHT SIDE OF THE SQUARE. A SMALL CIRCLE IS POSITIONED IN THE MIDDLE RIGHT SIDE OF THE DOOR RECTANGLE. A NARROW LARGER RECTANGLE IS CENTRALLY POSITIONED AT THE BOTTOM OF THE DOOR CUT-OUT. A SMALLER RECTANGLE IS CENTRALLY POSITIONED ON TOP OF THE LOWER, LARGER RECTANGLE. THESE RECTANGLES DEPICT STAIRS. AS VIEWED, A RECTANGULAR BOX SHAPED CUT-OUT IS POSITIONED TO THE LEFT OF THE RECTANGLE DOOR SHAPE. IT IS DIVIDED EQUALLY INTO FOUR SMALLER RECTANGLES BY A VERTICAL LINE AND A HORIZONTAL LINE. AS VIEWED, ON THE LEFT SIDE OF THE STYLIZED SQUARE CRADLE IS A LINE FORMING TWO LOOPS AND ATTACHING TO THE LEFT SIDE OF THE STYLIZED TELEPHONE HANDSET. THE HANDSET HAS A NARROW CUT-OUT THREE QUARTERS DOWN DISSECTING EACH SIDE LEAVING A ROUNDED BOTTOM ON EACH SIDE. THE WORDS "A WATCHFUL" ARE CENTERED UNDER THE STYLIZED SQUARE, HOUSE-LIKE CRADLE AND THE WORD "NEIGHBOR" IS CENTERED UNDER THE WORDS "A WATCHFUL".

FOR SECURITY SERVICES, NAMELY, MONITORING THE STATUS OR CONDITION OF PRIVATE PROPERTY OF OTHERS VIA ELECTRONIC MESSAGE ALERTS FROM THIRD PARTIES FOR THE PURPOSE OF PROVIDING SECURITY ALERTS TO PROPERTY OWNERS OF UNEXPECTED OCCURRENCES INVOLVING THEIR PROPERTY (U.S. CLS. 100 AND 101).

FIRST USE 3-21-2014; IN COMMERCE 3-21-2014.

4,593,521. LINDSAY A. CURCIO, BROOKLYN, NY. SN 85-768,159. PUB. 4-16-2013, FILED 10-31-2012.

**UNEE DAVIS**

THE MARK CONSISTS OF STANDARD CHARACTERS WITHOUT CLAIM TO ANY PARTICULAR FONT, STYLE, SIZE, OR COLOR.

NO CLAIM IS MADE TO THE EXCLUSIVE RIGHT TO USE "VISA", APART FROM THE MARK AS SHOWN.

FOR LEGAL SERVICES, NAMELY, IMMIGRATION AND NATIONALITY LAW (U.S. CLS. 100 AND 101).

FIRST USE 10-31-2000; IN COMMERCE 1-2-2001.

4,593,655. SHOWROOM LLC, FT. MOHAVE, AZ. SN 85-814,891. PUB. 5-28-2013, FILED 1-3-2013.

**IDENTITY ELEMENT**

THE MARK CONSISTS OF STANDARD CHARACTERS WITHOUT CLAIM TO ANY PARTICULAR FONT, STYLE, SIZE, OR COLOR.

**CLASS 45—(Continued).**

NO CLAIM IS MADE TO THE EXCLUSIVE RIGHT TO USE "IDENTITY", APART FROM THE MARK AS SHOWN.

FOR SECURITY PRINTING, NAMELY, ENCODING IDENTIFICATION INFORMATION ON VALUABLE DOCUMENTS AND PRODUCTS (U.S. CLS. 100 AND 101).

FIRST USE 5-11-2012; IN COMMERCE 5-11-2012.

---

4,593,752. SQUAREHUB INC., KIRKLAND, WA. SN 85-870,858. PUB. 7-23-2013, FILED 3-8-2013.

## SQUAREHUB

THE MARK CONSISTS OF STANDARD CHARACTERS WITHOUT CLAIM TO ANY PARTICULAR FONT, STYLE, SIZE, OR COLOR.

FOR ON-LINE SOCIAL NETWORKING SERVICES FOR SHARING INFORMATION AMONG MEMBERS OF FAMILIES AND SMALL GROUPS (U.S. CLS. 100 AND 101).

FIRST USE 5-16-2012; IN COMMERCE 5-16-2012.

---

4,593,803. GULF PEARL LTD., TORONTO, ONTARIO, CANADA. SN 85-900,592. PUB. 9-3-2013, FILED 4-10-2013.

## PICRATE.ME

THE MARK CONSISTS OF STANDARD CHARACTERS WITHOUT CLAIM TO ANY PARTICULAR FONT, STYLE, SIZE, OR COLOR.

FOR INTERNET BASED SOCIAL NETWORKING, INTRODUCTION, AND DATING SERVICES; INTERNET-BASED SOCIAL NETWORKING SERVICES (U.S. CLS. 100 AND 101).

FIRST USE 10-1-2013; IN COMMERCE 10-1-2013.

**CLASS 45—(Continued).**

4,593,871. WISHING AND HOPING L.L.C., PEORIA, IL. SN 85-924,624. PUB. 10-1-2013, FILED 5-6-2013.



THE MARK CONSISTS OF A LIT BIRTHDAY CANDLE WITH BARBER-POLE TYPE STRIPING AND WATER DROP-SHAPED FLAME WITH HEAVY OUTLINE AND WICK VISIBLE IN THE CENTER OF THE FLAME.

FOR ONLINE SOCIAL NETWORKING SERVICES IN THE FIELD OF PROVIDING A FORUM IN WHICH INDIVIDUALS CAN EXPRESS WISHES AND OTHERS MAY GRANT THOSE WISHES (U.S. CLS. 100 AND 101).

FIRST USE 9-1-2013; IN COMMERCE 9-1-2013.

---

4,594,201. HUMAN ENERGY, LLC, SAINT AUGUSTINE, FL. SN 86-002,482. PUB. 1-14-2014, FILED 7-3-2013.

## ENERGY ECHO

THE MARK CONSISTS OF STANDARD CHARACTERS WITHOUT CLAIM TO ANY PARTICULAR FONT, STYLE, SIZE, OR COLOR.

FOR PROVIDING A SOCIAL NETWORKING WEBSITE FOR ENTERTAINMENT PURPOSES (U.S. CLS. 100 AND 101).

FIRST USE 12-15-2013; IN COMMERCE 3-9-2014.

---

4,594,273. TUTTI, LLC, WESTLAKE VILLAGE, CA. SN 86-031,844. PUB. 3-4-2014, FILED 8-7-2013.

## TUTTI.FM

THE MARK CONSISTS OF STANDARD CHARACTERS WITHOUT CLAIM TO ANY PARTICULAR FONT, STYLE, SIZE, OR COLOR.

FOR ONLINE SOCIAL NETWORKING SERVICES IN THE FIELD OF MUSIC (U.S. CLS. 100 AND 101).

FIRST USE 4-17-2013; IN COMMERCE 12-16-2013.



**CLASS 45—(Continued).**

4,594,289. FIREFLY8, HILLSBORO, OR. SN 86-038,727. PUB. 12-31-2013, FILED 8-15-2013.



THE MARK CONSISTS OF THE STYLIZED WORDING "FIREFLY8".

FOR PROVIDING A RESOURCE WEBSITE PROVIDING INFORMATION IN THE FIELD OF PERSONAL DEVELOPMENT; PROVIDING INFORMATION IN THE FIELD OF PERSONAL DEVELOPMENT, NAMELY, IMPROVING ONESELF THROUGH ACHIEVEMENT OF TIMELY AND CHALLENGING GOALS; PROVIDING INFORMATION IN THE FIELD OF SELF-IMPROVEMENT (U.S. CLS. 100 AND 101).

FIRST USE 7-1-2013; IN COMMERCE 1-1-2014.

4,594,358. MEET ME MEDIA INC., LOS ANGELES, CA. SN 86-067,300. PUB. 2-11-2014, FILED 9-17-2013.

# Pass The Sugar

THE MARK CONSISTS OF STANDARD CHARACTERS WITHOUT CLAIM TO ANY PARTICULAR FONT, STYLE, SIZE, OR COLOR.

FOR COMPUTER DATING SERVICES; MATCHMAKING SERVICES; SOCIAL INTRODUCTION AGENCIES (U.S. CLS. 100 AND 101).

FIRST USE 3-1-2014; IN COMMERCE 3-1-2014.

**CLASS 45—(Continued).**

4,594,399. OUTLOOK AMUSEMENTS, INC., BURBANK, CA. SN 86-084,681. PUB. 3-4-2014, FILED 10-7-2013.

# Tomorrow Starts Today

THE MARK CONSISTS OF STANDARD CHARACTERS WITHOUT CLAIM TO ANY PARTICULAR FONT, STYLE, SIZE, OR COLOR.

FOR PSYCHIC AND ASTROLOGICAL READING SERVICES (U.S. CLS. 100 AND 101).

FIRST USE 12-31-2013; IN COMMERCE 12-31-2013.

4,594,412. SEINES, JENNIFER RAPHAEL, SAN DIEGO, CA. SN 86-087,798. PUB. 3-25-2014, FILED 10-10-2013.

# Less-Stress Organizing Solutions

THE MARK CONSISTS OF STANDARD CHARACTERS WITHOUT CLAIM TO ANY PARTICULAR FONT, STYLE, SIZE, OR COLOR.

NO CLAIM IS MADE TO THE EXCLUSIVE RIGHT TO USE "ORGANIZING SOLUTIONS", APART FROM THE MARK AS SHOWN.

FOR ORGANIZATIONAL SERVICES FOR HOME OR PERSONAL PURPOSES, NAMELY, ORGANIZATION OF PERSONAL SPACE AND PERSONAL TIME MANAGEMENT (U.S. CLS. 100 AND 101).

FIRST USE 9-25-2013; IN COMMERCE 9-25-2013.

\* \* \* \* \*

PRIOR UNITED STATES CLASSIFICATION

APPLICATION IN ONE CLASS

CERTIFICATION MARKS

CLASS B—SERVICES

4,593,302. A-LIGN SECURITY AND COMPLIANCE SERVICES, LLC, TAMPA, FL. SN 85-573,209. PUB. 10-29-2013, FILED 3-19-2012.



NO CLAIM IS MADE TO THE EXCLUSIVE RIGHT TO USE "SECURITY COMPLIANCE," "ISO 27001," AND "INFORMATION SECURITY MANAGEMENT SYSTEM", APART FROM THE MARK AS SHOWN.

THE COLOR(S) GOLD, BLACK, AND WHITE IS/ARE CLAIMED AS A FEATURE OF THE MARK.

THE MARK CONSISTS OF TWO CIRCLES, ONE INSIDE THE OTHER, AND A BANNER CENTERED NEAR THE BOTTOM OF SAID CIRCLES. THE INNER CIRCLE IS DIVIDED INTO THREE HORIZONTAL BANDS, WHEREIN THE UPPER BAND IS SHADED IN A DARK GOLD; THE

MIDDLE BAND IS SHADED IN A LIGHT GOLD AND CONTAINS THE WORDING "A-LIGN" CENTERED NEAR THE TOP, WHEREIN THE "A" AND THE DOT OF THE "I" IS A DARK GOLD COLOR AND THE "-LIGN" PORTION OF THE WORDING IS BLACK; AND THE LOWER BAND IS SHADED HORIZONTALLY FROM TOP TO BOTTOM FROM DARK GOLD TO WHITE TO DARK GOLD WITH THE WORDS "ISO 27001" IN BLACK LETTERING WITHIN THE WHITE SHADED PORTION. SURROUNDING THE TOP OF THE INNER CIRCLE, AND CONTAINED BY THE OUTER CIRCLE, ARE THE WORDS "SECURITY" AND "COMPLIANCE" IN BLACK LETTERING. THE OUTER CIRCLE IS OUTLINED WITH A THIN BLACK LINE AND SHADED FROM A LIGHT GOLD, ON THE LEFT HALF, AND BECOMES A DARK GOLD ON THE RIGHT HALF. CENTERED AT THE BOTTOM OF THE TWO CIRCLES IS A STYLIZED GOLD-SHADED BANNER WITH THE WORDS "INFORMATION SECURITY MANAGEMENT SYSTEM" IN BLACK LETTERING, WHEREIN SAID BANNER IS OUTLINED WITH A THIN BLACK LINE, AND IS SHADED IN BANDS OF GOLD AND WHITE.

THE CERTIFICATION MARK, AS INTENDED TO BE USED BY AUTHORIZED PERSONS, IS INTENDED TO CERTIFY THAT THE CERTIFIED PARTIES' INFORMATION SECURITY MANAGEMENT SYSTEM SERVICES ARE FOUND TO CONFORM TO THE INTERNATIONAL ORGANIZATION FOR STANDARDIZATION ISO 27001 MANAGEMENT SYSTEM STANDARDS.

FOR BUSINESS SERVICES, NAMELY, REGULATORY COMPLIANCE SERVICES; APPLICATION SERVICE PROVIDER SERVICES, BANKING AND FINANCIAL SERVICES, DATA CENTER PROVIDER SERVICES, ENERGY AND UTILITY SERVICES, GOVERNMENT SERVICES, NAMELY, REGULATORY COMPLIANCE SERVICES; INSURANCE SERVICES, PROFESSIONAL SERVICES, NAMELY, REGULATORY COMPLIANCE SERVICES; SOFTWARE AS A SERVICE SERVICES, NON-PROFIT RELIGIOUS CHARITABLE FUNDRAISING SERVICES, ALL IN THE FIELD OF INFORMATION SECURITY MANAGEMENT SYSTEMS (U.S. CL. B).

FIRST USE 4-27-2014; IN COMMERCE 4-27-2014.

\* \* \* \* \*

# SUPPLEMENTAL REGISTER

These registrations are not subject to opposition.

## SECTION 1.— INTERNATIONAL CLASSIFICATION

The short titles associated below with the international class numbers are terms designed merely for quick identification and are not an official part of the international classification. The full names of international classes are given in section 6.1 of the trademark rules of practice.

The designation "U.S. Cl." appearing in this section refers to the U.S. class in effect prior to Sep. 1, 1973 rather than the international class which applies to applications filed on or after that date. For adoption of international classification see notice in the OFFICIAL GAZETTE of Jun. 26, 1973 (911 O.G. TM 210).

### Application in more than one class

4,594,557. BOEN, WILLIAM C, LINCOLN, CA. SN 76-715,252.  
FILED P.R. 10-24-2013; AM. S.R. 6-11-2014.

4,594,573. FEM, INC., ALISO VIEJO, CA. SN 85-799,154.  
FILED P.R. 12-10-2012; AM. S.R. 4-24-2014.

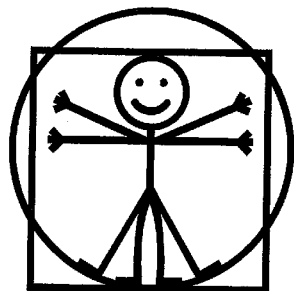

THE MARK CONSISTS OF A STICK FIGURE OF AN INDIVIDUAL WITH TWO PAIRS OF ARMS AND LEGS OUTWARDLY EXTENDED AND POSITIONED WITHIN A SQUARE AND A CIRCLE.

#### CLASS 9—ELECTRICAL AND SCIENTIFIC APPARATUS

FOR DOWNLOADABLE ELECTRONIC BOOKS DIRECTED TO HEALTH AND FITNESS PROGRAMS (U.S. CLS. 21, 23, 26, 36 AND 38).

FIRST USE 8-18-2013; IN COMMERCE 8-18-2013.

#### CLASS 16—PAPER GOODS AND PRINTED MATTER

FOR PRINTED BOOKS DIRECTED TO HEALTH AND FITNESS PROGRAMS (U.S. CLS. 2, 5, 22, 23, 29, 37, AND 50).

FIRST USE 8-18-2013; IN COMMERCE 8-18-2013.

**FEM** inc.

NO CLAIM IS MADE TO THE EXCLUSIVE RIGHT TO USE "INC.", APART FROM THE MARK AS SHOWN.

THE COLOR(S) RED IS/ARE CLAIMED AS A FEATURE OF THE MARK.

THE MARK CONSISTS OF THE WORDS "FEM INC." IN THE COLOR RED. THE WORD "FEM" IS CAPITALIZED AND THE WORD "INC." IS IN LOWER CASE.

#### CLASS 35—ADVERTISING AND BUSINESS

FOR BUSINESS ADVISORY SERVICES IN THE FIELD OF MEDIA AND ENTERTAINMENT, NAMELY, BUSINESS ADVISORY SERVICES WITH RESPECT TO MEDIA EFFICACY MEASUREMENT AND BUSINESS ADVISORY SERVICES WITH RESPECT TO CONTENT (U.S. CLS. 100, 101 AND 102).

FIRST USE 10-0-2012; IN COMMERCE 10-0-2012.

#### CLASS 41—EDUCATION AND ENTERTAINMENT

FOR PROVIDING, PRODUCING, AND DISTRIBUTING ONLINE ENTERTAINMENT CONTENT, NAMELY, PROVIDING A WEBSITE FEATURING NON-DOWNLOADABLE MULTIMEDIA VIDEO CLIPS IN THE FIELD OF ENTERTAINMENT AND FEMALE EMPOWERMENT, AND PRODUCING AND DISTRIBUTING SUCH VIDEOS; PRODUCING AND DISTRIBUTING SOCIAL NETWORKING CONTENT, NAMELY, VIDEOS IN THE FIELD OF SOCIAL NETWORKING; PROVIDING A WEBSITE FEATURING NON-DOWNLOADABLE MULTIMEDIA VIDEO CLIPS IN THE FIELD OF ENTERTAINMENT AND FEMALE EMPOWERMENT; PROVIDING ONLINE PUBLICATIONS IN THE NATURE OF NEWSLETTERS, MAGAZINES, AND REPORTS, CURRENT EVENT NEWS, AND ORIGINAL EDUCATION RESEARCH FOR FEMALE AUDIENCES IN THE FIELD OF FEMALE EMPOWERMENT; PROVIDING ONLINE EDUCATIONAL SERVICES, NAMELY, SEMINARS, CLASSES, AND WORKSHOPS FOR FEMALE AUDIENCES IN THE FIELD OF FEMALE EMPOWERMENT; PROVIDING A WEBSITE FEATURING NON-DOWNLOADABLE VIDEOS IN THE FIELD OF SOCIAL NETWORKING (U.S. CLS. 100, 101 AND 107).

FIRST USE 10-0-2012; IN COMMERCE 10-0-2012.

**CLASS 42—SCIENTIFIC AND COMPUTER SERVICES**

FOR PROVIDING ON-LINE NON-DOWNLOADABLE COMPUTER PROGRAMS AND COMPUTER SOFTWARE FOR ACCESSING AND VIEWING GENDER-BASED CONTENT (U.S. CLS. 100 AND 101).

FIRST USE 12-29-2013; IN COMMERCE 12-29-2013.

4,594,580. FARRELL TOPCO LIMITED, LONDON, UNITED KINGDOM. SN 85-832,485. FILED P.R. 1-25-2013; AM. S.R. 7-17-2014.

# FARRELL

THE MARK CONSISTS OF STANDARD CHARACTERS WITHOUT CLAIM TO ANY PARTICULAR FONT, STYLE, SIZE, OR COLOR.

OWNER OF ERPN CMNTY TM OFC REG. NO. 009873779, DATED 9-13-2011, EXPIRES 4-6-2021.

**CLASS 3—COSMETICS AND CLEANING PREPARATIONS**

FOR PERFUMES; EAU DE COLOGNE; OILS FOR TOILETRY PURPOSES; NON-MEDICATED TOILETRIES; SHAMPOOS; COSMETICS; PERSONAL GROOMING AND DRESSING PRODUCTS, NAMELY, HAIR DRESSING FOR MEN AND WOMEN; NON-MEDICATED HAIR, SKIN, BODY AND NAIL CARE PREPARATIONS; SOAPS; ESSENTIAL OILS; HAIR LOTIONS; BODY LOTIONS; HAIR DYES AND SPRAYS; COSMETIC PREPARATIONS FOR USE IN THE BATH AND SHOWER; DEPLATORIES; DENTIFRICES; SHOE CREAM; SHOE POLISH; SHOE WAX (U.S. CLS. 1, 4, 6, 50, 51 AND 52).

**CLASS 9—ELECTRICAL AND SCIENTIFIC APPARATUS**

FOR EYEWEAR; SPECTACLES; SUNGLASSES; SUNGLASSES AND SPECTACLES CASES; SUNGLASSES AND SPECTACLES FRAMES; DIGITAL MUSIC DOWNLOADABLE FROM THE INTERNET; DOWNLOADABLE ELECTRONIC PUBLICATIONS IN THE NATURE OF MAGAZINES IN THE FIELD OF MUSIC AND FASHION; DOWNLOADABLE TELEPHONE RING TONES; VIDEO AND AUDIO RECORDINGS FEATURING MUSIC AND FASHION; COMPACT DISCS FEATURING MUSIC AND FASHION; AUDIO TAPES, CASSETTES AND CARTRIDGES FEATURING MUSIC AND FASHION; VIDEO TAPES, CASSETTES AND CARTRIDGES FEATURING MUSIC AND FASHION; BLANK MAGNETIC TAPES, DISCS AND WIRES ALL FOR BEARING SOUND OR VIDEO RECORDINGS; OPTICAL COMPACT DISCS FEATURING MUSIC AND FASHION; APPARATUS FOR RECORDING, TRANSMISSION OR REPRODUCTION OF SOUND OR IMAGES; MOTION PICTURE FILMS ABOUT MUSIC AND FASHION; VIDEO GAME SOFTWARE (U.S. CLS. 21, 23, 26, 36 AND 38).

**CLASS 14—JEWELRY**

FOR JEWELLERY; CHRONOMETRIC AND HOROLOGICAL INSTRUMENTS; WATCHES; CLOCKS; PRECIOUS METALS AND THEIR ALLOYS; PRECIOUS METAL KNOBS; STATUES OF PRECIOUS METAL; TIE CLIPS OF PRECIOUS METAL; KEY HOLDERS OF PRECIOUS METALS; KEY FOBS OF PRECIOUS METAL (U.S. CLS. 2, 27, 28 AND 50).

**CLASS 18—LEATHER GOODS**

FOR ARTICLES MADE OF LEATHER OR OF IMITATION LEATHER, NAMELY, LEATHER BRIEFCASES, LEATHER HANDBAGS; SMALL LEATHER ARTICLES AND ACCESSORIES, NAMELY, LEATHER KEY CASES; DUFFEL BAGS; TRAVELLING BAGS; LUGGAGE; HOLLERS; BACKPACKS; ATTACHE CASES; HANDBAGS; WALLETS; PURSES; UMBRELLAS AND PARASOLS; VANITY CASES SOLD EMPTY (U.S. CLS. 1, 2, 3, 22 AND 41).

**CLASS 25—CLOTHING**

FOR CLOTHING, NAMELY, T-SHIRTS, POLO SHIRTS, SHIRTS, TROUSERS, SHORTS, SOCKS, COATS, JACKETS, WAISTCOAT, DRESSES, BEACHWEAR; HEADGEAR, NAMELY, HATS, CAPS; AND FOOTWEAR; CLOTHING ACCESSORIES, NAMELY, SCARVES, TIES; FASHION, SPORTING AND FORMAL FOOTWEAR; BELTS FOR CLOTHING; GLOVES; KNIT DRESSES; KNIT BOTTOMS; JUMPERS; SWEATSHIRTS; DENIM JACKETS; LEATHERWEAR, NAMELY, LEATHER SHIRTS, LEATHER PANTS, LEATHER JACKETS; SUITS; CASUAL AND FORMAL SHIRTS; VESTS; SOCKS; HOSIERY; UNDERWEAR; LINGERIE; SPORTS JERSEYS; SPORTS JACKETS; SWIM WEAR; BELTS (U.S. CLS. 22 AND 39).

**CLASS 35—ADVERTISING AND BUSINESS**

FOR RETAIL STORE SERVICES FEATURING COSMETICS, TOILETRIES, BEAUTY PRODUCTS, MACHINES FOR HOUSEHOLD USE, OPTICAL GOODS, SUNGLASSES, SPECTACLES, CAMERAS, DOMESTIC ELECTRICAL AND ELECTRONIC EQUIPMENT, LINENS, JEWELLERY, CLOCKS, WATCHES, STATIONERY, PUBLICATIONS, LEATHER GOODS, BAGS, LUGGAGE, FURNITURE, HOUSEHOLD CONTAINERS AND UTENSILS, FURNISHINGS, TEXTILES, CLOTHING, FOOTWEAR, HEADWEAR, HABERDASHERY, TOYS AND GAMES, SPORTS EQUIPMENT, SOUND AND VIDEO RECORDINGS, DVDS, CDS, FOODSTUFFS, DRINKS AND TOBACCO PRODUCTS; ON-LINE RETAIL STORE SERVICES AND MAIL ORDER RETAIL SERVICES FEATURING COSMETICS, TOILETRIES, BEAUTY PRODUCTS, MACHINES FOR HOUSEHOLD USE, OPTICAL GOODS, SUNGLASSES, SPECTACLES, CAMERAS, DOMESTIC ELECTRICAL AND ELECTRONIC EQUIPMENT, LINENS, JEWELLERY, CLOCKS, WATCHES, STATIONERY, PUBLICATIONS, LEATHER GOODS, BAGS, LUGGAGE, FURNITURE, HOUSEHOLD CONTAINERS AND UTENSILS, FURNISHINGS, TEXTILES, CLOTHING, FOOTWEAR, HEADWEAR, HABERDASHERY, TOYS AND GAMES, SPORTS EQUIPMENT, SOUND AND VIDEO RECORDINGS, DVDS, CDS, FOODSTUFFS, DRINKS AND TOBACCO PRODUCTS (U.S. CLS. 100, 101 AND 102).

4,594,588. NATIONAL FORENSIC LEAGUE, RIPON, WI. SN 85-861,316. FILED P.R. 2-27-2013; AM. S.R. 6-16-2014.

### NATIONAL SPEECH & DEBATE ASSOCIATION

THE MARK CONSISTS OF STANDARD CHARACTERS WITHOUT CLAIM TO ANY PARTICULAR FONT, STYLE, SIZE, OR COLOR.

NO CLAIM IS MADE TO THE EXCLUSIVE RIGHT TO USE "ASSOCIATION", APART FROM THE MARK AS SHOWN.

#### CLASS 35—ADVERTISING AND BUSINESS

FOR PUBLIC ADVOCACY TO PROMOTE AWARENESS OF DEBATE AND PUBLIC SPEAKING; PROMOTING PUBLIC AWARENESS OF DEBATE AND PUBLIC SPEAKING (U.S. CLS. 100, 101 AND 102).

FIRST USE 4-0-2014; IN COMMERCE 4-0-2014.

#### CLASS 41—EDUCATION AND ENTERTAINMENT

FOR COMPETITIONS IN THE FIELD OF DEBATE AND PUBLIC SPEAKING; ORGANIZING, SANCTIONING AND CONDUCTING DEBATE COMPETITIONS; PROVIDING AN ACADEMIC HONOR SOCIETY IN WHICH STUDENTS ARE ADMITTED IN RECOGNITION OF ACHIEVEMENT IN THE FIELDS OF DEBATE AND PUBLIC SPEAKING; EDUCATIONAL SERVICES, NAMELY, PROVIDING INSTRUCTION IN THE FIELDS OF DEBATE AND PUBLIC SPEAKING; PROVISION OF INFORMATION RELATING TO DEBATE AND PUBLIC SPEAKING; PROVIDING ONLINE INFORMATION IN THE FIELDS OF DEBATE AND PUBLIC SPEAKING (U.S. CLS. 100, 101 AND 107).

FIRST USE 6-16-2014; IN COMMERCE 6-16-2014.

4,594,599. RT FISHER EDUCATIONAL ENTERPRISES, INC., OAKLAND, CA. SN 85-889,595. FILED P.R. 3-28-2013; AM. S.R. 12-9-2013.

### The Educators' Institute

THE MARK CONSISTS OF STANDARD CHARACTERS WITHOUT CLAIM TO ANY PARTICULAR FONT, STYLE, SIZE, OR COLOR.

NO CLAIM IS MADE TO THE EXCLUSIVE RIGHT TO USE "INSTITUTE", APART FROM THE MARK AS SHOWN.

#### CLASS 16—PAPER GOODS AND PRINTED MATTER

FOR PRINTED EDUCATIONAL MATERIALS, NAMELY, TRAINING MATERIALS, CURRICULUM GUIDES, LESSON PLANS, TEACHER EVALUATION MODELS, AND COMMON CORE CONVERSION PROGRAMS, ALL IN THE FIELD OF K-12 EDUCATION (U.S. CLS. 2, 5, 22, 23, 29, 37, 38 AND 50).

FIRST USE 6-20-2011; IN COMMERCE 6-20-2011.

#### CLASS 41—EDUCATION AND ENTERTAINMENT

FOR PROVIDING CONTINUING PROFESSIONAL EDUCATIONAL COURSES TO EDUCATORS AND BUSINESS PROFESSIONALS IN THE FIELD OF K-12 EDUCATION; PROVIDING ONLINE NON-DOWNLOADABLE EDUCATIONAL RESOURCES TO PROFESSIONAL EDUCATORS, NAMELY, TRAINING MATERIALS, CURRICULUM GUIDES, LESSON PLANS, TEACHER EVALUATION MODELS, AND COMMON CORE CONVERSION PROGRAMS, ALL IN THE FIELD OF K-12 EDUCATION; PROVIDING RENTAL SERVICES OF TRAINING FACILITIES FOR EDUCATIONAL SEMINARS, WORKSHOPS AND COURSES FOR EDUCATORS, AND PROVIDING RENTAL SERVICES OF AUDIO AND VIDEO EQUIPMENT TO AND FOR EDUCATORS FOR USE AT SUCH FACILITIES (U.S. CLS. 100, 101 AND 107).

FIRST USE 6-20-2011; IN COMMERCE 6-20-2011.

4,594,602. ALLERGY SUITES, LLC, SHEBOYGAN, WI. SN 85-915,670. FILED P.R. 4-26-2013; AM. S.R. 7-9-2014.

## Allergy Suites

THE MARK CONSISTS OF STANDARD CHARACTERS WITHOUT CLAIM TO ANY PARTICULAR FONT, STYLE, SIZE, OR COLOR.

#### CLASS 37—CONSTRUCTION AND REPAIR

FOR CLEANING SERVICES, NAMELY, CLEANING AND SANITIZING HARD AND SOFT SURFACES FOR ARENAS, STADIUMS, SCHOOLS, AND OTHER PUBLIC VENUES (U.S. CLS. 100, 103 AND 106).

FIRST USE 4-15-2013; IN COMMERCE 4-15-2013.

#### CLASS 40—MATERIAL TREATMENT

FOR AIR PURIFICATION SERVICES PROVIDED TO ARENAS, STADIUMS, SCHOOLS, AND OTHER PUBLIC VENUES (U.S. CLS. 100, 103 AND 106).

FIRST USE 4-15-2013; IN COMMERCE 4-15-2013.

#### CLASS 43—HOTEL AND RESTAURANT SERVICES

FOR CATERING SERVICES OFFERING ALLERGY-FRIENDLY FOODS TO ARENAS, STADIUMS, SCHOOLS, AND OTHER PUBLIC VENUES (U.S. CLS. 100 AND 101).

FIRST USE 4-15-2013; IN COMMERCE 4-15-2013.

#### CLASS 45—PERSONAL AND LEGAL SERVICES

FOR SECURITY GUARD SERVICES TO CONTROL ACCESS AND PREVENT CONTAMINATION OF SPECIFIED AREAS PROVIDED TO ARENAS, STADIUMS, SCHOOLS, AND OTHER PUBLIC VENUES (U.S. CLS. 100 AND 101).

FIRST USE 4-15-2013; IN COMMERCE 4-15-2013.

4,594,605. APOLLO EDUCATION GROUP, INC., PHOENIX, AZ. SN 85-918,114. FILED P.R. 4-29-2013; AM. S.R. 6-25-2014.

## Phoenix Career Services

THE MARK CONSISTS OF STANDARD CHARACTERS WITHOUT CLAIM TO ANY PARTICULAR FONT, STYLE, SIZE, OR COLOR.

NO CLAIM IS MADE TO THE EXCLUSIVE RIGHT TO USE "CAREER SERVICES", APART FROM THE MARK AS SHOWN.

### CLASS 35—ADVERTISING AND BUSINESS

FOR PROVIDING INFORMATION IN THE FIELD OF PROFESSIONAL DEVELOPMENT, NAMELY, RESUME BUILDING AND INTERVIEW PREPARATION; PROVIDING EMPLOYMENT INFORMATION; PROVIDING AN ON-LINE INFORMATION DIRECTORY FEATURING EMPLOYMENT AND EMPLOYER INFORMATION; ON-LINE PROFESSIONAL NETWORKING SERVICES (U.S. CLS. 100, 101 AND 102).

FIRST USE 12-11-2012; IN COMMERCE 12-11-2012.

### CLASS 41—EDUCATION AND ENTERTAINMENT

FOR ON-LINE JOURNALS, NAMELY, BLOGS, FEATURING CAREER PLANNING, PERSONAL AND PROFESSIONAL DEVELOPMENT, AND EMPLOYMENT; CAREER COUNSELING SERVICES, NAMELY, PROVIDING ADVICE CONCERNING EDUCATION OPTIONS TO PURSUE CAREER OPPORTUNITIES (U.S. CLS. 100, 101 AND 107).

FIRST USE 12-11-2012; IN COMMERCE 12-11-2012.

### CLASS 42—SCIENTIFIC AND COMPUTER SERVICES

FOR PROVIDING A WEBSITE FEATURING TECHNOLOGY THAT ENABLES USERS TO RESEARCH CAREER OPTIONS, CAREER-RELATED STATISTICS, AND EDUCATION REQUIREMENTS FOR CAREERS (U.S. CLS. 100 AND 101).

FIRST USE 12-11-2012; IN COMMERCE 12-11-2012.  
4,594,617. GITLAB.COM, UTRECHT, NETHERLANDS. SN 85-968,232. FILED P.R. 6-24-2013; AM. S.R. 6-18-2014.

# GitLab

THE MARK CONSISTS OF STANDARD CHARACTERS WITHOUT CLAIM TO ANY PARTICULAR FONT, STYLE, SIZE, OR COLOR.

### CLASS 9—ELECTRICAL AND SCIENTIFIC APPARATUS

FOR DOWNLOADABLE COMPUTER SOFTWARE FOR COLLABORATIVELY BRAINSTORMING, DEVELOPING, MANAGING, PLANNING, COORDINATING, MODIFYING, TRACKING, TESTING, REVIEWING, PUBLISHING AND ARCHIVING DIGITAL COMPUTER PROGRAMS, DOCUMENTATION, TECHNICAL, DOCUMENTS, CONTRACTS, SPRINTS, STORIES, BUGS AND ISSUES (U.S. CLS. 21, 23, 26, 36 AND 38).

FIRST USE 1-1-1990; IN COMMERCE 1-1-1990.

### CLASS 42—SCIENTIFIC AND COMPUTER SERVICES

FOR COMPUTER SERVICES, NAMELY, HOSTING AND MAINTAINING AN ON-LINE WEB SITE FOR OTHERS FOR COLLABORATIVELY BRAINSTORMING, DEVELOPING, MANAGING, PLANNING, COORDINATING, MODIFYING, TRACKING, TESTING, REVIEWING, PUBLISHING AND ARCHIVING DIGITAL COMPUTER PROGRAMS, DOCUMENTATION, TECHNICAL, DOCUMENTS, CONTRACTS, SPRINTS, STORIES, BUGS AND ISSUES; CONSULTING SERVICES IN THE FIELD OF CLOUD COMPUTING; CONSULTING SERVICES IN THE FIELD OF DESIGN, SELECTION, IMPLEMENTATION AND USE OF COMPUTER HARDWARE AND SOFTWARE SYSTEMS FOR OTHERS; IT CONSULTING SERVICES (U.S. CLS. 100 AND 101).

FIRST USE 1-1-1990; IN COMMERCE 1-1-1990.

4,594,619. PROLIANT HEALTH, INC., ANKENY, IA. SN 85-974,813. FILED P.R. 7-1-2013; AM. S.R. 5-14-2014.

## SUPER SERUM

THE MARK CONSISTS OF STANDARD CHARACTERS WITHOUT CLAIM TO ANY PARTICULAR FONT, STYLE, SIZE, OR COLOR.

NO CLAIM IS MADE TO THE EXCLUSIVE RIGHT TO USE "SERUM", APART FROM THE MARK AS SHOWN.

### CLASS 1—CHEMICALS

FOR INGREDIENT, NAMELY, SERUM ALBUMIN CONCENTRATE, USED IN THE MANUFACTURE OF NUTRITIONAL SUPPLEMENT IN THE NATURE OF A NUTRIENT-DENSE, PROTEIN-BASED DRINK; ACTIVE CHEMICAL INGREDIENT FOR USE IN THE MANUFACTURE OF DIETARY AND NUTRITIONAL SUPPLEMENTS (U.S. CLS. 1, 5, 6, 10, 26 AND 46).

FIRST USE 2-1-2014; IN COMMERCE 2-1-2014.

### CLASS 5—PHARMACEUTICALS

FOR NUTRITIONAL SUPPLEMENT IN THE NATURE OF A NUTRIENT-DENSE, PROTEIN-BASED DRINK MIX; DIETARY AND NUTRITIONAL SUPPLEMENTS (U.S. CLS. 6, 18, 44, 46, 51 AND 52).

FIRST USE 2-1-2014; IN COMMERCE 2-1-2014.

4,594,621. GYFT, INC., DBA GYFT PLATFORM, INC., REDWOOD CITY, CA. SN 85-982,045. FILED P.R. 6-26-2012; AM. S.R. 7-15-2014.

4,594,627. EVAN CREE, DBA TRADITIONAL LACROSSE, HOGANSBURG, NY. SN 86-041,441. FILED P.R. 8-19-2013; AM. S.R. 6-5-2014.

**TRADITIONAL**  
LACROSSE

**GYFT**

THE MARK CONSISTS OF STANDARD CHARACTERS WITHOUT CLAIM TO ANY PARTICULAR FONT, STYLE, SIZE, OR COLOR.

**CLASS 35—ADVERTISING AND BUSINESS**

FOR BUSINESS SERVICES, NAMELY, PROVIDING DISTRIBUTION CHANNELS IN THE NATURE OF AN ONLINE MARKETPLACE FOR STORED VALUE, PREPAID, AND GIFT CARDS; PROMOTING, ADVERTISING AND MARKETING THE GOODS AND SERVICES OF OTHERS; DEVELOPING PROMOTIONAL CAMPAIGNS FOR BUSINESS; PROVIDING A WEBSITE FEATURING AN ONLINE MARKETPLACE FOR EXCHANGING STORED VALUE, PREPAID, AND GIFT CARD VALUE AND PAYMENT CARDS WITH OTHER USERS (U.S. CLS. 100, 101 AND 102).

FIRST USE 9-9-2012; IN COMMERCE 9-9-2012.

**CLASS 38—COMMUNICATION**

FOR PROVIDING ONLINE FORUMS AND ELECTRONIC BULLETIN BOARDS FOR TRANSMISSION OF MESSAGES AMONG COMPUTER USERS RELATED TO BUSINESS (U.S. CLS. 100, 101 AND 104).

FIRST USE 9-9-2012; IN COMMERCE 9-9-2012.

**CLASS 41—EDUCATION AND ENTERTAINMENT**

FOR BLOGGING SERVICES RELATED TO BUSINESS, NAMELY, PROVIDING ON-LINE JOURNALS IN THE NATURE OF BLOGS IN THE FIELD OF BUSINESS (U.S. CLS. 100, 101 AND 107).

FIRST USE 9-9-2012; IN COMMERCE 9-9-2012.

**CLASS 42—SCIENTIFIC AND COMPUTER SERVICES**

FOR APPLICATION SERVICE PROVIDER, NAMELY, HOSTING, MANAGING, DEVELOPING, ANALYZING, AND MAINTAINING APPLICATIONS, SOFTWARE, AND WEBSITES FOR OTHERS IN THE FIELD OF BUSINESS; APPLICATION SERVICE PROVIDER, NAMELY, PROVIDING SOFTWARE AS A SERVICE FEATURING SOFTWARE FOR CONDUCTING FINANCIAL TRANSACTIONS (U.S. CLS. 100 AND 101).

FIRST USE 9-9-2012; IN COMMERCE 9-9-2012.

NO CLAIM IS MADE TO THE EXCLUSIVE RIGHT TO USE "LACROSSE", APART FROM THE MARK AS SHOWN. THE MARK CONSISTS OF THE STYLIZED WORD "TRADITIONAL" OVER THE STYLIZED WORD "LACROSSE".

**CLASS 25—CLOTHING**

FOR CAPS; HATS; JACKETS; PINNIES IN THE NATURE OF SCRIMMAGE VESTS FOR USE IN SPORTS; SHORTS; SPORTS JERSEYS; SWEATERS; SWEATPANTS; SWEATSHIRTS; T-SHIRTS (U.S. CLS. 22 AND 39).

FIRST USE 6-0-2012; IN COMMERCE 10-0-2013.

**CLASS 28—TOYS AND SPORTING GOODS**

FOR ATHLETIC PROTECTIVE PADS FOR ARMS; LACROSSE BALL BAGS; LACROSSE BALLS; LACROSSE GLOVES; LACROSSE STICK BAGS; LACROSSE STICK HANDLES; LACROSSE STICK HEADS; LACROSSE STICK STRINGS; LACROSSE STICKS; SHOULDER PADS FOR ATHLETIC USE (U.S. CLS. 22, 23, 38 AND 50).

FIRST USE 6-0-2012; IN COMMERCE 10-0-2013.

4,594,631. BEST PRACTICES INSTITUTE, INC., PALM BEACH GARDENS, FL. SN 86-050,472. FILED P.R. 8-28-2013; AM. S.R. 3-24-2014.

**skillrater**

THE MARK CONSISTS OF THE WORD "SKILLRATER" IN STYLIZED LOWER-CASE FONT.

**CLASS 35—ADVERTISING AND BUSINESS**

FOR BUSINESS CONSULTATION SERVICES IN THE NATURE OF CANDIDATE EVALUATION AND COMPARISON; PROVIDING ONLINE DATABASES FEATURING INFORMATION RELATING TO EMPLOYERS AND EMPLOYEES AND PLACES OF EMPLOYMENT; PROVIDING RATINGS VIA A GLOBAL COMPUTER NETWORK ON POTENTIAL EMPLOYEES (U.S. CLS. 100, 101 AND 102).

FIRST USE 12-20-2012; IN COMMERCE 12-20-2012.

**CLASS 42—SCIENTIFIC AND COMPUTER SERVICES**

FOR COMPUTER SERVICES, NAMELY, HOSTING A SOFTWARE AS A SERVICE (SAAS) PROVIDING CUSTOMIZED SKILL RATING AND PERFORMANCE FEEDBACK ENABLING INDIVIDUALS AND ORGANIZATIONS TO CREATE A PERSONALIZED SOCIAL NETWORK SO AS TO FACILITATE SKILL RATING AND PERFORMANCE FEEDBACK BASED ON THE ORGANIZATIONS PERSONAL GOALS AND CUSTOMIZED SKILL SETS; HOSTING SOFTWARE AS A SERVICE ENABLING USERS TO RECEIVE FEEDBACKS AND RATINGS ON RESPECTIVE SKILLS BASING OFF AND LINKED TO A SPECIFIC ACTIVITY OR A SERIES OF RELATED ACTIVITIES; HOSTING SOFTWARE AS A SERVICE ENABLING USERS TO GIVE AND RECEIVE FEEDBACKS AND SKILL RATINGS FROM RATERS HAVING DIFFERENT RELATIONSHIPS WITH THE USER WHILE USING THE SAME REFERENCE ACTIVITY WHEN GIVING FEEDBACKS AND SKILL RATINGS, THUS PROVIDING THE USER WITH A TRUE MULTI-RATING 360-DEGREE FEEDBACK BASED OFF A REFERENCE ACTIVITY TRACKED OVER TIME; HOSTING SOFTWARE AS A SERVICE PROVIDING A RATING SCHEME THAT GIVES A RATER AN OPPORTUNITY TO PROVIDE APPRECIATION AND ADVICE TO A RATE ALONG WITH RATINGS OF A SET OF SKILLS TRACKED AND UPDATED OVER TIME; COMPUTER SERVICES IN THE NATURE OF CUSTOMIZED WEB PAGES FEATURING USER DEFINED INFORMATION, PERSONAL PROFILES, AUDIO AND IMAGES (U.S. CLS. 100 AND 101).

FIRST USE 12-20-2012; IN COMMERCE 12-20-2012.

4,594,653. IMPACT UNLIMITED, INC., DAYTON, NJ. SN 86-076,915. FILED P.R. 9-27-2013; AM. S.R. 6-30-2014.

THE GLOBAL AGENCY FOR  
EXPERIENTIAL ENVIRONMENTS

THE MARK CONSISTS OF STANDARD CHARACTERS WITHOUT CLAIM TO ANY PARTICULAR FONT, STYLE, SIZE, OR COLOR.

**CLASS 35—ADVERTISING AND BUSINESS**

FOR CONSULTATION SERVICES IN THE FIELD OF ADVERTISING AND EVENT PLANNING FOR BUSINESS PURPOSES; CONDUCTING BUSINESS AND MARKET RESEARCH, BUSINESS CONSULTATION, BUSINESS MARKETING CONSULTING SERVICES, MARKET ANALYSIS SERVICES; PUBLIC RELATIONS SERVICES; ADVERTISING AND MARKETING SERVICES RELATING TO MEDIA PLANNING, NAMELY, ASSISTING OTHERS IN DETERMINING APPROPRIATE AND COST-EFFECTIVE MEDIA AND MARKETING STRATEGIES TO TARGET AN AUDIENCE; DIRECT MAIL ADVERTISEMENTS, BILLBOARD ADVERTISEMENTS AND ADVERTISEMENTS FOR DISSEMINATION VIA AN ON-LINE ELECTRONIC COMMUNICATIONS NETWORK; PREPARING AUDIO-VISUAL PRESENTATIONS FOR USE IN ADVERTISING (U.S. CLS. 100, 101 AND 102).

FIRST USE 9-0-2012; IN COMMERCE 9-0-2012.

**CLASS 42—SCIENTIFIC AND COMPUTER SERVICES**

FOR GRAPHIC ART DESIGN FOR OTHERS; INTERIOR DECORATING CONSULTATION FOR MUSEUMS, SHOWROOMS AND BUSINESSES; WEBSITE DESIGN FOR OTHERS, AND DESIGN FOR OTHERS IN THE FIELD OF INTERACTIVE COMPUTER PROGRAMS FEATURING EDUCATIONAL AND PROMOTIONAL MATERIALS FOR USE IN ADVERTISING, PUBLIC RELATIONS AND MARKETING SERVICES (U.S. CLS. 100 AND 101).

FIRST USE 9-0-2012; IN COMMERCE 9-0-2012.

4,594,706. CALIFORNIA RESIDENTIAL MITIGATION PROGRAM, A JOINT EXERCISE OF POWERS AGENCY, SACRAMENTO, CA. SN 86-155,521. FILED P.R. 12-31-2013; AM. S.R. 6-27-2014.

**CALIFORNIA RESIDENTIAL  
MITIGATION PROGRAM**

THE MARK CONSISTS OF STANDARD CHARACTERS WITHOUT CLAIM TO ANY PARTICULAR FONT, STYLE, SIZE, OR COLOR.

NO CLAIM IS MADE TO THE EXCLUSIVE RIGHT TO USE "MITIGATION PROGRAM", APART FROM THE MARK AS SHOWN.

**CLASS 35—ADVERTISING AND BUSINESS**

FOR PROVIDING FINANCIAL INCENTIVE AWARDS FOR THE PROMOTION AND ADOPTION OF SEISMIC MITIGATION EFFORTS IN RESIDENTIAL STRUCTURES BY HOMEOWNERS; PROMOTING THE GOODS AND SERVICES OF OTHERS BY PROVIDING AN ONLINE COMPUTER WEB SITE THAT LISTS QUALIFIED HOME CONTRACTORS, INSURERS, AND OTHER BUSINESSES RELATED TO THE STRUCTURAL RETROFITTING OF RESIDENTIAL HOMES (U.S. CLS. 100, 101 AND 102).

FIRST USE 9-23-2013; IN COMMERCE 9-23-2013.

**CLASS 41—EDUCATION AND ENTERTAINMENT**

FOR EDUCATIONAL SERVICES, NAMELY, PROVIDING ONLINE NON-DOWNLOADABLE VIDEOS, CLASSES, SEMINARS, AND WORKSHOPS FEATURING HOME SAFETY, EARTHQUAKE RISK, HOW TO PREPARE FOR AND PROTECT AGAINST EARTHQUAKE RISK, AND HOW TO RETROFIT HOMES; EDUCATIONAL SERVICES, NAMELY, PROVIDING ONLINE NON-DOWNLOADABLE VIDEOS, CLASSES, SEMINARS, AND WORKSHOPS REGARDING SEISMIC RETROFIT EDUCATION (U.S. CLS. 100, 101 AND 107).

FIRST USE 9-23-2013; IN COMMERCE 9-23-2013.



4,594,728. WOODY CREEK DISTILLERS, LLC, WOODY CREEK, CO. SN 86-199,010. FILED 2-20-2014.

4,594,733. RIMKUS CONSULTING GROUP, INC., HOUSTON, TX. SN 86-207,298. FILED P.R. 2-28-2014; AM. S.R. 2-28-2014.

## WOODY CREEK DISTILLERS

THE MARK CONSISTS OF STANDARD CHARACTERS WITHOUT CLAIM TO ANY PARTICULAR FONT, STYLE, SIZE, OR COLOR.

OWNER OF U.S. REG. NO. 4,553,539.

NO CLAIM IS MADE TO THE EXCLUSIVE RIGHT TO USE "DISTILLERS", APART FROM THE MARK AS SHOWN.

### CLASS 41—EDUCATION AND ENTERTAINMENT

FOR ENTERTAINMENT SERVICES, NAMELY, ALCOHOL TASTINGS (U.S. CLS. 100, 101 AND 107).  
FIRST USE 3-7-2013; IN COMMERCE 3-7-2013.

### CLASS 43—HOTEL AND RESTAURANT SERVICES

FOR BAR AND LOUNGE SERVICES (U.S. CLS. 100 AND 101).  
FIRST USE 3-7-2013; IN COMMERCE 3-7-2013.

---

4,594,729. CRANBERRY ISLES FISHERMEN'S CO-OPERATIVE, INC., ISLESFORD, ME. SN 86-201,753. FILED P.R. 2-24-2014; AM. S.R. 7-11-2014.

## LITTLE CRANBERRY LOBSTER

THE MARK CONSISTS OF STANDARD CHARACTERS WITHOUT CLAIM TO ANY PARTICULAR FONT, STYLE, SIZE, OR COLOR.

NO CLAIM IS MADE TO THE EXCLUSIVE RIGHT TO USE "LOBSTER", APART FROM THE MARK AS SHOWN.

### CLASS 29—MEATS AND PROCESSED FOODS

FOR LOBSTERS, NOT LIVE (U.S. CL. 46).  
FIRST USE 5-8-2014; IN COMMERCE 5-8-2014.

### CLASS 31—NATURAL AGRICULTURAL PRODUCTS

FOR LIVE LOBSTERS; LOBSTERS, LIVE (U.S. CLS. 1 AND 46).  
FIRST USE 5-8-2014; IN COMMERCE 5-8-2014.

## The Consulting Expert

THE MARK CONSISTS OF STANDARD CHARACTERS WITHOUT CLAIM TO ANY PARTICULAR FONT, STYLE, SIZE, OR COLOR.

OWNER OF U.S. REG. NOS. 2,879,287, 3,890,291, AND OTHERS.

NO CLAIM IS MADE TO THE EXCLUSIVE RIGHT TO USE "CONSULTING", APART FROM THE MARK AS SHOWN.

### CLASS 35—ADVERTISING AND BUSINESS

FOR FORENSIC CONSULTATION IN THE FIELD OF BUSINESS, NAMELY, BUSINESS INVESTIGATIONS, EVALUATIONS, AND EXPERT BUSINESS APPRAISALS, BUSINESS RISK MANAGEMENT CONSULTATION, COST AND SCHEDULE MONITORING, AND CONSTRUCTION INSURANCE CLAIMS AUDITING SERVICES (U.S. CLS. 100, 101 AND 102).  
FIRST USE 2-10-2014; IN COMMERCE 2-10-2014.

### CLASS 36—INSURANCE AND FINANCIAL

FOR FORENSIC CONSULTATION IN THE FIELD OF FINANCE, NAMELY, BUSINESS VALUATION SERVICES, COMPLEX FINANCIAL ANALYSIS, FORENSIC ACCOUNTING ANALYSIS, FINANCIAL ASSESSMENT OF COMMERCIAL DAMAGES AND LOST PROFITS, FINANCIAL ASSESSMENT OF CONSTRUCTION INSURANCE CLAIMS (U.S. CLS. 100, 101 AND 102).  
FIRST USE 2-10-2014; IN COMMERCE 2-10-2014.

### CLASS 37—CONSTRUCTION AND REPAIR

FOR FORENSIC CONSULTATION IN THE FIELD OF CONSTRUCTION, NAMELY, BUILDING CONSTRUCTION AND BUILDING CONSTRUCTION DEFECTS (U.S. CLS. 100, 103 AND 106).  
FIRST USE 2-10-2014; IN COMMERCE 2-10-2014.

### CLASS 42—SCIENTIFIC AND COMPUTER SERVICES

FOR FORENSIC CONSULTATION IN THE FIELD OF SCIENCE, NAMELY, PHYSICS, BIOLOGY, CHEMISTRY, METALLURGY, MARINE SCIENCE, GEOLOGY, HYDROLOGY, HYDROGEOLOGY, TOXICOLOGY, AND BIOMECHANICS; FORENSIC CONSULTATION IN THE FIELD OF SCIENCE, NAMELY SCIENCE AS IT RELATES TO ENVIRONMENT, MOLD AND INDOOR AIR QUALITY, PRODUCT LIABILITY, ACCIDENT RECONSTRUCTION, INDUSTRIAL LOSSES, CATASTROPHES; TECHNICAL FORENSIC CONSULTATION IN THE FIELD OF ENGINEERING (U.S. CLS. 100 AND 101).  
FIRST USE 2-10-2014; IN COMMERCE 2-10-2014.

**CLASS 45—PERSONAL AND LEGAL SERVICES**

FOR EXPERT WITNESS SERVICES IN LEGAL MATTERS IN THE FIELD OF FORENSICS; INVESTIGATIONS INVOLVING FRAUDULENT BUSINESS ASSET MISAPPROPRIATION AND TRACING, AND BUSINESS AND INSURANCE FRAUD PREVENTION, DETECTION, AND INVESTIGATION (U.S. CLS. 100 AND 101).  
FIRST USE 2-10-2014; IN COMMERCE 2-10-2014.

---

4,594,750. AMERICAN ROAD & TRANSPORTATION BUILDERS ASSOCIATION, WASHINGTON, DC. SN 86-226,029. FILED P.R. 3-19-2014; AM. S.R. 6-17-2014.

## Transportation Investment Advocacy Center

THE MARK CONSISTS OF STANDARD CHARACTERS WITHOUT CLAIM TO ANY PARTICULAR FONT, STYLE, SIZE, OR COLOR.

**CLASS 35—ADVERTISING AND BUSINESS**

FOR PUBLIC POLICY SERVICES, NAMELY, PROVIDING A WEBSITE FEATURING INFORMATION TO ASSIST PRIVATE CITIZENS, LEGISLATORS, ORGANIZATIONS AND BUSINESSES IN SUCCESSFULLY INCREASING TRANSPORTATION INFRASTRUCTURE INVESTMENT AT THE STATE AND LOCAL LEVELS THROUGH THE LEGISLATIVE AND BALLOT INITIATIVE PROCESSES (U.S. CLS. 100, 101 AND 102).  
FIRST USE 3-14-2014; IN COMMERCE 3-14-2014.

**CLASS 41—EDUCATION AND ENTERTAINMENT**

FOR EDUCATIONAL SERVICES, NAMELY, WEBINARS, WORKSHOPS AND WEB-BASED TRAINING DESIGNED TO ASSIST PRIVATE CITIZENS, LEGISLATORS, ORGANIZATIONS AND BUSINESSES IN SUCCESSFULLY INCREASING TRANSPORTATION INFRASTRUCTURE INVESTMENT AT THE STATE AND LOCAL LEVELS THROUGH THE LEGISLATIVE AND BALLOT INITIATIVE PROCESSES (U.S. CLS. 100, 101 AND 107).

FIRST USE 3-14-2014; IN COMMERCE 3-14-2014.  
4,594,752. BOREN, HEATHER B, DBA ESTATE MATCH, WOODLAND HILLS, CA. SN 86-227,461. FILED P.R. 3-20-2014; AM. S.R. 6-26-2014.

## ESTATE MATCH

THE MARK CONSISTS OF STANDARD CHARACTERS WITHOUT CLAIM TO ANY PARTICULAR FONT, STYLE, SIZE, OR COLOR.

**CLASS 35—ADVERTISING AND BUSINESS**

FOR MATCHING CONSUMERS WITH REAL ESTATE PROFESSIONALS IN THE FIELD OF REAL ESTATE SERVICES VIA COMPUTER NETWORK (U.S. CLS. 100, 101 AND 102).  
FIRST USE 1-28-2014; IN COMMERCE 1-28-2014.

**CLASS 36—INSURANCE AND FINANCIAL**

FOR REAL ESTATE BROKERAGE; REAL ESTATE CONSULTANCY (U.S. CLS. 100, 101 AND 102).  
FIRST USE 1-28-2014; IN COMMERCE 1-28-2014.

---

4,594,754. NATIONAL TRADE PRODUCTIONS, INC., ALEXANDRIA, VA. SN 86-228,602. FILED P.R. 3-21-2014; AM. S.R. 6-27-2014.

## North American MotorSports Expo

THE MARK CONSISTS OF STANDARD CHARACTERS WITHOUT CLAIM TO ANY PARTICULAR FONT, STYLE, SIZE, OR COLOR.

NO CLAIM IS MADE TO THE EXCLUSIVE RIGHT TO USE "EXPO", APART FROM THE MARK AS SHOWN.

**CLASS 35—ADVERTISING AND BUSINESS**

FOR ARRANGING AND CONDUCTING TRADE SHOW EXHIBITIONS IN THE FIELD OF MOTORSPORTS; ARRANGING AND CONDUCTING TRADE SHOWS IN THE FIELD OF MOTORSPORTS (U.S. CLS. 100, 101 AND 102).

FIRST USE 3-7-2014; IN COMMERCE 3-7-2014.

**CLASS 41—EDUCATION AND ENTERTAINMENT**

FOR EDUCATIONAL SERVICES, NAMELY, CONDUCTING SEMINARS, CONFERENCES AND WORKSHOPS IN THE FIELD OF MOTORSPORTS AND DISTRIBUTION OF PRINTED MATERIALS IN CONNECTION THEREWITH IN HARD COPY OR ELECTRONIC FORMAT ON THE SAME TOPICS (U.S. CLS. 100, 101 AND 107).

FIRST USE 3-7-2014; IN COMMERCE 3-7-2014.

4,594,755. STOLLER, JOHN, WAYLAND, MA. SN 86-228,756.  
FILED P.R. 3-21-2014; AM. S.R. 7-10-2014.

4,594,780. NATURAL BEST NUTRITION INC., HALLANDALE, FL. SN 86-282,309. FILED P.R. 5-15-2014; AM. S.R. 6-10-2014.



THE COLOR(S) BLUE AND YELLOW IS/ARE CLAIMED AS A FEATURE OF THE MARK.

THE MARK CONSISTS OF A BLUE AND YELLOW HEART CONTAINING THE LETTERS "BOS". THE COLOR WHITE IN THE LETTERS AND IN THE BACKGROUND REPRESENTS TRANSPARENT AREAS.

#### CLASS 18—LEATHER GOODS

FOR TOTE BAGS (U.S. CLS. 1, 2, 3, 22 AND 41).  
FIRST USE 3-21-2014; IN COMMERCE 3-21-2014.

#### CLASS 25—CLOTHING

FOR SHIRTS (U.S. CLS. 22 AND 39).  
FIRST USE 2-25-2014; IN COMMERCE 2-25-2014.

4,594,770. EAST ARBOR GOODS, LLC, PLYMOUTH, MI. SN 86-237,978. FILED P.R. 3-31-2014; AM. S.R. 7-7-2014.

## EAST ARBOR GOODS

THE MARK CONSISTS OF STANDARD CHARACTERS WITHOUT CLAIM TO ANY PARTICULAR FONT, STYLE, SIZE, OR COLOR.

NO CLAIM IS MADE TO THE EXCLUSIVE RIGHT TO USE "GOODS", APART FROM THE MARK AS SHOWN.

#### CLASS 18—LEATHER GOODS

FOR CANVAS SHOPPING BAGS (U.S. CLS. 1, 2, 3, 22 AND 41).  
FIRST USE 2-8-2014; IN COMMERCE 2-13-2014.

#### CLASS 21—HOUSEWARES AND GLASS

FOR GLASS BEVERAGEWARE; GLASS DISHES; MUGS (U.S. CLS. 2, 13, 23, 29, 30, 33, 40 AND 50).  
FIRST USE 2-8-2014; IN COMMERCE 2-13-2014.

## NATURAL BEST NUTRITION

THE MARK CONSISTS OF STANDARD CHARACTERS WITHOUT CLAIM TO ANY PARTICULAR FONT, STYLE, SIZE, OR COLOR.

OWNER OF U.S. REG. NO. 4,322,345.

NO CLAIM IS MADE TO THE EXCLUSIVE RIGHT TO USE "NATURAL" AND "NUTRITION", APART FROM THE MARK AS SHOWN.

#### CLASS 5—PHARMACEUTICALS

FOR DIETARY AND NUTRITIONAL SUPPLEMENTS; HERBS FOR MEDICINAL PURPOSES; VITAMINS (U.S. CLS. 6, 18, 44, 46, 51 AND 52).

FIRST USE 8-0-2013; IN COMMERCE 8-0-2013.

#### CLASS 35—ADVERTISING AND BUSINESS

FOR ON-LINE RETAIL STORE SERVICES FEATURING VITAMINS, HERBS, DIETARY SUPPLEMENTS AND NUTRITIONAL SUPPLEMENTS; RETAIL STORE SERVICES FEATURING VITAMINS, HERBS, DIETARY SUPPLEMENTS AND NUTRITIONAL SUPPLEMENTS (U.S. CLS. 100, 101 AND 102).

FIRST USE 8-0-2013; IN COMMERCE 8-0-2013.

4,594,781. WESTERN HUNTER, CHANDLER, AZ. SN 86-293,330. FILED P.R. 5-28-2014; AM. S.R. 6-30-2014.

## WESTERN HUNTER

THE MARK CONSISTS OF STANDARD CHARACTERS WITHOUT CLAIM TO ANY PARTICULAR FONT, STYLE, SIZE, OR COLOR.

#### CLASS 16—PAPER GOODS AND PRINTED MATTER

FOR MAGAZINES FEATURING HUNTING, OUTDOOR LIFE, INCLUDING GEAR, TACTICS, INFORMATION AND ADVENTURE (U.S. CLS. 2, 5, 22, 23, 29, 37, 38 AND 50).

FIRST USE 7-1-2002; IN COMMERCE 7-1-2002.

#### CLASS 25—CLOTHING

FOR ATHLETIC APPAREL, NAMELY, SHIRTS, PANTS, JACKETS, FOOTWEAR, HATS AND CAPS, ATHLETIC UNIFORMS (U.S. CLS. 22 AND 39).

FIRST USE 7-1-2002; IN COMMERCE 7-1-2002.

**CLASS 41—EDUCATION AND ENTERTAINMENT**

FOR ENTERTAINMENT IN THE NATURE OF ONGOING TELEVISION PROGRAM IN THE FIELD OF HUNTING, OUTDOOR LIFE, INCLUDING GEAR, TACTICS, INFORMATION AND ADVENTURE (U.S. CLS. 100, 101 AND 107).  
FIRST USE 1-2-2013; IN COMMERCE 1-2-2013.

\* \* \* \* \*

## SECTION 2.— INTERNATIONAL CLASSIFICATION

The short titles associated below with the international class numbers are terms designed merely for quick identification and are not an official part of the international classification. The full names of international classes are given in section 6.1 of the trademark rules of practice.

The designation "U.S. Cl." appearing in this section refers to the U.S. class in effect prior to Sep. 1, 1973 rather than the international class which applies to applications filed on or after that date. For adoption of international classification see notice in the OFFICIAL GAZETTE of Jun. 26, 1973 (911 O.G. TM 210).

### Application in one class

#### CLASS 1—CHEMICALS

4,594,563. NEW ENGLAND BIOLABS, INC., IPSWICH, MA. SN 85-509,035. FILED P.R. 1-5-2012; AM. S.R. 5-27-2014.

**WARMSTART**

THE MARK CONSISTS OF STANDARD CHARACTERS WITHOUT CLAIM TO ANY PARTICULAR FONT, STYLE, SIZE, OR COLOR.

FOR REAGENTS FOR RESEARCH USE IN NON-PCR (POLYMERASE CHAIN REACTION) REACTIONS CONTAINING NUCLEIC ACIDS; DIAGNOSTIC REAGENTS FOR CLINICAL OR MEDICAL LABORATORY USE IN NON-PCR (POLYMERASE CHAIN REACTION) REACTIONS CONTAINING NUCLEIC ACIDS (U.S. CLS. 1, 5, 6, 10, 26 AND 46).

FIRST USE 3-13-2012; IN COMMERCE 3-13-2012.

4,594,690. CONSEAL INTERNATIONAL INCORPORATED, NORWOOD, MA. SN 86-127,107. FILED P.R. 11-22-2013; AM. S.R. 6-12-2014.

**WOODWORX**

THE MARK CONSISTS OF STANDARD CHARACTERS WITHOUT CLAIM TO ANY PARTICULAR FONT, STYLE, SIZE, OR COLOR.

FOR FIRE-RESISTING CHEMICAL COMPOSITIONS AND CHEMICAL BARRIERS TO PROTECT WOOD FROM INSECTS, MOLD, BACTERIA AND OTHER ORGANISMS. ALL FOR WOOD AND ARTICLES OF WOOD (U.S. CLS. 1, 5, 6, 10, 26 AND 46).

FIRST USE 6-30-2010; IN COMMERCE 6-30-2010.

#### CLASS 1—(Continued).

4,594,777. BIONIC SOIL SOLUTIONS INTERNATIONAL, LLC, SANTA FE, NM. SN 86-249,743. FILED P.R. 4-11-2014; AM. S.R. 7-22-2014.

**Bionic Soil Solutions**

THE MARK CONSISTS OF STANDARD CHARACTERS WITHOUT CLAIM TO ANY PARTICULAR FONT, STYLE, SIZE, OR COLOR.

NO CLAIM IS MADE TO THE EXCLUSIVE RIGHT TO USE "SOIL SOLUTIONS", APART FROM THE MARK AS SHOWN.

FOR CHEMICAL PREPARATIONS FOR STABILIZING SOIL AND DUST (U.S. CLS. 1, 5, 6, 10, 26 AND 46).

FIRST USE 8-1-2013; IN COMMERCE 8-1-2013.

#### CLASS 2—PAINTS

4,594,622. AQUARIUS MARINE COATINGS LTD, SHILLINGSTONE, DORSET, UNITED KINGDOM. SN 86-017,568. FILED P.R. 7-23-2013; AM. S.R. 7-2-2014.

**COPPER COAT**

THE MARK CONSISTS OF STANDARD CHARACTERS WITHOUT CLAIM TO ANY PARTICULAR FONT, STYLE, SIZE, OR COLOR.

FOR ANTI-FOULING PAINTS CONTAINING COPPER (U.S. CLS. 6, 11 AND 16).

FIRST USE 4-16-2008; IN COMMERCE 4-16-2008.

#### CLASS 3—COSMETICS AND CLEANING PREPARATIONS

**CLASS 3—(Continued).**

4,594,603. CROW RIVER ANIMAL HOSPITAL, LTD., HOWARD LAKE, MN. SN 85-915,839. FILED P.R. 4-26-2013; AM. S.R. 7-15-2014.

**ANIMALEO**

THE MARK CONSISTS OF STANDARD CHARACTERS WITHOUT CLAIM TO ANY PARTICULAR FONT, STYLE, SIZE, OR COLOR.

FOR ESSENTIAL OILS (U.S. CLS. 1, 4, 6, 50, 51 AND 52).

FIRST USE 2-17-2014; IN COMMERCE 2-17-2014.

4,594,610. SUN & SKIN CARE RESEARCH, LLC, COCOA, FL. SN 85-957,847. FILED P.R. 6-12-2013; AM. S.R. 6-27-2014.

**SURFER FORMULA**

THE MARK CONSISTS OF STANDARD CHARACTERS WITHOUT CLAIM TO ANY PARTICULAR FONT, STYLE, SIZE, OR COLOR.

FOR HAND LOTIONS; BODY LOTIONS; HAND CREAMS; FACIAL MOISTURIZERS; FACIAL CLEANSERS; SKIN CLEANSERS; SKIN MOISTURIZERS; BODY WASH; SUN CARE LOTIONS; NON-MEDICATED SUN CARE CREAMS; NON-MEDICATED SUN CARE SPRAYS; NON-MEDICATED SUN CARE GELS; SELF-TANNING PREPARATIONS (U.S. CLS. 1, 4, 6, 50, 51 AND 52).

FIRST USE 6-15-2013; IN COMMERCE 6-15-2013.

4,594,615. JOHNSON & JOHNSON, NEW BRUNSWICK, NJ. SN 85-966,426. FILED P.R. 6-21-2013; AM. S.R. 7-15-2014.

**HIGH PERFORMANCE SKINCARE**

THE MARK CONSISTS OF STANDARD CHARACTERS WITHOUT CLAIM TO ANY PARTICULAR FONT, STYLE, SIZE, OR COLOR.

FOR FACIAL SKIN LOTIONS; SKIN MOISTURIZERS; ANTI-AGING MOISTURIZERS; SKIN CREAMS; ANTI-AGING CREAMS; EYE CREAMS; ANTI-WRINKLE CREAMS; AND SUNBLOCK PREPARATIONS (U.S. CLS. 1, 4, 6, 50, 51 AND 52).

FIRST USE 1-0-2014; IN COMMERCE 1-0-2014.

**CLASS 3—(Continued).**

4,594,645. SHILET, PARDES CHANA, ISRAEL. SN 86-070,103. FILED P.R. 9-20-2013; AM. S.R. 7-8-2014.

**argan woman**

THE MARK CONSISTS OF STANDARD CHARACTERS WITHOUT CLAIM TO ANY PARTICULAR FONT, STYLE, SIZE, OR COLOR.

FOR BEAUTY MASKS, SHAMPOOS, AND HAIR CONDITIONERS, ALL OF THE FOREGOING CONTAINING ARGAN OIL (U.S. CLS. 1, 4, 6, 50, 51 AND 52).

FIRST USE 5-1-2014; IN COMMERCE 5-1-2014.

4,594,686. MADDISON, LAURA, TAVERNIER, FL. SN 86-114,549. FILED P.R. 11-9-2013; AM. S.R. 7-2-2014.

**THE KEYS SALT SCRUB**

THE MARK CONSISTS OF STANDARD CHARACTERS WITHOUT CLAIM TO ANY PARTICULAR FONT, STYLE, SIZE, OR COLOR.

NO CLAIM IS MADE TO THE EXCLUSIVE RIGHT TO USE "SALT SCRUB", APART FROM THE MARK AS SHOWN.

FOR SALT SCRUBS FOR HANDS, FEET, SKIN, BODY, AND SCALP; BODY SCRUBS; NON-MEDICATED SKIN CARE PREPARATIONS (U.S. CLS. 1, 4, 6, 50, 51 AND 52).

FIRST USE 10-1-2012; IN COMMERCE 10-31-2013.

4,594,697. TRI-COASTAL DESIGN GROUP, INC., WHARTON, NJ. SN 86-140,268. FILED P.R. 12-11-2013; AM. S.R. 7-1-2014.

**MARSHMALLOW FLUFF**

THE MARK CONSISTS OF STANDARD CHARACTERS WITHOUT CLAIM TO ANY PARTICULAR FONT, STYLE, SIZE, OR COLOR.

FOR BATH GEL; BATH SALTS; BATH SOAPS; BODY CREAM; BODY LOTION; BODY OIL; BODY SCRUB; BODY SPRAYS; BUBBLE BATH; DUSTING POWDER; FOOT SCRUBS; LIP BALM; LIP GLOSS; LIQUID SOAP (U.S. CLS. 1, 4, 6, 50, 51 AND 52).

FIRST USE 9-10-2010; IN COMMERCE 9-10-2010.

**CLASS 4—LUBRICANTS AND FUELS**

**CLASS 4—(Continued).**

4,594,642. TM SALES & MARKETING GROUP CO, LLC, ST. CHARLES, MO. SN 86-067,500. FILED P.R. 9-17-2013; AM. S.R. 6-16-2014.

# Fast Fire

THE MARK CONSISTS OF STANDARD CHARACTERS WITHOUT CLAIM TO ANY PARTICULAR FONT, STYLE, SIZE, OR COLOR.

NO CLAIM IS MADE TO THE EXCLUSIVE RIGHT TO USE "FIRE", APART FROM THE MARK AS SHOWN.

FOR SOLID FIRE STARTERS (U.S. CLS. 1, 6 AND 15). FIRST USE 1-5-2013; IN COMMERCE 1-5-2013.

**CLASS 5—(Continued).**

4,594,671. K10 HOLDINGS, LLC, NEW YORK, NY. SN 86-096,804. FILED P.R. 10-21-2013; AM. S.R. 7-1-2014.



THE MARK CONSISTS OF THE IMAGE OF CASCADING WATER DROPLETS.

FOR DIETARY SUPPLEMENTS FOR PETS (U.S. CLS. 6, 18, 44, 46, 51 AND 52).

FIRST USE 2-29-2012; IN COMMERCE 2-29-2012.

4,594,713. THREE LOLLIES LLC, WEST HILLS, CA. SN 86-178,055. FILED P.R. 1-28-2014; AM. S.R. 7-16-2014.

**CLASS 5—PHARMACEUTICALS**

4,594,595. PEST MANAGEMENT, INC., KERRVILLE, TX. SN 85-875,609. FILED P.R. 3-13-2013; AM. S.R. 7-2-2014.

# BioLogic RTU

THE MARK CONSISTS OF STANDARD CHARACTERS WITHOUT CLAIM TO ANY PARTICULAR FONT, STYLE, SIZE, OR COLOR.

NO CLAIM IS MADE TO THE EXCLUSIVE RIGHT TO USE "RTU", APART FROM THE MARK AS SHOWN.

FOR ANTIMICROBIAL COATINGS TO TREAT THE GROWTH OF MOLD, MILDEW, BACTERIA AND FUNGUS ON VARIOUS SURFACES; BIOSTATIC ANTIMICROBIAL PREPARATIONS FOR TREATING AND PREVENTING THE GROWTH OF BACTERIA, MOLD, MILDEW, ALGAE AND YEAST (U.S. CLS. 6, 18, 44, 46, 51 AND 52).

FIRST USE 1-0-2014; IN COMMERCE 1-0-2014.

# Hangover Naturals

THE MARK CONSISTS OF STANDARD CHARACTERS WITHOUT CLAIM TO ANY PARTICULAR FONT, STYLE, SIZE, OR COLOR.

OWNER OF U.S. REG. NO. 3,912,270.

NO CLAIM IS MADE TO THE EXCLUSIVE RIGHT TO USE "NATURALS", APART FROM THE MARK AS SHOWN.

FOR DIETARY AND NUTRITIONAL SUPPLEMENTS (U.S. CLS. 6, 18, 44, 46, 51 AND 52).

FIRST USE 5-17-2014; IN COMMERCE 6-1-2014.

4,594,774. DO VITAMINS, RENO, NV. SN 86-243,305. FILED P.R. 4-4-2014; AM. S.R. 7-15-2014.

# DailyD

THE MARK CONSISTS OF STANDARD CHARACTERS WITHOUT CLAIM TO ANY PARTICULAR FONT, STYLE, SIZE, OR COLOR.

FOR DIETARY SUPPLEMENTS CONTAINING VITAMIN D (U.S. CLS. 6, 18, 44, 46, 51 AND 52).

FIRST USE 5-21-2014; IN COMMERCE 6-1-2014.

**CLASS 7—MACHINERY**

4,594,667. HUSQVARNA AB, HUSKVARNA, SWEDEN. SN 86-092,034. FILED P.R. 10-15-2013; AM. S.R. 7-3-2014.

**SMARTSWITCH**

THE MARK CONSISTS OF STANDARD CHARACTERS WITHOUT CLAIM TO ANY PARTICULAR FONT, STYLE, SIZE, OR COLOR.  
FOR ELECTRONIC IGNITIONS FOR TRACTORS AND LAWNMOWERS (U.S. CLS. 13, 19, 21, 23, 31, 34 AND 35).  
FIRST USE 8-0-2013; IN COMMERCE 8-0-2013.

**CLASS 9—ELECTRICAL AND SCIENTIFIC APPARATUS**

4,594,556. ASA ELECTRONICS, LLC., ELKHART, IN. SN 76-714,266. FILED P.R. 5-29-2013; AM. S.R. 6-26-2014.

**BARNVIEW**

THE MARK CONSISTS OF STANDARD CHARACTERS WITHOUT CLAIM TO ANY PARTICULAR FONT, STYLE, SIZE, OR COLOR.  
FOR WIRELESS SURVEILLANCE CAMERAS; SYSTEMS FOR USE WITH WIRELESS SECURITY CAMERAS, NAMELY, SWITCHERS, MONITORS, MICROPHONES, AND RECORDERS (U.S. CLS. 21, 23, 26, 36 AND 38).  
FIRST USE 8-5-2013; IN COMMERCE 8-5-2013.

4,594,565. MARKOUS, MARCELO ARTURO, BUENOS AIRES, ARGENTINA. SN 85-585,410. FILED P.R. 3-30-2012; AM. S.R. 7-1-2013.

**NOROLL**

THE MARK CONSISTS OF STANDARD CHARACTERS WITHOUT CLAIM TO ANY PARTICULAR FONT, STYLE, SIZE, OR COLOR.  
PRIORITY CLAIMED UNDER SEC. 44(D) ON ARGENTINA APPLICATION NO. 3118952, FILED 9-30-2011, REG. NO. 2546986, DATED 12-21-2012, EXPIRES 12-21-2022.  
THE WORDING "NOROLL" HAS NO MEANING IN A FOREIGN LANGUAGE.  
FOR GYROSCOPIC ANTI-ROLL STABILIZERS FOR SHIPS, BOATS, MARINE VESSELS AND WATERCRAFT (U.S. CLS. 21, 23, 26, 36 AND 38).

**CLASS 9—(Continued).**

4,594,582. POLAR PRODUCTS, INC., STOW, OH. SN 85-836,512. FILED P.R. 1-30-2013; AM. S.R. 7-5-2014.

**COOL58**

THE MARK CONSISTS OF STANDARD CHARACTERS WITHOUT CLAIM TO ANY PARTICULAR FONT, STYLE, SIZE, OR COLOR.  
FOR PROTECTIVE BODY COOLING GEAR, NAMELY, ACTIVE COOLING VESTS, ACTIVE COOLING NECK AND UPPER SPINE WRAPS, ACTIVE COOLING WRIST WRAPS, ACTIVE COOLING LEG WRAPS, ACTIVE COOLING HAT LINERS AND ACTIVE COOLING SEAT CUSHIONS TO PREVENT INJURY DUE TO OVERHEATING (U.S. CLS. 21, 23, 26, 36 AND 38).  
FIRST USE 12-1-2012; IN COMMERCE 12-1-2012.

4,594,591. TRILOGY LLC, GLENDALE, AZ. SN 85-871,533. FILED P.R. 3-8-2013; AM. S.R. 6-17-2014.

**TRAINERATER**

THE MARK CONSISTS OF STANDARD CHARACTERS WITHOUT CLAIM TO ANY PARTICULAR FONT, STYLE, SIZE, OR COLOR.  
FOR DOWNLOADABLE SOFTWARE IN THE NATURE OF A MOBILE APPLICATION TO BE USED BY CONSUMERS TO RATE, COMMENT, REVIEW AND RECOMMEND PERSONAL TRAINERS AND FITNESS COACHES (U.S. CLS. 21, 23, 26, 36 AND 38).  
FIRST USE 11-0-2012; IN COMMERCE 1-0-2013.

4,594,597. GEORGETOWN UNIVERSITY, WASHINGTON, DC. SN 85-877,568. FILED P.R. 3-15-2013; AM. S.R. 7-16-2014.

**2 DAY METHOD**

OWNER OF U.S. REG. NO. 3,411,897.  
THE MARK CONSISTS OF THE NUMERAL "2" TO THE LEFT OF THE TERMS "DAY" AND "METHOD" WITH THE TERM "DAY" ABOVE THE WORD "METHOD".  
FOR DOWNLOADABLE COMPUTER SOFTWARE AND APPLICATION SOFTWARE FOR MOBILE PHONES FOR TRACKING PHYSICAL INDICATORS OF FERTILITY IN THE FIELD OF NATURAL FAMILY PLANNING (U.S. CLS. 21, 23, 26, 36 AND 38).  
FIRST USE 7-14-2014; IN COMMERCE 7-14-2014.



**CLASS 9—(Continued).**

4,594,600. DAVID L HOYT, CHICAGO, IL. SN 85-893,653.  
FILED P.R. 4-3-2013; AM. S.R. 7-11-2014.

**JUST 2 WORDS**

THE MARK CONSISTS OF STANDARD CHARACTERS WITHOUT CLAIM TO ANY PARTICULAR FONT, STYLE, SIZE, OR COLOR.

FOR COMPUTER APPLICATION SOFTWARE FOR MOBILE PHONES, HANDHELD COMPUTERS, TABLETS AND OTHER ELECTRONIC DEVICES, NAMELY, SOFTWARE FOR COMPUTER GAME PROGRAMS (U.S. CLS. 21, 23, 26, 36 AND 38).

FIRST USE 7-8-2013; IN COMMERCE 7-8-2013.

4,594,606. VIDO VATION CORPORATION, IRVINE, CA. SN 85-925,692. FILED P.R. 5-7-2013; AM. S.R. 7-7-2014.

**VIDOPTIC**

THE MARK CONSISTS OF STANDARD CHARACTERS WITHOUT CLAIM TO ANY PARTICULAR FONT, STYLE, SIZE, OR COLOR.

FOR AUDIO-VIDEO RECEIVERS; DIGITAL MEDIA RECEIVERS; ELECTRONIC AND OPTICAL COMMUNICATIONS INSTRUMENTS AND COMPONENTS, NAMELY, DIGITAL TRANSMITTERS; ELECTRONIC AND OPTICAL COMMUNICATIONS INSTRUMENTS AND COMPONENTS, NAMELY, OPTICAL RECEIVERS; ELECTRONIC AND OPTICAL COMMUNICATIONS INSTRUMENTS AND COMPONENTS, NAMELY, OPTICAL TRANSCIEVERS; ELECTRONIC TRANSMITTERS AND RECEIVERS FOR AUDIO AND VIDEO SIGNALS; ETHERNET TRANSCEIVERS; FIBER OPTIC INSTRUMENTS, NAMELY, TRANSMITTERS, RECEIVERS, MEDIA CONVERTERS AND FIBER TRANSPORT APPARATUS; MULTIPLEXERS; RECEIVERS FOR AUDIO AND VIDEO SIGNALS; TELECOMMUNICATIONS AND DATA NETWORKING HARDWARE, NAMELY, DEVICES FOR TRANSPORTING AND AGGREGATING VOICE, DATA, AND VIDEO COMMUNICATIONS ACROSS MULTIPLE NETWORK INFRASTRUCTURES AND COMMUNICATIONS PROTOCOLS; TELECOMMUNICATIONS EQUIPMENT, NAMELY, FIBER-OPTIC TRANSCIEVERS, FIBER OPTIC REPEATERS, CONVERTERS AND OPTIMIZERS, WAVE DIVISION MULTIPLEXERS, FREE-SPACE OPTICS TRANSMISSION SYSTEMS, SWITCHES INCLUDING ETHERNET SWITCHES AND ROUTERS, FIBER-TO-THE-HOME AND ETHERNET-OVER-VDSL ACCESS AGGREGATORS, TERMINATORS AND REPEATERS, AND REMOTE PRESENCE MANAGEMENT PRODUCTS, NAMELY, SWITCHES, AND CONSOLE, ALARM, SENSOR AND POWER MANAGEMENT DEVICES; TELECOMMUNICATIONS TRANSMITTERS; TELEVISION TRANSMITTERS; TRANSCIEVERS; TRANSMITTERS OF ELECTRONIC SIGNALS; VIDEO MULTIPLEXERS; VIDEO TRANSMISSION APPARATUS (U.S. CLS. 21, 23, 26, 36 AND 38).

FIRST USE 4-3-2013; IN COMMERCE 4-3-2013.

**CLASS 9—(Continued).**

4,594,609. REACTORY FACTORY LLC, LAKELAND, FL. SN 85-955,226. FILED P.R. 6-10-2013; AM. S.R. 7-2-2014.



THE MARK CONSISTS OF A STYLIZED GEAR SURROUNDING AN ATOMIC SYMBOL, A NUCLEAR REACTOR COOLING TOWER AND THE WORDS "REACTORY FACTORY".

FOR DOWNLOADABLE MUSICAL SOUND RECORDINGS (U.S. CLS. 21, 23, 26, 36 AND 38).

FIRST USE 12-15-2010; IN COMMERCE 11-8-2011.

4,594,663. MAGNA-GUARD, INC., SAN DIEGO, CA. SN 86-088,839. FILED P.R. 10-10-2013; AM. S.R. 6-16-2014.

**VITAL FLUIDS ANALYSIS**

THE MARK CONSISTS OF STANDARD CHARACTERS WITHOUT CLAIM TO ANY PARTICULAR FONT, STYLE, SIZE, OR COLOR.

NO CLAIM IS MADE TO THE EXCLUSIVE RIGHT TO USE "ANALYSIS", APART FROM THE MARK AS SHOWN.

FOR BRAKE FLUID TESTERS; TESTERS FOR VEHICLE FLUIDS, NAMELY, TRANSMISSION FLUID, POWER STEERING FLUID, AND BRAKE FLUID (U.S. CLS. 21, 23, 26, 36 AND 38).

FIRST USE 2-15-2010; IN COMMERCE 2-15-2010.

4,594,673. HAHAA S COMEDY LLC, WASHINGTON, DC. SN 86-098,679. FILED P.R. 10-22-2013; AM. S.R. 6-27-2014.

**TOP COMEDY RINGTONES**

THE MARK CONSISTS OF STANDARD CHARACTERS WITHOUT CLAIM TO ANY PARTICULAR FONT, STYLE, SIZE, OR COLOR.

**CLASS 9—(Continued).**

NO CLAIM IS MADE TO THE EXCLUSIVE RIGHT TO USE "RINGTONES", APART FROM THE MARK AS SHOWN.

FOR AUDIO AND VIDEO RECORDINGS FEATURING COMEDIC SOUNDS, ONE-LINERS, STAND-UP ROUTINES, AND PARODIES; DIGITAL MATERIALS, NAMELY, DOWNLOADABLE AUDIO RECORDINGS FEATURING COMEDIC SOUNDS, ONE-LINERS, STAND-UP ROUTINES, AND PARODIES; DOWNLOADABLE RINGTONES, DIGITAL SOUND FILES, DIGITAL RECORDINGS, WEBCASTS, PODCASTS AND GRAPHICS VIA THE INTERNET AND WIRELESS DEVICES (U.S. CLS. 21, 23, 26, 36 AND 38).  
FIRST USE 7-7-2010; IN COMMERCE 7-7-2010.

---

4,594,704. GOYAL, MANU, GLENSHAW, PA. AND GOYAL, ANKUR, GLENSHAW, PA. SN 86-153,683. FILED P.R. 12-28-2013; AM. S.R. 6-11-2014.

**AGVHD GRADER**

THE MARK CONSISTS OF STANDARD CHARACTERS WITHOUT CLAIM TO ANY PARTICULAR FONT, STYLE, SIZE, OR COLOR.

FOR MEDICAL SOFTWARE FOR MANAGING PATIENT MEDICAL INFORMATION (U.S. CLS. 21, 23, 26, 36 AND 38).

FIRST USE 4-9-2014; IN COMMERCE 4-9-2014.

---

4,594,737. BEAL, KEVIN, HOUSTON, TX. AND APOSTOLAKIS, LOUIS W., WEST LAKE HILLS, TX. SN 86-209,647. FILED P.R. 3-3-2014; AM. S.R. 6-27-2014.

**KEGDATA**

THE MARK CONSISTS OF STANDARD CHARACTERS WITHOUT CLAIM TO ANY PARTICULAR FONT, STYLE, SIZE, OR COLOR.

FOR COMPUTER HARDWARE AND PERIPHERAL DEVICES AND COMPUTER SOFTWARE FOR THE RESTAURANT AND BAR INDUSTRY FOR MONITORING ALCOHOLIC BEVERAGE USAGE, TAKING LIQUID VOLUME MEASUREMENTS, PREVENTING PROFIT LOSSES VIA USAGE REPORTS, ALERTING USER TO LOW ALCOHOLIC BEVERAGE VOLUME, SENDING WARNING EMAILS TO USER REGARDING INVENTORY MANAGEMENT ACTIONS REQUIRED, SENDING EMAILS TO ALCOHOLIC BEVERAGE SUPPLIERS FOR AUTOMATIC ORDER PROCESSING, MANAGING TRANSACTIONAL DATA, PROVIDING STATISTICAL ANALYSIS AND PRODUCING NOTIFICATIONS AND REPORTS; SENSORS FOR USE IN MEASURING TEMPERATURE AND VOLUME OF LIQUIDS (U.S. CLS. 21, 23, 26, 36 AND 38).  
FIRST USE 3-4-2014; IN COMMERCE 3-4-2014.

**CLASS 9—(Continued).**

4,594,740. HVAC DISTRIBUTORS, INC., MOUNT JOY, PA. SN 86-214,656. FILED P.R. 3-7-2014; AM. S.R. 6-25-2014.

**HVAC MobileSales**

THE MARK CONSISTS OF STANDARD CHARACTERS WITHOUT CLAIM TO ANY PARTICULAR FONT, STYLE, SIZE, OR COLOR.

FOR DOWNLOADABLE MOBILE APPLICATION FOR PURCHASING HEATING, VENTILATION, AND AIR CONDITIONING EQUIPMENT AND FOR MANAGING CUSTOMER ACCOUNTS IN CONNECTION THEREWITH (U.S. CLS. 21, 23, 26, 36 AND 38).

FIRST USE 3-4-2014; IN COMMERCE 3-29-2014.

---

4,594,743. APPLIED BUSINESS SOFTWARE, INC., SIGNAL HILL, CA. SN 86-215,045. FILED P.R. 3-7-2014; AM. S.R. 6-19-2014.

**The Loan Office**

THE MARK CONSISTS OF STANDARD CHARACTERS WITHOUT CLAIM TO ANY PARTICULAR FONT, STYLE, SIZE, OR COLOR.

NO CLAIM IS MADE TO THE EXCLUSIVE RIGHT TO USE "LOAN", APART FROM THE MARK AS SHOWN.

FOR SOFTWARE FOR MANAGING LOANS (U.S. CLS. 21, 23, 26, 36 AND 38).

FIRST USE 3-7-2014; IN COMMERCE 3-7-2014.

---

4,594,779. GRIFFIN TECHNOLOGY, INC., NASHVILLE, TN. SN 86-255,582. FILED P.R. 4-17-2014; AM. S.R. 6-9-2014.

**SPORTCUFF**

THE MARK CONSISTS OF STANDARD CHARACTERS WITHOUT CLAIM TO ANY PARTICULAR FONT, STYLE, SIZE, OR COLOR.

FOR PROTECTIVE ARMBANDS SPECIALLY ADAPTED FOR PERSONAL ELECTRONIC DEVICES, NAMELY, SMARTPHONES, FITNESS TRACKERS AND PORTABLE MEDIA PLAYERS (U.S. CLS. 21, 23, 26, 36 AND 38).

FIRST USE 3-15-2013; IN COMMERCE 4-0-2013.

**CLASS 10—MEDICAL APPARATUS**

**CLASS 10—(Continued).**

4,594,575. VOLCANO CORPORATION, SAN DIEGO, CA. SN 85-802,320. FILED P.R. 12-13-2012; AM. S.R. 6-12-2014.

**PRECISION GUIDED THERAPY**

THE MARK CONSISTS OF STANDARD CHARACTERS WITHOUT CLAIM TO ANY PARTICULAR FONT, STYLE, SIZE, OR COLOR.

NO CLAIM IS MADE TO THE EXCLUSIVE RIGHT TO USE "THERAPY", APART FROM THE MARK AS SHOWN.

FOR MEDICAL SYSTEMS AND DEVICES FOR DIAGNOSTICS, THERAPEUTICS AND MEDICAL IMAGING, NAMELY, MULTI-MODAL INTRAVASCULAR MEDICAL SYSTEMS PRIMARILY COMPRISED OF CATHETERS AND MEDICAL GUIDEWIRES AND ALSO INCLUDES COMPUTER SOFTWARE FOR RECEIVING, PROCESSING, TRANSMITTING AND DISPLAYING PHYSIOLOGICAL DATA AND IMAGES, COMPUTER HARDWARE AND ELECTRICAL CONTROLLERS FOR USE THEREWITH WHILE CONNECTED TO PATIENTS DURING MEDICAL TREATMENTS AND MEDICAL DIAGNOSTICS (U.S. CLS. 26, 39 AND 44).  
FIRST USE 7-0-2013; IN COMMERCE 7-0-2013.

4,594,593. HOLLE, MORGAN, DEERFIELD BEACH, FL. AND HOLLE, DANIEL, DEERFIELD BEACH, FL. SN 85-873,578. FILED P.R. 3-12-2013; AM. S.R. 6-30-2014.

**Baby Bone**

THE MARK CONSISTS OF STANDARD CHARACTERS WITHOUT CLAIM TO ANY PARTICULAR FONT, STYLE, SIZE, OR COLOR.

NO CLAIM IS MADE TO THE EXCLUSIVE RIGHT TO USE "BABY", APART FROM THE MARK AS SHOWN.

FOR TEETHING RINGS (U.S. CLS. 26, 39 AND 44).  
FIRST USE 11-24-2013; IN COMMERCE 11-24-2013.

4,594,773. ORTHOPEDIC SCIENCES, INC., SEAL BEACH, CA. SN 86-241,388. FILED P.R. 4-3-2014; AM. S.R. 6-24-2014.

**THE JOINT PRESERVATION  
COMPANY**

THE MARK CONSISTS OF STANDARD CHARACTERS WITHOUT CLAIM TO ANY PARTICULAR FONT, STYLE, SIZE, OR COLOR.

**CLASS 10—(Continued).**

NO CLAIM IS MADE TO THE EXCLUSIVE RIGHT TO USE "COMPANY", APART FROM THE MARK AS SHOWN.

FOR MEDICAL AND SURGICAL APPARATUS AND INSTRUMENTS, NAMELY, ORTHOPEDIC FIXATION DEVICE USED IN ORTHOPEDIC TRANSPLANT AND/OR IMPLANT SURGERY; ORTHOPEDIC JOINT IMPLANTS MADE OF ARTIFICIAL MATERIALS; SURGICAL INSTRUMENTS FOR USE IN ORTHOPEDIC AND SPINAL SURGERY (U.S. CLS. 26, 39 AND 44).  
FIRST USE 1-21-2009; IN COMMERCE 1-21-2009.

4,594,778. TECBRAKE, INC., DBA TEK-MEDICAL CORPORATION, HOUSTON, TX. SN 86-253,922. FILED P.R. 4-16-2014; AM. S.R. 7-3-2014.

**TEK MEDICAL**

THE MARK CONSISTS OF STANDARD CHARACTERS WITHOUT CLAIM TO ANY PARTICULAR FONT, STYLE, SIZE, OR COLOR.

FOR MEDICAL EQUIPMENT, NAMELY, DURABLE MEDICAL EQUIPMENT IN THE NATURE OF LOW FREQUENCY ELECTRIC THERAPY APPARATUSES; ORTHOTICS EQUIPMENT IN THE NATURE OF BACK AND SPINE BRACES; AND SPINE CORRECTING EQUIPMENT IN THE NATURE OF POSTURE PUMPS (U.S. CLS. 26, 39 AND 44).  
FIRST USE 7-1-2010; IN COMMERCE 7-1-2010.

**CLASS 11—ENVIRONMENTAL CONTROL AP-  
PARATUS**

4,594,558. SULTAN OF SWIM.COM, LLC., TUCSON, AZ. SN 76-715,442. FILED P.R. 11-26-2013; AM. S.R. 4-11-2014.

**JET ARRAY**

NO CLAIM IS MADE TO THE EXCLUSIVE RIGHT TO USE "JET", APART FROM THE MARK AS SHOWN.

FOR HOT TUB JETS; WHIRLPOOL JETS; JET NOZZLES FOR HOT TUBS; JET NOZZLES FOR POOLS (U.S. CLS. 13, 21, 23, 31 AND 34).  
FIRST USE 8-0-2013; IN COMMERCE 8-0-2013.

**CLASS 11—(Continued).**

4,594,614. SMART ELECTRIC, LLC, HUNTINGDON VALLEY, PA. SN 85-966,308. FILED P.R. 6-21-2013; AM. S.R. 7-2-2014.

**SMART BULB**

THE MARK CONSISTS OF STANDARD CHARACTERS WITHOUT CLAIM TO ANY PARTICULAR FONT, STYLE, SIZE, OR COLOR.

OWNER OF U.S. REG. NO. 1,688,948.

FOR CEILING FANS; CRANK-POWERED PORTABLE LAMP; ELECTRIC FANS; ELECTRIC LIGHT BULBS; ELECTRIC LIGHTING FIXTURES; FLOOR LAMPS; HALOGEN LIGHT BULBS; INCANDESCENT LIGHT BULBS; LAMPS; LED LIGHT BULBS; LIGHT BULBS; LUMINARIES; PORTABLE UTILITY LIGHTS (U.S. CLS. 13, 21, 23, 31 AND 34).

FIRST USE 6-20-2013; IN COMMERCE 6-20-2013.

**CLASS 11—(Continued).**

4,594,639. OHIO FLAME, LLC, COLUMBIANA, OH. SN 86-063,669. FILED P.R. 9-13-2013; AM. S.R. 7-2-2014.

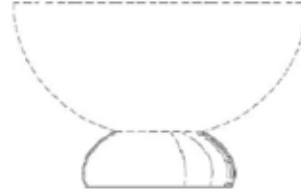

THE MARK CONSISTS OF A THREE-DIMENSIONAL CONFIGURATION OF A PORTABLE FIREPLACE BASE SHAPED LIKE AN UPSIDE-DOWN BOWL ON WHICH THE REST OF THE PORTABLE FIREPLACE IS SECURED. THE DOTTED LINES IN THE DRAWING ARE NOT A FEATURE OF THE MARK BUT INSTEAD SHOW THE POSITION OF THE MARK ON THE GOODS.

FOR PORTABLE FIRE PLACES (U.S. CLS. 13, 21, 23, 31 AND 34).

FIRST USE 9-11-2013; IN COMMERCE 9-11-2013.

**CLASS 12—VEHICLES**

4,594,564. SANTANA CYCLES, INC., LA VERNE, CA. SN 85-539,543. FILED P.R. 2-10-2012; AM. S.R. 6-21-2013.

**BILAMINATE DAMPING**

THE MARK CONSISTS OF STANDARD CHARACTERS WITHOUT CLAIM TO ANY PARTICULAR FONT, STYLE, SIZE, OR COLOR.

FOR BICYCLE FRAMES AND PARTS THEREOF (U.S. CLS. 19, 21, 23, 31, 35 AND 44).

FIRST USE 3-4-2012; IN COMMERCE 3-4-2012.

4,594,624. ROHL, LLC, IRVINE, CA. SN 86-033,661. FILED P.R. 8-9-2013; AM. S.R. 7-16-2014.

**CASWELL**

THE MARK CONSISTS OF STANDARD CHARACTERS WITHOUT CLAIM TO ANY PARTICULAR FONT, STYLE, SIZE, OR COLOR.

FOR PLUMBING AND SHOWER FIXTURES, NAMELY, FAUCETS, SHOWER HEADS, RESTS FOR SHOWER HEADS IN THE NATURE OF A BRACKET SPECIFICALLY DESIGNED FOR HANDHELD SHOWER HEADS, HAND SHOWERS, THERMOSTATIC CONTROL FOR SHOWERS, AND SHOWER MIXERS (U.S. CLS. 13, 21, 23, 31 AND 34).

FIRST USE 3-27-2014; IN COMMERCE 3-27-2014.

4,594,612. RADIO FLYER INC., CHICAGO, IL. SN 85-965,184. FILED P.R. 6-20-2013; AM. S.R. 6-24-2014.

**ALL TERRAIN WAGON**

THE MARK CONSISTS OF STANDARD CHARACTERS WITHOUT CLAIM TO ANY PARTICULAR FONT, STYLE, SIZE, OR COLOR.

NO CLAIM IS MADE TO THE EXCLUSIVE RIGHT TO USE "WAGON", APART FROM THE MARK AS SHOWN.

FOR WAGONS (U.S. CLS. 19, 21, 23, 31, 35 AND 44).

FIRST USE 1-4-1996; IN COMMERCE 1-4-1996.

**CLASS 14—JEWELRY**

4,594,626. MATHI SENAPATHI, IRVINE, CA. SN 86-040,577.  
FILED P.R. 8-16-2013; AM. S.R. 6-7-2014.



THE MARK CONSISTS OF SINGLE STAR WITH SIX POINTS, WITHIN A CIRCLE, ABSTRACT DESIGN WITHIN CENTER OF STAR.

FOR JEWELRY (U.S. CLS. 2, 27, 28 AND 50).  
FIRST USE 1-1-2014; IN COMMERCE 1-1-2014.

4,594,646. BETTER SILVER S.P.A., BRESSANVIDO (VI), ITALY. SN 86-070,208. FILED P.R. 9-20-2013; AM. S.R. 7-3-2014.

The text "Roma 1947" is written in a highly stylized, cursive script. The letters are fluid and interconnected, with a vintage feel. The "R" is particularly large and decorative.

OWNER OF U.S. REG. NO. 2,392,956.  
THE MARK CONSISTS OF THE TERMS "ROMA 1947" IN A STYLIZED FONT.

THE ENGLISH TRANSLATION OF "ROMA" IN THE MARK IS "ROME".

FOR JEWELRY MADE IN WHOLE OR SIGNIFICANT PART OF SILVER (U.S. CLS. 2, 27, 28 AND 50).  
FIRST USE 5-31-2014; IN COMMERCE 5-31-2014.

4,594,674. DETROIT WATCH COMPANY, LLC, BLOOMFIELD HILLS, MI. SN 86-100,567. FILED P.R. 10-24-2013; AM. S.R. 6-26-2014.

**DETROIT WATCH COMPANY**

THE MARK CONSISTS OF STANDARD CHARACTERS WITHOUT CLAIM TO ANY PARTICULAR FONT, STYLE, SIZE, OR COLOR.

**CLASS 14—(Continued).**

NO CLAIM IS MADE TO THE EXCLUSIVE RIGHT TO USE "WATCH COMPANY", APART FROM THE MARK AS SHOWN.

FOR WATCHES; WRIST WATCHES (U.S. CLS. 2, 27, 28 AND 50).

FIRST USE 5-15-2014; IN COMMERCE 6-1-2014.

4,594,676. DETROIT WATCH COMPANY, LLC, BLOOMFIELD HILLS, MI. SN 86-100,784. FILED P.R. 10-24-2013; AM. S.R. 6-26-2014.

**DETROIT WATCH CO.**

THE MARK CONSISTS OF STANDARD CHARACTERS WITHOUT CLAIM TO ANY PARTICULAR FONT, STYLE, SIZE, OR COLOR.

NO CLAIM IS MADE TO THE EXCLUSIVE RIGHT TO USE "WATCH CO.", APART FROM THE MARK AS SHOWN.

FOR WATCHES; WRIST WATCHES (U.S. CLS. 2, 27, 28 AND 50).

FIRST USE 5-15-2014; IN COMMERCE 6-1-2014.

4,594,689. ELENA CASTANEDA, NEW YORK, NY. SN 86-127,008. FILED P.R. 11-22-2013; AM. S.R. 7-8-2014.

**Bling Jewelry**

THE MARK CONSISTS OF STANDARD CHARACTERS WITHOUT CLAIM TO ANY PARTICULAR FONT, STYLE, SIZE, OR COLOR.

OWNER OF U.S. REG. NOS. 3,646,492 AND 4,128,486.

NO CLAIM IS MADE TO THE EXCLUSIVE RIGHT TO USE "JEWELRY", APART FROM THE MARK AS SHOWN.

FOR JEWELRY (U.S. CLS. 2, 27, 28 AND 50).  
FIRST USE 8-8-2011; IN COMMERCE 8-8-2011.

**CLASS 14—(Continued).**

4,594,776. AVIANNES, INC. NEW YORK, NY. SN 86-247,214. FILED P.R. 4-9-2014; AM. S.R. 7-23-2014.

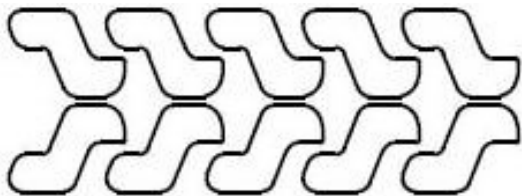

THE MARK CONSISTS OF CONSISTS OF REPEATING AND TESSELLATING PATTERN OF "S'S" IN TWO ROWS, EACH ROW FACING AN OPPOSITE DIRECTION. THE MARK IS NOT LIMITED TO POSITION OR PLACEMENT FOR JEWELRY (U.S. CLS. 2, 27, 28 AND 50). FIRST USE 4-1-2014; IN COMMERCE 4-1-2014.

**CLASS 15—MUSICAL INSTRUMENTS**

4,594,569. DRUM WORKSHOP, INC., OXNARD, CA. SN 85-774,715. FILED P.R. 11-8-2012; AM. S.R. 5-27-2014.

**DESIGN SERIES**

THE MARK CONSISTS OF STANDARD CHARACTERS WITHOUT CLAIM TO ANY PARTICULAR FONT, STYLE, SIZE, OR COLOR.

FOR DRUM SETS; BASS DRUMS; SNARE DRUMS; FLOOR TOM TOMS; HANGING TOM TOMS; CYMBALS; DRUM PEDALS; DRUM STANDS; DRUM STICKS; DRUM HARDWARE AND DRUM BEATERS (U.S. CLS. 2, 21 AND 36).

FIRST USE 1-17-2013; IN COMMERCE 2-25-2013.

**CLASS 16—PAPER GOODS AND PRINTED MATTER**

4,594,561. MARIE WOLF, PROSSER, WA. AND MICHAEL WOLF, PROSSER, WA. SN 85-481,013. FILED P.R. 11-26-2011; AM. S.R. 1-8-2014.

**Marie Catoinette**

THE MARK CONSISTS OF STANDARD CHARACTERS WITHOUT CLAIM TO ANY PARTICULAR FONT, STYLE, SIZE, OR COLOR.

THE NAME "MARIE CATOINETTE" IDENTIFIES THE PSEUDONYM OF MARIE WOLF, A LIVING INDIVIDUAL, WHOSE CONSENT IS OF RECORD.

FOR CHILDREN'S BOOKS; SERIES OF FICTION WORKS, NAMELY, NOVELS AND BOOKS (U.S. CLS. 2, 5, 22, 23, 29, 37, 38 AND 50).

FIRST USE 3-14-2013; IN COMMERCE 3-14-2013.

**CLASS 16—(Continued).**

4,594,586. PLAYBOY ENTERPRISES INTERNATIONAL, INC., BEVERLY HILLS, CA. SN 85-850,323. FILED P.R. 2-14-2013; AM. S.R. 7-10-2014.

**MANTRACK**

THE MARK CONSISTS OF STANDARD CHARACTERS WITHOUT CLAIM TO ANY PARTICULAR FONT, STYLE, SIZE, OR COLOR.

FOR MAGAZINE SECTIONS IN THE FIELD OF PRODUCTS AND SERVICES OF INTEREST TO MEN (U.S. CLS. 2, 5, 22, 23, 29, 37, 38 AND 50).

FIRST USE 9-0-1992; IN COMMERCE 9-0-1992.

4,594,629. 85086 MAGAZINE, LLC, PHOENIX, AZ. SN 86-044,416. FILED P.R. 8-21-2013; AM. S.R. 7-8-2014.

**85086 MAGAZINE**

THE MARK CONSISTS OF STANDARD CHARACTERS WITHOUT CLAIM TO ANY PARTICULAR FONT, STYLE, SIZE, OR COLOR.

NO CLAIM IS MADE TO THE EXCLUSIVE RIGHT TO USE "MAGAZINE", APART FROM THE MARK AS SHOWN. FOR GENERAL FEATURE MAGAZINES (U.S. CLS. 2, 5, 22, 23, 29, 37, 38 AND 50).

FIRST USE 1-4-2013; IN COMMERCE 8-9-2013.

4,594,633. JINDAL POLY FILMS LIMITED, GULAOTHI, INDIA. SN 86-054,412. FILED P.R. 9-3-2013; AM. S.R. 7-19-2014.

**Jindal**  
Films

NO CLAIM IS MADE TO THE EXCLUSIVE RIGHT TO USE "FILMS", APART FROM THE MARK AS SHOWN.

**CLASS 16—(Continued).**

THE MARK CONSISTS OF THE WORD "JINDAL" AND THE WORD "FILMS" WHEREIN THE WORD "FILMS" IS LOCATED DIRECTLY BELOW THE LETTERS "DAL" OF THE WORD "JINDAL".

FOR PLASTIC FILM FOR PACKAGING (U.S. CLS. 2, 5, 22, 23, 29, 37, 38 AND 50).

FIRST USE 11-26-2013; IN COMMERCE 11-26-2013.

---

**SANTAFESTYLE**

THE MARK CONSISTS OF STANDARD CHARACTERS WITHOUT CLAIM TO ANY PARTICULAR FONT, STYLE, SIZE, OR COLOR.

FOR PUBLICATIONS, NAMELY, PRINTED MAGAZINES CONTAINING LISTINGS FOR THE SALE OR LEASE OF REAL ESTATE AND ADVERTISEMENTS FOR REAL ESTATE RELATED SERVICES (U.S. CLS. 2, 5, 22, 23, 29, 37, 38 AND 50).

FIRST USE 10-31-2011; IN COMMERCE 10-31-2011.

---

**THE EXPANSIVE LEADERSHIP  
MODEL**

THE MARK CONSISTS OF STANDARD CHARACTERS WITHOUT CLAIM TO ANY PARTICULAR FONT, STYLE, SIZE, OR COLOR.

FOR BOOKS IN THE FIELD OF LEADERSHIP, LEADERSHIP EDUCATION, AND EXECUTIVE LEADERSHIP; EDUCATIONAL PUBLICATIONS, NAMELY, HANDOUTS, WORKBOOKS, MANUALS, SURVEYS, AND ASSESSMENTS IN THE FIELDS OF LEADERSHIP, LEADERSHIP EDUCATION, AND EXECUTIVE LEADERSHIP; PRINTED PAMPHLETS, BROCHURES, MANUALS, BOOKS, BOOKLETS, LEAFLETS, INFORMATIONAL FLYERS, INFORMATIONAL SHEETS AND NEWSLETTERS, ADHESIVE BACKED STICKERS, AND KITS COMPRISING ONE OR MORE OF THE FOREGOING MATERIALS IN THE FIELD OF LEADERSHIP, LEADERSHIP EDUCATION, AND EXECUTIVE LEADERSHIP (U.S. CLS. 2, 5, 22, 23, 29, 37, 38 AND 50).

FIRST USE 11-21-2007; IN COMMERCE 11-21-2007.

**CLASS 16—(Continued).**

4,594,720. EDITORIAL MOTORPRESS TELEVISA, S.A. DE C.V., SANTA FE, MEXICO. SN 86-190,543. FILED P.R. 2-11-2014; AM. S.R. 6-25-2014.

**MOTOCICLISMO PANAMERICANO**

THE MARK CONSISTS OF STANDARD CHARACTERS WITHOUT CLAIM TO ANY PARTICULAR FONT, STYLE, SIZE, OR COLOR.

OWNER OF MEXICO REG. NO. 500826, DATED 12-7-1994, EXPIRES 12-7-2014.

OWNER OF U.S. REG. NO. 3,420,827.

THE ENGLISH TRANSLATION OF "MOTOCICLISMO PANAMERICANO" IN THE MARK IS "PANAMERICAN MOTORCYCLING".

FOR MAGAZINE IN THE FIELD OF MOTORCYCLING (U.S. CLS. 2, 5, 22, 23, 29, 37, 38 AND 50).

---

4,594,757. HELTEMES, MONICA J., DAYTON, MN. SN 86-229,364. FILED P.R. 3-23-2014; AM. S.R. 6-30-2014.

**The Heart Does Not Forget**

THE MARK CONSISTS OF STANDARD CHARACTERS WITHOUT CLAIM TO ANY PARTICULAR FONT, STYLE, SIZE, OR COLOR.

FOR BOOKMARKS (U.S. CLS. 2, 5, 22, 23, 29, 37, 38 AND 50).

FIRST USE 3-18-2014; IN COMMERCE 3-18-2014.

---

4,594,767. CLASSICAL CONVERSATIONS MULTI MEDIA, INC., WEST END, NC. SN 86-237,575. FILED P.R. 3-31-2014; AM. S.R. 7-7-2014.

**CLASSICAL ACTS & FACTS**

THE MARK CONSISTS OF STANDARD CHARACTERS WITHOUT CLAIM TO ANY PARTICULAR FONT, STYLE, SIZE, OR COLOR.

FOR EDUCATIONAL PUBLICATIONS, NAMELY, EDUCATIONAL FLASHCARDS FOR PARENTS AND ELEMENTARY AND SECONDARY STUDENTS IN THE FIELDS OF HISTORY, SCIENCE, MUSIC, FINE ARTS, PHILOSOPHY, AND SCRIPTURE (U.S. CLS. 2, 5, 22, 23, 29, 37, 38 AND 50).

FIRST USE 11-2-2009; IN COMMERCE 11-2-2009.

**CLASS 16—(Continued).**

4,594,768. CLASSICAL CONVERSATIONS MULTI MEDIA, INC., WEST END, NC. SN 86-237,591. FILED P.R. 3-31-2014; AM. S.R. 7-7-2014.

**TRIVIUM TABLES**

THE MARK CONSISTS OF STANDARD CHARACTERS WITHOUT CLAIM TO ANY PARTICULAR FONT, STYLE, SIZE, OR COLOR.

FOR PRINTED MATERIALS, NAMELY, PRINTED FOLDED, MULTI-PANEL POSTERS FOR PARENTS AND ELEMENTARY AND SECONDARY STUDENTS IN THE FIELDS OF GEOGRAPHY, LANGUAGE, MATHEMATICS, SCIENCE, LOGIC, RHETORIC, WRITING, POETRY, HISTORY, AND LITERATURE (U.S. CLS. 2, 5, 22, 23, 29, 37, 38 AND 50).

FIRST USE 4-1-2011; IN COMMERCE 4-1-2011.

**CLASS 19—(Continued).**

4,594,623. FLOOD FLAPS, LLC, DBA FLOOD FLAPS, LLC, MT. PLEASANT, SC. SN 86-024,448. FILED 7-31-2013.

**FLOOD FLAPS**

THE MARK CONSISTS OF STANDARD CHARACTERS WITHOUT CLAIM TO ANY PARTICULAR FONT, STYLE, SIZE, OR COLOR.

OWNER OF U.S. REG. NO. 4,339,851.

NO CLAIM IS MADE TO THE EXCLUSIVE RIGHT TO USE "FLAPS", APART FROM THE MARK AS SHOWN.

FOR CONSTRUCTION MATERIALS, NAMELY, SEALED CRAWL SPACE BUILDING FOUNDATION WALL VENT NOT OF METAL (U.S. CLS. 1, 12, 33 AND 50).

FIRST USE 2-22-2013; IN COMMERCE 2-22-2013.

**CLASS 19—NON-METALLIC BUILDING MATERIALS**

4,594,577. LIFETIME TOOL & BUILDING PRODUCTS, LLC, WINCHESTER, VA. SN 85-820,179. FILED P.R. 1-10-2013; AM. S.R. 6-12-2014.

**ULTIMATE PIPE FLASHING**

THE MARK CONSISTS OF STANDARD CHARACTERS WITHOUT CLAIM TO ANY PARTICULAR FONT, STYLE, SIZE, OR COLOR.

NO CLAIM IS MADE TO THE EXCLUSIVE RIGHT TO USE "PIPE FLASHING", APART FROM THE MARK AS SHOWN.

FOR ROOF, SIDE AND WALL ATTACHMENTS AND FLASHINGS, NAMELY, SURFACE PENETRATION AND PIPE FLASHINGS MADE PRIMARILY OF PVC AND SILICONE FOR PREVENTING AND CONTROLLING WATER, MOISTURE, INSECTS, FUNGAL AND MOLD PENETRATION AND STRUCTURAL DETERIORATION, FOR PROTECTING VENT, FIXTURE AND BARRIER INTERSECTIONS FROM ENVIRONMENTAL DAMAGE, FOR DIRECTING OR RESISTING MOVEMENT OF COLLECTED NATURAL ENVIRONMENTAL SOLID MATERIALS AND THE GENERAL PROTECTION OF PROPERTY AND PERSONS (U.S. CLS. 1, 12, 33 AND 50).

FIRST USE 2-17-2012; IN COMMERCE 2-17-2012.

4,594,707. FAULKS BROS. CONSTRUCTION, INC., WAUPACA, WI. SN 86-156,089. FILED P.R. 1-2-2014; AM. S.R. 1-2-2014.

**Dirt Cheap Infield Mix**

THE MARK CONSISTS OF STANDARD CHARACTERS WITHOUT CLAIM TO ANY PARTICULAR FONT, STYLE, SIZE, OR COLOR.

NO CLAIM IS MADE TO THE EXCLUSIVE RIGHT TO USE "INFIELD MIX", APART FROM THE MARK AS SHOWN.

FOR SOILS FOR APPLICATION TO SPORTS FIELDS (U.S. CLS. 1, 12, 33 AND 50).

FIRST USE 6-30-2012; IN COMMERCE 6-30-2012.

**CLASS 20—FURNITURE AND ARTICLES NOT OTHERWISE CLASSIFIED**



**CLASS 20—(Continued).**

4,594,718. ULTIMATE GAME CHANGER, LLC, ENCINTAS, CA. SN 86-185,670. FILED P.R. 2-5-2014; AM. S.R. 7-2-2014.

**ULTIMATE GAME CHANGER**

THE MARK CONSISTS OF STANDARD CHARACTERS WITHOUT CLAIM TO ANY PARTICULAR FONT, STYLE, SIZE, OR COLOR.

FOR PORTABLE PRIVACY DIVIDER FOR USE WITH SPLIT-SCREEN VIDEO GAME PLAYING, WHICH PREVENTS A PLAYER FROM VIEWING ANOTHER PLAYER'S SCREEN PORTION (U.S. CLS. 2, 13, 22, 25, 32 AND 50).

FIRST USE 5-17-2013; IN COMMERCE 2-3-2014.

**CLASS 21—HOUSEWARES AND GLASS**

4,594,669. J & D BRUSH CO., INC., HAUPPAUGE, NY. SN 86-095,955. FILED P.R. 10-18-2013; AM. S.R. 6-26-2014.

**THE WET SPRAY**

THE MARK CONSISTS OF STANDARD CHARACTERS WITHOUT CLAIM TO ANY PARTICULAR FONT, STYLE, SIZE, OR COLOR.

OWNER OF U.S. REG. NOS. 4,330,506 AND 4,384,066.

NO CLAIM IS MADE TO THE EXCLUSIVE RIGHT TO USE "SPRAY", APART FROM THE MARK AS SHOWN.

FOR EMPTY SPRAY BOTTLES (U.S. CLS. 2, 13, 23, 29, 30, 33, 40 AND 50).

FIRST USE 10-0-2013; IN COMMERCE 10-0-2013.

4,594,771. U.S. MARINE CORPS, A COMPONENT OF THE U.S. DEPARTMENT OF THE NAVY, WASHINGTON, DC. SN 86-238,808. FILED P.R. 4-1-2014; AM. S.R. 7-10-2014.

**DEVIL DOGS**

THE MARK CONSISTS OF STANDARD CHARACTERS WITHOUT CLAIM TO ANY PARTICULAR FONT, STYLE, SIZE, OR COLOR.

OWNER OF U.S. REG. NO. 4,456,838.

FOR COFFEE MUGS; CUPS AND MUGS; MUGS (U.S. CLS. 2, 13, 23, 29, 30, 33, 40 AND 50).

FIRST USE 2-5-2011; IN COMMERCE 2-5-2011.

**CLASS 22—CORDAGE AND FIBERS****CLASS 22—(Continued).**

4,594,555. CROSSFORD INTERNATIONAL, LLC, STAMFORD, CT. SN 76-714,010. FILED P.R. 4-23-2013; AM. S.R. 3-31-2014.

**Mini-Split Bib**

THE MARK CONSISTS OF STANDARD CHARACTERS WITHOUT CLAIM TO ANY PARTICULAR FONT, STYLE, SIZE, OR COLOR.

NO CLAIM IS MADE TO THE EXCLUSIVE RIGHT TO USE "MINI-SPLIT", APART FROM THE MARK AS SHOWN.

FOR FLEXIBLE PLASTIC BAG WITH SUPPORTING FRAME FOR CAPTURING AND DISPOSING OF DIRTY WATER AND DEBRIS WHILE CLEANING FINNED COILS OF MINI-SPLIT AIR CONDITIONING SYSTEMS (U.S. CLS. 1, 2, 7, 19, 22, 42 AND 50).

FIRST USE 5-1-2013; IN COMMERCE 5-1-2013.

4,594,559. HIGH CALIPER GROWING, INC., OKLAHOMA CITY, OK. SN 85-226,890. FILED P.R. 1-26-2011; AM. S.R. 11-14-2013.

**OREGON'S FAVORITE POT**

THE MARK CONSISTS OF STANDARD CHARACTERS WITHOUT CLAIM TO ANY PARTICULAR FONT, STYLE, SIZE, OR COLOR.

OWNER OF U.S. REG. NO. 2,927,512.

NO CLAIM IS MADE TO THE EXCLUSIVE RIGHT TO USE "POT", APART FROM THE MARK AS SHOWN.

FOR FABRIC CONTAINERS FOR GROWING PLANTS (U.S. CLS. 1, 2, 7, 19, 22, 42 AND 50).

FIRST USE 11-0-2010; IN COMMERCE 11-0-2010.

4,594,560. HIGH CALIPER GROWING, INC., OKLAHOMA CITY, OK. SN 85-226,912. FILED P.R. 1-26-2011; AM. S.R. 11-14-2013.

**COLORADO'S FAVORITE POT**

THE MARK CONSISTS OF STANDARD CHARACTERS WITHOUT CLAIM TO ANY PARTICULAR FONT, STYLE, SIZE, OR COLOR.

OWNER OF U.S. REG. NO. 2,927,512.

NO CLAIM IS MADE TO THE EXCLUSIVE RIGHT TO USE "POT", APART FROM THE MARK AS SHOWN.

FOR FABRIC CONTAINERS FOR GROWING PLANTS (U.S. CLS. 1, 2, 7, 19, 22, 42 AND 50).

FIRST USE 1-0-2011; IN COMMERCE 1-0-2011.

**CLASS 24—FABRICS**

4,594,576. HAMCO, INC., GONZALES, LA. SN 85-805,295.  
FILED P.R. 12-18-2012; AM. S.R. 7-3-2014.

**CHAIR TOPPER**

THE MARK CONSISTS OF STANDARD CHARACTERS WITHOUT CLAIM TO ANY PARTICULAR FONT, STYLE, SIZE, OR COLOR.

OWNER OF U.S. REG. NOS. 2,122,791, 2,719,702, AND 3,739,751.

NO CLAIM IS MADE TO THE EXCLUSIVE RIGHT TO USE "CHAIR", APART FROM THE MARK AS SHOWN.

FOR DISPOSABLE AND/OR NON-DISPOSABLE MAT NOT MADE OF PAPER WHICH AFFIXES DIRECTLY TO A CHAIR SURFACE TO PROTECT THE SURFACE FROM FOOD OR DRINK SPILLAGE OR FROM DAMAGE FROM A HIGH CHAIR OR BOOSTER SEAT (U.S. CLS. 42 AND 50).

FIRST USE 9-1-2013; IN COMMERCE 9-1-2013.

---

4,594,643. ALOK INTERNATIONAL INC., DALLAS, TX. SN 86-068,682. FILED P.R. 9-18-2013; AM. S.R. 6-17-2014.

**COTLIN**

THE MARK CONSISTS OF STANDARD CHARACTERS WITHOUT CLAIM TO ANY PARTICULAR FONT, STYLE, SIZE, OR COLOR.

FOR BED LINEN; BED SHEETS; BED THROWS; DUVETS; TOWELS (U.S. CLS. 42 AND 50).

FIRST USE 2-1-2014; IN COMMERCE 2-1-2014.

---

4,594,711. LITTLE UPSTARTS USA INC., PITTSFIELD, MA. SN 86-169,421. FILED P.R. 1-18-2014; AM. S.R. 6-26-2014.

**Ottoman Originals**

THE MARK CONSISTS OF STANDARD CHARACTERS WITHOUT CLAIM TO ANY PARTICULAR FONT, STYLE, SIZE, OR COLOR.

FOR TEXTILE FABRICS FOR HOME AND COMMERCIAL INTERIORS; TEXTILE FABRICS FOR THE MANUFACTURE OF CLOTHING; TEXTILE FABRICS FOR USE IN MAKING CLOTHING AND HOUSEHOLD FURNISHINGS; TEXTILE FABRICS FOR USE IN THE MANUFACTURE OF GARMENTS, BAGS, JACKETS, GLOVES, AND APPAREL; TEXTILE HANDKERCHIEFS; TEXTILE TABLECLOTHS (U.S. CLS. 42 AND 50).

FIRST USE 5-1-2012; IN COMMERCE 5-1-2012.

**CLASS 25—CLOTHING**

4,594,566. PERKINS, CATHY, ANTHONY, FL. SN 85-698,615.  
FILED P.R. 8-8-2012; AM. S.R. 7-10-2014.



THE COLOR(S) BLACK, PINK, WHITE IS/ARE CLAIMED AS A FEATURE OF THE MARK.

THE MARK CONSISTS OF THE WORD "WOMEN" IN BLACK STYLIZED FONT TO THE LEFT OF A STICK FIGURE WOMAN IN BLACK STANDING ABOVE THE WORDS "THE IMPROVED MAN!" WITH THE WORDS "THE" AND "MAN!" IN BLACK STYLIZED FONT AND THE WORD "IMPROVED" IN PINK STYLIZED FONT. BOTH THE LETTER "O" IN "WOMEN" AND THE STICK FIGURE WOMAN HAVE PINK LIPS AND A PINK BOW. BELOW THE "N" IN "WOMAN" IS AN ELLIPSIS. ALL OF THE FOREGOING APPEARS OVER A WHITE BACKGROUND.

FOR TEE SHIRTS, TANK TOPS, BABY DOLL TEE SHIRTS, LADIES' TEE SHIRTS, HALTER TOPS, CASUAL TOPS FOR WOMEN (U.S. CLS. 22 AND 39).

FIRST USE 2-21-2013; IN COMMERCE 5-21-2013.

---

4,594,584. WOLFF SHOE COMPANY, FENTON, MO. SN 85-844,005. FILED P.R. 2-7-2013; AM. S.R. 7-16-2014.

**PURPLE COLLECTION**

THE MARK CONSISTS OF STANDARD CHARACTERS WITHOUT CLAIM TO ANY PARTICULAR FONT, STYLE, SIZE, OR COLOR.

NO CLAIM IS MADE TO THE EXCLUSIVE RIGHT TO USE "COLLECTION", APART FROM THE MARK AS SHOWN.

FOR FOOTWEAR (U.S. CLS. 22 AND 39).

FIRST USE 12-31-2011; IN COMMERCE 12-31-2011.

**CLASS 25—(Continued).**

4,594,594. DIVINE CHILD, SPRINGFIELD, NJ. SN 85-875,156.  
FILED P.R. 3-13-2013; AM. S.R. 5-17-2014.

## Divine Child

THE MARK CONSISTS OF STANDARD CHARACTERS WITHOUT CLAIM TO ANY PARTICULAR FONT, STYLE, SIZE, OR COLOR.

NO CLAIM IS MADE TO THE EXCLUSIVE RIGHT TO USE "CHILD", APART FROM THE MARK AS SHOWN.

FOR PANTS; SHIRTS; SHORTS; T-SHIRTS (U.S. CLS. 22 AND 39).

FIRST USE 5-1-2013; IN COMMERCE 5-1-2013.

4,594,632. FORBES, MALCOLM A., DBA DREAM ROUTE, WESLEY CHAPEL, FL. SN 86-053,515. FILED P.R. 9-1-2013; AM. S.R. 5-15-2014.

dream  
route

THE MARK CONSISTS OF "DREAM ROUTE" WRITTEN IN ALL LOWER CASE LETTERS, WITH HORIZONTAL LINE IN-BETWEEN WORDS "DREAM" AND "ROUTE". THE WORD "DREAM" IS ABOVE HORIZONTAL LINE (LEFT ALIGNED), "ROUTE" IS UNDER THE HORIZONTAL LINE (RIGHT ALIGNED).

FOR BELTS; HOODS; SPORTS CAPS AND HATS; WOMEN'S CLOTHING, NAMELY, SHIRTS, DRESSES, SKIRTS, BLOUSES; WRIST BANDS; MEN'S CLOTHING, NAMELY, T-SHIRTS, PANTS, SHORTS, POLO SHIRTS (U.S. CLS. 22 AND 39).

FIRST USE 1-31-2013; IN COMMERCE 8-0-2013.

4,594,640. INGELMO & COMPANY INC., MIAMI, FL. SN 86-064,230. FILED P.R. 9-13-2013; AM. S.R. 7-9-2014.

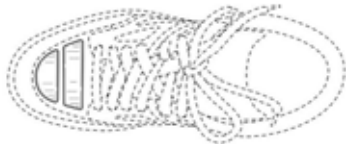

THE MARK CONSISTS OF A FOOTWEAR TOE DESIGN COMPRISING A HALF MOON SHAPE IN COMBINATION WITH A QUASI-RECTANGULAR SHAPE.

FOR FOOTWEAR (U.S. CLS. 22 AND 39).

FIRST USE 9-1-2009; IN COMMERCE 9-1-2009.

**CLASS 25—(Continued).**

4,594,649. MAURICE, GREGORY, EWA BEACH, HI. SN 86-071,562. FILED P.R. 9-23-2013; AM. S.R. 6-25-2014.



THE STIPPLING IS FOR SHADING PURPOSES ONLY. THE MARK CONSISTS OF A DESIGN OF CROSSED RIBBON MADE TO LOOK LIKE WOMEN'S LEGS WEARING HIGH HEELS, WITHIN THE RIBBON DESIGN IS THE WORDING "WALKING IN HER SHOES"; BELOW THE RIBBON IS THE WORDING "NO ONE HAS THE RIGHT TO LOVE YOU TO DEATH".

FOR T-SHIRTS (U.S. CLS. 22 AND 39).

FIRST USE 4-1-2013; IN COMMERCE 4-1-2013.

4,594,660. HAMCO, INC., GONZALES, LA. SN 86-087,202. FILED P.R. 10-9-2013; AM. S.R. 7-3-2014.

## The Bib with a Lid

THE MARK CONSISTS OF STANDARD CHARACTERS WITHOUT CLAIM TO ANY PARTICULAR FONT, STYLE, SIZE, OR COLOR.

FOR BIBS NOT OF PAPER THAT HAVE AN INTEGRATED FOOD CONTAINER FITTED INTO, AND SOLD AS A COMPONENT OF THE BIBS, ALONG WITH A REMOVABLE COVER FOR THE FOOD CONTAINER, ALL SOLD AS A UNIT (U.S. CLS. 22 AND 39).

FIRST USE 1-21-2014; IN COMMERCE 1-21-2014.

**CLASS 25—(Continued).**

4,594,664. GALARZA, GABRIEL D, LOGANVILLE, GA. SN 86-090,038. FILED P.R. 10-11-2013; AM. S.R. 7-15-2014.

grind don't know sleep

THE MARK CONSISTS OF STANDARD CHARACTERS WITHOUT CLAIM TO ANY PARTICULAR FONT, STYLE, SIZE, OR COLOR.

FOR T-SHIRTS (U.S. CLS. 22 AND 39).  
FIRST USE 9-14-2013; IN COMMERCE 9-14-2013.

4,594,665. BRICKYARD TRADEMARKS, INC., INDIANAPOLIS, IN. SN 86-090,847. FILED P.R. 10-14-2013; AM. S.R. 6-29-2014.

KISS THE BRICKS

THE MARK CONSISTS OF STANDARD CHARACTERS WITHOUT CLAIM TO ANY PARTICULAR FONT, STYLE, SIZE, OR COLOR.

FOR FOOTWEAR; HEADWEAR; JACKETS; PANTS; SHORTS; SWEATSHIRTS; WEARABLE GARMENTS AND CLOTHING, NAMELY, SHIRTS (U.S. CLS. 22 AND 39).

FIRST USE 7-31-2013; IN COMMERCE 7-31-2013.

4,594,683. PARDO VENTURES LLC, DBA ÑO PRODUCTIONS, SHERMAN OAKS, CA. SN 86-111,191. FILED P.R. 11-5-2013; AM. S.R. 7-1-2014.



THE COLOR(S) RED, WHITE AND BLUE. IS/ARE CLAIMED AS A FEATURE OF THE MARK.

THE MARK CONSISTS OF THE WORDING "CUBAMERICAN" WITH "CUB" IN RED, "MERI" IN BLUE, "CAN" IN WHITE, AND THE MIDDLE "A" IN HALF RED AND HALF BLUE, WITH A LARGE WHITE STAR IN THE MIDDLE AND SMALLER WHITE STARS DOWN EACH SIDE. THE COLOR BLACK IN THE MARK REPRESENTS BACKGROUND, AND IS NOT CLAIMED AS A FEATURE OF THE MARK.

FOR OPEN-NECKED TEE SHIRTS, CAPS, LONG SLEEVED TEE SHIRTS, SWEATERS (U.S. CLS. 22 AND 39).

FIRST USE 9-1-2012; IN COMMERCE 6-14-2013.

**CLASS 25—(Continued).**

4,594,692. ATTEBERY, LUCAS, KENT, NYACK, NY. SN 86-129,833. FILED P.R. 11-26-2013; AM. S.R. 6-25-2014.

LifeStyleClothing  
Cooperative

THE MARK CONSISTS OF STANDARD CHARACTERS WITHOUT CLAIM TO ANY PARTICULAR FONT, STYLE, SIZE, OR COLOR.

NO CLAIM IS MADE TO THE EXCLUSIVE RIGHT TO USE "COOPERATIVE", APART FROM THE MARK AS SHOWN.

FOR ATHLETIC PANTS; ATHLETIC SHORTS; BASEBALL CAPS AND HATS; BOARD SHORTS; CARGO PANTS; DENIMS; MEN'S SOCKS; SWEATERS; T-SHIRTS (U.S. CLS. 22 AND 39).

FIRST USE 12-1-2013; IN COMMERCE 1-1-2014.

4,594,700. FRESH PEAR INC., RICHMOND HILL, CANADA. SN 86-142,618. FILED P.R. 12-13-2013; AM. S.R. 6-11-2014.

UNDEESHOP

THE MARK CONSISTS OF STANDARD CHARACTERS WITHOUT CLAIM TO ANY PARTICULAR FONT, STYLE, SIZE, OR COLOR.

FOR SOCKS; T-SHIRTS; UNDERGARMENTS; UNDERSHIRTS; UNDERWEAR (U.S. CLS. 22 AND 39).

FIRST USE 12-1-2013; IN COMMERCE 12-1-2013.

4,594,702. RISE, SAN LEANDRO, CA. SN 86-148,543. FILED P.R. 12-19-2013; AM. S.R. 7-3-2014.

Rise Basketball Apparel

THE MARK CONSISTS OF STANDARD CHARACTERS WITHOUT CLAIM TO ANY PARTICULAR FONT, STYLE, SIZE, OR COLOR.

NO CLAIM IS MADE TO THE EXCLUSIVE RIGHT TO USE "BASKETBALL APPAREL", APART FROM THE MARK AS SHOWN.

FOR CLOTHING FOR ATHLETIC USE, NAMELY, PADDED ELBOW COMPRESSION SLEEVES BEING PART OF AN ATHLETIC GARMENT; HATS; HEADWEAR; JERSEYS; SHOES; SHORTS; SOCKS; SWEATERS; T-SHIRTS (U.S. CLS. 22 AND 39).

FIRST USE 9-20-2010; IN COMMERCE 9-20-2010.

**CLASS 25—(Continued).**

4,594,714. U.S. MARINE CORPS, A COMPONENT OF THE U.S. DEPARTMENT OF THE NAVY, WASHINGTON, DC. SN 86-182,680. FILED P.R. 2-3-2014; AM. S.R. 7-10-2014.

# YUT

THE MARK CONSISTS OF STANDARD CHARACTERS WITHOUT CLAIM TO ANY PARTICULAR FONT, STYLE, SIZE, OR COLOR.

FOR SHIRTS (U.S. CLS. 22 AND 39).  
FIRST USE 4-12-2011; IN COMMERCE 4-12-2011.

4,594,761. GIAMMONA COLLECTIVE, LLC, APEX, NC. SN 86-232,141. FILED P.R. 3-26-2014; AM. S.R. 6-30-2014.

# GIAMMONA COLLECTIVE

THE MARK CONSISTS OF STANDARD CHARACTERS WITHOUT CLAIM TO ANY PARTICULAR FONT, STYLE, SIZE, OR COLOR.

NO CLAIM IS MADE TO THE EXCLUSIVE RIGHT TO USE "COLLECTIVE", APART FROM THE MARK AS SHOWN.

FOR CLOTHING, NAMELY, TOPS, BOTTOMS, JEANS, JACKETS, SKIRTS, DRESSES (U.S. CLS. 22 AND 39).  
FIRST USE 3-24-2014; IN COMMERCE 3-24-2014.

**CLASS 28—TOYS AND SPORTING GOODS**

4,594,579. KENNETH A. FISCHER SR., FRAMINGHAM, MA. SN 85-832,167. FILED P.R. 1-25-2013; AM. S.R. 6-16-2014.

# Hydro Bells

THE MARK CONSISTS OF STANDARD CHARACTERS WITHOUT CLAIM TO ANY PARTICULAR FONT, STYLE, SIZE, OR COLOR.

FOR DUMB-BELLS (U.S. CLS. 22, 23, 38 AND 50).  
FIRST USE 1-19-2014; IN COMMERCE 1-19-2014.

**CLASS 28—(Continued).**

4,594,583. BALANCED BODY, INC., SACRAMENTO, CA. SN 85-839,057. FILED P.R. 2-1-2013; AM. S.R. 6-24-2014.

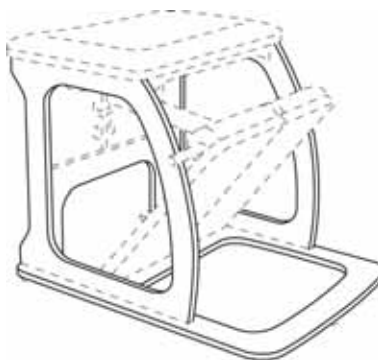

THE MARK CONSISTS OF A THREE-DIMENSIONAL RECOGNIZABLE CONFIGURATION OF THE NON-FUNCTIONAL ASPECTS OF AN EXERCISE APPARATUS KNOWN AS A STEP CHAIR. THE MARK CONSISTS OF THE SHAPES OF THE TWO SIDE PANELS, THE BACK PANEL, AND THE BASE PANEL. EACH OF THE TWO SIDE PANELS FORMS A HOLLOW RIGHT-ANGLE TRAPEZOID WITH ROUNDED INTERIOR CORNERS, AN ARCuate FRONT EDGE, AND A STEPPED-IN BACK EDGE. THE BACK PANEL FORMS A HORSESHOE SHAPE HAVING ROUNDED INTERIOR CORNERS. THE BASE PANEL FORMS A HOLLOW RECTANGULAR SHAPE HAVING ROUNDED INTERIOR AND EXTERIOR CORNERS. THE BROKEN LINES DEPICTING THE SEAT, PEDALS, SPRING, AND SPRING ATTACHMENT MECHANISM INDICATE PLACEMENT OF THE MARK ON THE GOODS AND ARE NOT PART OF THE MARK.

FOR EXERCISE MACHINES; MANUALLY-OPERATED EXERCISE EQUIPMENT; EXERCISE EQUIPMENT, NAMELY, STAIR-STEPPING MACHINES (U.S. CLS. 22, 23, 38 AND 50).

FIRST USE 8-9-2007; IN COMMERCE 8-9-2007.

4,594,596. TRAININGMASK, LLC, CADILLAC, MI. SN 85-876,503. FILED P.R. 3-14-2013; AM. S.R. 11-13-2013.

# Simulate High Altitude Training

THE MARK CONSISTS OF STANDARD CHARACTERS WITHOUT CLAIM TO ANY PARTICULAR FONT, STYLE, SIZE, OR COLOR.

FOR BODY-TRAINING APPARATUS; EXERCISE EQUIPMENT, NAMELY, RESISTANCE TRAINING EXERCISE MASKS WHICH RESTRICT AIRFLOW; MARTIAL ARTS TRAINING EQUIPMENT; PHYSICAL FITNESS EQUIPMENT, NAMELY, RESISTANCE TRAINING EXERCISE MASKS WHICH RESTRICT AIRFLOW; TRAINING APPARATUS FOR BOXING, MARTIAL ARTS, AND SIMILAR SPORTS (U.S. CLS. 22, 23, 38 AND 50).

FIRST USE 10-1-2010; IN COMMERCE 10-1-2010.

**CLASS 28—(Continued).**

4,594,652. VANECKO, IVAN, KAPPEL-GRAFENHAUSEN, FED REP GERMANY. SN 86-075,581. FILED P.R. 9-26-2013; AM. S.R. 7-10-2014.

**FINGER CAR**

THE MARK CONSISTS OF STANDARD CHARACTERS WITHOUT CLAIM TO ANY PARTICULAR FONT, STYLE, SIZE, OR COLOR.

PRIORITY CLAIMED UNDER SEC. 44(D) ON ERP N CMNTY TM OFC APPLICATION NO. 011780913, FILED 4-30-2013, REG. NO. 011780913, DATED 9-25-2013, EXPIRES 4-30-2023.

NO CLAIM IS MADE TO THE EXCLUSIVE RIGHT TO USE "CAR", APART FROM THE MARK AS SHOWN.

FOR MODEL TOY VEHICLES; TOY VEHICLES; TOY VEHICLES AND ACCESSORIES THEREFOR (U.S. CLS. 22, 23, 38 AND 50).

FIRST USE 6-23-2014; IN COMMERCE 6-23-2014.

**CLASS 29—MEATS AND PROCESSED FOODS**

4,594,726. IMMERGOOD, SAVANNAH, GA. SN 86-197,382. FILED P.R. 2-19-2014; AM. S.R. 6-25-2014.

**FRESHCRUSH OIL**

THE MARK CONSISTS OF STANDARD CHARACTERS WITHOUT CLAIM TO ANY PARTICULAR FONT, STYLE, SIZE, OR COLOR.

NO CLAIM IS MADE TO THE EXCLUSIVE RIGHT TO USE "OIL", APART FROM THE MARK AS SHOWN.

FOR OLIVE OIL (U.S. CL. 46).

FIRST USE 6-20-2014; IN COMMERCE 6-20-2014.

4,594,680. CHRISTIAN BIBLE GAMES, THE VILLAGES, FL. SN 86-107,055. FILED P.R. 10-31-2013; AM. S.R. 6-27-2014.

**Bible Lingo Christian Bingo**

THE MARK CONSISTS OF STANDARD CHARACTERS WITHOUT CLAIM TO ANY PARTICULAR FONT, STYLE, SIZE, OR COLOR.

NO CLAIM IS MADE TO THE EXCLUSIVE RIGHT TO USE "BIBLE" AND "BINGO", APART FROM THE MARK AS SHOWN.

FOR BIBLE BINGO GAME PLAYING EQUIPMENT (U.S. CLS. 22, 23, 38 AND 50).

FIRST USE 6-0-2012; IN COMMERCE 9-0-2013.



4,594,775. OMEGA SEA, INC., NEWPORT, RI. SN 86-246,057. FILED 4-8-2014.

4,594,691. CHRISTIAN BIBLE GAMES LLC, THE VILLAGES, FL. SN 86-128,798. FILED P.R. 11-25-2013; AM. S.R. 6-27-2014.

**Christian Bible Games**

THE MARK CONSISTS OF STANDARD CHARACTERS WITHOUT CLAIM TO ANY PARTICULAR FONT, STYLE, SIZE, OR COLOR.

FOR BIBLE AND RELIGIOUS RELATED GAMES CONSISTING OF CARDS AND CHIPS (U.S. CLS. 22, 23, 38 AND 50).

FIRST USE 6-0-2012; IN COMMERCE 9-0-2013.

NO CLAIM IS MADE TO THE EXCLUSIVE RIGHT TO USE "LOBSTER", APART FROM THE MARK AS SHOWN.

THE MARK CONSISTS OF A MAP SHOWING THE SAINT LAWRENCE RIVER AND CHALEUR BAY WITH AN OVERLAY OF A LOBSTER CLAW OUTLINING SAID BAY. THE SHADING IS A FEATURE OF THE MARK AND IS NOT INTENDED TO INDICATE COLOR. THE WORDS "CHALEUR BAY LOBSTER" APPEARS BELOW THE LOBSTER CLAW.

FOR SEAFOOD, NOT LIVE (U.S. CL. 46).

FIRST USE 11-1-2013; IN COMMERCE 11-1-2013.

**CLASS 30—STAPLE FOODS**

**CLASS 30—(Continued).**

4,594,571. LAURENCEAU, WALDA, MELVILLE, NY. SN 85-782,608. FILED P.R. 11-19-2012; AM. S.R. 6-30-2014.

# TeaFèy

THE MARK CONSISTS OF STANDARD CHARACTERS WITHOUT CLAIM TO ANY PARTICULAR FONT, STYLE, SIZE, OR COLOR.

THE WORD "TEAFEY" TRANSLATES INTO ENGLISH AS "TEA LEAF".

FOR SPICE BLENDS; TEA (U.S. CL. 46).  
FIRST USE 12-31-2012; IN COMMERCE 12-31-2012.

**CLASS 30—(Continued).**

4,594,655. CHAMBERLAIN, HOLLIE, CARLSBAD, CA. SN 86-081,965. FILED P.R. 10-3-2013; AM. S.R. 6-24-2014.

# CARLSBAD COOKIE COMPANY

THE MARK CONSISTS OF STANDARD CHARACTERS WITHOUT CLAIM TO ANY PARTICULAR FONT, STYLE, SIZE, OR COLOR.

NO CLAIM IS MADE TO THE EXCLUSIVE RIGHT TO USE "COOKIE COMPANY", APART FROM THE MARK AS SHOWN.

FOR COOKIES (U.S. CL. 46).  
FIRST USE 3-24-2014; IN COMMERCE 3-24-2014.

4,594,585. POK POK IP, LLC, PORTLAND, OR. SN 85-845,054. FILED P.R. 2-8-2013; AM. S.R. 6-4-2014.

# SOM

THE MARK CONSISTS OF STANDARD CHARACTERS WITHOUT CLAIM TO ANY PARTICULAR FONT, STYLE, SIZE, OR COLOR.

OWNER OF U.S. REG. NO. 4,083,169.

THE ENGLISH TRANSLATION OF "SOM" IN THE MARK IS "SOUR", "TART", OR "ORANGE".

FOR VINEGAR; DRINKING VINEGAR (U.S. CL. 46).  
FIRST USE 12-20-2010; IN COMMERCE 12-20-2010.

4,594,668. HEB GROCERY COMPANY, LP, SAN ANTONIO, TX. SN 86-092,598. FILED P.R. 10-16-2013; AM. S.R. 7-3-2014.

# TAMALES AGUILAR

THE MARK CONSISTS OF STANDARD CHARACTERS WITHOUT CLAIM TO ANY PARTICULAR FONT, STYLE, SIZE, OR COLOR.

OWNER OF U.S. REG. NO. 4,434,137.

NO CLAIM IS MADE TO THE EXCLUSIVE RIGHT TO USE "TAMALES", APART FROM THE MARK AS SHOWN.

FOR TAMALES WRAPPED IN CORN HUSKS, PLANTAIN LEAVES, OR BANANA LEAVES CONTAINING MASA OR MAIZE AND ONE OR MORE OF THE FOLLOWING INGREDIENTS, BEEF, PORK, CHICKEN, SHRIMP, BEANS, CHEESE, CREAM CHEESE, CORN, PEPPERS, ONIONS, CARROTS, POTATOES, RAISINS OR FRUIT (U.S. CL. 46).

FIRST USE 11-20-2013; IN COMMERCE 11-20-2013.

4,594,637. THERRIEN, KRISTY, POMONA, CA. SN 86-060,522. FILED P.R. 9-10-2013; AM. S.R. 7-9-2014.

# Pastry Pop

THE MARK CONSISTS OF STANDARD CHARACTERS WITHOUT CLAIM TO ANY PARTICULAR FONT, STYLE, SIZE, OR COLOR.

FOR CANDY; LOLLIPOP WITH BAKED GOOD INSIDE (U.S. CL. 46).

FIRST USE 5-31-2013; IN COMMERCE 8-19-2013.

4,594,699. HARD SCOOP, INC., MOUNT PLEASANT, SC. SN 86-141,568. FILED P.R. 12-12-2013; AM. S.R. 5-6-2014.

# SKINNY SCOOP

THE MARK CONSISTS OF STANDARD CHARACTERS WITHOUT CLAIM TO ANY PARTICULAR FONT, STYLE, SIZE, OR COLOR.

FOR FROZEN OR CHILLED FOODS, NAMELY, ICE CREAM AND ICE CREAM CAKES INFUSED WITH ALCOHOL SPIRITS (U.S. CL. 46).

FIRST USE 5-1-2014; IN COMMERCE 5-1-2014.

**CLASS 30—(Continued).**

4,594,719. GREAT DEAL INC, BROOKLYN, NY. SN 86-190,142. FILED P.R. 2-11-2014; AM. S.R. 6-13-2014.

**SUPERIOR QUALITY**

THE MARK CONSISTS OF STANDARD CHARACTERS WITHOUT CLAIM TO ANY PARTICULAR FONT, STYLE, SIZE, OR COLOR.

FOR SUGAR SUBSTITUTES (U.S. CL. 46).  
FIRST USE 1-4-2014; IN COMMERCE 1-4-2014.

---

4,594,738. CUPCAKE CRAZY, LLC, DBA CUPCAKE CRAZY, CINCINNATI, OH. SN 86-209,961. FILED P.R. 3-4-2014; AM. S.R. 7-7-2014.

**Flying Pig Cake Pops**

THE MARK CONSISTS OF STANDARD CHARACTERS WITHOUT CLAIM TO ANY PARTICULAR FONT, STYLE, SIZE, OR COLOR.

NO CLAIM IS MADE TO THE EXCLUSIVE RIGHT TO USE "CAKE POPS", APART FROM THE MARK AS SHOWN. FOR BAKERY GOODS AND DESSERT ITEMS, NAMELY, CAKES, COOKIES, PASTRIES, CANDIES, AND FROZEN CONFECTIONS FOR RETAIL AND WHOLESALE DISTRIBUTION AND CONSUMPTION ON OR OFF THE PREMISES (U.S. CL. 46).

FIRST USE 2-22-2014; IN COMMERCE 2-25-2014.

---

4,594,753. 3 PORCH FARM INC., COMER, GA. SN 86-228,369. FILED P.R. 3-21-2014; AM. S.R. 7-16-2014.

**HONEYPOP**

THE MARK CONSISTS OF STANDARD CHARACTERS WITHOUT CLAIM TO ANY PARTICULAR FONT, STYLE, SIZE, OR COLOR.

FOR EDIBLE FRUIT ICES (U.S. CL. 46).  
FIRST USE 4-6-2012; IN COMMERCE 4-6-2012.

**CLASS 30—(Continued).**

4,594,769. SAMBA FLAVOR INCORPORATED, DBA SAMBA FLAVOR, SUWANEE, GA. SN 86-237,970. FILED P.R. 3-31-2014; AM. S.R. 7-3-2014.

**BLACK CHIMICHURRI**

THE MARK CONSISTS OF STANDARD CHARACTERS WITHOUT CLAIM TO ANY PARTICULAR FONT, STYLE, SIZE, OR COLOR.

NO CLAIM IS MADE TO THE EXCLUSIVE RIGHT TO USE "CHIMICHURRI", APART FROM THE MARK AS SHOWN.

FOR CHIMICHURRI SAUCE; DIPPING SAUCES; MARINADES (U.S. CL. 46).

FIRST USE 1-31-2013; IN COMMERCE 3-7-2013.

**CLASS 31—NATURAL AGRICULTURAL PRODUCTS**

---

4,594,695. SHEFFER, THOMAS P. DBA MAPLE VALLEY FARM, MIO, MI. SN 86-135,868. FILED P.R. 12-5-2013; AM. S.R. 7-15-2014.

**Maple Valley Farm**

THE MARK CONSISTS OF STANDARD CHARACTERS WITHOUT CLAIM TO ANY PARTICULAR FONT, STYLE, SIZE, OR COLOR.

NO CLAIM IS MADE TO THE EXCLUSIVE RIGHT TO USE "FARM", APART FROM THE MARK AS SHOWN.

FOR LIVESTOCK, NAMELY, SHEEP, GOATS, RABBITS, POULTRY (U.S. CLS. 1 AND 46).

FIRST USE 8-4-1974; IN COMMERCE 4-27-2012.

---

4,594,710. WADA FARMS MARKETING GROUP, LLC, IDAHO FALLS, ID. SN 86-165,965. FILED P.R. 1-15-2014; AM. S.R. 6-9-2014.

**smalls**

THE MARK CONSISTS OF STANDARD CHARACTERS WITHOUT CLAIM TO ANY PARTICULAR FONT, STYLE, SIZE, OR COLOR.

FOR FRESH POTATOES (U.S. CLS. 1 AND 46).  
FIRST USE 12-20-2013; IN COMMERCE 12-20-2013.



**CLASS 32—LIGHT BEVERAGES**

4,594,587. CHURCH, DANNIE, NORTH WILKESBORO, NC. SN 85-852,496. FILED P.R. 2-18-2013; AM. S.R. 6-3-2014.

**Vineyard's Premium**

THE MARK CONSISTS OF STANDARD CHARACTERS WITHOUT CLAIM TO ANY PARTICULAR FONT, STYLE, SIZE, OR COLOR.

FOR FRUIT JUICE; NON-ALCOHOLIC CIDER (U.S. CLS. 45, 46 AND 48).  
FIRST USE 11-1-2013; IN COMMERCE 11-1-2013.

**CLASS 33—WINES AND SPIRITS**

4,594,628. BOATHOUSE BEVERAGE LLC, WESTPORT, CT. SN 86-043,547. FILED P.R. 8-21-2013; AM. S.R. 6-2-2014.

**SPIKEDSELTZER**

THE MARK CONSISTS OF STANDARD CHARACTERS WITHOUT CLAIM TO ANY PARTICULAR FONT, STYLE, SIZE, OR COLOR.

FOR FLAVORED BREWED ALCOHOLIC BEVERAGES IN THE NATURE OF BEER (U.S. CLS. 47 AND 49).  
FIRST USE 5-14-2013; IN COMMERCE 5-14-2013.

4,594,730. ROBERTS IRVINE VINEYARDS, LLC, ASHLAND, OR. SN 86-201,836. FILED P.R. 2-24-2014; AM. S.R. 7-2-2014.

**IRVINE FAMILY VINEYARDS**

THE MARK CONSISTS OF STANDARD CHARACTERS WITHOUT CLAIM TO ANY PARTICULAR FONT, STYLE, SIZE, OR COLOR.

NO CLAIM IS MADE TO THE EXCLUSIVE RIGHT TO USE "FAMILY VINEYARDS", APART FROM THE MARK AS SHOWN.

FOR ALCOHOLIC BEVERAGES EXCEPT BEERS; WINE (U.S. CLS. 47 AND 49).  
FIRST USE 9-0-2010; IN COMMERCE 9-0-2010.

**SERVICE MARKS****CLASS 35—ADVERTISING AND BUSINESS****CLASS 35—(Continued).**

4,594,574. WMK, INC., AKRON, OH. SN 85-799,627. FILED P.R. 12-11-2012; AM. S.R. 6-16-2014.

**MOBILITY EXPO**

THE MARK CONSISTS OF STANDARD CHARACTERS WITHOUT CLAIM TO ANY PARTICULAR FONT, STYLE, SIZE, OR COLOR.

NO CLAIM IS MADE TO THE EXCLUSIVE RIGHT TO USE "EXPO", APART FROM THE MARK AS SHOWN.

FOR ARRANGING, PROMOTING AND CONDUCTING CONSUMER EXHIBITIONS AND TRADE SHOWS FOR MODIFIED VEHICLES, ADAPTIVE EQUIPMENT, AND DISABILITY-RELATED PRODUCTS AND SERVICES FOR SENIORS AND PERSONS WITH DISABILITIES (U.S. CLS. 100, 101 AND 102).  
FIRST USE 10-14-2010; IN COMMERCE 10-14-2010.

4,594,589. ELECTRONIC IMAGING SERVICES, INC., DBA VESTCOM RETAIL SOLUTIONS, LITTLE ROCK, AR. SN 85-863,401. FILED P.R. 2-28-2013; AM. S.R. 7-2-2014.

**bannerStrips**

THE MARK CONSISTS OF STANDARD CHARACTERS WITHOUT CLAIM TO ANY PARTICULAR FONT, STYLE, SIZE, OR COLOR.

OWNER OF U.S. REG. NO. 4,486,557.

FOR MARKETING SERVICES, NAMELY, ARRANGING AND CONDUCTING MARKETING, PRODUCT PLACEMENT, PRODUCT PRICING, AND MERCHANDISING CAMPAIGNS FOR RETAILERS (U.S. CLS. 100, 101 AND 102).

FIRST USE 1-0-2013; IN COMMERCE 1-0-2013.

4,594,604. THE BOSTON CONSULTING GROUP, INC., BOSTON, MA. SN 85-917,193. FILED P.R. 4-29-2013; AM. S.R. 6-19-2014.

**BRAND ADVOCACY INDEX**

THE MARK CONSISTS OF STANDARD CHARACTERS WITHOUT CLAIM TO ANY PARTICULAR FONT, STYLE, SIZE, OR COLOR.

**CLASS 35—(Continued).**

NO CLAIM IS MADE TO THE EXCLUSIVE RIGHT TO USE "INDEX", APART FROM THE MARK AS SHOWN.

FOR PROVIDING INFORMATION IN THE FIELD OF BUSINESS ANALYTICS AND CONSUMER-DERIVED PRODUCT FEEDBACK (U.S. CLS. 100, 101 AND 102).  
FIRST USE 2-0-2013; IN COMMERCE 2-0-2013.

---

4,594,608. FAMIS, INC., MIAMI, FL. SN 85-942,970. FILED P.R. 5-27-2013; AM. S.R. 7-8-2014.

**POWDER DEPOT**

THE MARK CONSISTS OF STANDARD CHARACTERS WITHOUT CLAIM TO ANY PARTICULAR FONT, STYLE, SIZE, OR COLOR.

NO CLAIM IS MADE TO THE EXCLUSIVE RIGHT TO USE "DEPOT", APART FROM THE MARK AS SHOWN.

FOR COMPUTERIZED ON-LINE RETAIL STORE SERVICES IN THE FIELD OF POWDER COATING, POWDER COATING SUPPLIES AND EQUIPMENT; RETAIL POWDER COATING, POWDER COATING SUPPLIES AND EQUIPMENT STORES (U.S. CLS. 100, 101 AND 102).

FIRST USE 5-7-2013; IN COMMERCE 5-7-2013.

---

4,594,620. COVERWRAP COMMUNICATIONS LLC, VERO BEACH, FL. SN 85-981,785. FILED P.R. 7-9-2012; AM. S.R. 7-9-2014.

**COVERWRAP**

THE MARK CONSISTS OF STANDARD CHARACTERS WITHOUT CLAIM TO ANY PARTICULAR FONT, STYLE, SIZE, OR COLOR.

FOR ADVERTISING AGENCIES; DISSEMINATION OF ADVERTISING MATTER; CONDUCTING MARKETING STUDIES AND RESEARCH, NAMELY, CONSUMER RESEARCH AND MARKET RESEARCH SURVEYS; COMMERCIAL INFORMATION AGENCIES; PUBLICATION OF PUBLICITY TEXTS; SALES PROMOTION FOR SERVICES; UPDATING OF ADVERTISING MATERIAL (U.S. CLS. 100, 101 AND 102).

FIRST USE 1-1-2010; IN COMMERCE 3-1-2011.

**CLASS 35—(Continued).**

4,594,641. GSI US, INC., LAWRENCEVILLE, NJ. SN 86-066,978. FILED P.R. 9-17-2013; AM. S.R. 6-27-2014.

**GLN REGISTRY**

THE MARK CONSISTS OF STANDARD CHARACTERS WITHOUT CLAIM TO ANY PARTICULAR FONT, STYLE, SIZE, OR COLOR.

OWNER OF U.S. REG. NO. 3,080,933.

NO CLAIM IS MADE TO THE EXCLUSIVE RIGHT TO USE "REGISTRY", APART FROM THE MARK AS SHOWN.

FOR MAINTAINING A REGISTRY FEATURING STANDARDIZED IDENTIFICATION INFORMATION USED TO IDENTIFY LEGAL ENTITIES, FUNCTIONAL ENTITIES, PHYSICAL LOCATIONS, AND SUPPLY CHAIN PARTNERS; PROVIDING AN ON-LINE COMPUTER DATABASE FEATURING A REGISTRY OF STANDARDIZED IDENTIFICATION INFORMATION ON LEGAL ENTITIES, FUNCTIONAL ENTITIES, PHYSICAL LOCATIONS AND SUPPLY CHAIN PARTNERS FOR THE PURPOSE OF IMPROVING THE ACCURACY OF SUPPLY CHAIN ACTIVITIES (U.S. CLS. 100, 101 AND 102).

FIRST USE 5-19-2010; IN COMMERCE 5-19-2010.

---

4,594,651. PARTSSOURCE, INC., AURORA, OH. SN 86-073,890. FILED P.R. 9-25-2013; AM. S.R. 7-3-2014.

**EBUSINESS SOLUTIONS**

THE MARK CONSISTS OF STANDARD CHARACTERS WITHOUT CLAIM TO ANY PARTICULAR FONT, STYLE, SIZE, OR COLOR.

NO CLAIM IS MADE TO THE EXCLUSIVE RIGHT TO USE "EBUSINESS", APART FROM THE MARK AS SHOWN.

FOR ORDER FULFILLMENT SERVICES; PROCUREMENT SERVICES, NAMELY, PURCHASING MEDICAL REPLACEMENT PARTS FOR OTHERS (U.S. CLS. 100, 101 AND 102).

FIRST USE 6-15-2010; IN COMMERCE 6-15-2010.

**CLASS 35—(Continued).**

4,594,661. DIAO, INC., ALHAMBRA, CA. SN 86-087,213.  
FILED P.R. 10-9-2013; AM. S.R. 7-6-2014.

# DIAO

THE MARK CONSISTS OF STANDARD CHARACTERS WITHOUT CLAIM TO ANY PARTICULAR FONT, STYLE, SIZE, OR COLOR.

FOR WHOLESALE DISTRIBUTORSHIP OF AUTOMOTIVE PARTS AND ACCESSORIES (U.S. CLS. 100, 101 AND 102).

FIRST USE 1-1-2013; IN COMMERCE 1-1-2013.

---

4,594,662. SUITELIFE PERSONAL CONCIERGE & EVENTS, INC., DBA STOGIES & STILETTOS, ORANGE PARK, FL. SN 86-087,547. FILED P.R. 10-9-2013; AM. S.R. 7-7-2014.

# Stogies & Stilettos

THE MARK CONSISTS OF STANDARD CHARACTERS WITHOUT CLAIM TO ANY PARTICULAR FONT, STYLE, SIZE, OR COLOR.

FOR ARRANGING AND CONDUCTING TRADE SHOW EXHIBITIONS IN THE FIELD OF CIGARS AND SHOES (U.S. CLS. 100, 101 AND 102).

FIRST USE 3-1-2011; IN COMMERCE 3-1-2011.

---

4,594,670. QOUPONS, INC. WINTER SPRINGS, FL. SN 86-096,281. FILED P.R. 10-20-2013; AM. S.R. 6-13-2014.

# qoupons

THE MARK CONSISTS OF STANDARD CHARACTERS WITHOUT CLAIM TO ANY PARTICULAR FONT, STYLE, SIZE, OR COLOR.

**CLASS 35—(Continued).**

NO CLAIM IS MADE TO THE EXCLUSIVE RIGHT TO USE "COUPONS", APART FROM THE MARK AS SHOWN.

FOR PROCESSING MANUFACTURER'S COUPONS; PROMOTING THE GOODS AND SERVICES OF OTHERS BY PROVIDING A WEB SITE FEATURING COUPONS, REBATES, PRICE-COMPARISON INFORMATION, PRODUCT REVIEWS, LINKS TO THE RETAIL WEB SITES OF OTHERS, AND DISCOUNT INFORMATION; PROMOTING THE GOODS OF OTHERS, NAMELY, PROVIDING COUPONS, REBATES AND VOUCHERS FOR THE GOODS OF OTHERS; PROMOTING THE GOODS OF OTHERS, NAMELY, PROVIDING INFORMATION REGARDING DISCOUNTS, COUPONS, REBATES, VOUCHERS AND SPECIAL OFFERS FOR THE GOODS OF OTHERS; PROMOTING THE SALE OF GOODS AND SERVICES OF OTHERS THROUGH ELECTRONIC COUPONING, PROMOTIONS AND DISCOUNTS; PROMOTIONAL SERVICES, NAMELY, DISTRIBUTION OF ADVERTISING FLYERS, COUPONS, CATALOGS AND PROMOTIONAL ITEMS OF OTHERS; PROMOTIONAL SERVICES, NAMELY, PROMOTING THE GOODS OF OTHERS BY MEANS OF PROVIDING ONLINE COUPONS (U.S. CLS. 100, 101 AND 102).

FIRST USE 6-27-2013; IN COMMERCE 6-27-2013.

---

4,594,672. BENNETT, WAYNE, SACRAMENTO, CA. SN 86-097,630. FILED P.R. 10-22-2013; AM. S.R. 6-30-2014.

# School Makeover

THE MARK CONSISTS OF STANDARD CHARACTERS WITHOUT CLAIM TO ANY PARTICULAR FONT, STYLE, SIZE, OR COLOR.

FOR BUSINESS CONSULTATION IN THE FIELD OF EDUCATION LEADERSHIP DEVELOPMENT; EVENT PLANNING AND MANAGEMENT FOR MARKETING, BRANDING, PROMOTING OR ADVERTISING THE GOODS AND SERVICES OF OTHERS; PROMOTING PUBLIC INTEREST IN EDUCATION, RECOGNITION, CAREER ADVANCEMENT, AND LEADERSHIP FOR ELITE MANAGERS AND EXECUTIVES IN CORPORATIONS AND PROFESSIONAL SERVICE FIRMS; SPECIAL EVENT PLANNING FOR BUSINESS PURPOSES; SPECIAL EVENT PLANNING FOR COMMERCIAL, PROMOTIONAL OR ADVERTISING PURPOSES (U.S. CLS. 100, 101 AND 102).

FIRST USE 11-1-2012; IN COMMERCE 11-1-2012.

**CLASS 35—(Continued).**

4,594,677. BENNETT, WAYNE, SACRAMENTO, CA. SN 86-102,816. FILED P.R. 10-28-2013; AM. S.R. 6-30-2014.

## Backpack Builders

THE MARK CONSISTS OF STANDARD CHARACTERS WITHOUT CLAIM TO ANY PARTICULAR FONT, STYLE, SIZE, OR COLOR.

FOR BUSINESS CONSULTATION IN THE FIELD OF EDUCATION LEADERSHIP DEVELOPMENT; EVENT PLANNING AND MANAGEMENT FOR MARKETING, BRANDING, PROMOTING OR ADVERTISING THE GOODS AND SERVICES OF OTHERS; PROMOTING PUBLIC INTEREST IN EDUCATION; RECOGNITION, CAREER ADVANCEMENT, AND LEADERSHIP FOR ELITE MANAGERS AND EXECUTIVES IN CORPORATIONS AND PROFESSIONAL SERVICE FIRMS; SPECIAL EVENT PLANNING FOR BUSINESS PURPOSES; SPECIAL EVENT PLANNING FOR COMMERCIAL, PROMOTIONAL OR ADVERTISING PURPOSES (U.S. CLS. 100, 101 AND 102).

FIRST USE 1-1-2002; IN COMMERCE 1-1-2002.

4,594,682. VILLAGE PEOPLE, L.L.C., DBA VILLAGE REAL ESTATE SERVICES, NASHVILLE, TN. SN 86-108,298. FILED 11-1-2013.

## Go Green Nashville

THE MARK CONSISTS OF STANDARD CHARACTERS WITHOUT CLAIM TO ANY PARTICULAR FONT, STYLE, SIZE, OR COLOR.

FOR CONSULTING SERVICES IN THE FIELDS OF ENERGY CONSUMPTION AND USAGE CONSERVATION TO IMPROVE ENERGY EFFICIENCY BY FACILITATING IMPROVEMENT IN THE ENERGY EFFICIENCY OF EXISTING RESIDENTIAL BUILDINGS AND EXISTING COMMERCIAL BUILDINGS, NAMELY, COORDINATING THE PERFORMANCE OF BUILDING ENERGY AUDITS WHICH PROVIDE ENERGY EFFICIENCY RECOMMENDATIONS; PROMOTING THE GOODS AND SERVICES OF OTHERS BY PROVIDING INFORMATION ABOUT REBATE PROGRAMS AND STATE AND LOCAL UTILITY CAMPAIGNS FOR REDUCING ENERGY USAGE AND IMPROVING ENERGY EFFICIENCY (U.S. CLS. 100, 101 AND 102).

FIRST USE 12-1-2009; IN COMMERCE 12-1-2009.

**CLASS 35—(Continued).**

4,594,696. FEDERAL HOME LOAN MORTGAGE CORPORATION, MCLEAN, VA. SN 86-137,056. FILED P.R. 12-6-2013; AM. S.R. 7-7-2014.

## Multi-Indicator Market Index

THE MARK CONSISTS OF STANDARD CHARACTERS WITHOUT CLAIM TO ANY PARTICULAR FONT, STYLE, SIZE, OR COLOR.

NO CLAIM IS MADE TO THE EXCLUSIVE RIGHT TO USE "MARKET INDEX", APART FROM THE MARK AS SHOWN.

FOR REAL ESTATE RELATED INDEX ASSESSING THE NATIONAL, STATE AND LOCAL MARKET STRENGTH OF HOUSING (U.S. CLS. 100, 101 AND 102). FIRST USE 3-26-2014; IN COMMERCE 3-26-2014.

4,594,701. AMERICAN METAL SUPPLY CO., BLUE ASH, OH. SN 86-146,171. FILED P.R. 12-17-2013; AM. S.R. 6-23-2014.

## 24-7 SUPPLY

THE MARK CONSISTS OF STANDARD CHARACTERS WITHOUT CLAIM TO ANY PARTICULAR FONT, STYLE, SIZE, OR COLOR.

FOR DISTRIBUTORSHIP SERVICES IN THE FIELD OF INDUSTRIAL, INSTITUTIONAL, COMMERCIAL, AND JANITORIAL EQUIPMENT AND SUPPLIES FOR THE MANUFACTURING, METALS AND PLASTICS INDUSTRIES; RETAIL STORE SERVICES IN THE FIELD OF INDUSTRIAL, INSTITUTIONAL, COMMERCIAL, AND JANITORIAL EQUIPMENT AND SUPPLIES FOR THE MANUFACTURING, METALS AND PLASTICS INDUSTRIES, ACCESSIBLE ON-LINE, BY TELEPHONE AND BY MAIL ORDER; WHOLESALE OUTLETS FEATURING INDUSTRIAL, INSTITUTIONAL, COMMERCIAL, AND JANITORIAL EQUIPMENT AND SUPPLIES FOR THE MANUFACTURING, METALS AND PLASTICS INDUSTRIES (U.S. CLS. 100, 101 AND 102).

FIRST USE 11-7-2013; IN COMMERCE 11-7-2013.

**CLASS 35—(Continued).**

4,594,708. PARK, B. CHRISTINE, MIRAMAR, FL. SN 86-160,103. FILED P.R. 1-8-2014; AM. S.R. 6-30-2014.

## Entrepreneurial Business Facilitator

THE MARK CONSISTS OF STANDARD CHARACTERS WITHOUT CLAIM TO ANY PARTICULAR FONT, STYLE, SIZE, OR COLOR.

FOR BUSINESS CONSULTING SERVICES, NAMELY, FORMULATION OF BEST PRACTICES FOR ANY TYPE NEW BUSINESSES STARTED BY AN ENTREPRENEUR (U.S. CLS. 100, 101 AND 102).

FIRST USE 8-1-2013; IN COMMERCE 8-1-2013.

---

4,594,709. PACIFIC RADIO EXCHANGE, INC., BURBANK, CA. SN 86-164,700. FILED P.R. 1-14-2014; AM. S.R. 7-3-2014.

## SERVING THE PROFESSIONALS

THE MARK CONSISTS OF STANDARD CHARACTERS WITHOUT CLAIM TO ANY PARTICULAR FONT, STYLE, SIZE, OR COLOR.

FOR ON-LINE RETAIL STORE SERVICES FEATURING AUDIO AND AUDIO-VISUAL WIRES AND CABLES AND RELATED TOOLS AND EQUIPMENT, SUCH AS CABLE STRIPPERS, TESTING METERS; RETAIL SHOPS FEATURING AUDIO AND AUDIO-VISUAL WIRES AND CABLES AND RELATED TOOLS AND EQUIPMENT, SUCH AS CABLE STRIPPERS, TESTING METERS (U.S. CLS. 100, 101 AND 102).

FIRST USE 1-0-1992; IN COMMERCE 1-0-1992.

---

4,594,722. LOOTOK, LTD., NEW YORK, NY. SN 86-193,192. FILED P.R. 2-13-2014; AM. S.R. 6-11-2014.

## BCM VALUE MAP

THE MARK CONSISTS OF STANDARD CHARACTERS WITHOUT CLAIM TO ANY PARTICULAR FONT, STYLE, SIZE, OR COLOR.

NO CLAIM IS MADE TO THE EXCLUSIVE RIGHT TO USE "BCM", APART FROM THE MARK AS SHOWN.

FOR BUSINESS CONSULTATION IN THE FIELD OF DISASTER RECOVERY AND BUSINESS CONTINUITY MANAGEMENT; DISASTER RECOVERY SERVICES, NAMELY, BUSINESS PLANNING AND BUSINESS CONTINUITY CONSULTING (U.S. CLS. 100, 101 AND 102).

FIRST USE 3-20-2014; IN COMMERCE 3-20-2014.

**CLASS 35—(Continued).**

4,594,731. BUILDER DESIGNS, OLATHE, KS. SN 86-204,543. FILED P.R. 2-26-2014; AM. S.R. 7-3-2014.

## builder cloud

THE MARK CONSISTS OF STANDARD CHARACTERS WITHOUT CLAIM TO ANY PARTICULAR FONT, STYLE, SIZE, OR COLOR.

FOR MARKETING SERVICES; ON-LINE BUSINESS DIRECTORIES FEATURING HOME BUILDER INFORMATION; SEARCH ENGINE OPTIMIZATION; WEB SITE OPTIMIZATION (U.S. CLS. 100, 101 AND 102).

FIRST USE 1-1-2014; IN COMMERCE 1-1-2014.

---

4,594,732. BLACK HILLS VAPORS LLC., RAPID CITY, SD. SN 86-205,981. FILED P.R. 2-27-2014; AM. S.R. 6-20-2014.

## BLACK HILLS VAPORS

THE MARK CONSISTS OF STANDARD CHARACTERS WITHOUT CLAIM TO ANY PARTICULAR FONT, STYLE, SIZE, OR COLOR.

NO CLAIM IS MADE TO THE EXCLUSIVE RIGHT TO USE "VAPORS", APART FROM THE MARK AS SHOWN.

FOR ONLINE RETAIL AND RETAIL STORE SERVICES FEATURING ELECTRONIC CIGARETTES AND ELECTRONIC CIGARETTE ACCESSORIES (U.S. CLS. 100, 101 AND 102).

FIRST USE 11-16-2013; IN COMMERCE 12-10-2013.

---

4,594,735. DAHMS, TIMOTHY, F., KEY WEST, FL. SN 86-208,623. FILED P.R. 3-2-2014; AM. S.R. 3-2-2014.

## The Museum of Iced Tea

THE MARK CONSISTS OF STANDARD CHARACTERS WITHOUT CLAIM TO ANY PARTICULAR FONT, STYLE, SIZE, OR COLOR.

NO CLAIM IS MADE TO THE EXCLUSIVE RIGHT TO USE "MUSEUM", APART FROM THE MARK AS SHOWN.

FOR RETAIL STORE SERVICES FEATURING A WIDE VARIETY OF CONSUMER GOODS OF OTHERS (U.S. CLS. 100, 101 AND 102).

FIRST USE 1-21-2014; IN COMMERCE 2-21-2014.

**CLASS 35—(Continued).**

4,594,747. TRACTOR SUPPLY CO. OF TEXAS, LP, BRENTWOOD, TN. SN 86-220,843. FILED P.R. 3-13-2014; AM. S.R. 7-7-2014.

**PET APPRECIATION WEEK**

THE MARK CONSISTS OF STANDARD CHARACTERS WITHOUT CLAIM TO ANY PARTICULAR FONT, STYLE, SIZE, OR COLOR.

FOR RETAIL STORE SERVICES FEATURING PET-RELATED PRODUCTS, PET SUPPLIES, AND PET ACCESSORIES; PROMOTING PUBLIC AWARENESS OF THE NEED FOR ANIMAL ADOPTION, ANIMAL RESCUE, RESPONSIBLE PET OWNERSHIP, AND THE PROPER CARE, TREATMENT, AND TRAINING OF PETS; PROVIDING CONSUMER INFORMATION IN THE FIELD OF PETS, NAMELY, PET-RELATED PRODUCTS, PET TREATS, PET TOYS, AND PET ADOPTION (U.S. CLS. 100, 101 AND 102).

FIRST USE 5-0-2011; IN COMMERCE 5-0-2011.

4,594,756. APRIGLIANO, TERESA, NEW HYDE PARK, NY. AND AMODEO, JOHN, NEW HYDE PARK, NY. SN 86-229,141. FILED P.R. 3-22-2014; AM. S.R. 7-7-2014.

**The Partner Project**

THE MARK CONSISTS OF STANDARD CHARACTERS WITHOUT CLAIM TO ANY PARTICULAR FONT, STYLE, SIZE, OR COLOR.

FOR PROMOTING PUBLIC AWARENESS OF RELATIONSHIP VIOLENCE, DOMESTIC VIOLENCE, AND INTIMATE PARTNER VIOLENCE (U.S. CLS. 100, 101 AND 102).

FIRST USE 10-2-2013; IN COMMERCE 10-2-2013.

4,594,766. ARIZONA FINE VIOLINS, LLC, CHANDLER, AZ. SN 86-236,580. FILED P.R. 3-31-2014; AM. S.R. 7-10-2014.

**Arizona Fine Violins**

THE MARK CONSISTS OF STANDARD CHARACTERS WITHOUT CLAIM TO ANY PARTICULAR FONT, STYLE, SIZE, OR COLOR.

**CLASS 35—(Continued).**

NO CLAIM IS MADE TO THE EXCLUSIVE RIGHT TO USE "FINE VIOLINS", APART FROM THE MARK AS SHOWN.

FOR RETAIL SHOPS FEATURING VIOLIN FAMILY INSTRUMENTS, NAMELY, VIOLINS, VIOLAS, CELLOS, BASSES AND RELATED ACCESSORIES (U.S. CLS. 100, 101 AND 102).

FIRST USE 3-1-2014; IN COMMERCE 3-1-2014.

4,594,772. ZIGBRO INC., LAKE FOREST, IL. SN 86-239,130. FILED P.R. 4-1-2014; AM. S.R. 7-7-2014.

**Lake Forest Jewelers**

THE MARK CONSISTS OF STANDARD CHARACTERS WITHOUT CLAIM TO ANY PARTICULAR FONT, STYLE, SIZE, OR COLOR.

NO CLAIM IS MADE TO THE EXCLUSIVE RIGHT TO USE "JEWELERS", APART FROM THE MARK AS SHOWN. FOR RETAIL JEWELRY STORES (U.S. CLS. 100, 101 AND 102).

FIRST USE 0-0-1927; IN COMMERCE 0-0-1927.

**CLASS 36—INSURANCE AND FINANCIAL**

4,594,581. HURRICANE SANDY NEW JERSEY RELIEF FUND INC., CHATHAM, NJ. SN 85-835,194. FILED P.R. 1-29-2013; AM. S.R. 11-20-2013.



NO CLAIM IS MADE TO THE EXCLUSIVE RIGHT TO USE "RELIEF FUND", APART FROM THE MARK AS SHOWN.

THE COLOR(S) GREEN, WHITE, RED AND GRAY IS/ARE CLAIMED AS A FEATURE OF THE MARK.

THE MARK CONSISTS OF A GREEN SQUARE, WITH THE WORDS "HURRICANE SANDY" WRITTEN HORIZONTALLY ON THE LEFT SIDE OF THE SQUARE IN GRAY LETTERS, AN OUTLINE OF THE STATE OF NEW JERSEY SHOWN IN WHITE, AND THE WORDS "NEW JERSEY" IN DARK GREEN FONT SHOWN ABOVE THE WORDS "RELIEF FUND" WRITTEN IN RED LETTERS AND OUTLINED IN WHITE.

FOR CHARITABLE SERVICES, NAMELY, PROVIDING FINANCIAL FUNDRAISING ACTIVITIES FOR ORGANIZATIONS THAT SUPPORT INDIVIDUALS IMPACTED BY NATURAL DISASTERS (U.S. CLS. 100, 101 AND 102).

FIRST USE 11-3-2012; IN COMMERCE 11-3-2012.

**CLASS 36—(Continued).**

4,594,601. UTAH TRANSIT AUTHORITY, SALT LAKE CITY, UT. SN 85-899,409. FILED P.R. 4-9-2013; AM. S.R. 6-12-2014.

# FAREPAY

THE MARK CONSISTS OF STANDARD CHARACTERS WITHOUT CLAIM TO ANY PARTICULAR FONT, STYLE, SIZE, OR COLOR.

FOR ISSUING PREPAID DEBIT CARDS FOR MASS TRANSIT SERVICES FOR THE PUBLIC; ON-LINE PREPAID CARD SERVICES FOR MASS TRANSIT SERVICES FOR THE PUBLIC; PREPAID CARD SERVICES, NAMELY, PROCESSING ELECTRONIC PAYMENTS THROUGH PREPAID CARDS, INCLUDING THOSE MADE FOR TRAVEL ON MASS TRANSIT (U.S. CLS. 100, 101 AND 102).

FIRST USE 10-14-2013; IN COMMERCE 10-14-2013.

4,594,616. MCLARENS GLOBAL LIMITED, LONDON WC1R4JS, UNITED KINGDOM. SN 85-968,129. FILED P.R. 6-24-2013; AM. S.R. 7-17-2014.

# Norcross

THE MARK CONSISTS OF STANDARD CHARACTERS WITHOUT CLAIM TO ANY PARTICULAR FONT, STYLE, SIZE, OR COLOR.

FOR CLAIMS ADMINISTRATION FOR THE INSURANCE AND SELF-INSURED MARKETS, FEATURING INSURANCE CLAIMS MANAGEMENT, CLAIMS ADJUSTMENT, FISCAL LOSS ASSESSMENT, AND FINANCIAL PRE-RISK SURVEY SERVICES (U.S. CLS. 100, 101 AND 102).

FIRST USE 8-15-2013; IN COMMERCE 8-15-2013.

4,594,618. POWER CAPITAL PARTNERS LLC, WHITE PLAINS, NY. SN 85-971,151. FILED P.R. 6-26-2013; AM. S.R. 7-7-2014.

# POWER CAPITAL PARTNERS

THE MARK CONSISTS OF STANDARD CHARACTERS WITHOUT CLAIM TO ANY PARTICULAR FONT, STYLE, SIZE, OR COLOR.

**CLASS 36—(Continued).**

NO CLAIM IS MADE TO THE EXCLUSIVE RIGHT TO USE "CAPITAL PARTNERS", APART FROM THE MARK AS SHOWN.

FOR FINANCIAL SERVICES, NAMELY, INVESTMENT ADVICE, INVESTMENT MANAGEMENT, INVESTMENT CONSULTATION AND INVESTMENT OF FUNDS FOR OTHERS, INCLUDING PRIVATE AND PUBLIC EQUITY AND DEBT INVESTMENT SERVICES (U.S. CLS. 100, 101 AND 102).

FIRST USE 10-31-2011; IN COMMERCE 10-31-2011.

4,594,630. A QUICK RELEASE BAIL BONDS, LLC, SANFORD, FL. SN 86-048,659. FILED P.R. 8-27-2013; AM. S.R. 6-10-2014.

# Quick Release Bail Bonds

THE MARK CONSISTS OF STANDARD CHARACTERS WITHOUT CLAIM TO ANY PARTICULAR FONT, STYLE, SIZE, OR COLOR.

NO CLAIM IS MADE TO THE EXCLUSIVE RIGHT TO USE "BAIL BONDS", APART FROM THE MARK AS SHOWN.

FOR BAIL BONDING (U.S. CLS. 100, 101 AND 102).

FIRST USE 6-6-2013; IN COMMERCE 6-6-2013.

4,594,657. SAN JOAQUIN HILLS TRANSPORTATION CORRIDOR AGENCY AND FOOTHILL/EASTERN TRANSPORTATION CORRIDOR AGENCY, IRVINE, CA. SN 86-082,432. FILED P.R. 10-3-2013; AM. S.R. 6-27-2014.

# ONE-TIME-TOLL

THE MARK CONSISTS OF STANDARD CHARACTERS WITHOUT CLAIM TO ANY PARTICULAR FONT, STYLE, SIZE, OR COLOR.

FOR ELECTRONIC TOLL ROAD FEE COLLECTION SERVICES (U.S. CLS. 100, 101 AND 102).

FIRST USE 1-1-2014; IN COMMERCE 1-1-2014.

4,594,694. ALLOY VENTURES, INC., PALO ALTO, CA. SN 86-134,779. FILED P.R. 12-4-2013; AM. S.R. 6-27-2014.

# DDX VENTURES

THE MARK CONSISTS OF STANDARD CHARACTERS WITHOUT CLAIM TO ANY PARTICULAR FONT, STYLE, SIZE, OR COLOR.

**CLASS 36—(Continued).**

NO CLAIM IS MADE TO THE EXCLUSIVE RIGHT TO USE "VENTURES", APART FROM THE MARK AS SHOWN.

FOR VENTURE CAPITAL ADVISORY, FINANCING, FUNDING AND FUND MANAGEMENT SERVICES; INCUBATION SERVICES, NAMELY, PROVIDING FINANCING TO START-UP BUSINESSES (U.S. CLS. 100, 101 AND 102).

FIRST USE 11-25-2013; IN COMMERCE 11-25-2013.

---

4,594,734. LUPUS THERAPEUTICS, INC., WASHINGTON, DC. SN 86-207,668. FILED P.R. 2-28-2014; AM. S.R. 7-1-2014.

**LupusTherapeutics**

THE MARK CONSISTS OF THE TERM "LUPUSTHERAPEUTICS" IN A STYLIZED FONT.

FOR CHARITABLE FUNDRAISING SERVICES; ACCEPTING AND ADMINISTERING MONETARY CHARITABLE CONTRIBUTIONS TO FUND MEDICAL RESEARCH; PROVIDING GRANTS FOR MEDICAL RESEARCH (U.S. CLS. 100, 101 AND 102).

FIRST USE 2-24-2014; IN COMMERCE 2-24-2014.

---

4,594,742. ILLINI CORPORATION, SPRINGFIELD, IL. SN 86-214,785. FILED P.R. 3-7-2014; AM. S.R. 6-30-2014.

**MIDWEST BANKING SERVICES**

THE MARK CONSISTS OF STANDARD CHARACTERS WITHOUT CLAIM TO ANY PARTICULAR FONT, STYLE, SIZE, OR COLOR.

NO CLAIM IS MADE TO THE EXCLUSIVE RIGHT TO USE "BANKING SERVICES", APART FROM THE MARK AS SHOWN.

FOR MORTGAGE LENDING SERVICES; SERVICING OF MORTGAGE LOANS; FINANCIAL SERVICES, NAMELY, MONEY LENDING (U.S. CLS. 100, 101 AND 102).

FIRST USE 2-0-2014; IN COMMERCE 2-0-2014.

---

4,594,744. RTP CAPITAL ADVISORS, DURHAM, NC. SN 86-215,622. FILED 3-9-2014.

**RTP CAPITAL ADVISORS**

THE MARK CONSISTS OF STANDARD CHARACTERS WITHOUT CLAIM TO ANY PARTICULAR FONT, STYLE, SIZE, OR COLOR.

OWNER OF U.S. REG. NO. 4,486,532.

**CLASS 36—(Continued).**

NO CLAIM IS MADE TO THE EXCLUSIVE RIGHT TO USE "CAPITAL ADVISORS", APART FROM THE MARK AS SHOWN.

FOR CAPITAL ADVISORY FOR INVESTMENTS; BROKERAGE FOR REAL ESTATE INVESTMENTS; REAL ESTATE PROPERTY MANAGEMENT; CAPITAL INVESTMENT SERVICES; FINANCIAL ASSET MANAGEMENT; FINANCIAL SERVICES, NAMELY, INVESTMENT ADVICE, INVESTMENT MANAGEMENT, INVESTMENT CONSULTATION AND INVESTMENT OF FUNDS FOR OTHERS, INCLUDING PRIVATE AND PUBLIC EQUITY AND DEBT INVESTMENT SERVICES; FUNDS INVESTMENT; MANAGEMENT OF A CAPITAL INVESTMENT FUND; REAL ESTATE FUNDS INVESTMENT SERVICES; REAL ESTATE INVESTMENT SERVICES (U.S. CLS. 100, 101 AND 102).

FIRST USE 10-22-2012; IN COMMERCE 10-22-2012.

---

4,594,763. GREGORY ENTERPRISES, INC., ADA, OK. SN 86-233,058. FILED P.R. 3-26-2014; AM. S.R. 6-27-2014.

**EZ PAY**

THE MARK CONSISTS OF STANDARD CHARACTERS WITHOUT CLAIM TO ANY PARTICULAR FONT, STYLE, SIZE, OR COLOR.

OWNER OF U.S. REG. NO. 4,179,771.

FOR FACILITATING AND ARRANGING FOR THE FINANCING OF FOUNDATION, LEVELING, SUPPORTING AND REPAIR SERVICES AND SEAWALL, LAKEWALL, AND RETAINING WALL STABILIZATION AND REPAIR SERVICES (U.S. CLS. 100, 101 AND 102).

FIRST USE 6-1-2009; IN COMMERCE 6-1-2009.

---

4,594,764. LONE STAR RENTERS LLC, ALLEN, TX. SN 86-234,717. FILED P.R. 3-27-2014; AM. S.R. 6-30-2014.

**Lone Star Renters**

THE MARK CONSISTS OF STANDARD CHARACTERS WITHOUT CLAIM TO ANY PARTICULAR FONT, STYLE, SIZE, OR COLOR.

FOR REAL ESTATE LISTING SERVICES FOR APARTMENT RENTALS (U.S. CLS. 100, 101 AND 102).

FIRST USE 2-6-2014; IN COMMERCE 2-21-2014.

---

**CLASS 37—CONSTRUCTION AND REPAIR**



**CLASS 37—(Continued).**

4,594,611. ABE FRANCHISING, L.L.C., LONGVIEW, TX. SN 85-960,302. FILED P.R. 6-14-2013; AM. S.R. 6-27-2014.

**AUTOBODY EXPRESS**

THE MARK CONSISTS OF STANDARD CHARACTERS WITHOUT CLAIM TO ANY PARTICULAR FONT, STYLE, SIZE, OR COLOR.

FOR AUTOMOTIVE COLLISION REPAIR SERVICES; AUTOMOTIVE MAINTENANCE AND REPAIR; AUTOMOTIVE REFINISHING (U.S. CLS. 100, 103 AND 106).  
FIRST USE 1-1-2002; IN COMMERCE 1-1-2002.

4,594,675. SOLID STEEL BUILDINGS, INC., PITTSBURGH, PA. SN 86-100,684. FILED P.R. 10-24-2013; AM. S.R. 7-8-2014.

**Solid Steel Buildings**

THE MARK CONSISTS OF STANDARD CHARACTERS WITHOUT CLAIM TO ANY PARTICULAR FONT, STYLE, SIZE, OR COLOR.

NO CLAIM IS MADE TO THE EXCLUSIVE RIGHT TO USE "STEEL BUILDINGS", APART FROM THE MARK AS SHOWN.

FOR BUILDING CONSTRUCTION; BUILDING CONSTRUCTION SERVICES; CONSTRUCTION OF BUILDINGS; STEEL STRUCTURE CONSTRUCTION WORKS (U.S. CLS. 100, 103 AND 106).

FIRST USE 6-1-2012; IN COMMERCE 6-1-2012.

4,594,762. EMERGENCY RESTORATION EXPERTS, LLC, CHARLOTTE, NC. SN 86-232,990. FILED P.R. 3-26-2014; AM. S.R. 7-1-2014.

**EMERGENCY RESTORATION  
XPERTS**

THE MARK CONSISTS OF STANDARD CHARACTERS WITHOUT CLAIM TO ANY PARTICULAR FONT, STYLE, SIZE, OR COLOR.

NO CLAIM IS MADE TO THE EXCLUSIVE RIGHT TO USE "RESTORATION", APART FROM THE MARK AS SHOWN.

FOR RESTORATION SERVICES IN THE FIELD OF WATER, SMOKE AND FIRE DAMAGE (U.S. CLS. 100, 103 AND 106).

FIRST USE 3-26-2014; IN COMMERCE 3-26-2014.

**CLASS 38—COMMUNICATION**

4,594,654. FREEMAN, RICHARD W., REIDSVILLE, NC. SN 86-080,473. FILED P.R. 10-2-2013; AM. S.R. 7-2-2014.

**Carolina Classic Hits**

THE MARK CONSISTS OF STANDARD CHARACTERS WITHOUT CLAIM TO ANY PARTICULAR FONT, STYLE, SIZE, OR COLOR.

FOR RADIO BROADCASTING (U.S. CLS. 100, 101 AND 104).

FIRST USE 9-5-2012; IN COMMERCE 11-14-2012.

4,594,698. VANNOD BRUNO, PARIS, FRANCE. SN 86-140,312. FILED P.R. 12-11-2013; AM. S.R. 7-2-2014.

**The Programmatic Agency**

THE MARK CONSISTS OF STANDARD CHARACTERS WITHOUT CLAIM TO ANY PARTICULAR FONT, STYLE, SIZE, OR COLOR.

OWNER OF FRANCE REG. NO. 123962911, DATED 11-22-2012, EXPIRES 11-22-2022.

FOR BROADCASTING SERVICES, NAMELY, TRANSMISSION OF ADVERTISING PROGRAMS AND MEDIA ADVERTISING COMMUNICATIONS VIA DIGITAL COMMUNICATIONS NETWORKS (U.S. CLS. 100, 101 AND 104).

**CLASS 39—TRANSPORTATION AND STORAGE**

4,594,625. GARY BRIERE, SUNDERLAND, MA. SN 86-034,572. FILED P.R. 8-11-2013; AM. S.R. 1-22-2014.

**Berkshires to Boston  
Bicycle Tour**

THE MARK CONSISTS OF STANDARD CHARACTERS WITHOUT CLAIM TO ANY PARTICULAR FONT, STYLE, SIZE, OR COLOR.

NO CLAIM IS MADE TO THE EXCLUSIVE RIGHT TO USE "BICYCLE TOUR", APART FROM THE MARK AS SHOWN.

FOR CONDUCTING SIGHTSEEING TRAVEL TOURS BY BICYCLE (U.S. CLS. 100 AND 105).

FIRST USE 10-10-2011; IN COMMERCE 1-15-2012.

**CLASS 39—(Continued).**

4,594,687. ADVENTURE BUS AND TOUR, HOLLYWOOD, FL. SN 86-115,053. FILED P.R. 11-11-2013; AM. S.R. 7-7-2014.

**Adventure Bus and Tour**

THE MARK CONSISTS OF STANDARD CHARACTERS WITHOUT CLAIM TO ANY PARTICULAR FONT, STYLE, SIZE, OR COLOR.

NO CLAIM IS MADE TO THE EXCLUSIVE RIGHT TO USE "BUS AND TOUR", APART FROM THE MARK AS SHOWN.

FOR ARRANGING TRAVEL TOURS; ARRANGING TRAVEL TOURS FOR TOURIST; BUS CHARTERING; BUS TRANSPORT; CONDUCTING SIGHTSEEING TRAVEL TOURS BY BUS; CONDUCTING SIGHTSEEING TRAVEL TOURS FOR OTHERS; ORGANISATION OF SIGHTSEEING TRAVEL TOURS; PERSONAL TRAVEL TOUR GUIDE SERVICES; TRANSPORTATION OF PASSENGERS AND/OR GOODS BY BUS; TRAVEL TOUR CONDUCTING; TRAVEL TOUR GUIDE SERVICES; TRAVEL TOUR OPERATING; TRAVEL TOUR OPERATING AND ORGANISING; TRAVEL TOUR ORGANISING (U.S. CLS. 100 AND 105).  
FIRST USE 4-7-2010; IN COMMERCE 4-7-2010.

**CLASS 41—(Continued).**

4,594,562. AEC SCIENCE & TECHNOLOGY, LLC, CHADDS FORD, PA. SN 85-494,724. FILED P.R. 12-14-2011; AM. S.R. 6-20-2012.

**The Federal Design & Construction Outlook Conference**

THE MARK CONSISTS OF STANDARD CHARACTERS WITHOUT CLAIM TO ANY PARTICULAR FONT, STYLE, SIZE, OR COLOR.

FOR ORGANIZATION OF EXHIBITIONS, LECTURE MEETINGS AND CONFERENCES RELEVANT TO THE DESIGN AND CONSTRUCTION OF HOUSING, BUILDINGS, INFRASTRUCTURE AND CITIES (U.S. CLS. 100, 101 AND 107).

FIRST USE 11-16-2011; IN COMMERCE 11-16-2011.

4,594,570. BOEHRINGER INGELHEIM VETMEDICA, INC., ST. JOSEPH, MO. SN 85-782,438. FILED P.R. 11-19-2012; AM. S.R. 7-1-2014.

**ORAL VACCINATION LEARNING PROGRAM**

THE MARK CONSISTS OF STANDARD CHARACTERS WITHOUT CLAIM TO ANY PARTICULAR FONT, STYLE, SIZE, OR COLOR.

NO CLAIM IS MADE TO THE EXCLUSIVE RIGHT TO USE "PROGRAM", APART FROM THE MARK AS SHOWN. FOR EDUCATIONAL SERVICES, NAMELY, PROVIDING TRAINING ON THE USE, HANDLING AND ADMINISTRATION OF ORAL SWINE VACCINES (U.S. CLS. 100, 101 AND 107).

FIRST USE 11-20-2008; IN COMMERCE 11-20-2008.

4,594,693. UNLEASHED, LLC, WAYLAND, MA. SN 86-130,295. FILED P.R. 11-26-2013; AM. S.R. 7-9-2014.

**Taxi Fare Finder**

THE MARK CONSISTS OF STANDARD CHARACTERS WITHOUT CLAIM TO ANY PARTICULAR FONT, STYLE, SIZE, OR COLOR.

NO CLAIM IS MADE TO THE EXCLUSIVE RIGHT TO USE "TAXI", APART FROM THE MARK AS SHOWN.

FOR PROVIDING TRAVEL INFORMATION TO TRAVELERS REGARDING FARES, TIMETABLES AND PUBLIC TRANSPORT (U.S. CLS. 100 AND 105).  
FIRST USE 11-8-2007; IN COMMERCE 11-8-2007.

4,594,592. ERICKSEN, GREGORY S., BOUNTIFUL, UT. SN 85-871,850. FILED P.R. 3-9-2013; AM. S.R. 7-17-2014.

**PARK CITY FILM STUDIOS**

**CLASS 41—EDUCATION AND ENTERTAINMENT**

THE MARK CONSISTS OF STANDARD CHARACTERS WITHOUT CLAIM TO ANY PARTICULAR FONT, STYLE, SIZE, OR COLOR.

**CLASS 41—(Continued).**

NO CLAIM IS MADE TO THE EXCLUSIVE RIGHT TO USE "FILM STUDIOS", APART FROM THE MARK AS SHOWN. FOR PROVIDING COURSES OF INSTRUCTION AT THE HIGH SCHOOL, COLLEGE, POST GRADUATE LEVEL; PROVIDING FOR THE PRODUCTION OF FILMS, MOVIES, TELEVISION, AND SOUND AND MUSICAL RECORDINGS (U.S. CLS. 100, 101 AND 107). FIRST USE 7-8-2014; IN COMMERCE 7-8-2014.

**CLASS 41—(Continued).**

4,594,634. RAZAK, BOBBY, LOS ANGELES, CA. SN 86-055,693. FILED P.R. 9-4-2013; AM. S.R. 6-24-2014.

**HISTORY OF MMA**

THE MARK CONSISTS OF STANDARD CHARACTERS WITHOUT CLAIM TO ANY PARTICULAR FONT, STYLE, SIZE, OR COLOR.

FOR ENTERTAINMENT IN THE NATURE OF AN ONGOING SPECIAL VARIETY, NEWS, MUSIC OR COMEDY SHOW FEATURING MIXED MARTIAL ARTS BROADCAST OVER TELEVISION, SATELLITE, AUDIO, AND VIDEO MEDIA; ENTERTAINMENT SERVICES, NAMELY, AN ONGOING SERIES FEATURING MIXED MARTIAL ARTS PROVIDED THROUGH THE INTERNET AND TELEVISION; ENTERTAINMENT SERVICES, NAMELY, DISPLAYING A SERIES OF FILMS; ENTERTAINMENT SERVICES, NAMELY, PROVIDING A WEB SITE FEATURING NON-DOWNLOADABLE MUSICAL PERFORMANCES, MUSICAL VIDEOS, RELATED FILM CLIPS, PHOTOGRAPHS, AND OTHER MULTIMEDIA MATERIALS FEATURING MIXED MARTIAL ARTS; ENTERTAINMENT SERVICES, NAMELY, THE PROVISION OF CONTINUING MIXED MARTIAL ARTS FEATURING THE INTERNET AND TELEVISION DELIVERED BY WEB AND TELEVISION; ENTERTAINMENT, NAMELY, A CONTINUING MIXED MARTIAL ARTS THEMED SHOW BROADCAST OVER TELEVISION, SATELLITE, AUDIO, AND VIDEO MEDIA; PROVIDING A WEB SITE FEATURING INFORMATION ON HISTORIC FIGURES; PROVIDING AN INTERNET WEBSITE PORTAL FEATURING ENTERTAINMENT NEWS AND INFORMATION SPECIFICALLY IN THE FIELD OF MIXED MARTIAL ARTS (U.S. CLS. 100, 101 AND 107).

FIRST USE 1-13-2012; IN COMMERCE 1-13-2012.

4,594,598. HEMINGWAY, DEE, TRINIDAD, CA. AND JAGGERS, DAN II, TRINIDAD, CA. SN 85-884,573. FILED P.R. 3-23-2013; AM. S.R. 6-30-2014.

**Vintage Rock 'n Soul**

THE MARK CONSISTS OF STANDARD CHARACTERS WITHOUT CLAIM TO ANY PARTICULAR FONT, STYLE, SIZE, OR COLOR.

NO CLAIM IS MADE TO THE EXCLUSIVE RIGHT TO USE "ROCK" AND "SOUL", APART FROM THE MARK AS SHOWN.

FOR ENTERTAINMENT SERVICES IN THE NATURE OF LIVE MUSICAL PERFORMANCES; ENTERTAINMENT, NAMELY, LIVE MUSIC CONCERTS; ENTERTAINMENT, NAMELY, LIVE PERFORMANCES BY A MUSICAL BAND; ENTERTAINMENT, NAMELY, LIVE PERFORMANCES BY MUSICAL BANDS; ENTERTAINMENT, NAMELY, LIVE PERFORMANCES BY ROCK GROUPS; LIVE PERFORMANCES BY A MUSICAL GROUP; LIVE PERFORMANCES FEATURING PRERECORDED VOCAL AND INSTRUMENTAL PERFORMANCES VIEWED ON A BIG SCREEN; MUSIC COMPOSITION FOR OTHERS; PRESENTATION OF LIVE SHOW PERFORMANCES; PROVIDING A WEBSITE FEATURING INFORMATION IN THE FIELD OF MUSIC AND ENTERTAINMENT; PROVIDING A WEBSITE FOR ENTERTAINMENT PURPOSES FEATURING LOCAL EVENTS ABOUT MUSIC (U.S. CLS. 100, 101 AND 107).

FIRST USE 8-1-2012; IN COMMERCE 2-1-2013.

4,594,635. UPRIGHT, NAFISSA SHIREEN, MAPLE RIDGE, CANADA. SN 86-056,925. FILED P.R. 9-5-2013; AM. S.R. 6-18-2014.

**The WorkStyle**

THE MARK CONSISTS OF STANDARD CHARACTERS WITHOUT CLAIM TO ANY PARTICULAR FONT, STYLE, SIZE, OR COLOR.

FOR PROFESSIONAL COACHING SERVICES IN THE FIELD OF LEADERSHIP, ADVANCEMENT AND MONEY MINDSET (U.S. CLS. 100, 101 AND 107).

FIRST USE 1-1-2013; IN COMMERCE 1-1-2013.

**CLASS 41—(Continued).**

4,594,638. PALEO FOUNDATION, INC., MARINA DEL REY, CA. SN 86-062,966. FILED P.R. 9-12-2013; AM. S.R. 6-30-2014.

**PALEO MOVEMENT**

THE MARK CONSISTS OF STANDARD CHARACTERS WITHOUT CLAIM TO ANY PARTICULAR FONT, STYLE, SIZE, OR COLOR.

FOR EDUCATIONAL SERVICES, NAMELY, PRESENTING CONTINUING EDUCATIONAL SEMINARS AND WORKSHOPS IN THE FIELDS OF HEALTH, DIET, AND FITNESS; EDUCATIONAL SERVICES, NAMELY, CONDUCTING ON-LINE EXHIBITIONS, CONFERENCES, SYMPOSIUMS, PRESENTATIONS, VENDOR FORUMS, TECHNICAL DEMONSTRATIONS, DISPLAYS, INTERACTIVE EXHIBITS, PROGRAMS, EDUCATIONAL DEMONSTRATIONS, WORKSHOPS, SEMINARS, COMPUTER EDUCATION AND TRAINING, ALL IN THE FIELDS OF HEALTH, DIET, AND FITNESS; PROVIDING ON-LINE PUBLICATIONS, NAMELY, NON-DOWNLOADABLE MAGAZINES IN THE FIELDS OF HEALTH, DIET, AND FITNESS (U.S. CLS. 100, 101 AND 107).

FIRST USE 7-31-2013; IN COMMERCE 7-31-2013.

4,594,644. VIGGIANO, CHRISTOPHER M., LONG VALLEY, NJ. AND LUNDQUIST, STEVE, LONG VALLEY, NJ. SN 86-069,798. FILED P.R. 9-19-2013; AM. S.R. 6-19-2014.

**Isshin Shorinji Ryu  
Okinawa Te**

THE MARK CONSISTS OF STANDARD CHARACTERS WITHOUT CLAIM TO ANY PARTICULAR FONT, STYLE, SIZE, OR COLOR.

THE ENGLISH TRANSLATION OF "ISSHIN SHORINJI RYU OKINAWA TE" IN THE MARK IS "ONE HEART / MIND OF THE LITTLE PINE FOREST TEMPLE SCHOOL OF THE OKINAWAN HAND".

FOR MARTIAL ARTS INSTRUCTION; OPERATING OF MARTIAL ARTS' SCHOOLS (U.S. CLS. 100, 101 AND 107).

FIRST USE 1-21-1968; IN COMMERCE 1-21-1968.

**CLASS 41—(Continued).**

4,594,647. LIFE HOLISTIC CENTER LLC, MOUNTAIN TOP, PA. SN 86-070,635. FILED P.R. 9-20-2013; AM. S.R. 7-7-2014.

**Seven Sacred Flames Reiki**

THE MARK CONSISTS OF STANDARD CHARACTERS WITHOUT CLAIM TO ANY PARTICULAR FONT, STYLE, SIZE, OR COLOR.

NO CLAIM IS MADE TO THE EXCLUSIVE RIGHT TO USE "REIKI", APART FROM THE MARK AS SHOWN.

FOR EDUCATIONAL SERVICES, NAMELY, CONDUCTING CLASSES, SEMINARS, CONFERENCES, WORKSHOPS, RETREATS, CAMPS AND FIELD TRIPS IN THE FIELD OF SPIRITUAL, MENTAL, EMOTIONAL, PHYSICAL ENLIGHTMENT AND DISTRIBUTION OF TRAINING MATERIAL IN CONNECTION THEREWITH (U.S. CLS. 100, 101 AND 107).

FIRST USE 1-17-2014; IN COMMERCE 3-22-2014.

4,594,648. NEGOTIATION EXPERTISE, LLC, PEORIA, AZ. SN 86-071,382. FILED P.R. 9-22-2013; AM. S.R. 6-8-2014.

**MASTER CERTIFIED  
NEGOTIATION EXPERT**

THE MARK CONSISTS OF STANDARD CHARACTERS WITHOUT CLAIM TO ANY PARTICULAR FONT, STYLE, SIZE, OR COLOR.

OWNER OF U.S. REG. NO. 3,546,054.

FOR EDUCATIONAL SERVICES, NAMELY, CONDUCTING CLASSES AND WORKSHOPS IN THE FIELD OF REAL ESTATE AND NEGOTIATION AND DISTRIBUTION OF COURSE AND EDUCATIONAL MATERIALS IN CONNECTION THEREWITH ; EDUCATIONAL SERVICES, NAMELY, PROVIDING TRAINING OF REAL ESTATE AGENTS FOR CERTIFICATION IN THE FIELD OF NEGOTIATION SKILLS (U.S. CLS. 100, 101 AND 107).

FIRST USE 1-13-2010; IN COMMERCE 1-13-2010.

4,594,656. DSH INVESTMENTS LLC, HOOVER, AL. SN 86-082,310. FILED P.R. 10-3-2013; AM. S.R. 7-1-2014.

**Money Coach**

THE MARK CONSISTS OF STANDARD CHARACTERS WITHOUT CLAIM TO ANY PARTICULAR FONT, STYLE, SIZE, OR COLOR.

**CLASS 41—(Continued).**

NO CLAIM IS MADE TO THE EXCLUSIVE RIGHT TO USE "COACH", APART FROM THE MARK AS SHOWN.

FOR PROFESSIONAL COACHING SERVICES IN THE FIELD OF PERSONAL AND BUSINESS FINANCE (U.S. CLS. 100, 101 AND 107).

FIRST USE 1-1-2000; IN COMMERCE 1-1-2000.

---

4,594,658. JOSEPH BRENNIA, LONGMONT, CO. SN 86-085,115. FILED P.R. 10-8-2013; AM. S.R. 6-30-2014.

**BRENNIA METHOD**

THE MARK CONSISTS OF STANDARD CHARACTERS WITHOUT CLAIM TO ANY PARTICULAR FONT, STYLE, SIZE, OR COLOR.

NO CLAIM IS MADE TO THE EXCLUSIVE RIGHT TO USE "METHOD", APART FROM THE MARK AS SHOWN.

FOR EDUCATIONAL SERVICES, NAMELY, MUSIC LESSONS AND MUSIC INSTRUCTION; PROVIDING AND DISTRIBUTING INSTRUCTION MATERIALS IN CONNECTION WITH MUSIC INSTRUCTION (U.S. CLS. 100, 101 AND 107).

FIRST USE 12-15-2013; IN COMMERCE 12-15-2013.

---

4,594,659. JOSEPH BRENNIA, LONGMONT, CO. SN 86-085,116. FILED P.R. 10-8-2013; AM. S.R. 6-30-2014.

**FRETBOARDING**

THE MARK CONSISTS OF STANDARD CHARACTERS WITHOUT CLAIM TO ANY PARTICULAR FONT, STYLE, SIZE, OR COLOR.

FOR EDUCATIONAL SERVICES, NAMELY, PROVIDING ONLINE INSTRUCTION IN THE FIELD OF MUSIC VIA AN ONLINE WEBSITE; PROVIDING A WEBSITE FEATURING INFORMATION IN THE FIELD OF MUSIC (U.S. CLS. 100, 101 AND 107).

FIRST USE 4-1-2013; IN COMMERCE 4-1-2013.

---

4,594,666. WARD, TODD. HUNTINGTON, IN. SN 86-091,524. FILED P.R. 10-15-2013; AM. S.R. 7-3-2014.

**The Fort Wayne Jazz  
Orchestra**

THE MARK CONSISTS OF STANDARD CHARACTERS WITHOUT CLAIM TO ANY PARTICULAR FONT, STYLE, SIZE, OR COLOR.

**CLASS 41—(Continued).**

NO CLAIM IS MADE TO THE EXCLUSIVE RIGHT TO USE "JAZZ ORCHESTRA", APART FROM THE MARK AS SHOWN.

FOR ENTERTAINMENT, NAMELY, LIVE PERFORMANCES BY MUSICAL BANDS (U.S. CLS. 100, 101 AND 107).

FIRST USE 1-1-2013; IN COMMERCE 1-1-2013.

---

4,594,712. YOGA JOURNEYS PRODUCTIONS, INC, DBA YOGA JOURNEYS, SCRANTON, PA. SN 86-169,636. FILED P.R. 1-19-2014; AM. S.R. 7-21-2014.

**Good News Crews**

THE MARK CONSISTS OF STANDARD CHARACTERS WITHOUT CLAIM TO ANY PARTICULAR FONT, STYLE, SIZE, OR COLOR.

NO CLAIM IS MADE TO THE EXCLUSIVE RIGHT TO USE "NEWS", APART FROM THE MARK AS SHOWN.

FOR PRODUCTION OF DVDS, VIDEOTAPES AND TELEVISION PROGRAMS FEATURING THE REPORTING OF POSITIVE NEWS STORIES BY CHILDREN, COMMUNITY AND FAMILIES; PRODUCTION OF DVDS, VIDEOTAPES AND TELEVISION PROGRAMS FEATURING KID'S REPORTING ON HEALTHY LIFESTYLE CHOICES AND POSITIVE NEWS STORIES; PRODUCTION OF DVDS, VIDEOTAPES AND TELEVISION PROGRAMS FEATURING NEWS REPORTING OF MIND, BODY AND SPIRITUAL HEALTH AND WELLNESS; PRODUCTION AND DISTRIBUTION OF VIDEOS REPORTING NEWS IN THE FIELDS OF NUTRITION, HEALTHY LIFESTYLE CHOICES AND MIND, BODY AND SPIRITUAL HEALTH AND WELLNESS; CREATING AND DEVELOPING CONCEPTS FOR TELEVISION AND WEB PROGRAMS; PRODUCTION OF TELEVISION AND WEB PROGRAMS; EDUCATIONAL AND ENTERTAINMENT SERVICES, NAMELY, A CONTINUING PROGRAM ABOUT REPORTING POSITIVE/GOOD NEWS STORIES, HEALTHY LIFESTYLE NEWS REPORTING AND MIND, BODY AND SPIRITUAL HEALTH AND WELLNESS ACCESSIBLE BY RADIO, TELEVISION, SATELLITE, AUDIO, VIDEO AND COMPUTER NETWORKS; ENTERTAINMENT IN THE NATURE OF ONGOING TELEVISION PROGRAMS IN THE FIELDS OF NEWS REPORTING, HEALTHY LIFESTYLE CHOICES AND MIND, BODY AND SPIRITUAL HEALTH AND WELLNESS ACCESSIBLE BY RADIO, TELEVISION, SATELLITE, AUDIO, VIDEO AND COMPUTER NETWORKS; PROVIDING A WEBSITE FEATURING INFORMATION AND RESOURCES, NAMELY, NON-DOWNLOADABLE PUBLICATIONS IN THE NATURE OF AUDIO FILES, VIDEO FILES, PHOTOGRAPHS AND OTHER CONTENT IN THE NATURE OF POSITIVE, INSPIRING NEWS STORIES ALL REPORTING POSITIVE NEWS STORIES BY CHILDREN IN THE FIELDS OF HEALTHY LIFESTYLE INSTRUCTION, HEALTHY LIFESTYLE CHOICES AND MIND, BODY AND SPIRITUAL HEALTH AND WELLNESS; PROVIDING PRIVATE, PUBLIC AND MULTIMEDIA EDUCATIONAL SERVICES IN THE FIELDS OF HEALTHY LIFESTYLE CHOICES AND MIND, BODY AND SPIRITUAL HEALTH AND WELLNESS VIA CLASSES, WORKSHOPS AND SEMINARS AND PROVIDING VIDEO, AUDIO AND LITERATURE RESOURCES IN CONNECTION THEREWITH; NEWS REPORTING BY CHILDREN, COMMUNITY AND FAMILIES IN THE FIELD OF SUSTAINABILITY AND OTHER HEALTHY LIFESTYLE CHOICES (U.S. CLS. 100, 101 AND 107).

FIRST USE 3-29-2013; IN COMMERCE 1-19-2014.

**CLASS 41—(Continued).**

4,594,715. HOWABOUTWE, LLC, DALLAS, TX. SN 86-183,434. FILED P.R. 2-4-2014; AM. S.R. 6-6-2014.

**THE DATE REPORT**

THE MARK CONSISTS OF STANDARD CHARACTERS WITHOUT CLAIM TO ANY PARTICULAR FONT, STYLE, SIZE, OR COLOR.

NO CLAIM IS MADE TO THE EXCLUSIVE RIGHT TO USE "REPORT", APART FROM THE MARK AS SHOWN.

FOR PROVIDING INFORMATION, NEWS AND COMMENTARY IN THE FIELD OF CURRENT EVENTS RELATING TO DATING AND SINGLEHOOD (U.S. CLS. 100, 101 AND 107).

FIRST USE 4-5-2010; IN COMMERCE 4-5-2010.

4,594,716. HOWABOUTWE, LLC, DALLAS, TX. SN 86-183,466. FILED P.R. 2-4-2014; AM. S.R. 6-6-2014.

the **DATEREPORT**

NO CLAIM IS MADE TO THE EXCLUSIVE RIGHT TO USE "REPORT", APART FROM THE MARK AS SHOWN.

THE MARK CONSISTS OF THE WORDS "THE DATE REPORT" IN STYLIZED FONT.

FOR PROVIDING INFORMATION, NEWS AND COMMENTARY IN THE FIELD OF CURRENT EVENTS RELATING TO DATING AND SINGLEHOOD (U.S. CLS. 100, 101 AND 107).

FIRST USE 4-5-2010; IN COMMERCE 4-5-2010.

**CLASS 41—(Continued).**

4,594,724. NASE WORLDWIDE, INC., FLAGLER BEACH, FL. SN 86-195,176. FILED P.R. 2-17-2014; AM. S.R. 6-9-2014.

**VirtualCCard**

THE MARK CONSISTS OF STANDARD CHARACTERS WITHOUT CLAIM TO ANY PARTICULAR FONT, STYLE, SIZE, OR COLOR.

FOR EDUCATIONAL SERVICES, NAMELY, PROVIDING DIGITAL GRADUATION CERTIFICATES FOLLOWING SUCCESSFUL COMPLETION OF TRAINING IN THE FIELD OF SCUBA DIVING (U.S. CLS. 100, 101 AND 107).

FIRST USE 7-1-2013; IN COMMERCE 7-1-2013.

4,594,739. RENTON MEDIA LLC, DENVER, CO. SN 86-211,429. FILED P.R. 3-5-2014; AM. S.R. 6-10-2014.

**LEND ACADEMY**

THE MARK CONSISTS OF STANDARD CHARACTERS WITHOUT CLAIM TO ANY PARTICULAR FONT, STYLE, SIZE, OR COLOR.

OWNER OF U.S. REG. NO. 4,310,781.

NO CLAIM IS MADE TO THE EXCLUSIVE RIGHT TO USE "ACADEMY", APART FROM THE MARK AS SHOWN.

FOR EDUCATION SERVICES, NAMELY, PROVIDING A WEBSITE IN THE NATURE OF PROVIDING ONLINE INSTRUCTION IN THE FIELD OF ONLINE LENDING, PEER-TO-PEER LENDING, INVESTMENT ADVISORY SERVICES, AND INVESTMENT FUND MANAGEMENT; PODCASTS, NAMELY, PROVIDING PODCASTS IN THE FIELD OF ONLINE LENDING, PEER-TO-PEER LENDING, INVESTMENT ADVISORY SERVICES, AND INVESTMENT FUND MANAGEMENT; ONLINE VIDEO COURSES, AND THE PRESENTATION OF DISCUSSION FORUMS IN THE NATURE OF ONLINE LENDING, PEER-TO-PEER LENDING, INVESTMENT ADVISORY SERVICES, AND INVESTMENT FUND MANAGEMENT, ALL OF THE AFOREMENTIONED BEING IN THE FIELDS OF ONLINE LENDING, PEER-TO-PEER LENDING, INVESTMENT ADVISORY SERVICES, AND INVESTMENT FUND MANAGEMENT (U.S. CLS. 100, 101 AND 107).

FIRST USE 3-3-2014; IN COMMERCE 3-3-2014.

**CLASS 41—(Continued).**

4,594,741. JEFF SCOTT, LLC, LAS VEGAS, NV. SN 86-214,720.  
FILED P.R. 3-7-2014; AM. S.R. 7-8-2014.

AMERICA'S ENTERTAINMENT  
COMPANY

THE MARK CONSISTS OF STANDARD CHARACTERS WITHOUT CLAIM TO ANY PARTICULAR FONT, STYLE, SIZE, OR COLOR.

NO CLAIM IS MADE TO THE EXCLUSIVE RIGHT TO USE "ENTERTAINMENT COMPANY", APART FROM THE MARK AS SHOWN.

FOR ENTERTAINMENT IN THE NATURE OF LIVE PERFORMANCES BY MUSICIANS, COMEDIANS, AND THEATRE PERFORMANCE; FILM PRODUCTION (U.S. CLS. 100, 101 AND 107).

FIRST USE 9-28-2010; IN COMMERCE 9-28-2010.

4,594,746. GUERRIERO, LLC, DEERFIELD BEACH, FL. SN 86-218,503. FILED P.R. 3-12-2014; AM. S.R. 6-23-2014.

CITY INSTITUTE OF  
TECHNOLOGY

THE MARK CONSISTS OF STANDARD CHARACTERS WITHOUT CLAIM TO ANY PARTICULAR FONT, STYLE, SIZE, OR COLOR.

NO CLAIM IS MADE TO THE EXCLUSIVE RIGHT TO USE "INSTITUTE OF TECHNOLOGY", APART FROM THE MARK AS SHOWN.

FOR EDUCATIONAL SERVICES, NAMELY, PROVIDING ON-LINE COURSES OF INSTRUCTION AT THE COLLEGE AND GRADUATE LEVEL; EDUCATIONAL SERVICES, NAMELY, PROVIDING COURSES OF INSTRUCTION AT THE COLLEGE AND GRADUATE LEVEL (U.S. CLS. 100, 101 AND 107).

FIRST USE 2-0-2014; IN COMMERCE 2-0-2014.

4,594,748. ACES & ANGELS, LLC, LAS VEGAS, NV. SN 86-225,042. FILED P.R. 3-18-2014; AM. S.R. 7-2-2014.

TEXAS STATE POKER  
CHAMPIONSHIPS

THE MARK CONSISTS OF STANDARD CHARACTERS WITHOUT CLAIM TO ANY PARTICULAR FONT, STYLE, SIZE, OR COLOR.

**CLASS 41—(Continued).**

NO CLAIM IS MADE TO THE EXCLUSIVE RIGHT TO USE "POKER CHAMPIONSHIPS", APART FROM THE MARK AS SHOWN.

FOR ORGANIZING, CONDUCTING AND OPERATING POKER TOURNAMENTS (U.S. CLS. 100, 101 AND 107).

FIRST USE 2-23-2014; IN COMMERCE 2-23-2014.

4,594,749. VALDES, EBNER J., DBA QUALITY MUSIC PROFESSIONAL RECORDS, BOSTON, MA. SN 86-225,106. FILED P.R. 3-18-2014; AM. S.R. 7-3-2014.

Quality Music Professional  
Records

THE MARK CONSISTS OF STANDARD CHARACTERS WITHOUT CLAIM TO ANY PARTICULAR FONT, STYLE, SIZE, OR COLOR.

NO CLAIM IS MADE TO THE EXCLUSIVE RIGHT TO USE "RECORDS", APART FROM THE MARK AS SHOWN. FOR MUSIC PRODUCTION SERVICES (U.S. CLS. 100, 101 AND 107).

FIRST USE 1-1-2012; IN COMMERCE 1-1-2012.

4,594,751. WJG LLC, ROCKVILLE, MD. SN 86-226,766. FILED P.R. 3-20-2014; AM. S.R. 7-3-2014.

Prep1on1

THE MARK CONSISTS OF STANDARD CHARACTERS WITHOUT CLAIM TO ANY PARTICULAR FONT, STYLE, SIZE, OR COLOR.

FOR EDUCATION SERVICES, NAMELY, PROVIDING TUTORING IN THE FIELD OF ACADEMIC SUBJECTS AND COLLEGE TEST PREPARATION (U.S. CLS. 100, 101 AND 107).

FIRST USE 5-27-2014; IN COMMERCE 5-27-2014.

4,594,758. GOGGLE WORKS, LLC, READING, PA. SN 86-229,578. FILED P.R. 3-24-2014; AM. S.R. 7-3-2014.

arts festival Reading

THE MARK CONSISTS OF STANDARD CHARACTERS WITHOUT CLAIM TO ANY PARTICULAR FONT, STYLE, SIZE, OR COLOR.

**CLASS 41—(Continued).**

NO CLAIM IS MADE TO THE EXCLUSIVE RIGHT TO USE "ARTS FESTIVAL", APART FROM THE MARK AS SHOWN.  
 FOR ORGANIZING AN ARTS FESTIVAL FOR CULTURAL OR ENTERTAINMENT PURPOSES FEATURING JURIED ARTISTS AND CRAFTSMEN, HOT GLASS DEMONSTRATIONS, PERFORMING ARTS, MUSIC AND FOOD (U.S. CLS. 100, 101 AND 107).  
 FIRST USE 6-1-2011; IN COMMERCE 6-1-2011.

---

4,594,760. DENNIS J. BARELA, DBA TEMECULA'S BEST DJ, TEMECULA, CA. SN 86-231,317. FILED P.R. 3-25-2014; AM. S.R. 6-26-2014.

**Temecula's Best DJ**

THE MARK CONSISTS OF STANDARD CHARACTERS WITHOUT CLAIM TO ANY PARTICULAR FONT, STYLE, SIZE, OR COLOR.  
 NO CLAIM IS MADE TO THE EXCLUSIVE RIGHT TO USE "DJ", APART FROM THE MARK AS SHOWN.  
 FOR DISC JOCKEY SERVICES (U.S. CLS. 100, 101 AND 107).  
 FIRST USE 12-6-2013; IN COMMERCE 12-6-2013.

---

4,594,765. BOULD, LLC, LAKEWOOD, CO. SN 86-236,442. FILED P.R. 3-30-2014; AM. S.R. 7-9-2014.

**Green Building Hack-a-thon**

THE MARK CONSISTS OF STANDARD CHARACTERS WITHOUT CLAIM TO ANY PARTICULAR FONT, STYLE, SIZE, OR COLOR.  
 FOR EDUCATIONAL SERVICES, NAMELY, CONDUCTING BOTH IN-PERSON AND ONLINE CLASSES, SEMINARS, CONFERENCES, AND WORKSHOPS IN THE FIELDS OF GREEN, ENVIRONMENTAL, AND HIGHLY EFFICIENT BUILDING CONSTRUCTION AND DISTRIBUTION OF TRAINING MATERIALS IN CONNECTION THEREWITH (U.S. CLS. 100, 101 AND 107).  
 FIRST USE 4-1-2013; IN COMMERCE 6-1-2013.

**CLASS 42—SCIENTIFIC AND COMPUTER SERVICES****CLASS 42—(Continued).**

4,594,567. PASSPORT HEALTH COMMUNICATIONS, INC., FRANKLIN, TN. SN 85-740,608. FILED P.R. 9-27-2012; AM. S.R. 4-15-2013.

**PATIENTTRACK**

THE MARK CONSISTS OF STANDARD CHARACTERS WITHOUT CLAIM TO ANY PARTICULAR FONT, STYLE, SIZE, OR COLOR.  
 FOR PROVIDING TEMPORARY USE OF A WEB-BASED SOFTWARE APPLICATION FOR MONITORING PATIENT WAIT TIME AND THROUGHPUT IN ORDER TO OPTIMIZE STAFF PRODUCTIVITY AND INCREASE PATIENT SATISFACTION AT HEALTHCARE FACILITIES (U.S. CLS. 100 AND 101).  
 FIRST USE 6-26-2012; IN COMMERCE 6-26-2012.

---

4,594,568. KULA CAUSES, INC., DENVER, CO. SN 85-769,089. FILED P.R. 11-1-2012; AM. S.R. 3-11-2014.

**Cause-Related Loyalty Marketing**

THE MARK CONSISTS OF STANDARD CHARACTERS WITHOUT CLAIM TO ANY PARTICULAR FONT, STYLE, SIZE, OR COLOR.  
 FOR DEVELOPING AND MANAGING AN ONLINE SOFTWARE PLATFORM FOR USE BY BUSINESSES TO INCREASE BRAND LOYALTY THROUGH CONSUMER DRIVEN CHARITABLE GIVING VIA A GLOBAL NETWORK (U.S. CLS. 100 AND 101).  
 FIRST USE 11-13-2011; IN COMMERCE 11-13-2011.

---

4,594,607. SITEZOOGLER INC., HUDSON, CANADA. SN 85-931,009. FILED P.R. 5-14-2013; AM. S.R. 6-12-2014.

**ONESHEET**

THE MARK CONSISTS OF STANDARD CHARACTERS WITHOUT CLAIM TO ANY PARTICULAR FONT, STYLE, SIZE, OR COLOR.  
 FOR WEBSITE DESIGN AND DEVELOPMENT FOR OTHERS; WEBSITE DESIGN CONSULTANCY; PROVIDING AN INTERACTIVE WEBSITE FEATURING TECHNOLOGY THAT ALLOWS USERS TO DESIGN AND DEVELOP THEIR WEBSITES; DESIGNING, CREATING, MAINTAINING, AND HOSTING ELECTRONIC COMMERCE AND ADVERTISING WEBSITES FOR OTHERS (U.S. CLS. 100 AND 101).  
 FIRST USE 7-7-2011; IN COMMERCE 7-7-2011.



**CLASS 42—(Continued).**

4,594,613. SHANTZ ENTERPRISES, INC., FLAGSTAFF, AZ. SN 85-966,291. FILED P.R. 6-21-2013; AM. S.R. 7-6-2014.

**FORENSIC DATA SOLUTIONS**

THE MARK CONSISTS OF STANDARD CHARACTERS WITHOUT CLAIM TO ANY PARTICULAR FONT, STYLE, SIZE, OR COLOR.

NO CLAIM IS MADE TO THE EXCLUSIVE RIGHT TO USE "FORENSIC", APART FROM THE MARK AS SHOWN. FOR COMPUTER FORENSIC SERVICES; CONSULTING SERVICES IN THE FIELDS OF FORENSIC SCIENCE (U.S. CLS. 100 AND 101).

FIRST USE 12-0-2010; IN COMMERCE 1-0-2011.

4,594,705. BRUNS, EVELYN, HENDERSON, NV. SN 86-154,941. FILED P.R. 12-31-2013; AM. S.R. 6-27-2014.

**SECRET DINER**

THE MARK CONSISTS OF STANDARD CHARACTERS WITHOUT CLAIM TO ANY PARTICULAR FONT, STYLE, SIZE, OR COLOR.

FOR QUALITY MANAGEMENT SERVICES, NAMELY, PROVIDING QUALITY EVALUATION OF FOOD AND SERVICES AT RESTAURANT FACILITIES BY SENDING AN EVALUATOR TO THE FACILITY UNDER THE GUISE OF A CUSTOMER (U.S. CLS. 100 AND 101).

FIRST USE 11-1-2013; IN COMMERCE 11-1-2013.

4,594,723. F.T.B ONLINE LTD, TEL AVIV, ISRAEL. SN 86-194,808. FILED P.R. 2-15-2014; AM. S.R. 6-12-2014.

**PRO RANK TRACKER**

THE MARK CONSISTS OF STANDARD CHARACTERS WITHOUT CLAIM TO ANY PARTICULAR FONT, STYLE, SIZE, OR COLOR.

NO CLAIM IS MADE TO THE EXCLUSIVE RIGHT TO USE "RANK TRACKER", APART FROM THE MARK AS SHOWN.

FOR COMPUTER AND TECHNOLOGICAL PROFESSIONAL SERVICES, NAMELY, PROVIDING A WEBSITE FEATURING NON-DOWNLOADABLE SOFTWARE TO TRACK AND MANAGE SEARCH ENGINE RANKINGS FOR WEBSITES (U.S. CLS. 100 AND 101).

FIRST USE 1-20-2014; IN COMMERCE 1-20-2014.

**CLASS 42—(Continued).**

4,594,727. MOHAN, RAM B., SANTA CLARA, CA. SN 86-198,332. FILED P.R. 2-19-2014; AM. S.R. 7-9-2014.



THE MARK CONSISTS OF THE STYLIZED WORDING "IKEYPASS".

FOR ON-LINE NON-DOWNLOADABLE SOFTWARE FOR MANAGING USER PASSWORDS (U.S. CLS. 100 AND 101).

FIRST USE 4-1-2014; IN COMMERCE 4-12-2014.

4,594,736. ADVANCED STRATEGIC TECHNOLOGY LLC, SHERBORN, MA. SN 86-209,187. FILED P.R. 3-3-2014; AM. S.R. 7-18-2014.

**Advanced Strategic  
Technology**

THE MARK CONSISTS OF STANDARD CHARACTERS WITHOUT CLAIM TO ANY PARTICULAR FONT, STYLE, SIZE, OR COLOR.

NO CLAIM IS MADE TO THE EXCLUSIVE RIGHT TO USE "TECHNOLOGY", APART FROM THE MARK AS SHOWN.

FOR CONSULTING SERVICES IN THE FIELD OF HIGH PERFORMANCE COMPUTING, ENTERPRISE ARCHITECTURE, AND LOW LATENCY COMPUTING (U.S. CLS. 100 AND 101).

FIRST USE 6-16-1985; IN COMMERCE 1-1-2011.

4,594,745. H2OLAP LLC, KATY, TX. SN 86-215,642. FILED P.R. 3-9-2014; AM. S.R. 6-18-2014.

**Aquifer Risk Index**

THE MARK CONSISTS OF STANDARD CHARACTERS WITHOUT CLAIM TO ANY PARTICULAR FONT, STYLE, SIZE, OR COLOR.

**CLASS 42—(Continued).**

NO CLAIM IS MADE TO THE EXCLUSIVE RIGHT TO USE "RISK INDEX", APART FROM THE MARK AS SHOWN.

FOR APPLICATION SERVICE PROVIDER (ASP) FEATURING SOFTWARE FOR USE IN LEVERAGING ANALYTICS TO IDENTIFY, MANAGE AND MITIGATE AQUIFER RISKS; APPLICATION SERVICE PROVIDER (ASP), NAMELY, HOSTING COMPUTER SOFTWARE APPLICATIONS OF OTHERS; APPLICATION SERVICE PROVIDER FEATURING APPLICATION PROGRAMMING INTERFACE (API) SOFTWARE FOR USING ANALYTICS TO IDENTIFY, MANAGE AND MITIGATE AQUIFER RISKS; APPLICATION SERVICE PROVIDER, NAMELY, HOSTING, MANAGING, DEVELOPING, ANALYZING, AND MAINTAINING APPLICATIONS, SOFTWARE, AND WEB SITES, OF OTHERS IN THE FIELDS OF HEALTHCARE, BENEFITS PROGRAMS, EMPLOYEE PRODUCTIVITY, RISK MANAGEMENT; APPLICATION SERVICE PROVIDER, NAMELY, HOSTING, MANAGING, DEVELOPING, AND MAINTAINING APPLICATIONS, SOFTWARE, AND WEB SITES, IN THE FIELDS OF PERSONAL PRODUCTIVITY, WIRELESS COMMUNICATION, MOBILE INFORMATION ACCESS, AND REMOTE DATA MANAGEMENT FOR WIRELESS DELIVERY OF CONTENT TO HANDHELD COMPUTERS, LAPTOPS AND MOBILE ELECTRONIC DEVICES; APPLICATION SERVICE PROVIDER, NAMELY, HOSTING, MANAGING, DEVELOPING, ANALYZING, AND MAINTAINING APPLICATIONS, SOFTWARE AND WEB SITES OF OTHERS IN THE FIELDS OF WATER DATA SCIENCE; CLOUD COMPUTING FEATURING SOFTWARE FOR USE IN USING ANALYTICS TO IDENTIFY, MANAGE AND MITIGATE AQUIFER RISKS; COMPUTER HARDWARE AND SOFTWARE DESIGN; COMPUTER MONITORING SERVICE WHICH TRACKS APPLICATION SOFTWARE PERFORMANCE, PERFORMS PERIODIC MAINTENANCE AND PROVIDES REPORTS AND ALERTS CONCERNING SUCH PERFORMANCE; COMPUTER NETWORK DESIGN AND COMPUTER SOFTWARE DESIGN FOR THE USE OF ANALYTICS IN IDENTIFYING, MANAGING AND MITIGATING AQUIFER RISKS; COMPUTER PROGRAMMING AND SOFTWARE DESIGN; COMPUTER SERVICES, NAMELY, ACTING AS AN APPLICATION SERVICE PROVIDER IN THE FIELD OF INFORMATION MANAGEMENT TO HOST COMPUTER APPLICATION SOFTWARE FOR THE PURPOSE OF USING ANALYTICS TO IDENTIFY, MANAGE AND MITIGATE AQUIFER RISKS; ACTING AS AN APPLICATION SERVICE PROVIDER IN THE FIELD OF KNOWLEDGE MANAGEMENT TO HOST COMPUTER APPLICATION SOFTWARE FOR THE PURPOSE OF USING ANALYTICS TO IDENTIFY, MANAGE AND MITIGATE AQUIFER RISKS; COMPUTER SERVICES, NAMELY, REMOTE AND ON-SITE MANAGEMENT OF REAL-TIME MONITORING DEVICES OF OTHERS; COMPUTER SERVICES, NAMELY, REMOTE MANAGEMENT OF REAL-TIME MONITORING DEVICES FOR OTHERS; COMPUTER SOFTWARE CONSULTANCY; COMPUTER SOFTWARE CONSULTATION; COMPUTER SOFTWARE CONSULTING; COMPUTER SOFTWARE DESIGN; COMPUTER SOFTWARE DESIGN AND UPDATING; COMPUTER SOFTWARE DESIGN FOR OTHERS; COMPUTER SOFTWARE DEVELOPMENT; COMPUTER SOFTWARE DEVELOPMENT AND COMPUTER PROGRAMMING DEVELOPMENT FOR OTHERS; COMPUTER SOFTWARE DEVELOPMENT IN THE FIELD OF MOBILE APPLICATIONS; COMPUTER SOFTWARE DEVELOPMENT IN THE FIELD OF USING ANALYTICS TO IDENTIFY, MANAGE AND MITIGATE AQUIFER RISKS; COMPUTER SOFTWARE DEVELOPMENT, COMPUTER PROGRAMMING AND MAINTENANCE OF COMPUTER SOFTWARE FOR USING ANALYTICS TO IDENTIFY, MANAGE AND MITIGATE AQUIFER RISKS; CONSULTANCY IN THE FIELD OF SOFTWARE DESIGN; CONSULTING SERVICES FOR OTHERS IN THE FIELD OF DESIGN, PLANNING, AND IMPLEMENTATION PROJECT MANAGEMENT OF USING ANALYTICS TO IDENTIFY, MANAGE AND MITIGATE AQUIFER RISKS; CONSULTING SERVICES IN THE FIELD OF PROVIDING ONLINE, NON-DOWNLOADABLE SOFTWARE AND APPLICATIONS; CONSULTING SERVICES IN THE FIELD OF SOFTWARE AS A SERVICE (SAAS); CONSULTING SERVICES IN THE FIELDS OF SELECTION, IMPLEMENTATION AND USE OF COMPUTER HARDWARE AND SOFTWARE SYSTEMS FOR OTHERS; DATA AUTOMATION AND COLLEC-

**CLASS 42—(Continued).**

TION SERVICE USING PROPRIETARY SOFTWARE TO EVALUATE, ANALYZE AND COLLECT SERVICE DATA; DESIGN AND DEVELOPMENT OF COMPUTER GAME SOFTWARE AND VIRTUAL REALITY SOFTWARE; DESIGN AND DEVELOPMENT OF COMPUTER SOFTWARE FOR USING ANALYTICS TO IDENTIFY, MANAGE AND MITIGATE AQUIFER RISKS; DESIGN AND DEVELOPMENT OF ON-LINE COMPUTER SOFTWARE SYSTEMS; DESIGN AND DEVELOPMENT OF SOFTWARE AND HARDWARE FOR COMPRESSION AND DECOMPRESSION OF MULTIMEDIA CONTENTS; DESIGN AND DEVELOPMENT OF SOFTWARE AND HARDWARE FOR DATA AND MULTIMEDIA CONTENT CONVERSION FROM AND TO DIFFERENT PROTOCOLS; DESIGN AND DEVELOPMENT OF SOFTWARE AND HARDWARE FOR DIGITAL SIGNAL PROCESSING; DESIGN AND DEVELOPMENT OF SOFTWARE AND HARDWARE FOR MULTIMEDIA DATA STORING AND RECALLING; DESIGN AND DEVELOPMENT OF SOFTWARE AND HARDWARE FOR PROCESSING AND DISTRIBUTION OF MULTIMEDIA CONTENTS; DESIGN AND DEVELOPMENT OF SOFTWARE AND HARDWARE FOR PRODUCING, RECORDING AND PROCESSING DIGITAL AND ANALOGUE SIGNALS; DESIGN AND DEVELOPMENT OF SOFTWARE AND HARDWARE FOR SIGNAL AMPLIFICATION AND TRANSMISSION; DESIGN AND DEVELOPMENT OF SOFTWARE AND HARDWARE FOR USING ANALYTICS TO IDENTIFY, MANAGE AND MITIGATE AQUIFER RISKS; DESIGN AND DEVELOPMENT OF ANALYTICAL SOFTWARE TO IDENTIFY AQUIFER RISKS USING METRICS AND KEY PERFORMANCE INDICATORS; DESIGN AND WRITING OF COMPUTER SOFTWARE; DESIGN FOR OTHERS IN THE FIELD OF ANALYTICAL SOFTWARE TO IDENTIFY AQUIFER RISKS USING METRICS AND KEY PERFORMANCE INDICATORS; DESIGN OF COMPUTER MACHINE AND COMPUTER SOFTWARE FOR COMMERCIAL ANALYSIS AND REPORTING; DESIGN OF COMPUTER NETWORKS AND SOFTWARE FOR OTHERS FOR THE IDENTIFICATION, MANAGEMENT AND MITIGATION OF AQUIFER RISKS USING ANALYTICS, METRICS AND KEY PERFORMANCE INDICATORS; DESIGN, DEVELOPMENT AND IMPLEMENTATION OF SOFTWARE; DESIGN, DEVELOPMENT, AND IMPLEMENTATION OF SOFTWARE FOR USING ANALYTICS TO IDENTIFY, MANAGE AND MITIGATE AQUIFER RISKS; DESIGN, DEVELOPMENT, INSTALLATION AND MAINTENANCE OF COMPUTER SOFTWARE; DESIGN, INSTALLATION, UPDATING AND MAINTENANCE OF COMPUTER SOFTWARE; DESIGN, MAINTENANCE, DEVELOPMENT AND UPDATING OF COMPUTER SOFTWARE; DESIGNING AND DEVELOPING COMPUTER GAME SOFTWARE AND VIDEO GAME SOFTWARE FOR USE WITH COMPUTERS, VIDEO GAME PROGRAM SYSTEMS AND COMPUTER NETWORKS; DESIGNING COMPUTER SOFTWARE FOR CONTROLLING SELF-SERVICE TERMINALS; DESIGNING AQUIFER RISK MANAGEMENT SOFTWARE LEVERAGING ANALYTICS, METRICS AND KEY PERFORMANCE INDICATORS; DEVELOPING AND UPDATING COMPUTER SOFTWARE; DEVELOPING COMPUTER SOFTWARE; DEVELOPING CUSTOMIZED SOFTWARE FOR OTHERS; DEVELOPING CUSTOMIZED SOFTWARE IN THE FIELD OF AQUIFER RISK MANAGEMENT AND WATER DATA SCIENCE FOR OTHERS; DEVELOPMENT OF CUSTOMIZED SOFTWARE FOR OTHERS FOR USE IN RISK ASSESSMENT, INFORMATION SECURITY, BUSINESS ANALYSIS, AUDIT AND AUDIT PLANNING, AND SALES MANAGEMENT; DEVELOPMENT OF SOFTWARE FOR SECURE NETWORK OPERATIONS; DEVELOPMENT, UPDATING AND MAINTENANCE OF SOFTWARE AND DATABASE SYSTEMS; INSTALLATION AND MAINTENANCE OF AQUIFER RISK MANAGEMENT SOFTWARE; INSTALLATION AND REPAIR OF COMPUTER SOFTWARE, INCLUDING MOBILE PERFORMANCE OF SUCH SERVICES ON CUSTOMER PREMISES; INSTALLATION OF COMPUTER SOFTWARE; INSTALLATION OF AQUIFER RISK MANAGEMENT SOFTWARE; INTERNET-BASED APPLICATION SERVICE PROVIDER, NAMELY, HOSTING, MANAGING, DEVELOPING, ANALYZING, AND MAINTAINING THE CODE, APPLICATIONS, AND SOFTWARE FOR WEB SITES OF OTHERS; PLATFORM AS A SERVICE (PAAS) FEATURING COMPUTER SOFTWARE PLATFORMS FOR USING ANALYTICS TO

**CLASS 42—(Continued).**

IDENTIFY, MANAGE AND MITIGATE AQUIFER RISKS; PROVIDING A WEB SITE FEATURING TEMPORARY USE OF NON-DOWNLOADABLE SOFTWARE FOR USING ANALYTICS TO IDENTIFY, MANAGE AND MITIGATE AQUIFER RISKS; PROVIDING A WEBSITE FEATURING NON-DOWNLOADABLE SOFTWARE FOR USING ANALYTICS TO IDENTIFY, MANAGE AND MITIGATE AQUIFER RISKS; PROVIDING A WEBSITE FEATURING ON-LINE NON-DOWNLOADABLE SOFTWARE THAT ENABLES USERS TO GENERATE AQUIFER RISK INDICES FROM HYDROLOGIC, HYDROGEOLOGIC, AND CLIMATOLOGICAL DATA; PROVIDING A WEBSITE FEATURING RESOURCES, NAMELY, A WEBSITE FEATURING PRIMARILY NON-DOWNLOADABLE SOFTWARE FOR USING ANALYTICS TO IDENTIFY, MANAGE AND MITIGATE AQUIFER RISKS AND ALSO FEATURING NON-DOWNLOADABLE PUBLICATIONS IN THE NATURE OF METRICS AND KEY PERFORMANCE INDICATORS IN THE FIELD OF WATER DATA SCIENCE; PROVIDING A WEBSITE FEATURING RESOURCES, NAMELY, NON-DOWNLOADABLE SOFTWARE FOR ANALYZING HYDROLOGIC, HYDROGEOLOGIC, GEOLOGIC AND CLIMATOLOGICAL DATA; PROVIDING INFORMATION RELATING TO ON-LINE NON-DOWNLOADABLE SOFTWARE TO FACILITATE ELECTRONIC COMMUNICATION BETWEEN INDIVIDUALS PROVIDED VIA THE INTERNET; PROVIDING ON-LINE NON-DOWNLOADABLE GEOGRAPHIC INFORMATION SYSTEM (GIS) SOFTWARE; PROVIDING ON-LINE NON-DOWNLOADABLE SOFTWARE FOR DATA MINING AND PREDICTIVE ANALYTICS; PROVIDING TEMPORARY USE OF A NON-DOWNLOADABLE WEB APPLICATION FOR USING ANALYTICS TO IDENTIFY, MANAGE AND MITIGATE AQUIFER RISKS; PROVIDING TEMPORARY USE OF A WEB-BASED SOFTWARE APPLICATION FOR USING ANALYTICS TO IDENTIFY, MANAGE AND MITIGATE AQUIFER RISKS; PROVIDING TEMPORARY USE OF NON-DOWNLOADABLE COMPUTER SOFTWARE FOR TRACKING DOCUMENTS OVER COMPUTER NETWORKS, INTRANETS AND THE INTERNET; PROVIDING TEMPORARY USE OF ON-LINE NON-DOWNLOADABLE CLOUD COMPUTING SOFTWARE FOR USING ANALYTICS TO IDENTIFY, MANAGE AND MITIGATE AQUIFER RISKS; PROVIDING TEMPORARY USE OF ON-LINE NON-DOWNLOADABLE SOFTWARE AND APPLICATIONS FOR USING ANALYTICS TO IDENTIFY, MANAGE AND MITIGATE AQUIFER RISKS; PROVIDING TEMPORARY USE OF ON-LINE NON-DOWNLOADABLE SOFTWARE DEVELOPMENT TOOLS FOR USING ANALYTICS TO IDENTIFY, MANAGE AND MITIGATE AQUIFER RISKS; PROVIDING TEMPORARY USE OF ON-LINE NON-DOWNLOADABLE SOFTWARE FOR USING ANALYTICS TO IDENTIFY, MANAGE AND MITIGATE AQUIFER RISKS; PROVIDING TEMPORARY USE OF ONLINE NON-DOWNLOADABLE MIDDLEWARE FOR PROVIDING AN INTERFACE BETWEEN REAL-TIME MONITORING DEVICES AND ANALYTICAL SOFTWARE; RENTAL AND MAINTENANCE OF COMPUTER SOFTWARE; RENTAL OF APPLICATION SOFTWARE; RENTAL OF COMPUTER SOFTWARE; RENTAL OF COMPUTER SOFTWARE AND PROGRAMS; RESEARCH AND DEVELOPMENT OF COMPUTER SOFTWARE; RESEARCH, DEVELOPMENT, DESIGN AND UPGRADING OF COMPUTER SOFTWARE; SERVICES FOR UPDATING COMPUTER SOFTWARE; SOFTWARE AS A SERVICE (SAAS) SERVICES FEATURING SOFTWARE FOR USING ANALYTICS TO IDENTIFY, MANAGE AND MITIGATE AQUIFER RISKS; SOFTWARE AS A SERVICE (SAAS) SERVICES FEATURING SOFTWARE FOR USING ANALYTICS TO IDENTIFY, MANAGE AND MITIGATE AQUIFER RISKS; SOFTWARE AS A SERVICE (SAAS) SERVICES, NAMELY, HOSTING SOFTWARE FOR USE BY OTHERS FOR USE IN DEVELOPING METRICS AND KEY PERFORMANCE INDICATORS FOR AQUIFER RISK MANAGEMENT; SOFTWARE AUTHORING; SOFTWARE DESIGN AND DEVELOPMENT; SOFTWARE DEVELOPMENT AND PRODUCT DEVELOPMENT CONSULTING IN THE FIELD OF HYDROGEOLOGY; SOFTWARE DEVELOPMENT AND PRODUCT DEVELOPMENT IN THE FIELD OF HYDRO-

**CLASS 42—(Continued).**

GEOLOGY; SOFTWARE DEVELOPMENT CONSULTING IN THE FIELD OF HYDROGEOLOGY; SOFTWARE DEVELOPMENT FOR OTHERS IN THE FIELD OF SOFTWARE CONFIGURATION MANAGEMENT; SOFTWARE DEVELOPMENT IN THE FIELD OF WATER DATA SCIENCE; TECHNICAL SUPPORT SERVICES, NAMELY, REMOTE ADMINISTRATION AND MANAGEMENT OF IN-HOUSE AND HOSTED DATACENTER DEVICES, DATABASES AND SOFTWARE APPLICATIONS; TECHNICAL SUPPORT SERVICES, NAMELY, TROUBLESHOOTING OF COMPUTER SOFTWARE PROBLEMS; TECHNOLOGY SPECIFICATION, NAMELY, ANALYZING TECHNOLOGY REQUIREMENTS AND DEVELOPING RECOMMENDATIONS FOR THE COMPUTER SOFTWARE AND SYSTEMS AND OTHER TECHNOLOGY NEEDED TO MEET THOSE REQUIREMENTS, IN THE FIELD OF WATER DATA SCIENCE; UPDATING AND DESIGN OF COMPUTER SOFTWARE; UPDATING OF COMPUTER SOFTWARE; WRITING AND UPDATING COMPUTER SOFTWARE (U.S. CLS. 100 AND 101).

FIRST USE 2-24-2010; IN COMMERCE 2-24-2010.

**CLASS 43—HOTEL AND RESTAURANT SERVICES**

4,594,590. APPLEBEE'S INTERNATIONAL, INC., KANSAS CITY, MO. SN 85-869,523. FILED P.R. 3-7-2013; AM. S.R. 7-1-2014.

**ULTIMATE TRIOS**

THE MARK CONSISTS OF STANDARD CHARACTERS WITHOUT CLAIM TO ANY PARTICULAR FONT, STYLE, SIZE, OR COLOR.

FOR RESTAURANT SERVICES, NAMELY, OFFERING A COMBINATION MEAL MENU WHEREBY CUSTOMERS SELECT ITEMS FROM A LIST OF APPETIZERS (U.S. CLS. 100 AND 101).

FIRST USE 2-1-2012; IN COMMERCE 2-1-2012.

4,594,684. RRI FINANCIAL, INC., COLUMBUS, OH. SN 86-113,795. FILED P.R. 11-8-2013; AM. S.R. 7-2-2014.



OWNER OF U.S. REG. NO. 2,954,176.  
THE COLOR(S) RED, BROWN, AND WHITE IS/ARE CLAIMED AS A FEATURE OF THE MARK.

**CLASS 43—(Continued).**

THE MARK CONSISTS OF A THREE-DIMENSIONAL CONFIGURATION OF A SIDEWALK CANOPY FEATURING A RED RECTANGULAR ROOF WITH A SLIGHT SLOPING ANGLE, ATOP A WHITE BEAMED LATTICE FRAMEWORK, SUPPORTED BY SIX VERTICAL WHITE POSTS. A BROWN FENCE COMPRISED OF SEVEN HORIZONTAL BOARDS AND TOPPED BY A BROWN RAIL RUNS THE LENGTH OF THE THREE VERTICAL POSTS SUPPORTING THE LOWER EDGE OF THE CANOPY ROOF. THE BROWN FENCING AND THE SLOPING RED ROOF ARE CLAIMED AS FEATURES OF THE MARK. THE MATTER SHOWN IN BROKEN OR DOTTED LINES IS NOT PART OF THE MARK AND SERVES ONLY TO SHOW THE POSITION OR PLACEMENT OF THE MARK.

FOR HOTEL SERVICES; MOTEL SERVICES (U.S. CLS. 100 AND 101).

FIRST USE 9-20-2013; IN COMMERCE 9-20-2013.

4,594,685. RRI FINANCIAL, INC., COLUMBUS, OH. SN 86-113,796. FILED P.R. 11-8-2013; AM. S.R. 7-2-2014.



OWNER OF U.S. REG. NO. 2,954,176.

THE COLOR(S) RED, BROWN AND WHITE IS/ARE CLAIMED AS A FEATURE OF THE MARK.

THE MARK CONSISTS OF A THREE-DIMENSIONAL CONFIGURATION OF A SIDEWALK CANOPY FEATURING A RED RECTANGULAR ROOF WITH A SLIGHT SLOPING ANGLE, ATOP A WHITE BEAMED LATTICE FRAMEWORK, SUPPORTED BY SIX VERTICAL WHITE POSTS. A BROWN FENCE COMPRISED OF SEVEN HORIZONTAL BOARDS AND TOPPED BY A BROWN RAIL RUNS THE LENGTH OF THE THREE VERTICAL POSTS SUPPORTING THE LOWER EDGE OF THE CANOPY ROOF. BENEATH IT IS LIGHTING THAT CREATES A RED GLOWING EFFECT. THE RED GLOWING EFFECT LIGHTING, THE BROWN FENCING AND THE SLOPING RED ROOF ARE CLAIMED AS FEATURES OF THE MARK. THE COLOR BLACK IS NOT CLAIMED AS A FEATURE OF THE MARK BUT SERVES ONLY TO REPRESENT BACKGROUND AREA. THE MATTER SHOWN IN BROKEN OR DOTTED LINES IS NOT PART OF THE MARK AND SERVES ONLY TO SHOW THE POSITION OR PLACEMENT OF THE MARK.

FOR HOTEL SERVICES; MOTEL SERVICES (U.S. CLS. 100 AND 101).

FIRST USE 9-20-2013; IN COMMERCE 9-20-2013.

**CLASS 43—(Continued).**

4,594,703. CALIFORNIA GOGI GROUP, LLC, LOS ANGELES, CA. SN 86-149,684. FILED P.R. 12-20-2013; AM. S.R. 6-16-2014.

**CALIFORNIA GOGI**

THE MARK CONSISTS OF STANDARD CHARACTERS WITHOUT CLAIM TO ANY PARTICULAR FONT, STYLE, SIZE, OR COLOR.

THE ENGLISH TRANSLATION OF "GOGI" IN THE MARK IS "MEAT" IN KOREAN LANGUAGE.

FOR RESTAURANT SERVICES, NAMELY, PROVIDING OF FOOD AND BEVERAGES FOR CONSUMPTION ON AND OFF THE PREMISES (U.S. CLS. 100 AND 101).

FIRST USE 2-15-2013; IN COMMERCE 2-15-2013.

**CLASS 44—MEDICAL, BEAUTY AND AGRICULTURAL SERVICES**

4,594,572. THE NOSE AND SINUS INSTITUTE OF BOCA RATON, BOCA RATON, FL. SN 85-789,290. FILED P.R. 11-28-2012; AM. S.R. 6-30-2014.

**NOSE AND SINUS INSTITUTE  
OF BOCA RATON**

THE MARK CONSISTS OF STANDARD CHARACTERS WITHOUT CLAIM TO ANY PARTICULAR FONT, STYLE, SIZE, OR COLOR.

NO CLAIM IS MADE TO THE EXCLUSIVE RIGHT TO USE "NOSE AND SINUS INSTITUTE", APART FROM THE MARK AS SHOWN.

FOR HEALTHCARE (U.S. CLS. 100 AND 101).

FIRST USE 6-30-2014; IN COMMERCE 6-30-2014.

4,594,578. BODY DETOX CENTER, LLC, CALHAN, CO. SN 85-830,177. FILED P.R. 1-23-2013; AM. S.R. 7-11-2014.



NO CLAIM IS MADE TO THE EXCLUSIVE RIGHT TO USE "CENTER", APART FROM THE MARK AS SHOWN.

**CLASS 44—(Continued).**

THE MARK CONSISTS OF THE WORD "BODY" ABOVE THE WORD "DETOX" ABOVE THE WORD "CENTER" ALL IN THE CENTER OF A WHITE OVAL SURROUNDED BY A BLACK BORDER.

FOR HEALTH CARE SERVICES, NAMELY, WELLNESS PROGRAMS (U.S. CLS. 100 AND 101).

FIRST USE 9-15-2006; IN COMMERCE 9-15-2006.

---

4,594,717. PENCHAS, JONATHAN, HOUSTON, TX. SN 86-184,012. FILED P.R. 2-4-2014; AM. S.R. 6-6-2014.

PERMANENT NEW TEETH IN ONE  
DAY

THE MARK CONSISTS OF STANDARD CHARACTERS WITHOUT CLAIM TO ANY PARTICULAR FONT, STYLE, SIZE, OR COLOR.

FOR DENTISTRY; ORAL SURGERY AND DENTAL IMPLANT SERVICES (U.S. CLS. 100 AND 101).

FIRST USE 12-1-2013; IN COMMERCE 12-1-2013.

---

4,594,721. HOLISTIC VETERINARY OPTIONS, LLC, MADISON, WI. SN 86-191,260. FILED P.R. 2-12-2014; AM. S.R. 6-7-2014.

HOLISTIC VETERINARY OPTIONS

THE MARK CONSISTS OF STANDARD CHARACTERS WITHOUT CLAIM TO ANY PARTICULAR FONT, STYLE, SIZE, OR COLOR.

NO CLAIM IS MADE TO THE EXCLUSIVE RIGHT TO USE "VETERINARY", APART FROM THE MARK AS SHOWN.

FOR VETERINARY SERVICES; VETERINARY DENTISTRY; VETERINARY CHIROPRACTIC SERVICES; VETERINARY ACUPUNCTURE; VETERINARY NUTRITIONAL THERAPY SERVICES (U.S. CLS. 100 AND 101).

FIRST USE 0-0-2011; IN COMMERCE 0-0-2011.

---

**CLASS 45—PERSONAL AND LEGAL SERVICES**

**CLASS 45—(Continued).**

4,594,636. THE CHEER SOCIAL, LLC, LUCAS, KY. SN 86-057,412. FILED P.R. 9-6-2013; AM. S.R. 6-25-2014.

## CHEER SOCIAL

THE MARK CONSISTS OF STANDARD CHARACTERS WITHOUT CLAIM TO ANY PARTICULAR FONT, STYLE, SIZE, OR COLOR.

FOR PROVIDING AN INTERACTIVE SOCIAL NETWORKING WEBSITE IN THE FIELD OF CHEERLEADING; PROVIDING ONLINE SOCIAL NETWORKING SERVICES IN THE FIELD OF CHEERLEADING; PROVIDING AN INTERACTIVE SOCIAL NETWORKING WEBSITE THAT ALLOWS USERS TO REVIEW, UPLOAD, DOWNLOAD AND SHARE TEXT, GRAPHIC IMAGES, PHOTOGRAPHIC IMAGES, AUDIO CONTENT, VIDEO CONTENT, DATA AND OTHER INFORMATION IN THE FIELD OF CHEERLEADING; PROVIDING AN INTERACTIVE SOCIAL NETWORKING WEBSITE THAT ALLOWS USERS TO CREATE PERSONAL PROFILES FEATURING INFORMATION IN THE FIELD OF CHEERLEADING; PROVIDING AN INTERACTIVE SOCIAL NETWORKING WEBSITE THAT CONNECTS CHEERLEADING COACHES WITH CHEERLEADERS FOR PURPOSES OF RECRUITMENT FOR CHEERLEADING TEAMS (U.S. CLS. 100 AND 101).

FIRST USE 2-10-2014; IN COMMERCE 2-10-2014.

---

4,594,678. GEODATA DEVELOPMENT GROUP LLC, CORONA, CA. SN 86-106,292. FILED P.R. 10-31-2013; AM. S.R. 7-1-2014.

## BIBLE FIGURES OF SPEECH

THE MARK CONSISTS OF STANDARD CHARACTERS WITHOUT CLAIM TO ANY PARTICULAR FONT, STYLE, SIZE, OR COLOR.

FOR PROVIDING AN ONLINE SEARCHABLE DATABASE FEATURING INFORMATION ABOUT RELIGION, SPECIFICALLY ON FIGURES OF SPEECH AS THEY ARE FOUND IN THE BIBLE WHICH DEFINE ORIGINS, HISTORIC USAGE, AND COMMON FORMS, AND INCLUDING REFERENCES TO SCRIPTURAL LANGUAGES AND PASSAGES (U.S. CLS. 100 AND 101).

FIRST USE 8-13-2013; IN COMMERCE 6-24-2014.

**CLASS 45—(Continued).**

4,594,679. GEODATA DEVELOPMENT GROUP LLC, CORONA, CA. SN 86-106,293. FILED P.R. 10-31-2013; AM. S.R. 7-1-2014.

**CLASS 45—(Continued).**

4,594,725. BAY AREA LAW CENTER, PC, SAN JOSE, CA. SN 86-197,057. FILED P.R. 2-18-2014; AM. S.R. 6-16-2014.

**FIGURE OF SPEECH DICTIONARY**

THE MARK CONSISTS OF STANDARD CHARACTERS WITHOUT CLAIM TO ANY PARTICULAR FONT, STYLE, SIZE, OR COLOR.

FOR PROVIDING AN ONLINE SEARCHABLE DATABASE FEATURING INFORMATION ABOUT RELIGION, SPECIFICALLY ON FIGURES OF SPEECH AS THEY ARE FOUND IN THE BIBLE WHICH DEFINE ORIGINS, HISTORIC USAGE, AND COMMON FORMS, AND INCLUDING REFERENCES TO SCRIPTURAL LANGUAGES AND PASSAGES AND DEFINITIONS WORDS USED IN FIGURATIVE LANGUAGE (U.S. CLS. 100 AND 101).

FIRST USE 8-13-2013; IN COMMERCE 6-24-2014.

**BAY AREA LAW CENTER**

THE MARK CONSISTS OF STANDARD CHARACTERS WITHOUT CLAIM TO ANY PARTICULAR FONT, STYLE, SIZE, OR COLOR.

NO CLAIM IS MADE TO THE EXCLUSIVE RIGHT TO USE "LAW CENTER", APART FROM THE MARK AS SHOWN.

FOR LEGAL SERVICES (U.S. CLS. 100 AND 101).  
FIRST USE 2-25-2014; IN COMMERCE 2-25-2014.

---

4,594,759. MONS INDUSTRIES, CORP., ROAD TOWN, TORTOLA, BR.VIRGIN ISLANDS. SN 86-230,316. FILED 3-24-2014.

**ARABIAN DATE.COM**

THE MARK CONSISTS OF STANDARD CHARACTERS WITHOUT CLAIM TO ANY PARTICULAR FONT, STYLE, SIZE, OR COLOR.

NO CLAIM IS MADE TO THE EXCLUSIVE RIGHT TO USE "DATE.COM", APART FROM THE MARK AS SHOWN.

FOR DATING SERVICES; INTERNET-BASED DATING, SOCIAL INTRODUCTION AND SOCIAL NETWORKING SERVICES (U.S. CLS. 100 AND 101).  
FIRST USE 2-20-2014; IN COMMERCE 2-20-2014.

\* \* \* \* \*

PRIOR UNITED STATES CLASSIFICATION

APPLICATION IN ONE CLASS

CERTIFICATION MARKS

**CLASS B—SERVICES**

4,594,650. VALUE INNORUPTION ADVISORS LLC, SEWICKLEY, PA. SN 86-072,735. FILED P.R. 9-24-2013; AM. S.R. 7-11-2014.

**CVM**

THE MARK CONSISTS OF STANDARD CHARACTERS WITHOUT CLAIM TO ANY PARTICULAR FONT, STYLE, SIZE, OR COLOR.

THE CERTIFICATION MARK, AS USED OR INTENDED TO BE USED BY PERSONS AUTHORIZED BY THE CERTIFIER, CERTIFIES OR IS INTENDED TO CERTIFY THAT THE SERVICES ARE PROVIDED BY AN INDIVIDUAL WHO HAS COMPLETED TRAINING AND HAS TESTED PROFESSIONAL COMPETENCY IN RENDERING BUSINESS CONSULTING SERVICES, NAMELY, PRICING AND VALUE STRATEGY CONSULTING IN THE FIELD OF CUSTOMER VALUE MODELING.

FOR BUSINESS CONSULTING SERVICES, NAMELY, PRICING AND VALUE STRATEGY CONSULTING IN THE FIELD OF CUSTOMER VALUE MODELING (U.S. CL. B).

FIRST USE 8-28-2013; IN COMMERCE 9-13-2013.

\* \* \* \* \*

# TRADEMARK REGISTRATIONS RENEWED

The designation "U.S. Cl." appearing in this section refers to the U.S. class in effect prior to Sep. 1, 1973 rather than the international class which applies to applications filed on or after that date. For adoption of international classification see notice in the OFFICIAL GAZETTE of Jun. 26, 1973 (911 O.G. TM 210).

99,132.	WALTHAM (STYLIZED). U.S. CL. 27. (INT. CL. 14). REG. 8-18-1914.	782,042.	GRUNDFOS. U.S. CL. 23. (INT. CL. 7). REG. 12-22-1964.
104,651.	SARGENT AND DESIGN. U.S. CL. 25. (INT. CL. 6). REG. 6-8-1915.	782,185.	SEALSKIN. U.S. CL. 51. (INT. CL. 3). REG. 12-22-1964.
186,659.	DU PONT AND DESIGN. U.S. CL. 6. (INT. CL. 1). REG. 7-22-1924.	783,815.	KYDEX. INT. CL. 1. (U.S. CL. 1). REG. 1-26-1965.
324,021.	FIVE O'CLOCK AND DESIGN. U.S. CL. 49. (INT. CL. 33). REG. 5-7-1935.	790,295.	PRATT & WHITNEY DEPENDABLE ENGINES AND DESIGN. U.S. CL. 23. (INT. CL. 7). REG. 6-1-1965.
324,022.	FIVE O'CLOCK. U.S. CL. 49. (INT. CL. 33). REG. 5-7-1935.	790,961.	"SLIK CHIK ". U.S. CL. 19. (INT. CL. 12). REG. 6-15-1965.
408,003.	ELKALOY. U.S. CL. 21. (INT. CL. 9). REG. 7-11-1944.	976,232.	O AND DESIGN. U.S. CL. 14. (INT. CL. 6). REG. 1-8-1974.
409,791.	HERCULITE. U.S. CL. 33. (INT. CL. 21). REG. 10-24-1944.	976,308.	EKTELON. U.S. CL. 22. (INT. CL. 28). REG. 1-8-1974.
584,817.	SPRAYIT. U.S. CL. 21. (INT. CL. 7). REG. 1-19-1954.	976,767.	PANAFLEX. U.S. CL. 26. (INT. CL. 9). REG. 1-15-1974.
592,409.	CUSHYFOOT (STYLIZED). U.S. CL. 23. (INT. CL. 7). REG. 7-13-1954.	983,205.	STABILOY. U.S. CL. 21. (INT. CL. 9). REG. 5-7-1974.
592,435.	VULCO-FLEX (STYLIZED). U.S. CL. 35. (INT. CL. 17). REG. 7-13-1954.	986,714.	MISCELLANEOUS DESIGN. U.S. CL. 6. (INT. CL. 1). REG. 6-25-1974.
592,905.	CRYSTIC (STYLIZED). U.S. CL. 6. (INT. CL. 1). REG. 7-27-1954.	987,611.	CHARLES JOURDAN. U.S. CL. 3. (INT. CL. 18). REG. 7-9-1974.
594,056.	A.R.. U.S. CLS. 6 AND 14. (INT. CLS. 1, 6 AND 14). REG. 8-24-1954.	987,843.	ACRODISC. U.S. CL. 31. (INT. CL. 11). REG. 7-9-1974.
594,097.	MICROLITE. U.S. CL. 12. (INT. CL. 17). REG. 8-24-1954.	987,895.	NYVEL. U.S. CL. 37. (INT. CL. 16). REG. 7-9-1974.
594,953.	MISCELLANEOUS DESIGN. U.S. CL. 100. (INT. CL. 42). REG. 9-7-1954.	987,952.	VELLUX/ROYAL. U.S. CL. 42. (INT. CLS. 22, 24, 26 AND 27). REG. 7-9-1974.
605,321.	HYLINE. U.S. CL. 12. (INT. CL. 19). REG. 5-3-1955.	988,350.	TK AND DESIGN. U.S. CL. 23. (INT. CL. 7). REG. 7-16-1974.
608,233.	HIL-TEX (STYLIZED). U.S. CL. 16. (INT. CL. 2). REG. 7-5-1955.	988,356.	BERKEL AND DESIGN. U.S. CL. 23. (INT. CL. 7). REG. 7-16-1974.
608,273.	SKY CLIMBER. U.S. CL. 23. (INT. CL. 7). REG. 7-5-1955.	988,534.	X-PAND'R. U.S. CL. 46. (INT. CL. 30). REG. 7-16-1974.
608,402.	TABASCO. U.S. CL. 46. (INT. CL. 30). REG. 7-5-1955.	988,743.	BOX-MOUNT (STYLIZED). U.S. CL. 13. (INT. CL. 6). REG. 7-23-1974.
762,209.	GW AND DESIGN. U.S. CL. 19. (INT. CL. 12). REG. 12-31-1963.	988,795.	TITE-LITE. U.S. CL. 21. (INT. CL. 9). REG. 7-23-1974.
770,661.	NIGHTSCAPING. U.S. CL. 21. (INT. CL. 11). REG. 6-2-1964.	988,860.	WHIRLTRONICS. U.S. CL. 23. (INT. CL. 7). REG. 7-23-1974.
771,073.	AMSTED (STYLIZED). U.S. CL. 19. (INT. CL. 12). REG. 6-9-1964.	988,905.	AEROVANE (STYLIZED). U.S. CL. 26. (INT. CL. 9). REG. 7-23-1974.
773,051.	BREDA AND DESIGN. U.S. CL. 9. (INT. CL. 13). REG. 7-14-1964.	988,983.	VIBRAM. U.S. CL. 39. (INT. CL. 25). REG. 7-23-1974.
773,164.	SIMPLEX. U.S. CL. 25. (INT. CL. 6). REG. 7-14-1964.	989,062.	LIBBY'S. U.S. CL. 46 ONLY. (INT. CLS. 29, 30 AND 32). REG. 7-23-1974.
773,510.	CARAVELLE. U.S. CL. 17. (INT. CL. 34). REG. 7-21-1964.	989,070.	RANCH. U.S. CL. 46. (INT. CL. 30). REG. 7-23-1974.
773,703.	FIRST IMPRESSIONS (STYLIZED). U.S. CL. 39. (INT. CLS. 10, 25 AND 26). REG. 7-21-1964.	989,213.	GREYHOUND. U.S. CL. 105. (INT. CL. 39). REG. 7-23-1974.
773,916.	NUCLEANT. U.S. CL. 6. (INT. CL. 1). REG. 7-28-1964.	989,301.	SILADIUM. INT. CL. 14. (U.S. CL. 28). REG. 7-30-1974.
774,084.	ARMORLITE. U.S. CL. 26. (INT. CLS. 1, 9 AND 10). REG. 7-28-1964.	989,524.	MICROTEMP. U.S. CL. 21. (INT. CL. 9). REG. 7-30-1974.
774,679.	MEL-FRY. U.S. CL. 46. (INT. CL. 29). REG. 8-4-1964.	989,702.	HUNT'S. U.S. CL. 46. (INT. CLS. 1, 5, 29, 30, 31 AND 32). REG. 7-30-1974.
774,828.	TURN-LOC. U.S. CL. 13. (INT. CL. 6). REG. 8-11-1964.	990,791.	3M (STYLIZED). U.S. CL. 23. (INT. CL. 16). REG. 8-13-1974.
775,055.	FPI. U.S. CL. 44. (INT. CL. 10). REG. 8-11-1964.	991,299.	W (STYLIZED). U.S. CL. 23. (INT. CL. 7). REG. 8-20-1974.
775,464.	CABA (STYLIZED). U.S. CL. 44. (INT. CL. 10). REG. 8-18-1964.	991,500.	MEYRA. U.S. CL. 44. (INT. CL. 10). REG. 8-20-1974.
775,592.	COVERAL. U.S. CL. 6. (INT. CL. 1). REG. 8-25-1964.	991,886.	EIS. U.S. CLS. 21 AND 101. (INT. CLS. 17 AND 35). REG. 8-27-1974.
777,672.	MASTER POOLS. U.S. CL. 12. (INT. CL. 19). REG. 9-29-1964.	992,007.	ESTATE LABEL. U.S. CL. 37. (INT. CL. 16). REG. 8-27-1974.
778,004.	CUCLAD. INT. CL. 1. (U.S. CL. 1). REG. 10-6-1964.	992,658.	MISCELLANEOUS DESIGN. U.S. CL. 47. (INT. CL. 33). REG. 9-3-1974.
778,091.	TECHNIBILT. U.S. CL. 19. (INT. CL. 12). REG. 10-6-1964.	993,559.	TITE-GRIP. U.S. CL. 6. (INT. CL. 4). REG. 9-24-1974.
781,592.	BUSPERSE. U.S. CL. 6. (INT. CL. 1). REG. 12-15-1964.		



994,126. NEW SEABURY. U.S. CL. 101. (INT. CL. 36). REG. 9-24-1974.  
 995,825. COULTER. U.S. CL. 26. (INT. CL. 9). REG. 10-15-1974.  
 996,557. MACALLAN. U.S. CL. 49. (INT. CL. 33). REG. 10-22-1974.  
 997,168. IT'S US. OR RUST. U.S. CL. 103. (INT. CL. 37). REG. 10-29-1974.  
 998,973. TRAVELER. INT. CL. 16. (U.S. CL. 37). REG. 11-26-1974.  
 999,369. METABLEN. INT. CL. 1. (U.S. CL. 1). REG. 12-10-1974.  
 1,000,072. ROEHLER. INT. CL. 7. (U.S. CL. 23). REG. 12-24-1974.  
 1,002,333. FESTIVAL. U.S. CL. 46. (INT. CL. 29). REG. 1-21-1975.  
 1,002,703. MARLEN. INT. CL. 10. (U.S. CL. 44). REG. 1-28-1975.  
 1,004,188. TYTON. INT. CL. 6. (U.S. CL. 13). REG. 2-11-1975.  
 1,004,877. SAMANTHA. INT. CL. 28. (U.S. CL. 22). REG. 2-18-1975.  
 1,012,851. DUOBOND. INT. CL. 9. (U.S. CL. 21). REG. 6-10-1975.  
 1,013,418. ACRI-LOK. INT. CL. 9. (U.S. CL. 26). REG. 6-17-1975.  
 1,015,280. CANVASETTE. INT. CL. 16. (U.S. CL. 37). REG. 7-8-1975.  
 1,263,376. SEDIS AND DESIGN. INT. CLS. 6 AND 12. (U.S. CLS. 13 AND 19). REG. 1-10-1984.  
 1,264,101. AUGAT AND DESIGN. INT. CL. 9. (U.S. CLS. 21 AND 26). REG. 1-17-1984.  
 1,264,211. 1170. INT. CL. 16. (U.S. CL. 37). REG. 1-17-1984.  
 1,265,165. DANNON. INT. CL. 29. (U.S. CL. 46). REG. 1-24-1984.  
 1,265,872. NATURE'S RECIPE. INT. CL. 30. (U.S. CL. 46). REG. 1-31-1984.  
 1,268,374. I-C-KOOLER. INT. CL. 9. (U.S. CLS. 21 AND 26). REG. 2-21-1984.  
 1,271,740. DE PAUL. INT. CLS. 16, 20, 21, 24 AND 41. (U.S. CLS. 33, 37, 38, 42, 50 AND 107). REG. 3-27-1984.  
 1,281,459. CN. INT. CLS. 12, 36, 37, 39 AND 42. (U.S. CLS. 19, 100, 102, 103 AND 105). REG. 6-12-1984.  
 1,284,733. ESCAPE FROM THE ORDINARY. INT. CL. 42. (U.S. CLS. 100 AND 101). REG. 7-3-1984.  
 1,285,024. C AND DESIGN. INT. CL. 9. (U.S. CL. 26). REG. 7-10-1984.  
 1,285,083. A/T 2000. INT. CL. 9. (U.S. CL. 26). REG. 7-10-1984.  
 1,285,156. CBW AND DESIGN. INT. CL. 11. (U.S. CL. 34). REG. 7-10-1984.  
 1,285,165. MOTORHEAD AND DESIGN. INT. CL. 12. (U.S. CLS. 19, 23 AND 35). REG. 7-10-1984.  
 1,285,510. LAGOSTA. INT. CL. 33. (U.S. CL. 47). REG. 7-10-1984.  
 1,285,700. ELECTROCLEAR. INT. CL. 2. (U.S. CL. 16). REG. 7-17-1984.  
 1,285,718. STICK IT AND DESIGN. INT. CL. 3. (U.S. CLS. 5 AND 51). REG. 7-17-1984.  
 1,285,725. EASYGEL. INT. CL. 3. (U.S. CL. 51). REG. 7-17-1984.  
 1,285,910. C&D. INT. CL. 9. (U.S. CL. 21). REG. 7-17-1984.  
 1,285,931. BLUE EYE BEAM. INT. CL. 11. (U.S. CL. 21). REG. 7-17-1984.  
 1,285,933. EXAPOR. INT. CL. 11. (U.S. CL. 31). REG. 7-17-1984.  
 1,285,960. MACLAREN. INT. CLS. 12, 20 AND 24. (U.S. CLS. 19, 32, 42 AND 44). REG. 7-17-1984.  
 1,286,268. ELI'S. INT. CL. 30. (U.S. CL. 46). REG. 7-17-1984.  
 1,286,315. VAT GOLD. INT. CL. 33. (U.S. CL. 49). REG. 7-17-1984.  
 1,286,437. FYR-BACK. INT. CL. 37. (U.S. CL. 103). REG. 7-17-1984.  
 1,286,657. GASTROCCULT. INT. CL. 1. (U.S. CL. 18). REG. 7-24-1984.  
 1,286,666. AFILAN. INT. CL. 1. (U.S. CL. 6). REG. 7-24-1984.  
 1,286,760. TISSEEL (STYLIZED). INT. CL. 5. (U.S. CL. 18). REG. 7-24-1984.  
 1,286,762. FORTAZ. INT. CL. 5. (U.S. CL. 18). REG. 7-24-1984.  
 1,286,808. BARD. INT. CLS. 5 AND 10. (U.S. CL. 44). REG. 7-24-1984.  
 1,286,911. RAYCHEM. INT. CL. 9. (U.S. CLS. 21 AND 38). REG. 7-24-1984.  
 1,286,976. 301. INT. CL. 9. (U.S. CL. 21). REG. 7-24-1984.  
 1,287,048. WELTMEISTER. INT. CL. 12. (U.S. CLS. 19 AND 23). REG. 7-24-1984.  
 1,287,049. W WELTMEISTER AND DESIGN. INT. CL. 12. (U.S. CLS. 19 AND 23). REG. 7-24-1984.  
 1,287,060. MIGNON FAGET. INT. CL. 14. (U.S. CL. 28). REG. 7-24-1984.  
 1,287,294. JEFFERSON (STYLIZED). INT. CL. 39. (U.S. CL. 105). REG. 7-24-1984.  
 1,287,303. THE SPIRIT OF AUSTRALIA. INT. CL. 39. (U.S. CL. 105). REG. 7-24-1984.  
 1,287,428. AP. INT. CL. 42. (U.S. CLS. 100 AND 104). REG. 7-24-1984.  
 1,287,735. UMI. INT. CL. 9. (U.S. CL. 21). REG. 7-31-1984.  
 1,287,736. ELCUT. INT. CL. 9. (U.S. CL. 21). REG. 7-31-1984.  
 1,288,363. YOUNG PEOPLE PRINTS AND DESIGN. INT. CL. 42. (U.S. CL. 100). REG. 7-31-1984.  
 1,288,542. D-BLAZE (STYLIZED). INT. CL. 1. (U.S. CL. 6). REG. 8-7-1984.  
 1,288,640. MISCELLANEOUS DESIGN. INT. CL. 6. (U.S. CL. 13). REG. 8-7-1984.  
 1,288,894. LANDOLL CENTERFOLD AND DESIGN. INT. CL. 12. (U.S. CL. 19). REG. 8-7-1984.  
 1,289,086. ROYAL BRIERLEY CRYSTAL (STYLIZED). INT. CL. 21. (U.S. CLS. 13, 33 AND 34). REG. 8-7-1984.  
 1,289,150. PITFALL!. INT. CL. 28. (U.S. CLS. 22, 23, 38 AND 50). REG. 8-7-1984.  
 1,289,153. MY DAY. INT. CL. 28. (U.S. CL. 22). REG. 8-7-1984.  
 1,289,457. S & K AND DESIGN. INT. CL. 42. (U.S. CL. 101). REG. 8-7-1984.  
 1,289,480. BONGARD. INT. CLS. 7 AND 11. (U.S. CLS. 13, 21, 23, 31 AND 34). REG. 8-7-1984.  
 1,290,661. OMEGA AND DESIGN. INT. CL. 14 ONLY. (U.S. CLS. 2, 27, 28 AND 50). REG. 8-21-1984.  
 1,290,880. RPJ. INT. CL. 11. (U.S. CL. 34). REG. 8-21-1984.  
 1,291,006. SPEEDI-GRIP. INT. CL. 16. (U.S. CL. 37). REG. 8-21-1984.  
 1,291,729. LILJEHOLMENS. INT. CL. 4. (U.S. CL. 15). REG. 8-28-1984.  
 1,291,754. COMPRITOL. INT. CL. 5. (U.S. CL. 18). REG. 8-28-1984.  
 1,291,859. KAWASAKI (STYLIZED). INT. CL. 7. (U.S. CLS. 21 AND 23). REG. 8-28-1984.  
 1,292,454. PROCASTER TOURNAMENT. INT. CL. 28. (U.S. CL. 22). REG. 8-28-1984.  
 1,293,821. CIMPAT. INT. CL. 5. (U.S. CL. 44). REG. 9-11-1984.  
 1,294,361. DIAMOND COAT STANDARD CHARACTER MARK. INT. CL. 21. (U.S. CLS. 2 AND 13). REG. 9-11-1984.  
 1,295,415. OXYCUR. INT. CL. 3. (U.S. CL. 51). REG. 9-18-1984.  
 1,295,444. DELLASUPER STANDARD CHARACTER MARK. INT. CL. 3. (U.S. CL. 52). REG. 9-18-1984.  
 1,297,449. PULL-UPS. INT. CL. 10. (U.S. CL. 44). REG. 9-25-1984.  
 1,298,339. PLAX. INT. CL. 5. (U.S. CL. 18). REG. 10-2-1984.  
 1,298,427. ULTRA FLOW. INT. CL. 7. (U.S. CL. 23). REG. 10-2-1984.  
 1,298,428. TWIST & TUCK. INT. CL. 7. (U.S. CL. 23). REG. 10-2-1984.  
 1,299,258. HUMBOLDT WEDAG. INT. CLS. 6, 7, 9 AND 11. (U.S. CLS. 2, 12, 13, 14, 21, 23, 25, 26, 31, 34 AND 50). REG. 10-9-1984.  
 1,301,390. TEGLAR. INT. CL. 9. (U.S. CLS. 21, 23, 26, 36 AND 38). REG. 10-23-1984.  
 1,303,410. LIFE-LINE (STYLIZED). INT. CL. 5. (U.S. CL. 18). REG. 11-6-1984.  
 1,303,725. ROGERS R AND DESIGN. INT. CL. 19. (U.S. CL. 12). REG. 11-6-1984.  
 1,304,220. ROGERS R AND DESIGN. INT. CL. 42. (U.S. CL. 101). REG. 11-6-1984.  
 1,304,527. NO-TOX. INT. CL. 2. (U.S. CL. 11). REG. 11-13-1984.  
 1,304,544. GUN SCRUBBER. INT. CL. 3. (U.S. CLS. 6 AND 52). REG. 11-13-1984.  
 1,305,969. A-PAK. INT. CL. 22. (U.S. CL. 2). REG. 11-20-1984.  
 1,306,331. GARDEN VILLAS. INT. CL. 36. (U.S. CLS. 101 AND 102). REG. 11-20-1984.  
 1,309,341. NORTHERN TRUST BROKERAGE. INT. CL. 36. (U.S. CLS. 101 AND 102). REG. 12-11-1984.  
 1,310,469. ORANGE BLOSSOM SPECIAL II. INT. CL. 41. (U.S. CL. 107). REG. 12-18-1984.  
 1,311,687. AIPG. U.S. CL. 200. REG. 12-25-1984.  
 1,312,681. THE COAL MINER'S DAUGHTER. INT. CL. 41. (U.S. CL. 107). REG. 1-1-1985.  
 1,313,179. MAXAM. INT. CL. 8. (U.S. CL. 23). REG. 1-8-1985.

- 1,313,427. PHARMCAL. INT. CL. 17. (U.S. CL. 1). REG. 1-8-1985.
- 1,315,448. UR (STYLIZED). INT. CL. 7. (U.S. CL. 23). REG. 1-22-1985.
- 1,317,686. LE PRIX. INT. CL. 8. (U.S. CL. 23). REG. 2-5-1985.
- 1,318,414. CAESARS SANDWICHES. INT. CL. 30. (U.S. CL. 46). REG. 2-5-1985.
- 1,324,041. BEKINOX. INT. CL. 6. (U.S. CL. 13). REG. 3-12-1985.
- 1,325,700. ABA (STYLIZED). INT. CL. 16. (U.S. CLS. 21 AND 38). REG. 3-19-1985.
- 1,326,899. ABA. INT. CL. 16. (U.S. CLS. 21 AND 38). REG. 3-26-1985.
- 1,326,999. APS. INT. CLS. 20 AND 35. (U.S. CLS. 2 AND 101). REG. 3-26-1985.
- 1,328,647. ISLAND SNOW. INT. CLS. 25 AND 42 ONLY. (U.S. CLS. 39 AND 101). REG. 4-2-1985.
- 1,329,314. EXCEL AND DESIGN. INT. CL. 9. (U.S. CL. 26). REG. 4-9-1985.
- 1,329,463. MULE. INT. CL. 13. (U.S. CL. 9). REG. 4-9-1985.
- 1,331,152. WAGON TRAIN. INT. CL. 31. (U.S. CL. 46). REG. 4-16-1985.
- 1,331,309. PGA PROFESSIONAL GOLFERS' ASSOCIATION OF AMERICA 1916 AND DESIGN. INT. CL. 41. (U.S. CL. 107). REG. 4-16-1985.
- 1,331,514. BUTROL. INT. CL. 1. (U.S. CL. 6). REG. 4-23-1985.
- 1,337,923. REVIVO. INT. CL. 19. (U.S. CL. 12). REG. 5-28-1985.
- 1,338,927. INTOXIMETER. INT. CL. 9. (U.S. CL. 26). REG. 6-4-1985.
- 1,341,463. THE FACILITATOR. INT. CL. 36. (U.S. CL. 102). REG. 6-11-1985.
- 1,344,129. SCHOLASTIC. INT. CL. 9. (U.S. CL. 38). REG. 6-25-1985.
- 1,346,155. PET TAXI (STYLIZED). INT. CL. 18. (U.S. CL. 3). REG. 7-2-1985.
- 1,346,797. K-KLAD. INT. CL. 40. (U.S. CL. 106). REG. 7-2-1985.
- 1,347,371. SESSION. INT. CL. 9. (U.S. CLS. 21 AND 36). REG. 7-9-1985.
- 1,349,001. SCORPION. INT. CL. 9. (U.S. CL. 21). REG. 7-16-1985.
- 1,349,915. ROUGH COUNTRY. INT. CL. 34. (U.S. CL. 17). REG. 7-16-1985.
- 1,765,069. M.O.S.T. AND DESIGN. INT. CL. 42. (U.S. CL. 100). REG. 4-13-1993.
- 1,801,662. QUINTA DE LA ROSA. INT. CL. 33. (U.S. CL. 47). REG. 10-26-1993.
- 1,816,718. SEABEACON. INT. CL. 9. (U.S. CL. 26). REG. 1-18-1994.
- 1,817,187. ENTERTAINMENT TONIGHT AND DESIGN. INT. CL. 41. (U.S. CL. 107). REG. 1-18-1994.
- 1,817,288. MONARFLEX. INT. CLS. 17, 19 AND 22. (U.S. CLS. 1, 3, 12 AND 22). REG. 1-18-1994.
- 1,817,419. AYA. INT. CL. 14. (U.S. CL. 28). REG. 1-18-1994.
- 1,822,624. TEXAS LONGHORN ARMS, INC. AND DESIGN. INT. CL. 13. (U.S. CLS. 2 AND 9). REG. 2-22-1994.
- 1,822,683. KAPLAN. INT. CLS. 16 AND 41. (U.S. CLS. 38 AND 107). REG. 2-22-1994.
- 1,824,049. PINE-O-PINE STANDARD CHARACTER MARK. INT. CL. 3. (U.S. CLS. 6 AND 52). REG. 3-1-1994.
- 1,824,826. SLENDER WORLD CHANGES LIVES AND DESIGN. INT. CL. 3. (U.S. CL. 51). REG. 3-8-1994.
- 1,825,755. TIME:FRAME. INT. CL. 9. (U.S. CL. 38). REG. 3-8-1994.
- 1,826,862. QUARTON (STYLIZED). INT. CL. 9. (U.S. CLS. 21 AND 26). REG. 3-15-1994.
- 1,833,185. NITESTAR. INT. CL. 9. (U.S. CL. 26). REG. 4-26-1994.
- 1,835,665. PAUL HARRIS FELLOW AND DESIGN. INT. CLS. 36 AND 41. (U.S. CLS. 102 AND 107). REG. 5-10-1994.
- 1,837,934. GOSSARD. INT. CL. 25. (U.S. CLS. 22 AND 39). REG. 5-31-1994.
- 1,841,363. DUSTIN. INT. CL. 21. (U.S. CL. 29). REG. 6-21-1994.
- 1,841,957. SANDWICH MAKER. INT. CL. 29. (U.S. CL. 46). REG. 6-28-1994.
- 1,842,659. DME. INT. CLS. 7 AND 11. (U.S. CLS. 23, 31 AND 34). REG. 7-5-1994.
- 1,843,233. THE WHITESIDEWALLS ROCK 'N' ROLL REVUE AND DESIGN. INT. CL. 41. (U.S. CL. 107). REG. 7-5-1994.
- 1,843,427. RICITOS DE ORO (STYLIZED). INT. CL. 3. (U.S. CL. 52). REG. 7-5-1994.
- 1,843,572. ACUSNARE AND DESIGN. INT. CL. 10. (U.S. CL. 44). REG. 7-5-1994.
- 1,843,787. HYDROTAIL. INT. CL. 28. (U.S. CLS. 22, 23, 38 AND 50). REG. 7-5-1994.
- 1,843,811. LA PLACITA MEXICANA. INT. CL. 30. (U.S. CL. 46). REG. 7-5-1994.
- 1,843,984. SENIORS COALITION. INT. CL. 42. (U.S. CL. 100). REG. 7-5-1994.
- 1,844,026. BIOLOGIQUE RECHERCHE. INT. CL. 3. (U.S. CL. 51). REG. 7-12-1994.
- 1,844,300. PACIFIC ENERGY AND DESIGN. INT. CL. 11. (U.S. CL. 34). REG. 7-12-1994.
- 1,844,319. MISCELLANEOUS DESIGN. INT. CLS. 12 AND 25. (U.S. CLS. 19, 21, 23, 31, 35, 39 AND 44). REG. 7-12-1994.
- 1,844,615. SOUTHERN TURF NURSERIES. INT. CL. 31 ONLY. (U.S. CLS. 1 AND 46). REG. 7-12-1994.
- 1,844,750. SERVTECH. INT. CL. 37. (U.S. CL. 103). REG. 7-12-1994.
- 1,844,815. TUTOR TIME AND DESIGN. INT. CLS. 41 AND 42. (U.S. CLS. 100 AND 107). REG. 7-12-1994.
- 1,844,832. PTI AND DESIGN. INT. CL. 41. (U.S. CL. 107). REG. 7-12-1994.
- 1,844,968. WELD-R-WHITE. INT. CLS. 1 AND 4. (U.S. CLS. 6 AND 15). REG. 7-12-1994.
- 1,845,286. QUEST. INT. CL. 1. (U.S. CL. 6). REG. 7-19-1994.
- 1,845,550. CHALLENGER. INT. CL. 12. (U.S. CL. 19). REG. 7-19-1994.
- 1,845,604. MEGA3000. INT. CL. 17. (U.S. CL. 35). REG. 7-19-1994.
- 1,845,626. CUSHION FIRM. INT. CL. 20. (U.S. CL. 32). REG. 7-19-1994.
- 1,845,814. GOLD'N PRIDE. INT. CL. 31. (U.S. CL. 46). REG. 7-19-1994.
- 1,845,897. APPLIED SOFTWARE. INT. CLS. 37 AND 42. (U.S. CLS. 100, 101 AND 103). REG. 7-19-1994.
- 1,845,907. FIREROCK. INT. CL. 37. (U.S. CL. 103). REG. 7-19-1994.
- 1,845,923. SOUTHERN PACIFIC LINES. INT. CL. 39. (U.S. CL. 105). REG. 7-19-1994.
- 1,846,011. AMERILAWYER. INT. CL. 42. (U.S. CLS. 100 AND 101). REG. 7-19-1994.
- 1,846,052. MISCELLANEOUS DESIGN. INT. CL. 42. (U.S. CL. 100). REG. 7-19-1994.
- 1,846,191. BEDAZZLED. INT. CL. 12. (U.S. CL. 19). REG. 7-19-1994.
- 1,846,292. PIASTEN. INT. CL. 30. (U.S. CL. 46). REG. 7-19-1994.
- 1,846,295. EVERYTHING YOU LOVE ABOUT COFFEE. INT. CL. 30. (U.S. CL. 46). REG. 7-19-1994.
- 1,846,311. LA PLACITA MEXICANA. INT. CL. 32. (U.S. CLS. 45 AND 46). REG. 7-19-1994.
- 1,846,462. AROMASIN. INT. CL. 5. (U.S. CL. 18). REG. 7-26-1994.
- 1,846,475. NEM AND DESIGN. INT. CLS. 6 AND 12. (U.S. CLS. 13, 14 AND 19). REG. 7-26-1994.
- 1,846,495. MET-TRACK. INT. CL. 7. (U.S. CL. 23). REG. 7-26-1994.
- 1,846,574. ALCOBLOW. INT. CL. 9. (U.S. CLS. 21, 23, 26, 36 AND 38). REG. 7-26-1994.
- 1,846,674. JBC. INT. CL. 14. (U.S. CL. 28). REG. 7-26-1994.
- 1,846,683. CHERISHED TEDDIES. INT. CL. 15. (U.S. CL. 36). REG. 7-26-1994.
- 1,846,749. CABIN CRAFT. INT. CL. 19. (U.S. CL. 12). REG. 7-26-1994.
- 1,846,762. CENTURY CC. INT. CL. 20. (U.S. CLS. 32 AND 44). REG. 7-26-1994.
- 1,846,840. BARRACUDA. INT. CL. 28. (U.S. CLS. 22 AND 26). REG. 7-26-1994.
- 1,846,877. TEC FOODS, INC. GOLDEN CAKES AND DESIGN. INT. CL. 30. (U.S. CL. 46). REG. 7-26-1994.
- 1,847,205. TOUGHTRACE. INT. CL. 3. (U.S. CL. 1). REG. 7-26-1994.
- 1,847,437. PREPARE. INT. CL. 31. (U.S. CL. 46). REG. 7-26-1994.
- 1,847,498. KIDS ADJUSTING THROUGH SUPPORT. INT. CL. 42. (U.S. CL. 100). REG. 7-26-1994.
- 1,847,802. VOIELLO. INT. CL. 30. (U.S. CL. 46). REG. 8-2-1994.
- 1,847,974. SHOPKO. INT. CL. 42. (U.S. CLS. 100 AND 101). REG. 8-2-1994.
- 1,848,016. INDULGE. INT. CL. 1. (U.S. CLS. 6 AND 46). REG. 8-2-1994.

- 1,848,342. FIRST INDUSTRIAL BUILDINGS & LAND AND DESIGN. INT. CL. 37. (U.S. CLS. 100, 101 AND 103). REG. 8-2-1994.
- 1,848,454. DSX. INT. CL. 1. (U.S. CL. 5). REG. 8-9-1994.
- 1,848,957. T-CELL PLUS. INT. CL. 5. (U.S. CL. 18). REG. 8-9-1994.
- 1,849,328. WONDER GRIP. INT. CL. 21. (U.S. CLS. 21 AND 29). REG. 8-9-1994.
- 1,849,502. DAIRY-LO. INT. CL. 29. (U.S. CL. 46). REG. 8-9-1994.
- 1,849,543. T-CELL PLUS. INT. CL. 32. (U.S. CL. 45). REG. 8-9-1994.
- 1,849,689. SWIRE. INT. CLS. 12 AND 16. (U.S. CLS. 19, 21, 23, 31, 35, 37, 38 AND 44). REG. 8-9-1994.
- 1,849,951. DAIWA AND DESIGN. INT. CL. 25. (U.S. CLS. 22 AND 39). REG. 8-16-1994.
- 1,850,130. T AND DESIGN. INT. CL. 42. (U.S. CL. 100). REG. 8-16-1994.
- 1,850,234. THE IDEA CHANNEL. INT. CL. 9. (U.S. CL. 38). REG. 8-16-1994.
- 1,850,387. EGG.LAND'S BEST. INT. CL. 29. (U.S. CL. 46). REG. 8-16-1994.
- 1,851,199. CTS RELIEF KIT. INT. CL. 10. (U.S. CL. 44). REG. 8-23-1994.
- 1,851,279. MISCELLANEOUS DESIGN. INT. CL. 5. (U.S. CL. 18). REG. 8-30-1994.
- 1,851,841. MAXTECH. INT. CL. 2. (U.S. CL. 16). REG. 8-30-1994.
- 1,852,160. IMEDEEN. INT. CL. 5. (U.S. CL. 18). REG. 9-6-1994.
- 1,852,224. LEXON. INT. CLS. 9, 14, 16 AND 18 ONLY. (U.S. CLS. 3, 21, 22, 23, 26, 27, 28, 32, 36, 37, 38 AND 41). REG. 9-6-1994.
- 1,852,740. ALPHAPOINTE. INT. CL. 42. (U.S. CL. 100). REG. 9-6-1994.
- 1,852,957. R & D DECISION ADVISOR. INT. CL. 9. (U.S. CL. 38). REG. 9-6-1994.
- 1,853,258. FROG JUICE. INT. CL. 32. (U.S. CLS. 45 AND 46). REG. 9-6-1994.
- 1,853,479. ISU. INT. CL. 6. (U.S. CL. 2). REG. 9-13-1994.
- 1,853,498. TRAV-L-CUTTER. INT. CL. 7. (U.S. CL. 23). REG. 9-13-1994.
- 1,853,615. LIFE OUTREACH INTERNATIONAL AND DESIGN. INT. CLS. 16 AND 42. (U.S. CLS. 38 AND 100). REG. 9-13-1994.
- 1,854,803. ENRICH BITS. INT. CL. 31. (U.S. CL. 46). REG. 9-20-1994.
- 1,855,170. TOYO. INT. CL. 16. (U.S. CL. 38). REG. 9-20-1994.
- 1,856,966. MISCELLANEOUS DESIGN. INT. CL. 36. (U.S. CL. 102). REG. 10-4-1994.
- 1,857,725. ROCK CITY. INT. CLS. 21, 25 AND 41. (U.S. CLS. 2, 3, 30, 39, 50 AND 107). REG. 10-11-1994.
- 1,857,906. THE GUARDIAN. INT. CL. 36. (U.S. CL. 102). REG. 10-11-1994.
- 1,859,962. LEWER LIFE INSURANCE COMPANY. INT. CL. 36. (U.S. CLS. 101 AND 102). REG. 10-25-1994.
- 1,860,084. MENTOR DRIVER PROGRAM. INT. CL. 41. (U.S. CL. 107). REG. 10-25-1994.
- 1,862,516. FORM-A-DRAIN. INT. CL. 19. (U.S. CL. 12). REG. 11-15-1994.
- 1,863,499. LECTRON. INT. CL. 7. (U.S. CL. 23). REG. 11-22-1994.
- 1,863,535. SPECAC. INT. CL. 9. (U.S. CLS. 21, 23, 26, 36 AND 38). REG. 11-22-1994.
- 1,863,721. RUBORE. INT. CL. 17. (U.S. CLS. 12, 19 AND 35). REG. 11-22-1994.
- 1,867,575. LIFE. INT. CL. 11. (U.S. CL. 31). REG. 12-13-1994.
- 1,867,636. STORESAFE. INT. CL. 19. (U.S. CL. 12). REG. 12-13-1994.
- 1,867,637. HOMESAFE. INT. CL. 19. (U.S. CL. 12). REG. 12-13-1994.
- 1,869,022. THE KENNEDY GROUP. INT. CLS. 16 AND 42 ONLY. (U.S. CLS. 2, 37, 100 AND 101). REG. 12-20-1994.
- 1,869,024. HOLIDAY TRIMS. INT. CLS. 26 AND 28. (U.S. CLS. 40 AND 50). REG. 12-20-1994.
- 1,870,036. SAFE LIFE. INT. CL. 41. (U.S. CL. 107). REG. 12-27-1994.
- 1,871,160. PRO-WATCH. INT. CL. 9. (U.S. CL. 38). REG. 1-3-1995.
- 1,871,465. ES UNA SALSA...MUY SALSA!. INT. CL. 30. (U.S. CL. 46). REG. 1-3-1995.
- 1,871,864. SEPPRA-LITE. INT. CL. 9. (U.S. CL. 26). REG. 1-3-1995.
- 1,871,919. COUNTERSAFE. INT. CL. 19. (U.S. CL. 12). REG. 1-3-1995.
- 1,872,163. GONESH. INT. CL. 21 ONLY. (U.S. CL. 34). REG. 1-10-1995.
- 1,872,226. H (STYLIZED). INT. CLS. 7 AND 11. (U.S. CLS. 23, 31 AND 34). REG. 1-10-1995.
- 1,872,962. AIRLINK. INT. CL. 42. (U.S. CLS. 100 AND 101). REG. 1-10-1995.
- 1,873,117. DRIVE WITH PRIDE. INT. CL. 9. (U.S. CL. 21). REG. 1-10-1995.
- 1,875,103. KAVALIER. INT. CL. 9. (U.S. CL. 26). REG. 1-24-1995.
- 1,875,397. GRANDE CLASSICS. INT. CL. 29. (U.S. CL. 46). REG. 1-24-1995.
- 1,878,394. MISCELLANEOUS DESIGN. INT. CL. 3. (U.S. CL. 51). REG. 2-14-1995.
- 1,878,440. DUCTMATE. INT. CL. 6. (U.S. CL. 12). REG. 2-14-1995.
- 1,880,806. MISCELLANEOUS DESIGN. INT. CL. 34. (U.S. CL. 17). REG. 2-28-1995.
- 1,881,339. LUMIFIER. INT. CL. 9. (U.S. CL. 26). REG. 2-28-1995.
- 1,881,755. SHAHNAZ HERBALS (STYLIZED). INT. CL. 3. (U.S. CLS. 51 AND 52). REG. 3-7-1995.
- 1,885,597. Q-BIT. INT. CL. 20. (U.S. CLS. 2 AND 50). REG. 3-21-1995.
- 1,887,726. CAL-C-FRESH. INT. CL. 5. (U.S. CL. 18). REG. 4-4-1995.
- 1,890,081. RANGE STAR. INT. CL. 31. (U.S. CL. 46). REG. 4-18-1995.
- 1,890,150. MR. HOCKEY. INT. CL. 36. (U.S. CL. 107). REG. 4-18-1995.
- 1,890,653. IMRA. INT. CL. 35. (U.S. CL. 101). REG. 4-18-1995.
- 1,892,679. FUNFIL. INT. CL. 22. (U.S. CL. 1). REG. 5-2-1995.
- 1,892,888. COMFIDERM. INT. CL. 3. (U.S. CL. 51). REG. 5-9-1995.
- 1,893,033. SOVTEK. INT. CL. 9. (U.S. CLS. 21 AND 26). REG. 5-9-1995.
- 1,894,030. SAMPLE SENTRY. INT. CL. 11. (U.S. CL. 31). REG. 5-16-1995.
- 1,894,319. CRIMEGUARD. INT. CL. 36. (U.S. CL. 102). REG. 5-16-1995.
- 1,894,529. BOUNDARY. INT. CL. 5. (U.S. CL. 6). REG. 5-16-1995.
- 1,894,993. TRENDNET. INT. CL. 9. (U.S. CL. 26). REG. 5-23-1995.
- 1,897,423. CRUISER. INT. CL. 9. (U.S. CLS. 21 AND 26). REG. 6-6-1995.
- 1,898,790. MINIHEART. INT. CL. 10. (U.S. CL. 44). REG. 6-13-1995.
- 1,899,743. ENDO MINI-RETRACT. INT. CL. 10. (U.S. CL. 44). REG. 6-13-1995.
- 1,899,965. OFF LIMITS. INT. CL. 25. (U.S. CLS. 22 AND 39). REG. 6-13-1995.
- 1,901,383. TECHNICAL NETWORK. INT. CL. 42. (U.S. CL. 100). REG. 6-20-1995.
- 1,903,148. SPALON MONTAGE. INT. CL. 42. (U.S. CLS. 101 AND 107). REG. 7-4-1995.
- 1,903,227. ASMG AND DESIGN. INT. CL. 42. (U.S. CL. 100). REG. 7-4-1995.
- 1,903,681. YOU'LL SAFFOLA AND DESIGN. INT. CL. 29. (U.S. CL. 46). REG. 7-4-1995.
- 1,904,430. INSTANT ROAD REPAIR. INT. CL. 19. (U.S. CLS. 1, 12, 33 AND 50). REG. 7-11-1995.
- 1,905,319. ADI. INT. CL. 7. (U.S. CL. 23). REG. 7-18-1995.
- 2,693,612. THINKING STRINGS AND DESIGN. INT. CL. 9. (U.S. CLS. 21, 23, 26, 36 AND 38). REG. 3-4-2003.
- 2,730,925. CLASSICAL CARTOON FESTIVAL. INT. CL. 41. (U.S. CLS. 100, 101 AND 107). REG. 6-24-2003.
- 2,756,719. SCENTS OF STYLE. INT. CL. 4. (U.S. CLS. 1, 6 AND 15). REG. 8-26-2003.
- 2,775,008. ANGEL THERAPY. INT. CL. 41. (U.S. CLS. 100, 101 AND 107). REG. 10-21-2003.
- 2,777,151. ROSIE. INT. CL. 41 ONLY. (U.S. CLS. 100, 101 AND 107). REG. 10-28-2003.
- 2,781,243. NETINFO. INT. CLS. 16 AND 41. (U.S. CLS. 2, 5, 22, 23, 29, 37, 38, 50, 100, 101 AND 107). REG. 11-11-2003.
- 2,788,120. SUNDG. INT. CL. 25. (U.S. CLS. 22 AND 39). REG. 12-2-2003.
- 2,791,562. FAHM. U.S. CL. B. REG. 12-9-2003.
- 2,791,563. FELLOW FAHM AND DESIGN. U.S. CL. B. REG. 12-9-2003.

- 2,795,046. SIZABLES. INT. CL. 16. (U.S. CLS. 2, 5, 22, 23, 29, 37, 38 AND 50). REG. 12-16-2003.
- 2,801,777. VALUE RECOVERY VR (STYLIZED). INT. CL. 42. (U.S. CLS. 100 AND 101). REG. 1-6-2004.
- 2,801,854. PEX. INT. CL. 41. (U.S. CLS. 100, 101 AND 107). REG. 1-6-2004.
- 2,801,918. RADMIN. INT. CL. 9. (U.S. CLS. 21, 23, 26, 36 AND 38). REG. 1-6-2004.
- 2,802,136. CI COPART AND DESIGN. INT. CL. 35. (U.S. CLS. 100, 101 AND 102). REG. 1-6-2004.
- 2,802,419. QUESTIA. INT. CL. 41. (U.S. CLS. 100, 101 AND 107). REG. 1-6-2004.
- 2,802,420. QUESTIA AND DESIGN. INT. CL. 41. (U.S. CLS. 100, 101 AND 107). REG. 1-6-2004.
- 2,802,423. ULTRA-TEMP. INT. CL. 6. (U.S. CLS. 2, 12, 13, 14, 23, 25 AND 50). REG. 1-6-2004.
- 2,802,599. HANG UP AND DRIVE. INT. CL. 16. (U.S. CLS. 2, 5, 22, 23, 29, 37, 38 AND 50). REG. 1-6-2004.
- 2,802,668. LOST LUGGAGE. INT. CLS. 16 AND 18. (U.S. CLS. 1, 2, 3, 5, 22, 23, 29, 37, 38, 41 AND 50). REG. 1-6-2004.
- 2,802,904. PHOENIX X-RAY AND DESIGN. INT. CLS. 9 AND 10. (U.S. CLS. 21, 23, 26, 36, 38, 39 AND 44). REG. 1-6-2004.
- 2,802,912. FLIGHTTOPS. INT. CLS. 35 AND 39. (U.S. CLS. 100, 101, 102 AND 105). REG. 1-6-2004.
- 2,803,186. MISCELLANEOUS DESIGN. INT. CL. 44. (U.S. CLS. 100 AND 101). REG. 1-6-2004.
- 2,804,847. ERELATE. INT. CLS. 35 AND 38. (U.S. CLS. 100, 101, 102 AND 104). REG. 1-13-2004.
- 2,806,437. THE FOOD BANK FOR NEW YORK CITY FOOD FOR SURVIVAL AND DESIGN. INT. CLS. 41 AND 43. (U.S. CLS. 100, 101 AND 107). REG. 1-20-2004.
- 2,807,344. RADIO TIME. INT. CL. 41. (U.S. CLS. 100, 101 AND 107). REG. 1-20-2004.
- 2,808,191. NYC BANK-TO-BANK PARTNERSHIP. INT. CL. 43. (U.S. CLS. 100 AND 101). REG. 1-27-2004.
- 2,808,248. TRAILS WEST AND DESIGN. INT. CL. 12. (U.S. CLS. 19, 21, 23, 31, 35 AND 44). REG. 1-27-2004.
- 2,808,867. PAK II. INT. CL. 36. (U.S. CLS. 100, 101 AND 102). REG. 1-27-2004.
- 2,809,801. ABB. INT. CLS. 7, 8, 9, 16, 35, 37, 38, 40, 41 AND 42 ONLY. (U.S. CLS. 2, 5, 13, 19, 21, 22, 23, 26, 28, 29, 31, 34, 35, 36, 37, 38, 44, 50, 100, 101, 102, 103, 104, 106 AND 107 ONLY). REG. 2-3-2004.
- 2,811,875. STEEL SHIELD. INT. CL. 16. (U.S. CLS. 2, 5, 22, 23, 29, 37, 38 AND 50). REG. 2-3-2004.
- 2,812,318. DOGTOWN. INT. CL. 25. (U.S. CLS. 22 AND 39). REG. 2-10-2004.
- 2,812,328. HENRY LO-SLOPE. INT. CL. 19. (U.S. CLS. 1, 12, 33 AND 50). REG. 2-10-2004.
- 2,813,143. HEALTHY EMAIL AND DESIGN. INT. CL. 42. (U.S. CLS. 100 AND 101). REG. 2-10-2004.
- 2,813,966. LICK SHOT. INT. CL. 3. (U.S. CLS. 1, 4, 6, 50, 51 AND 52). REG. 2-10-2004.
- 2,814,690. OVOLAB. INT. CL. 42. (U.S. CLS. 100 AND 101). REG. 2-17-2004.
- 2,819,363. DELDRUM. INT. CL. 20. (U.S. CLS. 2, 13, 22, 25, 32 AND 50). REG. 3-2-2004.
- 2,820,634. PATENT SOLUTIONS. INT. CL. 42. (U.S. CLS. 100 AND 101). REG. 3-9-2004.
- 2,821,396. AM PM AND DESIGN. INT. CLS. 35 AND 43. (U.S. CLS. 100, 101 AND 102). REG. 3-9-2004.
- 2,823,814. FAIRY TALES AND DESIGN. INT. CL. 3. (U.S. CLS. 1, 4, 6, 50, 51 AND 52). REG. 3-16-2004.
- 2,824,985. ELA M. INT. CL. 9. (U.S. CLS. 21, 23, 26, 36 AND 38). REG. 3-23-2004.
- 2,827,992. KWIKBOND. INT. CL. 19. (U.S. CLS. 1, 12, 33 AND 50). REG. 3-30-2004.
- 2,831,510. MISCELLANEOUS DESIGN. INT. CL. 3. (U.S. CLS. 1, 4, 6, 50, 51 AND 52). REG. 4-13-2004.
- 2,832,040. I CAN COPE. INT. CL. 41. (U.S. CLS. 100, 101 AND 107). REG. 4-13-2004.
- 2,836,701. INFOFOUNDRY. INT. CL. 42. (U.S. CLS. 100 AND 101). REG. 4-27-2004.
- 2,837,324. CITRUS. INT. CL. 43. (U.S. CLS. 100 AND 101). REG. 4-27-2004.
- 2,838,941. TRANSPWR (STYLIZED). INT. CL. 9. (U.S. CLS. 21, 23, 26, 36 AND 38). REG. 5-4-2004.
- 2,841,649. DIEBOLD OPTEVA. INT. CL. 9. (U.S. CLS. 21, 23, 26, 36 AND 38). REG. 5-11-2004.
- 2,843,942. SMARTSTEAM. INT. CL. 11. (U.S. CLS. 13, 21, 23, 31 AND 34). REG. 5-18-2004.
- 2,845,080. PAHM. U.S. CL. B. REG. 5-25-2004.
- 2,846,740. DE LA ESTANCIA. INT. CL. 30. (U.S. CL. 46). REG. 5-25-2004.
- 2,847,004. THE AFRICA CHANNEL AND DESIGN. INT. CLS. 38 AND 41. (U.S. CLS. 100, 101, 104 AND 107). REG. 5-25-2004.
- 2,847,917. ARCAFFE PASSIONE D'ESPRESSO AND DESIGN. INT. CL. 30. (U.S. CL. 46). REG. 6-1-2004.
- 2,847,923. TRANSPWR. INT. CL. 9. (U.S. CLS. 21, 23, 26, 36 AND 38). REG. 6-1-2004.
- 2,848,218. WEMBLEY. INT. CL. 3. (U.S. CLS. 1, 4, 6, 50, 51 AND 52). REG. 6-1-2004.
- 2,850,581. RU ROCKHILL UNDERWRITING AND DESIGN. INT. CL. 36. (U.S. CLS. 100, 101 AND 102). REG. 6-8-2004.
- 2,853,197. OPTI-FIRM. INT. CL. 3. (U.S. CLS. 1, 4, 6, 50, 51 AND 52). REG. 6-15-2004.
- 2,854,712. HELP IS JUST A CLICK AWAY. INT. CL. 42. (U.S. CLS. 100 AND 101). REG. 6-15-2004.
- 2,855,347. DIGICERT. INT. CL. 45. (U.S. CLS. 100 AND 101). REG. 6-15-2004.
- 2,856,629. KLEIN KURVE. INT. CL. 8. (U.S. CLS. 23, 28 AND 44). REG. 6-22-2004.
- 2,857,528. TATTOO JOHNNY. INT. CL. 16. (U.S. CLS. 2, 5, 22, 23, 29, 37, 38 AND 50). REG. 6-29-2004.
- 2,858,179. ZUBROWKA BISON VODKA AND DESIGN. INT. CL. 33. (U.S. CLS. 47 AND 49). REG. 6-29-2004.
- 2,858,182. ANDRITZ (STYLIZED). INT. CLS. 6, 7, 9, 11 AND 20. (U.S. CLS. 2, 12, 13, 14, 19, 21, 22, 23, 25, 26, 31, 32, 34, 35, 36, 38 AND 50). REG. 6-29-2004.
- 2,858,474. HIGHLY SENSITIVE PEOPLE. INT. CL. 35. (U.S. CLS. 100, 101 AND 102). REG. 6-29-2004.
- 2,858,623. ME-3 SOLUTION. INT. CL. 44. (U.S. CLS. 100 AND 101). REG. 6-29-2004.
- 2,858,624. ME-2 SOLUTION. INT. CL. 44. (U.S. CLS. 100 AND 101). REG. 6-29-2004.
- 2,858,625. ME-1 SOLUTION. INT. CL. 44. (U.S. CLS. 100 AND 101). REG. 6-29-2004.
- 2,858,626. ME-4 SOLUTION. INT. CL. 44. (U.S. CLS. 100 AND 101). REG. 6-29-2004.
- 2,858,792. IRIS AND DESIGN. INT. CL. 9. (U.S. CLS. 21, 23, 26, 36 AND 38). REG. 6-29-2004.
- 2,859,182. SPRINGBOK. INT. CL. 25 ONLY. (U.S. CLS. 22 AND 39). REG. 7-6-2004.
- 2,859,214. NEWPORT. INT. CL. 29. (U.S. CL. 46). REG. 7-6-2004.
- 2,859,215. NEWPORT PRIDE. INT. CL. 29. (U.S. CL. 46). REG. 7-6-2004.
- 2,859,254. DIGITAL ATELIER. INT. CL. 42. (U.S. CLS. 100 AND 101). REG. 7-6-2004.
- 2,859,260. BUTTER-KRUST. INT. CL. 30. (U.S. CL. 46). REG. 7-6-2004.
- 2,859,301. POHL EUROPLATE. INT. CLS. 6, 17 AND 19. (U.S. CLS. 1, 2, 5, 12, 13, 14, 23, 25, 33, 35 AND 50). REG. 7-6-2004.
- 2,859,310. COURBIS. INT. CLS. 12 AND 17 ONLY. (U.S. CLS. 1, 5, 12, 13, 19, 21, 23, 31, 35, 44 AND 50). REG. 7-6-2004.
- 2,859,334. PROMONTORY THE RANCH CLUB. INT. CL. 36. (U.S. CLS. 100, 101 AND 102). REG. 7-6-2004.
- 2,859,353. CTV AND DESIGN. INT. CLS. 38 AND 41. (U.S. CLS. 100, 101, 104 AND 107). REG. 7-6-2004.
- 2,859,406. TOASTER. INT. CL. 25. (U.S. CLS. 22 AND 39). REG. 7-6-2004.
- 2,859,458. STOP SHORT OF ADDICTION AND DESIGN. INT. CLS. 41 AND 44. (U.S. CLS. 100, 101 AND 107). REG. 7-6-2004.
- 2,859,476. DOWNSTREAM TECHNOLOGIES AND DESIGN. INT. CL. 9. (U.S. CLS. 21, 23, 26, 36 AND 38). REG. 7-6-2004.
- 2,859,480. ISCALA (STYLIZED). INT. CLS. 9 AND 42 ONLY. (U.S. CLS. 21, 23, 26, 36, 38, 100 AND 101). REG. 7-6-2004.
- 2,859,515. STERLING AMERICAN PROPERTY. INT. CL. 36. (U.S. CLS. 100, 101 AND 102). REG. 7-6-2004.
- 2,859,532. ANTIBAC. INT. CL. 17. (U.S. CLS. 1, 5, 12, 13, 35 AND 50). REG. 7-6-2004.
- 2,859,558. ENV. INT. CL. 11. (U.S. CLS. 13, 21, 23, 31 AND 34). REG. 7-6-2004.
- 2,859,575. MINEBEA. INT. CL. 12. (U.S. CLS. 19, 21, 23, 31, 35 AND 44). REG. 7-6-2004.
- 2,859,576. MINEBEA. INT. CL. 9. (U.S. CLS. 21, 23, 26, 36 AND 38). REG. 7-6-2004.
- 2,859,577. MINEBEA. INT. CL. 7. (U.S. CLS. 13, 19, 21, 23, 31, 34 AND 35). REG. 7-6-2004.

- 2,859,595. SALON BELLAGIO. INT. CL. 44. (U.S. CLS. 100 AND 101). REG. 7-6-2004.
- 2,859,663. TOTAL QUALITY FRANCHISING. INT. CL. 35. (U.S. CLS. 100, 101 AND 102). REG. 7-6-2004.
- 2,859,678. LP LITIGATION PRESENTATION AND DESIGN. INT. CL. 42. (U.S. CLS. 100 AND 101). REG. 7-6-2004.
- 2,859,691. BENEFITMALL. INT. CLS. 35 AND 36. (U.S. CLS. 100, 101 AND 102). REG. 7-6-2004.
- 2,859,752. SILQUAT. INT. CL. 1. (U.S. CLS. 1, 5, 6, 10, 26 AND 46). REG. 7-6-2004.
- 2,859,759. NATIONAL ASSOCIATION OF CORPORATE DIRECTORS. INT. CLS. 16, 35 AND 41. (U.S. CLS. 2, 5, 22, 23, 29, 37, 38, 50, 100, 101, 102 AND 107). REG. 7-6-2004.
- 2,859,760. NACD. INT. CLS. 16, 35 AND 41. (U.S. CLS. 2, 5, 22, 23, 29, 37, 38, 50, 100, 101, 102 AND 107). REG. 7-6-2004.
- 2,859,768. RHYTHM & CULTURE. INT. CLS. 9 AND 25. (U.S. CLS. 21, 22, 23, 26, 36, 38 AND 39). REG. 7-6-2004.
- 2,859,848. A ACERAY AND DESIGN. INT. CLS. 20 AND 40. (U.S. CLS. 2, 13, 22, 25, 32, 50, 100, 103 AND 106). REG. 7-6-2004.
- 2,859,860. MAOLA AND DESIGN. INT. CL. 30. (U.S. CL. 46). REG. 7-6-2004.
- 2,859,899. UNCLAIMED DIAMONDS. INT. CL. 35. (U.S. CLS. 100, 101 AND 102). REG. 7-6-2004.
- 2,859,911. BRANDASSEMBLER. INT. CL. 35. (U.S. CLS. 100, 101 AND 102). REG. 7-6-2004.
- 2,859,939. EUROCINE. INT. CLS. 1, 5 AND 42. (U.S. CLS. 1, 5, 6, 10, 18, 26, 44, 46, 51, 52, 100 AND 101). REG. 7-6-2004.
- 2,859,955. MICHEL CLUIZEL. INT. CL. 30. (U.S. CL. 46). REG. 7-6-2004.
- 2,859,976. M MARKETRON AND DESIGN. INT. CL. 41. (U.S. CLS. 100, 101 AND 107). REG. 7-6-2004.
- 2,859,999. EP ENTERTAINMENT PARTNERS AND DESIGN. INT. CLS. 9, 35, 36 AND 42. (U.S. CLS. 21, 23, 26, 36, 38, 100, 101 AND 102). REG. 7-6-2004.
- 2,860,016. IST TO KNOW. INT. CL. 36. (U.S. CLS. 100, 101 AND 102). REG. 7-6-2004.
- 2,860,027. BLADERUNNER. INT. CL. 12. (U.S. CLS. 19, 21, 23, 31, 35 AND 44). REG. 7-6-2004.
- 2,860,081. THE LUDACRIS FOUNDATION. INT. CL. 25. (U.S. CLS. 22 AND 39). REG. 7-6-2004.
- 2,860,088. ABSOLUTE WHITE. INT. CL. 3. (U.S. CLS. 1, 4, 6, 50, 51 AND 52). REG. 7-6-2004.
- 2,860,193. TRUE NORTH KNIVES. TNK AND DESIGN. INT. CL. 8. (U.S. CLS. 23, 28 AND 44). REG. 7-6-2004.
- 2,860,296. CPI CARD GROUP AND DESIGN. INT. CLS. 9, 16 AND 20. (U.S. CLS. 2, 5, 13, 21, 22, 23, 25, 26, 29, 32, 36, 37, 38 AND 50). REG. 7-6-2004.
- 2,860,320. SAM THE COOKING GUY. INT. CL. 41. (U.S. CLS. 100, 101 AND 107). REG. 7-6-2004.
- 2,860,403. GRYPHIUS. INT. CL. 9. (U.S. CLS. 21, 23, 26, 36 AND 38). REG. 7-6-2004.
- 2,860,404. CAFE MIMI. INT. CL. 9. (U.S. CLS. 21, 23, 26, 36 AND 38). REG. 7-6-2004.
- 2,860,410. PHOCON. INT. CL. 1. (U.S. CLS. 1, 5, 6, 10, 26 AND 46). REG. 7-6-2004.
- 2,860,475. MISCELLANEOUS DESIGN. INT. CL. 9 ONLY. (U.S. CLS. 21, 23, 26, 36 AND 38). REG. 7-6-2004.
- 2,860,528. PRESTOLITE. INT. CLS. 7 AND 9. (U.S. CLS. 13, 19, 21, 23, 26, 31, 34, 35, 36 AND 38). REG. 7-6-2004.
- 2,860,545. RIDE EVERYWHERE. INT. CL. 35. (U.S. CLS. 100, 101 AND 102). REG. 7-6-2004.
- 2,860,589. HYOSUNG. INT. CL. 6. (U.S. CLS. 2, 12, 13, 14, 23, 25 AND 50). REG. 7-6-2004.
- 2,860,590. CHATEAU ANDRE ZILTENER. INT. CL. 33. (U.S. CLS. 47 AND 49). REG. 7-6-2004.
- 2,860,730. XYREM. INT. CL. 5. (U.S. CLS. 6, 18, 44, 46, 51 AND 52). REG. 7-6-2004.
- 2,860,737. C3 (STYLIZED). INT. CL. 10. (U.S. CLS. 26, 39 AND 44). REG. 7-6-2004.
- 2,860,767. BATTLESHIP NEW JERSEY AND DESIGN. INT. CLS. 9, 14, 16, 18, 21, 25, 26, 28, 35 AND 41. (U.S. CLS. 1, 2, 3, 5, 13, 21, 22, 23, 26, 27, 28, 29, 30, 33, 36, 37, 38, 39, 40, 41, 42, 50, 100, 101, 102 AND 107). REG. 7-6-2004.
- 2,860,768. NINJA GAIDEN. INT. CL. 9. (U.S. CLS. 21, 23, 26, 36 AND 38). REG. 7-6-2004.
- 2,860,837. MYSTIC HEROES. INT. CL. 9. (U.S. CLS. 21, 23, 26, 36 AND 38). REG. 7-6-2004.
- 2,860,848. E-Z SKALPER. INT. CL. 7. (U.S. CLS. 13, 19, 21, 23, 31, 34 AND 35). REG. 7-6-2004.
- 2,860,915. SABIA. INT. CLS. 9 AND 37. (U.S. CLS. 21, 23, 26, 36, 38, 100, 103 AND 106). REG. 7-6-2004.
- 2,860,955. HUSKY. INT. CLS. 7 AND 8 ONLY. (U.S. CLS. 13, 19, 21, 23, 28, 31, 34, 35 AND 44). REG. 7-6-2004.
- 2,860,999. AIMBRIDGE. INT. CL. 36. (U.S. CLS. 100, 101 AND 102). REG. 7-6-2004.
- 2,861,024. AQUACAT. INT. CL. 1. (U.S. CLS. 1, 5, 6, 10, 26 AND 46). REG. 7-6-2004.
- 2,861,037. ENVIRONMENTAL CLASS. INT. CL. 19. (U.S. CLS. 1, 12, 33 AND 50). REG. 7-6-2004.
- 2,861,089. PALAZZO SERIES. INT. CL. 19. (U.S. CLS. 1, 12, 33 AND 50). REG. 7-6-2004.
- 2,861,288. TRV. INT. CL. 12. (U.S. CLS. 19, 21, 23, 31, 35 AND 44). REG. 7-6-2004.
- 2,861,325. QUADARM. INT. CLS. 40 AND 42. (U.S. CLS. 100, 101, 103 AND 106). REG. 7-6-2004.
- 2,861,327. BORN IN THE USA AND DESIGN. INT. CL. 12. (U.S. CLS. 19, 21, 23, 31, 35 AND 44). REG. 7-6-2004.
- 2,861,345. SCANTRON AND DESIGN. INT. CLS. 9, 16, 35, 37, 38, 41 AND 42. (U.S. CLS. 2, 5, 21, 22, 23, 26, 29, 36, 37, 38, 50, 100, 101, 102, 103, 104, 106 AND 107). REG. 7-6-2004.
- 2,861,390. MARIACHI MADNESS. INT. CL. 9. (U.S. CLS. 21, 23, 26, 36 AND 38). REG. 7-6-2004.
- 2,861,538. HICKORY RIVER SMOKEHOUSE. INT. CLS. 35 AND 43. (U.S. CLS. 100, 101 AND 102). REG. 7-6-2004.
- 2,861,636. SKI SKOOT. INT. CL. 28. (U.S. CLS. 22, 23, 38 AND 50). REG. 7-6-2004.
- 2,861,661. SOFTCURVE. INT. CL. 6. (U.S. CLS. 2, 12, 13, 14, 23, 25 AND 50). REG. 7-6-2004.
- 2,861,681. ANTIS (STYLIZED). INT. CL. 33. (U.S. CLS. 47 AND 49). REG. 7-6-2004.
- 2,861,692. MERCER STREET STUDIO. INT. CL. 25. (U.S. CLS. 22 AND 39). REG. 7-6-2004.
- 2,861,717. MODIFIED.COM. INT. CL. 41. (U.S. CLS. 100, 101 AND 107). REG. 7-6-2004.
- 2,861,761. THE ARCHITECTURAL COLOR COLLECTION. INT. CL. 19. (U.S. CLS. 1, 12, 33 AND 50). REG. 7-6-2004.
- 2,861,796. BUILDING SAFETY JOURNAL. INT. CL. 41. (U.S. CLS. 100, 101 AND 107). REG. 7-6-2004.
- 2,861,813. LANSYSTEM. INT. CL. 9. (U.S. CLS. 21, 23, 26, 36 AND 38). REG. 7-6-2004.
- 2,861,848. ONE TOUCH. INT. CL. 9. (U.S. CLS. 21, 23, 26, 36 AND 38). REG. 7-13-2004.
- 2,861,859. EC155. INT. CLS. 9, 12 AND 28 ONLY. (U.S. CLS. 19, 21, 22, 23, 26, 31, 35, 36, 38, 44 AND 50). REG. 7-13-2004.
- 2,861,996. MISCELLANEOUS DESIGN. INT. CL. 16. (U.S. CLS. 2, 5, 22, 23, 29, 37, 38 AND 50). REG. 7-13-2004.
- 2,862,029. ATLANTIS. INT. CL. 9. (U.S. CLS. 21, 23, 26, 36 AND 38). REG. 7-13-2004.
- 2,862,094. YEF. INT. CLS. 35 AND 36. (U.S. CLS. 100, 101 AND 102). REG. 7-13-2004.
- 2,862,113. ENERGIE (STYLIZED). INT. CLS. 11 AND 35. (U.S. CLS. 13, 21, 23, 31, 34, 100, 101 AND 102). REG. 7-13-2004.
- 2,862,184. CONDUCTOP. INT. CL. 2. (U.S. CLS. 6, 11 AND 16). REG. 7-13-2004.
- 2,862,376. PROBLOC. INT. CL. 10. (U.S. CLS. 26, 39 AND 44). REG. 7-13-2004.
- 2,862,388. MISCELLANEOUS DESIGN. INT. CL. 35. (U.S. CLS. 100, 101 AND 102). REG. 7-13-2004.
- 2,862,401. VENICA. INT. CL. 33. (U.S. CLS. 47 AND 49). REG. 7-13-2004.
- 2,862,461. LIFETIME SKIN CARE CENTERS AND DESIGN. INT. CL. 44. (U.S. CLS. 100 AND 101). REG. 7-13-2004.
- 2,862,506. PICKOSOFT. INT. CLS. 9 AND 42. (U.S. CLS. 21, 23, 26, 36, 38, 100 AND 101). REG. 7-13-2004.
- 2,862,646. CINEVILLE. INT. CL. 41. (U.S. CLS. 100, 101 AND 107). REG. 7-13-2004.
- 2,862,823. RAZZPOTLE. INT. CL. 30. (U.S. CL. 46). REG. 7-13-2004.
- 2,862,848. IEEE AND DESIGN. INT. CLS. 16 AND 41. (U.S. CLS. 2, 5, 22, 23, 29, 37, 38, 50, 100, 101 AND 107). REG. 7-13-2004.

- 2,862,938. HELPING PEOPLE CREATE, PROTECT AND PRESERVE THEIR NET WORTH. INT. CL. 36. (U.S. CLS. 100, 101 AND 102). REG. 7-13-2004.
- 2,862,960. EVERGREEN CHILDREN'S ACADEMY AND DESIGN. INT. CL. 41. (U.S. CLS. 100, 101 AND 107). REG. 7-13-2004.
- 2,862,978. MUDSOLV. INT. CLS. 1 AND 37. (U.S. CLS. 1, 5, 6, 10, 26, 46, 100, 103 AND 106). REG. 7-13-2004.
- 2,863,002. PURE GIVING.COM ENVIRONMENTAL LIFESTYLE GIFTS AND DESIGN. INT. CL. 3 ONLY. (U.S. CLS. 1, 4, 6, 50, 51 AND 52). REG. 7-13-2004.
- 2,863,011. ACCESS SERIES. INT. CL. 12. (U.S. CLS. 19, 21, 23, 31, 35 AND 44). REG. 7-13-2004.
- 2,863,014. PUREGIVING. INT. CL. 3 ONLY. (U.S. CLS. 1, 4, 6, 50, 51 AND 52). REG. 7-13-2004.
- 2,863,023. ELEADERTECH. INT. CL. 41. (U.S. CLS. 100, 101 AND 107). REG. 7-13-2004.
- 2,863,032. CHEF'SCHOICE. INT. CL. 30. (U.S. CL. 46). REG. 7-13-2004.
- 2,863,074. START SMART. INT. CL. 42 ONLY. (U.S. CLS. 100 AND 101). REG. 7-13-2004.
- 2,863,121. FIT-RITE AUTOMOTIVE. INT. CL. 35 ONLY. (U.S. CLS. 100, 101 AND 102). REG. 7-13-2004.
- 2,863,152. BSE. INT. CLS. 16, 36 AND 41. (U.S. CLS. 2, 5, 22, 23, 29, 37, 38, 50, 100, 101, 102 AND 107). REG. 7-13-2004.
- 2,863,198. PROMOS. INT. CL. 10. (U.S. CLS. 26, 39 AND 44). REG. 7-13-2004.
- 2,863,211. MEGASEAL. INT. CL. 2. (U.S. CLS. 6, 11 AND 16). REG. 7-13-2004.
- 2,863,230. CLIENTLINE. INT. CL. 36. (U.S. CLS. 100, 101 AND 102). REG. 7-13-2004.
- 2,863,260. CST DATA. INT. CLS. 39 AND 40. (U.S. CLS. 100, 103, 105 AND 106). REG. 7-13-2004.
- 2,863,371. ALION. INT. CLS. 35, 41 AND 42 ONLY. (U.S. CLS. 100, 101, 102 AND 107). REG. 7-13-2004.
- 2,863,382. WHERE RESEARCH INFORMS DESIGN. INT. CL. 41. (U.S. CLS. 100, 101 AND 107). REG. 7-13-2004.
- 2,863,456. BARRINGTON. INT. CL. 19. (U.S. CLS. 1, 12, 33 AND 50). REG. 7-13-2004.
- 2,863,485. HEDGE WIZARD. INT. CL. 7. (U.S. CLS. 13, 19, 21, 23, 31, 34 AND 35). REG. 7-13-2004.
- 2,863,535. INITIATIVE. INT. CL. 18. (U.S. CLS. 1, 2, 3, 22 AND 41). REG. 7-13-2004.
- 2,863,669. ENVISION. INT. CL. 31. (U.S. CLS. 1 AND 46). REG. 7-13-2004.
- 2,863,815. ULTRABUFFER. INT. CL. 9. (U.S. CLS. 21, 23, 26, 36 AND 38). REG. 7-13-2004.
- 2,863,910. SANTA.COM. INT. CL. 41. (U.S. CLS. 100, 101 AND 107). REG. 7-20-2004.
- 2,863,911. SANTA.COM. INT. CL. 42. (U.S. CLS. 100 AND 101). REG. 7-20-2004.
- 2,863,912. SANTA.COM. INT. CL. 35. (U.S. CLS. 100, 101 AND 102). REG. 7-20-2004.
- 2,863,970. "TAKE CARE OF THE LAND, AND THE LAND WILL TAKE CARE OF YOU". INT. CL. 19. (U.S. CLS. 1, 12, 33 AND 50). REG. 7-20-2004.
- 2,864,009. THE ENTREPRENEURS NAVIGATOR SYSTEM. INT. CLS. 36 AND 41. (U.S. CLS. 100, 101, 102 AND 107). REG. 7-20-2004.
- 2,864,029. MANCHESTER UNITED. INT. CLS. 9, 14, 16, 18, 20, 21, 24, 25, 27 AND 28 ONLY. (U.S. CLS. 1, 2, 3, 5, 13, 19, 20, 21, 22, 23, 25, 26, 27, 28, 29, 30, 32, 33, 36, 37, 38, 39, 40, 41, 42 AND 50). REG. 7-20-2004.
- 2,864,080. ROTOSOUND AND DESIGN. INT. CL. 15. (U.S. CLS. 2, 21 AND 36). REG. 7-20-2004.
- 2,864,088. BRECKENRIDGE. INT. CL. 41. (U.S. CLS. 100, 101 AND 107). REG. 7-20-2004.
- 2,864,102. CLECO AND DESIGN. INT. CLS. 35, 36, 37, 39 AND 40. (U.S. CLS. 100, 101, 102, 103, 105 AND 106). REG. 7-20-2004.
- 2,864,157. SO-CAL SPEED SHOP EST. 1946 AND DESIGN. INT. CL. 12. (U.S. CLS. 19, 21, 23, 31, 35 AND 44). REG. 7-20-2004.
- 2,864,219. EVERSTRAIGHT QC AND DESIGN. INT. CLS. 7 AND 12. (U.S. CLS. 13, 19, 21, 23, 31, 34, 35 AND 44). REG. 7-20-2004.
- 2,864,320. GMR. INT. CL. 35. (U.S. CLS. 100, 101 AND 102). REG. 7-20-2004.
- 2,864,369. MISCELLANEOUS DESIGN. INT. CL. 35. (U.S. CLS. 100, 101 AND 102). REG. 7-20-2004.
- 2,864,370. MISCELLANEOUS DESIGN. INT. CL. 35. (U.S. CLS. 100, 101 AND 102). REG. 7-20-2004.
- 2,864,371. MISCELLANEOUS DESIGN. INT. CL. 37. (U.S. CLS. 100, 103 AND 106). REG. 7-20-2004.
- 2,864,444. HSI. INT. CLS. 16 AND 44. (U.S. CLS. 2, 5, 22, 23, 29, 37, 38, 50, 100 AND 101). REG. 7-20-2004.
- 2,864,482. EUREDUC. INT. CL. 10. (U.S. CLS. 26, 39 AND 44). REG. 7-20-2004.
- 2,864,574. THE FRESH GROCER. INT. CL. 35. (U.S. CLS. 100, 101 AND 102). REG. 7-20-2004.
- 2,864,784. SANOGUARD AND DESIGN. INT. CL. 5. (U.S. CLS. 6, 18, 44, 46, 51 AND 52). REG. 7-20-2004.
- 2,864,819. ROADTRIP. INT. CL. 11 ONLY. (U.S. CLS. 13, 21, 23, 31 AND 34). REG. 7-20-2004.
- 2,864,837. MEDCAP. INT. CL. 36. (U.S. CLS. 100, 101 AND 102). REG. 7-20-2004.
- 2,864,842. AMERICA'S FAVORITE GARAGE DOORS. INT. CL. 19. (U.S. CLS. 1, 12, 33 AND 50). REG. 7-20-2004.
- 2,864,849. EPIS. INT. CLS. 35 AND 42. (U.S. CLS. 100, 101 AND 102). REG. 7-20-2004.
- 2,864,888. VERSA-LASTIC. INT. CL. 10. (U.S. CLS. 26, 39 AND 44). REG. 7-20-2004.
- 2,864,906. XENOCOS. INT. CL. 42. (U.S. CLS. 100 AND 101). REG. 7-20-2004.
- 2,864,927. SUPER MONKEY BALL. INT. CL. 9. (U.S. CLS. 21, 23, 26, 36 AND 38). REG. 7-20-2004.
- 2,864,978. MISCELLANEOUS DESIGN. INT. CLS. 3, 10, 25 AND 35. (U.S. CLS. 1, 4, 6, 22, 26, 39, 44, 50, 51, 52, 100, 101 AND 102). REG. 7-20-2004.
- 2,865,002. SALVATOR. INT. CL. 32. (U.S. CLS. 45, 46 AND 48). REG. 7-20-2004.
- 2,865,046. "FRIENDLY SERVICE, NO SURPRISES!" STANDARD CHARACTER MARK. INT. CL. 42. (U.S. CLS. 100 AND 101). REG. 7-20-2004.
- 2,865,079. MATERNE. INT. CL. 29. (U.S. CL. 46). REG. 7-20-2004.
- 2,865,136. A S ARTISTIC SILVER AND DESIGN. INT. CL. 14. (U.S. CLS. 2, 27, 28 AND 50). REG. 7-20-2004.
- 2,865,187. INGA. INT. CL. 33. (U.S. CLS. 47 AND 49). REG. 7-20-2004.
- 2,865,402. ACTIONVIEW. INT. CL. 36. (U.S. CLS. 100, 101 AND 102). REG. 7-20-2004.
- 2,865,408. ROCKWELL COLLINS. INT. CL. 9. (U.S. CLS. 21, 23, 26, 36 AND 38). REG. 7-20-2004.
- 2,865,515. PIPCO. INT. CL. 25. (U.S. CLS. 22 AND 39). REG. 7-20-2004.
- 2,865,684. MOR. INT. CL. 9. (U.S. CLS. 21, 23, 26, 36 AND 38). REG. 7-20-2004.
- 2,865,688. ARIMAA. INT. CL. 28. (U.S. CLS. 22, 23, 38 AND 50). REG. 7-20-2004.
- 2,865,703. AEROPILATES. INT. CL. 28. (U.S. CLS. 22, 23, 38 AND 50). REG. 7-20-2004.
- 2,865,720. COLORLOGIC. INT. CL. 11. (U.S. CLS. 13, 21, 23, 31 AND 34). REG. 7-20-2004.
- 2,865,746. POPSTER. INT. CL. 9. (U.S. CLS. 21, 23, 26, 36 AND 38). REG. 7-20-2004.
- 2,865,963. PROMONTORY THE RANCH CLUB AND DESIGN. INT. CL. 37. (U.S. CLS. 100, 103 AND 106). REG. 7-27-2004.
- 2,865,964. PROMONTORY THE RANCH CLUB AND DESIGN. INT. CL. 36. (U.S. CLS. 100, 101 AND 102). REG. 7-27-2004.
- 2,866,164. COLLEGE EXPRESS. INT. CL. 39. (U.S. CLS. 100 AND 105). REG. 7-27-2004.
- 2,866,165. DIPLOMA SHOWCASE FRAMES. INT. CL. 16. (U.S. CLS. 2, 5, 22, 23, 29, 37, 38 AND 50). REG. 7-27-2004.
- 2,866,170. CHARLIE CHIANG'S. INT. CLS. 29, 35 AND 43. (U.S. CLS. 46, 100, 101 AND 102). REG. 7-27-2004.
- 2,866,314. BIOFOAM (STYLIZED). INT. CL. 21. (U.S. CLS. 2, 13, 23, 29, 30, 33, 40 AND 50). REG. 7-27-2004.
- 2,866,465. EXAM ADVANTAGE. INT. CL. 9. (U.S. CLS. 21, 23, 26, 36 AND 38). REG. 7-27-2004.
- 2,866,541. ONE WORKNET. INT. CLS. 35 AND 42. (U.S. CLS. 100, 101 AND 102). REG. 7-27-2004.
- 2,866,600. PASSKEY-ENABLED. INT. CL. 42. (U.S. CLS. 100 AND 101). REG. 7-27-2004.
- 2,866,683. CIVILIAN RATIONS (C-RATS). INT. CL. 39. (U.S. CLS. 100 AND 105). REG. 7-27-2004.
- 2,866,699. INTEGRE. INT. CL. 42. (U.S. CLS. 100 AND 101). REG. 7-27-2004.
- 2,866,770. SAL FRY AND DESIGN. INT. CL. 29. (U.S. CL. 46). REG. 7-27-2004.
- 2,866,787. MOSQUITOMAX MISTING SYSTEMS AND DESIGN. INT. CL. 9. (U.S. CLS. 21, 23, 26, 36 AND 38). REG. 7-27-2004.

- 2,866,812. SHAPERS. INT. CL. 6. (U.S. CLS. 2, 12, 13, 14, 23, 25 AND 50). REG. 7-27-2004.
- 2,866,813. WHITE LIGHTNING. INT. CL. 5. (U.S. CLS. 6, 18, 44, 46, 51 AND 52). REG. 7-27-2004.
- 2,866,986. YOU'RE THE CHEF AND DESIGN. INT. CLS. 16, 21, 25 AND 41. (U.S. CLS. 2, 5, 13, 22, 23, 29, 30, 33, 37, 38, 39, 40, 50, 100, 101 AND 107). REG. 7-27-2004.
- 2,867,049. PLAYONLINE (STYLIZED). INT. CLS. 9 AND 41 ONLY. (U.S. CLS. 21, 23, 26, 36, 38, 100, 101 AND 107). REG. 7-27-2004.
- 2,867,158. JACK DANIEL'S OLD NO.7 BRAND TENNESSEE WHISKEY AND DESIGN. INT. CL. 21. (U.S. CLS. 2, 13, 23, 29, 30, 33, 40 AND 50). REG. 7-27-2004.
- 2,867,292. OPSXML. INT. CL. 9. (U.S. CLS. 21, 23, 26, 36 AND 38). REG. 7-27-2004.
- 2,867,371. DELTA. INT. CL. 20. (U.S. CLS. 2, 13, 22, 25, 32 AND 50). REG. 7-27-2004.
- 2,867,419. PROSANTÉ (STYLIZED). INT. CL. 3. (U.S. CLS. 1, 4, 6, 50, 51 AND 52). REG. 7-27-2004.
- 2,868,017. LIVE LIFE TO THE FRESHEST. INT. CL. 43. (U.S. CLS. 100 AND 101). REG. 7-27-2004.
- 2,868,032. FORNO DE MINAS AND DESIGN. INT. CL. 30. (U.S. CL. 46). REG. 7-27-2004.
- 2,868,088. DESIGN YOUR MATS. INT. CL. 40. (U.S. CLS. 100, 103 AND 106). REG. 7-27-2004.
- 2,868,146. SWISS WATCH INTERNATIONAL. INT. CL. 14 ONLY. (U.S. CLS. 2, 27, 28 AND 50). REG. 7-27-2004.
- 2,868,237. DREAM CREAM. INT. CL. 3. (U.S. CLS. 1, 4, 6, 50, 51 AND 52). REG. 8-3-2004.
- 2,868,346. ST BARTH. INT. CLS. 35, 41 AND 44. (U.S. CLS. 100, 101, 102 AND 107). REG. 8-3-2004.
- 2,868,523. DAVACO. INT. CL. 37. (U.S. CLS. 100, 103 AND 106). REG. 8-3-2004.
- 2,868,524. DAVACO AND DESIGN. INT. CL. 37. (U.S. CLS. 100, 103 AND 106). REG. 8-3-2004.
- 2,868,635. W OLD WAVERLY AND DESIGN. INT. CLS. 36, 37 AND 41 ONLY. (U.S. CLS. 100, 101, 102, 103, 106 AND 107). REG. 8-3-2004.
- 2,868,765. SELLE SAN MARCO AND DESIGN. INT. CL. 12. (U.S. CLS. 19, 21, 23, 31, 35 AND 44). REG. 8-3-2004.
- 2,868,873. APHL. INT. CLS. 16, 35 AND 41. (U.S. CLS. 2, 5, 22, 23, 29, 37, 38, 50, 100, 101, 102 AND 107). REG. 8-3-2004.
- 2,868,992. IMAGINE IT...WE CAN DO IT!. INT. CL. 40. (U.S. CLS. 100, 103 AND 106). REG. 8-3-2004.
- 2,869,029. CHAN LUU. INT. CL. 14. (U.S. CLS. 2, 27, 28 AND 50). REG. 8-3-2004.
- 2,869,439. GAMMAPLEX. INT. CL. 5. (U.S. CLS. 6, 18, 44, 46, 51 AND 52). REG. 8-3-2004.
- 2,869,531. SAL-FRY STANDARD CHARACTER MARK. INT. CL. 29. (U.S. CL. 46). REG. 8-3-2004.
- 2,869,687. THE ZEPPELIN. INT. CL. 29. (U.S. CL. 46). REG. 8-3-2004.
- 2,869,691. C-5 GALAXY. INT. CL. 29. (U.S. CL. 46). REG. 8-3-2004.
- 2,869,741. TRI-JETS. INT. CL. 36. (U.S. CLS. 100, 101 AND 102). REG. 8-3-2004.
- 2,869,874. PRO PATCH STANDARD CHARACTER MARK. INT. CL. 9. (U.S. CLS. 21, 23, 26, 36 AND 38). REG. 8-3-2004.
- 2,869,935. AUTOZORB. INT. CL. 17. (U.S. CLS. 1, 5, 12, 13, 35 AND 50). REG. 8-3-2004.
- 2,869,985. PERQUE TRIPLE EFA GUARD. INT. CL. 5. (U.S. CLS. 6, 18, 44, 46, 51 AND 52). REG. 8-3-2004.
- 2,869,992. HENRY DAVID THOREAU SCHOLARSHIPS. INT. CLS. 35 AND 36. (U.S. CLS. 100, 101 AND 102). REG. 8-3-2004.
- 2,870,210. RRT-NPS. U.S. CL. 200. REG. 8-3-2004.
- 2,870,211. CRT-NPS. U.S. CL. 200. REG. 8-3-2004.
- 2,870,212. REVOLUTIONARY PRODUCTS FOR THE FOOD INDUSTRY. INT. CL. 18. (U.S. CLS. 1, 2, 3, 22 AND 41). REG. 8-3-2004.
- 2,870,284. ALAMO INDUSTRIAL AND DESIGN. INT. CLS. 7 AND 35. (U.S. CLS. 13, 19, 21, 23, 31, 34, 35, 100, 101 AND 102). REG. 8-3-2004.
- 2,870,432. PORK CHECKOFF (STYLIZED). INT. CLS. 16, 25, 35 AND 41. (U.S. CLS. 2, 5, 22, 23, 29, 37, 38, 39, 50, 100, 101, 102 AND 107). REG. 8-3-2004.
- 2,870,520. SP 345. INT. CL. 12. (U.S. CLS. 19, 21, 23, 31, 35 AND 44). REG. 8-3-2004.
- 2,870,546. AQUA TEEN HUNGER FORCE. INT. CL. 25. (U.S. CLS. 22 AND 39). REG. 8-3-2004.
- 2,870,627. POCKET SNAILS. INT. CL. 9. (U.S. CLS. 21, 23, 26, 36 AND 38). REG. 8-3-2004.
- 2,870,877. BEACHGLASS HAWAII. INT. CLS. 14 AND 35. (U.S. CLS. 2, 27, 28, 50, 100, 101 AND 102). REG. 8-10-2004.
- 2,870,944. RENT-A-CENTER. INT. CLS. 40, 41, 42 AND 43. (U.S. CLS. 100, 101, 103, 106 AND 107). REG. 8-10-2004.
- 2,870,954. DISNEY'S BEAUTY AND THE BEAST. INT. CL. 25. (U.S. CLS. 22 AND 39). REG. 8-10-2004.
- 2,871,009. BOAT TO PLATE IN 48. INT. CLS. 35 AND 39. (U.S. CLS. 100, 101, 102 AND 105). REG. 8-10-2004.
- 2,871,210. CYBERSOFT. INT. CLS. 9, 41 AND 42. (U.S. CLS. 21, 23, 26, 36, 38, 100, 101 AND 107). REG. 8-10-2004.
- 2,871,292. FLYING FOSSILS. INT. CL. 37. (U.S. CLS. 100, 103 AND 106). REG. 8-10-2004.
- 2,872,000. FIRST POINT. INT. CLS. 35 AND 45 ONLY. (U.S. CLS. 100, 101 AND 102). REG. 8-10-2004.
- 2,872,086. CARBODILITE. INT. CL. 1 ONLY. (U.S. CLS. 1, 5, 6, 10, 26 AND 46). REG. 8-10-2004.
- 2,872,131. CO> OPERATION AND DESIGN. INT. CL. 9. (U.S. CLS. 21, 23, 26, 36 AND 38). REG. 8-10-2004.
- 2,872,327. ALTAMIRA. INT. CL. 35. (U.S. CLS. 100, 101 AND 102). REG. 8-10-2004.
- 2,872,379. DUONEB AND DESIGN. INT. CL. 5. (U.S. CLS. 6, 18, 44, 46, 51 AND 52). REG. 8-10-2004.
- 2,872,678. PREVIFEM. INT. CL. 5. (U.S. CLS. 6, 18, 44, 46, 51 AND 52). REG. 8-10-2004.
- 2,872,679. TRI-PREVIFEM. INT. CL. 5. (U.S. CLS. 6, 18, 44, 46, 51 AND 52). REG. 8-10-2004.
- 2,872,705. BRASS RANCH. INT. CL. 35. (U.S. CLS. 100, 101 AND 102). REG. 8-10-2004.
- 2,872,855. CARLTON. INT. CL. 14. (U.S. CLS. 2, 27, 28 AND 50). REG. 8-10-2004.
- 2,872,936. BRADY'S. INT. CL. 33. (U.S. CLS. 47 AND 49). REG. 8-10-2004.
- 2,872,938. CARDIO ROCK. INT. CL. 9. (U.S. CLS. 21, 23, 26, 36 AND 38). REG. 8-10-2004.
- 2,873,181. AKUCCELL. INT. CL. 1. (U.S. CLS. 1, 5, 6, 10, 26 AND 46). REG. 8-17-2004.
- 2,873,340. LYNX. INT. CL. 9. (U.S. CLS. 21, 23, 26, 36 AND 38). REG. 8-17-2004.
- 2,873,343. HIGH FIVE POKER AND DESIGN. INT. CL. 41. (U.S. CLS. 100, 101 AND 107). REG. 8-17-2004.
- 2,873,664. CAREER CARE ABOUT MAKING A DIFFERENCE. INT. CL. 35. (U.S. CLS. 100, 101 AND 102). REG. 8-17-2004.
- 2,873,803. EUSTIS INSURANCE & BENEFITS. INT. CL. 36. (U.S. CLS. 100, 101 AND 102). REG. 8-17-2004.
- 2,873,804. EUSTIS INSURANCE. INT. CL. 36. (U.S. CLS. 100, 101 AND 102). REG. 8-17-2004.
- 2,873,939. CELLMAX. INT. CLS. 3 AND 5. (U.S. CLS. 1, 4, 6, 18, 44, 46, 50, 51 AND 52). REG. 8-17-2004.
- 2,874,138. AAASUITE. INT. CL. 9. (U.S. CLS. 21, 23, 26, 36 AND 38). REG. 8-17-2004.
- 2,874,425. PEPZINGI AND DESIGN. INT. CL. 5. (U.S. CLS. 6, 18, 44, 46, 51 AND 52). REG. 8-17-2004.
- 2,874,508. MASTER'S TOUCH. INT. CL. 30. (U.S. CL. 46). REG. 8-17-2004.
- 2,874,570. IT'S WOEBER'S FOR GOODNESS SAKES. INT. CL. 35. (U.S. CLS. 100, 101 AND 102). REG. 8-17-2004.
- 2,874,574. MISCELLANEOUS DESIGN. INT. CL. 31. (U.S. CLS. 1 AND 46). REG. 8-17-2004.
- 2,875,487. MANIFOLD PRODUCTS. INT. CL. 42 ONLY. (U.S. CLS. 100 AND 101). REG. 8-17-2004.
- 2,875,551. FIRE BET. INT. CL. 41. (U.S. CLS. 100, 101 AND 107). REG. 8-17-2004.
- 2,875,711. PAN PA'YA! AND DESIGN. INT. CLS. 35 AND 43. (U.S. CLS. 100, 101 AND 102). REG. 8-17-2004.
- 2,875,712. RÉ VIVE. GET THE GLOW. (STYLIZED). INT. CL. 3. (U.S. CLS. 1, 4, 6, 50, 51 AND 52). REG. 8-17-2004.
- 2,875,944. MISCELLANEOUS DESIGN. INT. CL. 11 ONLY. (U.S. CLS. 13, 21, 23, 31 AND 34). REG. 8-24-2004.
- 2,876,220. AIR FRANCE. INT. CL. 39. (U.S. CLS. 100 AND 105). REG. 8-24-2004.
- 2,876,494. NASHVILLE WRAPS (STYLIZED). INT. CLS. 16 AND 35. (U.S. CLS. 2, 5, 22, 23, 29, 37, 38, 50, 100, 101 AND 102). REG. 8-24-2004.

- 2,876,601. EUSTIS BENEFITS. INT. CL. 36. (U.S. CLS. 100, 101 AND 102). REG. 8-24-2004.
- 2,876,771. OSGI. INT. CL. 9. (U.S. CLS. 21, 23, 26, 36 AND 38). REG. 8-24-2004.
- 2,877,221. THANK YOU AND DESIGN. INT. CL. 29 ONLY. (U.S. CL. 46). REG. 8-24-2004.
- 2,877,275. TWILLY. INT. CL. 25. (U.S. CLS. 22 AND 39). REG. 8-24-2004.
- 2,877,366. BRAIN HIGHWAYS. INT. CLS. 9 AND 41. (U.S. CLS. 21, 23, 26, 36, 38, 100, 101 AND 107). REG. 8-24-2004.
- 2,878,723. LEWIS LABS RDA. INT. CL. 5. (U.S. CLS. 6, 18, 44, 46, 51 AND 52). REG. 8-31-2004.
- 2,879,789. WHISPER ROCK. INT. CLS. 25, 36, 37, 41 AND 42. (U.S. CLS. 22, 39, 100, 101, 102, 103, 106 AND 107). REG. 8-31-2004.
- 2,880,562. CARVERS. INT. CL. 42. (U.S. CLS. 100 AND 101). REG. 9-7-2004.
- 2,880,842. EX-FACTORY AND DESIGN. INT. CL. 35. (U.S. CLS. 100, 101 AND 102). REG. 9-7-2004.
- 2,880,843. X AND DESIGN. INT. CL. 35. (U.S. CLS. 100, 101 AND 102). REG. 9-7-2004.
- 2,881,662. EXTREME E. INT. CL. 7. (U.S. CLS. 13, 19, 21, 23, 31, 34 AND 35). REG. 9-7-2004.
- 2,881,993. JVM. INT. CL. 9. (U.S. CLS. 21, 23, 26, 36 AND 38). REG. 9-7-2004.
- 2,882,575. RED-TECH. INT. CL. 9. (U.S. CLS. 21, 23, 26, 36 AND 38). REG. 9-7-2004.
- 2,883,324. HAIR A GO-GO. INT. CL. 44. (U.S. CLS. 100 AND 101). REG. 9-7-2004.
- 2,883,510. RESISTANCE. INT. CL. 3 ONLY. (U.S. CLS. 1, 4, 6, 50, 51 AND 52). REG. 9-14-2004.
- 2,883,690. EX-FACTORY. INT. CL. 35. (U.S. CLS. 100, 101 AND 102). REG. 9-14-2004.
- 2,884,010. LAND O LAKES AND DESIGN. INT. CL. 29. (U.S. CL. 46). REG. 9-14-2004.
- 2,884,207. GRAUVELL. INT. CL. 28. (U.S. CLS. 22, 23, 38 AND 50). REG. 9-14-2004.
- 2,884,475. SWEET FREEDOM. INT. CL. 30. (U.S. CL. 46). REG. 9-14-2004.
- 2,884,574. Z-LOTION. INT. CL. 5. (U.S. CLS. 6, 18, 44, 46, 51 AND 52). REG. 9-14-2004.
- 2,884,784. POWERSHIP. INT. CL. 35. (U.S. CLS. 100, 101 AND 102). REG. 9-14-2004.
- 2,885,061. BELLEPORT. INT. CL. 18. (U.S. CLS. 1, 2, 3, 22 AND 41). REG. 9-14-2004.
- 2,885,558. GLOBAL. INT. CLS. 37 AND 39. (U.S. CLS. 100, 103, 105 AND 106). REG. 9-21-2004.
- 2,885,583. RBC AND DESIGN. INT. CLS. 35, 36 AND 42. (U.S. CLS. 100, 101 AND 102). REG. 9-21-2004.
- 2,885,594. GELLY ROLL AND DESIGN. INT. CL. 16. (U.S. CLS. 2, 5, 22, 23, 29, 37, 38 AND 50). REG. 9-21-2004.
- 2,885,637. TEKNIA. INT. CL. 3. (U.S. CLS. 1, 4, 6, 50, 51 AND 52). REG. 9-21-2004.
- 2,885,935. BODLEIAN LIBRARY. INT. CL. 16. (U.S. CLS. 2, 5, 22, 23, 29, 37, 38 AND 50). REG. 9-21-2004.
- 2,885,979. ASSOCIATION OF PUBLIC HEALTH LABORATORIES. INT. CLS. 16, 35 AND 41. (U.S. CLS. 2, 5, 22, 23, 29, 37, 38, 50, 100, 101, 102 AND 107). REG. 9-21-2004.
- 2,886,288. XENOC'S. INT. CL. 9. (U.S. CLS. 21, 23, 26, 36 AND 38). REG. 9-21-2004.
- 2,886,430. TVS AND DESIGN. INT. CL. 21. (U.S. CLS. 2, 13, 23, 29, 30, 33, 40 AND 50). REG. 9-21-2004.
- 2,886,676. OFFICERIGHT. INT. CL. 7. (U.S. CLS. 13, 19, 21, 23, 31, 34 AND 35). REG. 9-21-2004.
- 2,886,780. ERADICAL. INT. CL. 35. (U.S. CLS. 100, 101 AND 102). REG. 9-21-2004.
- 2,889,534. SERVICE AUTO GLASS. INT. CLS. 1 AND 12. (U.S. CLS. 1, 5, 6, 10, 19, 21, 23, 26, 31, 35, 44 AND 46). REG. 9-28-2004.
- 2,890,190. ALDECOUNT. INT. CL. 5. (U.S. CLS. 6, 18, 44, 46, 51 AND 52). REG. 9-28-2004.
- 2,890,265. PHOSEON TECHNOLOGY AND DESIGN. INT. CLS. 9 AND 11. (U.S. CLS. 13, 21, 23, 26, 31, 34, 36 AND 38). REG. 9-28-2004.
- 2,890,342. JOLLY CRITTERS. INT. CL. 28. (U.S. CLS. 22, 23, 38 AND 50). REG. 9-28-2004.
- 2,890,392. FERTILE FOCUS. INT. CL. 9. (U.S. CLS. 21, 23, 26, 36 AND 38). REG. 9-28-2004.
- 2,890,447. KNOX OUT. INT. CL. 1. (U.S. CLS. 1, 5, 6, 10, 26 AND 46). REG. 9-28-2004.
- 2,893,320. HOMEFREE (STYLIZED). INT. CL. 36. (U.S. CLS. 100, 101 AND 102). REG. 10-12-2004.
- 2,894,192. ILQ. INT. CL. 28. (U.S. CLS. 22, 23, 38 AND 50). REG. 10-19-2004.
- 2,895,717. MISCELLANEOUS DESIGN. INT. CL. 16. (U.S. CLS. 2, 5, 22, 23, 29, 37, 38 AND 50). REG. 10-19-2004.
- 2,896,185. BTL BACNET TESTING LABORATORIES AND DESIGN. U.S. CL. A. REG. 10-19-2004.
- 2,897,022. METALPROGETTI AND DESIGN. INT. CL. 7. (U.S. CLS. 13, 19, 21, 23, 31, 34 AND 35). REG. 10-26-2004.
- 2,897,041. OPODO AND DESIGN. INT. CLS. 39 AND 42 ONLY. (U.S. CLS. 100, 101 AND 105). REG. 10-26-2004.
- 2,897,318. PGA NATIONAL AND DESIGN. INT. CL. 25. (U.S. CLS. 22 AND 39). REG. 10-26-2004.
- 2,898,463. MOZART. INT. CL. 33. (U.S. CLS. 47 AND 49). REG. 11-2-2004.
- 2,898,809. CASCADE NATURAL GAS CORPORATION. INT. CL. 35. (U.S. CLS. 100, 101 AND 102). REG. 11-2-2004.
- 2,898,834. SP SPORT 270. INT. CL. 12. (U.S. CLS. 19, 21, 23, 31, 35 AND 44). REG. 11-2-2004.
- 2,899,112. REPAIR REMODEL RESTORE AND MORE. INT. CL. 37. (U.S. CLS. 100, 103 AND 106). REG. 11-2-2004.
- 2,899,491. TYSABRI. INT. CL. 5. (U.S. CLS. 6, 18, 44, 46, 51 AND 52). REG. 11-2-2004.
- 2,899,558. CLEARING THE PATH TO GLOBAL SUCCESS. INT. CL. 36. (U.S. CLS. 100, 101 AND 102). REG. 11-2-2004.
- 2,900,671. DXI. INT. CLS. 1, 9 AND 10. (U.S. CLS. 1, 5, 6, 10, 21, 23, 26, 36, 38, 39, 44 AND 46). REG. 11-2-2004.
- 2,901,557. HARVEST RESERVE. INT. CL. 29. (U.S. CL. 46). REG. 11-9-2004.
- 2,902,319. PRIMITIVE CHEF STANDARD CHARACTER MARK. INT. CL. 16. (U.S. CLS. 2, 5, 22, 23, 29, 37, 38 AND 50). REG. 11-9-2004.
- 2,903,890. FAGE 0 %. INT. CL. 29. (U.S. CL. 46). REG. 11-16-2004.
- 2,903,892. NOMARK PLUS. INT. CL. 17. (U.S. CLS. 1, 5, 12, 13, 35 AND 50). REG. 11-16-2004.
- 2,904,076. ENVIRON AND DESIGN. INT. CL. 3. (U.S. CLS. 1, 4, 6, 50, 51 AND 52). REG. 11-23-2004.
- 2,904,126. VISUALSONICS. INT. CLS. 9 AND 10. (U.S. CLS. 21, 23, 26, 36, 38, 39 AND 44). REG. 11-23-2004.
- 2,905,311. YOUR PETS, OUR PASSION. INT. CLS. 16, 18, 28, 31 AND 35 ONLY. (U.S. CLS. 1, 2, 3, 5, 22, 23, 29, 37, 38, 41, 46, 50, 100, 101 AND 102). REG. 11-23-2004.
- 2,905,765. BRINGING ART TO LIFE. INT. CLS. 35 AND 42. (U.S. CLS. 100, 101 AND 102). REG. 11-30-2004.
- 2,905,778. MISCELLANEOUS DESIGN. INT. CL. 44. (U.S. CLS. 100 AND 101). REG. 11-30-2004.
- 2,905,842. LEONI. INT. CL. 9. (U.S. CLS. 21, 23, 26, 36 AND 38). REG. 11-30-2004.
- 2,906,013. DUSTGUARD AND DESIGN. INT. CL. 9. (U.S. CLS. 21, 23, 26, 36 AND 38). REG. 11-30-2004.
- 2,906,454. AXES. INT. CLS. 9 AND 42. (U.S. CLS. 21, 23, 26, 36, 38, 100 AND 101). REG. 11-30-2004.
- 2,906,544. VIGNE FARMS. INT. CL. 41. (U.S. CLS. 100, 101 AND 107). REG. 11-30-2004.
- 2,906,736. GLASSYBABY STANDARD CHARACTER MARK. INT. CL. 21. (U.S. CLS. 2, 13, 23, 29, 30, 33, 40 AND 50). REG. 11-30-2004.
- 2,907,020. QIK JOE SAFEPET. INT. CL. 1. (U.S. CLS. 1, 5, 6, 10, 26 AND 46). REG. 11-30-2004.
- 2,907,536. LOG HOMES CANADA. INT. CLS. 19 AND 37. (U.S. CLS. 1, 12, 33, 50, 100, 103 AND 106). REG. 12-7-2004.
- 2,907,890. TIDBITS AND DESIGN. INT. CL. 16. (U.S. CLS. 2, 5, 22, 23, 29, 37, 38 AND 50). REG. 12-7-2004.
- 2,907,962. MICROGRIP (STYLIZED). INT. CL. 2. (U.S. CLS. 6, 11 AND 16). REG. 12-7-2004.
- 2,908,174. KING BABY. INT. CL. 14. (U.S. CLS. 2, 27, 28 AND 50). REG. 12-7-2004.
- 2,908,175. KING BABY AND DESIGN. INT. CL. 14. (U.S. CLS. 2, 27, 28 AND 50). REG. 12-7-2004.
- 2,908,290. NOLTING. INT. CL. 7. (U.S. CLS. 13, 19, 21, 23, 31, 34 AND 35). REG. 12-7-2004.
- 2,908,416. CVA. INT. CL. 41. (U.S. CLS. 100, 101 AND 107). REG. 12-7-2004.
- 2,908,841. ETCP STANDARD CHARACTER MARK. INT. CL. 35. (U.S. CLS. 100, 101 AND 102). REG. 12-7-2004.



- 2,909,529. MORRISON MANAGEMENT SPECIALISTS. INT. CLS. 43 AND 44. (U.S. CLS. 100 AND 101). REG. 12-14-2004.
- 2,909,533. FERROXCUBE AND DESIGN. INT. CLS. 9 AND 21. (U.S. CLS. 2, 13, 21, 23, 26, 29, 30, 33, 36, 38, 40 AND 50). REG. 12-14-2004.
- 2,910,746. BACHELOR ESB. INT. CL. 32. (U.S. CLS. 45, 46 AND 48). REG. 12-14-2004.
- 2,910,891. APCO INSTITUTE. INT. CLS. 16 AND 41. (U.S. CLS. 2, 5, 22, 23, 29, 37, 38, 50, 100, 101 AND 107). REG. 12-14-2004.
- 2,911,292. COLESON'S CATCH AND DESIGN. INT. CL. 29. (U.S. CL. 46). REG. 12-14-2004.
- 2,911,472. ISOMERS. INT. CLS. 3 AND 5. (U.S. CLS. 1, 4, 6, 18, 44, 46, 50, 51 AND 52). REG. 12-14-2004.
- 2,912,748. HOOP N BUDDYZ. INT. CL. 7. (U.S. CLS. 13, 19, 21, 23, 31, 34 AND 35). REG. 12-21-2004.
- 2,912,787. SRS TECHNOLOGY AND DESIGN. INT. CL. 7. (U.S. CLS. 13, 19, 21, 23, 31, 34 AND 35). REG. 12-21-2004.
- 2,913,137. DEAR ABBY STANDARD CHARACTER MARK. INT. CL. 16. (U.S. CLS. 2, 5, 22, 23, 29, 37, 38 AND 50). REG. 12-21-2004.
- 2,913,602. CHRIS CRAFT AND DESIGN. INT. CL. 24. (U.S. CLS. 42 AND 50). REG. 12-21-2004.
- 2,914,647. PRE POST STANDARD CHARACTER MARK. INT. CL. 5. (U.S. CLS. 6, 18, 44, 46, 51 AND 52). REG. 12-28-2004.
- 2,915,691. XTERRA AND DESIGN. INT. CL. 12. (U.S. CLS. 19, 21, 23, 31, 35 AND 44). REG. 1-4-2005.
- 2,917,659. FX INDEXLINK. INT. CL. 36. (U.S. CLS. 100, 101 AND 102). REG. 1-11-2005.
- 2,919,075. COLESON'S CATCH AND DESIGN. INT. CL. 29. (U.S. CL. 46). REG. 1-18-2005.
- 2,919,385. C COWAY AND DESIGN. INT. CL. 11. (U.S. CLS. 13, 21, 23, 31 AND 34). REG. 1-18-2005.
- 2,919,556. SEE TOMORROW TODAY. INT. CL. 44. (U.S. CLS. 100 AND 101). REG. 1-18-2005.
- 2,920,000. RAPIDMELTS. INT. CL. 5. (U.S. CLS. 6, 18, 44, 46, 51 AND 52). REG. 1-18-2005.
- 2,921,001. LAC (STYLIZED). INT. CL. 9. (U.S. CLS. 21, 23, 26, 36 AND 38). REG. 1-25-2005.
- 2,922,934. QUALITY AUTO CENTERS AND DESIGN. INT. CL. 37. (U.S. CLS. 100, 103 AND 106). REG. 2-1-2005.
- 2,922,985. THE BITTER TRUTH STANDARD CHARACTER MARK. INT. CL. 16. (U.S. CLS. 2, 5, 22, 23, 29, 37, 38 AND 50). REG. 2-1-2005.
- 2,923,065. FRANCHISE WORKS STANDARD CHARACTER MARK. INT. CL. 35. (U.S. CLS. 100, 101 AND 102). REG. 2-1-2005.
- 2,923,308. PURIFIER STANDARD CHARACTER MARK. INT. CL. 9. (U.S. CLS. 21, 23, 26, 36 AND 38). REG. 2-1-2005.
- 2,924,295. ARM & HAMMER. INT. CL. 16. (U.S. CLS. 2, 5, 22, 23, 29, 37, 38 AND 50). REG. 2-1-2005.
- 2,925,212. TRAILSOURCE STANDARD CHARACTER MARK. INT. CL. 39. (U.S. CLS. 100 AND 105). REG. 2-8-2005.
- 2,925,797. CUSTOMER VALUE DELIVERY. INT. CL. 39. (U.S. CLS. 100 AND 105). REG. 2-8-2005.
- 2,927,251. MISCELLANEOUS DESIGN. INT. CL. 5. (U.S. CLS. 6, 18, 44, 46, 51 AND 52). REG. 2-22-2005.
- 2,927,510. GLACIER'S EDGE STANDARD CHARACTER MARK. INT. CL. 18. (U.S. CLS. 1, 2, 3, 22 AND 41). REG. 2-22-2005.
- 2,927,769. "SUCCESS THROUGH SERVICE" (STYLIZED). INT. CL. 36. (U.S. CLS. 100, 101 AND 102). REG. 2-22-2005.
- 2,927,901. PACPOLY STANDARD CHARACTER MARK. INT. CL. 25. (U.S. CLS. 22 AND 39). REG. 2-22-2005.
- 2,929,279. OPTIMYZE. INT. CL. 1. (U.S. CLS. 1, 5, 6, 10, 26 AND 46). REG. 3-1-2005.
- 2,929,943. STRATICS. INT. CL. 35. (U.S. CLS. 100, 101 AND 102). REG. 3-8-2005.
- 2,931,380. ACADIAN NUTRITIONAL PRODUCTS FOR QUALITY CROPS AND DESIGN. INT. CL. 1. (U.S. CLS. 1, 5, 6, 10, 26 AND 46). REG. 3-8-2005.
- 2,931,987. TWILIGHT ALE. INT. CL. 32. (U.S. CLS. 45, 46 AND 48). REG. 3-8-2005.
- 2,934,953. BRIGHT SMILES BEGIN AT COAST STANDARD CHARACTER MARK. INT. CL. 44. (U.S. CLS. 100 AND 101). REG. 3-22-2005.
- 2,936,017. BOAT ED. INT. CL. 41. (U.S. CLS. 100, 101 AND 107). REG. 3-29-2005.
- 2,936,912. WEATHER GUARD. INT. CL. 21. (U.S. CLS. 2, 13, 23, 29, 30, 33, 40 AND 50). REG. 3-29-2005.
- 2,937,871. THE SPICE EXPERIENCE STANDARD CHARACTER MARK. INT. CL. 30. (U.S. CL. 46). REG. 4-5-2005.
- 2,938,591. M MORELIGHT AND DESIGN. INT. CL. 11. (U.S. CLS. 13, 21, 23, 31 AND 34). REG. 4-5-2005.
- 2,938,767. SPEED STICK 24/7. INT. CL. 3. (U.S. CLS. 1, 4, 6, 50, 51 AND 52). REG. 4-5-2005.
- 2,939,641. GAYLAWNET. INT. CL. 42. (U.S. CLS. 100 AND 101). REG. 4-12-2005.
- 2,941,077. MISCELLANEOUS DESIGN. INT. CLS. 1, 2 AND 42. (U.S. CLS. 1, 5, 6, 10, 11, 16, 26, 46, 100 AND 101). REG. 4-19-2005.
- 2,941,358. LIVING WELL INTO THE FUTURE STANDARD CHARACTER MARK. INT. CL. 35. (U.S. CLS. 100, 101 AND 102). REG. 4-19-2005.
- 2,941,770. PLAY GOLF AMERICA STANDARD CHARACTER MARK. INT. CL. 41. (U.S. CLS. 100, 101 AND 107). REG. 4-19-2005.
- 2,942,572. THE COMPANY JET. INT. CL. 36. (U.S. CLS. 100, 101 AND 102). REG. 4-19-2005.
- 2,942,734. THE MOST TRUSTED NAME IN SPORTS FLOORING. INT. CL. 37. (U.S. CLS. 100, 103 AND 106). REG. 4-19-2005.
- 2,943,009. XODOL. INT. CL. 5. (U.S. CLS. 6, 18, 44, 46, 51 AND 52). REG. 4-19-2005.
- 2,943,433. OXY-OXC (STYLIZED). INT. CL. 5. (U.S. CLS. 6, 18, 44, 46, 51 AND 52). REG. 4-26-2005.
- 2,943,966. PLAYFILL STANDARD CHARACTER MARK. INT. CL. 17. (U.S. CLS. 1, 5, 12, 13, 35 AND 50). REG. 4-26-2005.
- 2,944,491. AFLA-GUARD. INT. CL. 5. (U.S. CLS. 6, 18, 44, 46, 51 AND 52). REG. 4-26-2005.
- 2,947,244. VIDEO SENTINEL. INT. CL. 9. (U.S. CLS. 21, 23, 26, 36 AND 38). REG. 5-10-2005.
- 2,947,259. INVICTA AND DESIGN. INT. CL. 14. (U.S. CLS. 2, 27, 28 AND 50). REG. 5-10-2005.
- 2,947,537. GAMBLER STANDARD CHARACTER MARK. INT. CL. 34. (U.S. CLS. 2, 8, 9 AND 17). REG. 5-10-2005.
- 2,947,919. HITCHHUNTER AND DESIGN. INT. CL. 35. (U.S. CLS. 100, 101 AND 102). REG. 5-10-2005.
- 2,947,920. HITCHHUNTER STANDARD CHARACTER MARK. INT. CL. 35. (U.S. CLS. 100, 101 AND 102). REG. 5-10-2005.
- 2,949,080. BRAVO! -EARLY CHILDHOOD CURRICULUM. INT. CL. 41. (U.S. CLS. 100, 101 AND 107). REG. 5-10-2005.
- 2,949,358. INVENERGY. INT. CL. 40. (U.S. CLS. 100, 103 AND 106). REG. 5-10-2005.
- 2,949,670. FINE TOUCH. INT. CL. 10. (U.S. CLS. 26, 39 AND 44). REG. 5-10-2005.
- 2,949,842. CHIPOTLE MEXICAN GRILL AND DESIGN. INT. CL. 43. (U.S. CLS. 100 AND 101). REG. 5-10-2005.
- 2,952,187. K AND DESIGN. INT. CL. 1. (U.S. CLS. 1, 5, 6, 10, 26 AND 46). REG. 5-17-2005.
- 2,952,596. JACK CREEK CELLARS. INT. CL. 33. (U.S. CLS. 47 AND 49). REG. 5-17-2005.
- 2,953,974. LO-LYE RELAXER STANDARD CHARACTER MARK. INT. CL. 3. (U.S. CLS. 1, 4, 6, 50, 51 AND 52). REG. 5-17-2005.
- 2,954,986. EZ STENT STANDARD CHARACTER MARK. INT. CL. 10. (U.S. CLS. 26, 39 AND 44). REG. 5-24-2005.
- 2,955,021. INTERNATIONAL CENTER FOR VASECTOMY REVERSAL STANDARD CHARACTER MARK. INT. CL. 44. (U.S. CLS. 100 AND 101). REG. 5-24-2005.
- 2,956,088. JERKYUSA.COM STANDARD CHARACTER MARK. INT. CL. 35. (U.S. CLS. 100, 101 AND 102). REG. 5-24-2005.
- 2,956,115. WORKING CME STANDARD CHARACTER MARK. INT. CL. 41. (U.S. CLS. 100, 101 AND 107). REG. 5-24-2005.
- 2,956,334. WEEKEND AMERICA STANDARD CHARACTER MARK. INT. CL. 41. (U.S. CLS. 100, 101 AND 107). REG. 5-24-2005.
- 2,956,475. JAMAICAN STYLE STANDARD CHARACTER MARK. INT. CL. 25. (U.S. CLS. 22 AND 39). REG. 5-31-2005.
- 2,958,255. OYAMEL. INT. CL. 43. (U.S. CLS. 100 AND 101). REG. 5-31-2005.

- 2,958,829. THE COOKING AND ENTERTAINING SUPER-STORE STANDARD CHARACTER MARK. INT. CL. 35. (U.S. CLS. 100, 101 AND 102). REG. 5-31-2005.
- 2,959,804. MISCELLANEOUS DESIGN. INT. CL. 28. (U.S. CLS. 22, 23, 38 AND 50). REG. 6-7-2005.
- 2,960,836. COSANI INT. CL. 25. (U.S. CLS. 22 AND 39). REG. 6-7-2005.
- 2,961,371. DEFINING AUTHENTIC. INT. CL. 25. (U.S. CLS. 22 AND 39). REG. 6-7-2005.
- 2,961,848. CHEM-SET STANDARD CHARACTER MARK. INT. CL. 1. (U.S. CLS. 1, 5, 6, 10, 26 AND 46). REG. 6-14-2005.
- 2,962,310. ERIE FEDERAL CREDIT UNION FINANCIAL SOLUTIONS FROM LOCAL PEOPLE YOU TRUST AND DESIGN. INT. CL. 36. (U.S. CLS. 100, 101 AND 102). REG. 6-14-2005.
- 2,962,322. DONNA SHARP STANDARD CHARACTER MARK. INT. CLS. 9, 16 AND 18 ONLY. (U.S. CLS. 1, 2, 3, 5, 21, 22, 23, 26, 29, 36, 37, 38, 41 AND 50). REG. 6-14-2005.
- 2,962,881. MEETUP STANDARD CHARACTER MARK. INT. CL. 38. (U.S. CLS. 100, 101 AND 104). REG. 6-21-2005.
- 2,963,032. AJS STANDARD CHARACTER MARK. INT. CL. 19. (U.S. CLS. 1, 12, 33 AND 50). REG. 6-21-2005.
- 2,963,075. B BRIDALS BY LORI AND DESIGN. INT. CL. 35. (U.S. CLS. 100, 101 AND 102). REG. 6-21-2005.
- 2,963,323. TIJON AND DESIGN. INT. CL. 3. (U.S. CLS. 1, 4, 6, 50, 51 AND 52). REG. 6-21-2005.
- 2,963,899. THREE ANGELS BROADCASTING NETWORK. INT. CL. 41. (U.S. CLS. 100, 101 AND 107). REG. 6-28-2005.
- 2,964,043. PIERRE'S STANDARD CHARACTER MARK. INT. CL. 30. (U.S. CL. 46). REG. 6-28-2005.
- 2,964,081. PRECISION STANDARD CHARACTER MARK. INT. CL. 5. (U.S. CLS. 6, 18, 44, 46, 51 AND 52). REG. 6-28-2005.
- 2,964,122. CROWN CZAR STANDARD CHARACTER MARK. INT. CL. 33. (U.S. CLS. 47 AND 49). REG. 6-28-2005.
- 2,964,246. CARPET KING AND DESIGN. INT. CLS. 35 AND 37. (U.S. CLS. 100, 101, 102, 103 AND 106). REG. 6-28-2005.
- 2,964,524. MISCELLANEOUS DESIGN. INT. CL. 35. (U.S. CLS. 100, 101 AND 102). REG. 7-5-2005.
- 2,964,533. BAL AFRICAIN STANDARD CHARACTER MARK. INT. CL. 36. (U.S. CLS. 100, 101 AND 102). REG. 7-5-2005.
- 2,964,738. MOSCATO ALLEGRO STANDARD CHARACTER MARK. INT. CL. 33. (U.S. CLS. 47 AND 49). REG. 7-5-2005.
- 2,964,753. VISIONVIEW STANDARD CHARACTER MARK. INT. CL. 42. (U.S. CLS. 100 AND 101). REG. 7-5-2005.
- 2,964,848. SCORELOGIX (STYLIZED). INT. CL. 36. (U.S. CLS. 100, 101 AND 102). REG. 7-5-2005.
- 2,964,981. RESI-COST. INT. CLS. 9 AND 37. (U.S. CLS. 21, 23, 26, 36, 38, 100, 103 AND 106). REG. 7-5-2005.
- 2,965,071. SPOT SHOT AND DESIGN. INT. CL. 3. (U.S. CLS. 1, 4, 6, 50, 51 AND 52). REG. 7-5-2005.
- 2,965,179. RAPOSAP STANDARD CHARACTER MARK. INT. CL. 37. (U.S. CLS. 100, 103 AND 106). REG. 7-5-2005.
- 2,965,184. PAINTLOGIC STANDARD CHARACTER MARK. INT. CL. 9. (U.S. CLS. 21, 23, 26, 36 AND 38). REG. 7-5-2005.
- 2,965,201. NITROUS LTD AND DESIGN. INT. CL. 41. (U.S. CLS. 100, 101 AND 107). REG. 7-5-2005.
- 2,965,222. COSC, INC. STANDARD CHARACTER MARK. INT. CL. 35. (U.S. CLS. 100, 101 AND 102). REG. 7-5-2005.
- 2,965,397. MACRX OF TEXAS. INT. CL. 37. (U.S. CLS. 100, 103 AND 106). REG. 7-5-2005.

\* \* \* \* \*

# TRADEMARK REGISTRATIONS CANCELED

The designation "U.S. Cl." appearing in this section refers to the U.S. class in effect prior to Sep. 1, 1973 rather than the international class which applies to applications filed on or after that date. For adoption of international classification see notice in the OFFICIAL GAZETTE of Jun. 26, 1973 (911 O.G. TM 210).

## SECTION 7(D)

1,635,690. SCAN!. INT. CL. 35. REG. 2-19-1991.  
2,005,023. REACHMASTER. INT. CL. 7. REG. 10-1-1996.  
2,763,726. EXECUTIVE RELOCATION. INT. CL. 35. REG. 9-16-2003.  
2,827,440. RELOCATION REDEFINED. INT. CL. 35. REG. 3-30-2004.  
2,870,120. SIRVA AND DESIGN. INT. CLS. 35, 36 AND 39. REG. 8-3-2004.  
3,174,709. STAMIGEN. INT. CL. 5. REG. 11-21-2006.  
3,215,646. VOCABULYRICS STANDARD CHARACTER MARK. INT. CL. 9. REG. 3-6-2007.  
3,345,484. PRICED TO MOVE STANDARD CHARACTER MARK. INT. CL. 39. REG. 11-27-2007.  
3,354,842. SALE OF THE CENTURY STANDARD CHARACTER MARK. INT. CL. 9. REG. 12-18-2007.  
3,381,225. SALE OF THE CENTURY STANDARD CHARACTER MARK. INT. CL. 9. REG. 2-12-2008.  
3,431,302. MOVEOURHOME STANDARD CHARACTER MARK. INT. CLS. 35 AND 39. REG. 5-20-2008.  
3,461,374. SIRVA AND DESIGN. INT. CL. 35. REG. 7-8-2008.  
3,461,375. WE'LL GET YOU FROM REAL ESTATE AGENT TO MORTGAGE TO MOVED IN. STANDARD CHARACTER MARK. INT. CL. 35. REG. 7-8-2008.  
3,522,233. SAVA STANDARD CHARACTER MARK. INT. CL. 33. REG. 10-21-2008.  
3,548,601. OCULUS NSPACE STANDARD CHARACTER MARK. INT. CL. 9. REG. 12-23-2008.  
4,161,401. SABERTOOTH STANDARD CHARACTER MARK. INT. CL. 6. REG. 6-19-2012.  
4,161,402. SABERTOOTH STANDARD CHARACTER MARK. INT. CL. 14. REG. 6-19-2012.  
4,161,403. SABERTOOTH STANDARD CHARACTER MARK. INT. CL. 24. REG. 6-19-2012.  
4,161,405. SABERTOOTH STANDARD CHARACTER MARK. INT. CL. 20. REG. 6-19-2012.  
4,161,407. SABERTOOTH STANDARD CHARACTER MARK. INT. CL. 21. REG. 6-19-2012.  
4,161,408. SABERTOOTH STANDARD CHARACTER MARK. INT. CL. 26. REG. 6-19-2012.  
4,161,410. SABERTOOTH STANDARD CHARACTER MARK. INT. CL. 36. REG. 6-19-2012.  
4,164,713. SABERTOOTH STANDARD CHARACTER MARK. INT. CL. 33. REG. 6-26-2012.  
4,164,715. SABERTOOTH STANDARD CHARACTER MARK. INT. CL. 43. REG. 6-26-2012.  
4,164,719. SABERTOOTH STANDARD CHARACTER MARK. INT. CL. 37. REG. 6-26-2012.  
4,164,720. SABERTOOTH STANDARD CHARACTER MARK. INT. CL. 39. REG. 6-26-2012.  
4,256,385. SABERTOOTH STANDARD CHARACTER MARK. INT. CL. 8. REG. 12-11-2012.  
4,256,398. SABERTOOTH STANDARD CHARACTER MARK. INT. CL. 35. REG. 12-11-2012.  
4,274,836. BLUEWATER RENTALS STANDARD CHARACTER MARK. INT. CL. 36. REG. 1-15-2013.  
4,287,086. FERRERA (STYLIZED). INT. CL. 9. REG. 2-5-2013.  
4,352,421. SABERTOOTH STANDARD CHARACTER MARK. INT. CL. 41. REG. 6-18-2013.

4,366,229. THE WORLD'S FINEST CANDY BOUTIQUE STANDARD CHARACTER MARK. INT. CL. 30. REG. 7-9-2013.  
4,369,460. TIRAT ZVI STANDARD CHARACTER MARK. INT. CL. 29. REG. 7-16-2013.  
4,426,353. FIVE STAR P E R F U M E NEW YORK AND DESIGN. INT. CL. 3. REG. 10-29-2013.  
4,513,026. MW (STYLIZED). INT. CL. 14 ONLY. REG. 4-15-2014.

---

## SECTION 8

881,693. VALENCIA. U.S. CL. 28. REG. 12-2-1969.  
902,589. FTS. U.S. CL. 26. REG. 11-17-1970.  
944,064. SERENITY (STYLIZED). U.S. CL. 32. REG. 10-3-1972.  
1,148,801. RELIABILITY. INT. CL. 9. REG. 3-24-1981.  
1,151,892. INFO-PLUS. INT. CL. 35. REG. 4-21-1981.  
1,187,240. PRETTY NEAT. INT. CL. 20. REG. 1-19-1982.  
1,190,067. FRANCO. INT. CL. 25. REG. 2-16-1982.  
1,226,472. MAILCRAFTERS. INT. CL. 7. REG. 2-8-1983.  
1,328,647. ISLAND SNOW. INT. CLS. 28 AND 30 ONLY. REG. 4-2-1985.  
1,588,096. WESTERHALL PLANTATION. INT. CL. 33. REG. 3-20-1990.  
1,591,771. ALLEGRO COMPOSER. INT. CL. 9. REG. 4-17-1990.  
1,593,110. TROPICAL CARGO AND DESIGN. INT. CL. 25. REG. 4-24-1990.  
1,625,711. MICROVISION (STYLIZED). INT. CL. 9. REG. 12-4-1990.  
1,626,522. FREEDOM. INT. CL. 2. REG. 12-11-1990.  
1,646,084. TROPICAL. INT. CL. 25. REG. 5-28-1991.  
1,677,499. TECTONICS. INT. CL. 11. REG. 3-3-1992.  
1,682,829. DYMAG. INT. CL. 12. REG. 4-14-1992.  
1,704,093. BODYGUARD. INT. CL. 5. REG. 7-28-1992.  
1,719,470. SEASONS (STYLIZED). INT. CL. 16. REG. 9-22-1992.  
1,721,549. CAT COMPASS. INT. CL. 9. REG. 10-6-1992.  
1,757,530. HABITROL. INT. CL. 5. REG. 3-9-1993.  
1,783,517. GYM RAT. INT. CL. 28. REG. 7-20-1993.  
1,795,261. CHAMBERCARE. INT. CL. 36. REG. 9-28-1993.  
1,810,335. GRAPHLINE. INT. CLS. 1, 7, 9 AND 17. REG. 12-14-1993.  
1,844,615. SOUTHERN TURF NURSERIES. INT. CL. 37 ONLY. REG. 7-12-1994.  
1,848,806. ST. NICHOLAS SQUARE. INT. CL. 28 ONLY. REG. 8-9-1994.  
1,852,224. LEXON. INT. CL. 34 ONLY. REG. 9-6-1994.  
1,995,092. ICE PALACE AND DESIGN. INT. CL. 41. REG. 8-20-1996.  
2,160,186. OMNIQUEST AND DESIGN. INT. CL. 9. REG. 5-26-1998.  
2,280,179. FOOT & ANKLE CENTERS OF AMERICA. INT. CL. 35. REG. 9-21-1999.  
2,317,190. UNITED AUTO (STYLIZED). INT. CL. 35. REG. 2-8-2000.  
2,573,915. CAPIENT AND DESIGN. INT. CL. 42. REG. 5-28-2002.

- 2,686,445. PIZZARÉ (STYLIZED). INT. CL. 43. REG. 2-11-2003.
- 2,749,891. KILL DEVIL'S FROZEN CUSTARD & BEACH FRIES. INT. CL. 43. REG. 8-12-2003.
- 2,757,292. SCOOTERCROSS. INT. CL. 41. REG. 8-26-2003.
- 2,788,211. WHITEHEAD MANN. INT. CLS. 16, 35, 41 AND 44. REG. 12-2-2003.
- 2,793,367. AIRMAX. INT. CL. 9. REG. 12-16-2003.
- 2,793,372. ORICA. INT. CL. 42. REG. 12-16-2003.
- 2,793,373. KEYPORT. INT. CL. 9. REG. 12-16-2003.
- 2,793,384. VIGORIL AND DESIGN. INT. CL. 5. REG. 12-16-2003.
- 2,793,387. AL SAFA. INT. CL. 29. REG. 12-16-2003.
- 2,793,389. KETOR. INT. CL. 5. REG. 12-16-2003.
- 2,793,390. CHICAGOLAND SPEEDWAY AND DESIGN. INT. CLS. 6, 12, 14, 16, 20, 21, 24, 25, 28 AND 34. REG. 12-16-2003.
- 2,793,393. ON THE INSIDE. INT. CL. 41. REG. 12-16-2003.
- 2,793,409. SIZZLE. INT. CL. 20. REG. 12-16-2003.
- 2,793,419. JMC. INT. CLS. 39 AND 42. REG. 12-16-2003.
- 2,793,423. TRASH AND DESIGN. INT. CLS. 18 AND 25. REG. 12-16-2003.
- 2,793,437. MISCELLANEOUS DESIGN. INT. CL. 5. REG. 12-16-2003.
- 2,793,438. BRANDSDIRECT AND DESIGN. INT. CL. 35. REG. 12-16-2003.
- 2,793,441. VALUEWEB. INT. CLS. 38 AND 42. REG. 12-16-2003.
- 2,793,444. CHEFSHOP.COM AND DESIGN. INT. CL. 35. REG. 12-16-2003.
- 2,793,457. NINTENDO GAMECUBE. INT. CL. 9. REG. 12-16-2003.
- 2,793,462. HABURI. INT. CL. 35. REG. 12-16-2003.
- 2,793,472. COYOTE AND DESIGN. INT. CL. 36. REG. 12-16-2003.
- 2,793,474. KIDDIPICK. INT. CL. 31. REG. 12-16-2003.
- 2,793,481. ETCTV. INT. CL. 38. REG. 12-16-2003.
- 2,793,492. GLOBAL FOREST PURE SCIENCE. AND DESIGN. INT. CLS. 16, 41 AND 42. REG. 12-16-2003.
- 2,793,496. LIFEGUIDE. INT. CL. 16. REG. 12-16-2003.
- 2,793,498. LIFEGUIDE. INT. CL. 41. REG. 12-16-2003.
- 2,793,506. METACAT AND DESIGN. INT. CLS. 9 AND 42. REG. 12-16-2003.
- 2,793,515. REDCHIP AND DESIGN. INT. CL. 36. REG. 12-16-2003.
- 2,793,528. CREATIVE SOLUTIONS. INT. CLS. 35 AND 42. REG. 12-16-2003.
- 2,793,529. TX2000. INT. CL. 7. REG. 12-16-2003.
- 2,793,546. MISCELLANEOUS DESIGN. INT. CL. 12. REG. 12-16-2003.
- 2,793,555. OCE INTRA LOGIC (STYLIZED). INT. CLS. 9, 37 AND 42. REG. 12-16-2003.
- 2,793,558. ACTIVSTUDIO. INT. CL. 9. REG. 12-16-2003.
- 2,793,562. GEOSIM. INT. CLS. 9, 35 AND 42. REG. 12-16-2003.
- 2,793,566. MISCELLANEOUS DESIGN. INT. CLS. 16, 18, 25, 27, 28, 41 AND 42. REG. 12-16-2003.
- 2,793,593. A & W (STYLIZED). INT. CL. 42. REG. 12-16-2003.
- 2,793,600. MK AND DESIGN. INT. CL. 7. REG. 12-16-2003.
- 2,793,602. PASSMED. INT. CL. 10. REG. 12-16-2003.
- 2,793,607. NICE RACK. INT. CL. 25. REG. 12-16-2003.
- 2,793,611. RITMO LATINO. INT. CLS. 16 AND 41. REG. 12-16-2003.
- 2,793,622. DESLINC. INT. CL. 9. REG. 12-16-2003.
- 2,793,623. GTA AND DESIGN. INT. CLS. 39 AND 42. REG. 12-16-2003.
- 2,793,626. LIFE STUFF STORAGE. INT. CLS. 37 AND 42. REG. 12-16-2003.
- 2,793,636. MISCELLANEOUS DESIGN. INT. CL. 29. REG. 12-16-2003.
- 2,793,650. FSP 3000. INT. CLS. 9 AND 42. REG. 12-16-2003.
- 2,793,652. METALJACKET STANDARD CHARACTER MARK. INT. CLS. 1, 2, 3, 37 AND 40. REG. 12-16-2003.
- 2,793,674. DTS. INT. CL. 9. REG. 12-16-2003.
- 2,793,678. HP HACIENDA PVBICA AND DESIGN. INT. CLS. 18 AND 25. REG. 12-16-2003.
- 2,793,680. KORYO HAND. INT. CL. 9. REG. 12-16-2003.
- 2,793,688. AMERICAN FORECLOSURES. INT. CLS. 16, 35 AND 36. REG. 12-16-2003.
- 2,793,695. TM55. INT. CL. 9. REG. 12-16-2003.
- 2,793,697. GUTTER KING. INT. CL. 37. REG. 12-16-2003.
- 2,793,700. FASHION AFFORDABLE. INT. CL. 20. REG. 12-16-2003.
- 2,793,732. ROBERT KUO. INT. CL. 20. REG. 12-16-2003.
- 2,793,745. SERENA. INT. CL. 10. REG. 12-16-2003.
- 2,793,762. 401(K) SOLUTION. INT. CL. 9. REG. 12-16-2003.
- 2,793,770. DELTA ALPHA DELTA. INT. CL. 16. REG. 12-16-2003.
- 2,793,795. PAPERLINX (STYLIZED). INT. CL. 16. REG. 12-16-2003.
- 2,793,815. DMI INDUSTRIES. INT. CLS. 6 AND 40. REG. 12-16-2003.
- 2,793,832. VOICE.TRUST AND DESIGN. INT. CLS. 9 AND 42. REG. 12-16-2003.
- 2,793,836. NATURE TECH. INT. CL. 5. REG. 12-16-2003.
- 2,793,851. NF NATIONAL FLIGHT AND DESIGN. INT. CL. 37. REG. 12-16-2003.
- 2,793,853. CITY OF SPARTANBURG SOUTH CAROLINA AND DESIGN. INT. CLS. 25 AND 39. REG. 12-16-2003.
- 2,793,865. PROFORMA PROUSA. INT. CLS. 35 AND 40. REG. 12-16-2003.
- 2,793,879. BELGRAVIA. INT. CL. 33. REG. 12-16-2003.
- 2,793,887. SEEDS & GRAINS. INT. CL. 3. REG. 12-16-2003.
- 2,793,897. IDEA PORTFOLIO. INT. CL. 16. REG. 12-16-2003.
- 2,793,900. NEUTRAQ. INT. CLS. 3, 5 AND 16. REG. 12-16-2003.
- 2,793,903. 9 AND DESIGN. INT. CLS. 25 AND 41. REG. 12-16-2003.
- 2,793,937. PHOTON GENERATOR. INT. CL. 11. REG. 12-16-2003.
- 2,793,942. CALEIDO AND DESIGN. INT. CL. 11. REG. 12-16-2003.
- 2,793,946. METTLER TOLEDO AND DESIGN. INT. CL. 9. REG. 12-16-2003.
- 2,793,952. SPEC FENCE AND DESIGN. INT. CL. 19. REG. 12-16-2003.
- 2,793,955. ZETETIC INSTITUTE. INT. CLS. 41 AND 42. REG. 12-16-2003.
- 2,793,956. INSUL-TAP. INT. CL. 9. REG. 12-16-2003.
- 2,793,962. Q CERTIFIED AND DESIGN. INT. CL. 36. REG. 12-16-2003.
- 2,793,967. MISCELLANEOUS DESIGN. INT. CL. 36. REG. 12-16-2003.
- 2,793,971. VIRTUAL ADTAKER. INT. CLS. 9, 35 AND 42. REG. 12-16-2003.
- 2,793,980. MISCELLANEOUS DESIGN. INT. CL. 41. REG. 12-16-2003.
- 2,793,986. PARTY BITES. INT. CL. 29. REG. 12-16-2003.
- 2,793,996. TEEN MANIA'S GLOBAL EXPEDITIONS LIFE-CHANGING ADVENTURES AND DESIGN. INT. CL. 45. REG. 12-16-2003.
- 2,793,999. MISCELLANEOUS DESIGN. INT. CLS. 25 AND 35. REG. 12-16-2003.
- 2,794,016. SPEEDSTER. INT. CLS. 10 AND 11. REG. 12-16-2003.
- 2,794,017. MISCELLANEOUS DESIGN. INT. CL. 25. REG. 12-16-2003.
- 2,794,022. AXIMA AND DESIGN. INT. CL. 37. REG. 12-16-2003.
- 2,794,029. NATIONAL CENTER FOR REMANUFACTURING AND RESOURCE RECOVERY AND DESIGN. INT. CL. 42. REG. 12-16-2003.
- 2,794,030. SAN FRANCISCO PASTA COMPANY. INT. CL. 30. REG. 12-16-2003.
- 2,794,033. THE FASTEST WAY TO SHOP FOR PAPER, ENVELOPES AND INK.. INT. CL. 35. REG. 12-16-2003.
- 2,794,042. ENVELOC AND DESIGN. INT. CL. 9. REG. 12-16-2003.
- 2,794,046. SENIOR FINANCIAL CARE. INT. CL. 36. REG. 12-16-2003.
- 2,794,059. INGLENOOK CHABLIS. INT. CL. 33. REG. 12-16-2003.

- 2,794,066. COLEMAN HINES CH AND DESIGN. INT. CLS. 35 AND 36. REG. 12-16-2003.
- 2,794,072. DUNRATH PARTNERS. INT. CLS. 35 AND 36. REG. 12-16-2003.
- 2,794,078. S3 AND DESIGN. INT. CL. 9. REG. 12-16-2003.
- 2,794,082. LAMMICO AND DESIGN. INT. CL. 36. REG. 12-16-2003.
- 2,794,084. BRUTE FORCE. INT. CL. 41. REG. 12-16-2003.
- 2,794,091. NANOWAVE. INT. CLS. 7 AND 10. REG. 12-16-2003.
- 2,794,093. TRANSENDA CENTRAL. INT. CL. 9. REG. 12-16-2003.
- 2,794,097. STERI-AID. INT. CL. 10. REG. 12-16-2003.
- 2,794,105. LAWN ANNOUNCEMENTS. INT. CL. 45. REG. 12-16-2003.
- 2,794,108. METAGLIP. INT. CL. 5. REG. 12-16-2003.
- 2,794,113. GOD RULES AND DESIGN. INT. CL. 25. REG. 12-16-2003.
- 2,794,116. PAGEONE. INT. CL. 35. REG. 12-16-2003.
- 2,794,132. XANDROS. INT. CL. 9. REG. 12-16-2003.
- 2,794,133. XANDROS AND DESIGN. INT. CL. 9. REG. 12-16-2003.
- 2,794,137. EHA. INT. CL. 36. REG. 12-16-2003.
- 2,794,141. CLEARFLOW. INT. CL. 11. REG. 12-16-2003.
- 2,794,149. DELIVERING THE GOODS SINCE 1865. INT. CL. 35. REG. 12-16-2003.
- 2,794,155. DISCOVER A BETTER WAY. INT. CL. 42. REG. 12-16-2003.
- 2,794,163. STORM STRIPES. INT. CL. 25. REG. 12-16-2003.
- 2,794,176. S TEXAS SPINE & JOINT HOSPITAL AND DESIGN. INT. CL. 44. REG. 12-16-2003.
- 2,794,180. SASSY. INT. CL. 30. REG. 12-16-2003.
- 2,794,186. UNIFIED BARCODE & RFID. INT. CL. 35. REG. 12-16-2003.
- 2,794,188. AGE EXPERT. INT. CL. 3. REG. 12-16-2003.
- 2,794,189. HAPPY HARVEST AND DESIGN. INT. CLS. 29 AND 30. REG. 12-16-2003.
- 2,794,192. SPYTREK ESPIONAGE-THEMED EXCURSIONS AND DESIGN. INT. CL. 41. REG. 12-16-2003.
- 2,794,193. N & N SWEATBAND. INT. CL. 25. REG. 12-16-2003.
- 2,794,206. CRESA PARTNERS. INT. CLS. 35, 36, 37 AND 42. REG. 12-16-2003.
- 2,794,208. FISH-BOWL. INT. CL. 25. REG. 12-16-2003.
- 2,794,211. QUICK SUPPORT ROD AND DESIGN. INT. CL. 6. REG. 12-16-2003.
- 2,794,213. PRIJEMS. INT. CL. 35. REG. 12-16-2003.
- 2,794,214. EVERYBODY BAR. INT. CL. 5. REG. 12-16-2003.
- 2,794,217. LANZZINO. INT. CL. 25. REG. 12-16-2003.
- 2,794,218. LEURENIER. INT. CL. 25. REG. 12-16-2003.
- 2,794,221. ZIKUA. INT. CL. 9. REG. 12-16-2003.
- 2,794,232. G GOLDGRATE (STYLIZED). INT. CL. 19. REG. 12-16-2003.
- 2,794,233. COAST TIRE AND DESIGN. INT. CLS. 35 AND 37. REG. 12-16-2003.
- 2,794,234. I PROMISE PROGRAM AND DESIGN. INT. CL. 35. REG. 12-16-2003.
- 2,794,236. NORLUX. INT. CL. 11. REG. 12-16-2003.
- 2,794,243. CHRISTIAN COLLECTION BY ABUNDANT FUNDS. INT. CL. 36. REG. 12-16-2003.
- 2,794,244. E (STYLIZED). INT. CL. 26. REG. 12-16-2003.
- 2,794,264. CIGGY BUTTZ. INT. CLS. 25 AND 41. REG. 12-16-2003.
- 2,794,271. THE CENTRAL VIRGINIAN. INT. CL. 16. REG. 12-16-2003.
- 2,794,272. THE GOOCHLAND COURIER. INT. CL. 16. REG. 12-16-2003.
- 2,794,274. GINO POMPEII. INT. CL. 25. REG. 12-16-2003.
- 2,794,275. S AMERICAN TRADITION SIGNATURE COLORS AND DESIGN. INT. CL. 2. REG. 12-16-2003.
- 2,794,276. HARRIS HAWK. INT. CL. 35. REG. 12-16-2003.
- 2,794,278. P PREFERRED HEALTH PROFESSIONALS AND DESIGN. INT. CL. 36. REG. 12-16-2003.
- 2,794,279. COUNTRY'S BEST LOG HOMES. INT. CL. 16. REG. 12-16-2003.
- 2,794,288. SIMPLY SAFE. INT. CL. 11. REG. 12-16-2003.
- 2,794,291. MORENCI CANDLES AND DESIGN. INT. CL. 4. REG. 12-16-2003.
- 2,794,298. COUTURECORDS. INT. CL. 14. REG. 12-16-2003.
- 2,794,306. K AND DESIGN. INT. CL. 41. REG. 12-16-2003.
- 2,794,310. EST. 1992 RIB CRIB BARBECUE AND DESIGN. INT. CL. 43. REG. 12-16-2003.
- 2,794,311. STORM SHIELD. INT. CL. 25. REG. 12-16-2003.
- 2,794,324. ALLIONBLUE. INT. CL. 9. REG. 12-16-2003.
- 2,794,336. HEAR WITH YOUR EYES. INT. CL. 41. REG. 12-16-2003.
- 2,794,355. RANDOM TOUCH. INT. CLS. 9 AND 41. REG. 12-16-2003.
- 2,794,356. SUNBURST. INT. CLS. 9 AND 35. REG. 12-16-2003.
- 2,794,366. GOLDEN CLASSIC OVEN ROASTED CHICKEN BREAST AND DESIGN. INT. CL. 29. REG. 12-16-2003.
- 2,794,372. WIREMANAGER. INT. CL. 9. REG. 12-16-2003.
- 2,794,380. MONROE. INT. CL. 20. REG. 12-16-2003.
- 2,794,395. COMFORT LOUNGER. INT. CL. 20. REG. 12-16-2003.
- 2,794,430. IMATCHUP.COM. INT. CL. 45. REG. 12-16-2003.
- 2,794,434. BLACK HILLS GOLD. INT. CL. 13. REG. 12-16-2003.
- 2,794,439. TOILET BOYS. INT. CL. 41. REG. 12-16-2003.
- 2,794,441. RACE DAY. INT. CL. 41. REG. 12-16-2003.
- 2,794,452. MISCELLANEOUS DESIGN. INT. CL. 42. REG. 12-16-2003.
- 2,794,482. FEEL BETTER. INT. CL. 44. REG. 12-16-2003.
- 2,794,505. CHATEAU LA PAWS. INT. CL. 33. REG. 12-16-2003.
- 2,794,507. MAKING YOUR NET... WORK. INT. CL. 42. REG. 12-16-2003.
- 2,794,516. IT'S MY LIFE. INT. CLS. 38, 41 AND 45. REG. 12-16-2003.
- 2,794,536. CPR EZY AND DESIGN. INT. CL. 10. REG. 12-16-2003.
- 2,794,537. KALEIDOCRETE. INT. CLS. 7 AND 40. REG. 12-16-2003.
- 2,794,559. CHI'S RESEARCH CORPORATION AND DESIGN. INT. CL. 42. REG. 12-16-2003.
- 2,794,563. SHO TOO. INT. CLS. 38 AND 41. REG. 12-16-2003.
- 2,794,565. KENPO. INT. CL. 25. REG. 12-16-2003.
- 2,794,568. XUMU AND DESIGN. INT. CLS. 18 AND 25. REG. 12-16-2003.
- 2,794,573. IST ABOARD. INT. CL. 38. REG. 12-16-2003.
- 2,794,575. EARLY BIRD. INT. CL. 20. REG. 12-16-2003.
- 2,794,579. EVENT ALARM AND DESIGN. INT. CL. 9. REG. 12-16-2003.
- 2,794,592. GEESEPEACE AND DESIGN. INT. CLS. 16 AND 41. REG. 12-16-2003.
- 2,794,596. SANDSTORM ENTERPRISES. INT. CL. 9. REG. 12-16-2003.
- 2,794,600. MI MIRAGE-INK AND DESIGN. INT. CLS. 9 AND 42. REG. 12-16-2003.
- 2,794,610. THE NEIGHBORHOOD COMPANY. INT. CL. 37. REG. 12-16-2003.
- 2,794,624. EARTH UPDATE AND DESIGN. INT. CL. 9. REG. 12-16-2003.
- 2,794,629. ADK. INT. CL. 9. REG. 12-16-2003.
- 2,794,632. THERMIBEADS. INT. CL. 10. REG. 12-16-2003.
- 2,794,635. MULTAQ. INT. CL. 5. REG. 12-16-2003.
- 2,794,646. ADNEXUS. INT. CL. 35. REG. 12-16-2003.
- 2,794,655. CT COUPLER. INT. CL. 9. REG. 12-16-2003.
- 2,794,661. WI AND DESIGN. INT. CLS. 9 AND 11. REG. 12-16-2003.
- 2,794,668. MISCELLANEOUS DESIGN. INT. CLS. 35, 37 AND 40. REG. 12-16-2003.
- 2,794,681. EOS. INT. CL. 16. REG. 12-16-2003.
- 2,794,685. QWEST. INT. CL. 16. REG. 12-16-2003.
- 2,794,687. TROPHY. INT. CL. 12. REG. 12-16-2003.
- 2,794,693. SAY I. INT. CLS. 35, 36 AND 42. REG. 12-16-2003.
- 2,794,696. CHANGING HOMES FOR CHANGING LIFESTYLES. INT. CL. 37. REG. 12-16-2003.
- 2,794,709. SPIRIT PFC FUEL PURIFIER AND DESIGN. INT. CL. 1. REG. 12-16-2003.
- 2,794,711. AVATAR (STYLIZED). INT. CLS. 41 AND 42. REG. 12-16-2003.
- 2,794,716. H2ODYSSEY (STYLIZED). INT. CL. 25. REG. 12-16-2003.

- 2,794,717. SMART BANKING. REAL VALUE.. INT. CL. 36. REG. 12-16-2003.
- 2,794,723. NAUGHTY NB BISCOTTI AND DESIGN. INT. CL. 30. REG. 12-16-2003.
- 2,794,724. HOMEWOOD HEADLINES. INT. CLS. 9 AND 43. REG. 12-16-2003.
- 2,794,728. M MINGZU AND DESIGN. INT. CL. 25. REG. 12-16-2003.
- 2,794,732. POWER DOG AND DESIGN. INT. CL. 5. REG. 12-16-2003.
- 2,794,738. SOLRING AND DESIGN. INT. CL. 42. REG. 12-16-2003.
- 2,794,753. MIDNIGHT BLUE. INT. CLS. 40, 41 AND 42. REG. 12-16-2003.
- 2,794,759. TRANSFORMING HEALTHCARE RECRUITING AND STAFFING. INT. CL. 35. REG. 12-16-2003.
- 2,794,760. TRANSFORMING HEALTHCARE CAREERS. INT. CL. 35. REG. 12-16-2003.
- 2,794,764. PIERRE DEUX. INT. CL. 27. REG. 12-16-2003.
- 2,794,767. MISCELLANEOUS DESIGN. INT. CL. 35. REG. 12-16-2003.
- 2,794,772. PHOENIX STAR. INT. CL. 31. REG. 12-16-2003.
- 2,794,777. CRDIRECT (STYLIZED). INT. CL. 36. REG. 12-16-2003.
- 2,794,778. ELECTRIC MOBILITY AND DESIGN. INT. CL. 12. REG. 12-16-2003.
- 2,794,781. WEATHERBY LOCUMS. INT. CL. 35. REG. 12-16-2003.
- 2,794,788. GLOBAL QUEST. INT. CLS. 35 AND 42. REG. 12-16-2003.
- 2,794,806. MISCELLANEOUS DESIGN. INT. CL. 32. REG. 12-16-2003.
- 2,794,807. SNOW AND DESIGN. INT. CL. 32. REG. 12-16-2003.
- 2,794,809. REAL CONDITIONS. REAL SITUATIONS. REAL RESULTS. INT. CL. 41. REG. 12-16-2003.
- 2,794,812. HOMEWORKNOW. INT. CL. 41. REG. 12-16-2003.
- 2,794,815. BATH WIZARD. INT. CL. 1. REG. 12-16-2003.
- 2,794,861. VARNISH FINE ART. INT. CLS. 35 AND 41. REG. 12-16-2003.
- 2,794,874. WAGGERS CHAMPION CHIPS. INT. CL. 31. REG. 12-16-2003.
- 2,794,883. SNOW BLAZER. INT. CL. 8. REG. 12-16-2003.
- 2,794,887. JILLYBEANS AND DESIGN. INT. CL. 30. REG. 12-16-2003.
- 2,794,891. TERRAPIN. INT. CL. 32. REG. 12-16-2003.
- 2,794,893. FLAGSHIP BLEND. INT. CL. 30. REG. 12-16-2003.
- 2,794,897. ELENE (STYLIZED). INT. CL. 3. REG. 12-16-2003.
- 2,794,899. ROCKWORTH POWERTASK. INT. CL. 7. REG. 12-16-2003.
- 2,794,905. RED BOX. INT. CL. 9. REG. 12-16-2003.
- 2,794,925. THE SPILL CONTROL PEOPLE. INT. CL. 1. REG. 12-16-2003.
- 2,794,929. JET. INT. CL. 22. REG. 12-16-2003.
- 2,794,943. URANGATANG. INT. CL. 42. REG. 12-16-2003.
- 2,794,947. LIVING SOLUTIONS. INT. CL. 9. REG. 12-16-2003.
- 2,794,955. DTX. INT. CL. 10. REG. 12-16-2003.
- 2,794,956. LITMAN/GREGORY. INT. CL. 36. REG. 12-16-2003.
- 2,794,957. EASTFARER. INT. CL. 39. REG. 12-16-2003.
- 2,794,963. POWERCHIP. INT. CL. 9. REG. 12-16-2003.
- 2,794,965. CICCABELLA. INT. CL. 25. REG. 12-16-2003.
- 2,794,967. NUTRIMALT. INT. CL. 5. REG. 12-16-2003.
- 2,794,979. NANOSELECTION. INT. CL. 42. REG. 12-16-2003.
- 2,794,980. MISCELLANEOUS DESIGN. INT. CL. 3. REG. 12-16-2003.
- 2,794,984. OODLES OF DOODLES. INT. CL. 28. REG. 12-16-2003.
- 2,794,992. TUNER JAM. INT. CL. 41. REG. 12-16-2003.
- 2,794,993. VALUE AMERICA. INT. CL. 35. REG. 12-16-2003.
- 2,794,996. FLEXI-DRAIN. INT. CL. 27. REG. 12-16-2003.
- 2,795,010. TRUE INDULGENCE. INT. CL. 4. REG. 12-16-2003.
- 2,795,014. THE GRID. INT. CL. 19. REG. 12-16-2003.
- 2,795,030. TALK TO ME. INT. CLS. 28 AND 31. REG. 12-16-2003.
- 2,795,034. TREASURED TAILS. INT. CL. 20. REG. 12-16-2003.
- 2,795,067. WALLYPONG. INT. CL. 28. REG. 12-16-2003.
- 2,795,079. HEALTHY FURNITURE. INT. CL. 20. REG. 12-16-2003.
- 2,795,081. SPIN-FRYER. INT. CL. 11. REG. 12-16-2003.
- 2,795,108. MISCELLANEOUS DESIGN. INT. CL. 36. REG. 12-16-2003.
- 2,795,111. LABEL LIBERATION. INT. CL. 41. REG. 12-16-2003.
- 2,795,112. EPISODE III. INT. CLS. 38 AND 41. REG. 12-16-2003.
- 2,795,141. SCOTIA CAPITAL AND DESIGN. INT. CLS. 9, 16 AND 36. REG. 12-16-2003.
- 2,795,142. MISCELLANEOUS DESIGN. INT. CLS. 9, 35, 38 AND 42. REG. 12-16-2003.
- 2,795,146. SYNOETICS. INT. CL. 9. REG. 12-16-2003.
- 2,795,168. MARVEL MOUSE. INT. CL. 16. REG. 12-16-2003.
- 2,795,172. TLC LIGHTING. INT. CL. 35. REG. 12-16-2003.
- 2,795,173. DUAL-CON. INT. CL. 9. REG. 12-16-2003.
- 2,795,197. LUNA ROSSA AND DESIGN. INT. CLS. 12, 25 AND 41. REG. 12-16-2003.
- 2,795,200. MARCH MADNESS. INT. CLS. 6, 14 AND 28. REG. 12-16-2003.
- 2,795,208. SHAWGARD. INT. CL. 1. REG. 12-16-2003.
- 2,795,221. INFINYNS. INT. CL. 35. REG. 12-16-2003.
- 2,795,232. IQNAVIGATOR. INT. CLS. 9 AND 42. REG. 12-16-2003.
- 2,795,245. TREKKER PROPERTIES. INT. CL. 36. REG. 12-16-2003.
- 2,795,246. OPTILOCK. INT. CL. 10. REG. 12-16-2003.
- 2,795,260. PIGGYPOINTS. INT. CLS. 35 AND 38. REG. 12-16-2003.
- 2,795,261. RETRO HOME. INT. CLS. 20 AND 35. REG. 12-16-2003.
- 2,795,269. KL11. INT. CL. 12. REG. 12-16-2003.
- 2,795,274. PALMS A MALOOF CASINO RESORT AND DESIGN. INT. CL. 42. REG. 12-16-2003.
- 2,795,275. MISCELLANEOUS DESIGN. INT. CL. 12. REG. 12-16-2003.
- 2,795,280. SERVICE COLLISION REPAIR CENTER AND DESIGN. INT. CL. 37. REG. 12-16-2003.
- 2,795,295. MONTEREY. INT. CL. 19. REG. 12-16-2003.
- 2,795,307. M AND DESIGN. INT. CL. 42. REG. 12-16-2003.
- 2,795,335. MAZDA RX-8. INT. CL. 12. REG. 12-16-2003.
- 2,795,350. MISCELLANEOUS DESIGN. INT. CL. 41. REG. 12-16-2003.
- 2,795,352. MISCELLANEOUS DESIGN. INT. CL. 42. REG. 12-16-2003.
- 2,795,353. PEACHTREE WEB TRANSACTION CENTER. INT. CL. 9. REG. 12-16-2003.
- 2,795,354. PEACHTREE WEB ACCOUNTING. INT. CLS. 9, 36 AND 42. REG. 12-16-2003.
- 2,795,357. MISCELLANEOUS DESIGN. INT. CL. 7. REG. 12-16-2003.
- 2,795,362. WOMEN AND COMPANY. INT. CLS. 36 AND 41. REG. 12-16-2003.
- 2,795,373. TERRAZZO. INT. CL. 36. REG. 12-16-2003.
- 2,795,377. INTERNATIONAL GROOVING & GRINDING ASSOCIATION AND DESIGN. U.S. CL. 200. REG. 12-16-2003.
- 2,795,383. MOBILE DISKONCHIP. INT. CL. 9. REG. 12-16-2003.
- 2,795,389. JANE NOT PLAIN. INT. CL. 28. REG. 12-16-2003.
- 2,795,394. BIG AIR SHREDDER. INT. CL. 20. REG. 12-16-2003.
- 2,795,396. FACE LAB. INT. CL. 9. REG. 12-16-2003.
- 2,795,399. VERTIGONE. INT. CL. 10. REG. 12-16-2003.
- 2,795,409. ZOASIS. INT. CL. 16. REG. 12-16-2003.
- 2,795,414. CONCIERGE PLUS. INT. CL. 35. REG. 12-16-2003.
- 2,795,416. SOUTHERN COMFORT (STYLIZED). INT. CL. 18. REG. 12-16-2003.
- 2,795,418. SOUTHERN COMFORT (STYLIZED). INT. CL. 26. REG. 12-16-2003.
- 2,795,425. CARPE DIEM. INT. CL. 3. REG. 12-16-2003.
- 2,795,448. BRIDGING. INT. CL. 35. REG. 12-16-2003.
- 2,795,461. S-FORCE AND DESIGN. INT. CL. 9. REG. 12-16-2003.
- 2,795,465. BEAVER WARRIOR. INT. CL. 28. REG. 12-16-2003.

- 2,795,466. AMAZING DISCOVERIES. INT. CL. 41. REG. 12-16-2003.
- 2,795,467. LANE LOCK. INT. CL. 16. REG. 12-16-2003.
- 2,795,483. COMFORT AIR. INT. CL. 12. REG. 12-16-2003.
- 2,795,488. PROCONNECT (STYLIZED). INT. CL. 9. REG. 12-16-2003.
- 2,795,489. REWRAP. INT. CL. 16. REG. 12-16-2003.
- 2,795,503. STPROF. INT. CL. 9. REG. 12-16-2003.
- 2,795,518. BOSTON FOUNDATION FOR SIGHT AND DESIGN. INT. CL. 36. REG. 12-16-2003.
- 2,795,525. COMMERCE C COMMERCIAL LEASING (STYLIZED). INT. CLS. 35, 39, 42 AND 44. REG. 12-16-2003.
- 2,795,527. FX FLEETEXPERTS AND DESIGN. INT. CLS. 35 AND 36. REG. 12-16-2003.
- 2,795,531. FARR BETTER FLASHER. INT. CL. 28. REG. 12-16-2003.
- 2,795,533. SMARTCOMP. INT. CL. 35. REG. 12-16-2003.
- 2,795,570. BUILDING AMERICA. INT. CLS. 38 AND 39. REG. 12-16-2003.
- 2,795,584. SPRING. INT. CL. 39. REG. 12-16-2003.
- 2,795,585. PRORAIL. INT. CL. 6. REG. 12-16-2003.
- 2,795,587. TOUCH'EM ALL TEAMMATES AND DESIGN. INT. CLS. 25 AND 36. REG. 12-16-2003.
- 2,795,590. MICROLINER. INT. CL. 3. REG. 12-16-2003.
- 2,795,591. FIRST KISS. INT. CL. 31. REG. 12-16-2003.
- 2,795,599. THE 8 TECHNIQUES OF INNOVATIVE THINKING AND DESIGN. INT. CL. 41. REG. 12-16-2003.
- 2,795,605. TROUTTOWNUSA. INT. CL. 36. REG. 12-16-2003.
- 2,795,617. YOU'RE BRILLIANT. WE'RE SMART. IMAGINE THE POSSIBILITIES.. INT. CL. 40. REG. 12-16-2003.
- 2,795,626. PXS PASSION IN EXCESS. INT. CL. 33. REG. 12-16-2003.
- 2,795,628. QUIRKIES. INT. CL. 28. REG. 12-16-2003.
- 2,795,631. PHOTOOSE. INT. CL. 9. REG. 12-16-2003.
- 2,795,633. DAY MATTENESS. INT. CL. 3. REG. 12-16-2003.
- 2,795,643. TAURUS HEX BULLET. INT. CL. 13. REG. 12-16-2003.
- 2,795,644. RAGING THIRTY. INT. CL. 13. REG. 12-16-2003.
- 2,795,660. AIR ASSISTANT. INT. CL. 9. REG. 12-16-2003.
- 2,795,673. CARB ERASE. INT. CL. 5. REG. 12-16-2003.
- 2,795,675. "BRATZ BOYZ". INT. CLS. 16 AND 28. REG. 12-16-2003.
- 2,795,694. TRADITION BOOKS. INT. CL. 16. REG. 12-16-2003.
- 2,795,711. PRINCIPAL SECRET CLASSIC. INT. CL. 3. REG. 12-16-2003.
- 2,795,713. POWERBASE. INT. CL. 28. REG. 12-16-2003.
- 2,795,732. HISTORIC REGION RICHMOND EASY TO LOVE AND DESIGN. INT. CL. 35. REG. 12-16-2003.
- 2,795,737. BURGUNDY PEARLS. INT. CL. 29. REG. 12-16-2003.
- 2,795,747. E-CENTRIX. INT. CL. 10. REG. 12-16-2003.
- 2,795,757. MEDALIST. INT. CL. 14. REG. 12-16-2003.
- 2,795,761. MARKONE. INT. CL. 36. REG. 12-16-2003.
- 2,795,768. WOG (STYLIZED). INT. CLS. 41 AND 45. REG. 12-16-2003.
- 2,795,785. RENDERMONKEY. INT. CL. 9. REG. 12-16-2003.
- 2,795,791. OUTERMOST. INT. CL. 9. REG. 12-16-2003.
- 2,795,805. AWARD. INT. CL. 9. REG. 12-16-2003.
- 2,795,807. MISCELLANEOUS DESIGN. INT. CLS. 5 AND 25. REG. 12-16-2003.
- 2,795,810. MTX. INT. CL. 25. REG. 12-16-2003.
- 2,795,817. TINY AND DESIGN. INT. CL. 31. REG. 12-16-2003.
- 2,795,819. PHOTOMODULATION. INT. CL. 44. REG. 12-16-2003.
- 2,795,821. MISCELLANEOUS DESIGN. INT. CL. 12. REG. 12-16-2003.
- 2,795,829. J AND DESIGN. INT. CL. 12. REG. 12-16-2003.
- 2,795,834. HOMETOWN CONTENT AND DESIGN. INT. CL. 41. REG. 12-16-2003.
- 2,795,838. HOUSE OF TAYLOR. INT. CL. 3. REG. 12-16-2003.
- 2,795,859. CUT-AWAY. INT. CL. 10. REG. 12-16-2003.
- 2,795,864. BIG FAT FUN. INT. CL. 3. REG. 12-16-2003.
- 2,795,866. TRICLIP. INT. CL. 10. REG. 12-16-2003.
- 2,795,868. KIR. INT. CL. 25. REG. 12-16-2003.
- 2,795,870. ASSOCIATED PACKAGING TECHNOLOGIES. INT. CL. 20. REG. 12-16-2003.
- 2,795,878. AIR-BALANCE. INT. CL. 20. REG. 12-16-2003.
- 2,795,879. NERDWORKS. INT. CL. 35. REG. 12-16-2003.
- 2,795,880. MISCELLANEOUS DESIGN. INT. CL. 35. REG. 12-16-2003.
- 2,795,882. FLEXICORE. INT. CL. 10. REG. 12-16-2003.
- 2,795,883. STONE SENTINEL. INT. CL. 40. REG. 12-16-2003.
- 2,795,884. YOUNGER EVERY DAY. INT. CL. 5. REG. 12-16-2003.
- 2,795,887. EDGE. INT. CL. 34. REG. 12-16-2003.
- 2,795,899. XTENSION AND DESIGN. INT. CL. 12. REG. 12-16-2003.
- 2,795,913. NATURAL LIVING. INT. CLS. 20 AND 24. REG. 12-16-2003.
- 2,795,915. EYE GLITZERS. INT. CL. 3. REG. 12-16-2003.
- 2,795,923. BLAH BLAH BLAH. INT. CL. 3. REG. 12-16-2003.
- 2,795,924. TAHITI REEF CLUB. INT. CL. 25. REG. 12-16-2003.
- 2,795,947. D PROGRAM FOR SENSITIVE SKIN (STYLIZED). INT. CL. 3. REG. 12-16-2003.
- 2,795,950. ICETOUCH AND DESIGN. INT. CL. 25. REG. 12-16-2003.
- 2,795,968. FEMFREE. INT. CL. 10. REG. 12-16-2003.
- 2,795,970. PEGACONNECT. INT. CL. 9. REG. 12-16-2003.
- 2,795,972. PEGAREELAY. INT. CL. 9. REG. 12-16-2003.
- 2,795,973. PEGASEARCH. INT. CL. 9. REG. 12-16-2003.
- 2,795,978. FILE-RESCUE PLUS. INT. CL. 9. REG. 12-16-2003.
- 2,795,983. ROEX. INT. CL. 3. REG. 12-16-2003.
- 2,795,985. BOTTOMLESS BOWL. INT. CLS. 35, 41 AND 42. REG. 12-16-2003.
- 2,795,989. DTHEATRE AND DESIGN. INT. CL. 9. REG. 12-16-2003.
- 2,795,990. FIREBALL. INT. CL. 9. REG. 12-16-2003.
- 2,795,991. TOMORROW KNIGHTS. INT. CL. 16. REG. 12-16-2003.
- 2,796,008. A MATTER OF TASTE AND DESIGN. INT. CL. 31. REG. 12-16-2003.
- 2,796,017. MILLE. INT. CL. 11. REG. 12-16-2003.
- 2,796,023. MISCELLANEOUS DESIGN. INT. CL. 25. REG. 12-16-2003.
- 2,796,027. TRANSATO. INT. CL. 35. REG. 12-16-2003.
- 2,796,031. THE SPEYSIDE EXPERIENCE. INT. CL. 33. REG. 12-16-2003.
- 2,796,049. MEGA FX. INT. CL. 28. REG. 12-16-2003.
- 2,796,062. CRAFTMATIC. INT. CL. 12. REG. 12-16-2003.
- 2,796,065. CHECK CHAT. INT. CL. 35. REG. 12-16-2003.
- 2,796,070. RFPIC. INT. CL. 9. REG. 12-16-2003.
- 2,796,073. MISCELLANEOUS DESIGN. INT. CL. 9. REG. 12-16-2003.
- 2,796,078. LIBERTY THE CREATIVE SOLUTION EXPERTS. INT. CLS. 35 AND 42. REG. 12-16-2003.
- 2,796,080. AIR WAND. INT. CL. 7. REG. 12-16-2003.
- 2,796,099. MAYTAG AND DESIGN. INT. CL. 11. REG. 12-16-2003.
- 2,796,100. GREEN APPLE BREEZE. INT. CLS. 3 AND 5. REG. 12-16-2003.
- 2,796,103. INTERVALIDATE. INT. CL. 9. REG. 12-16-2003.
- 2,796,104. MIXED EMOTIONS. INT. CL. 3. REG. 12-16-2003.
- 2,796,110. BIOCRIQUE. INT. CL. 38. REG. 12-16-2003.
- 2,796,116. SHE SPIES. INT. CL. 41. REG. 12-16-2003.
- 2,796,118. FUNDAMENTAL BASEBALL AND DESIGN. INT. CL. 41. REG. 12-16-2003.
- 2,796,125. TRIMA ACCEL AND DESIGN. INT. CL. 10. REG. 12-16-2003.
- 2,796,129. APPLEBONE VINEYARD. INT. CL. 33. REG. 12-16-2003.
- 2,796,136. SMARTHEAT. INT. CL. 10. REG. 12-16-2003.
- 2,796,143. CXP6000. INT. CL. 9. REG. 12-16-2003.
- 2,796,144. PURE DIGITAL. INT. CL. 9. REG. 12-16-2003.
- 2,796,146. PINNACLE. INT. CL. 6. REG. 12-16-2003.
- 2,796,168. BLUEGRASS PRODUCTS. INT. CL. 19. REG. 12-16-2003.
- 2,796,177. ALMVS. INT. CL. 33. REG. 12-16-2003.
- 2,796,179. LUMATION. INT. CL. 1. REG. 12-16-2003.
- 2,796,182. HP PRO. INT. CL. 19. REG. 12-16-2003.

- 2,796,186. ATB. INT. CL. 10. REG. 12-16-2003.  
2,796,189. DOCMEMO. INT. CL. 38. REG. 12-16-2003.  
2,796,198. JUST WHAT YOU NEED.. INT. CL. 43. REG. 12-16-2003.  
2,796,202. BARRACUDA. INT. CL. 9. REG. 12-16-2003.  
2,796,214. SHOCKSHIELD. INT. CL. 18. REG. 12-16-2003.  
2,796,221. REFLECTMANAGER. INT. CL. 9. REG. 12-16-2003.  
2,796,245. U-RES-Q. INT. CL. 9. REG. 12-16-2003.  
2,796,246. X-L-ON. INT. CL. 25. REG. 12-16-2003.  
2,796,247. ASHBURY. INT. CL. 6. REG. 12-16-2003.  
2,796,252. SUN ELEUTHERO. INT. CL. 30. REG. 12-16-2003.  
2,796,277. M AND DESIGN. INT. CLS. 35 AND 39. REG. 12-16-2003.  
2,796,280. PRESENT TRUTH. INT. CLS. 16 AND 41. REG. 12-16-2003.  
2,796,286. SORRENTO. INT. CL. 11. REG. 12-16-2003.  
2,796,293. HEIGH-HO. INT. CLS. 25 AND 35. REG. 12-16-2003.  
2,796,304. KS23836. INT. CL. 9. REG. 12-16-2003.  
2,796,310. BLINDDATER.COM. INT. CL. 38. REG. 12-16-2003.  
2,796,311. BLINDDATER. INT. CL. 42. REG. 12-16-2003.  
2,796,319. ALTAMODA. INT. CLS. 14 AND 35. REG. 12-16-2003.  
2,796,325. SMARTCHIP. INT. CL. 28. REG. 12-16-2003.  
2,796,327. PACIENTES ASOCIADOS. INT. CL. 42. REG. 12-16-2003.  
2,796,328. TENANT MARKETPLACE. INT. CL. 42. REG. 12-16-2003.  
2,796,337. LONGER LASTING HAIR COLOUR - GUARANTEED!. INT. CL. 3. REG. 12-16-2003.  
2,796,343. CABLEHIDER. INT. CL. 9. REG. 12-16-2003.  
2,796,350. KONFERENCEKALL.COM. INT. CL. 38. REG. 12-16-2003.  
2,796,353. CHARITY REWARDS. INT. CL. 35. REG. 12-16-2003.  
2,796,359. COCHON PORK CERDO AND DESIGN. INT. CL. 33. REG. 12-16-2003.  
2,796,360. BOEUF BEEF TERNERA AND DESIGN. INT. CL. 33. REG. 12-16-2003.  
2,796,364. THE ART OF BUSINESS AND SOCIAL INTERACTION (STYLIZED). INT. CL. 41. REG. 12-16-2003.  
2,796,374. GALLERYOFGUNS.COM. INT. CL. 35. REG. 12-16-2003.  
2,799,400. PROFLOLIN. INT. CL. 5. REG. 12-23-2003.  
2,801,569. BIKERTOOLS.COM. INT. CL. 35. REG. 12-30-2003.  
2,809,801. ABB. INT. CLS. 1, 2, 3, 4, 6, 10, 11, 12, 14, 17, 18, 19, 20, 21, 25, 26, 36 AND 39 ONLY. REG. 2-3-2004.  
2,859,182. SPRINGBOK. INT. CL. 41 ONLY. REG. 7-6-2004.  
2,859,310. COURBIS. INT. CL. 20 ONLY. REG. 7-6-2004.  
2,859,480. ISCALA (STYLIZED). INT. CL. 16 ONLY. REG. 7-6-2004.  
2,860,475. MISCELLANEOUS DESIGN. INT. CLS. 16, 18, 25, 28, 35 AND 41 ONLY. REG. 7-6-2004.  
2,860,955. HUSKY. INT. CL. 9 ONLY. REG. 7-6-2004.  
2,863,371. ALION. INT. CL. 9 ONLY. REG. 7-13-2004.  
2,868,635. W OLD WAVERLY AND DESIGN. INT. CL. 16 ONLY. REG. 8-3-2004.  
2,872,086. CARBODILITE. INT. CL. 2 ONLY. REG. 8-10-2004.  
2,877,221. THANK YOU AND DESIGN. INT. CLS. 30 AND 32 ONLY. REG. 8-24-2004.  
2,905,311. YOUR PETS, OUR PASSION. INT. CL. 20 ONLY. REG. 11-23-2004.  
2,918,792. ACCESS AND DESIGN. INT. CL. 9. REG. 1-18-2005.  
2,927,087. HEADWORX. INT. CL. 25. REG. 2-22-2005.  
2,962,322. DONNA SHARP STANDARD CHARACTER MARK. INT. CL. 24 ONLY. REG. 6-14-2005.  
2,985,425. ALL CLEAR POOL & SPA STANDARD CHARACTER MARK. INT. CL. 37. REG. 8-16-2005.  
3,005,486. VIRGIN ISLANDS UNIVERSITY (STYLIZED). INT. CLS. 25 AND 41. REG. 10-11-2005.  
3,195,157. AMPLIFIER VENTURES PARTNERS STANDARD CHARACTER MARK. INT. CL. 36. REG. 1-2-2007.  
3,230,472. FAUS GROUP ALWAYS THE LEADER IN DESIGN AND TECHNOLOGY INNOVATION. AND DESIGN. INT. CL. 19. REG. 4-17-2007.  
3,243,884. TINGLE MINGLE STANDARD CHARACTER MARK. INT. CL. 41. REG. 5-22-2007.  
3,254,119. MISCELLANEOUS DESIGN. INT. CL. 16. REG. 6-19-2007.  
3,269,855. GOOD SENSE MAKES SENSE STANDARD CHARACTER MARK. INT. CL. 29. REG. 7-24-2007.  
3,271,376. ST. JOHNS INVESTMENT MANAGEMENT STANDARD CHARACTER MARK. INT. CL. 36. REG. 7-31-2007.  
3,273,249. TAQUERIA EL AMIGO "PARA CHUPARSE LOS DEDOS" AND DESIGN. INT. CL. 43. REG. 8-7-2007.  
3,274,024. KIYO AND DESIGN. INT. CL. 25. REG. 8-7-2007.  
3,274,218. GILMAN CIOCIA TAX & FINANCIAL PLANNING AND DESIGN. INT. CL. 35. REG. 8-7-2007.  
3,277,178. TEQUIFROOTERS STANDARD CHARACTER MARK. INT. CL. 33. REG. 8-7-2007.  
3,283,948. CREDENTIALCHECK STANDARD CHARACTER MARK. INT. CL. 45. REG. 8-21-2007.  
3,285,543. E PDC PAEC AND DESIGN. INT. CL. 41. REG. 8-28-2007.  
3,293,962. SUM POOSIE ENERGY DRINK AND DESIGN. INT. CLS. 25 AND 32. REG. 9-18-2007.  
3,296,380. BILL'S GHOST AND SPIRITS ESTABLISHED 1982 AND DESIGN. INT. CL. 35. REG. 9-25-2007.  
3,300,115. EFAMILY.COM KEEPING YOUR CIRCLE CONNECTED AND DESIGN. INT. CL. 42. REG. 9-25-2007.  
3,310,486. PS PILLAR & STONE INTERNATIONAL LLC DEFINE . DISCLOSE . DELIVER AND DESIGN. INT. CL. 14. REG. 10-16-2007.  
3,314,297. TREVISAN TELLKAMP POWDER COATING SYSTEM STANDARD CHARACTER MARK. INT. CL. 7. REG. 10-16-2007.  
3,315,954. THE XHL INTERNATIONAL STANDARD CHARACTER MARK. INT. CL. 41. REG. 10-23-2007.  
3,321,660. DRILLCRAFT STANDARD CHARACTER MARK. INT. CL. 7. REG. 10-23-2007.  
3,323,903. U.S. RECORDINGS AND DESIGN. INT. CLS. 35, 38, 39 AND 42. REG. 10-30-2007.  
3,329,506. DATA QUEST LTD. AND DESIGN. INT. CL. 45. REG. 11-6-2007.  
3,333,750. GEMSHOW ON THE WEB WWW.GEMSHOWONTHEWEB.COM AND DESIGN. INT. CL. 35. REG. 11-13-2007.  
3,337,271. GRIDLOCK (STYLIZED). INT. CL. 25. REG. 11-13-2007.  
3,338,927. BOOSTBRIDGE STANDARD CHARACTER MARK. INT. CL. 9. REG. 11-20-2007.  
3,338,961. FEEL THE FEAR...AND DO IT ANYWAY STANDARD CHARACTER MARK. INT. CL. 41. REG. 11-20-2007.  
3,341,235. DP (STYLIZED). INT. CL. 16. REG. 11-20-2007.  
3,343,184. KING OF BLONDES STANDARD CHARACTER MARK. INT. CL. 44. REG. 11-27-2007.  
3,344,154. ELEGANT LIGHTING FOR EVERYDAY LIVING STANDARD CHARACTER MARK. INT. CL. 11. REG. 11-27-2007.  
3,346,796. AIRPORT MEDICAL OFFICES EWR JFK LGA AND DESIGN. INT. CL. 44. REG. 12-4-2007.  
3,347,722. BODY GIRL AND DESIGN. INT. CL. 3. REG. 12-4-2007.  
3,348,114. KOMPETITIVEEDGE STANDARD CHARACTER MARK. INT. CL. 35. REG. 12-4-2007.  
3,349,653. CERNER BEYONDNOW STANDARD CHARACTER MARK. INT. CL. 9. REG. 12-4-2007.  
3,350,609. EGGROLL. INT. CL. 28. REG. 12-11-2007.  
3,350,612. OFFICIAL BEER OF THE INTERNET. INT. CLS. 16, 21, 25 AND 28. REG. 12-11-2007.  
3,350,613. QUEST AIR AND DESIGN. INT. CLS. 7, 11 AND 37. REG. 12-11-2007.



- 3,350,614. PLUG AND PRODUCE. INT. CL. 42. REG. 12-11-2007.
- 3,350,615. MUNDO PADRES. INT. CLS. 38 AND 41. REG. 12-11-2007.
- 3,350,616. PROVIDER CARENET. INT. CLS. 9, 38 AND 39. REG. 12-11-2007.
- 3,350,617. DYNAMIC INTERNATIONAL VALUE CLASS. INT. CL. 36. REG. 12-11-2007.
- 3,350,618. SMOOTH JAZZ NETWORK. INT. CL. 35. REG. 12-11-2007.
- 3,350,619. HARTL POWERCRUSHER AND DESIGN. INT. CLS. 7, 8 AND 9. REG. 12-11-2007.
- 3,350,620. LADYBIRD. INT. CL. 25. REG. 12-11-2007.
- 3,350,625. BRIGHT MINDS AND DESIGN. INT. CL. 16. REG. 12-11-2007.
- 3,350,626. AFP LEARNING SYSTEM AND DESIGN. INT. CLS. 16 AND 41. REG. 12-11-2007.
- 3,350,628. TROXZN. INT. CL. 5. REG. 12-11-2007.
- 3,350,631. MARTIN MYSTERY (STYLIZED). INT. CLS. 3, 9, 16, 18, 25, 28, 35, 38, 40 AND 41. REG. 12-11-2007.
- 3,350,635. CHANGES FOR WOMEN STANDARD CHARACTER MARK. INT. CL. 41. REG. 12-11-2007.
- 3,350,636. THE BEAN STANDARD CHARACTER MARK. INT. CL. 28. REG. 12-11-2007.
- 3,350,637. ADVANCING BUSINESS EXCELLENCE STANDARD CHARACTER MARK. INT. CLS. 16, 35 AND 41. REG. 12-11-2007.
- 3,350,638. RAVEN (STYLIZED). INT. CL. 9. REG. 12-11-2007.
- 3,350,639. GAIT BY DEBEER STANDARD CHARACTER MARK. INT. CL. 28. REG. 12-11-2007.
- 3,350,641. TAKIRON STANDARD CHARACTER MARK. INT. CL. 10. REG. 12-11-2007.
- 3,350,643. REEARTH (STYLIZED). INT. CLS. 18 AND 26. REG. 12-11-2007.
- 3,350,646. PROGRESSIVE MANUFACTURING SUMMIT & AWARDS STANDARD CHARACTER MARK. INT. CL. 41. REG. 12-11-2007.
- 3,350,650. YOUR NUTZ ULTIMATE FASHION STATEMENT FOR YOUR VEHICLE AND DESIGN. INT. CLS. 12 AND 20. REG. 12-11-2007.
- 3,350,653. CHENILLE-IT STANDARD CHARACTER MARK. INT. CL. 16. REG. 12-11-2007.
- 3,350,654. RADAR STANDARD CHARACTER MARK. INT. CL. 35. REG. 12-11-2007.
- 3,350,655. RADAR AND DESIGN. INT. CL. 35. REG. 12-11-2007.
- 3,350,656. NMCC FOUNDATION AND DESIGN. INT. CL. 36. REG. 12-11-2007.
- 3,350,657. FANISODE (STYLIZED). INT. CL. 41. REG. 12-11-2007.
- 3,350,659. FAST MORTGAGE STANDARD CHARACTER MARK. INT. CL. 36. REG. 12-11-2007.
- 3,350,662. PROJECT H.E.R.O. STANDARD CHARACTER MARK. INT. CLS. 35 AND 36. REG. 12-11-2007.
- 3,350,663. GO2 COLA AND DESIGN. INT. CL. 32. REG. 12-11-2007.
- 3,350,664. SILICONWORKS INTERNATIONAL STANDARD CHARACTER MARK. INT. CL. 10. REG. 12-11-2007.
- 3,350,665. N.O.W NEW ORLEANS NOW.NET AND DESIGN. INT. CL. 41. REG. 12-11-2007.
- 3,350,667. PACIFIC BUFFET & GRILL STANDARD CHARACTER MARK. INT. CL. 43. REG. 12-11-2007.
- 3,350,668. M1 DATA & ANALYTICS STANDARD CHARACTER MARK. INT. CL. 35. REG. 12-11-2007.
- 3,350,669. SHORT MAGAZINE! (STYLIZED). INT. CL. 16. REG. 12-11-2007.
- 3,350,670. LUCKY L FARM MINIATURES (254) 853-2152 AND DESIGN. INT. CL. 44. REG. 12-11-2007.
- 3,350,672. HAZEL BROWN STANDARD CHARACTER MARK. INT. CLS. 18 AND 25. REG. 12-11-2007.
- 3,350,673. RH WEEKLY STANDARD CHARACTER MARK. INT. CL. 16. REG. 12-11-2007.
- 3,350,674. V AND DESIGN. INT. CL. 5. REG. 12-11-2007.
- 3,350,675. COLLINSIAN CONCEPTS CLASSROOM IN A SUITCASE CRIASC KD AND DESIGN. INT. CLS. 9 AND 16. REG. 12-11-2007.
- 3,350,678. PURTONE AND DESIGN. INT. CL. 9. REG. 12-11-2007.
- 3,350,679. POWER ANSWER STANDARD CHARACTER MARK. INT. CLS. 9 AND 42. REG. 12-11-2007.
- 3,350,680. LANGUAGE COMPUTER AND DESIGN. INT. CLS. 9 AND 42. REG. 12-11-2007.
- 3,350,681. PEOPLEAGGREGATOR STANDARD CHARACTER MARK. INT. CLS. 9 AND 42. REG. 12-11-2007.
- 3,350,682. QUALITY TESTED . SHUSTER LABS . AND DESIGN. INT. CLS. 35 AND 42. REG. 12-11-2007.
- 3,350,683. BRIDES NEW JERSEY STANDARD CHARACTER MARK. INT. CL. 16. REG. 12-11-2007.
- 3,350,684. IDEALINK STANDARD CHARACTER MARK. INT. CL. 9. REG. 12-11-2007.
- 3,350,685. MISCELLANEOUS DESIGN. INT. CL. 25. REG. 12-11-2007.
- 3,350,688. LOGITIN STANDARD CHARACTER MARK. INT. CL. 35. REG. 12-11-2007.
- 3,350,689. COASTAL INLAND HEIGHTS STANDARD CHARACTER MARK. INT. CL. 37. REG. 12-11-2007.
- 3,350,690. COASTAL INLAND HEIGHTS (STYLIZED). INT. CL. 37. REG. 12-11-2007.
- 3,350,692. VARIX STANDARD CHARACTER MARK. INT. CL. 1. REG. 12-11-2007.
- 3,350,693. THE CHICAGO JAZZ ENSEMBLE AND DESIGN. INT. CLS. 20, 21 AND 26. REG. 12-11-2007.
- 3,350,697. ASTILEAN MATRIX STANDARD CHARACTER MARK. INT. CL. 41. REG. 12-11-2007.
- 3,350,698. YOUR WINNING HAND STANDARD CHARACTER MARK. INT. CL. 20. REG. 12-11-2007.
- 3,350,700. H. E. S. (STYLIZED). INT. CL. 9. REG. 12-11-2007.
- 3,350,703. COUNTRY LIFESTYLE STANDARD CHARACTER MARK. INT. CL. 16. REG. 12-11-2007.
- 3,350,704. MYCOMMUNITYASSOCIATION.COM YOUR COMMUNITY CLICK AND DESIGN. INT. CL. 42. REG. 12-11-2007.
- 3,350,705. LEADING THE WAY TO YOUR DOOR STANDARD CHARACTER MARK. INT. CL. 39. REG. 12-11-2007.
- 3,350,707. HYDROLAGE STANDARD CHARACTER MARK. INT. CL. 3. REG. 12-11-2007.
- 3,350,714. HTDI FINANCIAL AND DESIGN. INT. CL. 36. REG. 12-11-2007.
- 3,350,716. DESIGNATED WOMAN STANDARD CHARACTER MARK. INT. CL. 36. REG. 12-11-2007.
- 3,350,719. EDDIE DOMINGUEZ'S TUPINAMBA "MEXICAN FOOD SUPREME" AND DESIGN. INT. CL. 43. REG. 12-11-2007.
- 3,350,721. RHINO MOTORCYCLES (STYLIZED). INT. CL. 12. REG. 12-11-2007.
- 3,350,724. ADVANTAGE, YOURS. STANDARD CHARACTER MARK. INT. CL. 35. REG. 12-11-2007.
- 3,350,725. THE SUPER FUN SHOW! AND DESIGN. INT. CL. 41. REG. 12-11-2007.
- 3,350,726. NATIONAL PARK EXPLORER STANDARD CHARACTER MARK. INT. CL. 9. REG. 12-11-2007.
- 3,350,727. GREAT DIGITAL CARDS THAT SERVE A GREATER GOOD STANDARD CHARACTER MARK. INT. CL. 38. REG. 12-11-2007.
- 3,350,729. HANBAT SHUL-LUNG-TANG STANDARD CHARACTER MARK. INT. CL. 43. REG. 12-11-2007.
- 3,350,730. MISCELLANEOUS DESIGN. INT. CL. 43. REG. 12-11-2007.
- 3,350,732. SERVICEKEY STANDARD CHARACTER MARK. INT. CL. 35. REG. 12-11-2007.
- 3,350,734. SÉDUIRE STANDARD CHARACTER MARK. INT. CL. 33. REG. 12-11-2007.
- 3,350,735. BE COOL @ SCHOOL STANDARD CHARACTER MARK. INT. CL. 32. REG. 12-11-2007.
- 3,350,736. MISCELLANEOUS DESIGN. INT. CL. 7. REG. 12-11-2007.
- 3,350,737. UNIGY (STYLIZED). INT. CL. 7. REG. 12-11-2007.
- 3,350,739. COCOCANDLENUTS AND DESIGN. INT. CL. 4. REG. 12-11-2007.

- 3,350,742. SPECTRUS AND DESIGN. INT. CLS. 9, 11 AND 17. REG. 12-11-2007.
- 3,350,745. CIGNA BRIDGE STANDARD CHARACTER MARK. INT. CL. 35. REG. 12-11-2007.
- 3,350,746. RHINO CHOPPERS STANDARD CHARACTER MARK. INT. CL. 12. REG. 12-11-2007.
- 3,350,747. RHINO CUSTOMS STANDARD CHARACTER MARK. INT. CL. 12. REG. 12-11-2007.
- 3,350,753. 3 THREE LINE LOTTO KENTUCKY LOTTERY AND DESIGN. INT. CL. 41. REG. 12-11-2007.
- 3,350,755. DYLANO AND DESIGN. INT. CL. 25. REG. 12-11-2007.
- 3,350,757. VTERM STANDARD CHARACTER MARK. INT. CL. 9. REG. 12-11-2007.
- 3,350,758. 500% COOL STANDARD CHARACTER MARK. INT. CL. 32. REG. 12-11-2007.
- 3,350,761. PODFERENCE STANDARD CHARACTER MARK. INT. CL. 38. REG. 12-11-2007.
- 3,350,765. MY MAIL ZONE STANDARD CHARACTER MARK. INT. CL. 35. REG. 12-11-2007.
- 3,350,768. LUCKYFOOLPOKER DON'T BE A FOOL, BE A LUCKY FOOL LUCKY FOOL AND DESIGN. INT. CL. 28. REG. 12-11-2007.
- 3,350,769. MISCELLANEOUS DESIGN. INT. CLS. 9 AND 27. REG. 12-11-2007.
- 3,350,773. GOLDFIRE RESEARCHER STANDARD CHARACTER MARK. INT. CL. 9. REG. 12-11-2007.
- 3,350,774. OSTEO-GIDE STANDARD CHARACTER MARK. INT. CL. 5. REG. 12-11-2007.
- 3,350,781. SIXTHREEZERO STANDARD CHARACTER MARK. INT. CL. 12. REG. 12-11-2007.
- 3,350,782. SOLUTIONS FOR BUSINESS AND DESIGN. INT. CL. 35. REG. 12-11-2007.
- 3,350,787. MOPPET BOOKS OLIVER MORELAND LIBRARY AND DESIGN. INT. CL. 16. REG. 12-11-2007.
- 3,350,789. PEARLS JUST FOR GIRLS STANDARD CHARACTER MARK. INT. CL. 14. REG. 12-11-2007.
- 3,350,794. COLOR BLIND DATING STANDARD CHARACTER MARK. INT. CL. 45. REG. 12-11-2007.
- 3,350,796. POSITIVE SPACE AND DESIGN. INT. CLS. 35, 41, 44 AND 45. REG. 12-11-2007.
- 3,350,798. F AND DESIGN. INT. CL. 6. REG. 12-11-2007.
- 3,350,799. KINGLY STANDARD CHARACTER MARK. INT. CL. 25. REG. 12-11-2007.
- 3,350,803. AVITON AND DESIGN. INT. CL. 9. REG. 12-11-2007.
- 3,350,804. AVITON AND DESIGN. INT. CL. 10. REG. 12-11-2007.
- 3,350,805. LIKERR STANDARD CHARACTER MARK. INT. CL. 25. REG. 12-11-2007.
- 3,350,806. KAREN HEFFERNAN'S STRENGTH CLUB STANDARD CHARACTER MARK. INT. CL. 41. REG. 12-11-2007.
- 3,350,807. THE ORIGINAL 93 OCTANE FEED BOOSTER! STANDARD CHARACTER MARK. INT. CL. 31. REG. 12-11-2007.
- 3,350,809. MOO-LA-PALOOZA STANDARD CHARACTER MARK. INT. CL. 41. REG. 12-11-2007.
- 3,350,812. ADVERTAS STANDARD CHARACTER MARK. INT. CL. 35. REG. 12-11-2007.
- 3,350,813. BATIFOL (STYLIZED). INT. CL. 43. REG. 12-11-2007.
- 3,350,817. LEAPCARD AND DESIGN. INT. CL. 35. REG. 12-11-2007.
- 3,350,818. COAST 2 COAST FINE ART SERVICES, INC. (STYLIZED). INT. CL. 39. REG. 12-11-2007.
- 3,350,819. FLYGRID.NET STANDARD CHARACTER MARK. INT. CLS. 9 AND 42. REG. 12-11-2007.
- 3,350,820. PAYLESS PERKS AND DESIGN. INT. CL. 39. REG. 12-11-2007.
- 3,350,825. PAINTMAKER STANDARD CHARACTER MARK. INT. CL. 9. REG. 12-11-2007.
- 3,350,827. CHAIRMAN OF POKER STANDARD CHARACTER MARK. INT. CL. 41. REG. 12-11-2007.
- 3,350,829. MID-MISSOURI TECH CENTER, LLC STANDARD CHARACTER MARK. INT. CLS. 35, 36 AND 39. REG. 12-11-2007.
- 3,350,830. HAMEX (STYLIZED). INT. CL. 28. REG. 12-11-2007.
- 3,350,831. JOHN CROWE STANDARD CHARACTER MARK. INT. CL. 25. REG. 12-11-2007.
- 3,350,833. PLAYRAY STANDARD CHARACTER MARK. INT. CLS. 38 AND 41. REG. 12-11-2007.
- 3,350,834. PFIZER COMMUNITY HEALTH ADVOCACY AND DESIGN. INT. CLS. 16 AND 44. REG. 12-11-2007.
- 3,350,835. ANAUVE (STYLIZED). INT. CL. 25. REG. 12-11-2007.
- 3,350,837. GOOD HARBOR COFFEE AND TEA AND DESIGN. INT. CLS. 35 AND 43. REG. 12-11-2007.
- 3,350,839. FREDDISSIMO GELATERIA GELATO & DOLCI IL BUON GELATO ARTIGIANALE AND DESIGN. INT. CL. 30. REG. 12-11-2007.
- 3,350,840. WALLSTARS STANDARD CHARACTER MARK. INT. CL. 16. REG. 12-11-2007.
- 3,350,841. WILD WILD WEST BAND STANDARD CHARACTER MARK. INT. CL. 41. REG. 12-11-2007.
- 3,350,844. MISCELLANEOUS DESIGN. INT. CLS. 38 AND 42. REG. 12-11-2007.
- 3,350,845. LIMO TRAVELER STANDARD CHARACTER MARK. INT. CL. 39. REG. 12-11-2007.
- 3,350,850. SCRAPPER'S ALLEY STANDARD CHARACTER MARK. INT. CL. 35. REG. 12-11-2007.
- 3,350,851. RCI MEMBER DOLLARS STANDARD CHARACTER MARK. INT. CL. 36. REG. 12-11-2007.
- 3,350,852. KIDZCAST STANDARD CHARACTER MARK. INT. CL. 41. REG. 12-11-2007.
- 3,350,854. FINDING EMU! STANDARD CHARACTER MARK. INT. CL. 3. REG. 12-11-2007.
- 3,350,855. MODE MOBILE ORDER & DATA ENTRY AND DESIGN. INT. CL. 9. REG. 12-11-2007.
- 3,350,859. OUTSOURCE THE MARKETING DISCIPLINE FOR SUCCESS STANDARD CHARACTER MARK. INT. CL. 35. REG. 12-11-2007.
- 3,350,861. NATIONAL BARCODE AND DESIGN. INT. CL. 35. REG. 12-11-2007.
- 3,350,865. LIFESTYLE FAMILY FITNESS STANDARD CHARACTER MARK. INT. CL. 41. REG. 12-11-2007.
- 3,350,866. LIFESTYLE FAMILY FITNESS AND DESIGN. INT. CL. 41. REG. 12-11-2007.
- 3,350,867. RAVEN PERFORMING ARTS THEATER AND DESIGN. INT. CL. 41. REG. 12-11-2007.
- 3,350,868. RISE SURF STANDARD CHARACTER MARK. INT. CL. 25. REG. 12-11-2007.
- 3,350,871. SANATOGEN STANDARD CHARACTER MARK. INT. CL. 5. REG. 12-11-2007.
- 3,350,872. CHIEF MEMORY OFFICER STANDARD CHARACTER MARK. INT. CL. 9. REG. 12-11-2007.
- 3,350,876. QUICKSORT AND DESIGN. INT. CL. 39. REG. 12-11-2007.
- 3,350,877. W.O.W. WIZARD OF WORK STANDARD CHARACTER MARK. INT. CL. 41. REG. 12-11-2007.
- 3,350,878. YOUR LOGO AT WORK STANDARD CHARACTER MARK. INT. CL. 35. REG. 12-11-2007.
- 3,350,879. TAICHILATES AND DESIGN. INT. CL. 41. REG. 12-11-2007.
- 3,350,880. SALONSOFT STANDARD CHARACTER MARK. INT. CL. 9. REG. 12-11-2007.
- 3,350,882. SEYMOUR'S INSIDER CAREERREPORT STANDARD CHARACTER MARK. INT. CL. 41. REG. 12-11-2007.
- 3,350,883. SECURE DNC DIRECT NUMERICAL CONTROL AND DESIGN. INT. CL. 9. REG. 12-11-2007.
- 3,350,884. MICRO5 STANDARD CHARACTER MARK. INT. CL. 24. REG. 12-11-2007.
- 3,350,885. + LESS DESIGN STANDARD CHARACTER MARK. INT. CL. 9. REG. 12-11-2007.
- 3,350,886. DEVELOPMENTOR STANDARD CHARACTER MARK. INT. CL. 25. REG. 12-11-2007.
- 3,350,887. LUNA ELIXIR STANDARD CHARACTER MARK. INT. CL. 32. REG. 12-11-2007.
- 3,350,893. CREATIVE MINDS STANDARD CHARACTER MARK. INT. CL. 25. REG. 12-11-2007.

- 3,350,902. GIVE THE PLANET A HUG! RECYCLE YOUR RUG! STANDARD CHARACTER MARK. INT. CL. 27. REG. 12-11-2007.
- 3,350,903. GBF GREEK BABY FASHION AND DESIGN. INT. CL. 25. REG. 12-11-2007.
- 3,350,907. WORLDTELEMETRY AND DESIGN. INT. CL. 42. REG. 12-11-2007.
- 3,350,908. ROADMAP TO MEANINGFUL MIDLIFE STANDARD CHARACTER MARK. INT. CL. 9. REG. 12-11-2007.
- 3,350,910. ABSORBENT MIND MONTESSORI ACADEMY STANDARD CHARACTER MARK. INT. CL. 41. REG. 12-11-2007.
- 3,350,911. PIRANHA AND DESIGN. INT. CL. 15. REG. 12-11-2007.
- 3,350,914. MR.BLACK DANCE DEN STANDARD CHARACTER MARK. INT. CLS. 35, 41 AND 43. REG. 12-11-2007.
- 3,350,915. M M. BRASIL AND DESIGN. INT. CL. 20. REG. 12-11-2007.
- 3,350,923. A AND DESIGN. INT. CLS. 6, 7, 12 AND 17. REG. 12-11-2007.
- 3,350,926. NOVASOLS STANDARD CHARACTER MARK. INT. CLS. 1, 5, 29, 30 AND 32. REG. 12-11-2007.
- 3,350,928. I AM INSPIRED BY STANDARD CHARACTER MARK. INT. CL. 25. REG. 12-11-2007.
- 3,350,929. MEALS & STEALS STANDARD CHARACTER MARK. INT. CL. 35. REG. 12-11-2007.
- 3,350,930. THE COLORS OF HAWAII STANDARD CHARACTER MARK. INT. CL. 16. REG. 12-11-2007.
- 3,350,932. C5 AND DESIGN. INT. CL. 33. REG. 12-11-2007.
- 3,350,933. QIRO (STYLIZED). INT. CL. 42. REG. 12-11-2007.
- 3,350,934. QIRO (STYLIZED). INT. CL. 38. REG. 12-11-2007.
- 3,350,935. QIRO (STYLIZED). INT. CL. 36. REG. 12-11-2007.
- 3,350,936. QIRO STANDARD CHARACTER MARK. INT. CL. 35. REG. 12-11-2007.
- 3,350,945. TIDBIT STANDARD CHARACTER MARK. INT. CL. 28. REG. 12-11-2007.
- 3,350,947. KAWALLI ALABASTA STANDARD CHARACTER MARK. INT. CL. 3. REG. 12-11-2007.
- 3,350,948. FAST RELIEF FROM ORDINARY TV STANDARD CHARACTER MARK. INT. CL. 41. REG. 12-11-2007.
- 3,350,950. HEALTH FROM WITHIN CHIROPRACTIC WELLNESS CENTERS AND DESIGN. INT. CL. 44. REG. 12-11-2007.
- 3,350,953. LINK LS SOURCE AND DESIGN. INT. CLS. 37 AND 42. REG. 12-11-2007.
- 3,350,954. BELLA MIGLIORE STANDARD CHARACTER MARK. INT. CL. 30. REG. 12-11-2007.
- 3,350,962. THEJAVAEXCHANGECAFE AND DESIGN. INT. CL. 41. REG. 12-11-2007.
- 3,350,966. MISCELLANEOUS DESIGN. INT. CL. 35. REG. 12-11-2007.
- 3,350,967. 4 IN 1 TOPPERS STANDARD CHARACTER MARK. INT. CL. 20. REG. 12-11-2007.
- 3,350,971. JUGGERNAUTS M. C. EST.2006 CLARKSVILLE, TN AND DESIGN. INT. CL. 35. REG. 12-11-2007.
- 3,350,972. LATINO FUTURE STANDARD CHARACTER MARK. INT. CL. 16. REG. 12-11-2007.
- 3,350,973. LEXSTREAM STANDARD CHARACTER MARK. INT. CL. 9. REG. 12-11-2007.
- 3,350,974. PORTLAND STANDARD CHARACTER MARK. INT. CL. 12. REG. 12-11-2007.
- 3,350,975. LOOPIN STANDARD CHARACTER MARK. INT. CL. 38. REG. 12-11-2007.
- 3,350,976. SCHMAPPLETS STANDARD CHARACTER MARK. INT. CLS. 9, 35, 39 AND 42. REG. 12-11-2007.
- 3,350,983. DON'T PUSH—CONNECT STANDARD CHARACTER MARK. INT. CL. 35. REG. 12-11-2007.
- 3,350,984. TURNAROUND TECHNIQUES STANDARD CHARACTER MARK. INT. CL. 41. REG. 12-11-2007.
- 3,350,985. I NOSH THEREFORE I AM STANDARD CHARACTER MARK. INT. CLS. 21 AND 25. REG. 12-11-2007.
- 3,350,986. PETE ZADUNRITE STANDARD CHARACTER MARK. INT. CL. 43. REG. 12-11-2007.
- 3,350,989. MISCELLANEOUS DESIGN. INT. CLS. 9, 35, 39 AND 42. REG. 12-11-2007.
- 3,350,992. ONENESS DEEKSHA STANDARD CHARACTER MARK. INT. CL. 41. REG. 12-11-2007.
- 3,350,994. MISCELLANEOUS DESIGN. INT. CLS. 35, 38, 39, 41 AND 42. REG. 12-11-2007.
- 3,350,995. DBINDER STANDARD CHARACTER MARK. INT. CLS. 9 AND 42. REG. 12-11-2007.
- 3,351,000. SMARTSHEET.COM STANDARD CHARACTER MARK. INT. CL. 42. REG. 12-11-2007.
- 3,351,002. MISCELLANEOUS DESIGN. INT. CLS. 35, 41 AND 42. REG. 12-11-2007.
- 3,351,005. WORK BETTER STANDARD CHARACTER MARK. INT. CLS. 35, 36 AND 41. REG. 12-11-2007.
- 3,351,010. IMH REAL ESTATE FINANCIERS STANDARD CHARACTER MARK. INT. CL. 36. REG. 12-11-2007.
- 3,351,013. OUR EARTH MUSIC STANDARD CHARACTER MARK. INT. CL. 45. REG. 12-11-2007.
- 3,351,014. FUN WITH PANDA (STYLIZED). INT. CL. 41. REG. 12-11-2007.
- 3,351,015. DR. SCOTT'S HEALTH CARE SECRETS STANDARD CHARACTER MARK. INT. CL. 9. REG. 12-11-2007.
- 3,351,017. SPONSOREDWHIPS.COM STANDARD CHARACTER MARK. INT. CL. 35. REG. 12-11-2007.
- 3,351,019. A ACCESS ALLIED AND DESIGN. INT. CL. 35. REG. 12-11-2007.
- 3,351,020. BOOMERBOX STANDARD CHARACTER MARK. INT. CL. 41. REG. 12-11-2007.
- 3,351,021. CAPZLES STANDARD CHARACTER MARK. INT. CLS. 9, 35 AND 45. REG. 12-11-2007.
- 3,351,022. BROWN PALACE HOTEL AND DESIGN. INT. CL. 43. REG. 12-11-2007.
- 3,351,023. WE FIGHT TO WIN STANDARD CHARACTER MARK. INT. CL. 45. REG. 12-11-2007.
- 3,351,025. TOWN SQUARE STANDARD CHARACTER MARK. INT. CL. 16. REG. 12-11-2007.
- 3,351,027. OUTSIDE THE DREAM STANDARD CHARACTER MARK. INT. CL. 36. REG. 12-11-2007.
- 3,351,030. ESPRIT STANDARD CHARACTER MARK. INT. CL. 7. REG. 12-11-2007.
- 3,351,032. MOTIVES STUDIOS STANDARD CHARACTER MARK. INT. CL. 41. REG. 12-11-2007.
- 3,351,033. FLAGSHIP PUBLISHING GROUP STANDARD CHARACTER MARK. INT. CL. 41. REG. 12-11-2007.
- 3,351,035. ABUND STANDARD CHARACTER MARK. INT. CL. 7. REG. 12-11-2007.
- 3,351,036. BTU GEEK STANDARD CHARACTER MARK. INT. CL. 41. REG. 12-11-2007.
- 3,351,037. GSFX STANDARD CHARACTER MARK. INT. CL. 9. REG. 12-11-2007.
- 3,351,040. KENNY PENNY STANDARD CHARACTER MARK. INT. CL. 16. REG. 12-11-2007.
- 3,351,041. FABRI-TEC STANDARD CHARACTER MARK. INT. CL. 17. REG. 12-11-2007.
- 3,351,046. SDO SKIN WELLNESS DRYNESS ODOR CONTROL TREATED FIBERS LOWER PH FOR SKIN PROTECTION AND DESIGN. INT. CL. 5. REG. 12-11-2007.
- 3,351,048. GENO'S FRESH CATCH GRILL STANDARD CHARACTER MARK. INT. CL. 43. REG. 12-11-2007.
- 3,351,049. GENO'S DOCKSIDE DELI STANDARD CHARACTER MARK. INT. CL. 43. REG. 12-11-2007.
- 3,351,052. HEALTHINSURANCEFINDER STANDARD CHARACTER MARK. INT. CL. 35. REG. 12-11-2007.
- 3,351,056. FILLET MON DOG GOURMET HOTDOGS AND DESIGN. INT. CL. 43. REG. 12-11-2007.
- 3,351,057. FRESHEN YOUR BODY FRESHEN YOUR LIFE STANDARD CHARACTER MARK. INT. CL. 5. REG. 12-11-2007.

- 3,351,058. EDUCATIONAL ODYSSEYS STANDARD CHARACTER MARK. INT. CL. 39. REG. 12-11-2007.
- 3,351,059. VENTURELEAP STANDARD CHARACTER MARK. INT. CL. 35. REG. 12-11-2007.
- 3,351,060. JULIA STANDARD CHARACTER MARK. INT. CL. 23. REG. 12-11-2007.
- 3,351,061. HICHAIN STANDARD CHARACTER MARK. INT. CL. 1. REG. 12-11-2007.
- 3,351,062. PRECISIONMELT STANDARD CHARACTER MARK. INT. CL. 1. REG. 12-11-2007.
- 3,351,063. THE LDC FORUM STANDARD CHARACTER MARK. INT. CL. 35. REG. 12-11-2007.
- 3,351,064. GOT SWAGGER STANDARD CHARACTER MARK. INT. CL. 25. REG. 12-11-2007.
- 3,351,065. LORMANDI.COM (STYLIZED). INT. CL. 35. REG. 12-11-2007.
- 3,351,067. THE TRACIAK COLLECTION STANDARD CHARACTER MARK. INT. CL. 14. REG. 12-11-2007.
- 3,351,069. PHILIPPE LANGDON STANDARD CHARACTER MARK. INT. CL. 20. REG. 12-11-2007.
- 3,351,070. CARE AND DESIGN. INT. CL. 44. REG. 12-11-2007.
- 3,351,071. SAINT CHARLES MAGAZINE FOR GRACIOUS LIVING IN ST. CHARLES COUNTY (STYLIZED). INT. CL. 16. REG. 12-11-2007.
- 3,351,079. BLIND MELON STANDARD CHARACTER MARK. INT. CL. 25. REG. 12-11-2007.
- 3,351,082. SHOES ON A SHOESTRING STANDARD CHARACTER MARK. INT. CL. 35. REG. 12-11-2007.
- 3,351,085. BANTIS STANDARD CHARACTER MARK. INT. CL. 35. REG. 12-11-2007.
- 3,351,086. RDL AND DESIGN. INT. CL. 41. REG. 12-11-2007.
- 3,351,090. LIFE STYLE MAKEOVERS AND DESIGN. INT. CL. 41. REG. 12-11-2007.
- 3,351,091. COPTERVIEWS AND DESIGN. INT. CL. 41. REG. 12-11-2007.
- 3,351,094. C THE SCOTTSDALE CENTER FOR DENTISTRY AND DESIGN. INT. CL. 41. REG. 12-11-2007.
- 3,351,095. SINGLEBOUND CREATIVE STANDARD CHARACTER MARK. INT. CL. 42. REG. 12-11-2007.
- 3,351,096. IMH SECURED LOAN FUND STANDARD CHARACTER MARK. INT. CL. 36. REG. 12-11-2007.
- 3,351,097. TUNE TOON STANDARD CHARACTER MARK. INT. CL. 16. REG. 12-11-2007.
- 3,351,098. HARMONY FUSIONWAVE AWARENESS STANDARD CHARACTER MARK. INT. CL. 41. REG. 12-11-2007.
- 3,351,099. BIGG CITY STANDARD CHARACTER MARK. INT. CL. 41. REG. 12-11-2007.
- 3,351,101. JOB SPA EMPLOYEE ENGAGEMENT STANDARD CHARACTER MARK. INT. CLS. 35 AND 42. REG. 12-11-2007.
- 3,351,103. MISCELLANEOUS DESIGN. INT. CL. 36. REG. 12-11-2007.
- 3,351,108. YABASTA STANDARD CHARACTER MARK. INT. CL. 25. REG. 12-11-2007.
- 3,351,109. WELL HUNG STANDARD CHARACTER MARK. INT. CL. 35. REG. 12-11-2007.
- 3,351,110. MIDDLE DISTANCE RUNNER AND DESIGN. INT. CL. 9. REG. 12-11-2007.
- 3,351,111. OXBURY STANDARD CHARACTER MARK. INT. CL. 44. REG. 12-11-2007.
- 3,351,113. AUNT SALLY'S GOURMET FIGS & BERRIES NEW ORLEANS AND DESIGN. INT. CL. 29. REG. 12-11-2007.
- 3,351,119. RETHINKING DATA MESSAGING STANDARD CHARACTER MARK. INT. CL. 9. REG. 12-11-2007.
- 3,351,122. RNINSIDER.COM AND DESIGN. INT. CL. 35. REG. 12-11-2007.
- 3,351,125. SMILES INCLUDED AND DESIGN. INT. CL. 35. REG. 12-11-2007.
- 3,351,129. TERRA NOVA STANDARD CHARACTER MARK. INT. CL. 36. REG. 12-11-2007.
- 3,351,131. MISCELLANEOUS DESIGN. INT. CL. 41. REG. 12-11-2007.
- 3,351,132. C CLARENDON AND DESIGN. INT. CL. 25. REG. 12-11-2007.
- 3,351,133. ELIXIR LIGHT HEALING STANDARD CHARACTER MARK. INT. CL. 44. REG. 12-11-2007.
- 3,351,134. THE EXCELSIOR PLANET STANDARD CHARACTER MARK. INT. CL. 14. REG. 12-11-2007.
- 3,351,135. QE QE QUANENTERTAINMENT (STYLIZED). INT. CL. 41. REG. 12-11-2007.
- 3,351,136. TALKER STANDARD CHARACTER MARK. INT. CL. 9. REG. 12-11-2007.
- 3,351,142. REFLECTIONS STANDARD CHARACTER MARK. INT. CL. 43. REG. 12-11-2007.
- 3,351,144. SPRING CHO REAL ESTATE GROUP AND DESIGN. INT. CL. 36. REG. 12-11-2007.
- 3,351,147. PHYTOLACTUM STANDARD CHARACTER MARK. INT. CL. 3. REG. 12-11-2007.
- 3,351,152. GIRL POWDER STANDARD CHARACTER MARK. INT. CL. 35. REG. 12-11-2007.
- 3,351,154. PHYTOLOOK STANDARD CHARACTER MARK. INT. CL. 3. REG. 12-11-2007.
- 3,351,155. FONTCLOUD STANDARD CHARACTER MARK. INT. CLS. 35 AND 42. REG. 12-11-2007.
- 3,351,159. ABUND STANDARD CHARACTER MARK. INT. CL. 9. REG. 12-11-2007.
- 3,351,161. SEE A ROOM STANDARD CHARACTER MARK. INT. CL. 42. REG. 12-11-2007.
- 3,351,162. MATCH 13 STANDARD CHARACTER MARK. INT. CL. 9. REG. 12-11-2007.
- 3,351,174. MALIBU SURFSKATES STANDARD CHARACTER MARK. INT. CL. 28. REG. 12-11-2007.
- 3,351,177. THE PURPLE TANGERINE (STYLIZED). INT. CLS. 25 AND 35. REG. 12-11-2007.
- 3,351,178. SPA AT HOME AND DESIGN. INT. CL. 4. REG. 12-11-2007.
- 3,351,183. DOCUMENT MANAGEMENT EXTENSIONS STANDARD CHARACTER MARK. INT. CL. 9. REG. 12-11-2007.
- 3,351,186. ADVANTAGE TURF RESTORE STANDARD CHARACTER MARK. INT. CL. 1. REG. 12-11-2007.
- 3,351,187. PLASTIC EARTH AND DESIGN. INT. CL. 40. REG. 12-11-2007.
- 3,351,188. BEVONA WOOD STANDARD CHARACTER MARK. INT. CL. 17. REG. 12-11-2007.
- 3,351,189. GRANBY STEEL TANKS STANDARD CHARACTER MARK. INT. CL. 6. REG. 12-11-2007.
- 3,351,190. RESERVOIRS D'ACIER GRANBY STANDARD CHARACTER MARK. INT. CL. 6. REG. 12-11-2007.
- 3,351,191. PEA SOUP ACCESSORIES FOR KIDS AND DESIGN. INT. CL. 35. REG. 12-11-2007.
- 3,351,193. VETCLOT OC STANDARD CHARACTER MARK. INT. CL. 5. REG. 12-11-2007.
- 3,351,196. MISCELLANEOUS DESIGN. INT. CL. 41. REG. 12-11-2007.
- 3,351,197. CAPTAIN PAPILLION PRESENTS KIDPIRATES.-COM PLUNDER YE NOT THE GOOD EARTH AND SEA AND DESIGN. INT. CL. 41. REG. 12-11-2007.
- 3,351,200. GRACIOUS HOME STANDARD CHARACTER MARK. INT. CL. 16. REG. 12-11-2007.
- 3,351,202. GRACIOUS HOME STANDARD CHARACTER MARK. INT. CL. 20. REG. 12-11-2007.
- 3,351,203. VRETS REAL ESTATE TRAINING AND DESIGN. INT. CLS. 9 AND 41. REG. 12-11-2007.
- 3,351,204. TECHNICALLY CORRECT : ALWAYS APPROPRIATE STANDARD CHARACTER MARK. INT. CLS. 18 AND 25. REG. 12-11-2007.
- 3,351,209. GRACIOUS HOME STANDARD CHARACTER MARK. INT. CL. 1. REG. 12-11-2007.
- 3,351,210. AIS STANDARD CHARACTER MARK. INT. CLS. 41 AND 42. REG. 12-11-2007.
- 3,351,211. METABAL STANDARD CHARACTER MARK. INT. CL. 5. REG. 12-11-2007.
- 3,351,213. MORRIS KELLY COLLECTION STANDARD CHARACTER MARK. INT. CL. 20. REG. 12-11-2007.

- 3,351,214. DGA STANDARD CHARACTER MARK. INT. CL. 36. REG. 12-11-2007.
- 3,351,215. BELIZE MOTHER NATURE'S BEST KEPT SECRET AND DESIGN. INT. CL. 35. REG. 12-11-2007.
- 3,351,220. MISCELLANEOUS DESIGN. INT. CL. 35. REG. 12-11-2007.
- 3,351,225. MISCELLANEOUS DESIGN. INT. CL. 34. REG. 12-11-2007.
- 3,351,227. TERRA SOLUTIONS GROUP GEOGRAPHIC INFORMATION SYSTEMS FOR BUSINESS AND DESIGN. INT. CL. 42. REG. 12-11-2007.
- 3,351,229. MILLERMATIC STANDARD CHARACTER MARK. INT. CL. 9. REG. 12-11-2007.
- 3,351,231. SMARTMOVE AUTO STANDARD CHARACTER MARK. INT. CL. 39. REG. 12-11-2007.
- 3,351,233. KENDLE COLLEGE STANDARD CHARACTER MARK. INT. CL. 41. REG. 12-11-2007.
- 3,351,237. MAKING HR A DRIVER OF RESULTS STANDARD CHARACTER MARK. INT. CL. 35. REG. 12-11-2007.
- 3,351,239. OLD BRIDGE DENTAL STANDARD CHARACTER MARK. INT. CL. 44. REG. 12-11-2007.
- 3,351,240. OUTER BANKS BIKE RALLY 64 AND DESIGN. INT. CL. 35. REG. 12-11-2007.
- 3,351,243. ASPEN BAY CANDLES AND DESIGN. INT. CL. 4. REG. 12-11-2007.
- 3,351,245. SENIORS FIRST REVERSE MORTGAGE SPECIALISTS AND DESIGN. INT. CL. 36. REG. 12-11-2007.
- 3,351,249. IT'S LIKE NATURAL DAYLIGHT INDOORS STANDARD CHARACTER MARK. INT. CL. 11. REG. 12-11-2007.
- 3,351,251. CAPTAIN ALMIGHTY STANDARD CHARACTER MARK. INT. CL. 41. REG. 12-11-2007.
- 3,351,253. MISCELLANEOUS DESIGN. INT. CLS. 9 AND 28. REG. 12-11-2007.
- 3,351,256. TOP GREEN STANDARD CHARACTER MARK. INT. CL. 7. REG. 12-11-2007.
- 3,351,258. KAREN SCHOLL HORSEMANSHIP FOR WOMEN STANDARD CHARACTER MARK. INT. CL. 41. REG. 12-11-2007.
- 3,351,261. VETERANS ENERGY SOLUTIONS, LLC AND DESIGN. INT. CL. 40. REG. 12-11-2007.
- 3,351,263. PRIME REALTY USA AND DESIGN. INT. CL. 35. REG. 12-11-2007.
- 3,351,265. LOGOS TECHNOLOGIES AND DESIGN. INT. CLS. 9 AND 42. REG. 12-11-2007.
- 3,351,266. FROM THE MAKERS OF MISSION TORTILLAS AND DESIGN. INT. CL. 30. REG. 12-11-2007.
- 3,351,267. YOOTER AND DESIGN. INT. CL. 35. REG. 12-11-2007.
- 3,351,269. ITMUSTBE STANDARD CHARACTER MARK. INT. CL. 42. REG. 12-11-2007.
- 3,351,272. ICECOLDSAKE AND DESIGN. INT. CL. 35. REG. 12-11-2007.
- 3,351,274. METARIZON AND DESIGN. INT. CL. 35. REG. 12-11-2007.
- 3,351,281. DRIVE, CONVERT & MEASURE AND DESIGN. INT. CL. 35. REG. 12-11-2007.
- 3,351,282. CATCH CLEAN AND DESIGN. INT. CL. 28. REG. 12-11-2007.
- 3,351,283. MULTILINK SPRINT STANDARD CHARACTER MARK. INT. CL. 5. REG. 12-11-2007.
- 3,351,284. TEAM DOUBLE-CLICK STANDARD CHARACTER MARK. INT. CL. 35. REG. 12-11-2007.
- 3,351,285. PROVIDING THE PEOPLE... VIRTUALLY! TEAM DOUBLE-CLICK AND DESIGN. INT. CL. 35. REG. 12-11-2007.
- 3,351,286. ATTENTION NGN STANDARD CHARACTER MARK. INT. CL. 35. REG. 12-11-2007.
- 3,351,287. LE FLASH STANDARD CHARACTER MARK. INT. CL. 9. REG. 12-11-2007.
- 3,351,288. INDIEKAZOO STANDARD CHARACTER MARK. INT. CL. 42. REG. 12-11-2007.
- 3,351,290. PAYCHEK PLUS STANDARD CHARACTER MARK. INT. CL. 9. REG. 12-11-2007.
- 3,351,291. TRUIIMAGE STANDARD CHARACTER MARK. INT. CL. 16. REG. 12-11-2007.
- 3,351,292. STAR MEDICAL STANDARD CHARACTER MARK. INT. CL. 39. REG. 12-11-2007.
- 3,351,293. TRUEIMAGE STANDARD CHARACTER MARK. INT. CL. 16. REG. 12-11-2007.
- 3,351,294. CHILDREN OF THE WORLD AND DESIGN. INT. CLS. 16 AND 41. REG. 12-11-2007.
- 3,351,295. ALBEMARLE LONDON AND DESIGN. INT. CL. 25. REG. 12-11-2007.
- 3,351,296. THYADINE STANDARD CHARACTER MARK. INT. CL. 5. REG. 12-11-2007.
- 3,351,297. WE LOWER YOUR COST OF LIVING! STANDARD CHARACTER MARK. INT. CL. 35. REG. 12-11-2007.
- 3,351,299. ONE DESTINATION, UNLIMITED POSSIBILITIES STANDARD CHARACTER MARK. INT. CL. 35. REG. 12-11-2007.
- 3,351,300. HARRAH'S LUCKY-BREAK AND DESIGN. INT. CL. 41. REG. 12-11-2007.
- 3,351,301. DESKTOP SCHOOL SUPPLIES AND DESIGN. INT. CL. 35. REG. 12-11-2007.
- 3,351,308. PT AND DESIGN. INT. CLS. 25, 28 AND 41. REG. 12-11-2007.
- 3,351,310. PERFIT STANDARD CHARACTER MARK. INT. CL. 9. REG. 12-11-2007.
- 3,351,312. BIG DAY PHOTOGRAPHY STANDARD CHARACTER MARK. INT. CL. 41. REG. 12-11-2007.
- 3,351,314. SUBLIME PHOTOGRAPHY STANDARD CHARACTER MARK. INT. CL. 41. REG. 12-11-2007.
- 3,351,315. THE POSITIVE ZONE AND DESIGN. INT. CL. 41. REG. 12-11-2007.
- 3,351,318. IQ212 STANDARD CHARACTER MARK. INT. CL. 41. REG. 12-11-2007.
- 3,351,319. 4 (STYLIZED). INT. CL. 41. REG. 12-11-2007.
- 3,351,320. HEX AND DESIGN. INT. CL. 9. REG. 12-11-2007.
- 3,351,321. V.I.P. CLEANERS STANDARD CHARACTER MARK. INT. CLS. 35, 37 AND 39. REG. 12-11-2007.
- 3,351,322. TUESDAY NIGHT SUPPER CLUB AND DESIGN. INT. CL. 41. REG. 12-11-2007.
- 3,351,324. RITE AID RITE CARE AND DESIGN. INT. CL. 44. REG. 12-11-2007.
- 3,351,327. KEMPT AND DESIGN. INT. CL. 18. REG. 12-11-2007.
- 3,351,328. THE WORLD'S TOUGHEST LOCKS STANDARD CHARACTER MARK. INT. CL. 12. REG. 12-11-2007.
- 3,351,330. HALMAR STANDARD CHARACTER MARK. INT. CL. 9. REG. 12-11-2007.
- 3,351,332. LIST'D STANDARD CHARACTER MARK. INT. CL. 35. REG. 12-11-2007.
- 3,351,333. NEW YORK INTERACTIVE MEDIA STANDARD CHARACTER MARK. INT. CL. 41. REG. 12-11-2007.
- 3,351,336. SEDONA MEDSPA AND DESIGN. INT. CL. 44. REG. 12-11-2007.
- 3,351,339. BLACK DIAMOND VIDEO AND DESIGN. INT. CL. 9. REG. 12-11-2007.
- 3,351,341. PROMISED LAND PLANTATION STANDARD CHARACTER MARK. INT. CL. 35. REG. 12-11-2007.
- 3,351,342. CHEATSERVER STANDARD CHARACTER MARK. INT. CL. 42. REG. 12-11-2007.
- 3,351,343. SPATINI SPA EVENTS WITH A TWIST AND DESIGN. INT. CL. 44. REG. 12-11-2007.
- 3,351,344. IBACKS (STYLIZED). INT. CL. 35. REG. 12-11-2007.
- 3,351,346. HANDIRECORDS AND DESIGN. INT. CL. 16. REG. 12-11-2007.
- 3,351,350. MYHELPDESK STANDARD CHARACTER MARK. INT. CL. 42. REG. 12-11-2007.
- 3,351,353. OSO STANDARD CHARACTER MARK. INT. CL. 36. REG. 12-11-2007.
- 3,351,354. MISCELLANEOUS DESIGN. INT. CL. 36. REG. 12-11-2007.
- 3,351,355. Q AND DESIGN. INT. CL. 39. REG. 12-11-2007.

- 3,351,356. THE MONEY COLLEGE APPLIED KNOWLEDGE IS POWER THE MONEY COLLEGE YOUR SOURCE FOR FINANCIAL EDUCATION NON SEBI SED ALIIS AND DESIGN. INT. CL. 41. REG. 12-11-2007.
- 3,351,357. VITAMIN WONDERS (CREATED BY NATURE . HARNESSSED BY MANKIND) AND DESIGN. INT. CL. 5. REG. 12-11-2007.
- 3,351,360. FUNKY GOLF GRIPS STANDARD CHARACTER MARK. INT. CL. 28. REG. 12-11-2007.
- 3,351,361. Q. SIMPLE. QUICK. EASY. (STYLIZED). INT. CL. 39. REG. 12-11-2007.
- 3,351,362. NEIGHBORHOOD STORAGE STANDARD CHARACTER MARK. INT. CL. 39. REG. 12-11-2007.
- 3,351,365. HELL BOUND SOUND AND DESIGN. INT. CL. 41. REG. 12-11-2007.
- 3,351,366. CONSCIOUSLY SOCIAL STANDARD CHARACTER MARK. INT. CL. 41. REG. 12-11-2007.
- 3,351,367. MUSIC IS MY NATURE STANDARD CHARACTER MARK. INT. CL. 25. REG. 12-11-2007.
- 3,351,368. PRIVATE EYE STANDARD CHARACTER MARK. INT. CL. 3. REG. 12-11-2007.
- 3,351,371. GRINDMODECONNECT.COM STANDARD CHARACTER MARK. INT. CL. 42. REG. 12-11-2007.
- 3,351,377. S\*MZ MATH TUTOR FOR KIDS AND DESIGN. INT. CL. 41. REG. 12-11-2007.
- 3,351,378. URBAN FOREST HOME AND DESIGN. INT. CL. 35. REG. 12-11-2007.
- 3,351,380. CUB CADET AND DESIGN. INT. CLS. 7 AND 12. REG. 12-11-2007.
- 3,351,382. ¡SÓLO COLOQUE Y HORNEE! STANDARD CHARACTER MARK. INT. CL. 30. REG. 12-11-2007.
- 3,351,383. WISCONSIN HEART & VASCULAR INSTITUTE AND DESIGN. INT. CL. 44. REG. 12-11-2007.
- 3,351,385. BUSINESS. MADE PERSONAL. STANDARD CHARACTER MARK. INT. CL. 36. REG. 12-11-2007.
- 3,351,387. ITRIBUTE AND DESIGN. INT. CL. 42. REG. 12-11-2007.
- 3,351,388. FITNESS BY CORRY STANDARD CHARACTER MARK. INT. CL. 41. REG. 12-11-2007.
- 3,351,389. CELEBSTER STANDARD CHARACTER MARK. INT. CL. 41. REG. 12-11-2007.
- 3,351,390. NETFORENSICS STANDARD CHARACTER MARK. INT. CL. 9. REG. 12-11-2007.
- 3,351,391. L L LACK CONSTRUCTION AND DESIGN. INT. CL. 37. REG. 12-11-2007.
- 3,351,392. ARMOR FASTOR STANDARD CHARACTER MARK. INT. CL. 9. REG. 12-11-2007.
- 3,351,393. HALFWAY TO HAZARD STANDARD CHARACTER MARK. INT. CL. 41. REG. 12-11-2007.
- 3,351,395. DINUBA BROOM AND DESIGN. INT. CL. 21. REG. 12-11-2007.
- 3,351,405. HCP STANDARD CHARACTER MARK. INT. CL. 36. REG. 12-11-2007.
- 3,351,407. TIMEDIRECT STANDARD CHARACTER MARK. INT. CL. 42. REG. 12-11-2007.
- 3,351,408. YOUNGARTS STANDARD CHARACTER MARK. INT. CL. 16. REG. 12-11-2007.
- 3,351,409. KNOWLEDGEAGENCY A TW POWELL COMPANY STANDARD CHARACTER MARK. INT. CL. 42. REG. 12-11-2007.
- 3,351,410. TMB OPTICAL STANDARD CHARACTER MARK. INT. CLS. 9 AND 42. REG. 12-11-2007.
- 3,351,411. ST SATURDAY THURSDAY AND DESIGN. INT. CL. 41. REG. 12-11-2007.
- 3,351,417. ROYAL HAWAIIAN SURF ACADEMY STANDARD CHARACTER MARK. INT. CL. 25. REG. 12-11-2007.
- 3,351,419. ALL AMERICAN FOOTBALL LEAGUE STANDARD CHARACTER MARK. INT. CL. 41. REG. 12-11-2007.
- 3,351,420. ROYAL HAWAIIAN SURF ACADEMY AND DESIGN. INT. CL. 25. REG. 12-11-2007.
- 3,351,421. STING SURVEILLANCE STANDARD CHARACTER MARK. INT. CL. 37. REG. 12-11-2007.
- 3,351,422. JUST ROUGHIN' IT ADVENTURE CO. STANDARD CHARACTER MARK. INT. CL. 39. REG. 12-11-2007.
- 3,351,423. NEXSEM STANDARD CHARACTER MARK. INT. CL. 9. REG. 12-11-2007.
- 3,351,427. AN INTELLIGENT APPROACH TO FITNESS STANDARD CHARACTER MARK. INT. CL. 41. REG. 12-11-2007.
- 3,351,430. RAPPORTICA AND DESIGN. INT. CL. 35. REG. 12-11-2007.
- 3,351,432. MADRE SICILIA STANDARD CHARACTER MARK. INT. CL. 29. REG. 12-11-2007.
- 3,351,433. ONE BAND ONE DAY ONE MASSIVE WORLD STAGE STANDARD CHARACTER MARK. INT. CL. 38. REG. 12-11-2007.
- 3,351,434. FAMOUS DISCOVERIES STANDARD CHARACTER MARK. INT. CL. 35. REG. 12-11-2007.
- 3,351,435. CHAMBERCHARGE STANDARD CHARACTER MARK. INT. CL. 36. REG. 12-11-2007.
- 3,351,436. YORK RESIDENTIAL STANDARD CHARACTER MARK. INT. CL. 37. REG. 12-11-2007.
- 3,351,438. MORDECAI INVESTMENTS STANDARD CHARACTER MARK. INT. CL. 36. REG. 12-11-2007.
- 3,351,440. DISAL STANDARD CHARACTER MARK. INT. CL. 5. REG. 12-11-2007.
- 3,351,441. ALL ABOUT THE WIN! STANDARD CHARACTER MARK. INT. CL. 41. REG. 12-11-2007.
- 3,351,443. NEIGHBORHOOD SNOOP AND DESIGN. INT. CL. 36. REG. 12-11-2007.
- 3,351,444. SIMPLE WINE FOR A COMPLEX WORLD STANDARD CHARACTER MARK. INT. CL. 33. REG. 12-11-2007.
- 3,351,445. SENDING ALOHA AROUND THE WORLD STANDARD CHARACTER MARK. INT. CL. 35. REG. 12-11-2007.
- 3,351,446. MOGUL BEER STANDARD CHARACTER MARK. INT. CL. 32. REG. 12-11-2007.
- 3,351,448. "BETTER PLANS - BRIGHTER SMILES" STANDARD CHARACTER MARK. INT. CL. 36. REG. 12-11-2007.
- 3,351,452. HIPPIE GRENADE STANDARD CHARACTER MARK. INT. CL. 41. REG. 12-11-2007.
- 3,351,453. TXCO AND DESIGN. INT. CL. 39. REG. 12-11-2007.
- 3,351,454. TXCO AND DESIGN. INT. CL. 42. REG. 12-11-2007.
- 3,351,457. LASERITE STANDARD CHARACTER MARK. INT. CL. 40. REG. 12-11-2007.
- 3,351,458. EROTIC LUXURY STANDARD CHARACTER MARK. INT. CL. 35. REG. 12-11-2007.
- 3,351,460. FORCE FOR GOOD STANDARD CHARACTER MARK. INT. CL. 25. REG. 12-11-2007.
- 3,351,463. SAVE GAS . SAVE THE PLANET PUMP 'EM UP AND DESIGN. INT. CL. 35. REG. 12-11-2007.
- 3,351,464. GROUND LOUNGE STANDARD CHARACTER MARK. INT. CL. 20. REG. 12-11-2007.
- 3,351,467. FRIDAYLIGHT AND DESIGN. INT. CLS. 4 AND 41. REG. 12-11-2007.
- 3,351,470. RODGERSHARDIN STANDARD CHARACTER MARK. INT. CL. 37. REG. 12-11-2007.
- 3,351,471. MISCELLANEOUS DESIGN. INT. CL. 12. REG. 12-11-2007.
- 3,351,473. HR AND DESIGN. INT. CL. 37. REG. 12-11-2007.
- 3,351,476. CITYWHEELS STANDARD CHARACTER MARK. INT. CL. 39. REG. 12-11-2007.
- 3,351,477. YARNTOPIA STANDARD CHARACTER MARK. INT. CL. 35. REG. 12-11-2007.
- 3,351,478. COOL WAVES STANDARD CHARACTER MARK. INT. CL. 21. REG. 12-11-2007.
- 3,351,480. X AND DESIGN. INT. CLS. 1 AND 2. REG. 12-11-2007.
- 3,351,483. WE'RE IN YOUR CORNER STANDARD CHARACTER MARK. INT. CL. 41. REG. 12-11-2007.
- 3,351,484. KIDSLAND STANDARD CHARACTER MARK. INT. CL. 41. REG. 12-11-2007.

- 3,351,486. S SAVON FREIGHT AND DESIGN. INT. CL. 39. REG. 12-11-2007.
- 3,351,487. BALKAN BEATZ STANDARD CHARACTER MARK. INT. CL. 41. REG. 12-11-2007.
- 3,351,488. HEY SUGAR! STANDARD CHARACTER MARK. INT. CL. 30. REG. 12-11-2007.
- 3,351,492. V3 UNLIMITED STANDARD CHARACTER MARK. INT. CL. 35. REG. 12-11-2007.
- 3,351,493. A DWELLING PLACE REALTY STANDARD CHARACTER MARK. INT. CL. 36. REG. 12-11-2007.
- 3,351,498. SALON SECRETS STANDARD CHARACTER MARK. INT. CLS. 40 AND 44. REG. 12-11-2007.
- 3,351,499. MISCELLANEOUS DESIGN. INT. CL. 43. REG. 12-11-2007.
- 3,351,501. LA OPTIMA STANDARD CHARACTER MARK. INT. CL. 44. REG. 12-11-2007.
- 3,351,502. LA OPTIMA AND DESIGN. INT. CL. 44. REG. 12-11-2007.
- 3,351,503. NIMBLE MIND AND DESIGN. INT. CL. 41. REG. 12-11-2007.
- 3,351,504. DLL . RAINWEAR . AND DESIGN. INT. CL. 25. REG. 12-11-2007.
- 3,351,505. "PUDDLE STOMP IN STYLE" STANDARD CHARACTER MARK. INT. CL. 25. REG. 12-11-2007.
- 3,351,506. LEAN FAST STANDARD CHARACTER MARK. INT. CL. 5. REG. 12-11-2007.
- 3,351,507. SPARE SOLES STYLISH COMFORT FOR YOUR FEET AND DESIGN. INT. CL. 25. REG. 12-11-2007.
- 3,351,510. JLP AVIATION MAINTENANCE AND DESIGN. INT. CL. 37. REG. 12-11-2007.
- 3,351,511. 2COMPLEX STANDARD CHARACTER MARK. INT. CL. 41. REG. 12-11-2007.
- 3,351,512. BLACK ROGUE STANDARD CHARACTER MARK. INT. CL. 41. REG. 12-11-2007.
- 3,351,513. THE LITERACY AMBASSADOR STANDARD CHARACTER MARK. INT. CL. 41. REG. 12-11-2007.
- 3,351,514. RISKPRESS STANDARD CHARACTER MARK. INT. CL. 41. REG. 12-11-2007.
- 3,351,515. DICKYVIBE STANDARD CHARACTER MARK. INT. CL. 41. REG. 12-11-2007.
- 3,351,516. SPONGE PAL STANDARD CHARACTER MARK. INT. CL. 28. REG. 12-11-2007.
- 3,351,519. GOOD LIVING ORGANIC AND DESIGN. INT. CL. 35. REG. 12-11-2007.
- 3,351,520. 2CUTE STANDARD CHARACTER MARK. INT. CL. 28. REG. 12-11-2007.
- 3,351,521. L.A.M.O! LOOK AT ME ONLY! STANDARD CHARACTER MARK. INT. CL. 28. REG. 12-11-2007.
- 3,351,522. ENHANCER AIR COOLED (STYLIZED). INT. CL. 7. REG. 12-11-2007.
- 3,351,523. SAYSO STANDARD CHARACTER MARK. INT. CL. 16. REG. 12-11-2007.
- 3,351,524. THE BIG BLOW OFF STANDARD CHARACTER MARK. INT. CL. 3. REG. 12-11-2007.
- 3,351,526. EYES AND DESIGN. INT. CLS. 35 AND 44. REG. 12-11-2007.
- 3,351,527. THE DAMAGE IS DONE STANDARD CHARACTER MARK. INT. CL. 3. REG. 12-11-2007.
- 3,351,528. CREATIVE JUICE STANDARD CHARACTER MARK. INT. CL. 3. REG. 12-11-2007.
- 3,351,532. WAS HIS STANDARD CHARACTER MARK. INT. CL. 45. REG. 12-11-2007.
- 3,351,533. BLACK PLAGUE ENTERTAINMENT STANDARD CHARACTER MARK. INT. CL. 41. REG. 12-11-2007.
- 3,351,538. HAPPY TRAILS STANDARD CHARACTER MARK. INT. CL. 39. REG. 12-11-2007.
- 3,351,539. HAPPY TRAILS WITH ALAMO AL MO AND DESIGN. INT. CL. 39. REG. 12-11-2007.
- 3,351,542. MOMMY COME LATELY AND DESIGN. INT. CL. 44. REG. 12-11-2007.
- 3,351,544. EAMONN STANDARD CHARACTER MARK. INT. CL. 9. REG. 12-11-2007.
- 3,351,545. CN TS AND DESIGN. INT. CL. 42. REG. 12-11-2007.
- 3,351,547. SAVE. GIVE. SMILE. STANDARD CHARACTER MARK. INT. CLS. 35 AND 36. REG. 12-11-2007.
- 3,351,549. HONEST THOMAS STANDARD CHARACTER MARK. INT. CL. 41. REG. 12-11-2007.
- 3,351,551. IMBROSIA STANDARD CHARACTER MARK. INT. CL. 9. REG. 12-11-2007.
- 3,351,552. ZB SPELLING CONNECTIONS STANDARD CHARACTER MARK. INT. CL. 16. REG. 12-11-2007.
- 3,351,556. WATERWAYS HOMES AND DESIGN. INT. CL. 37. REG. 12-11-2007.
- 3,351,558. MYPAYDAYLOAN.COM STANDARD CHARACTER MARK. INT. CL. 36. REG. 12-11-2007.
- 3,351,565. MADE WITH LOVE IN BRAZIL STANDARD CHARACTER MARK. INT. CLS. 14 AND 25. REG. 12-11-2007.
- 3,351,568. MINDFREEZE STANDARD CHARACTER MARK. INT. CL. 45. REG. 12-11-2007.
- 3,351,569. EMERGENCYSMART STANDARD CHARACTER MARK. INT. CL. 35. REG. 12-11-2007.
- 3,351,570. UNLOCKED RECORDINGS STANDARD CHARACTER MARK. INT. CL. 35. REG. 12-11-2007.
- 3,351,571. V VEGETATE AND DESIGN. INT. CL. 43. REG. 12-11-2007.
- 3,351,574. EZTURNER STANDARD CHARACTER MARK. INT. CL. 7. REG. 12-11-2007.
- 3,351,576. GOFREE STANDARD CHARACTER MARK. INT. CL. 36. REG. 12-11-2007.
- 3,351,579. SETANTA SPORTS AND DESIGN. INT. CL. 38. REG. 12-11-2007.
- 3,351,580. CULINARY CREATIONS CATERING WITH A CREATIVE TOUCH STANDARD CHARACTER MARK. INT. CL. 43. REG. 12-11-2007.
- 3,351,581. CULINARY CREATIONS CAFÉ & PASTRY SHOPPE STANDARD CHARACTER MARK. INT. CL. 43. REG. 12-11-2007.
- 3,351,582. CULINARY CREATIONS CATERING STANDARD CHARACTER MARK. INT. CL. 43. REG. 12-11-2007.
- 3,351,583. SETANTA SPORTS STANDARD CHARACTER MARK. INT. CL. 38. REG. 12-11-2007.
- 3,351,586. SETANTA STANDARD CHARACTER MARK. INT. CL. 38. REG. 12-11-2007.
- 3,351,587. NAWIS STANDARD CHARACTER MARK. INT. CL. 25. REG. 12-11-2007.
- 3,351,588. RHINO-PAN STANDARD CHARACTER MARK. INT. CL. 6. REG. 12-11-2007.
- 3,351,589. RHINO - PAN AND DESIGN. INT. CL. 6. REG. 12-11-2007.
- 3,351,591. CINEMA OF FEAR STANDARD CHARACTER MARK. INT. CL. 28. REG. 12-11-2007.
- 3,351,593. MINING THE CULTURE FOR THE VALUES AND SYMBOLS THAT BUILD POWERFUL BRANDS STANDARD CHARACTER MARK. INT. CLS. 35 AND 42. REG. 12-11-2007.
- 3,351,595. SUN TOUCHED COLLECTION STANDARD CHARACTER MARK. INT. CL. 31. REG. 12-11-2007.
- 3,351,599. PSB LLC AND DESIGN. INT. CL. 5. REG. 12-11-2007.
- 3,351,602. BLAZE BAIL BONDS STANDARD CHARACTER MARK. INT. CL. 36. REG. 12-11-2007.
- 3,351,603. ZB SPELLING CONNECTIONS STANDARD CHARACTER MARK. INT. CL. 9. REG. 12-11-2007.
- 3,351,604. PISTOL PETE'S STANDARD CHARACTER MARK. INT. CL. 3. REG. 12-11-2007.
- 3,351,607. BUY SMARTER STANDARD CHARACTER MARK. INT. CL. 35. REG. 12-11-2007.
- 3,351,615. LOCKER'S STANDARD CHARACTER MARK. INT. CL. 35. REG. 12-11-2007.
- 3,351,616. BOTTOM FEEDERS BOAT HULL BOTTOM GRAPHICS STANDARD CHARACTER MARK. INT. CL. 16. REG. 12-11-2007.
- 3,351,618. ULTRALUX STANDARD CHARACTER MARK. INT. CL. 11. REG. 12-11-2007.

- 3,351,619. SIGIL GAMES ONLINE AND DESIGN. INT. CL. 41. REG. 12-11-2007.
- 3,351,625. IT'S YOUR REALITY. AND IT'S PRETTY COMPELLING STUFF! STANDARD CHARACTER MARK. INT. CL. 41. REG. 12-11-2007.
- 3,351,626. COSMIC REIKI STANDARD CHARACTER MARK. INT. CL. 44. REG. 12-11-2007.
- 3,351,627. ZMOR STANDARD CHARACTER MARK. INT. CL. 33. REG. 12-11-2007.
- 3,351,629. BWP STANDARD CHARACTER MARK. INT. CL. 9. REG. 12-11-2007.
- 3,351,630. SNEAKADOO STANDARD CHARACTER MARK. INT. CL. 9. REG. 12-11-2007.
- 3,351,631. SUN CRUNCHERS STANDARD CHARACTER MARK. INT. CL. 29. REG. 12-11-2007.
- 3,351,633. CASTELGARDEN STANDARD CHARACTER MARK. INT. CLS. 7, 8 AND 12. REG. 12-11-2007.
- 3,351,635. THESTEMCELLEXCHANGE.COM STANDARD CHARACTER MARK. INT. CL. 42. REG. 12-11-2007.
- 3,351,636. OPENCOLLABNET AND DESIGN. INT. CL. 38. REG. 12-11-2007.
- 3,351,637. OPENCOLLABNET AND DESIGN. INT. CL. 41. REG. 12-11-2007.
- 3,351,638. THE JUNTO GROUP STANDARD CHARACTER MARK. INT. CL. 35. REG. 12-11-2007.
- 3,351,639. OPENCOLLABNET AND DESIGN. INT. CL. 42. REG. 12-11-2007.
- 3,351,640. MR. LIGHTBULB STANDARD CHARACTER MARK. INT. CL. 37. REG. 12-11-2007.
- 3,351,641. MAKE IT ORIGINAL STANDARD CHARACTER MARK. INT. CL. 43. REG. 12-11-2007.
- 3,351,642. COOKEVER STANDARD CHARACTER MARK. INT. CL. 21. REG. 12-11-2007.
- 3,351,643. EAST COAST MEETS WEST COAST STANDARD CHARACTER MARK. INT. CL. 35. REG. 12-11-2007.
- 3,351,645. URCUTE STANDARD CHARACTER MARK. INT. CL. 16. REG. 12-11-2007.
- 3,351,647. YOU ARE CUTE, SHOW THE WORLD! STANDARD CHARACTER MARK. INT. CL. 45. REG. 12-11-2007.
- 3,351,651. YOUR REVENUE SYNCHRONIZED STANDARD CHARACTER MARK. INT. CL. 35. REG. 12-11-2007.
- 3,351,652. ACADEMIA STANDARD CHARACTER MARK. INT. CL. 10. REG. 12-11-2007.
- 3,351,656. CE AND DESIGN. INT. CL. 36. REG. 12-11-2007.
- 3,351,662. PAID BILLCOLLECTOR SMALL BUSINESS BILLING AND DEBT COLLECTION SOFTWARE IN A BOX AND DESIGN. INT. CL. 9. REG. 12-11-2007.
- 3,351,665. CLIMB ATLANTA STANDARD CHARACTER MARK. INT. CL. 36. REG. 12-11-2007.
- 3,351,666. STRUTS STANDARD CHARACTER MARK. INT. CL. 43. REG. 12-11-2007.
- 3,351,668. ROCHE AND DESIGN. INT. CL. 5. REG. 12-11-2007.
- 3,351,669. ROCHE AND DESIGN. INT. CL. 5. REG. 12-11-2007.
- 3,351,671. FLOSSY THE FEEL BETTER BUNNY STANDARD CHARACTER MARK. INT. CL. 28. REG. 12-11-2007.
- 3,351,673. INVOLUTION STANDARD CHARACTER MARK. INT. CL. 42. REG. 12-11-2007.
- 3,351,674. S-LOOP STANDARD CHARACTER MARK. INT. CL. 42. REG. 12-11-2007.
- 3,351,680. SPITKIT STANDARD CHARACTER MARK. INT. CLS. 1 AND 5. REG. 12-11-2007.
- 3,351,682. ONDEMAND AND DESIGN. INT. CL. 9. REG. 12-11-2007.
- 3,351,686. SELECTVIEW STANDARD CHARACTER MARK. INT. CLS. 19 AND 20. REG. 12-11-2007.
- 3,351,688. MIXLIXIR STANDARD CHARACTER MARK. INT. CL. 5. REG. 12-11-2007.
- 3,351,689. KRITTERS IN THE MAILBOX STANDARD CHARACTER MARK. INT. CL. 35. REG. 12-11-2007.
- 3,351,690. PEDIATRIC EYECARE OF STATEN ISLAND AND DESIGN. INT. CL. 44. REG. 12-11-2007.
- 3,351,694. OPENCOLLABNET AND DESIGN. INT. CL. 9. REG. 12-11-2007.
- 3,351,695. AQUAFOUR STANDARD CHARACTER MARK. INT. CL. 29. REG. 12-11-2007.
- 3,351,696. MATHEW & MATHEW STANDARD CHARACTER MARK. INT. CL. 25. REG. 12-11-2007.
- 3,351,703. ECO-SENSUAL STANDARD CHARACTER MARK. INT. CL. 3. REG. 12-11-2007.
- 3,351,704. ENTERTAINMENT ON THE MOVE STANDARD CHARACTER MARK. INT. CL. 38. REG. 12-11-2007.
- 3,351,707. THE BEST WAY TO TEST STANDARD CHARACTER MARK. INT. CL. 35. REG. 12-11-2007.
- 3,351,708. IS-3 STANDARD CHARACTER MARK. INT. CL. 10. REG. 12-11-2007.
- 3,351,713. NEXT RO STANDARD CHARACTER MARK. INT. CL. 11. REG. 12-11-2007.
- 3,351,714. AZO STANDARD CHARACTER MARK. INT. CL. 33. REG. 12-11-2007.
- 3,351,715. DREAM . SHOP . CREATE SEAL & CO. CHILDREN'S CLOTHING & FURNISHINGS AND DESIGN. INT. CL. 35. REG. 12-11-2007.
- 3,351,716. WILDSIDESALMON STANDARD CHARACTER MARK. INT. CL. 31. REG. 12-11-2007.
- 3,351,718. INVESTORS TRUST AND DESIGN. INT. CL. 36. REG. 12-11-2007.
- 3,351,723. PLAY PALS STANDARD CHARACTER MARK. INT. CL. 41. REG. 12-11-2007.
- 3,351,725. FLIP 'N FUN STANDARD CHARACTER MARK. INT. CL. 28. REG. 12-11-2007.
- 3,351,729. KING THIEF STANDARD CHARACTER MARK. INT. CL. 41. REG. 12-11-2007.
- 3,351,730. MY BODY BEATS STANDARD CHARACTER MARK. INT. CL. 35. REG. 12-11-2007.
- 3,351,733. RED SIXTY STANDARD CHARACTER MARK. INT. CL. 41. REG. 12-11-2007.
- 3,351,738. POWERED BY BLUEPRINT STANDARD CHARACTER MARK. INT. CL. 36. REG. 12-11-2007.
- 3,351,739. BELIEVE... AND LIVE IT. STANDARD CHARACTER MARK. INT. CL. 44. REG. 12-11-2007.
- 3,351,744. FACETMAP STANDARD CHARACTER MARK. INT. CL. 9. REG. 12-11-2007.
- 3,351,745. REAGENTFORECLOSURES STANDARD CHARACTER MARK. INT. CL. 36. REG. 12-11-2007.
- 3,351,746. PRIMEWOMAN (STYLIZED). INT. CL. 16. REG. 12-11-2007.
- 3,351,747. ENCENUE (STYLIZED). INT. CL. 41. REG. 12-11-2007.
- 3,351,748. SKY FACET STANDARD CHARACTER MARK. INT. CL. 35. REG. 12-11-2007.
- 3,351,749. THE MODEL MATCH STANDARD CHARACTER MARK. INT. CL. 45. REG. 12-11-2007.
- 3,351,750. THE WHISKEY RIVER BAND STANDARD CHARACTER MARK. INT. CL. 41. REG. 12-11-2007.
- 3,351,752. SIDITY AND DESIGN. INT. CL. 25. REG. 12-11-2007.
- 3,351,753. MOB MOTORCYCLES OF BEND INC (STYLIZED). INT. CL. 25. REG. 12-11-2007.
- 3,351,754. ESPARKS COFFEE AND DESIGN. INT. CL. 43. REG. 12-11-2007.
- 3,351,755. TACO BELL AND DESIGN. INT. CLS. 30 AND 43. REG. 12-11-2007.
- 3,351,759. MARIA PIA STANDARD CHARACTER MARK. INT. CL. 30. REG. 12-11-2007.
- 3,351,760. LAKELAND COLLEGE ONLINE STANDARD CHARACTER MARK. INT. CL. 41. REG. 12-11-2007.
- 3,351,763. THE UNBIASED, PRACTICAL LINK BETWEEN WHAT MANAGEMENT NEEDS AND WHAT TECHNOLOGY CAN DELIVER STANDARD CHARACTER MARK. INT. CL. 42. REG. 12-11-2007.
- 3,351,766. ZOICHEM AND DESIGN. INT. CL. 1. REG. 12-11-2007.



- 3,351,769. YES YOU CAN DO IT! AND DESIGN. INT. CL. 41. REG. 12-11-2007.
- 3,351,770. IT MEANS A GREAT DEAL. STANDARD CHARACTER MARK. INT. CL. 35. REG. 12-11-2007.
- 3,351,771. JETSETRIX STANDARD CHARACTER MARK. INT. CLS. 35 AND 41. REG. 12-11-2007.
- 3,351,772. GLOBESETTER STANDARD CHARACTER MARK. INT. CL. 39. REG. 12-11-2007.
- 3,351,775. OFFICIAL LOAN OFFICER FOR THE SPRING HOMEBUYING SEASON STANDARD CHARACTER MARK. INT. CL. 36. REG. 12-11-2007.
- 3,351,779. THE TAN RESORT GROUP STANDARD CHARACTER MARK. INT. CL. 43. REG. 12-11-2007.
- 3,351,782. PEA SOUP BABY AND DESIGN. INT. CL. 35. REG. 12-11-2007.
- 3,351,783. FALCON ENTERTAINMENT AND DESIGN. INT. CLS. 35 AND 41. REG. 12-11-2007.
- 3,351,785. PROVITAE STANDARD CHARACTER MARK. INT. CL. 1. REG. 12-11-2007.
- 3,351,787. THAI PASSION STANDARD CHARACTER MARK. INT. CL. 43. REG. 12-11-2007.
- 3,351,788. WHITEBOND PROTECTION STANDARD CHARACTER MARK. INT. CL. 3. REG. 12-11-2007.
- 3,351,789. BIG BEAR PRODUCTIONS, LTD. STANDARD CHARACTER MARK. INT. CL. 41. REG. 12-11-2007.
- 3,351,792. FAT BAT STANDARD CHARACTER MARK. INT. CL. 28. REG. 12-11-2007.
- 3,351,793. THE LITTLE ENGINE THAT COULD STANDARD CHARACTER MARK. INT. CL. 28. REG. 12-11-2007.
- 3,351,794. CRAB SMART DIPPERS STANDARD CHARACTER MARK. INT. CL. 29. REG. 12-11-2007.
- 3,351,795. CRAB SMART TOPPERS STANDARD CHARACTER MARK. INT. CL. 29. REG. 12-11-2007.
- 3,351,801. STUDIO BY JCPENNEY HOME COLLECTION AND DESIGN. INT. CLS. 11, 20, 21, 24 AND 27. REG. 12-11-2007.
- 3,351,804. STRUTS YOU KNOW YOU WANT SOME... WINGS BURGERS & MORE AND DESIGN. INT. CL. 43. REG. 12-11-2007.
- 3,351,806. INDIE MEMPHIS AND DESIGN. INT. CL. 41. REG. 12-11-2007.
- 3,351,807. D MO BABY AND DESIGN. INT. CL. 25. REG. 12-11-2007.
- 3,351,808. FEDEX KINKO'S OFFICE AND PRINT CENTER AND DESIGN. INT. CL. 35. REG. 12-11-2007.
- 3,351,810. PURE, ALL-NATURAL PRODUCTS. PURE, ALL-NATURAL RESULTS. STANDARD CHARACTER MARK. INT. CL. 5. REG. 12-11-2007.
- 3,351,815. LAGUÍA DORADA DORADAS SON MEJORES QUE AMARILLAS AND DESIGN. INT. CL. 16. REG. 12-11-2007.
- 3,351,816. REVOLUTION SPORTS TRAINING STANDARD CHARACTER MARK. INT. CL. 41. REG. 12-11-2007.
- 3,351,817. PROTECTING TODAY'S INVESTMENTS FOR TOMORROW'S INNOVATIONS STANDARD CHARACTER MARK. INT. CL. 16. REG. 12-11-2007.
- 3,351,821. IW AND DESIGN. INT. CL. 41. REG. 12-11-2007.
- 3,351,822. SWIRL EVENTS STANDARD CHARACTER MARK. INT. CL. 41. REG. 12-11-2007.
- 3,351,825. VAMMRIX STANDARD CHARACTER MARK. INT. CL. 5. REG. 12-11-2007.
- 3,351,827. HD HDESIGNCENTER.COM "WE CAN MAKE YOU BOBBLE" AND DESIGN. INT. CL. 28. REG. 12-11-2007.
- 3,351,831. ADSAVER MAGAZINE STANDARD CHARACTER MARK. INT. CL. 16. REG. 12-11-2007.
- 3,351,834. FLOORMASTER STANDARD CHARACTER MARK. INT. CL. 7. REG. 12-11-2007.
- 3,351,835. MEXICO MAGICO STANDARD CHARACTER MARK. INT. CL. 29. REG. 12-11-2007.
- 3,351,839. AMBERVISION STANDARD CHARACTER MARK. INT. CL. 9. REG. 12-11-2007.
- 3,351,846. THUY (STYLIZED). INT. CLS. 25 AND 35. REG. 12-11-2007.
- 3,351,852. LIMOGREEN STANDARD CHARACTER MARK. INT. CL. 39. REG. 12-11-2007.
- 3,351,866. GRAND EPICURE G E AND DESIGN. INT. CL. 21. REG. 12-11-2007.
- 3,351,871. TEENS FOR GREENS STANDARD CHARACTER MARK. INT. CL. 16. REG. 12-11-2007.
- 3,351,872. NAVAJO PRIDE AND DESIGN. INT. CLS. 30 AND 31. REG. 12-11-2007.
- 3,351,874. AIG VALIC PROFILE RETIREMENT PROGRAM STANDARD CHARACTER MARK. INT. CL. 36. REG. 12-11-2007.
- 3,351,877. ULTRATHANE STANDARD CHARACTER MARK. INT. CL. 3. REG. 12-11-2007.
- 3,351,880. DEAR PRUITT AND DESIGN. INT. CL. 25. REG. 12-11-2007.
- 3,351,881. LUCKYSWIPE AND DESIGN. INT. CL. 41. REG. 12-11-2007.
- 3,351,882. L I T T L E M C N E A L (STYLIZED). INT. CL. 25. REG. 12-11-2007.
- 3,351,883. THERMO GENETICS EXTREME RAPID WEIGHTLOSS SYSTEM G TECH AND DESIGN. INT. CL. 5. REG. 12-11-2007.
- 3,351,888. BOTOX CARE CONNECTION STANDARD CHARACTER MARK. INT. CL. 35. REG. 12-11-2007.
- 3,351,889. FIFTEEN FORTY STANDARD CHARACTER MARK. INT. CL. 33. REG. 12-11-2007.
- 3,351,891. AIG HOUSEHOLD SAFEGUARD STANDARD CHARACTER MARK. INT. CL. 36. REG. 12-11-2007.
- 3,351,893. DR.SCHOLL'S AND DESIGN. INT. CL. 5. REG. 12-11-2007.
- 3,351,898. AIG INHERITANCE LIFE STANDARD CHARACTER MARK. INT. CL. 36. REG. 12-11-2007.
- 3,351,899. AIG UNITED GUARANTY'S MI HOTLINE STANDARD CHARACTER MARK. INT. CL. 36. REG. 12-11-2007.
- 3,351,902. AIG GROUP INDEMNITY DENTAL STANDARD CHARACTER MARK. INT. CL. 36. REG. 12-11-2007.
- 3,351,903. AIG GROUP DISABILITYCARE STANDARD CHARACTER MARK. INT. CL. 36. REG. 12-11-2007.
- 3,351,904. AIG GROUP PPO DENTAL STANDARD CHARACTER MARK. INT. CL. 36. REG. 12-11-2007.
- 3,351,905. AIG ROPTERM MVP STANDARD CHARACTER MARK. INT. CL. 36. REG. 12-11-2007.
- 3,351,906. MOVEIN MINUTES AND DESIGN. INT. CL. 35. REG. 12-11-2007.
- 3,351,907. AIG GROUP HOSPITALCARE STANDARD CHARACTER MARK. INT. CL. 36. REG. 12-11-2007.
- 3,351,908. AIG GROUP EMERGENCYCARE STANDARD CHARACTER MARK. INT. CL. 36. REG. 12-11-2007.
- 3,351,909. AIG SELECT-A-TERM STANDARD CHARACTER MARK. INT. CL. 36. REG. 12-11-2007.
- 3,351,910. AIG TRAVEL STANDARD CHARACTER MARK. INT. CLS. 36 AND 39. REG. 12-11-2007.
- 3,351,912. ROCHE AND DESIGN. INT. CL. 5. REG. 12-11-2007.
- 3,351,913. AIG UNITED GUARANTY'S MORTGAGE BASICS STANDARD CHARACTER MARK. INT. CLS. 36 AND 41. REG. 12-11-2007.
- 3,351,915. JOYFUL EVENTS PLANNER STANDARD CHARACTER MARK. INT. CL. 35. REG. 12-11-2007.
- 3,351,917. NATURE'S BALANCE. INT. CLS. 7, 30, 40, 41, 42 AND 44. REG. 12-11-2007.
- 3,351,918. HELISTAT. INT. CLS. 9, 42 AND 45. REG. 12-11-2007.
- 3,351,919. TNS-GLOBAL. INT. CL. 35. REG. 12-11-2007.
- 3,351,921. QWEST DSL PRO DELUXE. INT. CL. 38. REG. 12-11-2007.
- 3,351,923. OMNISEAL. INT. CLS. 9, 11 AND 35. REG. 12-11-2007.

- 3,351,924. LEAF AWAY DEBRIS-FREE AND DESIGN. INT. CLS. 6 AND 37. REG. 12-11-2007.
- 3,351,927. FLEX EZ STANDARD CHARACTER MARK. INT. CL. 5. REG. 12-11-2007.
- 3,351,928. CHARIZMA AN INSTANT ATTRACTION AND DESIGN. INT. CL. 14. REG. 12-11-2007.
- 3,351,929. PLASTIC WELDING TECHNOLOGIES STANDARD CHARACTER MARK. INT. CLS. 35 AND 37. REG. 12-11-2007.
- 3,351,931. MINDSPIN TECHNOLOGIES STANDARD CHARACTER MARK. INT. CL. 42. REG. 12-11-2007.
- 3,351,933. S.M.A.R.T. T.A.L.K. STANDARD CHARACTER MARK. INT. CL. 41. REG. 12-11-2007.
- 3,351,935. EXCELSIOR 1860 FRETTE HOME COLLECTION AND DESIGN. INT. CLS. 24 AND 27. REG. 12-11-2007.
- 3,351,936. STEAM WHISTLE AND DESIGN. INT. CL. 32. REG. 12-11-2007.
- 3,351,938. INFINIFLOW STANDARD CHARACTER MARK. INT. CLS. 9, 37 AND 42. REG. 12-11-2007.
- 3,351,940. VISOR BUFF AND DESIGN. INT. CL. 25. REG. 12-11-2007.
- 3,351,944. SPOIL ME STANDARD CHARACTER MARK. INT. CL. 3. REG. 12-11-2007.
- 3,351,945. SECRET STONE AND DESIGN. INT. CL. 33. REG. 12-11-2007.
- 3,351,946. OSTEOTRANS STANDARD CHARACTER MARK. INT. CL. 10. REG. 12-11-2007.
- 3,351,947. SPRUCE GOOSE STANDARD CHARACTER MARK. INT. CL. 15. REG. 12-11-2007.
- 3,351,950. MISCELLANEOUS DESIGN. INT. CL. 9. REG. 12-11-2007.
- 3,351,951. JA COATING STANDARD CHARACTER MARK. INT. CLS. 1, 5, 6, 40 AND 42. REG. 12-11-2007.
- 3,351,955. GUD STANDARD CHARACTER MARK. INT. CL. 32. REG. 12-11-2007.
- 3,351,956. RED PYRAMID STANDARD CHARACTER MARK. INT. CLS. 9, 28, 38, 41 AND 42. REG. 12-11-2007.
- 3,351,958. MISCELLANEOUS DESIGN. INT. CL. 31. REG. 12-11-2007.
- 3,351,960. LONDON DESIGN WEEK AT CHELSEA HARBOUR DESIGN CENTRE STANDARD CHARACTER MARK. INT. CL. 35. REG. 12-11-2007.
- 3,351,964. ALL WORRIED MX AND DESIGN. INT. CLS. 12, 16, 25 AND 28. REG. 12-11-2007.
- 3,351,965. GT AND DESIGN. INT. CL. 9. REG. 12-11-2007.
- 3,351,966. VIRTUAL EARTH STANDARD CHARACTER MARK. INT. CLS. 35 AND 42. REG. 12-11-2007.
- 3,351,967. IO AND DESIGN. INT. CLS. 9, 38 AND 41. REG. 12-11-2007.
- 3,351,972. BREADSTORY ALL TIME BEST SELLER BY JUN AND DESIGN. INT. CLS. 30 AND 43. REG. 12-11-2007.
- 3,351,973. GAME FACE STANDARD CHARACTER MARK. INT. CL. 25. REG. 12-11-2007.
- 3,351,974. PEACEFUL HEROES STANDARD CHARACTER MARK. INT. CL. 41. REG. 12-11-2007.
- 3,351,975. HELIODISC STANDARD CHARACTER MARK. INT. CLS. 9, 11 AND 42. REG. 12-11-2007.
- 3,351,978. A LITTLE OBSESSION AMONG FRIENDS STANDARD CHARACTER MARK. INT. CL. 35. REG. 12-11-2007.
- 3,351,979. AROUND STANDARD CHARACTER MARK. INT. CLS. 16, 38 AND 41. REG. 12-11-2007.
- 3,351,980. V GAY & LESBIAN LEADERSHIP CONFERENCE AND DESIGN. INT. CL. 41. REG. 12-11-2007.
- 3,351,983. VIRTUAL SPA STANDARD CHARACTER MARK. INT. CL. 44. REG. 12-11-2007.
- 3,351,984. COOTER CAY STANDARD CHARACTER MARK. INT. CLS. 16 AND 25. REG. 12-11-2007.
- 3,351,985. IJ IFFY JONES AND DESIGN. INT. CL. 25. REG. 12-11-2007.
- 3,351,986. LYNNE LARSON STANDARD CHARACTER MARK. INT. CL. 25. REG. 12-11-2007.
- 3,351,987. ANDREJOIS HYGIENE AND DESIGN. INT. CLS. 11 AND 21. REG. 12-11-2007.
- 3,351,988. SOXRIGHT STANDARD CHARACTER MARK. INT. CL. 35. REG. 12-11-2007.
- 3,351,990. MISCELLANEOUS DESIGN. INT. CLS. 9, 35 AND 42. REG. 12-11-2007.
- 3,351,994. DIGITool AND DESIGN. INT. CL. 9. REG. 12-11-2007.
- 3,351,995. MISCELLANEOUS DESIGN. INT. CLS. 35, 36 AND 42. REG. 12-11-2007.
- 3,351,996. WHOLLYFLEX STANDARD CHARACTER MARK. INT. CL. 9. REG. 12-11-2007.
- 3,351,997. ID INSURE STANDARD CHARACTER MARK. INT. CLS. 9, 37, 38 AND 42. REG. 12-11-2007.
- 3,351,999. PERFECTSTROKE AND DESIGN. INT. CLS. 16, 28, 35 AND 41. REG. 12-11-2007.
- 3,352,001. FAITH PETS STANDARD CHARACTER MARK. INT. CL. 41. REG. 12-11-2007.
- 3,352,002. PIVOT STANDARD CHARACTER MARK. INT. CL. 10. REG. 12-11-2007.
- 3,352,003. VIGORANIC STANDARD CHARACTER MARK. INT. CL. 1. REG. 12-11-2007.
- 3,352,004. MISCELLANEOUS DESIGN. INT. CL. 33. REG. 12-11-2007.
- 3,352,005. COT'N WASH (STYLIZED). INT. CL. 3. REG. 12-11-2007.
- 3,352,006. SAFE-TERGENT STANDARD CHARACTER MARK. INT. CL. 3. REG. 12-11-2007.
- 3,352,009. THE BALANCE COMPANY STANDARD CHARACTER MARK. INT. CLS. 5, 9 AND 41. REG. 12-11-2007.
- 3,352,014. CAMPUS RENEWAL DESIGN AND DESIGN. INT. CLS. 35, 36, 37 AND 42. REG. 12-11-2007.
- 3,352,015. KIUCHI YUZU WINE I'M A JAPANESE CITRUS. AND DESIGN. INT. CL. 33. REG. 12-11-2007.
- 3,352,016. MISCELLANEOUS DESIGN. INT. CLS. 29, 30 AND 32. REG. 12-11-2007.
- 3,352,017. NINFA'S MEXICAN RESTAURANT SINCE 1973 THE ORIGINAL AND DESIGN. INT. CL. 43. REG. 12-11-2007.
- 3,352,019. SCREEDMASTER STANDARD CHARACTER MARK. INT. CLS. 11 AND 19. REG. 12-11-2007.
- 3,352,020. CHUCK A BUCK STANDARD CHARACTER MARK. INT. CL. 36. REG. 12-11-2007.
- 3,352,026. QNN AND DESIGN. INT. CL. 41. REG. 12-11-2007.
- 3,352,027. PUSHTOCOMMUNICATION STANDARD CHARACTER MARK. INT. CLS. 9, 35, 38 AND 42. REG. 12-11-2007.
- 3,352,032. BB BEST BRANDS CORP. AND DESIGN. INT. CL. 30. REG. 12-11-2007.
- 3,352,035. SDM SERVICES THE PERSONAL TOUCH IN HEALTH MANAGEMENT STANDARD CHARACTER MARK. INT. CL. 44. REG. 12-11-2007.
- 3,352,037. AMARETTINI DI SARONNO STANDARD CHARACTER MARK. INT. CL. 30. REG. 12-11-2007.
- 3,352,039. DREAMSPRING STANDARD CHARACTER MARK. INT. CLS. 9, 16 AND 42. REG. 12-11-2007.
- 3,352,041. SNATTS STANDARD CHARACTER MARK. INT. CLS. 29 AND 30. REG. 12-11-2007.
- 3,352,042. LK (STYLIZED). INT. CL. 36. REG. 12-11-2007.
- 3,352,043. MASERATI CLASSICHE AND DESIGN. INT. CLS. 12, 16, 37 AND 41. REG. 12-11-2007.
- 3,352,044. ENDURO VAC STINGER AND DESIGN. INT. CL. 7. REG. 12-11-2007.
- 3,352,045. DON'T BLINK STANDARD CHARACTER MARK. INT. CL. 35. REG. 12-11-2007.
- 3,352,047. JAILHOUSE RED STANDARD CHARACTER MARK. INT. CL. 33. REG. 12-11-2007.
- 3,352,048. AT-WATCH AND DESIGN. INT. CLS. 9 AND 42. REG. 12-11-2007.
- 3,352,050. LCARE STANDARD CHARACTER MARK. INT. CL. 41. REG. 12-11-2007.
- 3,352,051. FOR WIRELESS THAT WORKS STANDARD CHARACTER MARK. INT. CLS. 9 AND 42. REG. 12-11-2007.

- 3,352,054. CHERRY BON BON STANDARD CHARACTER MARK. INT. CL. 31. REG. 12-11-2007.
- 3,352,059. ZM STANDARD CHARACTER MARK. INT. CL. 11. REG. 12-11-2007.
- 3,352,065. BUCKINGHAM ESTATE STANDARD CHARACTER MARK. INT. CLS. 16, 21, 22, 25 AND 33. REG. 12-11-2007.
- 3,352,066. CECYBRARY STANDARD CHARACTER MARK. INT. CL. 41. REG. 12-11-2007.
- 3,352,067. ROOFER'S TRACKRECORD AND DESIGN. INT. CL. 35. REG. 12-11-2007.
- 3,352,072. PD LONDON (STYLIZED). INT. CLS. 37 AND 42. REG. 12-11-2007.
- 3,352,078. TAILGATE PAD STANDARD CHARACTER MARK. INT. CL. 24. REG. 12-11-2007.
- 3,352,082. KUDO LEAVES AND DESIGN. INT. CL. 30. REG. 12-11-2007.
- 3,352,083. KUDO LEAVES STANDARD CHARACTER MARK. INT. CL. 30. REG. 12-11-2007.
- 3,352,084. MISCELLANEOUS DESIGN. INT. CLS. 3, 9, 14, 18 AND 25. REG. 12-11-2007.
- 3,352,087. STEPPER'S NETWORK STANDARD CHARACTER MARK. INT. CL. 41. REG. 12-11-2007.
- 3,352,088. MISCELLANEOUS DESIGN. INT. CL. 5. REG. 12-11-2007.
- 3,352,089. SIDP STANDARD CHARACTER MARK. INT. CL. 9. REG. 12-11-2007.
- 3,352,094. TCF THE COMEDY FESTIVAL AND DESIGN. INT. CLS. 25 AND 41. REG. 12-11-2007.
- 3,352,097. THE WARDROBE SHRINK STANDARD CHARACTER MARK. INT. CL. 45. REG. 12-11-2007.
- 3,352,098. CARROT CULTURE STANDARD CHARACTER MARK. INT. CLS. 9, 16 AND 41. REG. 12-11-2007.
- 3,352,100. MISCELLANEOUS DESIGN. INT. CLS. 9, 16 AND 41. REG. 12-11-2007.
- 3,352,101. YOUR PERSONAL COACH YPCOACH.COM AND DESIGN. INT. CL. 41. REG. 12-11-2007.
- 3,352,102. WELCOME HOME STANDARD CHARACTER MARK. INT. CL. 5. REG. 12-11-2007.
- 3,352,104. SUPER CHISEL STANDARD CHARACTER MARK. INT. CL. 7. REG. 12-11-2007.
- 3,352,107. WORLDS OF GOOD FORTUNE AND DESIGN. INT. CL. 16. REG. 12-11-2007.
- 3,352,109. 55° FIFTY FIVE DEGREES WINE + DESIGN AND DESIGN. INT. CL. 43. REG. 12-11-2007.
- 3,352,110. AROUND TOWN BY CARLA WASHINGTON, MO AND DESIGN. INT. CL. 18. REG. 12-11-2007.
- 3,352,111. CRAWDADDY'S STANDARD CHARACTER MARK. INT. CL. 25. REG. 12-11-2007.
- 3,352,113. SYNDIANT AND DESIGN. INT. CL. 42. REG. 12-11-2007.
- 3,352,115. HORNO DE PIEDRA STANDARD CHARACTER MARK. INT. CL. 30. REG. 12-11-2007.
- 3,352,119. VMIX AND DESIGN. INT. CLS. 35, 38 AND 41. REG. 12-11-2007.
- 3,352,120. TASTEBUD ENTERTAINMENT STANDARD CHARACTER MARK. INT. CLS. 16 AND 41. REG. 12-11-2007.
- 3,352,123. FITNESS FOR HEALTH STANDARD CHARACTER MARK. INT. CL. 41. REG. 12-11-2007.
- 3,352,124. FITNESS FOR HEALTH STANDARD CHARACTER MARK. INT. CL. 44. REG. 12-11-2007.
- 3,352,133. GRANTIUM STANDARD CHARACTER MARK. INT. CLS. 9, 16, 41 AND 42. REG. 12-11-2007.
- 3,352,136. AM ALFONSO MARINA EBANISTA AND DESIGN. INT. CL. 20. REG. 12-11-2007.
- 3,352,137. QSVS QUEBEC SOCIETY OF VASCULAR SCIENCES AND DESIGN. INT. CLS. 9, 35, 36, 41 AND 44. REG. 12-11-2007.
- 3,352,143. AS INDIVIDUAL AS YOU ARE STANDARD CHARACTER MARK. INT. CLS. 44 AND 45. REG. 12-11-2007.
- 3,352,146. EXTREME RAPPEL STANDARD CHARACTER MARK. INT. CL. 28. REG. 12-11-2007.
- 3,352,148. SNOWDRIFT STANDARD CHARACTER MARK. INT. CL. 32. REG. 12-11-2007.
- 3,352,149. IT REALIZED STANDARD CHARACTER MARK. INT. CL. 9. REG. 12-11-2007.
- 3,352,151. CINCO DE MAYO AND DESIGN. INT. CL. 35. REG. 12-11-2007.
- 3,352,152. SHEAR HARMONY (STYLIZED). INT. CL. 44. REG. 12-11-2007.
- 3,352,154. HH CTY VAN PHONG PHAM HONG HA SINCE 1959 AND DESIGN. INT. CL. 16. REG. 12-11-2007.
- 3,352,156. M1 (STYLIZED). INT. CL. 25. REG. 12-11-2007.
- 3,352,157. TCMS TOTAL CALL MANAGEMENT SOLUTIONS AND DESIGN. INT. CL. 38. REG. 12-11-2007.
- 3,352,159. SOFT LOCK STANDARD CHARACTER MARK. INT. CL. 15. REG. 12-11-2007.
- 3,352,162. WOOD RANCH BBQ & GRILL AND DESIGN. INT. CL. 43. REG. 12-11-2007.
- 3,352,163. ENGAGE STANDARD CHARACTER MARK. INT. CL. 42. REG. 12-11-2007.
- 3,352,165. BIKEBANDIT.COM AND DESIGN. INT. CL. 35. REG. 12-11-2007.
- 3,352,166. SPECIAL HERBS SPECIAL FORMULAS AND DESIGN. INT. CL. 5. REG. 12-11-2007.
- 3,352,169. ISLAND INK-JET (STYLIZED). INT. CL. 35. REG. 12-11-2007.
- 3,352,170. THE HUBLEY TOY LINE AND DESIGN. INT. CL. 35. REG. 12-11-2007.
- 3,352,171. MISCELLANEOUS DESIGN. INT. CLS. 9, 16 AND 41. REG. 12-11-2007.
- 3,352,172. BETTER LIVING. BY DESIGN. STANDARD CHARACTER MARK. INT. CL. 37. REG. 12-11-2007.
- 3,352,173. MOBILESYNC AND DESIGN. INT. CL. 9. REG. 12-11-2007.
- 3,352,176. LASCOLINAS EAR, NOSE, THROAT & ALLERGY AND DESIGN. INT. CL. 44. REG. 12-11-2007.
- 3,352,177. WONDERFUL '50S STANDARD CHARACTER MARK. INT. CL. 9. REG. 12-11-2007.
- 3,352,181. UPTIME SCIENCE STANDARD CHARACTER MARK. INT. CL. 42. REG. 12-11-2007.
- 3,352,182. ROCK FOR AIDS AWARENESS AND DESIGN. INT. CL. 35. REG. 12-11-2007.
- 3,352,187. SAFETYSTEEL STANDARD CHARACTER MARK. INT. CLS. 19 AND 21. REG. 12-11-2007.
- 3,352,188. TELEMONITOR STANDARD CHARACTER MARK. INT. CL. 9. REG. 12-11-2007.
- 3,352,190. KLLP STANDARD CHARACTER MARK. INT. CLS. 16, 41 AND 42. REG. 12-11-2007.
- 3,352,198. FRIENDS OF AFRICA - INTERNATIONAL STANDARD CHARACTER MARK. INT. CL. 41. REG. 12-11-2007.
- 3,352,199. REDBONES STANDARD CHARACTER MARK. INT. CL. 31. REG. 12-11-2007.
- 3,352,201. THE ENGAGEMENT MARKETERS STANDARD CHARACTER MARK. INT. CL. 36. REG. 12-11-2007.
- 3,352,202. WILD FANGS STANDARD CHARACTER MARK. INT. CLS. 9 AND 41. REG. 12-11-2007.
- 3,352,206. FAITH OUT LOUD STANDARD CHARACTER MARK. INT. CLS. 35 AND 41. REG. 12-11-2007.
- 3,352,207. MISCELLANEOUS DESIGN. INT. CL. 9. REG. 12-11-2007.
- 3,352,212. QUICKPAY STANDARD CHARACTER MARK. INT. CLS. 35 AND 36. REG. 12-11-2007.
- 3,352,214. ACANDIS STANDARD CHARACTER MARK. INT. CL. 10. REG. 12-11-2007.
- 3,352,215. MAMITA'S FRESH ASPARAGUS AND DESIGN. INT. CL. 31. REG. 12-11-2007.
- 3,352,216. PASSION REWARDED. HISTORY PRESERVED. STANDARD CHARACTER MARK. INT. CL. 35. REG. 12-11-2007.
- 3,352,219. FIND GORGEOUS STANDARD CHARACTER MARK. INT. CLS. 35 AND 37. REG. 12-11-2007.
- 3,352,220. DREAMFET STANDARD CHARACTER MARK. INT. CL. 9. REG. 12-11-2007.
- 3,352,222. IONA AND DESIGN. INT. CL. 33. REG. 12-11-2007.

- 3,352,225. BLUE STAR BENEFITS AND DESIGN. INT. CL. 36. REG. 12-11-2007.
- 3,352,228. BERING SEA CRABBERS AND DESIGN. INT. CL. 25. REG. 12-11-2007.
- 3,352,230. ARE YOU HAVING FUN YET? STANDARD CHARACTER MARK. INT. CLS. 35 AND 37. REG. 12-11-2007.
- 3,352,231. AMERICAN INITIATIVES PARTNERSHIPS IN THE PUBLIC INTEREST AND DESIGN. INT. CL. 35. REG. 12-11-2007.
- 3,352,235. MONMOUTH UNIVERSITY. NEW JERSEY 1933 AND DESIGN. INT. CL. 16. REG. 12-11-2007.
- 3,352,238. LIFESPACES STANDARD CHARACTER MARK. INT. CLS. 9, 37 AND 42. REG. 12-11-2007.
- 3,352,239. ELIFESPACES STANDARD CHARACTER MARK. INT. CLS. 9, 37 AND 42. REG. 12-11-2007.
- 3,352,240. POP CHERUB STANDARD CHARACTER MARK. INT. CL. 3. REG. 12-11-2007.
- 3,352,241. STERI-SPRAY STANDARD CHARACTER MARK. INT. CL. 11. REG. 12-11-2007.
- 3,352,244. FERROUS STANDARD CHARACTER MARK. INT. CLS. 35, 36, 39 AND 40. REG. 12-11-2007.
- 3,352,246. DECIBEL MARKETING SERVICES AND DESIGN. INT. CL. 35. REG. 12-11-2007.
- 3,352,249. GRUPO AMENAZA (STYLIZED). INT. CLS. 9 AND 41. REG. 12-11-2007.
- 3,352,252. ALPHAGIRLZ SPORTSPLEX FOR FEMALE ATHLETES AND DESIGN. INT. CL. 41. REG. 12-11-2007.
- 3,352,253. VIA PENDIO STANDARD CHARACTER MARK. INT. CL. 18. REG. 12-11-2007.
- 3,352,256. GET MANIC STANDARD CHARACTER MARK. INT. CL. 42. REG. 12-11-2007.
- 3,352,257. ACCESS STANDARD CHARACTER MARK. INT. CL. 41. REG. 12-11-2007.
- 3,352,258. ACCESS AND DESIGN. INT. CL. 41. REG. 12-11-2007.
- 3,352,261. SPIRIT EDGE STANDARD CHARACTER MARK. INT. CLS. 38 AND 41. REG. 12-11-2007.
- 3,352,263. GROUP 1 SOFTWARE (STYLIZED). INT. CL. 9. REG. 12-11-2007.
- 3,352,264. MANOTO AND DESIGN. INT. CL. 42. REG. 12-11-2007.
- 3,352,265. STRAIGHTWAY STANDARD CHARACTER MARK. INT. CL. 41. REG. 12-11-2007.
- 3,352,266. MALEX STANDARD CHARACTER MARK. INT. CL. 35. REG. 12-11-2007.
- 3,352,269. WINSTON STANDARD CHARACTER MARK. INT. CL. 28. REG. 12-11-2007.
- 3,352,270. DIRTY BEATS STANDARD CHARACTER MARK. INT. CL. 25. REG. 12-11-2007.
- 3,352,271. MISCELLANEOUS DESIGN. INT. CL. 41. REG. 12-11-2007.
- 3,352,272. SOURCILS DESIGN STANDARD CHARACTER MARK. INT. CL. 3. REG. 12-11-2007.
- 3,352,273. A AND DESIGN. INT. CL. 41. REG. 12-11-2007.
- 3,352,274. CALL AND IDENTITY COACHING STANDARD CHARACTER MARK. INT. CL. 41. REG. 12-11-2007.
- 3,352,275. MISCELLANEOUS DESIGN. INT. CL. 41. REG. 12-11-2007.
- 3,352,278. MISCELLANEOUS DESIGN. INT. CLS. 16 AND 25. REG. 12-11-2007.
- 3,352,280. ASI STANDARD CHARACTER MARK. INT. CL. 35. REG. 12-11-2007.
- 3,352,283. HD SIGNAL PROCESSING AND DESIGN. INT. CL. 9. REG. 12-11-2007.
- 3,352,285. PLAZA FIESTA! AND DESIGN. INT. CL. 36. REG. 12-11-2007.
- 3,352,287. PLUG BOSS STANDARD CHARACTER MARK. INT. CL. 7. REG. 12-11-2007.
- 3,352,288. HOUSTON TECHNOLOGY SHOWCASE STANDARD CHARACTER MARK. INT. CL. 35. REG. 12-11-2007.
- 3,352,291. SERVERVAULT STANDARD CHARACTER MARK. INT. CL. 42. REG. 12-11-2007.
- 3,352,293. SERV STANDARD CHARACTER MARK. INT. CLS. 29 AND 30. REG. 12-11-2007.
- 3,352,295. FUNRISE AND DESIGN. INT. CL. 28. REG. 12-11-2007.
- 3,352,299. TECHNOLOGY DIMENSIONS STANDARD CHARACTER MARK. INT. CL. 37. REG. 12-11-2007.
- 3,352,300. CITIZEN BASE INITIATIVE STANDARD CHARACTER MARK. INT. CLS. 35 AND 36. REG. 12-11-2007.
- 3,352,304. HERE'S TO YOUR HEALTH STANDARD CHARACTER MARK. INT. CL. 44. REG. 12-11-2007.
- 3,352,307. SMART PATIENTS, SMART CARDS, SMART MEDICINE STANDARD CHARACTER MARK. INT. CL. 44. REG. 12-11-2007.
- 3,352,308. HS AND DESIGN. INT. CLS. 9 AND 44. REG. 12-11-2007.
- 3,352,314. HARDWOOD HIDEAWAY STANDARD CHARACTER MARK. INT. CL. 20. REG. 12-11-2007.
- 3,352,315. FERRET STANDARD CHARACTER MARK. INT. CL. 9. REG. 12-11-2007.
- 3,352,316. ATRRELIF STANDARD CHARACTER MARK. INT. CL. 5. REG. 12-11-2007.
- 3,352,317. HYBRID ZIP SYSTEM STANDARD CHARACTER MARK. INT. CL. 25. REG. 12-11-2007.
- 3,352,320. EARTHA COMMUNITY ATLAS STANDARD CHARACTER MARK. INT. CLS. 42 AND 45. REG. 12-11-2007.
- 3,352,324. CRANKCASE STANDARD CHARACTER MARK. INT. CL. 9. REG. 12-11-2007.
- 3,352,328. FAMILY 911 STANDARD CHARACTER MARK. INT. CL. 41. REG. 12-11-2007.
- 3,352,329. REDEFINING BRIDESMAIDS STANDARD CHARACTER MARK. INT. CL. 25. REG. 12-11-2007.
- 3,352,330. PETE'S GRILL STANDARD CHARACTER MARK. INT. CL. 43. REG. 12-11-2007.
- 3,352,332. CLASSICS AND DESIGN. INT. CL. 43. REG. 12-11-2007.
- 3,352,333. CAVALLO'S PIZZA & PASTA AND DESIGN. INT. CL. 43. REG. 12-11-2007.
- 3,352,334. PETE'S GRILL AND DESIGN. INT. CL. 43. REG. 12-11-2007.
- 3,352,335. PETS OK STANDARD CHARACTER MARK. INT. CLS. 35 AND 36. REG. 12-11-2007.
- 3,352,336. TRASH BEE GONE STANDARD CHARACTER MARK. INT. CL. 39. REG. 12-11-2007.
- 3,352,337. THE CREATIVES AND DESIGN. INT. CL. 23. REG. 12-11-2007.
- 3,352,338. THE CREATIVES AND DESIGN. INT. CL. 26. REG. 12-11-2007.
- 3,352,340. MISCELLANEOUS DESIGN. INT. CL. 35. REG. 12-11-2007.
- 3,352,341. BOOMYEAH STANDARD CHARACTER MARK. INT. CL. 35. REG. 12-11-2007.
- 3,352,343. NRS CENTER FOR COMPLIANCE PROFESSIONALS STANDARD CHARACTER MARK. INT. CL. 41. REG. 12-11-2007.
- 3,352,346. WM WEATHERMATIC AND DESIGN. INT. CLS. 9 AND 11. REG. 12-11-2007.
- 3,352,347. ZERO LIFT STANDARD CHARACTER MARK. INT. CL. 10. REG. 12-11-2007.
- 3,352,348. SEBILLON STANDARD CHARACTER MARK. INT. CL. 43. REG. 12-11-2007.
- 3,352,349. THE BRIDGE AND DESIGN. INT. CL. 25. REG. 12-11-2007.
- 3,352,350. THE CHEESE WORKS LTD STANDARD CHARACTER MARK. INT. CL. 35. REG. 12-11-2007.
- 3,352,356. NATURO STANDARD CHARACTER MARK. INT. CL. 1. REG. 12-11-2007.
- 3,352,357. ENVOX CT CONNECT STANDARD CHARACTER MARK. INT. CL. 9. REG. 12-11-2007.
- 3,352,359. AMERICAN REVERSE MORTGAGE STANDARD CHARACTER MARK. INT. CL. 36. REG. 12-11-2007.
- 3,352,360. COLETECH CHASSIS PLUS STANDARD CHARACTER MARK. INT. CL. 12. REG. 12-11-2007.

- 3,352,361. ROCK 'N GO STANDARD CHARACTER MARK. INT. CL. 28. REG. 12-11-2007.
- 3,352,362. OUR BUSINESS IS DEVELOPING YOURS STANDARD CHARACTER MARK. INT. CLS. 9 AND 35. REG. 12-11-2007.
- 3,352,368. MISCELLANEOUS DESIGN. INT. CLS. 37 AND 42. REG. 12-11-2007.
- 3,352,374. ESIS E-RISK MANAGER STANDARD CHARACTER MARK. INT. CL. 42. REG. 12-11-2007.
- 3,352,375. WHAT TEXAS MAKES...MAKES TEXAS STANDARD CHARACTER MARK. INT. CL. 35. REG. 12-11-2007.
- 3,352,376. SARATHAN RECORDS AND DESIGN. INT. CL. 41. REG. 12-11-2007.
- 3,352,379. MASTERFOODS USA AND DESIGN. INT. CL. 30. REG. 12-11-2007.
- 3,352,385. SPROUT POUCH STANDARD CHARACTER MARK. INT. CL. 18. REG. 12-11-2007.
- 3,352,388. CARYTOWN COFFEE & TEA CO. STANDARD CHARACTER MARK. INT. CLS. 30 AND 43. REG. 12-11-2007.
- 3,352,389. CARYTOWN COFFEE SERVICE STANDARD CHARACTER MARK. INT. CLS. 30 AND 43. REG. 12-11-2007.
- 3,352,391. SOMETHING TO SEE STANDARD CHARACTER MARK. INT. CL. 9. REG. 12-11-2007.
- 3,352,392. NH THE NAME HUT AND DESIGN. INT. CL. 35. REG. 12-11-2007.
- 3,352,393. SECURE MODEL CITY OF THE FUTURE STANDARD CHARACTER MARK. INT. CLS. 37 AND 45. REG. 12-11-2007.
- 3,352,396. HUSH COLLECTION STANDARD CHARACTER MARK. INT. CL. 26. REG. 12-11-2007.
- 3,352,397. AGENT 2 AGENT (STYLIZED). INT. CL. 36. REG. 12-11-2007.
- 3,352,398. BEAUTY TRESS STANDARD CHARACTER MARK. INT. CL. 26. REG. 12-11-2007.
- 3,352,402. THE GIFT OF GAB STANDARD CHARACTER MARK. INT. CL. 30. REG. 12-11-2007.
- 3,352,408. GSI AND DESIGN. INT. CL. 9. REG. 12-11-2007.
- 3,352,409. DICKERSON VINEYARD STANDARD CHARACTER MARK. INT. CL. 33. REG. 12-11-2007.
- 3,352,411. IT'S NOT JUST AN OFFICE, IT'S YOUR BUSINESS. STANDARD CHARACTER MARK. INT. CL. 37. REG. 12-11-2007.
- 3,352,412. SOCCER FOR PEACE AND DESIGN. INT. CL. 36. REG. 12-11-2007.
- 3,352,413. THE CEO CORNER STANDARD CHARACTER MARK. INT. CL. 38. REG. 12-11-2007.
- 3,352,414. THE EDGE STANDARD CHARACTER MARK. INT. CL. 20. REG. 12-11-2007.
- 3,352,415. THE FAMILY FEAST STANDARD CHARACTER MARK. INT. CL. 45. REG. 12-11-2007.
- 3,352,426. PROTECTED BY CATSEYE PEST CONTROL AND DESIGN. INT. CL. 37. REG. 12-11-2007.
- 3,352,428. SYMMETRY WORKFORCE SOLUTIONS STANDARD CHARACTER MARK. INT. CL. 35. REG. 12-11-2007.
- 3,352,432. WAVEMASTER STANDARD CHARACTER MARK. INT. CL. 9. REG. 12-11-2007.
- 3,352,433. TRÉS JOLIEDAYS PALLC. EXPERIENCE THE DIFFERENCE AND DESIGN. INT. CL. 44. REG. 12-11-2007.
- 3,352,436. KING MOUNTAIN STANDARD CHARACTER MARK. INT. CL. 34. REG. 12-11-2007.
- 3,352,438. LAUGHLIN 2006 STANDARD CHARACTER MARK. INT. CLS. 16, 25 AND 26. REG. 12-11-2007.
- 3,352,440. ELEVATE GROUP STANDARD CHARACTER MARK. INT. CL. 35. REG. 12-11-2007.
- 3,352,443. PSYCHO-CELLULAR HEALING STANDARD CHARACTER MARK. INT. CL. 44. REG. 12-11-2007.
- 3,352,444. AFS STANDARD CHARACTER MARK. INT. CL. 9. REG. 12-11-2007.
- 3,352,446. EAGLE AQUACULTURE, INC. AND DESIGN. INT. CL. 31. REG. 12-11-2007.
- 3,352,447. TRANSFER-MATIONAL ARTICULATION STANDARD CHARACTER MARK. INT. CL. 41. REG. 12-11-2007.
- 3,352,448. DEVCENTER STANDARD CHARACTER MARK. INT. CLS. 9 AND 42. REG. 12-11-2007.
- 3,352,449. BAYVIEW FURNITURE (STYLIZED). INT. CL. 35. REG. 12-11-2007.
- 3,352,452. MISCELLANEOUS DESIGN. INT. CLS. 3 AND 21. REG. 12-11-2007.
- 3,352,453. TOOLING EXPRESS AND DESIGN. INT. CLS. 7, 40 AND 42. REG. 12-11-2007.
- 3,352,457. LIBBY CHARMETTES STANDARD CHARACTER MARK. INT. CLS. 14 AND 35. REG. 12-11-2007.
- 3,352,458. MAGNA STUNT STANDARD CHARACTER MARK. INT. CL. 28. REG. 12-11-2007.
- 3,352,459. RIVULET AND DESIGN. INT. CL. 9. REG. 12-11-2007.
- 3,352,461. MICHELLE KAMINS STANDARD CHARACTER MARK. INT. CL. 14. REG. 12-11-2007.
- 3,352,462. MOTHERS WORK (STYLIZED). INT. CL. 35. REG. 12-11-2007.
- 3,352,463. SUPER WASHABLE FLAT AND DESIGN. INT. CL. 2. REG. 12-11-2007.
- 3,352,465. NET CLICKS STANDARD CHARACTER MARK. INT. CL. 35. REG. 12-11-2007.
- 3,352,468. CENTEX-GUARANTEED PRICE GUARD HOME COST AND DESIGN. INT. CL. 36. REG. 12-11-2007.
- 3,352,470. COLE AND DESIGN. INT. CLS. 9, 16 AND 35. REG. 12-11-2007.
- 3,352,474. 20/20 BIORESPONSE A DIVISION OF 20/20 GENESYSTEMS, INC. AND DESIGN. INT. CL. 1. REG. 12-11-2007.
- 3,352,479. ORACOLO STANDARD CHARACTER MARK. INT. CL. 23. REG. 12-11-2007.
- 3,352,481. THE IB OPTIONS INTELLIGENCE REPORT STANDARD CHARACTER MARK. INT. CL. 36. REG. 12-11-2007.
- 3,352,485. CRUISING CANVAS STANDARD CHARACTER MARK. INT. CL. 12. REG. 12-11-2007.
- 3,352,488. WATERFIELD CAPITAL AND DESIGN. INT. CL. 36. REG. 12-11-2007.
- 3,352,489. IN PERSON AND DESIGN. INT. CL. 42. REG. 12-11-2007.
- 3,352,493. CARPCO STANDARD CHARACTER MARK. INT. CL. 7. REG. 12-11-2007.
- 3,352,497. GEO CENTURY STANDARD CHARACTER MARK. INT. CL. 42. REG. 12-11-2007.
- 3,352,498. REEF GEL STANDARD CHARACTER MARK. INT. CLS. 5 AND 31. REG. 12-11-2007.
- 3,352,500. TRIBORD STANDARD CHARACTER MARK. INT. CLS. 6, 21 AND 24. REG. 12-11-2007.
- 3,352,502. "FOR EVERY STAGE OF YOUR LIFE" STANDARD CHARACTER MARK. INT. CL. 42. REG. 12-11-2007.
- 3,352,503. RHOM AND DESIGN. INT. CL. 41. REG. 12-11-2007.
- 3,352,506. GET IN THE ZONE STANDARD CHARACTER MARK. INT. CL. 19. REG. 12-11-2007.
- 3,352,507. AMPP STANDARD CHARACTER MARK. INT. CL. 35. REG. 12-11-2007.
- 3,352,508. INTEGRATED E SOLUTIONS STANDARD CHARACTER MARK. INT. CL. 42. REG. 12-11-2007.
- 3,352,509. ALT WORLDWIDE CHAUFFEURED SERVICES AND DESIGN. INT. CL. 39. REG. 12-11-2007.
- 3,352,510. CIRCUIT CRASHERS STANDARD CHARACTER MARK. INT. CL. 28. REG. 12-11-2007.
- 3,352,511. JUAN EIGHTY STANDARD CHARACTER MARK. INT. CL. 28. REG. 12-11-2007.
- 3,352,512. MO'HAWK STANDARD CHARACTER MARK. INT. CL. 28. REG. 12-11-2007.
- 3,352,513. POP-UP CRAZY CRASHERS STANDARD CHARACTER MARK. INT. CL. 28. REG. 12-11-2007.
- 3,352,514. POPPIN' RAIL GRIND STANDARD CHARACTER MARK. INT. CL. 28. REG. 12-11-2007.

- 3,352,515. STREET PACK STANDARD CHARACTER MARK. INT. CL. 28. REG. 12-11-2007.
- 3,352,517. GOTMICE STANDARD CHARACTER MARK. INT. CLS. 9 AND 16. REG. 12-11-2007.
- 3,352,521. JERSEY SHORE FILM FESTIVAL STANDARD CHARACTER MARK. INT. CL. 25. REG. 12-11-2007.
- 3,352,522. AUTOMAVEN STANDARD CHARACTER MARK. INT. CL. 9. REG. 12-11-2007.
- 3,352,523. MIRAVAL LIFE IN BALANCE (STYLIZED). INT. CLS. 16, 41, 43 AND 44. REG. 12-11-2007.
- 3,352,525. TEACHLETS STANDARD CHARACTER MARK. INT. CL. 41. REG. 12-11-2007.
- 3,352,758. VISAMONITOR. INT. CL. 42. REG. 12-11-2007.
- 3,352,765. ELECTRIC INTERACTIVE. INT. CL. 41. REG. 12-11-2007.
- 3,352,771. DR. ROCK. INT. CL. 32. REG. 12-11-2007.
- 3,352,773. HIBACHIBBQ AND DESIGN. INT. CLS. 21 AND 30. REG. 12-11-2007.
- 3,352,775. HARLEM GLOBETROTTERS. INT. CL. 18. REG. 12-11-2007.
- 3,352,776. SOLPRODUCE. INT. CL. 31. REG. 12-11-2007.
- 3,352,777. ACUATIVE AND DESIGN. INT. CLS. 37, 38 AND 42. REG. 12-11-2007.
- 3,352,778. STAIN MULE. INT. CL. 1. REG. 12-11-2007.
- 3,352,779. AMAZÔNIA CHURRASCARIA (STYLIZED). INT. CL. 43. REG. 12-11-2007.
- 3,352,784. DHC. INT. CL. 5. REG. 12-11-2007.
- 3,352,785. EQUALTEMP. INT. CLS. 20 AND 24. REG. 12-11-2007.
- 3,352,786. LITE OWL AND DESIGN. INT. CL. 11. REG. 12-11-2007.
- 3,352,787. CHAT THE PLANET. INT. CL. 25. REG. 12-11-2007.
- 3,352,791. TACCO-LINI. INT. CL. 30. REG. 12-11-2007.
- 3,352,796. LEE METAL BUILDING SYSTEMS. INT. CL. 6. REG. 12-11-2007.
- 3,352,801. ASAP SCHOOLS. INT. CLS. 9, 16 AND 41. REG. 12-11-2007.
- 3,352,803. FIRST CAPITAL BUSINESS CREDIT. INT. CL. 36. REG. 12-11-2007.
- 3,352,804. FIRST CAPITAL TEMPFUNDS. INT. CL. 36. REG. 12-11-2007.
- 3,352,806. TINGLER. INT. CL. 3. REG. 12-11-2007.
- 3,352,807. 3G. INT. CL. 7. REG. 12-11-2007.
- 3,352,809. RELOAD. INT. CL. 1. REG. 12-11-2007.
- 3,352,813. ISABELL WERTH AND DESIGN. INT. CLS. 18 AND 25. REG. 12-11-2007.
- 3,352,816. STREAMLINING YOUR DIGITAL WORLD STANDARD CHARACTER MARK. INT. CL. 38. REG. 12-11-2007.
- 3,352,817. OSCAR DE LA RENTA STANDARD CHARACTER MARK. INT. CLS. 20 AND 24. REG. 12-11-2007.
- 3,352,818. INSTEAD OF CLAY STANDARD CHARACTER MARK. INT. CL. 3. REG. 12-11-2007.
- 3,352,819. SENSIBLE CARBS STANDARD CHARACTER MARK. INT. CL. 29. REG. 12-11-2007.
- 3,352,826. RADAR RECORDS AND DESIGN. INT. CLS. 9 AND 41. REG. 12-11-2007.
- 3,352,827. MULTICULTURAL PLAYING FIELD STANDARD CHARACTER MARK. INT. CLS. 9 AND 16. REG. 12-11-2007.
- 3,352,830. EULA STANDARD CHARACTER MARK. INT. CLS. 16 AND 25. REG. 12-11-2007.
- 3,352,832. OT HOME ONE TOUCH FOR DIGITAL HOME AND DESIGN. INT. CLS. 7, 9, 11, 16, 35, 41 AND 42. REG. 12-11-2007.
- 3,352,836. IGNITOR AND DESIGN. INT. CL. 9. REG. 12-11-2007.
- 3,352,838. DREMAK STANDARD CHARACTER MARK. INT. CL. 41. REG. 12-11-2007.
- 3,352,839. EDAC STANDARD CHARACTER MARK. INT. CL. 10. REG. 12-11-2007.
- 3,352,842. MISCELLANEOUS DESIGN. INT. CL. 16. REG. 12-11-2007.
- 3,352,843. ARBOSANA IRTA I-43 STANDARD CHARACTER MARK. INT. CL. 31. REG. 12-11-2007.
- 3,352,845. NITROMAX STANDARD CHARACTER MARK. INT. CL. 12. REG. 12-11-2007.
- 3,352,846. T AND DESIGN. INT. CL. 25. REG. 12-11-2007.
- 3,352,847. THERMACORE STANDARD CHARACTER MARK. INT. CL. 25. REG. 12-11-2007.
- 3,352,848. ILO AND DESIGN. INT. CL. 9. REG. 12-11-2007.
- 3,352,849. VB VICIOUS BITCHES AND DESIGN. INT. CL. 25. REG. 12-11-2007.
- 3,352,850. KORONEIKI IRTA I-38 STANDARD CHARACTER MARK. INT. CL. 31. REG. 12-11-2007.
- 3,352,856. X DGX DEPENDABLE GLOBAL EXPRESS AND DESIGN. INT. CL. 39. REG. 12-11-2007.
- 3,352,857. WHERE BAKING TRADITIONS BEGIN STANDARD CHARACTER MARK. INT. CL. 30. REG. 12-11-2007.
- 3,352,860. OPTVIPA STANDARD CHARACTER MARK. INT. CL. 9. REG. 12-11-2007.
- 3,352,864. ONWORDS AND UPWORDS STANDARD CHARACTER MARK. INT. CL. 20. REG. 12-11-2007.
- 3,352,867. ATLANTIC BILLFISH COMPANY STANDARD CHARACTER MARK. INT. CL. 25. REG. 12-11-2007.
- 3,352,870. MGRI STANDARD CHARACTER MARK. INT. CL. 9. REG. 12-11-2007.
- 3,352,873. RASTA RIOT STANDARD CHARACTER MARK. INT. CL. 30. REG. 12-11-2007.
- 3,352,874. HAPPY ANARCHIST STANDARD CHARACTER MARK. INT. CL. 25. REG. 12-11-2007.
- 3,352,875. PUNCH-HAIR-MATIC STANDARD CHARACTER MARK. INT. CL. 10. REG. 12-11-2007.
- 3,352,877. FORMERLY FIT AND DESIGN. INT. CL. 44. REG. 12-11-2007.
- 3,352,878. ITHEATER STANDARD CHARACTER MARK. INT. CL. 9. REG. 12-11-2007.
- 3,352,880. SANDING S. SANDING AND DESIGN. INT. CL. 25. REG. 12-11-2007.
- 3,352,882. SCIENCE ASSESSMENT SERIES AND DESIGN. INT. CL. 16. REG. 12-11-2007.
- 3,352,884. HOOKBALL STANDARD CHARACTER MARK. INT. CL. 28. REG. 12-11-2007.
- 3,352,886. GRIPDOCK STANDARD CHARACTER MARK. INT. CL. 9. REG. 12-11-2007.
- 3,352,889. MORTGAGES. NONPRIME MADE EASY. STANDARD CHARACTER MARK. INT. CL. 36. REG. 12-11-2007.
- 3,352,890. IMAGIA AND DESIGN. INT. CL. 42. REG. 12-11-2007.
- 3,352,892. GDE AND DESIGN. INT. CLS. 35 AND 41. REG. 12-11-2007.
- 3,352,895. MODIZO RECORDS AND DESIGN. INT. CL. 9. REG. 12-11-2007.
- 3,352,898. STROKES AHEAD OF THE REST STANDARD CHARACTER MARK. INT. CL. 31. REG. 12-11-2007.
- 3,352,899. FE-NE-TIKS (STYLIZED). INT. CL. 3. REG. 12-11-2007.
- 3,352,900. TOBACCO FREE...FOR LIFE STANDARD CHARACTER MARK. INT. CL. 44. REG. 12-11-2007.
- 3,352,901. MI CANTON STANDARD CHARACTER MARK. INT. CL. 36. REG. 12-11-2007.
- 3,352,908. PROFESSOR PENDLETON PENCIL (STYLIZED). INT. CL. 16. REG. 12-11-2007.
- 3,352,910. FARMSTRONG STANDARD CHARACTER MARK. INT. CL. 36. REG. 12-11-2007.
- 3,352,911. USIOASIS (STYLIZED). INT. CL. 42. REG. 12-11-2007.
- 3,352,912. MISCELLANEOUS DESIGN. INT. CL. 16. REG. 12-11-2007.
- 3,352,914. ALBUMIT! STANDARD CHARACTER MARK. INT. CL. 9. REG. 12-11-2007.
- 3,352,916. ONPATH STANDARD CHARACTER MARK. INT. CL. 41. REG. 12-11-2007.
- 3,352,917. JOSHUASYSTEMS STANDARD CHARACTER MARK. INT. CL. 41. REG. 12-11-2007.

- 3,352,919. ROOSTER LIPS MOUTH GUARDS STANDARD CHARACTER MARK. INT. CL. 28. REG. 12-11-2007.
- 3,352,920. NEUTRON AND DESIGN. INT. CLS. 9, 38 AND 42. REG. 12-11-2007.
- 3,352,921. EXIT GAMES AND DESIGN. INT. CLS. 9, 38 AND 42. REG. 12-11-2007.
- 3,352,924. MANHATTAN DREAMS STANDARD CHARACTER MARK. INT. CL. 3. REG. 12-11-2007.
- 3,352,925. E-INFO A PRACTICE OF HARRIS BEACH AND DESIGN. INT. CL. 35. REG. 12-11-2007.
- 3,352,926. MI TIERRA STANDARD CHARACTER MARK. INT. CL. 36. REG. 12-11-2007.
- 3,352,928. S (STYLIZED). INT. CL. 7. REG. 12-11-2007.
- 3,352,929. WORD WARMERS STANDARD CHARACTER MARK. INT. CL. 16. REG. 12-11-2007.
- 3,352,930. EARTH DESIGNS AND DESIGN. INT. CL. 37. REG. 12-11-2007.
- 3,352,931. COMFORT MATRIX STANDARD CHARACTER MARK. INT. CLS. 20 AND 24. REG. 12-11-2007.
- 3,352,934. BARCHES AND DESIGN. INT. CL. 25. REG. 12-11-2007.
- 3,352,936. TEMPEST HOT-T AND DESIGN. INT. CL. 5. REG. 12-11-2007.
- 3,352,937. BRIB STANDARD CHARACTER MARK. INT. CL. 25. REG. 12-11-2007.
- 3,352,938. PARTY SHOE ELIXIR STANDARD CHARACTER MARK. INT. CL. 3. REG. 12-11-2007.
- 3,352,940. SOUL REVIVAL STANDARD CHARACTER MARK. INT. CL. 25. REG. 12-11-2007.
- 3,352,941. INCOLOR COLLECTION STANDARD CHARACTER MARK. INT. CL. 14. REG. 12-11-2007.
- 3,352,942. CHEWY CAFE STANDARD CHARACTER MARK. INT. CL. 25. REG. 12-11-2007.
- 3,352,943. CHEWY CAFE STANDARD CHARACTER MARK. INT. CL. 9. REG. 12-11-2007.
- 3,352,944. JON JONZ (STYLIZED). INT. CL. 25. REG. 12-11-2007.
- 3,352,945. SHOP SHIELD AND DESIGN. INT. CL. 42. REG. 12-11-2007.
- 3,352,946. THE SILENT AUCTION FOR LIFE (STYLIZED). INT. CL. 35. REG. 12-11-2007.
- 3,352,947. BLUE FOG STANDARD CHARACTER MARK. INT. CL. 35. REG. 12-11-2007.
- 3,352,951. VITRIA STANDARD CHARACTER MARK. INT. CL. 5. REG. 12-11-2007.
- 3,352,952. MONOTECH STANDARD CHARACTER MARK. INT. CL. 23. REG. 12-11-2007.
- 3,352,953. CYBERCISE STANDARD CHARACTER MARK. INT. CL. 41. REG. 12-11-2007.
- 3,352,954. BUZZ CENTRAL STANDARD CHARACTER MARK. INT. CL. 9. REG. 12-11-2007.
- 3,352,955. PURSNICKETIES STANDARD CHARACTER MARK. INT. CL. 18. REG. 12-11-2007.
- 3,352,957. DAD'S HOME SERVICES & CONSTRUCTION "WHEN ONLY THE BEST WILL DO" AND DESIGN. INT. CL. 37. REG. 12-11-2007.
- 3,352,958. DAD'S CONSTRUCTION "WHEN ONLY THE BEST WILL DO" AND DESIGN. INT. CL. 37. REG. 12-11-2007.
- 3,352,962. MATTRESSMAX STANDARD CHARACTER MARK. INT. CL. 20. REG. 12-11-2007.
- 3,352,963. THE BACK THAT HOLDS 'EM STANDARD CHARACTER MARK. INT. CL. 14. REG. 12-11-2007.
- 3,352,964. MISCELLANEOUS DESIGN. INT. CL. 14. REG. 12-11-2007.
- 3,352,965. FEELING MUSHY? SEND A GUSHY! STANDARD CHARACTER MARK. INT. CL. 38. REG. 12-11-2007.
- 3,352,966. VISIONARY STANDARD CHARACTER MARK. INT. CL. 9. REG. 12-11-2007.
- 3,352,974. HAMILTON SMITH ASSOCIATES STANDARD CHARACTER MARK. INT. CL. 45. REG. 12-11-2007.
- 3,352,975. CRIPPLE DOG AND DESIGN. INT. CLS. 12, 25, 35, 37 AND 40. REG. 12-11-2007.
- 3,352,976. SPEED WAXER AND DESIGN. INT. CL. 8. REG. 12-11-2007.
- 3,352,977. FUEL FOR YOUR FIRE STANDARD CHARACTER MARK. INT. CL. 43. REG. 12-11-2007.
- 3,352,978. EASYWAY GOURMET STANDARD CHARACTER MARK. INT. CL. 41. REG. 12-11-2007.
- 3,352,981. ALL SEASON GARDEN STANDARD CHARACTER MARK. INT. CL. 31. REG. 12-11-2007.
- 3,352,983. FINALLY FAIR! NO MATTER WHO. NO MATTER WHERE. STANDARD CHARACTER MARK. INT. CL. 36. REG. 12-11-2007.
- 3,352,984. TRADITIONS GREAT NORTHWEST CLOTHING CO. STANDARD CHARACTER MARK. INT. CL. 25. REG. 12-11-2007.
- 3,352,985. ALWAYS SMOOTH STANDARD CHARACTER MARK. INT. CL. 3. REG. 12-11-2007.
- 3,352,987. LEARNINGCAST STANDARD CHARACTER MARK. INT. CL. 41. REG. 12-11-2007.
- 3,352,988. THICK BOOST STANDARD CHARACTER MARK. INT. CL. 3. REG. 12-11-2007.
- 3,352,989. A DROP OF DAWN MAKES A DIFFERENCE AND SO CAN YOU STANDARD CHARACTER MARK. INT. CL. 3. REG. 12-11-2007.
- 3,352,990. A DROP OF DAWN MAKES A DIFFERENCE STANDARD CHARACTER MARK. INT. CL. 3. REG. 12-11-2007.
- 3,352,991. MPOWER HEALTH STANDARD CHARACTER MARK. INT. CL. 36. REG. 12-11-2007.
- 3,352,993. MISCELLANEOUS DESIGN. INT. CL. 25. REG. 12-11-2007.
- 3,352,994. MISCELLANEOUS DESIGN. INT. CL. 16. REG. 12-11-2007.
- 3,352,995. MISCELLANEOUS DESIGN. INT. CL. 14. REG. 12-11-2007.
- 3,352,996. U-CONNECT STANDARD CHARACTER MARK. INT. CL. 42. REG. 12-11-2007.
- 3,352,997. PLEX STANDARD CHARACTER MARK. INT. CL. 25. REG. 12-11-2007.
- 3,353,001. CUSTOMPLUS STANDARD CHARACTER MARK. INT. CL. 36. REG. 12-11-2007.
- 3,353,003. TRULYU STANDARD CHARACTER MARK. INT. CL. 45. REG. 12-11-2007.
- 3,353,004. TRULY U AND DESIGN. INT. CL. 45. REG. 12-11-2007.
- 3,353,005. CHINESE PATH STANDARD CHARACTER MARK. INT. CL. 16. REG. 12-11-2007.
- 3,353,008. DIVINE MADMAN COFFEE STANDARD CHARACTER MARK. INT. CL. 30. REG. 12-11-2007.
- 3,353,010. HOTEL WINE BEER & SPIRITS AND DESIGN. INT. CL. 43. REG. 12-11-2007.
- 3,353,012. THE ART OF ONE STANDARD CHARACTER MARK. INT. CL. 10. REG. 12-11-2007.
- 3,353,015. SATIN EDGE STANDARD CHARACTER MARK. INT. CL. 25. REG. 12-11-2007.
- 3,353,016. SENSATIONAL STILES STANDARD CHARACTER MARK. INT. CL. 19. REG. 12-11-2007.
- 3,353,018. HOTEL SIERRA AND DESIGN. INT. CL. 43. REG. 12-11-2007.
- 3,353,019. HOTEL SIERRA AND DESIGN. INT. CL. 43. REG. 12-11-2007.
- 3,353,020. TRULYU STANDARD CHARACTER MARK. INT. CL. 36. REG. 12-11-2007.
- 3,353,021. TRULY U AND DESIGN. INT. CL. 36. REG. 12-11-2007.
- 3,353,023. 8 (STYLIZED). INT. CL. 18. REG. 12-11-2007.
- 3,353,026. CANADA DRY STANDARD CHARACTER MARK. INT. CL. 5. REG. 12-11-2007.
- 3,353,031. CARROT CAKE STANDARD CHARACTER MARK. INT. CL. 3. REG. 12-11-2007.
- 3,353,033. DOORMERICAN STANDARD CHARACTER MARK. INT. CLS. 6 AND 19. REG. 12-11-2007.
- 3,353,036. MODEL4U STANDARD CHARACTER MARK. INT. CL. 35. REG. 12-11-2007.
- 3,353,038. CANOFIL STANDARD CHARACTER MARK. INT. CL. 25. REG. 12-11-2007.
- 3,353,039. GOT 2 KNOW STANDARD CHARACTER MARK. INT. CL. 41. REG. 12-11-2007.

- 3,353,040. AMERICAN IDOL STANDARD CHARACTER MARK. INT. CL. 29. REG. 12-11-2007.
- 3,353,043. SOHO STANDARD CHARACTER MARK. INT. CL. 30. REG. 12-11-2007.
- 3,353,044. VDATE STANDARD CHARACTER MARK. INT. CL. 45. REG. 12-11-2007.
- 3,353,045. MYCREDENTIALS AND DESIGN. INT. CL. 35. REG. 12-11-2007.
- 3,353,048. SOUTHERN SUN TANNING SALON AND DESIGN. INT. CL. 44. REG. 12-11-2007.
- 3,353,049. HAMILTON SMITH ASSOCIATES AND DESIGN. INT. CL. 45. REG. 12-11-2007.
- 3,353,050. FITZPATRICK FARRIER SERVICES INC. SOUND SHOEING SOLUTIONS AND DESIGN. INT. CL. 44. REG. 12-11-2007.
- 3,353,051. L AND DESIGN. INT. CL. 35. REG. 12-11-2007.
- 3,353,052. PUBLIC WORKSHOP IN A BOX STANDARD CHARACTER MARK. INT. CL. 35. REG. 12-11-2007.
- 3,353,054. ABILITY LEAGUE STANDARD CHARACTER MARK. INT. CL. 35. REG. 12-11-2007.
- 3,353,056. CHATTY STANDARD CHARACTER MARK. INT. CL. 28. REG. 12-11-2007.
- 3,353,057. MISCELLANEOUS DESIGN. INT. CL. 31. REG. 12-11-2007.
- 3,353,059. IEQA STANDARD CHARACTER MARK. INT. CL. 35. REG. 12-11-2007.
- 3,353,060. EXTERRA STANDARD CHARACTER MARK. INT. CL. 7. REG. 12-11-2007.
- 3,353,064. VIVID STANDARD CHARACTER MARK. INT. CL. 15. REG. 12-11-2007.
- 3,353,066. JEMETER STANDARD CHARACTER MARK. INT. CL. 9. REG. 12-11-2007.
- 3,353,068. TEKLIMNER STANDARD CHARACTER MARK. INT. CL. 41. REG. 12-11-2007.
- 3,353,070. ERJ (STYLIZED). INT. CL. 25. REG. 12-11-2007.
- 3,353,073. CIF STANDARD CHARACTER MARK. INT. CL. 6. REG. 12-11-2007.
- 3,353,074. ASPEN STANDARD CHARACTER MARK. INT. CL. 14. REG. 12-11-2007.
- 3,353,076. CALL BOX AND DESIGN. INT. CL. 9. REG. 12-11-2007.
- 3,353,079. PROFESSIONAL DESTINY STANDARD CHARACTER MARK. INT. CL. 35. REG. 12-11-2007.
- 3,353,080. REFER A FRIEND. BUILD YOUR COMMUNITY STANDARD CHARACTER MARK. INT. CL. 36. REG. 12-11-2007.
- 3,353,081. EIGHT ELEMENTS ESSENTIAL FOR A VIBRANT LIFE AFTER 50 STANDARD CHARACTER MARK. INT. CL. 41. REG. 12-11-2007.
- 3,353,082. TROPICANA PURE PREMIUM 100% PURE & NATURAL ORANGE JUICE AND DESIGN. INT. CL. 32. REG. 12-11-2007.
- 3,353,083. TROPICANA PURE PREMIUM 100% PURE & NATURAL ORANGE JUICE AND DESIGN. INT. CL. 32. REG. 12-11-2007.
- 3,353,084. VENUS STANDARD CHARACTER MARK. INT. CL. 30. REG. 12-11-2007.
- 3,353,085. DORADO VALLEY STANDARD CHARACTER MARK. INT. CL. 30. REG. 12-11-2007.
- 3,353,086. SCENT DRIFTER STANDARD CHARACTER MARK. INT. CL. 28. REG. 12-11-2007.
- 3,353,093. TROPICANA PURE PREMIUM NO PULP ORIGINAL 100% PURE & NATURAL ORANGE JUICE AND DESIGN. INT. CL. 32. REG. 12-11-2007.
- 3,353,094. AETNA HEALTHY LIVING STANDARD CHARACTER MARK. INT. CL. 36. REG. 12-11-2007.
- 3,353,098. CHARLES & DAVID STANDARD CHARACTER MARK. INT. CL. 30. REG. 12-11-2007.
- 3,353,099. ACU-CONES STANDARD CHARACTER MARK. INT. CL. 10. REG. 12-11-2007.
- 3,353,100. SMART CLINICIAN STANDARD CHARACTER MARK. INT. CL. 9. REG. 12-11-2007.
- 3,353,101. CLEVER-ELEPHANT STANDARD CHARACTER MARK. INT. CL. 9. REG. 12-11-2007.
- 3,353,102. BUDGETEZ STANDARD CHARACTER MARK. INT. CL. 9. REG. 12-11-2007.
- 3,353,103. TURN WORDS INTO CUSTOMERS STANDARD CHARACTER MARK. INT. CL. 35. REG. 12-11-2007.
- 3,353,104. STAND AS ONE STANDARD CHARACTER MARK. INT. CL. 16. REG. 12-11-2007.
- 3,353,105. PEACELOVELIFE STANDARD CHARACTER MARK. INT. CL. 25. REG. 12-11-2007.
- 3,353,107. PASTEBUDS STANDARD CHARACTER MARK. INT. CL. 3. REG. 12-11-2007.
- 3,353,110. NITRATOR STANDARD CHARACTER MARK. INT. CL. 1. REG. 12-11-2007.
- 3,353,111. MASTER THE IMPULSE FACTOR STANDARD CHARACTER MARK. INT. CL. 11. REG. 12-11-2007.
- 3,353,112. RATIO STANDARD CHARACTER MARK. INT. CL. 9. REG. 12-11-2007.
- 3,353,118. EDGERYDOO2 (STYLIZED). INT. CL. 9. REG. 12-11-2007.
- 3,353,120. CAKESTERS STANDARD CHARACTER MARK. INT. CL. 30. REG. 12-11-2007.
- 3,353,124. VETBAC STANDARD CHARACTER MARK. INT. CL. 3. REG. 12-11-2007.
- 3,353,127. SIMPLY SOCIALS STANDARD CHARACTER MARK. INT. CL. 30. REG. 12-11-2007.
- 3,353,128. FH (STYLIZED). INT. CL. 16. REG. 12-11-2007.
- 3,353,129. AGENCY 318 STANDARD CHARACTER MARK. INT. CL. 35. REG. 12-11-2007.
- 3,353,131. SO MANY WAYS TO WIN PALA CASINO SPA RESORT STANDARD CHARACTER MARK. INT. CL. 41. REG. 12-11-2007.
- 3,353,133. CHOCOLATE FISH STANDARD CHARACTER MARK. INT. CL. 28. REG. 12-11-2007.
- 3,353,135. SAVING GRACE STANDARD CHARACTER MARK. INT. CL. 41. REG. 12-11-2007.
- 3,353,138. DAILY GENTLE CLEANSING & DIGESTION STANDARD CHARACTER MARK. INT. CL. 5. REG. 12-11-2007.
- 3,353,141. COME AS YOU ARE STANDARD CHARACTER MARK. INT. CL. 45. REG. 12-11-2007.
- 3,353,142. ALL NIGHT STANDARD CHARACTER MARK. INT. CL. 5. REG. 12-11-2007.
- 3,353,146. CLUBFIX STANDARD CHARACTER MARK. INT. CL. 3. REG. 12-11-2007.
- 3,353,148. VERICEPT. INT. CL. 9. REG. 12-11-2007.
- 3,353,151. COSTA BRAVA. INT. CL. 29. REG. 12-11-2007.
- 3,353,153. POOH. INT. CL. 9. REG. 12-11-2007.
- 3,353,154. KNOWLEDGE ASSEMBLY. INT. CL. 9. REG. 12-11-2007.
- 3,353,158. FLORIDA DEPUTY SHERIFFS ASSOCIATION AND DESIGN. INT. CL. 35. REG. 12-11-2007.
- 3,353,161. PUREIÁN. INT. CL. 32. REG. 12-11-2007.
- 3,353,162. SICILY TODAY. INT. CL. 16. REG. 12-11-2007.
- 3,353,165. WORLDSCAPE. INT. CLS. 9, 35, 41 AND 42. REG. 12-11-2007.
- 3,353,166. YOUR VISION, OUR FUTURE. INT. CL. 10. REG. 12-11-2007.
- 3,353,168. 20" TWENTY INCHES STRONG AND DESIGN. INT. CLS. 12 AND 25. REG. 12-11-2007.
- 3,353,170. SOFTWARE AGITATION. INT. CLS. 9, 35 AND 42. REG. 12-11-2007.
- 3,353,174. MYHEALTHCOMPASS QUALITY MATTERS. CHOOSE WISELY. AND DESIGN. INT. CL. 35. REG. 12-11-2007.
- 3,353,176. ZOPPINI AND DESIGN. INT. CL. 9. REG. 12-11-2007.
- 3,353,179. HOME HEARTBEAT. INT. CL. 9. REG. 12-11-2007.
- 3,353,185. ROTO-GRIP. INT. CL. 8. REG. 12-11-2007.
- 3,353,186. CINNAFUSION. INT. CL. 30. REG. 12-11-2007.
- 3,353,187. LUTHERAN LIFE. INT. CL. 16. REG. 12-11-2007.
- 3,353,191. ENTREATING CARDS. INT. CL. 16. REG. 12-11-2007.
- 3,353,193. OXYMAGIC. INT. CL. 3. REG. 12-11-2007.
- 3,353,194. CAT HOUSE LOUNGE. INT. CL. 43. REG. 12-11-2007.
- 3,353,196. STRETCHERS. INT. CL. 30. REG. 12-11-2007.
- 3,353,197. SOURBUNGA. INT. CL. 30. REG. 12-11-2007.
- 3,353,198. FIZZIX. INT. CL. 30. REG. 12-11-2007.



- 3,353,199. HEART WISE STANDARD CHARACTER MARK. INT. CL. 30. REG. 12-11-2007.
- 3,353,200. BLADDER BREAK. INT. CL. 41. REG. 12-11-2007.
- 3,353,203. LOVE AND HOPE AND DESIGN. INT. CL. 14. REG. 12-11-2007.
- 3,353,206. ELAPH STANDARD CHARACTER MARK. INT. CL. 41. REG. 12-11-2007.
- 3,353,207. MISCELLANEOUS DESIGN. INT. CL. 41. REG. 12-11-2007.
- 3,353,208. MISCELLANEOUS DESIGN. INT. CL. 25. REG. 12-11-2007.
- 3,353,212. ZISION STANDARD CHARACTER MARK. INT. CL. 8. REG. 12-11-2007.
- 3,353,213. APOLLO ADVANCES IN PREVENTION THROUGH OPTIMAL LIPID LOWERING (STYLIZED). INT. CLS. 16 AND 41. REG. 12-11-2007.
- 3,353,214. SUSTAINABLE EARTH AND DESIGN. INT. CL. 3. REG. 12-11-2007.
- 3,353,215. MISCELLANEOUS DESIGN. INT. CLS. 9 AND 16. REG. 12-11-2007.
- 3,353,216. CHEETAH STANDARD CHARACTER MARK. INT. CLS. 9 AND 16. REG. 12-11-2007.
- 3,353,223. EVEREST AND DESIGN. INT. CL. 10. REG. 12-11-2007.
- 3,353,225. POP-SPEC STANDARD CHARACTER MARK. INT. CL. 10. REG. 12-11-2007.
- 3,353,226. MARS STANDARD CHARACTER MARK. INT. CL. 9. REG. 12-11-2007.
- 3,353,229. HOT N HIP STANDARD CHARACTER MARK. INT. CL. 41. REG. 12-11-2007.
- 3,353,231. JOIA BOTANICALS STANDARD CHARACTER MARK. INT. CL. 3. REG. 12-11-2007.
- 3,353,232. OLYMPUS SUPPORTVISION STANDARD CHARACTER MARK. INT. CL. 37. REG. 12-11-2007.
- 3,353,236. VAULT FIELD STANDARD CHARACTER MARK. INT. CL. 33. REG. 12-11-2007.
- 3,353,239. HYDRA BRIGHT STANDARD CHARACTER MARK. INT. CL. 3. REG. 12-11-2007.
- 3,353,241. DESTINATION GAMES STANDARD CHARACTER MARK. INT. CL. 9. REG. 12-11-2007.
- 3,353,242. TOP DOG STANDARD CHARACTER MARK. INT. CL. 35. REG. 12-11-2007.
- 3,353,244. LES MILLS AND DESIGN. INT. CLS. 9, 16, 25, 28 AND 41. REG. 12-11-2007.
- 3,353,247. PLIMOTH ROCKS STANDARD CHARACTER MARK. INT. CL. 16. REG. 12-11-2007.
- 3,353,248. COLOR FX STANDARD CHARACTER MARK. INT. CL. 11. REG. 12-11-2007.
- 3,353,249. THE NRE STANDARD CHARACTER MARK. INT. CL. 35. REG. 12-11-2007.
- 3,353,251. N-GAGE STANDARD CHARACTER MARK. INT. CL. 6. REG. 12-11-2007.
- 3,353,252. ALSO (STYLIZED). INT. CLS. 9 AND 41. REG. 12-11-2007.
- 3,353,254. SPECIALOPS PAINTBALL STANDARD CHARACTER MARK. INT. CL. 35. REG. 12-11-2007.
- 3,353,255. OLYMPUS SUPPORTVISION AND DESIGN. INT. CL. 37. REG. 12-11-2007.
- 3,353,256. MERLIN STANDARD CHARACTER MARK. INT. CL. 10. REG. 12-11-2007.
- 3,353,257. SOFA WORLD STANDARD CHARACTER MARK. INT. CL. 20. REG. 12-11-2007.
- 3,353,259. PERSONAL EXPRESSIONS STANDARD CHARACTER MARK. INT. CL. 3. REG. 12-11-2007.
- 3,353,261. ID-CAB STANDARD CHARACTER MARK. INT. CL. 9. REG. 12-11-2007.
- 3,353,263. AMERICAN IDOL STANDARD CHARACTER MARK. INT. CL. 18. REG. 12-11-2007.
- 3,353,264. LIBERTY BANJO COMPANY STANDARD CHARACTER MARK. INT. CL. 15. REG. 12-11-2007.
- 3,353,265. WINTERSPRINGSUMMERFOOTBALL STANDARD CHARACTER MARK. INT. CL. 41. REG. 12-11-2007.
- 3,353,266. ACTION LIVING STANDARD CHARACTER MARK. INT. CL. 35. REG. 12-11-2007.
- 3,353,272. MAGNIFEYE STANDARD CHARACTER MARK. INT. CL. 20. REG. 12-11-2007.
- 3,353,273. CONNECT WITH THE CAFÉ STANDARD CHARACTER MARK. INT. CL. 35. REG. 12-11-2007.
- 3,353,274. MAESTRO BARISTA STANDARD CHARACTER MARK. INT. CL. 11. REG. 12-11-2007.
- 3,353,276. BALD BOY CLOTHING AND DESIGN. INT. CL. 25. REG. 12-11-2007.
- 3,353,278. COLORFACTS STANDARD CHARACTER MARK. INT. CL. 9. REG. 12-11-2007.
- 3,353,279. CAMDEN VALE STANDARD CHARACTER MARK. INT. CL. 35. REG. 12-11-2007.
- 3,353,281. MONA STANDARD CHARACTER MARK. INT. CL. 1. REG. 12-11-2007.
- 3,353,282. LAGUNA BEACH THE REAL ORANGE COUNTY AND DESIGN. INT. CLS. 9 AND 38. REG. 12-11-2007.
- 3,353,284. RUTHERFORD UNIVERSITY STANDARD CHARACTER MARK. INT. CL. 41. REG. 12-11-2007.
- 3,353,285. OPEN INVENTOR STANDARD CHARACTER MARK. INT. CL. 9. REG. 12-11-2007.
- 3,353,286. EXPRESSMAB STANDARD CHARACTER MARK. INT. CL. 42. REG. 12-11-2007.
- 3,353,287. TODAY'S CONVERSION VAN STANDARD CHARACTER MARK. INT. CL. 12. REG. 12-11-2007.
- 3,353,293. AD EXCHANGE STANDARD CHARACTER MARK. INT. CL. 9. REG. 12-11-2007.
- 3,353,294. ROCKT STANDARD CHARACTER MARK. INT. CL. 25. REG. 12-11-2007.
- 3,353,297. GENERRA STANDARD CHARACTER MARK. INT. CL. 25. REG. 12-11-2007.
- 3,353,298. INFERENT STANDARD CHARACTER MARK. INT. CLS. 9 AND 41. REG. 12-11-2007.
- 3,353,299. KUNG FU FAT'S ASIA CAFE & NOODLE HOUSE AND DESIGN. INT. CL. 43. REG. 12-11-2007.
- 3,353,300. DANGELIER STANDARD CHARACTER MARK. INT. CL. 14. REG. 12-11-2007.
- 3,353,301. AVESO STANDARD CHARACTER MARK. INT. CLS. 2 AND 9. REG. 12-11-2007.
- 3,353,302. SEA GOLD AND DESIGN. INT. CL. 29. REG. 12-11-2007.
- 3,353,303. FIT IT IN STANDARD CHARACTER MARK. INT. CL. 41. REG. 12-11-2007.
- 3,353,304. SASSE COLLECTION STANDARD CHARACTER MARK. INT. CL. 25. REG. 12-11-2007.
- 3,353,305. FUSING PROFIT AND SALES STANDARD CHARACTER MARK. INT. CL. 41. REG. 12-11-2007.
- 3,353,307. SKITTLES STANDARD CHARACTER MARK. INT. CL. 25. REG. 12-11-2007.
- 3,353,313. FACIOCIRCUIT STANDARD CHARACTER MARK. INT. CL. 10. REG. 12-11-2007.
- 3,353,315. SOLITAIRE STANDARD CHARACTER MARK. INT. CL. 17. REG. 12-11-2007.
- 3,353,316. PROVISOIR WEALTH STANDARD CHARACTER MARK. INT. CL. 9. REG. 12-11-2007.
- 3,353,318. CANDIE'S STANDARD CHARACTER MARK. INT. CL. 21. REG. 12-11-2007.
- 3,353,319. MATCHTRAC STANDARD CHARACTER MARK. INT. CL. 36. REG. 12-11-2007.
- 3,353,320. UNIQLO DESIGN STUDIO STANDARD CHARACTER MARK. INT. CLS. 40, 41 AND 42. REG. 12-11-2007.
- 3,353,321. FIBERSLAM STANDARD CHARACTER MARK. INT. CL. 9. REG. 12-11-2007.
- 3,353,322. WACHOVIA EDUCATION LOAN STANDARD CHARACTER MARK. INT. CL. 36. REG. 12-11-2007.
- 3,353,323. TRICOT JOLI STANDARD CHARACTER MARK. INT. CL. 25. REG. 12-11-2007.
- 3,353,324. FAN SPECS STANDARD CHARACTER MARK. INT. CL. 9. REG. 12-11-2007.
- 3,353,325. ALUMNI SPECS STANDARD CHARACTER MARK. INT. CL. 9. REG. 12-11-2007.

- 3,353,330. ANGRY GENES ANGRY JEANS STANDARD CHARACTER MARK. INT. CL. 25. REG. 12-11-2007.
- 3,353,332. MOVIE TALK STANDARD CHARACTER MARK. INT. CL. 28. REG. 12-11-2007.
- 3,353,335. HAUS STANDARD CHARACTER MARK. INT. CL. 36. REG. 12-11-2007.
- 3,353,336. TDC TOURISM DEVELOPMENT CORPS AND DESIGN. INT. CL. 35. REG. 12-11-2007.
- 3,353,339. QCONCERT STANDARD CHARACTER MARK. INT. CL. 9. REG. 12-11-2007.
- 3,353,340. QAUDIOFX STANDARD CHARACTER MARK. INT. CL. 9. REG. 12-11-2007.
- 3,353,341. REFINED HYDRAULIC STANDARD CHARACTER MARK. INT. CL. 25. REG. 12-11-2007.
- 3,353,344. SCUBA JOE STANDARD CHARACTER MARK. INT. CL. 9. REG. 12-11-2007.
- 3,353,346. FLEX LOADER STANDARD CHARACTER MARK. INT. CL. 7. REG. 12-11-2007.
- 3,353,347. CONVENIENCE & COMPANY STANDARD CHARACTER MARK. INT. CL. 35. REG. 12-11-2007.
- 3,353,352. RAPPERS STANDARD CHARACTER MARK. INT. CL. 30. REG. 12-11-2007.
- 3,353,353. LYBREL STANDARD CHARACTER MARK. INT. CL. 5. REG. 12-11-2007.
- 3,353,358. BRITE BUOY STANDARD CHARACTER MARK. INT. CL. 40. REG. 12-11-2007.
- 3,353,359. HOT PICKS STANDARD CHARACTER MARK. INT. CL. 9. REG. 12-11-2007.
- 3,353,361. X-ARM STANDARD CHARACTER MARK. INT. CLS. 6 AND 9. REG. 12-11-2007.
- 3,353,362. TV FOR TV FANS STANDARD CHARACTER MARK. INT. CLS. 38 AND 41. REG. 12-11-2007.
- 3,353,364. MAILROX STANDARD CHARACTER MARK. INT. CL. 20. REG. 12-11-2007.
- 3,353,365. TANeko TAVERN STANDARD CHARACTER MARK. INT. CL. 43. REG. 12-11-2007.
- 3,353,368. BEYOND THE SCRIPT STANDARD CHARACTER MARK. INT. CLS. 35 AND 41. REG. 12-11-2007.
- 3,353,370. 20/20 INSIGHT STANDARD CHARACTER MARK. INT. CL. 9. REG. 12-11-2007.
- 3,353,372. NEPTUNE'S EXPLORATION INC. STANDARD CHARACTER MARK. INT. CL. 9. REG. 12-11-2007.
- 3,353,373. CELEBRATE YOUR CHILD'S LOVE OF LEARNING STANDARD CHARACTER MARK. INT. CL. 16. REG. 12-11-2007.
- 3,353,374. MISCELLANEOUS DESIGN. INT. CL. 1. REG. 12-11-2007.
- 3,353,376. USIBOO STANDARD CHARACTER MARK. INT. CLS. 9 AND 42. REG. 12-11-2007.
- 3,353,378. LOVING YOUR GRANDBABY STANDARD CHARACTER MARK. INT. CL. 16. REG. 12-11-2007.
- 3,353,379. MINX STANDARD CHARACTER MARK. INT. CL. 3. REG. 12-11-2007.
- 3,353,380. MISCELLANEOUS DESIGN. INT. CL. 3. REG. 12-11-2007.
- 3,353,381. CROWNS BY JESUS AND ME STANDARD CHARACTER MARK. INT. CL. 25. REG. 12-11-2007.
- 3,353,384. US APRES SKI TEAM STANDARD CHARACTER MARK. INT. CL. 25. REG. 12-11-2007.
- 3,353,400. ALL ARE ONE STANDARD CHARACTER MARK. INT. CL. 43. REG. 12-11-2007.
- 3,353,402. LOUIS GARNEAU (STYLIZED). INT. CLS. 9, 12, 18, 21, 25 AND 28. REG. 12-11-2007.
- 3,353,403. MY PANINI STANDARD CHARACTER MARK. INT. CL. 43. REG. 12-11-2007.
- 3,353,407. AFFECTIS STANDARD CHARACTER MARK. INT. CL. 42. REG. 12-11-2007.
- 3,353,410. PRIDE AND DESIGN. INT. CLS. 37 AND 40. REG. 12-11-2007.
- 3,353,412. P PROFORM AND DESIGN. INT. CLS. 2 AND 17. REG. 12-11-2007.
- 3,353,413. FIVE S AND DESIGN. INT. CLS. 35 AND 41. REG. 12-11-2007.
- 3,353,414. ORYX STANDARD CHARACTER MARK. INT. CL. 5. REG. 12-11-2007.
- 3,353,415. HAPPYGREENBEE AND DESIGN. INT. CL. 25. REG. 12-11-2007.
- 3,353,416. VERITAS FORUM BOOKS STANDARD CHARACTER MARK. INT. CL. 16. REG. 12-11-2007.
- 3,353,417. E-PAS PROPERTIES AND SERVICES RIGHT AT YOUR FINGERTIPS STANDARD CHARACTER MARK. INT. CL. 35. REG. 12-11-2007.
- 3,353,418. KIDSCANTRAVEL STANDARD CHARACTER MARK. INT. CLS. 35, 38, 39 AND 41. REG. 12-11-2007.
- 3,353,421. HUNGRYMOVER.COM STANDARD CHARACTER MARK. INT. CL. 39. REG. 12-11-2007.
- 3,353,425. SHILOH STANDARD CHARACTER MARK. INT. CL. 11. REG. 12-11-2007.
- 3,353,426. XTRA LIFE LYCRA AND DESIGN. INT. CL. 24. REG. 12-11-2007.
- 3,353,427. SUGAR COOKIE STANDARD CHARACTER MARK. INT. CL. 3. REG. 12-11-2007.
- 3,353,428. JHCOLLECTIBLES STANDARD CHARACTER MARK. INT. CL. 18. REG. 12-11-2007.
- 3,353,430. AYUN STANDARD CHARACTER MARK. INT. CL. 33. REG. 12-11-2007.
- 3,353,431. ONEDOSEPLUS STANDARD CHARACTER MARK. INT. CL. 10. REG. 12-11-2007.
- 3,353,434. SPIRIT OF BRANDTJEN FARM (STYLIZED). INT. CL. 37. REG. 12-11-2007.
- 3,353,437. CENTER FOR HEALTH TRANSFORMATION AND DESIGN. INT. CLS. 9, 16, 35, 41 AND 44. REG. 12-11-2007.
- 3,353,439. YOUR NEIGHBORHOOD COMMUNICATIONS COMPANY STANDARD CHARACTER MARK. INT. CL. 38. REG. 12-11-2007.
- 3,353,441. ALL FLO PRO STANDARD CHARACTER MARK. INT. CL. 11. REG. 12-11-2007.
- 3,353,443. MISCELLANEOUS DESIGN. INT. CL. 38. REG. 12-11-2007.
- 3,353,444. MISCELLANEOUS DESIGN. INT. CLS. 35 AND 41. REG. 12-11-2007.
- 3,353,447. GREAT EYEDEAS, INC. STANDARD CHARACTER MARK. INT. CLS. 35, 36, 41 AND 42. REG. 12-11-2007.
- 3,353,448. SHERWOOD FOREST CHARITIES STANDARD CHARACTER MARK. INT. CL. 36. REG. 12-11-2007.
- 3,353,449. GREAT EYEDEAS INC. AND DESIGN. INT. CLS. 35, 36, 41 AND 42. REG. 12-11-2007.
- 3,353,450. THE VIEWPOINTS COLLECTION STANDARD CHARACTER MARK. INT. CL. 14. REG. 12-11-2007.
- 3,353,454. SLIDE FEELERS STANDARD CHARACTER MARK. INT. CL. 9. REG. 12-11-2007.
- 3,353,458. CPC CAROLINA PERSONNEL COMPANY AND DESIGN. INT. CL. 35. REG. 12-11-2007.
- 3,353,459. COFFEE WITH A KICK STANDARD CHARACTER MARK. INT. CL. 30. REG. 12-11-2007.
- 3,353,462. BRONCOLIN COLD STANDARD CHARACTER MARK. INT. CLS. 5 AND 30. REG. 12-11-2007.
- 3,353,464. CLARY EYE OPTOMETRY AND DESIGN. INT. CLS. 35 AND 44. REG. 12-11-2007.
- 3,353,467. IDC AND INTEGRATED DATA CORPORATION AND DESIGN. INT. CL. 9. REG. 12-11-2007.
- 3,353,470. LASER LINE A STRAIGHT LINE EVERY TIME AND DESIGN. INT. CL. 9. REG. 12-11-2007.
- 3,353,471. MISCELLANEOUS DESIGN. INT. CL. 9. REG. 12-11-2007.
- 3,353,472. JETERA STANDARD CHARACTER MARK. INT. CL. 35. REG. 12-11-2007.
- 3,353,474. ALL THE BUZZ STANDARD CHARACTER MARK. INT. CL. 3. REG. 12-11-2007.
- 3,353,477. LIVING SMART STANDARD CHARACTER MARK. INT. CL. 16. REG. 12-11-2007.
- 3,353,478. IJOY RIDE LIVE. PLAY. RELAX. AND DESIGN. INT. CL. 28. REG. 12-11-2007.

- 3,353,481. BOWTIE STANDARD CHARACTER MARK. INT. CLS. 16, 35, 41, 42 AND 44. REG. 12-11-2007.
- 3,353,484. METACURE STANDARD CHARACTER MARK. INT. CL. 42. REG. 12-11-2007.
- 3,353,485. MERCATO GRILLE AND DESIGN. INT. CL. 30. REG. 12-11-2007.
- 3,353,486. IMAGE INFO STANDARD CHARACTER MARK. INT. CL. 9. REG. 12-11-2007.
- 3,353,487. MOLD DEFENSE STANDARD CHARACTER MARK. INT. CL. 19. REG. 12-11-2007.
- 3,353,488. MANTA RAY BAY AND DESIGN. INT. CL. 29. REG. 12-11-2007.
- 3,353,489. ZEBRATOP STANDARD CHARACTER MARK. INT. CL. 6. REG. 12-11-2007.
- 3,353,491. SMART TAG WIZARD STANDARD CHARACTER MARK. INT. CL. 9. REG. 12-11-2007.
- 3,353,492. OPTIONS STANDARD CHARACTER MARK. INT. CL. 26. REG. 12-11-2007.
- 3,353,493. ACCUPRO AND DESIGN. INT. CL. 9. REG. 12-11-2007.
- 3,353,494. TERRACEM STANDARD CHARACTER MARK. INT. CL. 1. REG. 12-11-2007.
- 3,353,500. MOBILE COMMAND CENTER STANDARD CHARACTER MARK. INT. CL. 9. REG. 12-11-2007.
- 3,353,501. ON FOOT FILMS STANDARD CHARACTER MARK. INT. CL. 9. REG. 12-11-2007.
- 3,353,504. DEBITPASS AND DESIGN. INT. CL. 36. REG. 12-11-2007.
- 3,353,507. OTI-SWIM STANDARD CHARACTER MARK. INT. CL. 5. REG. 12-11-2007.
- 3,353,508. DEFINING MOMENTS STANDARD CHARACTER MARK. INT. CL. 16. REG. 12-11-2007.
- 3,353,510. CHB STANDARD CHARACTER MARK. INT. CL. 12. REG. 12-11-2007.
- 3,353,516. P PREMIUM POWER PRODUCTS AND DESIGN. INT. CL. 9. REG. 12-11-2007.
- 3,353,517. WORLDLINE AND DESIGN. INT. CL. 2. REG. 12-11-2007.
- 3,353,521. THE POKER LOTTERY AND DESIGN. INT. CL. 41. REG. 12-11-2007.
- 3,353,522. YOU GLOW AND DESIGN. INT. CL. 3. REG. 12-11-2007.
- 3,353,523. EBOLA CRISIS STANDARD CHARACTER MARK. INT. CL. 9. REG. 12-11-2007.
- 3,353,525. YOGA MANNA STANDARD CHARACTER MARK. INT. CL. 5. REG. 12-11-2007.
- 3,353,526. GO-TO FLIES STANDARD CHARACTER MARK. INT. CL. 16. REG. 12-11-2007.
- 3,353,528. CONTINUOUS SPRAY AND DESIGN. INT. CL. 3. REG. 12-11-2007.
- 3,353,533. PARTY HARD STANDARD CHARACTER MARK. INT. CL. 3. REG. 12-11-2007.
- 3,353,534. THE VIEW FROM THE BAY STANDARD CHARACTER MARK. INT. CL. 41. REG. 12-11-2007.
- 3,353,535. EMERGING MEDIA DYNAMICS STANDARD CHARACTER MARK. INT. CLS. 16 AND 35. REG. 12-11-2007.
- 3,353,538. PLAYER ON BOARD STANDARD CHARACTER MARK. INT. CL. 16. REG. 12-11-2007.
- 3,353,540. INTERSTELLAR TECHNOLOGIES CORPORATION AND DESIGN. INT. CLS. 9, 35 AND 42. REG. 12-11-2007.
- 3,353,542. ORGANIC. IT JUST FEELS RIGHT. STANDARD CHARACTER MARK. INT. CLS. 23 AND 24. REG. 12-11-2007.
- 3,353,543. LXR LUSTRELAB INC. AND DESIGN. INT. CL. 37. REG. 12-11-2007.
- 3,353,544. PROGRESO AND DESIGN. INT. CL. 36. REG. 12-11-2007.
- 3,353,549. TARG-B-QUE RIB SAUCE A KLINGON TRADITION AND DESIGN. INT. CL. 30. REG. 12-11-2007.
- 3,353,550. FLI AND DESIGN. INT. CL. 25. REG. 12-11-2007.
- 3,353,551. MISCELLANEOUS DESIGN. INT. CLS. 38 AND 41. REG. 12-11-2007.
- 3,353,553. XPRO STANDARD CHARACTER MARK. INT. CL. 1. REG. 12-11-2007.
- 3,353,554. BEFORE KIDS ... (STYLIZED). INT. CLS. 9, 16, 21, 25 AND 35. REG. 12-11-2007.
- 3,353,556. BRAINY PARENTS STANDARD CHARACTER MARK. INT. CLS. 9 AND 16. REG. 12-11-2007.
- 3,353,557. RAPIDE STANDARD CHARACTER MARK. INT. CLS. 38 AND 42. REG. 12-11-2007.
- 3,353,558. LIFESTYLESEXPO AND DESIGN. INT. CLS. 16, 35 AND 41. REG. 12-11-2007.
- 3,353,559. MARGARITAVILLE STANDARD CHARACTER MARK. INT. CL. 20. REG. 12-11-2007.
- 3,353,560. GLASSTONE STANDARD CHARACTER MARK. INT. CL. 19. REG. 12-11-2007.
- 3,353,561. DURAPUFF STANDARD CHARACTER MARK. INT. CL. 11. REG. 12-11-2007.
- 3,353,562. SELLSIUS STANDARD CHARACTER MARK. INT. CL. 36. REG. 12-11-2007.
- 3,353,563. CNX GAS AND DESIGN. INT. CL. 42. REG. 12-11-2007.
- 3,353,564. INNOVATIVE SPINAL TECHNOLOGIES STANDARD CHARACTER MARK. INT. CL. 10. REG. 12-11-2007.
- 3,353,565. WITCHES IN BIKINIS STANDARD CHARACTER MARK. INT. CL. 41. REG. 12-11-2007.
- 3,353,567. THE CLICK LIST STANDARD CHARACTER MARK. INT. CL. 41. REG. 12-11-2007.
- 3,353,568. HUNTING CAMP AND DESIGN. INT. CL. 29. REG. 12-11-2007.
- 3,353,569. TLOAC AND DESIGN. INT. CL. 3. REG. 12-11-2007.
- 3,353,570. ADF AND DESIGN. INT. CLS. 29 AND 30. REG. 12-11-2007.
- 3,353,571. DRINK'IN STANDARD CHARACTER MARK. INT. CL. 33. REG. 12-11-2007.
- 3,353,572. MONSTER STANDARD CHARACTER MARK. INT. CL. 3. REG. 12-11-2007.
- 3,353,573. STUDY POD STANDARD CHARACTER MARK. INT. CL. 16. REG. 12-11-2007.
- 3,353,575. BO JACKSON BO (STYLIZED). INT. CL. 29. REG. 12-11-2007.
- 3,353,576. EMPOWER MINT STANDARD CHARACTER MARK. INT. CL. 3. REG. 12-11-2007.
- 3,353,578. HUMI-RID STANDARD CHARACTER MARK. INT. CL. 11. REG. 12-11-2007.
- 3,353,579. ABSOLUTELY IRRESISTIBLE STANDARD CHARACTER MARK. INT. CL. 30. REG. 12-11-2007.
- 3,353,581. DUOTRIM STANDARD CHARACTER MARK. INT. CL. 16. REG. 12-11-2007.
- 3,353,586. ENLACE SPANISH YELLOW PAGES AND DESIGN. INT. CL. 16. REG. 12-11-2007.
- 3,353,589. GRIFFIN AND DESIGN. INT. CL. 35. REG. 12-11-2007.
- 3,353,590. PROVEN. RELIABLE. UNMISTAKABLY ALTRO-NIX – THE POWER BEHIND THE NAME STANDARD CHARACTER MARK. INT. CL. 42. REG. 12-11-2007.
- 3,353,591. ALTRONIX – THE POWER BEHIND THE NAME STANDARD CHARACTER MARK. INT. CLS. 40 AND 42. REG. 12-11-2007.
- 3,353,597. STEAM YOUR BLING STANDARD CHARACTER MARK. INT. CL. 21. REG. 12-11-2007.
- 3,353,599. TRAVELLINK STANDARD CHARACTER MARK. INT. CL. 9. REG. 12-11-2007.
- 3,353,600. BETSTATION STANDARD CHARACTER MARK. INT. CL. 9. REG. 12-11-2007.
- 3,353,601. LONG TOURING STANDARD CHARACTER MARK. INT. CL. 12. REG. 12-11-2007.
- 3,353,602. MISCELLANEOUS DESIGN. INT. CL. 30. REG. 12-11-2007.
- 3,353,603. DRAMA WORLD STANDARD CHARACTER MARK. INT. CL. 25. REG. 12-11-2007.
- 3,353,605. CHESAPEAKE BAY AND DESIGN. INT. CLS. 20 AND 28. REG. 12-11-2007.
- 3,353,610. ERECTOR XL STANDARD CHARACTER MARK. INT. CL. 5. REG. 12-11-2007.
- 3,353,613. COMMANDPOINT AND DESIGN. INT. CL. 9. REG. 12-11-2007.

- 3,353,614. SUMMER FROST STANDARD CHARACTER MARK. INT. CL. 5. REG. 12-11-2007.
- 3,353,617. SPA EXPERIENCES FROM THE BRITTANY COAST OF FRANCE STANDARD CHARACTER MARK. INT. CLS. 3 AND 35. REG. 12-11-2007.
- 3,353,618. ENSAGA STANDARD CHARACTER MARK. INT. CL. 42. REG. 12-11-2007.
- 3,353,620. CONTINUITY IN AN UNCERTAIN WORLD STANDARD CHARACTER MARK. INT. CL. 36. REG. 12-11-2007.
- 3,353,621. PINSTRIPE RECORDS STANDARD CHARACTER MARK. INT. CL. 9. REG. 12-11-2007.
- 3,353,624. SWITCH STANDARD CHARACTER MARK. INT. CL. 9. REG. 12-11-2007.
- 3,353,625. H-E-B SHOWTIME STANDARD CHARACTER MARK. INT. CL. 41. REG. 12-11-2007.
- 3,353,628. AROMA FRESH STANDARD CHARACTER MARK. INT. CL. 30. REG. 12-11-2007.
- 3,353,629. SMARTRAIL AND DESIGN. INT. CL. 19. REG. 12-11-2007.
- 3,353,631. WATER WITH A PURPOSE STANDARD CHARACTER MARK. INT. CL. 5. REG. 12-11-2007.
- 3,353,633. WHERE SERVICE MEETS STYLE STANDARD CHARACTER MARK. INT. CL. 44. REG. 12-11-2007.
- 3,353,634. IBLAST STANDARD CHARACTER MARK. INT. CL. 9. REG. 12-11-2007.
- 3,353,637. DACORE STANDARD CHARACTER MARK. INT. CL. 35. REG. 12-11-2007.
- 3,353,641. DRAMA LOUNGE STANDARD CHARACTER MARK. INT. CL. 41. REG. 12-11-2007.
- 3,353,645. MISCELLANEOUS DESIGN. INT. CL. 2. REG. 12-11-2007.
- 3,353,651. AMERICAN CHANG AND DESIGN. INT. CL. 25. REG. 12-11-2007.
- 3,353,654. STOUT STANDARD CHARACTER MARK. INT. CL. 5. REG. 12-11-2007.
- 3,353,655. ACCESS GROWTH STANDARD CHARACTER MARK. INT. CL. 35. REG. 12-11-2007.
- 3,353,657. ONE NAPA PLACE STANDARD CHARACTER MARK. INT. CL. 37. REG. 12-11-2007.
- 3,353,658. WELLAstrate STANDARD CHARACTER MARK. INT. CL. 3. REG. 12-11-2007.
- 3,353,660. FOCALYST STANDARD CHARACTER MARK. INT. CLS. 16, 35 AND 41. REG. 12-11-2007.
- 3,353,670. SAUCE FREE STANDARD CHARACTER MARK. INT. CL. 25. REG. 12-11-2007.
- 3,353,674. SWEEZIEL GALOUPS' FINE DELECTABLES (STYLIZED). INT. CLS. 29 AND 30. REG. 12-11-2007.
- 3,353,677. SKY SOUL MUSIC AND DESIGN. INT. CL. 9. REG. 12-11-2007.
- 3,353,678. SKY HITS STANDARD CHARACTER MARK. INT. CL. 9. REG. 12-11-2007.
- 3,353,680. ...FOR A WORLD THAT IS WAITING. STANDARD CHARACTER MARK. INT. CL. 44. REG. 12-11-2007.
- 3,353,682. CAPTAIN'S RESERVE STANDARD CHARACTER MARK. INT. CL. 33. REG. 12-11-2007.
- 3,353,690. VOLTRON AND DESIGN. INT. CL. 17. REG. 12-11-2007.
- 3,353,691. VOLTRON AND DESIGN. INT. CL. 22. REG. 12-11-2007.
- 3,353,692. LUMINESCENT STANDARD CHARACTER MARK. INT. CLS. 3 AND 5. REG. 12-11-2007.
- 3,353,693. UMS AND DESIGN. INT. CL. 35. REG. 12-11-2007.
- 3,353,694. MISCELLANEOUS DESIGN. INT. CLS. 9, 41 AND 42. REG. 12-11-2007.
- 3,353,695. FIGURE EIGHT 8 VANISH (STYLIZED). INT. CL. 3. REG. 12-11-2007.
- 3,353,696. HWANGTOEBANG OAKDOL CHIMDAE AND DESIGN. INT. CL. 20. REG. 12-11-2007.
- 3,353,697. ORGANIC PIONEERS STANDARD CHARACTER MARK. INT. CLS. 18, 24 AND 25. REG. 12-11-2007.
- 3,353,698. PROPER HABITAT STANDARD CHARACTER MARK. INT. CL. 25. REG. 12-11-2007.
- 3,353,699. SAN FRANCISCO DRAGONS STANDARD CHARACTER MARK. INT. CL. 25. REG. 12-11-2007.
- 3,353,703. HIPGRIP STANDARD CHARACTER MARK. INT. CL. 9. REG. 12-11-2007.
- 3,353,706. MOUNTAIN DEW CODE RED AND DESIGN. INT. CL. 3. REG. 12-11-2007.
- 3,353,707. HERB'S AND DESIGN. INT. CL. 33. REG. 12-11-2007.
- 3,353,708. HERB'S AND DESIGN. INT. CL. 33. REG. 12-11-2007.
- 3,353,709. HERB'S AND DESIGN. INT. CL. 33. REG. 12-11-2007.
- 3,353,710. HERB'S AND DESIGN. INT. CL. 33. REG. 12-11-2007.
- 3,353,712. BUILDING BUSINESS COMMUNITIES FOR SUCCESS STANDARD CHARACTER MARK. INT. CLS. 36, 37 AND 42. REG. 12-11-2007.
- 3,353,713. FLAVOR & HEAT IN HARMONY STANDARD CHARACTER MARK. INT. CL. 30. REG. 12-11-2007.
- 3,353,714. MAGIC MAKEOVER STANDARD CHARACTER MARK. INT. CL. 28. REG. 12-11-2007.
- 3,353,715. LEVER 2000 VASELINE AND DESIGN. INT. CL. 3. REG. 12-11-2007.
- 3,353,718. CIERGE STANDARD CHARACTER MARK. INT. CLS. 39 AND 43. REG. 12-11-2007.
- 3,353,720. POP-DELIC STANDARD CHARACTER MARK. INT. CL. 25. REG. 12-11-2007.
- 3,353,721. INSUL SORB STANDARD CHARACTER MARK. INT. CL. 17. REG. 12-11-2007.
- 3,353,722. MAURICE M STANDARD CHARACTER MARK. INT. CL. 14. REG. 12-11-2007.
- 3,353,724. EI ELECTRIC INTERNET AND DESIGN. INT. CL. 38. REG. 12-11-2007.
- 3,353,725. HOME CONVENIENCE SOLUTIONS STANDARD CHARACTER MARK. INT. CL. 42. REG. 12-11-2007.
- 3,353,729. SHOUSHAN STANDARD CHARACTER MARK. INT. CL. 25. REG. 12-11-2007.
- 3,353,733. MYGAMEROOM STANDARD CHARACTER MARK. INT. CL. 41. REG. 12-11-2007.
- 3,353,738. INTASOLRX SOLUTIONS STANDARD CHARACTER MARK. INT. CL. 35. REG. 12-11-2007.
- 3,353,743. HOBOKEN FLOORS STANDARD CHARACTER MARK. INT. CL. 19. REG. 12-11-2007.
- 3,353,746. BOUTIQUE BRONZE CAMOUFLAGE STANDARD CHARACTER MARK. INT. CL. 3. REG. 12-11-2007.
- 3,353,747. NEW JERSEY PRIDE AND DESIGN. INT. CL. 25. REG. 12-11-2007.
- 3,353,748. CAESAR SENSATION STANDARD CHARACTER MARK. INT. CL. 30. REG. 12-11-2007.
- 3,353,749. LA RIPTIDE AND DESIGN. INT. CL. 25. REG. 12-11-2007.
- 3,353,750. LA AND DESIGN. INT. CL. 41. REG. 12-11-2007.
- 3,353,754. CUSTOM INSPECTOR AND DESIGN. INT. CL. 9. REG. 12-11-2007.
- 3,353,765. THE BERRIES STANDARD CHARACTER MARK. INT. CL. 9. REG. 12-11-2007.
- 3,353,766. PMI CERTIFIED OPM3 CONSULTANT STANDARD CHARACTER MARK. U.S. CL. B. REG. 12-11-2007.
- 3,353,768. NAPA GIRL STANDARD CHARACTER MARK. INT. CL. 33. REG. 12-11-2007.
- 3,353,769. I'M IN STANDARD CHARACTER MARK. INT. CLS. 39 AND 43. REG. 12-11-2007.
- 3,353,774. BRITENOTE STANDARD CHARACTER MARK. INT. CL. 16. REG. 12-11-2007.
- 3,353,780. DISTANCE DRIVEN GEOMETRY STANDARD CHARACTER MARK. INT. CL. 28. REG. 12-11-2007.
- 3,353,781. LIPIDSHIELD STANDARD CHARACTER MARK. INT. CL. 5. REG. 12-11-2007.
- 3,353,782. SEIDMAN WEALTHLIX STANDARD CHARACTER MARK. INT. CL. 36. REG. 12-11-2007.
- 3,353,786. 12 GAUGE STANDARD CHARACTER MARK. INT. CL. 9. REG. 12-11-2007.

- 3,353,787. THE BEST CHANCE TO WIN. STANDARD CHARACTER MARK. INT. CL. 41. REG. 12-11-2007.
- 3,353,789. UNIVERSAL SOLUTIONS STYLING O BOTI-CÁRIO STANDARD CHARACTER MARK. INT. CL. 3. REG. 12-11-2007.
- 3,353,790. STARFALL STANDARD CHARACTER MARK. INT. CL. 34. REG. 12-11-2007.
- 3,353,791. BOLOTO GROUP STANDARD CHARACTER MARK. INT. CL. 36. REG. 12-11-2007.
- 3,353,792. BMAIL STANDARD CHARACTER MARK. INT. CL. 38. REG. 12-11-2007.
- 3,353,793. PROTONMEDIA STANDARD CHARACTER MARK. INT. CLS. 9 AND 42. REG. 12-11-2007.
- 3,353,794. PROTONMEDIA AND DESIGN. INT. CLS. 9 AND 42. REG. 12-11-2007.
- 3,353,795. RACE AND CHASE STANDARD CHARACTER MARK. INT. CL. 28. REG. 12-11-2007.
- 3,353,799. SPOGA4KIDS STANDARD CHARACTER MARK. INT. CL. 9. REG. 12-11-2007.
- 3,353,802. AGE RETALIATOR STANDARD CHARACTER MARK. INT. CL. 3. REG. 12-11-2007.
- 3,353,810. TPOTD STANDARD CHARACTER MARK. INT. CL. 41. REG. 12-11-2007.
- 3,353,812. FUEL FOR THE FIGHT STANDARD CHARACTER MARK. INT. CL. 36. REG. 12-11-2007.
- 3,353,813. SQUADRA PILOTI STANDARD CHARACTER MARK. INT. CL. 38. REG. 12-11-2007.
- 3,353,814. EXPANDEX MODIFIED TAPIOCA STARCH AND DESIGN. INT. CL. 30. REG. 12-11-2007.
- 3,353,815. IC-UC QUICK SIGHT STANDARD CHARACTER MARK. INT. CL. 9. REG. 12-11-2007.
- 3,353,817. MY BROWNSKIN STANDARD CHARACTER MARK. INT. CL. 35. REG. 12-11-2007.
- 3,353,818. SMART AND DESIGN. INT. CL. 35. REG. 12-11-2007.
- 3,353,824. PARENTAL CONTROL OUR RIGHT. OUR RESPONSIBILITY. AND DESIGN. INT. CL. 35. REG. 12-11-2007.
- 3,353,825. MISCELLANEOUS DESIGN. INT. CLS. 41 AND 44. REG. 12-11-2007.
- 3,353,826. PILLS FOR PENNIES AND DESIGN. INT. CL. 35. REG. 12-11-2007.
- 3,353,827. LINGUANET STANDARD CHARACTER MARK. INT. CLS. 38 AND 41. REG. 12-11-2007.
- 3,353,828. SYNERGY STANDARD CHARACTER MARK. INT. CL. 35. REG. 12-11-2007.
- 3,353,829. ACTIVE IRON MANAGEMENT STANDARD CHARACTER MARK. INT. CL. 44. REG. 12-11-2007.
- 3,353,831. CHOP UP STANDARD CHARACTER MARK. INT. CL. 41. REG. 12-11-2007.
- 3,353,835. ENERGY EFFICIENT STANDARD CHARACTER MARK. INT. CL. 3. REG. 12-11-2007.
- 3,353,836. BLUEQ STANDARD CHARACTER MARK. INT. CL. 9. REG. 12-11-2007.
- 3,353,837. HILLSIDE STANDARD CHARACTER MARK. INT. CLS. 29 AND 30. REG. 12-11-2007.
- 3,353,838. MISCELLANEOUS DESIGN. INT. CL. 29. REG. 12-11-2007.
- 3,353,839. MISCELLANEOUS DESIGN. INT. CL. 30. REG. 12-11-2007.
- 3,353,840. SET TILE SPACER (STYLIZED). INT. CL. 19. REG. 12-11-2007.
- 3,353,841. COMFORT STRETCH STANDARD CHARACTER MARK. INT. CL. 25. REG. 12-11-2007.
- 3,353,842. BABY BIBLE WEAR STANDARD CHARACTER MARK. INT. CL. 25. REG. 12-11-2007.
- 3,353,849. REVENUE CATALYST STANDARD CHARACTER MARK. INT. CL. 35. REG. 12-11-2007.
- 3,353,851. RMJ LABORATORIES, INC. AND DESIGN. INT. CL. 42. REG. 12-11-2007.
- 3,353,853. BOLOTO CONNECTION STANDARD CHARACTER MARK. INT. CL. 45. REG. 12-11-2007.
- 3,353,854. GEAR GRIP STANDARD CHARACTER MARK. INT. CL. 8. REG. 12-11-2007.
- 3,353,857. SALT STANDARD CHARACTER MARK. INT. CL. 9. REG. 12-11-2007.
- 3,353,859. SOLARA UV2 STANDARD CHARACTER MARK. INT. CL. 9. REG. 12-11-2007.
- 3,353,860. MALECRYSTALBALL STANDARD CHARACTER MARK. INT. CLS. 9 AND 41. REG. 12-11-2007.
- 3,353,864. ELITE CINEMA STANDARD CHARACTER MARK. INT. CL. 9. REG. 12-11-2007.
- 3,353,865. MAGICAL INNOVATIONS INC. STANDARD CHARACTER MARK. INT. CL. 42. REG. 12-11-2007.
- 3,353,867. JUMP TRITON COLLECTION (STYLIZED). INT. CL. 18. REG. 12-11-2007.
- 3,353,868. MISCELLANEOUS DESIGN. INT. CL. 33. REG. 12-11-2007.
- 3,353,869. WHERE ARE YOU GOING? STANDARD CHARACTER MARK. INT. CL. 43. REG. 12-11-2007.
- 3,353,870. KNOW MORE. CHOOSE WELL. FEEL BETTER. STANDARD CHARACTER MARK. INT. CL. 44. REG. 12-11-2007.
- 3,353,871. QUIET LAVENDER WHISPER STANDARD CHARACTER MARK. INT. CL. 5. REG. 12-11-2007.
- 3,353,875. WE NEVER FAIL WHEN IT COMES TO MAIL STANDARD CHARACTER MARK. INT. CL. 35. REG. 12-11-2007.
- 3,353,877. ANGEL HANDS STANDARD CHARACTER MARK. INT. CL. 10. REG. 12-11-2007.
- 3,353,878. FOOTIME STANDARD CHARACTER MARK. INT. CL. 9. REG. 12-11-2007.
- 3,353,879. THE OK ETHICS COMPASS AWARD AND DESIGN. INT. CL. 41. REG. 12-11-2007.
- 3,353,880. TIME OUT CHICAGO STUDENT GUIDE STANDARD CHARACTER MARK. INT. CL. 16. REG. 12-11-2007.
- 3,353,881. EZ CLIP STANDARD CHARACTER MARK. INT. CL. 20. REG. 12-11-2007.
- 3,353,887. HACKER TOPCOAT STANDARD CHARACTER MARK. INT. CL. 19. REG. 12-11-2007.
- 3,353,888. AMAZING BUG SPRAY STANDARD CHARACTER MARK. INT. CL. 5. REG. 12-11-2007.
- 3,353,889. VAMONOS STANDARD CHARACTER MARK. INT. CL. 16. REG. 12-11-2007.
- 3,353,890. MASQUE DIVINA STANDARD CHARACTER MARK. INT. CL. 3. REG. 12-11-2007.
- 3,353,894. ASIAN MEALS TRULY ASIAN! AND DESIGN. INT. CL. 30. REG. 12-11-2007.
- 3,353,896. SPOONBEND STANDARD CHARACTER MARK. INT. CL. 35. REG. 12-11-2007.
- 3,353,898. SPOUSAL ASSETACCESS STANDARD CHARACTER MARK. INT. CL. 36. REG. 12-11-2007.
- 3,353,900. DURATONE STANDARD CHARACTER MARK. INT. CL. 2. REG. 12-11-2007.
- 3,353,901. ARCHITEK BY HOWARD STANDARD CHARACTER MARK. INT. CL. 21. REG. 12-11-2007.
- 3,353,906. VENETIAN BLENDS STANDARD CHARACTER MARK. INT. CL. 3. REG. 12-11-2007.
- 3,353,907. AFFETTATI STANDARD CHARACTER MARK. INT. CL. 29. REG. 12-11-2007.
- 3,353,911. CASCADA STANDARD CHARACTER MARK. INT. CL. 13. REG. 12-11-2007.
- 3,353,912. COUTURE WITHIN STANDARD CHARACTER MARK. INT. CL. 25. REG. 12-11-2007.
- 3,353,916. V-LOCK STANDARD CHARACTER MARK. INT. CL. 9. REG. 12-11-2007.
- 3,353,917. INTIMATES WITH INSIGHT STANDARD CHARACTER MARK. INT. CL. 25. REG. 12-11-2007.
- 3,353,918. ENVYCHIC AND DESIGN. INT. CL. 25. REG. 12-11-2007.
- 3,353,923. DEBRIS-FREE STANDARD CHARACTER MARK. INT. CL. 20. REG. 12-11-2007.
- 3,353,926. R HANG UPS STANDARD CHARACTER MARK. INT. CLS. 6 AND 20. REG. 12-11-2007.
- 3,353,928. OPMEM STANDARD CHARACTER MARK. INT. CL. 9. REG. 12-11-2007.
- 3,353,930. MISCELLANEOUS DESIGN. INT. CLS. 14, 18, 24, 25 AND 28. REG. 12-11-2007.

- 3,353,932. SUPERWAVE STANDARD CHARACTER MARK. INT. CL. 7. REG. 12-11-2007.
- 3,353,934. PRIMA (STYLIZED). INT. CL. 9. REG. 12-11-2007.
- 3,353,938. WE'VE GOT YOU COVERED STANDARD CHARACTER MARK. INT. CL. 36. REG. 12-11-2007.
- 3,353,941. BIG. BOLD. CONFIDENT. BEAUTIFUL. STANDARD CHARACTER MARK. INT. CL. 16. REG. 12-11-2007.
- 3,353,946. CURVITECTURE STANDARD CHARACTER MARK. INT. CL. 42. REG. 12-11-2007.
- 3,353,948. CRYPTTEGRITY AND DESIGN. INT. CL. 9. REG. 12-11-2007.
- 3,353,951. FLIRTTITUDE STANDARD CHARACTER MARK. INT. CL. 25. REG. 12-11-2007.
- 3,353,952. JASON & LARRY'S STANDARD CHARACTER MARK. INT. CL. 33. REG. 12-11-2007.
- 3,353,953. GUSANITO STANDARD CHARACTER MARK. INT. CLS. 14, 16, 18, 25 AND 28. REG. 12-11-2007.
- 3,353,954. SKINJOY AND DESIGN. INT. CL. 25. REG. 12-11-2007.
- 3,353,955. JACK TARR STANDARD CHARACTER MARK. INT. CL. 33. REG. 12-11-2007.
- 3,353,956. CLOSET TAILORS STANDARD CHARACTER MARK. INT. CL. 35. REG. 12-11-2007.
- 3,353,957. CLOSET TAILORS AND DESIGN. INT. CL. 35. REG. 12-11-2007.
- 3,353,958. SURGICARE STANDARD CHARACTER MARK. INT. CL. 25. REG. 12-11-2007.
- 3,353,959. CACHET STANDARD CHARACTER MARK. INT. CL. 33. REG. 12-11-2007.
- 3,353,960. MACEXPERIENCE STANDARD CHARACTER MARK. INT. CL. 38. REG. 12-11-2007.
- 3,353,963. FENOMENAL STANDARD CHARACTER MARK. INT. CL. 16. REG. 12-11-2007.
- 3,353,964. GALA GOURMET STANDARD CHARACTER MARK. INT. CL. 29. REG. 12-11-2007.
- 3,353,966. SLICE OF LIFE STANDARD CHARACTER MARK. INT. CL. 35. REG. 12-11-2007.
- 3,353,967. IAC AND DESIGN. INT. CLS. 9, 37 AND 42. REG. 12-11-2007.
- 3,353,970. HATTEY BUILT STANDARD CHARACTER MARK. INT. CL. 25. REG. 12-11-2007.
- 3,353,972. WELL MATE STANDARD CHARACTER MARK. INT. CL. 12. REG. 12-11-2007.
- 3,353,974. EASYCENTER STANDARD CHARACTER MARK. INT. CL. 35. REG. 12-11-2007.
- 3,353,977. STARDUST STANDARD CHARACTER MARK. INT. CL. 11. REG. 12-11-2007.
- 3,353,981. NET-G3 STANDARD CHARACTER MARK. INT. CL. 9. REG. 12-11-2007.
- 3,353,982. THE KNITTING LAB STANDARD CHARACTER MARK. INT. CL. 35. REG. 12-11-2007.
- 3,353,983. M (STYLIZED). INT. CL. 5. REG. 12-11-2007.
- 3,353,984. MISCELLANEOUS DESIGN. INT. CL. 33. REG. 12-11-2007.
- 3,353,985. THE TRUE FLAVORS OF MEXICO! STANDARD CHARACTER MARK. INT. CL. 43. REG. 12-11-2007.
- 3,353,986. E AND DESIGN. INT. CL. 42. REG. 12-11-2007.
- 3,353,987. NORTHCOURSE STANDARD CHARACTER MARK. INT. CLS. 35 AND 36. REG. 12-11-2007.
- 3,353,988. MISCELLANEOUS DESIGN. INT. CL. 35. REG. 12-11-2007.
- 3,353,989. X-BEAM STANDARD CHARACTER MARK. INT. CL. 8. REG. 12-11-2007.
- 3,353,994. CERALON STANDARD CHARACTER MARK. INT. CL. 9. REG. 12-11-2007.
- 3,353,996. PHYVE STANDARD CHARACTER MARK. INT. CLS. 35 AND 42. REG. 12-11-2007.
- 3,354,000. MDX STANDARD CHARACTER MARK. INT. CL. 36. REG. 12-11-2007.
- 3,354,002. MARKET DATA EXPRESS STANDARD CHARACTER MARK. INT. CL. 36. REG. 12-11-2007.
- 3,354,003. COLLECTIDOLL STANDARD CHARACTER MARK. INT. CL. 28. REG. 12-11-2007.
- 3,354,004. FAT LOSERS STANDARD CHARACTER MARK. INT. CL. 9. REG. 12-11-2007.
- 3,354,005. 2B COLORFUL STANDARD CHARACTER MARK. INT. CL. 28. REG. 12-11-2007.
- 3,354,007. GRACIAS STANDARD CHARACTER MARK. INT. CL. 16. REG. 12-11-2007.
- 3,354,009. I FISH, IT HAPPENS STANDARD CHARACTER MARK. INT. CL. 16. REG. 12-11-2007.
- 3,354,011. OMNIVANT STANDARD CHARACTER MARK. INT. CL. 42. REG. 12-11-2007.
- 3,354,012. LIFE EVENTS LEGAL PLAN STANDARD CHARACTER MARK. INT. CL. 36. REG. 12-11-2007.
- 3,354,013. CHUGLIFE X AND DESIGN. INT. CL. 25. REG. 12-11-2007.
- 3,354,014. MILLER REACHING OUT STANDARD CHARACTER MARK. INT. CL. 35. REG. 12-11-2007.
- 3,354,020. DEFIENT (STYLIZED). INT. CL. 41. REG. 12-11-2007.
- 3,354,021. PACIFIC MIST STANDARD CHARACTER MARK. INT. CL. 44. REG. 12-11-2007.
- 3,354,022. HOBOKENFLOORS ADVANTAGE AND DESIGN. INT. CL. 35. REG. 12-11-2007.
- 3,354,023. LIVE A GIANT LIFE STANDARD CHARACTER MARK. INT. CL. 36. REG. 12-11-2007.
- 3,354,025. AMBIOSYSTEMS STANDARD CHARACTER MARK. INT. CL. 9. REG. 12-11-2007.
- 3,354,026. HULI SUES STANDARD CHARACTER MARK. INT. CL. 43. REG. 12-11-2007.
- 3,354,027. MAXEXP STANDARD CHARACTER MARK. INT. CL. 9. REG. 12-11-2007.
- 3,354,028. LIFESHADES STANDARD CHARACTER MARK. INT. CL. 11. REG. 12-11-2007.
- 3,354,032. CHILLSTREAM STANDARD CHARACTER MARK. INT. CL. 9. REG. 12-11-2007.
- 3,354,033. INVEST WHERE YOU SPEND STANDARD CHARACTER MARK. INT. CL. 36. REG. 12-11-2007.
- 3,354,034. CONNECTORING STANDARD CHARACTER MARK. INT. CL. 41. REG. 12-11-2007.
- 3,354,035. JOBEXPRESS STANDARD CHARACTER MARK. INT. CL. 42. REG. 12-11-2007.
- 3,354,037. MADE WITH MAXX MAXIMIZES ABSORBENCY. MINIMIZES WASTE. SPC AND DESIGN. INT. CL. 17. REG. 12-11-2007.
- 3,354,038. THE TOP GYM STANDARD CHARACTER MARK. INT. CL. 41. REG. 12-11-2007.
- 3,354,040. WHERE JUSTICE BEGINS FOR YOU AND YOUR FAMILY STANDARD CHARACTER MARK. INT. CL. 42. REG. 12-11-2007.
- 3,354,041. ADMIRATION STANDARD CHARACTER MARK. INT. CL. 11. REG. 12-11-2007.
- 3,354,042. AMMAT STANDARD CHARACTER MARK. INT. CL. 35. REG. 12-11-2007.
- 3,354,043. TIME FOR ME SKINPHORIA STANDARD CHARACTER MARK. INT. CL. 35. REG. 12-11-2007.
- 3,354,046. TCS ICEFLOW STANDARD CHARACTER MARK. INT. CL. 1. REG. 12-11-2007.
- 3,354,049. LX STANDARD CHARACTER MARK. INT. CL. 10. REG. 12-11-2007.
- 3,354,050. HEART SISTERS STANDARD CHARACTER MARK. INT. CL. 45. REG. 12-11-2007.
- 3,354,052. OUTLAND RESEARCH STANDARD CHARACTER MARK. INT. CL. 42. REG. 12-11-2007.
- 3,354,053. BABY ME FOREVER STANDARD CHARACTER MARK. INT. CL. 35. REG. 12-11-2007.
- 3,354,060. THE NEW WAY TO PHONE STANDARD CHARACTER MARK. INT. CL. 38. REG. 12-11-2007.
- 3,354,063. IMPORTANT OCCASIONS.COM AND DESIGN. INT. CL. 45. REG. 12-11-2007.
- 3,354,064. FANTASISTA STANDARD CHARACTER MARK. INT. CL. 28. REG. 12-11-2007.
- 3,354,066. TURBO-BOOSTER STANDARD CHARACTER MARK. INT. CL. 10. REG. 12-11-2007.
- 3,354,068. MALAVA STANDARD CHARACTER MARK. INT. CLS. 30 AND 32. REG. 12-11-2007.
- 3,354,069. MARSHALL GOLF STANDARD CHARACTER MARK. INT. CL. 28. REG. 12-11-2007.

- 3,354,070. FRIENDS ARE A TRIP STANDARD CHARACTER MARK. INT. CLS. 38 AND 39. REG. 12-11-2007.
- 3,354,071. MI ANGELITO POMADA POMPIS STANDARD CHARACTER MARK. INT. CL. 5. REG. 12-11-2007.
- 3,354,072. U.S. READING TEAM STANDARD CHARACTER MARK. INT. CL. 25. REG. 12-11-2007.
- 3,354,073. KID SAVAGE STANDARD CHARACTER MARK. INT. CL. 9. REG. 12-11-2007.
- 3,354,076. COCONUT CHARLIE'S PET DIRECTORY STANDARD CHARACTER MARK. INT. CL. 35. REG. 12-11-2007.
- 3,354,077. WATERSTIK STANDARD CHARACTER MARK. INT. CL. 16. REG. 12-11-2007.
- 3,354,080. RYZAS STANDARD CHARACTER MARK. INT. CL. 25. REG. 12-11-2007.
- 3,354,082. SPIRE STANDARD CHARACTER MARK. INT. CL. 39. REG. 12-11-2007.
- 3,354,083. SPIRE STANDARD CHARACTER MARK. INT. CL. 43. REG. 12-11-2007.
- 3,354,084. THE BAYER DREAM FUND STANDARD CHARACTER MARK. INT. CL. 36. REG. 12-11-2007.
- 3,354,085. MISCELLANEOUS DESIGN. INT. CL. 42. REG. 12-11-2007.
- 3,354,086. 1 DAWG STANDARD CHARACTER MARK. INT. CL. 42. REG. 12-11-2007.
- 3,354,087. INTERNET MEDIA UNLEASHED STANDARD CHARACTER MARK. INT. CL. 42. REG. 12-11-2007.
- 3,354,088. 1 DAWG AND DESIGN. INT. CL. 42. REG. 12-11-2007.
- 3,354,089. EP STANDARD CHARACTER MARK. INT. CL. 28. REG. 12-11-2007.
- 3,354,090. LVCG AND DESIGN. INT. CL. 16. REG. 12-11-2007.
- 3,354,091. LIENA BAY STANDARD CHARACTER MARK. INT. CL. 11. REG. 12-11-2007.
- 3,354,093. STERITEX STANDARD CHARACTER MARK. INT. CL. 10. REG. 12-11-2007.
- 3,354,095. SALUGEN AND DESIGN. INT. CL. 5. REG. 12-11-2007.
- 3,354,096. SALUGEN STANDARD CHARACTER MARK. INT. CL. 5. REG. 12-11-2007.
- 3,354,097. GENOTRIM STANDARD CHARACTER MARK. INT. CL. 5. REG. 12-11-2007.
- 3,354,098. HEAD OF THE TRAIL STANDARD CHARACTER MARK. INT. CL. 39. REG. 12-11-2007.
- 3,354,099. THE GIVING ZONE STANDARD CHARACTER MARK. INT. CL. 9. REG. 12-11-2007.
- 3,354,102. HEALTHY REWARDS IT'S MORE THAN JUST A TREAT AND DESIGN. INT. CL. 31. REG. 12-11-2007.
- 3,354,105. PSIGURU 2 IN 1 PRESET REGULATOR POWER SYSTEM STANDARD CHARACTER MARK. INT. CL. 9. REG. 12-11-2007.
- 3,354,108. RUNNIN' WILD RENEGADES AND DESIGN. INT. CL. 41. REG. 12-11-2007.
- 3,354,110. REGENCY MERCHANT SOLUTIONS STANDARD CHARACTER MARK. INT. CL. 36. REG. 12-11-2007.
- 3,354,111. SECURITY FROM ABOVE STANDARD CHARACTER MARK. INT. CL. 20. REG. 12-11-2007.
- 3,354,112. POPVASE STANDARD CHARACTER MARK. INT. CL. 21. REG. 12-11-2007.
- 3,354,113. LUNA DE MIEL HONEYMOON STANDARD CHARACTER MARK. INT. CL. 33. REG. 12-11-2007.
- 3,354,114. REDSHIFT VENTURES STANDARD CHARACTER MARK. INT. CL. 36. REG. 12-11-2007.
- 3,354,115. SKIN TINS STANDARD CHARACTER MARK. INT. CL. 6. REG. 12-11-2007.
- 3,354,117. SIN TIN STANDARD CHARACTER MARK. INT. CL. 6. REG. 12-11-2007.
- 3,354,121. LAGA AND DESIGN. INT. CL. 35. REG. 12-11-2007.
- 3,354,122. MEXQUEST STANDARD CHARACTER MARK. INT. CL. 36. REG. 12-11-2007.
- 3,354,123. MAURIZIO DISTEFANO...HAIR & MORE STANDARD CHARACTER MARK. INT. CL. 44. REG. 12-11-2007.
- 3,354,125. DREAMPOND STANDARD CHARACTER MARK. INT. CL. 11. REG. 12-11-2007.
- 3,354,126. BEEBOO BIG BUBBLE MIX AND DESIGN. INT. CL. 28. REG. 12-11-2007.
- 3,354,127. SEASONAL SKINCARE STANDARD CHARACTER MARK. INT. CLS. 3 AND 35. REG. 12-11-2007.
- 3,354,128. MADISON NATIONAL BANK STANDARD CHARACTER MARK. INT. CL. 36. REG. 12-11-2007.
- 3,354,130. SENSESUIT STANDARD CHARACTER MARK. INT. CL. 9. REG. 12-11-2007.
- 3,354,133. BATH BUNNY STANDARD CHARACTER MARK. INT. CLS. 3 AND 21. REG. 12-11-2007.
- 3,354,134. BATH BUNNY AND DESIGN. INT. CLS. 3 AND 21. REG. 12-11-2007.
- 3,354,139. NOT JUST ANY SUSHI, IT'S "HISSHO SUSHI" STANDARD CHARACTER MARK. INT. CL. 30. REG. 12-11-2007.
- 3,354,142. TWO IS THE ESSENCE OF ROMANCE STANDARD CHARACTER MARK. INT. CLS. 14 AND 35. REG. 12-11-2007.
- 3,354,143. IT TAKES TWO STANDARD CHARACTER MARK. INT. CLS. 14 AND 35. REG. 12-11-2007.
- 3,354,145. INSPIRED MADNESS STANDARD CHARACTER MARK. INT. CL. 3. REG. 12-11-2007.
- 3,354,146. COAUDIT STANDARD CHARACTER MARK. INT. CL. 42. REG. 12-11-2007.
- 3,354,147. ALTER YOUR EGO STANDARD CHARACTER MARK. INT. CL. 12. REG. 12-11-2007.
- 3,354,148. BEEBOO STANDARD CHARACTER MARK. INT. CL. 28. REG. 12-11-2007.
- 3,354,149. LUCKY BABIES STANDARD CHARACTER MARK. INT. CL. 9. REG. 12-11-2007.
- 3,354,151. SNEAKY PEAKY STANDARD CHARACTER MARK. INT. CL. 3. REG. 12-11-2007.
- 3,354,153. THE GIRLS HAVE IT STANDARD CHARACTER MARK. INT. CL. 3. REG. 12-11-2007.
- 3,354,154. WIRELESS ANGLER STANDARD CHARACTER MARK. INT. CL. 38. REG. 12-11-2007.
- 3,354,155. ZEDA STANDARD CHARACTER MARK. INT. CL. 3. REG. 12-11-2007.
- 3,354,156. TANGERINI TINI STANDARD CHARACTER MARK. INT. CL. 3. REG. 12-11-2007.
- 3,354,157. GRAPELICIOUS TINI STANDARD CHARACTER MARK. INT. CL. 3. REG. 12-11-2007.
- 3,354,159. TUTTI FRUTTI TINI STANDARD CHARACTER MARK. INT. CL. 3. REG. 12-11-2007.
- 3,354,161. ACTIVE READER STANDARD CHARACTER MARK. INT. CL. 16. REG. 12-11-2007.
- 3,354,163. IMMERSIMAP STANDARD CHARACTER MARK. INT. CL. 42. REG. 12-11-2007.
- 3,354,164. NIGELLE AX STANDARD CHARACTER MARK. INT. CL. 3. REG. 12-11-2007.
- 3,354,167. CLERK STANDARD CHARACTER MARK. INT. CL. 20. REG. 12-11-2007.
- 3,354,168. BANFIELD'S SEASON OF SUPPERS STANDARD CHARACTER MARK. INT. CL. 43. REG. 12-11-2007.
- 3,354,172. INVISIBLE ELEGANCE STANDARD CHARACTER MARK. INT. CL. 25. REG. 12-11-2007.
- 3,354,174. STEP 2 STANDARD CHARACTER MARK. INT. CL. 1. REG. 12-11-2007.
- 3,354,175. ENERGYTELE.COM STANDARD CHARACTER MARK. INT. CL. 9. REG. 12-11-2007.
- 3,354,176. LINCOLN BUTTERFIELD ANIMATION & PRODUCTION AND DESIGN. INT. CL. 41. REG. 12-11-2007.
- 3,354,177. DIARY OF A FOODIE STANDARD CHARACTER MARK. INT. CL. 43. REG. 12-11-2007.
- 3,354,179. COLLEGETODAY STANDARD CHARACTER MARK. INT. CL. 41. REG. 12-11-2007.
- 3,354,180. CAREER DISCOVERY MDY STANDARD CHARACTER MARK. INT. CL. 41. REG. 12-11-2007.

- 3,354,182. BRANDTRACE STANDARD CHARACTER MARK. INT. CL. 35. REG. 12-11-2007.
- 3,354,183. HANDWRITING DECODED STANDARD CHARACTER MARK. INT. CL. 9. REG. 12-11-2007.
- 3,354,184. WILD WILD 777 STANDARD CHARACTER MARK. INT. CL. 9. REG. 12-11-2007.
- 3,354,186. VETDEC STANDARD CHARACTER MARK. INT. CL. 41. REG. 12-11-2007.
- 3,354,187. RISE ABOVE 150X40 STANDARD CHARACTER MARK. INT. CL. 5. REG. 12-11-2007.
- 3,354,189. LIGHT BLASTER STANDARD CHARACTER MARK. INT. CL. 28. REG. 12-11-2007.
- 3,354,191. TUMMYWISE STANDARD CHARACTER MARK. INT. CL. 35. REG. 12-11-2007.
- 3,354,195. PUSHPOINT STANDARD CHARACTER MARK. INT. CLS. 9 AND 41. REG. 12-11-2007.
- 3,354,198. SOURCE OF LIFESTYLE STANDARD CHARACTER MARK. INT. CL. 5. REG. 12-11-2007.
- 3,354,199. OMG STANDARD CHARACTER MARK. INT. CL. 41. REG. 12-11-2007.
- 3,354,200. JADE LOUNGE STANDARD CHARACTER MARK. INT. CL. 25. REG. 12-11-2007.
- 3,354,201. DONT GO AROUND THIRSTY STANDARD CHARACTER MARK. INT. CL. 32. REG. 12-11-2007.
- 3,354,203. MASS DISTRACTION STANDARD CHARACTER MARK. INT. CL. 35. REG. 12-11-2007.
- 3,354,204. MASS DISTRACTION STANDARD CHARACTER MARK. INT. CL. 41. REG. 12-11-2007.
- 3,354,205. SELL RIGHT. RETIRE WELL. STANDARD CHARACTER MARK. INT. CL. 35. REG. 12-11-2007.
- 3,354,207. CHUB CITY STANDARD CHARACTER MARK. INT. CL. 16. REG. 12-11-2007.
- 3,354,208. SMART BITES STANDARD CHARACTER MARK. INT. CL. 29. REG. 12-11-2007.
- 3,354,214. WE MAKE 'EM-YOU BAKE 'EM STANDARD CHARACTER MARK. INT. CL. 43. REG. 12-11-2007.
- 3,354,215. GREEN ONIONS SUPPLY AND DESIGN. INT. CL. 9. REG. 12-11-2007.
- 3,354,216. BRIGHTLINGS STANDARD CHARACTER MARK. INT. CL. 28. REG. 12-11-2007.
- 3,354,217. XYZZY PRESS STANDARD CHARACTER MARK. INT. CLS. 9, 16 AND 41. REG. 12-11-2007.
- 3,354,221. MARK 4 STANDARD CHARACTER MARK. INT. CL. 12. REG. 12-11-2007.
- 3,354,222. USE IT FOR GOOD STANDARD CHARACTER MARK. INT. CL. 9. REG. 12-11-2007.
- 3,354,223. USE IT FOR GOOD STANDARD CHARACTER MARK. INT. CL. 38. REG. 12-11-2007.
- 3,354,224. LET'S CRAM STANDARD CHARACTER MARK. INT. CL. 35. REG. 12-11-2007.
- 3,354,230. ANDO AND DESIGN. INT. CL. 25. REG. 12-11-2007.
- 3,354,232. ZONDAS STANDARD CHARACTER MARK. INT. CL. 29. REG. 12-11-2007.
- 3,354,234. QUARK FREEDOM STANDARD CHARACTER MARK. INT. CL. 25. REG. 12-11-2007.
- 3,354,235. CVN CARDIOSOURCE VIDEO NETWORK AND DESIGN. INT. CLS. 41 AND 44. REG. 12-11-2007.
- 3,354,236. NEW CURVED WIPERS ARE FLAT OUT BETTER STANDARD CHARACTER MARK. INT. CL. 12. REG. 12-11-2007.
- 3,354,239. NEVER SAY DIE STANDARD CHARACTER MARK. INT. CL. 25. REG. 12-11-2007.
- 3,354,240. BIO-SPONGE STANDARD CHARACTER MARK. INT. CL. 10. REG. 12-11-2007.
- 3,354,241. GUND FUN AND DESIGN. INT. CL. 28. REG. 12-11-2007.
- 3,354,242. ECO-CONDITIONER STANDARD CHARACTER MARK. INT. CL. 11. REG. 12-11-2007.
- 3,354,243. LIFECORE DENTAL STANDARD CHARACTER MARK. INT. CL. 10. REG. 12-11-2007.
- 3,354,244. LIFECORE DENTAL AND DESIGN. INT. CL. 10. REG. 12-11-2007.
- 3,354,246. GOODSHAPEDESIGN STANDARD CHARACTER MARK. INT. CL. 42. REG. 12-11-2007.
- 3,354,247. BIODNOL STANDARD CHARACTER MARK. INT. CLS. 4 AND 35. REG. 12-11-2007.
- 3,354,255. HOOPLOVE STANDARD CHARACTER MARK. INT. CL. 25. REG. 12-11-2007.
- 3,354,256. DENTAL ADVANTAGE AND DESIGN. INT. CL. 21. REG. 12-11-2007.
- 3,354,257. ROBERTS FAMILY DENTAL "HOW MAY WE BRIGHTEN YOUR SMILE?" AND DESIGN. INT. CL. 44. REG. 12-11-2007.
- 3,354,262. LIVEBOARD STANDARD CHARACTER MARK. INT. CL. 9. REG. 12-11-2007.
- 3,354,263. DELLA CRESTA STANDARD CHARACTER MARK. INT. CL. 33. REG. 12-11-2007.
- 3,354,264. I-TEC STANDARD CHARACTER MARK. INT. CL. 14. REG. 12-11-2007.
- 3,354,265. IN-TENSION STANDARD CHARACTER MARK. INT. CL. 20. REG. 12-11-2007.
- 3,354,266. THE MIX SHOPS STANDARD CHARACTER MARK. INT. CL. 36. REG. 12-11-2007.
- 3,354,269. THE FLOWERS THAT LAST A LIFETIME STANDARD CHARACTER MARK. INT. CL. 14. REG. 12-11-2007.
- 3,354,270. BLANKEAZE STANDARD CHARACTER MARK. INT. CL. 25. REG. 12-11-2007.
- 3,354,272. THE CHALLENGE IS ON! STANDARD CHARACTER MARK. INT. CL. 28. REG. 12-11-2007.
- 3,354,275. OPENWAY STANDARD CHARACTER MARK. INT. CL. 9. REG. 12-11-2007.
- 3,354,276. Q BANQUE AND DESIGN. INT. CL. 25. REG. 12-11-2007.
- 3,354,278. IV SCIENCE STANDARD CHARACTER MARK. INT. CL. 5. REG. 12-11-2007.
- 3,354,279. GO FIGURE STANDARD CHARACTER MARK. INT. CL. 25. REG. 12-11-2007.
- 3,354,280. CADORO (STYLIZED). INT. CL. 28. REG. 12-11-2007.
- 3,354,281. MY WHEEL STANDARD CHARACTER MARK. INT. CL. 28. REG. 12-11-2007.
- 3,354,282. CREW IN THE CROWD STANDARD CHARACTER MARK. INT. CL. 41. REG. 12-11-2007.
- 3,354,284. GO-TAINER AND DESIGN. INT. CL. 6. REG. 12-11-2007.
- 3,354,285. COHERENCE FROM CHAOS STANDARD CHARACTER MARK. INT. CLS. 35 AND 45. REG. 12-11-2007.
- 3,354,286. RAINFLOWER MIST STANDARD CHARACTER MARK. INT. CL. 3. REG. 12-11-2007.
- 3,354,288. HARDWARE NOW STANDARD CHARACTER MARK. INT. CLS. 6 AND 20. REG. 12-11-2007.
- 3,354,289. D.ATLANTIS STANDARD CHARACTER MARK. INT. CL. 14. REG. 12-11-2007.
- 3,354,291. JOB DESK STANDARD CHARACTER MARK. INT. CL. 20. REG. 12-11-2007.
- 3,354,292. MISCELLANEOUS DESIGN. INT. CLS. 30 AND 43. REG. 12-11-2007.
- 3,354,293. INSTA FLOSS AND DESIGN. INT. CL. 21. REG. 12-11-2007.
- 3,354,295. MYGIG STANDARD CHARACTER MARK. INT. CL. 9. REG. 12-11-2007.
- 3,354,296. RAVE CRM STANDARD CHARACTER MARK. INT. CL. 42. REG. 12-11-2007.
- 3,354,297. TWISTED CRUNCHY STANDARD CHARACTER MARK. INT. CL. 30. REG. 12-11-2007.
- 3,354,300. SPACE-METRICS DESIGN SOLUTIONS STANDARD CHARACTER MARK. INT. CL. 9. REG. 12-11-2007.
- 3,354,302. SUSSEX CLOCK WORKS STANDARD CHARACTER MARK. INT. CL. 14. REG. 12-11-2007.
- 3,354,303. NO MORE DUST STANDARD CHARACTER MARK. INT. CL. 3. REG. 12-11-2007.
- 3,354,304. SKYE BLUE STANDARD CHARACTER MARK. INT. CL. 41. REG. 12-11-2007.
- 3,354,306. TWISTED PUFFS STANDARD CHARACTER MARK. INT. CL. 30. REG. 12-11-2007.
- 3,354,308. STEADICAM ULTRA 2 (STYLIZED). INT. CL. 9. REG. 12-11-2007.



- 3,354,309. HAIRDO DO GREAT HAIR EVERY DAY STANDARD CHARACTER MARK. INT. CL. 26. REG. 12-11-2007.
- 3,354,311. WACHOVIA POSSIBILITIES REWARDS STANDARD CHARACTER MARK. INT. CLS. 35 AND 36. REG. 12-11-2007.
- 3,354,315. ADAPTIVEEYE STANDARD CHARACTER MARK. INT. CL. 9. REG. 12-11-2007.
- 3,354,316. ACADIA STANDARD CHARACTER MARK. INT. CL. 18. REG. 12-11-2007.
- 3,354,317. SHORTEEZ. STANDARD CHARACTER MARK. INT. CLS. 38 AND 41. REG. 12-11-2007.
- 3,354,320. MY DOVE STANDARD CHARACTER MARK. INT. CL. 30. REG. 12-11-2007.
- 3,354,326. MY FIRST BABY STANDARD CHARACTER MARK. INT. CL. 28. REG. 12-11-2007.
- 3,354,327. FLASH 'N FUN WRIST LOLLIPOP CANDY (STYLIZED). INT. CL. 30. REG. 12-11-2007.
- 3,354,328. YOU'VE EARNED MORE THAN POINTS STANDARD CHARACTER MARK. INT. CLS. 36 AND 43. REG. 12-11-2007.
- 3,354,329. DEEP CUTS STANDARD CHARACTER MARK. INT. CL. 5. REG. 12-11-2007.
- 3,354,331. CONQR I STANDARD CHARACTER MARK. INT. CL. 25. REG. 12-11-2007.
- 3,354,333. PUREPRO STANDARD CHARACTER MARK. INT. CL. 11. REG. 12-11-2007.
- 3,354,334. KARÓDLA STANDARD CHARACTER MARK. INT. CL. 41. REG. 12-11-2007.
- 3,354,335. FUNDAMENTALLY UNSTABLE STANDARD CHARACTER MARK. INT. CLS. 16 AND 25. REG. 12-11-2007.
- 3,354,340. CMPS LEARNING GALLERY STANDARD CHARACTER MARK. INT. CL. 38. REG. 12-11-2007.
- 3,354,341. REFINEDKNIT STANDARD CHARACTER MARK. INT. CL. 24. REG. 12-11-2007.
- 3,354,342. SHOCK BLOCKS STANDARD CHARACTER MARK. INT. CL. 9. REG. 12-11-2007.
- 3,354,343. TROUVE STANDARD CHARACTER MARK. INT. CL. 21. REG. 12-11-2007.
- 3,354,344. BRAIN RELOAD RECHARGE YOUR BRAIN AND DESIGN. INT. CL. 5. REG. 12-11-2007.
- 3,354,345. D'LYRICIST STANDARD CHARACTER MARK. INT. CL. 41. REG. 12-11-2007.
- 3,354,347. WAY2QUIT AND DESIGN. INT. CL. 5. REG. 12-11-2007.
- 3,354,348. XOMEKA STANDARD CHARACTER MARK. INT. CLS. 14, 20 AND 35. REG. 12-11-2007.
- 3,354,350. SKIN OVERRIDE COMPLEX STANDARD CHARACTER MARK. INT. CL. 3. REG. 12-11-2007.
- 3,354,357. MISCELLANEOUS DESIGN. INT. CL. 41. REG. 12-11-2007.
- 3,354,359. HEALING HANDS OF GAMBIA, INC. AND DESIGN. INT. CL. 44. REG. 12-11-2007.
- 3,354,361. THE MOM REPORT STANDARD CHARACTER MARK. INT. CL. 41. REG. 12-11-2007.
- 3,354,362. MAMIYA ZD STANDARD CHARACTER MARK. INT. CL. 9. REG. 12-11-2007.
- 3,354,363. POWER TO THE PROCESS STANDARD CHARACTER MARK. INT. CL. 35. REG. 12-11-2007.
- 3,354,364. THE SWEETEST, SOFTEST NECK WRAP ON EARTH STANDARD CHARACTER MARK. INT. CL. 20. REG. 12-11-2007.
- 3,354,371. PIT CREW BRAND AND DESIGN. INT. CL. 16. REG. 12-11-2007.
- 3,354,373. TRAVELUSA STANDARD CHARACTER MARK. INT. CL. 36. REG. 12-11-2007.
- 3,354,374. THE SOPHISTICATED LADIES STANDARD CHARACTER MARK. INT. CL. 41. REG. 12-11-2007.
- 3,354,375. VIRTUAL LAGUNA BEACH STANDARD CHARACTER MARK. INT. CL. 38. REG. 12-11-2007.
- 3,354,377. GENUINE IMAGE GI "WEAR WHAT YOU FEEL" (STYLIZED). INT. CL. 25. REG. 12-11-2007.
- 3,354,379. FIREHOSE STANDARD CHARACTER MARK. INT. CL. 33. REG. 12-11-2007.
- 3,354,381. SURDRY STANDARD CHARACTER MARK. INT. CL. 1. REG. 12-11-2007.
- 3,354,382. SPARKLE BY TOO STANDARD CHARACTER MARK. INT. CL. 3. REG. 12-11-2007.
- 3,354,383. SUDDEN IMPULSE STANDARD CHARACTER MARK. INT. CL. 9. REG. 12-11-2007.
- 3,354,384. MAKING WATER WELL STANDARD CHARACTER MARK. INT. CL. 3. REG. 12-11-2007.
- 3,354,386. SMART STICKS STANDARD CHARACTER MARK. INT. CL. 28. REG. 12-11-2007.
- 3,354,389. WELCOME POINTE STANDARD CHARACTER MARK. INT. CL. 9. REG. 12-11-2007.
- 3,354,392. SNACK NATURALS STANDARD CHARACTER MARK. INT. CL. 29. REG. 12-11-2007.
- 3,354,393. BOWECO STANDARD CHARACTER MARK. INT. CL. 16. REG. 12-11-2007.
- 3,354,394. ZERO INJURY PROGRAM STANDARD CHARACTER MARK. INT. CL. 35. REG. 12-11-2007.
- 3,354,395. FABBY FINDS STANDARD CHARACTER MARK. INT. CL. 35. REG. 12-11-2007.
- 3,354,396. @T ORP STANDARD CHARACTER MARK. INT. CL. 9. REG. 12-11-2007.
- 3,354,398. CARMEL STANDARD CHARACTER MARK. INT. CL. 9. REG. 12-11-2007.
- 3,354,400. SOLID POWER AND DESIGN. INT. CLS. 3 AND 9. REG. 12-11-2007.
- 3,354,401. THE CONS STANDARD CHARACTER MARK. INT. CL. 9. REG. 12-11-2007.
- 3,354,402. ETHERPIN STANDARD CHARACTER MARK. INT. CL. 38. REG. 12-11-2007.
- 3,354,404. TEX STANDARD CHARACTER MARK. INT. CL. 28. REG. 12-11-2007.
- 3,354,405. BRUNO STANDARD CHARACTER MARK. INT. CL. 28. REG. 12-11-2007.
- 3,354,408. MISCELLANEOUS DESIGN. INT. CL. 33. REG. 12-11-2007.
- 3,354,410. BAMBA TOYS STANDARD CHARACTER MARK. INT. CL. 35. REG. 12-11-2007.
- 3,354,411. SUPER DELUXE STANDARD CHARACTER MARK. INT. CL. 41. REG. 12-11-2007.
- 3,354,412. SUPER DELUXE STANDARD CHARACTER MARK. INT. CL. 38. REG. 12-11-2007.
- 3,354,415. LYMPHEDIVAS MEDICALLY CORRECT FASHION AND DESIGN. INT. CL. 10. REG. 12-11-2007.
- 3,354,416. CLOSE UP STANDARD CHARACTER MARK. INT. CL. 20. REG. 12-11-2007.
- 3,354,417. MAXDATA STANDARD CHARACTER MARK. INT. CL. 38. REG. 12-11-2007.
- 3,354,418. MONARCH COVE STANDARD CHARACTER MARK. INT. CL. 41. REG. 12-11-2007.
- 3,354,419. V.P.M. STANDARD CHARACTER MARK. INT. CL. 41. REG. 12-11-2007.
- 3,354,420. A AUGITS AND DESIGN. INT. CL. 45. REG. 12-11-2007.
- 3,354,423. THE COMPETITION IS ON STANDARD CHARACTER MARK. INT. CL. 41. REG. 12-11-2007.
- 3,354,425. STARR STANDARD CHARACTER MARK. INT. CL. 35. REG. 12-11-2007.
- 3,354,426. I LOVE YOU BABY STANDARD CHARACTER MARK. INT. CL. 9. REG. 12-11-2007.
- 3,354,427. MISSION L.U.C.K. STANDARD CHARACTER MARK. INT. CL. 9. REG. 12-11-2007.
- 3,354,428. MISCELLANEOUS DESIGN. INT. CL. 41. REG. 12-11-2007.
- 3,354,429. GIRLNEXT STANDARD CHARACTER MARK. INT. CL. 41. REG. 12-11-2007.
- 3,354,431. UP START STANDARD CHARACTER MARK. INT. CL. 5. REG. 12-11-2007.
- 3,354,433. THE FLÓ APPROACH STANDARD CHARACTER MARK. INT. CLS. 36 AND 41. REG. 12-11-2007.
- 3,354,436. SIMONE STANDARD CHARACTER MARK. INT. CL. 25. REG. 12-11-2007.

- 3,354,437. KEYMILES PREFERRED STANDARD CHARACTER MARK. INT. CLS. 9 AND 36. REG. 12-11-2007.
- 3,354,439. MASTERFIT STANDARD CHARACTER MARK. INT. CL. 6. REG. 12-11-2007.
- 3,354,440. HYFLEX PRECISION PROTECTION (STYLIZED). INT. CL. 9. REG. 12-11-2007.
- 3,354,441. FOSSA AND DESIGN. INT. CL. 25. REG. 12-11-2007.
- 3,354,442. COOLEY GODWARD KRONISH LLP (STYLIZED). INT. CL. 42. REG. 12-11-2007.
- 3,354,443. APNA ENERGY STANDARD CHARACTER MARK. INT. CL. 4. REG. 12-11-2007.
- 3,354,445. WELLNESS EFFECT STANDARD CHARACTER MARK. INT. CL. 44. REG. 12-11-2007.
- 3,354,449. THE CONTENDER STANDARD CHARACTER MARK. INT. CL. 25. REG. 12-11-2007.
- 3,354,450. NIGHT & DAY STANDARD CHARACTER MARK. INT. CL. 5. REG. 12-11-2007.
- 3,354,451. SUPER TRUCK SHOWROOM STANDARD CHARACTER MARK. INT. CL. 37. REG. 12-11-2007.
- 3,354,452. CUERVO BLACK STANDARD CHARACTER MARK. INT. CL. 33. REG. 12-11-2007.
- 3,354,454. METROSPARK STANDARD CHARACTER MARK. INT. CL. 38. REG. 12-11-2007.
- 3,354,457. CAROLE LITTLE. INT. CL. 14. REG. 12-11-2007.
- 3,354,459. HERE! TUNES AND DESIGN. INT. CLS. 9 AND 41. REG. 12-11-2007.
- 3,354,461. THE WONDERFUL WORLD OF DISNEY STANDARD CHARACTER MARK. INT. CL. 20. REG. 12-11-2007.
- 3,354,465. ELEXA STANDARD CHARACTER MARK. INT. CL. 3. REG. 12-11-2007.
- 3,354,470. SLOT ON AND DESIGN. INT. CL. 9. REG. 12-11-2007.
- 3,354,475. FLOW AND TELL STANDARD CHARACTER MARK. INT. CL. 41. REG. 12-11-2007.
- 3,354,478. CBP STANDARD CHARACTER MARK. INT. CL. 5. REG. 12-11-2007.
- 3,354,479. CLASSIC POOH AND DESIGN. INT. CL. 16. REG. 12-11-2007.
- 3,354,481. THE WONDERFUL WORLD OF DISNEY STANDARD CHARACTER MARK. INT. CL. 28. REG. 12-11-2007.
- 3,354,483. DENTAGENETICS STANDARD CHARACTER MARK. INT. CL. 5. REG. 12-11-2007.
- 3,354,484. CLASSIC POOH AND DESIGN. INT. CL. 25. REG. 12-11-2007.
- 3,354,487. AUTO XPRESS (STYLIZED). INT. CLS. 11, 14, 20, 21 AND 27. REG. 12-11-2007.
- 3,354,491. INTUITIVE WELL STANDARD CHARACTER MARK. INT. CL. 42. REG. 12-11-2007.
- 3,354,493. RATATOUILLE STANDARD CHARACTER MARK. INT. CL. 20. REG. 12-11-2007.
- 3,354,495. RATATOUILLE STANDARD CHARACTER MARK. INT. CL. 3. REG. 12-11-2007.
- 3,354,496. RATATOUILLE STANDARD CHARACTER MARK. INT. CL. 18. REG. 12-11-2007.
- 3,354,497. RATATOUILLE STANDARD CHARACTER MARK. INT. CL. 24. REG. 12-11-2007.
- 3,354,498. SUN SHINE AND DESIGN. INT. CL. 3. REG. 12-11-2007.
- 3,354,499. SONOMACRISPS AND DESIGN. INT. CL. 29. REG. 12-11-2007.
- 3,354,502. GORKY PARK AND DESIGN. INT. CL. 41. REG. 12-11-2007.
- 3,354,504. KARAOKE.COM. INT. CLS. 25 AND 42. REG. 12-11-2007.
- 3,354,505. METREON. INT. CL. 25. REG. 12-11-2007.
- 3,354,506. DEPARTMENT 69. INT. CL. 25. REG. 12-11-2007.
- 3,354,507. ONE PIECE STANDARD CHARACTER MARK. INT. CL. 6. REG. 12-11-2007.
- 3,354,511. CLINICAL ONCOLOGY NEWS STANDARD CHARACTER MARK. INT. CL. 16. REG. 12-11-2007.
- 3,354,512. APPLIED CLINICAL EDUCATION STANDARD CHARACTER MARK. INT. CL. 41. REG. 12-11-2007.
- 3,354,514. CUSTOM MORTGAGE SOLUTIONS (STYLIZED). INT. CL. 36. REG. 12-11-2007.
- 3,354,515. FLEXIKORK (STYLIZED). INT. CL. 19. REG. 12-11-2007.
- 3,354,516. VERTICAL-TO-HORIZONTAL DRAINAGE (STYLIZED). INT. CL. 27. REG. 12-11-2007.
- 3,354,519. SEMINARS IN THE MAIL STANDARD CHARACTER MARK. INT. CLS. 9, 16, 35 AND 41. REG. 12-11-2007.
- 3,354,520. RESOURCE KIT STANDARD CHARACTER MARK. INT. CLS. 9, 16 AND 35. REG. 12-11-2007.
- 3,354,522. 1-800-HOUSING STANDARD CHARACTER MARK. INT. CLS. 35 AND 36. REG. 12-11-2007.
- 3,354,523. US PRIME LAND STANDARD CHARACTER MARK. INT. CLS. 35 AND 36. REG. 12-11-2007.
- 3,354,524. THE KEEPSAKE TOOTH STANDARD CHARACTER MARK. INT. CL. 40. REG. 12-11-2007.
- 3,354,526. IN UTAH THIS WEEK STANDARD CHARACTER MARK. INT. CLS. 16 AND 35. REG. 12-11-2007.
- 3,354,527. QUALITYMARK STANDARD CHARACTER MARK. INT. CL. 37. REG. 12-11-2007.
- 3,354,532. STREETTUNER STANDARD CHARACTER MARK. INT. CL. 9. REG. 12-11-2007.
- 3,354,534. NORTH AMERICAN POLO LEAGUE STANDARD CHARACTER MARK. INT. CLS. 35 AND 41. REG. 12-11-2007.
- 3,354,535. PUSH TOOL AND DESIGN. INT. CL. 28. REG. 12-11-2007.
- 3,354,536. AUDDINO PIZZA STANDARD CHARACTER MARK. INT. CL. 43. REG. 12-11-2007.
- 3,354,537. STREAMLINE STANDARD CHARACTER MARK. INT. CL. 7. REG. 12-11-2007.
- 3,354,538. AUTO SERVICE EXPRESS STANDARD CHARACTER MARK. INT. CL. 37. REG. 12-11-2007.
- 3,354,539. WILMINGTON FUNDAMENTALLY WEIGHTED LARGE COMPANY STRATEGY STANDARD CHARACTER MARK. INT. CL. 36. REG. 12-11-2007.
- 3,354,540. FRIDGE BALLS STANDARD CHARACTER MARK. INT. CL. 5. REG. 12-11-2007.
- 3,354,541. WILMINGTON FUNDAMENTALLY WEIGHTED SMALL COMPANY STRATEGY STANDARD CHARACTER MARK. INT. CL. 36. REG. 12-11-2007.
- 3,354,542. REALTIME MONEY STANDARD CHARACTER MARK. INT. CL. 36. REG. 12-11-2007.
- 3,354,543. DISTEMPERMENT STANDARD CHARACTER MARK. INT. CL. 16. REG. 12-11-2007.
- 3,354,544. ALIANZA LATINA DE BÉISBOL STANDARD CHARACTER MARK. INT. CL. 41. REG. 12-11-2007.
- 3,354,547. DRIVECOPY STANDARD CHARACTER MARK. INT. CL. 9. REG. 12-11-2007.
- 3,354,548. ENHANCED MANDATORY CONVERTIBLES STANDARD CHARACTER MARK. INT. CL. 36. REG. 12-11-2007.
- 3,354,552. SIMPOSIUM INTERNACIONAL DE BIBLIOTECAS DIGITALES STANDARD CHARACTER MARK. INT. CL. 41. REG. 12-11-2007.
- 3,354,553. AFFORDABLE LUXURY SPECIALIST STANDARD CHARACTER MARK. INT. CL. 36. REG. 12-11-2007.
- 3,354,554. KOOL KENNEL STANDARD CHARACTER MARK. INT. CL. 11. REG. 12-11-2007.
- 3,354,555. AFFORDABLE LUXURY CONDO SPECIALIST STANDARD CHARACTER MARK. INT. CL. 36. REG. 12-11-2007.
- 3,354,556. REAL ESTATE OPORTUNITIES UNDER PREFERENTIAL TERMS IN A PROTECTED ENVIRONMENT STANDARD CHARACTER MARK. INT. CL. 36. REG. 12-11-2007.

- 3,354,560. CALIFORNIA BIKE WEEK STANDARD CHARACTER MARK. INT. CLS. 35 AND 41. REG. 12-11-2007.
- 3,354,562. BROAD SPECTRUM JOINT SUPPORT STANDARD CHARACTER MARK. INT. CL. 5. REG. 12-11-2007.
- 3,354,563. SUPER FISH STANDARD CHARACTER MARK. INT. CL. 43. REG. 12-11-2007.
- 3,354,564. THE DEMO CENTER STANDARD CHARACTER MARK. INT. CL. 41. REG. 12-11-2007.
- 3,354,565. LOUNGER STANDARD CHARACTER MARK. INT. CL. 12. REG. 12-11-2007.
- 3,354,566. AUTOVOLUME STANDARD CHARACTER MARK. INT. CL. 9. REG. 12-11-2007.
- 3,354,567. RESPONDERNET STANDARD CHARACTER MARK. INT. CL. 9. REG. 12-11-2007.
- 3,354,568. MISCELLANEOUS DESIGN. INT. CL. 33. REG. 12-11-2007.
- 3,354,569. ANTIQUES & COLLECTIBLES JOURNAL STANDARD CHARACTER MARK. INT. CL. 16. REG. 12-11-2007.
- 3,354,575. PROCESS BASED LEADERSHIP AND DESIGN. INT. CL. 41. REG. 12-11-2007.
- 3,354,578. ICE CREAM BISTRO STANDARD CHARACTER MARK. INT. CL. 43. REG. 12-11-2007.
- 3,354,581. EMOTION TECHNOLOGY STANDARD CHARACTER MARK. INT. CL. 9. REG. 12-11-2007.
- 3,354,582. EMOTION TOOL STANDARD CHARACTER MARK. INT. CL. 9. REG. 12-11-2007.
- 3,354,584. THE CRITICAL PATH FOUNDATION STANDARD CHARACTER MARK. INT. CL. 36. REG. 12-11-2007.
- 3,354,586. POPCORN POTATOES STANDARD CHARACTER MARK. INT. CL. 29. REG. 12-11-2007.
- 3,354,587. JELLYZ STANDARD CHARACTER MARK. INT. CL. 25. REG. 12-11-2007.
- 3,354,589. ADVANCED TECHNOLOGY SOLUTIONS STANDARD CHARACTER MARK. INT. CLS. 37 AND 42. REG. 12-11-2007.
- 3,354,590. THE WORLD'S FIRST PROFESSIONAL GRADE PLUG N GO SECURITY SYSTEM STANDARD CHARACTER MARK. INT. CL. 9. REG. 12-11-2007.
- 3,354,597. THE CAT COACH AND DESIGN. INT. CL. 41. REG. 12-11-2007.
- 3,354,599. TORRINI STANDARD CHARACTER MARK. INT. CL. 25. REG. 12-11-2007.
- 3,354,600. JUST A TOWEL STANDARD CHARACTER MARK. INT. CL. 41. REG. 12-11-2007.
- 3,354,602. BEST RANK STANDARD CHARACTER MARK. INT. CL. 35. REG. 12-11-2007.
- 3,354,607. HEAT STANDARD CHARACTER MARK. INT. CL. 10. REG. 12-11-2007.
- 3,354,608. CHARLESTON GOLF & TENNIS STANDARD CHARACTER MARK. INT. CL. 35. REG. 12-11-2007.
- 3,354,610. OPTIMAL DAILY INTAKE STANDARD CHARACTER MARK. INT. CL. 5. REG. 12-11-2007.
- 3,354,614. RUSTIC BAKERY STANDARD CHARACTER MARK. INT. CL. 30. REG. 12-11-2007.
- 3,354,615. GEOTOURGUIDE STANDARD CHARACTER MARK. INT. CL. 9. REG. 12-11-2007.
- 3,354,616. THE BUSINESS RESOURCE CONNECTION STANDARD CHARACTER MARK. INT. CL. 35. REG. 12-11-2007.
- 3,354,617. MEDEDONDEMAND STANDARD CHARACTER MARK. INT. CL. 41. REG. 12-11-2007.
- 3,354,618. FLEETCARDSUSA STANDARD CHARACTER MARK. INT. CLS. 35 AND 36. REG. 12-11-2007.
- 3,354,619. CONVERSION ANALYST STANDARD CHARACTER MARK. INT. CL. 9. REG. 12-11-2007.
- 3,354,620. MISCELLANEOUS DESIGN. INT. CLS. 8, 16 AND 21. REG. 12-11-2007.
- 3,354,622. MISCELLANEOUS DESIGN. INT. CL. 19. REG. 12-11-2007.
- 3,354,623. DOUBLE BALLOON ENTEROSCOPY STANDARD CHARACTER MARK. INT. CL. 10. REG. 12-11-2007.
- 3,354,624. AUTO BROKERS OF AMERICA STANDARD CHARACTER MARK. INT. CL. 36. REG. 12-11-2007.
- 3,354,625. THE BROADCAST AMERICAN RADIO AND TELEVISION SCRIPT LIBRARY STANDARD CHARACTER MARK. INT. CL. 41. REG. 12-11-2007.
- 3,354,626. LICORICE CHALK STANDARD CHARACTER MARK. INT. CL. 30. REG. 12-11-2007.
- 3,354,630. MONTREAL VIP STANDARD CHARACTER MARK. INT. CL. 39. REG. 12-11-2007.
- 3,354,631. VENICE NUTRITION STANDARD CHARACTER MARK. INT. CL. 44. REG. 12-11-2007.
- 3,354,634. E-WEAR STANDARD CHARACTER MARK. INT. CL. 9. REG. 12-11-2007.
- 3,354,635. SEVEN ELEMENTS OF A COMPLIANCE PROGRAM STANDARD CHARACTER MARK. INT. CL. 35. REG. 12-11-2007.
- 3,354,636. PROFESSIONAL CLAY TOOLS STANDARD CHARACTER MARK. INT. CLS. 8 AND 16. REG. 12-11-2007.
- 3,354,637. INDIANAPOLIS LUXURY HOME TOUR STANDARD CHARACTER MARK. INT. CL. 16. REG. 12-11-2007.
- 3,354,638. MODERN MEDIASPHERE STANDARD CHARACTER MARK. INT. CLS. 35 AND 41. REG. 12-11-2007.
- 3,354,639. FESLER STANDARD CHARACTER MARK. INT. CLS. 12 AND 28. REG. 12-11-2007.
- 3,354,642. LIGHT'N'UP AND DESIGN. INT. CL. 25. REG. 12-11-2007.
- 3,354,643. BLACKOUT DRUNK STANDARD CHARACTER MARK. INT. CL. 25. REG. 12-11-2007.
- 3,354,644. PARTY ONLINE STANDARD CHARACTER MARK. INT. CLS. 35, 38, 41 AND 42. REG. 12-11-2007.
- 3,354,645. ACTIVE GOVERNANCE STANDARD CHARACTER MARK. INT. CL. 9. REG. 12-11-2007.
- 3,354,649. MOOREA PASSION FRUIT STANDARD CHARACTER MARK. INT. CL. 3. REG. 12-11-2007.
- 3,354,651. MISCELLANEOUS DESIGN. INT. CL. 25. REG. 12-11-2007.
- 3,354,652. INTERNATIONAL CUSTOMER MANAGEMENT INSTITUTE STANDARD CHARACTER MARK. INT. CL. 16. REG. 12-11-2007.
- 3,354,654. SPORTSMAN LITE STANDARD CHARACTER MARK. INT. CL. 20. REG. 12-11-2007.
- 3,354,655. EMPLOYEE REWARDS BONUS CHECKING STANDARD CHARACTER MARK. INT. CL. 36. REG. 12-11-2007.
- 3,354,656. THE LITE BRA STANDARD CHARACTER MARK. INT. CL. 25. REG. 12-11-2007.
- 3,354,657. ACTORS PAGES STANDARD CHARACTER MARK. INT. CL. 41. REG. 12-11-2007.
- 3,354,659. ULTIMATE RELATIONSHIP PROGRAM STANDARD CHARACTER MARK. INT. CL. 9. REG. 12-11-2007.
- 3,354,660. MISCELLANEOUS DESIGN. INT. CL. 15. REG. 12-11-2007.
- 3,354,661. PORTRAITWEAVERS STANDARD CHARACTER MARK. INT. CL. 37. REG. 12-11-2007.
- 3,354,662. 1-800-LENDING AND DESIGN. INT. CL. 36. REG. 12-11-2007.
- 3,354,666. THE MASS STACK STANDARD CHARACTER MARK. INT. CL. 5. REG. 12-11-2007.
- 3,354,669. SPA PILL STANDARD CHARACTER MARK. INT. CL. 1. REG. 12-11-2007.
- 3,354,670. AK WILD SALMON AND DESIGN. INT. CL. 25. REG. 12-11-2007.
- 3,354,671. LEGALIZA TEXAS STANDARD CHARACTER MARK. INT. CL. 45. REG. 12-11-2007.
- 3,354,672. CARD HOLDER REWARDS + BENEFITS STANDARD CHARACTER MARK. INT. CL. 35. REG. 12-11-2007.
- 3,354,676. F PORT 65-70 RED 60-65 YOUNG RED 55-60 WHITE 50-55 ROSE 45-50 CHAMPAGNE 38-45 (STYLIZED). INT. CL. 8. REG. 12-11-2007.

- 3,354,677. ULTIMATE FLOOR DESIGN CENTER STANDARD CHARACTER MARK. INT. CL. 35. REG. 12-11-2007.
- 3,354,678. FOR THE STRONGEST TURF STANDARD CHARACTER MARK. INT. CLS. 1 AND 44. REG. 12-11-2007.
- 3,354,680. KARAKO STANDARD CHARACTER MARK. INT. CL. 35. REG. 12-11-2007.
- 3,354,728. SOFTFLEX STANDARD CHARACTER MARK. INT. CL. 8. REG. 12-18-2007.
- 3,354,868. BATANI-KHALFANI STANDARD CHARACTER MARK. INT. CL. 25. REG. 12-18-2007.
- 3,356,498. EMERALD CITY SMOOTHIE STANDARD CHARACTER MARK. INT. CL. 35. REG. 12-18-2007.
- 3,361,163. STEELBOOK (STYLIZED). INT. CLS. 8, 14, 28, 39 AND 41 ONLY. REG. 1-1-2008.
- 3,364,585. SD AND DESIGN. INT. CLS. 18 AND 41 ONLY. REG. 1-8-2008.
- 3,365,609. VAN CHEONG TEA STANDARD CHARACTER MARK. INT. CL. 21 ONLY. REG. 1-8-2008.
- 3,367,172. JUMP THE SHARK STANDARD CHARACTER MARK. INT. CL. 16 ONLY. REG. 1-8-2008.
- 3,370,593. RESISTANCE FALL OF MAN STANDARD CHARACTER MARK. INT. CL. 41 ONLY. REG. 1-15-2008.
- 3,395,764. KING OF BUCKS STANDARD CHARACTER MARK. INT. CLS. 18, 20, 25 AND 28 ONLY. REG. 3-11-2008.
- 3,396,490. SURVIVE THE OFFROAD STANDARD CHARACTER MARK. INT. CL. 41 ONLY. REG. 3-11-2008.
- 3,401,816. AMERICANS UNITED FOR SEPARATION OF CHURCH AND STATE STANDARD CHARACTER MARK. INT. CL. 9 ONLY. REG. 3-25-2008.
- 3,434,008. LAPIZ AND DESIGN. INT. CL. 16 ONLY. REG. 5-27-2008.
- 3,459,916. ROOMSERVICE. INT. CLS. 16 AND 24 ONLY. REG. 7-8-2008.
- 3,462,765. RUSH UNIVERSITY MEDICAL CENTER. INT. CLS. 9, 14, 20 AND 28 ONLY. REG. 7-8-2008.
- 3,462,787. THE PLAYFUL GARDEN AND DESIGN. INT. CL. 21 ONLY. REG. 7-8-2008.
- 3,463,425. MISCELLANEOUS DESIGN. INT. CL. 20 ONLY. REG. 7-8-2008.
- 3,463,511. MISSOURI UNIVERSITY OF SCIENCE AND TECHNOLOGY STANDARD CHARACTER MARK. INT. CL. 25 ONLY. REG. 7-8-2008.
- 3,464,097. GENTIVA AND DESIGN. INT. CLS. 9, 35, 36 AND 42 ONLY. REG. 7-8-2008.
- 3,464,098. MISCELLANEOUS DESIGN. INT. CLS. 9, 35, 36 AND 42 ONLY. REG. 7-8-2008.
- 3,469,820. SATORI ACADEMY STANDARD CHARACTER MARK. INT. CL. 28 ONLY. REG. 7-15-2008.
- 3,469,972. ANDALUCIA (STYLIZED). INT. CL. 38 ONLY. REG. 7-15-2008.
- 3,472,076. ADR AND DESIGN. INT. CLS. 41 AND 44 ONLY. REG. 7-22-2008.
- 3,481,831. SERVICE360 STANDARD CHARACTER MARK. INT. CL. 9 ONLY. REG. 8-5-2008.
- 3,488,118. RE/MAX UNIVERSITY STANDARD CHARACTER MARK. INT. CL. 38 ONLY. REG. 8-19-2008.
- 3,489,779. GAME TIME STANDARD CHARACTER MARK. INT. CLS. 11, 16 AND 20 ONLY. REG. 8-19-2008.
- 3,496,765. FABRISOLV STANDARD CHARACTER MARK. INT. CL. 1 ONLY. REG. 9-2-2008.
- 3,500,039. COAST HOTELS & RESORTS AND DESIGN. INT. CLS. 39 AND 41 ONLY. REG. 9-9-2008.
- 3,500,825. EVITE STANDARD CHARACTER MARK. INT. CLS. 38, 39, 40, 41 AND 43 ONLY. REG. 9-16-2008.
- 3,518,699. CALL ALFA (STYLIZED). INT. CL. 36 ONLY. REG. 10-21-2008.
- 3,518,877. A | U | R (STYLIZED). INT. CL. 18 ONLY. REG. 10-21-2008.
- 3,561,923. O CEDAR PROFESSIONAL STANDARD CHARACTER MARK. INT. CL. 28 ONLY. REG. 1-13-2009.
- 3,578,316. KLEMM STANDARD CHARACTER MARK. INT. CL. 6 ONLY. REG. 2-24-2009.
- 3,642,758. QMANIA AND DESIGN. INT. CL. 42 ONLY. REG. 6-23-2009.
- 3,645,992. KENYON NOBLE LUMBER HARDWARE AND DESIGN. INT. CL. 19 ONLY. REG. 6-30-2009.
- 3,648,287. LEANGRC STANDARD CHARACTER MARK. INT. CLS. 36, 41, 42 AND 45 ONLY. REG. 6-30-2009.

---

**SECTION 71**

- 3,253,879. MISCELLANEOUS DESIGN. INT. CL. 35. REG. 6-19-2007.
- 3,283,201. HÖEGH AUTOLINERS STANDARD CHARACTER MARK. INT. CL. 7. REG. 8-21-2007.
- 3,352,526. CINÉMA YVESSAINTLAURENT AND DESIGN. INT. CL. 3. REG. 12-11-2007.
- 3,352,527. MOSCHINO COUTURE! AND DESIGN. INT. CL. 3. REG. 12-11-2007.
- 3,352,528. WET-PROTECT 21 AND DESIGN. INT. CLS. 1, 2 AND 4. REG. 12-11-2007.
- 3,352,530. LOUISE FEUILLERE (STYLIZED). INT. CLS. 3, 16, 24 AND 25. REG. 12-11-2007.
- 3,352,533. JAWS STANDARD CHARACTER MARK. INT. CL. 10. REG. 12-11-2007.
- 3,352,534. MOLDA DRYING - INGREDIENTS - SOLUTIONS AND DESIGN. INT. CLS. 5, 29, 30, 40, 42 AND 43. REG. 12-11-2007.
- 3,352,536. DIPTYQUE PARFUMEUR PARIS 34 BOULEVARD SAINT GERMAIN DIPTYQUE 34 BOULEVARD SAINT AND DESIGN. INT. CLS. 3, 4 AND 35. REG. 12-11-2007.
- 3,352,537. PREVENTAN STANDARD CHARACTER MARK. INT. CLS. 5 AND 35. REG. 12-11-2007.
- 3,352,539. MAISON CALAVAS STANDARD CHARACTER MARK. INT. CLS. 3, 14, 18, 21 AND 25. REG. 12-11-2007.
- 3,352,540. JUSTINX STANDARD CHARACTER MARK. INT. CLS. 1 AND 2. REG. 12-11-2007.
- 3,352,544. OSITRACK STANDARD CHARACTER MARK. INT. CL. 9. REG. 12-11-2007.
- 3,352,545. INTERRETIRE (STYLIZED). INT. CL. 36. REG. 12-11-2007.
- 3,352,547. M (STYLIZED). INT. CLS. 9, 35 AND 36. REG. 12-11-2007.
- 3,352,549. HEIDI.COM AND DESIGN. INT. CLS. 24 AND 25. REG. 12-11-2007.
- 3,352,550. DANISH SELECTION AND DESIGN. INT. CL. 29. REG. 12-11-2007.
- 3,352,551. M2M EXPANDING WIRELESS POSSIBILITIES (STYLIZED). INT. CLS. 9, 37, 38, 41 AND 42. REG. 12-11-2007.
- 3,352,552. M MARKETMAKER (STYLIZED). INT. CLS. 35 AND 36. REG. 12-11-2007.
- 3,352,555. FIAT GROUP AND DESIGN. INT. CLS. 6, 9, 12, 16, 18, 25, 28 AND 37. REG. 12-11-2007.
- 3,352,556. SAATIPRINT AND DESIGN. INT. CLS. 1 AND 24. REG. 12-11-2007.
- 3,352,558. MISCELLANEOUS DESIGN. INT. CLS. 9 AND 18. REG. 12-11-2007.
- 3,352,560. POLTINA AND DESIGN. INT. CLS. 32 AND 33. REG. 12-11-2007.
- 3,352,561. KER BELL STANDARD CHARACTER MARK. INT. CLS. 19, 20 AND 21. REG. 12-11-2007.
- 3,352,565. RESIGRIND STANDARD CHARACTER MARK. INT. CLS. 1, 7, 17, 21 AND 40. REG. 12-11-2007.
- 3,352,566. ONESACK AND DESIGN. INT. CL. 17. REG. 12-11-2007.
- 3,352,568. CTOP ONE COMPUTER TO OFFSET PLATE AND DESIGN. INT. CLS. 7 AND 9. REG. 12-11-2007.

- 3,352,572. FLEXTEC STANDARD CHARACTER MARK. INT. CL. 1. REG. 12-11-2007.
- 3,352,573. VESTEL AND DESIGN. INT. CLS. 7, 9, 11 AND 35. REG. 12-11-2007.
- 3,352,575. REVABILITY STANDARD CHARACTER MARK. INT. CL. 12. REG. 12-11-2007.
- 3,352,576. OKÉ FAIR TRADE AND DESIGN. INT. CLS. 29 AND 31. REG. 12-11-2007.
- 3,352,578. ATYARTHA STANDARD CHARACTER MARK. INT. CL. 36. REG. 12-11-2007.
- 3,352,579. AAK AARHUSKARLSHAMN AND DESIGN. INT. CLS. 1, 3, 4, 5 AND 29. REG. 12-11-2007.
- 3,352,580. MISCELLANEOUS DESIGN. INT. CLS. 16, 35 AND 41. REG. 12-11-2007.
- 3,352,581. MASSTER PLUS AND DESIGN. INT. CLS. 10 AND 35. REG. 12-11-2007.
- 3,352,584. MEDIGOLD STANDARD CHARACTER MARK. INT. CL. 5. REG. 12-11-2007.
- 3,352,586. SHORTSTRAW STANDARD CHARACTER MARK. INT. CLS. 24 AND 25. REG. 12-11-2007.
- 3,352,587. BATTLEPAD (STYLIZED). INT. CLS. 9 AND 20. REG. 12-11-2007.
- 3,352,589. GIVE ME HOPE AND DESIGN. INT. CLS. 14 AND 25. REG. 12-11-2007.
- 3,352,591. KENZO AND DESIGN. INT. CLS. 18 AND 25. REG. 12-11-2007.
- 3,352,594. LIPTIDE STANDARD CHARACTER MARK. INT. CLS. 1 AND 5. REG. 12-11-2007.
- 3,352,598. DAL 1877 BARILLA PARMA . ITALIA . AND DESIGN. INT. CL. 30. REG. 12-11-2007.
- 3,352,599. BOREOUT STANDARD CHARACTER MARK. INT. CLS. 16, 25 AND 41. REG. 12-11-2007.
- 3,352,601. ZANONE FLEXWOOL STANDARD CHARACTER MARK. INT. CL. 25. REG. 12-11-2007.
- 3,352,602. SPORTING LADIES STANDARD CHARACTER MARK. INT. CL. 25. REG. 12-11-2007.
- 3,352,603. AWGASM AND DESIGN. INT. CLS. 25 AND 28. REG. 12-11-2007.
- 3,352,606. OPTIBLUE STANDARD CHARACTER MARK. INT. CL. 10. REG. 12-11-2007.
- 3,352,607. GET YOUR ZOOM BACK STANDARD CHARACTER MARK. INT. CL. 10. REG. 12-11-2007.
- 3,352,609. PANTHER STANDARD CHARACTER MARK. INT. CL. 9. REG. 12-11-2007.
- 3,352,612. EQUALITY STANDARD CHARACTER MARK. INT. CLS. 20, 22, 23, 27, 28, 29, 30, 31 AND 32. REG. 12-11-2007.
- 3,352,613. STX (STYLIZED). INT. CLS. 9 AND 42. REG. 12-11-2007.
- 3,352,614. WATER LITTLE AND DESIGN. INT. CLS. 31 AND 32. REG. 12-11-2007.
- 3,352,616. OLIO DI OLIVA ISNARDI PIETRO ISNARDI & C. S.P.A. - ONEGLIA AND DESIGN. INT. CL. 29. REG. 12-11-2007.
- 3,352,617. PLATIN (STYLIZED). INT. CL. 12. REG. 12-11-2007.
- 3,352,618. DUCOSTONE STANDARD CHARACTER MARK. INT. CL. 19. REG. 12-11-2007.
- 3,352,620. ENEXTRO STANDARD CHARACTER MARK. INT. CLS. 6 AND 9. REG. 12-11-2007.
- 3,352,621. K K DDP (STYLIZED). INT. CLS. 16, 18 AND 25. REG. 12-11-2007.
- 3,352,622. V-PROTEQ (STYLIZED). INT. CL. 40. REG. 12-11-2007.
- 3,352,623. MEMOSEAL STANDARD CHARACTER MARK. INT. CLS. 16, 35, 39 AND 40. REG. 12-11-2007.
- 3,352,624. NCLEAR (STYLIZED). INT. CLS. 7 AND 9. REG. 12-11-2007.
- 3,352,626. MISCELLANEOUS DESIGN. INT. CL. 9. REG. 12-11-2007.
- 3,352,629. VIEILLE VILLE STANDARD CHARACTER MARK. INT. CL. 33. REG. 12-11-2007.
- 3,352,633. SOT STANDARD CHARACTER MARK. INT. CLS. 1 AND 3. REG. 12-11-2007.
- 3,352,634. RUFF TRIGGER STANDARD CHARACTER MARK. INT. CLS. 9, 38 AND 42. REG. 12-11-2007.
- 3,352,636. LITTLE MARC STANDARD CHARACTER MARK. INT. CLS. 16 AND 18. REG. 12-11-2007.
- 3,352,640. REGERO VR (STYLIZED). INT. CLS. 7 AND 11. REG. 12-11-2007.
- 3,352,642. GRAND EMPEREUR NAPOLEON (STYLIZED). INT. CL. 33. REG. 12-11-2007.
- 3,352,643. OLD TOWN STANDARD CHARACTER MARK. INT. CL. 33. REG. 12-11-2007.
- 3,352,644. ELEMENTAL STANDARD CHARACTER MARK. INT. CLS. 39 AND 43. REG. 12-11-2007.
- 3,352,647. BR (STYLIZED). INT. CLS. 18 AND 25. REG. 12-11-2007.
- 3,352,650. SPINLIGHT AND DESIGN. INT. CL. 9. REG. 12-11-2007.
- 3,352,651. MISCELLANEOUS DESIGN. INT. CLS. 10, 37 AND 42. REG. 12-11-2007.
- 3,352,653. PUNTO G PUNTO GELATO ITALIANO AND DESIGN. INT. CLS. 11 AND 20. REG. 12-11-2007.
- 3,352,654. ENSIGN STANDARD CHARACTER MARK. INT. CLS. 9, 16, 18 AND 25. REG. 12-11-2007.
- 3,352,655. PRIMA AND DESIGN. INT. CL. 7. REG. 12-11-2007.
- 3,352,657. B-GENIO STANDARD CHARACTER MARK. INT. CL. 5. REG. 12-11-2007.
- 3,352,658. MR—EASE AND DESIGN. INT. CL. 5. REG. 12-11-2007.
- 3,352,660. ENDO SPONGE AND DESIGN. INT. CL. 5. REG. 12-11-2007.
- 3,352,661. AKIA AND DESIGN. INT. CLS. 25 AND 28. REG. 12-11-2007.
- 3,352,662. LOT STANDARD CHARACTER MARK. INT. CLS. 1 AND 3. REG. 12-11-2007.
- 3,352,664. SINK-GUARD STANDARD CHARACTER MARK. INT. CLS. 11 AND 20. REG. 12-11-2007.
- 3,352,665. BOGNER HOMESHOPPING AND DESIGN. INT. CLS. 9, 16, 38 AND 41. REG. 12-11-2007.
- 3,352,669. UFLEX STANDARD CHARACTER MARK. INT. CL. 9. REG. 12-11-2007.
- 3,352,670. MEINL AIRPORTS INTERNATIONAL AND DESIGN. INT. CLS. 35, 36 AND 42. REG. 12-11-2007.
- 3,352,672. JETLOGO STANDARD CHARACTER MARK. INT. CLS. 38 AND 42. REG. 12-11-2007.
- 3,352,673. ONTOMANTICS THE ONTOLOGY OF BUSINESS SEMANTICS STANDARD CHARACTER MARK. INT. CLS. 35, 36 AND 42. REG. 12-11-2007.
- 3,352,679. EPOLOGIC STANDARD CHARACTER MARK. INT. CL. 5. REG. 12-11-2007.
- 3,352,680. FERROLOGIC STANDARD CHARACTER MARK. INT. CL. 5. REG. 12-11-2007.
- 3,352,681. DAYWELL AND DESIGN. INT. CL. 30. REG. 12-11-2007.
- 3,352,684. PLANOLITH STANDARD CHARACTER MARK. INT. CLS. 6, 7, 9, 19, 37 AND 40. REG. 12-11-2007.
- 3,352,687. WORLD'S LEADING CLUBS AND DESIGN. INT. CLS. 16, 25, 28 AND 44. REG. 12-11-2007.
- 3,352,688. AEROSLEEPER AND DESIGN. INT. CLS. 12 AND 39. REG. 12-11-2007.
- 3,352,689. HOME SWIM AND DESIGN. INT. CLS. 1, 6, 7, 19 AND 28. REG. 12-11-2007.
- 3,352,690. BIFLUX AND DESIGN. INT. CLS. 11 AND 21. REG. 12-11-2007.
- 3,352,691. VSP STANDARD CHARACTER MARK. INT. CLS. 9 AND 42. REG. 12-11-2007.
- 3,352,694. ESPRESSIONE STANDARD CHARACTER MARK. INT. CL. 16. REG. 12-11-2007.
- 3,352,695. OMFUL AND DESIGN. INT. CLS. 7, 9, 40 AND 42. REG. 12-11-2007.
- 3,352,696. MISCELLANEOUS DESIGN. INT. CLS. 6, 7, 8, 12, 17 AND 42. REG. 12-11-2007.
- 3,352,698. DOMAINE DE BROIX STANDARD CHARACTER MARK. INT. CL. 33. REG. 12-11-2007.
- 3,352,701. DADANCO STARLINE STANDARD CHARACTER MARK. INT. CLS. 11, 35 AND 42. REG. 12-11-2007.
- 3,352,707. FEMIFECT STANDARD CHARACTER MARK. INT. CL. 5. REG. 12-11-2007.

- 3,352,708. DEXICOM STANDARD CHARACTER MARK. INT. CLS. 1 AND 42. REG. 12-11-2007.
- 3,352,709. MISCELLANEOUS DESIGN. INT. CL. 21. REG. 12-11-2007.
- 3,352,710. I AM RED (STYLIZED). INT. CLS. 38 AND 41. REG. 12-11-2007.
- 3,352,712. I AM RED STANDARD CHARACTER MARK. INT. CLS. 38 AND 41. REG. 12-11-2007.
- 3,352,713. KH AND DESIGN. INT. CLS. 35, 41 AND 42. REG. 12-11-2007.
- 3,352,714. CARBIX STANDARD CHARACTER MARK. INT. CLS. 36, 39 AND 42. REG. 12-11-2007.
- 3,352,718. TORREVILLA STANDARD CHARACTER MARK. INT. CL. 33. REG. 12-11-2007.
- 3,352,719. RB AND DESIGN. INT. CL. 19. REG. 12-11-2007.
- 3,352,721. SPEEDY HIBIGENS STANDARD CHARACTER MARK. INT. CL. 3. REG. 12-11-2007.
- 3,352,722. CURA STANDARD CHARACTER MARK. INT. CL. 20. REG. 12-11-2007.
- 3,352,724. KGB AND DESIGN. INT. CL. 39. REG. 12-11-2007.
- 3,352,725. KGB (STYLIZED). INT. CL. 39. REG. 12-11-2007.
- 3,352,726. KGB (STYLIZED). INT. CL. 39. REG. 12-11-2007.
- 3,352,728. LIMOS (STYLIZED). INT. CLS. 9 AND 42. REG. 12-11-2007.
- 3,352,730. NGPS (STYLIZED). INT. CLS. 5 AND 31. REG. 12-11-2007.
- 3,352,732. MISCELLANEOUS DESIGN. INT. CL. 25. REG. 12-11-2007.
- 3,352,733. SOPHISTI STANDARD CHARACTER MARK. INT. CL. 9. REG. 12-11-2007.
- 3,352,735. CHILL OUT CONCEPT STANDARD CHARACTER MARK. INT. CL. 35. REG. 12-11-2007.
- 3,352,739. SUPREMIA GRUP INGREDIENTE ALIMENTARE INGREDIENTUL PERFOMANTEI TALE! AND DESIGN. INT. CLS. 1, 2, 29 AND 30. REG. 12-11-2007.
- 3,352,740. AROMAGICAL INFORMATICS AND DESIGN. INT. CLS. 1, 3 AND 30. REG. 12-11-2007.
- 3,352,741. ESPACE-TEMPS STANDARD CHARACTER MARK. INT. CL. 14. REG. 12-11-2007.
- 3,352,742. ULTRASINGLE STANDARD CHARACTER MARK. INT. CL. 7. REG. 12-11-2007.
- 3,352,743. MYENGLISHCV AND DESIGN. INT. CL. 35. REG. 12-11-2007.
- 3,352,744. SPYK-TEE (STYLIZED). INT. CL. 28. REG. 12-11-2007.
- 3,352,745. IN LOVE STANDARD CHARACTER MARK. INT. CL. 28. REG. 12-11-2007.
- 3,352,746. TYMATIC STANDARD CHARACTER MARK. INT. CLS. 6 AND 7. REG. 12-11-2007.
- 3,352,748. SIGMA STANDARD CHARACTER MARK. INT. CL. 9. REG. 12-11-2007.
- 3,352,751. SACRED HOURS STANDARD CHARACTER MARK. INT. CL. 14. REG. 12-11-2007.
- 3,352,753. VALICORAM (STYLIZED). INT. CL. 5. REG. 12-11-2007.
- 3,352,755. VILLACENTENO STANDARD CHARACTER MARK. INT. CL. 29. REG. 12-11-2007.
- 3,369,752. MISCELLANEOUS DESIGN. INT. CLS. 18 AND 28 ONLY. REG. 1-15-2008.
- 3,373,316. ARMEO STANDARD CHARACTER MARK. INT. CLS. 10 AND 28 ONLY. REG. 1-22-2008.
- 3,431,377. ROMEXIS (STYLIZED). INT. CLS. 10, 35 AND 42 ONLY. REG. 5-20-2008.
- 3,445,463. QIASYMPHONY STANDARD CHARACTER MARK. INT. CL. 42. REG. 6-10-2008.
- 3,462,418. FORTNUM & MASON PICCADILLY SINCE 1707 AND DESIGN. INT. CLS. 18, 25, 29, 31 AND 34 ONLY. REG. 7-8-2008.
- 3,462,470. ZIMMERMANN AND DESIGN. INT. CLS. 9 AND 40 ONLY. REG. 7-8-2008.
- 3,462,488. HORAGE STANDARD CHARACTER MARK. INT. CLS. 14, 18 AND 25 ONLY. REG. 7-8-2008.
- 3,462,646. I ROSCILLI AND DESIGN. INT. CLS. 5, 29, 32 AND 33 ONLY. REG. 7-8-2008.
- 3,462,657. YES YOUNG ENGINEERS SUPPORT AND DESIGN. INT. CLS. 35 AND 42 ONLY. REG. 7-8-2008.
- 3,468,068. RITEC STANDARD CHARACTER MARK. INT. CLS. 1 AND 19 ONLY. REG. 7-15-2008.
- 3,468,204. HERD NAVIGATOR STANDARD CHARACTER MARK. INT. CLS. 9, 42 AND 44 ONLY. REG. 7-15-2008.
- 3,472,466. CASINOCAM AND DESIGN. INT. CLS. 9, 41 AND 42 ONLY. REG. 7-22-2008.
- 3,485,325. X-ROLL STANDARD CHARACTER MARK. INT. CLS. 7, 9, 11 AND 42 ONLY. REG. 8-12-2008.
- 3,505,586. GP GIRARD-PERREGAUX (STYLIZED). INT. CLS. 14 AND 25 ONLY. REG. 9-23-2008.
- 3,512,809. C 200 (STYLIZED). INT. CLS. 7 AND 9 ONLY. REG. 10-7-2008.

---

**INADVERTENTLY ISSUED REGISTRATION  
NUMBERS**

- 4,550,039. JEANS & A CUTE TOP SHOP STANDARD CHARACTER MARK. INT. CL. 35. REG. 6-17-2014. RESTORED TO SN 85-797,449.

\* \* \* \* \*

# TRADEMARK REGISTRATIONS AMENDED, CORRECTED, ETC.

The designation "U.S. Cl." appearing in this section refers to the U.S. class in effect prior to Sep. 1, 1973 rather than the international class which applies to applications filed on or after that date. For adoption of international classification see notice in the OFFICIAL GAZETTE of Jun. 26, 1973 (911 O.G. TM 210).

Any change to the registration will be indicated at the bottom of each entry under ELEMENTS AMENDED, CORRECTED OR RESTRICTED. With the exception of changes to the goods and services, additions to the registration will appear in asterisks and deletions of the registration will appear in brackets. Elements which are only changed will be listed with no punctuation. As to the goods/services statement, amendments to the goods/services will appear in asterisks and deletions will appear in brackets. In addition if any change to the goods/services occurs, the element "Goods/Services" will be listed under ELEMENTS AMENDED, CORRECTED OR RESTRICTED.

1,294,361. REG. 9-11-1984. NATIONAL PRESTO INDUSTRIES, INC. (WISCONSIN CORPORATION) 3925 NORTH HASTINGS WAY, EAU CLAIRE, WI, 547033703, SN 73-440,394. FILED 8-22-1983. PRINCIPAL REGISTER.

1,844,300. REG. 7-12-1994. PACIFIC ENERGY FIREPLACE PRODUCTS LTD. (CANADA CORPORATION) 2975 ALLENBY ROAD, DUNCAN, BRITISH COLUMBIA, CANADA, V9L 3Y2, SN 74-414,022. FILED 7-19-1993. PRINCIPAL REGISTER.

## DIAMOND COAT

THE MARK CONSISTS OF STANDARD CHARACTERS WITHOUT CLAIM TO ANY PARTICULAR FONT, STYLE, SIZE, OR COLOR.

OWNER OF U.S. REG. NO. 1,159,201.  
INT. CL. 21/U.S. CLS. 2 AND 13  
FOR COOKWARE WITH PROTECTIVE NON-STICK COATING.

FIRST USE 7-31-1979; IN COMMERCE 7-31-1979.

ELEMENTS AMENDED  
OWNER ADDRESS  
MARK



NO CLAIM IS MADE TO THE EXCLUSIVE RIGHT TO USE "ENERGY", APART FROM THE MARK AS SHOWN.  
INT. CL. 11/U.S. CL. 34  
FOR WOOD STOVES AND GAS STOVES.  
FIRST USE 2-9-1981; IN COMMERCE 7-16-1982.

ELEMENTS AMENDED  
MARK

1,824,049. REG. 3-1-1994. INDUSTRIAS ALEN, S.A. DE C.V. (MEXICO CORPORATION) BLVD. DIAZ ORDAN NO. 1000, SANTA CATARINA, N.L. 66350, MEXICO., SN 74-396,287. FILED 6-1-1993. PRINCIPAL REGISTER.

## PINE-O-PINE

THE MARK CONSISTS OF STANDARD CHARACTERS WITHOUT CLAIM TO ANY PARTICULAR FONT, STYLE, SIZE, OR COLOR.

INT. CL. 3/U.S. CLS. 6 AND 52  
FOR HOUSEHOLD CLEANING PREPARATIONS.  
FIRST USE 12-0-1976; IN COMMERCE 12-0-1976.

ELEMENTS AMENDED  
MARK

1,874,609. REG. 1-17-1995. STACK-ON PRODUCTS CO. (ILLINOIS CORPORATION) 1360 OLD RAND ROAD, WAUCONDA, IL, 60084, SN 74-308,574. FILED 8-28-1992. PRINCIPAL REGISTER.

## ROAD BOX

NO CLAIM IS MADE TO THE EXCLUSIVE RIGHT TO USE "BOX", APART FROM THE MARK AS SHOWN.

INT. CL. 12/U.S. CL. 19  
FOR AUTOMOTIVE/TRUCK TOOL BOX MADE OF PLASTIC.  
FIRST USE 9-1-1992; IN COMMERCE 9-8-1992.

ELEMENTS CORRECTED  
OWNER NAME

1,924,170. REG. 10-3-1995. NOVA SOUTHEASTERN UNIVERSITY, INC. (FLORIDA CORPORATION) 3301 COLLEGE AVENUE, FORT LAUDERDALE, FL, 33314, SN 74-552,731. FILED 7-25-1994. PRINCIPAL REGISTER.

2,232,132. REG. 3-16-1999. DOUMAK INC. (DELAWARE CORPORATION) 2201 TOUHY AVE., ELK GROVE VILLAGE, IL, 60007, SN 75-437,018. FILED 2-19-1998. PRINCIPAL REGISTER.



**CAMPFIRE**

INT. CL. 30/U.S. CL. 46  
 FOR MARSHMALLOWS [, MARSHMALLOW CREME,  
 AND CRISP RICE TREATS ].  
 FIRST USE 1-1-1917; IN COMMERCE 1-1-1917.

ELEMENTS AMENDED  
 GOODS/SERVICES

NO CLAIM IS MADE TO THE EXCLUSIVE RIGHT TO USE "UNIVERSITY", APART FROM THE MARK AS SHOWN.

THE MARK CONSISTS OF THREE CONCENTRIC CIRCLES. THE CENTER-MOST CIRCLE CONTAINING THE LETTERS "NSU" WITH A BAR APPEARING OVER AND UNDER THE LETTERS, AND A HALF SUNRISE APPEARING ABOVE THE TOP BAR, IN THE NEXT CIRCLE, THE WORDS "NOVA SOUTHEASTERN UNIVERSITY" APPEAR WITH DOTS BETWEEN "NOVA SOUTHEASTERN" AND "UNIVERSITY". THE FINAL CONCENTRIC CIRCLE CONTAINS NO WORDING AND IS THIN, DEFINING THE OUTER EDGE OF THE SEAL DESIGN.

INT. CL. 41/U.S. CL. 107

FOR EDUCATIONAL SERVICES, NAMELY COURSES OF INSTRUCTION AT THE UNIVERSITY LEVEL.  
 FIRST USE 1-11-1994; IN COMMERCE 1-11-1994.

ELEMENTS AMENDED  
 MARK

2,756,247. REG. 8-26-2003. CASA ARMANDO GUILLERMO PRIETO, S.A. DE C.V. (MEXICO SOCIEDAD ANONIMA DE CAPITAL VARIABLE) BOSQUES DE DURAZNOS NO. 61, COL., MEXICO, MEXICO, 11700, SN 78-163,331. FILED 9-12-2002. PRINCIPAL REGISTER.

**EL SEÑORIO**



2,217,455. REG. 1-12-1999. DOUMAK INC. (DELAWARE CORPORATION) 2201 TOUHY AVE., ELK GROVE VILLAGE, DE, 60007, SN 75-453,711. FILED 3-20-1998. PRINCIPAL REGISTER.



NO CLAIM IS MADE TO THE EXCLUSIVE RIGHT TO USE THE DEPICTION OF THE AGAVE PLANT, APART FROM THE MARK AS SHOWN.

THE MARK CONSISTS OF THE WORDS "EL SEÑORIO" ABOVE A DRAWING OF THREE AGAVE PLANTS.

THE ENGLISH TRANSLATION OF THE WORDS "EL SEÑORIO" IS "THE MANOR".

INT. CL. 33/U.S. CLS. 47 AND 49

FOR TEQUILA, NAMELY MESCAL.  
 FIRST USE 8-17-1999; IN COMMERCE 12-26-2001.

INT. CL. 30/U.S. CL. 46

FOR MARSHMALLOWS [, MARSHMALLOW CREME AND CRISP RICE-BASED SNACK FOODS ].  
 FIRST USE 1-1-1917; IN COMMERCE 1-1-1917.

ELEMENTS AMENDED  
 GOODS/SERVICES

ELEMENTS AMENDED  
 \*DISCLAIMER\*  
 \*DESCRIPTION OF MARK\*  
 \*TRANSLATION OF MARK\*  
 MARK



2,808,248. REG. 1-27-2004. TRAILS WEST MANUFACTURING OF IDAHO, INC. (IDAHO CORPORATION) 65 NORTH 800 WEST, PRESTON, ID. 83263, SN 76-494,355. FILED 2-25-2003. PRINCIPAL REGISTER.



THE MARK CONSISTS OF A HORSESHOE LYING ON ITS SIDE WITH THE WORD "TRAILS" SUPERIMPOSED ON THE TOP HALF OF THE HORSESHOE AND THE WORD "WEST" SUPERIMPOSED ON THE BOTTOM HALF OF THE HORSESHOE, AND A SILHOUETTE OF A HORSEHEAD WITH A DIAMOND ON ITS FOREHEAD APPEARING WITHIN THE HORSESHOE.

INT. CL. 12/U.S. CLS. 19, 21, 23, 31, 35 AND 44  
FOR HORSE AND LIVESTOCK TRAILERS.  
FIRST USE 8-19-1997; IN COMMERCE 8-19-1997.

ELEMENTS AMENDED  
\*DESCRIPTION OF MARK\*  
MARK  
[DISCLAIMER]

2,820,274. REG. 3-2-2004. MIZUNO CORPORATION (JAPAN CORPORATION) 1-23, KITAHAMA 4-CHOME, CHUO-KU, OSAKA-SHI, OSAKA 541-8583, JAPAN., SN 76-362,622. FILED 1-23-2002. PRINCIPAL REGISTER.



NO CLAIM IS MADE TO THE EXCLUSIVE RIGHT TO USE "BODY WARMING TECHNOLOGY", APART FROM THE MARK AS SHOWN.

THE MARK CONSISTS OF THE WORDS "B BREATH THERMO" ON TOP OF THE WORDS "BODY WARMING TECHNOLOGY", ALL INSIDE A BOX.

INT. CL. 25/U.S. CLS. 22 AND 39

FOR CLOTHING:, NAMELY, [BASEBALL UNIFORMS, BASEBALL STOCKINGS,] BASEBALL UNDERSHIRTS, [BASEBALL UNDER STOCKINGS, BASEBALL SLIDING PANTS, BADMINTON SHIRTS, BADMINTON PANTS AND SHORTS, BADMINTON SKIRTS, TENNIS JACKETS, TENNIS SHIRTS, TENNIS PANTS, TENNIS SHORTS AND SKIRTS, TABLE TENNIS JACKETS, TABLE TENNIS PANTS AND SHORTS, TABLE TENNIS SHIRTS, BASKETBALL SHIRTS, BASKETBALL PANTS, BASKETBALL JERSEYS,] GOLF SHIRTS, [GOLF VESTS, GOLF JACKETS, GOLF PANTS, GOLF SOCKS, GOLF RAINCOATS, GOLF RAIN JACKETS AND PANTS, GOLF SWEATERS, FOOTBALL JACKETS, FOOTBALL PANTS, FOOTBALL SHIRTS, FOOTBALL HOSE BEING SOCKS AND STOCKINGS, VOLLEYBALL JACKETS, VOLLEYBALL WARM-UP SHIRTS, VOLLEYBALL WARM-UP PANTS, VOLLEYBALL SHIRTS, VOLLEYBALL PANTS, SKI JACKETS, SKI PANTS, SKI ANORAK

COATS, SKI STOCKINGS AND SOCKS; TRACK AND FIELD PANTS, TRACK AND FIELD WARM-UP SHIRTS, TRACK AND FIELD WARM-UP PANTS, GYMNASIIC SHIRTS, GYMNASIIC PANTS, MOUNTAINEERING JACKETS, MOUNTAINEERING SHIRTS, MOUNTAINEERING PANTS, MOUNTAINEERING SOCKS, SOCCER SHIRTS, SOCCER PANTS, WET SUITS, WATER SKI JACKETS; SUITS, COATS, JACKETS, SHIRTS,] UNDERWEAR, T-SHIRTS, [ SHORTS, SWEAT SHIRTS, SWEAT PANTS,] GLOVES [ , POLO SHIRTS, BLOUSONS, VESTS, CARDIGANS, TROUSERS, SLACKS, SHORT PANTS, SOCKS AND HOSE, RAIN WEARS, SKIRTS, CULOTTES AND WIND PROTECTION JACKETS, BLOUSES; CAPS AND HATS:, NAMELY, BASEBALL CAPS, TENNIS CAPS, GOLF CAPS, GOLF SUN VISORS, SKI CAPS, SWIM CAPS].

FIRST USE 2-1-2002; IN COMMERCE 2-1-2002.

ELEMENTS AMENDED  
MARK

2,843,298. REG. 5-18-2004. WAKEFERN FOOD CORP. (NEW JERSEY CORPORATION), DBA PRICE RITE, 5000 RIVERSIDE DRIVE, KEASBEY, NJ, 08832, SN 75-357,548. FILED 9-16-1997. PRINCIPAL REGISTER.

## PRICE RITE

OWNER OF U.S. REG. NOS. 1,892,424 AND 1,903,120.  
INT. CL. 3/U.S. CLS. 1, 4, 6, 50, 51 AND 52

FOR COSMETICS AND CLEANING PREPARATIONS, NAMELY, [ LAUNDRY DETERGENT, ] DISHWASHER DETERGENT, [ WINDOW CLEANER; ] COTTON PUFFS FOR COSMETIC PURPOSES; [ EMERY BOARDS; ] NAIL POLISH REMOVER; [ CORNSTARCH FOR PERSONAL USE; ] COTTON SWABS; [ BABY OIL; ] TALCUM POWDER; [ HAIR CARE PRODUCTS, NAMELY, SHAMPOOS, CONDITIONERS, ENTANGLES, \* DETANGLERS, \* CREAMS, LOTIONS; NON-MEDICATED SKIN CARE PRODUCTS, NAMELY, LOTIONS, CREAMS, AFTER SHAVE LOTION, SHAVING LOTIONS; ] MOUTHWASH, MOUTH RINSES, DENTURE TABLETS.

FIRST USE 2-0-1998; IN COMMERCE 2-0-1998.

INT. CL. 5/U.S. CLS. 6, 18, 44, 46, 51 AND 52

FOR MEDICATED SKIN CARE PRODUCTS, NAMELY, [ CREAMS, ] OINTMENTS, [ LOTIONS AND SPRAYS; WITCH HAZEL; MEDICATED SHAMPOO; MEDICATED LIP BALM; ] VITAMINS AND NUTRITIONAL SUPPLEMENTS; FEMININE HYGIENE PRODUCTS, NAMELY, SANITARY NAPKINS, SHIELDS, [ TAMPONS, ] DOUCHE; ADHESIVE BANDAGES; [ GAUZE BANDAGES; ] PEROXIDE FOR MEDICINAL USE; EPSOM SALT; [ MINERAL OIL; ALCOHOL FOR MEDICINAL USE; ] STERILE PADS; [ STERILE COTTON; ] ANALGESICS; ANTACIDS; [ ANTI-DIARRHEAL PREPARATIONS; COUGH AND COLD PREPARATIONS; COUGH DROPS; NASAL SPRAY; ALLERGY MEDICATIONS; EYE SOLUTIONS, CONTACT LENS CARE SOLUTIONS; ] LAXATIVES [ ; SUPPOSITORIES ].

FIRST USE 2-0-1998; IN COMMERCE 2-0-1998.

INT. CL. 8/U.S. CLS. 23, 28 AND 44

FOR [ RAZOR BLADES ].

FIRST USE 3-0-1998; IN COMMERCE 3-0-1998.

INT. CL. 11/U.S. CLS. 13, 21, 23, 31 AND 34

FOR LIGHT BULBS.

FIRST USE 5-0-1999; IN COMMERCE 5-0-1999.

INT. CL. 16/U.S. CLS. 2, 5, 22, 23, 29, 37, 38 AND 50

FOR PAPER COFFEE FILTERS, TOILET PAPER, PAPER NAPKINS.

FIRST USE 6-0-1998; IN COMMERCE 6-0-1998.

INT. CL. 21/U.S. CLS. 2, 13, 23, 29, 30, 33, 40 AND 50

FOR [ POWDER PUFFS, DENTAL FLOSS, TOOTH BRUSHES, LATEX GLOVES, MOPS AND BROOMS ].

FIRST USE 2-0-1998; IN COMMERCE 2-0-1998.

INT. CL. 29/U.S. CL. 46

FOR DAIRY PRODUCTS, NAMELY, MILK, CHEESE, EGGS, HALF AND HALF, SOUR CREAM; NON-DAIRY CREAMER; EDIBLE OILS AND FATS; PROCESSED FRUITS; [ FRUIT-BASED PIE FILLINGS; ] PROCESSED VEGETABLES; SOUPS; POTATO CHIPS.

FIRST USE 6-0-1997; IN COMMERCE 6-0-1997.  
INT. CL. 30/U.S. CL. 46

FOR BREAD, ROLLS, FLOUR, [ CAKES, CUSTARD BASED PIE FILLINGS, CHOCOLATE BASED PIE FILLINGS, ] TEA BAGS, TOASTER PASTRIES, OATMEAL, [ PANCAKE MIX, ] RICE, COOKIES, CRACKERS, SAUCES, PASTA, [ SOY PASTA WITH SAUCE, ] PRETZELS.

FIRST USE 2-0-1998; IN COMMERCE 2-0-1998.  
INT. CL. 31/U.S. CLS. 1 AND 46

FOR [ PET FOOD, ] CAT LITTER.

FIRST USE 2-0-1998; IN COMMERCE 2-0-1998.

ELEMENTS CORRECTED  
GOODS/SERVICES

FOR (( ANTI-THEFT WARNING APPARATUS FOR AUTOMOBILES ))).

FIRST USE 8-19-2002; IN COMMERCE 8-19-2002.  
INT. CL. 16/U.S. CLS. 2, 5, 22, 23, 29, 37, 38 AND 50

FOR [ INKING RIBBONS; INKING RIBBON CASSETTES; PAPER NAMELY, PRINTING PAPER, POSTCARD PAPER; CARD PAPER; TRANSFER PAPER; PAPER AND PLASTIC LABELING SHEETS FOR COMPUTER PRINTERS AND WORD PROCESSORS; PAPER AND PLASTIC IRON-ON DESIGN TRANSFER SHEETS; STATIONERY; POSTCARDS; GREETING CARDS; BUSINESS CARDS; PRINTED MATTER, NAMELY, BOOKLETS IN THE NATURE OF INSTRUCTION MANUALS, AND TRANSPARENT SHEETS FOR OVERHEAD PROJECTORS ].

FIRST USE 12-31-1988; IN COMMERCE 12-31-1988.

ELEMENTS CORRECTED  
GOODS/SERVICES

2,847,601. REG. 6-1-2004. ALPS ELECTRIC CO., LTD. (JAPAN CORPORATION) 1-7, YUKIGAYA-OTSUKAMACHI, OTAKU, TOKYO, JAPAN, 145-8501, SN 75-511,286. FILED 6-30-1998. PRINCIPAL REGISTER.

## ALPS

OWNER OF U.S. REG. NOS. 991,859, 1,928,822 AND OTHERS.

INT. CL. 9/U.S. CLS. 21, 23, 26, 36 AND 38

FOR [VIDEO GAME MACHINES AND CONTROLLER; COMMERCIAL PHOTO MACHINES FOR TAKING PICTURES; BAR CODE READERS; MAGNETIC CARTRIDGES FOR FLOPPY DISK DRIVES;] ELECTROLUMINESCENT PANELS AND SWITCH BOARDS; [LIQUID CRYSTAL DISPLAY;] MAGNETIC ENCODERS; [ MAGNETIC TAPE UNITS;] OPTICAL LENSES; LASER MODULES; OPTICAL NETWORK [ NODULES ] \* MODULES \* [AUDIO-VIDEO COMPACT DISCS, AND CD-V; [ RECORDER ] \* RECORDED \* CD-ROMS; COMPACT DISC DRIVES, AND CD-V AND CD-ROM COMPACT DISC CHANGERS AND COMPACT DISC MAGAZINES; COMPUTERS;] COMPUTER PERIPHERALS; [ COMPUTER MEMORIES;] RECORDED COMPUTER SOFTWARE FOR OPERATION OF COMPUTER PERIPHERALS, COMPUTER INPUT APPARATUS AND COMPUTER PRINTERS; TRACK PADS, [MOUSE,] KEYBOARDS; PRINTERS; [PRINTER CABLES;] DATA TRANSMISSION UNITS FOR COMPUTERS; [COMPUTER MOUSE;] [ DRIVE ] \*DRIVER \* BOARDS; [WORD PROCESSORS; IMAGE SCANNERS; OPTICAL CHARACTER READERS;] REMOTE CONTROL FOR ELECTRONIC APPARATUS, NAMELY, TV, DVD, VCR, DISC PLAYERS AND RECORDERS, RADIO APPARATUS, TAPE PLAYERS AND RECORDERS, VIDEO APPARATUS, CAR NAVIGATION APPARATUS; [MAGNETIC HEADS;] ELECTRIC/ELECTRONIC LOCKS; TELECOMMUNICATION TRANSMITTERS; TRANSMITTERS OF ELECTRONIC SIGNALS; TELECOMMUNICATION TRANSMITTING SETS; ELECTRIC CONNECTIONS; [CONNECTIONS FOR ELECTRIC LINES;] ELECTRICAL CONNECTORS; BROADCASTING SATELLITE SYSTEM ANTENNAS; BROADCASTING SATELLITE SYSTEM TELEVISION CONVERTERS; [CATV HEAD ENDS;] ELECTRIC/ELECTRONIC DOOR CLOSURES AND OPENERS; FM-RADIO RECEIVERS; FREQUENCY SYNTHESIZERS; HIGH FREQUENCY OSCILLATORS; RADIO FREQUENCY MODULATORS; TRANSCEIVER UNITS; TURNERS AND MODULAR UNITS; [VIDEO RECORDERS; TAPE RECORDERS; FACSIMILE MACHINES;] BATTERY CHARGERS; ELECTRICITY INVERTERS; JOYSTICK CONTROLLERS; ELECTRICAL SENSORS; FLUID LEVEL SENSORS; PRESSURE SENSORS, THROTTLE POSITION SENSORS; CONTROL PANELS; ELECTRICAL LIGHT DIMMERS; ELECTRICAL CONVERTERS; [VIDEO GAME PROGRAMS, MEMORY CARDS AND] CONTROLLERS FOR VIDEO GAME MACHINES.

FIRST USE 12-31-1972; IN COMMERCE 12-31-1972.

INT. CL. 12/U.S. CLS. 19, 21, 23, 31, 35 AND 44

3,103,863. REG. 6-13-2006. CHEVRON INTELLECTUAL PROPERTY LLC (DELAWARE LIMITED LIABILITY COMPANY) 6001 BOLLINGER CANYON ROAD, SAN RAMON, CA, 94583, SN 78-658,788. FILED 6-27-2005. PRINCIPAL REGISTER.

## HYDRAZONE

THE MARK CONSISTS OF STANDARD CHARACTERS WITHOUT CLAIM TO ANY PARTICULAR FONT, STYLE, SIZE, OR COLOR.

INT. CL. 35/U.S. CLS. 100, 101 AND 102

FOR RETAIL OUTLET SERVICES, NAMELY CONVENIENCE STORES.

FIRST USE 5-7-2005; IN COMMERCE 5-7-2005.

ELEMENTS AMENDED  
MARK

3,156,014. REG. 10-17-2006. PINNACLE FOODS GROUP LLC (DELAWARE LIMITED LIABILITY COMPANY) 399 JEFFERSON ROAD, PARSIPPANY, NJ, 070543707, SN 78-304,823. FILED 9-24-2003. PRINCIPAL REGISTER.

## SIGNATURE

THE MARK CONSISTS OF STANDARD CHARACTERS WITHOUT CLAIM TO ANY PARTICULAR FONT, STYLE, SIZE, OR COLOR.

SEC. 2(F).

INT. CL. 30/U.S. CL. 46

FOR BAKING MIXES, NAMELY, CAKE MIXES AND PASTRY MIXES.

FIRST USE 1-0-2004; IN COMMERCE 1-0-2004.

ELEMENTS AMENDED  
MARK  
[DISCLAIMER]

3,189,273. REG. 12-26-2006. HOLOGIC, INC. (DELAWARE CORPORATION) 35 CROSBY DRIVE, BEDFORD, MA, 01730, SN 78-798,872. FILED 1-25-2006. PRINCIPAL REGISTER.

3,317,895. REG. 10-23-2007. THE ANTIQUE MOTORCYCLE CLUB OF AMERICA, INC. (FLORIDA NON-PROFIT CORPORATION) P.O. BOX 93430, LAKE LAND, FL, 33804, SN 78-906,483. FILED 6-13-2006. PRINCIPAL REGISTER.

THE ANTIQUE MOTORCYCLE CLUB OF AMERICA



OWNER OF U.S. REG. NOS. 1,676,316, 2,858,447 AND 2,911,395.

NO CLAIM IS MADE TO THE EXCLUSIVE RIGHT TO USE "SLIDE", APART FROM THE MARK AS SHOWN. INT. CL. 10/U.S. CLS. 26, 39 AND 44

FOR MEDICAL TESTING SPECIMEN SLIDES FOR USE IN THE DETECTION AND DIAGNOSIS OF CANCER, INFECTIOUS DISEASE, AND OTHER DISEASES. FIRST USE 6-0-2003; IN COMMERCE 6-0-2003.

ELEMENTS CORRECTED  
DATE OF FIRST USE  
DATE OF FIRST USE IN COMMERCE

3,302,324. REG. 10-2-2007. THE ANTIQUE MOTORCYCLE CLUB OF AMERICA, INC. (FLORIDA NON-PROFIT CORPORATION) P.O. BOX 93430, LAKE LAND, FL, 33804, SN 78-906,491. FILED 6-13-2006. PRINCIPAL REGISTER.

THE ANTIQUE MOTORCYCLE CLUB OF AMERICA

THE MARK CONSISTS OF STANDARD CHARACTERS WITHOUT CLAIM TO ANY PARTICULAR FONT, STYLE, SIZE, OR COLOR. SEC. 2(F).

INT. CL. 41/U.S. CLS. 100, 101 AND 107  
FOR ENTERTAINMENT SERVICES, NAMELY, CONDUCTING MOTORCYCLE MEETS AND SHOWS AND JUDGING CONTESTS IN THE FIELD OF MOTORCYCLES; EDUCATIONAL SERVICES, NAMELY, CONDUCTING SEMINARS AND WORKSHOPS IN THE FIELDS OF MOTORCYCLES AND MOTORCYCLE SAFETY. FIRST USE 5-23-1954; IN COMMERCE 5-23-1954.

ELEMENTS CORRECTED  
ENTITY

THE MARK CONSISTS OF STANDARD CHARACTERS WITHOUT CLAIM TO ANY PARTICULAR FONT, STYLE, SIZE, OR COLOR. SEC. 2(F).

INT. CL. 9/U.S. CLS. 21, 23, 26, 36 AND 38  
FOR COMPACT DISKS FEATURING INFORMATION ON MOTORCYCLES, MOTORCYCLE SAFETY, MOTORCYCLE SHOWS AND SUBJECT MATTER DIRECT TO MOTORCYCLE ENTHUSIASTS. FIRST USE 12-31-2001; IN COMMERCE 12-31-2001.

INT. CL. 14/U.S. CLS. 2, 27, 28 AND 50  
FOR ORNAMENTAL PINS AND JEWELRY. FIRST USE 12-31-1988; IN COMMERCE 12-31-1988.

INT. CL. 16/U.S. CLS. 2, 5, 22, 23, 29, 37, 38 AND 50  
FOR PRINTED MATTER, NAMELY, NAMELY, MAGAZINES AND NEWSLETTERS, FEATURING INFORMATION ON MOTORCYCLES, MOTORCYCLE SAFETY, MOTORCYCLE SHOWS AND SUBJECT MATTER DIRECT TO MOTORCYCLE ENTHUSIASTS; CALENDARS; DECALS; OFFICE REQUISITES, NAMELY PENS. FIRST USE 6-8-1955; IN COMMERCE 6-8-1955.

INT. CL. 21/U.S. CLS. 2, 13, 23, 29, 30, 33, 40 AND 50  
FOR MUGS. FIRST USE 12-31-1988; IN COMMERCE 12-31-1988.

INT. CL. 25/U.S. CLS. 22 AND 39  
FOR CLOTHING, NAMELY, SHIRTS, JACKETS, HATS, AND TIES. FIRST USE 9-30-1986; IN COMMERCE 9-30-1986.

INT. CL. 26/U.S. CLS. 37, 39, 40, 42 AND 50  
FOR EMBROIDERED PATCHES FOR CLOTHING. FIRST USE 3-31-1984; IN COMMERCE 3-31-1984.

INT. CL. 35/U.S. CLS. 100, 101 AND 102  
FOR ASSOCIATION SERVICES, NAMELY PROMOTING THE INTERESTS OF INDIVIDUALS AND ASSOCIATIONS INTEREST IN MOTORCYCLES. FIRST USE 4-16-1954; IN COMMERCE 4-16-1954.

INT. CL. 41/U.S. CLS. 100, 101 AND 107  
FOR ENTERTAINMENT SERVICES, NAMELY, CONDUCTING MOTORCYCLE MEETS AND SHOWS AND JUDGING CONTESTS IN THE FIELD OF MOTORCYCLES; EDUCATIONAL SERVICES, NAMELY, CONDUCTING SEMINARS AND WORKSHOPS IN THE FIELDS OF MOTORCYCLES AND MOTORCYCLE SAFETY. FIRST USE 5-23-1954; IN COMMERCE 5-23-1954.

ELEMENTS CORRECTED  
ENTITY

3,317,904. REG. 10-23-2007. THE ANTIQUE MOTORCYCLE CLUB OF AMERICA, INC. (FLORIDA NON-PROFIT CORPORATION) P.O. BOX 93430, LAKE LAND, FL, 33804, SN 78-907,436. FILED 6-13-2006. PRINCIPAL REGISTER.

THE ANTIQUE MOTORCYCLE

THE MARK CONSISTS OF STANDARD CHARACTERS WITHOUT CLAIM TO ANY PARTICULAR FONT, STYLE, SIZE, OR COLOR.

SEC. 2(F).  
 INT. CL. 16/U.S. CLS. 2, 5, 22, 23, 29, 37, 38 AND 50  
 FOR PRINTED MATTER, NAMELY, NAMELY, MAGAZINES AND NEWSLETTERS, FEATURING INFORMATION ON MOTORCYCLES, MOTORCYCLE SAFETY, MOTORCYCLE SHOWS AND SUBJECT MATTER DIRECT TO MOTORCYCLE ENTHUSIASTS; CALENDARS; DECALS; OFFICE REQUISITES, NAMELY PENS.  
 FIRST USE 9-30-1970; IN COMMERCE 9-30-1970.

ELEMENTS CORRECTED  
 ENTITY

---

3,334,970. REG. 11-13-2007. THE ANTIQUE MOTORCYCLE CLUB OF AMERICA, INC. (FLORIDA NON-PROFIT CORPORATION) P.O. BOX 93430, LAKELAND, FL, 33804, SN 78-907,389. FILED 6-13-2006. PRINCIPAL REGISTER.



NO CLAIM IS MADE TO THE EXCLUSIVE RIGHT TO USE 1954, APART FROM THE MARK AS SHOWN.  
 THE MARK CONSISTS OF A WHEEL, CYLINDER AND A PAIR OF WINGS.  
 INT. CL. 41/U.S. CLS. 100, 101 AND 107  
 FOR ENTERTAINMENT SERVICES, NAMELY, CONDUCTING MOTORCYCLE MEETS AND SHOWS AND JUDGING CONTESTS IN THE FIELD OF MOTORCYCLES; EDUCATIONAL SERVICES, NAMELY, CONDUCTING SEMINARS AND WORKSHOPS IN THE FIELDS OF MOTORCYCLES AND MOTORCYCLE SAFETY.  
 FIRST USE 5-23-1954; IN COMMERCE 5-23-1954.

ELEMENTS CORRECTED  
 ENTITY

---

3,365,794. REG. 1-8-2008. THE ANTIQUE MOTORCYCLE CLUB OF AMERICA, INC. (FLORIDA NON-PROFIT CORPORATION) P.O. BOX 93430, LAKELAND, FL, 33804, SN 78-906,505. FILED 6-13-2006. PRINCIPAL REGISTER.

**AMCA**

THE MARK CONSISTS OF STANDARD CHARACTERS WITHOUT CLAIM TO ANY PARTICULAR FONT, STYLE, SIZE, OR COLOR.  
 INT. CL. 16/U.S. CLS. 2, 5, 22, 23, 29, 37, 38 AND 50

FOR PRINTED MATTER, NAMELY, MAGAZINES AND NEWSLETTERS FEATURING INFORMATION ON MOTORCYCLES, MOTORCYCLE SAFETY, MOTORCYCLE SHOWS AND SUBJECT MATTER DIRECTED TO MOTORCYCLE ENTHUSIASTS; CALENDARS; DECALS; OFFICE REQUISITES, NAMELY, PENS.  
 FIRST USE 9-30-1986; IN COMMERCE 9-30-1986.  
 INT. CL. 35/U.S. CLS. 100, 101 AND 102  
 FOR ASSOCIATION SERVICES, NAMELY, PROMOTING THE INTERESTS OF INDIVIDUALS AND ASSOCIATIONS INTEREST IN MOTORCYCLES.  
 FIRST USE 9-30-1986; IN COMMERCE 9-30-1986.  
 INT. CL. 41/U.S. CLS. 100, 101 AND 107  
 FOR ENTERTAINMENT SERVICES, NAMELY, CONDUCTING MOTORCYCLE MEETS AND SHOWS AND JUDGING CONTESTS IN THE FIELD OF MOTORCYCLES; EDUCATIONAL SERVICES, NAMELY, CONDUCTING SEMINARS AND WORKSHOPS IN THE FIELDS OF MOTORCYCLES AND MOTORCYCLE SAFETY.  
 FIRST USE 3-31-1970; IN COMMERCE 3-31-1970.

ELEMENTS CORRECTED  
 ENTITY

---

3,371,261. REG. 1-22-2008. WILLIAMS, KASTNER & GIBBS PLLC (WASHINGTON PROFESSIONAL LIMITED LIABILITY COMPANY) TWO UNION SQUARE, 601 UNION STREET, SUITE 4100, SEATTLE, WA, 981012380, SN 76-676,788. FILED 5-14-2007. PRINCIPAL REGISTER.

**WILLIAMS KASTNER**  

OWNER OF U.S. REG. NOS. 2,697,777 AND 2,717,366.  
 INT. CL. 45/U.S. CLS. 100 AND 101  
 FOR LEGAL SERVICES.  
 FIRST USE 3-1-2007; IN COMMERCE 3-1-2007.

ELEMENTS CORRECTED  
 OWNER NAME

---

3,385,905. REG. 2-19-2008. WORLD OF JEANS & TOPS (CALIFORNIA CORPORATION) 10 WHATNEY, IRVINE, CA, 92618, SN 76-664,214. FILED 8-7-2006. PRINCIPAL REGISTER.

**BLUE CROWN**

THE MARK CONSISTS OF STANDARD CHARACTERS WITHOUT CLAIM TO ANY PARTICULAR FONT, STYLE, SIZE, OR COLOR.  
 INT. CL. 3/U.S. CLS. 1, 4, 6, 50, 51 AND 52  
 FOR PERFUME AND COLOGNE.  
 FIRST USE 11-19-2007; IN COMMERCE 11-19-2007.

ELEMENTS CORRECTED  
 OWNER NAME

3,422,761. REG. 5-6-2008. COUNSEL FINANCIAL SERVICES, LLC (DELAWARE LIMITED LIABILITY COMPANY) 6400 MAIN STREET, SUITE 120, WILLIAMSVILLE, NY, 14221, SN 77-295,907. FILED S.R. 10-4-2007; AM. P.R. 10-4-2007. PRINCIPAL REGISTER.

### Loans to Litigators . . . Just Ask.

THE MARK CONSISTS OF STANDARD CHARACTERS WITHOUT CLAIM TO ANY PARTICULAR FONT, STYLE, SIZE, OR COLOR.  
INT. CL. 36/U.S. CLS. 100, 101 AND 102  
FOR ACCOUNTS RECEIVABLES FINANCING; FACILITATING AND ARRANGING FOR THE FINANCING OF PLAINTIFF AND ATTORNEY FUNDING; FINANCING SERVICES.  
FIRST USE 4-1-2007; IN COMMERCE 4-1-2007.

ELEMENTS CORRECTED  
CITIZENSHIP

3,436,538. REG. 5-27-2008. DEVICE TECHNOLOGIES, INC. (MASSACHUSETTS CORPORATION) 155 NORTHBORO ROAD, STE 8, SOUTHBOROUGH, MA, 01772, SN 76-593,750. FILED 5-24-2004. PRINCIPAL REGISTER.

## GROUND-FAST

THE MARK CONSISTS OF STANDARD CHARACTERS WITHOUT CLAIM TO ANY PARTICULAR FONT, STYLE, SIZE, OR COLOR.  
INT. CL. 9/U.S. CLS. 21, 23, 26, 36 AND 38  
FOR ELECTRO MAGNETIC INTERFERENCE AND RADIO FREQUENCY INTERFERENCE, EMI AND RIF SHIELDING STRIPS.  
FIRST USE 1-9-2008; IN COMMERCE 1-9-2008.

ELEMENTS CORRECTED  
OWNER NAME

3,454,507. REG. 6-24-2008. THE LIBRARY SQUARE FOUNDATION FOR ART, CULTURE AND SCIENCE (UTAH NON-PROFIT CORPORATION) 209 EAST 500 SOUTH, SALT LAKE CITY, UT, 84111, SN 77-069,677. FILED 12-21-2006. PRINCIPAL REGISTER.



INT. CL. 41/U.S. CLS. 100, 101 AND 107  
FOR INFORMAL EDUCATIONAL SERVICES, NAMELY, PROVIDING CLASSES AND LEARNING PROGRAMS, WITH THE USE OF EXHIBITS, IN THE FIELDS OF ART, CULTURE, AND SCIENCE.  
FIRST USE 3-31-2007; IN COMMERCE 3-31-2007.

ELEMENTS AMENDED  
MARK

3,457,923. REG. 7-1-2008. FRANCISCAN VINEYARDS, INC. (DELAWARE CORPORATION) 1178 GALLERON ROAD, ST. HELENA, CA, 94574, SN 77-356,861. FILED 12-20-2007. PRINCIPAL REGISTER.

## RAVENSWOOD

THE MARK CONSISTS OF STANDARD CHARACTERS WITHOUT CLAIM TO ANY PARTICULAR FONT, STYLE, SIZE, OR COLOR.  
INT. CL. 30/U.S. CL. 46  
FOR [ BARBEQUE SAUCE; ] PICANTE SAUCE; READY-MADE SAUCES; SAUCES; SAUCES FOR BARBECUED MEAT.  
FIRST USE 8-0-2004; IN COMMERCE 8-0-2004.

ELEMENTS AMENDED  
GOODS/SERVICES  
MARK

3,460,208. REG. 7-8-2008. HMP COMMUNICATIONS, LLC (DELAWARE LIMITED LIABILITY COMPANY) 83 GENERAL WARREN BOULEVARD, SUITE 100, MALVERN, PA, 19355, SN 77-104,018. FILED 2-9-2007. PRINCIPAL REGISTER.

## Podiatry Today

THE MARK CONSISTS OF STANDARD CHARACTERS WITHOUT CLAIM TO ANY PARTICULAR FONT, STYLE, SIZE, OR COLOR.  
NO CLAIM IS MADE TO THE EXCLUSIVE RIGHT TO USE "PODIATRY", APART FROM THE MARK AS SHOWN.  
INT. CL. 16/U.S. CLS. 2, 5, 22, 23, 29, 37, 38 AND 50  
FOR PRINTED PERIODICALS IN THE FIELD OF PODIATRY FEATURING INFORMATIVE, HOW-TO-CLINICAL ARTICLES AND PRACTICE MANAGEMENT FEATURES.  
FIRST USE 3-0-1989; IN COMMERCE 3-0-1989.

ELEMENTS CORRECTED  
OWNER ADDRESS  
CITIZENSHIP

3,462,419. REG. 7-8-2008. FABORY NEDERLAND B.V. (NETHERLANDS LIMITED LIABILITY COMPANY) ZENHEUVELENWEG 44, NL-5048 AN TILBURG, NETHERLANDS., SN 79-021,068. FILED 9-30-2005. PRINCIPAL REGISTER.



OWNER OF INTERNATIONAL REGISTRATION 0837975 DATED 6-4-2004, EXPIRES 6-4-2024.  
OWNER OF U.S. REG. NOS. 1,137,330 AND 1,186,383.  
INT. CL. 1/U.S. CLS. 1

FOR CHEMICAL PRODUCTS, NAMELY, AUTOMOBILE BRAKE SYSTEM SEALANTS AND TIRE PUNCTURE SEALANTS, PREMIXED ADHESIVE FOAM CEMENT, GLUES AND ADHESIVE TAPES FOR INDUSTRIAL USE.

FIRST USE ; IN COMMERCE .

INT. CL. 3/U.S. CLS. 1, 4, 6, 50, 51 AND 52

FOR SKIN CLEANSERS, NAMELY, CLEANING, SCOURING AND ABRASIVE LIQUIDS AND POWDERS FOR SKIN, SOAP DETERGENT; SOAPS.

FIRST USE ; IN COMMERCE .

INT. CL. 4/U.S. CLS. 1, 6 AND 15

FOR INDUSTRIAL OILS AND GREASES; INDUSTRIAL AND AUTOMOTIVE LUBRICANTS.

FIRST USE ; IN COMMERCE .

INT. CL. 6/U.S. CLS. 2, 12, 13, 14, 23, 25 AND 50

FOR [ COMMON METALS AND THEIR ALLOYS, NAMELY, STEEL AND ITS ALLOYS, BRASS AND ITS ALLOYS, COPPER AND ITS ALLOYS, TITANIUM AND ITS ALLOYS; BUILDING MATERIALS OF METAL, NAMELY, METAL SOFFITS, METAL CLADDING; TRANSPORTABLE BUILDINGS MADE OF METAL; MATERIALS OF METAL FOR RAILWAY TRACKS; NON-ELECTRIC CABLES AND WIRES OF COMMON METAL; METAL IRONMONGERY AND SMALL ITEMS OF METAL HARDWARE FOR LOCKSMITHING APPLICATIONS, NAMELY, PINS, DEADBOLTS, LOCK RINGS AND KEYS, METAL STRAP-HINGES AND CLOSURES FOR DOORS, WINDOWS AND VIEWING WINDOWS FOR USE IN INDUSTRIAL MACHINERY; METAL SCREWS, METAL NUTS, METAL BOLTS, METAL PLUGS, METAL SNAP RINGS, METAL CLAMPING PLATES, METAL COTTER PINS AND BALL LOCK PINS, THREADED METAL RODS, METAL FASTENING INSERTS, NAMELY, METAL CONCRETE INSERTS, METAL EXPANSION SHIELDS, METAL WEDGE ANCHORS, METAL DRILLING ANCHORS AND METAL SAFETY ANCHORS, METAL FRAME FIXINGS IN THE NATURE OF BRACKETS AND ANCHORS, METAL CAVITY FIXINGS IN THE NATURE OF BRACKETS, METAL TOGGLE PLUGS, METAL WALL PLUGS, METAL CLAMPS, METAL BEAM CLIPS, METAL ROPE CLIPS, METAL CHAIN SHACKLES, METAL GATE HOOKS, METAL U-BOLTS, METAL HOSE CLAMPS, METAL WASHERS FOR SPACING OR SECUREMENT OF FASTENERS, METAL PUSH-IN CAPS FOR TUBING ENDS, METAL PEGS, NAILS, METAL RIVETS, METAL CRAMPS, WIRES, METAL WATTLE FOR USE IN BUILDING CONSTRUCTION, WIRE MESH, METAL BRAKE CABLE AND FENCE TENSIONERS, BINDING SCREWS OF METAL FOR CABLES; METAL CRANK HANDLES IN THE FORM OF BARS AND NON-PLASTICIZED RINGS, METAL CHAINS, METAL SPLIT PINS, BELT TENSIONERS OF METAL, PLASTIC-COATED, ZINC-COATED METAL POLES IN PIPE FORM; PLASTIC-COATED METAL GARDEN DOORS, METAL PIPES, METAL FLANGES AND BUSHINGS ].

FIRST USE ; IN COMMERCE .

INT. CL. 8/U.S. CLS. 23, 28 AND 44

FOR [ HAND-OPERATED TOOLS AND IMPLEMENTS, NAMELY, SAWS, SHEARS, WRENCHES, PUTTY KNIVES, DRILLS, GENERAL PURPOSE HAND GRINDERS FOR USE IN WOODWORKING AND METALWORKING, AXES, CHISELS, DIES, HAMMERS, SHOVELS, PLIERS, SCISSORS, PUNCHES, PIPE CUTTERS, RASPS, REAMERS, SCRAPERS, SHARPENING WHEELS, SOCKET WRENCHES, SOCKET SPANNERS AND SQUARES; GARDENING TOOLS, NAMELY, EARTH DRILLS, PRUNE SAWS, RAKES, AND SPADES ].

FIRST USE ; IN COMMERCE .

INT. CL. 17/U.S. CLS. 1, 5, 12, 13, 35 AND 50

FOR LUTING AGENTS, NAMELY, FILLING AGENT IN THE NATURE OF PIPE JOINT COMPOUND AND SEALS FOR METAL AND NON-METAL PIPE CONNECTIONS.

FIRST USE ; IN COMMERCE .

INT. CL. 20/U.S. CLS. 2, 13, 22, 25, 32 AND 50

FOR [ NON-METALLIC FASTENING MATERIALS, NAMELY, NON-METALLIC STRAP HINGES, NON-METAL SCREWS, NON-METAL NUTS, NON-METAL BOLTS, NON-METAL PLUGS IN THE NATURE OF FILLINGS AND COVERINGS FOR HOLES OR OPENINGS, NON-METAL SNAP RINGS, NON-METAL CLAMPING PLATES, NON-METAL COTTER PINS AND BALL LOCK PINS, NON-METAL AND NON-PAPER CLOSURES FOR DOORS, WINDOWS AND FOR USE IN SECURING LATCHES IN INDUSTRIAL MACHINERY; NON-METAL AND NON-PAPER CLOSURES FOR CONTAINERS; BINDING SCREWS NOT OF METAL FOR CABLES ].

FIRST USE ; IN COMMERCE .

INT. CL. 35/U.S. CLS. 100, 101 AND 102

FOR CONSULTING SERVICES RELATING TO THE PURCHASE OF APPROPRIATE FASTENING MATERIALS.

FIRST USE ; IN COMMERCE .

INT. CL. 37/U.S. CLS. 100, 103 AND 106

FOR REPAIR OF EQUIPMENT FOR TECHNICAL USE, NAMELY, HAND TOOLS AND IMPLEMENTS; PROVIDING INFORMATION AND CONSULTATION IN THE FIELD OF THE USE AND INSTALLATION OF APPROPRIATE FASTENING MATERIALS.

FIRST USE ; IN COMMERCE .

ELEMENTS CORRECTED  
GOODS/SERVICES

3,463,010. REG. 7-8-2008. UNITED STATES LUGGAGE COMPANY, LLC (NEW YORK LIMITED LIABILITY COMPANY) 400 WIRELESS BOULEVARD, HAUPPAUGE, NY, 11788, SN 77-043,207. FILED 11-14-2006. PRINCIPAL REGISTER.



The logo for SmartStrap features the word "Smart" in a bold, red, sans-serif font, followed by the word "Strap" in a black, sans-serif font. A stylized graphic of a strap with a buckle is positioned above the letter "a" in "Strap".

THE APPLICANT CLAIMS COLOR AS A FEATURE OF THE MARK, NAMELY, BLACK, GRAY AND RED.

THE MARK CONSISTS OF THE WORD "SMART" IN RED FOLLOWED BY THE WORD "STRAP" IN BLACK WITH A REPRESENTATION OF A STRAP IN THREE POSITIONS IN SHADES OF GRAY OVER THE "A".

INT. CL. 9/U.S. CLS. 21, 23, 26, 36 AND 38

FOR LAPTOP CARRYING CASES.

FIRST USE 7-0-2003; IN COMMERCE 7-0-2003.

INT. CL. 18/U.S. CLS. 1, 2, 3, 22 AND 41

FOR BUSINESS CASES; LUGGAGE; TOTE BAGS.

FIRST USE 7-0-2003; IN COMMERCE 7-0-2003.

ELEMENTS CORRECTED  
OWNER NAME  
CITIZENSHIP  
ENTITY

3,475,250. REG. 7-29-2008. GROUNDS FOR HEALTH, INC. (VERMONT NON-PROFIT CORPORATION) 92 SOUTH MAIN STREET, WATERBURY, VT. 05676. SN 77-288,550. FILED 9-25-2007. PRINCIPAL REGISTER.



THE COLOR(S) BLUE AND BROWN IS/ARE CLAIMED AS A FEATURE OF THE MARK.

THE MARK CONSISTS OF THE WORDS "GROUNDS FOR HEALTH" WITH EACH WORD ON A SEPARATE LINE. THE WORDS "GROUNDS" AND "HEALTH" ARE IN LOWER-EASE LETTERS, AND THE WORD "FOR" IS IN UPPER-CASE LETTERS. A DEPICTION OF A COFFEE BEAN, COLORED BROWN, IS USED IN PLACE OF THE LETTER "O" IN THE WORD "GROUNDS". THE REMAINDER OF THE LETTERS IN THE WORDS "GROUNDS" AND "HEALTH" ARE COLORED BLUE. THE WORD "FOR" IS COLORED BROWN.

INT. CL. 44/U.S. CLS. 100 AND 101  
FOR PROVIDING MEDICAL SERVICES TO WOMEN IN UNDERDEVELOPED COUNTRIES.  
FIRST USE 1-1-2000; IN COMMERCE 1-1-2000.

ELEMENTS CORRECTED  
OWNER NAME  
OWNER ADDRESS

\_\_\_\_\_

3,477,983. REG. 7-29-2008. SYNVASIVE TECHNOLOGY, INC. (CALIFORNIA CORPORATION) 345 EAST MAIN STREET, WARSAW, IN, 46580, SN 78-638,441. FILED 5-26-2005. PRINCIPAL REGISTER.

eLIBRA

THE MARK CONSISTS OF STANDARD CHARACTERS WITHOUT CLAIM TO ANY PARTICULAR FONT, STYLE, SIZE, OR COLOR.

INT. CL. 10/U.S. CLS. 26, 39 AND 44  
FOR INSTRUMENT SET FOR KNEE SURGERY COMPRISING ASSEMBLIES, PLATES AND FASTENERS FOR A TOTAL KNEE REPLACEMENT; SURGICAL INSTRUMENTS FOR KNEE SURGERY [ ; SURGICAL EQUIPMENT, NAMELY, STERILE TRAYS ].  
FIRST USE 7-9-2007; IN COMMERCE 7-9-2007.

ELEMENTS AMENDED  
GOODS/SERVICES

3,479,273. REG. 8-5-2008. KENWOOD INVESTMENTS, L.P. (TEXAS LIMITED PARTNERSHIP), DBA TUSCAN LAKES DEVELOPMENT, L.P., 5005 RIVERWAY, SUITE 500, HOUSTON, TX. 77056. SN 77-233,836. FILED 7-19-2007. PRINCIPAL REGISTER.

TUSCAN LAKES

THE MARK CONSISTS OF STANDARD CHARACTERS WITHOUT CLAIM TO ANY PARTICULAR FONT, STYLE, SIZE, OR COLOR.

INT. CL. 37/U.S. CLS. 100, 103 AND 106  
FOR REAL ESTATE DEVELOPMENT.  
FIRST USE 2-1-2004; IN COMMERCE 2-1-2004.

ELEMENTS CORRECTED  
OWNER NAME  
OWNER ADDRESS

\_\_\_\_\_

3,479,274. REG. 8-5-2008. KENWOOD INVESTMENTS, L.P. (TEXAS LIMITED PARTNERSHIP), DBA TUSCAN LAKES DEVELOPMENT, L.P., 5005 RIVERWAY, SUITE 500, HOUSTON, TX. 77056. SN 77-233,889. FILED 7-19-2007. PRINCIPAL REGISTER.



INT. CL. 37/U.S. CLS. 100, 103 AND 106  
FOR REAL ESTATE DEVELOPMENT.  
FIRST USE 2-1-2004; IN COMMERCE 2-1-2004.

ELEMENTS CORRECTED  
OWNER NAME  
OWNER ADDRESS

\_\_\_\_\_

3,498,836. REG. 9-9-2008. PRO ONE JANITORIAL, INC. (WISCONSIN CORPORATION) 1101 ASHWAUBENON STREET, GREEN BAY, WI, 54304, SN 77-391,923. FILED 2-8-2008. PRINCIPAL REGISTER.

PRO ONE JANITORIAL

THE MARK CONSISTS OF STANDARD CHARACTERS WITHOUT CLAIM TO ANY PARTICULAR FONT, STYLE, SIZE, OR COLOR.

NO CLAIM IS MADE TO THE EXCLUSIVE RIGHT TO USE "JANITORIAL", APART FROM THE MARK AS SHOWN.  
INT. CL. 37/U.S. CLS. 100, 103 AND 106

FOR JANITORIAL SERVICES.  
FIRST USE 6-1-1994; IN COMMERCE 6-1-1994.

ELEMENTS CORRECTED  
OWNER NAME  
OWNER ADDRESS

3,511,652. REG. 10-7-2008. NORTHWEST MONTANA HUMAN RESOURCES, INC. (MONTANA CORPORATION), DBA COMMUNITY ACTION PARTNERSHIP OF NORTHWEST MONTANA, 214 MAIN STREET, KALISPELL, MT, 59901, SN 77-407,848. FILED 2-27-2008. PRINCIPAL REGISTER.

"Home is Where I Want to Be."

3,507,740. REG. 9-30-2008. DOCSTOC INC. (DELAWARE CORPORATION) 409 SANTA MONICA BOULEVARD, SUITE 2A, SANTA MONICA, CA, 90401, SN 77-384,097. FILED 1-30-2008. PRINCIPAL REGISTER.

THE MARK CONSISTS OF STANDARD CHARACTERS WITHOUT CLAIM TO ANY PARTICULAR FONT, STYLE, SIZE, OR COLOR.  
INT. CL. 44/U.S. CLS. 100 AND 101  
FOR HOME HEALTH CARE SERVICES.  
FIRST USE 3-1-1996; IN COMMERCE 3-1-1996.

**DOCSTOC**

ELEMENTS CORRECTED  
\*DBA/AKA\*  
OWNER NAME

THE MARK CONSISTS OF STANDARD CHARACTERS WITHOUT CLAIM TO ANY PARTICULAR FONT, STYLE, SIZE, OR COLOR.

THE WORDING "DOCSTOC" HAS NO MEANING OTHER THAN TRADEMARK SIGNIFICANCE.  
INT. CL. 42/U.S. CLS. 100 AND 101

FOR ONLINE SERVICES, NAMELY, PROVIDING A WEBSITE TO ENABLE CONSUMERS AND USERS TO UPLOAD, POST, SHOW, VIEW, DISPLAY, CATEGORIZE, SEARCH, DOWNLOAD, RATE, COMMENT UPON, STORE, TAG, BLOG, AND SHARE DOCUMENTS AND OTHER MEDIA OR INFORMATION OVER THE INTERNET OR OTHER COMMUNICATIONS NETWORKS.  
FIRST USE 4-30-2007; IN COMMERCE 4-30-2007.

3,560,072. REG. 1-13-2009. DATA AND CONTACT MANAGEMENT SOLUTIONS, LLC (DELAWARE LIMITED LIABILITY COMPANY) SUITE A600; 7601 PENN AVENUE SOUTH, MINNEAPOLIS, MN, 55423, SN 77-428,185. FILED 3-21-2008. PRINCIPAL REGISTER.

**Probate Finder**

ELEMENTS CORRECTED  
OWNER NAME  
OWNER ADDRESS

THE MARK CONSISTS OF STANDARD CHARACTERS WITHOUT CLAIM TO ANY PARTICULAR FONT, STYLE, SIZE, OR COLOR.

NO CLAIM IS MADE TO THE EXCLUSIVE RIGHT TO USE "PROBATE", APART FROM THE MARK AS SHOWN.  
SEC. 2(F).  
INT. CL. 35/U.S. CLS. 100, 101 AND 102

FOR PROVIDING ESTATE DATA MANAGEMENT SERVICES TO OTHERS, NAMELY, LOCATING ESTATES AND ORGANIZING THEM INTO A DATABASE OF EXISTING ESTATE ACCOUNTS, MATCHING CUSTOMER ACCOUNTS TO ESTATE RECORDS IN A DATABASE, AND MAINTAINING A DATABASE THAT AUTOMATES AND PRIORITIZES THE CLAIM GENERATION AND FILING PROCESS.  
FIRST USE 5-29-2002; IN COMMERCE 5-29-2002.

3,510,307. REG. 9-30-2008. CERVEZAS CUAUHEMOC MOC-TEZUMA, S.A. DEC.V. (MEXICO CORPORATION) AV. ALFONSO REYES 2202 NTE., BELLAVISTA, MONTERREY, NUEVO LEON, NM., SN 77-462,096. FILED P.R. 4-30-2008; AM. S.R. 8-22-2008. SUPPLEMENTAL REGISTER.

**BEERS OF MEXICO**

ELEMENTS CORRECTED  
CITIZENSHIP

THE MARK CONSISTS OF STANDARD CHARACTERS WITHOUT CLAIM TO ANY PARTICULAR FONT, STYLE, SIZE, OR COLOR.

NO CLAIM IS MADE TO THE EXCLUSIVE RIGHT TO USE "BEERS", APART FROM THE MARK AS SHOWN.  
INT. CL. 32/U.S. CLS. 45, 46 AND 48

FOR BEER.  
FIRST USE 2-28-2007; IN COMMERCE 2-28-2007.

3,587,213. REG. 3-10-2009. TRENITALIA S.P.A. (ITALY JOINT STOCK COMPANY) PIAZZA DELLA CROCE ROSSA, 1, I-00161 ROMA, ITALY., SN 79-032,807. FILED 12-28-2004. PRINCIPAL REGISTER.



ELEMENTS AMENDED  
MARK  
[DESCRIPTION OF MARK]  
[COLOR DESCRIPTION STATEMENT]

PRIORITY DATE OF 7-29-2004 IS CLAIMED.



OWNER OF INTERNATIONAL REGISTRATION 0908285 DATED 12-28-2004, EXPIRES 12-28-2014.

THE TRADEMARK CONSISTS OF THE COMBINATION OF A STYLIZED LETTER "A" AND A STYLIZED LETTER "V", THE LETTER "A" BEING FORMED IN ITS LEFT SIDE, BY AN UPWARD OBLIQUE STROKE, AND IN ITS RIGHT SIDE OF A STROKE WHICH CURVES, SO TO FORM A LETTER "V", THE WHOLE BEING INTERSECTED IN ITS UPPER PART BY A HORIZONTAL LINE WHICH CONSTITUTES THE CENTRAL LINE OF THE LETTER "A", ALL LINES BEING OF A DEBASED THICKNESS TOWARDS THE ENDS.

INT. CL. 12/U.S. CLS. 19, 21, 23, 31, 35 AND 44

FOR AUTOMOBILES, TRUCKS, BUSES, VANS, TRACTORS, TRAILERS, MOTORCYCLES, MOPEDS, AEROPLANES, VEHICULAR BALLOONS, [ BOATS, SHIPS, ] HELICOPTERS, VEHICLES ENGINES FOR AUTOMOBILES, MOTORCYCLES AND TRAINS, LAND VEHICLE STRUCTURAL PARTS AND ENGINES; VEHICLE UPHOLSTERY, ANTI-THEFT DEVICES FOR VEHICLES; LOCOMOTIVES; RAIL VEHICLES, NAMELY, TRAINS; COACHES, MASS TRANSIT VEHICLES, NAMELY, BUSES, RAILWAY CARS, RAILWAY BOGIES, FREIGHT RAIL WAGONS; RAIL-BOUND BUSES; TRAINS IN THE NATURE OF CABLE CARS; TROLLEY BUS; LUGGAGE RACKS FOR MOTOR CARS; FUNICULAR AND CABLE RAILWAYS CARS; ELECTRIC DRIVES FOR LAND-BOUND VEHICLE; ELECTRIC TRACTION ENGINES FOR LAND VEHICLES; BRAKES FOR LAND VEHICLES; AUTOMOBILE BODIES, AIR TURBINES FOR LAND VEHICLES; RAILWAY WHEELS; ELECTRIC CURRENT CARRIER CONVERTERS FOR TRAINS, ROLLING STOCK FOR RAILWAYS.

FIRST USE ; IN COMMERCE .

INT. CL. 14/U.S. CLS. 2, 27, 28 AND 50

FOR CLOCKS, WATCHES, CHRONOMETERS, WRIST-WATCHES, WATCH CASES, SUN DIALS, GOODS OF PRECIOUS METAL, NAMELY, COFFEE AND TEA SERVICES, SERVING PLATTERS, COFFEE AND TEA POTS, NON-MONETARY COINS, CIGARETTES LIGHTERS, ASHTRAYS, SCULPTURES, BELT BUCKLES, JEWELLERY BOXES, AND NON-ELECTRIC CANDELABRAS; JEWELLERY.

FIRST USE ; IN COMMERCE .

INT. CL. 16/U.S. CLS. 2, 5, 22, 23, 29, 37, 38 AND 50

FOR PENS, CRAYONS, OFFICE MACHINES, NAMELY, OFFICE LABELLING MACHINES, STATIONERY, PAPER SHEETS FOR NOTE TAKING, WIRE-BOUND NOTEBOOKS, ENVELOPES, WRAPPING PAPER, PAPER BOARDS, TERRESTRIAL GLOBES, PAPER AND CARDBOARD CONTAINERS, PAPER LABEL, PRINTED TICKETS, PRINTED MATTER, NAMELY, BOOKS AND MAGAZINES IN THE FIELD OF TRAVEL, POSTCARDS, GREETING CARDS, PAINTING SETS, BATHROOM TISSUE MADE OF PAPER, PAPER FILTERS FOR COFFEE MAKERS, FACIAL TISSUE, TABLE LINEN MADE OF PAPER, GARBAGE BAGS MADE OF PAPER AND PLASTIC, TOILET PAPER, PAPER DOILIES, PAPER NAPKINS, PAPER HANDKERCHIEFS, [ VACUUM CLEANERS BAGS, ] BUSINESS CARDS.

FIRST USE ; IN COMMERCE .

INT. CL. 18/U.S. CLS. 1, 2, 3, 22 AND 41

FOR BAGS, NAMELY, HANDBAGS, TOTE BAGS, GYM BAGS, SCHOOLBAGS, TRAVEL BAGS, LEATHER POCKETBOOKS; LEATHER HIDES, TRUNKS; WAIST PACKS, BRIEFCASES, DOCUMENT CASES, BACKPACKS, WALLETS, POUCHES OF LEATHER, BUSINESS CASES AND CARD CASES, NAMELY, CALLING CARD CASES, BUSINESS CARD CASES AND CALLING CARD CASES; KEY CASES; LUGGAGE, PARASOLS, UMBRELLAS, WALKING STICKS; BRIEFCASE-TYPE PORTFOLIOS; CLOTHING FOR DOGS, HARNESS AND SADDLERY; COSMETIC CASES SOLD EMPTY; INFANT CARRIERS WORN ON THE BODY.

FIRST USE ; IN COMMERCE .

INT. CL. 20/U.S. CLS. 2, 13, 22, 25, 32 AND 50

FOR FURNITURE, WINDOW BLINDS, SLEEPING BAGS, CUSHIONS, MATTRESSES, BADGES IN THE NATURE OF PLASTIC NAME BADGES, CLOTHES HANGERS, NON METAL AND NON PAPER CLOSURES FOR CONTAINERS, DISPLAY RACKS, PLASTIC STORAGE DRUMS, PICTURE FRAMES; WOOD AND PLASTIC BOXES AND DISPLAY CASES; FIXED TOWEL DISPENSERS NOT OF METAL; STATUES OF BONE, IVORY, PLASTIC AND WOOD; GIFT PACKAGE DECORATIONS MADE OF PLASTIC; MATTRESSES FOR RECREATIONAL USE.

FIRST USE ; IN COMMERCE .

INT. CL. 21/U.S. CLS. 2, 13, 23, 29, 30, 33, 40 AND 50

FOR PORTABLE BEVERAGE COOLERS, PORTABLE BEVERAGE DISPENSERS, COOLERS FOR WINE, KNIFE BOARDS, BOTTLES SOLD EMPTY, GLASS BOWLS, DISHES, CUPS, HAND-OPERATED COFFEE GRINDERS, NON ELECTRIC COFFEE PERCOLATORS, TEA KETTLES, ALL PURPOSE PORTABLE HOUSEHOLD CONTAINERS, HOUSEHOLD CONTAINER FOR FOOD, FRYING PANS, POTS, DRINKING GLASSES, RUBBER HOUSEHOLD GLOVES, GARDEN HOSES, BOTTLE OPENERS, TOOTHPICKS, DRINKING VESSELS, HEAT-INSULATED VESSELS, SERVING SPOONS; CHINA, EARTHENWARE AND GLASS SCULPTURES; BROOMS, DUSTERS, TOILET BRUSHES, DUSTBINS, NON ELECTRIC CARPET CLEANERS, CLEANING CLOTH, COSMETIC BRUSHES, SHAVING BRUSHES, HAIR BRUSHES, COMBS, SOAP HOLDERS, SERVIETTE HOLDERS, TOILET PAPER HOLDERS.

FIRST USE ; IN COMMERCE .

INT. CL. 25/U.S. CLS. 22 AND 39

FOR CLOTHING, NAMELY, PULLOVERS, CARDIGANS, SWEATERS, TROUSERS, SKIRTS, JACKETS, BLOUSES, SHIRTS, JEANS, SWEATPANTS, SHORTS, SWEATSHIRTS, SUITS, DRESSES, OVERCOATS, COATS, RAINCOATS, BELTS, JERSEYS, NECKWEAR, SOCKS AND STOCKINGS; TIGHTS, VESTS, WAISTCOATS, JUMPERS, TRACKSUITS, BLOUSONS, GYM SUITS, KNICKERS, T-SHIRTS, ANORAKS, LOUNGEWEAR, UNDERWEAR; BEACHWEAR, SLEEPWEAR; HEADWEAR, HATS AND CAPS, SCARVES, GLOVES, SHOES, SANDALS, BOOTS.

FIRST USE ; IN COMMERCE .

INT. CL. 28/U.S. CLS. 22, 23, 38 AND 50

FOR SPORTING ARTICLES, NAMELY, SPORT BALLS AND SOCCER GLOVES, KNEE GUARDS AND LEG GUARDS, SURFBOARD, SKIS, TENNIS RACKETS, HOCKEY STICKS, ROLLER SKATES AND ICE SKATES, MANUALLY OPERATED SPORTING MACHINES, NAMELY, TREADMILLS, STAIR-STEPPERS, ROWERS AND STATIONERY EXERCISE BIKES; BARBELLS WITH AND WITHOUT WEIGHTS, EXERCISE WEIGHTS AND HAND BARS FOR MUSCULAR TRAINING; DUMBBELLS FOR WEIGHT LIFTING AND EXERCISE BENCHES; CHILDREN TOYS, NAMELY, TOYS, GAMES AND PLAYTHINGS, NAMELY, TOY FIGURES, PLAY FIGURES, ACTION FIGURES, DOLLS, DOLL CLOTHING, DOLL STYLING HEADS, TOY VEHICLES, TOY VEHICLE TRACK SETS, AND PLAY-SETS, ACCESSORIES AND CASES FOR ALL OF THE FOREGOING; PLUSH TOYS, BOARD GAMES; ELECTRONIC GAMES, NAMELY, ELECTRONIC EDUCATIONAL GAME MACHINES FOR CHILDREN; TOY MODEL VEHICLES, KITES; PROMOTIONAL GAME CARDS; PLAYING CARDS .

FIRST USE ; IN COMMERCE .

INT. CL. 34/U.S. CLS. 2, 8, 9 AND 17

FOR ASHTRAYS NOT OF PRECIOUS METAL, FLINT FOR LIGHTERS, CIGAR CUTTERS, CIGARETTE CASES, TOBACCO, CIGARETTES, CIGARS, MATCHES, CIGARETTES LIGHTERS NOT OF PRECIOUS METAL, ROLLING CIGARETTE PAPER, TOBACCO POUCHES, SNUFF, TOBACCO SPITTOON.

FIRST USE ; IN COMMERCE .

INT. CL. 35/U.S. CLS. 100, 101 AND 102

FOR ADVERTISING CONSULTANCY, BUSINESS CONSULTANCY, IMPORT-EXPORT AGENCIES, ECONOMIC AND MARKET ANALYSIS, BUSINESS INFORMATION AND INVESTIGATION, BUSINESS MERCHANDISING SERVICE, NAMELY, MARKETING, PRODUCT MERCHANDISING, RETAIL AND WHOLESALE DISTRIBUTORSHIP SERVICES FEATURING CLOTHING, FOOD AND BEVERAGES, BOOKS AND NEWSPAPERS; ORGANIZATION AND HOLDING OF FAIRS AND EXHIBITIONS FOR COMMERCIAL AND ADVERTISING PURPOSES, LOCATION OF FREIGHT CARS BY COMPUTERS, TRAVEL MANAGEMENT, MERCHANDISE PACKAGING, CHAMBER OF COMMERCE SERVICES, NAMELY, PROMOTING BUSINESS AND TOURISM SERVICES IN NEW YORK AREA, PUBLIC RELATIONS SERVICES, RESTAURANT FRANCHISING.

FIRST USE ; IN COMMERCE .

INT. CL. 38/U.S. CLS. 100, 101 AND 104

FOR BROADCASTING SERVICES, NAMELY, RADIO BROADCASTING, TELEVISION BROADCASTING; TELECOMMUNICATION ACCESS SERVICES, ELECTRONIC AND DIGITAL TRANSMISSION OF VOICE DATA IMAGES SIGNALS AND MESSAGES; INTERNET CAFE SERVICES, NAMELY, PROVIDING TELECOMMUNICATION CONNECTIONS TO THE INTERNET IN A CAFE ENVIRONMENT; RENTAL OF TELECOMMUNICATION LINES; RENTAL OF EQUIPMENT FOR TELECOMMUNICATIONS; PROVIDING ACCESS TO TELECOMMUNICATION AND GLOBAL OR COMPUTER NETWORKS; TRANSMISSION OF NEWS.  
FIRST USE ; IN COMMERCE .

3,600,512. REG. 3-31-2009. FORCE-FACING OUR RISK OF CANCER EMPOWERED, INC. (FLORIDA CORPORATION) 16057 TAMPA PALMS BLVD., W., #373, TAMPA, FL, 33647. SN 77-380,657. FILED P.R. 1-25-2008; AM. S.R. 2-23-2009. SUPPLEMENTAL REGISTER.

# PREVIVOR

INT. CL. 39/U.S. CLS. 100 AND 105

FOR TRANSPORT OF PASSENGERS AND GOODS BY AERIAL, TERRESTRIAL AND NAVAL VEHICLES; AIRPORT, RAILWAYS STATION SERVICES, NAMELY, TRAIN PARKING, TRAIN HAULING, VEHICLE TOWING AND SHIP PARKING, SHIP HAULING, SHIP TOWING; CHARTERING OF PLANES, YACHTS, BOATS, TRAINS, BUSES, CARS, RENTAL OF AERIAL, TERRESTRIAL AND NAVAL VEHICLES; VEHICLE PARKING; RENTAL OF WAREHOUSE SPACE; WAREHOUSING STORAGE; TRAVEL AGENCY SERVICES, NAMELY, MAKING RESERVATIONS AND BOOKINGS FOR TRAVEL AND TOURIST AGENCY SERVICES; ORGANIZATION OF TRAVEL AND TOURS, NAMELY, ARRANGING TRAVEL TOURS; TRAVEL BOOKING AGENCIES SERVICES FOR TRAIN SERVICES, TRAIN TICKETS, AEROPLANE TICKETS, BUS TICKETS, SHIP TICKETS AND BOAT TICKETS; TRAVEL, TOUR AND TRAFFIC INFORMATION SERVICES; TRANSPORT BROKERAGE; ENERGY, GAS AND WATER DISTRIBUTION SERVICES; OIL DISTRIBUTION SERVICES, NAMELY, TRANSMISSION OF OIL THROUGH PIPELINES; WATER SUPPLY SERVICES; PACKAGING ARTICLES FOR TRANSPORTATION; ELECTRONIC STORAGE OF DOCUMENTS.  
FIRST USE ; IN COMMERCE .

THE MARK CONSISTS OF STANDARD CHARACTERS WITHOUT CLAIM TO ANY PARTICULAR FONT, STYLE, SIZE, OR COLOR.

INT. CL. 36/U.S. CLS. 100, 101 AND 102

FOR CHARITABLE FUNDRAISING AND ACCEPTING AND ADMINISTERING MONETARY CHARITABLE CONTRIBUTIONS TO ADVOCATE AND TO EDUCATE WOMEN ABOUT FAMILY HISTORY AND GENETIC FACTORS THAT CREATE A PREDISPOSITION TO CANCER.

FIRST USE 2-20-2001; IN COMMERCE 2-20-2001.

ELEMENTS AMENDED  
MARK

INT. CL. 43/U.S. CLS. 100 AND 101

FOR ARRANGING AND PROVIDING OF TEMPORARY HOUSING ACCOMMODATION; MAKING HOTEL RESERVATIONS FOR OTHERS; PROVIDING OF TEMPORARY ACCOMMODATION AND CONVENTION FACILITIES; RESTAURANT, BAR AND CAFETERIA SERVICES, SELF SERVICE RESTAURANT; CHILD CARE CENTRES AND SERVICES; CONTRACT FOOD SERVICES; PET BOARDING SERVICES.  
FIRST USE ; IN COMMERCE .

3,601,627. REG. 4-7-2009. CARMA LABORATORIES, INC. (WISCONSIN CORPORATION) 5801 WEST AIRWAYS AVENUE, FRANKLIN, WI, 53132, SN 77-528,460. FILED 7-22-2008. PRINCIPAL REGISTER.



INT. CL. 45/U.S. CLS. 100 AND 101

FOR ACCIDENT INVESTIGATIONS; ALARM RESPONSE AND VERIFICATION SERVICES; ASSIGNMENT OF MEMBERSHIP IDENTIFICATION NUMBERS TO AFFIX TO VALUABLES TO FACILITATE THEIR RECOVERY FOLLOWING LOSS OR THEFT; COMPILING INVENTORIES OF PERSONAL ITEMS FOR OTHERS FOR INSURANCE OR SECURITY PURPOSES; CONSULTING SERVICES IN THE FIELD OF MAINTAINING THE SECURITY AND INTEGRITY OF DATABASES; DAY AND NIGHT GUARDS; ESCORT SERVICES; ELECTRONIC MONITORING SERVICES FOR SECURITY PURPOSES FOR RAILWAYS, AIRWAYS, MOTORWAYS AND NAVAL TRACKS; SECURITY CONTROL OF PERSONS AND LUGGAGE ON AERIAL, TERRESTRIAL AND NAVAL VEHICLES AND IN AIRPORTS, PORTS AND STATIONS.  
FIRST USE ; IN COMMERCE .

OWNER OF U.S. REG. NOS. 1,526,475 AND 2,093,176.  
THE MARK CONSISTS OF A RECTANGLE ON AN ANGLE WITH THE WORD "CARMEX" INSIDE THE RECTANGLE AND A SHADOW BEHIND THE BANNER.

INT. CL. 3/U.S. CLS. 1, 4, 6, 50, 51 AND 52  
FOR LIP BALM.  
FIRST USE 0-0-1937; IN COMMERCE 0-0-1937.  
INT. CL. 5/U.S. CLS. 6, 18, 44, 46, 51 AND 52  
FOR MEDICATED LIP BALM.  
FIRST USE 0-0-1937; IN COMMERCE 0-0-1937.

ELEMENTS CORRECTED  
GOODS/SERVICES

ELEMENTS AMENDED  
\*DESCRIPTION OF MARK\*  
MARK  
[DISCLAIMER]

3,626,258. REG. 5-26-2009. DATA AND CONTACT MANAGEMENT SOLUTIONS, LLC (DELAWARE LIMITED LIABILITY COMPANY) SUITE A600; 7601 PENN AVENUE SOUTH, MINNEAPOLIS, MN, 55423, SN 77-573,944. FILED 9-19-2008. PRINCIPAL REGISTER.



NO CLAIM IS MADE TO THE EXCLUSIVE RIGHT TO USE "SERVICES", APART FROM THE MARK AS SHOWN. THE COLOR(S) GREEN, BLACK AND GREY IS/ARE CLAIMED AS A FEATURE OF THE MARK.

THE MARK CONSISTS OF "DCM" IN GREEN LOWER CASE LETTERS WITH A BLACK BRANCH EMERGING FROM THE MIDDLE OF THE LETTER "D" AND EXTENDING OVER "CM" SPLITTING INTO THREE SUB-BRANCHES, WITH A SMALL GREEN LEAF AT THE END OF THE BRANCH; UNDERNEATH THE LETTERS "DCM" IS THE WORD "SERVICES" IN GREY LOWERCASE LETTERS.

INT. CL. 36/U.S. CLS. 100, 101 AND 102

FOR ACQUISITION AND PROCESSING OF MONETARY CLAIMS, NAMELY, PROCESSING OF MONETARY CLAIMS AGAINST THE ESTATE OF DECEASED ACCOUNT HOLDERS.

FIRST USE 2-0-2008; IN COMMERCE 2-0-2008.

ELEMENTS CORRECTED  
CITIZENSHIP

3,650,963. REG. 7-7-2009. BROADMARGINS LIMITED (UNITED KINGDOM LIMITED COMPANY) SHORTS GARDENS, LONDON, WC2H 9AT, UNITED KINGDOM., SN 77-640,581. FILED 12-29-2008. PRINCIPAL REGISTER.



NO CLAIM IS MADE TO THE EXCLUSIVE RIGHT TO USE "BARGAIN YARNS", APART FROM THE MARK AS SHOWN.

THE STIPPLING IS FOR SHADING PURPOSES ONLY. THE MARK CONSISTS OF AN ABSTRACTED DRAWING OF BALL OF YARN WITH TAG ALONG WITH THE WORDS "BARGAIN YARNS".

INT. CL. 35/U.S. CLS. 100, 101 AND 102

FOR RETAIL STORE AND ON-LINE RETAIL STORE SERVICES FEATURING ARTS AND CRAFTS FINDINGS AND HOBBY CRAFT KITS, NAMELY, YARN, PATTERNS, BOOKS, NEEDLES AND ACCESSORIES.

FIRST USE 3-27-2007; IN COMMERCE 3-27-2007.

ELEMENTS CORRECTED  
OWNER ADDRESS  
CITIZENSHIP

3,767,815. REG. 3-30-2010. UNISHIPPERS GLOBAL LOGISTICS, LLC (DELAWARE LIMITED LIABILITY COMPANY) 746 EAST WINCHESTER, SUITE 200, SALT LAKE CITY, UT, 84107, SN 77-035,873. FILED 11-3-2006. PRINCIPAL REGISTER.

## Unishippers Freight

THE MARK CONSISTS OF STANDARD CHARACTERS WITHOUT CLAIM TO ANY PARTICULAR FONT, STYLE, SIZE, OR COLOR.

OWNER OF U.S. REG. NOS. 1,518,213, 3,009,096 AND OTHERS.

NO CLAIM IS MADE TO THE EXCLUSIVE RIGHT TO USE "FREIGHT", APART FROM THE MARK AS SHOWN. INT. CL. 39/U.S. CLS. 100 AND 105

FOR SHIPPING AND DELIVERY SERVICES, NAMELY, PICKUP, TRANSPORTATION, AND DELIVERY OF PACKAGES AND LETTERS BY VARIOUS MODES OF TRANSPORTATION, NAMELY, VIA GROUND, OCEAN, RAIL, LESS-THAN-TRUCKLOAD, AND FULL TRUCK LOAD.

FIRST USE 1-26-2010; IN COMMERCE 1-26-2010.

ELEMENTS CORRECTED  
CITIZENSHIP

3,638,331. REG. 6-16-2009. GLEA LLC (NEVADA LIMITED LIABILITY COMPANY) 220 E. LAS COLINAS BLVD., SUITE C-210, IRVING, TX, 75039, SN 77-579,427. FILED 9-26-2008. PRINCIPAL REGISTER.

## YEA NETWORKS

THE MARK CONSISTS OF STANDARD CHARACTERS WITHOUT CLAIM TO ANY PARTICULAR FONT, STYLE, SIZE, OR COLOR.

NO CLAIM IS MADE TO THE EXCLUSIVE RIGHT TO USE "NETWORK", APART FROM THE MARK AS SHOWN. INT. CL. 41/U.S. CLS. 100, 101 AND 107

FOR RADIO PROGRAM SYNDICATION SERVICES; RADIO ENTERTAINMENT PRODUCTION SERVICES.

FIRST USE 10-10-2007; IN COMMERCE 10-10-2007.

ELEMENTS AMENDED  
MARK

3,767,816. REG. 3-30-2010. UNISHIPPERS GLOBAL LOGISTICS, LLC (DELAWARE LIMITED LIABILITY COMPANY) 746 EAST WINCHESTER, SUITE 200, SALT LAKE CITY, UT, 84107, SN 77-035,874. FILED 11-3-2006. PRINCIPAL REGISTER.

## Unishippers Express

THE MARK CONSISTS OF STANDARD CHARACTERS WITHOUT CLAIM TO ANY PARTICULAR FONT, STYLE, SIZE, OR COLOR.

OWNER OF U.S. REG. NOS. 151,821, 3,009,096 AND OTHERS.

NO CLAIM IS MADE TO THE EXCLUSIVE RIGHT TO USE "EXPRESS", APART FROM THE MARK AS SHOWN.

INT. CL. 39/U.S. CLS. 100 AND 105

FOR SHIPPING AND DELIVERY SERVICES, NAMELY, PICKUP, TRANSPORTATION, AND DELIVERY OF PACKAGES AND LETTERS BY VARIOUS MODES OF TRANSPORTATION, NAMELY, VIA GROUND, OCEAN, RAIL, LESS-THAN-TRUCKLOAD, AND FULL TRUCK LOAD.

FIRST USE 1-26-2010; IN COMMERCE 1-26-2010.

ELEMENTS CORRECTED  
CITIZENSHIP

3,771,836. REG. 4-6-2010. BIOFRONTERA PHARMA GMBH (FED REP GERMANY LIMITED LIABILITY COMPANY) HEMMELRATHER WEG, 201, 51377 LEVERKUSEN, FED REP GERMANY., SN 79-070,762. FILED 5-27-2009. PRINCIPAL REGISTER.

## BELIXOS

THE MARK CONSISTS OF STANDARD CHARACTERS WITHOUT CLAIM TO ANY PARTICULAR FONT, STYLE, SIZE, OR COLOR.

OWNER OF INTERNATIONAL REGISTRATION 1007314 DATED 5-27-2009, EXPIRES 5-27-2019.

INT. CL. 5/U.S. CLS. 6, 18, 44, 46, 51 AND 52

FOR PHARMACEUTICAL PREPARATIONS FOR THE TREATMENT AND PREVENTION OF DERMATOLOGICAL DISEASES AND SKIN DISORDERS; MEDICINES FOR HUMAN PURPOSES, NAMELY, PHARMACEUTICALS FOR THE TREATMENT AND PREVENTION OF DERMATOLOGICAL DISEASES AND SKIN DISORDERS; MEDICINES FOR VETERINARY PURPOSES, NAMELY, PHARMACEUTICALS FOR THE TREATMENT AND PREVENTION OF DERMATOLOGICAL DISEASES AND SKIN DISORDERS; CHEMICAL PREPARATIONS FOR MEDICAL PURPOSES, NAMELY, PHARMACEUTICALS FOR THE TREATMENT AND PREVENTION OF DERMATOLOGICAL DISEASES AND SKIN DISORDERS; CHEMICAL PREPARATIONS FOR VETERINARY PURPOSES, NAMELY, MEDICINES FOR THE TREATMENT OF DERMATOLOGICAL DISEASES AND SKIN DISORDERS; TOPICAL OINTMENT AND GELS FOR THE MEDICAL AND THERAPEUTIC TREATMENT OF DERMATOLOGICAL DISEASES AND SKIN DISORDERS; [ \* ALL AFOREMENTIONED GOODS NOT FOR THE TREATMENT OF CANCER AND LEUKEMIA AND THE TREATMENT OF ADVERSE EFFECTS OF THE TREATMENT OF CANCER AND LEUKEMIA, IN PARTICULAR NOT FOR PHARMACEUTICAL PREPARATIONS ON THE BASIS OF MISTLETOE FOR THE TREATMENT OF PRE-CANCEROUS LESIONS, SOLID TUMORS, MALIGNANT HEMOBLASTOSES, L E U K E M I A S, LYMPHOGRANULOMATOSIS, LYMPHOMAS, PLASMACYTOMA, FOR THE STIMULATION OF THE BONE

MARROW FUNCTION AND NUTRITIONAL OR DIETARY SUPPLEMENTS \* ] \* ALL AFOREMENTIONED GOODS NOT FOR THE TREATMENT OF CANCER AND LEUKEMIA AND THE TREATMENT OF SIDE-EFFECTS OCCURRING DURING THE TREATMENT OF CANCER AND LEUKEMIA, PARTICULARLY PHARMACEUTICAL PREPARATIONS ON THE BASIS OF MISTLETOES FOR THE TREATMENT OF PRECANCEROUS LESIONS, SOLID TUMORS, MALIGNANT HEMOBLASTOSES, LEUKEMIAS, LYMPHOGRANULOMATOSIS, LYMPHOMAS, PLASMACYTOMS, FOR STIMULATING THE BONE MARROW FUNCTIONS AND AS NUTRITIONAL SUPPLEMENTS \*.

FIRST USE ; IN COMMERCE .

ELEMENTS CORRECTED  
GOODS/SERVICES

3,790,335. REG. 5-18-2010. ELGO-ELECTRIC GMBH (FED REP GERMANY LIMITED LIABILITY COMPANY (GMBH)) CARL-BENZ-STRASSE 1, 78239 RIELASINGEN, FED REP GERMANY., SN 79-062,847. FILED 10-7-2008. PRINCIPAL REGISTER.

## ELGO ELECTRONIC

THE MARK CONSISTS OF STANDARD CHARACTERS WITHOUT CLAIM TO ANY PARTICULAR FONT, STYLE, SIZE, OR COLOR.

PRIORITY DATE OF 4-11-2008 IS CLAIMED.

OWNER OF INTERNATIONAL REGISTRATION 0986881 DATED 10-7-2008, EXPIRES 10-7-2018.

NO CLAIM IS MADE TO THE EXCLUSIVE RIGHT TO USE "ELECTRONIC", APART FROM THE MARK AS SHOWN.

INT. CL. 9/U.S. CLS. 21, 23, 26, 36 AND 38

FOR ELECTRONIC, ELECTRO-MECHANICAL AND MAGNETIC POSITION INDICATOR, POSITION CONTROLLER, LENGTH MEASURING DEVICES AND ANGLE MEASURING DEVICES, NAMELY, ROTARY ENCODERS, SIGNAL PROCESSING DEVICES AND ELECTRONIC DATA TRANSMISSION DEVICES ALL ESPECIALLY FOR TRANSPORT, ELEVATOR, LIFT, AUTOMATION, AUTOMOTIVE, MEDICAL AND HANDLING TECHNOLOGY AS WELL AS MECHANICAL ENGINEERING AND INDUSTRIAL MANUFACTURING TECHNOLOGY, \* ALL AFOREMENTIONED DEVICES FOR USE IN THE TRANSPORT, ELEVATOR AND LIFT TECHNOLOGY, AUTOMATION ENGINEERING, MEDICAL AND CONVEYOR TECHNOLOGY, MECHANICAL ENGINEERING AND INDUSTRIAL PRODUCTION TECHNOLOGY \*.

FIRST USE ; IN COMMERCE .

INT. CL. 37/U.S. CLS. 100, 103 AND 106

FOR MAINTENANCE AND REPAIR OF EQUIPMENT FOR TRANSPORT, ELEVATOR, LIFT, INDUSTRIAL AUTOMATION CONTROLS, AUTOMOTIVE, MEDICAL, MATERIAL HANDLING AND INDUSTRIAL MANUFACTURING TECHNOLOGY.

FIRST USE ; IN COMMERCE .

INT. CL. 42/U.S. CLS. 100 AND 101

FOR SCIENTIFIC AND INDUSTRIAL RESEARCH AND DEVELOPMENT, PARTICULARLY IN THE AREAS OF TRANSPORTATION, ELEVATOR, LIFT, AUTOMATION, AUTOMOTIVE, MEDICAL AND HANDLING TECHNOLOGY AS WELL AS MECHANICAL ENGINEERING AND INDUSTRIAL MANUFACTURING TECHNOLOGY, DEVELOPMENT OF COMPUTER PROGRAMS.

FIRST USE ; IN COMMERCE .

ELEMENTS CORRECTED  
GOODS/SERVICES

3,912,960. REG. 2-1-2011. EPIC HOLDING COMPANY, INC. (NEW JERSEY CORPORATION) 1007 JERSEY AVENUE, NEW BRUNSWICK, NJ, 08901, SN 77-902,780. FILED 12-30-2009. PRINCIPAL REGISTER.



NO CLAIM IS MADE TO THE EXCLUSIVE RIGHT TO USE "GREEN", APART FROM THE MARK AS SHOWN.

THE COLOR(S) WHITE, DARK GREEN, AND LIGHT GREEN IS/ARE CLAIMED AS A FEATURE OF THE MARK.

THE MARK CONSISTS OF A DARK GREEN RECTANGLE WITH THE WORDS "GREEN ESSENTIALS" IN WHITE ACROSS THE TOP OF THE RECTANGLE. SUPERIMPOSED OVER THE DARK GREEN RECTANGLE IS A SMALLER RECTANGLE WITH A STYLIZED MOUNTAIN SCENE WITHIN THE RECTANGLE. THE SKY IS WHITE, THE MOUNTAINS ARE IN SHADES OF LIGHT GREEN. IN FRONT OF THE MOUNTAINS ARE TWO EVERGREEN TREES, ONE IN DARK GREEN AND ONE IN LIGHT GREEN.

INT. CL. 3/U.S. CLS. 1, 4, 6, 50, 51 AND 52

FOR CLEANING PREPARATIONS FOR COMMERCIAL, INDUSTRIAL AND INSTITUTIONAL USE; DETERGENT PREPARATIONS FOR DISHWASHING, CLEANING PREPARATIONS FOR CARPET, FABRIC AND FLOORS; DEGREASING PREPARATIONS FOR SURFACES AND FLOORS; CLEANING PREPARATIONS FOR BATHROOMS; CLEANING PREPARATIONS FOR STAIN REMOVAL; CLEANING PREPARATIONS FOR GRILLS AND OVENS, ALL THE AFOREMENTIONED MADE IN WHOLE WITH INGREDIENTS CERTIFIED TO BE ENVIRONMENTALLY-FRIENDLY.

FIRST USE 10-29-2009; IN COMMERCE 12-18-2009.

ELEMENTS CORRECTED  
OWNER NAME

FOR DISPENSERS THAT COUNT OR MEASURE OUTPUT FOR USE WITH MANUAL DISHWASHING PREPARATIONS, OR WAREWASHING PREPARATIONS, OR CLEANING PRODUCTS FOR COMMERCIAL, INDUSTRIAL AND INSTITUTIONAL USE, NAMELY, PRE-SOAKS, DETERGENTS, SANITIZERS, RINSE AGENTS, DEODORIZERS, MULTI-SURFACE CLEANERS, ALL-PURPOSE CLEANERS, DISINFECTANTS, GLASS CLEANERS, PLASTIC CLEANERS, RESTROOM MAINTENANCE PRODUCTS, AND FLOOR CARE PRODUCTS .  
FIRST USE 10-29-2009; IN COMMERCE 12-18-2009.

ELEMENTS CORRECTED  
OWNER NAME

3,973,602. REG. 6-7-2011. WORLDWIDE INSURANCE NETWORK, INC. (NORTH CAROLINA CORPORATION) 1589 SKEET CLUB ROAD #102-PMB 349, HIGH POINT, NC, 27265, SN 85-142,476. FILED 9-30-2010. PRINCIPAL REGISTER.

## SMART CHOICE

THE MARK CONSISTS OF STANDARD CHARACTERS WITHOUT CLAIM TO ANY PARTICULAR FONT, STYLE, SIZE, OR COLOR.

OWNER OF U.S. REG. NO. 2,553,113.

INT. CL. 36/U.S. CLS. 100, 101 AND 102

FOR INSURANCE SERVICES, NAMELY, ARRANGING FOR INDEPENDENT INSURANCE AGENTS TO REPRESENT INSURANCE COMPANIES NOT OTHERWISE REPRESENTED.

FIRST USE 1-21-1998; IN COMMERCE 1-21-1998.

ELEMENTS CORRECTED  
OWNER NAME

3,915,816. REG. 2-8-2011. EPIC HOLDING COMPANY, INC. (NEW JERSEY CORPORATION) 1007 JERSEY AVENUE, NEW BRUNSWICK, NJ, 08901, SN 77-902,515. FILED 12-29-2009. PRINCIPAL REGISTER.



NO CLAIM IS MADE TO THE EXCLUSIVE RIGHT TO USE "DISPENSING SYSTEM", APART FROM THE MARK AS SHOWN.

THE MARK CONSISTS OF THE TERM "AVATAR" CENTERED WITHIN A RECTANGLE. CENTERED BELOW THE RECTANGLE ARE THE TERMS "DISPENSING SYSTEM". ABOVE THE "AV" PORTION OF THE TERM "AVATAR" IS A STYLIZED WATER DROP DESIGN.

INT. CL. 9/U.S. CLS. 21, 23, 26, 36 AND 38

4,002,187. REG. 7-26-2011. SFM, LLC (DELAWARE LIMITED LIABILITY COMPANY) 11811 N. TATUM BLVD., #2400, PHOENIX, AZ, 85028, SN 85-197,622. FILED 12-14-2010. PRINCIPAL REGISTER.



OWNER OF U.S. REG. NOS. 2,798,632, 3,748,830 AND OTHERS.

NO CLAIM IS MADE TO THE EXCLUSIVE RIGHT TO USE "FARMERS MARKET", APART FROM THE MARK AS SHOWN.

THE COLOR(S) GREEN, LIGHT GREEN, SILVER, PURPLE, PINK, BLACK, LIGHT BROWN, BROWN, YELLOW, ORANGE AND RED IS/ARE CLAIMED AS A FEATURE OF THE MARK.

THE MARK CONSISTS OF THE WORDING "SPROUTS FARMERS MARKET" IN GREEN LETTERING. THE LETTERING "SPROUTS" IS OUTLINED IN SILVER. ABOVE THE WORDING IS THE STYLIZED DESIGN OF FRUIT SPECIFICALLY PURPLE GRAPES, A SLICE OF WATERMELON WHICH IS PINK, GREEN AND BLACK, A LIGHT BROWN PEAR WITH A BROWN STEM, A GREEN LIME, A YELLOW LEMON, AN ORANGE COLORED ORANGE, TWO RED APPLES WITH BROWN STEMS, A LIGHT GREEN APPLE WITH A BROWN STEM, TWO RED STRAWBERRIES WITH GREEN STEMS, A BROWN AND BLACK PINEAPPLE WITH A GREEN STEM, A LIGHT GREEN PEAR WITH A BLACK STEM AND A BUNCH OF YELLOW BANANAS. ALL OF THE FRUITS ARE LINED IN BLACK. THE COLOR WHITE IS USED FOR SHADING AND BACKGROUND AND IS NOT PART OF THE MARK.

INT. CL. 35/U.S. CLS. 100, 101 AND 102  
FOR RETAIL GROCERY STORES.  
FIRST USE 12-0-2007; IN COMMERCE 12-0-2007.

ELEMENTS CORRECTED  
OWNER ADDRESS

4,017,964. REG. 8-30-2011. EVANS, JAY A JR (UNITED STATES INDIVIDUAL), DBA SYNCRON TECHNOLOGIES, PO BOX 1501, DUNEDIN, FL. 346971501, SN 85-001,358. FILED 3-29-2010. PRINCIPAL REGISTER.

**Syncon**  
Technologies  
Inc.

NO CLAIM IS MADE TO THE EXCLUSIVE RIGHT TO USE "TECHNOLOGIES INC.", APART FROM THE MARK AS SHOWN.

THE COLOR(S) RED AND BLACK IS/ARE CLAIMED AS A FEATURE OF THE MARK.

THE MARK CONSISTS OF THE WORD "SYNCRON" IN RED AND THE WORD "TECHNOLOGIES INC." IN BLACK.  
INT. CL. 42/U.S. CLS. 100 AND 101

FOR TECHNICAL SUPPORT SERVICES, NAMELY, COMPUTER SOFTWARE INSTALLATION, MAINTENANCE AND REPAIR.

FIRST USE 9-16-2004; IN COMMERCE 9-16-2004.

ELEMENTS CORRECTED  
GOODS/SERVICES

4,072,516. REG. 12-20-2011. CHAMPAGNE ALAIN THIENOT (FRANCE SOCIÉTÉ PAR ACTIONS SIMPLIFIÉE) 14 RUE DES MOISSONS, F-51100 REIMS, FRANCE., SN 79-090,851. FILED 11-4-2010. PRINCIPAL REGISTER.



PRIORITY DATE OF 5-4-2010 IS CLAIMED.  
OWNER OF INTERNATIONAL REGISTRATION 1060698 DATED 11-4-2010, EXPIRES 11-4-2020.

THE COLOR(S) ORANGE AND WHITE IS/ARE CLAIMED AS A FEATURE OF THE MARK.

THE MARK CONSISTS OF A STYLIZED, WHITE LETTER "T" OUTLINED AGAINST AN ORANGE OVAL DESIGN.

INT. CL. 33/U.S. CLS. 47 AND 49

FOR WINES OF FRENCH ORIGIN, NAMELY, CHAMPAGNE.

FIRST USE ; IN COMMERCE .

INT. CL. 35/U.S. CLS. 100, 101 AND 102

FOR BUSINESS MANAGEMENT AND ORGANIZATION CONSULTANCY; DIRECT MAIL ADVERTISING; CONDUCTING MARKETING STUDIES; ORGANIZATION OF EXHIBITIONS FOR COMMERCIAL OR ADVERTISING PURPOSES; ORGANIZATION OF TRADE FAIRS FOR COMMERCIAL OR ADVERTISING PURPOSES; ADVERTISING AGENCIES; ON-LINE ADVERTISING ON A COMPUTER NETWORK; \* ALL THESE SERVICES EXCLUSIVELY IN CONNECTION WITH THE PRESENTATION AND MARKETING OF WINES AND CHAMPAGNE \*.

FIRST USE ; IN COMMERCE .

INT. CL. 38/U.S. CLS. 100, 101 AND 104

FOR COMMUNICATIONS BY AND BETWEEN COMPUTERS AND COMPUTER TERMINALS; COMPUTER-AIDED TRANSMISSION OF MESSAGES AND IMAGES; \* ALL THESE SERVICES EXCLUSIVELY IN CONNECTION WITH THE PRESENTATION AND MARKETING OF WINES AND CHAMPAGNE \*.

FIRST USE ; IN COMMERCE .

ELEMENTS CORRECTED  
GOODS/SERVICES

4,091,961. REG. 1-24-2012. PRECISION CUSTOM COATINGS LLC (DELAWARE LIMITED LIABILITY COMPANY) 200 MALTESE DRIVE, TOTOWA, NJ, 075121404, SN 85-145,931. FILED 10-6-2010. PRINCIPAL REGISTER.

**SLUMBERSHIELD**

THE MARK CONSISTS OF STANDARD CHARACTERS WITHOUT CLAIM TO ANY PARTICULAR FONT, STYLE, SIZE, OR COLOR.

INT. CL. 20/U.S. CLS. 2, 13, 22, 25, 32 AND 50

FOR BEDDING PROTECTORS AND ENCASEMENTS, NAMELY, MATTRESS PROTECTORS, MATTRESS ENCASEMENTS, BOX SPRING PROTECTORS, BOX SPRING ENCASEMENTS, PILLOW PROTECTORS, PILLOW ENCASEMENTS, QUILT AND COMFORTER PROTECTORS, QUILT AND COMFORTER ENCASEMENTS, KITS CONTAINING ONE OR MORE OF THE AFORESAID PROTECTORS AND ENCASEMENTS.

FIRST USE 12-8-2010; IN COMMERCE 12-8-2010.

ELEMENTS CORRECTED  
CITIZENSHIP

4,116,370. REG. 3-20-2012. THE CLEANING AUTHORITY, LLC (MARYLAND LIMITED LIABILITY COMPANY) SUITE 200, 7230 LEE DEFOREST DRIVE, COLUMBIA, MD, 20723, SN 85-161.012. FILED P.R. 10-26-2010; AM. S.R. 1-25-2012. SUPPLEMENTAL REGISTER.

## DETAIL-CLEAN ROTATION SYSTEM

THE MARK CONSISTS OF STANDARD CHARACTERS WITHOUT CLAIM TO ANY PARTICULAR FONT, STYLE, SIZE, OR COLOR.

NO CLAIM IS MADE TO THE EXCLUSIVE RIGHT TO USE "SYSTEM", APART FROM THE MARK AS SHOWN.

INT. CL. 37/U.S. CLS. 100, 103 AND 106  
FOR MAID SERVICES.

FIRST USE 12-31-2006; IN COMMERCE 12-31-2006.

ELEMENTS CORRECTED  
OWNER NAME

4,119,060. REG. 3-27-2012. HUMANITY UNITED (CALIFORNIA CORPORATION) 1991 BROADWAY, SUITE 200, REDWOOD CITY, CA, 94063, SN 78-909,419. FILED 6-15-2006. PRINCIPAL REGISTER.

## HUMANITY UNITED

THE MARK CONSISTS OF STANDARD CHARACTERS WITHOUT CLAIM TO ANY PARTICULAR FONT, STYLE, SIZE, OR COLOR.

INT. CL. 35/U.S. CLS. 100, 101 AND 102

FOR PUBLIC POLICY RESEARCH SERVICES AIMED AT ENDING MASS ATROCITIES AND HUMAN SLAVERY; ADVOCATING ON BEHALF OF OTHERS BY PROMOTING PUBLIC AWARENESS OF THE NEED FOR, AND PROMOTING PUBLIC SUPPORT OF AND PARTICIPATION IN EFFORTS AIMED AT ENDING MASS ATROCITIES AND HUMAN SLAVERY; ADVOCATING ON BEHALF OF OTHERS BY CONDUCTING MARKET AND PUBLIC POLICY RESEARCH AND ANALYSIS, NAMELY, INFORMATION GATHERING, STUDY, FIELD-BASED ANALYSIS, INVESTIGATION OF NEW APPROACHES, AND ITERATIVE REFINEMENT OF IDEAS AND PLANS IN COLLABORATION WITH OTHERS, ALL TO PROMOTE THE DEVELOPMENT OF SOLUTIONS FOR THE PROTECTION OF HUMAN RIGHTS AND THE PROMOTION OF HUMAN DIGNITY; ADVOCATING ON BEHALF OF OTHERS THROUGH LOBBYING OF COMMERCIAL, NOT-FOR-PROFIT, GOVERNMENTAL, AND NON-GOVERN-

MENTAL ORGANIZATIONS IN SUPPORT OF ADOPTING AND SUPPORTING MEASURES FOR THE PROTECTION OF HUMAN RIGHTS AND THE PROMOTION OF HUMAN DIGNITY; CHARITABLE SERVICES, NAMELY, ORGANIZING NETWORKS OF INDIVIDUALS AND INSTITUTIONS WITH THE PURPOSE OF FACILITATING AND FURTHERING THE IMPLEMENTATION OF CHARITABLE AND PHILANTHROPIC PROGRAMS; ADMINISTRATION AND MANAGEMENT OF RESEARCH GRANTS; EDUCATION LEADERSHIP DEVELOPMENT; MARKET RESEARCH; PUBLIC OPINION POLLING; PUBLIC OPINION SURVEYS; CONDUCTING MARKET RESEARCH SURVEYS; PROMOTING PUBLIC AWARENESS OF HUMAN NEEDS, NAMELY, PROMOTING PUBLIC AWARENESS OF THE SCOPE OF, THE NEED TO ADDRESS, INSTITUTIONAL OBSTACLES TO, SOLUTIONS FOR, AND THE ROLE OF VARIOUS ACTORS IN RELATION TO THREATS TO BASIC HUMAN RIGHTS, MASS ATROCITIES, HUMAN SLAVERY AND HUMAN CRUELTY; EMPLOYMENT AND NETWORK RECRUITING, NAMELY, RECRUITING PROFESSIONALS, VOLUNTEERS AND WORKERS IN THE FIELD OF CHARITABLE ACTIVITIES RELATING TO ENDING MASS ATROCITIES AND HUMAN SLAVERY, RELIEF OF POVERTY AND HUNGER, HEALTH AND ACCESS TO MEDICAL CARE, EDUCATION AND SOCIAL WELFARE, HUMAN RIGHTS AND MOBILITY, AND DISASTER RELIEF; PROMOTING ECONOMIC DEVELOPMENT THROUGH THE PROVISION OF BUSINESS AND MANAGERIAL CONSULTATION, AND BUSINESS INFORMATION IN THE FIELD OF PLANNING, ORGANIZING, MONITORING AND IMPLEMENTING PROJECTS AIMED AT BUILDING ENDURING INSTITUTIONS AND PRACTICES, ENCOURAGING GROWTH AND ENTREPRENEURSHIP THROUGH MICROFINANCE AND OTHER FORMS OF CREDIT, ENSURING ACCOUNTABILITY, AND SUPPORTING ECONOMIC AND POLITICAL STABILITY BY ADDRESSING BASIC HUMAN RIGHTS; PROMOTING ECONOMIC DEVELOPMENT THROUGH PUBLIC ADVOCACY IN THE NATURE OF PROMOTING AWARENESS OF THE NEED FOR PLANNING, ORGANIZING, MONITORING AND IMPLEMENTING PROJECTS AIMED AT BUILDING ENDURING INSTITUTIONS AND PRACTICES, ENCOURAGING GROWTH AND ENTREPRENEURSHIP THROUGH MICROFINANCE AND OTHER FORMS OF CREDIT, ENSURING ACCOUNTABILITY, AND SUPPORTING ECONOMIC AND POLITICAL STABILITY BY ADDRESSING BASIC HUMAN RIGHTS; CHARITABLE SERVICES, NAMELY, SUPPORTING NETWORKS OF CHARITABLE AND PHILANTHROPIC INDIVIDUALS AND INSTITUTIONS BY PROVIDING CONSULTATION AND ADVICE REGARDING ADVERTISING, AND CREATION AND DISSEMINATION OF ADVERTISING MATERIALS FOR EDUCATIONAL ACTIVITIES AND ENTERTAINMENT EVENTS, WITH THE PURPOSE OF FACILITATING AND FURTHERING THE IMPLEMENTATION OF CHARITABLE AND PHILANTHROPIC PROGRAMS.

FIRST USE 7-1-2008; IN COMMERCE 7-1-2008.

INT. CL. 36/U.S. CLS. 100, 101 AND 102

FOR CHARITABLE FUNDRAISING; PHILANTHROPIC SERVICES CONCERNING MONETARY DONATIONS; PROVIDING GRANTS AND MONETARY DONATIONS TO ORGANIZATIONS AND INDIVIDUALS PROMOTING AWARENESS OF, ORGANIZING RESPONSES TO, AND PROVIDING SERVICES TO ADDRESS MASS ATROCITIES, HUMAN SLAVERY, HUMAN CRUELTY, THE PROTECTION OF HUMAN RIGHTS AND THE PROMOTION OF HUMAN DIGNITY; PROVIDING GRANTS AND MONETARY DONATIONS TO ORGANIZATIONS AND INDIVIDUALS WORKING TO BUILD ENDURING INSTITUTIONS AND PRACTICES TO REDUCE THE INCIDENCE AND LIMIT THE IMPACT OF MASS ATROCITIES AND OTHER VIOLATIONS OF BASIC HUMAN RIGHTS; PROVIDING GRANTS AND MONETARY DONATIONS TO ORGANIZATIONS AND INDIVIDUALS WORKING TO MOVE PUBLIC POLICY AND POLITICAL WILL TOWARD PRODUCTIVE INTERVENTION TO PREVENT OR STOP MASS ATROCITIES AND OTHER VIOLATIONS OF BASIC HUMAN RIGHTS; CHARITABLE SERVICES, NAMELY, PROVIDING GRANTS AND MONETARY DONATIONS TO SUPPORT NETWORKS OF IN-

DIVIDUALS AND INSTITUTIONS WITH THE PURPOSE OF FACILITATING AND FURTHERING THE IMPLEMENTATION OF CHARITABLE AND PHILANTHROPIC PROGRAMS; PROVIDING GRANTS AND MONETARY DONATIONS TO SUPPORT PROJECTS AIMED AT BUILDING ENDURING INSTITUTIONS AND PRACTICES, ENCOURAGING GROWTH AND ENTREPRENEURSHIP THROUGH MICROFINANCE AND OTHER FORMS OF CREDIT, ENSURING ACCOUNTABILITY, AND SUPPORTING ECONOMIC AND POLITICAL STABILITY BY ADDRESSING BASIC HUMAN RIGHTS.

FIRST USE 7-1-2008; IN COMMERCE 7-1-2008.  
INT. CL. 41/U.S. CLS. 100, 101 AND 107

FOR DEVELOPMENT AND DISSEMINATION OF EDUCATIONAL MATERIALS TO OTHERS IN RELATION TO PROMOTING AWARENESS OF, ORGANIZING RESPONSES TO, AND PROVIDING SERVICES TO ADDRESS MASS ATROCITIES, HUMAN SLAVERY, HUMAN CRUELTY, THE PROTECTION OF HUMAN RIGHTS AND THE PROMOTION OF HUMAN DIGNITY; ARRANGING AND CONDUCTING OF EDUCATIONAL CONFERENCES, DISCUSSIONS, AND COLLOQUIA; ARRANGING AND CONDUCTING ONLINE EDUCATIONAL CONFERENCES, DISCUSSIONS, AND COLLOQUIA VIA COMPUTER AND COMMUNICATION NETWORKS IN THE FIELDS OF EDUCATION, COLLABORATION, COORDINATION, AND SUPPORT IN RELATION TO PROMOTING AWARENESS OF, ORGANIZING RESPONSES TO, AND PROVIDING SERVICES TO ADDRESS MASS ATROCITIES, HUMAN SLAVERY, HUMAN CRUELTY, THE PROTECTION OF HUMAN RIGHTS AND THE PROMOTION OF HUMAN DIGNITY.

FIRST USE 7-1-2008; IN COMMERCE 7-1-2008.  
INT. CL. 45/U.S. CLS. 100 AND 101

FOR ADVOCATING ON BEHALF OF OTHERS, NAMELY, LEGAL CONSULTATION AND LEGAL SERVICES IN THE FIELDS OF NEGOTIATION, PROSECUTION SUPPORT, AND LEGAL REPRESENTATION RELATING TO THE PROTECTION OF HUMAN RIGHTS AND THE PROMOTION OF HUMAN DIGNITY.

FIRST USE 7-1-2008; IN COMMERCE 7-1-2008.

ELEMENTS CORRECTED  
OWNER NAME  
OWNER ADDRESS

4,123,910. REG. 4-10-2012. FELIX DENNIS (UNITED KINGDOM INDIVIDUAL) 2ND FLOOR, 9-11 KINGLY STREET, LONDON, UNITED KINGDOM, W1B5PN, SN 85-142,670. FILED 9-30-2010. PRINCIPAL REGISTER.

**PROSPER**

THE MARK CONSISTS OF STANDARD CHARACTERS WITHOUT CLAIM TO ANY PARTICULAR FONT, STYLE, SIZE, OR COLOR.

PRIORITY CLAIMED UNDER SEC. 44(D) ON UNITED KINGDOM APPLICATION NO. 2543558, FILED 3-30-2010, REG. NO. 2543558, DATED 10-15-2010.

INT. CL. 9/U.S. CLS. 21, 23, 26, 36 AND 38

FOR DOWNLOADABLE ELECTRONIC PUBLICATIONS, NAMELY, MAGAZINES, NEWSPAPERS, NEWSLETTERS, PERIODICALS IN THE FIELD OF FINANCIAL INFORMATION; \* ALL EXCLUDING TEACHING AND COURSE MATERIAL FOR USE IN RELATION TO BUSINESS AND INVESTING TRAINING \*

FIRST USE ; IN COMMERCE .  
INT. CL. 16/U.S. CLS. 2, 5, 22, 23, 29, 37, 38 AND 50

FOR MAGAZINES, NEWSPAPERS, NEWSLETTERS, PERIODICALS IN THE FIELD OF FINANCIAL INFORMATION; \* ALL EXCLUDING PUBLICATIONS IN THE FIELD OF EDUCATION AND TRAINING REGARDING BUSINESS AND INVESTING \* .

FIRST USE ; IN COMMERCE .  
INT. CL. 41/U.S. CLS. 100, 101 AND 107

FOR PUBLICATION OF MAGAZINES, NEWSPAPERS, NEWSLETTERS, PERIODICALS, ELECTRONIC MAGAZINES; ALL EXCLUDING EDUCATIONAL, PERSONAL COACHING AND TEACHING SERVICES IN THE FIELDS OF BUSINESS AND INVESTING \* .

FIRST USE ; IN COMMERCE .

ELEMENTS AMENDED  
GOODS/SERVICES

4,164,030. REG. 6-26-2012. DATA AND CONTACT MANAGEMENT SOLUTIONS, LLC (DELAWARE LIMITED LIABILITY COMPANY) SUITE A600; 7601 PENN AVENUE SOUTH, MINNEAPOLIS, MN, 55423, SN 85-451,655. FILED 10-20-2011. PRINCIPAL REGISTER.



NO CLAIM IS MADE TO THE EXCLUSIVE RIGHT TO USE "PROBATE FINDER ONDEMAND", APART FROM THE MARK AS SHOWN.

THE MARK CONSISTS OF L-SHAPED BLOCKS SITTING DIAGONALLY OPPOSITE EACH OTHER WITH THE INSIDE OF EACH BLOCK SITUATED TO FORM A SQUARE FOLLOWED TO THE RIGHT OF THE SQUARE ARE THE WORDS "PROBATE FINDER ONDEMAND".

INT. CL. 35/U.S. CLS. 100, 101 AND 102

FOR PROVIDING VIA A WEBSITE ESTATE SERVICES TO OTHERS, NAMELY, LOCATING ESTATES AND ORGANIZING THEM INTO A DATABASE OF EXISTING ESTATE ACCOUNTS, MATCHING CUSTOMER ACCOUNTS TO ESTATE RECORDS IN A DATABASE, AND MAINTAINING A DATABASE THAT AUTOMATES AND PRIORITIZES THE CLAIM GENERATION AND FILING PROCESS.

FIRST USE 7-6-2009; IN COMMERCE 7-6-2009.

ELEMENTS CORRECTED  
CITIZENSHIP

4,168,145. REG. 7-3-2012. POSITIVE BEVERAGE, LLC (DELAWARE LIMITED LIABILITY COMPANY) 15228 SPEC-TRUM, IRVINE, CA, 92618, SN 76-704,488. FILED 9-14-2010. PRINCIPAL REGISTER.

**POSITIVE H2O SIMPLY BENEFICIAL**

THE MARK CONSISTS OF STANDARD CHARACTERS WITHOUT CLAIM TO ANY PARTICULAR FONT, STYLE, SIZE, OR COLOR.

NO CLAIM IS MADE TO THE EXCLUSIVE RIGHT TO USE "H2O", APART FROM THE MARK AS SHOWN.

INT. CL. 32/U.S. CLS. 45, 46 AND 48

FOR BEVERAGES, NAMELY, STILL [OR SPARKLING ] FILTERED WATER .

FIRST USE 4-2-2012; IN COMMERCE 4-2-2012.

ELEMENTS AMENDED  
GOODS/SERVICES



OWNER NAME  
OWNER ADDRESS

---

4,177,724. REG. 7-24-2012. SHANDONG BUCHANG PHARMACEUTICAL INCORPORATED COMPANY (CHINA CORPORATION) NO. 369, ZHONGHUA WEST ROAD, SHANDONG PROVINCE, CHINA., SN 85-090,572. FILED 7-22-2010. PRINCIPAL REGISTER.

稳心

THE MARK CONSISTS OF THE TWO CHINESE CHARACTERS WEN XIN.

THE NON-LATIN CHARACTERS IN THE MARK TRANSLITERATE TO "WEN XIN" AND THIS MEANS NOTHING IN ENGLISH.

INT. CL. 5/U.S. CLS. 6, 18, 44, 46, 51 AND 52

FOR MEDICINES FOR THE TREATMENT OF PAIN, FEVER, INFLAMMATION, RHEUMATISM AND GOUT, AND USE IN THE TREATMENT OF NERVOUS SYSTEM DISEASE, MENTAL DISORDERS DISEASE, CARDIOVASCULAR SYSTEM DISEASE, RESPIRATORY SYSTEM DISEASE, DIGESTIVE SYSTEM DISEASE, GENITO-URINARY SYSTEM DISEASE, BLOOD SYSTEM DISEASE, ENDOCRINE SYSTEM DISEASE, IMMUNE SYSTEM DISEASE, SKIN DISEASE, GYNECOLOGICAL DISEASE AND TUMOR; TRADITIONAL CHINESE MEDICINES IN THE NATURE OF CHINESE PATENT MEDICINES FOR THE TREATMENT OF PAIN, FEVER, INFLAMMATION, RHEUMATISM AND GOUT, AND USE IN THE TREATMENT OF NERVOUS SYSTEM DISEASE, MENTAL DISORDERS DISEASE, CARDIOVASCULAR SYSTEM DISEASE, RESPIRATORY SYSTEM DISEASE, DIGESTIVE SYSTEM DISEASE, GENITO-URINARY SYSTEM DISEASE, BLOOD SYSTEM DISEASE, ENDOCRINE SYSTEM DISEASE, IMMUNE SYSTEM DISEASE, SKIN DISEASE, GYNECOLOGICAL DISEASE AND TUMOR; PHARMACEUTICAL PREPARATIONS AND MEDICINAL HERBS ALL FOR THE TREATMENT OF PAIN, FEVER, INFLAMMATION, RHEUMATISM AND GOUT, AND USE IN THE TREATMENT OF NERVOUS SYSTEM DISEASE, MENTAL DISORDERS DISEASE, CARDIOVASCULAR SYSTEM DISEASE, RESPIRATORY SYSTEM DISEASE, DIGESTIVE SYSTEM DISEASE, GENITO-URINARY SYSTEM DISEASE, BLOOD SYSTEM DISEASE, ENDOCRINE SYSTEM DISEASE, IMMUNE SYSTEM DISEASE, SKIN DISEASE, GYNECOLOGICAL DISEASE AND TUMOR; RAW MATERIALS PHARMACEUTICALS, NAMELY, MEDICINAL HERBAL EXTRACTS FOR MEDICAL PURPOSES, VITAMIN AND MINERAL PREPARATIONS FOR USE AS INGREDIENTS IN THE PHARMACEUTICAL INDUSTRY; BIOLOGICAL PREPARATIONS FOR THE TREATMENT OF PAIN, FEVER, INFLAMMATION, RHEUMATISM AND GOUT, AND USE IN THE TREATMENT OF NERVOUS SYSTEM DISEASE, MENTAL DISORDERS DISEASE, CARDIOVASCULAR SYSTEM DISEASE, RESPIRATORY SYSTEM DISEASE, DIGESTIVE SYSTEM DISEASE, GENITO-URINARY SYSTEM DISEASE, BLOOD SYSTEM DISEASE, ENDOCRINE SYSTEM DISEASE, IMMUNE SYSTEM DISEASE, SKIN DISEASE, GYNECOLOGICAL DISEASE AND TUMOR; MEDICINES FOR THE TREATMENT OF PAIN IN THE GUMS AND PERIODONTIA; SANITARY STERILIZING PREPARATIONS, NAMELY, DISINFECTANTS FOR MEDICAL INSTRUMENTS AND MEDICAL CLEANSERS FOR SKIN AND WOUNDS; SOLUTIONS FOR CONTACT LENSES; DIETETIC FOODS ADAPTED FOR MEDICAL PURPOSES AND NUTRITIONAL ADDITIVES FOR MEDICAL PURPOSES, NAMELY, VITAMINS, GINSENG FOR MEDICINAL USE AND ROYAL JELLY FOR MEDICAL USE; DIETETIC FOOD PREPARATIONS ADAPTED FOR MEDICAL PURPOSES, NAMELY, DIETARY AND NUTRITIONAL SUPPLEMENTS, NUTRITIONAL ADDITIVES FOR MEDICAL PURPOSES FOR USE IN FOODS AND DIETARY SUPPLEMENTS FOR HUMAN CONSUMPTION, ALL FOR TREATMENT OF TRACE ELEMENT DEFICIENCY; IN-

FANT FORMULA, NAMELY, INFANT MILK POWDER; AIR PURIFYING PREPARATIONS; VETERINARY PREPARATIONS, NAMELY, VETERINARY VACCINES FOR ANTI-INFLAMMATION AND PAIN RELIEF; PESTICIDES; HERBICIDES; SANITARY TOWELS; STERILE PAPER TOWEL, NAMELY, MEDICATED PRE-MOISTENED TOWELETES; STICKING PLASTERS FOR MEDICAL PURPOSES; MEDICAL ADHESIVE TAPE; MEDICAL DRESSINGS, NAMELY, GAUZE AND COTTON FOR MEDICAL PURPOSES; SURGICAL DRESSINGS; SURGICAL TISSUES, NAMELY, HYGIENIC BANDAGES; FIRST-AID KITS; FILLINGS FOR TEETH. FIRST USE 6-1-1995; IN COMMERCE 6-15-2010.

ELEMENTS CORRECTED  
OWNER NAME  
OWNER ADDRESS

---

4,179,226. REG. 7-24-2012. INVESTCLOUD, INC. (DELAWARE CORPORATION) 8800 WILSHIRE BLVD., BEVERLY HILLS, CA, 90211, SN 85-485,384. FILED 12-1-2011. PRINCIPAL REGISTER.

All in One Place

THE MARK CONSISTS OF STANDARD CHARACTERS WITHOUT CLAIM TO ANY PARTICULAR FONT, STYLE, SIZE, OR COLOR.

INT. CL. 42/U.S. CLS. 100 AND 101

FOR CLOUD COMPUTING FEATURING SOFTWARE FOR USE IN MANAGEMENT AND STORAGE OF FINANCIAL INFORMATION.

FIRST USE 6-1-2011; IN COMMERCE 6-15-2011.

ELEMENTS CORRECTED  
OWNER NAME  
CITIZENSHIP

---

4,179,263. REG. 7-24-2012. INVESTCLOUD, INC. (DELAWARE CORPORATION) 8800 WILSHIRE BLVD., BEVERLY HILLS, CA, 90211, SN 85-485,944. FILED 12-2-2011. PRINCIPAL REGISTER.

InvestCloud

THE MARK CONSISTS OF STANDARD CHARACTERS WITHOUT CLAIM TO ANY PARTICULAR FONT, STYLE, SIZE, OR COLOR.

INT. CL. 42/U.S. CLS. 100 AND 101

FOR CLOUD COMPUTING FEATURING SOFTWARE FOR USE IN MANAGEMENT AND STORAGE OF FINANCIAL INFORMATION.

FIRST USE 1-1-2011; IN COMMERCE 1-15-2011.

ELEMENTS CORRECTED  
OWNER NAME  
CITIZENSHIP

4,179,441. REG. 7-24-2012. INVESTCLOUD, INC. (DELAWARE CORPORATION) 8800 WILSHIRE BLVD., BEVERLY HILLS, CA, 90211, SN 85-503,347. FILED 12-23-2011. PRINCIPAL REGISTER.

FOR RESTAURANT AND BAR SERVICES.  
FIRST USE 2-0-2007; IN COMMERCE 2-0-2007.

ELEMENTS CORRECTED  
CITIZENSHIP

## InvestCloud CustomPort

---

THE MARK CONSISTS OF STANDARD CHARACTERS WITHOUT CLAIM TO ANY PARTICULAR FONT, STYLE, SIZE, OR COLOR.

NO CLAIM IS MADE TO THE EXCLUSIVE RIGHT TO USE "CUSTOM PORT", APART FROM THE MARK AS SHOWN.

INT. CL. 42/U.S. CLS. 100 AND 101

FOR CLOUD COMPUTING FEATURING SOFTWARE FOR USE IN MANAGEMENT AND STORAGE OF FINANCIAL INFORMATION.

FIRST USE 6-1-2011; IN COMMERCE 6-1-2011.

ELEMENTS CORRECTED  
OWNER NAME  
CITIZENSHIP

---

4,179,504. REG. 7-24-2012. INVESTCLOUD, INC. (DELAWARE CORPORATION) 8800 WILSHIRE BLVD., BEVERLY HILLS, CA, 90211, SN 85-526,486. FILED 1-26-2012. PRINCIPAL REGISTER.

4,222,911. REG. 10-9-2012. THE SAUL ZAENTZ COMPANY (DELAWARE CORPORATION) 2600 TENTH STREET, BERKELEY, CA, 94710, SN 85-367,773. FILED 7-11-2011. PRINCIPAL REGISTER.

## HOBBITON

THE MARK CONSISTS OF STANDARD CHARACTERS WITHOUT CLAIM TO ANY PARTICULAR FONT, STYLE, SIZE, OR COLOR.

INT. CL. 28/U.S. CLS. 22, 23, 38 AND 50

FOR 3-D PUZZLES; JIGSAW PUZZLES.

FIRST USE 0-0-2003; IN COMMERCE 0-0-2003.

ELEMENTS CORRECTED  
GOODS/SERVICES

---

## IDR

THE MARK CONSISTS OF STANDARD CHARACTERS WITHOUT CLAIM TO ANY PARTICULAR FONT, STYLE, SIZE, OR COLOR.

INT. CL. 42/U.S. CLS. 100 AND 101

FOR CLOUD COMPUTING FEATURING SOFTWARE FOR USE IN MANAGEMENT AND STORAGE OF FINANCIAL INFORMATION.

FIRST USE 1-1-2011; IN COMMERCE 1-15-2011.

ELEMENTS CORRECTED  
OWNER NAME  
CITIZENSHIP

---

4,212,976. REG. 9-25-2012. WEBB GOLDEN VALLEY LLC (MINNESOTA LIMITED LIABILITY COMPANY) 5410 WAYZATA BLVD, GOLDEN VALLEY, MN, 55416, SN 85-483,165. FILED 11-29-2011. PRINCIPAL REGISTER.

4,252,166. REG. 12-4-2012. H.A.G. IMPORT CORPN. (AUSTRALIA) PTY LTD (AUSTRALIA REGISTERED AUSTRALIAN COMPANY) 11-27 MILLERS ROAD, BROOKLYN VIC 3012, AUSTRALIA., SN 79-108,867. FILED 9-22-2011. PRINCIPAL REGISTER.



## BAD DAY BAR

THE MARK CONSISTS OF STANDARD CHARACTERS WITHOUT CLAIM TO ANY PARTICULAR FONT, STYLE, SIZE, OR COLOR.

NO CLAIM IS MADE TO THE EXCLUSIVE RIGHT TO USE "BAR", APART FROM THE MARK AS SHOWN.

INT. CL. 43/U.S. CLS. 100 AND 101

PRIORITY DATE OF 3-23-2011 IS CLAIMED.  
OWNER OF INTERNATIONAL REGISTRATION 1105961 DATED 9-22-2011, EXPIRES 9-22-2021.

THE MARK CONSISTS OF A HERALDIC LION WITH LONG HAIR AND A LONG TAIL STANDING ON ITS HIND LEGS WITH ITS FORE LEGS IN A STRIKING POSITION.

INT. CL. 8/U.S. CLS. 23, 28 AND 44

FOR CUTLERY, NAMELY, KNIVES, FORKS AND SPOONS; HAND-OPERATED SPREADERS FOR FOOD, NAMELY, SPREADERS IN THE NATURE OF A SMALL KNIFE FOR BUTTER OR CHEESE; MORTAR AND PESTLES; HAND TOOLS AND HAND-OPERATED IMPLEMENTS, NAMELY, TONGS, NUTCRACKERS, NON-ELECTRIC CAN OPENERS, HAND-OPERATED FOOD DICERS, HAND OPERATED FOOD SLICERS, HAND-OPERATED FOOD PROCESSORS, HAND-OPERATED CUTTING TOOLS, HAND OPERATED TOOLS FOR MAKING SHAVED ICE, NON-ELECTRIC FRUIT AND VEGETABLE PEELERS, NON-ELECTRIC PIZZA CUTTERS AND SLICERS, KNIFE SHARPENERS, NON-ELECTRIC ICE CRUSHERS; HAND-OPERATED IMPLEMENTS FOR THE SERVING OF FOOD, NAMELY, SERVING KNIVES; SERVING KNIVES; SERVING UTENSILS, NAMELY, CARVING KNIVES.

FIRST USE : IN COMMERCE .

INT. CL. 16/U.S. CLS. 2, 5, 22, 23, 29, 37, 38 AND 50

FOR [ GOODS MADE FROM PAPER AND CARDBOARD, NAMELY, STORAGE CONTAINERS MADE OF PAPER, TABLE MATS AND PLACE MATS OF PAPER, PAPER TABLE CLOTHS, DECORATIVE PAPER CENTERPIECES, PAPER TOWELS, HANDKERCHIEFS OF PAPER, PAPER BABY BIBS, PAPER CAKE DECORATIONS, PAPER DOILIES, PAPER FLOOR MATS, PAPER TRAY COVERS, PAPER WASHCLOTHS, SCENTED PAPER DRAWER LINERS, SPECIALTY PAPERS, NAMELY, VEGETABLE PARCHMENT FOR USE IN FOOD WRAPPING, PREPARATION, PROCESSING AND PACKAGING APPLICATIONS; ] TABLE LINEN OF PAPER; NAPERY OF PAPER, NAMELY, PAPER NAPKINS; PACKAGING CONTAINERS COMPRISED PREDOMINANTLY OF PAPER WITH PLASTIC-LINED PAPER BOARD FOR SOLIDS OR LIQUIDS; PACKAGING MATERIAL MADE OF STARCHES, NAMELY, PACKAGING COMPRISED OF STARCH-BASED MATERIALS IN THE NATURE OF A PAPER SUBSTITUTE FOR FOOD, BEVERAGES AND CONSUMER PRODUCTS.

FIRST USE : IN COMMERCE .

INT. CL. 21/U.S. CLS. 2, 13, 23, 29, 30, 33, 40 AND 50

FOR \* FOR USE WITH FOOD OR DRINK \* HOUSEHOLD OR KITCHEN UTENSILS AND CONTAINERS NOT OF PRECIOUS METAL OR COATED THEREWITH, NAMELY, CANISTER SETS, BREAD BINS, BREAD BOARDS, CONTAINERS FOR HOUSEHOLD OR KITCHEN USE, SPICE RACKS, CONTAINERS FOR FOODS, HOUSEHOLD STORAGE CONTAINERS FOR PET FOOD, INSULATED CONTAINERS FOR FOOD OR BEVERAGE FOR DOMESTIC USE, SOAP CONTAINERS, TRASH CONTAINERS FOR HOUSEHOLD USE, LUNCH BOXES, HAND OPERATED COFFEE GRINDERS, CHOPSTICKS, COOKERY MOULDS, COOKIE CUTTERS, COOKIE JARS, COOKING SKEWERS, CRUET STANDS FOR OIL AND VINEGAR, CRUETS, CUTTING BOARDS, NON-ELECTRIC FRUIT PRESSES FOR HOUSEHOLD USE, GLASS JARS, INSULATING JARS, FOOD PRESERVING JARS OF GLASS, NON-ELECTRIC KETTLES, TEA KETTLES, WHISKS, CORN COB HOLDERS, MIXING SPOONS, NON-ELECTRIC KITCHEN MIXERS, JUGS, FLASKS, GRATERS, SPATULAS, SIEVES, STRAINERS, TURNERS, COOKING UTENSILS, NAMELY, GRILL COVERS, ROLLING PINS, POT AND PAN SCRAPERS, SPLATTER SCREENS, KITCHEN TONGS, FOOD SCOOPS, DOG FOOD SCOOPS, TEA INFUSERS, TEA STRAINERS, TEA POTS, TEA SERVICE, TEA SETS, TEA BALLS, NON-ELECTRIC WAFFLE IRONS, PORTABLE COOLERS, COOLERS FOR WINE, VESSELS OF METAL FOR MAKING ICES AND ICED DRINKS IN THE NATURE OF COCKTAIL SHAKERS, ICE PAILS, CORKSCREWS, URNS, ICE CUBE MOULDS, ICE SCOOPS, ICE CREAM SCOOPS, CONTAINERS FOR ICE, BASINS, BUTTER DISHES AND COVERS, EGG CUPS, NON-ELECTRIC EGG BEATERS, PITCHERS, DISH COVERS, COFFEE MEASURES, COFFEE POTS, COFFEE SERVERS, COFFEE SERVICE, COFFEE STIRRERS, NON-ELECTRIC COFFEE MAKERS, COFFEE PLUNGERS IN THE NATURE OF NON-ELECTRIC COFFEE POTS, NON-ELECTRIC COFFEE PERCOLATORS, NON-ELECTRIC COFFEE GRINDERS, VACUUM BOTTLE STOPPERS, BOTTLE OPENERS, BOTTLE STOPPERS SPECIALLY ADAPTED FOR USE WITH WINE BOTTLES, BOWLS, PLATES, LAZY SUSANS, DRINKING VESSELS, SUGAR BOWLS, MUGS, CUPS, DISHES, UTENSILS FOR BARBECUES, NAMELY, FORKS, TONGS AND TURNERS; GLASSWARE, NAMELY, BEVERAGE GLASSWARE, DRINKING VESSELS, COFFEE PLUNGERS IN THE NATURE OF NON-ELECTRIC COFFEE POTS, TEA PLUNGERS IN THE NATURE OF

NON-ELECTRIC TEA POTS, NON-ELECTRIC COFFEE PERCOLATORS, COFFEE SERVICE, COFFEE POTS, CANDLE RINGS, CANDLESTICKS, DECANTERS, SALT AND PEPPER SHAKERS, SALT CELLARS, GLASS STOPPERS, TOOTHPICK HOLDERS NOT OF PRECIOUS METAL, SALT AND PEPPER GRINDERS, SUGAR BOWLS, NAPKIN RINGS, GOBLETS, BEER MUGS, COCKTAIL SHAKERS, KNIFE RESTS, TEA POTS, TEA SERVICE, NAPKIN HOLDERS, PEPPER POTS, WINE TASTERS; DINNERWARE; COOKWARE, NAMELY, CASSEROLE DISHES, FRYING PANS, MUFFIN TINS, CAKE TINS, CUP CAKE MOULDS, PAPER BAKING CUPS, COOKING STEAMERS, SAUCEPANS, WAFFLE IRONS, GRILLS, PORTABLE COOKING KITS FOR OUTDOOR USE, RICE COOKING POTS, WIRE BASKETS, BAKING DISHES, BASTING SPOONS, COOKING FORKS, POTS, PANS; SERVINGWARE, NAMELY, SERVINGWARE FOR SERVING FOOD AND DRINKS, SERVING TRAYS, PIE SERVERS; SERVING WARE FOR SERVING FOOD AND DRINKS; CROCKERY, NAMELY, POTS, DISHES, PLATES, DRINKING CUPS AND SAUCERS, BOWLS, SERVING BOWLS AND TRAYS; CHINAWARE, PORCELAIN AND EARTHENWARE, NAMELY, NON-ELECTRIC KETTLES, TEA KETTLES, TEA INFUSERS, TEA STRAINERS, TEA POTS, TEA SERVICE, TEA SETS, TEA BALLS, COFFEE PLUNGERS IN THE NATURE OF NON-ELECTRIC COFFEE POTS, COFFEE PERCOLATORS, COFFEE SERVICE, COFFEE POTS, CANDLE RINGS, CANDLESTICKS, DECANTERS, SALT AND PEPPER SHAKERS, SALT CELLARS, TOOTHPICK HOLDERS, SALT AND PEPPER GRINDERS, SUGAR BOWLS, NAPKIN RINGS, OIL AND VINEGAR CRUETS, GOBLETS, BEER MUGS, COCKTAIL SHAKERS, KNIFE RESTS, NAPKIN HOLDERS, JARS FOR JAMS AND JELLIES; PEPPER POTS, WINE TASTERS, BOWLS, PLATES, MUGS, CUPS, DISHES, SOUP TUREENS, LAZY SUSANS; VASES; HAND-OPERATED FOOD GRINDERS.

FIRST USE : IN COMMERCE .

INT. CL. 24/U.S. CLS. 42 AND 50

FOR [ TEXTILES AND TEXTILE GOODS, NAMELY, BED LINEN, TOWELS OF TEXTILE, HANDKERCHIEFS OF TEXTILE, PLACE MATS OF TEXTILE, TEXTILE SERVIETTES, QUILTS OF TEXTILE, TEXTILE TABLECLOTHS, LAP RUGS, TRAVELLING RUGS, CLOTH COASTERS, OVEN MITTS; ] TABLE LINEN; TEXTILE NAPERY, NAMELY, LINEN TABLE CLOTHS, COASTERS, NAPKINS AND PLACE MATS.

FIRST USE : IN COMMERCE .

ELEMENTS CORRECTED  
GOODS/SERVICES

4,266,549. REG. 1-1-2013. BENEDETTI, MASSIMO (ITALY INDIVIDUAL) VIA NIRANO 15, MARANELLO (MO), ITALY, 41053, AND MALVERTI, MARCO (ITALY INDIVIDUAL) VIALE ISONZO 45, SASSUOLO (MO), ITALY, 41049, AND FRIGIERI, ALBERTO (ITALY INDIVIDUAL) VIA DON PELLONI 2, SPEZZANO DI FIORANO MO, ITALY, 41040, SN 85-359,740. FILED 6-29-2011. PRINCIPAL REGISTER.



PRIORITY CLAIMED UNDER SEC. 44(D) ON ITALY APPLICATION NO. MO2011/C322, FILED 4-28-2011, REG. NO. 0001454443, DATED 7-26-2011, EXPIRES 4-28-2021.

THE COLOR(S) RED, WHITE AND BLUE IS/ARE CLAIMED AS A FEATURE OF THE MARK.

THE MARK CONSISTS OF THE WORDS "NEW-LINE" WRITTEN IN STYLIZED RED LETTERS, SEPARATED BY A BLUE HYPHEN, ALL INSIDE A WHITE OVAL WITH A BLUE OUTER BORDER.

INT. CL. 7/U.S. CLS. 13, 19, 21, 23, 31, 34 AND 35

FOR (BASED ON USE IN COMMERCE) COOLING RADIATORS FOR ENGINES, RADIATORS FOR VEHICLES AND RELATED PARTS THEREOF, NAMELY, CLAMPS AND RADIATOR SHROUDS; AIRCRAFT ENGINES; PARTS OF ENGINES IN THE NATURE OF AIR FILTER FOR ENGINES, FANS FOR MACHINE ENGINES, VEHICLE INTAKE MANIFOLDS, AND EXHAUST MANIFOLDS FOR ENGINES.

FIRST USE 3-31-2000; IN COMMERCE 3-31-2005.  
INT. CL. 12/U.S. CLS. 19, 21, 23, 31, 35 AND 44  
FOR ENGINES FOR LAND VEHICLES.  
FIRST USE ; IN COMMERCE .

ELEMENTS CORRECTED  
OWNER ADDRESS

A GLOBAL COMPUTER NETWORK; PROVIDING ONLINE ELECTRONIC PUBLICATIONS, NAMELY, MAGAZINES, COURSE GUIDES AND BOOKS IN THE FIELD OF CAREER INFORMATION, SELF ESTEEM AND BODY ISSUES, MONETARY MATTERS, SOCIAL AND PEER PRESSURE ISSUES, PERSONAL SAFETY, WRITING, TIME AND STRESS MANAGEMENT, RELATIONSHIPS AND PERSONAL DEVELOPMENT; PUBLICATION OF EDUCATIONAL MATERIALS; \* THE AFOREMENTIONED SERVICES SPECIFICALLY DESIGNED TO ASSIST GIRLS WITH THE TRANSITION FROM PRIMARY TO SECONDARY SCHOOL \* .  
FIRST USE ; IN COMMERCE .

ELEMENTS CORRECTED  
GOODS/SERVICES

4,307,334. REG. 3-26-2013. ENLIGHTEN EDUCATION PTY LTD (AUSTRALIA PRIVATE COMPANY) 20 JOHN SAVAGE CRESCENT, WEST PENNANT HILLS NSW 2125, AUSTRALIA., SN 79-117,778. FILED 7-11-2012. PRINCIPAL REGISTER.

4,374,727. REG. 7-30-2013. DOCSTOC INC. (DELAWARE CORPORATION), DBA LICENSE123, 409 SANTA MONICA BLVD, SUITE 2A, SANTA MONICA, CA, 90401, SN 85-646,445. FILED 6-7-2012. PRINCIPAL REGISTER.

# THE JOURNEY

THE MARK CONSISTS OF STANDARD CHARACTERS WITHOUT CLAIM TO ANY PARTICULAR FONT, STYLE, SIZE, OR COLOR.

PRIORITY DATE OF 6-28-2012 IS CLAIMED.  
OWNER OF INTERNATIONAL REGISTRATION 1128925 DATED 7-11-2012, EXPIRES 7-11-2022.  
INT. CL. 41/U.S. CLS. 100, 101 AND 107

FOR EDUCATIONAL SERVICES, NAMELY, THE ORGANISATION, CONDUCTING AND PROVISION OF EDUCATIONAL COURSES, CLASSES AND WORKSHOPS TO CHILD AND TEENAGE STUDENTS IN THE FIELD OF CAREER INFORMATION, SELF ESTEEM AND BODY ISSUES, MONETARY MATTERS, SOCIAL AND PEER PRESSURE ISSUES, PERSONAL SAFETY, WRITING, TIME AND STRESS MANAGEMENT, RELATIONSHIPS AND PERSONAL DEVELOPMENT; EDUCATIONAL SERVICES, NAMELY, TRAINING IN THE FIELD OF PROVIDING CAREER INFORMATION, SELF ESTEEM AND BODY ISSUES, MONETARY MATTERS, SOCIAL AND PEER PRESSURE ISSUES, PERSONAL SAFETY, WRITING, TIME AND STRESS MANAGEMENT; DISSEMINATION OF EDUCATIONAL MATERIAL OF OTHERS IN THE FIELD OF CAREER INFORMATION, SELF ESTEEM AND BODY ISSUES, MONETARY MATTERS, SOCIAL AND PEER PRESSURE ISSUES, PERSONAL SAFETY, WRITING, TIME AND STRESS MANAGEMENT, RELATIONSHIPS AND PERSONAL DEVELOPMENT; ADVISORY SERVICES IN THE FIELD OF EDUCATION; PROVIDING EDUCATION INFORMATION; RESEARCH IN THE FIELD OF EDUCATION; PROVIDING INFORMATION, INCLUDING ONLINE, ABOUT EDUCATION, EDUCATIONAL TRAINING, SPORTING AND CULTURAL ACTIVITIES; PROVISION OF EDUCATIONAL COURSES IN THE FIELD OF CAREER INFORMATION, SELF ESTEEM AND BODY ISSUES, MONETARY MATTERS, SOCIAL AND PEER PRESSURE ISSUES, PERSONAL SAFETY, WRITING, TIME AND STRESS MANAGEMENT, RELATIONSHIPS AND PERSONAL DEVELOPMENT; VOCATIONAL GUIDANCE IN THE NATURE OF EDUCATION OR TRAINING ADVICE; ARRANGING AND CONDUCTING OF WORKSHOPS IN THE FIELD OF CAREER INFORMATION, SELF ESTEEM AND BODY ISSUES, MONETARY MATTERS, SOCIAL AND PEER PRESSURE ISSUES, PERSONAL SAFETY, WRITING, TIME AND STRESS MANAGEMENT, RELATIONSHIPS AND PERSONAL DEVELOPMENT; ARRANGING AND CONDUCTING OF SEMINARS IN THE FIELD OF CAREER INFORMATION, SELF ESTEEM AND BODY ISSUES, MONETARY MATTERS, SOCIAL AND PEER PRESSURE ISSUES, PERSONAL SAFETY, WRITING, TIME AND STRESS MANAGEMENT, RELATIONSHIPS AND PERSONAL DEVELOPMENT; ELECTRONIC PUBLICATION OF EDUCATIONAL INFORMATION ON A WIDE RANGE OF TOPICS, INCLUDING ONLINE AND OVER

# License123

THE MARK CONSISTS OF STANDARD CHARACTERS WITHOUT CLAIM TO ANY PARTICULAR FONT, STYLE, SIZE, OR COLOR.

INT. CL. 9/U.S. CLS. 21, 23, 26, 36 AND 38  
FOR DOWNLOADABLE FORMS, APPLICATIONS, AND INFORMATION REGARDING DOMESTIC GOVERNMENT LAWS AND REGULATORY REQUIREMENTS FOR OBTAINING BUSINESS LICENSES AND PERMITS.

FIRST USE 3-8-2012; IN COMMERCE 3-8-2012.  
INT. CL. 42/U.S. CLS. 100 AND 101  
FOR PROVIDING USE OF ONLINE NON-DOWNLOADABLE SOFTWARE FOR USE IN PREPARING AND FILING APPLICATIONS FOR BUSINESS LICENSES AND PERMITS.  
FIRST USE 3-8-2012, IN COMMERCE 3-8-2012.

ELEMENTS CORRECTED  
OWNER NAME

4,381,010. REG. 8-6-2013. HEALTH LINE INTERNATIONAL CORP. (WYOMING CORPORATION) 803 N 1250 W, UNIT 1, CENTERVILLE, UT, 84014, SN 85-623,173. FILED 5-11-2012. PRINCIPAL REGISTER.

# UNI-PICC

THE MARK CONSISTS OF STANDARD CHARACTERS WITHOUT CLAIM TO ANY PARTICULAR FONT, STYLE, SIZE, OR COLOR.

INT. CL. 10/U.S. CLS. 26, 39 AND 44  
FOR PERIPHERAL INSERTED CENTRAL CATHETERS AND MEDICAL KITS INCLUDING CATHETERS.  
FIRST USE 12-8-2011; IN COMMERCE 7-31-2012.

ELEMENTS CORRECTED  
CITIZENSHIP

4,381,989. REG. 8-13-2013. WEBB GOLDEN VALLEY LLC (MINNESOTA LIMITED LIABILITY COMPANY) 5410 WAYZATA BLVD, GOLDEN VALLEY, MN, 55416, SN 85-483,159. FILED 11-29-2011. PRINCIPAL REGISTER.

GOOD DAY CAFÉ

THE MARK CONSISTS OF STANDARD CHARACTERS WITHOUT CLAIM TO ANY PARTICULAR FONT, STYLE, SIZE, OR COLOR.

NO CLAIM IS MADE TO THE EXCLUSIVE RIGHT TO USE "CAFE", APART FROM THE MARK AS SHOWN.

INT. CL. 43/U.S. CLS. 100 AND 101  
FOR RESTAURANT AND BAR SERVICES.  
FIRST USE 2-0-2007; IN COMMERCE 2-0-2007.

ELEMENTS CORRECTED  
CITIZENSHIP

4,390,083. REG. 8-27-2013. "NEUER WALL" TREUHAND GMBH (FED REP GERMANY GMBH) AM SANDTORKAI 41, 20457 HAMBURG, FED REP GERMANY., SN 79-118,234. FILED 7-24-2012. PRINCIPAL REGISTER.

PT

THE MARK CONSISTS OF STANDARD CHARACTERS WITHOUT CLAIM TO ANY PARTICULAR FONT, STYLE, SIZE, OR COLOR.

PRIORITY DATE OF 1-24-2012 IS CLAIMED.

OWNER OF INTERNATIONAL REGISTRATION 1130040 DATED 7-24-2012, EXPIRES 7-24-2022.

INT. CL. 9/U.S. CLS. 21, 23, 26, 36 AND 38

FOR CONNECTIONS FOR ELECTRIC LINES, ELECTRIC WIRE CONNECTIONS, ELECTRIC COUPLINGS, ELECTRIC WIRES, ELECTRIC CABLES; ELECTRIC CONDUCTORS; ELECTRIC CONNECTIONS AND CONNECTORS, ELECTRICAL AND ELECTRONIC CONNECTORS; CONNECTORS FOR ELECTRONICS CIRCUITS; \* ALL OF THE AFOREMENTIONED GOODS FOR CONDUCTING ELECTRICITY \*.

FIRST USE ; IN COMMERCE .

ELEMENTS CORRECTED  
GOODS/SERVICES

4,405,602. REG. 9-24-2013. ATLANTIC BEVERAGE COMPANY, INC. (NEW JERSEY CORPORATION) 14 MECHANIC STREET, UNIT 12, EDISON, NJ, 08820, SN 85-669,346. FILED 7-5-2012. PRINCIPAL REGISTER.



NO CLAIM IS MADE TO THE EXCLUSIVE RIGHT TO USE "SAN MARINO", APART FROM THE MARK AS SHOWN.

THE COLOR(S) RED, GREEN, YELLOW, WHITE AND BLACK IS/ARE CLAIMED AS A FEATURE OF THE MARK.

THE MARK CONSISTS OF THE WORDS "SAN MARINO" IN STYLIZED YELLOW FONT OUTLINED IN RED WITH A HORIZONTAL BAR IN YELLOW, WHITE AND RED ABOVE THE WORDS, THE SIDES OF WHICH FEATURE A DESIGN OF HAY IN RED AND GREEN, ALL OF WHICH IS ON A BLACK BACKGROUND.

INT. CL. 29/U.S. CL. 46

FOR CANNED VEGETABLES, NAMELY, TOMATOES, MUSHROOMS, ARTICHOKE, OLIVES, PEPPERS, CARROTS, CORN; CANNED SEAFOOD, NAMELY, TUNA, SARDINES, CLAMS, CRABMEAT; DRIED FOODS, NAMELY, TOMATOES, MUSHROOMS; OLIVE OIL.

FIRST USE 1-15-1991; IN COMMERCE 4-15-1991.

ELEMENTS CORRECTED  
OWNER NAME

4,427,008. REG. 11-5-2013. BECKER MINING SYSTEMS AG (FED REP GERMANY JOINT STOCK COMPANY) BARBARASTRAÙE 3, 66299 FRIEDRICHSTHAL, FED REP GERMANY., SN 79-112,033. FILED 10-13-2011. PRINCIPAL REGISTER.

Becker Mining

THE MARK CONSISTS OF STANDARD CHARACTERS WITHOUT CLAIM TO ANY PARTICULAR FONT, STYLE, SIZE, OR COLOR.

PRIORITY DATE OF 8-31-2011 IS CLAIMED.

OWNER OF INTERNATIONAL REGISTRATION 1113718 DATED 10-13-2011, EXPIRES 10-13-2021.

NO CLAIM IS MADE TO THE EXCLUSIVE RIGHT TO USE "MINING", APART FROM THE MARK AS SHOWN. SEC. 2(F).

INT. CL. 6/U.S. CLS. 2, 12, 13, 14, 23, 25 AND 50

FOR STEEL CONSTRUCTION MATERIALS FOR FACILITIES AND EQUIPMENT FOR SUPPORT WITH REGARD TO MINING, NAMELY, RAILS BARS, JOINTS, SHEETS, DRUMS, PIPES AND TUBES; TYPICAL COMPONENTS OF ROPE ATTACHMENTS OF METAL, NAMELY, SOCKETS, THREADED STUDS, THIMBLES, PLATES, METAL LOCKING MECHANISMS, AND CATCHES; BOXES OF METAL.

FIRST USE ; IN COMMERCE .

INT. CL. 7/U.S. CLS. 13, 19, 21, 23, 31, 34 AND 35

FOR MACHINERY AND EQUIPMENT, FOR MINING AND TUNNEL CONSTRUCTION, NAMELY, BORING MACHINES, EARTH DRILLING MACHINES, HAND-HELD PNEUMATIC DRILLS AND HAMMERS, TRUCK MILLS FOR MINING PURPOSES, ROOF SUPPORTS, PUMPS FOR MACHINES, CONVEYORS, LOADERS, PLOWS, CRUSHERS, BUNKERS; DRIVE SYSTEMS FOR MINING, NAMELY, VARIABLE FREQUENCY DRIVERS, INVERTERS, MOTOR RECOGNITION NODES, POWER CENTERS, NAMELY, MOBILE TRANSFORMERS; MOTOR STARTERS, TRANSFORMERS, CONTROL DEVICES FOR PNEUMATICS, ELECTRICS AND HYDRAULICS INCLUDING PUMPS, REGULATORS AND VALVES, PIPES AND VESSELS ALL FOR MINING MACHINES AND MOTORS; HYDRAULIC AND PNEUMATIC CONTROLS FOR MINING MACHINES AND MOTORS, NAMELY, PUMPS, REGULATORS AND VALVES, PIPES, VESSELS, AND PNEUMATIC, HYDRAULIC, DIESEL AND ELECTRICAL MOTORS; ROPE DRIVEN CONVEYANCE SYSTEMS, NAMELY, WINCHES AND CABLE REELS.

FIRST USE ; IN COMMERCE .

INT. CL. 9/U.S. CLS. 21, 23, 26, 36 AND 38

FOR OBSERVATION INSTRUMENTS AND PHOTO TELEGRAPHY APPARATUS, NAMELY, CAMERAS, VIDEO, COMPUTER AND TELE-OPERATION MONITORS FOR MINING, INDUSTRIAL AND PLANT MONITORING; OPTICAL, MECHANICAL AND ELECTRIC SENSORS IN THE NATURE OF ENVIRONMENTAL, INDUCTION, MAGNETIC, ULTRASONIC, CAPACITANCE, OPTIC SENSORS AND CONTROLLERS AND STRAIN GAUGES THEREFOR, SOFTWARE FOR THE OPERATIONAL MANAGEMENT, MONITORING AND COMMUNICATING BETWEEN ELECTRICAL, ELECTRONIC AND CONTROL EQUIPMENT AND SYSTEMS; ELECTRONIC CONTROL EQUIPMENT FOR MINING, NAMELY, COLLISION WARNING SYSTEM, CONTROL DEVICES FOR MINING MACHINES AND FOR MINING MACHINES WITH INTRINSICALLY SAFE AND FLAMEPROOF DESIGN; FIBER OPTIC CONTROLLERS AND SWITCHES FOR TAGGING AND TRACKING, VOIP CONTROLLER FOR TRANSFERS OF SPEECH MESSAGES VIA DIGITAL DATA NETWORKS, TRAFFIC MANAGEMENT CONTROLLER FOR CONTROLLING MINING EQUIPMENT, TRACKING CONTROLLER FOR MINING EQUIPMENT, FUEL MANAGEMENT CONTROLLER FOR MINING EQUIPMENT, ACCESS CONTROLLER FOR MINING EQUIPMENT, CONVEYOR CONTROLLER; INTERCOMMUNICATION SYSTEMS, NAMELY, COMPUTER COMMUNICATIONS SERVERS AND WIRELESS COMMUNICATION DEVICES FOR VOICE, DATA OR IMAGE TRANSMISSION; ELECTRICAL SWITCHGEAR AND TRANSFORMERS; CONVERTERS; MAGNETIC SWITCHES; MEASURING AND ANALYSIS EQUIPMENT, NAMELY, FILLING LEVEL MEASURING INSTRUMENTS AND DETECTORS; TRANSPONDERS, TRANSDUCERS AND TRANSCIEVERS INCLUDING ELECTROMAGNETIC, RADAR, LICENSE FREE BAND TRANSPONDERS / TRANSPONDERS AND BAR CODE, OPTICAL, SMART CARD READERS; COMMUNICATION TECHNOLOGY SYSTEMS, NAMELY, RADIO AND WIRELESS BASED DEVICES FOR DATA, VIDEO AND AUDIO COMMUNICATION INCLUDING HANDHELD RADIO AND WIRELESS PHONES, AMPLIFIERS AND WIRELESS ACCESS POINT DEVICES, LEAKY FEEDERS, NAMELY, CABLES FOR TRANSMISSION OF DATA; WIRELESS MESH NETWORKS OF SENDER AND RECEIVER TRANSMITTERS, WIRELESS TRANSMITTERS, WIRELESS LOCAL AREA NETWORKS; TERRESTRIAL TRUNKED RADIO (TETRA), DIGITAL SURFACE AND UNDERGROUND RADIO, MICRO WAVE TRANSMISSION APPARATUS FOR DELIVERING RADIO PROGRAMS AND MESSAGES; SOFTWARE SYSTEMS FOR MONITORING POWER USAGE OVER COMPUTER AND OTHER NETWORKS AND THEIR ACCESSORIES, NAMELY, JUNCTION BOXES, INTRINSICALLY SAFE SWITCHES, NAMELY, NET CONNECTORS USING LOW ENERGY; ROUTERS, TELEPHONES, VOIP CONTROLLERS, WIRELESS HANDHELD COMPUTERS, WIRELESS PERSONAL DIGITAL ASSISTANTS, AND

FLAME PROOF PC AND PROGRAMMABLE LOGIC CONTROLLERS (PLC), ANTENNAS, TELECOMMUNICATION SWITCHES, COUPLER AND OTHER DEVICES, NAMELY, FIBER OPTIC AND COPPER-BASED PLUGS, AND SOCKETS; FIBER OPTIC CONNECTORS AND DISTRIBUTION DEVICES FOR FIBRE OPTIC AND COPPER CABLE-BASED NETWORKS; COMPUTER CABLE FOR DATA TRANSMISSION; ELECTRICAL AND ELECTRONIC ACCESSORIES, NAMELY, COUPLER, PLUGS, ADAPTERS, BATTERY CHARGERS, CONNECTIONS FOR ELECTRIC AND FIBER OPTIC LINES AND CABLE.

FIRST USE ; IN COMMERCE .

INT. CL. 12/U.S. CLS. 19, 21, 23, 31, 35 AND 44

FOR MINING TRANSPORTATION SYSTEMS AND CARS FOR PEOPLE AND MATERIAL AND THEIR PARTS AND ACCESSORIES, NAMELY, CAPTIVATED AND OPEN RAIL HAULAGE SYSTEMS COMPRISED OF RAIL VEHICLE TRAINS AND STRUCTURAL PARTS THEREFORE, CHAIRLIFTS AND MONORAIL SYSTEMS, CARS AND COMPONENTS THEREFOR; \* ALL AFOREMENTIONED GOODS EXCEPT FOR THE MARITIME FIELD \*

FIRST USE ; IN COMMERCE .

INT. CL. 37/U.S. CLS. 100, 103 AND 106

FOR INSTALLATION, MAINTENANCE AND REPAIR OF MINING AND TUNNELING MACHINES, FACILITIES AND EQUIPMENT.

FIRST USE ; IN COMMERCE .

INT. CL. 42/U.S. CLS. 100 AND 101

FOR DESIGN, PROGRAMMING, RENTAL AND MAINTENANCE OF COMPUTER SOFTWARE AND COMPUTER SYSTEMS; PROGRAMMING OF SOFTWARE FOR MINING AND TUNNELING MACHINES, FACILITIES AND EQUIPMENT; SCIENTIFIC RESEARCH AND DEVELOPMENT RELATING TO MINING AND TUNNELING MACHINES, FACILITIES AND EQUIPMENT.

FIRST USE ; IN COMMERCE .

ELEMENTS CORRECTED  
GOODS/SERVICES

4,432,202. REG. 11-12-2013. DOCSTOC INC. (DELAWARE CORPORATION), DBA LICENSE123, 409 SANTA MONICA BLVD., SUITE 2A, SANTA MONICA, CA, 90401, SN 85-890,930. FILED 3-29-2013. PRINCIPAL REGISTER.

# License123

THE MARK CONSISTS OF STANDARD CHARACTERS WITHOUT CLAIM TO ANY PARTICULAR FONT, STYLE, SIZE, OR COLOR.

INT. CL. 35/U.S. CLS. 100, 101 AND 102

FOR ASSISTING OTHERS IN PREPARING AND FILING APPLICATIONS FOR BUSINESS LICENSES AND PERMITS.

FIRST USE 8-13-2012; IN COMMERCE 8-13-2012.

INT. CL. 45/U.S. CLS. 100 AND 101

FOR PROVIDING AN ONLINE NON-DOWNLOADABLE DATABASE FEATURING INFORMATION REGARDING DOMESTIC GOVERNMENT LAWS AND REGULATORY REQUIREMENTS FOR OBTAINING BUSINESS APPLICATIONS, LICENSES, AND PERMITS; OBTAINING FOR OTHERS OF GOVERNMENT AND REGULATORY BUSINESS LICENSES AND PERMITS.

FIRST USE 8-13-2012; IN COMMERCE 8-13-2012.

ELEMENTS CORRECTED  
OWNER NAME  
OWNER ADDRESS

4,437,909. REG. 11-26-2013. SMI - IP PTY LIMITED (AUSTRALIA REGISTERED COMPANY) 435A KENT STREET, SYDNEY NSW 2000, AUSTRALIA., SN 79-118,795. FILED 3-27-2012. PRINCIPAL REGISTER.

4,459,815. REG. 12-31-2013. INSPIRATO LLC (DELAWARE LIMITED LIABILITY COMPANY) 1637 WAZEE STREET, SUITE 400, DENVER, CO, 80202, SN 85-669,645. FILED 7-5-2012. PRINCIPAL REGISTER.



PRIORITY DATE OF 9-27-2011 IS CLAIMED.  
OWNER OF INTERNATIONAL REGISTRATION 1131460 DATED 3-27-2012, EXPIRES 3-27-2022.

NO CLAIM IS MADE TO THE EXCLUSIVE RIGHT TO USE "MEDIA INDEX" AND "GLOBAL" AND "DATA", APART FROM THE MARK AS SHOWN.

THE MARK CONSISTS OF THE STYLIZED WORDING "SMI" NEXT TO THE WORDING "STANDARD MEDIA INDEX" SEPARATED BY A VERTICAL LINE, AND THE WORDING "GLOBAL INTELLIGENT DATA" BELOW.

INT. CL. 9/U.S. CLS. 21, 23, 26, 36 AND 38

FOR DOWNLOADABLE ELECTRONIC DATABASES IN THE FIELDS OF MARKET RESEARCH AND ANALYSIS, MEDIA RESEARCH, ADVERTISING RESEARCH, MEDIA SALES MEASUREMENT; COMPUTER PROGRAMS USED TO MANAGE AND ANALYSE AND PREPARE REPORTS CONTAINING THE AFORESAID INFORMATION; COMPUTER SOFTWARE PROGRAMS, DATABASE MANAGEMENT PROGRAMS AND MANUALS SOLD AS A UNIT USED TO CREATE, ACCESS, VIEW, REVIEW, MANIPULATE, CATEGORIZE, ANALYSE, FORMAT, AND PREPARE AND PRINT REPORTS FROM DATA AND INFORMATION IN ALL SUCH DATABASES, ALL IN DOWNLOADABLE FORM OR RECORDED ON COMPUTER MEDIA; \* ALL THESE GOODS/SERVICES ONLY IN RELATION TO MEDIA SERVICES AND MEDIA INFORMATION SERVICES \*.

FIRST USE ; IN COMMERCE .  
INT. CL. 35/U.S. CLS. 100, 101 AND 102

FOR MEDIA MARKET RESEARCH SERVICES; ADVERTISING RESEARCH SERVICES; MARKET ANALYSIS SERVICES IN THE FIELD OF MEDIA BUYING MEASUREMENT SERVICES; BUSINESS DATA ANALYSIS, NAMELY, ANALYSING AND EVALUATING DATA OBTAINED BY CONDUCTING RESEARCH SURVEYS, POLLS, ANALYSES AND EVALUATIONS, AND ONLINE SURVEY PANELS, AND PREPARING BUSINESS REPORTS THEREON; DATA COLLECTION FOR OTHERS, NAMELY, COLLECTION AND ANALYSIS OF QUALITY METRIC DATA FOR A NETWORK OF MEDIA PROVIDERS FOR BUSINESS PURPOSES; PREPARATION OF BUSINESS REPORTS; \* ALL THESE GOODS/SERVICES ONLY IN RELATION TO MEDIA SERVICES AND MEDIA INFORMATION SERVICES \* .

FIRST USE ; IN COMMERCE .  
INT. CL. 38/U.S. CLS. 100, 101 AND 104

FOR PROVIDING ACCESS TO ONLINE ELECTRONIC DATABASES AND WEBSITES IN THE FIELDS OF MEDIA RESEARCH, ADVERTISING RESEARCH, MEDIA SALES MEASUREMENT, MEDIA RATINGS; \* ALL THESE GOODS/SERVICES ONLY IN RELATION TO MEDIA SERVICES AND MEDIA INFORMATION SERVICES \* .

FIRST USE ; IN COMMERCE .

ELEMENTS CORRECTED  
GOODS/SERVICES

# JAUNT

THE MARK CONSISTS OF STANDARD CHARACTERS WITHOUT CLAIM TO ANY PARTICULAR FONT, STYLE, SIZE, OR COLOR.

INT. CL. 36/U.S. CLS. 100, 101 AND 102

FOR REAL ESTATE SERVICES, NAMELY, RENTAL, LEASING AND MANAGEMENT OF [ VACATION HOMES ] \* LUXURY VACATION HOMES OFFERED ON A MEMBERS-ONLY BASIS \* .

FIRST USE 7-18-2012; IN COMMERCE 7-18-2012.

ELEMENTS AMENDED  
GOODS/SERVICES

4,464,516. REG. 1-14-2014. MACROMILL, INC. (JAPAN CORPORATION) 2-16-1, KONAN, MINATO-KU TOKYO 108-0075, JAPAN., SN 79-131,079. FILED 4-3-2013. PRINCIPAL REGISTER.

# Questant

THE MARK CONSISTS OF STANDARD CHARACTERS WITHOUT CLAIM TO ANY PARTICULAR FONT, STYLE, SIZE, OR COLOR.

PRIORITY DATE OF 3-19-2013 IS CLAIMED.  
OWNER OF INTERNATIONAL REGISTRATION 1162664 DATED 4-3-2013, EXPIRES 4-3-2023.

INT. CL. 35/U.S. CLS. 100, 101 AND 102

FOR ADVERTISING AND PUBLICITY SERVICES; PROMOTING THE GOODS AND SERVICES OF OTHERS THROUGH THE ISSUANCE OF TRADING STAMPS; BUSINESS MANAGEMENT ANALYSIS AND BUSINESS CONSULTANCY; PUBLIC OPINION SURVEYS AND ANALYSIS, AND BUSINESS CONSULTANCY RELATED THERETO; COMPUTERIZED MARKETING RESEARCH; MARKETING RESEARCH AND ANALYSIS, AND PROVIDING INFORMATION RELATED THERETO; PROVIDING INFORMATION CONCERNING COMMERCIAL SALES; BUSINESS MANAGEMENT OF HOTELS; PREPARATION [ , AUDITING OR CERTIFICATION ] OF FINANCIAL STATEMENTS; EMPLOYMENT AGENCIES; AUCTIONEERING; IMPORT-EXPORT AGENCIES; ARRANGING NEWSPAPER SUBSCRIPTIONS FOR OTHERS; SHORTHAND; MESSAGE TRANSCRIPTION; STENOGRAPHIC TRANSCRIPTION; DOCUMENT REPRODUCTION; OFFICE FUNCTIONS, NAMELY, FILING, IN PARTICULAR DOCUMENTS OR MAGNETIC TAPE; COMPILATION OF INFORMATION INTO COMPUTER DATABASES; PROVIDING ASSISTANCE TO OTHERS IN THE OPERATION OF DATA PROCESSING APPARATUS NAMELY, IN THE OPERATION OF COMPUTERS, TYPEWRITERS, TELEGRAPH MACHINES AND OTHER SIMILAR OFFICE MA-



CHINES, FOR MARKETING RESEARCH, MARKETING RESEARCH STUDIES AND CONSUMER RESEARCH; RECEPTION SERVICES, NAMELY, PROVIDING IN PERSON BUSINESS DIRECTORY INFORMATION FOR VISITORS IN BUILDINGS; PUBLICITY MATERIAL RENTAL; RENTAL OF TYPEWRITERS, COPYING MACHINES AND WORD PROCESSORS IN THE NATURE OF ELECTRONIC TYPEWRITERS; PROVIDING EMPLOYMENT INFORMATION; PROVIDING INFORMATION ON NEWSPAPER ARTICLES, NAMELY, NEWS CLIPPING SERVICES; RENTAL OF VENDING MACHINES.

FIRST USE ; IN COMMERCE .

ELEMENTS CORRECTED  
GOODS/SERVICES

4,473,029. REG. 1-28-2014. EVAC OY (FINLAND CORPORATION) SINIMAENTIE 14, FI-02630 ESPOO, FINLAND., SN 79-125,210. FILED 9-10-2012. PRINCIPAL REGISTER.



PRIORITY DATE OF 4-12-2012 IS CLAIMED.  
OWNER OF INTERNATIONAL REGISTRATION 1147659 DATED 9-10-2012, EXPIRES 9-10-2022.

THE COLOR(S) GREEN, WHITE AND BLUE IS/ARE CLAIMED AS A FEATURE OF THE MARK.

THE MARK CONSISTS OF THE TERM "EVAC" IN WHITE INSIDE OF A CIRCLE THAT IS GREEN AT THE TOP AND BLUE AT THE BOTTOM WITH A WHITE WAVY BAND RUNNING THROUGH THE MIDDLE OF THE CIRCLE.

INT. CL. 7/U.S. CLS. 13, 19, 21, 23, 31, 34 AND 35

FOR MACHINES AND MACHINE TOOLS, NAMELY, POWER OPERATED BLOWERS AND VACUUM PUMPS FOR VACUUM TOILETS FOR SHIPS; PUMPS AND COMPRESSORS FOR MACHINES; MOTORS AND ENGINES EXCEPT FOR LAND VEHICLES; MACHINE COUPLING AND TRANSMISSION COMPONENTS EXCEPT FOR LAND VEHICLES; [ ALL THE AFORESAID GOODS TO BE USED IN THE BUILDING, MARINE SHIPBUILDING AND OFFSHORE INDUSTRY ] \* ALL THE AFOREMENTIONED GOODS TO BE USED IN THE FIELD OF WASTE AND WASTE WATER COLLECTION AND TREATMENT SOLUTIONS, INCLUDING VACUUM TOILETS, FOR THE BUILDING, MARINE (SHIPBUILDING) AND OFFSHORE INDUSTRY \*.

FIRST USE ; IN COMMERCE .

INT. CL. 11/U.S. CLS. 13, 21, 23, 31 AND 34

FOR APPARATUS AND EQUIPMENT FOR WATER SUPPLY AND SANITARY PURPOSES, NAMELY, VACUUM TOILETS, VACUUM OPERATED OR VACUUM ENHANCED SEWAGE PURIFICATION APPARATUS, WATER OR LIQUID COLLECTION MACHINES IN THE NATURE OF THICKENING AND DEWATERING MACHINES FOR USE IN TREATMENT OF LIQUIDS, TRANSPORTATION AND TREATMENT SYSTEMS AND INSTALLATIONS AND PLANTS, NAMELY, SEWAGE TREATMENT PLANTS AND INSEPARABLE COMPONENTS THEREOF INCLUDING IN THE NATURE OF TOILETS, DISCHARGE VALVES FOR TOILETS, GREY WATER VALVES FOR TOILETS, FAUCETS, GREASE TRAPS, FLOOR DRAINS, BLOWERS, AIR AND LIQUID INJECTORS, VACUUM PUMPS, WATER FILTERS, AD-

DITIVE INJECTORS FOR DISBURSING SOLIDS AND/OR LIQUIDS FOR PURIFICATION AND STERILIZATION PURPOSES, SLUICES, WASTE WATER TREATMENT STORAGE TANKS, SEPARATORS FOR THE CLEANING AND PURIFICATION OF LIQUIDS, AND CONTROLLERS AND MONITORING UNITS INCORPORATED THEREIN; [ ALL THE AFORESAID GOODS TO BE USED IN THE BUILDING, MARINE SHIPBUILDING AND OFFSHORE INDUSTRY ] \* ALL THE AFOREMENTIONED GOODS TO BE USED IN THE FIELD OF WASTE AND WASTE WATER COLLECTION AND TREATMENT SOLUTIONS, INCLUDING VACUUM TOILETS, FOR THE BUILDING, MARINE (SHIPBUILDING) AND OFFSHORE INDUSTRY \*.

FIRST USE ; IN COMMERCE .

INT. CL. 37/U.S. CLS. 100, 103 AND 106

FOR BUILDING CONSTRUCTION AND REPAIR; INSTALLATION SERVICES OF VACUUM TOILETS AND WASTE WATER TREATMENT APPARATUS; [ ALL THE AFORESAID SERVICES TO BE USED IN THE BUILDING, MARINE SHIPBUILDING AND OFFSHORE INDUSTRY ] \* ALL THE AFOREMENTIONED SERVICES TO BE USED IN THE FIELD OF WASTE AND WASTE WATER COLLECTION AND TREATMENT SOLUTIONS, INCLUDING VACUUM TOILETS, FOR THE BUILDING, MARINE (SHIPBUILDING) AND OFFSHORE INDUSTRY \*.

FIRST USE ; IN COMMERCE .

INT. CL. 40/U.S. CLS. 100, 103 AND 106

FOR TREATMENT OF MATERIALS, NAMELY, WASTE WATER TREATMENT FOR USE IN THE BUILDING, MARINE SHIPBUILDING AND OFFSHORE INDUSTRY; [ \* ALL THE AFORESAID SERVICES TO BE USED IN THE BUILDING, MARINE (SHIPBUILDING) AND OFFSHORE INDUSTRY \* ] \* ALL THE AFOREMENTIONED SERVICES TO BE USED IN THE FIELD OF WASTE AND WASTE WATER COLLECTION AND TREATMENT SOLUTIONS, INCLUDING VACUUM TOILETS, FOR THE BUILDING, MARINE (SHIPBUILDING) AND OFFSHORE INDUSTRY \*.

FIRST USE ; IN COMMERCE .

ELEMENTS CORRECTED  
GOODS/SERVICES

4,491,073. REG. 3-4-2014. KARI WHITE (UNITED STATES INDIVIDUAL), MAYOR B., 1/2, 419 N. SIERRA BONITA AVE., LOS ANGELES, CA. 90036, SN 86-020,551. FILED 7-26-2013. PRINCIPAL REGISTER.

Mayor B.

THE MARK CONSISTS OF STANDARD CHARACTERS WITHOUT CLAIM TO ANY PARTICULAR FONT, STYLE, SIZE, OR COLOR.

INT. CL. 20/U.S. CLS. 2, 13, 22, 25, 32 AND 50

FOR BEDS FOR HOUSEHOLD PETS.

FIRST USE 1-1-2013; IN COMMERCE 3-1-2013.

ELEMENTS CORRECTED  
\*DBA/AKA\*  
OWNER NAME  
CITIZENSHIP  
ENTITY



4,492,898. REG. 3-11-2014. KURT KRANNICH (FED REP GERMANY INDIVIDUAL) HOFACKERSTRASSE 19, WEIL DER STADT/HAUSEN, FED REP GERMANY, 71263, SN 79-098,107. FILED 3-28-2011. PRINCIPAL REGISTER.

# LUXOR

THE MARK CONSISTS OF STANDARD CHARACTERS WITHOUT CLAIM TO ANY PARTICULAR FONT, STYLE, SIZE, OR COLOR.

PRIORITY DATE OF 12-28-2010 IS CLAIMED.

OWNER OF INTERNATIONAL REGISTRATION 1079274 DATED 3-28-2011, EXPIRES 3-28-2021.

INT. CL. 4/U.S. CLS. 1, 6 AND 15

FOR INDUSTRIAL OILS AND GREASES; INDUSTRIAL LUBRICANTS; DUST ABSORBING, WETTING AND BINDING COMPOSITIONS FOR USE IN THE MANUFACTURE OF PHOTOVOLTAIC MODULES; FUELS AND LIGHTING FUELS; ELECTRICAL ENERGY; CANDLES AND WICKS FOR CANDLES FOR LIGHTING; ALL THE AFORESAID GOODS FOR USE IN THE FIELD OF RENEWABLE ENERGY.

FIRST USE ; IN COMMERCE .

INT. CL. 6/U.S. CLS. 2, 12, 13, 14, 23, 25 AND 50

FOR FIXING MATERIAL OF METAL, NAMELY, METAL FASTENERS FOR MOUNTING SOLAR PANELS; MATERIALS OF METAL FOR SCAFFOLDS, METAL RACKS, METAL POLES, STAKES AND MASTS OF METAL FOR MOUNTING SOLAR PANELS, METAL BUILDING PROFILES AND FRAMES FOR SOLAR MODULES AND FOR CONSTRUCTION PURPOSES; ALL THE AFORESAID GOODS FOR USE IN THE FIELD OF RENEWABLE ENERGY.

FIRST USE ; IN COMMERCE .

INT. CL. 9/U.S. CLS. 21, 23, 26, 36 AND 38

FOR SCIENTIFIC, NAUTICAL, SURVEYING, PHOTOGRAPHIC, CINEMATOGRAPHIC, OPTICAL, WEIGHING, MEASURING, SIGNALLING, CHECKING, LIFE-SAVING AND TEACHING APPARATUS AND INSTRUMENTS, NAMELY, ELECTRONIC DEVICE FOR MONITORING AND OPTIMIZING PHOTOVOLTAIC ARRAYS AND ELECTRONIC SENSORS FOR MEASURING SOLAR RADIATION; \* EXCLUDING VIDEO, PHOTOGRAPHIC AND LIGHTING APPARATUS AND INSTRUMENTS USED IN CONNECTION WITH BORESCOPES OR MICROSCOPES; \* APPARATUS AND INSTRUMENTS FOR CONDUCTING, SWITCHING, TRANSFORMING, ACCUMULATING, REGULATING OR CONTROLLING ELECTRICITY, NAMELY, SOLAR PANELS FOR PRODUCTION OF ELECTRICITY; SOLAR CELLS; PHOTOVOLTAIC CELLS AND MODULES; PHOTOVOLTAIC INVERTERS; APPARATUS FOR CONVERTING ELECTRONIC RADIATION TO ELECTRICAL ENERGY, NAMELY, PHOTOVOLTAIC ROOFING MEMBERS, PHOTOVOLTAIC SOLAR MODULES, PHOTOVOLTAIC CLADDING PANELS, PHOTOVOLTAIC SOLAR HYBRID MODULES, PHOTOVOLTAIC THERMAL HYBRID MODULES, PHOTOVOLTAIC THERMAL MODULE; PHOTOVOLTAIC SYSTEMS CONSISTING OF SOLAR MODULES FOR POWER GENERATION, INVERTERS, ELECTRONIC APPARATUS AND INSTRUMENTS FOR CONTROLLING, REGULATING, ACCUMULATING AND MONITORING; SOLAR PANEL SYSTEMS CONSISTING OF SOLAR MODULES, SOLAR COLLECTORS AND INVERTERS FOR POWER GENERATION; ELECTRONIC APPARATUS AND INSTRUMENTS FOR CONTROLLING, REGULATING, ACCUMULATING AND MONITORING OF POWER GENERATION; BLANK MAGNETIC DATA CARRIERS, DATA PROCESSING

APPARATUS; EXCEPT APPARATUS FOR GAMES ADAPTED FOR USE WITH TELEVISION SETS ONLY, COMPUTER PROGRAMS, ELECTRONIC COMPONENTS FOR APPARATUS ADAPTED FOR USE WITH TELEVISION SETS ONLY, PREPAID GAMING MACHINES, GAMING MACHINES, GAMING MACHINES OTHER THAN THOSE ADAPTED FOR USE WITH TELEVISION SETS ONLY; ALL THE AFORESAID GOODS BEING FOR USE IN THE FIELD OF RENEWABLE ENERGY \* AND EXCLUDING BATTERIES, ACCUMULATORS, CHARGERS FOR ACCUMULATORS, SAFETY SWITCHGEARS FOR MAINS POWER FAILURE \*.

FIRST USE ; IN COMMERCE .

INT. CL. 11/U.S. CLS. 13, 21, 23, 31 AND 34

FOR [ APPARATUS FOR HEATING, STEAM GENERATING, COOKING, REFRIGERATING, DRYING, VENTILATING AND WATER CONDUIT PURPOSES, NAMELY, SOLAR COLLECTORS, SOLAR ENERGY RECEIVERS, SOLAR REACTORS, SOLAR HEAT COLLECTION PANELS, AND PARABOLIC MIRRORS DESIGNED FOR THE COLLECTION OF SOLAR ENERGY; SOLAR ENERGY BASED COOLING APPARATUS; SOLAR WATER HEATERS; SOLAR THERMAL INSTALLATIONS, NAMELY, SOLAR THERMAL MODULES; SOLAR COLLECTORS AND SOLAR MODULES FOR HEAT GENERATION AND SYSTEMS CONSISTING THEREOF; SOLAR COLLECTORS AND SOLAR ENERGY RECEIVERS FOR ROOF INSTALLATIONS AND OPEN-AIR INSTALLATIONS ].

FIRST USE ; IN COMMERCE .

INT. CL. 19/U.S. CLS. 1, 12, 33 AND 50

FOR NON-METAL BUILDING MATERIALS FOR MOUNTING SOLAR PANELS, NON-METAL ARCHITECTURAL MOULDINGS, NAMELY, BUILDING PROFILE LEDGES; ASPHALT, PITCH AND BITUMEN; NON-METALLIC TRANSPORTABLE BUILDINGS; MONUMENTS, NOT OF METAL; ROOFING, NOT OF METAL, INCORPORATING SOLAR CELLS.

INT. CL. 35/U.S. CLS. 100, 101 AND 102

FOR ADVERTISING SERVICES; BUSINESS MANAGEMENT SERVICES; BUSINESS ADMINISTRATION; PROVIDING OFFICE FUNCTIONS; PROFESSIONAL BUSINESS AND ORGANIZATIONAL PLANNING OF SYSTEMS AND PLANTS FOR REGENERATIVE ENERGY GENERATION; PROFESSIONAL BUSINESS MANAGEMENT AND BUSINESS ORGANIZATION CONSULTANCY FOR SYSTEMS AND PLANTS FOR REGENERATIVE ENERGY GENERATION; BUSINESS PROJECT MANAGEMENT, IN PARTICULAR FOR SYSTEMS AND PLANTS IN THE FIELD OF RENEWABLE ENERGY; ARRANGING OF COMMERCIAL CONTRACTS FOR OTHERS FOR THE BUYING AND SELLING OF POWER SUPPLIES.

INT. CL. 37/U.S. CLS. 100, 103 AND 106

FOR BUILDING CONSTRUCTION; REPAIR SERVICES, NAMELY, REPAIR SERVICES OF INDIVIDUAL COMPONENTS IN THE FIELD OF PHOTOVOLTAIC AND SOLAR THERMAL ENERGY; INSTALLATION SERVICES, NAMELY, INSTALLATION OF PHOTOVOLTAIC AND SOLAR THERMAL ENERGY EQUIPMENT, AND INSTALLATION OF SOLAR ENERGY SYSTEMS AND ALTERNATIVE ENERGY PRODUCTS FOR RESIDENTIAL AND COMMERCIAL USE; CONSTRUCTION, CLEANING, REPAIR AND MAINTENANCE OF SYSTEMS AND PLANTS IN THE FIELD OF RENEWABLE ENERGY; SCAFFOLDING ERECTION, CONSTRUCTION AND REPAIR; ROOFING SERVICES.

INT. CL. 39/U.S. CLS. 100 AND 105

FOR TRANSPORT OF GOODS BY AIR, BUS, MARINE, RAILWAY, TRUCK; PACKAGING AND STORAGE OF GOODS, NAMELY, PHOTOVOLTAIC AND SOLAR THERMAL ENERGY EQUIPMENT; ARRANGING OF TRAVEL TOURS; TRANSMISSION AND TRANSPORT, NAMELY, DISTRIBUTION OF ELECTRICITY, THERMAL HEAT, GAS OR WATER; DELIVERY OF ELECTRICITY, THERMAL HEAT, GAS OR WATER FOR SUPPLY TO CUSTOMERS; DELIVERY AND DISTRIBUTION OF ENERGY.

INT. CL. 40/U.S. CLS. 100, 103 AND 106

FOR TREATMENT OF MATERIALS FOR THE PRODUCTION OF ENERGY, GENERATION OF ENERGY.

INT. CL. 42/U.S. CLS. 100 AND 101

FOR SCIENTIFIC AND TECHNOLOGICAL SERVICES, NAMELY, RESEARCH, TECHNOLOGY PLANNING, DEVELOPMENT AND DESIGN IN THE FIELDS OF SOLAR ENERGY AND RENEWABLE ENERGY; INDUSTRIAL ANALYSIS AND RESEARCH SERVICES, NAMELY, INDUSTRIAL RESEARCH IN THE FIELDS OF SOLAR ENERGY AND RENEWABLE ENERGY; CREATION AND DEVELOPMENT OF COMPUTER HARDWARE AND SOFTWARE; TECHNOLOGICAL ANALYSIS AND PREPARATION OF TECHNICAL CERTIFICATES FOR ASSESSMENT OF PROJECTS AND PROJECT PARTNERS IN THE FIELDS OF SOLAR ENERGY AND RENEWABLE ENERGY; TECHNOLOGICAL PLANNING AND DESIGN OF PROJECTS AND TECHNOLOGICAL COORDINATION OF SYSTEMS AND PLANTS IN THE FIELD OF RENEWABLE ENERGY; QUALITY MANAGEMENT SERVICES, NAMELY, QUALITY TESTING OF PRODUCTS FOR CERTIFICATION PURPOSES; SURVEYING; CONSTRUCTION DRAFTING AND ARCHITECTURAL CONSULTANCY; DEVELOPMENT SERVICES, FOR OTHERS, IN THE FIELD OF RENEWABLE ENERGIES; ENGINEERING SERVICES; EXCEPT SERVICES IN CONNECTION WITH APPARATUS FOR GAMES ADAPTED FOR USE WITH TELEVISION RECEIVERS ONLY, COMPUTER PROGRAMS, ELECTRONIC COMPONENTS FOR APPARATUS ADAPTED FOR USE WITH TELEVISION RECEIVERS ONLY, PREPAID GAMING MACHINES, GAMING MACHINES, OTHER GAMING MACHINES ADAPTED FOR USE WITH TELEVISION RECEIVERS ONLY.

FIRST USE ; IN COMMERCE .

ELEMENTS CORRECTED  
GOODS/SERVICES

FOR SEMI-FINISHED PRODUCTS MADE OF PLASTICS, RUBBER AND GUM IN FORM OF PELLETS, RODS, FOILS, FOAMS, FIBERS, FILMS AND SHEETS; SEALING MATERIALS; SEMI-FINISHED RUBBER AND GUM IN THE FORM OF BLOCK, PLATES, RODS, FOILS, CORDS OR BANDS AND PLASTIC IN EXTRUDED FORM FOR USE IN THE MANUFACTURE OF SUCTION CARRIERS AND VACUUM CUPS; \* EXCEPT MATERIALS FOR LEATHER REINFORCEMENT, AS WELL AS SHOE TOE CAP MATERIALS; ALL AFOREMENTIONED GOODS EXCLUSIVELY BEING COMPONENTS FOR VACUUM EXHAUSTERS \*.

FIRST USE ; IN COMMERCE .

ELEMENTS CORRECTED  
GOODS/SERVICES

4,503,042. REG. 3-25-2014. LIFESTYLE DOMAIN HOLDINGS, INC. (DELAWARE CORPORATION) 312 WALNUT ST., SUITE 1800, CINCINNATI, OH, 45202, SN 85-847,957. FILED 2-12-2013. PRINCIPAL REGISTER.

4,496,658. REG. 3-18-2014. FIPA GMBH (FED REP GERMANY LIMITED LIABILITY COMPANY) FREISINGER STRASSE 30, 85737 ISMANING, FED REP GERMANY,, SN 79-127,840. FILED 2-7-2013. PRINCIPAL REGISTER.

# Varioflex

THE MARK CONSISTS OF STANDARD CHARACTERS WITHOUT CLAIM TO ANY PARTICULAR FONT, STYLE, SIZE, OR COLOR.

PRIORITY DATE OF 8-24-2012 IS CLAIMED.

OWNER OF INTERNATIONAL REGISTRATION 1154420 DATED 2-7-2013, EXPIRES 2-7-2023.  
INT. CL. 1/U.S. CLS. 1

FOR CHEMICALS USED IN INDUSTRY AND SCIENCE; UNPROCESSED ARTIFICIAL RESINS; UNPROCESSED PLASTICS; \* EXCEPT DIPPING HARDENERS FOR SHOE TOE CAP MATERIALS; ALL AFOREMENTIONED GOODS EXCLUSIVELY BEING COMPONENTS FOR VACUUM EXHAUSTERS \*.

FIRST USE ; IN COMMERCE .

INT. CL. 7/U.S. CLS. 13, 19, 21, 23, 31, 34 AND 35

FOR MACHINE PARTS AND EQUIPMENT FOR VACUUM AND GRIPPER MACHINES, NAMELY, VACUUM CUPS; VACUUM SUCTION GRIPPERS MADE OF PLASTICS OR GLASS, SUCTION CUP SUSPENSIONS AND VACUUM SUCTION CUPS MADE OF GUM, RUBBER AND OTHER POLYMER OR ELASTOMERS FOR VACUUM CUPS.

FIRST USE ; IN COMMERCE .

INT. CL. 17/U.S. CLS. 1, 5, 12, 13, 35 AND 50

# ULIVE

THE MARK CONSISTS OF STANDARD CHARACTERS WITHOUT CLAIM TO ANY PARTICULAR FONT, STYLE, SIZE, OR COLOR.

INT. CL. 38/U.S. CLS. 100, 101 AND 104

FOR BROADCASTING AND STREAMING OF AUDIO-VISUAL MEDIA CONTENT IN THE FIELDS OF LIFESTYLE, FOOD AND COOKING, INTERIOR DESIGN AND DECORATION, HOME DESIGN, HOME BUILDING, HOME IMPROVEMENT, HOME REPAIR, HOME RENOVATION, REAL ESTATE, ARCHITECTURE, GARDENING, GARDEN DESIGN AND RENOVATION, TRAVEL, ADVENTURE, CULTURE, PARENTING, PETS, PHOTOGRAPHY, BEAUTY, FASHION, BOOKS, MOVIES, TELEVISION, AND MUSIC \*; EXCLUDING SPORTS, \* VIA A GLOBAL COMPUTER NETWORK; WEBCASTING SERVICES; PROVIDING ONLINE ELECTRONIC BULLETIN BOARDS AND FORUMS FOR TRANSMISSION OF MESSAGES AMONG USERS IN THE FIELDS OF LIFESTYLE, FOOD AND COOKING, INTERIOR DESIGN AND DECORATION, HOME DESIGN, HOME BUILDING, HOME IMPROVEMENT, HOME REPAIR, HOME RENOVATION, REAL ESTATE, ART, CRAFTS, ARCHITECTURE, GARDENING, GARDEN DESIGN AND RENOVATION, TRAVEL, ADVENTURE, CULTURE, PARENTING, FITNESS, PETS, PHOTOGRAPHY, BEAUTY, FASHION, BOOKS, MOVIES, TELEVISION, AND MUSIC \*; EXCLUDING SPORTS \* ; VIDEO ON-DEMAND TRANSMISSION SERVICES.

FIRST USE 6-30-2013; IN COMMERCE 6-30-2013.

ELEMENTS AMENDED  
GOODS/SERVICES

4,503,043. REG. 3-25-2014. LIFESTYLE DOMAIN HOLDINGS, INC. (DELAWARE CORPORATION) 312 WALNUT ST., SUITE 1800, CINCINNATI, OH, 45202, SN 85-847,958. FILED 2-12-2013. PRINCIPAL REGISTER.

# ULIVE

THE MARK CONSISTS OF STANDARD CHARACTERS WITHOUT CLAIM TO ANY PARTICULAR FONT, STYLE, SIZE, OR COLOR.

INT. CL. 41/U.S. CLS. 100, 101 AND 107

FOR EDUCATIONAL AND ENTERTAINMENT SERVICES, NAMELY, PROVIDING A WEBSITE FEATURING AUDIO-VISUAL CONTENT, NAMELY, TELEVISION PROGRAMMING IN THE FIELD OF LIFESTYLE, FOOD AND COOKING, INTERIOR DESIGN AND DECORATION, HOME DESIGN, HOME BUILDING, HOME IMPROVEMENT, HOME REPAIR, HOME RENOVATION, REAL ESTATE, ART, CRAFTS, ARCHITECTURE, GARDENING, GARDEN DESIGN AND RENOVATION, TRAVEL, ADVENTURE, CULTURE, PARENTING, PETS, PHOTOGRAPHY, BEAUTY, FASHION, BOOKS, MOVIES, AND MUSIC \*, EXCLUDING SPORTS \* ; PROVIDING A WEBSITE FEATURING AUDIO-VISUAL CONTENT, NAMELY, NON-DOWNLOADABLE VIDEOS, NON-DOWNLOADABLE VIDEO CLIPS, AUDIO CLIPS, TEXT AND PHOTOGRAPHS IN THE FIELD OF ART, PARENTING CONCERNING EDUCATION AND ENTERTAINMENT OF CHILDREN, PHOTOGRAPHY, BOOKS, MOVIES, TELEVISION, AND MUSIC \*, EXCLUDING SPORTS \* ; PROVIDING BLOGS IN THE NATURE OF AN ONLINE JOURNAL OVER THE INTERNET IN THE FIELDS OF LIFESTYLE, FOOD AND COOKING, INTERIOR DESIGN AND DECORATION, HOME DESIGN, HOME BUILDING, HOME IMPROVEMENT, HOME REPAIR, HOME RENOVATION, REAL ESTATE, ART, CRAFTS, ARCHITECTURE, GARDENING, GARDEN DESIGN AND RENOVATION, TRAVEL, ADVENTURE, CULTURE, PARENTING, FITNESS, PETS, PHOTOGRAPHY, BEAUTY, FASHION, BOOKS, MOVIES, TELEVISION, AND MUSIC \*, EXCLUDING SPORTS \*

FIRST USE 6-30-2013; IN COMMERCE 6-30-2013.

ELEMENTS AMENDED  
GOODS/SERVICES

4,508,535. REG. 4-8-2014. VYON BEAUTY GMBH (FED REP GERMANY LIMITED LIABILITY COMPANY) GRUNERSTRABE 133, 40239 DÜSSELDORF, FED REP GERMANY., SN 79-123,071. FILED 10-17-2012. PRINCIPAL REGISTER.

# VYON

THE MARK CONSISTS OF STANDARD CHARACTERS WITHOUT CLAIM TO ANY PARTICULAR FONT, STYLE, SIZE, OR COLOR.

PRIORITY DATE OF 5-7-2012 IS CLAIMED.  
OWNER OF INTERNATIONAL REGISTRATION 1142587 DATED 10-17-2012, EXPIRES 10-17-2022.

THE WORDING "VYON" HAS NO MEANING IN A FOREIGN LANGUAGE.

INT. CL. 3/U.S. CLS. 1, 4, 6, 50, 51 AND 52

FOR COSMETICS, FILLED COSMETIC SETS COMPRISING FACIAL CREAMS; COSMETIC PENCILS, COSMETIC MASSAGE OILS, COSMETIC SKIN CREAMS, COSMETIC SKIN CARE PREPARATIONS, OILS FOR PERFUMES AND SCENTS, PERFUMERY, SUN SCREEN PREPARATIONS, COSMETIC SKIN TANNING PREPARATIONS, TISSUES IMPREGNATED WITH COSMETIC LOTIONS, BEAUTY MASKS, CLEANSING MILK FOR TOILET PURPOSES AND BODY CARE PURPOSES, LOTIONS FOR COSMETIC PURPOSES, OILS FOR TOILET PURPOSES AND BODY CARE PURPOSES, OILS FOR COSMETIC PURPOSES; [ALL THE AFORESAID GOODS OTHER THAN COSMETIC INTIMATE HYGIENE PREPARATIONS, INTIMATE CARE CREAMS, INTIMATE DEODORANTS, WASH TISSUES FOR INTIMATE HYGIENE AND INTIMATE WASH LOTIONS] \* ALL AFOREMENTIONED GOODS EXCEPT COSMETIC PREPARATIONS FOR INTIMATE CARE, OINTMENTS FOR INTIMATE CARE, DEODORANTS FOR INTIMATE CARE, WASHING CLOTHS FOR INTIMATE CARE AND WASHING LOTIONS FOR INTIMATE CARE \*

FIRST USE ; IN COMMERCE .

ELEMENTS CORRECTED  
GOODS/SERVICES

4,508,549. REG. 4-8-2014. FRANCESCA (FRANCE SOCIÉTÉ ANONYME) 6B RUE PRECHTER, F-67000 STRASBOURG, FRANCE., SN 79-125,594. FILED 12-18-2012. PRINCIPAL REGISTER.

PRIORITY DATE OF 6-22-2012 IS CLAIMED.  
OWNER OF INTERNATIONAL REGISTRATION 1148662 DATED 12-18-2012, EXPIRES 12-18-2022.

THE COLOR(S) RED IS/ARE CLAIMED AS A FEATURE OF THE MARK.

THE MARK CONSISTS OF A STYLIZED LOWER CASE LETTER "F" IN RED.

INT. CL. 29/U.S. CL. 46

FOR MEAT, FISH, POULTRY AND GAME; MEAT, FISH OR POULTRY EXTRACTS; PRESERVED, DRIED AND COOKED FRUIT AND VEGETABLES; JELLIES, JAMS, COMPOTES; EGGS, MILK AND DAIRY PRODUCTS, EXCLUDING ICE CREAM, ICE MILK AND FROZEN YOGURT; CHEESE, YOGURT; EDIBLE OILS, EDIBLE OLIVE OILS, EDIBLE FATS, MILK BEVERAGES, NAMELY, MILK, MILK SHAKES; BOUILONS, CHARCUTERIE, SALTED MEATS, CANNED FISH, TINNED MEAT, TINNED FRUITS, TINNED VEGETABLES, TINNED SHELLFISH, SHELLFISH NOT LIVE, CRUSTACEANS NOT LIVE, EDIBLE MOLLUSCS NOT LIVE, PROCESSED FISH SPAWN, FRUIT SALADS, VEGETABLE SALADS, PICKLES, THICK SOUPS, FRUIT PULP, VEGETABLE PUREE, TOMATO PUREE, TOMATO PASTE FOR COOKING, PROCESSED EDIBLE SEEDS; PREPARED OR COOKED MEALS CONSISTING PRIMARILY OF MEAT, POULTRY, GAME, FISH, FRUIT, VEGETABLES, SHELLFISH, CRUSTACEANS, MOLLUSCS, EGGS AND MILK PRODUCTS EXCLUDING ICE CREAM, ICE MILK AND FROZEN YOGURT.

INT. CL. 30/U.S. CL. 46

FOR COFFEE; [ TEA; ] COCOA; SUGAR; RICE; ARTIFICIAL COFFEE; FLOUR; PREPARATIONS MADE FROM CEREALS, NAMELY, BREAD, PASTRY, CEREAL-BASED SNACK FOOD, PROCESSED CEREALS, PASTA, PIZZA, FRENCH TOAST; CONFECTIONERY MADE OF SUGAR; ICE; HONEY; YEAST; SALT; PEPPER; MUSTARD; VINEGAR; CONDIMENT SAUCES; SEASONING SAUCES; SPICES; ICES FOR REFRESHMENT; EDIBLE ICES; PASTA; FLAVORINGS OTHER THAN ESSENTIAL OILS; SEASONINGS; RUSKS; COOKIES; BISCUITS; BRIOCHES; BEVERAGES MADE WITH COFFEE; BEVERAGES MADE WITH CHOCOLATE; BEVERAGES MADE WITH COCOA; [ BEVERAGES MADE WITH TEA; ] DRIED CEREAL FLAKES; CHOCOLATE; CRACKERS; ICE CREAM; CAKES; WAFFLES; NON-MEDICINAL HERBAL INFUSIONS; MEAT GRAVIES; KETCHUP; COFFEE BEVERAGES WITH MILK; CHOCOLATE BEVERAGES WITH MILK; POPCORN; MAYONNAISE; MUESLI; GINGERBREAD; FRUIT JELLY CANDY; PEPPER SEASONINGS; PIZZAS; RAVIOLI; STUFFED PASTA; SAUCES FOR SALADS; SANDWICHES; PANINIS; PROCESSED SEMOLINA, PROCESSED WHEAT; SORBETS; TABBOULEH; TOMATO SAUCE; SALTED OR SWEET PIES; SAVORY OR SWEET TARTS; MEAT PIES; FROZEN YOGHURT; READY-MADE OR COOKED DISHES MADE WITH DOUGH, PASTA, RICE, SEMOLINA, WHEAT, CEREALS; PRESERVED GARDEN HERBS AS SEASONING.  
 FIRST USE ; IN COMMERCE .

INT. CL. 39/U.S. CLS. 100 AND 105

FOR TRANSPORT, PACKAGING AND STORAGE OF GOODS, NAMELY, FOOD PRODUCTS; DELIVERY OF PARCELS, MEALS, PREPARED OR COOKED DISHES, FOODS OR FOOD PREPARATIONS; PACKAGING OF GOODS FOR STORAGE, DELIVERY, AND TRANSPORTATION, NAMELY, FOOD, PREPARED OR COOKED MEALS, MEALS; RENTAL OF STORAGE CONTAINERS; LOADING, UNLOADING AND STORAGE OF FOOD; DELIVERY OF FOOD, PREPARED OR COOKED MEALS, DISHES; PACKAGING OF PRODUCTS FOR STORAGE, DELIVERY AND TRANSPORTATION, NAMELY, FOOD, MEALS, PREPARED OR COOKED DISHES; WRAPPING OF PRODUCTS FOR PROTECTION DURING TRANSPORT, NAMELY FOOD, MEALS, PREPARED OR COOKED DISHES; STORAGE OF FOOD, MEALS, PREPARED OR COOKED DISHES; RENTAL OF WAREHOUSES; FREIGHT FORWARDING OF FOOD PRODUCTS, PREPARED OR COOKED DISHES, MEALS; INFORMATION ON TRANSPORT, DELIVERY AND STORAGE OF GOODS; DELIVERY OF GOODS ORDERED BY MAIL ORDER; RENTAL OF CARS FOR THE DELIVERY OF FOOD, PREPARED OR COOKED DISHES OR MEALS; RENTAL OF BICYCLES, MOTORCYCLES, CARS, LORRIES AND VANS INTENDED FOR THE DELIVERY OF FOOD, PREPARED OR COOKED DISHES OR MEALS; GARAGE RENTAL; AND RENTAL OF REFRIGERATORS.

INT. CL. 43/U.S. CLS. 100 AND 101

FOR SERVICES FOR PROVIDING FOOD AND DRINK; SERVICES OF BARS, COFFEE SHOPS, CAFETERIAS, SELF-SERVICE RESTAURANTS, FAST FOOD RESTAURANTS AND SNACK BARS; PROVIDING OF FOOD AND DRINK; RENTAL OF COOKING APPARATUS; RENTAL OF CHAIRS, TABLES, TABLE LINEN, TABLE CUTLERY, GLASSWARE; RENTAL OF BANQUET AND SOCIAL FUNCTION FACILITIES FOR SPECIAL OCCASIONS, NAMELY, RESTAURANTS, BARS, COFFEE SHOPS, CAFETERIAS; RESTAURANT SERVICES, NAMELY, PREPARATION AND PROVISION OF MEALS AND BEVERAGES.

ELEMENTS CORRECTED  
 GOODS/SERVICES

4,513,640. REG. 4-15-2014. THE FORMULA LLC (DELAWARE LIMITED LIABILITY COMPANY) 1740 TECHNOLOGY DRIVE SUITE 205, SAN JOSE, CA, 95110, SN 85-959,345. FILED 6-13-2013. PRINCIPAL REGISTER.

# THE FORMULA

THE MARK CONSISTS OF STANDARD CHARACTERS WITHOUT CLAIM TO ANY PARTICULAR FONT, STYLE, SIZE, OR COLOR.

INT. CL. 42/U.S. CLS. 100 AND 101

FOR SOFTWARE AS A SERVICE (SAAS) SERVICES FOR BUSINESSES FEATURING SOFTWARE FOR MANAGING CLIENT ACCOUNTS, ORGANIZING AND MANAGING CORPORATE OPERATIONS, ORGANIZING AND TRACKING CUSTOMER SERVICE, MANAGING HUMAN RESOURCES, ORGANIZING AND MANAGING PERSONNEL RECRUITMENT, CONDUCTING VIRTUAL TRAINING, ORGANIZING AND MANAGING SALES PIPELINE, ORGANIZING AND MANAGING MARKETING AND CONDUCTING ANALYSIS OF SALES AND MARKETING.

FIRST USE 1-31-2013; IN COMMERCE 1-31-2013.

ELEMENTS CORRECTED  
 CITIZENSHIP

4,520,684. REG. 4-29-2014. PUBLET, INC. (DELAWARE CORPORATION) 490 SECOND STREET, UNIT #200, SAN FRANCISCO, CA, 94107, SN 86-022,661. FILED 7-29-2013. PRINCIPAL REGISTER.

# PUBLISH ONCE. BE EVERYWHERE.

THE MARK CONSISTS OF STANDARD CHARACTERS WITHOUT CLAIM TO ANY PARTICULAR FONT, STYLE, SIZE, OR COLOR.

INT. CL. 9/U.S. CLS. 21, 23, 26, 36 AND 38

FOR COMPUTER SOFTWARE FOR USE AS A PUBLISHING TOOL FOR MULTIMEDIA STORYTELLING.

FIRST USE 6-10-2013; IN COMMERCE 6-10-2013.

ELEMENTS CORRECTED  
 OWNER NAME  
 CITIZENSHIP  
 ENTITY

4,523,766. REG. 5-6-2014. LANGENSCHIEDT GMBH & CO. KG (FED REP GERMANY LIMITED PARTNERSHIP) MIES-VAN-DER-ROHE-STRABE 5, 80807 MÜNCHEN, FED REP GERMANY., SN 79-120,694. FILED 5-25-2012. PRINCIPAL REGISTER.



PRIORITY DATE OF 5-8-2012 IS CLAIMED.  
OWNER OF INTERNATIONAL REGISTRATION 1136444 DATED 5-25-2012, EXPIRES 5-25-2022.

THE MARK CONSISTS OF THE LETTER "L" IN STYLIZED FONT.

INT. CL. 9/U.S. CLS. 21, 23, 26, 36 AND 38

FOR APPARATUS FOR RECORDING, TRANSMISSION OR REPRODUCTION OF SOUND OR IMAGES; MAGNETIC, OPTIC AND DIGITAL DATA CARRIERS, NAMELY, BLANK FLOPPY DISCS, BLANK MAGNETIC COMPUTER TAPES AND BLANK MAGNETIC TAPES FOR TAPE RECORDERS; BLANK OPTICAL DISCS; RECORDED CDS, CD-ROMS, CD-I, AND DVDS ALL FEATURING LANGUAGE TRAINING COURSES; LEARNING SOFTWARE IN THE NATURE OF EDUCATIONAL SOFTWARE FEATURING INSTRUCTION IN LANGUAGE LEARNING; LANGUAGE TRANSLATION SOFTWARE; ELECTRONIC BOOKS FEATURING DICTIONARIES AND LANGUAGE LEARNING COURSES RECORDED ON COMPUTER MEDIA; DOWNLOADABLE AND HAND-HELD ELECTRONIC DICTIONARIES AND ENCYCLOPEDIA; FLASH MEMORY CARDS; ELECTRONIC POCKET TRANSLATORS; COMPUTER SOFTWARE AND COMPUTER SOFTWARE APPLICATIONS FOR MOBILE COMPUTER SYSTEMS, MOBILE TERMINALS, MOBILE PHONES AND TABLETS FEATURING LANGUAGE TRAINING COURSES, LEARNING SOFTWARE IN THE NATURE OF EDUCATIONAL SOFTWARE FEATURING INSTRUCTION IN LANGUAGE LEARNING, LANGUAGE TRANSLATION SOFTWARE, ELECTRONIC BOOKS FEATURING DICTIONARIES AND LANGUAGE LEARNING COURSES, ELECTRONIC DICTIONARIES AND ENCYCLOPEDIA; READERS IN THE NATURE OF DIGITAL BOOK READERS AND ELECTRONIC READERS FOR ELECTRONIC BOOKS; DOWNLOADABLE SOUND AND IMAGE DATA FILES CONTAINING LANGUAGE LEARNING AND DICTIONARY CONTENT.

FIRST USE ; IN COMMERCE .

INT. CL. 16/U.S. CLS. 2, 5, 22, 23, 29, 37, 38 AND 50

FOR PUBLISHING MATTER AND PRINTED MATTER, NAMELY, BOOKS IN THE FIELD OF LANGUAGE LEARNING, DICTIONARIES, ENCYCLOPEDIA, HANDBOOKS IN THE FIELD OF SOFTWARE RELATING TO LANGUAGE LEARNING, ELECTRONIC DICTIONARIES AND ENCYCLOPEDIA AND ELECTRONIC POCKET TRANSLATORS; BOOKLETS IN THE FIELD OF LANGUAGE LEARNING, CD AND DVD COVER INSERTS IN THE NATURE OF INFORMATIONAL SHEETS FEATURING THE CONTENT OF THE CDS AND DVDS, NAMELY, LANGUAGE LEARNING, NEWSPAPERS, JOURNALS IN THE FIELD OF LANGUAGE LEARNING, BROCHURES IN THE FIELD OF LANGUAGE LEARNING, PERIODICALS IN THE FIELD OF LANGUAGE LEARNING, MAGAZINES IN THE FIELD OF LANGUAGE LEARNING, CATALOGS IN THE FIELD OF LANGUAGE LEARNING, AND PARTWORKS FEATURING LANGUAGE LEARNING COURSES; PRINTED INSTRUCTIONAL TEACHING MATERIAL IN THE FIELD OF LANGUAGE LEARNING.

FIRST USE ; IN COMMERCE .

INT. CL. 38/U.S. CLS. 100, 101 AND 104

FOR PROVIDING ACCESS TO INFORMATION ON THE INTERNET, NAMELY, PROVIDING ACCESS TO THE DATABASES AND WEBSITES OF OTHERS FEATURING DICTIONARY MATTERS, ELECTRONIC BOOKS (E-BOOKS), ELECTRONIC DICTIONARIES AND ENCYCLOPEDIA, HANDBOOKS, TEXTBOOKS, LANGUAGE LEARNING MATERIAL, TRAVEL GUIDES, BOOKLETS, NEWSPAPERS, JOURNALS, BROCHURES, PERIODICALS, MAGAZINES, CATALOGS AND PARTWORKS ON THE INTERNET; TRANSMISSION OF DIGITAL FILES; PROVIDING OF CHAT LINES UTILIZING THE INTERNET, PROVIDING ON-LINE CHAT ROOMS FOR TRANSMISSION OF MESSAGES AMONG USERS IN THE FIELD OF GENERAL INTEREST, PROVIDING INTERNET ACCESS TO INTERNET PLATFORMS AND OTHER SOCIAL MEDIA APPLICATIONS OF OTHERS FOR TRANSMISSION OF MESSAGES AMONG USERS IN THE FIELD OF GENERAL INTEREST; INFORMATION AND IMAGE ELECTRONIC TRANSMISSION VIA COMPUTERS; PROVIDING ACCESS TO DATABASES; TELEVISION BROADCASTING; PROVIDING E-MAIL SERVICES; ELECTRONIC TRANSMISSION OF MESSAGES AND INFORMATION; WEB MESSAGING SERVICES, NAMELY, FORWARDING MESSAGES OF ALL KIND TO INTERNET ADDRESSES; RENTING OF ACCESS TIME TO GLOBAL COMPUTER NETWORKS; PROVIDING USER ACCESS TO COMPUTER PROGRAMS IN DATA NETWORKS INCLUDING INTRANETS; CELLULAR TELEPHONE COMMUNICATION.

FIRST USE ; IN COMMERCE .

INT. CL. 41/U.S. CLS. 100, 101 AND 107

FOR EDUCATION AND PROVIDING OF TRAINING IN THE NATURE OF CLASSES, COURSES, SEMINARS, WORKSHOPS IN THE FIELD OF LANGUAGE LEARNING; SERVICES OF A PUBLISHING COMPANY, EXCEPT PRINTING, NAMELY, PUBLICATION OF HANDBOOKS, TEXTBOOKS, ENCYCLOPEDIA, DICTIONARIES, LANGUAGE LEARNING MATERIAL IN THE NATURE OF BOOKS, TRAVEL GUIDES, BOOKLETS, CD AND DVD COVER INSERTS, NEWSPAPERS, JOURNALS, BROCHURES, PERIODICALS, MAGAZINES AND CATALOGS; TRANSLATION SERVICES; PREPARING TRANSLATIONS VIA THE INTERNET; ONLINE ELECTRONIC PUBLICATION OF ELECTRONIC BOOKS, HANDBOOKS, TEXTBOOKS, ENCYCLOPEDIA, DICTIONARIES, \* PRINTED \* LANGUAGE LEARNING MATERIAL IN THE NATURE OF BOOKS, TRAVEL GUIDES, BOOKLETS, NEWSPAPERS, JOURNALS, BROCHURES, PERIODICALS, MAGAZINES AND CATALOGS; PROVIDING ONLINE-NON-DOWNLOADABLE ELECTRONIC BOOKS, HANDBOOKS, TEXTBOOKS, ENCYCLOPEDIA, DICTIONARIES, LANGUAGE LEARNING MATERIAL IN THE NATURE OF BOOKS, TRAVEL GUIDES, BOOKLETS, NEWSPAPERS, JOUR-

NALS, BROCHURES, PERIODICALS, MAGAZINES, AND CATALOGS PUBLISHED AS APPLICATIONS FOR MOBILE COMPUTER SYSTEMS, MOBILE TERMINALS, MOBILE PHONES AND TABLETS; PUBLICATION OF SOUND AND IMAGE DATA VIA THE INTERNET, NAMELY, DIGITAL VIDEO, AUDIO AND MULTIMEDIA PUBLISHING SERVICES; PRODUCTION OF RADIO AND TELEVISION PROGRAMS; EDUCATION CLASSES IN THE FIELD OF LANGUAGE LEARNING, QUALIFICATION CLASSES IN THE NATURE OF LANGUAGE CLASSES ALL PROVIDED ONLINE IN THE FORM OF E-LEARNING.

FIRST USE ; IN COMMERCE .

INT. CL. 42/U.S. CLS. 100 AND 101

FOR DEVELOPMENT, DESIGN, UPDATING AND MAINTENANCE OF COMPUTER SOFTWARE, INCLUDING COMPUTER SOFTWARE APPLICATIONS FOR MOBILE COMPUTER DEVICES; RENTAL OF COMPUTER SOFTWARE INCLUDING COMPUTER APPLICATIONS; DESIGN, PREPARATION IN THE NATURE OF CREATING AND UPDATING OF HOMEPAGES AND WEBSITES OF OTHERS; CONVERSION OF DATA OR DOCUMENTS FROM PHYSICAL TO ELECTRONIC MEDIA; DATA CONVERSION OF COMPUTER PROGRAMS AND DATA, NOT PHYSICAL CONVERSION; ELECTRONIC DATA STORAGE IN THE NATURE OF PROVIDING TEMPORARY USE OF ON-LINE NON-DOWNLOADABLE CLOUD COMPUTER SOFTWARE FOR USE IN ELECTRONIC STORAGE OF DATA; PROVIDING OR RENTING OF ELECTRONIC STORAGE SPACE, NAMELY, COMPUTER SERVICES IN THE NATURE OF HOSTING AND MAINTAINING AN ON-LINE WEB SITE FOR OTHERS FOR CLOUD COMPUTER FEATURING SOFTWARE FOR ELECTRONIC STORAGE; PROVIDING SEARCH ENGINES FOR OBTAINING DATA AND INFORMATION ON THE INTERNET.

FIRST USE ; IN COMMERCE .

ELEMENTS CORRECTED  
GOODS/SERVICES

4,523,781. REG. 5-6-2014. PETER BOYLE (UNITED KINGDOM INDIVIDUAL) 4A CONNSBROOK AVENUE, BELFAST BT4 1JT, UNITED KINGDOM., SN 79-123,661. FILED 6-19-2012. PRINCIPAL REGISTER.

# DIRTY RUBY

THE MARK CONSISTS OF STANDARD CHARACTERS WITHOUT CLAIM TO ANY PARTICULAR FONT, STYLE, SIZE, OR COLOR.

OWNER OF INTERNATIONAL REGISTRATION 1143947 DATED 6-19-2012, EXPIRES 6-19-2022.

NO CLAIM IS MADE TO THE EXCLUSIVE RIGHT TO USE "RUBY" FOR CLASSES 014 AND 035 ONLY, APART FROM THE MARK AS SHOWN.

INT. CL. 3/U.S. CLS. 1, 4, 6, 50, 51 AND 52

FOR COSMETICS; [ PERFUMERY; ] ESSENTIAL OILS; HAIR CARE PREPARATIONS; HAIR LOTIONS; FACIAL AND BODY CARE PRODUCTS IN THE FORM OF MILKS, CREAMS AND LOTIONS; SUN CREAMS AND SUN OILS; SHAMPOOS; DENTIFRICES; NON-MEDICATED PREPARATIONS FOR THE CARE OF THE SKIN; SOAPS; SANITARY PREPARATIONS AND SUBSTANCES BEING TOILETRIES; DEODORANTS AND ANTI-PERSPIRANTS; NON-MEDICATED TOILETRIES.

FIRST USE ; IN COMMERCE .

INT. CL. 14/U.S. CLS. 2, 27, 28 AND 50

FOR JEWELLERY CONTAINING RUBIES; JEWELRY WITHOUT RED COLORED STONES; WATCHES AND CLOCKS; TIMEPIECES; KEY RINGS AND KEY FOBs MADE OF PRECIOUS METAL OR COATED THEREWITH; FITTED JEWELLERY BOXES; JEWELLERY BOXES OF PRECIOUS METAL; TIE PINS AND CUFF LINKS OF PRECIOUS METAL; KEY HOLDERS MADE OF PRECIOUS METAL.

FIRST USE ; IN COMMERCE .

INT. CL. 18/U.S. CLS. 1, 2, 3, 22 AND 41

FOR ARTICLES MADE FROM LEATHER NOT INCLUDED IN OTHER CLASSES, NAMELY, WALLETS, PURSES, HANDBAGS, CLUTCH BAGS AND DRAWSTRING BAGS; ARTICLES MADE FROM IMITATION LEATHER NOT INCLUDED IN OTHER CLASSES, NAMELY, WALLETS, PURSES, HANDBAGS, CLUTCH BAGS [ AND DRAWSTRING BAGS ]; BACKPACKS; RUCKSACKS; HAVERSACKS; HOLDALLS; TRUNKS; SUITCASES; LUGGAGE, TAGS AND/OR STRAPS FOR LUGGAGE; TRAVEL BAGGAGE; VALISES; CLUTCH BAGS; DRAWSTRING BAGS; TRAVELLING BAGS; BEACH BAGS; BOOT AND SHOES BAGS FOR TRAVEL; DUFFEL BAGS; FLIGHT BAGS; GARMENT BAGS; [ BAGS FOR TRAVEL; ] GYM BAGS; HANDBAGS; OVERNIGHT BAGS; SHOULDER BAGS; SPORTS BAGS; TOILETRY BAGS; TRAVEL BAGS; GARMENT CARRIERS FOR TRAVEL; HAT BOXES OF LEATHER; HAT BOXES FOR TRAVEL, NOT OF PAPER OR CARDBOARD; WALLETS; PURSES; COIN HOLDERS IN THE NATURE OF PURSES AND WALLETS; BILLFOLDS; ATTACHE CASES; CASES FOR KEYS; BRIEFCASES; BUSINESS CARD CASES; CREDIT CARD CASES; CREDIT CARD HOLDERS; CASES FOR KEYS; DRIVING LICENSE CASES; UNFITTED VANITY CASES; UMBRELLAS, PARASOLS AND CASES THEREFOR; WALKING STICKS, WALKING CANES; GENERAL PURPOSE SPORTING ARTICLE BAGS; ARTICLES OF CLOTHING FOR ANIMALS; COLLARS AND/OR HARNESES FOR ANIMALS; SADDLERY; PARTS, FITTINGS AND ACCESSORIES FOR ALL THE AFORESAID.

FIRST USE ; IN COMMERCE .

INT. CL. 25/U.S. CLS. 22 AND 39

FOR ARTICLES OF CLOTHING, NAMELY, CARDIGANS, PULLOVERS, SHIRTS, T-SHIRTS, POLO SHIRTS, TROUSERS, SHORTS, SKIRTS, BLOUSES, JUMPERS, LEGGINGS, SWEAT SHIRTS, SWEAT PANTS, RIBBED WAIST PANTS, RUNNING SHORTS, RUNNING SUITS, SPORTS BRAS, TIGHTS AND YOGA PANTS, HOODED SWEATSHIRTS, JEANS, PRINTED T-SHIRTS, LINED AND UNLINED JACKETS, BLAZERS, JACKETS, COATS, GOWNS, LEOTARDS, PAJAMAS, SARONGS, ROBES, TANK TOPS, VESTS, SHORT SLEEVE AND LONG SLEEVE SHIRTS, BAGGY SHORTS, LONG SLEEVE EMBROIDERED T-SHIRTS, PRINTED AND EMBROIDERED SWEATSHIRTS, TROUSERS, FLEECE PULLOVERS, AND SOCKS; SHAWLS, WRAPS, PASHMINAS; ARTICLES OF UNDERCLOTHING; UNDERWEAR; LINGERIE; SWIMWEAR; WRIST BANDS; BEACH WEAR; BELTS; SLEEPWEAR; DRESSING GOWNS; BATHROBES; TIES; CRAVATS; HEADGEAR, NAMELY, CAPS AND HATS; HOODS; SCARVES; EAR MUFFS; HEADBANDS; FOOTWEAR; SHOES; SANDALS; BOOTS; SLIPPERS; PARTS AND FITTINGS FOR ALL THE AFORESAID [; BELTS MADE OF LEATHER ].

FIRST USE ; IN COMMERCE .

INT. CL. 35/U.S. CLS. 100, 101 AND 102

FOR RETAIL STORE SERVICES, WHOLESALE STORE SERVICES, ONLINE SHOPPING SERVICES AND MAIL ORDER CATALOGUE SERVICES CONNECTED WITH THE SALE OF COSMETICS, [ PERFUMERY, ] ESSENTIAL OILS, HAIR CARE PREPARATIONS, BODY CARE PRODUCTS, SUN CREAMS AND OILS, SHAMPOOS, DENTIFRICES, SKIN CARE PREPARATIONS, SOAPS, SANITARY PREPARATIONS AND SUBSTANCES, DEODORANTS AND ANTI-PERSPIRANTS, NON-MEDICATED TOILET PREPARATIONS, TOILETRIES, JEWELLERY, INCLUDING JEWELLERY CONTAINING RUBIES, TRINKETS, WATCHES AND CLOCKS, CHRONOMETRIC INSTRUMENTS, TIMEPIECES, KEY RINGS AND KEY FOBs MADE OF PRECIOUS METAL OR COATED THEREWITH, JEWELLERY BOXES, TIE PINS AND CUFFLINKS, ARTICLES MADE FROM LEATHER, ARTICLES MADE FROM IMITATION LEATHER, BELTS MADE OF LEATHER, BACKPACKS, RUCKSACKS, HAVERSACKS, HOLDALLS, TRUNKS, SUITCASES, LUGGAGE, TAGS AND/OR STRAPS FOR LUGGAGE, BAGGAGE, VALISES, BAGS, TRAVELLING BAGS, BEACH BAGS, BOOT BAGS, SHOE BAGS, CASUAL BAGS, DUFFEL BAGS, FLIGHTS BAGS, GARMENT BAGS, GYM BAGS, HANDBAGS, OVERNIGHT BAGS, SHOULDER BAGS, SPORTS BAGS, TOILETRY BAGS, TRAVEL BAGS, GARMENT CARRIERS, HAT BOXES, WALLETS, PURSES, COIN HOLDERS, BILLFOLDS, ATTACHE CASES, CASES FOR KEYS, KEY HOLDERS, BRIEFCASES, BUSINESS CARD CASES, CREDIT CARD CASES, CREDIT CARD HOLDERS, CASES FOR KEYS, DRIVING LICENSE CASES, VANITY CASES (NOT FITTED), TRAVELLING SETS OF LEATHER, UMBRELLAS, PARASOLS AND CASES THERE-

FOR, WALKING STICKS, WALKING CANES, DIARY COVERS (NOT ADAPTED), COVERS FOR SPORTING ARTICLES, ARTICLES OF CLOTHING FOR ANIMALS, COLLARS AND/OR HARNESES FOR ANIMALS, SADDLERY, ARTICLES OF CLOTHING, SHAWLS, WRAPS, PASHMINAS, ARTICLES OF OUTER CLOTHING, ARTICLES OF UNDERCLOTHING, UNDERWEAR, LINGERIE, SWIMWEAR, SPORTSWEAR, WRIST BANDS, BEACH WEAR, LEISUREWEAR, BELTS, SLEEPWEAR, DRESSING GOWNS, BATHROBES, TIES, CRAVATS, HEADGEAR, HATS, CAPS, HOODS, SCARVES, EAR MUFFS, HEADBANDS, FOOTWEAR, SOCKS, SHOES, SANDALS, BOOTS, SLIPPERS, AND PARTS, FITTINGS AND ACCESSORIES FOR ALL THE AFORESAID; INFORMATION, ADVISORY AND CONSULTANCY SERVICES RELATING TO THE FOREGOING.

FIRST USE ; IN COMMERCE .

ELEMENTS CORRECTED  
GOODS/SERVICES

4,532,425. REG. 5-20-2014. SEN CORPORATION (JAPAN CORPORATION) 1-1, OSAKI 2CHOME, SHINAGAWA-KU, TOKYO, JAPAN., SN 86-014,458. FILED 7-18-2013. PRINCIPAL REGISTER.

# UHE

THE MARK CONSISTS OF STANDARD CHARACTERS WITHOUT CLAIM TO ANY PARTICULAR FONT, STYLE, SIZE, OR COLOR.

PRIORITY CLAIMED UNDER SEC. 44(D) ON JAPAN APPLICATION NO. JP2013052350, FILED 7-5-2013, REG. NO. 5629276, DATED 11-8-2013, EXPIRES 11-8-2023.

INT. CL. 7/U.S. CLS. 13, 19, 21, 23, 31, 34 AND 35

FOR MACHINES FOR MANUFACTURING SEMICONDUCTOR DEVICES, INCLUDING ION IMPLANTATION MACHINES.

ELEMENTS CORRECTED  
FOREIGN APPLICATION NO.

4,532,426. REG. 5-20-2014. SEN CORPORATION (JAPAN CORPORATION) 1-1, OSAKI 2CHOME, SHINAGAWA-KU, TOKYO, JAPAN., SN 86-014,466. FILED 7-18-2013. PRINCIPAL REGISTER.

# SAion

THE MARK CONSISTS OF STANDARD CHARACTERS WITHOUT CLAIM TO ANY PARTICULAR FONT, STYLE, SIZE, OR COLOR.

PRIORITY CLAIMED UNDER SEC. 44(D) ON JAPAN APPLICATION NO. JP2013052351, FILED 7-5-2013, REG. NO. 5629277, DATED 11-8-2013, EXPIRES 11-8-2023.

INT. CL. 7/U.S. CLS. 13, 19, 21, 23, 31, 34 AND 35

FOR MACHINES FOR MANUFACTURING SEMICONDUCTOR DEVICES, INCLUDING ION IMPLANTATION MACHINES.

ELEMENTS CORRECTED  
FOREIGN APPLICATION NO.

4,535,800. REG. 5-27-2014. CONTROLWORX, L.L.C. (LOUISIANA LIMITED LIABILITY COMPANY) 17630 PERKINS ROAD, BATON ROUGE, LA, 70810, SN 85-870,581. FILED 3-8-2013. PRINCIPAL REGISTER.

# EngineWorx

THE MARK CONSISTS OF THE TERM "ENGINEWORX" WITH THE LETTER "O" IN WORX IN THE SHAPE OF A COG OR GEAR WHEEL.

INT. CL. 37/U.S. CLS. 100, 103 AND 106

FOR INSTALLATION, MAINTENANCE AND REPAIR OF INDUSTRIAL ENGINE AND COMPRESSOR SYSTEMS.

FIRST USE 3-7-2007; IN COMMERCE 3-7-2007.

INT. CL. 42/U.S. CLS. 100 AND 101

FOR CONSULTING SERVICES RELATED TO THE ANALYSIS AND EVALUATION OF INDUSTRIAL ENGINE AND COMPRESSOR SYSTEMS.

FIRST USE 3-7-2007; IN COMMERCE 3-7-2007.

ELEMENTS CORRECTED  
GOODS/SERVICES

4,541,855. REG. 6-3-2014. SCHNELLER LLC (DELAWARE LIMITED LIABILITY COMPANY) 6019 POWDERMILL ROAD, KENT, OH, 44240, SN 85-891,143. FILED 3-30-2013. PRINCIPAL REGISTER.

# SCHNELLER

THE MARK CONSISTS OF STANDARD CHARACTERS WITHOUT CLAIM TO ANY PARTICULAR FONT, STYLE, SIZE, OR COLOR.

OWNER OF U.S. REG. NO. 1,380,566.

SEC. 2(F).

INT. CL. 17/U.S. CLS. 1, 5, 12, 13, 35 AND 50

FOR NON-METAL FILM LAMINATES, NON-METAL REINFORCED LAMINATES, AND THERMOPLASTIC LAMINATES FOR USE IN AIRCRAFT AND RAILCAR INTERIORS; PLASTIC SHEET MATERIAL USED IN AIRCRAFT WINDOW SHADES; THIN FILM DECORATIVE NON-METAL LAMINATES FOR USE IN AIRCRAFT AND RAILCAR INTERIORS.

FIRST USE 0-0-1986; IN COMMERCE 0-0-1986.

INT. CL. 19/U.S. CLS. 1, 12, 33 AND 50

FOR BUILDING MATERIALS, NAMELY, INTERIOR WALL BOARDS, WALL PANELS NOT OF METAL, FLOORING AND FLOOR COVERINGS, BOTH NOT OF METAL, FOR USE IN AVIATION; \*AND\* RAIL [ , AND ARCHITECTURAL ] APPLICATIONS; NON-METAL FLOORING AND FLOOR COVERINGS FOR USE IN AIRCRAFT AND RAILCAR INTERIORS; RUBBER FLOOR COVERINGS FOR USE IN AIRCRAFT AND RAILCAR INTERIORS; NON-METAL FLOORS FOR USE IN AIRCRAFT AND RAILCAR INTERIORS.

FIRST USE 0-0-2004; IN COMMERCE 0-0-2004.

INT. CL. 27/U.S. CLS. 19, 20, 37, 42 AND 50

FOR FLOOR COVERINGS FOR USE IN AIRCRAFT AND RAILCAR INTERIORS; VINYL FLOOR COVERINGS FOR USE IN AIRCRAFT AND RAILCAR INTERIORS; WALLPAPER AND VINYL WALL COVERINGS.  
FIRST USE 0-0-1964; IN COMMERCE 0-0-1964.

ELEMENTS AMENDED  
GOODS/SERVICES

---

4,542,037. REG. 6-3-2014. PTAW INC. (CALIFORNIA CORPORATION) 1625 POTRERO AVE., SOUTH EL MONTE, CA, 91733, SN 85-917,347. FILED 4-29-2013. PRINCIPAL REGISTER.

## PT AUTO WAREHOUSE

THE MARK CONSISTS OF STANDARD CHARACTERS WITHOUT CLAIM TO ANY PARTICULAR FONT, STYLE, SIZE, OR COLOR.

NO CLAIM IS MADE TO THE EXCLUSIVE RIGHT TO USE "AUTO WAREHOUSE", APART FROM THE MARK AS SHOWN.

INT. CL. 35/U.S. CLS. 100, 101 AND 102  
FOR DISTRIBUTORSHIP SERVICES IN THE FIELD OF AFTERMARKET AUTOMOBILE PARTS .  
FIRST USE 4-1-2010; IN COMMERCE 4-1-2010.

ELEMENTS CORRECTED  
OWNER NAME

---

4,543,198. REG. 6-3-2014. DE GUSTIBUS (FRANCE SOCIÉTÉ A RESPONSABILITÉ LIMITEE (SARL)) 84 AVENUE VICTOR CRESSON, ISSY LES MOULINEAUX, FRANCE, 92130, SN 86-097,691. FILED 10-22-2013. PRINCIPAL REGISTER.

## RIVEA

THE MARK CONSISTS OF STANDARD CHARACTERS WITHOUT CLAIM TO ANY PARTICULAR FONT, STYLE, SIZE, OR COLOR.

OWNER OF FRANCE REG. NO. 123931202, DATED 7-2-2012, EXPIRES 7-2-2022.

INT. CL. 43/U.S. CLS. 100 AND 101  
FOR RESTAURANT SERVICES; FAST FOOD, BAR, CATERING, TEAROOM SERVICES.

ELEMENTS CORRECTED  
FOREIGN REG. NO.

4,548,471. REG. 6-10-2014. GO DADDY OPERATING COMPANY, LLC (DELAWARE LIMITED LIABILITY COMPANY) 14455 N . HAYDEN ROAD, SUITE 226, SCOTTSDALE, AZ, 85260, SN 85-770,713. FILED 11-2-2012. PRINCIPAL REGISTER.

## GOMOBILE

THE MARK CONSISTS OF STANDARD CHARACTERS WITHOUT CLAIM TO ANY PARTICULAR FONT, STYLE, SIZE, OR COLOR.

INT. CL. 9/U.S. CLS. 21, 23, 26, 36 AND 38

FOR COMPUTER SOFTWARE FOR CREATING, POSTING AND MAINTAINING WEBSITES FOR USE ON A GLOBAL COMPUTER NETWORK .

FIRST USE 3-8-2014; IN COMMERCE 3-8-2014.

ELEMENTS CORRECTED  
MARK

---

4,549,807. REG. 6-17-2014. COMMODITY FLOW LIMITED (UNITED KINGDOM LIMITED LIABILITY COMPANY) THE BARLEY MOW CENTRE, 10 BARLEY MOW PASSAGE, LONDON, UNITED KINGDOM, W4 4PH, SN 79-138,367. FILED 9-10-2013. PRINCIPAL REGISTER.

## C-FLOW

THE MARK CONSISTS OF STANDARD CHARACTERS WITHOUT CLAIM TO ANY PARTICULAR FONT, STYLE, SIZE, OR COLOR.

PRIORITY DATE OF 4-5-2013 IS CLAIMED.

OWNER OF INTERNATIONAL REGISTRATION 1181453 DATED 9-10-2013, EXPIRES 9-10-2023.

INT. CL. 9/U.S. CLS. 21, 23, 26, 36 AND 38

FOR COMPUTER SOFTWARE FOR THE ANALYSIS, REPORTING AND DISPLAY OF AUTOMATIC IDENTIFICATION SYSTEM (AIS) SHIP VOYAGE INFORMATION, REAL-TIME SHIP VOYAGE INFORMATION, HISTORIC SHIP VOYAGE INFORMATION; COMPUTER SOFTWARE FOR THE TRACKING OF WATERBORNE SHIPMENTS OF COMMODITIES; COMPUTER SOFTWARE FOR PROVIDING TRACKING, LOCATION INFORMATION ON SHIPS AND WATERBORNE SHIPMENTS OF COMMODITIES; DOWNLOADABLE ELECTRONIC PUBLICATIONS IN THE NATURE OF NEWSLETTERS, MAGAZINES, AND INFORMATIONAL SHEETS IN THE FIELD OF THE TRACKING OF SHIPS AND WATERBORNE SHIPMENTS OF COMMODITIES.  
FIRST USE ; IN COMMERCE .

INT. CL. 35/U.S. CLS. 100, 101 AND 102

FOR BUSINESS DATA ANALYSIS, NAMELY, ANALYSIS OF BUSINESS INFORMATION IN RELATION TO TRACKING OF SHIPS AND WATERBORNE SHIPMENTS OF COMMODITIES; PROVISION OF BUSINESS INFORMATION IN THE FIELD OF SHIPS AND WATERBORNE SHIPMENTS OF COMMODITIES.  
FIRST USE ; IN COMMERCE .

INT. CL. 42/U.S. CLS. 100 AND 101



FOR COMPUTER SOFTWARE AS A SERVICE (SAAS) SERVICES FEATURING SOFTWARE FOR THE ANALYSIS, REPORTING AND DISPLAY OF AUTOMATIC IDENTIFICATION SYSTEM (AIS) SHIP VOYAGE INFORMATION, REAL-TIME SHIP VOYAGE INFORMATION, HISTORIC SHIP VOYAGE INFORMATION; COMPUTER SOFTWARE AS A SERVICE (SAAS) SERVICES FEATURING SOFTWARE FOR THE TRACKING WATERBORNE SHIPMENTS OF COMMODITIES; COMPUTER SOFTWARE AS A SERVICE (SAAS) SERVICES FEATURING SOFTWARE FOR PROVIDING TRACKING, LOCATION INFORMATION ON SHIPS AND WATERBORNE SHIPMENTS OF COMMODITIES; HOSTING OF WEBSITES FOR THE TRACKING OF SHIPS AND WATERBORNE SHIPMENTS OF COMMODITIES FOR OTHERS; DESIGN AND DEVELOPMENT OF COMPUTER SOFTWARE FOR THE ANALYSIS, REPORTING AND DISPLAY OF SHIP INFORMATION, WATERBORNE SHIPMENTS OF COMMODITIES AND SHIP TRACKING; PROVISION OF METEOROLOGICAL INFORMATION; PROVISION OF GEOGRAPHICAL INFORMATION, NAMELY, CARTOGRAPHY AND MAPPING SERVICES.

FIRST USE ; IN COMMERCE .

ELEMENTS CORRECTED  
GOODS/SERVICES

4,553,278. REG. 6-17-2014. IT COSMETICS, LLC (DELAWARE LIMITED LIABILITY COMPANY) SUITE 317, 111 TOWN SQUARE PLACE, JERSEY CITY, NJ, 07310, SN 86-024,837. FILED 7-31-2013. PRINCIPAL REGISTER.

# EYELIFT IN A TUBE

THE MARK CONSISTS OF STANDARD CHARACTERS WITHOUT CLAIM TO ANY PARTICULAR FONT, STYLE, SIZE, OR COLOR.

INT. CL. 3/U.S. CLS. 1, 4, 6, 50, 51 AND 52

FOR COSMETICS; COSMETIC PREPARATIONS FOR BODY CARE; COSMETICS AND COSMETIC PREPARATIONS; COSMETICS AND MAKE-UP; FACE AND BODY CREAMS; LOTIONS FOR FACE AND BODY CARE; MAKE-UP; MAKE-UP FOR THE FACE AND BODY; NON-MEDICATED SKIN CARE PREPARATIONS.

FIRST USE 12-28-2013; IN COMMERCE 12-28-2013.

ELEMENTS CORRECTED  
MARK

4,556,227. REG. 6-24-2014. GOLDEN TOUCH TRANSPORTATION OF NY, INC. (NEW YORK CORPORATION) 109-15 14TH AVENUE, 2ND FLOOR, COLLEGE POINT, NY, 11356, SN 85-203,202. FILED 12-21-2010. PRINCIPAL REGISTER.



NO CLAIM IS MADE TO THE EXCLUSIVE RIGHT TO USE "NYC" AND "NEW YORK CITY", APART FROM THE MARK AS SHOWN.

THE MARK CONSISTS OF AN AIRPLANE WITHIN A CIRCLE FOLLOWED BY THE LETTERS AND WORDS "NYC AIRPORT YOUR EXPRESS RIDE TO NEW YORK CITY".

INT. CL. 39/U.S. CLS. 100 AND 105

FOR PASSENGER TRANSPORT; TRANSPORT OF PASSENGERS; TRANSPORTATION OF PASSENGERS AND PASSENGERS' LUGGAGE; TRANSPORTATION OF PASSENGERS AND/OR GOODS BY BUSES, VANS, SUVs, AND AUTOMOBILES.

FIRST USE 5-0-2010; IN COMMERCE 5-0-2010.

ELEMENTS CORRECTED  
OWNER NAME

4,556,464. REG. 6-24-2014. HARO, ROBERT B. (UNITED STATES INDIVIDUAL) 135-E LIVERPOOL DRIVE, CARDIFF, CA, 92007, SN 85-635,753. FILED 5-25-2012. PRINCIPAL REGISTER.



THE MARK CONSISTS OF A LEFT FACING BOOMERANG SHAPED DESIGN WITH THE STYLIZED WORD "RAVERSE" TO THE RIGHT OF IT.

INT. CL. 25/U.S. CLS. 22 AND 39

FOR CLOTHING, NAMELY, T-SHIRTS, SHIRTS, TOPS, SWEAT SHIRTS, SWEAT PANTS, HOODED JACKETS, GLOVES, HATS, CAPS, JACKETS, HEADBANDS; CLOTHING FOR ATHLETIC USE, NAMELY, PADDED SHIRTS, PANTS AND SHORTS, TIGHTS, VESTS, CYCLING PANTS, CYCLING JERSEYS, CYCLING SHORTS, CYCLING SHOES AND CYCLING GLOVES.

FIRST USE 11-15-2013; IN COMMERCE 11-15-2013.

ELEMENTS CORRECTED  
MARK

4,556,487. REG. 6-24-2014. FLOPEEZE INTERNATIONAL LIMITED (HONG KONG LIMITED LIABILITY COMPANY) TSIM SHA TSUI P.O. BOX 99017, TSIM SHA TSUI, KOWLOON, HONG KONG, CHINA., SN 85-656,454. FILED 6-20-2012. PRINCIPAL REGISTER.

# FLOPEEZE

THE MARK CONSISTS OF STANDARD CHARACTERS WITHOUT CLAIM TO ANY PARTICULAR FONT, STYLE, SIZE, OR COLOR.

OWNER OF JAPAN REG. NO. 5570186, DATED 3-29-2013, EXPIRES 3-29-2018.

INT. CL. 25/U.S. CLS. 22 AND 39

FOR SANDALS AND BEACH SHOES; SHOES FEATURING ROLL UP AND FOLDABLE SHOES; SOLES FOR FOOTWEAR; WATER REPELLING FOOTWEAR; WOMEN'S FOLDABLE SLIPPERS; WOMEN'S SHOES.

FIRST USE 3-3-2011; IN COMMERCE 8-8-2012.

ELEMENTS CORRECTED  
OWNER ADDRESS  
CITIZENSHIP

4,556,870. REG. 6-24-2014. LAKESTAR (G.P.) LIMITED (GUERNSEY COMPANY) LA TONNELLE HOUSE, LES BANQUEST, ST. SAMPSON, GUERNSEY, GY13HD, SN 85-850,443. FILED 2-14-2013. PRINCIPAL REGISTER.

# LAKESTAR

THE MARK CONSISTS OF STANDARD CHARACTERS WITHOUT CLAIM TO ANY PARTICULAR FONT, STYLE, SIZE, OR COLOR.

INT. CL. 36/U.S. CLS. 100, 101 AND 102

FOR VENTURE CAPITAL SERVICES, NAMELY, PROVIDING FINANCING TO EMERGING AND START-UP COMPANIES.

FIRST USE 7-23-2012; IN COMMERCE 12-21-2012.

ELEMENTS CORRECTED  
OWNER ADDRESS  
ENTITY

4,561,625. REG. 7-1-2014. DESIGNER LOLLIPOP (UTAH LIMITED LIABILITY COMPANY) 6995 SOUTH TOURIST LANE, NO. 3, WEST JORDAN, UT, 84081, SN 86-064,205. FILED P.R. 9-13-2013; AM. S.R. 5-15-2014. SUPPLEMENTAL REGISTER.

# DESIGNER LOLLIPOP

THE MARK CONSISTS OF STANDARD CHARACTERS WITHOUT CLAIM TO ANY PARTICULAR FONT, STYLE, SIZE, OR COLOR.

NO CLAIM IS MADE TO THE EXCLUSIVE RIGHT TO USE "LOLLIPOP", APART FROM THE MARK AS SHOWN.

INT. CL. 35/U.S. CLS. 100, 101 AND 102

FOR ONLINE RETAIL STORE SERVICES FEATURING CANDIES, CANDY, CANDY CAKE DECORATIONS, CANDY MINTS, PEPPERMINT CANDY, SUGARLESS CANDIES, LOLLIPOPS, SWEETS.

FIRST USE 11-6-2012; IN COMMERCE 11-6-2012.

ELEMENTS CORRECTED  
OWNER NAME

4,564,441. REG. 7-8-2014. DOMAINE SELECT WINE ESTATES, LLC (DELAWARE LIMITED LIABILITY COMPANY) 105 MADISON AVENUE, 13TH FLOOR, NEW YORK, NY, 10016, SN 85-171,310. FILED 11-8-2010. PRINCIPAL REGISTER.

# BOROUGH SPIRITS

NO CLAIM IS MADE TO THE EXCLUSIVE RIGHT TO USE "SPIRITS", APART FROM THE MARK AS SHOWN.

THE MARK CONSISTS OF THE STYLIZED WORDS BOROUGH SPIRITS WITH THE FIRST LETTER OF EACH WORD IN A LARGER TYPESIZE THAN THE REMAINING LETTERS.

INT. CL. 33/U.S. CLS. 47 AND 49

FOR SPIRITS.

FIRST USE 5-13-2014; IN COMMERCE 5-13-2014.

ELEMENTS CORRECTED  
CITIZENSHIP

4,565,991. REG. 7-15-2014. KUENKEL-WAGNER PROZESS-TECHNOLOGIE GMBH (FED REP GERMANY GMBH) HANNOVERSCHE STR. 59, 31061 ALFELD/LEINE, FED REP GERMANY., SN 79-134,648. FILED 4-23-2013. PRINCIPAL REGISTER.



PRIORITY DATE OF 10-23-2012 IS CLAIMED.  
OWNER OF INTERNATIONAL REGISTRATION 1171882 DATED 4-23-2013, EXPIRES 4-23-2023.

THE COLOR(S) TURQUOISE AND BLACK IS/ARE CLAIMED AS A FEATURE OF THE MARK.

THE MARK CONSISTS OF THE WORD "KÜNKEL-WAGNER" WHERE THE FIRST LETTER "K" AND THE LETTER "W" ARE IN TURQUOISE AND THE REMAINING LETTERS ARE IN BLACK.

INT. CL. 7/U.S. CLS. 13, 19, 21, 23, 31, 34 AND 35

FOR FOUNDRY MACHINES, IN PARTICULAR MOLDING MACHINES; MACHINE TOOLS, IN PARTICULAR FOR MANUFACTURING MOLDING FOUNDRY MACHINES; [ MOLDING ] \* MECHANIZED MOLDING \* MATERIAL CONVEYING MACHINES, IN PARTICULAR BELT CONVEYORS, PNEUMATIC CONVEYORS; MOLDING BOX FEEDERS AND MOLDING BOX EXCHANGE UNITS; MECHANICAL REGENERATION MACHINES FOR USED SAND COMPRISED OF ONE OR MORE OF THE FOLLOWING PIECES OF MACHINERY, NAMELY, MECHANICAL CONVEYORS, PNEUMATIC CONVEYORS, GRINDERS OF CONGLOMERATES, SEPARATORS AND SAND CONTAINERS; MECHANICAL SAND PREPARATION MACHINES; ROTARY INGOT CASTING MACHINES; MECHANICAL LOW-PRESSURE CASTING MACHINES; COMPONENT AND REPLACEMENT PARTS FOR ALL AFOREMENTIONED GOODS.

FIRST USE ; IN COMMERCE .

INT. CL. 35/U.S. CLS. 100, 101 AND 102

FOR PROVIDING OFFICE FUNCTIONS, NAMELY, DOCUMENTATION MANAGEMENT FOR FOUNDRY PLANTS AND MACHINES .

FIRST USE ; IN COMMERCE .

INT. CL. 37/U.S. CLS. 100, 103 AND 106

FOR INSTALLATION AND REPAIR OF FOUNDRY-COMPONENTS AND FOUNDRY MACHINES AS WELL AS SYSTEMS COMPOSED THEREOF; TROUBLESHOOTING OF PROBLEMS, NAMELY, REPAIR OF FOUNDRY PLANTS AND MACHINES; INSTALLATION SERVICES, NAMELY, IMPLEMENTING, OPTIMIZING AND ADJUSTING OF FOUNDRY PLANTS AND MACHINES; INSTALLATION SERVICES, NAMELY, REFITTING THE CONTROL OF FOUNDRY PLANTS AND MACHINES AS WELL AS REFITTING THE VALVE TECHNOLOGY OF FOUNDRY PLANTS AND MACHINES; INSTALLATION WORK, NAMELY, FOR EXPANDING THE PRODUCTION OF OPERATING FOUNDRY PLANTS AND MACHINES.

FIRST USE ; IN COMMERCE .

INT. CL. 42/U.S. CLS. 100 AND 101

AUGUST 26, 2014

U.S. PATENT AND TRADEMARK OFFICE

TM 2117

FOR TECHNICAL DESIGN OF MOLDING PLANTS,  
SAND PREPARATION PLANTS, ROTARY INGOT CAST-  
ING MACHINES, LOW-PRESSURE CASTING PLANTS,  
CASTING MACHINES; TECHNICAL CONSULTANCY IN  
THE FIELD OF ENGINEERING RELATING TO THE  
DEVELOPMENT OF IMPROVEMENT MEASURES FOR  
THE OPERATION OF FOUNDRY PLANTS AND MA-  
CHINES; TECHNICAL PLANNING OF TECHNICAL  
EXPANDING THE PRODUCTION OF FOUNDRY  
PLANTS AND MACHINES.  
FIRST USE ; IN COMMERCE .

ELEMENTS CORRECTED  
GOODS/SERVICES

\* \* \* \* \*

# TRADEMARK REGISTRATIONS—NEW CERTIFICATES

New Certificates issued under section 7(d) of the Trademark Act of 1946 for the unexpired term of the original registrations.

- 2,437,750. MISCELLANEOUS DESIGN. INT. CL. 25. R. GRIGGS GROUP LIMITED, WELLINGBOROUGH, NORTHANTS NN8 7SW, UNITED KINGDOM. REG. 3-27-2001. NEW CERT. SEC. 7(D) TO REGISTRANT.
- 
- 2,437,751. MISCELLANEOUS DESIGN. INT. CL. 25. R. GRIGGS GROUP LIMITED, NORTHANTS NN8 7SW, UNITED KINGDOM. REG. 3-27-2001. NEW CERT. SEC. 7(D) TO REGISTRANT.
- 
- 2,642,548. MISCELLANEOUS DESIGN. INT. CL. 36. GLOBAL PAYMENT HOLDING COMPANY, ATLANTA, GA. REG. 10-29-2002. NEW CERT. SEC. 7(D) TO REGISTRANT.
- 
- 2,904,858. AIRWAIR (STYLIZED). INT. CL. 25. R. GRIGGS GROUP LIMITED, IRTHLINGBOROUGH, NORTHANTS, UNITED KINGDOM. REG. 11-23-2004. NEW CERT. SEC. 7(D) TO REGISTRANT.
- 
- 3,016,028. BROTHERS IN ARMS STANDARD CHARACTER MARK. INT. CL. 9. GEARBOX SOFTWARE LLC, PLANO, TX. REG. 11-15-2005. NEW CERT. SEC. 7(D) TO REGISTRANT.
- 
- 3,096,435. PUSH TO PAY STANDARD CHARACTER MARK. INT. CL. 36. PROPAY USA, INC., OREM, UT. REG. 5-23-2006. NEW CERT. SEC. 7(D) TO REGISTRANT.
- 
- 3,313,095. BROTHERS IN ARMS ROAD TO HILL 30 STANDARD CHARACTER MARK. INT. CL. 9. GEARBOX SOFTWARE LLC, PLANO, TX. REG. 10-16-2007. NEW CERT. SEC. 7(D) TO REGISTRANT.
- 
- 3,536,640. ISCORES STANDARD CHARACTER MARK. INT. CL. 9. ASPROULIAS, PERIKLIS, ATHENS, GREECE. REG. 11-25-2008. NEW CERT. SEC. 7(D) TO REGISTRANT.
- 
- 3,574,063. MAINBOCHER STANDARD CHARACTER MARK. INT. CL. 25. STEIN MART BUYING CORP., JACKSONVILLE, FL. REG. 2-10-2009. NEW CERT. SEC. 7(D) TO REGISTRANT.
- 
- 4,168,140. POSITIVE CHARGE STANDARD CHARACTER MARK. INT. CL. 32. BLACK LINE EQUITY, L.L.C., NEWPORT BEACH, CA. REG. 7-3-2012. NEW CERT. SEC. 7(D) TO REGISTRANT.
- 
- 4,350,348. ROCCO'S OLD SCHOOL AND DESIGN. INT. CL. 3. GUGLIEMELLI, DINO, VALENCIA, CA. REG. 6-11-2013. NEW CERT. SEC. 7(D) TO REGISTRANT.

\* \* \* \* \*

# INDEX OF REGISTRANTS

AUGUST 26, 2014

(Registered; Renewed; Canceled; Amended, Corrected, etc.; New Certificates; 12c Publications.)

The designation "U.S. Cl." appearing in this section refers to the U.S. class in effect prior to Sep. 1, 1973 rather than the international class which applies to applications filed on or after that date. For adoption of international classification see notice in the OFFICIAL GAZETTE of Jun. 26, 1973 (911 O.G. TM 210).

'FORE SUPPLY' CO., ADDISON, IL, DBA COUNTRY CLUB SUPPLY, INC.:  
3,353,146, CANC. INT. CL. 3.  
"NEUER WALL" TREUHAND GMBH, FED REP GERMANY:  
4,390,083, COR. INT. CL. 9.  
"VESNA" LIMIT LIABILITY COMPANY, RUSSIAN FED.:  
3,352,560.  
A & M PROFESSIONAL POOL RENOVATIONS, LLC, PORT CHARLOTTE, FL:  
4,594,279, INT. CL. 37.  
A BOTTLED AFFAIR, LLC, DENVER, CO:  
4,592,753, PUB. 6-10-2014. MULTIPLE CLASS, INT. CLS. 35 AND 41.  
A DWELLING PLACE REALTY, LLC, FORT MILL, SC:  
3,351,493, CANC. INT. CL. 36.  
A QUICK RELEASE BAIL BONDS, LLC, SANFORD, FL:  
4,594,630, INT. CL. 36.  
A. DUDA & SONS, INC., OVIEDO, FL:  
4,594,021, INT. CL. 31.  
A. JAFFE, INC., NEW YORK, NY:  
3,353,450, CANC. INT. CL. 14.  
A. PERRI FARMS INC., RONKONKOMA, NY:  
3,351,595, CANC. INT. CL. 31.  
A.B. CLOSING CORPORATION, ORLANDO, FL:  
4,593,757, INT. CL. 35.  
A.C. ZINCS, INC., SEMINOLE, FL:  
4,594,266, INT. CL. 9.  
A-LIFE MEDICAL, INC., SAN DIEGO, CA:  
3,354,146, CANC. INT. CL. 42.  
A-LIGN SECURITY AND COMPLIANCE SERVICES, LLC, TAMPA, FL:  
4,593,302, U.S. CL. B.  
AAC TECHNOLOGIES HOLDINGS INC., GRAND CAYMAN KY1-1111, CAYMAN ISLANDS:  
4,593,530, INT. CL. 9.  
AAFL ENTERPRISES, LLC, NEW YORK, NY:  
3,351,419, CANC. INT. CL. 41.  
AAP CONSULTING GROUP, INC., LOS ANGELES, CA:  
3,350,975, CANC. INT. CL. 38.  
AAR CORP., WOOD DALE, IL:  
1,853,479, REN. 7-22-14, INT. CL. 6.  
AARC, LLC, SPARTANBURG, SC:  
4,594,387, INT. CL. 36.  
4,594,388, INT. CL. 36.  
AARHUSKARLSHAMN AB (PUBL), SWEDEN:  
3,352,579.  
AB INITIO SOFTWARE LLC, LEXINGTON, MA:  
2,872,131, REN. 7-23-14, INT. CL. 9.  
ABB ASEA BROWN BOVERI LTD, CH-8050 ZURICH, SWITZERLAND:  
2,809,801, REN. 7-21-14. MULTIPLE CLASS, INT. CLS. 7, 8, 9, 16, 35, 37, 38, 40, 41 AND 42.  
2,809,801, CANC. MULTIPLE CLASS, INT. CLS. 1, 2, 3, 4, 6, 10, 11, 12, 14, 17, 18, 19, 20, 21, 25, 26, 36 AND 39.  
ABBICK, MARION G., JUNCTION CITY, KS:  
3,352,159, CANC. INT. CL. 15.  
ABBOTT INFORMATICS CORPORATION, HOLLYWOOD, FL:  
4,593,198, INT. CL. 9.  
ABBOTT LABORATORIES, ABBOTT PARK, IL:  
3,353,256, CANC. INT. CL. 10.  
ABBOTT MEDICAL OPTICS INC, UNITED STATES:  
3,352,606.  
3,352,607.  
ABC SERVICES, INC., POTTSTOWN, PA, DBA LAWN ANNOUNCEMENTS:  
2,794,105, CANC. INT. CL. 45.  
ABDINOV AYAZ, CHINA:  
4,590,937, PUB. 6-10-2014. INT. CL. 18.  
ABE FRANCHISING, L.L.C., LONGVIEW, TX:  
4,594,611, INT. CL. 37.  
ABERCROMBIE & FITCH TRADING CO., NEW ALBANY, OH:  
4,593,162, INT. CL. 25.  
4,593,163, INT. CL. 25.  
4,593,164, INT. CL. 25.  
4,593,165, INT. CL. 25.  
4,593,374, INT. CL. 3.  
ABG EPE IP LLC, NEW YORK, NY:  
3,352,047, CANC. INT. CL. 33.  
ABILENE MACHINE, INC., ABILENE, KS:  
4,593,633, INT. CL. 35.  
ABL SERVICES, INC., TYLER, TX:  
4,592,427, PUB. 6-10-2014. INT. CL. 6.  
ABRAHAMS, LARRY, HEWLETT, NY:  
4,592,682, PUB. 6-10-2014. INT. CL. 42.  
ABRAMS, JAMES, SHAKER HEIGHTS, OH:  
4,594,393, INT. CL. 35.  
ABSIO CORPORATION, HIGHLANDS RANCH, CO:  
4,594,417, INT. CL. 42.  
4,594,418, INT. CL. 42.  
4,594,419, INT. CL. 42.  
4,594,422, INT. CL. 42.  
ABSORBENT MIND MONTESSORI ACADEMY, INC., PARAMUS, NJ:  
3,350,910, CANC. INT. CL. 41.  
ABUNDANCE ELECTRICAL (SHENZHEN) CO., LTD., SHENZHEN, GUANGDONG, CHINA:  
3,351,035, CANC. INT. CL. 7.  
3,351,159, CANC. INT. CL. 9.  
ABUNDANT LIFE MINISTRIES OF SPRINGFIELD, MISSOURI, INC., SPRINGFIELD, MO:  
2,796,280, CANC. MULTIPLE CLASS, INT. CLS. 16 AND 41.  
ACA CO-OPERATIVE LIMITED, KENTVILLE, NOVA SCOTIA, CANADA:  
3,354,208, CANC. INT. CL. 29.  
ACADIAN SEAPLANTS LIMITED, NOVA SCOTIA, CANADA:  
2,931,380, REN. 7-23-14, INT. CL. 1.  
ACANDIS GMBH & CO. KG, PFINTZTAL, FED REP GERMANY:  
3,352,214, CANC. INT. CL. 10.  
ACASIO, MARK, BRENTWOOD, CA:  
4,592,748, PUB. 6-10-2014. INT. CL. 41.  
ACCEL PERFORMANCE GROUP LLC, CLEVELAND, OH:  
2,795,488, CANC. INT. CL. 9.  
ACCESS & MOBILITY SOLUTIONS, LLC, AMHERST, NH:  
4,592,562, PUB. 6-10-2014. MULTIPLE CLASS, INT. CLS. 35 AND 37.  
ACCESS INTELLIGENCE, LLC, ROCKVILLE, MD:  
3,351,063, CANC. INT. CL. 35.

- ACCESS NURSES, INC., SAN DIEGO, CA:  
3,351,019, CANC. INT. CL. 35.
- ACCO BRANDS CORPORATION, LAKE ZURICH, IL:  
4,591,567, PUB. 3-4-2014. INT. CL. 16.
- ACCREDITED INDUSTRIES AND ASSOCIATES, INC.,  
GLENDALE, CA:  
3,352,003, CANC. INT. CL. 1.
- ACCUIITY INC., SKOKIE, IL:  
3,352,343, CANC. INT. CL. 41.
- ACCURITY VALCO, LLC, SCOTTSDALE, AZ:  
4,593,883, MULTIPLE CLASS, INT. CLS. 35 AND 36.
- ACD SYSTEMS INTERNATIONAL INC., VICTORIA, BC,  
CANADA:  
2,795,631, CANC. INT. CL. 9.
- ACERAY LLC, DENVER, CO:  
2,859,848, REN. 7-21-14. MULTIPLE CLASS, INT. CLS. 20  
AND 40.
- ACES & ANGELS, LLC, LAS VEGAS, NV:  
4,594,748, INT. CL. 41.
- ACI INTERNATIONAL, LOS ANGELES, CA:  
4,593,410, INT. CL. 25.
- ACID LABS, LLC, SANTA MONICA, CA:  
4,591,179, PUB. 6-10-2014. INT. CL. 9.
- ACKERMAN, NANCY, J, RANCHO MIRAGE, CA:  
3,353,836, CANC. INT. CL. 9.
- ACOSTA, INC., JACKSONVILLE, FL:  
4,593,880, INT. CL. 35.
- ACRISON, INCORPORATED, MOONACHIE, NJ:  
1,013,418, REN. 7-24-14. INT. CL. 9.
- ACTAGRO, LLC, BIOLA, CA:  
2,860,410, REN. 7-22-14. INT. CL. 1.
- ACTAVIS, INC., PARSIPPANY, NJ:  
4,594,119, INT. CL. 5.
- ACTIONSPACE LLC, SAINT-PETERSBURG, RUSSIAN  
FED.:  
4,592,076, PUB. 6-10-2014. INT. CL. 9.
- ACTIVISION PUBLISHING, INC., SANTA MONICA, CA,  
ACTIVISION, INC., MOUNTAIN VIEW, CA:  
1,289,150, REN. 7-18-14. INT. CL. 28.
- ACUITY WEALTH MANAGEMENT, LLC, HOPEWELL, NJ:  
4,591,697, PUB. 3-4-2014. INT. CL. 36.
- ACUSIMPLE, LLC, BOULDER, CO:  
4,592,438, PUB. 6-10-2014. INT. CL. 9.
- ADAGBADA, MUHAMMED, BRONX, NY AND BURWELL,  
TYRRELL, BRONX, NY:  
4,593,593, INT. CL. 25.
- ADAM EVERS, ALLEN, TX:  
4,593,643, MULTIPLE CLASS, INT. CLS. 5 AND 32.
- ADAMSON, DARREL, MANSFIELD, MO:  
2,794,537, CANC. MULTIPLE CLASS, INT. CLS. 7 AND  
40.
- ADAPTIVE SPECTRUM AND SIGNAL ALIGNMENT, INC.,  
REDWOOD CITY, CA:  
3,353,557, CANC. MULTIPLE CLASS, INT. CLS. 38 AND  
42.
- ADC TELECOMMUNICATIONS, INC., SHAKOPEE, MN:  
2,869,874, REN. 7-24-14. INT. CL. 9.
- ADED WEAR, INC., NAPERVILLE, IL:  
4,591,301, PUB. 6-10-2014. INT. CL. 41.
- ADERANS HAIR GOODS, INC., BEVERLY HILLS, CA:  
3,353,492, CANC. INT. CL. 26.
- ADEX MACHINING TECHNOLOGIES, LLC, GREENVILLE,  
SC:  
4,592,268, PUB. 6-10-2014. INT. CL. 40.
- ADEX MACHINING, LLC, GREENVILLE, SC:  
4,592,269, PUB. 6-10-2014. INT. CL. 40.
- ADF FOODS LTD., BOMBAY, INDIA:  
3,353,570, CANC. MULTIPLE CLASS, INT. CLS. 29 AND  
30.
- ADHESION GROUP, FRANCE:  
4,590,676, PUB. 6-10-2014. MULTIPLE CLASS, INT. CLS.  
33, 35, 38 AND 41.
- ADHESIVE PACKAGING SPECIALTIES, LLC, PEABODY,  
MA:  
1,305,969, REN. 7-22-14. INT. CL. 22.  
1,326,999, REN. 7-22-14. MULTIPLE CLASS, INT. CLS. 20  
AND 35.
- ADHETEC, FRANCE:  
4,590,811, PUB. 6-10-2014. MULTIPLE CLASS, INT. CLS.  
1, 16, 17 AND 40.
- ADJ, INC, SANTA CRUZ, CA:  
4,591,940, PUB. 6-10-2014. INT. CL. 11.
- ADLER, STEWART, NEW YORK, NY 10018, NY AND  
MICHAEL, YEHUDA, NEW YORK, NY:  
3,354,200, CANC. INT. CL. 25.
- ADP GAUSELMANN GMBH, 32339 ESPELKAMP, FED REP  
GERMANY:  
4,591,873, PUB. 6-10-2014. MULTIPLE CLASS, INT. CLS. 9  
AND 28.
- ADRIAN CHEN, FREMONT, CA, DBA SILICON VALLEY  
IMAGING CORPORATION:  
4,594,540, INT. CL. 9.
- ADRYLAN COMMUNICATIONS, INC., MURRIETA, CA:  
4,591,818, PUB. 6-10-2014. INT. CL. 9.
- ADSIL INC., DAYTONA BEACH, FL:  
2,907,962, REN. 7-24-14. INT. CL. 2.
- ADTERRACTIVE, INC., SAN FRANCISCO, CA:  
3,352,507, CANC. INT. CL. 35.
- ADVA OPTICAL NETWORKING SE, MEININGEN, FED  
REP GERMANY:  
2,793,650, CANC. MULTIPLE CLASS, INT. CLS. 9 AND  
42.
- ADVANCE MAGAZINE PUBLISHER, INC., NEW YORK,  
NY:  
3,350,683, CANC. INT. CL. 16.
- ADVANCE MAGAZINE PUBLISHERS INC., NEW YORK,  
NY:  
4,591,899, PUB. 6-10-2014. MULTIPLE CLASS, INT. CLS.  
35 AND 44.
- ADVANCE MAGAZINE PUBLISHERS, INC., NEW YORK,  
NY:  
4,591,557, PUB. 6-10-2014. INT. CL. 41.
- ADVANCE MERCHANDISING COMPANY, INC., ROA-  
NOKE, VA:  
3,354,303, CANC. INT. CL. 3.  
3,354,487, CANC. MULTIPLE CLASS, INT. CLS. 11, 14, 20,  
21 AND 27.
- ADVANCE WATCH COMPANY LTD., NEW YORK, NY:  
3,489,779, CANC. MULTIPLE CLASS, INT. CLS. 11, 16  
AND 20.
- ADVANCED & WISE TECHNOLOGY CORP., HSIN-CHU  
CITY, TAIWAN:  
2,793,593, CANC. INT. CL. 42.
- ADVANCED DEVELOPMENT DEPOT INC., DIAMOND  
BAR, CA:  
4,591,701, PUB. 6-10-2014. MULTIPLE CLASS, INT. CLS. 7  
AND 9.
- ADVANCED DIGITAL DATA, INC., FLANDERS, NJ:  
4,591,955, PUB. 6-10-2014. INT. CL. 9.
- ADVANCED FLOW ENGINEERING, INC., CORONA, CA:  
4,592,129, PUB. 6-10-2014. INT. CL. 7.
- ADVANCED INTEGRATED SOLUTIONS, BREA, CA:  
3,351,210, CANC. MULTIPLE CLASS, INT. CLS. 41 AND  
42.
- ADVANCED SLEEP CONCEPTS, INC., ROME, GA:  
3,352,962, CANC. INT. CL. 20.
- ADVANCED STRATEGIC TECHNOLOGY LLC, SHER-  
BORN, MA:  
4,594,736, INT. CL. 42.
- ADVANCED TECHNOLOGY SOLUTIONS, INC., FAIRFAX,  
IA:  
3,354,589, CANC. MULTIPLE CLASS, INT. CLS. 37 AND  
42.
- ADVANCEPIERRE FOODS, INC., CINCINNATI, OH:  
3,353,485, CANC. INT. CL. 30.
- ADVANTAGE MARKETING GROUP, INC., IRVING, TX:  
2,795,414, CANC. INT. CL. 35.
- ADVANTEK INTERNATIONAL CORPORATION, HOUS-  
TON, TX:  
3,354,491, CANC. INT. CL. 42.
- ADVENTIUM ENTERPRISES, LLC, MINNEAPOLIS, MN:  
4,592,204, PUB. 6-10-2014. INT. CL. 45.
- ADVENTURE BUS AND TOUR, HOLLYWOOD, FL:  
4,594,687, INT. CL. 39.

ADVERTAS, LLC, KATY, TX:  
3,350,812, CANC. INT. CL. 35.

ADVICENT SOLUTIONS, LP, MILWAUKEE, WI:  
4,593,675, INT. CL. 42.

AEC SCIENCE & TECHNOLOGY, LLC, CHADDS FORD, PA:  
4,594,562, INT. CL. 41.

AERIE BRIDGE SOLUTIONS, INC., SOUTH CHESTERFIELD, VA:  
4,591,333, PUB. 6-10-2014. INT. CL. 42.  
4,591,336, PUB. 6-10-2014. INT. CL. 42.

AERO DESIGN AND MANUFACTURING COMPANY, INC., DULUTH, MN:  
2,860,545, REN. 7-20-14. INT. CL. 35.

AEROPOSTALE WEST, INC., NEW YORK, NY:  
4,594,167, INT. CL. 28.

AEROVIRONMENT, INC., MONROVIA, CA:  
4,593,103, INT. CL. 9.  
4,593,104, INT. CL. 37.  
4,593,105, INT. CL. 9.  
4,593,106, INT. CL. 37.

AESCULAP AG, FED REP GERMANY:  
3,352,660.

AESTHETIC PRODUCTS, LLC, ATLANTA, GA:  
4,591,020, PUB. 6-10-2014. INT. CL. 44.

AETNA INC., BLUE BELL, PA:  
3,353,094, CANC. INT. CL. 36.

AFFECTIS PHARMACEUTICALS AG, MUNICH, FED REP GERMANY:  
3,353,407, CANC. INT. CL. 42.

AFFILIATED GENETICS, INC., SALT LAKE CITY, UT:  
4,592,321, PUB. 6-10-2014. INT. CL. 44.

AFL TELECOMMUNICATIONS LLC, DUNCAN, SC:  
2,861,813, REN. 7-18-14. INT. CL. 9.

AFRO FUSION CUISINE BRANDS LLC, WAUWATOSA, WI, DBA AFRO FUSION CUISINE:  
4,593,331, MULTIPLE CLASS, INT. CLS. 9, 16, 24, 25, 30, 40 AND 43.

AG GLOBAL PRODUCTS, LLC, LOS ANGELES, CA:  
4,593,491, INT. CL. 3.

AGENT2AGENT LLC, SCOTTSDALE, AZ:  
3,352,397, CANC. INT. CL. 36.

AGEOLOGY LLC, CHICAGO, IL:  
4,591,826, PUB. 6-10-2014. INT. CL. 9.

AGILE 3 SOLUTIONS LLC, SAN FRANCISCO, CA:  
4,593,561, INT. CL. 9.

AGITAR SOFTWARE INC., MOUNTAIN VIEW, CA:  
3,353,170, CANC. MULTIPLE CLASS, INT. CLS. 9, 35 AND 42.

AGNESIAN HEALTHCARE, INC., FOND DU LAC, WI:  
4,593,740, INT. CL. 44.

AGORA LLC, SEATTLE, WA:  
2,793,444, CANC. INT. CL. 35.

AGORA, INC., BALTIMORE, MD:  
2,864,444, REN. 7-22-14. MULTIPLE CLASS, INT. CLS. 16 AND 44.

AGRIREP, LLC, SPENCER, IA:  
4,594,436, INT. CL. 35.  
4,594,437, INT. CL. 35.

AGROFAIR BENELUX BV, NETHERLANDS:  
3,352,576.

AGRU/AMERICA, INC., GEORGETOWN, SC:  
4,594,365, INT. CL. 19.

AHIMSA CREATIONS L.L.C., SUGAR LAND, TX:  
4,593,838, INT. CL. 9.

AHL, INC., ASHLAND, VA:  
4,594,455, INT. CL. 13.

AHNLAB, INC., GYEONGGI-DO, REPUBLIC OF KOREA:  
4,593,613, INT. CL. 9.  
4,593,614, INT. CL. 9.  
4,593,615, INT. CL. 9.  
4,593,617, INT. CL. 9.  
4,593,683, INT. CL. 9.

AIM, LLC, LARGO, FL:  
2,869,935, REN. 7-22-14. INT. CL. 17.

AIR MASTER SYSTEMS, CORP., MUSKEGON, MI:  
4,591,783, PUB. 6-10-2014. INT. CL. 11.

AIR PRODUCTS AND CHEMICALS, INC., ALLENTOWN, PA:  
4,593,607, MULTIPLE CLASS, INT. CLS. 1 AND 3.  
4,593,739, MULTIPLE CLASS, INT. CLS. 1 AND 3.

AIR TECHNIQUES, INC., HICKSVILLE, NY:  
1,285,083, REN. 7-24-14. INT. CL. 9.

AIRBUS HELICOPTERS, 13725 MARGNANE CEDEX, FRANCE:  
2,861,859, REN. 7-24-14. MULTIPLE CLASS, INT. CLS. 9, 12 AND 28.

AIRCARE LABS LLC, PHILADELPHIA, PA:  
4,593,956, INT. CL. 42.

AIRNAMICS, NAPREDNI MEHATRONSKI SISTEMI D.O.O., SI-1215 MEDVODE, SLOVENIA:  
4,590,650, PUB. 6-10-2014. MULTIPLE CLASS, INT. CLS. 7, 9, 12 AND 42.

AIROOM, LLC, LINCOLNWOOD, IL:  
2,793,897, CANC. INT. CL. 16.

AIRPUL LLC, EXETER, NH:  
4,592,410, PUB. 6-10-2014. INT. CL. 9.

AIRWAIR INTERNATIONAL LTD., WOLLASTON, NORTHAMPTONSHIRE, UNITED KINGDOM:  
2,437,750 NEW CERT. 8-26-2014. INT. CL. 25.  
2,437,751 NEW CERT. 8-26-2014. INT. CL. 25.  
2,904,858 NEW CERT. 8-26-2014. INT. CL. 25.

AITHERENA LTD., LONDON, UNITED KINGDOM:  
4,593,252, INT. CL. 35.

AITON, ANGELA, LOS ANGELES, CA:  
3,351,749, CANC. INT. CL. 45.

AK STARFISH CO., ANCHORAGE, AK:  
3,354,670, CANC. INT. CL. 25.

AKADIA TAX RECRUITING LLC, NEW YORK, NY:  
4,594,136, INT. CL. 35.  
4,594,137, INT. CL. 35.

AKITA, INC., WILMINGTON, DE:  
4,593,860, INT. CL. 36.

AKRON BRASS COMPANY, WOOSTER, OH:  
2,794,661, CANC. MULTIPLE CLASS, INT. CLS. 9 AND 11.

AKTIESELSKABET BEAUVAIS, DENMARK:  
3,352,550.

AKTSIONERNO DROUJESTVO; "BULGARTABAC-HOLDING", BULGARIA:  
4,590,663, PUB. 6-10-2014. INT. CL. 34.

AKZO NOBEL CHEMICALS B.V., AMERSFOORT, NL-3818 LE, NETHERLANDS:  
2,873,181, REN. 7-21-14. INT. CL. 1.

AL PARTNERS, LLC, SCOTTSDALE, AZ:  
4,594,233, INT. CL. 43.

AL-AZMEYAH TRADING ESTABLISHMENT, RIYADH 11442, SAUDI ARABIA:  
4,591,278, PUB. 6-10-2014. INT. CL. 11.

AL-KAOURI, MOSTAFA, SALWA, LEBANON:  
4,594,310, INT. CL. 42.

ALABS CORP. DBA ACCUMEN, SAN DIEGO, CA:  
4,593,766, INT. CL. 35.

ALAMO FIREWORKS, INC., SAN ANTONIO, TX:  
3,353,911, CANC. INT. CL. 13.

ALAMO GROUP INC., SEGUIN, TX, TERRAIN KING CORPORATION, HOUSTON, TX:  
988,350, REN. 7-18-14. U.S. CL. 23 (INT. CL. 7).

ALAMO GROUP INC., SEGUIN, TX:  
2,870,284, REN. 7-24-14. MULTIPLE CLASS, INT. CLS. 7 AND 35.

ALAN HAYMES, NEW YORK, NY:  
4,594,503, INT. CL. 25.

ALBEMARLE ASSOCIATES, LLC., NEW YORK, NY:  
3,351,295, CANC. INT. CL. 25.

ALBERTSON'S LLC, BOISE, ID:  
3,351,770, CANC. INT. CL. 35.

ALBIE'S FOODS, INC., GAYLORD, MI:  
4,591,508, PUB. 6-10-2014. INT. CL. 30.

ALDAGEN, INC., DURHAM, NC:  
2,890,190, REN. 7-23-14. INT. CL. 5.

ALDI INC., BATAVIA, IL:  
2,794,189, CANC. MULTIPLE CLASS, INT. CLS. 29 AND 30.

- ALDINE, INC., NEW YORK, NY:  
4,591,369, PUB. 6-10-2014. MULTIPLE CLASS, INT. CLS. 35 AND 40.
- ALEGACY GROUP, LLC, WALLER, TX:  
4,594,536, INT. CL. 7.  
4,594,537, INT. CL. 7.
- ALEXIS AUSTIN, GRANBY, CT, DBA CURIO PRESS:  
4,592,354, PUB. 6-10-2014. INT. CL. 16.
- ALEXIS GINN, DYER, IN:  
4,593,817, INT. CL. 3.
- ALEYDIS CENTERS, LLC, ST. JOSEPH, MI:  
4,592,448, PUB. 6-10-2014. INT. CL. 10.
- ALFA CORPORATION, MONTGOMERY, AL:  
3,518,699, CANC. INT. CL. 36.
- ALFONS HARRIS, MORENO VALLEY, CA:  
4,592,643, PUB. 6-10-2014. INT. CL. 25.  
4,592,644, PUB. 6-10-2014. INT. CL. 25.
- ALFONSO MARINA Y COMPAÑIA, S.A. DE C.V., MÉXICO, DISTRITO FEDERAL, MEXICO:  
3,352,136, CANC. INT. CL. 20.
- ALFRED DUNHILL LIMITED, UNITED KINGDOM:  
3,352,654.
- ALGOPLUS CONSULTING LIMITED, HALIFAX, NOVA SCOTIA, CANADA:  
3,351,918, CANC. MULTIPLE CLASS, INT. CLS. 9, 42 AND 45.
- ALGORITHMRX, LLC, NORTH CHESTERFIELD, VA:  
4,591,227, PUB. 6-10-2014. INT. CL. 42.
- ALI, FARID, WASHINGTON, DC:  
2,859,768. REN. 7-22-14. MULTIPLE CLASS, INT. CLS. 9 AND 25.
- ALION SCIENCE AND TECHNOLOGY CORPORATION, MCLEAN, VA:  
2,863,371. REN. 7-24-14. MULTIPLE CLASS, INT. CLS. 35, 41 AND 42.  
2,863,371, CANC. INT. CL. 9.
- ALL ACCESS APPAREL, INC., MONTEBELLO, CA:  
4,593,989, INT. CL. 25.
- ALL CLEAR POOL & SPA, ELK GROVE, CA:  
2,985,425, CANC. INT. CL. 37.
- ALL POINTS INDUSTRIES, INC., POMPANO BEACH, FL, DBA ALL POINTS SCREW, BOLT & SPECIALTY CO.:  
3,354,288, CANC. MULTIPLE CLASS, INT. CLS. 6 AND 20.
- ALL THERAPY, WASHINGTON, DC:  
4,591,529, PUB. 6-10-2014. INT. CL. 44.
- ALLAGASH BREWING COMPANY, PORTLAND, ME:  
4,593,013, PUB. 6-10-2014. INT. CL. 32.
- ALLAIRE, ROSS, UPLAND, CA:  
3,350,692, CANC. INT. CL. 1.
- ALLAN, DAVID, MELBOURNE, VICTORIA, AUSTRALIA, DBA GAYLAWNET:  
2,939,641. REN. 7-18-14. INT. CL. 42.
- ALLEN GLOBAL, LLC, SPRINGFIELD, MO:  
4,591,954, PUB. 6-10-2014. INT. CL. 35.
- ALLEN PROFESSIONAL GRAPHICS GROUP, LLC, ATLANTA, GA, DBA S4G:  
4,591,438, PUB. 6-10-2014. INT. CL. 35.
- ALLEN TATE CO., INC., CHARLOTTE, NC:  
2,860,016. REN. 7-18-14. INT. CL. 36.
- ALLEN, ERICH STEPHAN, KINGSPORT, TN:  
4,592,018, PUB. 6-10-2014. INT. CL. 32.
- ALLERGAN, INC., IRVINE, CA:  
3,351,888, CANC. INT. CL. 35.
- ALLERGY SUITES, LLC, SHEBOYGAN, WI:  
4,594,602, MULTIPLE CLASS, INT. CLS. 37, 40, 43 AND 45.
- ALLIED BLENDERS AND DISTILLERS PRIVATE LIMITED, MUMBAI, INDIA:  
4,594,423, INT. CL. 33.
- ALLIED VAN LINES, INC., NAPERVILLE, IL:  
1,635,690, CANC. INT. CL. 35.
- ALLIED VAN LINES, INC., WESTMONT, IL:  
2,870,120, CANC. MULTIPLE CLASS, INT. CLS. 35, 36 AND 39.  
3,345,484, CANC. INT. CL. 39.  
3,461,374, CANC. INT. CL. 35.  
3,461,375, CANC. INT. CL. 35.
- ALLISON FORD AND JOSEPHINE CELIO PARTNERSHIP, THE, DIAMOND SPRINGS, CA:  
3,354,343, CANC. INT. CL. 21.
- ALLISON L. POHL, WINTER PARK, FL:  
4,594,499, INT. CL. 16.
- ALLISON, PATRICK, COLUMBUS, OH:  
4,591,262, PUB. 6-10-2014. INT. CL. 25.
- ALLOY VENTURES, INC., PALO ALTO, CA:  
4,594,694, INT. CL. 36.
- ALMARK PRODUCTS, INC, DELRAY BEACH, FL:  
3,353,610, CANC. INT. CL. 5.
- ALMEIDA, ROBERTO, CELEBRATION, FL:  
4,592,126, PUB. 6-10-2014. INT. CL. 35.
- ALMOND INTERNATIONAL, INC., PORT WASHINGTON, NY:  
3,353,722, CANC. INT. CL. 14.
- ALOK INTERNATIONAL INC., DALLAS, TX:  
4,594,643, INT. CL. 24.
- ALONGSIDE MANAGEMENT INCORPORATED, NORTH VA:  
3,353,305, CANC. INT. CL. 41.
- ALP LIGHTING & CEILING PRODUCTS, INC., NILES, IL:  
3,350,742, CANC. MULTIPLE CLASS, INT. CLS. 9, 11 AND 17.
- ALPHA CALLIGRAPHIC RESEARCH CAMBRIDGE LIMITED, CAMBRIDGE, CAMBRIDGESHIRE, UNITED KINGDOM:  
3,353,827, CANC. MULTIPLE CLASS, INT. CLS. 38 AND 41.
- ALPHA TECH PET, INC., LITTLETON, MA:  
3,353,124, CANC. INT. CL. 3.
- ALPHA TECHNOLOGY U.S.A. CORPORATION, LONGWOOD, FL, DBA FUTURECOW:  
4,594,056, INT. CL. 7.
- ALPHAGIRLZ, LOS ANGELES, CA:  
3,352,252, CANC. INT. CL. 41.
- ALPHAPOINTE ASSOCIATION FOR THE BLIND, KANSAS CITY, MO:  
1,852,740. REN. 7-22-14. INT. CL. 42.
- ALPINE ACCESS, INC., DENVER, CO:  
3,350,724, CANC. INT. CL. 35.
- ALPS ELECTRIC CO., LTD., TOKYO, JAPAN:  
2,794,324, CANC. INT. CL. 9.
- ALPS ELECTRIC CO., LTD., OTA-KU, TOKYO 145, JAPAN:  
2,847,601, COR. MULTIPLE CLASS, INT. CLS. 9 AND 12.
- ALRAHIB, AKRUM, MISSION VIEJO, CA:  
4,594,370, INT. CL. 9.
- ALSCHULER GROSSMAN LLP, SANTA MONICA, CA:  
3,351,023, CANC. INT. CL. 45.
- ALSO, BEVERLY HILLS, CA:  
3,353,252, CANC. MULTIPLE CLASS, INT. CLS. 9 AND 41.
- ALSTOM TRANSPORT SA, FRANCE:  
4,590,655, PUB. 12-24-2013. MULTIPLE CLASS, INT. CLS. 9, 12, 16, 18, 25, 35, 37, 38, 39, 40, 41, 42 AND 45.
- ALTA BUSINESS COMMUNITIES, LLC, DUBLIN, OH:  
3,353,712, CANC. MULTIPLE CLASS, INT. CLS. 36, 37 AND 42.
- ALTAIR, F-75016 PARIS, FRANCE:  
4,590,805, PUB. 6-10-2014. MULTIPLE CLASS, INT. CLS. 35 AND 38.
- ALTAMAREA INTELLECTUAL PROPERTY, LLC, NEW YORK, NY:  
4,591,258, PUB. 6-10-2014. INT. CL. 43.  
4,591,259, PUB. 6-10-2014. INT. CL. 43.
- ALTAMIRA, LLC, WESTON, CT:  
2,872,327. REN. 7-21-14. INT. CL. 35.
- ALTAMODA, LLC, FT. LAUDERDALE, FL:  
2,796,319, CANC. MULTIPLE CLASS, INT. CLS. 14 AND 35.
- ALTEC LIMITED CONSULTING, GROVE CITY, OH:  
4,593,787, INT. CL. 42.
- ALTRONIX CORPORATION, BROOKLYN, NY:  
3,353,590, CANC. INT. CL. 42.  
3,353,591, CANC. MULTIPLE CLASS, INT. CLS. 40 AND 42.



ALUMINIUM SYSTEMS NZ LIMITED, MT WELLINGTON, NEW ZEALAND:  
3,350,798, CANC. INT. CL. 6.

ALUMINUMSOLUTION.COM, BRAZORIA, TX:  
4,594,127, INT. CL. 7.

ALUX, INC., BELLEVUE, WA, DBA PRIMA CORPORATION:  
3,353,934, CANC. INT. CL. 9.

ALZHEIMER'S FOUNDATION OF AMERICA, INC., NEW YORK, NY:  
4,591,739, PUB. 2-25-2014, MULTIPLE CLASS, INT. CLS. 41 AND 44.

AM CONSERVATION GROUP, INC., CHARLESTON, SC:  
4,591,667, PUB. 6-10-2014, INT. CL. 11.  
4,591,668, PUB. 6-10-2014, INT. CL. 11.

AMAIN.COM, INC., CHICO, CA:  
4,594,515, INT. CL. 35.

AMAZING CAKES, INCORPORATED, MABLETON, GA, AKA THE AMAZING CAKES BAKERY:  
4,591,810, PUB. 6-10-2014, INT. CL. 30.

AMAZING CONCEALER COSMETICS, INC., LIBERTYVILLE, IL:  
3,354,498, CANC. INT. CL. 3.

AMAZONIA CHURRASCARIA N.V., NOORD, PALM BEACH, ARUBA:  
3,352,779, CANC. INT. CL. 43.

AMBERWODELECTRIC LLC, HURRICANE, UT, DBA MR. LIGHTBULB:  
3,351,640, CANC. INT. CL. 37.

AMBIOSYSTEMS LLC, POTSDAM, NY:  
3,354,025, CANC. INT. CL. 9.

AMBRUS SÁNDOR, H-1121 BUDAPEST, HUNGARY:  
4,590,635, PUB. 6-10-2014, MULTIPLE CLASS, INT. CLS. 9, 20 AND 37.

AMBUSH HEADS LLC, CLOVIS, CA, DBA AMBUSH HEADS, LLC:  
4,593,831, INT. CL. 7.  
4,593,832, INT. CL. 7.

AMC BURGERS, INC., SOUTHFIELD, MI:  
4,592,685, PUB. 6-10-2014, INT. CL. 30.  
4,592,975, PUB. 6-10-2014, INT. CL. 43.  
4,592,978, PUB. 6-10-2014, INT. CL. 43.

AMERESCO CANADA INC., NORTH YORK, ONTARIO, CANADA:  
3,352,014, CANC. MULTIPLE CLASS, INT. CLS. 35, 36, 37 AND 42.

AMERICA FOREVER PRODUCTIONS, LLC, SAN FRANCISCO, CA:  
4,592,687, PUB. 6-10-2014, INT. CL. 32.

AMERICA'S COLLECTIBLES NETWORK, INC., KNOXVILLE, TN:  
3,351,928, CANC. INT. CL. 14.

AMERICA'S HEALTH INSURANCE PLANS, INC., WASHINGTON, DC:  
2,791,562, REN. 7-22-14, U.S. CL. B.  
2,791,563, REN. 7-22-14, U.S. CL. B.  
2,845,080, REN. 7-22-14, U.S. CL. B.

AMERICAN ACADEMY OF FAMILY PHYSICIANS, LEAWOOD, KS:  
4,591,424, PUB. 6-10-2014, MULTIPLE CLASS, INT. CLS. 9, 16 AND 44.

AMERICAN AMARANTH LLC, CORAL GABLES, FL:  
4,591,716, PUB. 6-10-2014, MULTIPLE CLASS, INT. CLS. 9, 14, 18, 20 AND 25.

AMERICAN ASSOCIATED DRUGGISTS, INC., PHOENIX, AZ, DBA UNITED DRUGS:  
4,591,511, PUB. 6-10-2014, MULTIPLE CLASS, INT. CLS. 35 AND 45.

AMERICAN ASSOCIATION FOR CLINICAL CHEMISTRY, INC., WASHINGTON, DC:  
4,591,780, PUB. 6-10-2014, INT. CL. 35.

AMERICAN AUTOWASH, INC., MALVERN, PA:  
3,353,589, CANC. INT. CL. 35.

AMERICAN BAR ASSOCIATION, CHICAGO, IL:  
1,325,700, REN. 7-21-14, INT. CL. 16.  
1,326,899, REN. 7-21-14, INT. CL. 16.

AMERICAN BUILDING SUPPLY, INC., SACRAMENTO, CA:  
3,353,033, CANC. MULTIPLE CLASS, INT. CLS. 6 AND 19.

AMERICAN CANCER SOCIETY, INC., ATLANTA, GA:  
2,832,040, REN. 7-21-14, INT. CL. 41.

AMERICAN COLLEGE OF CARDIOLOGY FOUNDATION, WASHINGTON, DC:  
3,354,235, CANC. MULTIPLE CLASS, INT. CLS. 41 AND 44.

AMERICAN DISTRIBUTION COMPANY, LLC, ATMORE, AL:  
4,591,317, PUB. 6-10-2014, INT. CL. 8.

AMERICAN DWARF HOP ASSOCIATION, LLC, MOXEE, WA:  
4,593,903, INT. CL. 32.

AMERICAN FAUCET AND COATINGS CORPORATION, VISTA, CA:  
2,794,288, CANC. INT. CL. 11.

AMERICAN FORECLOSURES, INC., ORADELL, NJ:  
2,793,688, CANC. MULTIPLE CLASS, INT. CLS. 16, 35 AND 36.

AMERICAN HOLISTIC NURSES CREDENTIALING CORPORATION, CEDAR PARK, TX, DBA THE AMERICAN HOLISTIC NURSES CREDENTIALING CORPORATION:  
4,592,495, PUB. 6-10-2014, INT. CL. 42.

AMERICAN INFORMATION STRATEGIES, INC., SAN CLEMENTE, CA:  
3,352,280, CANC. INT. CL. 35.

AMERICAN INSTITUTE OF PROFESSIONAL GEOLOGISTS, THORNTON, CO:  
1,311,687, REN. 7-22-14, U.S. CL. 200.

AMERICAN INTERNATIONAL ASSURANCE, SPC, GRAND CAYMAN, CAYMAN ISLANDS:  
3,351,718, CANC. INT. CL. 36.

AMERICAN INTERNATIONAL GROUP, INC., NEW YORK, NY:  
1,894,319, REN. 7-24-14, INT. CL. 36.  
3,351,874, CANC. INT. CL. 36.  
3,351,891, CANC. INT. CL. 36.  
3,351,898, CANC. INT. CL. 36.  
3,351,899, CANC. INT. CL. 36.  
3,351,902, CANC. INT. CL. 36.  
3,351,903, CANC. INT. CL. 36.  
3,351,904, CANC. INT. CL. 36.  
3,351,905, CANC. INT. CL. 36.  
3,351,907, CANC. INT. CL. 36.  
3,351,908, CANC. INT. CL. 36.  
3,351,909, CANC. INT. CL. 36.  
3,351,910, CANC. MULTIPLE CLASS, INT. CLS. 36 AND 39.  
3,351,913, CANC. MULTIPLE CLASS, INT. CLS. 36 AND 41.  
4,594,349, INT. CL. 36.

AMERICAN INTERNATIONAL INDUSTRIES, CITY OF COMMERCE, CA:  
1,285,718, REN. 7-21-14, INT. CL. 3.

AMERICAN INTERNATIONAL INDUSTRIES, LOS ANGELES, CA:  
3,352,976, CANC. INT. CL. 8.

AMERICAN KIDNEY FUND, INC., ROCKVILLE, MD:  
4,590,614, PUB. 6-10-2014, MULTIPLE CLASS, INT. CLS. 36 AND 44.  
4,590,615, PUB. 6-10-2014, MULTIPLE CLASS, INT. CLS. 36 AND 44.

AMERICAN LUNG ASSOCIATION, CHICAGO, IL, NATIONAL TUBERCULOSIS ASSOCIATION, NEW YORK, NY:  
594,953, REN. 7-21-14, U.S. CL. 100 (INT. CL. 42).

AMERICAN LUNG ASSOCIATION-SOUTHEAST REGION, SMYRNA, GA:  
3,351,665, CANC. INT. CL. 36.

AMERICAN MEDICAL DIAGNOSTICS, INC., FAIRFAX, VA:  
2,956,115, REN. 7-18-14, INT. CL. 41.

AMERICAN METAL SUPPLY CO., BLUE ASH, OH:  
4,594,701, INT. CL. 35.

- AMERICAN MULTI-CINEMA, INC., LEAWOOD, KS:  
3,353,368, CANC. MULTIPLE CLASS, INT. CLS. 35 AND 41.
- AMERICAN REVERSE MORTGAGE CORPORATION, Ocala, FL:  
3,352,359, CANC. INT. CL. 36.
- AMERICAN ROAD & TRANSPORTATION BUILDERS ASSOCIATION, WASHINGTON, DC:  
4,594,750, MULTIPLE CLASS, INT. CLS. 35 AND 41.
- AMERICAN SPORTFISHING ASSOCIATION, ALEXANDRIA, VA:  
4,593,232, MULTIPLE CLASS, INT. CLS. 16, 25, 35 AND 41.
- AMERICAN TIRE DISTRIBUTORS, INC., HUNTERSVILLE, NC:  
4,593,721, INT. CL. 35.
- AMERICANS UNITED FOR SEPARATION OF CHURCH AND STATE, WASHINGTON, DC:  
3,401,816, CANC. INT. CL. 9.
- AMERIMARK DIRECT LLC, CLEVELAND, OH:  
3,354,043, CANC. INT. CL. 35.
- AMES TRUE TEMPER, INC., CAMP HILL, PA:  
2,794,883, CANC. INT. CL. 8.
- AMITY SYSTEMS, INC., MILPITAS, CA:  
3,353,226, CANC. INT. CL. 9.
- AMIVERIS ENTERPRISE, INC., VERNON HILLS, IL:  
4,592,616, PUB. 6-10-2014. INT. CL. 41.  
4,593,027, PUB. 6-10-2014. INT. CL. 41.
- AMLIN PLC, LONDON, UNITED KINGDOM:  
3,353,620, CANC. INT. CL. 36.
- AMMAT HOLDINGS, LLC, LAKE OZARK, MO:  
3,354,042, CANC. INT. CL. 35.
- AMNESIA INTERNATIONAL, LLC, AVENTURA, FL:  
4,593,474, INT. CL. 41.
- AMOVEO PRODUCTIONS, INC., LOS ANGELES, CA:  
4,591,392, PUB. 7-2-2013. INT. CL. 35.  
4,591,393, PUB. 7-2-2013. INT. CL. 41.
- AMPELIDAE SARL, FRANCE:  
4,590,846, PUB. 6-10-2014. INT. CL. 33.
- AMPLIFIER MANAGEMENT, LLC, MCLEAN, VA:  
3,195,157, CANC. INT. CL. 36.
- AMPLISINE LABS LLC, LUBBOCK, TX:  
4,593,629, MULTIPLE CLASS, INT. CLS. 9, 38 AND 42.  
4,593,630, MULTIPLE CLASS, INT. CLS. 9, 38 AND 42.
- AMRAPUR OVERSEAS INCORPORATED, GARDEN GROVE, CA:  
4,592,147, PUB. 6-10-2014. INT. CL. 24.
- AMSTED RAIL COMPANY, INC., CHICAGO, IL:  
771,073, REN. 7-18-14. U.S. CL. 19 (INT. CL. 12).
- AMTOTE INTERNATIONAL, INC., HUNT VALLEY, MD:  
3,353,600, CANC. INT. CL. 9.
- AMTRAN TECHNOLOGY CO., LTD., NEW TAIPEI CITY, TAIWAN:  
4,594,157, INT. CL. 9.
- AMUNDSON, GREGORY, SCANDIA, MN, DBA GREGORY AMUNDSON:  
4,592,341, PUB. 6-10-2014. INT. CL. 16.
- AMVAC CHEMICAL CORPORATION, NEWPORT BEACH, CA:  
4,592,992, PUB. 6-10-2014. MULTIPLE CLASS, INT. CLS. 1 AND 5.
- AMY SCHMIDT HAMILTON, KENSINGTON, MD:  
4,591,925, PUB. 6-10-2014. INT. CL. 35.
- AMYLIN PHARMACEUTICALS, LLC, SAN DIEGO, CA:  
4,593,455, INT. CL. 44.
- AN NENG INC., COLLEGE POINT, NY:  
3,353,023, CANC. INT. CL. 18.
- ANABIOS CORPORATION, SAN DIEGO, CA, FORMERLY ANABIOCARDIA CORPORATION:  
4,593,535, INT. CL. 42.
- ANALYSTS INTERNATIONAL CORPORATION, MINNEAPOLIS, MN:  
3,352,428, CANC. INT. CL. 35.
- ANAUVE, S.L., MADRID, SPAIN:  
3,350,835, CANC. INT. CL. 25.
- ANCHOR AVENUE COMPANY, LLC, BEVERLY HILLS, CA:  
4,592,799, PUB. 6-10-2014. INT. CL. 29.
- ANCIENT SUN NUTRITION, INC., ASHEVILLE, NC:  
3,353,525, CANC. INT. CL. 5.
- ANDEAN NATURALS, INC., FOSTER CITY, CA:  
4,591,921, PUB. 6-10-2014. INT. CL. 31.  
4,591,922, PUB. 6-10-2014. INT. CL. 31.
- ANDEAN WINERIES SRL, CORDOBA, CORDOBA, ARGENTINA:  
2,861,681, REN. 7-18-14. INT. CL. 33.
- ANDERSON PRESS INCORPORATED, FLORENCE, AL:  
998,973, REN. 7-22-14. INT. CL. 16.
- ANDERSON, GARY, NAGS HEAD, NC AND ANDERSON, GAIL, NAGS HEAD, NC:  
2,749,891, CANC. INT. CL. 43.
- ANDOR TECHNOLOGY PLC, UNITED KINGDOM:  
4,590,910, PUB. 6-10-2014. MULTIPLE CLASS, INT. CLS. 9 AND 42.
- ANDREAS FELSL, 83707 BAD WIESSEE, FED REP GERMANY:  
3,462,488.
- ANDREAS LESCH, AUSTRIA:  
4,590,640, PUB. 6-10-2014. MULTIPLE CLASS, INT. CLS. 9, 42 AND 45.
- ANDREJOIS HYGIENE, INC., BILLERICA, MA:  
3,351,987, CANC. MULTIPLE CLASS, INT. CLS. 11 AND 21.
- ANDREW EDWARD GUNN, GRABOUW, SOUTH AFRICA:  
3,352,222, CANC. INT. CL. 33.
- ANDREW LLC, HICKORY, NC:  
1,301,390, REN. 7-23-14. INT. CL. 9.
- ANDREW WADE GITLIN, NEW YORK, NY:  
4,592,932, PUB. 6-10-2014. MULTIPLE CLASS, INT. CLS. 29 AND 30.
- ANDRITZ AG, A-8045 GRAZ, AUSTRIA:  
2,858,182, REN. 7-22-14. MULTIPLE CLASS, INT. CLS. 6, 7, 9, 11 AND 20.
- ANDY GRAHAM, SANTA ROSA, CA:  
4,594,395, INT. CL. 15.
- ANESTHESIA SERVICE MEDICAL GROUP, INC., SAN DIEGO, CA:  
1,903,227, REN. 7-20-14. INT. CL. 42.
- ANGEION CORPORATION, ST. PAUL, MN:  
2,795,807, CANC. MULTIPLE CLASS, INT. CLS. 5 AND 25.
- ANGELIC BAKEHOUSE, INC., CUDAHY, WI:  
4,594,521, INT. CL. 30.
- ANGER MACHINING GMBH, AUSTRIA:  
4,590,675, PUB. 6-10-2014. MULTIPLE CLASS, INT. CLS. 7 AND 42.
- ANHUI NEWCENTER ELECTRONIC TECHNOLOGY CO., LTD., HEFEI, ANHUI, CHINA:  
4,592,613, PUB. 6-10-2014. INT. CL. 10.
- ANIKA THERAPEUTICS, INC., BEDFORD, MA:  
4,593,175, INT. CL. 5.
- ANIKUITE, LLC, LADERA RANCH, CA:  
3,353,597, CANC. INT. CL. 21.
- ANLIN INDUSTRIES, INC., CLOVIS, CA:  
2,795,295, CANC. INT. CL. 19.
- ANNABEL KARMEL GROUP HOLDINGS LTD, LONDON, UNITED KINGDOM:  
4,591,189, PUB. 6-10-2014. INT. CL. 21.
- ANSCO, INC., NEW YORK, NY:  
4,591,599, PUB. 6-10-2014. INT. CL. 25.
- ANODE, INC., NASHVILLE, TN:  
3,352,836, CANC. INT. CL. 9.
- ANS DIGITAL CORP, METUCHEN, NJ, TA NIXXELL:  
4,594,218, INT. CL. 9.
- ANSARINIA PROFESSIONAL CORPORATION, LAS VEGAS, NV:  
4,593,556, INT. CL. 10.
- ANSELL LIMITED, RICHMOND, VIC, AUSTRALIA:  
3,354,440, CANC. INT. CL. 9.
- ANTEA USA, INC., SHOREVIEW, MN:  
4,591,219, PUB. 6-10-2014. INT. CL. 35.
- ANTENNA DEXTERRA, INC., JERSEY CITY, NJ:  
3,353,500, CANC. INT. CL. 9.
- ANTHONY J. CATURANO, SAUGUS, MA:  
4,591,389, PUB. 6-10-2014. INT. CL. 43.

ANTHONY W. BELL, GULFPORT, MS:  
3,352,449, CANC. INT. CL. 35.

ANTI L'AGE INC., RIVERSIDE, CA:  
4,594,391, INT. CL. 5.

ANTI-DOPING RESEARCH, INC., LOS ANGELES, CA:  
3,472,076, CANC. MULTIPLE CLASS, INT. CLS. 41 AND 44.

ANTONINO, NIGRELLI, MIAMI, FL:  
4,591,837, PUB. 6-10-2014. INT. CL. 33.

ANYDAY DENTAL, LLC, ALPINE, UT:  
4,593,896, INT. CL. 44.

AOSMART INC., ALHAMBRA, CA:  
4,592,580, PUB. 6-10-2014. INT. CL. 9.

APAJA ONLINE ENTERTAINMENT OY, HELSINKI, FINLAND:  
3,350,833, CANC. MULTIPLE CLASS, INT. CLS. 38 AND 41.

APC BOOKKEEPING LLC, MACON, GA:  
4,592,257, PUB. 6-10-2014. INT. CL. 35.

APEM, FRANCE:  
4,590,682, PUB. 6-10-2014. INT. CL. 9.

APEX BIOTECHNOLOGY CORPORATION, HSINCHU CITY, TAIWAN:  
4,591,869, PUB. 6-10-2014. INT. CL. 9.

APEX BRANDS, INC., APEX, NC:  
3,353,989, CANC. INT. CL. 8.

APEX MEDICAL CORPORATION (D/B/A CAREX HEALTH BRANDS), SIOUX FALLS, SD:  
2,794,632, CANC. INT. CL. 10.

APNA HOLDINGS LLC, HOUSTON, TX:  
3,354,443, CANC. INT. CL. 4.

APOLLO EDUCATION GROUP, INC., PHOENIX, AZ:  
4,594,605, MULTIPLE CLASS, INT. CLS. 35, 41 AND 42.

APOLLO GROUP, INC., PHOENIX, AZ:  
3,352,257, CANC. INT. CL. 41.  
3,352,258, CANC. INT. CL. 41.

APPEARBY, LLC, NEW YORK, NY:  
4,592,449, PUB. 6-10-2014. INT. CL. 38.

APPENDAGE, WICHITA, KS:  
4,591,562, PUB. 6-10-2014. INT. CL. 25.

APPJACKET, INC., MARKHAM, ONTARIO, CANADA, FORMERLY HOME NETWORKS AND GAMING INC.:  
4,592,891, PUB. 6-10-2014. INT. CL. 9.

APPLAUSE LEARNING, INC., LAWRENCEVILLE, GA:  
4,591,626, PUB. 6-10-2014. INT. CL. 16.

APPLEBEE'S INTERNATIONAL, INC., KANSAS CITY, MO:  
4,594,590, INT. CL. 43.

APPLIED BUSINESS SOFTWARE, INC., SIGNAL HILL, CA:  
4,594,743, INT. CL. 9.

APPLIED DISCOVERY, INC., BELLEVUE, WA:  
2,794,155, CANC. INT. CL. 42.

APPLIED GENETICS INCORPORATED DERMATICS, FREEPORT, NY:  
3,353,802, CANC. INT. CL. 3.

APPLIED MATERIALS, INC., SANTA CLARA, CA:  
4,593,119, INT. CL. 7.

APPLIED SCIENCES AND INFORMATION SYSTEMS, INC., VIRGINIA BEACH, VA:  
4,593,979, MULTIPLE CLASS, INT. CLS. 9 AND 42.

APPLIED SOFTWARE TECHNOLOGY, INC., ATLANTA, GA:  
1,845,897, REN. 7-23-14. MULTIPLE CLASS, INT. CLS. 37 AND 42.

APPLIN, SUSAN M., NEWPORT BEACH, CA:  
3,354,076, CANC. INT. CL. 35.

APPROVED AERONAUTICS, LLC, POMONA, CA:  
3,350,923, CANC. MULTIPLE CLASS, INT. CLS. 6, 7, 12 AND 17.

APPSURDITY, INC., REDWOOD SHORES, CA:  
4,592,972, PUB. 6-10-2014. INT. CL. 35.

APRIGLIANO, TERESA, NEW HYDE PARK, NY AND AMODEO, JOHN, NEW HYDE PARK, NY:  
4,594,756, INT. CL. 35.

AQUANOVA AG, 64295 DARMSTADT, FED REP GERMANY:  
3,350,926, CANC. MULTIPLE CLASS, INT. CLS. 1, 5, 29, 30 AND 32.

AQUARII, INC., CAMILLUS, NY:  
4,594,345, INT. CL. 36.

AQUARIUS MARINE COATINGS LTD, SHILLINGSTONE, DORSET, UNITED KINGDOM:  
4,594,622, INT. CL. 2.

ARA AG, FED REP GERMANY:  
4,590,740, PUB. 6-10-2014. MULTIPLE CLASS, INT. CLS. 3, 18 AND 25.

ARABIAN HORSE ASSOCIATION OF ARIZONA, SCOTTSDALE, AZ:  
4,591,597, PUB. 6-10-2014. INT. CL. 41.

ARABICA FUNDING, INC., BROOKLYN CENTER, MN:  
3,352,148, CANC. INT. CL. 32.  
4,592,678, PUB. 6-10-2014. INT. CL. 35.

ARAMARK CORPORATION, PHILADELPHIA, PA:  
3,353,347, CANC. INT. CL. 35.

ARAMIS INC., NEW YORK, NY:  
3,353,380, CANC. INT. CL. 3.

ARAYOS LLC, BANGOR, ME, DBA DIAMONDS GENTLEMAN'S CLUB:  
4,591,975, PUB. 5-6-2014. MULTIPLE CLASS, INT. CLS. 41 AND 43.

ARBONNE INTERNATIONAL, LLC, IRVINE, CA:  
3,353,695, CANC. INT. CL. 3.

ARCAFFE' ESTERO S.R.L., 57121 LIVORNO, ITALY:  
2,847,917, REN. 7-22-14. INT. CL. 30.

ARCANANETWORKS, INC., NEWARK, CA:  
2,867,292, REN. 7-24-14. INT. CL. 9.

ARCHADVANTAGE, LLC, CHATTANOOGA, TN:  
4,591,310, PUB. 6-10-2014. MULTIPLE CLASS, INT. CLS. 35 AND 36.

ARCTIC CAT INC., THIEF RIVER FALLS, MN:  
2,861,288, REN. 7-18-14. INT. CL. 12.

ARGENTO SC, NEW YORK, NY:  
4,594,425, INT. CL. 9.

ARGO-HYTOS GMBH, KRAICHTAL, FED REP GERMANY:  
1,285,933, REN. 7-19-14. INT. CL. 11.

ARGON MEDICAL DEVICES, INC., ATHENS, TX:  
2,794,955, CANC. INT. CL. 10.

ARISTOCRAT TECHNOLOGIES AUSTRALIA PTY LTD., NORTH RYDE, NSW, AUSTRALIA:  
4,591,593, PUB. 6-10-2014. INT. CL. 9.  
4,591,607, PUB. 6-10-2014. INT. CL. 28.  
4,591,608, PUB. 6-10-2014. INT. CL. 28.

ARISTOCRAT TECHNOLOGIES AUSTRALIA, PTY LTD., NORTH RYDE, AUSTRALIA:  
4,591,492, PUB. 6-10-2014. INT. CL. 28.

ARIZANT HEALTHCARE INC., EDEN PRARIE, MN TO ARIZANT HEALTHCARE INC., EDEN PRARIE, MN:  
2,796,136, CANC. INT. CL. 10.

ARIZONA BOARD OF REGENTS FOR AND ON BEHALF OF ARIZONA STATE UNIVERSITY, TEMPE, AZ:  
4,591,427, PUB. 6-10-2014. INT. CL. 41.

ARIZONA CHAPTER NATIONAL SAFETY COUNCIL, INC., PHOENIX, AZ:  
1,870,036, REN. 7-22-14. INT. CL. 41.

ARIZONA FINE VIOLINS, LLC, CHANDLER, AZ:  
4,594,766, INT. CL. 35.

ARIZONA MANUFACTURING & EMBROIDERY, INC., TEMPE, AZ:  
4,593,213, INT. CL. 28.

ARLON LLC, BEAR, DE:  
778,004, REN. 7-21-14. U.S. CL. 1 (INT. CL. 1).

ARMON LIMITED, 1211 GENEVA 3, SWITZERLAND, ANDREWS MACLAREN LTD., LONG BUCKBY, NORTHAMPTON, ENGLAND:  
1,285,960, REN. 7-22-14. MULTIPLE CLASS, INT. CLS. 12, 20 AND 24.

AROMA FRESH, LLC, VALENCIA, CA:  
3,353,628, CANC. INT. CL. 30.

ARPA INDUSTRIALE S.P.A., I-12042 BRA (CN), ITALY:  
4,590,831, PUB. 6-10-2014. MULTIPLE CLASS, INT. CLS. 17 AND 20.

ARROYO DISTRIBUTION GROUP, INC., LAS PIEDRAS, PUERTO RICO:  
3,353,677, CANC. INT. CL. 9.  
3,353,678, CANC. INT. CL. 9.

- ARSOA HONSHA CORPORATION, YAMANASHI-KEN 408-8522, JAPAN:  
4,590,642, PUB. 8-27-2013. MULTIPLE CLASS, INT. CLS. 5, 29, 30 AND 32.
- ART INVASION, MIAMI, FL:  
4,591,586, PUB. 6-10-2014. MULTIPLE CLASS, INT. CLS. 16 AND 20.
- ARTHREX, INC., NAPLES, FL:  
3,354,240, CANC. INT. CL. 10.
- ARTISAN SPIRITS LLC, NEW HAVEN, MO:  
4,592,248, PUB. 6-10-2014. INT. CL. 33.
- ARTOURA, INC, BELLEVUE, WA:  
4,591,242, PUB. 6-10-2014. MULTIPLE CLASS, INT. CLS. 35, 41 AND 42.
- ARTSLANDIA PUBLISHING, INC., PORTLAND, OR:  
4,591,909, PUB. 6-10-2014. INT. CL. 16.
- ARUBA NETWORKS, INC., SUNNYVALE, CA:  
3,352,051, CANC. MULTIPLE CLASS, INT. CLS. 9 AND 42.
- ARYZTA LLC, SAN LEANDRO, CA:  
3,352,857, CANC. INT. CL. 30.
- ASA ELECTRONICS, LLC., ELKHART, IN:  
4,594,556, INT. CL. 9.
- ASAH KASEI CHEMICALS CORPORATION, TOKYO 101-8101, JAPAN:  
4,592,845, PUB. 6-10-2014. INT. CL. 1.
- ASCENDED LIFE SOLUTIONS INCORPORATED, PALMDALE, CA:  
4,592,626, PUB. 6-10-2014. INT. CL. 25.
- ASCENTERA INC., SCHAUMBURG, IL:  
4,592,680, PUB. 6-10-2014. INT. CL. 42.
- ASGCO MANUFACTURING, INC., ALLENTOWN, PA:  
2,860,848, REN. 7-22-14. INT. CL. 7.  
4,590,963, PUB. 6-18-2013. INT. CL. 7.
- ASHER, SHALOM, JAMAICA, NY:  
4,591,276, PUB. 6-10-2014. INT. CL. 25.
- ASHLEY CHILDS, LOS ANGELES, CA, DBA ASHLEY CHILDS:  
4,592,396, PUB. 6-10-2014. INT. CL. 14.
- ASHLEY CROUCH, DADE CITY, FL:  
4,592,974, PUB. 6-10-2014. MULTIPLE CLASS, INT. CLS. 16 AND 25.
- ASHOKA: INNOVATORS FOR THE PUBLIC, ARLINGTON, VA:  
3,352,300, CANC. MULTIPLE CLASS, INT. CLS. 35 AND 36.
- ASHWORTH, LLC, CARLSBAD, CA:  
4,594,101, MULTIPLE CLASS, INT. CLS. 18, 25 AND 28.
- ASIA ACCESS, INC., BURNSVILLE, MN:  
2,894,192, REN. 7-19-14. INT. CL. 28.
- ASIAMA-KISIEDU, STEPHEN, RIVERSIDE, CA:  
3,351,460, CANC. INT. CL. 25.
- ASPEN LICENSING INTERNATIONAL, INC., WEST PALM BEACH, FL:  
3,353,074, CANC. INT. CL. 14.
- ASPRIA HOLDINGS B.V., NETHERLANDS:  
3,352,687.
- ASSEMBLED INVESTMENTS (PROPRIETARY) LIMITED, STELLENBOSCH, W. CAPE, SOUTH AFRICA:  
4,591,698, PUB. 6-10-2014. INT. CL. 33.
- ASSET HEALTH, INC., TROY, MI:  
4,593,478, MULTIPLE CLASS, INT. CLS. 35, 41 AND 42.
- ASSOCIATED ENVIRONMENTAL SYSTEMS, INC., AYER, MA:  
4,592,024, PUB. 6-10-2014. INT. CL. 9.  
4,592,025, PUB. 6-10-2014. INT. CL. 9.
- ASSOCIATED MATERIALS, LLC, CUYAHOGA FALLS, OH, DBA ALSIDE:  
2,861,761, REN. 7-20-14. INT. CL. 19.
- ASSOCIATED PRESS, THE, NEW YORK, NY:  
1,287,428, REN. 7-23-14. INT. CL. 42.
- ASSOCIATION FOR FINANCIAL PROFESSIONALS, INC., BETHESDA, MD:  
3,350,626, CANC. MULTIPLE CLASS, INT. CLS. 16 AND 41.
- ASSOCIATION FRANCOIS-XAVIER BAGNOUD - FXB INTERNATIONAL, SION, SWITZERLAND:  
2,793,566, CANC. MULTIPLE CLASS, INT. CLS. 16, 18, 25, 27, 28, 41 AND 42.
- ASSOCIATION OF FORMER INTELLIGENCE OFFICERS, INC., FALLS CHURCH, VA:  
4,591,962, PUB. 6-10-2014. MULTIPLE CLASS, INT. CLS. 35 AND 41.
- ASSOCIATION OF PUBLIC HEALTH LABORATORIES, INC., THE, SILVER SPRING, MD:  
2,868,873, REN. 7-24-14. MULTIPLE CLASS, INT. CLS. 16, 35 AND 41.
- ASSOCIATION OF PUBLIC-SAFETY-COMMUNICATIONS OFFICIALS-INTERNATIONAL, INC., DAYTONA BEACH, FL, DBA APCO INTERNATIONAL:  
2,910,891, REN. 7-21-14. MULTIPLE CLASS, INT. CLS. 16 AND 41.
- ASSURED SOFTWARE LIMITED, KELOWNA, BC, CANADA:  
4,593,253, INT. CL. 9.
- ASTILEAN, AUREL A., EAST HAMPTON, NY:  
3,350,697, CANC. INT. CL. 41.
- ASTRAZENECA AB, SODERTALJE, SWEDEN:  
3,353,213, CANC. MULTIPLE CLASS, INT. CLS. 16 AND 41.
- ASYMMETRIC TECHNOLOGIES, LLC, COLUMBUS, OH:  
4,591,421, PUB. 6-10-2014. INT. CL. 35.  
4,591,423, PUB. 6-10-2014. INT. CL. 35.
- ATA RETAIL SERVICES, INC., PLEASANTON, CA:  
4,593,495, MULTIPLE CLASS, INT. CLS. 9, 16 AND 21.
- ATHENA'S HOME NOVELTIES, INC., WOONSOCKET, RI:  
2,864,978, REN. 7-24-14. MULTIPLE CLASS, INT. CLS. 3, 10, 25 AND 35.
- ATHENE ANNUITY & LIFE ASSURANCE COMPANY, GREENVILLE, SC:  
4,593,754, INT. CL. 36.
- ATHLEISURE, INC., A CALIFORNIA CORPORATION, VISTA, CA, DBA SUN DIEGO:  
3,364,585, CANC. MULTIPLE CLASS, INT. CLS. 18 AND 41.
- ATHLETIC ARTIST TRAINING, COVINA, CA:  
4,593,649, INT. CL. 41.
- ATI TECHNOLOGIES INC., CALGARY, ALBERTA, CANADA:  
2,795,785, CANC. INT. CL. 9.
- ATKINS, CHANDLER, LAKE LUZERNE, NY:  
4,591,414, PUB. 6-10-2014. INT. CL. 39.
- ATLANTIC CAPITAL BANCSHARES, INC., ATLANTA, GA:  
4,594,472, INT. CL. 36.  
4,594,532, INT. CL. 36.
- ATLANTIC CITY COIN & SLOT SERVICE, PLEASANTVILLE, NJ:  
3,351,441, CANC. INT. CL. 41.
- ATLANTIC PRODUCE EXCHANGE, LLC, TALLAHASSEE, FL:  
4,593,742, INT. CL. 31.
- ATLANTIC RICHFIELD COMPANY, HOUSTON, TX:  
2,821,396, REN. 7-22-14. MULTIPLE CLASS, INT. CLS. 35 AND 43.
- ATLAS COPCO ROCK DRILLS AB, SPARDOER, SWEDEN:  
3,350,619, CANC. MULTIPLE CLASS, INT. CLS. 7, 8 AND 9.
- ATLETICO SANTA ROSA, SANTA ROSA, CA:  
4,592,111, PUB. 6-10-2014. INT. CL. 41.
- ATLINK COMMUNICATIONS, INC., HOUSTON, TX:  
4,592,191, PUB. 6-10-2014. INT. CL. 9.
- ATOM MEDICAL CORPORATION, JAPAN:  
4,590,863, PUB. 6-10-2014. INT. CL. 10.  
4,590,884, PUB. 6-10-2014. INT. CL. 10.
- ATTEBERY, LUCAS, KENT, NYACK, NY:  
4,594,692, INT. CL. 25.
- AUBURN UNIVERSITY, AUBURN, AL:  
4,593,594, INT. CL. 25.
- AUCTION PROFILE ANALYTICS, LLC, NORFOLK, VA:  
4,593,328, INT. CL. 9.
- AUDDINO, LTD., COLUMBUS, OH:  
3,354,536, CANC. INT. CL. 43.
- AUGUST D. MARTIN, ALBUQUERQUE, NM:  
4,594,360, INT. CL. 15.
- AULT, RICHARD M., CHIPLEY, FL:  
4,591,114, PUB. 6-10-2014. MULTIPLE CLASS, INT. CLS.

- 6, 35 AND 37.  
AUNT SALLY'S PRALINE SHOP, INC., NEW ORLEANS, LA:  
3,351,113, CANC. INT. CL. 29.  
AURORA ALGAE, INC., HAYWARD, CA:  
4,593,144, MULTIPLE CLASS, INT. CLS. 1, 5 AND 29.  
4,593,145, MULTIPLE CLASS, INT. CLS. 1, 5 AND 29.  
AUSTRALIAN GOLD, LLC, INDIANAPOLIS, IN:  
3,353,379, CANC. INT. CL. 3.  
3,353,746, CANC. INT. CL. 3.  
AUTISM CENTER OF TULSA, INC., TULSA, OK:  
4,591,915, PUB. 6-10-2014. INT. CL. 35.  
AUTO BROKERS OF AMERICA, INC., ROSEVILLE, CA:  
3,354,624, CANC. INT. CL. 36.  
AUTO INSURANCE SPECIALISTS LLC, CERRITOS, CA:  
4,591,688, PUB. 6-10-2014. INT. CL. 35.  
AUTO-KAPS, LLC, RIVERHEAD, NY:  
2,795,357, CANC. INT. CL. 7.  
AUTOFORM ENGINEERING GMBH, SWITZERLAND:  
3,352,748.  
AUTOMATED SOLUTIONS, LLC, SAWMILLS, NC:  
987,895. REN. 7-22-14. U.S. CL. 37 (INT. CL. 16).  
AUTOMOTIVE DISTRIBUTIONS GROUP, INC., VERO  
BEACH, FL:  
4,591,534, PUB. 6-10-2014. MULTIPLE CLASS, INT. CLS. 7  
AND 9.  
AUTOMOTIVE SERVICE ASSOCIATION, BEDFORD, TX:  
3,351,682, CANC. INT. CL. 9.  
AV EDITIONS, FRANCE:  
3,352,745.  
AVAMERE GROUP, LLC, WILSONVILLE, OR:  
3,352,143, CANC. MULTIPLE CLASS, INT. CLS. 44 AND  
45.  
AVANTOR PERFORMANCE MATERIALS, INC., CENTER  
VALLEY, PA, MALINCKRODT CHEMICAL WORKS, ST.  
LOUIS, MO:  
594,056. REN. 7-22-14. MULTIPLE CLASS, U.S. CLS. 6  
(INT. CL. 1) AND 14 (INT. CLS. 6 AND 14).  
AVANZA CORPORATION, SHENZHEN, GUANGDONG,  
CHINA:  
4,593,976, INT. CL. 9.  
AVATAR PHARMACEUTICAL SERVICES INCORPO-  
RATED, MENDON, MA:  
2,794,711, CANC. MULTIPLE CLASS, INT. CLS. 41 AND  
42.  
AVDEL UK LIMITED, WELWYN GARDEN CITY, HERT-  
FORDSHIRE, UNITED KINGDOM:  
2,793,529, CANC. INT. CL. 7.  
AVERY WEIGH-TRONIX B.V., LOCHEM, NETHERLANDS:  
988,356. REN. 7-19-14. U.S. CL. 23 (INT. CL. 7).  
AVIANNES, INC, NEW YORK, NY:  
4,594,776, INT. CL. 14.  
AVIATOR SPORTS AND RECREATION, LLC, BROOKLYN,  
NY:  
3,352,271, CANC. INT. CL. 41.  
3,352,273, CANC. INT. CL. 41.  
3,352,275, CANC. INT. CL. 41.  
AVIGDORI, ROEI, LOS ANGELES, CA AND YEHOA,  
YARON, LOS ANGELES, CA:  
3,354,657, CANC. INT. CL. 41.  
AVMETRICS, SIMI VALLEY, CA:  
4,591,464, PUB. 6-10-2014. INT. CL. 36.  
AVO ADMARKET & ADMARKET LIST, INC., BELLEVUE,  
WA:  
4,592,013, PUB. 6-10-2014. INT. CL. 35.  
AVON PRODUCTS, INC., NEW YORK, NY:  
4,594,262, INT. CL. 3.  
4,594,343, INT. CL. 3.  
AWARE, INC., BEDFORD, MA:  
3,351,629, CANC. INT. CL. 9.  
AWESOME PRODUCTS, INC., BUENA PARK, CA:  
4,594,500, INT. CL. 3.  
AWL & SUNDRY, NORTH BERGEN, NJ:  
4,594,431, INT. CL. 35.  
AWOX, MONTPELLIER, FRANCE:  
4,590,701, PUB. 6-10-2014. MULTIPLE CLASS, INT. CLS. 9  
AND 11.  
AXEL LTD. CO., IVENESS, FL:  
4,590,965, PUB. 6-10-2014. INT. CL. 35.  
AXIMA SERVICES, 1000 BRUSSELS, BELGIUM:  
2,794,022, CANC. INT. CL. 37.  
AYA INTERNATIONAL, LLC, NEW YORK, NY:  
1,817,419, REN. 7-24-14. INT. CL. 14.  
AYERS, MARSHA, SEVIERVILLE, TN AND SMITH, LINDA  
LEE, SEVIERVILLE, TN:  
3,354,050, CANC. INT. CL. 45.  
AZIMUT-BENETTI S.P.A., ITALY:  
4,590,868, PUB. 6-10-2014. INT. CL. 12.  
B & F SYSTEM, INC.; THE, DALLAS, TX:  
1,313,179, REN. 7-24-14. INT. CL. 8.  
B BEAUTIFUL, LLC, AZUSA, CA:  
4,594,491, INT. CL. 3.  
B KOUTURE LLC, INGLEWOOD, CA:  
4,591,374, PUB. 6-10-2014. INT. CL. 25.  
B.R., PARIS, FRANCE:  
1,844,026, REN. 7-20-14. INT. CL. 3.  
BABE YOU LLC, BARRINGTON, RI:  
4,593,654, MULTIPLE CLASS, INT. CLS. 3, 14, 18 AND 25.  
BABEL STREET, LLC, RESTON, VA:  
4,591,211, PUB. 6-10-2014. INT. CL. 42.  
BACARDI & COMPANY LIMITED, FL-9490 VADUZ, LIECH-  
TENSTEIN:  
4,590,840, PUB. 6-10-2014. MULTIPLE CLASS, INT. CLS.  
33, 41 AND 43.  
BACARDI & COMPANY LIMITED, VADUZ, LIECHTEN-  
STEIN:  
4,594,224, INT. CL. 33.  
BACKCOUNTRY GARAGE, LLC, KETCHUM, ID:  
4,591,561, PUB. 6-10-2014. INT. CL. 25.  
BACNET INTERNATION, INC., MARIETTA, GA:  
2,896,185, REN. 7-24-14. U.S. CL. A.  
BADGE-A-MINIT, LTD., OGLESBY, IL:  
4,592,587, PUB. 6-10-2014. INT. CL. 9.  
BAF INDUSTRIES, SANTA ANA, CA:  
3,352,818, CANC. INT. CL. 3.  
BAGELS N GREENS CONEY LLC, BROOKLYN, NY:  
4,591,302, PUB. 6-10-2014. INT. CL. 43.  
BAHTCHE LLC, FRISCO, TX:  
4,592,277, PUB. 6-10-2014. INT. CL. 43.  
BAIAMONTE, MATTHEW, HOLLYWOOD, FL:  
4,591,009, PUB. 6-10-2014. MULTIPLE CLASS, INT. CLS.  
28 AND 41.  
BAILEY, BRAD, CHANDLER, AZ:  
4,592,050, PUB. 6-10-2014. INT. CL. 37.  
BAJDA, NADI, EDEN PRAIRIE, MN:  
4,592,668, PUB. 6-10-2014. INT. CL. 16.  
BAKER & TAYLOR, INC., CHARLOTTE, NC:  
4,593,150, INT. CL. 35.  
BAKER ROOFING COMPANY, RALEIGH, NC:  
4,592,689, PUB. 6-10-2014. INT. CL. 37.  
BALANCED BITES LLC, ESSEX FELLS, NJ:  
4,592,182, PUB. 6-10-2014. INT. CL. 41.  
BALANCED BODY, INC., SACRAMENTO, CA:  
4,594,583, INT. CL. 28.  
BALANCED FINANCES, LLC, ROSSFORD, OH:  
3,353,102, CANC. INT. CL. 9.  
BALESTRA RENATO, ITALY:  
3,352,719.  
BALL HORTICULTURAL COMPANY, WEST CHICAGO, IL:  
2,795,591, CANC. INT. CL. 31.  
BALLIETT, SETH, PORTLAND, ME:  
4,591,990, PUB. 4-22-2014. INT. CL. 25.  
BALLY GAMING, INC., LAS VEGAS, NV:  
2,873,343, REN. 7-24-14. INT. CL. 41.  
2,875,551, REN. 7-24-14. INT. CL. 41.  
BALLY GAMING, INC., LAS VEGAS, NV, DBA BALLY  
TECHNOLOGIES:  
4,593,492, INT. CL. 28.  
4,593,493, INT. CL. 28.  
BALTIKO SPIRITS LLC, THE WOODLANDS, TX:  
4,591,910, PUB. 6-10-2014. INT. CL. 33.  
BAMB ECOLOGICAL TECHNOLOGY, INC., METRO MAN-  
ILA, PHILIPPINES:  
4,591,356, PUB. 6-10-2014. INT. CL. 25.  
BAMBOO ISLE MASSAGE LLC, NEW BERLIN, WI:  
4,591,992, PUB. 6-10-2014. INT. CL. 44.

- BAMX ENTERPRISES, LOS ANGELES, CA:  
4,592,549, PUB. 6-10-2014. INT. CL. 14.
- BANANA EQUIPMENT, INC., MINNEAPOLIS, MN:  
4,593,147, INT. CL. 18.
- BAND JAM IT, LLC, WILMINGTON, DE:  
4,593,185, MULTIPLE CLASS, INT. CLS. 38, 41 AND 42.
- BANDAI NAMCO GAMES INC., TOKYO, JAPAN:  
4,593,187, INT. CL. 25.
- BANDOCK, JOSEPH JAN, JR., SPOKANE, WA:  
3,353,815, CANC. INT. CL. 9.
- BANGING TIMPANI, LLC, KANSAS CITY, MO:  
4,591,460, PUB. 6-10-2014. INT. CL. 41.
- BANGKAL DISTRIBUTORS, LLC, EDISON, NJ:  
3,351,695, CANC. INT. CL. 29.
- BANK OF AMERICA CORPORATION, CHARLOTTE, NC:  
3,354,635, CANC. INT. CL. 35.  
4,591,707, PUB. 6-10-2014. INT. CL. 36.
- BANK OF NOVA SCOTIA, THE, TORONTO, ONTARIO,  
CANADA:  
2,795,141, CANC. MULTIPLE CLASS, INT. CLS. 9, 16  
AND 36.
- BANKERS FIDELITY LIFE INSURANCE COMPANY,  
ATLANTA, GA:  
4,594,296, MULTIPLE CLASS, INT. CLS. 41 AND 42.
- BANTIS RESOURCES LLC, OVERLAND PARK, KS:  
3,351,085, CANC. INT. CL. 35.
- BARALDI SRL, ITALY:  
4,590,826, PUB. 6-10-2014. MULTIPLE CLASS, INT. CLS. 4  
AND 9.
- BARCODES LLC, CHICAGO, IL:  
3,350,861, CANC. INT. CL. 35.
- BARDUSCO, HELENA N., TAPPAN, NY:  
3,354,285, CANC. MULTIPLE CLASS, INT. CLS. 35 AND  
45.
- BARGAIN HUNTERS, INC., CHARLOTTE, NC:  
4,591,991, PUB. 6-10-2014. INT. CL. 35.
- BARILLA G. E R. FRATELLI - SOCIETÀ PER AZIONI,  
ITALY:  
3,352,598.
- BARILLA G. E R. FRATELLI - SOCIETA PER AZIONI,  
PARMA, ITALY:  
1,847,802, REN. 7-23-14. INT. CL. 30.
- BARKER, JANILYN, S. CHARLESTON, SC:  
3,350,854, CANC. INT. CL. 3.
- BARKER, KEVIN, BUCHANAN, MI:  
2,795,585, CANC. INT. CL. 6.
- BARLEY MOW BREWING COMPANY II, LLC, DUNEDIN,  
FL:  
4,593,064, PUB. 4-8-2014. INT. CL. 43.
- BARNETT CONSULTING GROUP LLC, CEDAR HILL, TX:  
3,350,732, CANC. INT. CL. 35.
- BARNEY KENT ABBOTT, DURANT, OK:  
4,591,859, PUB. 6-10-2014. INT. CL. 35.
- BARON T. LTD., NEW YORK, NY, DBA CARMEL CAR  
AND LIMOUSINE SERVICE:  
4,593,031, PUB. 6-10-2014. INT. CL. 9.
- BARON, MICHAEL, CORRALES, NM:  
4,593,876, INT. CL. 20.
- BAROSS, BETH, RIDGEWOOD, NJ:  
4,593,485, INT. CL. 45.
- BARRECORE LIMITED, LONDON, UNITED KINGDOM:  
4,591,373, PUB. 6-10-2014. MULTIPLE CLASS, INT. CLS.  
25 AND 41.
- BARRETT TECHNOLOGY, INC., CAMBRIDGE, MA:  
4,590,961, PUB. 6-10-2014. INT. CL. 9.
- BARTON, CHRISTINE M, NINE MILE FALLS, WA, DBA  
QUAIL AND POPPY:  
4,593,155, INT. CL. 35.
- BARTON, JOHN W., HOLLADAY, TN:  
2,794,600, CANC. MULTIPLE CLASS, INT. CLS. 9 AND  
42.
- BASEVIEW PRODUCTS, INC., ANN ARBOR, MI:  
2,794,372, CANC. INT. CL. 9.
- BASF SE, FED REP GERMANY:  
3,352,540.
- BASIS EDUCATIONAL GROUP, INC., TUCSON, AZ:  
4,594,067, INT. CL. 41.
- BASLER ELECTRIC COMPANY, HIGHLAND, IL:  
4,592,301, PUB. 6-10-2014. INT. CL. 9.
- BASS PRO TRADEMARKS, L.L.C., SPRINGFIELD, MO:  
3,395,764, CANC. MULTIPLE CLASS, INT. CLS. 18, 20, 25  
AND 28.
- BASS RIVER OUTDOORS, LLC, COLUMBIA CITY, IN:  
4,591,034, PUB. 6-10-2014. INT. CL. 28.
- BATANI-KHALFANI, D'IXARA, INGLEWOOD, CA:  
3,354,868, CANC. INT. CL. 25.
- BATC FOUNDATION, ROSEVILLE, MN:  
4,592,430, PUB. 6-10-2014. INT. CL. 35.
- BATH & BODY WORK BRAND MANAGEMENT, INC.,  
REYNOLDSBURG, OH:  
3,353,474, CANC. INT. CL. 3.
- BATH & BODY WORKS BRAND MANAGEMENT, INC.,  
REYNOLDSBURG, OH:  
3,353,617, CANC. MULTIPLE CLASS, INT. CLS. 3 AND  
35.  
3,354,364, CANC. INT. CL. 20.
- BATH WIZARD, INC., CHARLOTTE, NC:  
2,794,815, CANC. INT. CL. 1.
- BATTEN, CYNTHIA, BEL AIR, CA AND MCELWEE, TIM,  
BEL AIR, CA:  
4,592,337, PUB. 6-10-2014. INT. CL. 14.
- BATTLE BROTHERHOOD LTD, CONCORD, ONTARIO,  
CANADA:  
4,591,163, PUB. 6-10-2014. INT. CL. 41.
- BAUER INDUSTRIES, SACRAMENTO, CA:  
2,793,607, CANC. INT. CL. 25.
- BAUMAN RARE BOOKS, INC., PHILADELPHIA, PA:  
3,352,216, CANC. INT. CL. 35.
- BAUMANN PHILIPPE, FRANCE:  
3,352,673.
- BAUTE, CHRISTINE A., AGUA DULCE, CA:  
3,353,508, CANC. INT. CL. 16.
- BAXTER INTERNATIONAL INC., DEERFIELD, IL:  
1,286,760, REN. 7-23-14. INT. CL. 5.
- BAY AREA LAW CENTER, PC, SAN JOSE, CA:  
4,594,725, INT. CL. 45.
- BAYER AKTIENGESELLSCHAFT, 51373 LEVERKUSEN,  
FED REP GERMANY:  
3,354,084, CANC. INT. CL. 36.
- BAYER CONSUMER CARE AG, CH-4052 BASEL, SWITZER-  
LAND:  
3,350,871, CANC. INT. CL. 5.
- BAYER HEALTHCARE LLC, PITTSBURGH, PA:  
4,593,550, INT. CL. 5.
- BAYER INTELLECTUAL PROPERTY GMBH, FED REP  
GERMANY:  
4,590,772, PUB. 6-10-2014. INT. CL. 5.  
4,590,773, PUB. 6-10-2014. INT. CL. 5.
- BAYERISCHE MOTOREN WERKE; AKTIENGE-  
SELLSCHAFT, FED REP GERMANY:  
4,590,680, PUB. 6-10-2014. MULTIPLE CLASS, INT. CLS.  
9, 35, 38 AND 39.
- BAYROL SCANDINAVIA A/S, DENMARK:  
3,352,689.
- BB ENDEAVORS LLC, NEW YORK, NY:  
4,593,192, INT. CL. 32.
- BBMECHANICS, INC., WALNUT CREEK, CA, DBA  
BROADBAND MECHANICS:  
3,350,681, CANC. MULTIPLE CLASS, INT. CLS. 9 AND  
42.
- BC INTERNATIONAL COSMETIC & IMAGE SERVICES,  
INC., ORLANDO, FL:  
4,594,037, INT. CL. 3.
- BDM IT SOLUTIONS INC., CALGARY, AB, CANADA:  
4,593,533, INT. CL. 42.
- BDO SEIDMAN ALLIANCE PROGRAM, LLC, CHICAGO,  
IL:  
3,353,782, CANC. INT. CL. 36.
- BE OUR GUEST, LLC, HALEIWA, HI:  
4,593,971, INT. CL. 16.  
4,593,972, INT. CL. 35.
- BEACHY CREAM, LLC, SANTA MONICA, CA:  
4,591,134, PUB. 6-10-2014. INT. CL. 30.

BEAL, KEVIN, HOUSTON, TX AND APOSTOLAKIS, LOUIS W., WEST LAKE HILLS, TX:  
4,594,737, INT. CL. 9.

BEANS + BLINTZES, LLC, COSTA MESA, CA:  
4,591,065, PUB. 6-10-2014. INT. CL. 25.

BEAUCHAMP, MICHAEL T, NASHVILLE, TN, DBA SCOOTER SQUAD:  
4,591,936, PUB. 6-10-2014. INT. CL. 39.

BEAUREGARD, JAMES, SANTA CRUZ, CA, DBA BONNY DOON EQUESTRIAN PARK:  
2,906,544. REN. 7-21-14. INT. CL. 41.

BEAUTY HOLDING LLC, DENTON, TX:  
3,353,890, CANC. INT. CL. 3.  
3,353,906, CANC. INT. CL. 3.  
4,593,373, INT. CL. 8.

BEAUTY LAB, INC., OPA LOCKA, FL:  
4,591,283, PUB. 6-10-2014. INT. CL. 3.

BEAZLEY PLC, LONDON, UNITED KINGDOM:  
4,593,520, MULTIPLE CLASS, INT. CLS. 16, 35 AND 36.

BEAZLEY, DAVID, ASHLAND CITY, TN:  
3,352,228, CANC. INT. CL. 25.

BECKER MINING SYSTEMS AG, FED REP GERMANY:  
4,427,008, COR. MULTIPLE CLASS, INT. CLS. 6, 7, 9, 12, 37 AND 42.

BECKMAN COULTER, INC., BREA, CA:  
995,825. REN. 7-22-14. U.S. CL. 26 (INT. CL. 9).

BECKMAN COULTER, INC., BREA, CA, SMITHKLINE BECKMAN CORPORATION, PHILADELPHIA, PA:  
1,286,657. REN. 7-19-14. INT. CL. 1.

BECKMAN COULTER, INC., BREA, CA:  
2,900,671. REN. 7-21-14. MULTIPLE CLASS, INT. CLS. 1, 9 AND 10.  
4,592,367, PUB. 6-10-2014. INT. CL. 9.

BEDGEAR LLC, FARMINGDALE, NY:  
4,592,983, PUB. 6-10-2014. MULTIPLE CLASS, INT. CLS. 20 AND 24.

BEERS MICHAEL, AUSTIN, TX:  
3,352,287, CANC. INT. CL. 7.

BEHAR, ADAM SCOTT, HARRINGTON PARK, NJ:  
2,794,772, CANC. INT. CL. 31.

BEHR PROCESS CORPORATION, SANTA ANA, CA:  
4,592,228, PUB. 6-10-2014. INT. CL. 39.

BEICIP-FRANLAB, RUEIL MALMAISON, FRANCE:  
2,793,562, CANC. MULTIPLE CLASS, INT. CLS. 9, 35 AND 42.

BEIJING SHUNSI TONG GARMENT CO., LTD., HUIAIROU, BEIJING, CHINA:  
2,794,017, CANC. INT. CL. 25.

BEIJING THE CEREAL WAYFOOD TECHNOLOGY DEVELOPMENT CO., LTD., BEIJING, CHINA:  
3,353,602, CANC. INT. CL. 30.

BELAIR MANAGEMENT SERVICES, LLC, EVANS, GA, DBA THE VEIN GUYS:  
4,594,006, INT. CL. 44.

BELDEN INC., ST. LOUIS, MO, BELDEN CORPORATION, GENEVA, IL:  
1,012,851. REN. 7-19-14. INT. CL. 9.

BELFORD INSTRUMENT COMPANY, BALTIMORE, MD:  
988,905. REN. 7-22-14. U.S. CL. 26 (INT. CL. 9).

BELIZE TOURISM BOARD, BELIZE CITY, BELIZE:  
3,351,215, CANC. INT. CL. 35.

BELK STORES SERVICES, INC., CHARLOTTE, NC:  
4,594,071, INT. CL. 35.

BELL FOODS INTERNATIONAL, INC., GERVIAS, OR:  
4,593,681, INT. CL. 30.

BELL MEDIA INC., TORONTO, ONTARIO, CANADA:  
2,859,353. REN. 7-21-14. MULTIPLE CLASS, INT. CLS. 38 AND 41.

BELL, PHIL, SIOUX FALLS, SD:  
3,352,930, CANC. INT. CL. 37.

BELTZ, LARRY D., ST. PETERSBURG, FL:  
3,354,040, CANC. INT. CL. 42.

BENAROYA RESEARCH INSTITUTE AT VIRGINIA MASON, SEATTLE, WA:  
4,593,602, INT. CL. 42.

BENE, CATHERINE H., YORK, PA AND BENE, DAVID J., YORK, PA:  
3,351,526, CANC. MULTIPLE CLASS, INT. CLS. 35 AND 44.

BENEDETTI, MASSIMO, MARANELLO (MO), ITALY AND MALVERTI, MARCO, SASSUOLO (MO), ITALY AND FRIGIERI, ALBERTO, SPEZZANO DI FIORANO MO, ITALY:  
4,266,549, COR. MULTIPLE CLASS, INT. CLS. 7 AND 12.

BENEQ OY, FINLAND:  
3,352,624.

BENISTI, RICHARD, RALEIGH, NC:  
4,591,641, PUB. 6-10-2014. INT. CL. 35.

BENJAMIN A. BAPTIST, CHICAGO, IL:  
4,591,400, PUB. 6-10-2014. INT. CL. 10.

BENNETT, WAYNE, SACRAMENTO, CA:  
4,594,672, INT. CL. 35.  
4,594,677, INT. CL. 35.

BERD'S INNOVATION'S, LLC, RED LAKE FALLS, MN:  
4,591,056, PUB. 6-10-2014. INT. CL. 8.

BERKSHIRE PPM, INC., LITCHFIELD, CT:  
4,593,830, INT. CL. 26.

BERNARD EHRET DESIGN SARL, MOLSHEIM, FRANCE:  
3,353,867, CANC. INT. CL. 18.

BERNETTE APPAREL LLC, NEW YORK, NY:  
3,353,294, CANC. INT. CL. 25.

BERRY COLLEGE, INC., MT. BERRY, GA:  
4,591,325, PUB. 6-10-2014. INT. CL. 41.

BERRY, JAMES, AUSTELL, GA:  
4,592,229, PUB. 6-10-2014. INT. CL. 45.

BERRYMAN PRODUCTS, INC., ARLINGTON, TX, BERRYMAN PRODUCTS, INC., ARLINGTON, TX:  
993,559. REN. 7-18-14. U.S. CL. 6 (INT. CL. 4).

BERTHOLD TYPES LIMITED, CHICAGO, IL:  
4,592,519, PUB. 6-10-2014. INT. CL. 9.  
4,592,521, PUB. 6-10-2014. INT. CL. 9.  
4,592,522, PUB. 6-10-2014. INT. CL. 9.

BERTHOU, THANH THI, ZURICH, SWITZERLAND:  
4,592,904, PUB. 6-10-2014. INT. CL. 43.

BERWICK INSURANCE GROUP LLC, TUCSON, AZ:  
4,591,830, PUB. 6-10-2014. INT. CL. 36.

BESO BIOLOGICAL RESEARCH, INC., DIAMOND BAR, CA:  
4,592,718, PUB. 6-10-2014. INT. CL. 5.

BESS, EDWARD, NEW YORK, NY:  
3,351,368, CANC. INT. CL. 3.

BEST BRANDS CORP., ST. PAUL, MN:  
3,352,032, CANC. INT. CL. 30.

BEST BUYS DIRECT, INC., WAYNE, NJ:  
3,351,478, CANC. INT. CL. 21.

BEST FOOD SERVICES, INC., CHICAGO, IL:  
4,592,989, PUB. 6-10-2014. INT. CL. 29.

BEST LISTING BID, LLC, ST. LOUIS, MO:  
3,353,421, CANC. INT. CL. 39.

BEST PRACTICES INSTITUTE, INC., PALM BEACH GARDENS, FL:  
4,594,631, MULTIPLE CLASS, INT. CLS. 35 AND 42.

BEST SOFTWARE SB, INC., NORCROSS, GA TO SAGE SOFTWARE, INC., IRVINE, CA:  
2,795,354, CANC. MULTIPLE CLASS, INT. CLS. 9, 36 AND 42.

BESTE S.P.A., ITALY:  
4,590,755, PUB. 6-10-2014. MULTIPLE CLASS, INT. CLS. 23 AND 24.

BETH FORMAN, PARAMUS, NJ:  
4,591,661, PUB. 6-10-2014. INT. CL. 41.

BETTCHEER INDUSTRIES, INC., BIRMINGHAM, OH:  
4,593,069, INT. CL. 7.  
4,593,071, INT. CL. 7.

BETTER SILVER S.P.A., BRESSANVIDO (VI), ITALY:  
4,594,646, INT. CL. 14.

BETTYE HARRIS LARYNX CANCER AWARENESS CENTER, EASTPOINTE, MI:  
4,592,772, PUB. 6-10-2014. INT. CL. 35.

BEVERLY HILLS VAPOR, LOS ANGELES, CA:  
4,592,925, PUB. 6-10-2014. MULTIPLE CLASS, INT. CLS. 25 AND 34.

BEY, YASIN, NEW YORK, NY:  
4,591,177, PUB. 3-4-2014. INT. CL. 9.

BEYOND OCD, CHICAGO, IL:  
4,591,044, PUB. 6-10-2014. INT. CL. 41.

- BEYOND THE MIX INC., GARDEN CITY, NY:  
4,594,457, INT. CL. 41.
- BG DIRECT, LLC, SHELTON, CT:  
4,593,091, INT. CL. 18.
- BGASC, LLC, CALABASAS, CA:  
4,593,412, INT. CL. 35.
- BHA ALTAIR, LLC, FRANKLIN, TN:  
2,912,787, REN. 7-22-14, INT. CL. 7.
- BHI INTERNATIONAL INC., WALNUT, CA:  
4,592,201, PUB. 6-10-2014, INT. CL. 11.
- BIANCHI VENDING GROUP S.P.A., ITALY:  
4,590,902, PUB. 6-10-2014, MULTIPLE CLASS, INT. CLS. 7, 9 AND 11.
- BIANCO, MARY, LAS VEGAS, NV AND BIANCO, MAL-  
EAH, LAS VEGAS, NV:  
4,593,566, INT. CL. 30.
- BIEGEL, DAVID, BOZEMAN, MT:  
3,351,569, CANC. INT. CL. 35.
- BIERFISH RESTAURANT PARTNERS, LP, PHILADEL-  
PHIA, PA:  
4,593,356, INT. CL. 41.
- BIG BEAR PRODUCTIONS, LTD., FALLS CHURCH, VA:  
3,351,789, CANC. INT. CL. 41.
- BIG DAY PHOTOGRAPHY, INC., STONE MOUNTAIN, GA:  
3,351,312, CANC. INT. CL. 41.
- BIG JOHNS ACE, LLC, CEDAREDGE, CO:  
4,592,310, PUB. 6-10-2014, MULTIPLE CLASS, INT. CLS. 35 AND 37.
- BIG LEAGUE ANALYSIS, LLC, RALEIGH, NC:  
4,591,267, PUB. 6-10-2014, INT. CL. 41.
- BIG PINKY, LLC, TEMECULA, CA:  
4,594,475, MULTIPLE CLASS, INT. CLS. 18 AND 25.
- BIG RIG NETWORK, LLC, OKLAHOMA CITY, OK:  
4,591,663, PUB. 6-10-2014, INT. CL. 35.
- BIG WRASSE DIVERS, INC., WAIKOLOA, HI:  
4,592,002, PUB. 6-10-2014, INT. CL. 41.
- BIGG CITY HOLDINGS, LLC, COLORADO SPRINGS, CO:  
3,351,099, CANC. INT. CL. 41.
- BIGGER THAN THAT PRODUCTIONS, LLC, HOUSTON,  
TX:  
2,902,319, REN. 7-23-14, INT. CL. 16.
- BIKE BANDIT, LLC, SAN DIEGO, CA:  
3,352,165, CANC. INT. CL. 35.
- BIKE BARN, L.P., HOUSTON, TX:  
4,594,361, MULTIPLE CLASS, INT. CLS. 12, 16 AND 25.
- BIKER TOOLS, LLC., DAYTONA BEACH, FL:  
2,801,569, CANC. INT. CL. 35.
- BILANTIC SOFTWARE, LLC, ALBERTSON, NY:  
3,351,630, CANC. INT. CL. 9.
- BILI, INC., CITY OF INDUSTRY, CA:  
3,353,878, CANC. INT. CL. 9.
- BILL LODEN, PLANO, TX:  
4,593,605, INT. CL. 21.
- BILL ME LATER, INC., TIMONIUM, MD:  
3,353,938, CANC. INT. CL. 36.
- BILL'S GHOST & SPIRITS LLC, GUADALUPE, AZ:  
3,296,380, CANC. INT. CL. 35.
- BILLINGTON WELDING & MANUFACTURING, INC.,  
MODESTO, CA:  
4,591,678, PUB. 6-10-2014, INT. CL. 7.  
4,591,679, PUB. 6-10-2014, INT. CL. 7.
- BILTWELL CUSTOM MOTORCYCLE CORP., MURIETTA,  
CA, DBA BILTWELL, INC.:  
4,591,057, PUB. 6-10-2014, MULTIPLE CLASS, INT. CLS. 25 AND 26.
- BILTWELL CUSTOM MOTORCYCLE CORP., MURRIETA,  
CA, DBA BILTWELL INC.:  
4,591,062, PUB. 6-10-2014, INT. CL. 35.
- BIMBO BAKERIES USA, INC., HORSHAM, PA, STROEH-  
MANN BROTHERS COMPANY, WILLIAMSPORT, PA:  
989,070, REN. 7-21-14, U.S. CL. 46 (INT. CL. 30).
- BIMBO BAKERIES USA, INC., HORSHAM, PA:  
2,859,260, REN. 7-23-14, INT. CL. 30.
- BIO PRODUCTS LABORATORY LIMITED, ELSTREE,  
HERTFORDSHIRE, UNITED KINGDOM:  
2,869,439, REN. 7-21-14, INT. CL. 5.
- BIO-LOGIC, F-38640 CLAIX, FRANCE:  
3,352,691.
- BIO-RAD LABORATORIES, INC., HERCULES, CA:  
902,589, CANC. U.S. CL. 26.
- BIOCEUTICA LLC, DANVERS, MA:  
2,799,400, CANC. INT. CL. 5.
- BIOCLINICA, INC., NEWTON, PA:  
2,794,093, CANC. INT. CL. 9.
- BIOELEMENTS, INC., COLORADO SPRINGS, CO:  
4,594,073, INT. CL. 3.
- BIOEXPERTISE, INC, SUNNYVALE, CA:  
2,796,110, CANC. INT. CL. 38.
- BIOFARMA, FRANCE:  
3,352,753.
- BIOFRONTERA PHARMA GMBH, FED REP GERMANY:  
3,771,836, COR. INT. CL. 5.
- BIOGEN IDEC MA INC., CAMBRIDGE, MA:  
2,899,491, REN. 7-24-14, INT. CL. 5.  
4,593,229, INT. CL. 5.
- BIOLOTUS BIOTECHNOLOGY AG, SWITZERLAND:  
3,352,707.
- BIONIC SOIL SOLUTIONS INTERNATIONAL, LLC, SANTA  
FE, NM:  
4,594,777, INT. CL. 1.
- BIOTROPICS MALAYSIA BERHAD, KUALA LUMPUR,  
MALAYSIA:  
4,593,637, INT. CL. 5.
- BIOWORKS, INC., VICTOR, NY:  
4,594,221, INT. CL. 1.  
4,594,225, INT. CL. 1.
- BIRCHWOOD CASEY, LLC, EDEN PRAIRIE, MN:  
1,304,544, REN. 7-22-14, INT. CL. 3.
- BIRDS EYE FOODS LLC, PARSIPPANY, NJ:  
2,877,221, REN. 7-18-14, INT. CL. 29.  
2,877,221, CANC. MULTIPLE CLASS, INT. CLS. 30 AND 32.
- BISCOMERICA CORPORATION, RIALTO, CA:  
4,592,265, PUB. 6-10-2014, MULTIPLE CLASS, INT. CLS. 35, 39 AND 40.  
4,592,266, PUB. 6-10-2014, MULTIPLE CLASS, INT. CLS. 35, 39 AND 40.
- BITLIT MEDIA INC., VANCOUVER, BC, CANADA:  
4,593,792, INT. CL. 9.
- BITWISE SOLUTIONS, INC., NORTH RICHLAND HILLS,  
TX:  
2,802,912, REN. 7-23-14, MULTIPLE CLASS, INT. CLS. 35 AND 39.
- BIXLE LLC, BROOKLYN, NY:  
4,592,605, PUB. 6-10-2014, INT. CL. 28.
- BJ BALL LIMITED, AUCKLAND, NEW ZEALAND:  
4,591,088, PUB. 6-10-2014, MULTIPLE CLASS, INT. CLS. 9, 16, 35, 38 AND 39.
- BJ'S WHOLESALE CLUB, INC., WESTBOROUGH, MA:  
4,593,554, INT. CL. 16.  
4,593,588, MULTIPLE CLASS, INT. CLS. 5, 8, 16 AND 21.
- BKLYN1834, LLC, NEW YORK, NY:  
4,594,476, INT. CL. 35.
- BLACK DIAMOND VIDEO, INC., ALAMEDA, CA:  
3,351,339, CANC. INT. CL. 9.
- BLACK ENTERTAINMENT TELEVISION, INC., WASHING-  
TON, DC:  
3,353,831, CANC. INT. CL. 41.
- BLACK FOREST HOSPITALITY GROUP LLC, BROOKLYN,  
NY:  
4,594,072, INT. CL. 43.
- BLACK HILLS AMMUNITION, RAPID CITY, SD:  
2,794,434, CANC. INT. CL. 13.
- BLACK HILLS VAPORS LLC., RAPID CITY, SD:  
4,594,732, INT. CL. 35.
- BLACK PLAGUE ENTERTAINMENT, INC., BURLINGTON,  
NC:  
3,351,533, CANC. INT. CL. 41.
- BLACK POINT SEAFOOD INC., VERO BEACH, FL:  
4,591,573, PUB. 6-10-2014, INT. CL. 41.
- BLACKSEA COLLECTION INC., NEW YORK, NY:  
4,592,852, PUB. 6-10-2014, INT. CL. 18.
- BLACKSTOCK, JAMES F, BRENTWOOD, TN, DBA JAMES  
F BLACKSTOCK PLLC:  
4,592,815, PUB. 6-10-2014, INT. CL. 45.



BLACKSTONE COFFEE, FREDERICKSBURG, VA:  
4,592,006, PUB. 6-10-2014. MULTIPLE CLASS, INT. CLS. 40 AND 43.

BLACKSTRATUS, INC., EDISON, NJ:  
3,351,390, CANC. INT. CL. 9.

BLACKZEN, INC., IRVINE, CA:  
4,592,385, PUB. 6-10-2014. INT. CL. 9.

BLAKE & PENDLETON, INC., MACON, GA:  
4,592,825, PUB. 6-10-2014. MULTIPLE CLASS, INT. CLS. 35 AND 37.

BLANCHARD ENTERPRISES, INC., ROLLING MEADOWS, IL:  
3,351,346, CANC. INT. CL. 16.

BLANCHARD TRAINING AND DEVELOPMENT, INC., ESCONDIDO, CA:  
4,593,439, INT. CL. 16.  
4,593,440, INT. CL. 41.

BLANKLEY, ALISON LEIGH, LOS ANGELES, CA:  
3,350,672, CANC. MULTIPLE CLASS, INT. CLS. 18 AND 25.

BLAZE BAIL BONDS, INC., PERTH AMBOY, NJ:  
3,351,602, CANC. INT. CL. 36.

BLIND MELON, NEW YORK, NY:  
3,351,079, CANC. INT. CL. 25.

BLINDS BY NOON, SHUTTERS REAL SOON, SUWANEE, GA:  
3,351,686, CANC. MULTIPLE CLASS, INT. CLS. 19 AND 20.

BLISTEX INC., OAK BROOK, IL:  
4,593,176, INT. CL. 5.

BLONDE BYTES, SHERMAN OAKS, CA, DBA WHYDOI-DATE:  
4,592,093, PUB. 6-10-2014. INT. CL. 41.  
4,592,094, PUB. 6-10-2014. INT. CL. 41.

BLOOMAGE FREDA BIOPHARM CO., LTD., JINAN 250101, CHINA:  
4,591,428, PUB. 6-10-2014. INT. CL. 1.

BLOUNT, INC., PORTLAND, OR:  
3,352,104, CANC. INT. CL. 7.

BLUE CAST DENIM CO., INC., NEW YORK, NY:  
3,353,341, CANC. INT. CL. 25.

BLUE CROSS AND BLUE SHIELD OF FLORIDA, INC., JACKSONVILLE, FL:  
4,593,102, INT. CL. 36.

BLUE CROSS AND BLUE SHIELD OF KANSAS CITY, KANSAS CITY, MO:  
2,794,278, CANC. INT. CL. 36.

BLUE HERON PAPER COMPANY, OREGON CITY, OR:  
2,795,489, CANC. INT. CL. 16.

BLUE LINE EQUIPMENT, LLC, PRESCOTT, AZ:  
3,353,932, CANC. INT. CL. 7.

BLUE PACIFIC FLAVORS & FRAGRANCES, INC., CITY OF INDUSTRY, CA:  
4,593,700, INT. CL. 1.  
4,593,701, INT. CL. 1.

BLUE RIDGE SPIRITS BRANDS JV1, LLC, RENO, NV:  
4,591,986, PUB. 6-10-2014. INT. CL. 33.  
4,591,996, PUB. 6-10-2014. INT. CL. 33.

BLUE SEAL FEEDS, INC., LONDONDERRY, NH:  
3,353,057, CANC. INT. CL. 31.

BLUE SKY PUBLICATIONS, LLC, BOERNE, TX:  
3,350,703, CANC. INT. CL. 16.

BLUECLINICAL - INVESTIGACAO E DESENVOLVIMENTO EM SAUDE, LDA, 3045-016 COIMBRA, PORTUGAL:  
4,591,087, PUB. 9-17-2013. MULTIPLE CLASS, INT. CLS. 5 AND 42.

BLUEGRASS PRODUCTS, L.L.C., FLORENCE, KY:  
2,796,168, CANC. INT. CL. 19.

BLUEPOINT ALERT SOLUTIONS, LLC, ELGIN, IL:  
4,594,098, INT. CL. 37.

BLUEPRINT MORTGAGE, INC., CARLSBAD, CA:  
3,351,738, CANC. INT. CL. 36.

BLUEWAVE WATER BOTTLES, INC., COMPTON, CA:  
4,592,237, PUB. 6-10-2014. INT. CL. 21.

BMG IMPORT EXPORTS, INC., NEW YORK CITY, NY:  
4,592,702, PUB. 6-10-2014. INT. CL. 25.

BMI HOCKEY, L.L.C., BLOOMINGTON, IL:  
3,351,308, CANC. MULTIPLE CLASS, INT. CLS. 25, 28 AND 41.

BOARD OF REGENTS OF THE UNIVERSITY OF NEBRASKA, LINCOLN, NE:  
4,593,461, INT. CL. 25.

BOARD OF REGENTS OF THE UNIVERSITY OF WISCONSIN SYSTEM, MADISON, WI:  
4,591,520, PUB. 6-10-2014. MULTIPLE CLASS, INT. CLS. 25 AND 41.  
4,591,526, PUB. 6-10-2014. MULTIPLE CLASS, INT. CLS. 14, 16, 21 AND 28.

BOARD OF TRUSTEES, CLEVELAND PUBLIC LIBRARY, CLEVELAND, OH:  
2,794,812, CANC. INT. CL. 41.

BOATHOUSE BEVERAGE LLC, WESTPORT, CT:  
4,594,628, INT. CL. 33.

BOCK CONSULTING, INC., KIRKLAND, WA:  
3,354,394, CANC. INT. CL. 35.

BODEGA 11 LLC, PHOENIX, AZ:  
4,594,265, MULTIPLE CLASS, INT. CLS. 35 AND 43.

BODEGAS SAN HUBERTO S.A., BUENOS AIRES, ARGENTINA:  
4,590,983, PUB. 6-10-2014. INT. CL. 33.

BODY DETOX CENTER, LLC, CALHAN, CO:  
4,594,578, INT. CL. 44.

BODYTRACE HOLDINGS LIMITED, TST EAST, HONG KONG:  
4,594,550, INT. CL. 38.

BODYWISE LIMITED, ISLE OF WIGHT, UNITED KINGDOM:  
4,591,055, PUB. 11-26-2013. MULTIPLE CLASS, INT. CLS. 3, 5 AND 10.  
4,594,160, INT. CL. 5.

BOEHRINGER INGELHEIM INTERNATIONAL GMBH, 55218 INGELHEIM, FED REP GERMANY:  
4,590,816, PUB. 6-10-2014. MULTIPLE CLASS, INT. CLS. 41 AND 42.

BOEHRINGER INGELHEIM INTERNATIONAL GMBH, FED REP GERMANY:  
4,590,924, PUB. 6-10-2014. INT. CL. 5.

BOEHRINGER INGELHEIM VETMEDICA GMBH, INGELHEIM AM RHEIN, FED REP GERMANY:  
3,351,440, CANC. INT. CL. 5.

BOEHRINGER INGELHEIM VETMEDICA, INC., ST. JOSEPH, MO:  
4,594,570, INT. CL. 41.

BOEN, WILLIAM C, LINCOLN, CA:  
4,594,557, MULTIPLE CLASS, INT. CLS. 9 AND 16.

BOESEN MILWAUKEE, LLC, MILWAUKEE, WI:  
3,351,615, CANC. INT. CL. 35.

BOHAGER HOLDINGS, LLC, PUNTA GORDA, FL:  
4,593,017, PUB. 6-10-2014. INT. CL. 5.

BOHEMIA NURSERY, LLC, WEST OLIVE, MI:  
3,352,981, CANC. INT. CL. 31.

BOINNARD, LUDOVIC, SAN DIEGO, CA AND BLANCHARD, MARC, SAN DIEGO, CA:  
4,593,750, INT. CL. 25.

BOISE CASCADE WOOD PRODUCTS, L.L.C., BOISE, ID:  
2,963,032, REN. 7-22-14. INT. CL. 19.

BOJIC, DZANER, GLEN ELLYN, IL:  
3,351,487, CANC. INT. CL. 41.

BOLOTO GROUP, SCOTTSDALE, AZ:  
3,353,791, CANC. INT. CL. 36.  
3,353,853, CANC. INT. CL. 45.

BOLZAN, MARK J, BEDFORD, TX:  
2,965,397, REN. 7-21-14. INT. CL. 37.

BONAMAR CORPORATION, DORAL, FL:  
4,593,333, INT. CL. 29.

BOND JEWELERS, INC., PHILADELPHIA, PA:  
2,859,899, REN. 7-18-14. INT. CL. 35.

BONDED BUILDERS SERVICE CORP., ST. PETERSBURG, FL:  
4,594,316, INT. CL. 36.  
4,594,317, INT. CL. 36.

BONDED TECHNOLOGY CORPORATION, ROGERS, MN:  
4,594,524, INT. CL. 6.

BONES AND FEATHERS COLLECTIVE, INC., AUBURN HILLS, MI:  
4,591,469, PUB. 6-10-2014. MULTIPLE CLASS, INT. CLS.

- 14 AND 35.  
**BONGARD, 67810 HOLTZHEIM, FRANCE:**  
 1,289,480. REN. 7-24-14. MULTIPLE CLASS, INT. CLS. 7 AND 11.
- BONITA BAY CLUB, INC., BONITA SPRINGS, FL:**  
 2,795,350, CANC. INT. CL. 41.
- BONNE BELL, INC., WESTLAKE, OH:**  
 2,795,915, CANC. INT. CL. 3.
- BOO'S BUCKET LIST, LLC, RYE, NH:**  
 4,594,200, MULTIPLE CLASS, INT. CLS. 9, 16 AND 45.
- BOOBADOOBA, LLC, BEAVERTON, OR:**  
 4,591,723, PUB. 6-10-2014. INT. CL. 24.
- BOOMERBOX, LLC, ANNAPOLIS, MD:**  
 3,351,020, CANC. INT. CL. 41.
- BOOMYEAH INC., OREM, UT:**  
 3,352,340, CANC. INT. CL. 35.  
 3,352,341, CANC. INT. CL. 35.
- BOOTS & COOTS, INC., HOUSTON, TX:**  
 4,593,800, INT. CL. 9.
- BOREN, HEATHER B, WOODLAND HILLS, CA, DBA ESTATE MATCH:**  
 4,594,752, MULTIPLE CLASS, INT. CLS. 35 AND 36.
- BORQUET, COURTNEY G, KITTY HAWK, NC:**  
 4,592,961, PUB. 6-10-2014. INT. CL. 39.
- BOSE CORPORATION, FRAMINGHAM, MA:**  
 1,286,976. REN. 7-24-14. INT. CL. 9.
- BOSTIK SA, FRANCE:**  
 4,590,813, PUB. 6-10-2014. MULTIPLE CLASS, INT. CLS. 1, 16, 17 AND 19.
- BOSTON BAR ASSOCIATION, BOSTON, MA:**  
 4,591,903, PUB. 6-10-2014. MULTIPLE CLASS, INT. CLS. 16, 35, 41 AND 45.  
 4,591,904, PUB. 6-10-2014. INT. CL. 36.
- BOSTON FOUNDATION FOR SIGHT, NEEDHAM, MA:**  
 2,795,518, CANC. INT. CL. 36.
- BOTICA COMERCIAL FARMACEUTICA LTDA., SAO JOSE DOS PINHAIS, PARANA, BRAZIL:**  
 2,795,425, CANC. INT. CL. 3.  
 3,353,789, CANC. INT. CL. 3.
- BOTTLE ROCKET LLC, NEW YORK, NY:**  
 4,590,994, PUB. 6-10-2014. MULTIPLE CLASS, INT. CLS. 9 AND 42.
- BOULD, LLC, LAKEWOOD, CO:**  
 4,594,765, INT. CL. 41.
- BOULDER ORGANICS LLC, BOULDER, CO, DBA ORGANIC PET SUPERFOOD:**  
 4,591,049, PUB. 6-10-2014. MULTIPLE CLASS, INT. CLS. 31 AND 35.
- BOURNE LOGISTICS MARKETING, LTD., SILVER SPRINGS, NV:**  
 4,592,136, PUB. 6-10-2014. INT. CL. 45.
- BOWLING GREEN AREA CONVENTION & VISITORS BUREAU, BOWLING GREEN, KY:**  
 4,592,211, PUB. 6-10-2014. INT. CL. 35.
- BOWTIE, INC., IRVINE, CA:**  
 3,353,481, CANC. MULTIPLE CLASS, INT. CLS. 16, 35, 41, 42 AND 44.
- BOXWOOD WINERY, L.L.C., MIDDLEBURG, VA:**  
 4,593,020, PUB. 6-10-2014. MULTIPLE CLASS, INT. CLS. 41 AND 43.
- BOYD GROUP INC., THE, WINNIPEG, MANITOBA R3K 0Z8, CANADA:**  
 2,795,280, CANC. INT. CL. 37.
- BOZEMAN SPIRITS, LLC, BOZEMAN, MT:**  
 4,593,030, PUB. 6-10-2014. INT. CL. 33.
- BPSI HOLDINGS LLC, WILMINGTON, DE, COLORCON, INC., WEST POINT, PA:**  
 1,304,527. REN. 7-22-14. INT. CL. 2.
- BRACCO SUISSE S.A., MANNO, SWITZERLAND:**  
 4,591,769, PUB. 6-10-2014. MULTIPLE CLASS, INT. CLS. 9 AND 42.
- BRADLEY JOHN CHICK, SYDNEY, AUSTRALIA:**  
 4,590,918, PUB. 6-10-2014. INT. CL. 5.
- BRADLEY JOHN CHICK, SYDNEY NSW 2000, AUSTRALIA:**  
 4,590,919, PUB. 6-10-2014. INT. CL. 5.
- BRADY WORLDWIDE, INC., MILWAUKEE, WI:**  
 3,354,037, CANC. INT. CL. 17.
- BRAIN POWERED CONCEPTS, INC., FEEDING HILLS, MA:**  
 3,353,765, CANC. INT. CL. 9.
- BRAIN RELOAD LLC, CONCORD, CA:**  
 3,354,344, CANC. INT. CL. 5.
- BRAIN WAREHOUSE LLC, RANCHO SANTA FE, CA:**  
 3,351,052, CANC. INT. CL. 35.
- BRAMER CUSTOM DESIGN, INC., LOUISVILLE, KY:**  
 2,794,696, CANC. INT. CL. 37.
- BRAND PHOENIX LIMITED, DORKING, SURREY, UNITED KINGDOM:**  
 4,591,738, PUB. 6-10-2014. INT. CL. 33.
- BRANDCO, LLC, ENGLEWOOD CLIFFS, NJ:**  
 2,846,740. REN. 7-24-14. INT. CL. 30.
- BRANDMUSCLE, INC., CLEVELAND, OH:**  
 2,859,911. REN. 7-18-14. INT. CL. 35.
- BRANDON LONDON, CHARLOTTESVILLE, VA:**  
 4,591,131, PUB. 6-10-2014. INT. CL. 41.
- BRANNON LEHANE, HOOVER, AL:**  
 4,592,504, PUB. 6-10-2014. INT. CL. 25.
- BRAUSAM, JOSEPH R., ELGIN, IL:**  
 3,353,344, CANC. INT. CL. 9.
- BRAVO, MICHELLE A., SAN FRANCISCO, CA:**  
 3,351,739, CANC. INT. CL. 44.
- BREAD STORY BY JUN PTE. LTD., SINGAPORE, SINGAPORE:**  
 3,351,972, CANC. MULTIPLE CLASS, INT. CLS. 30 AND 43.
- BREAKLINE LLC, HOMEWOOD, AL:**  
 4,592,383, PUB. 6-10-2014. INT. CL. 9.
- BRENNER, TOMAS, ZOFINGEN, SWITZERLAND:**  
 3,351,059, CANC. INT. CL. 35.
- BRENT HATCH, SOUTH PASADENA, CA:**  
 3,352,328, CANC. INT. CL. 41.
- BREVARD COUNTY SHERIFF'S OFFICE, TITUSVILLE, FL:**  
 4,592,715, PUB. 6-10-2014. INT. CL. 41.
- BREWSTER, IVAN, BROOKLYN, NY:**  
 4,593,888, INT. CL. 14.
- BRICKYARD TRADEMARKS, INC., INDIANAPOLIS, IN:**  
 4,594,665, INT. CL. 25.
- BRIDALS BY LORI, INC., ATLANTA, GA:**  
 2,963,075. REN. 7-18-14. INT. CL. 35.
- BRIDGES, CHRISTOPHER B., CENTREVILLE, VA:**  
 2,860,081. REN. 7-21-14. INT. CL. 25.
- BRIDGEWAY CAPITAL, INC., PITTSBURGH, PA:**  
 4,593,133, INT. CL. 36.
- BRIDWELL, NORMAN, EDGARTOWN, MA:**  
 4,594,433, INT. CL. 9.
- BRIGGS & RILEY TRAVELWARE, LLC, HAUPPAUGE, NY:**  
 4,593,770, INT. CL. 18.  
 4,593,772, INT. CL. 18.
- BRIGHT HOUSE NETWORKS, LLC., E. SYRACUSE, NY:**  
 3,353,792, CANC. INT. CL. 38.
- BRILLIANT AGING, BOZEMAN, MT:**  
 4,592,546, PUB. 6-10-2014. INT. CL. 44.
- BRILLIANTSERVICE CO., LTD., JAPAN:**  
 4,590,858, PUB. 6-10-2014. MULTIPLE CLASS, INT. CLS. 7, 9, 11, 20, 21, 31, 41, 42, 44 AND 45.
- BRIM AGENCY, INC., SAN DIEGO, CA, DBA BEST RANK:**  
 3,354,602, CANC. INT. CL. 35.
- BRIMSTONE ORIGINALS, LLC, CLEARWATER, FL:**  
 3,353,964, CANC. INT. CL. 29.
- BRIN, HERVÉ, 97133 ST. BARTHÉLEMY F.W.I., FRANCE:**  
 2,868,346. REN. 7-21-14. MULTIPLE CLASS, INT. CLS. 35, 41 AND 44.
- BRINGMAN, ELLIOTT GORDON, SAN FRANCISCO, CA, DBA PRANACYCLE:**  
 4,591,124, PUB. 6-10-2014. INT. CL. 41.
- BRINGTHEHOOLA, ANSONIA, CT:**  
 4,592,363, PUB. 6-10-2014. MULTIPLE CLASS, INT. CLS. 28 AND 41.
- BRITT, MARK STEVEN, ORMOND BEACH, FL:**  
 3,352,485, CANC. INT. CL. 12.
- BROADCAST ARCHITECTURE, INC., WESTLAKE VILLAGE, CA:**  
 3,350,618, CANC. INT. CL. 35.
- BROADRIDGE SECURITIES PROCESSING SOLUTIONS, INC., JERSEY CITY, NJ:**  
 3,353,316, CANC. INT. CL. 9.

BROADUS, CALVIN, LOS ANGELES, CA:  
4,590,959, PUB. 5-14-2013. INT. CL. 41.

BROADWAYBOX, INC., NEW YORK, NY:  
4,592,107, PUB. 6-10-2014. MULTIPLE CLASS, INT. CLS.  
35, 41 AND 42.

BROCK, MICHAEL, HENDERSON, NV:  
4,591,144, PUB. 6-10-2014. INT. CL. 38.

BROCOR XCHANGE INC., MINNEAPOLIS, MN:  
4,594,355, INT. CL. 35.

BROMO LLC, PLANO, TX:  
3,016,028 NEW CERT. 8-26-2014. INT. CL. 9.  
3,313,095 NEW CERT. 8-26-2014. INT. CL. 9.

BRONCO BALL, LLC, FRISCO, TX:  
4,593,108, INT. CL. 41.

BROOKE, ROGER F., COLUMBUS, OH:  
1,704,093, CANC. INT. CL. 5.

BROOKS HOLDING COMPANY, NEW BRIGHTON, MN:  
2,796,008, CANC. INT. CL. 31.

BROOKS, GARY LEON, OKLAHOMA CITY, OK, DBA  
AMERICAN COLLEGE OF BOARD CERTIFIED ATTOR-  
NEYS AND BROOKS, DEBRA ANN, OKLAHOMA CITY,  
OK, DBA AMERICAN COLLEGE OF BOARD CERTIFIED  
ATTORNEYS:  
4,591,449, PUB. 6-10-2014. INT. CL. 35.

BROOKS, ROBERT, PHOENIX, AZ:  
2,795,768, CANC. MULTIPLE CLASS, INT. CLS. 41 AND  
45.

BROUILLETTE, DENISE, SAN FRANCISCO, CA:  
4,593,597, INT. CL. 41.

BROWN & BROWN, INC., TAMPA, FL:  
4,593,977, INT. CL. 36.

BROWN BROTHERS HARRIMAN & CO., NEW YORK, NY:  
2,865,402. REN. 7-20-14. INT. CL. 36.  
2,917,659. REN. 7-23-14. INT. CL. 36.

BROWN CREATIVE, INC., SEATTLE, WA:  
2,802,668. REN. 7-20-14. MULTIPLE CLASS, INT. CLS. 16  
AND 18.

BROWN MACHINE, LLC, BEAVERTON, MI:  
4,591,819, PUB. 6-10-2014. INT. CL. 7.

BROWN SHOE COMPANY, INC., ST. LOUIS, MO:  
2,796,246, CANC. INT. CL. 25.

BROWN, NADIA YVETTE, LAVEEN, AZ, DBA DOYENNE  
LEADERSHIP INSTITUTE:  
4,591,351, PUB. 6-10-2014. INT. CL. 41.

BROWN, RYAN JOSEPH, VANCOUVER, BC, CANADA:  
3,354,038, CANC. INT. CL. 41.

BROWN, SHAWN, CUMMING, GA:  
3,350,725, CANC. INT. CL. 41.

BROWN, TIFNI T, LOS ANGELES, CA, DBA BODYGIRL  
AND BROWN, MICHAEL P, SHERMAN OAKS, CA:  
3,347,722, CANC. INT. CL. 3.

BRUCE KAUFMAN, NORTHBROOK, IL:  
4,593,214, INT. CL. 41.

BRUNING, LYNNE A, DENVER, CO:  
4,591,105, PUB. 6-10-2014. INT. CL. 28.

BRUNS, EVELYN, HENDERSON, NV:  
4,594,705, INT. CL. 42.

BRUNSWICK CORPORATION, LAKE FOREST, IL:  
4,590,968, PUB. 6-10-2014. INT. CL. 21.

BRUNSWICK FAMILY BOAT CO. INC., KNOXVILLE, TN:  
2,794,687, CANC. INT. CL. 12.

BSE LIMITED, MUMBAI- 400001, INDIA:  
2,863,152. REN. 7-23-14. MULTIPLE CLASS, INT. CLS. 16,  
36 AND 41.

BUBBA FOODS, LLC, JACKSONVILLE, FL:  
4,591,339, PUB. 6-10-2014. INT. CL. 29.

BUC-EE'S, LTD., LAKE JACKSON, TX:  
4,594,484, INT. CL. 29.  
4,594,542, INT. CL. 28.

BUCKHEAD JIU-JITSU, ATLANTA, GA:  
4,592,676, PUB. 6-10-2014. INT. CL. 41.

BUCKINGHAM VINTNERS INTERNATIONAL LIMITED,  
SLOUGH, UNITED KINGDOM:  
3,352,065. CANC. MULTIPLE CLASS, INT. CLS. 16, 21, 22,  
25 AND 33.

BUCKLE BRANDS, INC., KEARNEY, NE:  
4,593,343, INT. CL. 25.

BUCKMAN LABORATORIES INTERNATIONAL, INC.,  
MEMPHIS, TN:  
1,331,514. REN. 7-18-14. INT. CL. 1.  
2,929,279. REN. 7-18-14. INT. CL. 1.

BUCKMAN LABORATORIES, INC., MEMPHIS, TN:  
781,592. REN. 7-18-14. U.S. CL. 6 (INT. CL. 1).

BUDDY SQUIRREL, LLC, ST. FRANCIS, WI:  
2,794,180, CANC. INT. CL. 30.

BUDGET BLINDS, INC., ORANGE, CA:  
4,592,370, PUB. 6-10-2014. INT. CL. 35.

BUDGET CASHFLOW KING LLC, CLIO, MI:  
4,593,415, INT. CL. 9.  
4,593,416, INT. CL. 9.

BUDHWANI, KARIM I., BIRMINGHAM, AL:  
3,351,551, CANC. INT. CL. 9.

BUFFALO BILLS, INC., ORCHARD PARK, NY:  
2,793,903, CANC. MULTIPLE CLASS, INT. CLS. 25 AND  
41.

BUFFETS, INC., GREER, SC, DBA OVATION BRANDS:  
4,592,360, PUB. 6-10-2014. INT. CL. 43.  
4,592,361, PUB. 6-10-2014. INT. CL. 43.

BUFORD, HELEN, NEW CITY, NY:  
4,592,512, PUB. 6-10-2014. INT. CL. 43.

BUITIME LLC, WESTLAKE, OH:  
4,593,522, MULTIPLE CLASS, INT. CLS. 35, 38 AND 42.

BUILD-A-BEAR RETAIL MANAGEMENT, INC., ST. LOUIS,  
MO:  
3,354,003, CANC. INT. CL. 28.  
3,354,005, CANC. INT. CL. 28.

BUILDER DESIGNS, OLATHE, KS:  
4,594,731, INT. CL. 35.

BUILDER'S BEST, INC., JACKSON, FL:  
4,594,198, MULTIPLE CLASS, INT. CLS. 6 AND 19.

BUILDING E DESIGN, INC., EAGAN, MN:  
3,352,253, CANC. INT. CL. 18.

BULLET FILMS PRODUCTIONS LIMITED, CAUSEWAY  
BAY, HONG KONG:  
4,591,058, PUB. 6-10-2014. MULTIPLE CLASS, INT. CLS.  
9, 18 AND 25.

BUMBLE BE HOLDINGS, LLC, LOS ANGELES, CA:  
4,592,948, PUB. 6-10-2014. INT. CL. 10.  
4,592,951, PUB. 6-10-2014. INT. CL. 10.

BUNTING, PHILIP G., PORTLAND, OR:  
4,592,493, PUB. 6-10-2014. INT. CL. 26.

BURNING GLASS INTERNATIONAL, INC., BOSTON, MA:  
4,593,606, MULTIPLE CLASS, INT. CLS. 9 AND 42.

BUROSITZMOBELFABRIK FRIEDRICH-W. DAUPHIN  
GMBH & CO, D-91238 OFFENHAUSEN, FED REP GER-  
MANY:  
2,795,878, CANC. INT. CL. 20.

BUSCHOW, JESSICA, BROOKLYN, NY:  
3,350,914, CANC. MULTIPLE CLASS, INT. CLS. 35, 41  
AND 43.

BUSINESS TRANSITION ACADEMY, INC., SOUTH HAMIL-  
TON, MA:  
4,592,472, PUB. 6-10-2014. MULTIPLE CLASS, INT. CLS.  
16, 35 AND 41.  
4,592,475, PUB. 6-10-2014. MULTIPLE CLASS, INT. CLS.  
35 AND 41.  
4,592,476, PUB. 6-10-2014. MULTIPLE CLASS, INT. CLS.  
35 AND 41.

BUSINESSMAP LTD., DIMITROVGRAD, BULGARIA:  
4,592,095, PUB. 6-10-2014. INT. CL. 42.

BUTLER, SHINE, STERN & PARTNERS, LLC, SAUSALITO,  
CA:  
3,351,002, CANC. MULTIPLE CLASS, INT. CLS. 35, 41  
AND 42.

BUYING INTERNATIONAL TRADING CO., LTD,  
GUANGZHOU, GUANGDONG, CHINA:  
4,592,596, PUB. 6-10-2014. INT. CL. 14.

BZDEK, CAZ, DENVER, CO:  
4,592,782, PUB. 6-10-2014. INT. CL. 41.

B2B INDUSTRIES, LLC, ADDISON, IL:  
4,592,548, PUB. 6-10-2014. INT. CL. 42.

BÜHLER AG, UZWIL, SWITZERLAND:  
3,351,917, CANC. MULTIPLE CLASS, INT. CLS. 7, 30, 40,  
41, 42 AND 44.

- C & F FOODS, INC., CITY OF INDUSTRY, CA:  
4,592,962, PUB. 6-10-2014. MULTIPLE CLASS, INT. CLS. 29 AND 30.
- C & S BINS, INC., WINTER HAVEN, FL:  
3,354,291, CANC. INT. CL. 20.
- C. L. HENDERSON PRODUCE, LLC, HENDERSONVILLE, NC:  
4,594,313, INT. CL. 31.
- C. R. BARD, INC., MURRAY HILL, NJ:  
1,286,808, REN. 7-21-14. MULTIPLE CLASS, INT. CLS. 5 AND 10.  
4,593,273, INT. CL. 10.
- C&D TECHNOLOGIES, INC., BLUE BELL, PA:  
1,285,910, REN. 7-18-14. INT. CL. 9.
- C&M VISION TECHNOLOGIES INC, HOUSTON, TX:  
4,591,831, PUB. 6-10-2014. MULTIPLE CLASS, INT. CLS. 9 AND 11.
- C-DAX LIMITED, CHRISTCHURCH, NEW ZEALAND:  
4,591,166, PUB. 6-10-2014. MULTIPLE CLASS, INT. CLS. 7, 8 AND 9.
- C-QUEST, INC., COMMERCE, CA:  
4,592,468, PUB. 6-10-2014. INT. CL. 25.
- CA IP HOLDINGS, LLC, BOYNTON BEACH, FL:  
4,594,051, INT. CL. 5.
- CABLE WINE SYSTEMS INC., TORONTO, CANADA:  
4,592,086, PUB. 6-10-2014. MULTIPLE CLASS, INT. CLS. 6 AND 20.
- CACCAVALE, GINO, NEW YORK, NY:  
4,593,922, MULTIPLE CLASS, INT. CLS. 9 AND 16.
- CAESARS INTERACTIVE ENTERTAINMENT, INC., LAS VEGAS, NV:  
4,591,524, PUB. 6-10-2014. INT. CL. 41.
- CAESARS LICENSE COMPANY, LLC, LAS VEGAS, NV:  
3,351,300, CANC. INT. CL. 41.  
3,351,322, CANC. INT. CL. 41.  
4,594,389, INT. CL. 39.
- CAFÉS NOVELL, S.A., SPAIN:  
4,590,882, PUB. 6-10-2014. INT. CL. 30.
- CAFFE VITA, INC., SEATTLE, WA:  
4,591,906, PUB. 6-10-2014. INT. CL. 30.
- CALASIA GROUP PTE. LTD., SINGAPORE 328369, SINGAPORE:  
4,590,787, PUB. 6-10-2014. INT. CL. 35.
- CALDWELL, ROBERT E., WINTER PARK, FL:  
4,591,734, PUB. 6-10-2014. INT. CL. 9.
- CALI GIRL CAKES LLC, BOLINGBROOK, IL:  
4,592,287, PUB. 6-10-2014. INT. CL. 35.
- CALIBER TRUCK CO., LLC, CAPITOLA, CA:  
4,593,545, INT. CL. 9.
- CALIFORNIA BIKE WEEK PARTNERS, LAKE ELSINORE, CA:  
3,354,560, CANC. MULTIPLE CLASS, INT. CLS. 35 AND 41.
- CALIFORNIA CLOSET COMPANY, INC., SAN RAFAEL, CA:  
2,793,626, CANC. MULTIPLE CLASS, INT. CLS. 37 AND 42.
- CALIFORNIA DRIED PLUM BOARD, SACRAMENTO, CA:  
3,354,191, CANC. INT. CL. 35.
- CALIFORNIA GOGI GROUP, LLC, LOS ANGELES, CA:  
4,594,703, INT. CL. 43.
- CALIFORNIA PUBLIC UTILITIES COMMISSION, SAN FRANCISCO, CA AND CALIFORNIA ENERGY COMMISSION, SACRAMENTO, CA:  
4,591,120, PUB. 6-10-2014. INT. CL. 35.
- CALIFORNIA RESIDENTIAL MITIGATION PROGRAM, A JOINT EXERCISE OF POWERS AGENCY, SACRAMENTO, CA:  
4,594,706, MULTIPLE CLASS, INT. CLS. 35 AND 41.
- CALIFORNIA WESTERN SCHOOL OF LAW, SAN DIEGO, CA:  
4,593,045, PUB. 6-10-2014. INT. CL. 41.  
4,593,056, PUB. 6-10-2014. INT. CL. 41.
- CALL IT YOURS CASSEROLES, LLC, COLUMBUS, GA:  
4,592,398, PUB. 6-10-2014. MULTIPLE CLASS, INT. CLS. 29, 30 AND 43.
- CALLAHAN, GLENN RALPH, SACRAMENTO, CA:  
3,354,247, CANC. MULTIPLE CLASS, INT. CLS. 4 AND 35.
- CALREC AUDIO LIMITED, YORKSHIRE, UNITED KINGDOM:  
3,352,283, CANC. INT. CL. 9.
- CALVERT RETAIL, INC., MONTCHANIN, DE:  
2,937,871, REN. 7-21-14. INT. CL. 30.  
2,958,829, REN. 7-22-14. INT. CL. 35.
- CALYPSO, LTD., CHARLOTTE AMALI, ST. THOMAS, US VIRGIN ISLANDS:  
1,588,096, CANC. INT. CL. 33.
- CALZATURIFICIO FRAU S.P.A., ITALY:  
4,590,808, PUB. 6-10-2014. INT. CL. 25.
- CAMARGO PHARMACEUTICAL SERVICES, LLC, CINCINNATI, OH:  
4,592,703, PUB. 6-10-2014. INT. CL. 42.
- CAMDEN VALE CORPORATION, OAK BROOK, IL:  
3,353,279, CANC. INT. CL. 35.
- CAMERON'S DELI INC., CROSS RIVER, NY, DBA CAMERON'S DELI:  
4,591,654, PUB. 6-10-2014. INT. CL. 43.
- CAMICERIA C.A.M. S.R.L., SCANDICCI, FLORENCE, ITALY:  
3,354,599, CANC. INT. CL. 25.
- CAMILLE BECKMAN CORPORATION, EAGLE, ID:  
4,592,169, PUB. 6-10-2014. INT. CL. 3.
- CAMOPLAST SOLIDEAL INC., SHERBROOKE, QUEBEC, CANADA:  
1,845,550, REN. 7-22-14. INT. CL. 12.
- CAMP GOOD DAYS AND SPECIAL TIMES, INC., PITTSFORD, NY:  
1,847,498, REN. 7-21-14. INT. CL. 42.
- CAMPER & NICHOLSONS (DESIGNS) LIMITED, SOUTHAMPTON, ENGLAND:  
1,281,459, REN. 7-21-14. MULTIPLE CLASS, INT. CLS. 12, 36, 37, 39 AND 42.
- CAMPUS CRUSADE FOR CHRIST, INC., ORLANDO, FL:  
3,351,294, CANC. MULTIPLE CLASS, INT. CLS. 16 AND 41.
- CAMPUS CRUSADE FOR CHRIST, INC., ORLANDO, FL, AKA CRU:  
4,591,066, PUB. 6-10-2014. INT. CL. 16.  
4,591,067, PUB. 6-10-2014. INT. CL. 38.
- CAMPUS CRUSADE FOR CHRIST, INC., ORLANDO, FL:  
4,591,785, PUB. 6-10-2014. INT. CL. 45.  
4,591,786, PUB. 6-10-2014. INT. CL. 41.
- CAMPUS CRUSADE FOR CHRIST, INC., ORLANDO, FL, AKA CRU:  
4,591,787, PUB. 6-10-2014. INT. CL. 41.
- CAMY BEAUTY CO., LTD., CHANG HWA HSIEN, TAIWAN:  
3,353,569, CANC. INT. CL. 3.
- CANADY, KAREN S., LOS ANGELES, CA, DBA BIKIE GIRL BLOOMERS:  
4,592,873, PUB. 6-10-2014. INT. CL. 35.
- CANDLE LAMP COMPANY, LLC, CORONA, CA:  
4,593,210, INT. CL. 4.
- CANDO, KATHRYN M., WILMINGTON, NC:  
3,353,191, CANC. INT. CL. 16.
- CANEY PUTTERWORKS LLC, WESTFORD, MA:  
4,591,636, PUB. 6-10-2014. INT. CL. 28.
- CANNON BOILER WORKS, INC., NEW KENSINGTON, PA:  
1,285,156, REN. 7-22-14. INT. CL. 11.
- CANONICAL LIMITED, DOUGLAS, ISLE OF MAN:  
3,351,990, CANC. MULTIPLE CLASS, INT. CLS. 9, 35 AND 42.
- CANOPY LICENSING, LLC, NAPA, CA:  
4,594,363, INT. CL. 33.
- CANOPY MANAGEMENT, LLC, NAPA, CA:  
4,594,364, INT. CL. 33.
- CANTINA VINI ARMANI A. - TERRE; DOMINICI SOCIETÀ A RESPONSABILITÀ LIMITATA IN SIGLA "CANTINA VINI; ARMANI A. - TERRE DOMINICI SOCIETÀ; A RESPONSABILITÀ LIMITATA IN SIGLA; "CANTINA VINI ARMANI A. S.R.L." E; "TERRE DOMINICI S.R.L.", ALA (TRENTO), ITALY:  
4,590,877, PUB. 6-10-2014. INT. CL. 33.

CANTWELL MATTRESS COMPANY, CORPUS CHRISTI, TX:  
4,592,419, PUB. 6-10-2014. INT. CL. 20.

CANVAS & CLAY, REDONDO BEACH, CA:  
4,592,801, PUB. 6-10-2014. INT. CL. 41.

CAPACITY OF TEXAS, INC., LONGVIEW, TX, DBA CAPACITY TRUCKS, INC.:  
4,591,558, PUB. 6-10-2014. MULTIPLE CLASS, INT. CLS. 35 AND 40.

CAPCOM GAME STUDIO VANCOUVER, INC., BRITISH COLUMBIA, CANADA:  
4,593,184, INT. CL. 9.

CAPIENT INCORPORATED, PLANO, TX:  
2,573,915, CANC. INT. CL. 42.

CAPITAL CITY REAL ESTATE, WASHINGTON, DC:  
4,592,311, PUB. 6-10-2014. INT. CL. 37.

CAPITAL IMPACT PARTNERS, ARLINGTON, VA:  
4,592,709, PUB. 6-10-2014. INT. CL. 36.

CAPITAL INDUSTRIES, INC., MATTITUCK, NY:  
2,827,992. REN. 7-24-14. INT. CL. 19.

CAPITAL ONE FINANCIAL CORPORATION, RICHMOND, VA:  
4,593,948, INT. CL. 36.  
4,593,951, INT. CL. 9.

CAPITAL RICE CO., LTD., BANGKOK 10600, THAILAND:  
4,594,382, INT. CL. 30.

CAPITAL STAINLESS, INC., GILBERT, AZ:  
4,591,696, PUB. 6-10-2014. MULTIPLE CLASS, INT. CLS. 1 AND 7.

CAPITOL AUTO GROUP, INC., SALEM, OR:  
4,592,757, PUB. 6-10-2014. MULTIPLE CLASS, INT. CLS. 35 AND 37.

CAPLAN INDUSTRIES INC., RICHMOND, BRITISH COLUMBIA, CANADA:  
2,794,211, CANC. INT. CL. 6.

CAPLOON ENTERPRISES, LLC, MONTCLAIR, NJ:  
3,351,523, CANC. INT. CL. 16.

CAPPELLINO, SAMUEL PHILLIP, WEBSTER, NY:  
3,354,642, CANC. INT. CL. 25.

CAPRA, KRIS E., PALM DESERT, CA:  
3,352,978, CANC. INT. CL. 41.

CAPTERRA, INC., ARLINGTON, VA:  
4,591,378, PUB. 6-10-2014. INT. CL. 42.

CAPZLES, INC., CULVER CITY, CA:  
3,351,021, CANC. MULTIPLE CLASS, INT. CLS. 9, 35 AND 45.

CARBIDE PROBES, INC., DAYTON, OH:  
1,285,024. REN. 7-22-14. INT. CL. 9.

CARBON INNOVATIONS, LLC, HUNTSVILLE, UT:  
4,592,446, PUB. 6-10-2014. INT. CL. 28.

CARBON 38, INC., BEVERLY HILLS, CA:  
4,592,570, PUB. 6-10-2014. INT. CL. 25.

CARD, RICHARD, WINFIELD, IL AND CARD, JILL, WINFIELD, IL:  
4,550,039, CANC. IIRN. RESTORED TO S.N. 85-797,449.

CARDIAC PACEMAKERS, INC., ST. PAUL, MN:  
2,795,859, CANC. INT. CL. 10.

CARDIAC SCIENCE CORPORATION, BOTHELL, WA:  
3,353,825, CANC. MULTIPLE CLASS, INT. CLS. 41 AND 44.

CARDINAL ASSOCIATES, VANCOUVER, WA, DBA BERGSTROM NUTRITION:  
4,592,611, PUB. 6-10-2014. INT. CL. 5.

CARDINAL MCCLOSKEY SCHOOL AND HOME FOR CHILDREN, VALHALLA, NY:  
4,593,394, MULTIPLE CLASS, INT. CLS. 35, 36, 41, 43, 44 AND 45.  
4,593,395, MULTIPLE CLASS, INT. CLS. 35, 36, 41, 43, 44 AND 45.

CARE FOOD INDUSTRIES SDN BHD (113590-A), BANDAR SRI DAMANSARA, KUALA LUMPUR, MALAYSIA:  
3,353,894, CANC. INT. CL. 30.

CAREER EDUCATION CORPORATION, HOFFMAN ESTATES, IL:  
3,352,066, CANC. INT. CL. 41.

CAREER WISDOM INSTITUTE, MORAGA, CA:  
4,592,426, PUB. 6-10-2014. INT. CL. 41.

CARGILL THE NETHERLANDS HOLDING B.V., 1118 CZ SCHIPHOL, NETHERLANDS:  
4,594,398, INT. CL. 5.

CARGNONI, ROBERT A. AUSTIN, TX:  
4,592,222, PUB. 6-10-2014. INT. CL. 14.

CARHARTT, INC., DEARBORN, MI:  
4,592,759, PUB. 6-10-2014. INT. CL. 35.

CARIBWEAR, INC., FT. PIERCE, FL:  
3,352,867, CANC. INT. CL. 25.

CARINA AYDEN, WEST HOLLYWOOD, CA:  
4,592,864, PUB. 6-10-2014. INT. CL. 5.

CARIS MPI, INC., PHOENIX, AZ:  
4,593,363, MULTIPLE CLASS, INT. CLS. 42 AND 44.

CARL BUDDIG & COMPANY, HOMEWOOD, IL:  
2,793,986, CANC. INT. CL. 29.

CARL FREUDENBERG KG, WEINHEIM, FED REP GERMANY:  
3,561,923, CANC. INT. CL. 28.

CARL ZEISS AG, OBERKOCHEN, FED REP GERMANY:  
4,591,582, PUB. 6-10-2014. INT. CL. 9.

CARLEY, DON M., WESTERVILLE, OH:  
4,592,104, PUB. 6-10-2014. INT. CL. 16.

CARLISLE INSURANCE AGENCY, INC., ALICE, TX:  
4,592,537, PUB. 6-10-2014. INT. CL. 36.  
4,592,539, PUB. 6-10-2014. INT. CL. 36.

CARLISLE INTANGIBLE COMPANY, SYRACUSE, NY:  
3,352,845, CANC. INT. CL. 12.

CARLISLE WIDE PLANK FLOORS, INC., STODDARD, NH:  
4,594,162, INT. CL. 40.

CARLSON, JUSTIN, HOUSTON, TX:  
4,592,949, PUB. 6-10-2014. MULTIPLE CLASS, INT. CLS. 35 AND 42.  
4,592,957, PUB. 6-10-2014. INT. CL. 35.

CARLSON, JUSTIN, LA JOLLA, CA:  
4,592,959, PUB. 6-10-2014. MULTIPLE CLASS, INT. CLS. 35 AND 42.

CARLSON, JUSTIN, HOUSTON, TX:  
4,592,999, PUB. 6-10-2014. INT. CL. 35.  
4,593,051, PUB. 6-10-2014. INT. CL. 35.

CARMA LABORATORIES, INC., FRANKLIN, WI:  
3,601,627, AM. MULTIPLE CLASS, INT. CLS. 3 AND 5.

CARMIN, FLORENT, LOS ANGELES, CA:  
4,593,820, INT. CL. 33.

CAROL FRAZIER, EVANSTON, IL:  
4,592,297, PUB. 6-10-2014. INT. CL. 26.

CAROL SINGER ENTERPRISES, INC., CARROLLTON, TX:  
2,796,104, CANC. INT. CL. 3.

CAROLINA PERSONNEL COMPANY, INC., ALGONQUIN, IL:  
3,353,458, CANC. INT. CL. 35.

CAROLINE SUSAN BARON, NEW YORK, NY:  
4,594,053, INT. CL. 21.

CAROLINE'S, INC., SPARTANBURG, SC:  
4,594,529, INT. CL. 30.

CARPA DORADA, S.L., CASTELLÓN, SPAIN:  
4,591,197, PUB. 2-11-2014. INT. CL. 31.

CARPE, DAVID, LEXINGTON, MA:  
4,594,204, INT. CL. 9.

CARPET KING, INC., MINNEAPOLIS, MN:  
2,964,246. REN. 7-22-14. MULTIPLE CLASS, INT. CLS. 35 AND 37.

CARPETS FOR KIDS, ETC...INC., PORTLAND, OR:  
3,350,902, CANC. INT. CL. 27.

CARR, DAVID, BARNARD, VT:  
3,354,383, CANC. INT. CL. 9.

CARRIER CORPORATION, FARMINGTON, CT, SNYDER GENERAL CORPORATION, RED BUD, IL:  
1,290,880. REN. 7-21-14. INT. CL. 11.

CARRYLINE AKTIEBOLAG, SWEDEN:  
4,590,891, PUB. 6-10-2014. INT. CL. 7.

CARTON BREWING COMPANY, LLC, ATLANTIC HIGHLANDS, NJ:  
4,592,952, PUB. 6-10-2014. INT. CL. 32.

CARTOUN, ANDREW, NEWTOWN, CT:  
4,591,097, PUB. 6-10-2014. INT. CL. 9.

CARVER BREWING COMPANY, DURANGO, CO:  
2,880,562. REN. 7-22-14. INT. CL. 42.

- CARY, JENNIFER, PLANO, TX:  
2,794,298, CANC. INT. CL. 14.
- CASA ARMANDO GUILLERMO PRIETO, S.A. DE C.V., MEXICO, MEXICO:  
2,756,247, AM. INT. CL. 33.
- CASHBASISENTERPRISES LLC, AUSTIN, TX:  
4,592,826, PUB. 6-10-2014. INT. CL. 11.
- CASTELO DE LA ROSA, PABLO, HERMOSILLO, SONORA, MEXICO:  
3,353,302, CANC. INT. CL. 29.
- CASTER, 75008 PARIS, FRANCE:  
3,351,147, CANC. INT. CL. 3.  
3,351,154, CANC. INT. CL. 3.
- CASTLE BRANDS INC., NEW YORK, NY:  
2,872,936, REN. 7-24-14. INT. CL. 33.
- CASTLE WORKS, INC., BRIARCLIFF MANOR, NY:  
2,794,516, CANC. MULTIPLE CLASS, INT. CLS. 38, 41 AND 45.
- CASTRO PETERSEN, INC., LONG BEACH, CA:  
4,593,682, INT. CL. 35.
- CASTRO, LOUIS A., LAKE BALBOA, CA:  
4,592,578, PUB. 6-10-2014. INT. CL. 9.
- CATERPILLAR EJUICE INC, FULLERTON, CA:  
4,592,135, PUB. 6-10-2014. INT. CL. 30.
- CATSEYE HOLDING LLC, NAPLES, FL:  
3,352,426, CANC. INT. CL. 37.
- CAVALLINI PAPERS & CO, INC., SOUTH SAN FRANCISCO, CA:  
4,594,534, INT. CL. 16.
- CAVE LES COSTIERES DE POMEROLS (SOCIETE COOPERATIVE AGRICOLE DE VINIFICATION), F-34810 POMEROLS, FRANCE:  
4,590,852, PUB. 6-10-2014. INT. CL. 33.
- CAVE SPRINGS, INC., WILMINGTON, DE:  
3,352,462, CANC. INT. CL. 35.  
4,593,494, MULTIPLE CLASS, INT. CLS. 25 AND 35.
- CAVES DOM TEODOSIO, S.A., 2040-998 RIO MAIRO, PORTUGAL:  
1,285,510, REN. 7-24-14. INT. CL. 33.
- CB HOSPITALITY SERVICES LLC, SOMERVILLE, MA:  
4,592,123, PUB. 6-10-2014. INT. CL. 39.
- CBFN ACQUISITIONS, INC., FT. LAUDERDALE, FL TO AFFINITY GLOBAL, INC., CHICAGO, IL:  
2,793,441, CANC. MULTIPLE CLASS, INT. CLS. 38 AND 42.
- CBS RADIO INC., NEW YORK, NY:  
4,593,575, INT. CL. 41.
- CBS RADIO STATIONS INC., NEW YORK, NY:  
3,350,929, CANC. INT. CL. 35.
- CBS STUDIOS INC., STUDIO CITY, CA:  
1,817,187, REN. 7-23-14. INT. CL. 41.
- CBS STUDIOS INC., NEW YORK, NY:  
3,353,549, CANC. INT. CL. 30.
- CC MARINE BRAND ACQUISITION, LLC, SARASOTA, FL:  
2,913,602, REN. 7-23-14. INT. CL. 24.
- CCCS OF FORSYTH COUNTY, INC., WINSTON-SALEM, NC:  
2,794,046, CANC. INT. CL. 36.
- CDRE TM LLC, IRVINE, CA:  
4,594,681, INT. CL. 16.
- CEDARLANE NATURAL FOODS, INC., CARSON, CA:  
4,594,426, MULTIPLE CLASS, INT. CLS. 29 AND 30.
- CEDC INTERNATIONAL SP. Z O.O., 64-600 OBORNIKI WIELKOPOLSKIE, POLAND, PRZEDSIĘBIORSTWO POLMOS BIALYSTOK S.A., 15-950 BIALYSTOK, POLAND:  
2,858,179, REN. 7-24-14. INT. CL. 33.
- CELEBRITY SIGNATURES INTERNATIONAL, INC., KANSAS CITY, MO:  
3,354,309, CANC. INT. CL. 26.
- CELEBSTER, INC., MELBOURNE, FL:  
3,351,389, CANC. INT. CL. 41.
- CELGENE CORPORATION, SUMMIT, NJ:  
4,591,983, PUB. 6-10-2014. INT. CL. 42.  
4,591,985, PUB. 6-10-2014. INT. CL. 42.
- CELLSTROM GMBH, WIENER NEUDORF, AUSTRIA:  
4,590,744, PUB. 6-10-2014. MULTIPLE CLASS, INT. CLS. 7, 9, 11, 37, 39 AND 42.
- CELT CORPORATION, CALGARY, CANADA:  
4,590,978, PUB. 6-10-2014. INT. CL. 5.
- CENETRA LATOYA HUGHES, CHESTER, SC, DBA O'SWAN:  
4,594,468, INT. CL. 25.
- CENGAGE LEARNING, INC., STAMFORD, CT:  
2,802,419, REN. 7-21-14. INT. CL. 41.  
2,802,420, REN. 7-21-14. INT. CL. 41.
- CENTERSTONE INSURANCE AND FINANCIAL SERVICES, INC., DALLAS, TX:  
2,859,691, REN. 7-21-14. MULTIPLE CLASS, INT. CLS. 35 AND 36.
- CENTEX CORPORATION, DALLAS, TX:  
3,352,468, CANC. INT. CL. 36.
- CENTRAL MASS COURIERS, INC., WORCESTER, MA:  
3,350,705, CANC. INT. CL. 39.
- CENTRAL STATES MANUFACTURING, INC., LOWELL, AR:  
4,590,606, PUB. 6-10-2014. INT. CL. 6.
- CENTRE CITY DENTAL LABORATORY, INC., ESCONDIDO, CA, DBA PARADIGM DENTAL MODELS:  
4,591,858, PUB. 6-10-2014. INT. CL. 9.
- CENTRE SKATEBOARD DISTRIBUTION LTD., SANTA BARBARA, CA:  
4,590,625, PUB. 6-10-2014. INT. CL. 25.
- CENTRIC BRAND COLLECTIVE, INC., SEATTLE, WA:  
4,593,895, INT. CL. 35.
- CEQUAL PRODUCTS, INC., SANTA MONICA, CA:  
2,794,395, CANC. INT. CL. 20.
- CEQUENT PERFORMANCE PRODUCTS, INC., PLYMOUTH, MI:  
4,593,293, MULTIPLE CLASS, INT. CLS. 8, 9 AND 12.
- CERALON, LLC, BERKELEY, CA:  
3,353,994, CANC. INT. CL. 9.
- CERNER INNOVATION, INC., OVERLAND PARK, KS:  
3,349,653, CANC. INT. CL. 9.
- CERNER INNOVATION, INC., KANSAS CITY, KS:  
4,593,249, MULTIPLE CLASS, INT. CLS. 42 AND 44.
- CERTAINTED CORPORATION, VALLEY FORGE, PA:  
3,352,067, CANC. INT. CL. 35.
- CERVECERIA MODELO, S. DE R.L. DE C.V., C.P. 11320 MÉXICO CITY, MEXICO:  
4,594,168, INT. CL. 32.
- CERVEZAS CUAUHTEMOC MOCTEZUMA, S.A. DE C.V., MONTERREY, NUEVO LEON, NM:  
3,510,307, AM. INT. CL. 32.
- CESIDIO TALLINI, SOUTH FLORAL PARK, NY:  
4,592,162, PUB. 6-10-2014. U.S. CL. 200.
- CETELIFE, LOS ANGELES, CA:  
4,593,009, PUB. 6-10-2014. INT. CL. 44.
- CEVA ANIMAL HEALTH LLC, LENEXA, KS:  
4,591,576, PUB. 12-31-2013. INT. CL. 5.
- CGP INDUSTRIES SA, CEBAZAT, FRANCE:  
4,592,073, PUB. 6-10-2014. INT. CL. 16.
- CH REALTY VI/H DENVER BROWN PALACE L.P., DALLAS, TX:  
3,351,022, CANC. INT. CL. 43.
- CHABAD OF CALIFORNIA, LOS ANGELES, CA:  
3,351,467, CANC. MULTIPLE CLASS, INT. CLS. 4 AND 41.
- CHAD M. LARSON, SAVAGE, MN:  
4,593,372, INT. CL. 6.
- CHAIN IQ HOLDING AG, PFÄFFIKON SZ, SWITZERLAND:  
4,590,767, PUB. 3-4-2014. MULTIPLE CLASS, INT. CLS. 9, 35, 36, 38, 39, 41, 42 AND 45.
- CHAMBER OF COMMERCE OF THE UNITED STATES OF AMERICA, WASHINGTON, DC:  
4,592,059, PUB. 6-10-2014. INT. CL. 35.
- CHAMBERLAIN, HOLLIE, CARLSBAD, CA:  
4,594,655, INT. CL. 30.
- CHAMBERSELECT, LLC, NORFOLK, VA:  
3,351,435, CANC. INT. CL. 36.
- CHAMPAGNE ALAIN THIENOT, FRANCE:  
4,072,516, COR. MULTIPLE CLASS, INT. CLS. 33, 35 AND 38.

- CHAMPLAIN COLLEGE, INCORPORATED, BURLINGTON, VT:  
4,592,334, PUB. 6-10-2014. INT. CL. 28.
- CHAN LUU, INC., LOS ANGELES, CA:  
2,869,029, REN. 7-24-14. INT. CL. 14.
- CHANEY, DAVID M., LOS GATOS, CA:  
3,352,413, CANC. INT. CL. 38.
- CHANG CHIEN, TIEN-HO, GAOHSIUNG CITY, TAIWAN:  
4,591,623, PUB. 6-10-2014. INT. CL. 28.
- CHANG TYPE INDUSTRIAL CO., LTD., HO-LI, TAICHUNG COUNTY, TAIWAN:  
2,867,371, REN. 7-22-14. INT. CL. 20.
- CHANGA CLINTON INGRAM, COLUMBIA, MD AND JESSE INGRAM, COLUMBIA, MD AND DAMANI KONATA INGRAM, COLUMBIA, MD:  
4,593,401, INT. CL. 25.
- CHANGES FOR WOMEN FRANCHISE CORPORATION, GLOUCESTER, ONTARIO, CANADA:  
3,350,635, CANC. INT. CL. 41.
- CHANGSHA HAGEN BIOTECHNOLOGY CO., LTD., CHANGSHA CITY, HUNAN,, CHINA:  
4,592,658, PUB. 6-10-2014. INT. CL. 32.
- CHAOZHOU LIANYUAN CERAMICS MAKING CO., LTD., CHAOZHOU, GUANGDONG 521000, CHINA:  
3,352,709.
- CHARDER ELECTRONIC CO., LTD., TAICHUNG CITY 412, TAIWAN:  
4,592,813, PUB. 6-10-2014. INT. CL. 9.  
4,592,816, PUB. 6-10-2014. INT. CL. 10.
- CHARLES ANTON GEORGE, AIKEN, SC:  
4,592,561, PUB. 6-10-2014. INT. CL. 36.
- CHARLES JOURDAN FASHION GROUP, LLC, BOCA RATON, FL, SOCIETE DES CHAUSSURES SEDUCTA-CHARLES JOURDAN & FILS, 26100 ROMANS, FRANCE:  
987,611, REN. 7-22-14. U.S. CL. 3 (INT. CL. 18).
- CHARLES RIVER BROADCASTING COMPANY, WALTHAM, MA:  
2,730,925, REN. 7-22-14. INT. CL. 41.
- CHARLIE CHIANG'S, INC., GAITHERSBURG, MD:  
2,866,170, REN. 7-22-14. MULTIPLE CLASS, INT. CLS. 29, 35 AND 43.
- CHARTER COMMUNICATIONS HOLDING COMPANY L.L.C., ST. LOUIS, MO:  
4,591,882, PUB. 6-10-2014. MULTIPLE CLASS, INT. CLS. 38, 39 AND 42.
- CHARTMATE INC., KAOHSIUNG, TAIWAN:  
4,593,397, INT. CL. 11.
- CHASAM TOBACCO, LLC, MIAMI, FL:  
4,593,947, INT. CL. 34.
- CHASING THE TRUTH INC., MIAMI, FL:  
4,592,669, PUB. 6-10-2014. INT. CL. 28.
- CHATEAU ANDRE ZILTENER S.A., 4153 REINACH, SWITZERLAND:  
2,860,590, REN. 7-18-14. INT. CL. 33.
- CHATEAU DIANA LLC, HEALDSBURG, CA:  
4,593,862, INT. CL. 33.
- CHATTYWEAR LTD, UNITED KINGDOM:  
4,590,887, PUB. 6-10-2014. INT. CL. 25.
- CHAUVET & SONS, INC., SUNRISE, FL:  
4,592,179, PUB. 6-10-2014. INT. CL. 11.
- CHECKPOINT SYSTEMS, INC., THOROFARE, NJ:  
2,794,078, CANC. INT. CL. 9.
- CHEESEBOY PROPERTIES LLC, BOSTON, MA:  
4,593,002, PUB. 6-10-2014. INT. CL. 43.  
4,593,003, PUB. 6-10-2014. INT. CL. 43.  
4,593,004, PUB. 6-10-2014. INT. CL. 43.  
4,593,005, PUB. 6-10-2014. INT. CL. 43.  
4,593,006, PUB. 6-10-2014. INT. CL. 43.  
4,593,007, PUB. 6-10-2014. INT. CL. 43.  
4,593,032, PUB. 6-10-2014. INT. CL. 35.
- CHEETHAM, EDWARD J., NASHVILLE, TN:  
3,352,206, CANC. MULTIPLE CLASS, INT. CLS. 35 AND 41.
- CHEKALSKA, NATALIYA, NORTH MIAMI BEACH, FL:  
4,592,663, PUB. 6-10-2014. INT. CL. 41.
- CHELLY COSMETIC MANUFACTURING, INC., DORAL, FL:  
4,591,595, PUB. 6-10-2014. INT. CL. 3.
- CHELSEA FOOTBALL CLUB LIMITED, LONDON, UNITED KINGDOM:  
3,352,084, CANC. MULTIPLE CLASS, INT. CLS. 3, 9, 14, 18 AND 25.
- CHELSEA RHONE COMPANY, ANN ARBOR, MI:  
2,864,837, REN. 7-24-14. INT. CL. 36.
- CHEMICAL CONCEPTS, INC., HUNTINGDON VALLEY, PA:  
2,961,848, REN. 7-24-14. INT. CL. 1.
- CHEMSPEC1, LLC, MEMPHIS, TN:  
4,591,601, PUB. 6-10-2014. INT. CL. 3.
- CHEMTRADE WEST LIMITED PARTNERSHIP, TORONTO, CANADA:  
4,590,940, PUB. 6-10-2014. INT. CL. 1.
- CHEN, BIAO, FAIR LAWN, NJ AND HU, LIYAN, FAIR LAWN, NJ:  
4,592,824, PUB. 6-10-2014. INT. CL. 24.
- CHENG USA, INC., SOUTH SAN FRANCISCO, CA:  
4,593,429, INT. CL. 9.
- CHEROKEE INC., SHERMAN OAKS, CA:  
3,354,457, CANC. INT. CL. 14.
- CHERRY BEKAERT & HOLLAND, L.L.P., RICHMOND, VA:  
3,350,654, CANC. INT. CL. 35.  
3,350,655, CANC. INT. CL. 35.
- CHETAN PATIL, HOBOKEN, NJ:  
4,592,872, PUB. 6-10-2014. INT. CL. 44.
- CHETANA WILLIAMSON, SANTA MONICA, CA:  
4,594,394, INT. CL. 9.
- CHEVRON INTELLECTUAL PROPERTY LLC, SAN RAMON, CA:  
3,103,863, AM. INT. CL. 35.
- CHG MANAGEMENT, INC., SALT LAKE CITY, UT:  
2,794,759, CANC. INT. CL. 35.  
2,794,760, CANC. INT. CL. 35.
- CHIBBARO, LOUIS M., JR., WASHINGTON, DC:  
3,353,162, CANC. INT. CL. 16.
- CHICAGO INDUSTRIAL FASTENERS, AURORA, IL:  
3,353,073, CANC. INT. CL. 6.
- CHICAGO MANUFACTURING CENTER, CHICAGO, IL:  
3,354,425, CANC. INT. CL. 35.
- CHICAGOLAND SPEEDWAY CORPORATION, DAYTONA BEACH, FL:  
2,793,390, CANC. MULTIPLE CLASS, INT. CLS. 6, 12, 14, 16, 20, 21, 24, 25, 28 AND 34.
- CHIKA, AKRAM E., EL CAJON, CA:  
2,796,080, CANC. INT. CL. 7.
- CHIKARANOMOTO HOLDINGS CO., LTD, FUKUOKA CITY, FUKUOKA, JAPAN:  
4,594,290, INT. CL. 43.
- CHILLIWACK MOUNTAIN LOG HOMES LTD., CHILLIWACK, B.C., V2R4A2, CANADA:  
2,907,536, REN. 7-24-14. MULTIPLE CLASS, INT. CLS. 19 AND 37.
- CHINA MANUFACTURERS ALLIANCE, LLC, MONROVIA, CA:  
4,594,326, INT. CL. 12.  
4,594,467, INT. CL. 12.
- CHINA RESOURCE SNOW BREWERY (LIAONING) CO., LTD., SHENYANG, LIAONING, CHINA:  
2,794,806, CANC. INT. CL. 32.  
2,794,807, CANC. INT. CL. 32.
- CHINT GROUP CO., LTD., CHINA:  
3,352,626.
- CHIPOTLE MEXICAN GRILL, INC., DENVER, CO:  
2,949,842, REN. 7-21-14. INT. CL. 43.
- CHOCOLATE HOLLOW LLC., BURLINGTON, VT:  
4,592,431, PUB. 6-10-2014. INT. CL. 30.
- CHOISR INTERNET GMBH, BERLIN, FED REP GERMANY:  
4,594,179, MULTIPLE CLASS, INT. CLS. 35, 42 AND 45.
- CHOL WANG, INC., CENTERPOINT, AL, DBA WING IT!  
4,592,260, PUB. 6-10-2014. INT. CL. 43.
- CHONGQING CHUANDONG CHEMICAL (GROUP); CO., LTD., CHINA:  
4,590,838, PUB. 6-10-2014. INT. CL. 1.
- CHR&B, LLC, RANCHO SANTA FE, CA:  
3,354,672, CANC. INT. CL. 35.

- CHRIS FARMAND & COMPANY, PLLC, JACKSONVILLE, FL:  
4,592,394, PUB. 6-10-2014. INT. CL. 35.  
4,592,395, PUB. 6-10-2014. INT. CL. 35.
- CHRISTIAAN ALLEBEST, LAGUNA HILLS, CA:  
3,351,251, CANC. INT. CL. 41.
- CHRISTIAN BIBLE GAMES, THE VILLAGES, FL:  
4,594,680, INT. CL. 28.
- CHRISTIAN BIBLE GAMES LLC, THE VILLAGES, FL:  
4,594,691, INT. CL. 28.
- CHRISTIAN POHL GMBH, D-50769 KOLN, FED REP GERMANY:  
2,859,301, REN. 7-18-14. MULTIPLE CLASS, INT. CLS. 6, 17 AND 19.
- CHRISTOPH KELLER, EIGELTINGEN-MÜNCHHÖF, FED REP GERMANY:  
4,590,823, PUB. 6-10-2014. MULTIPLE CLASS, INT. CLS. 21, 32 AND 33.
- CHRISTOPHER LEIGH STUDIOS, LLC, GILBERT, AZ:  
4,591,710, PUB. 6-10-2014. INT. CL. 35.
- CHRISTOPHER MAIER, HOPE, NJ, DBA LAND OF MAKE BELIEVE:  
4,592,490, PUB. 6-10-2014. INT. CL. 41.
- CHRISTY, JOSEPH, TEMPE, AZ:  
3,351,296, CANC. INT. CL. 5.
- CHRONOMITE LABORATORIES, INC., CITY OF INDUSTRY, CA:  
4,591,639, PUB. 6-10-2014. INT. CL. 11.
- CHRYSLER LLC, AUBURN HILLS, MI:  
3,354,295, CANC. INT. CL. 9.
- CHS THERAPY TECHNOLOGIES CORP., SALT LAKE CITY, UT:  
2,794,767, CANC. INT. CL. 35.  
2,794,781, CANC. INT. CL. 35.
- CHUKWU, UCHENNA, N, MINNETONKA, MN:  
2,794,559, CANC. INT. CL. 42.
- CHURCH & DWIGHT CO., INC., EWING, NJ:  
2,924,295, REN. 7-21-14. INT. CL. 16.
- CHURCH & DWIGHT CO., INC., PRINCETON, NJ:  
3,354,465, CANC. INT. CL. 3.
- CHURCH GREEN BUSINESS SERVICES, TAUNTON, MA:  
3,351,354, CANC. INT. CL. 36.
- CHURCH HILL CLASSICS, LTD., MONROE, CT:  
2,866,165, REN. 7-22-14. INT. CL. 16.
- CHURCH LOANS & INVESTMENTS TRUST, AMARILLO, TX:  
4,592,375, PUB. 6-10-2014. INT. CL. 36.
- CHURCH, DANNIE, NORTH WILKESBORO, NC:  
4,594,587, INT. CL. 32.
- CICI ENTERPRISES, LP, COPPELL, TX:  
4,591,695, PUB. 6-10-2014. MULTIPLE CLASS, INT. CLS. 41 AND 43.
- CIENA CORPORATION, HANOVER, MD:  
4,594,330, INT. CL. 9.
- CIGNA INTELLECTUAL PROPERTY, INC., WILMINGTON, DE:  
3,350,745, CANC. INT. CL. 35.
- CILURZO, VINNIE, SANTA ROSA, CA AND CILURZO, NATALIE, SANTA ROSA, CA:  
4,593,270, INT. CL. 32.  
4,593,274, INT. CL. 32.
- CINEVILLE, INC., SANTA MONICA, CA:  
2,862,646, REN. 7-23-14. INT. CL. 41.
- CIRCLE ONE GLOBAL, INC., SHELLMAN, GA:  
2,944,491, REN. 7-22-14. INT. CL. 5.
- CISNEROS FONTANALS ART FOUNDATION, MIAMI, FL, DBA CIFO:  
4,591,615, PUB. 6-10-2014. INT. CL. 36.
- CITIGROUP INC., NEW YORK, NY:  
2,795,362, CANC. MULTIPLE CLASS, INT. CLS. 36 AND 41.
- CITIZENS DEVELOPMENT CORPS, INC., WASHINGTON, DC:  
3,353,336, CANC. INT. CL. 35.
- CITY OF ALBUQUERQUE CULTURAL SERVICES DEPARTMENT, ALBUQUERQUE, NM:  
3,351,131, CANC. INT. CL. 41.
- CITY OF MIAMI BEACH, MIAMI BEACH, FL:  
4,594,380, INT. CL. 3.  
4,594,381, INT. CL. 3.
- CITY OF SPARTANBURG, SPARTANBURG, SC:  
2,793,853, CANC. MULTIPLE CLASS, INT. CLS. 25 AND 39.
- CITY OPTICAL CO INC, INDIANAPOLIS, IN:  
2,923,308, REN. 7-23-14. INT. CL. 9.
- CITY STUMBLER, LOS ANGELES, CA:  
4,593,456, MULTIPLE CLASS, INT. CLS. 9, 35, 36 AND 42.
- CITY UNIVERSITY OF NEW YORK DOMINICAN STUDIES INSTITUTE, NEW YORK, NY:  
4,591,069, PUB. 6-10-2014. MULTIPLE CLASS, INT. CLS. 9 AND 41.
- CITY WIDE PROMOTIONS, INC, UPPER MARLBORO, MD, DBA PLATINUM STILETTOS:  
4,591,835, PUB. 6-10-2014. INT. CL. 25.
- CITYSTASH HOLDINGS, LLC, ARLINGTON, VA:  
4,592,598, PUB. 6-10-2014. INT. CL. 39.
- CITYWHEELS, LLC, CLEVELAND, OH:  
3,351,476, CANC. INT. CL. 39.
- CIVLAK, ALI, NORTHRIDGE, CA:  
4,592,909, PUB. 6-10-2014. INT. CL. 35.
- CJS BEVERAGE CORP., NEW YORK, NY:  
4,594,192, INT. CL. 33.  
4,594,193, INT. CL. 33.
- CLARENDON NEW YORK, INC., NEW YORK, NY:  
3,351,132, CANC. INT. CL. 25.
- CLARIANT AG, SWITZERLAND:  
3,352,708.  
4,590,698, PUB. 6-10-2014. MULTIPLE CLASS, INT. CLS. 1 AND 2.
- CLARIANT GMBH, 65929, FRANKFURT, FED REP GERMANY:  
1,286,666, REN. 7-24-14. INT. CL. 1.
- CLARK ATLANTA UNIVERSITY, INC., ATLANTA, GA:  
4,591,509, PUB. 6-10-2014. INT. CL. 41.
- CLARK FOODS, INC., NEW ALBANY, IN:  
4,594,469, INT. CL. 32.
- CLARK, RITA M., CUDJOE GARDENS, FL, DBA BLUE-WATER RENTALS:  
4,274,836, CANC. INT. CL. 36.
- CLARKE, CONRAD CHRISTOPHER, EAST ISLIP, NY, DBA CIDEA SOLUTIONS:  
4,593,087, INT. CL. 25.
- CLARKWESTERN DIETRICH BUILDING SYSTEMS LLC, WEST CHESTER, OH:  
4,591,063, PUB. 6-10-2014. INT. CL. 9.
- CLARY EYE ASSOCIATES, PLLC, ASHBURN, VA:  
3,353,464, CANC. MULTIPLE CLASS, INT. CLS. 35 AND 44.
- CLASSICAL CONVERSATIONS MULTI MEDIA, INC., WEST END, NC:  
4,594,767, INT. CL. 16.  
4,594,768, INT. CL. 16.
- CLAUS, CHRISTOPHER P, LONGMONT, CO:  
4,591,535, PUB. 6-10-2014. INT. CL. 3.
- CLAUSE, PORTES-LES-VALENCE, FRANCE:  
4,591,150, PUB. 6-10-2014. INT. CL. 31.
- CLAYTON BLOCK CO., INC., LAKEWOOD, NJ:  
3,353,560, CANC. INT. CL. 19.
- CLAYTON KIMBROUGH, BOWIE, MD:  
4,592,391, PUB. 6-10-2014. U.S. CL. 200.
- CLEAN DIESEL TECHNOLOGIES, INC., VENTURA, CA:  
4,591,015, PUB. 6-10-2014. INT. CL. 7.
- CLEAN SMOKE, LLC, SARASOTA, FL:  
4,594,463, INT. CL. 34.
- CLEAN WATER SERVICES, HILLSBORO, OR:  
4,593,914, INT. CL. 1.
- CLEAR IMAGE, INC., EL DORADO HILLS, CA, DBA IMPACT IMAGES:  
4,591,385, PUB. 6-10-2014. INT. CL. 17.  
4,591,386, PUB. 6-10-2014. INT. CL. 18.  
4,591,387, PUB. 6-10-2014. INT. CL. 21.
- CLEARWATER CAMP FOR GIRLS, MINOCQUA, WI:  
3,351,196, CANC. INT. CL. 41.



CLEARWATER PAPER CORPORATION, SPOKANE, WA:  
2,795,046. REN. 7-23-14. INT. CL. 16.  
4,593,486. INT. CL. 16.

CLEAVER COMPANY, INC., THE, NEW YORK, NY:  
4,593,146. INT. CL. 29.

CLECO CORPORATION, PINEVILLE, LA:  
2,864,102. REN. 7-23-14. MULTIPLE CLASS, INT. CLS. 35,  
36, 37, 39 AND 40.

CLEVER CLICKS, LLC, ESTERO, FL:  
4,592,900. PUB. 6-10-2014. MULTIPLE CLASS, INT. CLS.  
25 AND 41.

CLIF BAR & COMPANY, EMERYVILLE, CA:  
3,350,887. CANC. INT. CL. 32.

CLIMAFY.COM, INC, BROOKLYN, NY:  
4,591,260. PUB. 6-10-2014. MULTIPLE CLASS, INT. CLS.  
35, 41 AND 42.

CLINIQUE LABORATORIES, LLC, NEW YORK, NY:  
4,593,960. INT. CL. 3.  
4,594,306. INT. CL. 3.

CLOPAY BUILDING PRODUCTS COMPANY, INC., MA-  
SON, OH:  
2,864,842. REN. 7-21-14. INT. CL. 19.

CLOSET TAILORS LLC, ORANGE, CA:  
3,353,956. CANC. INT. CL. 35.

CLOSET TAILORS, INC., ORANGE, CA:  
3,353,957. CANC. INT. CL. 35.

CLOSET WORKS, INC., ELMHURST, IL:  
3,354,300. CANC. INT. CL. 9.

CLOUD B, INC., GARDENA, CA:  
4,594,378. INT. CL. 28.

CLOUDMILLS LLC, ORLANDO, FL:  
4,591,757. PUB. 6-10-2014. INT. CL. 9.

CLOVER ONE, LLC, WILMINGTON, DE:  
4,593,578. INT. CL. 7.  
4,593,579. INT. CL. 40.

CLOVERSHIELD, INC., LA JOLLA, CA:  
4,593,254. INT. CL. 5.

CLUB DE FUTBOL AMERICA, S.A. DE C.V., OBREGON  
MEXICO, MEXICO:  
4,591,609. PUB. 6-10-2014. INT. CL. 32.

CLUBHOUSE GRILL INC., ROCHESTER, NY:  
4,592,829. PUB. 6-10-2014. INT. CL. 43.

CM ENTERPRISES, CHATSWORTH, CA:  
4,592,632. PUB. 6-10-2014. INT. CL. 9.

CMPS INSTITUTE, LLC, ANN ARBOR, MI:  
3,354,340. CANC. INT. CL. 38.

CNI HOLDING CORPORATION, CLEARWATER, FL:  
2,793,481. CANC. INT. CL. 38.

CNX GAS CORPORATION, PITTSBURGH, PA:  
3,353,563. CANC. INT. CL. 42.

CO.GE.FIN. S.R.L., 25100 BRESCIA, ITALY:  
2,793,942. CANC. INT. CL. 11.

COACH MAX AZ LLC, SANDY, UT, DBA TRAINING  
THINK TANK:  
4,592,007. PUB. 6-10-2014. INT. CL. 41.

COACH SERVICES, INC., NEW YORK, NY:  
4,593,218. INT. CL. 24.

COAST DENTAL SERVICES, INC., TAMPA, FL:  
2,934,953. REN. 7-24-14. INT. CL. 44.

COAST HOTELS LIMITED, VANCOUVER, BC, CANADA:  
3,500,039. CANC. MULTIPLE CLASS, INT. CLS. 39 AND  
41.

COAST TIRE & AUTO SERVICE LTD., SAINT JOHN, NEW  
BRUNSWICK, CANADA:  
2,794,233. CANC. MULTIPLE CLASS, INT. CLS. 35 AND  
37.

COAST 2 COAST FINE ART SERVICES, INC., PHOENIX, AZ:  
3,350,818. CANC. INT. CL. 39.

COASTAL CONSERVATION ASSOCIATION, HOUSTON,  
TX:  
4,592,988. PUB. 6-10-2014. INT. CL. 35.

COATES BROTHERS PLC, LONDON, ENGLAND:  
1,626,522. CANC. INT. CL. 2.

COBB TUNING PRODUCTS LLC, PLANO, TX:  
3,354,532. CANC. INT. CL. 9.

COBE DEVELOPMENT, LC, MESA, AZ:  
3,352,411. CANC. INT. CL. 37.

CODAN HOLDING GMBH, 23738 LENSahn, FED REP  
GERMANY:  
3,354,093. CANC. INT. CL. 10.

CODE ADN, MONTANAY, FRANCE:  
4,591,547. PUB. 6-10-2014. INT. CL. 9.

CODE STRICT LLC, LOS ANGELES, CA:  
4,594,080. INT. CL. 9.

COEUR D'ALENE CASINO, WORLEY, ID:  
4,593,021. PUB. 6-10-2014. INT. CL. 25.  
4,593,022. PUB. 6-10-2014. INT. CL. 28.

COEUR D'ALENE TRIBE, WORLEY, ID, DBA COEUR  
D'ALENE TRIBAL CASINO:  
4,593,023. PUB. 6-10-2014. INT. CL. 18.

COGNIMED INC., LIVINGSTON, NJ:  
3,354,617. CANC. INT. CL. 41.

COGNIS IP MANAGEMENT GMBH, MONHEIM, FED REP  
GERMANY:  
1,848,454. REN. 7-18-14. INT. CL. 1.

COGNITEA, LLC, NEEDHAM, MA:  
4,594,407. INT. CL. 30.

COHEN, MICHAEL, MARTINEZ, GA:  
4,590,618. PUB. 6-10-2014. INT. CL. 16.

COHEN, MORGAN, BASEL, SWITZERLAND, DBA COHEN  
SYSTEMS:  
4,593,664. INT. CL. 9.

COLBY, GREG B., BRISTOL, IN:  
2,794,573. CANC. INT. CL. 38.

COLDX APS, HAVDRUP, DENMARK:  
3,350,628. CANC. INT. CL. 5.

COLE COMPANY, LLC, TULSA, OK:  
2,794,965. CANC. INT. CL. 25.

COLE CORPORATION INC., SEVERNA PARK, MD, DBA  
TITLE EXCELLENCE:  
4,591,359. PUB. 6-10-2014. INT. CL. 45.

COLEMAN HINES INC., PHOENIX, AZ:  
2,794,066. CANC. MULTIPLE CLASS, INT. CLS. 35 AND  
36.

COLEMAN, MICK, CHINO VALLEY, AZ:  
4,594,285. INT. CL. 42.

COLESON FOODS, INC., COLORADO SPRINGS, CO:  
2,911,292. REN. 7-18-14. INT. CL. 29.  
2,919,075. REN. 7-18-14. INT. CL. 29.

COLGATE-PALMOLIVE COMPANY, NEW YORK, NY:  
2,938,767. REN. 7-20-14. INT. CL. 3.  
4,593,662. INT. CL. 3.  
4,593,684. INT. CL. 3.  
4,593,689. INT. CL. 3.  
4,593,705. INT. CL. 3.  
4,593,744. INT. CL. 3.

COLIBRI CORPORATION, PROVIDENCE, RI:  
2,795,887. CANC. INT. CL. 34.

COLIN COWIE TRADEMARKS, LLC, NEW YORK, NY:  
4,591,149. PUB. 6-10-2014. INT. CL. 35.

COLLABNET, INC., BRISBANE, CA:  
3,351,636. CANC. INT. CL. 38.  
3,351,637. CANC. INT. CL. 41.  
3,351,639. CANC. INT. CL. 42.  
3,351,694. CANC. INT. CL. 9.

COLLEGETOWN RELOCATION, L.L.C., PRINCETON, NJ:  
2,796,293. CANC. MULTIPLE CLASS, INT. CLS. 25 AND  
35.

COLLINS, ANNE FRANCES, ENGLAND, UNITED KING-  
DOM:  
3,350,675. CANC. MULTIPLE CLASS, INT. CLS. 9 AND  
16.

COLLINS, MICHAEL, BLANCHARD, OK:  
4,593,352. MULTIPLE CLASS, INT. CLS. 13 AND 28.

COLON CANCER ALLIANCE, WASHINGTON, DC:  
4,591,794. PUB. 6-10-2014. INT. CL. 45.

COLON HYDROPREP SOLUTIONS, LLC, SOUTH LAKE  
TAHOE, CA:  
4,593,999. MULTIPLE CLASS, INT. CLS. 41 AND 44.

COLONIAL MIRROR & GLASS CORPORATION, BROOK-  
LYN, NY:  
3,352,187. CANC. MULTIPLE CLASS, INT. CLS. 19 AND  
21.

COLOPLAST A/S, HUMLEBAEK, DENMARK:  
3,353,225. CANC. INT. CL. 10.

- COLOPLAST A/S, DENMARK:  
4,590,839, PUB. 6-10-2014. INT. CL. 10.
- COLOR BLIND DATING, LLC, DEARBORN, MI:  
3,350,794, CANC. INT. CL. 45.
- COLOR ME MINE ENTERPRISES, INC., GLENDALE, CA,  
DBA COLOR ME MINE:  
4,592,070, PUB. 6-10-2014. INT. CL. 41.
- COLORADO BARRICADE COMPANY, LLC, DENVER, CO:  
4,591,467, PUB. 6-10-2014. INT. CL. 37.  
4,591,478, PUB. 6-10-2014. INT. CL. 37.
- COLUCCI, KATHRYN, MADISON, WI AND COLUCCI,  
LAMONT, MADISON, WI:  
4,594,066, INT. CL. 25.
- COLUMBIA COLLEGE CHICAGO, CHICAGO, IL:  
3,350,693, CANC. MULTIPLE CLASS, INT. CLS. 20, 21  
AND 26.
- COLUMBIA INSURANCE COMPANY, OMAHA, NE:  
3,354,234, CANC. INT. CL. 25.
- COLUMBIAN HOME PRODUCTS, LLC, TERRE HAUTE, IN:  
3,351,866, CANC. INT. CL. 21.
- COMERCIALIZADORA KRAVIVA SPA, SANTIAGO,  
CHILE:  
4,590,980, PUB. 6-10-2014. INT. CL. 5.
- COMFORT PRODUCTS, INC., MEMPHIS, TN:  
3,353,470, CANC. INT. CL. 9.
- COMMEMORATIVE BRANDS, INC., AUSTIN, TX:  
989,301, REN. 7-19-14. INT. CL. 14.
- COMMERCIAL BUSINESS SERVICES LLC, WAYCROSS,  
GA:  
3,350,807, CANC. INT. CL. 31.
- COMMODITY FLOW LIMITED, LONDON, UNITED KING-  
DOM:  
4,549,807, COR. MULTIPLE CLASS, INT. CLS. 9, 35 AND  
42.
- COMMONWEALTH NETWORK SOLUTIONS, GLEN AL-  
LEN, VA:  
3,351,545, CANC. INT. CL. 42.
- COMMONWELL HEALTH ALLIANCE INC., VIENNA, VA:  
4,591,111, PUB. 6-10-2014. MULTIPLE CLASS, INT. CLS.  
35, 42 AND 44.
- COMMUNICATION ARTS INSTITUTE, INC., EUREKA  
SPRINGS, AR:  
3,352,942, CANC. INT. CL. 25.  
3,352,943, CANC. INT. CL. 9.
- COMMUNITY ASSOCIATION WEB SOLUTIONS, INC.,  
PLANTATION, FL, DBA MYCOMMUNITYASSOCIA-  
TION.COM:  
3,350,704, CANC. INT. CL. 42.
- COMMUNITY EDUCATION GROUP, INC., WASHINGTON,  
DC:  
4,591,864, PUB. 6-10-2014. MULTIPLE CLASS, INT. CLS.  
35 AND 41.
- COMMUNITY INITIATIVES, SAN FRANCISCO, CA:  
4,591,513, PUB. 6-10-2014. INT. CL. 41.
- COMNISUS, LLC, SCHENEVUS, NY:  
3,353,107, CANC. INT. CL. 3.
- COMODITA LLC, WALPOLE, MA:  
4,592,306, PUB. 6-10-2014. INT. CL. 10.
- COMPAGNIE GERVAIS DANONE, 75009 PARIS, FRANCE:  
3,352,016, CANC. MULTIPLE CLASS, INT. CLS. 29, 30  
AND 32.
- COMPASS GROUP USA, INC., CHARLOTTE, NC:  
4,593,055, PUB. 6-10-2014. INT. CL. 43.
- COMPASS INTERNATIONAL CORPORATION LIMITED,  
CHAI WAN, HONG KONG:  
4,593,799, INT. CL. 9.
- COMPETITIVE SOLUTIONS, INC., RALEIGH, NC:  
3,354,575, CANC. INT. CL. 41.
- COMPLEMENTARY COATINGS CORP., MONTVALE, NJ:  
1,851,841, REN. 7-21-14. INT. CL. 2.
- COMPTOIR NOUVEAU DE LA PARFUMERIE, 75008 PARIS,  
FRANCE:  
4,591,450, PUB. 6-10-2014. INT. CL. 3.
- COMPU-IMAGING, INC., MIAMI, FL:  
3,353,517, CANC. INT. CL. 2.
- COMPUTER EVIDENCE SPECIALISTS, LLC, SAINT AU-  
GUSTINE, FL:  
4,592,456, PUB. 6-10-2014. INT. CL. 42.
- COMPUTER UPGRADE KING LLC, MIDLOTHIAN, VA:  
4,591,896, PUB. 6-10-2014. INT. CL. 35.
- COMPUTERLOGIC, INC., MACON, GA:  
2,965,184, REN. 7-24-14. INT. CL. 9.
- COMPUTERS FOR MARKETING CORPORATION, SAN  
FRANCISCO, CA, AKA CFMC:  
4,592,730, PUB. 6-10-2014. INT. CL. 9.
- CONAGRA FOODS RDM, INC., OMAHA, NE, HUNT-  
WESSON FOODS, INC., FULLERTON, CA:  
989,702, REN. 7-24-14. U.S. CL. 46 (INT. CLS. 1, 5, 29, 30, 31  
AND 32).
- CONAIR CIP, INC., STAMFORD, CT TO CONAIR COR-  
PORATION, STAMFORD, CT:  
2,796,017, CANC. INT. CL. 11.
- CONAIR CORPORATION, STAMFORD, CT:  
4,594,028, INT. CL. 21.
- CONCORD CONSULTING CORPORATION, SHERWOOD  
PARK, ALBERTA, CANADA:  
4,593,563, INT. CL. 35.
- CONCORD EFS, INC., GREENWOOD VILLAGE, CO:  
2,863,230, REN. 7-18-14. INT. CL. 36.
- CONCORDE CAPITAL INC., SOUTHWEST RANCHES, FL:  
2,793,999, CANC. MULTIPLE CLASS, INT. CLS. 25 AND  
35.
- CONCORDIA PUBLISHING HOUSE, ST. LOUIS, MO:  
3,353,187, CANC. INT. CL. 16.
- CONG TY CO PHAN VAN PHONG PHAM HONG HA  
(HONG HA STATIONERY JOINT STOCK COMPANY),  
HOAN KIEM, HA NOI, VIETNAM:  
3,352,154, CANC. INT. CL. 16.
- CONICAL HEALTH TECHNOLOGIES INC., BAINSVILLE,  
ONTARIO, CANADA:  
3,353,099, CANC. INT. CL. 10.
- CONNECTIONS EDUCATION LLC, BALTIMORE, MD:  
3,352,525, CANC. INT. CL. 41.
- CONNELLY, DAN, SAN DIEGO, CA AND PRIEBE, JOSH,  
HUNTINGTON BEACH, CA:  
4,591,370, PUB. 6-10-2014. INT. CL. 28.
- CONNEXIONS LOYALTY, INC., RICHMOND, VA:  
2,796,353, CANC. INT. CL. 35.
- CONNOR, JAMAR, BROOKLYN, NY:  
4,591,994, PUB. 6-10-2014. INT. CL. 9.
- CONOPCO, INC., ENGLEWOOD CLIFFS, NJ:  
3,353,715, CANC. INT. CL. 3.
- CONQUER GEAR INC., BOCA RATON, FL:  
4,591,872, PUB. 6-10-2014. INT. CL. 25.
- CONQUER YOURSELF LLC, TENINO, WA:  
3,354,331, CANC. INT. CL. 25.
- CONSCIOUS GIRLFRIEND, HEALDSBURG, CA, DBA HEA-  
LERS LIFE:  
4,592,368, PUB. 6-10-2014. INT. CL. 41.
- CONSCIOUSLY SOCIAL LLC, SOLANA BEACH, CA:  
3,351,366, CANC. INT. CL. 41.
- CONSEAL INTERNATIONAL INCORPORATED, NOR-  
WOOD, MA:  
4,594,690, INT. CL. 1.
- CONSERVATION INTERNATIONAL FOUNDATION, AR-  
LINGTON, VA:  
4,591,192, PUB. 6-10-2014. INT. CL. 9.
- CONSERVATIVE FOUNDATION, ENCINO, CA:  
4,592,181, PUB. 6-10-2014. INT. CL. 41.
- CONSORZIO TUTELA SPECK ALTO ADIGE - SÜDTIRO-  
LER SPECK CONSORTIUM, ITALY:  
4,590,630, PUB. 6-10-2014. INT. CL. 29.
- CONSPIRACY INC., LOS ANGELES, CA:  
4,592,928, PUB. 6-10-2014. INT. CL. 34.  
4,593,038, PUB. 6-10-2014. INT. CL. 34.
- CONSTELLATION BRANDS U.S. OPERATIONS, INC., CA-  
NANDAIGUA, NY:  
4,593,268, INT. CL. 33.
- CONSTRUCTION RESEARCH & TECHNOLOGY GMBH,  
TROSTBERG, FED REP GERMANY:  
4,593,251, INT. CL. 1.
- CONSUMER FINANCIAL PROTECTION BUREAU, WA-  
SHINGTON, DC:  
4,590,605, PUB. 6-10-2014. MULTIPLE CLASS, INT. CLS.  
35, 36 AND 41.

CONTEGO INTERNATIONAL, INC., ROCHESTER, IN:  
 4,591,884, PUB. 4-22-2014. INT. CL. 2.  
 CONTENDER PARTNERS, LLC, SANTA MONICA, CA:  
 3,354,449, CANC. INT. CL. 25.  
 CONTESSA PREMIUM FOODS, INC., SEWICKLEY, PA:  
 2,793,636, CANC. INT. CL. 29.  
 CONTINENTAL ACCESSORY CORPORATION, AMITY-  
 VILLE, NY:  
 4,593,679, MULTIPLE CLASS, INT. CLS. 16 AND 20.  
 CONTINENTAL AUTOMOTIVE GMBH, FED REP GER-  
 MANY:  
 4,590,806, PUB. 6-10-2014. MULTIPLE CLASS, INT. CLS.  
 7, 8, 9, 11, 12, 16, 35, 36, 37 AND 42.  
 CONTINENTAL GIRBAU, INC., OSHKOSH, WI:  
 4,591,251, PUB. 6-10-2014. MULTIPLE CLASS, INT. CLS. 7  
 AND 11.  
 CONTINENTAL GREEN, INC., NORTH HOLLYWOOD, CA:  
 4,591,838, PUB. 6-10-2014. INT. CL. 42.  
 CONTON, VERONICA, L., NEW YORK, NY:  
 3,353,381, CANC. INT. CL. 25.  
 CONTOUR DESIGN, INC., WINDHAM, NH:  
 3,351,310, CANC. INT. CL. 9.  
 CONTROLWORX, L.L.C., BATON ROUGE, LA:  
 4,535,800, COR. MULTIPLE CLASS, INT. CLS. 37 AND  
 42.  
 CONVERGYS INFORMATION MANAGEMENT GROUP  
 INC., CINCINNATI, OH:  
 2,795,221, CANC. INT. CL. 35.  
 CONVERSION CAPITAL, LLC, NEW YORK, NY:  
 4,593,634, MULTIPLE CLASS, INT. CLS. 35 AND 36.  
 CONVERSION VAN MARKETING ASSOCIATION, INC.,  
 ELKHART, IN:  
 3,353,287, CANC. INT. CL. 12.  
 CONVERTIBLE SOLUTIONS LLC, SEDALIA, MO:  
 3,353,128, CANC. INT. CL. 16.  
 CONWEST RESOURCES, INC., SAN FRANCISCO, CA:  
 3,351,783, CANC. MULTIPLE CLASS, INT. CLS. 35 AND  
 41.  
 COOK MEDICAL TECHNOLOGIES LLC, BLOOMINGTON,  
 IN:  
 1,843,572, REN. 7-20-14. INT. CL. 10.  
 2,795,866, CANC. INT. CL. 10.  
 2,796,186, CANC. INT. CL. 10.  
 3,353,012, CANC. INT. CL. 10.  
 COOKE, JOHN B., SUN LAKES, AZ:  
 3,351,516, CANC. INT. CL. 28.  
 COOKEVER, INC., FULLERTON, CA:  
 3,351,642, CANC. INT. CL. 21.  
 COOL GEAR INTERNATIONAL, LLC., JENKINTOWN, PA:  
 4,593,618, INT. CL. 11.  
 COOLEY LLP, PALO ALTO, CA:  
 3,354,442, CANC. INT. CL. 42.  
 COOPER & COMPANY, INC., CINCINNATI, OH:  
 4,591,587, PUB. 1-7-2014. INT. CL. 34.  
 COOPERATIVA AGRÍCOLA PISQUERA ELQUI LIMITADA,  
 PERALILLO- VICUÑA, CHILE:  
 4,590,999, PUB. 6-10-2014. INT. CL. 33.  
 COOVIT, INC., NEW YORK, NY:  
 4,593,090, MULTIPLE CLASS, INT. CLS. 38, 42 AND 45.  
 COPART, INC., DALLAS, TX:  
 2,802,136, REN. 7-18-14. INT. CL. 35.  
 COPELAND ENTERPRISES, SAN LUIS OBISPO, CA, DBA  
 COPELAND SPORTS:  
 3,351,978, CANC. INT. CL. 35.  
 COPIA INTERACTIVE, LLC, NEW YORK, NY:  
 4,593,132, MULTIPLE CLASS, INT. CLS. 38 AND 42.  
 COPPERTAIL BREWING CO LLC, TAMPA, FL:  
 4,594,509, INT. CL. 32.  
 COPTERVIEWS, LLC, MYRTLE BEACH, SC:  
 3,351,091, CANC. INT. CL. 41.  
 CORE CARE MEDICAL LLC, SPARTANBURG, SC:  
 4,593,855, INT. CL. 9.  
 CORMATRIX CARDIOVASCULAR, INC., ROSWELL, GA:  
 4,593,741, INT. CL. 5.  
 CORN PRODUCTS DEVELOPMENT, INC., WESTCHESTER,  
 IL:  
 3,353,814, CANC. INT. CL. 30.  
 4,593,379, MULTIPLE CLASS, INT. CLS. 1, 5 AND 42.  
 CORN PUBLISHING, WEST DES MOINES, IA:  
 4,591,914, PUB. 6-10-2014. INT. CL. 41.  
 CORNING OPTICAL COMMUNICATIONS BRANDS, INC.,  
 WILMINGTON, DE:  
 4,593,524, INT. CL. 9.  
 CORONEL, MARC, NORTH HOLLYWOOD, CA, DBA LIFE-  
 STYLE ATHLETICS:  
 4,592,300, PUB. 6-10-2014. INT. CL. 41.  
 4,592,803, PUB. 6-10-2014. INT. CL. 41.  
 CORRPAK BULK PACKAGING SYSTEMS, MONROE, LA:  
 4,591,493, PUB. 6-10-2014. INT. CL. 22.  
 CORSAN INVENTIONS CORP., AGUADILLA, PUERTO  
 RICO:  
 4,593,259, INT. CL. 28.  
 CORT, R. ANTHONY, PRINCETON, NJ:  
 3,353,960, CANC. INT. CL. 38.  
 COSCARELLI, MELISSA A., SPRINGFIELD, NJ:  
 3,352,849, CANC. INT. CL. 25.  
 COSMIC REIKI LLC, PHILADELPHIA, PA:  
 3,351,626, CANC. INT. CL. 44.  
 COSMICA S.A., LUXEMBOURG:  
 4,590,737, PUB. 6-10-2014. INT. CL. 3.  
 COSMO FREIGHT SOLUTIONS, INC., JAMAICA, NY:  
 4,592,213, PUB. 6-10-2014. INT. CL. 39.  
 COT'N WASH, INC., ARDMORE, PA:  
 3,352,005, CANC. INT. CL. 3.  
 COUGHLIN, CHRIS, GLENDALE, AZ:  
 4,594,523, INT. CL. 16.  
 COUNCIL FOR SCIENTIFIC AND INDUSTRIAL RE-  
 SEARCH, PRETORIA, GAUTENG, SOUTH AFRICA:  
 4,594,076, INT. CL. 1.  
 COUNSEL FINANCIAL SERVICES, LLC, WILLIAMSVILLE,  
 NY:  
 3,422,761, COR. INT. CL. 36.  
 COUPONS.COM INCORPORATED, MOUNTAIN VIEW, CA:  
 4,593,567, MULTIPLE CLASS, INT. CLS. 9 AND 42.  
 COUPONS, LLC, ATLANTA, GA:  
 2,794,993, CANC. INT. CL. 35.  
 COURBIS SYNTHÈSE S.A., F-26100 ROMANS, FRANCE:  
 2,859,310, REN. 7-18-14. MULTIPLE CLASS, INT. CLS. 12  
 AND 17.  
 2,859,310, CANC. INT. CL. 20.  
 COUSINS SUBMARINES, INC., MENOMONEE FALLS, WI:  
 3,350,809, CANC. INT. CL. 41.  
 COUSMOOR GIFTS, LLC, KIHEI, HI:  
 4,592,144, PUB. 6-10-2014. INT. CL. 35.  
 COVERWRAP COMMUNICATIONS LLC, VERO BEACH,  
 FL:  
 4,594,620, INT. CL. 35.  
 COVIDIEN LP, MANSFIELD, MA:  
 1,899,743, REN. 7-21-14. INT. CL. 10.  
 2,864,888, REN. 7-24-14. INT. CL. 10.  
 4,593,751, INT. CL. 10.  
 COWAY CO., LTD., CHOONGCHEONGNAM-DO, REPUB-  
 LIC OF KOREA:  
 2,919,385, REN. 7-23-14. INT. CL. 11.  
 COYLE, DOUGLAS, AUSTIN, TX AND HARRISON, ERIC,  
 AUSTIN, TX:  
 4,594,269, MULTIPLE CLASS, INT. CLS. 9 AND 41.  
 COYOTE MANAGEMENT, L.P., ADDISON, TX:  
 2,793,472, CANC. INT. CL. 36.  
 COZEN O'CONNOR, P.C., PHILADELPHIA, PA:  
 2,965,222, REN. 7-24-14. INT. CL. 35.  
 CPI HOLDINGS I, INC., LITTLETON, CO:  
 2,860,296, REN. 7-21-14. MULTIPLE CLASS, INT. CLS. 9,  
 16 AND 20.  
 CRAFT WHOLESALEERS, INC., REYNOLDSBURG, OH:  
 3,350,850, CANC. INT. CL. 35.  
 CRANBERRY ISLES FISHERMEN'S CO-OPERATIVE, INC.,  
 ISLESFORD, ME:  
 4,594,729, MULTIPLE CLASS, INT. CLS. 29 AND 31.  
 CRANEO B.V., NETHERLANDS:  
 3,352,620.  
 CRAWLSPACE SOLUTIONS A HEALTHY HOME, LLC,  
 HIGHLANDS, NC:  
 4,591,999, PUB. 6-10-2014. INT. CL. 37.  
 CREATIONS NELSON, PARIS, FRANCE:  
 4,590,851, PUB. 6-10-2014. INT. CL. 25.

- CREATIVE SAFETY SUPPLY, BEAVERTON, OR:  
4,592,839, PUB. 6-10-2014. INT. CL. 17.
- CREATIVE SOLUTIONS INTERNATIONAL, INC., WILMINGTON, DE:  
2,793,528, CANC. MULTIPLE CLASS, INT. CLS. 35 AND 42.
- CREATIVE SPIRITS, INC., SPIRIT LAKE, IA:  
4,592,979, PUB. 6-10-2014. INT. CL. 41.
- CREATURE COMFORTS BREWING COMPANY LLC, ATHENS, GA:  
4,594,250, INT. CL. 32.
- CREDENTIAL CHECK CORPORATION, TROY, MI:  
3,283,948, CANC. INT. CL. 45.
- CREDIT BUREAU OF GREATER GREENSBORO, INC., GREENSBORO, NC:  
2,872,000, REN. 7-23-14. MULTIPLE CLASS, INT. CLS. 35 AND 45.
- CREDITGUARD CORPORATION, HAMDEN, CT:  
4,592,294, PUB. 6-10-2014. INT. CL. 36.
- CREDO, LLC, WHITSETT, NC:  
3,352,447, CANC. INT. CL. 41.
- CRESA PARTNERS, LLC, BOSTON, MA:  
2,794,206, CANC. MULTIPLE CLASS, INT. CLS. 35, 36, 37 AND 42.
- CRESCENT ELECTRIC SUPPLY COMPANY, EAST DUBUQUE, IL:  
3,351,656, CANC. INT. CL. 36.
- CRF, INC., PLYMOUTH MEETING, PA, DBA CRF HEALTH:  
4,593,141, INT. CL. 42.
- CRI SOLUTIONS, INC., ELKRIDGE, MD:  
4,591,470, PUB. 6-10-2014. MULTIPLE CLASS, INT. CLS. 35 AND 42.
- CRIF CORPORATION, ATLANTA, GA:  
2,860,999, REN. 7-21-14. INT. CL. 36.
- CRIMSON CIRCLE LLC, INDIANAPOLIS, IN:  
4,592,805, PUB. 6-10-2014. INT. CL. 43.
- CRIPPLE DOG, INC., NORTH CHARLESTON, SC:  
3,352,975, CANC. MULTIPLE CLASS, INT. CLS. 12, 25, 35, 37 AND 40.
- CRISIS MANAGEMENT SYSTEMS, INC., CHARLOTTESVILLE, VA:  
4,591,717, PUB. 6-10-2014. INT. CL. 45.
- CRISTA MINISTRIES, SEATTLE, WA:  
3,352,261, CANC. MULTIPLE CLASS, INT. CLS. 38 AND 41.
- CRITICAL THINKING BOOKS & SOFTWARE, PACIFIC GROVE, CA:  
3,350,625, CANC. INT. CL. 16.
- CROSS CREEK ENTERPRISES, INC., RANCHO CUCAMON-GA, CA:  
4,594,138, INT. CL. 33.
- CROSS MACHINE TOOL CO., INC., LEXINGTON, TN:  
4,591,712, PUB. 6-10-2014. INT. CL. 13.
- CROSSBOW CONSULTING, L.P., RICHARDSON, TX:  
3,351,763, CANC. INT. CL. 42.
- CROSSFORD INTERNATIONAL, LLC, STAMFORD, CT:  
4,594,555, INT. CL. 22.
- CROSSROADS ENTERPRISES, LLC, ALBUQUERQUE, NM, DBA HERITAGE AUDIO VISUAL:  
4,592,067, PUB. 6-10-2014. INT. CL. 41.
- CROTHERS, BEVERLY LILLIAN, HERTFORDSHIRE, UNITED KINGDOM:  
4,591,037, PUB. 11-5-2013. MULTIPLE CLASS, INT. CLS. 9, 16 AND 41.  
4,591,038, PUB. 11-5-2013. MULTIPLE CLASS, INT. CLS. 18 AND 25.
- CROW RIVER ANIMAL HOSPITAL, LTD., HOWARD LAKE, MN:  
4,594,603, INT. CL. 3.
- CROWNWHEEL PARTNERS, LLC, MENLO PARK, CA:  
4,593,881, INT. CL. 36.
- CRT MEDICAL SYSTEMS, INC., NOVI, MI:  
4,593,943, INT. CL. 35.
- CRTS, INC., TULSA, OK:  
4,591,957, PUB. 6-10-2014. INT. CL. 37.
- CRUMB & GET IT COOKIE COMPANY INC., BLACKSBURG, VA:  
4,591,019, PUB. 4-23-2013. INT. CL. 35.  
4,591,023, PUB. 4-23-2013. INT. CL. 30.
- CRUMBS & COMFORT BY GRAZIELLA, LLC, STONERIDGE, VA, DBA CRUMBS & COMFORT BY GRAZIELLA; CRUMBS & COMFORT, LLC; CRUMBS AND COMFORT:  
4,593,344, MULTIPLE CLASS, INT. CLS. 30 AND 40.
- CRUZ BAY PUBLISHING, INC., EL SEGUNDO, CA:  
2,794,279, CANC. INT. CL. 16.  
4,592,942, PUB. 6-10-2014. INT. CL. 41.  
4,592,943, PUB. 6-10-2014. INT. CL. 41.
- CST DATA, LLC, CHARLOTTE, NC:  
2,863,260, REN. 7-23-14. MULTIPLE CLASS, INT. CLS. 39 AND 40.
- CULLETON, FRANK E., NASHUA, NH, DBA BODY MIND SYSTEMS:  
4,592,505, PUB. 6-10-2014. INT. CL. 41.
- CULMINATION PROJECT, LLC, VALLEY VILLAGE, CA:  
4,592,388, PUB. 6-10-2014. INT. CL. 35.  
4,592,399, PUB. 6-10-2014. INT. CL. 35.
- CULT OF 8, INC., MONTEREY, CA:  
4,593,216, INT. CL. 33.
- CULTURAL SURVIVAL, INC., CAMBRIDGE, MA:  
3,352,278, CANC. MULTIPLE CLASS, INT. CLS. 16 AND 25.
- CUMMINGS, BEN, VICTOR, NY:  
4,592,331, PUB. 6-10-2014. INT. CL. 21.
- CUMMINS-ALLISON CORP., MOUNT PROSPECT, IL:  
4,591,533, PUB. 6-10-2014. INT. CL. 36.
- CUPCAKE CRAZY, LLC, CINCINNATI, OH, DBA CUPCAKE CRAZY:  
4,594,738, INT. CL. 30.
- CURATORS OF THE UNIVERSITY OF MISSOURI, COLUMBIA, MO:  
3,463,511, CANC. INT. CL. 25.
- CURB, LINDA, NASHVILLE, TN:  
4,593,644, INT. CL. 16.
- CURE MEDICAL, LLC, NEWPORT BEACH, CA:  
4,591,923, PUB. 5-6-2014. INT. CL. 10.
- CURRENT TECHNOLOGIES, LLC, GERMANTOWN, MD:  
2,794,655, CANC. INT. CL. 9.
- CURT'S SPICE CO. & OILERIE, LLC, FISH CREEK, WI:  
4,594,507, INT. CL. 3.
- CURTIS 1000 INC., DULUTH, GA, CURTIS 1000 INC., SMYRNA, GA:  
1,291,006, REN. 7-24-14. INT. CL. 16.
- CURVES INTERNATIONAL, INC., WOODWAY, TX:  
4,592,707, PUB. 6-10-2014. INT. CL. 9.
- CURVITECTURE INC., BOULDER, CO:  
3,353,946, CANC. INT. CL. 42.
- CUSH FAMILY HOLDINGS PTY LTD., NOOSAVILLE QLD, AUSTRALIA:  
4,594,023, INT. CL. 28.
- CUSTOM MAT COMPANY, INC., HOUSTON, TX:  
4,592,352, PUB. 6-10-2014. INT. CL. 35.
- CUSTOM MOLDED PRODUCTS, INC., NEWNAN, GA:  
4,593,768, MULTIPLE CLASS, INT. CLS. 1, 6, 9, 21 AND 22.
- CUSTOM MORTGAGE SOLUTIONS, INC., CHARLOTTE, NC:  
3,354,514, CANC. INT. CL. 36.
- CVS PHARMACY, INC., WOONSOCKET, RI:  
4,591,680, PUB. 6-10-2014. INT. CL. 35.
- CYBER MEDICAL IMAGING, INC., LOS ANGELES, CA:  
4,591,086, PUB. 6-10-2014. MULTIPLE CLASS, INT. CLS. 9, 10, 41 AND 42.
- CYBER-CISE, INC., COLUMBIA, MD:  
3,352,953, CANC. INT. CL. 41.
- CYBERBODYSHOP, SAN JOSE, CA:  
4,592,012, PUB. 6-10-2014. INT. CL. 41.
- CYBERSOFT, INC., CONSHOHOCKEN, PA:  
2,871,210, REN. 7-24-14. MULTIPLE CLASS, INT. CLS. 9, 41 AND 42.
- CYFEX AG, SWITZERLAND:  
4,590,905, PUB. 6-10-2014. MULTIPLE CLASS, INT. CLS. 9 AND 10.

CYTYC CORPORATION, MARLBOROUGH, MA:  
3,189,273, COR. INT. CL. 10.

D & M NEW WORLD MANAGEMENT, INC., FREEPORT, NY:  
4,591,646, PUB. 6-10-2014. INT. CL. 33.

D.LAZZARONI & C S.P.A., 21047 SARONNO(VA), ITALY:  
3,352,037, CANC. INT. CL. 30.

D-MAC MARKETING, LLC., BETHLEHEM, PA:  
4,593,818, INT. CL. 30.

D'ATLANTIS, LOS ANGELES, CA:  
3,354,289, CANC. INT. CL. 14.

D'USSE LLC, CORAL GABLES, FL:  
4,591,244, PUB. 6-10-2014. INT. CL. 33.

DAB DOOR COMPANY, INC., HIALEAH GARDENS, FL:  
4,593,557, INT. CL. 6.

DACA DESIGN LLC, GARDEN CITY, NY:  
4,593,765, INT. CL. 9.

DACO CORPORATION, KENT, WA:  
4,594,091, MULTIPLE CLASS, INT. CLS. 7 AND 12.

DAD'S HOME SERVICES & CONSTRUCTION, INC., LAKE FOREST, CA:  
3,352,957, CANC. INT. CL. 37.  
3,352,958, CANC. INT. CL. 37.

DADDONA, MICHAEL, WATERBURY, CT:  
4,591,212, PUB. 6-10-2014. INT. CL. 37.

DAEWON MEDIA CO., LTD., SEOUL, REPUBLIC OF KOREA:  
4,593,441, INT. CL. 16.

DAHMS, TIMOTHY, F., KEY WEST, FL:  
4,594,735, INT. CL. 35.

DAI NIPPON INSATSU KABUSHIKI KAISHA, SHINJUKU-KU, TOKYO, JAPAN, DBA DAI NIPPON PRINTING CO., LTD.:  
4,592,151, PUB. 6-10-2014. MULTIPLE CLASS, INT. CLS. 9 AND 42.

DAILWILLIAMS, NIEESHA, SELDEN, NY AND WILLIAMS, TREMAYNE, SELDEN, NY:  
4,592,122, PUB. 6-10-2014. INT. CL. 35.

DAIRYLAND ELECTRICAL INDUSTRIES, INC., STOUGHTON, WI:  
4,591,231, PUB. 6-10-2014. INT. CL. 9.  
4,591,264, PUB. 6-10-2014. INT. CL. 9.

DAISY'S AROMAOLGY, INC., BEVERLY HILLS, CA:  
4,592,648, PUB. 6-10-2014. MULTIPLE CLASS, INT. CLS. 3 AND 4.

DAKLAK RUBBER INVESTMENT JOINT STOCK COMPANY, BUON MA THUOT, DAKLAK, VIETNAM:  
4,590,996, PUB. 6-10-2014. INT. CL. 17.

DAL-CON PROMOTIONS, INC., IRVINE, CA:  
3,352,438, CANC. MULTIPLE CLASS, INT. CLS. 16, 25 AND 26.

DALLAN S.P.A., ITALY:  
4,590,797, PUB. 6-10-2014. MULTIPLE CLASS, INT. CLS. 9, 37 AND 42.

DALLAS REGIONAL CHAMBER, DALLAS, TX:  
1,795,261, CANC. INT. CL. 36.

DALLAS UNIQUE INDOOR COMFORT, LTD., DALLAS, TX:  
4,592,309, PUB. 6-10-2014. INT. CL. 37.

DALLMEIER ELECTRONIC GMBH & CO. KG, REGENSBURG, FED REP GERMANY:  
3,472,466.

DAMON MEYER, ASHLAND, OH:  
4,594,045, INT. CL. 29.

DAN MAR CO., ARLINGTON, TX:  
4,591,628, PUB. 6-10-2014. INT. CL. 11.

DANA POSSICK, CANTON, GA:  
4,593,827, INT. CL. 35.

DANA UNDIEN SALES CORP., NEW YORK, NY:  
3,353,958, CANC. INT. CL. 25.

DANDRIDGE-MCKINNEY, KENYETTA, CLAYTON, NJ:  
3,351,371, CANC. INT. CL. 42.

DANFOSS DRIVES A/S, GRAASTEN, DENMARK:  
4,590,952, PUB. 6-10-2014. MULTIPLE CLASS, INT. CLS. 7 AND 9.

DANG BANH MI LLC, AUSTIN, TX:  
4,593,265, INT. CL. 43.

DANGEROUS CURVES, LLC, MEMPHIS, TN:  
4,594,260, INT. CL. 41.

DANIEL BENKENSTEIN, FED REP GERMANY:  
4,590,712, PUB. 6-10-2014. MULTIPLE CLASS, INT. CLS. 9, 35 AND 42.

DANIEL CHAPTER ONE, PORTSMOUTH, RI:  
2,914,647, REN. 7-24-14. INT. CL. 5.

DANIELA ERBSLÖH, FED REP GERMANY:  
4,590,792, PUB. 6-10-2014. MULTIPLE CLASS, INT. CLS. 9, 18 AND 25.  
4,590,793, PUB. 6-10-2014. MULTIPLE CLASS, INT. CLS. 9, 18 AND 25.

DANIELI & C. OFFICINE MECCANICHE S.P.A., BUTTRIO (UD), ITALY:  
4,591,102, PUB. 12-10-2013. MULTIPLE CLASS, INT. CLS. 7, 9 AND 11.

DANIELLE PETTIFOR, PALM BEACH GARDENS, FL, DBA CREATION FITNESS:  
4,592,635, PUB. 6-10-2014. INT. CL. 28.

DANIELLE REY, FRANCE:  
4,590,741, PUB. 6-10-2014. INT. CL. 3.

DANNON COMPANY, INC., THE, WHITE PLAINS, NY:  
1,265,165, REN. 7-24-14. INT. CL. 29.

DANRYAN INDUSTRIES, INC., WOODRIDGE, IL, DBA DIAPER ONE N DONE:  
4,592,471, PUB. 6-10-2014. MULTIPLE CLASS, INT. CLS. 16 AND 21.

DAOUST, CHRISTIAN, NOELVILLE, CANADA:  
4,591,413, PUB. 6-10-2014. INT. CL. 35.

DAP BRANDS COMPANY, MEDINA, OH:  
3,354,077, CANC. INT. CL. 16.

DARFON INNOVATION CORPORATION, NEIHU DIST, TAIPEI CTY, TAIWAN:  
4,593,693, INT. CL. 12.

DAS GESUNDHEITSHAUS GMBH, AUSTRIA:  
4,590,938, PUB. 6-10-2014. INT. CL. 20.

DATA MANAGEMENT, INCORPORATED, FARMINGTON, CT:  
2,861,996, REN. 7-21-14. INT. CL. 16.

DATA QUEST LTD., BOSTON, MA:  
3,329,506, CANC. INT. CL. 45.

DATA TECHNOLOGIES, INC., MOUNTLAKE TERRACE, WA:  
2,793,373, CANC. INT. CL. 9.

DATAACERT, INC., HOUSTON, TX:  
4,591,245, PUB. 6-10-2014. INT. CL. 9.  
4,591,246, PUB. 6-10-2014. INT. CL. 42.

DATACOLOR HOLDING AG, LUZERN, SWITZERLAND:  
3,350,825, CANC. INT. CL. 9.

DATACOLOR HOLDING AG, CH-6002 LUZERN, SWITZERLAND:  
3,353,278, CANC. INT. CL. 9.

DAUGHERTY SYSTEMS, INC., ST. LOUIS, MO:  
4,593,334, INT. CL. 42.

DAVACO, INC., DALLAS, TX:  
2,868,523, REN. 7-23-14. INT. CL. 37.  
2,868,524, REN. 7-23-14. INT. CL. 37.

DAVAR, ALI, VANCOUVER, BC, CANADA:  
4,593,158, INT. CL. 42.

DAVID G. MAJOR ASSOCIATES, INC., ALEXANDRIA, VA:  
2,794,192, CANC. INT. CL. 41.

DAVID HAM, SANTEE, CA:  
3,350,650, CANC. MULTIPLE CLASS, INT. CLS. 12 AND 20.

DAVID L HOYT, CHICAGO, IL:  
4,594,600, INT. CL. 9.

DAVID LACK, SANTA BARBARA, CA:  
3,351,391, CANC. INT. CL. 37.

DAVID WEBB-MANGAN, SCOTCH PLAINS, NJ:  
3,352,020, CANC. INT. CL. 36.

DAVID, ZOLTAN, AUSTIN, TX:  
3,353,300, CANC. INT. CL. 14.

DAVIDEK, DIRK R., HELOTES, TX:  
4,592,324, PUB. 6-10-2014. MULTIPLE CLASS, INT. CLS. 16, 21 AND 25.

DAVIDSON HOTEL COMPANY LLC, ATLANTA, GA:  
4,592,339, PUB. 6-10-2014. INT. CL. 43.  
4,592,342, PUB. 6-10-2014. INT. CL. 43.

- DAVIDSON, ELI, LOS ANGELES, CA:  
3,350,984, CANC. INT. CL. 41.
- DAVIDSON'S, INC., PRESCOTT, AZ:  
2,796,374, CANC. INT. CL. 35.
- DAWG, INC., PHOENIX, AZ:  
4,592,604, PUB. 6-10-2014. INT. CL. 35.
- DAWSON, IMANI, BROOKLYN, NY:  
4,591,287, PUB. 6-10-2014. MULTIPLE CLASS, INT. CLS. 35 AND 41.
- DAX CONSULTING, LLC, DALLAS, TX, DBA D MO BABY:  
3,351,807, CANC. INT. CL. 25.
- DCC, INC., SANDPOINT, ID:  
4,591,158, PUB. 6-10-2014. INT. CL. 44.
- DD IP HOLDER LLC, CANTON, MA:  
4,591,959, PUB. 6-10-2014. MULTIPLE CLASS, INT. CLS. 25, 29, 30, 32, 35 AND 43.
- DDP SOCIÉTÉ PAR ACTIONS SIMPLIFIÉE, FRANCE:  
3,352,621.
- DE GUSTIBUS, ISSY LES MOULINEAUX, FRANCE:  
4,543,198, COR. INT. CL. 43.
- DE LUCIA, ANTHONY, JR., HARDYSTON, NJ:  
4,592,286, PUB. 6-10-2014. INT. CL. 41.
- DE PAUL UNIVERSITY, CHICAGO, IL:  
1,271,740. REN. 7-21-14. MULTIPLE CLASS, INT. CLS. 16, 20, 21, 24 AND 41.
- DE WEERD BEHEER B.V., 1191 HD, NETHERLANDS:  
4,594,533, INT. CL. 25.
- DEALERS ONLY, LLC, HILLSBORO, OR:  
4,592,037, PUB. 6-10-2014. INT. CL. 35.
- DEAN SHARENOW, NEW YORK, NY:  
3,351,515, CANC. INT. CL. 41.
- DEAR, INC., ATLANTA, GA:  
4,593,638, INT. CL. 33.
- DEARMAN, CHRISTOPHER, R, HUNTLEY, IL:  
3,354,643, CANC. INT. CL. 25.
- DEBRA ALOUISE, SAN DIEGO, CA:  
4,593,694, INT. CL. 8.
- DECATHLON, VILLENEUVE D'ASCQ, FRANCE:  
3,350,769, CANC. MULTIPLE CLASS, INT. CLS. 9 AND 27.  
3,352,500, CANC. MULTIPLE CLASS, INT. CLS. 6, 21 AND 24.
- DECEASED CREDIT MANAGEMENT, LLC, MINNEAPOLIS, MN:  
3,560,072, COR. INT. CL. 35.  
3,626,258, COR. INT. CL. 36.  
4,164,030, COR. INT. CL. 35.
- DECORIA CONFECTIONERY CO., LTD., CHUNGNAM, REPUBLIC OF KOREA:  
4,591,806, PUB. 6-10-2014. INT. CL. 30.
- DEEC, INC., BELLEVUE, WA:  
4,593,763, INT. CL. 11.
- DEENA BAIKOWITZ, NEW YORK, NY:  
4,591,411, PUB. 6-10-2014. INT. CL. 41.  
4,591,412, PUB. 6-10-2014. INT. CL. 41.
- DEER STAGS CONCEPTS INC., NEW YORK, NY:  
3,352,997, CANC. INT. CL. 25.
- DEFLECTO, LLC, INDIANAPOLIS, IN:  
4,593,295, INT. CL. 27.
- DEL MILAGRO PHILBROOK REIKI STONES, INC., COOPER CITY, FL:  
4,594,007, INT. CL. 14.
- DEL MONTE FOODS, INC., SAN FRANCISCO, CA:  
4,593,409, INT. CL. 29.
- DELAVAL INC., KANSAS CITY, MO:  
1,295,444. REN. 7-24-14. INT. CL. 3.
- DELAWARE GOLF ADVENTURES, LLC, MOUNT PLEASANT, SC:  
3,354,608, CANC. INT. CL. 35.
- DELECTABLE DESIGNS LLC, FARMINGTON, MN:  
4,591,461, PUB. 6-10-2014. MULTIPLE CLASS, INT. CLS. 16 AND 35.
- DELHAGEN, DOUGLAS A, OCEAN GROVE, NJ:  
3,354,335, CANC. MULTIPLE CLASS, INT. CLS. 16 AND 25.
- DELICION, LLC, SIOUX FALLS, SD:  
4,593,480, MULTIPLE CLASS, INT. CLS. 9 AND 43.
- DELICION, LLC, SIOUX FALLS, SD, AKA DELICION:  
4,593,726, INT. CL. 41.
- DELICIOUS 62 LLC, SEATTLE, WA:  
4,594,385, INT. CL. 9.
- DELKOR SYSTEMS, INC., CIRCLE PINES, MN:  
3,353,346, CANC. INT. CL. 7.
- DELLA ROSA, ALESSANDRO, NEW YORK, NY:  
4,594,256, INT. CL. 25.  
4,594,257, INT. CL. 25.
- DELMAR GARDEN ENTERPRISES, INC., CHESTERFIELD, MO:  
1,306,331. REN. 7-18-14. INT. CL. 36.
- DELORME PUBLISHING COMPANY, INC., YARMOUTH, ME:  
3,352,320, CANC. MULTIPLE CLASS, INT. CLS. 42 AND 45.
- DELTA AXIS, INC., MEMPHIS, TN:  
3,351,806, CANC. INT. CL. 41.
- DELTEK, INC, HERNDON, VA:  
2,795,805, CANC. INT. CL. 9.
- DELUNA BY DESIGN, INC., NEW YORK, NY:  
4,593,173, INT. CL. 25.
- DEMARCO INTELLECTUAL PROPERTY, LLC, ARLINGTON, VA:  
4,592,744, PUB. 6-10-2014. INT. CL. 45.  
4,592,745, PUB. 6-10-2014. INT. CL. 45.
- DEMERT BRANDS, INC., LUTZ, FL:  
4,594,452, INT. CL. 3.  
4,594,453, INT. CL. 3.
- DEN-MAT HOLDINGS, LLC, LOMPOC, CA:  
2,964,081. REN. 7-24-14. INT. CL. 5.
- DENBY, MICHAEL L., SCOTTSDALE, AZ:  
2,795,821, CANC. INT. CL. 12.
- DENNIS J. BARELA, TEMECULA, CA, DBA TEMECULA'S BEST DJ:  
4,594,760, INT. CL. 41.
- DENNIS M. AMBROSE, NORTH WALES, PA:  
4,591,234, PUB. 6-10-2014. INT. CL. 22.
- DENNIS ROBINSON, LINCOLN, IL:  
4,591,444, PUB. 6-10-2014. MULTIPLE CLASS, INT. CLS. 30 AND 34.
- DENTAL ADVANTAGE, LLC, MINNEAPOLIS, MN:  
3,354,256, CANC. INT. CL. 21.
- DENTERPRISE INTERNATIONAL, INC., ORMOND BEACH, FL:  
4,592,096, PUB. 6-10-2014. INT. CL. 10.
- DENTON BENTON & STEELE, LLC, CHARLOTTSVILLE, VA:  
4,591,468, PUB. 6-10-2014. MULTIPLE CLASS, INT. CLS. 9, 25 AND 41.
- DENTON J. ANDERSON, AURORA, CO:  
3,333,750, CANC. INT. CL. 35.
- DENTSU INC., TOKYO, JAPAN:  
3,354,207, CANC. INT. CL. 16.
- DENVER EQUIPMENT COMPANY OF CHARLOTTE, INC., CHARLOTTE, NC:  
1,844,750. REN. 7-22-14. INT. CL. 37.
- DEPENDABLE GLOBAL EXPRESS, INC., RANCHO DOMINGUEZ, CA:  
3,352,856, CANC. INT. CL. 39.
- DEREK CLARK, TRACY, CA:  
3,350,659, CANC. INT. CL. 36.
- DERESPINIS MD. PATRICK A., STATEN ISLAND, NY:  
3,351,690, CANC. INT. CL. 44.
- DERMAZONE SOLUTIONS, INC., ST. PETERSBURG, FL:  
3,351,944, CANC. INT. CL. 3.
- DEROYAL INDUSTRIES, INC., POWELL, TN:  
2,949,670. REN. 7-23-14. INT. CL. 10.  
3,353,313, CANC. INT. CL. 10.
- DERUSHIA, BRIAN, MOUNT PLEASANT, MI:  
4,594,089, INT. CL. 35.
- DESCHUTES BREWERY, INC., BEND, OR:  
2,910,746. REN. 7-24-14. INT. CL. 32.  
2,922,985. REN. 7-24-14. INT. CL. 16.  
2,931,987. REN. 7-24-14. INT. CL. 32.
- DESIGN/BUILD TENANT IMPROVEMENTS, SAN DIEGO, CA:  
4,592,445, PUB. 6-10-2014. INT. CL. 41.

DESIGNER LOLLIPOP, WEST JORDAN, UT:  
4,561,625, COR. INT. CL. 35.

DESIREPATH MISSISSIPPI, LLC, ROSWELL, GA:  
3,351,243, CANC. INT. CL. 4.

DESOTO, L.L.C., JOLIET, IL:  
3,353,835, CANC. INT. CL. 3.

DESTINY HEALTH, INC., CHICAGO, IL:  
4,593,866, MULTIPLE CLASS, INT. CLS. 16, 35 AND 41.

DETROIT BLACK COMMUNITY FOOD SECURITY NETWORK, DETROIT, MI, AKA DBCFSN:  
4,591,391, PUB. 6-10-2014. MULTIPLE CLASS, INT. CLS. 35 AND 41.

DETROIT PISTONS BASKETBALL COMPANY, AUBURN HILLS, MI:  
3,341,235, CANC. INT. CL. 16.

DETROIT WATCH COMPANY, LLC, BLOOMFIELD HILLS, MI:  
4,594,674, INT. CL. 14.  
4,594,676, INT. CL. 14.

DEUTSCHE BANK SECURITIES INC., NEW YORK, NY:  
3,354,548, CANC. INT. CL. 36.

DEUTSCHE BORSE AG, 65760 ESCHBORN, FED REP GERMANY:  
4,591,121, PUB. 6-10-2014. INT. CL. 38.

DEVAUGHN, JAMES, BURKBURNETT, TX:  
4,593,159, INT. CL. 33.

DEVICE TECHNOLOGIES, INC., MARLBOROUGH, MA:  
3,436,538, COR. INT. CL. 9.

DEVLIN, DEAN, BEVERLY HILLS, CA:  
3,352,765, CANC. INT. CL. 41.

DEVRIGHT LLC, DALLAS, TX:  
4,591,978, PUB. 6-10-2014. INT. CL. 35.

DEW, DAVID L., JR., MORRO BAY, CA:  
4,591,196, PUB. 6-10-2014. MULTIPLE CLASS, INT. CLS. 25 AND 41.

DFO, LLC, SPARTANBURG, SC:  
4,592,498, PUB. 6-10-2014. INT. CL. 43.

DHC CORPORATION, TOKYO 106, JAPAN:  
3,352,784, CANC. INT. CL. 5.

DIAGEO BRANDS B.V., AMSTERDAM, NETHERLANDS, WILLIAM SANDERSON & SON LIMITED, SOUTH QUEENSFERRY, WEST LOTHIAN, SCOTLAND:  
1,286,315, REN. 7-18-14. INT. CL. 33.

DIAGEO CHATEAU & ESTATE WINES COMPANY, NAPA, CA:  
2,794,505, CANC. INT. CL. 33.

DIAGEO IRELAND, DUBLIN, IRELAND:  
4,594,093, INT. CL. 32.

DIAGEO NORTH AMERICA, INC., NORWALK, CT:  
4,593,024, PUB. 6-10-2014. INT. CL. 33.  
4,593,303, MULTIPLE CLASS, INT. CLS. 35 AND 41.

DIAMOND AIDS, INC., TOLEDO, OH:  
3,351,282, CANC. INT. CL. 28.

DIAMOND FOODS, INC., STOCKTON, CA:  
2,901,557, REN. 7-18-14. INT. CL. 29.

DIAMOND HONG, INC., BROOKLYN, NY:  
4,593,965, MULTIPLE CLASS, INT. CLS. 5 AND 30.  
4,593,967, MULTIPLE CLASS, INT. CLS. 5 AND 30.

DIAMOND MINDS BASEBALL ACADEMY, LLC, THREE BRIDGES, NJ:  
4,593,275, INT. CL. 41.

DIAMOND WIRELESS, LLC, SANDY, UT:  
4,591,956, PUB. 6-10-2014. MULTIPLE CLASS, INT. CLS. 35, 36 AND 38.

DIAO, INC., ALHAMBRA, CA:  
4,594,661, INT. CL. 35.

DIAZ, ALEX, ORLANDO, FL:  
3,353,918, CANC. INT. CL. 25.

DICKERSON VINEYARD LLC, PORTOLA VALLEY, CA:  
3,352,409, CANC. INT. CL. 33.

DIEBOLD, INCORPORATED, NORTH CANTON, OH:  
2,841,649, REN. 7-23-14. INT. CL. 9.

DIETARY PROS, INC, WAUSAU, WI, AKA DP LABS:  
4,593,346, INT. CL. 5.

DIFFUSION LANSA SARL, F-01172 GEX CEDEX, FRANCE:  
3,352,744.

DIGGING RECORDS, INC., HOMER GLEN, IL:  
4,591,740, PUB. 6-10-2014. INT. CL. 41.

DIGICERT, INC., LEHI, UT:  
2,855,347, REN. 7-24-14. INT. CL. 45.

DIGION, INC., FUKUOKA 814-0001, JAPAN:  
4,590,656, PUB. 6-10-2014. MULTIPLE CLASS, INT. CLS. 9 AND 42.

DIGION24, INC., SIMI VALLEY, CA:  
3,353,261, CANC. INT. CL. 9.

DIGISQUID STUDIOS, INC., LAKELAND, FL, DBA DIGISQUID:  
4,592,651, PUB. 6-10-2014. INT. CL. 42.

DIGITAL ATELIER, LLC, MERCERVILLE, NJ:  
2,859,254, REN. 7-23-14. INT. CL. 42.

DIGITAL NETWORKS NORTH AMERICA, INC., MAHWAH, NJ TO DIGITAL NETWORKS NORTH AMERICA, INC., MAHWAH, NJ:  
2,795,990, CANC. INT. CL. 9.

DIGITAL WEB GROUP INC, TUCSON, AZ:  
3,350,664, CANC. INT. CL. 10.

DIGITALPERSONA, INC., REDWOOD CITY, CA:  
2,861,848, REN. 7-24-14. INT. CL. 9.

DIGITECH COMPUTER, INC., BRIARCLIFF MANOR, NY:  
4,592,726, PUB. 6-10-2014. MULTIPLE CLASS, INT. CLS. 9 AND 42.

DIGITS2WORDS, GREENCASTLE, IN:  
4,593,428, INT. CL. 9.

DILLARD'S, INC., LITTLE ROCK, AR:  
3,352,846, CANC. INT. CL. 25.

DILLINGHAM, KEITH, ASHEVILLE, NC:  
4,590,607, PUB. 6-10-2014. INT. CL. 25.

DIMARIA, ROSE, EAST HAMPSTEAD, NH:  
3,353,680, CANC. INT. CL. 44.

DIMARZIO, INC., STATEN ISLAND, NY:  
1,897,423, REN. 7-22-14. INT. CL. 9.

DINAH-MIGHT ADVENTURES, LP, SAN ANTONIO, TX:  
4,591,293, PUB. 6-10-2014. INT. CL. 16.

DINH, TU XUAN, PHILADELPHIA, PA:  
4,594,331, INT. CL. 44.

DIPTYQUE S.A.S., FRANCE:  
3,352,536.

DIRECT M. FRESH, S.A. DE C.V., SANTA CATARINA, MEXICO:  
4,593,986, INT. CL. 29.

DIRECTV, LLC, EL SEGUNDO, CA:  
3,350,948, CANC. INT. CL. 41.

DIRTY BEATS, LLC, WHITE PLAINS, NY:  
3,352,270, CANC. INT. CL. 25.

DISC INTELLECTUAL PROPERTIES, LLC, BURBANK, CA, DISC INTELLECTUAL PROPERTIES, LLC, BURBANK, CA:  
2,859,999, REN. 7-23-14. MULTIPLE CLASS, INT. CLS. 9, 35, 36 AND 42.

DISCOVERREADY, LLC, NEW YORK, NY:  
4,593,335, MULTIPLE CLASS, INT. CLS. 42 AND 45.

DISCOVERY COMMUNICATIONS, LLC, SILVER SPRING, MD:  
3,353,551, CANC. MULTIPLE CLASS, INT. CLS. 38 AND 41.  
4,593,034, PUB. 6-10-2014. INT. CL. 41.  
4,593,049, PUB. 6-10-2014. INT. CL. 41.  
4,593,050, PUB. 6-10-2014. INT. CL. 41.

DISNEY ENTERPRISES, INC., BURBANK, CA:  
2,870,954, REN. 7-21-14. INT. CL. 25.  
3,350,657, CANC. INT. CL. 41.  
3,353,153, CANC. INT. CL. 9.  
3,353,373, CANC. INT. CL. 16.  
3,353,534, CANC. INT. CL. 41.  
3,354,429, CANC. INT. CL. 41.  
3,354,461, CANC. INT. CL. 20.  
3,354,479, CANC. INT. CL. 16.  
3,354,481, CANC. INT. CL. 28.  
3,354,484, CANC. INT. CL. 25.  
4,590,610, PUB. 6-10-2014. MULTIPLE CLASS, INT. CLS. 3, 9, 14, 16, 18, 20, 21, 24 AND 25.  
4,594,182, INT. CL. 3.

DISTEFANO, MAURIZIO, COCONUT GROVE, FL:  
3,354,123, CANC. INT. CL. 44.

DISTILLED SPIRITS EPICENTER, LLC, LOUISVILLE, KY:  
4,591,832, PUB. 6-10-2014. MULTIPLE CLASS, INT. CLS.

- 21 AND 25.  
4,591,833, PUB. 6-10-2014. MULTIPLE CLASS, INT. CLS. 16, 18, 21, 25, 28 AND 32.
- DISTILLERIE MICHEL BOINAUD, FRANCE:  
3,352,642.
- DISTRIBUIDORA DE ALIMENTOS NATURALES Y NUTRICIONALES, S.A. DE C.V., DISTRITO FEDERAL, MEXICO:  
3,353,462, CANC. MULTIPLE CLASS, INT. CLS. 5 AND 30.
- DISTRIBUTION AMERICA, INC., CHARLOTTE, NC:  
3,353,637, CANC. INT. CL. 35.
- DISTURBING LONDON RECORDS; LIMITED, UNITED KINGDOM:  
4,590,856, PUB. 6-10-2014. MULTIPLE CLASS, INT. CLS. 3, 9, 14, 16, 18, 25, 35 AND 41.
- DITTMAN INCENTIVE MARKETING CORPORATION, NEW BRUNSWICK, NJ:  
4,594,142, INT. CL. 35.
- DITTMAR COMPANY, VIENNA, VA:  
4,591,784, PUB. 6-10-2014. INT. CL. 36.
- DIVERSEY, INC., STURTEVANT, WI:  
4,591,699, PUB. 6-10-2014. INT. CL. 21.
- DIVERSIFIED DYNAMICS CORPORATION, MINNEAPOLIS, MN:  
4,593,488, INT. CL. 16.
- DIVERSION ENTERPRISES, LLC, LOS ANGELES, CA:  
4,592,256, PUB. 6-10-2014. INT. CL. 35.
- DIVINE CANINES, WEST LAKE HILLS, TX:  
4,592,316, PUB. 6-10-2014. INT. CL. 44.
- DIVINE CHILD, SPRINGFIELD, NJ:  
4,594,594, INT. CL. 25.
- DJ ASHBA, WEST HOLLYWOOD, CA:  
4,593,152, INT. CL. 16.
- DJO, LLC, VISTA, CA:  
4,593,702, INT. CL. 10.
- DJR HOLDINGS, LLC, NEW YORK, NY:  
4,591,604, PUB. 6-10-2014. INT. CL. 38.
- DLP LIMITED, BRADDAN, ISLE OF MAN, UNITED KINGDOM:  
3,352,019, CANC. MULTIPLE CLASS, INT. CLS. 11 AND 19.
- DME COMPANY LLC, MADISON HTS, MI, FAIRCHILD INDUSTRIES, INC., CHANTILLY, VA:  
1,842,659, REN. 7-21-14. MULTIPLE CLASS, INT. CLS. 7 AND 11.
- DMET LLC, LEAGUE CITY, TX:  
4,591,320, PUB. 6-10-2014. INT. CL. 5.
- DMI INDUSTRIES, INC., WEST FARGO, ND:  
2,793,815, CANC. MULTIPLE CLASS, INT. CLS. 6 AND 40.
- DMITRI ZNOSKO, MOSCOW, RUSSIAN FED.:  
2,801,918, REN. 7-21-14. INT. CL. 9.
- DNA, LTD., CEDAR RAPIDS, IA:  
1,824,826, REN. 7-23-14. INT. CL. 3.
- DND COMMUNICATIONS, LLC, ST. CHARLES, MO:  
3,351,071, CANC. INT. CL. 16.
- DO OUTDOORS, INC., SPRINGFIELD, MO:  
4,593,276, INT. CL. 28.
- DO VITAMINS, RENO, NV:  
4,594,774, INT. CL. 5.
- DO-ALL TRAPS, LLC, NASHVILLE, TN, DBA DO-ALL OUTDOORS, LLC:  
4,592,677, PUB. 6-10-2014. INT. CL. 8.
- DOANE COLLEGE, CRETE, NE:  
4,591,279, PUB. 6-10-2014. INT. CL. 41.
- DOCSTOC INC., BEVERLY HILLS, CA:  
3,507,740, COR. INT. CL. 42.
- DOCSTOC INC., SANTA MONICA, CA, DBA LICENSE123:  
4,374,727, COR. MULTIPLE CLASS, INT. CLS. 9 AND 42.  
4,432,202, COR. MULTIPLE CLASS, INT. CLS. 35 AND 45.
- DOCUSIGN, INC., SEATTLE, WA:  
4,593,806, MULTIPLE CLASS, INT. CLS. 38, 42 AND 45.
- DOG STAR BAKERY, LLC, LITTLE ROCK, AR:  
4,592,893, PUB. 6-10-2014. INT. CL. 31.
- DOGBUTTERFIELD L.L.C., TRAVERSE CITY, MI:  
3,354,176, CANC. INT. CL. 41.
- DOLPHIN MEDIA, KANATA, ONTARIO, CANADA:  
3,353,694, CANC. MULTIPLE CLASS, INT. CLS. 9, 41 AND 42.
- DOMAINE DES BROIX SAS, FRANCE:  
3,352,629.  
3,352,643.  
3,352,698.
- DOMAINE SELECT WINE ESTATES, LLC, NEW YORK, NY:  
4,564,441, COR. INT. CL. 33.
- DON'T BLINK AGENCY, LLC, SEATTLE, WA:  
3,352,045, CANC. INT. CL. 35.
- DONG GUAN CROWN SHIN; BABY APPLIANCES CO., LTD., CHINA:  
4,590,782, PUB. 6-10-2014. INT. CL. 12.
- DONGBU FARM HANNONG CO., LTD., REPUBLIC OF KOREA:  
4,590,939, PUB. 6-10-2014. INT. CL. 1.
- DONNA SHARP, INC., SHEPHERDSVILLE, KY:  
2,962,322, REN. 7-18-14. MULTIPLE CLASS, INT. CLS. 9, 16 AND 18.  
2,962,322, CANC. INT. CL. 24.
- DONNELL, ROBERT, SEBASTOPOL, CA:  
4,593,811, INT. CL. 33.
- DONNELLY, JULIANN, BRADENTON, FL, DBA JULSTRO WORLDWIDE, LLC:  
4,592,205, PUB. 6-10-2014. INT. CL. 16.
- DONUT RISING LLC, CHICO, CA:  
4,592,514, PUB. 6-10-2014. INT. CL. 30.
- DONVAND LIMITED, LONDON EC1M 7AJ, UNITED KINGDOM:  
2,793,623, CANC. MULTIPLE CLASS, INT. CLS. 39 AND 42.
- DOOBLE INC., NEW YORK, NY:  
4,591,879, PUB. 6-10-2014. INT. CL. 35.
- DOODLE ENTERPRISES LLC, DETROIT, MI:  
4,594,227, MULTIPLE CLASS, INT. CLS. 35, 39 AND 42.
- DOODLEBUGS! HOLDING COMPANY, INC., CHEEKTO-WAGA, NY:  
2,949,080, REN. 7-23-14. INT. CL. 41.
- DOOLAN, DANIEL L., MESA, AZ:  
3,352,778, CANC. INT. CL. 1.
- DORCICH, DAVID, LOS ANGELES, CA AND SAUNDERS, PAULINE, LOS ANGELES, CA:  
4,593,239, INT. CL. 3.
- DOREEN VIRTUE, LLC, LAHAINA, HI:  
2,775,008, REN. 7-21-14. INT. CL. 41.
- DORRANCE PUBLISHING COMPANY, INC., PITTSBURGH, PA:  
4,592,603, PUB. 6-10-2014. INT. CL. 41.  
4,592,606, PUB. 6-10-2014. INT. CL. 41.
- DOSKOCIL MANUFACTURING COMPANY, INC., ARLINGTON, TX:  
1,346,155, REN. 7-22-14. INT. CL. 18.  
2,795,628, CANC. INT. CL. 28.
- DOUBLE D HOLDINGS, LLC, NEWARK, NJ, DBA BETTER BITES:  
4,591,099, PUB. 6-10-2014. MULTIPLE CLASS, INT. CLS. 25 AND 43.
- DOUECK, STEVE, BROOKLYN, NY:  
3,352,521, CANC. INT. CL. 25.
- DOUG EDMONDS, PHILOMATH, OR AND JACQUE LUSK, PHILOMATH, OR:  
4,593,907, INT. CL. 35.
- DOUGLAS BLAINE, PALMYRA, NJ:  
4,593,260, INT. CL. 25.
- DOUGLAS G. CHONG SERVICES, LLC, DUBLIN, CA, AKA DGC SERVICES LLC:  
4,591,560, PUB. 6-10-2014. INT. CL. 37.
- DOUMAK INC., ELK GROVE VILLAGE, DE:  
2,217,455, AM. INT. CL. 30.
- DOUMAK INC., ELK GROVE VILLAGE, IL:  
2,232,132, AM. INT. CL. 30.
- DOVE BIOTECH INC., NEW YORK, NY:  
4,593,833, INT. CL. 1.
- DOVES NEST ENTERPRISES LLC, MARIETTA, GA, DBA DOVES NEST ENTERPRISES LLC:  
4,592,392, PUB. 6-10-2014. INT. CL. 45.



DOW AGROSCIENCES LLC, INDIANAPOLIS, IN:  
4,593,001, PUB. 6-10-2014. INT. CL. 5.

DOWDELL, JENNIFER, CLARENCE, NY:  
4,593,148, INT. CL. 24.

DOWNSTREAM TECHNOLOGIES, LLC, MARLBOROUGH,  
MA:  
2,859,476. REN. 7-21-14. INT. CL. 9.

DR PEPPER/SEVEN UP, INC., PLANO, TX:  
3,353,026, CANC. INT. CL. 5.  
4,593,713, INT. CL. 21.

DR. FRESH, LLC, BUENA PARK, CA:  
1,849,328. REN. 7-23-14. INT. CL. 21.  
2,860,088. REN. 7-21-14. INT. CL. 3.

DR. JAMES D. KRYSOSIK, NORTHFIELD, OH:  
4,593,924, INT. CL. 5.

DRAKE NELSON LLC, MUSKOGEE, OK:  
4,591,497, PUB. 6-10-2014. INT. CL. 35.

DRAMASTICS, CHINO, CA:  
4,592,888, PUB. 6-10-2014. INT. CL. 25.

DRAWLOOP TECHNOLOGIES, INC., TAMPA, FL:  
3,351,674, CANC. INT. CL. 42.

DREAMS IN GLASS, INC., INDIALANTIC, FL:  
4,591,500, PUB. 6-10-2014. INT. CL. 41.

DREAMSPRING PTY LIMITED, BURLEIGH WATERS,  
AUSTRALIA:  
3,352,039, CANC. MULTIPLE CLASS, INT. CLS. 9, 16  
AND 42.

DREAMWELL, LTD., LAS VEGAS, NV:  
2,794,380, CANC. INT. CL. 20.

DREAMWORKS ANIMATION L.L.C., GLENDALE, CA:  
4,594,175, INT. CL. 9.  
4,594,188, INT. CL. 28.

DREMAK, LLC., DALLAS, TX:  
3,352,838, CANC. INT. CL. 41.

DRESS-FOR-LESS GMBH, 65439 FLORSHEIM AM MAIN,  
FED REP GERMANY:  
2,793,462, CANC. INT. CL. 35.

DRG TEXAS, LP, BERNE, IN:  
3,351,025, CANC. INT. CL. 16.

DROPBOX, INC., SAN FRANCISCO, CA:  
4,591,452, PUB. 6-10-2014. INT. CL. 35.  
4,591,453, PUB. 6-10-2014. INT. CL. 41.

DROW INTERNATIONAL INVESTMENT LTD., TORTOLA,  
BR.VIRGIN ISLANDS:  
4,592,057, PUB. 6-10-2014. INT. CL. 14.  
4,592,058, PUB. 6-10-2014. INT. CL. 25.

DRUM WORKSHOP, INC., OXNARD, CA:  
4,591,036, PUB. 6-10-2014. INT. CL. 15.  
4,594,569, INT. CL. 15.

DRVITA, INC., LAS VEGAS, NV:  
4,593,939, MULTIPLE CLASS, INT. CLS. 3 AND 5.

DRY CREEK LANDFILL, INC., WHITE CITY, OR:  
4,591,821, PUB. 6-10-2014. INT. CL. 1.

DRYBAR HOLDINGS LLC, DALLAS, TX:  
4,593,367, MULTIPLE CLASS, INT. CLS. 3 AND 8.

DSH INDIANA, INC., CARMEL, IN:  
3,354,115, CANC. INT. CL. 6.  
3,354,117, CANC. INT. CL. 6.

DSH INVESTMENTS LLC, HOOVER, AL:  
4,594,656, INT. CL. 41.

DSM IP ASSETS B.V., HEERLEN, NETHERLANDS:  
4,591,559, PUB. 5-6-2014. INT. CL. 3.

DU-MORE, INC., ROGERS, AR:  
1,285,725. REN. 7-22-14. INT. CL. 3.

DUAL MACHINE PRODUCTS LIMITED, MISSISSAUGA,  
ONTARIO, CANADA:  
2,795,173, CANC. INT. CL. 9.

DUCATI MOTOR HOLDING S.P.A., ITALY:  
4,590,699, PUB. 6-10-2014. MULTIPLE CLASS, INT. CLS.  
3, 7, 9, 12, 14, 16, 18, 25 AND 28.

DUCOSTONE GMBH, FED REP GERMANY:  
3,352,618.

DUCTMATE INDUSTRIES, INC., CHARLEROI, PA:  
1,878,440. REN. 7-24-14. INT. CL. 6.

DUNCAN COFFEE COMPANY, HOUSTON, TX:  
3,352,375, CANC. INT. CL. 35.

DUNCAN ENTERPRISES, INC, FRESNO, CA, DBA ILOVE-  
TOCREATE:  
4,594,253, MULTIPLE CLASS, INT. CLS. 2 AND 16.

DUNCAN ENTERPRISES, INC., FRESNO, CA, DBA ILOVE-  
TOCREATE:  
4,593,937, MULTIPLE CLASS, INT. CLS. 2 AND 28.  
4,593,938, INT. CL. 16.

DUNNAM, FREDERICK TODD, VICTORIA, TX:  
4,593,425, INT. CL. 43.

DUNRATH PARTNERS LLC, HIGHLAND PARK, IL:  
2,794,072, CANC. MULTIPLE CLASS, INT. CLS. 35 AND  
36.

DURBIN FAMILY WINES, LLC, FURLONG, PA:  
4,594,042, INT. CL. 33.  
4,594,043, INT. CL. 33.  
4,594,140, INT. CL. 33.

DURHAM FITNESS INNOVATIONS, LLC, LANDOVER,  
MD:  
4,591,032, PUB. 6-10-2014. INT. CL. 28.

DUSABLON, KEVIN, ALLSTON, MA:  
3,351,549, CANC. INT. CL. 41.

DUTTINE-CAVATAIO FUND, PITTSBURGH, PA:  
4,593,911, INT. CL. 36.

DUTTON III, DAVID H, HILTON HEAD, SC:  
4,593,901, INT. CL. 29.  
4,593,902, INT. CL. 30.

DYANN P. TIDY, MALIBU, CA:  
4,593,784, INT. CL. 44.

DYMAG RACING U.K. LIMITED, CHIPPENHAM, WILT-  
SHIRE SN14 6LH, ENGLAND:  
1,682,829, CANC. INT. CL. 12.

DYNACOMWARE TAIWAN INC., TAIPEI, TAIWAN:  
4,593,553, INT. CL. 9.

DYNACRAFT BSC, INC., AMERICAN CANYON, CA:  
1,846,191. REN. 7-18-14. INT. CL. 12.

DYNAXYS, LLC, SILVER SPRING, MD:  
3,354,063, CANC. INT. CL. 45.

D2MP MEDIA, LLC, CLEVELAND, OH:  
4,594,154, INT. CL. 38.

D3F, LLC, NEW YORK, NY:  
4,593,973, INT. CL. 9.

E. I. DU PONT DE NEMOURS & COMPANY, WILMING-  
TON, DE:  
186,659. REN. 7-24-14. U.S. CL. 6 (INT. CL. 1).

E. I. DU PONT DE NEMOURS AND COMPANY, WILMING-  
TON, DE:  
3,353,654, CANC. INT. CL. 5.

E.C.S. COMPANY, LLC, BELLEVUE, WA:  
3,356,498, CANC. INT. CL. 35.

E.J. BOGNAR, INC., PITTSBURGH, PA:  
605,321. REN. 7-24-14. U.S. CL. 12 (INT. CL. 19).  
1,337,923, REN. 7-24-14. INT. CL. 19.

E&B GIFTWARE LLC, ELMSFORD, NY:  
4,593,504, INT. CL. 16.

E-ELIGIBILITY, INC., LOS ALTOS, CA:  
4,593,211, INT. CL. 45.

E-FILLIATE, INC., RANCHO CORDOVA, CA:  
4,594,146, INT. CL. 9.

E-Z BOX OF RICHMOND, L.C., MONTPELIER, VA:  
3,353,578, CANC. INT. CL. 11.

EAD COSMETICS LLC, FORT LAUDERDALE, FL:  
4,592,284, PUB. 6-10-2014. INT. CL. 44.

EADS SOGERMA, FRANCE:  
4,590,756, PUB. 6-10-2014. MULTIPLE CLASS, INT. CLS.  
12 AND 20.

EAGLE AQUACULTURE, INC., AUBURN, AL:  
3,352,446, CANC. INT. CL. 31.

EAGLE METALWARE (KUNSHAN) CO.,LTD., JIANGSU,  
CHINA:  
4,591,847, PUB. 6-10-2014. INT. CL. 6.

EAGLE/MARK IV EQUIPMENT & LEASING, INC., MANS-  
FIELD, OH, DBA EAGLE MARK IV EQUIPMENT, INC.:  
3,354,221, CANC. INT. CL. 12.

EAR HEART MUSIC, BROOKLYN, NY:  
4,591,174, PUB. 6-10-2014. INT. CL. 41.

EARL J. PEQUEEN, WATSONVILLE, CA:  
4,593,422, INT. CL. 9.

- EARLY MUSIC FOUNDATION, INC., NEW YORK, NY:  
4,591,515, PUB. 6-10-2014. INT. CL. 35.
- EARTHSCAPE USA LLC, MESA, AZ:  
4,594,518, MULTIPLE CLASS, INT. CLS. 1 AND 22.
- EARTHWAYS FOUNDATION, MALIBU, CA:  
4,592,786, PUB. 6-10-2014. INT. CL. 36.
- EASIFY, INC., CHICAGO, IL:  
4,591,887, PUB. 6-10-2014. INT. CL. 41.
- EAST ARBOR GOODS, LLC, PLYMOUTH, MI:  
4,594,770, MULTIPLE CLASS, INT. CLS. 18 AND 21.
- EAST OF CHICAGO PIZZA COMPANY, WILLARD, OH:  
3,350,986, CANC. INT. CL. 43.
- EAST PARIS PARTNERS, LLC, HOLLAND, MI:  
2,795,373, CANC. INT. CL. 36.
- EAST TENNESSEE CHILDREN'S HOSPITAL ASSOCIATION, INC., KNOXVILLE, TN:  
4,592,313, PUB. 6-10-2014. INT. CL. 44.
- EAST TEXAS PROPERTY SEARCH, INC., HUNTSVILLE, TX:  
4,592,295, PUB. 6-10-2014. INT. CL. 36.
- EASTERN BROADCASTING CO., LTD., TAIPEI, TAIWAN:  
3,353,443, CANC. INT. CL. 38.  
3,353,444, CANC. MULTIPLE CLASS, INT. CLS. 35 AND 41.
- EASTERN CONNECTICUT HEALTH NETWORK, INC., MANCHESTER, CT:  
4,591,953, PUB. 6-10-2014. INT. CL. 44.
- EASTERN KENTUCKY UNIVERSITY, RICHMOND, KY:  
4,592,444, PUB. 6-10-2014. INT. CL. 25.
- EASTMAN OUTDOORS, INC., FLUSHING, MI:  
3,352,873, CANC. INT. CL. 30.
- EASTMAN, THOMAS, ROCHESTER, MN:  
3,351,747, CANC. INT. CL. 41.
- EASTON, KATHARINE, KAILUA-KONA, HI:  
2,870,877, REN. 7-23-14. MULTIPLE CLASS, INT. CLS. 14 AND 35.
- EASTSIDE LONGBOARDS LLC, PORTLAND, OR, DBA EASTSIDE LONGBOARDS:  
4,592,463, PUB. 6-10-2014. INT. CL. 28.
- EASY E-JUNKIE LLC, BLACKSBURG, VA:  
4,593,390, INT. CL. 42.
- EATON CORPORATION, CLEVELAND, OH:  
3,353,179, CANC. INT. CL. 9.
- EB GIFTWARE LLC, ELMSFORD, NY:  
4,593,551, INT. CL. 8.
- EBATES PERFORMANCE MARKETING, INC., SAN FRANCISCO, CA:  
4,593,660, INT. CL. 9.
- EBI, LLC, PARSIPPANY, NJ:  
4,594,514, INT. CL. 5.
- EBM ASSOCIATES, LLC, SANTA BARBARA, CA:  
4,592,758, PUB. 6-10-2014. INT. CL. 33.
- EBSCO INDUSTRIES, INC., BIRMINGHAM, AL:  
4,591,031, PUB. 7-30-2013. MULTIPLE CLASS, INT. CLS. 6, 12 AND 20.
- ECA CORPORATION, ROGERS, AR, DBA EVERGREEN CHILDREN'S ACADEMY:  
2,862,960, REN. 7-24-14. INT. CL. 41.
- ECCO SKO A/S, DK-6261 BREDEBRO, DENMARK:  
4,590,849, PUB. 6-10-2014. INT. CL. 25.
- ECHOBIT, LLC, GOLDEN VALLEY, MN:  
4,593,319, INT. CL. 9.  
4,593,320, INT. CL. 9.  
4,593,321, INT. CL. 9.
- ECI HEALTHCARE PARTNERS CORP., TRAVERSE CITY, MI:  
4,591,435, PUB. 6-10-2014. MULTIPLE CLASS, INT. CLS. 35 AND 44.  
4,591,436, PUB. 6-10-2014. MULTIPLE CLASS, INT. CLS. 35 AND 44.  
4,591,437, PUB. 6-10-2014. MULTIPLE CLASS, INT. CLS. 35 AND 44.
- ECKLER INDUSTRIES, INC., TITUSVILLE, FL:  
1,287,048, REN. 7-24-14. INT. CL. 12.  
1,287,049, REN. 7-24-14. INT. CL. 12.
- ECLAT TEXTILE CO., LTD., TAIPEI, TAIWAN:  
4,593,957, MULTIPLE CLASS, INT. CLS. 23, 24 AND 25.
- ECO NOVUM GMBH, FED REP GERMANY:  
4,590,799, PUB. 6-10-2014. MULTIPLE CLASS, INT. CLS. 9, 36, 38 AND 42.
- ECO PRODUCT GROUP, LLC, PITTSBURGH, PA:  
4,593,308, INT. CL. 2.
- ECOLAB USA INC., ST. PAUL, MN:  
3,354,400, CANC. MULTIPLE CLASS, INT. CLS. 3 AND 9.  
4,591,629, PUB. 6-10-2014. MULTIPLE CLASS, INT. CLS. 1, 3, 5, 8, 9 AND 21.
- ECOVACS ROBOTICS (SUZHOU) CO., LTD, CHINA:  
4,590,795, PUB. 6-10-2014. INT. CL. 7.
- EDDIE H. GREEN, KANSAS CITY, MO AND CECILIA J. GREEN, KANSAS CITY, MO:  
3,351,446, CANC. INT. CL. 32.
- EDELMAN ENTERPRISES, INC., NEW ORLEANS, LA:  
3,350,665, CANC. INT. CL. 41.
- EDEVICE, SA, FRANCE:  
4,590,633, PUB. 3-4-2014. MULTIPLE CLASS, INT. CLS. 9, 38 AND 42.
- EDGAR, JOHN C, KILDEER, IL:  
3,351,070, CANC. INT. CL. 44.
- EDGE BLUE, INC., TOKYO 154-0024, JAPAN:  
4,590,857, PUB. 6-10-2014. INT. CL. 25.  
4,590,859, PUB. 6-10-2014. INT. CL. 25.
- EDGE INOVA INTERNATIONAL, INC., BOZEMAN, MT:  
3,353,986, CANC. INT. CL. 42.
- EDGE CRAFT CORPORATION, AVONDALE, PA:  
2,863,032, REN. 7-24-14. INT. CL. 30.
- EDGEWORKS CORP., NEWTOWN SQUARE, PA:  
4,591,627, PUB. 6-10-2014. INT. CL. 35.
- EDIBLE ARRANGEMENTS, LLC, WALLINGFORD, CT:  
4,591,967, PUB. 6-10-2014. INT. CL. 30.  
4,592,507, PUB. 6-10-2014. INT. CL. 30.  
4,592,970, PUB. 6-10-2014. INT. CL. 29.
- EDITORIAL MOTORPRESS TELEVISIA, S.A. DE C.V., SANTA FE, MEXICO:  
4,594,720, INT. CL. 16.
- EDMONSTON, MALCOM L., JR., PRAIRIEVILLE, LA:  
3,352,919, CANC. INT. CL. 28.
- EDTECHTEACHER, INC., CHESTNUT HILL, MA:  
4,591,443, PUB. 6-10-2014. MULTIPLE CLASS, INT. CLS. 35 AND 41.
- EDUCATION EXPERIENCES INC., LOS ANGELES, CA:  
3,350,886, CANC. INT. CL. 25.
- EDUCATION INTERNATIONAL COOPERATION (EIC) GROUP LTD, TORTOLA, BR.VIRGIN ISLANDS:  
4,591,846, PUB. 6-10-2014. INT. CL. 41.
- EDUCATION NORTHWEST, PORTLAND, OR:  
4,591,458, PUB. 6-10-2014. INT. CL. 41.  
4,591,459, PUB. 6-10-2014. INT. CL. 41.
- EDUCATIONAL PRODUCTS, INC., MONTEREY, CA, AKA EPI:  
3,351,301, CANC. INT. CL. 35.
- EDV PACKAGING SOLUTIONS, S.A., SPAIN:  
4,590,733, PUB. 6-10-2014. MULTIPLE CLASS, INT. CLS. 17, 20 AND 40.
- EDWARD BROCKINGTON, BALTIMORE, MD:  
4,591,853, PUB. 6-10-2014. INT. CL. 9.
- EDWARD GEISTLICH SOHNE AG FUR CHEMISCHE INDUSTRIE, WOLHUSEN, SWITZERLAND:  
3,350,774, CANC. INT. CL. 5.
- EDWARD HINES LUMBER, BUFFALO GROVE, IL:  
4,593,856, INT. CL. 35.
- EDWARD SNELL & CO. LTD., PROSPECTION, SOUTH AFRICA:  
3,353,955, CANC. INT. CL. 33.
- EDWARD WYNN LLC, ARCADIA, CA:  
4,591,289, PUB. 6-10-2014. INT. CL. 5.
- EFFICIENT DRIVETRAINS, INC., SAN JOSE, CA:  
4,591,624, PUB. 6-10-2014. INT. CL. 9.
- EFTEKHARI, AFSHIN, ORANGE, CA:  
4,591,426, PUB. 6-10-2014. INT. CL. 35.
- EG SPORTS, LLC, CHICAGO, IL:  
3,353,787, CANC. INT. CL. 41.
- EGGLAND'S BEST, LLC, JEFFERSONVILLE, PA, EGGLAND'S BEST, INC., KING OF PRUSSIA, PA:  
1,850,387, REN. 7-22-14. INT. CL. 29.

EIS, INC., ATLANTA, GA:  
991,886, REN. 7-22-14. MULTIPLE CLASS, U.S. CLS. 21  
(INT. CL. 17) AND 101 (INT. CL. 35).

EISENHARDT, JODIE SUE, HOUSTON, TX:  
4,593,568, INT. CL. 25.  
4,593,569, INT. CL. 25.

EL RECORDS LLC, NEW YORK, NY:  
3,354,564, CANC. INT. CL. 41.

ELAPH PUBLISHING LIMITED, RICHMOND UPON  
THAMES, UNITED KINGDOM:  
3,353,206, CANC. INT. CL. 41.  
3,353,207, CANC. INT. CL. 41.

ELCOCK FUNERAL HOME, INC., SOUTH RICHMOND  
HILL, NY:  
4,591,748, PUB. 6-10-2014. INT. CL. 45.

ELDER RESOURCE CENTER, LLC, COOPER CITY, FL:  
4,593,111, MULTIPLE CLASS, INT. CLS. 35 AND 44.  
4,593,112, MULTIPLE CLASS, INT. CLS. 35 AND 44.  
4,593,113, MULTIPLE CLASS, INT. CLS. 35 AND 44.

ELEADER TECH.COM, INC., SALT LAKE CITY, UT,  
ELEADER TECH.COM, INC., SALT LAKE CITY, UT:  
2,863,023, REN. 7-22-14. INT. CL. 41.

ELEASE DONOVAN SWIMWEAR, INC., HOLLYWOOD, FL:  
4,592,031, PUB. 6-10-2014. INT. CL. 25.

ELECNOR, S.A., BILBAO, SPAIN:  
4,593,370, MULTIPLE CLASS, INT. CLS. 37 AND 42.

ELECTRIC MOBILITY CORPORATION, SEWELL, NJ:  
2,794,778, CANC. INT. CL. 12.

ELECTRIC PIG, LLC, SAN FRANCISCO, CA:  
3,351,095, CANC. INT. CL. 42.

ELECTRO SCIENTIFIC INDUSTRIES, INC., PORTLAND,  
OR:  
1,625,711, CANC. INT. CL. 9.

ELECTRONIC IMAGING SERVICES, INC., LITTLE ROCK,  
AR, DBA VESTCOM RETAIL SOLUTIONS:  
4,594,589, INT. CL. 35.

ELECTRONIC TRANSACTIONS ASSOCIATION, WA-  
SHINGTON, DC:  
4,594,528, MULTIPLE CLASS, INT. CLS. 35 AND 41.

ELENA CASTANEDA, NEW YORK, NY:  
4,594,689, INT. CL. 14.

ELEVATE GROUP HOLDINGS, LLC, DALLAS, TX:  
3,352,440, CANC. INT. CL. 35.

ELEVATION BED LLC, WILMINGTON, DE:  
2,796,062, CANC. INT. CL. 12.

ELGO-ELECTRIC GMBH, FED REP GERMANY:  
3,790,335, COR. MULTIPLE CLASS, INT. CLS. 9, 37 AND  
42.

ELIANT, INC., SAN CLEMENTE, CA:  
4,592,469, PUB. 6-10-2014. INT. CL. 35.

ELITE BRANDS INC., NEW YORK, NY:  
4,592,208, PUB. 6-10-2014. INT. CL. 9.

ELITE CINEMA, L.L.C., SAMMAMISH, WA:  
3,353,864, CANC. INT. CL. 9.

ELIZABETH BEVERAGE COMPANY, LLC, PENNSAUKEN,  
NJ:  
3,352,771, CANC. INT. CL. 32.

ELIZABETH CHARLES CORPORATION, EDINA, MN, ELI-  
ZABETH CHARLES CORPORATION, EDINA, MN:  
1,903,148, REN. 7-22-14. INT. CL. 42.

ELIZABETH HERRERA, BROOKLYN, NY:  
4,592,529, PUB. 6-10-2014. MULTIPLE CLASS, INT. CLS. 3  
AND 5.  
4,592,530, PUB. 6-10-2014. MULTIPLE CLASS, INT. CLS. 3  
AND 5.

ELLAROSE PTY LTD, SOUTH YARRA, 3141, VICTORIA,  
AUSTRALIA, TA GOOD OPTICAL SERVICES:  
3,353,324, CANC. INT. CL. 9.  
3,353,325, CANC. INT. CL. 9.

ELLIOT, MICHAEL, LOS ANGELES, CA:  
4,594,169, MULTIPLE CLASS, INT. CLS. 3 AND 44.

ELLIOTT, BRANDON, WILLIMANTIC, CT:  
4,593,418, INT. CL. 28.

ELLISON FIRST ASIA, LLC, NEW YORK, NY:  
4,593,779, INT. CL. 24.

EMC CORPORATION, HOPKINTON, MA:  
4,593,482, INT. CL. 38.

EMERALD CITY BAND, INC., PLANO, TX:  
4,592,754, PUB. 6-10-2014. INT. CL. 41.

EMERGENCY RESTORATION EXPERTS, LLC, CHAR-  
LOTTE, NC:  
4,594,762, INT. CL. 37.

EMERGING MEDIA DYNAMICS, INC., BETHESDA, MD:  
3,353,535, CANC. MULTIPLE CLASS, INT. CLS. 16 AND  
35.

EMERIK HOTEL, LLC, BEVERLY HILLS, CA:  
4,594,111, INT. CL. 43.

EMERSON ELECTRIC CO., ST. LOUIS, MO:  
989,524, REN. 7-23-14. U.S. CL. 21 (INT. CL. 9).

EMILCOTONI S.P.A., ITALY:  
4,590,848, PUB. 6-10-2014. INT. CL. 23.

EMILIANI, MARIO L, WETHERSFIELD, CT, DBA THE  
CLBM, LLC:  
4,592,403, PUB. 6-10-2014. INT. CL. 41.

EMILIO PUCCI INTERNATIONAL B.V., BAARN, NETHER-  
LANDS:  
4,593,389, INT. CL. 25.

EMILIO PUCCI INTERNATIONAL B.V., NL-3743KN  
BAARN, NETHERLANDS:  
4,593,421, INT. CL. 35.

EMKAR ILAC; SANAYI VE TICARET ANONIM SIRKETI,  
TURKEY:  
4,590,693, PUB. 6-10-2014. MULTIPLE CLASS, INT. CLS.  
3, 5 AND 21.

EMMA 1997 CO., LTD., TAIPEI CITY, TAIWAN:  
4,593,969, INT. CL. 3.

EMMANUEL WILMES, BELGIUM:  
4,590,915, PUB. 6-10-2014. MULTIPLE CLASS, INT. CLS.  
25, 28, 32, 35 AND 41.

EMPATHY MARKETING LIMITED, SAGGART, CO. DU-  
BLIN, IRELAND:  
2,795,260, CANC. MULTIPLE CLASS, INT. CLS. 35 AND  
38.

EMPHASIS ON EXCELLENCE, INC., RENO., NV:  
4,591,809, PUB. 6-10-2014. MULTIPLE CLASS, INT. CLS. 9  
AND 16.

EMPIRIX INC., BILLERICA, MA:  
4,594,244, INT. CL. 9.

EMPLOYEE & FAMILY RESOURCES, INC., DES MOINES,  
IA:  
3,353,081, CANC. INT. CL. 41.

EMPLOYERS HEALTH ALLIANCE, LLC, EUGENE, OR:  
2,794,137, CANC. INT. CL. 36.

EMPREINTE, BREST, FRANCE:  
4,591,519, PUB. 6-10-2014. INT. CL. 25.

EMRIE BROOKE FOSTER, MILFORD, PA:  
3,353,101, CANC. INT. CL. 9.

ENDGAME ENTERPRISES, LLC, WESTMINSTER, CO:  
4,594,263, INT. CL. 41.  
4,594,264, INT. CL. 41.  
4,594,375, INT. CL. 41.  
4,594,376, INT. CL. 41.

ENDOSENSE SA, SWITZERLAND:  
4,590,728, PUB. 6-10-2014. MULTIPLE CLASS, INT. CLS. 9  
AND 10.

ENERGEN SOLUTIONS PTY LTD, AUSTRALIA:  
4,590,708, PUB. 6-10-2014. MULTIPLE CLASS, INT. CLS. 7  
AND 11.

ENERGIE LLC, WHEAT RIDGE, CO:  
2,862,113, REN. 7-23-14. MULTIPLE CLASS, INT. CLS. 11  
AND 35.

ENERGY INTERACTIV FITNESS, ST. JAMES, NY:  
4,592,679, PUB. 6-10-2014. INT. CL. 41.

ENERGY TELECOM, INC., MIAMI BEACH, FL:  
3,354,175, CANC. INT. CL. 9.

ENERGYICT, AFGEKORT EICT, NAAMLOZE VEN-  
NOOTSCHAP, BELGIUM:  
4,590,832, PUB. 6-10-2014. MULTIPLE CLASS, INT. CLS.  
9, 38 AND 42.

ENESCO, LLC, ITASCA, IL, ENESCO CORPORATION, ELK  
GROVE VILLAGE, IL:  
1,846,683, REN. 7-22-14. INT. CL. 15.

ENESCO, LLC, ITASCA, IL:  
3,354,241, CANC. INT. CL. 28.

- ENGAGE THOUGHTWARE, LLC, BOUNTIFUL, UT:  
3,352,163, CANC. INT. CL. 42.
- ENGHOUSE INTERACTIVE INC., PHOENIX, AZ:  
3,352,357, CANC. INT. CL. 9.
- ENGINE READY, INC., SAN DIEGO, CA:  
3,354,619, CANC. INT. CL. 9.
- ENGLISH-MONTOYA, CARRIE A., SAN FRANCISCO, CA:  
2,794,568, CANC. MULTIPLE CLASS, INT. CLS. 18 AND 25.
- ENGLISH, BLEEKER & ASSOCIATES, INC., MAPLE GROVE, MN, DBA MINDSHARP:  
3,352,916, CANC. INT. CL. 41.
- ENGLISH, CARLTON L., PAEONIAN SPRINGS, VA:  
3,353,621, CANC. INT. CL. 9.
- ENGRO FOODS CANADA LTD., MISSISSAUGA, ONTARIO, CANADA:  
2,793,387, CANC. INT. CL. 29.
- ENLIGHTEN EDUCATION PTY LTD, AUSTRALIA:  
4,307,334, COR. INT. CL. 41.
- ENOITALIA S.P.A., CALMASINO DI BARDOLINO (VR), ITALY:  
3,353,571, CANC. INT. CL. 33.
- ENOR CORPORATION, NORTHVALE, NJ:  
3,351,792, CANC. INT. CL. 28.
- ENRICO SCHOLZ, FED REP GERMANY:  
4,590,780, PUB. 6-10-2014. MULTIPLE CLASS, INT. CLS. 16, 18 AND 25.
- ENSAGA ENERGY GROUP LLC, TULSA, OK:  
3,353,618, CANC. INT. CL. 42.
- ENSPERITY VENTURES INCORPORATED, ROAD TOWN, TORTOLA, BR.VIRGIN ISLANDS:  
4,594,432, INT. CL. 9.
- ENTERPRISE SRL, ITALY:  
4,590,684, PUB. 6-10-2014. MULTIPLE CLASS, INT. CLS. 9, 16, 29, 30, 33, 35, 38, 41 AND 43.
- ENTRANCE CONSULTING SERVICES, INC., HOUSTON, TX:  
4,592,319, PUB. 6-10-2014. INT. CL. 42.
- ENVASADORA AGUIDA, S.A. DE C.V., DOLORES HIDALGO, GTO, MEXICO:  
4,593,089, INT. CL. 32.
- ENVELOC, INC., MOBILE, AL:  
2,794,042, CANC. INT. CL. 9.
- ENVIRON SKIN CARE (PTY) LTD, KENILWORTH, SOUTH AFRICA, ENVIRON SKIN CARE CC, KENILWORTH, WESTERN CAPE, SOUTH AFRICA:  
2,904,076, REN. 7-21-14. INT. CL. 3.
- ENVIRONMENT RECLAMATION SERVICES, LLC, ERIE, PA:  
4,591,360, PUB. 6-10-2014. INT. CL. 36.
- ENVISION HEALTHCARE CORPORATION, GREENWOOD VILLAGE, CO:  
4,591,479, PUB. 6-10-2014. INT. CL. 35.  
4,591,480, PUB. 6-10-2014. INT. CL. 39.  
4,591,481, PUB. 6-10-2014. INT. CL. 41.  
4,591,482, PUB. 6-10-2014. INT. CL. 44.  
4,591,611, PUB. 6-10-2014. INT. CL. 35.  
4,591,612, PUB. 6-10-2014. INT. CL. 39.  
4,591,613, PUB. 6-10-2014. INT. CL. 41.  
4,591,614, PUB. 6-10-2014. INT. CL. 44.
- ENVISION PERIPHERALS, INC., FREMONT, CA:  
3,352,391, CANC. INT. CL. 9.
- EOSC LTD, WASHINGTON DEPOT, CT:  
4,594,268, INT. CL. 5.
- EPBZR, LLC, WILDOMAR, CA:  
4,591,845, PUB. 6-10-2014. INT. CL. 35.
- EPCON COMMUNITIES FRANCHISING, INC., DUBLIN, OH:  
3,354,527, CANC. INT. CL. 37.
- EPIC HOLDING COMPANY, INC., NEW BRUNSWICK, NJ:  
3,912,960, COR. INT. CL. 3.  
3,915,816, COR. INT. CL. 9.
- EPIS, INC., SANDPOINT, ID:  
2,864,849, REN. 7-18-14. MULTIPLE CLASS, INT. CLS. 35 AND 42.
- EPISCOPAL RETIREMENT HOMES, INC., CINCINNATI, OH:  
2,941,358, REN. 7-24-14. INT. CL. 35.
- EPLAN SOFTWARE & SERVICE; GMBH & CO. KG, FED REP GERMANY:  
4,590,822, PUB. 6-10-2014. MULTIPLE CLASS, INT. CLS. 9, 41 AND 42.
- EPLAN; SOFTWARE & SERVICE GMBH & CO. KG, FED REP GERMANY:  
4,590,821, PUB. 6-10-2014. MULTIPLE CLASS, INT. CLS. 9, 41 AND 42.
- EPOCH LACROSSE LLC, EDEN PRAIRIE, MN:  
4,593,015, PUB. 6-10-2014. INT. CL. 28.
- EPOCRATES, INC., SAN MATEO, CA:  
2,796,189, CANC. INT. CL. 38.
- EPSON AMERICA, INC., LONG BEACH, CA:  
3,350,872, CANC. INT. CL. 9.  
4,593,620, INT. CL. 9.
- EPSTEIN, NANCY C., TENAFLY, NJ:  
2,905,765, REN. 7-21-14. MULTIPLE CLASS, INT. CLS. 35 AND 42.
- EQUIPT4 LLC, POTOMAC, MD:  
4,592,922, PUB. 6-10-2014. INT. CL. 8.
- EQUU8 HORSEMANSHIP & THERAPEUTIC RIDING, BIG BEAR CITY, CA, DBA EQUU8:  
4,592,915, PUB. 6-10-2014. INT. CL. 44.
- ERBER AKTIENGESELLSCHAFT, AUSTRIA:  
3,352,730.
- EREPLACEMENTS, LLC, ANAHEIM, CA:  
3,353,516, CANC. INT. CL. 9.
- ERGOTRON, INC., ST. PAUL, MN:  
4,593,699, INT. CL. 6.
- ERIC MOWER AND ASSOCIATES, INC., BUFFALO, NY:  
4,593,402, INT. CL. 35.
- ERICH KRAUSE FINLAND OY, FI-00150 HELSINKI, FINLAND:  
4,590,709, PUB. 6-10-2014. MULTIPLE CLASS, INT. CLS. 9, 16, 18 AND 28.
- ERICKSEN, GREGORY S., BOUNTIFUL, UT:  
4,594,592, INT. CL. 41.
- ERIE FEDERAL CREDIT UNION, ERIE, PA:  
2,962,310, REN. 7-22-14. INT. CL. 36.
- ERREBI SPA, ITALY:  
3,352,647.
- ESCORT INC., WEST CHESTER, OH:  
3,354,566, CANC. INT. CL. 9.
- ESPOSITO, HEATHER J, LINCOLN, MA, DBA MEMORY ANGELS:  
4,592,314, PUB. 6-10-2014. INT. CL. 21.
- ESSE EV ÜRÜNLERİ PAZARLAMA; SANAYI VE TICARET ANONİM SİRKETİ, TURKEY:  
4,590,726, PUB. 6-10-2014. INT. CL. 35.
- ESSENTIAL EDUCATIONAL CONCEPTS LLC, WEST CHESTER, OH:  
2,863,002, REN. 7-22-14. INT. CL. 3.  
2,863,014, REN. 7-22-14. INT. CL. 3.
- ESSENTIUM MATERIALS, COLLEGE STATION, TX:  
4,592,837, PUB. 6-10-2014. INT. CL. 42.
- ESSEX CAPITAL CORPORATION, AS COLLATERAL AGENT, SANTA BARBARA, CA:  
3,354,224, CANC. INT. CL. 35.
- ESSILOR OF AMERICA, INC., DALLAS, TX:  
4,593,065, INT. CL. 9.
- ESTEBAN, 34880 LAVÉRUNE, FRANCE:  
4,591,807, PUB. 6-10-2014. INT. CL. 3.  
4,591,808, PUB. 6-10-2014. INT. CL. 3.
- ESTEE LAUDER INC., NEW YORK, NY:  
3,353,239, CANC. INT. CL. 3.
- ESTEFANÍA MARCO ALVAREZ, ELCHE (ALICANTE), SPAIN:  
4,590,760, PUB. 6-10-2014. MULTIPLE CLASS, INT. CLS. 18 AND 25.
- ESTEPP ENERGY LLC, LEXINGTON, KY, DBA ESTEPP ENERGY, LLC:  
4,592,117, PUB. 6-10-2014. INT. CL. 35.
- ESTREL CENTERS, BAY HARBOR ISLANDS, FL:  
4,592,170, PUB. 6-10-2014. INT. CL. 44.  
4,592,171, PUB. 6-10-2014. INT. CL. 44.
- ETRAILER CORPORATION, ST. CHARLES, MO:  
2,947,919, REN. 7-23-14. INT. CL. 35.  
2,947,920, REN. 7-23-14. INT. CL. 35.

ETS MAXIME TRIJOL, FRANCE:  
4,590,670, PUB. 6-10-2014. INT. CL. 33.

EUCLID MEDIA GROUP LLC, CLEVELAND, OH:  
4,592,609, PUB. 6-10-2014. INT. CL. 35.

EUREduc LA THERAPIE PNEUMATIQUE, 78310  
COIGNIERES, FRANCE:  
2,864,482. REN. 7-24-14. INT. CL. 10.

EURO PATISSERIE HOLDING B.V., DC TWELLO, NETH-  
ERLANDS:  
4,590,804, PUB. 6-10-2014. INT. CL. 30.

EUROCINE VACCINES AB, STOCKHOLM, SWEDEN:  
2,859,939. REN. 7-23-14. MULTIPLE CLASS, INT. CLS. 1,  
5 AND 42.

EUROFORM A/S, DENMARK:  
3,352,672.

EUROPEAN ENERGY EXCHANGE AG, FED REP GER-  
MANY:  
3,352,714.

EUROPEAN INTELLECTUAL PROPERTY SA, LUXEM-  
BOURG:  
4,590,748, PUB. 6-10-2014. MULTIPLE CLASS, INT. CLS.  
20 AND 24.

EUROWINEGATE S.A.S., MERPINS, FRANCE:  
2,795,626, CANC. INT. CL. 33.

EUSTIS INSURANCE, INC., METAIRIE, LA:  
2,873,803. REN. 7-24-14. INT. CL. 36.  
2,873,804. REN. 7-24-14. INT. CL. 36.  
2,876,601. REN. 7-24-14. INT. CL. 36.

EVAC OY, FINLAND:  
4,473,029, COR. MULTIPLE CLASS, INT. CLS. 7, 11, 37  
AND 40.

EVAN CREE, HOGANSBURG, NY, DBA TRADITIONAL  
LACROSSE:  
4,594,627, MULTIPLE CLASS, INT. CLS. 25 AND 28.

EVANGELICAL CHRISTIAN PUBLISHERS ASSOCIATION,  
PHOENIX, AZ:  
4,592,278, PUB. 6-10-2014. INT. CL. 41.

EVANS, JAY A JR, DUNEDIN, FL, DBA SYNCRON  
TECHNOLOGIES:  
4,017,964, COR. INT. CL. 42.

EVAPCO, INC., WESTMINSTER, MD:  
3,352,059, CANC. INT. CL. 11.

EVENTISIMO, S.L., SPAIN:  
4,590,652, PUB. 6-10-2014. MULTIPLE CLASS, INT. CLS.  
35, 39 AND 41.

EVER NEURO PHARMA GMBH, AUSTRIA:  
3,352,657.

EVEREADY BATTERY COMPANY, INC., ST. LOUIS, MO:  
4,593,291, INT. CL. 9.

EVERSTRAIGHT INDUSTRIAL CO., LTD., TAINAN, TAI-  
WAN:  
2,864,219. REN. 7-24-14. MULTIPLE CLASS, INT. CLS. 7  
AND 12.

EVERTIQ NEW MEDIA AB, SWEDEN:  
4,590,854, PUB. 6-10-2014. MULTIPLE CLASS, INT. CLS.  
35 AND 41.

EVITE, INC., WEST HOLLYWOOD, CA:  
3,500,825, CANC. MULTIPLE CLASS, INT. CLS. 38, 39, 40,  
41 AND 43.

EX LIBRIS LTD., JERUSALEM, ISRAEL:  
3,351,994, CANC. INT. CL. 9.

EX-FACTORY, INC., CHARLOTTE, NC:  
2,880,842. REN. 7-24-14. INT. CL. 35.  
2,880,843. REN. 7-24-14. INT. CL. 35.  
2,883,690. REN. 7-24-14. INT. CL. 35.

EX-SAKER STUDENTS ASSOCIATION, U.S.A, INC., NEW  
YORK, NY:  
4,591,406, PUB. 6-10-2014. INT. CL. 36.

EXAQTWORLD, JOINVILLE LE PONT, FRANCE:  
4,591,173, PUB. 4-29-2014. MULTIPLE CLASS, INT. CLS.  
9, 35 AND 38.

EXCEL DISPLAY CORP., NEW BRUNSWICK, NJ:  
1,329,314. REN. 7-24-14. INT. CL. 9.

EXCELLENT MEDIA GROUP, CO., LTD., ARCADIA, CA:  
3,352,878, CANC. INT. CL. 9.

EXCLUSIVE MECHANICAL SYSTEMS LTD., SHAWNIGAN  
LAKE, BC, CANADA:  
4,591,774, PUB. 6-10-2014. INT. CL. 8.

EXELON CORPORATION, PHILADELPHIA, PA:  
4,593,386, INT. CL. 42.

EXI INTERNATIONAL CORP., ST. PETERSBURG, FL, DBA  
FAMOUS DISCOVERIES:  
3,351,434, CANC. INT. CL. 35.

EXIGEN SERVICES, LTD., HAMILTON, BERMUDA:  
4,591,584, PUB. 12-31-2013. INT. CL. 35.

EXIT GAMES GMBH, 20457 HAMBURG, FED REP GER-  
MANY:  
3,352,920, CANC. MULTIPLE CLASS, INT. CLS. 9, 38  
AND 42.  
3,352,921, CANC. MULTIPLE CLASS, INT. CLS. 9, 38  
AND 42.

EXIT STRATEGIES, INC., VANCOUVER, WA:  
3,354,205, CANC. INT. CL. 35.

EXO-GALACTIC ENGINEERING L.L.C., EAGAN, MN:  
4,593,935, MULTIPLE CLASS, INT. CLS. 9 AND 42.

EXOTIC EXTRAS LTD, LAS VEGAS, NV:  
4,592,778, PUB. 6-10-2014. INT. CL. 35.

EXPENSEWATCH, INC., PLYMOUTH MEETING, PA:  
4,594,338, INT. CL. 42.

EXPERA SPECIALTY SOLUTIONS, LLC, KAUKAUNA, WI:  
2,811,875. REN. 7-23-14. INT. CL. 16.

EXPLORIUS EDUCATION AB, 441 33 ALINGSAS, SWEDEN:  
4,591,779, PUB. 6-10-2014. INT. CL. 41.

EXPONENTIAL INTERACTIVE, INC., EMERYVILLE, CA:  
3,353,103, CANC. INT. CL. 35.

EXPORTADORA RIO BLANCO LTDA., SANTIAGO, CHILE:  
4,593,544, INT. CL. 31.

EXSURCO MEDICAL, INC., BIRMINGHAM, OH:  
4,593,070, INT. CL. 10.

EXTRAVAGANCE MUSIC MANAGEMENT LIMITED,  
HERTFORDSHIRE HP4 1TD, UNITED KINGDOM:  
4,593,241, MULTIPLE CLASS, INT. CLS. 9 AND 41.

EXUDE, LLC, NEW YORK, NY:  
3,353,297, CANC. INT. CL. 25.

EYE WANT, INC., CHICAGO, IL:  
4,592,903, PUB. 6-10-2014. INT. CL. 44.

EYEMAGINATIONS, INC., TOWSON, MD:  
4,593,202, INT. CL. 42.

EYESHOUT MEDIA, INC., WATERLOO, CANADA:  
3,351,433, CANC. INT. CL. 38.

EZHEALTHCHOICE.COM, LTD., CANTON, OH:  
4,593,377, INT. CL. 35.  
4,593,378, INT. CL. 35.

F & L GROUP, INC., BROOKLYN, NY:  
4,592,705, PUB. 6-10-2014. INT. CL. 25.

F. ATLEE DODGE AIRCRAFT SERVICES, LLC, AURORA,  
CO:  
4,592,817, PUB. 6-10-2014. INT. CL. 40.

F. ZIMMERMANN GMBH, NEUHAUSEN A.D.F., FED REP  
GERMANY:  
3,462,470.

F.N.B. CORPORATION, NAPLES, FL:  
4,593,135, INT. CL. 36.

F.T.B ONLINE LTD, TEL AVIV, ISRAEL:  
4,594,723, INT. CL. 42.

F&B MASTERS INTERNATIONAL B.V., NETHERLANDS:  
4,590,906, PUB. 6-10-2014. MULTIPLE CLASS, INT. CLS.  
29 AND 32.

FABE S.R.L., ITALY:  
4,590,718, PUB. 6-10-2014. MULTIPLE CLASS, INT. CLS.  
10, 20 AND 24.

FABORY NEDERLAND B.V., NETHERLANDS:  
3,462,419, COR. MULTIPLE CLASS, INT. CLS. 1, 3, 4, 17,  
35 AND 37.

FACC AG, AUSTRIA:  
4,590,771, PUB. 6-10-2014. MULTIPLE CLASS, INT. CLS.  
12, 17 AND 42.

FAGE LUXEMBOURG S.A R.L., LUXEMBOURG, LUXEM-  
BOURG:  
2,903,890. REN. 7-23-14. INT. CL. 29.

FAHIMI SEAN A, IRVINE, CA:  
4,592,379, PUB. 6-10-2014. INT. CL. 35.

FAIRHAVEN HEALTH, LLC, BELLINGHAM, WA:  
2,890,392. REN. 7-21-14. INT. CL. 9.

- FAIRLIFE, LLC, CHICAGO, IL:  
4,593,257, INT. CL. 29.  
4,593,677, INT. CL. 29.
- FAIRMONT HOLDINGS, INC., DANIA, FL:  
4,593,166, INT. CL. 34.  
4,593,177, INT. CL. 34.
- FAIRY TALES HAIR CARE, INC., PASSAIC, NJ, AKA  
FAIRY TALES:  
2,823,814, REN. 7-22-14, INT. CL. 3.
- FALCK SCHMIDT INTERNATIONAL A/S, DK-5000  
ODENSE C, DENMARK:  
2,005,023, CANC. INT. CL. 7.
- FALCON INNOVATIONS (NORTHAMPTON); LIMITED,  
UNITED KINGDOM:  
4,590,922, PUB. 6-10-2014, INT. CL. 18.
- FAMILY DEVELOPMENT RESOURCES, INC., PARK CITY,  
UT:  
4,592,716, PUB. 6-10-2014, INT. CL. 41.
- FAMILY FEAST FRANCHISE MANAGEMENT LTD, CY-  
PRESS, TX:  
3,352,415, CANC. INT. CL. 45.
- FAMIS, INC., MIAMI, FL:  
4,594,608, INT. CL. 35.
- FAN FI INTERNATIONAL, INC., SPARKS, NV:  
4,593,558, INT. CL. 11.
- FANSHAWE FOODS LLC, NEW YORK, NY:  
4,594,329, INT. CL. 30.
- FANTASIA DISTRIBUTION, INC., ANAHEIM, CA:  
4,591,788, PUB. 6-10-2014, MULTIPLE CLASS, INT. CLS.  
30 AND 34.
- FARAGO, FRED G., PACOIMA, CA:  
1,848,957, REN. 7-24-14, INT. CL. 5.  
1,849,543, REN. 7-24-14, INT. CL. 32.  
1,853,258, REN. 7-23-14, INT. CL. 32.
- FARKAS, BARRY L., PITTSBURGH, PA:  
2,795,968, CANC. INT. CL. 10.
- FARMERS GROUP, INC., LOS ANGELES, CA:  
4,593,639, INT. CL. 36.
- FARMOBOTTLE, LLC, LOCUST VALLEY, NY:  
4,591,736, PUB. 6-10-2014, MULTIPLE CLASS, INT. CLS.  
29 AND 32.
- FARR OUTDOORS INC., TEMPLE, TX:  
4,592,160, PUB. 6-10-2014, INT. CL. 28.
- FARR, JUSTIN, CHALLIS, ID:  
2,795,531, CANC. INT. CL. 28.
- FARRELL TOPCO LIMITED, LONDON, UNITED KING-  
DOM:  
4,594,580, MULTIPLE CLASS, INT. CLS. 3, 9, 14, 18, 25  
AND 35.
- FARRELL, ROBERT, WALL, NJ:  
4,593,913, INT. CL. 8.
- FARRUGIO, GIUSEPPE, ARLINGTON, VA:  
2,686,445, CANC. INT. CL. 43.
- FASHION ACCESSORY BAZAAR, LLC, NEW YORK, NY:  
3,352,457, CANC. MULTIPLE CLASS, INT. CLS. 14 AND  
35.
- FASHIONETTE DOLLSWEAR LTD., LONDON, UNITED  
KINGDOM:  
4,593,306, MULTIPLE CLASS, INT. CLS. 18 AND 28.
- FAST RETAILING CO., LTD., YAMAGUCHI, JAPAN:  
3,353,320, CANC. MULTIPLE CLASS, INT. CLS. 40, 41  
AND 42.
- FASTER THAN MONKEYS, INC, LOS ALAMITOS, CA:  
3,536,640 NEW CERT. 8-26-2014, INT. CL. 9.
- FAT CITY, INC., SACRAMENTO, CA:  
3,353,299, CANC. INT. CL. 43.
- FAULKS BROS. CONSTRUCTION, INC., WAUPACA, WI:  
4,594,707, INT. CL. 19.
- FAUNUS GROUP INTERNATIONAL, INC., PHILADEL-  
PHIA, PA:  
2,899,558, REN. 7-21-14, INT. CL. 36.
- FAUS GROUP, INC., CALHOUN, GA:  
3,230,472, CANC. INT. CL. 19.
- FCC, LLC, WEST PAM BEACH, FL:  
3,352,803, CANC. INT. CL. 36.  
3,352,804, CANC. INT. CL. 36.
- FEDERAL EXPRESS CORPORATION, MEMPHIS, TN AND  
FEDEX OFFICE AND PRINT SERVICES, INC., DALLAS,  
TX:  
3,351,808, CANC. INT. CL. 35.
- FEDERAL HOME LOAN MORTGAGE CORPORATION,  
MCLEAN, VA:  
4,594,696, INT. CL. 35.
- FEDERATION EMPLOYMENT AND GUIDANCE SERVICE,  
INC. (F.E.G.S.), NEW YORK, NY:  
3,350,796, CANC. MULTIPLE CLASS, INT. CLS. 35, 41, 44  
AND 45.
- FEEDING AMERICA SAN DIEGO, SAN DIEGO, CA:  
4,594,084, MULTIPLE CLASS, INT. CLS. 39 AND 43.
- FEEL GOLF COMPANY, INC., FORT LAUDERDALE, FL:  
4,591,226, PUB. 6-10-2014, INT. CL. 41.
- FEELEY, LISA ANN, NOBLESVILLE, IN AND FEELEY,  
CRAIG J., NOBLESVILLE, IN:  
3,353,039, CANC. INT. CL. 41.
- FEIDA TOOLS (U.S.A.), INC., CITY OF INDUSTRY, CA:  
3,321,660, CANC. INT. CL. 7.
- FELIPE'S VENTURES, L.L.C., NEW ORLEANS, LA:  
4,592,312, PUB. 6-10-2014, MULTIPLE CLASS, INT. CLS.  
25 AND 43.
- FELIX DENNIS, LONDON, UNITED KINGDOM:  
4,123,910, AM. MULTIPLE CLASS, INT. CLS. 9, 16 AND  
41.
- FELO-WERKZEUGFABRIK HOLLAND-LETZ GMBH, 35279  
NEUSTADT, FED REP GERMANY:  
4,590,732, PUB. 6-10-2014, MULTIPLE CLASS, INT. CLS.  
7, 8 AND 20.
- FEM, INC., ALISO VIEJO, CA:  
4,594,573, MULTIPLE CLASS, INT. CLS. 35, 41 AND 42.
- FENG, KUO CHEN, WEST COVINA, CA:  
4,593,014, PUB. 6-10-2014, INT. CL. 8.  
4,593,016, PUB. 6-10-2014, INT. CL. 8.
- FENICIA S.P.A., I-20121 MILANO (MI), ITALY:  
4,590,746, PUB. 6-10-2014, MULTIPLE CLASS, INT. CLS.  
3, 9, 14, 18, 24 AND 35.
- FERMENTED PROJECT LLC, SAINT LOUIS, MO, DBA  
SIDE PROJECT BREWING:  
4,593,761, INT. CL. 32.
- FERNS, PHIL, ANDERSTON, UNITED KINGDOM:  
4,591,170, PUB. 6-10-2014, MULTIPLE CLASS, INT. CLS.  
9, 25, 35, 38, 41, 42 AND 45.
- FERRON, STEPHEN, PALOS VERDES, CA:  
2,795,467, CANC. INT. CL. 16.
- FERROXCUBE INTERNATIONAL HOLDING B.V., ROER-  
MOND, NETHERLANDS:  
2,909,533, REN. 7-24-14, MULTIPLE CLASS, INT. CLS. 9  
AND 21.
- FERTILE SOIL TEAS, LLC, SILVER SPRING, MD:  
4,591,308, PUB. 6-10-2014, INT. CL. 30.
- FESLER PRODUCTIONS, LLC, PHOENIX, AZ:  
3,354,639, CANC. MULTIPLE CLASS, INT. CLS. 12 AND  
28.
- FETZER VINEYARDS, HOPLAND, CA:  
3,353,984, CANC. INT. CL. 33.
- FIAT GROUP MARKETING & CORPORATE COMMUNI-  
CATION S.P.A., ITALY:  
3,352,555.  
4,590,734, PUB. 6-10-2014, MULTIPLE CLASS, INT. CLS.  
4, 12 AND 28.
- FIAT GROUP MARKETING & CORPORATE; COMMUNI-  
CATION S.P.A., I-10126 TORINO, ITALY:  
4,590,729, PUB. 6-10-2014, MULTIPLE CLASS, INT. CLS.  
4, 12 AND 28.
- FIBERARTS GUILD OF PITTSBURGH, INC., PITTSBURGH,  
PA:  
4,591,472, PUB. 6-10-2014, INT. CL. 41.  
4,591,474, PUB. 6-10-2014, INT. CL. 41.
- FIBERNET TELECOM GROUP, INC., NEW YORK, NY:  
3,350,844, CANC. MULTIPLE CLASS, INT. CLS. 38 AND  
42.
- FIELDING, LAWRENCE A., PRINCE GEORGE, B.C., CA-  
NADA, AKA FIELDING, LARRY:  
4,593,767, MULTIPLE CLASS, INT. CLS. 9 AND 16.
- FIELDS CORPORATION, TOKYO, JAPAN:  
3,353,930, CANC. MULTIPLE CLASS, INT. CLS. 14, 18, 24,

25 AND 28.  
FIEROTEC, INC., BALTIMORE, MD:  
3,354,504, CANC. MULTIPLE CLASS, INT. CLS. 25 AND 42.  
FIFTH THIRD BANCORP, CINCINNATI, OH:  
3,353,001, CANC. INT. CL. 36.  
FIGHTER'S MARKET INC., WILMINGTON, DE:  
4,591,274, PUB. 6-10-2014. INT. CL. 25.  
FILTRATION ADVICE, INC., DELRAY BEACH, FL:  
4,593,892, INT. CL. 11.  
FINALOPTION CORP, SAN JOSE, CA:  
4,592,320, PUB. 6-10-2014. INT. CL. 40.  
FINANCIERE GERARD JOULIE, PARIS, FRANCE:  
3,350,813, CANC. INT. CL. 43.  
3,352,348, CANC. INT. CL. 43.  
FINCA FLICHMAN, S.A., BUENOS AIRES, ARGENTINA:  
4,590,975, PUB. 6-10-2014. INT. CL. 33.  
FINDABILITY SCIENCES LLC, NORTH CHELMSFORD, MA:  
4,591,619, PUB. 6-10-2014. INT. CL. 42.  
FINE ESTATES FROM SPAIN, INC., DEDHAM, MA:  
3,522,233, CANC. INT. CL. 33.  
FIORE, LISA, REDONDO BEACH, CA:  
4,591,070, PUB. 6-10-2014. INT. CL. 5.  
FIORI NATURALI COMERCIO DE SORVETES LTDA., SAO PAULO, BRAZIL:  
3,350,839, CANC. INT. CL. 30.  
FIPA GMBH, FED REP GERMANY:  
4,496,658, COR. MULTIPLE CLASS, INT. CLS. 1, 7 AND 17.  
FIRBEST CO., LTD., JAPAN:  
4,590,759, PUB. 6-10-2014. MULTIPLE CLASS, INT. CLS. 22, 23, 24 AND 25.  
FIRE SOLUTIONS, INC., PHILADELPHIA, PA:  
2,794,777, CANC. INT. CL. 36.  
FIRE TAIL BRANDS, LLC, LAKE ST. LOUIS, MO:  
3,354,568, CANC. INT. CL. 33.  
FIRECRAFT PRODUCTS, INC., ST. JOHN'S, NL, CANADA:  
4,591,771, PUB. 6-10-2014. INT. CL. 13.  
FIREFLY8, HILLSBORO, OR:  
4,594,289, INT. CL. 45.  
FIREROCK, LLC, FOUNTAIN HILLS, AZ:  
1,845,907, REN. 7-24-14. INT. CL. 37.  
FIRST BANK AND TRUST, NEW ORLEANS, LA:  
3,351,385, CANC. INT. CL. 36.  
FIRST CITIZENS BANCSHARES, INC., RALEIGH, NC:  
4,594,332, INT. CL. 36.  
4,594,333, INT. CL. 36.  
FIRST FINANCIAL LEASING & FINANCE, INC., FORT LAUDERDALE, FL:  
4,594,372, INT. CL. 36.  
FIRST NIAGARA FINANCIAL GROUP, INC., BUFFALO, NY:  
4,593,340, INT. CL. 36.  
4,593,341, INT. CL. 36.  
FIRST NLC FINANCIAL SERVICES, LLC, DEERFIELD BEACH, FL:  
3,352,889, CANC. INT. CL. 36.  
FIRST SECURITY BANCORP, SEARCY, AR:  
4,590,603, PUB. 6-10-2014. INT. CL. 36.  
FIRSTMERIT CORPORATION, AKRON, OH:  
3,354,655, CANC. INT. CL. 36.  
FISCHER & WIESER SPECIALTY FOODS, INC., AUSTIN, TX:  
2,862,823, REN. 7-24-14. INT. CL. 30.  
FISCHER PANDA GMBH, PADERBORN, FED REP GERMANY:  
4,591,993, PUB. 6-10-2014. INT. CL. 7.  
FISH DADDY'S, LLC, COLLEGE STATION, TX:  
4,594,222, INT. CL. 43.  
FISHER SCIENTIFIC COMPANY L.L.C., PITTSBURGH, PA:  
4,593,496, INT. CL. 35.  
FISHING UNIVERSITY INC, SPRING HILL, TN:  
4,591,045, PUB. 6-10-2014. INT. CL. 41.  
FISHMAN, TONI R., SOUTH WINDSOR, CT:  
2,824,985, REN. 7-23-14. INT. CL. 9.  
FISHUSA, INC., ERIE, PA:  
4,591,331, PUB. 6-10-2014. INT. CL. 35.  
4,591,528, PUB. 6-10-2014. INT. CL. 35.  
FIT AND TUFF LLC, CORONA, NY, AKA F.A.T:  
4,594,085, INT. CL. 25.  
FITNESS BY CORRY, LLC, ALEXANDRIA, VA:  
3,351,388, CANC. INT. CL. 41.  
FITNESS FOR HEALTH, ROCKVILLE, MD:  
3,352,123, CANC. INT. CL. 41.  
3,352,124, CANC. INT. CL. 44.  
FITNESS LABS NUTRITION CORPORATION, TORRANCE, CA:  
2,795,673, CANC. INT. CL. 5.  
FITNESS VENTURES INTERNATIONAL, LLC, SANTA MONICA, CA:  
4,592,722, PUB. 6-10-2014. MULTIPLE CLASS, INT. CLS. 3 AND 7.  
FITZPATRICK FARRIER SERVICES, INC., LANCASTER, CA:  
3,353,050, CANC. INT. CL. 44.  
FIT4EVER, S.L., SPAIN:  
3,352,581.  
FIUS DISTRIBUTORS LLC, BOULDER, CO:  
4,592,881, PUB. 6-10-2014. INT. CL. 10.  
FIVE MORE MINUTES, LLC, EAST CHATHAM, NY:  
4,593,197, INT. CL. 41.  
FIXTURE-FIX, LLC, OYSTER BAY COVE, NY:  
4,592,540, PUB. 6-10-2014. INT. CL. 1.  
FÈ FIT LLC, ROUND ROCK, TX:  
4,594,447, MULTIPLE CLASS, INT. CLS. 9 AND 41.  
FLAGSHIP PUBLISHING, LLC, DELTONA, FL:  
3,351,033, CANC. INT. CL. 41.  
FLAM, ROBERT, NEW YORK, NY:  
4,592,568, PUB. 6-10-2014. INT. CL. 30.  
FLANDERS CORPORATION, WASHINGTON, NC:  
4,593,656, INT. CL. 11.  
FLATS LLC, CHICAGO, IL:  
4,593,546, MULTIPLE CLASS, INT. CLS. 36 AND 43.  
FLEET WHOLESALE SUPPLY CO., INC., APPLETON, WI:  
4,594,009, INT. CL. 2.  
FLEETCOR TECHNOLOGIES OPERATING COMPANY, LLC, NORCROSS, GA:  
3,354,618, CANC. MULTIPLE CLASS, INT. CLS. 35 AND 36.  
FLEXCO, LLC, ARDSLEY, NY:  
4,591,958, PUB. 6-10-2014. MULTIPLE CLASS, INT. CLS. 9, 38 AND 41.  
FLEXCON COMPANY, INC., SPENCER, MA:  
1,313,427, REN. 7-18-14. INT. CL. 17.  
FLEXIBLE TECHNOLOGIES, INC., GREENWOOD, SC:  
3,354,622, CANC. INT. CL. 19.  
FLEXITALLIC INVESTMENTS, INC., KINGWOOD, TX:  
4,593,289, INT. CL. 17.  
4,593,290, INT. CL. 17.  
FLEXMAASTER CANADA LTD., RICHMOND HILL, CANADA:  
4,591,299, PUB. 6-10-2014. INT. CL. 6.  
FLIGHTPATH, INC., NEW YORK, NY:  
4,592,713, PUB. 6-10-2014. MULTIPLE CLASS, INT. CLS. 35 AND 42.  
FLIPLINE IDS LLC, CLEVELAND, OH:  
4,592,048, PUB. 6-10-2014. INT. CL. 9.  
FLIR SYSTEMS, INC., WILSONVILLE, OR:  
4,593,179, INT. CL. 9.  
FLITE TEST, LLC, NEW PHILADELPHIA, OH:  
4,591,419, PUB. 6-10-2014. INT. CL. 28.  
FLIX ENTERTAINMENT LLC, ROUND ROCK, TX:  
4,591,926, PUB. 6-10-2014. INT. CL. 32.  
FLOOD FLAPS, LLC, MT. PLEASANT, SC, DBA FLOOD FLAPS, LLC:  
4,594,623, INT. CL. 19.  
FLOP STUDIOS, INC., GREENWOOD VILLAGE, CO:  
4,593,788, INT. CL. 9.  
FLOPEEZE INTERNATIONAL LIMITED, HONG KONG, CHINA:  
4,556,487, COR. INT. CL. 25.  
FLORATINE PRODUCTS GROUP, COLLIERVILLE, TN:  
3,354,678, CANC. MULTIPLE CLASS, INT. CLS. 1 AND

44.  
 FLOREANI, CHANTE, BELLINGHAM, WA:  
 4,592,258, PUB. 6-10-2014. INT. CL. 3.
- FLORES, FRANCISCO GONZÁLES, STA. PAULA, CA:  
 3,277,178, CANC. INT. CL. 33.
- FLORES, JIMMY, TARZANA, CA:  
 3,351,512, CANC. INT. CL. 41.
- FLORIDA CENTER CHAMBER OF COMMERCE INCORPORATED, ORLANDO, FL, DBA INTERNATIONAL DRIVE RESORT AREA CHAMBER OF COMMERCE:  
 4,591,343, PUB. 6-10-2014. INT. CL. 41.
- FLORIDA SHERIFFS ASSOCIATION, TALLAHASSEE, FL:  
 3,353,158, CANC. INT. CL. 35.
- FLORISTS' TRANSWORLD DELIVERY, INC., DOWNERS GROVE, IL:  
 4,593,631, INT. CL. 31.
- FLOWERS BAKERIES BRANDS, LLC, THOMASVILLE, GA:  
 1,265,872, REN. 7-18-14. INT. CL. 30.
- FLUFF MONKEY ENTERPRISES, LLC, SEVEN VALLEYS, PA:  
 4,594,163, MULTIPLE CLASS, INT. CLS. 3, 6, 9, 14, 16, 18, 21, 24, 25, 26 AND 28.
- FLUID POWER, INC., HUDSON, OH:  
 775,055, REN. 7-23-14. U.S. CL. 44 (INT. CL. 10).  
 775,464, REN. 7-21-14. U.S. CL. 44 (INT. CL. 10).
- FLUKE PRECISION MEASUREMENT LIMITED, NORWICH, NORFOLK, UNITED KINGDOM:  
 4,591,596, PUB. 6-10-2014. INT. CL. 9.
- FLYING FOSSILS, INC., RENO, NV:  
 2,871,292, REN. 7-22-14. INT. CL. 37.
- FLYNT, DEBORAH A., DAVIE, FL:  
 3,351,097, CANC. INT. CL. 16.
- FLYNT, MICHAEL, FRANKLIN, TN:  
 2,795,713, CANC. INT. CL. 28.
- FM INDUSTRIES, LLC, LA CANADA, CA:  
 4,593,753, INT. CL. 37.
- FMTM DISTRIBUTION LTD, UNITED KINGDOM:  
 3,352,751.
- FOAMFANATICS LLC, SEATTLE, WA:  
 3,350,967, CANC. INT. CL. 20.
- FOCALYST LLC, NEW YORK, NY:  
 3,353,660, CANC. MULTIPLE CLASS, INT. CLS. 16, 35 AND 41.
- FOCUS HOLDINGS, LLC, SUNRISE, FL:  
 4,591,927, PUB. 6-10-2014. MULTIPLE CLASS, INT. CLS. 35 AND 36.
- FOEDERIS, FRANCE:  
 4,590,890, PUB. 6-10-2014. MULTIPLE CLASS, INT. CLS. 9 AND 42.
- FONDATION POUR LA SAUVEGARDE ET LE DÉVELOPPEMENT DU DOMAINE DE CHANTILLY, FRANCE:  
 4,590,783, PUB. 6-10-2014. MULTIPLE CLASS, INT. CLS. 3 AND 4.
- FOOD BANK FOR NEW YORK CITY, BRONX, NY:  
 2,806,437, REN. 7-23-14. MULTIPLE CLASS, INT. CLS. 41 AND 43.  
 2,808,191, REN. 7-23-14. INT. CL. 43.
- FOODMACH PTY LTD, AUSTRALIA:  
 4,590,911, PUB. 6-10-2014. INT. CL. 7.
- FOOT & ANKLE CENTERS OF AMERICA, INC., EVANSVILLE, IN:  
 2,280,179, CANC. INT. CL. 35.
- FOOT PETALS, INC., PICKERINGTON, OH:  
 4,593,678, MULTIPLE CLASS, INT. CLS. 25 AND 35.
- FOOTBAL NORTHWEST LLC, KIRKLAND, WA:  
 3,353,265, CANC. INT. CL. 41.
- FOR WORLD PEACE PTE LTD, SINGAPORE, SINGAPORE:  
 3,350,992, CANC. INT. CL. 41.
- FORA CARE INC., MOORPARK, CA:  
 4,591,815, PUB. 6-10-2014. INT. CL. 10.
- FORBES, MALCOLM A., WESLEY CHAPEL, FL, DBA DREAM ROUTE:  
 4,594,632, INT. CL. 25.
- FORCE-FACING OUR RISK OF CANCER EMPOWERED, INC., TAMPA, FL:  
 3,600,512, AM. INT. CL. 36.
- FORD MOTOR COMPANY, DEARBORN, MI:  
 4,593,414, INT. CL. 12.
- FOREIGN CANDY COMPANY, INC., THE HULL, IA:  
 3,354,327, CANC. INT. CL. 30.
- FOREMAN PROGRAM & CONSTRUCTION MANAGERS, INC., ZELIENOPLE, PA:  
 2,965,179, REN. 7-24-14. INT. CL. 37.
- FOREST CAPITAL PARTNERS, LLC, BOSTON, MA:  
 4,591,762, PUB. 6-10-2014. MULTIPLE CLASS, INT. CLS. 35 AND 36.  
 4,591,763, PUB. 6-10-2014. MULTIPLE CLASS, INT. CLS. 35 AND 36.  
 4,591,764, PUB. 6-10-2014. MULTIPLE CLASS, INT. CLS. 35 AND 36.
- FORJAS TAURUS S/A, RIO GRANDE DO SUL, BRAZIL:  
 2,795,643, CANC. INT. CL. 13.
- FORM-A-FEED, INC., STEWART, MN:  
 4,594,506, INT. CL. 5.
- FORMS DISTRIBUTION CORP., ST. LOUIS, MO:  
 1,151,892, CANC. INT. CL. 35.
- FORREST, DAN, LAGRANGE, GA:  
 4,591,965, PUB. 6-10-2014. INT. CL. 25.
- FORSHER, JAMES M., BAINBRIDGE ISLAND, WA:  
 4,594,019, INT. CL. 16.
- FORSTHOFF, FRIDAY, DAVIS, CA:  
 3,352,001, CANC. INT. CL. 41.
- FORT BOISE PRODUCE CO., NYSSA, OR:  
 1,845,814, REN. 7-23-14. INT. CL. 31.
- FORTNUM & MASON PLC, LONDON, UNITED KINGDOM:  
 3,462,418.
- FORTWAY LIMITED, ROAD TOWN, TORTOLA, BR. VIRGIN ISLANDS:  
 4,594,202, INT. CL. 9.
- FORUM US, INC., HOUSTON, TX, DBA ASSOCIATED DYNAMICS:  
 1,905,319, REN. 7-23-14. INT. CL. 7.
- FORUM US, INC., HOUSTON, TX:  
 4,591,871, PUB. 6-10-2014. INT. CL. 11.
- FOSECO INTERNATIONAL LIMITED, STAFFORDSHIRE B78 3TL, ENGLAND:  
 773,916, REN. 7-19-14. U.S. CL. 6 (INT. CL. 1).
- FOSECO INTERNATIONAL LIMITED, DERBYSHIRE, UNITED KINGDOM:  
 775,592, REN. 7-19-14. U.S. CL. 6 (INT. CL. 1).
- FOSSA APPAREL, INC., FREMONT, CA:  
 3,354,441, CANC. INT. CL. 25.
- FOSTER AND ADOPTIVE FAMILY SERVICES, MOUTH JUNCTION, NJ:  
 4,591,676, PUB. 6-10-2014. MULTIPLE CLASS, INT. CLS. 16 AND 41.
- FOULADIAN, JEAN PIERRE, WOODLAND HILLS, CA:  
 4,594,501, INT. CL. 14.
- FOUNDATION DIGITAL, VALENCIA, CA:  
 4,591,935, PUB. 6-10-2014. MULTIPLE CLASS, INT. CLS. 35 AND 42.
- FOUNDATIONDB, LLC, VIENNA, VA:  
 4,593,746, MULTIPLE CLASS, INT. CLS. 9 AND 42.
- FOUNDATIONS RECOVERY NETWORK, LLC, BRENTWOOD, TN:  
 4,591,891, PUB. 6-10-2014. INT. CL. 35.
- FOURNITURES HOSPITALIERES CORPORATION FRANCE, HEIMSBRUNN, FRANCE:  
 3,351,652, CANC. INT. CL. 10.
- FOURTH WAVE STRATEGY INC., DARTMOUTH, NOVA SCOTIA, CANADA:  
 4,593,786, INT. CL. 41.
- FOX TELEVISION STUDIOS, INC., LOS ANGELES, CA:  
 3,353,135, CANC. INT. CL. 41.
- FOXBORO COMPANY, THE, FOXBORO, MA:  
 3,350,614, CANC. INT. CL. 42.
- FOXHOUND URBAN ADVENTURES, INC., SAN FRANCISCO, CA:  
 4,592,808, PUB. 6-10-2014. INT. CL. 41.
- FP HOLDINGS, L.P., LAS VEGAS, NV:  
 2,795,274, CANC. INT. CL. 42.
- FRACTAL ANALYTICS, INC., SAN MATEO, CA:  
 4,592,005, PUB. 6-10-2014. INT. CL. 35.
- FRAGOMEN, DEL REY, BERNSEN & LOEWY, LLP, NEW YORK, NY:  
 3,352,758, CANC. INT. CL. 42.



FRAISE, TRAVIS E., MONTROSE, IA:  
3,350,841, CANC. INT. CL. 41.

FRALEY, BRIAN, TOLEDO, OH:  
3,351,056, CANC. INT. CL. 43.

FRAM GROUP IP, LLC, LAKE FOREST, IL:  
4,591,148, PUB. 6-10-2014. INT. CL. 7.  
4,593,688, INT. CL. 7.

FRANCE TELECOM ESPANA, S.A., MADRID, SPAIN:  
3,350,615, CANC. MULTIPLE CLASS, INT. CLS. 38 AND 41.

FRANCESCA, FRANCE:  
4,508,549, COR. MULTIPLE CLASS, INT. CLS. 29, 30, 39 AND 43.

FRANCHISEWORKS.COM, LLC, WARMINSTER, PA:  
2,923,065, REN. 7-24-14. INT. CL. 35.

FRANCIS F. POLANSKY, M.D. AND RICHARD J. SCHMIDT, M.D., INC., PALO ALTO, CA:  
3,351,501, CANC. INT. CL. 44.  
3,351,502, CANC. INT. CL. 44.

FRANCISCAN VINEYARDS, INC., ST. HELENA, CA:  
3,457,923, AM. INT. CL. 30.

FRANCO MANUFACTURING CO., INC., METUCHEN, NJ:  
1,190,067, CANC. INT. CL. 25.

FRANCOTYP-POSTALIA, INC., ADDISON, IL, DBA FP MAILING SOLUTIONS:  
4,591,143, PUB. 6-10-2014. INT. CL. 35.  
4,591,145, PUB. 6-10-2014. INT. CL. 35.

FRANK BRUNCKHORST CO., L.L.C., BROOKLYN, NY:  
2,794,366, CANC. INT. CL. 29.  
4,594,245, INT. CL. 29.

FRANK-LIN DISTILLERS PRODUCTS, LTD., FAIRFIELD, CA:  
2,964,122, REN. 7-24-14. INT. CL. 33.

FRANK, KEITH, PAGOSA SPRINGS, CO AND GERLING, SCOTT, WHITTIER, CA:  
3,353,840, CANC. INT. CL. 19.

FRANKLIN WIRELESS CORPORATION, SAN DIEGO, CA:  
4,591,195, PUB. 6-10-2014. INT. CL. 9.

FRANZ INC., OAKLAND, CA:  
1,591,771, CANC. INT. CL. 9.

FRAUSTO, MONIQUE, LOS ANGELES, CA:  
4,591,598, PUB. 6-10-2014. INT. CL. 41.

FRAUTURE, WINSTON SALEM, NC:  
4,592,671, PUB. 6-10-2014. INT. CL. 25.

FRED MEYER STORES, INC., PORTLAND, OR:  
2,927,510, REN. 7-24-14. INT. CL. 18.  
3,352,984, CANC. INT. CL. 25.

FREE TO CHOOSE NETWORK, ERIE, PA:  
1,850,234, REN. 7-18-14. INT. CL. 9.

FREEDMAN ELECTRONICS PTY LIMITED, AUSTRALIA:  
4,590,692, PUB. 6-10-2014. INT. CL. 9.

FREEDOM AQUARIUM PRODUCTS, LLC, BOCA RATON, FL:  
3,353,441, CANC. INT. CL. 11.

FREEDOM VENTURE LLC, BOULDER CITY, NV:  
4,592,866, PUB. 6-10-2014. INT. CL. 16.

FREELANCE ADVENTURES INC., RIDGWAY, CO, DBA CHICKS WITH PICKS:  
4,592,322, PUB. 6-10-2014. INT. CL. 41.

FREELANCE ADVENTURES INC., RIDGWAY, CO:  
4,592,335, PUB. 6-10-2014. INT. CL. 41.  
4,592,404, PUB. 6-10-2014. INT. CL. 41.  
4,592,513, PUB. 6-10-2014. INT. CL. 41.

FREEMAN, RICHARD W., REIDSVILLE, NC:  
4,594,654, INT. CL. 38.

FREMANTLEMEDIA NORTH AMERICA, INC., BURBANK, CA:  
3,353,040, CANC. INT. CL. 29.  
3,353,263, CANC. INT. CL. 18.  
3,354,418, CANC. INT. CL. 41.

FREMANTLEMEDIA OPERATIONS BV, 1217 ET HILVERSUM, NETHERLANDS:  
3,354,842, CANC. INT. CL. 9.  
3,381,225, CANC. INT. CL. 9.

FRENCH TRANSIT, LTD., BURLINGAME, CA:  
1,878,394, REN. 7-18-14. INT. CL. 3.

FRENCH, FULLER, FORT WORTH, TX:  
3,354,625, CANC. INT. CL. 41.

FRENCHCREEK PRODUCTION, INC., FRANKLIN, PA:  
2,796,245, CANC. INT. CL. 9.

FRESENIUS MEDICAL CARE NEPHROLOGICA DEUTSCHLAND GMBH, FED REP GERMANY:  
3,352,679.  
3,352,680.

FRESH ASPARAGUS E.I.R.L. DE PERU, MIAMI, FL:  
3,352,215, CANC. INT. CL. 31.

FRESH CITY RESTAURANT HOLDINGS LLC, SCITUATE, MA:  
2,868,017, REN. 7-24-14. INT. CL. 43.

FRESH EXPRESS INCORPORATED, CHARLOTTE, NC:  
3,351,871, CANC. INT. CL. 16.

FRESH PEAR INC., RICHMOND HILL, CANADA:  
4,594,700, INT. CL. 25.

FRESHMAX LIMITED, CHRISTCHURCH, NEW ZEALAND:  
2,793,474, CANC. INT. CL. 31.

FRETTE S.P.A., LUXEMBOURG, LUXEMBOURG:  
3,351,935, CANC. MULTIPLE CLASS, INT. CLS. 24 AND 27.

FRICK, ANDREW, AFTON, MO:  
4,593,264, INT. CL. 28.

FRIEDLAND, STEPHEN, NEW YORK, NY:  
2,794,084, CANC. INT. CL. 41.

FRIENDS OF AFRICA - INTERNATIONAL, ASPEN, CO:  
3,352,198, CANC. INT. CL. 41.

FRIENDS OF THE GARDENAERIAL, INC., ROCHESTER, NY:  
4,591,375, PUB. 6-10-2014. MULTIPLE CLASS, INT. CLS. 35, 36 AND 41.

FRITO-LAY NORTH AMERICA, INC., PLANO, TX:  
3,354,297, CANC. INT. CL. 30.  
3,354,306, CANC. INT. CL. 30.  
4,593,307, INT. CL. 29.

FRITZ SCHAFFER GMBH, NEUNKIRCHEN, FED REP GERMANY:  
2,862,506, REN. 7-23-14. MULTIPLE CLASS, INT. CLS. 9 AND 42.

FROGTOWN CELLARS, LLLP, DAHLONEGA, GA:  
3,353,959, CANC. INT. CL. 33.

FROMARTHARIE, INC., WARREN, NJ:  
3,353,151, CANC. INT. CL. 29.

FRONCARE INC., CHALFONT, PA:  
4,592,670, PUB. 6-10-2014. INT. CL. 35.

FROST & SULLIVAN, SAN ANTONIO, TX:  
3,350,646, CANC. INT. CL. 41.

FROST PRODUCTS LIMITED, BURLINGTON, ONTARIO, CANADA:  
4,591,112, PUB. 6-10-2014. INT. CL. 42.

FRY'S ELECTRONICS, INC., SAN JOSE, CA:  
4,593,096, MULTIPLE CLASS, INT. CLS. 9, 16, 25, 28 AND 32.

FS INDUSTRIES LLC, BRADENTON, FL:  
4,592,800, PUB. 6-10-2014. INT. CL. 41.

FSR BEAUTY, LTD, NEW YORK, NY AND ALTCHEK, DOUGLAS - M.D., NEW YORK, NY:  
4,591,704, PUB. 6-10-2014. INT. CL. 3.

FSV PAYMENT SYSTEMS, INC., HOUSTON, TX:  
3,351,290, CANC. INT. CL. 9.

FUDEX GROUP S.P.A., ITALY:  
4,590,697, PUB. 6-10-2014. MULTIPLE CLASS, INT. CLS. 7 AND 11.

FUENTES, VICTOR, LOS ANGELES, CA:  
4,592,946, PUB. 6-10-2014. INT. CL. 16.

FUHU HOLDINGS, INC., EL SEGUNDO, CA:  
4,591,252, PUB. 6-10-2014. INT. CL. 9.

FUJIAN JINJIANG CANHUANG SHOES & GARMENTS CO., LTD., JINJIANG, FUJIAN, CHINA:  
2,794,728, CANC. INT. CL. 25.

FUJIFILM MEDICAL SYSTEMS U.S.A., INC., STAMFORD, CT:  
3,354,623, CANC. INT. CL. 10.

FUJIFILM SONOSITE, INC., BOTHELL, WA:  
2,904,126, REN. 7-21-14. MULTIPLE CLASS, INT. CLS. 9 AND 10.

- FUJIKURA GOMU KOGYO KABUSHIKI KAISHA ALSO TRADING AS FUJIKURA RUBBER LTD., TOKYO 135-0063, JAPAN:  
4,590,841, PUB. 6-10-2014. INT. CL. 28.
- FUJITSU LIMITED, KAWASAKI-SHI, KANAGAWA, 211-8588, JAPAN:  
3,352,027, CANC. MULTIPLE CLASS, INT. CLS. 9, 35, 38 AND 42.
- FUJITSU LIMITED, KAWASAKI-SHI KANAGAWA-KEN, JAPAN:  
3,352,860, CANC. INT. CL. 9.
- FULL SPECTRUM SOLUTIONS, INC., JACKSON, MI:  
3,351,618, CANC. INT. CL. 11.
- FULL SPEKTRUM, LLC, SAINT CLAIR SHORES, MI:  
4,591,071, PUB. 6-10-2014. INT. CL. 3.
- FULTON, JAMES WESLEY, SAN PEDRO, CA:  
4,593,576, MULTIPLE CLASS, INT. CLS. 9 AND 42.
- FUN WITH PANDA, LLC, WEST BLOOMFIELD, MI:  
3,351,014, CANC. INT. CL. 41.
- FUN, FIERCE & FABULOUS, LLC, PHILADELPHIA, PA:  
4,593,361, INT. CL. 18.
- FUNBALLZ APS, DK-8000 AARHUS C, DENMARK:  
4,591,229, PUB. 6-10-2014. INT. CL. 28.
- FUNDAMENTAL BASEBALL CAMP INC., THE, YONKERS, NY:  
2,796,118, CANC. INT. CL. 41.
- FUNK'D GOLF LTD., PRESTON, LANCASHIRE, UNITED KINGDOM:  
3,351,360, CANC. INT. CL. 28.
- FUNRISE TOYS LTD., KOWLOON, HONG KONG:  
3,352,295, CANC. INT. CL. 28.
- FURROW, GUY, NEW YORK, NY:  
2,794,439, CANC. INT. CL. 41.
- FURROWS, LANI, SAN DIEGO, CA:  
3,354,053, CANC. INT. CL. 35.
- FUSION MEDIA NETWORK, LLC, BURBANK, CA:  
4,594,414, INT. CL. 41.  
4,594,415, INT. CL. 41.
- FUSION ONE GLOBAL, LLC, GOLETA, CA:  
4,591,977, PUB. 6-10-2014. INT. CL. 21.
- FUSION PERFORMANCE MARKETING, LLC, ST. LOUIS, MO:  
4,591,115, PUB. 6-10-2014. INT. CL. 35.
- FWD MEDIA, INC., NEW YORK, NY:  
4,593,100, MULTIPLE CLASS, INT. CLS. 41 AND 42.
- FX LIFE SCIENCES AG, 6300 ZUG, SWITZERLAND:  
3,354,478, CANC. INT. CL. 5.
- F5 NETWORKS, INC., SEATTLE, WA:  
4,590,945, PUB. 6-10-2014. INT. CL. 9.  
4,592,699, PUB. 6-10-2014. INT. CL. 9.  
4,592,714, PUB. 6-10-2014. INT. CL. 9.  
4,592,997, PUB. 6-10-2014. INT. CL. 9.  
4,593,062, PUB. 6-10-2014. INT. CL. 9.
- G. H. LEIDENHEIMER BAKING CO., LTD., NEW ORLEANS, LA:  
4,591,997, PUB. 6-10-2014. INT. CL. 30.
- GAAD FASHION CREATION LIMITED, NASSAU, BAHAMAS:  
4,593,984, INT. CL. 35.
- GAELCO, MOVILES, S.L., BARCELONA, SPAIN:  
3,353,523, CANC. INT. CL. 9.
- GAINES MANUFACTURING, INC., POWAY, CA:  
2,861,661, REN. 7-23-14. INT. CL. 6.
- GAINES; EDWARD ALLEN, GEORGETOWN, KY:  
1,310,469, REN. 7-24-14. INT. CL. 41.
- GALARZA, GABRIEL D. LOGANVILLE, GA:  
4,594,664, INT. CL. 25.
- GALCO INDUSTRIAL ELECTRONICS, MADISON HEIGHTS, MI:  
4,591,825, PUB. 6-10-2014. MULTIPLE CLASS, INT. CLS. 35, 37 AND 42.
- GALERIE DE POP CO., LTD., TOKYO, JAPAN:  
4,593,196, INT. CL. 35.
- GALICKI & RISSIN LLC, FORT LEE, NJ:  
3,352,964, CANC. INT. CL. 14.
- GALICKI AND RISSIN LLC, FORT LEE, NJ:  
3,352,963, CANC. INT. CL. 14.
- GALLAGHER, CYNTHIA, SHREVEPORT, LA:  
4,592,240, PUB. 6-10-2014. INT. CL. 35.
- GALLANOSA, DAVID F., CHULA VISTA, CA:  
3,353,208, CANC. INT. CL. 25.
- GALLANTFEW, INC., WICHITA, KS:  
4,591,456, PUB. 6-10-2014. INT. CL. 38.
- GALLIK, GERALD, ROY, MEMPHIS, TN:  
2,912,748, REN. 7-22-14. INT. CL. 7.
- GAMEFLY, INC., LOS ANGELES, CA:  
3,351,342, CANC. INT. CL. 42.
- GAMELOGIC INC., WALTHAM, MA:  
3,353,200, CANC. INT. CL. 41.
- GAMING PARTNERS INTERNATIONAL USA, INC., LAS VEGAS, NV:  
2,796,325, CANC. INT. CL. 28.
- GAMO OUTDOOR USA, INC., FORT LAUDERDALE, FL:  
4,594,108, INT. CL. 8.
- GARCIA, VICTOR, MONTEBELLO, CA:  
4,592,139, PUB. 6-10-2014. INT. CL. 32.  
4,592,141, PUB. 6-10-2014. INT. CL. 32.  
4,592,142, PUB. 6-10-2014. INT. CL. 32.
- GARCOA, INC., CALABASAS, CA:  
3,350,707, CANC. INT. CL. 3.
- GARNER, ERIC J, VALENCIA, CA:  
4,592,233, PUB. 6-10-2014. INT. CL. 16.
- GARNER, RALPH, CHANDLER, AZ:  
3,354,420, CANC. INT. CL. 45.
- GARY BRIERE, SUNDERLAND, MA:  
4,594,625, INT. CL. 39.
- GARY L. SHARPE, NAPLES, FL:  
4,592,899, PUB. 6-10-2014. INT. CL. 42.
- GARY NULL & ASSOCIATES, INC., NEW YORK, NY:  
2,794,214, CANC. INT. CL. 5.
- GASVENTURE 1, LLC, MIAMI, FL:  
4,591,759, PUB. 6-10-2014. INT. CL. 37.
- GATES CORPORATION, THE, DENVER, CO:  
592,435, REN. 7-18-14. U.S. CL. 35 (INT. CL. 17).
- GATES CORPORATION, THE, DENVER, CO, GATES RUBBER COMPANY, THE, DENVER, CO:  
1,845,604, REN. 7-18-14. INT. CL. 17.
- GATSBY TECHNOLOGIES, LLC, LAWRENCEVILLE, NJ:  
4,591,577, PUB. 6-10-2014. INT. CL. 42.
- GATTEFOSSE SAS, 69800 SAINT-PRIEST, FRANCE, ETABLISSEMENTS GATTEFOSSE, SAINT-PRIEST (RHONE), FRANCE:  
1,291,754, REN. 7-24-14. INT. CL. 5.
- GAUGHEN HOLDINGS LLC, OXNARD, CA:  
3,354,113, CANC. INT. CL. 33.
- GAUTHIER, LUIS, T., PHILADELPHIA, PA:  
3,351,511, CANC. INT. CL. 41.
- GAY & LESBIAN LEADERSHIP INSTITUTE, INC., WASHINGTON, DC:  
3,351,980, CANC. INT. CL. 41.
- GDB INTERNATIONAL INC., NEW BRUNSWICK, NJ:  
4,594,410, INT. CL. 2.  
4,594,411, INT. CL. 2.
- GE SENSING & INSPECTION TECHNOLOGIES GMBH, HURTH, FED REP GERMANY:  
2,802,904, REN. 7-23-14. MULTIPLE CLASS, INT. CLS. 9 AND 10.
- GEERFAB, LLC, MILWAUKEE, WI:  
4,593,666, INT. CL. 17.  
4,593,667, INT. CL. 17.
- GEESEPEACE, FALLS CHURCH, VA:  
2,794,592, CANC. MULTIPLE CLASS, INT. CLS. 16 AND 41.
- GELSON'S MARKETS, ENCINO, CA:  
3,351,519, CANC. INT. CL. 35.
- GEMALTO S.A., MEUDON, FRANCE:  
3,353,301, CANC. MULTIPLE CLASS, INT. CLS. 2 AND 9.
- GENACAST VENTURES, LLC, WILMINGTON, DE:  
4,592,681, PUB. 6-10-2014. MULTIPLE CLASS, INT. CLS. 35 AND 36.
- GENECTIVE, FRANCE:  
4,590,788, PUB. 6-10-2014. MULTIPLE CLASS, INT. CLS. 1, 5, 31, 42 AND 44.

GENERAL CABLE INDUSTRIES, INC., HIGHLAND HEIGHTS, KY:  
983,205. REN. 7-22-14. U.S. CL. 21 (INT. CL. 9).  
2,860,528. REN. 7-24-14. MULTIPLE CLASS, INT. CLS. 7 AND 9.

GENERAL CABLE TECHNOLOGIES CORPORATION, HIGHLAND HEIGHTS, KY:  
2,838,941. REN. 7-22-14. INT. CL. 9.  
2,847,923. REN. 7-23-14. INT. CL. 9.  
2,865,684. REN. 7-23-14. INT. CL. 9.

GENERALE BISCUIT, 94150 RUNGIS,, FRANCE:  
3,353,579. CANC. INT. CL. 30.

GENERALIST INK, LLC, RIDGEFIELD, CT:  
4,593,450. INT. CL. 16.

GENERATION READY INC., NEW YORK, NY:  
4,594,069. INT. CL. 41.  
4,594,070. INT. CL. 41.  
4,594,120. INT. CL. 41.

GENERATOR HOSTELS LTD, LONDON, UNITED KINGDOM:  
4,590,681. PUB. 6-10-2014. MULTIPLE CLASS, INT. CLS. 35, 38, 39, 41 AND 43.

GENEX BIOSYSTEMS LIMITED, UNITED KINGDOM:  
3,352,594.

GENERATION, HAMBURG, NY:  
4,591,890. PUB. 6-10-2014. INT. CL. 41.

GENIECO, INC., CHICAGO, IL:  
1,872,163. REN. 7-23-14. INT. CL. 21.

GENLYTE THOMAS GROUP LLC, SOMERSET, NJ, ESQUIRE, INC., NEW YORK, NY:  
988,795. REN. 7-24-14. U.S. CL. 21 (INT. CL. 9).

GENLYTE THOMAS GROUP LLC, BURLINGTON, MA:  
3,353,248. CANC. INT. CL. 11.

GENOA CELLARS LLC, WOODINVILLE, WA:  
4,591,318. PUB. 6-10-2014. INT. CL. 33.

GENOME ID GROUP, LLC, GREENVILLE, NC:  
4,593,854. INT. CL. 42.

GENOMMA LAB INTERNACIONAL, S.A.B. DE C.V., MEXICO, D.F., MEXICO:  
4,593,255. INT. CL. 5.

GENOR BIOPHARMA CO. LTD., PUDONG, SHANGHAI, CHINA:  
4,593,083. INT. CL. 42.

GENRIGHT OFF ROAD, INC., SIMI VALLEY, CA:  
4,591,939. PUB. 6-10-2014. INT. CL. 12.

GENTIVA HEALTH SERVICES, INC., MELVILLE, NY:  
3,464,097. CANC. MULTIPLE CLASS, INT. CLS. 9, 35, 36 AND 42.  
3,464,098. CANC. MULTIPLE CLASS, INT. CLS. 9, 35, 36 AND 42.

GEO CENTURY LIMITED, ABERDEEN, UNITED KINGDOM:  
3,352,497. CANC. INT. CL. 42.

GEODATA DEVELOPMENT GROUP LLC, CORONA, CA:  
4,594,678. INT. CL. 45.  
4,594,679. INT. CL. 45.

GEOMAGWORLD SA, SWITZERLAND:  
4,590,763. PUB. 6-10-2014. MULTIPLE CLASS, INT. CLS. 9, 16, 28, 38, 41 AND 42.

GEORGE DELALLO COMPANY, INC., MT. PLEASANT, PA:  
4,592,343. PUB. 6-10-2014. INT. CL. 30.

GEORGETOWN UNIVERSITY, WASHINGTON, DC:  
4,594,597. INT. CL. 9.

GEORGIA LOUISE INC., NEW YORK, NY:  
4,591,643. PUB. 6-10-2014. MULTIPLE CLASS, INT. CLS. 3, 35 AND 44.

GEOX S.P.A, ITALY:  
4,590,809. PUB. 6-10-2014. MULTIPLE CLASS, INT. CLS. 18 AND 25.

GERBER SCIENTIFIC INTERNATIONAL, INC., SOUTH WINDSOR, CT:  
3,353,859. CANC. INT. CL. 9.

GERDES, PAUL, LONG GROVE, IL:  
2,794,738. CANC. INT. CL. 42.

GERRIT J. VERBURG CO., FENTON, MI:  
3,354,626. CANC. INT. CL. 30.

GESPAGRESO, S.L., ALZIRA, VALENCIA, SPAIN AND ASEMET CONSULTORES, S.L., ALZIRA, VALENCIA, SPAIN AND GREGEN, S.L., ALZIRA, VALENCIA, SPAIN:  
3,352,041. CANC. MULTIPLE CLASS, INT. CLS. 29 AND 30.

GESSNER AND ASSOCIATES, INC., ENCINITAS, CA:  
2,796,073. CANC. INT. CL. 9.

GESTION PARTICIPATIONS FINANCIERES ET IMMOBILIERES, 27240 LE RONCENAY-AUTHENAY, FRANCE:  
2,859,955. REN. 7-23-14. INT. CL. 30.

GEYMAN, RONALD, CHICAGO, IL:  
4,591,486. PUB. 6-10-2014. INT. CL. 35.

GFC BRANDS, INC., WILMINGTON, DE:  
3,352,151. CANC. INT. CL. 35.

GFC LENDING, LLC, PHOENIX, AZ:  
4,592,380. PUB. 6-10-2014. INT. CL. 35.  
4,592,381. PUB. 6-10-2014. INT. CL. 35.

GG BAILEY, LLC, CALHOUN, GA:  
2,868,088. REN. 7-23-14. INT. CL. 40.

GGP ITALY, S.P.A., CASTELFRANCO VENETO, ITALY:  
3,351,633. CANC. MULTIPLE CLASS, INT. CLS. 7, 8 AND 12.

GIAMMONA COLLECTIVE, LLC, APEX, NC:  
4,594,761. INT. CL. 25.

GIANLUCA MECH S.P.A., ASIGLIANO VENETO, ITALY:  
4,593,322. MULTIPLE CLASS, INT. CLS. 5, 30 AND 32.  
4,593,323. MULTIPLE CLASS, INT. CLS. 5, 30 AND 32.

GIANT 5 FUNDS, COLORADO SPRINGS, CO:  
3,354,023. CANC. INT. CL. 36.  
3,354,033. CANC. INT. CL. 36.

GIBBS WIRE & STEEL COMPANY, INC., SOUTHINGTON, CT:  
4,591,589. PUB. 6-10-2014. MULTIPLE CLASS, INT. CLS. 6 AND 40.  
4,591,590. PUB. 6-10-2014. MULTIPLE CLASS, INT. CLS. 6 AND 40.

GIBSON BRANDS, INC., NASHVILLE, TN:  
4,593,966. MULTIPLE CLASS, INT. CLS. 9 AND 15.

GIGA-BYTE TECHNOLOGY CO., LTD., NEW TAIPEI CITY, TAIWAN:  
4,590,967. PUB. 6-10-2014. INT. CL. 9.  
4,594,439. INT. CL. 9.

GILBERT AND OMOHUNDRO P.A., SILVER SPRING, MD:  
1,765,069. REN. 7-23-14. INT. CL. 42.

GILBERT, JAMES A, DBA 401K SOLUTION, SHERMAN OAKS, CA:  
2,793,762. CANC. INT. CL. 9.

GILDAN USA INC., CHARLESTON, SC:  
3,353,038. CANC. INT. CL. 25.  
4,593,223. INT. CL. 25.

GILLUM, RICHARD, GREENWOOD, IN:  
4,592,550. PUB. 6-10-2014. INT. CL. 44.

GILMAN CIOCIA, INC., POUGHKEEPSIE, NY:  
3,274,218. CANC. INT. CL. 35.

GINKGO INTERNATIONAL LTD., WOODBRIDGE, IL:  
1,317,686. REN. 7-18-14. INT. CL. 8.

GINN, ALEXIS, DYER, IN:  
4,593,816. INT. CL. 3.

GIRARD SYSTEMS, SAN CLEMENTE, CA:  
3,352,966. CANC. INT. CL. 9.

GIRGENTI, SALVATORE, BROOKLYN, NY:  
4,592,274. PUB. 6-10-2014. MULTIPLE CLASS, INT. CLS. 35 AND 36.  
4,592,275. PUB. 6-10-2014. MULTIPLE CLASS, INT. CLS. 35 AND 36.

GIRLS NITE IN INTERNATIONAL, BROWNSBURG, IN:  
4,591,861. PUB. 6-10-2014. INT. CL. 45.

GITLAB.COM, UTRECHT, NETHERLANDS:  
4,594,617. MULTIPLE CLASS, INT. CLS. 9 AND 42.

GIVAUDAN SA, 1214 VERNIER, SWITZERLAND:  
2,793,900. CANC. MULTIPLE CLASS, INT. CLS. 3, 5 AND 16.

GIVE ME HOPE SA, SWITZERLAND:  
3,352,589.

GIVN GOODS INC., ATLANTA, GA:  
4,594,320. INT. CL. 32.

GJELLYBOO LLC, MYRTLE BEACH, SC:  
4,591,653. PUB. 6-10-2014. INT. CL. 3.

- GLACIAL BLASTER, INC., GRAND RAPIDS, MI:  
4,591,816, PUB. 6-10-2014. INT. CL. 7.
- GLANBIA NUTRITIONALS (IRELAND) LIMITED, KILKENNY, IRELAND:  
3,354,666, CANC. INT. CL. 5.
- GLANBIA PLC, KILKENNY, IRELAND:  
4,591,432, PUB. 6-10-2014. INT. CL. 5.
- GLASCOE, DEIRDRE C., JACKSONVILLE, FL AND THE MINISTRY OF SECOND TIMOTHY, INC., ALEXANDRIA, VA:  
4,591,273, PUB. 10-29-2013. INT. CL. 16.
- GLASSYBABY LLC, SEATTLE, WA:  
2,906,736. REN. 7-21-14. INT. CL. 21.
- GLAXO GROUP LIMITED, BRENTFORD, MIDDLESEX, UNITED KINGDOM:  
1,286,762. REN. 7-24-14. INT. CL. 5.
- GLAXOSMITHKLINE BIOLOGICALS, S.A., RIXENSART, BELGIUM:  
3,351,825, CANC. INT. CL. 5.
- GLAXOSMITHKLINE LLC, WILMINGTON, DE:  
2,793,437, CANC. INT. CL. 5.  
3,354,347, CANC. INT. CL. 5.
- GLEA LLC, IRVING, TX:  
3,638,331, AM. INT. CL. 41.
- GLEANER LIFE INSURANCE SOCIETY, ADRIAN, MI:  
4,591,123, PUB. 6-10-2014. INT. CL. 36.
- GLENN C. BAILEY, CHANDLER, AZ:  
4,594,020, INT. CL. 41.
- GLOBAL ADVANCED IMAGING, LLC, LITTLE ROCK, AR:  
4,593,819, INT. CL. 44.
- GLOBAL CELLULAR, INC., ALPHARETTA, GA:  
4,593,301, INT. CL. 9.
- GLOBAL CONSCIOUS PTY LIMITED, SYDNEY, AUSTRALIA:  
4,591,498, PUB. 6-10-2014. INT. CL. 16.
- GLOBAL ESPRIT, INC., CHUNG HO CITY, TAIPEI HSIEN, TAIWAN:  
1,846,840. REN. 7-23-14. INT. CL. 28.
- GLOBAL FOREST SOCIETY, BANFF, ALBERTA, CANADA:  
2,793,492, CANC. MULTIPLE CLASS, INT. CLS. 16, 41 AND 42.
- GLOBAL MAX UNLIMITED GROUP, CORP, DORADO, PUERTO RICO:  
4,592,418, PUB. 6-10-2014. INT. CL. 35.
- GLOBAL PAYMENTS INC., ATLANTA, GA:  
2,642,548 NEW CERT. 8-26-2014. INT. CL. 36.
- GLOBAL PROTECTION CORP., BOSTON, MA:  
4,593,115, INT. CL. 5.
- GLOBAL QUEST LLC, CATAUMET, MA:  
2,794,788, CANC. MULTIPLE CLASS, INT. CLS. 35 AND 42.
- GLOBAL RENTAL CO., INC., BIRMINGHAM, AL:  
2,885,558. REN. 7-21-14. MULTIPLE CLASS, INT. CLS. 37 AND 39.
- GLOBAL TOTAL OFFICE, DOWNSVIEW, ONTARIO, CANADA:  
2,793,409, CANC. INT. CL. 20.
- GLOBAL 360, INC., DALLAS, TX:  
3,352,171, CANC. MULTIPLE CLASS, INT. CLS. 9, 16 AND 41.
- GLOBALFOUNDRIES INC., GRAND CAYMAN, CAYMAN ISLANDS:  
4,591,366, PUB. 6-10-2014. MULTIPLE CLASS, INT. CLS. 40 AND 42.
- GLOBECAST FRANCE, ISSY LES MOULINEAUX, FRANCE:  
4,591,433, PUB. 6-10-2014. MULTIPLE CLASS, INT. CLS. 9, 38 AND 42.
- GLOBERIDE, INC., HIGASHIKURUME-CITY, TOKYO, JAPAN:  
1,292,454. REN. 7-19-14. INT. CL. 28.  
1,849,951. REN. 7-23-14. INT. CL. 25.
- GLOBUS MEDICAL, INC., AUDUBON, PA:  
3,352,002, CANC. INT. CL. 10.
- GLOW MASSAGE, INC., OAKLAND, CA:  
4,591,029, PUB. 6-10-2014. MULTIPLE CLASS, INT. CLS. 16, 41 AND 44.  
4,591,030, PUB. 6-10-2014. MULTIPLE CLASS, INT. CLS. 16, 41 AND 44.
- GLUD & MARSTRAND A/S, DK-8723 LOSNING, DENMARK:  
3,361,163, CANC. MULTIPLE CLASS, INT. CLS. 8, 14, 28, 39 AND 41.
- GLYNLYON, INC., CHANDLER, AZ:  
3,351,483, CANC. INT. CL. 41.
- GMART ADS LLC, WASHINGTON, MI:  
4,592,290, PUB. 6-10-2014. INT. CL. 35.
- GMAS DESIGN LLC, MIAMI, FL:  
4,591,913, PUB. 6-10-2014. INT. CL. 21.
- GMR MARKETING LLC, NEW BERLIN, WI:  
2,864,320. REN. 7-22-14. INT. CL. 35.
- GMS ONLINE LIMITED, UNITED KINGDOM:  
3,352,545.
- GO DADDY OPERATING COMPANY, LLC, SCOTTSDALE, AZ:  
4,548,471, COR. INT. CL. 9.
- GO DEEP GEAR LLC, CONCORD, NC:  
4,591,409, PUB. 6-10-2014. INT. CL. 25.
- GO PAPA, LLLP, LITTLETON, CO:  
4,591,625, PUB. 6-10-2014. INT. CL. 20.
- GO R DESIGN, LLC, NEW EGYPT, NJ:  
3,350,768, CANC. INT. CL. 28.
- GO WIRELESS, INC., LAS VEGAS, NV:  
4,591,322, PUB. 6-10-2014. INT. CL. 35.
- GOCAKEGO, LLC, DENVER, CO:  
3,354,644, CANC. MULTIPLE CLASS, INT. CLS. 35, 38, 41 AND 42.
- GODFREY'S TCB, LLC, MURRIETA, CA:  
3,351,631, CANC. INT. CL. 29.
- GODLEY, ROBERT THOMAS, CHARLOTTE, NC, DBA FIRST INDUSTRIAL BUILDINGS & LAND:  
1,848,342. REN. 7-22-14. INT. CL. 37.
- GODWIN, MARK BOYD, SAN JOSE, CA:  
3,353,655, CANC. INT. CL. 35.
- GOGGLE WORKS, LLC, READING, PA:  
4,594,758, INT. CL. 41.
- GOLDEN EAGLE PUBLISHING COMPANY, INC., HOUSTON, TX:  
3,351,769, CANC. INT. CL. 41.
- GOLDEN LIGHTING, TALLAHASSEE, FL:  
3,344,154, CANC. INT. CL. 11.
- GOLDEN STATE INSTRUMENT COMPANY, TUSTIN, CA:  
3,352,408, CANC. INT. CL. 9.
- GOLDEN SUN, INC., SANTA CLARITA, CA:  
3,353,533, CANC. INT. CL. 3.
- GOLDEN TOUCH TRANSPORTATION OF NY, INC., COLLEGE POINT, NY:  
4,556,227, COR. INT. CL. 39.
- GOLDEN WEB, INC., SYLVANIA, OH:  
2,794,874, CANC. INT. CL. 31.
- GOLDEN WEST BIOLOGICALS, INC., TEMECULA, CA:  
4,591,664, PUB. 6-10-2014. INT. CL. 1.
- GOLDGRATE FIBREGLASS COMPANY LIMITED, 77-91 QUEEN = S ROAD WEST, HONG KONG:  
2,794,232, CANC. INT. CL. 19.
- GOLDHAR LEARNING SYSTEMS, INC., PASSAIC, NJ:  
4,591,012, PUB. 6-10-2014. INT. CL. 41.
- GOLDMARK STUDIOS INC., VANCOUVER, BC, V6E 4C2, CANADA:  
4,593,406, INT. CL. 42.
- GOLF DESIGN, U.S.A., GARDEN GROVE, CA:  
3,354,535, CANC. INT. CL. 28.
- GOLF SCHOOLS, INC., KENT, OH:  
2,794,809, CANC. INT. CL. 41.
- GONZALEZ, LUIS, SOUTH OZONE PARK, NY:  
4,592,867, PUB. 6-10-2014. INT. CL. 14.
- GOOD EATZ GOURMET CORP., KENILWORTH, NJ:  
4,592,883, PUB. 6-10-2014. INT. CL. 30.  
4,592,884, PUB. 6-10-2014. INT. CL. 35.  
4,593,052, PUB. 6-10-2014. INT. CL. 30.  
4,593,053, PUB. 6-10-2014. INT. CL. 30.  
4,593,054, PUB. 6-10-2014. INT. CL. 30.
- GOOD HARBOR COFFEE & TEA, INC., TRAVERSE CITY, MI:  
3,350,837, CANC. MULTIPLE CLASS, INT. CLS. 35 AND 43.

GOOD SHAPE, INC., BROOKLYN, NY:  
3,354,246, CANC. INT. CL. 42.

GOOD SMILE COMPANY, INC., JAPAN:  
4,590,898, PUB. 6-10-2014. INT. CL. 9.

GOODY PRODUCTS, INC., PEACHTREE CITY, GA:  
1,187,240, CANC. INT. CL. 20.

GOOGLE INC., MOUNTAIN VIEW, CA:  
4,593,243, MULTIPLE CLASS, INT. CLS. 9, 35 AND 38.

GORDON \* HOWARD ASSOCIATES, INC., LITTLETON, CO:  
4,593,445, INT. CL. 36.

GORDON TRUCKING, INC., PACIFIC, WA:  
4,593,342, MULTIPLE CLASS, INT. CLS. 35 AND 39.

GORDON, STEVE, LOS ANGELES, CA:  
4,591,575, PUB. 6-10-2014. INT. CL. 25.

GORTER GROUP B.V., NETHERLANDS:  
4,590,677, PUB. 6-10-2014. MULTIPLE CLASS, INT. CLS. 6, 19 AND 35.

GOURMENT BEVERAGES, L.L.C., MISSOULA, MT:  
4,594,095, INT. CL. 30.

GOVE-SIEBOLD GROUP, INC., BOYNTON BEACH, FL:  
3,354,004, CANC. INT. CL. 9.

GOVPROIT, INC, DUMFRIES, VA:  
4,591,328, PUB. 6-10-2014. INT. CL. 42.

GOVX, INC., LA JOLLA, CA:  
4,591,645, PUB. 6-10-2014. MULTIPLE CLASS, INT. CLS. 35 AND 41.

GOWER, JIM, JEMEZ SPRINGS, NM:  
4,593,756, INT. CL. 12.

GOYA FOODS, INC., SECAUCUS, NJ:  
1,843,811. REN. 7-18-14. INT. CL. 30.  
1,846,311. REN. 7-19-14. INT. CL. 32.

GOYAL, MANU, GLENSHAW, PA AND GOYAL, ANKUR, GLENSHAW, PA:  
4,594,704, INT. CL. 9.

GRABBER CONSTRUCTION PRODUCTS, INC., HIGHLAND, UT:  
1,288,640. REN. 7-22-14. INT. CL. 6.

GRACIOUS (IP) LLC, NEW YORK, NY:  
3,351,200, CANC. INT. CL. 16.  
3,351,202, CANC. INT. CL. 20.  
3,351,209, CANC. INT. CL. 1.

GRACO CHILDREN'S PRODUCTS INC., ATLANTA, GA:  
4,594,214, INT. CL. 20.

GRADY-WHITE BOATS, INC., GREENVILLE, NC:  
762,209. REN. 7-23-14. U.S. CL. 19 (INT. CL. 12).

GRAHAM WOODARD, SOUTH DAYTONA, FL AND ZANE BOWMAN, FLAGLER BEACH, FL:  
4,591,918, PUB. 6-10-2014. INT. CL. 41.

GRAHAM, MAURICE, RICHMOND, VA:  
3,352,274, CANC. INT. CL. 41.

GRANBY INDUSTRIES LIMITED PARTNERSHIP, GRANBY, QUEBEC:  
3,351,189, CANC. INT. CL. 6.  
3,351,190, CANC. INT. CL. 6.

GRAND CIRCUIT PRODUCTS, LLC, LOUISVILLE, KY:  
2,866,812. REN. 7-21-14. INT. CL. 6.  
2,866,813. REN. 7-21-14. INT. CL. 5.

GRAND CITRUS GROUP, LLC, HUNTINGTON BEACH, CA:  
4,594,232, INT. CL. 41.

GRANT, KATIE MILLER, HIXSON, TN:  
3,354,214, CANC. INT. CL. 43.

GRANTIUM INC., OTTAWA, ONTARIO, CANADA:  
3,352,133, CANC. MULTIPLE CLASS, INT. CLS. 9, 16, 41 AND 42.

GRAPEVINEONE LLC, CHICAGO, IL:  
4,593,781, MULTIPLE CLASS, INT. CLS. 9 AND 42.

GRAPHICS 4 GEAR LLC, FINLAYSON, MN:  
4,592,831, PUB. 6-10-2014. INT. CL. 14.

GRAPHLINE, INC., TAMARAC, FL:  
1,810,335, CANC. MULTIPLE CLASS, INT. CLS. 1, 7, 9 AND 17.

GRATITUDE INTERACTIVE LLC, SEATTLE, WA, DBA GRATITUDE INTERACTIVE:  
4,593,912, MULTIPLE CLASS, INT. CLS. 9 AND 35.

GRAUVELL, S.A., SANT JULIA DE LORIA, ANDORRA:  
2,884,207. REN. 7-24-14. INT. CL. 28.

GRAVITY BOULEVARD, LLC, TAMPA, FL:  
4,592,910, PUB. 6-10-2014. INT. CL. 45.

GRAY, JAMES, EWA BEACH, HI:  
3,351,625, CANC. INT. CL. 41.

GRAYHAWK DEVELOPMENT, INC., SCOTTSDALE, AZ:  
2,879,789. REN. 7-24-14. MULTIPLE CLASS, INT. CLS. 25, 36, 37, 41 AND 42.

GREAT AMERICAN DUCK RACES, INC., SCOTTSDALE, AZ, DBA GAME: GREAT AMERICAN MERCHANDISE AND EVENTS:  
4,591,548, PUB. 6-10-2014. INT. CL. 36.

GREAT DEAL INC, BROOKLYN, NY:  
4,594,719, INT. CL. 30.

GREAT EYEDEAS, INC., PLAYA DEL REY, CA:  
3,353,447, CANC. MULTIPLE CLASS, INT. CLS. 35, 36, 41 AND 42.  
3,353,449, CANC. MULTIPLE CLASS, INT. CLS. 35, 36, 41 AND 42.

GREAT LAKES ELECTRONIC CIGARETTES, LLC, SPARROWS POINT, MD:  
4,593,776, INT. CL. 34.

GREAT LAKES MEDICAL BILLING & PRACTICE MANAGEMENT, LLC, CHESTERFIELD, MI:  
4,593,809, INT. CL. 42.

GREAT NH RESTAURANTS, INC., BEDFORD, NH:  
4,593,676, INT. CL. 21.

GREAT PLAINS BLACK HISTORY MUSEUM, ARCHIVES AND INTERPRETATIVE CENTER, INC., OMAHA, NE:  
4,592,706, PUB. 6-10-2014. INT. CL. 41.

GREATER ALABAMA MULTIPLE LISTING SERVICE, INC., BIRMINGHAM, AL:  
4,592,357, PUB. 6-10-2014. INT. CL. 36.  
4,592,358, PUB. 6-10-2014. INT. CL. 36.

GREATER NEW YORK TOYOTA DEALERS ASSOCIATION, INC., THE, NEW YORK, NY:  
3,353,988, CANC. INT. CL. 35.

GREEK MUSIC AND VIDEO SUPERSTORE INC., ASTORIA, NY:  
3,350,903, CANC. INT. CL. 25.

GREEN BAY PACKERS, INC., GREEN BAY, WI:  
4,593,153, INT. CL. 43.  
4,593,156, INT. CL. 37.

GREEN BUSINESS ALLIANCE, INC., BOCA RATON, FL:  
4,592,177, PUB. 6-10-2014. INT. CL. 42.

GREEN DESK B.V., NL-1011 TB AMSTERDAM, NETHERLANDS:  
4,590,861, PUB. 6-10-2014. MULTIPLE CLASS, INT. CLS. 9, 12, 16, 25, 35 AND 41.

GREEN DIRT FARM, L.L.C., WESTON, MO:  
4,592,163, PUB. 6-10-2014. INT. CL. 29.

GREEN DOT BANK, PROVO, UT:  
4,592,871, PUB. 6-10-2014. MULTIPLE CLASS, INT. CLS. 35 AND 36.

GREEN INVESTMENTS, LLC, PHOENIX, AZ:  
4,593,844, INT. CL. 9.

GREEN LIGHT DIRECT SERVICES, INC., TEMPE, AZ:  
4,592,387, PUB. 6-10-2014. INT. CL. 35.

GREEN LIGHT INNOVATIONS, LAKE SAINT LOUIS, MO:  
4,593,851, INT. CL. 11.  
4,593,852, INT. CL. 9.

GREEN PRO, INC., STEWART, MN:  
3,352,356, CANC. INT. CL. 1.

GREEN, BRAD D., SAN DIEGO, CA:  
3,353,105, CANC. INT. CL. 25.

GREEN, NANCY SOKOL, CARLSBAD, CA:  
2,877,366. REN. 7-18-14. MULTIPLE CLASS, INT. CLS. 9 AND 41.

GREENBRIER IA, INC, WHITE SULPHUR SPRINGS, WV:  
4,592,270, PUB. 6-10-2014. MULTIPLE CLASS, INT. CLS. 16, 18, 21, 25 AND 28.

GREENHOUSE INTERNATIONAL LLC, NEWARK, DE:  
3,350,636, CANC. INT. CL. 28.

GREENHUNTER WATER, LLC, GRAPEVINE, TX:  
4,593,619, MULTIPLE CLASS, INT. CLS. 12 AND 39.

GREENSPRING MEDIA GROUP INC, MINNEAPOLIS, MN:  
3,354,637, CANC. INT. CL. 16.

GREENSTEIN, RENEE, NEW YORK, NY:  
4,591,290, PUB. 6-10-2014. INT. CL. 25.

- GREERWALKER LLP, CHARLOTTE, NC:  
4,592,494, PUB. 6-10-2014. INT. CL. 35.  
4,592,496, PUB. 6-10-2014. INT. CL. 35.
- GREGORY ENTERPRISES, INC., ADA, OK:  
4,594,763, INT. CL. 36.
- GRENSOURCE BRAND APPAREL, INC., RENTON, WA,  
DBA GREENSOURCE:  
4,592,112, PUB. 6-10-2014. INT. CL. 25.
- GREY PNEUMATIC CORP., MENOMONIE, WI:  
4,594,219, INT. CL. 35.
- GRIFFIN TECHNOLOGY, INC., NASHVILLE, TN:  
4,594,779, INT. CL. 9.
- GRIFFITH LABORATORIES INTERNATIONAL, INC., AL-  
SIP, IL:  
2,874,508. REN. 7-23-14. INT. CL. 30.
- GRIFOLS WORLDWIDE OPERATIONS LIMITED, IRE-  
LAND:  
4,590,903, PUB. 6-10-2014. INT. CL. 5.  
4,590,904, PUB. 6-10-2014. INT. CL. 5.  
4,590,916, PUB. 6-10-2014. INT. CL. 5.
- GRIGGS, ROBERT, OLD BRIDGE, NJ:  
3,351,239, CANC. INT. CL. 44.
- GRILL VENTURES, INC., ATLANTA, GA:  
3,353,403, CANC. INT. CL. 43.
- GRIMES, JANE, NOBLESVILLE, IN:  
4,591,901, PUB. 6-10-2014. INT. CL. 44.
- GRISI HNOS., S.A. DE C.V., COLONIA DEL VALLE,  
MEXICO:  
1,843,427. REN. 7-18-14. INT. CL. 3.
- GRIZZLY ADAMS, LLC, COEUR D'ALENE, ID:  
4,592,934, PUB. 6-10-2014. INT. CL. 38.
- GROM, CHRIS V, MANSFIELD, TX:  
4,593,327, INT. CL. 16.
- GROUNDWORKS FOR HEALTH, INC., BURLINGTON, VT:  
3,475,250, COR. INT. CL. 44.
- GROUP DCA, LLC, PARSIPPANY, NJ:  
4,593,299, INT. CL. 44.  
4,593,300, INT. CL. 44.
- GROUP PHOTOGRAPHERS ASSOCIATION, INC., SPO-  
KANE VALLEY, WA:  
3,350,855, CANC. INT. CL. 9.
- GROUP PUBLISHING, INC., LOVELAND, CO:  
3,352,954, CANC. INT. CL. 9.
- GROUPE LEA NATURE, PERIGNY CEDEX, FRANCE:  
4,590,812, PUB. 6-10-2014. MULTIPLE CLASS, INT. CLS.  
3, 5, 29 AND 30.
- GROWLERU FRANCO, LLC, CENTENNIAL, CO:  
4,594,049, INT. CL. 43.
- GRUMA CORPORATION, IRVING, TX:  
3,351,266, CANC. INT. CL. 30.
- GRUMA, S.A.B. DE C.V., SAN PEDRO GARZA GARCÍA,  
N.L., MEXICO:  
4,594,278, INT. CL. 30.
- GRUNDFOS HOLDING A/S, BJERRINGBRO, DENMARK,  
GRUNDFOS BJERRINGBRO PUMPEFABRIK A/S, BJER-  
RINGBRO, DENMARK:  
782,042. REN. 7-24-14. U.S. CL. 23 (INT. CL. 7).
- GRUPO CAROSI, S.A., AVENTURA, FL:  
4,594,015, INT. CL. 5.  
4,594,016, INT. CL. 5.
- GSA INDUSTRIES (AUST.) PTY. LTD., MELBOURNE,  
VICTORIA, AUSTRALIA:  
4,591,199, PUB. 6-10-2014. INT. CL. 11.
- GSE ENVIRONMENTAL, LLC, HOUSTON, TX:  
3,354,516, CANC. INT. CL. 27.
- GSI WORLD, GRAND PRAIRIE, TX:  
4,593,484, INT. CL. 25.
- GSM (OPERATIONS) PTY LTD, BURLEIGH HEADS, AUS-  
TRALIA:  
3,352,317, CANC. INT. CL. 25.
- GS1 US, INC., LAWRENCEVILLE, NJ:  
4,594,641, INT. CL. 35.
- GTECH CANADA ULC, MONCTON, NB, CANADA:  
2,796,202, CANC. INT. CL. 9.
- GTECH GERMANY GMBH, LÜBBECKE, FED REP GER-  
MANY:  
3,352,202, CANC. MULTIPLE CLASS, INT. CLS. 9 AND  
41.
- GUANGDONG GUANHAO HIGH-TECH CO., LTD, CHINA:  
4,590,878, PUB. 6-10-2014. INT. CL. 16.
- GUANGXI JINGUI PULP&PAPER CO.,LTD., GUANGXI,  
CHINA:  
4,593,796, INT. CL. 16.
- GUANGZHOU CITY BAIYUN LIANJIA FINE CHEMICAL  
FACTORY, CHINA:  
4,590,753, PUB. 6-10-2014. INT. CL. 3.
- GUANGZHOU LUCKYSKY INDUSTRY CO., LTD.,  
GUANGZHOU, CHINA:  
4,590,892, PUB. 6-10-2014. INT. CL. 9.
- GUARDAIR CORPORATION, CHICOPEE, MA:  
4,591,566, PUB. 6-10-2014. INT. CL. 7.
- GUARDED HORIZONS INC., ALEXANDRIA, VA:  
4,592,184, PUB. 6-10-2014. INT. CL. 38.
- GUARDIAN ALARM COMPANY, SOUTHFIELD, MI:  
1,872,962. REN. 7-18-14. INT. CL. 42.
- GUARDIAN INDUSTRIES CORP., AUBURN HILLS, MI:  
4,593,142, MULTIPLE CLASS, INT. CLS. 19 AND 20.
- GUARDIAN LIFE INSURANCE COMPANY OF AMERICA,  
THE, NEW YORK, NY:  
1,857,906. REN. 7-22-14. INT. CL. 36.
- GUARDIAN PREMIER SOLUTIONS, SAN ANTONIO, TX:  
4,592,584, PUB. 6-10-2014. INT. CL. 41.
- GUARDIAN SUPPLY COMPNAY LLC, BRISTOL, CT:  
4,594,520, INT. CL. 5.
- GUCCI AMERICA, INC., NEW YORK, NY:  
4,591,185, PUB. 6-10-2014. INT. CL. 18.
- GUERRIERO, LLC, DEERFIELD BEACH, FL:  
4,594,746, INT. CL. 41.
- GUIDEPOSTS A CHURCH CORPORATION, DANBURY,  
CT:  
4,593,131, INT. CL. 9.
- GULF COAST ADJUSTMENT SERVICE OF HOUSTON,  
INC., HOUSTON, TX, DBA GULF COAST CLAIMS  
SERVICE:  
4,591,908, PUB. 6-10-2014. INT. CL. 36.
- GULF PEARL LTD., TORONTO, ONTARIO, CANADA:  
4,593,803, INT. CL. 45.
- GULICK, DAVID R., BROOKLYN, NY:  
4,594,047, INT. CL. 25.
- GUNSKINS LLC, GRANTS PASS, OR:  
4,591,798, PUB. 6-10-2014. MULTIPLE CLASS, INT. CLS. 2  
AND 16.
- GUPPY GAMES INC., BELLEVUE, WA:  
3,354,342, CANC. INT. CL. 9.
- GURWITCH PRODUCTS, L.L.C., HOUSTON, TX:  
2,875,712. REN. 7-18-14. INT. CL. 3.
- GUSANITO.COM. S. DE R.L. DE C.V., GUADALAJARA,  
JALISCO, MEXICO, AKA GUSANITO:  
3,353,953, CANC. MULTIPLE CLASS, INT. CLS. 14, 16, 18,  
25 AND 28.
- GUTIER, MICKY, PHOENIX, AZ:  
4,594,319, MULTIPLE CLASS, INT. CLS. 3 AND 25.
- GUTIERREZ, RAFAEL, LOS ANGELES, CA:  
4,594,018, INT. CL. 38.
- GUTTER KING INTERNATIONAL, INC., COCOA, FL:  
2,793,697, CANC. INT. CL. 37.
- GYFT, INC., REDWOOD CITY, CA, DBA GYFT PLAT-  
FORM, INC.:  
4,594,621, MULTIPLE CLASS, INT. CLS. 35, 38, 41 AND  
42.
- GYPSY 05, INC., LOS ANGELES, CA:  
4,591,630, PUB. 2-25-2014. INT. CL. 25.
- G2 RESEARCH, INC., WINDER, GA:  
4,592,890, PUB. 6-10-2014. MULTIPLE CLASS, INT. CLS. 6  
AND 13.  
4,592,894, PUB. 6-10-2014. INT. CL. 13.  
4,592,986, PUB. 6-10-2014. MULTIPLE CLASS, INT. CLS.  
16 AND 25.  
4,592,987, PUB. 6-10-2014. MULTIPLE CLASS, INT. CLS.  
16 AND 25.
- G3 WORLDWIDE MAIL N.V., 1105 BH AMSTERDAM,  
NETHERLANDS ANTILLES:  
2,795,584, CANC. INT. CL. 39.
- H MART COMPANIES, INC., LYNDHURST, NJ:  
2,964,524. REN. 7-23-14. INT. CL. 35.

H. J. HEINZ FINANCE COMPANY, PITTSBURGH, PA:  
3,352,293, CANC. MULTIPLE CLASS, INT. CLS. 29 AND 30.

H.A.G. IMPORT CORPN. (AUSTRALIA) PTY LTD, BROOKLYN VIC 3012, AUSTRALIA:  
4,252,166, COR. MULTIPLE CLASS, INT. CLS. 8, 16, 21 AND 24.

HÄNEL GMBH & CO. KG, FED REP GERMANY:  
4,590,687, PUB. 6-10-2014. MULTIPLE CLASS, INT. CLS. 7, 37, 41, 42 AND 45.

HÄRTEREI HAUCK GMBH, FED REP GERMANY:  
3,352,622.

HAAG-STREIT HOLDING AG, SWITZERLAND:  
4,590,730, PUB. 6-10-2014. INT. CL. 10.  
4,590,731, PUB. 6-10-2014. INT. CL. 10.

HACH COMPANY, LOVELAND, CO:  
4,593,932, INT. CL. 9.

HACKER INDUSTRIES, INC., NEWPORT BEACH, CA:  
3,353,887, CANC. INT. CL. 19.

HACKETT, DAVID, ENCINITAS, CA AND HACKETT, ZANNAH, ENCINITAS, CA:  
3,351,174, CANC. INT. CL. 28.

HADDENHAM HEALTHCARE LIMITED, UNITED KINGDOM:  
4,590,669, PUB. 6-10-2014. MULTIPLE CLASS, INT. CLS. 5, 9, 10, 16, 41 AND 44.

HAGEMEYER NORTH AMERICA, INC., CHARLESTON, SC:  
3,353,690, CANC. INT. CL. 17.  
3,353,691, CANC. INT. CL. 22.

HAGERTY, JOHN J., LANSING, MI:  
3,352,900, CANC. INT. CL. 44.

HAHAAS COMEDY LLC, WASHINGTON, DC:  
4,594,673, INT. CL. 9.

HAIER AMERICA TRADING, L.L.C., NEW YORK, NY:  
3,354,242, CANC. INT. CL. 11.

HAITI ORIGINALE LLC, CORAL GABLES, FL:  
4,591,848, PUB. 6-10-2014. INT. CL. 35.

HAL ANTILLEN N.V., CURACAO, NETHERLANDS ANTILLES:  
2,794,957, CANC. INT. CL. 39.

HALEY & ALDRICH CONSTRUCTION SERVICES, INC., BURLINGTON, MA:  
4,592,203, PUB. 6-10-2014. INT. CL. 37.

HALFWAY TO HAZARD, LLC, NASHVILLE, TN:  
3,351,393, CANC. INT. CL. 41.

HALISCHUK, CORY, CLANDEBOYE, MANITOBA, CANADA:  
4,590,950, PUB. 6-10-2014. INT. CL. 19.

HALL DIGITAL FILMS, INC., NORTH HOLLYWOOD, CA:  
4,592,783, PUB. 6-10-2014. INT. CL. 41.

HALL, JULIA K, OAKLAND, CA, DBA I HEART NAIL ART:  
4,591,782, PUB. 6-10-2014. INT. CL. 3.

HALL, MICKEY A., COSTA MESA, CA:  
3,351,211, CANC. INT. CL. 5.

HALLER SCHWARZ, LONG BEACH, CA:  
3,354,072, CANC. INT. CL. 25.

HALLIBURTON ENERGY SERVICES, INC., CARROLLTON, TX:  
3,353,251, CANC. INT. CL. 6.  
4,593,762, INT. CL. 20.

HALLOWELL, ROBERT LEROY II, SOUTH PASADENA, CA:  
2,868,237, REN. 7-24-14. INT. CL. 3.

HALLOWES, JAMES M., ESCONDIDO, CA:  
2,858,474, REN. 7-19-14. INT. CL. 35.

HAMARI CHEMICALS, LTD., OSAKA, JAPAN:  
2,874,425, REN. 7-23-14. INT. CL. 5.

HAMBURG DONER L.L.C., LOVETTSVILLE, VA:  
3,351,641, CANC. INT. CL. 43.

HAMCO, INC., GONZALES, LA:  
4,594,576, INT. CL. 24.  
4,594,660, INT. CL. 25.

HAMDAN, TARIK D, TUCSON, AZ:  
4,594,004, INT. CL. 32.

HAMILTON SMITH ASSOCIATES, INC., DARIEN, IL:  
3,352,974, CANC. INT. CL. 45.  
3,353,049, CANC. INT. CL. 45.

HAMILTON, DAVID G., SAN DIEGO, CA:  
3,353,454, CANC. INT. CL. 9.

HAMMAD, IYAD, PARKLAND, UNITED STATES:  
3,352,396, CANC. INT. CL. 26.

HAMMAD, IYAD, PARKLAND, FL:  
3,352,398, CANC. INT. CL. 26.

HAMMES, MICHAEL, BOULDER, CO:  
3,353,231, CANC. INT. CL. 3.

HAMPTON PRODUCTS INTERNATIONAL CORPORATION, FOOTHILL RANCH, CA:  
4,594,346, INT. CL. 6.

HAMPTON, MIGUEL, JEFFERSONVILLE, IN:  
4,592,293, PUB. 6-10-2014. INT. CL. 30.

HAMPTONS ESCAPE, INC., HOLTSVILLE, NY:  
4,591,998, PUB. 6-10-2014. MULTIPLE CLASS, INT. CLS. 36 AND 43.

HANCHETT ENTRY SYSTEMS, INC., PHOENIX, AZ:  
3,350,700, CANC. INT. CL. 9.

HANCOCK, JOY A., LEONARDO, NJ, DBA ONE SMART COOKIE:  
3,352,937, CANC. INT. CL. 25.

HANDTE UMWELTTECHNIK GMBH, FED REP GERMANY:  
4,590,818, PUB. 6-10-2014. MULTIPLE CLASS, INT. CLS. 11, 37 AND 42.

HANDYMAN MATTERS, INC., LAKEWOOD, CO:  
2,899,112, REN. 7-21-14. INT. CL. 37.

HANGZHOU SKYHERB TECHNOLOGIES CO.,LTD., HANGZHOU, CHINA:  
4,594,303, INT. CL. 5.

HANIMEX MFG. CORPORATION, TAIPEI CITY, TAIWAN:  
3,350,830, CANC. INT. CL. 28.

HANLEY III, ALBERT V., MIAMI, FL:  
4,591,789, PUB. 6-10-2014. INT. CL. 41.

HANSEL 'N GRETEL BRAND, INC., GLENDALE, NY:  
3,350,877, CANC. INT. CL. 41.

HANSEN, DALE, PORTLAND, OR:  
3,352,806, CANC. INT. CL. 3.

HANSEN, JOHN, LAS VEGAS, NV:  
3,351,831, CANC. INT. CL. 16.

HANSOL EDUCATION, MAPOGU, SEOUL, REPUBLIC OF KOREA:  
3,351,484, CANC. INT. CL. 41.

HAPPE, MICHAEL, B-1331 ROSIERES, BELGIUM:  
4,592,303, PUB. 6-10-2014. INT. CL. 14.

HAPPY GREEN BEE, INC., PALM BEACH, FL:  
3,353,415, CANC. INT. CL. 25.

HAR-EL RIVI, NEW YORK, NY:  
4,591,888, PUB. 6-10-2014. INT. CL. 44.

HARALD RICHTER, ENGELSBRAND, FED REP GERMANY:  
3,353,703, CANC. INT. CL. 9.

HARBOR CONSULTING GROUP, SIOUX CENTER, IA:  
2,964,753, REN. 7-22-14. INT. CL. 42.

HARD SCOOP, INC., MOUNT PLEASANT, SC:  
4,594,699, INT. CL. 30.

HARD WODDER ATHLETICS, LLC, SCOTTSDALE, AZ:  
4,592,068, PUB. 6-10-2014. INT. CL. 25.

HARDEEN, DAMIAN, BAYSIDE, NY:  
4,594,217, INT. CL. 9.

HARFER ENTERPRISES, LLC, DISTRICT HEIGHTS, MD:  
4,594,061, INT. CL. 43.

HARLAND CLARKE CORP., SAN ANTONIO, TX:  
2,796,065, CANC. INT. CL. 35.  
2,929,943, REN. 7-20-14. INT. CL. 35.  
3,350,782, CANC. INT. CL. 35.

HARLEM GLOBETROTTERS INTERNATIONAL, INC., PHOENIX, AZ:  
3,352,775, CANC. INT. CL. 18.

HARO, ROBERT B., CARDIFF, CA:  
4,556,464, COR. INT. CL. 25.

HARPERCOLLINS CHRISTIAN PUBLISHING, INC., NASHVILLE, TN:  
3,352,912, CANC. INT. CL. 16.

HARPERCOLLINS PUBLISHERS, INC., NEW YORK, NY:  
2,794,681, CANC. INT. CL. 16.

HARRIS BEACH PLLC, PITTSFORD, NY:  
3,352,925, CANC. INT. CL. 35.

- HARRIS HAWK, LLC, WEST CHESTER, OH:  
2,794,276, CANC. INT. CL. 35.
- HARRISON, RALPH C., LUTHERVILLE, MD, DBA HARRISON CATERERS:  
4,592,192, PUB. 6-10-2014. INT. CL. 43.
- HARTFORD GROUP INC., DAYTON, NJ:  
3,351,377, CANC. INT. CL. 41.
- HASBRO, INC., PAWTUCKET, RI:  
4,594,077, INT. CL. 28.
- HATCO CORPORATION, MILWAUKEE, WI:  
4,591,501, PUB. 6-10-2014. INT. CL. 11.
- HAUSLADEN, VALERIE, LITTLETON, CO:  
3,353,079, CANC. INT. CL. 35.
- HAVIS SHIELDS EQUIPMENT CORPORATION, WARMINSTER, PA:  
3,350,755, CANC. INT. CL. 25.
- HAWABI, INC., SEMINOLE, FL:  
4,593,793, INT. CL. 25.
- HAWKINS, CYNTHIA K., FERNANDINA BEACH, FL, DBA REDBONES DOG BAKERY:  
3,352,199, CANC. INT. CL. 31.
- HAWORTH, INC., HOLLAND, MI:  
4,593,759, INT. CL. 20.
- HAYNES, STEVEN E., ALLEN, TX, DBA SPECIALIZED RISK:  
4,591,035, PUB. 6-10-2014. INT. CL. 45.
- HAYWARD INDUSTRIES, INC., ELIZABETH, NJ:  
2,865,720, REN. 7-21-14. INT. CL. 11.
- HAZELWOOD SOAP COMPANY INC, WAYNESVILLE, NC:  
4,591,721, PUB. 3-4-2014. INT. CL. 3.  
4,591,722, PUB. 3-4-2014. INT. CL. 3.
- HB&G BUILDING PRODUCTS, INC., TROY, AL:  
4,592,440, PUB. 6-10-2014. INT. CL. 19.
- HBC, LLC, ALLENTOWN, PA:  
4,591,418, PUB. 6-10-2014. INT. CL. 32.
- HBI BRANDED APPAREL ENTERPRISES, LLC, WINSTON-SALEM, NC:  
3,354,172, CANC. INT. CL. 25.  
4,593,663, INT. CL. 25.
- HBI BRANDED APPAREL LIMITED, INC., WINSTON-SALEM, NC:  
3,353,841, CANC. INT. CL. 25.  
3,354,279, CANC. INT. CL. 25.
- HD DESIGN CENTER, LLC, NEW PORT RICHEY, FL:  
3,351,827, CANC. INT. CL. 28.
- HDR POWER SYSTEMS, INC., COLOMBUS, OH:  
3,351,330, CANC. INT. CL. 9.
- HEADLANDS VENTURES, LLC DBA MIKE'S BIKES, NOVATO, CA:  
4,591,823, PUB. 6-10-2014. MULTIPLE CLASS, INT. CLS. 8, 11 AND 12.
- HEALDSBURG PERFORMING ARTS THEATER, HEALDSBURG, CA:  
3,350,867, CANC. INT. CL. 41.
- HEALING HANDS OF GAMBIA, INC., EAST LYME, CT:  
3,354,359, CANC. INT. CL. 44.
- HEALING WARRIORS PROGRAM, BOULDER, CO:  
4,591,572, PUB. 6-10-2014. INT. CL. 44.
- HEALTH AFFAIRS PTY LTD, CAMBERWELL, VICTORIA, AUSTRALIA:  
2,794,536, CANC. INT. CL. 10.
- HEALTH CARE SERVICE CORPORATION, CHICAGO, IL:  
4,594,299, INT. CL. 36.
- HEALTH FROM WITHIN, SC, ORLAND PARK, IL:  
3,350,950, CANC. INT. CL. 44.
- HEALTH LINE INTERNATIONAL CORP., CENTERVILLE, UT:  
4,381,010, COR. INT. CL. 10.
- HEALTH NEW ENGLAND, INC., SPRINGFIELD, MA:  
4,594,008, MULTIPLE CLASS, INT. CLS. 36 AND 44.
- HEALTH SERVICES GROUP, INC., PORTLAND, OR:  
4,593,626, MULTIPLE CLASS, INT. CLS. 36 AND 44.  
4,593,627, MULTIPLE CLASS, INT. CLS. 36 AND 44.  
4,593,628, MULTIPLE CLASS, INT. CLS. 36 AND 44.
- HEALTH VALLEY COMPANY, MELVILLE, NY:  
3,353,199, CANC. INT. CL. 30.
- HEALTH-ADE LLC, LOS ANGELES, CA:  
4,592,908, PUB. 6-10-2014. INT. CL. 30.
- HEALTHBEACON LIMITED, NEEDHAM, MA:  
4,592,510, PUB. 6-10-2014. INT. CL. 10.
- HEALTHCAPABLE, CHICAGO, IL:  
4,591,284, PUB. 6-10-2014. INT. CL. 39.
- HEALTHDATAINSIGHTS, INC., LAS VEGAS, NV:  
3,353,174, CANC. INT. CL. 35.
- HEALTHFIRST, INC., NEW YORK, NY:  
4,593,203, MULTIPLE CLASS, INT. CLS. 35, 36 AND 44.
- HEALTHSTAT, INC., CHARLOTTE, NC:  
4,591,051, PUB. 6-10-2014. MULTIPLE CLASS, INT. CLS. 35, 36 AND 44.  
4,591,052, PUB. 6-10-2014. INT. CL. 44.
- HEALTHY SOURCE, LLC, SAN ANTONIO, TX:  
4,590,620, PUB. 6-10-2014. INT. CL. 5.
- HEALTHY TIMES INC., POWAY, CA:  
4,592,619, PUB. 6-10-2014. MULTIPLE CLASS, INT. CLS. 3, 5 AND 30.
- HEART AND VASCULAR CENTER OF ARIZONA, P.C., PHOENIX, AZ:  
2,905,778, REN. 7-24-14. INT. CL. 44.
- HEARTLAND CORPORATION, OLATHE, KS:  
2,965,071, REN. 7-20-14. INT. CL. 3.
- HEARTMILES L.L.C., ALISO VIEJO, CA:  
4,593,075, INT. CL. 44.
- HEAT ATHLETICS ALL-STARS LLC, SUSSEX, WI:  
4,592,326, PUB. 6-10-2014. INT. CL. 41.
- HEAT CONTROLLER LLC, JACKSON, MI:  
4,591,951, PUB. 6-10-2014. INT. CL. 11.
- HEAT TRANSFER PRODUCTS GROUP, LLC, ATLANTA, GA:  
4,591,942, PUB. 6-10-2014. INT. CL. 11.
- HEAVEN SCENT PERFUMES INC, MIAMI, FL:  
2,848,218, REN. 7-21-14. INT. CL. 3.
- HEB GROCERY COMPANY, L.P., SAN ANTONIO, TX:  
3,353,259, CANC. INT. CL. 3.  
3,353,625, CANC. INT. CL. 41.
- HEB GROCERY COMPANY, LP, SAN ANTONIO, TX:  
4,594,668, INT. CL. 30.
- HED ENTERPRISES, INC., LAS VEGAS, NV:  
4,593,906, INT. CL. 3.
- HEFFLIN, TIMOTHY, GAITHERSBURG, MD:  
4,593,657, INT. CL. 25.
- HEIDI.COM SARL, CH-2072 SAINT-BLAISE, SWITZERLAND:  
3,352,549.
- HEINLE, KEN, W, SNOHOMISH, WA:  
3,352,414, CANC. INT. CL. 20.
- HELENA HOLDING COMPANY, WILMINGTON, DE:  
1,845,286, REN. 7-23-14. INT. CL. 1.
- HELENE PERFORMANCE, SAN DIEGO, CA:  
3,354,537, CANC. INT. CL. 7.
- HELLA AUSTRALIA PTY LTD, MENTONE VIC, AUSTRALIA:  
4,591,130, PUB. 6-10-2014. INT. CL. 11.
- HELLAS CONSTRUCTION, INC., AUSTIN, TX:  
4,594,220, INT. CL. 27.
- HELLO DOLLY LIMITED, CARDIFF, UNITED KINGDOM:  
4,591,053, PUB. 11-5-2013. MULTIPLE CLASS, INT. CLS. 16, 25 AND 28.
- HELMORE, IAN STEWART, HERTFORDSHIRE, UNITED KINGDOM:  
3,352,241, CANC. INT. CL. 11.
- HELSINN HEALTHCARE SA, SWITZERLAND:  
4,590,671, PUB. 6-10-2014. INT. CL. 5.  
4,590,672, PUB. 6-10-2014. INT. CL. 5.  
4,590,673, PUB. 6-10-2014. INT. CL. 5.  
4,590,674, PUB. 6-10-2014. INT. CL. 5.  
4,590,678, PUB. 6-10-2014. INT. CL. 5.
- HELTEMES, MONICA J., DAYTON, MN:  
4,594,757, INT. CL. 16.
- HEMINGWAY, DEE, TRINIDAD, CA AND JAGGERS, DAN II, TRINIDAD, CA:  
4,594,598, INT. CL. 41.
- HEMMINGS, CAMEISHA, AUGUSTS, GA:  
4,591,728, PUB. 6-10-2014. INT. CL. 9.
- HEMSLEY FRASER TRAINING GROUP LIMITED, PLYMOUTH, ENGLAND:  
4,591,441, PUB. 6-10-2014. MULTIPLE CLASS, INT. CLS.



16, 35 AND 41.  
HENDRICKSON USA, L.L.C., ITASCA, IL:  
2,795,483, CANC. INT. CL. 12.  
HENGST SE & CO. KG, MUNSTER, FED REP GERMANY:  
4,591,016, PUB. 6-10-2014. INT. CL. 7.  
HENKEL AG & CO. KGAA, FED REP GERMANY:  
3,352,572.  
HENRY COMPANY LLC, EL SEGUNDO, CA:  
2,812,328. REN. 7-23-14. INT. CL. 19.  
4,593,086, INT. CL. 2.  
HENRY DAVID THOREAU FOUNDATION, INC., SOMER-  
VILLE, MA:  
2,869,992. REN. 7-24-14. MULTIPLE CLASS, INT. CLS. 35  
AND 36.  
HEPTAGON HOLDINGS, LLC, LAS VEGAS, NV:  
3,353,194, CANC. INT. CL. 43.  
HER JUSTICE INC., NEW YORK, NY:  
4,594,240, MULTIPLE CLASS, INT. CLS. 36 AND 45.  
4,594,446, MULTIPLE CLASS, INT. CLS. 36 AND 45.  
HERAEUS NOBLELIGHT GMBH, D-63450 HANAU, FED  
REP GERMANY:  
2,794,016, CANC. MULTIPLE CLASS, INT. CLS. 10 AND  
11.  
HERALD, JAMES, NORTH HOLLYWOOD, CA:  
4,591,104, PUB. 6-10-2014. INT. CL. 41.  
HERAUD ASSOCIATES LIMITED, SHIBUYA-KU, TOKYO  
1500011, JAPAN:  
2,795,599, CANC. INT. CL. 41.  
HERBACEUTICALS, INC., NAPA, CA:  
2,873,939. REN. 7-24-14. MULTIPLE CLASS, INT. CLS. 3  
AND 5.  
HERCULES INCORPORATED, WILMINGTON, DE:  
2,861,024. REN. 7-24-14. INT. CL. 1.  
HERCUTECH, INC., PHOENIX, AZ:  
4,593,458, INT. CL. 19.  
HERE STUDIOS, LLC, DALLAS, TX:  
3,354,459, CANC. MULTIPLE CLASS, INT. CLS. 9 AND  
41.  
HERITAGE HEALTH SYSTEMS, INC., HOUSTON, TX:  
3,352,991, CANC. INT. CL. 36.  
3,354,373, CANC. INT. CL. 36.  
HERITAGE OF AMERICA, LLC, YUMA, AZ:  
3,354,186, CANC. INT. CL. 41.  
HERITAGE OF HARVEST, LLC, HACIENDA HEIGHTS, CA:  
4,592,424, PUB. 6-10-2014. INT. CL. 19.  
HERIVAUX, FERGUSON, BOSTON, MA:  
4,593,622, INT. CL. 25.  
HERMES INTERNATIONAL, PARIS, FRANCE:  
2,877,275. REN. 7-21-14. INT. CL. 25.  
HERMES MICROVISION, INC., HSINCHU CITY, TAIWAN:  
4,591,240, PUB. 2-25-2014. INT. CL. 9.  
HERNANDEZ, DANIEL, RIDGEWOOD, NY:  
4,592,000, PUB. 6-10-2014. INT. CL. 25.  
HERON, LESLEY A., LOUISVILLE, KY:  
4,593,498, INT. CL. 33.  
HERSHEY CHOCOLATE & CONFECTIONERY CORPORA-  
TION, WHEAT RIDGE, CO:  
3,353,186, CANC. INT. CL. 30.  
3,353,196, CANC. INT. CL. 30.  
3,353,197, CANC. INT. CL. 30.  
3,353,198, CANC. INT. CL. 30.  
HESKINS LTD., BRINSCALL, LANCASHIRE, UNITED  
KINGDOM:  
4,590,971, PUB. 6-10-2014. MULTIPLE CLASS, INT. CLS.  
21 AND 27.  
HESS CORPORATION, NEW YORK, NY:  
4,591,523, PUB. 6-10-2014. MULTIPLE CLASS, INT. CLS.  
30 AND 35.  
HESTER, DANIEL, WEST ORANGE, NJ:  
3,351,775, CANC. INT. CL. 36.  
HEWLETT-PACKARD DEVELOPMENT COMPANY, L.P.,  
HOUSTON, TX:  
4,593,815, INT. CL. 9.  
HI-HEALTH SUPERMART CORPORATION, SCOTTSDALE,  
AZ, DBA HI-HEALTH:  
4,594,223, INT. CL. 5.  
HIGEAR INNOVATIONS, LLC, FREDERICKTOWN, MO:  
4,594,123, INT. CL. 16.  
HIGH CALIPER GROWING, INC., OKLAHOMA CITY, OK:  
4,594,559, INT. CL. 22.  
4,594,560, INT. CL. 22.  
HIGH ROAD PRODUCTIONS, ALBUQUERQUE, NM:  
3,353,076, CANC. INT. CL. 9.  
HILL-ROM SERVICES, INC., BATESVILLE, IN, HILL-ROM  
COMPANY, INC., BATESVILLE, IN:  
1,846,762. REN. 7-22-14. INT. CL. 20.  
HILL, DANTRIEL M., NEW ORLEANS, LA:  
3,354,345, CANC. INT. CL. 41.  
HILLYARD ENTERPRISES, INC., ST. JOSEPH, MO, HILL-  
YARD CHEMICAL COMPANY, ST. JOSEPH, MO:  
608,233. REN. 7-19-14. U.S. CL. 16 (INT. CL. 2).  
HILLYARD ENTERPRISES, INC., ST. JOSEPH, MO:  
3,351,877, CANC. INT. CL. 3.  
HINDUSTAN PENCILS PRIVATE LIMITED, MUMBAI,  
INDIA:  
4,593,603, INT. CL. 16.  
HINES NURSERIES, INC., IRVINE, CA:  
3,352,054, CANC. INT. CL. 31.  
HINES, RYAN, FRANKLIN, KY:  
4,594,116, INT. CL. 5.  
HIPS-SISTER, INC., SAN DIEGO, CA:  
4,592,862, PUB. 6-10-2014. INT. CL. 18.  
4,592,865, PUB. 6-10-2014. INT. CL. 18.  
HIRSCH, CHARLES S., SANTA MONICA, CA:  
3,352,443, CANC. INT. CL. 44.  
HISPANIC NATIONAL MORTGAGE ASSOCIATION, INC.,  
SAN DIEGO, CA:  
3,353,335, CANC. INT. CL. 36.  
HISPANIC YELLOW PAGES OF AMERICA, INC., CHICA-  
GO, IL:  
3,351,815, CANC. INT. CL. 16.  
HITACHI CABLE, LTD., CHIYODA-KU, TOKYO 100-8166,  
JAPAN:  
3,351,996, CANC. INT. CL. 9.  
HITACHI DATA SYSTEMS CORPORATION, SANTA  
CLARA, CA:  
4,592,998, PUB. 6-10-2014. INT. CL. 9.  
HITFU, INC., LINDON, UT:  
4,592,623, PUB. 6-10-2014. INT. CL. 41.  
HLT DOMESTIC IP LLC, MCLEAN, VA:  
2,794,724, CANC. MULTIPLE CLASS, INT. CLS. 9 AND  
43.  
3,353,869, CANC. INT. CL. 43.  
HMP COMMUNICATIONS, LLC, MALVERN, PA:  
3,460,208, COR. INT. CL. 16.  
HMS INTERNATIONAL FABRICS CORP., SECAUCUS, NJ:  
4,593,723, INT. CL. 24.  
HNI TECHNOLOGIES INC., MUSCATINE, IA:  
3,354,167, CANC. INT. CL. 20.  
HOB ENTERTAINMENT, LLC, BEVERLY HILLS, CA:  
3,353,400, CANC. INT. CL. 43.  
HOBBY LOBBY STORES, INC., OKLAHOMA CITY, OK:  
2,756,719. REN. 7-21-14. INT. CL. 4.  
4,592,620, PUB. 6-10-2014. INT. CL. 23.  
HOBOKEN WOOD FLOORING LLC, WAYNE, NJ:  
3,353,743, CANC. INT. CL. 19.  
3,354,022, CANC. INT. CL. 35.  
HOCOMA AG, CH-8604 VOLKETSCHWIL, SWITZERLAND:  
3,373,316.  
HODAPP, EDWARD ELLIS, TEMECULA, CA:  
4,594,531, INT. CL. 9.  
HODGE, ROBERT BRUCE, GREENFIELD, NY:  
3,354,130, CANC. INT. CL. 9.  
HODGES, DAVID, WITTMANN, AZ AND HODGES, NORA,  
WITTMANN, AZ:  
4,592,172, PUB. 6-10-2014. MULTIPLE CLASS, INT. CLS.  
41 AND 42.  
HOECHST GMBH, 65926 FRANKFURT AM MAIN, FED REP  
GERMANY:  
2,793,389, CANC. INT. CL. 5.  
HOENTZSCH GERTRAUD, FT. MYERS, FL:  
4,592,516, PUB. 6-10-2014. MULTIPLE CLASS, INT. CLS.  
37 AND 43.  
HOFFMAN HAACK, ROBIN, CAPISTRANO BEACH, CA:  
4,593,987, INT. CL. 5.

- HOFFMANN-EITLE GBR, FED REP GERMANY:  
4,590,790, PUB. 6-10-2014. MULTIPLE CLASS, INT. CLS. 9, 35, 38 AND 42.
- HOFFMANN-LA ROCHE INC., NUTLEY, NJ:  
3,351,668, CANC. INT. CL. 5.  
3,351,669, CANC. INT. CL. 5.  
3,351,912, CANC. INT. CL. 5.
- HOLIDAY TRIMS, INC., BELGIUM, WI:  
1,869,024, REN. 7-23-14. MULTIPLE CLASS, INT. CLS. 26 AND 28.
- HOLISTIC PET CARE. LLC, TEMPE, AZ:  
4,591,981, PUB. 6-10-2014. INT. CL. 5.
- HOLISTIC VETERINARY OPTIONS, LLC, MADISON, WI:  
4,594,721, INT. CL. 44.
- HOLLAND LADY, INC., MEMPHIS, TN:  
4,592,541, PUB. 6-10-2014. INT. CL. 35.
- HOLLE, MORGAN, DEERFIELD BEACH, FL AND HOLLE, DANIEL, DEERFIELD BEACH, FL:  
4,594,593, INT. CL. 10.
- HOLLINGSEAD INTERNATIONAL, INC., GEORGETOWN, DE, HOLLINGSEAD-PRYOR, ENTERPRISES, INC., SANTA FE SPRINGS, CA:  
988,743, REN. 7-24-14. U.S. CL. 13 (INT. CL. 6).
- HOLMBERG, NANNETTE, SALT LAKE CITY, UT:  
3,350,653, CANC. INT. CL. 16.
- HOLY COMMUNION CHURCH, SPICEWOOD, TX:  
2,795,352, CANC. INT. CL. 42.
- HOLYFIELD, NORVELL A., MIAMI, FL, AKA OVER FIFTY FIERCE AND FABULOUS:  
4,591,532, PUB. 6-10-2014. INT. CL. 41.
- HOME AND GARDEN PARTY, LTD., MARSHALL, TX:  
3,353,558, CANC. MULTIPLE CLASS, INT. CLS. 16, 35 AND 41.
- HOME CONVENIENCE SOLUTIONS, INC., SARATOGA SPRINGS, NY:  
3,353,725, CANC. INT. CL. 42.
- HOME PORT ALLIANCE FOR THE USS NEW JERSEY, INC., CAMDEN, NJ:  
2,860,767, REN. 7-21-14. MULTIPLE CLASS, INT. CLS. 9, 14, 16, 18, 21, 25, 26, 28, 35 AND 41.
- HOMECOLOGY, INC., ROSWELL, GA, DBA HEDGEHOG LACROSSE:  
4,592,028, PUB. 6-10-2014. INT. CL. 28.
- HOMEFREE USA LLC, APPLETON, WI:  
2,893,320, REN. 7-18-14. INT. CL. 36.
- HOMEGOODS, INC., FRAMINGHAM, MA:  
4,594,261, INT. CL. 35.
- HOMEOCARE LABORATORIES INC., BRONX, NY TO HOMEOCARE LABORATORIES INC., BRONX, NY:  
2,793,384, CANC. INT. CL. 5.
- HOMER TLC, INC., WILMINGTON, DE:  
2,860,955, REN. 7-21-14. MULTIPLE CLASS, INT. CLS. 7 AND 8.  
2,860,955, CANC. INT. CL. 9.
- HOMESTEADERS LIFE COMPANY, WEST DES MOINES, IA:  
4,593,541, INT. CL. 36.
- HOMESTYLE DINING LLC, PLANO, TX:  
4,594,373, INT. CL. 43.
- HONEYWELL INTERNATIONAL INC., MORRISTOWN, NJ:  
1,871,160, REN. 7-21-14. INT. CL. 9.  
3,353,967, CANC. MULTIPLE CLASS, INT. CLS. 9, 37 AND 42.
- HONGKONG WILLRAISE INTERGRATED CIRCUIT CO., LIMITED, 41-47 MARBLE ROAD, HONG KONG:  
4,592,981, PUB. 6-10-2014. INT. CL. 34.  
4,592,982, PUB. 6-10-2014. INT. CL. 34.
- HOOD RIVER DISTILLERS, INC., HOOD RIVER, OR:  
4,591,580, PUB. 6-10-2014. INT. CL. 33.
- HOOPS PAT BURKE'S TRAINING FACILITY, LLC, MOUNT DORA, FL, FORMERLY HOOPS 31, LLC:  
4,592,079, PUB. 6-10-2014. MULTIPLE CLASS, INT. CLS. 41 AND 45.
- HOOTGRAM, LLC, LOS ANGELES, CA:  
4,590,616, PUB. 6-10-2014. INT. CL. 35.
- HOQUE ENTERPRISES LLC, DALLAS, TX:  
3,352,509, CANC. INT. CL. 39.
- HORMEL FOODS, LLC, AUSTIN, MN, GEO. A. HORMEL & COMPANY, AUSTIN, MN, DBA HORMEL FOODS CORPORATION:  
1,841,957, REN. 7-20-14. INT. CL. 29.
- HORMEL FOODS, LLC, AUSTIN, MN:  
3,350,954, CANC. INT. CL. 30.
- HORNE LLP, RIDGELAND, MS:  
4,592,610, PUB. 6-10-2014. MULTIPLE CLASS, INT. CLS. 35, 36 AND 45.
- HORSEMEN'S PRIDE, INC., STREETSBORO, OH:  
2,890,342, REN. 7-21-14. INT. CL. 28.
- HOSANNA, ALBUQUERQUE, NM:  
4,591,791, PUB. 6-10-2014. INT. CL. 45.
- HOSPICE CUP, INC., ANNAPOLIS, MD:  
1,856,966, REN. 7-22-14. INT. CL. 36.
- HOTEL FORUMS, LLC, CHICAGO, IL:  
3,353,010, CANC. INT. CL. 43.
- HOTEL VILLA MOZART, INC., SHORT HILLS, NY:  
3,351,759, CANC. INT. CL. 30.
- HOTHOUSE FICTION LTD., LONDON E1 6QL, UNITED KINGDOM:  
4,591,007, PUB. 6-10-2014. INT. CL. 16.
- HOUGHTON MIFFLIN COMPANY, BOSTON, MA:  
3,352,882, CANC. INT. CL. 16.
- HOUGHTON MIFFLIN HARCOURT PUBLISHING COMPANY, BOSTON, MA:  
4,593,066, INT. CL. 41.
- HOUSE OF BLOMBOS, LLC, NEW YORK, NY:  
4,591,156, PUB. 6-10-2014. INT. CL. 14.
- HOUSLEY OUTDOORS, INC., SEARCY, AR:  
3,353,086, CANC. INT. CL. 28.
- HOVEL CHENORHOKIAN, FRANCE:  
4,590,765, PUB. 6-10-2014. INT. CL. 14.
- HOWABOUTWE, LLC, DALLAS, TX:  
4,594,715, INT. CL. 41.  
4,594,716, INT. CL. 41.
- HOWDEN GROUP LIMITED, RENFREW, UNITED KINGDOM, HOWDEN GROUP PLC, RENFREW PA4 8XJ, GREAT BRITAIN:  
1,872,226, REN. 7-22-14. MULTIPLE CLASS, INT. CLS. 7 AND 11.
- HOWLE, WILLIAM T. III, HUNTSVILLE, AL:  
3,352,993, CANC. INT. CL. 25.  
3,352,994, CANC. INT. CL. 16.  
3,352,995, CANC. INT. CL. 14.
- HPCI SARL -; HENRI PLISSON CONSEIL ET INVESTISSEMENT, FRANCE:  
4,590,658, PUB. 6-10-2014. INT. CL. 9.
- HS TM, LLC, NEWARK, DE:  
2,895,717, REN. 7-21-14. INT. CL. 16.
- HTDI FINANCIAL, INC., GILBER, AZ:  
3,350,714, CANC. INT. CL. 36.
- HU, SHAO-YUAN, NANTUEN CHIU, TAICHUNG, TAIWAN:  
2,795,899, CANC. INT. CL. 12.
- HUB CITY PARTNERS, INC., AUSTIN, TX:  
3,351,405, CANC. INT. CL. 36.
- HUCK PATENTS, INC., WILMINGTON, DE:  
774,828, REN. 7-21-14. U.S. CL. 13 (INT. CL. 6).
- HUDSON BAY MINING AND SMELTING CO., LIMITED, TORONTO, ONTARIO, CANADA:  
3,351,766, CANC. INT. CL. 1.
- HUIMIO OY, ESPOO, FINLAND:  
4,594,184, INT. CL. 9.
- HUMAN CAPITAL MANAGEMENT SOLUTIONS, INC., CHICAGO, IL, DBA HIREWELL:  
4,593,728, INT. CL. 42.
- HUMAN ENERGY, LLC, SAINT AUGUSTINE, FL:  
4,594,201, INT. CL. 45.
- HUMAN TOUCH, LLC, LONG BEACH, CA:  
3,353,478, CANC. INT. CL. 28.
- HUMANA INC., LOUISVILLE, KY:  
4,593,411, INT. CL. 36.
- HUMETRIX, INC., DEL MAR, CA:  
3,353,376, CANC. MULTIPLE CLASS, INT. CLS. 9 AND 42.

HUNG, TACHUN, HSINCHU CITY, TAIWAN:  
4,593,537, MULTIPLE CLASS, INT. CLS. 9, 12 AND 42.  
4,593,538, MULTIPLE CLASS, INT. CLS. 9, 12 AND 42.

HUNT JR., EMORY, NEWARK, NJ, DBA FOOTBALL GAMEPLAN LLC:  
4,590,954, PUB. 6-10-2014. INT. CL. 41.

HUNTSMAN CANCER FOUNDATION, SALT LAKE CITY, UT:  
3,353,812, CANC. INT. CL. 36.

HURRICANE SANDY NEW JERSEY RELIEF FUND INC., CHATHAM, NJ:  
4,594,581, INT. CL. 36.

HURTADO, NICHOLAS, STUDIO CITY, CA AND CASILLAS, SCOTT, STUDIO CITY, CA:  
4,593,703, INT. CL. 9.

HUSQVARNA AB, HUSKVARNA, SWEDEN:  
4,594,667, INT. CL. 7.

HUSSEY, JAMES G, CUMMING, GA:  
3,351,037, CANC. INT. CL. 9.

HUTCHENS, SEAN, CARDIFF, CA:  
4,592,245, PUB. 6-10-2014. INT. CL. 35.

HVAC DISTRIBUTORS, INC., MOUNT JOY, PA:  
4,594,740, INT. CL. 9.

HY-VEE, INC., WEST DES MOINES, IA:  
3,353,098, CANC. INT. CL. 30.

HYATT CORPORATION, CHICAGO, IL:  
3,353,018, CANC. INT. CL. 43.  
3,353,019, CANC. INT. CL. 43.

HYDROSTRUCTURES, P.A., PITTSBORO, NC:  
4,591,315, PUB. 6-10-2014. INT. CL. 42.

HYGINEX INC., UNITED STATES:  
4,590,645, PUB. 6-10-2014. MULTIPLE CLASS, INT. CLS. 9, 35 AND 42.

HYLOMAR LIMITED, WIGAN, UNITED KINGDOM:  
4,591,383, PUB. 6-10-2014. MULTIPLE CLASS, INT. CLS. 1 AND 17.

HYOSUNG CORPORATION, SEOUL, REPUBLIC OF KOREA:  
2,860,589, REN. 7-20-14. INT. CL. 6.

HYPENETWORK SOLUTIONS OF FLORIDA, LLC, WEST PALM BEACH, FL:  
4,593,189, INT. CL. 5.

HYRAX INTERNATIONAL, LLC, WESTLAKE VILLAGE, CA:  
4,592,327, PUB. 6-10-2014. INT. CL. 35.  
4,592,328, PUB. 6-10-2014. INT. CL. 35.  
4,592,329, PUB. 6-10-2014. INT. CL. 35.

HYTWO, LLC, COHOES, NY:  
3,351,320, CANC. INT. CL. 9.

H2OLAP LLC, KATY, TX:  
4,594,745, INT. CL. 42.

I PROMISE PROGRAM, INC., DUNDAS, ONTARIO, CANADA:  
2,794,234, CANC. INT. CL. 35.

I.S.A. CORPORATION, SALEM, OR:  
2,927,901, REN. 7-18-14. INT. CL. 25.

I-PAINT S.R.L., ROMA, ITALY:  
4,591,737, PUB. 6-10-2014. INT. CL. 40.

I-SITE, INC., PHILADELPHIA, PA:  
4,590,622, PUB. 6-10-2014. INT. CL. 35.

IAN GLINKA, ARLINGTON, VA AND STEPHEN KILROY, ARLINGTON, VA AND ERIK DEAN, ARLINGTON, VA AND ALLAN CHAPPELEAR, ARLINGTON, VA AND STEPHEN J. SMITH, ALEXANDRIA, VA:  
3,351,110, CANC. INT. CL. 9.

IAN JAMES BURDEN, AUSTRALIA:  
4,590,843, PUB. 6-10-2014. MULTIPLE CLASS, INT. CLS. 20 AND 35.  
4,590,853, PUB. 6-10-2014. MULTIPLE CLASS, INT. CLS. 20 AND 35.

IAN LATERREUR INC., THE WOODLANDS, TX:  
4,592,356, PUB. 6-10-2014. INT. CL. 36.

IAN TOSCA, JOSEPH F., SEA GIRT, NJ:  
3,215,646, CANC. INT. CL. 9.

IBALL INSTRUMENTS LLC, EDMOND, OK:  
4,591,129, PUB. 6-10-2014. INT. CL. 7.

IBASIS, BURLINGTON, MA:  
4,592,876, PUB. 6-10-2014. INT. CL. 38.

IBASIS, INC., BURLINGTON, MA:  
3,353,889, CANC. INT. CL. 16.  
3,353,963, CANC. INT. CL. 16.  
3,354,007, CANC. INT. CL. 16.

IBG LLC, GREENWICH, CT:  
3,352,481, CANC. INT. CL. 36.

ICAHN SCHOOL OF MEDICINE AT MOUNT SINAI, NEW YORK, NY:  
3,352,304, CANC. INT. CL. 44.  
3,352,307, CANC. INT. CL. 44.

ICC INNOVATIVE CONCEPTS CORPORATION, CANTON, CT:  
3,353,854, CANC. INT. CL. 8.

ICE CREAM SKULLS, INC., RALEIGH, NC:  
4,592,149, PUB. 6-10-2014. MULTIPLE CLASS, INT. CLS. 6 AND 16.

ICE FUTURES EUROPE, LONDON, UNITED KINGDOM:  
4,590,974, PUB. 6-10-2014. INT. CL. 36.

ICE MARINE, HAMPTON ALDERSHOT, UNITED KINGDOM:  
2,860,027, REN. 7-18-14. INT. CL. 12.

ICL-IP AMERICA INC., ARDSLEY, NY, STAUFFER CHEMICAL COMPANY, WESTPORT, CT:  
1,286,437, REN. 7-23-14. INT. CL. 37.

ICON DE HOLDINGS LLC, WILMINGTON, DE:  
4,593,650, INT. CL. 27.

ICON UNION, INC., MONTEREY PARK, CA:  
4,592,187, PUB. 6-10-2014. INT. CL. 35.

ICONIC INVESTMENT LLC, CHINO, CA:  
4,591,605, PUB. 6-10-2014. INT. CL. 9.

ID INTERACTIVE LLC, DELRAY BEACH, FL:  
3,354,073, CANC. INT. CL. 9.  
3,354,149, CANC. INT. CL. 9.  
3,354,426, CANC. INT. CL. 9.  
3,354,427, CANC. INT. CL. 9.

IDAHO HEALTH INSURANCE EXCHANGE, BOISE, ID:  
4,594,276, INT. CL. 35.  
4,594,283, INT. CL. 35.

IDEAL IMAGE DEVELOPMENT CORPORATION, TAMPA, FL, DBA IDEAL IMAGE:  
4,594,236, INT. CL. 44.

IDEAVILLAGE PRODUCTS CORP., FAIRFIELD, NJ:  
3,354,540, CANC. INT. CL. 5.

IDEC PROMOTIONS LIMITED, LONDON, ENGLAND:  
3,351,960, CANC. INT. CL. 35.

IDEXX LABORATORIES, INC., WESTBROOK, ME:  
4,591,355, PUB. 6-10-2014. INT. CL. 10.

IWC CORP., NEW BERLIN, WI:  
4,591,730, PUB. 5-6-2014. MULTIPLE CLASS, INT. CLS. 9, 16, 35, 39 AND 42.

IFTTT, INC., SAN FRANCISCO, CA:  
4,592,223, PUB. 6-10-2014. INT. CL. 42.  
4,592,226, PUB. 6-10-2014. INT. CL. 42.

IG SHOUTOUT NETWORK LLC, NORTH HOLLYWOOD, CA:  
4,592,842, PUB. 6-10-2014. INT. CL. 35.

IGT, RENO, NV:  
3,353,372, CANC. INT. CL. 9.  
4,593,193, INT. CL. 9.  
4,594,504, INT. CL. 28.  
4,594,505, INT. CL. 28.

IGUS GMBH, COLOGNE, FED REP GERMANY:  
3,462,657.

IHC HOLLAND IE B.V., 3361 EP SLIEDRECHT, NETHERLANDS:  
4,591,137, PUB. 4-22-2014. INT. CL. 12.

IKS MEDIA AND TECHNOLOGY (2001) LTD., REGINA, SASKATCHEWAN, CANADA:  
2,794,905, CANC. INT. CL. 9.

IL PONTE FINANZIARIA S.P.A., SCANDICCI, FLORENCE, ITALY:  
3,352,349, CANC. INT. CL. 25.

ILLINI CORPORATION, SPRINGFIELD, IL:  
4,594,742, INT. CL. 36.

ILLINOIS TOOL WORKS INC., GLENVIEW, IL:  
1,853,498, REN. 7-21-14. INT. CL. 7.  
3,351,229, CANC. INT. CL. 9.  
3,351,834, CANC. INT. CL. 7.

- ILLUMNOVATE, LLC, WASHINGTON, DC:  
4,592,393, PUB. 6-10-2014. INT. CL. 42.
- IMAGE INFO, LLC, NEW YORK, NY:  
3,353,486, CANC. INT. CL. 9.
- IMAGIA TECHNOLOGIES, XIZHI CITY, TAIPEI COUNTY, TAIWAN:  
3,352,890, CANC. INT. CL. 42.
- IMAKE SOFTWARE & SERVICES, INC., BETHESDA, MD:  
3,353,293, CANC. INT. CL. 9.
- IMATION CORP., OAKDALE, MN:  
3,353,599, CANC. INT. CL. 9.
- IMG PRODUCTIONS, INC., NEW YORK, NY:  
4,593,571, INT. CL. 41.
- IMH FINANCIAL CORPORATION, SCOTTSDALE, AZ:  
3,351,010, CANC. INT. CL. 36.  
3,351,096, CANC. INT. CL. 36.
- IMMERGOOD, SAVANNAH, GA:  
4,594,726, INT. CL. 29.
- IMMERSIMAP LLC, ERIE, PA:  
3,354,163, CANC. INT. CL. 42.
- IMMOBILIARE METALPROGETTI S.R.L., PERUGIA, ITALY:  
2,897,022, REN. 7-24-14. INT. CL. 7.
- IMOTIONS - EMOTION TECHNOLOGY A/S, COPENHAGEN, DENMARK:  
3,354,581, CANC. INT. CL. 9.  
3,354,582, CANC. INT. CL. 9.
- IMPACT CONFECTIONS, INC., LITTLETON, CO:  
4,594,209, INT. CL. 30.
- IMPACT UNLIMITED, INC., DAYTON, NJ:  
4,594,653, MULTIPLE CLASS, INT. CLS. 35 AND 42.
- IMPACTO LLC, STAMFORD, CT:  
3,354,544, CANC. INT. CL. 41.
- IMRA AMERICA, INC., ANN ARBOR, MI:  
1,890,653, REN. 7-19-14. INT. CL. 35.
- IMUS MACABEE, LLC, MILPITAS, CA:  
4,593,600, INT. CL. 25.
- IN THE CAR, BEVERLY, MA:  
4,592,770, PUB. 6-10-2014. INT. CL. 41.
- IN THE GROOVE MUSIC LLC, MINNEAPOLIS, MN:  
4,591,154, PUB. 6-10-2014. MULTIPLE CLASS, INT. CLS. 41 AND 45.
- INA ACQUISITION CORP., WILMINGTON, DE:  
4,592,673, PUB. 6-10-2014. INT. CL. 7.  
4,592,995, PUB. 6-10-2014. INT. CL. 17.  
4,592,996, PUB. 6-10-2014. INT. CL. 37.
- INA CORPORATION, PHILADELPHIA, PA:  
3,352,374, CANC. INT. CL. 42.
- INC INTERNATIONAL COMPANY, KENNETT SQUARE, PA:  
4,594,312, MULTIPLE CLASS, INT. CLS. 9, 25 AND 28.  
4,594,341, MULTIPLE CLASS, INT. CLS. 9, 25 AND 28.  
4,594,342, MULTIPLE CLASS, INT. CLS. 9 AND 28.  
4,594,544, MULTIPLE CLASS, INT. CLS. 9 AND 28.
- INCOLOR CONCEPTS, INC., LOS ANGELES, CA:  
3,352,941, CANC. INT. CL. 14.
- INCREDIBLE TECHNOLOGIES, INC., VERNON HILLS, IL:  
4,594,090, INT. CL. 28.
- INDECOMM CORPORATION, GEORGE TOWN, GRAND CAYMAN, CAYMAN ISLANDS:  
3,323,903, CANC. MULTIPLE CLASS, INT. CLS. 35, 38, 39 AND 42.
- INDEPENDENCE BLUE CROSS, PHILADELPHIA, PA:  
4,592,115, PUB. 6-10-2014. MULTIPLE CLASS, INT. CLS. 35 AND 36.
- INDEX-WERKE GMBH & CO. KG HAHN & TESSKY, FED REP GERMANY:  
3,512,809.
- INDIEKAZOO LLC, AUSTIN, TX:  
3,351,288, CANC. INT. CL. 42.
- INDIGOVISION LIMITED, EDINBURGH, UNITED KINGDOM, TA INDIGOVISION:  
4,591,840, PUB. 6-10-2014. INT. CL. 9.
- INDUSTRIA FRIGORIFERI ITALIANA SPA; (IN BREVE IFI), ITALY:  
3,352,653.
- INDUSTRIAL AUTOMATION SPECIALISTS CORP., HAMPTON, VA:  
3,350,883, CANC. INT. CL. 9.
- INDUSTRIAL DE HERRAMIENTAS, S.A., AZCAPOTZALCO, MEXICO, ELECTRIC SPRAYIT COMPANY, THE, SHEBOYGAN, WI:  
584,817, REN. 7-23-14. U.S. CL. 21 (INT. CL. 7).
- INDUSTRIAS ALEN, S.A. DE C.V., SANTA CATARINA, N.L. 66350, MEXICO:  
1,824,049, REN. 7-20-14. INT. CL. 3.  
1,824,049, AM. INT. CL. 3.
- INDUSTRIAS LACTEAS SAN VICENTE, S.A., 24193 NAVATEJERA(LEON), SPAIN:  
4,594,141, INT. CL. 29.
- INETXPERTS CORP., ROCKVILLE, MD, DBA GET REAL HEALTH:  
4,592,830, PUB. 6-10-2014. INT. CL. 42.
- INFINITI LIMITED, IRVINE, UNITED KINGDOM:  
3,352,609.
- INFINITY LAWN AND GARDEN, INC., MILAN, IL:  
4,592,788, PUB. 6-10-2014. INT. CL. 19.  
4,592,795, PUB. 6-10-2014. INT. CL. 19.
- INFORMATION INTERNET LIMITED, UNITED KINGDOM:  
3,352,547.  
3,352,552.
- INFUSED COMPANY, DENVER, CO:  
4,593,383, MULTIPLE CLASS, INT. CLS. 35 AND 41.
- ING, LLC, SCOTCH PLAINS, NJ:  
2,793,700, CANC. INT. CL. 20.
- INGA, LORENZO, JR., ALESSANDRIA, ITALY:  
2,865,187, REN. 7-18-14. INT. CL. 33.
- INGELMO & COMPANY INC., MIAMI, FL:  
4,594,640, INT. CL. 25.
- INGENEUS INC., BELIZE CITY, BELIZE:  
3,351,680, CANC. MULTIPLE CLASS, INT. CLS. 1 AND 5.
- INGENIO DEL CAUCA S.A. INCAUCA S.A., CALI, VALLE DEL CAUCA, COLOMBIA:  
4,591,249, PUB. 6-10-2014. INT. CL. 30.
- INGURAN, LLC, NAVASOTA, TX, DBA SEXING TECHNOLOGIES:  
4,593,635, MULTIPLE CLASS, INT. CLS. 5, 31 AND 44.
- INLINE TABLES, MAGALIA, CA:  
4,592,542, PUB. 6-10-2014. INT. CL. 10.  
4,592,544, PUB. 6-10-2014. INT. CL. 10.  
4,592,545, PUB. 6-10-2014. INT. CL. 10.
- INNERWORKINGS (HOLDINGS) LIMITED, DUBLIN, IRELAND:  
3,353,298, CANC. MULTIPLE CLASS, INT. CLS. 9 AND 41.
- INNOBABY LLC, BARRINGTON, IL:  
4,591,517, PUB. 6-10-2014. INT. CL. 10.
- INNOCOR, INC., WEST LONG BRANCH, NJ:  
4,594,041, INT. CL. 20.
- INNOVATIE PSYCHOLOGISCHE; PSYCHIATRISCHE ZORG B.V., NETHERLANDS:  
4,590,690, PUB. 6-10-2014. MULTIPLE CLASS, INT. CLS. 9, 38 AND 44.
- INNOVATION TAP LLC, DRESHER, PA:  
4,593,665, INT. CL. 42.
- INNOVATIVE BREWING, LLC, CHICAGO, IL:  
4,591,527, PUB. 6-10-2014. MULTIPLE CLASS, INT. CLS. 32, 33, 35 AND 40.
- INNOVATIVE FOOD BRANDS, BRAMPTON, CANADA:  
3,353,352, CANC. INT. CL. 30.
- INNOVATIVE PRODUCT ACHIEVEMENTS, LLC, DULUTH, GA:  
4,591,930, PUB. 6-10-2014. INT. CL. 7.  
4,591,938, PUB. 6-10-2014. INT. CL. 7.
- INNOVATIVE SPINAL TECHNOLOGIES, INC., MANSFIELD, MA:  
3,353,564, CANC. INT. CL. 10.
- INNOVATIVE SPORTS LIMITED, KOWLOON, HONG KONG:  
4,593,564, MULTIPLE CLASS, INT. CLS. 6, 9, 11 AND 12.
- INNOVENTIVE POWER LLC, SOUTH ORANGE, NJ:  
4,593,149, INT. CL. 35.

INNOVUS PHARMACEUTICALS, INC., SAN DIEGO, CA:  
4,593,829, INT. CL. 5.

INQ-ENERGY, INC., STAFFORD, TX:  
4,594,551, INT. CL. 11.

INQUEST MARKETING, L.L.C., LEAWOOD, KS:  
3,350,983, CANC. INT. CL. 35.

INSCERCO MFG. INC., CRESTWOOD, IL:  
1,226,472, CANC. INT. CL. 7.

INSIGHTSNOW, INC., CORVALLIS, OR:  
3,354,182, CANC. INT. CL. 35.

INSITE MANAGED SOLUTIONS, CAPE CORAL, FL:  
4,592,227, PUB. 6-10-2014. INT. CL. 35.

INSPIRATO LLC, DENVER, CO:  
4,459,815, AM. INT. CL. 36.

INSPIRIT GROWTH, LLC, BLUE BELL, PA:  
4,594,079, INT. CL. 35.  
4,594,082, INT. CL. 35.

INSPIRIT GROWTH, LLC, BLUE BELL, PA, FORMERLY  
ACCEL-EX, LLC:  
4,594,144, INT. CL. 35.

INSTA-CREDIT AUTO MART, INC., COLLINSVILLE, IL:  
4,591,507, PUB. 6-10-2014. MULTIPLE CLASS, INT. CLS.  
35 AND 36.

INSTAGONE CONSUMER PRODUCTS, LLC, WALL TOWN-  
SHIP, NJ:  
4,592,447, PUB. 6-10-2014. INT. CL. 3.

INSTITUT DE RECERCA I TECNOLOGIA AGROLIMEN-  
TARIES (IRTA), BARCELONA, SPAIN:  
3,352,843, CANC. INT. CL. 31.  
3,352,850, CANC. INT. CL. 31.

INSTITUTE FOR FAMILY-CENTERED CARE, INC.,  
BETHESDA, MD, DBA INSTITUTE FOR PATIENT- AND  
FAMILY-CENTERED CARE:  
4,593,886, INT. CL. 35.

INSTITUTE OF INTERFAITH DIALOG FOR THE WORLD  
PEACE, INC., HOUSTON, TX:  
3,351,974, CANC. INT. CL. 41.

INSURANCE ZEBRA INC., AUSTIN, TX:  
4,594,487, MULTIPLE CLASS, INT. CLS. 35 AND 36.

INSYNC ANALYTICS LLC, PELHAM, NY:  
4,592,433, PUB. 6-10-2014. INT. CL. 36.

INTASOL GROUP LLC, SOMERVILL, NJ:  
3,353,738, CANC. INT. CL. 35.

INTEC VIDEO SYSTEMS, INC., LAGUNA HILLS, CA:  
2,947,244, REN. 7-24-14. INT. CL. 9.

INTEC, INC., MIAMI, FL:  
3,354,264, CANC. INT. CL. 14.

INTEGRATED DATA CORPORATION, LOS ANGELES, CA:  
3,352,173, CANC. INT. CL. 9.  
3,353,467, CANC. INT. CL. 9.

INTEGRATED E SOLUTIONS, INC., CHICAGO, IL:  
3,352,508, CANC. INT. CL. 42.

INTEGRE TECHNOLOGIES, LLC, PITTSFORD, NY:  
2,866,699, REN. 7-18-14. INT. CL. 42.

INTEGR8 FUELS INC., MAJURO, MARSHALL ISLANDS:  
4,593,398, MULTIPLE CLASS, INT. CLS. 4 AND 35.

INTELLIGENT BUILDINGS, LLC, CHARLOTTE, NC:  
3,351,005, CANC. MULTIPLE CLASS, INT. CLS. 35, 36  
AND 41.

INTELLIGENT DIGITAL HORIZON, OAKTON, VA:  
3,352,393, CANC. MULTIPLE CLASS, INT. CLS. 37 AND  
45.

INTELLIGENT MEDICAL OBJECTS, INC., NORTHBROOK,  
IL:  
4,593,802, MULTIPLE CLASS, INT. CLS. 9 AND 42.

INTELLIGENT NUTRIENTS, LLC, MINNEAPOLIS, MN:  
4,592,956, PUB. 6-10-2014. INT. CL. 4.

INTELLIGENTSIA COFFEE INC., CHICAGO, IL:  
4,593,828, MULTIPLE CLASS, INT. CLS. 21, 30, 40 AND  
43.

INTERACTIVE HEALTH, LLC, LONG BEACH, CA TO  
HUMAN TOUCH, LLC, LONG BEACH, CA:  
2,795,079, CANC. INT. CL. 20.

INTERCONTINENTAL GREAT BRANDS LLC, EAST HAN-  
OVER, NJ:  
3,353,120, CANC. INT. CL. 30.  
3,353,127, CANC. INT. CL. 30.

INTERLUNIA, INC., CARLSBAD, CA:  
4,592,153, PUB. 6-10-2014. INT. CL. 42.

INTERNATIONAL BIOMEDICAL, AUSTIN, TX:  
4,593,099, INT. CL. 10.

INTERNATIONAL BUSINESS & WINE SOCIETY LLC, NEW  
YORK, NY:  
4,592,933, PUB. 6-10-2014. INT. CL. 41.

INTERNATIONAL BUSINESS MACHINES CORPORATION,  
ARMONK, NY:  
4,592,255, PUB. 6-10-2014. MULTIPLE CLASS, INT. CLS. 9  
AND 16.

INTERNATIONAL CODE COUNCIL, WHITTIER, CA:  
2,861,796, REN. 7-18-14. INT. CL. 41.

INTERNATIONAL CODE COUNCIL, INC., FALLS  
CHURCH, VA:  
3,350,662, CANC. MULTIPLE CLASS, INT. CLS. 35 AND  
36.

INTERNATIONAL DIGITAL ENTERPRISE ALLIANCE,  
INC., ALEXANDRIA, VA:  
3,350,684, CANC. INT. CL. 9.

INTERNATIONAL DIRECT GROUP INC., NEW YORK, NY:  
2,795,924, CANC. INT. CL. 25.

INTERNATIONAL FLAVORS & FRAGRANCES INC., NEW  
YORK, NY:  
4,592,630, PUB. 6-10-2014. INT. CL. 1.

INTERNATIONAL GEM & JEWELRY SHOW, INC., ROCK-  
VILLE, MD:  
4,591,947, PUB. 6-10-2014. INT. CL. 41.

INTERNATIONAL GRAPHICS GROUP, LLC, CINCINNATI,  
OH:  
3,353,477, CANC. INT. CL. 16.

INTERNATIONAL GROOVING & GRINDING ASSOCIA-  
TION, WEST COXSACKIE, NY:  
2,795,377, CANC. U.S. CL. 200.

INTERNATIONAL HEROES BV, NETHERLANDS AND  
LEVITAS S.P.A., ITALY:  
3,352,558.

INTERNATIONAL MOTOR SPORTS ASSOCIATION LLC,  
DAYTONA BEACH, FL:  
4,592,289, PUB. 6-10-2014. INT. CL. 41.

INTERNATIONAL PROFIT ASSOCIATES, INC., BUFFALO  
GROVE, IL:  
4,590,621, PUB. 6-10-2014. MULTIPLE CLASS, INT. CLS.  
35 AND 36.

INTERNATIONAL ROADWAY RESEARCH LLP, HUMBLE,  
TX, SAFETY LIGHTS SALES AND LEASING, INC. OF  
TEXAS, HOUSTON, TX, DBA SAFETY LIGHTS CO.:  
1,904,430, REN. 7-23-14. INT. CL. 19.

INTERNATIONAL SURF VENTURES INC., CARLSBAD,  
CA:  
4,592,711, PUB. 6-10-2014. INT. CL. 28.

INTERNATIONAL TRAINING INSTITUTE FOR THE  
SHEET METAL AND AIR CONDITIONING INDUSTRY,  
ALEXANDRIA, VA, AKA ITI TRUST:  
4,591,230, PUB. 6-10-2014. INT. CL. 40.

INTERNATIONAL UNDERWRITERS GROUP LIMITED,  
GLEN INNES, AUCKLAND, NEW ZEALAND:  
3,351,933, CANC. INT. CL. 41.

INTERNATIONAL WEB PROPERTIES, LLC, INDIANAPO-  
LIS, IN:  
3,300,115, CANC. INT. CL. 42.

INTERSTATE AUTO GROUP, INC., EDINA, MN:  
3,351,231, CANC. INT. CL. 39.

INTERSTATE MUFFLER LLC, ELKTON, VA:  
4,591,162, PUB. 6-10-2014. MULTIPLE CLASS, INT. CLS. 7  
AND 37.

INTERSTELLAR TECHNOLOGIES CORPORATION, MON-  
ROVIA, CA:  
3,353,540, CANC. MULTIPLE CLASS, INT. CLS. 9, 35  
AND 42.

INTOXIMETERS, INC., ST. LOUIS, MO:  
1,338,927, REN. 7-18-14. INT. CL. 9.

INTRALOT, INC., DULUTH, GA:  
4,594,255, INT. CL. 9.

INTUIT INC., MOUNTAIN VIEW, CA:  
3,354,296, CANC. INT. CL. 42.

- INULINA Y MIEL DE AGAVE SA DE CV, CAPILLA DE GUADALUPE, MEXICO:  
3,353,084, CANC. INT. CL. 30.  
3,353,085, CANC. INT. CL. 30.
- INVANTIVE SOFTWARE BV, NETHERLANDS:  
4,590,896, PUB. 6-10-2014. INT. CL. 9.
- INVE TECHNOLOGIES, B-9200 BAASRODE, BELGIUM:  
2,864,784. REN. 7-18-14. INT. CL. 5.
- INVENERGY LLC, CHICAGO, IL:  
2,949,358. REN. 7-24-14. INT. CL. 40.
- INVENTEC CORPORATION, SHIH LIN DISTRICT, TAIPEI 111, TAIWAN:  
3,352,832, CANC. MULTIPLE CLASS, INT. CLS. 7, 9, 11, 16, 35, 41 AND 42.
- INVENTION MACHINE CORPORATION, BOSTON, MA:  
3,350,773, CANC. INT. CL. 9.
- INVENTION MINE LLC, CHICAGO, IL:  
4,592,489, PUB. 6-10-2014. INT. CL. 45.
- INVESTCLOUD, LLC, BEVERLY HILLS, CA:  
4,179,226, COR. INT. CL. 42.  
4,179,263, COR. INT. CL. 42.  
4,179,441, COR. INT. CL. 42.  
4,179,504, COR. INT. CL. 42.
- INVESTMENT RECOVERY ASSOCIATION, KANSAS CITY, MO:  
4,593,775, INT. CL. 9.
- INVESTOM, UAB, LITHUANIA:  
4,590,923, PUB. 6-10-2014. INT. CL. 35.
- INVESTOR BISTRO, LLC, RICHMOND, VT:  
4,593,318, INT. CL. 41.
- INVESTORS INSURANCE CORPORATION, SAN FRANCISCO, CA:  
2,795,761, CANC. INT. CL. 36.
- INVICTA WATCH COMPANY OF AMERICA, INC., HOLLYWOOD, FL:  
2,947,259. REN. 7-18-14. INT. CL. 14.
- INVISTA NORTH AMERICA S.A. R.L., WICHITA, KS:  
4,591,934, PUB. 6-10-2014. INT. CL. 22.
- INVISTA NORTH AMERICA S.A. R.L., WICHITA, KS:  
3,353,426, CANC. INT. CL. 24.
- INVOLUTION STUDIOS LLC, SUNNYVALE, CA:  
3,351,673, CANC. INT. CL. 42.
- IO ENTERPRISES, LLC, LEESBURG, VA:  
3,354,615, CANC. INT. CL. 9.
- IOWA STATE UNIVERSITY OF SCIENCE AND TECHNOLOGY, AMES, IA:  
3,353,624, CANC. INT. CL. 9.
- IOWA 80 GROUP, INC., WALCOTT, IA:  
3,354,451, CANC. INT. CL. 37.
- IOWA-DES MOINES SUPPLY, INC., DES MOINES, IA:  
4,594,420, MULTIPLE CLASS, INT. CLS. 30 AND 43.
- IP APPLICATIONS SOLUTIONS INC., VANCOUVER, CANADA:  
3,351,350, CANC. INT. CL. 42.
- IP CO., LLC, OSSINING, NY:  
2,794,668, CANC. MULTIPLE CLASS, INT. CLS. 35, 37 AND 40.
- IP HOLDINGS LLC, WILMINGTON, DE:  
3,353,318, CANC. INT. CL. 21.
- IPSWITCH, INC., LEXINGTON, MA:  
2,794,579, CANC. INT. CL. 9.
- IQ INNOVATIONS, LLC, COLUMBUS, OH:  
4,594,012, INT. CL. 41.
- IQCOPAY PATIENT PAYMENT SYSTEMS, LLC, MADISON, CT:  
4,591,176, PUB. 6-10-2014. INT. CL. 36.
- IQNAVIGATOR, INC., DENVER, CO TO IQNAVIGATOR, INC., DENVER, CO:  
2,795,232, CANC. MULTIPLE CLASS, INT. CLS. 9 AND 42.
- IQ212, INC., MARTINEZ, CA:  
3,351,318, CANC. INT. CL. 41.
- IR MEDIA VENTURES, LLC, BROOKLYN, NY:  
4,592,378, PUB. 6-10-2014. INT. CL. 41.
- IRENE SPAPENS, NETHERLANDS:  
4,590,869, PUB. 6-10-2014. INT. CL. 8.
- IRIS INTERNATIONAL, INC., BREA, CA:  
2,858,792. REN. 7-23-14. INT. CL. 9.
- IRON DOME LLC, ROCKVILLE, MD:  
4,592,473, PUB. 6-10-2014. INT. CL. 45.
- IRON-STAR EXCESS AGENCY LTD., HAMILTON HM 19, BERMUDA:  
4,593,077, INT. CL. 36.
- ISBIR SÜNGER SANAYI ANONIM SIRKETI, TURKEY:  
4,590,819, PUB. 6-10-2014. MULTIPLE CLASS, INT. CLS. 10, 20, 24 AND 35.
- ISCOOL ENTERTAINMENT, FRANCE:  
4,590,659, PUB. 6-10-2014. MULTIPLE CLASS, INT. CLS. 9, 41 AND 42.
- ISIK TARIM ÜRÜNLERİ; SANAYİ VE TİCARET ANONİM SIRKETİ, TURKEY:  
4,590,829, PUB. 6-10-2014. MULTIPLE CLASS, INT. CLS. 29, 30 AND 35.
- ISOLA USA CORP., CHANDLER, AZ:  
4,594,377, INT. CL. 17.  
4,594,379, INT. CL. 17.
- ISOMERS LABORATORIES INC., TORONTO, ONTARIO, CANADA:  
2,911,472. REN. 7-18-14. MULTIPLE CLASS, INT. CLS. 3 AND 5.
- ISOTERA LIMITED, HODDESDON, UNITED KINGDOM:  
4,591,017, PUB. 6-10-2014. INT. CL. 9.
- ISPORTSMEDIA, LLC, GILBERT, AZ:  
4,591,270, PUB. 6-10-2014. MULTIPLE CLASS, INT. CLS. 35 AND 42.
- ISTEC, INC., ALBUQUERQUE, NM:  
3,354,552, CANC. INT. CL. 41.
- IT COSMETICS, LLC, JERSEY CITY, NJ:  
4,553,278, COR. INT. CL. 3.
- IT'S A 10, INC., FORT LAUDERDALE, FL:  
4,592,966, PUB. 6-10-2014. INT. CL. 3.
- IT'S ACADEMIC, INC., NORTHBROOK, IL:  
3,352,929, CANC. INT. CL. 16.
- ITB TELEMATICS SOLUTIONS LLP, UNITED KINGDOM:  
4,590,724, PUB. 6-10-2014. INT. CL. 36.
- ITIP MUSIC LLC, ROGERS, AR:  
4,591,933, PUB. 6-10-2014. INT. CL. 9.
- ITMUSTBE, INC., VIDA, OR:  
3,351,269, CANC. INT. CL. 42.
- ITRIBUTE, INC., BROOKLYN, NY:  
3,351,387, CANC. INT. CL. 42.
- ITRON, INC., SPOKANE, WA:  
3,354,275, CANC. INT. CL. 9.
- ITS CONSULTING, S.R.O., SK-821 09 BRATISLAVA, SLOVAKIA:  
4,590,686, PUB. 6-10-2014. MULTIPLE CLASS, INT. CLS. 10 AND 44.
- ITSON INC., REDWOOD CITY, CA:  
4,593,453, MULTIPLE CLASS, INT. CLS. 38 AND 42.  
4,593,457, MULTIPLE CLASS, INT. CLS. 38 AND 42.
- ITT ENIDINE INC., ORCHARD PARK, NY:  
4,593,925, INT. CL. 7.
- IVANTAGE HEALTH ANALYTICS, INC., PORTSMOUTH, NH:  
4,592,333, PUB. 6-10-2014. INT. CL. 44.
- IVOCLEAR VIVADENT, INC., AMHERST, NY:  
3,351,283, CANC. INT. CL. 5.  
4,591,950, PUB. 6-10-2014. INT. CL. 5.
- IZEA, INC., WINTER PARK, FL:  
4,594,195, INT. CL. 35.
- J & B IMPORTERS, INC, MIAMI, FL:  
4,592,859, PUB. 6-10-2014. INT. CL. 12.
- J & D BRUSH CO., INC., HAUPPAUGE, NY:  
4,594,669, INT. CL. 21.
- J KAYLYNN LLC, SOUTHFIELD, MI, DBA ROSEY KAY:  
4,592,168, PUB. 6-10-2014. INT. CL. 4.
- J. & P. COATS, LIMITED, GLASGOW, SCOTLAND:  
3,351,060, CANC. INT. CL. 23.  
3,352,479, CANC. INT. CL. 23.

- J. BAXTER BRINKMANN INTERNATIONAL CORPORATION, DALLAS, TX:  
4,593,123, INT. CL. 24.  
4,593,124, INT. CL. 27.  
4,593,125, INT. CL. 4.  
4,593,126, INT. CL. 7.  
4,593,127, INT. CL. 8.  
4,593,129, INT. CL. 24.  
4,593,130, INT. CL. 27.
- J. C. PENNEY PRIVATE BRANDS, INC., PLANO, TX:  
3,351,801, CANC. MULTIPLE CLASS, INT. CLS. 11, 20, 21,  
24 AND 27.  
3,353,951, CANC. INT. CL. 25.
- J. WALTER COMPANY LIMITED, POINTE-CLAIRE, QUEBEC, CANADA:  
4,591,006, PUB. 6-10-2014, INT. CL. 4.
- J.B. HUNT TRANSPORT, INC., LOWELL, AR:  
2,925,797, REN. 7-23-14, INT. CL. 39.
- J.C. NEWMAN CIGAR COMPANY, TAMPA, FL:  
773,510, REN. 7-22-14, U.S. CL. 17 (INT. CL. 34).
- J.K. INTERNATIONALE, LLC, OVERLAND PARK, KS:  
4,594,149, INT. CL. 35.
- J.R. SIMPLOT COMPANY, BOISE, ID:  
4,593,061, PUB. 6-10-2014, INT. CL. 31.
- J.V.P. CONSULTING (ISRAEL) LTD., ISRAEL:  
4,590,704, PUB. 6-10-2014, MULTIPLE CLASS, INT. CLS.  
35, 36 AND 41.
- J'NICHE LLC, ARLINGTON, TX:  
4,592,196, PUB. 6-10-2014, INT. CL. 45.
- JAC ASSOCIATES, STEWARTSVILLE, NJ:  
4,591,885, PUB. 6-10-2014, INT. CL. 35.
- JACK DANIEL'S PROPERTIES, INC., SAN RAFAEL, CA:  
2,867,158, REN. 7-24-14, INT. CL. 21.
- JACK MCKRACKEN LLC, COLLEYVILLE, TX:  
4,591,510, PUB. 6-10-2014, INT. CL. 41.
- JACKSON HOLE SHOOTING, LLC, JACKSON, WY:  
4,593,011, PUB. 6-10-2014, INT. CL. 41.
- JACKSON NATIONAL LIFE INSURANCE COMPANY, LANSING, MI:  
4,592,629, PUB. 6-10-2014, INT. CL. 36.
- JACKSON, GREGORY L., ADDISON, TX:  
3,351,292, CANC. INT. CL. 39.
- JACKSON, MATTIE D., BRENTWOOD, TN:  
4,593,944, INT. CL. 41.  
4,593,945, INT. CL. 43.
- JACKSON, WILEY, II, ATLANTA, GA:  
3,353,266, CANC. INT. CL. 35.
- JACOBS CORPORATION, HARLAN, IA:  
2,796,146, CANC. INT. CL. 6.
- JACT MEDIA LLC, DALLAS, TX:  
3,351,544, CANC. INT. CL. 9.
- JAFFE, RUSSELL M., VIENNA, VA:  
2,869,985, REN. 7-18-14, INT. CL. 5.
- JAHN, STEVEN R., CHELSEA, MI:  
3,354,293, CANC. INT. CL. 21.
- JAKKS PACIFIC, INC., MALIBU, CA:  
4,593,513, INT. CL. 28.
- JAMAICAN STYLE, INC., RANCHO SANTA MARGARITA, CA:  
2,956,475, REN. 7-24-14, INT. CL. 25.
- JAMES BRESKI & COMPANY, INC., CHICAGO, IL:  
1,846,674, REN. 7-23-14, INT. CL. 14.
- JAMES CONNOLLY CONSULTING, LTD., SPOKANE VALLEY, WA:  
4,591,243, PUB. 6-10-2014, INT. CL. 1.
- JAMES MORLAND.; ELEMENTAL ADVENTURE LTD, UNITED KINGDOM:  
3,352,644.
- JAMES, KEITH, SAN FRANCISCO, CA:  
3,343,184, CANC. INT. CL. 44.
- JAMISON BEDDING, INC., NASHVILLE, TN:  
3,351,213, CANC. INT. CL. 20.
- JAMZOO TECHNOLOGY CO., LTD., DA'AN DIST TAIPEI CITY, TAIWAN:  
4,593,419, INT. CL. 42.
- JAMZOO TECHNOLOGY CO., LTD., DA'AN DIST. TAIPEI CITY, TAIWAN:  
4,593,420, INT. CL. 42.
- JANOME SEWING MACHINE COMPANY LIMITED, HACHIOJI-SHI, TOKYO, JAPAN:  
4,591,266, PUB. 6-10-2014, INT. CL. 7.
- JANOW, SUSAN BENAY, KAILUA, HI:  
3,350,930, CANC. INT. CL. 16.
- JANSON, PAUL A, GEORGETOWN, MA AND JANSON, MARY F, GEORGETOWN, MA:  
4,593,120, INT. CL. 21.
- JANSPORT APPAREL CORP., WILMINGTON, DE:  
2,796,214, CANC. INT. CL. 18.
- JANSSSENS SALES, INC., KIRKLAND, WA:  
4,592,390, PUB. 6-10-2014, INT. CL. 35.
- JANUS DEVELOPMENTAL SERVICES, INC., NOBLESVILLE, IN:  
4,594,460, MULTIPLE CLASS, INT. CLS. 35 AND 41.
- JANUS ET CIE, WEST HOLLYWOOD, CA:  
4,593,199, INT. CL. 20.
- JARED & PERRY METADATA, LLC, NASHVILLE, TN:  
4,592,654, PUB. 6-10-2014, INT. CL. 42.
- JASMINDER WALIA, CHIGWELL, ESSEX, UNITED KINGDOM AND JAMES BUTTERFIELD, ENFIELD, UNITED KINGDOM:  
4,590,631, PUB. 6-10-2014, MULTIPLE CLASS, INT. CLS.  
12, 18, 25 AND 35.
- JASON DIPIETRO, EAST PROVIDENCE, RI:  
4,593,857, INT. CL. 14.
- JASON FURIA, SPRINGFIELD, NJ:  
4,594,022, INT. CL. 44.
- JASPER COAL ENTERTAINMENT, LLC, BIRMINGHAM, AL:  
4,591,530, PUB. 6-10-2014, INT. CL. 41.
- JASPER CONRAN, UNITED KINGDOM:  
4,590,876, PUB. 6-10-2014, MULTIPLE CLASS, INT. CLS.  
14, 18 AND 24.
- JASTI, SRIDEVI, HOLLYWOOD, FL:  
3,353,274, CANC. INT. CL. 11.
- JAYA WELLNESS LLC, SALT LAKE CITY, UT:  
4,592,432, PUB. 6-10-2014, INT. CL. 5.
- JBI MANUFACTURING LLC, AURORA, CO:  
4,593,489, INT. CL. 20.
- JBR, INC., LINCOLN, CA:  
4,591,650, PUB. 6-10-2014, MULTIPLE CLASS, INT. CLS.  
30 AND 43.
- JEAN JOHNSON, HOUSTON, TX:  
4,591,127, PUB. 6-10-2014, MULTIPLE CLASS, INT. CLS.  
41 AND 45.
- JEAN KELLY, SEATTLE, WA:  
4,591,537, PUB. 6-10-2014, INT. CL. 9.
- JEAN-CLAUDE BIBOLLET, THONES, FRANCE:  
4,591,466, PUB. 6-10-2014, INT. CL. 15.
- JEF MARTENS, WASHINGTON, DC:  
4,592,593, PUB. 6-10-2014, MULTIPLE CLASS, INT. CLS. 9  
AND 25.
- JEFF SCOTT, LLC, LAS VEGAS, NV:  
4,594,741, INT. CL. 41.
- JEFFERSON PARTNERS L.P., MINNEAPOLIS, MN:  
1,287,294, REN. 7-21-14, INT. CL. 39.
- JEFFERSON STREET SIGNAGE DISTRICT, LLC, PHOENIX, AZ:  
4,593,685, MULTIPLE CLASS, INT. CLS. 35 AND 41.
- JEFFERY R. BUCKLEY, IDAHO FALLS, ID:  
4,591,180, PUB. 11-5-2013, INT. CL. 25.
- JEFFREY PRESS, INC., WINDSOR MILL, MD:  
3,351,457, CANC. INT. CL. 40.
- JEMETER LLC, DENVER, CO:  
3,353,066, CANC. INT. CL. 9.
- JEN USA INC., NORTH BRUNSWICK, NJ:  
3,352,924, CANC. INT. CL. 3.
- JENEICE S. MILLER, SAN DIEGO, CA:  
3,351,090, CANC. INT. CL. 41.
- JENKINS, ROZALEN J., MARSTONS MILLS, MA:  
3,354,028, CANC. INT. CL. 11.
- JENNY YOO COLLECTION, INC., NEW YORK, NY:  
3,352,329, CANC. INT. CL. 25.
- JENSEN, DAVID, LOS ANGELES, CA:  
4,594,688, INT. CL. 16.

- JENSEN, JACK, HOUSTON, TX:  
4,592,457, PUB. 6-10-2014. INT. CL. 44.  
4,592,802, PUB. 6-10-2014. INT. CL. 44.
- JEON, JEONG SOON, FLUSHING, NY:  
3,351,754, CANC. INT. CL. 43.
- JEREMY WAYNE SOLES, SPOTSYLVANIA, VA:  
4,591,514, PUB. 6-10-2014. INT. CL. 35.
- JERSEYFOURSURE LIMITED LIABILITY COMPANY,  
TOMS RIVER, NJ:  
4,592,279, PUB. 6-10-2014. INT. CL. 28.  
4,592,281, PUB. 6-10-2014. INT. CL. 9.
- JERVIS, KALI DAY, BROOKLYN, NY, DBA KALI DAY:  
4,593,393, MULTIPLE CLASS, INT. CLS. 14 AND 25.
- JESCO IRON CRAFT, INC., BOGOTA, NJ, DBA JESCRAFT:  
4,591,005, PUB. 6-10-2014. MULTIPLE CLASS, INT. CLS. 8  
AND 12.
- JESUS IN OUR LIVES, LLC, HOLLAND, MI:  
3,353,842, CANC. INT. CL. 25.
- JET CO., HUMBOLDT, IA:  
2,794,929, CANC. INT. CL. 22.
- JETTER AG, 71642 LUDWIGSBURG, FED REP GERMANY:  
3,352,613.
- JEUNESSE GLOBAL HOLDINGS, LLC, ALTAMONTE  
SPRINGS, FL:  
4,593,358, MULTIPLE CLASS, INT. CLS. 3 AND 5.
- JEWELRY BY MICHAEL TAHER LLC, EAST RUTHER-  
FORD, NJ:  
4,591,705, PUB. 6-10-2014. INT. CL. 14.
- JEWISH FEDERATION OF GREATER SEATTLE, SEATTLE,  
WA:  
4,594,228, INT. CL. 36.
- JGG ENTERPRISES, LLC, BUFFALO, NY:  
3,354,278, CANC. INT. CL. 5.
- JHONY USA INC., NEW YORK, NY:  
4,426,353, CANC. INT. CL. 3.
- JIANG, KELLY, RENTON, WA AND WANG, CHI TUNG,  
XINDIA DIST., TAIWAN:  
4,591,768, PUB. 6-10-2014. INT. CL. 16.
- JIANGSU DAYWELL FOODS CO., LTD, LIYANG CITY,  
JIANGSU PROVINCE, CHINA:  
3,352,681.
- JIANHU YONG JIE FOREIGN TRADE CO., LTD., JIANGSU,  
CHINA:  
4,592,646, PUB. 6-10-2014. INT. CL. 35.
- JIHUI PENG, NEW YORK, NY:  
3,351,133, CANC. INT. CL. 44.
- JILL STEPHENS, SEAL BEACH, CA:  
4,593,408, MULTIPLE CLASS, INT. CLS. 3 AND 5.
- JILL'S BRO'S L.L.C., CASPER, WY:  
2,794,887, CANC. INT. CL. 30.
- JINDAL POLY FILMS LIMITED, GULAO THI, INDIA:  
4,594,633, INT. CL. 16.
- JINI BABY INTERNATIONAL CO., LTD., CHANGHUA  
COUNTY, TAIWAN:  
4,593,523, MULTIPLE CLASS, INT. CLS. 5, 10 AND 25.
- JLP AVIATION MAINTENANCE LLC, KISSIMMEE, FL:  
3,351,510, CANC. INT. CL. 37.
- JMS CONSTRUCTORS, INC., KING OF PRUSSIA, PA, DBA  
VALUE DRY:  
4,592,364, PUB. 6-10-2014. INT. CL. 37.
- JMS FOODSERVICE, LLC, ORRVILLE, OH:  
2,794,893, CANC. INT. CL. 30.
- JMWILLIAMS LLC, NEW YORK, NY:  
4,593,601, INT. CL. 43.
- JNK INNOVATIONS, LLC, VAN ALSTYNE, TX:  
4,591,703, PUB. 6-10-2014. INT. CL. 6.  
4,591,706, PUB. 6-10-2014. INT. CL. 6.
- JNO DESIGN LLC, WOODBRIDGE, VA, DBA JNO DE-  
SIGNS:  
4,592,154, PUB. 6-10-2014. INT. CL. 42.
- JOANGIL ENTERPRISES, LLC, MORGANVILLE, NJ:  
3,352,877, CANC. INT. CL. 44.
- JOANNE FARBER, SKOKIE, IL:  
3,351,098, CANC. INT. CL. 41.
- JOBLING, PETER G., OAKVILLE, ONTARIO, CANADA:  
4,593,822, INT. CL. 30.
- JOBLISTING, INC., WALNUT, CA:  
4,592,250, PUB. 6-10-2014. INT. CL. 35.
- JOCKEY INTERNATIONAL, INC., KENOSHA, WI:  
4,593,794, MULTIPLE CLASS, INT. CLS. 25, 35 AND 45.
- JOHN ALLAN COMPANY, LLC, NEW YORK, NY:  
3,353,633, CANC. INT. CL. 44.
- JOHN B. SANFILIPPO & SON, INC., ELGIN, IL:  
3,354,392, CANC. INT. CL. 29.
- JOHN C. PRUSA, STOW, OH:  
4,591,403, PUB. 6-10-2014. INT. CL. 44.
- JOHN CROWE, LLC, TAMARAC, FL:  
3,350,831, CANC. INT. CL. 25.
- JOHN GIBSON ENTERPRISES, INC., SAN LUIS OBISPO,  
CA:  
4,592,875, PUB. 6-10-2014. INT. CL. 4.  
4,592,878, PUB. 6-10-2014. INT. CL. 34.
- JOHN HARDY LIMITED, TORTOLA, BR. VIRGIN ISLANDS:  
4,592,063, PUB. 6-10-2014. INT. CL. 14.
- JOHN R. DRUMMOND, MARIETTA, GA:  
3,353,264, CANC. INT. CL. 15.
- JOHN SWIRE & SONS LIMITED, LONDON SWIE 6AJ,  
ENGLAND:  
1,849,689, REN. 7-21-14. MULTIPLE CLASS, INT. CLS. 12  
AND 16.
- JOHN TODD ECOLOGICAL DESIGN, INC., WOODS HOLE,  
MA, FORMERLY JOHN TODD RESEARCH & DESIGN,  
INC.:  
4,592,749, PUB. 6-10-2014. INT. CL. 11.
- JOHN WAYNE CANCER FOUNDATION, NEWPORT  
BEACH, CA:  
4,591,521, PUB. 6-10-2014. INT. CL. 36.
- JOHNS MANVILLE, DENVER, CO, GLASS FIBERS, INC.,  
TOLEDO, OH:  
594,097, REN. 7-21-14. U.S. CL. 12 (INT. CL. 17).
- JOHNSON & JOHNSON, NEW BRUNSWICK, NJ, BERGER;  
RICHARD, NEW YORK, NY:  
1,298,339, REN. 7-24-14. INT. CL. 5.
- JOHNSON & JOHNSON, NEW BRUNSWICK, NJ:  
2,801,854, REN. 7-21-14. INT. CL. 41.  
4,593,672, INT. CL. 44.  
4,593,673, INT. CL. 44.  
4,594,615, INT. CL. 3.
- JOHNSON, JESSICA J., NEWPORT BEACH, CA:  
4,594,315, MULTIPLE CLASS, INT. CLS. 41 AND 45.
- JOHNSON, KEVIN, RICHMOND, CA AND KOHTZ, PETER,  
EL CERRITO, CA:  
4,593,371, INT. CL. 41.
- JOHNSTON, SHANNON A., ATLANTA, GA:  
3,351,109, CANC. INT. CL. 35.
- JOHNSTONE, DEBRA H., CAVE CREEK, AZ:  
3,354,445, CANC. INT. CL. 44.
- JOINT SMART, LLC, TRAVERSE CITY, MI:  
4,593,777, INT. CL. 10.
- JONES, ANNIE L., AUSTIN, TX:  
4,592,850, PUB. 6-10-2014. INT. CL. 42.
- JONES, CYNTHIA, BROOKLYN, NY:  
4,593,037, PUB. 6-10-2014. INT. CL. 9.
- JONES, LORI, HILL CITY, SD, DBA TOO FAT SISTERS AND  
INHOFER, SHELLY, HILL CITY, SD, DBA TOO FAT  
SISTERS:  
3,353,941, CANC. INT. CL. 16.
- JONES, MIKE, NOVI, MI:  
4,594,493, INT. CL. 25.
- JORDAN, BRIAN O., ATLANTA, GA:  
3,351,973, CANC. INT. CL. 25.
- JORDAN, MALEEK, ELMONT, NY:  
4,591,495, PUB. 6-10-2014. INT. CL. 25.
- JOSEPH BRENNNA, LONGMONT, CO:  
4,594,658, INT. CL. 41.  
4,594,659, INT. CL. 41.
- JOSEPH F. BASMAJI, WATERFORD, MI:  
4,593,387, INT. CL. 9.
- JOSEPH JAMES FEWER, AYLMEER, ONTARIO, CANADA:  
4,594,428, INT. CL. 1.
- JOSEPH VERDIER, FRANCE:  
4,590,739, PUB. 6-10-2014. INT. CL. 33.
- JOSHUA ROTH, LTD., ALBANY, OR:  
3,354,728, CANC. INT. CL. 8.
- JOSHUASYSTEMS, INC, WALDORF, MD:  
3,352,917, CANC. INT. CL. 41.



JOSÉ VICENTE CRESPO NAVARRO, SPAIN:  
4,590,749, PUB. 6-10-2014. INT. CL. 35.

JOUST 12 PRODUCTIONS, NEW YORK, NY:  
4,592,083, PUB. 6-10-2014. INT. CL. 41.

JOY MEDICAL DEVICES CORPORATION, KAOHSIUNG, TAIWAN, AKA JMD:  
4,591,043, PUB. 6-10-2014. INT. CL. 5.

JOY UNIVERSAL LIMITED, ROAD TOWN, TORTOLA, BR. VIRGIN ISLANDS:  
4,594,401, INT. CL. 12.

JOYCEE KENNEDY, DENVER, CO:  
3,351,671, CANC. INT. CL. 28.

JOYFUL EVENTS, LLC, FORT WORTH, TX:  
3,351,915, CANC. INT. CL. 35.

JPI COMMERCIAL, LLC, MINNEAPOLIS, MN:  
2,860,730, REN. 7-21-14. INT. CL. 5.

JPMORGAN CHASE & CO., NEW YORK, NY:  
2,795,108, CANC. INT. CL. 36.  
4,593,968, INT. CL. 36.

JPW INDUSTRIES INC., LAVERGNE, TN:  
4,590,951, PUB. 6-10-2014. INT. CL. 8.

JTM FOODS LLC, ERIE, PA:  
4,594,352, INT. CL. 30.

JUDY SINGER, INC., LOS ANGELES, CA:  
3,351,810, CANC. INT. CL. 5.

JUGGERNAUTS MOTORCYCLE CLUB, FORT CAMPBELL, TN:  
3,350,971, CANC. INT. CL. 35.

JUICEBOX WINE COMPANY LLC, MANCHESTER, MA:  
3,353,868, CANC. INT. CL. 33.

JUKIN MEDIA, INC., LOS ANGELES, CA:  
4,591,633, PUB. 6-10-2014. INT. CL. 45.

JULIE FELDMAN, LA JOLLA, CA, DBA BELLA BUNDLES:  
4,591,147, PUB. 9-17-2013. INT. CL. 24.

JULIUS SÄMANN LTD., HAMILTON, BERMUDA:  
4,592,854, PUB. 6-10-2014. MULTIPLE CLASS, INT. CLS. 3 AND 28.

JUNGLEE GAMES, INC, HAYWARD, CA, DBA JUNGLEE:  
4,590,977, PUB. 6-10-2014. INT. CL. 9.

JUNIOR ACHIEVEMENT USA, COLORADO SPRINGS, CO:  
4,591,687, PUB. 6-10-2014. INT. CL. 9.

JURASOFT AG, BERLIN, FED REP GERMANY:  
4,591,208, PUB. 6-10-2014. MULTIPLE CLASS, INT. CLS. 9, 35, 38, 42 AND 45.

JUST KEEP SWIMMING INC., EL CAJON, CA:  
4,591,488, PUB. 1-7-2014. INT. CL. 43.

JUST ROUGHIN IT ADVENTURE COMPANY, LLC, SCOTTSDALE, AZ:  
3,351,422, CANC. INT. CL. 39.

JUSTIN MCCLURE, WICHITA, KS:  
4,593,481, INT. CL. 28.

JVC KENWOOD CORPORATION, JAPAN:  
3,352,733.

JÖLLENBECK GMBH, 27404 WEERTZEN, FED REP GERMANY:  
3,352,587.

JØRGEN KRUISE A/S, DK-5550 LANGESKOV, DENMARK:  
4,590,626, PUB. 11-13-2012. MULTIPLE CLASS, INT. CLS. 3, 5, 10, 18, 20, 21, 25, 28 AND 35.

K&S VENTURES, BROOKLYN, NY:  
3,354,410, CANC. INT. CL. 35.

KABA ILCO CORP., ROCKY MOUNT, NC:  
773,164, REN. 7-22-14. U.S. CL. 25 (INT. CL. 6).

KABUSHIKI KAISHA ACCESS, CHIYODA-KU TOKYO, JAPAN, TA ACCESS CO., LTD.:  
2,918,792, CANC. INT. CL. 9.

KABUSHIKI KAISHA SEGA, OHTA-KU, TOKYO, JAPAN, DBA SEGA CORPORATION:  
2,864,927, REN. 7-21-14. INT. CL. 9.

KABUSHIKI KAISHA SQUARE ENIX (ALSO TRADING AS SQUARE ENIX CO., LTD.), TOKYO, JAPAN:  
2,867,049, REN. 7-22-14. MULTIPLE CLASS, INT. CLS. 9 AND 41.  
4,591,215, PUB. 6-10-2014. MULTIPLE CLASS, INT. CLS. 9 AND 41.

KABUSHIKIKAISHA BARUDAN, AICHI-KEN, JAPAN:  
4,591,152, PUB. 6-10-2014. INT. CL. 9.

KADANT, INC., QUEENSBURY, NY:  
3,350,736, CANC. INT. CL. 7.  
3,350,737, CANC. INT. CL. 7.

KAESHUA RESTAURANT GROUP, BOYNTON BEACH, FL:  
4,592,413, PUB. 6-10-2014. INT. CL. 43.

KAIZER CORP., TAMARAC, FL:  
4,594,003, INT. CL. 33.  
4,594,094, INT. CL. 33.

KAJEET, INC., BETHESDA, MD:  
3,354,222, CANC. INT. CL. 9.  
3,354,223, CANC. INT. CL. 38.

KALE, CHRISTI, HENDERSON, NV:  
4,594,451, INT. CL. 35.

KALESNIKOFF LUMBER COMPANY LIMITED, BRITISH COLUMBIA VIN 3L8, CANADA:  
2,863,970, REN. 7-24-14. INT. CL. 19.

KALKOMEY ENTERPRISES, INC., DALLAS, TX:  
2,936,017, REN. 7-18-14. INT. CL. 41.

KAM ENTERPRISES INC, WELLINGTON, FL:  
4,592,120, PUB. 6-10-2014. INT. CL. 41.

KAMEN, CHAD, PROSPECT, KY:  
4,591,944, PUB. 6-10-2014. INT. CL. 35.

KANG, SHINKU, SALT LAKE CITY, UT:  
4,592,026, PUB. 6-10-2014. INT. CL. 37.

KANG'S DISTRIBUTION, INC., CERRITOS, CA:  
3,352,901, CANC. INT. CL. 36.

KANSAS ASPHALT, INC., BUCYRUS, KS:  
4,591,190, PUB. 6-10-2014. INT. CL. 37.

KAO GERMANY GMBH, 64297 DARMSTADT, FED REP GERMANY, GOLDWELL G.M.B.H., CHEMISCHE FABRIK H. E. DOTTER, DARMSTADT-EBERSTADT, FED REP GERMANY:  
1,295,415, REN. 7-22-14. INT. CL. 3.

KAPLAN, INC., NEW YORK, NY, STANLEY H. KAPLAN EDUCATIONAL CENTER LTD., NEW YORK, NY:  
1,822,683, REN. 7-24-14. MULTIPLE CLASS, INT. CLS. 16 AND 41.

KAPLAN, JENNIFER BETH, SAN RAFAEL, CA, DBA YELLOW DOG PILATES:  
4,591,974, PUB. 6-10-2014. INT. CL. 41.

KARABETIAN IMPORT & DISTRIBUTION, INC., LOS ANGELES, CA:  
4,591,777, PUB. 6-10-2014. MULTIPLE CLASS, INT. CLS. 29 AND 32.

KARAKO SUITS LTD., LYNBROOK, NY:  
3,354,680, CANC. INT. CL. 35.

KARGER, ELIZABETH, OAKLAND, CA:  
4,593,961, INT. CL. 28.

KARI WHITE, LOS ANGELES, CA, MAYOR B.:  
4,491,073, COR. INT. CL. 20.

KARL STORZ GMBH & CO. KG, FED REP GERMANY:  
4,590,752, PUB. 6-10-2014. MULTIPLE CLASS, INT. CLS. 9, 35, 37, 41 AND 42.

KARMA CANDY INC., HAMILTON, ONTARIO, CANADA:  
4,591,477, PUB. 6-10-2014. INT. CL. 35.

KARSTEN MANUFACTURING CORPORATION, PHOENIX, AZ:  
1,289,153, REN. 7-24-14. INT. CL. 28.

KASHWERE L.L.C., NORTHBROOK, IL:  
4,592,588, PUB. 6-10-2014. MULTIPLE CLASS, INT. CLS. 24, 25, 28 AND 35.

KASPAR HAUSER CORP., VENICE, CA:  
4,593,897, INT. CL. 42.

KASTLE LLC, LOS ANGELES, CA:  
4,592,766, PUB. 6-10-2014. INT. CL. 41.

KATANYA, L.L.C., FAR HILLS, NJ:  
4,593,736, MULTIPLE CLASS, INT. CLS. 18 AND 25.

KAUSHIK, SOMYA, NEW YORK, NY:  
4,592,601, PUB. 6-10-2014. INT. CL. 42.

KAWALLI FASHION INC., LAWRENCEVILLE, GA:  
3,350,947, CANC. INT. CL. 3.

KAWASAKI JUKOGYO KABUSHIKI KAISHA (KAWASAKI HEAVY INDUSTRIES, LTD.), CHUO-KU, KOBE, JAPAN:  
1,291,859, REN. 7-23-14. INT. CL. 7.

KAYAK SOFTWARE CORPORATION, NORWALK, CT:  
3,350,994, CANC. MULTIPLE CLASS, INT. CLS. 35, 38, 39, 41 AND 42.

- KBA-NOTASYS SA, SWITZERLAND:  
3,352,568.
- KCD, INC., MULTIDISCIPLINED CREATIVE SOURCE,  
WILLIAMSTOWN, KY:  
4,593,208, INT. CL. 9.
- KCETLINK, BURBANK, CA:  
4,593,267, MULTIPLE CLASS, INT. CLS. 41 AND 45.
- KCG HOLDINGS, INC., JERSEY CITY, NJ:  
4,594,145, INT. CL. 36.
- KEATING & ASSOCIATES, INC., MANHATTAN, KS:  
2,864,009, REN. 7-24-14, MULTIPLE CLASS, INT. CLS. 36  
AND 41.
- KEENAN, LINDA K., COVINGTON, LA:  
1,593,110, CANC. INT. CL. 25.
- KEENE PROMOTIONS, INC., AUBURNDALE, MA:  
3,350,878, CANC. INT. CL. 35.
- KEEPSAKE BEAUTY LLC, ROCKVILLE, MD:  
4,594,148, INT. CL. 44.
- KEEPSAYK, LLC, CHICAGO, IL:  
4,593,228, INT. CL. 9.
- KELDAN GMBH, SWITZERLAND:  
4,590,834, PUB. 6-10-2014, MULTIPLE CLASS, INT. CLS. 9  
AND 11.
- KELLER MANUFACTURING COMPANY, ST. LOUIS, MO,  
DBA GARDEX:  
4,594,442, INT. CL. 8.
- KELLER, JANE, CHURCH HILL, MD:  
2,795,389, CANC. INT. CL. 28.
- KELLEY BAKER, VENICE, CA:  
4,591,451, PUB. 6-10-2014, INT. CL. 44.
- KELLOGG NORTH AMERICA COMPANY, BATTLE  
CREEK, MI:  
4,592,765, PUB. 6-10-2014, INT. CL. 30.  
4,592,976, PUB. 6-10-2014, INT. CL. 30.  
4,592,980, PUB. 6-10-2014, INT. CL. 30.  
4,594,199, INT. CL. 30.
- KEM-EN-TEC DIAGNOSTICS A/S, DK-2630 TAASTRUP,  
DENMARK:  
4,591,340, PUB. 12-24-2013, MULTIPLE CLASS, INT. CLS.  
1 AND 5.
- KEMBLE, TRACY, NEWPORT BEACH, CA:  
4,592,099, PUB. 6-10-2014, INT. CL. 41.
- KEMESA LLC, AVENTURA, FL:  
3,352,945, CANC. INT. CL. 42.
- KEMPT DESIGN LLC, BROOKLYN, NY:  
3,351,327, CANC. INT. CL. 18.
- KENDLE INTERNATIONAL, INC., CINCINNATI, OH:  
3,351,233, CANC. INT. CL. 41.
- KENEXA TECHNOLOGY, INC., WAYNE, PA:  
3,351,101, CANC. MULTIPLE CLASS, INT. CLS. 35 AND  
42.
- KENKO TOKINA USA, INC., HUNTINGTON BEACH, CA:  
4,593,298, INT. CL. 9.
- KENNEDY GROUP INCORPORATED, THE, WILLOUGH-  
BY, OH:  
1,869,022, REN. 7-20-14, MULTIPLE CLASS, INT. CLS. 16  
AND 42.
- KENNETH A. FISCHER SR., FRAMINGHAM, MA:  
4,594,579, INT. CL. 28.
- KENTON COUNTY AIRPORT BOARD, CINCINNATI, OH,  
DBA CINCINNATI/NORTHERN KENTUCKY INTERNA-  
TIONAL AIRPORT:  
4,591,588, PUB. 12-31-2013, INT. CL. 39.
- KENTUCKY DEPARTMENT OF AGRICULTURE, FRANK-  
FORT, KY:  
4,592,652, PUB. 6-10-2014, INT. CL. 35.
- KENTUCKY LOTTERY CORPORATION, LOUISVILLE, KY:  
3,350,753, CANC. INT. CL. 41.
- KENWOOD INVESTMENTS, L.P., HOUSTON, TX, DBA  
TUSCAN LAKES DEVELOPMENT, L.P.:  
3,479,273, COR. INT. CL. 37.  
3,479,274, COR. INT. CL. 37.
- KENYON-NOBLE LUMBER COMPANY, BOZEMAN, MT,  
KENYON NOBLE LUMBER CO.:  
3,645,992, CANC. INT. CL. 19.
- KENZO, FRANCE:  
3,352,591.  
4,590,825, PUB. 6-10-2014, INT. CL. 3.  
4,590,880, PUB. 6-10-2014, INT. CL. 3.
- KERBELL S.R.L., ITALY:  
3,352,561.
- KERDOON, DAVID, LOS ANGELES, CA:  
3,351,688, CANC. INT. CL. 5.
- KERTZ, MALCOLM GLEN, EL PASO, TX:  
3,352,452, CANC. MULTIPLE CLASS, INT. CLS. 3 AND  
21.
- KESSLER CHEMICAL, INC., BETHLEHEM, PA:  
2,952,187, REN. 7-23-14, INT. CL. 1.
- KESSLER INDUSTRIES, INC., WOODBRIDGE, NJ:  
3,354,091, CANC. INT. CL. 11.
- KEYCORP, CLEVELAND, OH:  
3,354,437, CANC. MULTIPLE CLASS, INT. CLS. 9 AND  
36.
- KGB CO., LTD., REPUBLIC OF KOREA:  
3,352,724.  
3,352,725.  
3,352,726.
- KHALIL, MOHAMMED ALI, BROOKLYN, NY:  
3,351,607, CANC. INT. CL. 35.
- KHD HUMBOLDT WEDAG GMBH, KOLN, FED REP  
GERMANY:  
1,299,258, REN. 7-21-14, MULTIPLE CLASS, INT. CLS. 6,  
7, 9 AND 11.
- KICKBALL CONCEPTS, LLC, GREAT FALLS, VA:  
3,352,931, CANC. MULTIPLE CLASS, INT. CLS. 20 AND  
24.
- KIDCAPERS LLC, ST. LOUIS PARK, MN:  
3,354,199, CANC. INT. CL. 41.
- KIDRO PRODUCTIONS, INC., NEW CITY, NY:  
2,777,151, REN. 7-24-14, INT. CL. 41.
- KIELY, SHAUN, SEATTLE, WA:  
4,591,518, PUB. 6-10-2014, INT. CL. 35.
- KIKI MCDONOUGH, LONDON, UNITED KINGDOM:  
4,593,904, INT. CL. 14.
- KIKOYNY, LLC, BROOKLYN, NY:  
4,591,106, PUB. 6-10-2014, INT. CL. 25.
- KILEE DISTRIBUTING, INC, DALLAS, TX:  
3,352,938, CANC. INT. CL. 3.
- KILIC DENIZ URUNLERI URETIMI IHRACAT; ITHALAT  
VE TICARET ANONIM SIRKETI, TURKEY:  
4,590,770, PUB. 6-10-2014, MULTIPLE CLASS, INT. CLS.  
29 AND 31.
- KILMER, BRAD R., EVANSVILLE, IN:  
3,353,860, CANC. MULTIPLE CLASS, INT. CLS. 9 AND  
41.
- KIM DALZELL INCORPORATED, ALBERTVILLE, MN:  
4,592,836, PUB. 6-10-2014, INT. CL. 25.
- KIM, JONG OH, LA CANADA, CA:  
3,350,729, CANC. INT. CL. 43.  
3,350,730, CANC. INT. CL. 43.
- KIM, TAE HO, SEOUL, REPUBLIC OF KOREA:  
4,592,594, PUB. 6-10-2014, MULTIPLE CLASS, INT. CLS.  
14, 25 AND 26.
- KIM, YOUNGHO, SURREY, BC, CANADA:  
4,592,789, PUB. 6-10-2014, INT. CL. 9.
- KIMBERLY-CLARK WORLDWIDE, INC., NEENAH, WI:  
1,297,449, REN. 7-22-14, INT. CL. 10.  
2,862,376, REN. 7-22-14, INT. CL. 10.
- KIMSAPRINCESS INC., WOODLAND HILLS, CA AND  
2DIE4KOURT, WOODLAND HILLS, CA AND KHLOMO-  
NEY INC., WOODLAND HILLS, CA:  
4,591,200, PUB. 6-10-2014, INT. CL. 21.
- KIMURA, KRIS H., LA HABRA, CA:  
4,592,202, PUB. 6-10-2014, INT. CL. 28.
- KINCAID, ELIZABETH, CHATTANOOGA, TN:  
2,883,324, REN. 7-21-14, INT. CL. 44.
- KINDRED, ARON BRANT, OFALLON, MO AND SMITH,  
STEPHEN MICHAEL, ST CHARLES, MO:  
3,351,319, CANC. INT. CL. 41.
- KING BABY STUDIO, INC., SANTA MONICA, CA:  
2,908,174, REN. 7-20-14, INT. CL. 14.  
2,908,175, REN. 7-20-14, INT. CL. 14.

KING COUNTY PUBLIC HOSPITAL DISTRICT NO. 2, KIRKLAND, WA:  
4,593,391, INT. CL. 44.

KING MOUNTAIN TOBACCO COMPANY, INC., WHITE SWAN, WA:  
3,352,436, CANC. INT. CL. 34.

KING OF HOUSTON PTE LTD, SINGAPORE:  
3,352,713.

KING STREET BREWING LLC, ANCHORAGE, AK, DBA KING STREET BREWING COMPANY:  
4,591,756, PUB. 3-4-2014. INT. CL. 32.

KINKISHARYO INTERNATIONAL, LLC, CANTON, MA:  
3,354,402, CANC. INT. CL. 38.

KIRK HAMMETT, LOS ANGELES, CA:  
4,593,360, INT. CL. 25.

KIRKLAND, REAGEN C., SOUTHLAKE, TX:  
4,591,797, PUB. 6-10-2014. INT. CL. 35.

KIRKWOOD YOUTH HOCKEY ASSOCIATION, KIRKWOOD, MO:  
2,794,306, CANC. INT. CL. 41.

KISMET CLOTHING CO, INC., CITY OF COMMERCE, CA:  
3,352,940, CANC. INT. CL. 25.

KISS CATALOG, LTD., PINE BROOK, NJ:  
4,594,183, INT. CL. 16.

KISSLETOE, LLC, PARK CITY, UT:  
4,593,905, INT. CL. 16.

KISTLER HOLDING AG, SWITZERLAND:  
4,590,648, PUB. 6-10-2014. INT. CL. 9.  
4,590,649, PUB. 6-10-2014. INT. CL. 9.

KIT KUHN A JEWELER DESIGNED FOR YOU, INC., GIG HARBOR, WA:  
4,593,008, PUB. 6-10-2014. INT. CL. 14.

KITCHENSIDE LLC, SAN DIEGO, CA:  
4,593,403, MULTIPLE CLASS, INT. CLS. 35, 41 AND 43.

KITTYSMART LLC, NORCO, CA:  
4,591,397, PUB. 6-10-2014. INT. CL. 20.

KIUCHI BREWERY GOSHIKAISHA, NAKA-SHI, IBARAKI, JAPAN:  
3,352,015, CANC. INT. CL. 33.

KIWI BURST, LLC, SMITHFIELD, RI:  
4,591,141, PUB. 8-27-2013. MULTIPLE CLASS, INT. CLS. 30 AND 43.

KIZYS, GINTARE, SANTA MONICA, CA, DBA GINTARE AND GINTARE JEWELRY:  
4,592,077, PUB. 6-10-2014. MULTIPLE CLASS, INT. CLS. 14 AND 42.

KLA-TENCOR CORPORATION, MILPITAS, CA:  
3,352,444, CANC. INT. CL. 9.

KLARUS LIGHTING TECHNOLOGY (HONG KONG) CO., LIMITED, KOWLOON, HONG KONG:  
4,592,583, PUB. 6-10-2014. INT. CL. 11.

KLB INDUSTRIES, BELLEFONTAINE, OH, NATIONAL EXTRUSION & MANUFACTURING COMPANY, BELLEFONTAINE, OH:  
1,846,475, REN. 7-24-14. MULTIPLE CLASS, INT. CLS. 6 AND 12.

KLEIN LABORATORIES INC, BRANFORD, CT:  
4,592,119, PUB. 6-10-2014. INT. CL. 44.

KLEIN TOOLS, INC., SKOKIE, IL:  
2,856,629, REN. 7-24-14. INT. CL. 8.

KLEMM BOHRTECHNIK GMBH, DROLSHAGEN, FED REP GERMANY:  
3,578,316, CANC. INT. CL. 6.

KLINKER BRICK WINERY, INC., LODI, CA:  
4,594,249, INT. CL. 33.

KLOUD 9 KIX, HOUSTON, TX:  
4,594,106, INT. CL. 25.

KNAPP, CAROLINE, NEW YORK, NY:  
4,592,814, PUB. 6-10-2014. INT. CL. 41.

KNAPP, NANCY MARY, CORONADO, CA:  
3,353,203, CANC. INT. CL. 14.

KNEZEVIC, MARIJA, BEDFORD HILLS, NY:  
4,593,915, MULTIPLE CLASS, INT. CLS. 35 AND 42.

KNOCK, INC., MINNEAPOLIS, MN:  
4,591,494, PUB. 12-24-2013. INT. CL. 42.

KNOVATION, INC., CINCINNATI, OH:  
4,593,076, INT. CL. 42.

KNOWLEDGEBASE MARKETING, INC., RICHARDSON, TX:  
2,804,847, REN. 7-18-14. MULTIPLE CLASS, INT. CLS. 35 AND 38.

KNOX FERTILIZER COMPANY, INC., KNOX, IN:  
2,890,447, REN. 7-18-14. INT. CL. 1.

KODAMA, INCORPORATED, KAILUA, HI:  
1,328,647, REN. 7-23-14. MULTIPLE CLASS, INT. CLS. 25 AND 42.

1,328,647, CANC. MULTIPLE CLASS, INT. CLS. 28 AND 30.

KOEI TECMO GAMES CO., LTD., KANAGAWA, JAPAN:  
2,860,768, REN. 7-21-14. INT. CL. 9.  
2,860,837, REN. 7-21-14. INT. CL. 9.

KOHL'S DEPARTMENT STORES, INC., MENOMONEE FALLS, WI TO KOHL'S ILLINOIS, INC., AURORA, IL:  
1,848,806, CANC. INT. CL. 28.

KOI CONCEPTS, LLC, DUARTE, CA:  
4,593,353, MULTIPLE CLASS, INT. CLS. 10 AND 35.

KOK LAND MANAGEMENT SERVICES, INC., MCDONALD, PA:  
4,591,516, PUB. 6-10-2014. INT. CL. 36.

KOLASINSKI, ANA LUCIA, COLLEGE STATION, TX, DBA PAPER INKPRESSIONS:  
4,591,220, PUB. 6-10-2014. MULTIPLE CLASS, INT. CLS. 16 AND 40.

KOLEV, KOLIO, DES PLAINES, IL:  
4,593,529, INT. CL. 33.

KOMORI CORPORATION, TOKYO, JAPAN:  
4,591,119, PUB. 6-10-2014. MULTIPLE CLASS, INT. CLS. 7 AND 9.

KOMPETITIVEEDGE, INC., SHERIDAN, CO:  
3,348,114, CANC. INT. CL. 35.

KONAMI DIGITAL ENTERTAINMENT CO., LTD., MINATO-KU, TOKYO, JAPAN:  
2,795,465, CANC. INT. CL. 28.

KONAMI GAMING, INC., LAS VEGAS, NV:  
2,861,390, REN. 7-20-14. INT. CL. 9.  
4,593,583, INT. CL. 28.  
4,593,584, INT. CL. 28.  
4,593,687, INT. CL. 28.

KONFERENCEKALL, LLC, NEW YORK, NY:  
2,796,350, CANC. INT. CL. 38.

KONINKLIJKE PHILIPS ELECTRONICS N.V., 5656 AE EINDHOVEN, NETHERLANDS:  
4,593,472, INT. CL. 11.

KONINKLIJKE PHILIPS N.V., NETHERLANDS:  
4,590,785, PUB. 6-10-2014. MULTIPLE CLASS, INT. CLS. 3, 5 AND 21.

KONINKLIJKE PHILIPS NV, NETHERLANDS:  
4,590,914, PUB. 6-10-2014. INT. CL. 10.  
4,590,917, PUB. 6-10-2014. INT. CL. 10.

KONOPELSKI, STEVEN, BAYVILLE, NY:  
4,593,384, INT. CL. 30.

KONZ, KAREN, HONOLULU, HI:  
3,352,335, CANC. MULTIPLE CLASS, INT. CLS. 35 AND 36.

KOSE CORPORATION, TOKYO, JAPAN:  
2,795,633, CANC. INT. CL. 3.

KOUZOUYAN, HOVSEP, LOS ANGELES, CA:  
2,960,836, REN. 7-21-14. INT. CL. 25.

KOVAR'S, INC., CARMICHAEL, CA:  
3,469,820, CANC. INT. CL. 28.

KOZY CUSHIONS, NEW YORK, NY:  
4,592,087, PUB. 6-10-2014. INT. CL. 20.

KP'S, LAGRANGE, KY:  
3,353,713, CANC. INT. CL. 30.

KPM AUTO, INC., ROSELLE PARK, NJ:  
2,922,934, REN. 7-18-14. INT. CL. 37.

KRAFT FOODS GROUP BRANDS LLC, NORTHFIELD, IL, KRAFT GENERAL FOODS, INC., NORTHFIELD, IL:  
1,846,295, REN. 7-23-14. INT. CL. 30.

KRAMER LABORATORIES, INC., MIAMI, FL:  
3,354,071, CANC. INT. CL. 5.

KRAMER, KAREN M., PALO ALTO, CA, DBA ZING LEGAL:  
4,591,659, PUB. 6-10-2014. INT. CL. 45.

- KRAUSE PUBLICATIONS INC., IOLA, WI:  
3,354,569, CANC. INT. CL. 16.
- KRAVET INC., BETHPAGE, NY:  
4,594,099, INT. CL. 35.  
4,594,100, INT. CL. 35.
- KRAVITZ, RUBIN AND KRAVITZ, ANNABELLE S., VIRGINIA BEACH, VA, DBA CADET LABORATORIES, MILLER, ROSE E., WORCESTER, MA, DBA CADET LABORATORIES:  
782,185, REN. 7-22-14. U.S. CL. 51 (INT. CL. 3).
- KREBSBACH, RENA, URBANDALE, IA:  
4,591,931, PUB. 6-10-2014. INT. CL. 41.
- KRISHEL, SCOTT, SAN DIEGO, CA:  
3,351,015, CANC. INT. CL. 9.
- KRISTENSEN, KARON C., METAIRIE, LA, DBA LULU-KATE, LLC:  
4,594,086, INT. CL. 35.  
4,594,087, INT. CL. 35.
- KRUD KUTTER, INC., CUMMING, GA:  
4,591,463, PUB. 6-10-2014. INT. CL. 3.
- KRUSE, DOUGLAS THOMPSON, TEMPLETON, CA:  
2,952,596, REN. 7-18-14. INT. CL. 33.
- KSN VENTURES, LLC, LOS ANGELOS, CA:  
3,354,436, CANC. INT. CL. 25.
- KUDO BEANS, INC., FORT LEE, NJ:  
3,352,082, CANC. INT. CL. 30.  
3,352,083, CANC. INT. CL. 30.
- KUEHN, HAGEN, TABARZ, FED REP GERMANY:  
4,593,997, MULTIPLE CLASS, INT. CLS. 39 AND 42.
- KUENKEL-WAGNER PROZESSTECHNOLOGIE GMBH, 31061 ALFELD/LEINE, FED REP GERMANY:  
4,565,991, COR. MULTIPLE CLASS, INT. CLS. 7, 35, 37 AND 42.
- KUHN S.A., FRANCE:  
4,590,727, PUB. 6-10-2014. MULTIPLE CLASS, INT. CLS. 7 AND 12.
- KUHN, CAROLE J., HAMILTON, OH:  
3,352,955, CANC. INT. CL. 18.
- KULA CAUSES, INC., DENVER, CO:  
4,594,568, INT. CL. 42.
- KUMAR, KAMAL, TOMS RIVER, NJ:  
4,594,060, INT. CL. 34.
- KUMHO TIRE CO., INC., JONGLO-GU, SEOUL, REPUBLIC OF KOREA:  
2,795,269, CANC. INT. CL. 12.
- KUO KAU PAPER PRODUCTS CO., LTD., TAIPEI, TAIWAN:  
4,591,364, PUB. 6-10-2014. INT. CL. 28.
- KURABIINICA OOD, BULGARIA:  
4,590,820, PUB. 6-10-2014. INT. CL. 30.
- KURIAN, SHELLEY, GRAPEVINE, TX:  
4,593,755, INT. CL. 41.
- KURT KRANNICH, WEIL DER STADT/HAUSEN, FED REP GERMANY:  
4,492,898, COR. MULTIPLE CLASS, INT. CLS. 4, 6, 9, 19, 35, 37, 39, 40 AND 42.
- KUSTOM MUSICAL AMPLIFICATION, INC., HEBRON, KY:  
3,353,786, CANC. INT. CL. 9.
- KVZ INTERNATIONAL LIMITED, ROAD TOWN, TORTOLA, BR. VIRGIN ISLANDS:  
2,861,692, REN. 7-18-14. INT. CL. 25.
- KW BRANDS, LLC, WEST MONROE, LA:  
4,593,072, INT. CL. 43.
- KW INDUSTRIES, INC., SUGAR LAND, TX:  
1,346,797, REN. 7-18-14. INT. CL. 40.
- KYDEX LLC, BLOOMSBURG, PA:  
783,815, REN. 7-24-14. U.S. CL. 1 (INT. CLS. 1, 3, 4, 17, 18, 19, 22 AND 31).
- KYLE G. MUIR, SALT LAKE CITY, UT:  
4,593,974, INT. CL. 25.  
4,593,975, INT. CL. 21.
- KYOWA CO., LTD (KYOWA KABUSHIKI KAISHA), TOKYO, JAPAN:  
4,591,690, PUB. 6-10-2014. MULTIPLE CLASS, INT. CLS. 16 AND 18.
- KÖNIG, PETER, FED REP GERMANY:  
3,352,528.
- K10 HOLDINGS, LLC, NEW YORK, NY:  
4,594,434, INT. CL. 5.  
4,594,671, INT. CL. 5.
- KÜHNE + NAGEL INTERNATIONAL AG, CH-8834 SCHINDELLEGI, SWITZERLAND:  
4,590,647, PUB. 6-10-2014. MULTIPLE CLASS, INT. CLS. 35, 36 AND 39.
- L.A. GEAR, INC., LOS ANGELES, CA:  
3,354,587, CANC. INT. CL. 25.
- L.O.F. INC., ELKHART, IN:  
4,593,810, INT. CL. 35.
- L&P PROPERTY MANAGEMENT COMPANY, SOUTH GATE, CA:  
4,592,455, PUB. 6-10-2014. INT. CL. 20.  
4,592,735, PUB. 6-10-2014. INT. CL. 9.
- L-3 COMMUNICATIONS SECURITY AND DETECTION SYSTEMS, INC., WOBURN, MA:  
4,593,215, INT. CL. 9.
- L'OREAL, PARIS, FRANCE:  
2,795,590, CANC. INT. CL. 3.  
2,883,510, REN. 7-24-14. INT. CL. 3.  
4,591,946, PUB. 6-10-2014. INT. CL. 3.  
4,593,869, INT. CL. 3.  
4,593,955, INT. CL. 3.  
4,594,113, INT. CL. 3.
- L'OREAL USA CREATIVE, INC., NEW YORK, NY:  
1,892,888, REN. 7-23-14. INT. CL. 3.  
2,796,337, CANC. INT. CL. 3.  
3,352,988, CANC. INT. CL. 3.  
4,593,625, INT. CL. 3.
- L'OREAL USA, INC., NEW YORK, NY:  
2,795,819, CANC. INT. CL. 44.
- LA BOITE, INC., LOWELL, MI:  
3,354,565, CANC. INT. CL. 12.
- LA LOOP, LLC, NEW YORK, NY:  
3,351,287, CANC. INT. CL. 9.
- LA MONTRE HERMES S.A., CH-2555 BRUGG, SWITZERLAND:  
3,352,741.
- LA TAPATIA TORTILLERIA, INC., FRESNO, CA:  
4,593,200, INT. CL. 30.  
4,593,201, INT. CL. 30.
- LA-HEM AB, 542 95 MARIESTAD, SWEDEN:  
3,352,004, CANC. INT. CL. 33.
- LABCOAT LIMITED, GALWAY, IRELAND:  
3,351,951, CANC. MULTIPLE CLASS, INT. CLS. 1, 5, 6, 40 AND 42.
- LABELUX GROUP GMBH, SWITZERLAND:  
4,590,691, PUB. 6-10-2014. MULTIPLE CLASS, INT. CLS. 35 AND 36.  
4,590,700, PUB. 6-10-2014. MULTIPLE CLASS, INT. CLS. 35 AND 36.
- LABHA INVESTMENT ADVISORS SA, SWITZERLAND:  
3,352,578.
- LABORDE, CAROL-ANN, ROYAL PALM BEACH, FL AND LABORDE, RALPH, ROYAL PALM BEACH, FL:  
4,593,244, INT. CL. 25.
- LAC BASKETBALL CLUB, INC., LOS ANGELES, CA:  
2,921,001, REN. 7-23-14. INT. CL. 9.
- LACHETEAU, F-44330 VALLET, FRANCE:  
2,796,359, CANC. INT. CL. 33.  
2,796,360, CANC. INT. CL. 33.
- LACHETEAU, VALLET, FRANCE:  
4,591,856, PUB. 6-10-2014. INT. CL. 33.
- LACKOVICH, JOEL, AUSTIN, TX:  
3,351,152, CANC. INT. CL. 35.
- LACTEAS GARCIA-BAQUERO, S.A., SPAIN:  
3,352,755.
- LAFARGE NORTH AMERICA INC., RESTON, VA:  
3,353,487, CANC. INT. CL. 19.  
3,353,494, CANC. INT. CL. 1.
- LAICA S.P.A., ITALY:  
3,352,690.
- LAIRD & COMPANY, SCOBEEVILLE, NJ:  
324,021, REN. 7-19-14. U.S. CL. 49 (INT. CL. 33).  
324,022, REN. 7-19-14. U.S. CL. 49 (INT. CL. 33).
- LAIYA ENTERPRISES INC., PARADISE VALLEY, AZ:  
4,593,596, INT. CL. 42.

LAKE CHALICE WINES LTD, RENWICK, MARLBOROUGH, NEW ZEALAND:  
4,592,774, PUB. 6-10-2014. INT. CL. 33.

LAKELAND COLLEGE, SHEBOYGAN, WI:  
3,351,760, CANC. INT. CL. 41.

LAKESTAR (G.P.) LIMITED, ST. SAMPSON, GUERNSEY:  
4,556,870, COR. INT. CL. 36.

LAKEVIEW INNOVATIONS, NEW YORK, NY:  
4,591,866, PUB. 6-10-2014. INT. CL. 25.

LAKEWAY PUBLISHERS, INC, MORRISTOWN, TN, DBA LAKEWAY PUBLISHERS OF VIRGINIA:  
2,794,271, CANC. INT. CL. 16.  
2,794,272, CANC. INT. CL. 16.

LAKME COSMETICS, S.L., 08029 BARCELONA, SPAIN:  
2,885,637, REN. 7-23-14. INT. CL. 3.

LALLEMAND USA, INC., MONTREAL, CANADA:  
3,351,785, CANC. INT. CL. 1.

LAMBS & IVY, INC., EL SEGUNDO, CA:  
4,592,847, PUB. 6-10-2014. INT. CL. 24.

LAMPO LICENSING, LLC, BRENTWOOD, TN:  
4,591,770, PUB. 6-10-2014. INT. CL. 41.

LAN, CAROLINE HUNGYU, PLACENTIA, CA:  
4,592,508, PUB. 6-10-2014. INT. CL. 3.

LANCASTER COLONY CORPORATION, COLUMBUS, OH:  
2,795,010, CANC. INT. CL. 4.

LANCOME PARFUMS ET BEAUTE & CIE, PARIS, FRANCE:  
3,352,240, CANC. INT. CL. 3.  
3,352,272, CANC. INT. CL. 3.  
4,592,737, PUB. 6-10-2014. INT. CL. 3.

LAND O'LAKES, INC., ARDEN HILLS, MN:  
2,884,010, REN. 7-22-14. INT. CL. 29.

LAND OF THOUSAND HILLS COFFEE COMPANY, INC., ROSWELL, GA:  
4,593,610, INT. CL. 30.

LANDOLL CORPORATION, MARYSVILLE, KS:  
1,288,894, REN. 7-24-14. INT. CL. 12.

LANDSTROM, DARRYL, MINNEAPOLIS, MN, DBA COLLEEN & COMPANY INC.:  
4,590,957, PUB. 3-4-2014. INT. CL. 30.

LANGENSCHIEDT GMBH & CO. KG, FED REP GERMANY:  
4,523,766, COR. MULTIPLE CLASS, INT. CLS. 9, 16, 38, 41 AND 42.

LANGUAGE COMPUTER CORPORATION, RICHARDSON, TX:  
3,350,679, CANC. MULTIPLE CLASS, INT. CLS. 9 AND 42.  
3,350,680, CANC. MULTIPLE CLASS, INT. CLS. 9 AND 42.

LANGUAGE IN MOTION, INC., WEST ROXBURY, MA, DBA ABC SPANISH IN MOTION:  
4,591,842, PUB. 6-10-2014. INT. CL. 41.

LANIADO, MOSHE, KEYPORT, NJ:  
4,594,482, INT. CL. 25.

LANSA HOLDINGS, INC., WILMINGTON, DE:  
2,906,454, REN. 7-22-14. MULTIPLE CLASS, INT. CLS. 9 AND 42.

LAROCQUE, ANNE MARIE, WESTERLY, RI, DBA ACCESSIBLE GARDENS:  
4,592,173, PUB. 6-10-2014. INT. CL. 21.

LARSON, CHRISTOPHER H., MR., NEW YORK, NY AND LARSON, LYNNE J., MRS., NEW YORK, NY:  
3,351,986, CANC. INT. CL. 25.

LARSON, REBECCA, MOODY, TX:  
3,350,670, CANC. INT. CL. 44.

LAS COLINAS EAR NOSE THROAT AND ALLERGY, IRVING, TX:  
3,352,176, CANC. INT. CL. 44.

LAS VEGAS CALENDAR GIRLS, INC., LAS VEGAS, NV:  
3,354,090, CANC. INT. CL. 16.

LAS VEGAS SANDS CORP., LAS VEGAS, NV:  
4,593,349, INT. CL. 41.  
4,593,611, INT. CL. 41.  
4,593,612, INT. CL. 41.

LASALLE INTERNATIONAL INC., MONTREAL (QUEBEC), CANADA:  
4,591,014, PUB. 6-10-2014. MULTIPLE CLASS, INT. CLS. 9, 16 AND 41.

LASERSHIELD SYSTEMS, INC., LAS CRUCES, NM:  
3,354,590, CANC. INT. CL. 9.

LAT ENTERPRISES, LLC, FALLS CHURCH, VA:  
4,591,313, PUB. 6-10-2014. INT. CL. 20.

LATICINIOS CONDESSA LTDA., CONCEICAO DO PARA, MINAS GERAIS, BRAZIL:  
2,868,032, REN. 7-24-14. INT. CL. 30.

LATIN VALLEY 2130, LLC, PHILADELPHIA, PA:  
4,594,334, INT. CL. 43.

LATINO FUTURE VENTURES CORP., PHOENIX, AZ:  
3,350,972, CANC. INT. CL. 16.

LATTEC I/S, HILLERØD, DENMARK:  
3,468,204.

LAURA CINOTTO, TACOMA, WA:  
4,590,970, PUB. 5-28-2013. MULTIPLE CLASS, INT. CLS. 16 AND 41.

LAURENCE F SANFORD, TEWKSBURY, MA:  
3,354,554, CANC. INT. CL. 11.

LAURENCEAU, WALDA, MELVILLE, NY:  
4,594,571, INT. CL. 30.

LAVECK, PATRICIA, ROCHESTER, NY:  
4,592,461, PUB. 6-10-2014. INT. CL. 30.

LAVELLE INDUSTRIES, INC., BURLINGTON, WI:  
4,592,525, PUB. 6-10-2014. INT. CL. 11.

LAVIN, ELIZABETH, WOOD LAKE, MN:  
4,592,045, PUB. 6-10-2014. INT. CL. 41.

LAVIN, RICHARD, SOUTH PASADENA, CA, DBA CARAFINA COLLECTIONS AND OROZCO LAVIN, MARIBEL, SOUTH PASADENA, CA, DBA CARAFINA COLLECTIONS:  
4,593,316, INT. CL. 18.

LAW, TIMOTHY MICHAEL, WOODSTOCK, GA:  
4,591,622, PUB. 6-10-2014. INT. CL. 41.

LAWRENCE G. WALTERS, P.A., LONGWOOD, FL, DBA WALTERS LAW GROUP:  
4,592,880, PUB. 6-10-2014. INT. CL. 9.

LAYMAN, JOHN, GILBERT, AZ:  
4,592,742, PUB. 6-10-2014. INT. CL. 16.

LB PROPERTY MANAGEMENT, INC., SHERMAN OAKS, CA:  
4,592,174, PUB. 6-10-2014. INT. CL. 36.

LC TRADEMARKS, INC., DETROIT, MI:  
1,318,414, REN. 7-22-14. INT. CL. 30.

LDC (SCOTLAND) LTD, KILMARNOCK, AYRSHIRE, UNITED KINGDOM:  
4,590,696, PUB. 6-10-2014. INT. CL. 33.

LE GROUPE INTERSAND DU CANADA INC., BOUCHERVILLE (QUEBEC), CANADA:  
4,591,083, PUB. 6-10-2014. MULTIPLE CLASS, INT. CLS. 1 AND 31.

LE, LAM, SAN JOSE, CA:  
3,354,125, CANC. INT. CL. 11.

LEADLINE, LLC, CHARLOTTE, NC:  
4,592,950, PUB. 6-10-2014. INT. CL. 41.

LEAPCARD, LLC, HENDERSON, NV:  
3,350,817, CANC. INT. CL. 35.

LEAPFROG ENTERPRISES, INC., EMERYVILLE, CA:  
3,354,216, CANC. INT. CL. 28.

LEAPFROG PRODUCT DEVELOPMENT LLC, CHICAGO, IL:  
4,593,934, INT. CL. 21.

LEARN.COM, INC, SUNRISE, FL:  
3,352,448, CANC. MULTIPLE CLASS, INT. CLS. 9 AND 42.

LEARNER FIRST LLC, BELLEVUE, WA:  
4,594,024, MULTIPLE CLASS, INT. CLS. 16, 35 AND 41.

LECTRON, INC., LORENA, TX:  
1,863,499, REN. 7-18-14. INT. CL. 7.

LEE COMPANY, FRANKLIN, TN:  
4,591,214, PUB. 6-10-2014. MULTIPLE CLASS, INT. CLS. 37 AND 42.

LEE, ERICA P., UPPER MARLBORO, MD:  
4,593,845, INT. CL. 36.

LEE, JUNG BOK, GANGWON-DO, REPUBLIC OF KOREA:  
4,590,833, PUB. 6-10-2014. INT. CL. 3.

LEE, MELINDA, SARASOTA, FL:  
3,353,799, CANC. INT. CL. 9.

- LEEDSTONE, LLC, MELROSE, MN:  
4,591,725, PUB. 6-10-2014. INT. CL. 35.
- LEEPER, LEE A., LAMBERTVILLE, NJ, DBA LEE METAL BUILDING SYSTEMS, LLC:  
3,352,796, CANC. INT. CL. 6.
- LEG AVENUE, INC., CITY OF INDUSTRY, CA:  
4,591,772, PUB. 6-10-2014. INT. CL. 35.
- LEGACY TM, L.P., HOUSTON, TX:  
3,352,017, CANC. INT. CL. 43.
- LEGAL STREET LIMITED, NEW ZEALAND:  
4,590,921, PUB. 6-10-2014. INT. CL. 45.
- LEGAL SURE, LLC, OWINGS MILLS, MD:  
4,592,062, PUB. 6-10-2014. INT. CL. 35.
- LEHMANN, RYAN P, LANCASTER, PA:  
3,353,881, CANC. INT. CL. 20.
- LEHNER, MARK P., NORTH HILLS, CA, DBA MADE-N-AMERICA:  
4,592,590, PUB. 6-10-2014. INT. CL. 41.
- LEIBOWITZ, DAVID MCQUADE, SAN ANTONIO, TX:  
2,802,599, REN. 7-20-14. INT. CL. 16.
- LEIF HØEGH & CO AS, SKØYEN, N-0212 OSLO, NORWAY:  
3,283,201.
- LEIGA IMPORT CORPORATION, IRVINE, CA:  
4,594,490, INT. CL. 34.
- LEINWEBER GMBH & CO. KG, FED REP GERMANY:  
4,590,702, PUB. 6-10-2014. MULTIPLE CLASS, INT. CLS. 3, 14, 18 AND 25.
- LEMAITRE VASCULAR, INC., BURLINGTON, MA TO MINVASIVE LTD., 44809 BOCHUM, FED REP GERMANY:  
2,795,246, CANC. INT. CL. 10.
- LENNON, ERIK, COACHELLA, CA:  
3,351,365, CANC. INT. CL. 41.
- LEO BURNETT COMPANY, INC., CHICAGO, IL:  
3,434,008, CANC. INT. CL. 16.
- LEON COUNTY, FLORIDA, TALLAHASSEE, FL:  
4,593,570, INT. CL. 28.
- LEONEL MANZANO LLC, AUSTIN, TX:  
4,592,401, PUB. 6-10-2014. INT. CL. 25.  
4,592,402, PUB. 6-10-2014. INT. CL. 25.
- LEONI AG, DE-90402 NURNBERG, FED REP GERMANY:  
2,905,842, REN. 7-21-14. INT. CL. 9.
- LES MILLS INTERNATIONAL LIMITED, AUCKLAND, NEW ZEALAND:  
3,353,244, CANC. MULTIPLE CLASS, INT. CLS. 9, 16, 25, 28 AND 41.
- LES SERVICES ÉNERGÉTIQUES ECOSYSTEM INC, QUÉBEC(QUÉBEC) GIV 2M2, CANADA:  
4,591,074, PUB. 6-10-2014. INT. CL. 41.  
4,591,075, PUB. 6-10-2014. INT. CL. 41.
- LEUPOLD & STEVENS, INC., BEAVERTON, OR:  
3,351,162, CANC. INT. CL. 9.
- LEVEL UP ENTERPRISES, INC., POMPANO BEACH, FL, DBA NERD FITNESS:  
4,592,134, PUB. 6-10-2014. INT. CL. 41.
- LEVI STRAUSS & CO., SAN FRANCISCO, CA:  
4,594,210, INT. CL. 25.
- LEVITON MANUFACTURING CO., INC., MELVILLE, NY:  
2,906,013, REN. 7-24-14. INT. CL. 9.
- LEVY, BONY, LOS ANGELES, CA:  
4,592,234, PUB. 6-10-2014. INT. CL. 14.
- LEWER LIFE INSURANCE COMPANY, KANSAS CITY, MO:  
1,859,962, REN. 7-22-14. INT. CL. 36.
- LEWIS LABORATORIES INTERNATIONAL, LTD., WESTPORT, CT:  
2,878,723, REN. 7-23-14. INT. CL. 5.  
3,174,709, CANC. INT. CL. 5.
- LEWIS, DONALD J., SAN JOSE, CA:  
3,352,170, CANC. INT. CL. 35.
- LEWIS, DOUG, MARYSVILLE, WA:  
3,353,698, CANC. INT. CL. 25.
- LEXICON INTERACTIVE, INC., NEW YORK, NY:  
4,592,704, PUB. 6-10-2014. INT. CL. 41.
- LEXISNEXIS RISK SOLUTIONS INC., ALPHARETTA, GA:  
4,591,724, PUB. 6-10-2014. MULTIPLE CLASS, INT. CLS. 35, 36 AND 45.
- LEXON, BOULOGNE BILLANCOURT, FRANCE:  
1,852,224, REN. 7-22-14. MULTIPLE CLASS, INT. CLS. 9, 14, 16 AND 18.  
1,852,224, CANC. INT. CL. 34.
- LEXSTREAM, LLC, NEWARK, NJ:  
3,350,973, CANC. INT. CL. 9.
- LF, LLC, MOUNT MOURNE, NC:  
2,794,275, CANC. INT. CL. 2.
- LG ELECTRONICS INC., SEOUL, REPUBLIC OF KOREA:  
4,590,982, PUB. 1-7-2014. MULTIPLE CLASS, INT. CLS. 7 AND 11.
- LG ELECTRONICS INC., SEOUL 150-721, REPUBLIC OF KOREA:  
4,591,076, PUB. 6-10-2014. MULTIPLE CLASS, INT. CLS. 9, 35 AND 38.  
4,591,077, PUB. 6-10-2014. INT. CL. 9.
- LI LIE, JIA DING, SHANGHAI, CHINA:  
4,592,806, PUB. 6-10-2014. INT. CL. 25.
- LI YAO WEN, NANJING, JIANGSU, CHINA:  
4,592,657, PUB. 6-10-2014. INT. CL. 18.  
4,593,028, PUB. 6-10-2014. INT. CL. 9.
- LIAO, XINHUI, SHEN ZHEN, CANADA:  
4,594,459, INT. CL. 25.
- LIATSIS, GAIL, MISSISSAUGA, ONTARIO, CANADA:  
3,352,773, CANC. MULTIPLE CLASS, INT. CLS. 21 AND 30.
- LIBBY'S BRAND HOLDING LIMITED, TORTOLA, BR. VIRGIN ISLANDS:  
989,062, REN. 7-22-14. U.S. CL. 46 (INT. CLS. 29, 30 AND 32).
- LIBERTY CARTON COMPANY, MINNEAPOLIS, MN:  
2,796,078, CANC. MULTIPLE CLASS, INT. CLS. 35 AND 42.
- LIBERTY GLOBAL EUROPE HOLDING B.V., NETHERLANDS:  
3,352,710.  
3,352,712.
- LIBERTY PROCUREMENT CO. INC., UNION, NJ:  
3,354,416, CANC. INT. CL. 20.
- LICKER, LORI, HOLBROOK, NY:  
3,352,908, CANC. INT. CL. 16.
- LIDAN MARINE AB, SWEDEN:  
4,590,774, PUB. 6-10-2014. MULTIPLE CLASS, INT. CLS. 35, 37 AND 42.  
4,590,775, PUB. 6-10-2014. MULTIPLE CLASS, INT. CLS. 35, 37 AND 42.
- LIDL STIFTUNG & CO. KG, NECKARSULM, FED REP GERMANY:  
4,591,505, PUB. 6-10-2014. MULTIPLE CLASS, INT. CLS. 1 AND 3.
- LIEBERMAN COMPANIES, INC., BLOOMINGTON, MN:  
4,593,294, INT. CL. 41.
- LIEBERMAN RESEARCH WORLDWIDE, LLC, LOS ANGELES, CA:  
4,591,473, PUB. 6-10-2014. INT. CL. 35.
- LIFE AFTER SPORTS AGENCY, LLC, WASHINGTON, DC:  
4,590,612, PUB. 6-10-2014. INT. CL. 35.
- LIFE ELEMENTS, INC., ATASCADERO, CA:  
4,591,941, PUB. 6-10-2014. INT. CL. 30.
- LIFE HOLISTIC CENTER LLC, MOUNTAIN TOP, PA:  
4,594,647, INT. CL. 41.
- LIFE IS SPORTS LLC, WELLESLEY, MA:  
4,592,793, PUB. 6-10-2014. INT. CL. 25.  
4,593,029, PUB. 6-10-2014. INT. CL. 25.
- LIFE LANGUAGES INSTITUTE, INC., DALLAS, TX:  
3,352,190, CANC. MULTIPLE CLASS, INT. CLS. 16, 41 AND 42.
- LIFE OF PURPOSE LLC, BOCA RATON, FL:  
4,593,304, INT. CL. 41.
- LIFE OUTREACH INTERNATIONAL, FORT WORTH, TX:  
1,853,615, REN. 7-19-14. MULTIPLE CLASS, INT. CLS. 16 AND 42.
- LIFE TECHNOLOGIES CORPORATION, CARLSBAD, CA:  
4,594,286, MULTIPLE CLASS, INT. CLS. 1 AND 9.  
4,594,413, INT. CL. 1.
- LIFECORE BIOMEDICAL, LLC, CHASKA, MN:  
3,354,243, CANC. INT. CL. 10.  
3,354,244, CANC. INT. CL. 10.

LIFEGUIDE CENTERS OF AMERICA, INC., LITTLE ROCK, AR:  
2,793,496, CANC. INT. CL. 16.  
2,793,498, CANC. INT. CL. 41.

LIFESAFETY POWER, INC., MUNDELEIN, IL:  
4,592,235, PUB. 6-10-2014. INT. CL. 9.

LIFESAFETY POWER, INC., WINDHAM, NH, DBA LIFE-SAFETY POWER, INC.:  
4,592,400, PUB. 6-10-2014. INT. CL. 9.

LIFESPACES, INC., CHARLESTON, SC:  
3,352,238, CANC. MULTIPLE CLASS, INT. CLS. 9, 37 AND 42.  
3,352,239, CANC. MULTIPLE CLASS, INT. CLS. 9, 37 AND 42.

LIFESTYLE BRANDS GROUP, INC., HONOLULU, HI:  
4,592,582, PUB. 6-10-2014. INT. CL. 3.

LIFESTYLE DOMAIN HOLDINGS, INC., CINCINNATI, OH:  
4,503,042, AM. INT. CL. 38.  
4,503,043, AM. INT. CL. 41.

LIFESTYLE FAMILY FITNESS, INC., SAINT PETERSBURG, FL:  
3,350,865, CANC. INT. CL. 41.  
3,350,866, CANC. INT. CL. 41.

LIFETIME TOOL & BUILDING PRODUCTS, LLC, WINCHESTER, VA:  
4,594,577, INT. CL. 19.

LIFETIME WINDOWS AND SIDING, INC., DENVER, CO:  
4,591,657, PUB. 3-4-2014. MULTIPLE CLASS, INT. CLS. 35 AND 37.

LIG SYSTEM CO., LTD., GYEONGI-DO, REPUBLIC OF KOREA:  
3,352,042, CANC. INT. CL. 36.

LIGHT EMISSION TECHNOLOGY, NEW YORK, NY:  
4,592,283, PUB. 6-10-2014. INT. CL. 11.

LIGHT OF TOMORROW, CHICAGO, IL:  
4,593,330, INT. CL. 41.

LIGHTSHIP INDUSTRIES, NAPLES, FL:  
3,353,877, CANC. INT. CL. 10.

LIGHTSPEED TECHNOLOGIES, LLC, NEW YORK, NY:  
3,351,129, CANC. INT. CL. 36.

LIGHTYEAR TECHNOLOGIES, INC., MCLEAN, VA:  
4,593,882, INT. CL. 42.

LILJEHOLMENS STEARINFABRIKS AB, OSKARSHAMM, SWEDEN:  
1,291,729, REN. 7-19-14. INT. CL. 4.

LILY FROM THE VILLAGE, LLC, PONTE VEDRA BEACH, FL, DBA LILY FROM THE VILLAGE:  
4,592,634, PUB. 6-10-2014. INT. CL. 30.

LILY MCNEAL, LLC, LOS ANGELES, CA:  
3,351,880, CANC. INT. CL. 25.  
3,351,882, CANC. INT. CL. 25.

LIM ACUPUNCTURE AND HERBS CLINIC, LOS ANGELES, CA:  
4,594,510, INT. CL. 44.

LIMECRAFT NV, BELGIUM:  
4,590,766, PUB. 6-10-2014. MULTIPLE CLASS, INT. CLS. 9, 38, 41 AND 42.

LIMNER, FRITZ, READING, MA:  
3,353,068, CANC. INT. CL. 41.

LIMOGREEN SERVICES LLC, NEW YORK, NY:  
3,351,852, CANC. INT. CL. 39.

LIN JIANSAN, CHINA:  
4,590,897, PUB. 6-10-2014. INT. CL. 25.

LINCO FOOD SYSTEMS A/S, DENMARK:  
4,590,662, PUB. 6-10-2014. MULTIPLE CLASS, INT. CLS. 7, 9, 11, 37, 40 AND 41.

LINCOLN GLOBAL, INC., CITY OF INDUSTRY, CA:  
4,593,621, INT. CL. 1.

LINDSAY A. CURCIO, BROOKLYN, NY:  
4,593,521, INT. CL. 45.

LINK SOURCE, LLC, GOLDEN, CO:  
3,350,953, CANC. MULTIPLE CLASS, INT. CLS. 37 AND 42.

LINSAFE, INC, MONMOUTH JUNCTION, NJ:  
3,353,948, CANC. INT. CL. 9.

LINVATEC CORPORATION, LARGO, FL:  
1,851,199, REN. 7-23-14. INT. CL. 10.

LIOELE COSMETIC CO., LTD., BUSAN 609-813, REPUBLIC OF KOREA:  
4,590,781, PUB. 6-10-2014. INT. CL. 3.

LION LABORATORIES LIMITED, BARRY, SOUTH GLAMORGAN, UNITED KINGDOM:  
1,846,574, REN. 7-24-14. INT. CL. 9.

LIONS GATE ENTERTAINMENT INC., SANTA MONICA, CA:  
2,860,475, REN. 7-24-14. INT. CL. 9.  
2,860,475, CANC. MULTIPLE CLASS, INT. CLS. 16, 18, 25, 28, 35 AND 41.

LIPIDSHIELD, MELBOURNE, FL:  
3,353,781, CANC. INT. CL. 5.

LIPIZZAN ASSOCIATION OF NORTH AMERICA, ANDERSON, IN:  
3,353,051, CANC. INT. CL. 35.

LIPSON ASSOCIATES, INC., NORTHBROOK, IL:  
3,354,121, CANC. INT. CL. 35.

LIQUIDPRACTICE LLC, ALBUQUERQUE, NM:  
4,594,197, MULTIPLE CLASS, INT. CLS. 9 AND 42.

LIQUIPEL IP, LLC., SANTA ANA, CA:  
4,593,749, INT. CL. 25.

LISA BLONDELL BROWNING, ORLANDO, FL:  
4,592,763, PUB. 6-10-2014. MULTIPLE CLASS, INT. CLS. 14 AND 25.

LITEHOUSE INCORPORATED, SANDPOINT, ID:  
3,353,748, CANC. INT. CL. 30.

LITIGATION PRESENTATION, INC., ATLANTA, GA:  
2,859,678, REN. 7-18-14. INT. CL. 42.

LITMAN, CRAIG A., LARKSPUR, CA AND GREGORY, KENNETH E., ORINDA, CA:  
2,794,956, CANC. INT. CL. 36.

LITTLE BAKERY IN THE GROVE, LLC, MIDDLE GROVE, NY:  
4,592,143, PUB. 6-10-2014. INT. CL. 30.

LITTLE BRIDGE, BROOKLYN, NY:  
4,593,805, INT. CL. 41.

LITTLE HURRICANE, LA MESA, CA:  
4,592,535, PUB. 6-10-2014. INT. CL. 35.

LITTLE UPSTARTS USA INC., PITTSFIELD, MA:  
4,594,711, INT. CL. 24.

LITTORAL MARINE, LLC, WILDWOOD, FL:  
4,593,950, INT. CL. 12.

LIU, XIANG, BEIJING, CHINA:  
4,593,503, MULTIPLE CLASS, INT. CLS. 25 AND 35.

LIVE FULLY ENGAGED LLC, COLORADO SPRINGS, CO:  
4,593,475, INT. CL. 42.

LIVEANSWER, INC., WILMINGTON, DE:  
4,592,088, PUB. 6-10-2014. INT. CL. 35.  
4,592,089, PUB. 6-10-2014. INT. CL. 35.

LIVELIFY, NORTHRIDGE, CA:  
4,592,834, PUB. 6-10-2014. INT. CL. 25.

LIVINGPLUG, INC., SAN FRANCISCO, CA:  
4,594,150, INT. CL. 9.

LKN BEVERAGES, LLC, MOORESVILLE, NC:  
4,592,640, PUB. 6-10-2014. INT. CL. 32.

LKQ CORPORATION, CHICAGO, IL:  
2,863,121, REN. 7-23-14. INT. CL. 35.

LLAO LLAO, S.L., SPAIN:  
4,590,628, PUB. 6-10-2014. MULTIPLE CLASS, INT. CLS. 30 AND 43.

LLC HANDWRITING DECODED, MADISON, WI:  
3,354,183, CANC. INT. CL. 9.

LLOYD HUGH MAGBIE, WARREN, ME:  
3,351,503, CANC. INT. CL. 41.

LM GOLF AUSTRALIA PTY LTD, AUSTRALIA:  
4,590,800, PUB. 6-10-2014. INT. CL. 21.

LMC OXFORD HOLDINGS LIMITED, UNITED KINGDOM:  
4,590,750, PUB. 6-10-2014. MULTIPLE CLASS, INT. CLS. 16, 35 AND 41.

LOCAL CORPORATION, IRVINE, CA:  
3,352,489, CANC. INT. CL. 42.

LOCAL INITIATIVES SUPPORT CORPORATION, NEW YORK, NY:  
4,592,138, PUB. 6-10-2014. MULTIPLE CLASS, INT. CLS. 35 AND 36.

LOEFFLER, FRANK J., OVERLAND PARK, KS:  
3,352,225, CANC. INT. CL. 36.

- LOG CABIN HOMES LTD., ROCKY MOUNT, NC:  
1,846,749, REN. 7-18-14. INT. CL. 19.
- LOGI ANALYTICS, INC., MCLEAN, VA:  
4,591,175, PUB. 6-10-2014. INT. CL. 9.
- LOGICAL APPS, INC., IRVINE, CA:  
3,354,645, CANC. INT. CL. 9.
- LOGITECH INTERNATIONAL S.A., APPLES, SWITZERLAND:  
3,354,032, CANC. INT. CL. 9.
- LOGITIN, LLC, JACKSON, TN:  
3,350,688, CANC. INT. CL. 35.
- LOGOS TECHNOLOGIES, INC., ARLINGTON, VA:  
3,351,265, CANC. MULTIPLE CLASS, INT. CLS. 9 AND 42.
- LONE STAR RENTERS LLC, ALLEN, TX:  
4,594,764, INT. CL. 36.
- LONGEVITY BIOTECH, INC., PHILADELPHIA, PA:  
4,593,118, MULTIPLE CLASS, INT. CLS. 1 AND 5.
- LONGHORN SMOKEHOUSE, INC., SHALIMAR, FL:  
2,861,538, REN. 7-21-14. MULTIPLE CLASS, INT. CLS. 35 AND 43.
- LOOTOK, LTD., NEW YORK, NY:  
4,594,722, INT. CL. 35.
- LOPEZ, EDUARDO, VAN NUYS, CA:  
4,592,729, PUB. 6-10-2014. INT. CL. 25.
- LORD TECHMARK, INC., WILMINGTON, DE TO LORD CORPORATION, CARY, NC:  
2,793,652, CANC. MULTIPLE CLASS, INT. CLS. 1, 2, 3, 37 AND 40.
- LORENZINO COLLECTIONS, INC., LOS ANGELES, CA:  
2,794,217, CANC. INT. CL. 25.  
2,794,218, CANC. INT. CL. 25.
- LORETO, CARLOS, NEW YORK, NY:  
4,594,519, INT. CL. 25.
- LORETTA LYNN ENTERPRISES, INC., NASHVILLE, TN:  
1,312,681, REN. 7-18-14. INT. CL. 41.
- LORI J. WINCHELL, DELRAY BEACH, FL:  
3,352,517, CANC. MULTIPLE CLASS, INT. CLS. 9 AND 16.
- LORUSSO LAW FIRM, PC, ATLANTA, GA:  
4,593,354, MULTIPLE CLASS, INT. CLS. 21, 25 AND 45.
- LOS ANGELES POTTERY, INC., WILMINGTON, CA:  
4,594,055, INT. CL. 21.
- LOUIS M. ROBINSON, PORTAGE, MI AND SUSAN GONZALES, LAWTON, MI:  
4,593,547, INT. CL. 25.
- LOUISIANA MEDICAL MUTUAL INSURANCE COMPANY, METAIRIE, LA:  
2,794,082, CANC. INT. CL. 36.
- LOUISVILLE PUBLIC MEDIA, INC., LOUISVILLE, KY:  
4,591,078, PUB. 6-10-2014. MULTIPLE CLASS, INT. CLS. 38 AND 41.
- LOVE GIVE LIVE, LITITZ, PA:  
4,593,801, INT. CL. 25.
- LOVE HENS, ORANGE, CA:  
4,593,840, INT. CL. 30.
- LOVEYOURBLING, YUCAIPA, CA:  
4,592,684, PUB. 6-10-2014. INT. CL. 14.
- LOVING, NEIL, MCKINNEY, TX:  
4,592,263, PUB. 6-10-2014. INT. CL. 35.
- LOWENSTEIN, CHAIM, JACKSONVILLE, FL AND KANE, TOM JR., SAINT PAUL, MN:  
3,351,392, CANC. INT. CL. 9.
- LOX EXTENSIONS LLC, SHELBY TWP, MI, DBA LOX EXTENSIONS LLC:  
4,594,368, INT. CL. 26.  
4,594,396, INT. CL. 26.
- LSL PLANNING, INC., GRAND RAPIDS, MI:  
3,353,052, CANC. INT. CL. 35.
- LT OVERSEAS NORTH AMERICA, INC., CYPRESS, CA:  
4,590,949, PUB. 6-10-2014. INT. CL. 30.
- LUCAS, KRISTEN, WORCESTER, MA AND WELLS, DEE, WORCESTER, MA:  
4,593,042, PUB. 6-10-2014. INT. CL. 25.
- LUCASFILM LTD., SAN FRANCISCO, CA:  
2,795,112, CANC. MULTIPLE CLASS, INT. CLS. 38 AND 41.
- LUCIGEN CORPORATION, MIDDLETON, WI:  
4,592,827, PUB. 6-10-2014. INT. CL. 1.
- LUCKY CONCH, LLC, KEY WEST, FL:  
4,593,909, INT. CL. 21.
- LUCKY CRAFT CO., LTD., OYABE-SHI, TOYAMA, JAPAN:  
3,354,064, CANC. INT. CL. 28.
- LUDMAN FIT CORPORATION, MONTCLAIR, NJ:  
4,594,139, INT. CL. 5.
- LUDOVICO, INC., LOS ANGELES, CA:  
4,592,701, PUB. 6-10-2014. INT. CL. 1.  
4,593,036, PUB. 6-10-2014. MULTIPLE CLASS, INT. CLS. 1 AND 34.
- LUDWIG BEMELMANS, LLC, THREE BRIDGES, NJ:  
4,591,949, PUB. 6-10-2014. MULTIPLE CLASS, INT. CLS. 16 AND 28.
- LUFTHANSA TECHNIK AG, FED REP GERMANY:  
3,352,688.
- LUHMAN, JOSEPH, WAUKEE, IA:  
4,593,727, INT. CL. 32.
- LUIS MOLINA ACEDO, S.A., 28040 MADRID, SPAIN:  
2,865,136, REN. 7-24-14. INT. CL. 14.
- LUITPOLD PHARMACEUTICALS, INC., SHIRLEY, NY:  
3,354,483, CANC. INT. CL. 5.
- LUNA INNOVATIONS INCORPORATED, ROANOKE, VA:  
3,352,839, CANC. INT. CL. 10.
- LUNSFORD FINANCIAL PLANNING, INC., LAWRENCEVILLE, GA:  
3,354,433, CANC. MULTIPLE CLASS, INT. CLS. 36 AND 41.
- LUPUS THERAPEUTICS, INC., WASHINGTON, DC:  
4,594,734, INT. CL. 36.
- LUSTRELAB LXR, INCORPORATED, ROME, GA:  
3,353,543, CANC. INT. CL. 37.
- LUTHER'S SMOKEHOUSE, INC., LEROY, KS:  
2,956,088, REN. 7-21-14. INT. CL. 35.
- LUVANIS S.A., LUXEMBOURG, LUXEMBOURG:  
3,574,063 NEW CERT. 8-26-2014. INT. CL. 25.
- LUXTERA INC., CARLSBAD, CA:  
4,592,114, PUB. 6-10-2014. INT. CL. 9.
- LWIN FAMILY CO., CHARLOTTE, NC, DBA HISSHO SUSHI:  
3,354,139, CANC. INT. CL. 30.
- LYDELL JEWELRY DESIGN STUDIO, INC., NEW YORK, NY:  
4,591,620, PUB. 6-10-2014. INT. CL. 14.  
4,591,621, PUB. 6-10-2014. INT. CL. 14.  
4,591,637, PUB. 6-10-2014. INT. CL. 14.
- LYMPHEDIVAS LLC, PHILADELPHIA, PA:  
3,354,415, CANC. INT. CL. 10.
- LYNX GRILLS, INC., DOWNEY, CA:  
4,593,500, MULTIPLE CLASS, INT. CLS. 6, 11 AND 21.
- LYONS GATE, LLC, CARSON CITY, NV:  
4,592,796, PUB. 6-10-2014. INT. CL. 37.
- M & A GLOBAL TECHNOLOGIES, INC., TALLAHASSEE, FL:  
3,351,178, CANC. INT. CL. 4.
- M & G PARTNERS, LLP, MILWAUKEE, WI:  
4,593,930, INT. CL. 16.
- M BRASIL ARTES OBJETOS LTDA, UBERLANDIA-MG, BRAZIL:  
3,350,915, CANC. INT. CL. 20.
- M. EDOUARD PASSAQUAY-BOLLÉ, CH-1224 CHÊNE-BOUGERIES, SWITZERLAND:  
4,590,900, PUB. 6-10-2014. INT. CL. 9.
- M. LEUZZI, JR & V. LEUZZI CEMENT CONTRACTORS, LLC, PHILADELPHIA, PA:  
4,591,972, PUB. 6-10-2014. INT. CL. 37.
- M. Z. BERGER & CO., INC., LONG ISLAND CITY, NY, WALTHAM WATCH COMPANY, WALTHAM, MA:  
99,132, REN. 7-21-14. U.S. CL. 27 (INT. CL. 14).
- M.EURYSTTHEE CLOTHING LLC, HOUSTON, TX:  
4,594,461, INT. CL. 25.
- M.H. CORBIN, INC., PLAIN CITY, OH:  
1,833,185, REN. 7-23-14. INT. CL. 9.
- M&C AKERS INC., IUKA, MS:  
4,594,211, INT. CL. 34.
- M/S GROSSMAN INC, CHATSWORTH, CA:  
3,353,111, CANC. INT. CL. 11.



MAC & CHEESE PRODUCTIONS, CHICAGO, IL:  
4,592,939, PUB. 6-10-2014. INT. CL. 41.

MACALLAN DISTILLERS LIMITED, THE, BANFFSHIRE,  
AB38 9RX, UNITED KINGDOM:  
996,557. REN. 7-24-14. U.S. CL. 49 (INT. CL. 33).

MACHELEDT, JEAN M, FORT COLLINS, CO, AKA GVTRA-  
DINGCOMPANY.COM:  
4,593,559, INT. CL. 35.

MACK EVENT PRODUCTIONS LLC, NYACK, NY:  
4,591,292, PUB. 12-24-2013. INT. CL. 43.

MACNEAL, MICHAEL, BROOKLYN, NY:  
4,592,003, PUB. 6-10-2014. MULTIPLE CLASS, INT. CLS.  
35 AND 41.

MACROMILL, INC., JAPAN:  
4,464,516, COR. INT. CL. 35.

MACSPORTS INC., LA VERNE, CA:  
4,593,388, INT. CL. 12.

MACY'S MERCHANDISING GROUP, INC., NEW YORK,  
NY:  
773,703. REN. 7-23-14. U.S. CL. 39 (INT. CLS. 10, 25 AND  
26).

MADDISON, LAURA, TAVERNIER, FL:  
4,594,686, INT. CL. 3.

MADE IN AMERICA, LLC, OAK CREEK, WI:  
4,592,261, PUB. 6-10-2014. INT. CL. 19.

MADEQUEST, DECATUR, GA:  
4,593,592, INT. CL. 42.

MADISON COUNSELING SOLUTIONS LLC, MADISON, WI:  
4,592,064, PUB. 6-10-2014. INT. CL. 44.

MADISON NATIONAL BANK, HAUPPAUGE, NY:  
3,354,128, CANC. INT. CL. 36.

MADNESS INC., WALNUT, CA:  
3,354,145, CANC. INT. CL. 3.

MAESA, INC., NEW YORK, NY:  
4,594,526, INT. CL. 3.

MAGAZINE EXCHANGE, INC., GRANTS PASS, OR:  
4,592,688, PUB. 6-10-2014. INT. CL. 28.

MAGEE CLOTHING, CO. DONEGAL, IRELAND:  
4,591,080, PUB. 6-10-2014. MULTIPLE CLASS, INT. CLS.  
18, 24 AND 25.

MAGEN DAVID YESHIVAH, BROOKLYN, NY:  
3,354,179, CANC. INT. CL. 41.  
3,354,180, CANC. INT. CL. 41.

MAGGY LONDON INTERNATIONAL, LTD., NEW YORK,  
NY:  
2,795,868, CANC. INT. CL. 25.

MAGICALBUTTER.COM PBC, PORT RICHEY, FL:  
4,592,725, PUB. 6-10-2014. INT. CL. 7.

MAGNA-GUARD, INC., SAN DIEGO, CA:  
4,594,663, INT. CL. 9.

MAHARAJA LIFE LIMITED, LONDON, UNITED KING-  
DOM:  
4,591,719, PUB. 6-10-2014. INT. CL. 43.

MAHNA MAHNA CO., LTD., JAPAN:  
4,513,026, CANC. INT. CL. 14.

MAHONEY, MOLLY, ORANGE, CA:  
4,592,347, PUB. 6-10-2014. INT. CL. 41.

MAID RIGHT FRANCHISING, LLC, ALPHARETTA, GA:  
4,594,092, INT. CL. 37.

MAIDENFORM LLC, WINSTON-SALEM, NC:  
3,354,656, CANC. INT. CL. 25.

MAIN III, GLENN A., MCMURRAY, PA:  
3,354,542, CANC. INT. CL. 36.

MAIN STREET AMERICA GROUP, INC., JACKSONVILLE,  
FL:  
4,591,692, PUB. 6-10-2014. INT. CL. 36.

MAINE BOATS, HOMES & HARBORS, INC., ROCKLAND,  
ME:  
4,592,323, PUB. 6-10-2014. INT. CL. 41.

MAINSAIL EPICUREAN HOTEL, LLLP, TAMPA, FL:  
4,592,762, PUB. 6-10-2014. INT. CL. 43.  
4,592,771, PUB. 6-10-2014. INT. CL. 43.  
4,592,775, PUB. 6-10-2014. INT. CL. 44.

MAINTENANCENET, INC., CARLSBAD, CA:  
3,481,831, CANC. INT. CL. 9.

MAISON CALAVAS, FRANCE:  
3,352,539.

MAJESTIC BRANDS INC, DANVILLE, CA:  
3,353,952, CANC. INT. CL. 33.

MAJOR LEAGUE LACROSSE LLC, BOSTON, MA:  
3,353,699, CANC. INT. CL. 25.  
3,353,747, CANC. INT. CL. 25.  
3,353,749, CANC. INT. CL. 25.  
3,353,750, CANC. INT. CL. 41.

MAJOR SURPLUS AND SURVIVAL, GARDENA, CA:  
4,591,666, PUB. 6-10-2014. INT. CL. 35.

MAJORPLANET STUDIOS, LLC, SAN FRANCISCO, CA:  
4,520,684, COR. INT. CL. 9.

MAKE DESIGN, ALAMEDA, CA, DBA PIPPA & CO.:  
4,594,282, INT. CL. 42.

MAKE HOBO MARKETING GMBH, FED REP GERMANY:  
3,352,658.

MAKEMESUSTAINABLE, CAMBRIDGE, MA:  
3,351,220, CANC. INT. CL. 35.

MAKERBOT INDUSTRIES, LLC, BROOKLYN, NY:  
4,591,880, PUB. 6-10-2014. MULTIPLE CLASS, INT. CLS.  
35 AND 36.  
4,592,927, PUB. 6-10-2014. INT. CL. 9.  
4,594,517, INT. CL. 9.

MAKLAF HOLDINGS, INC., CARSON CITY, NV:  
3,353,215, CANC. MULTIPLE CLASS, INT. CLS. 9 AND  
16.  
3,353,216, CANC. MULTIPLE CLASS, INT. CLS. 9 AND  
16.

MALACKI, EDWIN R., MCKEES ROCKS, PA:  
3,354,080, CANC. INT. CL. 25.

MALAKIMAN, SHAHRIAR (SHAWN), SAN JOSE, CA:  
3,351,574, CANC. INT. CL. 7.

MALAVA, LLC, POWAY, CA:  
3,354,068, CANC. MULTIPLE CLASS, INT. CLS. 30 AND  
32.

MALCO THEATRES, INC., MEMPHIS, TN:  
4,592,467, PUB. 6-10-2014. INT. CL. 41.

MALEM MEDICAL LIMITED, UNITED KINGDOM:  
4,590,716, PUB. 6-10-2014. INT. CL. 10.

MALIBU ADVENTURES INC., MALIBU, CA, DBA MALIBU  
SURF SHACK:  
4,590,995, PUB. 6-10-2014. MULTIPLE CLASS, INT. CLS.  
24, 25, 28 AND 41.

MALIBU DESIGN GROUP, COMMERCE, CA:  
4,590,969, PUB. 6-10-2014. INT. CL. 25.

MALIBU WELLNESS, INC., MALIBU, CA:  
3,354,384, CANC. INT. CL. 3.

MALIK, AMIR, S, SAN RAMON, CA AND INDRIZZO,  
ZACHARY, T, MOORPARK, CA, AKA CASPER:  
4,592,080, PUB. 6-10-2014. INT. CL. 9.

MALMOUX, LUDOVIC, MALIBU, CA:  
3,352,874, CANC. INT. CL. 25.

MAMIYA AMERICA CORPORATION, NORTH WHITE  
PLAINS, NY:  
3,354,362, CANC. INT. CL. 9.

MANAR, JAMES DALE, SANTA BARBARA, CA:  
3,353,538, CANC. INT. CL. 16.

MANAS, MARIA, ESPERANZA, NEW YORK, NY, AKA  
DIAZ, MARIA, ESPERANZA:  
4,592,405, PUB. 6-10-2014. INT. CL. 25.

MANCHESTER UNITED LIMITED, OLD TRAFFORD  
MANCHESTER, UNITED KINGDOM:  
2,864,029. REN. 7-22-14. MULTIPLE CLASS, INT. CLS. 9,  
14, 16, 18, 20, 21, 24, 25, 27 AND 28.

MANDALAY RESORT GROUP, LAS VEGAS, NV:  
3,352,109, CANC. INT. CL. 43.

MANDO CORPORATION, KYUNGKI-DO, REPUBLIC OF  
KOREA:  
4,590,997, PUB. 6-10-2014. INT. CL. 12.

MANFRED EBERHARD, FED REP GERMANY:  
4,590,641, PUB. 6-10-2014. MULTIPLE CLASS, INT. CLS.  
25, 28 AND 41.

MANIC WEBS, INC., PHOENIX, AZ:  
3,352,256, CANC. INT. CL. 42.

MANIFESTO!, LLC, NAPA, CA:  
3,351,444, CANC. INT. CL. 33.

MANIFOLD PRODUCTS LLC, NATICK, MA:  
2,875,487. REN. 7-22-14. INT. CL. 42.

- MANTESSOFILHO, FLAVIO, SAO PAULO, BRAZIL, DBA FLYING BROS:  
4,591,222, PUB. 6-10-2014. INT. CL. 35.  
4,591,223, PUB. 6-10-2014. INT. CL. 25.
- MANTILLA DIAZ, MARCO, MIAMI, FL:  
4,592,633, PUB. 6-10-2014. INT. CL. 25.
- MANUEL ARREGUIN, TLALNEPANTLA DE BAZ MX, MEXICO:  
4,593,587, INT. CL. 41.
- MANVEENA'S SOLUTIONS, LLC., MOYOCK, NC:  
4,594,212, INT. CL. 3.
- MAOLA MILK AND ICE CREAM COMPANY, NEW BERN, NC:  
2,859,860. REN. 7-24-14. INT. CL. 30.
- MAP THE BRAND, INC., LOS ANGELES, CA:  
4,592,912, PUB. 6-10-2014. INT. CL. 35.
- MAQUET CRITICAL CARE AB, SWEDEN:  
4,590,695, PUB. 6-10-2014. INT. CL. 10.
- MARATHON MEDIA, PARIS, FRANCE:  
3,350,631, CANC. MULTIPLE CLASS, INT. CLS. 3, 9, 16, 18, 25, 28, 35, 38, 40 AND 41.
- MARATHON VENTURES INC., BELLEVUE, NE, DBA HERMAN'S NUT HOUSE:  
4,592,074, PUB. 6-10-2014. INT. CL. 29.
- MARAUDER CORPORATION, INDIAN WELLS, CA:  
3,351,662, CANC. INT. CL. 9.
- MARC JACOBS TRADEMARKS L.L.C., UNITED STATES:  
3,352,636.
- MARC MERTENS, LOS ANGELES, CA:  
4,593,841, MULTIPLE CLASS, INT. CLS. 35 AND 42.  
4,593,842, MULTIPLE CLASS, INT. CLS. 35 AND 42.
- MARCASIANO INC, NEW YORK, NY:  
3,351,565, CANC. MULTIPLE CLASS, INT. CLS. 14 AND 25.
- MARCEL BARREIRO, MIAMI LAKES, FL:  
4,591,865, PUB. 6-10-2014. INT. CL. 41.
- MARCO PIROVANO, ITALY:  
4,590,758, PUB. 6-10-2014. MULTIPLE CLASS, INT. CLS. 7, 25, 30 AND 43.
- MARCOAH GROUP USA, LLC, DELRAY BEACH, FL:  
4,592,216, PUB. 6-10-2014. INT. CL. 35.
- MARCONDES, GIL, DAVIE, FL:  
4,593,834, INT. CL. 14.
- MARCUM, COBY, DALLAS, TX:  
4,591,531, PUB. 6-10-2014. INT. CL. 14.
- MARGARA, FELIX JOE, PRATTVILLE, AL:  
3,352,503, CANC. INT. CL. 41.
- MARGARET MARILYN SMITH, WATERFORD, VA:  
4,593,278, INT. CL. 28.
- MARGARITAVILLE ENTERPRISES, LLC, PALM BEACH, FL:  
3,353,559, CANC. INT. CL. 20.
- MARGERLY MELCHIODE, DALLAS, TX:  
3,351,177, CANC. MULTIPLE CLASS, INT. CLS. 25 AND 35.
- MARICOPA COUNTY COMMUNITY COLLEGE DISTRICT, TEMPE, AZ:  
4,591,844, PUB. 6-10-2014. INT. CL. 41.
- MARIE RICCI COLLECTION, INC., ESSEX, CT:  
4,592,502, PUB. 6-10-2014. INT. CL. 27.
- MARIE WOLF, PROSSER, WA AND MICHAEL WOLF, PROSSER, WA:  
4,594,561, INT. CL. 16.
- MARINA BOURANTONIS, BRADENTON, FL:  
4,594,441, INT. CL. 41.
- MARINE SAFETY PRODUCTS, LLC, KISSIMMEE, FL:  
4,593,747, INT. CL. 25.
- MARISA JILL LLC, SUGAR HILL, GA:  
4,592,818, PUB. 6-10-2014. INT. CL. 42.
- MARK, MORLEY, WEST YORKSHIRE, UNITED KINGDOM:  
4,590,998, PUB. 6-10-2014. MULTIPLE CLASS, INT. CLS. 16 AND 28.
- MARK OFFICER, BROADBEACH QLD, AUSTRALIA:  
3,351,999, CANC. MULTIPLE CLASS, INT. CLS. 16, 28, 35 AND 41.
- MARKANNA STUDIOS, INC., ALBANY, CA, DBA MVB FONTS:  
2,860,403, REN. 7-18-14. INT. CL. 9.  
2,860,404, REN. 7-18-14. INT. CL. 9.
- MARKET DATA EXPRESS, LLC, CHICAGO, IL:  
3,354,000, CANC. INT. CL. 36.  
3,354,002, CANC. INT. CL. 36.
- MARKET VIEW LLC, HENDERSON, NV:  
4,592,558, PUB. 6-10-2014. INT. CL. 35.
- MARKET WATCH FRANCHISE & CONSULTING, INC., LAS VEGAS, NV:  
4,593,447, INT. CL. 5.
- MARKETING ASSOCIATES USA, INC., TAMPA, FL:  
3,354,389, CANC. INT. CL. 9.
- MARKETRON INTERNATIONAL, LLC, HAILEY, ID:  
2,859,976, REN. 7-21-14. INT. CL. 41.
- MARKLEY, ALEXANDER, PATASKALA, OH:  
3,352,266, CANC. INT. CL. 35.
- MARKOUS, MARCELO ARTURO, BUENOS AIRES, ARGENTINA:  
4,594,565, INT. CL. 9.
- MARKOW, HILARY, CHICAGO, IL AND THOMA, MARGARET, CHICAGO, IL:  
3,350,985, CANC. MULTIPLE CLASS, INT. CLS. 21 AND 25.
- MARKOWITZ, MICHAEL, NEW YORK, NY:  
3,351,591, CANC. INT. CL. 28.
- MARKS, SHELDON H., TUCSON, AZ:  
2,955,021, REN. 7-22-14. INT. CL. 44.
- MARLEEN R. MANLEY, ACWORTH, GA:  
3,353,118, CANC. INT. CL. 9.
- MARLEN MANUFACTURING AND DEVELOPMENT CO., BEDFORD, OH:  
1,002,703, REN. 7-22-14. INT. CL. 10.
- MARNICA, MIRELLA, TORONTO, ONTARIO, CANADA:  
3,350,609, CANC. INT. CL. 28.
- MARQUEZ, JUAN, EL PASO, TX AND MARQUEZ, ERIKA, EL PASO, TX:  
4,590,613, PUB. 6-10-2014. INT. CL. 35.
- MARQUIS THEATRE ASSOCIATES, NEW YORK, NY:  
4,591,948, PUB. 6-10-2014. INT. CL. 41.
- MARRIOTT INTERNATIONAL, INC., BETHESDA, MD:  
3,354,328, CANC. MULTIPLE CLASS, INT. CLS. 36 AND 43.
- MARS, INCORPORATED, MCLEAN, VA:  
3,352,379, CANC. INT. CL. 30.  
3,353,307, CANC. INT. CL. 25.  
3,354,320, CANC. INT. CL. 30.
- MARSHFIELD DOORSYSTEMS, INC., MARSHFIELD, WI:  
2,861,037, REN. 7-21-14. INT. CL. 19.
- MARTEX NUTRITION, INC, MIAMI GARDENS, FL:  
3,351,357, CANC. INT. CL. 5.
- MARTEX NUTRITION, INC, MIAMI, FL:  
3,351,883, CANC. INT. CL. 5.
- MARTHA STEWART LIVING OMNIMEDIA, INC., NEW YORK, NY:  
4,593,182, INT. CL. 5.
- MARTIN MANUFACTURING COMPANY, LLC, ROCKY MOUNT, NC:  
3,352,347, CANC. INT. CL. 10.
- MARTIN, CAREN S., MINNEAPOLIS, MN AND GUERIN, DENISE A., WHITE BEAR LAKE, MN:  
2,863,382, REN. 7-18-14. INT. CL. 41.
- MARTIN, PAULA, SAUGUS, MA:  
4,592,072, PUB. 6-10-2014. INT. CL. 44.
- MARTIN'S HONEY FARM & MEADERY, LLC, SENECA FALLS, NY, DBA IDOL RIDGE WINERY:  
4,592,734, PUB. 6-10-2014. INT. CL. 33.
- MARTINEZ TAYLOR, JOSE EDUARDO, TLAQUEPAQUE, JALISCO, MEXICO:  
4,593,060, PUB. 6-10-2014. INT. CL. 21.
- MARVEL CHARACTERS, INC., BURBANK, CA:  
4,591,487, PUB. 6-10-2014. INT. CL. 16.  
4,593,437, INT. CL. 16.
- MARVI ASESORES, S.C., MEXICO D.F., MEXICO:  
4,592,790, PUB. 6-10-2014. INT. CL. 5.  
4,592,791, PUB. 6-10-2014. INT. CL. 5.

MARY KAY INC., ADDISON, TX:  
4,594,155, MULTIPLE CLASS, INT. CLS. 3 AND 16.

MARYLAND OPTOMETRIC ASSOCIATION, LINTHICUM HEIGHTS, MD:  
4,592,038, PUB. 6-10-2014. MULTIPLE CLASS, INT. CLS. 35, 41 AND 44.

MAS AUTOMOTIVE DISTRIBUTION INC., LAVAL, QUEBEC, CANADA:  
3,352,360, CANC. INT. CL. 12.

MAS UNIVERSAL, LLC, MIAMI, FL, DBA KNOW THE RADIO SHOW, MOMMY TO MOGUL:  
4,591,367, PUB. 6-10-2014. INT. CL. 41.

MASCARI, MICHELLE, FT. LAUDERDALE, FL:  
3,354,600, CANC. INT. CL. 41.

MASCHINENFABRIK HEUTE GMBH & CO. KG, FED REP GERMANY:  
4,590,777, PUB. 6-10-2014. MULTIPLE CLASS, INT. CLS. 6, 11 AND 21.

MASCO CORPORATION OF INDIANA, INDIANAPOLIS, IN:  
3,353,425, CANC. INT. CL. 11.  
3,354,041, CANC. INT. CL. 11.

MASERATI S.P.A., MODENA, ITALY:  
3,352,043, CANC. MULTIPLE CLASS, INT. CLS. 12, 16, 37 AND 41.

MASERJIAN, SUE, NEW YORK, NY:  
3,353,729, CANC. INT. CL. 25.  
3,353,912, CANC. INT. CL. 25.

MASONIC MEDICAL RESEARCH LABORATORY, UTICA, NY, DBA CARDIAC RESEARCH INSTITUTE:  
4,592,009, PUB. 6-10-2014. INT. CL. 42.

MASONITE INTERNATIONAL CORPORATION, CONCORD, ONTARIO, CANADA:  
2,861,089, REN. 7-22-14. INT. CL. 19.

MASONITE INTERNATIONAL CORPORATION, MISSISSAUGA, ONTARIO, CANADA:  
2,863,456, REN. 7-23-14. INT. CL. 19.

MASS DISTRACTION, INC., LOS ANGELES, CA:  
3,354,203, CANC. INT. CL. 35.  
3,354,204, CANC. INT. CL. 41.

MASSAGE DELIVERY, INC., NEW EGYPT, NJ:  
4,594,450, INT. CL. 44.

MASTER DISTRIBUTOR LIMITED, HORSFORTH, LEEDS, UNITED KINGDOM:  
4,592,819, PUB. 6-10-2014. INT. CL. 8.

MASTER POOLS COOPERATIVE GUILD, INC., RICHMOND, VA:  
777,672, REN. 7-24-14. U.S. CL. 12 (INT. CL. 19).

MASTER PRODUCTS, INC., MCHENRY, IL:  
3,353,185, CANC. INT. CL. 8.

MASTRO'S RESTAURANTS, LLC, HOUSTON, TX:  
4,591,323, PUB. 6-10-2014. INT. CL. 43.

MATADOR HOLDING, A.S., SLOVAKIA:  
3,352,696.

MATCAL, INC., HADLEY, MA:  
2,869,687, REN. 7-22-14. INT. CL. 29.  
2,869,691, REN. 7-22-14. INT. CL. 29.

MATCH.COM, L.L.C., DALLAS, TX:  
3,353,141, CANC. INT. CL. 45.

MATERNE, DARDILLY, FRANCE:  
2,865,079, REN. 7-18-14. INT. CL. 29.

MATHEW, MATHEW A., OAKBROOK TERRACE, IL:  
3,351,696, CANC. INT. CL. 25.

MATHI SENAPATHI, IRVINE, CA:  
4,594,626, INT. CL. 14.

MATHIS, TYRE, NEWPORT NEWS, VA AND MATHIS, DARRILL, BROOKLYN, NY:  
4,593,899, INT. CL. 25.  
4,593,900, INT. CL. 25.

MATRIX PACKAGING MACHINERY LLC, SAUKVILLE, WI:  
4,593,874, INT. CL. 7.

MATSUSHITA ELECTRIC INDUSTRIAL CO., LTD., OSAKA, JAPAN:  
3,354,470, CANC. INT. CL. 9.

MATTEL, INC., EL SEGUNDO, CA:  
3,352,146, CANC. INT. CL. 28.  
3,352,361, CANC. INT. CL. 28.  
3,352,458, CANC. INT. CL. 28.  
3,352,510, CANC. INT. CL. 28.  
3,352,511, CANC. INT. CL. 28.  
3,352,512, CANC. INT. CL. 28.  
3,352,513, CANC. INT. CL. 28.  
3,352,514, CANC. INT. CL. 28.  
3,352,515, CANC. INT. CL. 28.  
3,353,056, CANC. INT. CL. 28.  
3,353,714, CANC. INT. CL. 28.  
3,353,795, CANC. INT. CL. 28.  
3,354,404, CANC. INT. CL. 28.  
3,354,405, CANC. INT. CL. 28.  
4,591,442, PUB. 6-10-2014. INT. CL. 28.  
4,593,107, INT. CL. 28.  
4,593,706, INT. CL. 28.  
4,593,707, INT. CL. 28.  
4,593,717, INT. CL. 28.  
4,593,718, INT. CL. 28.  
4,593,933, INT. CL. 28.  
4,594,205, INT. CL. 28.  
4,594,206, INT. CL. 28.  
4,594,229, INT. CL. 28.  
4,594,230, INT. CL. 28.

MATTHEW JOHN BADEN, SEVERNA PARK, MD AND ROBERT VINCENT LIBERATI 3RD, BOWIE, MD AND BRENDAN JOHN MARTIN, SEVERNA PARK, MD AND JOSEPH MALCOM SPRINGER, BOWIE, MD AND TYLER MICHAEL STEINBAUER, BOWIE, MD:  
4,592,618, PUB. 6-10-2014. INT. CL. 41.

MATTHEW KEENE, DOVER, NH:  
4,594,371, INT. CL. 25.

MAULDIN, PATRICIA ANN, DEERFIELD BEACH, FL:  
4,592,238, PUB. 6-10-2014. INT. CL. 44.

MAULDIN, WILLIAM S., WAXAHACHIE, TX:  
3,353,036, CANC. INT. CL. 35.

MAURICE, GREGORY, EWA BEACH, HI:  
4,594,649, INT. CL. 25.

MAURO SERGIO CAGGIANELLI, ITALY:  
4,590,723, PUB. 6-10-2014. MULTIPLE CLASS, INT. CLS. 18, 25 AND 35.

MAUSER USA, LLC, EAST BRUNSWICK, NJ:  
2,819,363, REN. 7-21-14. INT. CL. 20.

MAX ZELLER SOHNE AKTIENGESELLSCHAFT, ROMANSHORN, SWITZERLAND:  
4,593,731, INT. CL. 5.

MAXXSONICS USA, INC., LAKE ZURICH, IL:  
4,593,309, MULTIPLE CLASS, INT. CLS. 9 AND 17.

MAY IEV, HAWTHORNE, CA, DBA PINNUPS:  
4,593,609, INT. CL. 26.

MAYNE COATINGS CORP., LANGLEY, CANADA:  
4,593,204, INT. CL. 6.

MAYR-MELNHOF KARTON AG, VIENNA, AUSTRIA:  
4,593,417, MULTIPLE CLASS, INT. CLS. 35 AND 42.

MAYTAG PROPERTIES, LLC, ST. JOSEPH, MI:  
2,796,099, CANC. INT. CL. 11.  
4,594,267, INT. CL. 7.

MAZDA MOTOR OF AMERICA, INC., IRVINE, CA:  
2,795,335, CANC. INT. CL. 12.

MAZZA HEALTHCARE, LLC, BANNOCKBURN, IL:  
4,592,499, PUB. 6-10-2014. INT. CL. 39.

MBH RECREATION, LLC, MADISON, AL:  
4,592,102, PUB. 6-10-2014. INT. CL. 41.

MBM BUILDING SYSTEMS LIMITED, DUBLIN, IRELAND:  
4,591,377, PUB. 6-10-2014. MULTIPLE CLASS, INT. CLS. 16 AND 28.

MCBRIDE RESEARCH LABORATORIES, INC., DECATUR, GA:  
2,953,974, REN. 7-22-14. INT. CL. 3.

MCCAFFERTY, JAMES R., SANTA ANA, CA:  
2,795,394, CANC. INT. CL. 20.

MCCAIN FOODS USA, INC., LISLE, IL:  
3,354,586, CANC. INT. CL. 29.

MCCLURE, BROWN, & ASSOCIATES LLC, SOUTH RIDING, VA:  
4,591,995, PUB. 6-10-2014. INT. CL. 35.

- MCCORD, JEFFREY D., SEATTLE, WA:  
2,794,610, CANC. INT. CL. 37.
- MCDONALD, GLORIA, PHOENIX, AZ AND MCDONALD, SCOTT, PHOENIX, AZ:  
3,353,005, CANC. INT. CL. 16.
- MCDONALD'S CORPORATION, OAK BROOK, IL:  
2,795,307, CANC. INT. CL. 42.
- MCDUFFEE, P., SHAUN, MINNEAPOLIS, MN:  
2,927,769. REN. 7-21-14. INT. CL. 36.
- MCFARLAND, CLARENCE EUGENE, HUEYTOWN, AL:  
4,592,534, PUB. 6-10-2014. INT. CL. 35.
- MCGOWAN, JACOB WILLIAM, LECANTO, FL:  
4,592,318, PUB. 6-10-2014. INT. CL. 39.
- MCGUIRE, CARL, ARVADA, CO:  
4,591,979, PUB. 6-10-2014. INT. CL. 6.
- MCGURL, SCOT, BRATTLEBORO, MA:  
4,592,768, PUB. 6-10-2014. INT. CL. 41.
- MCIG, INC., BELLEVUE, WA:  
4,591,689, PUB. 2-25-2014. INT. CL. 9.
- MCILHENNY COMPANY, AVERY ISLAND, LA:  
608,402. REN. 7-24-14. U.S. CL. 46 (INT. CL. 30).
- MCKESSON FOUNDATION INC., SAN FRANCISCO, CA:  
4,592,886, PUB. 6-10-2014. INT. CL. 36.
- MCLARENS GLOBAL LIMITED, LONDON WC1R4JS, UNITED KINGDOM:  
4,594,616, INT. CL. 36.
- MCLEAR, THOMAS P., WALLINGFORD, CT:  
3,351,750, CANC. INT. CL. 41.
- MCMAHON, DOROTHY M., BLOOMFIELD HILLS, MI:  
3,350,716, CANC. INT. CL. 36.
- MCMASTER, ORLANDO, PEMBROKE PINES, FL:  
3,243,884, CANC. INT. CL. 41.
- MCMENAMINS, INC., PORTLAND, OR:  
4,592,755, PUB. 6-10-2014. INT. CL. 32.
- MCMILLEN, SANDRA L., WINDSOR, CO, DBA ORDINARY COUPLE TRAVELS:  
4,593,836, INT. CL. 39.
- MCPHERSON, RODNEY MACGREGOR, EAST WENATCHEE, WA:  
2,795,817, CANC. INT. CL. 31.
- MCSHANE & HITCHINGS, LLC, HARRISBURG, PA:  
3,351,532, CANC. INT. CL. 45.
- MCWANE, INC., BIRMINGHAM, AL:  
4,593,277, INT. CL. 2.
- MD NUTRITION LLC, MADISON, CT:  
4,591,594, PUB. 6-10-2014. INT. CL. 5.
- MDU RESOURCES GROUP, INC., BISMARCK, ND:  
1,860,084. REN. 7-24-14. INT. CL. 41.
- MDU RESOURCES GROUP, INC., BISMARCK, ND:  
2,898,809. REN. 7-24-14. INT. CL. 35.
- ME & RIZ LLC, MEDINA, MN:  
4,591,966, PUB. 6-10-2014. INT. CL. 16.
- MEADWESTVACO CORPORATION, RICHMOND, VA:  
4,593,351, INT. CL. 21.
- MEALIFFE, DIANE R, SCOTTS VALLEY, CA:  
3,351,504, CANC. INT. CL. 25.  
3,351,505, CANC. INT. CL. 25.
- MEATBALL MANAGEMENT LLC, BROOKLYN, NY:  
4,594,107, INT. CL. 30.
- MEDALLION TRANSPORTATION HOLDINGS INC., MOORESVILLE, NJ:  
4,591,280, PUB. 6-10-2014. INT. CL. 39.
- MEDALLION TRANSPORTATION HOLDINGS INC., MOORESVILLE, NC:  
4,591,281, PUB. 6-10-2014. INT. CL. 39.  
4,591,282, PUB. 6-10-2014. INT. CL. 39.
- MEDECOR PHARMA, BATON ROUGE, LA:  
4,592,877, PUB. 6-10-2014. INT. CL. 5.
- MEDICAL ADVISORS, INC., BLUE BELL, PA:  
1,901,383. REN. 7-23-14. INT. CL. 42.
- MEDICAL INNOVATIONS GROUP HOLDINGS, LTD, SOUTHEND-ON-SEA, ESSEX, UNITED KINGDOM:  
4,591,182, PUB. 4-29-2014. MULTIPLE CLASS, INT. CLS. 3, 5, 10, 11, 12 AND 24.
- MEDICAL MANAGEMENT INTERNATIONAL, INC., PORTLAND, OR:  
3,354,168, CANC. INT. CL. 43.  
3,354,543, CANC. INT. CL. 16.
- MEDICAMAT S.A., MALAKOFF, FRANCE:  
3,352,875, CANC. INT. CL. 10.
- MEDICINAL HONEY COMPANY PTY LTD, AUSTRALIA:  
3,352,584.
- MEDICREA INTERNATIONAL, FRANCE:  
3,352,533.
- MEDICREA TECHNOLOGIES, LA ROCHELLE, FRANCE:  
2,793,602, CANC. INT. CL. 10.
- MEDINA, SYLVIA M, IDAHO FALLS, ID, DBA GREEN KIDS CLUB, INC.:  
4,594,359, MULTIPLE CLASS, INT. CLS. 16 AND 28.
- MEDIVERSE INTERNATIONAL, INC., ARCADIA, CA:  
4,594,181, INT. CL. 5.
- MEDSCRIPT PHARMACY, LLC, ORLAND PARK, IL:  
4,592,559, PUB. 6-10-2014. INT. CL. 44.  
4,592,560, PUB. 6-10-2014. INT. CL. 44.
- MEDSTAR HEALTH, INC., COLUMBIA, MD:  
4,593,035, PUB. 6-10-2014. INT. CL. 44.
- MEDSTREAMING LLC, REDMOND, WA:  
4,591,358, PUB. 6-10-2014. MULTIPLE CLASS, INT. CLS. 9 AND 42.
- MEDTEX SWISS GMBH, WIDNAU, SWITZERLAND:  
4,590,810, PUB. 6-10-2014. INT. CL. 10.
- MEENAN, KEITH D., KINSALE, VA:  
3,353,236, CANC. INT. CL. 33.
- MEET ME MEDIA INC., LOS ANGELES, CA:  
4,594,358, INT. CL. 45.
- MEETME, INC., NEW HOPE, PA:  
4,594,178, INT. CL. 9.
- MEETUP, INC., NEW YORK, NY:  
2,962,881. REN. 7-22-14. INT. CL. 38.
- MEGA MY PIXEL, LLC, NASHVILLE, TN:  
4,593,527, INT. CL. 41.  
4,593,528, INT. CL. 41.
- MEGABASS INC., SHIZUOKA 431-3115, JAPAN:  
4,593,542, INT. CL. 28.
- MEGALOWMART HOLDINGS, INC., WALNUT, CA:  
4,592,639, PUB. 6-10-2014. INT. CL. 11.
- MEGALOWMART HOLDINGS, INC., PASADENA, CA:  
4,592,991, PUB. 6-10-2014. INT. CL. 9.
- MEGAN HENRY, CENTENNIAL, CO, DBA ACTIVE READER PUBLISHING:  
3,354,161, CANC. INT. CL. 16.
- MEHLENBACHER, JONATHAN L, MEMPHIS, TN:  
4,593,835, INT. CL. 9.
- MEHMET, BADISSE DAVID, NEW YORK, NY:  
3,351,568, CANC. INT. CL. 45.
- MEINL BANK AKTIENGESELLSCHAFT, VIENNA, AUSTRIA:  
3,253,879.
- MEINL BANK AKTIENGESELLSCHAFT, AUSTRIA:  
3,352,670.
- MELDRUM, RICHARD ALLEN, TAREE NSW 2430, AUSTRALIA AND MELDRUM, JO-ANNE, TAREE NSW 2430, AUSTRALIA:  
2,793,423, CANC. MULTIPLE CLASS, INT. CLS. 18 AND 25.
- MELODYWED, MOUNTAIN VIEW, CA:  
4,594,454, INT. CL. 41.
- MELTON-JOHNSON, BRENNAN W., SAN LUIS OBISPO, CA AND MELTON-JOHNSON, JENNIFER M., SAN LUIS OBISPO, CA:  
4,592,869, PUB. 6-10-2014. INT. CL. 21.  
4,592,914, PUB. 6-10-2014. INT. CL. 18.  
4,592,926, PUB. 6-10-2014. INT. CL. 28.
- MEMORIAL HEALTH UNIVERSITY MEDICAL CENTER, INC., SAVANNAH, GA:  
2,794,482, CANC. INT. CL. 44.
- MENSCH, GREG, WEST HAMPTON, NY:  
2,866,164. REN. 7-22-14. INT. CL. 39.
- MENSINGER, PAUL B., METAMORA, IL:  
2,866,465. REN. 7-24-14. INT. CL. 9.
- MENTISCORE SOLUTIONS LIMITED, LONDON, UNITED KINGDOM:  
4,592,486, PUB. 6-10-2014. INT. CL. 44.  
4,592,994, PUB. 6-10-2014. INT. CL. 44.
- MENUCHA CHESED SERVICES, CORP., BROOKLYN, NY:  
4,591,924, PUB. 6-10-2014. INT. CL. 41.

MERCK SANTE, LYON, FRANCE:  
2,794,108, CANC. INT. CL. 5.

MEREDITH CORPORATION, DES MOINES, IA:  
3,353,378, CANC. INT. CL. 16.

MERHOFF, TINA S., WINSTON-SALEM, NC:  
2,803,186. REN. 7-22-14. INT. CL. 44.

MERIVAARA CORPORATION, FINLAND:  
4,590,742, PUB. 6-10-2014. MULTIPLE CLASS, INT. CLS. 9, 10, 37, 41 AND 42.

MERIVAARA OY, FINLAND:  
4,590,721, PUB. 6-10-2014. MULTIPLE CLASS, INT. CLS. 9, 10, 20 AND 37.

MERLIV HOLDINGS, LLC, HILLIARD, OH:  
4,594,530, INT. CL. 25.

MERRIN, JOSH, LAS VEGAS, NV:  
3,353,521, CANC. INT. CL. 41.

MESTEK MACHINERY, INC., WESTFIELD, MA:  
4,591,288, PUB. 6-10-2014. INT. CL. 7.

MESTEK, INC., UNITED STATES:  
3,352,701.

MET- RX SUBSTRATE TECHNOLOGY, INC., BOHEMIA, NY:  
3,354,329, CANC. INT. CL. 5.

METACURE (USA) INC., ORANGEBURG, NY:  
3,353,484, CANC. INT. CL. 42.

METAGENICS, INC., ALISO VIEJO, CA, DBA BARIATRIC ADVANTAGE:  
4,592,940, PUB. 6-10-2014. INT. CL. 5.

METAL-FAB, INC., WICHITA, KS:  
4,593,116, INT. CL. 11.

METALLIC DESIGN STUDIO, INC., WEAVERVILLE, CA:  
3,353,489, CANC. INT. CL. 6.

METALS USA BUILDING PRODUCTS, L.P., HOUSTON, TX:  
3,351,588, CANC. INT. CL. 6.  
3,351,589, CANC. INT. CL. 6.

METAPS INC., JAPAN:  
4,590,871, PUB. 6-10-2014. INT. CL. 36.

METARIZON LLC, CHARLESTON, SC:  
3,351,274, CANC. INT. CL. 35.

METAVENTION, INC., EDEN PRAIRIE, MN:  
4,594,068, INT. CL. 10.

METREEL (NOTTINGHAM) LIMITED, DERBYSHIRE, DE7 5UA, ENGLAND:  
1,846,495. REN. 7-24-14. INT. CL. 7.

METRO CREATIVE GRAPHICS, INC., NEW YORK, NY:  
4,594,063, INT. CL. 9.

METROPOLITAN PROPERTY AND CASUALTY INSURANCE COMPANY, NEW YORK, NY:  
2,808,867. REN. 7-21-14. INT. CL. 36.

METROPOLITAN TRANSIT AUTHORITY OF HARRIS COUNTY, TEXAS, HOUSTON, TX:  
3,351,355, CANC. INT. CL. 39.  
3,351,361, CANC. INT. CL. 39.

METROSPARK, LLC, NEW YORK, NY:  
3,354,454, CANC. INT. CL. 38.

METTLER-TOLEDO, LLC, COLUMBUS, OH:  
2,793,946, CANC. INT. CL. 9.

MEXITAN PRODUCTS, INC., SPRING HILL, KS:  
3,350,739, CANC. INT. CL. 4.

MEXQUEST MORTGAGE CORPORATION, SACRAMENTO, CA:  
3,354,122, CANC. INT. CL. 36.

MEYERS, LEANNE, MANHATTAN BEACH, CA:  
4,591,122, PUB. 6-10-2014. INT. CL. 35.

MEYRA WILHELM MEYER GMBH & CO. KG, VLOTHO, FED REP GERMANY, MEYER, WILHELM, 4973 VLOTHO, FED REP GERMANY:  
991,500. REN. 7-19-14. U.S. CL. 44 (INT. CL. 10).

MGA ENTERTAINMENT, INC., VAN NUYS, CA:  
2,795,675, CANC. MULTIPLE CLASS, INT. CLS. 16 AND 28.

MGD ENTERPRISES, INC., SPRINGFIELD, MO:  
4,593,891, INT. CL. 37.

MGFB PROPERTIES, INC., PENSACOLA, FL:  
4,594,237, MULTIPLE CLASS, INT. CLS. 21 AND 25.

MGM TELEVISION ENTERTAINMENT INC., BEVERLY HILLS, CA:  
2,796,116, CANC. INT. CL. 41.

MH INSTRUMENTS, INC., TRABUCO CANYON, CA:  
3,352,324, CANC. INT. CL. 9.

MHMB LLC, WEST HOLLYWOOD, CA:  
4,593,508, INT. CL. 9.  
4,593,509, INT. CL. 9.

MI TIERRA TITLE, L.L.C., AUSTIN, TX:  
3,352,926, CANC. INT. CL. 36.

MI-TECH, RILLIEUX-LA-PAPE, FRANCE:  
4,590,707, PUB. 6-10-2014. MULTIPLE CLASS, INT. CLS. 9, 14 AND 18.

MICHAEL BROOKS, CHARLOTTE, NC:  
4,592,166, PUB. 6-10-2014. INT. CL. 41.

MICHAEL J. BEHM, EDEN PRAIRE, MN:  
4,593,085, INT. CL. 11.

MICHAEL J. CONNORS, SPARKS, NV:  
4,591,372, PUB. 6-10-2014. MULTIPLE CLASS, INT. CLS. 25 AND 41.

MICHAEL JOSEPH INC, FT. LAUDERDALE, FL:  
3,354,201, CANC. INT. CL. 32.

MICHAEL KANTROW, NEW YORK, NY:  
4,594,226, INT. CL. 35.

MICHAEL T. DUNN, HILLSBORO, OR, DBA MICHAEL T. DUNN PLUMBING:  
4,591,976, PUB. 6-10-2014. INT. CL. 37.

MICHAEL WILLIAMS, CAMBRIDGE, AUSTRALIA AND SUSAN WILLIAMS, CAMBRIDGE, AUSTRALIA:  
4,592,809, PUB. 6-10-2014. INT. CL. 8.

MICHAELA MOKROSOVA, VENICE, CA:  
4,592,727, PUB. 6-10-2014. INT. CL. 39.

MICHELE D. HUGHES, BRANFORD, CT AND JENNIFER C. HUGHES, BRANFORD, CT:  
3,350,787, CANC. INT. CL. 16.

MICHELIN NORTH AMERICA, INC., GREENVILLE, SC:  
3,353,601, CANC. INT. CL. 12.

MICHELLE KAMINS, MARINA DEL REY, CA:  
3,352,461, CANC. INT. CL. 14.

MICHIELS BREWING, LLC, ADA, MI:  
4,593,636, INT. CL. 32.

MICHIGAN STATE UNIVERSITY FEDERAL CREDIT UNION, EAST LANSING, MI:  
3,353,003, CANC. INT. CL. 45.  
3,353,004, CANC. INT. CL. 45.  
3,353,020, CANC. INT. CL. 36.  
3,353,021, CANC. INT. CL. 36.

MICRO FOCUS IP DEVELOPMENT LIMITED, NEWBURY, BERKSHIRE, UNITED KINGDOM:  
4,591,168, PUB. 12-24-2013. MULTIPLE CLASS, INT. CLS. 9, 41 AND 42.

MICROBAN PRODUCTS COMPANY, HUNTERSVILLE, NC, AKA MICROBAN PRODUCTS COMPANY:  
4,592,109, PUB. 6-10-2014. MULTIPLE CLASS, INT. CLS. 16 AND 22.

MICROCHIP TECHNOLOGY INCORPORATED, CHANDLER, AZ:  
2,796,070, CANC. INT. CL. 9.

MICRODYNAMICS TRANSACTIONAL MAIL, LLC, NAPERVILLE, IL:  
3,352,470, CANC. MULTIPLE CLASS, INT. CLS. 9, 16 AND 35.

MICROGRID SOLAR ENERGY, LLC, EARTH CITY, MO:  
4,593,743, MULTIPLE CLASS, INT. CLS. 35 AND 37.

MICROSOFT CORPORATION, REDMOND, WA:  
3,351,966, CANC. MULTIPLE CLASS, INT. CLS. 35 AND 42.  
3,352,816, CANC. INT. CL. 38.

MICROTHIN.COM, INC., ADDISON, IL:  
3,352,078, CANC. INT. CL. 24.

MID-MISSOURI BANCSHARES, INC., SPRINGFIELD, MO:  
3,350,829, CANC. MULTIPLE CLASS, INT. CLS. 35, 36 AND 39.

MIDNIGHT BLUE, LLC, GAITHERSBURG, MD:  
2,794,753, CANC. MULTIPLE CLASS, INT. CLS. 40, 41 AND 42.

MIDTECH R&D, INC., FAIRMONT, MN:  
4,593,668, INT. CL. 1.

MIDWAY FARMS AND FORAGE, HERINGTON, KS:  
4,591,902, PUB. 6-10-2014. INT. CL. 31.

- MIDWEST APPLIANCE PARTS CO. INC., CHICAGO, IL:  
4,592,554, PUB. 6-10-2014. INT. CL. 35.
- MIDWEST CUSTOM BOTTLING, LLC, PEWAUKEE, WI:  
4,594,174, INT. CL. 33.
- MIDWEST MOTORCYCLE SUPPLY DISTRIBUTORS  
CORP., PEVELY, MO:  
2,861,327. REN. 7-18-14. INT. CL. 12.
- MIDWEST RECREATIONAL PRODUCTS, INC., WAUKE-  
SHA, WI:  
4,591,187, PUB. 6-10-2014. INT. CL. 35.
- MIGDALES, THOMAS, GREENWOOD, SC:  
4,592,369, PUB. 6-10-2014. INT. CL. 43.
- MIGHTY STUDIOS LLC, SAMMAMISH, WA:  
4,591,747, PUB. 6-10-2014. INT. CL. 9.
- MIGNON FAGET LTD., NEW ORLEANS, LA:  
1,287,060. REN. 7-21-14. INT. CL. 14.
- MIGUEL TORRES, S.A., BARCELONA, SPAIN, TORRES,  
MIGUEL, BARCELONA, SPAIN:  
992,658. REN. 7-22-14. U.S. CL. 47 (INT. CL. 33).
- MIKE DE BRIE (OCEANIA) LIMITED, HOBSONVILLE,  
AUCKLAND, NEW ZEALAND:  
4,591,101, PUB. 6-10-2014. MULTIPLE CLASS, INT. CLS.  
18 AND 25.
- MIKE LEVEY PRODUCTIONS, INC., ENCINO, CA:  
2,795,466, CANC. INT. CL. 41.
- MILAZZO INDUSTRIES INC., PORT BLANCHARD PITT-  
STON, PA:  
2,907,020. REN. 7-23-14. INT. CL. 1.
- MILBON CO., LTD., OSAKA, JAPAN:  
3,354,164, CANC. INT. CL. 3.
- MILESTONE AV TECHNOLOGIES LLC, EDEN PRAIRIE,  
MN:  
4,594,000, INT. CL. 9.
- MILLER, ABIGAIL, PITTSBURGH, PA:  
3,353,554, CANC. MULTIPLE CLASS, INT. CLS. 9, 16, 21,  
25 AND 35.
- MILLER, CATHY P., HUNTSVILLE, AL:  
3,351,513, CANC. INT. CL. 41.
- MILLER, ROB, CAREFREE, AZ:  
3,354,108, CANC. INT. CL. 41.
- MILLER, ROBY, IOWA CITY, IA:  
4,594,335, INT. CL. 42.
- MILLERCOORS LLC, CHICAGO, IL:  
3,354,014, CANC. INT. CL. 35.
- MILTILINK DEVELOPMENTS LTD., NEW YORK, NY TO  
MILTILINK DEVELOPMENTS LTD., NEW YORK, NY:  
2,796,311, CANC. INT. CL. 42.
- MINDBODY, INC., SAN LUIS OBISPO, CA:  
4,593,985, INT. CL. 42.
- MINDBRIDGE INNOVATIONS, LLC, ALLENTOWN, PA:  
4,591,265, PUB. 6-10-2014. INT. CL. 10.
- MINDFUL PALATE, KATY, TX:  
4,593,499, INT. CL. 25.
- MINDJET, LLC, SAN FRANCISCO, CA:  
4,593,877, MULTIPLE CLASS, INT. CLS. 9 AND 42.
- MINDWARE HOLDINGS, INC., ROSEVILLE, MN:  
4,593,890, INT. CL. 28.
- MINDWORKS INC., WESTFIELD, IN:  
3,354,524, CANC. INT. CL. 40.
- MIND4RENT LLC, JENSEN BEACH, FL:  
4,591,673, PUB. 6-10-2014. INT. CL. 21.
- MINEBEA CO., LTD., MEGURO-KU, TOKYO, JAPAN:  
2,859,575. REN. 7-18-14. INT. CL. 12.  
2,859,576. REN. 7-18-14. INT. CL. 9.  
2,859,577. REN. 7-18-14. INT. CL. 7.
- MINNESOTA PUBLIC RADIO, ST. PAUL, MN:  
2,956,334. REN. 7-22-14. INT. CL. 41.
- MIRACLE-EAR, INC., PLYMOUTH, MN:  
2,858,623. REN. 7-22-14. INT. CL. 44.  
2,858,624. REN. 7-21-14. INT. CL. 44.  
2,858,625. REN. 7-22-14. INT. CL. 44.  
2,858,626. REN. 7-22-14. INT. CL. 44.
- MIRAGE RESORTS, INCORPORATED, LAS VEGAS, NV:  
2,859,595. REN. 7-18-14. INT. CL. 44.
- MIRANDOLA GAETANO, I-37060 BUTTAPIETRA (VERO-  
NA), ITALY:  
4,590,872, PUB. 6-10-2014. INT. CL. 30.
- MISSION PRODUCT HOLDINGS, INC., NEW YORK, NY:  
4,594,494, INT. CL. 28.
- MISSISSIPPI STATE UNIVERSITY, MISSISSIPPI STATE, MS:  
4,591,026, PUB. 6-10-2014. MULTIPLE CLASS, INT. CLS.  
25 AND 41.  
4,592,902, PUB. 6-10-2014. MULTIPLE CLASS, INT. CLS.  
25 AND 41.
- MISTAWAY SYSTEMS, INC., HOUSTON, TX:  
3,353,614, CANC. INT. CL. 5.
- MITCHELL, JOSEPH F., MR., SUTHERLIN, OR:  
3,353,501, CANC. INT. CL. 9.
- MITCHELL, THOMAS, MASCOUTAH, IL:  
3,351,587, CANC. INT. CL. 25.
- MITSUBISHI CHEMICAL CORPORATION, MINATO-KU,  
TOKYO, JAPAN:  
4,593,181, INT. CL. 11.
- MITSUBISHI ELECTRIC & ELECTRONICA USA, INC.,  
CYPRESS, CA:  
2,160,186, CANC. INT. CL. 9.
- MITSUBISHI MATERIALS CORPORATION, CHIYODA-KU,  
TOKYO, JAPAN:  
3,352,453, CANC. MULTIPLE CLASS, INT. CLS. 7, 40  
AND 42.
- MITSUBISHI RAYON CO., LTD., CHIYODA-KU, TOKYO,  
JAPAN:  
999,369. REN. 7-22-14. U.S. CL. 1 (INT. CL. 1).
- MITSUI CHEMICALS, INC., MINATO-KU, TOKYO, JAPAN,  
MITSUI TOATSU CHEMICALS, INCORPORATED,  
CHIYODA-KU, TOKYO, JAPAN:  
1,847,205. REN. 7-21-14. INT. CL. 3.
- MIURA VINEYARDS, LLC, NAPA, CA:  
2,796,177, CANC. INT. CL. 33.
- MIZSU CORPORATION, CORPUS CHRISTI, TX:  
3,352,111, CANC. INT. CL. 25.
- MIZUHO FINANCIAL GROUP, INC., JAPAN:  
4,590,685, PUB. 6-10-2014. INT. CL. 36.
- MIZUNO CORPORATION, OSAKA-SHI, OSAKA 541-8583,  
JAPAN:  
2,820,274, AM. INT. CL. 25.
- MIZUNO KABUSHIKI KAISHA (MIZUNO CORPORA-  
TION), OSAKA, 541-8538, JAPAN:  
2,795,950, CANC. INT. CL. 25.
- MK CUISINE GLOBAL LLC, BELFAST, ME, DBA MAT-  
THEW KENNEY CUISINE:  
4,591,635, PUB. 6-10-2014. INT. CL. 44.
- MK DIAMOND PRODUCTS, INC., TORRANCE, CA:  
2,793,600, CANC. INT. CL. 7.
- MMC SOFTWARE INTERNATIONAL CORP., LADYSMITH,  
BC, CANADA:  
4,590,985, PUB. 6-10-2014. MULTIPLE CLASS, INT. CLS.  
9, 35 AND 45.
- MOBILE REAL ESTATE, LLC, STAMFORD, CT:  
4,591,268, PUB. 6-10-2014. INT. CL. 35.
- MOBILEBITS CORP., SARASOTA, CA:  
4,593,427, MULTIPLE CLASS, INT. CLS. 9, 35 AND 45.
- MOCHI LLC, SCOTTSDALE, AZ:  
4,594,366, INT. CL. 5.
- MOCKETT, KEN, SAN CLEMENTE, CA:  
3,353,133, CANC. INT. CL. 28.
- MODERNO MEDIA, INC., BROOKLYN, NY:  
4,592,159, PUB. 6-10-2014. INT. CL. 35.
- MODKIT, LLC, CAMBRIDGE, MA:  
4,593,154, INT. CL. 9.
- MOEN INCORPORATED, NORTH OLMSTED, OH:  
4,593,288, MULTIPLE CLASS, INT. CLS. 6, 11, 17, 20, 21  
AND 27.
- MOGULDOM MEDIA GROUP, NEW YORK, NY:  
4,593,783, INT. CL. 39.
- MOHAN, RAM B., SANTA CLARA, CA:  
4,594,727, INT. CL. 42.
- MOHAWK CARPET DISTRIBUTION, INC, CHATSWORTH,  
GA:  
3,353,016, CANC. INT. CL. 19.
- MOISES COSTA PRIMO JALECO, P-1000-246 LISBOA, POR-  
TUGAL:  
3,352,735.
- MOKI MOBILITY, INC., LEHI, UT:  
4,591,750, PUB. 6-10-2014. MULTIPLE CLASS, INT. CLS. 9

AND 42.  
4,591,751, PUB. 6-10-2014. MULTIPLE CLASS, INT. CLS. 9 AND 42.

MOLDA AG, FED REP GERMANY:  
3,352,534.

MOLECULAR MACHINES, INC., MONTCLAIR, NJ:  
2,794,979, CANC. INT. CL. 42.

MOECULE-AMERICA, L.L.C., JOHNSTON, IA:  
4,592,376, PUB. 6-10-2014. INT. CL. 35.

MOLFINO HERMANOS SOCIEDAD ANÓNIMA, BECCAR, BUENOS AIRES, ARGENTINA:  
4,592,879, PUB. 6-10-2014. INT. CL. 29.

MOM INVENTORS, INC., WALNUT CREEK, CA:  
3,354,361, CANC. INT. CL. 41.

MOMENTIVE PERFORMANCE MATERIALS INC., WATERFORD, NY, ADVANCED CERAMICS CORPORATION, LAKEWOOD, OH:  
1,844,968, REN. 7-21-14. MULTIPLE CLASS, INT. CLS. 1 AND 4.

MONARFLEX S.R.O., STÚROVO, SLOVAKIA:  
1,817,288, REN. 7-23-14. MULTIPLE CLASS, INT. CLS. 17, 19 AND 22.

MONDELLI GROUP S.R.L., ROMA (RM), ITALY:  
3,462,646.

MONEYGRAM PAYMENT SOLUTIONS, INC., MINNEAPOLIS, MN:  
3,353,319, CANC. INT. CL. 36.

MONKEYS INDA MIDDLE, LLC, WILMINGTON, DE:  
4,594,161, INT. CL. 41.

MONMOUTH UNIVERSITY, WEST LONG BRANCH, NJ:  
3,352,235, CANC. INT. CL. 16.

MONO-SYSTEMS, INC., RYE BROOK, NY:  
2,796,343, CANC. INT. CL. 9.

MONODICA, SPARKS, NV:  
4,594,554, INT. CL. 25.

MONOSOL LLC, MERRILLVILLE, IN:  
4,593,470, MULTIPLE CLASS, INT. CLS. 17, 40 AND 42.

MONOTYPE GMBH, 61352 BAD HOMBURG V. D., FED REP GERMANY:  
3,351,155, CANC. MULTIPLE CLASS, INT. CLS. 35 AND 42.

MONS INDUSTRIES, CORP., ROAD TOWN, TORTOLA, BR. VIRGIN ISLANDS:  
4,594,759, INT. CL. 45.

MONSANTO TECHNOLOGY LLC, SAINT LOUIS, MO:  
3,351,817, CANC. INT. CL. 16.

MONSIEUR SHAHÉ KALAJDIJIAN, MONACO:  
4,590,736, PUB. 6-10-2014. MULTIPLE CLASS, INT. CLS. 3, 4, 41, 43 AND 44.

MONSTER DADDY, LLC, GREENVILLE, SC:  
3,353,572, CANC. INT. CL. 3.

MONSTER, INC., BRISBANE, CA:  
4,593,297, INT. CL. 9.

MONTAGE HOTELS & RESORTS, LLC, IRVINE, CA:  
4,591,496, PUB. 6-10-2014. INT. CL. 32.  
4,592,125, PUB. 6-10-2014. INT. CL. 43.

MONTEREY BAY AQUARIUM FOUNDATION, MONTEREY, CA:  
4,593,516, INT. CL. 43.

MONTFORT SERVICES SDN. BHD., TSIMSHATSUI, HONG KONG:  
1,837,934, REN. 7-22-14. INT. CL. 25.

MOORE, JONATHAN D, TRACY, MN:  
3,354,098, CANC. INT. CL. 39.

MOORE, LORRI S., SYLMAR, CA:  
3,354,304, CANC. INT. CL. 41.

MOOSE CREATIVE PTY LTD, EAST BENTLEIGH, AUSTRALIA:  
4,591,013, PUB. 6-10-2014. MULTIPLE CLASS, INT. CLS. 16 AND 28.  
4,591,430, PUB. 6-10-2014. MULTIPLE CLASS, INT. CLS. 16 AND 28.

MORAKI, INC., JAMUL, CA:  
4,592,892, PUB. 6-10-2014. INT. CL. 5.

MORDECAI INVESTMENTS, LLC, RALEIGH, NC:  
3,351,438, CANC. INT. CL. 36.

MOREAU TRUST, SARATOGA SPRINGS, NY:  
4,591,811, PUB. 6-10-2014. MULTIPLE CLASS, INT. CLS. 14, 16, 18, 21 AND 25.

MORELAND-PEARCE, KENNETH, BOSTON, MA, DBA RADAR DIGITAL:  
4,591,632, PUB. 6-10-2014. INT. CL. 35.

MORELIGHT CORP., APIA, WESTERN SAMOA:  
2,938,591, REN. 7-23-14. INT. CL. 11.

MORELLO FORNI DI MORELLO MARCO & C. S.A.S., CERANESI (GENOA), ITALY:  
4,593,262, MULTIPLE CLASS, INT. CLS. 7 AND 11.

MORENCI CANDLES INC., GORDON, TX:  
2,794,291, CANC. INT. CL. 4.

MORE2EXPLORE S.R.L., MONZA, ITALY:  
3,353,418, CANC. MULTIPLE CLASS, INT. CLS. 35, 38, 39 AND 41.

MORF3D, INC., SKOKIE, IL:  
4,592,597, PUB. 6-10-2014. MULTIPLE CLASS, INT. CLS. 40 AND 42.

MORGAN INCORPORATED, PRAIRIE VILLAGE, KS:  
1,783,517, CANC. INT. CL. 28.

MORGAN, DIANA, COLUMBUS, OH:  
4,591,342, PUB. 6-10-2014. INT. CL. 41.

MORIN, GERMAIN, EAST BRUNSWICK, NJ:  
4,593,758, MULTIPLE CLASS, INT. CLS. 9 AND 38.

MORINAGA NYUGYO KABUSHIKI KAISHA, TOKYO, JAPAN, TA MORINAGA MILK INDUSTRY CO., LTD.:  
3,353,983, CANC. INT. CL. 5.

MORLEY CANDY MAKERS, INC., CLINTON TOWNSHIP, MI:  
4,592,807, PUB. 6-10-2014. INT. CL. 30.

MORNING SUN AUSTRALIA PTY LTD, STRETTON, GLD, AUSTRALIA:  
4,592,010, PUB. 6-10-2014. MULTIPLE CLASS, INT. CLS. 29 AND 30.

MOROCH PARTNERS, L.P., DALLAS, TX:  
4,594,044, INT. CL. 35.

MORPHO DETECTION, INC., NEWARK, CA:  
4,591,805, PUB. 6-10-2014. INT. CL. 9.

MORRIS INTERNATIONAL, INC., DAVIDSON, NC:  
4,593,994, INT. CL. 30.

MORRIS WILLIAMS CORPORATION, PALM COAST, FL, DBA MORRIS WILLIAMS REALTY:  
4,592,249, PUB. 6-10-2014. INT. CL. 36.  
4,592,259, PUB. 6-10-2014. INT. CL. 9.

MORRIS, DAVID, TAMPA, FL AND MORGAN, ADRIAN, TAMPA, FL:  
3,351,464, CANC. INT. CL. 20.

MORRISON HOLDINGS, LLC, NEW YORK, NY:  
4,591,431, PUB. 6-10-2014. INT. CL. 25.

MORRISON MANAGEMENT SPECIALISTS, INC., ATLANTA, GA:  
2,909,529, REN. 7-21-14. MULTIPLE CLASS, INT. CLS. 43 AND 44.

MORTGAGE GRADER, INC., LAGUNA NIGUEL, CA:  
3,352,983, CANC. INT. CL. 36.

MORTON SALT, INC., CHICAGO, IL, MORTON-NORWICH PRODUCTS, INC., CHICAGO, IL:  
986,714, REN. 7-21-14. U.S. CL. 6 (INT. CL. 1).

MORVENT AIR CONDITIONING & HEATING, LLC, WEST CHESTER, PA:  
4,591,820, PUB. 6-10-2014. INT. CL. 37.

MOSCARET CONSULTING, INC., SAMMAMISH, WA:  
2,861,636, REN. 7-21-14. INT. CL. 28.

MOSCHINO S.P.A., ITALY:  
3,352,527.

MOSEFUND FARM, LLC, BRANCHVILLE, NJ:  
4,594,512, INT. CL. 29.

MOSHMAN, SARA, LINCOLN, NE:  
2,793,506, CANC. MULTIPLE CLASS, INT. CLS. 9 AND 42.

MOSQUITOMAX, LLC, KATY, TX, AKA MOSQUITOMAX MISTING SYSTEMS:  
2,866,787, REN. 7-22-14. INT. CL. 9.

MOTIONPOINT CORPORATION, COCONUT CREEK, FL:  
4,592,849, PUB. 6-10-2014. INT. CL. 42.  
4,592,977, PUB. 6-10-2014. INT. CL. 42.

MOTIVES STUDIO, INC., COSTA MESA, CA:  
3,351,032, CANC. INT. CL. 41.

- MOTO 1, DENVER, CO:  
3,352,156, CANC. INT. CL. 25.
- MOTORCYCLES OF BEND, INC, BEND, OR:  
3,351,753, CANC. INT. CL. 25.
- MOTORHEAD, LTD., FAIRFAX, VA:  
1,285,165, REN. 7-24-14. INT. CL. 12.
- MOTOVAN CORPORATION, BOUCHERVILLE, QUEBEC, CANADA:  
3,351,964, CANC. MULTIPLE CLASS, INT. CLS. 12, 16, 25 AND 28.
- MOUNTAIN STATES MUTUAL CASUALTY COMPANY, ALBUQUERQUE, NM:  
4,591,952, PUB. 6-10-2014. INT. CL. 36.
- MOVADO LLC, WILMINGTON, DE:  
2,795,757, CANC. INT. CL. 14.  
2,872,855, REN. 7-24-14. INT. CL. 14.
- MOVE OUT OF THE BOX LLC, WOODINVILLE, WA:  
4,592,091, PUB. 6-10-2014. INT. CL. 42.
- MOVENCORP INC., NEW YORK, NY:  
4,593,659, INT. CL. 36.
- MOVSOVITZ, SETH, JACKSONVILLE, FL:  
2,793,770, CANC. INT. CL. 16.
- MOZART DISTILLERIE GMBH, A-5020 SALZBURG, AUSTRIA:  
2,898,463, REN. 7-23-14. INT. CL. 33.
- MPF GROUP S.R.L., BAGNO A RIPOLI (FIRENZE), ITALY:  
3,353,176, CANC. INT. CL. 9.
- MPHISIS LIMITED, MAHADEVAPURA, BANGALOR, INDIA:  
4,593,548, INT. CL. 9.
- MR. AMORE STABLES, LLC, WINTER PARK, FL:  
4,591,800, PUB. 6-10-2014. INT. CL. 41.  
4,591,801, PUB. 6-10-2014. INT. CL. 41.
- MR. R.J.C., INC., TORRANCE, CA, DBA RJR FASHION FABRICS:  
4,593,946, INT. CL. 24.
- MR. ROOTER LLC, WACO, TX:  
4,591,634, PUB. 6-10-2014. INT. CL. 1.
- MRGRAPH LLC, PARKER, CO:  
4,594,323, INT. CL. 25.
- MRI SOFTWARE LLC, SOLON, OH:  
4,591,512, PUB. 6-10-2014. MULTIPLE CLASS, INT. CLS. 9 AND 42.
- MRS. LAURALICIOUS, LLC, WEST LINN, OR:  
4,593,139, INT. CL. 30.  
4,593,140, INT. CL. 30.
- MSA TECHNOLOGY, LLC, CRANBERRY TOWNSHIP, PA:  
2,873,340, REN. 7-21-14. INT. CL. 9.
- MSD CONSUMER CARE, INC., MEMPHIS, TN:  
3,353,142, CANC. INT. CL. 5.  
4,593,696, INT. CL. 3.
- MSSCIENTIFIC; CHROMATOGRAPHIE-HANDEL GMBH, FED REP GERMANY:  
4,590,666, PUB. 6-10-2014. MULTIPLE CLASS, INT. CLS. 7, 9, 10, 11 AND 35.
- MT GROUP LTD., DALLAS, TX:  
4,593,136, INT. CL. 35.  
4,593,137, INT. CL. 35.
- MTD PRODUCTS INC, VALLEY CITY, OH:  
2,863,485, REN. 7-18-14. INT. CL. 7.  
3,351,380, CANC. MULTIPLE CLASS, INT. CLS. 7 AND 12.
- MT3 MARKETING LLC, HOUSTON, TX:  
4,592,164, PUB. 6-10-2014. MULTIPLE CLASS, INT. CLS. 35, 41 AND 42.
- MUDDY COUTURE, JACKSONVILLE, TX:  
4,594,246, INT. CL. 25.
- MUIR, JAMES, VENICE, CA:  
2,812,318, REN. 7-18-14. INT. CL. 25.
- MULTICAST MEDIA TECHNOLOGIES, INC., ATLANTA, GA:  
3,352,026, CANC. INT. CL. 41.
- MULTICULTURAL INTEGRATED KIDNEY EDUCATION PROGRAM, PORTLAND, OR, DBA MIKE PROGRAM:  
4,591,091, PUB. 6-10-2014. MULTIPLE CLASS, INT. CLS. 36 AND 41.  
4,591,092, PUB. 6-10-2014. MULTIPLE CLASS, INT. CLS. 36 AND 41.
- MULTICULTURAL PLAYING FIELD, LLC, LOCUST, NJ:  
3,352,827, CANC. MULTIPLE CLASS, INT. CLS. 9 AND 16.
- MULTILINK DEVELOPMENTS LTD., NEW YORK, NY TO MULTILINK DEVELOPMENTS LTD., NEW YORK, NY:  
2,796,310, CANC. INT. CL. 38.
- MULTIMEDIA GAMES, INC., AUSTIN, TX:  
3,354,184, CANC. INT. CL. 9.  
4,593,589, INT. CL. 28.
- MUM SPORTS LLC, LAS VAGAS, CA:  
4,591,852, PUB. 6-10-2014. INT. CL. 12.
- MUNIZ, RICARDO, NEW YORK, NY:  
4,593,983, INT. CL. 25.
- MUNOZ, PAUL, TULSA, OK:  
3,353,550, CANC. INT. CL. 25.
- MURAD, INC., EL SEGUNDO, CA:  
3,350,932, CANC. INT. CL. 33.
- MURRAY SALES, INC., MONTREAL, CANADA:  
4,593,151, INT. CL. 9.
- MURZAN, INC., NORCROSS, GA:  
3,352,791, CANC. INT. CL. 30.
- MUSCLE MILITIA LLC., BAKERSFIELD, CA:  
4,591,857, PUB. 6-10-2014. INT. CL. 25.
- MUSCO OLIVE PRODUCTS, INC., TRACY, CA, DBA MUSCO FAMILY OLIVE COMPANY:  
2,795,737, CANC. INT. CL. 29.
- MUSESTREIZE, SOCIÉTÉ ANONYME, BELGIUM:  
4,590,657, PUB. 6-10-2014. MULTIPLE CLASS, INT. CLS. 9, 35, 36, 38 AND 42.
- MUSHYGUSHY.COM, LLC, PARSIPPANY, NJ:  
3,352,965, CANC. INT. CL. 38.
- MUSICAL ELECTRONICS LIMITED, KWUN TONG, KOWLOON, HONG KONG:  
3,350,803, CANC. INT. CL. 9.  
3,350,804, CANC. INT. CL. 10.
- MUSIM MAS HOLDINGS PTE LTD, SINGAPORE, SINGAPORE:  
4,590,986, PUB. 6-10-2014. INT. CL. 1.
- MUSTO LIMITED, UNITED KINGDOM:  
3,352,602.
- MUZAIC, GEORGE, CALGARY, ALBERTA, CANADA:  
4,592,721, PUB. 6-10-2014. INT. CL. 34.
- MVP REALTY ASSOCIATES, NAPLES, FL, DBA MVP REALTY:  
4,592,349, PUB. 6-10-2014. INT. CL. 36.
- MX USA, INC., HORSHAM, PA:  
4,591,894, PUB. 6-10-2014. INT. CL. 44.  
4,591,895, PUB. 6-10-2014. INT. CL. 44.
- MXC, LLC., PORTLAND, OR:  
4,591,345, PUB. 6-10-2014. INT. CL. 25.
- MY ART AND INNOVATION STUDIOS LLC, WEST BLOOMFIELD, MI:  
4,591,183, PUB. 6-10-2014. INT. CL. 35.
- MY BROWNSKIN, INC., DECATUR, GA:  
3,353,817, CANC. INT. CL. 35.
- MY GOODIE SPOT, INC., PLANTATION, FL:  
4,591,319, PUB. 6-10-2014. INT. CL. 40.
- MY SCRAP NETWORK LLC, HUDSON, OH:  
4,592,777, PUB. 6-10-2014. INT. CL. 35.
- MY WEBOLUTION LLC, DUNN LORING, VA:  
4,593,245, MULTIPLE CLASS, INT. CLS. 42 AND 45.
- MYASSIST, INC., STEVENS POINT, WI:  
3,353,718, CANC. MULTIPLE CLASS, INT. CLS. 39 AND 43.
- MYBODYBEATS, INC., ATLANTA, GA:  
3,351,730, CANC. INT. CL. 35.
- MYCREDENTIALS, INC., LAGUNA NIGUEL, CA:  
3,353,045, CANC. INT. CL. 35.
- MYERS, DONALD KEITH, JR., FREEPORT, PA:  
4,592,021, PUB. 6-10-2014. INT. CL. 30.
- MYGAMEROOM N.V., WILLEMSTAD, CURAÇAO, NETHERLANDS ANTILLES:  
3,353,733, CANC. INT. CL. 41.
- MYGIFTSTER CORPORATION, ARDEN HILLS, MN:  
4,591,060, PUB. 6-10-2014. INT. CL. 45.
- MYKIDBRAINIAC, INC., CASTLE PINES NORTH, CO, DBA MY MUSIC SKOOL:  
4,593,117, INT. CL. 35.



MYLAN SPECIALTY L.P., BASKING RIDGE, NJ:  
2,872,379. REN. 7-22-14. INT. CL. 5.

MYSTERY RANCH, LTD., BOZEMAN, MT:  
4,593,359. INT. CL. 18.

MYSZKOWSKI, MARIAN A., LANGLEY, WA:  
4,591,683. PUB. 6-10-2014. INT. CL. 16.

MYTUTOR INC., HUNTINGTON BEACH, CA:  
4,592,042. PUB. 6-10-2014. INT. CL. 41.  
4,592,043. PUB. 6-10-2014. INT. CL. 41.

M1 DATA & ANALYTICS, LLC, FORT LAUDERDALE, FL:  
3,350,668. CANC. INT. CL. 35.

M3 INVESTMENT GROUP, LLC, PALM BEACH, FL:  
3,353,059. CANC. INT. CL. 35.

N & N SWEATBAND COMPANY, GRETN, LA:  
2,794,193. CANC. INT. CL. 25.

N. EILERSEN A/S, DENMARK:  
4,590,888. PUB. 6-10-2014. INT. CL. 20.

N. FRED THIAGARAJAH, NEWPORT BEACH, CA:  
4,593,019. PUB. 6-10-2014. INT. CL. 45.

N. GABRIELE HUNGERFORD, NEW YORK, NY:  
4,592,674. PUB. 6-10-2014. MULTIPLE CLASS, INT. CLS.  
18, 20 AND 25.

N.V. BEKAERT S.A., BE-8550 ZWEVEGEM, BELGIUM:  
1,324,041. REN. 7-23-14. INT. CL. 6.

N.V. NEDERLANDSCHE APPARATENFABRIEK "NEDAP",  
NETHERLANDS:  
4,590,801. PUB. 6-10-2014. MULTIPLE CLASS, INT. CLS.  
9, 35 AND 42.

N'GENUITY ENTERPRISES CO., SCOTTSDALE, AZ:  
3,353,575. CANC. INT. CL. 29.

NAGAO, TOMOAKI, TOKYO, JAPAN:  
4,591,860. PUB. 6-10-2014. INT. CL. 25.

NAGGIAR VINEYARDS, LLC, GRASS VALLEY, CA:  
4,592,127. PUB. 6-10-2014. INT. CL. 44.

NAKIHEI, ROBERT, LYNNWOOD, WA:  
4,593,497. INT. CL. 9.

NALCO COMPANY, NAPERVILLE, IL:  
3,354,396. CANC. INT. CL. 9.

NAME RITE, LLC, TEMECULA, CA:  
3,351,324. CANC. INT. CL. 44.

NAMI, ARLINGTON, VA, DBA NATIONAL ALLIANCE ON  
MENTAL ILLNESS:  
4,591,188. PUB. 6-10-2014. INT. CL. 35.

NAMIN, STAS, MOSCOW, RUSSIAN FED.:  
3,354,502. CANC. INT. CL. 41.

NAMTTIP LLC, SOUTH SALEM, NY:  
4,592,503. PUB. 6-10-2014. INT. CL. 30.

NANCY A. BOLANIS, ARLINGTON, VA:  
4,594,025. INT. CL. 21.  
4,594,026. INT. CL. 21.  
4,594,027. INT. CL. 21.  
4,594,029. INT. CL. 21.

NANJING BIGEFEISI COMMERCIAL & TRADE CO.,LTD.,  
JIANGSU PROVINCE., CHINA:  
4,592,157. PUB. 6-10-2014. INT. CL. 43.  
4,592,158. PUB. 6-10-2014. INT. CL. 29.

NANO CORPORATION, YOKOHAMA, 236-0016, JAPAN:  
2,794,091. CANC. MULTIPLE CLASS, INT. CLS. 7 AND  
10.

NANO PET PRODUCTS,LLC, NORWALK, CT:  
4,591,100. PUB. 6-10-2014. INT. CL. 27.

NANSDISWARPERSAD P. LACHMANSINGH; REKHA S.;  
LACHMANSINGH, NETHERLANDS:  
3,352,721.

NAOMI JOHNSON, MONTCLAIR, NJ:  
4,593,595. INT. CL. 9.

NAPCP, INC., ATLANTA, GA:  
4,592,338. PUB. 6-10-2014. INT. CL. 35.

NARDOZZI, MICHAEL D, HAIKU, HI:  
3,353,970. CANC. INT. CL. 25.

NAS, LLC, WINSTON-SALEM, NC:  
2,793,438. CANC. INT. CL. 35.

NASE WORLDWIDE, INC., FLAGLER BEACH, FL:  
4,594,724. INT. CL. 41.

NASEER, FARHAN, FORT LAUDERDALE, FL:  
3,354,556. CANC. INT. CL. 36.

NASHVILLE WRAPS, HENDERSONVILLE, TN:  
2,876,494. REN. 7-22-14. MULTIPLE CLASS, INT. CLS. 16  
AND 35.

NASSAU CANDY DISTRIBUTORS, INC., HICKSVILLE, NY:  
4,594,435. INT. CL. 30.

NASSER, ALI, HOUSTON, TX:  
4,592,524. PUB. 6-10-2014. INT. CL. 36.

NATEL ENGINEERING CO., INC., CHATSWORTH, CA:  
4,592,055. PUB. 6-10-2014. MULTIPLE CLASS, INT. CLS.  
40 AND 42.

NATGAS RESOURCES LLC, PITTSBURGH, PA:  
4,594,156. INT. CL. 21.

NATIONAL ACTION SPORTS LLC, FORT WAYNE, IN:  
3,353,254. CANC. INT. CL. 35.

NATIONAL ASSOCIATION OF CORPORATE DIRECTORS,  
WASHINGTON, DC:  
2,859,759. REN. 7-22-14. MULTIPLE CLASS, INT. CLS. 16,  
35 AND 41.  
2,859,760. REN. 7-22-14. MULTIPLE CLASS, INT. CLS. 16,  
35 AND 41.

NATIONAL AUTOMOBILE DEALERS ASSOCIATION,  
MCLEAN, VA:  
4,592,101. PUB. 6-10-2014. MULTIPLE CLASS, INT. CLS.  
35 AND 36.

NATIONAL CENTER FOR VICTIMS OF CRIME, WA-  
SHINGTON, DC:  
4,592,425. PUB. 6-10-2014. MULTIPLE CLASS, INT. CLS.  
35 AND 36.

NATIONAL CENTER ON EDUCATION AND THE ECONO-  
MY, WASHINGTON, DC:  
4,591,898. PUB. 6-10-2014. INT. CL. 41.

NATIONAL CERTIFICATION BOARD FOR THERAPEUTIC  
MASSAGE & BODYWORK, INC., OAKBROOK TERRACE,  
IL:  
4,591,538. PUB. 6-10-2014. U.S. CL. B.  
4,591,549. PUB. 6-10-2014. U.S. CL. B.

NATIONAL CHILD SAFETY COUNCIL, JACKSON, MI:  
1,288,363. REN. 7-23-14. INT. CL. 42.

NATIONAL COUNCIL ON ALCOHOLISM AND DRUG  
DEPENDENCE OF MIDDLESEX COUNTY, INC., EAST  
BRUNSWICK, NJ:  
4,592,761. PUB. 6-10-2014. INT. CL. 41.

NATIONAL FLIGHT SERVICES, INC., SWANTON, OH, DBA  
NATIONAL FLIGHT:  
2,793,851. CANC. INT. CL. 37.

NATIONAL FOOTBALL LEAGUE, NEW YORK, NY:  
4,592,317. PUB. 6-10-2014. INT. CL. 36.

NATIONAL FORENSIC LEAGUE, RIPON, WI:  
4,594,588. MULTIPLE CLASS, INT. CLS. 35 AND 41.

NATIONAL FOUNDATION FOR ADVANCEMENT IN THE  
ARTS, INC., MIAMI, FL:  
3,351,408. CANC. INT. CL. 16.

NATIONAL GEOGRAPHIC SOCIETY, WASHINGTON, DC:  
4,593,170. INT. CL. 16.

NATIONAL GYPSUM PROPERTIES, LLC, CHARLOTTE,  
NC:  
3,353,412. CANC. MULTIPLE CLASS, INT. CLS. 2 AND  
17.

NATIONAL HOT ROD ASSOCIATION, GLENDORA, CA:  
4,594,172. INT. CL. 25.

NATIONAL INSURANCE AND INDEMNITY CORPORA-  
TION, BURLINGTON, VT, GREYHOUND CORPORA-  
TION, THE, PHOENIX, AZ:  
989,213. REN. 7-24-14. U.S. CL. 105 (INT. CL. 39).

NATIONAL INVESTORS, INC., REDFIELD, IA:  
2,862,938. REN. 7-24-14. INT. CL. 36.

NATIONAL LAND TITLE INSURANCE COMPANY, HOFF-  
MAN ESTATES, IL:  
3,351,103. CANC. INT. CL. 36.

NATIONAL OAK DISTRIBUTORS, INC., WEST PALM  
BEACH, FL:  
4,592,750. PUB. 6-10-2014. INT. CL. 2.

NATIONAL PASTEURIZED EGGS, LLC, LANSING, IL:  
4,591,321. PUB. 6-10-2014. INT. CL. 29.

NATIONAL PORK BOARD, CLIVE, IA:  
2,870,432. REN. 7-23-14. MULTIPLE CLASS, INT. CLS. 16,  
25, 35 AND 41.

NATIONAL PRESTO INDUSTRIES, INC., EAU CLAIRE, WI:  
1,294,361. REN. 7-21-14. INT. CL. 21.  
1,294,361. AM. INT. CL. 21.

- NATIONAL SPORTS CENTER FOR THE DISABLED, INC., DENVER, CO:  
3,353,054, CANC. INT. CL. 35.
- NATIONAL TRADE PRODUCTIONS, INC., ALEXANDRIA, VA:  
4,594,754, MULTIPLE CLASS, INT. CLS. 35 AND 41.
- NATIONAL VITAMIN CO., INC., CASA GRANDE, AZ:  
1,303,410, REN. 7-18-14, INT. CL. 5.
- NATIONAL WATERMELON PROMOTION BOARD, ORLANDO, FL:  
1,846,052, REN. 7-18-14, INT. CL. 42.
- NATIONWIDE EVICTION SERVICES, LLC, CHARLOTTE, NC:  
4,591,669, PUB. 6-10-2014, INT. CL. 42.
- NATROL, CHATSWORTH, CA:  
4,592,491, PUB. 6-10-2014, INT. CL. 5.
- NATROL, INC., CHATSWORTH, CA:  
4,592,090, PUB. 6-10-2014, INT. CL. 5.
- NATURAL BEST NUTRITION INC., HALLANDALE, FL:  
4,594,780, MULTIPLE CLASS, INT. CLS. 5 AND 35.
- NATURAL FACTORS NUTRITIONAL PRODUCTS LTD., COQUITLAM, BC, CANADA:  
4,593,526, INT. CL. 5.
- NATURAL MOTIVES LLC, CORAL GABLES, FL:  
4,593,311, INT. CL. 32.
- NATURAL ORGANICS, INC., MELVILLE, NY:  
3,354,198, CANC. INT. CL. 5.
- NATURALICIOUS, LLC, CANTON, MI:  
4,592,148, PUB. 6-10-2014, INT. CL. 3.
- NATURE TECHNOLOGIES, INC., BRADENTON, FL:  
2,793,836, CANC. INT. CL. 5.
- NATURE'S DYNAMICS, ORLANDO, FL:  
4,591,660, PUB. 6-10-2014, INT. CL. 5.
- NATURELAND PRODUCTS LTD., BURNABY, BC, CANADA:  
3,353,161, CANC. INT. CL. 32.
- NATUREX-DBS LLC, S. HACKENSACK, NJ:  
4,593,183, INT. CL. 5.
- NAUGHTY BISCOTTI, INC., SANTA CLARA, CA:  
2,794,723, CANC. INT. CL. 30.
- NAVAJO AGRICULTURAL PRODUCTS INDUSTRY, FARMINGTON, NM:  
3,351,872, CANC. MULTIPLE CLASS, INT. CLS. 30 AND 31.
- NAVITAS LLC, NOVATO, CA:  
4,590,960, PUB. 6-10-2014, MULTIPLE CLASS, INT. CLS. 5, 29 AND 30.
- NBA PROPERTIES, INC., NEW YORK, NY:  
2,796,023, CANC. INT. CL. 25.
- NBCUNIVERSAL MEDIA, LLC, NEW YORK, NY:  
4,593,518, INT. CL. 41.
- NCF COMPUTING & NETWORK SERVICES, INC., OCALA, FL:  
3,352,368, CANC. MULTIPLE CLASS, INT. CLS. 37 AND 42.
- NCI GROUP, INC., HOUSTON, TX:  
4,592,092, PUB. 6-10-2014, INT. CL. 6.
- NCL CORPORATION LTD., MIAMI, FL:  
4,591,296, PUB. 6-10-2014, INT. CL. 41.  
4,591,298, PUB. 6-10-2014, INT. CL. 41.
- NCS PEARSON, INC., BLOOMINGTON, MN:  
2,794,629, CANC. INT. CL. 9.
- NCSoft CORPORATION, SEOUL, REPUBLIC OF KOREA:  
3,353,241, CANC. INT. CL. 9.
- NCSTAR INC., CITY OF INDUSTRY, CA:  
4,593,399, INT. CL. 9.
- NDC INFRARED ENGINEERING LIMITED, MALDON ESSEX, UNITED KINGDOM:  
2,793,695, CANC. INT. CL. 9.
- NDN STAR, ENCINO, CA:  
4,592,856, PUB. 6-10-2014, INT. CL. 32.
- NEAL FAMILY VINEYARDS LLC, ST. HELENA, CA:  
3,351,889, CANC. INT. CL. 33.
- NEAL, MARCUS T. C., EAST SAINT LOUIS, IL:  
3,351,985, CANC. INT. CL. 25.
- NEENAH PAPER, INC., ALPHARETTA, GA, SIMPSON LEE PAPER COMPANY, SAN FRANCISCO, CA:  
992,007, REN. 7-23-14, U.S. CL. 37 (INT. CL. 16).
- NEFF, LLC, CAMARILLO, CA:  
4,591,489, PUB. 6-10-2014, MULTIPLE CLASS, INT. CLS. 14 AND 25.
- NEGOCIANTS NEW ZEALAND LIMITED, REMUERA, AUCKLAND, NEW ZEALAND:  
4,593,407, INT. CL. 33.
- NEGOTIATION EXPERTISE, LLC, PEORIA, AZ:  
4,594,648, INT. CL. 41.
- NEIGHBORHOOD SNOOP, DAWSONVILLE, GA:  
3,351,443, CANC. INT. CL. 36.
- NEIGHBORHOOD STORAGE CENTER CO. CORPORATION, OCALA, FL:  
3,351,362, CANC. INT. CL. 39.
- NEKAI CORP, HONOLULU, HI:  
4,592,710, PUB. 6-10-2014, INT. CL. 36.
- NELLA CHUNKY, LAS VEGAS, NV:  
4,591,305, PUB. 6-10-2014, MULTIPLE CLASS, INT. CLS. 9, 25 AND 30.
- NELSON, RENDY S., CHICAGO, IL:  
3,351,343, CANC. INT. CL. 44.
- NEOGEN CORPORATION, LANSING, MI:  
4,594,541, INT. CL. 1.
- NERDVANA COMPUTING, LLC, BATON ROUGE, LA, DBA NERDWORKS COMPUTING:  
2,795,879, CANC. INT. CL. 35.  
2,795,880, CANC. INT. CL. 35.
- NERDY STUDIOS, LLC, CHARLOTTE, NC:  
3,352,914, CANC. INT. CL. 9.
- NERO AG, KARLSBAD-ITTERSBAACH, FED REP GERMANY:  
2,863,815, REN. 7-19-14, INT. CL. 9.
- NESHAMA INTERFAITH CENTER INC., ALPHARETTA, GA:  
4,592,288, PUB. 6-10-2014, INT. CL. 41.  
4,592,292, PUB. 6-10-2014, INT. CL. 41.
- NEST SEEKERS LLC, NEW YORK, NY:  
4,591,867, PUB. 6-10-2014, INT. CL. 36.  
4,591,870, PUB. 6-10-2014, INT. CL. 36.  
4,591,897, PUB. 6-10-2014, INT. CL. 36.
- NET HEALTH SYSTEMS, INC., PITTSBURGH, PA:  
4,593,507, MULTIPLE CLASS, INT. CLS. 9, 16, 21 AND 41.
- NETHRA IMAGING INC., CUPERTINO, CA:  
3,354,315, CANC. INT. CL. 9.
- NETWORK BEAUTY & FASHION COSMÉTICA LTDA, SÃO PAULO-SP, BRAZIL:  
4,593,473, MULTIPLE CLASS, INT. CLS. 3 AND 35.
- NETWORKING SEMINARS INC., SCARSDALE, NY:  
4,591,332, PUB. 6-10-2014, INT. CL. 41.
- NETWORKS MARKETING GROUP, INC., CONCORD, NC:  
3,351,281, CANC. INT. CL. 35.
- NETZSCH-GERÄTEBAU GMBH, FED REP GERMANY:  
4,590,899, PUB. 6-10-2014, INT. CL. 9.
- NEUROSCIENCES RESEARCH FOUNDATION, INC., SAN DIEGO, CA:  
2,795,146, CANC. INT. CL. 9.
- NEUROSOFT CORP., BOCA RATON, FL:  
3,351,708, CANC. INT. CL. 10.
- NEVER SAY DIE PRODUCTIONS, INC., LOS ANGELES, CA:  
3,354,239, CANC. INT. CL. 25.
- NEW & LINGWOOD LIMITED, ETON, WINDSOR, BERKSHIRE, UNITED KINGDOM:  
4,594,213, INT. CL. 25.
- NEW AGEING INTERNATIONAL PTY LTD, SOUTH MELBOURNE, AUSTRALIA:  
4,591,164, PUB. 6-10-2014, INT. CL. 5.
- NEW ALBERTSON'S, INC., BOISE, ID:  
4,594,281, MULTIPLE CLASS, INT. CLS. 35 AND 44.
- NEW BALANCE ATHLETIC SHOE, INC., BOSTON, MA:  
3,352,847, CANC. INT. CL. 25.
- NEW BALANCE TORONTO LTD., TORONTO, ONTARIO, CANADA:  
4,593,436, INT. CL. 35.
- NEW ENGLAND AIKIKAI, INC., CAMBRIDGE, MA:  
3,352,842, CANC. INT. CL. 16.
- NEW ENGLAND BIOLABS, INC., IPSWICH, MA:  
4,594,563, INT. CL. 1.

NEW ENGLAND FARMS, INC., ASSONET, MA:  
4,591,945, PUB. 6-10-2014. INT. CL. 35.  
4,591,969, PUB. 6-10-2014. INT. CL. 35.

NEW GENERATION COMPUTING, INC., MIAMI LAKES, FL:  
3,352,149, CANC. INT. CL. 9.

NEW HAMPSHIRE PLASTICS, INC., MANCHESTER, NH:  
3,353,315, CANC. INT. CL. 17.

NEW JERSEY LAWYERS SERVICE, LLC, UNION, NJ, AKA NJLS COURIERS:  
4,592,622, PUB. 6-10-2014. INT. CL. 39.

NEW JERSEY WATERFOWLERS ASSOCIATION, INC., MONMOUTH BEACH, NJ:  
4,591,883, PUB. 6-10-2014. INT. CL. 41.

NEW KADAMPA TRADITION - INTERNATIONAL KADAMPA BUDDHIST UNION, ULVERSTON GB-CMA, UNITED KINGDOM:  
4,592,015, PUB. 6-10-2014. MULTIPLE CLASS, INT. CLS. 41 AND 45.

NEW KADAMPA TRADITION - INTERNATIONAL KADAMPA BUDDHIST UNIO, ULVERSTON GB-CMA, UNITED KINGDOM:  
4,592,041, PUB. 6-10-2014. MULTIPLE CLASS, INT. CLS. 41 AND 45.

NEW MEXICO CANCER CENTER FOUNDATION, ALBUQUERQUE, NM:  
3,350,656, CANC. INT. CL. 36.

NEW MILLENNIUM RECORDS, NEW YORK, NY:  
4,591,408, PUB. 6-10-2014. INT. CL. 35.

NEW SEABURY PROPERTIES, LLC, MT. KISCO, NY:  
994,126. REN. 7-19-14. U.S. CL. 101 (INT. CL. 36).

NEW SENSOR CORPORATION, LONG ISLAND CITY, NY:  
1,893,033. REN. 7-22-14. INT. CL. 9.

NEW STAGES HOME DESIGN, INC., ROCHESTER HILLS, MI:  
3,352,502, CANC. INT. CL. 42.

NEW STANLEY ASSOCIATES, LLLP, ESTES PARK, CO:  
4,593,716, INT. CL. 44.

NEW STETIC S.A., GUARNE, ANTIOQUIA, COLOMBIA:  
4,592,857, PUB. 6-10-2014. INT. CL. 10.

NEW VISION DISPLAY, INC., ROSEVILLE, CA:  
4,591,727, PUB. 6-10-2014. MULTIPLE CLASS, INT. CLS. 1 AND 9.  
4,591,729, PUB. 6-10-2014. MULTIPLE CLASS, INT. CLS. 1 AND 9.

NEW YORK COMMUNITY BANCORP, INC., WESTBURY, NY:  
4,592,408, PUB. 6-10-2014. INT. CL. 36.

NEW YORK INTERACTIVE MEDIA, INC, BROOKLYN, NY:  
3,351,333, CANC. INT. CL. 41.

NEW YORK LIFE INSURANCE COMPANY, NEW YORK, NY:  
1,341,463. REN. 7-24-14. INT. CL. 36.

NEW YORK MANOTO, WOODLAND HILLS, CA:  
3,352,264, CANC. INT. CL. 42.

NEW YORK UNIVERSITY, NEW YORK, NY:  
4,593,471, MULTIPLE CLASS, INT. CLS. 38, 41 AND 44.

NEWGISTICS, INC., AUSTIN, TX:  
4,594,048, MULTIPLE CLASS, INT. CLS. 35, 39, 40 AND 42.  
4,594,258, MULTIPLE CLASS, INT. CLS. 35, 39, 40 AND 42.

NEWPAGE CORPORATION, MIAMISBURG, OH:  
3,353,374, CANC. INT. CL. 1.

NEWPORT APOTHECARY, INC., NEWPORT BEACH, CA:  
4,592,194, PUB. 6-10-2014. INT. CL. 3.

NEWPORT COMPUTER SERVICES, INC., ROCHESTER, NH, DBA NCS GLOBAL:  
4,594,397, INT. CL. 9.

NEWSDOCK LIMITED, LEAMINGTON SPA, UNITED KINGDOM:  
4,591,964, PUB. 6-10-2014. INT. CL. 42.

NEWSPAPER AGENCY COMPANY, LLC, WEST VALLEY CITY, UT:  
3,354,526, CANC. MULTIPLE CLASS, INT. CLS. 16 AND 35.

NEWTELL SOLUTIONS, LLC, MIRAMAR, FL:  
4,593,734, INT. CL. 9.  
4,593,735, INT. CL. 9.

NEXANS, FRANCE:  
3,352,669.

NEXGEN PACKAGING, LLC, ROMEVILLE, IL:  
4,591,064, PUB. 6-10-2014. MULTIPLE CLASS, INT. CLS. 16 AND 24.

NEXSEM, INC., IRVINE, CA:  
3,351,423, CANC. INT. CL. 9.

NEXT INNOVATIONS, LTD., WALKER, MN:  
3,351,291, CANC. INT. CL. 16.  
3,351,293, CANC. INT. CL. 16.

NEXT STEP LIVING, INC., BOSTON, MA:  
4,591,330, PUB. 6-10-2014. INT. CL. 37.

NGN NEW GENERATION NETWORK GMBH, BERLIN, FED REP GERMANY:  
3,351,286, CANC. INT. CL. 35.

NGUYEN, TUONG, WESTMINSTER, CA:  
4,350,348 NEW CERT. 8-26-2014. INT. CL. 3.

NICE TIGHT WHITE ASH, LLC, FAIRHOPE, AL:  
4,593,990, MULTIPLE CLASS, INT. CLS. 25 AND 34.

NICHOLS, JENNA, MADISON, OH:  
4,592,180, PUB. 6-10-2014. INT. CL. 42.

NICKERSON, RODERICK N., FORT WORTH, TX:  
3,353,603, CANC. INT. CL. 25.

NICOPURE LABS, LLC, POMPTON PLAINS, NJ:  
4,591,059, PUB. 6-10-2014. MULTIPLE CLASS, INT. CLS. 1 AND 30.

NICOX SA, 06560 VALBONNE, FRANCE:  
3,352,316, CANC. INT. CL. 5.

NIDEC MOTOR CORPORATION, ST. LOUIS, MO:  
2,881,662. REN. 7-24-14. INT. CL. 7.

NIDRAS & ASSOCIATES INC, SAN FRANCISCO, CA:  
2,794,980, CANC. INT. CL. 3.

NIEBAUM-COPPOLA ESTATE WINERY, L.P., NAPA, CA:  
2,794,059, CANC. INT. CL. 33.  
3,353,682, CANC. INT. CL. 33.

NIGHTSCAPING, LLC, WEST CHESTER, PA:  
770,661. REN. 7-23-14. U.S. CL. 21 (INT. CL. 11).

NIJEL BINNS, LOS ANGELES, CA:  
4,592,298, PUB. 6-10-2014. INT. CL. 6.

NIKI BARR ENTERPRISES, LLC, ANNAPOLIS, MD:  
4,593,998, MULTIPLE CLASS, INT. CLS. 9 AND 41.

NIKKISO CO., LTD., JAPAN:  
4,590,925, PUB. 6-10-2014. INT. CL. 10.

NIKSUN, INC., PRINCETON, NJ:  
2,794,596, CANC. INT. CL. 9.

NILES STEEL TANK COMPANY, NILES, MI:  
4,593,212, MULTIPLE CLASS, INT. CLS. 6 AND 11.

NILFISK-ADVANCE, INC., PLYMOUTH, MN:  
3,353,060, CANC. INT. CL. 7.

NIMBLETV, INC., NEW YORK, NY:  
4,593,549, MULTIPLE CLASS, INT. CLS. 9, 38 AND 42.

NIMVIA, LLC, CHARLOTTE, NC:  
4,593,084, INT. CL. 42.

NINGBO SUNLIGHT MOTOR PARTS CO., LTD., 315175, CHINA:  
4,593,807, INT. CL. 12.

NINJA MOBILE, INC., TORRANCE, CA:  
3,354,154, CANC. INT. CL. 38.

NINTENDO OF AMERICA INC., REDMOND, WA:  
2,793,457, CANC. INT. CL. 9.

NINTH INNING BASEBALL, LLC, CHAMBLEE, GA:  
4,590,981, PUB. 12-24-2013. INT. CL. 25.

NIPPON DENKI KABUSHIKI KAISHA, TOKYO, JAPAN, DBA NEC CORPORATION:  
4,593,921, INT. CL. 9.

NIPPON SODA CO., LTD., CHIYODA-KU, TOKYO, JAPAN:  
4,593,574, INT. CL. 5.

NIPPON STEEL & SUMITOMO METAL CORPORATION, JAPAN:  
4,590,936, PUB. 6-10-2014. INT. CL. 6.

NIS HOLDINGS LLC, EDGEWATER, NJ:  
4,592,736, PUB. 6-10-2014. INT. CL. 9.

NISSAN JIDOSHA KABUSHIKI KAISHA, YOKOHAMA-SHI, KANAGAWA, JAPAN:  
2,915,691. REN. 7-24-14. INT. CL. 12.

- NISSAN JIDOSHA KABUSHIKI KAISHA, YOKOHAMA-SHI, KANAGAWA, JAPAN, TA NISSAN MOTOR CO., LTD.:  
4,591,329, PUB. 5-6-2014. INT. CL. 16.  
4,591,648, PUB. 4-22-2014. INT. CL. 9.
- NISSHINBO HOLDINGS INC., CHUO-KU, TOKYO, JAPAN:  
2,872,086. REN. 7-18-14. INT. CL. 1.  
2,872,086, CANC. INT. CL. 2.
- NISSIN DENTAL PRODUCTS, INC., KYOTO-SHI, KYOTO, JAPAN:  
4,591,855, PUB. 6-10-2014. INT. CL. 9.
- NITROUS LTD., NEW YORK, NY:  
2,965,201. REN. 7-24-14. INT. CL. 41.
- NO FEAR USA LIMITED, SHIREBROOK, UNITED KINGDOM:  
4,594,186, INT. CL. 18.  
4,594,187, INT. CL. 25.
- NO. 131 HOLDINGS INC., BROOKLYN, NY:  
4,593,671, INT. CL. 14.  
4,593,680, INT. CL. 14.
- NOBLE COLLECTIVE LLC, AZLE, TX:  
4,592,538, PUB. 6-10-2014. INT. CL. 25.
- NOBLE WARRIORS, INC., MIDLOTHIAN, VA:  
4,591,241, PUB. 6-10-2014. INT. CL. 45.
- NOK NOK LABS, INC., PALO ALTO, CA:  
4,593,462, INT. CL. 42.  
4,593,463, INT. CL. 42.  
4,593,464, INT. CL. 9.  
4,593,465, INT. CL. 9.  
4,593,466, INT. CL. 9.
- NOKIA CORPORATION, 02150 ESPOO, FINLAND:  
3,351,967, CANC. MULTIPLE CLASS, INT. CLS. 9, 38 AND 41.
- NOKIAN TYRES PLC, FINLAND:  
4,590,855, PUB. 6-10-2014. MULTIPLE CLASS, INT. CLS. 12 AND 35.
- NOLTERPHARMA, CORP., DELRAY BEACH, FL:  
3,354,431, CANC. INT. CL. 5.
- NOLTING MANUFACTURING, INC., HIAWATHA, IA:  
2,908,290. REN. 7-22-14. INT. CL. 7.
- NOOSA SURF COMPANY PTY LTD, TEWANTIN QLD 4565, AUSTRALIA:  
3,352,586.
- NORA PALLER, LOS ANGELES, CA:  
4,591,868, PUB. 6-10-2014. INT. CL. 41.
- NORDIC NATURALS, INC., WATSONVILLE, CA:  
4,594,309, INT. CL. 5.
- NORLUX CORP., CAROL STREAM, IL:  
2,794,236, CANC. INT. CL. 11.
- NORM THOMPSON OUTFITTERS, INC., BEVERLY, MA:  
1,284,733. REN. 7-18-14. INT. CL. 42.
- NORMERICA INC., PORT CREDIT, CANADA, AKA NORTHDOWN INDUSTRIES INC.:  
4,590,991, PUB. 6-10-2014. INT. CL. 31.
- NORPAC FOODS, INC., LAKE OSWEGO, OR:  
1,875,397. REN. 7-19-14. INT. CL. 29.  
3,352,819, CANC. INT. CL. 29.
- NORTE SALINEIRA SA IND. E COM. - NORSAL, BRANCA, BRAZIL:  
4,591,209, PUB. 10-29-2013. INT. CL. 30.
- NORTH AMERICA AUDIO GROUP, INC., EMERSON, NJ:  
3,350,678, CANC. INT. CL. 9.
- NORTH AMERICAN POLO LEAGUE, LLC, HOUSTON, TX:  
3,354,534, CANC. MULTIPLE CLASS, INT. CLS. 35 AND 41.
- NORTH AMERICAN SPECIALTY PRODUCTS LLC, HOUSTON, TX:  
1,862,516. REN. 7-24-14. INT. CL. 19.
- NORTH COAST SEA-FOODS CORP., BOSTON, MA:  
2,871,009. REN. 7-24-14. MULTIPLE CLASS, INT. CLS. 35 AND 39.
- NORTH PACIFIC YACHTS INC, SURREY, CANADA:  
3,353,510, CANC. INT. CL. 12.
- NORTH SHORE SOAP FACTORY, INC., WAIALUA, HI:  
4,592,140, PUB. 6-10-2014. INT. CL. 3.
- NORTHERN JET MANAGEMENT, INC., GRAND RAPIDS, MI:  
2,942,572. REN. 7-21-14. INT. CL. 36.
- NORTHERN TRUST CORPORATION, CHICAGO, IL, NORTHERN TRUST COMPANY; THE, CHICAGO, IL:  
1,309,341. REN. 7-22-14. INT. CL. 36.
- NORTHWEST MONTANA HUMAN RESOURCES, INC., KALISPELL, MT:  
3,511,652, COR. INT. CL. 44.
- NORTON, LINDA C., TINTON FALLS, NJ:  
2,794,943, CANC. INT. CL. 42.
- NOVA SOUTHEASTERN UNIVERSITY, INC., FORT LAUDERDALE, FL:  
1,924,170, AM. INT. CL. 41.
- NOVA, VICTOR, H., SANTA ANA, CA AND FLORES, EDUARDO, SANTA ANA, CA AND URRUTIA, LUIS, SANTA ANA, CA AND URRUTIA, AGUSTIN, SANTA ANA, CA AND URRUTIA, FLAVIO, SANTA ANA, CA AND URRUTIA, HECTOR, SANTA ANA, CA:  
3,352,249, CANC. MULTIPLE CLASS, INT. CLS. 9 AND 41.
- NOVARTIS AG, BASEL, SWITZERLAND:  
3,353,223, CANC. INT. CL. 10.
- NOVARTIS AG, SWITZERLAND:  
4,590,913, PUB. 6-10-2014. INT. CL. 5.  
4,590,926, PUB. 6-10-2014. INT. CL. 5.  
4,590,927, PUB. 6-10-2014. INT. CL. 5.  
4,590,928, PUB. 6-10-2014. INT. CL. 5.  
4,590,929, PUB. 6-10-2014. INT. CL. 5.  
4,590,930, PUB. 6-10-2014. INT. CL. 5.  
4,590,931, PUB. 6-10-2014. INT. CL. 5.  
4,590,932, PUB. 6-10-2014. INT. CL. 5.  
4,590,933, PUB. 6-10-2014. INT. CL. 5.  
4,590,934, PUB. 6-10-2014. INT. CL. 5.  
4,590,935, PUB. 6-10-2014. INT. CL. 5.
- NOVARTIS AG, BASEL, SWITZERLAND:  
4,591,133, PUB. 6-10-2014. INT. CL. 10.
- NOVARTIS CONSUMER HEALTH, INC., PARSIPPANY, NJ:  
1,757,530, CANC. INT. CL. 5.
- NOVASENTIS, INC., BURLINGAME, CA:  
4,593,454, INT. CL. 9.
- NOVELLO S.R.L., ITALY:  
4,590,830, PUB. 6-10-2014. MULTIPLE CLASS, INT. CLS. 6, 9 AND 18.
- NOVOGRATZ, ROBERT, NEW YORK, NY AND NOVOGRATZ, COURTNEY, NEW YORK, NY:  
4,590,979, PUB. 6-10-2014. MULTIPLE CLASS, INT. CLS. 21 AND 24.
- NOVOXEL LTD., NATANIA, ISRAEL:  
4,592,599, PUB. 6-10-2014. INT. CL. 10.  
4,592,600, PUB. 6-10-2014. INT. CL. 10.
- NOVUQARE B.V., NETHERLANDS:  
4,590,757, PUB. 6-10-2014. INT. CL. 10.
- NP IP HOLDINGS LLC, LAS VEGAS, NV:  
4,593,240, INT. CL. 41.
- NSI INDUSTRIES, LLC, HUNTERSVILLE, NC:  
2,793,956, CANC. INT. CL. 9.
- NTN BUZZTIME, INC., CARLSBAD, CA:  
2,794,441, CANC. INT. CL. 41.  
4,591,877, PUB. 6-10-2014. MULTIPLE CLASS, INT. CLS. 35 AND 41.
- NU AIR CORP., ROCK HILL, SC:  
2,794,899, CANC. INT. CL. 7.
- NUECO ENTERPRISES INC., SURREY, BC, CANADA:  
4,591,021, PUB. 12-24-2013. INT. CL. 9.
- NUNES D'AGRELLA, PETER ENRIQUE, JEFFERSON VALLEY, NY:  
3,352,362, CANC. MULTIPLE CLASS, INT. CLS. 9 AND 35.
- NURTURE, INC., NEW YORK, NY:  
4,594,362, INT. CL. 29.
- NUÑO, JORGE, LOS ANGELES, CA, DBA ROSARIO:  
4,594,002, INT. CL. 25.
- NUTRACLICK, LLC, BOSTON, MA:  
4,593,279, INT. CL. 5.  
4,594,374, INT. CL. 5.
- NUTRAMARKS, INC, PARK CITY, UT:  
2,793,887, CANC. INT. CL. 3.
- NUTRAMAX LABORATORIES, INC., EDGEWOOD, MD:  
3,354,562, CANC. INT. CL. 5.

NUTRITHORITY LLC, WICHITA, KS:  
4,594,481, INT. CL. 5.

NYCON CORPORATION, FAIRLESS HILLS, PA:  
4,591,886, PUB. 6-10-2014. INT. CL. 19.  
4,592,034, PUB. 6-10-2014. INT. CL. 19.

O.C. TANNER COMPANY, SALT LAKE CITY, UT:  
3,352,098, CANC. MULTIPLE CLASS, INT. CLS. 9, 16  
AND 41.  
3,352,100, CANC. MULTIPLE CLASS, INT. CLS. 9, 16  
AND 41.

O'BRIEN DISTRIBUTING, PETALUMA, CA:  
4,592,511, PUB. 6-10-2014. INT. CL. 3.

O'CONNELL MARKETING PTY LTD, AUSTRALIA:  
3,352,743.

O'CONNOR PROFESSIONAL GROUP, LLC, BOSTON, MA:  
4,592,607, PUB. 6-10-2014. INT. CL. 44.

O'DONNELL, EILEEN M., NORRIDGE, IL:  
1,899,965, REN. 7-19-14. INT. CL. 25.

O'NEILL BEVERAGE CO., LTD., PARLIER, CA:  
2,964,738, REN. 7-24-14. INT. CL. 33.

OA MANAGER, INC., BELLEVUE, WA:  
3,353,849, CANC. INT. CL. 35.

OAK FINANCIAL SOFTWARE CORP., SOUTH BEND, IN:  
4,594,030, INT. CL. 36.  
4,594,031, INT. CL. 36.

OAKLEAF WASTE MANAGEMENT, LLC, EAST HART-  
FORD, CT:  
3,352,336, CANC. INT. CL. 39.

OATS ANY TIME, PALMYRA, ME:  
4,591,107, PUB. 6-10-2014. INT. CL. 30.

OCCHIPINTI, CHRISTOPHER M., NORTH LAS VEGAS, NV  
AND CLARK, MICHELLE M., HENDERSON, NV:  
3,354,013, CANC. INT. CL. 25.

OCE-TECHNOLOGIES B.V., 5914 CA VENLO, NETHER-  
LANDS:  
2,793,555, CANC. MULTIPLE CLASS, INT. CLS. 9, 37  
AND 42.

OCEAN RIDERS ENGINEERING, INC., COCOA BEACH,  
FL:  
4,593,040, PUB. 6-10-2014. INT. CL. 42.

OCEANIC WINE BRANDS LIMITED, HEREFORDSHIRE,  
UNITED KINGDOM:  
3,352,612.

OCHOA MARQUEZ, JESUS ARTURO, CHICAGO, IL AND  
ALDERETE, JACQUELINE, CHICAGO, IL AND ROBLES,  
DELIA J, CHICAGO, IL:  
4,591,042, PUB. 6-10-2014. INT. CL. 41.

OCHSNER INTERNATIONAL, INC., WHEELING, IL:  
1,844,319, REN. 7-22-14. MULTIPLE CLASS, INT. CLS. 12  
AND 25.

OCPC, INC., SANTA ANA, CA:  
4,592,935, PUB. 6-10-2014. INT. CL. 3.

OCULUS INFO INC., TORONTO, ONTARIO, CANADA:  
3,548,601, CANC. INT. CL. 9.

ODELL BREWING COMPANY, FORT COLLINS, CO:  
4,594,546, INT. CL. 32.

ODL, INCORPORATED, ZEELAND, MI:  
2,796,182, CANC. INT. CL. 19.

ODYSSEY BEERWERKS, LLC, ARVADA, CO:  
4,591,602, PUB. 6-10-2014. INT. CL. 32.  
4,591,603, PUB. 6-10-2014. INT. CL. 32.

OFF CENTER LINE LLC, SCOTTSDALE, AZ:  
3,351,395, CANC. INT. CL. 21.

OH, SUNG, WEST COVINA, CA:  
3,353,361, CANC. MULTIPLE CLASS, INT. CLS. 6 AND 9.

OHIO FLAME, LLC, COLUMBIANA, OH:  
4,594,639, INT. CL. 11.

OHM & KARMA VENTURES, INC., NORTHRIDGE, CA:  
3,352,166, CANC. INT. CL. 5.

OHMING TECHNOLOGY, BOYNTON BEACH, FL:  
4,592,653, PUB. 6-10-2014. INT. CL. 9.

OJGAR S.R.O., PRAHA 5, CZECH REPUBLIC:  
1,875,103, REN. 7-20-14. INT. CL. 9.

OKI ELECTRIC INDUSTRY CO., LTD., TOKYO, JAPAN:  
4,593,286, INT. CL. 9.

OKLAHOMA BUSINESS ETHICS CONSORTIUM, INC.,  
OKLAHOMA CITY, OK:  
3,353,879, CANC. INT. CL. 41.

OKLAHOMA EMBROIDERY SUPPLY AND DESIGN, INC.,  
EDMOND, OK:  
2,794,244, CANC. INT. CL. 26.

OLAES ENTERPRISES, INC., POWAY, CA, DBA ODM:  
3,351,367, CANC. INT. CL. 25.

OLD MASTER PRODUCTS, INC., VAN NUYS, CA:  
4,592,576, PUB. 6-10-2014. INT. CL. 19.

OLD WORLD QUALITY FOODS, LLC., ELK GROVE  
VILLAGE, IL:  
4,593,171, INT. CL. 32.

OLIN CORPORATION, ST. LOUIS, MO:  
976,232, REN. 7-22-14. U.S. CL. 14 (INT. CL. 6).

OLINDA ELIZABETH LOPEZ DE GALILEA, ASUNCION,  
PARAGUAY:  
4,592,675, PUB. 6-10-2014. MULTIPLE CLASS, INT. CLS.  
14, 18 AND 25.

OLIVEROS, INC., MIAMI, FL:  
4,594,548, INT. CL. 34.

OLMSTEAD, JOSEPH DAVID, DAMMERON VALLEY, UT,  
DBA BEAUMONDE PRODUCTIONS:  
3,350,726, CANC. INT. CL. 9.

OLSON, LESLIE, ORLANDO, FL:  
4,593,978, INT. CL. 28.

OLSZEWSKI, MICHELLE, CHICAGO, IL:  
3,351,488, CANC. INT. CL. 30.

OLYMPUS CORPORATION, TOKYO, JAPAN:  
3,353,166, CANC. INT. CL. 10.  
3,353,232, CANC. INT. CL. 37.  
3,353,255, CANC. INT. CL. 37.

OMAX CORPORATION, KENT, WA:  
4,591,275, PUB. 6-10-2014. INT. CL. 9.

OMEGA FINANCIAL GROUP, SANTA BARBARA, CA:  
4,591,326, PUB. 6-10-2014. INT. CL. 36.

OMEGA SA (OMEGA AG) (OMEGA LTD.), BIENNE, SWIT-  
ZERLAND:  
1,290,661, REN. 7-24-14. INT. CL. 14.

OMEGA SEA, INC., NEWPORT, RI:  
4,594,775, INT. CL. 29.

OMIDYAR NETWORK COMMONS, LLC, REDWOOD CITY,  
CA:  
4,119,060, COR. MULTIPLE CLASS, INT. CLS. 35, 36, 41  
AND 45.

OMNI CABLE CORPORATION, WEST CHESTER, PA:  
4,594,216, INT. CL. 9.

OMNI PARTNERS, LLC, ATLANTA, GA:  
4,594,357, INT. CL. 41.

OMNIVANT, LLC, PLEASANTON, CA:  
3,354,011, CANC. INT. CL. 42.

OMRON CORPORATION, KYOTO-CITY, JAPAN:  
3,352,048, CANC. MULTIPLE CLASS, INT. CLS. 9 AND  
42.

OMRON CORPORATION, JAPAN:  
3,352,695.

OMRON HEALTHCARE, INC., LAKE FOREST, IL:  
4,594,421, INT. CL. 9.

ONCEPT, INC., PALO ALTO, CA:  
3,354,398, CANC. INT. CL. 9.

ONCQUE CORPORATION, TAICHUNG, TAIWAN:  
4,590,947, PUB. 6-10-2014. INT. CL. 9.

ONE BEER AT A TIME, LLC, GRAND RAPIDS, MI:  
4,591,186, PUB. 6-10-2014. INT. CL. 32.

ONE CENT TECHNOLOGIES HOLDINGS PTY LTD, MEL-  
BOURNE, VICTORIA, AUSTRALIA:  
4,591,824, PUB. 6-10-2014. MULTIPLE CLASS, INT. CLS.  
35 AND 39.

ONE OF A KIND PRODUCTS, INC., WARREN, MI:  
3,353,573, CANC. INT. CL. 16.

ONE TWO THREE FOUR INC, BKLYN, NY:  
4,369,460, CANC. INT. CL. 29.

ONE WORKPLACE L. FERRARI, LLC, SANTA CLARA, CA:  
2,866,541, REN. 7-22-14. MULTIPLE CLASS, INT. CLS. 35  
AND 42.

ONE WORLD IN CONCERT, INC., NEW YORK, NY:  
4,593,980, INT. CL. 41.

ONEDA HOLDINGS GROUP COMPANY LIMITED, HON-  
GKONG, CHINA:  
4,592,150, PUB. 6-10-2014. INT. CL. 9.

- ONESEAL A/S, DENMARK:  
3,352,566.
- ONION CRUNCH, INC., NEW YORK, NY:  
4,593,266, INT. CL. 29.
- ONLINE FUTURE INC., PORT ST. LUCIE, FL:  
3,351,057, CANC. INT. CL. 5.
- ONLINE HOLDINGS, LLC, ST. CHARLES, IL:  
3,353,769, CANC. MULTIPLE CLASS, INT. CLS. 39 AND 43.  
3,354,070, CANC. MULTIPLE CLASS, INT. CLS. 38 AND 39.
- ONTARIO GOOD ROADS ASSOCIATION, OAKVILLE, ONTARIO, CANADA:  
4,590,942, PUB. 6-10-2014. MULTIPLE CLASS, INT. CLS. 35, 36 AND 42.  
4,590,943, PUB. 6-10-2014. MULTIPLE CLASS, INT. CLS. 35, 36 AND 42.
- ONTECH DELAWARE INC., SAN DIEGO, CA:  
3,353,837, CANC. MULTIPLE CLASS, INT. CLS. 29 AND 30.
- OUBLADA, MONTREUIL SOUS BOIS, FRANCE:  
4,593,392, INT. CL. 41.
- OPC MARKETING, INC., ADDISON, TX:  
4,593,048, PUB. 6-10-2014. INT. CL. 9.
- OPEN COMPLIANCE & ETHICS GROUP, PHOENIX, AZ:  
3,648,287, CANC. MULTIPLE CLASS, INT. CLS. 36, 41, 42 AND 45.
- OPEN DOOR STUDIOS, SEATTLE, WA:  
3,354,428, CANC. INT. CL. 41.
- OPEN MIND TECHNOLOGIES AG, WESSLING, FED REP GERMANY:  
4,590,646, PUB. 6-10-2014. MULTIPLE CLASS, INT. CLS. 9, 16, 41 AND 42.
- OPENING CEREMONY IP LLC, NEW YORK, NY:  
4,592,812, PUB. 6-10-2014. MULTIPLE CLASS, INT. CLS. 18, 25 AND 35.
- OPENMED, WINDERMERE, FL:  
4,592,422, PUB. 6-10-2014. MULTIPLE CLASS, INT. CLS. 9 AND 42.
- OPERATION BBQ RELIEF, PLEASANT HILL, MO:  
4,592,198, PUB. 6-10-2014. MULTIPLE CLASS, INT. CLS. 35 AND 36.
- OPERATION DOG TAG, EAGAN, MN:  
4,592,039, PUB. 6-10-2014. INT. CL. 39.
- OPERATION INTERDEPENDENCE, GRAND JUNCTION, CO:  
2,866,683, REN. 7-21-14. INT. CL. 39.
- OPERATIONAL MEMORY L.L.C., RALEIGH, NC:  
3,353,928, CANC. INT. CL. 9.
- OPHTHALMIC AND OCULOPLASTIC SURGERY, INC., CHARDON, OH, DBA KELLIS EYE CENTER:  
4,592,302, PUB. 6-10-2014. INT. CL. 44.
- OPODO LIMITED, LONDON, UNITED KINGDOM:  
2,897,041, REN. 7-23-14. MULTIPLE CLASS, INT. CLS. 39 AND 42.
- OPPORTUNITY DETROIT LLC, DETROIT, MI:  
4,591,346, PUB. 6-10-2014. INT. CL. 35.
- OPPORTUNITY HOLDING CO., LLC, HENDERSON, NV:  
4,592,697, PUB. 6-10-2014. INT. CL. 5.  
4,592,887, PUB. 6-10-2014. INT. CL. 5.
- OPTICAL ZONU CORPORATION, VAN NUYS, CA, DBA OPTICAL ZONU CORPORATION:  
4,591,876, PUB. 6-10-2014. INT. CL. 9.
- OPTIMA WORLDWIDE LTD., KOLOA, HI:  
4,593,919, INT. CL. 1.
- OPTION ONE ENERGY, LLC., CHICAGO, IL:  
4,591,457, PUB. 6-10-2014. INT. CL. 35.
- OPTRONICS INTERNATIONAL, LLC, TULSA, OK:  
1,285,931, REN. 7-19-14. INT. CL. 11.
- ORACLE AMERICA, INC., REDWOOD SHORES, CA:  
2,881,993, REN. 7-24-14. INT. CL. 9.
- ORANGE COUNTY BAR FOUNDATION, INC., SANTA ANA, CA:  
2,859,458, REN. 7-18-14. MULTIPLE CLASS, INT. CLS. 41 AND 44.
- ORANGE HARP, INC., SAN FRANCISCO, CA:  
4,592,868, PUB. 6-10-2014. INT. CL. 35.
- ORBIT INDUSTRIES NJ, LLC, MARLBORO, NJ:  
3,350,945, CANC. INT. CL. 28.
- ORBIT IRRIGATION PRODUCTS, INC., BOUNTIFUL, UT:  
2,936,912, REN. 7-18-14. INT. CL. 21.
- ORCHIDS PAPER PRODUCTS COMPANY, PRYOR, OK:  
4,592,621, PUB. 6-10-2014. INT. CL. 16.
- ORDAN TRADING INC., RAMSEY, NJ:  
4,405,602, COR. INT. CL. 29.
- OREGON'S HEALTH CO-OP, PORTLAND, OR:  
4,593,839, INT. CL. 36.  
4,593,846, INT. CL. 36.  
4,593,847, INT. CL. 36.
- ORENDA INTERNATIONAL LLC, TEMPE, AZ:  
2,795,884, CANC. INT. CL. 5.
- ORGANIC FRESH FINGERS, INC., SALEM, OR:  
4,593,562, INT. CL. 29.
- ORICA AUSTRALIA PTY LTD, MELBOURNE VICTORIA, 3000, AUSTRALIA:  
2,793,372, CANC. INT. CL. 42.
- ORIGINAL BUFF, S.A., IGUALADA (BARCELONA) 08700, SPAIN:  
3,351,940, CANC. INT. CL. 25.
- ORIGINAL STRENGTH SYSTEMS, LLC, FUQUAY VARIANA, NC:  
4,592,299, PUB. 6-10-2014. INT. CL. 41.
- ORIOLE MEDIA CORP., TORONTO, CANADA:  
4,593,623, INT. CL. 35.
- ORLACO PRODUCTS B.V., BARNEVELD, NETHERLANDS:  
4,591,462, PUB. 6-10-2014. INT. CL. 9.
- ORLOFF, DANIEL, CHICO, CA:  
4,592,224, PUB. 6-10-2014. INT. CL. 25.
- ORR CORPORATION, LOUISVILLE, KY:  
4,594,527, MULTIPLE CLASS, INT. CLS. 35, 37 AND 42.
- ORTHO ORGANIZERS, INC., CARLSBAD, CA:  
3,354,049, CANC. INT. CL. 10.
- ORTHOPEDIC SCIENCES, INC., SEAL BEACH, CA:  
4,593,041, PUB. 6-10-2014. INT. CL. 10.  
4,594,773, INT. CL. 10.
- OSCAR DE LA RENTA, LTD., NEW YORK, NY:  
3,352,817, CANC. MULTIPLE CLASS, INT. CLS. 20 AND 24.
- OSGI ALLIANCE, SAN RAMON, CA:  
2,876,771, REN. 7-22-14. INT. CL. 9.
- OSIM INTERNATIONAL LTD, SINGAPORE, SINGAPORE:  
4,591,254, PUB. 6-10-2014. INT. CL. 9.
- OSMAN YUSUF, AUSTIN, TX:  
4,594,243, INT. CL. 35.  
4,594,408, INT. CL. 35.
- OSO LLC, BURLINGTON, MA:  
3,351,353, CANC. INT. CL. 36.
- OSTROFF, MATTHEW, CHELTENHAM, PA:  
3,352,899, CANC. INT. CL. 3.
- OT MOBILITY, INC., CUPERTINO, CA:  
4,594,170, MULTIPLE CLASS, INT. CLS. 9 AND 38.  
4,594,171, MULTIPLE CLASS, INT. CLS. 9 AND 38.
- OTO MELARA S.P.A., LA SPEZIA, ITALY:  
773,051, REN. 7-24-14. U.S. CL. 9 (INT. CL. 13).
- OTS B.V., 1066 WB AMSTERDAM, NETHERLANDS:  
4,592,905, PUB. 6-10-2014. INT. CL. 25.
- OTTAWA FIBRE L.P., OTTAWA K1G 3N2, CANADA:  
3,353,721, CANC. INT. CL. 17.
- OTTLITE TECHNOLOGIES, INC., TAMPA, FL:  
3,351,249, CANC. INT. CL. 11.
- OTWELL, TAYLOR W, BENTON, AR:  
4,592,219, PUB. 6-10-2014. INT. CL. 9.
- OUR EARTH MUSIC, INC., REDWOOD CITY, CA:  
3,351,013, CANC. INT. CL. 45.
- OUT FIT 7 LIMITED, LIMASSOL, CYPRUS:  
4,590,941, PUB. 6-10-2014. INT. CL. 42.
- OUTDOOR TRAVEL ADVENTURES INC., SAN DIEGO, CA:  
4,593,879, INT. CL. 39.
- OUTLAND RESEARCH, LLC, PISMO BEACH, CA:  
3,354,052, CANC. INT. CL. 42.
- OUTLOOK AMUSEMENTS, INC., BURBANK, CA:  
4,594,399, INT. CL. 45.
- OUTOKUMPU TECHNOLOGY OY, ESPOO, FINLAND:  
3,352,493, CANC. INT. CL. 7.

OUTSIDE THE DREAM FOUNDATION, MENLO PARK, CA:  
3,351,027, CANC. INT. CL. 36.

OVERRIDE COSMETICS, LLC, NEW YORK, NY:  
3,354,350, CANC. INT. CL. 3.

OVOLAB S.A.S. DI ALBERTO RICCI, TORINO, ITALY:  
2,814,690, REN. 7-24-14, INT. CL. 42.

OWLS HEAD DEVELOPMENT, LLC, ATLANTA, GA:  
3,350,689, CANC. INT. CL. 37.  
3,350,690, CANC. INT. CL. 37.

OVS PRODUCTS, LLC, IRVINE, CA:  
2,795,983, CANC. INT. CL. 3.

OX ENGINEERED PRODUCTS, LLC, CHARLESTON, IL:  
4,594,254, INT. CL. 17.

OX-EYE VINEYARDS LLC, STAUNTON, VA:  
4,594,424, INT. CL. 33.

OXBUILT CONSTRUCTION, LLC, MARIETTA, GA:  
4,592,416, PUB. 6-10-2014, INT. CL. 37.

OXBURY PORT O TOILETS, OXFORD, CT:  
3,351,111, CANC. INT. CL. 44.

OXFORD BIOMEDICA PLC, OXFORD, UNITED KINGDOM:  
4,591,003, PUB. 10-29-2013, MULTIPLE CLASS, INT. CLS. 1, 5, 10 AND 42.

OXFORD MARKETING CORPORATION, ATLANTA, GA:  
3,352,201, CANC. INT. CL. 36.

OYSTERS XO LLC, NEW YORK, NY, AKA OYSTERS XO:  
4,592,336, PUB. 6-10-2014, INT. CL. 43.

O4IT USA, LLC, MIAMI, FL:  
4,591,583, PUB. 6-10-2014, INT. CL. 38.

P & F NATURAL FOODS, LLC, YAKIMA, WA:  
3,354,232, CANC. INT. CL. 29.

P D J & ASSOCIATES INC., PHOENIX, AZ:  
4,591,072, PUB. 6-10-2014, MULTIPLE CLASS, INT. CLS. 25 AND 43.

P W ALLEN & COMPANY, TEWKESBURY, UNITED KINGDOM:  
3,351,923, CANC. MULTIPLE CLASS, INT. CLS. 9, 11 AND 35.

P.C. WOO, INC., LOS ANGELES, CA, DBA MEGATOYS:  
2,796,049, CANC. INT. CL. 28.

P.F. CHANG'S CHINA BISTRO, INC., SCOTTSDALE, AZ:  
3,353,365, CANC. INT. CL. 43.

P.L. THOMAS & CO., INC., MORRISTOWN, NJ:  
4,592,325, PUB. 6-10-2014, INT. CL. 35.

P.S. PIBBS, INC., FLUSHING, NY:  
3,353,923, CANC. INT. CL. 20.

P&L INDUSTRIES, INC., COTTONWOOD, AZ:  
4,593,225, MULTIPLE CLASS, INT. CLS. 8, 9, 13 AND 25.

PA'S PISTOLS BAR-B-QUE SAUCE, SOUTH GLENS FALLS, NY:  
4,592,683, PUB. 6-10-2014, INT. CL. 30.

PACIFIC BEACH TANNING STUDIOS, ST. LOUIS, MO:  
3,354,021, CANC. INT. CL. 44.

PACIFIC COAST FEATHER COMPANY, SEATTLE, WA:  
2,795,913, CANC. MULTIPLE CLASS, INT. CLS. 20 AND 24.  
4,594,242, INT. CL. 20.

PACIFIC ENERGY FIREPLACE PRODUCTS LTD., DUNCAN, BRITISH COLUMBIA, CANADA, PACIFIC ENERGY WOODSTOVES (1986) LTD., COBBLE HILL, BRITISH COLUMBIA, CANADA:  
1,844,300, REN. 7-24-14, INT. CL. 11.

PACIFIC ENERGY WOODSTOVES (1986) LTD., COBBLE HILL, BRITISH COLUMBIA, CANADA TO PACIFIC ENERGY FIREPLACE PRODUCTS LTD., DUNCAN, BRITISH COLUMBIA, CANADA:  
1,844,300, AM. INT. CL. 11.

PACIFIC FOOD, INC., WALLINGFORD, CT:  
3,350,667, CANC. INT. CL. 43.

PACIFIC HEALTH SCIENCES LLC, MALIBU, CA, DBA PACIFIC HEALTH SCIENCES:  
4,591,773, PUB. 6-10-2014, INT. CL. 5.

PACIFIC MARKETING WORKS, INC., LOS ANGELES, CA:  
3,353,720, CANC. INT. CL. 25.

PACIFIC RADIO EXCHANGE, INC., BURBANK, CA:  
4,594,709, INT. CL. 35.

PACIFIC TOYS, INC., COMMERCE, CA:  
3,351,520, CANC. INT. CL. 28.  
3,351,521, CANC. INT. CL. 28.

PACKED HOUSE PUBLICATIONS, LLC, GRAND PRAIRIE, TX:  
4,593,821, INT. CL. 21.

PADDY POWER PLC, DUBLIN, IRELAND:  
4,590,987, PUB. 12-3-2013, MULTIPLE CLASS, INT. CLS. 16, 38, 41 AND 45.  
4,590,992, PUB. 12-3-2013, MULTIPLE CLASS, INT. CLS. 16, 38, 41 AND 45.

PAINTER, BRUCE, FRISCO, TX:  
3,354,099, CANC. INT. CL. 9.

PAIOLI MECCANICA S.P.A., ALTEDO (BO), ITALY:  
2,793,546, CANC. INT. CL. 12.

PAIRSHARE, LLC, SANTA ROSA, CA:  
4,590,944, PUB. 5-3-2011, INT. CL. 9.

PAKORE LLC, NEW JERSEY, NJ:  
4,591,968, PUB. 6-10-2014, MULTIPLE CLASS, INT. CLS. 35 AND 42.

PALA BAND OF MISSION INDIANS, PALA, CA, DBA PALA CASINO:  
3,353,131, CANC. INT. CL. 41.

PALEO FOUNDATION, INC., MARINA DEL REY, CA:  
4,594,638, INT. CL. 41.

PALL CORPORATION, PORT WASHINGTON, NY, GELMAN INSTRUMENT COMPANY, ANN ARBOR, MI:  
987,843, REN. 7-24-14, U.S. CL. 31 (INT. CL. 11).

PALLMANN MASCHINENFABRIK GMBH & CO. KG, ZWEIBRÜCKEN, FED REP GERMANY:  
4,592,700, PUB. 6-10-2014, INT. CL. 7.

PALM FOODS, LLC, GREENWICH, CT:  
4,593,894, INT. CL. 43.

PALM TREE TECHNOLOGY, INC., REDDING, CT:  
3,351,997, CANC. MULTIPLE CLASS, INT. CLS. 9, 37, 38 AND 42.

PALMER, KATHY, JUPITER, FL:  
3,352,864, CANC. INT. CL. 20.

PAMPELONNE LLC, NEW YORK, NY:  
4,592,500, PUB. 6-10-2014, INT. CL. 33.

PAN PA' YA LTDA., BOGOTA, COLOMBIA:  
2,875,711, REN. 7-22-14, MULTIPLE CLASS, INT. CLS. 35 AND 43.

PANAMA JACK INTERNATIONAL, INC., ORLANDO, FL:  
4,594,153, INT. CL. 20.  
4,594,318, INT. CL. 9.

PANASONIC CORPORATION OF NORTH AMERICA, SECAUCUS, NJ:  
3,354,634, CANC. INT. CL. 9.

PANAVISION INTERNATIONAL L.P., WOODLAND HILLS, CA:  
976,767, REN. 7-18-14, U.S. CL. 26 (INT. CL. 9).

PANCIL, LLC, LA JOLLA, CA:  
3,353,790, CANC. INT. CL. 34.

PANHANDLE AREA EDUCATION CONSORTIUM, CHIPLEY, FL:  
3,285,543, CANC. INT. CL. 41.

PANORAMIC ENTERPRISE, LLC, MORGAN CITY, LA:  
4,592,100, PUB. 6-10-2014, INT. CL. 20.

PAPAYA LIMITED, LONDON, UNITED KINGDOM:  
3,351,979, CANC. MULTIPLE CLASS, INT. CLS. 16, 38 AND 41.

PAPENHAUSEN, MICHAEL, PETALUMA, CA:  
4,592,479, PUB. 6-10-2014, INT. CL. 3.

PAPER BLOOMS, HOUSTON, TX:  
4,592,565, PUB. 6-10-2014, INT. CL. 35.

PAPER CONVERTING MACHINE COMPANY, GREEN BAY, WI:  
1,298,427, REN. 7-23-14, INT. CL. 7.  
1,298,428, REN. 7-23-14, INT. CL. 7.

PAPERLINUX LIMITED (ACN/ARBN 005 146 350), VICTORIA, AUSTRALIA:  
2,793,795, CANC. INT. CL. 16.

PAPERPAK PRODUCTS, INC., GREENVILLE, NC:  
3,351,046, CANC. INT. CL. 5.

PAPILLION INC, NEW ORLEANS, LA:  
3,351,197, CANC. INT. CL. 41.

- PARADIGM INFOTECH INC., COLUMBIA, MD:  
4,592,581, PUB. 6-10-2014. INT. CL. 9.
- PARAGON SOFTWARE GMBH, D-79100 FREIBURG, FED REP GERMANY:  
3,354,547, CANC. INT. CL. 9.
- PARDO VENTURES LLC, SHERMAN OAKS, CA, DBA ÑO PRODUCTIONS:  
4,594,683, INT. CL. 25.
- PAREMUS LIMITED, LONDON, UNITED KINGDOM:  
3,351,938, CANC. MULTIPLE CLASS, INT. CLS. 9, 37 AND 42.
- PARETO LAB, LLC, CARLSBAD, CA:  
4,594,081, INT. CL. 28.
- PARFUMS CHRISTIAN DIOR, F-75008 PARIS, FRANCE:  
4,590,850, PUB. 6-10-2014. MULTIPLE CLASS, INT. CLS. 3 AND 25.
- PARIS PRESENTS INCORPORATED, GURNEE, IL:  
4,593,988, INT. CL. 3.
- PARK, B. CHRISTINE, MIRAMAR, FL:  
4,594,708, INT. CL. 35.
- PARK, CHANG HUN, REPUBLIC OF KOREA:  
3,352,661.
- PARK, PETE O., REDWOOD CITY, CA:  
3,351,771, CANC. MULTIPLE CLASS, INT. CLS. 35 AND 41.  
3,351,772, CANC. INT. CL. 39.
- PARKER, ANDRE, DEWAYNE, OKLAHOMA CITY, OK:  
3,254,119, CANC. INT. CL. 16.
- PARKFIELD GROUP LLC, MISSION VIEJO, CA:  
3,351,988, CANC. INT. CL. 35.
- PARLAIN CO., LTD., TSUEN WAN, HONG KONG:  
2,794,897, CANC. INT. CL. 3.
- PARLEE CYCLES, INC., BEVERLY, MA:  
4,592,649, PUB. 6-10-2014. INT. CL. 12.
- PARMALAT CANADA INC., ETOBICOKE, CANADA, PFI-ZER INC., NEW YORK, NY:  
1,849,502, REN. 7-22-14. INT. CL. 29.
- PARNICO, LLC, LOS ANGELES, CA:  
3,337,271, CANC. INT. CL. 25.
- PAROMI TEA, LLC, BETHESDA, MD:  
4,592,071, PUB. 5-6-2014. INT. CL. 30.
- PARSEMUS FOUNDATION, BERKELEY, CA:  
4,591,394, PUB. 1-1-2013. INT. CL. 36.  
4,591,395, PUB. 1-1-2013. INT. CL. 36.
- PARTNERSHIP BUCCI, GEORGE, A / HUDSON, SCOTT, T, TOLLAND, CT:  
3,351,931, CANC. INT. CL. 42.
- PARTSSOURCE, INC., AURORA, OH:  
4,594,651, INT. CL. 35.
- PASCUA YAQUI TRIBE, TUCSON, AZ:  
3,354,357, CANC. INT. CL. 41.
- PASSKEY INTERNATIONAL, INC., WALTHAM, MA:  
2,866,600, REN. 7-23-14. INT. CL. 42.
- PASSPORT HEALTH COMMUNICATIONS, INC., FRANKLIN, TN:  
4,594,567, INT. CL. 42.
- PASSWORD INDUSTRIES, INC., LONG BEACH, CA:  
4,592,937, PUB. 6-10-2014. INT. CL. 12.
- PASTEL, STEVEN HSI, COVINA, CA:  
4,594,477, INT. CL. 34.  
4,594,478, INT. CL. 34.  
4,594,479, INT. CL. 34.
- PAT & BILLY ENTERTAINMENT, INC., GARDEN GROVE, CA:  
3,351,086, CANC. INT. CL. 41.
- PATCH PRODUCTS, INC., BELOIT, WI:  
4,594,485, INT. CL. 28.
- PATCUD INVESTMENTS, INC., WILMINGTON, DE:  
3,353,907, CANC. INT. CL. 29.
- PATENT INVESTMENT & LICENSING COMPANY, LAS VEGAS, NV:  
4,592,955, PUB. 6-10-2014. INT. CL. 35.
- PATENT SOLUTIONS LP, DALLAS, TX:  
2,820,634, REN. 7-23-14. INT. CL. 42.
- PATMONT MOTOR WERKS, INC., MINDEN, NV:  
2,757,292, CANC. INT. CL. 41.
- PATRICIA I SUE, EMERYVILLE, CA:  
3,351,272, CANC. INT. CL. 35.
- PATRIOT BUICK PONTIAC GMC, INC., BOYERTOWN, PA:  
4,593,517, INT. CL. 35.
- PAUL DAVIES LONDON LIMITED, LONDON, ENGLAND:  
3,352,072, CANC. MULTIPLE CLASS, INT. CLS. 37 AND 42.
- PAUL'S PEACE, INC., ISELIN, NJ:  
4,591,718, PUB. 6-10-2014. INT. CL. 35.
- PAULANER BRAUEREI GMBH & CO. KG, MUNICH, FED REP GERMANY:  
2,865,002, REN. 7-18-14. INT. CL. 32.
- PAULIST NATIONAL CATHOLIC EVANGELIZATION ASSOCIATION, WASHINGTON, DC:  
2,793,980, CANC. INT. CL. 41.
- PAVAO, VINNIE, FALL RIVER, MA:  
4,594,325, INT. CL. 35.
- PAVLICK MARKETING, INC., AURORA, OH:  
4,592,638, PUB. 6-10-2014. INT. CL. 24.
- PAVLUS TRAVEL & CRUISE, INC., ALBUQUERQUE, NM:  
4,591,911, PUB. 6-10-2014. INT. CL. 39.
- PAXAR AMERICAS INC., MIAMISBURG, OH:  
1,264,211, REN. 7-19-14. INT. CL. 16.
- PAYFONT LIMITED, EDINBURGH, UNITED KINGDOM:  
4,591,312, PUB. 6-10-2014. MULTIPLE CLASS, INT. CLS. 9, 35, 36, 42 AND 45.
- PAYLESS CAR RENTAL, INC., CARSON CITY, NV:  
3,350,820, CANC. INT. CL. 39.
- PAYNE, DAVID M, STAR, ID:  
4,594,128, INT. CL. 13.
- PB INSTITUTE PARTNERS LIMITED PARTNERSHIP, WEST PALM BEACH, FL:  
4,591,207, PUB. 6-10-2014. INT. CL. 44.
- PC APPLETON, LLC, APPLETON, WI:  
3,351,723, CANC. INT. CL. 41.  
3,351,816, CANC. INT. CL. 41.
- PC FESTIVUS, LLC C/O LASALLE HOTEL PROPERTIES, BETHESDA, MD:  
4,593,502, INT. CL. 43.
- PCPARTPICKER, LLC, AUSTIN, TX:  
4,592,084, PUB. 6-10-2014. INT. CL. 35.
- PEA SOUP, INC., DEERFIELD, IL:  
3,351,191, CANC. INT. CL. 35.  
3,351,782, CANC. INT. CL. 35.
- PEACE REHABILITATION CENTER, MINNEAPOLIS, MN:  
4,591,570, PUB. 6-10-2014. MULTIPLE CLASS, INT. CLS. 14 AND 25.
- PEACE UNITED, LONDON, UNITED KINGDOM:  
4,591,022, PUB. 6-10-2014. MULTIPLE CLASS, INT. CLS. 25, 41 AND 43.
- PEAK PERFORMANCE CHIROPRACTIC, PLLC, GRAND RAPIDS, MI:  
4,594,190, MULTIPLE CLASS, INT. CLS. 35 AND 44.
- PEAVEY ELECTRONICS CORPORATION, MERIDIAN, MS:  
1,347,371, REN. 7-23-14. INT. CL. 9.  
1,349,001, REN. 7-22-14. INT. CL. 9.
- PEDILUXE FOOTWEAR, MARTHASVILLE, MO:  
4,592,506, PUB. 6-10-2014. INT. CL. 25.
- PEELS PLUS COMPANY INCORPORATED, WADING RIVER, NY:  
4,592,128, PUB. 6-10-2014. INT. CL. 3.
- PEG TECH INC., SAN JOSE, CA:  
4,592,858, PUB. 6-10-2014. INT. CL. 42.
- PEGASUS BUSINESS INTELLIGENCE, LP, DALLAS, TX:  
4,591,775, PUB. 6-10-2014. MULTIPLE CLASS, INT. CLS. 35 AND 36.
- PEGASYSYSTEMS INC., CAMBRIDGE, MA:  
2,795,970, CANC. INT. CL. 9.  
2,795,972, CANC. INT. CL. 9.  
2,795,973, CANC. INT. CL. 9.
- PEI LICENSING, INC., MIAMI, FL:  
1,646,084, CANC. INT. CL. 25.
- PEKIN LIFE INSURANCE COMPANY, PEKIN, IL:  
2,793,967, CANC. INT. CL. 36.
- PELES, JOSEPH, TEMPE, AZ:  
4,593,653, INT. CL. 25.
- PENCHAS, JONATHAN, HOUSTON, TX:  
4,594,717, INT. CL. 44.
- PENDERGAST, CHARLES R., BODEGA, CA:  
3,351,514, CANC. INT. CL. 41.



PENGUIN GROUP (USA) INC., NEW YORK, NY:  
3,351,793, CANC. INT. CL. 28.

PENNSYLVANIA ASSOCIATION OF RESOURCES FOR PEOPLE WITH MENTAL RETARDATION ("PAR"), HARRISBURG, PA:  
2,873,664, REN. 7-21-14. INT. CL. 35.

PENNSYLVANIA COLLEGE OF TECHNOLOGY, WILLIAMSPORT, PA:  
2,866,986, REN. 7-22-14. MULTIPLE CLASS, INT. CLS. 16, 21, 25 AND 41.

PENNY BRAVE, ORLANDO, FL:  
4,592,637, PUB. 6-10-2014. INT. CL. 25.

PENPHARM SA (PTY) LTD, JOHANNESBURG, SOUTH AFRICA:  
4,592,731, PUB. 6-10-2014. INT. CL. 5.

PENSION TECHNOLOGY GROUP, INC., BOSTON, MA:  
4,591,285, PUB. 6-10-2014. MULTIPLE CLASS, INT. CLS. 35 AND 42.

PENTAIR WATER POOL AND SPA, INC., SANFORD, NC:  
2,793,937, CANC. INT. CL. 11.

PEOPLE PEOPLE AB, 118 47 STOCKHOLM, SWEDEN:  
4,593,572, INT. CL. 9.

PEOPLE-SIDE SOLUTIONS, GRAND PRAIRIE, TX:  
4,592,515, PUB. 6-10-2014. INT. CL. 41.

PEOPLE'S CHOICE APPAREL, INC., HENDERSON, NV:  
4,592,145, PUB. 6-10-2014. INT. CL. 25.

PEOPLES CLUB OF NIGERIA INTERNATIONAL, EDISON, NJ:  
4,591,874, PUB. 6-10-2014. INT. CL. 41.

PEPSICO, INC., PURCHASE, NY:  
3,353,706, CANC. INT. CL. 3.

PERAZA, WILLIAM, JR, MIAMI BEACH, FL, AKA CHAIRMAN OF POKER:  
3,350,827, CANC. INT. CL. 41.

PERCEPTION, INC., GAITHERSBURG, MD:  
3,351,430, CANC. INT. CL. 35.

PEREZ, CEASAR A., SCOTTSDALE, AZ:  
4,591,889, PUB. 6-10-2014. INT. CL. 5.

PERFECT MY SILHOUETTE, LLC, N. MIAMI BEACH, FL:  
4,592,743, PUB. 6-10-2014. INT. CL. 3.  
4,592,746, PUB. 6-10-2014. INT. CL. 35.

PERFORM GROUP, LLC, YORK, PA:  
4,594,474, INT. CL. 35.

PERFORMANCE BRANDS, INC., SUNRISE, FL:  
3,354,151, CANC. INT. CL. 3.  
3,354,153, CANC. INT. CL. 3.  
3,354,155, CANC. INT. CL. 3.  
3,354,156, CANC. INT. CL. 3.  
3,354,157, CANC. INT. CL. 3.  
3,354,159, CANC. INT. CL. 3.

PERFORMANCE REVIEW INSTITUTE, WARRENDALE, PA:  
4,594,390, INT. CL. 42.

PERIO, INC., DUBLIN, OH:  
4,593,221, INT. CL. 8.  
4,593,222, INT. CL. 8.

PERKINS + WILL, INC., SAN FRANCISCO, CA:  
4,593,174, INT. CL. 19.

PERKINS, CATHY, ANTHONY, FL:  
4,594,566, INT. CL. 25.

PERMARA LLC, DAKOTA DUNES, SD:  
4,593,269, INT. CL. 25.

PERMASCAND AKTIEBOLAG, SWEDEN:  
4,590,881, PUB. 6-10-2014. MULTIPLE CLASS, INT. CLS. 6, 9, 14, 40 AND 42.

PERRY, KELLY-JANE, BATH, ME, DBA PULP JEWELRY & GIFTS:  
4,593,047, PUB. 6-10-2014. INT. CL. 14.

PERSHING INVESTMENTS LLC, NEWARK, DE:  
4,593,209, INT. CL. 36.

PEST MANAGEMENT, INC., KERRVILLE, TX:  
4,594,595, INT. CL. 5.

PEST SHIELD PEST CONTROL SERVICES, INC., SAN ANTONIO, TX:  
4,592,382, PUB. 6-10-2014. INT. CL. 37.

PET DREAMS INTERNATIONAL, INC., NEW YORK, NY:  
4,591,054, PUB. 6-10-2014. INT. CL. 20.

PET PRODUCTS DISTRIBUTION, LLC, SAN DIEGO, CA:  
4,593,128, INT. CL. 3.

PETCO ANIMAL SUPPLIES, INC., SAN DIEGO, CA:  
2,795,985, CANC. MULTIPLE CLASS, INT. CLS. 35, 41 AND 42.  
3,353,242, CANC. INT. CL. 35.

PETER BOYLE, UNITED KINGDOM:  
4,523,781, COR. MULTIPLE CLASS, INT. CLS. 3, 14, 18, 25 AND 35.

PETER BREHM, WEISENDORF, FED REP GERMANY:  
3,352,651.

PETER NYARI, CARLSBAD, CA AND KLARA NYARI, CARLSBAD, CA:  
4,593,941, INT. CL. 28.

PETERSON, CHRISTY L, WEST PALM BEACH, FL:  
4,592,811, PUB. 6-10-2014. INT. CL. 41.

PETERSON, GERRY K., ARLINGTON, TX:  
3,351,604, CANC. INT. CL. 3.

PETOSKEY PLASTICS, INC., PETOSKEY, MI, DBA RSC SALES COMPANY:  
4,592,589, PUB. 6-10-2014. INT. CL. 35.

PETRA NEMCOVA BRAND ENTERPRISES, LLC, NEW YORK, NY:  
4,591,396, PUB. 12-4-2012. INT. CL. 4.

PETSMART STORE SUPPORT GROUP, INC., PHOENIX, AZ:  
4,591,540, PUB. 6-10-2014. INT. CL. 1.  
4,591,541, PUB. 6-10-2014. INT. CL. 9.  
4,591,542, PUB. 6-10-2014. INT. CL. 11.  
4,591,543, PUB. 6-10-2014. INT. CL. 19.  
4,591,544, PUB. 6-10-2014. INT. CL. 17.  
4,591,545, PUB. 6-10-2014. INT. CL. 31.

PFFIP, LLC, NEWINGTON, NH:  
4,593,362, INT. CL. 9.

PFIZER CONSUMER HEALTHCARE AB, 191 90 SOLLENTUNA, SWEDEN:  
1,852,160, REN. 7-18-14. INT. CL. 5.

PFIZER ENTERPRISES SARL, L-1855, LUXEMBOURG, SCHERING AKTIENGESELLSCHAFT, D-1000 BERLIN 65, FED REP GERMANY:  
1,846,462, REN. 7-24-14. INT. CL. 5.

PFIZER INC., NEW YORK, NY:  
3,350,834, CANC. MULTIPLE CLASS, INT. CLS. 16 AND 44.  
4,593,658, INT. CL. 35.

PHANTOM SMOKE, CO., CHICAGO, IL:  
4,592,241, PUB. 6-10-2014. INT. CL. 34.

PHH SOLUTIONS AND TECHNOLOGIES, LLC, SPARKS, MD TO PHH SOLUTIONS AND TECHNOLOGIES, LLC, SPARKS, MD:  
2,795,527, CANC. MULTIPLE CLASS, INT. CLS. 35 AND 36.

PHH VEHICLE MANAGEMENT SERVICES, LLC, SPARKS, MD:  
4,594,427, INT. CL. 42.

PHI, INCORPORATED, CHESAPEAKE, VA:  
4,592,272, PUB. 6-10-2014. INT. CL. 35.

PHILADELPHIA PARKING AUTHORITY, PHILADELPHIA, PA:  
4,593,873, MULTIPLE CLASS, INT. CLS. 35, 39 AND 45.

PHILIGHT SOFTWARE INTERNATIONAL PTY LTD, MARGAROO WA 6064, AUSTRALIA:  
4,593,467, INT. CL. 9.

PHILIP D. GOLE, GRAND RAPIDS, MI:  
4,593,519, INT. CL. 41.

PHILIP JAMES CLARK, NEW ZEALAND AND PETER DAVID DARROCH, NEW ZEALAND:  
4,590,865, PUB. 6-10-2014. INT. CL. 33.

PHILIPPE LANGDON FURNITURE, INC, BELL GARDENS, CA:  
3,351,069, CANC. INT. CL. 20.

PHILIPPE ROTHLIN, CH-8645 JONA, SWITZERLAND:  
3,352,599.

PHILIPPE, ERIC, MIAMI, FL:  
3,352,892, CANC. MULTIPLE CLASS, INT. CLS. 35 AND 41.

PHILLIP JENNINGS TURF FARMS, LLC, SOPERTON, GA:  
3,352,898, CANC. INT. CL. 31.

- PHILLIPS SEAFOODS, INC., SEATTLE, WA:  
3,351,716, CANC. INT. CL. 31.
- PHILLIPS 66 COMPANY, HOUSTON, TX:  
4,590,619, PUB. 6-10-2014. INT. CL. 42.
- PHILLIPS-VAN BUREN, INC., LOS ANGELES, CA:  
2,913,137. REN. 7-21-14. INT. CL. 16.
- PHILOSOPHY, INC., PHOENIX, AZ:  
3,351,524, CANC. INT. CL. 3.  
3,351,527, CANC. INT. CL. 3.  
3,351,528, CANC. INT. CL. 3.  
3,353,031, CANC. INT. CL. 3.  
3,353,427, CANC. INT. CL. 3.  
3,353,576, CANC. INT. CL. 3.
- PHNS INC., ADDISON, TX:  
3,350,616, CANC. MULTIPLE CLASS, INT. CLS. 9, 38 AND 39.
- PHOEBE SNOW COMPANY INC., STRASBURG, PA:  
4,591,834, PUB. 6-10-2014. INT. CL. 30.
- PHOENIX VINTNERS, LLC, IPSWICH, MA, DBA THE TRAVELING VINEYARD:  
3,354,263, CANC. INT. CL. 33.
- PHOENIX VINTNERS, LLC, IPSWICH, MA, DBA TRAVELING VINEYARD:  
4,592,964, PUB. 6-10-2014. INT. CL. 33.
- PHOSEON TECHNOLOGY, INC., HILLSBORO, OR:  
2,890,265. REN. 7-23-14. MULTIPLE CLASS, INT. CLS. 9 AND 11.
- PHYSICIANS WEIGHT LOSS CENTERS OF AMERICA, INC., AKRON, OH:  
4,591,225, PUB. 6-10-2014. INT. CL. 35.
- PHYSITRACK LIMITED, UNITED KINGDOM:  
4,590,870, PUB. 6-10-2014. MULTIPLE CLASS, INT. CLS. 9, 35 AND 38.
- PI DELTA PSI FRATERNITY, INC., FLUSHING, NY:  
4,593,381, MULTIPLE CLASS, INT. CLS. 25 AND 35.
- PIACENTINI, JOSEPH, EAST NORTHPORT, NY:  
3,346,796, CANC. INT. CL. 44.
- PIAGGIO & C. S.P.A., PONTEDERA (PI), ITALY:  
4,591,556, PUB. 6-10-2014. INT. CL. 35.
- PIASTEN GMBH & CO. KG, FORCHHEIM, FED REP GERMANY:  
1,846,292. REN. 7-18-14. INT. CL. 30.
- PIC INTERNATIONAL INC, VISTA, CA:  
2,794,716, CANC. INT. CL. 25.
- PICCADILLY RESTAURANTS, LLC, BATON ROUGE, LA:  
3,352,330, CANC. INT. CL. 43.  
3,352,332, CANC. INT. CL. 43.  
3,352,333, CANC. INT. CL. 43.  
3,352,334, CANC. INT. CL. 43.
- PICUNCHE WINES LTDA., CASABLANCA, CHILE:  
3,353,430, CANC. INT. CL. 33.
- PIEDRA, FELIPA, SANTA ANA, CA:  
3,273,249, CANC. INT. CL. 43.
- PIERRE DEUX B.V., 1015 BL AMSTERDAM, NETHERLANDS:  
2,794,764, CANC. INT. CL. 27.
- PIETRO ISNARDI ALIMENTARI S.P.A., ITALY:  
3,352,616.
- PILEPRO LLC, CREEDMOOR, TX:  
4,593,432, INT. CL. 6.
- PILKINGTON, GEORGE, VIRGINIA BEACH, VA:  
4,594,304, INT. CL. 37.
- PILLAR AND STONE INTERNATIONAL INC., TIBURON, CA:  
3,310,486, CANC. INT. CL. 14.
- PIMBLEY, WALTER THOMSON, VESTAL, NY, AKA WALT PIMBLEY:  
4,591,238, PUB. 6-10-2014. INT. CL. 16.
- PIMENTEL, JASON SIMS, MARYSVILLE, CA:  
3,352,934, CANC. INT. CL. 25.
- PINDROPWORLD, LLC, SANDY, UT:  
4,591,068, PUB. 5-7-2013. INT. CL. 9.
- PINEAPPLE PARADE, LLC, BELLAIRE, TX:  
4,593,954, INT. CL. 35.
- PINEAU, BRAD, STRATFORD, PEI, CANADA:  
4,594,005, INT. CL. 42.
- PINELANDS NURSERY, INC., COLUMBUS, NJ, AKA PINELANDS NURSERY AND SUPPLY:  
4,592,221, PUB. 6-10-2014. INT. CL. 31.
- PINHEIRO, THYAGO, SOMERVILLE, MA:  
4,591,564, PUB. 12-31-2013. INT. CL. 25.
- PINNACLE ENTERTAINMENT, INC., LAS VEGAS, NV:  
4,592,967, PUB. 6-10-2014. INT. CL. 44.  
4,592,968, PUB. 6-10-2014. INT. CL. 43.  
4,592,969, PUB. 6-10-2014. INT. CL. 41.
- PINNACLE FOODS GROUP LLC, PARSIPPANY, NJ:  
3,156,014, AM. INT. CL. 30.
- PINNACLE POTASH INTERNATIONAL, LTD., AUSTIN, TX:  
4,593,952, INT. CL. 37.
- PIONEER KABUSHIKI KAISHA, KANAGAWA-KEN, 212-0031, JAPAN, DBA PIONEER CORPORATION:  
4,591,655, PUB. 6-10-2014. INT. CL. 9.
- PIPEVINE, LLC, LEESBURG, VA:  
4,592,612, PUB. 6-10-2014. INT. CL. 35.
- PIRANHA, CAMARILLO, CA:  
3,350,911, CANC. INT. CL. 15.
- PISGAH BREWING COMPANY, BLACK MOUNTAIN, NC:  
4,591,963, PUB. 6-10-2014. INT. CL. 32.
- PITNEY BOWES INC., DANBURY, CT:  
2,886,676. REN. 7-23-14. INT. CL. 7.
- PITNEY BOWES SOFTWARE INC., LANHAM, MD:  
3,352,263, CANC. INT. CL. 9.
- PITTIE CHICKS, COVINGTON TOWNSHIP, PA:  
4,592,195, PUB. 6-10-2014. INT. CL. 25.
- PIXAR, EMERYVILLE, CA:  
3,354,493, CANC. INT. CL. 20.  
3,354,495, CANC. INT. CL. 3.  
3,354,496, CANC. INT. CL. 18.  
3,354,497, CANC. INT. CL. 24.
- PIXEL PLANET, INC., CHICAGO, IL:  
3,352,269, CANC. INT. CL. 28.
- PIXIE AND PIRATE DESTINATIONS LLC, DISPUTANTA, VA:  
4,591,581, PUB. 3-4-2014. MULTIPLE CLASS, INT. CLS. 39 AND 43.
- PIZZAREV IP HOLDINGS, LLC, WESTLAKE VILLAGE, CA:  
4,592,650, PUB. 6-10-2014. INT. CL. 30.
- PLANCHOICE, INC., LOUISVILLE, KY:  
3,351,448, CANC. INT. CL. 36.
- PLANETARY GROUP, LLC, THE, LOS ANGELES, CA, DBA THE PLANETARY GROUP:  
4,591,277, PUB. 6-10-2014. MULTIPLE CLASS, INT. CLS. 35, 41 AND 42.
- PLANIMETRON INCORPORATED, DENVER, CO:  
1,825,755. REN. 7-23-14. INT. CL. 9.
- PLANMECA OY, HELSINKI, FINLAND:  
3,431,377.
- PLANNED PARENTHOOD/ORANGE AND SAN BERNARDINO COUNTIES, INC., ORANGE, CA:  
4,594,011, INT. CL. 44.
- PLANOLITH GMBH; MESSTECHNIK - SONDERMASCHINENBAU, 63741 ASCHAFFENBURG, FED REP GERMANY:  
3,352,684.
- PLANTE, WILLIAM, ST. CLAIR SHORES, MI:  
3,352,870, CANC. INT. CL. 9.
- PLASA NORTH AMERICA, NEW YORK, NY:  
2,908,841. REN. 7-22-14. INT. CL. 35.
- PLASTIC EARTH, SORRENTO, FL:  
3,351,187, CANC. INT. CL. 40.
- PLASTIC WELDING TECHNOLOGIES INTERNATIONAL, INC., DIAMOND SPRINGS, CA:  
3,351,929, CANC. MULTIPLE CLASS, INT. CLS. 35 AND 37.
- PLASTICS COLOR CORPORATION, CALUMET CITY, IL:  
4,592,415, PUB. 6-10-2014. INT. CL. 1.
- PLATT, ROBERT E., YOUNGSTOWN, OH:  
3,353,629, CANC. INT. CL. 19.
- PLAYBOY ENTERPRISES INTERNATIONAL, INC., BEVERLY HILLS, CA:  
3,353,824, CANC. INT. CL. 35.  
3,354,133, CANC. MULTIPLE CLASS, INT. CLS. 3 AND

21.  
3,354,134, CANC. MULTIPLE CLASS, INT. CLS. 3 AND 21.  
4,594,586, INT. CL. 16.
- PLAYDATE DIGITAL INC., NEW YORK, NY:  
4,593,483, INT. CL. 9.
- PLAZA FIESTA, ATLANTA, GA:  
3,352,285, CANC. INT. CL. 36.
- PNEUHAGE MANAGEMENT GMBH & CO. KG, FED REP GERMANY:  
3,352,617.
- PODFERENCE TECHNOLOGIES, INC., SOLANA BEACH, CA:  
3,350,761, CANC. INT. CL. 38.
- PODGUR, JULIE, MARBLEHEAD, MA:  
3,350,685, CANC. INT. CL. 25.
- POE, KIMBERLY L., VERO BEACH, FL:  
4,593,033, PUB. 6-10-2014. MULTIPLE CLASS, INT. CLS. 2 AND 3.
- POGGINZ, LLC, CHARLOTTE, NC:  
4,592,081, PUB. 6-10-2014. INT. CL. 9.
- POINT REYES CAPITAL MANAGEMENT LLC, PIEDMONT, CA:  
3,352,947, CANC. INT. CL. 35.
- POINTSERVE, INC., AUSTIN, TX, DBA MOBI:  
4,593,236, MULTIPLE CLASS, INT. CLS. 9 AND 42.  
4,593,237, MULTIPLE CLASS, INT. CLS. 9 AND 42.
- POK POK IP, LLC, PORTLAND, OR:  
4,594,585, INT. CL. 30.
- POLAR PRODUCTS, INC., STOW, OH:  
4,594,582, INT. CL. 9.
- POLARICA AB, SE-953 21 HAPARANDA, SWEDEN:  
4,590,866, PUB. 6-10-2014. INT. CL. 29.
- POLLARD BANKNOTE LIMITED PARTNERSHIP, WINNIPEG, MB, CANADA:  
4,593,487, INT. CL. 28.
- POLSTEIN, JASON M, MIAMI, FL AND POLSTEIN, MATTHEW E, MIAMI, FL AND POLSTEIN, MICHAEL A, MIAMI, FL AND POLSTEIN, CAROLE, MIAMI, FL AND POLSTEIN, LAUREN R, MIAMI, FL:  
3,351,253, CANC. MULTIPLE CLASS, INT. CLS. 9 AND 28.
- POMO RIDGE DISTRIBUTION, LLC, GEYSERVILLE, CA:  
4,592,918, PUB. 6-10-2014. INT. CL. 33.
- POPULAR BOOK COMPANY PTE LTD, SINGAPORE:  
3,352,580.
- POPULAR, INC., SAN JUAN, PUERTO RICO:  
3,351,576, CANC. INT. CL. 36.
- PORCH LIFE COOLERS L.L.C., SUMMERVILLE, SC:  
4,594,078, MULTIPLE CLASS, INT. CLS. 16, 21 AND 25.
- PORTER, ANNETTE L., CENTRAL ISLIP, NY:  
3,353,693, CANC. INT. CL. 35.
- PORTIA INTERNATIONAL TRADING LIMITED, NEW TERRITORIES, HONG KONG:  
4,593,858, INT. CL. 9.
- POSEIDON BARGE CORPORATION, FORT WAYNE, IN:  
4,591,715, PUB. 6-10-2014. MULTIPLE CLASS, INT. CLS. 37 AND 39.
- POSITIVE BEVERAGE, LLC, IRVINE, CA:  
4,168,140 NEW CERT. 8-26-2014. INT. CL. 32.  
4,168,145, AM. INT. CL. 32.
- POSITIVE LIFESTYLE INTERNATIONAL, LLC, TAMPA, FL:  
2,872,938. REN. 7-24-14. INT. CL. 9.
- POST FOODS, LLC, PARSIPPANY, NJ:  
4,594,133, INT. CL. 30.
- POST MANAGEMENT SELF-STORAGE, NEW YORK, NY:  
4,592,931, PUB. 6-10-2014. INT. CL. 39.
- POTOMAC METALS, INC., STERLING, VA:  
4,593,724, MULTIPLE CLASS, INT. CLS. 6, 35, 36, 37, 39 AND 40.  
4,593,725, MULTIPLE CLASS, INT. CLS. 6, 35, 36, 37, 39 AND 40.
- POULSEN JAY H., TREMONTON, UT:  
3,353,471, CANC. INT. CL. 9.
- POWER BOX AG, ZUG, SWITZERLAND:  
3,352,807, CANC. INT. CL. 7.
- POWER CAPITAL PARTNERS LLC, WHITE PLAINS, NY:  
4,594,618, INT. CL. 36.
- POWER PLAY INTERNATIONAL, INC., JACKSON, NJ:  
1,890,150, REN. 7-24-14. INT. CL. 36.
- POWER THREE WEB, LTDA., BARRIOTOURNON SAN JOSE, COSTA RICA:  
4,592,690, PUB. 6-10-2014. INT. CL. 42.
- POWERCHIP GROUP PTY. LTD., SOUTH MELBOURNE, VICTORIA, AUSTRALIA:  
2,794,963, CANC. INT. CL. 9.
- POWERMEDED LLC, GOSHEN, IN:  
4,591,565, PUB. 6-10-2014. INT. CL. 38.
- POWERSHIP, INC., OAK BROOK, IL:  
2,884,784, REN. 7-24-14. INT. CL. 35.
- POWERSOFT S.P.A., I-50018 SCANDICCI (FI), ITALY:  
4,590,689, PUB. 6-10-2014. INT. CL. 9.
- PPG ARCHITECTURAL FINISHES, INC., PITTSBURGH, PA:  
2,863,211, REN. 7-23-14. INT. CL. 2.  
3,352,463, CANC. INT. CL. 2.  
3,353,645, CANC. INT. CL. 2.
- PPG INDUSTRIES OHIO, INC., CLEVELAND, OH:  
409,791, REN. 7-22-14. U.S. CL. 33 (INT. CL. 21).  
1,285,700, REN. 7-21-14. INT. CL. 2.
- PPG KANSAI AUTOMOTIVE FINISHES TECHNOLOGY, LP, DOVER, DE:  
4,591,539, PUB. 6-10-2014. INT. CL. 2.
- PRADA S.A., LUXEMBOURG L-1118, LUXEMBOURG:  
2,795,197, CANC. MULTIPLE CLASS, INT. CLS. 12, 25 AND 41.
- PRAIRIE MOUNTAIN PUBLISHING COMPANY LLP, DENVER, CO:  
3,350,673, CANC. INT. CL. 16.
- PRAIRIE NORTH INCORPORATED, EDEN PRAIRIE, MN:  
2,794,709, CANC. INT. CL. 1.
- PRANA LIVING, LLC, CARLSBAD, CA:  
3,351,204, CANC. MULTIPLE CLASS, INT. CLS. 18 AND 25.
- PRAXELL, INC., NEW YORK, NY:  
3,353,544, CANC. INT. CL. 36.
- PRAXIS SOFTWARE, INC., ORLANDO, FL:  
3,354,567, CANC. INT. CL. 9.
- PRC-DESOTO INTERNATIONAL, INC., SYLMAR, CA:  
4,591,206, PUB. 6-10-2014. INT. CL. 17.
- PRE-PAID LEGAL SERVICES, INC., ADA, OK:  
3,354,012, CANC. INT. CL. 36.
- PRECIOUS CAT, INC., ENGLEWOOD, CO:  
4,591,024, PUB. 6-10-2014. INT. CL. 31.
- PRECIOUS MOMENTS, INC., CARTHAGE, MO:  
4,594,191, MULTIPLE CLASS, INT. CLS. 15, 16, 20 AND 21.
- PRECISION AUTOWERKS, LLC, COTO DE CAZA, CA, DBA RAPARMOR.COM:  
4,591,758, PUB. 6-10-2014. INT. CL. 9.
- PRECISION CUSTOM COATINGS LLC, TOTOWA, NJ:  
4,091,961, COR. INT. CL. 20.
- PRECISION DYNAMICS CORPORATION, VALENCIA, CA, AKA PDC:  
4,591,297, PUB. 6-10-2014. MULTIPLE CLASS, INT. CLS. 14, 16, 20 AND 35.
- PREFERRED GUEST, INC., STAMFORD, CT:  
4,593,490, INT. CL. 35.
- PREMERA BLUE CROSS, SEATTLE, WA:  
4,591,579, PUB. 6-10-2014. MULTIPLE CLASS, INT. CLS. 41 AND 44.
- PREMIER GROCERY, INC., PHOENIX, AZ:  
4,002,187, COR. INT. CL. 35.
- PREMIER HEALTHCARE ALLIANCE, LP, CHARLOTTE, NC:  
4,593,459, MULTIPLE CLASS, INT. CLS. 35, 36 AND 44.
- PREMIER LIQUEUR GROUP LIMITED, BELIZE CITY, BELIZE:  
4,591,353, PUB. 6-10-2014. INT. CL. 33.
- PREMIUM SELECT BIOTECH, LLC, ALBURG, VT:  
3,351,599, CANC. INT. CL. 5.
- PRENATAL DIAGNOSTIC PRODUCTS, LLC, LOS ANGELES, CA:  
4,593,248, INT. CL. 10.

- PRESSURE SPECIALIST INC., CRYSTAL LAKE, IL:  
3,354,105, CANC. INT. CL. 9.
- PRESTAGON LLC, PALO ALTO, CA:  
4,593,898, INT. CL. 21.
- PRETTY STAR STORE LLC, ROWLAND HEIGHTS, CA:  
4,592,116, PUB. 6-10-2014. MULTIPLE CLASS, INT. CLS. 20 AND 21.
- PREVENTIVE VITAMINS, L.L.C., DALLAS, TX:  
3,352,951, CANC. INT. CL. 5.
- PRICELINE.COM LLC, NORWALK, CT:  
4,591,674, PUB. 6-10-2014. MULTIPLE CLASS, INT. CLS. 35 AND 42.
- PRIDE INTERNATIONAL, INC., HOUSTON, TX:  
3,353,410, CANC. MULTIPLE CLASS, INT. CLS. 37 AND 40.
- PRIJEMS, INC., LOS ANGELES, CA:  
2,794,213, CANC. INT. CL. 35.
- PRIMA S.R.L., I-20157 MILANO, ITALY:  
3,352,655.
- PRIMARY INVESTMENTS GROUP LIMITED, ROAD TOWN, TORTOLA, BR.VIRGIN ISLANDS:  
3,353,138, CANC. INT. CL. 5.
- PRIME REALTY USA, LLC, CLIFTON, NJ:  
3,351,263, CANC. INT. CL. 35.
- PRIMEWOMAN, MANALAPAN, NJ:  
3,351,746, CANC. INT. CL. 16.
- PRIMEX WIRELESS, INC., LAKE GENEVA, WI:  
3,353,613, CANC. INT. CL. 9.
- PRINCE LAW OFFICES, PC, BECHTELSVILLE, PA, DBA FIREARMS INDUSTRY CONSULTING GROUP:  
4,591,161, PUB. 6-10-2014. INT. CL. 45.
- PRINCE SPORTS, LLC, NEW YORK, NY:  
976,308, REN. 7-22-14. U.S. CL. 22 (INT. CL. 28).
- PRINCESS CRUISE LINES, LTD., SANTA CLARITA, CA, DBA PRINCESS CRUISES:  
4,592,371, PUB. 6-10-2014. MULTIPLE CLASS, INT. CLS. 39, 41, 43 AND 44.  
4,592,377, PUB. 6-10-2014. MULTIPLE CLASS, INT. CLS. 39, 41, 43 AND 44.
- PRINTABLE TECHNOLOGIES, INC., SOLANA BEACH, CA:  
3,354,035, CANC. INT. CL. 42.
- PRIORITY PAYMENT SYSTEMS LLC, ALPHARETTA, GA:  
4,591,233, PUB. 6-10-2014. MULTIPLE CLASS, INT. CLS. 35, 36 AND 45.
- PRISM ASSURANCE, LTD., BURLINGTON, VT:  
4,591,731, PUB. 6-10-2014. INT. CL. 37.  
4,591,732, PUB. 6-10-2014. INT. CL. 40.  
4,591,733, PUB. 6-10-2014. INT. CL. 42.
- PRISTINE BAY, LLC, CINCINNATI, OH, DBA VIANDA:  
4,594,488, INT. CL. 5.  
4,594,489, INT. CL. 5.
- PRNT ENTERPRISES, LLC, FORT LAUDERDALE, FL:  
4,593,991, INT. CL. 9.  
4,593,992, INT. CL. 9.  
4,593,993, INT. CL. 9.
- PRO ONE JANITORIAL, INC., GREEN BAY, WI:  
3,498,836, COR. INT. CL. 37.
- PRO-AM PINBALL ASSOCIATION, INC., PITTSBURGH, PA:  
4,592,244, PUB. 6-10-2014. INT. CL. 35.
- PRO-DUO N.V., BELGIUM:  
4,590,837, PUB. 6-10-2014. INT. CL. 3.
- PROACTIVE HEALTH CARE COMMUNICATIONS INC., UPPER SADDLE RIVER, NJ:  
3,354,519, CANC. MULTIPLE CLASS, INT. CLS. 9, 16, 35 AND 41.  
3,354,520, CANC. MULTIPLE CLASS, INT. CLS. 9, 16 AND 35.
- PROACTIVE TRAINING SOLUTIONS, INC., SCOTTSDALE, AZ:  
4,592,262, PUB. 6-10-2014. INT. CL. 41.
- PROBIKER CORP., MIAMI, FL:  
4,592,108, PUB. 6-10-2014. INT. CL. 25.
- PROCESS EQUIPMENT SPECIALISTS, PLYMOUTH, MN:  
4,591,973, PUB. 6-10-2014. INT. CL. 7.
- PRODUCTION MINDS SD LIMITED, CYPRUS:  
4,590,784, PUB. 6-10-2014. MULTIPLE CLASS, INT. CLS. 9 AND 42.
- PROFESSIONAL BEAUTY ASSOCIATION, SCOTTSDALE, AZ:  
4,592,014, PUB. 6-10-2014. INT. CL. 35.
- PROFESSIONAL DAIRY PRODUCERS OF WISCONSIN, JUNEAU, WI:  
4,591,504, PUB. 6-10-2014. INT. CL. 41.
- PROFESSIONAL GOLFERS' ASSOCIATION OF AMERICA, THE, PALM BEACH GARDENS, FL:  
1,331,309, REN. 7-19-14. INT. CL. 41.
- PROFESSIONAL TAX INSTITUTES, INC., MANHATTAN, KS:  
1,844,832, REN. 7-20-14. INT. CL. 41.
- PROFILE PRODUCTS LLC, BUFFALO GROVE, IL:  
4,594,305, INT. CL. 1.  
4,594,535, MULTIPLE CLASS, INT. CLS. 19 AND 31.
- PROFORMA, INC., CLEVELAND, OH:  
2,793,865, CANC. MULTIPLE CLASS, INT. CLS. 35 AND 40.
- PROGENY SYSTEMS CORPORATION, MANASSAS, VA:  
4,591,665, PUB. 6-10-2014. MULTIPLE CLASS, INT. CLS. 9 AND 42.  
4,591,881, PUB. 6-10-2014. MULTIPLE CLASS, INT. CLS. 9 AND 42.
- PROGRESSIVE NUTRITION, LLC, BROOKVILLE, OH:  
2,863,669, REN. 7-20-14. INT. CL. 31.
- PROGRESSIVE PERCUSSION DRUM STUDIOS, INC., DURHAM, NC:  
4,592,232, PUB. 6-10-2014. INT. CL. 41.
- PROGRESSIVE PRODUCE CORPORATION, LOS ANGELES, CA:  
4,594,117, INT. CL. 31.
- PROJECT MANAGEMENT INSTITUTE, INC., NEWTOWN SQUARE, PA:  
3,353,766, CANC. U.S. CL. B.
- PROJECT NURSERY, LLC, SAN FRANCISCO, CA:  
4,592,572, PUB. 6-10-2014. INT. CL. 41.
- PROJECT PLANNING & MANAGEMENT, INC., GROSSE POINTE, MI:  
2,964,981, REN. 7-21-14. MULTIPLE CLASS, INT. CLS. 9 AND 37.
- PROJECTION DIGITAL LLC, DENVER, CO:  
4,592,155, PUB. 6-10-2014. INT. CL. 35.
- PROLIANT HEALTH, INC., ANKENY, IA:  
4,594,619, MULTIPLE CLASS, INT. CLS. 1 AND 5.
- PROLOGIX INTERNATIONAL CORPORATION, BOCA RATON, FL:  
3,354,676, CANC. INT. CL. 8.
- PROMED, LLC, NEWPORT, TN:  
2,796,103, CANC. INT. CL. 9.
- PROMETHEAN LIMITED, BLACKBURNE, LANCASHIRE, UNITED KINGDOM:  
2,793,558, CANC. INT. CL. 9.
- PROMISED LAND DEVELOPMENT AUTHORITY, INC, MADISON, GA:  
3,351,341, CANC. INT. CL. 35.
- PROMONTORY DEVELOPMENT, LLC, PHOENIX,, AZ:  
2,859,334, REN. 7-18-14. INT. CL. 36.  
2,865,963, REN. 7-21-14. INT. CL. 37.  
2,865,964, REN. 7-21-14. INT. CL. 36.
- PROMOTION MARKETING MANAGEMENT, LLC, KINGS PARK, NY:  
4,591,210, PUB. 6-10-2014. MULTIPLE CLASS, INT. CLS. 16 AND 41.
- PRONA AIR TOOL MANUFACTURING LIMITED, ABERDEEN, HONG KONG:  
4,591,760, PUB. 6-10-2014. INT. CL. 7.
- PRONTO MONEY TRANSFER INC., MANHATTAN BEACH, CA:  
4,593,348, INT. CL. 36.
- PROQR THERAPEUTICS B.V., NETHERLANDS:  
4,590,867, PUB. 6-10-2014. MULTIPLE CLASS, INT. CLS. 1, 5 AND 42.
- PROSA PRODUCTOS NATURALES, S.A. DE C.V., MÉXICO DF, MEXICO:  
4,593,282, MULTIPLE CLASS, INT. CLS. 3 AND 5.
- PROSPECTAS LLC, COLLEYVILLE, TX:  
4,594,052, INT. CL. 35.

PROTEUS PARTNERS, LLC, AUSTELL, GA:  
 4,593,539, INT. CL. 43.  
 PROTIVITI INC., MENLO PARK, CA:  
 2,794,693, CANC. MULTIPLE CLASS, INT. CLS. 35, 36  
 AND 42.  
 PROTOGENZ LLC., CARNATION, WA:  
 4,593,814, INT. CL. 8.  
 PROTONMEDIA, LLC, HARLEYSVILLE, PA:  
 3,353,793, CANC. MULTIPLE CLASS, INT. CLS. 9 AND  
 42.  
 PROTONMEDIA, LLC, LANSDALE, PA:  
 3,353,794, CANC. MULTIPLE CLASS, INT. CLS. 9 AND  
 42.  
 PROUDFIT, CHARLES, CINCINNATI, OH:  
 4,593,337, INT. CL. 45.  
 PROVO CRAFT & NOVELTY, INC., SOUTH JORDAN, UT:  
 3,353,212, CANC. INT. CL. 8.  
 PROX MANAGEMENT, LLC, MILFORD CENTER, OH, DBA  
 INNOVA PERFORMANCE PRODUCTS:  
 4,592,517, PUB. 6-10-2014. INT. CL. 1.  
 4,592,518, PUB. 6-10-2014. INT. CL. 1.  
 4,592,526, PUB. 6-10-2014. INT. CL. 1.  
 PROXIMO RESTAURANTS LLC, WASHINGTON, DC:  
 2,958,255, REN. 7-22-14. INT. CL. 43.  
 PS BUSINESS PARKS, L.P., GLENDALE, CA:  
 2,796,328, CANC. INT. CL. 42.  
 PT CENTRAL PROTEINAPRIMA TBK, JAKARTA 10210,  
 INDONESIA:  
 4,591,550, PUB. 6-10-2014. INT. CL. 29.  
 4,591,552, PUB. 6-10-2014. INT. CL. 29.  
 PUBLIC WORKS PARTNERS LLC, NEW YORK, NY:  
 4,592,373, PUB. 6-10-2014. MULTIPLE CLASS, INT. CLS.  
 35 AND 36.  
 PUBLISHING GROUP OF AMERICA, INC., FRANKLIN,  
 TN:  
 2,795,834, CANC. INT. CL. 41.  
 PUEBLO OF ISLETA, ISLETA, NM:  
 4,593,010, PUB. 6-10-2014. INT. CL. 41.  
 PUMA SE, HERZOGENAURACH, FED REP GERMANY:  
 3,369,752.  
 PUMP 'EM UP, ODESSA, FL:  
 3,351,463, CANC. INT. CL. 35.  
 PURCHASING POWER PLUS, LLC, SANFORD, FL:  
 4,592,121, PUB. 6-10-2014. INT. CL. 35.  
 4,592,124, PUB. 6-10-2014. INT. CL. 35.  
 PURE & NATURAL COMPANY, SCOTTSDALE, AZ:  
 3,353,871, CANC. INT. CL. 5.  
 3,354,286, CANC. INT. CL. 3.  
 PURE COUNTRY, INC., LYNN, NC:  
 3,354,661, CANC. INT. CL. 37.  
 PURE DIGITAL TECHNOLOGIES LLC, SAN FRANCISCO,  
 CA:  
 2,796,144, CANC. INT. CL. 9.  
 PURE PRODUCT GMBH, HAMBURG, FED REP GER-  
 MANY:  
 4,593,205, INT. CL. 32.  
 PURINA MILLS, LLC, ARDEN HILLS, MN:  
 1,847,437, REN. 7-23-14. INT. CL. 31.  
 PURINA MILLS, LLC, ST. LOUIS, MO:  
 1,854,803, REN. 7-21-14. INT. CL. 31.  
 PURPOSE 2 PLAY.COM, DALLAS, TX:  
 4,592,362, PUB. 6-10-2014. INT. CL. 41.  
 PUSHPAY IP LIMITED, GLENFIELD AUCKLAND, NEW  
 ZEALAND:  
 3,096,435 NEW CERT. 8-26-2014. INT. CL. 36.  
 PUTNAM COMPANY, INC., WALWORTH, WI:  
 1,892,679, REN. 7-22-14. INT. CL. 22.  
 PUTNAM INVESTMENTS, LLC, BOSTON, MA:  
 4,592,694, PUB. 6-10-2014. INT. CL. 36.  
 PYFROM, ESTELLA, WEST PALM BEACH, FL:  
 4,592,200, PUB. 6-10-2014. INT. CL. 41.  
 PYRAMID PUBLISHING & PRODUCTIONS, INC., CHICA-  
 GO, IL:  
 3,353,522, CANC. INT. CL. 3.  
 QANTAS AIRWAYS LIMITED, MASCOT NSW, AUSTRA-  
 LIA:  
 1,287,303, REN. 7-24-14. INT. CL. 39.  
 QIAGEN GMBH, 40724 HILDEN, FED REP GERMANY:  
 3,445,463.  
 QIRO GMBH, BERLIN, FED REP GERMANY:  
 3,350,933, CANC. INT. CL. 42.  
 3,350,934, CANC. INT. CL. 38.  
 3,350,935, CANC. INT. CL. 36.  
 3,350,936, CANC. INT. CL. 35.  
 QMANIA, INC., LONG BEACH, CA:  
 3,642,758, CANC. INT. CL. 42.  
 QOUPONS, INC, WINTER SPRINGS, FL:  
 4,594,670, INT. CL. 35.  
 QUAD/GRAPHICS MARKETING, LLC, SUSSEX, WI:  
 2,794,646, CANC. INT. CL. 35.  
 QUAD/GRAPHICS, INC., SUSSEX, WI:  
 2,861,325, REN. 7-20-14. MULTIPLE CLASS, INT. CLS. 40  
 AND 42.  
 QUADREM INTERNATIONAL, LTD., HAMILTON, BER-  
 MUDA:  
 3,352,212, CANC. MULTIPLE CLASS, INT. CLS. 35 AND  
 36.  
 QUAKER COFFEE COMPANY, INC., WYNNWOOD, PA:  
 3,354,292, CANC. MULTIPLE CLASS, INT. CLS. 30 AND  
 43.  
 QUAL CHEM, LLC, AKRON, OH:  
 4,593,797, MULTIPLE CLASS, INT. CLS. 3 AND 7.  
 4,593,798, MULTIPLE CLASS, INT. CLS. 3 AND 7.  
 QUALCOMM INCORPORATED, SAN DIEGO, CA:  
 3,353,339, CANC. INT. CL. 9.  
 3,353,340, CANC. INT. CL. 9.  
 4,593,234, INT. CL. 9.  
 QUALITAS MANUFACTURING, INC., ITASCA, IL:  
 1,867,636, REN. 7-22-14. INT. CL. 19.  
 1,867,637, REN. 7-22-14. INT. CL. 19.  
 1,871,919, REN. 7-22-14. INT. CL. 19.  
 QUALITY ASSURED SERVICES, INC., ORLANDO, FL:  
 3,351,707, CANC. INT. CL. 35.  
 QUALITY CHEKD DAIRIES, INC. (COOPERATIVE), NA-  
 PERVILLE, IL:  
 1,002,333, REN. 7-19-14. U.S. CL. 46 (INT. CL. 29).  
 QUALITY SOFTWARE SYSTEMS, INC., SOMERSET, NJ:  
 4,591,247, PUB. 6-10-2014. INT. CL. 9.  
 QUALITY TRUCK & EQUIPMENT CO., BLOOMINGTON,  
 IL:  
 4,591,311, PUB. 6-10-2014. INT. CL. 7.  
 4,591,685, PUB. 6-10-2014. INT. CL. 7.  
 QUAN ENTERTAINMENT, SAINT LOUIS, MO:  
 3,351,135, CANC. INT. CL. 41.  
 QUANTUM CORPORATION, SAN JOSE, CA:  
 4,590,993, PUB. 6-10-2014. MULTIPLE CLASS, INT. CLS.  
 9, 16, 37, 41 AND 42.  
 QUANT5, INC., CAMBRIDGE, MA:  
 4,591,250, PUB. 6-10-2014. INT. CL. 42.  
 QUARTON, INC., XIZHI DIST., TAIPEI, TAIWAN:  
 1,826,862, REN. 7-23-14. INT. CL. 9.  
 QUEST MEDIA & SUPPLIES, INC., SACRAMENTO, CA:  
 4,591,193, PUB. 6-10-2014. INT. CL. 42.  
 4,591,194, PUB. 6-10-2014. INT. CL. 42.  
 QUEST NUTRITION, LLC, MARINA DEL REY, CA:  
 4,591,303, PUB. 1-7-2014. MULTIPLE CLASS, INT. CLS. 5  
 AND 30.  
 QUESTAIR TECHNOLOGIES INC., BURNABY, BRITISH  
 COLUMBIA, CANADA:  
 3,350,613, CANC. MULTIPLE CLASS, INT. CLS. 7, 11  
 AND 37.  
 QUICKSORT, INC., SAN RAMON, CA:  
 3,350,876, CANC. INT. CL. 39.  
 QUILTS OF DENMARK A/S, DK-6580 VAMDRUP, DEN-  
 MARK:  
 3,352,785, CANC. MULTIPLE CLASS, INT. CLS. 20 AND  
 24.  
 QUINTA DA ROSA - VINHOS SA, PINHAO, PORTUGAL,  
 DOUROSA INVESTMENTS LIMITED, ST. HELIER, JER-  
 SEY, CHANNEL ISLANDS:  
 1,801,662, REN. 7-21-14. INT. CL. 33.  
 QUINWELL TRAVEL SERVICES, INC., ASHLAND, MA:  
 3,351,058, CANC. INT. CL. 39.  
 QUIST-NEWINS, MARY, EDINA, MN:  
 4,593,143, MULTIPLE CLASS, INT. CLS. 16, 36 AND 41.

- QUMPUS, INC., ALPHARETTA, GA:  
4,592,060, PUB. 6-10-2014. INT. CL. 35.
- QVC, INC., WEST CHESTER, PA:  
3,354,341, CANC. INT. CL. 24.
- QWEST COMMUNICATIONS INTERNATIONAL INC., DENVER, CO:  
2,794,685, CANC. INT. CL. 16.  
3,351,906, CANC. INT. CL. 35.  
3,351,921, CANC. INT. CL. 38.
- R. G. & H. INVESTMENTS PTY. LTD., WALES, AUSTRALIA:  
2,793,879, CANC. INT. CL. 33.
- R.D. SIMPSON, INC., NEW YORK, NY:  
4,591,379, PUB. 6-10-2014. INT. CL. 25.
- R.H. DONNELLEY BRE LLC, CARY, NC:  
3,352,465, CANC. INT. CL. 35.
- R&D ENTERPRISES, LLC, PLANO, TX:  
4,594,074, INT. CL. 43.  
4,594,075, INT. CL. 43.
- R&R NOVELTIES, INC., OKLAHOMA CITY, OK:  
4,593,258, INT. CL. 35.
- R-CAVS INC., GREENSBURG, PA:  
3,353,926, CANC. MULTIPLE CLASS, INT. CLS. 6 AND 20.
- R-GARDEN, INC., KETTLE FALLS, WA:  
4,592,947, PUB. 6-10-2014. INT. CL. 5.
- RABO AGRIFINANCE, INC., ST. LOUIS, MO:  
3,352,910, CANC. INT. CL. 36.  
4,594,383, INT. CL. 36.
- RACE ASSIST, LLC, HOUSTON, TX, DBA RA SPORTS MANAGEMENT, LLC:  
4,591,943, PUB. 6-10-2014. MULTIPLE CLASS, INT. CLS. 25 AND 41.
- RACK ROOM SHOES OF VIRGINIA LLC, CHARLOTTE, NC:  
2,794,208, CANC. INT. CL. 25.
- RACK ROOM SHOES OF VIRGINIA, LLC, CHARLOTTE, NC:  
4,594,247, INT. CL. 35.
- RACK-WILDNER & REESE, INC., PITTSBURGH, PA:  
2,794,116, CANC. INT. CL. 35.
- RADAR RECORDS, INC., LOS ANGELES, CA:  
3,352,826, CANC. MULTIPLE CLASS, INT. CLS. 9 AND 41.
- RADIA, NICK, GARDEN GROVE, CA:  
4,592,423, PUB. 6-10-2014. INT. CL. 35.
- RADIO AMATEUR SATELLITE CORPORATION, SILVER SPRING, MD:  
4,592,047, PUB. 6-10-2014. INT. CL. 41.
- RADIO FLYER INC., CHICAGO, IL:  
4,594,612, INT. CL. 12.
- RADU, MARY E., ST. HELENA, CA AND MANN, CHERYL D., OAKLAND, CA:  
3,350,908, CANC. INT. CL. 9.
- RAE-ANN HOLDINGS, INC., BAY VILLAGE, OH, DBA RAE-ANN SKILLED NURSING AND REHABILITATION CENTERS:  
4,592,664, PUB. 6-10-2014. INT. CL. 44.
- RAFIH, SEBASTIEN, NICE, FRANCE:  
4,593,510, INT. CL. 3.
- RAGLAND, ELDON, ARVADA, CO:  
4,593,962, INT. CL. 35.
- RAHN AG, SWITZERLAND:  
4,590,815, PUB. 6-10-2014. MULTIPLE CLASS, INT. CLS. 1 AND 3.
- RAIN AND HAIL INSURANCE SERVICE, INC., JOHNSTON, IA:  
4,591,269, PUB. 6-10-2014. INT. CL. 36.
- RAM INDUSTRIES, LLC, LEESPORT, PA:  
3,351,522, CANC. INT. CL. 7.
- RAMBOR LOGISTICS & ASSET MANAGEMENT PTY LTD, AUSTRALIA:  
4,590,710, PUB. 6-10-2014. MULTIPLE CLASS, INT. CLS. 7, 8 AND 37.  
4,590,711, PUB. 6-10-2014. MULTIPLE CLASS, INT. CLS. 7, 8 AND 37.
- RAMPF FORMEN GMBH, FED REP GERMANY:  
4,590,803, PUB. 6-10-2014. MULTIPLE CLASS, INT. CLS. 6, 7, 9, 37 AND 42.
- RAMSEY, ALMA L., EL PASO, TX:  
3,353,104, CANC. INT. CL. 16.
- RANCHITO ESCONDIDO LLC, BRYAN, TX:  
4,593,256, INT. CL. 41.
- RANDA CORP., NEW YORK, NY:  
2,794,274, CANC. INT. CL. 25.
- RANDI A. GALLI, M.D., INC., FRESNO, CA:  
4,591,455, PUB. 6-10-2014. INT. CL. 44.
- RANIERI FINE FOODS, INC., BROOKLYN, NY:  
3,351,432, CANC. INT. CL. 29.
- RANZ, LA PUENTE, CA:  
4,592,247, PUB. 6-10-2014. INT. CL. 9.
- RASMUSSEN, KYLE ROBERT, LITCHFIELD, MN:  
4,593,452, INT. CL. 44.
- RATE-MONITOR, INC., IRVINE, CA:  
4,592,896, PUB. 6-10-2014. INT. CL. 35.
- RATHJE, VICKY, SANTA ROSA VALLEY, CA:  
3,353,692, CANC. MULTIPLE CLASS, INT. CLS. 3 AND 5.
- RATLIFF ENTERPRISES INC., ATLANTA, GA:  
4,591,720, PUB. 6-10-2014. INT. CL. 16.
- RAVENITE, LLC, LOS ANGELES, CA:  
4,591,476, PUB. 6-10-2014. MULTIPLE CLASS, INT. CLS. 18, 21 AND 25.
- RAWLINGS SPORTING GOODS COMPANY, INC., ST. LOUIS, MO:  
3,350,639, CANC. INT. CL. 28.
- RAY ST. CLAIR ROOFING, INC., FAIRFIELD, OH:  
4,591,357, PUB. 6-10-2014. INT. CL. 37.
- RAYNAULD LTD., TAIPEI CITY, TAIWAN:  
4,591,000, PUB. 6-10-2014. INT. CL. 9.
- RAZAK, BOBBY, LOS ANGELES, CA:  
4,594,634, INT. CL. 41.
- RAZOR & TIE DIRECT, L.L.C., NEW YORK, NY:  
3,350,852, CANC. INT. CL. 41.
- RB DISTRIBUTION, INC., COLMAR, PA:  
4,593,207, MULTIPLE CLASS, INT. CLS. 7 AND 12.
- RBT ENTERPRISES LIMITED, KOWLOON, HONG KONG:  
4,592,020, PUB. 6-10-2014. INT. CL. 43.
- RCF S.P.A., 42124 REGGIO EMILIA, ITALY:  
4,593,078, INT. CL. 9.
- RCI CONSULTING INC., LAS VEGAS, NV:  
3,353,987, CANC. MULTIPLE CLASS, INT. CLS. 35 AND 36.
- RCI, LLC, PARSIPPANY, NJ:  
3,350,851, CANC. INT. CL. 36.
- RDF, INCORPORATED, ELDORADO, IL:  
2,943,966, REN. 7-24-14. INT. CL. 17.
- RE-ENERGIZING COMMUNICATIONS, INC., PROSPECT, KY:  
3,351,315, CANC. INT. CL. 41.
- RE/MAX, LLC, DENVER, CO:  
3,488,118, CANC. INT. CL. 38.
- REA, SHARON, SCOTTSDALE, AZ:  
4,592,861, PUB. 6-10-2014. INT. CL. 41.
- REACTION MANAGEMENT, INC., FLAGSTAFF, AZ, AKA RMI:  
4,592,065, PUB. 6-10-2014. INT. CL. 35.  
4,592,075, PUB. 6-10-2014. INT. CL. 35.
- REACTORY FACTORY LLC, LAKELAND, FL:  
4,594,609, INT. CL. 9.
- READY PAC PRODUCE, INC., IRWINDALE, CA:  
4,594,337, MULTIPLE CLASS, INT. CLS. 29 AND 30.
- REAGAN, SUSAN BECKMAN, POTOMAC, MD:  
4,592,406, PUB. 6-10-2014. INT. CL. 44.
- REAGENTFORECLOSURES, LLC, DEDHAM, MA:  
3,351,745, CANC. INT. CL. 36.
- REAL ESTATE LICENSE SERVICES, INC., SAN DIEGO, CA:  
3,352,801, CANC. MULTIPLE CLASS, INT. CLS. 9, 16 AND 41.
- REALITY REALTY PROFESSIONALS, LLC, STAFFORD, VA:  
4,592,078, PUB. 6-10-2014. INT. CL. 36.
- REALTECHNETWORK CORPORATION, CONGERS, NY:  
3,351,651, CANC. INT. CL. 35.
- REALWHEELS CORPORATION, GURNEE, IL:  
4,591,569, PUB. 6-10-2014. INT. CL. 9.

REBECCA AND JAMES PICKENS AND ASSOCIATES, LLC, PHILADELPHIA, PA, DBA SHE PAINTS PHILLY: 4,591,932, PUB. 6-10-2014. INT. CL. 37.

REBEL WINE CO. LLC, ST. HELENA, CA: 3,354,379, CANC. INT. CL. 33.

RECKITT & COLMAN (OVERSEAS) LIMITED, HULL, UNITED KINGDOM: 3,352,006, CANC. INT. CL. 3.

RECKITT BENCKISER (SWITZERLAND) AG, ZURICH, SWITZERLAND: 3,352,102, CANC. INT. CL. 5.

RECKITT BENCKISER LLC, PARSIPPANY, NJ: 2,796,100, CANC. MULTIPLE CLASS, INT. CLS. 3 AND 5.

RECOVERY EDU, LLC, JUPITER, FL: 4,591,483, PUB. 6-10-2014. INT. CL. 41.

RED DIAMOND, INC., MOODY, AL: 4,594,406, INT. CL. 30.

RED GIANT OIL COMPANY, COUNCIL BLUFFS, IA: 4,592,614, PUB. 6-10-2014. INT. CL. 4.

RED MOUNTAIN ENTERTAINMENT, BIRMINGHAM, AL: 4,591,656, PUB. 6-10-2014. INT. CL. 35.

RED SQUARE HOLDINGS LLC, SUNNY ISLES, FL: 4,592,564, PUB. 6-10-2014. INT. CL. 45.

RED STEER GLOVE COMPANY, SALEM, OR: 4,592,556, PUB. 6-10-2014. INT. CL. 28.

REDCHIP COMPANIES, L.L.C., SPOKANE, WA TO AURELIUS CONSULTING GROUP, INC., MAITLAND, FL: 2,793,515, CANC. INT. CL. 36.

REDD, DOMINIC, WASHINGTON, DC AND REDD, JENNIFER GRAHAM, WASHINGTON, DC: 3,351,571, CANC. INT. CL. 43.

REDFISH INSTRUMENTS, INC., SANTA CRUZ, CA: 4,592,509, PUB. 6-10-2014. INT. CL. 9.

REDSCHLAG HOLDING GMBH, 30419 HANNOVER, FED REP GERMANY: 4,590,660, PUB. 11-12-2013. INT. CL. 5.  
4,590,661, PUB. 11-12-2013. INT. CL. 5.

REDSHIFT VENTURES MANAGEMENT, INC., ARLINGTON, VA: 3,354,114, CANC. INT. CL. 36.

REED MIDEM, F-92100 BOULOGNE-BILLAN COURT, FRANCE: 4,590,632, PUB. 6-10-2014. MULTIPLE CLASS, INT. CLS. 9, 16, 35, 38 AND 41.

REED, HERB, MERIDEN, CT, DBA LUNKER CITY FISHING SPECIALTIES: 1,843,787, REN. 7-18-14. INT. CL. 28.

REFLECT SYSTEMS, INC., DALLAS, TX: 2,796,221, CANC. INT. CL. 9.

REFORMED BODIES, INC., DANIA, FL: 4,592,733, PUB. 6-10-2014. INT. CL. 41.

REGAL BELOIT AMERICA, INC., BELOIT, WI: 4,591,434, PUB. 6-10-2014. INT. CL. 7.  
4,591,465, PUB. 6-10-2014. INT. CL. 7.

REGENCY MERCHANT SOLUTIONS, LLC, GREENWOOD VILLAGE, CO: 3,354,110, CANC. INT. CL. 36.

REGENT-SUTTON, LLC, NEW YORK, NY: 4,591,384, PUB. 6-10-2014. INT. CL. 25.

REGERO, FRANCE: 3,352,640.

REGIONAL ECONOMIC MODELS, INC., AMHERST, MA: 3,353,370, CANC. INT. CL. 9.

REINHART, DAVID S., HOLDEN, MA: 4,594,449, INT. CL. 41.

RELATIVE EMOTION ENTERPRISES, INC., GREAT NECK, NY: 4,593,324, INT. CL. 42.  
4,593,325, INT. CL. 42.

RELATIVITY MEDIA, LLC, BEVERLY HILLS, CA: 4,593,080, INT. CL. 9.

RELIABILITY, INC., HOUSTON, TX: 1,148,801, CANC. INT. CL. 9.

RELIANCE RELOCATION SERVICES, INC., CHICAGO, IL: 3,351,995, CANC. MULTIPLE CLASS, INT. CLS. 35, 36 AND 42.

RELIGIOUS TECHNOLOGY CENTER, LOS ANGELES, CA: 4,591,429, PUB. 6-10-2014. INT. CL. 45.

RELLO LARA ENRIQUE, MEXICO CITY, MEXICO: 4,591,420, PUB. 6-10-2014. INT. CL. 33.

REMEND INC., SAN MATEO, CA: 3,352,207, CANC. INT. CL. 9.

REMY COINTREAU, COGNAC, FRANCE: 4,591,827, PUB. 6-10-2014. INT. CL. 35.

RENEWAGE ENERGY SOLUTIONS, INC., CULVER CITY, CA: 4,591,126, PUB. 2-25-2014. MULTIPLE CLASS, INT. CLS. 35 AND 42.

RENNER, LINDA, FORT WAYNE, IN: 2,795,034, CANC. INT. CL. 20.

RENT-A-CENTER WEST, INC., PLANO, TX: 2,870,944, REN. 7-18-14. MULTIPLE CLASS, INT. CLS. 40, 41, 42 AND 43.

RENTECH BOILER SYSTEMS, INC., ABILENE, TX: 4,592,482, PUB. 6-10-2014. INT. CL. 11.

RENTON MEDIA LLC, DENVER, CO: 4,594,739, INT. CL. 41.

RENTPATH, INC., NORCROSS, GA: 4,592,254, PUB. 6-10-2014. INT. CL. 35.

REPUBLIC PROMOTION CO., ORLANDO, FL: 3,351,411, CANC. INT. CL. 41.

REPUBLIC SERVICES, INC., PHOENIX, AZ: 4,594,429, INT. CL. 35.

REPUBLIK OF KALIFORNIA, INC., HERMOSA, CA: 4,593,958, INT. CL. 25.

RESCHCOR, INC., ELKHART, IN, FORMERLY OMEGA PLASTICS CORP.: 4,591,361, PUB. 6-10-2014. MULTIPLE CLASS, INT. CLS. 17, 19, 40 AND 42.

RESERVOIR LABS, INC., NEW YORK, NY: 3,353,857, CANC. INT. CL. 9.

RESIDENTIAL MORTGAGE GROUP, INC., MINNETONKA, MN: 3,353,080, CANC. INT. CL. 36.

RESIGNATION HOLDINGS, LLC, ALTADENA, CA, FORMERLY RESIGNATION BREWERY LLC: 4,594,300, INT. CL. 41.

RESILUX N.V., BELGIUM: 3,352,565.

RESOLUTE FP US INC., MONTREAL, CANADA: 3,354,393, CANC. INT. CL. 16.

RESOLUTION HEALTH, INC., SAN JOSE, CA: 4,592,066, PUB. 6-10-2014. MULTIPLE CLASS, INT. CLS. 35, 39 AND 44.

RESOURCES A LA CARTE, INC., LISLE, IL: 3,352,996, CANC. INT. CL. 42.

RESPONSE PRODUCTS LIMITED, WANCHAI, HONG KONG: 3,354,333, CANC. INT. CL. 11.

RESTAURANT INVESTORS, LLC, GREENSBORO, NC: 4,593,287, INT. CL. 43.

RETAIL ROYALTY COMPANY, LAS VEGAS, NV: 4,594,185, INT. CL. 3.

RETHYNC LTD, UNITED KINGDOM: 4,590,720, PUB. 6-10-2014. MULTIPLE CLASS, INT. CLS. 9, 35, 38 AND 42.

RETRO HOME, SEMINOLE, FL: 2,795,261, CANC. MULTIPLE CLASS, INT. CLS. 20 AND 35.

REVABILITY HOLDING B.V., NETHERLANDS: 3,352,575.

REVLON CONSUMER PRODUCTS CORPORATION, NEW YORK, NY: 3,353,272, CANC. INT. CL. 20.

REVMEDX, INC., WILSONVILLE, OR: 4,594,038, INT. CL. 10.

REVSPRING, INC., WIXOM, MI: 4,593,769, INT. CL. 39.

REWIRE ME LLC, NEW YORK, NY: 4,593,281, INT. CL. 44.

REY DANIELLE, F-31200 TOULOUSE, FRANCE: 4,590,893, PUB. 6-10-2014. INT. CL. 3.

- REY HERRERA, LOS ANGELES, CA, DBA CHILANTHROPY:  
4,591,039, PUB. 10-29-2013. INT. CL. 4.  
4,591,040, PUB. 10-29-2013. INT. CL. 4.  
4,591,041, PUB. 10-29-2013. INT. CL. 4.
- RGB SPECTRUM, ALAMEDA, CA:  
4,591,439, PUB. 6-10-2014. INT. CL. 9.
- RHC TRADING INC, HENDERSON, NV:  
4,592,220, PUB. 6-10-2014. INT. CL. 35.
- RHEINZINK GMBH & CO. KG, FED REP GERMANY:  
4,590,683, PUB. 6-10-2014. MULTIPLE CLASS, INT. CLS. 37 AND 42.
- RHINO MOTORCYCLES, INC., SUN VALLEY, CA:  
3,350,721, CANC. INT. CL. 12.  
3,350,746, CANC. INT. CL. 12.  
3,350,747, CANC. INT. CL. 12.
- RHINO SPORTS GROUP, LLC, WEAVERVILLE, NC:  
4,591,681, PUB. 6-10-2014. INT. CL. 28.  
4,591,682, PUB. 6-10-2014. INT. CL. 28.
- RHOD WILLIAMS, FRISCO, TX:  
4,592,330, PUB. 6-10-2014. INT. CL. 29.
- RHODES, ALEXANDER JULIAN, PITTSBURGH, PA:  
4,591,410, PUB. 6-10-2014. INT. CL. 41.
- RIBAUDO, CLIFFORD P, JERSEY CITY, NJ:  
4,592,641, PUB. 6-10-2014. INT. CL. 9.
- RICE LAKE WEIGHING SYSTEMS, INC., RICE LAKE, WI:  
3,354,363, CANC. INT. CL. 35.
- RICELAND FOODS, INC., STUTTGART, AR:  
2,866,770, REN. 7-24-14. INT. CL. 29.  
2,869,531, REN. 7-24-14. INT. CL. 29.
- RICHARD C, RAPP III, SOMERSET, NJ, AKA UNDER THE SUN SOLAR:  
4,592,212, PUB. 6-10-2014. INT. CL. 42.
- RICHARD HARRIS, INC., NEW YORK, NY, DBA HUA XIN INTERNATIONAL:  
3,353,651, CANC. INT. CL. 25.
- RICHARD WENDELL ARNESON III, RANCHO SANTA FE, CA:  
4,593,434, INT. CL. 9.  
4,593,435, INT. CL. 16.
- RICHARDSON, MAUREEN, SAN RAMON, CA:  
4,592,474, PUB. 6-10-2014. INT. CL. 36.
- RICHARDSON, ROY, WHITE PLAINS, NY AND WHIGHAM, RODNEY E., ATLANTA, GA:  
2,795,991, CANC. INT. CL. 16.
- RICHEMONT INTERNATIONAL SA, SWITZERLAND:  
4,590,894, PUB. 6-10-2014. INT. CL. 35.
- RICHEMONT ITALIA S.P.A., ITALY:  
3,352,694.
- RICHLINE GROUP, INC., MOUNT VERNON, NY:  
3,354,142, CANC. MULTIPLE CLASS, INT. CLS. 14 AND 35.  
3,354,143, CANC. MULTIPLE CLASS, INT. CLS. 14 AND 35.
- RICHLINE GROUP, INC., NEW YORK, NY:  
4,593,368, INT. CL. 14.
- RICHMIX DISTRIBUTORS, LLC, BELLINGHAM, WA:  
4,592,911, PUB. 6-10-2014. INT. CL. 10.
- RICHMOND METROPOLITAN CONVENTION AND VISITORS BUREAU, RICHMOND, VA:  
2,795,732, CANC. INT. CL. 35.
- RICHTER SCALE PRODUCTIONS, INC., DENVER, CO:  
2,794,336, CANC. INT. CL. 41.
- RICKY'S TRADEMARK HOLDINGS, INC., NEW YORK, NY:  
4,591,793, PUB. 6-10-2014. INT. CL. 35.
- RICOT, PATRICK, EVERETT, MA:  
4,593,868, INT. CL. 41.
- RIGHT CONNECTION MINISTRIES INTERNATIONAL, INC., MIAMI GARDENS, FL:  
4,591,568, PUB. 6-10-2014. INT. CL. 45.
- RIGHT PATH MARKETING LLC, HOUSTON, TX:  
3,350,859, CANC. INT. CL. 35.
- RIGHT SIDE, LLC, MENLO PARK, CA:  
4,591,755, PUB. 6-10-2014. INT. CL. 33.
- RILEE, JESSICA JANE, PASADENA, MD:  
4,591,271, PUB. 6-10-2014. INT. CL. 35.
- RILON LIMITED, NICOSIA, CYPRUS:  
4,591,920, PUB. 6-10-2014. MULTIPLE CLASS, INT. CLS. 9 AND 42.  
4,591,928, PUB. 6-10-2014. MULTIPLE CLASS, INT. CLS. 9 AND 42.
- RIMKUS CONSULTING GROUP, INC., HOUSTON, TX:  
4,594,733, MULTIPLE CLASS, INT. CLS. 35, 36, 37, 42 AND 45.
- RIMOWA GMBH, COLOGNE, FED REP GERMANY:  
4,594,356, INT. CL. 18.
- RINEHART, DIXIE, MONTROSE, CO:  
2,859,406, REN. 7-21-14. INT. CL. 25.
- RINI DAMMEN, BELGIUM:  
4,590,883, PUB. 6-10-2014. INT. CL. 41.
- RISE, SAN LEANDRO, CA:  
4,594,702, INT. CL. 25.
- RISE ABOVE NUTRITION, INC., WILLOWBROOK, IL:  
3,354,187, CANC. INT. CL. 5.
- RISE SURF LLC, TEXAS CITY, TX:  
3,350,868, CANC. INT. CL. 25.
- RISKMATCH, LLC, GREENWICH, CT:  
4,591,875, PUB. 6-10-2014. INT. CL. 42.
- RISLEY, AMELIA M., ROCHESTER, NY:  
3,350,698, CANC. INT. CL. 20.
- RITCHIE FEED & SEED INC., OTTAWA, CANADA:  
4,590,966, PUB. 6-10-2014. INT. CL. 42.
- RITEC INTERNATIONAL LIMITED, ENFIELD, MIDDLESEX, UNITED KINGDOM:  
3,468,068.
- RITMO LATINO, INC., TINTON FALLS, NJ:  
2,793,611, CANC. MULTIPLE CLASS, INT. CLS. 16 AND 41.
- RIVERA, RICKY L, PITTSFIELD, MA:  
4,593,719, INT. CL. 41.  
4,593,720, INT. CL. 41.
- RIVERCITY INTERNET GROUP, LLC, ST. LOUIS, MO:  
3,353,724, CANC. INT. CL. 38.
- RIVULET COMMUNICATIONS, INC., PORTSMOUTH, NH:  
3,352,459, CANC. INT. CL. 9.
- RIZE TECHNOLOGY CORPORATION, CHARLOTTE, NC:  
4,591,578, PUB. 6-10-2014. INT. CL. 42.
- RLR INDUSTRIES, INC., MABLETON, GA:  
3,353,561, CANC. INT. CL. 11.
- RLR MARKETING, FLOWER MOUND, TX:  
3,351,689, CANC. INT. CL. 35.
- RLR MEDIA LIMITED, PORT LOUIS, MAURITIUS:  
4,591,203, PUB. 4-8-2014. MULTIPLE CLASS, INT. CLS. 9 AND 41.
- RMJ LABORATORIES, INC., EDISON, NJ:  
3,353,851, CANC. INT. CL. 42.
- RMRH ENTERPRISES, LLC, PINEY FLATS, TN, DBA EAST TENNESSEE DISTILLERY:  
4,593,329, INT. CL. 33.
- ROACH, LYNDSEY, SAN CLEMENTE, CA AND ANDERSON, MICAH, SAN CLEMENTE, CA:  
4,594,322, INT. CL. 31.
- ROAD PLAYER, RAMONA, CA:  
4,593,884, INT. CL. 25.
- ROADNOISE PRODUCTIONS, LLC, CRYSTAL LAKE, IL:  
2,794,355, CANC. MULTIPLE CLASS, INT. CLS. 9 AND 41.
- ROASTING SOLUTIONS, LLC, DUBUQUE, IA:  
4,592,359, PUB. 6-10-2014. INT. CL. 30.
- ROBBINS INC., CINCINNATI, OH:  
2,942,734, REN. 7-24-14. INT. CL. 37.
- ROBBINS RESEARCH INTERNATIONAL, INC., SAN DIEGO, CA:  
3,354,659, CANC. INT. CL. 9.
- ROBBINS RICE COMPANY, COLUSA, CA:  
4,594,118, INT. CL. 30.
- ROBBINS-GIOIA, LLC, ALEXANDRIA, VA:  
1,721,549, CANC. INT. CL. 9.
- ROBERN, INC., BRISTOL, PA:  
4,593,795, INT. CL. 11.
- ROBERSON, HALLEY, DALLAS, TX:  
4,591,146, PUB. 6-10-2014. INT. CL. 45.
- ROBERT BENTLEY, INC., CAMBRIDGE, MA:  
2,836,701, REN. 7-22-14. INT. CL. 42.



ROBERT C. KNUDSEN, FAIRFAX STATION, VA:  
4,591,327, PUB. 6-10-2014. INT. CL. 9.

ROBERT KUO, LTD., INC., LOS ANGELES, CA:  
2,793,732, CANC. INT. CL. 20.

ROBERT, EVELYN, SAN FRANCISCO, CA:  
4,594,495, INT. CL. 3.

ROBERTS IRVINE VINEYARDS, LLC, ASHLAND, OR:  
4,594,730, INT. CL. 33.

ROBERTS, JONELL, DECATUR, GA:  
3,354,257, CANC. INT. CL. 44.

ROBINSON & ROBINSON INC., LOS ANGELES, CA:  
3,353,257, CANC. INT. CL. 20.

ROBINSON, STEPHEN W., BATTLE CREEK, MI:  
2,795,067, CANC. INT. CL. 28.

ROBINSON, TANNER G., MESILLA PARK, NM:  
4,591,647, PUB. 6-10-2014. INT. CL. 25.

ROBLES, JOSE L., LONG BEACH, CA:  
3,350,799, CANC. INT. CL. 25.

ROBLIN ATHLETIC INC., WINNIPEG, MANITOBA, CANADA:  
4,591,178, PUB. 6-10-2014. INT. CL. 25.  
4,591,191, PUB. 6-10-2014. MULTIPLE CLASS, INT. CLS.  
10 AND 25.

ROBOT TRACTOR, LLC, DRIPPING SPRINGS, TX:  
3,351,125, CANC. INT. CL. 35.

ROCCO & LOLA, AUSTIN, TX:  
4,594,287, INT. CL. 30.

ROCHE DIAGNOSTICS GMBH, 68305 MANHEIM, FED REP GERMANY:  
4,592,941, PUB. 5-6-2014. INT. CL. 44.

ROCHESTER INSTITUTE OF TECHNOLOGY, ROCHESTER, NY:  
2,794,029, CANC. INT. CL. 42.

ROCK N ROLL IMPORTS, STOCKTON, CA:  
4,593,081, INT. CL. 33.

ROCK SECURITY, LLC, DETROIT, MI:  
4,593,889, INT. CL. 9.

ROCK YOUR AWARENESS, NEWARK, CA:  
3,352,182, CANC. INT. CL. 35.

ROCKHILL UNDERWRITING MANAGEMENT L.L.C., KANSAS CITY, MO:  
2,850,581. REN. 7-22-14. INT. CL. 36.

ROCKIN' HOUSE RECORDS, INC., CHICAGO, IL:  
4,592,435, PUB. 6-10-2014. INT. CL. 9.

ROCKMORE INDUSTRIES, LLC, BOISE, ID:  
3,351,506, CANC. INT. CL. 5.

ROCKWALL INDEPENDENT SCHOOL DISTRICT, ROCKWALL, TX:  
4,593,586, MULTIPLE CLASS, INT. CLS. 25 AND 41.

ROCKWELL AUTOMATION, INC., MILWAUKEE, WI:  
2,865,408. REN. 7-18-14. INT. CL. 9.

ROCKY BRANDS, INC., NELSONVILLE, OH:  
3,350,884, CANC. INT. CL. 24.

ROCKY MOUNTAIN ELK FOUNDATION, INC., MISSOURI, MT:  
2,862,388. REN. 7-24-14. INT. CL. 35.

ROCO RESCUE, INC., BATON ROUGE, LA:  
4,594,508, INT. CL. 20.

RODDICK, JUSTINE, SANTA BARBARA, CA:  
3,351,458, CANC. INT. CL. 35.

RODEOROOTER AND PLUMBING, SUNNYVALE, CA:  
4,594,046, INT. CL. 37.

RODGERSHARDIN, LLC, ATLANTA, GA:  
3,351,470, CANC. INT. CL. 37.  
3,351,473, CANC. INT. CL. 37.

ROGER GARMENTS, LLC, MONTEBELLO, CA:  
4,593,599, INT. CL. 25.

ROGERS GROUP, INC., NASHVILLE, TN:  
1,303,725. REN. 7-22-14. INT. CL. 19.  
1,304,220. REN. 7-21-14. INT. CL. 42.

ROGUE PLAY, INC., IRVINE, CA:  
4,593,996, MULTIPLE CLASS, INT. CLS. 9 AND 42.

ROHDE, JUSTIN W., ASHEVILLE, NC, DBA ECO-HUTS:  
4,592,470, PUB. 6-10-2014. INT. CL. 19.

ROHDE, JUSTIN W., ASHEVILLE, NC:  
4,592,547, PUB. 6-10-2014. INT. CL. 19.

ROHL, LLC, IRVINE, CA:  
4,594,624, INT. CL. 11.

ROLF C. HAGEN INC., MONTREAL, QUEBEC, CANADA:  
4,593,920, INT. CL. 31.

ROLL-RITE, LLC, ALGER, MI:  
4,591,982, PUB. 6-10-2014. INT. CL. 7.

ROLLE, RENO, ALPHARETTA, GA:  
2,795,081, CANC. INT. CL. 11.

ROMET LIMITED, MISSISSAUGA, ONTARIO, CANADA:  
2,793,674, CANC. INT. CL. 9.

ROMEX WORLD TRADE COMPANY, L.L.C., ALEXANDRIA, LA:  
2,795,014, CANC. INT. CL. 19.

RON SACHS COMMUNICATIONS, INC., TALLAHASSEE, FL:  
3,352,231, CANC. INT. CL. 35.

RON WALKER ENTERPRISES, INC., MUSCLE SHOALS, AL:  
3,353,048, CANC. INT. CL. 44.

RONALD BLUE & CO., ROSWELL, GA:  
4,592,555, PUB. 6-10-2014. MULTIPLE CLASS, INT. CLS.  
35 AND 36.  
4,592,557, PUB. 6-10-2014. MULTIPLE CLASS, INT. CLS.  
35 AND 36.

RONSON CORPORATION, WOODBRIDGE, NJ:  
3,353,977, CANC. INT. CL. 11.

ROOM SERVICE INTERIORS LTD., COQUITLAM, BRITISH COLUMBIA, CANADA:  
3,459,916, CANC. MULTIPLE CLASS, INT. CLS. 16 AND  
24.

ROSE HILL BAND, RHOME, TX:  
4,591,691, PUB. 6-10-2014. INT. CL. 41.

ROSE, SHIRLEY R., LOS ANGELES, CA:  
3,354,272, CANC. INT. CL. 28.

ROSENBAUER AMERICA, LLC, LYONS, SD:  
4,592,944, PUB. 6-10-2014. INT. CL. 9.

ROSS, ELLEN B., BRODHEADSVILLE, PA:  
2,794,113, CANC. INT. CL. 25.

ROSS, ELYSA, PALM BEACH GARDENS, FL:  
4,591,485, PUB. 6-10-2014. INT. CL. 3.

ROSSWIL LLC, MEMPHIS, TN, CONWOOD CORPORATION, MEMPHIS, TN:  
1,349,915. REN. 7-21-14. INT. CL. 34.

ROSSWIL LLC, MEMPHIS, TN, CONWOOD COMPANY, L.P., MEMPHIS, TN:  
1,880,806. REN. 7-21-14. INT. CL. 34.

ROTA AMERICA, INC., SAN JOSE, CA:  
3,354,215, CANC. INT. CL. 9.

ROTARY INTERNATIONAL, EVANSTON, IL:  
1,835,665. REN. 7-20-14. MULTIPLE CLASS, INT. CLS. 36  
AND 41.

ROTH, MORDCHAI, UPPER SADDLE RIVER, NJ:  
4,593,590, INT. CL. 11.  
4,593,591, INT. CL. 11.

ROTHSCHILD, DEBORAH V., MORGANVILLE, NJ:  
4,592,895, PUB. 6-10-2014. INT. CL. 25.

ROTIFORM, LLC, WESTMINSTER, CA:  
4,592,428, PUB. 6-10-2014. INT. CL. 12.

ROTSOUND MANUFACTURING LTD, SEVENOAKS, KENT TN13 2HU, UNITED KINGDOM:  
2,864,080. REN. 7-21-14. INT. CL. 15.

ROUGH BROTHERS, INC., CINCINNATI, OH:  
4,593,068, INT. CL. 6.

ROWMARK LLC, FINDLAY, OH:  
2,903,892. REN. 7-21-14. INT. CL. 17.

ROYAL ARCH MARKETING, LLC, MIAMI, FL:  
3,352,392, CANC. INT. CL. 35.

ROYAL BANK OF CANADA, MONTREAL QUEBEC, CANADA:  
2,885,583. REN. 7-23-14. MULTIPLE CLASS, INT. CLS. 35,  
36 AND 42.

ROYAL BATTERY DISTRIBUTORS, INC., KISSIMMEE, FL:  
4,591,300, PUB. 6-10-2014. INT. CL. 9.

ROYAL BEAUTY INC., SOUTH EL MONTE, CA:  
4,592,792, PUB. 6-10-2014. INT. CL. 14.

ROYAL BRIERLEY CRYSTAL LIMITED, DUDLEY DY1 4SH, UNITED KINGDOM, STEVENS & WILLIAMS LIMITED, WEST MIDLANDS, ENGLAND:  
1,289,086. REN. 7-24-14. INT. CL. 21.

- ROYAL FINANCIAL INVESTMENT GROUP LLC, PENSACOLA, FL:  
4,592,008, PUB. 6-10-2014. INT. CL. 36.
- ROYAL HAWAIIAN SURF ACADEMY LIMITED, LAHAINA, HI:  
3,351,417, CANC. INT. CL. 25.  
3,351,420, CANC. INT. CL. 25.
- ROYAL ICE CREAM COMPANY, CLEVELAND, OH:  
2,964,043, REN. 7-22-14. INT. CL. 30.
- ROYAL MAX ENTERPRISES, INC., BROOKLYN, NY:  
3,353,330, CANC. INT. CL. 25.
- ROYAL MEDICAL SOLUTIONS, INC., SAN ANTONIO, TX:  
4,594,351, INT. CL. 10.
- ROYALE CONCIERGE, INC., NEW YORK, NY:  
4,591,272, PUB. 6-10-2014. INT. CL. 45.
- ROYALTY PARTNERS, LIMITED PARTNERSHIP, ANDOVER, MA:  
2,795,030, CANC. MULTIPLE CLASS, INT. CLS. 28 AND 31.
- ROZAR, WILLIAM, BROOKLYN, NY:  
3,353,565, CANC. INT. CL. 41.
- RP DELIO AND COMPANY, INC., HONOLULU, HI:  
4,591,600, PUB. 6-10-2014. INT. CL. 7.
- RPI PROPERTIES 102 LLC, ORLANDO, FL, DBA STASIS GAMES:  
4,592,874, PUB. 6-10-2014. INT. CL. 9.
- RRI FINANCIAL, INC., COLUMBUS, OH:  
4,594,684, INT. CL. 43.  
4,594,685, INT. CL. 43.
- RSC EQUIPMENT RENTAL, INC., SCOTTSDALE, AZ:  
3,353,413, CANC. MULTIPLE CLASS, INT. CLS. 35 AND 41.
- RSDG INTERNATIONAL, INC., MONROVIA, CA:  
3,352,944, CANC. INT. CL. 25.
- RT FISHER EDUCATIONAL ENTERPRISES, INC., OAKLAND, CA:  
4,594,599, MULTIPLE CLASS, INT. CLS. 16 AND 41.
- RTP CAPITAL ADVISORS, DURHAM, NC:  
4,594,744, INT. CL. 36.
- RTR FOOD CONCEPTS INC., SAN FRANCISCO, CA:  
4,594,057, INT. CL. 43.
- RUBY WEB LLC, ARBON, ID, DBA KIDSEMAIL.ORG:  
4,592,846, PUB. 6-10-2014. INT. CL. 38.
- RUCRACKED?, LLC, HUTCHINSON, KS:  
4,592,627, PUB. 6-10-2014. INT. CL. 37.
- RUGBY WORLD CUP LIMITED, IRELAND:  
4,590,639, PUB. 6-10-2014. MULTIPLE CLASS, INT. CLS. 25, 28 AND 41.
- RUIZ FOOD PRODUCTS, INC., DINUBA, CA:  
4,594,203, INT. CL. 30.
- RUIZ, FRANCISCO, ATLANTA, GA:  
4,592,230, PUB. 6-10-2014. INT. CL. 35.
- RUMPELT, TINO, LEIPZIG, FED REP GERMANY, TA VISARIO:  
4,590,688, PUB. 6-10-2014. INT. CL. 40.
- RUN BUSINESS SOLUTIONS, INC., AMARILLO, TX:  
4,593,790, INT. CL. 42.
- RUNWAY SERVICES CORPORATION, ADAMS CENTER, NY:  
4,592,573, PUB. 6-10-2014. INT. CL. 3.
- RUPRECHT, PAMELA R., LAKELAND, MN:  
4,593,380, INT. CL. 11.
- RUSH UNIVERSITY MEDICAL CENTER, CHICAGO, IL:  
3,462,765, CANC. MULTIPLE CLASS, INT. CLS. 9, 14, 20 AND 28.
- RUSLYN HOLDINGS PTY LTD, HEATHCOTE NSW 2232, AUSTRALIA:  
4,591,651, PUB. 6-10-2014. INT. CL. 9.
- RUSSOUND/FMP, INC., NEWMARKET, NH:  
3,353,112, CANC. INT. CL. 9.
- RUSTIC BAKERY, LARKSPUR, CA:  
3,354,614, CANC. INT. CL. 30.
- RUTHERFORD UNIVERSITY, INC., EVANSTON, WY:  
3,353,284, CANC. INT. CL. 41.
- RXINSIDER, LTD, WEST WARWICK, RI:  
3,351,122, CANC. INT. CL. 35.
- RYAN, PATRICK, TROY, NY:  
4,593,250, INT. CL. 35.
- RYC ALIMENTOS, S.A. DE C.V., PUEBLA, MEXICO:  
3,351,835, CANC. INT. CL. 29.
- S & P INGREDIENT DEVELOPMENT, LLC, MINNETONKA, MN:  
4,591,125, PUB. 6-10-2014. INT. CL. 30.
- S & S CHEMICAL, DURANGO, CO:  
3,351,061, CANC. INT. CL. 1.  
3,351,062, CANC. INT. CL. 1.
- S J M & L, INC., AUSTIN, TX:  
3,351,344, CANC. INT. CL. 35.
- S. C. JOHNSON & SON, INC., RACINE, WI:  
4,593,733, INT. CL. 21.
- S. EVANS FAMILY, L.P., HIGLEY, AZ:  
3,354,578, CANC. INT. CL. 43.
- S.C.SUPREMIA GRUP S.R.L., ROMANIA:  
3,352,739.
- S&K SALES CO., VIRGINIA BEACH, VA:  
1,289,457, REN. 7-21-14. INT. CL. 42.
- S-L SNACKS NATIONAL, LLC, CHARLOTTE, NC:  
4,594,064, INT. CL. 30.  
4,594,065, INT. CL. 30.
- SAATI S.P.A., ITALY:  
3,352,556.
- SABERTOOTH MOTORCYCLES, LLC, NEEDHAM, MA:  
4,161,401, CANC. INT. CL. 6.  
4,161,402, CANC. INT. CL. 14.  
4,161,403, CANC. INT. CL. 24.  
4,161,405, CANC. INT. CL. 20.  
4,161,407, CANC. INT. CL. 21.  
4,161,408, CANC. INT. CL. 26.  
4,161,410, CANC. INT. CL. 36.  
4,164,713, CANC. INT. CL. 33.  
4,164,715, CANC. INT. CL. 43.  
4,164,719, CANC. INT. CL. 37.  
4,164,720, CANC. INT. CL. 39.  
4,256,385, CANC. INT. CL. 8.  
4,256,398, CANC. INT. CL. 35.  
4,352,421, CANC. INT. CL. 41.
- SABIA, INC., SAN DIEGO, CA:  
2,860,915, REN. 7-20-14. MULTIPLE CLASS, INT. CLS. 9 AND 37.
- SABREMARK LIMITED PARTNERSHIP, SOUTHLAKE, TX:  
2,793,367, CANC. INT. CL. 9.
- SACRED HEART UNIVERSITY, INCORPORATED, FAIRFIELD, CT:  
4,591,337, PUB. 1-7-2014. INT. CL. 25.
- SADDLEFIRE HOLDINGS, LLC, BETHESDA, MD, DBA SADDLEFIRE VENTURES:  
4,594,126, INT. CL. 44.
- SAFE SOLUTIONS CARPET CLEANING, FRANKLIN, TN:  
4,592,218, PUB. 6-10-2014. INT. CL. 37.
- SAFEGUARD PROPERTIES MANAGEMENT, LLC, VALLEY VIEW, OH:  
4,594,553, INT. CL. 42.
- SAFELITE GROUP, INC., COLUMBUS, OH:  
2,889,534, REN. 7-24-14. MULTIPLE CLASS, INT. CLS. 1 AND 12.  
4,591,390, PUB. 6-10-2014. MULTIPLE CLASS, INT. CLS. 35 AND 37.
- SAFERSONIC; MEDIZINPRODUKTE HANDELS GMBH, AUSTRIA:  
4,590,779, PUB. 6-10-2014. MULTIPLE CLASS, INT. CLS. 10 AND 44.
- SAFESPACE PRODUCTIONS, L.L.C., NEW YORK, NY, DBA NEXT NEXT ENTERTAINMENT:  
3,352,787, CANC. INT. CL. 25.
- SAFETEC COMPLIANCE SYSTEMS, VANCOUVER, WA:  
4,592,267, PUB. 6-10-2014. INT. CL. 42.
- SAFEWAY DRIVING SYSTEMS, LLC, HOUSTON, TX:  
4,592,452, PUB. 6-10-2014. INT. CL. 41.
- SAFEWAY INC., PLEASANTON, CA:  
3,350,663, CANC. INT. CL. 32.
- SAFFORD, WILLIAM, SAN DIEGO, CA:  
4,594,110, INT. CL. 25.
- SAFRON, JEREMY, MAKAWOA, HI:  
4,593,438, INT. CL. 28.

SAGE ENVIRONMENTAL CONSULTING, L.P., AUSTIN, TX:  
2,865,046. REN. 7-22-14. INT. CL. 42.

SAGE PUBLICATIONS, INC., THOUSAND OAKS, CA:  
4,592,459. PUB. 6-10-2014. INT. CL. 16.

SAGE SOFTWARE, INC., IRVINE, CA:  
2,795,353. CANC. INT. CL. 9.

SAGGEZZA, INC., CHICAGO, IL:  
4,591,235. PUB. 6-10-2014. INT. CL. 42.  
4,591,236. PUB. 6-10-2014. INT. CL. 42.  
4,591,237. PUB. 6-10-2014. INT. CL. 42.

SAI GLOBAL INC., CLEVELAND, OH:  
3,350,637. CANC. MULTIPLE CLASS, INT. CLS. 16, 35 AND 41.

SAI MAA, LLC, EVERGREEN, CO:  
4,592,916. PUB. 6-10-2014. INT. CL. 41.  
4,592,917. PUB. 6-10-2014. INT. CL. 41.  
4,592,919. PUB. 6-10-2014. INT. CL. 41.  
4,592,921. PUB. 6-10-2014. INT. CL. 41.

SAIGON 2 GARMENT JOINT-STOCK COMPANY, HO CHI MINH CITY, VIETNAM:  
3,352,880. CANC. INT. CL. 25.

SAILPOINT TECHNOLOGIES, INC., AUSTIN, TX:  
4,593,063. PUB. 6-10-2014. INT. CL. 9.

SAKURA COLOR PRODUCTS CORPORATION, OSAKA-SHI, OSAKA-FU, JAPAN:  
2,885,594. REN. 7-22-14. INT. CL. 16.

SALENTEIN ARGENTINA B.V., NETHERLANDS:  
4,590,722. PUB. 6-10-2014. INT. CL. 33.

SALGUERO, MICHAEL A., WILLIAMSBURG, MA:  
3,351,638. CANC. INT. CL. 35.

SALON SECREST, BROOKLYN, NY:  
3,351,498. CANC. MULTIPLE CLASS, INT. CLS. 40 AND 44.

SALONS UNLIMITED, INC., DORAVILLE, GA:  
4,592,566. PUB. 6-10-2014. INT. CL. 3.

SALSA Y SON - SANTA FE, LLC, SANTA FE, NM:  
3,353,985. CANC. INT. CL. 43.

SALUGEN, INC., SAN DIEGO, CA:  
3,354,095. CANC. INT. CL. 5.  
3,354,096. CANC. INT. CL. 5.  
3,354,097. CANC. INT. CL. 5.

SAM SALEM & SON, LLC, NEW YORK CITY, NY:  
4,594,252. INT. CL. 24.

SAMBA FLAVOR INCORPORATED, SUWANEE, GA, DBA SAMBA FLAVOR:  
4,594,769. INT. CL. 30.

SAMSARA CONSULTING, REDMOND, WA:  
4,591,157. PUB. 6-10-2014. INT. CL. 45.

SAMSON AL, HOBOKEN, NJ, DBA ALSAMSON FUNCTIONAL SALES & CONSULTING:  
4,593,695. INT. CL. 5.

SAMSONITE IP HOLDINGS S.A.R.L., L-1931 LUXEMBOURG, LUXEMBOURG:  
2,863,535. REN. 7-22-14. INT. CL. 18.  
2,885,061. REN. 7-18-14. INT. CL. 18.  
3,354,316. CANC. INT. CL. 18.

SAMSUNG ELECTRONICS CO., LTD., SUWON-SI, GYEONGGI-DO, REPUBLIC OF KOREA:  
3,352,089. CANC. INT. CL. 9.  
4,591,011. PUB. 6-10-2014. INT. CL. 9.  
4,591,028. PUB. 6-10-2014. INT. CL. 9.

SAMSUNG ELECTRONICS CO., LTD., GYEONGGI-DO, REPUBLIC OF KOREA:  
4,591,048. PUB. 6-10-2014. INT. CL. 9.

SAMSUNG ELECTRONICS CO., LTD., SUWON-SI, GYEONGGI-DO, REPUBLIC OF KOREA:  
4,591,172. PUB. 6-10-2014. INT. CL. 9.  
4,591,380. PUB. 6-10-2014. INT. CL. 9.  
4,591,662. PUB. 6-10-2014. INT. CL. 9.

SAMSØE & SAMSØE HOLDING A/S, KØBENHAVN N, DENMARK:  
4,590,907. PUB. 6-10-2014. MULTIPLE CLASS, INT. CLS. 18 AND 25.

SAN DIEGO MEDIA, INC., SAN DIEGO, CA:  
3,354,027. CANC. INT. CL. 9.

SAN FRANCISCO FEDERAL CREDIT UNION, SAN FRANCISCO, CA:  
2,794,717. CANC. INT. CL. 36.

SAN FRANCISCO PASTA COMPANY, HAYWARD, CA:  
2,794,030. CANC. INT. CL. 30.

SAN JOAQUIN HILLS TRANSPORTATION CORRIDOR AGENCY AND FOOTHILL/EASTERN TRANSPORTATION CORRIDOR AGENCY, IRVINE, CA:  
4,594,657. INT. CL. 36.

SANA PHARMA AS, OSLO, NORWAY:  
4,594,350. MULTIPLE CLASS, INT. CLS. 3 AND 5.

SANCHES, KYLIE, NEDERLAND, TX:  
4,594,497. INT. CL. 25.

SANCHEZ, DAVID, JERSEY CITY, NJ:  
3,354,276. CANC. INT. CL. 25.

SANDERS, BRYAN J, GIRARD, OH:  
3,354,538. CANC. INT. CL. 37.

SANDERS, ROBIN, ALTADENA, CA:  
3,350,669. CANC. INT. CL. 16.

SANDISK CORPORTION, MILPITAS, CA:  
3,351,950. CANC. INT. CL. 9.

SANDISK ENTERPRISE IP LLC, MILPITAS, CA:  
4,593,190. INT. CL. 9.

SANDISK IL LTD., KFAR SABA, ISRAEL:  
2,795,383. CANC. INT. CL. 9.

SANDVIK INNOVATIONS LLC, WAYNE, PA TO DEVRIAN INNOVATIONS, LLC, WARREN, NJ:  
2,795,168. CANC. INT. CL. 16.

SANOFI, PARIS, FRANCE:  
2,794,635. CANC. INT. CL. 5.  
4,591,098. PUB. 6-10-2014. INT. CL. 9.  
4,592,938. PUB. 4-29-2014. INT. CL. 5.

SANTA HOLDINGS, LLC, PALM BEACH GARDENS, FL:  
2,863,910. REN. 7-22-14. INT. CL. 41.  
2,863,911. REN. 7-22-14. INT. CL. 42.  
2,863,912. REN. 7-22-14. INT. CL. 35.

SANTA ROSA SUNRISE ROTARY CLUB, SANTA ROSA, CA:  
4,591,776. PUB. 6-10-2014. INT. CL. 36.

SANTANA CYCLES, INC., LA VERNE, CA:  
4,594,564. INT. CL. 12.

SANTANDER, JORGE L, CANYON COUNTRY, CA:  
4,591,440. PUB. 6-10-2014. INT. CL. 25.

SAPHERIOR GMBH & CO.KG, FED REP GERMANY:  
4,590,768. PUB. 6-10-2014. INT. CL. 45.

SARAH BROKAW, VENICE, CA:  
4,593,122. INT. CL. 45.

SARATHAN RECORDS, LLC, SEATTLE, WA:  
3,352,376. CANC. INT. CL. 41.

SARDANA KARIN, CHANDLER, AZ:  
3,352,157. CANC. INT. CL. 38.

SARGENT MANUFACTURING COMPANY, NEW HAVEN, CT, SARGENT & COMPANY, NEW HAVEN, CT:  
104,651. REN. 7-19-14. U.S. CL. 25 (INT. CL. 6).

SARIANA LLC, SAN DIEGO, CA:  
4,593,760. MULTIPLE CLASS, INT. CLS. 9 AND 16.

SARIS TECHNOLOGIES, INC., ORLANDO, FL:  
3,351,332. CANC. INT. CL. 35.

SARKLI-REPECHAGE LTD., SECAUCUS, NJ:  
2,853,197. REN. 7-22-14. INT. CL. 3.

SARL JEAN MARC BROCARD, PREHY, FRANCE:  
3,351,714. CANC. INT. CL. 33.

SASA GROUP LLC, SAN DIEGO, CA:  
3,351,225. CANC. INT. CL. 34.

SASSE ORIGINALS LLC, WESTERN SPRINGS, IL:  
3,353,304. CANC. INT. CL. 25.

SATCO PRODUCTS, INC., BRENTWOOD, NY:  
2,859,558. REN. 7-18-14. INT. CL. 11.

SATCOM DIRECT, INC., SATELLITE BEACH, FL:  
4,591,735. PUB. 6-10-2014. INT. CL. 9.

SAUCE FREE, INC., CLEARWATER, FL:  
3,353,670. CANC. INT. CL. 25.

SAUEREISEN, INC., PITTSBURGH, PA:  
2,862,184. REN. 7-22-14. INT. CL. 2.

SAVANNAH MUSIC FESTIVAL, INC., SAVANNAH, GA:  
4,592,485. PUB. 6-10-2014. INT. CL. 41.  
4,592,487. PUB. 6-10-2014. INT. CL. 41.  
4,592,488. PUB. 6-10-2014. INT. CL. 41.

- SAVEALOT PHARMACY, INC., LINCOLN, NE:  
3,353,826, CANC. INT. CL. 35.
- SAVEOLOGY.COM, LLC, FT. LAUDERDALE, FL:  
3,351,297, CANC. INT. CL. 35.  
3,351,299, CANC. INT. CL. 35.
- SAVING PROMISE INC., WASHINGTON, DC:  
4,593,168, INT. CL. 35.
- SAVON FREIGHT LLC, YOUNGTOWN, AZ:  
3,351,486, CANC. INT. CL. 39.
- SAXO BANK A/S, DENMARK:  
4,590,886, PUB. 6-10-2014. INT. CL. 36.
- SBEMCO INTERNATIONAL INC., ALGONA, IA:  
2,794,996, CANC. INT. CL. 27.
- SBF DEVELOPMENT CORPORATION, EDINA, MN:  
3,353,434, CANC. INT. CL. 37.
- SCA HYGIENE PRODUCTS AB, S-405 03 GOTEBOG, SWEDEN:  
3,354,450, CANC. INT. CL. 5.
- SCALA LICENSE B.V., AMSTERDAM, NETHERLANDS:  
2,859,480. REN. 7-21-14. MULTIPLE CLASS, INT. CLS. 9 AND 42.  
2,859,480, CANC. INT. CL. 16.
- SCAN MAILBOXES SOLUTIONS, LLC, AUSTIN, TX:  
4,592,417, PUB. 6-10-2014. INT. CL. 35.
- SCANNER MONKEY, LLC, CYPRESS, TX:  
4,592,531, PUB. 6-10-2014. MULTIPLE CLASS, INT. CLS. 35 AND 41.  
4,592,533, PUB. 6-10-2014. MULTIPLE CLASS, INT. CLS. 35 AND 41.
- SCANTRON CORPORATION, EAGAN, MN:  
2,861,345. REN. 7-20-14. MULTIPLE CLASS, INT. CLS. 9, 16, 35, 37, 38, 41 AND 42.
- SCHAFFER, KENNETH B., NEW YORK, NY:  
4,592,344, PUB. 6-10-2014. INT. CL. 9.
- SCHEELS ALL SPORTS, INC., FARGO, ND:  
4,594,050, INT. CL. 41.  
4,594,109, INT. CL. 41.
- SCHELL BROTHERS LLC, REHOBOTH BEACH, DE, TA SCHELL BROTHERS:  
4,591,294, PUB. 6-10-2014. INT. CL. 37.
- SCHERING-PLOUGH HEALTHCARE PRODUCTS, INC., MEMPHIS, TN:  
3,351,893, CANC. INT. CL. 5.  
3,353,528, CANC. INT. CL. 3.
- SCHIFF NUTRITION INTERNATIONAL, INC., SALT LAKE CITY, UT:  
4,593,339, INT. CL. 5.
- SCHILLER, HENRI, PARIS, FRANCE:  
1,293,821. REN. 7-23-14. INT. CL. 5.
- SCHLIAPNIK, JAIME, SAN DIEGO, CA:  
3,352,830, CANC. MULTIPLE CLASS, INT. CLS. 16 AND 25.
- SCHLUMBERGER TECHNOLOGY CORPORATION, SUGAR LAND, TX:  
2,862,978. REN. 7-20-14. MULTIPLE CLASS, INT. CLS. 1 AND 37.
- SCHMAP LIMITED, HONG KONG, HONG KONG:  
3,350,976, CANC. MULTIPLE CLASS, INT. CLS. 9, 35, 39 AND 42.  
3,350,989, CANC. MULTIPLE CLASS, INT. CLS. 9, 35, 39 AND 42.
- SCHMIDT, MAXWELL, TEMPE, AZ:  
4,592,659, PUB. 6-10-2014. INT. CL. 25.
- SCHNEIDER ELECTRIC INDUSTRIES SAS, FRANCE:  
3,352,544.
- SCHNELLER LLC, KENT, OH:  
4,541,855, AM. MULTIPLE CLASS, INT. CLS. 17, 19 AND 27.
- SCHOLASTIC INC., NEW YORK, NY:  
1,344,129. REN. 7-24-14. INT. CL. 9.  
4,594,248, INT. CL. 41.
- SCHOLL, KAREN M, MESA, AZ AND SCHOLL, MARK L, MESA, AZ:  
3,351,258, CANC. INT. CL. 41.
- SCHOTT AKTIENGESELLSCHAFT, FED REP GERMANY:  
4,590,864, PUB. 6-10-2014. INT. CL. 10.
- SCHREUS, HANS W, LITTLE RIVER, SC:  
4,592,595, PUB. 6-10-2014. INT. CL. 33.
- SCHWAN'S IP, LLC, MARSHALL, MN:  
3,353,129, CANC. INT. CL. 35.
- SCHWARZ ETIENNE S.A., SWITZERLAND:  
4,590,725, PUB. 6-10-2014. INT. CL. 14.
- SCHWEISS DISTRIBUTING, INC., FAIRFAX, MN:  
3,354,507, CANC. INT. CL. 6.
- SCHWEIZER, KENNETH R, LARKSPUR, CA:  
3,351,040, CANC. INT. CL. 16.
- SCHWINN ACQUISITION LLC, MADISON, WI:  
790,961. REN. 7-22-14. U.S. CL. 19 (INT. CL. 12).
- SCHWYZER MILCHHUUS AG, SWITZERLAND:  
4,590,889, PUB. 6-10-2014. INT. CL. 29.
- SCIENTIFIC GAMES HOLDINGS LIMITED, IRELAND:  
2,865,746. REN. 7-23-14. INT. CL. 9.
- SCJ VENDING CORP., WOODBURY, NY:  
3,351,635, CANC. INT. CL. 42.
- SCOMMEGNA, ROGER, BOONVILLE, CA:  
4,592,350, PUB. 6-10-2014. INT. CL. 30.
- SCORE RETAIL NEDERLAND BV, NETHERLANDS:  
3,352,732.
- SCORELOGIX, NEWARK, DE:  
2,964,848. REN. 7-24-14. INT. CL. 36.
- SCOSCHE INDUSTRIES, INC., OXNARD, CA:  
4,593,219, INT. CL. 9.
- SCOTT & WHITE HEALTHCARE, TEMPLE, TX:  
4,591,405, PUB. 6-10-2014. INT. CL. 44.
- SCOTT BADER COMPANY LIMITED, NORTHAMPTON, ENGLAND, SCOTT BADER & COMPANY LIMITED, WOLLASTON, WELLINGBOROUGH, NORTHAMPTON, ENGLAND:  
592,905. REN. 7-21-14. U.S. CL. 6 (INT. CL. 1).
- SCOTTSDALE CENTER FOR DENTISTRY, LLC, SCOTTSDALE, AZ:  
3,351,094, CANC. INT. CL. 41.
- SCRIPPS NETWORKS, LLC, KNOXVILLE, TN:  
4,591,347, PUB. 5-20-2014. MULTIPLE CLASS, INT. CLS. 38 AND 41.
- SCRIPTED, INC., NEW YORK, NY:  
4,591,371, PUB. 6-10-2014. MULTIPLE CLASS, INT. CLS. 35 AND 41.
- SCRUBLIFE, INC., PRINCETON, NJ:  
4,593,206, INT. CL. 41.
- SDI DEVELOPMENT, INC., BURBANK, CA, DBA SONY DEVELOPMENT. :  
3,354,505, CANC. INT. CL. 25.
- SEAL INC. D/B/A SEAL & CO., SUMMIT, NJ:  
3,351,715, CANC. INT. CL. 35.
- SEALY TECHNOLOGY LLC, TRINITY, NC:  
1,845,626. REN. 7-24-14. INT. CL. 20.
- SEAPORT AIRLINES, INC., PORTLAND, OR:  
4,594,549, INT. CL. 39.
- SEARS BRANDS, LLC, HOFFMAN ESTATES, IL:  
4,594,513, INT. CL. 35.
- SEASONAL SKINCARE, INC., DAVIE, FL:  
3,354,127, CANC. MULTIPLE CLASS, INT. CLS. 3 AND 35.
- SECCION AMARILLA USA, LLC, MIRAMAR, FL:  
3,353,586, CANC. INT. CL. 16.
- SECHREST, TODD, PEORIA, AZ AND BRYAN, DYLAN, PEORIA, AZ:  
4,594,440, INT. CL. 25.
- SECURITY FROM ABOVE, LLC, MESA, AZ:  
3,354,111, CANC. INT. CL. 20.
- SEDAL, S.L., SPAIN:  
4,590,651, PUB. 6-10-2014. INT. CL. 11.
- SEDIS, TROYES, FRANCE:  
1,263,376. REN. 7-21-14. MULTIPLE CLASS, INT. CLS. 6 AND 12.
- SEDONA MEDSPA, LLC, ALPHARETTA, GA:  
3,351,336, CANC. INT. CL. 44.
- SEDONA SKIES GALLERY, INC, SEDONA, AZ:  
3,352,107, CANC. INT. CL. 16.
- SEDUS STOLL AG, WALDSHUT-TIENGEN, FED REP GERMANY:  
2,794,575, CANC. INT. CL. 20.
- SEE A ROOM INC., BRADENTON, FL:  
3,351,161, CANC. INT. CL. 42.

- SEE ROCK CITY, INC., LOOKOUT MOUNTAIN, GA:  
1,857,725. REN. 7-23-14. MULTIPLE CLASS, INT. CLS. 21,  
25 AND 41.
- SEEING MACHINES LIMITED, ACTON, AUSTRALIAN  
CAPITAL TERRITORY 2601, AUSTRALIA:  
2,795,396. CANC. INT. CL. 9.
- SEGANEST SEGURIDAD MEDICA Y DE ANESTESIA S.A.S-  
SEGANEST SAS., CALI, VALLE DEL CAUCA, COLOM-  
BIA:  
4,591,082. PUB. 6-10-2014. INT. CL. 10.
- SEGMENT ENTERTAINMENT, INC., SAN DIEGO, CA:  
2,860,320. REN. 7-18-14. INT. CL. 41.
- SEI INVESTMENTS DEVELOPMENTS, INC., WILMING-  
TON, DE:  
4,592,672. PUB. 6-10-2014. INT. CL. 41.
- SEIKO EPSON KABUSHIKI KAISHA, TOKYO, JAPAN, TA  
SEIKO EPSON CORPORATION:  
3,350,885. CANC. INT. CL. 9.
- SEIKO EPSON KABUSHIKI KAISHA, SHINJUKU-KU, TO-  
KYO, JAPAN, TA SEIKO EPSON CORPORATION:  
3,350,995. CANC. MULTIPLE CLASS, INT. CLS. 9 AND  
42.
- SEINES, JENNIFER RAPHAEL, SAN DIEGO, CA:  
4,594,412. INT. CL. 45.
- SELECTED INDEPENDENT FUNERAL HOMES, DEER-  
FIELD, IL:  
4,592,189. PUB. 6-10-2014. INT. CL. 41.  
4,592,190. PUB. 6-10-2014. INT. CL. 41.
- SELECTIVE MICRO TECHNOLOGIES, COLUMBUS, OH:  
4,594,239. INT. CL. 1.
- SELFISH MACHINES, LLC, SAN ANTONIO, TX:  
4,592,860. PUB. 6-10-2014. MULTIPLE CLASS, INT. CLS. 9  
AND 41.
- SELKIRK CORPORATION, RICHARDSON, TX:  
2,802,423. REN. 7-21-14. INT. CL. 6.
- SELLARS ABSORBENT MATERIALS, INC., MILWAUKEE,  
WI:  
3,354,371. CANC. INT. CL. 16.
- SELLE SAN MARCO DI GIRARDI COMM. LUIGI S.P.A.,  
36028 ROSSANO VENETO (VICENZA), ITALY:  
2,868,765. REN. 7-18-14. INT. CL. 12.
- SELLSIUS, LLC, NEW YORK, NY:  
3,353,562. CANC. INT. CL. 36.
- SELVENTA, INC., CAMBRIDGE, MA:  
3,353,154. CANC. INT. CL. 9.
- SEMINOLE TRIBE OF FLORIDA, HOLLYWOOD, FL:  
3,351,881. CANC. INT. CL. 41.
- SEMISOUTH LABORATORIES, INC., STARKVILLE, MS:  
3,352,220. CANC. INT. CL. 9.
- SEN CORPORATION, SHINAGAWA-KU, TOKYO, JAPAN:  
4,532,425. COR. INT. CL. 7.  
4,532,426. COR. INT. CL. 7.
- SENCO PRODUCTS, INC., CINCINNATI, OH:  
3,354,439. CANC. INT. CL. 6.
- SENIOR RECRUITERS, INC., OZARK, MO:  
4,591,752. PUB. 6-10-2014. INT. CL. 45.
- SENIORS COALITION, INC., THE, WASHINGTON, DC:  
1,843,984. REN. 7-21-14. INT. CL. 42.
- SENOPLAST KLEPSCH & CO. GMBH, 5721 PIESENDORF,  
AUSTRIA:  
2,859,532. REN. 7-18-14. INT. CL. 17.
- SENIOR JAVA'S COFFEE, LLC, GRAFTON, WI:  
3,353,459. CANC. INT. CL. 30.
- SENTAI HOLDINGS, LLC, HOUSTON, TX:  
4,592,001. PUB. 6-10-2014. INT. CL. 9.
- SENTRY EQUIPMENT CORP., OCONOMOWOC, WI:  
1,894,030. REN. 7-24-14. INT. CL. 11.
- SENVOL LLC, PHILADELPHIA, PA:  
4,592,061. PUB. 6-10-2014. INT. CL. 35.
- SENYX LLC, BREA, CA:  
4,592,696. PUB. 6-10-2014. INT. CL. 9.
- SERFLING, DALE R. SERFLING, LINDA M., BECKER, MN,  
DBA BIG D'S PIZZA, LLC:  
4,591,224. PUB. 6-10-2014. INT. CL. 43.
- SERGEANT'S PET CARE PRODUCTS, INC., ALLEGAN, MI:  
2,794,967. CANC. INT. CL. 5.
- SERGEANT'S PET CARE PRODUCTS, INC., ALLEGAN, ME:  
4,594,416. INT. CL. 16.
- SERGTEC CORPORATION, BRONX, NY:  
4,592,011. PUB. 6-10-2014. INT. CL. 37.
- SERKET RACING LLC, LAKE WORTH, FL:  
4,591,675. PUB. 6-10-2014. INT. CL. 36.
- SERVERVAULT CORP., DULLES, VA:  
3,352,291. CANC. INT. CL. 42.
- SERVICE EXCHANGE SOLUTIONS ENTERPRISE, INC.,  
MISSISSAUGA, ONTARIO, CANADA:  
4,593,186. MULTIPLE CLASS, INT. CLS. 9, 35, 36, 41, 42  
AND 45.
- SERVICE GUARD INSURANCE AGENCY, L.L.P., AUSTIN,  
TX:  
4,591,362. PUB. 6-10-2014. INT. CL. 36.
- SERVIENTREGA S.A., BOGOTÁ, COLOMBIA:  
4,590,958. PUB. 6-10-2014. INT. CL. 35.
- SETANTA SPORTS NORTH AMERICA LTD., SAN FRAN-  
CISCO, CA:  
3,351,579. CANC. INT. CL. 38.  
3,351,583. CANC. INT. CL. 38.  
3,351,586. CANC. INT. CL. 38.
- SETTLERS LIFE INSURANCE COMPANY, MADISON, WI:  
4,592,243. PUB. 6-10-2014. INT. CL. 36.
- SEUNGKWAN, ROH, SEOUL, REPUBLIC OF KOREA:  
3,353,696. CANC. INT. CL. 20.
- SEVEN CORNERS, INC., CARMEL, IN:  
4,593,444. INT. CL. 36.
- SEVEN FOR ALL MANKIND, LLC, VERNON, CA:  
3,353,070. CANC. INT. CL. 25.
- SEVEN GABLES GUTTERS, INC., ALPHARETTA, GA:  
3,351,924. CANC. MULTIPLE CLASS, INT. CLS. 6 AND  
37.
- SEVEN MANAGEMENT SERVICES, INC., BEVERLY HILLS,  
CA:  
4,593,709. INT. CL. 44.
- SEVEN ONE, INC., CALABASAS, CA:  
4,592,110. PUB. 6-10-2014. INT. CL. 35.
- SEVEN WELLS, LLC, COSTA MESA, CA, DBA I. E.  
DISTRIBUTION:  
4,594,158. MULTIPLE CLASS, INT. CLS. 25 AND 28.
- SEVENTH GENERATION, INC., BURLINGTON, VT:  
4,594,164. MULTIPLE CLASS, INT. CLS. 3, 5 AND 16.
- SFN PROFESSIONAL SERVICES LLC, FORT LAUDER-  
DALE, FL:  
3,350,882. CANC. INT. CL. 41.
- SFV VENTURES, INC., GRANADA HILLS, CA:  
4,593,585. INT. CL. 35.
- SGT, INC., GREENBELT, MD, AKA STINGER GHAFAR-  
IAN TECHNOLOGIES, INC.:  
4,594,238. MULTIPLE CLASS, INT. CLS. 35 AND 42.
- SHABAZZ, KEVIN, LAS VEGAS, NV:  
4,591,795. PUB. 6-10-2014. INT. CL. 41.
- SHAEFER, LISA CAVETT, SAN ANTONIO, TX:  
3,352,786. CANC. INT. CL. 11.
- SHAFFER, W. BENJAMIN, GALENA, OH:  
4,593,114. MULTIPLE CLASS, INT. CLS. 9, 16 AND 18.
- SHAHNAZ HERBALS & SHAHNAZ AYURVEDICS, NEW  
DELHI-, INDIA:  
1,881,755. REN. 7-22-14. INT. CL. 3.
- SHAKLEE CORPORATION, PLEASANTON, CA:  
2,867,419. REN. 7-23-14. INT. CL. 3.
- SHALIK, MORRIS & COMPANY, LLP, WESTBURY, NY:  
4,592,840. PUB. 6-10-2014. INT. CL. 35.
- SHAMAN PHYTOCEUTICALS, LLC, CHATTANOOGA, TN:  
3,351,927. CANC. INT. CL. 5.
- SHAMANIC DE-ARMORING, LLC, PHOENIX, AZ:  
4,592,016. PUB. 6-10-2014. INT. CL. 41.  
4,592,017. PUB. 6-10-2014. INT. CL. 41.
- SHAMILLE A. WENER, EAST HIGHLAND, CA, DBA  
SIDITY CO.:  
3,351,752. CANC. INT. CL. 25.
- SHAMIR OPTICAL INDUSTRY LTD., ISRAEL:  
4,590,679. PUB. 6-10-2014. INT. CL. 9.
- SHAN DONG TENGDA STAINLESS STEEL PRODUCTS  
CO., LTD., SHANDONG, CHINA:  
4,594,480. INT. CL. 6.
- SHANDONG BUCHANG PHARMACEUTICAL CO., LTD.,  
SHANDONG PROVINCE, CHINA:  
4,177,724. COR. INT. CL. 5.

- SHANGHAI HEJIAN ERA E-COMMERCE CO., LTD., SHANGHAI, CHINA:  
4,592,624, PUB. 6-10-2014. INT. CL. 5.
- SHANGHAI JINKA FLOORING TECHNOLOGY CO., LTD., SHANGHAI 201806, CHINA:  
4,593,887, MULTIPLE CLASS, INT. CLS. 19 AND 27.
- SHANGHAI SANFEI FITNESS CO., LTD., SHANGHAI, CHINA:  
4,592,784, PUB. 6-10-2014. INT. CL. 28.
- SHANGHAI XRUN RESIN CO., LTD, CHINA:  
4,590,827, PUB. 6-10-2014. INT. CL. 1.
- SHANTZ ENTERPRISES, INC., FLAGSTAFF, AZ:  
4,594,613, INT. CL. 42.
- SHAOXING KANGKE CAPSULE CO., LTD., ZHEJIANG PROVINCE, CHINA:  
4,590,860, PUB. 6-10-2014. INT. CL. 5.
- SHAPES & COLORS LLC, TROY, MI, DBA SHAPES & COLORS:  
4,592,019, PUB. 6-10-2014. MULTIPLE CLASS, INT. CLS. 9 AND 41.
- SHARESPOST, INC, SAN BRUNO, CA:  
4,591,988, PUB. 6-10-2014. INT. CL. 36.
- SHARP INDUSTRIES, INC., TORRANCE, CA:  
3,352,928, CANC. INT. CL. 7.
- SHAW CONTRACT FLOORING SERVICES, INC., DALTON, GA:  
3,352,952, CANC. INT. CL. 23.
- SHAW INDUSTRIES GROUP, INC., DALTON, GA TO COLUMBIA INSURANCE COMPANY, OMAHA, NE:  
2,795,208, CANC. INT. CL. 1.
- SHEAR MADNESS, INC., LEAWOOD, KS:  
3,352,152, CANC. INT. CL. 44.
- SHEEHAN, JOHN C., EDEN PRAIRIE, MN:  
4,592,728, PUB. 6-10-2014. INT. CL. 36.
- SHEFFER, THOMAS P, MIO, MI, DBA MAPLE VALLEY FARM:  
4,594,695, INT. CL. 31.
- SHELL TRADEMARK MANAGEMENT BV, THE HAGUE, NETHERLANDS:  
4,594,324, INT. CL. 4.
- SHELLBACK TACTICAL INC, WEST COVINA, CA:  
4,592,810, PUB. 6-10-2014. INT. CL. 35.  
4,592,882, PUB. 6-10-2014. INT. CL. 35.
- SHELLEF HOLDINGS INC, GREAT NECK, NY:  
3,496,765, CANC. INT. CL. 1.
- SHENERGY HOLDINGS INC, BOZEMAN, MT:  
4,591,090, PUB. 6-10-2014. MULTIPLE CLASS, INT. CLS. 41, 44 AND 45.
- SHENZHEN COMEN MEDICAL INSTRUMENTS CO., LTD., SHENZHEN, GUANGDONG, CHINA:  
4,591,073, PUB. 6-10-2014. INT. CL. 10.
- SHENZHEN DADITONG TECHNOLOGY CO., LTD., SHENZHEN, GUANGDONG, CHINA:  
4,592,579, PUB. 6-10-2014. MULTIPLE CLASS, INT. CLS. 9 AND 25.
- SHENZHEN HENGXING JEWELRY CO., LTD., SHENZHEN, GUANGDONG, CHINA:  
4,591,201, PUB. 6-10-2014. MULTIPLE CLASS, INT. CLS. 14 AND 35.  
4,591,202, PUB. 6-10-2014. MULTIPLE CLASS, INT. CLS. 14 AND 35.  
4,591,204, PUB. 6-10-2014. MULTIPLE CLASS, INT. CLS. 14 AND 35.  
4,591,205, PUB. 6-10-2014. MULTIPLE CLASS, INT. CLS. 14 AND 35.
- SHENZHEN JIAPENG JIYU DESIGN CO., LTD., SHENZHEN, CHINA:  
4,592,655, PUB. 6-10-2014. INT. CL. 34.
- SHENZHEN SHIDAI ZHONGCHUANG INVESTMENT CO., LTD., SHENZHEN CITY, CHINA:  
4,591,304, PUB. 6-10-2014. INT. CL. 25.
- SHERMAN SAMUEL, SARAH, LOS ANGELES, CA:  
4,593,230, INT. CL. 24.
- SHERMAN, ROBIN D., SAN DIEGO, CA:  
3,353,008, CANC. INT. CL. 30.
- SHERWOOD FOREST CHARITIES, INC., INDEPENDENCE, OH:  
3,353,448, CANC. INT. CL. 36.
- SHIEL MEDICAL LABORATORY, BROOKLYN, NY:  
4,591,571, PUB. 6-10-2014. INT. CL. 42.
- SHIELDS, JOHN, CLERMONT, FL:  
4,594,354, INT. CL. 34.
- SHIFTPLANNING, INC., DAGSBORO, DE:  
4,594,522, INT. CL. 42.
- SHIGEMATSU, SETSU, CORONA, CA:  
4,594,340, INT. CL. 16.
- SHILET, PARDES CHANA, ISRAEL:  
4,594,645, INT. CL. 3.
- SHIMANO INC., SAKAI CITY, OSAKA, JAPAN:  
2,959,804, REN. 7-22-14. INT. CL. 28.
- SHINING OCEAN, INC., SUMNER, WA:  
3,351,794, CANC. INT. CL. 29.  
3,351,795, CANC. INT. CL. 29.
- SHIONOGI INC., FLORHAM PARK, NJ:  
2,943,009, REN. 7-18-14. INT. CL. 5.
- SHIPMAN & GOODWIN LLP, HARTFORD, CT:  
4,592,820, PUB. 6-10-2014. INT. CL. 41.  
4,592,821, PUB. 6-10-2014. INT. CL. 45.  
4,592,822, PUB. 6-10-2014. INT. CL. 9.  
4,592,823, PUB. 6-10-2014. INT. CL. 16.
- SHISEIDO COMPANY, LTD., TOKYO 104-8010, JAPAN:  
2,795,947, CANC. INT. CL. 3.
- SHOGA, WAIL, HUNTINGTON BEACH, CA:  
4,593,413, INT. CL. 43.
- SHOGUN SERVICES LLC, FORD, VA, DBA SHOGUN SERVICES:  
4,592,053, PUB. 6-10-2014. INT. CL. 37.
- SHOOT-A-WAY, INC., UPPER SANDUSKY, OH:  
4,591,365, PUB. 6-10-2014. INT. CL. 28.
- SHOP SMART, LLC, CHICAGO, IL:  
4,593,910, INT. CL. 35.
- SHOPKO STORES OPERATING CO., LLC, GREEN BAY, WI:  
1,847,974, REN. 7-24-14. INT. CL. 42.
- SHOW CIGARS, INC., NEW CASTLE, PA:  
4,592,443, PUB. 6-10-2014. INT. CL. 34.
- SHOWROOM LLC, FT. MOHAVE, AZ:  
4,593,655, INT. CL. 45.
- SHOWTIME NETWORKS INC., NEW YORK, NY:  
2,794,563, CANC. MULTIPLE CLASS, INT. CLS. 38 AND 41.
- SHUSTER LABORATORIES, INC., CANTON, MA:  
3,350,682, CANC. MULTIPLE CLASS, INT. CLS. 35 AND 42.
- SIBA, LLC, WATKINSVILLE, GA, DBA SIBA SPORTS:  
4,591,218, PUB. 6-10-2014. INT. CL. 35.
- SIDESHOW NETWORK, INC., ANAHEIM, CA:  
3,354,638, CANC. MULTIPLE CLASS, INT. CLS. 35 AND 41.
- SIEGEL OIL COMPANY, DENVER, CO:  
4,591,291, PUB. 6-10-2014. INT. CL. 42.
- SIEGWERK DRUCKFARBEN AG & CO. KGAA, SIEGBURG, FED REP GERMANY:  
2,941,077, REN. 7-18-14. MULTIPLE CLASS, INT. CLS. 1, 2 AND 42.
- SIEMENS MEDICAL INSTRUMENTS PTE LTD, SINGAPORE 139959, SINGAPORE:  
4,590,664, PUB. 6-10-2014. INT. CL. 10.
- SIEMENS SCHWEIZ AG, SWITZERLAND:  
4,590,735, PUB. 6-10-2014. MULTIPLE CLASS, INT. CLS. 36, 37 AND 42.
- SIEMENS VAI METALS TECHNOLOGIES GMBH, A-4031 LINZ, AUSTRIA:  
4,590,714, PUB. 6-10-2014. INT. CL. 7.
- SIERRA BUILDING SCIENCE CENTER, SACRAMENTO, CA:  
3,351,036, CANC. INT. CL. 41.
- SIERRA ENERGY, DAVIS, CA:  
4,593,110, MULTIPLE CLASS, INT. CLS. 7 AND 42.
- SIERRA HEALTHSTYLES LLC, TUCSON, AZ:  
3,352,523, CANC. MULTIPLE CLASS, INT. CLS. 16, 41, 43 AND 44.
- SIERRA NEVADA CORPORATION, SPARKS, NV:  
4,591,110, PUB. 6-10-2014. INT. CL. 9.
- SIGGITT LLC, LAS VEGAS, NV:  
4,593,581, INT. CL. 42.  
4,593,582, INT. CL. 42.

SIGIL GAMES ONLINE, INC., CARLSBAD, CA:  
3,351,619, CANC. INT. CL. 41.

SIGMA ALIMENTOS, S.A. DE C.V., SAN PEDRO GARZA GARCIA, NUEVO LEON, MEXICO:  
3,352,115, CANC. INT. CL. 30.

SIGN & GRAPHICS HOLDINGS LLC., PLYMOUTH, MI:  
2,868,992, REN. 7-24-14, INT. CL. 40.

SIGN SMART LLC, OLDSMAR, FL:  
4,590,989, PUB. 6-10-2014, INT. CL. 35.

SIGNATURE FUNDRAISING, INC, LANCASTER, CA:  
2,794,243, CANC. INT. CL. 36.

SIGNATURE HEALTHCARE, LLC, LOUISVILLE, KY:  
4,593,764, INT. CL. 44.

SIGNATURE INNOVATIONS, LLC, WOOD DALE, IL:  
3,354,515, CANC. INT. CL. 19.

SIGNET ARMORLITE INC., CARLSBAD, CA, ARMORLITE LENS COMPANY, INC. THE, PASADENA, CA:  
774,084, REN. 7-24-14, U.S. CL. 26 (INT. CLS. 1, 9 AND 10).

SILI GOODNESS, INC., POST FALLS, ID:  
4,592,797, PUB. 6-10-2014, INT. CL. 10.  
4,592,798, PUB. 6-10-2014, INT. CL. 10.

SILICON GRAPHICS INTERNATIONAL CORP., FREMONT, CA:  
3,353,285, CANC. INT. CL. 9.

SILTECH LLC, DACULA, GA:  
2,859,752, REN. 7-24-14, INT. CL. 1.

SILVER DOLLAR OPTICAL CORPORATION, ONEONTA, NY:  
2,795,791, CANC. INT. CL. 9.

SILVER LININGS, LLC, WILLIAMSBURG, VA:  
3,352,388, CANC. MULTIPLE CLASS, INT. CLS. 30 AND 43.  
3,352,389, CANC. MULTIPLE CLASS, INT. CLS. 30 AND 43.

SILVER STAR A.G., LTD., THOUSAND OAKS, CA:  
3,352,219, CANC. MULTIPLE CLASS, INT. CLS. 35 AND 37.  
3,352,230, CANC. MULTIPLE CLASS, INT. CLS. 35 AND 37.

SILVERSTONE GROUP, INCORPORATED, OMAHA, NE:  
4,594,409, INT. CL. 42.

SILVERWIZ LTD., SOFIA, BULGARIA:  
4,592,667, PUB. 6-10-2014, INT. CL. 42.

SIMILASAN AG, JONEN, SWITZERLAND:  
4,594,336, INT. CL. 5.

SIMMONS ENGINEERING CORPORATION, WHEELING, IL:  
4,591,970, PUB. 6-10-2014, INT. CL. 7.

SIMMONS, SHERRIN E, LAS VEGAS, NV:  
3,350,928, CANC. INT. CL. 25.

SIMON, LARRY, QUOGUE, NY:  
4,593,365, INT. CL. 5.

SIMONMED IMAGING INCORPORATED, SCOTTSDALE, AZ, DBA SIMONMED IMAGING INC.:  
2,919,556, REN. 7-22-14, INT. CL. 44.

SIMONS, DAVID J., KEY WEST, FL:  
4,592,351, PUB. 6-10-2014, MULTIPLE CLASS, INT. CLS. 18 AND 25.

SIMPLE MAN PRODUCTS, LLC, WILSON, NC:  
3,351,984, CANC. MULTIPLE CLASS, INT. CLS. 16 AND 25.

SIMPLIVITY CORPORATION, WESTBOROUGH, MA:  
4,593,369, INT. CL. 9.

SINCLAIR FINANCE COMPANY, SALT LAKE CITY, UT:  
2,872,705, REN. 7-23-14, INT. CL. 35.

SINGH, RAM K., LAS VEGAS, NV:  
3,353,229, CANC. INT. CL. 41.

SINGLE CUP COFFEE LIMITED, OTTAWA, ONTARIO, CANADA:  
4,594,438, INT. CL. 30.

SINGLE TOUCH INTERACTIVE, INC., ENCINITAS, CA:  
4,591,363, PUB. 6-10-2014, INT. CL. 35.

SINO HARVEST LIMITED, KWUN TONG, KOWLOON, HONG KONG:  
3,354,636, CANC. MULTIPLE CLASS, INT. CLS. 8 AND 16.

SINOPOLY NEW ENERGY INVESTMENT; CO., LTD., CHINA:  
4,590,743, PUB. 6-10-2014, INT. CL. 9.

SIP ON PRODUCTIONS, LLC, LYNWOOD, CA:  
4,594,040, INT. CL. 32.

SIREN DATA MANAGEMENT COMPANY LLC, SANTA CLARA, CA:  
4,590,604, PUB. 6-10-2014, MULTIPLE CLASS, INT. CLS. 35, 36 AND 42.

SIRVA RELOCATION LLC, INDEPENDENCE, OH:  
2,763,726, CANC. INT. CL. 35.  
2,827,440, CANC. INT. CL. 35.

SIRVA RELOCATION LLC, MAYFIELD HEIGHTS, OH:  
3,431,302, CANC. MULTIPLE CLASS, INT. CLS. 35 AND 39.

SITA NV, 1043 CH AMSTERDAM, NETHERLANDS:  
4,591,046, PUB. 6-10-2014, MULTIPLE CLASS, INT. CLS. 9, 35, 37, 38, 39 AND 42.

SITIZOOGLE INC., HUDSON, CANADA:  
4,594,607, INT. CL. 42.

SITE4HIRE.COM, INC., BOCA RATON, FL:  
3,350,966, CANC. INT. CL. 35.

SITIME CORPORATION, SUNNYVALE, CA:  
4,593,651, INT. CL. 9.  
4,593,652, INT. CL. 9.

SITV, INC., GLENDALE, CA:  
3,354,475, CANC. INT. CL. 41.

SIUFFE, RYAN, SANTA BARBARA, CA:  
4,594,367, INT. CL. 25.

SIX CONTINENTS HOTELS, INC., ATLANTA, GA:  
4,593,964, INT. CL. 43.

SIX FLAGS THEME PARKS, INC., GRAND PRAIRIE, TX:  
4,593,580, MULTIPLE CLASS, INT. CLS. 6, 9, 20, 21, 25, 28 AND 41.

SJG LLC, PHOENIX, AZ:  
4,592,844, PUB. 6-10-2014, INT. CL. 30.

SK HOLDINGS CO., LTD., SEOUL, REPUBLIC OF KOREA:  
4,591,984, PUB. 6-10-2014, INT. CL. 35.

SKECHERS U.S.A., INC. II, MANHATTAN BEACH, CA:  
4,593,161, INT. CL. 14.

SKIDMORE, JODI K, WELCHES, OR AND EMMERLING, PHILIP C., WELCHES, OR:  
3,353,865, CANC. INT. CL. 42.

SKINVISIBLE PHARMACEUTICALS, INC., LAS VEGAS, NV:  
4,593,138, INT. CL. 5.

SKOY ENTERPRISES, LLC, ENCINITAS, CA, AKA SKOY:  
4,592,870, PUB. 6-10-2014, INT. CL. 21.

SKULLCANDY, INC., PARK CITY, UT:  
4,593,645, INT. CL. 9.  
4,593,646, INT. CL. 9.  
4,593,647, MULTIPLE CLASS, INT. CLS. 9 AND 28.  
4,593,648, MULTIPLE CLASS, INT. CLS. 9 AND 28.

SKURKA AEROSPACE INC., CAMARILLO, CA:  
4,591,404, PUB. 6-10-2014, INT. CL. 7.

SKY CLIMBER, LLC, DELAWARE, OH, ARMITH CORPORATION, REDWOOD CITY, CA:  
608,273, REN. 7-24-14, U.S. CL. 23 (INT. CL. 7).

SKYE ELLIS, FED REP GERMANY:  
3,352,614.

SKYERA, INC., SAN JOSE, CA:  
4,593,382, INT. CL. 9.

SKYFACET LLC, NEW YORK, NY:  
3,351,748, CANC. INT. CL. 35.

SKYWALKER HAVEN LLC, LAYTON, UT, DBA SKY TRAMPOLINE ARENA:  
4,591,749, PUB. 3-4-2014, MULTIPLE CLASS, INT. CLS. 35 AND 41.

SLADE GORTON & CO. INC., BOSTON, MA:  
3,353,488, CANC. INT. CL. 29.

SLATE DENTAL CORPORATION, ROCKLIN, CA:  
4,592,437, PUB. 6-10-2014, INT. CL. 44.

SLEEP DATA SERVICES, LLC, SAN DIEGO, CA:  
4,594,196, INT. CL. 44.

SLIGHTLY SALTY LLC., WAILUKU, HI:  
4,592,692, PUB. 6-10-2014, INT. CL. 43.

- SLIP SAVERS LLC, ELKINS PARK, PA, FORMERLY EMES, LLC:  
4,592,971, PUB. 6-10-2014. INT. CL. 37.
- SLOANE ROW, LLC, LOS ANGELES, CA:  
4,592,631, PUB. 6-10-2014. INT. CL. 42.
- SLOWEAR SPA, ITALY:  
3,352,601.
- SMALL, PEGGY, KALISPELL, MT AND SMALL, LARRY, KALISPELL, MT:  
4,594,151, INT. CL. 25.
- SMART BUSINESS ADVISORY AND CONSULTING, LLC, DEVON, PA:  
3,353,818, CANC. INT. CL. 35.
- SMART DIGITAL LLC, ASHLAND, OH:  
4,592,355, PUB. 6-10-2014. INT. CL. 9.
- SMART ELECTRIC, LLC, HUNTINGDON VALLEY, PA:  
4,594,614, INT. CL. 11.
- SMART PAPERS HOLDINGS LLC, HAMILTON, OH:  
2,795,617, CANC. INT. CL. 40.
- SMARTDRAW, LLC, SAN DIEGO, CA:  
4,591,454, PUB. 6-10-2014. INT. CL. 42.
- SMARTORG, INC., MENLO PARK, CA, IDS PARTNERS, MENLO PARK, CA:  
1,852,957, REN. 7-24-14. INT. CL. 9.
- SMARTPOOL INCORPORATED, LAKEWOOD, NJ:  
3,352,044, CANC. INT. CL. 7.  
3,354,669, CANC. INT. CL. 1.
- SMARTPRICE SALES AND MARKETING, NORTHBROOK, IL:  
4,594,448, INT. CL. 30.
- SMARTRG INC., VANCOUVER, WA:  
4,592,458, PUB. 6-10-2014. INT. CL. 9.  
4,592,462, PUB. 6-10-2014. INT. CL. 9.  
4,592,464, PUB. 6-10-2014. INT. CL. 9.  
4,592,465, PUB. 6-10-2014. INT. CL. 9.  
4,592,466, PUB. 6-10-2014. INT. CL. 9.
- SMARTSHEET.COM, INC., BELLEVUE, WA:  
3,351,000, CANC. INT. CL. 42.
- SMARTY EARS, DESOTO, TX:  
4,591,980, PUB. 6-10-2014. INT. CL. 9.
- SMI - IP PTY LIMITED, AUSTRALIA:  
4,437,909, COR. MULTIPLE CLASS, INT. CLS. 9, 35 AND 38.
- SMITH & NEPHEW ORTHOPAEDICS AG, ROTKREUZ, SWITZERLAND:  
2,863,198, REN. 7-21-14. INT. CL. 10.
- SMITH-ANDERSON ENTERPRISES, INC., NAPA, CA:  
4,592,708, PUB. 6-10-2014. INT. CL. 33.
- SMITH, MURRAY, DALLAS, TX:  
4,592,206, PUB. 6-10-2014. INT. CL. 11.
- SMITH, ROBERT M., SAN FRANCISCO, CA:  
4,592,483, PUB. 6-10-2014. INT. CL. 45.
- SMITH, RODERICK S., WESTLAKE VILLAGE, CA:  
3,354,334, CANC. INT. CL. 41.
- SMITH, STEPHANIE M. SCOTTSDALE, AZ, DBA MED-SHAPE WEIGHT LOSS CLINIC, LLC:  
4,591,652, PUB. 3-4-2014. INT. CL. 5.
- SMS SIEMAG AKTIENGESELLSCHAFT, 40237 DÜSSELDORF, FED REP GERMANY:  
3,485,325.
- SNACKSALAD MARKETING & TECHNOLOGIES INC., TORRANCE, CA:  
3,354,499, CANC. INT. CL. 29.
- SNAPONE, INC., PRINCETON, NJ:  
4,593,936, INT. CL. 9.
- SNOWPLOW ANALYTICS LIMITED, LONDON EC2A 4RQ, UNITED KINGDOM:  
4,591,388, PUB. 6-10-2014. MULTIPLE CLASS, INT. CLS. 9, 35 AND 42.
- SNRWORX.COM LLC, OVERLAND PARK, KS:  
4,593,923, INT. CL. 25.
- SOAR NO MORE, LLC, NAMPA, ID:  
4,593,872, MULTIPLE CLASS, INT. CLS. 25 AND 28.
- SOARING STAR PRODUCTIONS, LLC, SURPRISE, AZ:  
2,870,627, REN. 7-21-14. INT. CL. 9.
- SOAVE ENTEPRISES L.L.C., DETROIT, MI:  
3,352,244, CANC. MULTIPLE CLASS, INT. CLS. 35, 36, 39 AND 40.
- SOBRIO, LLC, STORRS, CT:  
4,592,569, PUB. 6-10-2014. INT. CL. 42.
- SOCCER FOR PEACE, INC., NEW YORK, NY:  
3,352,412, CANC. INT. CL. 36.
- SOCIÉTÉ DES SCIENCES VASCULAIRES DU QUÉBEC, MONTREAL, CANADA:  
3,352,137, CANC. MULTIPLE CLASS, INT. CLS. 9, 35, 36, 41 AND 44.
- SOCIAL HOUSE, INC., LOS ANGELES, CA:  
4,591,018, PUB. 3-26-2013. INT. CL. 35.
- SOCIEDAD AGRICOLA REQUINGUA LIMITADA, SANTIAGO, CHILE:  
4,593,194, INT. CL. 33.
- SOCIÉTÉ AIR FRANCE, 95747 ROISSY-CHARLES-DEGAULLE, FRANCE:  
2,876,220, REN. 7-21-14. INT. CL. 39.
- SOCIÉTÉ DES PRODUITS NESTLE S. A., VEVEY, SWITZERLAND:  
2,905,311, REN. 7-24-14. MULTIPLE CLASS, INT. CLS. 16, 18, 28, 31 AND 35.  
2,905,311, CANC. INT. CL. 20.
- SOCIETY OF PRODUCT LICENSORS COMMITTED TO EXCELLENCE, BUFFALO, NY:  
4,592,252, PUB. 6-10-2014. MULTIPLE CLASS, INT. CLS. 35 AND 41.
- SODERWORLD ENTERPRISES, LLC, WILLOWBROOK, IL:  
4,594,311, INT. CL. 11.  
4,594,314, INT. CL. 11.
- SOF LEI LI, LLC, ATLANTA, GA:  
4,593,849, MULTIPLE CLASS, INT. CLS. 41 AND 43.
- SOFIDEL S.P.A., ITALY:  
4,590,908, PUB. 6-10-2014. MULTIPLE CLASS, INT. CLS. 3, 5, 6, 16, 20 AND 21.
- SOFRIGAM, RUEIL MALMAISON, FRANCE:  
4,591,334, PUB. 6-10-2014. MULTIPLE CLASS, INT. CLS. 6, 9 AND 20.
- SOFT GOLD GHEE, INC., SAN FRANCISCO, CA:  
4,593,808, INT. CL. 3.
- SOFT STYLE INC., BOULDER, CO:  
4,591,893, PUB. 6-10-2014. INT. CL. 5.
- SOFTCAMP CO., LTD., SEOUL, REPUBLIC OF KOREA:  
4,594,124, INT. CL. 9.  
4,594,125, INT. CL. 9.
- SOFTFOUNDRY TECHNOLOGY (NINGBO) CO., LTD., NINGBO, ZHEJIANG, CHINA:  
4,593,686, INT. CL. 38.
- SOFTWARE FX, INC., BOCA RATON, FL:  
3,353,491, CANC. INT. CL. 9.
- SOFTWARE SHELF INTERNATIONAL, INC., CLEARWATER, FL:  
2,795,978, CANC. INT. CL. 9.
- SOFTWARE SOLUTIONS INTEGRATED, LLC, SHELBYVILLE, IL:  
4,592,843, PUB. 6-10-2014. INT. CL. 9.
- SOGEVAL LABORATORIES, INC., COPPELL, TX:  
3,353,507, CANC. INT. CL. 5.
- SOGEVAL LABORATORIES, INC., IRVING, TX:  
4,591,638, PUB. 6-10-2014. INT. CL. 5.  
4,593,366, INT. CL. 5.
- SOH, JOHNSON, SINGAPORE, SINGAPORE:  
4,594,010, INT. CL. 28.
- SOHO HOUSE LIMITED, LONDON, UNITED KINGDOM:  
4,591,139, PUB. 3-25-2014. MULTIPLE CLASS, INT. CLS. 30, 41 AND 43.
- SOIL-TECH, INC., LAS VEGAS, NV:  
4,591,398, PUB. 6-10-2014. INT. CL. 1.  
4,591,399, PUB. 6-10-2014. INT. CL. 37.
- SOKKIA TOPCON CO., LTD., ATSUGI CITY, KANAGAWA, JAPAN:  
2,882,575, REN. 7-21-14. INT. CL. 9.
- SOL NY CORPORATION, GARDEN CITY PARK, NY:  
4,592,723, PUB. 6-10-2014. INT. CL. 11.
- SOL PRODUCE S.A., LIMA, PERU:  
3,352,776, CANC. INT. CL. 31.
- SOLAS CORPORATION, GLENWOOD SPRINGS, CO:  
4,592,712, PUB. 6-10-2014. INT. CL. 36.



- SOLENIKOLATA GIDA SANAYI VE TICARET ANONIM SIRKETI, SEHITKAMIL GAZIANTEP, TURKEY:  
4,592,898, PUB. 6-10-2014. INT. CL. 30.
- SOLID STEEL BUILDINGS, INC., PITTSBURGH, PA:  
4,594,675, INT. CL. 37.
- SOLOROSA, SAINT HELENA, CA:  
3,351,627, CANC. INT. CL. 33.
- SOLOSOL MOVEMENT, LLC, MANHATTAN BEACH, CA:  
4,594,104, INT. CL. 25.
- SOLSWELL, NEWPORT BEACH, CA:  
4,591,563, PUB. 6-10-2014. INT. CL. 25.
- SOLUTIONS BY CHILCOTT LLC, NEODESHA, KS:  
4,592,738, PUB. 6-10-2014. INT. CL. 12.
- SOLUTIONS BY DESIGN, INC., NEW YORK, NY, DBA SOLUTIONS BY DESIGN, INC.:  
4,593,514, INT. CL. 42.
- SOMMERS, JONATHAN, ATLANTA, GA:  
3,351,214, CANC. INT. CL. 36.
- SONIFER, S.A., E-30007 MURCIA, SPAIN:  
4,590,644, PUB. 6-10-2014. MULTIPLE CLASS, INT. CLS. 9, 11 AND 21.
- SONNY'S FRANCHISE COMPANY, WINTER PARK, FL:  
4,591,900, PUB. 6-10-2014. INT. CL. 30.  
4,594,464, INT. CL. 36.
- SONOMA WINE COMPANY, GRATON, CA:  
4,593,169, INT. CL. 33.
- SONY COMPUTER ENTERTAINMENT AMERICA LLC, SAN MATEO, CA:  
3,370,593, CANC. INT. CL. 41.  
3,396,490, CANC. INT. CL. 41.
- SONY COMPUTER ENTERTAINMENT INC., TOKYO, JAPAN:  
4,591,929, PUB. 6-10-2014. MULTIPLE CLASS, INT. CLS. 9 AND 16.
- SONY CORPORATION, TOKYO, JAPAN:  
2,795,461, CANC. INT. CL. 9.
- SONY CORPORATION, TOKYO 108-0075, JAPAN:  
4,590,717, PUB. 6-10-2014. INT. CL. 9.
- SONY MOBILE COMMUNICATIONS AB, SWEDEN:  
3,352,551.
- SONY PICTURES TELEVISION INC., CULVER CITY, CA:  
3,351,704, CANC. INT. CL. 38.
- SOREMARTEC S.A., LUXEMBOURG:  
4,590,794, PUB. 6-10-2014. MULTIPLE CLASS, INT. CLS. 29, 30 AND 32.
- SORENSEN, CLIFFORD G., HUNTSVILLE, UT:  
2,796,327, CANC. INT. CL. 42.
- SOUDAL, NAAMLOZE VENNOOTSCHAP, BELGIUM:  
4,590,653, PUB. 6-10-2014. MULTIPLE CLASS, INT. CLS. 1, 17 AND 21.  
4,590,654, PUB. 6-10-2014. MULTIPLE CLASS, INT. CLS. 1, 17 AND 21.
- SOUL FOOD CYPHER LLC, ATLANTA, GA:  
4,592,197, PUB. 6-10-2014. INT. CL. 35.
- SOUND MEDICAL ADVICE PUBLISHING, INC., PORTLAND, OR:  
3,353,100, CANC. INT. CL. 9.
- SOURCE GLOBAL ENTERPRISES, INC., BRONX, NY:  
3,354,265, CANC. INT. CL. 20.
- SOURCE INTERLINK MAGAZINES, LLC, EL SEGUNDO, CA:  
2,861,717, REN. 7-21-14. INT. CL. 41.  
4,593,375, INT. CL. 14.  
4,593,376, INT. CL. 14.
- SOURCE INTERNATIONAL, INC., ORANGE PARK, FL:  
4,592,315, PUB. 6-10-2014. INT. CL. 36.
- SOURCE/INC., CHICAGO, IL:  
3,351,593, CANC. MULTIPLE CLASS, INT. CLS. 35 AND 42.
- SOUTH AFRICAN RUGBY UNION, WESTERN CAPE, SOUTH AFRICA:  
2,859,182, REN. 7-20-14. INT. CL. 25.  
2,859,182, CANC. INT. CL. 41.
- SOUTH BASIN MAYORS AND REEVES INC., WINNIPEG, MANITOBA, CANADA, DBA LAKE FRIENDLY:  
4,594,327, INT. CL. 35.
- SOUTH CAROLINA OVARIAN CANCER FOUNDATION, GREENVILLE, SC:  
4,591,335, PUB. 6-10-2014. INT. CL. 35.
- SOUTH JERSEY TRANSPORTATION AUTHORITY, HAMMONTON, NJ:  
4,592,752, PUB. 6-10-2014. INT. CL. 35.
- SOUTHCORP BRANDS PTY LIMITED, ARTARMON NSW 2064, AUSTRALIA:  
3,351,945, CANC. INT. CL. 33.
- SOUTHEAST BANK, ATHENS, TN:  
4,593,704, INT. CL. 36.
- SOUTHERN COMFORT PROPERTIES, INC., SAN RAFAEL, CA:  
2,795,416, CANC. INT. CL. 18.  
2,795,418, CANC. INT. CL. 26.
- SOUTHERN SALES & MARKETING GROUP, INC., ATLANTA, GA:  
4,594,259, INT. CL. 20.
- SOUTHERN SPINE, LLC, MACON, GA:  
4,593,674, INT. CL. 10.
- SOUTHLAND SAFETY, LLC, HENDERSON, TX:  
4,592,501, PUB. 6-10-2014. INT. CL. 35.
- SOVEE, LLC, CHATTANOOGA, TN:  
4,591,314, PUB. 6-10-2014. INT. CL. 42.
- SOVEREIGN BRANDS, LLC, NEW YORK, NY:  
4,591,089, PUB. 12-24-2013. MULTIPLE CLASS, INT. CLS. 32, 33 AND 43.
- SOWIND S.A., LA CHAUX-DE-FONDS, SWITZERLAND:  
3,505,586.
- SP BANCORP, INC., PLANO, TX:  
4,592,273, PUB. 6-10-2014. INT. CL. 35.
- SPACE BRANDS LIMITED, UNITED KINGDOM:  
4,590,745, PUB. 6-10-2014. INT. CL. 3.
- SPACE UPDATE, INC., HOUSTON, TX:  
2,794,624, CANC. INT. CL. 9.
- SPANNER LIMITED, KITCHENER, ONTARIO, CANADA:  
4,590,946, PUB. 6-10-2014. MULTIPLE CLASS, INT. CLS. 18 AND 25.
- SPARBER TRANSPORT, S.A., SPAIN:  
4,590,847, PUB. 6-10-2014. INT. CL. 39.
- SPARK INDUSTRIES, LLC, CAMARILLO, CA:  
4,594,035, INT. CL. 34.
- SPARK PUBLIC RELATIONS, LLC, SAN FRANCISCO, CA, DBA SPARKPR:  
4,593,057, PUB. 6-10-2014. INT. CL. 35.
- SPARROW STRATEGY, LLC., PORTLAND, OR:  
4,592,563, PUB. 6-10-2014. INT. CL. 35.
- SPARTAN RACE, INC., BOSTON, MA:  
4,593,296, INT. CL. 41.
- SPC RESOURCES, INC., HARTSVILLE, SC:  
2,795,870, CANC. INT. CL. 20.
- SPEC/MIX, INC., MENDOTA HEIGHTS, MN:  
2,793,952, CANC. INT. CL. 19.
- SPECAC LIMITED, SLOUGH, BERKSHIRE, UNITED KINGDOM:  
1,863,535, REN. 7-18-14. INT. CL. 9.
- SPECIALTY GRANULES INVESTMENTS LLC, WAYNE, NJ:  
4,591,670, PUB. 6-10-2014. INT. CL. 19.  
4,591,671, PUB. 6-10-2014. INT. CL. 19.
- SPECIALTY'S CAFE & BAKERY, INC., PLEASANTON, CA:  
4,592,889, PUB. 6-10-2014. INT. CL. 30.
- SPECTRATED, INC., MOUNT VERNON, OH:  
4,592,199, PUB. 6-10-2014. INT. CL. 10.
- SPECTRUM GROUP, BEVERLY HILLS, CA:  
3,353,414, CANC. INT. CL. 5.
- SPECTRUM RESEARCH GROUP, INC., SARASOTA, FL:  
3,353,774, CANC. INT. CL. 16.
- SPEEDBALL ART PRODUCTS CO., L.L.C., STATESVILLE, NC, HUNT MANUFACTURING CO., PHILADELPHIA, PA:  
1,015,280, REN. 7-21-14. INT. CL. 16.
- SPEER, MICHAEL, GRANADA HILLS, CA:  
4,592,662, PUB. 6-10-2014. INT. CL. 35.
- SPEIGEL & UTERERA, P.A., MIAMI, FL, LAW FIRM OF LAWRENCE J. SPIEGEL, P.A., THE CORAL GABLES, FL:  
1,846,011, REN. 7-21-14. INT. CL. 42.

- SPELLBINDERS PAPER ARTS COMPANY, LLC, PHOENIX, AZ:  
4,593,722, INT. CL. 8.
- SPERBER, JOSHUA D. BERKELEY, CA AND MANDEL, LEV L, BERKELEY, CA:  
3,351,108, CANC. INT. CL. 25.
- SPEYSIDE DISTILLERY COMPANY LTD, GLASGOW, SCOTLAND:  
2,796,031, CANC. INT. CL. 33.
- SPICE ENTERTAINMENT, INC., CHICAGO, IL:  
3,354,317, CANC. MULTIPLE CLASS, INT. CLS. 38 AND 41.
- SPIER, JOSEPH ALLEN, SOUTH ST. PAUL, MN:  
3,354,506, CANC. INT. CL. 25.
- SPINECORE, INC., SUMMIT, NJ TO SPINECORE, INC., SUMMIT, NJ:  
2,795,882, CANC. INT. CL. 10.
- SPINEVISION S.A., 75012 PARIS, FRANCE:  
2,860,737, REN. 7-18-14, INT. CL. 10.
- SPINGO SOLUTIONS, INC., DRAPER, UT, AKA SPINGO SOLUTIONS, LLC:  
4,594,545, INT. CL. 35.
- SPIRAC ENGINEERING AB, SWEDEN:  
4,590,776, PUB. 6-10-2014, MULTIPLE CLASS, INT. CLS. 7 AND 11.
- SPLIT ROCK SUPPLY CHAIN SOLUTIONS INC, GRAND RAPIDS, MI:  
4,594,241, INT. CL. 39.
- SPONSORED WHIPS LLC, WILMINGTON, DE:  
3,351,017, CANC. INT. CL. 35.
- SPORT YOUR COLOR, LLC, TORRINGTON, CT:  
4,592,049, PUB. 6-10-2014, INT. CL. 25.
- SPORTING LIFE BAR GROUP, LLC, BEVERLY HILLS, CA:  
4,593,778, INT. CL. 43.
- SPORTPET DESIGNS, INC., WAUKESHA, WI:  
3,353,605, CANC. MULTIPLE CLASS, INT. CLS. 20 AND 28.
- SPORTS LICENSED DIVISION OF THE ADIDAS GROUP, LLC, CANTON, MA:  
2,961,371, REN. 7-21-14, INT. CL. 25.
- SPORTSMAN'S WAREHOUSE, INC., MIDVALE, UT:  
3,354,654, CANC. INT. CL. 20.
- SPORTWATER BEVERAGES LLC, STAMFORD, CT:  
4,591,261, PUB. 3-4-2014, INT. CL. 5.
- SPOTCAST INC., CALGARY, ALBERTA, CANADA:  
4,591,316, PUB. 6-10-2014, INT. CL. 9.
- SPOTLIGHT PTY LTD., SOUTH MELBOURNE, AUSTRALIA:  
3,352,337, CANC. INT. CL. 23.  
3,352,338, CANC. INT. CL. 26.
- SPOTLY INC., GRAND CAYMAN, CAYMAN ISLANDS:  
4,592,973, PUB. 6-10-2014, INT. CL. 9.
- SPRA-GREEN LAWN FERTILIZER, LLC, PORTALES, NM:  
4,592,036, PUB. 6-10-2014, INT. CL. 1.
- SPRAGUE, JOHN, ALISO VIEJO, CA:  
3,351,713, CANC. INT. CL. 11.
- SPRING CHO REAL ESTATE GROUP, LLC, ROANOKE, VA:  
3,351,144, CANC. INT. CL. 36.
- SPRING LAKE COMMUNICATIONS LLC, TAMPA, FL:  
4,592,193, PUB. 6-10-2014, INT. CL. 45.
- SPRIZA INC, PALO ALTO, CA:  
4,592,103, PUB. 6-10-2014, MULTIPLE CLASS, INT. CLS. 35 AND 42.
- SPROUT POUCH INC., MISSOULA, MT:  
3,352,385, CANC. INT. CL. 18.
- SPX COOLING TECHNOLOGIES, INC., OVERLAND PARK, KS:  
2,794,141, CANC. INT. CL. 11.
- SPX CORPORATION, CHARLOTTE, NC:  
2,795,660, CANC. INT. CL. 9.
- SQUADRA PILOTI, LLC, REDONDO BEACH, CA:  
3,353,813, CANC. INT. CL. 38.
- SQUAREHUB INC., KIRKLAND, WA:  
4,593,752, INT. CL. 45.
- SQUAXIN ISLAND TRIBE, SHELTON, WA:  
4,591,159, PUB. 1-7-2014, INT. CL. 41.
- SQUIRRELS LLC, NORTH CANTON, OH:  
4,591,617, PUB. 3-4-2014, INT. CL. 9.
- SRDGM LIMITED, LONDON, WC1B 3HH, UNITED KINGDOM:  
4,591,128, PUB. 10-29-2013, INT. CL. 3.
- SRI SPORTS LIMITED, KOBE-SHI, JAPAN:  
3,353,780, CANC. INT. CL. 28.
- SRI USA, INC., TONAWANDA, NY:  
2,870,520, REN. 7-21-14, INT. CL. 12.  
2,898,834, REN. 7-24-14, INT. CL. 12.
- SSC GROUP, LLC, NORTH HILLS, CA:  
4,591,117, PUB. 6-10-2014, INT. CL. 41.
- ST. CHARLES CONSULTING GROUP LLC, ST. CHARLES, IL:  
4,594,105, INT. CL. 9.
- ST. JOHNS INVESTMENT MANAGEMENT COMPANY, LLC, JACKSONVILLE, FL:  
3,271,376, CANC. INT. CL. 36.
- STACK-ON PRODUCTS CO., WAUCONDA, IL:  
1,874,609, COR. INT. CL. 12.
- STACY GOLDBERG'S WHAT'S IN YOUR CART?, LLC, DETROIT, MI, DBA SAVORFULL:  
4,593,285, MULTIPLE CLASS, INT. CLS. 35 AND 44.
- STADLER HOLDING KG, FED REP GERMANY:  
4,590,879, PUB. 6-10-2014, MULTIPLE CLASS, INT. CLS. 12, 25 AND 35.
- STAFFORD, ERIN, DALLAS, TX:  
4,591,987, PUB. 6-10-2014, INT. CL. 14.
- STAFFORD, WILLIAM, KANSAS CITY, MO:  
4,592,523, PUB. 6-10-2014, INT. CL. 25.
- STALLERGENES SA, 92160 ANTONY, FRANCE:  
4,593,632, INT. CL. 5.
- STALLEX SKIN CARE, INC., BURLINGTON FLATS, NY, STALLEX SKIN CARE, INC., NEW YORK, NY:  
2,884,574, REN. 7-24-14, INT. CL. 5.
- STAMINA PRODUCTS, INC., SPRINGFIELD, MO:  
2,865,703, REN. 7-23-14, INT. CL. 28.
- STAMPEDE MEAT, INC., BRIDGEVIEW, IL:  
4,592,035, PUB. 4-29-2014, INT. CL. 29.
- STANDEX INTERNATIONAL CORPORATION, SALEM, NH, STANDEX INTERNATIONAL CORPORATION, ANDOVER, MA:  
1,000,072, REN. 7-24-14, INT. CL. 7.
- STANFORD 8 OWNER, LLC, PALM BEACH GARDENS, FL:  
4,592,617, PUB. 6-10-2014, INT. CL. 43.
- STANGE LAW FIRM, PC, BRENTWOOD, MO:  
4,592,434, PUB. 6-10-2014, INT. CL. 45.
- STANLY ADVISORS, LLC, NAPA, CA:  
3,353,657, CANC. INT. CL. 37.
- STAPLES THE OFFICE SUPERSTORE, LLC, FRAMINGHAM, MA:  
3,353,581, CANC. INT. CL. 16.  
3,353,974, CANC. INT. CL. 35.
- STAPLES, INC., FRAMINGHAM, MA:  
3,353,214, CANC. INT. CL. 3.
- STAR OF GEORGIA FOUNDATION, INC, ALPHARETTA, GA, DBA STAR OF GEORGIA FOUNDATION:  
4,591,338, PUB. 6-10-2014, INT. CL. 35.
- STARBOARD COLLECTION, LLC, SOUTH BURLINGTON, VT:  
4,593,532, INT. CL. 21.
- STARDUST MEMORIALS, LLC, TRAVERSE CITY, MI:  
4,592,420, PUB. 6-10-2014, INT. CL. 35.
- STARMARK INTERNATIONAL, INC., FORT LAUDERDALE, FL:  
4,592,591, PUB. 6-10-2014, INT. CL. 9.
- STARMAX RESOURCE LLC, MAPLE HEIGHTS, OH:  
1,841,363, REN. 7-22-14, INT. CL. 21.
- START TREATMENT & RECOVERY CENTERS, INC., BROOKLYN, NY:  
4,594,180, MULTIPLE CLASS, INT. CLS. 9, 41, 42, 44 AND 45.
- STARTUP WEEKEND, SEATTLE, WA:  
4,593,959, INT. CL. 35.
- STATE NUCLEAR POWER TECHNOLOGY; CORPORATION LTD., XICHENG DISTRICT; BEIJING, CHINA:  
4,590,824, PUB. 6-10-2014, MULTIPLE CLASS, INT. CLS. 1, 4, 6, 9, 11, 16, 17, 19, 35, 37, 39, 40, 41, 42 AND 45.

STAVRINIDES, JIM, SAN FRANCISCO, CA, DBA CALIFORNIA DETAILING:  
1,873,117. REN. 7-24-14. INT. CL. 9.

STAY EXPRESS WORLDWIDE, INC., DALLAS, TX:  
4,592,936, PUB. 6-10-2014. INT. CL. 43.

STEAM WHISTLE BREWING INC., TORONTO, ONTARIO, CANADA:  
3,351,936, CANC. INT. CL. 32.

STEEL CITY NDT, LLC, MONROEVILLE, PA:  
4,591,907, PUB. 6-10-2014. INT. CL. 42.

STEEL HORSES M.C. LLC, BROOKLYN, NY:  
3,351,643, CANC. INT. CL. 35.

STEELE STREET BANK & TRUST, DENVER, CO:  
4,591,502, PUB. 6-10-2014. INT. CL. 36.

STEIDINGER MEAT PROCESSING, INC., FAIRBURY, IL:  
4,590,608, PUB. 6-10-2014. INT. CL. 29.

STEINBECK BREWING COMPANY, HAYWARD, CA:  
4,590,976, PUB. 6-10-2014. INT. CL. 32.

STEINERT SENSING SYSTEMS AS, NORWAY:  
4,590,920, PUB. 6-10-2014. INT. CL. 9.

STEKLARNA HRASTNIK D.O.O., SLOVENIA:  
4,590,719, PUB. 6-10-2014. MULTIPLE CLASS, INT. CLS. 21, 34, 35, 40 AND 42.

STELLA & DOT LLC, SAN BRUNO, CA:  
4,591,677, PUB. 2-25-2014. INT. CL. 25.

STELLAR CONNECTIONS LLC, DENVER, CO:  
3,354,034, CANC. INT. CL. 41.

STEMP SYSTEMS GROUP, INC., LONG ISLAND CITY, NY:  
4,591,919, PUB. 6-10-2014. INT. CL. 42.

STEPHANIE KO, RENTON, WA, AKA STEPHANIE R. W. KO:  
4,592,536, PUB. 6-10-2014. INT. CL. 30.

STEPHANIE RODNEZ, PLANTATION, FL:  
4,594,207, INT. CL. 25.

STEPHEN J. COHEN, UPPER SADDLE RIVER, NJ:  
4,593,336, INT. CL. 25.

STEPHEN WALDEN, PHOENIX, AZ:  
4,593,338, INT. CL. 8.

STEPS THERAPY, INC., WHITE PLAINS, NY:  
4,591,348, PUB. 6-10-2014. MULTIPLE CLASS, INT. CLS. 41 AND 44.  
4,591,349, PUB. 6-10-2014. MULTIPLE CLASS, INT. CLS. 41 AND 44.

STERLING EQUITIES, INC., GREAT NECK, NY:  
2,859,515. REN. 7-22-14. INT. CL. 36.

STERLING JEWELERS INC., AKRON, OH:  
4,590,990, PUB. 6-10-2014. INT. CL. 14.

STERLING RESTAURANT SUPPLY, LLC, STERLING, VA:  
4,593,525, INT. CL. 35.

STEVE NGUYEN, M.D., P.A., ORLANDO, FL:  
4,594,295, INT. CL. 44.

STEVEN C. DOSS, AUSTIN, TX, DBA IMPACTSTRONG:  
4,592,835, PUB. 6-10-2014. INT. CL. 41.

STEVEN MADDEN, LTD., LONG ISLAND CITY, NY:  
4,594,538, INT. CL. 18.  
4,594,539, INT. CL. 18.

STEVEN, BAILEY J, PLYMOUTH, MA:  
3,353,247, CANC. INT. CL. 16.

STEWART BROWN, INC., VENTURA, CA:  
3,353,697, CANC. MULTIPLE CLASS, INT. CLS. 18, 24 AND 25.

STHREE IP LIMITED, LONDON, UNITED KINGDOM:  
4,590,875, PUB. 6-10-2014. INT. CL. 35.

STING SURVEILLANCE, LLC, HENDERSON, NV:  
3,351,421, CANC. INT. CL. 37.

STMICROELECTRONICS, INC., CARROLLTON, TX:  
2,795,503, CANC. INT. CL. 9.

STOCKPILE, INC., PALO ALTO, CA:  
4,593,157, MULTIPLE CLASS, INT. CLS. 35 AND 36.

STOLLER, JOHN, WAYLAND, MA:  
4,594,755, MULTIPLE CLASS, INT. CLS. 18 AND 25.

STONE, SANDY, ROSCOE, NY, DBA STONE REALTY:  
2,795,605, CANC. INT. CL. 36.

STONY CREEK BREWERY, LLC, BRANFORD, CT:  
4,593,640, INT. CL. 32.

STOP AGING NOW, LLC, BETHESDA, MD:  
4,591,341, PUB. 6-10-2014. INT. CL. 5.

STOP, LLC, LAS VEGAS, NV:  
4,594,403, INT. CL. 41.

STORY, DANA, WESTLAKE VILLAGE, CA:  
4,593,875, INT. CL. 8.

STORYCO, LLC, ST. HELENA, CA:  
3,350,734, CANC. INT. CL. 33.

STRAGITEK CORP., CALGARY, ALBERTA, CANADA:  
2,793,622, CANC. INT. CL. 9.

STRANDS OF COLOR, SOUTH JORDAN, UT:  
3,350,789, CANC. INT. CL. 14.

STRANGELOVE IP LICENSING PTY LTD, AUSTRALIA:  
4,590,901, PUB. 6-10-2014. INT. CL. 32.

STRATEGIC GLOBAL ASSISTANCE, INC., ELKHART, IN:  
4,592,450, PUB. 6-10-2014. INT. CL. 45.

STRATEGY CAFÉ, INC., RICHMOND, VA:  
3,353,273, CANC. INT. CL. 35.

STRAUSS CYCLING LLC, BOULDER, CO:  
4,592,741, PUB. 6-10-2014. MULTIPLE CLASS, INT. CLS. 6, 11 AND 12.

STRAUSS, PAUL L., CHICAGO, IL:  
3,353,810, CANC. INT. CL. 41.

STRAYHAN INVESTMENTS, INC, SACRAMENTO, CA, DBA RUBICON BREWING COMPANY:  
4,591,368, PUB. 6-10-2014. INT. CL. 43.

STREETLINKS LLC, KANSAS CITY, MO:  
4,593,160, MULTIPLE CLASS, INT. CLS. 9 AND 36.

STREETSPACE, INC., SAN FRANCISCO, CA:  
2,795,142, CANC. MULTIPLE CLASS, INT. CLS. 9, 35, 38 AND 42.

STREITER, RUTH, BROOKLYN, NY:  
4,590,984, PUB. 6-10-2014. MULTIPLE CLASS, INT. CLS. 41 AND 44.

STRENGTH TIME, LLC, HUBBARD, IL:  
3,350,806, CANC. INT. CL. 41.

STRIDER SPORTS INTERNATIONAL, INC., RAPID CITY, SD:  
3,351,471, CANC. INT. CL. 12.

STRING KING LACROSSE LLC, LOS ANGELES, CA:  
4,593,312, MULTIPLE CLASS, INT. CLS. 25, 28 AND 41.

STRNAD, CARLA G., WASHINGTON, MO:  
3,352,110, CANC. INT. CL. 18.

STRUTS, LLC, OXFORD, AL:  
3,351,666, CANC. INT. CL. 43.  
3,351,804, CANC. INT. CL. 43.

STU CLOTT, SAN DIEGO, CA:  
4,592,130, PUB. 6-10-2014. INT. CL. 37.

STUART DEAN, INC., NEW YORK, NY:  
2,795,883, CANC. INT. CL. 40.

STUART, HELENA, NEW YORK, NY:  
4,593,227, INT. CL. 25.

STUDER MASCHINENBAU AG, SWITZERLAND:  
4,590,643, PUB. 6-10-2014. MULTIPLE CLASS, INT. CLS. 6, 7 AND 11.

STURM, RUGER & COMPANY, INC., SOUTHPORT, CT:  
4,593,479, INT. CL. 13.

STYLEWHILE LTD., HELSINKI, FINLAND:  
4,593,313, MULTIPLE CLASS, INT. CLS. 9 AND 35.

SUBLIME PHOTOGRAPHY, INC., STONE MOUNTAIN, GA:  
3,351,314, CANC. INT. CL. 41.

SUBURBAN FRANCHISE SYSTEMS, INC., ATLANTA, GA:  
2,796,198, CANC. INT. CL. 43.

SUCCEED MANAGEMENT SOLUTIONS, LLC, LAKE OSWEGO, OR:  
4,592,691, PUB. 6-10-2014. INT. CL. 42.

SUGAR SISTERS LLC, OKLAHOMA CITY, OK:  
4,593,044, PUB. 6-10-2014. INT. CL. 3.

SUGARFINA, LOS ANGELES, CA:  
4,366,229, CANC. INT. CL. 30.

SUITABLE TECHNOLOGIES, INC., PALO ALTO, CA:  
4,593,468, MULTIPLE CLASS, INT. CLS. 9, 41 AND 42.  
4,593,469, MULTIPLE CLASS, INT. CLS. 9, 41 AND 42.

SUITELIFE PERSONAL CONCIERGE & EVENTS, INC., ORANGE PARK, FL, DBA STOGIES & STILETTOS:  
4,594,662, INT. CL. 35.

SUITICAL INTERNATIONAL BV, 2718 JR ZOETERMEER, NETHERLANDS:  
4,591,799, PUB. 6-10-2014. INT. CL. 18.

- SUIZA FRUIT CORPORATION, SAN JUAN, PUERTO RICO:  
4,591,905, PUB. 6-10-2014. INT. CL. 32.
- SUK YEE SMITH, MECHANICSBURG, PA:  
4,593,931, MULTIPLE CLASS, INT. CLS. 16, 41 AND 45.
- SULLIVAN, JOHN DERMOT, PERTH, AUSTRALIA, DBA SHARELY:  
4,591,606, PUB. 6-10-2014. MULTIPLE CLASS, INT. CLS. 9 AND 42.
- SULTAN OF SWIM.COM, LLC., TUCSON, AZ:  
4,594,558, INT. CL. 11.
- SUMITOMO CHEMICAL CO., LTD., TOKYO, JAPAN:  
2,796,179, CANC. INT. CL. 1.
- SUMMIT AGRO USA, LLC, CARY, NC:  
4,593,697, MULTIPLE CLASS, INT. CLS. 1 AND 5.
- SUMOL-GESTAO DE MARCAS, S.A., 2795-854 CARNAXIDE, PORTUGAL:  
3,351,955, CANC. INT. CL. 32.
- SUN & SKIN CARE RESEARCH, LLC, COCOA, FL:  
4,594,610, INT. CL. 3.
- SUN CHLORELLA CORP., KYOTO, JAPAN:  
2,796,252, CANC. INT. CL. 30.
- SUNBURST DIGITAL INC., ELGIN, IL:  
2,794,356, CANC. MULTIPLE CLASS, INT. CLS. 9 AND 35.
- SUNDOG PRODUCTIONS, LLC, FAIRFAX, VA:  
2,788,120, REN. 7-21-14. INT. CL. 25.
- SUNDRY CLOTHING, INC, CULVER CITY, CA:  
4,593,804, INT. CL. 25.
- SUNEJA, RANDEEP, KATY, TX:  
4,593,560, INT. CL. 44.
- SUNFOOD, LLC, LEWES, DE:  
4,592,004, PUB. 6-10-2014. INT. CL. 5.
- SUNG HO DONG, YANGJU-SI, GYEONGGI-DO, REPUBLIC OF KOREA:  
4,590,874, PUB. 6-10-2014. INT. CL. 25.
- SUNNY FONG MIND AND BODY FITNESS, CONCORD, MA:  
3,350,879, CANC. INT. CL. 41.
- SUNNY MERCHANDISE CORP., VERNON, CA:  
4,287,086, CANC. INT. CL. 9.
- SUNNYLION LLC, SANTA MONICA, CA:  
4,591,892, PUB. 6-10-2014. INT. CL. 9.
- SUNRISE TOURS & TRAVEL, INC., FREEPORT, NY:  
4,591,610, PUB. 6-10-2014. INT. CL. 39.
- SUNTRUST BANKS, INC., ATLANTA, GA:  
4,593,738, INT. CL. 36.
- SUPER FISH, INC., TAMPA, FL:  
3,354,563, CANC. INT. CL. 43.
- SUPER G FUNDING, LLC, NEWPORT BEACH, CA:  
4,594,470, INT. CL. 36.
- SUPERGIANT GAMES, LLC, SAN FRANCISCO, CA:  
4,593,476, INT. CL. 9.
- SUPERSTATION, INC., ATLANTA, GA:  
3,352,094, CANC. MULTIPLE CLASS, INT. CLS. 25 AND 41.
- SUPERTEC MACHINERY INC., PARAMOUNT, CA:  
4,591,248, PUB. 6-10-2014. INT. CL. 35.
- SUPPLY CHAIN FINANCE INC., OMAHA, NE, DBA SUPPLY CHAIN FINANCE:  
4,594,208, INT. CL. 35.
- SURFACES SOUTHEAST, INC., MIAMI, FL:  
4,591,350, PUB. 6-10-2014. INT. CL. 19.
- SURVEY SAMPLING INTERNATIONAL, LLC, SHELTON, CT:  
4,591,136, PUB. 6-10-2014. INT. CL. 9.
- SUSAN ARMSTRONG, ELIZABETHTOWN, IL:  
4,592,133, PUB. 6-10-2014. INT. CL. 41.
- SUSAN JEFFERS, SANTA MONICA, CA:  
3,338,961, CANC. INT. CL. 41.
- SUSTAINABLE SWINE RESOURCES, LLC, LAKE MILLS, WI:  
4,594,231, INT. CL. 31.
- SUSTAINED MOTION CAR COLLECTION, LLC, NAPLES, FL:  
4,593,511, INT. CL. 35.  
4,593,512, INT. CL. 35.  
4,593,515, INT. CL. 35.
- SUTCLIFFE & SON LLC, IRVINE, CA:  
4,594,215, INT. CL. 33.
- SUTTON, CLINT WADE, KIRVIN, TX:  
3,352,265, CANC. INT. CL. 41.
- SUZANNE EVANS COACHING OF SOUTH CAROLINA, LLC, MURRELLS INLET, SC:  
4,593,280, INT. CL. 41.
- SUZANNE GAROFALO DESIGN L.L.C., SEDRO WOOLLEY, WA, DBA SUZANNE GAROFALO DESIGN:  
4,592,271, PUB. 6-10-2014. INT. CL. 14.
- SVEN BOILLAT, SWITZERLAND:  
4,590,873, PUB. 6-10-2014. INT. CL. 35.
- SVUS PHARMA A.S., CZECH REPUBLIC:  
3,352,537.
- SWAIN AUSTRALIAN TOURS (2003), INC., ARDMORE, PA:  
4,594,392, INT. CL. 39.
- SWAN PRODUCTS, LLC, NEW YORK, NY:  
4,593,460, INT. CL. 17.
- SWANSON, DAVID L, NEW RICHMOND, WI AND SWANSON, PATRICIA L, NEW RICHMOND, WI:  
1,843,233, REN. 7-21-14. INT. CL. 41.
- SWARTZ, ADAM, PA FURNACE, PA:  
4,592,661, PUB. 6-10-2014. INT. CL. 25.
- SWAT ENTERPRISE, LLC, SAN ANTONIO, TX, DBA BIOTECHS:  
4,592,851, PUB. 6-10-2014. INT. CL. 37.
- SWEDISH ORPHAN BIOVITRUM AB (PUBL), STOCKHOLM, SWEDEN:  
4,593,097, MULTIPLE CLASS, INT. CLS. 5, 10, 35, 42 AND 45.  
4,593,098, MULTIPLE CLASS, INT. CLS. 5, 10, 35, 42 AND 45.
- SWIFT BRANDS COMPANY, GREELEY, CO:  
4,592,264, PUB. 6-10-2014. INT. CL. 29.
- SWIFT RESPONSE, LLC, WESTON, FL:  
4,594,466, INT. CL. 17.
- SWIM STRONG FOUNDATION, INC., EAST ELMHURST, NY:  
4,593,188, INT. CL. 25.
- SWINERTON INCORPORATED, SAN FRANCISCO, CA:  
2,864,369, REN. 7-18-14. INT. CL. 35.  
2,864,370, REN. 7-18-14. INT. CL. 35.  
2,864,371, REN. 7-18-14. INT. CL. 37.
- SWIRL EVENTS INC., NEW YORK, NY:  
3,351,822, CANC. INT. CL. 41.
- SWIRLIFY, LLC, SAN LUIS OBISPO, CA:  
4,593,853, MULTIPLE CLASS, INT. CLS. 35, 42 AND 43.
- SWISS WATCH INTERNATIONAL, INC., HOLLYWOOD, FL:  
2,868,146, REN. 7-22-14. INT. CL. 14.
- SWISSTECH HOLDING AG, SWITZERLAND:  
3,352,633.  
3,352,662.
- SYAL, RAJ, LAKE FOREST, CA:  
4,594,511, INT. CL. 43.
- SYED, OMAR A., DALLAS, TX:  
2,865,688, REN. 7-23-14. INT. CL. 28.
- SYNDIANT, INC., DALLAS, TX:  
3,352,113, CANC. INT. CL. 42.
- SYNDICAT MIXTE DE L'ESCEM, FRANCE:  
4,590,667, PUB. 6-10-2014. MULTIPLE CLASS, INT. CLS. 16 AND 41.
- SYNERGY COMPANY, THE, MOAB, UT:  
1,851,279, REN. 7-18-14. INT. CL. 5.
- SYNERGY FRANCHISING CORPORATION, VALPARAISO, IN:  
3,353,828, CANC. INT. CL. 35.
- SYNGENTA PARTICIPATIONS AG, BASEL, SWITZERLAND, SANDOZ AG (SANDOZ LTD., SANDOZ S.A.), BASLE, SWITZERLAND:  
1,885,597, REN. 7-22-14. INT. CL. 20.
- SYNGENTA PARTICIPATIONS AG, BASEL, SWITZERLAND:  
1,894,529, REN. 7-22-14. INT. CL. 5.  
2,927,251, REN. 7-23-14. INT. CL. 5.
- SYNKY GAMES, INC, MIAMI, FL:  
4,591,555, PUB. 6-10-2014. INT. CL. 41.

SYNTHOMER DEUTSCHLAND GMBH, MARL, FED REP GERMANY:  
 4,593,350, MULTIPLE CLASS, INT. CLS. 1 AND 2.  
 SYNVASIVE TECHNOLOGY, INC., WARSAW, IN:  
 3,477,983, AM. INT. CL. 10.  
 SYRATECH CORPORATION, EAST BOSTON, MA:  
 881,693, CANC. U.S. CL. 28.  
 SYSCO CORPORATION, HOUSTON, TX:  
 1,848,016, REN. 7-22-14, INT. CL. 1.  
 2,859,214, REN. 7-20-14, INT. CL. 29.  
 2,859,215, REN. 7-20-14, INT. CL. 29.  
 SYSTEMFORWARD AMERICA, INC., LAFAYETTE, LA:  
 4,594,308, MULTIPLE CLASS, INT. CLS. 37 AND 45.  
 SYSTEMS PAVING, INC., SANTA ANA, CA, DBA SYSTEM PAVERS:  
 4,592,345, PUB. 6-10-2014, MULTIPLE CLASS, INT. CLS. 37, 42 AND 44.  
 4,593,018, PUB. 6-10-2014, MULTIPLE CLASS, INT. CLS. 37, 42 AND 44.  
 SYSYNC LLC, MECHANICSBURG, PA:  
 4,593,405, INT. CL. 42.  
 SZAMES BARBARA, FRANCE:  
 3,352,530.  
 T BOVEE PRODUCTS LLC, COLEMAN, MI:  
 4,594,280, INT. CL. 21.  
 T J CRAFTERS, TUCKER, GA:  
 4,592,029, PUB. 6-10-2014, INT. CL. 4.  
 T.L.S. PARTS, INC., RANCHO CORDOVA, CA:  
 4,592,855, PUB. 6-10-2014, INT. CL. 35.  
 T.R. EXPORT & IMPORT CO., SONIPAT, INDIA:  
 2,794,565, CANC. INT. CL. 25.  
 3,350,893, CANC. INT. CL. 25.  
 T.Y.C. BROTHER INDUSTRIAL CO., LTD., TAINAN, TAIWAN:  
 4,591,382, PUB. 6-10-2014, MULTIPLE CLASS, INT. CLS. 7, 11 AND 12.  
 TAB INDIA GRANITES PVT. LTD., JAIPUR, INDIA:  
 4,592,209, PUB. 6-10-2014, INT. CL. 19.  
 4,592,210, PUB. 6-10-2014, INT. CL. 19.  
 TAB LABORATORIES, INC., HUNTINGTON BEACH, CA:  
 4,594,039, INT. CL. 3.  
 TABLE 12 PRODUCTIONS, INC., BROOKLYN, NY:  
 4,594,492, INT. CL. 35.  
 TABTALE LTD., TEL AVIV, ISRAEL:  
 4,591,503, PUB. 6-10-2014, INT. CL. 9.  
 TACO BELL CORP., IRVINE, CA:  
 3,351,755, CANC. MULTIPLE CLASS, INT. CLS. 30 AND 43.  
 TADROS, MARC, PIERREFONDS, CANADA:  
 3,354,630, CANC. INT. CL. 39.  
 TAE-WOO YOO, CHUNGHEONGNAM-DO, REPUBLIC OF KOREA:  
 2,793,680, CANC. INT. CL. 9.  
 TAGWHALE, INC., BROOKLYN, NY:  
 4,593,953, INT. CL. 35.  
 TAHOE JOE'S, INC., GREER, SC:  
 4,591,960, PUB. 6-10-2014, INT. CL. 30.  
 4,591,961, PUB. 6-10-2014, INT. CL. 29.  
 TAICA CORPORATION, MINATO-KU, TOKYO, JAPAN:  
 4,590,751, PUB. 6-10-2014, MULTIPLE CLASS, INT. CLS. 17, 40 AND 42.  
 TAIWAN PAIHO LIMITED, HO MEI TOWN, CHANGHUA HSIEN, TAIWAN:  
 3,352,884, CANC. INT. CL. 28.  
 TAKAO ASAYAMA, MOUNTAIN VIEW, CA:  
 4,593,885, INT. CL. 3.  
 TAKASAGO KORYO KOGYO KABUSHIKI KAISHA, OHTA-KU; TOKYO 144-8721, JAPAN, TA TAKASAGO INTERNATIONAL CORPORATION:  
 3,352,740.  
 TAKIRON CO., LTD., OSAKA-SHI, OSAKA, JAPAN:  
 3,350,641, CANC. INT. CL. 10.  
 3,351,946, CANC. INT. CL. 10.  
 TALBOT LIFTING & SECURITY EUROPE LIMITED, CLONSKEAGH DUBLIN 4, IRELAND:  
 4,593,995, MULTIPLE CLASS, INT. CLS. 6 AND 22.  
 TALKMARKETS, LLC, HIGHLAND PARK, NJ:  
 4,591,989, PUB. 6-10-2014, INT. CL. 36.  
 TAMBRANDS, INC., CINCINNATI, OH:  
 4,594,344, INT. CL. 5.  
 TAMPA BAY ARENA, L.P., TAMPA, FL:  
 1,995,092, CANC. INT. CL. 41.  
 TAN IP, LLC, GLEN BURNIE, MD:  
 3,351,779, CANC. INT. CL. 43.  
 TANA OY, VAAJAKOSKI, FINLAND:  
 4,591,079, PUB. 11-12-2013, INT. CL. 7.  
 TANEA FLANDERS, BROOKLYN, NY, DBA DESIGN YOU COACHING:  
 4,592,296, PUB. 6-10-2014, INT. CL. 41.  
 TANG, BRIAN, MOUNTAIN VIEW, CA:  
 2,954,986, REN. 7-23-14, INT. CL. 10.  
 TANGLA HOTELS & RESORTS WORLDWIDE CO. LIMITED, DES VOEUX ROAD C CENTRAL, HONG KONG:  
 4,593,067, MULTIPLE CLASS, INT. CLS. 35 AND 43.  
 TAPATIO FOODS, LLC, VERNON, CA:  
 1,871,465, REN. 7-24-14, INT. CL. 30.  
 TAPCO INTERNATIONAL CORPPORATION, WIXOM, MI:  
 4,593,774, INT. CL. 19.  
 TAPJOY, INC., SAN FRANCISCO, CA:  
 4,594,298, INT. CL. 9.  
 TARP TEAM HOLDING APS, DK-7000 FREDERICIA, DENMARK:  
 4,590,761, PUB. 6-10-2014, MULTIPLE CLASS, INT. CLS. 35 AND 41.  
 TASTE BUDS, INC., NEW ORLEANS, LA:  
 4,592,365, PUB. 6-10-2014, INT. CL. 43.  
 4,592,366, PUB. 6-10-2014, INT. CL. 43.  
 TASTEIA, LLC, GARDEN GROVE, CA:  
 4,591,912, PUB. 6-10-2014, INT. CL. 30.  
 TASTEBUD ENTERTAINMENT, INC., NEWPORT COAST, CA:  
 3,352,120, CANC. MULTIPLE CLASS, INT. CLS. 16 AND 41.  
 TASTEFULLY SIMPLE, INC., ALEXANDRIA, MN:  
 4,591,746, PUB. 6-10-2014, MULTIPLE CLASS, INT. CLS. 21, 25, 29, 30, 32 AND 35.  
 TASTY COCKTAILS, LLC, HENDERSON, NV:  
 4,593,082, INT. CL. 43.  
 TATE & LYLE INGREDIENTS AMERICAS LLC, DECATUR, IL:  
 988,534, REN. 7-21-14, U.S. CL. 46 (INT. CL. 30).  
 TATTOO JOHNNY INC., FAYETTEVILLE, GA AND TATTOO JOHNNY INC., FAYETTEVILLE, GA:  
 2,857,528, REN. 7-21-14, INT. CL. 16.  
 TAURUS INTERNATIONAL MANUFACTURING, INC., MIAMI, FL:  
 2,795,644, CANC. INT. CL. 13.  
 TAYLOR RAMSDELL CREATIONS, LLC, LOS ANGELES, CA:  
 4,591,445, PUB. 6-10-2014, INT. CL. 41.  
 4,591,446, PUB. 6-10-2014, INT. CL. 41.  
 TBC WORLDWIDE, INC., SAN MATEO, CA:  
 3,352,009, CANC. MULTIPLE CLASS, INT. CLS. 5, 9 AND 41.  
 TBD-Z INC., CUDAHY, CA:  
 3,350,805, CANC. INT. CL. 25.  
 TBK GBR (VERTRETUNGSBERECHTIGTER GESELLSCHAFT: MATTHIAS GRILL), MUNICH, FED REP GERMANY:  
 4,590,814, PUB. 6-10-2014, INT. CL. 45.  
 TBRC, INC., TEMECULA, CA:  
 3,354,616, CANC. INT. CL. 35.  
 TCI INTERNATIONAL, INC., FREMONT, CA:  
 3,350,638, CANC. INT. CL. 9.  
 TDR MANAGEMENT, INC., DALWORTHINGTON GARDENS, TX:  
 3,351,082, CANC. INT. CL. 35.  
 TDS TELECOMMUNICATIONS CORPORATION, MADISON, WI:  
 3,354,417, CANC. INT. CL. 38.  
 TEA FORTE, INC., CONCORD, MA:  
 4,592,478, PUB. 6-10-2014, INT. CL. 30.  
 TEA SECTION, AUSTIN, TX:  
 4,593,246, INT. CL. 30.  
 TEAL ELECTRONICS CORPORATION, SAN DIEGO, CA:  
 3,338,927, CANC. INT. CL. 9.

- TEALIFE, L.P., DALLAS, TX:  
3,352,936, CANC. INT. CL. 5.
- TEAM DOUBLE-CLICK, INC., LODI, WI:  
3,351,284, CANC. INT. CL. 35.  
3,351,285, CANC. INT. CL. 35.
- TEAMMATES FOR KIDS FOUNDATION, WHEAT RIDGE, CO:  
2,795,587, CANC. MULTIPLE CLASS, INT. CLS. 25 AND 36.
- TEC FOODS, INC., CHICAGO, IL:  
1,846,877, REN. 7-21-14. INT. CL. 30.
- TECBRAKE, INC., HOUSTON, TX, DBA TEK-MEDICAL CORPORATION:  
4,594,778, INT. CL. 10.
- TECHNIBILT, LTD., NEWTON, NC:  
778,091, REN. 7-22-14. U.S. CL. 19 (INT. CL. 12).
- TECHNICAL COMMUNITIES, INC, SAN BRUNO,, CA:  
3,352,246, CANC. INT. CL. 35.
- TECHNOFORM CAPRANO + BRUNNHOFER GMBH, 34117 KASSEL, FED REP GERMANY:  
4,593,970, MULTIPLE CLASS, INT. CLS. 6 AND 19.
- TECHNOLOGY AND ENTREPRENEURSHIP CENTER OF HOUSTON, INC., HOUSTON, TX:  
3,352,288, CANC. INT. CL. 35.
- TECHNOLOGY DIMENSIONS, INC., ORANGE, CA:  
3,352,299, CANC. INT. CL. 37.
- TECHTRONIC FLOOR CARE TECHNOLOGY LIMITED, ROAD TOWN, TORTOLA, BR.VIRGIN ISLANDS:  
4,593,226, INT. CL. 7.
- TECH3 BUSINESS SYSTEMS, LLC, HOUSTON, TX:  
4,592,030, PUB. 6-10-2014. INT. CL. 42.
- TECNAU S.R.L., IVREA, ITALY:  
4,591,047, PUB. 6-10-2014. INT. CL. 7.
- TECNOMATIC S.P.A., ITALY:  
4,590,634, PUB. 6-10-2014. MULTIPLE CLASS, INT. CLS. 7, 12 AND 42.
- TECSERV, INC., WEST VALLEY CITY, UT:  
2,794,452, CANC. INT. CL. 42.
- TECTUM, INC., NEWARK, OH:  
3,351,041, CANC. INT. CL. 17.
- TEDDI A. SEGAL, P.A., MIAMI BEACH, FL:  
3,354,553, CANC. INT. CL. 36.  
3,354,555, CANC. INT. CL. 36.
- TEDDY S.P.A., RIMINI (RN), ITALY:  
2,793,678, CANC. MULTIPLE CLASS, INT. CLS. 18 AND 25.
- TEE AND ELL WEIGHT LIFTING AND EXERCISE ENTERPRISES, INC., COLUMBUS, OH:  
4,592,480, PUB. 6-10-2014. MULTIPLE CLASS, INT. CLS. 9, 16 AND 41.
- TEELING WHISKEY COMPANY LTD, IRELAND:  
4,590,909, PUB. 6-10-2014. INT. CL. 33.
- TEEN MANIA MINISTRIES, INC., GARDEN VALLEY, TX:  
2,793,996, CANC. INT. CL. 45.
- TELEBRANDS CORPORATION, FAIRFIELD, NJ:  
3,351,839, CANC. INT. CL. 9.
- TELEDRIFT COMPANY, MOORE, OK:  
4,591,525, PUB. 6-10-2014. INT. CL. 9.
- TELEPHONETICS, INC., MIRAMAR, FL:  
4,592,553, PUB. 6-10-2014. INT. CL. 38.  
4,592,695, PUB. 6-10-2014. INT. CL. 38.
- TELEPRO-DIRECT, INC., EDGEWATER, NJ:  
4,591,354, PUB. 6-10-2014. INT. CL. 3.
- TELESOFT TECHNOLOGIES LTD, BLANDFORD ST MARY, UNITED KINGDOM:  
4,591,232, PUB. 6-10-2014. INT. CL. 9.
- TELEVISA, S.A. DE C.V., SANTA FE, MEXICO:  
4,591,425, PUB. 6-10-2014. MULTIPLE CLASS, INT. CLS. 9 AND 41.
- TELEVISIÓN NACIONAL DE CHILE, SANTIAGO, CHILE:  
4,591,228, PUB. 6-10-2014. INT. CL. 38.
- TELLIER, FRANCE:  
4,590,629, PUB. 6-10-2014. MULTIPLE CLASS, INT. CLS. 8 AND 21.
- TELLKAMP SYSTEMS, INC., SANTA FE SPRINGS, CA AND TREVISAN COMETAL, VERONA, ITALY:  
3,314,297, CANC. INT. CL. 7.
- TELNEXUS INVESTMENTS, LLC, BERKELEY, CA:  
4,592,175, PUB. 6-10-2014. INT. CL. 38.
- TELSKO INDUSTRIES, INC., GARLAND, TX:  
3,352,346, CANC. MULTIPLE CLASS, INT. CLS. 9 AND 11.
- TELSOURCE CORPORATION, TOTOWA, NJ:  
3,352,777, CANC. MULTIPLE CLASS, INT. CLS. 37, 38 AND 42.
- TELSTRA CORPORATION LIMITED, MELBOURNE VIC, AUSTRALIA:  
4,590,778, PUB. 6-10-2014. MULTIPLE CLASS, INT. CLS. 9, 35, 37, 41 AND 42.
- TEMPORARY REPAIR LLC, PLYMOUTH, IN:  
4,592,386, PUB. 6-10-2014. INT. CL. 37.
- TENCENT HOLDINGS LIMITED, GRAND CAYMAN, CAYMAN ISLANDS:  
4,591,001, PUB. 6-10-2014. MULTIPLE CLASS, INT. CLS. 9, 35, 36, 38, 39, 41 AND 42.
- TENENZ, INC., BLOOMINGTON, MN:  
4,591,741, PUB. 6-10-2014. MULTIPLE CLASS, INT. CLS. 35, 41 AND 42.
- TENNECO AUTOMOTIVE OPERATING COMPANY INC., LAKE FOREST, IL:  
3,354,147, CANC. INT. CL. 12.
- TEQUILA CUERVO LA ROJENA, S.A. DE C.V., CODIGO 45070, MEXICO:  
3,354,452, CANC. INT. CL. 33.
- TERRA SOLUTIONS GROUP, GLASTONBURY, CT:  
3,351,227, CANC. INT. CL. 42.
- TERRAGROUP CORPORATION, ALLENTOWN, PA:  
1,867,575, REN. 7-21-14. INT. CL. 11.
- TERRAPIN BEER COMPANY, ATHENS, GA:  
2,794,891, CANC. INT. CL. 32.
- TERRE D'OC CREATIONS, MANOSQUE (VILLENEUVE), FRANCE:  
4,593,347, MULTIPLE CLASS, INT. CLS. 3, 4 AND 21.
- TERRE DE VIGNERONS-UNION PRODIFFU, FRANCE:  
4,590,836, PUB. 6-10-2014. MULTIPLE CLASS, INT. CLS. 33, 35, 39 AND 41.
- TERRELL, ALICE G., COCONUT CREEK, FL:  
4,592,167, PUB. 6-10-2014. INT. CL. 43.
- TERRYBEAR, INC., ST. PAUL, MN:  
4,593,940, MULTIPLE CLASS, INT. CLS. 18, 20 AND 21.
- TERUMO BCT, INC., LAKEWOOD, CO:  
2,796,125, CANC. INT. CL. 10.
- TERVELA INC., ACTON, MA:  
3,351,119, CANC. INT. CL. 9.
- TESSCO COMMUNICATIONS INCORPORATED, HUNT VALLEY, MD, TESSCO, INC., SPARKS, MD:  
1,850,130, REN. 7-24-14. INT. CL. 42.
- TETRA PROPERTY MANAGEMENT, LLC, GOSHEN, CA:  
3,353,754, CANC. INT. CL. 9.
- TETRACHEM DECONTAMINATION SERVICES, LLC, JONESBORO, AR:  
4,592,907, PUB. 6-10-2014. INT. CL. 1.
- TETRIS HOLDING, LLC, WILMINGTON, DE:  
4,592,832, PUB. 6-10-2014. INT. CL. 11.  
4,592,985, PUB. 6-10-2014. MULTIPLE CLASS, INT. CLS. 9 AND 41.
- TEVA PHARMACEUTICAL INDUSTRIES LTD., JERUSALEM, ISRAEL:  
4,590,972, PUB. 6-10-2014. INT. CL. 5.  
4,590,973, PUB. 6-10-2014. INT. CL. 5.
- TEVA WOMEN'S HEALTH, INC., WOODCLIFF LAKE, NJ:  
4,594,032, INT. CL. 10.  
4,594,036, INT. CL. 10.
- TEXAS BRIGADE BBQ, LLC, GETTYSBURG, PA:  
4,591,916, PUB. 6-10-2014. INT. CL. 30.
- TEXAS FARM PRODUCTS COMPANY, NACOGDOCHES, TX:  
1,890,081, REN. 7-22-14. INT. CL. 31.
- TEXAS LONGHORN ARMS, INC., RICHMOND, TX:  
1,822,624, REN. 7-24-14. INT. CL. 13.
- TEXAS RESEARCH INTERNATIONAL, INC., AUSTIN, TX:  
4,593,178, INT. CL. 1.
- TEXAS SPINE AND JOINT HOSPITAL, L.L.P., TYLER, TX:  
2,794,176, CANC. INT. CL. 44.

TEXAS TECH UNIVERSITY HEALTH SCIENCES CENTER, LUBBOCK, TX:  
4,592,282, PUB. 6-10-2014. INT. CL. 42.

TEXEIRA, KIRK, SAN DIEGO, CA:  
4,592,965, PUB. 6-10-2014. INT. CL. 41.

TEXOLLINI, INC., LONG BEACH, CA:  
4,591,025, PUB. 6-10-2014. MULTIPLE CLASS, INT. CLS. 24 AND 25.

TEXTILE WORLD1, MONMOUTH JUNCTION, NJ, DBA UP2DATE FASHION:  
4,594,097, INT. CL. 25.

TGIC IMPORTERS, INC., WOODLAND HILLS, CA:  
3,353,768, CANC. INT. CL. 33.

THACKREY, SEAN HALEY, BOLINAS, CA:  
4,593,949, INT. CL. 33.

THAI PASSION INC., AUSTIN, TX:  
3,351,787, CANC. INT. CL. 43.

THALMANN, CHRIS, SAN FRANCISCO, CA:  
3,351,452, CANC. INT. CL. 41.

THE ABSOLUT COMPANY AKTIEBOLAG, STOCKHOLM, SWEDEN:  
4,592,958, PUB. 6-10-2014. INT. CL. 33.

THE AFRICA CHANNEL LLC, NORTH HOLLYWOOD, CA:  
2,847,004, REN. 7-21-14. MULTIPLE CLASS, INT. CLS. 38 AND 41.

THE ALMOND BOARD OF CALIFORNIA, MODESTO, CA:  
4,591,971, PUB. 6-10-2014. MULTIPLE CLASS, INT. CLS. 18 AND 41.

THE AMERICAN ASSOCIATION OF IMMUNOLOGISTS, INC., BETHESDA, MD:  
4,592,913, PUB. 6-10-2014. MULTIPLE CLASS, INT. CLS. 9, 16, 35 AND 41.

THE ANNEXUS GROUP, LLC, SCOTTSDALE, AZ:  
4,594,121, MULTIPLE CLASS, INT. CLS. 16, 36 AND 41.  
4,594,122, MULTIPLE CLASS, INT. CLS. 16, 36 AND 41.

THE ANTIQUE MOTORCYCLE CLUB OF AMERICA, INC., LAKELAND, FL:  
3,302,324, COR. INT. CL. 41.  
3,317,895, COR. MULTIPLE CLASS, INT. CLS. 9, 14, 16, 21, 25, 26, 35 AND 41.  
3,317,904, COR. INT. CL. 16.  
3,334,970, COR. INT. CL. 41.  
3,365,794, COR. MULTIPLE CLASS, INT. CLS. 16, 35 AND 41.

THE ARROW GROUP, LTD., NEW YORK, NY:  
2,908,416, REN. 7-24-14. INT. CL. 41.

THE ASSOCIATION OF PUBLIC HEALTH LABORATORIES, INC., SILVER SPRING, MD:  
2,885,979, REN. 7-24-14. MULTIPLE CLASS, INT. CLS. 16, 35 AND 41.

THE AUTO EXCHANGE, LLC, TUSTIN, CA:  
4,591,415, PUB. 6-10-2014. INT. CL. 36.  
4,591,416, PUB. 6-10-2014. INT. CL. 36.  
4,591,417, PUB. 6-10-2014. INT. CL. 36.

THE BANK OF NEW YORK MELLON, NEW YORK, NY:  
2,781,243, REN. 7-22-14. MULTIPLE CLASS, INT. CLS. 16 AND 41.

THE BANK OF NOVA SCOTIA, TORONTO, ONTARIO, CANADA:  
3,350,617, CANC. INT. CL. 36.

THE BARBARA BUSH FOUNDATION FOR FAMILY LITERACY, INC., TALLAHASSEE, FL:  
4,592,963, PUB. 6-10-2014. INT. CL. 35.

THE BARTER FOUNDATION, INCORPORATED, ABINGDON, VA:  
4,592,833, PUB. 6-10-2014. INT. CL. 41.

THE BASIC SCIENCE LABS, LLC, ROCKWALL, TX, DBA L.N. PRIZ LABS:  
4,592,340, PUB. 6-10-2014. INT. CL. 5.

THE BILTMORE COMPANY, ASHEVILLE, NC:  
4,591,422, PUB. 6-10-2014. INT. CL. 41.

THE BLACK & DECKER CORPORATION, TOWNSON, MD:  
2,796,247, CANC. INT. CL. 6.

THE BODY EVOLUTION, INC., OGDEN, UT:  
4,593,442, INT. CL. 5.  
4,593,443, INT. CL. 5.  
4,593,449, MULTIPLE CLASS, INT. CLS. 5 AND 25.

THE BODY SHOPPE, COVINGTON, WA:  
4,592,146, PUB. 6-10-2014. INT. CL. 41.

THE BOSTON CONSULTING GROUP, INC., BOSTON, MA:  
4,594,604, INT. CL. 35.

THE BRADBURY COMPANY, INC., MOUNDRIDGE, KS:  
4,593,908, MULTIPLE CLASS, INT. CLS. 7 AND 9.

THE BRAINY BABY COMPANY, LLC, ALPHARETTA, GA:  
3,353,556, CANC. MULTIPLE CLASS, INT. CLS. 9 AND 16.

THE BULK-PRICED FOOD SHOPPE, LLC, GREENVILLE, WI:  
4,591,672, PUB. 6-10-2014. INT. CL. 35.

THE BUNKER INC., KANSAS CITY, MO:  
4,592,698, PUB. 6-10-2014. INT. CL. 25.

THE CAMPAIGN FOR LIFE IN AMERICA, INC., LEWISBURG, PA:  
3,352,946, CANC. INT. CL. 35.

THE CARTOON NETWORK, INC., ATLANTA, GA:  
2,870,546, REN. 7-23-14. INT. CL. 25.

THE CAT COACH, LLC, REDWOOD CITY, CA:  
3,354,597, CANC. INT. CL. 41.

THE CENTER FOR COGNITIVE SPORTS PERFORMANCE, INC., PORTLAND, ME:  
4,593,850, MULTIPLE CLASS, INT. CLS. 35 AND 41.

THE CHANCELLOR MASTERS AND SCHOLARS OF THE UNIVERSITY OF OXFORD, OXFORD, UNITED KINGDOM:  
2,885,935, REN. 7-21-14. INT. CL. 16.

THE CHARACTER LAB INC., NEW YORK, NY:  
4,592,291, PUB. 6-10-2014. INT. CL. 41.

THE CHEER SOCIAL, LLC, LUCAS, KY:  
4,594,636, INT. CL. 45.

THE CHUCK OLSEN COMPANY, INC., VISALIA, CA:  
1,331,152, REN. 7-22-14. INT. CL. 31.

THE CIGAR GUYS INTERNATIONAL, MIAMI, FL:  
4,591,536, PUB. 6-10-2014. INT. CL. 34.

THE CLEANING AUTHORITY, LLC, COLUMBIA, MD:  
4,116,370, COR. INT. CL. 37.

THE CLOROX COMPANY, OAKLAND, CA:  
3,353,193, CANC. INT. CL. 3.  
4,593,058, PUB. 6-10-2014. INT. CL. 21.

THE COCA-COLA COMPANY, ATLANTA, GA:  
3,353,303, CANC. INT. CL. 41.

THE COLEMAN COMPANY, INC., WICHITA, KS:  
2,864,819, REN. 7-20-14. INT. CL. 11.

THE COLORS OF MALENT, LLC, NASHUA, NH:  
4,593,167, INT. CL. 16.

THE COMMUNITY FOUNDATION OF MIDDLE TENNESSEE, NASHVILLE, TN:  
4,592,156, PUB. 6-10-2014. INT. CL. 41.

THE CONS, SAN FRANCISCO, CA:  
3,354,401, CANC. INT. CL. 9.

THE CORPORATION OF MERCER UNIVERSITY, MACON, GA:  
4,593,430, INT. CL. 41.

THE CORYN GROUP II, LLC, NEWTOWN SQUARE, PA:  
4,591,084, PUB. 6-10-2014. MULTIPLE CLASS, INT. CLS. 39 AND 43.

THE CRAZY NUTZ COMPANY, LLC, NEWNAN, GA:  
4,591,765, PUB. 6-10-2014. INT. CL. 29.

THE CRITICAL PATH INSTITUTE (C-PATH), TUCSON, AZ:  
3,354,584, CANC. INT. CL. 36.

THE CYNJA L.L.C., WASHINGTON, DC:  
4,594,502, INT. CL. 16.

THE DATE DETECTIVE, LLC, PITTSBURGH, PA:  
4,592,082, PUB. 6-10-2014. INT. CL. 42.

THE DERMATOLOGY CENTER, LLC, MUNCIE, IN:  
2,862,461, REN. 7-24-14. INT. CL. 44.

THE DETROIT INSTITUTE OF ARTS AND FRIENDS OF AFRICAN AND AFRICAN-AMERICAN ART, DETROIT, MI:  
2,964,533, REN. 7-22-14. INT. CL. 36.

THE DETROIT ZOOLOGICAL SOCIETY, ROYAL OAK, MI:  
4,593,859, INT. CL. 41.

THE DIFFERENCE A2C LLC, MARIETTA, GA:  
4,592,838, PUB. 6-10-2014. INT. CL. 35.

THE DOUBLECLICKS LLC, PORTLAND, OR:  
4,592,285, PUB. 6-10-2014. INT. CL. 41.

- THE DOUX UNLTD LLC, AE-ARMED FORCES EUROPE, GA:  
4,591,448, PUB. 6-10-2014. INT. CL. 3.
- THE EARLY YEARS, INC., GIBSONIA, PA, AKA EARLY YEARS CHILD CARE:  
4,591,644, PUB. 6-10-2014. INT. CL. 43.
- THE EDUCATION CENTER, LLC, GREENSBORO, NC:  
4,594,251, MULTIPLE CLASS, INT. CLS. 16, 41 AND 42.
- THE ELECTRIC GRAPEVINE, INC., COSTA MESA, CA:  
3,354,230, CANC. INT. CL. 25.
- THE ELI'S CHEESECAKE COMPANY, CHICAGO, IL:  
1,286,268, REN. 7-22-14. INT. CL. 30.
- THE ELIZABETH TAYLOR COSMETICS COMPANY, LOS ANGELES, CA:  
2,795,838, CANC. INT. CL. 3.
- THE EMPTY VASE, INC., WEST HOLLYWOOD, CA:  
4,591,642, PUB. 6-10-2014. MULTIPLE CLASS, INT. CLS. 31 AND 39.
- THE EQUIPMENT LEASING COMPANY LTD., MISSISSAUGA, CANADA, TA ISLAND INK-JET:  
3,352,169, CANC. INT. CL. 35.
- THE EXCELSIOR PLANET, LLC, PHILADELPHIA, PA:  
3,351,134, CANC. INT. CL. 14.
- THE EXECUTORS OF FRANCISCO COLL MONGE ESTATE, OSCEOLA, IA. FORMERLY FRANCISCO COLL:  
4,591,140, PUB. 6-10-2014. INT. CL. 41.
- THE FARINATA PROJECT, LLC, CHICAGO, IL:  
4,591,841, PUB. 6-10-2014. INT. CL. 30.
- THE FINOVATE GROUP, INC., SEATTLE, WA:  
4,592,773, PUB. 6-10-2014. INT. CL. 35.
- THE FORMULA LLC, SAN JOSE, CA:  
4,513,640, COR. INT. CL. 42.
- THE FORUM, WILSONVILLE, OR:  
4,591,401, PUB. 6-10-2014. INT. CL. 35.  
4,591,402, PUB. 6-10-2014. INT. CL. 35.
- THE GALLEY, LLC, TULSA, OK:  
4,592,520, PUB. 6-10-2014. INT. CL. 11.
- THE GARDEN VARIETY VODKA COMPANY LLC, NORTH MIAMI, FL:  
3,353,707, CANC. INT. CL. 33.  
3,353,708, CANC. INT. CL. 33.  
3,353,709, CANC. INT. CL. 33.  
3,353,710, CANC. INT. CL. 33.
- THE GIFT OF GAB, LLC, NEW YORK, NY:  
3,352,402, CANC. INT. CL. 30.
- THE GO PROJECT, INC., NEW YORK, NY:  
4,591,828, PUB. 6-10-2014. MULTIPLE CLASS, INT. CLS. 41 AND 45.  
4,591,829, PUB. 6-10-2014. MULTIPLE CLASS, INT. CLS. 36, 41 AND 45.
- THE GOLDEN EYE LLC, SANTA FE, NM:  
4,592,477, PUB. 6-10-2014. INT. CL. 35.
- THE GUARANTEE COMPANY OF NORTH AMERICA USA, SOUTHFIELD, MI:  
4,591,061, PUB. 6-10-2014. INT. CL. 36.
- THE GUARDIAN LIFE INSURANCE COMPANY OF AMERICA, NEW YORK, NY:  
3,353,898, CANC. INT. CL. 36.
- THE HARBECK COMPANY, INC., DALLAS, TX:  
3,352,987, CANC. INT. CL. 41.
- THE HARD PLACES COMMUNITY, JACKSON, MS, AKA WALK AGAINST TRAFFICK:  
4,591,631, PUB. 6-10-2014. INT. CL. 45.
- THE HARTZ MOUNTAIN CORPORATION, SECAUCUS, NJ:  
3,351,725, CANC. INT. CL. 28.  
3,354,102, CANC. INT. CL. 31.
- THE HEALTHCARE CHAPLAINCY NETWORK., NEW YORK, NY:  
4,592,188, PUB. 6-10-2014. INT. CL. 45.
- THE HUNDREDS IS HUGE, INC., VERNON, CA:  
4,594,458, INT. CL. 14.
- THE IAMS COMPANY, CINCINNATI, OH:  
4,594,274, INT. CL. 31.
- THE IDEA NETWORK, LTD., BRISTOL, UNITED KINGDOM:  
3,354,112, CANC. INT. CL. 21.
- THE INSTITUTE OF ELECTRICAL AND ELECTRONICS ENGINEERS, INC., PISCATAWAY, NJ:  
2,862,848, REN. 7-23-14. MULTIPLE CLASS, INT. CLS. 16 AND 41.
- THE INTAGIO GROUP, INC., SAN FRANCISCO, CA:  
3,354,082, CANC. INT. CL. 39.  
3,354,083, CANC. INT. CL. 43.
- THE J. M. SMUCKER COMPANY, ORRVILLE, OH:  
4,592,767, PUB. 6-10-2014. INT. CL. 29.
- THE KNITTING LAB LLC, BASKING RIDGE, NJ:  
3,353,982, CANC. INT. CL. 35.
- THE LAIRE GROUP, INC., WEDDINGTON, NC:  
4,590,617, PUB. 6-10-2014. INT. CL. 45.
- THE LANGUAGE HOUSE TEFL LANGUAGE S.R.O., MINNEAPOLIS, MN:  
4,591,862, PUB. 6-10-2014. INT. CL. 41.
- THE LIBRARY SQUARE FOUNDATION FOR ART, CULTURE AND SCIENCE, SALT LAKE CITY, UT:  
3,454,507, AM. INT. CL. 41.
- THE LIFE HOUSE CHIROPRACTIC, CHAPPAQUA, NY:  
4,594,456, INT. CL. 35.
- THE LIFE IS GOOD COMPANY, BOSTON, MA:  
3,463,425, CANC. INT. CL. 20.
- THE LITTLE POTATO COMPANY LTD., EDMONTON, ABLERTA, CANADA:  
4,591,002, PUB. 6-10-2014. INT. CL. 31.
- THE LITTLE TIKES COMPANY, VAN NUYS, CA:  
4,591,169, PUB. 6-10-2014. INT. CL. 28.
- THE LUCCI CORP., PETERBOROUGH, NH:  
4,592,481, PUB. 6-10-2014. INT. CL. 20.
- THE MADE GROUP, LOS ANGELES, CA:  
4,593,026, PUB. 6-10-2014. INT. CL. 25.
- THE MARFO COMPANY, COLUMBUS, OH, DBA MARSALA MANUFACTURING COMPANY:  
4,591,499, PUB. 6-10-2014. INT. CL. 14.
- THE MARKETING STORE, LLC, CHICAGO, IL:  
4,593,916, INT. CL. 28.
- THE MCMAHON GROUP, NEW YORK, NY:  
3,354,511, CANC. INT. CL. 16.  
3,354,512, CANC. INT. CL. 41.
- THE MEMORY COMPANY, LLC, PHENIX CITY, AL:  
4,593,598, INT. CL. 21.
- THE METROPOLITAN ST. LOUIS SEWER DISTRICT, ST. LOUIS, MO:  
4,591,753, PUB. 6-10-2014. MULTIPLE CLASS, INT. CLS. 35 AND 44.  
4,591,754, PUB. 6-10-2014. INT. CL. 35.
- THE MILLWORK TRADING CO., LTD. D/B/A LI & FUNG USA, NEW YORK, NY:  
3,353,428, CANC. INT. CL. 18.
- THE MINISTRY OF SECOND TIMOTHY, INC., ALEXANDRIA, VA AND GLASCOE, DEIRDRE C., JACKSONVILLE, FL:  
4,591,239, PUB. 10-29-2013. INT. CL. 45.
- THE MIX, LLC, SCOTTSDALE, AZ:  
3,354,266, CANC. INT. CL. 36.
- THE MONEY COLLEGE, LLC, LEXINGTON, KY:  
3,351,356, CANC. INT. CL. 41.
- THE MOSTERT GROUP, LLC, LEXINGTON, KY:  
4,592,740, PUB. 6-10-2014. INT. CL. 42.
- THE MOUNT SINAI HOSPITAL, NEW YORK, NY:  
3,352,308, CANC. MULTIPLE CLASS, INT. CLS. 9 AND 44.
- THE NATIONAL BOARD FOR RESPIRATORY CARE, INC., OLATHE, KS:  
2,870,210, REN. 7-23-14. U.S. CL. 200.  
2,870,211, REN. 7-23-14. U.S. CL. 200.
- THE NATIONAL COLLEGIATE ATHLETIC ASSOCIATION, INDIANAPOLIS, IN:  
2,795,200, CANC. MULTIPLE CLASS, INT. CLS. 6, 14 AND 28.
- THE NATIONAL RESEARCH EXCHANGE LLC, NEW YORK, NY:  
3,353,249, CANC. INT. CL. 35.
- THE NAVIGATORS, COLORADO SPRINGS, CO:  
4,592,990, PUB. 6-10-2014. INT. CL. 41.



THE NEW JERSEY AUDUBON SOCIETY, BERNARDSVILLE, NJ:  
4,592,429, PUB. 6-10-2014. INT. CL. 41.

THE NEW MEXICO EDUCATIONAL ASSISTANCE FOUNDATION, ALBUQUERQUE, NM:  
4,591,708, PUB. 6-10-2014. INT. CL. 36.

THE NEWARK GROUP, INC., CRANFORD, NJ:  
4,594,445, INT. CL. 27.

THE NOSE AND SINUS INSTITUTE OF BOCA RATON, BOCA RATON, FL:  
4,594,572, INT. CL. 44.

THE NUTRO COMPANY, FRANKLIN, TN:  
2,874,574, REN. 7-18-14. INT. CL. 31.

THE OLD MINE BREWING COMPANY, ERIE, CO, DBA THE OLD MINE:  
4,592,411, PUB. 6-10-2014. INT. CL. 43.

THE OLD WAVERLY GOLF CLUB, LLC, WEST POINT, MS:  
2,868,635, REN. 7-23-14. MULTIPLE CLASS, INT. CLS. 36, 37 AND 41.  
2,868,635, CANC. INT. CL. 16.

THE OLIVER WHITE HILL FOUNDATION, RICHMOND, VA:  
4,593,079, MULTIPLE CLASS, INT. CLS. 35, 36 AND 41.

THE OUTFIT, INC., BEVERLY, MA:  
4,594,272, INT. CL. 42.

THE PILLSBURY COMPANY, MINNEAPOLIS, MN:  
3,351,382, CANC. INT. CL. 30.

THE PLAYFUL GARDEN, NAPA, CA:  
3,462,787, CANC. INT. CL. 21.

THE PM GROUP INC., SAN ANTONIO, TX:  
3,354,282, CANC. INT. CL. 41.

THE POLE PALACE LLC, PORTLAND, OR:  
4,591,878, PUB. 6-10-2014. INT. CL. 41.

THE PROCTER & GAMBLE COMPANY, CINCINNATI, OH:  
3,351,788, CANC. INT. CL. 3.  
3,352,985, CANC. INT. CL. 3.  
3,352,989, CANC. INT. CL. 3.  
3,352,990, CANC. INT. CL. 3.  
4,593,224, INT. CL. 5.  
4,593,837, INT. CL. 3.  
4,594,033, INT. CL. 3.  
4,594,034, INT. CL. 3.  
4,594,473, INT. CL. 3.

THE PROFESSIONAL CONNECTION INCORPORATED, FORT LAUDERDALE, FL, DBA FLYINSTYLE:  
4,593,942, INT. CL. 9.

THE PROFESSIONAL GOLFERS' ASSOCIATION OF AMERICA, PALM BEACH GARDENS, FL:  
2,897,318, REN. 7-24-14. INT. CL. 25.  
2,941,770, REN. 7-21-14. INT. CL. 41.

THE RADIAN GROUP LLC, MELVILLE, NY:  
3,353,634, CANC. INT. CL. 9.

THE RAINBOW CONFECTION, LLC, MONROE, WI, DBA RAINBOW CONFECTIONS:  
4,592,236, PUB. 6-10-2014. INT. CL. 30.

THE RANDOM ACTS OF KINDNESS FOUNDATION, DENVER, CO:  
4,592,105, PUB. 6-10-2014. INT. CL. 41.

THE RIB CRIB BBQ, INC., TULSA, OK:  
2,794,310, CANC. INT. CL. 43.

THE RONALD REAGAN PRESIDENTIAL LIBRARY FOUNDATION, SIMI VALLEY, CA:  
4,593,180, MULTIPLE CLASS, INT. CLS. 9 AND 39.

THE ROUND TABLE FRANCHISE CORPORATION, CONCORD, CA:  
4,593,608, INT. CL. 43.

THE SAM BERNSTEIN LAW FIRM, PLLC, FARMINGTON HILLS, MI:  
2,854,712, REN. 7-23-14. INT. CL. 42.

THE SAUL ZAENTZ COMPANY, BERKELEY, CA:  
4,222,911, COR. INT. CL. 28.

THE SOCIETY FOR THE PROMOTION OF JAPANESE ANIMATION, ANAHEIM, CA, AKA SPJA:  
4,591,171, PUB. 6-10-2014. MULTIPLE CLASS, INT. CLS. 35 AND 41.

THE SPECTRANETICS CORPORATION, COLORADO SPRINGS, CO:  
3,354,066, CANC. INT. CL. 10.

THE SUN PRODUCTS CORPORATION, WILTON, CT:  
4,594,173, INT. CL. 20.  
4,594,543, INT. CL. 3.

THE SUNSHINE STORY, LLC, LAKELAND, FL:  
4,593,577, MULTIPLE CLASS, INT. CLS. 16 AND 31.

THE SWIFT INNOVATION CORP, CENTENNIAL, CO:  
4,591,135, PUB. 12-31-2013. INT. CL. 42.

THE TENNIS PLACE, INC, BEVERLY HILLS, CA:  
4,592,348, PUB. 6-10-2014. INT. CL. 41.

THE TETRA CORPORATION, EATON RAPIDS, MI:  
4,593,661, INT. CL. 3.

THE THREE RING BREWING CO., LLC, ASHEVILLE, NC:  
4,594,547, INT. CL. 32.

THE THRIFT ALLIANCE, NASHVILLE, TN:  
3,351,547, CANC. MULTIPLE CLASS, INT. CLS. 35 AND 36.

THE TIFFEN COMPANY, LLC, HAUPPAUGE, NY:  
3,354,308, CANC. INT. CL. 9.

THE TORO COMPANY, BLOOMINGTON, MN:  
4,591,767, PUB. 6-10-2014. INT. CL. 28.  
4,594,291, INT. CL. 7.

THE TORONTO-DOMINION BANK, TORONTO, CANADA:  
2,795,525, CANC. MULTIPLE CLASS, INT. CLS. 35, 39, 42 AND 44.

THE TRACIAK COLLECTION, TECUMSEH, MI:  
3,351,067, CANC. INT. CL. 14.

THE TRUCE COMPANY, WOODLAND HILLS, CA:  
4,593,043, PUB. 6-10-2014. INT. CL. 34.

THE TRUSTEE OF THE AMERICAN ASSOCIATION OF FRANCHISEES & DEALERS TRUST, A CALIFORNIA TRUST, THE TRUSTEE BEING ROBERT L. PURVIN, JR. A U.S. CITIZEN, PALM DESERT, CA:  
2,859,663, REN. 7-24-14. INT. CL. 35.

THE TRUSTEES OF THE VALASKANTJIS FAMILY TRUST, SAN CLEMENTE, CA:  
4,594,013, INT. CL. 43.

THE UNIVERSITY OF MANCHESTER, MANCHESTER M13 9PL, UNITED KINGDOM:  
4,590,786, PUB. 6-10-2014. MULTIPLE CLASS, INT. CLS. 1 AND 35.

THE UPPER DECK COMPANY, CARLSBAD, CA:  
3,350,840, CANC. INT. CL. 16.

THE VALSPAR CORPORATION, MINNEAPOLIS, MN:  
4,594,292, INT. CL. 2.  
4,594,293, INT. CL. 2.  
4,594,297, INT. CL. 2.  
4,594,348, INT. CL. 2.

THE VAPE HEADQUARTERS, BERGENFIELD, NJ:  
4,592,106, PUB. 6-10-2014. INT. CL. 35.

THE VAPORATORY, LLC, ALTAMONTE SPRINGS, FL:  
4,592,666, PUB. 6-10-2014. INT. CL. 30.

THE VELVET SHOESTRING, INC., WILLIAMSBURG, VA:  
4,592,739, PUB. 6-10-2014. INT. CL. 35.

THE VERITAS FORUM, CAMBRIDGE, MA:  
3,353,416, CANC. INT. CL. 16.

THE WARRANTY GROUP, INC., CHICAGO, IL:  
2,793,962, CANC. INT. CL. 36.

THE WELL COMMUNITY CHURCH, FRESNO, CA:  
4,594,165, INT. CL. 16.  
4,594,166, INT. CL. 41.

THE WELLCARE MANAGEMENT GROUP, INC., TAMPA, FL:  
4,593,332, INT. CL. 36.  
4,593,431, MULTIPLE CLASS, INT. CLS. 36 AND 41.

THE WESTBEAN COFFEE ROASTERS INC., SAN DIEGO, CA:  
4,592,552, PUB. 6-10-2014. INT. CL. 30.

THE WINE GROUP LLC, TRACY, CA:  
4,592,421, PUB. 6-10-2014. INT. CL. 33.

THE WORLD BIRTHDAY CONNECTION LIMITED, UNITED KINGDOM:  
4,590,842, PUB. 6-10-2014. MULTIPLE CLASS, INT. CLS. 9, 16, 35, 38, 41 AND 45.

THE WORLD OF KREAM LLC, AVENTURA, FL:  
4,592,225, PUB. 6-10-2014. INT. CL. 25.

THE WUNDERGLO FOUNDATION, LOS ANGELES, CA:  
4,593,711, INT. CL. 36.  
4,593,712, INT. CL. 36.

- THEATREZONE INC., NAPLES, FL:  
4,592,642, PUB. 6-10-2014. INT. CL. 41.
- THEE LEFT HAND BLACK LLC, NEW YORK, NY:  
4,593,534, INT. CL. 25.
- THEFACESHOP CO., LTD., SEOUL, REPUBLIC OF KOREA:  
4,591,081, PUB. 6-10-2014. INT. CL. 3.
- THERA-LINK LLC, RICHARDSON, TX:  
4,594,462, INT. CL. 42.
- THERAPY DOGS INTERNATIONAL, INC., FLANDERS, NJ:  
4,591,184, PUB. 6-10-2014. INT. CL. 45.
- THERATIVE, INC., LIVERMORE, CA:  
3,354,607, CANC. INT. CL. 10.
- THERMO FINNIGAN LLC, SAN JOSE, CA:  
4,592,719, PUB. 6-10-2014. INT. CL. 9.
- THERMOTEKNIK SYSTEMS LTD., WATERBEACH, CAMBRIDGE, UNITED KINGDOM:  
4,592,732, PUB. 6-10-2014. INT. CL. 9.
- THERRIEN, KRISTY, POMONA, CA:  
4,594,637, INT. CL. 30.
- THINK TELEVISUAL LLC, CHICAGO, IL:  
4,593,573, MULTIPLE CLASS, INT. CLS. 9, 38, 41 AND 42.
- THINK TRADING, INC., PALM BEACH GARDENS, FL:  
4,594,275, INT. CL. 3.
- THINKFUN INC., ALEXANDRIA, VA:  
2,794,984, CANC. INT. CL. 28.
- THINKGLOBAL INC., NORTHAMPTON, MA:  
4,591,116, PUB. 6-10-2014. INT. CL. 35.
- THINKING STRINGS, L.L.C., RICHMOND, MA:  
2,693,612, REN. 7-21-14. INT. CL. 9.
- THINKOPERATIONS, LLC, AUSTIN, TX:  
4,592,780, PUB. 6-10-2014. MULTIPLE CLASS, INT. CLS. 3 AND 10.  
4,592,785, PUB. 6-10-2014. INT. CL. 3.
- THOMAS BLAINE ROGERS, RAVENNA, MI:  
4,592,384, PUB. 6-10-2014. INT. CL. 35.
- THOMAS COOK UK LIMITED, PETERBOROUGH, UNITED KINGDOM:  
2,793,419, CANC. MULTIPLE CLASS, INT. CLS. 39 AND 42.
- THOMAS G. FARIA CORPORATION, UNCASVILLE, CT:  
3,350,757, CANC. INT. CL. 9.
- THOMAS GARRITY STEELE, PEQUANNOCK, NJ:  
3,350,845, CANC. INT. CL. 39.
- THOMAS HUDSON DOZIER, II, LIVERMORE, CA, DBA MISOPHONIA TREATMENT INSTITUTE:  
4,591,863, PUB. 6-10-2014. INT. CL. 9.
- THOMAS, JUSTIN, TORONTO, CANADA:  
2,795,111, CANC. INT. CL. 41.
- THOMAS, RITA LEIGH, VALENCIA, CA:  
4,593,448, INT. CL. 16.
- THOMPSON HOLDINGS, L.P., NEW YORK, NY:  
3,351,958, CANC. INT. CL. 31.
- THORNE RESEARCH, INC., SANDPOINT, ID:  
4,591,155, PUB. 6-10-2014. INT. CL. 5.
- THORO-PACKAGING, CORONA, CA:  
4,594,134, MULTIPLE CLASS, INT. CLS. 16, 40 AND 42.
- THORRINGTON CAPITAL, LLC, KINDERHOOK, NY:  
4,592,414, PUB. 6-10-2014. INT. CL. 35.
- THREE ANGELS BROADCASTING NETWORK, INC., WEST FRANKFORT, IL:  
2,963,899, REN. 7-23-14. INT. CL. 41.
- THREE LEAF PARTNERS, LLC, SANTA BARBARA, CA:  
3,350,727, CANC. INT. CL. 38.
- THREE LOLLIES LLC, WEST HILLS, CA:  
4,594,713, INT. CL. 5.
- THREE SAVED SISTERS, LLC, LITTLETON, CO:  
4,592,022, PUB. 6-10-2014. INT. CL. 16.  
4,592,023, PUB. 6-10-2014. INT. CL. 16.
- THRILLA CLOTHING COMPANY, EL DORADO HILLS, CA:  
4,591,151, PUB. 6-10-2014. INT. CL. 25.
- THRONEBURG, JAMES L., STATESVILLE, NC:  
3,353,966, CANC. INT. CL. 35.
- THROWBOY, REDMOND, WA:  
4,592,407, PUB. 6-10-2014. INT. CL. 28.
- THUASNE, PARIS, FRANCE:  
2,793,745, CANC. INT. CL. 10.
- THULE IP AB, MALMO, SWEDEN:  
4,593,272, INT. CL. 12.
- THUMAN, GREGORY L., BALTIMORE, MD:  
3,351,965, CANC. INT. CL. 9.
- THUNDERBIRD SCHOOL OF GLOBAL MANAGEMENT, GLENDALE, AZ:  
4,592,751, PUB. 6-10-2014. INT. CL. 35.
- THUY, LCC, NEW YORK, NY:  
3,351,846, CANC. MULTIPLE CLASS, INT. CLS. 25 AND 35.
- TICK BUSTERS, LLC, MIDDLESEX, NJ, DBA TICK BUSTERS LLC:  
4,591,376, PUB. 6-10-2014. INT. CL. 37.
- TICKETLAB LLC, CHICAGO, IL:  
4,592,586, PUB. 6-10-2014. INT. CL. 41.
- TICKTIN, PETER, DEERFIELD BEACH, FL:  
4,591,618, PUB. 6-10-2014. INT. CL. 45.
- TIDBITS MEDIA, INC., MONTGOMERY, AL:  
2,907,890, REN. 7-21-14. INT. CL. 16.
- TIDELAND SIGNAL CORPORATION, HOUSTON, TX:  
1,816,718, REN. 7-22-14. INT. CL. 9.
- TIEMCO, LTD., SUMIDA-KU, TOKYO, JAPAN:  
4,591,475, PUB. 6-10-2014. INT. CL. 9.
- TIES AND VIBES, DES PLAINES, IL, DBA TIES AND VIBES:  
4,592,863, PUB. 6-10-2014. INT. CL. 25.  
4,592,923, PUB. 6-10-2014. INT. CL. 25.
- TIJON, LLC, MIAMI, FL:  
2,963,323, REN. 7-23-14. INT. CL. 3.
- TILCOR ROOFING SYSTEMS LIMITED, AUCKLAND, NEW ZEALAND, DBA TILCOR ROOFING SYSTEMS LIMITED:  
4,593,235, INT. CL. 6.
- TILE TECH INC., LOS ANGELES, CA:  
4,591,095, PUB. 6-10-2014. INT. CL. 19.
- TIMA S.P.A., ITALY:  
3,352,634.
- TIMBERMAN, BRIDGET, WEST CHESTER, PA:  
3,354,395, CANC. INT. CL. 35.
- TIME OUT AMERICA LLC, NEW YORK, NY:  
3,353,880, CANC. INT. CL. 16.
- TIMEHRI TECHNOLOGIES, LLC, SANTA CLARITA, CA:  
3,350,880, CANC. INT. CL. 9.
- TIMOTHY D. HUDDLESTON, LLC., HIGH SPRINGS, FL:  
3,351,064, CANC. INT. CL. 25.
- TIMOTHY TELYMONDE, KEYPORT, NJ:  
4,592,585, PUB. 6-10-2014. INT. CL. 36.
- TINSLEY, KATHRYN, LONG BEACH, CA:  
4,591,686, PUB. 3-4-2014. INT. CL. 44.
- TINY DOG PRESS, BALTIMORE, MD:  
4,593,745, INT. CL. 16.
- TIPQUICK PARTNERS LLC, WASHINGTON, DC:  
4,592,756, PUB. 6-10-2014. INT. CL. 36.
- TIS INDUSTRIES LLC, CITY OF INDUSTRY, CA:  
3,353,168, CANC. MULTIPLE CLASS, INT. CLS. 12 AND 25.
- TISCH MULTIPLE SCLEROSIS CENTER OF NEW YORK, INC., NEW YORK, NY:  
4,592,497, PUB. 6-10-2014. INT. CL. 42.
- TISCH, UNLIMITED LLC, CHICAGO, IL:  
4,593,555, INT. CL. 20.
- TISKIEWIC, HANA, BRADENTON, FL:  
4,591,742, PUB. 6-10-2014. INT. CL. 24.  
4,591,743, PUB. 6-10-2014. INT. CL. 28.
- TITAN MANAGEMENT GROUP, LLC, BRENTWOOD, TN:  
4,594,194, INT. CL. 42.
- TITANZ PLUMBING INC., PORT CHARLOTTE, FL:  
4,592,305, PUB. 6-10-2014. INT. CL. 37.
- TJ SEVEN INCORPORATION, PINOLE, CA:  
4,593,812, INT. CL. 29.
- TLC BRANDS LIMITED, LONDON, UNITED KINGDOM:  
2,927,087, CANC. INT. CL. 25.
- TLC LIGHTING, INC., MAYFIELD, KY:  
2,795,172, CANC. INT. CL. 35.
- TM SALES & MARKETING GROUP CO, LLC, ST. CHARLES, MO:  
4,594,642, INT. CL. 4.
- TMB OPTICAL, LLC, SEVEN HILLS, OH:  
3,351,410, CANC. MULTIPLE CLASS, INT. CLS. 9 AND

42.  
TNA AUTO SALES, PARTS, AND REPAIR INC., EL MONTE, CA:  
4,542,037, COR. INT. CL. 35.
- TNS GROUP HOLDINGS LIMITED, LONDON W51UA, UNITED KINGDOM:  
3,351,919, CANC. INT. CL. 35.
- TOAST OUR VETS FOUNDATION, REDONDO BEACH, CA:  
4,591,352, PUB. 6-10-2014. INT. CL. 36.
- TOFIXIT!, INC., PHOENIX, AZ:  
4,594,062, INT. CL. 35.
- TOGO'S EATERIES, INC., SAN JOSE, CA:  
3,352,977, CANC. INT. CL. 43.
- TOKUTAKE INDUSTRY CO., LTD., JAPAN:  
4,590,835, PUB. 6-10-2014. INT. CL. 25.
- TOLAND MARKETING, INC., OXNARD, CA:  
2,793,393, CANC. INT. CL. 41.
- TOM CORBETT FOR GOVERNOR, HARRISBURG, PA:  
4,592,161, PUB. 6-10-2014. MULTIPLE CLASS, INT. CLS. 35 AND 36.
- TOMATO BAR LLC, VALPARAISO, IN:  
4,592,442, PUB. 6-10-2014. INT. CL. 43.
- TONE IT UP, LLC, HERMOSA BEACH, CA:  
4,593,121, INT. CL. 25.
- TONY MARREN, PROVO, UT:  
4,593,433, INT. CL. 36.
- TOO MARKER PRODUCTS, INC., TOKYO, JAPAN:  
4,592,574, PUB. 6-10-2014. INT. CL. 16.  
4,592,575, PUB. 6-10-2014. INT. CL. 16.  
4,592,760, PUB. 6-10-2014. INT. CL. 16.
- TOONUP SNIPPETS, INC., WAYNE, PA:  
4,594,294, INT. CL. 38.
- TOOTH TASTES, INC., MANHATTAN BEACH, CA:  
4,593,092, INT. CL. 3.
- TOP TOBACCO, L.P., GLENVIEW, IL:  
2,947,537, REN. 7-22-14. INT. CL. 34.
- TOPAIR, INC., PARMA, ID:  
3,351,256, CANC. INT. CL. 7.
- TOPCO HOLDINGS, INC., ELK GROVE VILLAGE, IL:  
4,593,870, INT. CL. 16.  
4,594,114, INT. CL. 30.  
4,594,115, INT. CL. 30.
- TOPCON POSITIONING SYSTEMS, INC., LIVERMORE, CA:  
3,353,981, CANC. INT. CL. 9.
- TOPERA, INC., SCOTTSDALE, AZ:  
4,593,231, INT. CL. 10.
- TOPICAL GEAR LLC, AUSTIN, TX:  
4,592,764, PUB. 6-10-2014. INT. CL. 10.
- TOPLINE PARTNERS, LLC, IRVINE, CA:  
4,591,591, PUB. 6-10-2014. INT. CL. 9.
- TORO RIDE, INC., GLENDALE, CA:  
4,592,353, PUB. 6-10-2014. INT. CL. 9.
- TORREVILLA VITICOLTORI ASSOCIATI -: SOC. COOP. AGRICOLA, ITALY:  
3,352,718.
- TOSA, MARK, NEEDHAM, MA:  
4,590,962, PUB. 6-10-2014. INT. CL. 35.
- TOTAL HEALTH MINISTRIES, INC., WHEATON, IL:  
4,592,374, PUB. 6-10-2014. MULTIPLE CLASS, INT. CLS. 41, 44 AND 45.
- TOTAL KIDS CORP., GYEONGGI-DO, REPUBLIC OF KOREA:  
4,591,093, PUB. 6-10-2014. INT. CL. 25.
- TOTALLY TANKER INTERIORS, INC, BAINBRIDGE ISLAND, WA, DBA TOTALLY TANKER INTERIORS, INC.:  
4,591,506, PUB. 6-10-2014. INT. CL. 37.
- TOTOKU ELECTRIC CO., LTD., MINATO-KU, TOKYO, JAPAN:  
4,591,309, PUB. 6-10-2014. MULTIPLE CLASS, INT. CLS. 9 AND 10.
- TOUSA DELAWARE, INC., WILMINGTON, DE:  
3,352,172, CANC. INT. CL. 37.
- TOWNE BANK, SUFFOLK, VA:  
3,351,245, CANC. INT. CL. 36.
- TOY STATE INDUSTRIAL LTD., KOWLOON, HONG KONG:  
3,354,189, CANC. INT. CL. 28.
- TOYO INK SC HOLDINGS CO., LTD., TOKYO, JAPAN:  
1,855,170, REN. 7-24-14. INT. CL. 16.
- TOYOTA JIDOSHA KABUSHIKI KAISHA, TOYOTA-SHI, AICHI-KEN, JAPAN, TA TOYOTA MOTOR CORPORATION:  
4,591,803, PUB. 6-10-2014. MULTIPLE CLASS, INT. CLS. 38, 42 AND 45.
- TPO, INC., FALLS CHURCH, VA:  
3,351,237, CANC. INT. CL. 35.
- TRACTOR SUPPLY CO. OF TEXAS, LP, BRENTWOOD, TN:  
4,594,747, INT. CL. 35.
- TRADEMAVEN GROUP, LLC, CHICAGO, IL:  
3,352,522, CANC. INT. CL. 9.
- TRADITION PUBLISHING COMPANY, LLC, NORTH MAN-KATO, MN:  
2,795,694, CANC. INT. CL. 16.
- TRAFFIX, INC., PEARL RIVER, NY:  
2,794,430, CANC. INT. CL. 45.
- TRAILS WEST MANUFACTURING OF IDAHO, INC., PRE-STON, ID:  
2,808,248, REN. 7-22-14. INT. CL. 12.  
2,808,248, AM. INT. CL. 12.
- TRAILSOURCE.COM, INC., CRESTED BUTTE, CO:  
2,925,212, REN. 7-22-14. INT. CL. 39.
- TRAINING TREATS, LLC, NASHVILLE, TN:  
4,592,372, PUB. 6-10-2014. INT. CL. 30.
- TRAININGMASK, LLC, CADILLAC, MI:  
4,594,596, INT. CL. 28.
- TRAMONTINA S.A., CUTLERIA, SUGAR LAND, TX:  
4,591,804, PUB. 6-10-2014. INT. CL. 21.
- TRANSAMERICA FINANCIAL LIFE INSURANCE COMPANY, HARRISON, NY:  
4,593,315, INT. CL. 36.
- TRANSATO, WILLISTON, VT:  
2,796,027, CANC. INT. CL. 35.
- TRANSFAIR USA, OAKLAND, CA, DBA FAIR TRADE USA:  
4,591,306, PUB. 6-10-2014. MULTIPLE CLASS, INT. CLS. 35, 36, 41 AND 42.  
4,591,307, PUB. 6-10-2014. MULTIPLE CLASS, INT. CLS. 35, 36, 41 AND 42.
- TRANSIT WIRELESS, LLC, LONG ISLAND CITY, NY:  
4,591,050, PUB. 6-10-2014. INT. CL. 35.
- TRANSITION-PATH INC., OAKVILLE, ONTARIO, CANADA:  
4,592,532, PUB. 6-10-2014. INT. CL. 35.
- TRANSLATION RIGHT-LEFT, LLC, TRENTON, NJ:  
4,594,088, INT. CL. 38.
- TRANSPARENT LANGUAGE, INC., NASHUA, NH:  
3,351,136, CANC. INT. CL. 9.
- TRASCHER, KENNETH G., MONROE, LA:  
4,593,220, MULTIPLE CLASS, INT. CLS. 6 AND 37.
- TRAVEL DAILY NEWS, INC., WASHINGTON, DC:  
4,593,782, INT. CL. 41.
- TRAVEL MEDICINE, INC., NORTHAMPTON, MA:  
2,794,097, CANC. INT. CL. 10.
- TRAVISMATHEW, LLC, HUNTINGTON BEACH, CA:  
4,592,906, PUB. 6-10-2014. INT. CL. 25.  
4,594,328, INT. CL. 35.
- TREDEGAR FILM PRODUCTS CORPORATION, RICHMOND, VA:  
4,592,332, PUB. 6-10-2014. INT. CL. 17.
- TREE FORT, LLC, SAINT LOUIS, MO:  
3,351,729, CANC. INT. CL. 41.
- TREK BICYCLE CORPORATION, WATERLOO, WI:  
3,350,974, CANC. INT. CL. 12.
- TREKKER PROPERTIES INVESTMENT COMPANY, L.L.C., CHICAGO, IL:  
2,795,245, CANC. INT. CL. 36.
- TRELLEBORG AB, TRELLEBORG, SWEDEN:  
592,409, REN. 7-19-14. U.S. CL. 23 (INT. CL. 7).
- TRELLEBORG SEALING SOLUTIONS KALMAR AB, KALMAR, SWEDEN:  
1,863,721, REN. 7-21-14. INT. CL. 17.
- TRENDNET, INC., TORRANCE, CA:  
1,894,993, REN. 7-19-14. INT. CL. 9.
- TRENDTOWN, LLC, MILWAUKEE, WI:  
2,795,448, CANC. INT. CL. 35.

- TRENDY TOTS, INC., BROOKLYN, NY:  
4,591,640, PUB. 6-10-2014. INT. CL. 35.
- TRENITALIA S.P.A., I-00161 ROMA, ITALY:  
3,587,213, COR. MULTIPLE CLASS, INT. CLS. 12, 14, 16,  
18, 20, 21, 25, 28, 34, 35, 38, 39, 43 AND 45.
- TRES AGUILAS ENTERPRISES LLC, SAN ANTONIO, TX:  
4,592,132, PUB. 6-10-2014. INT. CL. 41.
- TRES JOLIE DAY SPA LLC, SOUTHBURY, CT:  
3,352,433, CANC. INT. CL. 44.
- TREVE, CHARLENE V., ROSELLE, IL:  
3,354,374, CANC. INT. CL. 41.
- TREW GROUP, INC., AUSTIN, TX, DBA TREW MARKET-  
ING:  
4,594,307, INT. CL. 9.
- TRI-CEE CORP., HILLSBOROUGH, NJ:  
3,351,580, CANC. INT. CL. 43.  
3,351,581, CANC. INT. CL. 43.  
3,351,582, CANC. INT. CL. 43.
- TRI-COASTAL DESIGN GROUP, INC., WHARTON, NJ:  
4,592,439, PUB. 6-10-2014. INT. CL. 3.  
4,594,697, INT. CL. 3.
- TRI-STATE ASSOCIATED SERVICES, INC., KINGSTON,  
NY:  
4,592,185, PUB. 6-10-2014. INT. CL. 42.
- TRI/MARK CORPORATION, NEW HAMPTON, IA:  
2,863,011, REN. 7-24-14. INT. CL. 12.
- TRICO PRODUCTS CORPORATION, ROCHESTER HILLS,  
MI:  
3,354,236, CANC. INT. CL. 12.
- TRICOR DIRECT, INC., BRANFORD, CT:  
2,794,925, CANC. INT. CL. 1.
- TRICORE HEALTH GROUP, INC., OLDSMAR, FL:  
4,591,004, PUB. 6-10-2014. INT. CL. 3.
- TRINITY HIGHWAY PRODUCTS, LLC, DALLAS, TX:  
4,593,771, INT. CL. 6.
- TRIOLOGY LLC, GLENDALE, AZ:  
4,594,591, INT. CL. 9.
- TRIPADVISOR LLC, NEWTON, MA:  
4,591,153, PUB. 6-10-2014. MULTIPLE CLASS, INT. CLS.  
9, 35 AND 43.
- TRIPLE C FOODS, LLC, FLATONIA, TX:  
3,353,568, CANC. INT. CL. 29.
- TRIPLE S ENTERPRISES INC., CLARINDA, IA:  
4,592,665, PUB. 6-10-2014. INT. CL. 37.
- TRITELE WORLD SALES, EUGENE, OR:  
3,353,888, CANC. INT. CL. 5.
- TROCHE, MILYSAN, LOS ANGELES, CA, CA, DBA MY-  
HAUTCLOSET.COM:  
4,591,033, PUB. 6-10-2014. INT. CL. 35.
- TRODAT GMBH, WELS, AUSTRIA:  
4,592,046, PUB. 6-10-2014. INT. CL. 1.
- TROFAST MEDIA LLC, WESTPORT, CT:  
4,592,567, PUB. 6-10-2014. INT. CL. 36.  
4,592,960, PUB. 6-10-2014. INT. CL. 41.
- TRONICSXCHANGE, INC., CHATSWORTH, CA:  
4,591,008, PUB. 6-10-2014. MULTIPLE CLASS, INT. CLS.  
35 AND 37.
- TROPICAL PARADISE, INC., BEDFORD, MA:  
3,350,735, CANC. INT. CL. 32.  
3,350,758, CANC. INT. CL. 32.
- TROPICANA PRODUCTS, INC., BRADENTON, FL:  
3,353,082, CANC. INT. CL. 32.  
3,353,083, CANC. INT. CL. 32.  
3,353,093, CANC. INT. CL. 32.
- TRU TRANSFORMATION COACHING, LLC, BROOKLYN,  
NY:  
4,592,253, PUB. 6-10-2014. INT. CL. 41.
- TRU-GRIND, INC., PALATINE, IL:  
4,592,615, PUB. 6-10-2014. INT. CL. 8.
- TRUDEAU, PIERRE, ST-EDOUARD-NAPIERVILLE, QUE-  
BEC, CANADA AND PERRAS, GUY, ST-EDOUARD-  
NAPIERVILLE, QUEBEC, CANADA:  
3,354,069, CANC. INT. CL. 28.
- TRUE FITNESS TECHNOLOGY, INC., O'FALLON, MO:  
3,354,281, CANC. INT. CL. 28.  
4,594,058, INT. CL. 28.  
4,594,059, INT. CL. 28.
- TRUE SOURCE HONEY, LLC, WASHINGTON, DC:  
4,594,284, INT. CL. 35.
- TRUMP SPORTS CO., LTD., ERH LINE CHEN, TAIWAN:  
3,354,280, CANC. INT. CL. 28.
- TRUSTEES OF THE NATIONAL ENERGY MANAGEMENT  
INSTITUTE COMMITTEE ("NEMIC") AS A JOINTLY  
ADMINISTERED TAFT-HARTLEY LABOR MANAGE-  
MENT TRUST ESTABLISHED BY THE SHEET METAL  
WORKERS INTERNATIONAL ASSOCIATION ("SMWIA")  
AND THE SHEET METAL AIR CONDITIONING CON-  
TRACTORS NATIONAL ASSOCIATION ("SMACNA"),  
FAIRFAX, VA:  
4,591,324, PUB. 6-10-2014. INT. CL. 35.
- TRUSTONIC LIMITED, UNITED KINGDOM:  
4,590,895, PUB. 6-10-2014. MULTIPLE CLASS, INT. CLS.  
9, 16, 41, 42 AND 45.
- TRYON MEDIA, LLC, DULUTH, MN:  
4,590,609, PUB. 6-10-2014. INT. CL. 35.
- TS 14 PLUS AUSTRALIA PTY LTD, ABBOTSFORD VIC 3067,  
AUSTRALIA:  
4,590,636, PUB. 6-10-2014. MULTIPLE CLASS, INT. CLS.  
14, 18, 25 AND 35.  
4,590,637, PUB. 6-10-2014. MULTIPLE CLASS, INT. CLS.  
14, 18, 25 AND 35.
- TSETSOKHA, VLADIMIR, SAN FRANCISCO, CA AND  
REYFER, YELENA, SAN FRANCISCO, CA:  
3,351,065, CANC. INT. CL. 35.
- TSRC, INC., ASHLAND, VA:  
2,794,033, CANC. INT. CL. 35.
- TTK PROTECTIVE DEVICES LIMITED, CHENNAI (TAMIL-  
NADU) - 600 086, INDIA:  
4,590,862, PUB. 6-10-2014. INT. CL. 10.
- TTS SENSE AS, NORWAY:  
3,352,742.
- TTS TOOLTECHNIC SYSTEMS AG & CO. KG, WENDLIN-  
GEN, FED REP GERMANY:  
4,590,844, PUB. 6-10-2014. MULTIPLE CLASS, INT. CLS.  
7, 35, 36 AND 37.
- TUFFALOY PRODUCTS, INC., GREER, SC:  
408,003, REN. 7-22-14. U.S. CL. 21 (INT. CL. 9).
- TUNE UP FITNESS WORLDWIDE INC., STUDIO CITY, CA:  
4,591,766, PUB. 6-10-2014. INT. CL. 41.
- TUNEIN, INC., PALO ALTO, CA:  
2,807,344, REN. 7-22-14. INT. CL. 41.
- TUNGSTEN CAPITAL PARTNERS, LLC, SOUTH EUCLID,  
OH:  
2,795,275, CANC. INT. CL. 12.
- TUPINAMBA, INC, DALLAS, TX:  
3,350,719, CANC. INT. CL. 43.
- TURF CARE SUPPLY CORP., BRUNSWICK, OH:  
3,354,046, CANC. INT. CL. 1.
- TURF RESTORE, ST. CHARLES, MO:  
3,351,186, CANC. INT. CL. 1.
- TURF SCIENCE LABORATORIES, INC., NATIONAL CITY,  
CA:  
3,352,809, CANC. INT. CL. 1.
- TURISMO ANDALUZ, S.A., MALAGA, SPAIN:  
3,469,972, CANC. INT. CL. 38.
- TURKEY ON RYE MUSIC, LOS ANGELES, CA, DBA  
EXOTIC LOCATION RECORDINGS:  
4,592,625, PUB. 6-10-2014. MULTIPLE CLASS, INT. CLS. 9  
AND 41.
- TURNER BROADCASTING SYSTEM, INC., ATLANTA, GA:  
3,354,411, CANC. INT. CL. 41.  
3,354,412, CANC. INT. CL. 38.
- TURNER CONSULTING GROUP, INC., WASHINGTON,  
DC:  
4,592,460, PUB. 6-10-2014. INT. CL. 42.
- TURNER NETWORK TELEVISION, INC., ATLANTA, GA:  
3,353,641, CANC. INT. CL. 41.
- TURNER SPORTS, INC., ATLANTA, GA:  
4,593,025, PUB. 6-10-2014. INT. CL. 41.
- TURTLE STONE CO., LTD., KANAGAWA-KEN, JAPAN:  
4,593,982, MULTIPLE CLASS, INT. CLS. 18 AND 25.
- TURTLE WAX, INC., WILLOWBROOK, IL:  
4,593,310, INT. CL. 3.

- TUT'S INTERNATIONAL EXPORT AND IMPORT CO., INC., DEARBORN, MI:  
4,591,714, PUB. 6-10-2014. INT. CL. 29.
- TUTOR TIME LEARNING CENTERS, LLC, NOVI, MI, FLORIDA ACADEMIC ENTERPRISES, INC., FORT LAUDERDALE, FL:  
1,844,815. REN. 7-23-14. MULTIPLE CLASS, INT. CLS. 41 AND 42.
- TUTORVILLE, LLC, HOUSTON, TX, AKA TUTORVILLE:  
4,591,649, PUB. 3-11-2014. INT. CL. 41.
- TUTTI, LLC, WESTLAKE VILLAGE, CA:  
4,594,273, INT. CL. 45.
- TV GUIDE MAGAZINE GROUP, INC., LOS ANGELES, CA:  
3,353,362, CANC. MULTIPLE CLASS, INT. CLS. 38 AND 41.
- TV GUIDE ONLINE HOLDINGS LLC, NEW YORK, NY:  
3,367,172, CANC. INT. CL. 16.
- TVC HOLDING, INC., OKLAHOMA CITY, OK:  
4,592,214, PUB. 6-10-2014. INT. CL. 45.  
4,592,215, PUB. 6-10-2014. INT. CL. 35.  
4,592,217, PUB. 6-10-2014. INT. CL. 39.
- TVS S.P.A., URBINO (PS), ITALY:  
2,886,430. REN. 7-18-14. INT. CL. 21.
- TW POWELL CO. INC., NEW YORK, NY:  
3,351,409, CANC. INT. CL. 42.
- TW VERICEPT CORPORATION, CHICAGO, IL:  
3,353,148, CANC. INT. CL. 9.
- TWEEN BRANDS INVESTMENT, LLC, NEW ALBANY, OH:  
3,354,382, CANC. INT. CL. 3.
- TWENTIETH CENTURY FOX FILM CORPORATION, LOS ANGELES, CA:  
4,593,292, INT. CL. 39.  
4,593,305, INT. CL. 39.  
4,593,317, INT. CL. 9.
- TWIN CITIES PUBLIC TELEVISION, INC., ST. PAUL, MN:  
4,593,501, INT. CL. 41.
- TXCO RESOURCES INC. SAN ANTONIO, TX:  
3,351,453, CANC. INT. CL. 39.  
3,351,454, CANC. INT. CL. 42.
- TYCO ELECTRONICS AMP GMBH, FED REP GERMANY:  
4,590,762, PUB. 6-10-2014. INT. CL. 9.
- TYCO ELECTRONICS CORPORATION, BERWYN, PA, RAYCHEM CORPORATION, MENLO PARK, CA:  
1,286,911. REN. 7-24-14. INT. CL. 9.
- TYCO ELECTRONICS CORPORATION, BERWYN, PA:  
4,593,109, MULTIPLE CLASS, INT. CLS. 8, 9, 16 AND 20.
- TYCO ELECTRONICS LOGISTICS A.G., STEINACH, ST. GALLEN, SWITZERLAND TO GE POWER ELECTRONICS, INC., PLANO, TX:  
2,796,304, CANC. INT. CL. 9.
- TYCO ELECTRONICS SERVICES GMBH, SCHAFFHAUSEN, SWITZERLAND:  
1,264,101. REN. 7-18-14. INT. CL. 9.
- TYLER, RONALD E JR., COLUMBUS, OH:  
3,354,377, CANC. INT. CL. 25.
- TYMATIC LIMITED, MAYFIELD, EAST SUSSEX TN20 6RJ, UNITED KINGDOM:  
3,352,746.
- TYSON FOODS, INC., SPRINGDALE, AR:  
4,592,848, PUB. 6-10-2014. INT. CL. 29.
- TYTEL, MALLARY, SIOUX FALLS, SD TO TYTEL, MALLARY, SIOUX FALLS, SD:  
2,795,533, CANC. INT. CL. 35.
- T2 BIOSYSTEMS, INC., LEXINGTON, MA:  
4,591,812, PUB. 6-10-2014. INT. CL. 44.
- U ART RICH, LLC, NEW YORK, NY:  
4,591,286, PUB. 6-10-2014. INT. CL. 25.
- U. S. PRIME LAND, INC., SARASOTA, FL:  
3,354,523, CANC. MULTIPLE CLASS, INT. CLS. 35 AND 36.
- U.S. BANK N.A., MINNEAPOLIS, MN:  
3,353,504, CANC. INT. CL. 36.
- U.S. CARE MANAGEMENT, INC., JACKSONVILLE, FL:  
3,352,035, CANC. INT. CL. 44.
- U.S. GAMES SYSTEMS, INC., STAMFORD, CT:  
3,353,332, CANC. INT. CL. 28.
- U.S. KIDS GOLF LLC, NORCROSS, GA:  
4,591,917, PUB. 6-10-2014. INT. CL. 28.
- U.S. MARINE CORPS, A COMPONENT OF THE U.S. DEPARTMENT OF THE NAVY, WASHINGTON, DC:  
4,594,714, INT. CL. 25.  
4,594,771, INT. CL. 21.
- UAB "NORDCURRENT", LITHUANIA:  
4,590,764, PUB. 6-10-2014. MULTIPLE CLASS, INT. CLS. 9, 16 AND 28.
- UCHIHASHI ESTEC CO., LTD, OSAKA, JAPAN:  
1,287,736. REN. 7-21-14. INT. CL. 9.
- UCHIHASI ESTEC CO., LTD, OSAKA, JAPAN:  
1,287,735. REN. 7-21-14. INT. CL. 9.
- UCOUNTICS LLC, MILLBURN, NJ:  
4,592,239, PUB. 6-10-2014. INT. CL. 42.
- UGAM SOLUTIONS PRIVATE LIMITED, GOREGAON (W), MUMBAI, INDIA:  
4,591,745, PUB. 6-10-2014. INT. CL. 35.
- UHS OF DELAWARE, INC., KING OF PRUSSIA, PA:  
4,591,553, PUB. 6-10-2014. INT. CL. 44.  
4,592,484, PUB. 6-10-2014. INT. CL. 44.  
4,592,551, PUB. 6-10-2014. MULTIPLE CLASS, INT. CLS. 37 AND 42.  
4,592,924, PUB. 6-10-2014. MULTIPLE CLASS, INT. CLS. 9 AND 44.
- ULTIMATE APOCALYPSE APPAREL LLC, PORT SAINT LUCIE, FL:  
4,593,233, INT. CL. 25.
- ULTIMATE FLOOR DESIGN CENTER, LLC, RENTON, WA:  
3,354,677, CANC. INT. CL. 35.
- ULTIMATE GAME CHANGER, LLC, ENCINTAS, CA:  
4,594,718, INT. CL. 20.
- ULTRA STORES, INC., CHICAGO, IL:  
3,354,269, CANC. INT. CL. 14.
- ULTRATECH INTERNATIONAL, INC., JACKSONVILLE, FL:  
4,593,861, INT. CL. 2.
- ULTRAVISION HOLDINGS, LLC, DALLAS, TX:  
4,591,693, PUB. 6-10-2014. INT. CL. 9.  
4,591,694, PUB. 6-10-2014. INT. CL. 9.
- UNCOMMON CONTENT PARTNERS LLC, NEW YORK, NY:  
4,591,711, PUB. 6-10-2014. INT. CL. 41.
- UNDERGROUND PERFORMANCE LLC, LAKE BARRINGTON, IL:  
4,591,546, PUB. 6-10-2014. INT. CL. 41.
- UNEEDA DOLL COMPANY, LTD, HENDERSON, NY:  
1,004,877. REN. 7-18-14. INT. CL. 28.
- UNEEDA DOLL COMPANY, LTD., NEW YORK, NY:  
3,354,326, CANC. INT. CL. 28.
- UNHINGED PRODUCTIONS, LLC, LUBBOCK, TX:  
4,593,791, INT. CL. 33.
- UNICHEMA CHEMIE BV, GOUDA, NETHERLANDS:  
3,353,281, CANC. INT. CL. 1.
- UNIFIED BARCODE & RFID, INC., HOFFMAN ESTATES, IL:  
2,794,186, CANC. INT. CL. 35.
- UNIFIED BRANDS, INC., JACKSON, MS:  
2,843,942. REN. 7-22-14. INT. CL. 11.
- UNIFIED CELLULAR, INC., LINCOLNSHIRE, IL:  
4,591,839, PUB. 6-10-2014. INT. CL. 35.
- UNIFIED COMMUNICATIONS INTEROPERABILITY FORUM, INC., MILFORD, DE:  
4,593,094, INT. CL. 42.  
4,593,095, INT. CL. 42.  
4,593,101, INT. CL. 42.
- UNILEVER PLC, MERSEYSIDE, UNITED KINGDOM:  
2,795,864, CANC. INT. CL. 3.  
2,795,923, CANC. INT. CL. 3.
- UNILEVER PLC, MERSEYSIDE ENGLAND, UNITED KINGDOM:  
4,593,404, INT. CL. 3.
- UNILIN FLOORING NC, LLC, CALHOUN, GA:  
4,593,385, INT. CL. 19.
- UNION PACIFIC RAILROAD COMPANY, OMAHA, NE, SOUTHERN PACIFIC TRANSPORTATION COMPANY, SAN FRANCISCO, CA:  
1,845,923. REN. 7-22-14. INT. CL. 39.
- UNION PACIFIC RAILROAD COMPANY, OMAHA, NE:  
2,795,570, CANC. MULTIPLE CLASS, INT. CLS. 38 AND

39.  
 UNIQUE MAILING SERVICES, INC., DOWNERS GROVE, IL:  
 3,353,875, CANC. INT. CL. 35.  
 UNISHIPERS GLOBAL LOGISTICS, LLC, SALT LAKE CITY, UT:  
 3,767,815, COR. INT. CL. 39.  
 3,767,816, COR. INT. CL. 39.  
 UNITED AUTO GROUP, INC., BLOOMFIELD HILLS, MI:  
 2,317,190, CANC. INT. CL. 35.  
 UNITED BRANDS PRODUCTS DESIGN, DEVELOPMENT AND MARKETING, INC., SOUTH SAN FRANCISCO, CA:  
 4,592,636, PUB. 6-10-2014. INT. CL. 4.  
 UNITED BUSINESS MEDIA LLC, MANHASSET, NY:  
 3,354,652, CANC. INT. CL. 16.  
 UNITED FISHING ADVENTURES, LLC, LOXAHATCHEE, FL:  
 4,593,616, INT. CL. 35.  
 UNITED INVESTMENT GROUP OF LOUISIANA, LLC, SHREVEPORT, LA:  
 4,592,453, PUB. 6-10-2014. INT. CL. 44.  
 4,592,993, PUB. 6-10-2014. INT. CL. 44.  
 UNITED METAL RECEPTACLE CORP., POTTSVILLE, PA:  
 3,353,900, CANC. INT. CL. 2.  
 3,353,901, CANC. INT. CL. 21.  
 UNITED PHOSPHORUS, INC., KING OF PRUSSIA, PA:  
 4,593,981, INT. CL. 5.  
 UNITED RADIO INCORPORATED, HEBRON, KY:  
 4,590,988, PUB. 6-10-2014. INT. CL. 9.  
 UNITED RENTALS, INC., STAMFORD, CT:  
 4,593,451, INT. CL. 42.  
 UNITED SEATING & MOBILITY, LLC, HAZELWOOD, MO:  
 4,593,691, MULTIPLE CLASS, INT. CLS. 7, 10, 12, 37, 39, 40 AND 41.  
 4,593,698, MULTIPLE CLASS, INT. CLS. 7, 10, 12, 37, 39, 40 AND 41.  
 UNITED STATES ANTI-DOPING AGENCY, COLORADO SPRINGS, CO, AKA USADA:  
 4,591,484, PUB. 6-10-2014. INT. CL. 9.  
 UNITED STATES AUTOSOUND COMPETITION, LOWELL, AR:  
 2,794,992, CANC. INT. CL. 41.  
 UNITED STATES BOWLING CONGRESS, INC., ARLINGTON, TX:  
 4,592,853, PUB. 6-10-2014. MULTIPLE CLASS, INT. CLS. 35 AND 41.  
 UNITED STATES LUGGAGE COMPANY, LLC, HAUPPAUGE, NY:  
 3,463,010, COR. MULTIPLE CLASS, INT. CLS. 9 AND 18.  
 UNITED STATES NUTRITION, INC., RONKONKOMA, NY:  
 3,354,610, CANC. INT. CL. 5.  
 UNITED STATES PIPE AND FOUNDRY COMPANY, BIRMINGHAM, AL:  
 1,004,188, REN. 7-24-14. INT. CL. 6.  
 UNITED STATES POSTAL SERVICE, WASHINGTON, DC:  
 4,591,744, PUB. 6-10-2014. INT. CL. 16.  
 UNITED TECHNOLOGIES CORPORATION, HARTFORD, CT, UNITED AIRCRAFT CORPORATION, EAST HARTFORD, CT:  
 790,295, REN. 7-24-14. U.S. CL. 23 (INT. CL. 7).  
 UNITED TRADE MARK LIMITED, MALTA:  
 4,590,638, PUB. 6-10-2014. MULTIPLE CLASS, INT. CLS. 9, 35, 38 AND 41.  
 UNITED WAY OF CENTRAL OHIO, INC., COLUMBUS, OH:  
 2,863,074, REN. 7-22-14. INT. CL. 42.  
 UNITEDHEALTH GROUP INCORPORATED, MINNETONKA, MN:  
 4,593,477, INT. CL. 35.  
 UNITRACK INDUSTRIES, INC., MILFORD, DE, CALABRO INDUSTRIES, INC., UPPER DARBY, PA:  
 1,268,374, REN. 7-24-14. INT. CL. 9.  
 UNIVERA, INC., SEATTLE, WA:  
 4,594,486, INT. CL. 5.  
 UNIVERSAL BEVERAGE OPERATING LTD., HAMILTON, BERMUDA:  
 3,350,612, CANC. MULTIPLE CLASS, INT. CLS. 16, 21, 25 AND 28.  
 UNIVERSAL CITY STUDIOS LLC, UNIVERSAL CITY, CA:  
 4,592,027, PUB. 6-10-2014. INT. CL. 41.  
 4,592,051, PUB. 6-10-2014. INT. CL. 25.  
 4,592,052, PUB. 6-10-2014. INT. CL. 18.  
 4,592,054, PUB. 6-10-2014. INT. CL. 28.  
 4,592,056, PUB. 6-10-2014. INT. CL. 9.  
 4,593,261, INT. CL. 9.  
 4,593,263, INT. CL. 9.  
 4,594,054, INT. CL. 43.  
 4,594,234, INT. CL. 41.  
 UNIVERSAL DE DESARROLLOS ELECTRONICOS, S.A., TERASSA, BARCELONA, SPAIN:  
 3,352,177, CANC. INT. CL. 9.  
 UNIVERSAL REFINER CORPORATION, MONTESANO, WA:  
 1,315,448, REN. 7-21-14. INT. CL. 7.  
 UNIVERSAL SEAFOOD, INC., NORTH HOLLYWOOD, CA:  
 4,591,796, PUB. 6-10-2014. INT. CL. 29.  
 UNIVERSAL WINES & SPIRITS, LLC, MIAMI, FL:  
 3,354,408, CANC. INT. CL. 33.  
 UNIVERSITY OF LOUISVILLE ATHLETIC ASSOCIATION, INC., LOUISVILLE, KY:  
 3,352,050, CANC. INT. CL. 41.  
 UNIVERSITY OF NOTRE DAME DU LAC, NOTRE DAME, IN:  
 4,591,854, PUB. 6-10-2014. INT. CL. 41.  
 UNIVERSITY OF THE VIRGIN ISLANDS CORP., ST. THOMAS, US VIRGIN ISLANDS:  
 3,005,486, CANC. MULTIPLE CLASS, INT. CLS. 25 AND 41.  
 UNIVERSITY PEDIATRIC DENTISTRY, P.C., WILLIAMS-VILLE, NY:  
 4,592,137, PUB. 6-10-2014. INT. CL. 44.  
 UNLEASHED, LLC, WAYLAND, MA:  
 4,594,693, INT. CL. 39.  
 UNLOCKED RECORDINGS, INC., MANHATTAN BEACH, CA:  
 3,351,570, CANC. INT. CL. 35.  
 UP, INC., LOS ANGELES, CA:  
 4,592,040, PUB. 6-10-2014. INT. CL. 3.  
 UPRIGHT, NAFISSA SHIREEN, MAPLE RIDGE, CANADA:  
 4,594,635, INT. CL. 41.  
 UPTIME SCIENCE CORPORATION, ALPHARETTA, GA, DBA UPTIME SCIENCE CORPORATION:  
 3,352,181, CANC. INT. CL. 42.  
 UPWIND SOLUTIONS, INC., SAN DIEGO, CA:  
 4,591,263, PUB. 6-10-2014. MULTIPLE CLASS, INT. CLS. 35, 37, 40 AND 42.  
 URBAN DEVELOPMENT CORPORATION, PHILADELPHIA, PA:  
 4,594,430, INT. CL. 37.  
 URBAN FOREST HOME, OAKLAND, CA:  
 3,351,378, CANC. INT. CL. 35.  
 URBANIMMERSIVE INC., LAVAL, QUÉBEC, CANADA:  
 4,590,955, PUB. 6-10-2014. INT. CL. 42.  
 URCUTE ENTERTAINMENT, LLC, BRIDGEPORT, CT:  
 3,351,645, CANC. INT. CL. 16.  
 3,351,647, CANC. INT. CL. 45.  
 URS FEDERAL SERVICES, INC., SAN FRANCISCO, CA:  
 4,591,295, PUB. 6-10-2014. INT. CL. 9.  
 URSUL, F-75010 PARIS, FRANCE:  
 4,590,694, PUB. 6-10-2014. MULTIPLE CLASS, INT. CLS. 14 AND 18.  
 USA DOG CRATES, INC., MELBOURNE, FL, DBA DENHAUS:  
 3,352,314, CANC. INT. CL. 20.  
 USINTERNETWORKING, INC., ANNAPOLIS, MD:  
 3,352,911, CANC. INT. CL. 42.  
 USP, INC., VISTA, CA:  
 3,353,954, CANC. INT. CL. 25.  
 UTAH TRANSIT AUTHORITY, SALT LAKE CITY, UT:  
 4,594,601, INT. CL. 36.  
 UTUPA, INC., BELLEVUE, WA:  
 4,594,483, INT. CL. 9.  
 UTV MEDIA (GB) LIMITED, UNITED KINGDOM:  
 4,590,706, PUB. 6-10-2014. MULTIPLE CLASS, INT. CLS. 9, 38 AND 41.

V.I.P. PET FOODS PTY LTD, YATALA, QUEENSLAND, AUSTRALIA:  
4,591,616, PUB. 6-10-2014. INT. CL. 31.

V-DAY CORPORATION, NEW YORK, NY:  
4,593,242, MULTIPLE CLASS, INT. CLS. 14 AND 26.

V-MARK ENTERPRISES LTD., VANCOUVER, CANADA:  
4,594,102, INT. CL. 9.

V-MARK ENTERPRISES LTD., VANCOUVER ,B.C, CANADA:  
4,594,103, INT. CL. 9.

VACO, LLC, BRENTWOOD, TN:  
4,593,748, INT. CL. 35.

VACVAL, JURAJ, NASSAU, BAHAMAS:  
4,594,135, INT. CL. 14.

VAIL TRADEMARKS, INC., BROOMFIELD, CO:  
2,864,088. REN. 7-22-14. INT. CL. 41.

VALDES, EBNER J., BOSTON, MA, DBA QUALITY MUSIC PROFESSIONAL RECORDS:  
4,594,749, INT. CL. 41.

VALENCIA TRADEMARK CORPORATION, HOUSTON, TX:  
2,837,324. REN. 7-23-14. INT. CL. 43.

VALENTINO S.P.A, ITALY:  
4,590,798, PUB. 6-10-2014. MULTIPLE CLASS, INT. CLS. 18 AND 25.

VALENTINO S.P.A., ITALY:  
4,590,817, PUB. 6-10-2014. INT. CL. 3.

VALERO ENERGY PARTNERS GP LLC, SAN ANTONIO, TX:  
4,594,277, INT. CL. 39.

VALLMAR STUDIOS LLC, STOW, OH:  
4,591,709, PUB. 6-10-2014. MULTIPLE CLASS, INT. CLS. 28 AND 41.

VALPAK DIRECT MARKETING SYSTEMS, INC., LARGO, FL:  
3,350,765, CANC. INT. CL. 35.

VALUE CITY OF MICHIGAN, INC., WESTLAND, MI:  
3,354,302, CANC. INT. CL. 14.

VALUE INNORUPTION ADVISORS LLC, SEWICKLEY, PA:  
4,594,650, U.S. CL. B.

VALUE RECOVERY, INC., BRIDGEPORT, NJ:  
2,801,777. REN. 7-21-14. INT. CL. 42.

VALUEVISION MEDIA, INC., EDEN PRAIRIE, MN:  
4,593,396, INT. CL. 21.

VAN CHEONG TEA, INC., RICHMOND, BRITISH COLUMBIA, CANADA:  
3,365,609, CANC. INT. CL. 21.

VANECKO, IVAN, KAPPEL-GRAFENHAUSEN, FED REP GERMANY:  
4,594,652, INT. CL. 28.

VANGUARD TRADEMARK HOLDINGS USA LLC, ST. LOUIS, MO:  
3,351,538, CANC. INT. CL. 39.  
3,351,539, CANC. INT. CL. 39.

VANGUARD TRADEMARK HOLDINGS USA LLC, ST. LOUIS, DC:  
4,592,152, PUB. 6-10-2014. INT. CL. 39.

VANN, MARK, HONOLULU, HI AND SMITH, LISA, HONOLULU, HI:  
3,354,026, CANC. INT. CL. 43.

VANNOD BRUNO, PARIS, FRANCE:  
4,594,698, INT. CL. 38.

VARNISH FINE ART LLC, SAN FRANCISCO, CA:  
2,794,861, CANC. MULTIPLE CLASS, INT. CLS. 35 AND 41.

VARONIS SYSTEMS, INC., NEW YORK, NY:  
4,592,747, PUB. 6-10-2014. MULTIPLE CLASS, INT. CLS. 9 AND 42.

VARSITY SPIRIT CORPORATION, MEMPHIS, TN:  
4,593,424, INT. CL. 25.

VASIU, ADRIAN, VANCOUVER, BRITISH COLUMBIA, CANADA:  
3,353,417, CANC. INT. CL. 35.

VASQUEZ, JAVIER EDUARDO, MIAMI, FL:  
4,592,787, PUB. 6-10-2014. INT. CL. 41.

VASQUEZ, OSCAR M, KERMAN, CA AND MITCHELL VIRRUETA, ALAN, FIREBAUGH, CA AND ANDRADE, IRVIN FABIAN, FIREBAUGH, CA:  
4,591,781, PUB. 6-10-2014. INT. CL. 41.

VAUGHAN CO., INC., MONTESANO, WA:  
4,594,400, INT. CL. 7.  
4,594,402, INT. CL. 7.  
4,594,404, INT. CL. 7.  
4,594,405, INT. CL. 7.

VAUGHN GROOMING, LLC, MIAMI, FL:  
4,593,669, MULTIPLE CLASS, INT. CLS. 3 AND 35.

VAULT BREWING COMPANY, YARDLEY, PA:  
4,591,109, PUB. 3-4-2014. MULTIPLE CLASS, INT. CLS. 25, 32 AND 43.

VAVA SHOES, INC., SYRACUSE, NY, DBA J. MICHAEL SHOES:  
4,593,552, INT. CL. 25.

VBS DISTRIBUTION, HUNTINGTON BEACH, CA:  
4,591,802, PUB. 4-22-2014. INT. CL. 5.

VDATE LLC, CHICAGO, IL:  
3,353,044, CANC. INT. CL. 45.

VECTOR PRODUCTS, INC., FT. LAUDERDALE, FL:  
3,352,886, CANC. INT. CL. 9.

VECTOR...A MOVE AHEAD, INC., SAN FRANCISCO, CA:  
3,354,284, CANC. INT. CL. 6.

VEE GEE SCIENTIFIC, INC., KIRKLAND, WA:  
3,353,493, CANC. INT. CL. 9.

VEECO INSTRUMENTS INC., PLAINVIEW, NY:  
4,594,001, INT. CL. 7.

VEHICLEARTZ LLC, LINEVILLE, AL:  
4,592,577, PUB. 6-10-2014. INT. CL. 16.

VELCON FILTERS, LLC, COLORADO SPRINGS, CO:  
4,593,710, INT. CL. 7.

VELECTA PARAMOUNT, PARIS, FRANCE:  
2,875,944. REN. 7-19-14. INT. CL. 11.

VELLO SYSTEMS, INC., MENLO PARK, CA:  
3,352,432, CANC. INT. CL. 9.

VELOCITY CONSULTING SPECIALIST, PETAL, MS:  
4,591,407, PUB. 6-10-2014. INT. CL. 5.

VELOPOWER CONSULTING LLC, SARATOGA SPRINGS, NY, DBA ROAMPLATE:  
4,594,235, INT. CL. 35.

VENICA & VENICA DI GIANNI E GIORGIO VENICA S.S. SOCIETA AGRICOLA., DOLEGNA DEL COLLIO (GO), ITALY:  
2,862,401. REN. 7-24-14. INT. CL. 33.

VENICE NUTRITION LLC, JOHNS CREEK, GA:  
3,354,631, CANC. INT. CL. 44.

VENTRIA BIOSCIENCE, SACRAMENTO, CA:  
3,353,286, CANC. INT. CL. 42.

VENTURA FOODS, LLC, BREA, CA:  
774,679. REN. 7-22-14. U.S. CL. 46 (INT. CL. 29).

VENTURA FOODS, LLC, BREA, CA, SAFFOLA QUALITY FOODS, INC., LOS ANGELES, CA:  
1,903,681. REN. 7-22-14. INT. CL. 29.

VENTURE CAPITAL & CONSULTING GROUP, LLC, RIDGEFIELD, CT:  
3,353,472, CANC. INT. CL. 35.

VENTURE MEASUREMENT COMPANY LLC, SPARTANBURG, SC:  
1,871,864. REN. 7-22-14. INT. CL. 9.

VERASSURE LLC, A WHOLLY OWNED SUBSIDIARY OF FROST PLLC, LITTLE ROCK, AR, DBA FACTA:  
4,592,207, PUB. 6-10-2014. INT. CL. 35.

VERBOVSZKY, ESTHER A. L., ROCKY RIVER, OH:  
2,795,829, CANC. INT. CL. 12.

VERIDIANT, LLC, EAST WINDSOR, NJ, DBA THINKTASTIC SOFTWARE:  
4,591,165, PUB. 3-4-2014. MULTIPLE CLASS, INT. CLS. 9 AND 42.

VERISMO WINE LLC, NAPA, CA:  
4,593,926, INT. CL. 33.  
4,593,927, INT. CL. 33.  
4,593,928, INT. CL. 33.  
4,593,929, INT. CL. 33.

VERITEQ IP HOLDING CORPORATION, DELRAY BEACH, FL:  
3,353,431, CANC. INT. CL. 10.

- VERMONT ORGANIC FIBER COMPANY, LLC, MIDDLE-BURY, VT:  
3,353,542, CANC. MULTIPLE CLASS, INT. CLS. 23 AND 24.
- VERQU LLC, NESHANIC STATION, NJ:  
4,592,183, PUB. 6-10-2014. INT. CL. 9.
- VERSACO LLC, OLD TAPPAN, NJ:  
4,591,522, PUB. 6-10-2014. MULTIPLE CLASS, INT. CLS. 9 AND 21.
- VERSUS, L.P., PHILADELPHIA, PA:  
3,354,423, CANC. INT. CL. 41.
- VERTESS HOLDINGS, LLC, TUCSON, AZ:  
4,594,321, INT. CL. 35.
- VERTIGO TATTOO AND BODY PIERCING, INC., MANNS HARBOR, NC:  
3,351,240, CANC. INT. CL. 35.
- VERTIGONE, INC., FORT WORTH, TX:  
2,795,399, CANC. INT. CL. 10.
- VERUS OPTICAL, NEWBERG, OR:  
4,592,984, PUB. 6-10-2014. INT. CL. 9.
- VERY CLEVER STUFF, INC., LOS ANGELES, CA:  
3,353,674, CANC. MULTIPLE CLASS, INT. CLS. 29 AND 30.
- VESSAL, CARALYN, VILLANOVA, PA:  
4,594,288, INT. CL. 5.
- VESTEL ELEKTRONIK; SANAYI VE TICARET ANONIM SIRKETI, TURKEY:  
3,352,573.
- VESTEM INDÚSTRIA E COMÉRCIO DE CONFECÇÕES LTDA, SÃO PAULO, BRAZIL:  
4,591,592, PUB. 6-10-2014. INT. CL. 25.
- VETERAN TIRE AND RUBBER INC., SAN JOSE, CA:  
4,592,602, PUB. 6-10-2014. INT. CL. 12.
- VETERANS ENERGY SOLUTIONS, LLC, MIAMI, FL:  
3,351,261, CANC. INT. CL. 40.
- VETRIX, CUMMING, GA:  
4,591,142, PUB. 6-10-2014. INT. CL. 10.
- VETS PLUS, INC., MENOMONIE, WI:  
1,887,726, REN. 7-22-14. INT. CL. 5.
- VETSTREET, INC., LOS ANGELES, CA:  
2,795,409, CANC. INT. CL. 16.
- VIACOM INTERNATIONAL INC., NEW YORK, NY:  
3,353,282, CANC. MULTIPLE CLASS, INT. CLS. 9 AND 38.  
3,353,567, CANC. INT. CL. 41.  
3,354,375, CANC. INT. CL. 38.  
3,354,419, CANC. INT. CL. 41.
- VIAPLAY, LOS ANGELES, CA:  
4,593,641, MULTIPLE CLASS, INT. CLS. 9 AND 28.
- VIBRAM S.P.A., 21041 ALBIZZATE (VARESE), ITALY:  
988,983, REN. 7-18-14. U.S. CL. 39 (INT. CL. 25).
- VIBRANT CONCEPTS, INC., ALISO VIEJO, CA:  
4,592,492, PUB. 6-10-2014. MULTIPLE CLASS, INT. CLS. 16, 29 AND 30.
- VIBRATEx, INC., NAPA, CA:  
4,594,498, INT. CL. 10.
- VICK-KALAR, MARILYN, MINNETONKA, MN, DBA VISION ARTISTRY:  
4,592,178, PUB. 6-10-2014. INT. CL. 16.
- VICTOIRE FIGOTIN, IRVINE, CA, DBA FRENCHLY YOURS:  
4,591,344, PUB. 6-10-2014. INT. CL. 41.
- VICTOR COMPANY OF JAPAN, LIMITED, YOKOHAMA-CITY, JAPAN:  
2,795,989, CANC. INT. CL. 9.
- VICTOR HERNANDEZ, WALNUT, CA, DBA MOBSTAR INDUSTRIES:  
4,592,044, PUB. 6-10-2014. INT. CL. 25.
- VICTORIA PRINCIPAL PRODUCTIONS, INC., NASHVILLE, TN:  
2,795,711, CANC. INT. CL. 3.
- VICTORIA'S SECRET STORES BRAND MANAGEMENT, INC., REYNOLDSBURG, OH:  
3,354,649, CANC. INT. CL. 3.  
4,592,841, PUB. 6-10-2014. INT. CL. 25.  
4,593,000, PUB. 6-10-2014. INT. CL. 25.  
4,593,046, PUB. 6-10-2014. INT. CL. 3.
- VICTOROV, VICTOR, SAINT-PETERSBURG, RUSSIAN FED.:  
3,350,819, CANC. MULTIPLE CLASS, INT. CLS. 9 AND 42.
- VICTORY MEDIA, INC., CORAOPOLIS, PA, DBA VICTORY TECH:  
4,591,381, PUB. 6-10-2014. INT. CL. 35.
- VIDOVAION CORPORATION, IRVINE, CA:  
4,594,606, INT. CL. 9.
- VIETNAM SOUTHERN FOOD CORPORATION, HO CHI MINH CITY, VIETNAM:  
4,590,624, PUB. 6-10-2014. INT. CL. 30.
- VIEVU, LLC, SEATTLE, WA:  
4,593,732, INT. CL. 9.
- VIGGIANO, CHRISTOPHER M., LONG VALLEY, NJ AND LUNDQUIST, STEVE, LONG VALLEY, NJ:  
4,594,644, INT. CL. 41.
- VILLAGE PEOPLE, L.L.C., NASHVILLE, TN, DBA VILLAGE REAL ESTATE SERVICES:  
4,594,682, INT. CL. 35.
- VILLANUEVA HOLDING COMPANY, LLC, HOUSTON, TX:  
4,594,112, INT. CL. 33.
- VILLARREAL, VIVIAN DAVID, GONZALES, LA:  
4,594,143, INT. CL. 9.
- VINACE, LLC, CHARLOTTE, NC, MINERAL RESEARCH & DEVELOPMENT CORPORATION, CHARLOTTE, NC:  
1,288,542, REN. 7-24-14. INT. CL. 1.
- VINCENT TULL COMPANY, LLC, HENDERSON, NV:  
4,593,093, MULTIPLE CLASS, INT. CLS. 25 AND 33.
- VINEYARD VINES LLC, STAMFORD, CT:  
4,592,543, PUB. 6-10-2014. MULTIPLE CLASS, INT. CLS. 14, 18 AND 24.
- VINIDEX PTY LIMITED, AUSTRALIA:  
3,352,664.
- VINTAGE PHARMACEUTICALS, LLC, MALVERN, PA:  
2,872,678, REN. 7-23-14. INT. CL. 5.  
2,872,679, REN. 7-23-14. INT. CL. 5.
- VINTAGE WINE ESTATES, INC., SANTA ROSA, CA:  
2,796,129, CANC. INT. CL. 33.
- VIORA LTD., HERZLIAH PITUACH, ISRAEL:  
4,593,714, INT. CL. 10.
- VIP FRANCHISE GROUP, LLC, CLIFTON, NJ:  
3,351,321, CANC. MULTIPLE CLASS, INT. CLS. 35, 37 AND 39.
- VIRBAC, CARROS 06516, FRANCE:  
4,591,085, PUB. 6-10-2014. MULTIPLE CLASS, INT. CLS. 9, 10, 18 AND 45.
- VIRGINIA COMMONWEALTH UNIVERSITY, RICHMOND, VA:  
4,592,769, PUB. 6-10-2014. INT. CL. 25.  
4,592,953, PUB. 6-10-2014. MULTIPLE CLASS, INT. CLS. 14, 16, 21, 24, 25 AND 28.
- VIRGINIA WINERIES ASSOCIATION, THE, RICHMOND, VA:  
4,591,113, PUB. 6-10-2014. INT. CL. 41.
- VIRTUAL ADTAKER LLC, CASTLE ROCK, CO:  
2,793,971, CANC. MULTIPLE CLASS, INT. CLS. 9, 35 AND 42.
- VIRTUS STRENGTH AND CONDITIONING, FULLERTON, CA:  
4,591,851, PUB. 6-10-2014. INT. CL. 41.
- VISION SOURCE L.P., KINGWOOD, TX:  
4,594,347, INT. CL. 9.
- VISION WHEEL, INC., DECATUR, AL:  
4,592,131, PUB. 6-10-2014. INT. CL. 12.  
4,592,307, PUB. 6-10-2014. INT. CL. 12.
- VISTA MARINA INN, INC., KITCHENER, CANADA:  
3,351,142, CANC. INT. CL. 43.
- VISTANOMICS, INC., MONTROSE, CA:  
2,794,221, CANC. INT. CL. 9.
- VISUAL SUPPLY CO., OAKLAND, CA:  
4,591,813, PUB. 2-25-2014. INT. CL. 42.
- VISUALMARK INTERNACIONAL, S.L., SPAIN:  
3,352,650.
- VITA ZAHNFABRIK H. RAUTER GMBH & CO. KG, 79713 BAD SÄCKINGEN, FED REP GERMANY:  
4,591,198, PUB. 6-10-2014. INT. CL. 5.



VITA ZAHNFABRIK H. RAUTER GMBH & CO. KG, BAD SACKINGEN, FED REP GERMANY:  
4,591,490, PUB. 6-10-2014. INT. CL. 10.

VITAL CONNECT, INC., CAMPBELL, CA:  
4,594,270, INT. CL. 10.

VITAL JUICE CO, INC., SEATTLE, WA:  
4,593,878, MULTIPLE CLASS, INT. CLS. 29 AND 32.  
4,593,917, MULTIPLE CLASS, INT. CLS. 29 AND 32.  
4,593,918, MULTIPLE CLASS, INT. CLS. 29 AND 32.

VITALSURGE, L.L.C., JOPLIN, MO:  
3,353,631, CANC. INT. CL. 5.

VITAMARK INTERNATIONAL, INC., HOUSTON, TX:  
3,350,674, CANC. INT. CL. 5.

VITAMIN A ENTERPRISES, INC., COSTA MESA, CA:  
4,593,191, INT. CL. 25.

VITAMIN COTTAGE NATURAL FOOD MARKETS, INC., LAKEWOOD, CO, DBA NATURAL GROCERS BY VITAMIN COTTAGE:  
4,593,446, INT. CL. 35.

VITAX LIMITED, UNITED KINGDOM:  
4,590,828, PUB. 6-10-2014. INT. CL. 7.

VIVA OPTIQUE, INC., SOMERVILLE, NJ:  
3,353,916, CANC. INT. CL. 9.

VIVID ENTERTAINMENT, LLC, LOS ANGELES, CA:  
3,353,064, CANC. INT. CL. 15.

VIVID MEDICAL INC., PALO ALTO, CA:  
4,593,730, MULTIPLE CLASS, INT. CLS. 9 AND 10.

VIVISCAPE, GOSHEN, IN:  
4,591,551, PUB. 12-24-2013. MULTIPLE CLASS, INT. CLS. 9 AND 44.

VMI HOLLAND B.V., NETHERLANDS:  
4,590,885, PUB. 6-10-2014. MULTIPLE CLASS, INT. CLS. 7, 37 AND 42.

VMIX MEDIA INC., SAN DIEGO, CA:  
3,352,119, CANC. MULTIPLE CLASS, INT. CLS. 35, 38 AND 41.

VOGL THOMAS, FED REP GERMANY AND SCHOLZ MARKUS, FED REP GERMANY AND ARMBRÜSTER JENS, FED REP GERMANY:  
4,590,802, PUB. 6-10-2014. MULTIPLE CLASS, INT. CLS. 6, 19 AND 20.

VOGT, BETH, COLORADO SPRINGS, CO:  
3,351,542, CANC. INT. CL. 44.

VOICE.TRUST AG, D-81379 MUNICH, FED REP GERMANY:  
2,793,832, CANC. MULTIPLE CLASS, INT. CLS. 9 AND 42.

VOISPOT, LLC, BOCA RATON, FL:  
4,593,345, INT. CL. 42.

VOLCANO CORPORATION, SAN DIEGO, CA:  
4,594,575, INT. CL. 10.

VOLTAGE ENTERTAINMENT USA, INC., SAN FRANCISCO, CA:  
4,591,817, PUB. 6-10-2014. INT. CL. 9.

VON SCHRADER COMPANY, RACINE, WI:  
3,351,030, CANC. INT. CL. 7.

VONAGE MARKETING LLC, HOLMDEL, NJ:  
3,354,060, CANC. INT. CL. 38.

VORTEX POLYMERS, INC., CARSON, CA:  
3,351,480, CANC. MULTIPLE CLASS, INT. CLS. 1 AND 2.

VRETS, LLC, COLORADO SPRINGS, CO:  
3,351,203, CANC. MULTIPLE CLASS, INT. CLS. 9 AND 41.

VROOP, LLC, NORTH ATTLEBORO, MA:  
3,354,262, CANC. INT. CL. 9.

VYON BEAUTY GMBH, FED REP GERMANY:  
4,508,535, COR. INT. CL. 3.

VYST ENTERPRISES, INC., MT. PLEASANT, MI:  
4,593,012, PUB. 6-10-2014. INT. CL. 9.

V3 UNLIMITED, VIRGINIA BEACH, VA:  
3,351,492, CANC. INT. CL. 35.

W. A. HOLDING COMPANY, LLC, SAN FRANCISCO, CA:  
4,591,027, PUB. 6-10-2014. MULTIPLE CLASS, INT. CLS. 18, 21, 25, 35, 41, 43 AND 44.

WADA FARMS MARKETING GROUP, LLC, IDAHO FALLS, ID:  
4,594,710, INT. CL. 31.

WAGGENER EDSTROM WORLDWIDE, INC., LAKE OSWEGO, OR:  
4,594,176, INT. CL. 35.

WAGGING TAILS PET RESORT INCORPORATED, EAGAN, MN:  
4,594,443, INT. CL. 43.  
4,594,444, INT. CL. 43.

WAHINE'S, INC., SAN DIEGO, CA:  
3,351,445, CANC. INT. CL. 35.

WAKEFERN FOOD CORP., ELIZABETH, NJ, DBA PRICE RITE:  
2,843,298, COR. MULTIPLE CLASS, INT. CLS. 3, 5, 11, 16, 29, 30 AND 31.

WAKEFERN FOOD CORP., KEASBEY, NJ:  
2,864,574, REN. 7-24-14. INT. CL. 35.

WAKODO COMPANY LIMITED, TOKYO, JAPAN:  
3,352,088, CANC. INT. CL. 5.

WAL-MART STORES, INC., BENTONVILLE, AR:  
3,352,848, CANC. INT. CL. 9.  
4,592,945, PUB. 6-10-2014. INT. CL. 30.

WALD & CO., INC., GREENWOOD, MO:  
1,329,463, REN. 7-24-14. INT. CL. 13.

WALGREEN CO., DEERFIELD, IL:  
2,794,947, CANC. INT. CL. 9.

WALI ELECTRIC, INC., HAYWARD, CA:  
4,593,963, INT. CL. 9.

WALK AGAINST TRAFFICK, JACKSON, MS, AKA W.A.T.:  
4,594,496, INT. CL. 35.

WALKER, DONNIE RAY, CARSON, CA:  
3,354,255, CANC. INT. CL. 25.

WALL STREET CAFE, INC., FARMINGTON HILLS, MI:  
3,350,962, CANC. INT. CL. 41.

WALTER JACOBI AND SONS, INC., BELMONT, CA:  
944,064, CANC. U.S. CL. 32.

WALTERS, PEGGY A., FRIENDSVILLE, TN:  
3,353,972, CANC. INT. CL. 12.

WALWORTH COUNTY, WISCONSIN A WISCONSIN MUNICIPAL CORPORATION, ELKHORN, WI:  
4,592,454, PUB. 6-10-2014. INT. CL. 35.

WAMAFRAMA ENTERTAINMENT, LLC, HENDERSON, NV:  
4,593,195, INT. CL. 35.

WAN HUA FOODS INC, SEATTLE, WA:  
4,591,574, PUB. 6-10-2014. INT. CL. 30.

WAP3 TECHNOLOGIES GMBH, D-50678 KÖLN, FED REP GERMANY:  
3,351,956, CANC. MULTIPLE CLASS, INT. CLS. 9, 28, 38, 41 AND 42.

WARD, TODD, HUNTINGTON, IN:  
4,594,666, INT. CL. 41.

WARGAMING.NET LLP, UNITED KINGDOM:  
4,590,703, PUB. 6-10-2014. MULTIPLE CLASS, INT. CLS. 9 AND 41.

WARNACO U.S., INC., MILFORD, CT:  
3,353,015, CANC. INT. CL. 25.  
3,353,917, CANC. INT. CL. 25.

WARNER BROS. ENTERTAINMENT INC., BURBANK, CA:  
4,593,715, INT. CL. 41.

WARREN LEVINSON, DENVER, CO:  
4,593,670, INT. CL. 16.

WASHBURN & CO., ROEBUCK, SC:  
4,591,257, PUB. 6-10-2014. INT. CL. 35.

WASHINGTON HOSPITAL CENTER CORPORATION, WASHINGTON, DC:  
4,590,948, PUB. 4-17-2012. INT. CL. 44.

WASTEZERO, INC., RALEIGH, NC:  
4,593,326, INT. CL. 39.

WATCHSTAR, LLC, COLUMBIA, MD:  
4,591,138, PUB. 6-10-2014. INT. CL. 14.

WATER SOFT INC., WEST WARWICK, RI:  
1,677,499, CANC. INT. CL. 11.

WATERFIELD, J. RANDALL, IRVINE, CA AND WATERFIELD, RICHARD R., IRVINE, CA:  
3,352,488, CANC. INT. CL. 36.

WATERS TECHNOLOGIES CORPORATION, WILMINGTON, DE:  
2,862,029, REN. 7-23-14. INT. CL. 9.

- WATERWAYS JOINT VENTURE IV, NAPLES, FL:  
3,351,556, CANC. INT. CL. 37.
- WATKINS MANUFACTURING CORPORATION, VISTA, CA:  
2,796,286, CANC. INT. CL. 11.
- WATSON PHARMACEUTICALS, INC., CORONA, CA:  
3,353,829, CANC. INT. CL. 44.
- WAVE CONNECTS, INC., CARLSBAD, CA:  
4,592,804, PUB. 6-10-2014. INT. CL. 37.
- WAYMOUTH FARMS, INC., NEW HOPE, MN:  
3,269,855, CANC. INT. CL. 29.
- WAYNE QUIRK, ST. CATHARINES, ON, CANADA:  
4,591,010, PUB. 6-10-2014. INT. CL. 41.
- WBC ACQUISITION, LLC, ARMONK, NY:  
3,352,350, CANC. INT. CL. 35.
- WBI INVESTMENTS, INC., RED BANK, NJ:  
4,593,059, PUB. 6-10-2014. INT. CL. 36.
- WE LOVE APPS S.L., SS REYES, SPAIN, DBA MOVIN'APP:  
4,592,660, PUB. 6-10-2014. INT. CL. 9.
- WE LOVE APPS S.L., SS REYES 28701, SPAIN, DBA MOVIN'APP:  
4,593,039, PUB. 6-10-2014. INT. CL. 9.
- WEATHERFORD/LAMB, INC., HOUSTON, TX:  
4,591,585, PUB. 6-10-2014. INT. CL. 7.
- WEAVER POPCORN COMPANY, INC., NOBLESVILLE, IN:  
4,593,823, INT. CL. 30.
- WEB RIVER GROUP, INC., TAMPA, FL, DBA WEB RIVER GROUP:  
4,591,790, PUB. 6-10-2014. INT. CL. 35.
- WEBB GOLDEN VALLEY LLC, GOLDEN VALLEY, MN:  
4,212,976, COR. INT. CL. 43.  
4,381,989, COR. INT. CL. 43.
- WEBB, NICHOLAS, REDDING, CA:  
4,593,357, INT. CL. 35.
- WEBMD LLC, NEW YORK, NY:  
3,353,870, CANC. INT. CL. 44.
- WECHTECH TECHNOLOGIES, LLC, CORAL SPRINGS, FL:  
2,794,507, CANC. INT. CL. 42.
- WECO PRODUCTS INC., LONG BEACH, CA:  
3,354,174, CANC. INT. CL. 1.
- WEDI GMBH, EMSDETTEN, FED REP GERMANY:  
4,591,096, PUB. 6-10-2014. MULTIPLE CLASS, INT. CLS. 11, 17, 19 AND 20.
- WEEDA, KURT FRANCIS, BRAHAM, MN:  
3,353,358, CANC. INT. CL. 40.
- WEI TAO CO., LTD., TAIPEI, TAIWAN:  
3,353,838, CANC. INT. CL. 29.  
3,353,839, CANC. INT. CL. 30.
- WEINER, DR. MICHAEL A., SAN FRANCISCO, CA:  
4,592,920, PUB. 6-10-2014. INT. CL. 41.
- WEISNER, ANDREA PADILLA, CARLSBAD, CA:  
3,351,507, CANC. INT. CL. 25.
- WEISS, JODY R., NEW YORK, NY:  
3,351,703, CANC. INT. CL. 3.
- WELCH, RICHARD K. WEST PALM BEACH, FL:  
3,354,009, CANC. INT. CL. 16.
- WELCOMING AMERICA, INC., DECATUR, GA:  
4,590,964, PUB. 6-10-2014. INT. CL. 41.
- WELDSALE COMPANY LLC, PHILA, PA:  
4,593,692, INT. CL. 20.
- WELLA AKTIENGESELLSCHAFT, DARMSTADT, FED REP GERMANY:  
3,353,658, CANC. INT. CL. 3.
- WELLNESS CREATIONS, LLC, NEW YORK, NY:  
4,594,369, MULTIPLE CLASS, INT. CLS. 5, 40, 42 AND 44.
- WELLS ENTERPRISES, INC., LE MARS, IA:  
2,884,475, REN. 7-21-14. INT. CL. 30.
- WELLS FARGO & COMPANY, SAN FRANCISCO, CA:  
3,354,311, CANC. MULTIPLE CLASS, INT. CLS. 35 AND 36.
- WELLS FARGO BANK, N.A., MINNEAPOLIS, MN:  
3,353,322, CANC. INT. CL. 36.
- WELLS, CAROL J., SAN RAFAEL, CA:  
2,943,433, REN. 7-24-14. INT. CL. 5.
- WELLS, LUANNE, BETTENDORF, IA:  
4,593,531, INT. CL. 44.
- WELLSTAR HEALTH SYSTEM, INC., MARIETTA, GA:  
3,353,437, CANC. MULTIPLE CLASS, INT. CLS. 9, 16, 35, 41 AND 44.
- WELLTEC A/S, ALLEROD, DENMARK:  
4,590,705, PUB. 6-10-2014. MULTIPLE CLASS, INT. CLS. 7, 9 AND 37.
- WELLTOK, INC., DENVER, CO:  
4,594,147, INT. CL. 9.
- WELSPUN GLOBAL BRANDS LIMITED, MUMBAI 400013, INDIA:  
4,593,217, INT. CL. 24.
- WELTE, DIANE, DANBURY, IA:  
4,592,901, PUB. 6-10-2014. INT. CL. 25.
- WENJOR CORPORATION, WINTER SPRINGS, FL:  
3,351,188, CANC. INT. CL. 17.
- WERTH, ISABELL, RHEINBERG, FED REP GERMANY:  
3,352,813, CANC. MULTIPLE CLASS, INT. CLS. 18 AND 25.
- WEST COAST WING CHUN, SIGNAL HILL, CA:  
4,591,471, PUB. 6-10-2014. INT. CL. 41.
- WEST MARINE IHC I, INC., WATSONVILLE, CA:  
3,353,110, CANC. INT. CL. 1.
- WESTECH BUILDING PRODUCTS, INC., HOUSTON, TX:  
3,352,506, CANC. INT. CL. 19.
- WESTERMARCK, JOEL C., LAUDERHILL, FL:  
3,352,188, CANC. INT. CL. 9.
- WESTERN HUNTER, CHANDLER, AZ:  
4,594,781, MULTIPLE CLASS, INT. CLS. 16, 25 AND 41.
- WESTERN NATIONAL MUTUAL INSURANCE COMPANY, MINNEAPOLIS, MN:  
4,592,781, PUB. 6-10-2014. INT. CL. 36.
- WESTERN RESERVE LIFE ASSURANCE CO. OF OHIO, ST. PETERSBURG, FL:  
4,593,314, INT. CL. 36.
- WESTMED, INC., GREENWOOD VILLAGE, CO:  
1,898,790, REN. 7-24-14. INT. CL. 10.
- WESTONE LABORATORIES, INC., COLORADO SPRINGS, CO:  
4,591,256, PUB. 6-10-2014. INT. CL. 9.
- WESTRIDGE LABORATORIES, INC., SANTA ANA, CA:  
4,591,167, PUB. 6-10-2014. INT. CL. 35.
- WETHERINGTON, KELLY, MABLETON, GA:  
4,592,113, PUB. 6-10-2014. MULTIPLE CLASS, INT. CLS. 39 AND 41.
- WGBH EDUCATIONAL FOUNDATION, BOSTON, MA:  
3,354,177, CANC. INT. CL. 43.
- WHAT ARE MINDS FOR, INC., KRESGEVILLE, PA:  
4,592,098, PUB. 6-10-2014. INT. CL. 42.
- WHIRLTRONICS, INC., BUFFALO, MN:  
988,860, REN. 7-22-14. U.S. CL. 23 (INT. CL. 7).  
991,299, REN. 7-22-14. U.S. CL. 23 (INT. CL. 7).
- WHITE, RACHEL, ATLANTA, GA:  
4,592,885, PUB. 6-10-2014. INT. CL. 45.
- WHITEHEAD MANN LIMITED, LONDON, UNITED KINGDOM:  
2,788,211, CANC. MULTIPLE CLASS, INT. CLS. 16, 35, 41 AND 44.
- WHITEN, LEON, CHICAGO, IL:  
3,352,087, CANC. INT. CL. 41.
- WHITESTONE TEC, RANCHO SANTA FE, CA, DBA WHITESTONE TEC:  
4,592,451, PUB. 6-10-2014. INT. CL. 42.
- WHITESTONE WORKS, LLC, NEW YORK, NY, DBA WHITESTONE WORKS:  
4,593,825, INT. CL. 35.  
4,593,826, INT. CL. 35.
- WHITETAIL PROPERTIES REAL ESTATE, LLC, PITTSFIELD, IL:  
4,591,181, PUB. 6-10-2014. MULTIPLE CLASS, INT. CLS. 35 AND 41.
- WHITMAN'S CANDIES, INC., OVERLAND PARK, KS:  
3,353,043, CANC. INT. CL. 30.
- WHITNEY FOSTER, TUSTIN, CA:  
4,591,447, PUB. 6-10-2014. INT. CL. 25.
- WHITTAKER, SARAH J., WAYCROSS, GA:  
3,352,097, CANC. INT. CL. 45.
- WHO CUTS, LLC, ATLANTA, GA:  
4,593,364, INT. CL. 42.
- WHOELSE UG, BERLIN, FED REP GERMANY:  
4,592,033, PUB. 6-10-2014. INT. CL. 42.

WHOKNOWS, INC., MOUNTAIN VIEW, CA:  
4,593,543, MULTIPLE CLASS, INT. CLS. 9 AND 42.

WHOLE BODY RESEARCH, LLC, STUDIO CITY, CA:  
4,592,628, PUB. 6-10-2014. INT. CL. 5.

WHOLE FOODS MARKET IP, L.P., AUSTIN, TX:  
4,592,571, PUB. 6-10-2014. INT. CL. 36.  
4,594,159, MULTIPLE CLASS, INT. CLS. 35, 39, 42 AND 43.  
4,594,177, MULTIPLE CLASS, INT. CLS. 9, 41, 43 AND 44.

WHOLESOME GENERATION, AUSTIN, TX:  
4,593,536, MULTIPLE CLASS, INT. CLS. 41 AND 43.

WHOWANNA, INC., OKOTOKS, ALBERTA, CANADA:  
4,592,118, PUB. 6-10-2014. INT. CL. 9.

WICKEN, CHRISTOPHER J., WESTMINSTER, CO:  
4,594,384, INT. CL. 20.  
4,594,386, INT. CL. 20.

WIESER & ZELZNICK, INC., CHICAGO, IL:  
4,593,690, INT. CL. 30.

WILCO FARMERS, MOUNT ANGEL, OR:  
4,592,794, PUB. 6-10-2014. INT. CL. 1.

WILD EARTH NATURALS, INC, MESQUITE, NV:  
4,591,778, PUB. 6-10-2014. INT. CL. 3.

WILD HORSES APPAREL, LLC, VERNON, CA:  
4,592,717, PUB. 6-10-2014. INT. CL. 25.

WILD IRISHMAN ADVISORY, LLC, GREENWOOD VIL-  
LAGE, CO:  
4,593,893, INT. CL. 35.

WILDERMUTH, ANNA S., ELMHURST, IL:  
2,796,364, CANC. INT. CL. 41.

WILDERNESS ADVENTURES PRESS, INC., BELGRADE,  
MT:  
3,353,526, CANC. INT. CL. 16.

WILDLIFE RESEARCH CENTER, INC., RAMSEY, MN:  
4,593,729, INT. CL. 5.

WILEY, SHANNON P. STUART, FL:  
3,351,616, CANC. INT. CL. 16.

WILKES, JULIE, COLUMBUS, OH:  
3,354,195, CANC. MULTIPLE CLASS, INT. CLS. 9 AND 41.

WILKHAHN WILKENING + HAHNE GMBH + CO., FED  
REP GERMANY:  
3,352,722.

WILKINSON, MURRAY DEAN, KELOWNA, BRITISH CO-  
LUMBIA, CANADA:  
3,353,276, CANC. INT. CL. 25.

WILLIAM DATA SYSTEMS LIMITED, EAST GRINSTEAD,  
UNITED KINGDOM:  
3,352,315, CANC. INT. CL. 9.

WILLIAM GRANT & SONS IRISH BRANDS LIMITED,  
DUBLIN, IRELAND:  
4,593,283, INT. CL. 33.

WILLIAM HACKETT CHAINS LIMITED, WEST MID-  
LANDS, UNITED KINGDOM:  
4,591,937, PUB. 6-10-2014. INT. CL. 7.

WILLIAM M. BIRD AND COMPANY, INC., CHARLESTON,  
SC:  
2,794,149, CANC. INT. CL. 35.

WILLIAMS-SONOMA, INC., SAN FRANCISCO, CA:  
4,593,505, MULTIPLE CLASS, INT. CLS. 21 AND 35.  
4,593,506, MULTIPLE CLASS, INT. CLS. 21 AND 35.  
4,593,540, INT. CL. 35.

WILLIAMS, KASTNER & GIBBS PLLC, SEATTLE, WA:  
3,371,261, COR. INT. CL. 45.

WILLIAMS, KRISTEN, TOMBALL, TX:  
4,594,014, INT. CL. 41.

WILLIAMS, MORDECAI P., JR., FAIRFAX, VA:  
4,590,611, PUB. 6-10-2014. INT. CL. 25.

WILLIAMS, MOZELL, JR, NORTH CHICAGO, IL:  
3,352,895, CANC. INT. CL. 9.

WILLY BOGNER GMBH & CO.; KOMMANDITGE-  
SELLSCHAFT AUF AKTIEN, FED REP GERMANY:  
3,352,665.

WILMINGTON TRUST COMPANY, WILMINGTON, DE:  
3,354,539, CANC. INT. CL. 36.  
3,354,541, CANC. INT. CL. 36.

WILSON, JULIA A., WASHINGTON, DC:  
4,592,527, PUB. 6-10-2014. INT. CL. 35.

WILSON, TRAVIS T., OAKLAND, CA:  
3,351,744, CANC. INT. CL. 9.

WILZIG, KARIN, NEW YORK, NY:  
4,592,828, PUB. 6-10-2014. INT. CL. 14.

WINDOWS, LLC, CARMEL, IN, DBA RENEWAL BY AN-  
DERSEN:  
4,592,608, PUB. 6-10-2014. INT. CL. 37.

WINDSOR HOLDING COMPANY, COTATI, CA:  
4,592,686, PUB. 6-10-2014. INT. CL. 19.  
4,592,720, PUB. 6-10-2014. INT. CL. 19.

WINE NOT, FRANCE:  
4,590,769, PUB. 6-10-2014. INT. CL. 21.

WINERY EXCHANGE, INC., NOVATO, CA:  
4,593,426, INT. CL. 33.

WINGFAN LTD. & CO. KG, HAMBURG, FED REP GER-  
MANY:  
4,590,754, PUB. 6-10-2014. MULTIPLE CLASS, INT. CLS. 7  
AND 11.

WINSOR TEMPS OF NEW YORK, INC., ISELIN, NJ:  
4,592,246, PUB. 6-10-2014. INT. CL. 35.

WINSTON PRODUCTS LLC, CLEVELAND, OH:  
4,593,604, MULTIPLE CLASS, INT. CLS. 6, 8, 9, 11, 12  
AND 20.

WINTERS, GLENN, NEW LEBANON, NY:  
4,593,813, INT. CL. 7.

WIORA, JOHN, NAPERVILLE, IL AND WIORA, NANCY,  
NAPERVILLE, IL:  
4,593,565, INT. CL. 28.

WISCONSIN HEART SC, MADISON, WI:  
3,351,383, CANC. INT. CL. 44.

WISE CHOICE PRODUCTS, INC., EL CAJON, CA:  
4,594,017, INT. CL. 5.

WISE.IO, INC., BERKELEY, CA:  
4,591,217, PUB. 6-10-2014. INT. CL. 9.

WISHING AND HOPING L.L.C., PEORIA, IL:  
4,593,871, INT. CL. 45.

WJG LLC, ROCKVILLE, MD:  
4,594,751, INT. CL. 41.

WMK, INC., AKRON, OH:  
4,594,574, INT. CL. 35.

WMS GAMING INC., WAUKEGAN, IL:  
3,353,359, CANC. INT. CL. 9.

WNBA ENTERPRISES, LLC, SECAUCUS, NJ:  
4,591,761, PUB. 6-10-2014. INT. CL. 9.

WOD OUTLET, JAMESTOWN, NC:  
4,592,308, PUB. 6-10-2014. INT. CL. 35.

WOEBER MUSTARD MANUFACTURING COMPANY,  
SPRINGFIELD, OH:  
2,874,570, REN. 7-24-14. INT. CL. 35.

WOERNER SPORTS TURF INTERNATIONAL OF HAWAII,  
LLC, FOLEY, AL:  
1,844,615, REN. 7-23-14. INT. CL. 31.  
1,844,615, CANC. INT. CL. 37.

WOLFF SHOE COMPANY, FENTON, MO:  
4,594,584, INT. CL. 25.

WOLO MANUFACTURING CORP., DEER PARK, NY:  
4,591,118, PUB. 6-10-2014. INT. CL. 9.

WOLVERINE WORLD WIDE, INC., ROCKFORD, MI:  
4,593,074, INT. CL. 25.

WOMEN ON A MISSION TO EARN COMMISSION, LONG-  
WOOD, FL, DBA WOAMTEC:  
4,591,160, PUB. 6-10-2014. INT. CL. 35.

WONG, TREVOR S., CORAM, NY:  
4,592,304, PUB. 6-10-2014. INT. CL. 9.

WOOD RANCH BARBECUE & GRILL, INC., AGOURA  
HILLS, CA:  
3,352,162, CANC. INT. CL. 43.

WOOD, JEFF, PARK CITY, UT:  
3,353,384, CANC. INT. CL. 25.

WOODMEISTER MASTER BUILDERS, INC., HOLDEN, MA:  
4,591,213, PUB. 6-10-2014. INT. CL. 37.  
4,591,216, PUB. 6-10-2014. INT. CL. 37.

WOODY CREEK DISTILLERS, LLC, WOODY CREEK, CO:  
4,594,728, MULTIPLE CLASS, INT. CLS. 41 AND 43.

WOOLWORTHS PLC, LONDON NW1 6JL, UNITED KING-  
DOM:  
3,350,620, CANC. INT. CL. 25.

- WOOREE NANOPHIL CO., LTD., REPUBLIC OF KOREA:  
4,590,715, PUB. 6-10-2014. INT. CL. 24.
- WORDS OF LIFE CHRISTIAN CENTER, BRONX, NY:  
4,591,221, PUB. 6-10-2014. MULTIPLE CLASS, INT. CLS.  
9, 16 AND 45.
- WORK FORCE, INC., WALPOLE, MA:  
2,794,163, CANC. INT. CL. 25.  
2,794,311, CANC. INT. CL. 25.
- WORKFLOWONE LLC, DAYTON, OH:  
4,592,085, PUB. 6-10-2014. INT. CL. 35.
- WORKING WITH COLOUR PTY LTD; ACN 069 622 215,  
AUSTRALIA:  
3,352,603.
- WORKSHOP XI, INC., SAN RAFAEL, CA:  
4,593,238, MULTIPLE CLASS, INT. CLS. 18 AND 28.
- WORLD ANTHEM TECHNOLOGIES, INC., PENNS PARK,  
PA:  
3,351,407, CANC. INT. CL. 42.
- WORLD BUDDHIST-HANMI ASSOCIATION, THE, LA  
PUENTE, CA, DBA DARI RULAI TEMPLE:  
4,593,400, INT. CL. 45.
- WORLD GYM INTERNATIONAL IP, LLC, LOS ANGELES,  
CA:  
3,351,427, CANC. INT. CL. 41.
- WORLD OF JEANS & TOPS, IRVINE, CA:  
3,385,905, COR. INT. CL. 3.
- WORLD PAC INTERNATIONAL, A.G., STURTEVANT, WI:  
2,870,212, REN. 7-21-14. INT. CL. 18.
- WORLD RENEW, GRAND RAPIDS, MI:  
4,592,176, PUB. 6-10-2014. MULTIPLE CLASS, INT. CLS.  
35, 36 AND 41.
- WORLD TECH, INC., HOUSTON, TX:  
3,293,962, CANC. MULTIPLE CLASS, INT. CLS. 25 AND  
32.
- WORLD WRESTLING ENTERTAINMENT, INC., STAM-  
FORD, CT:  
4,593,423, MULTIPLE CLASS, INT. CLS. 41 AND 45.  
4,594,083, INT. CL. 28.  
4,594,271, INT. CL. 41.
- WORLDSCAPE, INC., MARTINSVILLE, NJ:  
3,353,165, CANC. MULTIPLE CLASS, INT. CLS. 9, 35, 41  
AND 42.
- WORLDTELEMETRY, INC., TULSA, OK:  
3,350,907, CANC. INT. CL. 42.
- WORLDWIDE EQUIPMENT EXCHANGE, LLC, SALT LAKE  
CITY, UT:  
4,591,132, PUB. 6-10-2014. INT. CL. 45.
- WORLDWIDE INSURANCE NETWORK, INC., HIGH  
POINT, NC:  
3,973,602, COR. INT. CL. 36.
- WOW KNIT, INC., LOS ANGELES, CA:  
3,353,323, CANC. INT. CL. 25.
- WP IP, LLC, NEW YORK, NY, WEST POINT-PEPPERELL,  
INC., WEST POINT, GA:  
987,952, REN. 7-22-14. U.S. CL. 42 (INT. CLS. 22, 24, 26  
AND 27).
- WRANN, REBECCA, J, WEST HOLLYWOOD, CA:  
3,351,983, CANC. INT. CL. 44.
- WRH MARKETING AG, CH-8032 HINWIL, SWITZERLAND:  
3,352,623.
- WRIGHT MEDICAL TECHNOLOGY, INC., ARLINGTON,  
TN:  
2,795,747, CANC. INT. CL. 10.
- WRIT LEGAL, KENSINGTON, MD:  
4,592,280, PUB. 6-10-2014. INT. CL. 45.  
4,592,346, PUB. 6-10-2014. INT. CL. 45.
- WSG TOUR 18 IV, LP, DALLAS, TX:  
4,591,491, PUB. 6-10-2014. INT. CL. 41.
- WU, JASON, NEW YORK, NY:  
4,593,088, MULTIPLE CLASS, INT. CLS. 9 AND 18.
- WUNDERKRAUT HOLDING S.A., LUXEMBOURG:  
4,590,665, PUB. 6-10-2014. MULTIPLE CLASS, INT. CLS.  
9, 35, 38, 41 AND 42.
- WUXI JUST-PET CO.,LTD, WUXI CITY, CHINA:  
4,590,807, PUB. 6-10-2014. INT. CL. 18.
- WWRD, INC, WINDSOR, CA:  
4,594,465, INT. CL. 20.
- WYERS PRODUCTS GROUP, INC., CENTENNIAL, CO:  
3,351,328, CANC. INT. CL. 12.
- WYETH LLC, MADISON, NJ:  
1,719,470, CANC. INT. CL. 16.  
3,353,353, CANC. INT. CL. 5.
- WYNDHAM HOTELS AND RESORTS, LLC, PARSIPPANY,  
NJ:  
4,594,339, INT. CL. 36.
- WYNN RESORTS HOLDINGS, LLC, LAS VEGAS, NV:  
4,593,073, INT. CL. 35.
- X-L SUPPLIES & SUNDRIES, INC., ANAHEIM, CA:  
3,354,620, CANC. MULTIPLE CLASS, INT. CLS. 8, 16  
AND 21.
- XALT ENERGY, LLC, WILMINGTON, DE:  
4,593,355, INT. CL. 9.
- XANDRIE, FRANCE:  
4,590,668, PUB. 6-10-2014. MULTIPLE CLASS, INT. CLS.  
9, 28, 35, 38, 41 AND 42.
- XANDROS, INC., NEW YORK, NY:  
2,794,132, CANC. INT. CL. 9.  
2,794,133, CANC. INT. CL. 9.
- XENCOR, INC., MONROVIA, CA:  
3,353,553, CANC. INT. CL. 1.
- XENOC S.A., SASSENAGE, FRANCE:  
2,864,906, REN. 7-21-14. INT. CL. 42.  
2,886,288, REN. 7-21-14. INT. CL. 9.
- XEROCOLE, INC., BOULDER, CO:  
4,592,436, PUB. 6-10-2014. INT. CL. 42.
- XEROX CORPORATION, NORWALK, CT:  
2,796,143, CANC. INT. CL. 9.
- XHL INTERNATIONAL, LLC, PORTLAND, OR:  
3,315,954, CANC. INT. CL. 41.
- XIA MEN AI MEI SEN BAO ZHUANG; YOU XIAN GONG  
SI, CHINA:  
4,590,738, PUB. 6-10-2014. INT. CL. 7.
- XIAMEN CITY SPARK IMP. & EXP. CO., LTD., XIAMEN,  
CHINA:  
4,591,094, PUB. 6-10-2014. INT. CL. 18.
- XIAO SHU, WUHAN, HUBEI, CHINA:  
4,592,647, PUB. 6-10-2014. INT. CL. 16.
- XILINMEN FURNITURE CO., LTD., ZHEJIANG PRO-  
VINCE, CHINA:  
4,592,954, PUB. 6-10-2014. MULTIPLE CLASS, INT. CLS.  
20 AND 24.
- XITEBIO TECHNOLOGIES, INC., WINNIPEG, MANITOBA,  
CANADA:  
4,593,780, INT. CL. 1.
- XOMEKA, INC., HILLSBORO, OR:  
3,354,348, CANC. MULTIPLE CLASS, INT. CLS. 14, 20  
AND 35.
- XPRESSDOCS PARTNERS, LTD., FORT WORTH, TX:  
4,592,397, PUB. 6-10-2014. INT. CL. 42.
- XTREME BUBBLES, LLC, MINNEAPOLIS, MN:  
3,354,126, CANC. INT. CL. 28.  
3,354,148, CANC. INT. CL. 28.
- XTREME TOOLS INTERNATIONAL, INC., MIAMI, FL:  
4,593,271, INT. CL. 3.
- XYDIAS, ALEX B., SUN VALLEY, CA, DBA SO-CAL SPEED  
SHOP:  
2,864,157, REN. 7-22-14. INT. CL. 12.
- XYZZY PRESS, LLC, BRENTWOOD, TN:  
3,354,217, CANC. MULTIPLE CLASS, INT. CLS. 9, 16  
AND 41.
- Y.Z.Y. INC., MIAMI, FL:  
2,813,966, REN. 7-22-14. INT. CL. 3.
- Y.Z.Y., INC., MIAMI, FL:  
2,831,510, REN. 7-22-14. INT. CL. 3.
- YAHFOUFI, HUSSEIN, SAN DIEGO, CA, DBA APPSPLIT:  
4,591,103, PUB. 6-10-2014. MULTIPLE CLASS, INT. CLS. 9  
AND 35.
- YAHOO! INC., SUNNYVALE, CA:  
2,862,094, REN. 7-24-14. MULTIPLE CLASS, INT. CLS. 35  
AND 36.
- YAMAMOTO, ANTHONY KIYOSHI, COSTA MESA, CA:  
3,274,024, CANC. INT. CL. 25.
- YANIV, WENDY, MARIETTA, GA:  
4,592,231, PUB. 6-10-2014. INT. CL. 39.

YARDI SYSTEMS, INC., GOLETA, CA:  
4,594,096, INT. CL. 35.

YARDS BREWING COMPANY, LLC, PHILADELPHIA, PA:  
4,593,843, INT. CL. 32.

YAREMENKO SERHII VASYLOVYCH, UKRAINE:  
4,590,912, PUB. 6-10-2014. INT. CL. 35.

YARNMARKET, LLC, PICKERINGTON, OH:  
3,650,963, COR. INT. CL. 35.

YARNTOPIA, LLC, KATY, TX:  
3,351,477, CANC. INT. CL. 35.

YCARO, LLC, JUPITER, FL:  
2,794,732, CANC. INT. CL. 5.

YELJIM FISHING LURES LLC, RUSHSYLVANIA, OH:  
4,593,867, INT. CL. 28.

YELLOW FIN, INC., AUSTIN, TX:  
3,353,896, CANC. INT. CL. 35.

YIELDQUEST SECURITIES, ATLANTA, GA:  
4,592,693, PUB. 6-10-2014. INT. CL. 36.

YILLIO, INC., RALEIGH, NC:  
4,592,897, PUB. 6-10-2014. MULTIPLE CLASS, INT. CLS. 9 AND 35.

YIWU JIMAO ELECTRONIC TECHNOLOGY CO., LTD.,  
YIWU CITY, ZHEJIANG, CHINA:  
4,592,656, PUB. 6-10-2014. INT. CL. 14.

YKK CORPORATION, TOKYO, JAPAN:  
3,350,643, CANC. MULTIPLE CLASS, INT. CLS. 18 AND 26.

YO MAMA'S BIG FAT BOOTY BAND L.L.C., HOLLY  
SPRINGS, NC:  
3,354,651, CANC. INT. CL. 25.

YOGA JOURNEYS PRODUCTIONS, INC, SCRANTON, PA,  
DBA YOGA JOURNEYS:  
4,594,712, INT. CL. 41.

YOKOGAWA ELECTRIC CORPORATION, TOKYO, JAPAN:  
2,874,138, REN. 7-22-14. INT. CL. 9.

YONGKANG QINGWU INDUSTRY & TRADE CO.,LTD,  
ZHEJIANG PROVINCE, CHINA:  
4,592,645, PUB. 6-10-2014. INT. CL. 29.

YOO, KENNY K., LOS ANGELES, CA:  
4,594,516, INT. CL. 25.

YOOTER INTERACTIVE MARKETING LLC, POTTSVILLE,  
PA:  
3,351,267, CANC. INT. CL. 35.

YORK RESIDENTIAL, LLC, ATLANTA, GA:  
3,351,436, CANC. INT. CL. 37.

YOU B-YOU, APOPKA, FL, DBA BEHOOVEME:  
4,591,843, PUB. 6-10-2014. INT. CL. 35.

YOUNG MOUNTAIN TEA, LLC, EUGENE, OR:  
4,592,776, PUB. 6-10-2014. INT. CL. 30.

YOUNG WOMEN'S CHRISTIAN ASSOCIATION OF SALT  
LAKE CITY, SALT LAKE CITY, UT:  
4,592,779, PUB. 6-10-2014. INT. CL. 41.

YOUNGS, LESLIE G., CARMICHAEL, CA:  
3,351,733, CANC. INT. CL. 41.

YOUR PERSONAL COACH, LLC, WEST ORANGE, NJ:  
3,352,101, CANC. INT. CL. 41.

YOUR PRIVATE ITALY, LLC, ANNAPOLIS, MD:  
4,591,684, PUB. 6-10-2014. INT. CL. 39.

YOURTEL AMERICA, INC., KANSAS CITY, MO:  
3,353,439, CANC. INT. CL. 38.

YS HEALTH, MT, PROSPECT, IL:  
4,592,186, PUB. 6-10-2014. INT. CL. 5.

YTEL, INC., IRVINE, CA:  
4,591,822, PUB. 6-10-2014. MULTIPLE CLASS, INT. CLS.  
35, 38 AND 42.

YU SHIN CHEMICAL CO., LTD., TAIPEI, TAIWAN:  
2,866,314, REN. 7-24-14. INT. CL. 21.

YUPO CORPORATION, TOKYO, JAPAN:  
4,593,247, INT. CL. 16.

YUSUF, OSMAN, AUSTIN, TX:  
4,594,353, INT. CL. 35.

YUTRON CO., LTD., NEW TAIPEI CITY 235, TAIWAN:  
4,593,737, INT. CL. 9.

YVES SAINT LAURENT PARFUMS, 92200 NEUILLY SUR  
SEINE, FRANCE:  
2,794,188, CANC. INT. CL. 3.

YVES SAINT LAURENT PARFUMS, FRANCE:  
3,352,526.

YVES SAINT LAURENT PARFUMS, PARIS, FRANCE:  
4,591,850, PUB. 6-10-2014. INT. CL. 3.

YX PROPERTIES, LLC, OMAHA, NE:  
2,796,277, CANC. MULTIPLE CLASS, INT. CLS. 35 AND  
39.

Z BRAND MARKETING, LLC, HIGHLAND, UT:  
4,592,929, PUB. 6-10-2014. INT. CL. 29.  
4,592,930, PUB. 6-10-2014. INT. CL. 30.

Z OPTION, INC., LEWISVILLE, TX:  
4,591,792, PUB. 6-10-2014. INT. CL. 9.

Z-MAN FISHING PRODUCTS, INC., HANAHAN, SC:  
3,354,089, CANC. INT. CL. 28.

Z-MEDICA, LLC, WALLINGFORD, CT:  
3,351,193, CANC. INT. CL. 5.

ZADOYAN, ARMENAK, VAN NUYS, CA AND SHAKH-  
GELDYAN, VAHE, VAN NUYS, CA:  
4,592,409, PUB. 6-10-2014. INT. CL. 35.

ZAGGORA LIMITED, UNITED KINGDOM:  
4,590,747, PUB. 6-10-2014. MULTIPLE CLASS, INT. CLS.  
3, 25, 28, 35, 41 AND 44.

ZAKRYTOE AKTSIONERNOE OBSHCHESTVO "PHARM-  
SINTEZ", RU-111024 MOSCOW, RUSSIAN FED.:  
4,590,791, PUB. 6-10-2014. MULTIPLE CLASS, INT. CLS. 3  
AND 5.

ZANER-BLOSER, INC., COLUMBUS, OH:  
3,351,552, CANC. INT. CL. 16.  
3,351,603, CANC. INT. CL. 9.

ZANINI, LUCA, BUTTIGLIERA ALTA (TO), ITALY:  
3,354,660, CANC. INT. CL. 15.

ZAPPA FAMILY TRUST, THE, STUDIO CITY, CA:  
2,865,515, REN. 7-22-14. INT. CL. 25.

ZARVAD III LTDA., SAN JOSE, COSTA RICA:  
3,351,558, CANC. INT. CL. 36.

ZEENIE DOLLZ LLC, GARDEN GROVE, CA:  
4,593,785, INT. CL. 28.

ZELBY, LLC, PAWTUCKET, RI:  
2,886,780, REN. 7-24-14. INT. CL. 35.

ZELCO INDUSTRIES, INC., MOUNT VERNON, NY:  
1,881,339, REN. 7-20-14. INT. CL. 9.

ZENMARK BRANDING SERVICES, INCORPORATED, SAN  
FRANCISCO, CA:  
3,353,996, CANC. MULTIPLE CLASS, INT. CLS. 35 AND  
42.

ZEPHTEX INDUSTRIES, INC., SAN CLEMENTE, CA:  
4,591,814, PUB. 6-10-2014. INT. CL. 14.

ZERO MOTORCYCLES, INC., SCOTTS VALLEY, CA:  
4,590,623, PUB. 3-16-2010. INT. CL. 12.

ZETETIC INSTITUTE, TUCSON, AZ:  
2,793,955, CANC. MULTIPLE CLASS, INT. CLS. 41 AND  
42.

ZF FRIEDRICHSHAFEN AG, 88046 FRIEDRICHSHAFEN,  
FED REP GERMANY:  
4,590,789, PUB. 6-10-2014. INT. CL. 9.

ZHANG PENG, HENAN, CHINA:  
4,592,592, PUB. 6-10-2014. INT. CL. 9.

ZHANG, JUN, PAW PAW, MI:  
4,591,700, PUB. 6-10-2014. INT. CL. 30.

ZHEJIANG ANHONG PLUMBING CO.,LTD., CHINA:  
4,590,796, PUB. 6-10-2014. INT. CL. 11.

ZHEJIANG HISOAR PHARMACEUTICAL CO., LTD., CHI-  
NA:  
4,590,713, PUB. 6-10-2014. INT. CL. 5.

ZHEJIANG TOPSUN LOGISTIC CONTROL CO., LTD.,  
317600 ZHEJIANG, CHINA:  
4,590,845, PUB. 6-10-2014. MULTIPLE CLASS, INT. CLS.  
6, 7, 8, 12 AND 22.

ZHEJIANG XINAO TEXTILES INC., ZHEJIANG PRO-  
VINCE, CHINA:  
4,594,129, INT. CL. 23.  
4,594,130, INT. CL. 25.  
4,594,131, INT. CL. 23.  
4,594,132, INT. CL. 25.

ZHONE TECHNOLOGIES, INC., OAKLAND, CA:  
3,353,321, CANC. INT. CL. 9.

ZHONG'AO HOLDINGS GROUP CO., LTD, DEZHOU,  
SHANDONG, CHINA:  
4,592,069, PUB. 6-10-2014. INT. CL. 29.

- ZHOU, HUITANG, BLOOMINGTON, IN:  
4,591,253, PUB. 6-10-2014. MULTIPLE CLASS, INT. CLS. 1 AND 5.
- ZICAM, LLC, SCOTTSDALE, AZ:  
2,920,000, REN. 7-21-14. INT. CL. 5.
- ZIEBART INTERNATIONAL CORPORATION, TROY, MI:  
997,168, REN. 7-22-14. U.S. CL. 103 (INT. CL. 37).
- ZIGBRO INC., LAKE FOREST, IL:  
4,594,772, INT. CL. 35.
- ZIGI ENTERPRISES, INC., NEW YORK, NY:  
4,593,134, INT. CL. 18.
- ZIKE, LLC, GREENVILLE, SC:  
4,593,789, INT. CL. 12.
- ZILKNATION, REDWOOD CITY, CA:  
4,594,525, INT. CL. 35.
- ZIMMERMAN, MICHAEL, WACO, TX:  
3,354,671, CANC. INT. CL. 45.
- ZIMMERMANN HOMES, LLC, FALLS CHURCH, VA:  
4,592,276, PUB. 6-10-2014. INT. CL. 37.
- ZINCOS PRODUCTS INC., GATINEAU, CANADA, DBA WHOLESALE OF PRODUCTS:  
4,591,108, PUB. 6-10-2014. INT. CL. 18.
- ZINUS INC., SAN LEANDRO, CA:  
4,593,824, INT. CL. 20.
- ZIPPYDOGS, LLC, SEATTLE, WA:  
2,794,264, CANC. MULTIPLE CLASS, INT. CLS. 25 AND 41.
- ZIPSTEAL LLC, MORRIS PLAINS, NJ:  
4,594,152, INT. CL. 9.
- ZIRC COMPANY, BUFFALO, MN:  
4,593,624, INT. CL. 3.
- ZIXCORP SYSTEMS, INC., DALLAS, TX:  
2,813,143, REN. 7-21-14. INT. CL. 42.
- ZIZZLE ACQUISITION COMPANY, BANNOCKBURN, IL:  
3,354,386, CANC. INT. CL. 28.
- ZLM ACQUISITIONS, L.L.C., ORANGE BEACH, AL:  
3,351,048, CANC. INT. CL. 43.  
3,351,049, CANC. INT. CL. 43.
- ZODIAK MEDIA, F-92200 NEUILLY-SUR-SEINE, FRANCE:  
4,590,627, PUB. 6-10-2014. MULTIPLE CLASS, INT. CLS. 38 AND 45.
- ZODIAX A.S., PRAHA 4 - KUNRATICE, CZECH REPUBLIC:  
4,590,956, PUB. 6-10-2014. MULTIPLE CLASS, INT. CLS. 14, 35 AND 40.
- ZOE MARKETING, INC., SAN DIEGO, CA:  
4,592,528, PUB. 6-10-2014. MULTIPLE CLASS, INT. CLS. 25 AND 35.
- ZOOLIFE, INC., ESCONDIDO, CA:  
3,352,498, CANC. MULTIPLE CLASS, INT. CLS. 5 AND 31.
- ZOOM L.L.C., SPRINGVILLE, NY:  
3,353,364, CANC. INT. CL. 20.
- ZOU JIANQUAN, CHANGDE, HUNAN, CHINA:  
4,591,836, PUB. 6-10-2014. INT. CL. 15.
- ZUCARO, ANDREW, FAIRFIELD, NJ:  
3,354,381, CANC. INT. CL. 1.  
4,592,242, PUB. 6-10-2014. INT. CL. 7.
- ZUCKERFORSCHUNG TULLN; GESELLSCHAFT M.B.H., AUSTRIA:  
3,352,728.
- ZUKERMAN, DAVID BENADERET, MONTEVIDEO, URUGUAY:  
4,591,702, PUB. 6-10-2014. MULTIPLE CLASS, INT. CLS. 39 AND 45.
- ZUMA DENTAL, LLC, LOS ANGELES, CA:  
4,593,284, INT. CL. 10.
- ZUMTOBEL LIGHTING GMBH, DORNBIERN, AUSTRIA:  
3,351,975, CANC. MULTIPLE CLASS, INT. CLS. 9, 11 AND 42.
- ZUP, LLC, WILLIAMSBURG, VA, FORMERLY GLEN WADE DUFF:  
4,592,412, PUB. 6-10-2014. INT. CL. 28.
- ZYGOTE MEDIA GROUP, INC., AMERICAN FORK, UT:  
4,594,189, MULTIPLE CLASS, INT. CLS. 9, 41 AND 42.
- Z24 LANDSCAPING INC., TORRANCE, CA:  
4,591,713, PUB. 6-10-2014. INT. CL. 44.
- 0960980 B.C. LTD., DAWSON CREEK, BC, CANADA:  
4,593,848, MULTIPLE CLASS, INT. CLS. 35 AND 41.
- 1 DAWG, LLC, LEAWOOD, KS:  
3,354,085, CANC. INT. CL. 42.  
3,354,086, CANC. INT. CL. 42.  
3,354,087, CANC. INT. CL. 42.  
3,354,088, CANC. INT. CL. 42.
- 1-800-HOUSING.NET LLC., LITTLE ROCK, AR, DBA 1-800-HOUSING:  
3,354,522, CANC. MULTIPLE CLASS, INT. CLS. 35 AND 36.
- 1-800-LENDING, INC., STERLING, VA:  
3,354,662, CANC. INT. CL. 36.
- 1C LIMITED LIABILITY COMPANY, MOSCOW, RUSSIAN FED., AKA 1C LLC:  
4,593,642, MULTIPLE CLASS, INT. CLS. 9 AND 42.
- 1FW TRAINING, LLC, ANTHEM, AZ:  
4,593,773, MULTIPLE CLASS, INT. CLS. 25 AND 41.
- 100% NATURAL GOURMET INC, SCOTTSDALE, AZ, DBA MADISON GROUP CONSULTANTS:  
3,351,499, CANC. INT. CL. 43.
- 1010DATA, INC., NEW YORK, NY:  
4,592,097, PUB. 6-10-2014. INT. CL. 42.
- 1214 FOUNDATION, INC., NEWTOWN, CT:  
4,592,441, PUB. 6-10-2014. INT. CL. 36.
- 13 & B TRADING, LEVITTOWN, NY, DBA TRICHOTOMY CLOTHING:  
4,594,471, INT. CL. 25.
- 138060 CANADA INC., QUEBEC, CANADA:  
2,860,193, REN. 7-22-14. INT. CL. 8.
- 15 FOOTER, LLC, CONYERS, GA:  
4,593,172, INT. CL. 25.
- 2 GUYS LOANS, LLC, PROVO, UT:  
4,591,255, PUB. 6-10-2014. INT. CL. 36.
- 2 SCOOPS, LLC, BEVERLY, MA:  
4,593,708, MULTIPLE CLASS, INT. CLS. 30 AND 43.
- 2 VIRTUES, INC., PAWTUCKET, RI:  
3,354,270, CANC. INT. CL. 25.
- 2DOCSORGANIC, LLC, ARMONK, NY:  
4,591,554, PUB. 6-10-2014. MULTIPLE CLASS, INT. CLS. 32 AND 35.
- 2UP LLC, NORRISTOWN, PA:  
4,592,251, PUB. 6-10-2014. INT. CL. 41.
- 20/20 GENESYSTEMS, INC., ROCKVILLE, MD:  
3,352,474, CANC. INT. CL. 1.
- 21ST CENTURY JET CORPORATION, RENO, NV:  
2,869,741, REN. 7-18-14. INT. CL. 36.
- 24-7 TELCOM, INC., EAU CLAIRE, WI:  
4,591,658, PUB. 6-10-2014. MULTIPLE CLASS, INT. CLS. 37, 38, 42 AND 45.
- 247.COM LLC, HENDERSON, NV:  
4,593,863, INT. CL. 39.  
4,593,864, INT. CL. 41.  
4,593,865, INT. CL. 43.
- 29:11, INC., SPRING, TX:  
3,351,821, CANC. INT. CL. 41.
- 3 PORCH FARM INC., COMER, GA:  
4,594,753, INT. CL. 30.
- 3 ZEROS CORP, BIRMINGHAM, MI:  
4,594,552, INT. CL. 30.
- 3M COMPANY, ST. PAUL, MN:  
990,791, REN. 7-18-14. U.S. CL. 23 (INT. CL. 16).
- 3SDM LTD, SWAY, UNITED KINGDOM:  
4,591,849, PUB. 6-10-2014. INT. CL. 12.
- 3X30 YOGA, LLC, COSTA MESA, CA:  
4,592,724, PUB. 6-10-2014. INT. CL. 41.
- 337 TECHNOLOGY LIMITED, BEIJING, CHINA:  
4,594,301, INT. CL. 9.  
4,594,302, INT. CL. 9.
- 360 LIVE MEDIA, LLC, WASHINGTON, DC:  
4,592,389, PUB. 6-10-2014. INT. CL. 35.
- 4INTERNET, LLC, LAS VEGAS, NV:  
4,591,726, PUB. 6-10-2014. INT. CL. 35.
- 43RD STREET RESTAURANT, LLC, NEW YORK, NY:  
4,590,953, PUB. 6-10-2014. INT. CL. 43.
- 630 ENTERPRISES, TORRANCE, CA:  
3,350,781, CANC. INT. CL. 12.
- 7 DIAMONDS CLOTHING CO. INC., TUSTIN, CA:  
2,795,810, CANC. INT. CL. 25.

703 HOLDINGS, INC., ATLANTA, GA:  
3,354,020, CANC. INT. CL. 41.  
80-20 SOFTWARE, INC., BELLEVUE, WA:  
3,351,183, CANC. INT. CL. 9.  
85086 MAGAZINE, LLC, PHOENIX, AZ:  
4,594,629, INT. CL. 16.  
8708975 CANADA INC., MONTREAL, QUEBEC, CANADA:  
3,518,877, CANC. INT. CL. 18.  
9 LINE APPAREL LLC, SAVANNAH, GA:  
4,592,165, PUB. 6-10-2014, INT. CL. 25.

9001-6262 QUEBEC INC., SAINT-AUGUSTIN-DE-DES-  
MAURES, QUEBEC, CANADA:  
3,353,402, CANC. MULTIPLE CLASS, INT. CLS. 9, 12, 18,  
21, 25 AND 28.  
9151-8886 QUÉBEC INC., BERTHIER-SUR-MER, CANADA:  
3,351,947, CANC. INT. CL. 15.  
92101 CONDO GURU INC., SAN DIEGO, CA:  
4,592,032, PUB. 6-10-2014, INT. CL. 35.

\* \* \* \* \*